

McGRAW-HILL  
CONCISE  
ENCYCLOPEDIA *of*  
SCIENCE AND  
TECHNOLOGY  
FIFTH EDITION

McGRAW-HILL  
**CONCISE**  
ENCYCLOPEDIA  
OF SCIENCE &  
TECHNOLOGY

FIFTH EDITION

McGRAW-HILL

---

**CONCISE  
ENCYCLOPEDIA  
OF SCIENCE &  
TECHNOLOGY**

**FIFTH EDITION**

McGraw-Hill

---

New York Chicago San Francisco Lisbon London Madrid Mexico City  
Milan New Delhi San Juan Seoul Singapore Sydney Toronto

**Library of Congress Cataloging in Publication Data**

McGraw-Hill concise encyclopedia of science & technology.—5th ed.

p. cm.

Includes bibliographical references and index.

ISBN 0-07-142957-3

1. Science—Encyclopedias. 2. Technology—  
Encyclopedias. I. Title: Concise encyclopedia of science &  
technology.

Q121.M29 2004  
503—dc22

2004054909

This material was extracted from the *McGraw-Hill Encyclopedia of Science & Technology*, Ninth Edition, © 2002, Eighth Edition, © 1997, Seventh Edition, © 1992, Sixth Edition, © 1987, Fifth Edition, © 1982 by The McGraw-Hill Companies, Inc. All rights reserved.

McGRAW-HILL CONCISE ENCYCLOPEDIA OF SCIENCE & TECHNOLOGY, Fifth Edition, copyright © 2005 by The McGraw-Hill Companies, Inc. All rights reserved. Printed in the United States of America. Except as permitted under the United States Copyright Act of 1976, no part of this publication may be reproduced or distributed in any form or by any means, or stored in a database or retrieval system, without the prior written permission of the publisher.

1 2 3 4 5 6 7 8 9 0 DOW/DOW 0 10 9 8 7 6 5 4

This book was printed on acid-free paper.

It was set in Helvetica Black and Souvenir Light by TechBooks, Fairfax, Virginia.

The book was printed and bound by RR Donnelley, The Lakeside Press.

# Contents

<b>Staff</b> .....	vi
<b>Consulting Editors</b> .....	vii
<b>Preface</b> .....	ix
<b>Organization of the Encyclopedia</b> .....	xi
<b>Articles A–Z</b> .....	1–2421
<b>Appendix</b> .....	2425–2569
Bibliographies .....	2425
U.S. Customary System and the metric system .....	2449
International System .....	2449
Conversion factors for the measurement systems .....	2449
Units of temperature in measurement systems .....	2454
Symbols for the chemical elements .....	2454
Chemical nomenclature .....	2454
Symbols in scientific writing .....	2455
Mathematical signs and symbols .....	2458
Mathematical notation .....	2458
Fundamental constants .....	2460
Fundamental particles .....	2463
Geologic time scale and related aspects .....	2464
Biographical listing .....	2465
<b>Contributors</b> .....	2489–2569
Contributor Initials .....	2489
Contributor Affiliations .....	2513
<b>Index</b> .....	2571

# Editorial Staff

**Mark D. Licker**, Publisher

**Elizabeth Geller**, Managing Editor

**Jonathan Weil**, Senior Staff Editor

**David Blumel**, Editor

**Alyssa Rappaport**, Editor

**Charles Wagner**, Manager, Digital Content

**Renee Taylor**, Editorial Assistant

# Editing, Design, and Production Staff

**Roger Kasunic**, Vice President—Editing, Design, and Production

**Joe Faulk**, Editing Manager

**Frank Kotowski, Jr.**, Senior Editing Supervisor

**Ron Lane**, Art Director

**Vincent Piazza**, Assistant Art Director

**Thomas G. Kowalczyk**, Production Manager

**Pamela A. Pelton**, Senior Production Supervisor

# Consulting Editors

- Dr. Milton B. Adesnik.** *Department of Cell Biology, New York University School of Medicine, New York.* CELL BIOLOGY.
- Prof. P. W. Atkins.** *Department of Chemistry, Lincoln College/Oxford University, Oxford, England.* THERMODYNAMICS.
- A. Earle Bailey.** *Deceased; formerly, Superintendent of Electrical Science, National Physical Laboratory, London.* ELECTRICITY AND ELECTROMAGNETISM.
- Prof. William P. Banks.** *Chairman, Department of Psychology, Pomona College, Claremont, California.* PHYSIOLOGICAL AND EXPERIMENTAL PSYCHOLOGY.
- Prof. Ted Barnes.** *Physics Division, Oak Ridge National Laboratory, Oak Ridge, Tennessee.* ELEMENTARY PARTICLE PHYSICS.
- Dr. Paul Barrett.** *Department of Palaeontology, The Natural History Museum, London.* VERTEBRATE PALEONTOLOGY.
- Prof. Ray Benekohal.** *Department of Civil and Environmental Engineering, University of Illinois at Urbana-Champaign.* TRANSPORTATION ENGINEERING.
- Prof. Carrol Bingham.** *Department of Physics, University of Tennessee, Knoxville.* NUCLEAR AND ELEMENTARY PARTICLE PHYSICS.
- Michael L. Bosworth.** *Vienna, Virginia.* NAVAL ARCHITECTURE AND MARINE ENGINEERING.
- Dr. Chaim Braun.** *Retired; formerly, Altos Management Consultants, Inc., Los Altos, California.* NUCLEAR ENGINEERING.
- Robert D. Briskman.** *Technical Executive, Sirius Satellite Radio, New York.* TELECOMMUNICATIONS.
- Prof. Richard O. Buckius.** *Department of Mechanical and Industrial Engineering, University of Illinois at Urbana-Champaign.* MECHANICAL ENGINEERING.
- Prof. Laurie J. Butler.** *Department of Chemistry, University of Chicago.* PHYSICAL CHEMISTRY.
- Dr. Mark Chase.** *Molecular Systematics Section, Jodrell Laboratory, Royal Botanic Gardens, Kew, Richmond, Surrey, United Kingdom.* PLANT TAXONOMY.
- Prof. Wai-Fah Chen.** *Dean, College of Engineering, University of Hawaii, Honolulu.* CIVIL ENGINEERING.
- Dr. John F. Clark.** *Director, Graduate Studies, and Professor, Space Systems, Spaceport Graduate Center, Florida Institute of Technology, Satellite Beach.* SPACE TECHNOLOGY.
- Dr. J. John Cohen.** *Department of Immunology, University of Colorado School of Medicine, Denver.* IMMUNOLOGY.
- Prof. David L. Cowan.** *Chairman, Department of Physics and Astronomy, University of Missouri, Columbia.* CLASSICAL MECHANICS AND HEAT.
- Prof. Mark Davies.** *Department of Mechanical & Aeronautical Engineering, University of Limerick, Ireland.* AERONAUTICAL ENGINEERING AND PROPULSION.
- Dr. Peter J. Davies.** *Professor, Department of Plant Biology, Cornell University, Ithaca, New York.* PLANT PHYSIOLOGY.
- Dr. Michael R. Descour.** *Optical Sciences Center, University of Arizona, Tucson.* ELECTROMAGNETIC RADIATION AND OPTICS.
- Dr. M. E. El-Hawary.** *Associate Dean of Engineering, Dalhousie University, Halifax, Nova Scotia, Canada.* ELECTRICAL POWER ENGINEERING.
- Prof. Turgay Ertekin.** *Chairman, Department of Petroleum and Natural Gas Engineering, Pennsylvania State University, University Park.* PETROLEUM ENGINEERING.
- Prof. Alton M. Ferendeci.** *Department of Electrical and Computer Engineering and Computer Science, University of Cincinnati, Ohio.* PHYSICAL ELECTRONICS.
- Barry A. J. Fisher.** *Director, Scientific Services Bureau, Los Angeles County Sheriff's Department, California.* FORENSIC SCIENCE & TECHNOLOGY.
- Peter A. Gale.** *Chief Naval Architect, John J. McMullen Associates, Inc., Arlington, Virginia.* NAVAL ARCHITECTURE AND MARINE ENGINEERING.
- Dr. Richard L. Greenspan.** *The Charles Stark Draper Laboratory, Cambridge, Massachusetts.* NAVIGATION.
- Dr. John P. Harley.** *Department of Biological Sciences, Eastern Kentucky University, Richmond.* MICROBIOLOGY.
- Prof. Terry Harrison.** *Department of Anthropology, Paleoanthropology Laboratory, New York University, New York.* ANTHROPOLOGY AND ARCHEOLOGY.
- Dr. Ralph E. Hoffman.** *Associate Professor, Yale Psychiatric Institute, Yale University School of Medicine, New Haven, Connecticut.* PSYCHIATRY.
- Dr. Gary C. Hogg.** *Chair, Department of Industrial Engineering, Arizona State University.* INDUSTRIAL AND PRODUCTION ENGINEERING.
- Prof. Gordon Holloway.** *Department of Mechanical Engineering, University of New Brunswick, Canada.* FLUID MECHANICS.
- Dr. S. C. Jong.** *Senior Staff Scientist and Program Director, Mycology and Protistology Program, American Type Culture Collection, Manassas, Virginia.* MYCOLOGY.
- Dr. Peter M. Kareiva.** *Director of Conservation and Policy Projects, Environmental Studies Institute, Santa Clara University, Santa Clara, California.* ECOLOGY AND CONSERVATION.
- Prof. Gabriel N. Karpouzian.** *Aerospace Engineering Department, U.S. Naval Academy, Annapolis, Maryland.* AEROSPACE ENGINEERING AND PROPULSION.
- Dr. Bryan A. Kibble.** *National Physical Laboratory, Teddington, Middlesex, United Kingdom.* ELECTRICITY AND ELECTROMAGNETISM.
- Dr. Arnold G. Kluge.** *Division of Reptiles and Amphibians, Museum of Zoology, Ann Arbor, Michigan.* SYSTEMATICS.
- Prof. Robert E. Knowlton.** *Department of Biological Sciences, George Washington University, Washington, DC.* INVERTEBRATE ZOOLOGY.

- Dr. Cynthia Larive.** *Department of Chemistry, University of Kansas, Lawrence.* INORGANIC CHEMISTRY.
- Prof. Chao-Jun Li.** *Department of Chemistry, Tulane University, New Orleans, Louisiana.* ORGANIC CHEMISTRY.
- Dr. Donald W. Linzey.** *Wytheville Community College, Wytheville, Virginia.* VERTEBRATE ZOOLOGY.
- Dr. Philip V. Lopresti.** *Retired; formerly, Engineering Research Center, AT&T Bell Laboratories, Princeton, New Jersey.* ELECTRONIC CIRCUITS.
- Dr. Andrew D. Luster.** *Department of Medicine, Massachusetts General Hospital, Charlestown.* IMMUNOLOGY AND VIROLOGY.
- Prof. Barry M. McCoy.** *C. N. Yang Institute of Theoretical Physics, Department of Physics and Astronomy, State University of New York at Stony Brook.* THEORETICAL PHYSICS.
- Prof. Scott M. McLennan.** *Chair, Department of Geosciences, State University of New York at Stony Brook.* GEOLOGY (PHYSICAL, HISTORICAL, AND SEDIMENTARY).
- Dr. Philip L. Marston.** *Department of Physics, Washington State University, Pullman.* ACOUSTICS.
- Dr. Ramon A. Mata-Toledo.** *Associate Professor of Computer Science, James Madison University, Harrisonburg, Virginia.* COMPUTERS.
- Prof. Krzysztof Matyjaszewski.** *J. C. Warner Professor of Natural Sciences, Department of Chemistry, Carnegie Mellon University, Pittsburgh, Pennsylvania.* POLYMER SCIENCE AND ENGINEERING.
- Dr. Henry F. Mayland.** *Soil Scientist, Northwest Irrigation and Soils Research Laboratory, USDA-ARS, Kimberly, Idaho.* SOILS.
- Prof. Joel S. Miller.** *Department of Chemistry, University of Utah, Salt Lake City.* INORGANIC CHEMISTRY.
- Dr. Orlando J. Miller.** *Professor Emeritus, Center for Molecular Medicine and Genetics, Wayne State University School of Medicine, Detroit, Michigan.* GENETICS AND EVOLUTION.
- Prof. Jay M. Pasachoff.** *Director, Hopkins Observatory, Williams College, Williamstown, Massachusetts.* ASTRONOMY.
- Prof. David J. Pegg.** *Department of Physics, University of Tennessee, Knoxville.* ATOMIC AND MOLECULAR PHYSICS.
- Prof. J. Jeffrey Peirce.** *Department of Civil and Environmental Engineering, Edmund T. Pratt Jr. School of Engineering, Duke University, Durham, North Carolina.* ENVIRONMENTAL ENGINEERING.
- Dr. William C. Peters.** *Professor Emeritus, Mining and Geological Engineering, University of Arizona, Tucson.* MINING ENGINEERING.
- Prof. Allan D. Pierce.** *Department of Aerospace & Mechanical Engineering, Boston University.* ACOUSTICS.
- Prof. Arthur N. Popper.** *Department of Biology, University of Maryland, College Park.* NEUROSCIENCE.
- Dr. Kenneth P. H. Pritzker.** *Pathologist-in-Chief and Director, Head, Connective Tissue Research Group, and Professor, Laboratory Medicine and Pathobiology, University of Toronto, Mount Sinai Hospital, Toronto, Ontario, Canada.* MEDICINE AND PATHOLOGY.
- Prof. Justin Revenaugh.** *Department of Geology and Geophysics, University of Minnesota, Minneapolis.* GEOPHYSICS.
- Dr. Roger M. Rowell.** *USDA-Forest Service, Forest Products Laboratory, Madison, Wisconsin.* FORESTRY.
- Prof. John L. Safko.** *Department of Physics and Astronomy, University of South Carolina, Columbia.* CLASSICAL MECHANICS.
- Dr. Andrew P. Sage.** *Founding Dean Emeritus and First American Bank Professor, University Professor, School of Information Technology and Engineering, George Mason University, Fairfax, Virginia.* CONTROL AND INFORMATION SYSTEMS.
- Prof. Ivan K. Schuller.** *Department of Physics, University of California, San Diego.* CONDENSED-MATTER PHYSICS.
- Richard P. Schulz.** *American Electric Power Co., Gahanna, Ohio.* ELECTRICAL POWER ENGINEERING.
- Dr. David M. Sherman.** *Department of Earth Sciences, University of Bristol, United Kingdom.* MINERALOGY.
- Dr. Steven A. Slack.** *Associate Vice President for Agricultural Administration, Director, Ohio Agricultural Research and Development Center, and Associate Dean for Research, College of Food, Agricultural, and Environmental Sciences, Ohio State University, Wooster.* PLANT PATHOLOGY.
- Prof. Arthur A. Spector.** *Department of Biochemistry, University of Iowa, Iowa City.* BIOCHEMISTRY.
- Dr. Bruce A. Stanley.** *Director, Scientific Programs, Section of Technology Development and Research Resources, Penn State College of Medicine, Hershey, Pennsylvania.* PHYSIOLOGY.
- Prof. Anthony P. Stanton.** *Carnegie Mellon University, Pittsburgh, Pennsylvania.* GRAPHIC ARTS AND PHOTOGRAPHY.
- Dr. Trent Stephens.** *Department of Biological Sciences, Idaho State University, Pocatello.* DEVELOPMENTAL BIOLOGY.
- Prof. John F. Timoney.** *Department of Veterinary Science, University of Kentucky, Lexington.* VETERINARY MEDICINE.
- Prof. Sam Treiman.** *Deceased; formerly, Department of Physics, Joseph Henry Laboratories, Princeton University, Princeton, New Jersey.* THEORETICAL PHYSICS.
- Dr. Bruce A. Voyles.** *Professor, Department of Biological Chemistry, Grinnell College, Iowa.* VIROLOGY.
- Dr. Sally E. Walker.** *Associate Professor of Geology and Marine Science, University of Georgia, Athens.* INVERTEBRATE PALEONTOLOGY.
- Prof. Pao K. Wang.** *Department of Atmospheric and Oceanic Sciences, University of Wisconsin-Madison.* METEOROLOGY AND CLIMATOLOGY.
- Dr. Nicole Y. Weekes.** *Pomona College, Claremont, California.* NEUROPSYCHOLOGY.
- Prof. Frank M. White.** *Department of Mechanical Engineering, University of Rhode Island, Kingston.* FLUID MECHANICS.
- Prof. Mary Anne White.** *Killam Research Professor in Materials Science, Department of Chemistry, Dalhousie University, Halifax, Nova Scotia, Canada.* MATERIALS SCIENCE AND METALLURGIC ENGINEERING.
- Prof. Thomas A. Wikle.** *Head, Department of Geography, Oklahoma State University, Stillwater.* PHYSICAL GEOGRAPHY.
- Dr. Gary Wnek.** *Department of Chemical Engineering, Virginia Commonwealth University, Richmond.* CHEMICAL ENGINEERING.
- Dr. James C. Wyant.** *University of Arizona Optical Sciences Center, Tucson.* ELECTROMAGNETIC RADIATION AND OPTICS.



# Preface

For more than four decades, the *McGraw-Hill Encyclopedia of Science & Technology* has been an indispensable scientific reference work for a broad range of readers, from students to professionals and interested general readers. Found in many thousands of libraries around the world, its 20 volumes authoritatively cover every major field of science. However, the needs of many readers will also be served by a concise work still covering the full breadth of science and technology.

With this in mind, the editors conceived a shorter version of the multivolume work that would retain the authoritativeness, accuracy, clarity, timeliness, quality, and coverage in a convenient, concise format. The result is the *McGraw-Hill Concise Encyclopedia of Science & Technology*, Fifth Edition. To achieve this convenient single volume, the editors extracted the essential text from each article in the parent work while retaining the same proportionality between subjects. The length of each article generally suits the importance and complexity of the subject as well as the current state of knowledge on this topic. The material has been condensed so that it is appropriate to the likely requirements of the reader seeking helpful information without

extensive detail. The articles retain the identity of the original authors, all recognized experts, whose affiliations are included in a complete alphabetical listing of Contributors.

The reader will find over 7300 alphabetically arranged entries, many illustrated with images or diagrams. Most include cross references to other articles for background reading or further study. Dual measurement units (U.S. Customary and International System) are used throughout. The Appendix includes useful information complementing the articles. Finally, the Index provides quick access to specific information the reader needs.

This concise reference will fill the need for accurate, current scientific and technical information in a convenient, economical format. It can serve as the starting point for research by anyone seriously interested in science, even professionals seeking information outside their own specialty. It should prove to be a much used and much trusted addition to the reader's bookshelf.

**MARK D. LICKER**  
Publisher

# Organization of the Encyclopedia

**Alphabetization.** The 7300 article titles are sequenced on a word-by-word basis, not letter by letter. Hyphenated words are treated as separate words. In occasional inverted article titles, the comma provides a full stop. The Index is alphabetized on the same principles. Readers can turn directly to the pages for much of their research. An example of sequencing is:

<b>Air</b>	<b>Air pressure</b>
<b>Air brake</b>	<b>Air-traffic control</b>
<b>Air-cushion vehicle</b>	<b>Airborne radar</b>
<b>Air pollution</b>	<b>Aircraft</b>
<b>Air pollution, indoor</b>	<b>Aistopoda</b>

**Cross references.** Virtually every article has cross references set in CAPITALS AND SMALL CAPITALS. These references offer the user the option of turning to other articles in the volume for related information.

**Measurement units.** Since some readers prefer the U.S. Customary system while others require the metric or International System of Units (SI), measurements in the Encyclopedia are given in dual units. Insight into the measurement systems is

provided by the discussion in the Appendix, which also has handy conversion tables.

**Contributors.** The authorship of each article is specified at its conclusion, in the form of the contributor's initials for brevity. The contributor's full name and affiliation may be found in the "Contributor Affiliations" section at the back of the volume.

**Appendix.** Every user should explore the variety of succinct information supplied by the Appendix, which includes measurement tables, mathematical notation, fundamental constants, and scientific notation; and a biographical listing of scientists. For users wishing to go beyond the scope of this Encyclopedia, recommended books and journals are listed in the Bibliographies subsection of the Appendix; the titles are grouped by subject area.

**Index.** The 30,000-entry Index offers the reader the time-saving convenience of being able to quickly locate specific information in the text, rather than approaching the Encyclopedia via article titles only. This elaborate breakdown of the volume's contents assures both the general reader and the professional of efficient use of the *McGraw-Hill Concise Encyclopedia of Science & Technology*.

# A

**A15 phases** A series of intermetallic compounds which have a particular crystal structure and the chemical formula  $A_3B$ , where A represents a transition element and B can be either a transition or a nontransition element. Many A15 compounds exhibit the phenomenon of superconductivity at relatively high temperatures in the neighborhood of 20 K ( $-424^\circ\text{F}$ ) and in high magnetic fields on the order of several tens of teslas (several hundred kilogauss). High-temperature-high-field superconductivity has a number of important technological applications and is a challenging fundamental research area in condensed-matter physics. See SUPERCONDUCTIVITY.

The A15 compounds crystallize in a structure in which the unit cell, the repeating unit of the crystal structure, has the overall shape of a cube. The B atoms are located at the corners and in the center of the cube, while the A atoms are arranged in pairs on the cube faces (see illustration). A special characteristic of the A15 crystal structure is that the A atoms form mutually orthogonal linear chains that run throughout the crystal lattice, as shown in the illustration. The extraordinary superconducting properties of the A15 compounds are believed to be primarily associated with these linear chains of transition-element A atoms. See CRYSTAL.

Processes have been developed for preparing multifilamentary superconducting wires that consist of numerous filaments of a superconducting A15 compound, such as  $\text{Nb}_3\text{Sn}$ , embedded in a nonsuperconducting copper matrix. Superconducting wires can be used in electric power transmission lines and to wind electrically lossless coils (solenoids) for superconducting electrical machinery (motors and generators) and magnets. Superconducting magnets are employed to produce intense magnetic fields for laboratory research, confinement of high-temperature plasmas in nuclear fusion research, bending beams of charged

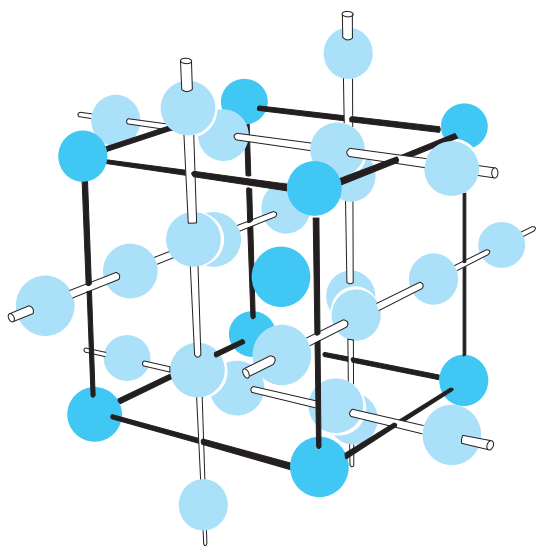

**A15 crystal structure of the  $A_3B$  intermetallic compounds.** The light spheres represent the A atoms; the dark spheres represent the B atoms. The linear chains of A atoms are emphasized.

particles in accelerators, levitation of highspeed trains, mineral separation, and energy storage. See SUPERCONDUCTING DEVICES.

[M.B.Ma.]

**Aardvark** A nocturnal, burrowing, insectivorous mammal of the genus *Orycteropus* in the order Tubulidentata. It averages 6 ft (1.8 m) in length and is covered with short, sparse hair (see illustration).



**The cape aardvark (*Orycteropus afer*) ranges from Ethiopia to southern Africa.**

The aardvark is structurally modified for its diet of ants. The adult lacks canines and incisors; the only teeth are 20 crushing or cheek teeth in a series of 5 upper and 5 lower teeth on both sides of the jaw. These teeth, which do not have roots or enamel, continually grow throughout the life of the animal, have the appearance of tubelike structures of dentine, and are the basis for the ordinal name Tubulidentata. The short, stout, powerful forelimbs terminate in flat claws, which enable the aardvark to burrow rapidly into termite mounds. The head is long and narrow, ending in a tubular snout. The long tubular tongue extends up to 18 in. (45 cm) from the mouth.

Some disagreement exists as to the number of species of *Orycteropus*. The aardvark is edible and economically important for its thick hide which resembles pigskin. See ANTEATER; DENTITION; MAMMALIA; TUBULIDENTATA.

[C.B.C.]

**Abaca** One of the strongest of the hard fibers, commercially known as Manila hemp. Abaca is obtained from the leafstalks of a member of the banana family, *Musa textilis*. The plant resembles the fruiting banana, but is a bit shorter in stature, bears small inedible fruits, and has leaves that stand more erect than those of the banana, and that are slightly narrower, more pointed, and 5–7 ft (1.5–2 m) long. The plant was domesticated long ago in the southern Philippines.

Abaca prefers a warm climate with year-round rainfall, high humidity, and absence of strong winds. Soils must always be moist but the plant does not tolerate waterlogging. Abaca grows best on alluvial soils in the southern Philippines and northern Borneo below 1500 ft (450 m) elevation. The plant is best propagated by rootstalk suckers. There are about 75 varieties grown

## 2 Abacus

in the Philippines, grouped into seven categories, each of which varies slightly in height, length, and quality and yield of fiber.

The fiber ranges 6–14 ft (1.8–4.2 m) in strand length, is lustrous, and varies from white to dull yellow. As one of the longest and strongest plant fibers, resistant to fresh and salt water, abaca is favored for marine hawsers and other high-strength ropes. Abaca is also used in sackings, mattings, strong papers, and handicraft art goods.

Abaca is affected by several diseases, of which the chief are bunchy top, mosaic, and wilt. Bunchy top is caused by a virus spread by the banana aphid (*Pentalonia nigronervosa*). Mosaic is also caused by a virus spread by aphids (chiefly *Rhopalosiphum nymphaeae* and *Aphis gossypii*). Abaca wilt is caused by a soil or water-borne fungus, chiefly attacking plant roots. [E.G.N.]

**Abacus** An early mechanical calculator whose design has evolved through the centuries, with two styles in use today. Both the Chinese and the Japanese styles consist of a frame with a crossbeam. They may be made from many different materials, such as wood or brass. Rods or wires carrying sliding beads extend vertically through the crossbeam. The Chinese *suan pan* has two beads above the beam on each rod and five beads below. Each rod of the Japanese *soroban* carries one bead above and four below.

In working with whole numbers, the rightmost rod represents the ones position, with each rod to the left representing the tens, hundreds, thousands, and so forth, respectively. The beads below the crossbeam represent one of that rod's units (that is, a one, a ten, a hundred, and so forth), and those above represent five. Beads are moved from the outer position toward the crossbeam when used to represent a number (see illustration).

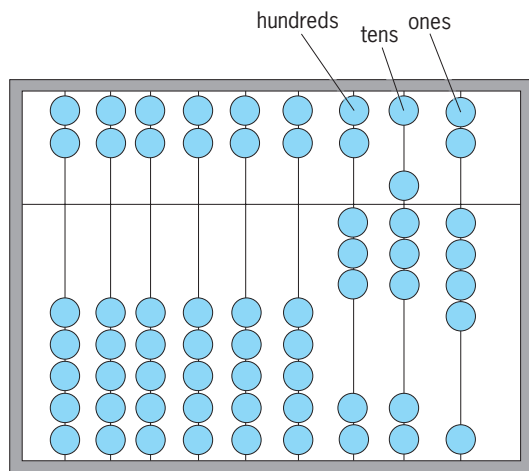

Beads positioned to represent 384 on a Chinese abacus.

The abacus, in contrast to the electronic calculator, is simply an aid to mental computation. A well-developed facility with numbers is required in order to use it effectively. For this reason, it is the calculator of choice for teachers in the Far East. The advent of the electronic calculator, while a boon to the scientific community, may have little impact on shop owners who are comfortable with the abacus. See CALCULATORS. [M.K.G.]

**Abalone** A gastropod mollusk comprising the single genus *Haliotis*, family Haliotidae, also known as ear shell, ormer, or paua. The abalones are cosmopolitan species of temperate and tropical seas. They are active nocturnally and feed principally on algae.

The shell is flattened, with an enlarged body whorl and reduced spire, and looks like an ear (see illustration). Characteristically, the shell is perforated by a series of small pores which allow for more direct elimination of water from the mantle cavity.

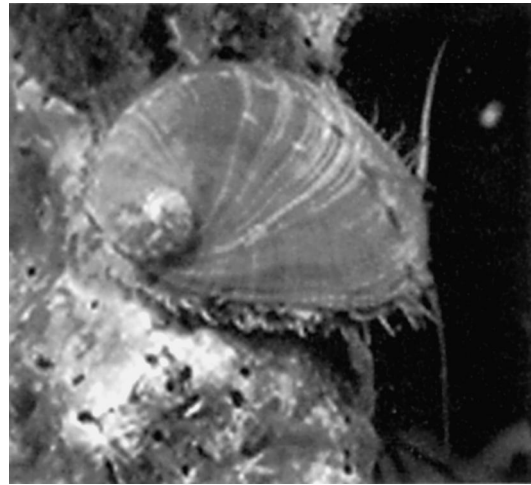

Typical abalone ear-shaped shell perforated by pores.

Exposed parts of the body are pigmented and show a varying range of colors, such as black, green, or brown. The larvae are pelagic and free-swimming among the plankton in coastal waters for about 2 days, after which they settle down and develop to the adult. See CIRCULATION; GASTROPODA; RESPIRATORY PIGMENTS (INVERTEBRATE). [C.B.C.]

**Abdomen** A major body division of the vertebrate trunk lying posterior to the thorax; and in mammals, bounded anteriorly by the diaphragm and extending to the pelvis. The diaphragm separates the abdominal or peritoneal cavity from the pleural and pericardial cavities of the thorax. In all pulmonate vertebrates (possessing lungs or lunglike organs) other than mammals, the lungs lie in the same cavity with the abdominal viscera, and this cavity is known as the pleuroperitoneal cavity.

The large coelomic cavity that occupies the abdomen contains the viscera within the peritoneal sac. Connecting sheets of peritoneum from the body wall to the various organs form the mesenteries. Other folds of the peritoneum form the omenta.

The term abdomen is also applied to a similar major body division of arthropods and other animals. [W.J.B.]

**Aberration (astronomy)** The apparent change in direction of a source of light caused by an observer's component of motion perpendicular to the impinging rays.

To visualize the effect, first imagine a stationary telescope (illustration a) aimed at a luminous source such as a star, with photons traveling concentrically down the tube to an image at the center of the focal plane. Next give the telescope a component of motion perpendicular to the incoming rays (illustration b). Photons passing the objective require a finite time to travel the length of the tube. During this time the telescope has moved a short distance, causing the photons to reach a spot on the focal plane displaced from the former image position. To return the image to the center, the telescope must be tilted in the direction of motion by an amount sufficient to ensure that the photons once again come concentrically down the tube in its frame of reference (illustration c). The necessary tilt angle  $\alpha$  is given by  $\tan \alpha = v/c$ , where  $v$  is the component of velocity perpendicular to the incoming light and  $c$  is the velocity of light. (An analogy illustrating aberration is the experience that, in order for the feet to remain dry while walking through vertically falling rain, it is necessary to tilt an umbrella substantially forward.)

This discovery provided the first direct physical confirmation of the Copernican theory. A second important application of aberration has been its clear-cut demonstration that, as is axiomatic to special relativity, light reaching the Earth has a velocity

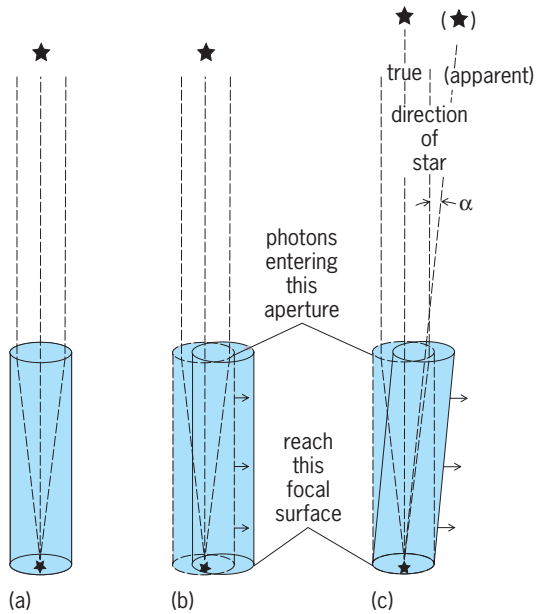

**Demonstration of aberration.** (a) Fixed telescope; photons form image at center of focal plane, (b) Moving telescope; image is displaced from center, (c) Tilted moving telescope is required to restore image to center.

unaffected by the relative motion of the source toward or away from the Earth. See LIGHT; PARALLAX (ASTRONOMY). [H.J.S.]

**Aberration (optics)** A departure of an optical image-forming system from ideal behavior. Ideally, such a system will produce a unique image point corresponding to each object point. In addition, every straight line in the object space will have as its corresponding image a unique straight line. A simi-

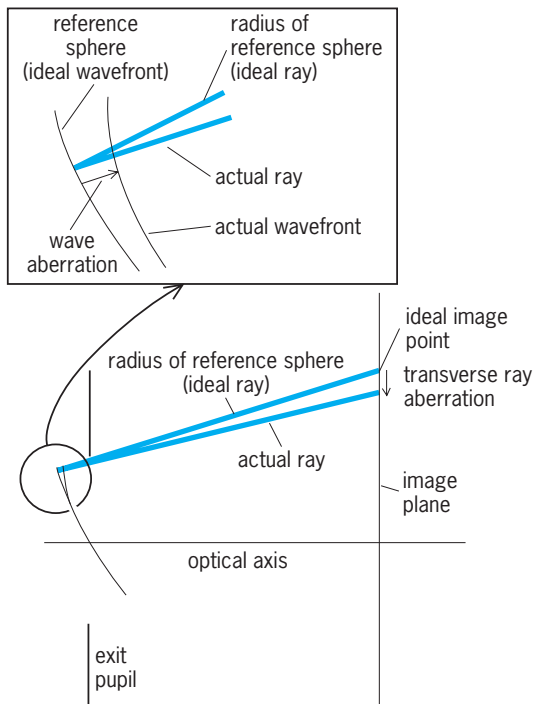

**Diagram of the image space of an optical system, showing aberration measures: the wave aberration and the transverse ray aberration.**

lar one-to-one correspondence will exist between planes in the two spaces. This type of mapping of object space into image space is called a collinear transformation. When the conditions for a collinear transformation are not met, the departures from that ideal behavior are termed aberrations. They are classified into two general types, monochromatic aberrations and chromatic aberrations. The monochromatic aberrations apply to a single color, or wavelength, of light. The chromatic aberrations are simply the chromatic variation, or variation with wavelength, of the monochromatic aberrations. See CHROMATIC ABERRATION; GEOMETRICAL OPTICS; OPTICAL IMAGE.

The monochromatic aberrations can be described in several ways. Wave aberrations are departures of the geometrical wavefront from a reference sphere with its vertex at the center of the exit pupil and its center of curvature located at the ideal image point. The wave aberration is measured along the ray and is a function of the field height and the pupil coordinates of the reference sphere (see illustration).

Transverse ray aberrations are measured by the transverse displacement from the ideal image point to the ray intersection with the ideal image plane. The chief monochromatic aberrations are spherical (aperture) aberrations, coma, astigmatism, curvature of field, and distortion. See CHROMATIC ABERRATION; GEOMETRICAL OPTICS; LENS (OPTICS); OPTICAL IMAGE; OPTICAL SURFACES.

Each surface in an optical system introduces aberrations as the light beam passes through the system. The aberrations of the entire system consist of the sum of the surface contributions, some of which may be positive and others negative. The challenge of optical design is to balance these contributions so that the total aberrations of the system are tolerably small. In a well-corrected system the individual surface contributions are many times larger than the tolerance value, so that the balance is rather delicate, and the optical system must be made with a high degree of precision. See LENS (OPTICS); OPTICAL SURFACES. [R.V.S.]

**Abrasive** A material of extreme hardness that is used to shape other materials by a grinding or abrading action. Abrasive materials may be used either as loose grains, as grinding wheels, or as coatings on cloth or paper. They may be formed into ceramic cutting tools that are used for machining metal in the same way that ordinary machine tools are used. Because of their superior hardness and refractory properties, they have advantages in speed of operation, depth of cut, and smoothness of finish.

Abrasive products are used for cleaning and machining all types of metal, for grinding and polishing glass, for grinding logs to paper pulp, for cutting metals, glass, and cement, and for manufacturing many miscellaneous products such as brake linings and nonslip floor tile.

The important natural abrasives are diamond, corundum, emery, garnet, feldspar, calcined clay, lime, chalk, and silica,  $\text{SiO}_2$ , in its many forms—sandstone, sand, flint, and diatomite.

The synthetic abrasive materials are silicon carbide, aluminum oxide, titanium carbide, and boron carbide. The synthesis of diamond puts this material in the category of manufactured abrasives. [J.F.McM.]

**Abscisic acid** One of the five major plant hormones. It has a number of important functions in plant growth and development. The name abscisic acid (ABA) is derived from the ability of the substance to promote abscission. It is also a potent inhibitor of growth. In this capacity it helps to induce and prolong dormancy of buds. Abscisic acid is a powerful inhibitor of seed germination and has an important role in the closure of stomata. See ABSCISSION; DORMANCY.

Abscisic acid is distributed throughout the plant body but is found in highest concentrations in leafy tissues, fruits, and seeds. The principal site of ABA synthesis is the chloroplast. Synthesis of ABA increases markedly when the plant is under stress.

## 4 Abscission

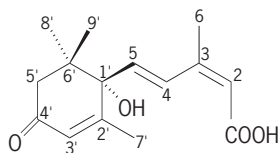

Structural formula for +-abscisic acid.

The chemical structure of ABA is shown in the illustration. ABA is a member of the terpenoid family of chemicals, which includes a number of essential oils, insect hormones, steroids, gibberellins, carotenoids, and natural rubber. It is a weak organic acid, as are two other plant hormones, auxin and gibberellin. Natural ABA is dextrorotatory, hence the “+” in front of the name. See AUXIN; GIBBERELLIN; PLANT HORMONES. [F.T.A.]

**Abscission** The process whereby a plant sheds one of its parts. Leaves, flowers, seeds, and fruits are parts commonly abscised. Almost any plant part, from very small buds and bracts to branches several inches in diameter, may be abscised by some species. However, other species, including many annual plants, may show little abscission, especially of leaves.

Abscission may be of value to the plant in several ways. It can be a process of self-pruning, removing injured, diseased, or senescent parts. It permits the dispersal of seeds and other reproductive structures. It facilitates the recycling of mineral nutrients to the soil. It functions to maintain homeostasis in the plant, keeping in balance leaves and roots, and vegetative and reproductive parts.

In most plants the process of abscission is restricted to an abscission zone at the base of an organ (see illustration); here separation is brought about by the disintegration of the walls of a special layer of cells, the separation layer. The portion of the abscission zone which remains on the plant commonly develops into a corky protective layer that becomes continuous with the cork of the stem.

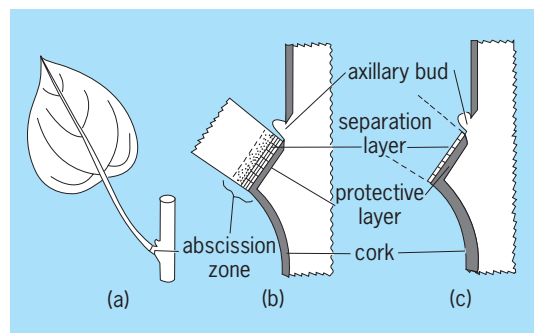

Diagrams of the abscission zone of a leaf. (a) A leaf with the abscission zone indicated at the base of the petiole. (b) The abscission zone layers shortly before abscission and (c) the layers after abscission.

Auxin applied experimentally to the distal (organ) side of an abscission zone retards abscission, while auxin applied to the proximal (stem) side accelerates abscission. The gibberellins are growth hormones which influence abscission. When applied to young fruits or to leaves, they tend to promote growth, delay maturation, and thereby indirectly prevent or delay abscission. Abscisic acid has the ability to promote abscission and senescence and to retard growth. Small amounts of ethylene have profound effects on the growth of plants and can distort and reduce growth and promote senescence and abscission. See ABS-CISIC ACID; AUXIN. [F.T.A.]

**Absolute zero** The temperature at which an ideal gas would exert no pressure. The Kelvin scale of temperatures is

defined in terms of the triple point of water,  $T_3 = 273.16^\circ$  (where the solid, liquid, and vapor phases coexist), and absolute zero. Temperature is measured most simply via the constant-volume ideal-gas thermometer, in which a small amount of gas is introduced (in order to limit the effect of interactions between molecules) and then sealed off, and the gas pressure  $P$  referenced to its value at the triple point  $P(T_3)$  is measured. The ideal-gas law applies if the molecules in a gas exert no forces on one another and if they are not attracted to the walls. Absolute zero is the temperature at which the pressure of a truly ideal gas would vanish. See TEMPERATURE MEASUREMENT.

According to classical physics, all motion would cease at absolute zero; however, the quantum-mechanical uncertainty principle requires that there be a small amount of residual motion (zero-point motion) even at absolute zero. See KINETIC THEORY OF MATTER; UNCERTAINTY PRINCIPLE.

Temperature can also be defined from the Boltzmann distribution. If a collection of spin-1/2 magnetic ions is placed in a magnetic field, the ratio of the occupancy of the lower to the higher energy state is given by the equation below. Here  $k$  is

$$\frac{N_l}{N_H} = \exp \frac{|\Delta E|}{kT}$$

Boltzmann's constant,  $\Delta E$  is the magnitude of the difference in energy between the states, and  $T$  is the Kelvin temperature. Thus, at high temperatures the two states have nearly equal occupation probability, while the lower energy state is progressively favored at lower temperatures. At absolute zero, only the lower energy level is occupied. This relation allows for the possibility of negative temperatures when the population of the higher energy state exceeds that of the lower state. See BOLTZMANN CONSTANT; BOLTZMANN STATISTICS.

Negative temperatures notwithstanding, the third law of thermodynamics states that the absolute zero of temperature cannot be attained by any finite number of steps. The lowest (and hottest) temperatures that have been achieved are on the order of a picokelvin ( $10^{-12}$  K). These are spin temperatures of nuclei which are out of equilibrium with the lattice vibrations and electrons of a solid. The lowest temperatures to which the electrons have been cooled are on the order of 10 microkelvins in metallic systems. See LOW-TEMPERATURE PHYSICS; TEMPERATURE.

[J.M.Pa.; D.M.Le.]

**Absorption** Either the taking up of matter in bulk by other matter, as in the dissolving of a gas by a liquid; or the taking up of energy from radiation by the medium through which the radiation is passing. In the first case, an absorption coefficient is defined as the amount of gas dissolved at standard conditions by a unit volume of the solvent. Absorption in this sense is a volume effect: The absorbed substance permeates the whole of the absorber. In absorption of the second type, attenuation is produced which in many cases follows Lambert's law and adds to the effects of scattering if the latter is present.

Absorption of electromagnetic radiation can occur in several ways. For example, microwaves in a waveguide lose energy to the walls of the guide. For nonperfect conductors, the wave penetrates the guide surface and energy in the wave is transferred to the atoms of the guide. Light is absorbed by atoms of the medium through which it passes, and in some cases this absorption is quite distinctive. Selected frequencies from a heterochromatic source are strongly absorbed, as in the absorption spectrum of the Sun. Electromagnetic radiation can be absorbed by the photoelectric effect, where the light quantum is absorbed and an electron of the absorbing atom is ejected, and also by Compton scattering. Electron-positron pairs may be created by the absorption of a photon of sufficiently high energy. Photons can be absorbed by photoproduction of nuclear and subnuclear particles, analogous to the photoelectric effect.

Sound waves are absorbed at suitable frequencies by particles suspended in the air (wavelength of the order of the particle size),

where the sound energy is transformed into vibrational energy of the absorbing particles.

Absorption of energy from a beam of particles can occur by the ionization process, where an electron in the medium through which the beam passes is removed by the beam particles. The finite range of protons and alpha particles in matter is a result of this process. In the case of low-energy electrons, scattering is as important as ionization, so that range is a less well-defined concept. Particles themselves may be absorbed from a beam. For example, in a nuclear reaction an incident particle  $X$  is absorbed into nucleus  $Y$ , and the result may be that another particle  $Z$ , or a photon, or particle  $X$  with changed energy comes out. Low-energy positrons are quickly absorbed by annihilating with electrons in matter to yield two gamma rays. [M.H.H.]

In the chemical process industries and in related areas such as petroleum refining and fuels purification, absorption usually means gas absorption. This is a unit operation in which a gas (or vapor) mixture is contacted with a liquid solvent selected to preferentially absorb one, or in some cases more than one, component from the mixture. The purpose is either to recover a desired component from a gas mixture or to rid the mixture of an impurity. In the latter case, the operation is often referred to as scrubbing.

When the operation is employed in reverse, that is, when a gas is utilized to extract a component from a liquid mixture, it is referred to as gas desorption, stripping, or sparging.

In gas absorption, either no further changes occur to the gaseous component once it is absorbed in the liquid solvent, or the absorbed component (solute) will become involved in a chemical reaction with the solvent in the liquid phase. In the former case, the operation is referred to as physical gas absorption, and in the latter case as gas absorption with chemical reaction. See GAS ABSORPTION OPERATIONS; UNIT OPERATIONS. [W.F.F.]

**Absorption (biology)** The net movement (transport) of water and solutes from outside an organism to its interior. The unidirectional flow of materials into an animal from the environment generally takes place across the alimentary tract, the lungs, or the skin, and in each location a specific cell layer called an epithelium regulates the passage of materials.

Absorption across epithelia may occur by several different passive and active processes. Simple diffusion is the net movement of molecules from the apical to basolateral surfaces of an epithelium down chemical and electrical gradients without the requirement of cellular energy sources. Facilitated diffusion across the epithelium is similar to simple diffusion in that energy is not required, but in this process, molecular interaction with protein binding sites (carriers) in one or both membranes must occur to facilitate the transfer. Active molecular transport involves the use of membrane protein carriers as well as cellular energy supplies to move a transported molecule up an electrochemical gradient across the epithelium. Endocytosis and phagocytosis are also examples of active transport because metabolic energy is required, but in these processes whole regions of the cell membrane are used to engulf fluid or particles, rather than to bring about molecular transfer using single-membrane proteins. See CELL MEMBRANES; ENDOCYTOSIS; OSMOREGULATORY MECHANISMS; PHAGOCYTOSIS.

Although a wide variety of ions are absorbed by different types of epithelial cells, the mechanisms of  $\text{Na}^+$  and  $\text{Cl}^-$  transport in mammalian small intestine are perhaps best known in detail. Transepithelial transport of these two ions occurs in this tissue by three independent processes: active  $\text{Na}^+$  absorption, not coupled directly to the flow of other solutes but accompanied indirectly by the diffusional absorption of  $\text{Cl}^-$ ; coupled  $\text{NaCl}$  absorption; and cotransport of  $\text{Na}^+$  with a wide variety of nutrient molecules. See ION TRANSPORT.

Net water transport across the epithelium is coupled to net ion transport in the same direction. Pump sites for  $\text{Na}^+$  are believed to be located along the lateral borders of epithelial cells. Energy-

dependent  $\text{Na}^+$  efflux from the cells to the intercellular spaces creates a local increase in osmotic pressure within these small compartments. An osmotic pressure gradient becomes established here, with greatest solute concentrations located nearest the tight junctions. Water flows into the cell across the brush border membrane and out the lateral membranes in response to the increased osmotic pressure in the paracellular spaces. Once water is in the intercellular compartment, a buildup of hydrostatic pressure forces the transported fluid to the capillary network. [G.A.A.]

**Absorption of electromagnetic radiation** The process whereby the intensity of a beam of electromagnetic radiation is attenuated in passing through a material medium by conversion of the energy of the radiation to an equivalent amount of energy appearing within the medium; the radiant energy is converted into heat or some other form of molecular energy. A perfectly transparent medium permits the passage of a beam of radiation without any change in intensity other than that caused by the spread or convergence of the beam, and the total radiant energy emergent from such a medium equals that which entered it, whereas the emergent energy from an absorbing medium is less than that which enters, and, in the case of highly opaque media, is reduced practically to zero. No known medium is opaque to all wavelengths of the electromagnetic spectrum; similarly, no material medium is transparent to the whole electromagnetic spectrum. A medium which absorbs a relatively wide range of wavelengths is said to exhibit general absorption, while a medium which absorbs only restricted wavelength regions of no great range exhibits selective absorption for those particular spectral regions. For example, ordinary window glass is transparent to visible light, but shows general absorption for ultraviolet radiation of wavelengths below about 310 nanometers, while colored glasses show selective absorption for specific regions of the visible spectrum. The color of objects which are not self-luminous and which are seen by light reflected or transmitted by the object is usually the result of selective absorption of portions of the visible spectrum. See COLOR; ELECTROMAGNETIC RADIATION.

The capacity of a medium to absorb radiation depends on a number of factors, mainly the electronic and nuclear constitution of the atoms and molecules of the medium, the wavelength of the radiation, the thickness of the absorbing layer, and the variables which determine the state of the medium, of which the most important are the temperature and the concentration of the absorbing agent. In special cases, absorption may be influenced by electric or magnetic fields. The state of polarization of the radiation influences the absorption of media containing certain oriented structures, such as crystals of other than cubic symmetry. See STARK EFFECT; ZEEMAN EFFECT.

Lambert's law, also called Bouguer's law or the Lambert-Bouguer law, expresses the effect of the thickness of the absorbing medium on the absorption. If  $I$  is the intensity to which a monochromatic parallel beam is attenuated after traversing a thickness  $d$  of the medium, and  $I_0$  is the intensity of the beam at the surface of incidence (corrected for loss by reflection from this surface), the variation of intensity throughout the medium is expressed by Eq. (1), in which  $\alpha$  is a constant for the medium

$$I = I_0 e^{-\alpha d} \quad (1)$$

called the absorption coefficient. This exponential relation can be expressed in an equivalent logarithmic form as in Eq. (2), where

$$\log_{10}(I_0/I) = (\alpha/2.303)d = kd \quad (2)$$

$k = \alpha/2.303$  is called the extinction coefficient for radiation of the wavelength considered. The quantity  $\log_{10}(I_0/I)$  is often called the optical density, or the absorbance of the medium.

Beer's law refers to the effect of the concentration of the absorbing medium, that is, the mass of absorbing material per unit of volume, on the absorption. This relation is of prime

## 6 Abstract algebra

importance in describing the absorption of solutions of an absorbing solute, since the solute's concentration may be varied over wide limits, or the absorption of gases, the concentration of which depends on the pressure. The effects of thickness  $d$  and concentration  $c$  on absorption of monochromatic radiation can be combined in a single mathematical expression, given in Eq. (3), in which  $k'$  is a constant for a given absorbing substance

$$I = I_0 e^{-k'cd} \quad (3)$$

(at constant wavelength and temperature), independent of the actual concentration of solute in the solution. In logarithms, the relation becomes Eq. (4).

$$\log_{10}(I_0/I) = (k'/2.303)cd = \epsilon cd \quad (4)$$

The values of the constants  $k'$  and  $\epsilon$  in Eqs. (3) and (4) depend on the units of concentration. If the concentration of the solute is expressed in moles per liter, the constant  $\epsilon$  is called the molar extinction coefficient. Some authors employ the symbol  $a_M$ , which is called the molar absorbance index, instead of  $\epsilon$ .

If Beer's law is adhered to, the molar extinction coefficient does not depend on the concentration of the absorbing solute, but usually changes with the wavelength of the radiation, with the temperature of the solution, and with the solvent.

Absorption of radiation by matter always involves the loss of energy by the radiation and a corresponding gain in energy by the atoms or molecules of the medium. The energy absorbed from radiation appears as increased internal energy, or in increased vibrational and rotational energy of the atoms and molecules of the absorbing medium. As a general rule, translational energy is not directly increased by absorption of radiation, although it may be indirectly increased by degradation of electronic energy or by conversion of rotational or vibrational energy to that of translation by intermolecular collisions.

The energy acquired by matter by absorption of visible or ultraviolet radiation, although primarily used to excite electrons to higher energy states, usually ultimately appears as increased kinetic energy of the molecules, that is, as heat. It may, however, under special circumstances, be reemitted as electromagnetic radiation. Fluorescence is the reemission, as radiant energy, of absorbed radiant energy, normally at wavelengths the same as or longer than those absorbed. The radiant reemission of absorbed radiant energy at wavelengths longer than those absorbed, for a readily observable interval after withdrawal of the exciting radiation, is called phosphorescence. Phosphorescence and fluorescence are special cases of luminescence, which is defined as light emission that cannot be attributed merely to the temperature of the emitting body. See FLUORESCENCE; FLUORESCENT LAMP; LUMINESCENCE; PHOSPHORESCENCE. [W.W.]

**Abstract algebra** A term used synonymously with modern algebra and general algebra to describe the type of algebra which has been developed since the mid-1920s and has become a basic idiom of contemporary mathematics. In contrast with the earlier algebra, which was highly computational and was confined to the study of specific systems generally based on real and complex numbers, abstract algebra is conceptual and axiomatic and deals with systems which are arbitrary sets of elements of unspecified type, together with certain compositions satisfying prescribed lists of axioms.

A good insight into the difference between the older and the present approach can be obtained by comparing the older matrix theory with the more abstract linear algebra. Both deal with roughly the same portion of mathematics, the former a direct perspective which stresses calculations with matrices, the latter from an axiomatic and geometric viewpoint which treats vector spaces and linear transformations as the basic notions, and matrices as secondary to these. See LINEAR ALGEBRA; MATRIX THEORY.

Abstract algebra deals with a number of important algebraic structures, such as groups, rings, and lattices. See GROUP THEORY; RING THEORY. [N.J.]

**Abstract data type** A mathematical entity consisting of a set of values (the carrier set) and a collection of operations that manipulate them. For example, the Integer abstract data type consists of a carrier set containing the positive and negative whole numbers and 0, and a collection of operations manipulating these values, such as addition, subtraction, multiplication, equality comparison, and order comparison. See ABSTRACT ALGEBRA.

**Abstraction.** To abstract is to ignore some details of a thing in favor of others. Abstraction is important in problem solving because it allows problem solvers to focus on essential details while ignoring the inessential, thus simplifying the problem and bringing to attention those aspects of the problem involved in its solution. Abstract data types are important in computer science because they provide a clear and precise way to specify what data a program must manipulate, and how the program must manipulate its data, without regard to details about how data are represented or how operations are implemented. Once an abstract data type is understood and documented, it serves as a specification that programmers can use to guide their choice of data representation and operation implementation, and as a standard for ensuring program correctness.

A realization of an abstract data type that provides representations of the values of its carrier set and algorithms for its operations is called a data type. Programming languages typically provide several built-in data types, and usually also facilities for programmers to create others. Most programming languages provide a data type realizing the Integer abstract data type, for example. The carrier set of the Integer abstract data type is a collection of whole numbers, so these numbers must be represented in some way. Programs typically use a string of bits of fixed size (often 32 bits) to represent Integer values in base two, with one bit used to represent the sign of the number. Algorithms that manipulate these strings of bits implement the operations of the abstract data type. See ALGORITHM; PROGRAMMING LANGUAGES.

Realizations of abstract data types are rarely perfect. Representations are always finite, while carrier sets of abstract data types are often infinite. Many individual values of some carrier sets (such as real numbers) cannot be precisely represented on digital computers. Nevertheless, abstract data types provide the standard against which the data types realized in programs are judged.

**Usefulness.** Such specifications of abstract data types provide the basis for their realization in programs. Programmers know which data values need to be represented, which operations need to be implemented, and which constraints must be satisfied. Careful study of program code and the appropriate selection of tests help to ensure that the programs are correct. Finally, specifications of abstract data types can be used to investigate and demonstrate the properties of abstract data types themselves, leading to better understanding of programs and ultimately higher-quality software. See COMPUTER PROGRAMMING; SOFTWARE ENGINEERING; SHRINK FIT.

**Relation to object-oriented paradigm.** A major trend in computer science is the object-oriented paradigm, an approach to program design and implementation using collections of interacting entities called objects. Objects incorporate both data and operations. In this way they mimic things in the real world, which have properties (data) and behaviors (operations). Objects that hold the same kind of data and perform the same operations form a class.

Abstract data values are separated from abstract data type operations. If the values in the carrier set of an abstract data type can be reconceptualized to include not only data values but also abstract data type operations, then the elements of the carrier set become entities that incorporate both data and operations,



like objects, and the carrier set itself is very much like a class. The object-oriented paradigm can thus be seen as an outgrowth of the use of abstract data types. See OBJECT-ORIENTED PROGRAMMING. [C.Fo.]

**Acantharia** A subclass of Actinopodea. These marine protozoans are related to the Radiolaria and possess a nonliving, organic capsular wall surrounding a central mass of cytoplasm. The intracapsular cytoplasm is connected to the extra-capsular cytoplasm by fine cytoplasmic strands passing through pores in the capsular wall. Skeletons are typically constructed of celestite (strontium sulfate) instead of silica. The basic structural elements are 20 rods which pass through the capsule to the center in regular arrangement (polar and equatorial; see illustration). An equatorial rod forms an angle of 90° with a polar rod, and other groups are arranged with similar exactness. This type of skeleton may be modified by addition of a latticework, apparently composed of plates, each fused with a skeletal rod. Some genera show a double latticework, concentric with the central capsule.

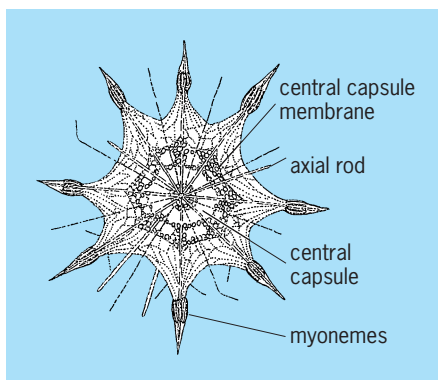

**Acantharia: *Acanthometra pellucida*.**

Pseudopodia are more or less permanent. Zooxanthellae are of at least two kinds: dinophyceae containing trichocysts in the cytoplasm; and a group of algae characterized, among other things, by numerous discoidal plastids each of which contains an interlamellar pyrenoid.

Myonemes (myophrisks) are significant components of the hydrostatic apparatus and apparently regulate the buoyancy of Acantharia by expanding or contracting portions of the extra-capsular cytoplasmic sheath.

Although essentially pelagic, Acantharia may move vertically with the help of their hydrostatic apparatus. Little is known about the ecology or distribution of Acantharia. The Gulf Stream is rich in Acantharia in spring and summer, but rather poor in other seasons.

The taxonomy of Acantharia is under review, but according to one scheme there are two orders: Acanthometrida, and Acanthophractida. See ACANTHOMETRIDA; ACANTHOPHRACTIDA; ACTINOPODEA; PROTOZOA; SARCODINA; SARCOMASTIGOPHORA. [O.R.A.]

**Acanthite** The mineral name applied to the monoclinic form of silver sulfide ( $Ag_2S$ ) that is stable at room temperature. Two different crystalline structures are assumed in succession as temperature is increased. At a temperature of about 176–178°C (349–352°F), depending on stoichiometry, acanthite transforms rapidly to argentite, which is body-centered cubic, space group  $Im\bar{3}m$ . The cell contains two  $Ag_2S$  units and has a lattice constant that ranges from 0.4860 nm at 186°C (367°F) to 0.4889 nm at 325°C (617°F). At 586–620°C (1087–1148°F), again depending on stoichiometry, argentite transforms to a face-centered cubic

structure. The details of the atomic arrangement in this phase are not known.

Acanthite is an important silver ore. Notable deposits in the United States include Butte, Montana; Aspen and Leadville, Colorado; and the Comstock Lode in Nevada. The mineral is also common in Mexican mines at Guanajuato. Other major deposits occur in Bolivia, Peru, and Chile. Especially fine crystals have been found in Saxony and in the Harz Mountains in Germany. Silver sulfide is encountered in everyday life as the black tarnish that develops on silver objects. See CRYSTAL STRUCTURE. [B.J.Wu.]

**Acanthocephala** A distinct phylum of helminths, the adults of which are parasitic in the alimentary canal of vertebrates. They are commonly known as the spiny-headed worms. The phylum comprises the orders Archiacanthocephala, Palaeacanthocephala, and Eocanthocephala. Over 500 species have been described from all classes of vertebrates, although more species occur in fish than in birds and mammals and only a relatively few species are found in amphibians and reptiles. The geographical distribution of acanthocephalans is worldwide, but genera and species do not have a uniform distribution because some species are confined to limited geographic areas. Host specificity is well established in some species, whereas others exhibit a wide range of host tolerance. The same species never occurs normally, as an adult, in coldblooded and warm-blooded definitive hosts. More species occur in fish than any other vertebrate; however, Acanthocephala have not been reported from elasmobranch fish. The fact that larval development occurs in arthropods gives support to the postulation that the ancestors of Acanthocephala were parasites of primitive arthropods during or before the Cambrian Period and became parasites of vertebrates as this group arose and utilized arthropods for food. See PALAEACANTHOCEPHALA.

Adults of various species show great diversity in size, ranging in length from 0.04 in. (1 mm) in some species found in fish to over 16 in. (400 mm) in some mammalian species.

The body of both males and females has three subdivisions: the proboscis armed with hooks, spines, or both; an unspined neck; and the posterior trunk. The proboscis is the primary organ for attachment to the intestinal wall of the host. In most species the proboscis is capable of introversion into a saclike structure, the proboscis receptacle. The proboscis receptacle and neck can be retracted into the body cavity but without inversion. The body cavity, or pseudocoel, contains all the internal organs, the most conspicuous of which are the reproductive organs. There is no vestige of a digestive system in any stage of the life cycle. The reproductive organs of the male consist of a pair of testes and specialized cells, the cement glands. The products of the testes and cement glands are discharged through a penis. Female Acanthocephala are unique in that the ovary exists as a distinct organ only in the very early stages of development and later breaks up to form free-floating egg balls. The eggs are fertilized as they are released from the egg balls and are retained within the ligament sacs until embryonation is complete. The nervous system is composed of a chief ganglion or brain located within the proboscis receptacle. Two nerve trunks pass through the wall of the proboscis receptacle to innervate the trunk wall. Modified protonephridial organs are found closely adherent to the reproductive system, but in most species specialized excretory organs are completely lacking. [D.V.Mo.]

**Acanthodii** A subclass of importance, including the earliest known jawed fishes or gnathostomes, first appearing in the Lower Silurian and surviving until the Lower Permian. They were usually small, less than 8 in. (20 cm) in length, though a few may have been as much as 100 in. (250 cm) long. The body was fusiform, the mouth terminal or nearly so, the eyes large, and the nasal capsules small. The tail was heterocercal; there were one or two dorsal fins, and all fins except the caudal had a spine on the anterior edge (see illustration). The scales had

## 8 Acanthometrida

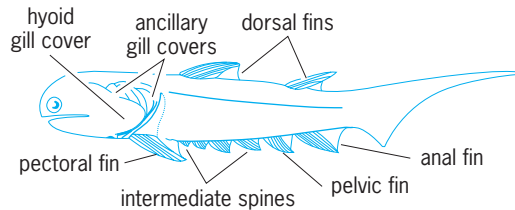

Lateral view of *Climatius reticulatus* (Climatiidae), about 6 in. (15 cm) long.

a square or rhombic crown and typically were nonoverlapping; they grew by periodic additions all around, lacked a pulp chamber, and were composed superficially of dentine or mesodentine and basally of bone, often acellular. Acanthodii are best considered as a subclass of Teleostomi, collateral with Osteichthyes, and can be classified as follows:

- Subclass Acanthodii
  - Order Climatiida
    - Family Climatiidae
    - Family Diplacanthidae
    - ?Family Gyracanthidae
  - Order Ischnacanthida
    - Family Ischnacanthidae
  - Order Acanthodida
    - Family Acanthodidae

See CHONDRICHTHYES; TELEOSTOMI.

[R.H.De.]

**Acanthometrida** An order of Acantharia. These marine protozoans have a skeleton limited to 20 radially arranged rods which extend from the center, forming a characteristic pattern in which angles are quite exact, as in *Acanthometra* (see illustration). The cytoplasm surrounding the spines contains a conical

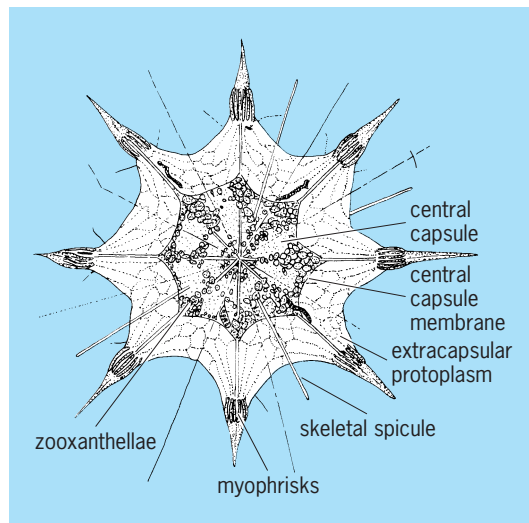

*Acanthometra*. (After L. H. Hyman, *The Invertebrates*, vol. 1, McGraw-Hill, 1940).

array of contractile microfilaments (myophrisks or myonemes) that act to expand or contract the gelatinous sheath surrounding the cell, a phenomenon that is apparently responsible for changes in the level of flotation. See ACANTHARIA; ACTINOPODEA; PROTOZOA; SARCODINA; SARCOMASTIGOPHORA. [O.R.A.]

**Acanthophractida** An order of Acantharia. In this group of protozoans, skeletons typically include a latticework

shell, although the characteristic skeletal rods are recognizable. The latticework may be spherical or ovoid, is fused with the skeletal rods, and is typically concentric with the central capsule. The body is usually covered with a single or double gelatinous sheath through which the skeletal rods emerge. Myonemes extend from the gelatinous sheath to each skeletal rod. These marine forms live mostly below depths of 150–200 ft (45–60 m). The order includes *Colectopsis*, *Diploconus*, *Dorotaspis*, and many other genera. See ACANTHARIA; ACTINOPODEA; PROTOZOA; SARCODINA; SARCOMASTIGOPHORA. [R.P.H.]

**Acari** A subclass of Arachnida, the mites and ticks; also called Acarina. All are small (0.004–1.2 in. or 0.1–30 mm, most less than 0.08 in. or 2 mm in length), have lost most traces of external body segmentation, and have the mouthparts borne on a discrete body region, the gnathosoma. They are apparently most closely related to Opiliones and Ricinulei.

The chelicerae may be chelate or needlelike. Pedipalps are generally smaller than the walking legs, and are simple or sometimes weakly chelate. Legs may be modified by projections, enlarged claws, heavy spines, or bladelikey rows of long setae for crawling, clinging to hosts, transferring spermatophores, or swimming. Mites frequently have one or two simple eyes (ocelli) anterolaterally on the idiosoma (occasionally one anteromedially as well). The ganglia of the central nervous system are coalesced into a single “brain” lying around the esophagus. A simple dorsal heart is present in a few larger forms.

Mites are ubiquitous, occurring from oceanic trenches below 13,200 ft (4000 m) to over 20,800 ft (6300 m) in the Himalayas and suspended above 3300 ft (1000 m) in the atmosphere; there are species in Antarctica. Soil mites show the least specialized adaptations to habitat and are frequently well-sclerotized predators. Inhabitants of stored grains, cheese, and house dust are also relatively unspecialized. The dominant forms inhabiting mosses are heavily sclerotized beetle mites (Oribatidae). Flowering plant associates include spider mites (Tetranychidae) and gall mites (Eriophyidae). Fungivores are usually weakly sclerotized inhabitants of moist or semiaquatic habitats, while the characteristic fresh-water mites include sluggish crawlers, rapid swimmers, and planktonic drifters. Mites associated with invertebrate animals include internal, external, and social parasites as well as inactive phoretic stages on Insecta, Crustacea, Myriapoda, Chelicerata, Mollusca, and Parazoa. A similar diversity of species are parasites or commensals of vertebrates. Some parasitic mites are disease vectors. Over 30,000 species have been described, and it is estimated that as many as 500,000 may exist. See ARACHNIDA. [D.B.]

**Acceleration** The time rate of change of velocity. Since velocity is a directed or vector quantity involving both magnitude and direction, a velocity may change by a change of magnitude (speed) or by a change of direction or both. It follows that acceleration is also a directed, or vector, quantity. If the magnitude of the velocity of a body changes from  $v_1$  ft/s to  $v_2$  ft/s in  $t$  seconds, then the average acceleration  $a$  has a magnitude given by Eq. (1):

$$a = \frac{\text{velocity change}}{\text{elapsed time}} = \frac{v_2 - v_1}{t_2 - t_1} = \frac{\Delta v}{\Delta t} \quad (1)$$

To designate it fully the direction should be given, as well as the magnitude. See VELOCITY.

Instantaneous acceleration is defined as the limit of the ratio of the velocity change to the elapsed time as the time interval approaches zero. When the acceleration is constant, the average acceleration and the instantaneous acceleration are equal.

Whenever a body is acted upon by an unbalanced force, it will undergo acceleration. If it is moving in a constant direction, the acting force will produce a continuous change in speed. If it

is moving with a constant speed, the acting force will produce an acceleration consisting of a continuous change of direction. In the general case, the acting force may produce both a change of speed and a change of direction.

Angular acceleration is a vector quantity representing the rate of change of angular velocity of a body experiencing rotational motion. If, for example, at an instant  $t_1$ , a rigid body is rotating about an axis with an angular velocity  $\omega_1$ , and at a later time  $t_2$ , it has an angular velocity  $\omega_2$ , the average angular acceleration  $\alpha$  is given by Eq. (2), in radians per second per second.

$$\bar{\alpha} = \frac{\omega_2 - \omega_1}{t_2 - t_1} = \frac{\Delta\omega}{\Delta t} \quad (2)$$

The instantaneous angular acceleration is given by  $\alpha = d\omega/dt$ . [R.D.Ru.]

When a body moves in a circular path with constant linear speed at each point in its path, it is also being constantly accelerated toward the center of the circle under the action of the force required to constrain it to move in its circular path. This acceleration toward the center of path is called radial acceleration. The component of linear acceleration tangent to the path of a particle subject to an angular acceleration about the axis of rotation is called tangential acceleration. See ACCELERATION MEASUREMENT; ROTATIONAL MOTION. [C.E.H.; R.J.S.]

**Accelerator mass spectrometry** The use of a combination of mass spectrometers and an accelerator to measure the natural abundances of very rare radioactive isotopes. These abundances are frequently lower than parts per trillion. The most important applications of accelerator mass spectrometry are in archeological and geophysical studies, as, for example, in radiocarbon dating by the counting of the rare carbon-14 (radiocarbon;  $^{14}\text{C}$ ) isotope. See DATING METHODS; GEOCHRONOMETRY; PARTICLE ACCELERATOR.

The advantage of counting the radioactive atoms themselves rather than their decay products is well illustrated by radiocarbon dating, which requires the measurement of the number of  $^{14}\text{C}$  atoms in a sample. The long half-life of 5730 years for  $^{14}\text{C}$  implies that only 15 beta-particle emissions per minute are observed from 1 g of contemporary carbon. However, an accelerator mass spectrometer can be used to count the  $^{14}\text{C}$  atoms at over 15 per second from a milligram sample of carbon. Consequently, accelerator mass spectrometry can be used to date samples that are a thousand times smaller than those that are dated by using the beta-particle counting method, and the procedure is carried out about 120 times faster.

For the study of many rare radioactive atoms, accelerator mass spectrometry also has the important advantage that there can be no background except for contamination with the species being studied. For example, significant interference with the beta-particle counting of radiocarbon from cosmic rays and natural radioactivity occurs for carbon samples about 25,000 years old. In contrast, accelerator mass spectrometer measurements are affected only by the natural contamination of the sample which becomes serious for samples about 50,000 years old.

**Apparatus.** The success of accelerator mass spectrometry results from the use of more than one stage of mass spectrometry and at least two stages of ion acceleration. The illustration shows the layout of an ideal accelerator mass spectrometer for radiocarbon studies, divided for convenience into three stages.

The first part of the accelerator mass spectrometer is very similar to a conventional mass spectrometer. In the second stage, a tandem accelerator first accelerates negative ions to the central high-voltage electrode, converts them into positive ions by several successive collisions with gas molecules in a region of higher gas pressure, known as a stripping canal, and then further accelerates the multiply charged positive ions through the same voltage difference back to ground potential. In the third stage, the

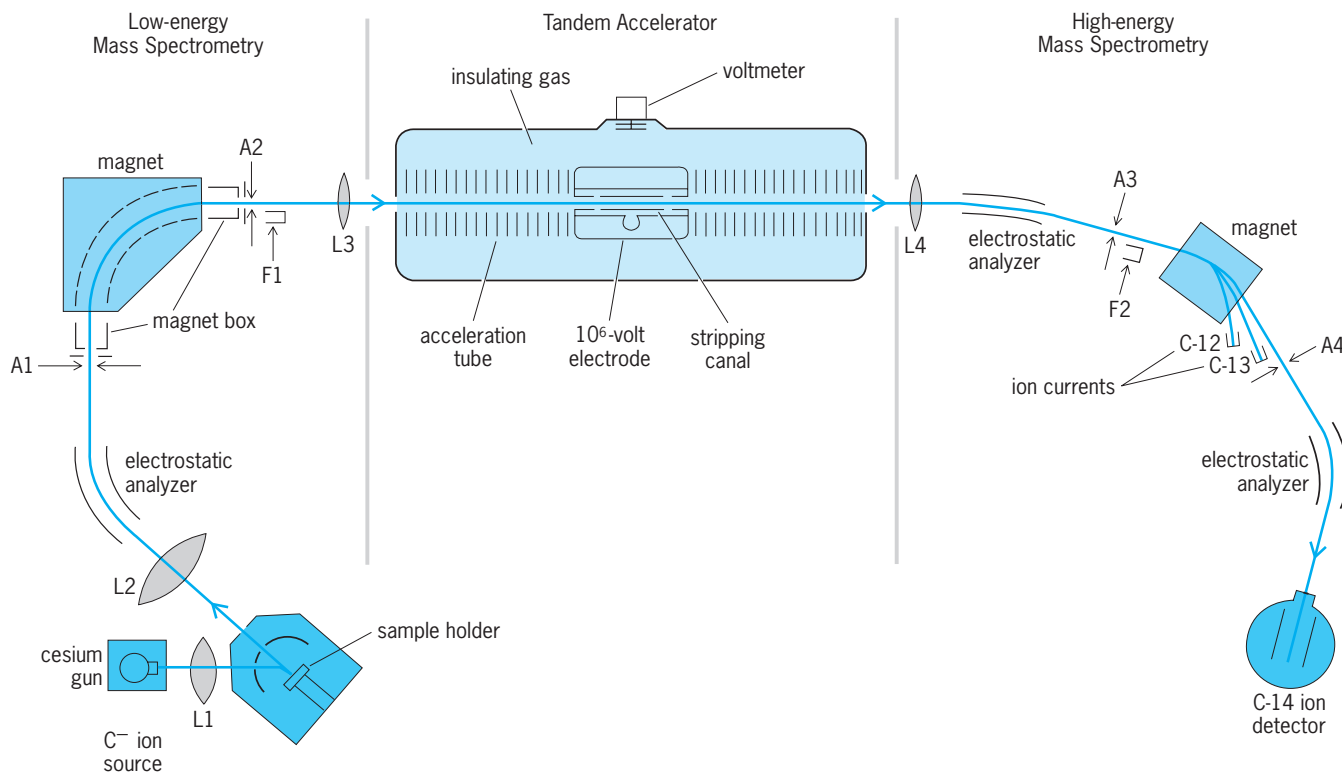

Simplified diagram of an accelerator mass spectrometer used for radiocarbon dating. The equipment is divided into three sections. Electric lenses L1–L4 are used to focus the ion beams; apertures A1–A4 and charge collection cups F1 and F2 are used for setting up the equipment.

## 10 Accelerometer

accelerated ions are analyzed further by the high-energy mass spectrometer.

**Distinguishing features.** The features that clearly distinguish accelerator mass spectrometry from conventional mass spectrometry are the elimination of molecular ions and isobars from the mass spectrometry.

A tandem accelerator provides a convenient way of completely eliminating molecular ions from the mass spectrometry because ions of a few megaelectronvolts can lose several electrons on passing through the region of higher gas pressure in the stripping canal. Molecules with more than two electrons missing have not been observed, so that accelerator mass spectrometry utilizing charge  $-3$  ions is free of molecular interferences.

The use of a negative-ion source, which is necessary for tandem acceleration, can also ensure the complete separation of atoms of nearly identical mass (isobars). In the case of radio-carbon analysis, the abundant stable  $^{14}\text{N}$  ions and the very rare radioactive  $^{14}\text{C}$  ions are separated completely because the negative ion of nitrogen is unstable whereas the negative ion of carbon is stable. In other cases, it is possible to count the ions without any background in the ion detectors because of their high energy. In many cases, it is also possible to identify the ion. See MASS SPECTROMETRY. [A.E.L.]

**Accelerometer** A mechanical or electromechanical instrument that measures acceleration. The two general types of accelerometers measure either the components of translational acceleration or angular acceleration.

Most translational accelerometers fall into the category of seismic instruments, which means the accelerations are not measured with respect to a reference point. Of the two types of seismic instruments, one measures the attainment of a predefined acceleration level and the other measures acceleration continuously. In one version of the first type of instrument, a seismic mass is suspended from a bar made of brittle material which fails in tension at a predetermined acceleration level.

Continuously measuring seismic instruments are composed of a damped or an undamped spring-supported seismic mass which is mounted by means of the spring to a housing. The seismic mass is restrained to move along a predefined axis. Also provided is some type of sensing device to measure acceleration.

The type of sensing device used to measure the acceleration determines whether the accelerometer is a mechanical or an electromechanical instrument. One type of mechanical accelerometer consists of a liquid-damped cantilever spring-mass system, a shaft attached to the mass, and a small mirror mounted on the shaft. A light beam reflected by the mirror passes through a slit, and its motion is recorded on moving photographic paper. The type of electromechanical sensing device classifies the accelerometer as variable-resistance, variable-inductance, piezoelectric, piezotransistor, or servo type of instrument or transducer.

There are several different types of angular accelerometers. In one type the damping fluid serves as the seismic mass. Under angular acceleration the fluid rotates relative to the housing and causes on two symmetrical vanes a pressure which is a measure of the angular acceleration. Another type of instrument has a fluid-damped symmetrical seismic mass in the form of a disk which is so mounted that it rotates about the normal axis through its center of gravity. The angular deflection of the disk, which is restrained by a spring, is proportional to the angular acceleration. [R.C.Du.; T.I.]

**Acceptor atom** An impurity atom in a semiconductor which can accept or take up one or more electrons from the crystal and become negatively charged. An atom which substitutes for a regular atom of the material but has one less valence electron may be expected to be an acceptor atom. For example, atoms of boron, aluminum, gallium, or indium are acceptors in germanium and silicon (illus. *a*), and atoms of antimony and bismuth are acceptors in tellurium crystals. Acceptor atoms tend

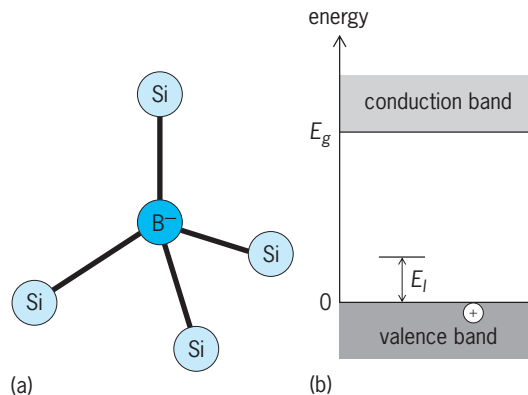

**Trivalent acceptor atom, boron (B), in the elemental semiconductor silicon (Si).** (a) Boron atom in a substitutional position, that is, replacing silicon, a tetravalent host atom, by completing the four tetrahedral covalent bonds with its nearest neighbor silicon atoms. This requires an electron to be accepted from the valence band, thus making boron negatively charged. (b) Energy diagram showing that the absence of an electron in the valence band is equivalent to a positive charge carrier, a hole, which is bound to boron via Coulomb attraction with an ionization energy  $E_i$ .  $E_g$  = energy gap separating valence band from conduction band.

to increase the number of holes (positive charge carriers) in the semiconductor (illus. *b*). The energy gained when an electron is taken up by an acceptor atom from the valence band of the crystal is the ionization energy of the atom. See DONOR ATOM; SEMICONDUCTOR. [H.Y.F.; A.K.R.]

**Acetal** A geminal diether ( $R_1 = \text{H}$ ). Ketals, considered a subclass of acetals, are also geminal diethers ( $R_1 = \text{C}$ , aliphatic or aromatic). Acetals are (1) independent structural units or a part of certain biological and commercial polymers, (2) blocking or protecting groups for complex molecules undergoing selective synthetic transformations, and (3) entry compounds for independent organic chemical reactions. See POLYACETAL.

Acetals are easily prepared by the reaction of aldehydes with excess alcohol, under acid-catalyzed conditions. This is usually a two-step process (see reaction below) in which an aldehyde is

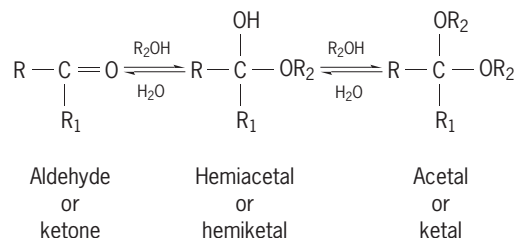

treated with an alcohol to yield a less stable hemiacetal, which then reacts with additional alcohol to give the acetal. Protonic or Lewis acids are effective catalysts for acetal formation; dehydrating agents, such as calcium chloride and molecular sieves, can also be used for molecules, such as sugars, where acids may cause problems. Less common acetal preparations are Grignard reagent condensation with orthoformates and mercuric-catalyzed additions of alcohols to acetylenes. See ALDEHYDE; KETONE; ORGANIC SYNTHESIS. [C.F.B.]

**Acetic acid** A colorless, pungent liquid,  $\text{CH}_3\text{COOH}$ , melting at  $16.7^\circ\text{C}$  and boiling at  $118.0^\circ\text{C}$ . Acetic acid is the sour principle in vinegar. Concentrated acid is called glacial acetic acid because of its readiness to crystallize at cool temperatures.

Acetic acid is manufactured by three main routes: butane liquid-phase catalytic oxidation in acetic acid solvent, palladium-copper salt-catalyzed oxidation of ethylene in aqueous solution, and methanol carbonylation in the presence of rhodium catalyst. Large quantities of acetic acid are recovered in the manufacture

of cellulose acetate and polyvinyl alcohol. Some acetic acid is produced in the oxidation of higher olefins, aromatic hydrocarbons, ketones, and alcohols. See OXIDATION PROCESS; WOOD CHEMICALS.

Pure acetic acid is completely miscible with water, ethanol, diethyl ether, and carbon tetrachloride, but is not soluble in carbon disulfide. In a water solution, acetic acid is a typical weakly ionized acid ( $K_a = 1.8 \times 10^{-5}$ ). Acetic acid neutralizes many oxides and hydroxides, and decomposes carbonates to furnish acetate salts, which are used in textile dyeing and finishing, as pigments, and as pesticides; examples are verdigris, white lead, and paris green. See VINEGAR. [F.W.]

**Acetone** A chemical compound,  $\text{CH}_3\text{COCH}_3$ . A colorless liquid with an ethereal odor, it is the first member of the homologous series of aliphatic ketones. Its physical properties include boiling point  $56.2^\circ\text{C}$  ( $133.2^\circ\text{F}$ ), melting point  $-94.8^\circ\text{C}$  ( $-138.6^\circ\text{F}$ ), and specific gravity 0.791.

Acetone is used as a solvent for cellulose ethers, cellulose acetate, cellulose nitrate, and other cellulose esters. Cellulose acetate is spun from acetone solution. Lacquers, based on cellulose esters, are used in solution in mixed solvents including acetone. [D.A.S.]

**Acetylcholine** A naturally occurring quaternary ammonium cation ester, with the formula  $\text{CH}_3(\text{O})\text{COC}_2\text{H}_4\text{N}(\text{CH}_3)_3$ , that plays a prominent role in nervous system function. The great importance of acetylcholine derives from its role as a neurotransmitter for cholinergic neurons, which innervate many tissues, including smooth muscle and skeletal muscle, the heart, ganglia, and glands. The effect of stimulating a cholinergic nerve, for example, the contraction of skeletal muscle or the slowing of the heartbeat, results from the release of acetylcholine from the nerve endings.

Acetylcholine is synthesized at axon endings from acetyl coenzyme A and choline by the enzyme choline acetyltransferase, and is stored at each ending in hundreds of thousands of membrane-enclosed synaptic vesicles. When a nerve impulse reaches an axon ending, voltage-gated calcium channels in the axonal membrane open and calcium, which is extremely low inside the cell, enters the nerve ending. The increase in calcium-ion concentration causes hundreds of synaptic vesicles to fuse with the cell membrane and expel acetylcholine into the synaptic cleft (exocytosis). The acetylcholine released at a neuromuscular junction binds reversibly to acetylcholine receptors in the muscle endplate membrane, a postsynaptic membrane that is separated from the nerve ending by a very short distance. The receptor is a cation channel which opens when two acetylcholine molecules are bound, allowing a sodium current to enter the muscle cell and depolarize the membrane. The resulting impulse indirectly causes the muscle to contract.

Acetylcholine must be rapidly removed from a synapse in order to restore it to its resting state. This is accomplished in part by diffusion but mainly by the enzyme acetylcholinesterase, which hydrolyzes acetylcholine.

Acetylcholinesterase is a very fast enzyme: one enzyme molecule can hydrolyze 10,000 molecules of acetylcholine in 1 s. Any substance that efficiently inhibits acetylcholinesterase will be extremely toxic. [I.B.W.]

**Acetylene** An organic compound with the formula  $\text{C}_2\text{H}_2$  or  $\text{HC}\equiv\text{CH}$ . The first member of the alkynes, acetylene is a gas with a narrow liquid range; the triple point is  $-81^\circ\text{C}$  ( $-114^\circ\text{F}$ ). The heat of formation ( $\Delta H_f^\circ$ ) is  $+227$  kilojoules/mole, and acetylene is the most endothermic compound per carbon of any hydrocarbon. The compound is thus extremely energy-rich and can decompose with explosive force. At one time acetylene was a basic compound for much chemical manufacturing. It is highly reactive and is a versatile source of other reactive compounds.

The availability of acetylene does not depend on petroleum liquids, since it can be prepared by hydrolysis of calcium car-

bide ( $\text{CaC}_2$ ), obtained from lime ( $\text{CaO}$ ), and charcoal or coke (C). In modern practice, methane ( $\text{CH}_4$ ) is passed through a zone heated to  $1500^\circ\text{C}$  ( $2732^\circ\text{F}$ ) for a few milliseconds, and acetylene is then separated from the hydrogen in the effluent gas.

The main use of acetylene is in the manufacture of compounds derived from butyne-1,4-diol. The latter is obtained by condensation of acetylene with two moles of formaldehyde and is converted to butyrolactone, tetrahydrofuran, and pyrrolidone. Two additional products, vinyl fluoride and vinyl ether, are also based on acetylene.

Because of the very high heat of formation and combustion, an acetylene-oxygen mixture provides a very high temperature flame for welding and metal cutting. For this purpose acetylene is shipped as a solution in acetone, loaded under pressure in cylinders that contain a noncombustible spongy packing. See ALKYNE. [J.A.Mo.]

**Acid and base** Two interrelated classes of chemical compounds, the precise definitions of which have varied considerably with the development of chemistry. Some of these controversies are still unresolved.

Acids initially were defined only by their common properties as substances which had a sour taste, dissolved many metals, and reacted with alkalis (or bases) to form salts. For a time it was believed that a common constituent of all acids was the element oxygen, but gradually it became clear that, if there were an essential element, it was hydrogen, not oxygen. This concept of an acid proved to be satisfactory for about 50 years.

Bases initially were defined as those substances which reacted with acids to form salts (they were the "base" of the salt). The alkalis, soda and potash, were the best-known bases, but it soon became clear that there were other bases, notably ammonia and the amines.

When the concept of ionization of chemical compounds in water solution became established, acids were defined as substances which ionized in aqueous solution to give hydrogen ions,  $\text{H}^+$ , and bases were substances which reacted to give hydroxide ions,  $\text{OH}^-$ . These definitions are sometimes known as the Arrhenius-Ostwald theory of acids and bases. Their use makes it possible to discuss acid and base equilibria and also the strengths of individual acids and bases.

A powerful and wide-ranging protonic theory of acids and bases was introduced by J. N. Brønsted in 1923 and was rapidly accepted. Somewhat similar ideas were advanced almost simultaneously by T. M. Lowry and the new theory is occasionally called the Brønsted-Lowry theory. The Brønsted definitions of acids and bases are: An acid is a species which can act as a source of protons; a base is a species which can accept protons. Compared to the water (Arrhenius) theory, this represents only a slight change in the definition of an acid but a considerable extension of the term base. In addition to hydroxide ion, the bases now include a wide variety of uncharged species, such as ammonia and the amines, as well as numerous charged species, such as the anions of weak acids. In fact, every acid can generate a base by loss of a proton. Acids and bases which are related in this way are known as conjugate acid-base pairs, and the table lists examples.

As the table shows, strengths of acids and bases are not independent. A very strong Brønsted acid implies a very weak conjugate base and vice versa. A qualitative ordering of acid strength or base strength permits a rough prediction of the extent to which an acid-base reaction will go. The rule is that a strong acid and a strong base will react extensively with each other, whereas a weak acid and a weak base will react together only very slightly.

Studies of catalysis have played a large role in the acceptance of a set of quite different definitions of acids and bases, those due to G. N. Lewis: An acid is a substance which can accept an electron pair from a base; a base is a substance which can donate an electron pair. Bases under the Lewis definition are very similar

## 12 Acid anhydride

Conjugate acid-base pairs				
	Acids		Bases	
Strong acids	H <sub>2</sub> SO <sub>4</sub>	—————	HSO <sub>4</sub> <sup>-</sup>	Weak bases
	HCl	—————	Cl <sup>-</sup>	
	H <sub>3</sub> O <sup>+</sup>	—————	H <sub>2</sub> O	
	HSO <sub>4</sub> <sup>-</sup>	—————	SO <sub>4</sub> <sup>2-</sup>	
	HF <sub>(aq)</sub>	—————	F <sup>-</sup>	
	CH <sub>3</sub> COOH	—————	CH <sub>3</sub> COO <sup>-</sup>	
Weak acids	NH <sub>4</sub> <sup>+</sup>	—————	NH <sub>3</sub>	Strong bases
	NCO <sub>3</sub> <sup>-</sup>	—————	CO <sub>3</sub> <sup>2-</sup>	
	H <sub>2</sub> O	—————	OH <sup>-</sup>	
	C <sub>2</sub> H <sub>5</sub> OH	—————	C <sub>2</sub> H <sub>5</sub> O <sup>-</sup>	

to those defined by Brønsted, but the Lewis definition for acids is very much broader.

Another comprehensive theory was proposed by M. Usanovich in 1939 and is sometimes known as the positive-negative theory. Acids are defined as substances which form salts with bases, give up cations, and add themselves to anions and free electrons. Bases are similarly defined as substances which give up anions or electrons and add themselves to cations. So far, this theory has had little acceptance, quite possibly because the definitions are too broad to be very useful. See HYDROGEN ION. [F.A.L.; R.H.Bo.]

**Acid anhydride** One of an important class of reactive organic compounds derived from acids via formal intermolecular dehydration.

Anhydrides of straight-chain acids containing from 2 to 12 carbon atoms are liquids with boiling points higher than those of the parent acids. They are relatively insoluble in cold water and are soluble in alcohol, ether, and other common organic solvents. The lower members are pungent, corrosive, and weakly lacrimatory. Anhydrides from acids with more than 12 carbon atoms and cyclic anhydrides from dicarboxylic acids are crystalline solids.

Because the direct intermolecular removal of water from organic acids is not practicable, anhydrides must be prepared by means of indirect processes. A general method involves interaction of an acid salt with an acid chloride.

Acetic anhydride, the most important aliphatic anhydride, is manufactured by air oxidation of acetaldehyde, using as catalysts the acetates of copper and cobalt, shown in reaction (1).

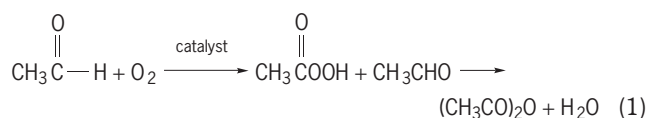

Cyclic anhydrides are obtained by warming succinic or glutaric acids, either alone, with acetic anhydride, or with acetyl chloride. Under these conditions, adipic acid first forms linear, polymeric anhydride mixtures, from which the monomer is obtained by slow, high-vacuum distillation. Cyclic anhydrides are also formed by simple heat treatment of cis-unsaturated dicarboxylic acids, for example, maleic and glutaric acids; and of aromatic 1,2-dicarboxylic acids, for example, phthalic acid. Commercially, however, both phthalic (1) and maleic (2)

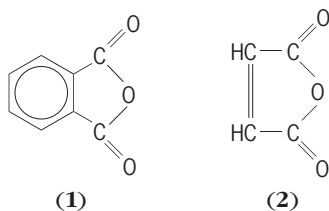

anhydrides are primary products of manufacture, being formed

by vapor-phase, catalytic (vanadium pentoxide), air oxidation of naphthalene and benzene, respectively; at the reaction temperature, the anhydrides form directly.

Anhydrides are used in the preparation of esters. Ethyl acetate and butyl acetate (from butyl alcohol and acetic anhydride) are excellent solvents for cellulose nitrate lacquers. Acetates of high-molecular-weight alcohols are used as plasticizers for plastics and resins. Cellulose and acetic anhydride give cellulose acetate, used in acetate rayon and photographic film. The reaction of anhydrides with sodium peroxide forms peroxides (acetyl peroxide is violently explosive), used as catalysts for polymerization reactions and for addition of alkyl halides to alkenes. In Friedel-Crafts reactions, anhydrides react with aromatic compounds, forming ketones such as acetophenone.

Maleic anhydride reacts with many dienes to give hydroaromatics of various complexities (Diels-Alder reaction). Maleic anhydride is used commercially in the manufacture of alkyd resins from polyhydric alcohols. Soil conditioners are produced by basic hydrolysis of the copolymer of maleic anhydride with vinyl acetate.

Phthalic anhydride and alcohols form esters (phthalates) used as plasticizers for plastics and resins. Condensed with phenols and sulfuric acid, phthalic anhydride yields phthaleins, such as phenolphthalein; with *m*-dihydroxybenzenes under the same conditions, xanthene dyes form, for example, fluorescein. Phthalic anhydride is used in manufacturing glyptal resins (from the anhydride and glycerol) and in manufacturing anthraquinone. Heating phthalic anhydride with ammonia gives phthalimide, used in Gabriel's synthesis of primary amines, amino acids, and anthranilic acid (*o*-aminobenzoic acid). With alkaline hydrogen peroxide, phthalic anhydride yields monoperoxyphthalic acid, used along with benzoyl peroxide as polymerization catalysts, and as bleaching agents for oils, fats, and other edibles.

Anhydrides react with water to form the parent acid, with alcohols to give esters, and with ammonia to yield amides; and with primary or secondary amines, they furnish *N*-substituted and *N,N*-disubstituted amides, respectively. See ACYLATION; DIELS-ALDER REACTION; ESTER. [P.E.F.]

**Acid-base indicator** A substance that reveals, through characteristic color changes, the degree of acidity or basicity of solutions. Indicators are weak organic acids or bases which exist in more than one structural form (tautomers) of which at least one form is colored. Intense color is desirable so that very little indicator is needed; the indicator itself will thus not affect the acidity of the solution.

Common-acid base indicators			
Common name	pH range	Color change (acid to base)	pK
Methyl violet	0-2, 5-6	Yellow to blue violet to violet	
Metacresol purple	1.2-2.8, 7.3-9.0	Red to yellow to purple	1.5
Thymol blue	1.2-2.8, 8.0-9.6	Red to yellow to blue	1.7
Tropeoline 00 (Orange IV)	1.4-3.0	Red to yellow	
Bromphenol blue	3.0-4.6	Yellow to blue	4.1
Methyl orange	2.8-4.0	Orange to yellow	3.4
Bromcresol green	3.8-5.4	Yellow to blue	4.9
Methyl red	4.2-6.3	Red to yellow	5.0
Chlorphenol red	5.0-6.8	Yellow to red	6.2
Bromcresol purple	5.2-6.8	Yellow to purple	6.4
Bromthymol blue	6.0-7.6	Yellow to blue	7.3
Phenol red	6.8-8.4	Yellow to red	8.0
Cresol red	2.0-3.0, 7.2-8.8	Orange to amber to red	8.3
Orthocresolphthalein	8.2-9.8	Colorless to red	
Phenolphthalein	8.4-10.0	Colorless to pink	9.7
Thymolphthalein	10.0-11.0	Colorless to red	9.9
Alizarin yellow GG	10.0-12.0	Yellow to lilac	
Malachite green	11.4-13.0	Green to colorless	

Acid-base indicators are commonly employed to mark the end of an acid-base titration or to measure the existing pH of a solution. Care must be used to compare colors only within the indicator range. A color comparator may also be used, employing standard color filters instead of buffer solutions.

The indicator range is the pH interval of color change of the indicator. In this range there is competition between indicator and added base for the available protons; the color change, for example, yellow to red, is gradual rather than instantaneous. Observers may, therefore, differ in selecting the precise point of change.

The table lists many of the common indicators, their ranges of pH and color change, and pK values. See ACID AND BASE; HYDROGEN ION; TITRATION. [A.L.H.]

**Acid halide** One of a large group of organic substances possessing the halocarbonyl group,

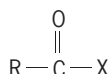

in which X stands for fluorine, chlorine, bromine, or iodine. The terms acyl and aroyl halides refer to aliphatic or aromatic derivatives, respectively.

The great inherent reactivity of acid halides precludes their free existence in nature; all are made by synthetic processes. In general, acid halides have low melting and boiling points and show little tendency toward molecular association. With the exception of the formyl halides (which do not exist), the lower members are pungent, corrosive, lacrimatory liquids that fume in moist air. The higher members are low-melting solids.

Acid chlorides are prepared by replacement of carboxylic hydroxyl of organic acids by treatment with phosphorus trichloride, phosphorus pentachloride, or thionyl chloride.

Although acid bromides may be prepared by these methods, acid iodides are best prepared from the acid chloride treatment with either  $\text{CaI}_2$  or HI, and acid fluorides from the acid chloride by interaction with HF or antimony fluoride.

The reactivity of acid halides centers upon the halocarbonyl group, resulting in substitution of the halogen by appropriate structures. Thus with substances containing active hydrogen atoms (for example, water, primary and secondary alcohols, ammonia, and primary and secondary amines), hydrogen chloride is formed together with acids, esters, amides, and *N*-substituted amides, respectively. [P.E.F.]

**Acid rain** Precipitation that incorporates anthropogenic acids and acidic materials. The deposition of acidic materials on the Earth's surface occurs in both wet and dry forms as rain, snow, fog, dry particles, and gases. Although 30% or more of the total deposition may be dry, very little information that is specific to this dry form is available. In contrast, there is a large and expanding body of information related to the wet form: acid rain or acid precipitation. Acid precipitation, strictly defined, contains a greater concentration of hydrogen ( $\text{H}^+$ ) than of hydroxyl ( $\text{OH}^-$ ) ions, resulting in a solution pH less than 7. Under this definition, nearly all precipitation is acidic. The phenomenon of acid deposition, however, is generally regarded as being anthropogenic, that is, resulting from human activity.

Theoretically, the natural acidity of precipitation corresponds to a pH of 5.6, which represents the pH of pure water in equilibrium with atmospheric concentrations of carbon dioxide. Atmospheric moisture, however, is not pure, and its interaction with ammonia, oxides of nitrogen and sulfur, and windblown dust results in a pH between 4.9 and 6.5 for most "natural" precipitation. The distribution and magnitude of precipitation pH in the United States (illustration) suggest the impact of anthropogenic rather than natural causes. The areas of highest precipitation acidity (lowest pH) correspond to areas within and downwind of heavy industrialization and urbanization where

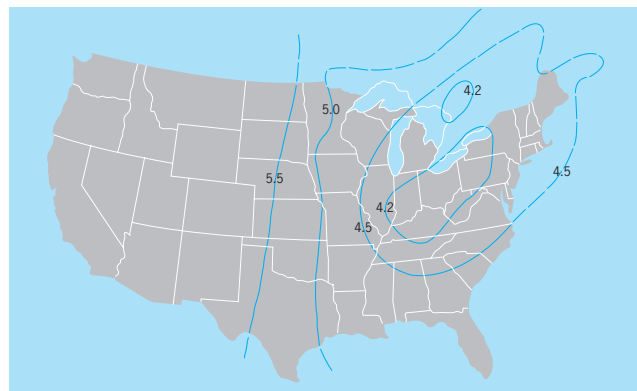

Distribution of rainfall pH in the eastern United States.

emissions of sulfur and nitrogen oxides are high. It is with these emissions that the most acidic precipitation is thought to originate.

The transport of acidic substances and their precursors, chemical reactions, and deposition are controlled by atmospheric processes. In general, it is convenient to distinguish between physical and chemical processes, but it must be realized that both types may be operating simultaneously in complicated and interdependent ways. The physical processes of transport by atmospheric winds and the formation of clouds and precipitation strongly influence the patterns and rates of acidic deposition, while chemical reactions govern the forms of the compounds deposited.

There are a number of chemical pathways by which the primary pollutants, sulfur dioxide ( $\text{SO}_2$ ) from industry, nitric oxide (NO) from both industry and automobiles, and reactive hydrocarbons mostly from trees, are transformed into acid-producing compounds. Some of these pathways exist solely in the gas phase, while others involve the aqueous phase afforded by the cloud and precipitation. As a general rule, the volatile primary pollutants must first be oxidized to more stable compounds before they are efficiently removed from the atmosphere. Ironically, the most effective oxidizing agents, hydrogen peroxide ( $\text{H}_2\text{O}_2$ ) and ozone ( $\text{O}_3$ ), arise from photochemical reactions involving the primary pollutants themselves. See AIR POLLUTION.

The effect of acid deposition on a particular ecosystem depends largely on its acid sensitivity, its acid neutralization capability, the concentration and composition of acid reaction products, and the amount of acid added to the system. As an example, the major factors influencing the impact of acidic deposition on lakes and streams are (1) the amount of acid deposited; (2) the pathway and travel time from the point of deposition to the lake or stream; (3) the buffering characteristics of the soil through which the acidic solution moves; (4) the nature and amount of acid reaction products in soil drainage and from sediments; and (5) the buffering capacity of the lake or stream.

Acid precipitation may injure trees directly or indirectly through the soil. Foliar effects have been studied extensively, and it is generally accepted that visible damage occurs only after prolonged exposure to precipitation of pH 3 or less (for example, acid fog or clouds). Measurable effects on forest ecosystems will then more likely result indirectly through soil processes than directly through exposure of the forest canopy. Many important declines in the condition of forest trees have been reported in Europe and North America during the period of increasing precipitation acidity. These cases include injury to white pine in the eastern United States, red spruce in the Appalachian Mountains of eastern North America, and many economically important species in central Europe. Since forest trees are continuously stressed by competition for light, water, and nutrients; by disease organisms; by extremes in climate; and by atmospheric pollutants, establishing acid deposition as the cause of these declines

## 14 Acipenseriformes

is made more difficult. Each of these sources of stress, singly or in combination, produces similar injury. However, a large body of information indicates that accelerated soil acidification resulting from acid deposition is an important predisposing stress that in combination with other stresses has resulted in increased decline and mortality of sensitive tree species and widespread reduction in tree growth. See FOREST ECOSYSTEM; TERRESTRIAL ECOSYSTEM.

Acidic deposition impacts aquatic ecosystems by harming individual organisms and by disrupting flows of energy and materials through the ecosystem. The effect of acid deposition is commonly assessed by studying aquatic invertebrates and fish. Aquatic invertebrates live in the sediments of lakes and streams and are vitally important to the cycling of energy and material in aquatic ecosystems. These small organisms break down large particulate organic matter for further degradation by microorganisms, and they are an important food source for fish, aquatic birds, and predatory invertebrates.

Currently, there are concerns that acid deposition is causing the loss of fish species, through physiological damage and by reproductive impairment. While fish die from acidification, their numbers and diversity are more likely to decline from a failure to reproduce. The effects of acid deposition on individuals in turn elicit changes in the composition and abundance of communities of aquatic organisms. The degree of change depends on the severity of acidification, and the interaction of other factors, such as metal concentrations and the buffering capacity of the water. The pattern most characteristic of aquatic communities in acidified waters is a loss of species diversity, and an increase in the abundance of a few, acid-tolerant taxa.

Community-level effects may occur indirectly, as a result of changes in the food supply and in predator-prey relations. Reduction in the quality and amount of periphyton may decrease the number of herbivorous invertebrates, which may in turn reduce the number of organisms (predatory invertebrates and fish) that feed upon herbivorous invertebrates. The disappearance of fish may result in profound changes in plant and invertebrate communities. Dominant fish species function as keystone predators, controlling the size distribution, diversity, and numbers of invertebrates. Their reduction alters the interaction within and among different levels of the food web and the stability of the ecosystem as a whole.

The impact of acid deposition on terrestrial and aquatic ecosystems is not uniform. While increases in acid deposition may stress some ecosystems and reduce their stability and productivity, others may be unaffected. The degree and nature of the impact depend on the acid input load, organismal susceptibility, and buffering capacity of the particular ecosystem. See BIOGEOCHEMISTRY. [R.R.Sc./D.Lam./H.B.Pi./D.Ge.]

**Acipenseriformes** An archaic order of actinopterygian fishes, represented by the sturgeons and paddlefishes. The characters include a highly chondrified internal skeleton; fins which are archaic and sharklike in appearance, with more than one ray per pterygiophore; a caudal fin which is strongly heterocercal; scales which are reduced and often form five lengthwise series of bony plates; rostrum produced; and weak jaws (see illustration). Fleshy barbels are present on the lower surface of the snout. The cartilaginous skeleton of the acipenseriform fishes was long regarded as primitive, and was taken as indicative of alliance with the Chondrichthyes. Research reveals, however, that this is secondary, and the true relationship is with the typical bony fishes.

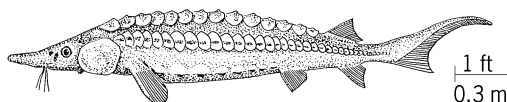

Lake sturgeon (*Acipenser fulvescens*).

The Acipenseriformes include three families: the extinct Chondrosteidae; the sturgeon family, Acipenseridae, with 4 Recent genera and about 23 species; and the paddlefish family, Polyodontidae, consisting of two Recent species, *Psephurus gladius* of China and *Polyodont spathula* of the eastern United States. See ACTINOPTERYGII; OSTEICHTHYES; STURGEON. [R.M.B.]

**Acoela** An order of marine Turbellaria, generally regarded as primitive, and lacking protonephridia, oviducts, yolk glands, permanent digestive cavity, and strictly delimited gonads. The nervous system is epidermal in the most primitive representatives, but it is generally submuscular and consists of three to six pairs of longitudinal strands without anterior concentrations recognizable as a brain. The anterior or median ventral mouth opens into a simple pharynx which lacks elaborate musculature and leads directly to the syncytial vacuolated mass of endoderm forming the spongy intestinal tissue and lacking any true lumen.

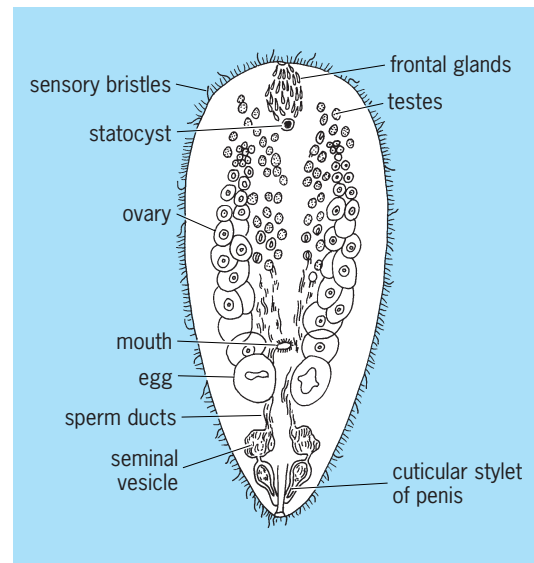

**Acoela:** *Childia spinosa*.

Eyes are often absent; when present they are of the usual paired turbellarian pigment-cup type, with one to a few pigment and retinal cells. The epidermis, typically, is uniformly ciliated, and locomotion is accomplished by means of rapid, smooth ciliary gliding or swimming.

The acoels (see illustration) are mostly small (one to several millimeters in length). They are virtually worldwide in distribution, living beneath stones, among algae, on the bottom mud, or interstitially, from the littoral zone to deeper waters. A few are pelagic (in tropical and subtropical zones), and others have become symbiotic, living entocommensally in various invertebrates but mainly in echinoderms. See COELENTERATA; PLATYHELMINTHES; TURBELLARIA. [J.B.J.]

**Aconchulinida** An order of the subclass Filosia comprising a small group of naked amebas which form filamentous pseudopodia (filopodia). The genus *Penardia*, possibly the only valid one in the order, includes filopodia-forming amebas with variable shape, an outer zone of clear ectoplasm, and inner cytoplasm often containing many vacuoles and sometimes zoochlorellae (see illustration). Pseudopodia are sometimes extended primarily at the poles of the organism, but also may fuse laterally to form small sheets of clear cytoplasm. A single nucleus and one water-elimination vesicle are characteristic of these amebas. Size of described species ranges from less



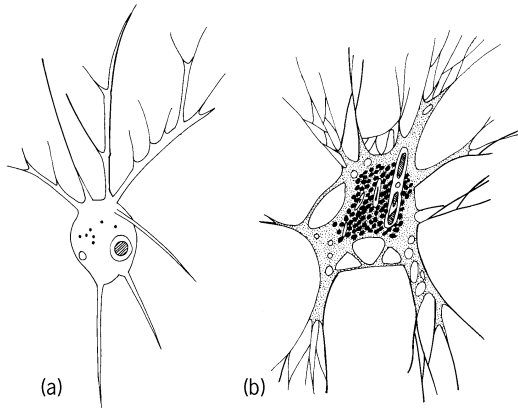

Aconchulinida. (a) *Penardia cometa*. (b) *P. mutabllis*.

than 10 to about 400 micrometers. See FILOSLA; PROTOZOA; SARCODINA; SARCOMASTIGOPHORA. [R.P.H.]

**Acorales** An order of monocotyledonous angiosperms composed of a single genus, *Acorus* (sweet flag or sweet calamus), with two species widespread in the Northern Hemisphere. Formerly, *Acorus* was included in the aroid family, Araceae, but several lines of evidence, including deoxyribonucleic acid (DNA) sequences, have firmly established it as the first-branching lineage of the monocotyledons. These species are emergent aquatics with peculiar inflorescences, and they are unusual among the monocots in having characters otherwise confined to the magnoliid dicots, such as the anther formation and the presence of ethereal oils. These oils are the basis of the species' frequent use as a medicine to treat toothache and dysentery, and as an ointment in religious ceremonies. See MAGNOLIOPHYTA. [M.W.C.]

**Acoustic emission** A method of nondestructive testing and materials characterization that uses mechanical waves moving through materials. It is similar to seismology, except in being concerned with the scale of engineering structures, such as aircraft, bridges, and chemical tanks. When a structure is subjected to external force (or stress), a defect (for example, a crack or welding flaw) on the structure is activated and enlarged dynamically, and thus generates waves, which spread through materials at a certain speed. Such waves, known as acoustic emission signals, are detected by sensors attached on the surfaces of the structure. Mechanical vibration due to acoustic emission signals is weak and requires high-sensitivity sensors and electronic amplification before it can be analyzed. See SEISMOLOGY.

In nondestructive testing of structures, acoustic emission signals are typically evaluated in order to know if the failure of a structure is imminent; if cracks and other defects, presumed to be present in any structure, are active; the positions of such active defects; and whether a structure with such defects can be safely operated. In evaluating material behavior and quality, acoustic emission is used to assess how a material responds to mechanical stress, that is, when and how it changes shape permanently and how it proceeds to eventual fracture; how an alloy withstands repeated application of stress (known as fatigue); the level of stress and corrosive environment that lead to failure of a material; and the types of microscopic failure processes that arise in a material under stress. See METAL, MECHANICAL PROPERTIES OF; PLASTIC DEFORMATION OF METAL; STRESS AND STRAIN.

Acoustic emission signals emanating from their sources contain information about the source, such as the direction and speed of crack opening. For example, the high-speed cracking of brittle materials (such as high-strength steels and ceramics) produces short, fast-varying acoustic emission signals, which are typically plotted against time measured in microseconds. In

contrast, slow-growing defects in plastics result in longer, slowly varying signals, which are typically plotted on a time scale of milliseconds. Because of the distortion of waves during the propagation through a complex structure and detection by a sensor, however, much of the information is lost. Thus, the presence of detectable acoustic emission signals is the most important clue in assessing the integrity of the structure.

By detecting one such signal at multiple sensor positions, the location of its source can be determined from the timing of signal arrivals. The basic principle of triangulation is the same as practiced in seismology, except that the differences in signal arrival times are of the order of microseconds to milliseconds. The speed of wave propagation is a material constant, determined by the stiffness and mass density of the propagating medium.

A typical sensor uses a piezoelectric ceramic element, which converts mechanical vibration into an electrical signal, which can be amplified 1000 to 10,000 times. Various electrical measurement techniques are used to characterize and analyze the signals received. It is common to obtain and record several features of acoustic emission signals. These form the basis of real-time analysis and decision-making. In laboratory studies, the entire waveforms are also recorded for detailed analysis after testing. See PIEZOELECTRICITY. [K.O.]

**Acoustic holography** The recording of sound waves in a two-dimensional pattern (the hologram) and the use of the hologram to reconstruct the entire sound field throughout a three-dimensional region of space. Acoustical holography is an outgrowth of optical holography, invented by Dennis Gabor in 1948. The wave nature of both light and sound make holography possible. Acoustical holography involves reconstruction of the sound field that arises due to radiation of sound at a boundary, such as the vibrating body of a violin, the fuselage of an aircraft, or the surface of a submarine. Both acoustical holography and optical holography rely on the acquisition of an interferogram, a two-dimensional recording at a single frequency of the phase and amplitude of an acoustic or electromagnetic field, usually in a plane. Gabor called this interferogram a hologram. See HOLOGRAPHY; INVERSE SCATTERING THEORY.

Two distinct forms of acoustical holography exist. In farfield acoustical holography (FAH), the hologram is recorded far removed from the source. This form of acoustical holography is characterized by the fact that the resolution of the reconstruction is limited to a half-wavelength. This resolution restriction is removed, however, when the hologram is recorded in the acoustic nearfield, an important characteristic of nearfield acoustical holography (NAH), invented by E. G. Williams and J. D. Maynard in 1980.

Nearfield acoustical holography has been used in the automotive industry to study interior noise and tire noise, in musical acoustics to study vibration and radiation of violin-family instruments, and in the aircraft industry to study interior cabin noise and fuselage vibrations. Applications are also found in underwater acoustics, especially in studies of vibration, radiation, and scattering from ships and submarines. See ACOUSTIC NOISE; MUSICAL ACOUSTICS; UNDERWATER SOUND.

Typically, temporal acoustic data are acquired by measurement of the acoustic pressure with a single microphone or hydrophone, which scans an imaginary two-dimensional surface. In some cases, an array of microphones is used and the pressure is measured instantaneously by the array. The measured data are processed in a computer to reconstruct the pressure at the surface of the object as well as the vibration of the surface. The measured time data are Fourier-transformed into the frequency domain, creating a set of holograms, one for each frequency bin in the transform. In the inversion process, each hologram is broken up into a set of waves or modes whose propagation characteristics are known from basic principles. Each wave or mode is then back-propagated to the source surface by multiplication by

## 16 Acoustic impedance

the known inverse propagator, and the field is then recomposed by addition of all these waves or modes. See FOURIER SERIES AND TRANSFORMS. [E.G.Wi.]

**Acoustic impedance** At a given surface, the complex ratio of effective sound pressure averaged over the surface to the effective flux (volume velocity or particle velocity multiplied by the surface area) through it. The unit is the  $N \cdot s/m^5$  (newton-second/meter<sup>5</sup>), or the mks acoustic ohm. In the cgs system the unit is the  $dyn \cdot s/cm^5$  (dyne-second/centimeter<sup>5</sup>). See SOUND PRESSURE.

Specific acoustic impedance is the complex ratio of the effective sound pressure at a point to the effective particle velocity at a point. The unit is the  $N \cdot s/m^3$ , or the mks rayl. In the cgs system the unit is the  $dyn \cdot s/cm^3$ , or the rayl. The difference between specific acoustic impedance and acoustic impedance is in the specification of impedance at a point, as compared to the average over a surface.

Characteristic acoustic impedance is the ratio of effective sound pressure at a point to the particle velocity at that point in a free, progressive wave. This ratio is equal to the product of the density of the medium times the speed of sound in the medium. The characteristic impedance of a sound wave is analogous to the characteristic electrical impedance of an infinitely long, dissipationless transmission line. It is common in acoustical analyses to represent specific acoustic impedances in terms of their ratio to the characteristic impedance of air.

Acoustic impedance, being a complex quantity, can have real and imaginary components analogous to those in an electrical impedance. In applying this analogy, the real part of the acoustic impedance is termed acoustic resistance, and the imaginary part is termed acoustic reactance. See ELECTRICAL IMPEDANCE. [W.J.G.]

**Acoustic interferometer** An instrument that is sensitive to the interference of two or more acoustic waves. It provides information on acoustic wavelengths that is useful in determining the velocity and absorption of sound in samples of gases, liquids, and materials, and it yields information on the nonlinear properties of solids.

In its simplest form, an acoustic interferometer for use in liquids has a fixed piezoelectric crystal (acting as a transmitter) tuned to the frequency of interest and a parallel reflector at a variable distance from it. Driven by an oscillating electrical voltage, the piezoelectric crystal generates a sound wave, which in turn is reflected by the reflector. The acoustic pressure amplitude on the front face of the crystal depends on the velocity amplitude at the face and the distance to the reflecting surface. The amplitude ratio (radiation impedance) of the acoustic pressure to the velocity and the relative phase shift between the two oscillating quantities depend solely on the distance to the reflecting surface. If the reflector acts as a rigid surface, this amplitude ratio is ideally zero whenever the net round-trip distance between the crystal and the reflector is an odd number of half-wavelengths because the reflected wave is then exactly out of phase with the incident wave at the crystal's location. The crystal then draws the maximum current since the oscillations are unimpeded. See ACOUSTIC IMPEDANCE; PIEZOELECTRICITY; WAVE MOTION; WAVELENGTH.

During operation, the current drawn by the crystal is monitored as the reflector is gradually moved away from the crystal. Whenever the reflector position is such that the crystal is at a pressure antinode (place of maximum pressure in a standing wave), there is a strong dip in the current drawn due to the relatively high radiation impedance presented by the standing wave to the crystal face. Consecutive antinodes are a half-wavelength apart. For a given frequency  $f$ , a measured distance  $L$  between the location of any one antinode and that of its  $n$ th successor yields the wavelength  $2L/n$  and the speed of sound  $c = 2Lf/n$ . An acoustic interferometer based on this principle can achieve a precision

of 0.01%. Since the current drawn by the crystal is relatively insensitive to the frequency for a given radiation impedance, the sound speed can also be determined by keeping the distance between the crystal and the reflector fixed and gradually sweeping the frequency.

The pressure nodes and antinodes correspond to the local maxima and minima, respectively, in the current drawn. The peak of the current amplitude decreases with the distance traversed by the reflector. If the separation distance is sufficiently large that the exponential decrease associated with absorption dominates any spreading losses, the absorption coefficient for the medium can be derived by measurement of the ratios of current amplitudes at two successive points where the current drawn is a local maximum. See SOUND; SOUND ABSORPTION; ULTRASONICS. [G.S.K.W.; A.D.P.; S.I.M.]

**Acoustic levitation** The use of intense acoustic waves to hold a body that is immersed in a fluid medium against the force of gravity without obvious mechanical support.

Levitation can occur in the presence of fluid flow, including the back-and-forth fluid flow produced by the passage of an acoustic wave. Such acoustically generated forces are extremely small in common experience. But intense acoustic waves are nonlinear in their basic character and, therefore, may exert a net acoustic radiation pressure on an object sufficient to balance the gravitational force and thus levitate it. See ACOUSTIC RADIATION PRESSURE.

The applications of acoustic levitation in air or other gas include an acoustic positioning module that has been carried in the space shuttle and used in fundamental studies of the oscillation and fission of spinning drops. An acoustic levitation furnace has been designed to study the possibility of containerless solidification of molten materials. See SPACE PROCESSING.

Applications of the levitation of objects in liquids have included measurements of the ultimate tensile strengths of liquids, mechanical characterization of superheated and supercooled liquids, the measurement of properties of biological materials (including human red blood cells and lipids from the porpoise dome), the study of shape oscillations and interfacial tension of levitated drops, and the evaporation of charged drop arrays levitated electroacoustically. See SOUND. [R.E.A.]

**Acoustic microscope** An instrument that utilizes focused acoustic waves to produce images of surface and subsurface features in materials, and to measure elastic properties on a microscopic scale. It has been used to image and measure local elastic properties in metals, ceramics, semiconductor integrated circuits, polymeric materials, and biological materials including individual cells. The development of scanning probe microscopy has led to a new type of acoustic microscope capable of imaging elastic properties at nanometer resolution. [S.Sa.]

**Acoustic mine** A mine that either passively listens to a target's sound noises or periodically interrogates its environment by actively emitting acoustic pulses that may return echoes if prospective targets come within range. A mine is an underwater weapon consisting of a shell case containing high explosives. Mines can be planted by airplanes, surface ships, or submarines. There are three types: drifting mines, moored mines held at a given depth by a cable anchored to the bottom, and bottom mines, which rest on the sea floor. A mine can be activated by various means, such as by contact with a target, by sensing a target's magnetic field, by listening to the acoustic noises from a target, by sensing the excess pressure field from a target passing above it, by reception of acoustic echoes that a target may return to the mine's sonar after it has sent out its interrogating pings, or by a combination of these. See SONAR. [G.C.G.]

**Acoustic noise** Unwanted sound. Noise control is the process of obtaining an acceptable noise environment for

people in different situations. Understanding noise and its control requires a knowledge of the major sources of noise, sound propagation, human response to noise, and the physics of methods of controlling noise. The continuing increase in noise levels from many different human activities in industrialized societies has led to the term noise pollution.

Noise as an unwanted by-product of an industrialized society affects not only the operators of machines and vehicles, but also other occupants of buildings in which machines are installed, passengers of vehicles, and most importantly the communities in which machines, factories, and vehicles are operated. [M.J.Cr.]

**Acoustic radiation pressure** The net pressure exerted on a surface or interface by an acoustic wave. One might presume that the back-and-forth oscillation of fluid caused by the passage of an acoustic wave will not exert any net force on an object, and this is true for sound waves normally encountered. Intense sound waves, however, can exert net forces in one direction of sufficient magnitude (proportional to the sound intensity) to balance gravitational forces and thus levitate an object in air.

Forces due to acoustic radiation pressure have been used to calibrate acoustic transmitters, to deform and break up liquids, to collect like objects or to separate particles (including biological cells) based on mechanical properties, and to position objects in a sound field, sometimes levitating the sample so that independent studies of the object's properties can be performed. Single bubble sonoluminescence phenomena depend on acoustic radiation forces to maintain a bubble in a zone while its substantial radial oscillations take place. See ACOUSTIC LEVITATION; SOUND; SONOCHEMISTRY; ULTRASONICS. [R.E.A.]

**Acoustic radiometer** A device to measure the acoustic power or intensity of a sound beam by means of the force or torque that the beam exerts on an inserted object or interface. The underlying theory involves the concept of radiation pressure. Such pressure occurs, for example, when a plane sound wave is partially reflected at an interface between two materials, with the nonlinear interaction between the incident and reflected waves giving rise to a steady pressure on the interface. If a narrow beam is incident on the interface and the transmitted wave is fully absorbed by the second material, the magnitude of the radiation force  $F$  (area integral of radiation pressure) equals a constant times  $W/c$ , where  $W$  is the power of the sound beam and  $c$  is the sound speed.

A modern acoustic radiometer, used to measure the total power of an ultrasonic sound beam in water and other liquids, employs a vane suspended in the fluid in such a manner that its displacement in a direction normal to its face is proportional to the net force pushing on its front face. The vane is ideally of dimensions somewhat larger than the incident beam's diameter, so that the encountered force is associated with the entire incident beam. To eliminate the possibility of sound being reflected toward the transmitting transducer, the vane is oriented at  $45^\circ$  to the incident sound beam. The vane's horizontal displacement is made to be proportional to the imposed force by fastening the vane at one end of a long pendulum whose rotation from the vertical is opposed by the effect of gravity, such that the apparent spring constant for displacement in a direction at  $45^\circ$  to the face is approximately  $Mg/L$ , where  $M$  is the apparent mass of the vane (corrected for the presence of water),  $g$  is the acceleration of gravity, and  $L$  is the length of the pendulum. A nonlinear acoustics theory for such a circumstance yields a proportionality relation between the net horizontal radiation force on the vane and the acoustic power associated with the incident beam. Because the deflection of the vane is proportional to the radiation force, the acoustic power can be determined. See BUOYANCY; PENDULUM.

The concept of the vane device evolved from that of the Rayleigh disk, which was a circular disk that could rotate about its diameter and whose deflection from a nominal  $45^\circ$  orienta-

tion was opposed by a torsional spring. The Rayleigh disk was taken to have a radius much smaller than the wavelength, and its use ideally yielded a measurement of the local acoustic intensity that would have existed at the center of the disk were the disk not present. See ACOUSTIC RADIATION PRESSURE; SOUND; SOUND INTENSITY; SOUND PRESSURE. [A.D.P.; S.I.Ma.]

**Acoustic resonator** A device consisting of a combination of elements having mass and compliance whose acoustical reactances cancel at a given frequency. Resonators are often used as a means of eliminating an undesirable frequency component in an acoustical system. In other instances resonators are used to produce an increase in the sound pressure in an acoustic field at a particular frequency.

Resonators are useful most often in the control of low-frequency sound. They are of particular value in reducing the noise from sources having constant frequency excitation.

Resonators have also found considerable application in architectural acoustics. It is often difficult to obtain adequate control of reverberation time at low frequencies in a large studio or auditorium using conventional acoustical materials. A number of designs for these spaces have included the construction of resonators behind walls or in the ceiling to obtain increased low-frequency absorption and thus provide more satisfactory reverberation characteristics. See ARCHITECTURAL ACOUSTICS.

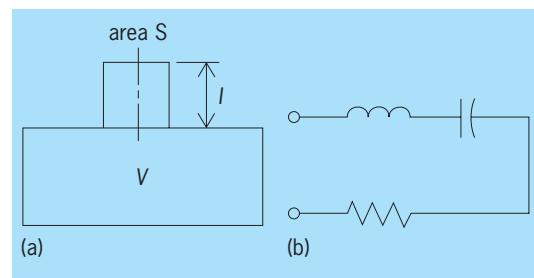

Helmholtz resonator. (a) Acoustical unit. (b) Electrical analog.

The Helmholtz resonator (see illustration) is the simplest and most often utilized acoustical resonator. The unit consists of a straight tube of length  $l$  and cross-sectional area  $S$ , connected to a closed volume  $V$ . This combination is directly analogous to the simple series  $LC$  electrical circuit. See ACOUSTIC IMPEDANCE; MUFFLER. [W.J.G.]

**Acoustic signal processing** A discipline that deals generally with the extraction of information from acoustic signals in the presence of noise and uncertainty. Acoustic signal processing has expanded from the improvement of music and speech sounds and a tool to search for oil and submarines to include medical instrumentation; techniques for efficient transmission, storage, and presentation of music and speech; and machine speech recognition. Undersea processing has expanded to studying underwater weather and long-term global ocean temperature changes, mammal tracking at long ranges, and monitoring of hot vents. These techniques stem from the rapid advances in computer science, especially the development of large, inexpensive memories and ever-increasing processing speeds.

Sound can be said to be low and slow compared to computers. The audio frequencies are low, spanning roughly the range from 15 to 25,000 hertz, with seismic frequencies below this range and frequencies relevant to medical ultrasonics above. All of these frequencies are well within the limits of analog-to-digital input samplers and digital-to-analog output converters that form the bridges between continuous-time physical waveforms and the

## 18 Acoustic torpedo

streams of digits handled by a computer. The speed of sound is slow, about 335 m/s (1100 ft/s) in air and 1500 m/s (5000 ft/s) in water, compared to light and radio waves at  $3 \times 10^8$  m/s ( $10^9$  ft/s), the upper limit for electrical signals in computer circuits. A computer can carry out thousands of elementary computations between input samples. See ANALOG-TO-DIGITAL CONVERTER; DIGITAL-TO-ANALOG CONVERTER; SOUND.

Signal processors "think" in two domains. One domain is the pictures of waveforms, the sound pressure as it changes in time. This time-domain picture is  $s(t)$ ;  $t$  is time, and  $s$  might be the sound pressure or a microphone voltage. The other picture is the complex magnitude at every important frequency during an interval of time. This frequency-domain or spectrum picture is  $S(f | T_n)$ ;  $f$  is the frequency in hertz, and  $T_n$  is the  $n$ th time interval. J. Fourier (1768–1830) formalized his series version of this picture and showed that  $s(t)$  could be calculated from  $S(f)$ , and vice versa. Mathematicians have developed other versions of spectral transforms, each with its special area of application. See FOURIER SERIES AND TRANSFORMS; INTEGRAL TRANSFORM.

Each domain picture provides the same information, but sometimes it is easier to think, or compute, using one domain rather than the other. The computer version used is the DFT (discrete Fourier transform). Transforms were formerly time-consuming computations; for  $N$  points in one domain the time needed was proportional to  $N$  squared. In the 1960s a layered algorithm was developed to speed up the DFT. The emphasis is on sample sizes which are integer powers of 2. These fast Fourier transforms have had a major impact on spectral processing.

One example of acoustic signal processing for biomedical purposes is its use in restoring hearing. The cochlea in the inner ear is nature's time-domain-to-frequency-domain transformer, exciting a line of nerve endings in response to something like the short-time spectrum of the input. For people in whom this natural mechanism is dysfunctional but the cochlear nerve is intact, a technology is developing based on modest DFT analysis of sound near an ear, feeding perhaps 32 channels to an implanted microconnector in the cochlear nerve bundle. See HEARING (HUMAN); HEARING AID; PHYSIOLOGICAL ACOUSTICS.

One of the most difficult signal processing areas is machine recognition of spoken speech. Vocabulary size and number of speakers are key parameters. The fundamental problems are: (1) words are not spoken separately, but in streams of connected sound, (2) a phrase is seldom said the same way every time, (3) the vocabulary is enormous, and (4) there is a huge variety of speaker accents and rhythms. The signal processing must segment an utterance into phonemes, words, or phrases; pick out key features; or compare the whole segment with a library for likely matches. [T.G.Bi.]

**Acoustic torpedo** An autonomous undersea vehicle that can be launched from submarines, surface ships, or aircraft to attack enemy submarines and surface ships. Its main components are a guidance and control system, a power plant to provide propulsive and electrical energy, a propulsor to control speed and direction, and a warhead. The launching platform performs the function of determining the approximate location of the target and launching the torpedo in the proper direction. The torpedo typically utilizes an acoustic sensor in its nose and is controlled by an on-board computer. During its operation, the torpedo searches the volume of the ocean determined by the launch platform. It progresses through the following phases: detection (an object is present), classification (the object is a target of interest), homing (steer at the object), and detonation of the warhead. See GUIDANCE SYSTEMS; HOMING. [F.W.Sy.]

**Acoustics** The science of sound, which in its most general form endeavors to describe and interpret the phenomena associated with motional disturbances from equilibrium of elastic media. An elastic medium is one such that if any part of it is

displaced from its original position with respect to the rest, as for example by an impact, it will return to its original state when the disturbing influence is removed. Acoustics was originally limited to the human experience produced by the stimulation of the human ear by sound incident from the surrounding air. Modern acoustics, however, deals with all sorts of sounds which have no relation to the human ear, for example, seismological disturbances and ultrasonics.

Basic acoustics may be divided into three branches, namely, production, transmission, and detection of sound. Any change of stress or pressure producing a local change in density or a local displacement from equilibrium in an elastic medium can serve as a source of sound. Transmission of sound takes place through an elastic medium by means of wave motion. The most important sound waves are harmonic waves, defined as waves for which the propagated disturbance at any point in its path varies sinusoidally with time with a definite frequency or number of complete cycles per second (the unit being the hertz). Acoustics deals with waves of all frequencies, but not all frequencies are audible by human beings, for whom the average range of audibility extends from 20 to 20,000 Hz. Sound below 20 Hz is referred to as infrasonic, and that above 20,000 Hz is called ultrasonic.

The detection of sound is made possible by the incidence of transmitted sound energy on an appropriate acoustic transducer, such as the ear. For modern applied acoustics, transducers such as the microphone, based on the piezoelectric effect, are widely used. Generally speaking, any transducer used as a source of sound is also available as a detector, though the sensitivity varies considerably with the type. [R.B.L.]

**Acoustooptics** The field of science and technology that is concerned with the diffraction of visible or infrared light (usually from a laser) by high-frequency sound in the frequency range of 50–2000 MHz. The term "acousto" is a historical misnomer; sound in this frequency range should properly be called ultrasonic. Such sound cannot be supported by air, but propagates as a mechanical wave disturbance in amorphous or crystalline solids, with a sound velocity ranging from 0.6 to 6 km/s (0.4 to 4 mi/s) and a wavelength from 3 to 100  $\mu$ m. See LASER; ULTRASONICS.

The sound wave causes a displacement of the solid's molecules either in the direction of propagation (longitudinal wave) or perpendicular to it (shear wave). In either case, it sets up a corresponding wave of refractive-index variation through local dilatation or distortion of the solid medium. It is this wave that diffracts the light by acting as a three-dimensional grating, analogous to x-diffraction in crystals. The fact that the grating is moving is responsible for shifting the frequency of the diffracted light through the Doppler effect. See DIFFRACTION GRATING; DOPPLER EFFECT; REFRACTION OF WAVES; WAVE MOTION; X-RAY DIFFRACTION.

Since the 1960s, acoustooptics has moved from a scientific curiosity to a relevant technology. This evolution was initially driven by the need for fast modulation and deflection of light beams, and later by demands for more general optical processing. It was made possible by the invention of lasers, the development of efficient ultrasonic transducers, and the formulation of realistic models of sound-light interaction. See TRANSDUCER. [A.K.]

**Acquired immune deficiency syndrome (AIDS)** A viral disease of humans caused by the human immunodeficiency virus (HIV), which attacks and compromises the body's immune system. Individuals infected with HIV proceed through a spectrum of stages that ultimately lead to the critical end point, acquired immune deficiency syndrome. The disease is characterized by a profound progressive irreversible depletion of T-helper-inducer lymphocytes (CD4+ lymphocytes), which leads to the onset of multiple and recurrent opportunistic infections by other viruses, fungi, bacteria, and protozoa, as well

as various tumors (Kaposi's sarcoma, lymphomas). HIV infection is transmitted by sexual intercourse (heterosexual and homosexual), by blood and blood products, and perinatally from infected mother to child (prepartum, intrapartum, and postpartum via breast milk).

Since retroviruses such as HIV-1 integrate their genetic material into that of the host cell, infection is generally lifelong and cannot be eliminated easily. Therefore, medical efforts have been directed toward preventing the spread of virus from infected individuals. See RETROVIRUS.

Approximately 50–70% of individuals with HIV infection experience an acute mononucleosis-like syndrome approximately 3–6 weeks following primary infection. In the acute HIV syndrome, symptoms include fever, pharyngitis, lymphadenopathy, headache, arthralgias, myalgias, lethargy, anorexia, nausea, and erythematous maculopapular rash. These symptoms usually persist for 1–2 weeks and gradually subside as an immune response to HIV is generated.

Although the length of time from initial infection to development of the clinical disease varies greatly from individual to individual, a median time of approximately 10 years has been documented for homosexual or bisexual men, depending somewhat on the mode of infection. Intravenous drug users experience a more aggressive course than homosexual men and hemophiliacs because their immune systems have already been compromised.

As HIV replication continues, the immunologic function of the HIV-infected individual declines throughout the period of clinical latency. At some point during that decline (usually after the CD4+ lymphocyte count has fallen below 500 cells per microliter), the individual begins to develop signs and symptoms of clinical illness, and sometimes may demonstrate generalized symptoms of lymphadenopathy, oral lesions, herpes zoster, and thrombocytopenia.

Secondary opportunistic infections are a late complication of HIV infection, usually occurring in individuals with less than 200 CD4+ lymphocytes per microliter. They are characteristically caused by opportunistic organisms such as *Pneumocystis carinii* and cytomegalovirus that do not ordinarily cause disease in individuals with a normally functioning immune system. However, the spectrum of serious secondary infections that may be associated with HIV infection also includes common bacterial pathogens, such as *Streptococcus pneumoniae*. Secondary opportunistic infections are the leading cause of morbidity and mortality in persons with HIV infection. Tuberculosis has also become a major problem for HIV-infected individuals. Therefore, HIV-infected individuals are administered protective vaccines (pneumococcal) as well as prophylactic regimens for the prevention of infections with *P. carinii*, *Mycobacterium tuberculosis*, and *M. avium* complex. See OPPORTUNISTIC INFECTIONS; PNEUMOCOCCUS; STREPTOCOCCUS; TUBERCULOSIS.

Antiretroviral treatment with deoxyribonucleic acid (DNA) precursor analogs—for example, azidothymidine (AZT), dideoxyinosine (ddI), and dideoxycytidine (ddC)—has been shown to inhibit HIV infection by misincorporating the DNA precursor analogs into viral DNA by the viral DNA polymerase. Nevertheless, these agents are not curative and do not completely eradicate the HIV infection. [A.M.Ma.; E.P.Go.]

**Acquired immunological tolerance** An induced state in which antigens originally regarded as foreign become regarded as self by the immune system. Tolerance can be induced (tolerization) in all of the cells of the immune system, including T cells (also known as T lymphocytes), the antibody-forming B cells (also known as B lymphocytes), and natural killer cells. Artificially induced immunological tolerance can be helpful in a number of clinical settings. Inducing self-tolerance in the immune system could be an approach to curing autoimmune diseases.

Tolerization can also be used to facilitate organ transplantation. Despite improvements in immunosuppressive drug therapy, teaching the immune system to regard a set of foreign antigens

presented by the organ graft as self (that is, tolerance induction) has become an important goal for several reasons: (1) It would eliminate the need for chronic immunosuppressive therapy, which is associated with lifelong increased risks of infection and malignancy, and other side effects. (2) It would prevent chronic rejection (a major problem even with immunosuppressive therapy), which often leads to late graft loss. (3) It presents a less toxic alternative to the unacceptably high levels of nonspecific immunosuppressive therapy that would likely be required to prevent rejection of xenografts (grafts from a donor of another species). See TRANSPLANTATION BIOLOGY.

Many strategies for inducing immunological tolerance involve reproducing the mechanisms involved in natural central tolerance—the phenomenon by which self-tolerance is maintained among immature lymphocytes developing in the central lymphoid organs. For developing T cells, tolerance occurs in the thymus, the central organ for T cell development. For B cells, development occurs in the bone marrow, and an encounter with self antigens can induce tolerance there among the immature cells.

The transplantation of bone marrow or other sources of hematopoietic (blood cell-producing) stem cells provides a very powerful means of inducing T cell central tolerance. The clinical potential of bone marrow or other types of hematopoietic cell transplantation for the induction of transplantation tolerance in humans has not yet been realized.

Peripheral tolerance comprises mechanisms to prevent immune responses among mature lymphocytes in the peripheral tissues. One major mechanism of T cell and B cell peripheral tolerance is anergy, in which the cells cannot be fully activated by encounter with the antigens that their receptors recognize. Numerous methods of inducing T and B cell anergy have been described.

Another major mechanism of peripheral tolerance is suppression, in which both B cells and T cells may be rendered tolerant of a specific antigen through the activity of substances or cells that actively suppress the lymphocyte's function. Numerous means of inducing B cell and T cell suppression have been described, and convincing evidence implicates cells with the ability to suppress T cell alloresponses (immune responses to alloantigens) in transplantation models. See IMMUNOSUPPRESSION. [M.Sy.]

**Acrothoracica** An order of the subclass Cirripedia. All members burrow into shells of mollusks and thoracican barnacles, echinoderm tests, polyzoans, dead coral, and limestone. The normal three pairs of cirriped mouthparts are present: mandibles, maxillules, and maxillae. Four to six pairs of cirri occur, often greatly reduced in size, the first pair close to the oral appendages and the remainder packed together at the posterior end of the body. The sexes are separate; dwarf males are found on the mantle or wall of the burrow of the female. Naupliar larval stages may be omitted, but a cypris larva always occurs in the life cycle. Three families, about eight genera, and 40 species are recognized. See CIRRIPIEDIA. [H.G.St.]

**Acrylonitrile** An explosive, poisonous, flammable liquid, boiling at 171°F (77.3°C), partly soluble in water. It may be regarded as vinyl cyanide, and its systematic name is 2-propenenitrile. Acrylonitrile is prepared by ammoxidation of propylene over various sorts of catalysts, chiefly metallic oxides.

Most of the acrylonitrile produced is consumed in the manufacture of acrylic and modacrylic fibers. Substantial quantities are used in acrylonitrile-butadiene-styrene (ABS) resins, in nitrile elastomers, and in the synthesis of adiponitrile by electrodimmerization. Smaller amounts of acrylonitrile are used in cyanoethylation reactions, in the synthesis of drugs, dyestuffs, and pesticides, and as co-monomers with vinyl acetate, vinylpyridine, and similar monomers.

Acrylonitrile undergoes spontaneous polymerization, often with explosive force. It polymerizes violently in the presence of suitable alkaline substances. See NITRILE; POLYMERIZATION. [F.W.]

**Actinaria** An order of the Zoantharia known as the sea anemones, which are the most widely distributed of the anthozoans. Usually they are solitary animals which live under the low-tide mark attached to some solid object by a basal expansion or pedal disk. They feed on various prey such as copepods, mollusks, annelids, crustaceans, and fish. The burrowing species lack a pedal disk and bury their elongated bodies in the soft sediment of the oceans.

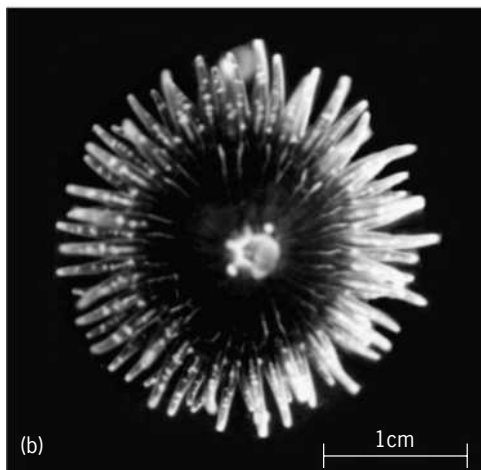
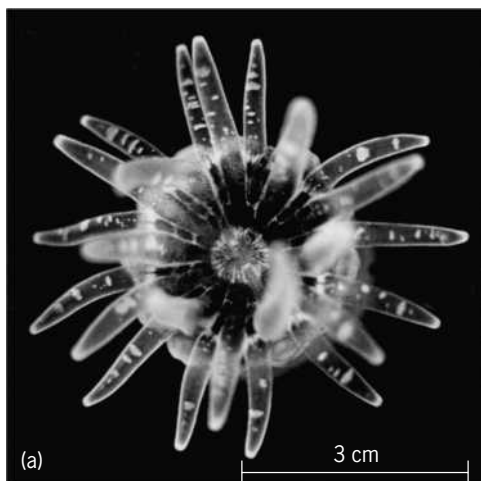

Actinaria: *Anthopleura* sp. (a) Young, (b) Adult.

The freely retractile, skeletonless polyp has a cylindrical body, with a thick, tough, rough column wall often bearing rugae, verrucae, tubercles, or suckers (see illustration). The body is often encrusted with sand grains, pebbles, and other detritus. Some species have smooth, thin walls. Nematocysts discharge a toxic substance; however, the human skin is seldom affected by this. The colors of anemones vary with species and many variations occur even among the same species. The tentacles increase in number regularly and are arranged in several cycles. There are 6 primary, 6 secondary, 12 tertiary, 24 quaternary, and so forth in the hexamerous type. The musculature is the most highly developed in the coelenterates.

Most actinians are dioecious. Developing larvae pass through the *Edwardsia* stage then the *Halcampoides* stage. Longitudinal fission frequently occurs as well as budding. Sometimes new individuals result from laceration. See COELENTERATA; ZOANTHARIA.

[K.At.]

**Actinide elements** The series of elements beginning with actinium (atomic number 89) and including thorium, protactinium, uranium, and the transuranium elements through the element lawrencium (atomic number 103). These elements have a strong chemical resemblance to the lanthanide, or rare-earth, elements of atomic numbers 57 to 71. Their atomic numbers, names, and chemical symbols are: 89, actinium (Ac), the prototype element, sometimes not included as an actual member of the actinide series; 90, thorium (Th); 91, protactinium (Pa); 92, uranium (U); 93, neptunium (Np); 94, plutonium (Pu); 95, americium (Am); 96, curium (Cm); 97, berkelium (Bk); 98, californium (Cf); 99, einsteinium (Es); 100, fermium (Fm); 101, mendelevium (Md); 102, nobelium (No); 103, lawrencium (Lr). Except for thorium and uranium, the actinide elements are not present in nature in appreciable quantities. The transuranium elements were discovered and investigated as a result of their synthesis in nuclear reactions. All are radioactive and except for thorium and uranium, weighable amounts must be handled with special precautions.

Most actinide elements have the following in common: trivalent cations which form complex ions and organic chelates; soluble sulfates, nitrates, halides, perchlorates, and sulfides; and acid-insoluble fluorides and oxalates. See ACTINIUM; LAWRENCIUM; PERIODIC TABLE; PROTACTINIUM; THORIUM; TRANSURANIUM ELEMENTS; URANIUM. [G.T.S.]

**Actinium** A chemical element, Ac, atomic number 89, and atomic weight 227.0. Actinium was discovered by A. Debierne in 1899. Milligram quantities of the element are available by irradiation of radium in a nuclear reactor. Actinium-227 is a beta-emitting element whose half-life is 22 years. Six other radioisotopes with half-lives ranging from 10 days to less than 1 minute have been identified.

The relationship of actinium to the element lanthanum, the prototype rare earth, is striking. In every case, the actinium compound can be prepared by the method used to form the corresponding lanthanum compound with which it is isomorphous in the solid, anhydrous state. See ACTINIDE ELEMENTS; LANTHANUM; NUCLEAR REACTION; RADIOACTIVITY. [S.F.]

**Actinobacillus** A genus of gram-negative, immotile and nonspore-forming, oval to rod-shaped, often pleomorphic bacteria which occur as parasites or pathogens in mammals (including humans), birds, and reptiles. They are facultatively aerobic, capable of fermenting carbohydrates (without production of gas) and of reducing nitrates. The genomic DNA contains between 40 and 47 mol % guanine plus cytosine. The actinobacillus group shares many biological properties with the genus *Pasteurella*. See PASTEURELLA.

*Actinobacillus (Pasteurella) ureae* and *A. hominis* occur in the respiratory tract of healthy humans and may be involved in the pathogenesis of sinusitis, bronchopneumonia, pleural empyema, and meningitis. *Actinobacillus actinomycetemcomitans* occurs in the human oral microflora, and together with anaerobic or capnophilic organisms may cause endocarditis and suppurative lesions in the upper alimentary tract. Actinobacilli are susceptible to most antibiotics of the  $\beta$ -lactam family, aminoglycosides, tetracyclines, chloramphenicol, and many other antibacterial chemotherapeutics. See ANTIBIOTIC; MEDICAL BACTERIOLOGY. [W.Ma.]

**Actinomycetes** A heterogeneous collection of bacteria that form branching filaments. The actinomycetes encompass two different groups of filamentous bacteria: the actinomycetes per se and the nocardia/streptomycete complex. Historically, the actinomycetes were called the ray fungi and were thought to be related to the true fungi, such as bread molds, because they formed mats (mycelia) of branching filaments (hyphae). However, unlike the true fungi, the actinomycetes have thin hyphae (0.5–1.5 micrometers in diameter) with genetic material coiled

inside as free DNA. The cell wall of the hyphae is made up of a cross-linked polymer containing short chains of amino acids and long chains of amino sugars. In general, actinomycetes do not have membrane-bound cell organelles. Actinomycetes are susceptible to a wide range of antibiotics that are used to treat bacterial diseases, such as penicillin and tetracycline. See AMINO SUGAR; ANTIBIOTIC.

Members of the genus *Actinomyces* are most often found in the mouth and gastrointestinal tract of humans and other animals. *Actinomyces* do not require oxygen for growth and are sometimes referred to as anaerobic bacteria. It is actually the requirement for elevated levels of carbon dioxide rather than the negative effect of oxygen that characterizes *Actinomyces*. When displaced from their normal sites within the mouth or gastrointestinal tract, *Actinomyces* may cause diseases in humans, such as lung abscesses, appendicitis, and lumpy jaw, which is also seen in cattle. Serious ulcers of the cornea of the eye have been caused by contact lens contaminated with saliva containing *Actinomyces*.

The nocardia/streptomycete complex constitutes a continuous spectrum of organisms from those most like true bacteria to those that are superficially most like fungi. The nocardiae represent the transition, having members that resemble the bacteria that cause diphtheria (*Corynebacterium*) and tuberculosis (*Mycobacterium*). Members of the genus *Nocardia* require oxygen for growth, are found in soil and water, and have the ability to use a wide range of organic material as a source of energy. A few species of *Nocardia* cause disease in humans. Nocardiae inhaled from the soil may cause a disease of the lungs similar to tuberculosis. A few species produce clinically useful antibiotics. The streptomycetes have long branching filaments and two types of mycelia. The cell walls are typical bacterial cell walls and do not contain the fatty acids found in nocardiae and mycobacteria. Streptomycetes require oxygen for growth, are found in soil and water, and have the ability to utilize a wide range of organic materials as nutrients. The streptomycetes are particularly important in degradation of dead plant materials in soil; the aroma of fresh soil and newly dug potatoes is actually due to streptomycetes. Streptomycetes do not produce disease in humans or animals and are best known for producing many clinically useful antibiotics, including streptomycin, tetracycline, and cephalosporin. There are many other genera of actinomycetes, defined on the bases of morphology, chemical composition of cell walls, or unique roles in nature. See BACTERIA; DIPHTHERIA; MEDICAL BACTERIOLOGY; SOIL MICROBIOLOGY; TUBERCULOSIS. [S.G.B.]

**Actinomyxida** An order of the protozoan class Myxosporidea (subphylum Cnidospora) characterized by the production of trivalved spores with three polar capsules and one to many sporoplasms. The spore membrane may be extended into anchor-shaped processes, which may have bifurcate tips. These parasites are found in the body cavity or in the intestinal lining of fresh-water annelids and in marine worms of the phylum Sipunculoidea. The life cycle for most species is not well known. See CNIDOSPORA; MYXOSPORIDEA; PROTOZOA. [R.F.N.]

**Actinophage** Any of a number of bacteriophages that infect and lyse bacteria of the order Actinomycetales. Actinophages of particular interest are those that include in their host range any organisms of the genus *Streptomyces*, the source of most of the therapeutically useful antibiotics. Contamination of a culture with a specific actinophage may result in lysis and destruction of the bacteria, which obviously halts antibiotic production. The problem of phage contamination is often solved by the isolation and use of a phage-resistant mutant of the antibiotic-producing bacterium. See BACTERIOPHAGE. [L.B.]

**Actinophryida** An order of Heliozoia. In these protozoans, a centroplast, a highly organized test, and a capsule

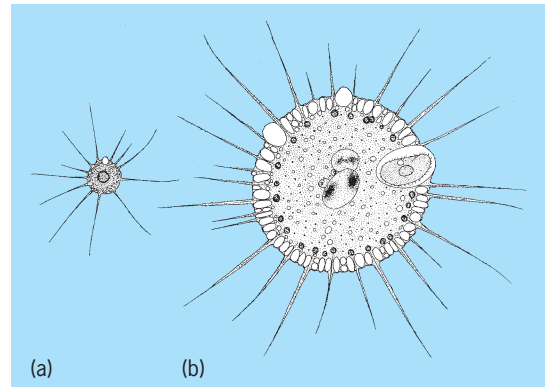

**Actinophryida:** (a) *Actinosphaerium eichorni*. (b) *Actinophrys pontica*. (After P. P. Hall, *Protozoology*, Prentice-Hall, 1953)

are lacking (see illustration). The organisms may be uninucleate, as in *Actinophrys*, or multinucleate, as in *Actinosphaerium* (fresh water) and *Camptonema* (marine). The outer cytoplasm is usually highly vacuolated. In uninucleate genera the nucleus is approximately central. Axopodia are present, and their axial filaments end near the nucleus in uninucleate types. See ACTINOPODEA; HELIOZOIA; PROTOZOA; SARCODINA. [R.P.H.]

**Actinopodea** A class of Sarcodina. Some of these protozoans have more or less permanent pseudopodia, composed of axial filaments surrounded by a cytoplasmic envelope (axopodia); others have delicate and often radially arranged filopodia (filamentous pseudopodia) or filoreticulopodia (filamentous branched pseudopodia) without axial filaments. Although some are stalked and sessile, most are floating types. There are four subclasses: Radiolaria, Acantharia, Heliozoia, and Proteomyxidia. See ACANTHARIA; HELIOZOIA; PROTEOMYXIDIA; RADIOLARIA; SARCODINA. [R.P.H.]

**Actinopterygii** A group of bony fishes, also known as actinops or ray-finned fishes, containing about half of all vertebrate species and about 96% of all living "fishes" (a non-monophyletic group derived from more than one lineage when tetrapods are excluded). Living Actinopterygii comprise Polypteriformes (bichirs and reedfish), Acipenseriformes (sturgeons and paddlefishes), Lepisosteiformes (gars), Amiiformes (bowfins), and Teleostei (teleosts). Actinops are characterized by the presence of a single dorsal fin, an enclosed sensory canal in the dentary bone, a specialized tissue called ganoin, and several other anatomical characters. About 40% of living actinopterygian species live exclusively or almost exclusively in fresh water. The rest inhabit mostly marine, brackish, or combination environments.

The fossil record indicates that actinopterygians are at least as old as the Late Silurian (about 420 million years before present). Fossil actinopterygians are speciose and extremely abundant, making up the majority of vertebrate fossils that are known by complete skeletons. Many major radiations of early actinopterygians, such as pycnodonts, semionotiforms, and palaeonisciforms, have been extinct for tens of millions of years. Other early actinopterygian groups, such as the Cheirolepiiformes, have been extinct for hundreds of millions of years. Based on the fossil record, the most major differentiation of the group began in the late Mesozoic. See AMIIFORMES; POLYPTERIFORMES; SEMIONOTIFORMES. [L.G.]

**Action** Any one of a number of related integral quantities which serve as the basis for general formulations of the dynamics of both classical and quantum-mechanical systems. The term has been associated with four quantities: the fundamental action  $S$ ,

## 22 Activated carbon

for general paths of a dynamical system; the classical action  $S_C$ , for the actual path; the modified action  $S'$ , for paths restricted to a particular energy; and action variables, for periodic motions.

A dynamical system can be described in terms of some number  $N$  of coordinate degrees of freedom that specify its configuration. As the vector  $q$  whose components are the degrees of freedom  $q_1, q_2, \dots, q_N$  varies with time  $t$ , it traces a path  $q(t)$  in an  $N$ -dimensional space. The fundamental action  $S$  is the integral of the lagrangian of the system taken along any path  $q(t)$ , actual or virtual, starting from a specified configuration  $q_1$  at a specified time  $t_1$ , and ending similarly at configuration  $q_2$  and time  $t_2$ . The value of this action  $S[q(t)]$  depends on the particular path  $q(t)$ . The actual path  $q_C(t)$  which is traversed when the system moves according to newtonian classical mechanics gives an extremum value of  $S$ , usually a minimum, relative to the other paths. This is Hamilton's least-action principle. The extremum value depends only on the end points and is called the classical action  $S_C(q_1, q_2; t_1, t_2)$ .

An important variant of Hamilton's principle applies when the virtual paths  $q(t)$  are restricted to motions all of the same energy  $E$ , but no longer to a specific time interval,  $t_1 - t_2$ . The modified action  $S' = S - E(t_1 - t_2)$  obeys a modified least-action principle, usually called Maupertuis' principle, namely, that the classical path gives again an extremal value of  $S'$  relative to all paths of that energy. Maupertuis' principle is closely related to Fermat's principle of least time in classical optics for the path of light rays of a definite frequency through a region of inhomogeneous refractive index. See HAMILTON'S PRINCIPLE; MINIMAL PRINCIPLES.

In quantum mechanics, as originally formulated by E. Schrödinger, the state of particles is described by wave functions which obey the Schrödinger wave equation. States of definite energy in, say, atoms are described by stationary wave functions, which do not move in space. Nonstationary wave functions describe transitory processes such as the scattering of particles, in which the state changes. Both stationary and nonstationary state wave functions are determined, in principle, once the Schrödinger wave propagator (also called the Green function) between any two points  $q_1$  and  $q_2$  is known. In a fundamental restatement of quantum mechanics, R. Feynman showed that all paths from  $q_1$  to  $q_2$ , including the virtual paths, contribute to the wave propagator. Each path contributes a complex phase-term  $\exp i(\phi[q(t)])$ , where the phase  $\phi$  is proportional to the action for that path. The resulting sum over paths, appropriately defined, is the path integral (or functional integral) representation of the Schrödinger wave propagator. The path integral has become the general starting point for most formulations of quantum theories of particles and fields. The classical path  $q_C(t)$  of least action now plays the role in the wave function as being the path of stationary phase. See PROPAGATOR (FIELD THEORY). [B.G.]

**Activated carbon** A powdered, granular, or pelleted form of amorphous carbon characterized by very large surface area per unit volume because of an enormous number of fine pores. Activated carbon is capable of collecting gases, liquids, or dissolved substances on the surface of its pores.

Adsorption on activated carbon is selective, favoring nonpolar over polar substances. Compared with other commercial adsorbents, activated carbon has a broad spectrum of adsorptive activity, excellent physical and chemical stability, and ease of production from readily available, frequently waste materials. See ADSORPTION.

Almost any carbonaceous raw material can be used for the manufacture of activated carbon. Wood, peat, and lignite are commonly used for the decolorizing materials. Bone char made by calcining bones is used in large quantity for sugar refining. Nut shells (particularly coconut), coal, petroleum coke, and other residues in either granular, briqueted, or pelleted form are used for adsorbent products.

Activation is the process of treating the carbon to open an enormous number of pores in the 1.2- to 20-nanometer-diameter range (gas-adsorbent carbon) or up to 100-nm-diameter range (decolorizing carbons). After activation, the carbon has the large surface area (500–1500 m<sup>2</sup>/g) responsible for the adsorption phenomena. Carbons that have not been subjected previously to high temperatures are easiest to activate. Selective oxidation of the base carbon with steam, carbon dioxide, flue gas, or air is one method of developing the pore structure. Other methods require the mixing of chemicals, such as metal chlorides (particularly zinc chloride) or sulfides or phosphates, potassium sulfide, potassium thiocyanate, or phosphoric acid, with the carbonaceous matter, followed by calcining and washing the residue. See CARBON; CHARCOAL. [H.B.A.]

**Activation analysis** A technique in which a neutron, charged particle, or gamma photon is captured by a stable nuclide to produce a different, radioactive nuclide which is then measured. The technique is specific, highly sensitive, and applicable to almost every element in the periodic table.

In neutron activation analysis (NAA), the most widely used form of activation analysis, the sample to be analyzed is placed in a nuclear reactor where it is exposed to a flux of thermal neutrons. Some of these neutrons are captured by isotopes of elements in the sample; this results in the formation of a nuclide with the same atomic number, but with one more mass unit of weight. A prompt gamma ray is immediately emitted by the new nuclide.

Measurement of the induced radioactivities is the key to activation analysis. This is usually obtained from the gamma-ray spectra of the induced radionuclides. Gamma rays from radioactive isotopes have unique, discrete energies, and a device that converts such rays into electronic signals that can be amplified and displayed as a function of energy is a gamma-ray spectrometer. It consists of a detector [germanium doped with lithium, GeLi, or sodium iodide doped with thallium, NaI(Tl)] and associated electronics.

Activation analysis can also be performed with charged particles (protons or He<sup>3+</sup> ions, for example), but because fluxes of such particles are usually lower than reactor neutron fluxes and cross sections are much smaller, charged-particle methods are usually reserved for special samples. Charged particles penetrate only a short distance into samples, which is another disadvantage. A variant called proton-induced x-ray emission (PIXE) has been highly successful in analyzing air particulates on filters.

Activation analysis has been applied to a variety of samples. It is particularly useful for small (1 mg or less) samples, and one irradiation can provide information on 30 or more elements. Samples such as small amounts of pollutants, fly ash, very pure experimental alloys, and biological tissue have been successfully studied by neutron activation analysis. Of particular interest has been its use in forensic studies; paint, glass, tape, and other specimens of physical evidence have been assayed for legal purposes. In addition, the method has been used for authentication of art objects and paintings where only a small sample is available. See FORENSIC CHEMISTRY; NUCLEAR REACTION; PARTICLE DETECTOR; RADIOISOTOPE. [W.S.L.]

**Active sound control** The modification of sound fields by using additional sound transmitted from loudspeakers. The signals from the loudspeakers are controlled electronically by using digital signal processing techniques.

The physical principle underlying the active control of sound is interference. That is, the sound pressure fluctuations produced at a given point in space by two sources of sound simply add together at each point in time. Thus if a secondary source of sound is made to produce the opposite pressure fluctuation to a given primary source at a given point in space, the net result will be silence at that point. See INTERFERENCE OF WAVES.



The developments in modern electronics during the latter part of the twentieth century enabled the practical implementation of the active control of sound with much greater ease than was possible before. A detection microphone is first used to sense the primary sound. The electrical signal from this microphone is passed through an analog low-pass filter, then sampled and converted into digital format. This resulting sequence of numbers is then passed through a digital filter prior to being converted back into an analog signal and fed to the loudspeaker comprising the secondary source. The value of the output from the digital filter at a given time is typically calculated from both the current and a number of previous values of the input sequence. These values are multiplied by a series of numbers comprising the filter coefficients before being added together to produce the output value at that particular time. These arithmetic operations can be carried out extremely fast on a special-purpose microprocessor that is used to implement the digital filter. An error microphone is then used to sense the degree of interference between the primary and secondary sound. See DIGITAL FILTER; MICROPROCESSOR.

The coefficients of the digital filter are chosen to ensure that the waveform of the sound radiated from the loudspeaker is aligned in time in order to be (as far as possible) opposite to the waveform produced at the error microphone by the primary source. When the waveform of the primary sound is unpredictable, it is important to ensure that the time taken to process and transmit the secondary sound is sufficiently short that it arrives soon enough at the error microphone to cancel the primary sound. This basic approach to the problem is often referred to as feed-forward active control, since it makes use of the advanced warning of the arrival of unwanted sound. This is provided by the finite time required for sound to propagate from the detection microphone to the error microphone.

Some physical limitations of the technique can be overcome simply by increasing the number of secondary sources used to control the field. For example, if 10 loudspeakers are used to control a pure-tone sound field, it is possible in principle to produce 10 points of silence in the field. Of course, depending upon the geometrical arrangement and the acoustical environment of the primary and secondary sources, increases in level may well be produced at other positions. Another strategy is to drive the secondary sources in order to minimize the sound level at a number of error microphones which is larger than the number of secondary sources. Under these circumstances it is possible to produce widespread reductions in sound level. All that is required is the detection of the frequency of the primary source; this reference signal is then sampled and passed through a digital filter associated with each secondary source. (This signal is uncorrupted by feedback from the secondary source outputs.) The coefficients of these filters are then adjusted adaptively in response to the signals sampled at the error microphones by using a multichannel generalization of a common algorithm. This ensures the minimization of the sum of the squared outputs from the error microphones and thus the suppression of the sound field.

Many acoustic waveforms of practical interest are highly unpredictable. Examples include the waveforms of the noise generated inside an automobile due to the airflow past the passenger cabin and the vibrations generated by the contact of the tires with the road. In addition, there may be multiple primary sources of such unwanted sound. In these cases it becomes more difficult to find reference signals that give a prior indication of the acoustic pressure fluctuations well before their arrival at the ears of the occupants. However, it is possible to find the optimal matrix of digital filters that ensures the minimization of the sum of the time-averaged signals from a number of error microphones. See ACOUSTIC NOISE; ADAPTIVE SIGNAL PROCESSING; CONTROL SYSTEMS; SOUND. [P.A.N.]

**Activity (thermodynamics)** The activity of a substance is a thermodynamic property that is related to the chem-

ical potential of that substance. Activities are closely related to measures of concentration, such as partial pressures and mole fractions. The conditions that hold in chemical reaction equilibrium and in phase equilibrium can be expressed in terms of activities of the species involved.

The activity  $a_i$  of chemical species  $i$  in a phase (a homogeneous portion) of a thermodynamic system is defined by Eq. (1), where

$$a_i \equiv \exp[(\mu_i - \mu_i^\circ)/RT] \quad (1)$$

$\mu_i$  is the chemical potential of  $i$  in that phase,  $\mu_i^\circ$  is the chemical potential of  $i$  in its standard state,  $R$  is the gas constant, and  $T$  is the absolute temperature. Equation (1) shows that the activity  $a_i$  depends on the choice of standard state for species  $i$ . Since  $\mu_i$  is an intensive quantity that depends on the temperature, pressure, and composition of the phase,  $a_i$  is an intensive function of these variables.  $a_i$  is dimensionless. When  $\mu_i = \mu_i^\circ$ , then  $a_i = 1$ . The degree of departure of  $a_i$  from 1 measures the degree of departure of the chemical potential from its standard-state value. The chemical potential is defined by  $\mu_i \equiv \partial G/\partial n_i$ , where  $G$  is the Gibbs energy of the phase,  $n_i$  is the number of moles of substance  $i$  in the phase, and the partial derivative is taken at constant temperature, pressure, and amounts of all substances except  $i$ . See FREE ENERGY.

From Eq. (1), it follows that  $\mu_i$  is given by Eq. (2). The chem-

$$\mu_i = \mu_i^\circ + RT \ln a_i \quad (2)$$

ical potentials  $\mu_i$  are key thermodynamic quantities of a phase, since all thermodynamic properties of the phase can be found if the chemical potentials in the phase are known as functions of temperature, pressure, and composition. Activities are more convenient to work with than chemical potentials, because the chemical potential of a substance in a phase goes to minus infinity as the amount of that substance in the phase goes to zero; also, one can determine only a value of  $\mu_i$  relative to its value in some other state, whereas one can determine the actual value of each  $a_i$ . [I.N.L.]

**Acylation** A process in which a hydrogen atom in an organic compound is replaced by an acyl group (R—CO, where R = an organic group). The reaction involves substitution by a nucleophile (electron donor) at the electrophilic carbonyl group (C=O) of a carboxylic acid derivative. The substitution usually proceeds by an addition-elimination sequence. Two common reagents, with the general formula RCOX, that bring about acylation are acid halides (X = Cl, Br) and anhydrides (X = OCOR). There are also other acylating reagents. The carboxylic acid (X = OH) itself can function as an acylating agent when it is protonated by a strong acid catalyst as in the direct esterification of an alcohol. Typical nucleophiles in the acylation reaction are alcohols (ROH) or phenols (ArOH), both of which give rise to esters, and ammonia or amines (RNH<sub>2</sub>), which give amides. See ACID ANHYDRIDE; ACID HALIDE; AMIDE; AMINE. [J.A.Mo.]

**Adaptation (biology)** A characteristic of an organism that makes it fit for its environment or for its particular way of life. For example, the Arctic fox (*Alopex lagopus*) is well adapted for living in a very cold climate. Appropriately, it has much thicker fur than similar-sized mammals from warmer places; measurement of heat flow through fur samples demonstrates that the Arctic fox and other arctic mammals have much better heat insulation than tropical species. Consequently, Arctic foxes do not have to raise their metabolic rates as much as tropical mammals do at low temperatures. The insulation is so effective that Arctic foxes can maintain their normal deep body temperatures of 100°F (38°C) even when the temperature of the environment falls to -112°F (-80°C). Thus, thick fur is obviously an adaptation to life in a cold environment. See THERMOREGULATION.

In contrast to that clear example, it is often hard to be sure of the effectiveness of what seems to be an adaptation. For example, the scombrid fishes (tunnies and mackerel) seem to be

## 24 Adaptive control

adapted to fast, economical swimming. The body has an almost ideal streamlined shape. However, some other less streamlined-looking fishes are equally fast for their sizes. There are no measurements of the energy cost of scombrid swimming, but measurements on other species show no clear relationship between energy cost and streamlining.

Evolution by natural selection tends to increase fitness, making organisms better adapted to their environment and way of life. It might be inferred that this would ultimately lead to perfect adaptation, but this is not so. It must be remembered that evolution proceeds by small steps. For example, squids do not swim as well as fish. The squid would be better adapted for swimming if it evolved a fishlike tail instead of its jet propulsion mechanism, but evolution cannot make that change because it would involve moving down from the lesser adaptive summit before climbing the higher one. [R.M.A.]

**Adaptive control** A special type of nonlinear control system which can alter its parameters to adapt to a changing environment. The changes in environment can represent variations in process dynamics or changes in the characteristics of the disturbances. See *NONLINEAR CONTROL THEORY*.

A normal feedback control system can handle moderate variations in process dynamics. The presence of such variations is, in fact, one reason for introducing feedback. There are, however, many situations where the changes in process dynamics are so large that a constant linear feedback controller will not work satisfactorily. For example, the dynamics of a supersonic aircraft change drastically with Mach number and dynamic pressure, and a flight control system with constant parameters will not work well. See *FLIGHT CONTROLS*.

Adaptive control is also useful for industrial process control. Since delay and holdup times depend on production, it is desirable to retune the regulators when there is a change in production. Adaptive control can also be used to compensate for changes due to aging and wear. See *PROCESS CONTROL*. [K.J.A.]

**Adaptive management** An approach to management of natural resources that emphasizes how little is known about the dynamics of ecosystems and that as more is learned management will evolve and improve. Natural systems are very complex and dynamic, and human observations about natural processes are fragmentary and inaccurate. As a result, the best way to use the available resources in a sustainable manner remains to be determined. Furthermore, much of the variability that affects natural populations is unpredictable and beyond human control. This combination of ignorance and unpredictability means that the ways in which ecosystems respond to human interventions are unknown and can be described only in probabilistic terms. Nonetheless, management decisions need to be made. Adaptive management proceeds despite this uncertainty by treating human interventions in natural systems as large-scale experiments from which more may be learned, leading to improved management in the future.

A key first step in the development of an adaptive management program is the assessment of the problem. During this stage, existing knowledge and interdisciplinary experience is synthesized and formally integrated by developing a dynamic model of the system. This modeling exercise helps to identify key information gaps and to postulate hypotheses about possible system responses to human intervention consistent with available information. Different management policies have to be screened in order to narrow down the alternatives to a few plausible candidates.

The second stage involves the formal design of a management and monitoring program. To the extent that new information can result in improved future management, adaptive management programs may include large-scale experiments deliberately designed to accelerate learning. Some management actions may

be more effective than others at filling the relevant information gaps. In cases where spatial replication is possible (such as small lakes, patches of forest, and reefs), policies that provide contrasts between different management units will be much more informative about the system dynamics than those that apply the same rule everywhere. There are other barriers to the implementation of large-scale management experiments. Experiments usually have associated costs; thus, in order to be worthwhile, benefits derived from learning must overcompensate short-term sacrifices. Choices may be also restricted by social concerns or biological constraints, or they may have unacceptably high associated risks.

Once a plan for action has been chosen, the next stage is to implement the program in the field. This is one of the most difficult steps, because it involves a concerted and sustained effort from all sectors involved in the use, assessment, and management of the natural resources. Beyond the implementation of specific initial actions, putting in place an adaptive management program involves a long-term commitment to monitoring the compliance of the plan, evaluating the effects of management interventions, and adjusting management accordingly.

No matter how thorough and complete the initial assessment and design may have been, systems may always respond in manners that could not be foreseen at the planning stage. Ecosystems exhibit long-term, persistent changes at the scale of decades and centuries; thus, recent experience is not necessarily a good basis for predicting future behavior. The effects of global climatic change on the dynamics of ecosystems, which are to a large extent unpredictable, will pose many such management challenges. Adaptive management programs have to include a stage of evaluation and adjustment. Outcomes of past management decisions must be compared with initial forecasts, models have to be refined to reflect new understanding, and management programs have to be revised accordingly. New information may suggest new uncertainties and innovative management approaches, leading to another cycle of assessment, design, implementation, and evaluation. [A.M.Pa.]

**Adaptive optics** The science of optical systems in which a controllable optical element, usually a deformable mirror, is used to optimize the performance of the system, for example, to maintain a sharply focused image in the presence of wavefront aberrations. A distinction is made between active optics, in which optical components are modified or adjusted by external control to compensate slowly changing disturbances, and adaptive optics, which applies to closed-loop feedback systems employing sensors and data processors, operating at much higher frequencies. See *CONTROL SYSTEMS*.

In a typical adaptive optics system (see illustration) the distorted light beam to be compensated is reflected from the

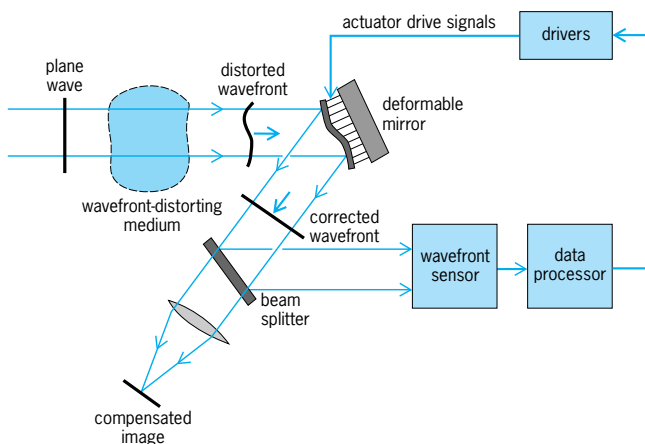

Typical adaptive optics system using discrete components.

deformable mirror and is sampled by a beam splitter. The light sample is analyzed in a wavefront sensor that determines the error in each part of the beam. The required corrections are computed and applied to the deformable mirror whose surface forms the shape necessary to flatten the reflected wavefront. The result is to remove the optical error at the sampling point so that the light passing through the beam splitter may be focused to a sharp image. Nonlinear optical devices are also capable of performing some adaptive optics functions; these devices operate at high optical power levels. See *ABERRATION (OPTICS)*; *GEOMETRICAL OPTICS*; *NONLINEAR OPTICAL DEVICES*.

The practical development of adaptive optics started in the late 1960s. Its main applications have been to compensate for the effects of atmospheric turbulence in ground-based astronomical telescopes and to improve the beam quality of high-power lasers. Adaptive optics is now used routinely at several astronomical observatories. [J.W.Ha.]

**Adaptive signal processing** Signal processing deals with the extraction of information from signals. The devices that perform this task can be physical hardware devices, specialized software codes, or combinations of both. Some notable applications, in areas ranging from biomedical engineering to wireless communications, include the suppression of interference arising from noisy measurement sensors, the elimination of distortions introduced when signals travel through transmission channels, and the recovery of signals embedded in a multitude of echoes created by multipath effects in mobile communications.

**Statistically based systems.** Any functional system is expected to meet certain performance specifications. The requirements, as well as the design methodology, vary according to the nature of the end application. One distinctive design methodology, which dominated much of the earlier work in the information sciences, especially in the 1950s and 1960s, is based on statistical considerations. This framework assumes the availability of information in advance about the statistical nature of the signals involved, and then proceeds to design systems that optimize some statistical criterion. The resulting optimal designs are, in general, complex to implement. Only in special, yet important cases have they led to successful breakthroughs culminating with the Wiener and Kalman filters. See *ESTIMATION THEORY*; *OPTIMIZATION*.

Moreover, in many situations a design that is motivated by statistical considerations may not be immediately feasible, because complete knowledge of the necessary statistical information may not be available. It may even happen that the statistical conditions vary with time. It therefore may be expected, in these scenarios, that the performance of any statistically based optimal design will degrade as the real physical application deviates from the modeling assumptions.

**Adaptive systems.** Adaptive systems are devices that adjust themselves to an ever-changing environment; the structure of an adaptive system changes in such a way that its performance improves through a continuing interaction with its surroundings. Its superior performance in nonstationary environments results from its ability to track slow variations in the statistics of the signals and to continually seek optimal designs.

Adaptive signal processing deals with the design of adaptive systems for signal-processing applications. Related issues arise in control design, where the objective is to alter the behavior of a system, and lead to the study of adaptive control strategies; the main issue is the stability of the system under feedback. See *ADAPTIVE CONTROL*.

**Operation.** The operation of an adaptive system can be illustrated with a classical example in system identification. The illustration shows a plant (or system) whose input-output behavior is unknown and may even be time variant. The objective is to design an adaptive system that provides a good approximation to the input-output map of the plant. For this purpose, the plant is excited by a known input signal, and the response is

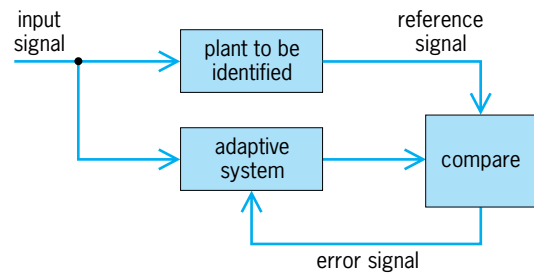

**Adaptive system identification.**

taken as a reference signal. Moreover, a structure is chosen for the adaptive system, say a finite-impulse response structure of adequate length, and it is excited by the same input signal as the plant. At each time instant the output of the finite-impulse response system is compared with the reference signal, and the resulting error signal is used to change the coefficients of the finite-impulse response configuration. This learning process is continued over time, and the output of the adaptive system is expected to provide better tracking of the plant output as time progresses, especially when the structure of the plant is time invariant or varies only slowly with time. [A.H.Sa.; B.Ha.; T.Ka.]

**Addictive disorders** Addictive disease disorders are characterized by the chronic use of a drug (such as heroin, cocaine, or amphetamines), alcohol, or similar substances. These disorders usually result in (1) the development of tolerance for the substance, with the need for increasing amounts to achieve the desired effect; (2) physical dependence, characterized by a sequence of well-defined signs and physiological symptoms, such as the withdrawal or abstinence syndrome on cessation of use of the substance; and (3) compulsive drug-seeking behavior, with chronic, regular, or intermittent use, despite possible harm to self or others. Since the early 1960s, research has been increasing in the biology of addictive diseases, and emphasis has shifted from only psychological, sociological, and epidemiological studies to investigations of the metabolic, neurobiological, and molecular bases of addiction.

The four major addictive diseases are alcoholism, narcotic (or opiate) addiction, cocaine and other stimulant addiction, and nicotine addiction. Drug addiction may also occur after chronic use of other types of agents such as barbiturates, benzodiazepines, and marijuana. See *ALCOHOLISM*; *BARBITURATES*; *COCAINE*; *NARCOTIC*; *OPIATES*.

Opiate receptors (cell structures that function as an intermediary between the opioid and the physiological response) here conclusively identified in mammals (including humans) in 1973. Since then, it has been determined that there are at least three different types of opioid receptors—mu receptors, delta receptors, and kappa receptors. The genes encoding each of these receptor types were cloned for the first time in 1992, beginning with the delta opioid receptor. Subsequent to the discovery of specific opioid receptors, endogenous ligands which bind to these receptors, the so-called endogenous opioids, were discovered. Opioids include substances that are produced endogenously (such as the enkephalins, endorphins, and dynorphins) and may be produced synthetically. Exogenous synthetic opioids are used extensively in the treatment of pain. See *ENDORPHINS*.

It is not known to what extent the endogenous opioids play a role in addictive diseases. It has been suggested that narcotic addiction may be a disorder characterized by (1) a relative or absolute deficiency of endogenous opioids; (2) an end organ or receptor failure to respond to normal or possibly increased levels of endogenous opioids; (3) genetic or acquired (for example, short-acting opiate or stimulant drug-induced) abnormalities in the feedback control of the synthesis, release, and processing, or degradation of one or more types of the endogenous opioids; or (4) genetic variations in the opioid receptors.

The possible role of endogenous opioids in alcoholism is also not clear. It has been shown that a specific opioid antagonist, naloxone, may reverse or ameliorate some of the signs and symptoms and physical abnormalities of the acute alcohol intoxication syndrome. However, this apparent beneficial effect of an opioid antagonist may not be related to the addictive disease *per se*, but may be due to the counteracting of the possible acute release of large amounts of endogenous opioids in response to excessive acute alcohol ingestion. Whether there are some common mechanisms with a genetic, metabolic, or purely behavioral basis underlying these two addictive diseases has not yet been defined.

There are three approaches to the management of opiate (primarily heroin) addiction: pharmacological treatment, drug-free treatment following detoxification, and incarceration. Statistical data over the last century reveal that after release from prison, completion of drug-free treatment, or discontinuation of chronic pharmacological treatment with methadone or other mu agonists, partial agonists, or antagonists, fewer than 30% of former long-term heroin addicts are able to stay drug-free. (Long-term addiction is defined as more than 1 year of daily use of several doses of heroin, with tolerance, physical dependence, and drug-seeking behavior.)

Since the 1960s, methadone maintenance treatment has been documented to be medically safe and the most effective available treatment for heroin addiction. Unlike heroin, which has a 3-min half-life in humans, and its major metabolite, morphine, which has a half-life of 4–6 h, methadone has a 24-h half-life. Therefore, when given orally daily, methadone prevents the signs and symptoms of narcotic abstinence and also prevents drug hunger, without causing any narcotic-induced euphoria during the 24 h between doses. Steady moderate to high doses of methadone can be used in the treatment of addiction over long periods of time without tolerance developing to these desired effects. Because of the high degree of cross-tolerance developed for other narcotics, a patient receiving methadone maintenance treatment does not experience any narcotic high or other effects after self-administration of a dose of short-acting narcotic such as heroin. Through this cross-tolerance mechanism, methadone blocks any illicit narcotic effect. 60–90% of heroin addicts who have entered into methadone maintenance treatment will stay in treatment voluntarily for 1 year or more. Illicit opiate abuse drops to less than 15% during such treatment when adequate doses of methadone (usually 60–150 mg per day) are administered. Cocaine or polydrug abuse or alcohol abuse may persist in 20–30% of patients even in excellent methadone programs, since methadone maintenance is specific for treatment of narcotic dependency. Chronic methadone treatment also brings about the normalization of the multiple physiological alterations caused by chronic heroin abuse. Methadone-maintained patients, who are not chronic abusers of other drugs or alcohol, are able to work, to attend school, and to take part in normal socialization, including restoration of family life. However, when maintenance treatment is discontinued, over 70% of all patients will return to opiate abuse within 2 years.

A second type of pharmacological treatment of narcotic addiction is chronic treatment with a specific narcotic antagonist, naltrexone. This drug also prevents any narcotic effect from illicitly administered heroin, but does so by way of direct opioid receptor blocking, with displacement of endogenous or exogenous opioids from receptor binding. Naltrexone treatment has limited acceptance by unselected opiate addicts; only 15–30% of former narcotic addicts entering treatment with this agent remain in treatment for 6 months or more. Therefore, although it may be a worthwhile treatment for some small defined special populations, it does not seem to be an effective treatment for the majority of unselected long-term heroin addicts.

Drug-free treatment involving either long-term institutionalization in a drug-free residence or, less frequently, attendance at an outpatient resource, has resulted in long-term success in ap-

proximately 10–30% of all unselected heroin addicts who enter treatment.

Alcoholism has been difficult to treat over a long-term period. There is no specific pharmacological replacement treatment for alcoholism. Disulfiram (Antabuse) is an agent which blocks the metabolism of acetaldehyde, the major metabolite of ethanol. When a person treated with Antabuse drinks alcohol, there is a rapid buildup of acetaldehyde and a severe physiological syndrome ensues, which frequently prevents or modifies further immediate drinking behavior.

The most widely used treatment of alcoholism is self-help groups, such as Alcoholics Anonymous (AA), where mutual support is available on a 24-h basis, along with group recognition of chronic problems with alcohol. However, only around 20–40% of severe chronic alcoholics are able to stay alcohol-free for more than 2 years even under such management. Early studies of the use of an opioid antagonist naltrexone or nalmefene for the treatment of chronic alcoholism have shown that about 50% of the subjects had reduced numbers and magnitudes of relapse events. Ethanol, unlike heroin and other narcotics, has many well-defined severes, specific toxic effects on several organs, including the liver, brain, and reproductive system, so even relatively short drug-free intervals will decrease exposure to this toxin. Therefore, it has been suggested that success in treatment of alcoholism be measured in part by increasing lengths of alcohol-free intervals, and not just by permanent restoration of the alcohol-free state.

Cocaine addiction may also involve disruption of the endogenous opioid system in addition to the well-known primary effect of cocaine in blocking reuptake of dopamine by the synaptic dopamine transporter protein. This effect results in the accumulation of dopamine in the synapse and similar actions at the serotonin and norepinephrine reuptake transporter. Demonstrated changes in the mu and kappa endogenous opioid system increase the complexity of the effect of cocaine and may contribute to its resultant reinforcing properties leading to addiction, as well as to the drug craving and relapse. This may explain in part the resultant difficulties in developing a pharmacotherapeutic approach for the treatment of cocaine addiction. [M.J.Kr.]

**Addition** One of the four fundamental operations of arithmetic and algebra. The term addition is applied to many kinds of objects other than numbers. For example, two vectors  $\mathbf{x}$ ,  $\mathbf{y}$  are added to produce a third vector  $\mathbf{z}$  obtained from them by the “parallelogram” law, and two sets  $A$ ,  $B$  are added to form a third set  $C$  consisting of all the elements of  $A$  and of  $B$ . See CALCULUS OF VECTORS.

As an operation on pairs of real or complex numbers, addition is associative, Eq. (1), and commutative, Eq. (2); and multiplication is distributive over addition, Eq. (3). There are

$$a + (b + c) = (a + b) + c \quad (1)$$

$$a + b = b + a \quad (2)$$

$$a(b + c) = a \cdot b + a \cdot c \quad (3)$$

important mathematical structures in which an addition operation is defined that lacks one or more of these properties. See ALGEBRA; DIVISION; MULTIPLICATION; NUMBER THEORY; SUBTRACTION.

[L.M.B.]

**Adenohypophysis hormone** Of the endocrine glands, the anterior pituitary, or adenohypophysis, occupies the prime place because, through the secretion of various hormones, it controls the functioning of certain other endocrine glands, namely, the adrenal cortex, the thyroid, and the gonads. In addition, hormones from the anterior pituitary influence the growth and metabolism of the organism through direct action on skeletal, muscular, and other tissues. The pituitary maintains control over the various target organs by a feedback mechanism which is sensitive to circulating levels of hormones from the target organs.

Pituitary hormones are also released in response to metabolic conditions which they help to control. One factor influencing the secretion of growth hormone, for example, is the level of blood glucose.

There are eight anterior pituitary hormones whose existence has been firmly established for some time. They include the two gonadotropic hormones, interstitial-cell stimulating hormone (ICSH, or luteinizing hormone, LH) and follicle-stimulating hormone (FSH); thyrotropic hormone (thyroid-stimulating hormone, TSH); lactogenic hormone (prolactin); growth hormone (GH, or somatotropin, STH); adrenocorticotropin hormone (ACTH, or adrenocorticotropin, or corticotropin); and the two melanocyte-stimulating hormones ( $\alpha$ -MSH and  $\beta$ -MSH). In addition, two peptides have been isolated which are structurally related to ACTH and the MSHs. These peptides have been designated  $\beta$ -lipotropic hormone ( $\beta$ -LPH) and  $\gamma$ -lipotropic hormone ( $\gamma$ -LPH). The hormones of the adenohypophysis are composed of amino acids in peptide linkage and are therefore classed as either polypeptides or proteins, depending on their size. In addition, three of the hormones, TSH, ICSH, and FSH, contain carbohydrate and are therefore categorized as glycoproteins. See AMINO ACIDS; HORMONE; PROTEIN.

In the female, FSH initiates the development of ovarian follicles. ICSH, acting synergistically with FSH, is necessary for the final stages of follicular maturation and the production of estrogen. ICSH also stimulates the development of the corpus luteum. In the male, FSH stimulates spermatogenesis through its action on the germinal epithelium of the testis, and ICSH primarily activates the Leydig cells which produce androgen.

TSH stimulates the growth of the thyroid gland and the secretion of thyroid hormones.

Through a process which requires other hormones as well, lactogenic hormone stimulates the mammary gland to secrete milk. There is evidence that in some species of mammals lactogenic hormone also plays a role in maintaining the corpus luteum in the ovary. In contrast to all nonprimate species investigated, a distinct lactogenic hormone has never been isolated from the pituitaries of the monkey or the human. In these two species a hormone containing lactogenic activity can indeed be isolated from the pituitary, but it also has growth-promoting activity and in major respects corresponds to growth hormones isolated from nonprimate species. Thus, in nonprimates, a distinct growth hormone, having no lactogenic activity, can be isolated from the pituitary gland. In the primates, however, growth-promoting and lactogenic activities are present in the same molecule. In spite of its dual activities, the primate hormone is usually referred to simply as growth hormone, which promotes an increase in body size. It stimulates the growth of bones, muscles, and other tissues and enhances the effects of other pituitary hormones on their target organs. Although certain cellular effects of growth hormone are known, such as increasing incorporation of amino acids into muscle protein, the biochemical mechanisms whereby this hormone exerts its effects at the cellular level remain a mystery.

The hormone ACTH stimulates the growth of the adrenal cortex and the secretion of cortisol and other cortical hormones. An interesting aspect of the ACTH molecule is that it contains in part a sequence found in the melanocyte-stimulating hormones and lipotropic hormones (see below). In accordance with their chemical similarities, it is not surprising that all of these hormones exhibit both melanocyte-stimulating and lipolytic activities.

The melanocyte-stimulating hormones are also called intermedians, since they can be isolated from the intermediate lobe of the pituitary in those animals which have a distinct intermediate lobe. Melanocyte-stimulating activity refers to the ability of these hormones to cause dispersion of pigment granules in melanocytes, producing a darkening of the skin. Two types of MSHs have been isolated.  $\alpha$ -MSH is the most potent melanocyte-stimulating hormone;  $\beta$ -MSH has about 50% of the activity of  $\alpha$ -MSH, while ACTH and the LPHs have about 1%.

In 1965–1966,  $\beta$ -lipotropic hormone and  $\gamma$ -lipotropic hormone, were isolated from the pituitaries of sheep and chemically characterized. The term lipotropic refers to the lipolytic activity of these substances on adipose tissue. Subsequently, it was learned that they also possessed melanocyte-stimulating activity. Lipolytic activity refers to the ability of certain hormones to stimulate the breakdown of lipid in adipose tissue to free fatty acids and glycerol. As has been mentioned, ACTH and the MSHs are also lipolytic hormones, and are, in fact, of greater potency in this regard than the LPHs. See ANIMAL GROWTH; LACTATION; PITUITARY GLAND; THYROID GLAND. [C.H.L.]

**Adenosine diphosphate (ADP)** A coenzyme and an important intermediate in cellular metabolism as the partially dephosphorylated form of adenosine triphosphate. The compound is 5'-adenylic acid with an additional phosphate group attached through a pyrophosphate bond. ADP is produced from adenosine triphosphate and reconverted to this compound in coupled reactions concerned with the energy metabolism of living systems. ADP is also produced from 5'-adenylic acid by the transfer of a phosphate group from adenosine triphosphate in a reaction that is catalyzed by an enzyme, myokinase. See METABOLISM. [M.D.]

**Adenosine triphosphate (ATP)** A coenzyme and one of the most important compounds in the metabolism of all organisms, since it serves as a coupling agent between different enzymatic reactions. Adenosine triphosphate is adenosine diphosphate (ADP) with an additional phosphate group attached through a pyrophosphate linkage to the terminal phosphate group (see illustration). ATP is a powerful donor of phosphate groups to suitable acceptors because of the pyrophosphate nature of the bonds between its three phosphate radicals. For instance, in the phosphorylation of glucose, which is an essential reaction in carbohydrate metabolism, the enzyme hexokinase catalyzes the transfer of the terminal phosphate group.

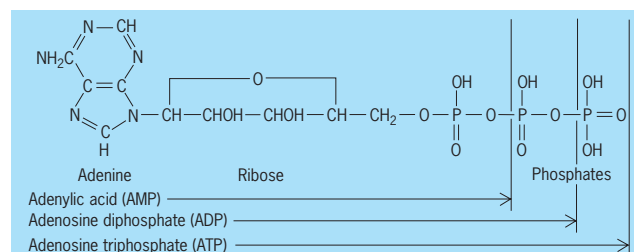

Structure of adenylic acid and phosphate derivatives ADP and ATP.

ATP serves as the immediate source of energy for the mechanical work performed by muscle. In its presence, the muscle protein actomyosin contracts with the formation of adenosine diphosphate and inorganic phosphate. ATP is also involved in the activation of amino acids, a necessary step in the synthesis of protein. See MUSCLE.

In metabolism, ATP is generated from adenosine diphosphate and inorganic phosphate mainly as a consequence of energy-yielding oxidation-reduction reactions. In respiration, ATP is generated during the transport of electrons from the substrate to oxygen via the cytochrome system. In photosynthetic organisms, ATP is generated as a result of photochemical reactions. See CARBOHYDRATE METABOLISM; CYTOCHROME.

By virtue of its energy-rich pyrophosphate bonds, ATP serves as a link between sources of energy available to a living system and the chemical and mechanical work which is associated with growth, reproduction, and maintenance of living substance. For this reason, it has been referred to as the storehouse of energy

of living systems. Because ATP, ADP, and adenylic acid are constantly interconverted through participation in various metabolic processes, they act as coenzymes for the coupled reactions in which they function. See BIOCHEMISTRY; BIOLOGICAL OXIDATION; COENZYME; METABOLISM. [M.D.]

**Adeno-SV40 hybrid virus** A type of defective virus particle in which part of the genetic material of papovavirus SV40 is encased within an adenovirus protein coat (capsid). Adenovirus progeny possesses properties different from those of the original parent adenovirus. It produces tumors in newborn hamsters; it replicates in monkey cell cultures; and although it does not produce infectious SV40, it causes monkey cells in culture to produce a new cellular antigen known to be specifically induced by SV40—the SV40 tumor, or T, antigen. The new virus stock therefore behaves like a hybrid. It has proved to be a population of two distinct kinds of virus particles. One kind of particle is a true adenovirus. The other particle is the adeno-SV40 hybrid, which has an adenovirus coat, but whose genetic material appears to consist of defective adenovirus type 7 DNA, representing about 85% of the adenovirus genome, covalently linked to a portion (about 50%) of an SV40 genome.

In this virus population the particle carrying the SV40 genetic material has been termed PARA (particle aiding replication of adenovirus). The PARA is considered an unconditionally defective virus, since under no known conditions can it reproduce itself except in a cell coinfecting with adenovirus. The adenovirus is considered conditionally defective, since it can reproduce independently in human cells but not in monkey cells. See ADENOVIRIDAE; ANIMAL VIRUS. [J.L.Me.]

**Adenoviridae** A family of viral agents associated with pharyngoconjunctival fever, acute respiratory disease, epidemic keratoconjunctivitis, and febrile pharyngitis in children. A number of types have been isolated from tonsils and adenoids removed from surgical patients. Although most of the illnesses caused by adenoviruses are respiratory, adenoviruses are frequently excreted in stools, and certain adenoviruses have been isolated from sewage. Distinct serotypes of mammalian and avian species are known. These genera contain 87 and 14 species, respectively. See ANIMAL VIRUS.

Infective virus particles, 70 nanometers in diameter, are icosahedrons with shells (capsids) composed of 252 subunits (capsomeres). No outer envelope is known. The genome is double-stranded deoxyribonucleic acid (DNA), with a molecular weight of  $20\text{--}25 \times 10^6$ . Three major soluble antigens are separable from the infectious particle by differential centrifugation. These antigens—a group-specific antigen common to all adenovirus types, a type-specific antigen unique for each type, and a toxinlike material which also possesses group specificity—represent virus structural protein subunits that are produced in large excess of the amount utilized for synthesis of infectious virus.

The known types of adenoviruses of humans total at least 33, and previously unrecognized types continue to be isolated. The serotypes are antigenically distinct in neutralization tests, but they share a complement-fixing antigen, which is probably a smaller soluble portion of the virus.

The virus does not commonly produce acute disease in laboratory animals but is cytopathogenic, that is, destroys cells, in cultures of human tissue. Certain human adenovirus serotypes produce cancer when injected into newborn hamsters.

Base ratio determinations have revealed three distinct groups of adenoviruses: those with a low guanine plus cytosine (G + C) content (48–49%); those with an intermediate G + C content (50–53%); and those with a high G + C content (56–60%). The strongly oncogenic adenovirus types 12, 18, and 31 are the only members of the group with low G + C, and certain adenoviruses in the intermediate group (types 3, 7, 14, 16, and 21) are mildly oncogenic. The adenovirus mRNA observed

in transformed and tumor cells has a G + C content of 50–52% in the DNA. This suggests that viral DNA regions containing 47–48% G + C are integrated into the tumor cells or that such regions are preferentially transcribed. However, the mRNA from tumor cells induced by one subgroup such as the highly oncogenic adenoviruses (types 12 and 18) do not hybridize with DNA from the other two subgroups. Apparently, different viral-coded information is involved in carcinogenesis by the three different groups of adenoviruses.

With simian adenovirus 7 (SA7), the intact genome, as well as the heavy and light halves of the viral DNA, is capable of inducing tumors when injected into newborn hamsters. Extensive studies have failed to demonstrate adenovirus DNA or viral-specific mRNA in human tumors.

Live virus vaccines against type 4 and type 7 have been developed and used extensively in military populations. When both are administered simultaneously, vaccine recipients respond with neutralizing antibodies against both virus types. See ADENO-SV40 HYBRID VIRUS; ANTIGEN; COMPLEMENT-FIXATION TEST; DEPENDOVIRUS; NEUTRALIZATION REACTION (IMMUNOLOGY); VIRUS CLASSIFICATION. [J.L.Me.; M.E.Re.]

**Adhesive** A material capable of fastening two other materials together by means of surface attachment. The terms glue, mucilage, mastic, and cement are synonymous with adhesive. In a generic sense, the word adhesive implies any material capable of fastening by surface attachment, and thus will include inorganic materials such as portland cement and solders. In a practical sense, however, adhesive implies the broad set of materials composed of organic compounds, mainly polymeric, which can be used to fasten two materials together. The materials being fastened together by the adhesive are the adherends, and an adhesive joint or adhesive bond is the resulting assembly. Adhesion is the physical attraction of the surface of one material for the surface of another.

The phenomenon of adhesion has been described by many theories. The most widely accepted and investigated is the wettability-adsorption theory. This theory states that for maximum adhesion the adhesive must come into intimate contact with the surface of the adherend. That is, the adhesive must completely wet the adherend. This wetting is considered to be maximized when the intermolecular forces are the same forces as are normally considered in intermolecular interactions such as the van der Waals, dipole-dipole, dipole-induced dipole, and electrostatic interactions. Of these, the van der Waals force is considered the most important. The formation of chemical bonds at the interface is not considered to be of primary importance for achieving maximum wetting, but in many cases it is considered important in achieving durable adhesive bonds. See ADSORPTION; CHEMICAL BONDING; INTERMOLECULAR FORCES.

The greatest growth in the development and use of organic compound-based adhesives came with the application of synthetically derived organic polymers. Broadly, these materials can be divided into two types: thermoplastics and thermosets. Thermoplastic adhesives become soft or liquid upon heating and are also soluble. Thermoset adhesives cure upon heating and then become solid and insoluble. Those adhesives which cure under ambient conditions by appropriate choice of chemistry are also considered thermosets. See POLYMER.

Pressure-sensitive adhesives are mostly thermoplastic in nature and exhibit an important property known as tack. That is, pressure-sensitive adhesives exhibit a measurable adhesive strength with only a mild applied pressure. Pressure-sensitive adhesives are derived from elastomeric materials, such as polybutadiene or polyisoprene.

Structural adhesives are, in general, thermosets and have the property of fastening adherends that are structural materials (such as metals and wood) for long periods of time even when the adhesive joint is under load. Phenolic-based structural

adhesives were among the first structural adhesives to be developed and used. The most widely used structural adhesives are based upon epoxy resins. An important property for a structural adhesive is resistance to fracture (toughness). Thermoplastics, because they are not cured, can deform under load and exhibit resistance to fracture. As a class, thermosets are quite brittle, and thermoset adhesives are modified by elastomers to increase their resistance to fracture.

Hot-melt adhesives are used for the manufacture of corrugated paper, in packaging, in bookbinding, and in shoe manufacture. Pressure-sensitive adhesives are most widely used in the form of coatings on tapes, such as electrical tape and surgical tape. Structural adhesives are applied in the form of liquids, pastes, or 100% adhesive films. Epoxy liquids and pastes are very widely used adhesive materials, having application in many assembly operations ranging from general industrial to automotive to aerospace vehicle construction. Solid-film structural adhesives are used widely in aircraft construction. Acrylic adhesives are used in thread-locking operations and in small-assembly operations such as electronics manufacture which require rapid cure times. The largest-volume use of adhesives is in plywood and other timber products manufacture. Adhesives for wood bonding range from the natural products (such as blood or casein) to the very durable phenolic-based adhesives. See BOOK MANUFACTURE; MUCILAGE; PLYWOOD. [A.V.P.]

**Adhesive bonding** The process of using an adhesive to manufacture an assembly. The adhesive-bonded assembly is known as an adhesive joint, and the materials to which the adhesive adheres are known as the adherends.

Adhesive joints are designed by first knowing the loads that are to be supported by the joint. Adherends and adhesives are chosen according to the needs of the application, that is, the stiffness, toughness (fracture resistance), and elongation. Mechanical engineering principles are applied to ensure that the joint can support the necessary load. A properly designed adhesive joint will provide for adherend failure rather than adhesive failure unless the joint is designed to be reworked or reused. Usually, the design is subjected to a test protocol before going into production.

Adhesive joints are made by means of surface attachment; thus the condition of the adherend surface must be taken into account. This is particularly important when the adhesive joint is to be exposed to adverse environmental conditions such as temperature and humidity. In general, the purpose of a surface preparation is to remove weak boundary layers (such as oils and greases), increase the adherend surface energy, and provide a surface with enough mechanical roughness to "key" the adhesive into the surface of the adherend. In some cases, a primer is applied to the adherend before applying the adhesive.

For a proper adhesive joint, the adhesive must "wet" the adherend; that is, the adhesive must come into intimate contact with the adherend. As a guideline, the adhesive must have a liquid surface energy less than the critical wetting tension of the adherend. If the adherend's surface has been properly prepared or primed, this is usually achievable. Alternatively, the correct adhesive can be chosen such that this condition of intimate contact is achievable. See INTERFACE OF PHASES; SURFACE TENSION.

Joint assembly is an important consideration in adhesive bonding. In many cases, the adhesive has a "set time"; that is, the adhesive has little, or no strength until some solidification takes place. During the solidification process, the adherends must be kept in place.

Pressure-sensitive adhesives usually require no processing to solidify, as they are already viscoelastic solids; that is, they display both liquidlike and solidlike character. Adhesives such as rubber-based adhesives and contact bond adhesives require the evaporation of solvent or water to solidify. Other adhesives undergo a

chemical reaction to solidify. For example, two-part epoxy adhesives must be properly mixed in order to effect the solidification or "cure" of the adhesive. Some adhesives require the application of heat to cure the adhesive. Other adhesives are cured by the action of light or some other actinic source of energy. Hot-melt adhesives are heated to and applied in the liquid state, and solidify upon cooling.

Adhesives are used in a wide range of applications, including electronics, automotive, aircraft, furniture construction, and plywood manufacture, to name some. Adhesives are also used in many noncritical applications such as paper binding, carton sealing (hot-melt adhesives), and envelope sealing. In medicine, adhesives are used as tissue sealants during surgeries and transdermal drug delivery systems. See ADHESIVE. [A.V.P.]

**Adiabatic demagnetization** The removal or diminution of a magnetic field applied to a magnetic substance when the latter has been thermally isolated from its surroundings. The process concerns paramagnetic substances almost exclusively, in which case a drop in temperature of the working substance is produced (magnetic cooling). See PARAMAGNETISM.

Nuclear magnetic moments are one or two thousand times smaller than their ionic (that is, electronic) counterparts, and the characteristic temperature of their mutual interaction lies in the microkelvin rather than millikelvin region. Successful experiments in nuclear adiabatic demagnetization date from the mid-1950s. See ABSOLUTE ZERO; CRYOGENICS; LOW-TEMPERATURE PHYSICS. [R.P.Hu.]

**Adiabatic process** A thermodynamic process in which the system undergoing the change exchanges no heat with its surroundings. An increase in entropy or degree of disorder occurs during an irreversible adiabatic process. However, reversible adiabatic processes are isentropic; that is, they take place with no change in entropy. In an adiabatic process, compression always results in warming, and expansion always results in cooling. See ENTROPY; ISENTROPIC PROCESS.

During an adiabatic process, temperature changes are due to internal system fluctuations. For example, the events inside an engine cylinder are nearly adiabatic because the wide fluctuations in temperature take place rapidly, compared to the speed with which the cylinder surfaces can conduct heat. Similarly, fluid flow through a nozzle may be so rapid that negligible exchange of heat between fluid and nozzle takes place. The compressions and rarefactions of a sound wave are rapid enough to be considered adiabatic. See NOZZLE; SOUND; THERMODYNAMIC PROCESSES. [P.E.Bl.]

**Adipose tissue** A type of connective tissue that is specialized for the storage of neutral fats (lipids). Adipose cells have names reflecting their gross physical appearance: white fat, which can be yellowish if the animal's diet is rich in carotenoids, and brown fat, containing vascularization and respiratory pigments.

White fat is the more common type of adipose cell. These cells are found in a wide variety of locations in the mammalian body, and their function varies from location to location. For example, they may act to store food reserves and to provide thermal and physical insulation. The number of white adipose cells and the amount of fat in a cell are regulated by various factors, including genetics, hormones, diet, innervation, and physical activity. Many animals, especially migratory and hibernating mammals, greatly increase their fat reserves in preparation for travel or for hibernation.

Brown adipose tissue is mainly found in subscapular, interscapular, and mediastinal areas. Brown adipose cells are associated with thermogenesis (heat production), mainly in hibernating and newborn mammals. See CONNECTIVE TISSUE; LIPID. [T.Ge.]

**Admittance** The ratio of the current to the voltage in an alternating-current circuit. In terms of complex current  $I$  and voltage  $V$ , the admittance of a circuit is given by Eq. (1), and is related to the impedance of the circuit  $Z$  by Eq. (2).  $Y$  is a complex number given by Eq. (3).  $G$ , the real part of the admittance,

$$Y = \frac{I}{V} \quad (1)$$

$$Y = \frac{1}{Z} \quad (2)$$

$$Y = G + jB \quad (3)$$

is the conductance of the circuit, and  $B$ , the imaginary part of the admittance, is the susceptance of the circuit. The units of admittance are called siemens or mhos (reciprocal ohms). See CONDUCTANCE; SUSCEPTANCE. [J.O.S.]

**Adrenal gland** A complex endocrine organ in proximity to the kidney. Adrenal gland tissue is present in all vertebrates. The adrenal consists of two functionally distinct tissues: steroidogenic cells and catecholamine-secreting cells. While "adrenal" refers to the gland's proximity to the kidney, significant variation exists among vertebrates in its anatomic location as well as the relationship of the two endocrine tissues which make up the gland. In mammals, steroidogenic cells are separated into distinct zones that together form a cortex. This cortical tissue surrounds the catecholamine-secreting cells, constituting the medulla. In most other vertebrates, this unique anatomic cortical-medullary relationship is not present. In species of amphibians and fish, adrenal cells are found intermingling with kidney tissue, and the steroidogenic cells are often termed interrenal tissue.

**Development.** The adrenal gland forms from two primordia: cells of mesodermal origin which give rise to the steroid-secreting cells, and neural cells of ectodermal origin which develop into the catecholamine-secreting tissue (also known as chromaffin tissue). In higher vertebrates, mesenchymal cells originating from the coelomic cavity near the genital ridge proliferate to form a cluster of cells destined to be the adrenal cortex. During the second month of human development, cells of the neural crest migrate to the region of the developing adrenal and begin to proliferate on its surface. The expanding cortical tissue encapsulates the neural cells forming the cortex and medulla. In mammals, three distinct zones form within the cortex: the outermost zona glomerulosa, the middle zona fasciculata, and the inner zona reticularis. The glomerulosa cells contain an enzyme, aldosterone synthase, which converts corticosterone to aldosterone, the principal steroid (mineralocorticoid) secreted from this zone. The inner zones (fasciculata and reticularis) primarily secrete glucocorticoids and large amounts of sex steroid precursors. In many lower vertebrates, the two tissues form from similar primordia but migrate and associate in different ways to the extent that in some cases the two tissues develop in isolation from each other.

**Comparative anatomy.** While the paired adrenals in mammals have a characteristic cortical-medullary arrangement with distinct zonation present in the cortex, such distinctions are lacking in nonmammalian species. In more primitive fishes, chromaffin cells form in isolation from steroidogenic tissue. A general trend is present, however, throughout vertebrates for a closer association of chromaffin and steroidogenic tissues. Zonation in steroidogenic tissue is largely confined to mammals, although suggestions of separate cell types have been postulated in birds and in some other species.

**Comparative endocrinology.** Hormones are secreted from the cells of both the medulla and the cortex.

**Chromaffin cells.** In all vertebrates, chromaffin cells secrete catecholamines into circulation. In most species, the major catecholamine secreted is epinephrine, although significant amounts of norepinephrine are released by many animals. Some dopamine is also secreted. No phylogenetic trend is obvious to explain or predict the ratio of epinephrine to norepinephrine se-

creted in a given species. A given species may release the two catecholamines in different ratios, depending on the nature of the stimulus. The great majority of the norepinephrine in circulation actually originates from that which is released from non-adrenal sympathetic nerve endings and leaks into the bloodstream. In addition to catecholamines, chromaffin cells secrete an array of other substances, including proteins such as chromogranin A and opioid peptides. See also EPINEPHRINE.

Biologic effects of catecholamines are mediated through their binding to two receptor classes,  $\alpha$ - and  $\beta$ -adrenergic receptors. Further examination of these receptors has revealed that subclasses of each type exist and likely account for the responses on different target tissues. In general, biologic responses to catecholamines include mobilization of glucose from liver and muscle, increased alertness, increased heart rate, and stimulation of metabolic rate.

**Steroid hormones.** In broad terms, most steroids secreted by adrenal steroidogenic cells are glucocorticoids, mineralocorticoids, or sex hormone precursors. However, these classes have been established largely on the basis of differential actions in mammals. The principal glucocorticoids are cortisol and corticosterone, while the main mineralocorticoid is aldosterone. This division of action holds for mammalian species and likely for reptiles and birds. In other vertebrates, such as fish and amphibians, steroids from the interrenal tissue do not show such specialized actions; instead, most show activities of both glucocorticoid and mineralocorticoid type. Mammals, birds, reptiles, and amphibians secrete cortisol, corticosterone, and aldosterone. The ratios of the two glucocorticoids vary across species; in general, corticosterone is the more important product in nonmammalian species. Even within mammals, a large variation exists across species, due to the relative ratio of cortisol to corticosterone from the adrenal cortex.

Effects of adrenal-derived steroids in lower vertebrates involve a diverse array of actions, including control of distribution and availability of metabolic fuels such as glucose, and regulation of sodium and extracellular fluid volume. In nonmammalian vertebrates, corticosterone, cortisol, and aldosterone possess mineralocorticoid effects. Other areas where adrenal steroids likely contribute to biologic processes include control of protein, fat, and carbohydrate balance; reproduction; and growth and development. See STEROID. [R.J.K.]

**Adrenal gland disorders** Malfunctions of the paired adrenal glands. The adrenal glands each consist of two morphologically and functionally distinct components, the cortex and medulla. These secrete different types of hormones: the cortex secretes steroids and the medulla secretes amines. The cortex is controlled by hormones from the anterior pituitary and the kidney; the medulla is directly controlled by the nervous system. Although the cortex and medulla are functionally separate, they both contribute to the mammalian body's response to outside stimuli, especially stress. See PITUITARY GLAND; STEROID.

The adrenal glands can have congenital defects and can be damaged by infections and destructive tumors. Anencephaly, that is, gross underdevelopment of the brain in fetal life, leads to hypoplasia of the adrenal cortex. The cortex is also, although rarely, invaded by acute bacterial diseases, for example, septicemia due to the colon bacillus or meningococcus, which can result in failure of the adrenal cortex followed by shock and death (Waterhouse-Friderichsen syndrome). Chronic infection of the cortex by the tubercle bacillus or a fungal infection such as histoplasmosis can cause primary adrenal deficiency. Cancer may spread to the adrenal glands, and there are uncommon primary tumors of the adrenal that do not secrete hormones. The most important disorders of the adrenal cortex and medulla are those characterized by abnormal hormone secretion.

**Adrenal cortex.** There are a number of disorders of the adrenal cortex. Primary adrenal cortical insufficiency, or Addison's disease, is rare, but if it is not treated it always results in death. The disease is usually caused by autoimmune



destruction of the adrenals, by tuberculosis, or less often by chronic fungal diseases. Symptoms include lassitude, muscular weakness, weight loss, prostration during minor illnesses, low blood pressure, and brown pigmentation of the skin. The water and electrolyte loss associated with this condition results from deficiency of the adrenal hormone, aldosterone. Maintenance therapy with small daily doses of hydrocortisone and synthetic, salt-retaining steroids permits a normal life. See ALDOSTERONE; TUBERCULOSIS.

Secondary adrenal cortical insufficiency sometimes accompanies pituitary failure due to tumors, vascular accidents, chronic infectious diseases, or granulomas. The clinical picture differs from Addison's disease: weak, listless, and intolerant of minor illness, individuals also are pale and usually show neurologic signs related to the pituitary lesion. Treatment consists of cortisol, thyroid hormone, and sex steroids. A more common form of secondary adrenal failure follows long-term administration of high doses of semisynthetic steroids for treatment of such diseases as rheumatoid arthritis, asthma, and acute lymphoblastic leukemia. See THYROID GLAND.

Manifestations of adrenal cortical hyperfunction, or hyperadrenocorticism, can result from excessive secretion of steroid hormones normally secreted by the adrenal cortex. The four classes of adrenal cortical hormones include mineralocorticoids, such as aldosterone, which regulate salt retention; glucocorticoids, such as cortisol, that affect carbohydrate and protein metabolism, muscle function, and blood pressure; androgens, such as dehydroepiandrosterone; and estrogens, such as estradiol. See ANDROGEN; ESTROGEN.

Excess secretion of aldosterone produces hyperaldosteronism. The classic primary form arises from a small unilateral tumor known as an adenoma of the adrenal cortex, from bilateral nodular overgrowth of the cortex, or sometimes from overfunction of the kidney's renin-angiotensin system which stimulates the cortex to secrete too much aldosterone (Bartter's syndrome). The affected individuals have high blood pressure, muscle weakness, and decreased levels of potassium in the blood. The tumors can be removed surgically. In cases where there is no tumor, the individual can be treated with diuretics that act by physiologically opposing the action of aldosterone on the kidney. Secondary hyperaldosteronism occurs in very severe hypertension and in advanced liver disease (cirrhosis), kidney disease (nephrotic syndrome), and heart failure when the body retains excess salt and water with swelling.

Excessive secretion of cortisol produces hypercortisolism, or Cushing's syndrome. Clinical manifestations include obesity of the trunk with thin arms and legs, round red face, thin skin, brittle bones, high blood pressure, diabetes mellitus, and, in women, virilism (masculinity). If not treated, Cushing's syndrome is fatal within five years because of complications of hypertension or infections. The most common cause of Cushing's syndrome is overactivity of the pituitary gland, often due to a small tumor that secretes excess adrenocorticotropic hormone. The disease is difficult to treat; methods include surgical removal of the pituitary tumor, x-ray or proton-beam treatment of the pituitary region, chemotherapy, or surgical removal of both adrenals. If the excess cortisol secretion is controlled, the individual can lead a normal life, although sometimes requiring hormone replacement. See CANCER (MEDICINE).

**Adrenal medulla.** There is no recognized hormone deficiency of the adrenal medulla in humans. Excess secretion of norepinephrine and epinephrine accompanies pheochromocytoma, a rare adrenal medullary tumor that may be single or multiple, benign or malignant. Sometimes the tumor occurs in multiple endocrine adenomatosis, type II (Sipple's syndrome), characterized clinically by pheochromocytoma, tumors of the parathyroid glands with high blood calcium, and carcinoma of the thyroid. Treatment is difficult, and consists of careful surgical removal of the tumor. Neuroblastoma (in children), ganglioneuroblastoma, and ganglioneuroma are malignant tumors of the adrenal medulla or sympathetic ganglia; they may secrete

amines that have only a minor effect on blood pressure. The clinical importance of these tumors arises from their extreme malignancy, but some are known to regress spontaneously. See ENDOCRINE MECHANISMS; EPINEPHRINE. [N.P.C.]

**Adsorption** A process in which atoms or molecules move from a bulk phase (that is, solid, liquid, or gas) onto a solid or liquid surface. An example is purification by adsorption where impurities are filtered from liquids or gases by their adsorption onto the surface of a high-surface-area solid such as activated charcoal. Other examples include the segregation of surfactant molecules to the surface of a liquid, the bonding of reactant molecules to the solid surface of a heterogeneous catalyst, and the migration of ions to the surface of a charged electrode.

Adsorption is to be distinguished from absorption, a process in which atoms or molecules move into the bulk of a porous material, such as the absorption of water by a sponge. Sorption is a more general term that includes both adsorption and absorption. Desorption refers to the reverse of adsorption, and is a process in which molecules adsorbed on a surface are transferred back into a bulk phase. The term adsorption is most often used in the context of solid surfaces in contact with liquids and gases. Molecules that have been adsorbed onto solid surfaces are referred to generically as adsorbates, and the surface to which they are adsorbed as the substrate or adsorbent. See ABSORPTION.

At the molecular level, adsorption is due to attractive interactions between a surface and the species being adsorbed. The magnitude of these interactions covers approximately two orders of magnitude (8–800 kilojoules/mole), similar to the range of interactions found between atoms and molecules in bulk phases. Traditionally, adsorption is classified according to the magnitude of the adsorption forces. Weak interactions (<40 kJ/mol) analogous to those between molecules in liquids give rise to what is called physical adsorption or physisorption. Strong interactions (>40 kJ/mol) similar to those found between atoms within a molecule (for example, covalent bonds) give rise to chemical adsorption or chemisorption. In physisorption the adsorbed molecule remains intact, but in chemisorption the molecule can be broken into fragments on the surface, in which case the process is called dissociative chemisorption.

The extent of adsorption depends on physical parameters such as temperature, pressure, and concentration in the bulk phase, and the surface area of the adsorbent, as well as on chemical parameters such as the elemental nature of the adsorbate and the adsorbent. Low temperatures, high pressures, high surface areas, and highly reactive adsorbates or adsorbents generally favor adsorption.

Adsorption is directly applied in processes such as filtration and detergent action.

Adsorption also plays an important role in processes such as heterogeneous catalysis, electrochemistry, adhesion, lubrication, and molecular recognition. In heterogeneous catalysis, gas or solution-phase molecules adsorb onto the catalyst surface, and reactions in the adsorbed monolayer lead to products which are desorbed from the surface. In electrochemistry, molecules adsorbed to the surface of an electrode donate or accept electrons from the electrode as part of oxidation or reduction reactions. In adhesion and lubrication, the chemical and mechanical properties of adsorbed monolayers play a role in determining how solid surfaces behave when in contact with one another. In biological systems, the adsorption of atoms and molecules onto the surface of a cell membrane is the first step in molecular recognition. See ELECTROCHEMISTRY; MOLECULAR RECOGNITION. [B.E.Be.]

**Adsorption operations** Processes for separation of gases based on the adsorption effect. When a pure gas or a gas mixture is contacted with a solid surface, some of the gas molecules are concentrated at the surface due to gas-solid attractive forces, in a phenomenon known as adsorption. The gas is called the adsorbate and the solid is called the adsorbent.

## 32 Aerial photograph

Adsorption can be either physical or chemical. Physisorption resembles the condensation of gases to liquids, and it may be mono- or multilayered on the surface. Chemisorption is characterized by the formation of a chemical bond between the adsorbate and the adsorbent.

If one component of a gas mixture is strongly adsorbed relative to the others, a surface phase rich in the strongly adsorbed species is created. This effect forms the basis of separation of gas mixtures by gas adsorption operations. Gas adsorption has become a fast-growing unit operation for the chemical and petrochemical industries, and it is being applied to solve many different kinds of gas separation and purification problems of practical importance. See ADSORPTION; UNIT OPERATIONS.

Most separations and purifications of gas mixtures are done in packed columns (that is, columns filled with solid adsorbent particles). Desorption of adsorbates from a column is usually accomplished by heating the column with a hot, weakly adsorbed gas; lowering the column pressure; purging the column with a weakly adsorbed gas; or combinations of these methods.

Microporous adsorbents like zeolites, activated carbons, silica gels, and aluminas are commonly employed in industrial gas separations. These solids exhibit a wide spectrum of pore structures, surface polarity, and chemistry which makes them specifically selective for separation of many different gas mixtures. Separation is normally based on the equilibrium selectivity. However, zeolites and carbon molecular sieves can also separate gases based on molecular shape and size factors which influence the rate of adsorption. See MOLECULAR SIEVE; ZEOLITE.

The most frequent industrial applications of gas adsorption have been the drying of gases, solvent vapor recovery, and removal of impurities or pollutants. The adsorbates in these cases are present in dilute quantities. These separations use a thermal-swing adsorption process whereby the adsorption is carried out at a near-ambient temperature followed by thermal regeneration using a portion of the cleaned gas or steam. The adsorbent is then cooled and reused.

Pressure-swing adsorption processes are used for separating bulk gas mixtures. The adsorption is carried out at an elevated pressure level to give a product stream enriched in the more weakly adsorbed component. After the column is saturated with the strongly adsorbed component, it is regenerated by depressurization and purging with a portion of the product gas. The cycle is repeated after raising the pressure to the adsorption level. Key examples of pressure-swing adsorption processes are the production of enriched oxygen and nitrogen from air; production of ultrapure hydrogen from various hydrogen-containing streams such as steam-methane reformer off-gas; and separation of normal from branched-chain paraffins. Both thermal-swing and pressure-swing adsorption processes use multiple adsorbent columns to maintain continuity, so that when one column is undergoing adsorption the others are in various stages of regeneration modes. The thermal-swing adsorption processes typically use long cycle times (hours) in contrast to the rapid cycle times (minutes) for pressure-swing adsorption processes. [A.L.M.; S.Sir.]

**Aerial photograph** A photograph of a portion of the Earth's surface taken from an aircraft or from a satellite. Most often, photographs are taken sequentially and overlap each other, to give complete coverage of the area of interest. Thus they may be viewed stereoscopically to give a three-dimensional view of the Earth's surface. Although the camera in the aircraft may be pointed obliquely to the side of the line of flight, the most common type of aerial photograph is taken with the camera pointed vertically downward beneath the plane.

Aerial photographs have two main uses, the making of planimetric and topographic maps, and interpretation or data-gathering in a variety of specialized fields. All modern topographic (contour) maps are made from stereoscopic aerial photographs, usually black-and-white panchromatic vertical photographs. The science of making accurate measurements

and maps from aerial photographs is called photogrammetry. The geometric discrepancy between the distribution of features seen on the photograph and their actual distribution on the Earth's surface depends on several variables, the most important of which is the relief of the surface. The error becomes greater as relief increases. Photogrammetry deals with these errors and allows highly accurate and complete map production. Topographic maps are made from one or more stereoscopic pairs of aerial photographs by means of optical-mechanical plotting machines or mathematical methods (analytical photogrammetry). See CARTOGRAPHY; GEOPHYSICAL EXPLORATION; TOPOGRAPHIC SURVEYING AND MAPPING.

The other major use of aerial photographs is photo interpretation, utilizing all types of film. Photo interpretation is the attempt to extract information about the Earth's surface (and sometimes, subsurface) from aerial photographs. The systematic study of aerial photographs, particularly when they are viewed stereoscopically, gives specialists the ability to gather rapidly, record, map, and interpret a great deal of information. In addition, an aerial photograph is a record at a moment in time; photographs taken at intervals give an excellent record of the change with time in surface features of the Earth. [L.H.L.]

**Aerodynamic force** The force exerted on a body whenever there is a relative velocity between the body and the air. There are only two basic sources of aerodynamic force: the pressure distribution and the frictional shear stress distribution exerted by the airflow on the body surface. The pressure exerted by the air at a point on the surface acts perpendicular to the surface at that point; and the shear stress, which is due to the frictional action of the air rubbing against the surface, acts tangentially to the surface at that point. The distribution of pressure and shear stress represent a distributed load over the surface. The net aerodynamic force on the body is due to the net imbalance between these distributed loads as they are summed (integrated) over the entire surface. See BOUNDARY-LAYER FLOW; FLUID FLOW; WIND STRESS.

For purposes of discussion, it is convenient to consider the aerodynamic force on an airfoil (see illustration). The net resultant aerodynamic force  $R$  acting through the center of pressure on the airfoil represents mechanically the same effect as that due to the actual pressure and shear stress loads distributed over the body surface. The velocity of the airflow  $V_\infty$  is called the free-stream velocity or the free-stream relative wind. By definition, the component of  $R$  perpendicular to the relative wind is the lift,  $L$ , and the component of  $R$  parallel to the relative wind is the drag  $D$ . The orientation of the body with respect to the direction of the free stream is given by the angle of attack,  $\alpha$ . The magnitude

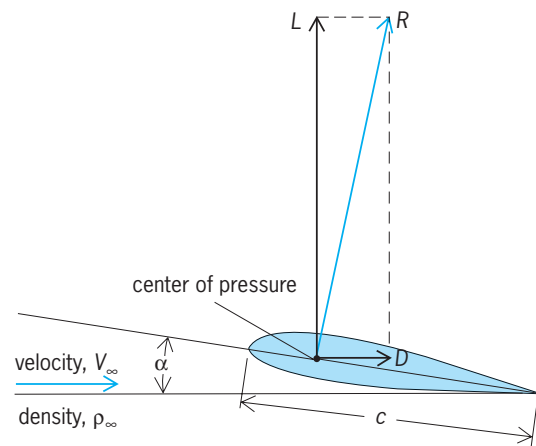

Resultant aerodynamic force ( $R$ ), and its resolution into lift ( $L$ ) and drag ( $D$ ) components.

of the aerodynamic force  $R$  is governed by the density  $\rho_\infty$  and velocity of the free stream, the size of the body, and the angle of attack. See AIRFOIL.

An important measure of aerodynamic efficiency is the ratio of lift to drag,  $L/D$ . The higher the value of  $L/D$ , the more efficient is the lifting action of the body. The value of  $L/D$  reaches a maximum, denoted by  $(L/D)_{\max}$ , at a relatively low angle of attack. Beyond a certain angle the lift decreases with increasing  $\alpha$ . In this region, the wing is said to be stalled. In the stall region the flow has separated from the top surface of the wing, creating a type of slowly recirculating dead-air region, which decreases the lift and substantially increases the drag. See FLIGHT CHARACTERISTICS. [J.D.A.]

**Aerodynamic sound** Sound that is generated by the unsteady motion of a gas and its interaction with surrounding surfaces. Aerodynamic sound or noise may be pleasant, such as the sound generated by a flute, or unpleasant, such as the noise of an aircraft on landing or takeoff, or the impulsive noise of a helicopter in descending or forward flight.

Sources of aerodynamic sound may be classified according to their multipole order. Sources associated with unsteady mass addition to the gas are called monopoles. These could be caused by the unsteady mass flux in a jet exhaust or the pulsation of a body. The sound power radiated by monopoles scales with the fourth power of a characteristic source velocity. Sources related to unsteady forces acting on the gas are called dipoles. The singing in telephone wires is related to the nearly periodic lift variations caused by vortex shedding from the wires. Such sources, called dipoles, generate a sound power that scales with the sixth power of the characteristic source velocity. See KARMAN VORTEX STREET.

A turbulent fluid undergoes local compression and extension as well as shearing. These events are nearly random on the smallest scales of turbulent motion but may have more organization at the largest scales. The earliest theories of aerodynamic noise, called acoustic analogies, related these unsteady stresses in the fluid to the noise that they would generate in a uniform ambient medium with a constant speed of sound. Such sources are called quadrupoles. The sound power that they radiate scales with the eighth power of the characteristic source velocity. See TURBULENT FLOW.

Subsequent extensions of these theories allowed for the motion of these sources relative to a listener. This may result in a Doppler shift in frequency and a convective amplification of the sound if the sources are moving toward the listener. In addition, if the sources are embedded in a sheared flow, such as the exhaust plume of a jet engine, the sound is refracted away from the jet downstream axis. As sound propagates away from the source region, it experiences attenuation due to spherical spreading and real-gas and relaxational effects. The latter effects are usually important only for high-amplitude sound or sound propagation over large distances. See ATMOSPHERIC ACOUSTICS; DOPPLER EFFECT; SOUND ABSORPTION. [P.J.M.]

**Aerodynamic wave drag** The force retarding an airplane, especially in supersonic flight, as a consequence of the formation of shock waves. Although the physical laws governing flight at speeds in excess of the speed of sound are the same as those for subsonic flight, the nature of the flow about an airplane and, as a consequence, the various aerodynamic forces and moments acting on the vehicle at these higher speeds differ substantially from those at subsonic speeds. Basically, these variations result from the fact that at supersonic speeds the airplane moves faster than the disturbances of the air produced by the passage of the airplane. These disturbances are propagated at roughly the speed of sound and, as a result, primarily influence only a region behind the vehicle.

The primary effect of the change in the nature of the flow at supersonic speeds is a marked increase in the drag, resulting from

the formation of shock waves about the configuration. These strong disturbances, which may extend for many miles from the airplane, cause significant energy losses in the air, the energy being drawn from the airplane. At supersonic flight speeds these waves are swept back obliquely, the angle of obliqueness decreasing with speed. For the major parts of the shock waves from a well-designed airplane, the angle of obliqueness is equal to  $\sin^{-1}(1/M)$ , where  $M$  is the Mach number, the ratio of the flight velocity to the speed of sound. See SHOCK WAVE; SUPERSONIC FLIGHT.

The shock waves are associated with outward diversions of the airflow by the various elements of the airplane. This diversion is caused by the leading and trailing edges of the wing and control surfaces, the nose and aft end of the fuselage, and other parts of the vehicle. Major proportions of these effects also result from the wing incidence required to provide lift.

For a well-designed vehicle, wave drag is usually roughly equal to the sum of the basic skin friction and the induced drag due to lift. See AERODYNAMIC FORCE; AIRFOIL; TRANSONIC FLIGHT.

The wave drag at the zero lift condition is reduced primarily by decreasing the thickness-chord ratios for the wings and control surfaces and by increasing the length-diameter ratios for the fuselage and bodies. Also, the leading edge of the wing and the nose of the fuselage are made relatively sharp. With such changes, the severity of the diversions of the flow by these elements is reduced, with a resulting reduction of the strength of the associated shock waves. Also, the supersonic drag wave can be reduced by shaping the fuselage and arranging the components on the basis of the area rule. See WING; WING STRUCTURE.

The wave drag can also be reduced by sweeping the wing panels. Some wings intended for supersonic flight have large amounts of leading-edge sweep and little or no trailing-edge sweep. The shape changes required are now determined using very complex fluid-dynamic relationships and supercomputers. See COMPUTATIONAL FLUID DYNAMICS. [R.T.Wh.]

**Aerodynamics** The applied science that deals with the dynamics of airflow and the resulting interactions between this airflow and solid boundaries. The solid boundaries may be a body immersed in the airflow, or a duct of some shape through which the air is flowing. Although, strictly speaking, aerodynamics is concerned with the flow of air, in modern times the term has been liberally interpreted as dealing with the flow of gases in general.

Depending on its practical objectives, aerodynamics can be subdivided into external and internal aerodynamics. External aerodynamics is concerned with the forces and moments on, and heat transfer to, bodies moving through a fluid (usually air). Examples are the generation of lift, drag, and moments on airfoils, wings, fuselages, engine nacelles, and whole airplane configurations; wind forces on buildings; the lift and drag on automobiles; and the aerodynamic heating of high-speed aerospace vehicles such as the space shuttle. Internal aerodynamics involves the study of flows moving internally through ducts. Examples are the flow properties inside wind tunnels, jet engines, rocket engines, and pipes. In short, aerodynamics is concerned with the detailed physical properties of a flow field and also with the net effect of these properties in generating an aerodynamic force on a body immersed in the flow, as well as heat transfer to the body. See AERODYNAMIC FORCE; AEROTHERMODYNAMICS.

Aerodynamics can also be subdivided into various categories depending on the dominant physical aspects of a given flow. In low-density flow the characteristic size of the flow field, or a body immersed in the flow, is of the order of a molecular mean free path (the average distance that a molecule moves between collisions with neighboring molecules); while in continuum flow the characteristic size is much greater than the molecular mean free path. More than 99% of all practical aerodynamic flow problems fall within the continuum category. See RAREFIED GAS FLOW.

Continuum flow can be subdivided into viscous flow, which is dominated by the dissipative effects of viscosity (friction), thermal conduction, and mass diffusion; and inviscid flow, which is, by definition, a flow in which these dissipative effects are negligible. Both viscous and inviscid flows can be subdivided into incompressible flow, in which the density is constant, and compressible flow, in which the density is a variable. In low-speed gas flow, the density variation is small and can be ignored. In contrast, in a high-speed flow the density variation is keyed to temperature and pressure variations, which can be large, so the flow must be treated as compressible. See COMPRESSIBLE FLOW; FLUID FLOW; INCOMPRESSIBLE FLOW; VISCOSITY.

In turn, compressible flow is subdivided into four speed regimes: subsonic flow, transonic flow, supersonic flow, and hypersonic flow. These regimes are distinguished by the value of the Mach number, which is the ratio of the local flow velocity to the local speed of sound.

A flow is subsonic if the Mach number is less than 1 at every point. Subsonic flows are characterized by smooth streamlines with no discontinuity in slope. The flow over light, general-aviation airplanes is subsonic. See SUBSONIC FLIGHT.

A transonic flow is a mixed region of locally subsonic and supersonic flow. The flow far upstream of the airfoil can be subsonic, but as the flow moves around the airfoil surface it speeds up, and there can be pockets of locally supersonic flow over both the top and bottom surfaces of the airfoil. See TRANSONIC FLIGHT.

In a supersonic flow, the local Mach number is greater than 1 everywhere in the flow. Supersonic flows are frequently characterized by the presence of shock waves. Across shock waves, the flow properties and the directions of streamlines change discontinuously, in contrast to the smooth, continuous variations in subsonic flow. See SUPERSONIC FLIGHT.

Hypersonic flow is a regime of very high supersonic speeds. A conventional rule is that any flow with a Mach number equal to or greater than 5 is hypersonic. Examples include the space shuttle during ascent and reentry into the atmosphere, and the flight of the X-15 experimental vehicle. The kinetic energy of many hypersonic flows is so high that, in regions where the flow velocity decreases, kinetic energy is traded for internal energy of the gas, creating high temperatures. Aerodynamic heating is a particularly severe problem for bodies immersed in a hypersonic flow. See ATMOSPHERIC ENTRY; HYPERSONIC FLIGHT. [J.D.A.]

**Aeroelasticity** The branch of applied mechanics which deals with the interaction of aerodynamic, inertial, and structural forces. It is important in the design of airplanes, helicopters, missiles, suspension bridges, power lines, tall chimneys, and even stop signs. Variations on the term aeroelasticity have been coined to denote additional significant interactions. Aerothermoelasticity is concerned with effects of aerodynamic heating on aeroelastic behavior in high-speed flight. Aeroservoelasticity deals with the interaction of automatic controls and aeroelastic response and stability. In the field of hydroelasticity, a liquid rather than air generates the fluid forces.

The primary concerns of aeroelasticity include flying qualities (that is, stability and control), flutter, and structural loads arising from maneuvers and atmospheric turbulence. Methods of aeroelastic analysis differ according to the time dependence of the inertial and aerodynamic forces that are involved. For the analysis of flying qualities and maneuvering loads wherein the aerodynamic loads vary relatively slowly, quasi-static methods are applicable, although autopilot interaction could require more general methods. The remaining problems are dynamic, and methods of analysis differ according to whether the time dependence is arbitrary (that is, transient or random) or simply oscillatory in the steady state.

The redistribution of airloads caused by structural deformation will change the lifting effectiveness on the aerodynamic surfaces from that of a rigid vehicle. The simultaneous analysis of the equilibrium and compatibility among the external airloads, the internal structural and inertial loads, and the total flow distur-

bance, including the disturbance resulting from structural deformation, leads to a determination of the equilibrium aeroelastic state. If the airloads tend to increase the total flow disturbance, the lift effectiveness is increased; if the airloads decrease the total flow disturbance, the effectiveness decreases.

The airloads induced by means of a control-surface deflection also induce an aeroelastic loading of the entire system. Equilibrium is determined as in the analysis of load redistribution. Again, the effectiveness will differ from that of a rigid system, and may increase or decrease depending on the relationship between the net external loading and the deformation.

A self-excited vibration is possible if a disturbance to an aeroelastic system gives rise to unsteady aerodynamic loads such that the ensuing motion can be sustained. At the flutter speed a critical phasing between the motion and the loading permits extraction of an amount of energy from the airstream equal to that dissipated by internal damping during each cycle and thereby sustains a neutrally stable periodic motion. At lower speeds any disturbance will be damped, while at higher speeds, or at least in a range of higher speeds, disturbances will be amplified.

Transient meteorological conditions such as wind shears, vertical drafts, mountain waves, and clear air or storm turbulence impose significant dynamic loads on aircraft. So does buffeting during flight at high angles of attack or at transonic speeds. The response of the aircraft determines the stresses in the structure and the comfort of the occupants. Aeroelastic behavior makes a condition of dynamic overstress possible; in many instances, the amplified stresses can be substantially higher than those that would occur if the structure were much stiffer. See CLEAR-AIR TURBULENCE (CAT); LOADS; DYNAMIC; TRANSONIC FLIGHT. [W.P.R.]

**Aeromonas** A bacterial genus in the family Vibrionaceae comprising oxidase-positive, facultatively anaerobic, monotrichously flagellated gram-negative rods. The mesophilic species are *A. hydrophila*, *A. caviae*, and *A. sobria*; the psychrophilic one is *A. salmonicida*. Aeromonads are of aquatic origin and are found in surface and waste water but not in seawater. They infect chiefly cold-blooded animals such as fishes, reptiles, and amphibians and only occasionally warm-blooded animals and humans. Human wound infections may occur following contact with contaminated water. Septicemia has been observed mostly in patients with abnormally low white blood counts or liver disease. There is evidence of intestinal carriers. The three mesophilic species are also associated with diarrheal disease (enteritis and colitis) worldwide. See DIARRHEA.

A related lophotrichous genus, *Plesiomonas* (single species, *P. shigelloides*), is also known as an aquatic bacterium and is associated with diarrhea chiefly in subtropical and tropical areas. It is also found in many warm-blooded animals. Systemic disease in humans is rare. See MEDICAL BACTERIOLOGY. [A.W.C.V.G.]

**Aeronautical engineering** That branch of engineering concerned primarily with the special problems of flight and other modes of transportation involving a heavy reliance on aerodynamics or fluid mechanics. The main emphasis is on airplane and missile flight, but aeronautical engineers work in many related fields such as hydrofoils, which have many problems in common with aircraft wings, and with such devices as air-cushion vehicles, which make use of airflow around the base to lift the vehicle a few feet off the ground, whereupon it is propelled forward by use of propellers or gas turbines. See AERODYNAMICS; AIR-CUSHION VEHICLE; AIRPLANE; FLUID MECHANICS; HYDROFOIL CRAFT; MISSILE.

Aeronautical engineering expanded dramatically after 1940. Flight speeds increased from a few hundred miles per hour to satellite and space-vehicle velocities. The common means of propulsion changed from propellers to turboprops, turbojets,

ramjets, and rockets. This change gave rise to new applications of basic science to the field and a higher reliance on theory and high-speed computers in design and testing, since it was often not feasible to proceed by experimental methods only. See JET PROPULSION; PROPULSION; ROCKET PROPULSION; SPACE TECHNOLOGY.

Aeronautical engineers frequently serve as system integrators of important parts of a design. For example, the control system of an aircraft involves, among other considerations, aerodynamic input from flow calculations and wind-tunnel tests; the structural design of the aircraft (since the flexibility and strength of the structure must be allowed for); the mechanical design of the control system itself; electrical components, such as servomechanisms; hydraulic components, such as hydraulic boosters; and interactions with other systems that affect the control of the aircraft, such as the propulsion system. The aeronautical engineer is responsible for ensuring that all of these factors operate smoothly together.

Aircraft and missile structural engineers have raised the technique of designing complex structures to a level never considered possible before the advent of high-speed computers. Structures can now be analyzed in great detail and the results incorporated directly into computer-aided design (CAD) programs. See COMPUTER-AIDED DESIGN AND MANUFACTURING. [J.R.Se.]

**Aeronautical meteorology** The branch of meteorology that deals with atmospheric effects on the operation of vehicles in the atmosphere, including winged aircraft, lighter-than-air devices such as dirigibles, rockets, missiles, and projectiles. The air which supports flight or is traversed on the way to outer space contains many potential hazards.

Poor visibility caused by fog, snow, dust, and rain is a major cause of aircraft accidents and the principal cause of flight cancellations or delays.

The weather conditions of ceiling and visibility required by regulations for crewed aircraft during landing or takeoff are determined by electronic and visual aids operated by the airport and installed in the aircraft. The accurate forecasting of terminal conditions is critical to flight economy, and to safety where sophisticated landing aids are not available. Improved prediction methods are under continuing investigation and development, and are based on mesoscale and microscale meteorological analyses, electronic computer calculations, radar observations of precipitation areas, and observations of fog trends. See MESOMETEOROLOGY; MICROMETEOROLOGY.

Atmospheric turbulence is principally represented in vertical currents and their departures from steady, horizontal airflow. When encountered by an aircraft, turbulence produces abrupt excursions in aircraft position, sometimes resulting in discomfort or injury to passengers, and sometimes even structural damage or failure. Major origins of turbulence are (1) mechanical, caused by irregular terrain below the flow of air; (2) thermal, associated with vertical currents produced by heating of air in contact with the Earth's surface; (3) thunderstorms and other convective clouds (Fig. 1); (4) mountain wave, a regime of disturbed airflow leeward of mountains or hills, often comprising both smooth and breaking waves formed when stable air is forced to ascend over the mountains; and (5) wind shear, usually variations of horizontal wind in the vertical direction, occurring along air-mass boundaries, temperature inversions (including the tropopause), and in and near the jet stream.

While encounters with strong turbulence anywhere in the atmosphere represent substantial inconvenience, encounters with rapid changes in wind speed and direction at low altitude can be catastrophic. Generally, wind shear is most dangerous when encountered below 1000 ft (300 m) above the ground, where it is identified as low-altitude wind shear. Intense convective microbursts, downdrafts usually associated with thunderstorms, have caused many aircraft accidents often resulting in a great loss of life. The downdraft emanating from convective clouds, when nearing the Earth's surface, spreads horizontally as outrushing

rain-cooled air. When entering a microburst outflow, an aircraft first meets a headwind that produces increased performance by way of increased airspeed over the wings. Then within about 5 s, the aircraft encounters a downdraft and then a tailwind with decreased performance. A large proportion of microburst accidents, both after takeoff and on approach to landing, are caused by this performance decrease, which can result in rapid descent. See THUNDERSTORM.

Turbulence and low-altitude wind shear can readily be detected by a special type of weather radar, termed Doppler radar. By measuring the phase shift of radiation backscattered by hydrometeors and other targets in the atmosphere, both turbulence and wind shear can be clearly identified. It is anticipated that Doppler radars located at airports, combined with more thorough pilot training regarding the need to avoid microburst wind shear, will provide desired protection from this dangerous aviation weather phenomenon. See DOPPLER RADAR.

Since an aircraft's speed is given by a propulsive component plus the speed of the air current bearing the aircraft, there are aiding or retarding effects depending on wind direction in relation to the track flown. Wind direction and speed vary only moderately from day to day and from winter to summer in certain parts of the world, but fluctuations of the vector wind at middle and high latitudes in the troposphere and lower stratosphere can exceed 200 knots (100 mph). The role of the aeronautical meteorologist is to provide accurate forecasts of the wind and temperature field, in space and time, through the operational ranges of each aircraft involved. For civil jet-powered aircraft, the optimum flight plan must always represent a compromise among wind, temperature, and turbulence conditions. See UPPER-ATMOSPHERE DYNAMICS; WIND.

The jet stream is a meandering, shifting current of relatively swift wind flow which is embedded in the general westerly circulation at upper levels. Sometimes girdling the globe at middle and subtropical latitudes, where the strongest jets are found, this band of strong winds, generally 180–300 mi (300–500 km) in width, has great operational significance for aircraft flying at cruising levels of 4–9 mi (6–15 km). The jet stream challenges the forecaster and the flight planner to utilize tailwinds to the greatest extent possible on downwind flights and to avoid retarding headwinds as much as practicable on upwind flights. As with considerations of wind and temperature, altitude and horizontal coordinates are considered in flight planning for jet-stream conditions. Turbulence in the vicinity of the jet stream is also a forecasting problem. See JET STREAM.

An electrical discharge or lightning strike to or from an aircraft is experienced as a blinding flash and a muffled explosive sound. Atmospheric conditions favorable for lightning strikes follow a consistent pattern, characterized by solid clouds or enough clouds for the aircraft to be flying intermittently on instruments; active precipitation of an icy character; and ambient air temperature near or below 32°F (0°C). Saint Elmo's fire, radio static, and choppy air often precede the strike. However, the charge separation processes necessary for the production of strong electrical fields is destroyed by strong turbulence. Thus turbulence and lightning usually do not coexist in the same space. See ATMOSPHERIC ELECTRICITY; LIGHTNING.

Modern aircraft operation finds icing to be a major factor in the safe flight. Icing usually occurs when the air temperature is near or below freezing (32°F or 0°C) and the relative humidity is 80% or more. Clear ice is most likely to form when the air temperature is between 32 and –4°F (0 and –20°C) and the liquid water content of the air is high (large drops or many small drops). As these drops impinge on the skin of an aircraft, the surface temperature of which is 32°F (0°C) or less, the water freezes into a hard, high-density solid. When the liquid water content is small and when snow or ice pellets may also be present, the resulting rime ice formation is composed of drops and encapsulated air, producing an ice that is less dense and opaque in appearance. Accurate forecasts and accurate delineation of freezing conditions are essential for safe aircraft operations. [J.T.Le.; J.M.]

**Aeronautics** The science and art of flying through the air. This term now refers to all aspects of flight in the atmosphere, from design and manufacturing to operation and maintenance of aircraft and spacecraft, and extends to the economics and logistics of airline operation. See AIR TRANSPORTATION.

Contributors to the field of aeronautics come from many disciplines, including engineering, particularly aeronautical engineering, business administration, economics, computer technology, and such basic disciplines as physics, chemistry, and materials science. Pilot training is another traditional source of entry into the field. Specialties which are important for aeronautics include aerodynamics, airfoil theory, heat transfer, compressor and turbine analysis, jet propulsion, and structural design. See AERODYNAMICS; AERONAUTICAL ENGINEERING; AIRFOIL; ASTRONAUTICS; HEAT TRANSFER; JET PROPULSION; TURBINE PROPULSION. [J.R.Se.]

**Aeronomy** The study of the chemistry and physics of the regions above the tropopause or upper part of the atmosphere. The region of the atmosphere below the tropopause is the site of most of the weather phenomena that so directly affect all life on the planet; this region has primarily been the domain of meteorology.

The chemical and physical properties of the atmosphere and the changes that result from external and internal forces impact all altitudes and global distributions of atoms, molecules, ions, and electrons, both in composition and in density. Dynamical effects are seen in vertical and horizontal atmospheric motion, and energy is transferred through radiation, chemistry, conduction, convection, and wave propagation.

The atmosphere of the Earth is separated into regions defined by the variation of temperature with height. In the middle atmosphere, that region of the atmosphere between the tropopause and the mesopause (10–100 km or 6–60 mi), the temperature varies from 250 K (–9.7°F) at the tropopause to 300 K (80°F) at the stratopause and back down to 200 K (–100°F) at the mesopause (see illustration). These temperatures are average values, and they vary with season and heat and winds due to the effect of the Sun on the atmosphere. Over this same height interval the atmospheric density varies by over five orders of magnitude. Although there is a constant mean molecular weight over this region, that is, a constant relative abundance of the major atmospheric constituents of molecular oxygen and nitrogen, there are a number of minor constituents that have a profound influence on the biosphere and an increasing influence on the change in the atmosphere below the tropopause associated with the general topic of global change. These constituents, called the greenhouse gases (water vapor, ozone, carbon dioxide, methane, chlorine compounds, nitrogen oxides, chlorofluorocarbons, and others), are all within the middle atmosphere. See MESOSPHERE; STRATOSPHERE; TROPOSPHERE.

Understanding the aeronomy of the middle atmosphere requires the study of the physical motion of the atmosphere. The particular composition and chemistry at any given time, location, or altitude depends on how the various constituents are transported from one region to another. Thus, global circulation models for both horizontal and vertical motions are needed to completely specify the chemical state of the atmosphere. In understanding the dynamics of the middle atmosphere, internal gravity waves and acoustic gravity waves play significant roles at different altitudes, depending on whether the particle motion associated with the wave is purely transverse to the direction of propagation or has some longitudinal component. These waves originate primarily in meteorological events such as wind shears, turbulent storms, and weather fronts; and their magnitude can also depend on orographic features on the Earth's surface. See MIDDLE-ATMOSPHERE DYNAMICS.

The upper atmosphere is that region above the middle atmosphere that extends from roughly 100 km (60 mi) to the limit of the detectable atmosphere of the planet. This region is characterized by an increasing temperature until it reaches a constant exospheric temperature. There is a slow transition from the

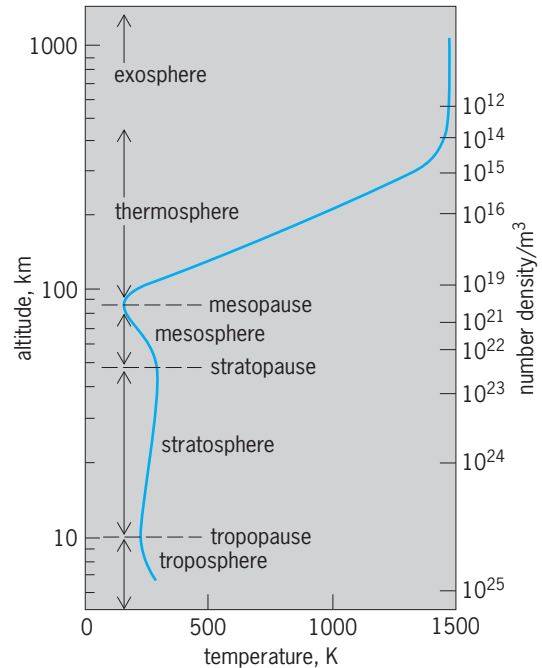

**Typical atmospheric temperature variation with altitude and constituent number density (number of atoms and molecules per cubic meter) at high solar activity.** °F = (K × 1.8) – 459.67. 1 km = 0.6 mi.

region of constant mean molecular weight associated with the middle atmosphere to that of almost pure atomic hydrogen at high altitudes of the exosphere. This is also the region of transition between transport dominated by collision and diffusion, and transport influenced by plasma convection in the magnetic field. The neutral density varies by over ten orders of magnitude from one end to the other and is dominated by molecular processes in the high-density region and an increasing importance of atomic, electron, and ion processes as the density decreases with altitude.

As the Sun sets on the atmosphere, dramatic changes due to the loss of the solar radiation occur. The excitation of the atmosphere declines, and chemical reactions between the constituents become more and more dominant as the night progresses. When observed with very sensitive instruments, the night sky appears to glow at various colors of light. Prominent green and red atomic emissions due to oxygen at 555.7 and 630 nm, respectively, and yellow sodium light at 589 nm appear, while molecular bands of the hydroxyl radical and molecular oxygen even further in the red collectively contribute most of the total intensity of the nightglow spectrum.

The aurora that appears in the southern and northern polar regions is the optical manifestation of the energy loss of energetic particles precipitating into the atmosphere. The region of highest probability of occurrence is called the auroral oval. At high altitudes, electrons and ions present in the magnetosphere are accelerated along magnetic field lines into the atmosphere at high polar latitudes. See AURORA; MAGNETOSPHERE. [G.J.R.]

**Aerosol** A suspension of small particles in a gas. The particles may be solid or liquid or a mixture of both. Aerosols are formed by the conversion of gases to particles, the disintegration of liquids or solids, or the resuspension of powdered material. Aerosol formation from a gas results in much finer particles than disintegration processes (except when condensation takes place directly on existing large particles). Dust, smoke, fume, haze, and mist are common terms for aerosols. Dust usually refers to solid particles produced by disintegration, while smoke and fume particles are generally smaller and formed from the gas phase. Mists

are composed of liquid droplets. These special terms are helpful but are difficult to define exactly.

Aerosol particles range in size from molecular clusters on the order of 1 nanometer to 100 micrometers. The stable clusters formed by homogeneous nucleation and the smallest solid particles that compose agglomerates have a significant fraction of their molecules in the surface layer.

Aerosols are important in the atmospheric sciences and air pollution; inhalation therapy and industrial hygiene; manufacture of pigments, fillers, and metal powders; and fabrication of optical fibers. Atmospheric aerosols influence climate directly and indirectly. They directly affect radiation transfer on global and regional scales. Indirect effects result from their role as cloud condensation nuclei in changing droplet size distributions that affect the optical properties of clouds and precipitation. There is evidence that the stratospheric aerosol is significant in ozone destruction. See METEOROLOGICAL OPTICS; RADIATIVE TRANSFER.

The atmospheric aerosol consists of material emitted directly from sources (primary component) and material formed by gas-to-particle conversion in the atmosphere (secondary component). The secondary component is usually the result of chemical reactions which take place in either the gas or aerosol phases. Contributions to the atmospheric aerosol come from both natural and anthropogenic sources. The effects of the atmospheric aerosol are largely determined by the size and chemical composition of the individual particles and their morphology (shape or fractal character). For many applications, the aerosol can be characterized sufficiently by measuring the particle size distribution function and the average distribution of chemical components with respect to particle size. The chemical composition of the atmospheric aerosol can be used to resolve its sources, natural or anthropogenic, by a method based on chemical signatures. Particle-to-particle variations in chemical composition and particle structural characteristics can also be measured; they probably affect the biochemical behavior and nucleating properties of aerosols.

Aerosol optical properties depend on particle size distribution and refractive index, and the wavelength of the light. These are determining factors in atmospheric visibility and the radiation balance.

Effects of the atmospheric aerosol on human health have led to the establishment of ambient air-quality standards by the United States and other industrialized nations. Adverse health effects have stimulated many controlled studies of aerosol inhalation by humans and animals. There is much uncertainty concerning the chemical components of the atmospheric aerosol that produce adverse health effects detected in epidemiological studies. See AIR POLLUTION.

Aerosols containing pharmaceutical agents have long been used in the treatment of lung diseases such as asthma. Current efforts are directed toward systemic delivery of drugs, such as aerosolized insulin, which are transported across the alveolar walls into the blood.

Aerosol processes are used routinely in the manufacture of fine particles. Aerosol reaction engineering refers to the design of such processes, with the goal of relating product properties to the properties of the aerosol precursors and the process conditions. The most important large-scale commercial systems are flame reactors for production of pigments and powdered materials such as titania and fumed silica. Optical fibers are fabricated by an aerosol process in which a combustion-generated silica fume is deposited on the inside walls of a quartz tube a few centimeters in diameter, along with suitable dopant aerosols to control refractive index. Pyrolysis reactors are used in carbon black manufacture. Micrometer-size iron and nickel powders are produced industrially by the thermal decomposition of their carbonyls. Large pilot-scale aerosol reactors are operated using high-energy electron beams to irradiate flue gases from fossil fuel combustion. The goal is to convert sulfur oxides and nitrogen oxides to ammonium sulfate and nitrate that can be sold as a fertilizer.

Atmospheric aerosols and aerosols emitted from industrial sources are normally composed of mixtures of chemical compounds. Each chemical species is distributed with respect to particle size in a way that depends on its source and past history; hence, different substances tend to accumulate in different particle size ranges. This effect has been observed for emissions from pulverized coal combustion and municipal waste incinerators, and it undoubtedly occurs in emissions from other sources. Chemical segregation with respect to size has important implications for the effects of aerosols on public health and the environment, because particle transport and deposition depend strongly on particle size. [S.K.F.]

**Aerospace medicine** The special field of medicine that deals with humans in environments encountered beyond the surface of the Earth. It includes both aviation medicine and space medicine and is concerned with humans, their environment, and the vehicles in which they fly. Its objective is to ensure human health, safety, well-being, and effective performance through careful selection and training of flight personnel, protection from the unique flight environment and its physiological and psychological effects, and understanding of the flight vehicle and humans' interaction with it.

The environment encountered in air or space flight is very different from that on Earth. Consequently aerospace medicine must deal with the physics of the atmosphere and space and with the conditions and influences introduced by the flight vehicle. Aerospace medicine is therefore concerned with the physiological effects of changes in barometric pressure, atmospheric constituents, toxic substances, acceleration, weightlessness, noise, vibration, ionizing radiation, and thermal and other environmental stresses, as well as psychological stresses and their effects on behavior and performance.

The flight conditions of advanced supersonic aircraft introduce extreme variations in temperature, extensive and sudden changes in pressure, and rapid acceleration. Exposure to the low pressure at altitudes may release nitrogen gas normally held in the blood in solution and thus produce bends symptoms. As altitude increases, oxygen continues to constitute 21% of the atmosphere, but the decreased pressure of the upper atmosphere and consequently of the oxygen results in reduced oxygenation of the blood, affecting physical well-being and the ability to think and to reason. The physiological problems of acceleration are an integral part of aerospace medicine because humans are exposed to forces of acceleration almost constantly throughout flight that are different from the 1-g environment of Earth. When positive *g* (increased acceleration) forces are applied to the body, the blood is forced downward away from the head and heart, and blackout and unconsciousness may occur. Under negative *g* (decreased acceleration) conditions, the blood is forced upward so that the blood vessels of the head are engorged. This may result in red-out, a condition in which the visual field reddens due to engorged eye blood vessels, and unconsciousness. See ACCELERATION.

All of the environmental hazards incumbent in flight in aircraft are present in space flight, but space also has unique hazards, of which weightlessness is paramount. The equilibrium of many biological systems is disrupted by extended exposure to weightlessness.

Neurovestibular effects associated with space motion sickness occur during the first few days in orbit. At the same time there is a shift in body fluids toward the head, and faces become puffy. This is followed by a loss of fluids and electrolytes. With decreased fluids, red blood cell mass slowly decreases for about 60 days into flight. Cardiovascular deconditioning also occurs within the first month. These systems in general appear to acclimate to the weightless environment in 4–6 weeks. Postflight symptoms include orthostatic intolerance associated with shifts in body fluid and resultant cardiopulmonary neuroreceptor reflex responses. Difficulties in postural equilibrium and occasionally motion sickness accompany neurovestibular readaptation. See WEIGHTLESSNESS.

The potential biological effects of galactic cosmic radiation include damage to bone marrow and lymphopoietic, intestinal, and gonadal tissues, as well as infertility, cancer induction, and heritable effects. Shielding and radioprotective chemicals afford some protection from space radiation. Total shielding is impossible, however, because of the excess weight it would impart to the spacecraft and the ability of heavy ions to penetrate even heavy shielding. Space medicine consequently has the responsibility to identify appropriate protective procedures, define exposure limits, and develop therapeutic measures. See RADIATION BIOLOGY; RADIATION INJURY (BIOLOGY).

Countermeasures used to prevent or control deleterious physiological responses to space flight include physical, psychological, pharmacological, and nutritional means. Specifically, these include exercise, especially of the lower extremities, by using unique bicycles and treadmills; a vacuum suit that applies negative pressure to the lower body to stress the cardiovascular system; salt water loading on the last day of flight to increase blood volume and prevent orthostatic intolerance; and nutritional supplements including calcium. Pharmacologic agents may be used to curb space sickness symptoms and to protect against radiation. [T.W.H.]

**Aerospike engine** The aerospike engine (Fig. 1a) is an advanced liquid-propellant rocket engine with unique operat-

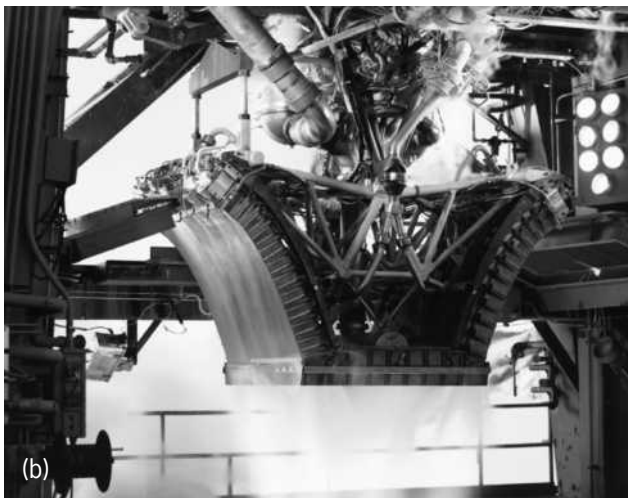

Fig. 1. Static firing tests of (a) aerospike engine with 250,000 pounds (1,112,000 newtons) of thrust, and (b) linear aerospike engine with 125,000 pounds (556,000 newtons) of thrust. Both engines use hydrogen/oxygen propellants. (Boeing Company, Rocketdyne Division)

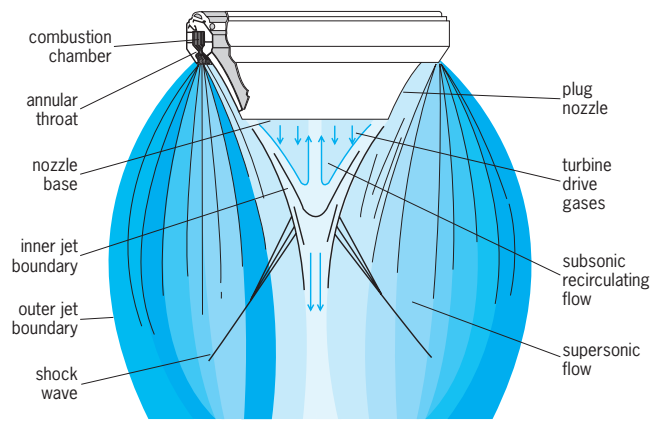

Fig. 2. Aerospike engine with plug nozzle, torus-shaped combustion chamber, and combustion gases expanding outside the nozzle. (Boeing Company, Rocketdyne Division)

ing characteristics and performance advantages over conventional rocket engines. It combines a contoured axisymmetric plug nozzle (Fig. 2), an annular torus-shaped combustion chamber, conventional turbopumps, a turbine exhaust system that injects the turbine drive gases into the base of the plug nozzle, and a simple combustion tap-off engine cycle. The aerospike is one-quarter the length of a conventional rocket engine, yet it delivers comparable performance (efficiency) at high altitude and superior performance at low altitude. The low-altitude performance advantage is primarily due to the fact that the plug nozzle compensates for altitude whereas the nozzle of a conventional rocket engine does not. While the plug nozzle and its benefits are not new to the field of air-breathing propulsion, the aerospike represents the first application of this type of nozzle to the field of rocket propulsion. Typical propellants are liquid hydrogen (fuel) and liquid oxygen (oxidizer).

**Linear aerospike.** A variation is the linear aerospike engine (Fig. 1b). This rocket engine concept offers the same performance advantages as the annular aerospike while offering some unique configurational advantages owing to its linear shape. The combustion chamber is made up of a series of modular chamber segments, and the gas generator engine cycle is used in place of the combustion tap-off cycle.

**Advanced launch vehicles.** Interest has been renewed in single-stage-to-orbit reusable launch vehicles. Numerous studies have shown that reduced launch costs will be best achieved through the development of a fully reusable single-stage-to-orbit vehicle.

Unlike multistage launch vehicles that depend upon one rocket propulsion system for boost and others for high-altitude operation, future single-stage-to-orbit vehicles will be dependent on a single rocket propulsion system from boost to orbit insertion. While each rocket engine of a multistage vehicle can be individually tailored to meet the requirements of its portion of the trajectory, rocket engines for single-stage-to-orbit vehicles must provide high performance over the entire flight trajectory. Thus, advanced rocket propulsion technologies that further increase the performance of liquid-propellant rocket engines will be required. The aerospike engine is one of these advanced propulsion concepts. See ROCKET PROPULSION; SPACECRAFT PROPULSION.

[J.E.Be.]

**Aerostatics** The science of the equilibrium of gases and of solid bodies immersed in them when under the influence only of natural gravitational forces. Aerostatics is concerned with the balance between the weight of the gases and the weight of any object within them. Archimedes' law that an immersed body experiences a buoyancy force equal to the weight of the fluid displaced is the principal law of aerostatics, if the fluid is air, or of



hydrostatics, if the fluid is water. Some phases of meteorology and the flight of balloons and dirigibles are based on aerostatics. In meteorology cloud and fog subsidence and simple pressure and temperature relations with altitude are predicted from aerostatic principles. See HYDROSTATICS. [J.R.Se.]

**Aerothermodynamics** Flow of gases in which heat exchanges produce a significant effect on the flow. Traditionally, aerodynamics treats the flow of gases, usually air, in which the thermodynamic state is not far different from standard atmospheric conditions at sea level. In such a case the pressure, temperature, and density are related by the simple equation of state for a perfect gas; and the rest of the gas's properties, such as specific heat, viscosity, and thermal conductivity, are assumed constant. Because fluid properties of a gas depend upon its temperature and composition, analysis of flow systems in which temperatures are high or in which the composition of the gas varies (as it does at high velocities) requires simultaneous examination of thermal and dynamic phenomena. For instance, at hypersonic flight speed the characteristic temperature in the shock layer of a blunted body or in the boundary layer of a slender body is proportional to the square of the Mach number. These are aerothermodynamic phenomena.

Two problems of particular importance require aerothermodynamic considerations: combustion and high-speed flight. Chemical reactions sustained by combustion flow systems produce high temperatures and variable gas composition. Because of oxidation (combustion) and in some cases dissociation and ionization processes, these systems are sometimes described as aerothermochemical. In high-speed flight the kinetic energy used by a vehicle to overcome drag forces is converted into compression work on the surrounding gas and thereby raises the gas temperature. Temperature of the gas may become high enough to cause dissociation (at Mach number  $\geq 7$ ) and ionization (at Mach number  $\geq 12$ ); thus the gas becomes chemically active and electrically conducting. See COMBUSTION; HYPERSONIC FLIGHT; JET PROPULSION; MACH NUMBER; ROCKET PROPULSION. [S.Y.C.]

**Affective disorders** A group of psychiatric conditions, also known as mood disorders, characterized by disturbances of affect, emotion, thinking, and behavior. Depression is the most common of these disorders, and about 10–20% of those affected also experience manic episodes. The affective disorders are not distinct diseases but are psychiatric syndromes that likely have multiple or complex etiologies.

**Clinical syndromes.** The most common form of affective disorder is a major depressive episode. The episode is defined by a pervasively depressed or low mood (which is experienced most of the day over a period of 2 weeks or longer) and at least four associated symptoms affecting sleep, appetite, hedonic capacity, interest, and behavior.

Major depressive episodes have several clinical forms. Melancholia is a severe episode characterized by anhedonia, marked anorexia with weight loss, early morning awakening, observable motor disturbances (extreme slowing, or retardation, or pacing and stereotypic agitated behaviors), and diurnal mood variation (mood is worse in the morning). See ANOREXIA NERVOSA.

Common among young patients, especially women, is a milder syndrome historically referred to as atypical depression. Atypical depression is characterized by intact mood reactivity (one's spirits can go up or down in response to day-to-day events) and reverse symptoms: oversleeping, overeating, or gaining weight. Significant anxiety symptoms, including phobias and panic attacks, also are common in atypical depression.

A more chronic, insidious form of depression known as dysthymia "smolders" at a subsyndromal level (that is, there are three or four daily symptoms) for at least 2 years. Dysthymia often begins early in life and, historically, has been intertwined with atypical and neurotic characteristics.

A manic episode is heralded by euphoric or irritable mood and at least four of the following: increased energy, activity, self-esteem, or speed of thought; decreased sleep; poor judgment; and risk-taking. About one-half of manic episodes are psychotic. The delusions of mania typically reflect grandiose or paranoid themes. Most people who have manic episodes also experience recurrent depressive episodes.

The term bipolar affective disorder has largely replaced the old term manic-depression, although both names convey the cyclical nature of this illness. The classical presentation (which includes full-blown manic episodes) is known as type 1 disorder. The diagnosis of bipolar type 2 disorder is used when there are recurrent depressive episodes and at least one hypomania. The diagnosis of cyclothymia is used when neither hypomanias nor depressions have reached syndromal levels.

Two variations of bipolar episodes are increasingly recognized. A mixed episode is diagnosed when the symptoms of mania and depression coexist. The term rapid cycling is used when there have been four or more episodes within a time frame of 1 year.

A number of affective disorders follow a seasonal pattern. A pattern of recurrent fall/winter depressions (also known as seasonal affective disorder) has generated considerable interest because it may be treated with bright white light, which artificially lengthens the photoperiod.

Literally all forms of affective disorder can be caused by general medical illnesses and medications that affect brain function (such as antihypertensives, hormonal therapies, steroids, and stimulant drugs). The diagnosis "mood disorder associated with a general medical condition" is applied to these conditions.

**Pathophysiology.** The affective disorders have diverse biopsychosocial underpinnings that result, at least in part, in extreme or distorted responses of several neurobehavioral systems. The neurobehavioral systems of greatest relevance regulate a person's drives and pursuits, responses to acute stress, and capacity to dampen or quiet pain or distress.

Although there is considerable evidence that affective disorders are heritable, vulnerability is unlikely to be caused by a single gene. It is likely that some combination of genes conveys greater risk and, like an amplifier, distorts the neural signals evoked by stress and distress. See BEHAVIOR GENETICS; HUMAN GENETICS.

Research permits several firm conclusions about brain neurochemistry in stress and depression. Acute stress mobilizes the release of three vital brain monoamines—serotonin, norepinephrine, and dopamine—as well as glucocorticoids such as cortisol. Sustained and unresolvable stress eventually depletes the neurotransmitters (cortisol levels remain high), inducing a behavioral state of learned helplessness. Severe depression, especially recurrent episodes of melancholia, affects the brain similarly.

Psychosocial and neurobiologic vulnerabilities, no doubt, intersect. For example, harsh early maltreatment, neglect, or other abuses can have lasting effects on both self-concept and brain responses to stress.

**Epidemiology.** The lifetime rates of affective disorders are increasing, with an earlier age of onset. The onset of major depression most often occurs in the late 20s to mid-30s; dysthymia and bipolar disorder typically begin about a decade earlier. However, no age group is immune to an affective disorder. Vulnerability is not related to social class or race, although the affluent are more likely to receive treatment.

**Treatment.** Most episodes of dysthymia and major depressive disorder respond to treatment with either psychotherapy or antidepressant medication, either singly or in combination. Many experts now recommend the newer forms of psychotherapy, including cognitive behavior therapy and interpersonal therapy, because they have been better studied than more traditional psychoanalytic therapies and because they have been found to be as effective as medications.

Nearly 30 antidepressant medications are available worldwide, with most falling into three classes: tricyclic

antidepressants (TCAs), selective serotonin reuptake inhibitors (SSRIs), and monoamine oxidase reuptake inhibitors (MAOIs). Most classes of antidepressants enhance the efficiency of serotonin or norepinephrine neurotransmission. Antidepressants are not habit-forming and have no mood-elevating effects for nondepressed people. See PSYCHOPHARMACOLOGY; PSYCHOTHERAPY.

Acute manic episodes are usually treated with either lithium salts or divalproex sodium. Psychotic symptoms and severe agitation sometimes warrant the acute use of antipsychotic drugs. Although psychotherapy does not have a major role in the acute treatment of mania, it may help people come to terms with their illness, cope more effectively with stress, or curb minor depressive episodes.

When pharmacotherapies are not effective, the oldest proven treatment of the affective disorders, electroconvulsive therapy (ECT), still provides a powerful alternative. Today, ECT is a highly modified and carefully monitored treatment that has little in common with its depictions in the movies. Nevertheless, confusion and transient amnesia are still problems. See ELECTROCONVULSIVE THERAPY. [M.E.T.]

**Aflatoxin** Any of a group of secondary metabolites produced by the common molds *Aspergillus flavus* and *A. parasiticus* that cause a toxic response in vertebrates when introduced in low concentration by a natural route. The group constitutes a type of mycotoxin. The naturally occurring aflatoxins are identified in physicochemical assays as intensely blue (aflatoxins B<sub>1</sub> and B<sub>2</sub>) or blue-green (aflatoxins G<sub>1</sub> and G<sub>2</sub>) fluorescent compounds under long-wave ultraviolet light. The common structural feature of the four major aflatoxins is a dihydrodifurano or tetrahydrodifurano group fused to a substituted coumarin group (see illustration). The relative proportions of the four major aflatoxins synthesized by *Aspergillus* reflect the genetic constitution of the producing strain and the parameters associated with fungal growth. In addition, derivative aflatoxins are produced as metabolic or environmental products. See TOXIN.

Aflatoxins are formed through a polyketide pathway involving a series of enzymatically catalyzed reactions. In laboratory cultures, aflatoxins are biosynthesized after active growth has ceased, as is typical for secondary metabolites. By using blocked mutants and metabolic inhibitors, many of the intermediates have been identified as brightly colored anthraquinones.

Aflatoxins are potent molecules with many biological effects. They are toxigenic, carcinogenic, mutagenic, and teratogenic in various animal species. Aflatoxin B<sub>1</sub> is usually the most abundant naturally occurring member of the family, and most studies on the pharmacological activity of aflatoxin have been conducted with this congener. Aflatoxin B<sub>1</sub> is the most potent hepatocarcinogenic agent known, although the liver by no means is the only organ susceptible to aflatoxin carcinogenesis. Aflatoxin is listed as a probable human carcinogen by the International Agency for Research on Cancer. See LIVER DISORDERS; PLANT PATHOLOGY.

Aflatoxins are a major agricultural problem. Contamination can occur in the field, during harvest, or in storage and processing. Corn, rice, cottonseed, and peanuts are the major crops regularly displaying high levels of aflatoxin contamination. Since *A. flavus* and *A. parasiticus* are nearly ubiquitous in the natural environment, numerous other grain, legume, nut, and spice crops, as well as coffee and cocoa, have been reported to contain aflatoxins. Given the potential of aflatoxins as human carcinogens and their known activity as toxins in animal feeds, many international regulatory agencies monitor aflatoxin levels in susceptible crops. Prevention is the main line of defense against aflatoxins entering the food chain. Moisture, temperature, and composition of the substrate are the chief factors affecting fungal growth and toxin production. In the field, insect damage is often involved. Detoxification is a last line of defense. Several commercially feasible methods of ammoniation have been de-

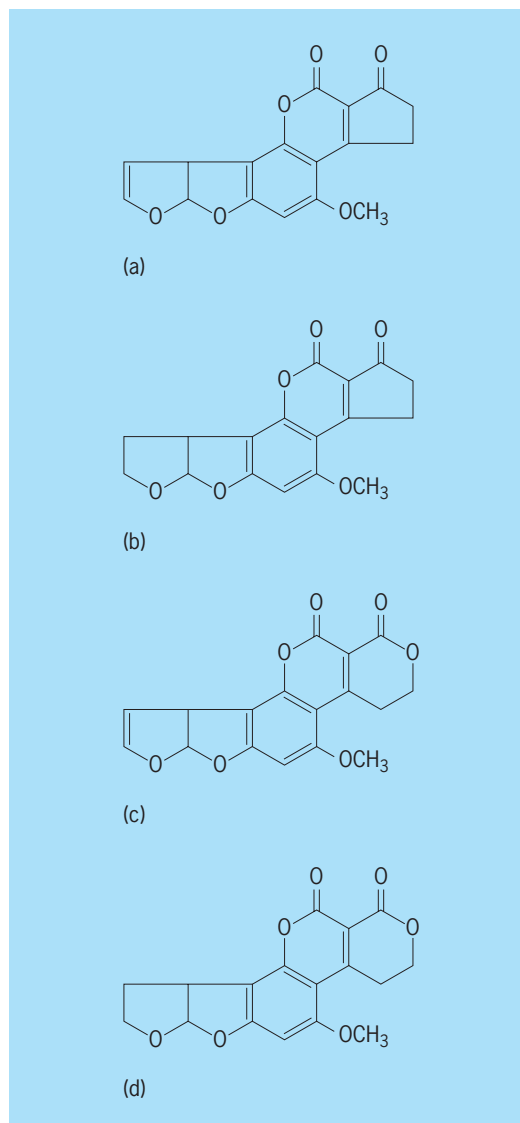

Structures of major naturally occurring aflatoxins. (a) B<sub>1</sub>. (b) B<sub>2</sub>. (c) G<sub>1</sub>. (d) G<sub>2</sub>.

veloped for reducing levels of aflatoxin contamination in animal feeds. See AGRONOMY; MYCOTOXIN. [J.W.Be.]

**Africa** A continent that straddles the Equator, extending between 37°N and 35°S. It is the second largest continent, exceeded by Eurasia. The area, shared by 55 countries, is 11,700,000 mi<sup>2</sup> (30,300,00 km<sup>2</sup>), approximately 20% of the world's total land area. Despite its large area, it has a simple geological structure, a compact shape with a smooth outline, and a symmetrical distribution of climate and vegetation.

Africa has few inlets or natural harbors and a small number of offshore islands that are largely volcanic in origin. Madagascar is the largest island, with an area of 250,000 mi<sup>2</sup> (650,000 km<sup>2</sup>).

Africa is primarily a high interior plateau bounded by steep escarpments. These features show evidence of the giant faults created during the drift of neighboring continents. The surface of the plateau ranges from 4000–5000 ft (1200–1500 m) in the south to about 1000 ft (300 m) in the Sahara. These differences in elevation are particularly apparent in the Great Escarpment region in southern Africa, where the land suddenly drops from 5000 ft (1500 m) to a narrow coastal belt. Although most of the continent is classified as plateau, not all of its surface is flat. Rather, most of its physiographic features have been

differentially shaped by processes such as folding, faulting, volcanism, erosion, and deposition. See ESCARPMENT; FAULT AND FAULT STRUCTURES; PLATEAU.

The rift valley system is one of the most striking features of the African landscape. Sliding blocks have created wide valleys 20–50 mi (30–80 km) wide bounded by steep walls of variable depth and height. Within the eastern and western branches of the system, there is a large but shallow depression occupied by Lake Victoria. See RIFT VALLEY.

Several volcanic features are associated with the rift valley system. The most extensive of these are the great basalt highlands that bound either side of the rift system in Ethiopia. These mountains rise over 10,000 ft (3000 m), with the highest peak, Ras Dashan, reaching 15,158 ft (4500 m). There are also several volcanic cones, including the most renowned at Mount Elgon (14,175 ft; 4321 m); Mount Kenya (17,040 ft; 5194 m); and Mount Kilimanjaro, reaching its highest point at Mount Kibo (19,320 ft; 5889 m). Mounts Kenya and Kilimanjaro are permanently snowcapped. See BASALT.

Since the Equator transects the continent, the climatic conditions in the Northern Hemisphere are mirrored in the Southern Hemisphere. Nearly three-quarters of the continent lies within the tropics and therefore has high temperatures throughout the year. Frost is uncommon except in mountainous areas or some desert areas where nighttime temperatures occasionally drop below freezing. These desert areas also record some of the world's highest daytime temperatures, including an unconfirmed record of 136.4°F (58°C) at Azizia, Tripoli. See EQUATOR.

Africa can be classified into broad regions based on the climatic conditions and their associated vegetation and soil types. The tropical rainforest climate starts at the Equator and extends toward western Africa. The region has rainfall up to 200 in. (500 cm) per year and continuously high temperatures averaging 79°F (26°C). The eastern equatorial region does not experience these conditions because of the highlands and the presence of strong seasonal winds that originate from southern Asia.

The areal extent of the African rainforest region (originally 18%) has dwindled to less than 7% as a result of high rates of deforestation. Despite these reductions, the region is still one of the most diverse ecological zones in the continent. See RAINFOREST.

Extensive savanna grasslands are found along the Sudanian zone of West Africa, within the Zambezi region and the Somalia-Masai plains. Large areas such as the Serengeti plains in the Somalia-Masai plains are home to a diverse range of wild animals.

The tropical steppe forms a transition zone between the humid areas and the deserts. This includes the area bordering the south of the Sahara that is known as the Sahel, the margins of the Kalahari basin, and the Karoo grasslands in the south.

The structural evolution of the continent has much to do with the drainage patterns. Originally, most of the rivers did not drain into the oceans, and many flowed into the large structural basins of the continent. However, as the continental drift occurred and coasts became more defined, the rivers were forced to change courses, and flow over the escarpments in order to reach the sea. Several outlets were formed, including deep canyons, waterfalls, cataracts, and rapids as the rivers carved out new drainage patterns across the landscape. Most of the rivers continue to flow through or receive some of their drainage from the basins, but about 48% of them now have a direct access into the surrounding oceans. The major rivers are the Nile, Congo (Zaire), Niger, and Zambezi. See RIVER.

The tremendous diversity in wildlife continues to be one of the primary attractions of this continent. Africa is one of the few remaining places where one can view game fauna in a natural setting. There is a tremendous diversity in species, including birds, reptiles, and large mammals. Wildlife are concentrated in central and eastern Africa because of the different types of vegetation which provide a wide range of habitats.

Africa is not a densely populated continent. With an estimated population of 743,000,000, its average density is 64 per square mile (26 per square kilometer). However, some areas have large concentrations, including the Nile valley, the coastal areas of northern and western Africa, the highland and volcanic regions of eastern Africa, and parts of southern Africa. These are mostly areas of economic or political significance. [F.L.M.]

**African horsesickness** A highly fatal insect-borne viral disease of horses and mules, and a mild subclinical disease in donkeys and zebras. It normally occurs in sub-Saharan Africa but occasionally spreads to North Africa, the Iberian Peninsula, and Asia Minor.

The African horsesickness virus is an orbivirus (family Reoviridae) measuring 68–70 nanometers in diameter. The outer layer of the double-layered protein shell is ill defined and diffuse and is formed by two polypeptides. The highly structured core consists of five structural proteins arranged in icosahedral symmetry. The viral genome is composed of 10 double-stranded ribonucleic acid (RNA) segments (genes) ranging in size from 240,000 to 2,530,000 daltons. Nine distinct serotypes which can be distinguished by neutralization tests are known. The virus can be cultivated in various cell cultures, in the brains of newborn mice, and in embryonated hen eggs by intravascular inoculation. See ANIMAL VIRUS.

African horsesickness is a noncontagious disease that can readily be transmitted by the injection of infective blood or organ suspensions. In nature, the virus is biologically transmitted by midges of the genus *Culicoides*, such as *C. imicola*. The disease has a seasonal incidence in temperate regions (late summer to autumn), and its prevalence is influenced by climatic conditions favoring insect breeding (for example, warm, moist conditions in low-lying areas). Mechanical transmission by large biting flies is possible, but plays a much smaller role than biological transmission in the epidemiology of this disease.

There is no specific treatment for this disease. Infected animals should be given complete rest as the slightest exertion may result in death. Stabling of horses at night during the African horsesickness season reduces exposure to insect vectors and hence the risk of disease transmission. Prophylactic vaccination is the most practical and effective control measure. In epidemic situations outside Africa, the causal virus should be serotyped as soon as possible, allowing the use of a monovalent vaccine. However, in endemic regions it is imperative to use a polyvalent vaccine, which should render protection against all nine serotypes of African horsesickness virus. See DISEASE; EPIDEMIC; VACCINATION. [B.E.]

**Afterburner** A device in a turbojet aircraft engine, between turbine and nozzle, which improves thrust by the burning of additional fuel (see illustration). To develop additional

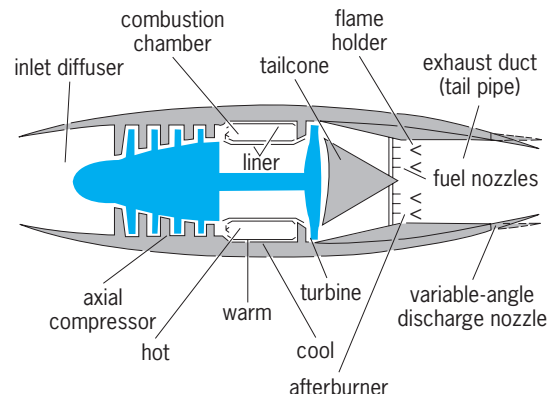

Diagram of turbojet engine showing afterburner.

thrust for takeoff and climb and for periods of dash of military aircraft, it is advantageous to augment the engine thrust. This is done by afterburning, also called reheating, tail-pipe burning, or postcombustion. The augmentation of thrust obtained by afterburning may be well over 40% of the normal thrust and at supersonic flight can exceed 100% of normal thrust. See TURBOJET. [B.P.]

**Agar** A major constituent of the cell walls of certain red algae, especially members of the families Gelidiaceae and Gracilariaceae. Extracted for its gelling properties, it is one of three algal polysaccharides of major economic importance, the others being alginate and carrageenan. Agar is composed of two similar fractions, agarose and agarpectin, in which the basic unit is galactose, linked alternately  $\alpha$ -1,3-(D-galactose) and  $\beta$ -1,4-( $\alpha$ -L-galactose).

Agar is prepared by boiling the algae in water, after which the filtered solution is cooled, purified, and dried. It is an amorphous, translucent material that is packaged in granules, flakes, bricks, or sheets. One of its chief uses is as a gelling agent in media for culturing microorganisms. It is also used in making confections, as an emulsifier in cosmetics and food products, as a sizing agent, as an inert carrier of drugs in medicine, and as a laxative. See CULTURE; RHODOPHYCEAE. [P.C.Si; R.L.Moe.]

**Agate** A variety of chalcedonic quartz that is distinguished by the presence of color banding in curved or irregular patterns (see illustration). Most agate used for ornamental purposes is composed of two or more tones or intensities of brownish-red, often interlayered with white, but it is also commonly composed of various shades of gray and white. Since agate is relatively porous, it can be dyed permanently in red, green, blue, and a variety of other colors.



Section of polished agate showing the characteristic banding. (Field Museum of Natural History, Chicago)

The term agate is also used with prefixes to describe certain types of chalcedony in which banding is not evident. Moss agate is a milky or almost transparent chalcedony containing dark inclusions in a dendritic pattern. Iris agate exhibits an iridescent color effect. Fortification, or landscape, agate is translucent and contains inclusions that give it an appearance reminiscent of familiar natural scenes. Banded agate is distinguished from onyx by the fact that its banding is curved or irregular, in contrast to the straight, parallel layers of onyx. The properties of agate are those of chalcedony: refractive indices of 1.535 and 1.539, a hardness of  $6\frac{1}{2}$  to 7, and a specific gravity of about 2.60. See CHALCEDONY; GEM; QUARTZ. [R.T.L.]

**Agglutination reaction** A reaction in which suspended particles are aggregated or clumped. It occurs upon the

admixture of another type of particle, a change in the composition of the suspending fluid, or the addition of a soluble agent that acts as a bridge between two or more particles. The reaction is a secondary one in that the process resulting in agglutination occurs after the primary antigen-antibody linkage has taken place.

The particles undergoing agglutination may be either unicellular or microscopic multicellular organisms (such as bacteria and parasites), individual cells of multicellular organisms (such as erythrocytes and lymphocytes), or artificial particles (such as beads of plastic, glass, or polysaccharide). The immunological specificity of agglutination depends upon the uniqueness of the reaction between a marker substance on one type of particle and a receptor on either another type of particle or a specific antibody in solution. The marker can be a usual biological component of the surface of the particle or blood group substance on red cells. It can be an enzymatically or a chemically modified chemical group on the surface of biological particles. It can also be an adsorbed or a chemically attached substance. The attachment can be to biological particles or artificial ones. The receptor can be a biological component of the particle, an attached antibody, or antibody in solution. A reverse reaction is one in which the antibody is attached to a particle and the addition of the antigen causes the mixture to clump. Inhibition of agglutination can also be used to test for antigens, especially of low molecular weight, in a manner similar to that for agglutination itself. See ANTIGEN-ANTIBODY REACTION; IMMUNOASSAY. [A.B.]

**Agglutinin** A substance that will cause a clumping of particles such as bacteria or erythrocytes. Of major importance are the specific or immune agglutinins, which are antibodies that will agglutinate bacteria containing the corresponding antigens on their surfaces. Agglutinins are readily determined, and their presence is of diagnostic value to indicate present or past host contact with the microbial agent sufficient to result in antibody formation. See AGGLUTINATION REACTION; ANTIBODY.

Analogous reactions involve erythrocytes and their corresponding antibodies, the hemagglutinins. Hemagglutinins to a variety of erythrocytes occur in many normal sera, and their amounts may be increased by immunization. The blood group isoagglutinins of humans and animals are important special cases which must be considered in all proposed blood transfusions lest transfusion reactions result. See BLOOD GROUPS. [H.P.T.]

**Aggression** Behavior that is intended to threaten or inflict physical injury on another person or organism; a broader definition may include such categories as verbal attack, discriminatory behavior, and economic exploitation. The inclusion of intention in defining aggression makes it difficult to apply the term unequivocally to animals in which there is no clear means of determining the presence or absence of intention. As a result, animal violence is usually equated with aggression. There are four main approaches to understanding the causes or origins of human aggression. First, the basis may be differences among people, due either to physiological difference or to early childhood experiences. Second, there are sociological approaches which seek the causes of aggression in social factors such as economic deprivation and social (including family) conflicts. Third, causes may be found in the power relations of society as whole, where aggression arises as a function of control of one group by another. Fourth, aggression may be viewed as an inevitable (genetic) part of human nature; this approach has a long history and has produced extensive arguments. Given the wide variation in aggressive behavior in different societies and the occasional absence of such behavior in some groups and some individuals, a general human genetic factor is unlikely. However, some genetic disposition to react with force when an individual is blocked from reaching a goal may provide an evolutionary basis for the widespread occurrence of violence and aggression. The existence of different kinds of aggression suggests that different evolutionary scenarios need to be invoked and that aggression is not due to a

single evolutionary event; it is likely that aggression is multiterminated and rarely, if ever, due to a single factor. See BEHAVIOR GENETICS.

Aggression in humans ranges through fear-induced aggression, parental disciplinary aggression, maternal aggression, and sexual aggression. One clearly biologically adaptive type, defensive aggression, occurs when fight responses are mobilized in defense of an organism's vital interests, such as obtaining food or the protection of its young. The aim of defensive aggression is not destruction but the preservation of life. Thus, aggression can serve both destructive and constructive purposes. Among animals, the varieties of aggression include most of the human types as well as predatory aggression, territorial defense, and sexually related aggression in competition for a mate. [G.M.]

**Aging** Definitions of aging differ between biologists and behavioral scientists. Biologists regard aging as reflecting the sum of multiple and typical biological decrements occurring after sexual maturation; behavioral scientists view it as reflecting regular and expected changes occurring in genetically representative organisms advancing through the life cycle under normal environmental conditions. It is difficult to define normal aging, since many changes observed in older adults and previously perceived as concomitants of normal aging are now recognized as effects of disease in later life. The behavioral science view allows for incremental as well as decremental changes with aging. Senescence is not always equated with aging; it is viewed as the increasing vulnerability or decreasing capacity of an organism to maintain homeostasis as it progresses through its life span. Gerontology refers to the study of aging. Geriatrics refers to the clinical science that is concerned with health and illness in the elderly.

Inquiries into why organisms age involve both the purpose of aging and the process of aging. There are theories, but no conclusive evidence, in both areas. The most common explanations of the purpose of aging are based on theories that aging is adaptive for a species. Theories about the process of aging concern how people age. These biological theories address two sets of factors—intrinsic and extrinsic to the organism. Intrinsic factors are influences operating on the body from within, such as the impact of genetic programming. Extrinsic factors are influences on the body from the environment, such as the impact of cumulative stresses. Despite an abundance of theories to explain the process of aging, its mechanisms remain a mystery.

It is important to differentiate between life expectancy and life span. Life expectancy is the average number of years of life in a given species; it is significantly influenced by factors beyond aging alone, such as famine and disease. Life span is the maximum number of years of life possible for that species; it is more fundamentally linked to the process of aging itself. Over the centuries, life expectancy has increased (due to improved sanitation and health care practices); life span has not. Approximately 115 years appears to be the upper limit of life span in humans. See DEATH; HUMAN GENETICS. [G.D.C.]

**Agnosia** An impairment in the recognition of stimuli in a particular sensory modality. True agnosias are associative defects, where the perceived stimulus fails to arouse a meaningful state. An unequivocal diagnosis of agnosia requires that the recognition failure not be due to sensory-perceptual deficits, to generalized intellectual impairment, or to impaired naming (as in aphasia). Because one or more of these conditions frequently occur with agnosia, some clinical scientists have questioned whether pure recognition disturbances genuinely exist; but careful investigation of appropriate cases has affirmed agnosia as an independent entity which may occur in the visual, auditory, or somesthetic modalities. See APHASIA.

The patient with visual object agnosia, though quite able to identify objects presented auditorily or tactually, cannot name or give other evidence of recognizing visually presented objects. Because visual object agnosia is a rather rare disorder, knowledge of its underlying neuropathology is incomplete. Most reported

cases have shown bilateral occipital lobe lesions, with the lesion extending deep into the white matter and often involving the corpus callosum. Prosopagnosia is the inability to recognize familiar faces. Persons well known to the individual before onset of the condition, including members of the immediate family, are not recognized. In many instances, individuals fail to recognize picture or mirror images of themselves. Isolated impairment of reading is frequently considered to be an exotic form of aphasia. Logically, however, it may be considered as a visual-verbal agnosia (also referred to as pure word blindness or alexia without agraphia). Individuals with this disorder show a marked reduction in their ability to read the printed word, though their writing and other language modalities remain essentially intact.

The term auditory agnosia is most often used to indicate failure to recognize nonverbal acoustic stimuli despite adequate hearing sensitivity and discrimination. In most well-documented cases of agnosia for sounds, the subjects have had bilateral temporal lobe lesions. Auditory-verbal agnosia (or pure word deafness) is a disturbance in comprehension of spoken language, in the presence of otherwise intact auditory functioning and essentially normal performance in other language modalities. The person's speech expression is remarkably intact in comparison with the gross impairment in understanding speech. Like its visual analog, visual-verbal agnosia, this is a disconnection syndrome. It is produced by damage to the left primary auditory cortex (or the tracts leading to it) coupled with a lesion to the corpus callosum. Phonagnosia is a disturbance in the recognition of familiar voices. The person has good comprehension of what is spoken, but the speaker cannot be identified. See BRAIN; HEARING (HUMAN); HEMISPHERIC LATERALITY; PSYCHOACOUSTICS; VISION. [G.J.C.]

**Agonomycetes** Mitosporic or anamorphic (asexual or imperfect) fungi (Deuteromycotina) that not only lack fruit bodies but also fail to produce conidia, the thallus consisting of septate hyphae. Somatic structures of propagation or survival, termed propagules, are varied and include chlamydo-spores and bulbils. Hyphae are modified to form sclerotia, pseudosclerotia, rhizomorphs, strands, and cords. About 40 genera (with +30 synonyms) containing 220 species are recognized. The Agonomycetes constitute an artificial group that does not consist of closely related genera and is recognized for its practicality rather than homogeneous taxonomic composition. They are circumscribed not only by what they lack, such as conidia, asci and ascospores, basidia and basidiospores, and zygospores, but also by the apparent superficial similarity between some of the members in, for example, hyphal, chlamydo-spore, and sclerotial form.

Agonomycetes are generally considered to be combative species which are persistent and long-lived, largely because of the resistant nature of their vegetative structures and their slow and intermittent reproduction or complete absence of reproduction. Whether they are capable of defending captive resources and have good enzymatic competence, which are other features of combative species, is largely unknown. However, they occupy diverse ecological niches, including aquatic habitats, soil, wood in various stages of decay, other decaying plant material, and dung. They also function as root and foliar pathogens, and many cause serious diseases in terms of host damage and economic loss, especially of roots, corms, and bulbs. Agonomycetes sometimes cause damage in commercial mushroom-growing environments, and *Papulaspora byssina* in particular is associated with the brown plaster mold problem in mushroom beds. *Armillaria*, a basidiomycete with a *Rhizomorpha* agonomycete state, is a severe parasite of a wide range of woody and herbaceous plants. See DEUTEROMYCOTINA; PLANT PATHOLOGY. [B.C.S.]

**Agouti** A large rodent that resembles the rabbit or hare in size and shape as well as in the elongated hindlegs, which make them well adapted for speed (see illustration). The agouti and the closely related smaller acouchi are inhabitants of clearings in



The agouti (*Dasyprocta aguti*), a rodent found in Mexico, South America, and the West Indies.

forested areas of the Amazon region. Some range into Central America and as far as the Guianas.

Thirteen species of agouti have been described, the most common being *Dasyprocta aguti*. Some authorities are of the opinion that all of these are varieties or subspecies of *D. aguti*. The acouchi is represented by two species, the green acouchi (*Myoprocta pratti*) and the red acouchi (*M. acouchy*). See RODENTIA.

[C.B.C.]

**Agricultural aircraft** Aircraft designed, or adapted from a general utility airframe, for use in agriculture and forestry and for control of insect vectors of human, animal, and plant diseases. Agricultural aircraft have become an indispensable tool for high-productivity agriculture and have contributed to the worldwide crop production revolution. Aircraft use covers a wide range of agricultural crop and pest applications, including control of competing weeds and unwanted brush and trees, control of insect and disease pests, application of plant nutrients, and broadcast seeding of many crops. See FERTILIZER; PESTICIDE.

The principal advantages of either fixed- or rotary-wing aircraft for the treatment of crops lies with their ability to rapidly cover large crop acreages and to travel over rough terrain, irrigation structures, and wet fields. This timeliness factor is often considered critical to optimum pest control and effective crop protection. The primary disadvantage is their inability to direct the released material onto the target crop with the precision that can be accomplished with ground-based applications. Increasing limitations are being placed on aircraft use, especially when highly toxic crop chemicals are to be applied to small fields and where sensitive nontarget crops are grown nearby.

Application equipment is an integral part of agricultural aircraft. This includes hoppers to hold the material to be applied, pumps or spinning devices to move material from the hoppers to the spreading or spraying equipment, and spreading or spraying equipment for dry and wet materials, respectively. The aerodynamic wake or air dispersion produced by the action of the wing or helicopter rotor and the mass of air displaced by the aircraft in motion are utilized to aid in spreading either liquid or dry materials. The interaction of the wing or rotor length and the length of the spray boom, along with the strength of the wake and height of flight, controls the usable swath width laid down by the aircraft.

While larger, faster-flying (up to 140 mi/h or 225 km/h) aircraft can accomplish greater hourly productivity, other factors such as size and location of crop fields, distance to fields from suitable landing strips, and time lost in field turns also affect field productivity. Helicopters, which can turn quickly and can land and be serviced close to crop fields or even on landing docks on top of service trucks, can thus gain back some of the lowered productivity of these aircraft due to smaller load capacity and lower field speeds. However, it is the greater application precision and downblast from their rotary wing (at reduced forward speeds) that has generated the increased use of helicopters, in spite of their greater initial and operating costs. See AGRICULTURE; AIRPLANE; HELICOPTER.

[N.B.A.]

**Agricultural chemistry** The science of chemical compositions and changes involved in the production, protection, and use of crops and livestock. As a basic science, it embraces, in addition to test-tube chemistry, all the life processes through which humans obtain food and fiber for themselves and feed for their animals. As an applied science or technology, it is directed toward control of those processes to increase yields, improve quality, and reduce costs. One important branch of it, chemurgy, is concerned chiefly with utilization of agricultural products as chemical raw materials.

The goals of agricultural chemistry are to expand understanding of the causes and effects of biochemical reactions related to plant and animal growth, to reveal opportunities for controlling those reactions, and to develop chemical products that will provide the desired assistance or control. Every scientific discipline that contributes to agricultural progress depends in some way on chemistry. Hence agricultural chemistry is not a distinct discipline, but a common thread that ties together genetics, physiology, microbiology, entomology, and numerous other sciences that impinge on agriculture.

Chemical materials developed to assist in the production of food, feed, and fiber include scores of herbicides, insecticides, fungicides, and other pesticides, plant growth regulators, fertilizers, and animal feed supplements. Chief among these groups from the commercial point of view are manufactured fertilizers, synthetic pesticides (including herbicides), and supplements for feeds. The latter include both nutritional supplements (for example, minerals) and medicinal compounds for the prevention or control of disease. See AGRICULTURAL SCIENCE (ANIMAL); AGRICULTURAL SCIENCE (PLANT); AGRICULTURE; FERTILIZER; HERBICIDE; PESTICIDE; SOIL.

[R.N.H.]

**Agricultural engineering** A discipline concerned with solving the engineering problems of providing food and fiber for the people of the world. These problems include designing improved tools to work the soil and harvest the crops, as well as developing water supplies for agriculture and systems for irrigating and draining the land where necessary. Agricultural engineers design buildings in which to house animals or store grains. They also work on myriad problems of processing, packaging, transporting, and distributing the food and fiber products. Agricultural engineering combines the disciplines of mechanical, civil, electrical, and chemical engineering with a basic understanding of biological sciences and agricultural practices. Some agricultural engineers work directly with farmers. Most, however, work with the companies that manufacture and supply equipment, feeds, fertilizers, and pesticides. Others work for companies that provide services to farmers, such as developing irrigation and drainage systems or erecting buildings and facilities. Still others work with food-processing companies. See AGRICULTURAL BUILDINGS; AGRICULTURAL MACHINERY; AGRICULTURE.

[R.E.Ga.]

**Agricultural machinery** Mechanized systems of food and fiber production used in agriculture. These systems extend from initial tillage of the soil through planting, cultural practices during the growing season, protection from pests, harvesting, conditioning, livestock feeding, and delivery for processing. The use of hydraulic power has made possible highly specialized mechanisms to perform intricate operations. Hydraulic power offers the advantages of being easily controlled and automated. Sophisticated technology is used to increase the precision needed in modern agriculture: lasers for laying out fields for surface irrigation systems; microprocessors for sensing and controlling intricate operations, such as controlling feed mixtures for dairy cows and grading fruits and vegetables; and electronic devices in the automation of many harvesters.

Primary and secondary tillage equipment, such as plows, disks, and harrows, are designed to prepare the seedbed and root zones for crop production. Multipurpose machines are used where a high degree of precision and specialization is needed.

The illustration shows a machine that may be used to simultaneously rototill the soil, form beds and irrigation furrows, incorporate a herbicide, and plant the seed in one trip across the field. Laser land-leveling machinery allows the farmer to prepare a field for surface irrigation by grading the field to an exact slope. See IRRIGATION (AGRICULTURE).

Agricultural planting equipment is commonly used for the planting of raw uncoated seed. For some crops, other types of planting equipment may be used to plant tubers, such as potatoes, and transplants, such as tomatoes. No-till planters have been developed for the planting of seed into undisturbed soil; no-till farming eliminates all primary and secondary tillage normally conducted between cropping years, and therefore the soil remains undisturbed.

Crop cultivation is accomplished primarily to rid the crop of competing weeds. Cultivation equipment is normally quite simple and is designed to cut, slice, bury, or rip out weeds.

Crop chemicals, such as fertilizers and pesticides, are routinely used in agricultural production. Liquid pesticides are commonly applied with high- or low-pressure sprayers mounted on tractors, trailers, trucks, and aircraft. Air-blast or orchard-type sprayers utilize a high-speed airstream to carry the liquid chemical to the surface being treated. Dry chemicals, such as fertilizers, are applied with either broadcast or band-type applicators. Broadcast applicators spread the chemical over the entire field surface at a prescribed rate, while band-type applicators apply the chemical at a prescribed rate in strips or bands across the field. See AGRICULTURAL AIRCRAFT; FERTILIZING.

Mechanized operations around farmsteads vary from very little on subsistence-type farms to nearly complete on larger commercial farms. These operations are for either crop conditioning or materials handling. The equipment is powered by electric motors if it is stationary, and by tractor hydraulics or power takeoff shafts if it is portable. Stationary equipment includes conveyors and grinders, and portable equipment includes feed wagons, mixers, and manure spreaders.

Self-propelled hay cubers compress hay into small cubes to make it easy to handle with conveyors. Practically all small grains are harvested by self-propelled combines that cut the crop and deliver the grain to a truck. Cotton harvesting is done by stripping the fiber-containing bolls from the plant or by rotating spindles that collect the fibers with a twisting action and release them in an airstream that carries them into a hopper.

The biggest demand for hand labor has been in the harvest of fruits and vegetables. Much research has been done on breeding of plants and on machine development to reduce hand labor, primarily during harvesting. Most successful attempts have uti-



Multipurpose machine used for precision tillage, planting, bed shaping, and fertilizing in one pass, and for later bed shaping, cultivating, and fertilizing. (Johnson Farm Machinery Co.)

lized shaking of trees or vines to remove fruits. Most of these machines are nonselective, that is, all of the crop is harvested in one operation whether it is mature or not. Selection for color, maturity, and size is usually done by people on machines or at grading stations. Electronics are used for color maturity sorting on tomato harvesters. There are several selective harvesters in use, but on a very limited basis. See AGRICULTURAL SOIL AND CROP PRACTICES; AGRICULTURE; DAIRY MACHINERY. [J.W.Ru.; M.O'B.]

**Agricultural meteorology** A branch of meteorology that examines the effects and impacts of weather and climate on crops, rangeland, livestock, and various agricultural operations. The branch of agricultural meteorology dealing with atmospheric-biospheric processes occurring at small spatial scales and over relatively short time periods is known as micrometeorology, sometimes called crop micrometeorology for managed vegetative ecosystems and animal biometeorology for livestock operations. The branch that studies the processes and impacts of climatic factors over larger time and spatial scales is often referred to as agricultural climatology. See CLIMATOLOGY; MICROMETEOROLOGY.

Agricultural meteorology, or agrometeorology, addresses topics that often require an understanding of biological, physical, and social sciences. It studies processes that occur from the soil depths where the deepest plant roots grow to the atmospheric levels where seeds, spores, pollen, and insects may be found. Agricultural meteorologists characteristically interact with scientists from many disciplines.

Agricultural meteorologists collect and interpret weather and climate data needed to understand the interactions between vegetation and animals and their atmospheric environments. The climatic information developed by agricultural meteorologists is valuable in making proper decisions for managing resources consumed by agriculture, for optimizing agricultural production, and for adopting farming practices to minimize any adverse effects of agriculture on the environment. Such information is vital to ensure the economic and environmental sustainability of agriculture now and in the future. See WEATHER OBSERVATIONS.

Agricultural meteorologists also quantify, evaluate, and provide information on the impact and consequences of climate variability and change on agriculture. Increasingly, agricultural meteorologists assist policy makers in developing strategies to deal with climatic events such as floods, hail, or droughts and climatic changes such as global warming and climate variability.

Agricultural meteorologists are involved in many aspects of agriculture, ranging from the production of agronomic and horticultural crops, trees, and livestock to the final delivery of agricultural products to market. They study the energy and mass exchange processes of heat, carbon dioxide, water vapor, and trace gases such as methane, nitrous oxide, and ammonia, within the biosphere on spatial scales ranging from a leaf to a watershed and even to a continent. They study, for example, the photosynthesis, productivity, and water use of individual leaves, whole plants, and fields. They also examine climatic processes at time scales ranging from less than a second to more than a decade. [B.L.B.]

**Agriculture** The art and science of crop and livestock production. In its broadest sense, agriculture comprises the entire range of technologies associated with the production of useful products from plants and animals, including soil cultivation, crop and livestock management, and the activities of processing and marketing. The term agribusiness has been coined to include all the technologies that mesh in the total inputs and outputs of the farming sector. In this light, agriculture encompasses the whole range of economic activities involved in manufacturing and distributing the industrial inputs used in farming; the farm production of crops, animals, and animal products; the processing of these materials into finished products; and the provision of products at a time and place demanded by consumers.

Many different factors influence the kind of agriculture practiced in a particular area. Among these are climate, soil, water

availability, topography, nearness to markets, transportation facilities, land costs, and general economic level. Climate, soil, water availability, and topography vary widely throughout the world. This variation brings about a wide range in agricultural production enterprises. Certain areas tend toward a specialized agriculture, whereas other areas engage in a more diversified agriculture. As new technology is introduced and adopted, environmental factors are less important in influencing agricultural production patterns. Continued growth in the world's population makes critical the continuing ability of agriculture to provide needed food and fiber.

The primary agricultural products consist of crop plants for human food and animal feed and livestock products. The crop plants can be divided into 10 categories: grain crops (wheat, for flour to make bread, many bakery products, and breakfast cereals; rice, for food; maize, for livestock feed, syrup, meal, and oil; sorghum grain, for livestock feed; and oats, barley, and rye, for food and livestock feed); food grain legumes (beans, peas, lima beans, and cowpeas, for food; and peanuts, for food and oil); oil seed crops (soybeans, for oil and high-protein meal; and linseed, for oil and high-protein meal); root and tuber crops (principally potatoes and sweet potatoes); sugar crops (sugarbeets and sugarcane); fiber crops (principally cotton, for fiber to make textiles and for seed to produce oil and high-protein meal); tree and small fruits; nut crops; vegetables; and forages (for support of livestock pastures and range grazing lands and for hay and silage crops). The forages are dominated by a wide range of grasses and legumes, suited to different conditions of soil and climate.

Livestock products include cattle, for beef, tallow, and hides; dairy cattle, for milk, butter, cheese, ice cream, and other products; sheep, for mutton (lamb) and wool; pigs, for pork and lard; poultry (chiefly chickens but also turkeys and ducks) for meat and eggs; and horses, primarily for recreation. See BEEF CATTLE PRODUCTION; DAIRY CATTLE PRODUCTION; POULTRY PRODUCTION; SHEEP; SWINE PRODUCTION. [J.J.]

**Agroecosystem** A model for the functionings of an agricultural system, with all inputs and outputs. An ecosystem may be as small as a set of microbial interactions that take place on the surface of roots, or as large as the globe. An agroecosystem may be at the level of the individual plant-soil-microorganism system, at the level of crops or herds of domesticated animals, at the level of farms or agricultural landscapes, or at the level of entire agricultural economies.

**Characteristics.** Agroecosystems differ from natural ecosystems in several fundamental ways. First, the energy that drives all autotrophic ecosystems, including agroecosystems, is either directly or indirectly derived from solar energy. However, the energy input to agroecosystems includes not only natural energy (sunlight) but also processed energy (fossil fuels) as well as human and animal labor. Second, biodiversity in agroecosystems is generally reduced by human management in order to channel as much energy and nutrient flow as possible into a few domesticated species. Finally, evolution is largely, but not entirely, through artificial selection where commercially desirable phenotypic traits are increased through breeding programs and genetic engineering. Agroecosystems are usually examined from a range of perspectives including energy flux, exchange of materials, nutrient budgets, and population and community dynamics.

Solar energy influences agroecosystem productivity directly by providing the energy for photosynthesis and indirectly through heat energy that influences respiration, rates of water loss, and the heat balance of plants and animals. See BIOLOGICAL PRODUCTIVITY; ECOLOGICAL ENERGETICS; PHOTOSYNTHESIS.

Nutrient uptake from soil by crop plants or weeds is primarily mediated by microbial processes. Some soil bacteria fix atmospheric nitrogen into forms that plants can assimilate. Other organisms influence soil structure and the exchange of nutrients, and still other microorganisms may excrete ammonia and other metabolic by-products that are useful plant nutrients. There are many complex ways that microorganisms influence nutrient

cycling and uptake by plants. Some microorganisms are plant pathogens that reduce nutrient uptake in diseased plants. Larger organisms may influence nutrient uptake indirectly by modifying soil structure or directly by damaging plants. See SOIL MICROBIOLOGY.

Although agroecosystems may be greatly simplified compared to natural ecosystems, they can still foster a rich array of population and community processes such as herbivory, predation, parasitization, competition, and mutualism. Crop plants may compete among themselves or with weeds for sunlight, soil nutrients, or water. Cattle overstocked in a pasture may compete for forage and thereby change competitive interactions among pasture plants, resulting in selection for unpalatable or even toxic plants. Indeed, one important goal of farming is to find the optimal densities for crops and livestock. See HERBIVORY; POPULATION ECOLOGY; WEEDS.

Widespread use of synthetic chemical pesticides has bolstered farm production worldwide, primarily by reducing or eliminating herbivorous insect pests. Traditional broad-spectrum pesticides such as DDT, however, can have far-ranging impacts on agroecosystems. For instance, secondary pest outbreaks associated with the use of many traditional pesticides are not uncommon due to the elimination of natural enemies or resistance of pests to chemical control. Growers and pesticide developers in temperate regions have begun to focus on alternative means of control. Pesticide developers have begun producing selective pesticides, which are designed to target only pest species and to spare natural enemies, leaving the rest of the agroecosystem community intact. Many growers are now implementing integrated pest management programs that incorporate the new breed of biorational chemicals with cultural and other types of controls. See FOREST PEST CONTROL; PESTICIDE.

**Genetic engineering.** The last few decades have seen tremendous advances in molecular approaches to engineering desirable phenotypic traits in crop plants. Although artificially modifying crop plants is nothing new, the techniques used in genetic engineering allow developers to generate new varieties an order-of-magnitude faster than traditional plant breeding. In addition, genetic engineering differs from traditional breeding in that the transfer of traits is no longer limited to same-species organisms. Scientists are still assessing the effects that the widespread deployment of these traits may have on agroecosystems and natural ecosystems. There is some concern, for instance, that engineered traits may escape, via genes in pollen transferred by pollinators, and become established in weedy populations of plants in natural ecosystems, in some cases creating conservation management problems and new breeds of superweeds. As with pesticides, there is evidence that insects are already becoming resistant to some more widespread traits used in transgenic plants, such as the antiherbivore toxin produced by the bacterium *Bacillus thuringiensis*. See BIOTECHNOLOGY; GENETIC ENGINEERING. [C.R.Ca.; C.A.H.; J.E.Ba.]

**Agronomy** The science and study of crops and soils. Agronomy is the umbrella term for a number of technical research and teaching activities: crop physiology and management, soil science, plant breeding, and weed management frequently are included in agronomy; soil science may be treated separately; and vegetable and fruit crops generally are not included. Thus, agronomy refers to extensive field cultivation of plant species for human food, livestock and poultry feed, fibers, oils, and certain industrial products. See AGRICULTURE.

Agronomic studies include some basic research, but the specialists in this field concentrate on applying information from the more basic disciplines, among them botany, chemistry, genetics, mathematics, microbiology, and physiology. Agronomists also interact closely with specialists in other applied areas such as ecology, entomology, plant pathology, and weed science. The findings of these collaborative efforts are tested and recommended to farmers through agricultural extension agents or commercial channels to bring this knowledge into practice. This



critical area is now focused on the efficiency of resource use, profitability of management practices, and minimization of the impact of farming on the immediate and the off-farm environment. See AGRICULTURAL SOIL AND CROP PRACTICES; AGROECOSYSTEM; SOIL CONSERVATION. [C.A.F.]

**Aharonov-Bohm effect** The predicted effect of an electromagnetic vector or scalar potential in electronic interference phenomena, in the absence of electric or magnetic fields on the electrons.

The fundamental equations of motion for a charged object are usually expressed in terms of the magnetic field  $\vec{B}$  and the electric field  $\vec{E}$ . The force  $\vec{F}$  on a charged particle can be conveniently written as in the equations below, where  $q$  is the particle's charge,

$$\vec{F} = q\vec{E} \quad \vec{F} = q\vec{v} \times \vec{B}$$

$\vec{v}$  is its velocity, and the symbol  $\times$  represents the vector product. Associated with  $\vec{E}$  is a scalar potential  $V$  defined at any point as the work  $W$  necessary to move a charge from minus infinity to that point,  $V = W/q$ . Generally, only the difference in potentials between two points matters in classical physics, and this potential difference can be used in computing the electric field. Similarly, associated with  $\vec{B}$  is a vector potential  $\vec{A}$ , a convenient mathematical aid for calculating the magnetic field. See CALCULUS OF VECTORS; ELECTRIC FIELD; MAGNETIC FIELD; POTENTIALS.

In quantum mechanics, however, the basic equations that describe the motion of all objects contain  $\vec{A}$  and  $V$  directly, and they cannot be simply eliminated. Nonetheless, it was initially believed that these potentials had no independent significance. In 1959, Y. Aharonov and D. Bohm discovered that both the scalar and vector potentials should play a major role in quantum mechanics. They proposed two electron interference experiments in which some of the electron properties would be sensitive to changes of  $\vec{A}$  or  $V$ , even when there were no electric or magnetic fields present on the charged particles. The absence of  $\vec{E}$  and  $\vec{B}$  means that classically there are no forces acting on the particles, but quantum-mechanically it is still possible to change the properties of the electron. These counterintuitive predictions are known as the Aharonov-Bohm effect.

Surprisingly, the Aharonov-Bohm effect plays an important role in understanding the properties of electrical circuits whose wires or transistors are smaller than a few micrometers. The electrical resistance in a wire loop oscillates periodically as the magnetic flux threading the loop is increased, with a period of  $h/e$  (where  $h$  is Planck's constant and  $e$  is the charge of the electron), the normal-metal flux quantum. In single wires, the electrical resistance fluctuates randomly as a function of magnetic flux. Both these observations, which were made possible by advances in the technology for fabricating small samples, reflect an Aharonov-Bohm effect. They have opened up a new field of condensed-matter physics because they are a signature that the electrical properties are dominated by quantum-mechanical behavior of the electrons, and that the rules of the classical physics are no longer operative. See QUANTUM MECHANICS. [R.A.Web.]

**Aileron** The hinged rear portion of an aircraft wing, moved differentially on each side of the aircraft to obtain lateral or roll control moments. The angular settings of the ailerons are controlled by the human or automatic pilot through the flight control system. Typical flap- and spoiler-type ailerons are shown in the illustration. See FLIGHT CONTROLS.

The operating principles of ailerons are the same as for all trailing-edge hinged control devices. Deflection of an aileron changes the effective camber, or airfoil curvature relative to the wing chord, of the entire wing forward of the aileron. With the trailing edge deflected upward, reduced local flow velocities are produced on the upper wing surface, and increased local flow velocities are produced on the lower wing surface. By Bernoulli's law, this results in a reduction of lift over the portion of the wing forward of the aileron, and on the aileron itself. Conversely,

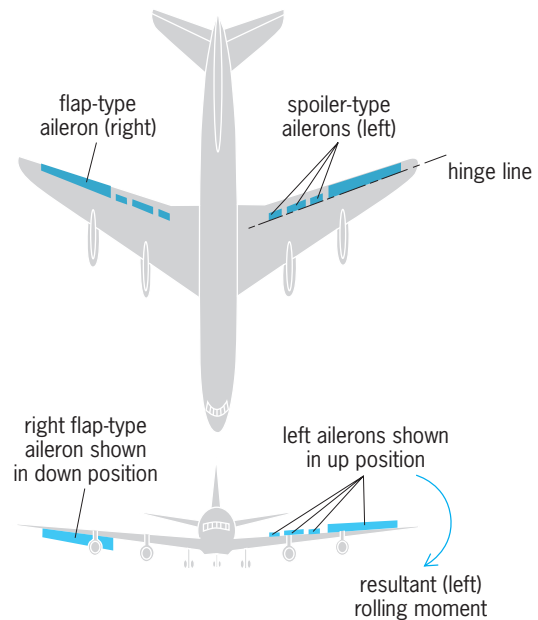

Flap- and spoiler-type ailerons on jet transport airplane.

trailing-edge down deflection of a flap-type aileron increases the lift in the same areas. Ailerons are located as close as possible to the wing tips, to maximize rolling moment by increasing the moment arm of the force due to the change in wing lift. In the case of flap-type ailerons, when the trailing edge is raised on one wing, say the left, the trailing edge of the aileron on the opposite or right wing is lowered by about the same amount. The decrease in lift on the left wing is accompanied by a lift increase on the right wing. While the net wing lift remains about the same, a rolling moment or torque about the aircraft's fore-and-aft axis develops in a left, or counterclockwise, direction as seen by the pilot.

Flap-type ailerons are replaced or supplemented by spoiler-type ailerons for a variety of reasons. Spoiler ailerons are usually installed forward of the landing flaps on commercial jet transports, in order to supplement aileron effectiveness during landing approaches, when the landing flaps are extended. Greatly reduced takeoff and landing speeds can be obtained by devoting the trailing edge of the entire wing to high-lift flaps. This is made possible by substituting spoilers for flap-type ailerons.

[M.J.A.]

**Air** A predominantly mechanical mixture of a variety of individual gases enveloping the terrestrial globe to form the Earth's atmosphere. In this sense air is one of the three basic components, air, water, and land (atmosphere, hydrosphere, and lithosphere), that interblend to form the life zone at the face of the Earth. See ATMOSPHERE. [C.V.C.]

**Air armament** That category of weapons which are typically delivered on target by fixed or rotary-wing aircraft, with the exception of nuclear weapons. Specifically included are guns and ammunition, rockets, free-fall bombs, cluster weapons that consist of a dispenser and submunitions, air-to-air and air-to-surface guided weapons, mines, and antiradiation missiles. Nuclear weapons such as the air-launched cruise missile and nuclear bombs, which are delivered by aircraft, are considered strategic weapons, a specific class of air armament.

The most widely used aircraft guns outside the former Communist countries are the French DEFA and British Aden 30-mm guns, followed by the United States 20-mm M61 Vulcan. The most modern aircraft guns are the 27-mm Mauser developed for multirole use on the German, Italian, and British multirole combat aircraft (MRCA) Tornado, and the large 30-mm GAU-8 and

GAU-13 antiarmor guns which carry high-explosive incendiary (HEI) and armor-piercing incendiary (API) ammunition.

Free rockets, or unguided rockets, developed during World War II, are more accurate than bombs but less accurate than guns. Although rocket systems are often considered obsolete, virtually all major powers maintain one or more in their arsenal. *See* ROCKET.

Conventional bombs employing TNT or TNT-based mixtures have been made in many types and sizes. Armor-piercing bombs were designed for use against concrete fortifications and submarine pens. Demolition bombs have thin steel cases and maximum explosive loads. General-purpose bombs are a compromise between armor-piercing and demolition. Bombs have been made to deliver virtually anything against any type of target. Some examples are incendiary bombs to ignite wooden buildings; napalm or jellied gasoline for use against anything that can be damaged by flame; underwater bombs for use against hydroelectric dams; cluster bombs, which separate and disperse to saturate an area; and leaflet bombs to deliver propaganda.

An entirely new class of aircraft armament known as cluster weapons has evolved since the 1950s. It is partly an outgrowth of cluster bombs from World War II and partly a result of the realization that many targets, notably personnel and light vehicles, could be destroyed more efficiently with several small bombs than with one large bomb. The primary advantage of cluster weapons over unitaries is their large footprint or area covered, which compensates for delivery errors and target uncertainty errors incurred by unguided weapons.

Although not normally included as part of the field of aircraft armament, fire control is the term that covers the sighting, aiming, and computation which enables the pilot or aircrew to hit the target. Basically, it examines the conditions of the engagement and indicates when to release the armament in order to obtain hits.

Guided weapons is a generic term which applies to any of the previously described ballistic systems when they are deliberately perturbed from their ballistic path after launch in order to increase the probability of hitting a target. There are three fundamental problems in guided weapons: determining where the target is or will be, determining where the weapon is, and correcting the weapon's location to coincide with the target's location at the time of closest encounter. The first two problems are called guidance; the third, control. Control is usually accomplished by aerodynamic-control-surface deflection. *See* AUTOPILOT; FLIGHT CONTROLS.

There are five fundamental concepts of guidance, namely inertial guidance, command guidance, active guidance, semiactive guidance, and passive guidance, and many different implementations of each. In command guidance, the weapon system operator or on-board sensors observe the relative location of weapon and target and direct trajectory corrections. In an active guidance system, electromagnetic emissions, for example, radar, microwave, or laser, are transmitted from the weapon to the target, and the return energy reflections are measured to determine range and angle to the target. Semiactive guidance resembles active guidance except that the illumination of the target is provided by a designator not located on the weapon. Passive guidance uses the natural emissions radiating from targets to uniquely acquire a target and subsequently guide the weapon to the target. *See* LIDAR; RADAR.

The ultimate objective of a weapon system is to be completely autonomous. An example of an autonomous system is one combining inertial and passive or active terminal guidance, and the appropriate algorithms to acquire the target after launch without operator intervention. In this case, the weapon is launched into an area where targets are known to exist, and, upon reaching the area, the weapon searches and finds its own target, homes in on it, and destroys it. The trend toward weapons that can autonomously acquire targets allows weapons to be built that have a substantial standoff capability which increases the survivability

of the launch platform, improves accuracy, increases proficiency, and reduces the logistical burden.

There are two classes of smart weapons. The first class consists of those guided weapons that possess some form of terminal guidance and home in on the target. Weapon systems in this class include laser-guided bombs. The second class of smart weapons includes those that autonomously acquire the target after launch, and are usually termed lock-on-after-launch, fire-and-forget, or brilliant weapons. [S.La.]

**Air brake** A friction type of energy-conversion mechanism used to retard, stop, or hold a vehicle or other moving element. The activating force is applied by a difference in air pressure. With an air brake, a slight effort by the operator can quickly apply full braking force. *See* FRICTION.

The air brake, operated by compressed air, is used in buses; heavy-duty trucks, tractors, and trailers; and off-road equipment. The air brake is required by law on locomotives and railroad cars. The wheel-brake mechanism is usually either a drum or a disk brake. The choice of an air brake instead of a mechanical, hydraulic, or electrical brake depends partly on the availability of an air supply and the method of brake control.

In a motor vehicle, the air-brake system consists of three subsystems: the air-supply, air-delivery, and parking/emergency systems. The air-supply system includes the compressor, reservoirs, governor, pressure gage, low-pressure indicator, and safety valve. The engine-driven compressor takes in air and compresses it for use by the brakes and other air-operated components. The compressor is controlled by a governor that maintains air compression within a preselected range. The compressed air is stored in reservoirs. The air-delivery system includes a foot-operated brake valve, one or more relay valves, the quick-release valve, and the brake chambers. The system delivers compressed air from the air reservoirs to the brake chambers, while controlling the pressure of the air. The amount of braking is thereby regulated. In the brake chambers, the air pressure is converted into a mechanical force to apply the brakes. As the pressure increases in each brake chamber, movement of the diaphragm pushrod forces the friction element against the rotating surface to provide braking. When the driver releases the brake valve, the quick-release valve and the relay valve release the compressed air from the brake chambers. The parking/emergency system includes a parking-brake control valve and spring brake chambers. These chambers contain a strong spring to mechanically apply the brakes (if the brakes are properly adjusted) when air pressure is not available. During normal vehicle operation, the spring is held compressed by system air pressure acting on a diaphragm. For emergency stopping, the air-brake system is split into a front brake system and a rear brake system. If air pressure is lost in the front brake system, the rear brake system will continue to operate. However, the supply air will be depleted after several brake applications. Loss of air pressure in the rear brake system makes the front brake system responsible for stopping the vehicle, until the supply air is depleted. [D.L.An.]

**Air conditioning** The control of certain environmental conditions including air temperature, air motion, moisture level, radiant heat energy level, dust, various pollutants, and microorganisms.

Comfort air conditioning refers to control of spaces to promote the comfort, health, or productivity of the inhabitants. Spaces in which air is conditioned for comfort include residences, offices, institutions, sports arenas, hotels, factory work areas, and motor vehicles. Process air-conditioning systems are designed to facilitate the functioning of a production, manufacturing, or operational activity.

A comfort air-conditioning system is designed to help maintain body temperature at its normal level without undue stress and to provide an atmosphere which is healthy to breathe. The heat-dissipating factors of temperature, humidity, air motion, and

radiant heat flow must be considered simultaneously. Within limits, the same amount of comfort (or, more objectively, of heat-dissipating ability) is the result of a combination of these factors in an enclosure. Conditions for constant comfort are related to the operative temperature. The perception of comfort is related to one's metabolic heat production, the transfer of this heat to the environment, and the resulting physiological adjustments and body temperature.

Engineering of an air-conditioning system starts with selection of design conditions; air temperature and relative humidity are principal factors. Next, loads on the system are calculated. Finally, equipment is selected and sized to perform the indicated functions and to carry the estimated loads.

Each space is analyzed separately. A cooling load will exist when the sum of heat released within the space and transmitted to the space is greater than the loss of heat from the space. A heating load occurs when the heat generated within the space is less than the loss of heat from it. Similar considerations apply to moisture. See AIR COOLING.

The rate at which heat is conducted through the building envelope is a function of the temperature difference across the envelope and the thermal resistance of the envelope (R value). Overall R values depend on materials of construction and their thickness along the path of heat flow, and air spaces with or without reflectances and emittances, and are evaluated for walls and roofs exposed to outdoors, and basements or slab exposed to earth. In some cases, thermal insulations may be added to increase the R value of the envelope.

Solar heat loads are an especially important part of load calculation because they represent a large percentage of heat gain through walls, windows, and roofs, but are very difficult to estimate because solar irradiation is constantly changing. See SOLAR RADIATION.

Humidity as a load on an air-conditioning system is treated by the engineer in terms of its latent heat, that is, the heat required to condense or evaporate the moisture, approximately 1000 Btu/lb (2324 kilojoules/kg) of moisture. People at rest or at light work generate about 200 Btu/h (586 W). Steaming from kitchen activities and moisture generated as a product of combustion of gas flames, or from all drying processes, must be calculated. As with heat, moisture travels through the space envelope, and its rate of transfer is calculated as a function of the difference in vapor pressure across the space envelope and the permeance of the envelope construction. See HUMIDITY CONTROL.

A complete air-conditioning system is capable of adding and removing heat and moisture and of filtering airborne substitutes, such as dust and odorants, from the space or spaces it serves. Systems that heat, humidify, and filter only, for control of comfort in winter, are called winter air-conditioning systems; those that cool, dehumidify, and filter only are called summer air-conditioning systems, provided they are fitted with proper controls to maintain design levels of temperature, relative humidity, and air purity. See AIR FILTER.

Built-up or field-erected systems are composed of factory-built subassemblies interconnected by means such as piping, wiring, and ducting during final assembly on the building site. Their capacities range up to thousands of tons of refrigeration and millions of Btu per hour of heating. Most large buildings are so conditioned.

There are three principal types of central air-conditioning systems: all-air, all-water, and air-processed in a central air-handling apparatus. In one type of all-air system, called dual-duct, warm air and chilled air are supplied to a blending or mixing unit in each space. In a single-duct all-air system, air is supplied at a temperature for the space requiring the coldest air, then reheated by steam or electric or hot-water coils in each space. [R.L.K.; E.C.Sh.]

**Air cooling** Lowering of air temperature for comfort, process control, or food preservation. Air and water vapor occur together in the atmosphere. The mixture is commonly cooled

by direct convective heat transfer of its internal energy (sensible heat) to a surface or medium at lower temperature. In the most compact arrangement, transfer is through a finned (extended surface) coil, metallic and thin, inside of which is circulating either chilled water, antifreeze solution, brine, or boiling refrigerant. The fluid acts as the heat receiver. Heat transfer can also be directly to a wetted surface, such as water droplets in an air washer or a wet pad in an evaporative cooler. See AIR CONDITIONING; HEAT TRANSFER.

For evaporative cooling, nonsaturated air is mixed with water. Some of the sensible heat transfers from the air to the evaporating water. The heat then returns to the airstream as latent heat of water vapor. The technique is employed for air cooling of machines where higher humidities can be tolerated; for cooling of industrial areas where high humidities are required, as in textile mills; and for comfort cooling in hot, dry climates, where partial saturation results in cool air at relatively low humidity. See HUMIDITY.

In the evaporative cooler the air is constantly changed and the water is recirculated, except for that portion which has evaporated and which must be made up. Water temperature remains at the adiabatic saturation (wet-bulb) temperature. If water temperature is controlled, as by refrigeration, the leaving air temperature can be controlled within wide limits. Entering warm, moist air can be cooled below its dew point so that, although it leaves close to saturation, it leaves with less moisture per unit volume of air than when it entered. An apparatus to accomplish this is called an air washer. It is used in many industrial and comfort air-conditioning systems, and performs the added functions of cleansing the airstream of dust and of gases that dissolve in water, and in winter, through the addition of heat to the water, of warming and humidifying the air.

The most important form of air cooling is by finned coils, inside of which circulates a cold fluid or cold, boiling refrigerant (see illustration). The latter is called a direct-expansion (DX) coil. In most applications the finned surfaces become wet as condensation occurs simultaneously with sensible cooling. Usually, the required amount of dehumidification determines the temperature at which the surface is maintained and, where this results in air that is colder than required, the air is reheated to the proper temperature. Droplets of condensate are entrained in the airstream, removed by a suitable filter (eliminator), collected in a drain pan, and wasted.

Well water is available for air cooling in much of the world. Temperature of water from wells 30 to 60 ft (10 to 20 m) deep is approximately the average year-round air temperature in the locality of the well. For installations that operate only occasionally, such as some churches and meeting halls, water recirculated and cooled over ice offers an economical means for space cooling.

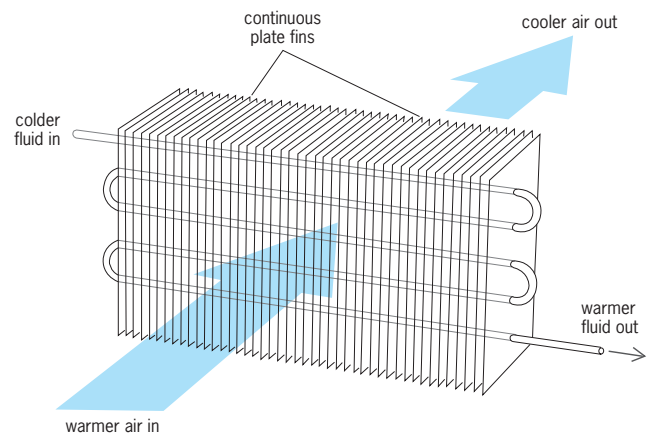

Typical extended-surface air-cooling coil.

## 50 Air-cushion vehicle

Where electric power is readily available, the cooling function of the ice is performed by a mechanical refrigerator. [R.L.K.]

**Air-cushion vehicle** A transportation vehicle, also called a hovercraft, that rides slightly above the Earth's surface on a cushion of air. The air is continuously forced under the vehicle by a fan, generating the cushion that greatly reduces friction between the moving vehicle and the surface. The air is usually delivered through ducts and injected at the periphery of the vehicle in a downward and inward direction. The design of the vehicle's underside, combined with seals or skirts attached below the hull around the perimeter, restrains the air, creating the cushion. Because the vehicle is not in contact with the surface, it has six dimensions of motion. See DEGREE OF FREEDOM (MECHANICS); DUCTED FAN.

Generally, an air-cushion vehicle is an amphibious aerostatic craft capable of slight vertical lift regardless of forward speed. This type of air-cushion vehicle can operate equally well over ice, water, marsh, or relatively level land. A variation is the surface-effect ship (SES), which has rigid side hulls that ride in the water like a catamaran, containing the air cushion and reducing air loss. See AERODYNAMIC FORCE; AEROSTATICS.

Commercial uses of air-cushion vehicles include transportation, supply, and pipeline and cable inspection and maintenance. In scheduled service, large air-cushion vehicles have been used to ferry cars and passengers across the English Channel (Fig. 1). Military missions of air-cushion vehicles, which can be lightly armed, include patrolling, and transporting troops and equipment from ship to shore and across the beach. Small air-cushion vehicles are available in single-seat, two-seat, and four-seat versions. Most are personal sport craft for recreational use on land or over calm water. Air-cushion vehicles of various sizes and maximum speeds are employed by government agencies in law enforcement, fire fighting, and disaster relief. See NAVAL SURFACE SHIP.



Fig. 2. Wing-in-ground-effect craft used over water as a commuter vehicle. (FlareCRAFT Corp.)

Another type of vehicle relying on a cushion of air for support is the wing-in-ground-effect (WIG) craft, also called the wing-in-surface-effect (WISE) craft. Similar in design to an aircraft, the ground-effect craft is an aerodynamic vehicle that generally travels only over water and requires forward speed to provide lift. It is designed to take advantage of two characteristics of an airfoil moving through air while close to the surface: (1) Air pressure builds up under the wing, producing greater lift than if the wing were in conventional flight; and (2) the induced drag of the wing is less than in conventional flight because wingtip vortices are weaker and downwash angle decreases. The result is an increase in the ratio of lift to drag when a craft is flying in ground effect. See AERODYNAMIC FORCE; AERODYNAMICS; AIRCRAFT; AIRCRAFT DESIGN; AIRFOIL; AIRPLANE.

Several types and sizes of wing-in-ground-effect vehicles are available (Fig. 2). Some designs utilize composite construction and are comparable in performance with hydrofoils. See HYDROFOIL CRAFT. [D.L.An.]

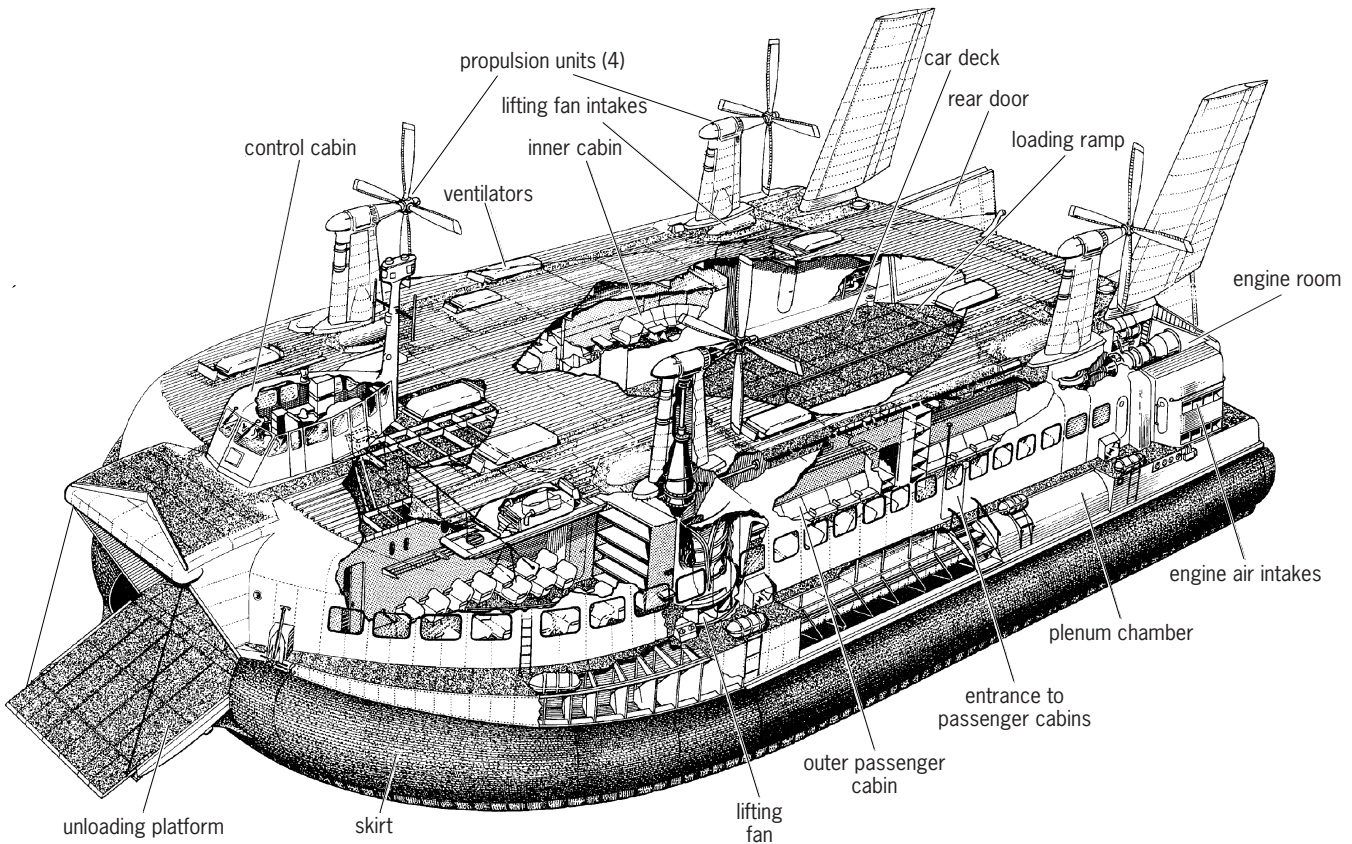

Fig. 1. Air-cushion vehicle used to transport cars and passengers across the English Channel. (British Hovercraft Corp.)

**Air filter** A component of most systems in which air is used for industrial processes, for ventilation, or for comfort air conditioning. The function of an air filter is to reduce the concentration of solid particles in the airstream to a level that can be tolerated by the process or space occupancy purpose. See VENTILATION.

Solid particles in the airstream range in size from 0.01 micrometer to objects that can be caught by ordinary fly screens, such as lint, feathers, and insects. The particles generally include soot, ash, soil, lint, and smoke, but may include almost any organic or inorganic material, even bacteria and mold spores. This wide variety of airborne contaminants, added to the diversity of systems in which air filters are used, makes it impossible to have one type that is best for all applications.

Three basic types of air filters are in common use: viscous impingement, dry, and electronic. The principles employed by these filters in removing airborne solids are viscous impingement, interception, impaction, diffusion, and electrostatic precipitation. Some filters utilize only one of these principles; others employ combinations. A fourth method, inertial separation, is finding increasing use as a result of the construction boom throughout most of the Middle East. [M.A.B.]

**Air heater** A component of a steam-generating unit that absorbs heat from the products of combustion after they have passed through the steam-generating and superheating sections. Heat recovered from the gas is recycled to the furnace by the combustion air and is absorbed in the steam-generating unit, with a resultant gain in overall thermal efficiency. Use of preheated combustion air also accelerates ignition and promotes rapid burning of the fuel. Air heaters often are used in conjunction with economizers, because the temperature of the inlet air is less than that of the feedwater to the economizer, and in this way it is possible to reduce further the temperature of flue gas before it is discharged to the stack. See BOILER ECONOMIZER. [G.W.K.]

**Air mass** In meteorology, an extensive body of the atmosphere which is relatively homogeneous horizontally. An air mass may be followed on the weather map as an entity in its day-to-day movement in the general circulation of the atmosphere. The expressions air mass analysis and frontal analysis are applied to the analysis of weather maps in terms of the prevailing air masses and of the zones of transition and interaction (fronts) which separate them.

The relative horizontal homogeneity of an air mass stands in contrast to sharper horizontal changes in a frontal zone. The horizontal extent of important air masses is reckoned in millions of square miles. In the vertical dimension an air mass extends at most to the top of the troposphere, and frequently is restricted to the lower half or less of the troposphere. See FRONT; METEOROLOGY; WEATHER MAP.

The occurrence of air masses as they appear on the daily weather maps depends upon the existence of air-mass source regions, areas of the Earth's surface which are sufficiently uniform that the overlying atmosphere acquires similar characteristics throughout the region. See ATMOSPHERIC GENERAL CIRCULATION.

The thermodynamic properties of air mass determine not only the general character of the weather in the extensive area that it covers, but also to some extent the severity of the weather activity in the frontal zone of interaction between air masses. Those properties which determine the primary weather characteristics of an air mass are defined by the vertical distribution of water vapor and heat (temperature). On the vertical distribution of water vapor depend the presence or absence of condensation forms and, if present, the elevation and thickness of fog or cloud layers. On the vertical distribution of temperature depend the relative warmth or coldness of the air mass and, more importantly, the vertical gradient of temperature, known as the lapse rate. The lapse rate determines the stability or instability of the air mass for thermal convection and consequently, the stratiform or convective cellular structure of the cloud forms and precipita-

tion. The most unstable moist air mass is characterized by severe turbulence and heavy showers or thundershowers. In the most stable air mass there is observed an actual increase (inversion) of temperature with increase of height at low elevations. See TEMPERATURE INVERSION. [H.C.Wi.; E.Ke.]

**Air navigation** The process of planning and directing the progress of an aircraft between selected geographic points or over a selected route. The primary tasks involved are planning the flight, guiding it safely along the desired route, conforming with the rules of flight and with special procedures such as noise abatement, and maximizing fuel efficiency.

The simplest form of air navigation is pilotage, in which the pilot directs the aircraft by visual reference to objects on the ground. More complex methods rely upon navigational aids external to the aircraft or upon self-contained, independent systems. See PILOTAGE.

Dead reckoning is the process of estimating one's current position from measurements of the change in position since the last accurate position fix. In an aircraft, dead reckoning requires an airspeed indicator, outside-air-temperature gage, altimeter, clock, compass, and chart (map). The high accuracy and the increasing availability of real-time satellite based position fixes will eventually relegate dead reckoning to a backup role used primarily during outages of high quality satellite signals. See DEAD RECKONING.

**Flight planning.** Air navigation begins with a flight plan. For a flight in visual meteorological conditions (VMC), a simple plan may start with drawing a course line on a specially designed aeronautical chart between the point of departure and the destination. From the chart and the course line, the pilot, using a protractor, determines the true course (in degrees clockwise from true north), magnetic variation, and distance to be flown, usually in nautical miles. Following a preflight weather briefing, the pilot has the necessary facts to prepare a simple flight plan: wind direction and velocity, which were included in the briefing; true course, which was determined from the course line on the chart; and true airspeed, which is calculated by applying the corrections for temperature and altitude to the indicated airspeed. With the wind, true course, and true airspeed, the pilot can construct a wind triangle to determine the effect of the wind on speed and heading. With the planned groundspeed and the distance to be flown in miles, the pilot can compute the flight time and the fuel required. Extra fuel is added to assure an adequate reserve upon landing.

The process assumes greater complexity for a higher-performance aircraft, for a longer flight, or for a flight in adverse weather. The flight plan of a commercial jet is commonly prepared on a large specially programmed computer.

Air navigation is three-dimensional, and selection of a flight altitude is an important part of the planning process. Light, piston-engine aircraft are usually operated at altitudes of 10,000 ft (3000 m) or less, while jet aircraft commonly operate at much higher altitudes, where they may take advantage of the jet's increased fuel economy. During flight planning for large turboprop and jet aircraft, the time en route and the fuel used at various altitudes or over different routes are often compared to select the optimum altitude and route.

**Altimetry.** Aircraft altitude may be obtained from a barometric altimeter, a radio altimeter, or the Global Positioning System (GPS). A barometric altimeter translates the linear pressure changes experienced during climbs or descents into an indication of aircraft altitude. A radio altimeter (also known as a radar altimeter) shows actual altitude above the terrain immediately below the aircraft. The Global Positioning System is designed to provide accurate altitude information, unaffected by the errors found in barometric altimetry.

**Navigation charts.** All navigation requires special maps or charts such as topographic maps intended for pilotage or radio navigation charts intended to be used with ground radio aids. Aeronautical maps such as sectional charts show terrain contours

**Electronic navigation systems**

System	Frequency band
VOR*	108–118 MHz
DME*, TACAN	960–1215 MHz
ILS localizer*	108–112 MHz
ILS glideslope*	329–335 MHz
Doppler radar	10–20 GHz
Loran-C	90–110 kHz
MLS	5.0–5.25 GHz
GPS	1227, 1575 MHz
ADF/NDB*	190–1600 kHz
Weather radar	5, 9 GHz

\*Internationally standardized systems.

and the elevation of significant terrain and other obstacles, such as mountain peaks, buildings, and television towers.

**Operational air navigation.** The operational phase of air navigation commences with the preflight cockpit check of clocks, radios, compasses, and other flight and navigation equipment.

After the flight is on course toward the first fix, the pilot's primary navigational task is to assure that the aircraft stays on course. If navigation is by pilotage, the pilot frequently checks the aircraft's position by reference to topographic features on the aeronautical chart being used, and the aircraft's heading is corrected as necessary to follow the course. Using dead reckoning, the pilot estimates the time that the aircraft is expected to be over the next fix, based on the speed thus far made good and the speed anticipated over the next segment.

The most common form of en route navigation over land masses in the western world uses a network of very high-frequency (VHF) omnidirectional radio range (VOR) stations. VOR transmitters are spaced at strategic intervals, averaging about 100 mi (160 km) between stations within the United States, but sometimes much farther apart. Designated routes between VOR stations are referred to as airways.

VOR transmitters emit a directional signal which can be received and interpreted by suitably equipped aircraft. The pilot can then determine the direction from the ground station to the aircraft, measured in degrees magnetic and referred to as a radial. Distance from the station is displayed when a distance-measuring equipment (DME) transmitter is colocated with the VOR. An airway is defined by a series of VOR stations along an airway route. Modern automatic pilots can follow the selected VOR radial automatically, leaving the human pilot to monitor the flight and make necessary adjustments as succeeding stations are selected along the route. *See* AUTOPILOT; DISTANCE-MEASURING EQUIPMENT; VOR (VHF OMNIDIRECTIONAL RANGE).

A high-altitude jet starts descending miles from the landing airport. Unpressurized aircraft carrying passengers fly much lower, but their descent must be more gradual to minimize passenger discomfort in adjusting to the change in atmospheric pressure. Regardless of the aircraft type, the pilot estimates as accurately as possible the time and point to start descending. Every instrument approach for landing has its own chart, containing such things as the radio frequency and identification of the aids to be used, altitudes to be observed at various points during the approach, heading of the final approach course, minimum weather conditions required for the approach, missed approach instructions, and airport altitude.

The preferred aid for instrument landing use is ILS. It consists of two separate radio beams: one called the localizer is aligned very precisely with the runway centerline, and the other called the glideslope is projected upward at a slight angle from the landing touchdown point on the runway. By following the two beams very closely on the cockpit instruments, the pilot can line up with the runway and descend safely for landing, regardless of weather.

**Additional navigation aids and systems.** The navigation systems discussed thus far—VOR for en route use and ILS for terminal use—are sometimes augmented or replaced by other

navigational equipment and systems. These systems are particularly useful for long-distance flights or when more conventional navigational aids are minimal or nonexistent. The table lists the principal frequency bands that are used by the electronic systems discussed, and indicates which systems are internationally standardized. [D.E.C.]

**Air pollution** The presence in the atmospheric environment of natural and artificial substances that affect human health or well-being, or the well-being of any other specific organism. Pragmatically, air pollution also applies to situations where contaminants impact structures and artifacts or esthetic sensibilities (such as visibility or smell). Most artificial impurities are injected into the atmosphere at or near the Earth's surface. The lower atmosphere (troposphere) cleanses itself of some of these pollutants in a few hours or days as the larger particles settle to the surface and soluble gases and particles encounter precipitation or are removed through contact with surface objects. Unfortunately, removal of some pollutants (for example, sulfates and nitrates) by precipitation and dry deposition results in acid deposition, which may cause serious environmental damage. Also, mixing of the pollutants into the upper atmosphere may dilute the concentrations near the Earth's surface, but can cause long-term changes in the chemistry of the upper atmosphere, including the ozone layer. *See* ATMOSPHERE; TROPOSPHERE.

**Types of sources.** Sources may be characterized in a number of ways. First, a distinction may be made between natural and anthropogenic sources. Another frequent classification is in terms of stationary (power plants, incinerators, industrial operations, and space heating) and moving (motor vehicles, ships, aircraft, and rockets) sources. Another classification describes sources as point (a single stack), line (a line of stacks), or area (city).

Different types of pollution are conveniently specified in various ways: gaseous, such as carbon monoxide, or particulate, such as smoke, pesticides, and aerosol sprays; inorganic, such as hydrogen fluoride, or organic, such as mercaptans; oxidizing substances, such as ozone, or reducing substances, such as oxides of sulfur and oxides of nitrogen; radioactive substances, such as iodine-131; inert substances, such as pollen or fly ash; or thermal pollution, such as the heat produced by nuclear power plants.

Air contaminants are produced in many ways and come from many sources; it is difficult to identify all the various producers. Also, for some pollutants such as carbon dioxide and methane, the natural emissions sometimes far exceed the anthropogenic emissions.

Both anthropogenic and natural emissions are variable from year to year, depending on fuel usage, industrial development, and climate. In some countries where pollution control regulations have been implemented, emissions have been significantly reduced. For example, in the United States sulfur dioxide emissions dropped by about 30% between 1970 and 1992, and carbon monoxide (CO) emissions were cut by over 30% in the same period. However, in some developing countries emissions continually rise as more cars are put on the road and more industrial facilities and power plants are constructed. In dry regions, natural emissions of nitrogen oxides (NO<sub>x</sub>), carbon dioxide (CO<sub>2</sub>), and hydrocarbons can be greatly increased during a season with high rainfall and above-average vegetation growth.

The anthropogenic component of most estimates of the methane budget is about two-thirds. Ruminant production and emissions from rice paddies are regarded as anthropogenic because they result from human agricultural activities. The perturbations to carbon dioxide since the industrial revolution are also principally the result of human activities. These emissions have not yet equilibrated with the rest of the carbon cycle and so have had a profound effect on atmospheric levels, even though emissions from fossil fuel combustion are dwarfed by natural emissions.

**Effects.** The major concern with air pollution relates to its effects on humans. Since most people spend most of their time indoors, there has been increased interest in air-pollution concentrations in homes, workplaces, and shopping areas. Much of the early information on health effects came from occupational health studies completed prior to the implementation of general air-quality standards.

Air pollution principally injures the respiratory system, and health effects can be studied through three approaches, clinical, epidemiological, and toxicological. Clinical studies use human subjects in controlled laboratory conditions, epidemiological studies assess human subjects (health records) in real-world conditions, and toxicological studies are conducted on animals or simple cellular systems. Of course, epidemiological studies are the most closely related to actual conditions, but they are the most difficult to interpret because of the lack of control and the subsequent problems with statistical analysis. Another difficulty arises because of differences in response among different people. For example, elderly asthmatics are likely to be more strongly affected by sulfur dioxide than the teenage members of a hiking club. See EPIDEMIOLOGY.

Damage to vegetation by air pollution is of many kinds. Sulfur dioxide may damage field crops such as alfalfa and trees such as pines, especially during the growing season (Fig. 1). Both hydrogen fluoride (HF) and nitrogen dioxide (NO<sub>2</sub>) in high concentrations have been shown to be harmful to citrus trees and ornamental plants, which are of economic importance in central Florida. Ozone and ethylene are other contaminants that cause damage to certain kinds of vegetation.

Air pollution can affect the dynamics of the atmosphere through changes in longwave and shortwave radiation processes. Particles can absorb or reflect incoming short-wave solar radiation, keeping it from the Earth's surface during the day. Greenhouse gases can absorb long-wave radiation emitted by the Earth's surface and atmosphere.

Carbon dioxide, methane, fluorocarbons, nitrous oxides, ozone, and water vapor are important greenhouse gases. These represent a class of gases that selectively absorb long-wave radiation. This effect warms the temperature of the Earth's atmosphere and surface higher than would be found in the absence of an atmosphere (the greenhouse effect). Because the amount of greenhouse gases in the atmosphere is rising, there is a possibility that the temperature of the atmosphere will gradually rise, possibly resulting in a general warming of the global climate over a time period of several generations. See GREENHOUSE EFFECT.

Researchers are also concerned with pollution of the stratosphere (10–50 km or 6–30 mi above the Earth's surface) by aircraft and by broad surface sources. The stratosphere is important, because it contains the ozone layer, which absorbs part of the Sun's short-wave radiation and keeps it from reaching the surface. If the ozone layer is significantly depleted, an increase in skin cancer in humans is expected. Each 1% loss of ozone is estimated to increase the skin cancer rate 3–6%. See STRATOSPHERE.

Visibility is reduced as concentrations of aerosols or particles increase. The particles do not just affect visibility by themselves but also act as condensation nuclei for cloud or haze formation. In each of the three serious air-pollution episodes discussed above, smog (smoke and fog) were present with greatly reduced visibility.

**Chemistry.** Air pollution can be divided into primary and secondary compounds, where primary pollutants are emitted directly from sources (for example, carbon monoxide, sulfur dioxide) and secondary pollutants are produced by chemical reactions between other pollutants and atmospheric gases and particles (for example, sulfates, ozone). Most of the chemical transformations are best described as oxidation processes. In many cases these secondary pollutants can have significant environmental effects, such as acid rain and smog.

Smog is the best-known example of secondary pollutants formed by photochemical processes, as a result of primary emissions of nitric oxide (NO) and reactive hydrocarbons from an-

thropogenic sources such as transportation and industry as well as natural sources. Energy from the Sun causes the formation of nitrogen dioxide, ozone (O<sub>3</sub>), and peroxyacetalnitrate, which cause eye irritation and plant damage.

It has been shown that when emissions of sulfur dioxide and nitrogen oxide from tall power plant and other industrial stacks are carried over great distances and combined with emissions from other areas, acidic compounds can be formed by complex chemical reactions. In the absence of anthropogenic pollution sources, the average pH of rain is around 5.6 (slightly acidic). In the eastern United States, acid rain with a pH less than 5.0 has been measured and consists of about 65% dilute sulfuric acid, 30% dilute nitric acid, and 5% other acids. [S.R.H.; P.J.S.]

**Air pollution, indoor** The presence of gaseous and particulate contaminants in the indoor environment. Most pollution is due to human (anthropomorphic) sources. Natural sources do exist, including plants, animals, and other living organisms, and water sources that release various chemical aerosols. Contamination can occur from infiltration indoors of atmospheric pollutants generated outdoors, and thus the indoor environment is affected by meteorological conditions.

Natural sources are soils and water that release radon progeny, volatile organic compounds, fungi, and such. Chemical releases (emissions) originate from various types of appliances, combustion sources (including those in garages), building materials and water, and living organisms that release allergens (for example, dander from pets). Carbon dioxide (CO<sub>2</sub>) is generated by combustion and living organisms. Other sources involve molds, microorganisms (such as bacteria and viruses), insects and arthropods, and pollen from outdoor and indoor plants. Human activity has been noted to increase air contamination from all of these sources. Some pollutants are individually generated such as tobacco smoke or are generated through use of consumer products. See PARTICULATES; RADON.

The generation and behavior of pollutants from sources in enclosed environments are also affected by most meteorological factors. Indoor environments are often sealed to the extent that the weather is cold or hot. Infiltration of pollutants is affected also by climate, temperature, humidity, barometric pressure, and wind speed and direction. The small particles and the gases that infiltrate most, that is, nitrogen oxide (NO<sub>x</sub>) and volatile organic compounds, are affected by outdoor concentrations, tightness (being sealed, with little air exchange), operation of heating and cooling systems, convection currents, full growth (or lack thereof) of local trees and shrubs, and so forth. Indoor environments also possess individual characteristics of ventilation, dispersion, and deposition. Some gases, for example, sulfur dioxide (SO<sub>2</sub>) and ozone (O<sub>3</sub>), infiltrating the indoor environment are absorbed readily by materials and exist in high concentrations only when the outdoor concentrations are very high. Chemical-physical mass-balance models are used to estimate pollutant concentrations, as are statistical models. See AEROSOL; OZONE. [M.D.L.]

**Air pressure** The force per unit area that the air exerts on any surface in contact with it, arising from the collisions of the air molecules with the surface. It is equal and opposite to the pressure of the surface against the air, which for atmospheric air in normal motion approximately balances the weight of the atmosphere above, about 15 pounds per square inch (psi) at sea level. It is the same in all directions and is the force that balances the weight of the column of mercury in the Torricellian barometer, commonly used for its measurement. See BAROMETER.

The units of pressure traditionally used in meteorology are based on the bar, defined as equal to 1,000,000 dynes/cm<sup>2</sup>. One bar equals 1000 millibars or 100 centibars.

In the meter-kilogram-second or International System of Units (SI), the unit of force, the pascal (Pa), is equal to 1 newton/m<sup>2</sup>. One millibar equals 100 pascals. The normal pressure at sea level is 1013.25 millibars or 101.325 kilopascals.

Also widely used in practice are units based on the height of the mercury barometer under standard conditions, expressed commonly in millimeters or in inches. The standard atmosphere (760 mmHg) is also used as a unit, mainly in engineering, where large pressures are encountered. The following equivalents show the conversions between the commonly used units of pressure, where (mmHg)<sub>n</sub> and (in. Hg)<sub>n</sub> denote the millimeter and inch of mercury, respectively, under standard (normal) conditions, and where (kg)<sub>n</sub> and (lb)<sub>n</sub> denote the weight of a standard kilogram and pound mass, respectively, under standard gravity.

$$\begin{aligned}
 1 \text{ kPa} &= 10 \text{ millibars} = 1000 \text{ N/m}^2 \\
 &= 7.50062 \text{ (mmHg)}_n \\
 &= 0.295300 \text{ (in. Hg)}_n \\
 1 \text{ millibar} &= 100 \text{ Pa} = 1000 \text{ dynes/cm}^2 \\
 &= 0.750062 \text{ (mmHg)}_n \\
 &= 0.0295300 \text{ (in. Hg)}_n \\
 1 \text{ atm} &= 101.325 \text{ kPa} = 1013.25 \text{ millibars} \\
 &= 760 \text{ (mmHg)}_n = 29.9213 \text{ (in. Hg)}_n \\
 &= 14.6959 \text{ (lb)}_n/\text{in.}^2 \\
 &= 1.03323 \text{ (kg)}_n/\text{cm}^2 \\
 1 \text{ (mmHg)}_n &= 1 \text{ torr} = 0.03937008 \text{ (in. Hg)}_n \\
 &= 1.333224 \text{ millibars} \\
 &= 133.3224 \text{ Pa} \\
 1 \text{ (in. Hg)}_n &= 33.8639 \text{ millibars} \\
 &= 25.4 \text{ (mmHg)}_n \\
 &= 3.38639 \text{ kPa}
 \end{aligned}$$

Because of the almost exact balancing of the weight of the overlying atmosphere by the air pressure, the latter decreases with height. A standard equation is used in practice to calculate the vertical distribution of pressure with height above sea level. The temperature distribution in a standard atmosphere, based on mean values in middle latitudes, has been defined by international agreement. The use of the standard atmosphere yields a definite relation between pressure and height. This relation is used in all altimeters which are basically barometers of the aneroid type. The difference between the height estimated from the pressure and the actual height is often considerable; but since the same standard relationship is used in all altimeters, the difference is the same for all altimeters at the same location, and so causes no difficulty in determining the relative position of aircraft. Mountains, however, have a fixed height, and accidents have been caused by the difference between the actual and standard atmosphere. See ALTIMETER.

In addition to the large variation with height, atmospheric pressure varies in the horizontal and with time. The variations of air pressure at sea level, estimated in the case of observations over land by correcting for the height of the ground surface, are routinely plotted on a map and analyzed, resulting in the familiar weather map representation with its isobars showing highs and lows. The movement of the main features of the sea-level pressure distribution, typically from west to east, produces characteristic fluctuations of the pressure at a fixed point, varying by a few percent within a few days. Smaller-scale variations of sea-level pressure, too small to appear on the ordinary weather map, are also present. These are associated with various forms of atmospheric motion, such as small-scale wave motion and turbulence. Relatively large variations are found in and near thunderstorms, the most intense being the low-pressure region in a tornado. The pressure drop within a tornado can be a large fraction of an atmosphere, and is the principal cause of the explosion of buildings over which a tornado passes. See WEATHER MAP.

It is a general rule that in middle latitudes at localities below 1000 m (3280 ft) in height above sea level, the air pressure on the continents tends to be slightly higher in winter than in spring, summer, and autumn; whereas at considerably greater heights on the continents and on the ocean surface, the reverse is true.

The practical importance of air pressure lies in its relation to the wind and weather. It is because of these relationships that pressure is a basic parameter in weather forecasting, as is evident from its appearance on the ordinary weather map.

The large-scale variations of pressure at sea level shown on a weather map are associated with characteristic patterns of vertical motion of the air, which in turn affect the weather. Descent of air in a high heats the air and dries it by adiabatic compression, giving clear skies, while the ascent of air in a low cools it and causes it to condense and produce cloudy and rainy weather. These processes at low levels, accompanied by others at higher levels, usually combine to justify the clear-cloudy-rainy marking on the household barometer. [R.J.D.; E.Ke.]

**Air register** A device attached to an air-distributing duct for the purpose of discharging air into the space to be heated or cooled. These openings are referred to as registers, diffusers, supply outlets, or grills (see illustration). By common acceptance, a register is an opening provided with means for discharging the air in a confined jet, whereas a diffuser is an outlet which discharges the air in a spreading jet. Both registers and diffusers may be placed at a number of locations in a room, including the floor, baseboard, low on the sidewall, window sill, high on the sidewall, or ceiling.



One of the more common diffusers, a round ceiling type. (Titus Manufacturing Corp.)

For heating, the preferred location is in the floor, at the baseboard, or at the low sidewall of the outside wall, preferably under a window. For cooling, the preferred location is high on the inside wall or the ceiling. For year-round air conditioning in homes, a compromise location is the floor, baseboard, or low sidewall at the exposed wall, especially if adequate air velocity in an upward direction is provided at the supply outlet. [S.Ko.]

**Air separation** Separation of atmospheric air into its primary constituents. Nitrogen, oxygen, and argon are the primary constituents of air. Small quantities of neon, helium, krypton, and xenon are present at constant concentrations and can be separated as products. Varying quantities of water, carbon dioxide, hydrocarbons, hydrogen, carbon monoxide, and trace environmental impurities (sulfur and nitrogen oxides, chlorine) are present depending upon location and climate. Typical quantities are shown in the table. These impurities are removed during air separation to maximize efficiency and avoid hazardous operation. See AIR; ARGON; HELIUM; KRYPTON; NEON; XENON.

Three different technologies are used for the separation of air: cryogenic distillation, ambient temperature adsorption, and membrane separations. The latter two have evolved to full commercial status. Membrane technology is economical for the production of nitrogen and oxygen-enriched air (up to about 40% oxygen) at small scale. Adsorption technology produces nitrogen



**Composition of dry air**

Component	Percent by volume	Component	Parts per million by volume
Nitrogen	78.084	Carbon dioxide	350–400
Oxygen	20.946	Neon	18.2
Argon	0.934	Helium	5.2
		Krypton	1.1
		Xenon	0.09
		Methane	1–15
		Acetylene	0–0.5
		Other hydrocarbons	0–5

and medium-purity oxygen (85–95% oxygen) at flow rates up to 100 tons/day. The cryogenic process can generate oxygen or nitrogen at flows of 2500 tons/day from a single plant and make the full range of products.

Air separation is a major industry. Nitrogen and oxygen rank second and third in the scale of production of commodity chemicals; and air is the primary source of argon, neon, krypton, and xenon. Oxygen is used for steel, chemicals manufacture, and waste processing. Important uses are in integrated gasification combined cycle production of electricity, waste water treatment, and oxygen-enriched combustion. Nitrogen provides inert atmospheres for fuel, steel, and chemical processing and for the production of semiconductors. [R.M.Th.]

**Air temperature** The temperature of the atmosphere represents the average kinetic energy of the molecular motion in a small region, defined in terms of a standard or calibrated thermometer in thermal equilibrium with the air. Many different types of thermometer are used for the measurement of air temperature, the most common depending on the expansion of mercury with temperature, the variation of electrical resistance with temperature, or the thermoelectric effect (thermocouple). See TEMPERATURE; THERMOMETER.

The temperature of a given small mass of air varies with time because of heat added or subtracted from it, and also because of work done during changes of volume.

The rate at which the temperature changes at a particular point, that is, as measured by a fixed thermometer, depends on the movement of air as well as physical processes such as absorption and emission of radiation, heat conduction, and changes of phase of water involving latent heat of condensation and freezing. The large changes of air temperature from day to day are mainly due to the horizontal movement of air, bringing relatively cold or warm air masses to a particular point, as the large-scale pressure-wind systems move across the weather map. See AIR MASS; AIR PRESSURE.

Temperatures near the surface are read at one or more fixed times daily, and the day's extremes are obtained from special maximum and minimum thermometers, or from the trace (thermogram) of a continuously recording instrument (thermograph). The average of these two extremes, technically the midrange, is considered in the United States to be the day's average temperature. The true daily mean, obtained from a thermogram, is closely approximated by the mean of 24 hourly readings, but may differ from the midrange by 1 or 2°F (0.6 or 1°C), on the average. In many countries temperatures are read daily at three or four fixed times, so that their weighted mean closely approximates the true daily mean.

Averages of daily maximum and minimum temperature for a single month for many years give mean daily maximum and minimum temperatures for that month. The average of these values is the mean monthly temperature, while their difference is the mean daily range for that month. Monthly means, averaged through the year, give the mean annual temperature; the mean annual range is the difference between the hottest and coldest mean monthly values. The hottest and coldest temperatures in a month are the monthly extremes; their averages over

a period of years give the mean monthly maximum and minimum (used extensively in Canada), while the absolute extremes for the month (or year) are the hottest and coldest temperatures ever observed. The interdiurnal range or variability for a month is the average of the successive differences, regardless of sign, in daily temperatures.

Over the oceans the mean daily, interdiurnal, and annual ranges are slight, because water absorbs the insolation and distributes the heat through a thick layer. In tropical regions the interdiurnal and annual ranges over the land are small also, because the annual variation in insolation is relatively small. The daily range also is small in humid tropical regions, but may be large (up to 40°F or 22°C) in deserts. Interdiurnal and annual ranges increase generally with latitude, and also with distance from the ocean; the mean annual range defines continentality. The daily range depends on aridity, altitude, and noon Sun elevation. See ATMOSPHERE; INSOLATION; RADIATION. [R.J.D.]

**Air-traffic control** A service to promote the safe, orderly, and expeditious flow of air traffic. Safety is principally a matter of preventing collisions with other aircraft, obstructions, and the ground; assisting aircraft in avoiding hazardous weather; assuring that aircraft do not operate in airspace where operations are prohibited; and assisting aircraft in distress. Orderly and expeditious flow assures the efficiency of aircraft operations along the routes selected by the operator. It is provided through the equitable allocation of system resources to individual flights.

In the United States, air-traffic control (ATC) is the product of the National Airspace System (NAS), comprising airspace; air navigation facilities and equipment; airports and landing areas; aeronautical charts, information, and publications; rules, regulations, and procedures; technical information; and personnel.

**Flight rules.** Two principal categories of rules governing air traffic are visual flight rules (VFR) and instrument flight rules (IFR). Visual flight rules govern the procedures for conducting flight where the visibility, the ceiling, and the aircraft distance from clouds are equal to or greater than established minima. Ceiling is the height above the Earth's surface of the lowest layer of clouds or obscuring phenomenon that significantly restricts visibility. The minima for operation under visual flight rules vary by airspace. In controlled airspace, the ceiling must be at least 1000 ft (305 m) and the visibility must be at least 3 statute miles (4830 m). The aircraft must remain clear of clouds, at least 500 ft (150 m) below, 1000 ft (305 m) above, and 2000 ft (610 m) horizontally. Instrument flight rules go into effect when visibility, distance from clouds, and ceiling conditions are less than the minima specified for visual flight rules. To operate under these rules, the pilot must pass an instrument flight examination and have an adequately instrumented aircraft.

Aircraft operating under visual flight rules (VFR aircraft) maintain separation from other aircraft visually. IFR aircraft in controlled airspace operate in accordance with clearances and instructions provided by air-traffic controllers for the purpose of maintaining separation and expediting the flow of traffic. Flight crews operating under instrument flight rules are responsible for seeing and avoiding other aircraft, but the air-traffic control clearances they receive provide substantial added assurance of safe separation. Consequently, flight crews often will operate under instrument flight rules even though the weather satisfies visual meteorological conditions.

**Flight plans.** A flight plan is filed with the authority providing air-traffic control services [in the United States, the Federal Aviation Administration (FAA)] to convey information about the intended flight of the aircraft. All flight plans contain essentially the same information, that is, aircraft identification number, make and model, and color; planned true airspeed and cruising altitude; origin and destination airports; planned departure time

and estimated time en route; planned route of flight, fuel, and number of people on board; pilot's name and address; navigation equipment on board; and the aircraft's radio call sign, if different from the aircraft identification number.

Generally, a flight plan is not required for a flight under visual flight rules. However, if a flight plan is filed and the aircraft is overdue at its destination, search and rescue procedures will be initiated. Hence the flight plan under visual flight rules provides a significant safety benefit. An IFR flight plan is required for operation in controlled airspace when instrument meteorological conditions prevail.

**Airspace.** The two principal categories of airspace are controlled and uncontrolled airspace. In controlled airspace some or all aircraft are required to operate in accordance with air-traffic control clearances in order to assure safety, to meet user needs for air-traffic control, or to accommodate high volumes of traffic. Air-traffic control services including air-to-ground communications and navigation aids are provided in controlled airspace. Uncontrolled airspace simply is airspace that has not been designated as controlled; air-traffic control services may not be available in such airspace.

Two specific examples of controlled airspace are class A (the positive control area or PCA) and class B (the terminal control area or TCA). The positive control area is, with a few exceptions, the airspace within the conterminous 48 states and Alaska extending from 18,000 to 60,000 ft (5490 to 18,290 m) above mean sea level. Terminal control areas are centered on primary airports and extend from the surface to specified altitudes. An air-traffic control clearance and prescribed equipment are required prior to operating within a terminal control area regardless of weather conditions.

**Air-to-ground communications.** Two-way air-to-ground voice communications between civil pilots and air-traffic controllers are conducted in the very high frequency (VHF) band. In addition, certain radio navigation aids can provide one-way communications from controllers to aircraft. These channels generally are used to broadcast weather and aeronautical information to pilots. See RADIO SPECTRUM ALLOCATIONS.

Air-to-ground data communications (that is, data link) increasingly are used to transfer information to and from the cockpit. Many of the communications errors associated with humans incorrectly reading, speaking, and hearing text are eliminated by communications protocols that detect errors in data transmissions, by electronically displaying the information received, and by storing the received information so that it can be reviewed. Data link also permits large quantities of data to be exchanged between ground-based and airborne computers. Civil aviation is exploiting three data-link media: some VHF voice channels, Mode S, and communications satellites.

**Radio navigation aids.** Radio navigation aids are used to determine the plan position of the aircraft (that is, the position in the horizontal plane) in coordinates referenced either to the navigation aid or to the Earth (that is, latitude and longitude). For most operations, the aircraft vertical position is determined by sensing atmospheric pressure on board and converting this pressure to altitude, based on a standard model of the atmosphere. For the landing phase of flight, precision landing aids provide horizontal and vertical position referenced to the runway. See ALTIMETER.

VOR is a principal system used for determining plan position, with approximately 1000 ground stations nationwide. The system provides the magnetic azimuth from the VOR station to the receiving aircraft accurate to  $\pm 1^\circ$ . Position determinations can be obtained from the intersection of radials from VORs with overlapping coverage volumes. With the addition of distance-measuring equipment at a VOR station, it is possible to obtain a position determination from a single station. See DISTANCE-MEASURING EQUIPMENT; RHO-THETA SYSTEM; VOR (VHF OMNIDIRECTIONAL RANGE).

Nondirectional radio beacon is an older technology, with few installations remaining. The system radiates a continuous signal

from which direction-finding receivers can determine the azimuth to the ground station. See DIRECTION-FINDING EQUIPMENT.

Loran C is a pulsed system, with chains of ground stations each consisting of one master station and at least two secondary stations organized to transmit their signals in synchronism. Loran C coverage in the United States includes the conterminous 48 states and southern Alaska. See LORAN.

In order to conduct approaches and landings in low-visibility conditions, it is necessary that an electronic glideslope (or glide-path) be provided as a reference for controlling the descent of the aircraft. In addition, a stable guidance signal is required to align the aircraft with the runway centerline. The instrument landing system (ILS) has been the standard means for providing precision landing guidance to the runway, and is installed on approximately 1000 runways in the United States. The localizer antenna transmits the lateral (left and right) guidance signal over a  $20^\circ$  sector,  $10^\circ$  on both sides of the extended runway centerline. The glideslope antenna transmits the elevation guidance signal over a  $1.4^\circ$  sector,  $0.7^\circ$  on both sides of the glidepath, which is normally  $3.0^\circ$  above the horizontal. See INSTRUMENT LANDING SYSTEM (ILS).

A new standard system for providing precision approach guidance, the microwave landing system (MLS) has been designed to eliminate limitations of the instrument landing system. It utilizes scanning-beam technology to provide proportional landing guidance over  $80^\circ$  in azimuth ( $40^\circ$  on both sides of the extended runway centerline) and  $15^\circ$  in elevation. The system can provide three-dimensional landing guidance within the scanned volume, thereby permitting curved approaches and approaches at higher glideslope angles than those available from the instrument landing system. See MICROWAVE LANDING SYSTEM (MLS).

The constellation of Global Positioning System (GPS) satellites provides a highly accurate worldwide position determination and time transfer capability. In the horizontal plane, the position determined by a GPS receiver is within 330 ft (100 m) of the true receiver position at least 95% of the time. The vertical position is accurate to within 459 ft (140 m) on the same 95% probability basis. In addition, the receiver provides Coordinated Universal Time (UTC) with an accuracy of 310 ns (95% probability). Coordinated Universal Time is an internationally accepted time standard that never differs from Greenwich Mean Time by more than 1 s. The principal advantages of GPS are its accuracy and worldwide coverage. See AIR NAVIGATION; ELECTRONIC NAVIGATION SYSTEMS; SATELLITE NAVIGATION SYSTEMS.

**Surveillance systems.** Air-traffic controllers use radar to monitor the positions of aircraft and to monitor areas of heavy precipitation. The radar information is used to develop clearances and instructions for separating aircraft operating under instrument flight rules, and to provide traffic advisories to IFR aircraft and to VFR aircraft receiving the traffic advisory service. Traffic advisories provide the ranges, bearings, and altitudes of aircraft in the pilot's immediate vicinity. The pilot is responsible for visually acquiring and avoiding any traffic that may be a collision threat. Two principal types of radar are used in civil air-traffic control: secondary, or beacon, radar and primary radar. See RADAR.

Secondary radar is an interrogate-respond system. The rotating directional antenna of the ground station transmits a pulse pair to the transponder in the aircraft. The pulse spacing encodes one of two messages, "transmit your altitude" (the Mode C interrogation) or "transmit your identity" (the Mode A interrogation). The aircraft transponder transmits an encoded pressure-altitude reply in response to the first interrogation and a four-digit identity code, assigned by air-traffic control and entered into the transponder by the pilot, in response to the second.

Primary radar operates by transmitting high-power, radio-frequency pulses from a rotating directional antenna. The energy is reflected from any aircraft in the directional beam and received by the antenna. The aircraft is displayed at the azimuth corresponding to the pointing direction of the antenna and the range corresponding to the round-trip time between pulse transmission

and receipt of the reflected signal. Primary radar has the advantage that aircraft without air-traffic control transponders can be detected, and energy reflected from heavy precipitation indicates to the controller areas of potentially hazardous weather. However, extraneous returns (clutter) from surrounding buildings and terrain can reduce the effectiveness of primary radar in detecting aircraft. At most air-traffic control radar sites, the secondary radar antenna is mounted on the primary radar antenna, and they are turned by a common drive system.

The secondary radar system has been improved through the addition of Mode S, which employs more sophisticated signaling formats than Modes A and C. Each aircraft transponder is permanently assigned a unique address and interrogations therefore can be addressed to individual aircraft.

In the oceanic environment, the ground-based surveillance systems described above obviously cannot be used. Oceanic operations are now based on rigid procedures and high-frequency (HF) communications that sometimes are unreliable. With the advent of commercially available mobile satellite communication systems, the development of a technique called automatic dependent surveillance (ADS) has been undertaken to provide real-time position information from aircraft over the ocean. In the operation of this system, the position of the aircraft, as determined from on-board navigation sensors, is communicated to air-traffic control facilities when requested by satellite relay. This position information can be displayed to controllers as though it had been determined by a radar system.

**Automation.** The principal elements of the controller's workstation are the plan view display, a track ball or mouse, the data-entry keyboard, printed flight strips showing the flight plans of aircraft for which the controller is responsible, and interfaces with communications facilities linking the controller with aircraft and with other controllers and facilities. The plan view display shows two principal types of data, map data and radar data. Map data include the locations of airports and their runways, navigation aids, airways, obstructions, and the geographical limits of the facility's airspace. Radar data comprise the positions of aircraft, including their altitudes, ground speeds, and radio call signs, as well as areas of precipitation. The data-entry keyboard allows the controller to modify data stored in the automation system, including flight plans. Extensive automation (computer) equipment is used in maintaining the flight-plan databases and processing radar data. A number of automation aids have been developed to assist controllers in separating aircraft as well as in sequencing and metering aircraft into and out of busy terminal areas.

Flight management computer systems are installed in aircraft for the purpose of guiding the aircraft along its planned route of flight while minimizing operating costs by selecting optimum speeds and altitudes. Extensive databases are stored in the flight management computer system (FMCS), including the current flight plan, wind velocities and air temperatures along the planned route of flight, and the positions and operating frequencies of the radionavigation aids to be used. Interfaces with the FMCS for air-to-ground data communications permit changes to be made to the databases in flight and allow information to be extracted, such as automatic dependent surveillance position reports and estimated times of arrival at specific points along the planned route of flight. See AIRCRAFT INSTRUMENTATION.

Airborne collision avoidance systems are installed in aircraft to provide ground-independent protection from midair collisions, as a backup to the conventional air-traffic control system. Within the United States, the system is known as the Traffic Alert and Collision Avoidance System (TCAS). The TCAS equipment in the aircraft interrogates the secondary surveillance radar transponders in proximate aircraft and processes the replies to determine if any aircraft is on a collision course. Traffic advisories are displayed to the pilot to portray the range, bearing, and relative altitude of any aircraft that penetrates a protection volume around the TCAS-equipped aircraft. A resolution advi-

sory will be displayed to tell the pilot how to maneuver to avoid a collision, if necessary.

**Airways and procedures.** Two fixed-route systems have been established for air navigation. From 1200 ft (360 m) above the surface up to but not including 18,000 ft (5490 m) above mean sea level, there are designated airways based on VORs and nondirectional beacons. The most prevalent are the so-called victor (V) airways defined by VORs. Jet (J) routes are defined from 18,000 to 45,000 ft (5490 to 13,710 m) above mean sea level, based solely on VORs.

There are three principal categories of procedures: departure procedures for leaving terminal areas, arrival procedures for entering terminal areas, and en route procedures. Departure procedures prescribe the process for route clearance delivery to an aircraft, for providing takeoff runway and taxi instructions, and for defining or placing limitations on the climb-out route of the aircraft. Generally, pilots of IFR aircraft call the clearance delivery controller for their route clearance prior to taxiing. The route in the clearance may differ from the filed route because of system restrictions such as excess traffic, facility outages, and weather.

En route procedures deal principally with reporting aircraft flight progress to air-traffic control (position reporting) when the aircraft is outside radar coverage or is operating in holding patterns.

Arrival procedures prescribe the process for making the transition from the en route structure to the terminal area, for approaching the landing runway, and for executing a missed approach when a landing cannot be accomplished. An instrument approach procedure is a series of predetermined maneuvers by reference to flight instruments for the orderly transfer of an aircraft from an initial approach fix to a landing or to a point from which a landing can be made visually. Several procedures, using different navigation and approach aids, may be established for an airport.

**Facilities.** Air-traffic control facilities include flight service stations, air-route traffic control centers (ARTCCs), and terminal facilities. Flight service stations provide preflight briefings for pilots, accept flight plans, broadcast aviation weather information, assist lost aircraft and aircraft in distress, and monitor the operation of radio navigation aids. Air-route traffic control centers monitor all IFR aircraft not under the control of military or terminal facilities. They assure separation of IFR aircraft by issuing clearances and instructions as necessary and issuing traffic advisories, provide weather advisories, accept amendments to flight plans from flight crews, and assist aircraft in distress. Flight plans submitted to flight service stations usually are transmitted to the parent air-route traffic control center, where they are processed and the route clearance is generated.

At terminal facilities, the ground controller position is responsible for all ground traffic not on active runways. The local controller has jurisdiction over the active runways and the airspace close to the airport. Controllers generally visually acquire and track aircraft and direct their movements by using radio or, when an aircraft has no operating radio, signal lights. In some locations, however, radar indicator equipment is installed in the tower to electronically display traffic that is being tracked by the local air-traffic control radar. See AIR TRANSPORTATION. [C.A.Mi.]

**Air transportation** The movement of passengers and cargo by aircraft such as airplanes and helicopters. Air transportation has become the primary means of common-carrier traveling. Greatest efficiency and value are obtained when long distances are traveled, high-value payloads are moved, immediate needs must be met, or surface terrain prevents easy movement or significantly raises transport costs. Although the time and cost efficiencies obtained decrease as distance traveled is reduced, air transport is often worthwhile even for relatively short distances. Air transportation also provides a communication link, which is sometimes vital, between the different groups of people being served. [D.V.M.]

**Airborne radar** Radar equipment carried by commercial and military aircraft. These aircraft use airborne radar systems to assist in weather assessment and navigation. Military systems also provide other specialized capabilities such as targeting of hostile aircraft for air-to-air combat, detection and tracking of moving ground targets, targeting of ground targets for bombing missions, and very accurate terrain measurements for assisting in low-altitude flights. Airborne radars are also used to map and monitor the Earth's surface for environmental and topological study.

Airborne radars present unique design challenges, mainly in the severe nature of the ground echo received by the radar and in the installation constraints on the size of the radar. The peculiar clutter situation governs the nature of the signal processing, and the installation limitations influence the antenna design and the radio frequency to be used (the two being strongly related) as well as the packaging of the rest of the radar. Similar considerations influence the design of space-based radars as well.

A particularly valuable use of airborne radar is weather assessment. Radars generally operating in the C or X bands (around 6 GHz or around 10 GHz, respectively) permit both penetration of heavy precipitation, required for determining the extent of thunderstorms, and sufficient reflection from less intense precipitation. See METEOROLOGICAL RADAR; RADAR METEOROLOGY.

Another basic and valuable airborne radar function is altimetry. The aircraft's altitude can be continuously measured, using (generally) C-band frequencies (around 6 GHz), low-power transmission, and a downward-oriented antenna beam. Sometimes, information from additional beams (looking somewhat forward, for example) is combined with measurements of the Doppler shift of the ground echo received to further aid in navigation. Another type of radar used in navigation is the radar beacon, in which a ground-based receiver detects an interrogation pulse from the aircraft and sends back a so-called reply on a different frequency, to which the receiver on the aircraft is tuned. See AIR-TRAFFIC CONTROL; ALTIMETER; DOPPLER EFFECT; SURVEILLANCE RADAR.

Airborne radars are used effectively to provide high-resolution mapping of Earth's (or other planetary) surface, with a technique called synthetic aperture radar (SAR). The processing uses the fact that surface objects produce a Doppler shift (due to the aircraft's flight) unique to their position as the aircraft passes by; this Doppler history is indicative of the scatterer's lateral, or cross-range, position at the particular range determined by the usual echo timing. With very stable radars and well-measured flight characteristics (and other focusing methods), picture cells (pixels) of 1 ft × 1 ft (0.3 m × 0.3 m) can be formed in the processed images from radars tens or hundreds of miles away. The resolution is somewhat like that possible had the flight path itself been used as a huge antenna, the synthetic aperture.

[R.T.H.]

**Aircraft** Any vehicle which carries one or more persons and which navigates through the air. The two main classifications of aircraft are lighter-than-air and heavier-than-air. The term lighter-than-air is applied to all aircraft which sustain their weight by displacing an equal weight of air, for example, blimps and dirigibles. Heavier-than-air craft are supported by giving the surrounding air a momentum in the downward direction equal to the weight of the aircraft. See AIRPLANE; CONVERTIPLANE; HELICOPTER.

[R.G.Bo.]

**Aircraft collision avoidance system** Electronic equipment in an aircraft that gives the pilot relative position information concerning nearby aircraft; some versions also display resolution advisories of maneuvers to avoid a collision. The system operates independently of ground-based air-traffic control equipment, but makes use of transponders carried by most aircraft to reply to air-traffic control surveillance.

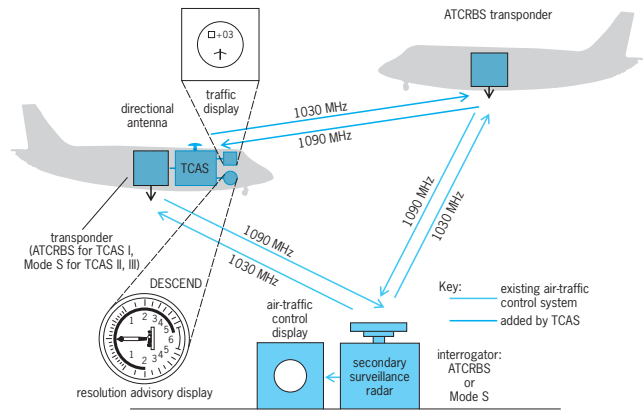

**Relation of the Traffic Alert and Collision Avoidance System (TCAS) to the existing air-traffic control system. TCAS interrogations elicit replies from transponders of nearby aircraft, enabling TCAS to show the pilot their relative position on a traffic display, and when appropriate, to issue a resolution advisory. Here, TCAS instructs the pilot to descend to avoid a threat aircraft 300 ft above.**

To achieve surveillance of aircraft carrying Air-Traffic Control Radar Beacon System (ATCRBS) transponders (see illustration), TCAS transmits interrogations once per second using 0.8-microsecond pulses at 1030 MHz, in a format similar to those of the ground radars. The transponders reply with a block of 0.45- $\mu$ s pulses at 1090 MHz, their sequence announcing the aircraft's barometric altitude quantized to the nearest 100 ft (30.5 m). TCAS measures the round-trip time from its interrogation to the received reply to determine the slant range, and decodes the altitude information contained in the reply sequence.

The collision avoidance logic must distinguish a genuine collision threat from routine safe passages. The relative range rate is derived from successive range reports. Likewise, an altitude rate is estimated from the other aircraft's altitude, and also for the system's aircraft. An estimate of the time of closest approach ( $\tau$ ) can be calculated from the equation below.

$$\tau = \frac{-\text{range}}{\text{range rate}}$$

Each nearby aircraft is evaluated once per second, and is deemed a threat if the range is already small or if  $\tau$  is small, and if the relative altitude is predicted to be small. When a threat is declared, the effects of potential climb and descent maneuvers are estimated. The maneuver sense that gives the greater separation is chosen, except that a vertical crossing is not selected if the noncrossing sense gives adequate separation. An advisory is selected (such as limit climb; do not climb; descend) that is predicted to prevent a collision while minimizing the displacement from the aircraft's flight path.

An important part of TCAS is its traffic display, enabling crews to locate nearby traffic even when weather hinders visual sighting. At present, the format in use depicts nearby aircraft in plan view, centered about the TCAS aircraft (see illustration). [A.D.Z.]

**Aircraft compass system** An instrument that indicates the bearing, or angle of the direction in which an aircraft is pointing in the horizontal plane. A compass may indicate magnetic heading or bearing, bearing referenced to a radio signal source, or bearing with respect to an inertially maintained line of position.

In modern commercial jet transport or military fighter aircraft, the primary sensor of the aircraft compass system is the inertial reference system (IRS). This system provides a gyroscopically derived reference to an inertial reference axis by sensing the linear and angular accelerations of the aircraft and continuously integrating these values to provide angular and linear velocities. The inertial reference system derives its position and attitude in

an inertial frame referenced to true north. This approach represents an increase in precision over the original compass systems, which developed their lines of position referenced to magnetic north. See GYROSCOPE; INERTIAL GUIDANCE SYSTEM.

The magnetic and true bearings of the aircraft are presented on computer-generated cathode-ray tubes or flat-panel displays. These displays present aircraft heading in the form of a compass rose on both the primary flight display and the navigation display.

The magnetic compass remains a simple, inexpensive, and reliable instrument for indicating the aircraft bearing. Limitations in the accuracy of this compass are due to the accelerations and vibrations of the aircraft, the local induced magnetic field of the aircraft, and lack of knowledge of local magnetic variation (the difference between true north and magnetic north). The magnetic compass is a secondary sensor of bearing on jet transports and most military aircraft, although it remains the primary instrument for many small, general aviation aircraft. This compass is typically a stand-alone instrument consisting of a card indicating the bearing installed in a liquid-filled case. The liquid serves to dampen rapid aircraft movements or oscillations. See MAGNETIC COMPASS.

In some aircraft, the magnetic compass has been coupled with a gyroscopic element to provide the gyroslaved, or gyrosynchronized, magnetic compass. The gyrosynchronized compass uses a directional gyro to determine the local horizon and to sense accelerations and thus correct for gravity effects on the compass output. See AIRCRAFT INSTRUMENTATION. [R.W.Sc.]

**Aircraft design** The process of designing an aircraft, generally divided into three distinct phases: conceptual design, preliminary design, and detail design. Each phase has its own unique characteristics and influence on the final product. These phases all involve aerodynamic, propulsion, and structural design, and the design of aircraft systems.

**Design phases.** Conceptual design activities are characterized by the definition and comparative evaluation of numerous alternative design concepts potentially satisfying an initial statement of design requirements. The conceptual design phase is iterative in nature. Design concepts are evaluated, compared to the requirements, revised, reevaluated, and so on until convergence to one or more satisfactory concepts is achieved. During this process, inconsistencies in the requirements are often exposed, so that the products of conceptual design frequently include a set of revised requirements.

During preliminary design, one or more promising concepts from the conceptual design phase are subjected to more rigorous analysis and evaluation in order to define and validate the design that best meets the requirements. Extensive experimental efforts, including wind-tunnel testing and evaluation of any unique materials or structural concepts, are conducted during preliminary design. The end product of preliminary design is a complete aircraft design description including all systems and subsystems. See WIND TUNNEL.

During detail design the selected aircraft design is translated into the detailed engineering data required to support tooling and manufacturing activities.

**Requirements.** The requirements used to guide the design of a new aircraft are established either by an emerging need or by the possibilities offered by some new technical concept or invention. Requirements can be divided into two general classes: technical requirements (speed, range, payload, and so forth) and economic requirements (costs, maintenance characteristics, and so forth).

**Aerodynamic design.** Initial aerodynamic design centers on defining the external geometry and general aerodynamic configuration of the new aircraft.

The aerodynamic forces that determine aircraft performance capabilities are drag and lift. The basic, low-speed drag level of the aircraft is conventionally expressed as a term at zero lift com-

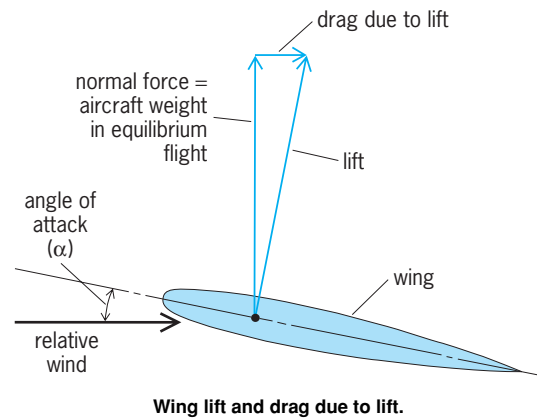

posed of friction and pressure drag forces plus a term associated with the generation of lift, the drag due to lift or the induced drag. Since wings generally operate at a positive angle to the relative wind (angle of attack) in order to generate the necessary lift forces, the wing lift vector is tilted aft, resulting in a component of the lift vector in the drag direction (see illustration). See AERODYNAMIC FORCE; AIRFOIL; WING.

Aircraft that fly near or above the speed of sound must be designed to minimize aerodynamic compressibility effects, evidenced by the formation of shock waves and significant changes in all aerodynamic forces and moments. Compressibility effects are mediated by the use of thin airfoils, wing and tail surface sweepback angles, and detailed attention to the lengthwise variation of the cross-sectional area of the configuration. See COMPRESSIBLE FLOW; SHOCK WAVE.

The size and location of vertical and horizontal tail surfaces are the primary parameters that determine aircraft stability and control characteristics. Developments in digital computing and flight-control technologies have made the concept of artificial stability practical. See STABILITY AUGMENTATION.

**Propulsion design.** Propulsion design comprises the selection of an engine from among the available models and the design of the engine's installation on or in the aircraft.

Selection of the best propulsion concept involves choosing from among a wide variety of types ranging from reciprocating engine-propeller power plants through turboprops, turbojets, turboprops, and ducted and unducted fan engine developments. The selection process involves aircraft performance analyses comparing flight performance with the various candidate engines installed. In the cases where the new aircraft design is being based on a propulsion system which is still in development, the selection process is more complicated. See AIRCRAFT ENGINE; TURBOFAN; TURBOPROP.

Once an engine has been selected, the propulsion engineering tasks are to design the air inlet for the engine, and to assure the satisfactory physical and aerodynamic integration of the inlet, engine, and exhaust nozzle or the engine nacelles with the rest of the airframe. The major parameters to be chosen include the throat area, the diffuser length and shape, and the relative bluntness of the inlet lips.

**Structural design.** Structural design begins when the first complete, integrated aerodynamic and propulsion concept is formulated. The process starts with preliminary estimates of design airloads and inertial loads (loads due to the mass of the aircraft being accelerated during maneuvers).

During conceptual design, the structural design effort centers on a first-order structural arrangement which defines major structural components and establishes the most direct load paths through the structure that are possible within the constraints of the aerodynamic configuration. An initial determination of structural and material concepts to be used is made at this time, for example, deciding whether the wing should be constructed from

built-up sheet metal details, or by using machined skins with integral stiffeners, or from fiber-reinforced composite materials.

During preliminary design, the structural design effort expands into consideration of dynamic loads, airframe life, and structural integrity. Dynamic loading conditions arise from many sources: landing impact, flight through turbulence, taxiing over rough runways, and so forth. See LOADS.; DYNAMIC.

Airframe life requirements are usually stated in terms of desired total flight hours or total flight cycles. To the structural designer this translates into requirements for airframe fatigue life. Fatigue life measures the ability of a structure to withstand repeated loadings without failure. Design for high fatigue life involves selection of materials and the design of structural components that minimize concentrated stresses.

Structural integrity design activities impose requirements for damage tolerance, the ability of the structure to continue to support design loads after specified component failures. Fail-safe design approaches are similar to design for fatigue resistance: avoidance of stress concentrations and spreading loads out over multiple supporting structural members. See STRUCTURAL DESIGN.

**Aircraft systems design.** Aircraft systems include all of those systems and subsystems required for the aircraft to operate. Mission systems are those additional systems and subsystems peculiar to the role of military combat aircraft. The major systems are power systems, flight-control systems, navigation and communication systems, crew systems, the landing-gear system, and fuel systems.

Design of these major subsystems must begin relatively early in the conceptual design phase, because they represent large dimensional and volume requirements which can influence overall aircraft size and shape or because they interact directly with the aerodynamic concept (as in the case of flight-control systems) or propulsion selection (as in the case of power systems).

During preliminary design, the aircraft system definition is completed to include additional subsystems. The installation of the many aircraft system components and the routing of tubing and wiring through the aircraft are complex tasks which are often aided by the construction of partial or complete aircraft mock-ups. These are full scale models of the aircraft, made of inexpensive materials, which aid in locating structural and system components. See AIRPLANE. [P.L.M.]

**Aircraft engine** A component of an aircraft that develops either shaft horsepower or thrust and incorporates design features most advantageous for aircraft propulsion. An engine developing shaft horsepower requires an additional means to convert this power to useful thrust for aircraft, such as a propeller, a fan, or a helicopter rotor. It is common practice in this case to designate the unit developing shaft horsepower as the aircraft engine, and the combination of engine and propeller, for example, as an aircraft power plant. In case thrust is developed directly as in a turbojet engine, the terms engine and power plant are used interchangeably.

Air-breathing types of aircraft engines use oxygen from the atmosphere to combine chemically with fuel carried in the vehicle, providing the energy for propulsion, in contrast to rocket types in which both the fuel and oxidizer are carried in the aircraft. See INTERNAL COMBUSTION ENGINE; JET PROPULSION; RECIPROCATING AIRCRAFT ENGINE; ROCKET PROPULSION; TURBINE PROPULSION. [R.Ha.]

**Aircraft fuel** The source of energy required for the propulsion of airborne vehicles. Aircraft fuel is burned with ambient air and is thereby distinct from rocket propellants, which carry both fuel and oxidant. An important criterion for aircraft fuel is that its energy density, or heat of combustion per unit of weight, be high. This allows reasonable expenditures of fuel during takeoff, efficient performance in flight, and long range of flight duration.

There are two general types of aircraft fuels in conventional use: gasolines for reciprocating (piston) engines, and kerosene-like fuels (called jet fuels) for turbine engines. Because of anticipated limitations in the supply of these crude-oil derived fuels, alternative fuels are being considered for future aircraft.

Piston engine fuels, or aviation gasolines, are special blends of gasoline stocks and additives that produce a high-performance fuel that is graded by its antiknock quality. The gasoline blending stocks are virgin (uncracked) naphtha, alkylate, and catalytically cracked gasoline. In general, the chemical composition of aviation gasoline can be approximated as  $C_xH_{1.9x}$  where the number of carbon atoms  $x$  is between 4 and approximately 10. Tetraethyllead (Tel) is a common additive used in concentrations of up to 4 ml/gal (1.057 ml/liter) of fuel to increase the antiknock quality of the fuel. See GASOLINE; NAPHTHA.

Turbine engine fuels are distillate hydrocarbon fuels, like kerosenes, used to operate turbojet, turbofan, and turboshaft engines. While all piston engine fuels have the same volatility but differ in combustion characteristics, jet fuels differ primarily in volatility; differences in their combustion qualities are minor. Turbine fuel contains aromatic hydrocarbons; limits are placed on this content owing to concerns about smoke and coke formation. An increasingly important requirement is to provide a fuel that is stable at relatively high temperatures.

Many forecasts of world crude production indicate a peak or plateau in the oil production rate before 2010; hence, the availability of crude-based fuels for aircraft is not certain. Alternative fuels made from coal, oil shale, or solar or nuclear energy plus a suitable raw material are being considered. [J.B.P.]

**Aircraft icing** Aircraft icing encompasses a range of conditions during which frozen precipitation forms on an aircraft. It is usually separated into two broad classifications, ground icing and in-flight icing. Icing can compromise flight safety by affecting the performance, stability, and control of the aircraft, and as a result the ability of the pilot to maintain the desired flight path.

**Ice accretion.** Ground icing occurs when the aircraft is on the ground, and becomes significant when it affects the aircraft's ability to take off. This form of icing occurs when ice, snow, or freezing rain collects on the upper surfaces of the aircraft or when frost forms on the aircraft.

In-flight icing forms when an aircraft flies through a cloud of supercooled precipitation. Water droplets approach the aircraft, approximately following the air streamlines. Near the surface of the aircraft, large changes in velocity exist. The droplets, because of their inertia, cannot change velocity rapidly enough to follow the air around the aircraft, and strike or impinge on the aircraft surface. Ice forms on the leading or forward-facing edges of the wings, tail, antennas, windshield, radome, engine inlet, and so forth. See CLOUD PHYSICS.

**Aerodynamics.** Probably the most dangerous way that ice acts on an aircraft is through its effect on the aerodynamics, which results in degraded performance and control. Small amounts of ice or frost add roughness to the airplane surfaces. The roughness increases the friction of the air over the surface; this is called skin friction.

Large accretions can drastically alter the shape of the wing. Then, in addition to skin friction, flow separation results in a further reduction in aerodynamic performance of the aircraft.

Aircraft control can be seriously affected by ice accretion. Ice accretion on the tail can lead to reduced elevator effectiveness, reducing the longitudinal control (nose up and down) of the aircraft. In some situations, the tail can stall or lose lift prematurely, resulting in the aircraft pitching nose down. Similarly, ice on the wing ahead of the aileron can result in roll upset. Both tail stall and roll upset are thought to be the cause of recent aircraft icing accidents. See AERODYNAMICS; FLIGHT CONTROLS.

**Ice protection.** All large aircraft and many light aircraft are equipped with in-flight ice protection systems to reduce the effect of ice. Ice protection systems are classified as de-ice or anti-ice

systems. De-ice systems allow some ice to accrete, and then they periodically remove the ice. Anti-ice systems prevent ice from forming either by heating the surface above 0°C (32°F) or through the use of freezing-point depressants. [M.B.B.]

**Aircraft instrumentation** A coordinated group of instruments that provide the flight crew with information about the aircraft and its subsystems. These instruments provide flight data, navigation, power plant performance, and aircraft auxiliary equipment operating information to the flight crew, air-traffic controllers, and maintenance personnel. While not considered as instrumentation, communication equipment is, however, directly concerned with the instrumentation and overall indirect control of the aircraft.

Situation information on the operating environment, such as weather reports and traffic advisories, has become a necessity for effective flight planning and decision making. The prolific growth and multiplicity of instruments in the modern cockpit and the growing need for knowledge about the aircraft's situation are leading to the introduction of computers and advanced electronic displays as a means for the pilot to better organize and assimilate this body of information.

Instrumentation complexity and accuracy are dictated by the aircraft's performance capabilities and the conditions under which it is intended to operate. Light aircraft may carry only a minimum set of instruments; an airspeed indicator, an altimeter, an engine tachometer and oil pressure gage, a fuel quantity indicator, and a magnetic compass. These instruments allow operation by a pilotage technique. See AIRSPEED INDICATOR; ALTIMETER; PILOTAGE.

Operation under low visibility and under Instrument Flight Rules (IFR) requires this same information in a more precise form and also requires attitude and navigation data. An attitude-director indicator (ADI) presents an artificial horizon, bank angle, and turn coordination data for attitude control without external visual reference. The attitude-director indicator may contain a vertical gyro within the indicator, or a gyro may be remotely located as a part of a flight director or navigational system. Flying through a large speed range at a variety of altitudes is simplified if the indicated airspeed is corrected to true airspeed for navigation purposes and the Mach number ( $M$ ) is also shown on the ADI for flight control and performance purposes. Rate-of-climb is provided by an instantaneous vertical-speed indicator (IVSI). Heading data are provided by a directional gyro or data derived from an inertial reference system. See GYROSCOPE; INERTIAL GUIDANCE SYSTEM.

Navigation aids include: very-high-frequency omnidirectional radio ranges (VOR) that transmit azimuth information for navigation at specified Earth locations; distance-measuring equipment (DME) that indicates the distance to radio aids on or near airports or to VORs; automatic direction finders (ADF) that give the bearing of other radio stations (generally low-frequency); low-range radio altimeters (LRRRA) which by radar determine the height of the aircraft above the terrain at low altitudes; and instrument landing systems (ILS) that show vertical and lateral deviation from a radio-generated glide-path signal for landing at appropriately equipped runways. Some inertial navigation systems include special-purpose computers that provide precise Earth latitude and longitude, ground speed, course, and heading. See AIR-TRAFFIC CONTROL; AUTOPILOT; DIRECTION-FINDING EQUIPMENT; DISTANCE-MEASURING EQUIPMENT; ELECTRONIC NAVIGATION SYSTEMS.

Engines require specific instruments to indicate limits and efficiency of operation. For reciprocating engines, instruments may display intake and exhaust manifold pressures, cylinder head and oil temperature, oil pressure, and engine speed. For jet engines, instruments display engine pressure ratio (EPR), exhaust gas temperature (EGT), engine rotor speed, oil temperature and pressure, and fuel flow. Vibration monitors on both types of engines indicate unbalance and potential trouble.

Depending on the complexity of the aircraft and the facilities that are provided, there is also an assortment of instruments and controls for the auxiliary systems.

Electronic technology developments include: ring laser gyros, strap-down inertial reference systems, microprocessor digital computers, color cathode-ray tubes (CRT), liquid crystal displays (LCD), light-emitting diodes (LED), and digital data buses. Application of this technology allows a new era of system integration and situation information on the aircraft flight deck and instrument panels. Commercial jet transports will use digital electronics to improve safety, performance, economics, and passenger service. The concept of an integrated flight management system (FMS) includes automatic flight control, electronic flight instrument displays, communications, navigation, guidance, performance management, and crew alerting to satisfy the requirements of the current and future air-traffic and energy-intensive environment.

Effective flight management is closely tied to providing accurate and timely information to the pilot. The nature of the pilot's various tasks determines the general types of data which must be available. The key is to provide these data in a form best suited for use. If the pilot is not required to accomplish extensive mental processing before information can be used, then more information can be presented and less effort, fewer errors, and lower training requirements can be expected. Computer-generated displays offer significant advances in this direction.

The electronic horizontal-situation indicator (EHSI) provides an integrated multicolor map display of the airplane's position, plus a color weather radar (WXR) display. The scale for the radar and map can be selected by the pilots. [B.C.H.]

**Aircraft propulsion** Flying machines obtain their propulsion by the rearward acceleration of matter. This is an application of Newton's third law: For every action there is an equal and opposite reaction.

In propeller-driven aircraft, the propulsive medium is the ambient air which is accelerated to the rear by the action of the propeller. The acceleration of the air that passes through the engine provides only a secondary contribution to the thrust.

In the case of turbojet and ramjet engines, the ambient air is again the propulsive medium, but the thrust is obtained by the acceleration of the air as it passes through the engine. After being compressed and heated in the engine, this air is ejected rearward from the engine at a greater velocity than it had when it entered. See JET PROPULSION.

Rockets carry their own propulsive medium. The propellants are burned at high pressure in a combustion chamber and are ejected rearward to produce thrust. See ROCKET PROPULSION.

In every case, the thrust provided is equal to the mass of propulsive medium per second multiplied by the increase in its velocity produced by the propulsive device. This is substantially Newton's second law. See FLUID FLOW.

The airplane lift-drag ratio  $L/D$  is a primary factor that determines the thrust required from the propulsion system to fly a given airplane. To sustain flight, the airplane lift must be equal to airplane gross weight, and the engine thrust must be equal to the airplane drag. The higher the lift-drag ratio, the more efficient is the airplane. A sharp reduction in  $L/D$  occurs with increase in flight Mach number in the vicinity of a Mach number of unity, and this is reflected in a sharp increase in the thrust required for flight. Flight Mach number is the ratio of the airplane speed to the speed of sound in the ambient atmosphere. At standard sea-level conditions, the speed of sound is 773 mi/h (346 m/s).

The competition among nations and among commercial airlines has created a continuing demand for increased flight speed. The reduction in aircraft  $L/D$  that accompanies an increase in speed (see illustration) requires an increase in engine thrust for an airplane of a given gross weight. For a given engine specific

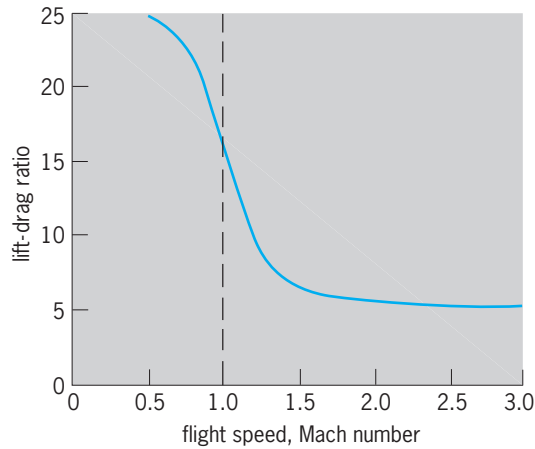

Lift-drag ratios of aircraft. Curve represents envelope of a variety of designs of various wing sweep angles. (Taken from 27th Wright Brothers Lecture by G. S. Schairer, *J. Aircraft*, vol. 1, no. 2, 1964)

weight, an increase in required engine thrust results in an increase in engine weight and hence a reduction in fuel load and payload that an airplane of a given gross weight can carry. If the engine weight becomes so large that no fuel can be carried by the airplane, the airplane has zero flight range regardless of the efficiency of the engine. At some speed before this point is reached, it becomes advantageous to shift to an engine type that has a lower specific engine weight even at the cost of an increased specific fuel consumption.

At low subsonic flight speeds, the piston-type reciprocating engine, because of its low specific fuel consumption, provides the best airplane performance in terms of payload and flight range. As flight speed increases, specific weight of reciprocating engines increases because of falling propeller efficiency. This effect, coupled with reduction in  $L/D$  which accompanies increase in flight speed, results in the weight of reciprocating engines becoming excessive at a flight speed of about 400 mi/h (180 m/s). At about this speed it is advantageous to shift to the lighter-weight turboprops even if the efficiency of the latter is poorer. At about 550 mi/h (245 m/s) it is advantageous to shift from the turboprop to the lighter but less efficient turbojet. Intermediate between the turboprop and turbojet in the spectrum of flight speeds is the turbofan. See RECIPROCATING AIRCRAFT ENGINE; TURBOFAN; TURBOJET; TURBOPROP. [B.Pi.]

**Aircraft rudder** The hinged rear portion of an airplane's vertical tail. The vertical tail is composed of the vertical stabilizer and the rudder. The vertical stabilizer is mounted to the fuselage and is fixed relative to it. The rudder is hinged to the rear of the vertical stabilizer (see illustration) and moves to the left or right in response to control inputs from the rudder pedals or from an automatic stability and control system.

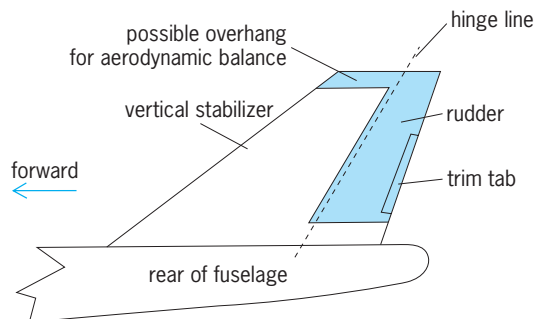

Vertical tail of an airplane, showing location of the rudder.

The rudder provides an aerodynamic moment about the aircraft's center of gravity for the purpose of yaw control. When the rudder turns clockwise, for example, as viewed from above, its trailing edge moves to the left, effectively adding camber to the vertical tail. The result is that an aerodynamic side force is produced on the vertical tail to the right. This force, in turn, produces a counterclockwise yawing moment about the airplane's center of gravity, resulting in a turn to the left. See AIRFOIL.

An additional, small, movable surface, known as a trim tab, may be hinged to the rudder. When deflected to a fixed position, the tab causes the rudder to deflect to, and hold, a desired angle. [B.W.McC.]

**Aircraft testing** Subjecting a complete aircraft or its components (such as wings, engines, or electronics systems) to simulated or actual flight conditions in order to measure and record physical phenomena that indicate operating characteristics. Testing is essential to the design, development, and acceptance of any new aircraft.

Aircraft and their components are tested to verify design theories, obtain empirical data where adequate theories do not exist, develop maximum flight performance, demonstrate flight safety, and prove compliance with performance requirements. Testing programs originate in laboratories with the evaluation of new design theory; progress through extensive tests of components, subsystems, and subsystem assemblies in controlled environments; and culminate with aircraft tests in actual operational conditions.

**Laboratory testing.** Instrument testing, in controlled conditions of environment and performance, is used extensively during the design performance assessment of new aircraft to avoid the costly and sometimes dangerous risks of actual flight.

A wind tunnel is basically an enclosed passage through which air is forced to flow around a model of a structure to be tested, such as an aircraft. Wind tunnels vary greatly in size and complexity, but all of them contain five major elements: an air-drive system, a controlled stream of air, a model, a test section, and measurement instruments. The drive system is usually a motor and one or more large fans that push air through the tunnel at carefully controlled speeds to simulate various flight conditions. A scale model of an actual or designed aircraft is supported inside the test section (see illustration), where instruments, balances, and sensors directly measure the aerodynamic characteristics of the model and its stream of airflow. Wind tunnel tests measure and evaluate airfoil (wing) and aircraft lift and drag characteristics with various configurations, stability and control parameters, air load distribution, shock wave interactions, stall characteristics, airflow separation patterns, control surface characteristics, and aeroelastic effects. See AIRFOIL.

Aircraft components are integrated into subsystems, system elements, and complete operational systems to help resolve interface problems. Integration tests establish functional and operational capability and evaluate complete system compatibility, operation, maintenance, safety, reliability, and best possible performance.

Rocket-propelled sled tests evaluate crew ejection escape systems for high-performance aircraft. A fuselage section, mounted on a sled, is propelled by rockets along fixed tracks. When a desired speed is reached, the ejection mechanism is automatically triggered, firing rockets that propel crew seats (containing instrumented mannequins) clear of the fuselage, and activating parachutes to limit the free-flight trajectory of the mannequins and allow safe descent to the ground. Water-propelled sled tests study landing gear systems and runway surface materials. Other dynamic ground tests include acceleration and arresting tests of aircraft fuel system venting, transfer, and delivery, which are evaluated while the system is subjected to flightlike forces and attitudes.



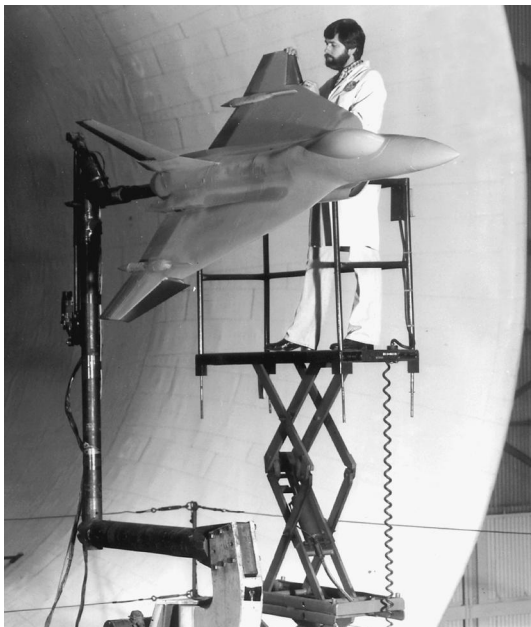

Scale model of fighter aircraft being mounted inside test section of large wind tunnel. (NASA)

Proof load tests of actual aircraft are usually done on one or more of the first airframes built. An airframe, mounted in a laboratory, is fitted with thousands of strain gages, the outputs of which are recorded on an automatic data-recording system. Simulated air and inertia loads are applied to airframe components, which are loaded simultaneously, in specified increments, to simulate loads encountered during takeoff, maneuvering flight, and landing. Loadings are increased to design limit and then to ultimate failure to locate possible points of excessive yield. Component parts and system subassemblies are also tested with various loadings while operating under expected extremes of temperature, humidity, and vibration to determine service life. See AIRFRAME. [M.Pa.]

**Flight simulation.** Aircraft flight and systems characteristics are represented with varying degrees of realism for research, design, or training simulation purposes. The representation is usually in the form of analytic expressions programmed on a digital computer. Flight simulation may be performed with or without a human pilot in the loop. The pilot imposes additional constraints on the simulator such as requiring a means of control in a manner consistent with the means provided in the aircraft being simulated. Flight simulation requires representation of the environment to an extent consistent with the purposes of the simulation, and it further requires that all events in the simulator occur in real time. Real time is a term which is used to indicate that all time relationships in the simulator are preserved with respect to what they would be in the airplane in flight. See REAL-TIME SYSTEMS.

Simulators range in size and complexity from actual aircraft, outfitted with special flight decks that can be reconfigured to test different systems, to desk-top simulators that can test individual or integrated components. [FCa.]

Simulators may be classified by their use in research, design, or training. Research simulators are usually employed to determine patterns of human behavior under various workloads or in response to different flight instrument display configurations or different aircraft dynamic characteristics. Design simulators are used to conduct tradeoff studies to evaluate different design approaches in the aircraft. The most pervasive use of flight simulators is for training operators of the aircraft and its systems and maintenance personnel. The simulator is in many cases a better training device than the aircraft. This is true because of the

safety, versatility, and speed with which critical maneuvers may be performed. [M.Pa.]

**Flight testing.** Flight testing can be considered the final step in the proving of a flight vehicle or system as capable of meeting its design objectives. This definition applies whether the concept is a complete vehicle, a vehicle subsystem, or a research concept. Flight testing can be categorized as research, development, and operational evaluation. These categories apply both to aircraft and to spacecraft and missiles.

The purpose of research testing is to validate or investigate a new concept or method with the goal of increasing the researchers' knowledge. Many times, the vehicle used is a one- or two-of-a-kind article designed specifically for the concept being investigated.

A new vehicle or subsystem enters development testing after it has been designed and the basic concepts proven in research flight testing. During this phase of testing, problems with the design are uncovered and solutions are developed for incorporation in the production aircraft.

Operational testing involves customer participation to evaluate the capability of the fully equipped vehicle to meet its intended mission objectives. Testing is performed to determine system reliability, define maintenance requirements, and evaluate special support equipment. Military vehicles are also tested to determine weapon delivery techniques and effectiveness, including target acquisition capabilities, ability to perform in all weather conditions, operational behavior in battlefield conditions, and, in the case of naval aircraft, carrier suitability. Commercial aircraft are tested for blind landing-approach systems, passenger services, baggage and cargo loading, noise levels, and safety provisions. Crew training simulators, handbooks, and procedures are also tested in this phase to demonstrate the ability to maintain and operate the aircraft effectively. [M.Wa.; D.W.D.]

**Airfoil** The cross section of a body that is placed in an airstream in order to produce a useful aerodynamic force in the most efficient manner possible. The cross sections of wings, propeller blades, windmill blades, compressor and turbine blades in a jet engine, and hydrofoils on a high-speed ship are examples of airfoils. See COMPRESSOR; PROPELLER (AIRCRAFT); TURBINE PROPULSION; WIND POWER; WING.

The mean camber line of an airfoil (see illustration) is the locus of points halfway between the upper and lower surfaces as measured perpendicular to the mean camber line itself. The most forward and rearward points of the mean camber line are the leading and trailing edges, respectively. The straight line connecting the leading and trailing edges is the chord line of the airfoil, and the distance from the leading to the trailing edge measured along the chord line is simply designated the chord of the airfoil, represented by  $c$ . The thickness of the airfoil is the distance from the upper to the lower surface, measured perpendicular to the chord line, and varies with distance along the chord. The maximum thickness, and where it occurs along the chord, is an important design feature of the airfoil. The camber is the maximum distance between the mean camber line and the chord line, measured perpendicular to the chord line. Both the maximum thickness and the camber are usually expressed in terms

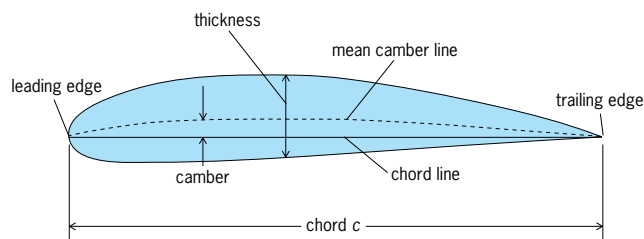

Airfoil nomenclature. The shape shown is an NACA 4415 airfoil.

of a percentage of the chord length; for example, a 12% thick airfoil has a maximum thickness equal to 0.12c.

The airfoil may be imagined as part of a wing which projects into and out of the page, stretching to plus and minus infinity. Such a wing, with an infinite span perpendicular to the page, is called an infinite wing. The aerodynamic force on the airfoil, by definition, is the force exerted on a unit span of the infinite wing. For this reason, airfoil data are frequently identified as infinite wing data.

The flow of air (or any fluid) over the airfoil results in an aerodynamic force (per unit span) on the airfoil, denoted by  $R$ . The relative wind is the magnitude and direction of the free-stream velocity far ahead of the airfoil. The angle between the chord line and relative wind is defined as the angle of attack of the airfoil, denoted by  $\alpha$ . By definition, the component of  $R$  perpendicular to the relative wind is the lift,  $L$ ; similarly, the component of  $R$  parallel to the relative wind is the drag,  $D$ .

The airfoil may be visualized as being supported by an axis perpendicular to the airfoil, and taken through any point on the airfoil. The airfoil has a tendency to twist about this axis; that is, there is an aerodynamic moment exerted on the airfoil. By definition, the moment is positive or negative if it tends to increase or decrease respectively the angle of attack (that is, if it tends to pitch the airfoil up or down, respectively). [J.D.A.]

**Airframe** The structural backbone of an aircraft that balances the internal and external loads acting upon the craft. These loads consist of internal mass inertia forces (equipment, payload, stores, fuel, and so forth), flight forces (propulsion thrust, lift, drag, maneuver, wind gusts, and so forth), and ground forces (taxi, landing, and so forth).

The strength capability of the airframe must be predictable to ensure that these applied loads can be withstood with an adequate margin of safety throughout the life of the airplane. In addition to strength, the airframe requires structural stiffness to prevent excessive deformation under load and to provide a satisfactory natural frequency of the structure (the number of times per second the structure will vibrate when a load is suddenly imposed or changed). The aerodynamic loads on the airframe can oscillate in magnitude under some circumstances, and if these oscillations are near the same rate as the natural frequency of the structure, runaway deflections (called flutter) and failure can occur. Consequently, adequate structural stiffness is needed to provide a natural frequency far above the danger range. See AEROELASTICITY.

The overall airframe structure is made up of a number of separate components, each of which performs discrete individual functions. The fuselage provides the accommodations of crew, passengers, cargo, fuel, and environmental control systems. The empennage consists of the vertical and horizontal stabilizers, which are used, respectively, for turning and pitching flight control. The wing passing through the air provides lift to the aircraft. Its related control devices, leading-edge slats and trailing-edge flaps, are used to increase this lift at slow airspeeds, such as during landing and takeoff, to prevent stalling and loss of lift. The ailerons increase lift on one side of the wing and reduce lift on the other in order to roll the airplane about its fore-and-aft axis. See AILERON; ELEVON; FUSELAGE; WING; WING STRUCTURE.

Performance requirements (range, payload, speed, altitude, landing and takeoff distance, and so forth) dictate that the airframe be designed and constructed so as to minimize its weight. All the airframe material must be arranged and sized so that it is utilized as near its capacity as possible, and so that the paths between applied loads and their reactions are as direct and as short as possible. The accomplishment of these goals, however, is compromised by constraints such as maintenance of the aerodynamic shape, the location of equipment, minimum sizes or thicknesses that are practical to manufacture, and structural stability, among others.

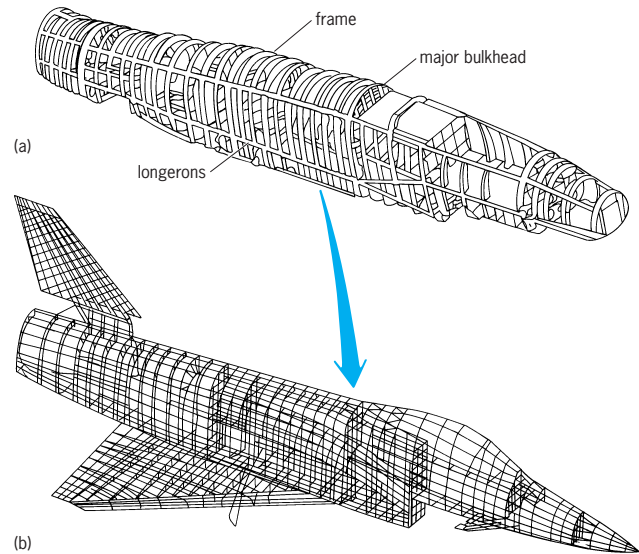

X-31 aircraft. (a) Fuselage structural load paths. (b) Finite element model. (Rockwell International)

To maintain structural efficiency (minimum weight), the material that forms the aerodynamic envelope of the airplane is also utilized as a primary load-carrying member of the airframe. For example, the thin sheets that are commonly used for outer fuselage skins are very efficient in carrying in-plane loads like tension and shear when they are stabilized (prevented from moving or deflecting out of the way when loads are applied). This structural support is provided by circumferential frames and longitudinal primary members called longerons. The compression loads are also carried in the longerons and the thin skins when they are additionally stabilized by multiple secondary longitudinal stiffeners that are normally located between the frames. Illustration a shows a typical fuselage primary load path structure indicating the frames and longerons. This skeleton will be covered by thin skins.

Various analytical techniques may be used to determine the internal stress levels for each of the airframe components. The most common analytical methods use the technique of reducing these highly complex structural arrangements into a group of well-defined simple structures known as finite elements. This simplification allows the load distribution to be solved by a series of algebraic equations.

The finite element model used for the determination of the internal load distribution must support various structural objectives that include the analysis of strength, stiffness, and damage tolerance characteristics of the aircraft. In order to accomplish these objectives the finite element model must represent the vehicle configuration in sufficient detail to define adequately the basic characteristics of the local structural load paths and provide for application of all external loading parameters. Illustration b shows the complete finite element model of an airframe. The many varied loading parameters include airloads, structural weight, engine thrust, landing gear reactions, fuel tanks, cargo, and passengers. Environmental factors such as cabin pressure and structural heating must also be considered. [L.M.La.; D.S.Kl.]

**Airglow** Visible, infrared, and ultraviolet emissions from the atoms and molecules in the atmosphere above 30 km (20 mi), generally in layers, and mostly between 70 and 300 km (45 and 200 mi). The airglow, together with the ionosphere, is found in the uppermost parts of the atmosphere that absorb the incoming energetic radiations from the Sun. While the airglow consists of spectral features similar to those of the aurora, it is mostly uniform

over the sky; and it is caused by the absorption of solar ultraviolet and x-radiations, rather than energetic particles. *See* AURORA.

The daytime airglow (dayglow) is caused mainly by fluorescence processes as molecules and atoms are photodissociated and photoionized. The photoelectrons that are produced in the ionization processes are a further source of airglow in their collisions with other atoms and molecules. *See* FLUORESCENCE.

Twilight offers an opportunity to observe resonant scattering of sunlight on layers such as those of the alkali atoms sodium, lithium, and potassium. As the Earth's shadow scans through the layers, the changes of intensity allow their heights (near 90 km or 55 mi) to be measured. *See* ALKALI EMISSIONS.

The nighttime airglow (nightglow) is predominantly due to recombination emissions. The ionospheric plasma recombines near the bottom of the F region (150–200 km or 90–120 mi) where the densities and thus collision frequencies are higher, producing bright atomic oxygen (O) spectral lines in the red (at 630 and 636 nanometers) and a weaker green (558-nm) line. [B.A.T.]

**Airplane** A heavier-than-air vehicle designed to use the pressures created by its motion through the air to lift and transport useful loads. To achieve practical, controllable flight, an airplane must consist of a source of thrust for propulsion, a geometric arrangement to produce lift, and a control system capable of maneuvering the vehicle within prescribed limits. Further, to be satisfactory, the vehicle should display stable characteristics, so that if it is disturbed from an equilibrium condition, forces and moments are created which return it to its original condition without necessitating corrective action on the part of the pilot. Efficient design will minimize the aerodynamic drag, thereby reducing the propulsive thrust required for a given flight condition, and will maximize the lifting capability per pound of airframe and engine weight, thereby increasing the useful, or transportable, load. *See* AIRCRAFT PROPULSION; AIRFRAME; FLIGHT CONTROLS. [D.C.H.]

**Airport engineering** A terminal facility used for aircraft takeoff and landing, and including facilities for handling passengers and cargo and for servicing aircraft. Facilities at airports are generally described as either airside, which commences at the secured boundary between terminal and apron and extends to the runway and to facilities beyond, such as navigational or remote air-traffic-control emplacements; or landside, which includes the terminal, cargo-processing, and land-vehicle approach facilities.

Airport design provides for convenient passenger access, efficient aircraft operations, and conveyance of cargo and support materials. Airports provide facilities for changing transportation modes, such as people transferring from cars and buses to aircraft, cargo transferring from shipping containers to trucks, or regional aircraft supplying passengers and cargo for intercontinental aircraft. In the United States, engineers utilize standards from the Federal Aviation Administration (FAA), aircraft performance characteristics, cost benefit analysis, and established building codes to prepare detailed layouts of the essential airport elements: airport site boundaries, runway layout, terminal-building configuration, support-building locations, roadway and rail access, and supporting utility layouts. Airport engineers constantly evaluate new mechanical and computer technologies that might increase throughput of baggage, cargo, and passengers.

**Site selection.** Site selection factors vary somewhat according to whether (1) an entirely new airport is being constructed or (2) an existing facility is being expanded. Few metropolitan areas have large areas of relatively undeveloped acreage within reasonable proximity to the population center to permit development of new airports. For those airports requiring major additional airfield capacity, however, and hence an entirely new site, the following factors must be evaluated for each alternate site: proximity to existing highways and major utilities; demo-

lition requirements; contamination of air, land, and water; air-traffic constraints such as nearby smaller airport facilities; nearby mountains; numbers of households affected by relocation and noise; political jurisdiction; potential lost mineral or agricultural production; and costs associated with all these factors. Some governments have elected to create sites for new airports using ocean fills. The exact configuration of the artificial island sites is critical due to the high foundation costs, both for the airport proper and for the required connecting roadway and rail bridges.

**Airfield configuration.** Since the runways and taxiways constitute the largest portion of the airport's land mass, their layout, based on long-term forecasts of numbers of aircraft landings and departures, is generally one of the first steps in the airport design. A paved runway surface 12,000 ft (3660 m) long and 150 ft (45 m) wide is suitable for most applications. Runway length requirements change according to the type of aircraft, temperature, altitude, and humidity encountered. A parallel taxiway is generally constructed 600 ft (180 m) from the runway (measured centerline to centerline). It is connected by shorter high-speed taxiways to allow arriving aircraft to leave the runway surface quickly in order to clear another aircraft arrival as quickly as possible. This combination is generally referred to as a runway-taxiway complex.

Ideally, airports can exclusively utilize parallel runway complexes so that incoming and departing aircraft can also be parallel for safe, simultaneous operations. Under these conditions, runway thresholds would be slightly staggered to avoid wake turbulence interference between incoming aircraft. Staggered thresholds might also be used to minimize crossing of active runways by taxiing aircraft. Each crossing is a potential aircraft delay and a safety hazard.

When airports have sufficiently high-velocity crosswinds or tailwinds from more than one direction, crosswind runways must also be provided. These crosswind runways are located at some angle to the primary runway as dictated by a wind rose analysis. *See* WIND ROSE.

Runways are paved with concrete, asphalt, concrete-treated base, or some combination of layers of these materials. Runways for larger aircraft require thicker, more expensive pavement sections. Engineers design these pavements for long design lives. The expected life of a concrete runway can be increased from 20 to 40 years, based on enhanced mix designs and sections. *See* CONCRETE; PAVEMENT.

A system of vehicle service roads must be provided around the perimeter of the airfield both for access to the runways and for security patrols of the perimeter fencing. Airfield security fencing with a series of access gates is monitored with patrols and, increasingly, a remote camera surveillance system.

**Terminal configuration.** The terminal is generally the airport building that houses ticketing, baggage claim, and transfer to ground transportation. The concourse is generally the combination of facilities for boarding aircraft, sorting baggage according to flight, and unloading cargo carried in commercial aircraft. Airport terminal and concourse configurations generally fall into three categories: (1) terminal contiguous with concourse satellite extensions (known as piers or fingers) used for boarding aircraft; (2) unit terminals, which serve as transfer points both from ground transportation modes into the building and from the building into the aircraft; (3) and detached terminal and concourses, sometimes referred to as a landside and airside terminals, connected by a people-mover train system, an underground walkway or a surface transport vehicle.

**Support buildings.** The primary types of support buildings required by the airlines for their airport operations are flight kitchens to prepare meals for passengers, hangars to service aircraft, and ground support equipment buildings to service ground support vehicles such as tugs, baggage carts, and service trucks. The high number of trips for support vehicles to travel from these buildings to load or service aircraft requires that the buildings be

located in reasonable proximity to the aircraft gates. However, the buildings should be sufficiently far to allow the concourses to be expanded without requiring demolition of these support facilities.

An airport requires fire equipment to provide extremely fast primary and secondary response to each and every runway. Locating the aircraft rescue and fire-fighting stations requires careful positioning with respect to the taxiway system. Other types of support buildings include storage buildings, employee facilities, administrative offices, vehicle maintenance buildings for snow removal and airport vehicles, roadway revenue plaza offices, and training facilities.

**Fuel and deicing facilities.** Economies of scale and safety considerations generally encourage the implementation of large, centralized common systems for aircraft fuel. The large storage tanks required to ensure adequate reserves of fuel are located in remote areas of the airport, generally in aboveground facilities. Underground distribution piping then transports the fuel to hydrant pits or truck fueling stations close to aircraft operations. This system, like most utilities, is designed with backup capacity by looping piping around each service area. If a break occurs in a section of pipe, valves are automatically closed and the supply direction is reversed. Fuel tanks require extensive analysis of structural, mechanical, and electrical design. These tanks are widely spaced to avoid the transmission of fire and to allow room for a surface detention area to store burning fuel. [G.S.E.]

**Airport noise** The unwanted sound from airport operations, primarily from aircraft of all types. It affects neighbors both adjacent to and farther from the airport.

Source noise control of jets has progressed with time. The first jet aircraft, called stage 1, had no noise control on their engines. Federal law now prohibits use of stage 1 in the United States. Simple muffling was added to the jet engines in the 1970s to give stage 2 aircraft. At the same time, improvements were made to the engine design, resulting in about 10 decibels of noise reduction for a given aircraft type. This type of engine powers the stage 3 aircraft. As of January 1, 2000, all large turbojet aircraft operating in the United States were stage 3, by federal mandate. In anticipation of the stage 3 mandate, owners of stage 2 aircraft could sometimes use an engine retrofit, called a hushkit, to meet the stage 3 noise criteria, prolonging the useful life of the aircraft. Additional improvements, starting in 1992, have continued to reduce aircraft noise emissions. In June 2001, the International Civil Organization (ICAO) adopted the next quieter level, called Chapter 4 of their regulations (Annex 16). It effectively eliminates hushkitted older aircraft from operating in countries which adopt these rules. See AIRCRAFT ENGINE PERFORMANCE; JET PROPULSION; MUFFLER; TURBOJET.

Airports can reduce the noise from backing up, repositioning, or taxiing by having the aircraft towed to or from the gate. The source noise during flight can be reduced by using lower thrust settings when planes fly over noise-sensitive areas. The most common path noise control is by use of barriers or berms. For effective noise reduction (at least 5 dB), the top of the barrier must intercept the line-of-sight between the aircraft engine and the observer.

Airport noise is measured with noise monitors, consisting of microphones and meters. Most large airports have a distributed network of permanent noise monitors which record observed noise levels and accumulate the data for future transfer to the airport's computer. Small airports are most likely to have only portable measuring equipment or to use consultants. See ACOUSTIC NOISE; NOISE MEASUREMENT. [N.S.T.]

**Airport surface detection equipment** A ground mapping system that uses analog radar equipment to provide surveillance of aircraft and other surface vehicles on an airport surface. It is used by air-traffic controllers in airport control towers to monitor and control the movement of aircraft

and vehicles. A situation display of the targets includes a map identifying the runways and taxiways and a visual map of the airport features, created through the contrast on the radar display resulting from the absence of returns from smooth concrete surfaces and the ground-clutter returns from grassy areas. An important safety function of the airport surface detection equipment (ASDE) is to determine whether or not a runway is clear for the next departure or arrival operation. This runway clearance determination is aided by the ASDE's capability to display an image of the aircraft in which the target's extremities (nose, tails, and wing tips), especially for large aircraft, are evident to the eye. See AIRPORT.

The ASDE antenna revolves at 60 revolutions per minute, providing a rapid update of target movements. It is located on a high vantage point, typically on top of the tower cab or on a special remote tower, that provides line-of-sight coverage of the desired areas. Modern ASDEs utilize digital processing and an interrogation technique called frequency agility, which permits the transmission of up to 16 different Ku-band frequencies within a cycle. These techniques optimize target detection in the presence of ground and rain clutter and the rejection of false targets. In the digital processing, different thresholds for rejecting clutter are used on specified areas of the airport surface, such as on paved surfaces versus grassy areas. These systems are designed to detect all aircraft and vehicles having a radar cross section of 30 ft<sup>2</sup> (3 m<sup>2</sup>) or greater, and will resolve two closely spaced targets when separated by 40 ft (12 m) in range or 80 ft (24 m) in azimuth at a range of 12,000 ft (3650 m). The basic coverage is the entire airport surface out to 24,000 ft (7300 m) in range and 200 ft (60 m) in altitude. Areas where coverage is not desired are ignored for detection and blanked out on the situation display.

The digital processing in modern ASDEs also provides the basis for automation functions that process target data to provide controllers with improved information. Principal automation features include target tracking, the application of runway safety logic functions to the tracks, and automatic alerting of the controller to dangerous situations determined by the logic. The design requirements for advanced surface surveillance systems include providing data that allows determination of target identity and target intent from flight-plan information or from data-link messages between the control tower and aircraft. See AIR-TRAFFIC CONTROL; ELECTRONIC NAVIGATION SYSTEMS; MOVING-TARGET INDICATION; RADAR. [R.A.Ba.]

**Airship** A propelled and steered aerial vehicle, dependent on the displacement of air by a lighter gas for lift. An airship, or dirigible balloon, is composed primarily of a streamlined hull, usually a prolate ellipsoid which contains one or more gas cells, fixed and movable tail surfaces for control, a car or cabin for the crew or passengers, and a propulsion system.

Two fundamentally different designs have been successfully used for past airships, the nonrigid and the rigid. A third type, the semirigid, is essentially a variant of the nonrigid type, differing by the addition of rigid keel.

A typical nonrigid airship, or blimp, consists of a flexible envelope, usually fabric, filled with lifting gas that is slightly pressurized. Internal air compartments (ballonets) expand and contract to maintain the pressure in the envelope as atmospheric pressure and temperature vary. Ballonet volume is controlled by ducting air from the prop wash or by electric blowers. The weights of the car structure, propulsion system, and other concentrated loads are supported by catenary systems attached to the envelope.

The nonrigid airships are historically significant for two reasons. First, a nonrigid airship was the first aircraft of any type to achieve controllable flight, in the 1850s. Second, nonrigid airships were the last type to be used on an extensive operational basis; the U.S. Navy decommissioned the last of its non-rigid airship fleet in the early 1960s.

The structure of a rigid airship (see illustration) was usually an aluminum ring-and-girder frame. An outer covering was at-



Akron, rigid airship of the U.S. Navy.

tached to the frame to provide a suitable aerodynamic surface. Several gas cells were arrayed longitudinally within the frame. These cells were free to expand and contract, thereby allowing for pressure and temperature variations. Thus, despite their nearly identical outward appearance, rigid and nonrigid airships were significantly different in their construction and operation.

Many modern airship vehicle concepts have been proposed. The fully buoyant conventional concepts are modern versions of the classical, fully buoyant, rigid, and nonrigid airship concepts. Fully buoyant means all the lift is provided by displacement. These airships would make extensive use of modern aircraft structural materials, propulsion systems, control systems, and electronics.

Other concepts include partially buoyant, or hybrid, designs in which the buoyant lift is substantially augmented by aerodynamic or propulsive lift. Thus, these vehicles are partly heavier than air and partly lighter than air. Some hybrids are short-takeoff and landing (STOL) vehicles, and others have vertical-takeoff and landing (VTOL) capability. An important advantage of the hybrids is that they promise to alleviate the costly ground-handling requirement of past airship designs. See SHORT TAKEOFF AND LANDING (STOL); VERTICAL TAKEOFF AND LANDING (VTOL).

Airships are once again being seriously considered for many civil and military applications. An airship's natural attributes compared with other vehicles draw attention to short-range transportation and to missions requiring high loiter time, that is, patrol and surveillance applications. See BALLOON. [M.D.A.]

**Airspeed indicator** A device that computes and displays speed of an aircraft relative to the air mass in which the aircraft is flying. The commonest type is the indicated airspeed meter, which measures differential pressure between the total ram pressure from the Pitot system and the total static pressure; it then converts this difference into units of speed (mi/h or knots) under standard conditions. Although the indicated values are incorrect above zero altitude, the relationship to the aircraft handling remains essentially unchanged, thus providing a measure of the flyability of the aircraft.

True airspeed indicators are similar but include a more complex mechanism that also senses both the absolute pressure and temperature, and compensates for the change of density of the air mass, thus obtaining true airspeed. This indication is of value in computing course information.

For those aircraft that reach higher speeds (transonic and supersonic), the ratio of the actual speed to the local speed of sound is used. Devices that compute this value are known as Machmeters. See MACH NUMBER; PITOT TUBE. [J.W.A.]

**Aistopoda** An order of extremely elongate, limbless fossil amphibians in the subclass Lepospondyli from Permian-Carboniferous rocks of North America and the British Isles. The order includes three families: Lethiscidae (*Lethiscus*), Ophider-

petontidae (*Coloraderpeton*, *Ophiderpeton*), and Phlegethontidae (*Aornerpeton*, *Phlegethontia*, *Sillerpeton*).

The skulls of aistopods are fenestrated and exhibit a reduced number of bony elements. The vertebral centra are holospondylous (single-pieced), hourglass-shaped, and fused to their neural arches. Vertebrae can exceed 200 in number and frequently bear foramina for passage of spinal nerves. Ribs typically bear a unique process, which gives them a K-shape in some species.

Most aistopods were presumably aquatic, although rib specializations, and the more gracile proportions of phlegethontids, suggest a rather snakelike, terrestrial habit. See AMPHIBIA; LEPOSPONDYLI. [C.F.W.]

**Albedo** A term referring to the reflecting properties of surfaces. White surfaces have albedos close to 1; black surfaces have albedos close to 0.

Several types of albedos are in common use. The Bond albedo ( $A_B$ ) determines the energy balance of a planet or satellite and is defined as the fraction of the total incident solar energy that the planet or satellite reflects to space. The "normal albedo" of a surface, more properly called the normal reflectance ( $r_n$ ), is a measure of the relative brightness of the surface when viewed and illuminated vertically. Such measurements are referred to as a perfectly white Lambert surface—a surface which absorbs no light and scatters the incident energy isotropically—usually approximated by magnesium oxide (MgO), magnesium carbonate (MgCO<sub>3</sub>), or some other bright material. See PHOTOMETRY; PLANET.

Bond albedos for solar system objects range from 0.9 for Saturn's icy satellite Enceladus and Neptune's Triton to values as low as 0.01–0.02 for dark objects such as the satellites of Mars. Cloud-shrouded Venus has the highest Bond albedo of any planet (0.76). The value for Earth is 0.35. The Bond albedo is defined over all wavelengths, and its value therefore depends on the spectrum of the incident radiation.

Normal reflectances of some common materials are listed in the table. The normal reflectances of many materials are strongly

Normal reflectances of materials\*

Material	Albedo
Lampblack	0.02
Charcoal	0.04
Carbonaceous meteorites	0.05
Volcanic cinders	0.06
Basalt	0.10
Iron meteorites	0.18
Chondritic meteorites	0.29
Granite	0.35
Olivine	0.40
Quartz	0.54
Pumice	0.57
Snow	0.70
Sulfur	0.85
Magnesium oxide	1.00

\* Powders; for wavelengths near 0.5 micrometer.

dependent on wavelength, a fact that is commonly used in planetary science to infer the composition of surfaces remotely. While the Bond albedo cannot exceed unity, the normal reflectance of a surface can if the material is more backscattering at opposition than the reference surface. [J.V.]

**Albite** A sodium-rich plagioclase feldspar mineral whose composition extends over the range Ab<sub>100</sub>An<sub>0</sub> to Ab<sub>90</sub>An<sub>10</sub>, where Ab (= albite) is NaAlSi<sub>3</sub>O<sub>8</sub> and An (= anorthite) is CaAl<sub>2</sub>Si<sub>2</sub>O<sub>8</sub>. Albite occurs in crustal igneous rocks as a major component of pegmatites and granites, in association with quartz, mica (usually muscovite), and potassium feldspar

(orthoclase or microcline). Sodium and potassium feldspars usually occur as distinct mineral grains, sizes varying from millimeter to meter scale. They are frequently intergrown; if the intergrowth is visually observable in a hand specimen, the composite material is known as macroperthite; if visible only in a microscope, microperthite; and if submicroscopic in scale, cryptoperthite. In metamorphic rocks albite is found in granitic gneisses, and it may be the principal component of arkose, a feldspar-dominant, sedimentary rock. Cleavelandite, a platy variety, is sometimes found in lithium-rich pegmatites. See ARKOSE; FELDSPAR; GNEISS; IGNEOUS ROCKS; PEGMATITE; PERTHITE. [P.H.R.]

**Albumin** A type of globular protein that is characterized by its solubility in water and in 50% saturated aqueous ammonium sulfate. Albumins are present in mammalian tissues, bacteria, molds, and plants, and in some foods. Serum albumin, which contains 584 amino acid residues, is the most abundant protein in human serum, and it performs two very important physiological functions. It is responsible for about 80% of the total osmotic regulation in blood, and it transports fatty acids from adipose tissue to muscle. When excessive amounts of albumin are found in the urine upon clinical examination, some form of kidney disease is usually indicated. Another important albumin, ovalbumin, is found in egg white. This protein is about two-thirds the size of serum albumin, and it contains sugar residues in addition to amino acid residues (that is, it is a glycoprotein). See PROTEIN. [J.M.M.]

**Alcohol** A member of a class of organic compounds composed of carbon, hydrogen, and oxygen. They can be considered as hydroxyl derivatives of hydrocarbons produced by the replacement of one or more hydrogens by one or more hydroxyl (S—OH) groups.

**Classification.** Alcohols may be mono-, di-, tri-, or polyhydric, depending upon the number of hydroxyl groups they possess. They are classified as primary ( $RCH_2OH$ ), secondary ( $R_2CHOH$ ), or tertiary ( $R_3COH$ ), depending on the number of hydrogen atoms attached to the carbon atom bearing the hydroxyl group. Alcohols can also be characterized by the molecular configuration of the hydrocarbon portion (aliphatic, cyclic, heterocyclic, or unsaturated). There are two systems in use for alcohol nomenclature, the common naming system and the IUPAC (International Union of Pure and Applied Chemistry) naming system. The common name is sometimes associated with the natural source of the alcohol or with the hydrocarbon portion (for example, methyl alcohol, ethyl alcohol). The IUPAC method is a systematic procedure with agreed-upon rules. The name of the alcohol is derived from the parent hydrocarbon which corresponds to the longest carbon chain in the alcohol. The final "e" in the hydrocarbon name is dropped and replaced with "ol"; and a number before the name indicates the position of the hydroxyl. Examples of these two systems are given in the table.

Oxidation of primary alcohols produces aldehydes ( $RCHO$ ) and carboxylic acids ( $RCO_2H$ ); oxidation of secondary alcohols yields ketones ( $RCOR'$ ). Dehydration of alcohols produces alkenes and ethers ( $ROR$ ). Reaction of alcohols with carboxylic acids results in the formation of esters ( $ROCOR'$ ), a reaction of great industrial importance. The hydroxyl group of an alcohol is readily replaced by halogens or pseudohalogens. See ALDEHYDE; ALKENE; CARBOXYLIC ACID; ESTER; ETHER; KETONE.

**Uses.** Industrially, the monohydric aliphatic alcohols are classified according to their uses as the lower alcohols (1–5 carbon atoms), the plasticizer-range alcohols (6–11 carbon atoms), and the detergent-range alcohols (12 or more carbon atoms). The lower alcohols are employed as solvents, extractants, and antifreezes. Esters of the lower alcohols are employed extensively

### Alcohols and their formulas

Name		
Common	IUPAC	Formula
Methyl alcohol	Methanol	$CH_3OH$
Ethyl alcohol	Ethanol	$CH_3CH_2OH$
<i>n</i> -Propyl alcohol	1-Propanol	$CH_3CH_2CH_2OH$
Isopropyl alcohol	2-Propanol	$(CH_3)_2CHOH$
<i>n</i> -Butyl alcohol	1-Butanol	$CH_3(CH_2)_2CH_2OH$
<i>sec</i> -Butyl alcohol	2-Butanol	$CH_3CH_2CHOHCH_3$
<i>tert</i> -Butyl alcohol	2-Methyl-2-propanol	$(CH_3)_3COH$
Isobutyl alcohol	2-Methyl-1-propanol	$(CH_3)_2CHCH_2OH$
<i>n</i> -Amyl alcohol	1-Pentanol	$CH_3(CH_2)_3CH_2OH$
<i>n</i> -Hexyl alcohol	1-Hexanol	$CH_3(CH_2)_4CH_2OH$
Allyl alcohol	2-Propen-1-ol	$CH_2=CHCH_2OH$
Crotyl alcohol	2-Buten-1-ol	$CH_3CH=CHCH_2OH$
Ethylene glycol	1,2-Ethandiol	$HOCH_2CH_2OH$
Propylene glycol	1,2-Propanediol	$CH_3CHOHCH_2OH$
Trimethylene glycol	1,3-Propanediol	$HOCH_2CH_2CH_2OH$
Glycerol	1,2,3-Propanetriol	$CH_2OHCHOHCH_2OH$

as solvents for lacquers, paints, varnishes, inks, and adhesives. The plasticizer-range alcohols find their primary use in the form of esters as plasticizers and also as lubricants in high-speed applications such as jet engines. The detergent-range alcohols are used in the form of sulfate and ethoxysulfate esters in detergents and surfactants.

Alcohols are derived either from natural-product processing, such as the fermentation of carbohydrates and the reductive cleavage of natural fats and oils, or by chemical synthesis based on the hydrocarbons derived from petroleum or the synthesis gas from coal.

The fermentation of sugars and starches (carbohydrates) to produce alcoholic beverages has been employed at least since history has been recorded. The industrial fermentation process is the biological transformation of a carbohydrate by a highly specialized strain of yeast to produce the desired product, such as ethanol, or 1-butanol and acetone. Fermentation is no longer the major source of 1-butanol, but still accounts for all potable ethanol and a large proportion of the ethanol used industrially worldwide. As sources of hydrocarbons based on petroleum continue to be depleted, fermentation processes based on renewable raw materials are likely to become more important. See DISTILLED SPIRITS; FERMENTATION. [P.E.F.]

**Alcohol fuel** Any alcohol burned as a fuel. If available, any alcohol may be used as a fuel, but ethanol and methanol are the only ones which are sufficiently inexpensive. Alcohols are useful fuels, even though the oxygen atom in any alcohol molecule reduces its heating value, because the molecular structure increases the combustion efficiency. See COMBUSTION; GASOLINE.

Ethanol burns well in engines designed for gasoline and has a high octane rating. However, because of the high cost of the raw materials required, or of their conversion, it costs much more than gasoline. Gasohol is produced by dissolving 5–15% absolute (water-free) alcohol in gasoline. The 5% water fraction in 95% alcohol causes phase separation because of its insolubility, making 95% alcohol unsuitable for use in gasohol. See ETHYL ALCOHOL; OCTANE NUMBER.

Carbon in any material can be converted to methanol. Natural gas has been favored as a raw material, and its energy may be delivered at a much lower cost if the gas is converted to methanol than if it is piped directly or if the gas is converted to liquefied natural gas, shipped, and stored at its cryogenic temperature. See LIQUEFIED NATURAL GAS (LNG); NATURAL GAS.

Methanol is the most versatile and cheapest liquid fuel that can be made. It is also less flammable than gasoline; accidental fires are extinguished with water instead of being spread as flaming films. When it combusts, it yields neither particulates (soot) nor sulfur oxides, and yields lower quantities of nitrogen oxides

than any other fuel. When produced from natural gas or solid fuel, methanol can always be regasified to give substitute natural gas (SNG) with only a small loss of energy. Even when expensive chemical-grade methanol is used in automobiles with relatively insignificant changes, the mileage costs are less for these vehicles than when they use gasoline as a fuel. See METHANOL.

[D.F.O.]

**Alcoholism** The continuous or excessive use of alcohol (ethanol) with associated pathologic results. Alcoholism is characterized by constant or periodic intoxication, although the pattern of consumption varies markedly. Individuals admitted for the first time to an alcoholism treatment center typically have been consuming approximately 3–4 oz (80–100 g) of pure alcohol per day, corresponding to about seven to nine drinks or bottles of beer or glasses of wine. Studies have shown that problem drinking in these populations starts at about 2 oz/day (60 g/day), that is, four to five drinks per day, and that these are consumed in rapid succession, leading to intoxication on three or more days per week. Individuals who consume these levels of alcohol have also a greater than average risk of developing alcoholic liver cirrhosis. However, the levels should not be taken as absolute, since they can vary greatly in different individuals, according to body weight and other factors.

The symptoms and consequences associated with severe alcohol consumption also vary greatly; that is, in some individuals only a few may be present. These may consist of the development of physical dependence manifested as a state of physical discomfort or hyperexcitability (tremors or shakes) that are reduced by continued consumption; the development of tolerance to the effects of alcohol, which leads individuals to increase their consumption; accidents while intoxicated; blackouts, characterized by loss of memory of events while intoxicated; work problems, including dismissal; loss of friends and family association; marital problems, including divorce; financial losses, including bankruptcy or continual unemployment. Medical problems can include gastric ulcers, pancreatitis, liver disease, and brain atrophy. The last is often associated with cognitive deficiencies, as shown by the inability to comprehend relatively simple instructions or to memorize a series of numbers. See COGNITION.

Almost without exception, individuals seeking an early treatment for their alcohol problems have very good probabilities of recovery. The lesser the number of presenting problems described above, the better the chances of favorable outcome, and so an early identification of problem drinking by family, friends, employers, or physicians becomes very important. The types of intervention vary greatly, progressing from self-monitoring techniques to intensive outpatient and inpatient programs to Alcoholics Anonymous groups.

The exact mechanisms of the pharmacological actions of alcohol are not known. Alcohol can act as a stimulant at lower doses and as a depressant at higher doses. Even at very low doses alcohol can impair the sensitivity to odors and taste. Also, low doses are known to alter motor coordination and time and space perception, important aspects of car driving. Some effects are already seen at levels of 0.05%. Pain sensitivity is diminished with moderate doses. In some individuals, alcohol is known to diminish feelings of self-criticism and to inhibit fear and anxiety, effects which are probably related to an alcohol-induced sociability. These effects act, no doubt, as psychological reinforcers for the use of alcoholic beverages.

It is generally accepted that alcohol affects the nerve cell by preventing the production and propagation of electric impulses along a network consisting of axons and synapses. A major finding in the mid-1980s was that some of the neurologic effects of alcohol can be quickly reversed by new experimental drugs. Studies have shown that alcohol enhances the actions of an inhibitory brain neurotransmitter referred to as gamma-aminobutyric acid (GABA). Benzodiazepines, such as diazepam, are anxiety-reducing and sedative drugs which also enhance the

effects of GABA. These effects can be reduced by experimental antagonist molecules, which interact in the brain in the same regions where GABA is found. See SYNAPTIC TRANSMISSION.

The liver is responsible for about 80% of the metabolism of alcohol. In the liver, alcohol is first oxidized to acetaldehyde and then to acetate, which is metabolized in many tissues, including the brain, heart, and muscles. A 150-lb (68-kg) person metabolizes approximately 0.4 oz (10 g) of pure alcohol per hour (about 1 oz of a distilled beverage per hour) or, if alcohol is continuously present in the bloodstream, about 8–10 oz (190–240 g) of pure alcohol per day, equivalent to 1300–1600 calories per day. Since alcoholic beverages contain negligible levels of essential nutrients, these calories are called “empty calories.” Many alcoholics show malnutrition due to the fact that an important part of their caloric intake is alcohol. Alcohol also impairs the absorption and the metabolism of some essential nutrients. In the presence of alcohol, about 80% of oxygen consumed by the liver is devoted to the metabolism of alcohol; as a consequence, other substances such as fats, normally oxidized by the liver, are not metabolized, leading to fat accumulation in the liver. See LIVER; MALNUTRITION.

Alcoholic liver disease is characterized by two conditions: failure of the liver to detoxify noxious substances and to produce essential products; and increased resistance to blood flow through the liver. Alcoholic liver disease and liver cirrhosis rank among the 10 leading causes of mortality in the United States and Canada. See CIRRHOSIS.

There is abundant evidence that tendency to alcoholism can be of familial origin, due to environmental, cultural, and genetic factors. A Swedish study demonstrated that identical twins are twice as likely to have a common alcoholic problem as fraternal twins. In an American-Danish study, it was shown that children of alcoholic parents are more likely to develop alcoholism (18%) than children of nonalcoholic parents (4%) when both groups of children were adopted by nonrelatives within 6 weeks of birth. See BEHAVIOR GENETICS; BEHAVIORAL TOXICOLOGY. [Y.I.]

Pharmacotherapy for alcohol rehabilitation has been gaining wider acceptance. Specific pharmacotherapies which have received the most research attention utilize naltrexone and disulfiram. Other promising pharmacological interventions are acamprostate and buspirone. Naltrexone is an opiate receptor antagonist which blocks the effects of endogenous opioids in the brain. Research from animal studies suggests that alcohol activates endogenous opioid systems and, thereby, may contribute to the pleasurable effects produced by alcohol consumption. Consequently, naltrexone might reduce the reinforcing effects of alcohol consumed by people and decrease their incentive to drink. Disulfiram is a drug which causes an inhibition of the enzyme aldehyde dehydrogenase, leading to an increase in acetaldehyde blood levels. This rise will produce nausea, vomiting, tachycardia, difficulty in breathing, and changes in blood pressure leading to hypotension. Acamprostate may function to reduce alcohol-induced euphoria related to the effects of excitatory neurotransmitters such as *N*-methyl-D-aspartate and have some blocking effects on opiate receptors. Buspirone, a nonbenzodiazepine anti-anxiety agent, may decrease anxiety symptoms associated with a protracted alcohol withdrawal syndrome, thus reducing alcohol relapse potential. Both of these medications require further investigation to determine their effectiveness as a pharmacotherapeutic agent in the treatment of alcoholism. [S.Mar.]

**Alcyonacea** An order of the subclass Alcyonaria. Alcyonacea, the soft corals (see illustration), are littoral anthozoans, which form massive or dendriform colonies with yellowish, brown, or olive colors. Most attach to some solid substratum; however, some remain free in sandy or muddy places. The only skeletal structures are small, elongated, spindle-shaped or rod-like, warty sclerites which are scattered over the mesoglea. The colony is supple and leathery. The polyp body is embedded in the coenenchyme, from which retractile anthocodia protrude in

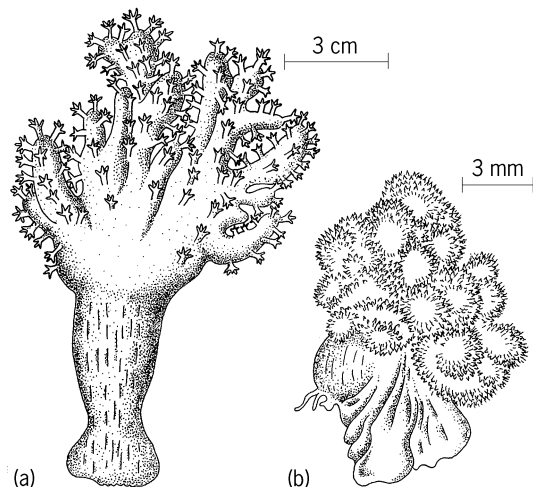

Alcyonaceans. (a) *Alcyonium palmatum* (after Y. De/age).  
(b) *Dendronephthya* sp. (after H. Utinomi).

*Alcyonium*. In *Xenia* and *Heteroxenia*, anthocodia are nonretractile. The polyp base is protected by many sclerites and is termed a calyx. See ALCYONARIA; COELENTERATA. [K.At.]

**Alcyonaria** A subclass of the Anthozoa. These coelenterates are colonial; most are sedentary and littoral, and some live at great depths. The ordinary polyp, the autozoid, has eight motile, contractile, hollow, pinnately branched tentacles. Eight complete mesenteries are present, of which the dorsal or asulcal pair is the most developed and bears the largest, heavily ciliated ectodermal filaments. The remaining mesenteries bear endodermal filaments having many glandular cells. Longitudinal retractor muscles are strongly developed on their ventral or sulcal surfaces. The stomodeum or pharynx, with a single siphonoglyph in its sulcal edge, is lined by a ciliated glandular epithelium. The gastrovascular cavity of each polyp is interconnected by complex canal systems or solenia. These permeate the colonial spiculiferous mesoglea or coenenchyme. The skeleton is formed by a deposition of horny material secreted by ectoderm cells, or by ectodermal scleroblasts which secrete calcareous spicules or sclerites of various shapes. The musculatures are not particularly well developed.

The oral end of the polyp is termed the anthocodium. The basal portion, or anthostele, is embedded in coenenchyme containing numerous ameoboid cells and scleroblasts.

The Alcyonaria are characterized by a strongly developed siphonoglyph, which serves to circulate water in a colony. Alcyonaria are either dioecious or monoecious. The gonads ripen in the endodermal mesenteric filaments. The daughter polyp buds asexually from the solenial system or from a parent's body wall. Pennatulacea and some other forms are dimorphic. The siphonozoid is smaller than the autozoid. It lacks tentacles or the tentacles are rudimentary and usually sterile. See ANTHOZOA; COELENTERATA. [K.At.]

**Aldebaran** A cool red giant star, prominently located in the constellation Taurus. With its red color, it appropriately represents the eye of the Bull. At a distance of 20 parsecs (65 light-years), Aldebaran, or  $\alpha$  Tauri, is among the nearest (and brightest) giant stars to the Sun. The star is an example of a K-type giant, a very common type of evolved star that derives its energy from the thermonuclear burning of helium in a core surrounded by a thin, hydrogen-burning shell. Its spectral type of K5III corresponds to an effective temperature of 6700°F (4000 K) and a radius of about 40 times the Sun. It is nearly 150 times more luminous than the Sun and, as is typical for K giants, its brightness varies by a modest amount. Aldebaran is accompanied in

a long-period binary-star system by a cool dwarf companion star some 100,000 times fainter than the giant. See BINARY STAR; GIANT STAR; STAR; TAURUS. [H.A.McA.]

**Aldehyde** One of a class of organic chemical compounds represented by the general formula RCHO. Formaldehyde, the simplest aldehyde, has the formula HCHO, where R is hydrogen. For all other aldehydes, R is a hydrocarbon radical which may be substituted with other groups such as halogen or hydroxyl (see table). Because of their high chemical reactivity, aldehydes are important intermediates for the manufacture of resins, plasticizers, solvents, dyes, and pharmaceuticals.

#### Aldehydes and their formulas

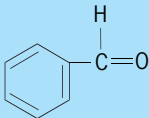
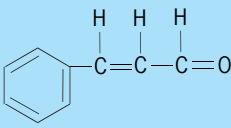
Compound	Formula
Formaldehyde	HCHO
Acetaldehyde	CH <sub>3</sub> CHO
Acetaldol	CH <sub>3</sub> CHOHCH <sub>2</sub> CHO
Propionaldehyde	C <sub>2</sub> H <sub>5</sub> CHO
n-Butyraldehyde	CH <sub>3</sub> (CH <sub>2</sub> ) <sub>2</sub> CHO
Isobutyraldehyde	(CH <sub>3</sub> ) <sub>2</sub> CHCHO
Acrolein	CH <sub>2</sub> =CHCHO
Crotonaldehyde	CH <sub>3</sub> CH=CHCHO
Chloral	CCl <sub>3</sub> CHO
Chloral hydrate	CCl <sub>3</sub> CH(OH) <sub>2</sub>
Benzaldehyde	
Cinnamaldehyde	

At room temperature formaldehyde is a colorless gas. The other low-molecular-weight aldehydes are colorless liquids having characteristic, somewhat acrid odors. The unsaturated aldehydes acrolein and crotonaldehyde are powerful lacrimators. The important reactions of aldehydes include oxidation, reduction, aldol condensation, Cannizzaro reaction, and reactions with compounds containing nitrogen.

Because of the importance of aldehydes as chemical intermediates, many industrial and laboratory syntheses have been developed. The more important of these methods include catalytic dehydrogenation of primary alcohols, oxidation of primary alcohols, oxidation of olefins, and hydroformylation of olefins. See FORMALDEHYDE. [P.E.F.]

**Alder** A deciduous tree, *Alnus rubra*, which grows from Alaska to northern California and eastern Idaho. It is recognized by its stalked buds, simple leaves, and dry, conelike, ellipsoid fruit. With the big-leaf maple it shares the role of principal hardwood tree in the Pacific Northwest, where most of the commercially important trees are conifers. The wood is used in furniture. See FAGALES. [A.H.G./K.P.D.]

**Aldosterone** The steroid hormone found in the biologically active amorphous fraction that remains after separation of the various crystalline steroid substances, such as cortisol and corticosterone, from adrenal extracts. In solution, aldosterone



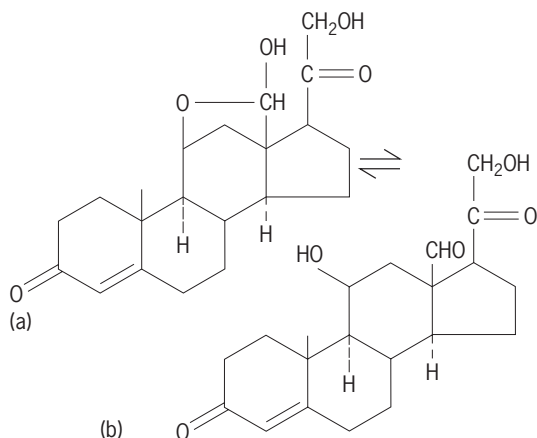

Structures for two forms of aldosterone in an equilibrium mixture, (a) aldo and (b) lactol.

exists as an equilibrium mixture of aldo and lactol forms (see illustration).

The chief function of aldosterone is the regulation of electrolyte metabolism, that is, promotion of sodium retention and enhancement of potassium excretion. Aldosterone is the most potent of the hormones which are concerned in this type of metabolism. See ADRENAL GLAND; HORMONE; STEROID. [C.H.L.]

**Alfalfa** The world's most valuable forage legume, *Medicago sativa*, known also as lucerne. It is grown for hay, pasture, and silage. Valued highly as livestock feed, alfalfa hay cut at a late bud or early bloom stage (and cured properly) contains 17–24% protein and is a good source of certain vitamins and minerals. See ROSALES.

Alfalfa is a herbaceous perennial legume characterized by a deep taproot, which shows a varying degree of branching. Erect or semierect stems, bearing an abundance of leaves, grow to a height of 2–3 ft (0.6–0.9 m). The number of stems arising from a single woody crown may vary from just a few to 50 or more. New stems develop when older ones are mature or have been cut or grazed. Flowers are borne on axillary racemes which vary greatly in size and number of flowers. Flower color is predominantly purple, or bluish-purple, but white, cream, yellow, green, lavender, and reddish-purple occur. The fruit is a legume, or pod, usually spirally coiled in *M. sativa*, but crescent-shaped or straight in *M. falcata*. Seeds are small and the color varies from yellow to brown.

Reproduction in alfalfa is mainly by cross-fertilization. Pollination is effected largely by bees. Seed production is favored by bright sunny days, cool nights, an abundance of bees, and dry weather for harvesting.

Alfalfa is widely adapted to temperate and subtropical climates and soils. It is grown from 40°S in Argentina and New Zealand to 60°N in Canada, Sweden, and Russia. It is not well adapted to humid tropical conditions.

Deep fertile loams are best and good drainage is essential. The water requirement for sustained high yields is great, and moisture deficiency often is a serious limiting factor in areas dependent on natural rainfall.

More than 80 improved cultivars of alfalfa are recognized as eligible for seed certification in the United States. These trace to three basic stocks: *M. sativa*, purple-flowered, narrow-crowned, and erect; *M. falcata*, yellow-flowered, somewhat prostrate, with deep-set crown and branching roots; and an intermediate form, often called variegated, derived from crossing *M. sativa* and *M. falcata*. [C.H.H.]

**Alfvén waves** Propagating oscillations in electrically conducting fluids or gases in which a magnetic field is present.

Magnetohydrodynamics deals with the effects of magnetic fields on fluids and gases which are efficient conductors of electricity. Molten metals are generally good conductors of electricity, and they exhibit magnetohydrodynamic phenomena. Gases can be efficient conductors of electricity if they become ionized. Ionization can occur at high temperatures or through the ionizing effects of high-energy (usually ultraviolet) photons. A gas which consists of free electrons and ions is called a plasma. Most gases in space are plasmas, and magnetohydrodynamic phenomena are expected to play a fundamental role in the behavior of matter in the cosmos. See PLASMA (PHYSICS).

Waves are a particularly important aspect of magnetohydrodynamics. They transport energy and momentum from place to place and may, therefore, play essential roles in the heating and acceleration of cosmical and laboratory plasmas. A wave is a propagating oscillation. If waves are present, a given parcel of the fluid undergoes oscillations about an equilibrium position. The parcel oscillates because there are restoring forces which tend to return it to its equilibrium position. In an ordinary gas, the only restoring force comes from the thermal pressure of the gas. This leads to one wave mode: the sound wave. If a magnetic field is present, there are two additional restoring forces: the tension associated with magnetic field lines, and the pressure associated with the energy density of the magnetic field. These two restoring forces lead to two additional wave modes. Thus there are three magnetohydrodynamic wave modes. However, each restoring force does not necessarily have a unique wave mode associated with it. Put another way, each wave mode can involve more than one restoring force. Thus the usual sound wave, which involves only the thermal pressure, does not appear as a mode in magnetohydrodynamics. The three modes have different propagation speeds, and are named fast mode (F), slow mode (S), and intermediate mode (I). The intermediate mode is sometimes called the Alfvén wave, but some scientists refer to all three magnetohydrodynamic modes as Alfvén waves. The intermediate mode is also called the shear wave. Some scientists give the name magnetosonic mode to the fast mode.

**Basic equations.** The magnetohydrodynamic wave modes are analyzed by using the magnetohydrodynamic equations for the motion of a conducting fluid in a magnetic field, combined with Maxwell's equations and Ohm's law. See MAXWELL'S EQUATIONS.

It is possible to combine Ohm's law with Faraday's law of induction. The resultant equation is called the magnetohydrodynamic induction equation, which is the mathematical statement of the "frozen-in" theorem. This theorem states that magnetic field lines can be thought of as being frozen into the fluid, with the proviso that the fluid is always allowed to slip freely along the field lines. It is the coupling between the fluid and the magnetic field which makes magnetohydrodynamic waves possible. The oscillating magnetic field lines cause oscillations of the fluid parcels, while the fluid provides a mass loading on the magnetic field lines. This mass loading has the effect of slowing down the waves, so that they propagate at speeds much less than the speed of light (which is the propagation speed of waves in a vacuum). See ELECTROMAGNETIC RADIATION; LIGHT.

Unfortunately, the basic equations are too difficult to be of much use because some of them are nonlinear; that is, they contain products of the quantities for which a solution is sought. Nonlinear magnetohydrodynamics is still only in its infancy, and only a few specialized solutions are known. In order to get solvable equations, scientists accept the limitation of dealing with small-amplitude waves and linearize the equations, so that products of the unknowns are removed. Fortunately, much can still be learned from this procedure; the resulting equations have solutions which are harmonic in time and space. See HARMONIC MOTION.

The motions are pure shears. There is no compression of the plasma. The tension in the magnetic field lines is the only

restoring force involved in the propagation of the wave. This mode is therefore closely analogous to the propagation of waves on a string.

Because these waves channel energy along magnetic fields, they may be responsible for the observed fact that cosmic plasmas are strongly heated in the presence of magnetic fields.

The fast mode is difficult to analyze. However, many cosmic and laboratory plasmas satisfy the strong-magnetic-field case where the fast mode is more easily understood.

Fast waves are compressive, and the magnetic field strength fluctuates as well. Thus fast waves are governed by the two restoring forces associated with the tension and pressure in the magnetic field.

The fast mode can propagate energy across the magnetic field.

Like the fast mode, the slow mode is difficult to study in general, and the discussion will again be confined to strong magnetic fields. The slow mode in a strong field is equivalent to sound waves which are guided along the strong magnetic field lines. The strong magnetic field lines can be thought of as a set of rigid pipes which allow free fluid motion along the pipes, but which restrict motion in the other two directions. The motions on the individual pipes are not coupled together, and thus the slow mode is analogous to the sound waves on a set of independent organ pipes. The slow mode channels energy along the magnetic field. Because the sound speed is small, by assumption, the slow mode transmits energy less effectively than the fast or intermediate modes.

Only small-amplitude waves have been considered. Real waves have finite amplitude, and nonlinear effects can sometimes be important. One such effect is the tendency of waves to steepen, ultimately forming magnetohydrodynamic shock waves and magnetohydrodynamic discontinuities. There is an abundance of magnetohydrodynamic discontinuities in the solar wind. See SHOCK WAVE; SOLAR WIND.

It is also possible that waves can degenerate into turbulence. There are indications that this too happens in the solar wind. See TURBULENT FLOW.

Only waves in a spatially uniform background have been considered. While the analysis of magnetohydrodynamic waves in a nonuniform background is complicated, it is possible to consider an extreme limit, in which the background is uniform except at certain surfaces where it changes discontinuously. Surfaces can support magnetohydrodynamic waves, which are in some respects similar to waves on the surface of a lake. These waves may play important roles in heating cosmic and laboratory plasmas. See MAGNETOHYDRODYNAMICS. [J.V.H.]

**Algae** An informal assemblage of predominantly aquatic organisms that carry out oxygen-evolving photosynthesis but lack specialized water-conducting and food-conducting tissues. They may be either prokaryotic (lacking an organized nucleus) and therefore members of the kingdom Monera, or eukaryotic (with an organized nucleus) and therefore members of the kingdom Plantae, constituting with fungi the subkingdom Thallobionta. They differ from the next most advanced group of plants, Bryophyta, by their lack of multicellular sex organs sheathed with sterile cells and by their failure to retain an embryo within the female organ. Many colorless organisms are referable to the algae on the basis of their similarity to photosynthetic forms with respect to structure, life history, cell wall composition, and storage products. The study of algae is called algology (from the Latin *alga*, meaning sea wrack) or phycology (from the Greek *phykos*, seaweed). See BRYOPHYTA; PLANT KINGDOM; THALLOBIONTA.

**General form and structure.** Algae range from unicells 1–2 micrometers in diameter to huge thalli [for example, kelps often 100 ft (30 m) long] with functionally and structurally distinctive tissues and organs. Unicells may be solitary or colonial, attached or free-living, with or without a protective cover, and motile or nonmotile. Colonies may be irregular or with a distinctive pat-

tern, the latter type being flagellate or nonmotile. Multicellular algae form packets, branched or unbranched filaments, sheets one or two cells thick, or complex thalli, some with organs resembling roots, stems, and leaves (as in the brown algal orders Fucales and Laminariales). Coenocytic algae, in which the protoplast is not divided into cells, range from microscopic spheres to thalli 33 ft (10 m) long with a complex structure of intertwined siphons (as in the green algal order Bryopsidales).

**Classification.** Sixteen major phyletic lines (classes) are distinguished on the basis of differences in pigmentation, storage products, cell wall composition, flagellation of motile cells, and structure of such organelles as the nucleus, chloroplast, pyrenoid, and eyespot. These classes are interrelated to varying degrees, the interrelationships being expressed by the arrangement of classes into divisions (the next-higher category). Among phycologists there is far greater agreement on the number of major phyletic lines than on their arrangement into divisions.

#### Superkingdom Prokaryotae

##### Kingdom Monera

Division Cyanophycota (= Cyanophyta, Cyanochloronta)

Class Cyanophyceae, blue-green algae

Division Prochlorophycota (= Prochlorophyta)

Class Prochlorophyceae

#### Superkingdom Eukaryotae

##### Kingdom Plantae

##### Subkingdom Thallobionta

Division Rhodophycota (= Rhodophyta, Rhodophycophyta)

Class Rhodophyceae, red algae

Division Chromophycota (= Chromophyta)

Class: Chrysophyceae, golden or golden-brown algae

Prymnesiophyceae (= Haptophyceae)

Xanthophyceae (= Tribophyceae), yellow-green algae

Eustigmatophyceae

Bacillariophyceae, diatoms

Dinophyceae, dinoflagellates

Phaeophyceae, brown algae

Raphidophyceae, chloromonads

Cryptophyceae, cryptomonads

Division Euglenophycota (= Euglenophyta, Euglenophycophyta)

Class Euglenophyceae

Division Chlorophycota (= Chlorophyta, Chlorophycophyta)

Class: Chlorophyceae, green algae

Charophyceae, charophytes

Prasinophyceae

Placing more taxonomic importance on motility than on photosynthesis, zoologists traditionally have considered flagellate unicellular and colonial algae as protozoa, assigning each phyletic line the rank of order. See BACILLARIOPHYCEAE; CHRYSOPHYCEAE; CRYPTOPHYCEAE; CYANOPHYCEAE; DINOPHYCEAE; EUGLENOPHYCEAE; EUKARYOTAE; EUSTIGMATOPHYCEAE; PHAEOPHYCEAE; PRASINOPHYCEAE; PROCHLOROPHYCEAE; PROKARYOTAE; PROTOZOA; PRYMNESIOPHYCEAE; RAPHDOPHYCEAE; RHODOPHYCEAE; THALLOBIONTA; XANTHOPHYCEAE.

Although some unicellular algae are naked or sheathed by mucilage or scales, most are invested with a covering (wall, pellicle, or lorica) of diverse composition and construction. These coverings consist of at least one layer of polysaccharide (cellulose, alginate, agar, carrageenan, mannan, or xylan), protein, or peptidoglycan that may be impregnated or encrusted with calcium carbonate, iron, manganese, or silica. They are often perforated and externally ornamented. Diatoms have a complex wall composed almost entirely of silica. In multicellular and

coenocytic algae, most reproductive cells are naked, but vegetative cells have walls whose composition varies from class to class. See CELL WALLS (PLANT).

**Characteristics.** Prokaryotic algae lack membrane-bounded organelles. Eukaryotic algae have an intracellular architecture comparable to that of higher plants but more varied. Among cell structures unique to algae are contractile vacuoles in some freshwater unicells, gas vacuoles in some planktonic blue-green algae, ejectile organelles in dinoflagellates and cryptophytes, and eyespots in motile unicells and reproductive cells of many classes. Chromosome numbers vary from  $n = 2$  in some red and green algae to  $n \geq 300$  in some dinoflagellates. The dinoflagellate nucleus is in some respects intermediate between the chromatin region of prokaryotes and the nucleus of eukaryotes and is termed mesokaryotic. Some algal cells characteristically are multinucleate, while others are uninucleate. Chloroplasts, which always originate by division of preexisting chloroplasts, have the form of plates, ribbons, disks, networks, spirals, or stars and may be positioned centrally or along the cell wall. Photosynthetic membranes (thylakoids) are arranged in distinctive patterns and contain pigments diagnostic of individual classes. See CELL (BIOLOGY); CELL PLASTIDS; CHROMOSOME; PHOTOSYNTHESIS; PLANT CELL.

In all classes of algae except Prochlorophyceae, there are cells that are capable of movement. The slow, gliding movement of certain blue-green algae, diatoms, and reproductive cells of red algae presumably results from extracellular secretion of mucilage. Ameboid movement, involving pseudopodia, is found in certain Chrysophyceae and Xanthophyceae. An undulatory or peristaltic movement occurs in some Euglenophyceae. The fastest movement is produced by flagella, which are borne by unicellular algae and reproductive cells of multicellular algae representing all classes except Cyanophyceae, Prochlorophyceae, and Rhodophyceae.

Internal movement also occurs in algae in the form of cytoplasmic streaming and light-induced orientation of chloroplasts. See CELL MOTILITY; CILIA AND FLAGELLA.

Sexual reproduction is unknown in prokaryotic algae and in three classes of eukaryotic unicells (Eustigmatophyceae, Cryptophyceae, and Euglenophyceae), in which the production of new individuals is by binary fission. In sexual reproduction, which is found in all remaining classes, the members of a copulating pair of gametes may be morphologically indistinguishable (isogamous), morphologically distinguishable but with both gametes motile (anisogamous), or differentiated into a motile sperm and a relatively large nonmotile egg (oogamous). Gametes may be formed in undifferentiated cells or in special organs (gametangia), male (antheridia) and female (oogonia). Sexual reproduction may be replaced or supplemented by asexual reproduction, in which special cells (spores) capable of developing directly into a new alga are formed in undifferentiated cells or in distinctive organs (sporangia). See REPRODUCTION (PLANT).

Most algae are autotrophic, obtaining energy and carbon through photosynthesis. All photosynthetic algae liberate oxygen and use chlorophyll *a* as the primary photosynthetic pigment. Secondary (accessory) photosynthetic pigments, which capture light energy and transfer it to chlorophyll *a*, include chlorophyll *b* (Prochlorophyceae, Euglenophyceae, Chlorophycota), chlorophyll *c* (Chromophycota), fucoxanthin among other xanthophylls (Chromophycota), and phycobiliproteins (Cyanophyceae, Rhodophyceae, Cryptophyceae). Other carotenoids, especially  $\beta$ -carotene, protect the photosynthetic pigments from oxidative bleaching. Except for different complements of accessory pigments (resulting in different action spectra), photosynthesis in algae is identical to that in higher plants. Carbon is predominantly fixed through the  $C_3$  pathway. See CAROTENOID; CHLOROPHYLL.

The source of carbon for most photosynthetic algae is carbon dioxide ( $CO_2$ ), but some can use bicarbonate. Many photosynthetic algae are also able to use organic substances (such as

hexose sugars and fatty acids) and thus can grow in the dark or in the absence of  $CO_2$ . Colorless algae obtain both energy and carbon from a wide variety of organic compounds in a process called oxidative assimilation.

Numerous substances are liberated into water by living algae, often with marked ecological effects. These extracellular products include simple sugars and sugar alcohols, wall polysaccharides, glycolic acid, phenolic substances, and aromatic compounds. Some secreted substances inhibit the growth of other algae and even that of the secreting alga. Some are toxic to fishes and terrestrial animals that drink the water.

**Occurrence.** Algae are predominantly aquatic, inhabiting fresh, brackish, and marine waters without respect to size or degree of permanence of the habitat. They may be planktonic (free-floating or motile) or benthic (attached). Benthic marine algae are commonly called seaweeds. Substrates include rocks (outcrops, boulders, cobbles, pebbles), plants (including other algae), animals, boat bottoms, piers, debris, and less frequently sand and mud. Some species occur on a wide variety of living organisms, suggesting that the hosts are providing only space. Many species, however, have a restricted range of hosts and have been shown to be (or are suspected of being) at least partially parasitic. All reef-building corals contain dinoflagellates, without which their calcification ability is greatly reduced. Different phases in a life history may have different substrate preferences. Many fresh-water algae have become adapted to a nonaquatic habitat, living on moist soil, masonry and wooden structures, and trees. A few parasitize higher plants (especially in the tropics), producing diseases in such crops as tea, coffee, and citrus. Thermophilic algae (again, chiefly blue-greens) live in hot springs at temperatures up to  $163^\circ F$  ( $73^\circ C$ ), forming a calcareous deposit known as tufa. One of the most remarkable adaptations of certain algae (blue-greens and greens) is their coevolution with fungi to form a compound organism, the lichen. See LICHENS; PHYTOPLANKTON; TUFAs.

**Geographic distribution.** Fresh-water algae, which are distributed by spores or fragments borne by the wind or by birds, tend to be widespread if not cosmopolitan, their distribution being limited by the availability of suitable habitats. Certain species, however, are characteristic of one or another general climatic zone, such as cold-temperate regions or the tropics. Marine algae, which are spread chiefly by water-borne propagules or reproductive cells, often have distinctive geographic patterns. Many taxonomic groups are widely distributed, but others are characteristic of particular climatic zones or geographic areas. See PLANT GEOGRAPHY.

**Economic importance.** Numerous red, brown, and green seaweeds as well as a few species of fresh-water algae are consumed by the peoples of eastern Asia, Indonesia, Polynesia, and the North Atlantic. Large brown seaweeds may be chopped and added to poultry and livestock feed or applied whole as fertilizer for crop plants. The purified cell-wall polysaccharides of brown and red algae (alginate, agar, carrageenan) are used as gelling, suspending, and emulsifying agents in numerous industries. Some seaweeds have specific medicinal properties, such as effectiveness against worms. Petroleum is generally believed to result from bacterial degradation of organic matter derived primarily from planktonic algae.

Planktonic algae, as the primary producers in oceans and lakes, support the entire aquatic trophic pyramid and thus are the basis of the fisheries industry. Concomitantly, their production of oxygen counteracts its uptake in animal respiration. The ability of certain planktonic algae to assimilate organic nutrients makes them important in the treatment of sewage. See FOOD WEB.

On the negative side, algae can be a nuisance by imparting tastes and odors to drinking water, clogging filters, and making swimming pools, lakes, and beaches unattractive. Sudden growths (blooms) of planktonic algae can produce toxins of varying potency. In small bodies of fresh water, the toxin (usually from

blue-green algae) can kill fishes and livestock that drink the water. In the ocean, toxins produced by dinoflagellate blooms (red tides) can kill fishes and render shellfish poisonous to humans.

**Fossil algae.** At least half of the classes of algae are represented in the fossil record, usually abundantly, in the form of siliceous, calcareous, or organic remains, impressions, or indications. Blue-green algae were among the first inhabitants of the Earth, appearing in rocks at least as old as 2.3 billion years. Their predominance in shallow Precambrian seas is indicated by the extensive development of stromatolites.

All three classes of seaweeds (reds, browns, and greens) were well established by the close of the Precambrian, 600 million years ago (mya). By far the greatest number of fossil taxa belong to classes whose members are wholly or in large part planktonic. Siliceous frustules of diatoms and endoskeletons of silicoflagellates, calcareous scales of coccolithophorids, and highly resistant organic cysts of dinoflagellates contribute slowly but steadily to sediments blanketing ocean floors, as they have for tens of millions of years. Cores obtained in the Deep Sea Drilling Project have revealed an astounding chronology of the appearance, rise, decline, and extinction of a succession of species and genera. From this chronology, much can be deduced about the climate, paleogeography, and ecology of particular geological periods. See PALEOBOTANY; STROMATOLITE. [P.C.Si.; R.L.Moe.]

**Algebra** The branch of mathematics dealing with the solution of equations. These equations involve unknowns, or variables, along with fixed numbers from a specified system. The origins of algebra were based on the need to develop equations that modeled real-world problems. From this came a very extensive theory based on the need to find the values that can be successfully used in the equations.

**Number systems.** Classical algebra is conducted in one of several number systems. The most basic is the natural numbers, consisting of the counting numbers: 1, 2, 3, 4, . . . . The natural numbers along with their negatives and 0 form the set of integers: . . . , -2, -1, 0, 1, 2, . . . . Any number which can be expressed as a quotient  $a/b$  of two integers  $a$  and  $b$  is called a rational number. If the decimal expansion of a number either is repeating or terminates in a string of zeros, it is always possible to find integers  $a$  and  $b$  such that the quotient  $a/b$  gives the original number. Numbers where the decimal expansion cannot be written as a quotient of integers are the so-called irrational numbers. Early mathematicians did not recognize the existence of such numbers until geometric considerations showed that they must exist as the lengths of sides of right triangles.

The sets of rational numbers and irrational numbers have no elements in common, and together they make up the real-number system. It is within the system of real numbers that algebraic tasks are most often performed. However, there is a still larger set of numbers, known as the complex numbers, which serve much more completely in solving equations. The complex numbers consist of numbers of the form  $a + bi$ , where  $i$  is a symbol representing  $-1$ . The symbol  $i$  is commonly called the imaginary root of  $-1$ , and the numbers of the form  $bi$  are known as the set of imaginary numbers. In a complex number  $a + bi$ , the real number  $a$  is called the real part while the real number  $b$  is the imaginary part.

Real numbers are often represented on a number line (Fig. 1a). The complex numbers can be represented on a two-dimensional plane (Fig. 1b), by plotting the real part on the horizontal axis and the imaginary part on the vertical axis.

**Operations.** Within any number system there is a set of operations which can be performed on some or all of the members of the system. Operations take a pair of numbers in the system and produce a single new number from this pair. The most standard operations are addition (+), multiplication ( $\cdot$ ), subtraction ( $-$ ), and division ( $\div$ ). A set is closed under an operation if the application of the operation to any pair of numbers in the set results in another number in the same set. For example, the set

of natural numbers is closed under  $+$  but not under  $-$  (since, for example,  $1 - 2 = -1$  is not a natural number). The rational numbers, the real numbers, and the complex numbers are closed under all four of the basic operations (except in the case where division by 0 may occur). See ARITHMETIC.

Other operations arise from the four basic ones. Exponentiation is derived from the process of repeatedly multiplying a number by itself. If  $n$  is a positive integer, the symbol  $a^n$  indicates that the number  $a$  is multiplied by itself  $n$  times. If  $n > 0$  is an integer, then  $a^{-n}$  refers to the quotient  $1/a^n$ . Fractional exponents can also be considered by defining  $a^{1/n}$  to be the number  $b$  such that  $b^n = a$ . This notion is further extended by letting  $a^{m/n} = (a^{1/n})^m$ . For real numbers, some fractional exponents may not exist. For example,  $(-1)^{1/2}$  is not a real number. The complex numbers, however, are closed with respect to exponentiation.

**Algebraic expressions.** In algebra, symbols are frequently used to designate unknown values. For example, letters such as  $x$  and  $y$  can stand for any one of a set of numbers satisfying certain conditions. These symbols are combined with numbers and the basic operations to form algebraic expressions such as (1).

$$3x^2 + 5y^3x - 6 \quad \frac{(x^5 - 1)^{3xy}}{y^2 + 2^x} \quad (1)$$

The symbols are usually called variables, while the numbers (or constants) multiplied by them are the coefficients of the expression. The coefficients are all assumed to come from a designated number system. Algebraic expressions take on specific values when each of the variables involved is assigned a numerical value.

**Algebraic equations.** A statement is a relationship between several algebraic expressions. This relationship can be equality ( $=$ ) or an inequality ( $<$  or  $>$ ), but in any case it puts restrictions on the values of the variables. For example, each of expressions (2) represents a relationship between the variables  $x$  and  $y$ , while Eq. (3) relates the three variables,  $x$ ,  $y$ , and  $z$ .

$$x^2 + 3xy = y - 3 \quad 2xy > y^5 - 1 \quad (2)$$

$$4z - 2xy = 5 + yz^2 \quad (3)$$

If, when specific values from an appropriate number system are substituted for the variables in an equation, the resulting statement is true, then these numbers are said to be a solution to the equation. The solutions of a particular equation are dependent on the number system in use. For instance, the

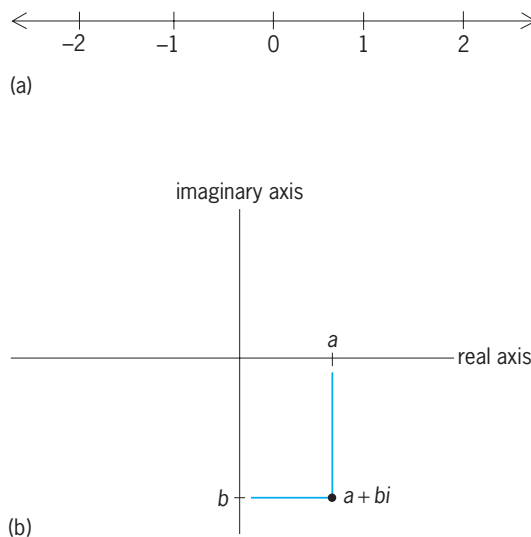

Fig. 1. Representations of number systems. (a) Of real numbers on a number line. (b) Of complex numbers on a two-dimensional plane.

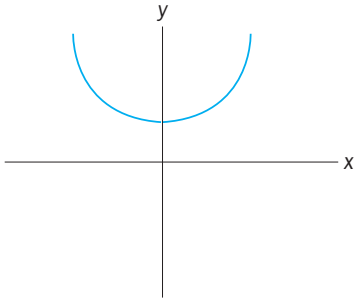
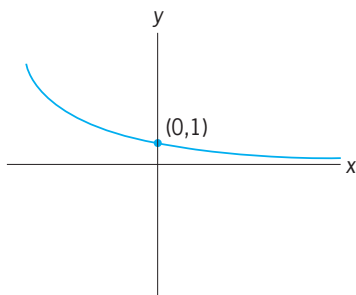

Fig. 2. Graph of the function  $f(x) = x^2 + 3$ .

equation  $x^4 = 2$  has no solutions in the set of rational numbers, two solutions ( $x = 2^{1/4}$  and  $x = -2^{1/4}$ ) in the real numbers, and four solutions in the complex field.

**Functions.** Some of the most fundamental algebraic equations are those involving two variables. When one of these variables, say  $y$ , can be expressed in terms of the other variable, say  $x$ , in such a way that each value of  $x$  produces exactly one value of  $y$ , then the relationship described by the equation is known as a function. More general relationships which may or may not produce unique values of  $y$  from each value of  $x$  are called relations. In a function such as has been described, the variable  $x$  is called the independent variable while the resulting variable  $y$  is called the dependent variable. The possible values that can be used by the independent variable make up the domain of the function (or, more generally, the relation). The resulting values of the dependent variable compose the range of the function. It is most common and quite practical to write a variable  $y$  which is dependent on a variable  $x$  in the form  $y = f(x)$ .

**Graphs.** Relations, and more specifically functions, are frequently represented effectively with graphs. If an equation involves the variables  $x$  and  $y$ , then a two-dimensional coordinate system can be used to depict the values that correspond in the equation. All of the ordered pairs  $(x, y)$  given by the equation



(a)

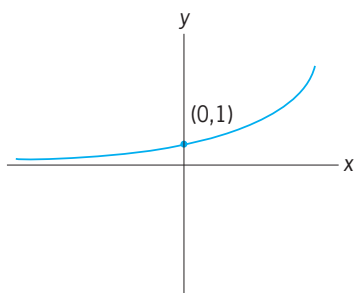

(b)

Fig. 3. Graphs of exponential functions. (a) Decreasing graph of  $y = (\frac{1}{2})^x$ . (b) Increasing graph of  $y = 2^x$ .

combine to give a complete graphic representation of the relationship described by the equation (Fig. 2).

**Polynomials.** There are many special functions which are commonly used to describe real situations. One of the most basic is the polynomial, which is a function of the form (4). Each

$$f(x) = a_0 + a_1x + a_2x^2 + \cdots + a_nx^n \quad (4)$$

coefficient  $a_0, a_1, \dots, a_n$  is a real number, and the exponents of the variables are nonnegative integers. The largest exponent of  $x$  is called the degree of the polynomial. When graphed, a polynomial of degree  $n$  will reverse directions no more than  $n - 1$  times.

Even in the real numbers, a polynomial often may be factored into other polynomials of lesser degree. This allows for analysis of the polynomial by consideration of the simpler factors.

**Rational functions.** Functions which are of the form  $f(x) = g(x)/h(x)$ , where  $g(x)$  and  $h(x)$  are polynomials, are called rational functions. They frequently appear in instances where comparisons of two polynomials are necessary.

**Exponential functions.** In general, an exponential function is one which has the form  $f(x) = b^x$  for some constant  $b$  in the number system. The graphs of these functions take on one of two basic types. The graph is decreasing if  $0 < b < 1$  (Fig. 3a), and it is increasing if  $b > 1$  (Fig. 3b).

Exponential functions are of special importance in describing a situation where the rate of growth is proportional to the amount present. Among the situations that can be described by exponential functions are those involving the calculation of interest, radioactive decay, and population growth.

**Logarithmic functions.** Another function that plays an especially important role in algebra is the logarithm. The logarithm function is defined in terms of exponentials by reversing the roles of the  $x$  and  $y$  variables, as in Eqs. (5).

$$y = \log_b x \leftrightarrow x = b^y \quad (5)$$

[W.B.P.]

**Algebraic geometry** The study of zero sets of polynomial equations. Examples are the parabola  $y - x^2 = 0$ , thought of as sitting in the  $(x, y)$ -plane, and the locus of all points  $(t, t^2, t^3, t^4)$ , which is defined by Eqs. (1), in the coordinate space with

$$y^2 = xz \quad yx = wz \quad wy = x^2 \quad (1)$$

coordinates  $w, x, y, z$ . Another interesting example is an elliptic curve, typically defined by an equation like Eq. (2), where  $A$  and

$$y^2 = x(x - A)(x - B) \quad (2)$$

$B$  are constants. Objects such as these are called affine algebraic sets. They exist in affine  $n$ -space, denoted  $A^n$ , which is defined to be the coordinate space with coordinates  $x_1, \dots, x_n$ . The coordinate ring  $k[V]$  of an affine algebraic set  $V$  is the set of functions on  $V$  obtained by restriction from polynomial functions on the ambient affine space. These functions can be added, subtracted, and multiplied (that is, they form a ring). For example, the coordinate ring of the parabola has in it functions  $y$  and  $x$  satisfying  $y = x^2$ . This relation can be used to eliminate all references to  $y$ , so that the coordinate ring of the parabola is identified with the ring of polynomials in  $x$ . See ANALYTIC GEOMETRY; RING THEORY.

The possibility of studying a question geometrically via the zero loci of polynomials or algebraically via the algebra of the coordinate ring gives the subject much of its power and flavor. This has led to an amazing growth in applications to other disciplines. For example, the integers  $\dots, -2, -1, 0, 1, 2, \dots$  form a ring that is algebraically similar to the coordinate ring of the affine line, and algebrogeometric methods have come to play a central role in number theory. In studying the path space of strings and the partition function, modern physicists have made the moduli space of curves a central object of research. Finally, a number of differential equations in engineering and physics can best be studied algebrogeometrically, although their solutions

are not algebraic functions. See DIFFERENTIAL EQUATION; NUMBER THEORY. [S.J.B.]

**Alginate** A major constituent (10–47% dry weight) of the cell walls of brown algae. Extracted for its suspending, emulsifying, and gelling properties, it is one of three algal polysaccharides of major economic importance, the others being agar and carrageenan. The chief sources of alginate are members of the family Fucaceae (rockweeds) and the order Laminariales (kelps), harvested from naturally occurring stands on North Atlantic and North Pacific shores.

Because of its colloidal properties, alginate finds numerous industrial applications, especially in the food, textile, paper, printing, paint, cosmetics, and pharmaceutical industries. About half of the consumption is in the making of ice cream and other dairy products, in which alginate prevents the formation of coarse ice crystals and provides a smooth texture. As an additive to paint, it keeps the pigment in suspension and minimizes brush marks. An alginate gel is used in making dental impressions. See AGAR; CARRAGEENAN; ICE CREAM; MILK; PHAEOPHYCEAE. [P.C.Si; R.L.Moe.]

**Algorithm** A well-defined procedure to solve a problem. The study of algorithms is a fundamental area of computer science. In writing a computer program to solve a problem, a programmer expresses in a computer language an algorithm that solves the problem, thereby turning the algorithm into a computer program. See COMPUTER PROGRAMMING.

**Operation.** An algorithm generally takes some input, carries out a number of effective steps in a finite amount of time, and produces some output. An effective step is an operation so basic that it is possible, at least in principle, to carry it out using pen and paper. In computer science theory, a step is considered effective if it is feasible on a Turing machine or any of its equivalents. A Turing machine is a mathematical model of a computer used in an area of study known as computability, which deals with such questions as what tasks can be algorithmically carried out and what cannot. See AUTOMATA THEORY; RECURSIVE FUNCTION.

Many computer programs deal with a substantial amount of data. In such applications, it is important to organize data in appropriate structures to make it easier or faster to process the data. In computer programming, the development of an algorithm and the choice of appropriate data structures are closely intertwined, and a decision regarding one often depends on knowledge of the other. Thus, the study of data structures in computer science usually goes hand in hand with the study of related algorithms. Commonly used elementary data structures include records, arrays, linked lists, stacks, queues, trees, and graphs.

**Applications.** Many algorithms are useful in a broad spectrum of computer applications. These elementary algorithms are widely studied and considered an essential component of computer science. They include algorithms for sorting, searching, text processing, solving graph problems, solving basic geometric problems, displaying graphics, and performing common mathematical calculations.

Sorting arranges data objects in a specific order, for example, in numerically ascending or descending orders. Internal sorting arranges data stored internally in the memory of a computer. Simple algorithms for sorting by selection, by exchange, or by insertion are easy to understand and straightforward to code. However, when the number of objects to be sorted is large, the simple algorithms are usually too slow, and a more sophisticated algorithm, such as heap sort or quick sort, can be used to attain acceptable performance. External sorting arranges stored data records.

Searching looks for a desired data object in a collection of data objects. Elementary searching algorithms include linear search and binary search. Linear search examines a sequence of data objects one by one. Binary search adopts a more sophisticated strategy and is faster than linear search when searching a large ar-

ray. A collection of data objects that are to be frequently searched can also be stored as a tree. If such a tree is appropriately structured, searching the tree will be quite efficient.

A text string is a sequence of characters. Efficient algorithms for manipulating text strings, such as algorithms to organize text data into lines and paragraphs and to search for occurrences of a given pattern in a document, are essential in a word processing system. A source program in a high-level programming language is a text string, and text processing is a necessary task of a compiler. A compiler needs to use efficient algorithms for lexical analysis (grouping individual characters into meaningful words or symbols) and parsing (recognizing the syntactical structure of a source program). See SOFTWARE ENGINEERING; WORD PROCESSING.

A graph is useful for modeling a group of interconnected objects, such as a set of locations connected by routes for transportation. Graph algorithms are useful for solving those problems that deal with objects and their connections—for example, determining whether all of the locations are connected, visiting all of the locations that can be reached from a given location, or finding the shortest path from one location to another.

Mathematical algorithms are of wide application in science and engineering. Basic algorithms for mathematical computation include those for generating random numbers, performing operations on matrices, solving simultaneous equations, and numerical integration. Modern programming languages usually provide predefined functions for many common computations, such as random number generation, logarithm, exponentiation, and trigonometric functions.

In many applications, a computer program needs to adapt to changes in its environment and continue to perform well. An approach to make a computer program adaptive is to use a self-organizing data structure, such as one that is reorganized regularly so that those components most likely to be accessed are placed where they can be most efficiently accessed. A self-modifying algorithm that adapts itself is also conceivable. For developing adaptive computer programs, biological evolution has been a source of ideas and has inspired evolutionary computation methods such as genetic algorithms. See GENETIC ALGORITHMS.

Certain applications require a tremendous amount of computation to be performed in a timely fashion. An approach to save time is to develop a parallel algorithm that solves a given problem by using a number of processors simultaneously. The basic idea is to divide the given problem into subproblems and use each processor to solve a subproblem. The processors usually need to communicate among themselves so that they may cooperate. The processors may share memory, through which they can communicate, or they may be connected by communication links into some type of network such as a hypercube. See CONCURRENT PROCESSING; MULTIPROCESSING; SUPER-COMPUTER. [S.C.Hs.]

**Alicyclic hydrocarbon** An organic compound that contains one or more closed rings of carbon atoms. The term alicyclic specifically excludes carbocyclic compounds with an array of  $\pi$ -electrons characteristic of aromatic rings. Compounds with one to five alicyclic rings of great variety and complexity are found in many natural products such as steroids and terpenes. By far the majority of these have six-membered rings. See AROMATIC HYDROCARBON; STEROID; TERPENE.

**Structures and nomenclature.** The bonding in cyclic hydrocarbons is much the same as that in open-chain alkanes and alkenes. An important difference, however, is the fact that the atoms in a ring are part of a closed loop. Complete freedom of rotation about a carbon-carbon bond (C—C) is not possible; the ring has faces or sides, like those of a plate.

Simple monocyclic hydrocarbons are usually represented as bond line structures; for example, cyclopropane (**1a**) is usually

represented as structure (1b) and methylcycloheptane as structure (2). These hydrocarbons are named by adding the prefix

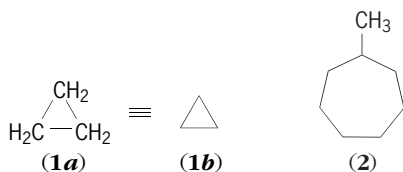

cyclo to the stem of the alkane corresponding to the number of atoms in the ring. When two or more substituents are attached to the ring, the relative positions and orientation must be specified: *cis* on the same side and *trans* on the other, as in *cis*-1,2-dimethylcyclopentane (3) and *trans*-1,3-dimethylcyclopentane (4).

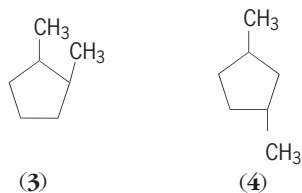

In bicyclic compounds the rings can be joined in three ways: spirocyclic, fused, and bridged, as illustrated in the structures for spiro[4.5]decane (5), bicyclo[4.3.0]nonane (6), and bicyclo[2.2.1]heptane (7). In each case the name indicates the total

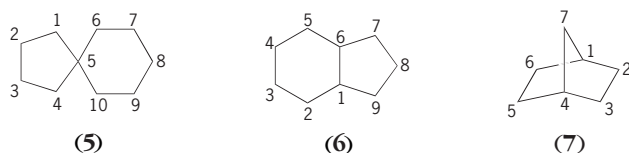

number of carbon atoms, and the number of atoms in each bridge. Atoms are numbered as shown.

Any of these bicyclic systems can be transformed to a tricyclic array by introduction of another bond between nonadjacent carbons, as in structure (8), or an additional ring, as in structure (9).

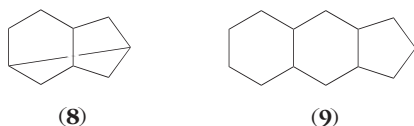

Cyclic structure gives rise to the possibility of compounds made up of molecular subunits that are linked mechanically rather than chemically. In rotaxanes (10), bulky groups are introduced at the ends of a long chain that is threaded through a large ring (>C<sub>30</sub>). Cyclization of the ends leads to a catenane (11). Several examples of compounds with these structures have been prepared.

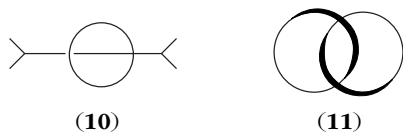

The boiling points, melting points, and densities of cycloalkanes are all higher than those of their open-chain counterparts, reflecting the more compact structures and greater association in both liquid and solid. Geometrical constraints in the smaller rings have significant effects on reactions of cycloalkanes and derivatives. Because of ring strain, ring-opening reactions of cyclopropane, such as isomerization to propene, take place under conditions that do not affect alkanes or larger-ring cycloalkanes.

Comparison of reaction rates of compounds with different ring size or *cis*-*trans* configuration has provided important insights about reaction mechanism and conformational analysis.

**Ring-forming reactions.** A number of useful methods have been devised that lead to alicyclic rings. These reactions are of three types: C-C bond formation between atoms in an open-chain precursor, cycloaddition or cyclooligomerization, and expansion or contraction of a more readily available ring. In cycloaddition, two molecules react with formation of two bonds; in cyclooligomerization, three or more molecules combine to form three or more bonds.

Two alicyclic compounds are manufactured in large volume; both are products of the petroleum industry. Cyclopentadiene (12) is formed from various alkylcyclopentanes in naphtha fractions during the refining process. It is a highly reactive diene and spontaneously dimerizes in a 4 + 2 cycloaddition [see reaction below]; it is used as a copolymer in several resins.

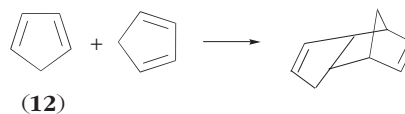

Cyclohexane is produced in large quantity by hydrogenation of benzene. The principal use of cyclohexane is conversion by oxidation in air to a mixture of cyclohexanol and the ketone, which is then oxidized further to adipic acid for the manufacture of nylon. See ORGANIC SYNTHESIS. [J.A.Mo.]

**Alismatales** A small order of flowering plants, division Magnoliophyta (Angiospermae), which gives its name to the subclass Alismatidae of the class Liliopsida (monocotyledons). It consists of three families (Alismataceae, Butomaceae, and Limnocaritaceae) and less than a hundred species. They are aquatic and semiaquatic herbs with a well-developed, biseriate perianth that is usually differentiated into three sepals and three petals, and with a gynoeceum of several or many, more or less separate carpels. Each flower is usually subtended by a bract. *Butomus umbellatus* (flowering rush) and species of *Sagittaria* (arrowhead, family Alismataceae) of this order are sometimes cultivated as ornamentals. See LILIOPSIDA; MAGNOLIOPHYTA.

The Alismatales and some related orders have often been treated as a single order Helobiae or Helobiales, embracing most of what is here treated as the subclass Alismatidae. See ALISMATIDAE; PLANT KINGDOM. [A.Cr.]

**Alismatidae** A relatively primitive subclass of the class Liliopsida (monocotyledons) of the division Magnoliophyta (Angiospermae), the flowering plants, consisting of 4 orders, 16 families, and less than 500 species. Typically they are aquatic or semiaquatic, with apocarpous flowers and nonendospermous seeds. They have trinucleate pollen, and the stomates usually have two subsidiary cells. The orders Alismatales, Hydrocharitales, and Najadales are closely related among themselves and have often been treated as a single order, Helobiae or Helobiales. The Triuridales differ from the other orders in being terrestrial and mycotrophic, without chlorophyll, and in having abundant endosperm in the seeds. See ALISMATALES; HYDROCHARITALES; TRIURIDALES; MAGNOLIOPHYTA; NAJADALES; PLANT KINGDOM. [A.Cr.; T.M.Ba.]

**Alkali** Any compound having highly basic properties, strong acid taste, and ability to neutralize acids. Aqueous solutions of alkalis are high in hydroxyl ions, have a pH above 7, and turn litmus paper from red to blue. Caustic alkalis include sodium hydroxide (caustic soda), the sixth-largest-volume chemical produced in the United States, and potassium hydroxide. They are extremely destructive to human tissue; external burns should be washed with large amounts of water. The milder alkalis are the carbonates of the alkali metals; these include the industrially important sodium carbonate (soda ash) and potassium carbonate (potash), as well as the carbonates of lithium, rubidium, and

cesium, and the volatile ammonium hydroxide. Sodium bicarbonate is a still milder alkaline material. See ACID AND BASE; PH.

About 50% of the caustic soda produced goes into making many chemical products, about 16% into pulp and paper, 6.5% each into aluminum, petroleum, and textiles (including rayon), with smaller percentages into soap and synthetic detergents, and cellophane. For soda ash, about 50% goes to react mainly with sand in making glass, 25% to making miscellaneous chemicals, 6.5% each to alkaline cleaners and pulp and paper, and a few percent to water treatment and other uses. See ALKALI METALS; ELECTROCHEMICAL PROCESS; GLASS; HYDROXIDE; PAPER; SOAP.

[D.F.O.]

**Alkali emissions** Light emissions in the upper atmosphere from elemental lithium, potassium, and especially sodium. These alkali metals are present in the upper atmosphere at altitudes from about 50 to 62 mi (80 to 100 km) and are very efficient in resonant scattering of sunlight. The vertical column contents (number of atoms per square meter) of the alkali atoms are easily deduced from their respective emission intensities. First detected with ground-based spectrographs, the emissions were observed mainly at twilight since they tend to be overwhelmed by intense scattered sunlight present in the daytime. A chemiluminescent process gives rise to so-called nightglow emissions at the same wavelengths. The development of lidars (laser radars) that are tuned to the resonance lines have enabled accurate resolution of the concentrations of these elements versus altitude for any time of the day. See AERONOMY; AIRGLOW; CHEMILUMINESCENCE.

There is little doubt that the origin of these metals is meteoritic ablation. Rocket-borne mass spectrometers have found that meteoritic ions are prevalent above the peaks of neutral atoms with a composition similar to that found in carbonaceous chondrites, a common form of meteorites. The ratio of the concentrations of ions to neutral atoms rises rapidly with altitude above 55 mi (90 km). See METEORITE.

Sodium (Na) is the most abundant alkali metal in meteorites. The sodium D-lines, a doublet at 589 and 589.6 nanometers, were first detected in the nightglow in the late 1920s and at twilight a decade later. The nominal peak concentration of sodium is  $3 \times 10^9$  atoms  $m^{-3}$  near 55 mi (90 km) where the total gas concentration of the atmosphere is  $7 \times 10^{19}$  atoms (or molecules)  $m^{-3}$ .

Potassium (K) is 15 times less abundant than sodium in meteorites. The ratio of the potassium and sodium column contents in the mesosphere ranges from 1/10 to 1/100. The potassium doublet at 767 and 770 nm is estimated to have a nightglow intensity near the night sky background, 50 times smaller than the typical intensity of the sodium nightglow. The potassium nightglow has never been detected.

Lithium (Li) is 35 times less abundant in meteorites than potassium, and 500 times less abundant than sodium. Nevertheless, the lithium emission at 671 nm has been observed at twilight by spectrometers and at night by lidars. The lithium nightglow emission is undetectable. [W.Sw.]

**Alkali metals** The elements of group I in the periodic table (lithium, sodium, potassium, rubidium, cesium, francium). Of the alkali metals, lithium differs most from the rest of the group, and tends to resemble the alkaline-earth metals (group II of the periodic table) in many ways. In this respect lithium behaves as do many other elements that are the first members of groups in the periodic table; these tend to resemble the elements in the group to the right rather than those in the same group. Francium, the heaviest of the alkali-metal elements, has no stable isotopes and exists only in radioactive form.

In general, the alkali metals are soft, low-melting, reactive metals. This reactivity accounts for the fact that they are never found uncombined in nature but are always in chemical combination with other elements. This reactivity also accounts for the fact

that they have no utility as structural metals (with the possible exception of lithium in alloys) and that they are used as chemical reactants in industry rather than as metals in the usual sense. The reactivity in the alkali-metal series increases in general with increase in atomic weight from lithium to cesium. See CESIUM; ELECTROCHEMICAL SERIES; FRANCIUM; LITHIUM; PERIODIC TABLE; SODIUM. [M.Si.]

**Alkaline-earth metals** Usually calcium, strontium, and barium, the heaviest members of group II of the periodic table (excepting radium). Other members of the group are beryllium, magnesium, and radium, sometimes included among the alkaline-earth metals. Beryllium resembles aluminum more than any other element, and magnesium behaves more like zinc and cadmium. The gap between beryllium and magnesium and the remainder of the elements of group II makes it desirable to discuss these elements separately. Radium is often treated separately because of its radioactivity.

The alkaline earths form a closely related group of highly metallic elements in which there is a regular gradation of properties. The metals, none of which occurs free in nature, are all harder than potassium or sodium, softer than magnesium or beryllium, and about as hard as lead. The metals are somewhat brittle, but are malleable, extrudable, and machinable. They conduct electricity well; the specific conductivity of calcium is 45% of that of silver. The oxidation potentials of the triad are as great as those of the alkali metals.

The elements and their compounds find important industrial uses in low-melting alloys, deoxidizers, and drying agents and as cheap sources of alkalinity. See BARIUM; BERYLLIUM; CALCIUM; MAGNESIUM; PERIODIC TABLE; RADIUM; STRONTIUM. [R.F.R.]

**Alkaloid** A cyclic organic compound that contains nitrogen in a negative oxidation state and is of limited distribution among living organisms. Over 10,000 alkaloids of many different structural types are known; and no other class of natural products possesses such an enormous variety of structures. Therefore, alkaloids are difficult to differentiate from other types of organic nitrogen-containing compounds.

Simple low-molecular-weight derivatives of ammonia, as well as polyamines and acyclic amides, are not considered alkaloids because they lack a cyclic structure in some part of the molecule. Amines, amine oxides, amides, and quaternary ammonium salts are included in the alkaloid group because their nitrogen is in a negative oxidation state (the oxidation state designates the positive or negative character of atoms in a molecule). Nitro and nitroso compounds are excluded as alkaloids. The almost-ubiquitous nitrogenous compounds, such as amino acids, amino sugars, peptides, proteins, nucleic acids, nucleotides, porphyrins, and vitamins, are not alkaloids. However, compounds that are exceptions to the classical-type definition (that is, a compound containing nitrogen, usually a cyclic amine, and occurring as a secondary metabolite), such as neutral alkaloids (colchicine, piperine), the  $\beta$ -phenyl-ethylanines, and the purine bases (caffeine, theophylline, theobromine), are accepted as alkaloids.

Alkaloids often occur as salts of plant acids such as malic, meconic, and quinic acids. Some plant alkaloids are combined with sugars, for example, solanine in potato (*Solanum tuberosum*) and tomatine in tomato (*Lycopersicon esculentum*). Others occur as amides, for example, piperine from black pepper (*Piper nigrum*), or as esters, for example, cocaine from coca leaves (*Erythroxylum coca*). Still other alkaloids occur as quaternary salts or tertiary amine oxides.

While most alkaloids have been isolated from plants, a large number have been isolated from animal sources. They occur in mammals, anurans (frogs, toads), salamanders, arthropods (ants, millipedes, ladybugs, beetles, butterflies), marine organisms, mosses, fungi, and certain bacteria.



Many alkaloids exhibit marked pharmacological activity, and some find important uses in medicine. Atropine, the optically inactive form of hyoscyamine, is used widely in medicine as an antidote to cholinesterase inhibitors such as physostigmine and insecticides of the organophosphate type; it is also used in drying cough secretions. Morphine and codeine are narcotic analgesics, and codeine is also an antitussive agent, less toxic and less habit-forming than morphine. Colchicine, from the corms and seeds of the autumn crocus, is used as a gout suppressant. Caffeine, which occurs in coffee, tea, cocoa, and cola, is a central nervous system stimulant; it is used as a cardiac and respiratory stimulant and as an antidote to barbiturate and morphine poisoning. Emetine, the key alkaloid of ipecac root (*Cephaelis ipecacuanha*), is used in the treatment of amebic dysentery and other protozoal infections. Epinephrine or adrenaline (see structure), produced in most animal species

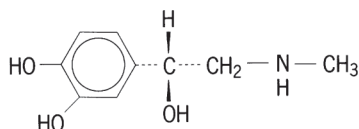

by the adrenal medulla, is used as a bronchodilator and cardiac stimulant and to counter allergic reactions, anesthesia, and cardiac arrest. See EPINEPHRINE. [S.W.Pe.]

**Alkane** A compound with the general formula  $C_nH_{2n+2}$ . Alkanes are open-chain (aliphatic or noncyclic) hydrocarbons with no multiple bonds or functional groups. They consist of tetrahedral carbon atoms, up to  $10^5$  carbons or more in length. The C-C  $\sigma$  bonds are formed from  $sp^3$  orbitals, and there is free rotation around the bond axis.

Alkanes provide the parent names for all other aliphatic compounds in systematic nomenclature. Alkanes are designated by the ending -ane appended to a stem denoting the chain length. The straight-chain isomer is designated by the prefix C (normal); other isomers are named by specifying the size of the branch and its location (see table). The number of isomers increases enormously in larger molecules; thus there are 75 isomers of  $C_{10}H_{22}$  and over 4 billion for  $C_{30}H_{62}$ .

Alkanes with four or fewer carbons are gases at atmospheric pressure. Higher C alkanes are liquids or, above about 20 carbons, solids known as paraffin wax. Alkanes have densities lower than that of water and have very low water solubility; other properties depend on the degree of branching. The heat of formation ( $\Delta H_f^\circ$ ) is a measure of the energy content of a compound relative to the component elements in standard states. For example, comparison of heat of formation values for three alkane isomers with the molecular formula  $C_5H_{12}$  indicates that the relative energy content of the three pentane isomers decreases with increased branching, that is, the branched isomer is thermodynamically most stable. See PARAFFIN.

**Nomenclature and properties of alkanes**

Name	Structure	Boiling point, °C (°F)	Heat of formation ( $\Delta H_f^\circ$ ), kJ
Methane	CH <sub>4</sub>	-162 (-260)	-74.5
Ethane	CH <sub>3</sub> CH <sub>3</sub>	-89 (-128)	-83.45
Propane	CH <sub>3</sub> CH <sub>2</sub> CH <sub>3</sub>	-42 (-44)	-104.6
Butane	CH <sub>3</sub> (CH <sub>2</sub> ) <sub>2</sub> CH <sub>3</sub>	-0.5 (33)	-125.7
2-Methylpropane (isobutane)	(CH <sub>3</sub> ) <sub>2</sub> CHCH <sub>3</sub>	-11.7 (10.9)	-134.2
Pentane	CH <sub>3</sub> (CH <sub>2</sub> ) <sub>3</sub> CH <sub>3</sub>	36.1 (97.0)	-146.87
2-Methylbutane (isopentane)	(CH <sub>3</sub> ) <sub>2</sub> CHCH <sub>2</sub> CH <sub>3</sub>	29.9 (85.8)	-153.7
2,2-Dimethyl propane (neopentane)	(CH <sub>3</sub> ) <sub>4</sub> C	9.4 (49)	-167.9
Hexane	CH <sub>3</sub> (CH <sub>2</sub> ) <sub>4</sub> CH <sub>3</sub>	68.7 (156)	-167.0

Alkanes are the major components of natural gas and petroleum, which are the only significant sources. Much smaller amounts of alkanes have been produced from coal at various times and locations, either indirectly by the Fischer-Tropsch process or by direct liquefaction. See FISCHER-TROPSCH PROCESS; NATURAL GAS; PETROLEUM.

Individual lower alkanes can be separated from the more volatile distillate fractions of petroleum, but beyond the C<sub>7</sub>-C<sub>8</sub> range the alkanes obtained are mixtures of many isomers. Compounds of a specific structure can be prepared in a laboratory scale by chemical synthesis. Various C-C bond-forming steps such as coupling or condensation are carried out to build up the desired carbon skeleton. The final step is usually removal of a functional group by some type of reduction.

Much of the chemistry of alkanes begins at the petroleum refinery, where several reactions are carried out to adjust the hydrocarbon composition of crude oil to that needed for a constantly changing set of applications. Major reactions are (1) isomerization of straight-chain alkanes to branched compounds; (2) cracking to produce smaller molecules; (3) alkylation, for example, combination of propylene and butane to give 2,3-dimethylpentane; and (4) cyclodehydrogenation (platforming), in which aromatizations occur. An important objective in some of these processes is to increase the yield of highly branched alkanes in the C<sub>6</sub>-C<sub>8</sub> range needed for gasoline. See ALKYLATION (PETROLEUM); AROMATIZATION; CRACKING; GASOLINE.

By far the most important end use of alkanes is combustion as fuel to provide heat and electric or motive power. In most cases, complete oxidation is not achieved, and varying amounts of incompletely oxidized fragments, carbon monoxide, and elemental carbon are produced.

Controlled partial oxidation is possible if all the C-H bonds in an alkane are equivalent or if one C-H bond is significantly weaker than all the others. An example of the latter situation is isobutane, which is converted to the hydroperoxide on industrial scale for the manufacture of *t*-butyl alcohol. See AUTOXIDATION; COMBUSTION.

Alkanes have been referred to as paraffin hydrocarbons to indicate their low affinity or reactivity. They contain no unshared electron pairs or accessible empty bonding orbitals, and they are unaffected by many reagents that attack  $\pi$ -bonds or other functional groups. One type of reaction that does occur is substitution by a radical chain process. Examples are chlorination and vapor-phase nitration, involving the odd-electron species Cl $\cdot$  and NO<sub>2</sub> $\cdot$ , respectively. Neither reaction is selective; when two or more types of C-H bonds are present in the alkane, mixtures of products are usually obtained. Thus propane gives rise to 1- and 2-chloropropanes as well as dichloro compounds. Nitration of propane leads to a mixture of 1- and 2-nitropropane, and also nitromethane and nitroethane by C-C bond cleavage. See HALOGENATED HYDROCARBON; HALOGENATION; NITRATION. [J.A.Mo.]

**Alkene** One of the class of acyclic hydrocarbons containing one or more carbon-to-carbon double bonds. Alkenes (also called olefins) and alkynes (also called acetylenes) together constitute the family of organic compounds called unsaturated hydrocarbons, since they contain less than the number of hydrogens found in the corresponding saturated compound, alkane. When the double bond is present in a nonaromatic ring (alicyclic hydrocarbon), the compound is termed a cycloalkene. Hydrocarbons containing more than one double bond are termed dienes, trienes, and so forth, or collectively, polyenes. See ALICYCLIC HYDROCARBON; ALKANE; ALKYNE.

In naming alkenes by the system of the International Union of Pure and Applied Chemistry (IUPAC), the longest chain containing the double bond is identified. The presence of the double bond is indicated by changing the "-ane" ending of the alkane having the same number of carbon atoms to "-ene," and the position of the double bond is indicated by a prefixed number.

## Alkenes and dienes (common name given in parentheses)

Name	Formula
Ethene (ethylene)	$\text{CH}_2 = \text{CH}_2$
Propene (propylene)	$\text{CH}_2 = \text{CHCH}_3$
1-Butene	$\text{CH}_2 = \text{CHCH}_2\text{CH}_3$
2-Butene	$\text{CH}_3\text{CH} = \text{CHCH}_3$
2-Methylpropene (isobutylene)	$\begin{array}{c} \text{CH}_3 \\   \\ \text{CH}_2 = \text{CCH}_3 \end{array}$
1,3-Butadiene	$\text{CH}_2 = \text{CHCH} = \text{CH}_2$
2-Methyl-1,3-butadiene (isoprene)	$\begin{array}{c} \text{CH}_3 \\   \\ \text{CH}_2 = \text{CCH} = \text{CH}_2 \end{array}$

Examples are given in the table, with common or nonsystematic names which are still frequently used given in parentheses.

The lower alkenes and dienes which have up to five carbon atoms are gases at room temperature and pressure. Higher alkenes are colorless liquids or solids. Like other hydrocarbons, alkenes are insoluble in water. Liquid alkenes have specific gravities well below 1.0. Alkenes may undergo polymerization, cyclization, and addition reactions. A major share of structural and elastic polymers are based on homopolymers or copolymers of alkenes and dienes. Alkenes and dienes cyclize readily under various conditions.

Addition reactions of alkenes are among the most important in the entire field of organic chemistry. Industrially, high-octane gasoline is made by the acid-catalyzed alkylation of the three- and four-carbon alkenes. A variety of alkylated aromatics are made by the alkylation of benzene with olefins.

The commercially important alkenes are produced on a large scale in the petroleum industry by thermal or catalytic cracking processes. In the laboratory, most methods for the preparation of alkenes involve some type of elimination reaction, in which atoms or groups on adjacent carbon atoms are removed with concomitant formation of the carbon-carbon double bond. See ALKYLATION (PETROLEUM); CRACKING; HALOGENATION; HYDROGENATION. [P.E.F.]

**Alkylation (petroleum)** In the petroleum industry, a chemical process in which an alkene (ethylene, propylene, and so forth) and a hydrocarbon, usually 2-methylpropane, are combined to produce a higher-molecular-weight and higher-carbon-number product. The product has a higher octane rating and is used to improve the quality of gasoline-range fuels. The process was originally developed during World War II to produce high-octane aviation gasoline. Its current main application is in the production of unleaded automotive gasoline. See ALKENE; GASOLINE.

The alkylation reaction is initiated by the addition of a proton ( $\text{H}^+$ ) to the olefin [reaction (1)]. The protonated olefin

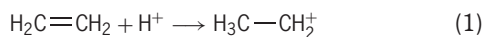

(carbonium ion) then reacts with the isobutane by abstraction of a proton from the isobutane to produce the *t*-butyl carbonium ion [reaction (2)]. Reaction of this tertiary carbonium ion

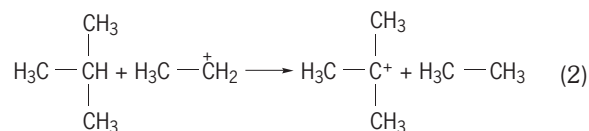

with the olefin proceeds by combination of the two species [reaction (3)] to produce a more complex six-carbon carbonium ion which yields a stabilized product by abstraction of a proton from another molecule of isobutane [reaction (4)].

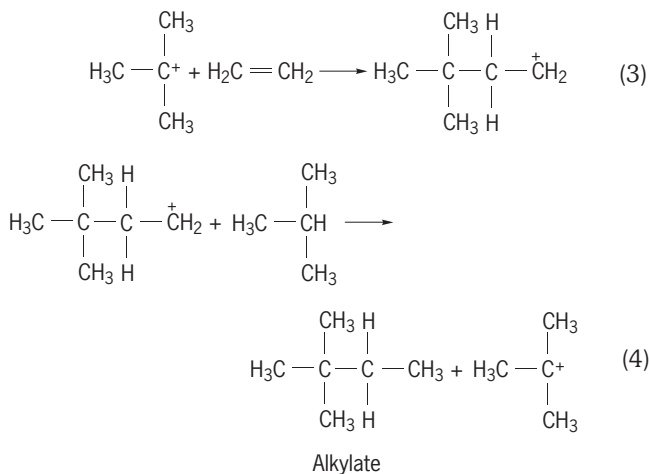

The reaction progresses to more product by reaction of the *t*-butyl and carbonium ion, as already shown in reaction (3). See REACTIVE INTERMEDIATES. [J.G.S.]

**Alkyne** One of a group of organic compounds containing a carbon-to-carbon triple-bond linkage ( $-\text{C}\equiv\text{C}-$ ). They are termed acetylenes or alkynes. While exhibiting many of the characteristics of alkenes as regards unsaturation, the acetylenes have many unique properties. Since the bonding in alkyne molecules is linear,  $\text{R}-\text{C}\equiv\text{C}-\text{R}$ , *cis-trans* isomerism is not possible. In the simplest alkyne, acetylene ( $\text{HC}\equiv\text{CH}$ ), or in monosubstituted acetylenes, the hydrogen attached to triply bonded carbon is acidic to such a degree that it is replaceable with metals such as sodium. Structural formulas of several alkynes are as follows:

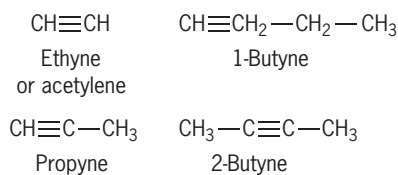

General methods for the preparation of alkynes depend on dehydrohalogenation of  $\alpha,\beta$ -dihaloparaffins, conversion of aldehydes or ketones to dihaloparaffins with subsequent dehydrohalogenation, and alkylation of metallic acetylides with alkyl halides in liquid ammonia. Grignard reagents of 1-alkynes behave similarly.

The reactions of triply bonded carbon compounds are in general similar to those of compounds containing ethylenic bonds. Addition reactions proceed in two stages to form first a vinyl compound or substituted ethylene, and second the substituted paraffin. In the presence of catalytic quantities of alkoxides, acetylene adds to alcohols and phenols to give vinyl ethers. Reactions of this type, in which addition takes place by replacement of hydrogen with a vinyl group, are termed vinylation. Another form of addition reaction known as ethynylation involves the addition of acetylene to unsaturated compounds. A general reaction of alkynes involves the addition of carbon monoxide and water, or other compounds having an active hydrogen, in the presence of nickel carbonyl.

Polymerization of alkynes may yield acyclic, aromatic, or alicyclic derivatives. In the presence of cuprous chloride, acetylene dimerizes to vinyl acetylene, which adds hydrogen chloride to give chloroprene (2-chloro-1,3-butadiene). Polymerization of

chloroprene in the presence of free radical initiators gives the commercially important synthetic rubber, neoprene. Thermal polymerization of acetylene yields benzene as the major product and also a wide variety of polynuclear aromatic compounds. Of great theoretical and practical importance is the polymerization of acetylene to the cyclic tetramer, cyclooctatetraene. See ACETYLENE; ALKENE. [C.A.Co./P.E.F.]

**Allantois** A fluid-filled sac- or sausalike, extraembryonic membrane lying between the outer chorion and the inner amnion and yolk sac of the embryos of reptiles, birds, and mammals. It is composed of an inner layer of endoderm cells, continuous with the endoderm of the embryonic gut, or digestive tract, and an outer layer of mesoderm, continuous with the splanchnic mesoderm of the embryo. It arises as an outpouching of the ventral floor of the hindgut and dilates into a large allantoic sac which spreads throughout the extraembryonic coelom. The allantois remains connected to the hindgut by a narrower allantoic stalk which runs through the umbilical cord. See AMNION; CHORION; GERM LAYERS.

The allantois eventually fuses with the overlying chorion to form the compound chorioallantois, which lies just below the shell membranes in reptiles and birds. The chorioallantois is supplied with an extensive network of blood vessels and serves as an important respiratory and excretory organ for gaseous interchange. The allantoic cavity also serves as a reservoir for kidney wastes in some mammals, in reptiles, and in birds. In the latter two groups the allantois assists in the absorption of albumin. In some mammals, including humans, the allantois is vestigial and may regress, yet the homologous blood vessels persist as the important umbilical arteries and veins connecting the embryo with the placenta. See FETAL MEMBRANE; PLACENTATION. [N.T.S.]

**Allele** Any of a number of alternative forms of a gene. Allele is a contraction of allelomorph, a term used to designate one of the alternative forms of a unit showing mendelian segregation. New alleles arise from existing ones by mutation. The diversity of alleles produced in this way is the basis for hereditary variation and evolution. The different alleles of a given gene determine the degree to which the specific hereditary characteristic controlled by that gene is manifested. The particular allele which causes that characteristic to be expressed in a normal fashion is often referred to as the wild-type allele. Mutations of the wild-type allele result in mutant alleles, whose functioning in the development of the organism is generally impaired relative to that of the wild-type allele. See DEOXYRIBONUCLEIC ACID (DNA); GENE; GENE ACTION; GENETIC CODE; MENDELISM; MUTATION.

An allele occupies a fixed position or locus in the chromosome. In the body cells of most higher organisms, including humans, there are two chromosomes of each kind and hence two alleles of each kind of gene, except for the sex chromosomes. Such organisms and their somatic cells are said to carry a diploid complement of alleles. A diploid individual is homozygous if the same allele is present twice, or heterozygous if two different alleles are present. Let *A* and *a* represent a pair of alleles of a given gene; then *A/A* and *a/a* are the genetic constitutions or genotypes of the two possible homozygotes, while *A/a* is the genotype of the heterozygote. Usually the appearance or phenotype of the *A/a* individuals resembles that of the *A/A* type; *A* is then said to be the dominant allele and *a* the recessive allele. In the case of the sex chromosomes, one sex (usually the male in most higher animals, with the exception of birds) has only one X chromosome, and the Y lacks almost all of the genes in X. The male thus carries only one dose of X-linked genes and is said to be hemizygous for alleles carried on his X chromosome. As a result, if a male inherits a recessive mutant allele such as color blindness on his X chromosome, he expresses color blindness because he lacks the wild-type allele on his Y chromosome. See CHROMOSOME; SEX-LINKED INHERITANCE.

In a population of diploid individuals, it is possible to have more than two alleles of a given gene. The aggregate of such alleles is called a multiple allelic series. Since genes are linear sequences of hundreds or even thousands of nucleotide base pairs, the potential number of alleles of a given gene which can arise by base substitution alone is enormous. [E.B.L.]

**Allelopathy** The biochemical interactions among all types of plants, including microorganisms. The term is usually interpreted as the detrimental influence of one plant upon another but is used more and more, as intended originally, to encompass both detrimental and beneficial interactions. At least two forms of allelopathy are distinguished: (1) the production and release of an allelochemical by one species inhibiting the growth of only other adjacent species, which may confer competitive advantage for the allelopathic species; and (2) autoallelopathy, in which both the species producing the allelochemical and unrelated species are indiscriminately affected. The term allelopathy, frequently restricted to interactions among higher plants, is now applied to interactions among plants from all divisions, including algae. Even interactions between plants and herbivorous insects or nematodes in which plant substances attract, repel, deter, or retard the growth of attacking insects or nematodes are considered to be allelopathic. Interactions between soil microorganisms and plants are important in allelopathy. Fungi and bacteria may produce and release inhibitors or promoters. Some bacteria enhance plant growth through fixing nitrogen, others through providing phosphorus. The activity of nitrogen-fixing bacteria may be affected by allelochemicals, and this effect in turn may influence ecological patterns. The rhizosphere must be considered the main site for allelopathic interactions. See NITROGEN FIXATION; RHIZOSPHERE.

Allelopathy is clearly distinguished from competition: In allelopathy a chemical is introduced by the plant into the environment, whereas in competition the plant removes or reduces such environmental components as minerals, water, space, gas exchange, and light. In the field, both allelopathy and competition usually act simultaneously. [M.Ru.]

**Allergy** Altered reactivity in humans and animals to allergens (substances foreign to the body that cause allergy) induced by exposure through injection, inhalation, ingestion, or skin contact. The most common clinical manifestations of allergy are hay fever, asthma, hives, atopic (endogenous) eczema, and eczematous skin lesions caused by direct contact with allergens such as poison ivy or certain chemicals.

A large variety of substances may cause allergies: pollens, animal proteins, molds, foods, insect venoms, foreign serum proteins, industrial chemicals, and drugs. Most natural allergens are proteins or polysaccharides of moderate molecular size (molecular weights of 10,000 to 200,000). Chemicals or drugs of lower molecular weight (haptens) have first to bind to the body's own proteins (carriers) in order to become fully effective allergens.

For the development of the hypersensitivity state underlying clinical allergies, repeated contact with the allergen is required. Duration of the sensitization period is usually dependent upon the sensitizing strength of the allergen and the intensity of exposure. Some allergens (for example, saliva, urine, and hair proteins of domestic animals) are more sensitizing than others. In most instances, repeated contact with minute amounts of allergen is required; several annual seasonal exposures to grass pollens or ragweed pollen usually occur before an overt manifestation of hay fever. On the other hand, allergy to cow milk proteins in infants can develop within a few weeks. When previous contacts with allergens have not been apparent (for example, antibiotics in food), an allergy may become clinically manifest even upon the first conscious encounter with the offending substance.

Besides the intrinsic sensitizing properties of allergens, individual predisposition of the allergic person to become sensitized also plays an important role. Clinical manifestations, such as hay fever, allergic asthma, and atopic (endogenous) dermatitis, occur more frequently in some families. In other clinical forms of allergy, genetic predisposition, though possibly present as well, is not as evident.

Exposure to sensitizing allergens may induce several types of immune response, and the diversity of immunological mechanisms involved is responsible for the various clinical forms of allergic reactions which are encountered in practice. Three principal types of immune responses are encountered: the production of IgE antibodies, IgG or IgM antibodies, and sensitized lymphocytes. See ANTIBODY; IMMUNOGLOBULIN.

Diagnosis of allergic diseases encompasses several facets. Since many clinical manifestations of allergy are mimicked by nonallergic mechanisms, it is usually necessary to use additional diagnostic procedures to ascertain whether the person has developed an immune response toward the incriminated allergen. Such procedures primarily consist of skin tests, in which a small amount of allergen is applied on or injected into the skin. If the individual is sensitized, a local immediate reaction ensues, taking the form of a wheal (for IgE-mediated reactions), or swelling and redness occurs after several hours (for delayed hypersensitivity reactions). The blood may also be analyzed for IgE and IgG antibodies by serological assays, and sensitized lymphocytes are investigated by culturing them with the allergen.

Since the discovery of the responsible allergens markedly influences therapy and facilitates prediction of the allergy's outcome, it is important to achieve as precise a diagnosis as possible. Most tests indicate whether the individual is sensitized to a given allergen, but not whether the allergen is in fact still causing the disease. Since in most cases the hypersensitive state persists for many years, it may well happen that sensitization is detected for an allergen to which the individual is no longer exposed and which therefore no longer causes symptoms. In such cases, exposition tests, consisting of close observation of the individual after deliberate exposure to the putative allergen, may yield useful information.

The most efficient treatment, following identification of the offending allergen, remains elimination of allergen from the person's environment and avoidance of further exposure. This form of treatment is essential for allergies caused by most household and workplace allergens. See ANTIGEN; HYPERSENSITIVITY.

[A.L.deW.]

**Alligator** Large aquatic reptile of the family Alligatoridae. Common usage generally restricts the name to the two living species of the genus *Alligator*. The American alligator (*A. mississippiensis*) ranges throughout the southeastern United States from coastal North Carolina (southeastern Virginia in historical times) to the Rio Grande in Texas, and north into southeastern Oklahoma and southern Arkansas (see illustration).

The second species is the Chinese alligator (*A. sinensis*), restricted to the region of the Yangtze River valley in China, where it inhabits burrows in the floodplains and riverbanks. It is also an endangered species and is now protected in China.

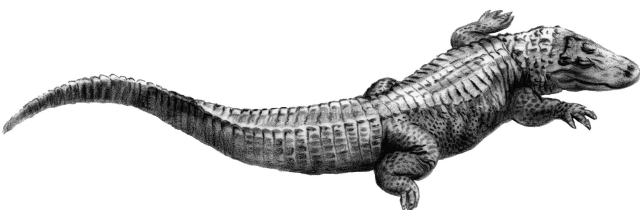

American alligator (*Alligator mississippiensis*).

The American alligator is by far the larger of the two species, reaching a length in excess of 15 ft (4.5 m). The average length of *A. sinensis* is 4–5 ft (1.2–1.5 m). See REPTILIA. [H.W.C.]

**Allocoela** An order of the Turbellaria, mainly marine but with some fresh-water and terrestrial species. They possess a well-defined gut, with a simple, variable (modified dolioform) or plicate pharynx and a diverticulated intestine. The nervous system has three or four pairs of longitudinal nerves, with connecting commissures. The ovary is paired. The testes are follicular, and a well-defined penis papilla is present. There is a pair of protonephridia, often with two or three main branches to each and with a number of nephridiopores. Anterior ciliated pits or grooves are common; eyes and statocysts are less so, but present in some.

Allocoels are generally 0.04–0.40 in. (1–10 mm) in length and cylindrical in shape, but sometimes plump or elongate. They are generally grayish white to brown, but may be more brightly colored due to gut contents or yellow to orange lipid reserves. They occur in the littoral zone among algae, on sandy or muddy bottoms, and occasionally in clear rock pools. See TURBELLARIA.

[J.B.J.]

**Allometry** The study of changes in the characteristics of organisms with body size. Characteristics such as body parts or timing of reproductive events do not necessarily change in direct proportion to body size, and the ways in which they change relative to body size can often provide insights into organisms' construction and behavior. Large organisms are often not merely magnified small ones.

Many characteristics, ranging from brain size and heart rate to life span and population density, change consistently with body size. These relationships normally fit a simple power function given by Eq. (1), where  $y$  is the variable under study,  $m$  is

$$y = km^b \quad (1)$$

body mass,  $k$  is the allometric constant, and  $b$  is the allometric exponent. The use of logarithms makes the equation easier to visualize—the exponent becomes the slope of a straight line when the logarithm of the variable ( $y$ ) is plotted against the logarithm of body mass ( $m$ ) [Eq. (2)].

$$\log(y) = \log(k) + b \log(m) \quad (2)$$

Unless the allometric exponent ( $b$ ) equals 1, the ratio of  $y/m$  varies with  $m$ . The terms isometry, positive allometry, and negative allometry are sometimes used for  $b = 1$ ,  $b > 1$ , and  $b < 1$ , respectively. If the variable of interest is the mass of an organ, under isometry the organ mass is a fixed proportion of body mass; under positive allometry the larger organisms have disproportionately large organs; and under negative allometry the larger organisms have disproportionately small organs. See LOGARITHM.

Allometry is perhaps most powerful when known allometric relations are coupled with theory to produce new hypotheses that can be tested. For example, mammal species with large bodies grow more slowly, mature later, have fewer but larger young after longer gestation periods, and live longer than do small species; these traits remain correlated with each other among deviations from the allometric lines. Allometric models predict not only the allometric exponents but also the correlations among the deviations. The models even provide a framework for asking questions vital to understanding scaling, such as what factors affect the evolution of body size itself. See BIOPHYSICS. [A.Pu.; P.H.Ha.]

**Allosteric enzyme** Any one of the special bacterial enzymes involved in regulatory functions. End-product inhibition is a bacterial control mechanism whereby the end product of a biosynthetic pathway can react with the first enzyme of the pathway and prevent its activity. This end-product inhibition is a device through which a cell conserves its economy by shutting off the synthesis of building blocks when too many are present.

A model to explain the action of allosteric enzymes suggests that the enzyme molecule is a complex consisting of identical subunits, each of which has a site for binding the substrate and another for binding the regulatory substance. These subunits interact in such a way that two conformational forms may develop. One form is in a relaxed condition (*R* state) and has affinity for the substrate and activator; the other form is in a constrained or taut condition (*T* state) and has affinity for the inhibitor. The forms exist in a state of equilibrium, but this balance can be readily tipped by binding one of the reactants. The substrate and activator are bound by the relaxed form; when this happens, the balance is tipped in favor of that state. Conversely, the inhibitor will throw the balance toward the constrained state. The balance is thus tipped one way or the other, depending on the relative concentrations of substrate and inhibitor. Since the two states require subunit interaction for their maintenance, it can be seen why dissociation of the subunits leads to a simple monomeric enzyme which no longer exhibits allosteric effects. The model also shows how the binding sites may interact in either a cooperative or antagonistic manner. See ENZYME. [J.S.G.]

**Allotheria** One of the four subclasses of Mammalia, containing a single order, the Multituberculata. The Allotheria first appeared in the Late Jurassic and survived well into the Cenozoic, a period of at least 100,000,000 years. Fossils are known from North America, Europe, and Asia.

The diagnostic features of the subclass are in the dentition. There is a pair of enlarged incisors above and below; reduced lateral incisors may persist in the upper jaw. Canines are absent, leaving a diastema between incisors and cheek teeth. Premolars are variable and often reduced. The lower molars have five or more cusps in two parallel longitudinal rows, and the upper molars have two or three parallel rows of cusps; hence the molars are multituberculate. See DENTITION; MAMMALIA; MULTITUBERCULATA. [D.D.D./F.S.S.]

**Allowance** An intentional difference in sizes of two mating parts. With running or sliding fits, allowance is a clearance, usually for a film of oil. In this sense, allowance is the space "allowed" for motion between parts.

With force or shrink fits allowance is an interference of metal; that is, a portion of metal in one part tends to occupy the same space as the adjacent portion of metal in the mating part. In this sense, allowance is the interference "allowed" to produce pressure between parts. See FORCE FIT; LOCATION FIT; PRESS FIT; RUNNING FIT; SHRINK FIT; TOLERANCE. [P.H.B.]

**Alloy** A metal product containing two or more elements (1) as a solid solution, (2) as an intermetallic compound, or (3) as a mixture of metallic phases. Alloys are frequently described on the basis of their technical applications. They may also be categorized and described on the basis of compositional groups. For example, See BERYLLIUM ALLOYS; IRON ALLOYS.

Except for native copper and gold, the first metals of technological importance were alloys. Bronze, an alloy of copper and tin, is appreciably harder than copper. This quality made bronze so important an alloy that it left a permanent imprint on the civilization of several millennia ago now known as the Bronze Age. Today the tens of thousands of alloys involve almost every metallic element of the periodic table.

Alloys are used because they have specific properties or production characteristics that are more attractive than those of the

pure, elemental metals. For example, some alloys possess high strength; others have low melting points; others are refractory with high melting temperatures; some are especially resistant to corrosion; and others have desirable magnetic, thermal, or electrical properties. These characteristics arise from both the internal and the electronic structure of the alloy. An alloy is usually harder than a pure metal and may have a much lower conductivity.

Bearing alloys are used for metals that encounter sliding contact under pressure with another surface; the steel of a rotating shaft is a common example. Most bearing alloys contain particles of a hard intermetallic compound that resist wear. These particles, however, are embedded in a matrix of softer material which adjusts to the hard particles so that the shaft is uniformly loaded over the total surface. The most familiar bearing alloy is babbit. Bearings made by powder metallurgy techniques are widely used because they permit the combination of materials which are incompatible as liquids, for example, bronze and graphite, and also permit controlled porosity within the bearings so that they can be saturated with oil before being used, the so-called oilless bearings. See ANTI-FRICTION BEARING; WEAR.

Certain alloys resist corrosion because they are noble metals. Among these alloys are the precious-metal alloys. Other alloys resist corrosion because a protective film develops on the metal surface. This passive film is an oxide which separates the metal from the corrosive environment. Stainless steels and aluminum alloys exemplify metals with this type of protection. The bronzes, alloys of copper and tin, also may be considered to be corrosion-resisting. See CORROSION; STAINLESS STEEL.

Dental alloys contain precious metals. Amalgams are predominantly silver-mercury alloys, but they may contain minor amounts of tin, copper, and zinc for hardening purposes. Liquid mercury is added to a powder of a precursor alloy of the other metals. After being compacted, the mercury diffuses into the silver-base metal to give a completely solid alloy. Gold-base dental alloys are preferred over pure gold because gold is relatively soft. The most common dental gold alloy contains gold, silver, and copper. For higher strengths and hardnesses, palladium and platinum are added, and the copper and silver are increased so that the gold content drops. Vitallium and other corrosion-resistant alloys are used for bridgework and special applications. See SILVER ALLOYS.

Die-casting alloys have melting temperatures low enough so that in the liquid form they can be injected under pressure into steel dies. Such castings are used for automotive parts and for office and household appliances which have moderately complex shapes. Most die castings are made from zinc-base or aluminum-base alloys. Magnesium-base alloys also find some application when weight reduction is paramount. Low-melting alloys of lead and tin are not common because they lack the necessary strength for the above applications. See METAL CASTING.

In certain alloy systems a liquid of a fixed composition freezes to form a mixture of two basically different solids or phases. An alloy that undergoes this type of solidification process is called a eutectic alloy. A homogeneous liquid of this composition on slow cooling freezes to form a mixture of particles of nearly pure copper embedded in a matrix (background) of nearly pure silver.

The advantageous mechanical properties inherent in composite materials have been known for many years. Attention is being given to eutectic alloys as they are basically natural composite materials. See EUTECTICS; METAL MATRIX COMPOSITE.

Fusible alloys generally have melting temperatures below that of tin (449°F or 232°C), and in some cases as low as 122°F (50°C). Using eutectic compositions of metals such as lead, cadmium, bismuth, tin, antimony, and indium achieves these low melting temperatures. These alloys are used for many purposes, for example, in fusible elements in automatic sprinklers, forming and stretching dies, filler for thin-walled tubing that is being bent, and anchoring dies, punches, and parts being machined.

High-temperature alloys have high strengths at high temperatures. In addition to having strength, these alloys must resist oxidation by fuel-air mixtures and by steam vapor. At temperatures up to about 1380°F (750°C), the austenitic stainless steels serve well. An additional 180°F (100°C) may be realized if the steels also contain 3% molybdenum. Both nickel-base and cobalt-base alloys, commonly categorized as superalloys, may serve useful functions up to 2000°F (1100°C). Nichrome, a nickel-base alloy containing chromium and iron, is a fairly simple superalloy. More sophisticated alloys invariably contain five, six, or more components; for example, an alloy called René-41 contains Cr, Al, Ti, Co, Mo, Fe, C, B, and Ni. Other alloys are equally complex. A group of materials called cermets, which are mixtures of metals and compounds such as oxides and carbides, have high strength at high temperatures, and although their ductility is low, they have been found to be usable. One of the better-known cermets consists of a mixture of titanium carbide and nickel, the nickel acting as a binder or cement for the carbide. See CERMET.

Metals are bonded by three principal procedures: welding, brazing, and soldering. Welded joints melt the contact region of the adjacent metal; thus the filler material is chosen to approximate the composition of the parts being joined. Brazing and soldering alloys are chosen to provide filler metal with an appreciably lower melting point than that of the joined parts. Typically, brazing alloys melt above 750°F (400°C), whereas solders melt at lower temperatures. See BRAZING; SOLDERING.

Aluminum and magnesium, with densities of 2.7 and 1.75 g/cm<sup>3</sup>, respectively, are the bases for most of the light-metal alloys. Titanium (4.5 g/cm<sup>3</sup>) may also be regarded as a light-metal alloy if comparisons are made with metals such as steel and copper. Aluminum and magnesium must be hardened to receive extensive application. Age-hardening processes are used for this purpose. See ALUMINUM; MAGNESIUM.

Low-expansion alloys include Invar, the dimensions of which do not vary over the atmospheric temperature range, and Kovar, which is widely used because its expansion is low enough to match that of glass. See THERMAL EXPANSION.

Soft and hard magnetic materials involve two distinct categories of alloys. The former consists of materials used for magnetic cores of transformers and motors, and must be magnetized and demagnetized easily. For alternating-current applications, silicon-ferrite is commonly used. This is an alloy of iron containing as much as 5% silicon. Permalloy and some comparable cobalt-base alloys are used in the communications industry. Ceramic ferrites, although not strictly alloys, are widely used in high-frequency applications because of their low electrical conductivity and negligible induced-energy losses in the magnetic field. Permanent or hard magnets may be made from steels which are mechanically hardened, either by deformation or by quenching. The Alnicos are also widely used for magnets. Since these alloys cannot be forged, they must be produced in the form of castings. The newest hard magnets are being produced from alloys of cobalt and the rare-earth type of metals. See MAGNETIC MATERIALS.

In addition to their use in coins and jewelry, precious metals such as silver, gold, and the heavier platinum metals are used extensively in electrical devices in which contact resistances must remain low, in catalytic applications to aid chemical reactions, and in temperature-measuring devices such as resistance thermometers and thermocouples. The unit of alloy impurity is commonly expressed in karats, where each karat is a  $\frac{1}{24}$  part. The most common precious-metal alloy is sterling silver (92.5% Ag, with the remainder being unspecified, but usually copper). The copper is very beneficial in that it makes the alloy harder and stronger than pure silver.

Metallic implants demand extreme corrosion resistance because body fluids contain nearly 1% NaCl, along with minor amounts of other salts, with which the metal will be in contact for indefinitely long periods of time. Type 316 stainless steels resist pitting corrosion but are subject to crevice corrosion. Vital-

lium and other cobalt-base alloys have orthopedic applications. Titanium alloys gained wide usage in Europe during the early 1970s for pacemakers and for retaining devices in artificial heart valves. While excellent for corrosion resistance, this alloy is subject to mechanical wear; therefore, it is not satisfactory in hip-joint prostheses and applications with similar frictional contacts. See PROSTHESIS.

Shape memory alloys have a very interesting and desirable property. In a typical case, a metallic object of a given shape is cooled from a given temperature  $T_1$  to a lower temperature  $T_2$  where it is deformed so as to change its shape. Upon reheating from  $T_2$  to  $T_1$  the shape change accomplished at  $T_2$  is recovered so that the object returns to its original configuration. This thermoelastic property of the shape memory alloys is associated with the fact that they undergo a martensitic phase transformation (that is, a reversible change in crystal structure that does not involve diffusion) when they are cooled or heated between  $T_1$  and  $T_2$ . Shape memory alloys are capable of being employed in a number of useful applications. One example is for thermostats; another is for couplings on hydraulic lines or electrical circuits.

Superconducting alloys, with zero resistivity, are of great interest in the design of certain fusion reactors which require very large magnetic fields to contain the plasma in a closed system. The advantage of the use of a material with a resistivity approaching zero is obvious. However, two significant problems are involved in the use of superconducting alloys in large electromagnetics: the critical temperature, and the fact that above a certain critical current density the superconducting materials tend to become normal conductors with a finite resistance. Serious materials problems still have to be solved before these materials can be used successfully. See SUPERCONDUCTIVITY.

Thermocouple alloys include Chromel and Alumel. These two alloys together form the widely used Chromel-Alumel thermocouple, which can measure temperatures up to 2200°F (1204°C). Another common thermocouple alloy, constantan, is used to form iron-constantan and copper-constantan couples, employed at lower temperatures. See STEEL; THERMOCOUPLE.

[L.H.V.V./R.E.R.H.]

As discussed here, prosthetic alloys are alloys used in internal prostheses, that is, surgical implants such as artificial hips and knees. External prostheses are devices that are worn by patients outside the body; alloy selection criteria are different from those for internal prostheses. Alloy selection criteria for surgical implants can be stringent primarily because of biomechanical and chemical aspects of the service environment. The most widely used prosthetic alloys therefore include high-strength, corrosion-resistant ferrous, cobalt-based, or titanium-based alloys: for example, cold-worked stainless steel; cast Vitallium; a wrought alloy of cobalt, nickel, chromium, molybdenum, and titanium; titanium alloyed with aluminum and vanadium; and commercial-purity titanium. See PROSTHESIS.

[J.Br.]

An alloy of niobium and titanium (NbTi) has a great number of applications in superconductivity; it becomes superconducting at 9.5 K (critical superconducting temperature,  $T_c$ ). This alloy is preferred because of its ductility and its ability to carry large amounts of current at high magnetic fields, represented by  $J_c(H)$  [where  $J_c$  is the critical current and  $H$  is a given magnetic field], and still retain its superconducting properties. Novel high-temperature superconducting materials may have revolutionary impact on superconductivity and its applications. These materials are ceramic, copper oxide-based materials that contain at least four and as many as six elements. Typical examples are yttrium-barium-copper-oxygen ( $T_c$  93 K); bismuth-strontium-calcium-copper-oxygen ( $T_c$  110 K); and thallium-barium-calcium-copper-oxygen ( $T_c$  125 K). These materials become superconducting at such high temperatures that refrigeration is simpler, more dependable, and less expensive. See CERAMICS; SUPERCONDUCTIVITY.

[D.Gu.]

**Alloy structures** Metals in actual commercial use are almost exclusively alloys, and not pure metals, since it is possible for the designer to realize an extensive variety of physical properties in the product by varying the metallic composition of the alloy. As a case in point, commercially pure or cast iron is very brittle because of the small amount of carbon impurity always present, while the steels are much more ductile, with greater strength and better corrosion properties. In general, the highly purified single crystal of a metal is very soft and malleable, with high electrical conductivity, while the alloy is usually harder and may have a much lower conductivity. The conductivity will vary with the degree of order of the alloy, and the hardness will vary with the particular heat treatment used. For commercial applications of alloys and other information see ALLOY.

The basic knowledge of structural properties of alloys is still in large part empirical, and indeed, it will probably never be possible to derive formulas which will predict which metals to mix in a certain proportion and with a certain heat treatment to yield a specified property or set of properties. However, a set of rules exists which describes the qualitative behavior of certain groups of alloys. These rules are statements concerning the relative sizes of constituent atoms for alloy formation, and concerning what kinds of phases to expect in terms of the valence of the constituent atoms. The rules were discovered in a strictly empirical way, and for the most part, the present theoretical understanding of alloys consists of rudimentary theories which describe how the rules arise from the basic principles of physics. [R.M.T.]

**Size factor.** The empirical rules for alloy formation state that, for substitutional alloys, the size of the constituents must be approximately the same, whereas one of the constituents of an interstitial alloy must be small compared to the other. Simply stated, the size factor recognizes the importance of choosing two metals which can fit together in a lattice structure. In order to define the concept of size, one must refer to the general ideas of the band theory of solids. According to this theory, the valence electrons of the metal atoms are detached from the immediate vicinity of the atom and contribute to the conduction band. In the conduction band the electrons have many of the characteristics of free particles similar to the atoms of a gas. The conduction electrons are spread over the metal, filling the interstices between the remaining ion cores of the metal atoms. The electrons of the inner shells remain tightly bound to the individual ions, however. See FREE-ELECTRON THEORY OF METALS; VALENCE.

**Interstitial alloys.** Examples of interstitial alloys are some of the alloys of the transition elements and, most familiarly, those of iron. The iron lattice is face-centered cubic at medium temperatures. If the face-centered lattice is considered to be made up of hard spheres of radius  $a_0$ , the largest atom which can be fitted into an interstitial position (the cube center) has a radius  $0.59a_0$ . There are only four neutral atoms which have smaller radii than this value for the transition-metal group. They are hydrogen, carbon, nitrogen, and boron. Carbon is actually an exception to the rule for iron, as it has a radius of  $0.63a_0$  for the iron lattice. Actually, these four elements are not metals in their normal state, even though they do form metallic alloys with the transition metals. See CRYSTAL DEFECTS; CRYSTAL STRUCTURE; CRYSTALLOGRAPHY.

**Substitutional alloys.** In the substitutional primary solutions the solute atom takes the place of one of the solvent atoms. In this case the size of the solvent and solute must be nearly the same. It is possible to calculate in a crude way the maximum permissible difference in size. The size difference is reflected in a lattice distortion, which is a contribution to the internal energy of the system.

The substitutional alloys are the commonest type of alloy structure and have received the most study. Cu-Au is a good example of the substitutional alloy. The atomic sizes are very close, and the electronic structures of Cu and Au are very similar. As a result, this system forms a single primary solid solution system from one end of the composition diagram to the other. The only complex-

ities are due to ordering phenomena, which will be discussed later.

**Valence factor.** In addition to the effects of the size of the ions on the formation of alloys, the electronic structure of the atoms involved also plays a role. It is the electronic configuration of the atoms which determines why mixtures of some elements form metallic alloys, whereas some form insulating compounds. Qualitatively, it is found that alloys are formed from the atoms of the middle of the electrochemical series of the elements. The reason is that there is always a tendency for the ions of the metallic state to polarize with respect to their neighbors and form an ionic solid instead of the metallic one. If the tendency is strong, no metallic alloy state can be formed; hence, only elements from the middle of the series, where there is little change in the ionization potential from one atom to another, can form successful alloys. See ELECTROCHEMICAL SERIES.

**Stoichiometry.** Closely related to the polarization effect is the reason why the alloys are nonstoichiometric (that is, why they form mixtures which do not consist of small-number ratios of one element to the other) and form homogeneous phases over wide ranges of composition. For example, copper and gold mix homogeneously for any composition. This result is in striking contrast to the behavior of the ionic compounds such as sodium chloride, NaCl. See STOICHIOMETRY.

In NaCl an excess Na ion is bound in the crystal with an energy less by about 1 eV than a normal ion, and this energy discrepancy is large enough so that, when the crystal becomes far from stoichiometric, the homogeneous compound is no longer formed. The excess constituent forms a separate phase, either as Na metal crystals embedded in the matrix or as bubbles of  $\text{Cl}_2$ . The energy discrepancy in the case of NaCl is primarily due to the excess of charge of one sign or the other when the wrong ion is on a lattice site. Since the lattice is completely ionized, the excess charge due to the excess ion amounts to the complete ionic charge. See IONIC CRYSTALS.

**Screening length.** A further effect is the screening of the polarization around the gold atom by the conduction electrons themselves. In this case, when the region around the gold is polarized, a voltage difference is also generated. Hence, the electrons of the metal tend to rush into the affected region to even out the discrepancy. However, it is not possible to redress the balance completely, and a region of the order of the size of the gold atomic volume itself remains polarized. The size of this region is indicated by the screening length of the electrons of the metal, which are here listed for several metals in units of lattice spacing  $a_0$ : Cu, 1.1; Al, 1.4; Tl, 1.0; Fe, 3.2; and Ni, 4.8.

**Structure and electron density.** It appears that in numerous cases there is a tendency for a particular type of crystal structure to correspond to a particular electron density in the conduction band. Thus, when zinc is alloyed to copper, near the 50% composition there is a phase change from the face-centered-cubic (fcc) lattice of copper to a body-centered-cubic (bcc) lattice. If it is assumed that all the valence electrons of all the atoms are contributed to the conduction band, there will be an average of 1.5 electrons per atom of the alloy in this band, since the valence of copper is 1 and the valence of zinc is 2. For the alloys  $\text{Cu}_3\text{Al}$  and  $\text{Cu}_5\text{Sn}$ , the crystal structure is also bcc for the same average free electron concentration.

H. Jones has used the free-electron theory of metals modified by perturbation theory to derive an expression for the difference in energy of the electrons of the fcc and bcc crystals. His result is that as the Brillouin zone is filled, at first the energy is very nearly equal for the two crystals. The energy of the fcc crystal then drops below that of the bcc crystal at an electron concentration of about 1 electron per atom; but at a concentration close to 1.5, the situation reverses and the bcc crystal becomes more stable. Similar discussions have been given for the hexagonal lattices; these show that certain distortions of the symmetry of the perfect hexagonal lattice which occur are due to electronic effects related to filling the Brillouin zone. See BRILLOUIN ZONE.

However, in spite of the seeming success of the theory in confirming the electron compound concept in terms of the interaction of the electrons with the boundaries of the Brillouin zone, the Jones treatment must be considered a very limited theory. First of all, Jones assumed, when he adopted the free-electron picture, that the role of the ions in the alloy is a minor one. On the other hand, when a zinc atom is placed in a copper lattice, it is necessary that the vicinity of the zinc atom be highly polarized, according to the discussion of the preceding section. In a 50% alloy of Cu-Zn, the atomic volume of a zinc ion will have only 1.5 electrons to cancel the charge of a double ionized core. Thus, the lattice cell of the zinc atom has a net charge of  $+1/2$ . Hence, the valence electrons from zinc atoms cannot be freely contributed to the free-electron cloud of the crystal. There must be a considerable clumping of this charge around the various different ions of the alloy in such a way that the excess charge of the ions is screened. In addition, there is some evidence from the experiments on nuclear magnetic resonance in dilute alloys that the electron density in the conduction band does not change as the divalent ion is added, in direct contradiction to the simple free-electron picture.

**Order-disorder in alloys.** In the preceding discussion on the formation of alloys, it was tacitly assumed that the atoms of the two constituents were randomly distributed on the lattice of the alloy. In very dilute primary solutions the random distribution holds because the free energy of the system in the completely random state is lower than that of a more symmetric state. To be more specific, in a dilute solution of metal B in metal A, if there is no gain of internal energy by ordering B (placing the atoms of B in a regular arrangement on the lattice sites of A), the free energy,  $U - TS$ , is a minimum when B is completely randomized.

On the other hand, if an appreciable percentage of the lattice sites are occupied by B and if there is a difference in the interatomic forces between A-B nearest-neighbor atom pairs and those between A-A or B-B pairs, the situation is different. The internal energy of the alloy is then given by Eq. (1), where  $N_{AB}$

$$U = N_{AB}E_{AB} + N_{AA}E_{AA} + N_{BB}E_{BB} \quad (1)$$

is the number of A-B nearest-neighbor pairs in the alloy,  $E_{AB}$  is the energy of interaction between an A-B pair, and so on. It is assumed that the alloy atoms interact appreciably only when they are nearest neighbors. If the interaction between A-B pairs is greater than that between B-B or A-A pairs, then the state of lowest energy is that in which the number of like pairs is minimized. This state is also a completely ordered state of the crystal.

For any given temperature the equilibrium state of the crystal is that for which the free energy is minimized, and a balance is struck between the contradictory tendencies of the  $U$  and  $TS$  terms of the free energy. At low temperatures the  $U$  term can be expected to predominate, and ordering will usually occur, while at higher temperatures the entropy term will predominate, and a transition to a disordered state is usual.

**Long- and short-range order.** The ordering of a crystal is described in terms of two different order parameters. One is called local or short-range order, and the other is called long-range order. For the initial discussion of the long- and short-range order parameters, a 50% A-B alloy will be considered. It will also be supposed that the lattice structure is bcc and that the unlike pair interaction is the stronger one. The advantage of the bcc lattice for the discussion is that, in this lattice, all the neighbors of any given atom can be made unlike atoms.

In the completely ordered state every atom of the crystal is surrounded by unlike nearest neighbors, and the crystal becomes disordered when some of the A atoms exchange with B atoms. The long-range order parameter  $\Sigma$  is a measure of the number of such interchanges and expresses the number of sites occupied

by the wrong atom, as in Eq. (2). Here  $n_a$  is the number of A sites

$$\Sigma = \frac{2n_a}{N} - 1 \quad (2)$$

occupied by A atoms, and  $N$  is the total number of A lattice sites. The quantity  $\Sigma$  varies from  $-1$  to  $+1$ , and the state of complete disorder corresponds to  $\Sigma = 0$ .

The short-range order expresses the fact that the neighbors surrounding any given A atom will have a tendency to be all B atoms. If this tendency is averaged over the lattice, the short-range order  $\sigma$  is defined in Eq. (3). Here  $\sigma$  is the local-order

$$\sigma = 2(q - 1/2) \quad (3)$$

parameter, and  $q$  is the number of A-B pairs in the crystal divided by the total number of atom pairs in the crystal. The parameter  $\sigma$  has the range  $-1$  to  $+1$ , with complete disorder at  $\sigma = 0$ .

**Variation with temperature.** A good qualitative notion of the behavior of the order of a crystal is obtained by observing the variation of the order parameter of a crystal as a function of temperature. The long-range order decreases from a state of complete order at absolute zero temperature. At a critical transition temperature which depends on the strength of the A-B bonds relative to the A-A bonds, the long-range order drops to zero. The local order also starts at absolute zero with a maximum value, but decreases more slowly than the long-range order does and remains finite for all temperatures.

The discussion up till now has been based on the model of a 50% alloy in a simple lattice. The theory for a material in which the composition is allowed to vary over the entire composition diagram is exceedingly complicated. The complication is due to the difficulty of specifying the types of order configurations which are possible, and computing their entropy. However, the general results are still comparable with the simple case. Long- and short-range order parameters can still be defined, with a transition temperature at the point where the long-range order disappears. The short-range order again persists to a considerable degree even above the transition temperature.

**Transition temperature.** The existence of the transition temperature amounts to a change of phase, because there is an attendant singularity in the specific-heat curve of the material. The phase change may be of the first or second order, depending on the type of singularity present in the long-range order at the transition temperature. A general rule seems to be that for lattices in which the completely ordered state has only neighbors of A-B bonds, the transition is second order. The bcc lattice is such a case, as has already been explained. However, in close-packed lattices such as the fcc lattice, it is not possible for all the bonds of a 50% alloy to be of the sort A-B, and in such cases, it is found experimentally that the transition is first order.

**Detection of order.** The presence of order in a crystal and the transition from the ordered to the disordered state are detected by a variety of techniques. The resistance of the alloy at low temperatures varies with the order of the crystal because the electron waves of the crystal are sensitive to irregularities in the crystal, so that as disorder increases, the resistivity increases also. X-ray and neutron scattering of the lattice are also functions of the degree of order for the same reason. The specific heat of the crystal varies with the order, since as the crystal loses its order, energy must be supplied to the lattice to form the A-A and B-B bonds which have higher energy. At the transition temperature the specific heat rises to a sharp peak, which is easily detected. See NEUTRON DIFFRACTION; X-RAY DIFFRACTION.

**Superlattices.** The x-ray and neutron scattering of a completely ordered crystal have an interesting peculiarity. In the Bragg scattering processes new lines appear, called superlattice lines. The name is derived from the fact that the lines correspond to the appearance of a secondary crystalline structure in the lattice. Their explanation is clear in the light of the discussion of the ordered lattice. For a 50% A-B lattice in the bcc form, the



A atoms form the corners of the cube, while the B atoms are at the center positions. The crystal is then composed of two interpenetrating simple cubic crystals, and is called a superlattice. The x-ray lines for two simple cubic structures appear instead of those for a bcc crystal. [R.M.T.]

**Allspice** The dried, unripe fruits of a small, tropical, evergreen tree, *Pimenta officinalis*, of the myrtle family (Myrtaceae). This species is a native of the West Indies and parts of Central and South America. The spice, alone or in mixtures, is much used in sausages, pickles, sauces, and soups. The extracted oil is used for flavoring and in perfumery. Allspice is so named because its flavor resembles that of a combination of cloves, cinnamon, and nutmeg. See MYRTALES; SPICE AND FLAVORING. [PD.St.E.L.C.]

**Almanac** A book that contains astronomical or meteorological data arranged according to days, weeks, and months of a given year and may also include diverse information of a nonastronomical character. This article is restricted to astronomical and navigational almanacs.

*The Astronomical Almanac* contains ephemerides, which are tabulations, at regular time intervals, of the orbital positions and rotational orientation of the Sun, Moon, planets, satellites, and some minor planets. It also contains mean places of stars, quasars, pulsars, galaxies, and radio sources, and the times for astronomical phenomena such as eclipses, conjunctions, occultations, sunrise, sunset, twilight, moonrise, and moonset. This volume contains the fundamental astronomical data needed by astronomers, geodesists, navigators, surveyors, and space scientists. The theory and methods on which *The Astronomical Almanac* is based are provided in the *Explanatory Supplement to the Astronomical Almanac*. See ASTRONOMICAL COORDINATE SYSTEMS; EPHEMERIS.

While *The Astronomical Almanac* is basically designed for the determination of positions of astronomical objects as observed from the Earth, *The Nautical Almanac* and *The Air Almanac* are designed to determine the navigator's position from the tabulated position of the celestial object. *The Nautical Almanac* contains hourly values of the Greenwich hour angle and declination of the Sun, Moon, Venus, Mars, Jupiter, and Saturn and the sidereal hour angle and declination of 57 stars for every third day. Monthly apparent positions are tabulated for an additional 173 navigational stars. The positions are tabulated to an angular accuracy of 0.1 minute of arc, which is equivalent to 0.1 nautical mile (0.2 km). Since tabular quantities must be combined to derive the navigational fix, this tabular accuracy is sufficient to produce a computed position with an error no greater than 0.3 to 0.4 nmi (0.6 to 0.7 km). *The Air Almanac* gives the positions of the Sun, first point of Aries, three planets, and the Moon at 10-min intervals. As necessary, information is adjusted so that the tabulated data at any given time can be used during the interval to the next entry, without interpolation, to an accuracy sufficient for practical air navigation. While designed for air navigators, *The Air Almanac* is used by mariners who accept the reduced accuracy in exchange for its greater convenience compared with *The Nautical Almanac*.

The latest source of high-precision astronomical data is the *Multi-Year Interactive Computer Almanac (MICA)*, which provides data on compact disks. Thus, in addition to being able to compute the almanac data as published, the user is able to compute data for a particular location and time. [P.K.S.]

**Almond** A small deciduous tree, *Prunus amygdalus* (also known as *P. dulcis* or *Amygdalus communis*), closely related to the peach and other stone fruits and grown widely for its edible seeds. Almonds are of two general types: the bitter type is a source of prussic acid and flavoring extracts, and the sweet type has various food uses. Almond kernels contain approximately 50% fat or oil, 20% protein, 20% carbohydrate, and a variety of minerals and vitamins. See ROSALES.

In the United States, commercial production is limited to California. Spain is the second leading producer, but the amount produced is about one-half that of the United States. Italy has historically been a leading producer, primarily from the Bari and Sicily areas, but production has declined sharply.

Almonds are used in a variety of products. Some are roasted whole and salted to be used as snacks. Others are blanched (the skin is removed) by steam and subjected to slicing, dicing, or halving. These may be roasted, and go into products such as candy bars, bakery products, ice cream, and almond paste, among many other uses. [D.E.K.]

**Alpaca** A member of the camel family, Camelidae, which belongs to the mammalian order Artiodactyla, the even-toed ungulates. The alpaca (*Lama pacos*) is found at elevations above 12,000 ft (3600 m) along the shores of Lake Titicaca on the boundaries of Peru and Bolivia.

The alpaca's neck and head are elongate, and the upper lip has a deep cleft. The long, slender legs terminate in two toes; the feet are digitigrade, that is, the animals walk on the toes and not on the entire foot or the tip of the digits. The long, fine repellent hair, or wool, ranges in color from black to white and is highly prized for manufacturing cloth, particularly the white wool. Like many breeds of domesticated animals, the alpaca has been bred to produce pure strains for the wool. Although the alpaca is raised chiefly for its wool, its flesh is edible and palatable. See ARTIODACTYLA; CAMEL; LLAMA; MAMMALIA; NATURAL FIBER. [C.B.C.]

**Alpha Centauri** The third brightest star in the sky, apparent magnitude  $-0.3$ , and the brightest in the southern constellation Centaurus. It is the closest star to the Sun at a distance of 1.35 parsecs ( $2.59 \times 10^{13}$  mi or  $4.16 \times 10^{13}$  km), and its light takes more than 4 years to reach the Earth. See CENTAURUS.

Alpha Centauri is in reality a triple system, the two main components orbiting each other with period of nearly 80 years. The orbit is eccentric, and their mean separation is approximately 23 astronomical units.  $\alpha$  Cen A and B, as they are also known, are main-sequence stars of spectral types G2 and K1, respectively, and the brightest of the two is very similar to the Sun in mass, luminosity, and effective temperature. See ASTRONOMICAL UNIT; BINARY STAR; SPECTRAL TYPE.

The third component of this system, known as Proxima Centauri, is a faint reddish star of 11th magnitude, approximately  $2.2^\circ$  away in the sky. Proxima is actually slightly closer to the Sun, which makes it the Earth's nearest neighbor in space. The linear separation from  $\alpha$  Cen A and B is estimated to be about 13,000 astronomical units. Although the probability of such a close association in space and in projected motion occurring by chance among field stars is very small, measurements of the velocity of Proxima relative to the close binary cannot yet determine whether it is gravitationally bound. See STAR. [D.W.L.]

**Alpha fetoprotein** A glycoprotein that is normally present in significant amounts only in the serum of the fetus. It is produced in the yolk sac, the liver, and other tissues of the gastrointestinal tract. Its role is unknown, but alpha fetoprotein may function as a carrier (or modulator of the concentration) of a small ligand, as an immunosuppressive, as a modulator of intracellular transport of unsaturated fatty acids, as a factor in estrogen transport, or as a means of binding retinoic acid. Peak concentration of alpha fetoprotein in human fetal serum occurs at 13 weeks of gestation, and at that time it also reaches maximum levels in the amniotic fluid. Concentration of alpha fetoprotein in maternal serum peaks at approximately week 30–32 of gestation, reflecting the effect of both the production rate in the fetus, which is already declining at that age, and the mass of the growing fetal liver.

Substantially increased levels of alpha fetoprotein were first observed in association with certain tumors, especially of the

liver. Subsequently, increased concentrations were noted in the amniotic fluid and maternal serum of pregnant women carrying a fetus affected by an open-neural-tube defect. Thus, screening of maternal serum is now routine.

While the majority of pregnant women having a high concentration of serum alpha fetoprotein experience normal pregnancies, others manifest various problems, including multiple fetuses and placental abnormalities, or defects. Further, about one out of three pregnancies in which alpha fetoprotein is increased has an adverse outcome, including fetal growth retardation, low birth weight, and increased perinatal mortality. In pregnancies where the fetus is affected by trisomy 21 (Down syndrome), there is lower concentration of alpha fetoprotein than usual. See DOWN SYNDROME. [A.B.]

**Alpha particles** Helium nuclei, which are abundant throughout the universe both as radioactive-decay products and as key participants in stellar fusion reactions. Alpha particles can also be generated in the laboratory, either by ionizing helium or from nuclear reactions. They expend their energy rapidly as they pass through matter, primarily by taking part in ionization processes, and consequently have short penetration ranges. Numerous technological applications of alpha particles can be found in fields as diverse as medicine, space exploration, and geology. Alpha particles are also major factors in the health concerns associated with nuclear waste and other radiation hazards.

The helium nucleus, or alpha particle ( $\alpha$ ), with mass 4.00150 atomic mass units (u) and charge +2, is a strongly bound cluster of two protons ( $p$ ) and two neutrons ( $n$ ). Its stability is evident from mass-energy conservation in the hypothetical fusion reaction  $2p + 2n \rightarrow \alpha$ . The product mass ( $= 4.00150$  u) is less than the reactant mass ( $= 2 \times 1.00728$  u +  $2 \times 1.00866$  u) by 0.03038 u. By using Einstein's relation  $E = mc^2$  (where  $c$  is the speed of light), this decrease in mass  $m$  (the alpha-particle binding energy) is equivalent to 28.3 MeV of energy  $E$ . The enormous magnitude of this energy is reflected in the fact that the fusion transformation of hydrogen into helium is the main process responsible for the Sun's energy. See CONSERVATION OF ENERGY; ENERGY; HELIUM; NUCLEAR BINDING ENERGY; PROTON-PROTON CHAIN; STELLAR EVOLUTION.

**Alpha radioactivity.** Coulombic repulsion between the protons within a nucleus leads to increasingly larger ratios of neutron number  $N$  to proton number  $Z$  for stable nuclei, as the mass numbers increase. Neutron-deficient nuclei can improve their  $N/Z$  ratios by means of alpha decay. The decay occurs because the parent nucleus has a total mass greater than the sum of the masses of the daughter nucleus and the alpha particle. The energy converted from mass energy to kinetic energy, called the  $Q$  value, is shared between the daughter nucleus and the alpha particle in accordance with the conservation of momentum. Thus, each radioactive alpha-emitting nuclide emits the alpha with a characteristic kinetic energy, which is one fingerprint in identification of the emitter. See NUCLEAR REACTION; RADIOACTIVITY.

There are three major natural series, or chains, through which isotopes of heavy elements decay by successions of alpha decays. Within these series, and with all reaction-produced alpha emitters as well, each isotope decays with a characteristic half-life and emits alpha particles of particular energies and intensities. The presence of these radioactive nuclides in nature depends upon either a continuous production mechanism, for example the interaction of cosmic rays with the atmosphere, or extremely long half-lives of heavy radioactive nuclides produced in past cataclysmic astrophysical events, which accounts for uranium and thorium ores in the Earth. The relative abundances of uranium-238, uranium-235, and their stable final decay products in ores of heavy elements can be used to calculate the age of the ore, and presumably the age of the Earth. See GEOCHRONOMETRY.

In addition to the study of alpha-particle emitters that appear in nature, alpha decay has provided a useful tool to study artificial nuclei, which do not exist in nature due to their short

half-lives. Alpha decay is a very important decay mode for nuclei far from stability with a ratio of protons to neutrons that is too large to be stable, especially for nuclei with atomic mass greater than 150 u. Because of the ease of detecting and interpreting decay alpha particles, their observation has aided tremendously in studying these nuclei far from stability, extending the study of nuclei to the very edge of nuclear existence. Nuclear structure information for more than 400 nuclides has been obtained in this way. In addition, fine structure peaks appear in the alpha-particle spectra for many of these nuclides; each such fine structure peak gives similar information about an excited state in the daughter nucleus.

**Interactions with matter.** By virtue of their kinetic energy, double positive charge, and large mass, alpha particles follow fairly straight paths in matter, interacting strongly with atomic electrons as they slow down and stop. These electrons may be excited to higher energy states in their host atoms, or they may be ejected, forming ion pairs in which the initial host atom becomes positively charged and the electron leaves. The more energetic ejected electrons, known as delta electrons, cause considerable secondary ionization, which accounts for 60–80% of the total ionization. A cascade of processes occurs along the alpha particle's track, leading to tens of thousands of disruptive events per alpha particle. See RADIATION DAMAGE TO MATERIALS.

The amount of energy expended by an alpha particle to form a single ion pair in passing through a medium is nearly independent of the alpha particle's energy, but it depends strongly on the absorbing medium. While it takes about 35 eV in air and 43 eV in helium to form an ion pair, an energy of only 2.9 eV is required in germanium and 3.6 eV in silicon. The energies expended in gases are roughly correlated to their ionization potentials. For germanium, silicon, and other semiconductors, the lower ion pair energy is, effectively, the amount required to raise an electron to the conduction band. See IONIZATION POTENTIAL; SEMICONDUCTOR.

The distance (or range) that an alpha particle travels before it stops depends both on the energy of the particle and on the absorbing medium. The passage of alpha particles through silicon is a particularly important example. The semiconductor industry now produces chips so small that alpha particles from contaminants in the packaging materials can disrupt the memory-array areas of the chips, a serious problem which has been researched in considerable detail. See INTEGRATED CIRCUITS; RADIATION HARDENING.

In biological systems, the ionization and excitation produced by alpha particles can damage or kill cells. By rupturing chemical bonds and forming highly reactive free radicals, alpha particles can be far more destructive than other forms of radiation which interact less strongly with matter. See CHARGED PARTICLE BEAMS; RADIATION CHEMISTRY; RADIATION INJURY (BIOLOGY).

**Applications.** In the promising medical field of charged-particle radiotherapy, alpha particles are useful in the treatment of inaccessible tumors and vascular disorders. The ionizing power of alpha particles is concentrated near the ends of their paths. Thus they can deliver destructive energy to a tumor while doing little damage to nearby healthy tissue. With proper acceleration, positioning, and dosage, the energy can be delivered so precisely that alpha-particle radiotherapy is uniquely suited for treating highly localized tumors near sensitive normal tissue (for example, the spinal cord). See RADIOLOGY.

The element-specific energies of backscattered (Rutherford-scattered) alpha particles are used in remote probes to analyze the mineral composition of geological formations. In particular, alpha particles scattered by light elements transfer more energy than those scattered by heavy elements. In another alpha-particle device, the energy from  $^{238}\text{Pu}$  alpha decay is reliably harnessed in batteries based on the Brayton cycle, and used to power scientific equipment left on the Moon. Large power systems of this type are contemplated for use in space stations. See ION-SOLID INTERACTIONS; NUCLEAR BATTERY. [C.Bin.]

**Alpine vegetation** Plant growth forms characteristic of upper reaches of forests on mountain slopes. In such an environment, trees undergo gradual changes that, though subtle at first, may become dramatic beyond the dense forest as the zone of transition leads into the nonforested zone of the alpine tundra. In varying degrees, depending on the particular mountain setting, the forest is transformed from a closed-canopy forest to one of deformed and dwarfed trees interspersed with alpine tundra species. This zone of transition is referred to as the forest-alpine tundra ecotone. The trees within the ecotone are stunted, often shrublike, and do not have the symmetrical shape of most trees within the forest interior. See PLANT GEOGRAPHY.

The forest-alpine tundra ecotone is a mosaic of both tree and alpine tundra species; and it extends from timberline (the upper limit of the closed-canopy forest of symmetrically shaped, usually evergreen trees) to treeline (the uppermost limit of tree species) and the exposed alpine tundra. With elevational increases, tree deformation is magnified, tree height is reduced, and the total area occupied by trees becomes smaller as the alpine shrub, grass, and herbaceous perennials become more dominant.

The environment in which these tenacious individuals survive is harsh and involves a complex interaction of many factors, with the major controlling factor often being climate. The climate is characterized by a short growing season, low air temperatures, frozen soils, drought, high levels of ultraviolet radiation, irregular accumulation of snow, and strong winds. The interaction of all these factors produces varying levels of stress within the trees. See WIND.

The ultimate cause of the tree deformations and of the eventual complete cessation of tree growth lies in the inability of the tissues of the shoots and the needles to mature and prepare for the harsh environmental conditions. As the length of the growing season decreases with elevation, new needles often do not mature; they have thinner cuticles (the waxlike covering on the needles that protects against desiccation and wind abrasion), and they are less acclimated against low air temperatures. Factors that particularly affect the length of the growing season include air and soil temperatures, and the depth and distribution of snow. See AIR TEMPERATURE. [K.J.H.]

**Alternating current** Electric current that reverses direction periodically, usually many times per second. Electrical energy is ordinarily generated by a public or a private utility organization and provided to a customer, whether industrial or domestic, as alternating current.

One complete period, with current flow first in one direction and then in the other, is called a cycle, and 60 cycles per second (60 hertz) is the customary frequency of alternation in the United States and in all of North America. In Europe and in many other parts of the world, 50 Hz is the standard frequency. On aircraft a higher frequency, often 400 Hz, is used to make possible lighter electrical machines.

When the term alternating current is used as an adjective, it is commonly abbreviated to ac, as in ac motor. Similarly, direct current as an adjective is abbreviated dc.

The voltage of an alternating current can be changed by a transformer. This simple, inexpensive, static device permits generation of electric power at moderate voltage, efficient transmission for many miles at high voltage, and distribution and consumption at a conveniently low voltage. With direct (unidirectional) current it is not possible to use a transformer to change voltage. On a few power lines, electric energy is transmitted for great distances as direct current, but the electric energy is generated as alternating current, transformed to a high voltage, then rectified to direct current and transmitted, then changed back to alternating current by an inverter, to be transformed down to a lower voltage for distribution and use.

In addition to permitting efficient transmission of energy, alternating current provides advantages in the design of generators and motors, and for some purposes gives better operating char-

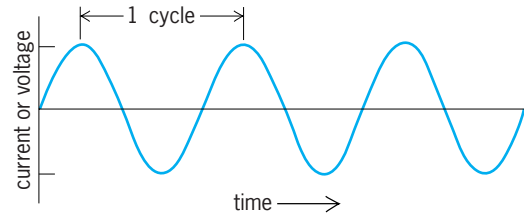

Fig. 1. Diagram of sinusoidal alternating current.

acteristics. Certain devices involving chokes and transformers could be operated only with difficulty, if at all, on direct current. Also, the operation of large switches (called circuit breakers) is facilitated because the instantaneous value of alternating current automatically becomes zero twice in each cycle and an opening circuit breaker need not interrupt the current but only prevent current from starting again after its instant of zero value.

Alternating current is shown diagrammatically in Fig. 1. In this diagram it is assumed that the current is alternating sinusoidally; that is, the current  $i$  is described by the equation below, where

$$i = I_m \sin 2\pi ft$$

$I_m$  is the maximum instantaneous current,  $f$  is the frequency in cycles per second (hertz), and  $t$  is the time in seconds. See SINE WAVE.

A sinusoidal form of current, or voltage, is usually approximated on practical power systems because the sinusoidal form results in less expensive construction and greater efficiency of operation of electric generators, transformers, motors, and other machines.

A useful measure of alternating current is found in the ability of the current to do work, and the amount of current is correspondingly defined as the square root of the average of the square of instantaneous current, the average being taken over an integer number of cycles. This value is known as the root-mean-square (rms) or effective current. It is measured in amperes. It is a useful measure for current of any frequency. The rms value of direct current is identical with its dc value. The rms value of sinusoidally alternating current is  $I_m/\sqrt{2}$  (see Fig. 1 and the equation). Other useful quantities are the phase difference  $\phi$  between voltage and current and the power factor. See PHASE (PERIODIC PHENOMENA); POWER FACTOR.

The phase angle and power factor of voltage and current in a circuit that supplies a load are determined by the load. Thus a load of pure resistance, such as an electric heater, has unity power factor. An inductive load, such as an induction motor, has a power factor less than 1 and the current lags behind the applied voltage. A capacitive load, such as a bank of capacitors, also has a power factor less than 1, but the current leads the voltage, and the phase angle  $\phi$  is a negative angle.

Three-phase systems are commonly used for generation, transmission, and distribution of electric power. A customer may be supplied with three-phase power, particularly if a large amount of power is used or the use of three-phase loads is desired. Small domestic customers are usually supplied with single-phase power. A three-phase system is essentially the same as three ordinary single-phase systems, with the three voltages of

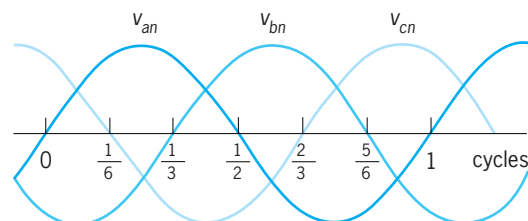

Fig. 2. Voltages of a balanced three-phase system.

the three single-phase systems out of phase with each other by one-third of a cycle (120 degrees), as shown in Fig. 2. The three-phase system is balanced if the maximum voltage in each of the three phases is equal, and if the three phase angles are equal,  $\frac{1}{3}$  cycle each as shown. It is only necessary to have three wires for a three-phase system (*a*, *b*, and *c* of Fig. 3) plus a fourth wire *n* to serve as a common return or neutral conductor. On some systems the earth is used as the common or neutral conductor.

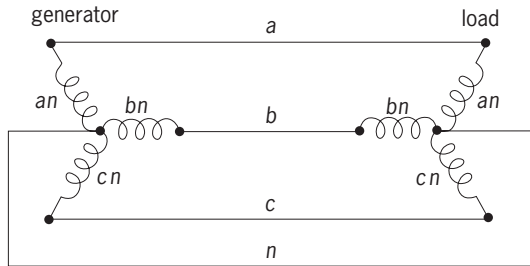

Fig. 3. Connections of a simple three-phase system.

Each phase of a three-phase system carries current and conveys power and energy. If the three loads on the three phases of the three-phase system are equal and the voltages are balanced, then the currents are balanced also. The sum of the three currents is then zero at every instant. This means that current in the common conductor (*n* of Fig. 3) is always zero, and that the conductor could theoretically be omitted entirely. In practice, the three currents are not usually exactly balanced, and either of two situations obtains. Either the common neutral wire *n* is used, in which case it carries little current (and may be of high resistance compared to the other three line wires), or else the common neutral wire *n* is not used, only three line wires being installed, and the three phase currents are thereby forced to add to zero even though this requirement results in some imbalance of phase voltages at the load.

The total instantaneous power from generator to load is constant (does not vary with time) in a balanced, sinusoidal, three-phase system. This results in smoother operation and less vibration of motors and other ac devices. In addition, three-phase motors and generators are more economical than single-phase machines.

AC circuits are also used to convey information. An information circuit, such as telephone, radio, or control, employs varying voltage, current, waveform, frequency, and phase. Efficiency is often low, the chief requirement being to convey accurate information even though little of the transmitted power reaches the receiving end. For further consideration of the transmission of information See RADIO; TELEPHONE; WAVEFORM.

An ideal power circuit should provide the customer with electric energy always available at unchanging voltage of constant waveform and frequency, the amount of current being determined by the customer's load. High efficiency is greatly desired. See CAPACITANCE; CIRCUIT (ELECTRICITY); ELECTRIC CURRENT; ELECTRIC FILTER; ELECTRICAL IMPEDANCE; ELECTRICAL RESISTANCE; INDUCTANCE; JOULE'S LAW; OHM'S LAW; RESONANCE (ALTERNATING-CURRENT CIRCUITS). [H.H.Sk.]

**Alternating-current generator** A machine that converts mechanical power into alternating-current electric power. Almost all electric power is produced by alternating-current (ac) generators that are driven by rotating prime movers. Most of the prime movers are steam turbines whose thermal energy comes from steam generators that use either fossil or nuclear fuel. Combustion turbines are often used for the smaller units and in cases where gas or oil is the available fuel. Where water power is available from dams, hydroelectric ac generators are powered by hydraulic turbines. Small sites may also use diesel or gasoline engines to drive the generator, but these units are usually used

only for standby generation or to provide electric power in remote areas. See DIESEL ENGINE; GAS TURBINE; HYDRAULIC TURBINE; HYDROELECTRIC GENERATOR; INTERNAL COMBUSTION ENGINE; STEAM ELECTRIC GENERATOR; STEAM TURBINE.

Alternating-current generators are used instead of direct-current (dc) generators because ac power can easily be stepped up in voltage, by using transformers, for more efficient transmission of power over long distances and in larger amounts. Similar transformers step the voltage down again at the utilization site to levels that are safer and more convenient for general use. See DIRECT-CURRENT GENERATOR; ELECTRIC POWER SYSTEMS; TRANSFORMER.

Most ac generators are synchronous machines, that is, the rotor is driven at a speed that is exactly related to the rated frequency of the ac network. Generators of this type have a stationary armature with three windings that are displaced at regular intervals around the machine to produce three-phase voltages. These machines also have a field winding that is attached to the rotor. This winding provides magnetic flux that crosses the air gap and links the stator coils to produce a voltage according to Faraday's law. The field winding is supplied with direct current, usually through slip rings. See ARMATURE; SLIP RINGS; WINDINGS IN ELECTRIC MACHINERY.

Induction generators, based on the principle of the induction motor, have been used in a few remote applications where maintenance of the excitation system is a problem. These units are essentially like induction motors, but are driven by a prime mover at speeds slightly above synchronous speed, forcing the unit to generate power due to the reverse slip. The units draw reactive power from the system and are not as efficient as synchronous generators. See INDUCTION MOTOR.

High-frequency single-phase generators have been built as induction alternators, usually with twice as many stator poles (teeth) as rotor poles, and with a constant air-gap flux supplied from a homopolar field coil in the center of the machine, pushing flux into the stator at one end and out at the other. Their effectiveness is lower than that of the synchronous machine because the flux is a pulsating unidirectional field, rather than an alternating field. See ALTERNATING CURRENT; ELECTRIC ROTATING MACHINERY; GENERATOR. [L.A.K.; P.M.A.]

**Alternating-current motor** An electrical machine that converts alternating-current (ac) electric energy to mechanical energy. Alternating-current motors are widely used because of the general availability of ac electric power and because they can be readily built with a variety of characteristics and in a large range of sizes, from a few watts to many thousands of kilowatts. They can be broadly classified into three groups—induction motors, synchronous motors, and ac series motors:

- Induction motors
  - Single-phase
    - Split-phase
      - Capacitor-start
      - Capacitor-run
  - Polyphase
- Synchronous motors
  - Single-phase
    - Permanent-magnet (PM)
    - Reluctance
    - Hysteresis
  - Polyphase
    - Wound-field
    - Permanent-magnet (PM)
    - Reluctance
- AC series or universal motors (single-phase)

See ALTERNATING CURRENT; DIRECT-CURRENT MOTOR.

The most common type of ac motor, both in total number and in total power, is the induction motor. In larger sizes these

machines employ a polyphase stator winding, which creates a rotating magnetic field when supplied with polyphase ac power. The speed of rotation depends upon the frequency of the supply and the number of magnetic poles created by the winding; thus, only a discrete number of speeds are possible with a fixed frequency supply.

Currents are induced in the closed coils of the rotor for any rotor speed different from the speed of the rotating field. The difference in speed is called the slip speed, and efficient energy conversion occurs only when the slip speed is small. These machines are, therefore, nearly constant-speed machines when operated from a constant-frequency supply. They are, however, routinely started from zero speed and accelerated through the inefficient high-slip-speed region to reach operating speed. See INDUCTION MOTOR; SLIP (ELECTRICITY).

In contrast to an induction motor, the rotor of a synchronous motor runs exactly at the rotating field speed and there are no induced rotor currents. Torque is produced by the interaction of the rotating field with a direct-current (dc) field created by injected dc rotor current or permanent magnets, or with a rotor magnetic structure that has an easy direction for magnetization (in the reluctance motor). Since for any frequency of excitation there is only one speed for synchronous torque, synchronous machines have no starting torque unless the frequency is variable. When the motor is used in fixed-frequency applications, an induction-machine winding is also placed on the rotor to allow starting as an induction motor and running as a synchronous motor. See SYNCHRONOUS MOTOR.

A dc motor with the armature and field windings in series will run on ac since both magnetic fields reverse when the current reverses. Since these machines run on ac or dc, they are commonly called universal motors. The speed can be controlled by varying the voltage, and these machines are therefore widely used in small sizes for domestic appliances that require speed control or higher speeds than can be attained with 60-Hz induction motors. See ELECTRIC ROTATING MACHINERY; MOTOR; UNIVERSAL MOTOR; WINDINGS IN ELECTRIC MACHINERY. [D.W.N.]

**Alternative fuel vehicle** Conventional fuels such as gasoline and diesel are gradually being replaced by alternative fuels such as gaseous fuels (natural gas and propane), alcohol (methanol and ethanol), and hydrogen. Conventional fuels can also be modified to a reformulated gasoline to help reduce toxic emissions. Technological advances in the automotive industry (such as in fuel cells and hybrid-powered vehicles) are helping to increase the demand for alternative fuels.

Vehicle emissions from natural gas and propane are expected to be lower and less harmful to the environment than those of conventional gasoline. Because natural gas and propane are less complex hydrocarbons, the levels of volatile organic compounds and ozone emissions should be reduced. Both of these fuels are introduced to the engine as a gas under most operating conditions and require minimal fuel enrichment during warm-up. Leaner burning fuels, they also achieve lower carbon dioxide and carbon monoxide levels than gasoline. However, because they burn at higher temperatures, emissions of nitrogen oxide are higher. An important property of gaseous fuels is their degree of resistance to engine knock. Because of their higher-octane value relative to gasoline, there is less of a tendency for these fuels to knock in spark-ignition engines. To achieve the optimal performance and maximum environmental benefits of natural gas and propane, technological advancements must continue to reduce the costs of dedicated vehicles to be competitive with conventional vehicles, and the necessary fueling infrastructure must be ensured.

The most significant advantage of alcohol fuels over gasoline is their potential to reduce ozone concentrations and to lower levels of carbon monoxide. Another important advantage is their very low emissions of particulates in diesel engine applications. In comparison with hydrocarbon-based fuels, the exhaust emis-

sions from vehicles burning low-level alcohol blends (such as gasohol containing 10% alcohol by volume) contain negligible amounts of aromatics and reduced levels of hydrocarbons and carbon monoxide but higher nitrogen oxide content.

Exposure to aldehydes, in particular formaldehyde which is considered carcinogenic, is an important air-pollution concern. The aldehyde fraction of unburned fuel, particularly for methanol, is appreciably greater than for hydrocarbon-based fuels; therefore, catalytic converters are required on methanol vehicles to reduce the level of formaldehyde to those associated with gasoline. See ALCOHOL FUEL.

Hydrogen-powered vehicles can use internal combustion engines or fuel cells. They can also be hybrid vehicles of various combinations. When hydrogen is used as a gaseous fuel in an internal combustion engine, its very low energy density compared to liquid fuels is a major drawback requiring greater storage space for the vehicle to travel a similar distance to gasoline. Although hybrid vehicles can be more efficient than conventional vehicles and result in lower emissions, the greatest potential to alleviate air-pollution problems is thought to be in the use of hydrogen-powered fuel cell vehicles. Though currently very expensive, fuel cells are more efficient than conventional internal combustion engines. They can operate with a variety of fuels, but the fuel of choice is gaseous hydrogen since it optimizes fuel cell performance and does not require on-board modification. See FUEL CELL; HYDROGEN.

Conventional gasoline is a complex mixture of many different chemical compounds. The U.S. Clean Air Act Amendments (CAAA) have served to increase interest in using regulated changes to motor fuel characteristics as a means of achieving environmental goals. The reformulated gasoline (RFG) program was designed to resolve ground-level ozone problems in urban areas. Under this program, compared to conventional gasoline, the amount of heavy hydrocarbons is limited in reformulated gasoline, and the fuel must include oxygenates and contain fewer olefins, aromatics, and volatile organic compounds. [M.He.]

**Altimeter** Any device which measures the height of an aircraft. The two chief types are the pressure altimeter, which measures the aircraft's distance above sea level, and the radar altimeter, which measures distance above the ground.

**Pressure altimeter.** A pressure altimeter precisely measures the pressure of the air at the level an aircraft is flying and converts the pressure measurement to an indication of height above sea level according to a standard pressure-altitude relationship. In essence, a pressure altimeter is a highly refined aneroid barometer since it utilizes an evacuated capsule whose movement or force is directly related to the pressure on the outside of the capsule. Various methods are used to sense the capsule function and cause a display to respond such that the pilot sees the altitude level much as one looks at a watch.

Because altitude measured in this manner is also subject to changes in local barometric pressure, altimeters are provided with a barosetting that allows the pilot to compensate for these weather changes, the sea-level air pressure to which the altimeter is adjusted appearing in a window of the dial. Flights below 18,000 ft (5486 m) must constantly contact the nearest traffic center to keep the altimeters so updated. Flights above 18,000 ft and over international waters utilize a constant altimeter setting of 29.92 in. Hg, or 1013.2 millibars (101.32 kilopascals), so that all high-flying aircraft have the same reference and will be inter-related, providing an extra margin of safety. See AIR NAVIGATION.

[J.W.A.]

**Radar altimeter.** A radar altimeter is a low-power radar that measures the distance of an aircraft (or other aerospace vehicle) above the ground. Radar altimeters are often used in aircraft during bad-weather landings. They are an essential part of many blind-landing and automatic navigation systems and are used over mountains to indicate terrain clearance. Special types are used in surveying for quick determination of profiles. Radar

altimeters are used in bombs, missiles, and shells as proximity fuses to cause detonation or to initiate other functions at set altitudes. Radar altimeters have been used on various spacecraft, starting with *Skylab* in 1973, to measure the shape of the geoid and heights of waves and tides over the oceans. Other spacecraft altimeters provide topographic information on other planets, particularly Venus. See AUTOMATIC LANDING SYSTEM; GROUND PROXIMITY WARNING SYSTEM.

Like other radar devices, the altimeter measures distance by determining the time required for a radio wave to travel to and from a target, in this case the Earth's surface. If the Earth were a perfectly flat horizontal plane or smooth sphere, the signal would come only from the closest point, and would be a true measure of altitude. Actually, the Earth is not smooth, and energy is scattered back to the radar from all parts of the surface illuminated by the transmitter. For the radar to measure distance to the ground accurately, it must distinguish between the energy from points near the vertical and that from more distant points.

Most radio altimeters use either pulse or frequency modulation, the former being more popular for high altitudes, and the latter for low altitudes. In a typical pulse altimeter the radio-frequency carrier is modulated with short pulses (under 0.25 microsecond). The short pulse permits measurements, even at low altitudes, of the time delay between the leading edge of the transmitted pulse and that of the pulse returned from the ground. Early pulse altimeters displayed the received signal on a cathode-ray tube with circular sweep, allowing the pilot to determine the leading-edge position of the echo signal. Modern pulse altimeters use a tracking gate system. One gate is kept close to the leading edge by a servo system that adjusts the position of the gate to the optimum delay point. A simple single-gate system can be used, but most pulse altimeters use two or three gates to achieve better distance measurement in the presence of noise and fading. See PULSE MODULATOR.

In a frequency-modulated (FM) altimeter, the frequency of a continuous carrier is swept in some manner, usually to give a triangular frequency-time curve. The difference in frequency between that received from the ground (but transmitted earlier) and that being transmitted is a measure of the time delay. See FREQUENCY MODULATION. [R.K.Mo.]

**Altitudinal vegetation zones** Intergrading regions on mountain slopes characterized by specific plant life forms or species composition, and determined by complex environmental gradients. Along an altitudinal transect of a mountain, there are sequential changes in the physiognomy (growth form) of the plants and in the species composition of the communities. See LIFE ZONES.

Such life zones are associated with temperature gradients present along mountain slopes. Research on patterns of altitudinal zonation has centered on the response of species and groups of species to a complex of environmental gradients. Measurements of a species along a gradient, for example, the number of individuals, biomass, or ground coverage, generally form a bell-shaped curve. Peak response of a species occurs under optimum conditions and falls off at both ends of the gradient. The unique response of each species is determined by its physiological, reproductive, growth, and genetic characteristics. Zones of vegetation along mountain slopes are formed by intergrading combinations of species that differ in their tolerance to environmental conditions. Zones are usually indistinct entities rather than discrete groupings of species. However, under some conditions of localized disjunctions, very steep sections of gradients, or competitive exclusion, discontinuities in the vegetation can create discrete communities. Vegetation zones are often defined by the distributions of species having the dominant growth form, most frequently trees.

Altitudinal vegetation zonation, therefore, is an expression of the response of individual species to environmental conditions. Plants along an altitudinal transect are exposed, not to a sin-

gle environmental gradient, but to a complex of gradients, the most important of which are solar radiation, temperature, and precipitation. Although these major environmental gradients exist in most mountain ranges of the world, the gradients along a single altitudinal transect are not always smooth because of topographic and climatic variability.

The solar energy received by mountain surfaces increases with altitude, associated with decreases in air density and the amount of dust and water vapor. An overcast sky is more efficient at reducing short-wave energy reaching low elevations and can increase the difference in energy input to 160%. However, more frequent clouds over high elevations relative to sunnier lower slopes commonly reduces this difference. Vegetation patterns are also strongly influenced by the decline in air temperature with increasing altitude, called the adiabatic lapse rate. Lapse rates are generally between 1.8°F to 3.6°F per 1000 ft (1°C to 2°C per 300 m), but vary with the amount of moisture present; wet air has a lower lapse rate. Thus, plants occurring at higher elevations generally experience cooler temperatures and shorter growing periods than low-elevation plants. Variation in the temperature gradient can be caused by differences in slope, aspect, radiation input, clouds, and air drainage patterns. The precipitation gradient in most mountains is the reverse of the temperature gradient: precipitation increases with altitude. See AIR TEMPERATURE; PRECIPITATION (METEOROLOGY).

General changes in vegetation with increases in altitude include reduction in plant size, slower growth rates, lower production, communities composed of fewer species, and less interspecific competition. However, many regional exceptions to these trends exist.

Characteristics of vegetation zones also vary with latitude. Mountains at higher latitudes have predominantly seasonal climates, with major temperature and radiation extremes between summer and winter. Equatorial and tropical mountains have a strong diurnal pattern of temperature and radiation input with little seasonal variation. The upper altitudinal limit of trees, and the maximum elevation of plant growth generally, decreases with distance from the Equator, with the exception of a depression near the Equator. [J.S.C.]

**Alum** A colorless to white crystalline substance which occurs naturally as the mineral kalunite and is a constituent of the mineral alunite. Alum is produced as aluminum sulfate by treating bauxite with sulfuric acid to yield alum cake or by treating the bauxite with caustic soda to yield papermaker's alum. Other industrial alums are potash alum, ammonium alum, sodium alum, and chrome alum (potassium chromium sulfate). Major uses of alum are as an astringent, styptic, and emetic. For water purification alum is dissolved. It then crystallizes out into positively charged crystals that attract negatively charged organic impurities to form an aggregate sufficiently heavy to settle out. Alum is also used in sizing paper, dyeing fabrics, and tanning leather. With sodium bicarbonate it is used in baking powder and in some fire extinguishers. See ALUMINUM; COLLOID. [F.H.R.]

**Aluminum** A metallic chemical element, symbol Al, atomic number 13, atomic weight 26.98154, in group 13 of the periodic system. Pure aluminum is soft and lacks strength, but it can be alloyed with other elements to increase strength and impart a number of useful properties. Alloys of aluminum are light, strong, and readily formable by many metalworking processes; they can be easily joined, cast, or machined, and accept a wide variety of finishes. Because of its many desirable physical, chemical, and metallurgical properties, aluminum has become the most widely used nonferrous metal. See PERIODIC TABLE.

Aluminum is the most abundant metallic element on the Earth and Moon but is never found free in nature. The element is widely distributed in plants, and nearly all rocks, particularly igneous rocks, contain aluminum in the form of aluminum silicate minerals. When these minerals go into solution, depending upon

the chemical conditions, aluminum can be precipitated out of the solution as clay minerals or aluminum hydroxides, or both. Under such conditions bauxites are formed. Bauxites serve as principal raw materials for aluminum production. See BAUXITE; CLAY MINERALS; IGNEOUS ROCKS; WEATHERING PROCESSES.

Aluminum is a silvery metal having a density of 1.56 oz/in.<sup>3</sup> at 68°F (2.70 g/cm<sup>3</sup> at 20°C). Naturally occurring aluminum consists of a single isotope, <sup>27</sup>Al. Aluminum crystallizes in the face-centered cubic structure with edge of the unit lattice cube of 4.0495 angstroms (0.40495 nanometer). Aluminum is known for its high electrical and thermal conductivities and its high reflectivity.

The electronic configuration of the element is 1s<sup>2</sup>2s<sup>2</sup>2p<sup>6</sup>3s<sup>2</sup>3p<sup>1</sup>. Aluminum exhibits a valence of +3 in all compounds, with the exception of a few high-temperature monovalent and divalent gaseous species.

Aluminum is stable in air and resistant to corrosion by seawater and many aqueous solutions and other chemical agents. This is due to protection of the metal by a tough, impervious film of oxide. At a purity greater than 99.95%, aluminum resists attack by most acids but dissolves in aqua regia. Its oxide film dissolves in alkaline solutions, and corrosion is rapid. See CORROSION.

Aluminum is amphoteric and can react with mineral acids to form soluble salts and to evolve hydrogen.

Molten aluminum can react explosively with water. The molten metal should not be allowed to contact damp tools or containers.

At high temperatures aluminum reduces many compounds containing oxygen, particularly metal oxides. These reactions are used in the manufacture of certain metals and alloys.

Applications in building and construction represent the largest single market of the aluminum industry. Millions of homes use aluminum doors, siding, windows, screening, and down-spouts and gutters. Aluminum is also a major industrial building product. Transportation is the second largest market. Many commercial and military aircraft have become virtually all-aluminum. In automobiles, aluminum is apparent in interior and exterior trim, grilles, wheels, air conditioners, automatic transmissions, and some radiators, engine blocks, and body panels. Aluminum is also found in rapid-transit car bodies, rail cars, forged truck wheels, cargo containers, and in highway signs, divider rails, and lighting standards. In aerospace, aluminum is found in aircraft engines, frames, skins, landing gear, and interiors, often making up 80% of a plane's weight. The food packaging industry is a fast-growing market.

In electrical applications, aluminum wire and cable are major products. Aluminum appears in the home as cooking utensils, cooking foil, hardware, tools, portable appliances, air conditioners, freezers, and refrigerators, and in sporting equipment such as skis, ball bats, and tennis rackets.

There are hundreds of chemical uses of aluminum and aluminum compounds. Aluminum powder is used in paints, rocket fuels, and explosives, and as a chemical reductant. See ALUMINUM ALLOYS. [A.S.Ru.]

**Aluminum alloys** Substances formed by the addition of one or more elements, usually metals, to aluminum. The principal alloying elements in aluminum-base alloys are magnesium, silicon, copper, zinc, and manganese. In wrought products, which constitute the greatest use of aluminum, the alloys are identified by four-digit numbers of the form NXXX, where the value of N denotes the alloy type and the principal alloying element(s) as follows: 1 (Al; at least 99% aluminum by weight), 2 (Cu), 3 (Mn), 4 (Si), 5 (Mg), 6 (Mg + Si), 7 (Zn), 8 (other). See ALUMINUM.

Iron and silicon are commonly present as impurities in aluminum alloys, although the amounts may be controlled to achieve specific mechanical or physical properties. Minor amounts of other elements, such as Cr, Zr, V, Pb, and Bi, are added to specific alloys for special purposes. Titanium additions are frequently employed to produce a refined cast structure.

Aluminum-base alloys are generally prepared by making the alloying additions to molten aluminum, forming a liquid solution. As the alloy freezes, phase separation occurs to satisfy phase equilibria requirements and the decrease in solubility as the temperature is lowered. The resultant solidified structure consists of grains of aluminum-rich solid solution and crystals of intermetallic compounds. See EUTECTICS.

A decrease in solubility with falling temperature also provides the basis for heat treatment of solid aluminum alloys. In this operation, the alloy is held for some time at a high temperature to promote dissolution of soluble phases and homogenization of the alloy by diffusion processes. The limiting temperature is the melting point of the lowest melting phase present. The time required depends both on temperature and on the distances over which diffusion must occur to achieve the desired degree of homogenization. The solution heat treatment is followed by a quenching operation in which the article is rapidly cooled, for example, by plunging it into cold or hot water or by the use of an air blast.

Casting alloys are significant users of secondary metal (recovered from scrap for reuse). Thus, casting alloys usually contain minor amounts of a variety of elements; these do no harm as long as they are kept within certain limits. The use of secondary metal is also of increasing importance in wrought alloy manufacturing as producers take steps to reduce the energy required in producing fabricated aluminum products. See ALLOY. [A.S.Ru.]

Since aluminum comprises 70–80% of the weight of an airframe, metallurgists have been pursuing aluminum alloy development programs directed toward producing materials which would be characterized by stronger, stiffer, and lighter-weight properties. In addition, the titanium alloys of aircraft gas turbines are prime targets for replacement by lighter-weight alloys. Researchers have improved aluminum alloys by adding lithium and by blending aluminum alloy powders and silicon carbide fibers to form a composite. See COMPOSITE MATERIAL. [T.H.S.]

**Alunite** A mineral of composition  $KAl_3(SO_4)_2(OH)_6$ . Alunite occurs in white to gray rhombohedral crystals or in fine-grained, compact masses. Alunite is produced by sulfurous vapors on acid volcanic rocks and also by sulfated meteoric waters affecting aluminous rocks. Alunite is used as a source of potash or for making alum. Alum has been manufactured from the well-known alunite deposits at Tolfa, near Civita Vecchia, Italy, since the mid-15th century. In the United States alunite is widespread in the West. See ALUM. [E.C.T.C.]

**Alzheimer's disease** A disease of the nervous system characterized by a progressive dementia that leads to profound impairment in cognition and behavior. Dementia occurs in a number of brain diseases where the impairment in cognitive abilities represents a decline from prior levels of function and interferes with the ability to perform routine daily activities (for example, balancing a checkbook or remembering appointments). Alzheimer's disease is the most common form of dementia, affecting 5% of individuals over age 65. The onset of the dementia typically occurs in middle to late life, and the prevalence of the illness increases with advancing age to include 25–35% of individuals over age 85. See AGING.

Memory loss, including difficulty in remembering recent events and learning new information, is typically the earliest clinical feature of Alzheimer's disease. As the illness progresses, memory of remote events and overlearned information (for example, date and place of birth) declines together with other cognitive abilities. In the later stages of Alzheimer's disease, there is increasing loss of cognitive function to the point where the individual is bedridden and requires full-time assistance with basic living skills (for example, eating and bathing). Behavioral disturbances that can accompany Alzheimer's disease include agitation, aggression, depressive mood, sleep disorder, and anxiety. See MEMORY.

The major neuropathological features of Alzheimer's disease include the presence of senile plaques, neurofibrillary tangles, and neuronal cell loss. Although the regional distribution of brain pathology varies among individuals, the areas commonly affected include the association cortical and limbic regions.

Deficits in cholinergic, serotonergic, noradrenergic, and peptidergic (for example, somatostatin) neurotransmitters have been demonstrated. Dysfunction of the cholinergic neurotransmitter system has been specifically implicated in the early occurrence of memory impairment in Alzheimer's disease, and it has been a target in the development of potential therapeutic agents. See ACETYLCHOLINE; NEUROBIOLOGY; NORADRENERGIC SYSTEM.

A definite diagnosis of Alzheimer's disease is made only by direct examination of brain tissue obtained at autopsy or by biopsy to determine the presence of senile plaques and neurofibrillary tangles. A clinical evaluation, however, can provide a correct diagnosis in more than 80% of cases. The clinical diagnosis of Alzheimer's disease requires a thorough evaluation to exclude all other medical, neurological, and psychiatric causes of the observed decline in memory and other cognitive abilities.

Although the cause of Alzheimer's disease is unknown, a number of factors that increase the risk of developing this form of dementia have been identified. Age is the most prominent risk factor, with the prevalence of the illness increasing twofold for each decade of life after age 60. Research in molecular genetics has shown that Alzheimer's disease is etiologically heterogeneous. Gene mutations on several different chromosomes are associated with familial inherited forms of Alzheimer's disease.

A major strategy for the treatment of Alzheimer's disease has focused on the relation between memory impairment and dysfunction of the acetylcholine neurotransmitter system. Other treatment strategies to delay or diminish the progression of Alzheimer's disease are being explored. Behavioral and pharmacological interventions are also available to treat the specific behavioral disturbances that can occur in Alzheimer's disease.

[G.Al.]

**Amalgam** An alloy of mercury. Practically all metals will form alloys or amalgams with mercury, with the notable exception of iron. Amalgams are used as dental materials, in the concentration of gold and silver from their ores, and as electrodes in various industrial and laboratory electrolytic processes. Amalgams used in dental work require the following composition: silver, 65% minimum; copper, 6% maximum; zinc, 2% maximum; and tin, 25% minimum. These amalgams are prepared by the dentist as needed, and harden within 3–5 min, but may be shaped by carving for 15 min or so. See ALLOY; GOLD; SILVER.

[E.E.W.]

**Amaranth** An annual plant (seldom perennial) of the genus *Amaranthus* (family Amaranthaceae), distributed worldwide in warm and humid regions. Amaranths are botanically distinguished by their small chaffy flowers, arranged in dense, green or red, monoecious or dioecious inflorescences, with zero to five perianth segments and two or three styles and stigmata, and by their dry membranous, indehiscent, one-seeded fruit. See FLOWER; FRUIT.

Physiological, genetic, and nutritional studies have revealed their potential economic value. Of particular interest are high rate of productivity as a rapidly growing summer crop, the large amounts of protein in both seed and leaf with high lysine, the overall high nutritional value, and the water use efficiency for the C<sub>4</sub> photosynthetic pathway. Amaranths are important in the culture, diet, and agricultural economy of the people of Mexico, Central and South America, Africa, and northern India. Genetic, ethnobotanical, and agronomic research has been undertaken to develop amaranths as an important food plant in modern agriculture.

[S.K.J.]

**Amateur radio** Two-way radio communications by individuals as a leisure-time activity. Amateur, or ham, radio is defined by international treaty as a "service of self-training, intercommunications, and technical investigation carried on by amateurs; that is, by duly authorized persons interested in radio technique solely with a personal aim and without pecuniary interest." See RADIO.

The government allows amateur operators many privileges because the hobby is partially based on service to the general public, and hams can be relied on to assist during emergencies. Groups of amateur operators meet annually to practice handling emergency communications in the field and to compete against other groups nationwide in performing certain emergency-related tasks. Amateur operators may set up warning and relief networks during the hurricane and tornado seasons, and handle communication when phone lines are damaged by disasters.

In addition to public service activities, amateurs enjoy many recreational activities, including DXing (where the objective is to contact amateurs in as many foreign countries as possible), contesting (where the amateurs compete for the maximum number of contacts in a given time span), and foxhunting (where the objective is to use radio skills to locate a hidden transmitter).

Since high-frequency (HF) signals (below 30 MHz) are reflected from the Kennelly-Heaviside ionosphere layers, amateurs are commonly able to carry out international communication. Very high frequencies (VHF; 30–300 MHz) and ultrahigh frequencies (UHF; 300–3000 MHz) have been subject to exploration by amateurs at the leading edge of communications technology. Amateurs bounce signals off the Moon or ionized meteor trails, and communicate through amateur operator-built earth satellites called OSCAR (orbiting satellites carrying amateur radio).

[S.Man.]

**Amber** Most commonly, a generic name for all fossil resins, although it has been restricted by some to refer only to succinite, the mineralogical species of fossil resin making up most of the Baltic Coast deposits. Resins generally are complex mixtures of mono-, sesqui-, di-, and triterpenoids; however, some resins contain aromatic phenols. Among the plants, primarily trees, that produce copious amounts of resin that may fossilize to become amber, two-thirds are tropical or subtropical.

Although ambers occur throughout the world in deposits from Carboniferous to Pleistocene in age, they have been reported most commonly from Cretaceous and Tertiary strata and often are associated with coal or lignites. Amber may contain beautifully preserved insects, spiders, flowers, leaves, and even small animals. The most extensively studied deposits are those from the Baltic Coast, Alaska, Canada, Burma, Dominican Republic, and Mexico.

When amber is used for jewelry, it usually is transparent yellow, reddish-brown, or "amber" color. Translucent or semitranslucent amber is used for pipe stems, decorating small boxes, and a variety of ornamental purposes. The specific gravity varies from 1.05 to 1.10, and hardness from 1 to 3 on Mohs scale.

At one time, chemical studies of amber were mineralogically oriented because the purpose was to describe and classify amber as a semiprecious gem. However, phytochemical studies comparing fossil and present-day resins are providing information regarding the botanical origins of ambers.

The predominantly tropical or subtropical occurrence of amber-producing plants through geologic time has led to evolutionary studies of the natural purpose of resins and their possible defensive role for trees against injury and disease inflicted by the high diversity of insects and fungi in tropical environments. See GEM; MINERALOGY; RESIN.

[J.H.L.]

**Ambergris** A fatty substance formed in the intestinal tract of the sperm whale (*Physeter catodon*). Ambergris contains acids, alkaloids, and a fatty substance, its main constituent, called



ambrein. Although fresh ambergris is soft and black and has an offensive odor, it hardens into pleasantly fragrant gray or yellow masses when exposed to the air, sun, and sea. Being lighter than water, it is found in lumps floating on tropical seas or cast up on the shores. It is also gathered directly from the abdomens of dead or captured whales. Collecting grounds for ambergris are principally on the shores of China, Japan, Africa, the Americas, tropical islands, and the Bahamas.

Ambergris is valued in the manufacture of perfumes. The ambergris is ground and used in the form of a tincture, dissolved in a dilute solution of alcohol, which when added to perfume acts as a fixative, increasing the duration of the fragrance while adding its own sweet, earthy scent. [S.P.P.]

**Amblygonite** A lithium aluminum phosphate mineral of basic formula  $\text{LiAl}(\text{PO}_4\text{F})$ . The structure of amblygonite consists of phosphate ( $\text{PO}_4$ ) groups of tetrahedra and  $\text{AlO}_6$  groups of octahedra. Each  $\text{PO}_4$  tetrahedron is connected to an  $\text{AlO}_6$  octahedron. Amblygonite crystallizes in the triclinic system. Its color is commonly white or gray with tints of blue, green, and yellow. Amblygonite is transparent to translucent and has a vitreous to pearly luster.

The best-known occurrences of amblygonite are in Montebas, France; the Black Hills of South Dakota; the White Picacho District in Arizona; pegmatite districts in Maine; the Tanco pegmatite in Manitoba, Canada; and Portland, Connecticut. While amblygonite has been mined as an ore of lithium, it is not a major ore. See PHOSPHATE MINERALS. [C.K.S.]

**Amblypygi** An order of arachnids, the tailless whip scorpions, comprising about 80 species of flattened, crablike forms from the tropical and warm temperate regions of the world. The somber red or brownish species vary considerably in size, from 0.16–1.80 in. (4 to 45 mm), the largest being *Acanthophyrnus coronatus* of California and Mexico. The pedipalps are long raptorial organs set with many sharp spines that grasp and crush insect prey. The first pair of legs is modified into very long, lash-like whips which are used as sensory feelers. No tail is present on the abdomen. The amblypygids are harmless, nocturnal types that live under stones, in rock fissures and caves, and frequently in houses. No venom or repellent glands are present. See ARACHNIDA. [W.J.Ger.]

**Ameba** Any protozoan moving by means of protoplasmic flow. In their entirety, the ameboid protozoa include naked amebas, those enclosed within a shell or test, as well as more highly developed representatives such as the heliozoians, radiolarians, and foraminiferans. Ameboid movement is accomplished by pseudopods—cellular extensions which channel the flow of protoplasm. Pseudopods take varied forms and help distinguish among the different groups. A lobe-shaped extension or lobopod is perhaps the simplest type of pseudopod. The shapelessness and plasticity of these locomotory organelles impart an asymmetric, continually changing aspect to the organism. Other, more developed, representatives have pseudopodial extensions containing fibrous supporting elements (axopods) or forming an extensive network of anastomosing channels (reticulopods). Though involved in locomotion, these organelles are also functional in phagocytosis—the trapping and ingesting of food organisms (usually bacteria, algae, or other protozoa) or detritus. See FORAMINIFERIDA; HELIOZOA; PHAGOCYTOSIS; RADIOLARIA.

Amebas range from small soil organisms, such as *Acanthamoeba* (20 micrometers), to the large fresh-water forms *Amoeba proteus* (600  $\mu\text{m}$ ; see illustration) and *Pelomyxa* (1 mm, or more). Some types, such as *Amoeba*, are uninucleate; others are multinucleate. Reproduction is by mitosis with nuclear division preceding cytoplasmic division to produce two daughters. Multinucleate forms have more unusual patterns of division, since nuclear division is not immediately or necessarily followed by cytoplasmic division. Transformation of the actively feeding

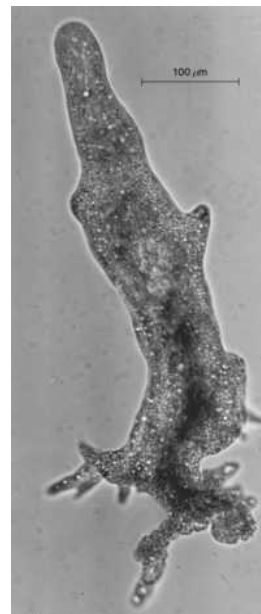

Phase-contrast photomicrograph of *Amoeba proteus*, a large fresh-water ameba. The organism is seen moving by means of a single lobose pseudopod.

ameba into a dormant cyst occurs in many species, particularly those found in soil or as symbionts. The resting stages allow survival over periods of desiccation, food scarcity, or transmission between hosts. See REPRODUCTION (ANIMAL).

Amebas are found in a variety of habitats, including fresh-water and marine environments, soil, and as symbionts and parasites in body cavities and tissues of vertebrates and invertebrates. Because of their manner of locomotion, amebas typically occur on surfaces, such as the bottom of a pond, on submerged vegetation, or floating debris. In soil, they are a significant component of the microfauna, feeding extensively on bacteria and small fungi. Amebas in marine habitats may be found as planktonic forms adapted for floating at the surface (having oil droplets to increase buoyancy and projections to increase surface area), where they feed upon bacteria, algae, and other protozoa. Several species of amebas may be found in the human intestinal tract as harmless commensals (for example, *Entamoeba coli*) or as important parasites responsible for amebic dysentery (*E. histolytica*). [F.L.Sc.]

**Americium** A chemical element, symbol Am, atomic number 95. The isotope  $^{241}\text{Am}$  is an alpha emitter with a half-life of 433 years. Other isotopes of americium range in mass from 232 to 247, but only the isotopes of mass 241 and 243 are important. The isotope  $^{241}\text{Am}$  is routinely separated from “old” plutonium and sold for a variety of industrial uses, such as 59-keV gamma sources and as a component in neutron sources. The longer-lived  $^{243}\text{Am}$  (half-life 7400 years) is a precursor in  $^{244}\text{Cm}$  production.

In its most prominent aqueous oxidation state, 3+, americium closely resembles the tripositive rare earths. The formal analogy to the rare earths is also marked in anhydrous compounds of both tripositive and tetrapositive americium. Americium is different in that it is possible to oxidize  $\text{Am}^{3+}$  to both the 5+ and 6+ states.

Americium metal has a vapor pressure markedly higher than that of its neighboring elements and can be purified by distillation. The metal is nonmagnetic and superconducting at 0.79 K. Under high pressure the metal has been compressed to 80% of its room-temperature volume and displays the  $\alpha$ -uranium structure. See ACTINIDE ELEMENTS; BERKELIUM; CURIUM; NUCLEAR REACTION; PERIODIC TABLE; TRANSURANIUM ELEMENTS. [R.A.Pe.]

**Amethyst** The transparent purple to violet variety of the mineral quartz. Amethyst is rare in the deep colors that characterize fine quality. It is usually colored unevenly and is often heated slightly in an effort to distribute the color more evenly. Heating at higher temperatures usually changes it to yellow or brown (rarely green), and further heating removes all color. The principal sources are Brazil, Arizona, Uruguay, and Russia. See GEM; QUARTZ. [R.T.L.]

**Amide** A derivative of a carboxylic acid with general formula  $RCONH_2$ , where R is hydrogen or an alkyl or aryl radical. Amides are divided into subclasses, depending on the number of substituents on nitrogen. The simple, or primary, amides are considered to be derivatives formed by replacement of the carboxylic hydroxyl group by the amino group,  $NH_2$ . They are named by dropping the "-ic acid" or "-oic acid" from the name of the parent carboxylic acid and replacing it with the suffix "amide." In the secondary and tertiary amides, one or both hydrogens are replaced by other groups. The presence of such groups is designated by the prefix capital N (for nitrogen).

Except for formamide, all simple amides are relatively low-melting solids, stable, and weakly acidic. They are strongly associated through hydrogen bonding, and hence soluble in hydroxylic solvents, such as water and alcohol. Because of ease of formation and sharp melting points, amides are frequently used for the identification of organic acids and, conversely, for the identification of amines.

Commercial preparation of amides involves thermal dehydration of ammonium salts of carboxylic acids. Thus, slow pyrolysis of ammonium acetate forms water and acetamide. *N,N*-dimethylacetamide may be similarly prepared from dimethylammonium acetate.

Amides are important chemical intermediates since they can be hydrolyzed to acids, dehydrated to nitriles, and degraded to amines containing one less carbon atom by the Hofmann reaction. In pharmacology, acetophenetidin is a popular analgesic. However, the most important commercial application of amides is in the preparation of polyamide resins, also called nylons. See ACID ANHYDRIDE; POLYAMIDE RESINS. [P.E.F.]

**Amiiformes** An order of Actinopterygian fishes, also known as the Halecomorphi. The characters include abbreviate heterocercal tail, in some almost symmetrical; usually fusiform body; median fin rays arranged one per pterygiophore; scales with a ganoine surface but typically thin; no spiracle; vascularized swim bladder with a duct; reduced maxilla which is free from the preopercle posteriorly; an orbit which is bordered below and behind by a series of enlarged bones; and, in Recent species, an enlarged gular plate and elongate dorsal fin.

The order, which appeared first in the Triassic, includes six families, of which only the Amiidae survived into the Cenozoic. The single Recent species, *Amia calva*, inhabits sluggish fresh waters of eastern North America. See ACTINOPTERYGII; OSTEICHTHYES. [R.M.B.]

**Amine** A member of a group of organic compounds which can be considered as derived from ammonia by replacement of one or more hydrogens by organic radicals. Generally amines are bases of widely varying strengths, but a few which are actually acidic are known.

Amines constitute one of the most important classes of organic compounds. The lone pair of electrons on the amine nitrogen enables amines to participate in a large variety of reactions as a base or a nucleophile. Amines play prominent roles in biochemical systems; they are widely distributed in nature in the form of amino acids, alkaloids, and vitamins. Many complex amines have pronounced physiological activity, for example, epinephrine (adrenalin), thiamin or vitamin  $B_1$ , and Novocaine. The odor of decaying fish is due to simple amines produced by bacterial action. Amines are used to manufacture many medi-

cal chemicals, such as sulfa drugs and anesthetics. The important synthetic fiber nylon is an amine derivative.

Amines are classified according to the number of hydrogens of ammonia which are replaced by radicals. Replacement of one hydrogen results in a primary amine ( $RNH_2$ ), replacement of two hydrogens results in a secondary amine ( $R_2NH$ ), and replacement of all three hydrogens results in a tertiary amine ( $R_3N$ ). The substituent groups (R) may be alkyl, aryl, or aralkyl. Another group of amines are those in which the nitrogen forms part of a ring (heterocyclic amines). Examples of such compounds are nicotine, which is obtained commercially from tobacco for use as an insecticide, and serotonin, which plays a key role as a chemical mediator in the central nervous system.

Many aromatic and heterocyclic amines are known by trivial names, and derivatives are named as substitution products of the parent amine. Thus,  $C_6H_5NH_2$ , is aniline and  $C_6H_5NHC_2H_5$  is *N*-ethylaniline.

According to the Brønsted-Lowry theory of acids and bases, amines are basic because they accept protons from acids. Stable salts suitable for the identification of amines are in general formed only with strong acids, such as hydrochloric, sulfuric, oxalic, chloroplatinic, or picric.

Commercial preparation of aliphatic amines can be accomplished by direct alkylation of ammonia or by catalytic alkylation of amines with alcohols at elevated temperatures. Reduction of various nitrogen functions carrying the nitrogen in a higher state of oxidation also leads to amines. Such functions are nitro, oximino, nitroso, and cyano. For the preparation of pure primary amines, Gabriel's synthesis and Hofmann's hypohalite reaction are preferred methods. The Bucherer reaction is satisfactory for the preparation of polynuclear primary aromatic amines. See AMINO ACIDS. [P.E.F.]

**Amino acid dating** Determination of the relative or absolute age of materials or objects by measurement of the degree of racemization of the amino acids present. With the exception of glycine, the amino acids found in proteins can exist in two isomeric forms called D- and L-enantiomers. Although the enantiomers of an amino acid rotate plane-polarized light in equal but opposite directions (the D form rotates it to the right and the L form to the left), their other chemical and physical properties are identical. It was discovered by L. Pasteur around 1850 that only L-amino acids are generally found in living organisms, but scientists still have not formulated a convincing reason to explain why life is based on only L-amino acids. See AMINO ACIDS.

Under conditions of chemical equilibrium, equal amounts of both enantiomers are present ( $D/L = 1.0$ ); this is called a racemic mixture. Living organisms maintain a state of disequilibrium through a system of enzymes that selectively utilize only the L-enantiomers. Once a protein has been synthesized and isolated from active metabolic processes, the L-amino acids are subject to a racemization reaction that converts them into a racemic mixture. Since racemization is a chemical process, the extent of racemization is dependent not only on the time that has elapsed since the L-amino acids were synthesized but also on the exposure temperature: the higher the temperature, the faster the rate of racemization. The rate of racemization is also different for most of the various amino acids. See RACEMIZATION.

A variety of analytical procedures can be used to separate amino acid enantiomers; gas chromatography and high-performance liquid chromatography are the most widely used. Since these techniques have sensitivities in the parts per billion range, only a few hundred milligrams of sample material are normally required. Samples are first hydrolyzed in hydrochloric acid to break down the proteins into free amino acids, which are then isolated by cation-exchange chromatography. See CHROMATOGRAPHY.

Since the late 1960s, the geochemical and biological significance of amino acid racemization has been extensively investigated. Geochemical uses of amino acid racemization include

the dating of fossils or, in the case of known age specimens, the determination of their temperature history. Fossil types such as bones, teeth, and shells have been studied, and racemization has been found to be particularly useful for dating specimens that were difficult to date by other methods. Racemization has also been observed in the metabolically inert tissues of living mammals. Racemization can be studied in certain organisms and used to assess the biological age of a variety of mammalian species; in addition, it may be important in determining the biological lifetime of certain proteins. Fossils have been found to contain both D- and L-amino acids, and the extent of racemization generally increases with geologic age. See ARCHEOLOGICAL CHEMISTRY; GEOCHRONOMETRY; RADIOCARBON DATING; ROCK AGE DETERMINATION. [J.L.Ba.]

**Amino acids** Organic compounds possessing one or more basic amino groups and one or more acidic carboxyl groups. Of the more than 80 amino acids which have been found in living organisms, about 20 serve as the building blocks for the proteins.

All the amino acids of proteins, and most of the others which occur naturally, are  $\alpha$ -amino acids, meaning that an amino group ( $-\text{NH}_2$ ) and a carboxyl group ( $-\text{COOH}$ ) are attached to the same carbon atom. This carbon (the  $\alpha$  carbon, being adjacent to the carboxyl group) also carries a hydrogen atom; its fourth valence is satisfied by any of a wide variety of substituent groups, represented by the letter R in the structural formula below.

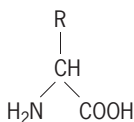

In the simplest amino acid, glycine, R is a hydrogen atom. In all other amino acids, R is an organic radical; for example, in alanine it is a methyl group ( $-\text{CH}_3$ ), while in glutamic acid it is an aliphatic chain terminating in a second carboxyl group ( $-\text{CH}_2-\text{CH}-\text{COOH}$ ). Chemically, the amino acids can be considered as falling roughly into nine categories based on the nature of R (see table).

**Occurrence.** Amino acids occur in living tissues principally in the conjugated form. Most conjugated amino acids are peptides, in which the amino group of one amino acid is linked to the carboxyl group of another. Amino acids are capable of linking together to form chains of various lengths, called polypeptides. Proteins are polypeptides ranging in size from about 50 to many thousand amino acid residues. Although most of the conjugated amino acids in nature are proteins, numerous smaller conjugates occur naturally, many with important biological activity. The line between large peptides and small proteins is difficult to draw, with insulin (molecular weight = 7000; 50 amino acids) usually being

considered a small protein and adrenocorticotrophic hormone (molecular weight = 5000; 39 amino acids) being considered a large peptide.

Free amino acids are found in living cells, as well as the body fluids of higher animals, in amounts which vary according to the tissue and to the amino acid. The amino acids which play key roles in the incorporation and transfer of ammonia, such as glutamic acid, aspartic acid, and their amides, are often present in relatively high amounts, but the concentrations of the other amino acids of proteins are extremely low, ranging from a fraction of a milligram to several milligrams per 100 g wet weight of tissue. The presence of free amino acids in only trace amounts points to the existence of extraordinarily efficient regulation mechanisms. Each amino acid is ordinarily synthesized at precisely the rate needed for protein synthesis.

**General properties.** The amino acids are characterized physically by the following: (1) the  $\text{pK}_1$ , or the dissociation constant of the various titratable groups; (2) the isoelectric point, or pH at which a dipolar ion does not migrate in an electric field; (3) the optical rotation, or the rotation imparted to a beam of plane-polarized light (frequently the D line of the sodium spectrum) passing through 1 decimeter of a solution of 100 grams in 100 milliliters; and (4) solubility. See IONIC EQUILIBRIUM; ISOELECTRIC POINT; OPTICAL ACTIVITY.

Since all of the amino acids except glycine possess a center of asymmetry at the  $\alpha$  carbon atom, they can exist in either of two optically active, mirror-image forms, or enantiomorphs. All of the common amino acids of proteins appear to have the same configuration about the  $\alpha$  carbon; this configuration is symbolized by the prefix L-. The opposite, generally unnatural, form is given the prefix D-. Some amino acids, such as isoleucine, threonine, and hydroxyproline, have a second center of asymmetry and can exist in four stereoisomeric forms. See STEREOCHEMISTRY.

At ordinary temperatures, the amino acids are white crystalline solids; when heated to high temperatures, they decompose rather than melt. They are stable in aqueous solution, and with few exceptions can be heated as high as  $120^\circ\text{C}$  ( $248^\circ\text{F}$ ) for short periods without decomposition, even in acid or alkaline solution. Thus, the hydrolysis of proteins can be carried out under such conditions with the complete recovery of most of the constituent free amino acids.

**Biosynthesis.** Since amino acids, as precursors of proteins, are essential to all organisms, all cells must be able to synthesize those they cannot obtain from their environment. The selective advantage of being able rapidly to shift from endogenous to exogenous sources of these compounds has led to the evolution of very complex and precise methods of adjusting the rate of synthesis to the available level of the compound. An immediately effective control is that of feedback inhibition. The biosynthesis of amino acids usually requires at least three enzymatic steps. In most cases so far examined, the amino acid end product of the biosynthetic pathway inhibits the first enzyme to catalyze a reaction specific to the biosynthesis of that amino acid. This inhibition is extremely specific; the enzymes involved have special sites for binding the inhibitor. This inhibition functions to shut off the pathway in the presence of transient high levels of the product, thus saving both carbon and energy for other biosynthetic reactions. When the level of the product decreases, the pathway begins to function once more.

The metabolic pathways by which amino acids are synthesized generally are found to be the same in all living cells investigated, whether microbial or animal. Biosynthetic mechanisms thus appear to have developed soon after the origin of life and to have remained unchanged through the divergent evolution of modern organisms.

Biosynthetic pathway diagrams reveal only one quantitatively important reaction by which organic nitrogen enters the amino groups of amino acids: the reductive amination of  $\alpha$ -ketoglutaric acid to glutamic acid by the enzyme glutamic acid dehydrogenase. All other amino acids are formed either by transamination

**Amino acids of proteins, grouped according to the nature of R**

Amino acids	R
Glycine	Hydrogen
Alanine, valine, leucine, isoleucine	Unsubstituted aliphatic chain
Serine, threonine	Aliphatic chain bearing a hydroxyl group
Aspartic acid, glutamic acid	Aliphatic chain terminating in an acidic carboxyl group
Asparagine, glutamine	Aliphatic chain terminating in an amide group
Arginine, lysine	Aliphatic chain terminating in a basic amino group
Cysteine, cystine, methionine	Sulfur-containing aliphatic chain
Phenylalanine, tyrosine	Terminates in an aromatic ring
Tryptophan, proline, histidine	Terminates in a heterocyclic ring

\*See articles on the individual amino acids listed in the table.

(transfer of an amino group, ultimately from glutamic acid) or by a modification of an existing amino acid. An example of the former is the formation of valine by transfer of the amino group from glutamic acid to  $\alpha$ -ketoisovaleric acid; an example of the latter is the reduction and cyclization of glutamic acid to form proline.

**Importance in nutrition.** The nutritional requirement for the amino acids of protein can vary from zero, in the case of an organism which synthesizes them all, to the complete list, in the case of an organism in which all the biosynthetic pathways are blocked. There are 8 or 10 amino acids required by certain mammals; most plants synthesize all of their amino acids, while microorganisms vary from types which synthesize all, to others (such as certain lactic acid bacteria) which require as many as 18 different amino acids. See NUTRITION; PROTEIN METABOLISM. [E.A.Ad.; P.T.M.; R.G.M.]

**Amino sugar** A sugar in which one or more nonglycosidic hydroxyl groups is replaced by an amino or substituted amino group. The most abundant example is D-glucosamine (2-amino-2-deoxy-D-glucose) [see illustration].

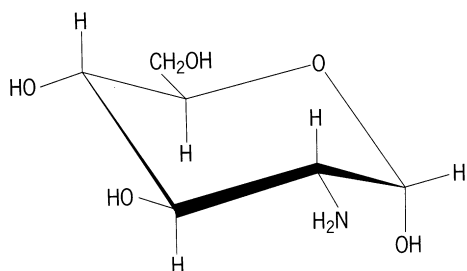

Structural formula of D-glucosamine ( $\alpha$ -pyranose ring form).

A linear polymer of *N*-acetyl-D-glucosamine is widely distributed as chitin, the exoskeletal material of arthropods. The glycoproteins of higher animals, which are components of the proteoglycans of cartilage and skin, consist of polysaccharides that are generally sulfated and have *N*-acetylated glucosamine or galactosamine alternating with a uronic acid.

Amino sugars are important constituents of glycoproteins and oligosaccharides involved in biological recognition. Amino sugars of the greatest structural diversity are found in microorganisms as constituents of cell walls, in antigenic carbohydrates produced at the cell surface, and as antibiotic substances secreted from the cell. Streptomycin is the first demonstrated example of numerous amino-sugar-containing antibiotics produced notably by Actinomycetes (bacteria). See CHITIN; GLYCOPROTEIN; OLIGOSACCHARIDE; POLYSACCHARIDE. [D.Ho.]

**para-Aminobenzoic acid** A compound also known as PABA, often considered to be a water-soluble vitamin. *p*-Aminobenzoic acid, with the structure below, is widely

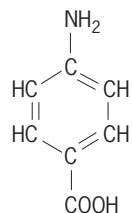

distributed in foods and has been isolated from liver, yeast, and other sources rich in vitamin B. *p*-Aminobenzoic acid is a part of the folic acid molecule, and its presence in a folic acid-deficient diet results in increased intestinal synthesis of the folic acid. *p*-Aminobenzoic acid antagonizes the bacteriostatic action of sulfonamides. It is an effective antirickettsial agent and has been

used to treat typhus, scrub typhus, and Rocky Mountain spotted fever. See FOLIC ACID. [S.N.G.]

**Ammeter** An instrument for the measurement of electric current. The unit of current, the ampere, is the base unit on which rests the International System (SI) definitions of all the electrical units. The operating principle of an ammeter depends on the nature of the current to be measured and the accuracy required. Currents may be broadly classified as direct current (dc), low-frequency alternating current (ac), or radio frequency. At frequencies above about 10 MHz, where the wavelength of the signal becomes comparable with the dimensions of the measuring instrument, current measurements become inaccurate and finally meaningless, since the value obtained depends on the position where the measurement is made. In these circumstances, power measurements are usually used. See CURRENT MEASUREMENT.

The measurement of current in terms of the voltage that appears across a resistive shunt through which the current passes has become the most common basis for ammeters, primarily because of the very wide range of current measurement that it makes possible, and more recently through its compatibility with digital techniques. See ELECTRICAL UNITS AND STANDARDS; MULTIMETER; VOLTMETER.

The moving-coil, permanent-magnet (d'Arsonval) ammeter remains important for direct-current measurement. Generally they are of modest accuracy, no better than 1%. Digital instruments have taken over all measurements of greater precision because of the greater ease of reading their indications where high resolution is required.

Moving-iron instruments are widely used as ammeters for low-frequency ac applications.

High-frequency currents are measured by the heating effect of the current passing through a physically small resistance element. In modern instruments the temperature of the center of the wire is sensed by a thermocouple, the output of which is used to drive a moving-coil indicator. See THERMOCOUPLE. [R.B.D.K.]

**Ammine** One of a group of complex compounds formed by the coordination of ammonia molecules with metal ions and, in a few instances, such as calcium, strontium, and barium, with metal atoms. Although ammines are formally analogous to many salt hydrates, the general characteristics of the group of ammines differ considerably from those of the hydrates. For example, hydrated Co(III) salts are strong oxidizing agents whereas Co(II) ammines are strong reducing agents. The ammines of principal interest are those of the transition metals and of the zinc family, but even here there is wide variation in stability or rate of decomposition. Ammines are prepared by treating aqueous solutions of the metal salt with ammonia or, in some instances, by the action of dry gaseous or liquid ammonia on the anhydrous salt. See AMMONIA; COORDINATION CHEMISTRY. [H.H.S.]

**Ammonia** The most familiar compound composed of the elements nitrogen and hydrogen,  $\text{NH}_3$ . It is formed as a result of the decomposition of most nitrogenous organic material, and its presence is indicated by its pungent and irritating odor.

Ammonia has a wide range of industrial and agricultural applications. Examples of its use are the production of nitric acid and ammonium salts, particularly the sulfate, nitrate, carbonate, and chloride, and the synthesis of hundreds of organic compounds including many drugs, plastics, and dyes. Its dilute aqueous solution finds use as a household cleansing agent. Anhydrous ammonia and ammonium salts are used as fertilizers, and anhydrous ammonia also serves as a refrigerant, because of its high heat of vaporization and relative ease of liquefaction. See FERTILIZER.

The physical properties of ammonia are analogous to those of water and hydrogen fluoride in that the physical constants are abnormal with respect to those of the binary hydrogen

compounds of the other members of the respective periodic families. These abnormalities may be related to the association of molecules through intermolecular hydrogen bonding. Ammonia is highly mobile in the liquid state and has a high thermal coefficient of expansion.

Most of the chemical reactions of ammonia may be classified under three chief groups: (1) addition reactions, commonly called ammoniation; (2) substitution reactions, commonly called ammonolysis; and (3) oxidation-reduction reactions.

Ammoniation reactions include those in which ammonia molecules add to other molecules or ions. Most familiar of the ammoniation reactions is the reaction with water to form ammonium hydroxide. The strong tendency of water and ammonia to combine is evidenced by the very high solubility of ammonia in water. Ammonia reacts readily with strong acids to form ammonium salts. Ammonium salts of weak acids in the solid state dissociate readily into ammonia and the free acid. Ammoniation occurs with a variety of molecules capable of acting as electron acceptors (Lewis acids), such as sulfur trioxide, sulfur dioxide, silicon tetrafluoride, and boron trifluoride. Included among ammoniation reactions is the formation of complexes (called amines) with many metal ions, particularly transition metal ions. Ammonolytic reactions include reactions of ammonia in which an amide group ( $-\text{NH}_2$ ), an imide group ( $=\text{NH}$ ), or a nitride group ( $\equiv\text{N}$ ) replaces one or more atoms or groups in the reacting molecule.

Oxidation-reduction reactions may be subdivided into those which involve a change in the oxidation state of the nitrogen atom and those in which elemental hydrogen is liberated. An example of the first group is the catalytic oxidation of ammonia in air to form nitric oxide. In the absence of a catalyst, ammonia burns in oxygen to yield nitrogen. Another example is the reduction with ammonia of hot metal oxides such as cupric oxide.

The physical and chemical properties of liquid ammonia make it appropriate for use as a solvent in certain types of chemical reactions. The solvent properties of liquid ammonia are, in many ways, qualitatively intermediate between those of water and of ethyl alcohol. This is particularly true with respect to dielectric constant; therefore, ammonia is generally superior to ethyl alcohol as a solvent for ionic substances but is inferior to water in this respect. On the other hand, ammonia is generally a better solvent for covalent substances than is water.

The Haber-Bosch synthesis is the major source of industrial ammonia. In a typical process, water gas ( $\text{CO}$ ,  $\text{H}_2$ ,  $\text{CO}_2$ ) mixed with nitrogen is passed through a scrubber cooler to remove dust and undecomposed material. The  $\text{CO}_2$  and  $\text{CO}$  are removed by a  $\text{CO}_2$  purifier and ammoniacal cuprous solution, respectively. The remaining  $\text{H}_2$  and  $\text{N}_2$  gases are passed over a catalyst at high pressures (up to 1000 atm or 100 megapascals) and high temperatures (approx. 1300°F or 700°C). Other industrial sources of ammonia include its formation as a byproduct of the destructive distillation of coal, and its synthesis through the cyanamide process. In the laboratory, ammonia is usually formed by its displacement from ammonium salts (either dry or in solution) by strong bases. Another source is the hydrolysis of metal nitrides. See AMIDE; NITROGEN. [H.H.S.]

**Ammonium salt** A product of a reaction between ammonia,  $\text{NH}_3$ , and various acids. The general reaction for formation is  $\text{NH}_3 + \text{HX} \rightarrow \text{NH}_4\text{X}$ . Examples of ammonium salts are ammonium chloride,  $\text{NH}_4\text{Cl}$ , ammonium nitrate,  $\text{NH}_4\text{NO}_3$ , ammonium sulfate,  $(\text{NH}_4)_2\text{SO}_4$ , and ammonium carbonate,  $(\text{NH}_4)_2\text{CO}_3$ . These compounds are addition products of ammonia and the acid. For this reason, their formulas are sometimes written as  $[\text{H}(\text{NH}_3)]\text{X}$ .

All ammonium salts decompose into ammonia and the acid when heated. Their stability, however, varies according to the nature of the acid. Salts of weak acids decompose at lower temperatures than do salts of strong acids.

Ammonium chloride is made by absorbing ammonia in hydrochloric acid. This salt, sometimes called sal ammoniac, is used in galvanizing iron, in textile dyeing, and in manufacturing dry cell batteries.

Ammonium nitrate is prepared from ammonia and nitric acid. It is used as a source of nitrous oxide,  $\text{N}_2\text{O}$ , or laughing gas, and in the manufacture of explosives. A mixture of ammonium nitrate and trinitrotoluene is known as amatol.

Ammonium sulfate, obtained from ammonia and sulfuric acid, is prepared commercially by passing ammonia and carbon dioxide,  $\text{CO}_2$ , into a suspension of finely ground calcium sulfate,  $\text{CaSO}_4$ . Large quantities are also produced as a byproduct of coke ovens and coal-gas works. The chief use of ammonium sulfate is as a fertilizer.

Ammonium carbonate may be prepared by bringing ammonia and carbon dioxide together in aqueous solution. It is also obtained by heating a mixture of ammonium sulfate and a fine suspension of calcium carbonate. See AMMONIA; FERTILIZER; HYDROLYSIS. [F.J.J.]

**Amnesia** A significant but relatively selective inability to remember. Amnesia can be characterized along two dimensions with respect to its onset: an inability to remember events that occurred after the onset of amnesia is referred to as anterograde amnesia, and a deficit in remembering events that occurred prior to the onset of amnesia is referred to as retrograde amnesia. Amnesia can be due to a variety of causes and can be classified according to whether the cause is primarily neurological or psychological in origin. Neurological amnesias are the result of brain dysfunction and can be transient or permanent. They are usually characterized by a severe anterograde amnesia and a relatively less severe retrograde amnesia. Transient amnesias are temporary memory disturbances and can range in duration from hours to months, depending on the cause and severity. They can be caused by epilepsy, head injury, and electroconvulsive therapy (most frequently used for the treatment of depression). In cases of transient global amnesia, an extensive amnesia that is usually sudden in onset and resolves within a day, the cause is still not known, although many believe that it is vascular in origin.

Permanent amnesia usually occurs following brain damage to either the diencephalons or the medial temporal lobe. Amnesia resulting from impairment to the medial temporal lobe can occur following anoxia, cerebrovascular accidents, head injury, and viral infections to the brain. The primary structures involved in the processing of memory within the medial temporal lobe are the hippocampus and the amygdala. One of the most common causes of diencephalic amnesia is Wernicke-Korsakoff syndrome, a disorder caused by a thiamine deficiency, usually related to chronic alcoholism.

Memory impairment that is not associated with brain damage is referred to as functional amnesia. Functional amnesia can be classified according to whether the amnesia is nonpathological or pathological. Nonpathological functional amnesia is a normal memory loss for events occurring during infancy and early childhood, sleep, hypnosis, and anesthesia. Pathological functional amnesia is an abnormal memory loss found in cases of functional retrograde amnesia and multiple personality. In contrast to neurological amnesia, pathological functional amnesia is usually associated with more severe retrograde than anterograde amnesia. See BRAIN; MEMORY. [R.S.Le.]

**Amnion** A thin, cellular, extraembryonic membrane forming a closed sac surrounding the embryo in all reptiles, birds, and mammals. It is present only in these forms; the collective term amniotes is applied to these animals. The amnion contains a serous fluid in which the embryo is immersed. See AMNIOTA.

Typically, the amnion wall is a tough, transparent, nerve-free, and nonvascular membrane consisting of two layers of cells: an inner, single-cell-thick layer of ectodermal epithelium and an outer covering of mesodermal, connective, and specialized

smooth muscular tissue. Early after the formation of the amnion, waves of contraction of the muscles pass over the amniotic sac and produce a characteristic rocking of the embryo. See GERM LAYERS.

The major function of the amnion and its fluid is to protect the delicate embryo. Thus, developmental stages of terrestrial animals are provided with the same type of cushioning against mechanical shock as is provided by the water environment of aquatic forms. See FETAL MEMBRANE. [N.T.S.]

**Amniota** A collective term for the classes Reptilia (reptiles), Aves (birds), and Mammalia (mammals) of the subphylum Vertebrata. The remaining vertebrates, including the several classes of fishes and the amphibians, are grouped together as the Anamnia. Members of the Amniota are characterized by having a series of specialized protective extraembryonic membranes during development. Three of the membranes—amnion, chorion or serosa, and allantois—occur only in this group, but a fourth, the yolk sac, is sometimes present and is found in many anamniotes. The presence of the extraembryonic membranes makes it possible for the embryonic development of the amniotes to take place out of the water. In the most primitive forms the early stages of development take place inside a shell-covered egg that is deposited on land. This pattern is typical of most reptiles, all birds, and some mammals. In these animals the amnion and chorion form fluid-filled sacs which protect the embryo from desiccation and shock. The allantois usually acts as a storage place for digestive and nitrogenous wastes and, in conjunction with the chorion, as a respiratory structure. In viviparous reptiles and mammals the chorion and allantois generally fuse and become more or less intimately associated with the uterine lining of the mother. Nutritive, excretory and respiratory exchanges take place across the chorioallantoic membrane between the allantoic circulation of the embryo and the uterine circulatory vessels of the mother. See ALLANTOIS; AMNION; ANAMNIA; CHORION; VERTEBRATA; YOLK SAC. [J.M.S.]

**Amoebida** An order of Lobosia without protective coverings (tests). These protozoa range in size from about 4 micrometers to 0.08–0.12 in. (2–3 mm). Pellicles may be thin, as in *Amoeba proteus*, or thicker and less flexible, as in *Thecamoeba verrucosa*. Pellicular folds may develop during locomotion, particularly in species with thick pellicles. Both flagellate and amoeboid stages occur in certain soil amoebas.

The term amoeboid movement is rather loose because locomotion of Amoebida varies somewhat from genus to genus. In some cases movement involves protoplasmic flow of the body as a whole, without typical pseudopodia. In *A. proteus* there may be several ridged indeterminate pseudopodia, into one of which the organism appears to flow in locomotion. In other species determinate pseudopodia never become large enough to direct locomotion. In some cases the form of the pseudopodia may vary in a single species. Certain amoebas commonly have a relatively inert posterior mass, the uroid, which may or may not be partially constricted, is sometimes covered with projections, and often contains food vacuoles. Locomotion involving protoplasmic flow depends upon sol-gel reversibility. See CELL MOTILITY.

Amoebas, normally phagotrophic, usually contain food vacuoles. Certain species contain crystals of apparently differing chemical nature. Other inclusions are globules of different sizes, mitochondria, and stored food reserves. In addition, bacteria or algae may occur in the cytoplasm, changing the color to a gray or green. Nuclei range in number from one to several hundred, as in *Chaos carolinensis*. The giant amoebas are visible without a microscope.

Those species found in the digestive tract of invertebrates and vertebrates include relatively harmless species and a few pathogens, such as *Entamoeba histolytica* of humans and

*E. invadens* of reptiles. *Entamoeba histolytica* causes amebiasis. In primary cases the amoebas are localized in the colon. Cases range from mild amebiasis to acute amoebic dysentery.

*Entamoeba coli*, a similar amoeba, does not invade human tissues. Also limited to the lumen of the colon are *Endolimax nana*, *Iodamoeba bütschlii*, and *Dientamoeba fragilis*. These four are relatively harmless although sometimes associated with digestive disturbances. Uncooked vegetables from soil fertilized with human feces are a potential source of infection. Standard methods of water purification seem reasonably protective, but it is difficult to control spread of cysts by food handlers. See LOBOSIA; PROTOZOA; SARCODINA; SARCOMASTIGOPHORA. [R.P.H.]

**Amorphous solid** A rigid material whose structure lacks crystalline periodicity; that is, the pattern of its constituent atoms or molecules does not repeat periodically in three dimensions. In the present terminology amorphous and noncrystalline are synonymous. A solid is distinguished from its other amorphous counterparts (liquids and gases) by its viscosity: a material is considered solid (rigid) if its shear viscosity exceeds  $10^{14.6}$  poise ( $10^{13.6}$  Pa · s). See CRYSTAL; VISCOSITY.

Oxide glasses, generally the silicates, are the most familiar amorphous solids. However, as a state of matter, amorphous solids are much more widespread than just the oxide glasses. There are both organic (for example, polyethylene and some hard candies) and inorganic (for example, the silicates) amorphous solids. Glasses can be prepared which span a broad range of physical properties. Dielectrics (for example,  $\text{SiO}_2$ ) have very low electrical conductivity and are optically transparent, hard, and brittle. Semiconductors (for example,  $\text{As}_2\text{SeTe}_2$ ) have intermediate electrical conductivities and are optically opaque and brittle. Metallic glasses have high electrical and thermal conductivities, have metallic luster, and are ductile and strong. See METALLIC GLASSES.

The obvious uses for amorphous solids are as window glass, container glass, and the glassy polymers (plastics). Less widely recognized but nevertheless established technological uses include the dielectrics and protective coatings used in integrated circuits, and the active element in photocopying by xerography, which depends for its action upon photoconduction in an amorphous semiconductor. In optical communications a highly transparent dielectric glass in the form of a fiber is used as the transmission medium.

It is the changes in short-range order (on the scale of a localized electron), rather than the loss of long-range order alone, that have a profound effect on the properties of amorphous semiconductors. For example, the difference in resistivity between the crystalline and amorphous states for dielectrics and metals is always less than an order of magnitude and is generally less than a factor of 3. For semiconductors, however, resistivity changes of 10 orders of magnitude between the crystalline and amorphous states are not uncommon, and accompanying changes in optical properties can also be large.

One class of amorphous semiconductors is the glassy chalcogenides, which contain one (or more) of the chalcogens sulfur, selenium, or tellurium as major constituents. These materials have application in switching and memory devices. Another group is the tetrahedrally bonded amorphous solids, such as amorphous silicon and germanium. These materials cannot be formed by quenching from the melt (that is, as glasses) but must be prepared by one of the deposition techniques mentioned above.

When amorphous silicon (or germanium) is prepared by evaporation, not all bonding requirements are satisfied, so a large number of dangling bonds are introduced into the material. These dangling bonds create states deep in the gap which limit the transport properties. The number of dangling bonds can be reduced by a thermal anneal below the crystallization temperature, but the number cannot be reduced sufficiently to permit doping. See SEMICONDUCTOR. [B.G.B.]

**Ampère's law** A law of electromagnetism which expresses the contribution of a current element of length  $dl$  to the magnetic induction (flux density)  $B$  at a point near the current. Ampère's law, sometimes called Laplace's law, was derived by A. M. Ampère after a series of experiments during 1820–1825.

Whenever an electric charge is in motion, there is a magnetic field associated with that motion. The flow of charges through a conductor sets up a magnetic field in the surrounding region. Any current may be considered to be broken up into infinitesimal elements of length  $dl$ , and each such element contributes

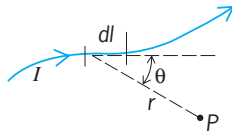

Graphic representation of Ampère's law.

to the magnetic induction at every point in the neighborhood. The contribution  $dB$  of the element is found to depend upon the current  $I$ , the length  $dl$  of the element, the distance  $r$  of the point  $P$  from the current element, and the angle  $\theta$  between the current element and the line joining the element to the point  $P$  (see illustration). Ampère's law expresses the manner of the dependence by Eq. (1). The field near a current may be calculated by finding

$$dB = k \frac{I dl \sin \theta}{r^2} \quad (1)$$

the vector sum of the contributions of all the various elements that make up the current.

The proportionality factor  $k$  depends upon the units used in Eq. (1) and upon the properties of the medium surrounding the current. In the SI system, the factor  $k$  is assigned a value of  $10^{-7}$  weber/ampere-meters when the current is in empty space. As in other equations associated with electric and magnetic fields, for example Coulomb's law, it is convenient to replace  $k$  by a new factor  $\mu_0$  related to  $k$  as in Eq. (2). This substitution removes

$$\mu_0 = 4\pi k \quad (2)$$

the factor  $4\pi$  from many derived equations in which it would otherwise appear. With this substitution Ampère's law becomes Eq. (3). The factor  $\mu_0$  is called the permeability of empty space.

$$dB = \frac{\mu_0 I dl \sin \theta}{4\pi r^2} \quad (3)$$

The direction of  $dB$  at each point may be described in terms of a right-hand rule. If the current element is grasped by the right hand with the thumb pointing in the direction of the current, the fingers encircle the current in the direction of the magnetic induction. [K.V.M.]

**Amphetamine** A stimulating drug that affects the brain and the body in a variety of ways, also known by the trade name Benzadrine. Chemically, amphetamine is a racemic mixture of the L and D isomers of  $\alpha$ -methyl- $\beta$ -phenethylamine. The L isomer has more pronounced effects on the body, while the D isomer (commonly referred to as Dexedrine) has a greater effect on the brain. On the whole, the pharmacological effects of amphetamine are to produce an increase in blood pressure, a relaxation of bronchial smooth muscle, a constriction of the blood vessels supplying the skin and mucous membranes, and a variety of alterations in behavior. The mechanisms by which amphetamine produces its effects are not precisely defined. The effects on the body seem to be mediated predominantly through an increase in the activity of the neurons in the sympathetic nervous system via the transmitter norepinephrine. Amphetamine has the ability to release norepinephrine from nerve terminals. The consequence of release is that amphetamine has a spectrum of activity similar to the normal physiological effects of

norepinephrine on the peripheral nervous system. Similarly, the major effects of amphetamine on the brain have been related to its ability to release norepinephrine in the hypothalamus, the reticular activating system, and the cerebral cortex. See CENTRAL NERVOUS SYSTEM; SYMPATHETIC NERVOUS SYSTEM.

The ability of amphetamine to contract blood vessels in the mucous membranes and to relax smooth muscles in the lung make it an efficacious nasal decongestant. Its ability to cause hyperventilation has resulted in its use as an analeptic. The arousing and insomnia-producing effects have been exploited to treat narcolepsy, a disease characterized by an inability to stay awake. Furthermore, the ability of amphetamine to cause a loss of appetite has promoted its use in diet programs as an anorexic. The enhanced sense of well-being and mild euphoria that are seen after taking amphetamine have led to its use in certain forms of psychiatric depression. One important use of amphetamine is in the treatment of hyperkinetic children, although the paradox of how a stimulant can reduce hyperkinetic behavior is not understood.

Just as the therapeutic uses of amphetamine are a consequence of its pharmacology, so are its side effects. The typical side effects on the body include dry mouth, heart rhythm alterations (palpitations and arrhythmias), hypertension, stomach cramps, and decreased urinary frequency. The central nervous system side effects include dizziness, dysphoria, headache, tremor, restlessness, insomnia, decreased appetite, increased aggressiveness, anxiety, and paranoid panic states. Extreme overdosage can result in convulsions, cerebral hemorrhaging, coma, and death.

The stimulant and euphorogenic side effects of amphetamine have made this drug subject to widespread abuse. The patterns of this abuse, however, vary greatly. The diversity of people taking amphetamine without proper medical supervision makes it difficult to characterize a typical user. More serious abuse occurs in some individuals who take the drug over long periods. As with other drugs of abuse, tolerance will occur after repeated dosing. Chronic use of large amounts of amphetamine can have severe effects on personality. It has been shown that large doses of amphetamine can induce a behavioral state in humans that is nearly indistinguishable from paranoid schizophrenia, but can be reversed upon cessation of the drug. The question of whether or not physical dependence occurs with amphetamine is unresolved. See ADDICTIVE DISORDERS; NARCOTIC. [R.E.C.]

**Amphibia** One of the four classes composing the superclass Tetrapoda of the subphylum Vertebrata, the other classes being Reptilia, Aves, and Mammalia. The living amphibians number approximately 2460 species, and are classified in three orders: the Anura or Salientia (frogs and toads, slightly less than 2000 species); Urodela or Caudata (salamanders, 300 species); and Apoda or Gymnophiona (caecilians, about 160 species). The orders in the subclasses Labyrinthodontia and Lepospondyli existed in the geologic past and are now extinct. A classification scheme for the Amphibia follows:

- Class Amphibia
  - Subclass Labyrinthodontia
    - Order: Ichthyostegalia
    - Temnospondyli
    - Antracosauria
  - Subclass Lepospondyli
    - Order: Nectridea
    - Aistopoda
    - Microsauria
    - Lysorophia
  - Subclass Lissamphibia
    - Order: Anura
    - Urodela
    - Apoda

A typical amphibian is characterized by a moist, glandular skin, the possession of gills at some point in its life history, four limbs, and an egg lacking the embryonic membrane called the amnion. See AMNION; ANAMNIA.

The closest relatives of the amphibians are the fishes, from which they evolved, and the reptiles, to which they gave rise. Present-day amphibians, however, are highly specialized animals, rather different from the primitive forms that probably first arose from crossopterygian fishes and far removed from those that gave rise to the earliest reptiles.

In general, modern amphibians as adults differ from fishes in lacking scales, breathing by means of the skin and lungs instead of gills, and having limbs in place of fins. There are many exceptions to these generalizations, however. Reptiles usually have a dry, scaly skin that is relatively impervious to water loss and very different from the amphibians with their moist skin that permits much evaporation. Young (larval) amphibians have gills, but there is no comparable gill-breathing, larval stage in the life history of a reptile. A most important difference between the two groups is the absence of the amnion in the Amphibia, and its presence in the Reptilia. Lacking this membrane, amphibian eggs must be laid in water or in very moist places. The amnion of the reptile egg makes it more able to resist desiccation, and the eggs can be laid in relatively dry places. The ability to resist water loss through the skin and the development of a land egg are perhaps the differences between reptiles and amphibians that are of the greatest evolutionary significance. See REPTILIA.

The all-important factor in amphibian life is water. Most species must return to the water to breed, and all must have access to water (even if only in the form of rain or dew) or die of dehydration in a short time. An important consequence of this basic fact of physiology is that vast arid and semiarid areas of the Earth are inhabited by a relatively few specialized amphibians. The majority of amphibian species are found in moist, tropical regions.

Amphibians are among the so-called cold-blooded animals; that is, the temperature of the body of an amphibian is not regulated internally to a high level as is that of mammals and birds, but fluctuates with that of the environment. An animal such as an amphibian that burns none of its food energy in keeping warm is able to get along on much less food than a bird or mammal of similar size. This advantage is offset by the inability of amphibians to be active under cold conditions that do not inhibit a warm-blooded animal. Thus the far northern and southern parts of the world which support large populations of birds and mammals are almost devoid of amphibian life. The amphibians mark a significant point in the evolution of the vertebrates, the transition from aquatic to terrestrial life. As animals neither divorced from the water nor fully at home on land, they suffer from their intermediate mode of life. Reptiles, and later mammals, came to dominate the land, and fishes the waters, leaving the amphibians of today as a relatively unimportant but nevertheless highly interesting group of vertebrates. See TETRAPODA; THERMOREGULATION. [R.G.Z.]

The fossil record of the three groups of living amphibians is extensive, and the earliest member of each has been found in Mesozoic rocks. However, no intermediary forms linking the three groups together have been found in the Mesozoic, and it is necessary to look in the Paleozoic, some 100 million years earlier, for the common ancestor of modern amphibians, with the earliest known amphibians having been found in the Upper Devonian rocks of Greenland.

It is clear that modern amphibians have a very long history extending back almost to the time of the origin and radiation of land vertebrates 340 million years ago. Their unique sensory biology and specialized glands must have evolved at that time and remained unchanged to the present day. [T.R.Sm.]

**Amphibole** A group of common ferromagnesian silicate minerals that occur as major or minor constituents in a wide

variety of rocks. The crystal structure of the amphiboles is very flexible and, as a result, the amphiboles show a larger range of chemical composition than any other group of minerals. The structural and chemical complexity of the amphiboles reveals considerable information on the geological processes that have affected the rocks in which they occur. See MINERAL.

A general formula for amphiboles may be written as  $A_{0-1}B_2C_5T_8O_{22}W_2$ , where

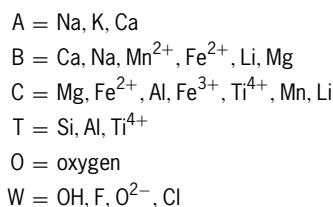

and the chemical species are written in order of their importance. Amphiboles are divided into four main groups, according to the type of chemical species in the B group:

$B = (\text{Fe}^{2+}, \text{Mg, Mn}^{2+}, \text{Li})_2$	Iron-magnesium-manganese amphiboles
$B = \text{Ca}_2$	Calcic amphiboles
$B = \text{NaCa}$	Sodic-calcic amphiboles
$B = \text{Na}_2$	Sodic amphiboles

Amphiboles can have orthorhombic and monoclinic symmetries; these can be distinguished either by x-ray crystallography or by the optical properties of the mineral in polarized light. See X-RAY CRYSTALLOGRAPHY.

Monoclinic amphiboles are by far the most common. The characteristic feature of the amphibole structure is the chain of corner-sharing tetrahedrally coordinated groups. Inspection of the structure down the y axis shows that the amphibole structure consists of sheets of tetrahedra interleaved with octahedrally coordinated C-group cations. In the monoclinic structure, the tetrahedral layers all stack in the x direction with the same sense of displacement (along the z direction) relative to the underlying layer, and hence the x axis is inclined to the z axis, producing a monoclinic structure. In the orthorhombic structure, the displacement of the tetrahedral layers reverses every third layer, and hence the x axis is orthogonal to the z axis, producing an orthorhombic structure. See CRYSTAL; CRYSTAL STRUCTURE; CRYSTALLOGRAPHY.

Amphiboles do not show the complete range of possible compositions suggested by the general chemical formula and common idealized compositions described above. In particular, there is not a continuous range of chemical composition between the four main amphibole groups: the iron-magnesium-manganese amphiboles, the calcic amphiboles, the sodic-calcic amphiboles, and the alkali amphiboles. This lack of so-called solid solution is a result of the structure not being able to accommodate two types of cations (positively charged atoms) of very different size (or charge) at the same set of sites in the structure of a single crystal.

The degree to which two amphiboles are immiscible often varies as a function of temperature and pressure; at high temperatures or pressures, miscibility is usually enhanced. The immiscible region, which is known as a miscibility gap, is narrow at high temperature but widens at lower temperature. When the amphibole composition is within the miscibility gap, a single amphibole is no longer stable. It is here that the process of exsolution (or unmixing) occurs. Coexisting amphiboles and exsolution textures are very informative about temperatures of crystallization and cooling history, particularly in metamorphic rocks. See PHASE EQUILIBRIUM; SOLID SOLUTION.

Amphiboles are common minerals in many types of igneous rocks, and the composition of the amphibole reflects the silica content of the rock. Calcic amphiboles, particularly pargasite, are characteristic of ultramafic and metabasaltic rocks



and are usually quite rich in magnesium. Titanium-rich hornblendes and kaersutites occur in intermediate rocks and are often strongly oxidized—an unusual feature in amphiboles from any other environment. Acidic rocks, particularly granites, contain a wide range of amphiboles, from hastingsite to riebeckite and arfvedsonite; these are often iron-rich and can contain significant amounts of more unusual elements such as Li, Zn, and Mn. Amphiboles usually weather very easily and hence are not important in sedimentary rocks, although they can be significant components of soil. Iron-rich alkali amphiboles can form at essentially ambient conditions in the sedimentary environment, but this occurrence is rare. Amphiboles are common and important rock-forming minerals in many types of metamorphic rocks. They are particularly abundant in rocks of basaltic composition at most grades of metamorphism.

Amphiboles are economically important as commercial asbestos minerals and as semiprecious gem materials. World asbestos production is dominated by the serpentine-group mineral chrysotile; but the amphibole minerals anthophyllite, cummingtonite-grunerite (amosite), actinolite, and riebeckite (crocidolite) are also important, particularly in Australia and South Africa. Some amphiboles with attractive physical properties are marketed as semiprecious gem material. Most important is nephrite, a dense compact form of fibrous actinolite that is a principal variety of jade. Fibrous riebeckite is marketed as one of the less common varieties of tiger's eye. Iridescent gedrite and gem-quality pargasite are used as semiprecious gems in contemporary jewelry. See GEM; JADE; MINERALOGY. [F.C.Ha.]

**Amphibolite** A class of metamorphic rocks with one of the amphibole minerals as the dominant constituent. Most of the amphibolites are dark green to black crystalline rocks that occur as extensive layers widely distributed in mountain belts and deeply eroded shield areas of the continental crust. Amphibolite is the main country rock that has been intruded by the large granite masses found in most mountain ranges, with small and large masses of amphibolite present also as inclusions in granites.

Amphibolites are the products of regional metamorphism and crustal deformation of older materials of appropriate composition. The features of the original rock are obliterated; thus it is difficult and sometimes impossible to determine the premetamorphic rock. Apparent differences in the formation of the bulk composition are used to classify amphibolites as ortho or para. Compositional relations between the minor elements titanium, chromium, and nickel have been used to distinguish the ortho from para amphibolites in some occurrences. See METAMORPHIC ROCKS. [G.W.DeV.]

**Amphidiscosa** An order of the subclass Amphidiscophora in the class Hexactinellida. These sponges are distinguished from the order Hemidiscosa in that the birotulates are amphidiscs. Examples of this order are *Pheronema*, *Monorhaphis*, and *Hyahnama*. The record of fossil Amphidiscosa is poor, but goes back to the Carboniferous *Uralonema*. See HEMIDISCOSA. [W.D.H.]

**Amphilinidea** An order of tapeworms of the subclass Cestodaria. They have a protrusible proboscis and frontal glands at the anterior end. No holdfast organ is evident. All members of the order inhabit the coelom of sturgeon and other fish. The only life history which is completely known is that of *Amphilina*. The 10-hooked embryos leave the parental uterus through a pore, and if upon escaping into the water they are eaten by an amphipod crustacean, they undergo further development to the proceroid larva. When the parasitized amphipod is eaten by a sturgeon, the larval worm enters its coelom and develops to sexual maturity. See CESTODARIA. [C.PR.]

**Amphionidacea** An order of the Eucarida comprising a single species, *Amphionides reynaudii*. Because of the similarity of its early larval stages to those found among the caridean shrimps, for more than a century it was classified as an aberrant member of the Caridea. However, the fact that the pleuron of the second abdominal somite never overlaps that of the first in any stage immediately distinguishes this species from all true Caridea. *Amphionides reynaudii* has worldwide distribution, primarily in equatorial regions. Adult females have been collected at depths between 21,000 and 111,000 ft (700 and 3700 m), while most larvae occur in depths of only 90–300 ft (30–100 m). See EUCARIDA. [P.A.McL.]

**Amphipoda** An order of crustaceans in the subclass Malacostraca, which lack a carapace, bear unstalked eyes, and respire by thoracic branchiae, or gills. The abdomen usually bears three pairs of biramous swimmerets (pleopods), three pairs of rather rigid uropods, and a telson which may be lobed or entire. The body is usually flattened laterally, and the pereopods (walking legs) are elongated so that walking is difficult. The maxillipeds lack epipodites. The sexes are separate, but reproductive and copulatory organs are very simple. The eggs are extruded by the female into a ventral brood pouch composed of setose lamellae attached to the medial bases of the legs. The young hatch as miniature adults, growing usually to a length of 0.12–0.48 in. (3–12 mm), and in exceptional cases to 5.6 in. (140 mm). See ISOPODA.

Four suborders are known, the Gammaridea, Hyperidea, Caprellidea, and Ingolfiellidea. Amphipods are very abundant in the oceans, being represented by 3200 species. More than 600 other species occur in streams, lakes, and subterranean waters and in terrestrial leaf molds and mosses. Many are excellent swimmers. Nonpelagic species of the suborders Gammaridea and Caprellidea live on aquatic bottoms, plants, and epifaunal growths. Predation by amphipods is occasional. Their mouthparts are well adapted for chewing; they either eat aquatic plants, debris, and detritus or swallow mud containing food particles.

Marine species are important food for various stages of many commercial fishes. Hyperiids are the principal food of seals at certain seasons, and also of balaenoid whales at times. One gammaridean genus, *Chelura*, is a minor wood borer, associated with the isopod *Limnoria*.

A few fossil species are known in Tertiary amber deposits. See AMBER; CAPRELLIDEA; GAMMARIDEA; HYPERIDEA; MALACOSTRACA. [J.L.B.]

**Amplifier** A device capable of increasing the magnitude of a physical quantity. This article discusses a couple of basic electronic amplifiers whose operation depends on transistors. Some amplifiers are magnetic, while others may take the form of rotating electrical machinery. Forms of nonelectrical amplifiers are hydraulic actuators and levers which are amplifiers of mechanical forces. See DIRECT-CURRENT MOTOR; HYDRAULIC ACTUATOR; LEVER.

The operation of an amplifier can be explained with a model (see illustration). A controlled voltage source of gain  $K$  generates

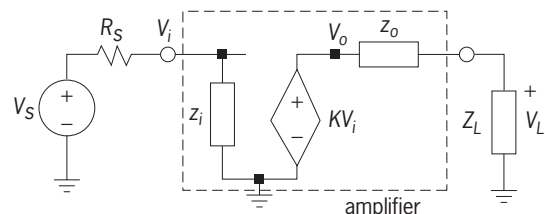

Amplifier model with source, load, and input and output impedances.

an output voltage  $V_o = KV_i$  from an input voltage  $V_i$ . This input voltage is obtained from a source voltage  $V_S$  with source resistance  $R_S$  via voltage division with the amplifier's input impedance  $z_i$ . The load voltage  $V_L$  across the load impedance  $Z_L$  is obtained from  $V_o$  by voltage division with the amplifier's output impedance  $z_o$ . The input voltage and load voltage are given by Eqs. (1), where  $k_i$  and  $k_o$ , respectively, express the effects of the amplifier loading the source and of the load impedance loading the amplifier. The impedances  $z_i$  and  $z_o$  mostly consist of a resistor in parallel with a capacitor; often they may be assumed to be purely resistive:  $z_i = r_i$  and  $z_o = r_o$ . From Eq. (1), the amplifier's operation is given by Eq. (2). Thus, the amplification is decreased

$$V_i = \frac{z_i}{z_i + R_S} V_S = k_i V_S \quad (1)$$

$$V_L = \frac{Z_L}{Z_L + z_o} V_o = k_o V_o$$

$$V_L = k_i K k_o V_S = \frac{z_i}{z_i + R_S} K \frac{Z_L}{Z_L + z_o} V_S \quad (2)$$

from the ideal value  $K$  by the two load factors  $k_i$  and  $k_o$ . The reduction in gain is avoided if the two factors equal unity, that is, if  $z_i = \infty$  and  $z_o = 0$ . Thus, in addition to the required gain  $K$ , a good amplifier has a very large input impedance  $z_i$  and a very small output impedance  $z_o$ . See GAIN.

The operational amplifier (op amp) is a commonly used general-purpose amplifier. It is implemented as an integrated circuit on a semiconductor chip, and functions as a voltage amplifier whose essential characteristics at low frequencies are very high voltage amplification, very high input resistance, and very low output resistance. See INTEGRATED CIRCUITS.

The transconductance amplifier has become widely used. In contrast to operational amplifiers, which convert an input voltage to an output voltage, transconductors are voltage-to-current converters described by the transconductance parameter  $g_m$ , which satisfies Eq. (3). Thus, the output current  $I_{out}$  is propor-

$$I_{out} = g_m V_{in} \quad (3)$$

tional to the input voltage  $V_{in}$ . As do operational amplifiers, ideal transconductors have an infinite input resistance, but they also have an infinite output resistance so that the output is an ideal current source. One of the attractive properties of transconductance amplifiers is their wide bandwidth. Very simple transconductance circuits can be designed which maintain their nominal  $g_m$  values over bandwidths of several hundred megahertz, whereas operational amplifiers often have high gain only over a frequency range of less than 100 Hz, after which the gain falls off rapidly. Consequently, in high-frequency communications applications, circuits built with transconductance amplifiers generally give much better performance than those with operational amplifiers.

Typically, amplifiers increase the power or signal levels from low-power sources, such as microphones, strain gages, magnetic disks, or antennas. After the small signals have been amplified, the amplifier's output stage must deliver the amplified signal efficiently, with minimal loss, and with no distortion to a load, such as a loudspeaker. [R.Sc.]

**Amplitude (wave motion)** The maximum magnitude (value without regard to sign) of the disturbance of a wave. The term "disturbance" refers to that property of a wave which perturbs or alters its surroundings. It may mean, for example, the displacement of mechanical waves, the pressure variations of a sound wave, or the electric or magnetic field of light waves. Sometimes in older texts the word amplitude is used for the disturbance itself; in that case, amplitude as meant there is called peak amplitude. This is no longer common usage.

If the medium which a wave disturbs dissipates the wave by some nonlinear behavior or other means, then the amplitude

will, in general, depend upon position. See DISPLACEMENT (MECHANICS); LIGHT; SOUND; WAVE MOTION. [S.A.Wi.]

**Amplitude modulation** The process or result of the process whereby the amplitude of a carrier wave is changed in accordance with a modulating wave. This broad definition includes applications using sinusoidal carriers, pulse carriers, or any other form of carrier, the amplitude factor of which changes in accordance with the modulating wave in any unique manner. See MODULATION.

Practical examples of amplitude modulation (AM) include AM radio broadcasting, single-sideband transmission systems, vestigial-sideband systems, frequency-division multiplexing, time-division multiplexing, phase-discrimination multiplexing, and reduced-carrier systems. See MULTIPLEXING; SINGLE SIDE-BAND.

Amplitude modulation is also defined in a more restrictive sense to mean modulation in which the amplitude factor of a sine-wave carrier is linearly proportional to the modulating wave. AM radio broadcasting is a familiar example. At the radio transmitter the modulating wave is the audio-frequency program signal to be communicated; the modulated wave that is broadcast is a radio-frequency, amplitude-modulated sinusoid. See AMPLITUDE-MODULATION RADIO.

In AM the modulated wave is composed of the transmitted carrier, which conveys no information, plus the upper and lower sidebands, which (assuming the carrier frequency exceeds twice the top audio frequency) convey identical and therefore mutually redundant information. J. R. Carson in 1915 was the first to recognize that, under these conditions and assuming adequate knowledge of the carrier, either sideband alone would uniquely define the message. This eventually led to the development of single-sideband (SSB) and vestigial-sideband (VSB) modulation. Apart from a scale factor, the spectrum of the upper sideband and lower sideband is the spectrum of the modulating wave displaced, respectively, without and with inversion by an amount equal to the carrier frequency. See AMPLITUDE-MODULATION DETECTOR; AMPLITUDE MODULATOR; FREQUENCY MODULATION. [H.S.Bl.]

**Amplitude-modulation detector** A device for recovering information from an amplitude-modulated (AM) electrical signal. Such a signal is received, usually at radio frequency, with information impressed in one of several forms. The carrier signal may be modulated by the information signal as double-sideband (DSB) suppressed-carrier (DSSC or DSBSC), double-sideband transmitted-carrier (DSTC or DSBTC), single-sideband suppressed-carrier (SSBSC or SSB), vestigial sideband (VSB), or quadrature-amplitude modulated (QAM).

The field of amplitude-modulation detector requirements splits by application, complexity, and cost into the two categories of synchronous and asynchronous detection. Analog implementation of nonlinear asynchronous detection, which is typically carried out with a diode circuit, is favored for consumer applications, AM-broadcast radio receivers, minimum-cost products, and less critical performance requirements. Synchronous detectors, in which the received signal is multiplied by a replica of the carrier signal, are implemented directly according to their mathematics and block diagrams, and the same general detector satisfies the detection requirements of all SSB, DSB, and VSB signals. Although synchronous detectors may operate in the analog domain by using integrated circuits, more commonly digital circuits are used because of cost, performance, reliability, and power advantages.

In synchronous detection there are two conceptual approaches: to reverse the modulation process (which is rather difficult), or to remodulate the signal from the passband (at or near the transmitter's carrier frequency) to the baseband (centered at dc or zero frequency). The remodulation approach is routine. Unfortunately, a nearly exact replica of the transmitter's

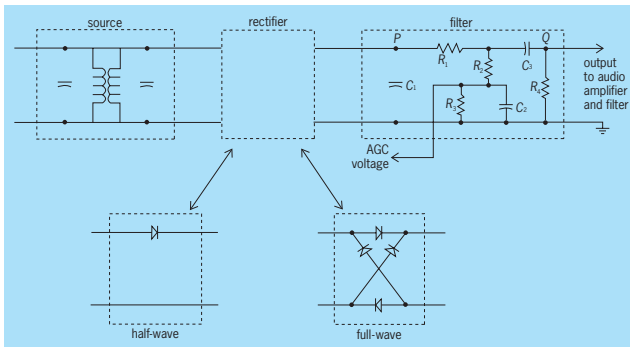

Diode detector circuit.  $P$  = input point of filter;  $Q$  = output point of filter.

carrier signal is needed at the receiver in order to synchronously demodulate a transmitted signal. Synchronous means that the carrier-signal reference in the receiver has the same frequency and phase as the carrier signal in the transmitter. There are three means available to obtain a carrier-signal reference. First, the carrier signal may actually be available via a second channel. There are no difficulties with this method because a perfect replica is in hand. Second, the carrier signal may be transmitted with the modulated signal. It then must be recovered by a circuit known as a phase-lock loop with potential phase and frequency errors. Third, the carrier signal may be synthesized by a local oscillator at the receiver, with great potential for errors. Unless otherwise stated, it will be assumed that a perfect replica of the carrier signal is available. See OSCILLATOR; PHASE-LOCKED LOOPS.

Asynchronous detection applies to DSB signals whose modulation index is less than 1, and is quite simple. First the received signal is full-wave rectified, then the result is low-pass filtered to eliminate the carrier frequency and its products, and finally the average value is removed (by dc blocking, that is, ac coupling). This result is identical to that which is obtained by synchronous detection with a reference that has been amplitude distorted to a square wave. The cheaper but less efficient half-wave rectifier can also be used, in which case the demodulation process is called envelope detection.

A diode detector circuit in a radio receiver has three stages (see illustration). The first stage is the signal source, which consists of a pair of tuned circuits that represent the last intermediate-frequency (i.f.) transformer which couples the signal energy out of the i.f.-amplifier stage into the detector. The second stage is a diode rectifier, which may be either full wave or half wave. Finally, the signal is passed through the third stage, a filter, to smooth high-frequency artifacts and remove the average value. See DIODE; INTERMEDIATE-FREQUENCY AMPLIFIER; RADIO RECEIVER; RECTIFIER.

The waveform shaping at the input point of the filter (see illustration) is determined by a capacitor  $C_1$  in parallel with an equivalent resistance of  $R_1$ , the latter in series with a parallel combination of resistors,  $R_2$  and  $R_4$ . The filter also has a capacitor  $C_3$  between  $R_2$  and  $R_4$ , and a parallel combination of a resistor  $R_3$  and a capacitor  $C_2$  in series with  $R_2$ . The reactances of both capacitors  $C_2$  and  $C_3$  are quite small at the information frequency, so the capacitors can be viewed as short circuits. Meanwhile, the  $C_3$ - $R_4$  combination serves as a dc-blocking circuit to eliminate the constant or dc component at the output point of the filter. In order to bias the output point properly for the next amplifier stage,  $R_4$  is replaced by a biasing resistor network in a real filter;  $R_4$  is the single-resistor equivalent. See ELECTRICAL IMPEDANCE.

The strength of the signal arriving at the detector is proportional to the mean value of the signal at the input point of the filter and is sensed as the automatic-gain-control (AGC) voltage. Changes in this voltage level are used to adjust the amplification before the detector so that the signal strength at the detector input can remain relatively constant, although the signal strength at

the receiver's antenna may fluctuate. Since capacitor  $C_2$  shunts all signal energy and any surviving carrier energy to ground, the AGC voltage is roughly the average value at the input point of the filter scaled by  $R_3/(R_1 + R_2 + R_3)$  because  $R_1$  is much smaller than  $R_4$ .

Additional filtering can be provided as necessary to reduce the noise to an acceptable level. This amplified and filtered signal is finally delivered to an output device, such as a loudspeaker. The ragged waveform of the filter output contrasts with the smooth waveform of the information signal. The raggedness vanishes as the ratio of the i.f. frequency to the information frequency increases. While a synthetic example with a low ratio can be used to clearly show the effects within the demodulator, the amplitude of this raggedness noise decreases in almost direct proportion to the increase in the frequency ratios. The raggedness of the output signal from the filter after half-wave rectification is much greater than that of the full-wave-rectifier case.

The actual worst-case ratio for standard-broadcast amplitude-modulation radio is 46.5:1. In this case the raggedness on the filtered outputs is reduced to a fuzz that can be seen in graphs of the waveforms but is well outside the frequency range of audio circuits, loudspeakers, and human hearing. See AMPLITUDE MODULATOR; MODULATION; WAVEFORM. [S.A.Wh.]

**Amplitude-modulation radio** Radio communication employing amplitude modulation of a radio-frequency carrier wave as the means of conveying the desired intelligence. In amplitude modulation the amplitude of the carrier wave is made to vary corresponding to the fluctuations of a sound wave, television image, or other information to be conveyed. See AMPLITUDE MODULATION; RADIO.

Amplitude modulation (AM), the oldest and simplest form of modulation, is widely used for radio services. The most familiar of these is broadcasting; others include radiotelephony and radiotelegraphy, television picture transmission, and navigational aids.

European and Asian countries use low frequencies in the range 150–255 kilohertz (kHz) for some broadcast services. An advantage of these frequencies is stable and relatively low-attenuation wave propagation. When not limited by atmospheric noise, large areas may be served by one station. In the United States these frequencies are reserved for navigational systems and so are not available for broadcasting.

The frequencies in the range from 535 to 1605 kHz are reserved all over the world for AM (standard) broadcasting. In the Western Hemisphere this band is divided into channels at 10-kHz intervals, certain channels being designated as clear, regional, and local, according to the licensed coverage and class of service. European medium-frequency (mf) broadcasting channels are assigned at 9-kHz intervals.

Small bands of high frequencies between 3000 and 5000 kHz are used in tropical areas of high atmospheric noise for regional broadcasting. This takes advantage of the lower atmospheric noise at these frequencies and permits service under conditions where medium frequencies have only severely limited coverage.

The first radiotelephony was by means of amplitude modulation, and its use has continued with increasing importance. Radiotelephony refers to two-way voice communication. Amplitude modulation and a modified form called single-sideband are used almost exclusively for radiotelephony on frequencies below 30 megahertz. Above 30 MHz, frequency or phase modulation is used almost exclusively, a notable exception being 118–132 MHz, where amplitude modulation is used for all two-way vhf radiotelephony in aviation operations.

The least expensive method known for communicating by telephony over distances longer than a few tens of miles is by using the high frequencies of 3–30 MHz. Furthermore, since radio is the only way to communicate with ships and aircraft, hf AM radiotelephony has remained essential to these operations,

except for short distances that can be covered from land stations using the very high frequencies.

Single-sideband (SSB) hf telephony is a modified form of amplitude modulation in which only one of the modulation sidebands is transmitted. In some systems the carrier is transmitted at a low level to act as a pilot frequency for the regeneration of a replacement carrier at the receiver. Since 1933 most transoceanic and intercontinental telephony has been by single-sideband reduced-carrier radio transmission on frequencies between 4000 and 27,000 kHz. In time, SSB will gradually displace AM radiotelephony to reduce serious interference due to overcrowding of the radio spectrum.

Amplitude-modulated radio has a dominant role in guidance and position location, especially in aviation, which is almost wholly under radio guidance.

Amplitude modulation is used everywhere for the broadcasting of the picture (video) portion of television. In England, France, and a few other places amplitude modulation is also used for the sound channel associated with the television picture, but frequency modulation is more commonly used for sound.

Countries of the Western Hemisphere, Japan, Philippines, Thailand, and Iran broadcast television video in an emission band of 4.25 MHz; the English video bandwidth is 3 MHz; the French system, 10 MHz. The rest of continental Europe (except the Soviet Union) use a bandwidth of 5.25 MHz. The carrier frequencies employed are between 40 and 216 MHz, and 470 to 890 MHz. A channel allocation includes the spectrum needed for both sound and picture. Japan and Australia also use 88–108 MHz for television broadcasting. [E.A.L.]

A number of systems for stereophonic AM radio broadcasting exist that allow stations to transmit two channels of information in the same spectrum space where only one could exist previously. The result is similar to that of stereophonic FM, audio cassette, and other binaural entertainment media. To transmit in AM stereo, a broadcast station employs a device known as an exciter to adapt its existing transmitter. The exciter has left- and right-channel audio inputs as well as summed audio- and radio-frequency outputs. Stereophonic audio program material is connected to the audio inputs, while the outputs attach to the AM transmitter. Stereophonic AM broadcasting methods all have their roots in a system known as quadrature multiplexing. This system allows the transmission of two channels of information on a single carrier frequency, but true quadrature transmissions are inherently incompatible with the majority of radios available to consumers. The differences between various systems employed to transmit stereophonic AM broadcasts all relate to the methods used to overcome this incompatibility. See AMPLITUDE MODULATION; RADIO; STEREOPHONIC RADIO TRANSMISSION. [S.Sa.]

**Amplitude modulator** A device for moving the frequency of an information signal, which is generally at baseband (such as an audio or instrumentation signal), to a higher frequency, by varying the amplitude of a mediating (carrier) signal. The motivation to modulate may be to shift the signal of interest from a frequency band (for example, the baseband, corresponding to zero frequency or dc) where electrical disturbances exist to another frequency band where the information signal will be subject to less electrical interference; to isolate the signal from shifts in the dc value, due to bias shifts with temperature or time of the characteristics of amplifiers, or other electronic circuits; or to prepare the information signal for transmission.

Familiar applications of amplitude modulators are standard-broadcast or amplitude-modulation (AM) radio; data modems (modem = modulator + demodulator); and remote sensing, where the information signal detected by a remote sensor is modulated by the remote signal-conditioning circuitry for transmission to an electrically quiet data-processing location. See AMPLITUDE-MODULATION RADIO; MODEM; REMOTE SENSING.

The primary divisions among amplitude modulators are double sideband (DSB); single sideband (SSB); vestigial sideband

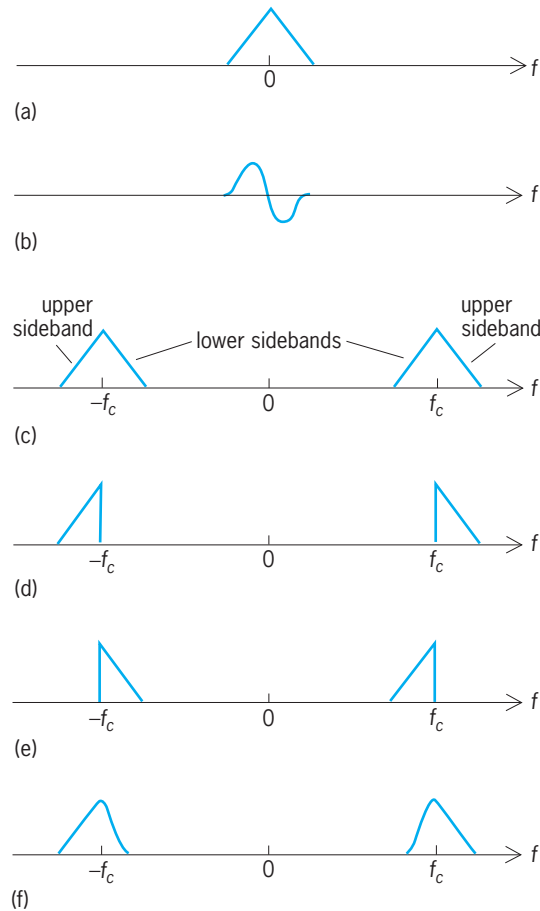

**Baseband spectra and spectra of outputs from suppressed-carrier modulators. Amplitudes and phases are shown as functions of frequency  $f$ .** (a) Baseband amplitude spectrum. (b) Baseband phase spectrum. (c) Amplitude spectrum of output from double-sideband (DSB) modulator. (d) Amplitude spectrum of output from upper single-sideband (SSB) modulator. (e) Amplitude spectrum of output from lower single-sideband (SSB) modulator. (f) Amplitude spectrum of output from vestigial-sideband (VSB) modulator.

(VSB); and quadrature amplitude (QAM), where two DSB signals share the same frequency and time slots simultaneously. Each of these schemes can be additionally tagged as suppressed carrier (SC) or transmitted carrier (TC).

To amplitude-modulate an information signal is (in its simplest form) to multiply it by a second signal, known as the carrier signal (because it then carries the information). A real (as opposed to complex) information signal at baseband, or one whose spectrum is centered about zero frequency, has an amplitude spectrum which is symmetric (an even function; illus. a) and a phase spectrum which is asymmetric (an odd function; illus. b) in frequency about zero. Because of this symmetry, the information in the upper or positive sideband (positive frequencies) replicates the information in the lower or negative sideband (negative frequencies). Balanced modulation or linear multiplication (that is, four-quadrant multiplication where each of the two inputs is free to take on positive or negative values without disturbing the validity of the product) of this information signal by a sinusoidal carrier of single frequency,  $f_c$ , moves the information signal from baseband and replicates it about the carrier frequencies  $f_c$  and  $-f_c$  (illus. c).

Linear multiplication (described above) produces double-sideband suppressed-carrier (DSSC or DSBSC) modulation of the carrier by the information. One of the redundant sidebands of information may be eliminated by filtering (which can be difficult and costly to do adequately) or by phase cancellation (which is

usually a much more reasonable process) to produce the more efficient single-sideband suppressed-carrier (SSBSC or SSB) modulation (illus. *d*, *e*). The process of only partially removing the redundant sideband (usually by deliberately imperfect filtering) and leaving only a vestige of it is called vestigial-sideband (VSB) modulation (illus. *f*). See ELECTRIC FILTER.

Receivers demand a carrier-signal reference to properly demodulate (detect) the transmitted signal. This reference may be provided in one of three ways: it may be transmitted with the modulated signal, for example, in double-sideband transmitted-carrier (DSTC or DSBTC) modulation, which is the method used for standard-broadcast AM radio; transmitted on a separate channel (often the case for instrumentation systems); or generated at the receiver.

DSSC modulation, no matter how it is disguised, is just ordinary (linear) multiplication, or a reasonable approximation to that multiplication. Furthermore, a DSTC signal can be modeled as a DSSC signal with the carrier added. Any amplitude modulator is therefore simply some sort of embodiment of a linear multiplier with or without a means to add the carrier.

High-level DSTC modulation is usually done by varying the power-supply voltage to the final high-power amplifier in the radio-frequency transmitter by summing the information signal with the dc output voltage of the power supply. Low-level DSTC modulation is carried out by integrated circuits that approximate the multiplications, followed by a linear amplifier. See AMPLIFIER.

Because of the falling costs and improving performance of digital devices, signals are now generally represented by digital data, that is, signal values which are sampled in time and encoded as numbers to represent their sampled values. Digital signal-processing (DSP) functions are carried out by some sequence of addition (or subtraction), multiplication, and delays. Efficient mechanization of each of these functions has been the subject of considerable effort. Digitally, waveform generation and linear multiplication are highly optimized processes. Advances in integrated-circuit fabrication techniques have so lowered the cost of digital circuits for modulation that the overwhelming majority of amplitude modulators in use are now digital. Custom application-specific integrated circuits (ASICs), general-purpose programmable DSP devices, and customizable arrays such as programmable logic arrays (PLAs) and field-programmable arrays (FPAs) are all in widespread use as amplitude modulators and demodulators. Digital modems as data transmission equipment dominate the production of amplitude modulators. See INTEGRATED CIRCUITS; AMPLITUDE MODULATION; MODULATION; MODULATOR. [S.A.Wh.]

**Amylase** An enzyme which breaks down (hydrolyzes) starch, the reserve carbohydrate in plants, and glycogen, the reserve carbohydrate in animals, into reducing fermentable sugars, mainly maltose, and reducing nonfermentable or slowly fermentable dextrans. Amylases are classified as saccharifying ( $\beta$ -amylase) and as dextrinizing ( $\alpha$ -amylases). The  $\alpha$ - and  $\beta$ -amylases are specific for the  $\alpha$ - and  $\beta$ -glucosidic bonds which connect the monosaccharide units into large aggregates, the polysaccharides. The  $\alpha$ -amylases are found in all types of organs and tissues, whereas  $\beta$ -amylase is found almost exclusively in higher plants. See CARBOHYDRATE; ENZYME; GLYCOGEN; MALTOSE.

In animals the highest concentrations of amylase are found in the saliva and in the pancreas. Salivary amylase is also known as ptyalin and is found in humans, the ape, pig, guinea pig, squirrel, mouse, and rat.

In plants, starch is broken down during the germination of seeds (rich in starch) by associated plant enzymes into sugars. These constitute the chief energy source in the early development of the plant.  $\beta$ -Amylase occurs abundantly in seeds and cereals such as malt. It also is found in yeasts, molds, and bacteria. [D.N.La.]

**Amyloidosis** A disorder characterized by the accumulation of an unusual extracellular fibrous protein (amyloid) in the connective tissue of the body. The deposition of amyloid may be widespread, involving major organs and leading to serious clinical consequences, or it may be very limited with little effect on health.

Amyloidosis has been classified clinically as: (1) primary amyloidosis, with no evidence for preexisting or coexisting disease; (2) amyloidosis associated with multiple myeloma; (3) secondary amyloidosis, associated with chronic infections (such as osteomyelitis, tuberculosis, leprosy), chronic inflammatory disease (such as rheumatoid arthritis, ankylosing spondylitis, regional enteritis), or neoplasms (such as medullary carcinoma of the thyroid); (4) hereditary amyloidosis, associated with familial Mediterranean fever and a variety of heritable neuropathic, renal, cardiovascular, and other syndromes; (5) local amyloidosis, with local, often tumorlike, deposits in isolated organs without evidence of systemic involvement; (6) amyloidosis associated with aging. There is no specific treatment for amyloidosis, but supportive treatment is very useful. [A.S.Co.]

**Anaerobic infection** An infection caused by anaerobic bacteria (organisms that are intolerant of oxygen). Most such infections are mixed, involving more than one anaerobe and often aerobic or facultative bacteria as well. Anaerobes are prevalent throughout the body as indigenous flora, and virtually all anaerobic infections arise endogenously, the principal exception being *Clostridium difficile* colitis. Factors predisposing to anaerobic infection include those disrupting mucosal or other surfaces (trauma, surgery, and malignancy or other disease), those lowering redox potential (impaired blood supply, tissue necrosis, and growth of nonanaerobic bacteria), drugs inactive against anaerobes (such as aminoglycosides), and virulence factors produced by the anaerobes (toxins, capsules, and collagenase, hyaluronidase, and other enzymes). Anaerobic gram-negative bacilli (*Bacteroides*, *Prevotella*, *Porphyromonas*, *Fusobacterium*) and anaerobic gram-positive cocci (*Peptostreptococcus*) are the most common anaerobic pathogens. *Clostridium* (spore formers) may cause serious infection. The prime pathogen among gram-positive nonsporulating anaerobic bacilli is *Actinomyces*. Of the infections commonly involving anaerobes, the oral and dental pleuropulmonary, intraabdominal, obstetric-gynecologic, and skin and soft tissue infections are most important in terms of frequency of occurrence. To document anaerobic infection properly, specimens for culture must be obtained so as to exclude normal flora and must be transported under anaerobic conditions. Therapy includes surgery and antimicrobial agents. See ANTIBIOTIC; GANGRENE; GAS; INFECTION. [S.M.F.]

**Analcime** A mineral with a framework structure in which all the aluminosilicate tetrahedral vertices are linked, thus alloying it to the feldspars, feldspathoids, and zeolites. Its formula is  $\text{Na}(\text{H}_2\text{O})[\text{AlSi}_2\text{O}_6]$ ; in this sense it is a tectosilicate.

The analcime structure type includes several other mineral species. These include high-temperature leucite, pollucite, and wairakite. Crystals are most frequently trapezohedra, and rarely the mineral is massive granular. Hardness is 5–5½ on Mohs scale; specific gravity is 2.27.

Analcime most frequently occurs as a low-temperature mineral in vesicular cavities in basalts, where it is associated with zeolites (particularly natrolite), datolite, prehnite, and calcite. Small grains are frequent constituents of sedimentary rocks and muds in oceanic basins associated with volcanic sources. See FELDSPAR; FELDSPATHOID; LEUCITE ROCK; ZEOLITE. [P.B.M.]

**Analgesic** Any of a group of drugs of diverse chemical structure and physiological effects which are commonly used for the relief of pain. To qualify as an analgesic a drug must selectively reduce or abolish pain without causing impairment

of consciousness, mental confusion, incoordination or paralysis, or other derangements of the nervous system.

The oldest and best-known of the class of narcotic alkaloid analgesics are opium, a drug obtained by extracting the juice of the poppy seed, and its most active alkaloid, morphine. Morphine and related drugs reduce or block the activation of pain neurons in the gray matter of the spinal cord, and at receptor sites in the brainstem and thalamus. In addition to their use as analgesic drugs, opiates have other biological effects such as sedation, pupillary constriction, suppression of cough reflex, respiratory depression, reduction of intestinal motility, impairment of segmental flexor reflexes, and decrease in body temperature. This functional diversity is attributed to the activation of other inhibitory systems of neurons. While morphine is the most powerful medical analgesic substance, there are many other naturally occurring alkaloids derived from opium. The best known of these is codeine. Common to all opiates is the attribute that if they are taken for weeks or months the recipient will need larger doses to obtain the same analgesic and sedative effects. This response is called tolerance. If the drug is stopped, disagreeable withdrawal or abstinence effects are experienced within hours to days. There is severe pain, sweating, salivation, hyperventilation, restlessness, and confusion. These abstinence symptoms, which are marks of habituation, pressure the addicted person to take extreme measures to obtain the narcotic in order to avoid the symptoms. *See* ADDICTIVE DISORDERS; ALKALOID; ENDORPHINS; MORPHINE ALKALOIDS; NARCOTIC; OPIATES; SEDATIVE.

Because of the strong addictive properties of morphine and related compounds, chemists have synthesized other drugs of similar chemical structure, in the hope of securing analgesia without addiction. This effort has been only partially successful. Methadone, a drug that has been given to addicts as a substitute for morphine, is an effective analgesic when taken orally and is less addictive than morphine. Meperidine (Demerol) is a strong synthetic analgesic but definitely addictive. Other synthetic analgesics are oxycodone (Percodan), levorphanol (levodromoran), propoxyphene (Darvon), and pentazocine (Talwin). The last two of this series cause little or no addiction but, unfortunately, are not strong analgesics. Another synthetic drug, Naloxone, blocks the analgesic effect of all opiate agonists and precipitates withdrawal symptoms in addicted individuals.

Another class of analgesic drugs, which are nonnarcotic (non-addictive), are the salicylates, the most familiar being acetylsalicylic acid (aspirin), and salicylatelike drugs such as phenylbutazone (Butazolidine), indomethacin (Indocin), acetaminophen, and phenacetin. These drugs are most effective in relieving skeletal pain due to inflammation (such as arthritis). Their analgesic properties, which are not nearly as strong as those of morphine and the synthetic opioids, are due to their action on both the peripheral and central nervous system. These drugs also have many other effects, such as reducing fever (antipyrexia) and preventing platelet agglutination. They are the most commonly used of all analgesic medications and are often combined with caffeine or a barbiturate sedative under a variety of trade names and sold for the relief of headache, backache, and so forth. *See* ASPIRIN; EICOSANOIDS; NERVOUS SYSTEM (VERTEBRATE); PAIN. [R.D.A.]

**Analog computer** A computer or computational device in which the problem variables are represented as continuous, varying physical quantities. An analog computer implements a model of the system being studied. The physical form of the analog may be functionally similar to that of the system, but more often the analogy is based solely upon the mathematical equivalence of the interdependence of the computer variables and the variables in the physical system. *See* SIMULATION.

**Types.** An analog computer is classified either in accordance with its use (general- or specific-purpose) or based on its construction (hydraulic, mechanical, or electronic). General-purpose implies programmability and adaptability to different

applications or the ability to solve many kinds of problems. Most electronic analog computers were general-purpose systems, either real-time analog computers in which the results were obtained without any significant time-scale changes, or high-speed repetitive operation computers.

Since the 1970s, digital computer programs have been developed which essentially duplicate the functionality of the analog computer. Modern simulation languages, such as ACSL, GASP, GPSS, SLAM, and Simscript, have replaced electronic analog computers. They provide nearly the same highly interactive and parallel solution capabilities of electronic analog computers, but without the technical shortcomings of electronics: accuracy inherently limited to 0.01%, effective bandwidths of 1 MHz, and cumbersome and time-consuming programming. Simulation languages also avoid the large purchase investments and the continual maintenance dependencies of complex electronic systems.

Another type of analog computer is the digital multiprocessor analog system, in which the relatively slow speeds of sequential digital increment calculations have been radically boosted through parallel processing. In this type of analog computer it is possible to retain the programming convenience and data storage of the digital computer while approximating the speed, interaction potential, and parallel computations of the traditional electronic analogs.

The digital multiprocessor analog computer typically utilizes several specially designed high-speed processors for the numerical integration functions, the data (or variable) memory distributions, the arithmetic functions, and the decision (logic and control) functions. All variables remain as fixed or floating-point digital data, accessible at all times for computational and operational needs.

**Description.** The typical modern general-purpose analog computer consists of a console containing a collection of operational amplifiers; computing elements, such as summing networks, integrator networks, attenuators, multipliers, and function generators; logic and interface units; control circuits; power supplies; a patch bay; and various meters and display devices. The patch bay is arranged to bring input and output terminals of all programmable devices to one location, where they can be conveniently interconnected by various patch cords and plugs to meet the requirements of a given problem. Prewired problem boards can be exchanged at the patch bay in a few seconds and new coefficients set up typically in less than a half hour. Extensive automatic electronic patching systems have been developed to permit fast setup, as well as remote and time-shared operation.

The analog computer basically represents an instrumentation of calculus, in that it is designed to solve ordinary differential equations. This capability lends itself to the implementation of simulated models of dynamic systems. The computer operates by generating voltages that behave like the physical or mathematical variables in the system under study. Each variable is represented as a continuously varying (or steady) voltage signal at the output of a programmed computational unit. Specific to the analog computer is the fact that individual circuits are used for each feature or equation being represented, so that all variables are generated simultaneously. Thus the analog computer is a parallel computer in which the configuration of the computational units allows direct interactions of the computed variables at all times during the solution of a problem.

**Programming.** To solve a problem using an analog computer, the problem solver goes through a procedure of general analysis, data preparation, analog circuit development, and patchboard programming. Test runs of subprograms may also be made to examine partial-system dynamic responses before eventually running the full program to derive specific and final answers. The problem-solving procedure typically involves eight major steps, as follows:

1. The problem under study is described with a set of mathematical equations or, when that is not possible, the system configuration and the interrelations of component influences are defined in block-diagram form, with each block described in terms of black-box input-output relationships.
2. Where necessary, the description of the system (equations or system block diagram) is rearranged in a form that may better suit the capabilities of the computer, that is, avoiding duplications or excessive numbers of computational units, or avoiding algebraic (nonintegrational) loops.
3. The assembled information is used to sketch out an analog circuit diagram which shows in detail how the computer could be programmed to handle the problem and achieve the objectives of the study.
4. System variables and parameters are then scaled to fall within the operational ranges of the computer. This may require revisions of the analog circuit diagram and choice of computational units.
5. The finalized circuit arrangement is patched on the computer problem board.
6. Numerical values are set up on the attenuators, the initial conditions of the entire system model established, and test values checked.
7. The computer is run to solve the equations or simulate the black boxes so that the resultant values or system responses can be obtained. This gives the initial answers and the "feel" for the system.
8. Multiple runs are made to check the responses for specific sets of parameters and to explore the influences of problem (system) changes, as well as the behavior which results when the system configuration is driven with different forcing functions.

**Hybrid computers.** The accuracy of the calculations on a digital computer can often be increased through double precision techniques and more precise algorithms, but at the expense of extended solution time, due to the computer's serial nature of operation. Also, the more computational steps there are to be done, the longer the digital computer will take to do them. On the other hand, the basic solution speed is very rapid on the analog computer because of its parallel nature, but increasing problem complexity demands larger computer size. Thus, for the analog computer the time remains the same regardless of the complexity of the problem, but the size of the computer required grows with the problem.

Interaction between the user and the computer during the course of any calculation, with the ability to vary parameters during computer runs, is a highly desirable and insight-generating part of computer usage. This hands-on interaction with the computed responses is simple to achieve with analog computers. For digital computers, interaction usually takes place through a computer keyboard terminal, between runs, or in an on-line stop-go mode. An often-utilized system combines the speed and interaction possibilities of an analog computer with the accuracy and programming flexibility of a digital computer. This combination is specifically designed into the hybrid computer.

In a modern analog-hybrid console, the mode switches in the integrators are interfaced with the digital computer to permit fast iterations of dynamic runs under digital computer control. Data flow in many ways and formats between the analog computer with its fast, parallel circuits and the digital computer with its sequential, logic-controlled programs. Special high-speed analog-to-digital and digital-to-analog converters translate between the continuous signal representations of variables in the analog domain and the numerical representations of the digital computer. Control and logic signals are more directly compatible and require only level and timing compatibility. See ANALOG-TO-DIGITAL CONVERTER; BOOLEAN ALGEBRA; DIGITAL-TO-ANALOG CONVERTER.

The programming of hybrid models is a more complex challenge than described above, requiring the user to consider the

parallel action of the analog computer interlaced with the step-by-step computations progression in the digital computer. For example, in simulating the mission of a space vehicle, the capsule control dynamics will typically be handled on the analog computer in continuous form, but interfaced with the digital computer, where the navigational trajectory is calculated. See COMPUTER. [P.A.H.]

**Analog states** States in neighboring nuclear isobars that have the same total angular momentum, parity, and isotopic spin. They also have nearly identical nuclear structure wave functions except for the transformation of one or more neutrons into an equivalent number of protons, which occupy the same single-particle states as the neutrons. Analog states (or isobaric analog states, IAS) have been observed throughout the periodic table, indicating that isotopic spin is a good quantum number. See ANGULAR MOMENTUM; I-SPIN; NUCLEAR STRUCTURE; PARITY (QUANTUM MECHANICS).

Since the nucleon-nucleon interaction has been found to be approximately charge-independent, it is possible to consider protons and neutrons as representing different charge states of a single particle, that is, a nucleon. Thus, a level (commonly referred to as a parent state) in a nucleus with  $Z$  protons and  $N$  neutrons can be expected to have an analog in the neighboring isobar with  $Z + 1$  protons and  $N - 1$  neutrons (and the same total number of nucleons,  $A = Z + N$ ), where the protons and neutrons occupy the same orbits as those in the parent state. The energy difference between the parent and analog states predominantly arises from the increased contribution from the electrostatic Coulomb interaction to the total energy arising from the extra proton in the analog state. From this amount must be subtracted the neutron-proton mass difference of 0.782 MeV (energies are given on the atomic mass scale). The agreement between such calculated energies of analog states and their measured values is in general fairly precise but not exact. The reason is that small additional factors influence the level energies, such as electromagnetic effects, a small charge-dependent nuclear interaction, isospin mixing, and nuclear structure effects.

The study of analog states provides important information used to test nuclear theories. For example, the double charge-exchange reactions ( $\pi^+$ ,  $\pi^-$ ) [where  $\pi^+$  and  $\pi^-$  represent a pion with positive and negative charge, respectively] have been used to identify double isobaric analog states, that is, analogs in isobars removed by 2 charge units. Such data have been useful for testing various formulas for predicting the relative masses of isobaric multiplets. Single and double charge-exchange reactions utilizing incident pions have also been used to investigate giant resonances built upon analog states. The single-particle structure of parent states can be studied by observing the particle decay of the analog state when the decay resides in the nuclear continuum. Measurements of the widths of analog states provide information pertaining to their fragmentation, for example, their mixing with states of the same spin and parity but with total isospin lower by one unit. [D.J.Ho.]

**Analog-to-digital converter** A device for converting the information contained in the value or magnitude of some characteristic of an input signal, compared to a standard or reference, to information in the form of discrete states of a signal, usually with numerical values assigned to the various combinations of discrete states of the signal.

Analog-to-digital (A/D) converters are used to transform analog information, such as audio signals or measurements of physical variables (for example, temperature, force, or shaft rotation) into a form suitable for digital handling, which might involve any of these operations: (1) processing by a computer or by logic circuits, including arithmetical operations, comparison, sorting, ordering, and code conversion, (2) storage until ready for

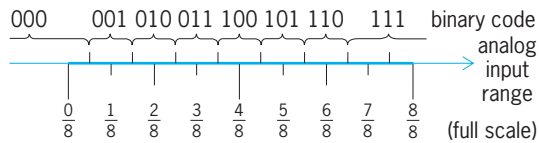

A three-bit binary representation of a range of input signals.

further handling, (3) display in numerical or graphical form, and (4) transmission.

If a wide-range analog signal can be converted, with adequate frequency, to an appropriate number of two-level digits, or bits, the digital representation of the signal can be transmitted through a noisy medium without relative degradation of the fine structure of the original signal. See COMPUTER GRAPHICS; DATA COMMUNICATIONS; DIGITAL COMPUTER.

Conversion involves quantizing and encoding. Quantizing means partitioning the analog signal range into a number of discrete quanta and determining to which quantum the input signal belongs. Encoding means assigning a unique digital code to each quantum and determining the code that corresponds to the input signal. The most common system is binary, in which there are  $2n$  quanta (where  $n$  is some whole number), numbered consecutively; the code is a set of  $n$  physical two-valued levels or bits (1 or 0) corresponding to the binary number associated with the signal quantum.

The illustration shows a typical three-bit binary representation of a range of input signals, partitioned into eight quanta. For example, a signal in the vicinity of  $3/8$ ; full scale (between  $5/16$  and  $7/16$ ) will be coded 011 (binary 3). See NUMBER SYSTEMS.

[D.H.S.]

**Analysis of variance** Total variation in experimental data is partitioned into components assignable to specific sources by the analysis of variance. This statistical technique is applicable to data for which (1) effects of sources are additive, (2) uncontrolled or unexplained experimental variations (which are grouped as experimental errors) are independent of other sources of variation, (3) variance of experimental errors is homogeneous, and (4) experimental errors follow a normal distribution. When data depart from these assumptions, one must exercise extreme care in interpreting the results of an analysis of variance. Statistical tests indicate the contribution of the components to the observed variation. See STATISTICS.

[R.L.Bri.]

**Analytic geometry** A branch of mathematics in which algebra is applied to the study of geometry; the subject is also called cartesian geometry. The basis for an algebraic treatment of geometry is provided by the existence of a one-to-one correspondence between the elements, "points" of a directed line  $g$ , and the elements, "numbers," that form the set of all real numbers. Such a correspondence establishes a coordinate system on  $g$ , and the number corresponding to a point of  $g$  is called its coordinate. The point  $O$  of  $g$  with coordinate zero is the origin of the coordinate system. A coordinate system on  $g$  is cartesian provided that for each point  $P$  of  $g$ , its coordinate is the directed distance  $\overline{OP}$ . Then all points of  $g$  on one side of  $O$  have positive coordinates (forming the positive half of  $g$ ) and all points on the other side have negative coordinates. The point with coordinate 1 is called the unit point. Since the relation  $\overline{OP} + \overline{PQ} = \overline{OQ}$  is clearly valid for each two points  $P, Q$  of directed line  $g$ , then  $\overline{PQ} = \overline{OQ} - \overline{OP} = q - p$ , where  $p$  and  $q$  are the coordinates of  $P$  and  $Q$ , respectively.

Choose any two intersecting lines  $g_1, g_2$  of the plane, with cartesian coordinate systems selected on each so that the intersection point has coordinate  $O$  in each system. To each point  $P$  of the plane an ordered pair of numbers  $(x, y)$  is attached as coordinates, where  $x$  is the coordinate of the point of intersection of  $g_1$  with the line through  $P$  parallel to  $g_2$  and  $y$  is the coordinate

of the point of intersection of  $g_2$  with the line through  $P$  parallel to  $g_1$ . The lines  $g_1$  and  $g_2$  are called the  $x$  axis and  $y$  axis, respectively. It is usually convenient to take the same scale on each axis; that is, the segments joining the unit points on the two axes to the origin are congruent. The notation  $P(x, y)$  denotes a point  $P$  with coordinates  $(x, y)$ . If  $\omega$  denotes the angle made by the positive halves of the two axes, and  $d$  the distance between points  $P_1(x_1, y_1)$  and  $P_2(x_2, y_2)$ , application of the law of cosines yields

$$d = [(x_1 - x_2)^2 + (y_1 - y_2)^2 + 2(x_1 - x_2)(y_1 - y_2) \cos \omega]^{1/2}$$

Since  $\cos 90^\circ = 0$ , this important formula is simplified by taking the axes mutually perpendicular. Though it is occasionally useful to employ oblique axes ( $\omega \neq 90^\circ$ ), the simplifications resulting from a rectangular cartesian coordinate system make it the usual choice. Such a cartesian coordinate system is assumed in what follows. Thus, the distance  $d$  between  $P_1(x_1, y_1)$  and  $P_2(x_2, y_2)$  is given by  $[(x_1 - x_2)^2 + (y_1 - y_2)^2]^{1/2}$ .

The correspondence between the geometric entity "point" and the arithmetic entity "pair of real numbers," upon which plane analytic geometry is based, results in associating with each geometric locus one or more equations that are satisfied by the coordinates of all those (and only those) points forming the locus (equations of the locus), and in associating with each system of equations in the variables  $x, y$  the figure (graph of the equations) whose points are determined by the pairs of numbers satisfying the equations. Thus the algebraic method of studying geometry is balanced by a geometric interpretation of algebra. A central problem in analytic geometry is that of finding equations of certain important figures among curves and surfaces. See CURVE FITTING.

By use of the formula for the distance of two points and the definition of a circle, an equation for a circle with center  $C(x_0, y_0)$  and radius  $r$  ( $r \geq 0$ ) is found to be  $(x - x_0)^2 + (y - y_0)^2 = r^2$ .

Much of plane analytic geometry deals with a class of curves which (from the way in which they were first studied) are known as conic sections or conics. A conic is the locus of a point  $P$  that moves so that its distance from a fixed point  $F$  (the focus) is in a constant positive ratio  $\epsilon$  (the eccentricity) to its distance from a fixed line (the directrix) which is not through  $F$ . Let  $(c, 0)$  be the coordinates of  $F$ ,  $c > 0$ , and take the  $y$  axis as the directrix. Then  $P(x, y)$  satisfies the equation  $[(x - c)^2 + y^2]^{1/2} = \epsilon x$ ; that is,  $(1 - \epsilon^2)x^2 + y^2 - 2cx + c^2 = 0$ , and it is easily seen that each point whose coordinates satisfy this equation is on the conic. Hence each conic is represented by a second-degree equation in the cartesian coordinates  $(x, y)$ . A conic is called a parabola, ellipse, or hyperbola accordingly as  $\epsilon = 1$ ,  $\epsilon < 1$ ,  $\epsilon > 1$ , respectively. See CONIC SECTION.

Let cartesian coordinate systems be established on each of three pairwise mutually perpendicular lines of 3-space that intersect in  $O$ , the common origin of the systems. Suppose equal scales and call the lines the  $x$  axis,  $y$  axis, and  $z$  axis. To each point  $P$  of space an ordered triple  $(x, y, z)$  of real numbers is attached as rectangular cartesian coordinates, where  $x$  is the coordinate of the foot of the perpendicular from  $P$  to the  $x$  axis, and  $y$  and  $z$  are similarly defined. Thus every point of space has unique coordinates, and each ordered triple of real numbers is the coordinates of a point of space. If  $d$  denotes the distance between two points  $P_1(x_1, y_1, z_1)$  and  $P_2(x_2, y_2, z_2)$ , then

$$d = [(x_1 - x_2)^2 + (y_1 - y_2)^2 + (z_1 - z_2)^2]^{1/2}$$

It follows from the definition of a sphere and the formula for distance between two points that

$$(x - a)^2 + (y - b)^2 + (z - c)^2 = r^2$$

is an equation for the sphere with center  $(a, b, c)$  and radius  $r$ , and by completing the squares of the  $x, y$ , and  $z$  terms in the equation

$$x^2 + y^2 + z^2 + 2Dx + 2Ey + 2Fz + G = 0$$



it is seen that the locus of such an equation is a sphere with positive or zero radius, or there is no (real) locus.

Any equation in just two of the three coordinates is an equation of a cylinder whose elements are parallel to the axis of the missing variable. Thus the locus in 3-space of  $x^2 + y^2 = r^2$  is a (right) circular cylinder whose elements are parallel to the  $z$  axis and which intersects the  $xy$  plane in the circle  $x^2 + y^2 = r^2, z = 0$ .

Any equation  $f(x,y,z) = 0$ , with  $f(x,y,z)$  homogeneous in  $x, y, z$  (for example,  $4xy - xz + yz = 0, x^3 - xy^2 + z^3 = 0$ ) has a cone with vertex  $O$  as locus.

A surface of revolution is obtained by rotating a plane curve  $C$  about a line  $g$  of its plane. If  $f(x,y) = 0, z = 0$  are equations of  $C$ , and  $g$  is the  $x$  axis, the resulting surface of revolution has equation  $f(x, \sqrt{y^2 + z^2}) = 0$ . Thus the surface generated by revolving the circle  $x_2 + (y - b)^2 = a^2, z = 0$ , about the  $x$  axis (the torus or anchor ring, if  $b > a$ ) has the equation

$$x^2 + (\sqrt{y^2 + z^2} - b)^2 = a^2$$

A quadric surface is the locus of points whose coordinates satisfy an equation of the form

$$Ax^2 + By^2 + Cz^2 + Dxy + Exz + Fyz + Gx + Hy + Jz + K = 0$$

where at least one coefficient of a second-degree term is not zero. Some surfaces obtained by rotating conics about a line belong to this class, for example, spheres, prolate and oblate spheroids (given by rotating an ellipse about its major and minor axes, respectively), hyperboloids and paraboloids resulting from rotations of hyperbolas and parabolas about their axes of symmetry, and right circular cones and cylinders. Cylinders with conics for directrix curves are also members. [L.M.BI.]

**Analytic hierarchy** A framework for solving a problem. The analytic hierarchy process is a systematic procedure for representing the elements of any problem. It organizes the basic rationality by breaking down a problem into its smaller constituents and then calls for only simple pairwise comparison judgments, to develop priorities in each level.

The analytic hierarchy process provides a comprehensive framework to cope with intuitive, rational, and irrational factors in making judgments at the same time. It is a method of integrating perceptions and purposes into an overall synthesis. The analytic hierarchy process does not require that judgments be consistent or even transitive. The degree of consistency (or

inconsistency) of the judgment is revealed at the end of the analytic hierarchy process.

People making comparisons use their feelings and judgment. Both vary in intensity. To distinguish among different intensities, the scale of absolute numbers in the table is useful.

The analytic hierarchy process can be decomposed into the following steps. Particular steps may be emphasized more in some situations than in others. Also as noted, interaction is generally useful for stimulation and for representing different points of view.

1. Define the problem and determine what knowledge is sought.
2. Structure the hierarchy from the top (the objectives from a broad perspective) through the intermediate levels (criteria on which subsequent levels depend) to the lowest level (which usually is a list of the alternatives).
3. Construct a set of pairwise comparison matrices for each of the lower levels, one matrix for each element in the level immediately above. An element in the higher level is said to be a governing element for those in the lower level since it contributes to it or affects it. In a complete simple hierarchy, every element in the lower level affects every element in the upper level. The elements in the lower level are then compared to each other, based on their effect on the governing element above. This yields a square matrix of judgments. The pairwise comparisons are done in terms of which element dominates the other. These judgments are then expressed as integers according to the judgment values in the table. If element A dominates element B, then the whole number integer is entered in row A, column B, and the reciprocal (fraction) is entered in row B, column A.
4. There are  $n(n - 1)/2$  judgments required to develop the set of matrices in step 3, where  $n$  is the number of elements in the lower level.
5. Having collected all the pairwise comparison data and entered the reciprocals together with  $n$  unit entries down the main diagonal, the eigenvalue problem  $Aw = \lambda_{\max} w$  is solved and consistency is tested, using the departure of  $\lambda_{\max}$  from  $n$  (see below).
6. Steps 3, 4, and 5 are performed for all levels and clusters in the hierarchy.
7. Hierarchical composition is now used to weigh the eigenvectors by the weights of the criteria, and the sum is taken over all weighted eigenvector entries corresponding to those in the lower level of the hierarchy.
8. The consistency ratio of the entire hierarchy is found by multiplying each consistency index by the priority of the corresponding criterion and adding them together. The result is then divided by the same type of expression, using the random consistency index corresponding to the dimensions of each matrix weighted by the priorities as before. The consistency ratio should be about 10% or less to be acceptable. If not, the quality of the judgments should be improved, perhaps by revising the manner in which questions are asked in making the pairwise comparisons. If this should fail to improve consistency, it is likely that the problem should be more accurately structured; that is, similar elements should be grouped under more meaningful criteria. A return to step 2 would be required, although only the problematic parts of the hierarchy may need revision. See DECISION THEORY; SYSTEMS ENGINEERING. [T.L.S.]

#### Scale of relative Importance

Intensity of relative importance	Explanation
1 (equal importance)	Two activities contribute equally to the objective
3 (slight importance of one over another)	Experience and judgment slightly favor one activity over another
5 (essential or strong importance)	Experience and judgment strongly favor one activity over another
7 (demonstrated importance)	An activity is strongly favored and its dominance is demonstrated in practice
9 (absolute importance)	The evidence favoring one activity over another is of the highest possible order of affirmation
2, 4, 6, 8 (intermediate values between the two adjacent judgments)	When compromise is needed
Reciprocals of above nonzero numbers (if an activity has one of the above numbers assigned to it when compared with second activity, the second activity has the reciprocal value when compared to the first)	

**Analytical chemistry** The science of chemical characterization and measurement. Qualitative analysis is concerned with the description of chemical composition in terms of elements, compounds, or structural units, whereas quantitative analysis is concerned with the measurement of amount.

Analytical chemistry, once limited to the determination of chemical composition in terms of the relative amounts of

elements or compounds in a sample, has been expanded to involve the spatial distribution of elements or compounds in a sample, the distinction between different crystalline forms of a given element or compound, the distinction between different chemical forms (such as the oxidation state of an element), the distinction between a component on the surface or in the interior of a particle, and the detection of single atoms on a surface. To permit these more detailed questions to be answered, as well as to improve the speed, accuracy, sensitivity, and selectivity of traditional analysis, a large variety of physical measurements are used. These methods are based on spectroscopic, electrochemical, chromatographic, chemical, and nuclear principles.

Modern analysis has also placed significant demands on sampling techniques. It has become necessary, for example, to handle very small liquid samples [in the nanoliter ( $10^{-9}$  liter) range or less] as part of the analysis of complex mixtures such as biological fluids and to simultaneously determine many different components. The sample may be a solid that must be converted through vaporization into a form suitable for analysis.

Spectroscopy includes the measurement of emission, absorption, reflection, and scattering phenomena resulting from interaction of a sample with gamma rays and x-rays at the high-energy end of the spectrum and with the less energetic ultraviolet, visible, infrared, and microwave radiation. See SPECTROSCOPY.

Lower-energy forms of excitation such as ultraviolet, visible, or infrared radiation are used in molecular spectroscopy. Ultraviolet radiation and visible radiation, which are reflective of the electronic structure of molecules, are used extensively for quantitative analysis. The radiation absorbed by the sample is measured. It is also possible to measure the radiation emitted (fluorescence). The absorption of infrared radiation is controlled by the properties of bonds between atoms, and it is accordingly most widely used for structure identification and determination. It is not widely used for quantitative analysis except for gases such as carbon monoxide (CO) and hydrocarbons. X-rays are used through emission of characteristic radiation, absorption, or diffraction. In the last case, characteristic diffraction patterns reveal information about specific structural entities, such as a particular crystalline form. Extended x-ray absorption fine structure (EXAFS) is based on the use of x-rays from a synchrotron source to reveal structural details such as interatomic distances. See INFRARED SPECTROSCOPY; X-RAY FLUORESCENCE ANALYSIS.

Though not strictly a spectroscopic technique, mass spectrometry is an important and increasingly applied method of analysis, especially for organic and biological samples. Among the applications are the analysis of more than 70 elements (spark-source mass spectrometry), surface analysis (secondary ion mass spectrometry and ion-probe mass spectrometry), and the determination of the structure of organic molecules and of proteins and peptides (high-resolution mass spectrometry). See MASS SPECTROMETRY.

Nuclear magnetic resonance measures the magnetic environment around individual atoms and provides one of the most important means for deducing the structure of a molecule. Atoms possessing nuclear spin are probed by monitoring the interaction between their nuclear spin and an applied external magnetic field. For large molecules these interactions are complex, and a variety of nuclear excitation techniques have been developed that permit establishment of the connectivity between the various atoms in a molecule. Since the technique is nondestructive, it can be used to monitor living systems. See NUCLEAR MAGNETIC RESONANCE (NMR).

Several forms of spectroscopy are especially useful for surface analysis. The scanning electron microscope (SEM) involves a finely collimated electron beam that sweeps across the surface to produce an image. At the same time the surface atoms are excited to emit characteristic x-rays, thus making it possible to obtain an image of the surface along with its spatially resolved elemental composition. The resolution of this technique (electron microprobe) is in the micrometer ( $10^{-4}$  cm) range. Images with a

resolution of angstroms ( $10^{-8}$  cm) have been obtained by using the techniques of atomic force microscopy (AFM) and scanning tunneling microscopy (STM), which correspond to the dimensions of individual atoms. A significant advantage of the latter two techniques is that a high vacuum is not required, so samples can be analyzed at atmospheric pressure. See ELECTRON-PROBE MICROANALYSIS; ELECTRON SPECTROSCOPY.

Potentiometry is the most widely applied electrochemical technique, since it includes a variety of ion-selective electrodes, the most important of which is the glass electrode used to measure pH. Other important ion-selective electrodes measure ions of sodium, potassium, calcium, sulfide, chloride, and fluoride. When the electrodes are used in conjunction with gas-permeable membranes, gases such as ammonia, carbon dioxide, and hydrogen sulfide can be measured. See ELECTROCHEMISTRY; pH.

[H.A.L.; G.S.W.]

Separation techniques include the various forms of chromatography and electrophoresis. They are based on the separation of a mixture of species in a sample due to differential migration. Two forces act in opposition: a stationary phase acts to retard a migrating species, while the mobile phase tends to promote migration. The mobile phase may be liquid (liquid chromatography) or gaseous (gas chromatography), while the stationary phase may be a solid or a solid covered with a thin film of liquid. The stationary phase is typically packed in a column through which the mobile phase is pumped. High-performance liquid chromatography (HPLC) has become especially important for the separation of complex mixtures of nonvolatile materials. Separations may often be accomplished in a matter of several minutes. The stationary phase can preferentially interact with the migrating species according to charge, size, hydrophobicity, or in some cases because of the special affinity which a species has for the stationary phase (affinity chromatography). The stationary phase can also be a thin layer of solid support deposited on a plate (thin-layer chromatography). See CHROMATOGRAPHY.

Alternatively, the driving force for separation will be the migration of charged species in an electric field (electrophoresis). The stationary phase may be a gel on a plate or in a tube, or a solution maintained in a capillary through which the analytes move. The important techniques in this area are capillary electrophoresis, isotachopheresis, and isoelectric focusing. See ELECTROPHORESIS.

Thermal methods are based on the heating of a sample over a range of temperatures. This approach may result in absorption of heat by the sample or in evolution of heat due to physical or chemical changes. Thermogravimetry involves the measurement of mass; differential thermal analysis involves a detection of chemical or physical processes through a measurement of the difference in temperature between a sample and a stable reference material; differential thermal calorimetry evaluates the heat evolved in such processes. A variety of calorimetric techniques are used to measure the extent of reactions that are otherwise difficult to evaluate. See CALORIMETRY.

[G.S.W.]

**Anamnia** Those vertebrate animals, sometimes called Anamniota, which lack an amnion in development. The amnion is a protective embryonic envelope that encloses the embryo and its surrounding liquid, the amniotic fluid, during fetal life. An amnion is present in mammals, birds, and reptiles (collectively called the Amniota), but is absent in fishes and amphibians. See AMNION; AMNIOTA; AMPHIBIA; PISCES (ZOOLOGY).

[R.M.B.]

**Anaphylaxis** A generalized or localized tissue reaction occurring within minutes of an antigen-antibody reaction. Similar reactions elicited by nonimmunologic mechanisms are termed anaphylactoid reactions. In humans, the clinical manifestations of anaphylaxis include reactions of the skin with itching, erythema, and urticaria; the upper respiratory tract with edema of

the larynx; the lower respiratory tract with dyspnea, wheezing, and cough; the gastrointestinal tract with abdominal cramps, nausea, vomiting, and diarrhea; and the cardiovascular system with hypotension and shock. Individuals undergoing anaphylactic reactions may develop any one, a combination, or all of the signs and symptoms. Anaphylaxis may be fatal within minutes, or may occur days or weeks after the reaction, if the organs sustained considerable damage during the hypotensive phase.

Anaphylaxis in humans is most often the result of the interaction of specific IgE antibody fixed to mast cells and antigen. Two molecules of IgE are bridged by the antigen, which may be a complex protein or chemical (haptén) bound to protein. The antigen-antibody interaction leads to increased cell-membrane permeability, with influx of calcium and release of either preformed or newly formed pharmacologic mediators from the granules. Preformed mediators include histamine and eosinophilic or neutrophilic chemotactic factors. Newly formed molecules include leukotrienes or slow-reacting substance of anaphylaxis and prostaglandins. The mediator action induces bronchoconstriction, vasodilation, cellular infiltration, and increased mucus production.

Another mechanism for induction of anaphylaxis in humans occurs when antigen binds to preformed IgG antibody and complement components interact with the antigen-antibody complex. The early components of the complement system bind to the antibody molecule, leading to activation of other complement components. During the activation, components known as anaphylatoxins (C3a and C5a) are released which may directly cause bronchoconstriction with respiratory impairment, and vasodilation with hypotension or shock. See COMPLEMENT; EICOSANOIDS.

Anaphylaxis due to IgE mechanisms has been associated with foreign proteins such as horse antitoxins, insulin, adrenocorticotrophic hormone (ACTH), protamine, and chymopapain injected into herniated discs; drugs such as penicillin and its derivatives; foods such as shellfish, nuts, and eggs; and venom of stinging insects. Anaphylaxis mediated by IgG is seen in blood-transfusion reactions and following the use of cryoprecipitate, plasma, or immunoglobulin therapy.

After the identification of the inciting agent for the anaphylactic reaction, prevention is the best mode of therapy. Immunotherapy with insect venom and desensitization with certain drugs are effective prophylactic measures. Individuals with recurrent episodes of anaphylaxis, when the etiological cause is unknown and preventive measures are impractical, should be provided with epinephrine in a form that can be self-administered whenever symptoms occur. See EPINEPHRINE.

The treatment of anaphylaxis is aimed at reducing the effect of the chemical mediators on the end organs and preventing further mediator release. The drug of choice for this is epinephrine given subcutaneously in repeated doses. Additionally, a clear airway and appropriate oxygenation must be maintained; hypotension should be treated, as should any cardiac arrhythmia. See ANTIGEN-ANTIBODY REACTION; HYPERSENSITIVITY; SHOCK SYNDROME. [S.B.Se.; J.N.F.]

**Anaplasmosis** A disease of ruminants caused by a specialized group of gram-negative bacteria of the order Rickettsiales, family Anaplasmataceae, genus *Anaplasma*. *Anaplasma* is an obligate intracellular parasite infecting erythrocytes of cattle, sheep, goats, and wild ruminants in most of the tropical and subtropical world. The most important species is *A. marginale*, which causes anemia and sometimes death in cattle. Anaplasmosis is one of the most important diseases of cattle and results in significant economic losses. See RICKETTSIOSES.

Transmission of *Anaplasma* occurs biologically by species of hard ticks. Rickettsiae are ingested with a blood meal and undergo complex development beginning in the tick gut. *Anaplasma* is transmitted from the salivary glands while ticks feed. Mechanical transmission occurs when the mouthparts of

biting flies become contaminated while feeding on infected cattle and then quickly move to uninfected animals. Contaminated needles and instruments for dehorning, castration, and tagging may also transmit the organism throughout a herd.

The average prepatent period is 21 days postinfection, but animals may not exhibit clinical disease for as long as 60 days after infection. In acute anaplasmosis, cattle exhibit depression, loss of appetite, increased temperature, labored breathing, dehydration, jaundice, and a decrease in milk production. Death may result from severe anemia, and abortions may occur. Recovered animals gradually regain condition but remain chronically infected and are subject to periodic relapses.

The clinical manifestations of anaplasmosis can be halted or prevented if tetracycline antibiotics are administered early. The drug inhibits rickettsial protein synthesis but does not kill the organism. Tetracyclines may also be added to feeds to prevent clinical symptoms. Controlling fly and tick populations by chemical spraying or dipping may be used to reduce the spread of disease. Vaccination with killed *A. marginale* from erythrocytes provides protection against the acute disease but does not prevent infection. Boosters must be given annually. The less virulent species, *A. centrale*, is used as a live vaccine in some countries and provides some protection against *A. marginale*, but it can revert to a virulent form. See ANTIBIOTIC; VACCINATION.

Once cattle are infected with *Anaplasma*, they remain persistently infected and may serve as reservoirs of infection for other cattle or tick vectors. During this time the parasitemia fluctuates and at times may be undetectable. The spread of anaplasmosis may occur when these carrier cattle are moved to nonendemic areas. Ticks have been shown to transmit new infections after feeding on animals with undetectable parasitemias. Carrier animals may also have relapse infections, producing new herd infections.

Cattle which recover from clinical anaplasmosis are protected from subsequent exposure to the same geographic strain of *Anaplasma*. Calves have a natural immunity to clinical disease if exposed within their first year. Protection is attributed to a complex combination of antibody and cell-mediated responses. See ANTIBIOTIC; IMMUNITY. [E.F.B.]

**Anapsida** A subclass of reptiles characterized by a roofed temporal region in which there are no temporal fenestrations. Chelonia (turtles), with living representatives, and the extinct Cotylosauria are the two major subdivisions of this subclass. The Mesosauria, an extinct group of aquatic reptiles from the early Permian, have been included, but the assignment is far from certain.

Among the cotylosaurs are found the most primitive known reptiles, which date from the Early Pennsylvanian. These forms and their immediate descendants flourished in the Permian and Triassic periods of the late Paleozoic and early Mesozoic eras, respectively. Turtles first appear as fossils in Triassic rocks and are well represented in the fossil record from that time to the present. Throughout their history anapsids have, for the most part, inhabited areas close to water, with some exceptions among the turtles, and many of them have been semiaquatic in habitat and adaptations. See MESOSAURIA. [E.C.O.]

**Anaspida** An extinct order of fresh- or brackish-water Agnatha, known from the Upper Silurian of Europe and Canada and from the Upper Devonian of Canada. The Middle Silurian Scottish *Jamoytius* is thought by some to be an anaspid.

Members of this group are small, not exceeding 10 in. (25 cm) in length, and typically have a slender, fusiform body covered with small scales and a rounded, jawless, terminal or sub-terminal mouth (see illustration). Long paired fins are present, at least in some genera, and the tail is unusual in having the muscular lobe turned downward. They were probably active, nectonic swimmers, adapted for feeding on minute particles.

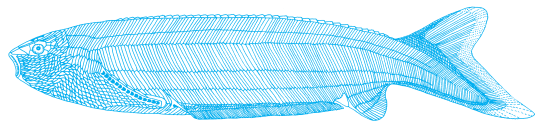

**Pharyngolepsis oblongus of the Anaspida, reconstruction.**  
(After A. Ritchie)

A relationship to Osteostraci and Petromyzonida is indicated by the single dorsal nostril lying in front of the pineal eye and between the large paired eyes and by the paired rows of circular gill openings; all three orders are grouped in the superorder Hyperoartii. Anaspida are possibly ancestral to living lampreys. See OSTEOSTRACI; PETROMYZONTIDA. [R.H.De.]

**Anatomy, regional** The detailed study of the anatomy of a part or region of the body of an animal, most commonly applied to regional human anatomy. This is in contrast, but supplementary, to study of organ systems where all the structures pertaining to the system are studied in their continuity.

There are many methods of dividing the body into regions for study, and one such means of classification is shown in the illustration. This system includes only externally visible areas; other systems would include special internal regions as well.

The head, trunk, and extremities are the principal regions. Subdivision of these can be carried out, as illustrated, so that many distinct areas or especially vital regions are indicated. There is no end to the dividing and subdividing a specialist may do to make the task eventually less difficult. [T.S.P.]

**Andalusite** A nesosilicate mineral, composition  $Al_2SiO_5$ , crystallizing in the orthorhombic system. It occurs commonly in large, nearly square prismatic crystals. There is poor prismatic cleavage; the luster is vitreous and the color red, reddish-brown, olive-green, or bluish. Transparent crystals may show strong dichroism, appearing red in one direction and green in another in transmitted light. The specific gravity is 3.1–3.2; hardness is 7.5 on Mohs scale, but may be less on the surface because of alteration. See SILICATE MINERALS.

Andalusite was first described in Andalusia, Spain, and was named after this locality. It is found abundantly in the White Mountains near Laws, California, where for many years it was mined for manufacture of spark plugs and other highly refractive porcelain. Chiastolite, in crystals largely altered to mica, is found in Lancaster and Sterling, Massachusetts. Water-worn pebbles of gem quality are found at Minas Gerais, Brazil. [C.S.Hu.]

**Andesine** A plagioclase feldspar with composition  $Ab_{70}An_{30}$  to  $Ab_{50}An_{50}$  ( $Ab = NaAlSi_3O_8$ ;  $An = CaAl_2Si_2O_8$ ). Andesine occurs primarily in igneous rocks, often in a glassy matrix as small, chemically zoned, lathlike crystals known as microlites. The rock types may be called andesinites (if dominantly feldspar), andesites, andesitic basalts (or olivine-bearing andesites, as in Hawaiian lava flows), or pyroxene-, hornblende- or biotite-andesites (all are volcanic). See ANDESITE; FELDSPAR; IGNEOUS ROCKS.

The symmetry of andesine is triclinic, hardness on the Mohs scale 6, specific gravity 2.69, melting point  $\sim 1210^\circ C$  ( $2210^\circ F$ ). If quenched at very high temperatures, andesine has an albitelike structure, with aluminum (Al) and silicon (Si) essentially disordered in the structural framework of the crystals. But, in the course of cooling, most natural andesines develop an Al-Si ordered structure called e-plagioclases. See ALBITE; CRYSTAL STRUCTURE.

Calcic andesines and labradorites ( $Ab_{55}An_{45}$ - $Ab_{40}An_{60}$ ) may exsolve into two distinctly intergrown lamellar phases whose regularity of stacking produces beautiful interference colors like those in the feathers of a peacock. Polished specimens of this material are called spectrolite in the gem trade, and at some lo-

calities (notably eastern Finland) crystals up to 10 in. (25 cm) are mined by hand. Smaller crystals are made into cabochons for jewelry. They may be abundant enough in the host rock to be valued as a decorative stone. See GEM; LABRADORITE. [P.H.R.]

**Andesite** A typical volcanic rock erupted from a volcano associated with convergent plate boundaries. The process of subduction, which defines convergent plate boundaries, pushes oceanic lithosphere beneath either oceanic lithosphere or continental lithosphere. Andesites are the principal rocks forming the volcanoes of the “ring of fire,” the arcuate chains of volcanoes which rim the Pacific Ocean basin. The Marianas and Izu-Bonin islands, the islands of Japan, the Aleutian Islands, the Cascade Range of the northwest United States, the Andes mountain chain of South America, and the Taupo Volcanic Zone of New Zealand are andesitic. See LITHOSPHERE; PLATE TECTONICS; VOLCANO.

Andesites are mostly dark-colored vesicular volcanic rocks which are typically porphyritic (containing larger crystals set in a fine groundmass). Phenocrysts (the larger crystals) comprise plagioclase; calcium-rich, calcium-poor pyroxene; and iron-titanium oxides set in a fine-grained, frequently glassy, groundmass. Some andesites contain phenocrysts of olivine, and some contain amphibole and biotite; these latter rocks generally contain more potassium. The porphyritic nature of andesites is derived from a complicated history of magmatic crystallization and evolution as the melts rise toward the surface from deep in the Earth. Phenocryst minerals commonly are strongly zoned and show evidence for disequilibrium during growth, consistent with an origin involving crystal fractionation and mixing processes. Andesites are readily classified in terms of their silicon dioxide ( $SiO_2$ ) content, between 53 and 63 wt %, and potassium oxide ( $K_2O$ ) content at a given  $SiO_2$  content. They can also be readily discriminated on a total alkali versus  $SiO_2$  diagram. Most andesite volcanoes erupt lavas and tephra (volcanic ash) which range in composition from basaltic andesite to dacite. Eruptions are often explosive, reflecting the relatively high water and gas content of the magmas. Pyroclastic flows are a particular feature of andesite-type volcanism and are among the most dangerous of volcanic hazards. See BASALT; LAVA; PYROCLASTIC ROCKS. [J.Ga.]

**Andreaeopsida** A class of the plant division Bryophyta, containing plants commonly called granite mosses. The class consists of one order and two families, the Andreaeobryaceae and the Andreaeaceae. The large tapered foot and short, massive seta of the Andreaeobryaceae show possible linkage to the Bryopsida, but the differences seem more fundamental and more significant than the similarities. The small, brittle plants grow as perennials on rocks in montane regions in dark red, red-brown, or blackish tufts. The stems are erect, simple or forked, and grow from a single apical cell with three cutting faces; they consist of a homogeneous tissue of thick-walled cells. The rhizoids are multicellular and filamentous or platelike. The leaves are spirally arranged, of various shapes and with or without a midrib. The leaf cells are thick-walled and often papillose. Paraphyses are present in both male and female inflorescences. See ANTHOCEROTOPSIDA; BRYOPHYTA; BRYOPSIDA; HEPATICOPSIDA; SPHAGNOPSIDA. [H.C.]

**Androgen** One of a class of steroid hormones. Androgens play a major role in the development and maintenance of masculine secondary sexual characters, for example, the seminal vesicle and prostate gland of the male mammal, and the comb, wattles, and spur of the male fowl. They also influence certain other secondary sexual characters, such as hair growth pattern and voice quality in humans. In the fowl, they affect the pattern and seasonal coloration of its feathers, as well as crowing. In addition, androgens affect nitrogen metabolism (anabolic). Androgens are produced in the testis, ovary, adrenal, and most likely, in the placenta. A small portion of the androgen is from corticoids,

or adrenal cortex steroids, and from other C<sub>21</sub> steroids, such as progesterone. See HORMONE; OVARY; PROGESTERONE; STEROID; TESTIS. [R.I.D.]

**Andromeda Galaxy** The spiral galaxy of type Sb nearest to the Milky Way system. This galaxy is a member of a small cluster of galaxies known as the Local Group. This group contains also the Milky Way system, the Triangulum Nebula (M33), the Large and Small Magellanic Clouds, NGC 6822, and several faint dwarf elliptical galaxies.

The Andromeda Galaxy M31 or NGC 224 is particularly important because it is close enough for its stellar and other content to be studied in great detail. The approximate distance to M31 is known from the apparent luminosities of the cepheid variable stars. The period-luminosity relation for cepheids, combined with the apparent brightness of these stars, gives a distance of about 2,500,000 light-years. All studies show that M31 is typical of other regular spiral galaxies of the Sb class. See CEPHEIDS; MILKY WAY GALAXY. [A.Sa.]

**Anechoic chamber** A room whose boundaries absorb effectively all the waves incident on them, thereby providing free-field conditions. A free field is a field whose boundaries exert negligible effect on the incident waves. In practice, it is a field in which the effects of the boundaries are negligible over the frequency range of interest. Acoustic chambers and radio-frequency and microwave chambers are examples.

**Acoustic chambers.** An acoustic anechoic chamber is a room in which essentially an acoustic free field exists. It is sometimes referred to as a free-field or dead room.

Free-field conditions can be approximated when the absorption by the boundaries of the room approaches 100%. To reduce sound reflected by the boundaries to a minimum, the absorption coefficient must be very high and the surface areas of the boundaries should be large.

The sound absorptive material usually installed in such rooms consists of glass fibers held together with a suitable binder. In order to achieve large surface area, a wall construction is used that includes wedges of sound absorptive material, the base of which is usually between 8 × 8 in. (20 × 20 cm) and 8 × 24 in. (20 × 60 cm), and the length of which is usually 3 to 5 ft (0.9 to 1.5 m). These wedges resemble stalagmites and stalactites and absorb about 99% of incident sound energy over most of the audio-frequency ranges. A horizontal net of thin steel cables just above floor wedges permits walking in the room. See REFLECTION OF SOUND; SOUND ABSORPTION. [C.M.H.]

**Radio-frequency and microwave chambers.** The radio-frequency or microwave anechoic chamber is a shielded (screened) enclosure in which internal reflections of electromagnetic waves are reduced to an absolute minimum, thus providing a zone that is free from radio noise, broadcast transmissions, and other extraneous signals, and that simulates free-space conditions. Its main use is to provide a controlled and well-defined environment for the testing of electronic equipment.

Shielded or screened enclosures may vary in size from small metallic boxes that are intended for the protection of circuit elements to large rooms capable of housing vehicles or aircraft. The purpose of such enclosures is to isolate sources of electromagnetic energy from electronic, radio, or other sensitive equipment which might suffer degradation of performance as a result of interaction with transmitters, radio-frequency heating equipment, and so forth. The provision of a radio-frequency quiet zone is an essential feature of many applications in electromagnetic tests and investigations, for example, the determination of antenna characteristics and the measurement of low-level emissions during electromagnetic compatibility assessments. See ELECTRICAL SHIELDING; ELECTROMAGNETIC COMPATIBILITY; MICROWAVE FREE-FIELD STANDARDS.

The attempt to reproduce free-space or open-field conditions within a shielded enclosure has led to the development of re-

sistive material to line the enclosure walls to absorb rather than reflect the radio-frequency energy and hence create an anechoic chamber. Such material must have good basic dielectric properties, with a relative permittivity near unity to minimize reflection at the interface, and to incorporate increasing resistive loss through the material. In practice, foam plastics are ideal for the purpose, and these can be readily loaded with carbon, ferrite, or other conducting particles on a graded or layer basis to provide the increasing loss. See ABSORPTION OF ELECTROMAGNETIC RADIATION; CAVITY RESONATOR; DIELECTRIC MATERIALS; ELECTROMAGNETIC RADIATION; PERMITTIVITY; RECIPROCITY PRINCIPLE; REFLECTION OF ELECTROMAGNETIC RADIATION. [G.A.J.]

**Anemia** A reduction in the total quantity of hemoglobin or of red blood cells (erythrocytes) in the circulation. Because it generally is impractical to measure the total quantity, measures of concentration are used instead. Hemoglobin is contained in red blood cells, which are suspended in plasma, the liquid component of blood. Therefore, concentration is affected not only by quantities of hemoglobin and red blood cells but also by plasma volume. Thus, the apparent anemia found in many women in the third trimester of pregnancy is not really anemia at all: the red cell mass is actually increased, but the plasma volume is expanded even more. In other words, hemodilution is present. Conversely, in dehydration and other circumstances of hemoconcentration, the plasma volume is reduced, thereby tending to mask anemia. See BLOOD; HEMOGLOBIN.

The three measures of concentration most often employed are the hemoglobin, the red blood cell count, and the volume of packed red cells. In a group of healthy individuals, the values for hemoglobin, red cell count, and hematocrit approximate a "normal" distribution. Values that are less than 2.5 standard deviations below the mean are indicative of anemia if other clinical factors do not indicate a condition of hemodilution. The mean values are greater for adult males than for adult females, and greater for adults than children. (Lower atmospheric oxygen tension at higher altitudes results in higher mean values for hemoglobin, red cells, and hematocrit in healthy individuals living under these conditions; hence, anemia would be defined at a higher value). In the state of health, the rate of production of new red blood cells (erythropoiesis) equals the rate of removal of senescent red blood cells. Anemia occurs if the rate of erythropoiesis is reduced below normal. It also occurs if hemorrhage or destruction (hemolysis) of red blood cells within the body increases the rate of loss of erythrocytes and the rate of erythropoiesis does not increase enough to compensate.

**Mechanisms.** Red blood cell production may be affected by several different mechanisms. Erythropoietin, a growth factor produced by healthy kidneys, stimulates the bone marrow to produce more erythroblasts and accelerates their maturation. The proliferative response of the bone marrow to anemia may be defective or absent if the production of erythropoietin is diminished or absent, as occurs in chronic renal disease and some endocrine disorders. Ineffective erythropoiesis also results when, in the intact, stimulated bone marrow, red blood cell precursors either fail to mature, or die in the bone marrow prior to their delivery to the circulation as erythrocytes.

Aplastic anemia occurs when the bone marrow stem cells that give rise to precursors of erythroblasts are markedly diminished in number or respond inadequately to erythropoietin. This condition occurs when the bone marrow is adversely affected by certain chemicals or autoantibodies; is injured by irradiation; atrophies, or is replaced by fat; is replaced by fibrous (scar) tissue; or is infiltrated by cancer cells.

Defective synthesis of deoxyribonucleic acid (DNA) and abnormal nuclear maturation result from malabsorption of vitamin B<sub>12</sub> (as in pernicious anemia) or dietary deficiency of folic acid or its malabsorption (sprue). These anemias are generally characterized by large red blood cells (macrocytes) and a specific morphological abnormality of the nuclear chromatin of erythroblasts

which characterizes them as megaloblasts, and the condition as megaloblastic anemia.

Defective synthesis of hemoglobin impairs cytoplasmic maturation. The majority of cases are due to deficiency of body stores of iron and to abnormal release of iron from reticuloendothelial stores. The former occurs in iron-deficiency anemia, and the latter in the anemia of chronic inflammatory diseases.

Acute blood loss reduces the total blood volume and produces symptoms of weakness, dizziness, thirst, faintness, and shock, in that order, according to increasing magnitude of blood loss. The anemia which results is not detectable by measures of concentration until hemodilution occurs over subsequent days, or more rapidly if replacement fluids are given intravenously. The proliferative response of the healthy marrow will correct the anemia in 2–6 weeks, depending upon the size of the deficit and provided there are sufficient body stores of iron, folic acid, and vitamin B<sub>12</sub>, required for hemoglobin synthesis. Chronic blood loss results in iron-deficiency anemia.

Hemolysis, the accelerated destruction of red blood cells, also induces a proliferative response from the marrow. However, it differs from hemorrhage because red blood cells are lost without plasma, and it thus diminishes the measures of concentration at the outset.

**Diagnosis and treatment.** Pallor, weakness, and fatigue are common to all anemias. They may not be noticed until anemia is advanced, if it is of gradual onset and there has been time for cardiovascular and biochemical adaptation. Faint jaundice in the sclerae is a feature of hemolytic anemia, whereas in anemia due to lack of vitamin B<sub>12</sub>, glossitis and neuropathy may be noted.

Macrocytic anemias are often found to be megaloblastic and due to deficiency of vitamin B<sub>12</sub> or folic acid. Administration of one of those vitamins will only cure individuals in whom its specific deficiency is established. Microcytic-hypochromic anemias are most often due to iron deficiency. The administration of iron will resolve iron-deficiency anemia. Prednisone and other adrenal corticosteroids are helpful in hemolytic anemias associated with autoantibodies.

Hereditary disorders are generally not amenable to therapy, except for those hemolytic diseases which may benefit after splenectomy. In all other cases, the treatment of the anemia is achieved by treating the underlying disease, such as hypothyroidism, rheumatoid arthritis, or leukemia. Blood transfusions are reserved for acute blood loss when symptoms of hypovolemia and shock are present, or in chronic anemia if there are signs of inadequate cardiovascular or pulmonary compensation and an underlying cause cannot be found or treated. See CLINICAL PATHOLOGY; HEMATOLOGIC DISORDERS. [A.H.]

**Anemometer** An instrument to measure the speed or velocity of gases either in a contained flow, such as airflow in a duct, or in unconfined flows, such as atmospheric wind. To determine the velocity, an anemometer detects change in some physical property of the fluid or the effect of the fluid on a mechanical device inserted into the flow.

An anemometer can measure the total velocity magnitude, the velocity magnitude in a plane, or the velocity component in a particular direction. The cup anemometer, for example, measures the velocity in a plane perpendicular to the axis of its rotation cups. If the cup anemometer is mounted with the shaft perpendicular to the horizontal, it will measure only the component of the wind that is parallel to the ground. Other anemometers, such as the pitot-static tube, are used with the tip aligned with the total velocity vector. Before using an anemometer, it is important to determine how it should be positioned and what component of the total velocity its measurement represents. See FLOW MEASUREMENT.

An anemometer usually measures gas flows that are turbulent. The cup anemometer, pitot-static tube, and thermal anemometer are mostly used to measure the mean velocity, while the hot-

wire, laser Doppler, and sonic anemometers are usually used when turbulence characteristics are being measured. (The term "thermal anemometer" is often used to mean any anemometer that uses a relationship between heat transfer and velocity to determine velocity.) [D.E.St.]

**Anesthesia** Loss of sensation with or without loss of consciousness. There are several ways of producing anesthesia, with the choice dependent on the type of surgery and the medical condition and preference of the patient.

During general anesthesia a state of complete insensitivity or unconsciousness is produced when anesthetic gases are inhaled; adjuvant drugs are often given intravenously. Although the mechanism of general anesthesia is unknown, the anesthetics act on the upper reticular formation of neurons in the thalamus and midbrain (neuronal structures necessary for activating the cerebral cortex and maintaining an active, attentive state).

Analgesia, without loss of consciousness, results from injecting a solution of local anesthetic drug either into the cerebrospinal fluid surrounding the spinal cord (spinal anesthesia) or into the epidural space surrounding the cerebrospinal fluid (epidural anesthesia). The local anesthetic acts by blocking the conduction of nerve impulses. Narcotic opioids are injected postoperatively into either the epidural space or cerebrospinal fluid for pain relief.

Analgesia can be localized to a small area, for example, the forearm, by injecting a local anesthetic solution around nerves supplying the area (the brachial plexus in the upper arm and chest supplies the forearm). Large peripheral nerves may also be blocked individually by using this method.

Acupuncture is an ancient procedure, once used only in China but now practiced in the United States and elsewhere. It involves inserting needles into specific points around the body, as determined from historical charts, and manipulation of the needles; sometimes electric current is applied. Weak analgesia results through alteration of pain perception. Although sometimes helpful for chronic pain, acupuncture generally has not been found satisfactory for surgical anesthesia. See CENTRAL NERVOUS SYSTEM; PAIN. [F.K.O.]

**Aneurysm** A localized, abnormal arterial dilation usually caused by a weakening of the vessel wall. Aneurysms are commonly found in the abdominal aorta, intracranial arteries, and thoracic aorta; however, they may also involve the femoral, popliteal, splenic, carotid, or renal arteries. Aneurysms vary in size from less than 1 in. (2.5 cm) to more than 4 in. (10 cm). They are usually classified as true or false: true aneurysms involve all layers of the artery (inner endothelium or intima, middle muscular layer or media, and outer connective tissue or adventitia); false aneurysms do not involve all layers. With the exception of intracranial aneurysms, atherosclerotic vessel disease is generally the cause of aneurysms; other causes include syphilis, trauma, cystic medial necrosis, bacterial infections, and arteritis.

The major clinical sign of all aneurysms (except intracranial) is a large pulsatile mass; other manifestations depend on the location of the aneurysm. The major complication of an aneurysm is rupture, the possibility of which is directly related to its size. Intracranial aneurysms, often called berry aneurysms, are congenital weaknesses in the intracranial arteries. These aneurysms are saclike outpocketings of the vessel and vary in size from 0.2 in. (0.4 cm) to greater than 0.6 in. (1.5 cm). The major manifestations are usually related to bleeding and can vary from a severe headache, to neurologic impairment, to death.

The best method of diagnosis is ultrasound or a computer x-ray analysis (computed tomography scan). The recommended treatment for all aneurysms is surgery. See ARTERIOSCLEROSIS; CARDIOVASCULAR SYSTEM; CIRCULATION DISORDERS; HEMORRHAGE; HYPERTENSION; MEDICAL IMAGING. [D.L.Ak.; M.D.K.]

**Angle modulation** Modulation in which the instantaneous angle varies in proportion to the modulating waveform.

When used in an analog manner, it is referred to as either frequency modulation (FM) or phase modulation (PM), depending upon whether the instantaneous frequency or instantaneous phase varies with the modulation. When used in a digital modulation format, it is referred to as either frequency-shift keying (FSK) or phase-shift keying (PSK). Both FSK and PSK can be used with either a binary or an  $M$ -ary alphabet, where  $M$  is an integer greater than 2. Indeed, the most common forms of PSK correspond to an input alphabet size of either two or four; while for FSK alphabets of two, four, or eight, symbols are typically employed. See FREQUENCY MODULATION; MODULATION; PHASE MODULATION. [L.B.M.]

**Anglesite** A mineral with the chemical composition  $PbSO_4$ . Anglesite occurs in white or gray, orthorhombic, tabular or prismatic crystals or compact masses. It is a common secondary mineral, usually formed by the oxidation of galena. Fracture is conchoidal and luster is adamantine. Hardness is 2.5–3 on Mohs scale and specific gravity is 6.38. The mineral does not occur in large enough quantity to be mined as an ore of lead, and is therefore of no particular commercial value. Fine exceptional crystals of anglesite have been found throughout the world. [E.C.T.C.]

**Anguilliformes** A large order of actinopterygian fishes containing the true eels. This group, also known as the Apodes, now includes the former order Saccopharyngiformes or Lyomeri (gulpers or gulper eels). The Anguilliformes have a ribbonlike, larval stage in development. The chief characters of the Anguilliformes include a pectoral girdle which, when present, is free from the head and suspended from the vertebral column; no symplectic, mesocoracoid, and posttemporal bones; pectoral fin present or absent; absence of a pelvic fin and girdle in recent forms; no fin spines; elongate body with numerous vertebrae; scales present or absent; paired orbitosphenoids; and restricted gill apertures.

The typical eels (suborder Anguilloidei) have a swim bladder with a duct, a small opercle, and 6–22 branchiostegals, and the premaxilla, mesethmoid, and lateral ethmoids are fused into a tooth-bearing ethmopremaxillary block that separates the maxillae. Eels, which date from the Upper Cretaceous, are classified in about 20 Recent families and 110 genera, and there are several hundred species. See EEL.

The gulpers (suborder Saccopharyngoidei) have degenerative adaptations, including loss of swim bladder, opercle, branchiostegal rays, caudal fin, scales, and ribs. The tremendous mouth is greatly modified (see illustration), the eyes are tiny and



Gulper eel (*Eupharynx bairdi*). (After G. B. Goode and T. H. Bean, *Oceanic Ichthyology*, U.S. Nat. Mus. Spec. Bull. no. 2, 1896)

placed far forward, the pharynx is enormously distensible, and the tail is slender and tapering. These are rare oceanic fishes, classified in three families, three genera, and nine species. Their fossil history is unknown. See ACTINOPTERYGII; OSTEICHTHYES; TELEOSTEI. [R.M.B.]

**Angular correlations** An experimental technique that involves measuring the manner in which the likelihood of occurrence (or intensity or cross section) of a particular decay or collision process depends on the directions of two or more radiations associated with the process. Traditionally, these radiations

are emissions from the decay or collision process. However, a variant on this technique in which the angular correlations are between an incident and emitted beam of radiation has been widely used; this variant is known as angular distributions.

The fundamental reason for performing such measurements, rather than just scrutinizing a single radiation in a particular direction or measuring the total intensity for a process, is that the angular correlation or angular distribution measurement provides much more information on both the decay or collision process and on the structure and properties of the emitter of the radiation. The technique is used to study a variety of decay and collision processes in atomic and molecular physics, condensed-matter (solid-state) and surface physics, and nuclear and particle physics.

The principal use of this technique in nuclear physics has been to determine the angular momentum, or spin, and parity of excited nuclear states which are radioactive, that is, decay spontaneously, by measuring in coincidence the radiation in specific directions from two successive transitions in the radioactive cascade. The measurements are generally of coincidences between gamma rays, but coincidences between gamma rays and electrons (beta particles) are also used. The form of the angular correlation, the measured intensity as a function of the angle between the two radiations, gives the information about the intermediate excited state in the cascade. See NUCLEAR SPECTRA; RADIOACTIVITY.

In atomic and molecular collisions as well as in nuclear and particle collisions, this technique is employed as a means of completely specifying the dynamics of the collision, with the added proviso that the energies of the emitted radiations are also to be measured. Wide use has been made of angular correlations in the impact ionization of atoms by electrons where the directions of both the scattered electron and the ejected electron are measured. See ATOMIC STRUCTURE AND SPECTRA; SCATTERING EXPERIMENTS (ATOMS AND MOLECULES). [S.T.M.]

**Angular momentum** In classical physics, the moment of linear momentum about an axis. A point particle with mass  $m$  and velocity  $\mathbf{v}$  has linear momentum  $\mathbf{p} = m\mathbf{v}$ . Let  $\mathbf{r}$  be an instantaneous position vector that locates the particle from an origin on a specified axis. The angular momentum  $\mathbf{L}$  can be written as the vector cross-product in Eq. (1).

$$\mathbf{L} = \mathbf{r} \times \mathbf{p} \quad (1)$$

See CALCULUS OF VECTORS; MOMENTUM.

The time rate of change of the angular momentum is equal to the torque  $\mathbf{N}$ . A rigid body satisfies two independent equations of motion (the dynamical equations) given by Eqs. (2) and (3),

$$\frac{d}{dt}\mathbf{p} = \mathbf{F} \quad (2)$$

$$\frac{d}{dt}\mathbf{L} = \mathbf{N} \quad (3)$$

where  $d/dt$  denotes the rate of change, the derivative with respect to time  $t$ . Only Eq. (2) is required for a point particle. Equation (2) indicates that a rigid body acts as a point particle located at its center of mass. The motion of the center of mass depends upon the net force  $\mathbf{F}$ , which is the vector sum of all applied forces. Equation (3) gives the angular motion about the center of mass. The case of statics occurs when the net force and net torque both vanish. See KINETICS (CLASSICAL MECHANICS); STATICS; TORQUE.

A symmetry is a transformation that leaves a physical system unchanged. A physical quantity is called invariant under a transformation if it remains the same after being transformed. For example, the solutions to Eqs. (2) and (3) are invariant under change of the coordinate origin or orientation of the  $\mathbf{i}$ ,  $\mathbf{j}$ , and  $\mathbf{k}$  axes. The freedom to choose any orientation of coordinate axes is called rotational invariance, because one choice of axes can be rotated into another. In physics, the rotational invariance

follows from the isotropy and homogeneity of space that has been experimentally established to high accuracy.

The study of symmetry shows that one of the deepest relations in physics is that between dynamics and conservation. A physical quantity is conserved if it is constant in time, although it may vary in space. Noether's theorem states that if a physical system is invariant under a continuous symmetry, a conservation law exists, provided that the observable in question decreases rapidly enough at infinity. Thus, when the force is zero everywhere (the system is invariant under translation in space), the linear momentum is conserved. If the torque is zero everywhere (the system is invariant under rotation), the angular momentum is conserved. If the system is invariant under translations in time, the total energy is conserved. See CONSERVATION LAWS (PHYSICS); CONSERVATION OF ENERGY; CONSERVATION OF MOMENTUM.

Quantum mechanics has a richer and more complicated structure than classical physics. Because of this, the relationship between symmetry and conservation is even more useful. See NON-RELATIVISTIC QUANTUM THEORY. [B.DeF.]

**Anharmonic oscillator** A generalized version of harmonic oscillator in which the relationship between force and displacement is nonlinear. The harmonic oscillator is a highly idealized system that oscillates with a single frequency, irrespective of the amount of pumping or energy injected into the system. Consequently, the harmonic oscillator's fundamental frequency of vibration is independent of the amplitude of the vibrations. Applications of the harmonic oscillator model abound in various fields, but perhaps the most commonly studied system is the Hooke's law mass-spring system. In the Hooke's law system the restoring force exerted on the mass is proportional to the displacement of the mass from its equilibrium position. This linear relationship between force and displacement mandates that the oscillation frequency of the mass will be independent of the amplitude of the displacement. See HARMONIC MOTION; HARMONIC OSCILLATOR; HOOKE'S LAW.

In a mechanical anharmonic oscillator, the relationship between force and displacement is not linear but depends upon the amplitude of the displacement. The nonlinearity arises from the fact that the spring is not capable of exerting a restoring force that is proportional to its displacement because of, for example, stretching in the material comprising the spring. As a result of the nonlinearity, the vibration frequency can change, depending upon the system's displacement. These changes in the vibration frequency result in energy being coupled from the fundamental vibration frequency to other frequencies through a process known as parametric coupling. See VIBRATION.

There are many systems throughout the physical world that can be modeled as anharmonic oscillators in addition to the nonlinear mass-spring system. For example, an atom, which consists of a positively charged nucleus surrounded by a negatively charged electronic cloud, experiences a displacement between the center of mass of the nucleus and the electronic cloud when an electric field is present. The amount of that displacement, called the electric dipole moment, is related linearly to the applied field for small fields, but as the magnitude of the field is increased, the field-dipole moment relationship becomes nonlinear, just as in the mechanical system. See DIPOLE MOMENT.

Further examples of anharmonic oscillators include the large-angle pendulum, which exhibits chaotic behavior as a result of its anharmonicity; nonequilibrium semiconductors that possess a large hot carrier population, which exhibit nonlinear behaviors of various types related to the effective mass of the carriers; and ionospheric plasmas, which also exhibit nonlinear behavior based on the anharmonicity of the plasma. In fact, virtually all oscillators become anharmonic when their pump amplitude increases beyond some threshold, and as a result it is necessary to use nonlinear equations of motion to describe their behavior. See CHAOS; PENDULUM; SEMICONDUCTOR. [D.R.A.]

**Anhydrite** A mineral with the chemical composition  $\text{CaSO}_4$ . Anhydrite occurs commonly in white and grayish granular masses, rarely in large, orthorhombic crystals. Fracture is uneven and luster is pearly to vitreous. Hardness is 3–3.5 on Mohs scale and specific gravity is 2.98. Anhydrite is an important rock-forming mineral and occurs in association with gypsum, limestone, dolomite, and salt beds. Under natural conditions, anhydrite hydrates slowly, but readily, to gypsum. It is not used as widely as gypsum. Anhydrite is of worldwide distribution. Large deposits occur in the Carlsbad district, Eddy County, New Mexico, and in salt-dome areas in Texas and Louisiana. See GYPSUM; SALINE EVAPORITE. [E.C.T.C.]

**Animal** Any living organism which possesses certain characteristics that distinguish it from plants. There is no single criterion that can be used to distinguish all animals from all plants. Animals usually lack chlorophyll and the ability to manufacture foods from raw materials available in the soil, water, and atmosphere. Animal cells are usually delimited by a flexible plasma or cell membrane rather than a cell wall. Animals generally are limited in their growth and most have the ability to move in their environment at some stage in their life history, whereas plants are usually not restricted in their growth and the majority are stationary.

The presence or lack of chlorophyll in an organism does not determine its affinity to the plant or animal kingdom. Among the protozoa, the class Phytamastigophora includes animals, such as the euglenids, which have chromatophores containing chlorophyll. These organisms are considered to be animals by zoologists and plants by phycologists. Higher parasitic plants and the large plant group Fungi also lack chlorophyll. Another borderline group is the slime molds: the Mycetozoa of zoologists and the Myxomycophyta of the botanists; these organisms exhibit both plant and animal characteristics during their life history. Movement is not a characteristic restricted to the animal kingdom; many of the thallophytes such as *Oscillatoria*, numerous bacteria, and colonial chlorophytes are motile.

Classifying organisms as plants or animals is difficult. Today biologists recognize up to five kingdoms. Most place the one-celled animals and plants, sometimes along with algae and certain other groups, into the Protista. Other kingdoms are the Monera for the bacteria and blue-green algae, and the Fungi for the slime molds and true fungi. These schemes for recognizing additional kingdoms have the practical advantage of eliminating the difficulties of delimiting and describing the kingdoms of multicellular animals and plants. See ANIMAL KINGDOM; PLANT KINGDOM. [W.J.B.]

**Animal communication** A discipline within the field of animal behavior that focuses upon the reception and use of signals. Animal communication could well include all of animal behavior, since a liberal definition of the term signal could include all stimuli perceived by an animal. However, most research in animal communication deals only with those cases in which a signal, defined as a structured stimulus generated by one member of a species, is subsequently used by and influences the behavior of another member of the same species in a predictable way (intraspecific communication). In this context, communication occurs in virtually all animal species.

The field of animal communication includes an analysis of the physical characteristics of those signals believed to be responsible in any given case of information transfer. A large part of this interest is due to technological improvements in signal detection, coupled with analysis of the signals obtained with such devices.

Information transmission between two individuals can pass in four channels: acoustic, visual, chemical, and electrical. An individual animal may require information from two or more channels simultaneously before responding appropriately to reception of a signal. Furthermore, a stimulus may evoke a response under one circumstance but be ignored in a different context.



Acoustic signals have characteristics that make them particularly suitable for communication, and virtually all animal groups have some forms which communicate by means of sound. Sound can travel relatively long distances in air or water, and obstacles between the source and the recipient interfere little with an animal's ability to locate the source. Sounds are essentially instantaneous and can be altered in important ways. Both amplitude and frequency modulation can be found in sounds emitted by animals; in some species sound signals have discrete patterns due to frequency and timing of utterances. Since a wide variety of sound signals are possible, each species can have a unique set of signals in its repertoire. See PHONORECEPTION.

Sound signals are produced and received primarily during sexual attraction, including mating and competition. They may also be important in adult-young interactions, in the coordination of movements of a group, in alarm and distress calls, and in intraspecific signaling during foraging behavior. See REPRODUCTIVE BEHAVIOR.

Visual signaling between animals can be an obvious component of communication. Besides the normal range of human vision (visible light), visual signals include additional frequencies in the infrared and ultraviolet ranges. The quality of light that is often considered is color, but other characteristics are important in visual communication. Alterations of brightness, pattern, and timing also provide versatility in signal composition. The visual channel suffers from the important limitation that all visual signals must be line of sight. Information transfer is therefore largely restricted to the daytime (except for animals such as fireflies) and to rather close-range situations.

Intraspecific visual signaling appears to occur primarily during mate attraction. The color dimorphism of birds, the patterns of butterfly wings, the posturing of some fish, and firefly flashing are examples. Some parent-young interactions involve visual signaling. A young bird in the nest may open its mouth when it sees the underside of its parent's beak. Other examples are the synchronized behavior observed in schooling fish and flocking birds.

Chemical signals, like visual and sound signals, can travel long distances, but with an important distinction. Distant transmission of chemical signals requires a movement of air or water. Therefore, an animal cannot perceive an odor from a distance; it can only perceive molecules brought to it by a current of air or water. Animals do not hunt for an odor source by moving other than upwind or upcurrent in water because chemical signals do not travel in still air or water since diffusion is far too slow.

The fact that chemical signals comprise molecules means that, unlike acoustical or visual signals, chemical signals have a time lag. Chemical signals have to be of an appropriate concentration if they are to be effective. A chemical normally considered to be an attractant can serve as a repellent if it is too strong. Chemical signals may persist for a while, and time must pass before the concentration drops below the threshold level for reception by a searching animal. Since molecules of different sizes and shapes have varying degrees of persistence in the environment, the chemical channel is often involved in territorial marking, odor trail formation, and mate attraction. This channel is particularly suitable where acoustical or visual signals might betray the location of a signaler to a potential predator.

The array of molecular structure is essentially limitless, permitting a species-specific nature for chemical signals. Unfortunately, that specificity can make interception and analysis of chemical signals a difficult matter for research.

Pheromones are chemical signals that are produced by an animal and are exuded to influence the behavior of other members of the same species. If pheromones are incorporated into a recipient's body (by ingestion or absorption), they may chemically alter the behavior of such an individual for a considerable period of time. See CHEMICAL ECOLOGY; CHEMORECEPTION; PHEROMONE.

Some electric fish and electric eels live in murky water and have electric generating organs that are really modified muscle

bundles. Communication by electric signaling is rapid; signals can travel throughout the medium (even murky water), and rather complex signals can be generated, permitting species-specific communication during sexual attraction. However, the electrical mode is apparently restricted to those species that have electric generating organs. See ELECTRIC ORGAN (BIOLOGY).

Animal communication is one of the most difficult areas of study in science for several reasons. First, experiments must be designed and executed in such a manner that extraneous cues (artifacts) are eliminated as potential causes of the observed results. Second, once supportive evidence has been obtained, each hypothesis must be tested. In animal communication studies, adequate tests often rely upon direct evidence—that is, evidence obtained by artificially generating the signal presumed responsible for a given behavioral act, providing that signal to a receptive animal, and actually evoking a specific behavioral act in a predictable manner. See ETHOLOGY; PSYCHOLINGUISTICS.

[A.M.We.]

**Animal evolution** The theory that modern animals are the modified descendants of animals that formerly existed and that these earlier forms descended from still earlier and different organisms.

Animals are multicellular organisms that feed by ingestion of other organisms or their products, being unable to derive energy through photosynthesis or chemosynthesis. Animals are currently classed into about 30 to 35 phyla, each of which has evolved a distinctive body plan or architecture.

All phyla began as invertebrates, but lineages of the phylum Chordata developed the internal skeletal armature, with spinal column, which was exploited in numerous fish groups and which eventually gave rise to terrestrial vertebrates. The number of phyla is uncertain partly because most of the branching patterns and the ancestral body plans from which putative phyla have arisen are not yet known. For example, arthropods (including crustaceans and insects) may have all diversified from a common ancestor that was a primitive arthropod, in which case they may be grouped into a single phylum; or several arthropod groups may have evolved independently from nonarthropod ancestors, in which case each such group must be considered a separate phylum. So far as known, all animal phyla began in the sea. See ANIMAL; ANIMAL KINGDOM.

Some features of the cells of primitive animals resemble those of the single-celled Protozoa, especially the flagellates, which have long been believed to be animal ancestors. Molecular phylogenies have supported this idea and also suggest that the phylum Coelenterata arose separately from all other phyla that have been studied by this technique. Thus animals may have evolved at least twice from organisms that are not themselves animals, and represent a grade of evolution and not a single branch (clade) of the tree of life. Sponges have also been suspected of an independent origin, and it is possible that some of the extinct fossil phyla arose independently or branched from sponges or cnidarians. See COELENTERATA; PORIFERA; PROTOZOA.

The earliest undoubted animal fossils (the Ediacaran fauna) are soft-bodied, and first appear in marine sediments nearly 650 million years (m.y.) old. This fauna lasted about 50 m.y. and consisted chiefly of cnidarians or cnidarian-grade forms, though it contains a few enigmatic fossils that may represent groups that gave rise to more advanced phyla. Then, nearly 570 m.y. ago, just before and during earliest Cambrian time, a diversification of body architecture began that produced most of the living phyla as well as many extinct groups. The body plans of some of these groups involved mineralized skeletons which, as these are more easily preserved than soft tissues, created for the first time an extensive fossil record. The soft-bodied groups were markedly diversified, though their record is so spotty that their history cannot be traced in detail. A single, exceptionally preserved soft-bodied fauna from the Burgess Shale of British Columbia that is about 530 m.y. old contains not only living soft-bodied worm phyla,

but extinct groups that cannot be placed in living phyla and do not seem to be ancestral to them. See CAMBRIAN; FOSSIL.

Following the early phase of rampant diversification and of some concurrent extinction of phyla and their major branches, the subsequent history of the durably skeletonized groups can be followed in a general way in the marine fossil record. The composition of the fauna changed continually, but three major associations can be seen: one dominated by the arthropodlike trilobites during the early Paleozoic, one dominated by articulate brachiopods and crinoids (Echinodermata) in the remaining Paleozoic, and one dominated by gastropod (snail) and bivalve (clam) mollusks during the Mesozoic and Cenozoic. The mass extinction at the close of the Paleozoic that caused the contractions in so many groups may have extirpated over 90% of marine species and led to a reorganization of marine community structure and composition into a modern mode. Resistance to this and other extinctions seems to have been a major factor in the rise of successive groups to dominance. Annelids, arthropods, and mollusks are the more important invertebrate groups that made the transition to land. The outstanding feature of terrestrial fauna is the importance of the insects, which appeared in the late Paleozoic and later radiated to produce the several million living species, surpassing all other life forms combined in this respect. See ANNELIDA; ARTHROPODA; CENOZOIC; INSECTA; MESOZOIC; MOLLUSCA; PALEOZOIC. [J.W.V.]

The phylum Chordata consists largely of animals with a backbone, the Vertebrata, including humans. The group, however, includes some primitive nonvertebrates, the protochordates: lancelets, tunicates, acorn worms, pterobranchs, and possibly the extinct graptolites and conodonts. The interrelationships of these forms are not well understood. With the exception of the colonial graptolites, they are soft-bodied and have only a very limited fossil record. They suggest possible links to the Echinodermata in developmental, biochemical, and morphological features. In addition, some early Paleozoic fossils, the carpoids, have been classified alternatively as chordates and as echinoderms, again suggesting a link. In spite of these various leads, the origin of the chordates remains basically unclear. See VERTEBRATA.

Chordates are characterized by a hollow, dorsal, axial nerve chord, a ventral heart, a system of slits in the larynx that serves variously the functions of feeding and respiration, a postanal swimming tail, and a notochord that is an elongate supporting structure lying immediately below the nerve chord. The protochordates were segmented, although sessile forms such as the tunicates show this only in the swimming, larval phase.

The first vertebrates were fishlike animals in which the pharyngeal slits formed a series of pouches that functioned as respiratory gills. An anterior specialized mouth permitted ingestion of food items large in comparison with those of the filter-feeding protochordates. Vertebrates are first known from bone fragments found in rocks of Cambrian age, but more complete remains have come from the Middle Ordovician. Innovations, related to greater musculoskeletal activity, included the origin of a supporting skeleton of cartilage and bone, a larger brain, and three pairs of cranial sense organs (nose, eyes, and ears). At first the osseous skeleton served as protective scales in the skin, as a supplement to the notochord, and as a casing around the brain. In later vertebrates the adult notochord is largely or wholly replaced by bone, which encloses the nerve chord to form a true backbone. All vertebrates have a heart which pumps blood through capillaries, where exchanges of gases with the external media take place. The blood contains hemoglobin in special cells which carry oxygen and carbon dioxide. In most fishes the blood passes from the heart to the gills and thence to the brain and other parts of the body. In most tetrapods, and in some fishes, blood passes to the lungs, is returned to the heart after oxygenation, and is then pumped to the various parts of the body.

The jawless fish, known as Agnatha, had a sucking-rasping mouth apparatus rather than true jaws. They enjoyed great suc-

cess from the Late Cambrian until the end of the Devonian. Most were heavily armored, although a few naked forms are known. They were weak swimmers and lived mostly on the bottom. The modern parasitic lampreys and deep-sea scavenging hagfish are the only surviving descendants of these early fish radiations. See DEVONIAN.

In the Middle to Late Silurian arose a new type of vertebrate, the Gnathostomata, characterized by true jaws and teeth. They constitute the great majority of fishes and all tetrapod vertebrates. The jaws are modified elements of the front parts of the gill apparatus, and the teeth are modified bony scales from the skin of the mouth. With the development of jaws, a whole new set of ecological opportunities was open to the vertebrates. Along with this, new swimming patterns appeared, made possible by the origin of paired fins, forerunners of which occur in some agnathans. See GNATHOSTOMATA; SILURIAN.

Four groups of fishes quickly diversified. Of these, the Placodermi and Acanthodii are extinct. The Placodermi were heavily armored fishes, the dominant marine carnivores of the Silurian and Devonian. The Acanthodii were filter-feeders mostly of small size. They are possibly related to the dominant groups of modern fishes, the largely cartilaginous Chondrichthyes (including sharks, rays, and chimaeras) and the Osteichthyes (the higher bony fishes). These also arose in the Late Silurian but diversified later. See ACANTHODII; CHONDRICHTHYES; OSTEICHTHYES; PLACODERMI.

The first land vertebrates, the Amphibia, appeared in the Late Devonian and were derived from an early group of osteichthyans called lobe-finned fishes, of which two kinds survive today, the Dipnoi or lungfishes, and the crossopterygian coelacanth *Latimeria*. They were lung-breathing fishes that lived in shallow marine waters and in swamps and marshes. The first amphibians fed and reproduced in or near the water. True land vertebrates, Reptilia, with a modified (amniote) egg that could survive on land, probably arose in the Mississippian. See AMNIOTA; AMPHIBIA; CROSSOPTERYGII; DIPNOI; MISSISSIPPIAN.

By the Middle Pennsylvanian a massive radiation of reptiles was in process. The most prominent reptiles belong in the Diapsida: dinosaurs, lizards and snakes, and pterosaurs (flying reptiles). The birds, Aves, which diverged from the dinosaur radiation in the Late Triassic or Early Jurassic, are considered to be feathered dinosaurs, and thus members of the Diapsida, whereas older authorities prefer to treat them as a separate case. In addition, there were several Mesozoic radiations of marine reptiles such as ichthyosaurs and plesiosaurs. Turtles (Chelonia) first appeared in the Triassic and have been highly successful ever since. See AVES; DINOSAUR; JURASSIC; PENNSYLVANIAN; REPTILIA.

The line leading to mammals can be traced to primitive Pennsylvanian reptiles, Synapsida, which diversified and spread worldwide during the Permian and Triassic. The first true mammals, based on characteristics of jaw, tooth, and ear structure, arose in the Late Triassic. Derived mammals, marsupials (Metatheria) and placentals (Eutheria), are known from the Late Cretaceous, but mammalian radiations began only in the early Cenozoic. By the end of the Eocene, all the major lines of modern mammals had become established. Molecular analyses (blood proteins, deoxyribonucleic acid, ribonucleic acid) of living mammals show that the most primitive group of placentals is the edentates (sloths, armadillos, and anteaters). An early large radiation included the rodents, primates (including monkeys, apes, and humans), and bats, possibly all closely related to the insectivores and carnivores. The newest radiations of mammals are of elephants and sea cows, while the whales are related to the artiodactyls (cattle, camels). See CENOZOIC; CRETACEOUS; EOCENE; MAMMALIA; PERMIAN; SYNAPSIDA; TRIASSIC. [K.S.Th.]

**Animal growth** The increase in mass or dimensions of an organism with time. It is one of the basic characteristics of living things and represents the visible result of a complex and interrelated series of metabolic and developmental events. One

of the unique features of biological growth is that the organism changes in size and shape, and to some extent in chemical composition, although it still retains its integrity and its individuality. This is true because growth fundamentally involves synthesis by the organism of more materials like itself.

Growth occurs by two main processes: increase in the number of cells and increase in the size of cells. Living cells, removed from the body and placed in an appropriate culture medium, display growth in its most uncomplicated form. They grow by synthesizing new protoplasm, dividing into smaller cells, and then repeating the process over and over as long as essential nutrients are supplied and accumulation of deleterious waste products is prevented.

In the intact animal, growth begins at, or soon after, the initiation of development. It involves cell division and synthesis of new protoplasm from raw material, either contained in the egg or derived from the environment. However, the process is much more complex than the growth of cells in tissue culture. Except in early embryonic development, growth is normally never dissociated from such processes as differentiation (diversification of cell structure and function) and morphogenesis (change in the form and pattern of the embryo). In later development, growth by cell enlargement is the predominant process. See ANIMAL MORPHOGENESIS; CELL DIVISION; DIFFERENTIATION; EMBRYOLOGY; MITOSIS; TISSUE CULTURE.

The vast majority of animals, including most protozoa, require already elaborated organic molecules in order to synthesize new living material during growth. For animals in general, the chemical requirements for growth are (1) water, (2) inorganic substances, (3) organic substances, especially certain amino acids, and fatty acids, and (4) accessory factors or vitamins. See AXENIC CULTURE.

Water is important to all living cells as the solvent and vehicle through which essential substances enter and metabolic waste products leave. The cells composing the growing embryo are no exception. The embryos of animals that develop in an aquatic medium, both fresh-water and marine, take up considerable amounts of water as the nonliving, stored components of the egg (yolk) become hydrolyzed and synthesized into the living and nonliving components of the embryo. See ABSORPTION (BIOLOGY).

Inorganic substances are needed in large quantities for the formation of skeletal and other supporting structures. In both invertebrates and vertebrates, silicon, calcium, magnesium, carbon as carbonate, and phosphorus as phosphate are extremely important. Salts of sodium, potassium, calcium, and magnesium are essential components of body fluids. They contribute to the osmotic properties of the body fluids and provide a milieu in which cells, tissues, and organs can function properly. Some trace elements, found in protoplasm in only minute amounts, are essential for growth. Many are probably involved in the formation and action of enzymes and enzyme cofactors. See ENZYME; OSMOREGULATORY MECHANISMS.

The organic compounds used by animals as raw materials for growth are carbohydrates, proteins, and fats, or their breakdown products. Carbohydrate apparently is not essential; laboratory animals can grow in the complete absence of carbohydrate. Fat, as such, is probably also nonessential, although some animals need certain unsaturated fatty acids to sustain growth. However, carbohydrates and fats are major sources of energy during the process of growth. See CARBOHYDRATE; LIPID.

Proteins represent the chief organic constituent of living tissues and are the most important raw material for growth. During growth, the proteins stored in the egg or provided as food from outside are digested into their constituent amino acids. These are then resynthesized into the substance of the living cells. The proteins synthesized by the organism have specific characteristics which depend upon the kinds and numbers of amino acids they contain; therefore not all proteins are equally capable of supporting growth. Proteins that fail to induce growth are deficient

in one or more essential amino acids (amino acids needed by the organism but which it cannot synthesize). See AMINO ACIDS; NUTRITION; PROTEIN.

In addition to the materials used to synthesize the bulk of the protoplasmic system, animal organisms also require certain accessory substances in order to grow. Some of these are now known as vitamins. See VITAMIN.

The growth of vertebrates is influenced by a specific growth hormone produced by the anterior lobe of the pituitary gland. Secretions from the thyroid gland, the adrenal cortex, and, in some instances, the gonads also affect growth, but perhaps less directly. Growth in various arthropods is controlled by hormone action. Molting, an essential prelude to growth in insects and crustaceans, is under hormonal control. See ENDOCRINE SYSTEM (INVERTEBRATE); ENDOCRINE SYSTEM (VERTEBRATE).

Growth determines not only the size of the animal but also its shape and form. As long as an animal grows at the same rate along all its dimensions, it will not change in bodily proportions. However, when the growth rate in certain directions is different from that along others, or when one or more parts of the growing organism develop more rapidly or more slowly than others, progressive changes in form result. Such relative growth is known as allometric growth, heterogony, or heterauxesis.

The form changes produced by alterations in body proportion are well illustrated in human development. At the second month of fetal life, the head and neck account for almost one-half the total volume of the fetus; at birth the relative size of the head is only 32% of the body; at maturity it is 10%. Conversely, at the same three stages, the legs comprise, respectively, 2%, 16%, and 29% of the total body volume. During this developmental span the relative size of the trunk remains constant at approximately 50% of body volume. Obviously, the growth of the head during prenatal development after the second fetal month is relatively smaller and that of the legs relatively larger than growth of the body as a whole.

There are many factors involved in the regulation of growth, some intrinsic, some environmental. One important factor is the histological differentiation of the cells of the organism; as differentiation proceeds, the rate of growth declines. Heredity is important in determining the limit and the rate of growth. Tall parents give rise to tall children, and the offspring of toy terriers and mastiffs grow to characteristic size. Hormonal influences also affect growth, as do such environmental factors as nutritive level, temperature, and degree of crowding. In most organisms, growth ceases at maturity, but in some, growth continues throughout life. Complete cessation of growth when the adult stage has been reached occurs mainly in terrestrial animals. [E.J.Bo.]

**Animal kingdom** One of five kingdoms of organisms: Animalia, Plantae, Fungi, Protista, and Monera. Animals are eukaryotic multicellular organisms that take food into their bodies and that develop from blastula embryos. Animal species are organized into phyla that are defined according to comparative patterns of development, body structures, behavior, biochemical pathways, modes of nutrition, and ancestry. See ANIMAL SYSTEMATICS.

Traditionally, animals have been grouped into invertebrates (without backbones) and vertebrates (with backbones). Vertebrates include mammals, amphibians, reptiles, birds, and fish. Members of all other animal phyla, more than 98% of all animal species, are invertebrates. Although invertebrates lack backbones, they achieve physical support by structures ranging from delicate glass spicules, to tough rings and rods, to hydrostatic pressure. The phylum Arthropoda alone comprises more than 1 million known species. If tropical species were better described, the arthropods might include as many as 10 million living species. See AMPHIBIA; AVES; CHONDRICHTHYES; CHORDATA; MAMMALIA; OSTEICHTHYES; REPTILIA. [K.V.S.]

**Animal morphogenesis** The development of form and pattern in animals. Animals have complex shapes and structural patterns which are faithfully reproduced during the embryonic development of each generation. Morphogenesis takes place by the generation of progressively more complex structures from a single cell: the fertilized egg, or zygote. The zygote divides repeatedly to form a multicellular embryo, within which groups of cells undergo structural and functional specialization (differentiation) in the precise spatial patterns that are recognized as tissues and organs.

Cell differentiation involves the differential expression of genes in the nuclear deoxyribonucleic acid (DNA) which code for the production of proteins specifying the structure and function of each cell type. During cleavage, nuclei divide equivalently so that all cells of the embryo receive the total complement of genes contained in the DNA of the zygote nucleus. However, cells in different regions of the embryo contain cytoplasm which differs in composition. The cytoplasmic composition of a cell controls which genes will be expressed in each region of the embryo, resulting in a patterned differentiation. Initially, different cell types arise because cells come to occupy unique positions; some cells are on the inside and others on the outside of the group of cells produced by the early divisions of the zygote. Interactions between subpopulations of cell types thus produced further alter regional cytoplasmic compositions, resulting in new patterns of gene expression. By means of many such interactions, all of the 200 or so different cell types of an animal body gradually emerge in the proper spatial patterns. See CELL DIFFERENTIATION; DEOXYRIBONUCLEIC ACID (DNA); GENE ACTION.

The structural patterns of animals and their parts exhibit polarity; that is, they display structural differences along one or more axes. In many animals, the overall polarities of the embryo are established during oogenesis and the period between fertilization and the first cleavage. For example, as the amphibian egg grows in the ovary, its posterior half becomes laden with yolk, and a dark pigment is deposited in the cortical cytoplasm of its anterior half. The line between the poles of these two halves defines the anterior-posterior axis of the future embryo. See FERTILIZATION; OOGENESIS; OVUM.

The dorsal-ventral axis develops perpendicular to the anterior-posterior axis, and is established by a reorganization of the zygote cytoplasm initiated by the events of fertilization. This axis can form in any of the planes which contain the anterior-posterior axis. The plane in which it actually forms is determined by the meridian at which the sperm enters the egg. Cytoplasmic reorganization occurs after fertilization. A tongue of yolk cytoplasm is formed on the elevated side as the heavy yolk flows down under the influence of gravity, and a new gray crescent appears on this side, its dorsal midline coinciding with the plane in which the anterior-posterior axis was tilted. The dorsal-ventral axis established by sperm entry becomes determined shortly before the first cleavage.

Two major cell types are formed during cleavage of the amphibian egg: large, yolk endoderm cells, and smaller, pigmented ectoderm cells, including the cells formed from the gray crescent region.

At the mid-blastula state, when the embryo consists of several thousand cells, an inductive interaction takes place between the endoderm cells and the gray crescent cells, causing the latter to become mesoderm cells. During gastrulation, these three cell types are rearranged to form three concentric layers, with ectoderm on the outside, endoderm on the inside, and mesoderm in between. The ectoderm develops into the skin epidermis and nervous system, endoderm into the organs of the alimentary tract, and mesoderm into muscles, skeleton, heart, kidneys, and connective tissue. See BLASTULATION; GASTRULATION; GERM LAYERS.

Prior to gastrulation, the prospective organ regions of the ectoderm and endoderm are not yet determined. Mesodermal organ regions, however, are highly self-organizing under these condi-

tions. Ectodermal and endodermal organ regions become determined during and after gastrulation by the inductive action of the mesoderm. For example, dorsal mesoderm normally invaginates and stretches out along the dorsal midline where it differentiates as notochord and trunk muscles. The ectoderm overlying the dorsal mesoderm differentiates as the central nervous system. See FATE MAPS (EMBRYOLOGY).

Once induced, organ regions can themselves induce additional organs from undetermined tissue. For example, the retina and iris of the eye develop from a vesicle growing out of the forebrain. This vesicle induces a lens from the overlying head ectoderm, and the lens then induces the cornea from head ectoderm to complete the eye. By means of such cascades of inductive interactions, all the organs of the body are blocked out. See EMBRYONIC INDUCTION.

Once determined, an organ region constitutes a developmental system, called a morphogenetic field, which specifies the detailed pattern of cell differentiation within the organ. Cells differentiate in patterns dictated by their relative positions within the field. It is generally accepted that graded molecular signals, or cues, are the basis of this positional information. It is proposed that the source of the signals is a set of boundary cells which define the limits of the field. All the cells of a field thus derive their positional information from a common set of boundary cells.

Most fields become inactive after the pattern they specify begins to differentiate; the ability to form normal organs after removal or interchange of cells is then lost. However, in some animals, the fields of certain organs can be reactivated by loss of a part, even in the adult. The missing part is then redeveloped in a process called regeneration. See REGENERATION (BIOLOGY).

Different kinds of cells secrete molecules of protein and protein complexed with carbohydrate which constitute specific types and patterns of extracellular matrix. The matrix stabilizes tissue and organ structure, guides migrating cells to their proper locations, and is a medium through which cell interactions take place. Cell interactions take place at cell surfaces, the molecular composition of which is distinct from one cell type to another, allowing them to recognize one another. These differences are reflected in varying degrees of adhesivity between different kinds of cells, and between cells and different kinds of extracellular matrix. Differential adhesivity is the property upon which cell migration, clustering, and rearrangement is based, and is thus important in creating the conditions for cell-cell and cell-matrix interactions. See CELLULAR ADHESION.

Another important mechanism for the development of complex patterns and shapes is the differential growth of organs and their parts. Differential growth is evident as soon as embryonic organ regions begin to develop. During the early part of their development, the growth rates of organs are controlled by intrinsic factors. At later stages of development, including postnatal life, organ growth is largely under the control of hormones secreted by cells of the endocrine glands.

Programmed cell death (apoptosis) is an important feature in the shaping of such structures as the head, limbs, hands, and feet of some animals. A striking example is foot development in ducks and chickens. Ducks have webbed toes while chickens do not. This difference results because as the chicken leg bud grows and forms the toes, the cells between the developing digits die. Various grafting and culturing experiments have indicated that it is a cell's relative position in the limb bud which establishes its fate to die at some later time in development. See ANIMAL GROWTH; DEVELOPMENTAL BIOLOGY; MOLECULAR BIOLOGY. [D.L.S.]

**Animal symmetry** Animal symmetry relates the organization of parts in animal bodies to the geometrical design that each type suggests. Spherical symmetry is exhibited by some protozoa, such as the Heliozoa and Radiolaria. The body is spherical with its parts concentrically around, or radiating from, a central point. Radial symmetry is exemplified by the echinoderms and most coelenterates. The body is structurally a

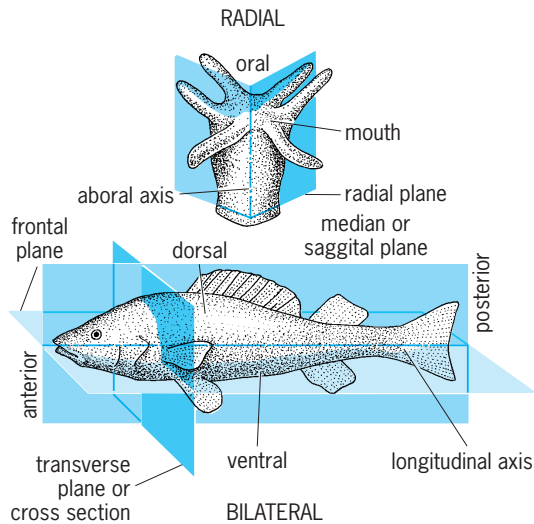

**Types of symmetry and the axes, planes, and regions in animal bodies.** (After T. I. Storer et al., eds., *General Zoology*, 6th ed., McGraw-Hill, 1979)

cylinder, tall or short, having a central axis named the longitudinal, anteroposterior, or oral-aboral axis (see illustration). Any plane through this axis divides the animal into like halves. Often several planes, from the axis outward, can divide the body into a number of like portions, or antimeres, five in most echinoderms. Ctenophores and many sea anemones and corals possess biradial symmetry, basically radial but with some parts arranged on one plane through the central axis. Most animals have bilateral, or two-sided, symmetry, in which a median or sagittal plane divides the body into equivalent right and left halves, each a mirror image of the other. [T.I.S.]

**Animal systematics** The comparative analysis of living and fossil species, including their discovery, description, evolutionary relationships to other species, and patterns of geographic distribution.

Systematics can be divided into four major fields. Taxonomy, often equated with systematics, is the discipline concerned with the discovery, description, and classification of organism groups, termed taxa (singular, taxon). Classification is the clustering of species into a hierarchical arrangement according to some criterion, usually an understanding of their relationships to other species. Phylogenetic analysis, an increasingly important aspect of systematics, is the discovery of the historical, evolutionary relationships among species; this pattern of relationships is termed a phylogeny. The fourth component of systematics is biogeography, the study of species' geographic distributions. Historical biogeography examines how species' distributions have changed over time in relationship to the history of landforms, ocean basins, and climate, as well as how those changes have contributed to the evolution of biotas (groups of species living together in communities and ecosystems).

Systematic data and interpretations underlie progress in all of biology. An understanding of relationships, in particular, is fundamental for interpreting comparative data across different kinds of organisms, whether those data be morphological, physiological, or biochemical. [J.Cr.]

**Animal virus** A small infectious agent that is unable to replicate outside a living animal cell. Unlike other intracellular obligatory parasites (for example, chlamydiae and rickettsiae), they contain only one kind of nucleic acid, either deoxyribonucleic acid (DNA) or ribonucleic acid (RNA). They do not replicate by binary fission. Instead, they divert the host cell's metabolism into synthesizing viral building blocks, which then

self-assemble into new virus particles that are released into the environment. During the process of this synthesis, viruses utilize cellular metabolic energy, many cellular enzymes, and organelles which they themselves are unable to produce. Animal viruses are not susceptible to the action of antibiotics. The extracellular virus particle is called a virion, while the name virus is reserved for various phases of the intracellular development. See RIBONUCLEIC ACID (RNA).

**Morphology.** Virions are small, 20–300 nanometers in diameter, and pass through filters which retain most bacteria. However, large virions (for example, vaccinia, which is 300 nm in diameter) exceed in size some of the smaller bacteria. The major structural components of the virion are proteins and nucleic acid, but some virions also possess a lipid-containing membranous envelope. The protein molecules are arranged in a symmetrical shell, the capsid, around the DNA or RNA. The shell and the nucleic acid constitute the nucleocapsid.

In electron micrographs of low resolution, virions appear to possess two basic shapes: spherical and cylindrical. High-resolution electron microscopy and x-ray diffraction studies of crystallized virions reveal that the "spherical" viruses are in fact polyhedral in their morphology, while the "cylindrical" virions display helical symmetry. The polyhedron most commonly encountered in virion structures is the icosahedron, in which the protein molecules are arranged on the surface of 20 equilateral triangles. Based on these morphological features, viruses are classified as helical or icosahedral. Certain groups of viruses do not exhibit any discernible features of symmetry and are classified as complex virions. Further distinction is made between virions containing RNA or DNA as their genomes and between those with naked or enveloped nucleocapsids.

**Viral nucleic acid.** The outer protein shell of the virion furnishes protection to the most important component, the viral genome, shielding it from destructive enzymes (ribonucleases or deoxyribonucleases). The viral genome carries information which specifies all viral structural and functional components required for the initiation and establishment of the infectious cycle and for the generation of new virions. This information may be contained in a double-stranded or single-stranded (parvoviruses) DNA, or double-stranded (reoviruses) or single-stranded RNA. The viral DNA may be linear or circular, and the viral RNA may be a single long chain or a number of shorter chains (fragmented genomes), each of which contains different genetic information. Furthermore, some RNA viruses have the genetic information expressed as a complementary nucleotide sequence. These are classified as negative-strand RNA viruses. Finally, the RNA tumor viruses have an intracellular DNA phase, during which the genetic information contained in the virion RNA is transcribed into a DNA and integrated into the host cell's genome. The discovery of this process came as a surprise, since it was believed that the flow of genetic information was unidirectional from DNA to RNA to protein and could not take place in the opposite direction. The transcription of RNA to DNA was termed reverse transcription, and the RNA tumor viruses are sometimes referred to as retroviruses. See GENETIC CODE.

When introduced into a susceptible cell by either chemical or mechanical means, the naked viral nucleic acid is in most cases itself infectious. Two exceptions are the negative-strand RNA viruses and the RNA tumor viruses. In these cases the RNA has to be first transcribed and reverse-transcribed, respectively, into the proper form of genetic information before the infectious process can take place. This task is carried out by means of an enzyme which is contained in the protein shell of the virion nucleocapsid. The whole nucleocapsid is therefore required for infectivity.

Viral infection is composed of several steps: adsorption, penetration, uncoating and eclipse, and maturation and release. Adsorption takes place on specific receptors in the membrane of an animal cell. The presence or absence of these receptors determines the tissue or species susceptibility to infection by a virus.

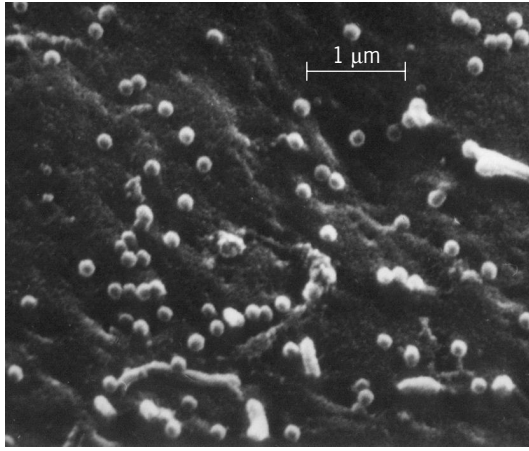

Scanning electron micrograph of the surface of a mouse cell infected with murine leukemia virus. A large number of virus particles are shown in the process of budding. (Courtesy of R. MacLeod)

Enveloped viruses exhibit surface spikes which are involved in adsorption; however, most animal viruses do not possess obvious attachment structures. Penetration takes place through invagination and ingestion of the virion by the cell membrane (phagocytosis or viropexis). Penetration is followed by uncoating of the nucleic acid, or in some cases by uncoating of the nucleocapsid. At this stage, the identity of the virion has disappeared, and viral infectivity cannot be recovered from disrupted cells. See PHAGOCYTOSIS.

The absence of infectious particles in cell extracts is characteristic of the eclipse period. During the eclipse the biochemical processes of the cell are manipulated to synthesize viral proteins and nucleic acids. The eclipse period in infections with DNA viruses starts with the transcription of the genetic information in the nucleus of the cell (except poxviruses), processing into mRNAs, and their translation into proteins (in the cytoplasm). This process is divided into early and late transcription. The early proteins are virus-encoded functional proteins which will participate in the synthesis of viral DNA and of intermediate and late viral proteins, as well as in the shutoff of various cellular functions which might be detrimental to viral synthesis. The major late products are the structural proteins of the nucleocapsid. Almost as soon as these proteins are synthesized, they assemble with newly synthesized DNA molecules into virion nucleocapsids.

The events of the eclipse period in infections with RNA viruses are similar, except that they take place in the cytoplasm (influenza virus excepted), and a division into early and late transcription cannot be made. In the case of positive-strand RNA viruses, the viral RNA is itself the mRNA. In infections with negative-strand RNA viruses, the virion RNA in the nucleocapsid is first transcribed into positive mRNAs. Intracellular nucleocapsids are present throughout the entire infectious cycle, and the eclipse period cannot be defined in the classical sense. RNA tumor viruses reverse-transcribe their RNA into DNA, which enters the cell nucleus and becomes integrated into the cellular DNA. All viral mRNAs and genomic RNAs are generated by transcription of the integrated DNA.

The event characteristic of the maturation step is virion assembly and release. In many cases the protein shell is assembled first (procapsid) and the nucleic acid is inserted into it. During this insertion, processing of some shell proteins by cleavage takes place and is accompanied by a modification of the structure to accommodate the nucleic acid. Unenveloped viruses which mature in the cytoplasm (for example, poliovirus) often exit the cell rapidly by a reverse-phagocytosis process, even before the breakdown of the cell. In some cases, however, a large number of virus particles may accumulate inside the cell in crystalline arrays called inclusion bodies. Viruses that mature in the nu-

cleus are usually released slowly, and the damage to the cell is extensive. Enveloped viruses exit the cell by a process of budding. Viral envelope proteins (glycoproteins) become inserted at various sites into the cell membrane, where they also interact with matrix proteins and with nucleocapsids. The cellular membrane then curves around the complex and forms a bud which detaches from the rest of the cell (see illustration).

**Effect of viral infections.** Two extreme types of effects are identified with viral infections: lytic infections, which cause cell death by a variety of mechanisms with cell lysis as the most common outcome, and persistent infections, accompanied either by no apparent change in the host cell or by some interference with normal growth control, as in transformation of normal to cancer cells. In animals, extensive destruction of tissue may accompany an infection by a lytic virus. See LYTIC INFECTION.

As a defense to certain conditions of infection, animal cells generate a group of substances called interferons which, by a complex mechanism, inhibit replication of viruses. They are specific to the cell species from which they were derived but not to the virus which elicited their generation. (Mouse interferon will protect mouse but not human cells from any viral infection.)

**Pathology.** Virus infections spread in several ways: through aerosols and dust, by direct contact with carriers or their excretions, and by bites or stings of animal and insect vectors. At the point of entry, infected cells undergo viremia. From there, the virus becomes disseminated by secretions. It is carried through the lymphatic system and bloodstream to other target organs, where secondary viremias occur (except in localized infections like warts). In most cases viral infections are of short duration and great severity. However, persistent infections are not uncommon (herpes, adeno, various paramyxoviruses like measles).

The afflicted organism mounts a variety of defenses, the most important of which is the immune response. Circulating antibodies against viral proteins are generated. Those interacting with virion surface proteins neutralize the infectious potential of the virus. Although the antibodies are specific against the virus which has elicited them, they will cross-react with closely related virus strains. The specificity of neutralizing antibodies obtained from experimentally injected animals is utilized for diagnostic purposes or in quantitative assays. In addition to the circulating antibodies, cell-mediated immune responses also take place. The most important of these is the production of cytotoxic thymus-derived lymphocytes, found in the lymph nodes, spleen, and blood. They destroy all cells which harbor in their membrane viral glycoproteins. The cell-mediated immunity has been demonstrated to be more important to the process of recovery than circulating antibodies. In spite of their beneficial role, immune responses often seriously contribute to the pathology of the disease. Circulating antigen-antibody complexes can lodge in organs and cause inflammation; cell-mediated responses have been known to produce severe shock syndromes in patients with a history of previous exposures to the virus. See ANTIBODY; AUTOIMMUNITY; IMMUNITY.

**Control.** Viruses are resistant to the antibiotics commonly used against bacterial infections. The use of chemotherapeutic agents with antiviral activity is plagued by their toxicity to the animal host. However, the application of vaccines has been successful in the control of several viruses. The vaccines elicit immune responses and provide sometimes life-long protection. Two types of vaccines have been applied: inactivated virus and live attenuated virus. Various inactivation procedures are available. An attenuated laboratory strain of smallpox has been applied so successfully that the disease is considered to be eradicated. A small probability of back mutations of the attenuated virus to a virulent strain makes applications of live vaccines somewhat riskier. On the other hand, protection is longer-lasting and, by virtue of spread to nonvaccinated individuals, more beneficial to the population group (herd effect). See CHEMOTHERAPY; POLIOMYELITIS; VACCINATION; VIRUS CHEMOPROPHYLAXIS.

In order to achieve full protection, it is important that the vaccine contain all the distinct antigenic types of the virus.

Development of monoclonal antibodies led to a better characterization of these types in naturally occurring viruses. This information will undoubtedly lead to better vaccines. Moreover, monoclonal antibodies have aided investigations into the molecular structure of viral antigenic groups and brightened future prospects for synthetic vaccines. See MONOCLONAL ANTIBODIES; VIRUS; VIRUS CLASSIFICATION. [M.E.Re.]

**Anise** One of the earliest aromatics mentioned in literature. The plant, *Pimpinella anisum* (Umbelliferae), is an annual herb about 2 ft (0.6 m) tall and a native of the Mediterranean region. It is cultivated extensively in Europe, Asia Minor, India, and parts of South America. The small fruits are used for flavoring cakes, curries, pastry, and candy. The distilled oil is used in medicine, soaps, perfumery, and cosmetics. See APIALES; SPICE AND FLAVORING. [P.D.St./E.L.C.]

**Anisomyaria** An order containing seven superfamilies of marine and brackish bivalves with byssal attachment at some time in their geological history (the Ostreacea are exceptional, with the lower valve attached by byssal cement at settlement, and with no record of ancestral attachment by byssal threads). The Anisomyaria possess some primitive features and some secondarily simple features: the hinge is edentulous or with inconspicuous teeth (except *Spondylus*); there are no siphons; minimal points of fusion occur between the left and right mantle lobes; the Mytilacea, Pteriacea, Pectinacea, and Anomiacea have filibranch ctenidia. Specialized features include simultaneous hermaphroditism in some Pectinacea, sex reversal and incubation of larvae in some Ostreacea, and protandrous hermaphroditism in others. Few features are common to all Anisomyaria, and the systematic status is debatable. Studies suggest addition of the isomyarian Arcacea and Limopsacea, and placing in an order Pteriomorpha, subclass Lamellibranchia, class Bivalvia. See BIVALVIA; MOLLUSCA. [R.D.P.]

**Ankerite** The carbonate mineral  $\text{Ca}(\text{Fe},\text{Mg})(\text{CO}_3)_2$ , also commonly containing some manganese. The mineral has hexagonal (rhombohedral) symmetry and has the cation-ordered structure of dolomite. The name is applied only to those species in which at least 20% of the magnesium positions are occupied by iron or manganese; species containing less iron are termed ferroan dolomites. The pure compound,  $\text{CaFe}(\text{CO}_3)_2$ , has never been found in nature and has never been synthesized as an ordered compound. See DOLomite. [A.M.G.]

Ankerite is commonly white to light brown, its specific gravity is about 3, and its hardness is about 4 on Mohs scale. See CARBONATE MINERALS. [A.M.G.]

**Annelida** The phylum comprising the multisegmented, invertebrate wormlike animals, of which the most numerous are the marine bristle worms and the most familiar the terrestrial earthworms. The Annelida (meaning little annuli or rings) include the Polychaeta (meaning many setae); the earthworms and fresh-water worms, or Oligochaeta (meaning few setae); the marine and fresh-water leeches or Hirudinea; and two other marine classes having affinities with the Polychaeta: the Archannelida (meaning primitive annelids), small heteromorphic marine worms, and the Myzostomaria (meaning sucker mouths), parasites of crinoid echinoderms. These five groups share few common characters and little resemblance except that most have a wormlike body. Typically they are bilaterally symmetrical, lack a skeleton, and have a short to long linear body divided into rings or segments, which are separated from one another by transverse walls or septa. The mouth is an anteroventral or anterior vent at the forward end of the alimentary tract, and the anus posterodorsal or posterior at the hind end of the gut. See ARCHANNELIDA; HIRUDINEA; MYZOSTOMARIA; OLIGOCHAETA; POLYCHAETA.

The linear series of segments, or metameres, from anterior to posterior ends constitute the annelid body. These segments

may be similar throughout, resulting in an annulated cylinder, as in earthworms and *Lumbrineris*. More frequently the successive segments are dissimilar, resulting in regions modified for particular functions. Each segment may be simple (uniannular) corresponding to a metamere, or it may be divided (multiannulate). The total number of segments varies from five to several hundred. Segments may have lateral fleshy outgrowths called parapodia (meaning side feet), armed with special secreted bristles or rods, called setae and acicula; they provide protection and aid in locomotion. Setae are lacking in Hirudinea and some polychaetes. The body is covered by a thin to thick epithelium which is never shed.

Annelids have sense organs of many kinds. Most conspicuous are those on the anterior and on parapodia. Eyes which function as photoreceptors may be variously developed. Feelers or tactoreceptors are frequently on the prostomium (a lobe of skin projecting from the first body segment) as antennae; on anterior segments as long filiform or thick fleshy tentacles; and on parapodia as cirri, papillae, scales, or tactile hairs. Cilia in bands or clusters or in grooves occur in specific patterns. The most conspicuous receptors are the large nuchal organs of amphinomid polychaetes, fleshy, folded, paired organs surrounding the cephalic structures.

Setae detect changes in the environment through their basal attachments. Shallow-water species often have short, strong, resistant setae, whereas abyssal species have long, slender, simple setae. Each organ is unique and well adapted to its role in the development, growth, protection, and reproduction of the species involved.

Chromatophores are cell clusters which change their shape and size to conform to the shadows of the animal's background, responding to changes in light intensities, and therefore are generally protective. They are well developed in translucent pelagic larvae which exist at the surface of the sea; they screen damaging intensities of light from delicate tissues. Oligochaetes and hirudineans, which generally lack eyes or special light receptors, are sensitive to light changes through the surface epithelium. See CHROMATOPHORE.

The alimentary tract of annelids is a straight or sinuous tube, consisting of mouth, pharynx, esophagus, stomach, gut, and pygidium or anus. The mouth may be a simple anterior (oligochaetes) or anteroventral (many polychaetes) pore provided with highly complex organs or accessory parts. Accessory organs include the grooved palpi of many polychaetes, which direct food to the mouth or also select and propel nutrients along ciliated tracts. The building organs and cementing glands of some tubicolous annelids are associated with the mouth; they select inert particles for shape and size and attach them in specific patterns to a basic secreted mucoid membrane, resulting in tubes which are highly characteristic.

The mouth is followed by the buccal cavity which may be modified as a phoboscis or saclike eversible pouch. The buccal cavity may be followed by a short to long muscularized eversible proboscis which captures and breaks up or compresses food particles. Its inner walls may be fortified by papillae or hard gnaths or jaws. A short esophagus leads to the muscular stomach or digestive region. Lateral ceca or pouches may be present, along esophageal and stomach portions, to increase the amount of surface for secretion and digestion, especially in short-bodied worms. Peristaltic (clapping and compressing) movements are rhythmic and result in the food bolus being digested, and wastes separated and pushed into the gut. In nonselective-feeding annelids the gut may be distended with great amounts of inert materials; in selective feeders there are few remains but those of living animals. The proctodaeum, or region preceding the anus, expels the wastes as fecal pellets of characteristic form.

The nervous system consists of a dorsal, bilaterally symmetrical, ganglionic mass or brain within or behind the preoral region. The brain is connected to the ventral cord through the circumesophageal connectives which extend about the oral cavity. The ventral cord may be single or paired, nearly smooth or nodular,

or ganglionated according to the segmental pattern of the body. The brain sends out lateral branches to the eyes, palpi, antennae, or other structures; the ventral cord has lateral branches to all fleshy parts which receive stimuli. A giant axon is an enlarged part of the ventral cord, present in many long, muscular, or actively moving oligochaetes and polychaetes. It permits rapid transfer of stimuli and muscular response, resulting in abrupt response.

The circulatory system consists of dorsal and ventral longitudinal, median vessels located above and below the alimentary tract. Lateral branches extend to all parts of the body. Pulsating or propelling contractile portions, sometimes called hearts, are in the anterior dorsal vessel or also at intervals in the ventral vessels. In oligochaetes these are segmental vessels of varying number connecting the dorsal and ventral vessels and surrounding some portion of the alimentary tract. The contained blood may be red, through the presence of a hemoglobinlike substance, or green, through the presence of chlorocruorin. These colors when diluted are yellow or colorless, as in many small annelids. See RESPIRATORY PIGMENTS (INVERTEBRATE).

Some annelids lack a closed circulatory system so that blood and coelomic fluids mix freely, resulting in a hemocoel; it may be partial or complete. Many annelids have a special organ called a cardiac or heart body surrounding the pulsating vessel and sometimes visible as a thick brown or red body of spongy tissue; its function is to dispose of circulatory wastes. The circulatory and coelomic fluids aid in maintaining turgidity of the annelid body, and with musculature control they act as a kind of skeleton.

Special organs for excretion are called nephridia. In their simplest form they are protonephridia, consisting of a strand of cells connecting the coelom to the body wall, usually a pair to a segment. More complex organs, or metanephridia, have a ciliated nephrostome or funnel opening into the coelom and continued to the surface as a complex organ. They function to transport wastes and at sexual maturity may serve to release gonadial products. Complex nephridia are present in all oligochaetes and many polychaetes.

The muscular system consists of an outer circular and an inner longitudinal system of muscles, each varying in extent and density according to species. In addition, an oblique series, between outer and inner layers, is well developed in annelids performing complex lateral movements. Long, very active burrowers or crawlers have an extensive musculature, whereas short, sluggish forms may have diminished musculature development. Movements are achieved mainly by coordinated muscular contractions and expansions of the laterally projecting parapodia or setae, resulting in an undulating or meandering movement. Swimming species may move from side to side or by successive forward darts and stops. Some annelids with reduced parapodia and a long proboscis use the latter in progression by extension and withdrawal of the eversible part of the alimentary tract.

The ability to replace lost parts is highly developed in annelids. Most frequent is the replacement of tail, parapodia, and setae. The anterior end may be replaced provided the break is post-pharyngeal. The torn end is first covered over with scar tissue, then differentiated into epithelial cells and all other tissues characteristic of the whole animal.

Depending on the species, reproduction may be sexual, asexual, or both. Sexual reproduction may be dioecious, in which male and female are similar, rarely dissimilar. Individuals may be hermaphroditic, both male and female, but with cross fertilization. Some annelids are protandric hermaphrodites, in which the sexual stages alternate. See PROTANDRY. [O.H.]

Fossil annelids, or segmented worms, are mostly soft-bodied, yet sufficiently common to indicate that this large and varied group of invertebrates has been abundant for more than 500 million years. The bulk of the annelidan fossil record is represented by the polychaetes. The earliest definite occurrences are from the Lower Cambrian of Greenland (Sirius Passet fauna).

The fossil record of oligochaetes is poor, in part because their predominantly terrestrial and fresh-water habitats have a relatively poor rock record. Nevertheless, the reproductive cocoons characteristic of the clitellates (oligochaetes and leeches) have been recognized as far back as the Triassic and may be more common as fossils than is generally realized. See FOSSIL. [S.C.M.]

**Anomopoda** An order of fresh-water branchiopod crustaceans, formerly included in the Cladocera. Exceptionally these organisms may be as much as 6 mm (0.24 in.) in length, but often are less than 1 mm (0.04 in.). So-called water fleas of the genus *Daphnia* are the most familiar anomopods. *Daphnia* and its close relatives swim freely in open water; however, many anomopods are benthic, predominantly crawling species. Worldwide in distribution, anomopods are among the most abundant and successful of all fresh-water invertebrates. See BRANCHIOPODA. [G.Fr.]

**Anopla** A class of the phylum Rhynchocoela which is divided into the orders Palaeonemertini and Heteronemertini. The simple tubular proboscis lacks stylets and resembles the body wall in structure. The mouth is posterior to the brain. The nervous system lies either immediately below the epidermis or among the musculature of the body wall. The vascular system is well developed. Anoplan rhynchocoelans are common on rocky shores, living beneath stones or interstitially in shell debris or coarser sands. See ENOPLA; HETERONEMERTINI; PALAEONEMERTINI; RHYNCHOCOELA. [J.B.J.]

**Anoplura** A small group of insects usually considered to constitute an order. They are commonly known as the sucking lice. All are parasites living in the covering hair of mammals. About 250 species are now known, and these comprise probably about half of the species in the world, but the group is known in detail to few persons.

These lice are distinguishable from the Mallophaga by their mouthparts and manner of feeding. The mouthparts consist of three very slender stylets which form a tube. When at rest, they are retracted in a pocket which lies just behind the mouth. The antennae are usually five-segmented, rarely three-segmented. The thoracic segments are always very closely fused and lack wings. The claw is one-segmented, and on at least one pair of legs this claw is enlarged and can be folded into a process from the tibia to grasp a hair of the host. In some species two and in others all of the legs are thus modified. The ovipositor

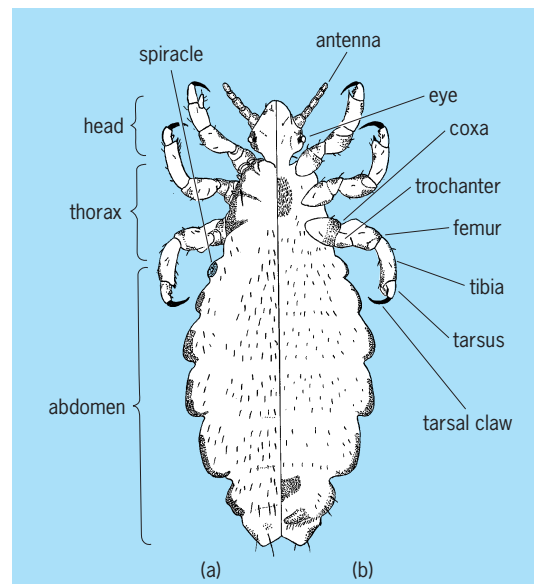

The louse *Pediculus humanus*, female, shown in (a) dorsal and (b) ventral views.



is very much reduced. It consists of but little more than two flaps which are able to close around a hair. Eyes are commonly lacking, and in those species in which they do occur, they are reduced to a pair of simple lenses or two light-receptive spots. All the species are quite small; the largest scarcely exceeds 0.2 in. (5 mm) in length and the smallest does not attain 0.04 in. (1 mm).

Feeding is accomplished by thrusting forth the tube formed by the stylets, piercing the skin of the host, and sucking blood by a pump in the throat of the insect. This habit of sucking blood gives the Anoplura a special importance. They take up any disease-producing organisms in the host's blood and may transfer these organisms to another individual. Thus, they transfer the organisms which cause epidemic typhus, relapsing fever, and trench fever. The transfer of a louse, from one host to another, can occur only when the hosts are in close bodily contact, as in the nest or at the time of mating. In the case of humans, the lice may become detached and enter the clothing or the bedding. In times of social disturbance, such as war or when people are crowded together as formerly occurred on ships, or in jails or slums, the opportunities for an exchange of these parasites are enormously increased. The close restriction of each species of lice to its special host is sufficient to account for the fact that diseases are not transferred from one species of mammal to another.

There are two species of lice which occur as common ectoparasites upon humans. One of them is *Pediculus humanus*, the head and body louse which transmits the diseases mentioned above (see illustration). The other species is *Phthirus pubis*, known as the crab louse. It transmits no known disease. The lice of the Old World monkeys are referred to another genus, *Pedicinus*. See INSECTA; MALLOPHAGA. [G.F.F./D.M.DeL.]

**Anorexia nervosa** A psychiatric disorder in which a dramatic reduction in caloric intake consequent to excessive dieting leads to significant bodily, physiological, biochemical, emotional, psychological, and behavioral disturbances. Anorexia nervosa is typically an illness of adolescent females: 90% of all cases begin in girls who are between 12 and 20 years of age. Nevertheless, this disorder can also occur in males, in prepubertal girls, and in women well into their third decade. Moreover, if the illness becomes chronic, it can persist into mid-life and beyond. Anorexia nervosa literally means "nervous loss of appetite" but appears to have little to do with such. Rather, there is usually a conscious decision made by a teen-age girl, most commonly around the ages of 14 or 18 years, to embark upon a diet. The amount of weight lost can vary considerably. The usual criterion for making a diagnosis of anorexia nervosa is a weight change of at least 25% from premonitory weight (to at least 15% below ideal weight in persons who were overweight at the onset). But this figure should be viewed as only a rule of thumb. In addition to these core disturbances, there is an array of associated symptoms and practices that characterize most persons with anorexia nervosa. Amenorrhea (absence of menstruation); increased physical activity; insomnia; use of emetics, cathartics, and diuretics; difficulty in recognizing satiation; and obsessional thinking and depression. The course and prognosis of anorexia nervosa is highly variable. While a high recovery rate, perhaps above 67%, is found in those persons whose illness begins acutely in their early teens and who quickly receive treatment, the outlook is considerably bleaker in those persons who develop the disorder later, who do not receive early treatment, and who develop bulimia.

Perhaps as many as 40–50% of anorectic patients whose illness persists for more than 1–2 years will develop the additional eating disturbance known as bulimia. Literally meaning "ox-hunger," bulimia refers to binge eating or compulsive overeating wherein thousands of calories are consumed in a relatively brief period of time (for example, 2 h). The binge characteristically involves carbohydrates and will usually culminate in self-induced vomiting. The precise nature of the relationship of bulimia to anorexia nervosa remains unclear. Not all anorectics become

bulimic and not all bulimics were anorectic. But dieting is common as a precursor to bulimia, and high premonitory weight and chronicity of weight loss seem to predispose the anorectic to developing bulimia.

Although there is a broad range of symptoms, personality styles, precipitants, and outcomes that characterize anorexia nervosa, there is no simple explanation of its origins. In one widely accepted conception, the illness is viewed as a desperate struggle by the vulnerable female adolescent to establish a sense of identity separate from that of her domineering, overbearing, controlling, and intrusive mother. There is considerable emphasis on viewing the family system as the matrix in which the illness develops and for which the illness must have significance. Anorexia is viewed as both a response to the lack of "living space" that the adolescent experiences and as a defense against the threats to the stability of the family system that the girl's normal development implies. Development of anorexia is thus a function of both individual and family. It should be noted, however, that these formulations suffer from a common problem. They are based on assessments of anorectic patients—and their families—after the illness has become established. Thus, these theories cannot very well differentiate among predisposing, precipitating, and sustaining factors.

There are numerous physical, physiological, and biochemical changes that reflect primarily, although not solely, the ravages of starvation. In addition to the general bodily emaciation they manifest, anorectic individuals show brittle nails, thinning hair, cold extremities, a slow pulse, a small heart, and a hypometabolic state. In anorectic women who also binge and vomit, tooth decay and enlargement of the salivary glands are common. A mild-to-moderate anemia and a diminished white blood cell count develop with progressive malnutrition. Diabetes insipidus can also occur in advanced cases. In addition, abnormalities in glucose tolerance and blood electrolytes have been observed. Particularly in women who vomit, the blood potassium level can be significantly low. See MALNUTRITION.

Because of the prominence of amenorrhea in its symptomatology, there has been a long-standing interest in the endocrinology of anorexia nervosa. A number of reliable hormonal abnormalities have been documented. Most prominent among these are diminished hypothalamic-pituitary-gonadal axis function and elevated hypothalamic-pituitary-adrenal axis function. Reversal of these endocrine aberrations usually occurs with clinical improvement, although considerable time may be required for full normalization. See ENDOCRINE MECHANISMS.

As with virtually all psychiatric conditions for which the etiology is unknown and where no single empirically effective treatment exists, the therapeutic approaches to anorexia nervosa are diverse and reflect the different disciplines, training biases, and experiences of their proponents. Individual, insight-oriented psychotherapy directed toward increasing confidence in identifying and accepting bodily feelings, and understanding the sources of one's low self-esteem and poor sense of self, has generally been the essence of treatment for nonhospitalized individuals, particularly before chronicity has set in. Individual psychotherapy still remains a critical part of any approach to treatment, but the recovery rate can be increased, perhaps beyond 80%, by the inclusion of regular family therapy as part of the treatment approach. In the hospital, the first priority of treatment is directed toward correcting the biological abnormalities created by the extreme dieting (and, when present, the vomiting). If the individual appears unable or unwilling to resume adequate caloric intake, despite firm but supportive nursing and concomitant individual and family psychotherapy, more extreme measures may have to be instituted, including behavior modification or intravenous hyperalimentation. There is some evidence that, particularly in anorectics who are also characterized by depression and bulimia, antidepressant or possibly anticonvulsant medication may be helpful in damping down the bingeing and thereby gradually normalizing eating behavior in general. See PSYCHOPHARMACOLOGY; PSYCHOTHERAPY. [J.L.Ka.]

**Anorthite** The calcium-rich plagioclase feldspar with composition  $Ab_0An_{100}$  to  $Ab_{10}An_{90}$  ( $Ab = NaAlSi_3O_8$ ;  $An = CaAl_2Si_2O_8$ ), occurring in olivine-rich igneous rocks and rare volcanic ejecta (for example, at Mount Vesuvius, Italy, and Miyakejima, Japan). Hardness is 6 on Mohs scale, specific gravity 2.76, melting point  $1550^\circ C$  ( $2822^\circ F$ ). The crystal structure of  $Ab_0An_{100}$  consists of an infinite three-dimensional array of corner-sharing  $[AlO_4]$  and  $[SiO_4]$  tetrahedra, alternately linked together in a framework of  $[Al_2Si_2O_8]_{\infty}^{2-}$  composition in which charge-balancing calcium ( $Ca^{2+}$ ) cations occupy four distinct, irregular cavities. Natural anorthite has no commercial uses, but the synthetic material  $[CaO \cdot Al_2O_3 \cdot 2SiO_2]$  (known as CAS<sub>2</sub>) is important in the ceramic industry and in certain composite materials with high-temperature applications. See FELDSPAR.

[P.H.R.]

**Anorthoclase** The name usually given to alkali feldspars which have a chemical composition ranging from  $Or_{40}Ab_{60}$  to  $Or_{10}Ab_{90} \pm$  up to approximately 20 mole % An ( $Or, Ab, An = KAlSi_3O_8, NaAlSi_3O_8, CaAl_2Si_2O_8$ ) and which deviate in one way or another from monoclinic symmetry tending toward triclinic symmetry. When found in nature, they usually do not consist of a single phase but are composed of two or more kinds of K- and Na-rich domains mostly of submicroscopic size. In addition, they are frequently polysynthetically twinned after either or both of the albite and pericline laws. It appears that they originally grew as the monoclinic monalbite phase, inverting and unmixing in the course of cooling during geological times. They are typically found in lavas or high-temperature rocks. See FELDSPAR; IGNEOUS ROCKS.

[F.H.L.]

**Anorthosite** A rock composed of 90 vol % or more of plagioclase feldspar. Strictly, the rock is composed entirely of crystals discernible with the eye, but some finely crystalline examples from the Moon have been called anorthosite or anorthositic breccia. Scientists have been fascinated with anorthosites because they are spectacular rocks (dark varieties are quarried and polished for ornamental use); valuable deposits of iron and titanium ore are associated with anorthosites; and the massif anorthosites appear to have been produced during a unique episode of ancient Earth history (about  $1-2 \times 10^9$  years ago).

Pure anorthosite has less than 10% of dark minerals—generally some combination of pyroxene, olivine, and oxides of iron and titanium; amphibole and biotite are rare, as are the light minerals apatite, zircon, scapolite, and calcite. Rocks with less than 90% but more than 78% of plagioclase are modified anorthosites (such as gabbroic anorthosite), and rocks with 78–65% of plagioclase are anorthositic (such as anorthositic gabbro). See GABBRO.

The structure, texture, and mineralogy vary with type of occurrence. One type of occurrence is as layers (up to several meters thick) interstratified with layers rich in pyroxene or olivine. The second type of occurrence is the massifs type and can have an area up to 11,600 mi<sup>2</sup> (30,000 km<sup>2</sup>). Commonly, the massifs are domical in shape and weakly layered. Possibly there is a third group of anorthosite occurrences: extremely ancient bodies of layered rock in which the layers of anorthosite contain calcium-rich plagioclase and the adjacent layers are rich in chromite and amphibole in addition to pyroxene. There are only a few examples of these apparently igneous complexes, in Greenland, southern Africa, and India. However, they appear to be terrestrial counterparts of lunar anorthosites.

By comparison with terrestrial occurrences, most lunar anorthosites are very fine grained, although one rock has crystals up to a centimeter long. Much of the fine grain size results from comminution by meteorite impact, and some of it probably results from rapid crystallization of impact melts. See ANDESINE; IGNEOUS ROCKS; LABRADORITE; METAMORPHISM; MOON.

[A.T.A.]

**Anostraca** An order of branchiopod crustaceans, known as fairy shrimps and, in some cases, brine shrimps. These organisms range up to about 4 in. (100 mm) in length, but usually are much smaller. The trunk consists of 19 to 27 segments, of which usually the first 11, sometimes the first 17 or 19, bear limbs, plus a telson bearing flattened furcal rami (see illustration). The trunk limbs are foliaceous, and all are of the same basic type but differ a little among themselves; each limb is differentiated into a series of endites and is usually filtratory. By beating in metachronal rhythm they propel the animal forward and draw food particles toward it. Anostracans usually swim with their ventral surface uppermost.

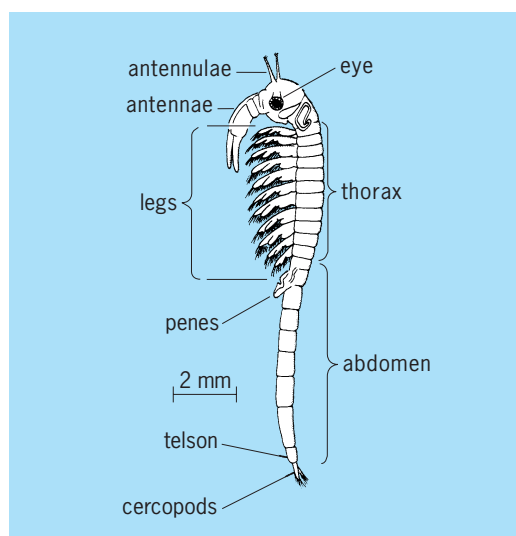

*Branchinecta paludosa*, male, small specimen, lateral aspect.

Most anostracans subsist on minute particles that they sieve from the water with their trunk limbs and pass forward to the mouthparts. Reproduction is usually bisexual, but some brine shrimps are parthenogenetic. Fairy shrimps frequent fresh water, usually temporary pools, in all regions of the world, but are also found in predator-free waters in Arctic and Antarctic regions. See BRANCHIOPODA.

[G.Fr.]

**Anoxic zones** Oxygen-depleted regions in marine environments. The dynamic steady state between oxygen supply and consumption determines the oxygen concentration. In regions where the rate of consumption equals the rate of supply, seawater becomes devoid of oxygen and thus anoxic. In the open ocean, the only large regions which approach anoxic conditions are between 165 and 3300 ft (50 and 1000 m) deep in the equatorial Pacific and between 330 and 3300 ft (100 and 1000 m) in the northern Arabian Sea and the Bay of Bengal in the Indian Ocean. The Pacific region consists of vast tongues extending from Central America and Peru nearly to the middle of the ocean in some places. In parts of this zone, oxygen concentrations become very low, 15  $\mu\text{mol/liter}$  (atmospheric saturation is 200–300  $\mu\text{mol/liter}$ ). Pore waters of marine sediments are sometimes anoxic a short distance below the sediment-water interface. The degree of oxygen consumption in sediment pore waters depends upon the amount of organic matter reaching the sediments and the rate of bioturbation (mixing of the surface sediment by benthic animals). In shallow regions (continental shelf and slope), pore waters are anoxic immediately below the sediment-water interface; in relatively rapid sedimentation-rate areas of the deep sea, the pore waters are usually anoxic within a few centimeters of the interface; and in pore waters

of slowly accumulating deep-sea sediments, oxygen may never become totally depleted. See MARINE SEDIMENTS.

Restricted basins (areas where water becomes temporarily trapped) are often either permanently or intermittently anoxic. Classic examples are the Black Sea, the Carioca Trench off the coast of Venezuela, and fiords which occupy the Norwegian and British Columbia coasts. Lakes which receive a large amount of nutrient inflow (either from natural or human-produced sources) are often anoxic during the period of summer stratification. See BLACK SEA; FIORD.

The chemistry of many elements dissolved in seawater (particularly the trace elements) is vastly changed by the presence or absence of oxygen. Since large areas of the ocean water mass are in contact with oxygen-depleted pore waters, the potential exists for anoxic conditions to have a marked effect on the chemistry of the sea. See SEAWATER; SEAWATER FERTILITY. [S.R.E.]

**Anseriformes** An order of birds comprising two families, the screamers (Anhimidae) of South America and the worldwide waterfowl (Anatidae). They are closely related to the Galliformes, with the screamers being a rather intermediate group. The giant, flightless diatrymids of the early Tertiary are specialized offshoots of the Anseriformes. See GALLIFORMES; GASTORNITHIFORMES.

The order Anseriformes is divided into the suborder Anhimae, containing the single family Anhimidae (screamers; 3 species), and the suborder Anseres, including only the family Anatidae (ducks, geese, and swans; 147 species). The waterfowl (Anatidae) are further subdivided into seven subfamilies, namely the primitive Anseranatinae (maggie goose of Australia), Dendrocygninae (tropical tree ducks), Anserinae (swans and geese), Tadorninae (shelducks of the Old World and South America), Anatinae (true ducks), Merginae (mainly Northern Hemisphere sea ducks and mergansers), and Oxyurinae (stiff-tailed ducks).

The South American screamers are turkey-sized, fowl-like aquatic birds with a short, heavy, chicken-like beak. The legs are of medium length and heavy, with four toes having only a basal web. They fly slowly but soar well. Screamers live in marshes, walk on mats of floating vegetation, and sometimes swim. They feed on vegetable matter, are gregarious, and nest in solitary pairs.

The waterfowl vary in size from pygmy geese to large swans. They occur worldwide in fresh and marine (coastal) waters. All species have strong legs and feet with webbed toes and a flattened bill with comb-like lamellae or teeth. The plumage is waterproof and varies from pure white to multihued to all black; females usually have a brown, cryptic plumage. The tongue is large and fleshy and serves in filter-feeding. Waterfowl feed on both plants and animals, obtained by filtering (many true ducks), grazing (swans and geese), and diving (sea ducks, mergansers, stiff-tailed ducks, and some true ducks). Diving ducks feed on mollusks and water plants, mergansers on fish. All species swim well, and most are strong fliers. Most species are gregarious except at breeding. Waterfowl are monogamous with a strong pair bond (some mate for life) and elaborate courtship.

The waterfowl are of immense economic importance. The mallard (*Anas platyrhynchos*; the common domesticated duck), muscovy duck (*Cairina moschata*), gray-lag goose (*Anser anser*; the common domesticated goose), and swan goose (*Anser cygnoid*) have been domesticated since ancient times for their flesh, eggs, and feathers. See AVES. [W.J.B.]

**Ant** All ants are classified in a single family, Formicidae; this reflects their limited structural variation. They are thought to have evolved from a wasp-like ectoparasite of soil insects. Australia contains many primitive species, including the bulldog ants, which are large and fierce and live in small colonies (subfamily Myrmicinae). A common tropical group (Ponerinae) has evolved specialists in group raiding for soil insects, espe-

cially preying upon the ubiquitous termites. Also tropical is a set of predacious species (Dorylinae) whose colonies can contain a million workers, but only one queen; as well as hunting in groups, the whole colony roams nomadically through the forests. Other subfamilies are no longer exclusively predacious: in the Formicinae, which include the most conspicuous temperate region ants, plant-sucking bugs are used as a source of honeydew which, though mainly sugary, contains some soluble proteins. Wood ants (*Formica* species) pile dead vegetation into huge mound nests inside which they can retain their body heat. From the nests they establish permanent trackways to aphid-bearing trees, on which they also capture many insect larvae, including those injurious to forest trees. Each tree is part of a large territory which is defended against neighboring colonies. Yellow ants (*Lasius flavus*) culture aphids of many sorts on roots belowground and apparently use their carcasses as meat; in Europe they build soil mounds in old hillside grassland. In the tropics the leaf-nesting ants (*Oecophylla* species), which use larval silk to bind leaves together into a nest, culture plant-bugs in trees as well as prey upon a variety of insects; they can be used to protect fruit bushes from harmful insects.

In subfamily Myrmicinae, though there are many simple, mundane species with mixed diets, some specialists have almost given up predation. Thus grain collectors store and eat seeds; any seeds that germinate are put out and, mixed with rubbish, may start new plants nearer home (surely agriculture in its infancy). Then there are the leaf-cutting ants (tribe Attini) of Central America that collect vegetation and feed it to a species of fungus whose special bodies they then eat. These ants secrete a battery of chemicals for stopping the growth of weed species. Ants of another subfamily (Pseudomyrmicinae) have close mutualistic relations with plants: the plants supply special hollow galls, stems, or swollen thorns and offer nourishing tissues inside; the ants live and feed in these cavities and in exchange protect the plant from phytophagous insects and other enemies.

All female ants are social insects (the males exist only briefly to provide sperm) that live in dense clusters in nests made to protect against weather and enemies and to provide a work surface on which to rear their young. There are two types of female: small, wingless ones (called workers) that construct and defend the nest as well as collect and prepare food for the almost helpless larvae; and large, winged ones (called queens) that fly off to copulate, disperse, and start new nests, and which, after breaking off their wings, not only lay most of the eggs (usually all the female eggs and often the male ones too) but stimulate and organize worker activity. Workers usually have ovaries but no sperm sac, and the few eggs each lays are unfertilized; though haploid, they can produce males by parthenogenesis, for sex is determined by a haplo-diploid mechanism as in most insects of this order (Hymenoptera). See HYMENOPTERA; SOCIAL INSECTS. [M.V.B.]

**Antarctic Circle** An imaginary line that delimits the northern boundary of Antarctica. It is a distinctive parallel of latitude at approximately 66°30' south. Thus it is located about 4590 mi (7345 km) south of the Equator and about 1630 mi (2620 km) north of the south geographic pole.

All of Earth's surface south of the Antarctic Circle experiences one or more days when the Sun remains above the horizon for at least 24 h. The Sun is at its most southerly position on or about December 21 (slightly variable from year to year). This date is known as the summer solstice in the Southern Hemisphere and as the winter solstice in the Northern Hemisphere. At this time, because Earth is tilted on its axis, the circle of illumination reaches 23.50° to the far side of the South Pole and stops short 23.50° to the near side of the North Pole.

The longest period of continuous sunshine at the Antarctic Circle is 24 h, and the highest altitude of the noon Sun is 47° above the horizon at the time of the summer solstice. The long days preceding and following the solstice allow a season of about 5 months of almost continuous daylight.

Six months after the summer solstice, the winter solstice (Southern Hemisphere terminology) occurs on or about June 21 (slightly variable from year to year). On this date the Sun remains below the horizon for 24 h everywhere south of the Antarctic Circle; thus the circle of illumination reaches 23.50° to the far side of the North Pole and stops short 23.50° to the near side of the South Pole. See ARCTIC OCEAN. [T.L.M.]

**Antarctic Ocean** The Antarctic Ocean, sometimes called the Southern Ocean, is the watery belt surrounding Antarctica. It includes the great polar embayments of the Weddell Sea and Ross Sea, and the deep circumpolar belt of ocean between 50 and 60°S and the southern fringes of the warmer oceans to the north. Its northern boundary is often taken as 30°S (see illustration). The Antarctic is a cold ocean, covered by sea ice during the winter from Antarctica's coast northward to approximately 60°S.

The remoteness of the Antarctic Ocean severely hampers the ability to observe its full character. The sparse data collected and the more recent addition of data obtained from satellite-borne sensors have led to an appreciation of the unique role that this ocean plays in the Earth's ocean and climate. Between 50 and 60°S there is the greatest of all ocean currents, the Antarctic Circumpolar Current sweeping seawater from west to east, blending waters of the Pacific, Atlantic, and Indian oceans. Observed within this current is the sinking of cool (approximately 4°C; 39.2°F), low-salinity waters to depths of near 1 km (0.6 mi), which then spreads along the base of the warm upper ocean waters or thermocline of more hospitable ocean environments. The cold polar atmosphere spreading northward from Antarctica removes great amount of heat from the ocean, heat which is carried to the sea surface from ocean depths, brought into the Antarctic Ocean from warmer parts of the ocean. At some sites along the margins of Antarctica, there is rapid descent of cold (near the freezing point of seawater, -1.9°C; 28.6°F) dense water, within thin convective plumes. This water reaches the sea floor, where it spreads northward, chilling the lower 2 km (1.2 mi) of the global ocean, even well north of the Equator.

The major flow is the Antarctic Circumpolar Current, or West Wind Drift (see illus). Along the Antarctic coast is the westward-

flowing East Wind Drift. The strongest currents are in the vicinity of the polar front zone and restricted passages such as the Drake Passage, and over deep breaks in the meridionally oriented submarine ridge systems.

The extreme cold of the polar regions causes an extensive ice field to form over the southern regions of the Antarctic Ocean. The extent of the ice is seasonal in that during the October-to-March period the area decreases, and it increases during the remaining months. The seasonal difference in the volume of sea ice is estimated as  $2.3 \times 10^{19}$  grams ( $8.1 \times 10^{17}$  oz). Satellite photographs reveal that the sea ice field is not uniform, but has many large polynyas (areas of water). The sea ice plays an important role in the heat balance since it reflects much more solar radiation (and therefore heat) into space than would be the case for a water surface. The polynyas would therefore be of special interest in radiation and heat-balance studies. In addition to the ice formed at sea, the ice calving at the coast of Antarctica introduces icebergs into the ocean at a rate of approximately  $1 \times 10^{18}$  g/year ( $3.5 \times 10^{12}$  oz/year). See HEAT BALANCE, TERRESTRIAL ATMOSPHERIC; ICEBERG; SEA ICE.

Glacial (fresh-water) ice and the ocean meet along the shores of Antarctica. This occurs not only at the northern face of the ice sheet but also at hundreds of meters depth along the bases of floating ice shelves. Ocean-glacial ice interaction is believed to be a major factor in controlling Antarctica's glacial ice mass balance and stability. [A.L.G.]

**Antarctica** The coldest, windiest, and driest continent, overlying the South Pole. The lowest temperature ever measured on Earth was recorded at the Russian Antarctic station of Vostok at -89.2°C (-128.5°F) in July 1983. Katabatic (cold, gravitational) winds with velocities up to 50 km/h (30 mi/h) sweep down to the coast and occasionally turn into blizzards with 150 km/h (nearly 100 mi/h) wind velocities. Antarctica's interior is a cold desert with only a few centimeters of water-equivalent precipitation, while the coastal areas average 30 cm (12 in.).

Antarctica's area is about 14 million square kilometers (5.4 million square miles), which is larger than the contiguous 48 United States and Mexico together. It is the third smallest continent, after Australia and Europe. About 98% of it is buried under a thick ice sheet, which in places is 4 km (13,000 ft) thick, making it the highest continent, with an average elevation of over 2 km (6500 ft).

Although most of Antarctica is covered by ice, some mountains rise more than 3 km (almost 10,000 ft) above the ice sheet. The largest of these ranges is the Transantarctic Mountains separating east from west Antarctica, and the highest peak in Antarctica is Mount Vinson, 5140 m (16,850 ft), in the Ellsworth Mountains. Other mountain ranges, such as the Gamburtsev Mountains in East Antarctica, are completely buried, but isolated peaks called nunataks frequently thrust through the ice around the coast.

The Antarctic ice sheet is the largest remnant of previous ice age glaciations. It has probably been in place for the last 20 million years and perhaps up to 50 million years. It is the largest reservoir of fresh water on Earth, with a volume of about 25 million cubic kilometers (6 million cubic miles). Glaciers flow out from this ice sheet and feed into floating ice shelves along 30% of the Antarctic coastline. The two biggest ice shelves are the Ross and Filchner-Ronne. These shelves may calve off numerous large tabular icebergs, with thicknesses of several hundred meters, towering as high as 70-80 m (250 ft) above the sea surface. See GLACIOLOGY.

Year-round life on land in Antarctica is sparse and primitive. North of the Antarctic Peninsula a complete cover of vegetation, including moss carpets and only two species of native vascular plants, may occur in some places. For the rest of Antarctica, only lichen, patches of algae in melting snow, and occasional microorganisms occur. In summer, however, numerous migrating birds nest and breed in rocks and cliffs on the continental margins,



Direction of the surface circulation and major surface boundaries of the Antarctic Ocean.

to disappear north again at the beginning of winter. South of the Antarctic Convergence, 43 species of flying birds breed annually. They include petrels, skuas, and terns, cormorants, and gulls. Several species of land birds occur on the subantarctic islands. The largest and best-known of the Antarctic petrels are the albatrosses, which breed in tussock grass on islands north of the pack ice. With a wing span of 3 m (10 ft), they roam freely over the westerly wind belt of the Southern Ocean. See PROCELLARIIFORMES. [G.We.]

**Antares**  $\alpha$  Scorpii, a cool supergiant star of spectral type M1b, whose red color stands out in the midsummer sky. With an effective temperature of approximately 6000°F (3600 K), Antares resembles Betelgeuse, the brightest of the red supergiants, and would fill the solar system beyond the orbit of Mars if it replaced the Sun. Antares is only about 100 parsecs (325 light-years) from the Sun, and its angular diameter of about 0.045 arc-second has been measured by interferometric and lunar occultation methods. Red supergiants of this type originate as stars with mass at least 20 times that of the Sun. Such stars quickly evolve through successive stages of thermonuclear fusion. Eventually, the supergiant star implodes in a type II supernova explosion. This fate is likely for Antares in less than a million years. Prior to this dramatic event, Antares will have shed up to 50% of its mass through a stellar wind of material blown away from the star into the surrounding interstellar medium. See BETELGEUSE; SCORPIUS; SPECTRAL TYPE; STELLAR EVOLUTION; SUPERGIANT STAR; SUPERNOVA.

Antares is a member of an association of young and primarily hot stars, and is gravitationally bound in a binary star system with a hot blue star of spectral type B3V. The two stars orbit each other with a period of about 900 years, from which their masses can be determined to be about 15 and 7 times that of the Sun for the red and blue components respectively. The interaction of the strong wind of matter from the supergiant with the radiation from the less massive, hot companion produces an unusual nebulosity surrounding the hot star. See BINARY STAR; NEBULA; STAR. [H.A.McA.]

**Anteater** A name associated with several animals in five different orders of the three major groups of living mammals (see table). They are so named because they are insectivorous, having a diet of ants and termites. The animal most frequently associated with this name is the ground-living *Myrmecophaga tridactyla*, the giant anteater, a member of the family Myrmecophagidae in the order Edentata (see illustration). This family has three other species, *Tamandua longicaudata*, *T. tetradactyla*, and *Cyclopes didactylus*, all of which are arboreal.

All four species are restricted to the tropical regions of South and Central America. *Myrmecophaga tridactyla* prefers the grasslands and more open forested areas. The animal is about 6 ft (1.8 m) long including the tail length, which measures about



The giant anteater (*Myrmecophaga tridactyla*).

#### Classification and scientific name of some animals commonly referred to as anteaters

Mammalian order	Scientific name	Common name
Monotremata	<i>Tachyglossus setosus</i>	Spiny anteater or Tasmanian echidna
	<i>T. aculeatus</i>	Australian echidna
	<i>Zaglossus bruijini</i>	Bruijn's echidna
	<i>Z. bartoni</i>	Barton's echidna
	<i>Z. bubuensis</i>	Bubu echidna
Marsupialia	<i>Myrmecobius fasciatus</i>	Marsupial anteater or banded anteater
	<i>M. rufus</i>	Rusty numbat
Pholidota	<i>Manis gigantea</i>	Scaly anteater or giant pangolin
	<i>M. temmincki</i>	Cape pangolin
	<i>M. tricuspis</i>	Tree pangolin
	<i>M. longicaudata</i>	Long-tailed tree pangolin
	<i>M. pentadactyla</i>	Chinese pangolin
	<i>M. crassicaudata</i>	Indian pangolin
	<i>M. javanica</i>	Malayan pangolin
Edentata	<i>Myrmecophaga tridactyla</i>	Giant anteater
	<i>Tamandua longicaudata</i>	Long-tailed anteater
	<i>T. tetradactyla</i>	Tamandua
	<i>Cyclopes didactylus</i>	Dwarf anteater
Tubulidentata	<i>Orycteropus afer</i>	Aardvark or Cape anteater

2 ft (0.6 m). It is toothless, and the head extends into a long, tubular snout with a small mouth opening. The tongue is long, protrusible, and covered with a viscous mucous material which entraps the insects. The front feet have greatly enlarged claws used for tearing into ant and termite mounds and as defensive weapons. The body is covered with long hair, and in *Cyclopes* the tail is prehensile. Usually a single young is produced by the female, which she may carry on her back until it is quite large. See AARDVARK; EDENTATA; MARSUPIALIA; MONOTREMATA; PHOLIDOTA; TUBULIDENTATA. [C.B.C.]

**Antelope** The name given to a group of hollow-horned, hoofed ruminants of the order Artiodactyla which are strictly confined to various areas of Africa and Asia. They are assigned to the subfamily Antilopinae in the family Bovidae and include 91 species in 31 genera.

In general, the third and fourth toes are well developed, while the second and fifth toes are reduced or absent. The males and usually the females have a pair of unbranched horns, which differ considerably in appearance among the various species of antelopes. These animals vary in size from the royal antelope (*Neotragus pygmaeus*), which is about 10–12 in. (25–30 cm) high at the shoulder, to the giant eland (*Taurotragus derbianus*), which measures about 6 ft (1.8 m) at the shoulder and weighs about 1 ton (0.9 metric ton). See ARTIODACTYLA; MAMMALIA. [C.B.C.]

**Antenna (electromagnetism)** The device that couples the transmitter or receiver network of a radio system to space. Radio waves are used to transmit signals from a source through space. The information is received at a destination which in some cases, such as radar, can be located at the transmitting source. Thus, antennas are used for both transmission and reception. See RADAR.

To be highly efficient, an antenna must have dimensions that are comparable with the wavelength of the radiation of interest. At long wavelengths such as the part of the spectrum used in broadcasting (a frequency of 1 MHz corresponds to a free-space wavelength  $\lambda$  of 300 m), the requirement on size poses severe structural problems, and it is consequently necessary to use structures that are portions of a wavelength in size (such as  $0.1 \lambda$  or  $0.25 \lambda$ ). Such antennas can be described as being little more than quasioleostatic probes protruding from the Earth's surface.

In order to control the spread of the energy, it is possible to combine antennas into arrays. As the wavelength gets shorter, it is possible to increase the size of the antenna relative to the wavelength; proportionately larger arrays are also possible, and

techniques that are familiar in acoustics and optics can be employed (Fig. 1). For example, horns can be constructed with apertures that are large compared with the wavelength. The horn can be designed to make a gradual transition from the transmission line, usually in this case a single-conductor waveguide, to free space. The result is broadband impedance characteristics as well as directivity in the distribution of energy in space. Another technique is to use an elemental antenna such as a horn or dipole together with a reflector or lens. The elemental antenna is essentially a point source, and the elementary design problem is the optical one of taking the rays from a point source and converting them into a beam of parallel rays. Thus a radio searchlight is constructed by using a paraboloidal reflector or a lens. A very large scale structure of this basic form used as a receiving antenna (together with suitably designed receivers) serves as a radio telescope. Antennas used for communicating with space vehicles or satellites are generally large (compared to wavelength) structures as well. See RADIO TELESCOPE; SPACE COMMUNICATIONS; TRANSMISSION LINES; WAVEGUIDE.

A small electric or magnetic dipole radiates no energy along its axis, the contour of constant energy being a toroid. The most basic requirements of an antenna usually involve this contour in space, called the radiation pattern. The purpose of a transmitting antenna is to direct power into a specified region, whereas the purpose of a receiving antenna is to accept signals from a specified direction. In the case of a vehicle, such as an automobile with a car radio, the receiving antenna needs a nondirectional pattern so that it can accept signals from variously located stations, and from any one station, as the automobile moves. The antenna of a broadcast station may be directional; for example, a station in a coastal city would have an antenna that concentrated most of the power over the populated land. The antenna for transmission to or from a communication satellite should have a narrow radiation pattern directed toward the satellite for efficient operation, preferably radiating essentially zero power in other directions to avoid interference. See DIRECTIVITY; RADIO BROADCASTING.

The plane of the electric field of the radiated electromagnetic wave depends on the direction in which the current flows on the antenna. The electric field is in a plane orthogonal to the axis of a magnetic dipole. This dependence of the plane of the radiated electromagnetic wave on the orientation and type of antenna is

termed polarization. A receiving antenna requires the same polarization as the wave that it is to intercept. By combining fields from electric and magnetic dipoles that have a common center, the radiated field can be elliptically polarized; by control of the contribution from each dipole, any ellipticity from plane polarization to circular polarization can be produced. See POLARIZATION OF WAVES.

The input impedance of an antenna is the ratio of the voltage to current at the terminals connecting the transmission line and transmitter or receiver to the antenna. The impedance can be real for an antenna tuned at one frequency but generally would have a reactive part at another frequency.

An array of antennas is an arrangement of several individual antennas so spaced and phased that their individual contributions add in the preferred direction and cancel in other directions. One practical objective is to increase the signal-to-noise ratio in the desired direction. Another objective may be to protect the service area of other radio stations, such as broadcast stations. See SIGNAL-TO-NOISE RATIO.

The simplest array consists of two antennas. It makes possible a wide variety of radiation patterns, from nearly uniform radiation in azimuth to a concentration of most of the energy into one hemisphere, or from energy in two or more equal lobes to radiation into symmetrical but unequal lobes.

For further control over the radiation pattern a preferred arrangement is the broadside box array. In this array, antennas are placed in a line perpendicular to the bidirectional beam. Individual antenna currents are identical in magnitude and phase. The array can be made unidirectional by placing an identical array  $90^\circ$  to the rear and holding its phase at  $90^\circ$ . The directivity of such a box array increases with the length or aperture of the array.

Further use of array concepts has enabled improvements in communications. By introducing a network for each antenna element, it is possible to receive a signal from a source direction and to return a signal in the direction of the source. The returned signal can be modulated or amplified or have its frequency changed. Such an array is called a retrodirective array. Basically, the array seeks out the incoming signal and returns one of useful characteristics, such as that which is needed for the communication between a moving vehicle and a stationary or slowly moving source.

The bandwidth of an antenna may be limited by pattern shape, polarization characteristics, and impedance performance. Bandwidth is critically dependent on the value of  $Q$ ; hence the larger the amount of stored reactive energy relative to radiated resistive energy, the less will be the bandwidth. See  $Q$  (ELECTRICITY).

Antennas whose mechanical dimensions are short compared to their operating wavelengths are usually characterized by low radiation resistance and large reactance. This combination results in a high  $Q$  and consequently a narrow bandwidth. Current distribution on a short conductor is sinusoidal with zero current at the free end, but because the conductor is so short electrically, typically less than  $30^\circ$  of a sine wave, current distribution will be essentially linear. By end loading to give a constant current distribution, the radiation resistance is increased four times, thus greatly improving the efficiency but not noticeably altering the pattern.

Long-wire antennas, or traveling-wave antennas, are usually one or more wavelengths long and are untuned or nonresonant.

There are two principal approaches to constructing frequency-independent antennas. The first is to shape the antenna so that it can be specified entirely by angles; hence when dimensions are expressed in wavelengths, they are the same at every frequency. Planar and conical equiangular spiral antennas adhere to this principle (Fig. 2a). The second approach depends upon complementary shapes. According to this principle, which is used in constructing log-periodic antennas, before the structure shape changes very much, when measured in wavelengths, the

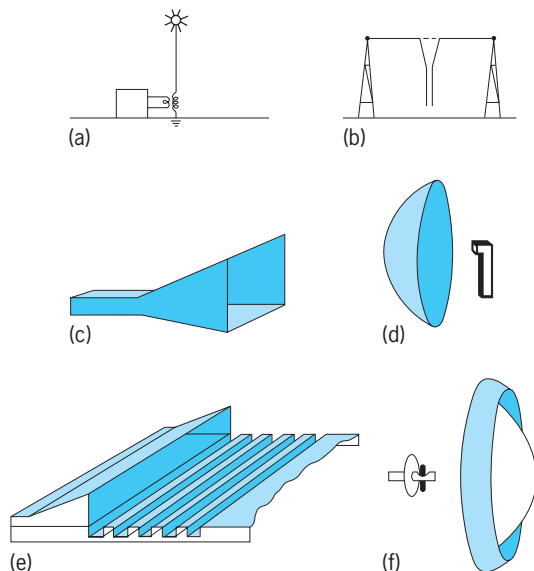

Fig. 1. Various types of antennas. (a) Top-loaded vertical mast; (b) center-fed horizontal antenna; (c) horn radiator; (d) paraboloidal reflector with a horn feed; (e) corrugated-surface wave system for end-fire radiation; (f) zoned dielectric lens with a dipole-disk feed. (After D. J. Angelakos and T. E. Everhart, *Microwave Communications*, Krieger, 1983)

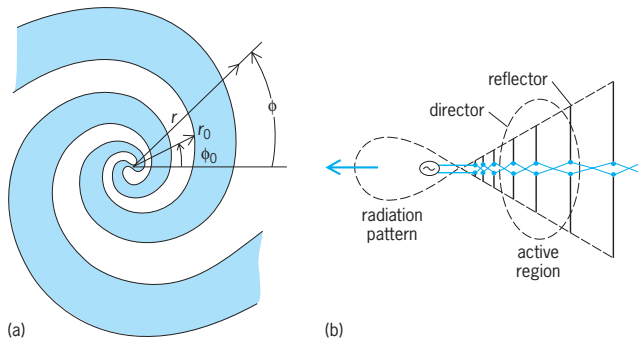

Fig. 2. Frequency-independent antennas. (a) Equiangular spiral (after D. J. Angelakos and T. E. Everhart, *Microwave Communications, Krieger, 1983*). (b) Log-periodic structure.

structure repeats itself (Fig. 2b). By combining periodicity and angle concepts, antenna structures of very large bandwidths become feasible.

When they are to be used at short wavelengths, antennas can be built as horns, mirrors, or lenses. Such antennas use conductors and dielectrics as surfaces or solids. See MICROWAVE OPTICS.

By using reflectors it is possible to achieve high gain, modify patterns, and eliminate backward radiation. A low-gain dipole, a slot, or a horn, called the primary aperture, radiates toward a larger reflector called the secondary aperture. The large reflector further shapes the radiated wave to produce the desired pattern.

A beam can be formed in a limited space by a two-reflector system. The commonest two-reflector antenna, the Cassegrain system, consists of a large paraboloidal reflector. It is illuminated by a hyperbolic reflector, which in turn is illuminated by the primary feed (Fig. 3).

A series of antennas are useful in situations which require a low profile. Slot antennas constitute a large portion of this group. In essence, replacing a wire (metal) by a slot (space), which is a complement of the wire, yields radiation characteristics that are basically the same as those of the wire antenna except that the electric and magnetic fields are interchanged.

Because flush-mounted antennas present a low profile and consequently low wind resistance, slot-type antennas have had considerable use in aircraft, space-launching rockets, missiles, and satellites. They have good radiation properties and are capable of being energized so as to take advantage of all the properties of arrays, such as scanning, being adaptive, and being retrodirective. These characteristics are obtained without physical motion of the antenna structures. Huge slot antenna arrays are commonly found on superstructures of aircraft carriers and other naval ships, and slot antennas are designed as integral parts of the structure of aircraft, such as the tail or wing.

The patch antenna consists of a thin metallic film which is attached to a dielectric substrate mounted on a metallic base. Depending on its use, the patch can be of different shapes and

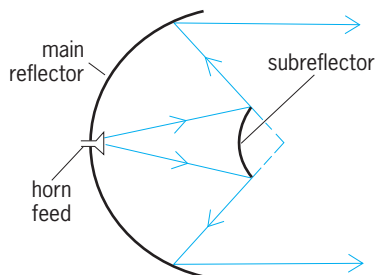

Fig. 3. Cassegrain system.

can be driven in various fashions. Driven at one end, the radiated electric field at this end has a polarization that is in phase with the radiated electric field at the farther end of the patch antenna.

Planar antennas are designed as integral parts of monolithic microwave integrated circuits (MMICs). Coupling can be effected through the use of planar (flush-mounted) antennas fabricated directly on the microelectronics chips (integrated circuits). This arrangement eliminates the need for coaxial lines, which at these microwave frequencies exhibit considerable losses. As is the case with other planar antennas, it is possible to design circuitry so as to obtain many, if not all, the properties of arrays mentioned above. The elements of these arrays can take on the form of slot antennas or patch antennas (of course with suitable modification for use on the MMICs). See MICROWAVE. [D.J.A.]

**Anthocerotopsida** A small class of the plant division Bryophyta, made up of plants commonly called hornworts. There is a single order with six genera.

**Gametophyte structure.** The gametophytes are flat thalli, often forming rosettes of uniform thickness (see illustration) or, in *Dendroceros*, with a thickened midrib and crisped unistratose wings. Ventral scales are absent. Rhizoids are unicellular, with thin, smooth walls. The thallus of undifferentiated tissue is sometimes provided with cavities containing mucilage (and often occupied by *Nostoc* colonies) and ventral pores leading to them. The cells are thin-walled and lack oil bodies; at least those at the surface have one, two, or more large chloroplasts with a central pyrenoid. Slime papillae (or mucilage hairs) are lacking. The stalked antheridia develop from internal cells and occur singly or in groups in cavities beneath the upper surface of the thallus and become exposed by the rupture of overlying tissue. The archegonia, also endogenous, are embedded in the dorsal tissue of the thallus. Paraphyses are lacking. The sporophyte is surrounded at the base by a tubular involucre (or completely surrounded in *Notothylas*). A calyptra is lacking.

**Sporophyte structure.** The sporophyte consists of a massive foot and an erect, long-cylindric, green capsule (see illustration), though in *Notothylas* the capsule is horizontal and spindle-shaped. The capsule, indeterminate in growth owing to a basal meristem, dehisces from the apex into two valves which are usually twisted when dry. The wall consists of several cell layers in a more or less solid tissue having one, two, or more chloroplasts per

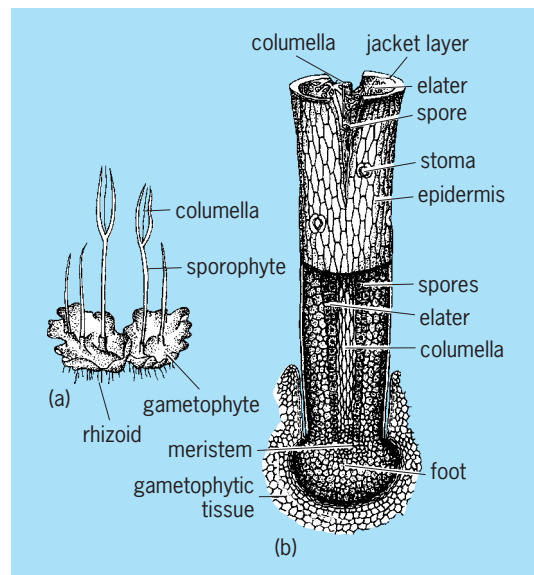

Hornwort *Anthoceros*. (a) Thalloid gametophyte with long hornlike sporophytes. (b) Elongated sporophyte with basal foot in gametophytic tissue. (After H. J. Fuller and O. Tippo, *College Botany, rev. ed., Holt, 1954*)

cell. Stomata with two guard cells are usually present. The spore sac, derived from the amphithecium, surrounds and overarches the slender columella (lacking in *Notothylas*). Spore maturation proceeds from the apex downward. The tetrahedral spores are mingled with pseudelaters of one to several cells, with or without spiral bands. A protonema is lacking. The haploid chromosome number is 5 or 6. See REPRODUCTION (PLANT).

The elongate capsule dehiscing by two valves and its indeterminate growth from a basal meristematic tissue are unique, as are the large chloroplasts with a central pyrenoid and the endogenous origin of sex organs. (The chloroplasts are sometimes single in the gametophyte and paired in the sporophyte.) The spore mother cells undergo meiosis directly, but the elater mother cells usually undergo several mitotic divisions before differentiation as pseudelaters of an unreduced chromosome number. As a result, the pseudelaters may be more numerous than the spores. (In the Hepaticopsida, by contrast, the spore mother cells undergo meiosis directly or undergo several mitotic divisions before meiosis, whereas the elater mother cells mature directly into diploid elaters.) See ANDREAEOPSIDA; BRYOPHYTA; BRYOPSIDA; HEPATICOPSIDA; SPHAGNOPSIDA. [H.Cr.]

**Anthophyllite** A magnesium-rich orthorhombic amphibole with perfect {210} cleavage and a color which varies from white to various shades of green and brown. It is a comparatively rare metamorphic mineral which occurs as slender prismatic needles, in fibrous masses, and sometimes in asbestiform masses. Anthophyllite may occur together with calcite, magnesite, dolomite, quartz, tremolite, talc, or enstatite in metacarbonate rocks; with plagioclase, quartz, orthopyroxene, garnet, staurolite, chlorite, or spinel in cordierite-anthophyllite rocks; and with quartz and hematite in metamorphosed iron formations, and with talc, olivine, chlorite, or spinel in metamorphosed ultrabasic rocks. Anthophyllite is distinguished from other amphiboles by optical examination or by x-ray diffraction, and from other minerals by its two cleavage directions at approximately 126° and 54°.

Anthophyllite has the general formula



with  $x < 1.0$ . For aluminum-poor varieties, up to about 40% of the Mg may be replaced by  $\text{Fe}^{2+}$ ; higher iron contents result in the formation of the monoclinic amphibole cummingtonite. Increasing the aluminum content in anthophyllite beyond  $x = 1.0$  results in the formation of the orthorhombic amphibole gedrite; aluminous anthophyllite can accommodate more  $\text{Fe}^{2+}$  than Al-poor varieties. See AMPHIBOLE; CUMMINGTONITE. [J.V.C.]

**Anthozoa** A class of the phylum Coelenterata. These organisms are marine, solitary or colonial, and exclusively polypoid coelenterates with no traces of a medusoid stage. Most anthozoans live attached to some firm object of the shore or on the sea bottom; some embed in the soft sediment. Anthozoans have a cylindrical body with an oral disk, mouth, stomodeum, hollow tentacles, endodermal gonad, and cellular mesoglea. The gastrovascular cavity is partitioned longitudinally into radial compartments by endodermal mesenteries or septa whose free edges, particularly, thicken and differentiate into mesenteric or septal filaments. The nervous system is a diffuse network of scattered nerve cells over the ectoderm and the endoderm. No localized sense organs are present.

Both sexual and asexual reproduction occurs. The germ cells are derived from the endoderm, and fertilization occurs either in the female gastrovascular cavity or in the sea. The zygote develops into either a ciliated swimming larva, the planula, or a young polyp.

The class Anthozoa includes the soft, horny, stony, and black corals, the sea pens, and sea anemones. The horny corals include the sea fans, sea whips, and sea feathers. The Anthozoa may be classified as listed here. Separate articles appear on each group.

#### Class Anthozoa

##### Subclass Alcyonaria (Octocorallia)

##### Order: Stolonifera

Telestacea

Coenothecalia

Alcyonacea

Gorgonacea

Pennatulacea

##### Subclass Zoantharia (Hexacorallia)

##### Order: Actiniaria

Scleractinia (Madreporaria)

Zoanthidea

Antipatharia

Ceriantharia

Rugosa

Tabulata

All anthozoans are marine and most are sedentary, except the free-swimming larval stages, while actinians, cerianthids, and pennatulans are somewhat movable. They are widely distributed over the world, extending from the Arctic to the Antarctic; however, they predominate in the tropic and subtropic areas of the Indo-Pacific Ocean. Actinians also inhabit colder water areas from which deep-sea species of gorgonians, pennatulans, and scleractinians have been collected.

Anthozoans seldom tolerate desiccation or heavy sedimentation. They are so sensitive to reduced salinity that they usually do not live near coastal areas where there is river drainage. Tropical corals are able to endure high temperatures and are adversely affected by low temperatures. Therefore, coral reefs are commonly located in tropic and subtropic regions. See COELENTERATA; HYDROZOA; SCYPHOZOA. [K.At.]

**Anthracosauria** An order of Carboniferous and Permian labyrinthodont amphibians much less common than their temnospondyl relatives but important as including the ancestors of reptiles. In contrast with temnospondyls, the pleurocentra are retained and developed in the vertebral column, the tabular bones of the skull roof are in contact with the parietals, and the cheek is primitively but loosely attached to the skull roof. See AMPHIBIA; LABYRINTHODONTIA; TEMNOSPONDYLI. [A.S.R.]

**Anthrax** An acute infectious zoonotic disease caused by the bacterium *Bacillus anthracis* and primarily associated with herbivorous mammals. Carnivorous mammals, birds, reptiles, amphibians, fish, and insects are generally resistant to anthrax infection. However, carnivorous and omnivorous mammals often succumb after ingestion of infected meat containing the anthrax toxins, which can cause swelling in the throat and suffocation. Humans primarily present with cutaneous lesions, appearing as black scabs or eschars, after contact with infected animals, carcasses, or animal products. See ZOONOSES.

Anthrax is responsible for the deaths of thousands of domesticated and wild herbivorous animals annually. Parts of Africa, Asia, southern Europe, and North and South America are subject to repeated outbreaks. In the Western Hemisphere, anthrax is well controlled in livestock.

*Bacillus anthracis* is a gram-positive, rod-shaped, endospore-forming bacterium, approximately 1.0–1.2 micrometers in diameter and 3–8  $\mu\text{m}$  long. The spores resist drying, cold, heat, and disinfectants, and can remain viable for many years in soil, water, and animal hides and products. *Bacillus anthracis* possesses three virulence factors: lethal toxin, edema toxin, and a poly-D-glutamic acid capsule. Lethal toxin is composed of two proteins, lethal factor and protective antigen. The protective antigen is produced by the anthrax bacillus at a molecular weight of 83 kDa, but must be cleaved by either serum or target cell surface proteases to 63 kDa before it complexes with lethal factor to form lethal toxin. The edema toxin is composed of edema factor and



protective antigen, and it is believed to complex in a manner similar to that seen for lethal toxin. Protective antigen plays a central role in that it is required for transport of lethal factor and edema factor into host target cells. The macrophage appears to be the primary host target cell for lethal toxin, whereas the neutrophil appears to be the target cell for edema toxin in addition to other cells involved in edema formation. The third virulence factor is the capsule, which inhibits phagocytosis through its negatively charged poly-D-glutamic acid composition. All three toxin components are encoded by a plasmid, pXO1, whereas the enzymes required for capsule synthesis are encoded for by the pXO2 plasmid. Strains lacking either or both plasmids are avirulent, such as the veterinary vaccine Sterne strain, which lacks the pXO2 plasmid. See EDEMA.

Anthrax consists of two clinical forms, cutaneous and septicemic. The cutaneous form begins as a blisterlike lesion that eventually becomes an intensely dark, relatively painless, edematous lesion forming a black eschar. The lesions rapidly become sterile after antibiotic therapy and take several weeks to resolve, even with treatment. The cutaneous form is reported only in humans, rabbits, swine, and horses.

The septicemic form arises from various initial sites of infection, including cutaneous, oropharyngeal, gastrointestinal, or inhalational exposures. The course of septicemic disease depends on the exposure route and the susceptibility of the animal host. The vast majority of systemic anthrax cases in herbivorous animals occur from trauma to mucosal linings of the mouth and upper alimentary canal caused by ingested fibrous foods. Inhalation anthrax is believed to be initiated by phagocytosis of spores within the lungs by alveolar macrophages. Spore-laden macrophages pass through lymphatic channels to the sinuses of regional lymph nodes or migrate to the spleen, where the spores germinate within the macrophages, multiply, and overwhelm and escape the macrophages to invade the efferent lymphatics. For other portals of entry, mesenteric lymph nodes become involved. The bacilli move to the spleen, where they induce pronounced splenomegaly (enlargement of the spleen), and finally enter the bloodstream, where they induce secondary sites of infection, massive bacilemia, toxemia, and sudden death. Failure of the blood to clot, hemorrhages of skin, hemorrhagic meningitis, and reduced rigor mortis are frequently found in anthrax-infected carcasses. Exposure of contaminated body fluids to the lower atmospheric levels of carbon dioxide results in sporulation of the bacilli. Therefore, opening of infected carcasses should be avoided.

Besides its central role for binding the lethal and edema toxins to target cells, protective antigen plays an important role in the host's protective immune response against anthrax, hence the term protective antigen. Vaccines lacking protective antigen are not protective. For United States and United Kingdom human anthrax vaccines, protective antigen bound to aluminum salts is the principal immunogen. However, veterinary vaccines are composed of viable spores of *B. anthracis* Sterne strain, a nonencapsulated toxigenic variant. Full protection against anthrax with the veterinary vaccine is afforded by primary and annual booster vaccinations. See INFECTIOUS DISEASE. [J.W.Ez.]

**Anthropology** The observation, measurement, and explanation of human variability in time and space. This includes both biological variability and the study of cultural, or learned, behavior among contemporary human societies. These studies are closely allied with the fields of archeology and linguistics. Studies range from rigorously scientific approaches, such as research into the physiology, demography, and ecology of hunter-gatherers, to more humanistic research on topics such as symbolism and ritual behavior. See ARCHEOLOGY; PHYSICAL ANTHROPOLOGY.

Anthropology lacks a unified theory comparable to neo-Darwinian evolution in the biological sciences and is characterized, instead, by a wide variety of subfields that analyze and inte-

grate studies of human behavior in different ways. Social-cultural anthropology examines the various ways in which learned techniques, values, and beliefs are transmitted from one generation to the next and acted upon in different situations. Most studies stress the historical development and internal structure and workings of particular cultural traditions, and anthropologists have amassed detailed bodies of documentation on different human societies. Significant, too, within social-cultural anthropology are cross-cultural studies that seek to identify essential structural or behavioral properties of human society. Modern scholars have sought to identify universal patterns of symbolic behavior and belief, and there are other social-cultural anthropologists actively testing these kinds of propositions in particular cases.

Increasingly, social-cultural anthropologists have applied their training and skills to issues of contemporary importance such as economic development in third world countries, public policies affecting ethnic minorities, and changes arising from contact between different societies (especially Western and non-Western ones). Sometimes referred to as applied anthropology, such studies are often made in situations where conflicting social values or expectations may arise.

Cultural linguistics is closely allied with both the goals and methods of social-cultural anthropology, especially with respect to the way in which linguists strive for a reliable understanding of how each different language works according to its own sound system (phonology) and grammatical structure. See PSYCHOLINGUISTICS.

There has been a developing tendency in anthropology toward integration of different subfields. For example, ethno-science is a subject in which anthropologists apply approaches derived from linguistics to understand the grammatical structure and manipulation of cognitive perceptions by people in different societies of such things as color, weather, and biotic environment. Another growing subfield is ethnoarchaeology, in which observations of material behavior (especially discard) in contemporary societies are used to interpret the archeological remains of prehistoric cultures. Modern anthropology is characterized by its breadth and diversity of approaches to the study of variability in human behavior. [R.A.G.]

**Anthropometry** The systematic quantitative representation of the human body. Anthropometric techniques are used to measure the absolute and relative variability in size and shape of the human body. Depending on the objective, anthropometric instrumentation may include weighing scale, anthropometer, skinfold calipers, body volume tanks, and bioelectrical impedance analyzers. Similarly, radiographic instruments and x-ray scanners such as dual-energy-ray absorption meters and ultrasound densitometers are used for quantifying cortical bone density, bone mass, subcutaneous fat density, and lean body mass.

Anthropometry follows a rigorous set of guidelines that include standardization of the measurement techniques, uniform landmarks, and establishing conditions of the measurements. Various references have been developed that can be used as base lines for expressing absolute and relative deviation from the average. Techniques of data analysis include the expression of individual values in the form of Z scores (the individual value minus the reference mean for the age and sex, divided by the corresponding standard deviation). This approach permits the investigator to express the measurements in terms of Z score units from the mean. Another approach involves expressing individual values in the form of percentiles placement. For this purpose, the investigator needs to compare the individual value to the percentile ranges given in the anthropometric standard. Thus, an individual measurement may be expressed as being either close to the 50th percentile or above or below the 95th or 5th percentile.

In biological anthropology and human paleontology, anthropometry is the technique of choice for quantifying variability and relationship of fossils and extant populations. Anthropometric

measurements of the head, face, and long bones are also used in analyzing fossil taxa (using measurements from radiographs). Anthropometry is the most universally applicable, inexpensive, and noninvasive method available to assess nutritional history throughout life. It has been used to assess and predict the health of societies. For example, since fat is the main form of energy storage, and body muscle is composed largely of protein, anthropometric measurements of body composition provide indirect estimates of energy and protein reserves of the body. Reserves can be depleted during chronic malnutrition, resulting in muscle wasting, while during overnutrition reserves can grow, resulting in obesity.

Anthropometry is also essential to the field of forensics, specifically forensic anthropology, which is concerned with the relationship between medicine and the law. Forensic anthropologists make extensive use of anthropometry in human identification, whether for isolated cadavers, commingled remains, victims of mass disasters, or genocide victims.

Anthropometric measurements of the head and face are extensively employed in orthodontic diagnosis, in treatment planning, and following orthodontic treatment. Measurements made from cephalometric radiographs also serve in the identification of syndromes. Extensions of cephalometry (measurement of the living human head) in three dimensions (cartesian anthropometry) are used in sculpting head forms for use in the reconstructive surgery of accident victims.

A relatively new use of anthropometry is for the design of clothing, equipment, and interiors. For example, through anthropometric techniques to establish human dimensions, gas masks, oxygen masks, dust masks, and respirators as well as military helmets have been designed. See ANIMAL GROWTH; ANTHROPOLOGY; BIOMETRICS; PHYSICAL ANTHROPOLOGY. [A.R.F.]

**Anthroposcopy** The observation of the human body (in contrast to anthropometry, the measurement of the human body). Inspection or observation of physical characteristics is the basic method of anthroposcopy, and in some instances the observations are made relative to a set of reference values or standards. Hence, the method has a high degree of subjectivity, although there is a trend toward more objective assessment of some characteristics.

Skin color; hair color, form, and distribution; and eye color are the more common physical characteristics assessed by anthroposcopy. Colorimetric charts or scales are the reference for comparison, with most emphasis on skin pigmentation. Problems with such scales relate to intermediate shades or gradations. The use of photometric devices that identify spectral wavelengths has provided more objective assessment of skin, hair, and eye color.

The assessment of physique is central to anthroposcopic studies. Physique refers to body build or form, that is, the total configuration of the body. The most widely used classification is the assessment of an individual's somatotype, which is based on the varying contributions of three components: endomorphy (laterality, fatness), mesomorphy (musculoskeletal dominance), and ectomorphy (linearity). The somatotype is a three-number rating, each referring to the contribution of endomorphy, mesomorphy, and ectomorphy, respectively, to an individual's somatotype. An individual's physique is defined by all three ratings so that specific component ratings may lose some of their meaning when analyzed separately. Studies of the development of pubic and axillary hair in both sexes, and facial hair in boys, breast development in girls, and genital development in boys rely on anthroposcopy. Ratings are made from standardized photographs or by visual inspection at clinical examination. Anthroposcopic ratings have been utilized successfully in the evaluation of relationships between physique and physical performance, in documenting physique changes during maturation, growth, and adulthood, and in estimating morphological distances among neighboring populations. See ANTHROPOLOGY; ANTHROPOMETRY. [R.M.Ma.]

**Anthuridea** A suborder of the Isopods. These crustaceans are characterized by slender, elongate, subcylindrical bodies, and by the fact that the outer branch of the paired tail appendage (uropod) arches over the base of the terminal abdominal segment, the telson (see illustration). The uropods of anthurideans attach laterally to the abdomen and together with the telson form a caudal fan.

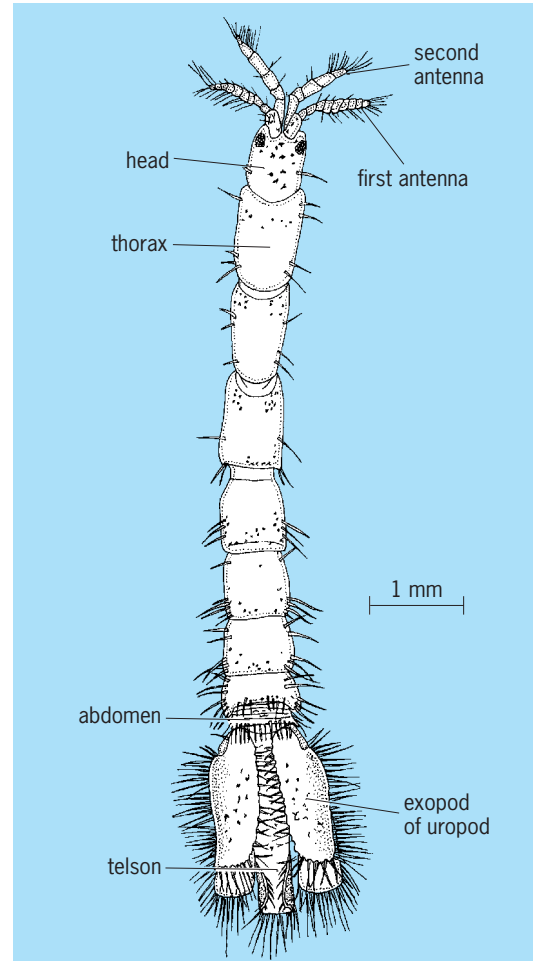

*Paranthura infundibulata*.

Marked sexual dimorphism is shown in the first pair of antennae which, in males of many species in both sections, develop brushlike whorls of setae on the flagellum. Female anthurideans carry the developing young beneath the thorax in a brood pouch, formed by overlapping plates originating from the bases of several pairs of legs. See SEXUAL DIMORPHISM.

Anthurideans are mostly marine, but some live in brackish or freshwater habitats. Some are facultative ectoparasites of fishes. See ISOPODA. [M.A.M.]

**Antibiotic** The original definition of an antibiotic was a chemical substance that is produced by a microorganism and, in dilute solutions, can inhibit the growth of, and even destroy, other microorganisms. This definition has been expanded to include similar inhibitory substances that are produced by plants, marine organisms, and total- or semisynthetic procedures. Since the discovery of penicillin by A. Fleming in 1928, thousands of antibiotics have been isolated and identified; some have been found to be of value in the treatment of infectious disease. They differ markedly in physicochemical and pharmacological properties, antimicrobial spectra, and mechanisms of action.

**Production.** Penicillin is produced by strains of the fungus *Penicillium notatum* and *P. chrysogenum*. Most of the other antibiotics in clinical use are produced by actinomycetes, particularly streptomycetes (natural antibiotics). Other antibiotics are produced by chemical synthesis (synthetic antibiotics). Based on structure, the major antibiotic classes are the  $\beta$ -lactams (penicillins and cephalosporins), aminoglycosides, macrolides, tetracyclines, quinolones, rifamycins, polyenes, azoles, glycopeptides, and polypeptides.

The key step in the production of natural antibiotics is a fermentation process. Strains of microorganisms, selected by elaborate screening procedures from randomly isolated pure cultures, are inoculated into sterile nutrient medium in large vats and incubated for varying periods of time. Different strains of a single microbial species may differ greatly in the amounts of antibiotics they produce. Strain selection is thus the most powerful tool in effecting major improvements in antibiotic yield. In addition, variations in culturing conditions often markedly affect the amount of antibiotic that is produced by a given strain. Chemical modifications of antibiotics produced by fermentation processes have led to semisynthetic ones with improved antimicrobial activity or pharmacological properties. See BACTERIAL PHYSIOLOGY AND METABOLISM; FERMENTATION.

**Antimicrobial activity.** All microorganisms can cause infectious diseases in animals and humans, though the majority of infections are caused by bacteria. Most antibiotics are active against bacteria. Although for the proper treatment of serious infections cultures and antibiotic sensitivities are required, antibiotic therapy is often empiric, with etiology being inferred from the clinical features of a disease.

Bacteria are divided into the gram positive and the gram negative; each group comprises a wide variety of different species. Staphylococci, pneumococci, and streptococci are the more common gram-positive organisms, while enterobacteria, *Pseudomonas*, and *Hemophilus* are the most common gram negative. Certain antibiotics are effective only against gram-positive bacteria. Others are effective against both gram-positive and gram-negative bacteria and are referred to as broad-spectrum antibiotics. See BACTERIA; MEDICAL BACTERIOLOGY.

Pathogenic fungi may be divided on the basis of their pathogenicity into true pathogens and opportunistic pathogens. The opportunistic occur mainly in debilitated and immunocompromised patients. Clinically useful antibiotics include amphotericin B, nystatin, griseofulvin and the azole antifungals. See FUNGI; MEDICAL MYCOLOGY; OPPORTUNISTIC INFECTIONS.

With some viruses that cause mild infections, such as the common-cold viruses (rhinoviruses), treatment is symptomatic. With others, such as the polio, smallpox (now eradicated), and hepatitis B viruses, the only way to prevent disease is by vaccination. With still other viruses, antibiotics, mostly synthetic, are the appropriate treatment. Clinically useful antibiotics are ribavirin, acyclovir, and zidovudine, which are active against, respectively, respiratory, herpes, and human immunodeficiency viruses. See ANIMAL VIRUS; VACCINATION.

Protozoa may be divided, on the basis of the site of infection, into intestinal, urogenital, blood, and tissue. Protozoan diseases such as malaria, trypanosomiasis, and amebiasis are particularly common in the tropics, in populations living under poor housing and sanitary conditions. In the developed countries, *P. carinii* is the most important opportunistic pathogen, being associated almost exclusively with acquired immune deficiency syndrome (AIDS). Antibiotics active against protozoa include metronidazole, trimethoprim-sulfamethoxazole, and quinine. See ACQUIRED IMMUNE DEFICIENCY SYNDROME (AIDS); MEDICAL PARASITOLOGY; PROTOZOA.

**Antitumor activity.** The observation of the antitumor activity of actinomycin sparked an intensive search for antitumor antibiotics in plants and microorganisms. Among the antibiotics used clinically against certain forms of cancer are daunorubicin, doxorubicin, mitomycin C, and bleomycin. See CANCER (MEDICINE).

**Mechanism of action.** Antibiotics active against bacteria are bacteriostatic or bacteriocidal; that is, they either inhibit growth of susceptible organisms or destroy them. On the basis of their mechanism of action, antibiotics are classified as (1) those that affect bacterial cell-wall biosynthesis, causing loss of viability and often cell lysis (penicillins and cephalosporins, bacitracin, cycloserine, vancomycin); (2) those that act directly on the cell membrane, affecting its barrier function and leading to leakage of intracellular components (polymyxin); (3) those that interfere with protein biosynthesis (chloramphenicol, tetracyclines, erythromycin, spectinomycin, streptomycin, gentamycin); (4) those that affect nucleic acid biosynthesis (rifampicin, novobiocin, quinolones); and (5) those that block specific steps in intermediary metabolism (sulfonamides, trimethoprim). See ENZYME; SULFONAMIDE.

Antibiotics active against fungi are fungistatic or fungicidal. Their mechanisms of action include (1) interaction with the cell membrane, leading to leakage of cytoplasmic components (amphotericin, nystatin); (2) interference with the synthesis of membrane components (ketoconazole, fluconazole); (3) interference with nucleic acid synthesis (5-fluorocytosine); and (4) interference with microtubule assembly (griseofulvin). See FUNGISTAT AND FUNGICIDE.

For an antibiotic to be effective, it must first reach the target site of action on or in the microbial cell. It must also reach the body site at which the infective microorganism resides in sufficient concentration, and remain there long enough to exert its effect. The concentration in the body must remain below that which is toxic to the human cells. The effectiveness of an antibiotic also depends on the severity of the infection and the immune system of the body, being significantly reduced when the immune system is impaired. Complete killing or lysis of the microorganism may be required to achieve a successful outcome. See IMMUNITY.

Antibiotics may be given by injection, orally, or topically. When given orally, they must be absorbed into the body and transported by the blood and extracellular fluids to the site of the infecting organisms. When they are administered topically, such absorption is rarely possible, and the antibiotics then exert their effect only against those organisms present at the site of application.

**Microbial resistance.** The therapeutic value of every antibiotic class is gradually eroded by the microbial resistance that invariably follows broad clinical use.

Some bacteria are naturally resistant to certain antibiotics (inherent resistance). Clinical resistance is commonly due to the emergence of resistant organisms following antibiotic treatment (acquired resistance). This emergence, in turn, is due to selection of resistant mutants of the infective species (endogenous resistance) or, usually, to transfer of resistance genes from other, naturally resistant species (exogenous resistance). A major challenge in antimicrobial chemotherapy is the horizontal spread of resistance genes and resistant strains, mostly in the hospital but also in the community. The consequences are increased patient morbidity and mortality, reduced drug options, and more expensive and toxic antibiotics.

Rapid detection of resistance and pathogen identification are critical for the rational use of antibiotics and implementation of infection control measures. In the absence of such information, treatment is empiric, usually involving broad-spectrum agents, which exacerbates resistance development. Inadequate infection control measures encourage dissemination of resistant strains.

**Importance.** It is estimated that the average duration of many infectious diseases and the severity of certain others have decreased significantly since the introduction of antibiotic therapy. The dramatic drop in mortality rates for such dreaded diseases as meningitis, tuberculosis, and septicemia offers striking evidence of the effectiveness of these agents. Bacterial pneumonia, bacterial endocarditis, typhoid fever, and certain sexually transmitted diseases are also amenable to treatment with antibiotics. So are infections that often follow viral or neoplastic diseases,

even though the original illness may not respond to antibiotic therapy. See EPIDEMIOLOGY.

Antibiotics in small amounts are widely used as feed supplements to stimulate growth of livestock and poultry. They probably act by inhibiting organisms responsible for low-grade infections and by reducing intestinal epithelial inflammation. Many experts believe that this use of antibiotics contributes to the emergence of antibiotic-resistant bacteria that could eventually pose a public health problem.

In cattle, sheep, and swine, antibiotics are effective against economically important diseases. The use of antibiotics in dogs and cats closely resembles their use in human medical practice. In fish farms, antibiotics are usually added to the food or applied to the fish by bathing. The incidence of infections in fish, and animals in general, may be reduced by the use of disease-resistant stock, better hygiene, and better diet. See AQUACULTURE.

Although effective against many microorganisms causing disease in plants, antibiotics are not widely used to control crop and plant diseases. Some of the limiting factors are instability of the antibiotic under field conditions, the possibility of harmful residues, and expense. Nevertheless, antibiotic control of some crop pathogens is being practiced, as is true of the rice blast in Japan, for example. See PLANT PATHOLOGY. [N.H.G.]

**Antibody** A protein found principally in blood serum and characterized by a specific reactivity with the corresponding antigen. Antibodies are important in resistance against disease, in allergy, and in blood transfusions, and can be utilized in laboratory tests for the detection of antigens or the estimation of immune status.

Antibodies are normally absent at birth unless derived passively from the mother through the placenta or colostrum. In time, certain antibodies appear in response to environmental antigens. Antibodies are also induced by artificial immunization with vaccines or following natural infections. The resulting antibody level declines over a period of months, but rapidly increases following renewed contact with specific antigen, even after a lapse of years. This is known as an anamnestic or booster response. See ALLERGY; BLOOD GROUPS; HYPERSENSITIVITY; ISOANTIGEN; VACCINATION.

Antibody reactivity results in precipitation of soluble antigens, agglutination of particulate antigens, increased phagocytosis of bacteria, neutralization of toxins, and dissolution of bacterial or other cells specifically sensitive to their action; the antibodies so revealed are termed precipitins, agglutinins, opsonins, antitoxins, and lysins. One antibody may give many such reactions, depending on conditions, so these classifications are not unique or exclusive.

Three principal groups (IgG, IgM, IgA) and two minor groups (IgD, IgE) of antibodies are recognized. These all form part of the wider classification of immunoglobulins. Antibody diversity is generated by amino acid substitutions that result in unique antigen-binding structures. See CELLULAR IMMUNOLOGY; IMMUNOGLOBULIN.

The development of the technology for producing monoclonal antibodies, which can bind to specific sites on target antigens, revolutionized the uses of antibodies in biology and medicine. Unfortunately, almost all monoclonal antibodies originate in mice, and the murine immunoglobulin serves as an antigen, frequently acting immunogenic in human recipients. See ANTIGEN; MONOCLONAL ANTIBODIES. [M.J.Po.]

**Anticline** A fold in layered rocks in which the strata are inclined down and away from the axes. The simplest anticlines (see illustration) are symmetrical, but in more highly deformed regions they may be asymmetrical, overturned, or recumbent. Most anticlines are elongate with axes that plunge toward the extremities of the fold, but some have no distinct trend; the latter are called domes. Generally, the stratigraphically older rocks are found toward the center of curvature of an anticline, but in more

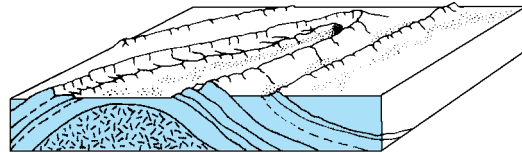

Diagram relating anticlinal structure to topography.

complex structures these simple relations need not hold. Under such circumstances, it is sometimes convenient to recognize two types of anticlines. Stratigraphic anticlines are those folds, regardless of their observed forms, that are inferred from stratigraphic information to have been anticlines originally. Structural anticlines are those that have forms of anticlines, regardless of their original form. See SYNCLINE. [P.H.O.]

**Antiferromagnetism** A property possessed by some metals, alloys, and salts of transition elements in which the atomic magnetic moments, at sufficiently low temperatures, form an ordered array which alternates or spirals so as to give no net total moment in zero applied magnetic field. The most direct way of detecting such arrangements is by means of neutron diffraction. See NEUTRON DIFFRACTION.

The transition temperature below which the spontaneous antiparallel magnetic ordering takes place is called the Néel temperature. A plot of the magnetic susceptibility of a typical antiferromagnetic powder sample versus temperature is shown in the illustration. Below the Néel point, which is characterized by the sharp kink in the susceptibility, the spontaneous ordering opposes the normal tendency of the magnetic moments to align parallel to the applied field. Above the Néel point, the substance is paramagnetic, and the susceptibility  $\chi$  obeys the Curie-Weisslaw, as in Eq. (1), with a negative paramagnetic Curie temperature  $-\theta$ . The Néel temperature is similar to the Curie temperature in ferromagnetism. See CURIE-WEISS LAW.

The cooperative transition that characterizes antiferromagnetism is thought to result from an interaction energy  $U$  of the form given in Eq. (2), where  $\mathbf{S}_i$  and  $\mathbf{S}_j$  are the spin angular

$$\chi = C/(T + \theta) \quad (1)$$

momentum vectors associated with the magnetic moments of neighbor atoms  $i$  and  $j$ , and  $J_{ij}$  is an interaction constant. If all

$$U = -2\sum J_{ij} \mathbf{S}_i \cdot \mathbf{S}_j \quad (2)$$

momentum vectors associated with the magnetic moments of neighbor atoms  $i$  and  $j$ , and  $J_{ij}$  is an interaction constant. If all

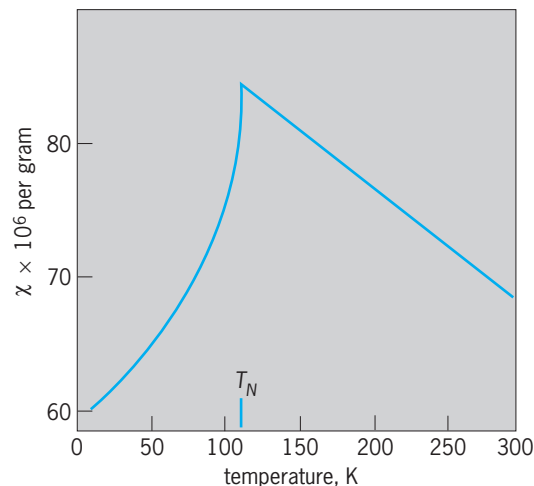

Magnetic susceptibility of powdered manganese oxide. (After H. Bizette, C. F. Squire, and B. Tsai, 1938)

$J_{ij}$  are positive, the lowest energy is achieved with all  $\mathbf{S}_i$  and  $\mathbf{S}_j$  parallel, that is, coupled ferromagnetically. Negative  $J_{ij}$  between nearest-neighbor pairs ( $i, j$ ) may lead to simple antiparallel arrays; if the distant neighbors also have sizable negative  $J_{ij}$ , a spiral array may have lowest total energy. The interaction constant in Eq. (2) probably arises from superexchange coupling. This is an effective coupling between magnetic spins which is indirectly routed via nonmagnetic atoms in salts and probably via conduction electrons in metals. See FERROMAGNETISM; HELIMAGNETISM.

The magnetic moments are known to have preferred direction. Anisotropic effects come from magnetic dipole forces and also from spin-orbit coupling combined with superexchange. Some nearly antiparallel arrays such as  $\text{Fe}_2\text{O}_3$  show a slight bending (called canting) and exhibit weak ferromagnetism. The anisotropy affects the susceptibility of powder samples and is of extreme importance in antiferromagnetic resonance. See MAGNETIC RESONANCE. [E.A.; FKe.]

**Antifreeze (biology)** Glycoprotein or protein molecules synthesized by polar and north temperate fishes to enable them to survive in freezing seawater. Similar antifreezes are found in some insects, but relatively little is known about their structure and function.

In a marine fish, the amount of salt and other small molecules in the blood depresses its freezing point to about  $30^\circ\text{F}$  ( $-0.8^\circ\text{C}$ ). In the winter, the polar oceans and the nearshore water of north temperate oceans are at the freezing point of seawater  $28.6^\circ\text{F}$  ( $-1.9^\circ\text{C}$ ). In the absence of ice, many fishes survive by supercooling, a thermodynamic state of equilibrium in which a solution (the body fluids of the fish in this case) can be in liquid state, in the absence of ice nuclei, at a temperature lower than the equilibrium freezing point. However, polar waters are often laden with ice that can enter the fish by ingestion of seawater. Propagation of ice in the body fluids or tissues of the fish always leads to freezing damage and death. To avoid freezing, many fishes have evolved biological antifreezes that further lower the freezing point of their body fluids to  $28^\circ\text{F}$  ( $-2.2^\circ\text{C}$ ), which is  $0.6^\circ\text{F}$  ( $0.3^\circ\text{C}$ ) below the freezing point of seawater. See CRYPTOBIOSIS. [A.L.DeV.]

**Antifreeze mixture** A chemical substance that, when added to a liquid such as water, reduces the freezing point of the mixture. Antifreezes are used in a wide variety of applications, the most common being automotive cooling systems. Antifreeze liquids are also used in refrigeration systems (as a secondary coolant), heating and air-conditioning systems, ice skating rinks, and solar energy units, and as deicing agents for runways and aircraft. See ENGINE COOLING; REFRIGERATION.

Properties of a desirable antifreeze include the ability to depress the freezing point of the liquid (typically water), good solubility, high boiling point (to provide boil-over protection), chemical compatibility with materials of construction, good heat transfer properties, appropriate viscosity, and low cost.

Chemicals that have been used as antifreezes include glycols, glycerol, brines (such as calcium chloride), and alcohols. Ethylene glycol is the most common antifreeze used in automotive cooling systems because of the outstanding freezing-point depression effect, boil-over protection, heat transfer characteristics, high flash point, and low vapor pressure. Propylene glycol, diethylene glycol, and methanol have also been used to a limited extent. Commercial automotive antifreezes contain corrosion inhibitors to protect the various types of metals in the cooling system. See ETHYLENE GLYCOL; INHIBITOR (CHEMISTRY).

Glycol antifreeze solutions are often used in aircraft deicing. These contain additional components for corrosion protection and wetting. Aircraft anti-icing fluids also contain a polymeric thickening agent to increase the fluid viscosity, which allows the fluid to adhere to the aircraft surface and provide protection against freezing for a limited period of time. [K.F.G.]

**Antifriction bearing** A machine element that permits free motion between moving and fixed parts. Antifriction bearings are essential to mechanized equipment; they hold or guide moving machine parts and minimize friction and wear.

In its simplest form, a bearing consists of a cylindrical shaft, called a journal, and a mating hole, serving as the bearing proper. Ancient bearings were made of such materials as wood, stone, leather, or bone, and later of metal. It soon became apparent for this type of bearing that a lubricant would reduce both friction and wear and prolong the useful life of the bearing. Petroleum oils and greases are generally used for lubricants, sometimes containing soap and solid lubricants such as graphite or molybdenum disulfide, talc, and similar substances.

**Materials.** The greatest single advance in the development of improved bearing materials took place in 1839, when I. Babbitt obtained a United States patent for a bearing metal with a special alloy. This alloy, largely tin, contained small amounts of antimony, copper, and lead. This and similar materials have made excellent bearings. They have a silvery appearance and are generally described as white metals or as Babbitt metals.

Wooden bearings are still used for limited applications in light-duty machinery and are frequently made of hard maple which has been impregnated with a neutral oil. Wooden bearings made of lignum vitae, the hardest and densest of all woods, are still used.

Some of the most successful heavy-duty bearing metals are now made of several distinct compositions combined in one bearing. This approach is based on the widely accepted theory of friction, which is that the best possible bearing material would be one which is fairly hard and resistant but which has an overlay of a soft metal that is easily deformed. Figure 1 shows bearings in which graphite, carbon, plastic, and rubber have been incorporated into a number of designs illustrating some of the material combinations that are presently available.

Rubber has proved to be a surprisingly good bearing material, especially under circumstances in which abrasives may be present in the lubricant. The rubber used is a tough resilient compound similar in texture to that in an automobile tire. Cast iron is one of the oldest bearing materials. It is still used where the duty is relatively light.

Porous metal bearings are frequently used when plain metal bearings are impractical because of lack of space or inaccessibility for lubrication. These bearings have voids of 16–36% of the volume of the bearing. These voids are filled with a lubricant by a vacuum technique. During operation they supply a limited amount of lubricant to the sliding surface between the journal and the bearing. In general, these bearings are satisfactory for light loads and moderate speeds.

**Lubricants.** The method of supplying the lubricant and the quantity of lubricant which is fed to the bearing by the supplying

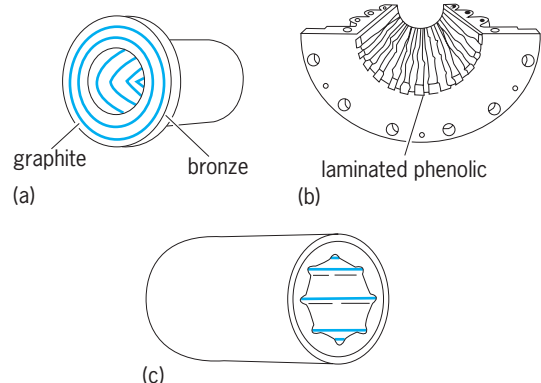

Fig. 1. Bearings with (a) graphite; (b) wood, plastic, and nylon (after J. J. O'Connor, ed., *Power's Handbook on Bearings and Lubrication*, McGraw-Hill, 1951); (c) rubber.

device will often be the greatest factor in establishing performance characteristics of the bearing. For example, if no lubricant is present, the journal and bearing will rub against each other in the dry state. Both friction and wear will be relatively high. The coefficient of friction of a steel shaft rubbing in a bronze bearing, for example, may be about 0.3 for the dry state. If lubricant is present even in small quantities, the surfaces hydrodynamic pressure in film become contaminated by this material whether it be an oil or a fat, and depending upon its chemical composition the coefficient of friction may be reduced to about 0.1. Now if an abundance of lubricant is fed to the bearing so that there is an excess flowing out of the bearing, it is possible to develop a self-generating pressure film in the clearance space as indicated in Fig. 2. These pressures can be sufficient to sustain a considerable load and to keep the rubbing surfaces of the bearing separated.

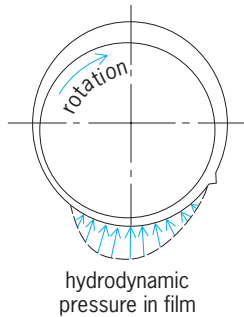

Fig. 2. Hydrodynamic fluid-film pressures in a journal bearing. (After W. Stanlar, ed., *Plant Engineering Handbook*, 2d ed., McGraw-Hill, 1959)

The types of oiling devices that usually result in insufficient feed to generate a complete fluid film are, for example, oil cans, drop-feed oilers, waste-packed bearings, and wick and felt feeders. Oiling schemes that provide an abundance of lubrication are oil rings, bath lubrication, and forced-feed circulating supply systems. The coefficient of friction for a bearing with a complete fluid film may be as low as 0.001.

**Fluid-film hydrodynamic bearings.** If the bearing surfaces can be kept separated, the lubricant no longer needs an oiliness agent. As a consequence, many extreme applications are presently found in which fluid-film bearings operate with lubricants consisting of water, highly corrosive acids, molten metals, gasoline, steam, liquid refrigerants, mercury, gases, and so on. The self-generation of pressure in such a bearing takes place no matter what lubricant is used, but the maximum pressure that is generated depends upon the viscosity of the lubricant. Thus, for example, the maximum load-carrying capacity of a gas-lubricated bearing is much lower than that of a liquid-lubricated bearing. The ratio of capacities is in direct proportion to the viscosity. Gas is the only presently known lubricant that can be used for operation at extreme temperatures. Because the viscosity of gas is so low, the friction generated in the bearing is correspondingly of a very low order. Thus gaslubricated machines can be operated at extremely high speeds because there is no serious problem in keeping the bearings cool.

The self-generating pressure principle is applied equally as well to thrust bearings as it is to journal bearings. The tilting-pad type of thrust bearing (Fig. 3a) excels in low friction and in reliability. A typical commercial thrust bearing (Fig. 3b) is made up of many tilting pads located in a circular position. One of the largest is on a hydraulic turbine at the Grand Coulee Dam. There, a bearing 96 in. (2.4 m) in diameter carries a load of 2,150,000 lb (9,560,000 newtons) with a coefficient of friction of about 0.0009.

**Fluid-film hydrostatic bearings.** Sleeve bearings of the self-generating pressure type, after being brought up to speed, operate with a high degree of efficiency and reliability. However, when the rotational speed of the journal is too low to maintain

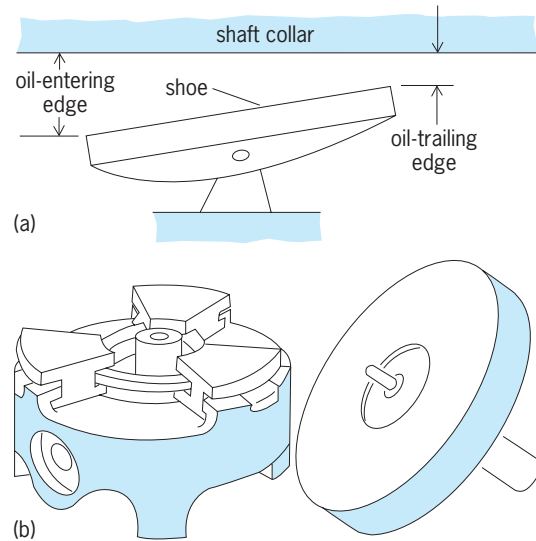

Fig. 3. Tilting-shoe-type bearing. (a) Schematic (after W. Stanlar, ed., *Plant Engineering Handbook*, 2d ed., McGraw-Hill, 1959). (b) Thrust bearing (after D. D. Fuller, *Theory and Practice of Lubrication for Engineers*, copyright © 1956 by John Wiley; used with permission).

a complete fluid film, or when starting, stopping, or reversing, the oil film is ruptured, friction increases, and wear of the bearing accelerates. This condition can be eliminated by introducing high-pressure oil to the area between the bottom of the journal and the bearing itself, as shown schematically in Fig. 4. If the pressure and quantity of flow are in the correct proportions, the shaft will be raised and supported by an oil-film whether it is rotating or not. Friction drag may drop to one-tenth of its original value or even less, and in certain kinds of heavy rotational equipment in which available torque is low, this may mean the difference between starting and not starting. This type of lubrication is called hydrostatic lubrication and, as applied to a journal bearing in the manner indicated, it is called an oil lift. Hydrostatic lubrication in the form of a step bearing has also been used on various machines to carry thrust.

Large structures have been floated successfully on hydrostatic-type bearings. For example, the Hale 200-in. (5-m) telescope on Palomar Mountain (California Institute of Technology/Palomar

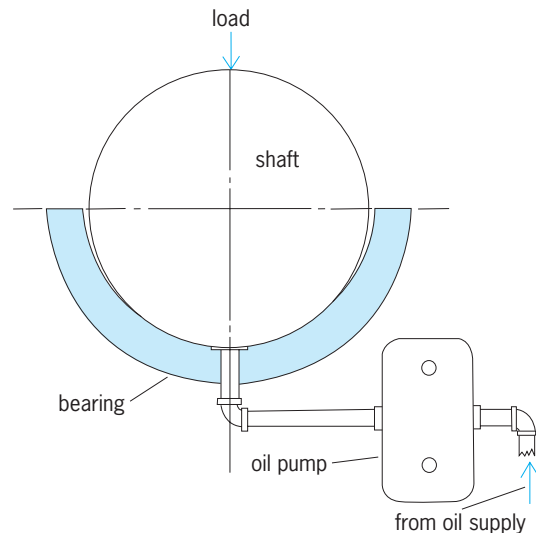

Fig. 4. Fluid-film hydrostatic bearing. Hydrostatic oil lift can reduce starting friction drag to less than one-tenth of usual starting drag. (After W. Stanlar, ed., *Plant Engineering Handbook*, 2d ed., McGraw-Hill, 1959)

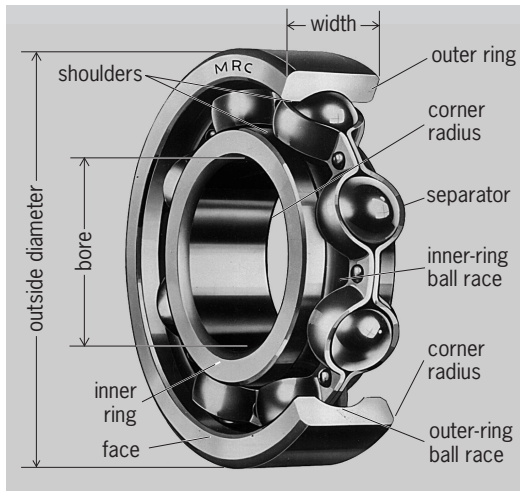

Fig. 5. Deep-groove ball bearing. (Marlin-Rockwell)

Observatory) weighs about 1,000,000 lb (450,000 kg); yet the coefficient of friction for the entire supporting system, because of the hydrostatic-type bearing, is less than 0.000004. The power required is extremely small and a  $\frac{1}{12}$ -hp (62-W) clock motor rotates the telescope while observations are being made.

**Rolling-element bearings.** Everyday experiences demonstrate that rolling resistance is much less than sliding resistance. This principle is used in the rolling-element bearing which has found wide use. In the development of the automobile, ball and roller bearings were found to be ideal for many applications, and today they are widely used in almost every kind of machinery.

These bearings are characterized by balls or cylinders confined between outer and inner rings. The balls or rollers are usually spaced uniformly by a cage or separator. The rolling elements are the most important because they transmit the loads from the moving parts of the machine to the stationary supports. Balls are uniformly spherical, but the rollers may be straight cylinders, or they may be barrel- or cone-shaped or of other forms, depending upon the purpose of the design. The rings, called the races, supply smooth, hard, accurate surfaces for the balls or rollers to roll on. Some types of ball and roller bearings are made without separators. In other types there is only the inner or the outer ring, and the rollers operate directly upon a suitably hardened and ground shaft or housing. Figure 5 shows a typical deep-grooved ball bearing, with the parts that are generally used.

These bearings may be classified by function into three groups: radial, thrust, and angular-contact bearings. Radial bearings are designed principally to carry a load in a direction perpendicular to the axis of rotation. However, some radial bearings, such as the deep-grooved bearings shown in Fig. 5, are also capable of carrying a thrust load, that is, a load parallel to the axis of rotation and tending to push the shaft in the axial direction. Some bearings, however, are designed to carry only thrust loads. Angular-contact bearings are especially designed and manufactured to carry heavy thrust loads and also radial loads.

A unique feature of rolling-element bearings is that their useful life is not determined by wear but by fatigue of the operating surfaces under the repeated stresses of normal use. Fatigue failure, which occurs as a progressive flaking or sifting of the surfaces of the races and rolling elements, is accepted as the basic reason for the termination of the useful life of such a bearing. [D.D.F.]

**Antigen** A substance that initiates and mediates the formation of the corresponding immune body, termed antibody. Antigens can also react with formed antibodies. Antigen-antibody reactions serve as host defenses against microorganisms and other foreign bodies, or are used in laboratory tests for detecting the

presence of either antigen or antibody. See ANTIBODY; ANTIGEN-ANTIBODY REACTION.

A protein immunogen (any substance capable of inducing an immune response) is usually composed of a large number of antigenic determinants. Thus, immunizing an animal with a protein results in the formation of a number of antibody molecules with different specificities. The antigenicity of a protein is determined by its sequence of amino acids as well as by its conformation. Antigens may be introduced into an animal by ingestion, inhalation, sometimes by contact with skin, or more regularly by injection into the bloodstream, skin, peritoneum, or other body part.

With a few exceptions, such as the autoantigens and the isoantigens of the blood groups, antigens produce antibody only in species other than the ones from which they are derived. All complete proteins are antigenic, as are many bacterial and other polysaccharides, some nucleic acids, and some lipids. Antigenicity may be modified or abolished by chemical treatments, including degradation or enzymatic digestion; it may be notably increased by the incorporation of antigen into oils or other adjuvants. See ISOANTIGEN.

Bacteria, viruses, protozoans, and other microorganisms are important sources of antigens. These may be proteins or polysaccharides derived from the outer surfaces of the cell (capsular antigens), from the cell interior (the somatic or O antigens), or from the flagella (the flagellar or H antigens). Other antigens either are excreted by the cell or are released into the medium during cell death and disruption; these include many enzymes and toxins, of which diphtheria, tetanus, and botulinus toxins are important examples. The presence of antibody to one of these constituent antigens in human or animal sera is presumptive evidence of past or present contact with specific microorganisms, and this finds application in clinical diagnosis and epidemiological surveys. See BOTULISM; DIPHTHERIA; TETANUS; TOXIN.

Microbial antigens prepared to induce protective antibodies are termed vaccines. They may consist of either attenuated living or killed whole cells, or extracts of these. Since whole microorganisms are complex structures, vaccines may contain 10 or more distinct antigens, of which generally not more than one or two engender a protective antibody. Examples of these are smallpox vaccine, a living attenuated virus; typhoid vaccine, killed bacterial cells; and diphtheria toxoid, detoxified culture fluid. Several independent vaccines may be mixed to give a combined vaccine, and thus reduce the number of injections necessary for immunization, but such mixing can result in a lesser response to each component of the mixture. See VACCINATION.

Allergens are antigens that induce allergic states in humans or animals. Examples are preparations from poison ivy, cottonseed, or horse dander, or simple chemicals such as formaldehyde or picryl chloride. See HETEROPHILE ANTIGEN; HYPERSENSITIVITY; IMMUNOLOGY. [M.J.Po.]

**Antigen-antibody reaction** A reaction that occurs when an antigen combines with a corresponding antibody to produce an immune complex. A substance that induces the immune system to form a corresponding antibody is called an immunogen. All immunogens are also antigens because they react with corresponding antibodies; however, an antigen may not be able to induce the formation of an antibody and therefore may not be an immunogen. For instance, lipids and all low-molecular-weight substances are not immunogenic. However, many such substances, termed haptens, can be attached to immunogens, called carriers, and the complex then acts as a new immunogen. See ANTIBODY; ANTIGEN.

A molecule of antibody has two identical binding sites for one antigen or more, depending on its class. Each site is quite small and can bind only a comparably small portion of the surface of the antigen, which is termed an epitope. The specificity of an antibody for an antigen depends entirely upon the possession of the appropriate epitope by an antigen. The binding site on

the antibody and the epitope on the antigen are complementary regions on the surface of the respective molecules which interlock in the antigen-antibody reaction. The intensity with which an antibody binds to the antigen depends on the exactitude of the fit between the respective binding site and epitope, as well as some inherent characteristics of the reacting molecules and factors in the environment. The epitope must be continuous spatially, but not structurally: in other words, if the molecule of the antigen consists of several chains, then an epitope may be formed by adjacent regions on two different chains, as well as by adjacent regions on the same chain. If the epitope is now modified either chemically (for example, by altering the hapten) or physically (for example, by causing the chains to separate), then its fit in the binding site will be altered or abolished, and the antigen will react with the antibody either less strongly or not at all.

The immune complex formed in the reaction consists of closely apposed, but still discrete, molecules of antigen and antibody. Therefore, the immune complex can dissociate into the original molecules. The proportion of the dissociated, individual molecules of antigen and antibody to those of the immune complex clearly depends on the intensity of the binding. These proportions can be measured in a standardized procedure, so that the concentration of antigen [Ag], antibody [Ab], and the immune complex [AgAb] becomes known. A fraction is then calculated and called either the dissociation constant or the association constant. The magnitude of either of these constants can be used subsequently to assess the intensity of the antigen-antibody reaction. See IMMUNOASSAY.

Only one epitope of its kind generally occurs on each molecule of antigen, other than that which consists of multiple, identical units, though many epitopes of different configuration are possible. Particles, however, either natural ones such as cells or suitably treated artificial ones made of, for example, latex or glass, typically carry multiple identical epitopes, as well as non-identical ones, because their surfaces contain many molecules of the same antigen. Immune complexes comprising many molecules eventually reach sufficient size to scatter light, at which point they can be detected by nephelometry or turbidimetry; if their growth continues, they become visible as precipitates, which can also be assayed by such methods as immunodiffusion. Since particles typically carry many molecules of antigen, they can be, in principle, aggregated and the reaction can be detected by inspection. Antigen-antibody reactions can also be detected at very low concentration of reactants through special techniques such as immunofluorescence and radioimmunoassay. See IMMUNOASSAY; IMMUNOFLUORESCENCE; IMMUNONEPHELOMETRY; RADIOIMMUNOASSAY.

The reaction between antigen and antibody is followed by a structural change in the remainder of the antibody molecule. The change results in the appearance of previously hidden regions of the molecule. Some of these hidden regions have specific functions, such as binding complement. Fixation of complement by immune complexes has been used to detect and measure antigen-antibody reactions. See COMPLEMENT.

The chief use of antigen-antibody reactions has been in the determination of blood groups for transfusion, serological ascertainment of exposure to infectious agents, and development of immunoassays for the quantification of various substances. See BLOOD GROUPS; IMMUNOLOGY; SEROLOGY. [A.B.]

**Antihistamine** A type of drug that inhibits the combination of histamine with histamine receptors. These drugs are termed either H-1 or H-2 receptor antagonists depending on which type of histamine receptor is involved. H-1 receptor antagonists are used largely for treating allergies, and H-2 receptor antagonists are used to treat peptic ulcer disease and related conditions. See HISTAMINE.

The primary therapeutic use of H-1 receptor antagonists is to antagonize the effects of histamine released from cells by antigen-antibody reactions; they can thus inhibit histamine-induced

effects, such as bronchoconstriction, skin reactions, for example, wheals and itching, and nasal inflammation. These drugs, therefore, are quite effective in reducing allergy signs and symptoms, especially if they are administered before contact with the relevant antigen; however they are not effective in treating asthma. Their effects vary widely, both among the drugs and from individual to individual; in young children excitement may be seen. Another common set of effects caused by many of these drugs, including dry mouth, blurred vision, and urinary retention, can be ascribed to their anticholinergic actions. H-1 receptor antagonists have low toxicity. The chief adverse effect is sedation. Overdoses of H-1 receptor antagonists may be associated with excitement or depression, and although there is no pharmacologic antidote for these drugs, good supportive care should be adequate in managing cases of poisoning. See ALLERGY; ANTIGEN-ANTIBODY REACTION; ASTHMA; SEDATIVE.

H-2 receptor antagonists are much newer. Histamine stimulates gastric acid secretion by combining with H-2 receptors. By preventing this combination, H-2 antagonists can reduce acid secretion in the stomach, an effect that makes these drugs useful in managing various conditions, such as peptic ulcer disease. See ULCER.

Other conditions in which H-2 antagonists are used to lower gastric acidity include reflux esophagitis, stress ulcers, and hypersecretory states such as the Zollinger-Ellison syndrome, in which tumor cells secrete large amounts of the hormone gastrin, which stimulates gastric acid secretion. In these conditions, administration of H-2 antagonists reduces symptoms and promotes healing.

The toxicity of H-2 antagonists is quite low, and adverse effects are reported by only 1-2% of patients. The most common side effects are gastrointestinal upsets, including nausea, vomiting, and diarrhea. [A.Bur.]

**Antimatter** Matter which is made up of antiparticles. At the most fundamental level every type of elementary particle has its anti-counterpart, its antiparticle. The existence of antiparticles was implied by the relativistic wave equation derived in 1928 by P. A. M. Dirac in his successful attempt to reconcile quantum mechanics and special relativity. The antiparticle of the electron (the positron) was first observed in cosmic rays by C. D. Anderson in 1932, while that of the proton (the antiproton) was produced in the laboratory and observed by E. Segré, O. Chamberlain, and their colleagues in 1955. See ELECTRON; ELEMENTARY PARTICLE; POSITRON; PROTON; QUANTUM MECHANICS; RELATIVITY.

The mass, intrinsic angular momentum (spin), and lifetime (in the case of unstable particles) of antiparticles and their particles are equal, while their electromagnetic properties, that is, charge and magnetic moment, are equal in magnitude but opposite in sign. Some neutrally charged particles such as the photon and  $\pi^0$  meson are their own antiparticles. Certain other abstract properties such as baryon number (protons and neutrons are baryons and have baryon number +1) and lepton number (electrons and muons are leptons and have lepton number +1) are reversed in sign between particles and antiparticles. See ANGULAR MOMENTUM; BARYON; LEPTON.

The quantum-mechanical operation of turning particles into their corresponding antiparticles is termed charge conjugation (*C*), that of reversing the handedness of particles is parity conjugation (*P*), and that of reversing the direction of time is time reversal (*T*). A fundamental theorem, the *CPT* theorem, states that correct theories of particle physics must be invariant under the simultaneous operation of *C*, *P*, and *T*. Simply put, the description of physics in a universe of antiparticles with opposite handedness where time runs backward must be the same as the description of the universe. One consequence of the *CPT* theorem is that the above-mentioned properties of antiparticles (mass, intrinsic angular momentum, lifetime, and the magnitudes of charge and magnetic moment) must be identical to those properties of the corresponding particles. This has been experimentally verified



to a high precision in many instances. See CPT THEOREM; PARITY (QUANTUM MECHANICS); TIME REVERSAL INVARIANCE.

When a particle and its antiparticle are brought together, they can annihilate into electromagnetic energy or other particles and their antiparticles in such a way that all memory of the nature of the initial particle and antiparticle is lost. Only the total energy and total angular momentum remain. In the reverse process, antiparticles can be produced in particle collisions with matter if the colliding particles possess sufficient energy to create the required mass. For example, a photon with sufficient energy which interacts with a nucleus can produce an electron-positron pair. See ELECTRON-POSITRON PAIR PRODUCTION.

Since mesons do not possess baryon or lepton number, only charge, energy, and angular momentum need be conserved in their production. Thus, a process such as a collision of a proton with a proton can produce a single neutral pi meson. Other quantum numbers, such as strangeness and charm, must be conserved if production of mesons possessing these quantum numbers is to proceed through strong or electromagnetic interactions. In these cases a particle with the negative values of the particular quantum number must also be produced. Such a process is termed associated production. See CHARM; QUANTUM NUMBERS.

Isolated neutral particles, notably  $K^0$  and  $B^0$  mesons, can spontaneously transform into their antiparticles via the weak interaction. These quantum-mechanical phenomena are termed  $K-\bar{K}$  or  $B-\bar{B}$  mixing, respectively. Mixing can lead to particle-antiparticle oscillations wherein a  $K^0$  can become its antiparticle, a  $\bar{K}^0$ , and later oscillate back to a  $K^0$ . It was through this phenomenon that observation of CP violation first occurred. That observation, coupled to the CPT theorem, implies that physics is not exactly symmetric under time reversal, for example, that the probability of a  $K^0$  becoming a  $\bar{K}^0$  is not exactly the same as that in the reverse process.

Experimental observations, both ground- and balloon-based, indicate that the number of cosmic ray antiprotons is less than 1/10,000 that of protons. This number is consistent with the antibaryon production that would be expected from collisions of cosmic protons with the Earth's atmosphere, and is consistent with the lack of appreciable antimatter in the Milky Way Galaxy. Attempts to find antimatter beyond the Milky Way involve searches for gamma radiation resulting from matter-antimatter annihilation in the intergalactic gas that exists between galactic clusters. The null results of these searches suggests that at least the local cluster of galaxies consists mostly of matter. If matter dominates everywhere in the universe, a question arises as to how this came to be. In the standard model of cosmology, the big bang model, the initial condition of the universe was that the baryon number was zero; that is, there was no preference of matter over antimatter. The current theory of how the matter-antimatter asymmetry evolved requires three ingredients: interactions in which baryon number is violated, time reversal (or CP) violation, and a lack of thermodynamic equilibrium. The last requirement was satisfied during the first few microseconds after the big bang. Time reversal violation has been observed in the laboratory in  $K^0$  decays, albeit perhaps not of sufficient size to explain the observed baryon-antibaryon asymmetry. But the first ingredient, baryon number violation, has not yet been observed in spite of sensitive searches. Thus, the origin of the dominance of matter over antimatter remains an outstanding mystery of particle and cosmological physics. See BIG BANG THEORY; COSMIC RAYS; COSMOLOGY; THERMODYNAMIC PROCESSES. [M.E.Z.]

**Antimicrobial agents** Chemical compounds biosynthetically or synthetically produced which either destroy or usefully suppress the growth or metabolism of a variety of microscopic or submicroscopic forms of life. On the basis of their primary activity, they are more specifically called antibacterial, antifungal, antiprotozoal, antiparasitic, or antiviral agents. Antibacterials which destroy are bactericides or germicides;

#### Common antimicrobial agents and their uses

Use	Agents
Chemotherapeutics (animals and humans)	
Antibacterials	Sulfonamides, isoniazid, <i>p</i> -aminosalicylic acid, penicillin, streptomycin, tetracyclines, chloramphenicol, erythromycin, novobiocin, neomycin, bacitracin, polymyxin
Antiparasitics (humans)	Emetine, quinine
Antiparasitics (animal)	Hygromycin, phenothiazine, piperazine
Antifungals	Griseofulvin, nystatin
Chemotherapeutics (plants)	Captan (N-trichlorothio-tetrahydrophthalimide), maneb (manganese ethylene bisdithiocarbamate), thiram (tetramethylthiuram disulfide)
Skin disinfectants	Alcohols, iodine, mercurials, silver compounds, quaternary ammonium compounds, neomycin
Water disinfectants	Chlorine, sodium hypochlorite
Air disinfectants	Propylene glycol, lactic acid, glycolic acid, levulinic acid
Gaseous disinfectants	Ethylene oxide, $\beta$ -propiolactone, formaldehyde
Clothing disinfectants	Neomycin
Animal-growth stimulants	Penicillin, streptomycin, bacitracin, tetracyclines, hygromycin
Food preservatives	Sodium benzoate, tetracycline

those which merely suppress growth are bacteriostatic agents. See ANTIBIOTIC; FUNGISTAT AND FUNGICIDE.

Of the thousands of antimicrobial agents, only a small number are safe chemotherapeutic agents, effective in controlling infectious diseases in plants, animals, and humans. A much larger number are used in almost every phase of human activity: in agriculture, food preservation, and water, skin, and air disinfection. A compilation of some common uses for antimicrobials is shown in the table.

The most important antimicrobial discovery of all time, that of the chemotherapeutic value of penicillin, was made in 1938. In the next 20 years, more than a score of new and useful microbially produced antimicrobials entered into daily use. New synthetic antimicrobials are found today by synthesis of a wide variety of compounds, followed by broad screening against many microorganisms. Biosynthetic antimicrobials, although first found in bacteria, fungi, and plants, are now being discovered primarily in actinomycetes.

Antimicrobial agents contain various functional groups. No particular structural type seems to favor antimicrobial activity. The search for correlation of structure with biological activity goes on, but no rules have yet appeared with which to forecast activity from contemplated structural changes. On the contrary, minor modifications may lead to unexpected loss of activity. [G.M.S.]

**Antimony** A chemical element, symbol Sb, atomic number 51. Antimony is not a naturally abundant element; it is occasionally found native, often in isomorphous mixture with arsenic, as allemonite. The symbol Sb is derived from the Latin name stibium.

The element is dimorphic, existing as a yellow, metastable form composed of  $Sb_4$  molecules, as in antimony vapor and the structural unit in yellow antimony; and a gray, metallic form, which crystallizes with a layered rhombohedral structure. Antimony differs from normal metals in having a lower electrical conductivity as a solid than as a liquid (as does its congener, bismuth). Metallic antimony is quite brittle, bluish-white with a typical metallic luster, but a flaky appearance. Although stable in air at normal temperatures, it burns brilliantly when heated, with the formation of a white smoke of  $Sb_2O_3$ . Vaporization of

the metal gives molecules of  $Sb_4O_6$ , which break down to  $Sb_2O_3$  above the transition temperature.

Antimony occurs in nature mainly as  $Sb_2S_3$  (stibnite, antimonite);  $Sb_2O_3$  (valentinite) occurs as a decomposition product of stibnite. Antimony is commonly found in ores of copper, silver, and lead. The metal antimonides  $NiSb$  (breithauptite),  $NiSbS$  (ullmannite), and  $Ag_2Sb$  (dicrasite) also are found naturally; there are numerous thioantimonates such as  $Ag_3SbS_3$  (pyrargyrite).

Antimony is produced either by roasting the sulfide with iron, or by roasting the sulfide and reducing the sublimate of  $Sb_4O_6$  thus produced with carbon; high-purity antimony is produced by electrolytic refining.

Commercial-grade antimony is used in many alloys (1–20%), especially lead alloys, which are much harder and mechanically stronger than pure lead; batteries, cable sheathing, antifriction bearings, and type metal consume almost half of all the antimony produced. The valuable property of Sn-Sb-Pb alloys, that they expand on cooling from the melt, thus enabling the production of sharp castings, makes them especially useful as type metal. [J.L.T.W.]

**Antioxidant** A substance that, when present at a lower concentration than that of the oxidizable substrate, significantly inhibits or delays oxidative processes, while being itself oxidized. In primary antioxidants, such as polyphenols, this antioxidative activity is implemented by the donation of an electron or hydrogen atom to a radical derivative, and in secondary antioxidants by the removal of an oxidative catalyst and the consequent prevention of the initiation of oxidation.

Antioxidants have diverse applications. They are used to prevent degradation in polymers, weakening in rubber and plastics, autoxidation and gum formation in gasoline, and discoloration of synthetic and natural pigments. They are used in foods, beverages, and cosmetic products to inhibit deterioration and spoilage. Interest is increasing in the application of antioxidants to medicine relating to human diseases attributed to oxidative stress.

The autoxidation process is shown in reactions (1), (2), and (3). Lipids, mainly those containing unsaturated fatty acids, such

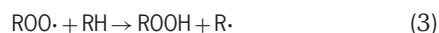

as linoleic acid [RH in reaction (1)], can undergo autoxidation via a free-radical chain reaction, which is unlikely to take place with atmospheric oxygen (ground state) alone. A catalyst (L) is required, such as light, heat, heavy-metal ions (copper or iron), or specific enzymes present in the biological system [reaction (1)]. The catalyst allows a lipid radical to be formed (alkyl radical  $R\cdot$ ) on a carbon atom next to the double bond of the unsaturated fatty acid. This radical is very unstable and reacts with oxygen [reaction (2)] to form a peroxy radical ( $ROO\cdot$ ), which in turn can react with an additional lipid molecule to form a hydroperoxide [ $ROOH$  in reaction (3)] plus a new alkyl radical, and hence to start a chain reaction. Reactions (2) and (3), the propagation steps, continue unless a decay reaction takes place (a termination step), which involves the combination of two radicals to form stable products. See AUTOXIDATION; CATALYSIS; CHAIN REACTION (CHEMISTRY).

When lipid autoxidation occurs in food, it can cause deterioration, rancidity, bad odor, spoilage, reduction in nutritional value, and possibly the formation of toxic by-products. Oxidation stress in a lipid membrane in a biological system can alter its structure, affect its fluidity, and change its function, causing disease.

An antioxidant can eliminate potential initiators of oxidation and thus prevent reaction (1). It can also stop the process by donating an electron and reducing one of the radicals in reaction (2) or (3), thus halting the propagation steps. A primary antioxidant can be effective if it is able to donate an electron

(or hydrogen atom) rapidly to a lipid radical and itself become more stable than the original radical. The ease of electron donation depends on the molecular structure of the antioxidant, which dictates the stability of the new radical. Many naturally occurring polyphenols, such as flavonoids, anthocyanins, and saponins, which can be found in wine, fruit, grain, vegetables, and almost all herbs and spices, are effective antioxidants that operate by this mechanism.

A secondary antioxidant can prevent reaction (1) from taking place by absorbing ultraviolet light, scavenging oxygen, chelating transition metals, or inhibiting enzymes involved in the formation of reactive oxygen species, for example, NADPH oxidase and xanthine oxidase (reducing molecular oxygen to superoxide and hydrogen peroxide), dopamine- $\beta$ -hydroxylase, and lipoxygenases. The common principle of action in the above examples is the removal of the component acting as the catalyst that initiates and stimulates the free-radical chain reaction. See ENZYME.

Among antioxidants, the synthetic compounds butylated hydroxyanisole (BHA), propyl gallate, ethoxyquin, and diphenylamine are commonly used as food additives. Quercetin belongs to a large natural group of antioxidants, the flavonoid family, with more than 6000 known members, many acting through both mechanisms described above. Ascorbic acid is an important water-soluble plasma antioxidant; it and the tocopherols, the main lipid soluble antioxidants, represent the antioxidants in biological systems.  $\beta$ -Carotene belongs to the carotenoid family, which includes lycopene, the red pigment in tomatoes; the family is known to be very effective in reacting with singlet oxygen ( $^1O_2$ ), a highly energetic species of molecular oxygen. See ASCORBIC ACID; CAROTENOID; FLAVONOID; FOOD PRESERVATION. [J.Va.; L.P.]

**Antipatharia** An order of the subclass Zoantharia. These animals are the black or horny corals which live in rather deep tropical and subtropical waters and usually form regular or irregularly branching plant-like colonies, often 6.6 or 9.9 ft (2 or 3 m) in height, with thorny, solid lamellar, horny axial skeletons (see illustration). *Stichopathes* forms an unbranching wirelike colony.

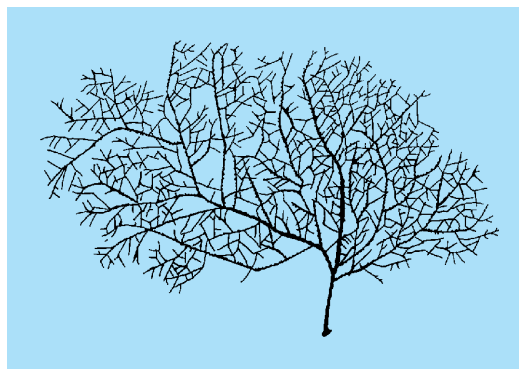

*Antipathes rhipidion.* (After F. Pax)

The polyp or zooid has six unbranched, nonretractile tentacles with a warty surface due to the presence of nematocysts. Six primary, complete, bilaterally arranged mesenteries occur, of which only two lateral ones bear filaments and gonads. Adjacent zooids are united by a coenenchyme, but their gastrovascular cavities have no connection. The musculature is the most weakly developed in the anthozoans.

The polyps are dioecious. Schizopathidae are dimorphic; the gastrozooid has a mouth and two tentacles, while the gonozooid, the only fertile polyp, lacks a mouth. See COELENTERATA; ZOANTHARIA. [K.At.]

**Antiresonance** The condition for which the impedance of a given electric, acoustic, or dynamic system is very high,

approaching infinity. In an electric circuit consisting of a capacitor and a coil in parallel, antiresonance occurs when the alternating-current line voltage and the resultant current are in phase. Under these conditions the line current is very small because of the high impedance of the parallel circuit at antiresonance. [J.Mar.]

**Antiseptic** A drug used to destroy or prevent the growth of infectious microorganisms on or in the human or animal body, that is, on living tissue. Many chemical substances have been employed as antiseptics.

Iodine is the most important of the halogens used as an antiseptic. Tincture of iodine (iodine in an alcohol solution) has been employed widely as a preoperative antiseptic and in first aid. Tincture of iodine is germicidal by laboratory test in 0.02% concentration, but 2.0% solutions are usually employed in surgery and first aid.

Compounds of mercury were used to prevent infection before the germ theory of disease was established. Because of their high toxicity and severe caustic action, such inorganic mercurials as mercuric chloride, mercuric oxycyanide, and potassium mercuric iodide have been largely replaced by certain organic mercury compounds. Organic mercurial compounds are far less toxic and are nonirritating in concentrated solutions. They are highly bacteriostatic, and in concentrated solutions germicidal as well. They are also nonspecific in antimicrobial activity.

Essential oils have been defined as odoriferous oily substances obtained from such natural sources as plants by steam distillation. Essential oils in alcoholic solutions also were early employed in place of the carbolic acid solution of Lister, and because of the toxic and corrosive action of mercury bichloride, they also replaced this compound. Alcoholic solution of essential oils was first developed in 1881 and was admitted as liquor antisepticus to the U.S. Pharmacopoeia in 1900 and to the National Formulary IV in 1916. Alcoholic solutions of essential oils as represented by liquor antisepticus have proved effective in a wide variety of clinical applications and in first aid.

Silver compounds have been widely used for a variety of purposes. Because of the bland nature of most of these compounds, they have been successfully used in the eyes, nose, throat, urethral tract, and other organs. The most widely used silver compounds are silver nitrate, ammoniacal silver nitrate solution, silver picrate, and certain colloidal silver preparations such as strong protein silver and mild silver protein. These are effective germicides of low tissue toxicity and are not counteracted by organic matter.

Such compounds as ethyl alcohol and isopropyl alcohol are germicidal rather than bacteriostatic and are effective against the vegetative forms of bacteria and virus, but do not kill spores. Ethyl alcohol in 62.5–70% solution is most commonly used, being widely employed for disinfecting the skin before hypodermic injections and other skin punctures. Isopropyl alcohol is equal, if not superior, to ethyl alcohol and is widely used for degerming the skin and for disinfecting oral thermometers. Alcohols are also widely used in other antiseptic preparations, in which they serve to lower the surface tension and to promote spreading and penetration.

Bisphenol compounds such as dichlorophene and tetrachlorophene are essentially bacteriostatic agents and are weaker as germicides. They have proved quite effective as skin-degerming agents, when used in soaps and other detergents, and as mildew-preventing formulations. The halogenated form, such as dichlorophene, tetrachlorophene, hexachlorophene, and bithionol, is most commonly employed. When used repeatedly on the skin, as in soaps and detergents, bisphenols have a tendency to remain for long periods, thus reducing skin bacteria to a significant degree. For this purpose they are especially useful in preoperative hand washing.

Quaternary ammonium compounds have high germicidal activity. Although they are more properly classified as surfaceactive disinfectants, some of them are employed in certain antiseptic

formulations, for instance, Zephiran, especially suited for use on the skin, and Cepacol, for mucous surfaces. Nontoxic and nonirritating, they may be used in place of alcohol after preoperative scrub-up. See ANTIMICROBIAL AGENTS; BIOASSAY. [G.FR./F.C.]

**Antisubmarine warfare** All measures required to combat enemy submarines, including strategy, operational employment of forces, tactics, and a wide variety of equipment and weapons to find and destroy submarines and to neutralize their weapons.

The key physical facts of antisubmarine warfare (ASW) are that submerged submarines are, effectively, invisible to surface observers and that sound is the only form of energy that travels any substantial distance underwater. All forms of antisubmarine warfare are based on strategies which cause the submarines to surrender either their invisibility (or stealth) or their mobility. Generally, since the submarine can be destroyed once it is located, the effort in antisubmarine warfare goes primarily into finding it.

Since invisibility is the key element of submarine operations, and since this is violated only by sound, sound sensor (that is, sonar) performance shapes the tactics of antisubmarine warfare. Sonars may be active, that is, the listening device may impose a signature on the target, or passive, in which case the device may listen for noise from the target. There are two limits on active sonar: water can transmit only a limited amount of energy, and active sensing will tend to alert the target submarine.

The distance that sound travels through the ocean depends on its frequency: under given conditions, the lower the frequency, the farther a sound signal will travel. The best low-frequency active sonars are the size of small boats, which is probably about the largest size that would be acceptable within a conventional hull. For lower frequencies, a towed array is employed. This is a line of passive transducers trailed far astern of a ship, at the optimum listening depth. Although the array can detect distant targets (perhaps positioned hundreds of miles away), it cannot provide range and bearing data that are sufficient for fire control. Therefore, an airplane or helicopter is generally used to search the area defined by the sensor quickly enough to detect the submarine before it leaves the area.

A major area of effort in antisubmarine warfare has been to distinguish ever fainter (more distant) submarine noises from the surrounding random ocean noise, so that attacks are not made against nonexistent targets; otherwise, weapons may be expended too quickly. This problem of identifying sounds of real objects is generally termed one of classification. It includes the challenge of distinguishing friendly from enemy submarines. See UNDERWATER SOUND.

The main weapons used in antisubmarine warfare are homing torpedoes (using active or passive sonars) and depth bombs, the latter generally fused to explode at a preset depth. In many cases, depth charges are propelled by rockets to the vicinity of the submarine. Because sonar range may exceed the range at which a torpedo can find a submarine target, several navies use missiles to carry homing torpedoes out to the point at which they are likely to find the target. Since World War II, torpedoes have generally replaced depth bombs or depth charges because the latter fall relatively slowly through the water so that a fast submarine can evade them.

Most antisubmarine warfare operations fall into three distinct categories: long-range detection (which may be followed by attacks, often by aircraft), interception by submarines, and counterattack by escorts.

If a submarine can be detected at very long range, it can be attacked by an airplane cued by the detection system. Until the end of the Cold War, much of United States antisubmarine strategy was based on the ability of fixed undersea arrays and strategic towed arrays to detect Russian submarines at great distances, of hundreds or even thousands of miles, in the open Atlantic and Pacific oceans. From the late 1970s on, the Russians

began to silence their nuclear submarines far more efficiently, and alternative forms of antisubmarine operation became more important. In the aftermath of the Cold War, United States naval operations were likely to occur in areas not covered by the fixed systems, and possibly not accessible to the slow towed-array ships. A deployable submarine detection system became essential.

Because it is almost invisible, a submarine can lie near enemy submarine bases in hopes of intercepting emerging enemy craft. Such interception was an important United States tactic against the Russian submarine force throughout the Cold War. In the absence of effective long-range detectors, this sort of submarine blockade becomes an important tactic.

If the submarines are likely to concentrate on ships as targets, and if they cannot be located efficiently at long ranges, then antisubmarine ships can be concentrated around the potential targets, in a convoy. Convoys do not actively protect the escorted ships against attack. Rather, they act as a deterrent, since any submarines that attack must surrender their invisibility, inviting counterattacks from escort ships. Convoy escorts were responsible for the bulk of all German submarines destroyed at sea in World War II.

There are four main platforms for antisubmarine warfare: surface ships equipped with sonars; airplanes equipped with sonobuoys (which they drop into the water); helicopters carrying both sonobuoys and dipping sonars; and submarines.

[N.F.]

**Antitoxin** An antibody that will combine with and generally neutralize a particular toxin. When the manifestations of a disease are caused primarily by a microbial toxin, the corresponding antitoxin, if available in time, may have a pronounced prophylactic or curative effect. Apart from this, the other properties of an antitoxin are those of the antibody family (IgG, IgA, IgM) to which it belongs. See ANTIBODY; BIOLOGICALS; IMMUNOGLOBULIN.

Antitoxins have been developed for nearly all microbial toxins. Diphtheria, tetanus, botulinus, gas gangrene, and scarlatinal toxins are important examples. Antitoxins may be formed in humans as a result of the disease or the carrier state, or following vaccination with toxoids, and these may confer active immunity. The status of this can be evaluated through skin tests, or by titration of the serum antitoxin level. See BOTULISM; DIPHTHERIA; GANGRENE; IMMUNITY; SKIN TEST; TETANUS; TOXIN-ANTITOXIN REACTION.

[H.P.T.]

**Anura** One of the three living orders (sometimes called Salientia) of the class Amphibia, which includes the frogs and toads. About 2400 species of frogs are known. Only the frozen polar regions and remote oceanic islands are without native frogs, and 80% of the species live in the tropics.

Frogs are short-bodied animals with a large mouth and protruding eyes. The externally visible part of the ear, absent in some forms, is the round, smooth tympanum situated on the side of the head behind the eye. There are five digits on the hindfeet and four on the front. Teeth may be present on the upper jaw and the vomerine bones of the roof of the mouth, but are found on the lower jaw of only one species. Often teeth are totally lacking, as in toads of the genera *Bufo* and *Rhinophrynus*. The short vertebral column consists of from 6 to 10 vertebrae, usually 9, and the elongate coccyx. The sacral vertebra precedes the coccyx and bears more or less enlarged lateral processes with which the pelvic girdle articulates. A characteristic feature of frogs is the fusion of the bones in the lower arm and lower leg, so that a single bone, the radioulna in the arm and the tibiofibula in the leg, occupies the position of two in most other tetrapods.

The one character of frogs that comes to the attention of most persons, including many who may never see a frog, is the voice. Most frogs have voices and use them in a variety of ways. In the breeding season great numbers of male frogs may congregate in



Fig. 1. Toad of the genus *Bufo* giving mating call with vocal sac expanded. (American Museum of Natural History)

favorable sites and call, each species giving its own characteristic vocalization. Because no two species breeding at the same time and place have identical calls, it is assumed that the call is important in aiding individuals to find the proper mate. In some species it appears that the female is active in selecting the mate and may be responding to the mating call, but the call may not act in exactly the same way in other species. The mating call is given with the mouth closed. Air is shunted back and forth between the lungs and the mouth, so frogs can call even though submerged. Many species possess one or two vocal sacs, which are expansible pockets of skin beneath the chin or behind the jaws. The sacs (Fig. 1), which may be inflated to a volume as great as that of the frog itself, serve as resonators.

Other noises made by frogs include the so-called fright scream given with the mouth open, and the warning chirp, which evidently serve as a sex recognition signal when one male contacts another. Some calls evidently serve as territorial signals.

Breeding and development typically take place in the following manner. The male grasps the female about the body with the forelegs, a procedure called amplexus, and fertilizes the eggs externally as they are extruded. The number of eggs may be quite large (up to 20,000 in the bullfrog or 25,000 in a common toad) or may be as few as one in a frog of the West Indies. The larva, called a tadpole, is at first limbless and has external gills and a muscular tail with dorsal and ventral fins (Fig. 2). At hatching there is no mouth opening present, but one soon forms that develops a horny beak and several rows of labial teeth not at all like the true teeth of the adult frog. Shortly after the tadpole hatches, the gills become enclosed within chambers and are no longer visible externally. Except for the gradual development of the hindlimbs, no additional external changes take place as the tadpole grows until the time for metamorphosis. The anterior limbs, which have been forming hidden in the gill chambers, break through the covering skin as metamorphosis begins. The tail dwindles in size as it is absorbed, while the mouth assumes the shape of that of the adult frog. Many other changes are

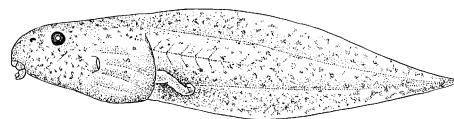

Fig. 2. The tadpole, or larval, stage of the frog *Rana pipiens*. (After W. F. Blair et al., *Vertebrates of the United States*, 2d ed., McGraw-Hill, 1968)

taking place internally, including shortening of the intestine and adapting it to the carnivorous diet of the adult frog.

All frogs are carnivorous. The kind of food seems to depend largely upon the size of the frog, whose capacious mouth permits somewhat astonishing feats of swallowing. A large bullfrog, for example, may snap up low-flying bats, ducklings, snakes, and turtles. Insects and other invertebrates form the bulk of the diet of most frogs. The tongue, moistened by a sticky secretion from the intermaxillary gland in the roof of the mouth, is used to catch smaller prey, while larger items of food may bring the front limbs into play. When swallowing, a frog will usually depress the eyeballs into the head to aid in forcing the food down the pharynx. In contrast to transformed frogs, most tadpoles are vegetarian and feed on algae. A few are largely carnivorous or sometimes cannibalistic, and even vegetarian species will scavenge for dead animal matter.

The habitats of frogs are as various as the places where fresh water accumulates. Lakes and streams are tenanted year-round by many species, and others migrate to these places in the breeding season. Any permanent source of water in the desert is likely to support a population of one or more species, and when rainstorms occur, the air around a temporary pool may be filled with mating calls for a few nights, while the frogs take advantage of the water for breeding. As often as not, the pool goes dry before the tadpoles metamorphose, and the adult frogs retreat underground to await another rain. Moist tropical regions provide an abundance of habitats little known to temperate regions, such as the air plants (bromeliads) that hold water and so provide a moist home and breeding site for frogs that may never leave the trees.

Although the majority of frogs fall into fairly well-defined familial categories, the arrangement of the families into subordinal groups by different authorities is not consistent, and there is controversy about the relationships of some smaller groups.

[R.G.Z.]

**Anxiety disorders** A group of distinct psychiatric disorders characterized by marked emotional distress and social impairment, including generalized anxiety disorder, panic disorder, obsessive-compulsive disorder, and posttraumatic stress disorder.

Generalized anxiety disorder (GAD) is characterized by excessive worry, tension, and anxiety. Accompanying physical symptoms include muscle tension, restlessness, fatigability, and sleep disturbances. GAD occurs in around 4–6% of the population and is the most frequently encountered anxiety disorder in primary care, where sufferers may seek help for the physical symptoms of the disorder. Studies of fear in animals and clinical studies of people with GAD suggest that similar brain circuits are involved in both cases. For example, numerous complex connections to other brain areas allows the amygdala to coordinate cognitive, emotional, and physiological responses to fear and anxiety. Thus in the “fight or flight” response, the organism makes cognitive-affective decisions about how to respond to the perceived danger and has a range of somatic (increased heart and respiration rate) and endocrine (release of stress hormones) responses that act together to increase the likelihood of avoiding the danger. Various neurotransmitter systems are responsible for mediating the communication between the functionally connected regions. Medications acting on these systems are thus effective in treating GAD. Although benzodiazepines have often been used, selective serotonin reuptake inhibitors (SSRIs) and norenergic/serotonergic reuptake inhibitors (NSRIs) are currently viewed as first-line options because of their favorable safety profile. Psychotherapy has also proven effective in the treatment of GAD. Cognitive-behavioral psychotherapy focuses on using behavioral techniques and changing underlying thought patterns.

Panic disorder (PD) is characterized by repeated, sudden, and unexpected panic attacks. Panic attacks are accompanied by a

range of physical symptoms, including respiratory (shortness of breath), cardiovascular (fast heart rate), gastrointestinal (nausea), and oculovestibular (dizziness) symptoms. The prevalence of PD is approximately 2% in the general population, is more common in women, and is often complicated by depression. The same brain circuits and neurotransmitters implicated in fear and GAD are also likely to play a role in PD. For treatment the first-line choice of medication should be an SSRI or NSRI. Benzodiazepines are effective alone or in combination with SSRIs, but their use as the only medication is generally avoided due to the potential for dependence and withdrawal. Cognitive-behavioral principles that address avoidance behavior and irrational dysfunctional beliefs are also effective.

Obsessive-compulsive disorder (OCD) is characterized by obsessions (unwanted, persistent, distressing thoughts) and compulsions (repetitive acts to relieve anxiety caused by obsessions). The disorder occurs in 2–3% of the population and often begins in childhood or adolescence. OCD is also seen in the context of certain infections, brain injury, and pregnancy. A range of evidence now implicates a brain circuit between the frontal cortex, basal ganglia, and thalamus in mediating OCD. Key neurotransmitters in this circuit include the dopamine and serotonin neurotransmitter system. SSRIs are current first-line treatments for OCD, with dopamine blockers added in those who do not respond to these agents. Behavioral therapy focuses on exposure and response prevention, while cognitive strategies address the distortions in beliefs that underlie the perpetuation of symptoms.

Social anxiety disorder (SAD) is characterized by persistent fears of embarrassment, scrutiny, or humiliation. People with SAD may avoid social situations and performance situations, resulting in marked disability. For some, symptoms are confined to one or more performance situations, while others may be generalized to include most social and performance situations. Generalized SAD is usually more severe and sufferers are more likely to have a family history of SAD. SAD is particularly common, with prevalence figures in some studies upwards of 10%. SAD is often complicated by depression, and people with SAD may self-medicate their symptoms with alcohol, leading to alcohol dependence. Brain-imaging studies have found that effective treatment with medication and psychotherapy normalizes activity in the amygdala and the closely related hippocampal region in SAD. SSRIs, NSRIs, and cognitive-behavioral therapy are all effective in the treatment of SAD. Monoamine oxidase inhibitors (MAOIs) and benzodiazepines are also known to be effective treatments, but have a number of disadvantages.

Posttraumatic stress disorder (PTSD) is an abnormal response to severe trauma. PTSD is characterized by distinct clusters of symptoms: reexperiencing of the event (for example, in flashbacks or dreams), avoidance (of reminders of the trauma), numbing of responsiveness to the environment, and increased arousal (for example, insomnia, irritability, and being easily startled). Although exposure to severe trauma occurs in more than 70% of the population, PTSD has a lifetime prevalence of 7–9% in the general population. Risk factors for developing PTSD following exposure to severe trauma include female gender, previous psychiatric history, trauma severity, and absence of social support after the trauma. Brain-imaging studies have suggested that in PTSD frontal areas of the brain may fail to effectively dampen the “danger alarm” of the amygdala. Whereas stress responses ordinarily recover after exposure to trauma, in PTSD they persist. There is growing evidence that functioning of the hypothalamic-pituitary-adrenal hormonal axis is disrupted in PTSD. However, other systems, such as serotonin and norepinephrine, may also be involved. Both SSRIs and cognitive-behavioral therapy are effective in decreasing PTSD symptoms. Behavioral techniques (using different forms of exposure in the safety of the consultation room) or cognitive retraining (addressing irrational thoughts on the trauma and its consequences) can both be helpful.

[P.D.C.; D.J.St.]

**Anyons** Particles obeying unconventional forms of quantum statistics. For many years it was believed that only two possible forms of quantum statistics, Bose-Einstein and Fermi-Dirac statistics, were possible, but in fact a continuum of possibilities exists. Elementary excitations (quasiparticles) in the fractional quantum Hall effect are anyons.

In quantum mechanics, in the behavior of identical particles there are important dynamical effects that have no classical analog. Thus, in the case of two indistinguishable particles A and B, the amplitude for the process that leads to A arriving at point  $x$  while B arrives at point  $y$  must be added to the amplitude for the process that leads to A arriving at  $y$  while B arrives at  $x$ —the so-called exchange process—because the final states cannot be distinguished. Actually the recipe of adding the amplitude for the exchange process is appropriate only for particles obeying Bose-Einstein statistics (bosons); for particles obeying Fermi-Dirac statistics (fermions), this amplitude must be subtracted. See FERMI-DIRAC STATISTICS; NONRELATIVISTIC QUANTUM THEORY.

The definition of anyons posits other possible recipes for adding exchange processes, refining the analysis of exchange to take account of the direction in which the exchange takes place. These more general possibilities can be defined only for particles whose motion is restricted to two space dimensions. However, many important materials are effectively two-dimensional, including microelectronic circuitry and the copper oxide layers of high-temperature superconductors. The quantum statistics of the quasiparticles in these systems is under investigation, but the fractional quantized Hall states are known to be anyons. See HALL EFFECT; QUANTUM STATISTICS; SUPERCONDUCTIVITY. [F.Wil.]

**Aorta** The main vessel of the systemic arterial circulation arising from the left ventricle of the heart; it is divided into three parts for convenience only. The first portion, the ascending aorta, passes upward under the pulmonary artery; the coronary arteries arise at the base of the ascending aorta behind the aortic valves. The second part, or aortic arch, curves over the hilum of the left lung, giving off the innominate, left carotid, and left subclavian arteries, which supply the neck, head, and forelimbs. The third portion, or descending aorta, continues downward in the thorax on the left side of the vertebral column to the diaphragm, giving off small arteries to the bronchi, esophagus, and other adjacent tissues. Below the diaphragm this vessel, known as the abdominal aorta, descends to the level of the fourth lumbar vertebra where it bifurcates into the two common iliac arteries supplying the hindlimbs.

In the abdomen the major branches of the aorta include the single celiac, superior mesenteric and inferior mesenteric, and the paired renal and internal spermatic (male) or ovarian (female) arteries. In addition, many small branches go to other organs and to the body wall. See SYSTEM. [W.J.B.]

**Apatite** The most abundant and widespread of the phosphate minerals, crystallizing in the hexagonal system. The apatite structure type includes no less than 10 mineral species and has the general formula  $X_5(YO_4)_3Z$ , where X is usually  $Ca^{2+}$  or  $Pb^{2+}$ , Y is  $P^{5+}$  or  $As^{5+}$ , and Z is  $F^-$ ,  $Cl^-$ , or  $(OH)^-$ . The apatite series takes  $X = Ca$ , whereas the pyromorphite series includes those members with  $X = Pb$ . Three end members form a complete solid-solution series involving the halide and hydroxyl anions. These are fluorapatite,  $Ca_5(PO_4)_3F$ ; chlorapatite,  $Ca_5(PO_4)_3Cl$ ; and hydroxyapatite,  $Ca_5(PO_4)_3(OH)$ . Thus, the general series can be written  $Ca_5(PO_4)_3(F,Cl,OH)$ , the fluoride member being the most frequent and often simply called apatite.

The apatite isomorphous series of minerals occurs as grains, blebs, or short to long hexagonal prisms terminated by pyramids, dipyramids, and the basal pinacoid. The minerals are transparent to opaque, and can be asparagus-green (asparagus stone), grayish-green, greenish-yellow, gray, brown, brownish-red, and

more rarely violet, pink, or colorless. Apatites are brittle, with hardness 5 on Mohs scale, and specific gravity 3.1–3.2; they are also botryoidal, fibrous, and earthy.

Apatite occurs in nearly every rock type as an accessory mineral. It often crystallizes in regional and contact metamorphic rocks, especially in limestone and associated with chondrodite and phlogopite. It is very common in basic to ultrabasic rocks; enormous masses occur associated with nephelinesyenites in the Kola Peninsula, Russia, and constitute valuable ores which also contain rare-earth elements. Large beds of oolitic, pulverulent, and compact fine-grained carbonate-apatites occur as phosphate rock, phosphorites, or colophonans. Extensive deposits of this kind occur in the United States in Montana and Florida and in North Africa. The material is mined for fertilizer and for the manufacture of elemental phosphorus. See FERTILIZER; PHOSPHORUS; PYROMORPHITE. [P.B.M.]

**Apes** The group of primates most closely related to humans. They include the African great apes, the gorilla and two species of chimpanzee; the Asian great ape, the orangutan; and the lesser apes from Asia, the gibbon and siamang. The apes can be distinguished from the rest of the primates by a number of anatomical and behavioral traits, which indicate their common origin; thus they are termed a monophyletic group called the Hominoidea.

Apes are distinguished from other primates through such obvious features as absence of tail and presence of an appendix. They share a number of specializations (synapomorphies) of the skeleton, which are useful as diagnostic characters, particularly when it comes to distinguishing fossil apes, because bones and teeth are the most readily preserved parts in the fossil record. The distal end of the humerus is especially useful, both because it is one of the most robust body parts, and therefore readily preserved, and because it is diagnostic of the ape condition, with a large trochlea (ulnar forearm articulation) and a well-developed trochlea ridge. The wrist is also modified for mobility of the joint. There are few synapomorphies of the skull, which in general retains the primitive primate condition except in individual species, but two shared specializations are the deep arched palate and relatively small incisive foramina. The teeth also are generally primitive, except in the broad, low-crowned incisors and enlarged molars. See DENTITION; FOSSIL APES; SKELETAL SYSTEM.

**Gibbons.** Each group of ape differs from this basic ape pattern in varying degrees. The gibbons retain many of the primitive ape characteristics. They have also developed a number of unique characters that are different from any other ape: they have very elongated arms (relative to body weight) with many modifications of the musculature for a brachiating form of locomotion (swinging by the arms); their legs are also lengthened, so that they are quite efficient bipeds; they have adopted a monogamous family system, which is unusual in primates, and one of the outcomes is role sharing between males and females and lack of size variation between the sexes; and they have also developed a complex system of vocal communication related both to their close social bonds and to their thick tropical forest environment, which makes visual communication difficult. At present there are six species of gibbon (*Hylobates*) occupying most parts of Southeast Asia where primary forest still remains. See SOCIAL MAMMALS.

**Orangutan.** The sister group to the gibbons is the great ape and human group, which is readily distinguished by the shared presence of enlarged premolars in all its members. Within this group can be distinguished the orangutan and the African apes. The orangutan (*Pongo pygmaeus*) has a great many specializations that support this separation, although because of its common heritage with the chimpanzee and gorilla, and the great increase in body size of all three, the orangutan has a superficial similarity which has led in the past to all being grouped in the same family, the Pongidae. The differences separating

the orangutan from other apes are in part biochemical—the structure of the blood proteins, for instance—and in part morphological. The deep face, enlarged premaxilla, narrow distance between the eyes, massive zygomatic bones, smooth floor of nose, and enlarged central incisors are all characters unique to the orangutan, and in all of these traits the African apes and humans retain the primitive ape condition. The orangutan is today confined to the tropical rain forests of Borneo and Sumatra, where it exists as a highly variable species. There are many biochemical and chromosomal differences both within and between populations, so that the possibility has been raised that, in fact, two separate species are present. This cannot be accepted on present evidence, but it would appear that the orangutan is a good example of ongoing evolution and incipient speciation. It is largely arboreal despite its great size, which ranges in body weight from 88 to 308 lb (40 to 140 kg). It leads a solitary or small-group existence, leading to the massive sexual-size variation indicated by its body weight variation. Little is known of its social structure.

**African apes.** The other part of the great ape group consists of the three African apes, the gorilla and two species of chimpanzee. They are distinguished from the orangutan (and other primates) by specializations of the wrist and frontal sinus and the development of massive brow ridges (all of which they also share with humans), and by a further series of unique modifications of the hand that are related to its unusual form of locomotion, called knuckle walking. Their legs are reduced in length (relative to body weight) so that their arms appear long in proportion to the rest of their body. The effects of this are further increased both by elongation of the hand and by the fact that when they walk quadrupedally on the ground they support their weight on the middle phalanges (finger bones) of the hand. This raises the body to a semiupright position even when the animals are walking on all fours.

The chimpanzee (*Pan troglodytes*) inhabits much of the forested region of tropical Africa, extending beyond the forest into more seasonal wooded habitats as well. The pygmy chimpanzee, or bonobo (*P. paniscus*), is confined to the southern loop of the Congo River where it inhabits mainly swamp forest. The gorilla is also confined to tropical Africa, but is divided into two rather distinct forms, the mountain gorilla (*Gorilla gorilla beringei*) and two lowland subspecies (*G. g. gorilla* and *G. g. manyeura*). The gorilla is the largest of the primates, with body weights ranging from 165 to 396 lb (75 to 180 kg), while the chimpanzee at 88–110 lb (40–50 kg) is much smaller. Gorilla social groups consist of a dominant male with several females and immature males and females, while chimpanzees live in fluctuating multimale or multifemale groups.

**Relationship to humans.** The orangutan is put into a separate group (or clade) from the other great apes (the chimpanzee, *Pan*, and the gorilla) because these have been shown to be more closely related to humans in evolutionary terms than they are to the orangutan. This signifies that the idea of the “great apes” encompassing all three is not valid, and the use of a single family, the Pongidae, to include them all is not correct. The great apes, however, have many superficial similarities to each other, mostly related to their large size, so that they may be said to be similar in grade, but in terms of clade (ancestral-descendant relationship) they are different. This could be recognized by restricting the use of the family Hominidae, but other classifications are also possible based on this set of relationships. See FOSSIL HUMANS.

[PA.]

**Aphasia** Impairment in the use of spoken or written language caused by injury to the brain which cannot be accounted for by paralysis or incoordination of the articulatory organs, impairment of hearing or vision, impaired level of consciousness, or impaired motivation to communicate. The language zone in the brain includes the portion of the frontal, temporal, and parietal lobes surrounding the sylvian fissure and structures deep to

these areas. In right-handed persons, with few exceptions, only injury in the left cerebral hemisphere produces aphasia. Lateralization of language function is variable in left-handers, and they are at greater risk for becoming aphasic from a lesion in either hemisphere. See HEMISPHERIC LATERALITY.

Distinctive recurring patterns of deficit are associated with particular lesion sites within the language zone. These patterns may entail selective impairment of articulation, ability to retrieve concept names, or syntactic organization. Other dissociations affect principally the auditory comprehension of speech, the repetition of speech, or the recognition of written words. The erroneous production of unintended words in speech (paraphasia), oral reading (paralexia), or writing (paragraphia) is a feature of some forms of aphasia.

Mixed forms of aphasia, caused by multiple lesions or lesions spanning anterior and posterior portions of the speech zone, are quite common, and massive destruction of the entire language area results in a global aphasia. Further, individual variations in behavioral manifestations of similar lesions have set limits on the strict assignment of function to structures within the language area.

Preadolescent children suffering aphasia after unilateral injury usually recover rapidly, presumably by virtue of the capacity of the right cerebral hemisphere early in life to acquire the language functions originally mediated by the left hemisphere. Capacity for recovery of function decreases during later adolescence and young adulthood.

Complete recovery in adults after a severe injury is much less common, and severe aphasia may persist unchanged for the duration of the person's life. Many patients are aided by remedial language training, while others continue severely impaired. See MEMORY. [H.G.]

**Aphid** One of a group of mostly soft-bodied plant-feeding insects of the suborder Homoptera, superfamily Aphidoidea. The worldwide fauna of over 4000 species is most abundant in north temperate regions. Aphids feed on phloem sap from vascular plants, tapping it through a feeding tube formed from modified mandibles and maxillae called stylets. In so doing they

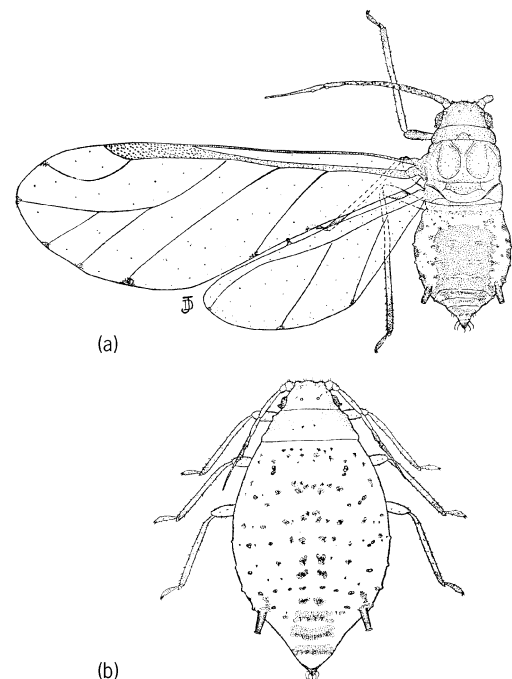

**Viviparae of the tulip bulb aphid: (a) the winged form and (b) the wingless form. (After J. Davidson, On some aphids infesting tulips, Bull. Entomol. Res., 18:51–62, 1927)**

may transmit viruses from plant to plant, spreading serious disease in crops such as potatoes, cereals, sugarbeet, and citrus. Plants sometimes react to aphid feeding by forming galls in which the aphids live protected from drought and enemies. The so-called Chinese gall is valued in commerce for its high tannin content.

Aphids have evolved complex life styles to exploit the changing growth phases of plants. Many divide their yearly cycle by flying between a primary host, on which sexual forms mate and lay winter eggs, and a secondary host, where only parthenogenetic females multiply. Only one generation of males and sexual oviparous females occurs each year, usually in autumn. Most parthenogenetic females are also viviparous, and reproduce very rapidly under favorable conditions. Viviparae are winged or wingless (see illustration). Development of young aphids can be switched toward either wingedness or sexuality by outside factors, such as crowding, decreasing temperature, or shortening days. Aphids in the tropics often remain wholly parthenogenetic.

[H.L.G.S.]

**Apiales** An order of flowering plants, division Magnoliophyta (Angiospermae), in the subclass Rosidae of the class Magnoliopsida (dicotyledons). The order (also known as Umbellales) consists of two families, the Araliaceae, with about 700 species, and the Umbelliferae, with about 3000. They are herbs or woody plants with mostly compound or conspicuously lobed or dissected leaves, well-developed secretory canals, and separate petals.

The Umbelliferae are mostly aromatic herbs, most numerous in temperate regions. The flowers consistently have an ovary of two carpels, ripening to form a dry fruit that splits into two halves, each containing a single seed. Some common garden vegetables and spice plants, including carrot (*Daucus carota*), parsnip (*Pastinaca sativa*), celery (*Apium graveolens*), parsley (*Petroselinum crispum*), caraway (*Carbum carvi*), and dill (*Anethum graveolens*), belong to the Umbelliferae, as do also such notorious poisonous plants as the poison hemlock (*Conium*) and water hemlock (*Cicuta*). See ANISE; CARROT; CELERY; FENNEL; MAGNOLIOPSIDA; PARSLEY; PARSNIP; ROSIDAE.

[A.Cr.]

**Apical dominance** Correlative inhibition of the growth of lateral (axillary) shoots exerted by the growing apical bud of the plant stem. Partial or complete apical dominance can also occur in the initiation of lateral roots and in the orientation of lateral organs such as branches, leaves, and stolons.

In the apical meristem, cell division occurs in the young forming leaves and along the flanks of the apical bud. As the number of cells increases, they elongate, pushing the apical meristem upward and leaving a small portion of the dividing cells behind the axil of each of the laterally forming leaves. This meristem, called the lateral meristem, may remain a small group of cells with little organization or may develop into an axillary bud possessing short internodes, unexpanded leaves, and an apical meristem. In roots, branching does not directly involve the apical meristem. Lateral roots do not form from organized buds but originate in the layer of cells between the endodermis and root vascular system (pericycle). See LATERAL MERISTEM; ROOT (BOTANY).

The degree of apical dominance over the lateral buds varies with the plant species. Some plants, such as pea and sunflower, exhibit strong apical dominance, causing the formation of single branchless shoots. Other plants, such as tomato, have weak apical dominance, allowing axillary bud growth and a bushy growth habit. Apical dominance can be broken by several factors, including apical bud removal (decapitation), horizontal positioning of the plant's main axis (gravistimulation), shoot inversion, low light intensity, or short-day photoperiods. In some situations, apical dominance is weakened as the plant becomes older. See PHOTOPERIODISM; PLANT MOVEMENTS.

Plant organs other than the main shoot are under the control of apical dominance. In roots, strong apical dominance causes tap-root growth, whereas weak apical dominance results in a fibrous root system. Leaves and branches which grow at characteristic angles to the main axis of the stem will grow more upright after removal of the apical bud of the main stem. The growth form of some organs is also controlled by the presence of the apical bud. Rhizomes (underground axillary shoots lacking chlorophyll and having rudimentary leaves) will grow upright, forming green, leafy shoots if the apical bud and all the aboveground axillary buds are removed. Lower plants, such as mosses and ferns, as well as fungi and algae, also exhibit apical dominance.

One hypothesis for the mechanism of apical dominance is based on the competition of nutrients between centers of growth. According to this hypothesis, nutrients are preferentially transported to the apical bud, causing deficiencies in the axillary buds. A second hypothesis for the mechanism of apical dominance proposes that one or more plant hormones, such as auxin, cytokinin, and gibberellin, acts as correlative signals. See AUXIN; CYTOKININS; GIBBERELLIN; PLANT GROWTH.

[M.Ha.]

**Apical meristem** Permanently embryonic tissue involved in cell division at the apices of plant roots and stems, and forming dynamic regions of growth. These apical meristems, usually consisting of small, densely cytoplasmic cells, become established during embryo development. Thereafter they divide, producing the primary plant body of root and shoot. Below the apical meristems, tissue differentiation begins: the protoderm gives rise to the epidermal system, the procambium to the primary vascular system, and the ground meristem to the pith and cortex (see illustration). Plant apical meristems have been the object of experiments on development similar to those carried out on animal embryos.

Root apical meristem is covered by a root cap, a region of parenchymatous, cells which has a protective function and is responsible for perceiving gravitational changes. Root tips have been shown to possess a central region, usually hemispherical, which consists of cells which rarely divide or synthesize deoxyribonucleic acid (DNA), and have less ribonucleic acid (RNA) and protein than adjacent cells; this region is known as the quiescent center. The cells which divide and give rise to root tissues lie around the periphery of this region. Cells in the quiescent center are regarded as cells that are mitotically young and genetically sound; they can renew the initial cells from time to time.

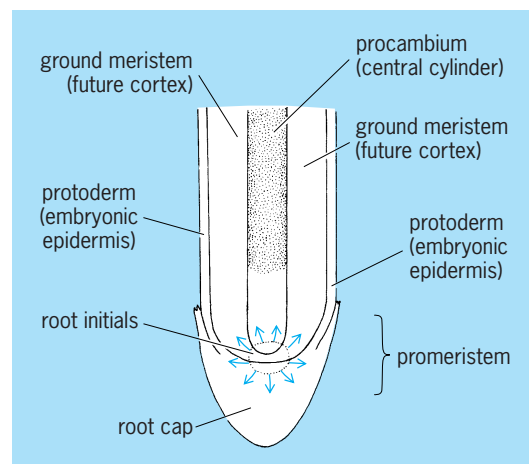

**Diagram of a root apical meristem. Cortex and central cylinder have separate initials; epidermis and root cap have a common origin.**



Shoot apices vary greatly in size and shape. The diameter can vary from about 50 micrometers to 0.14 in. (3.5 mm); the shape may be elongated and conical, dome-shaped, flat, or even slightly concave. The distance from the center of the apex to the youngest leaf primordium also varies considerably. Apices increase in size during the development of a single plant; for example, the apical meristem of flax (*Linum usitatissimum*) increases in area 20-fold from the seedling up to the time of flowering. Apices may also change in size during the time between the formation of one leaf primordium and the next. A single apical cell is present in shoot apices of bryophytes and vascular cryptogams; however, surrounding cells are also mitotically active, and these plants have multicellular apical meristems. In flowering plants, the outer layer or layers of cells (tunica) may divide predominantly by walls at right angles to the surface; the inner tissue (corpus), in less regular planes. Regions of the apical meristem may react differently to certain stains, reflecting so-called cytological zonation.

Cells in the central terminal region of the vegetative shoot apex divide less actively than those on the flanks or at the periphery, where leaf and bud primordia are formed. Various surgical experiments, involving incision of the apical meristem, have shown that new apices can be regenerated from portions of the flank. Excised apical meristems, devoid of leaf primordia, can be successfully grown on agar nutrient medium, in the presence of auxin, and will eventually yield new plants. See AUXIN; BUD; LEAF. [E.G.C.]

**Aplacophora** A class, also known as Solenogastres, of vermiform mollusks ubiquitous in the deep oceanic basins and trenches to 30,000 ft (9000 m) and common on the continental shelf and slope regions of the world, where they burrow through or creep upon the mud or wrap around alcyonarian corals. Most Aplacophora are less than 10.4 in. (10 mm) in length.

There are two distinct taxa: the subclass Chaetodermomorpha (= Caudofoveata; see illustration); and the subclass Neomeiomorpha (= Ventroplicida; Solenogastres).

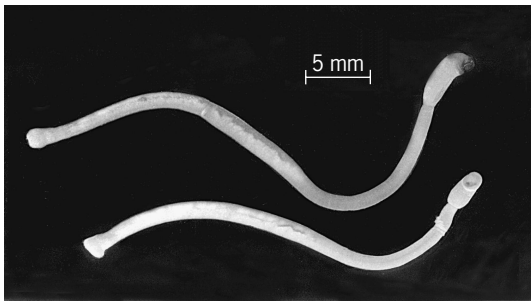

Living *Chaetoderma nitidulum*. (Courtesy of R. Robertson)

Several features are common to all Aplacophora. The ladderlike nervous system consists of paired lateral and ventral cords with many cross-commissures, a buccal ring, and cerebral and suprarectal ganglia. The coelom is restricted to coelomoducts, a spacious pericardium, and gonads that uniquely connect to the pericardium. There is a mantle cavity into which empty the anus and coelomoducts. Other molluscan characters present, but not common to all families, are a radula and its supports; paired gills in the mantle cavity; a mucus-secreting vestigial foot used in creeping; and a style sac containing a mucoid rod which turns against a chitinous gastric shield. See MOLLUSCA. [A.H.S.]

**Aplite** A fine-grained, sugary-textured rock, generally of granitic composition; also any body composed of such rock. This light-colored rock consists chiefly of quartz, microcline, or orthoclase perthite and sodic plagioclase, with small amounts of muscovite, biotite, or hornblende and traces of tourmaline, gar-

net, fluorite, and topaz. Much quartz and potash feldspar may be micrographically intergrown in cuneiform fashion. See GRANITE; IGNEOUS ROCKS.

Aplites may form dikes, veins, or stringers, generally not more than a few feet thick, with sharp or gradational walls. Some show banding parallel to their margins. Aplites usually occur within bodies of granite and more rarely in the country rock surrounding granite. They are commonly associated with pegmatites and may cut or be cut by pegmatites. See PEGMATITE. [C.A.C.]

**Apoda** The smallest order (sometimes called Gymnophiona) of the class Amphibia, known as the caecilians. These are worm-like, legless animals with indistinct or even hidden eyes. A series of annular grooves is usually present along the length of the body, heightening the resemblance to an earthworm. Most caecilians lead a burrowing existence, though members of one genus, *Typhlonectes*, are aquatic. Some species have the eyes hidden beneath the bones of the skull and probably are blind, but others at least are able to distinguish movement. A unique feature of the caecilians among modern Amphibia is the presence of scales buried in the skin of some species. There are more than 160 species of caecilians confined to tropical regions of both Eastern and Western hemispheres. Many species are less than 1 ft (0.3 m) in length, but three species of the genus *Caecilia* grow to over 3 ft (0.9 m). Some species lay eggs, while others bring forth their young alive. The embryos of the species that bear living young are nourished in the later part of their embryonic development by "uterine milk," which is secreted by the mother. In some of the species that lay eggs there is an aquatic larval stage. Caecilians are carnivorous, but little is known of their food habits. Captive specimens have fed on earthworms, and in the natural state caecilians have eaten lizards. See AMPHIBIA; ANURA; URODELA. [R.G.Z.]

**Apodiformes** An order of birds consisting of two dissimilar groups, the swifts (Apodi) and the hummingbirds (Trochili). These birds have been placed together because of several anatomical specializations of the wings and feathers. They are excellent fliers but have small, weak feet. The two groups share a unique crossover structure of a neck muscle which cannot be related to their ways of life.

The order Apodiformes is divided into the suborder Apodi, containing the families Aegialornithidae (fossils), Hemiprocnidae (crested swifts; 4 species), and Apodidae (swifts; 83 species), and the suborder Trochili, containing the single family Trochilidae (hummingbirds; 341 species).

Swifts are fast-flying, aerial birds with dull, hard plumage; long, curved, pointed wings; and a short, broad, weak bill and a wide gape, adapted to catching insects in flight. They rest by clinging to cliffs, hollow trees, and other vertical surfaces. Their nest is composed of sticks glued to these surfaces, with the extreme condition being a nest built completely of their glue-like mucus. Swifts are found worldwide except at high latitudes. True swifts never perch crosswise on branches, but crested swifts, found in tropical Asia to New Guinea, are able to perch on branches.

The hummingbirds are small, brightly colored, nectar-feeding birds, found only in the Western Hemisphere. The bill is slender and varies in length and shape, correlated closely with the shape of the flowers utilized by each species. They have a rapid wing beat and flight and are able to hover in front of a flower while feeding or even fly backward. Hummingbirds are attracted to the color red, and flowers specialized on hummingbirds for cross-pollination are red. They are among the smallest birds and include the bee hummingbird (*Mellisuga helenae*) of Cuba, the smallest of all birds. Hummingbirds can hibernate overnight to conserve energy. See AVES. [W.J.B.]

**Apophyllite** A hydrous calcium-potassium silicate containing fluorine. The composition is variable but approximates to

$KFCa_4(Si_2O_5)_4 \cdot 8H_2O$ . It resembles the zeolites, with which it is sometimes classified, but differs from most zeolites in having no aluminum. It exfoliates (swells) when heated, losing water, and is named from this characteristic; the water can be reabsorbed. It is essentially white, with a vitreous luster, but may show shades of green, yellow, or red. The symmetry is tetragonal, and the crystal structure contains sheets of linked  $SiO_4$  groups; this accounts for the perfect basal cleavage of the mineral. It occurs as a secondary mineral in cavities in basic igneous rocks, commonly in association with zeolites. The specific gravity is about 2.3–2.4, the hardness 4.5–5 on Mohs scale, the mean refractive index about 1.535, and the birefringence 0.002. See SILICATE MINERALS; ZEOLITE. [G.W.Br.]

**Aporidea** An order of tapeworms of uncertain composition and affinities, found in anseriform birds. The scolex may lack suckers and have only a simple rostellum with hooks, or it may have four large suckers and a complex glandular rostellum with small hooks. The small cylindroid body lacks segmentation, although some species have an internal serial arrangement of reproductive organs. Lack of reproductive ducts and openings to the outside prevents cross fertilization between strobilae. The life cycle is unknown. See CESTODA. [R.S.F.]

**Apostomatida** A group of ciliates comprising an order of the Holotrichia. The majority occur as commensals on marine crustaceans. Their life histories may become exceedingly complicated, and they appear to bear a direct relationship to the molting cycles of their hosts. Apostomes are particularly

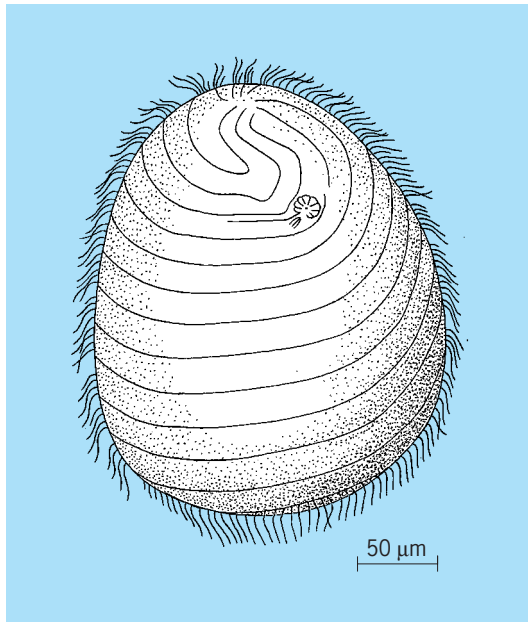

*Foettingeria*, an example of an apostomatid.

characterized by the presence of a unique rosette in the vicinity of an inconspicuous mouth opening and the possession of only a small number of ciliary rows wound around the body in a spiral fashion (see illustration). See CILIOPHORA; HOLOTRICHIA; PROTOZOA. [J.O.C.]

**Appendicitis** An inflammation of the vermiform appendix. Acute appendicitis is the most common cause of emergency abdominal surgery, occurring in 5–6% of the population of the United States. It develops when the lumen of the appendix becomes obstructed, usually by fecal material, a foreign body, or hyperplasia of lymphatic tissue that is normally present in the

wall of the appendix. The obstructed appendix becomes distended because of continued secretion of mucus by the lining cells. Typically, acute appendicitis progresses from obstruction of the lumen and distention of the appendix to spread of the inflammation beyond the appendix. Initially, there is localized peritonitis confined to the area of the appendix. If unrecognized and untreated, this may progress to an inflammatory mass or abscess, or to perforation of the appendix with resultant diffuse peritonitis, generalized toxic reaction, and even death. See APPENDIX (ANATOMY); PERITONITIS.

The usual progression of symptoms includes pain in the region around the navel; loss of appetite, nausea, and occasionally vomiting; localization of the pain to the right lower quadrant of the abdomen; and mild fever. Although the pain typically is localized in the right lower quadrant of the abdomen, there are variations because the appendix may be located in a number of other positions within the abdominal cavity. Fever is a fairly late sign, with mild elevation the rule; a high fever increases the suspicion of perforation or of some other inflammatory process. The diagnosis of appendicitis is generally made by history and physical examination, although laboratory and radiologic studies may be helpful in differentiating appendicitis from other conditions.

The treatment of acute appendicitis is prompt surgical removal of the inflamed appendix. Prior to surgery, the patient may be given intravenous fluids to correct dehydration and electrolyte imbalances. The use of antibiotics before surgery to decrease wound infection is often recommended. Antibiotics are continued after surgery in cases where the inflammation has extended beyond the appendix. Delay in removal of the appendix increases the chance of perforation. See ANTIBIOTIC; GASTROINTESTINAL TRACT DISORDERS. [A.L.I.]

**Appendicularia** A class of marine planktonic animals in the subphylum Tunicata. This class is characterized by the persistence of a tail, notochord, gill slits, and dorsal nerve cord throughout life and by a unique feeding structure, the “house.” Appendicularians are free-swimming, solitary animals that are believed to have evolved through neoteny from the tadpole larvae of a bottom-dwelling, ascidianlike, ancestral tunicate. They resemble a bent tadpole with a flat, muscular tail and a trunk containing all major organs. Included are a complex digestive system, reproductive organs, two ciliated openings of the gill slits (the spiracles) leading to a mucus-lined pharynx, a mucus-producing gland called the endostyle, and a simple circulatory system with a single, muscular heart. See NEOTENY.

Appendicularians feed primarily on small particles from 0.1 to 30 micrometers in diameter. Larger individuals may filter up to several thousand milliliters of seawater per day. As one of the few metazoan groups capable of capturing bacteria and tiny phytoplankton, appendicularians are important marine grazers which may significantly reduce phytoplankton populations in the ocean. About 13 genera and 70 species of appendicularians are known. They are found in all oceans of the world and are a common component of plankton samples, particularly in coastal waters. The most abundant genera are *Oikopleura* and *Fritillaria*. See CHORDATA; TUNICATA. [A.L.A.I.]

**Appendix (anatomy)** A narrow, elongated tube closed at one end, extending from the cecum, a blind pocket off the first part of the large intestine. It is found in only a few mammals. The size and detailed structure of the appendix vary markedly, depending on the species and the age of the individual. Most reptiles, birds, and mammals have a single or a paired cecum at the anterior end of the large intestine, but it is quite rare that this cecum has a thinner projection or true appendix.

In humans the appendix is about 3 in. (7.5 cm) long, but it varies greatly in both size and its specific location in the lower right quarter of the abdomen. The exact function of the human appendix is unknown, and it is considered to be a remnant of

a portion of the digestive tract which was once more functional and is now in the process of evolutionary regression. The appendixes presumably function in digestion in forms with larger ones. [T.S.P.]

**Apple** Apples (genus *Malus*) belong to the family Rosaceae. There are about 30 *Malus* species in the North Temperate Zone. The fruits of most species are edible. More apples are consumed than any other temperate-zone tree fruit. Apples are eaten fresh, processed into jellies or preserves, cooked in pies and pastries, or made into sauces. Apple juice is drunk fresh, or at various stages of fermentation as cider, applejack, or brandy. Apple cider vinegar is popular for use in salads and in many processed foods.

The "European" cultivated apple is now thought to have been derived principally from *M. pumila*, a Eurasian species which occurs naturally from the Balkans eastward to the Tien Shan of central Asia. In the wild, some forms of *M. pumila* approach present cultivars in size and quality. Another Asian species, *M. sylvestris*, whose range extends into western Europe, grows side by side with *M. pumila* and hybridizes with it in the Caucasus Mountains. Thus *M. sylvestris* probably also had some genetic input into the cultivated apple.

Wild apples, mainly the edible *M. baccata*, grow so thickly east of Lake Baikal in Siberia that the region is called Yablonovy Khrebet ("Apple Mountains").

The success of the Delicious and Golden Delicious cultivars may be laid to the demand for better-quality fresh fruit. Both originated on farms as chance seedlings near the end of the 19th century. In spite of the dominance of such "chance" cultivars, cultivars such as Cortland and Idared that were produced by scientific breeding have begun to achieve prominence. Most of the apple breeding programs under way earlier this century have ceased, but the few remaining ones are now introducing some exciting new cultivars. Many of the new cultivars are of excellent quality and in addition are resistant to the most damaging diseases, such as scab, rust, and fire blight. These cultivars promise to revolutionize apple growing in the future.

The apple is probably the most widely distributed fruit crop in the world, although it ranks behind grapes, bananas, and oranges in total production. There are substantial apple-growing areas on all temperate-zone continents; the United States, Italy, France, and Germany are leading producers.

Apples can be grown as far north as 60° latitude in the maritime climate of northwestern Europe. In North America, apple culture does not extend much above 50° north latitude. Away from the coasts, the buffering effects of the Great Lakes on temperature extremes facilitate heavy apple production in New York, Michigan, and Ontario. Hardier cultivars are continuing to be developed for use in colder regions. Apples can be grown in the tropics at higher elevations where sufficient chilling to break dormancy is available. Cultivars with lower chilling needs are being developed.

The principal apple-growing regions in North America are, in order of importance: the Northwest (Washington, Oregon, Idaho, and British Columbia), the Northeast (New York, New Jersey, New England, Ontario, Quebec, and Nova Scotia), the Cumberland-Shenandoah area (Pennsylvania, Maryland, Virginia, West Virginia, and North Carolina), Michigan, California, the Ohio Basin (Ohio, Indiana, and Illinois), and Colorado.

Apples may be sold fresh immediately, or after a period of storage, or they may be processed into less perishable products such as canned, frozen, or dried slices or chunks for baking, applesauce, apple juice or cider, and vinegar.

Fresh apples may be sold locally at roadside stands or at farmers' markets, or sold in wholesale quantities to supermarkets. Often, large quantities of fruit are traded by cooperatives or independent buyers for sale in distant markets. Thousands of tons of apples are shipped annually from the state of Washington to the Midwest and the East Coast. Apples can be stored for long

periods at low temperatures under controlled atmosphere (CA storage), so that fresh fruits are now available year round.

There is a large international trade in apples, particularly in Europe between the large producing countries of France and Italy and the net-importing countries of Germany, Britain, and Scandinavia, and from the United States to Canada. Apples grown in the Southern Hemisphere (Australia, New Zealand, South Africa, and Argentina) are shipped in large quantities to western Europe during the northern winter. See FRUIT, TREE; ROSALES. [H.S.A.; S.V.B.]

**Apraxia** An impairment in the performance of voluntary actions despite intact motor power and coordination, sensation and perception, and comprehension. The apraxic person knows the act to be carried out, and has the requisite sensory-motor capacities, yet performance is defective. The abnormality is highlighted when the act must be performed on demand and out of context. Defects in performance vary from total inability to initiate the action, to incorrect serial ordering of elements, to partial approximations. A common apraxic behavior is the use of a body part as an object. Pantomiming the act of brushing the teeth, for example, a person may run the index finger across the teeth as though it were a toothbrush, while in normal performance, the hand assumes the posture of holding and moving the brush.

Apraxia is usually observed in both upper extremities. When it occurs unilaterally, it is usually the left arm and hand that are affected. This has been explained by assuming that the left cerebral hemisphere is specialized in the organization of voluntary movements, just as it is in language. The left hand is under the immediate control of the right hemisphere, but for skilled voluntary actions, the right hemisphere is dependent on information transmitted from the dominant left hemisphere over the corpus callosum. Callosal lesions produce apraxia of the left hand, because the right hemisphere is incapable of organizing the plan of movement independently. With an appropriately placed left-hemisphere lesion, a bilateral apraxia will result. When the left-hemisphere lesion also destroys the primary motor zone, the right arm is paralyzed and the apraxia is masked. The observable apraxia on the left side is referred to as sympathetic apraxia. This is seen in many individuals with right hemiplegia (unilateral paralysis of the body) and Broca's aphasia. Another apraxia often coupled with Broca's aphasia is nonspeech oral apraxia (or buccofacial apraxia). Individuals with this disorder can be observed to struggle to perform such simple acts as protruding the tongue or licking the lips on command or imitation, even though these movements are executed easily as part of the act of eating. See APHASIA; HEMISPHERIC LATERALITY.

There are several disorders that are controversial with regard to their interpretation as forms of apraxia. The nonfluent speech pattern of Broca's aphasia, often riddled with speech-sound errors, is considered as apraxia of speech by some authorities, while others view it as an integral part of the linguistic deficit of the aphasia. In dressing apraxia and in some types of constructional apraxia, the defect appears to be perceptually based. Limb-kinetic apraxia is widely interpreted today as a mild spastic paresis, while ideational apraxia, commonly associated with dementia, is likely due to conceptual confusion rather than to a disturbance of motor organization. See AGNOSIA. [G.J.C.]

**Apricot** The stone fruit *Prunus armeniaca*, thought to be native to China and then distributed throughout Asia, Europe, and eventually to North and South America and Oceania. The species is genetically diverse and can grow in a wide range of climates depending upon the cultivar. Such diversity occurs in North America, where apricots are produced as far north as British Columbia, Canada, and as far south as Mexico. Most commercial production in the world is limited to areas where temperatures do not fall below -10 to -20°F (-23 to -29°C)



Castlebrite apricot branch with a fruit cluster.

for extended periods; however, certain cultivars can tolerate severer conditions. Many apricot cultivars can tolerate high summer temperatures in excess of 105°F (40°C). Some cultivars develop an internal browning of the flesh if high temperatures persist with fruit on trees. Apricots tend to bloom earlier than other stone fruit and are sensitive to frost. Frostfree areas are generally preferred.

Fruits for commerce are generally yellow to orange in skin color and flesh (Fig. 1). Apricot size ranges from small (about 25–30 g per fruit) to large (100–130 g). The fruit can be consumed fresh, dried, frozen, or processed as canned product, as juice, or as baby food (pureed). Flowers from most commercial cultivars are self-fertile, but examples of self-infertility are found in commercial cultivars. In those self-incompatible cultivars, cross-pollination with another cultivar is required. [S.M.So.]

**Apisdes** In astronomy, the two points in an elliptical orbit that are closest to, and farthest from, the primary body about which the secondary revolves. In the orbit of a planet or comet about the Sun, the apsidal points are, respectively, perihelion and aphelion. In the orbit of the Moon, the apsidal points are called perigee and apogee, while in the orbit of a satellite of Jupiter, these points are referred to as perijove and apojove. The major axis of an elliptical orbit is referred to as the line of apsidal points. See ORBITAL MOTION. [R.L.Du.]

**Apterygota** A subclass of Insecta including the wingless orders Archaeognatha (bristletails), Thysanura (silverfish), and the fossil Monura. The general body form is elongate and usually tapered toward the tail, which is provided with a segmented median caudal filament and (in living forms) paired posterolateral cerci, serving a sensory function. Organs of the head are similar to those of winged insects with mandibles, and compound eyes are present in some, but are reduced or absent in many thysanurans. Archaeognathans and most thysanurans are free living and feed on lichens, algae, or vegetable detritus; some thysanurans dwell in ant or termite nests, and a few can live in very hot, dry habitats, such as deserts or domestic heating vents. The sexes are generally similar, but the female has a recognizable ovipositor and lays eggs. Fertilization occurs indirectly, often after a courtship in which the female is guided by the male over

sperm placed on a thread or packaged in a spermatophore and picked up by the female. See COLLEMBOLA; DIPLURA; INSECTA; PTERYGOTA; THYSANURA. [W.L.Bro.]

**Aqua regia** A mixture of one part by volume of concentrated nitric acid and three parts of concentrated hydrochloric acid. Aqua regia was so named by the alchemists because of its ability to dissolve platinum and gold. Either acid alone will not dissolve these noble metals. [E.E.W.]

**Aquaculture** The cultivation of fresh-water and marine species (the latter type is often referred to as mariculture). Aquacultural ventures occur worldwide. China grows macroalgae (seaweeds) and carp. Japan cultures a wide range of marine organisms, including yellowtail, sea bream, salmonids, tuna, penaeid shrimp, oysters, scallops, abalone, and algae. Russia concentrates on the culture of fish such as sturgeon, salmon, and carp. North America grows catfish, trout, salmon, oysters, and penaeid shrimp. Europe cultures flatfish, trout, oysters, mussels, and eels. Presently, plant aquaculture is almost exclusively restricted to Japan, China, and Korea, where the national diets include substantial amounts of macroalgae.

The worldwide practice of aquaculture runs the gamut from low-technology extensive methods to highly intensive systems. At one extreme, extensive aquaculture can be little more than contained stock replenishment, using natural bodies of water such as coastal embayments, where few if any alterations of the environment are made. Such culture usually requires a low degree of management and low investment and operating costs; it generally results in low yields per unit area. At the other extreme, intensive aquaculture, animals are grown in systems such as tanks and raceways, where the support parameters are carefully controlled and dependence on the natural environment is minimal. Such systems require a high degree of management and usually involve substantial investment and operating costs, resulting in high yields per unit area.

A unique combination of highly intensive and extensive aquaculture occurs in ocean ranching, as commonly employed with anadromous fish (which return from the ocean to rivers at the time of spawning). The two most notable examples are the ranching of salmon and sturgeon. In both instances, highly sophisticated hatchery systems are used to rear young fish, which are then released to forage and grow in their natural environment. The animals are harvested upon return to their native rivers.

Intensive aquaculture brings with it high energy costs, necessitating the design of energy-efficient systems. As this trend continues, aquaculture will shift more to a year-round, mass-production industry using the least amount of land and water possible. With this change to high technology and dense culturing, considerable knowledge and manipulation of the life cycles and requirements of each species are necessary. Specifically, industrialized aquaculture has mandated the development of reproductive control, hatchery technology, feeds technology, disease control, and systems engineering.

Regardless of the type of system used, aquacultural products are marketed as are fisheries products (which are caught in the ocean), except for some advantages. For one, fisheries products often must be transported on boats and may experience spoilage; whereas cultured products, which are land-based, can be delivered fresh to the various nearby markets. Also, intensively cultured products through genetic selection can result in a more desirable food than those caught in the wild, with uniform size and improved taste resulting from controlled feeding and rearing in pollution-free water. See AGRICULTURE; MARINE FISHERIES. [W.H.C.; A.B.McG.]

**Aquarius** The Water Bearer, in astronomy, a large zodiacal constellation visible in both summer and autumn. Aquarius is the eleventh sign of the zodiac. To ancients, the constellation resembled a man pouring a stream of water from a jar. Four

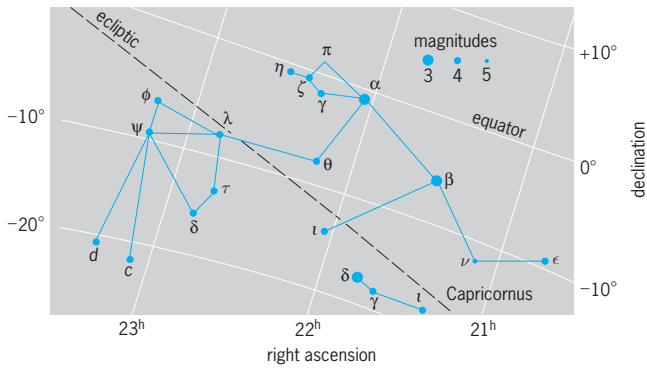

**Line pattern of the constellation Aquarius. The grid lines represent the coordinates of the sky. The apparent brightness, or magnitude, of the stars is shown by the sizes of the dots, which are graded by appropriate numbers as indicated.**

stars,  $\eta$ ,  $\zeta$ ,  $\pi$ , and  $\gamma$ , arranged like a Y, form the head of the Water Bearer (see illustration). The stream of water flows into the Fish's Mouth (Fomalhaut) in the constellation Pisces Austrinus (Southern Fish). Fomalhaut, bright and solitary in this part of the sky, is one of the relatively important navigational stars. From earliest time this constellation has been associated with water, probably because the Sun is seen in Aquarius during the rainy season of February. See CONSTELLATION. [C.-S.Y.]

**Aquifer** A subsurface zone that yields economically important amounts of water to wells. The term is synonymous with water-bearing formation. An aquifer may be porous rock, unconsolidated gravel, fractured rock, or cavernous limestone.

Aquifers are important reservoirs storing large amounts of water relatively free from evaporation loss or pollution. If the annual withdrawal from an aquifer regularly exceeds the replenishment from rainfall or seepage from streams, the water stored in the aquifer will be depleted. This mining of groundwater results in increased pumping costs and sometimes pollution from sea water or adjacent saline aquifers. Lowering the piezometric pressure in an unconsolidated artesian aquifer by overpumping may cause the aquifer and confining layers of silt or clay to be compressed under the weight of the overlying material. The resulting subsidence of the ground surface may cause structural damage to buildings, altered drainage paths, increased flooding, damage to wells, and other problems. See ARTESIAN SYSTEMS. [R.K.Li.]

**Arachnida** The largest class of the subphylum Chelicerata in the phylum Arthropoda. Most familiar of the included orders are the spiders, scorpions, harvestmen, and mites and ticks. Arachnids are mainly terrestrial and may be the oldest of the Recent terrestrial animals; scorpions are known from the Silurian (over  $4 \times 10^8$  years ago).

The arachnid body is divided into a cephalothorax (prosoma) and an abdomen (opisthosoma). The cephalothorax has six pairs of appendages: the chelicerae (jaws), a pair of pedipalps, and four pairs of walking legs. There are no antennae. The abdomen may be either segmented or unsegmented and usually lacks appendages, or the appendages may be modified into specialized structures, for example, the spinnerets of spiders.

As in other arthropods there is an exoskeleton, the outside layer of which (the epicuticle) consists mainly of lipids; it is water-repellent and prevents water loss. Respiration is by means of book lungs or tracheae or both. Arachnids have an open circulatory system. The heart lies in the anterior dorsal part of the abdomen. Blood enters the heart from the pericardial chamber through small openings (ostia). The blood is pumped into the prosoma through an anterior artery, and posteriorly through a posterior artery. It flows through vessels and chambers and

around the book lungs and then into the pericardial cavity and back to the heart.

Digestion takes place outside the body. The captured prey is held by the chelicerae while digestive enzymes are secreted over it; then the broth is sucked up. (The arachnids are predominantly predacious. The main exceptions are among the mites, where herbivores and parasites of plants and animals are common.) Excretory organs may be either thin-walled coxal glands that open to the outside on the basal segment (coxa) of each leg, or Malpighian tubules which enter the midgut.

The nervous system is concentrated in the cephalothorax except in the primitive scorpions, which have ganglia in each segment. The brain encircles the esophagus; the protocerebrum lies above the esophagus, the remainder of the brain below. Sense organs include simple eyes (ocelli), hollow hairs located at the tips of palps and legs that may be olfactory, fine hairs (trichobothria) on the appendages that are sensitive to air currents and vibrations, and membrane-covered pits in the exoskeleton called slit sense organs, that respond to tension in the exoskeleton and to some vibrations.

The genital opening and gonads are on the underside at the anterior of the abdomen. Males of many species perform an elaborate courtship. Females produce yolk-rich eggs and may provide some care to their young.

The Arachnida comprise more than 10 Recent orders: Scorpiones, Palpigradi, Schizomida, Uropygi, Amblypygi, Araneae, Solifugae (or Solpugida), Pseudoscorpionida, Opiliones, Ricinulei, and Acari. See ACARI; AMBLYPYGI; ARANEAE; ARTHROPODA; CHELICERATA; OPILIONES; PALPIGRADI; PSEUDOSCORPIONIDA; RICINULEI; SCHIZOMIDA; SCORPIONES; SOLIFUGAE; UROPYGI. [H.W.L.]

**Araeolaimida** An order of nematodes in which the amphids are simple spirals that appear as elongate loops, shepherd's crooks, question marks, or circular forms. The cephalic sensilla are often separated into three circlelets: the first two are papilliform or the second coniform, and the third is usually setiform; rarely are the second and third whorls combined. Body annulation is simple. The stoma is anteriorly funnel shaped and posteriorly tubular; rarely is it armed. Usually the esophagus ends in a bulb that may be valved. In all but a few taxa the females have paired gonads. Male preanal supplements are generally tubular, rarely papilloid.

There are three araeolaimid superfamilies: Araeolaimoidea, Axonolaimoidea, and Plectoidea. The distinguishing characteristics of the Araeolaimoidea are in the amphids (sensory receptors), stoma, and esophagus. The amphids are in the form of simple spirals, elongate loops, or hooks. Although araeolaimoids are chiefly found in the marine environment, many species have been collected from fresh water and soil.

The amphids in the Axonolaimoidea are generally prominent features of the anterior end, visible as a single-turn loop of a wide sausage shape. Feeding habits are unknown. All known species occur in marine or brackish-water environments.

Plectoidea comprise small free-living nematodes, found mainly in terrestrial habitats, frequently in moss; some are freshwater, and a few are marine. Those that inhabit moss cushions can withstand lengthy desiccation. For most, the feeding habit is unconfirmed; where it is known, they are microbivorous. Many are easily raised on agar cultures that support bacteria. See NEMATATA. [A.R.M.]

**Araeoscelida** An order of Paleozoic diapsid reptiles including the families Petrolacosauridae and Araeoscelidae. Members of these families resemble primitive modern lizards, such as the green iguana, in size and most body proportions, but are distinguished by their elongate necks and distal limb elements. *Petrolacosaurus*, from the Upper Pennsylvanian of Kansas, is the earliest known diapsid. The skull shows well-developed upper and lateral temporal openings and a sub-orbital fenestra that are characteristic of the diapsids.

The following derived features distinguish members of the Araeoscelida from other early diapsids: six to nine elongate neck vertebrae; a radius as long as the humerus and a tibia as long as the femur; expanded neural arches; posterior cervical and anterior dorsal neural spines with mamillary processes; a coracoid process; and enlarged lateral and distal pubic tubercles. In contrast to later diapsids, members of the Araeoscelida show no evidence of an impedance-matching middle ear. The stapes is massive, the quadrate is not emarginated for support of a tympanum, and there is no retroarticular process. See REPTILIA.

[R.L.C.]

**Aragonite** One of three naturally occurring mineral forms of calcium carbonate ( $\text{CaCO}_3$ ). The other forms (or polymorphs) are the abundant mineral calcite and the relatively rare mineral vaterite. Still other forms of calcium carbonate are known, but only as products of laboratory experiments. The name aragonite comes from Aragon, a province in Spain where especially fine specimens occur. See CALCITE.

Aragonite has an orthorhombic crystal structure in which layers of calcium (Ca) atoms alternate with layers of offset carbonate ( $\text{CO}_3$ ) groups. A common crystallographic feature of aragonite is twinning, in which regions of crystal are misoriented as though they were mirror images of each other. This can give rise to a pseudo-hexagonal symmetry which is readily identified in large crystals (see illustration). Aragonite crystals are usually colorless or white if seen individually; however, aggregates of small crystals may exhibit different colors. Most aragonites are nearly pure calcium carbonate; however, small amounts of strontium (Sr) and less commonly barium (Ba) and lead (Pb) may be present as impurities.

At the low temperatures and pressures found near the Earth's surface, aragonite is metastable and should invert spontaneously to calcite, which is stable at these conditions. This, in part, explains why calcite is far more abundant than aragonite. However, at low temperatures the transformation of aragonite to calcite effectively occurs only in the presence of water, and aragonite may persist for long periods of geologic time if isolated from water. Increased temperature also promotes the transformation to calcite. Despite being metastable, aragonite rather than calcite is sometimes the favored precipitate from certain solutions, such as seawater, in which magnesium (Mg) ions inhibit precipitation of calcite.

Aragonite occurs most abundantly as the hard skeletal material of certain fresh-water and marine invertebrate organisms, includ-

ing pelecypods, gastropods, and some corals. The accumulated debris from these skeletal remains can be thick and extensive, usually at the shallow sea floor, and with time may transform into limestone. Most limestones, however, contain calcite and little or no aragonite. The transformation of the aragonite to calcite is an important step in forming limestone and proceeds by the dissolution of aragonite followed by the precipitation of calcite in the presence of water. This process may take more than 100,000 years. See LIMESTONE.

Other occurrences of aragonite include cave deposits (often in unusual shapes) and weathering products of calcium-rich rocks.

[R.J.Re.]

**Arales** An order of flowering plants, division Magnoliophyta (Angiospermae), in the subclass Arcidae of the class Liliopsida (monocotyledons). It consists of two families, the Araceae, with about 1800 species, and the Lemnaceae, with only about 30.

The Araceae are herbs (seldom woody climbers) with ordinary roots, stems, and leaves (often broad and net-veined) and with the vessels confined to the roots. They have numerous tiny flowers grouped together in a small to very large spadix. They are commonest in forested tropical and subtropical regions. *Anthurium* (elephant ear), *Arisaema* (jack-in-the-pul-pit), *Dieffenbachia* (dumb cane), *Monstera*, and *Philodendron* are some well-known members of the Araceae.

The Lemnaceae, or duckweeds, are small, free-floating, thal-loid aquatics that are generally conceded to be derived from the Araceae. Their flowers, seldom seen, are much reduced and form a miniature spadix. *Pistia* (water lettuce), a free-floating aquatic (but not thalloid) aroid is seen as pointing the way toward *Spirodela*, the least reduced genus of the Lemnaceae. See ARECIDAE; LILIOPSIDA; MAGNOLIOPHYTA; PLANT KINGDOM. [A.Cr.]

**Araneae** A natural order of the class Arachnida, also called Araneida, commonly known as the spiders. These animals are widespread over most of the land areas of the world and are well adapted to many different habitats. They are known to be one of the oldest of all groups of arthropods, and their remains are known from the Devonian and Carboniferous geological deposits. Through successive geological periods spiders have become adapted to use insects as their chief source of food. On the other hand, certain insects consume the eggs of spiders, others parasitize the eggs, and still others capture adults and place them in their nests for food for their young.

Spiders have only two subdivisions of the body, the cephalothorax and the abdomen, joined by a slender pedicel. All parts of the body are covered by chitinous plates which often extend into curious outgrowths, such as spines, horns, and tubercles. Only simple paired eyes, ocelli, are present, with the number varying from eight, the most common number, to none in a few species inhabiting lightless habitats.

The first of six pairs of appendages are termed the chelicerae or jaws. The second pair of appendages is the six-segmented pedipalps, simple organs of touch and manipulation in the female, but curiously and often complexly modified in males for use in copulation. The four pairs of thoracic legs consist of seven segments each. Just in front of the genital opening in most females there is a more or less specific and often elaborately formed plate, the epigynum. This organ is of importance in the reproductive activities of the female. In most of the true spiders internal breathing tubules occur with ventral openings posterior to the genital apertures. Distinctive paired ventral spinnerets occur near the posterior end of the abdomen. In certain families a sieve-like plate lies immediately anterior to the foremost spinnerets. From this plate, the cribellum, a special kind of banded silk is extruded and used in conjunction with a comb on the fourth legs. The spinnerets and cribellum are directly associated with several types of abdominal glands and responsible for the production of the different types of silk characteristic of these animals.



**Aragonite.** Pseudo-hexagonally twinned specimen from Girgenti, Sicily. (*American Museum of Natural History specimens*)

Silk produced by spiders is a scleroprotein which is fine, light, elastic, and strong. It is used industrially only in the making of cross hairs in optical instruments. This use is diminishing as metal filaments and etched glass come into more common usage. In addition to the attractive orb webs, these animals also construct sheet webs, funnel webs, tube webs, and reticular webs. The spider's reliance upon silk extends its use to the making of egg cocoons, sperm webs by males, molting sheets, gossamer threads for ballooning, attachment disks, lining for burrows, hinges for trap doors, binding for captives, retreats, and drag lines.

No general agreement exists at present among araneologists concerning the classification and exact arrangement of the families of spiders. A. Petrunkevitch (1939) recognized 5 suborders: Liphistiomorphae containing only 2 families with a primitively segmented abdomen, and restricted to regions in the Eastern Hemisphere; Mygalomorphae with 8 families; Hypochilomorphae with a single relict family native to the southern Appalachian region; Dipneumonomorphae with 48 families; and finally the Apneumonomorphae with 3 families, which lack the book lungs and represent the most highly modified members of the order. There is now a tendency to increase the number of recognized families. See ARACHNIDA. [A.M.C.]

**Arboretum** An area set aside for the cultivation of trees and shrubs for educational and scientific purposes. An arboretum differs from a botanical garden in emphasizing woody plants, whereas a botanical garden includes investigation of the growth and development of herbaceous plants as well as trees and shrubs. The largest of the arboreta in the United States is the Arnold Arboretum of Harvard University, founded in 1872. See BOTANICAL GARDENS. [E.L.C.]

**Arboriculture** A branch of horticulture concerned with the selection, planting, and care of woody perennial plants. Knowing the potential form and size of plants is essential to effective landscape planning as well as to the care needed for plants. Arborists are concerned primarily with trees since they become large, are long-lived, and dominate landscapes both visually and functionally.

Plants can provide privacy, define space, and progressively reveal vistas; they can be used to reduce glare, direct traffic, reduce soil erosion, filter air, and attenuate noise; and they can be positioned so as to modify the intensity and direction of wind. They also influence the microclimate by evaporative cooling and interception of the Sun's rays, as well as by reflection and reradiation. Certain plants, however, can cause human irritations with their pollen, leaf pubescence, toxic sap, and strong fragrances from flowers and fruit. Additionally, trees can be dangerous and costly: branches can fall, and roots can clog sewers and break paving. See LANDSCAPE ARCHITECTURE. [R.W.Ha.]

**Arborvitae** A plant, sometimes called the tree of life, belonging to the genus *Thuja* of the order Pinales (Coniferales). It is characterized by flattened branchlets with two types of scalelike leaves. At the edges of the branchlets the leaves may be keeled or rounded; on the upper and lower surfaces they are flat, and often have resin glands. The cones, about 1/2 in. (1.25 cm) long, have the scales attached to a central axis. See PINALES; RESIN; SECRETORY STRUCTURES (PLANT).

The tree is valued both for its wood and as an ornamental. *Thuja occidentalis*, of the eastern United States, is known as the northern white cedar. It occurs in moist or swampy soil from Nova Scotia to Manitoba and in adjacent areas of the United States, and extends south in the Appalachians to North Carolina and Tennessee. Other important species include the giant arborvitae (*T. plicata*); oriental arborvitae (*T. orientalis*); and Japanese arborvitae (*T. standishii*). Among the horticultural forms are the dwarf pendulous and juvenile varieties. See FOREST AND FORESTRY; TREE. [A.H.G./K.P.D.]

**Arboviral encephalitides** A number of diseases, such as St. Louis, Japanese B, and equine encephalitis, which are caused by arthropod-borne viruses (abbreviated "arboviruses"). In their most severe human forms, the diseases invade the central nervous system and produce brain damage, with mental confusion, convulsions, and coma; death or serious aftereffects are frequent in severe cases. Inapparent infections are common.

The arbovirus "group" comprises more than 250 different viruses, many of them differing fundamentally from each other except in their ecological property of being transmitted through the bite of an arthropod. A large number of arboviruses of antigenic groups A and B are placed in the family Togaviridae, in two genera, alphavirus (serological group A) and flavivirus (serological group B). Still other arboviruses, related structurally and antigenically to one another but unrelated to Togaviridae, are included in the family Bunyaviridae, consisting chiefly of the numerous members of the Bunyamwera supergroup—a large assemblage of arboviruses in several antigenic groups which are cross-linked by subtle interrelationships between individual members. The nucleic acid genomes of all arboviruses studied thus far have been found to be RNA.

Members of serological group A include western equine encephalitis, eastern equine encephalitis, and Venezuelan equine encephalitis viruses; and Mayaro, Semliki Forest, Chikungunya, and Sindbis viruses, which have nonencephalitic syndromes. Group A viruses are chiefly mosquito-borne. Serological group B viruses include Japanese B, St. Louis, and Murray Valley encephalitis viruses (mosquito-borne), and the viruses of the Russian tick-borne complex, some of which produce encephalitis (Russian spring-summer), whereas others cause hemorrhagic fevers (Omsk, Kyasanur Forest) or other syndromes, such as louping ill. Also in group B are the nonneurotropic viruses of West Nile fever, yellow fever, dengue, and other diseases. See LOUPING ILL; YELLOW FEVER.

There is no proved specific treatment. In animals, hyperimmune serum given early may prevent death. Killed virus vaccines have been used in animals and in persons occupationally subjected to high risk. A live, attenuated vaccine against Japanese B encephalitis virus, developed in Japan, has been used experimentally with some success, not only in pigs to reduce amplification of the virus in this important vertebrate reservoir but also in limited trials in humans. In general, however, control of these diseases continues to be chiefly dependent upon elimination of the arthropod vector. See VIRUS. [J.L.Me.]

**Arc discharge** A type of electrical conduction in gases characterized by high current density and low potential drop. The electric arc was discovered by Humphry Davy in 1808, when he connected a piece of carbon to each side of an electric battery, touched the two pieces of carbon together, then drew them slightly apart. The result is a dazzling stream of ionized air, or plasma, at a temperature of 6000°C (10,800°F), the surface temperature of the Sun. A typical arc runs at a voltage drop of 100 V with a current drain of 10 A. The arc has negative resistance—the voltage drop decreases as the current increase—so a stabilizing resistor or inductor in series is required to maintain it. The high-temperature gas rises like a hot-air balloon while it remains anchored to the current-feeding electrodes at its ends. It thereby acquires an upward-curving shape, which accounts for its being called an arc.

There are many applications of such an intensely hot object. The brilliant arc and the incandescent carbon adjacent to it form the standard light source for movie theater projectors. The electronic flashgun in a camera uses an intense pulsed arc in xenon gas, simulating sunlight. Since no solid-state material can withstand this temperature for long, the arc is used industrially for welding steel and other metals. Alternatively, it can be used for cutting metal very rapidly. Electric arcs form automatically when the contacts in electrical switches in power networks are opened, and much effort goes into controlling and extinguishing them.

Lightning is an example of a naturally occurring electric arc. See ARC HEATING; ARC LAMP; ARC WELDING; CIRCUIT BREAKER; LIGHTNING; OPTICAL PROJECTION SYSTEMS; STROBOSCOPIC PHOTOGRAPHY; WELDING AND CUTTING OF MATERIALS.

The arc has been pushed to extremely high temperatures in the search for thermonuclear fusion, the record temperature being  $4 \times 10^5$  °C in a long pulse in helium. The arc temperature appears to be limited by the energy lost in intense radiation from the interface region between the intensely hot, fully ionized plasma core and the surrounding cooler, un-ionized gas. [I.A.; K.E.Lo.]

**Arc heating** The heating of matter by an electric arc. The matter may be solid, liquid, or gaseous. When the heating is direct, the material to be heated is one electrode; for indirect heating, the heat is transferred from the arc by conduction, convection, or radiation.

At atmospheric pressure, the arc behaves much like a resistor operating at temperatures of the order of thousands of kelvins. The energy source is extremely concentrated and can reach many millions of watts per cubic meter. Almost all materials can be melted quickly under these conditions, and chemical reactions can be carried out under oxidizing, neutral, or reducing conditions.

In a direct-arc furnace, the arc strikes directly between the graphite electrodes and the charge being melted. These furnaces are used in steelmaking, foundries, ferroalloy production, and some nonferrous metallurgical applications. Although an extremely large number of furnace types are available, they are all essentially the same. They consist of a containment vessel with a refractory lining, a removable roof for charging, electrodes to supply the energy for melting and reaction, openings and a mechanism for pouring the product, a power supply, and controls. The required accessory components include water-cooling circuits, gas cleaning and extraction equipment, cranes for charging the furnace, and ladles to remove the product. Because the electrodes are consumed by volatilization and reaction, a mechanism must be provided to feed them continuously through the electrode holders.

In submerged-arc furnaces, the arcs are below the solid feed and sometimes below the molten product. Submerged-arc furnaces differ from those used in steelmaking in that raw materials are fed continuously around the electrodes and the product and slag are tapped off intermittently. The furnace vessel is usually stationary. Submerged-arc furnaces are often used for carbothermic reductions (for example, to make ferroalloys), and the gases formed by the reduction reaction percolate up through the charge, preheating and sometimes prereducing it. Because of this, the energy efficiency of this type of furnace is high. The passage of the exhaust gas through the burden also filters it and thus reduces air-pollution control costs.

Although carbon arcs are plasmas, common usage of the term plasma torch suggests the injection of gas into or around the arc. This gas may be inert, neutral, oxidizing, or reducing, depending on the application and the electrodes used. Plasma torches are available at powers ranging from a few kilowatts to over 10 MW; usually they use direct-current electricity and water-cooled metallic electrodes.

Direct-current carbon arc furnaces operate on the basis that a direct-current arc is more stable than its alternating-current counterpart, and can, therefore, be run at lower current and higher voltage by increasing the arc length. This reduces both the electrode diameter and the electrode consumption compared to alternating-current operation at similar powers. Tests have also shown that injecting gas through a hole drilled through the center of the electrode further increases stability and reduces wear. Powdered ore and reductants may be injected with this gas, reducing the need for agglomerating the arc furnace feed.

In most cases, direct-current carbon arc furnaces have one carbon electrode, with the product forming the second electrode. The current is usually removed from the furnace through a

bottom constructed of electrically conducting material. Several direct-current plasma furnaces with powers ranging from 1 to 45 MW are in operation. [R.J.Mun.]

**Arc lamp** A type of electric-discharge lamp in which an electric current flows between electrodes through a gas or vapor. In most arc lamps the light results from the luminescence of the gas; however, in the carbon arc lamp the light is produced by the incandescence of one or both electrodes. The color of the arc depends upon the electrode material and the surrounding atmosphere. Most lamps have a negative resistance characteristic so that the resistance decreases after the arc has been struck. Therefore some form of current-limiting device is required in the electric circuit. For other electric-discharge lamps see VAPOR LAMP.

The carbon arc lamp was the first practical commercial electric lighting device, but the use of arc lamps at present is limited. In many of its previous functions, the carbon arc lamp has been superseded by the high-intensity mercury vapor lamp. Arc lamps are now used to obtain high brightness from a concentrated light source, where large amounts of radiant energy are needed, and where spectral distribution is an advantage. Typical uses of arc lamps are in projectors, searchlights, blueprinting, photography, therapeutics, and microscope lighting, and for special lighting in research. [J.O.K.]

**Arc welding** A welding process utilizing the concentrated heat of an electric arc to join metal by fusion of the parent metal and the addition of metal to the joint usually provided by a consumable electrode (see illustration). Electric current for the welding arc may be either direct or alternating, depending upon the material to be welded and the characteristics of the electrode used. The current source may be a rotating generator, rectifier, or transformer and must have transient and static volt-ampere characteristics designed for arc stability and weld performance.

There are three basic welding methods: manual, semiautomatic, and automatic. Manual welding is the oldest method, and though its proportion of the total welding market diminishes yearly, it is still the most common. Here an operator takes an electrode, clamped in a hand-held electrode holder, and manually guides the electrode along the joint as the weld is made. Usually the electrode is consumable; as the tip is consumed, the operator manually adjusts the position of the electrode to maintain a constant arc length.

Semiautomatic welding is becoming the most popular welding method. The electrode is usually a long length of small-diameter bare wire, usually in coil form, which the welding operator manually positions and advances along the weld joint. The consumable electrode is normally motor-driven at a preselected speed through the nozzle of a hand-held welding gun or torch.

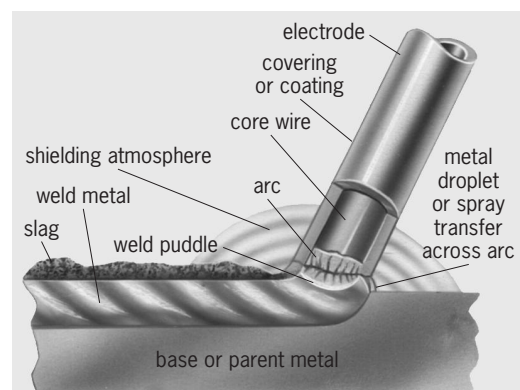

**Metallic welding arc.**



Automatic welding is very similar to semiautomatic welding, except that the electrode is automatically positioned and advanced along the prescribed weld joint. Either the work may advance below the welding head or the mechanized head may move along the weld joint.

There are, in addition to the three basic welding methods, many welding processes which may be common to one or more of these methods. A few of the more common are described below.

Carbon-electrode arc welding is in limited use for welding ferrous and nonferrous metals. Normally, the arc is held between the carbon electrode and the work. The carbon arc serves as a source of intense heat and simply fuses the base materials together, or filler material may be added from a separate source.

Shielded metal arc welding is the most widely used arc-welding process. A coated stick electrode is consumed during the welding operation, and therefore provides its own filler metal. The electrode coating burns in the intense heat of the arc and forms a blanket of gas and slag that completely shields the arc and weld puddle from the atmosphere. Its use is generally confined to the manual welding method.

Submerged-melt arc welding uses a consumable bare metal wire as the electrode, and a granular fusible flux over the work completely submerges the arc. This process is particularly adapted to welding heavy work in the flat position. High-quality welds are produced at greater speed with this method because as much as five times greater current density is used. Automatic or semiautomatic wire feed and control equipment is normally used for this process.

Tungsten-inert gas welding, often referred to as TIG welding, utilizes a virtually nonconsumable electrode made of tungsten. Impurities, such as thorium, are often purposely added to the tungsten electrode to improve its emissivity for direct-current welding. The necessary arc shielding is provided by a continuous stream of chemically inert gas, such as argon, helium, or argon-helium mixtures, which flows axially along the tungsten electrode that is mounted in a special welding torch. This process is used most often when welding aluminum and some of the more exotic space-age materials. When filler metal is desired, a separate filler rod is fed into the arc stream either manually or mechanically. Since no flux is required, the weld joint is clean and free of voids.

Metal-inert gas welding, often referred to as MIG welding, saw its greatest growth in the 1960s. It is similar to the TIG welding process, except that a consumable metal electrode, usually wire in spool form, replaces the nonconsumable tungsten electrode. This process is adaptable to either the semiautomatic or the automatic method. In addition to the inert gases, carbon dioxide has become increasingly common as a shielding means. [E.F.S.]

**Arcellinida** An order of Lobosia. The shell (test) of these protozoa has a single, well-defined aperture through which slender fingerlike pseudopodia (lobopodia) can be extended. The test often has an internal chitinous layer known as a glyco-calyx and an external layer composed of secreted siliceous elements, organic hollow platelets, or collected sand grains and other matter cemented together by an adhesive secretion. Most arcellinidans are uninucleate, but *Arcella* is binucleate. Food consists of bacteria and smaller protists. The order includes *Arcella*, *Centropyxis*, *Cochliopodium*, *Diffflugia*, and many other genera. See LOBOSIA; PROTOZOA; SARCODINA; SARCOMASTIGOPHORA. [O.R.A.]

**Arch** A structure, usually curved, that when subjected to vertical loads causes its two end supports to develop reactions with inwardly directed horizontal components. The designations of the various parts of an arch are given in the illustration. The commonest uses for an arch are as a bridge, supporting a road-

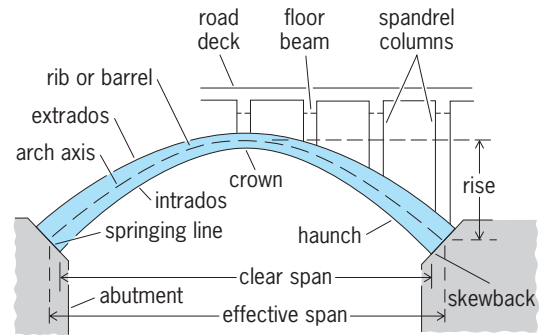

An open-spandrel, concrete, fixed-arch bridge.

way, railroad track, or footpath, and as part of a building, where it provides a large open space unobstructed by columns. Arches are usually built of steel, reinforced concrete, or timber.

On the basis of structural behavior, arches are classified as fixed (hingeless), single-hinged, two-hinged, or three-hinged. An arch is considered to be fixed when rotation is prevented at its supports. Reinforced concrete ribs are almost always fixed. For long-span steel structures only fixed solid-rib arches are used. Because of its greater stiffness, the fixed arch is better suited for long spans than hinged arches.

Concrete is relatively weak in tension and shear but strong in compression and is therefore ideal for arch construction. Precast reinforced concrete arches of the three-hinged type have been used in buildings for spans up to 160 ft (49 m).

Steel arches are solid-rib or braced-rib arches. Solid-rib arches usually have two hinges but may be hingeless. The braced-rib arch has a system of diagonal bracing replacing the solid web of the solid-rib arch. The world's longest arch spans are two-hinged arches of the braced-rib type. The spandrel-braced arch is essentially a deck truss with a curved lower chord, the truss being capable of developing horizontal thrust at each support. This type of arch is generally constructed with two or three hinges because of the difficulty of adequately anchoring the skewbacks.

Wood arches may be of the solid-rib or braced-rib type. Solid-rib arches are of laminated construction and can be shaped to almost any required form. Arches are usually built up of nominal 1- or 2-in. (2.5- or 5-cm) material because bending on individual laminations is more readily accomplished. Because of ease in fabrication and erection, most solid-rib arches are of the three-hinged type. This type has been used for spans of more than 200 ft (60 m). The lamella arch has been widely used to provide wide clear spans for gymnasiums and auditoriums. The wood lamella arch is more widely used than its counterpart in steel. The characteristic diamond pattern of lamella construction provides a unique and pleasing appearance. See BRIDGE; BUILDINGS; TRUSS. [C.N.G.]

The masonry arch can provide structure and beauty, is fire-proof, requires comparatively little maintenance, and has a high tolerance for foundation settlement and movement due to other environmental factors. Most arches are curved, but many hectares (acres) of floor in highrise office and public buildings are supported by hollow-tile jack (flat) arches. If a curved arch is wide (dimension normal to span), the arch is referred to as a barrel arch or vault. The vault cross section may have several different shapes. Contiguous vaults may be individual, may intersect, or may cross. A four-part vault is termed quadripartite. Contiguous quadripartite vaults that are supported at the corners by columns are masonry skeletons of large cathedrals.

Stone for masonry skeletons is cut from three classes of rock; igneous (granite, traprock), metamorphic (gneiss, slate, quartzite), and sedimentary (limestone, sandstone). The primary requirements for brick as a structural material are compressive strength and weathering resistance. Hollow clay tiles (terra-cotta)

for floor arches are made semiporous in order to improve fire resistance. See BRICK; METAMORPHIC ROCKS; SEDIMENTARY ROCKS.

[C.Bi.]

**Archaeobacteria** A group of prokaryotic organisms that are more closely related to eukaryotes than bacteria. Based on comparative analyses of small subunit ribosomal ribonucleic acid (rRNA) sequences and selected protein sequences, the three primary lines of descent from the common ancestor are the Archaea (archaeobacteria), the Bacteria, and the Eucarya (eukaryotes). Although the Archaea look like Bacteria cytologically (they are both prokaryotes), they are not closely related to them.

The Archaea can be divided into two evolutionary lineages on the basis of rRNA sequence comparisons, the Crenarchaeotae and the Euryarchaeotae. The crenarchaeotes are organisms that grow at high temperatures (thermophiles) and metabolize elemental sulfur. Most are strict anaerobes that reduce sulfur to hydrogen sulfide (sulfidogens), but a few can grow aerobically and oxidize sulfur to sulfuric acid. The euryarchaeotes have a number of different phenotypes. *Thermococcus* and *Pyrococcus* are sulfidogens like many crenarchaeotes. *Archaeoglobus* reduces sulfate to sulfide. *Thermoplasma* grows under acidic conditions aerobically or anaerobically (as a sulfidogen). Many euryarchaeotes are methane-producing anaerobes (methanogens) and some grow aerobically in the presence of very high concentrations of salt (halophiles). See METHANOGENESIS (BACTERIA).

The thermophilic archaea are found in high-temperature environments around the world. They have been isolated from soils and shallow marine sediments heated by nearby volcanoes and from deep-sea hydrothermal vents. Some are used as a source for heat-stable enzymes useful for industrial applications. The methanogenic archaea inhabit the digestive tracts of animals (especially ruminants like cows), sewage sludge digesters, swamps (where they produce marsh gas), and sediments of marine and fresh-water environments. They are of interest commercially because of their ability to produce methane from municipal garbage and some industrial wastes. Halophilic archaea live in the Great Salt Lake, the Dead Sea, alkaline salt lakes of Africa, and salt-preserved fish and animal hides. They are also commonly found in pools used to evaporate seawater to obtain salt.

The discovery of the Archaea caused a major revision in the understanding of evolutionary history. It had previously been thought that all prokaryotes belonged to one evolutionary lineage. Since their cellular organization is simpler, prokaryotes were assumed to be ancestors of eukaryotes. The discovery of the relationship of the Archaea to the Eucarya revealed that prokaryotes do not comprise a monophyletic group since they can be divided into two distinct lineages. Although the three descended from a common ancestor, modern eukaryotes may have arisen from fusions of bacterial and archaeal endosymbionts with ancestral eukaryotes. Chloroplasts and mitochondria arose from free-living bacteria which became endosymbionts. The discovery of the Archaea has also given microbiologists a better picture of the common ancestor. The deepest-branching eukaryotes (like *Giardia*) are strict anaerobes that lack mitochondria, and they diverged much later than the deepest-branching bacteria and archaea. The earliest archaea and bacteria (*Thermotoga* and *Aquifex*) are also anaerobes and are also extreme thermophiles. Therefore the common ancestor of these groups was probably also an extremely thermophilic anaerobe. Therefore, it is possible that life may have arisen in a relatively hot environment, perhaps like that found in deep-sea hydrothermal vents. See BACTERIA; EUKARYOTAE; PROKARYOTAE. [K.M.N.]

**Archaeocyatha** An extinct group of mainly Lower Cambrian marine sponges which, although lacking spicules, possessed an intricate, highly porous skeleton of calcite. It was probably a monophyletic group; that is, all representatives were derived from a single ancestor. The position of the Archaeocyatha within the Porifera is uncertain, but they were probably most

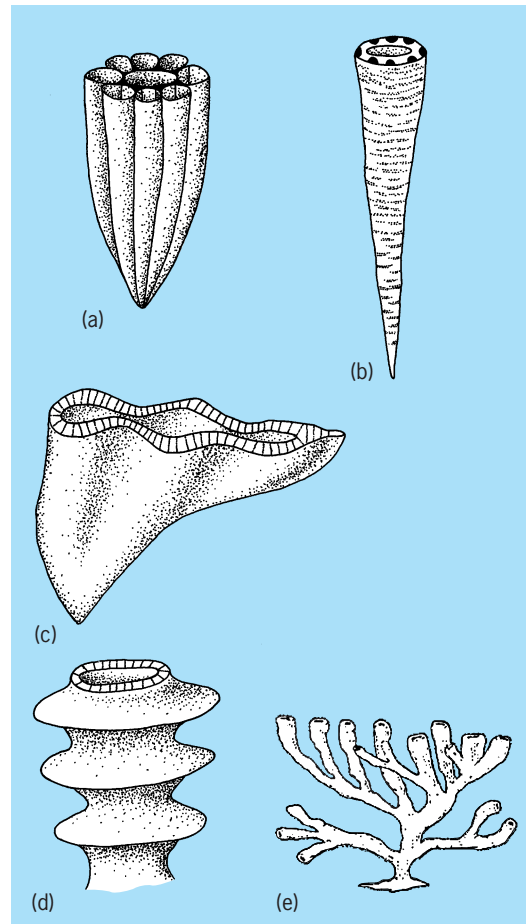

Some growth forms in the Archaeocyatha: (a) ribbed; (b) tubular conical; (c) asymmetric, conical; (d) annulated; (e) branching.

closely related to the class Demospongiae. Their fossil record is well known, as archaeocyaths represent the first large skeletal animals to have been associated with reefs; they were widespread in the shallow, warm waters that surrounded the many continents that occupied tropical latitudes during the Cambrian.

Archaeocyath sponges displayed a great variety of sizes and growth forms. They ranged from a few millimeters to over 500 mm in length and width, and included open cups, convoluted plates, and complex branching forms (see illustration). Archaeocyatha has been traditionally subdivided into two subclasses, the Regulars and Irregulars, according to differences in the early development of the skeleton. It has now been demonstrated, however, that these skeletal characters are a function of differences in soft-tissue distribution, which are independent of systematic placing. Regulars (orders Monocyathida, Ajacicyathida, Coscniocyathida, and Tabulacyathida) generally show no tabulae or dissepiments, and they are inferred to have had intervalla that were completely filled with soft tissue. By contrast, the skeletons of Irregulars (orders Archaeocyathida and Kazachstanicyathida) are believed to have borne soft tissue in their upper parts only, as they possessed abundant structures such as tabulae which served to section off abandoned areas of the skeleton as the soft tissue migrated upward. See PARAZOA; PORIFERA. [R.Wo.]

**Archaeognatha** An order of ancestrally wingless insects, commonly known as bristletails, in the subclass Apterygota; about 350 species are known in two families, Machilidae and Meinertellidae. All have slender, spindle-shaped bodies of about 0.4–0.8 in. (1–2 cm) in length, tapered tail-ward to a long,

multisegmented median caudal filament and paired cerci. The relatively thin integument is covered with pigmented scales after the first instar. The antennae are long and filiform, without intrinsic musculature in the flagellum, as in all true insects; and large, contiguous compound eyes are accompanied by a trio of ocelli. The mandibles are exposed and attached to the cranium by a single joint (condyle), and the maxillary palpi are extended, with seven segments, while the labial palpi have only three segments. Each leg has a large coxa, two-segmented trochanter, femur, tibia, and a two- or three-segmented tarsus terminating in a two-clawed pretarsus. The posterior pair or two pairs of coxae and most of the ventral abdominal coxites bear styles, which may represent modified legs. Outwardly projecting vesicles that are apparently water absorbing also occur on most coxites. Internally, the gut is relatively simple, with small crop, digestive ceca, and a dozen or more Malpighian tubules. The nervous system is primitive, with three thoracic and eight abdominal ganglia and twin connectives. Tracheae are well developed.

In mating, the male deposits sperm on a thread or in a spermatophore that is picked up by the female, but in at least one species sperm is placed directly on the female ovipositor. Immature forms are similar to adults in body form, though the first instar may lack cerci. Sexual maturity is attained after eight or more molts.

Bristletails live in a variety of habitats worldwide, often on stones or tree trunks where they find the algae and lichens that appear to be their principal sources of food. Most species are primarily nocturnal feeders. See **APTERYGOTA**. [W.L.Br.]

**Archaeopteridales** An order of extinct, free-sporing plants (cryptogams) that lived during the Late Devonian through Early Mississippian. The order includes the genera *Archaeopteris* which has been extensively investigated, *Actinoxylon*, *Actinopodium*, *Svalbardia*, *Eddyia*, and *Siderella*. *Archaeopteris* had a worldwide distribution on what today are Northern Hemisphere continents, as well as on Australia. The genus is characterized by an arborescent habit and large, determinate, deciduous, frondlike lateral branch systems that bear simple, oval to fan-shaped leaves, with dichotomous venation, which vary in different species from highly dissected to nearly entire. Archaeopteridales belongs to the class Progymnospermopsida. The progymnosperms are thought by some botanists to be ancestral to seed plants. See **PLANT KINGDOM**. [C.B.B.]

**Archaeornithes** One of the two subclasses of birds, the ancient birds, containing the single order Archaeopterygiformes, the most primitive taxon of birds. This taxon was established for the seven specimens (one feather impression and six skeletons) of the oldest known fossil bird, *Archaeopteryx lithographica* from the Late Jurassic limestones of Bavaria. All other fossil and living birds are placed in the second subclass, the Neornithes or modern birds.

*Archaeopteryx* is an outstanding example of an intermediate form demonstrating the pattern of mosaic evolution. It is pigeon-sized with a long feathered tail, a pair of feathers attached to each tail vertebra, and a fully feathered wing. The feathers are completely modern avian feathers. The skull has reptilian jaws with small sharp teeth; cranial kinesis is very similar to that of modern birds. The brain and eyes are somewhat larger than those features in most reptiles. The forelimb is modified to a wing, but with the three clawed fingers still unfused. The pectoral girdle is weak and reptilian except for the presence of a stout furcula (wishbone). A bony, keeled sternum is lacking, but ventral ribs (gastralia) exist. The body is moderately long and flexible. The sacrum is small, and the bones of the pelvic girdle are not fused strongly together. The pubis is not fully reversed. The bones of the tarsometatarsus are not fused together. The long tail is formed of a number of individual vertebrae.

*Archaeopteryx* probably was aboreal for part of its life, going into trees for hiding, sleeping, and nesting. It could descend to the

ground with a controlled glide and most likely foraged for food on the ground. There is no evidence that *Archaeopteryx* had the ability of powered flight or that flight in birds evolved to enable the bird to fly up from the ground. All evidence suggests that active, powered flight in birds evolved from the gliding stage and was to permit the animal to reach the ground from an elevated position in trees. *Archaeopteryx* climbed up tree trunks by using the sharp claws on its hands and feet to grip the tree. It is most likely that *Archaeopteryx* was an obligatory homoiotherm with feathers covering its body to reduce heat loss.

*Archaeopteryx* has many similarities with small carnivorous dinosaurs, and many workers have argued that birds evolved from this group of dinosaurs. See **AVES**; **DINOSAUR**; **NEORNITHES**; **REPTILIA**. [W.J.B.]

**Archaic ungulate** The most diverse group of early Tertiary mammals are the archaic ungulates (condylarths). Although closely related, they are not a monophyletic group but, along with various extinct and extant mammals, form the taxon Ungulata. They are ancestral to as many as 7 of 18 living orders of mammals: Artiodactyla, Cetacea, Hyracoidea, Perissodactyla, Proboscidea, Sirenia, and possibly Tubulidentata. Along with the Late Cretaceous zhelestids, best known from Asia, Ungulata forms the taxon Ungulatomorpha. Fossil (and molecular) evidence suggests that Ungulatomorpha separated from other placentals 85 million years ago. Early ungulatomorphs had lower-crowned, more squared molars compared to contemporary placentals, which have a more slicing dentition, indicating a trend toward omnivory and herbivory. Although "ungulate" implies hooves, most archaic ungulates had at best rudimentary hooves or even claws. See **ARTIODACTYLA**; **CETACEA**; **HYRACOIDEA**; **PERISSODACTYLA**; **PROBOSCIDEA**; **SIRENIA**; **TUBULIDENTATA**. [J.D.Ar.]

**Archean** A period of geologic time from about 3.8 to 2.5 billion years ago (Ga). During the Archean Eon a large percentage of the Earth's continental crust formed, plate tectonics began, very warm climates and oceans existed, and life appeared on Earth in the form of unicellular organisms.

PRECAMBRIAN	1	PROTEROZOIC (ALGONKIAN)	LATE
	2		MIDDLE
	3	ARCHEAN (ARCHEOZOIC)	EARLY
	4		

The occurrence of rock assemblages typical of arcs, oceanic plateaus, and oceanic islands and the presence of accretionary orogens in the very earliest vestiges of the geologic record at 4–3.5 Ga strongly supports some sort of plate tectonics operating on the Earth by this time. By 3 Ga, cratons, passive margins, and continental rifts were also widespread. Although plate tectonics appears to have occurred since 4 Ga, there are geochemical differences between Archean and younger rocks that indicate that Archean tectonic regimes must have differed in some respects from modern ones. The degree that Archean plate tectonics differed from modern plate tectonics is unknown; however, these differences are important in terms of the evolution of the Earth. See **PLATE TECTONICS**.

The oldest rocks occur as small, highly deformed terranes tectonically incorporated within Archean crustal provinces. Although the oldest known igneous rocks on Earth are the 4 Ga Acasta gneisses of northwest Canada, the oldest minerals are detrital zircons (zircons in sediments) from the 3 Ga Mount Narryer quartzites in western Australia.

The oldest isotopically dated rocks on Earth are the Acasta gneisses, which are a heterogeneous assemblage of highly deformed granitic rocks, tectonically interleaved with mafic and ultramafic rocks, and metasediments. Uranium-lead zircon ages

from the granitic components of these gneisses range from 4 to 3.6 Ga, and thus it would appear that this early crustal segment evolved over about 400 million years and developed a full range in composition of igneous rocks. The chemical compositions of Acasta mafic rocks are very much like less deformed Archean greenstones representing various oceanic tectonic settings. See DATING METHODS; ROCK AGE DETERMINATION.

The largest and best-preserved fragment of early Archean continental crust is the Itsaq Gneiss Complex in southwest Greenland. In this area, three terranes, each with its own tectonic and magmatic history, collided about 2.7 Ga, forming the continental nucleus of Greenland. Although any single terrane records less than 500 million years of precollisional history, collectively the terranes record over 1 billion years of history before their amalgamation.

The Archean is known for its reserves of iron, copper, zinc, nickel, and gold. Some of the world's largest copper-zinc deposits occur as massive sulfide beds associated with submarine volcanics in Archean greenstones in Canada and western Australia.

The Earth's first atmosphere was probably composed chiefly of gases such as helium and hydrogen inherited from the solar nebula from which the solar system formed, as well as from the asteroidlike bodies that collided to form Earth. As Earth heated up from core formation, it released gases and formed a secondary atmosphere composed chiefly of CO<sub>2</sub>, methane (CH<sub>4</sub>), nitrogen (N<sub>2</sub>), and water (H<sub>2</sub>O). In support of this view, the surviving rock record includes carbonates that reflect a carbon dioxide-rich atmosphere; and also one or more greenhouse gases (carbon dioxide, methane) must have been present to prevent the surface of the Earth from freezing over.

There are three lines of evidence for life in the Archean: (1) fossil stromatolites, which are laminated structures deposited by microorganisms; (2) fossils of cells or cellular tissue; and (3) carbonaceous matter identifiable from its carbon isotopic composition as a product of biologic activity. Some of the oldest fossil stromatolites occur in the 3.5 Ga Barberton greenstone in southern Africa and in the 3.5 Ga Pilbara greenstone in western Australia. [K.C.C.]

**Archeoastronomy** The interdisciplinary study that attempts to determine how much astronomy prehistoric people knew and how it influenced their lives. It involves multiple disciplines: astronomy to chart the heavens, archeology to probe the cultural context, engineering to survey sites, and ethnology to provide clues to the cultural past. Archeoastronomy has prompted valuable insights into the astronomy of the past, even to revolutionizing some models of prehistoric cultures. It has been suggested that archeoastronomy and its loose family of disciplines should be subsumed under a broader study, cultural astronomy. The reason to do cultural astronomy is that the sky can perform a special role in the scheme of cultural systems. The sky then serves as a cultural resource of many uses. The cultural context is the key to understanding the findings of archeoastronomers. Finding astronomical orientations at sites is easy; interpreting these as intentional alignments is hard. It is necessary to consider what their purpose might be (to keep a seasonal calendar? to regulate sacred time? both or neither?). The great danger is the imposition of modern astronomy and culture upon an alien culture of the past. See ARCHEOASTRONOMY; ASTRONOMY.

Every prehistoric culture appears to have developed its own astronomy. The traditional navigators of Oceania needed to memorize guide stars and to employ them as the bearing markers for island-to-island travel over thousands of kilometers of water. The Carib people of northern South America developed a calendar that relied on the positions of stars relative to each other and to the Sun at times of rising and setting. A bone from the shores of Lake Edward, Zaire and Uganda, may have markings of a lunar calendar, tallied at a time over 8000 years ago, perhaps used to forecast marine activity or the weather; a focus on the

Moon continues in Africa today. Chinese astronomical records cut into bones and shells may have begun as early as the twelfth century B.C., well before the Babylonians incised their earliest records on clay.

By the time the Spanish invaded Mesoamerica and South America, the use of astronomy went well beyond complex systems of cycles and calendars. For instance, in some Mayan cities knowledge of the cycles of Venus timed the onset of warfare. In others, key political events incorporated the summer solstice and perhaps conjunctions of Jupiter and Saturn. Ancient Inca city planning and politics embodied astronomy, such as the ceque system of radial lines from the Temple of the Sun in the valley of Cuzco. These lines mark the directions to sacred places as well as to specific astronomical phenomena. The ceque system had a calendric manifestation in knotted cords that tallied the days of the agricultural year. [M.Ze.]

**Archeological chemistry** The application of chemical techniques to the study of archeological finds, natural or anthropogenic, in order to ascertain their composition or age. Traditional chemical analysis uses wet methods, in which a sample is brought into solution and its components are assayed by precipitation or titration. These methods were applied to ancient coins as early as the late eighteenth century. The obvious need to minimize damage to an irreplaceable object spurred the development of microchemical techniques. Modern analysis relies on instrumental methods that require only very small samples or are entirely nondestructive. Although these methods rely on physical phenomena rather than chemical transformation, all procedures that are capable of the qualitative and quantitative determination of the atomic or molecular composition of the object under study are usually included under the broad heading of archeological chemistry.

Various analytical methods are utilized in archeological chemistry, including optical emission spectrography, atomic absorption spectroscopy, inductively coupled plasma, neutron activation analysis, x-ray fluorescence spectrometry, electron microprobe analysis, proton-induced x-ray emission, Auger electron spectroscopy, and x-ray photoelectron spectroscopy. It should be noted that these methods of analysis are not competing but complementary. The choice of method depends on the nature of the object, on the elements to be determined, and on the accuracy required. See ACTIVATION ANALYSIS; ATOMIC SPECTROMETRY; AUGER EFFECT; PROTON-INDUCED X-RAY EMISSION (PIXE); RADIOISOTOPE; X-RAY FLUORESCENCE ANALYSIS.

Organic materials constitute only a small portion of archeological finds, but since they include such basic necessities as food, drink, and clothing, they have the potential of revealing much about past life. Because they consist of covalently bound, complex, and sensitive molecules, their study requires special methods of analysis. Organic archeometry is the newest and most rapidly expanding field of archeological chemistry. Organic dyes have long been determined qualitatively and quantitatively by absorption spectroscopy in the visible and ultraviolet ranges. The extension into the infrared range allows not only the identification of organic materials by visual or computer-aided comparison of infrared spectra ("fingerprinting") but also some structural interpretation. Since organic residues typically consist of mixtures of dozens or even hundreds of individual compounds, the progress of organic archeometry has crucially depended on the development of chromatographic separation procedures. These include column chromatography, paper and thin-layer chromatography, gas chromatography, with or without prior pyrolysis, and liquid chromatography. All of these techniques not only separate mixtures into individual components but permit their identification if the rate at which they travel through the chromatographic substrate, the retention time, can be matched to those of authentic reference compounds.

Another method that is gaining use in organic archeometry is nuclear magnetic resonance spectrometry (NMR), which detects

a limited number of atomic nuclei, among them ordinary hydrogen, carbon-13, nitrogen-15, fluorine-19, and phosphorus-31, by their simultaneous interaction with an external magnetic field and a radio-frequency field. See GAS CHROMATOGRAPHY; INFRARED SPECTROSCOPY; MASS SPECTROMETRY; NUCLEAR MAGNETIC RESONANCE (NMR); SPECTROSCOPY.

The determination of the chemical composition of an archeological find is not an end in itself, but provides the archeologist with factual evidence not otherwise obtainable and touching on many aspects of early human life. The changing elemental composition of coins detects progressive debasement and reveals economic history and fiscal policy. The metals added to copper to make bronze and brass outline the history and spread of technology. The foodstuffs consumed are indicators of the advent and progress of agriculture and animal husbandry. Together, all these paint a picture of prehistoric social, cultural, and economic stratification. The composition of an object also offers clues to its geographic origin, which may be far from the excavation site. This provides evidence of trade and exchange in commodities and raw materials. See PREHISTORIC TECHNOLOGY.

While the most widely used methods for dating archeological material—radioactive decay, thermoluminescence, and archeomagnetism—deal with physical processes, three depend on the progress of conventional chemical reactions. (1) Amino acid dating uses the rate of racemization of optically active organic molecules. (2) Hydration dating measures the thickness of the weathering layer produced by the action of water on natural and artificial glass, including obsidian and flint. (3) NFU dating of bone relies on the loss of nitrogen (N) from the organic collagen component and on the uptake of fluorine (F) and uranium (U) by the inorganic hydroxyapatite component. Like all nonnuclear chemical reactions, these changes are a function not only of time but also of temperature, of acidity and, in the case of fluorine and uranium uptake, of the concentrations of these elements in the surrounding soil. Chemical methods cannot produce absolute dates unless these other variables are known or can be estimated reasonably closely. They are, however, useful in establishing relative ages of finds within a single site in which the depositional characteristics are likely to have been uniform. See AMINO ACID DATING; ARCHEOLOGICAL CHRONOLOGY; CHEMICAL MICROSCOPY; DATING METHODS; PALEOMAGNETISM; RACEMIZATION; RADIOCARBON DATING; THERMOLUMINESCENCE. [C.W.Be.]

**Archeological chronology** The establishment of the temporal sequence of human cultures. Prior to the discovery of nuclear and chemical dating methods, which provide an absolute time scale, archeologists used stratigraphy, lithic and ceramic typology, seriation, index fossils, and a limited range of chemical techniques to establish relative chronologies for cultural remains. The major chemical techniques used in dating of bones in relative sequence have been labeled F-U-N (for fluorine-uranium-nitrogen). In a single site or environment, bones of the same age usually absorb the same amount of fluorine and uranium while losing the same amount of nitrogen.

Since the mid-twentieth century numerous absolute (sometimes called chronometric) dating techniques have been devised by natural scientists. Some of these techniques can give results in calendar years, whereas others yield dates which are expressed in years but which cannot always be correlated precisely with the calendar. The major methods for absolute dating of archeological materials used include radiocarbon dating, dendrochronology, thermoluminescence dating, hydration dating, racemization, potassium-argon dating, lead-210 dating, and archeomagnetism. Many other techniques, for example, fission track dating, have been used to establish archeological chronology, and a host of physical and, to a lesser degree, chemical dating methods have been investigated. See DATING METHODS; DENDROCHRONOLOGY; FISSION TRACK DATING; PALEOMAGNETISM; RACEMIZATION; RADIOCARBON DATING; ROCK AGE DETERMINATION; THERMOLUMINESCENCE. [G.R.]

**Archeology** The scientific study of past material culture. The initial objective of archeology is to construct cultural chronologies, attempting to order past material culture into meaningful temporal segments. The intermediate objective is to breathe life into these chronologies by reconstructing past lifeways. The ultimate objective of contemporary archeology is to determine the cultural processes that underlie human behavior, both past and present.

The material culture of the past is of infinite variety. The scientific study of this evidence is such a broad task that there is no such thing as any single archeological method, although over the past century archeologists have evolved what can be termed an overall archeological approach. By constant confirmation, the archeologist often attempts to establish synchronism with what has already been established historically.

Archeologists use a number of types in order to categorize similar artifacts. Most common is the temporal type, a principle similar to the index fossil concept used by the geologist. A temporal type can be any kind of archeological artifact or feature, but ideally it is some object of common use in which the form is subject to change, due to either the whim of fashion or technological improvement. One example is the simple flint arrowhead with side barbs and central tang. It is typical of the British Bronze Age and was not in fashion earlier or later. Ceramic types have been established by archeologists working around the world, and a thoroughly tested ceramic chronology is invaluable as a temporal ordering device, no matter where the archeologist is working. The nature of the artifact employed as a temporal type is irrelevant, and its use may not even be known. Archeologists also establish other kinds of types. Functional types attempt to group artifacts on the basis of known or presumed functions. Technological types, divisions which reflect the mode of manufacture, are particularly helpful when studying stone tool manufacture.

The concept of culture is used in two different ways by contemporary archeologists. When dealing with cultural chronologies, the archeologist most commonly uses a modal or shared view of culture. It is this normative collection of shared ideas which causes artifacts to change in systematic ways through time, and temporal types can be established on the basis of this shared culture. When attempting to reconstruct lifeways, however, the archeologist can no longer rely on the shared aspects of culture. When transcending temporal associations, contemporary archeologists tend to view culture systematically, as people's extrasomatic (that is, learned) method of dealing with the social and cultural environment.

The principles of stratigraphy are applied to archeology in terms of the law of superposition, which states that, all else being equal, older deposits will tend to be buried beneath younger ones. Mere stratigraphic equivalence, however, does not necessarily indicate contemporaneity, as there can be misleading mixtures of successive occupational debris on one surface. Archeologists must therefore study the processes of cultural deposition in order to recognize the difference between intact and disturbed strata.

Contemporary excavation must be conducted with a plan, a firm research design that attempts to provide answers to definite questions. Archeology is one of the few sciences which destroys its own data in the process of generating them. Archeologists must therefore be extremely careful to make the appropriate observations at the time of excavation.

The task of deciphering meaning from past material culture is so complex that the archeologist is often required to borrow from allied disciplines in the physical and natural sciences, including geology, climatology, paleobotany, paleontology, mineralogy, physics, chemistry, and anthropology. The archeologist must have some understanding of all these sciences to extract from sites and materials every possible piece of information which may lead to a better understanding of prehistory. The archeologist must be able to record and publish every minor fact for the benefit of colleagues and successors, because the writing

of prehistory requires the synthesis of all archeological discovery and interpretation. See ARCHEOLOGICAL CHEMISTRY; PHYSICAL ANTHROPOLOGY. [D.H.Th.]

**Archiacanthocephala** An order of the phylum Acanthocephala. The adult worms are parasitic in terrestrial vertebrates. Some common archiacanthocephalans are *Oncicola canis*, *Moniliformis moniliformis*, and *Macracanthorhynchus hirudinaceus*.

*Oncicola canis* is a short plump acanthocephalan, primarily parasitic in dogs and other Canidae. It occurs also in cats. The body of the adult, 0.24–0.56 in. (6–14 mm) long, is short and heavy with irregular cross furrows. The globular proboscis has six spiral rows of six hooks each. The arthropod intermediate host is unknown. Cystacanths have been found in armadillos and in the esophageal walls of turkeys, which indicates a transport host in the life cycle.

*Moniliformis moniliformis* is an elongate acanthocephalan which is parasitic in house rats. The females are 4–12 in. (10–30 cm) long, whereas the males measure 2.4–5.2 in. (6–13 cm). The body of both sexes exhibits conspicuous pseudosegmentation except on the extremities. The proboscis is cylindrical with 12–15 rows of 10 or 11 hooks each. Cockroaches (*Periplaneta americana*) serve as the intermediate host; however, in Europe a beetle, *Blaps mucronata*, is the intermediate host. Occasionally infections have been found in humans.

*Macracanthorhynchus hirudinaceus* is the giant thornheaded worm of hogs and is probably the best known of all acanthocephalans because of its cosmopolitan distribution. Females measure 10–24 in. (25–60 cm) in length and the males 2–4 in. (5–10 cm). The worms are pinkish with a transversely wrinkled body which tapers from a rather broad anterior end to a slender posterior end. The proboscis is globular with six spiral rows of six hooks each. At least 25 species of scarabaeid beetle larvae have been reported as intermediate hosts. In addition to their occurrence in the domestic pig, adults have been reported to occur in squirrels, chipmunks, moles, and occasionally humans. This acanthocephalan is of considerable economic importance to the hog-raising industry. See ACANTHOCEPHALA. [D.V.Mo.]

**Archiannelida** A name applied to a small group of unrelated annelids, probably not primitive as the name implies. Some resemble existing families of polychaetes (see illustration). Most live in marine or brackish water and occur in intertidal and estuarine habitats. They are characterized by their vermiform body and small sizes. Lengths range from less than 0.04 in. (1 mm) to 0.4 in. (10 mm), rarely to 4 in. (100 mm). The number of segments varies from five to many, or segmentation is obscure. Parapodia with setae may be altogether lacking, and the epithelium may be ciliated. Cephalic and anal structures may be modified as holdfast organs to maintain existence in turbulent, intertidal zones and shifting sands. See POLYCHAETA.

Three families with about 82 species in 15 genera are recognized. The Nerillidae have well-developed parapodia and setae; they are known for 20 species in 7 genera, all but one limited to Europe and western Africa; *Nerilla* is worldwide. The Pro-

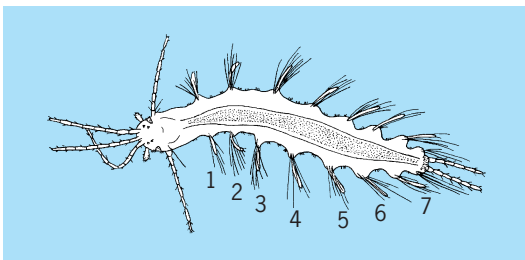

*Nerilla antennata* (Nerillidae) with segments 1 to 7. (After Schlieper, Zool. Anz. Leipzig, 62:233, 1925)

todrilidae are known through 47 species in 5 genera; the best known are *Polygordius*, *Protodrilus*, and *Saccocirrus*, which are recorded from cosmopolitan areas. The Dinophilidae are known through 17 species in 3 genera, of which the best known is *Dinophilus*, with 6 or 7 species. See ANNELIDA. [O.H.]

**Archidiidae** A subclass of the plant class Bryopsida (mosses). The Archidiidae consists of a single genus, *Archidium*, with 26 species, occurring in ephemeral habitats, especially in wet, grassy places. The small gametophytes consist of erect, simple or forked stems, and elongate, singly co-stale leaves in numerous rows. The capsules, usually terminal, are globose, immersed, and irregularly rupturing. The capsule wall consists of a single layer of cells; stomata, peristome, and columella are lacking. The spores are few, large (50–310 micrometers), and thick-walled. The calyptra is scarcely differentiated. See BRYIDAE; BRYOPHYTA; BRYOPSIDA; BUXBAUMIIDAE; DAWSONIIDAE; POLYTRICHIDAE; TETRAPHIDIDAE. [H.Cr.]

**Archigregarinida** An order of the protozoan subclass Gregarina, class Telosporae, subphylum Sporozoa. All gregarines are parasites of the digestive tract and body cavity of invertebrates or lower chordates; their large, mature trophozoites (vegetative stages) live outside the host's cells. The Archigregarinida are primitive gregarines and live in marine worms (annelids and lower chordates—enteropneustids, sipunculids, and ascidians). Their life cycle includes sexual and asexual phases and involves three periods of schizogony (multiple fission). There are only 28 named species in five genera. The most important genus is *Selenidium*, which has 24 species. Its members occur in the intestine of marine polychaete annelids, sipunculids, enteropneustids, and ascidians. See GREGARINIA; PROTOZOA; SPOROZOA; TELOSPOREA. [N.D.L.]

**Archimedes' principle** The principle that the net fluid force on a body submerged (or floating) in a stationary fluid is an upward force equal to the weight of the fluid displaced by the body. This concept, perhaps the oldest stated principle in fluid mechanics, was first put forth by Archimedes in the third century B.C.

In a static fluid, the weight of the fluid causes an increase in pressure with depth. Thus, at the surface of the fluid, the pressure is atmospheric pressure ( $p_0 = 14.7 \text{ lb/in.}^2 = 101 \text{ kilonewtons/m}^2$ ), while at a depth  $h$  the pressure has a larger value of  $p_1$ , given by Eq. (1), where  $\gamma$  is the specific weight

$$p_1 = p_0 + \gamma h \quad (1)$$

of the fluid (weight/volume). The difference in pressure force between the bottom and the top of a water column is therefore given by Eq. (2), where  $h'$  and  $A$  are the height and area

$$(p_b - p_t)A = \gamma h' A \quad (2)$$

of the column, and  $p_b$  and  $p_t$  are the pressures at the bottom and top of the column. This difference is precisely equal to the weight  $W$  of the water within the column, given by Eq. (3). If

$$W = \gamma(\text{volume}) = \gamma h' A \quad (3)$$

the water column were replaced with a solid object, the pressure forces on the object would be the same as on the original water column. That is, the net hydrostatic pressure force on the object, termed the buoyant force, would be equal to the weight of the water displaced (which is the statement of Archimedes' principle). The same concept holds for a body of arbitrary shape, which can be thought of as consisting of many small vertical columns fastened together. Archimedes' principle is valid for submerged or floating bodies in liquids or gases. See BUOYANCY; SPECIFIC GRAVITY. [B.R.M.]

**Architectural acoustics** The science of sound as it pertains to buildings. There are three major branches of architectural acoustics. (1) Room acoustics involves the design of the

interior of buildings to project properly diffused sound at appropriate levels and with appropriate esthetic qualities for music and adequate intelligibility for speech. (2) Noise control or noise management involves the reduction and control of noise between a potentially disturbing sound source and a listener. (3) Sound reinforcement and enhancement systems use electronic equipment to improve the quality of sounds heard in rooms.

**Room acoustics.** One essential component of room acoustics is an understanding of psychoacoustics and the qualitative evaluation of sounds heard by people in rooms. Psychoacoustics is the study of the psychology of sounds. It includes studies conducted in laboratories and in actual listening rooms of how people react to the level, frequency content, direction, and arrival time of sounds. These studies have established a set of relationships among the acoustical qualities that have been found to be important in the perception of sound, the room surfaces that contribute to these qualities, and the physical components of the sound field in a room that contribute to these properties. See PSYCHOACOUSTICS.

Several important design concepts are used to provide good listening conditions in rooms for speech and music. First is to provide good access to the direct sound for all people in the room. This usually involves raising the source of sound on an elevated stage, altar, or podium at the front of the room and sloping the floor surface to elevate the ears of people above the heads of those seated in front of them. The width and depth of the room should also be limited so that the natural direct sound can project from the speaker or instruments at the front of the room to the listeners. Second is to limit the background noise level in the room so that people can hear the sound they want to hear above the level of the ambient sound. Third is to limit the reverberation time in the room so that sounds are heard clearly and fully, while providing enough reverberant sound energy that sounds are heard as “full” and “live.” If there is too much reverberation in a room, the persistence of an initial syllable will cover up or mask the one that follows it, making it difficult to understand what is being said.

**Noise control.** Acoustical planning concepts for buildings include placing noisy activities away from activities that require relative quiet and locating noise-sensitive activities away from major sources of noise. Buffer spaces such as corridors or storage spaces are often used to separate two rooms that require acoustical privacy such as music rehearsal rooms in a school. Intruding noises from the exterior or from adjoining rooms can be reduced by using walls, ceilings, windows, and doors with appropriate transmission losses. A compound or double wall assembly can be used to reach a relatively high transmission loss with low mass per unit wall area. The separation between the two leaves or surfaces of the wall must be maintained as completely as possible for this to occur.

It is essential to control noise from building services. The location of air-conditioning plants on a site should be chosen so as to reduce propagation of noise to neighbors. Mechanical rooms in buildings that house air handling units, pumps, and other equipment should be located away from noise-sensitive rooms. Noise control treatments in the air-conditioning system include providing vibration isolators for equipment; providing flexible connections between ducts, conduits, and pipes to equipment; designing air ducts to operate with air velocities that will not create turbulent flow noise; and installing silencers or attenuators in the ducts to reduce noise produced by fans from traveling through the duct work. See MECHANICAL VIBRATION; VIBRATION ISOLATION.

**Sound reinforcement.** Sound reinforcement systems, electronic enhancement systems, and sound amplification systems are used in many buildings. A sound reinforcement system amplifies the natural acoustic sounds in a room that is too large for people to hear with just “natural” room acoustics. This type of system reinforces the natural sounds that come from the room, increasing their apparent loudness with a series of loudspeakers.

In an electronic enhancement system, loudspeakers act as virtual room surfaces to create the perception that sounds are reflected from these surfaces at the proper times and with the proper loudness. These systems usually have a network of loudspeakers located throughout a room and connected to a microprocessor. The microprocessor can delay the signals to arrive at times corresponding to reflected sounds from the virtual room surfaces. It can also add reverberation and other special acoustic effects to create a virtual acoustic space.

A sound amplification system makes all sounds played in a space louder. It is usually not designed to supplement the natural room acoustics or to provide subtle virtual room effects to the amplified sounds. [G.W.Sie.]

**Architectural engineering** A discipline that deals with the technological aspects of buildings, including the properties and behavior of building materials and components, foundation design, structural analysis and design, environmental system analysis and design, construction management, and building operation. Environmental systems, which may account for 45–70% of a building’s cost, include heating, ventilating and air conditioning, illumination, building power systems, plumbing and piping, storm drainage, building communications, acoustics, vertical and horizontal transportation, fire protection, alternate energy sources, heat recovery, and energy conservation. In addition, to help protect the public from unnecessary risk, architectural engineers must be familiar with the various building codes, plumbing, electrical, and mechanical codes, and the Life Safety Code. The latter code is similar to a building code and is designed to require planning and construction techniques in buildings which will minimize possible hazards to the occupants. See ELECTRICAL CODES; FIRE TECHNOLOGY.

Architectural engineering differs from other engineering disciplines in two important aspects. Most engineers work with other engineers, while most architectural engineers work or consult with architects. Furthermore, an architectural engineer not only must be fully qualified in engineering, but must also be thoroughly versed in all architectural considerations involved in design and construction. An architectural engineer designing a structural or environmental system is expected to be familiar not only with that system, but also with the multitude of architectural considerations which may affect its design, installation, and operation. See BUILDINGS; ENGINEERING. [T.S.D.]

**Archosauria** A subclass of reptiles more easily defined by listing its five component orders, four of them extinct, than by its anatomical characters. The earliest, most primitive archosaurs were the Thecodontia, from which arose independently the Saurischia (“lizard-hipped” dinosaurs), the Omithischia (“bird-hipped” dinosaurs), the Pterosauria (flying reptiles, including the pterodactyls), and the Crocodilia (including the living crocodiles,

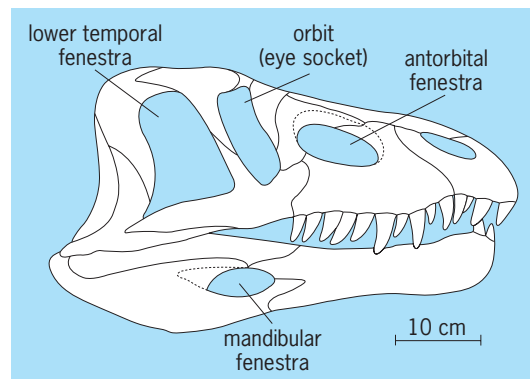

Skull of *Chasmatosaurus*, a primitive archosaur (order Thecodontia), from the Early Triassic of South Africa. (After Broili and Schroeder)

alligators, caimans, and gavials). See CROCODYLIA; ORNITHISCHIA; PTEROSAURIA; SAURISCHIA.

Many Archosauria are certainly bipeds. They have two pairs of openings (fenestrae) in the temporal region of the skull (diapsid condition) and never lose the bony arcades around those openings. Typically there are also one or more antorbital openings in front of the orbit, a character which is virtually confined to this subclass (see illustration).

The earliest archosaurs are Lower Triassic, with a single species in the uppermost Permian. The Archosauria were undoubtedly a highly successful group, with locomotor systems, sense organs, and probably physiological adaptations far superior to those of any other reptiles. See REPTILIA. [A.J.C.]

**Arctic and subarctic islands** Defined primarily by climatic rather than latitudinal criteria, arctic islands are those in the Northern Hemisphere where the mean temperature of the warmest month does not exceed 50°F (10°C) and that of the coldest is not above 32°F (0°C). Subarctic islands are those in the Northern Hemisphere where the mean temperature of the warmest month is over 50°F (10°C) for less than 4 months and that of the coldest is less than 32°F (0°C). Such islands generally are in high latitudes. Distribution of land and sea masses, ocean currents, and atmospheric circulation greatly modifies the effect of latitude so that it is often misleading to use location relative to the Arctic Circle as a significant criterion of arctic or subarctic. The largest proportion by area of the islands lies in the Western Hemisphere, primarily in Greenland and in the Canadian Arctic Archipelago. Within this general description, individual islands vary considerably (see table).

Physiographically, the islands include all the varied major landforms found elsewhere in the world, from rugged mountains over 8000 ft (2500 m) high, through plateaus and hills, to level plains only recently emerged from the sea. All have been glaciated except Sakhalin and some of the islands in the Bering Sea sector. Removal of the weight of ice sheets and the resultant crustal rebound has exposed prominent marine beaches and wave-cut cliffs on many of the islands. These now commonly occur at elevations of over 300 ft (150 m) above sea level.

The general climatic pattern of these islands is set by their location relative to the two semipermanent centers of low pressure over the Aleutian Islands and over Iceland. Most of the precipitation is cyclonic in origin. Because they are marine areas, the islands receive more precipitation than they otherwise would, yet even so this is very light for most of the arctic islands removed from the zone of cyclonic activity. Also, because they are marine areas, the islands, regions of low temperatures by definition, are not regions of extreme low temperatures. In general, the larger the island and the closer its proximity to a continental landmass, the higher are the summer temperatures and the lower its winter temperature. See POLAR METEOROLOGY.

The climatic differences between arctic and subarctic islands are reflected in their natural vegetation. The arctic islands are treeless. Natural vegetation consists of the tundra—mosses, sedges, lichens, grasses, and creeping shrubs. Bare ground is often exposed and in some places plant growth may be lacking completely except for a few rock-encrusting lichens. In such places the ground surface may consist of frost-shattered rock fragments, tidal mud flats, boulder-strewn fell fields, or snow patches and ice. Permafrost (permanently frozen ground) occurs throughout the Arctic (and in parts of the subarctic) and is reflected in impeded drainage and patterned ground. See PERMAFROST; TUNDRA.

The natural vegetation of subarctic islands characteristically is the boreal forest or taiga, composed predominantly of conifers such as spruce, fir, pine, and larch with deciduous trees such as birch, aspen, and willow; the latter are especially common in regrowth of clearings in the forest. Impeded drainage because of permafrost or glaciation gives rise to numerous ponds and muskeg areas. A transitional type of vegetation, the forest-tundra,

Size of larger arctic and subarctic islands\*

Name	Area	
	mi <sup>2</sup>	km <sup>2</sup>
Aleutian Is.		
Unimak I.	15,500	40,100
Unalaska I.	10,800	28,000
St. Lawrence I.	18,200	47,100
Nunivak I.	16,000	41,400
Kodiak I.	37,400	96,900
Canadian Arctic Archipelago	500,000	1,295,000
Baffin I.	196,000	507,000
Ellesmere I.	76,000	197,000
Victoria	84,000	217,000
Banks	27,000	70,000
Devon	21,000	55,000
Axel Heiberg	17,000	43,000
Melville	16,000	42,000
Southampton	16,000	42,000
Prince of Wales	13,000	33,033
Newfoundland	42,734	109,000
Greenland	840,000	2,176,000
Iceland	39,961	102,000
Svalbard (archipelago)	24,100	62,000
Vest-Spitsbergen	15,250	39,000
Franz Josef Land (archipelago)	7,000	18,000
Novaya Zemlya (archipelago)	36,000	93,000
Severnaya I.	21,000	54,000
Yughny I.	15,000	39,000
Severnaya Zemlya (archipelago)	14,000	36,000
New Siberian Is.	12,000	31,000
Wrangel I.	2,000	5,000
Sakhalin I.	27,000	70,000
Kuriloe Is.	6,000	16,000

\*Approximate only in some cases because of incomplete mapping.

is recognized on some subarctic islands in sectors where smaller trees are widely spaced and abundant mosses cover the ground. See MUSKEG; TAIGA.

The typical soils of the subarctic islands are podzols—the grayish-white surface soil beneath the raw humus layer and highly acidic in nature. The tundra soils of the arctic islands really consist only of a dark-brown peaty surface layer over poorly defined thin horizons, and much of the ground cannot properly be termed soil. [W.C.Wo.]

**Arctic Circle** The parallel of latitude approximately 66<sup>1</sup>/<sub>2</sub>° (66.55°) north of the Equator, or 23<sup>1</sup>/<sub>2</sub>° from the North Pole. The Arctic Circle has the same angular distance from the Equator as the inclination of the Earth's axis from the plane of the ecliptic. Thus, when the Earth in its orbit is at the Northern Hemisphere summer solstice, June 21, and the North Pole is tilted 23<sup>1</sup>/<sub>2</sub>° toward the Sun, the Sun's rays extend beyond the pole 23<sup>1</sup>/<sub>2</sub>° to the Arctic Circle, giving that parallel 24 h of sunlight. On this same date the Sun's rays at noon will just reach the horizon at the Antarctic Circle, 66<sup>1</sup>/<sub>2</sub>° south. The highest altitude of the noon Sun at the Arctic Circle is on June 21, when it is 47° above the horizon.

At the Arctic Circle the Sun remains above the horizon continuously only 24 h at the longest period. However, with twilight considered, it remains daylight or twilight continuously for about 5 months. Twilight can be considered to last until the Sun drops 18° below the horizon. See MATHEMATICAL GEOGRAPHY; SOLSTICE.

[V.H.E.]

**Arctic Ocean** The north polar ocean lying between North America and Asia, extending over about 386,000 mi<sup>2</sup> (10<sup>6</sup> km<sup>2</sup>). It is nearly completely covered by 6–9 ft (2–3 m) of ice in winter, and in summer it becomes substantially open only at its peripheries. Its extent has been variably defined, but it is



oceanographically appropriate to consider it bounded on the south by a line running from northern Greenland through Smith, Jones, and Lancaster sounds, along northwestern Baffin Island to the Canadian mainland, thence to the Alaskan coast, across Bering Strait, along the Siberian coast to Novaya Zemlya, across to Franz Josef Land and Spitsbergen, and over to northern Greenland. This definition omits the Barents, Norwegian, and Greenland seas and Baffin Bay, which have a pronounced North Atlantic character.

The central polar basin, somewhat triangular in shape, is surrounded by continental shelves which are interrupted only by the deep passage running through Fram Strait. The upper 650 ft (200 m) of the Arctic Ocean, referred to as Surface Water or Arctic Water, is characterized by a significant density stratification produced by the strong increase in salinity downward from the surface. This density stratification is of considerable importance, for it prevents a deep-reaching convection from developing within the Arctic Ocean and also prevents the heat of the underlying warm Atlantic Water from reaching the surface. The relatively low salinity at the surface is maintained against the upward diffusion of salt by the addition of fresh water, principally through river outflow. The upper 100–160 ft (30–50 m) of Surface Water tends to be relatively uniform vertically in temperature and salinity. Except for areas which become ice-free in summer, the water will be near the freezing point. Currents in the upper waters tend to be relatively slow (4 in./s or 10 cm/s or less), and they are similar in both speed and direction to the ice motion. The overall circulation in the upper waters has its ultimate cause in the prevailing wind pattern over the Arctic Ocean.

As in other oceans, the current at any instant can vary greatly from the mean condition. The most spectacular example observed in the Arctic Ocean occurs on an occasional basis in the Canadian Basin, consisting of a high-speed current core. See OCEAN CIRCULATION; SEAWATER.

Below the Surface Water, the temperature increases to a maximum, which over most of the region is about 33°F (0.5°C) and lies between 1000 and 1500 ft (300 and 500 m). The salinity is nearly uniform, and since at low temperatures the density of seawater depends almost solely on salinity, there is virtually no density stratification beneath the upper waters. Significant deviations from the stated temperature occur only in the southern Eurasian Basin closest to Spitsbergen, for it is there that the warm and saline water (called Atlantic Water) which maintains the temperature maximum throughout the Arctic Ocean first enters. This water has its origin in the North Atlantic. Once into the Arctic Ocean it sinks because of its high salinity and moves eastward along the Eurasian continental slope. Beneath the Atlantic Water lies cold, nearly uniform Bottom Water. These two water masses together constitute over 90% of the volume of the Arctic Ocean. The Bottom Water is formed in the Greenland Sea. [K.A.]

**Arcturus** The brightest star in the northern sky, apparent magnitude  $-0.10$ , also known as  $\alpha$  Boötis. It is a yellow giant star of spectral type K2, one of the nearest giants to the Earth at a distance of 11.3 parsecs ( $2.15 \times 10^{14}$  mi or  $3.47 \times 10^{14}$  km). Unlike the Sun, which is currently converting hydrogen into helium in its core, Arcturus has already exhausted its central hydrogen and has evolved away from the main sequence. It is approximately 25 times larger in diameter than the Sun, and more than 100 times more luminous. Its effective temperature is estimated to be 7700°F (4300 K). See SPECTRAL TYPE; STELLAR EVOLUTION.

Arcturus has a large space motion relative to the Sun, and it is a member of the high-velocity group of stars known as population II, associated with the halo of the Milky Way Galaxy. The pattern of chemical abundances is also quite typical of population II. See STELLAR POPULATION.

Precise measurements have revealed small variations in the radial velocity of Arcturus with a period close to 2 days, which are believed to be due to pulsation. Variations with much longer periods of 1 or 2 years have also been reported. Similar variations have also been found in other giant stars. See STAR. [D.W.L.]

**Area** The superficial contents of a geometrical figure of two dimensions. The area of any rectangle or square is the product of two adjacent sides, one of which may be called the base and the other the altitude. In general, any line segment that partially

#### Area formulas

Figure	Formula
Triangle	$\frac{hb}{2}$ , where $h$ = altitude, $b$ = base; $\frac{\sqrt{s(s-a)(s-b)(s-c)}}{4}$ , where $s = \frac{1}{2}(a+b+c)$ , and $a$ , $b$ , and $c$ are sides of the triangle
Rectangle	$ab$ , where $a$ and $b$ are adjacent sides
Square	$a^2$ , where $a$ = side
Parallelogram	$ab \sin \theta$ , where $a$ and $b$ are adjacent sides, and $\theta$ is the angle between the sides
Trapezoid	$\frac{1}{2}(a+b)h$ , where $a$ and $b$ are the parallel sides, and $h$ is the altitude
Quadrilateral	$\frac{1}{2}ab \sin \theta$ , where $a$ and $b$ are the diagonals, and $\theta$ is the angle between them
Regular polygon	$\frac{1}{4}n^2 l^2 \cot \frac{180^\circ}{n}$ , where $n$ is the number of sides, each of length $l$
Circle	$\pi r^2$ , where $r$ = radius
Ellipse	$\pi ab$ , where $a$ and $b$ are semiaxes
Sphere	$4\pi r^2$ , where $r$ = radius
Spherical triangle	$(A+B+C-\pi)r^2$ , where $A$ , $B$ , and $C$ are angles (radians), and $r$ is the radius

bounds a plane geometric figure may be called a base if its line does not separate the figure, and a perpendicular drawn to the base line from one of its points at greatest distance may be called the altitude. Some area formulas are given in the table. See EUCLIDEAN GEOMETRY. [J.S.F.]

**Arecales** An order of flowering plants, division Magnoliophyta (Angiospermae), of the subclass Arecidae in the class Liliopsida (monocotyledons). The name of the subclass is derived from the ordinal name. The order consists of the single family Arecaceae (Palmae), the palms, with more than 200 genera and nearly 3000 species, largely confined to tropical and subtropical regions. The order Arecales has also been called Palmales or Principes. Most palms are trees with an unbranched trunk and a terminal crown of large leaves. The plicate structure of all palm leaves relates to a complex ontogeny shared only by some of the Cyclanthaceae (Cyclanthales), in which new tissue continues to develop along the folds after the flanking tissues have matured. See ARECIDAE; CARNAUBA WAX; COCONUT; CYCLANTHALES; DATE; LILIOPSIDA; MAGNOLIOPHYTA; PLANT KINGDOM; VEGETABLE IVORY. [A.Cr.; T.M.Ba.]

**Arecidae** A subclass of the class Liliopsida (monocotyledons) of the division Magnoliophyta (Angiospermae), the flowering plants, consisting of four orders (Arecales, Cyclanthales, Pandanales, and Arales), five families, and nearly 6000 species. Except for the highly reduced family Lemnaceae (Arales), they have an inflorescence of usually numerous, small flowers, generally subtended by a prominent spathe and often aggregated into a spadix. Except in the Araceae (Arales), the endosperm seldom contains much starch. More than 80% of the species have broad, petiolate leaves that do not have the typical parallel venation commonly associated with monocotyledons, and more than half of the species are arborescent (likewise an unusual character among the monocotyledons). See ARALES; ARECALES; CYCLANTHALES; LILIOPSIDA; MAGNOLIOPHYTA; PANDANALES; PLANT KINGDOM. [A.Cr.; T.M.Ba.]

**Arenaceous rocks** The arenaceous rocks (arenites) include all those classic rocks whose particle sizes range from 0.8 to 0.0025 in. (2 to 1/16 mm), or if silt is included, to 1/256 mm. Some arenites are composed primarily of carbonate particles, in which case they are called calcarenites and grouped with the limestones. Some oolitic iron ores and glauconite beds are properly classified as arenites. But the vast majority of arenites are commonly called sandstones, and the two words are almost synonymous. See GRAYWACKE; OOLITE; SANDSTONE; SEDIMENTARY ROCKS. [R.S.]

**Argillaceous rocks** The argillaceous rocks (lutites) include shales, argillites, siltstones, and mudstones; they are clastic sediments whose constituent particles are less than 0.0025 in. or 1/16 mm (if siltstones are included) or less than 0.00015 in. or 1/256 mm (if siltstones are excluded). They are the most abundant sedimentary rock type, varying according to different estimates from 44 to 56% of the total sedimentary rock column. Claystone is indurated clay, which consists dominantly of fine material of which at least a major proportion is clay mineral (hydrous aluminum silicates). Shale is a laminated or fissile claystone or siltstone, in general more consolidated than claystone. Mudstone is a claystone that is blocky and massive. The term argillite is used for rocks which are more indurated than claystone or shale but not metamorphosed to slate. All these argillaceous rocks are consolidated equivalents of muds, oozes, silts, and clays. Loess is a finegrained, unconsolidated, wind-blown deposit. The term shale has been used by many authors generically to denote all of these types of rock. See BENTONITE; CLAY; CLAY MINERALS; LOESS; SEDIMENTARY ROCKS; SHALE. [R.S.]

**Argon** A chemical element, Ar, atomic number 18, and atomic weight 39.948. Argon is the third member of group 0 in the periodic table. The gaseous elements in this group are called the noble, inert, or rare gases, although argon is not actually rare. The Earth's atmosphere is the only natural argon source; however, traces of this gas are found in minerals and meteorites. Argon constitutes 0.934% by volume of the Earth's atmosphere. Of this argon, 99.6% is the argon-40 isotope; the remainder is argon-36 and argon-38. There is good evidence that all the argon-40 in the air was produced by the radioactive decay of the radioisotope potassium-40. See INERT GASES; PERIODIC TABLE.

Argon is colorless, odorless, and tasteless. The element is a gas under ordinary conditions, but it can be liquefied and solidified readily. Some salient properties of the gas are listed in the table. Argon does not form any chemical compounds in the ordinary sense of the word, although it does form some weakly bonded clathrate compounds with water, hydroquinone, and phenol. There is one atom in each molecule of gaseous argon.

The oldest large-scale use for argon is in filling electric light bulbs. Welding and cutting metal consumes the largest amount of argon. Metallurgical processing constitutes the most rapidly growing application. Argon and argon-krypton mixtures are used, along with a little mercury vapor, to fill fluorescent lamps. Argon mixed with a little neon is used to fill luminous electric-discharge tubes employed in advertising signs (similar to neon signs) when a blue or green color is desired instead of the red color of neon. Argon is also used in gas-filled thyatron, Geiger-Müller radiation counters, ionization chambers which measure cosmic radiation, and electron tubes of various kinds. Argon atmospheres are used in dry boxes during manipulation of very reactive chemicals in the laboratory and in sealed-package shipments of such materials.

Most argon is produced in air-separation plants. Air is liquefied and subjected to fractional distillation. Because the boiling point of argon is between that of nitrogen and oxygen, an argon-rich mixture can be taken from a tray near the center of the upper distillation column. The argon-rich mixture is further dis-

#### Properties of argon

Property	Value
Atomic number	18
Atomic weight (atmospheric argon)	39.948
Melting point (triple point), °C	-189.4
Boiling point at 1 atm pressure, °C	-185.9
Gas density at 0°C and 1 atm (101.325 kPa) pressure, g/liter	1.7840
Liquid density at normal boiling point, g/ml	1.3998
Solubility in water at 20°C, ml argon (STP) per 1000 g water at 1 atm (101.325 kPa) partial pressure of argon	33.6

tilled and then warmed and catalytically burned with hydrogen to remove oxygen. A final distillation removes hydrogen and nitrogen, yielding a very high-purity argon containing only a few parts per million of impurities. [A.W.F.]

**Arhynchobdellae** An order of the class Hirudinea (the leeches) which do not have an eversible proboscis, but frequently have three jaws armed with sharp teeth. The blood of these annelids contains hemoglobin. They may be divided into the Gnathobdellae, with jaws, and the Pharyngobdellae, without jaws.



*Erpobdella punctata*.

Gnathobdellae have bodies which are oval in cross section and have a conspicuous posterior sucker. The anterior sucker does not project beyond the sides of the body but forms a deep cup on the underside of the head in which the jaws can work to make their incision in the host. This group contains most of the important bloodsucking leech parasites of humans and other warm-blooded animals. The land leeches are members of this group. They occur in great numbers on vegetation in swamp and jungle areas and attach themselves to passing warm-blooded animals.

Pharyngobdellae are specialized for carnivorous diets, and in many cases have completely lost the jaws. They have a strong muscular pharynx which extends nearly half the length of the body. *Erpobdella* (see illustration) is common in lakes and streams in the Northern Hemisphere, while *Trocheta* tends to leave the water and forage in moist soil. See HIRUDINEA; RHYNCHOBDELLAE. [K.H.M.]

**Aries** The Ram, in astronomy, a zodiacal and autumnal constellation (see illustration). Among the 12 zodiacal constellations,

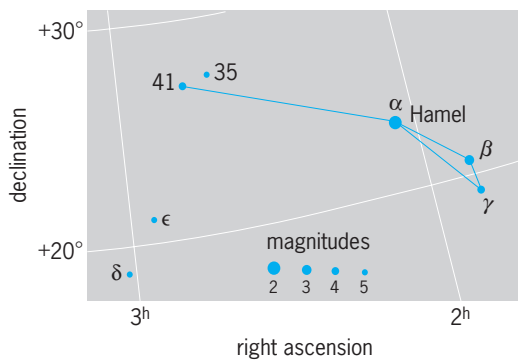

Line pattern of constellation Aries. Grid lines represent the coordinates of the sky. Apparent brightness, or magnitudes, of stars are shown by sizes of the dots, which are graded by appropriate numbers as indicated.

Aries was considered as the first, because about 2000 years ago when the zodiacal constellations were organized, the Sun was in Aries where it crossed the equator at vernal equinox. Today, because of the precession of the equinoxes, this reference point has moved into the constellation Pisces. However, Aries remains the first sign of the zodiac. See CONSTELLATION. [C.-S.Y.]

**Aristolochiales** An order of flowering plants, division Magnoliophyta (Angiospermae), in the subclass Magnoliidae of the class Magnoliopsida (dicotyledons). It contains only the family Aristolochiaceae, with seven genera and about 600 species, most of them in tropical and subtropical regions. Within its subclass the order is marked by the presence of ethereal oil cells, by its uniaferturate or nonaperturate pollen, and especially by its strongly perigynous to epigynous flowers, usually with united carpels, that typically lack petals and have the sepals joined into a highly irregular, corolloid calyx. Many of the species are climbing vines. *Aristolochia* (birthwort or Dutchman's pipe) and *Asarum* are well-known genera of the order. See FLOWER; MAGNOLIIDAE; MAGNOLIOPHYTA; MAGNOLIOPSIDA; POLLEN; RAFFLESIALES. [A.Cr.]

**Arithmetic** A branch of mathematics dealing with numbers, operations on numbers, and computation. Arithmetic is useful in solving many practical problems, such as buying, selling, budgets, sports statistics, and measurement. The usual numbers of arithmetic are whole numbers, fractions, decimals, and percents. Beyond the numbers of arithmetic are negative numbers, rational numbers, and irrational numbers. The rational and irrational numbers together constitute the real numbers.

**Whole numbers.** The whole numbers include the infinite sequence of counting numbers—one, two, three, four, five, . . .—and the number zero. For numbers to ten, a single symbol is used, and for larger numbers a combination of symbols.

Numbers to ten are designated with a single digit: 0, 1, 2, 3, 4, 5, 6, 7, 8, and 9. Numbers ten and greater are expressed by using a combination of the ten digits, with the place of the digit indicating the value of the digit. This place-value system, named the Hindu-Arabic numeration system, is now used around the world.

In a multidigit numeral, the value of each place from right to left is a successive power of ten, and the total values for all places are combined or added.

**Operations.** The basic operations are addition (+) and multiplication ( $\times$  or  $\cdot$ ), with subtraction ( $-$ ) and division ( $\div$ ) defined, respectively, by using addition and multiplication.

If two numbers,  $a$  and  $b$ , are combined or added, the result is a number,  $c$ , called the sum. In the example  $4 + 6 = 10$ , 4 and 6 are addends and 10 is the sum. The whole amount, 10, is the result of combining two parts, 4 and 6.

If a given number,  $n$ , sets of objects with the same number in each set,  $r$ , are combined, then multiplication of  $n$  and  $r$  is the total number of objects. In  $3 \times 4 = 12$ , 3 and 4 are factors and 12 is the product (see illustration).

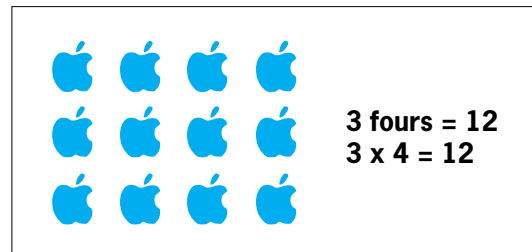

One meaning of multiplication.

Subtraction is the inverse operation to addition, finding an addend when a sum and one addend are known. If there are 18 children on the playground and 10 are boys, then the number of girls is  $18 - 10$  or 8, illustrating that the whole minus a part leaves the other part. Subtraction is used also to find the difference, for example, to see how many more are in one group of 18 children than in a group of 10 children. Subtraction is checked with addition;  $18 - 10 = 8$  because  $8 + 10 = 18$ .

Division is the inverse operation to multiplication, that is, finding a factor when a product and a factor are known. In  $12 \div 3 = 4$ , 12 is called the dividend, 3 is called the divisor, and 4 is the quotient.

**Fractions and decimals.** Understanding fractions and decimals, as well as operations on these numbers, is essential for practical uses and for long-term memory.

The initial and most basic idea is that a fraction shows "part of a whole." In the fraction  $3/4$ , read "three-fourths," the 4 shows the number of equal-size pieces in each whole unit as well as the size of one piece, "fourth." The 3 shows the number of equal-size pieces being taken or considered. The top number, 3, "numbers" the parts and is called the numerator. The bottom number, 4, "names" the parts and is called the denominator.

To show decimals less than one, the place value system for whole numbers is extended to the right of the ones place. The value of each place to the right is a successive power of  $1/10$ . The decimal point is needed to designate the ones place because the place on the right is no longer the ones place. The decimal point also separates the whole number from the decimal part.

Percents are another way to express fractions and decimals that show hundredths. For example, 7 hundredths can be expressed as  $7/100$ , as 0.07, or as 7%. All three expressions show the same part of a whole. See PERCENT. [J.N.P.]

**Arkose** An arenaceous rock that contains a high proportion of feldspar in addition to quartz and other detrital minerals. Arkose is also known as feldspathic sandstone. Although there is no universal agreement, many geologists consider a minimum of 25% feldspar a requisite for calling sandstone an arkose. Other geologists accept a lower value. Arkoses may contain a high proportion of other nonquartz detritus, such as igneous and metamorphic rock fragments, micas, amphiboles, and pyroxenes. Frequently the accessory heavy mineral suite consists of a variety of species.

Sedimentary structures of arkoses are similar in kind to those of the orthoquartzites. Cross-bedding, the major feature, may be displayed on a huge scale, some cross-bedded units being many feet thick. Arkoses are associated with a variety of clastic rocks, dominantly conglomerates, and reddish-colored shales. Arkoses also are found with basic lava flows. Most arkoses are found in

geosynclinal areas, but the thin, reworked, granite wash arkoses can be found on stable continental platforms. See GEOSYNCLINE.

The granite-wash arkoses appear to have formed as the result of a transgression of the sea over a land area underlain by granite. The fragmented granite in the soil and mantle rock is incorporated in the basal sediment. In some areas the original granite is changed so slightly that the arkose is called recomposed granite and may be almost indistinguishable from the original granite. Since high relief and climatic extremes generally are associated with orogenic movements, arkoses are usually interpreted as sediments that result from tectonically active regions. See ARENACEOUS ROCKS; FELDSPAR; GRAYWACKE; SANDSTONE; SEDIMENTARY ROCKS. [R.Si.]

**Armadillo** The name for 21 species of mammals of the order Edentata, a group characterized by the lack of enamel on their teeth. They are indigenous to the New World, especially South America.

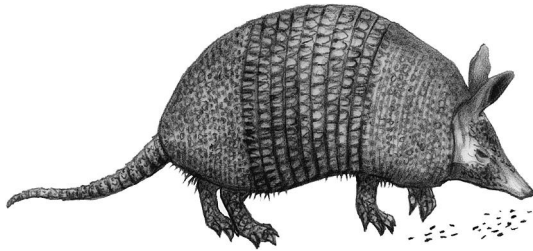

Nine-banded armadillo (*Dasypus novemcinctus*).

Armadillos range in size from the lesser pichiciego or fairy armadillo (*Chlamyphorus truncatus*), in which the adult is about 5 in. (7.5 cm) long, to the giant armadillo (*Priodontes giganteus*), which is about 4 ft (1.2 m) in length. The body is covered with horny dermal scales that replace the hair common to most mammals and overlay bony plates. These structures fuse to form rigid shields covering the anterior and posterior ends of the animal, whereas in the midregion they form jointed bands allowing a certain amount of flexibility. The giant armadillo has about 100 teeth, more than any other land mammal. The snout is long, and the tongue is cylindrical and viscous to assist in capturing food. The toes are clawed and are used by the animal to dig into ant and termite colonies for food, as well as for burrowing. When disturbed, many species roll into a ball or wedge themselves into the opening of a burrow.

The nine-banded armadillo (*Dasypus novemcinctus*; see illustration) is the best-known species and ranges from South America to the southwestern and southern United States. It is the only edentate which inhabits the United States, ranging from the Rio Grande area to Oklahoma and eastward along the coast to Louisiana. The nine-banded armadillo has been studied because of its unusual life cycle. Four young are born in a den or chamber at the end of the burrow. The young are always of the same sex and are identical quadruplets. See DENTITION; EDENTATA. [C.B.C.]

**Armature** That part of an electric rotating machine which includes the main current-carrying winding. The armature winding is the winding in which the electromotive force (emf) produced by magnetic flux rotation is induced. In electric motors this emf is known as the counterelectromotive force.

On machines with commutators, the armature is normally the rotating member. On most ac machines, the armature is the stationary member and is called the stator. The core of the armature is generally constructed of steel or soft iron to provide a good magnetic path, and is usually laminated to reduce eddy currents. The armature windings are placed in slots on the surface of the

core. On machines with commutators, the armature winding is connected to the commutator bars. On ac machines with stationary armatures, the armature winding is connected directly to the line. See COMMUTATOR; CORE LOSS; WINDINGS IN ELECTRIC MACHINERY. [A.R.E.]

**Armature reaction** The effects of the magnetomotive force (mmf) of the armature on the air-gap field of direct-current (dc) and synchronous alternating-current (ac) machines. Since armature current varies directly with the electrical or mechanical load on the machine, armature-reaction effects are load-dependent. In dc machines, the armature reaction causes a distorted flux-density distribution in the air gap. Due to the saturation of the armature teeth, the flux density is decreased by a greater amount under one pole tip than it is increased under the other, and therefore the armature reaction produces a demagnetizing effect, and the generated voltage or countervoltage will be reduced when the armature is loaded. In a generator this degrades the voltage regulation. In a motor it tends to increase the speed and may cause instability.

For dc machines subject to heavy overloads, rapidly reversing loads, or operation with a weak field, the resultant flux-distribution distortion by excessive armature reaction will cause nonuniform distribution of voltage between commutator segments, and may result in flashover between commutator segments. A pole-face (or compensating) winding, embedded in slots in the pole face and excited by armature current, is provided to neutralize the armature mmf under the pole faces. [G.McP.]

**Army armament** The weapons, equipment, and supplies that permit lethal or nonlethal devices to strike their targets. Armaments can be classified as field artillery, individual and crew-served weapons (infantry), armor and antiarmor, anti-aircraft, helicopter armaments, and mines and countermines.

**Field artillery.** Artillery can deliver highly lethal warheads to ranges well beyond the reach of infantry weapons. Artillery includes rockets, missiles, and self-propelled and towed howitzers (cannon). Artillery fire support is designed to meet adversarial forces by attacks on personnel and on medium and hard targets such as troop carriers and tanks. This mission is conducted at extended ranges with high-explosive projectiles, projectiles with shaped-charge submunitions, and the Copperhead guided projectile. Artillery can also channel, delay, and destroy oncoming forces by delivery of antipersonnel and antitank mines. Future goals include the use of smart munitions; increased range, lethality, and firing rates; new propulsion techniques; cartridge course correction in flight; and systems which permit much greater battlefield versatility.

**Individual and crew-served weapons (infantry).** Infantry armament is composed largely of line-of-sight, direct-fire weapons and indirect-fire mortar weapons used by nonmechanized light infantry (60-mm and 81-mm mortars) and mechanized infantry and armor divisions (120-mm mortars).

Many small-caliber weapons have been introduced as replacements or additions to the inventory. Improvements in hit probability, combat load, and target acquisition of small-caliber weapons over those of the current systems are being pursued. The long-term objective is a family of small arms that may feature composite materials, bursting ammunition, laser fire control, night-vision devices, and microelectronics.

The U.S. Army uses three mortar weapon systems: the 60-mm M224 lightweight company mortar, the 81-mm improved M252 mortar, and the 120-mm M120 mortar. The 107-mm M30 mortar has been replaced by the 120-mm M120 mortar (towed and ground mounted) and the 120-mm M121 mortar (carrier mounted). Each type of mortar fires a family of projectiles, including high-explosive, smoke, illuminating, and full-range and short-range practice cartridges.

The primary shoulder-launched infantry munitions consist of the AT4 recoilless rifle and the shoulder-launched multipurpose assault weapon-disposable (SMAW-D) bunker defeat munition.

**Armor and antiarmor.** The primary armored weapon systems consist of the M1 and M1A1 main battle Abrams tanks; the more lightly armored Bradley M2 infantry and M3 cavalry fighting vehicles; and the M113 family of armored personnel carriers. Major thrusts in armament development have resulted in conversion of the rifled 105-mm cannon in the M1 tank to the 120-mm smoothbore cannon in the M1A1 tank, and the utilization of tungsten and depleted-uranium long-rod penetrators for maximum antiarmor effectiveness. Increased protection against penetration by kinetic-energy and shaped-charge ammunition has been provided by the use of laminate Chobham-type armor and reactive armor.

**Air defense.** There are a number of air defense weapons. These include the Avenger Air Defense System, the hand-held Stinger rocket, and the Patriot system.

The Stinger is a human-portable, shoulder-fired, two-stage, infrared homing missile, designed to attack and destroy at short range any low-altitude, fixed- and rotary-wing aircraft with a high-explosive fragmentation warhead. The Stinger is to be replaced by the Linebacker Air Defense System.

The Avenger Air Defense System is mounted on a Humvee (high-mobility multipurpose wheeled vehicles; HMMWV). It is lightweight and transportable and designed to counter enemy cruise missiles, crewless aerial vehicles, and low-flying fixed-wing or rotary aircraft.

The Patriot system fires MIM-104 surface-to-air missiles at attacking aircraft and missiles at ranges up to 37.3 mi (62.3 km), providing medium- and high-altitude defense. It was used in the first Persian Gulf War to defend against Iraqi-launched SCUD missiles.

**Helicopter armaments.** The major combat aircraft used in support of ground operations are the AH-64 Apache and the AH-1 Cobra attack helicopters. Both helicopters are highly mobile and are capable of destroying moving armored columns and other point and area targets on the modern battlefield. See HELICOPTER.

**Mines.** The U.S. Army places great emphasis on the use of mines in modern warfare. A family of mines and modes of delivery have been developed, which include scatterable antipersonnel and antitank mines (family of scatterable mines; FASCAM) that have high utility because they can be emplaced by artillery, aircraft, and ground vehicles at close-in and extended ranges. They are autonomous after deployment, are effective over a time period, and self-destruct to permit occupation of the area by friendly forces.

[J.Ru.; G.Pa.; J.We.]

**Aromatic hydrocarbon** A hydrocarbon with a chemistry similar to that of benzene. Aromatic hydrocarbons are either benzenoid or nonbenzenoid. Benzenoid aromatic hydrocarbons contain one or more benzene rings and are by far the more common and the more important commercially. Nonbenzenoid aromatic hydrocarbons have carbon rings that are either smaller or larger than the six-membered benzene ring. Their importance arises mainly from a theoretical interest in understanding those structural features that impart the property of aromaticity.

Benzenoid aromatic hydrocarbons are also called arenes. Benzene itself is the prototypical arene. The properties associated with aromaticity have little to do with aroma, although the aromatic hydrocarbons were first studied in connection with naturally occurring fragrances. Instead, these compounds possess special stability; take part in certain types of reactions; and exhibit persistence of the structural integrity of aromatic rings during chemical reactions, while groups attached to those rings are chemically altered or manipulated.

**Benzene.** With molecular formula (1), benzene is highly unsaturated; it has three double bonds, alternating with single

bonds. The double bonds in the benzene structure can be arranged in two ways, (1') and (1''). Benzene is a resonance

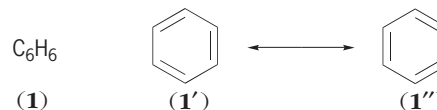

hybrid of these two structures, called Kekulé structures; the double-headed arrow is used to signify that the benzene structure is neither (1') nor (1''), but a single structure that is a hybrid of the two. That is, the bonds between adjacent carbon atoms are neither double nor single, but of some intermediate or hybrid type.

Each carbon atom in benzene is connected to three atoms, two adjacent carbon atoms and a hydrogen atom. These three bonds lie in a single plane and use three of the carbon's four valence electrons. The fourth valence electron of each carbon is located in a *p* orbital, extending perpendicularly above and below the plane of the other three bonds. These electrons, one from each carbon atom and called  $\pi$  electrons, form three molecular orbitals located above and below, but parallel to, the plane of the ring.

The symbol of a hexagon with an inscribed circle (2) is

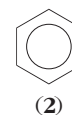

often used to express the delocalized nature of the  $\pi$  electrons in benzene and other arenes. There is physical evidence that the  $\pi$  electrons circulate around the ring carbons, as implied by this formula. For example, in the nuclear magnetic resonance (NMR) spectra of arenes, the chemical shifts of arene hydrogen atoms (protons) are characteristically at lower magnetic fields than those of protons attached to carbon-carbon double bonds. This difference is due to an induced magnetic field caused by circulation of the  $\pi$  electrons in the molecular orbitals above and below the arene ring plane. Indeed, this chemical shift difference, due to a diamagnetic ring current, is sometimes used as evidence for aromaticity in nonbenzenoid aromatic hydrocarbons. See DELOCALIZATION.

**Other arenes.** Besides benzene itself, several alkylbenzenes are commercially important and produced on a large scale—millions of pounds annually. Production is commonly by the cyclohydrogenation of alkanes at high temperatures over metallic catalysts such as platinum.

Benzene, toluene, and the xylenes are added to unleaded gasoline to raise the octane number. These arenes are also essential to the petrochemical industry. Products derived from them include polyesters, polyurethanes, polystyrene, and synthetic rubber; alkylbenzenesulfonate detergents; phenol and acetone; pharmaceuticals, flavors, and perfumes; plasticizers; and many others. See PETROCHEMICAL.

Arenes with fused rings are also known as polynuclear aromatic hydrocarbons. Rings are said to be fused when they share two carbon atoms. The simplest example is naphthalene (3), a colorless crystalline compound found in coal tar, best known as a moth repellent.

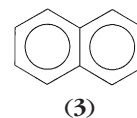

Additional arene rings can be fused. For example, anthracene, tetracene, and pentacene are linearly fused, while phenanthrene, triphenylene, and pyrene are angularly fused (see illustration). In general, angular fusion results in more stable systems than linear fusion. Phenanthrene, for example, is about 6 kcal/mol more stable than its linear isomer anthracene. Stability falls off

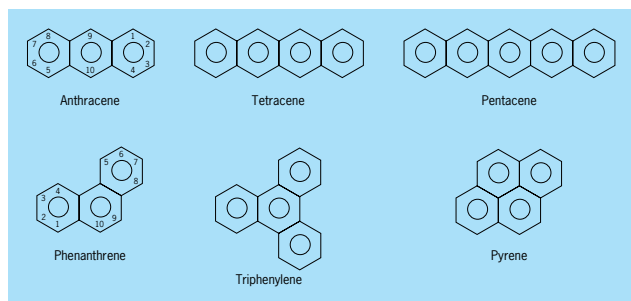

Structures of some fused-ring (polynuclear) aromatic hydrocarbons.

sharply in the linearly fused series, and compounds with more than seven such rings are unknown.

**Hückel rule.** From molecular orbital theory, E. Hückel derived the rule that planar, cyclic conjugated (alternate single and double bonds) systems with  $4n + 2\pi$  electrons ( $n$  is an integer, 0, 1, 2, ...) will be aromatic and have substantial resonance energy, whereas those with  $4n$  such electrons will not; indeed, it was later shown that  $4n$  systems are often destabilized, hence antiaromatic. Benzene is a  $4n + 2$  system ( $n = 1$ ) and aromatic. As striking confirmation of these ideas, pentalene (**4**), a planar

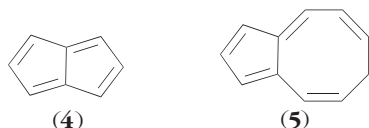

analog of cyclooctatetraene, is exceptionally reactive, unstable, and antiaromatic (a  $4n$  system,  $n = 2$ ), whereas the purple hydrocarbon azulene (**5**; a  $4n + 2$  system,  $n = 2$ , and an isomer of naphthalene) is stable and undergoes substitution reactions analogous to those of benzenoid arenes. [H.Ha.]

**Aromatization** The conversion of any nonaromatic hydrocarbon structures, especially those found in petroleum, to aromatic hydrocarbons. There are numerous routes and means to accomplish this transformation, the simplest and most important of which are direct dehydrogenation of naphthenes to aromatics, reaction (1); dehydroisomerization of naphthenes to aromatics, reaction (2); dehydrocyclization of aliphatics to aromatics, reaction (3); and high-temperature condensation of hydrocarbons to aromatics, reaction (4).

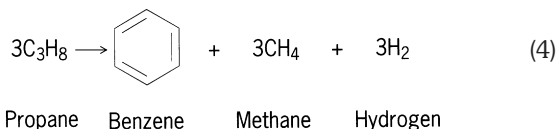
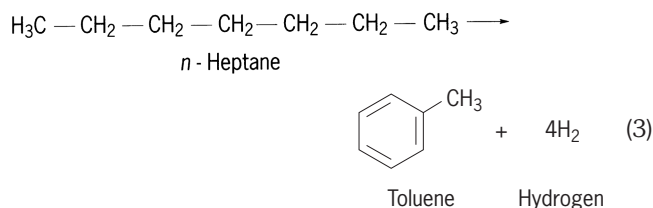
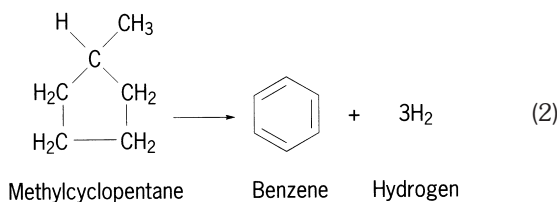
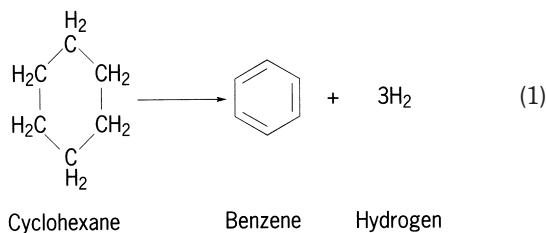

Reforming of naphthas with catalysts comprising small amounts of platinum on an acidified alumina support accomplishes reactions (1), (2), and (3) readily and simultaneously. It is a major process for benzene, toluene, and other aromatics from petroleum sources.

Reaction (4) illustrates one type of reaction that may occur in the high-temperature (600–800°C or 1100–1500°F) thermal cracking of petroleum fractions. See PETROLEUM PROCESSING AND REFINING. [B.S.G.; M.Sou.]

**Arsenic** A chemical element, symbol As, atomic number 33. Arsenic is found widely distributed in nature (approximately  $5 \times 10^{-4}$  of the Earth's crust). It is one of the 22 known elements composed of only one stable nuclide,  $^{75}\text{As}$ ; the atomic weight is 74.92158. There are 17 other radioactive arsenic nuclides known.

There are three polymorphic modifications of arsenic. The yellow cubic  $\alpha$ -form is made by condensing the vapor at very low temperatures. The black  $\beta$ -polymorph is isostructural with black phosphorus. Both these modifications revert to the stable  $\gamma$ -form, gray or metallic, rhombohedral arsenic, on heating or exposure to light. The metallic form is a moderately good thermal and electric conductor and is brittle, easily fractured, and of low ductility.

Arsenic is found native as the mineral scherbenkobalt, but generally occurs among surface rocks combined with sulfur or metals such as Mn, Fe, Co, Ni, Ag, or Sn. The principal arsenic mineral is FeAsS (arsenopyrite, mispickel); other metal arsenide ores are FeAs<sub>2</sub> (löllingite), NiAs (nicolite), CoAsS (cobalt glance), NiAsS (gersdorffite), and CoAs<sub>2</sub> (smaltite). Naturally occurring arsenates and thioarsenates are common, and most sulfide ores contain arsenic. As<sub>4</sub>S<sub>4</sub> (realgar) and As<sub>4</sub>S<sub>6</sub> (orpiment) are the most important sulfur-containing minerals. The oxide, arsenolite, As<sub>4</sub>O<sub>6</sub> is found as the product of the weathering of other arsenical minerals, and is also recovered from flue dusts collected during the extraction of Ni, Cu, and Sn from their ores; it also results when the arsenides of Fe, Co, or Ni are roasted in air or oxygen. The element may be obtained by roasting FeAsS or FeAs<sub>2</sub> in the absence of air or by reduction of As<sub>4</sub>O<sub>6</sub> carbon, when As<sub>4</sub> may be sublimed away.

Elemental arsenic has few uses. It is one of the few minerals available in 99.9999+% purity, which is largely used in the laser material GaAs and as a doping agent in the manufacture of various solid-state devices. Arsenic oxide is used in glass manufacture. The arsenic sulfides are used as pigments and in pyrotechnics. Dihydrogen arsenate is used in medicine, as are several other arsenic compounds. Most of the medicinal uses of arsenic compounds depend on their toxic nature. See ANTIMONY; PHOSPHORUS. [J.L.T.W.]

**Arsenopyrite** A mineral having composition FeAsS and crystallizing in the monoclinic system. Crystals have pseudo-orthorhombic symmetry because of twinning. The Mohs hardness is 5.5–6.0, and the specific gravity is 6.0. The luster is

metallic and the color silver-white. Arsenopyrite is the most widespread arsenic-bearing mineral. It is commonly found in veins containing gold (Lead, South Dakota; Deloro, Ontario), tin or tungsten minerals (Bolivia; Cornwall, England), or nickel-cobalt-silver minerals (Cobalt, Ontario; Freiberg, Germany). *See* ARSENIC. [L.Gr.]

**Art conservation chemistry** The application of chemistry to the technical examination, authentication, and preservation of cultural property. Chemists working in museums engage in a broad range of investigations, most frequently studying the chemical composition and structure of artifacts, their corrosion products, and the materials used in their repair, restoration, and conservation. The effects of the museum environment, including air pollutants, fluctuations in temperature and relative humidity, biological activity, and ultraviolet and visible illumination, represent a second major area of research. A third area of interest is the evaluation of the effectiveness, safety, and long-term stability of materials and techniques for the conservation of works of art. Though analytical techniques appear to dominate, many other areas of chemistry, biology, physics, and engineering, including polymer chemistry, kinetic studies, imaging methodologies, biodegradation studies, dating methods, computer modeling, metallography, and corrosion engineering, play active roles in conservation science.

Methods of examination may be divided into two classes: those that provide an image of the entire object (holistic examination) or a section of it; and those that provide an analysis at a point on the object, with or without sampling. Nondestructive methods, not requiring sampling, are always preferable. However, modern methods of analysis can be employed on such minute samples that they are in effect nondestructive. In some cases, samples must be taken for methods that are in principle nondestructive because the object is too large to fit into a sample chamber. The ability to analyze minute samples introduces the serious concern that the sample may not be representative of the composition of the artifact but may be an inclusion or contaminant introduced by the experimentalist. With specimens from painted surfaces, great care must be taken to identify areas of restoration.

A further concern arises from the differing depths from which signals originate. On a metal surface, ion scattering spectrometry (ISS) would see the initial fraction-of-a-nanometer, predominantly adsorbed species and contaminants. Secondary ion mass spectrometry (SIMS) would begin to penetrate the oxidized area; Auger electron spectrometry (AES) would examine the bulk of the oxidized layer; and x-ray-induced photoelectron spectrometry (XPS) would give data on the bulk sample some 10 nm below the specimen surface. *See* ACTIVATION ANALYSIS; ANALYTICAL CHEMISTRY; AUGER EFFECT; SURFACE PHYSICS; X-RAY.

The most commonly employed holistic method is x-ray radiography, where variations in the density and average atomic number of the sample attenuate an x-ray beam, leaving a negative image on film. Other methods, such as ultraviolet and infrared reflectance and fluorescence, are used to show areas of compositional difference indicating restoration or variation in the pigments used by the artist. *See* INFRARED IMAGING DEVICES; INFRARED RADIATION; LUMINESCENCE ANALYSIS; RADIOGRAPHY; ULTRAVIOLET RADIATION.

In the examination of paintings, small samples are taken under the binocular microscope, embedded in transparent resin, and polished to produce a cross section for microscopic examination. This permits a study of the artist's painting technique and shows how several layers may have been built up to achieve a desired effect. Conservation studies of the composition and technique embrace the entire spectrum of modern chemical analysis. *See* CHEMICAL MICROSCOPY; IMAGE PROCESSING; MICROSCOPE.

The separation of the fake from the authentic is a small but often spectacular aspect of the technical examination of artifacts. In some cases, direct age determination (dendrochronology for

panel paintings, fission track dating for uranium glass, radiocarbon dating for organic materials, thermoluminescence dating for ceramics) is possible. *See* ARCHEOLOGICAL CHRONOLOGY; DATING METHODS; DENDROCHRONOLOGY; FISSION TRACK DATING; RADIOCARBON DATING.

More commonly, the issue of authenticity turns upon anachronisms in composition or technique when the artifact in question is compared to accepted artifacts of the period. Thus, the greater part of the work in the conservation laboratory concerns the building of databases of analyses of composition, trace-element distributions, and studies of technique.

Many artifacts are sensitive to destructive agents in the museum atmosphere. Rapid changes in relative humidity will cause dimensional changes in wood furniture, polychrome sculpture, and panel paintings, leading to cracking and splitting of the wood with loss of painted surface decoration. High relative humidity can lead to mold growth and foxing on books and prints, while low relative humidity will cause photographic prints and films to become brittle.

Oxidation of iron objects, tarnishing of silver plate, and the development of corrosion products on lead artifacts by the action of formic and acetic acids emitted by wooden display cases have regularly been observed in museums.

The common air pollutants sulfur dioxide (SO<sub>2</sub>) and ozone (O<sub>3</sub>) have been monitored at elevated levels in museums, libraries, and archives. These pollutants cause the degradation of leather, spotting of photographic prints, and fading of dyes and pigments. Chemical methods of analysis are used to identify degradation products and to study the kinetics of degradation mechanisms. Specialists in air-pollution monitoring use analytical instrumentation to measure ambient pollution levels in museums. [N.S.B.]

**Arteriosclerosis** The name given a group of degenerative diseases of arteries characterized by thickening and hardening of their walls. The group includes three types of lesions: (1) atherosclerosis involves the aorta and its major branches; (2) medial sclerosis involves the muscular arteries of the legs; and (3) arteriolosclerosis involves the small branches of the arterial tree, called the arterioles.

Atherosclerosis is by far the most common and important form of arteriosclerosis, and the two terms are often used interchangeably. Atherosclerosis has global distribution and occurs in virtually epidemic proportions in the Western industrialized nations. Factors associated with the high incidence and severity of atheromas (anatomic lesions of atherosclerosis) include a high total caloric intake, high fat intake, sedentary living, aggressive personality, emotional stress, and cigarette smoking. Hypertension (high blood pressure) does not induce arteriosclerosis, but it augments its development and accelerates the progress of the disease if it is present. The excessive incidence of myocardial infarction (heart attack) in cigarette smokers has been clearly documented. High blood lipid levels especially of cholesterol and triglycerides are also associated with higher incidence. The strong supposition thus arose that environmental and nutritional factors are of prime etiologic importance in the development of the disease, although the specific cause has not been identified. *See* HEART DISORDERS; HYPERTENSION.

Atheromas begin within the lining layer of the aorta (intima) or its branches and subsequently extend into the middle layer (media) of these vessels. The basic lesion has been shown to be a focal overgrowth of the smooth muscle cells of these layers, possibly following from a mutation. The cells subsequently degenerate, producing an accumulation of lipids in their cytoplasm, then necrosis, and finally calcification and scarification. As these lesions enlarge in the intima, the overlying endothelial cells may become disrupted, and fibrin clots are deposited on the surface. The lumen of the vessel is diminished in diameter (stenosis) by both the atheromatous plaque and the overlying clot. The occurrence of successive layers of clots and enlarging

plaque produces narrowing of the lumen. If the process involves all layers of the arterial wall, it may weaken the wall, and an aneurysm may result.

When the atherosclerotic process occurs in the smaller branches of the aorta, complete occlusion may occur. If the process takes place in the vessels supplying blood to the heart muscle (coronary arteries), the blood supply may be restricted or stopped completely, producing a myocardial infarction. If the process involves the arteries supplying the brain, hemorrhage and stroke may occur. If arteries leading to the legs, arms, or internal organs are occluded, gangrene may result. Because of these sequelae, atherosclerosis assumes awesome importance as the major cause of death in the United States. *See* HEMORRHAGE.

Although the vast majority of cases of atherosclerosis appear to be principally caused by environmental factors, there are some specific genetic defects associated with the genesis of the process. Individuals with primary diabetes mellitus develop severe arteriosclerosis at an earlier age than nondiabetic individuals do. Familial hypercholesterolemia, homocystinuria, and hypothyroidism are other examples of metabolic defects associated with arteriosclerosis. *See* DIABETES; THYROID GLAND DISORDERS.

Medial sclerosis is an uncommon type of arteriosclerotic lesion, affecting arteries of the arms, legs, and genital tracts of both sexes. The disorder is characterized by ringlike calcifications within the media (middle layer) of affected vessels. The endothelial lining of the vessel is not altered, and occlusion of the vessel seldom occurs.

Arteriolosclerosis is an increased generalized thickening of the walls of arterioles related to hypertension. The change is often most prominent in the kidneys, although other internal organs may be similarly affected. Individuals with diabetes mellitus have an increased incidence of the lesion. *See* CIRCULATION DISORDERS.

[N.K.M.]

**Artesian systems** Groundwater conditions formed by water-bearing rocks (aquifers) in which the water is confined above and below by impermeable beds. Because the water table in the intake area of an artesian system is higher than the top of the aquifer in its artesian portion, the water is under sufficient head to cause it to rise in a well above the top of the aquifer. Many of the systems have sufficient head to cause the water to overflow at the surface, at least where the land surface is relatively low. Flowing artesian wells were extremely important during the early days of the development of groundwater from drilled wells, because there was no need for pumping. Their importance has diminished with the decline of head that has occurred in many artesian systems and with the development of efficient pumps and cheap power with which to operate the pumps.

[A.N.S./R.K.Li.]

**Arthritis** A group of diseases affecting joints or their component tissues. Several types of arthritis are recognized, and these can be divided into groups by their clinical course and pathologic appearance. There are four basic types of arthritis: inflammatory arthritis, degenerative joint disease, nonarticular rheumatism, and miscellaneous arthritis.

Inflammatory arthritis is characterized by inflammation of tissues associated with joints. Connective tissue diseases, crystal deposition diseases, infectious arthritis, and spondyloarthropathies are examples of inflammatory arthritis. Connective tissue diseases are a group of acute and chronic diseases characterized by involvement of joints, connective tissue, serosal membranes, and small blood vessels. These diseases are divided into acquired disorders (for example, rheumatoid arthritis, systemic lupus erythematosus, scleroderma, polymyositis, vasculitis) and rare hereditary diseases (for example, Ehlers-Danlos syndrome). Rheumatoid arthritis is the most common variety of inflammatory arthritis. It occurs in younger and middle-aged persons and is characterized by noninfectious inflammation of the synovium (joint-lining membrane) frequently associated with ex-

traarticular manifestations other than in the joints. The etiology is unknown, but genetic, immunologic, infectious, and psychologic disturbances have all been suggested. The systemic disease follows a variable but slowly progressive course, marked by spontaneous flares and remissions. There are three groups of crystal deposition disease classified according to type of crystal involvement: gout (monosodium urate), pseudogout (calcium pyrophosphate), and calcific tendonitis (hydroxyapatite). Infectious arthritis is an inflammatory joint disease caused by the invasion of the synovial joint by living microorganisms such as gonorrheal, streptococcal, and staphylococcal bacteria. Such arthritis usually results from a generalized infection but may appear following local spread or after trauma. The spondyloarthropathies are types of inflammatory arthritis characterized by involvement of the axial (central) skeleton (for example, the spine rather than the limbs). Ankylosing spondylitis and Reiter's syndrome are examples of the spondyloarthropathies. *See* CONNECTIVE TISSUE DISEASE; GONORRHEA; GOUT; STAPHYLOCOCCUS; STREPTOCOCCUS; URIC ACID.

Degenerative joint disease (osteoarthritis) is a ubiquitous joint disease characterized pathologically by deterioration of cartilage lining the joints and new bone formation beneath the cartilage. The disease is very common in older persons and is thought to be inherent in the aging process. Degenerative joint disease is marked by a progressive stiffness, loss of function, and destruction of the larger, weight-bearing joints of the body. With advancing age, the continued slow damage causes increasing disability. *See* AGING.

Nonarticular rheumatism is a group of diseases, also called soft-tissue rheumatism, that includes tendonitis, bursitis, tenosynovitis, and fibrositis. The etiology is unclear, but the disorder may relate to psychobiologic or sleep disturbances or muscular and soft-tissue abnormalities. *See* BURSITIS; RHEUMATISM.

Systemic diseases of other or unknown etiology may produce arthritis or joint destruction. There are neurologic, blood, and endocrine examples of these unusual rheumatic diseases.

Disability can often result from arthritis but can be curtailed by general health maintenance, rest, and rehabilitation. Occupational and physical therapies can be helpful. Diagnosis of the particular type of arthritis is extremely important in choosing drug therapy. Rheumatoid arthritis can be treated with nonsteroidal anti-inflammatory drugs such as aspirin. Disease-modifying antirheumatic drugs and immunosuppressive drugs are also frequently used. Osteoarthritis is treated with anti-inflammatory and analgesic drugs. Cortisone compounds are also used to treat arthritis, but the dosage and duration of treatment must be carefully monitored because of significant side effects. Surgical treatment includes arthroscopic surgery and joint replacement. *See* AUTOIMMUNITY; JOINT DISORDERS.

[R.Se.]

**Arthropoda** A phylum that includes the well-known insects, spiders, ticks, and crustaceans, as well as many smaller groups, some of which are known only as fossils. Arthropodous animals make up about 75% of all animals that have been described. The estimated number of known species exceeds 780,000. Of this number the class Insecta alone contains about 700,000 described species. Arthropods vary in size from the microscopic mites to the giant decapod crustaceans, such as the Japanese crab with an appendage span of 5 ft (1.5 m) or more.

The adult arthropod typically has a body composed of a series of ringlike segments, muscicularly movable on each other. The integument is sclerotized by the formation of hardening substances in the cuticle, and the segmental limbs are many-jointed. These characteristics, taken together, distinguish the arthropods from all other animals. Young stages may be quite different from the adults, and some parasitic species differ very radically from their relatives.

Arthropod evolution is no longer the clear-cut subdivision of a single phylum, Arthropoda, into three structurally divergent



subphyla. Advances in functional morphology, comparative embryology, spermatology, serology, and paleontology have brought an array of new hypotheses about relationships of arthropodous animals. At the center of debate is the question of monophyly versus polyphyly: Did all arthropodous animals evolve from a common ancestor or did several distinct lineages evolve along similar pathways? Two opposing classification schemes are presented; numerous variations on these schemes can be found in the literature. The first pair of classifications is as follows:

Phylum Uniramia  
 Subphylum: Onychophora  
     Myriapoda  
     Hexapoda (Insecta)  
 Phylum Trilobita (Trilobitomorpha)  
 Phylum Crustacea  
 Phylum Chelicerata

**Versus**

Phylum Arthropoda  
 Subphylum Arachnata  
     Superclass: Trilobita  
     Chelicerata  
 Subphylum Mandibulata  
     Superclass: Crustacea  
     Myriapoda  
     Insecta  
 Phylum Onychophora

Alternatively, a slightly different and expanded pair of classifications is as follows:

Phylum Uniramia  
 Subphylum Onychophora  
 Subphylum Myriapoda  
     Class: Chilopoda  
     Diplopoda  
     Symphyla  
     Pauropoda  
     Arthropleurida  
 Subphylum Hexapoda  
     Class: Protura  
     Collembola  
     Diplura  
     Thysanura  
     Pterygota (Insecta)  
 Phylum Crustacea  
     Class: Cephalocarida  
     Remipedia  
     Branchiopoda  
     Ostracoda  
     Tantulocarida  
     Maxillopoda  
     Malacostraca  
 Phylum Cheliceriformes  
     Subphylum Pycnogonida  
     Subphylum Chelicerata  
     Class: Merostomata  
     Arachnida  
 Phylum Trilobitomorpha  
     Class: Trilobitoidea  
     Trilobita

**Versus**

Phylum Onychophora  
 Phylum Arthropoda  
     Subphylum Cheliceromorpha  
     Infraphylum: Pycnogonida  
     Chelicerata

Superclass: Xiphosurida  
     Cryptopneustida  
 Class: Eurypterida  
     Archnida  
 Subphylum Ganthomorpha  
 Infraphylum: Trilobitomorpha  
     Class: Trilobita  
     Trilobitodea  
 Infraphylum: Mandibulata  
     Class: Cheloniellida  
     Crustacea  
     Myriapoda  
     Insecta

Body segmentation, or metamerism, is the most fundamental character of the arthropods, but it is shared by the annelid worms, so there can be little doubt that these two groups of animals are related. The limbs of all modern arthropods develop in the embryo from small lateroventral outgrowths of the body segments that lengthen and become jointed. Hence it may be inferred that the arthropods originated from some segmented worm that acquired similar lobelike limb rudiments and thus, as a crawling or walking animal, became distinguished from its swimming relatives. Then, with sclerotization of the integument, the limbs could lengthen and finally become jointed, providing greater locomotor efficiency. In their later evolution, some of these limbs became modified for many other purposes, such as feeding, grasping, swimming, respiration, silk spinning, egg laying, and sperm transfer. The body segments, corresponding to specialized sets of appendages, tend to become consolidated or united in groups, or tagmata, forming differentiated body regions, such as head, thorax, and abdomen. Annelida; Metameres.

Sclerotization of the cuticle may be continuous around the segments. More usually, it forms discrete segmental plates, or sclerites. A back plate of a segment is a tergum, or notum; a ventral plate is a sternum; and lateral plates are pleura. The consecutive tergal and sternal plates, unless secondarily united, are connected by infolded membranes, and are thus movable on each other by longitudinal muscles attached on anterior marginal ridges of the plates. Since nearly all the body and limb muscles are attached on integumental sclerites, there is little limit to the development of skeletomuscular mechanisms.

All arthropods have all the internal organs essential to any complex animal. An alimentary canal extends either straight or coiled from the subapical ventral mouth to the terminal anus. Its primary part is the endodermal stomach, or mesenteron, but there are added ectodermal ingrowths that form a stomodeum anteriorly and a proctodeum posteriorly. The nervous system includes a brain and a subesophageal ganglion in the head, united by connectives around the stomodeum, and a ventral nerve cord of interconnected ganglia. Some of the successive ganglia, however, may be condensed into composite ganglionic masses. Nerves proceed from the ganglia. Internal proprioceptors and surface sense organs of numerous kinds are present, chiefly tactile, olfactory, and optic. A usually tubular pulsatory heart lies along the dorsal side of the body and keeps the blood in circulation. In some arthropods arteries distribute the blood from the heart; in others it is discharged from the anterior end of the tube directly into the body cavity. The blood reenters the heart through openings along its sides.

Aquatic arthropods breathe by means of gills. Most terrestrial species have either flat air pouches or tubular tracheae opening from the outside surface; some have both. A few small, soft-bodied forms respire through the skin. Excretory organs open either at the bases of some of the appendages or into the alimentary canal. Most arthropods have separate sexes, but some are hermaphroditic, and parthenogenesis is of common occurrence. The genital openings differ in position in different

groups and are not always on the same body segment in the two sexes. See ARACHNIDA; CHELICERATA; CRUSTACEA; INSECTA; ONYCHOPHORA; TRILOBITA. [J.C.Ro.]

**Artichoke** *Cynara scolymus*, a herbaceous perennial plant, in the family Compositae; also called globe artichoke. Its origin is in the Mediterranean region. Artichoke requires a mild winter and cool summer with fog and little bright sunshine. It is a delicacy in Europe, Africa, and North and South America. Artichoke is also a medicinal plant; it is rich in the cynarin and ortho-phenol constituents. In the United States, artichokes are grown in the Pacific Coast area between south San Francisco and Los Angeles, mainly Monterey County.



Green Globe artichoke. (Burpee Seeds)

The marketable portion of the plant, the so-called bud, is actually the immature flower head, made up of numerous closely overlaid bracts or scales (see illustration). The edible portion consists of the tender bases of the bracts, the young flowers, and the receptacle or fleshy base upon which the flowers are borne. The bud can be various shapes, from round to oblong to flat, and the color can be light green to dark green, often with purple or red. [A.M.I.]

**Articulata (Echinodermata)** The only surviving subclass of the Crinoidea. It differentiated during Triassic times. The calyx is dicyclic, but considerable reduction of the infrabasals and basals may occur. The uniserial arms bear pinnules and usually branch, and the arm retains its movable articulation with the radial plate, despite the incorporation of the lower brachial ossicles into the calyx. Extant stalked forms with nodal rings of cirri (*Metacrinus*) are included in the order Isocrinida (see illustration). They do not tolerate turbulent waters and live at depths below current action, although they do inhabit shallow water when the conditions are suitable. The feather stars, of the order Comatulida, discard the stem when young, and thereafter remain free, either as swimming animals or as creeping benthic forms. They prefer shallow, clear water, rich in nutrients,

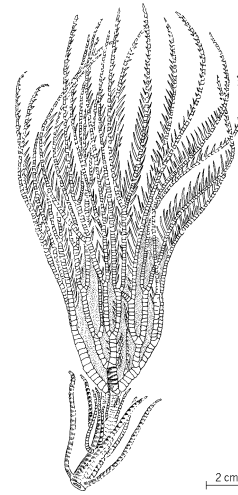

*Metacrinus cyaneus*, a living, articulate stalked crinoid.

and therefore abound on tropical coasts and in polar seas rather than in temperate waters. Four other orders have been defined. See CRINOIDEA; ECHINODERMATA. [H.B.F.]

**Artificial intelligence** The subfield of computer science concerned with understanding the nature of intelligence and constructing computer systems capable of intelligent action. It embodies the dual motives of furthering basic scientific understanding and making computers more sophisticated in the service of humanity.

Many activities involve intelligent action—problem solving, perception, learning, planning and other symbolic reasoning, creativity, language, and so forth—and therein lie an immense diversity of phenomena. Scientific concern for these phenomena is shared by many fields, for example, psychology, linguistics, and philosophy of mind, in addition to artificial intelligence. The starting point for artificial intelligence is the capability of the computer to manipulate symbolic expressions that can represent all manner of things, including knowledge about the structure and function of objects and people in the world, beliefs and purposes, scientific theories, and the programs of action of the computer itself.

Artificial intelligence is primarily concerned with symbolic representations of knowledge and heuristic methods of reasoning, that is, using common assumptions and rules of thumb. Two examples of problems studied in artificial intelligence are planning how a robot, or person, might assemble a complicated device, or move from one place to another; and diagnosing the nature of a person's disease, or of a machine's malfunction, from the observable manifestations of the problem. In both cases, reasoning with symbolic descriptions predominates over calculating.

The approach of artificial intelligence researchers is largely experimental, with small patches of mathematical theory. As in other experimental sciences, investigators build devices (in this case, computer programs) to carry out their experimental investigations. New programs are created to explore ideas about how intelligent action might be attained, and are also developed to test hypotheses about concepts or mechanisms involved in intelligent behavior.

The foundations of artificial intelligence are divided into representation, problem-solving methods, architecture, and knowledge. To work on a task, a computer must have an internal representation in its memory, for example, the symbolic description of a room for a moving robot, or a set of features describing a person with a disease. The representation also includes all the knowledge, including basic programs, for testing and measuring the structure, plus all the programs for transforming the structure

into another one in ways appropriate to the task. Changing the representation used for a task can make an immense difference, turning a problem from impossible to trivial.

Given the representation of a task, a method must be adopted that has some chance of accomplishing the task. Artificial intelligence has gradually built up a stock of relevant problem-solving methods (the so-called weak methods) that apply extremely generally.

An important feature of all the weak methods is that they involve search. One of the most important generalizations to arise in artificial intelligence is the ubiquity of search. It appears to underlie all intelligent action. In the worst case, the search is blind. In heuristic search extra information is used to guide the search.

Some of the weak methods are generate-and-test (a sequence of candidates is generated, each being tested for solutionhood); hill climbing (a measure of progress is used to guide each step); means-ends analysis (the difference between the desired situation and the present one is used to select the next step); impasse resolution (the inability to take the desired next step leads to a subgoal of making the step feasible); planning by abstraction (the task is simplified, solved, and the solution used as a guide); and matching (the present situation is represented as a schema to be mapped into the desired situation by putting the two in correspondence).

An intelligent agent—person or program—has multiple means for representing tasks and dealing with them. Also required is an architecture or operating framework within which to select and carry out these activities. Often called the executive or control structure, it is best viewed as a total architecture (as in computer architecture), that is, a machine that provides data structures, operations on those data structures, memory for holding data structures, accessing operations for retrieving data structures from memory, a programming language for expressing integrated patterns of conditional operations, and an interpreter for carrying out programs. Any digital computer provides an architecture, as does any programming language. Architectures are not all equivalent, and one important scientific question is what architecture is appropriate for a general intelligent agent.

In artificial intelligence, the basic paradigm of intelligent action is that of search through a space of partial solutions (called the problem space) for a goal situation. Each step offers several possibilities, leading to a cascading of possibilities that can be represented as a branching tree. The search is thus said to be combinatorial or exponential. For example, if there are 10 possible actions in any situation, and it takes a sequence of 12 steps to find a solution (a goal state), then there are  $10^{12}$  possible sequences in the exhaustive search tree. What keeps the search under control is knowledge, which suggests how to choose or narrow the options at each step. Thus the fourth fundamental concern is how to represent knowledge in the memory of the system so it can be brought to bear on the search when relevant.

An intelligent agent will have immense amounts of knowledge. This implies another major problem, that of discovering the relevant knowledge as the solution attempt progresses. Although this search does not include the combinatorial explosion characteristic of searching the problem space, it can be time consuming and hard. However, the structure of the database holding the knowledge (called the knowledge base) can be carefully tailored to suit the architecture in order to make the search efficient. This knowledge base, with its accompanying problems of encoding and access, constitutes the final ingredient of an intelligent system.

An example of artificial intelligence is computer perception. Perception is the formation, from a sensory signal, of an internal representation suitable for intelligent processing. Though there are many types of sensory signals, computer perception has focused on vision and speech. Perception might seem to be distinct

from intelligence, since it involves incident time-varying continuous energy distributions prior to interpretation in symbolic terms. However, all the same ingredients occur: representation, search, architecture, and knowledge. Speech perception starts with the acoustic wave of a human utterance and proceeds to an internal representation of what the speech is about. A sequence of representations is used: the digitization of the acoustic wave into an array of intensities; the formation of a small set of parametric quantities that vary continuously with time (such as the intensities and frequencies of the formants, bands of resonant energy characteristic of speech); a sequence of phons (members of a finite alphabet of labels for characteristic sounds, analogous to letters); a sequence of words; a parsed sequence of words reflecting grammatical structure; and finally a semantic data structure representing a sentence (or other utterance) that reflects the meaning behind the sounds.

A class of artificial intelligence programs called expert systems attempt to accomplish tasks by acquiring and incorporating the same knowledge that human experts have. Many attempts to apply artificial intelligence to medicine, government, and other socially significant tasks take the form of expert systems. Even though the emphasis is on knowledge, all the standard ingredients are present.

In careful tests, a number of expert systems have shown performance at levels of quality equivalent to or better than average practicing professionals (for example, average practicing physicians) on the restricted domains over which they operate. Nearly all large corporations and many smaller ones use expert systems. A common application is to provide technical assistance to persons who answer customers' trouble calls. Computer companies use expert systems to assist in configuring components from a parts catalog into a complete system that matches a customer's specifications, a kind of application that has been replicated in other industries tailoring assembled products to customers' needs. Troubleshooting and diagnostic programs are commonplace. Another widespread use of this technology is in software for home computers that assists taxpayers. One important lesson learned from incorporating artificial intelligence software into ongoing practice is that its success depends on many other aspects besides the intrinsic intellectual quality, for example, ease of interaction, integration into existing workflow, and costs.

Expert systems have sparked important insights in reasoning under uncertainty, causal reasoning, reasoning about knowledge, and acceptance of computer systems in the workplace. They illustrate that there is no hard separation between pure and applied artificial intelligence; finding what is required for intelligent action in a complex applied area makes a significant contribution to basic knowledge. See EXPERT SYSTEMS.

In addition to the subject areas mentioned above, significant work in artificial intelligence has been done on puzzles and reasoning tasks, induction and concept identification, symbolic mathematics, theorem proving in formal logic, natural language understanding and generation, vision, robotics, chemistry, biology, engineering analysis, computer-assisted instruction, and computer-program synthesis and verification, to name only the most prominent. As computers become smaller and less expensive, more and more intelligence is built into automobiles, appliances, and other machines, as well as computer software, in everyday use. See AUTOMATA THEORY; COMPUTER; CONTROL SYSTEMS; CYBERNETICS; DIGITAL COMPUTER; INTELLIGENT MACHINE; ROBOTICS.

[A.N.; B.G.Bu.]

**Artificially layered structures** Manufactured, reproducibly layered structures with layer thicknesses approaching interatomic distances. Modern thin-film techniques are at a stage at which it is possible to fabricate these structures, also known as artificial crystals or superlattices, opening up the possibility of engineering new desirable properties into materials. In addition, a variety of solid-state physics problems can be studied which

are otherwise inaccessible. The various possibilities include: the application of negative pressure, that is, stretching of the crystalline lattice; the study of dimensional crossover, that is, the transition from a situation in which the layers are isolated and two-dimensional in character to where the layers couple together to form a three-dimensional material; the study of collective behavior, that is, properties which depend on the cooperative behavior of the whole superlattice; and the effect and physics of multiple interfaces and surfaces. For a discussion of semiconductor superlattices see SEMICONDUCTOR HETEROSTRUCTURES; CRYSTAL.

The preparation techniques can be conveniently classified into two groups: evaporation and sputtering. In the evaporation system, two or more particle sources (thermal or electron beam gun) are aimed at a heated substrate where the artificially layered structure is grown. The sputtering method relies on bombarding targets of the proper materials with an inert gas, such as argon, thus producing the beams of the various elements. See SPUTTERING.

Once the artificially layered structure is prepared, it is necessary to characterize whether the layer structure is stable at the growth temperature. This is of considerable importance, since the interdiffusion of the constituents in many cases eliminates the layered growth. One of the most successful methods of characterizing layered growth has been x-ray diffraction. See ELECTRON MICROSCOPE.

Artificially layered structures are especially useful for the construction of mirrors for soft x-rays since there are no suitable, naturally occurring crystals for this purpose. Superlattices with zero temperature coefficient of resistivity are useful as resistor material, and high-critical-field-magnet tapes using superconducting-insulator superlattices have been proposed. See ELECTRICAL INSULATION; NEUTRON OPTICS; X-RAYS. [I.K.S.]

**Artiodactyla** An order comprising the even-toed ungulates (hoofed mammals). There are two main radiations: the predominantly omnivorous Bunodontia, including suoids (such as pigs, peccaries, and hippos); and the more herbivorous Selenodontia, including camels and ruminants (such as deer, giraffe, cattle, sheep, and antelope). Artiodactyla contains about 213 living species, making it the fifth most speciose order of mammals. First known from the early Eocene, artiodactyls have proliferated during the last 55 million years to reach great diversity (especially among the family Bovidae). Their radiation is often contrasted with that of the odd-toed ungulates, or Perissodactyla (horses, rhinos, and tapirs). Artiodactyls are also important for human economy and agriculture, comprising most of the domestic animals, providing milk, wool, and most of the meat supply. See PERISSODACTYLA.

Artiodactyls are defined by a unique morphology of the ankle joint, possessing a “double-pulley” astragalus (see illustration). This morphological feature is frequently considered to be a key innovation of artiodactyls, but its precise functional significance is poorly understood. Artiodactyls also have a paraxonic foot structure, where the axis of limb support passes between the third and fourth digits. The first toe is usually completely lost. In primitive artiodactyls and in suoids, the foot is four-toed, and the metapodials (hand and foot bones) are short and unfused as in the generalized mammalian condition (illus. a). In more derived artiodactyls, digits 2 and 5 have been reduced or lost entirely, and metapodials 3 and 4 are lengthened and fused to form a “cannon bone” (illus. b). It is this fusion of the metapodials with digits 3 and 4 free that gives ruminants their cloven-hoofed appearance (in contrast with the single and solid hoof of horses).

Despite their host of unique features, in terms of branching patterns artiodactyls represent an early divergence from the main stem of ungulate evolution. The earliest artiodactyls, rabbit-sized animals found in the Eocene of North America and Europe, are commonly known as dichobunids. By the late middle Eocene the

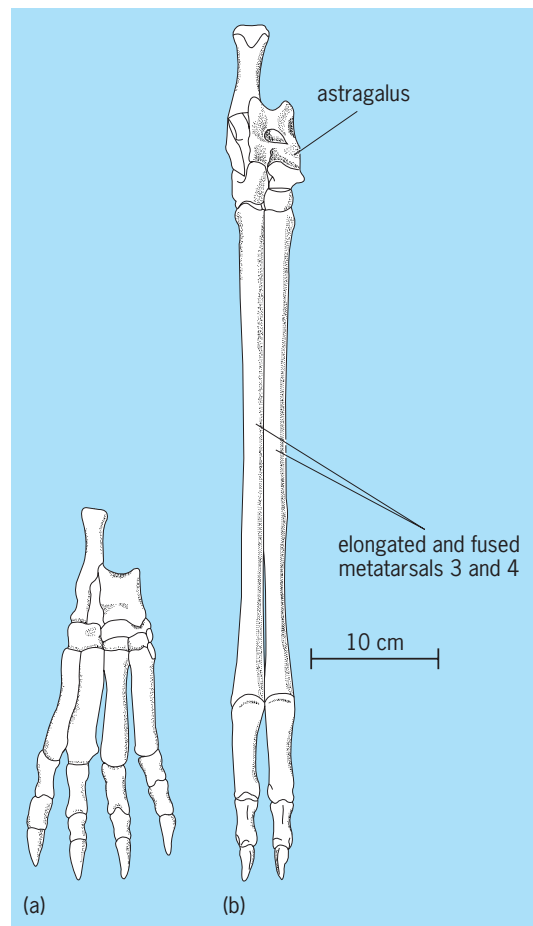

Representative left hindfeet of artiodactyls, showing the double-pulley astragalus. (a) Primitive condition, as in the Oligocene oreodont *Agriochoerus* (although the clawed condition in this animal is a secondary one). (b) Derived condition, as in the Miocene camelid *Oxydactylus*. (After A. S. Romer, *Vertebrate Paleontology*, 3d ed., University of Chicago Press, 1966)

earliest members of the two modern radiations, the Bunodontia and the Selenodontia, had arisen from among different groups of dichobunids. The three main types of living artiodactyls—suoids, camelids, and ruminants—can trace their roots back to this Eocene divergence. There has been much debate as to whether whales (order Cetacea) should be included among the Artiodactyla. Whales are clearly the sister taxon to artiodactyls among modern mammals, but some molecular studies imply that they are closely allied with the hippos. Morphologists and paleontologists would generally prefer to keep whales separate from artiodactyls. See CETACEA. [C.J.]

**Asbestos** Any of six naturally occurring minerals characterized by being extremely fibrous (asbestiform), being incombustible, and having high tensile strength. Historically they were utilized in commerce for fire protection; for fiber-reinforcing material in tiles, plastics, and cements; for friction materials; and for thousands of other uses. Currently the vast majority of asbestos used worldwide is chrysotile type, which is used for asbestos cement, friction products, coating and compounds, and roofing products. Because of great concern over the health effects of asbestos, many countries have promulgated strict regulations or bans on its use.

The six naturally occurring minerals exploited commercially for their desirable physical properties, which are in part derived from their asbestiform habit, are chrysotile asbestos—a member of the serpentine mineral group; and anthophyllite

asbestos, grunerite asbestos (known historically by the commercial name amosite), riebeckite asbestos (known historically by the commercial name crocidolite), tremolite asbestos, and actinolite asbestos—all members of the amphibole mineral group. Populations of these mineral fibers, however processed, can be demonstrated to be asbestos if the length varies independently of the diameter. The six minerals designated as asbestos also occur in a nonfibrous form.

The three principal diseases associated with exposure to the asbestos minerals are lung cancer; mesothelioma, a rare cancer of the pleural and peritoneal membranes that enclose the chest and abdominal cavities; and asbestosis, a nonmalignant disease characterized by a diffuse interstitial fibrosis of the lung, which causes the lung tissue to become stiff and exchange oxygen poorly. Excessive exposure to all the asbestos fiber types is associated with asbestosis and increased risk of lung cancer. Mesothelioma, a rare tumor accounting for approximately 1 in 10,000 deaths in the general population, can be dramatically increased by exposure to amosite, crocidolite, or tremolite asbestos. These last two fiber types are strongly associated with an increased incidence of nonoccupational mesothelioma and therefore are thought to present a risk at rather low exposures. See MUTAGENS AND CARCINOGENS; ONCOLOGY.

[M.Ro.; R.P.N.]

**Ascaridida** An order of nematodes in which the oral opening is generally surrounded by three or six labia; in some taxa labia are absent, but the cephalic sensilla are always evident. Usually there are eight cephalic or labial sensilla; the submedians may be fused and then only four sensilla are seen. The stoma varies from being completely reduced to spacious or globose. The esophagus varies from club shaped to nearly cylindrical, never rhabditoid. There may be posterior esophageal or anterior intestinal ceca. The collecting tubules of the excretory system may extend posteriorly and anteriorly. Males generally have two spicules; however, in some taxa there may be none or only one. The gubernaculum may also be present or absent. Though females generally have two ovaries, multiple ovaries do occur. The number of uteri is also variable: two, three, four, or six. Phasmids are sometimes large and pocketlike. Reportedly, the larvae lack a stomatal hook or barb.

The order probably comprises seven superfamilies: Ascarioidea, Seuratoidea, Camallanoidea, Dracunculoidea, Subuluroidea, Dioctophymatoidea, and Muspiceoidea (*incertae sedis*).

The Ascarioidea include about 65 genera which comprise large parasitic roundworms whose adult stages usually occur in the stomach or small intestine of terrestrial and aquatic mammals, birds, reptiles, and fishes; the parasitic larval stages of many species occur, either temporarily or indefinitely, in other parts of the host's body.

Many species have a direct life cycle. Others, mainly species with marine mammals, birds, and fishes as definitive hosts, require an intermediate host, such as a fish, amphibian, insect, crustacean, or small mammal. Infestation is typically characterized by pulmonary damage and distress initially, and digestive disturbances later. Damage may also occur during larval migration to other parts of the body, including the liver and brain.

Dracunculoidea, the superfamily of parasitic nematodes, comprise obligate tissue parasites of fishes, reptiles, and mammals. All known species require an intermediate host in order to complete their life cycle, and that host is always a water flea (*Cyclops*). The most widely known example is *Dracunculus medinensis*, the guinea worm.

Ingestion of water containing infective *Cyclops* is the only known source of infection. The encysted nematode larvae are released from *Cyclops* by the digestive juices of the duodenum. Then the larvae burrow through the intestinal wall, and upon

reaching the loose connective tissue, they develop to adulthood in 8 months to 1 year.

The gravid females, 28–48 in. (70–120 cm) long, migrate from the site of development to the surface of the skin, and a papule is formed, then a blister, usually on the lower extremities. When the blister comes in contact with fresh water, the uterus bursts through the anterior part of the nematode's body, and the worm also bursts, releasing cloudlike swarms of motile larvae. These larvae are then filtered from the water by *Cyclops* and subsequently ingested.

The formation of the blister and subsequent rupturing of the female produce a profound allergic reaction. This reaction results from the release of large amounts of toxic by-products from the worm. Upon discharge of larvae in fresh water, much of the allergic reaction abates. The reactions and systemic prodromes include erythema, urticarial rash, pruritus, vomiting, diarrhea, and giddiness. Septicemia, suppurating cysts, and chronic abscesses are not uncommonly associated with these infections. The worms can be removed surgically, or in the native manner of winding upon a stick. Chemotherapy is also available.

Control in endemic areas includes keeping infected persons from wading or bathing in water used for drinking purposes, and the education to avoid drinking suspect water. See NEMATATA.

[A.R.M.]

**Ascidacea** A class of Tunicata which occurs as solitary zooids or, by a process of asexual budding, develops into colonies.

Zooids vary in length from about 0.1 to 10 in. (a few millimeters to 25 cm). Individuals or colonies are invested by a protective covering, the tunic or test, made of polysaccharide material structurally close to cellulose. Beneath the test is the body wall or mantle. Each zooid has two apertures: inhalant (oral) and exhalant (atrial). Water currents, created by cilia on the margins of stigmata in the pharyngeal wall, draw water into the branchial sac, where it is filtered and passed out through the exhalant aperture. Digestive enzymes are secreted into the stomach, and a pyloric gland, of unknown function, enters at the junction of stomach and intestine. Gonads are hermaphroditic, and may be situated in the loop of the intestine or in the mantle wall.

Three orders of ascidian are recognized. Ascidiaceans occur throughout the seas of the world and at all depths, including the abyssal region. Most species feed on minute particulate matter, but a few are carnivores and engulf small zooplankters. See TUNICATA.

[I.Go.]

**Ascomycota** A phylum in the kingdom Fungi, representing the largest of the major groups of fungi, and distinguished by the presence of the ascus, a specialized saclike cell in which fusion of nuclei and reduction division occur and the resulting nuclei form ascospores. In most ascomycetes, each ascus contains eight ascospores, but the number may vary from one to several hundred. In the simplest ascomycetes (yeasts), the vegetative body (thallus) is unicellular; however, in the majority of ascomycetes, the thallus is more complex and consists of a tubular, threadlike hypha with cross walls which grows in or on the substrate. These hyphae eventually form structures called ascomata (ascocarps), on or in which the asci are formed. In addition to their sexual reproduction, most ascomycetes reproduce asexually by means of conidia.

Traditionally, the structure of the ascoma and ascus has served as the basis for subdividing the Ascomycota into five classes: Hemiascomycetes, Plectomycetes, Pyrenomycetes, Discosporomycetes, Loculoascomycetes. The introduction of molecular data, however, is changing concepts of the relationships

of different groups of ascomycetes and will eventually lead to a much-revised classification scheme. See DISCOMYCETES; HYMENOMYCETES; LOCULOASCOMYCETES; PLECTOMYCETES; PLECTOMYCETES.

The ascomycetes occur throughout the world in all types of habitats and on both living and dead substrates. An estimated 33,000 species are arranged in about 3300 genera, with new species being described regularly. Ecologically ascomycetes function as primary decomposers of plant materials, but they also are important as plant and human pathogens; in baking, brewing, and winemaking; in enzyme and acid production; and as sources of antibiotics and other drugs. See EUMYCOTA; FUNGI; PLANT PATHOLOGY; YEAST. [R.T.Ha.]

**Ascorbic acid** A white, crystalline compound, also known as vitamin C. It is highly soluble in water, which is a stronger reducing agent than the hexose sugars, which it resembles chemically. Vitamin C deficiency in humans has been known for centuries as scurvy. The compound has the structural formula shown below.

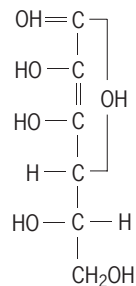

The stability of ascorbic acid decreases with increases in temperature and pH. This destruction by oxidation is a serious problem in that a considerable quantity of the vitamin C content of foods is lost during processing, storage, and preparation.

While vitamin C is widespread in plant materials, it is found sparingly in animal tissues. Of all the animals studied, only a few, including humans, require a dietary source of vitamin C. The other species are capable of synthesizing the vitamin in such tissues as liver and kidneys. Some drugs, particularly the terpene-like cyclic ketones, stimulate the production of ascorbic acid by rat tissues.

Vitamin C-deficient animals suffer from defects in their mesenchymal tissues. Their ability to manufacture collagen, dentine, and osteoid, the intercellular cement substances, is impaired. This may be related to a role of ascorbic acid in the formation of hydroxy-proline, an amino acid found in structural proteins, particularly collagen. People with scurvy lose weight and are easily fatigued. Their bones are fragile, and their joints sore and swollen. Their gums are swollen and bloody, and in advanced stages their teeth fall out. They also develop internal and subcutaneous hemorrhages.

There is evidence that vitamin C may play roles in stress reactions, in infectious disease, or in wound healing. Therefore, many nutritionists believe that the human intake of ascorbic acid should be many times more than that intake level which produces deficiency symptoms. The recommended dietary allowances of the Food and Nutrition Board of the National Research Council are 30 mg per day for 1- to 3-month infants, 80 mg per day for growing boys and girls, and 100 mg per day for pregnant and lactating women. These values represent an intake which tends to maintain tissue and plasma concentrations in a range similar to that of other well-nourished species of animals. See VITAMIN. [S.N.G.; W.A.Li.]

**Ascothoracica** An order of the subclass Cirripedia. Members are ecto- or endoparasites of coelenterates and echin-

oderms. The body is enclosed in a voluminous saclike mantle up to 0.8 in. (20 mm) long, whereas the body is only about one-fourth of this length (see illustration). Ascothoracica are not attached permanently to the host by the antennular region, but

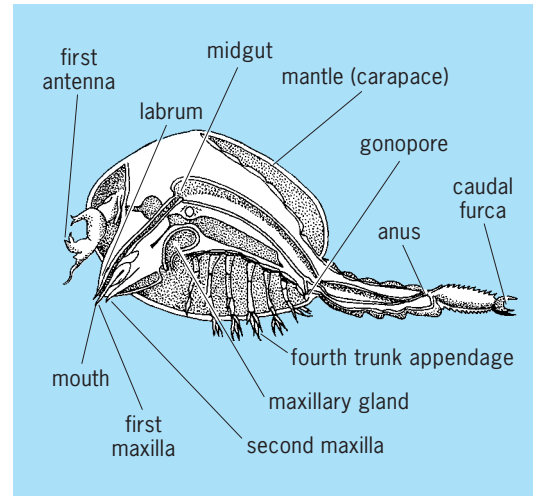

*Ascothorax ophiocetis*, a parasite in the bursae of brittle stars. (After R. D. Barnes, *Invertebrate Zoology*, 2d ed., Saunders, 1968)

the antennules may be modified as a clasping organ. Up to six pairs of thoracic appendages are present, reduced in number and development in the endoparasites. The mouth parts are modified for piercing and sucking. Unlike all other Cirripedia, Ascothoracica retain a more or less segmented abdomen in the adult. There are no cement glands present. Diverticula of the alimentary canal extend into the mantle. See CIRRIPIEDIA. [H.G.St.]

**Asellota** A suborder of the Isopoda containing aquatic species of considerable morphologic and ecologic diversity. These crustaceans are usually divided into three major groups, the Paraselloidea, Aselloidea, and Stenetrioidea. Asellotes such

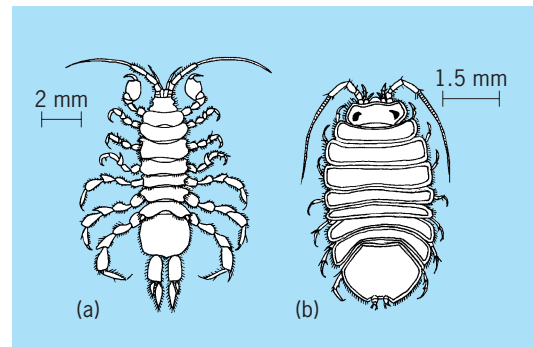

*Asellus communis*. (After H. S. Pratt, *Manual of the Common Invertebrate Animals*, rev. ed., McGraw-Hill, 1951)

as *Asellus* (see illustration) are found in freshwater streams; *Caecidotea*, in subterranean water; *Caecioniropsis*, in the interstices of marine sands as commensals with other isopods such as *Caecijaera* and *Jaera* and in shallow waters of the seas; and *Macrostylus*, in the greatest depth of the seas. See CRUSTACEA; ISOPODA. [R.J.Me.]

**Ash** A genus, *Fraxinus*, of deciduous trees of the olive family Oleaceae, order Scrophulariales, which have opposite, pinnate leaflets, except in one species, *F. anomala*, which has only a single leaflet. There are about 65 species in the Northern Hemisphere. This tree occurs in America south to Mexico, in Asia south to Java, and in Europe. See SCROPHULARIALES.

The white ash (*F. americana*), of the eastern United States, has stalked leaflets, rusty-colored winter buds, and an erect trunk that is valuable for lumber. The wood is light, strong, but flexible, and is used for oars, baseball bats, furniture, motor vehicle parts, boxes, baskets, and crates. The black ash (*F. nigra*) grows in wet soils in the northeastern United States and Canada and has sessile leaflets and friable outer bark. The wood of black ash is used for the same purposes as that of white ash. The red ash (*F. pennsylvanica*), also of the eastern United States and adjacent Canada, has pubescent (hairy) twigs and leafstalks. The uses of the wood of this species are also similar to those of white ash. Some species of ash are ornamental trees, such as the flowering ash (*F. ornus*) with gray winter buds and white flowers, and the European ash (*F. excelsior*) with black buds and sessile leaflets. See FOREST AND FORESTRY; TREE. [A.H.G./K.P.D.]

**Asia** The largest of the world's continents. With its peninsular extension, commonly called the continent of Europe, it is the major portion of the broad east-west extent of the Northern Hemisphere land masses. In many ways Asia is more a cultural concept than a physical entity. There is no logical physical separation between Asia and Europe, and even Africa is separated from Asia merely by the width of the Suez Canal. For convenience, however, the Eurasian land mass is considered to be divided by the Ural Mountains into Europe in the west and Asia in the east. Thus restricted, Asia has an area of about 17,700,000 mi<sup>2</sup> (45,800,000 km<sup>2</sup>), about one-third of the land area of the Earth. In the north, Siberia reaches past the 80th latitude. Southward, India and Sri Lanka (Ceylon) reach nearer than 10°N of the Equator, while the Indonesian islands extend more than 10°S of the Equator. The continental heart of Asia is more than 2000 mi (3200 km) from the nearest ocean. See CONTINENT; EUROPE.

**Topography.** In the topographic framework of Asia, the great mountain systems are the most impressive features. From the central knot of the mighty Pamirs and Kopet Dagh in the heart of the continent originate chains radiating in several directions. In the Peter the First Range there are such heights as Qullai Ismoili Somoni, 24,584 ft (7493 m), and Lenin Peak, 23,377 ft (7125 m), above sea level. Running westward through Afghanistan is the Hindu Kush, reaching elevations over 20,000 ft (6100 m). The mountain trendline continues, after a jog northwestward, in the Elburz of northern Iran and thence in the Armenian highlands and the Caucasus, each with elevations reaching 18,000 ft (5500 m), decreasing thereafter to the Pontus and Taurus ranges of northern and southern Turkey. In western and southern Iran are the massive Zagros and Makran ranges.

Southeastward from the Pamir knot run the three most imposing mountain chains on Earth: the Karakorum, which continues the line of the Hindu Kush eastward in an arc convex to the north; the Himalaya in an arc convex to the south; and the shorter Trans-Himalaya, or Nyen-chen Tangla, north of the Himalaya, with higher average elevations but peaks of lesser height. In all of these, the average elevations exceed 4 mi (6400 m), with several scores of peaks reaching a height in excess of 25,000 ft (7600 m) above sea level. Everest, 29,141 ft (8882 m), and Kinchinjunga, 28,146 ft (8579 m), lie in the Himalaya, while the peak designated as K2, 28,250 ft (8611 m), rises in the Karakorum.

In eastern Tibet the Himalaya and Nyen-chen Tangla bend sharply toward the south, and the former is cut through by the gorge of the Brahmaputra River. From the bend zone, great ridges divided by deep gorges run south to form the Burma-

China frontiers and the mountain backbones of the Malay peninsula and Vietnam. The Nan-ling system of south China diverges eastward to divide the Yang-tzu (Yangtze) from the Hsi (Si) drainage.

From the western Himalaya, the 11,000-ft (3400-m) Sulaiman Range runs south and, together with the Kirthar Range, divides West Pakistan from Afghanistan.

Beginning at heights over 20,000 ft (6100 m) and branching off from the Karakorum south of Kashgar, the Kuen-lun Mountains run eastward across western China. Genetically they form the longest mountain system of China. With their eastward extensions in the 12,000 ft (3700 m) Ch'in-ling and the lesser Ta-pieh mountains and Huai-yang hills, they reach almost to the Pacific. Together with the northeastward arc of the Altyn Tagh and the Nan Shan branching from it, the Kuen-lun forms the northern wall of the Tibetan plateau. Near the eastern end of the Kuen-lun proper lie the Amne Machin Mountains, with peaks up to 25,000 ft (7600 m) in elevation.

Northeastward of the Pamir knot runs the east-west oriented Tien Shan, over 1000 mi (1600 km) long and maintaining heights of 18,000–20,000 ft (5500–6100 m) over much of its length. Roughly parallel and trending east and west is a series of great ranges to its north, with mutual connections in the west. These include the Altai-Sayan, the Tannu Ola, and the Kentei, which form natural boundaries for Outer Mongolia. They continue the systems of young mountains crossing central Asia; farther northeast, they extend further in the Stanovoi Mountains of Eastern Siberia.

The Asian plateaus are in various stages of erosion and thus present a great variety of landscapes. The Tibetan plateau is a prime example. The western half, because of little rainfall, exhibits a rolling topography with relatively slight local relief except where mountain chains cross it; it is a land of internal drainage basins. Average elevations are over 16,000 ft (4900 m). The eastern half is humid or subhumid and is cut by numerous rivers, producing deep canyons and great ridges. In contrast to this is the Mongolian plateau. This plateau consists mostly of vast, rather level plains 3000–5000 ft (900–1500 m) high, surmounted in places by mountains, and containing broad, shallow basins divided by land swells of low elevation.

Other major topographic units of Asia are blocs of hill lands. Most of southern China and much of southeastern Asia comprise hills which may be roughly defined as slope lands with local relief under 1000–1500 ft (300–450 m) although in absolute elevation they may rise many thousands of feet above sea level. Hilly lands are found to predominate in the northern part of the Indian peninsula and along both flanks of the Indian plateau, where they are called ghats. In southern India are the Nilgiri and Cardomom hills, rising to mountainous elevations of 8000 ft (2400 m). Many parts of different plateaus have hilly regions where erosion has produced uneven local relief, as in the Shan or North Vietnam plateau. Hills are prominent features of southwestern Asia, including eastern Mediterranean regions, such as Israel, Syria, and Lebanon.

The most significant topographic units of Asia are the great alluvial plains and river deltas. The gross drainage pattern of Asia is radial; the rivers flow from the highlands in the heart of the continent and run outward in all directions. Only in the south, east, and north sectors of the continent do the rivers reach the sea. Flowing into the peripheral seas of the Pacific are such mighty rivers as the Mekong, the Hsi, the Yang-tzu, the Huai, the Yellow, and the Amur, each building large, heavily populated plains and, with the exception of the Amur, densely settled deltas. The Yellow Plain (North China Plain), with some 125,000 mi<sup>2</sup> (324,000 km<sup>2</sup>) of area, and the Yangtzu Plain, with about 75,000 mi<sup>2</sup> (194,000 km<sup>2</sup>), are among the most extensive alluvial plains of the Earth. In the shallow South China, East China, and Yellow seas, the deltas of the first five rivers mentioned above are pushing steadily seaward.

Important sectors of Asia, containing some 200,000,000 people, are completely insular. The most important are the Japanese, Philippine, and Indonesian islands and Taiwan. Almost all of Asia's islands lie in great volcanic arcs bounding large seas off the continent's Pacific coast. At least 160 active volcanoes are found here and in Kamchatka. Few islands lie along the Asiatic coasts of the Indian Ocean, although the Sunda chain of Indonesia has perhaps more of a claim to Indian Ocean frontage than to Pacific frontage. Sri Lanka is the only significant island in the northern part of the Indian Ocean west of Sumatra. In the Persian Gulf off the north coast of Arabia lies the small island Bahrein.

Few islands lie off the alluviated coastlands of northern Siberia. Some moderately large ones are included in the barren and rocky Severnaya Zemlya group, the New Siberian Islands, and Wrangel Island. The Commander Islands and Karaginski Island lie in the Bering Sea only a short distance from the Aleutians.

**Climates.** Five major climatic types may be distinguished in the Asian region: (1) the monsoonal system of eastern Asia, (2) the monsoonal system of southern Asia, (3) the equatorial regions of southeastern Asia and their extension into the Southern Hemisphere as they are influenced by the Australian monsoon, (4) the winter rainfall areas of southwestern Asia, and (5) the cyclonic and convectional storm systems of central and northern Asia.

Fundamental to understanding the climates of Asia are the vastness of the unbroken landmass and the long latitudinal stretch from the polar realm to south of the Equator. These are responsible for the great temperature and humidity extremes that occur. The greatest ranges of temperatures in the world have been recorded in interior Asia. Continentality, therefore, is the outstanding feature of climates of interior Asia. In coastal and insular areas of east Asia, however, winds moving over the warm, northward-flowing Japan Current and the western Pacific waters moderate the coastland and island climates. See MONSOON METEOROLOGY.

The driest portions of Asia include the vast areas of southern Mongolia, Hsin-chiang, former Soviet Central Asia, and southwestern Asia. Except for small, favored mountain areas, most of this region from the Gobi to the Red Sea gets less than 10 in. (25 cm) of precipitation per year. With the exception of southern Arabia, which is subtropical desert, these are mid-latitude desert and dry steppe regions. Favored with higher rainfall are the Yemen Mountains and the coastal mountains of Turkey, together with Lebanon, Syria, and northern Israel. The highlands of Armenia and the Elburz of Iran are favored also with more abundant rainfall, which may range from 25 to 50 in. (64 to 127 cm) or more per year.

The northeastern Siberian mountains and the Arctic coastal lands also receive meager rainfall, less than 8 in. (20 cm), but are not dry because evaporation is low and the water table is high. Most of Siberia has permafrost below a few feet of surface soil, so that rainwater does not filter far down into the earth. Between the arid belt of central Asia and the northeast Siberian low-precipitation zone, the annual rainfall ranges between 10 and 18 in. (25 and 45 cm).

In eastern Asia the precipitation increases in a southeasterly direction from interior Asia to the coast. The annual maximum seldom exceeds 80 in. (203 cm) in the wetter southeast coastal regions, whereas this drops to less than 30 in. (76 cm) in the North China Plain and less than 15 in. (38 cm) at the Great Wall. In some mountainous parts of Japan and Taiwan, the yearly average may be more than 100 in. (254 cm).

In the Indian subcontinent rainfall is heaviest along the western plateau fringe and in East Bengal, where it may average over 100 in. (254 cm) per year. The interior of the peninsula is relatively dry. Northwestern India and Pakistan share the drought of southwestern Asia. With the exception of the extreme north, Ceylon generally has abundant rainfall.

Southeastern Asia has the heaviest rainfall of the entire Asiatic region. The mainland mountains facing the southwest summer monsoon crossing the Bay of Bengal, and parts of the Vietnamese and Laotian cordilleras facing the humidified northeast winter monsoons of eastern Asia, regularly get average rainfalls of 120–150 in. (305–381 cm) or even more. Equally heavy rainfalls occur in the southwestern half of Sumatra, southwestern Java, the northwestern half of Borneo, and the Pacific fringe of the Philippine Islands. With a few small exceptions, southeastern Asia has no areas that are subject to severe drought.

**Vegetation.** Asia's vegetation belts and zones follow, in general, the climatic patterns from desert lands through tropical to Arctic margins.

A wide belt of tundra made irregular by topography occupies the entire Arctic lowland of Siberia with widths varying from 250 to 500 mi (400 to 800 km) north and south. It is widest in the extreme northeast and it extends southward and inland with higher elevations. The frozen subsoil permits the growth of little more than mosses, lichens, dwarfed trees, and scrub. See PERMAFROST; TUNDRA.

The largest unbroken expanse of forest in the world is the Siberian taiga, a dominantly coniferous forest of larches, spruce, fir, and pines, with such deciduous trees as birch and aspen occurring intermixed with the conifers or taking over as a secondary growth in burnt-over areas. The width of this belt in Siberia is more than 1000 mi (1600 km) and it stretches about 4000 mi (6400 km) from the Sea of Okhotsk to the Urals. See TAIGA.

Various admixtures of coniferous and deciduous trees compose the vegetation of mid-latitude mixed forests. In the west Siberian plain there is a narrow zone of mixed taiga and deciduous forests including oaks, maples, ash, and lindens. This zone, with a width of 50–100 mi (80–160 km), lies somewhat south of the parallel of 60°N and fades into the steppelands that form the great spring-wheat region of Siberia. Mixed midlatitude deciduous and coniferous forest areas of a similar type occupy most of Korea, the northern half of Honshu in Japan, and the hill lands surrounding the Yellow Plain, as well as the Ch'inling Mountains. In southern Asia these forests are found chiefly in a narrow belt of mountain land in the outer ranges of the Himalaya. The remaining areas of these mixed forests run from the Elburz Mountains through the Armenian highlands and the Black Sea fringe of Turkey to the Aegean coast, and in southwestern Asia in the Elburz of northern Iran.

From the mixed and deciduous forests of the west Siberian plain southward, an increasingly dry steppeland is encountered. It extends for 400–500 mi (640–800 km) in a belt about 1000 mi (1600 km) long between the Urals and the Altai-Sayan and associated uplands. The northern half of this belt with its higher annual precipitation of 12–16 in. (30–40 cm) is the agricultural heart of the plain. The southern part gradually changes to desert steppe and then to desert along about the 50th parallel. Eastward of Lake Baikal a broadened steppe zone occupies the Trans-Baikal region extending southward to the Gobi Desert of southern Mongolia and eastward to the Great Hsing-an Mountains, where the zone, about 200 mi (320 km) wide, runs southward in Inner Mongolia. The steppe zone in Inner Mongolia widens with the increasing moisture south of the Great Wall to include most of China's loess plateau. Grasses also form the natural vegetation of the Manchurian plain, with tall grass in the eastern portion thinning out to short-grass steppe in the Hsing-an Mountain flanks. The Gobi Desert is flanked by steppelands to its north, east, and south, as well as by mountain steppe zones in the eastern Altai and eastern T'ien Shan.

Mixed evergreen forests appear to be limited mostly to interior southern China and to Japan from the Kwanto Plain southward, South of the Yang-tzu Valley, this forest type extends from the coast at Shanghai to the gorge lands of eastern Tibet. In Asia the characteristic trees of the mixed forest include broad-leaved evergreen trees such as banyans and camphor, and coniferous



trees such as pines, cedars, and cypresses, as well as varieties of bamboo.

Tropical and subtropical rainforest is restricted to warm or hot regions of southern and southeastern Asia which get ample rainfall the year round or get so much rain during a large part of the year that a high groundwater table is maintained during the short dry season. The subtropical sectors are found along the southeastern China coast, in Taiwan, and in northern Burma; they merge with the tropical rainforest farther south, where rainfall and temperature increase. See RAINFOREST.

Monsoon tropical deciduous forests comprise the tropical parts of Asia which have a moderately high rainfall but a long dry season (usually in the low-sun period or winter). These forests consist mostly of mixed species, but sometimes a single species becomes dominant as a result of selection from frequent burnings.

A large region of savanna grassland surrounds the Thar Desert of northwestern India and occupies most of the Indus Valley, the Punjab, and the Kathiawar peninsula. Much of the drier interior peninsular Deccan of India also has this as a natural vegetation. Other Asian regions with similar cover are found in Yemen and the region in southeastern Arabia from Oman as far westward as the Qatar peninsula; and similar vegetation extends over the Korat plateau of Thailand, lower Thailand west of Bangkok, southern Cambodia, and small areas in interior Borneo and the Philippines. See SAVANNA.

Immense areas of central and southwestern Asia have little or no vegetative cover, and bare rock alternates with sand veneering. In places shifting sand dunes are formed. Although the deserts are not necessarily lifeless, the vegetation is so widely spaced that much bare ground is exposed. The tropical desert areas generally receive their meager rainfall in torrential downpours on rare occasions. After such rains numerous herbs may spring to life and flower, while the bunch grass here and there may become green for a short season. [H.J.Wi.]

**Asparagales** A large, widespread order of petaloid monocotyledons consisting of 29 families and about 26,000 species. Asparagales are clearly circumscribed in deoxyribonucleic acid (DNA) sequence analyses but are difficult to define morphologically, and separation from Liliales has proved particularly problematic. Phytomelan, a dark seedcoat pigment present in most families of Asparagales but not found in other plants, is an obvious characteristic of this order, although seeds of the largest family, Orchidaceae, and a few other taxa lack phytomelan. Most Asparagales are herbaceous perennials, but there are some vines including some species of asparagus (Asparagaceae), and woody taxa including aloes (Asphodelaceae). The order contains many horticultural taxa, including members of Orchidaceae (orchids), Amaryllidaceae (daffodils, belladonna lilies, and others), Iridaceae (irises, gladiolus, freesias), Convallariaceae (lily of the valley, Solomon's seal), and Hemerocallidaceae (daylilies), in addition to food crops including onions, leeks, and garlic (Alliaceae). See FLOWER; LILIACEAE; LILIOPSIDA; MAGNOLIOPHYTA; ORCHID; ORCHIDALES; PLANT KINGDOM. [M.EF.; M.W.C.]

**Asparagus** A dioecious perennial monocot (*Asparagus officinalis*) of Mediterranean origin belonging to the plant order Liliales. Asparagus is grown for its young shoots or spears, which are canned, frozen, or cooked fresh as a vegetable. These aerial stems arise from rhizomes (underground stems). The rhizomes and the fleshy and fibrous roots constitute the massive underground part of the plant. Blanched or white asparagus is grown by ridging soil over the rows and cutting the spears beneath the soil surface. Chemical weed control is commonly used.

Commercial production is limited to areas where crowns will have a dormant period of 3–5 months each year. Dormancy in the northern states is induced by low temperatures and in California by withholding irrigation. California, New Jersey, and

Washington are important asparagus-producing states. See LILIALES. [H.J.C.]

**Aspartame** A white, crystalline compound, 1-aspartyl-1-phenylalanine methyl ester (APM), with formula (1). It is slightly

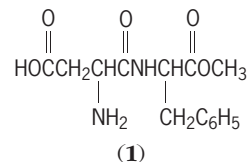

soluble in water. Its sweetening properties were discovered accidentally in 1965 when the compound, a dipeptide, was produced as an intermediate in the synthesis of the C-terminal tetrapeptide of gastrin. Aspartame is the L,L-diastereoisomer; the three other possible diastereoisomers are not sweet. The taste of aspartame would not have been predictable based on its component amino acids, aspartic acid and phenylalanine.

The sweetness of aspartame relative to sucrose is a function of the latter's concentration, and is also dependent upon the presence of other flavors and materials. In a number of applications, such as chewing gum and various fruit-flavored products, aspartame favorably extends and enhances the flavor perception, and it shows synergy with other sweeteners. The sweetness perception may also last longer with aspartame than with sucrose or other sweeteners. See SUCROSE; TASTE.

Aspartame is metabolized to its component amino acids, which are further metabolized by the usual metabolic pathways. Under certain conditions of heat and pH in aqueous solution, aspartame is transformed into its diketopiperazine derivative, 3,6-dioxo-5-benzyl-2-piperazineacetic acid (2), which is tasteless.

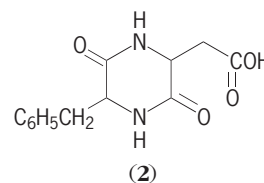

This property limits the use of aspartame when it is exposed to high temperatures, such as in baking. The stability of aspartame in aqueous solution is pH-dependent; it is most stable at a pH of approximately 4. The rate of conversion (its half-life is 262 days at 77°F or 25°C) is sufficiently slow under the conditions of normal use that aspartame has found an increasing number of applications in various food products, and is particularly successful in soft drinks. The safety of aspartame has been established by studies in animals and human beings. Aspartame has been approved in many countries for uses in both dry and wet applications. See FOOD ENGINEERING. [D.L.A.]

**Aspect ratio** As originally conceived, the ratio of the span of a wing or airfoil to the chord of a wing, where the span is the maximum cross-stream dimension and the chord is the dimension in the streamwise direction, as illustrated. This definition is unambiguous only in the case of a rectangular wing.

Because early wings were usually nearly rectangular, no confusion resulted from the original definition. Later, when wings were tapered or had complex planforms, another definition became necessary. It was desirable that the new and more general definition correspond to the old definition for the special case of the rectangular wing. The more general definition of geometrical aspect ratio which is now universally used is given in the equation below, where  $A$  is the aspect ratio and  $b$  and  $S$  are

$$A = b^2/S$$

defined in the illustration. Because  $S$  is equal to  $bc$  for a wing of

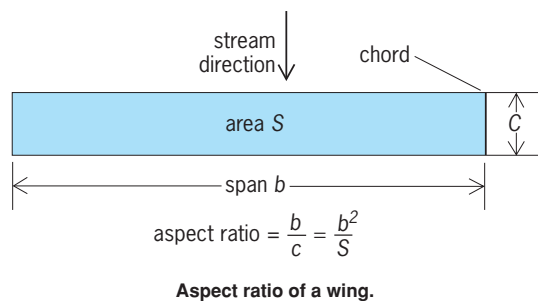

rectangular planform, the definition of aspect ratio given in the equation corresponds to the original idea of the ratio of the span to the chord for a rectangular wing. [A.E.V.D./R.L.Bi.]

**Asphalt and asphaltite** Varieties of naturally occurring bitumen. Asphalt is also produced as a petroleum by-product. Both substances are black and largely soluble in carbon disulfide. Asphalts are of variable consistency, ranging from a highly viscous fluid to a solid, whereas asphaltites are all solid. Asphalts fuse readily, but asphaltites fuse only with difficulty. Asphalts may, moreover, occur with or without appreciable percentages of mineral matter, but asphaltites usually have little or no associated mineral matter. See BITUMEN; IMPSONITE; WURTZILITE.

Many asphalts occur as viscous impregnations in sandstones, siltstones, and limestones. Most such deposits are thought to be petroleum reservoirs from which volatile constituents have been stripped by exposure of the rock. Relatively pure asphalt occurs in Kern, San Luis Obispo, and Santa Barbara counties, California. Occurrences of asphalt are also known in Kentucky and Oklahoma. Although asphalt seeps have long been known in France, Greece, Russia, Cuba, and other countries, the best known and largest are those of Venezuela and Trinidad.

The asphaltites (gilsonite, grahamite, and glance pitch) were probably derived from a saline lacustrine sapropel and owe their variable properties to differences in environment of deposition. These substances occur on a large scale in the Uinta Basin of northeastern Utah, where they are derived from upper Eocene Green River sediments, most of which are oil shales high in carbonate content. See OIL SHALE; SAPROPEL. [I.A.B.]

Asphalt is derived from petroleum in commercial quantities by removal of volatile components. It is an inexpensive construction material used primarily as a cementing and waterproofing agent. See PETROLEUM PRODUCTS.

Asphalt is composed of hydrocarbons and heterocyclic compounds containing nitrogen, sulfur, and oxygen; its components vary in molecular weight from about 400 to 5000. It is thermoplastic and viscoelastic; at high temperatures or over long loading times it behaves as a viscous fluid, while at low temperatures or short loading times it behaves as an elastic body.

The three distinct types of asphalt made from petroleum residues are straight-run, air-blown, and cracked. Straight-run asphalt, characterized by a nearly viscous flow, is used in the construction of pavement surfaces for roads and airport runways. Air-blown asphalt is resilient and has a viscosity that is less susceptible to temperature change than that of straight-run asphalt. It is used mainly for roofing, pipe coating, paints, underbody coatings, and paper laminates. Cracked asphalt, with limited applications such as dust laying or as an insulation board saturant, has a nearly viscous flow, and its viscosity is more susceptible to temperature change than straight-run asphalt. [T.K.M.]

**Aspidogastrea** A group of entoparasites considered to be a subclass or order of the Trematoda. They have strongly developed ventral holdfasts. Two families, Aspidogastridae and Stichocotylidae, are recognized. Aspidogastridae, which are the commonest, occur in various cavities of mollusks and in digestive

tracts of fishes and turtles. Elongate Stichocotylidae occur in the digestive tracts of skates. Little is known of the physiology of aspidogastreae, but they appear less host-specific than other trematodes. See DIGENEA; TREMATODA. [W.J.Ha.]

**Aspidorhynchiformes** A small order of specialized holostean fishes which are first recorded from Middle Jurassic deposits of Europe, and probably had a worldwide distribution in the warm seas of the Cretaceous Period. The order contains one family, Aspidorhynchidae, and two genera: *Aspidorhynchus* and *Belonostomus*. These fishes, some of which reached a length of over 3 ft (0.9 m), are characterized by a ganoid scale covering with much deepened scales along the flank, by an elongate fusiform body and head with long slender snout, and by an externally symmetrical tail. All the fins are small and fringing fulcra are reduced or absent. The dorsal and anal fins are positioned opposite one another far back on the body, and the pelvic fins are inserted closer to the anal than to the pectorals (see illustration). See HOLOSTEI.

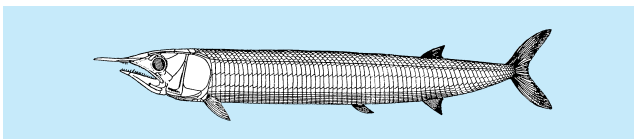

*Aspidorhynchus acutirostris*, Upper Jurassic, Bavaria. (After Assmann)

In the body form, fin position, and elongated snout, the aspidorhynchiforms resemble some of the living teleostean Exocoetidae (needlefishes and sauries). It seems likely that these two widely separated and unrelated groups of fishes shared a similar mode of life, being predacious open-water forms that utilized their long snouts and strong swimming ability in capturing prey. See OSTEICHTHYES; TELEOSTEI. [T.M.C.]

**Aspirin** The acetyl ester of salicylic acid, also known as 2-(acetyloxy)-benzoic acid and acetylsalicylic acid (see structure below). Aspirin is prepared by the acetylation of salicylic acid with acetic anhydride.

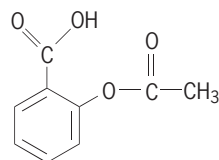

Aspirin is effective as an analgesic, antipyretic, and anti-inflammatory drug. It prevents the aggregation of platelets, and there is some evidence that it can prevent stroke. Aspirin, if tolerated, is the preferred drug for the treatment of rheumatoid arthritis, and it has been used in the treatment of osteoarthritis. Aspirin lowers fever, probably by acting on the hypothalamus. Salicylates inhibit aldose reductase in the lens; it has been suggested that they might retard the development of cataracts. Aspirin might encourage the development of Reye's syndrome, an acute encephalopathy which occurs in children who recover from viral disease, but this cause-and-effect relationship remains to be confirmed. See ANALGESIC; ARTHRITIS.

Intolerance to aspirin is not uncommon. It tends to develop in middle age and involve the skin or the respiratory tract, or both. Death rarely ensues because people rapidly become aware of their intolerance. [M.S.]

**Assembly machines** Machines that take discrete components as they come into an assembly department and bring them together so as to produce a configuration of some practical value. Such machines differ from packaging machinery in two ways: in assembly machinery, components must be inserted in

specific sequence and spatial attitude; and they must often be tested functionally as part of the assembly process.

Assembly machinery was originally conceived for situations where volume or hazard of production, parts size, or availability of labor made manual assembly impractical from an operational or economic viewpoint. The early applications of assembly machinery and the majority of modern applications are found in the automotive industry, consumer products, manufacturing, or hazardous assembly.

Assembly machinery can be classified in several ways, including work path (rotary, carousel, or linear, index-dwell ratios (continuous motion, intermittent motion, or power and free); actuation (mechanical, fluid power, or electronically programmable); work nest configuration (pallet or walking beam); and design (special or standard modular). The engineers who specify assembly machinery will usually select from one or more of these categories based on product size and weight, volume of production, product life cycle, future and present flexibility needs, human resources, and return on investment.

Rotary dial machines have a number of pallets fastened to a rotating dial or ring. Transfer devices are usually mounted to the machine base, while feeders are placed outside the periphery of the dial. Carousel machines are usually configured in race track shape. Work-holding nests (the machine elements used to hold all of the parts being assembled) are secured to one another (a configuration known as precision link) or fastened to a chain. Linear machines have an open-loop configuration in which pallets transport the product being assembled along one or more linear paths, rather than in a closed circuit such as rotary or carousel machines.

In any form of automatic assembly, production rates will be controlled by the single longest operation. If new parts can be added to the assembly without the fixture being stopped, the machine can be operated in a continuous motion.

Assembly machines perform several tasks: parts feeding (including orientation, separation, and transfer); parts joining (for example, welding, riveting, and soldering); parts inspection (condition, parameters, presence, and position); functional testing (for example, capacitance, torque, and pressure decay); marking (date coding, model number, and operational characteristics); and ejection (in controlled or uncontrolled positions). Many of the tasks of assembly machinery use commercial units identical to those used on manual lines. The unique task of automatic assembly machinery is that of parts feeding, which consists of accepting the component parts as they come to the assembly area and taking one of these components, separating that component from other parts, changing its spatial orientation to a usable insertion attitude, and transferring it from the orientation device into the work-holding fixture or into a partially completed assembly. See MANUFACTURING ENGINEERING; PRODUCTION METHODS. [F.R.I.]

**Astatine** A chemical element, At, atomic number 85. Astatine is the heaviest of the halogen groups, filling the place immediately below iodine in group VII of the periodic table. Astatine is a highly unstable element existing only in short-lived radioactive forms. About 25 isotopes have been prepared by nuclear reactions of artificial transmutation. The longest-lived of these is  $^{210}\text{At}$ , which decays with a half-life of only 8.3 h. It is unlikely that a stable or long-lived form will be found in nature or prepared artificially. The most important isotope, used for tracer studies, is  $^{211}\text{At}$ . Astatine exists in nature in uranium minerals, but only in the form of trace amounts of short-lived isotopes, continuously replenished by the slow decay of uranium. The total amount of astatine in the Earth's crust is less than 1 oz (28 g).

In aqueous solution, astatine resembles iodine except for differences attributable to the fact that astatine solutions are of necessity extremely dilute. Like the halogen iodine, when astatine exists as a free element in solution, it is extracted by benzene. The element in solution is reduced by agents such as sulfur dioxide

and is oxidized by bromine. It is more electropositive than the other halogens. It has oxidation states with coprecipitation characteristics similar to those of the iodide ion, free iodine, and the iodate ion. Powerful oxidizing agents produce an astatate ion, but not a perastate ion. The free state is most readily obtained and is characterized by high volatility and high extractability into organic solvents. See HALOGEN ELEMENTS. [E.K.H.]

**Asterales** An order of flowering plants, division Magnoliophyta (Angiospermae), which gives its name to the subclass Asteridae in the class Magnoliopsida (dicotyledons). The Asterales have often been included in the order Campanulales, but they are perhaps more closely allied to the Rubiales and Dipsacales. The order consists of only the very large family Asteraceae (Compositae), with about 20,000 species, occurring in nearly all parts of the world but most abundant and conspicuous in areas which are not densely forested. See CAMPANULALES; DIPSACALES; RUBIALES.



New England aster (*Aster novae-angliae*), a characteristic member of the order Asterales. (Courtesy of Alvin E. Staffen, National Audubon Society)

The Asterales are marked by their inferior ovary, single basal ovule, specialized pollen presentation mechanism, and pseudanthial, centripetally flowering heads which often have specialized marginal flowers with a strap-shaped corolla resembling the petal of an ordinary flower. Most members of the order are herbaceous, but some, such as the sagebrush (*Artemisia tridentata*), are shrubs, and a few tropical species are trees. Many well-known garden ornamentals, such as aster (see illustration), chrysanthemum, dahlia, daisy, sunflower (*Helianthus*), and zinnia, belong to the Asterales. A few garden vegetables, for example, lettuce (*Lactuca*) and artichoke (*Cynara*), and some common weeds, such as dandelion (*Taraxacum*), thistle (*Cirsium*), and ragweed (*Ambrosia*), also belong to the order. See ARTICHOKE; ASTERIDAE; LETTUCE; MAGNOLIOPHYTA; MAGNOLIOPSIDA; ORNAMENTAL PLANTS; PLANT KINGDOM; SUNFLOWER. [A.Cr.; T.M.Ba.]

**Asteridae** A large subclass of the class Magnoliopsida (dicotyledons) of the division Magnoliophyta (Angiospermae), the

flowering plants, consisting of 11 orders, 49 families, and more than 60,000 species. The Asteridae are mostly sympetalous with unitegmic, tenuinucellate ovules and with the stamens usually as many as, or fewer than, the corolla lobes and alternate with them. Most of them have two carpels, but a few have as many as five or even more carpels, and a few others are pseudomonomerous. The largest orders of the group are the Asterales (about 20,000 species), Scrophulariales (about 11,000 species), Lamiales (about 7800 species), and Rubiales (about 6500 species). Other orders are the Gentianales, Plantaginales, Solanales, Calitrichales, Campanulales, Calycerales, and Dipsacales. See individual articles on each order. See MAGNOLIOPHYTA; MAGNOLIOPSIDA; PLANT KINGDOM. [A.Cr.; T.M.Ba.]

**Asteroid** One of the many thousands of small planets (minor planets) revolving around the Sun, mainly between the orbits of Mars and Jupiter. Newly discovered asteroids are assigned a catalog number and name (such as 433 Eros) only after they are observed often enough to compute an accurate orbit. There are over 73,000 cataloged asteroids. See PLANET.

The majority of asteroids have semi-major axes (mean distances to the Sun; symbolized  $a$ ) between 2.2 and 3.2 astronomical units (1 AU = distance from Earth to the Sun =  $1.496 \times 10^8$  km =  $9.3 \times 10^7$  mi). However, numerous small asteroids orbit between Venus and Mars, and two large groups, the Trojan asteroids, orbit at Jupiter's distance from the Sun. See TROJAN ASTEROIDS.

In 1992, the first of the trans-Neptunian "asteroids" was discovered. Called Kuiper Belt objects (KBOs), about 900 had been found by mid-2004. They represent a population of bodies much more numerous than the main-belt or Trojan asteroids, but are more properly thought of as comets. There are also a modest number of minor planets orbiting the Sun in temporary orbits beyond Jupiter but well inside the Kuiper Belt; they are termed Centaurs. See COMET; KUIPER BELT.

Most asteroid orbits are more elliptical and inclined to the plane of the ecliptic than the orbits of major planets. A number of small asteroids (Amor objects) cross, but do not intersect, the orbit of Mars, and a few even cross the Earth's orbit (Apollo objects) or orbit inside the Earth's orbit (Athena objects).

Improvements in radar technology make it possible to image small asteroids that pass close to the Earth almost as well as by spacecraft flybys. For more distant asteroids the chief technique used to measure asteroid diameters is radiometry, which compares the brightness of reflected visible sunlight from an asteroid with the brightness of the asteroid's emitted thermal radiation in the infrared. See ALBEDO; INFRARED ASTRONOMY; OCCULTATION.

There are about 30 asteroids larger than 124 mi (200 km) in diameter; about 75% of them are soot black (geometric albedo of 3–5%). Asteroids are much more numerous at smaller sizes, generally following a size distribution characteristic of fragmentation processes, as would be expected if the asteroids were smashing into each other. Indeed, there are so many large asteroids confined in the volume of the asteroid belt that collisions sufficient to fragment all but the larger asteroids occur every few billion years, and much more often for smaller ones. Thus all asteroids have been extensively battered and many are collisional fragments.

Spectra of sunlight reflected from asteroids have shapes, including absorption bands, characteristic of different rock-forming minerals. Combined with the albedo data from radiometry, the spectral colors of surfaces of over 2000 asteroids show that more than three-quarters of them have very low albedos and are composed of carbon-rich material (often with hydrated, or water-rich, minerals). The black asteroids located in the middle and outer parts of the belt (called C type) resemble carbonaceous meteorites, which are believed to be among the most primitive materials in the solar system, little altered since the planets were forming. The black asteroids near the outer edge of the main belt have a reddish tinge and are not represented by known me-

teorites on the Earth; they are called P types, and may be even richer in organic components. Still farther out, many of the Trojans are even redder and more mysterious; they are termed D types. Closer to the inner edge of the belt, most asteroids are so-called S types, characterized by moderately high albedos and by absorption bands due to the common silicate minerals pyroxene and olivine. They also contain considerable metal, and probably are akin to either the stony-iron meteorites or the ordinary chondritic meteorites. The general progression of asteroid compositions is thought to reflect the variation with distance from the Sun in the composition of the original nebular dust from which the planets were formed. See COSMOCHEMISTRY; METEORITE; SOLAR SYSTEM.

Apollo, Amor, and Aten asteroids are of special interest, particularly because they stand a chance of striking the Earth. Indeed, Meteor Crater (Arizona), and other craters on the Earth and the Moon, testify to the potential for collisions with near-Earth asteroids. Many scientists believe that just such a collision  $6.5 \times 10^7$  years ago rendered most species of life, including the dinosaurs, extinct. A huge, eroded crater of that age on the Yucatán peninsula in Mexico must have been caused by the impact of an asteroid or comet about 10 mi (16 km) in diameter. In 1908, a small asteroid, perhaps 160 ft (50 m) across, exploded over the Tunguska region of Siberia with energy equivalent to 15 megatons of TNT. Only about one-third of the potentially threatening objects have been discovered so far.

After some tens of millions of years, most of the current crop of near-Earth asteroids will have struck the Earth, the Moon, the Sun, or one of the other inner planets, or will have been ejected from the solar system. Most are probably fragments of main-belt asteroids, traveling in chaotic orbits, just like their smaller cousins, the meteorites.

Current cosmogonical models for the origin of planets involve accretion from myriads of asteroidlike planetesimals. It is likely that asteroids are a remnant of the planetesimals that failed to accrete into a planet between Mars and Jupiter. Perhaps bombardment of the asteroid zone by large planetesimals scattered from massive, nearby Jupiter increased the relative velocities of asteroids to the present value of 3 mi/s (5 km/s) so that asteroids fragment rather than accrete when they meet each other. Instead of forming a planet, the asteroids have been smashing each other to bits.

Evidently some asteroids of primitive, nonvolatile solar composition were heated within the first few hundred million years after the origin of the solar system, perhaps by the solar wind or extinct radionuclides, and they melted. While the unmelted, weak, C-type asteroids may have been depleted by a large factor by collisions, most of the strong stony-iron cores of the melted proto-asteroids have survived; perhaps they are among the M- and S-type asteroids observed today. The asteroids still collide and fragment, occasionally spraying the inner solar system with chips that produce craters or fall as meteorites. [C.R.C.]

**Asterioidea** A subclass of the class Stellerioidea in the subphylum Asterozoa; asteroids are known as starfish (see illustration). The arms are not sharply demarcated from the rest of the body. The ambulacral ossicles never fuse to form vertebrae. The tube feet are locomotor organs, usually suctional, emerging from an open ambulacral groove. The dominant growth gradients are such as to cause the skeletal ossicles to lie in longitudinal rows known as series (for example, adambulacral series, ventrolateral series, and inferomarginal series).

For many years the Asterioidea and the Ophiuroidea were accorded separate class status, but in 1951 W. K. Spencer showed that they have a common origin. Most differences between these groups disappear when fossil forms are considered. Thus both groups are now ranked as subclasses of Asterozoa. The 1700 or so known fossil and recent species of Asterioidea are now grouped into six orders: Platysterida, Paxillosoida,

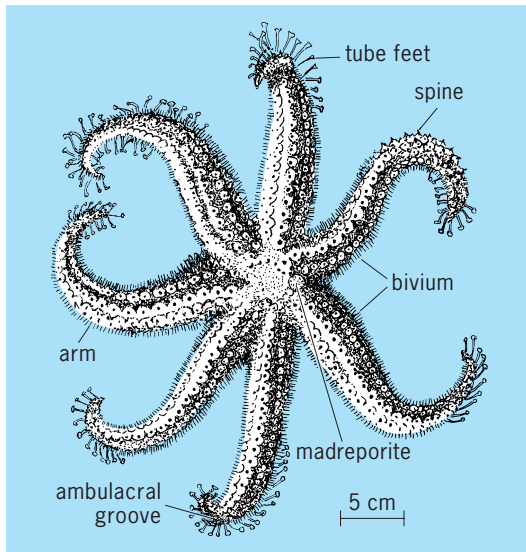

A representative asteroid, *Astrostole scabra*.

Valvatida, Forcipulatida, Notomyotida, and Trichasteropsida. Asteroids range in size from about 0.4 to 40 in. (10 mm to 1 m) across. Many starfish are brightly colored and attractive animals, but some are dowdy and cryptic. Their conjugated carotenoid pigments fade on preservation. Like most echinoderms, starfish have a lifespan of about 5 years. See OPHIUROIDEA.

Starfish inhabit all types of bottom throughout the world's seas and oceans. Some burrow in sand and mud, and others live on rocks and coral reefs, where they are at their most diverse. Most families show well-defined bathymetrical preferences, but there are exceptions. There are 12 families which occur at depths greater than 2 mi (3 km), and several genera extend below 4 mi (6.5 km).

The outer surface is coated with a thin layer of ciliated epithelium. Below this lies connective and muscle tissue which forms the body wall and in which the skeletal ossicles are embedded, forming the test. Some of the ossicles, notably the spines, protrude to the exterior. The arms can be slowly moved by the body wall musculature. Although 5 arms are common, up to 12 occur in a number of genera, and more than 12 may occur, as in *Acanthaster*.

Pedicellariae, small seizing organs used to grip intruders, occur in some starfish. They probably assist in protecting the delicate epithelium from predators and sediments. Pedicellariae are formed from two or four modified spines which are snapped together by adductor muscles like minute tongs. Their shape and type is important in classification because different orders of starfish have evolved different forms of pedicellariae. The well-developed water-vascular system follows the pattern for the phylum, with the following features. With the exception of some Paleozoic genera, the madreporite is always on the upper (aboral) side. There is usually only one madreporite situated interradially, but *Allostichaster* has 2 to 4 and *Acanthaster* up to 16 or more. The tube feet may be peglike and suckerless or columnar and suckered. The nervous system also follows the pattern for the phylum. Starfish cannot see, but they clearly detect changes in light intensity such as those caused by shadows. They have photosensitive eyespots located at the tip of each arm. The terminal tube feet of each ambulacrum appear to be especially sensitive to water-borne chemicals which may be emitted by prey species, and they are thus used in food detection.

Starfish are voracious feeders. The prey is detected by water-borne odors or by direct contact as the result of random movement. Small food, such as amphipods and young mollusks, may be engulfed whole. *Acanthaster* everts part of its stomach out

of the mouth and wraps it over coral polyps, which are thus digested outside the predator's body. The mouth is in the middle of the lower (oral) surface of the disk and leads through a short esophagus to the cardiac stomach. The number of lobes of this organ correspond to the arm number of the starfish. Above the cardiac stomach lies the pyloric stomach, again with as many branches as there are arms. In most species, a short intestine leads upward to the rectum and anus, generally situated near the middle of the upper (aboral) surface. In starfish which lack an anus, the feces are extruded through the mouth.

Asteroids are generally mature and able to reproduce at 1 year. They normally continue to grow for about 4 years, growth taking place when food is abundant. The sexes are usually separate, but in a few genera, such as *Fromia*, hermaphroditism occurs, the sex changing with age. Regeneration of lost or damaged parts is a characteristic of most genera. In *Linckia* this is most marked, and a whole new individual can be regenerated from a fragment of an arm. See ECHINODERMATA. [A.C.C.]

**Asteroxylales** A small extinct order of the class Lycopsidea that bridges the evolutionary gap between the primitive Zosterophylloids and relatively advanced Lycopsidea; hence the asteroxylaleans are often termed prelycopsideans. The best-known asteroxylalean species are of Early Devonian age, although similar forms survived to the Late Devonian. All possessed at least some hydrophytic features; together with a paucity of strengthening tissues, this characteristic suggests that they largely relied on hydrostatic pressure for structural support.

With the exception of *Asteroxylon*, asteroxylalean fossils are not well preserved. The asteroxylaleans are regarded as the most primitive lycopsids, but they can also be considered as the most advanced zosterophylloids; some authorities prefer to disperse the prelycopsideans among other taxa.

The pivotal plant in this order is *A. mackiei*, which originated from the remarkable biotic communities petrified in Lower Devonian volcanogenic cherts at Rhynie, Scotland. This species had naked horizontal rhizomes that produced primitive roots and aerial branches up to 20 in. (50 cm) high and 0.4 in. (1 cm) in diameter. The radially symmetrical actinostele (a star-shaped protostele) is typical of primitive lycopsids rather than zosterophylloids. Vascular traces extended toward, but did not enter, the densely packed clasping tissue outgrowths termed protomicrophylls.

The sporangia were homosporous, kidney shaped, and distributed singly and randomly among the leaves on the more distal axes. Like the zosterophylloids, *Asteroxylon* bore sporangia on stalks with a vascular supply that was independent of, and more extensive than, that of the surrounding enations. These reproductive structures are generally regarded as homologous with vegetative lateral branches. [R.M.Ba.; W.A.DiM.]

**Asthenosphere** A layer in the Earth's interior occurring approximately 50 mi (80 km) below the surface and extending to a depth of about 180 mi (300 km); it consists of rocks possessing less mechanical strength than the rocks above or below it. The asthenosphere is a relatively thin layer contained in a much larger region known as the mantle. The mantle is the solid portion of the Earth's interior that is located between the bottom of the Earth's crust (at about 15 mi or 25 km depth) and the top of the liquid outer core (at 1800 mi or 2900 km depth). The layers in the mantle that are above and below the asthenosphere are known as the lithosphere and the mesosphere respectively. The lithosphere is broken into 12 major tectonic plates that possess much greater mechanical strength than the underlying asthenosphere. See LITHOSPHERE.

The thermal structure of the asthenosphere, and indeed the very existence of this layer, is determined by the thermal convection process in the mantle. The convective flow in the mantle transports heat vertically upward from the deep interior, and it drives the observed horizontal motions of the tectonic plates. In

the deep mantle, below the lithosphere, the vertical advection of heat by the convective flow is sufficiently rapid to create an adiabatic depth variation of mantle temperature. In the lithosphere the velocities of the vertical flows are much smaller than in the deep mantle; therefore the depth variation of temperature in this region is determined by a balance between the horizontal advection of heat (due to the horizontal flow associated with the tectonic plate motions) and the vertical conduction of heat to the surface. The asthenosphere is, in effect, a layer in which the depth variation of temperature changes from a steep gradient in the lithosphere to a relatively flat gradient in the deep mantle.

Since the mantle flow occurs over geological time scales, the long-term mechanical strength of the mantle rocks may be defined as the amount of stress that must be applied to produce some specified flow velocity. The flow of the solid mantle is made possible by the presence of naturally occurring microscopic defects in the crystal grains that constitute mantle rocks. The movement of these defects, due to thermally generated internal stresses, allows the mantle to creep as though it were a fluid with an extremely high viscosity. The effective viscosity of mantle rocks is a direct measure of their long-term mechanical strength, and it is strongly dependent on the ratio between the temperature ( $T$ ) and the melting temperature ( $T_m$ ) of the rocks. An increase of the scaled temperature  $T/T_m$  (also called the homologous temperature) produces exponentially large decreases in the effective viscosity of rocks. In the asthenosphere the average mantle temperature is closest to the melting temperature; thus the effective viscosity (that is, mechanical strength) is lower there than above or below the asthenosphere. There is a smooth transition between the zone of reduced mechanical strength in the asthenosphere and the zone of greater strength in the adjoining portions of the mantle. Therefore it is not possible, or meaningful, to specify precise locations for the upper and lower boundaries of the asthenosphere. See RHEOLOGY.

The analysis of seismic data (for example, the travel times of seismic waves) has provided the only direct indication of the presence of the asthenosphere. Seismologists usually refer to the asthenosphere as a low-velocity zone on account of the reduction of seismic wave speeds in this layer. See SEISMOLOGY.

Seismologists have made considerable progress in the application of tomographic imaging techniques to map the three-dimensional variation of seismic wave speed in the mantle. A tomographic model of the relative perturbations of seismic shear velocity has been constructed; at a depth of 120 mi (200 km), this model indicates that the shear-velocity perturbations range from  $-2.5$  to  $+4.5\%$ . The coldest (that is, largest negative perturbation of) temperature is found below the continents. This local reduction of mantle temperature, and the corresponding increase of mechanical strength, may be sufficiently great that the concept of the asthenosphere (as a hotter and mechanically weak region) ceases to be valid below the continents. The concept of the asthenosphere is valid below the oceans, and there is an obvious concentration of hotter material below the plate boundaries, which are zones of active spreading (the so-called mid-oceanic ridges). This pattern suggests that the observed spreading at the mid-oceanic ridges is fed, and perhaps partially driven, by the upward ascent of hotter mantle material across the asthenosphere. When the ascent of this hotter material is sufficiently rapid (that is, adiabatic), the material begins to melt (and may thus produce surface eruptions of lava), because the temperature of this ascending material exceeds the local melting temperature. This partial melting can occur in the asthenosphere. See ISOSTASY; PLATE TECTONICS. [A.M.Fo.]

**Asthma** An allergic inflammatory disease of the airways, involving mast cells, eosinophils, macrophages, fibroblasts, and neutrophils. Such inflammatory changes are associated with widespread airflow obstruction, which is variable and improves (reverses) spontaneously or with appropriate therapy. Inflammation progresses to increased airway irritability (hyperresponsive-

ness) induced by the inhalation of allergens, cold air, and occupational factors. Although bronchospasm can be induced immediately after exposure to a specific allergen in an appropriately sensitized recipient, it is the late allergic response that most resembles the inflammatory reaction occurring in asthma. Central to this reaction is the release from mast cells, eosinophils, and lymphocytes of chemical mediators such as histamine, leukotrienes (potent bronchoconstricting agents), and various cytokines which perpetuate the response. Potent neurohumoral agents derived from neural pathways contribute further to the bronchospasm. See CYTOKININS; HYPERSENSITIVITY.

Wheezing, nocturnal breathlessness, coughing, and chest tightness often relieved by expectoration are highly suggestive of asthma. Episodes of breathlessness which result from exposure to an irritant (such as cold air) or an allergen (such as dust mites) following exercise or a viral infection and which are reversed spontaneously or with therapy are diagnostic of asthma. Eczema and edema in the folds of the nasal chambers are suggestive of a hereditary allergy, the major predictor of asthma. Objective measures of airflow obstruction which improved spontaneously or with therapy are also central to establishing an asthma diagnosis. Atopy, the genetic predisposition for developing an immunoglobulin-E (IgE) mediated (allergic) response to inhaled environmental allergens, is the strongest predisposing factor for developing asthma. Asthma may be classified, therefore, according to severity, etiology, or pattern of airflow obstruction. It is helpful to differentiate those factors that induce inflammation from those that incite acute bronchospasm in susceptible individuals. The association of an elevated serum IgE and the occurrence of asthma in all age groups, including those who are not atopic, makes antigenic stimulation causal in all instances of asthma. The severity of asthma can best be defined in terms of peak-flow monitoring (monitoring the severity of the allergy). Such evaluations as mild, moderate, and severe are useful in applying therapy in a stepwise manner contingent on severity. See IMMUNOGLOBULIN.

Successful management of asthma requires education of the sick individual coupled with the development of a partnership with an asthma management health-care team; assessing and monitoring the severity of asthma, with utilization of objective parameters of assessment (for example, the peak-flow meter, a device that measures the amount of air that enters and leaves the lungs); environmental management to avoid asthma triggers; and establishment of a drug regimen that controls asthma (medications include bronchodilators, which act as relievers, and bronchodilators, which act as preventers), as well as a written plan to prevent the condition from becoming worse. Adequate management of asthma should control the symptoms, prevent asthma attacks, return and maintain pulmonary function as close to normal as possible, maintain normal activity levels including exercise, avoid adverse side effects from the drugs, reduce and prevent irreversible airway changes, and prevent mortality. See ALLERGY; RESPIRATORY SYSTEM DISORDERS. [A.L.She.]

**Astomatida** An order of protozoans, subclass Holotrichia, in which all species are mouthless. All species are parasitic in other animals, typically oligochaete annelids. Many astomatids possess an elaborate holdfast organelle. *Anoplophrya* is a typical example. See CLIOPHORA; HOLOTTRICHIA; OLIGOCHAETA. [J.O.C.]

**Astrapotheria** A relatively small group of extinct South American ungulates, ranging from the late Paleocene to the late Miocene. They are customarily divided into two suborders: the late Paleocene–Eocene Trigonostylopoidea, and the early Eocene–late Miocene Astrapotheroidea.

One of the most spectacular and advanced members of the order was *Astrapotherium* (see illustration). This animal, known from the late Oligocene to the late Miocene, averaged 9–10 ft (2.7–3 m) in length, although some other forms grew even larger. The anterior part of the skull was striking with the huge,

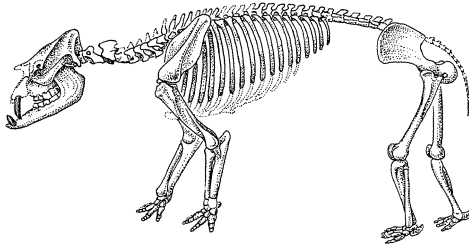

*Astrapotherium magnum* skeleton.

persistently growing, curving canines, whose function is unexplained. The retracted, chopped-off appearance of the snout region strongly suggests that this animal had a moderately large trunk. The front legs were somewhat more strongly constructed than the hind ones, and this makes the habits of this animal a puzzle. See MAMMALIA. [F.S.S.]

**Astrometry** That part of astronomy dealing with the position and motion of celestial objects, including solar system objects, stars, radio sources, and galaxies.

In 1994 the International Astronomical Union (IAU) adopted the International Celestial Reference Frame (ICRF), based on about 400 extragalactic radio sources, as the fundamental reference frame. This replaced the previous fundamental catalogs, such as the FK5, which were based on positions and proper motions of bright stars. The *Hipparcos Star Catalog*, based on observations of that astrometric satellite, provides an accurate optical catalog based on the International Celestial Reference Frame. Other star catalogs provide a denser coverage of the sky and can reach fainter magnitudes, but with reduced accuracies. The positions and proper motions of the stars provide a two-dimensional map of the sky for a given time. To provide the three-dimensional aspect, the parallaxes (which give the distances to the stars) and the radial velocities are necessary. With that information, it is possible to determine a three-dimensional position and velocity for each star. See ABERRATION (ASTRONOMY); CELESTIAL REFERENCE SYSTEM; FUNDAMENTAL STARS; PARALLAX (ASTRONOMY).

An extragalactic reference frame, defined by radio sources, has the advantage that since such sources are so distant they have no apparent motion. These sources are observed by means of very long baseline interferometry (VLBI), using radio antennas so that their positions can be determined to milliarcsecond accuracies. This accuracy compares favorably with the 0.1-arc-second accuracy of bright-star catalogs, which degrade with time because of the inaccuracies of proper motions. See RADIO TELESCOPE.

Observations can be made at different wavelengths, such as the radio, optical, and infrared, and the resulting star catalogs must be related to each other. Observations can be divided into those involving large-angle measurements and those employing small-angle measurements. See TELESCOPE.

Large-angle measurements determine the difference in position between objects over large angular distances in the sky. Transit circles, which made such observations in the past, are being replaced by more accurate observational techniques. Interferometers, observing radio, optical, or infrared wavelengths, combine the reception of the emission from a source at two separate detectors. By measuring the time difference between the two detections, a very accurate measurement of the angle to the source can be provided. In addition, the *Hipparcos Astrometric Satellite* used a technique for observing pairs of stars separated by approximately  $60^\circ$  to form a catalog of stars located throughout the sky.

Small-angle measurements provide accurate relative positions of the observed objects. They can also provide, by means of multiple observations, the parallaxes and motions of the stars with respect to the reference stars in the field. The charge-

coupled device (CCD) has replaced the photographic plate for small-angle measurements. See ASTRONOMICAL PHOTOGRAPHY; CHARGE-COUPLED DEVICES.

The speckle interferometer takes very rapid exposures (approximately 30 per second) to freeze atmospheric effects. These short exposures can then be added together to measure the separation, relative position, and magnitude between pairs of stars that could not be observed with such accuracy through the atmosphere. Thus, speckle interferometry is used primarily for double stars. See SPECKLE.

The atmosphere is the primary limitation on astrometric accuracy, and thus provides the impetus for plans to make observations from space or the lunar surface. See SATELLITE ASTRONOMY. [P.K.S.]

**Astronautical engineering** The engineering aspects of flight and navigation in space, also known as astronautics. Astronautical engineering deals with vehicles, instruments, and other equipment used in space, but not with the sociological or economic aspects of space flight, except as they influence the equipment.

There is a lack of parallelism between astronautical and aeronautical vehicle terminology. An aircraft is a self-contained vehicle, having within its structure essentially all the equipment required to transport its payload from one place to another. A spacecraft, in the more restricted sense, is the container for the payload. Sometimes the word is used to denote the container and payload. Most spacecraft, to date, have had either very limited propulsion or none at all. Since enormous speeds are the hallmark of all astronautical missions, unpowered spacecraft require a "booster," or "launch vehicle," usually a rocket many times as large as the spacecraft. The weight of the spacecraft, in fact, seldom exceeds 5% of the total launch vehicle weight.

It is extremely expensive to put a pound of payload into Earth orbit. Thus designers have been justified in going to great lengths to convert a pound of structure into a pound of payload. Great improvement appears possible in this respect; only the cost of the propellant seems to be irreducible. In view of the high cost of space operations, it is especially important that space vehicles operate long enough to successfully fulfill their missions. A severe reliability requirement is thus imposed upon vehicles and equipment intended for missions, such as journeys to the planets, which may require up to a year or more to accomplish. For complex equipment in space vehicles, operating lifetimes of this order of magnitude are difficult to attain. The requirements for high reliability and low weight add tremendously to the cost of the payloads themselves, to the extent that their cost approaches that of the launch vehicle. All space missions through 1975 used expendable launch vehicles. The space shuttle, a reusable launch vehicle, is expected to reduce the costs of Earth-to-orbit transportation. See SPACE SHUTTLE.

Gravity is a dominating influence in the design of space launch vehicles. Despite the fact that the pull of gravity extends to infinity, it is nonetheless possible to escape permanently from the Earth's gravity in the sense of never being drawn back to the ground. The key is speed. Circular velocity is the minimum at which a space vehicle can remain permanently above the Earth. At low altitudes, this velocity is about 25,000 ft/s (7.9 km/s). As the speed is increased above the circular velocity, the path of a vehicle becomes a larger circle or an elongated ellipse. When the speed reaches 37,000 ft/s, or about 7 mi/s (11.2 km/s), the path becomes a parabola and the vehicle will travel along one of the legs to infinity without further propulsion. See ESCAPE VELOCITY; SATELLITE.

These velocities are tremendous by any previous standard. To reach them, a vehicle must carry the corresponding amount of energy in the form of propellant.

Even with the most energetic propellants and the lightest structures, it has not yet been possible to reach orbital velocity with a single rocket. To overcome this seemingly insurmountable

obstacle, one rocket is carried as the payload of a larger one. When the larger burns out, the second is ignited and adds its velocity to that of the first. This is known as the step-rocket or staging technique. For lunar and planetary missions, lightweight vehicles, powerful propellants, and many stages are used. The lunar orbit rendezvous method required a total of six stages to take the Apollo astronauts to the Moon and back. See ROCKET STAGING; SPACECRAFT PROPULSION.

Although propulsion is the key to space flight, other elements are essential and present numerous new problems. One such element is guidance and control. For the ascent phase of space vehicle flight, guidance systems similar to those used for ballistic missiles are employed. Another control requirement of many types of space vehicles is that of maintaining the desired vehicle attitude over long periods of time. Displacement gyroscopes, even excellent ones with very low drift rates, cannot provide an accurate reference for days or weeks. Such devices must be corrected frequently by an external reference.

At least two such references are available: sources of electromagnetic radiation, and the gravitational gradient. The first might be used by such devices as a Sun seeker, a star tracker, or a horizon scanner. In the vicinity of the Earth (or any large celestial body) the difference in the pull of gravity between points on the craft having different distances from the Earth can be usefully employed.

Reaction wheels or other devices capable of storing angular momentum may be used to provide the torque to effect or maintain a given orientation. Such devices are very efficient, both from a weight and an energy standpoint, where disturbing torques on the spacecraft are small, random, and long continued. At the opposite end of the torque spectrum, torques that are large and uncompensating, rocket engines are the most suitable.

Vehicle and payload equipment require electric power. For small amounts of energy, chemical sources, such as batteries or chemically fueled generators, may be used. A great deal more energy can be obtained from a nuclear reactor. Energy also comes continuously from the Sun but at a fairly low density at Earth's distance.

Communications equipment comprises an essential item of nearly all space vehicles. This equipment is designed for light weight, low power consumption, and, usually, long life.

Although a large percentage of the problems of space flight are associated with the vehicles, it would be a mistake to assume that these constitute even a major fraction of the total operating system. Indeed, the cost of overcoming the Earth's gravity is so great that any portion of the total operation which can be performed on the ground should be done there. The supporting ground equipment consists of the preparation and launching equipment, and the tracking, communications, and payload-oriented equipment for turning the received data into usable form. For missions which involve return of space vehicles or booster rockets, recovery equipment may also be required. See LAUNCH COMPLEX; SPACECRAFT GROUND INSTRUMENTATION.

In their interaction with the terrestrial and atmospheric environment during reentry, space vehicles resemble ballistic missiles. However, although ballistic reentry techniques have been proved successful, the use of winged vehicles also has certain attractive aspects. There is a basic difference in these two methods in respect to the way atmospheric heat is handled. The ballistic approach absorbs the heat in the reentry body or rejects it back to the air by mass transfer. The winged vehicle dissipates the heat by radiation. Considerable research has been done on compromise reentry vehicles, such as the lifting body approach. The orbital stage of the shuttle is a winged craft designed to land like an airplane. It utilizes a combination of techniques to overcome the reentry heating problems: lift, temperature-resistant materials, and local ablative cooling. See ATMOSPHERIC ENTRY.

Astronautical engineering must contend with the unique environment of space outside the Earth's atmosphere. Although gravity is present in space, whenever a vehicle is coasting un-

propelled, the shell and everything in it are acted on equally by gravity and therefore appear weightless. Fluids do not flow naturally, but must be confined and extruded. Liquids exposed to the vacuum of space evaporate or freeze. External transfer of heat takes place only by radiation. Metals exposed to the ultraviolet rays of the Sun emit electrons. Small particles of cosmic dust strike external surfaces at fantastic velocities and gradually erode them. Cosmic radiation creates a spectrum of secondary radiation that may reach levels damaging to equipment or personnel.

[R.C.Tr.]

**Astronautics** The application of scientific principles and engineering techniques to flight in space. Astronautics deals with space vehicles in the sense that aeronautics deals with aircraft. The distinguishing feature between astronautics and aeronautics is the extent to which the vehicles are influenced by the Earth's atmosphere. Astronautics encompasses both crewed and uncrewed missions. See AERONAUTICS; ASTRONAUTICAL ENGINEERING; SPACE TECHNOLOGY.

The subject matter of astronautics is flight in regions where a vehicle overcomes gravitational attraction and controls its course by reactive propulsion. Aeronautics concerns flight in regions where a vehicle resists gravitational attraction and controls its course by aeromechanical forces. The distinction is convenient but not clear cut. Rockets, by their reaction, assist airplanes to take off. Space vehicles may glide back to Earth. See INTERPLANETARY PROPULSION.

[R.C.Tr.]

**Astronomical atlases** Sets of maps of celestial phenomena. Often developed in conjunction with catalogs that list position, brightness, and other features, maps provide a clear picture of the spatial relations between the phenomena.

In the nineteenth century the introduction of larger telescopes, steadier mounts, better graduated circles, and filar micrometers led to more extensive and precise star catalogs and atlases. Premier among these was the *Atlas des nordlichen gestirnten Himmels* (Bonn, 1863), organized by F. W. A. Argelander. These 40 charts showed the positions and magnitudes of 324,198 stars in the northern hemisphere. The charts, along with their companion star catalog, the *Bonner Durchmusterung*, or "B.D.," are still in use today. See ASTRONOMICAL CATALOGS.

By the 1880s photography was sufficiently well developed for astronomers to begin considering a photographic atlas of the heavens. In 1949, under sponsorship of the National Geographic Society, was begun the *Palomar Observatory Sky Survey*—the first photographic atlas that showed the sky in two colors. Taken with the 48-in. (1.2-m) Schmidt telescope, it reveals stars brighter than magnitude 20 situated north of  $-33^\circ$ . A new *Palomar Observatory Sky Survey* was begun in 1985. This atlas will use improved photographic plates to reach magnitude 22, in three colors. See ASTRONOMICAL PHOTOGRAPHY.

In addition to the photographic atlases, printed atlases continue to be published, usually in conjunction with star catalogs. Among the more popular atlases of this type are the *Smithsonian Astrophysical Observatory Star Catalog* and *Star Atlas of Reference Stars and Nonstellar Objects* (Washington, 1966); Antonin Becvar's *Skalnate Pleso Atlas* (Cambridge, 1949) and its successors; *Norton's Star Atlas* (Cambridge, 1979); and W. Tirion's *Sky Atlas 2000.0* (Cambridge, 1982).

Edwin Hubble, known as the founder of modern extragalactic astronomy, charted the distribution of galaxies in space and their morphology. The *Hubble Atlas of Galaxies* appeared in 1961, edited by Allan Sandage. See GALAXY, EXTERNAL; MILKY WAY GALAXY; NEBULA.

G. P. Kuiper's *Photographic Lunar Atlas* (Chicago, 1960) contains the best set of Moon plates based on terrestrial observations to date. Lunar probes have generated countless closeups of the lunar surface. A particularly beautiful photographic atlas of the Moon is the NASA publication *The Moon as Viewed by Lunar Orbiter* (Washington, 1970). As spacecraft explore more of the



solar system, atlases of more objects are becoming available. See MOON. [D.J.Wa.; C.T.K.]

**Astronomical catalogs** Lists or enumerations of astronomical data, generally ordered by increasing right ascension of the objects listed. Astronomical catalogs vary a great deal in form and content depending upon their use, which may be purely astronomical, or for navigation, time determination, geodesy, or space science applications. In some catalogs the essential data are stellar positions and motions, while in others astrophysical data, such as magnitudes, spectra, and radial velocities of stars, are important. There are also catalogs of special stellar and of nonstellar objects. See ASTRONOMICAL COORDINATE SYSTEMS.

A catalog regarded as the best representation of the celestial coordinate system at the time of its publication is called a fundamental star catalog.

The *Fifth Fundamental Catalogue*, designated *FK5*, was published by the Astronomisches Rechen-Institut in Heidelberg, Germany, in 1988. The catalog contains the positions (right ascensions and declinations) and their changes with time (proper motions and precession) of the 1535 stars in *FK4*, and an additional 3117 stars, down to an apparent visual magnitude of about 9.5. These catalogs, and other modern catalogs, have the standard epoch J2000.0, which is the date January 1, 2000, at 12 hours Universal Time.

The positions and proper motions of the stars in *FK5* provide a fundamental system for measurements of other star positions and proper motions, which may be carried out for a variety of problems arising in stellar astronomy.

Moderately bright stars (seventh to ninth magnitude), selected on the basis of one star per square degree of the sky, are related to the fundamental system by meridian circle observations. These stars form a system of sufficient density to serve as position references for photographic observations. Typical of catalogs of such reference stars is the *International Reference System (IRS)* catalog covering the entire sky from pole to pole with one star per square degree. It is the current world standard reference system.

A photographic survey of the northern celestial hemisphere resulted in the *AGK3 (Dritter Astronomische Gesellschaft Katalog, 1975)*, the third in a series of catalogs published by the German Astronomical Society. A revised version of this catalog has been published by the Astronomisches Rechen-Institut in Heidelberg as the *Position and Proper Motion (PPM) Catalog* of 181,731 stars north of  $-2.5^\circ$  declination. A similar photographic catalog for the southern celestial hemisphere with plates taken at the Royal Cape Observatory in South Africa is the *Second Cape Photographic Catalog (CPC2)*, published in 1970. It contains the positions of 250,000 stars.

An important photographic catalog covering the entire sky to a limiting magnitude of 13 is the result of an international undertaking involving 19 observatories, with each assigned zones of declination and observing with nearly identical telescopes. The catalog, known as the *Carte du Ciel (CdC)* or *Astrographic Catalogue (AC)*, finally completed for all zones in 1964, provides the positions of the stars in the form of rectangular coordinates, as measured on the plates.

Among the numerous catalogs of astrophysical data is the monumental *Henry Draper Catalog (HD)* of spectral classification, which with its extension includes data for 275,000 stars published in 10 volumes. The general acceptance of the U, B, V photometric system since its inception in the 1950s is shown by the compilation of a general catalog containing data for 87,000 stars (*Astronomy and Astrophysics*, suppl., vol. 71, 1987).

L. E. Dreyer's *New General Catalogue of Nebulae and Star-clusters* (1888) contains the objects originally classified as nonstellar, with galaxies included as nebulae. The catalog contains 7840 objects, and was supplemented by two index catalogs in 1895 and 1908 with an additional 5386 objects. The NGC and IC numbers assigned in these catalogs remain the most com-

monly used designations. See NEBULA; STAR CLUSTERS; VARIABLE STAR.

Since Dreyer's time, the number of known nonstellar optical objects has increased by an order of magnitude, and the data are scattered through the astronomical literature. R. S. Dixon and G. Sonneborn compiled *A Master List of Nonstellar Astronomical Objects* (1980) with approximately 185,000 listings from 270 catalogs, with multiple listings of objects appearing in several catalogs. [K.A.S.]

**Astronomical coordinate systems** Schemes for locating astronomical objects in space. To an observer on the Earth's surface, the stars of the night sky appear to be placed upon a spherical shell of infinite radius with the observer at the center. Celestial objects appear to move with respect to the stars, and at any given time their position on this imaginary sphere, called the celestial sphere, can be specified by two angles, called celestial coordinates, whose values depend upon what coordinate system is used. See CELESTIAL SPHERE.

Each coordinate system is defined by a fundamental plane and a principal axis. For example, on the Earth's surface, longitude and latitude coordinates are used to determine positions. In this system, which is analogous to astronomical coordinate systems, the fundamental plane is that of the Earth's Equator, and the principal axis is defined by a line running from the Earth's center to a point on the Equator at the longitude of Greenwich, England. See EQUATOR; LATITUDE AND LONGITUDE.

**Horizon system.** The boundary between the hemisphere of the sky that is visible and the hemisphere which is hidden from view by the Earth is called the horizon. The observer is located at the center of the horizon system, the pole directly overhead is termed the zenith, and the opposite pole, the nadir. These pole directions are aligned with a plumb line, which is determined by the observer's local gravity. The fundamental horizon plane is  $90^\circ$  from the poles, and for astronomical applications the principal axis is most often taken to pass through the north point. Great circles that pass through the zenith and nadir are termed vertical circles; the one passing through the east and west points is termed the prime vertical, and that passing through the north and south points is called the celestial meridian. The longitudinal coordinate of a celestial object is termed its azimuth and is most often measured eastward from the north point to the object's vertical circle; and the latitudinal coordinate, termed its altitude, is measured along the object's vertical circle, north or south from the horizon plane to the object. See HORIZON; ZENITH.

**Equatorial system.** The fundamental plane of the equatorial coordinate system can be visualized by imagining that the

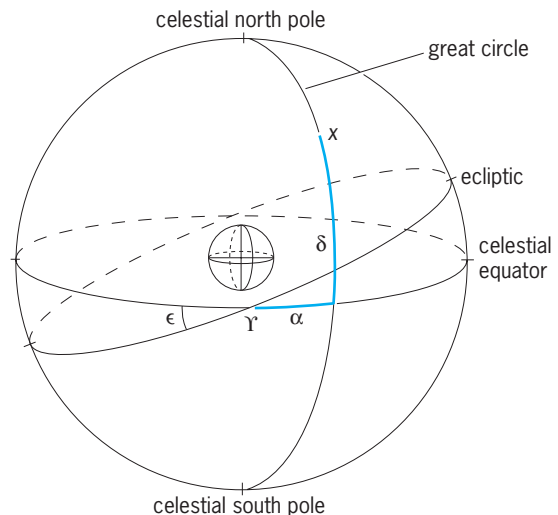

Equatorial system of astronomical coordinates.

Earth's equatorial plane is extended to intersect the celestial sphere. An alternate fundamental plane, the ecliptic plane, is the extension of the Earth's mean orbital plane onto the celestial sphere (see illustration). These planes intersect at two points, called equinoxes, with the angle between them  $\epsilon$  being termed the obliquity of the ecliptic. This angle is about  $23.4^\circ$ . See ECLIP-TIC; EQUINOX.

Due to the Earth's motion about the Sun, observers on Earth see an apparent motion of the Sun along the ecliptic plane. The point where the Sun's annual apparent motion takes it northward across the equatorial plane is called the vernal equinox  $\Upsilon$ , and the line between the Earth's center and this point defines the principal axis for both the equatorial and ecliptic coordinate systems. The apparent passage of the Sun through the vernal equinox, on about March 21, marks the beginning of spring in the Northern Hemisphere. Because of disturbing effects of the Sun and Moon on the Earth's figure, the Earth's rotation axis precesses, causing the celestial pole to describe an approximate circular motion about the ecliptic pole once every 26,000 years. This causes the location of the vernal equinox to drift westward along the ecliptic about 50 arc-seconds each year. Hence for an inertial coordinate system, where the principal axis is not moving, an epoch must be specified at which time the coordinate system is held fixed. In practice, the beginning of the year 2000 is most often used as an epoch. See EARTH ROTATION AND ORBITAL MOTION; PRECESSION OF EQUINOXES.

The north and south celestial poles represent the extension of the Earth's North and South poles onto the celestial sphere. For a celestial object (for example, object X in the illustration), the longitudinal coordinate is termed the right ascension  $\alpha$  and is measured eastward along the celestial equator from the vernal equinox  $\Upsilon$  to the great circle passing through the object and the north and south celestial poles. The latitudinal coordinate, called the declination  $\delta$ , is then measured along the object's great circle, north or south from the Equator to the object.

**Ecliptic system.** The ecliptic coordinate system is often used when representing the orbital motions of the planets, asteroids, and comets. The fundamental plane is that of the ecliptic, and as in the equatorial system, the principal axis is the line extending from the Earth's center to the vernal equinox.

**Galactic system.** Astronomers working with stars and other objects within the Milky Way Galaxy often find it convenient to use the galactic disk as the fundamental plane of their coordinate system, and the line extending from the galactic center to the Sun's location as the principal axis. See MILKY WAY GALAXY.

[D.K.Y.]

**Astronomical observatory** A telescope or telescopes, their protective enclosures (if any), support and headquarters buildings, and the staff of astronomers, engineers, technicians, and other support personnel. The telescopes can be optical or infrared (reflecting or refracting) inside a corotating dome, or radio dishes without enclosures.

The on-site support building contains the control room with the computers and control electronics to operate and point the telescope, as well as the data acquisition computers and electronics for detector instruments. It houses laboratories for testing and calibrations, a machine shop for emergency repair and fabrication of parts, and storage for inactive instruments or telescope optics. These areas are often incorporated into a single building along with the telescope and dome. Since telescopes are generally located at remote sites to maximize their usefulness, the administration and support offices are often located in a separate headquarters building miles away in a town or university.

Optical and infrared observatories are the most common types of observatory. They are often located in remote mountains to minimize the effects of contaminating artificial lights and atmospheric blurring. Some countries place their largest telescopes at the best sites in the world such as the 13,800-ft-high (4200-m)

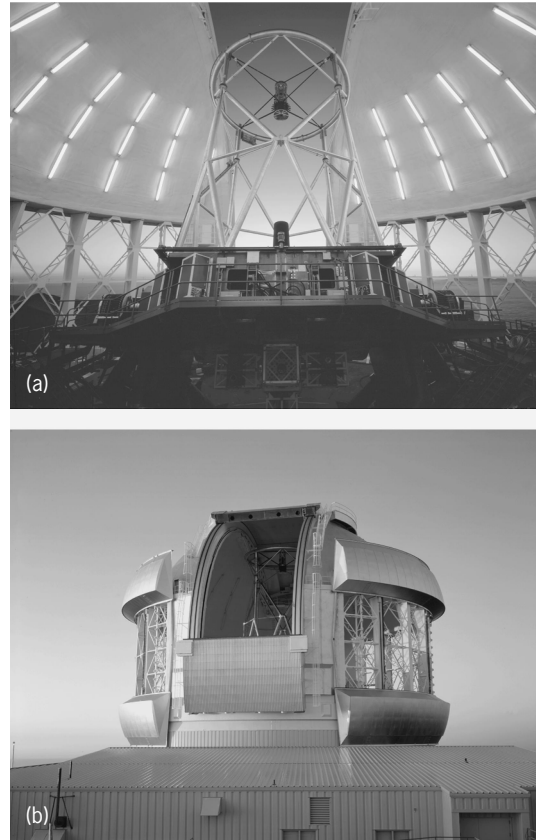

**Gemini North Observatory in Mauna Kea. (a) Telescope and interior of dome. (b) Exterior of dome. Vent gates surrounding the dome allow air to flow throughout the dome, thereby minimizing distortion of images due to swirling. (Neelon Crawford, Polar Fine Arts and Gemini Observatory)**

volcanic mountain Mauna Kea in Hawaii (see illustration) and La Palma in the Canary Islands.

Optical observatories study planets, stars, nebulae, and galaxies. A large aperture is needed to collect the faint light of these sources. Sizes typically range from 0.5 to 10 m (20–400 in.). The smaller telescopes can use glass lenses, the largest refractor being the University of Chicago 1.0-m (40-in.) Yerkes. For the largest telescopes, engineering and manufacturing constraints dictate the reflecting design. The 9.8-m (386-in.) Keck Telescope is the world's largest reflector. The Very Large Telescope Project seeks to combine the light from four 8.1-m (319-in.) telescopes to effectively have the light-gathering capability of a 16-m (630-in.) telescope.

Most optical observatories can also observe in the near-infrared region. Infrared observatories have been optimized to work farther into the longer (thermal) infrared. Since glass absorbs infrared light, all infrared telescopes are of the reflecting type. Special design techniques must be used, as the telescope itself glows in the infrared.

Radio observatories have become an essential complement to optical observatories. With their longer wavelengths, the radio telescopes can see through cosmic clouds and measure the properties (temperature, pressure, chemical composition, and velocities) of gases which pervade the universe. Since the wavelengths are so long, the telescopes must be large to achieve a high resolution (the ability to discriminate between two nearby sources), and radio dishes are typically tens to hundreds of meters wide.

The longer radio wavelengths allow the use of interferometers, where the signal from several small radio telescopes can be mathematically combined to yield results as if they had been collected

from a very large dish. The Very Large Array radio observatory in Socorro, New Mexico, has twenty-seven 25-m (82-ft) antennas arranged in a Y pattern, which can yield the resolution of a single telescope 36 km (22 mi) wide. The Very Long Baseline Array uses ten 25-m (82-ft) antennas spread from Hawaii to the Virgin Islands, allowing the resolution of a telescope dish that distance across.

Crewless balloons have been used to hoist telescopes above the absorbing atmosphere for gamma-ray, x-ray, and ultraviolet observations. Their lower cost (compared to space missions) is offset by the short duration of the observations. The National Aeronautics and Space Administration (NASA) successfully operated the Kuiper Airborne Observatory for 20 years. Space observatories have amply proven their worth despite their initial high cost and limited mission lifetimes. See SATELLITE (ASTRONOMY).

An astronomical instrument is the working heart of an observatory. The telescope exists solely to collect and funnel light into the instrument. Astronomical instruments range from a simple eyepiece for direct viewing (with different magnifications), to a camera for imaging on film or electronic detectors, to a spectrograph which records the wavelength distribution of light energy (analogous to a rainbow). The charge-coupled device (CCD) has now virtually supplanted the photographic plate. For radio telescopes the instrument is an amplifier that isolates and boosts the weak celestial electric signal. See ASTRONOMICAL SPECTROSCOPY; CAMERA; CHARGE-COUPLED DEVICES; SPECTROGRAPH.

Besides observing light (electromagnetic radiation), astronomers are mapping the universe via neutrinos, particles that can transverse matter with a minimum of interaction. Gravitational wave observatories attempt to detect ripples (gravitational waves or gravitons) in the fabric of space-time itself. See GRAVITATIONAL WAVES; NEUTRINO ASTRONOMY; TELESCOPE. [J.Ham.]

**Astronomical photography** The application of the photographic process to astronomy, including monochrome photography and color photography.

**Monochrome photography.** Monochrome photography was one of the premiere tools of astronomical research during most of the twentieth century. It offered two major advantages: the integration of signal (through time exposure) allowed the accumulation of photons from very faint objects which could not otherwise be seen; and the storage of information in an efficient and permanent form allowed protracted, in-depth study of astronomical objects away from the telescope. Monochrome astronomical photography became a standard technique that was applied to direct imaging, spectroscopy, photometry, polarimetry, and astrometry. See ASTROMETRY; PHOTOMETRY; POLARIMETRY.

Nonetheless, because astronomers were continually searching for increased sensitivity and wavelength coverage, the aggressive attempts to improve photographic emulsions had, by the 1970s, begun to reach the limits of what was reasonably attainable. At the same time a new type of electronic imager, the charge-coupled device (CCD), developed for military applications, began to become available to the scientific community. Space-based imaging applications of the charge-coupled device, particularly the development of the TI 800 × 800-px chip for use in the *Galileo* spacecraft, stimulated expanded use of this mode of imaging at ground-based observatories. By the end of the twentieth century, charge-coupled devices had become so pervasive in astronomical observatories that it was clear that monochrome astronomical photography was, in many respects, a technique of the past. Rarely used now by professional astronomers, the techniques of high-quality monochrome astrophotography are primarily preserved by amateur astronomers. Some advances are still being achieved, primarily through computer-processing of digitized photographic images. [E.R.Cr.]

**Color photography.** The language of astronomy abounds with references to color, and the concept of color is implicit in many of the measurements that astronomers make. Color index, for example, is a quantity related to the temperature of a star, while the redshift of a galaxy is used to indicate its recessional velocity. More directly, stars may be described as red giants or white dwarfs or even blue stragglers. See BLUE STRAGGLER STAR; COLOR INDEX; REDSHIFT; STAR.

These names reflect the underlying importance of color in astrophysics and cosmology, and though the colors involved are subtle and difficult to distinguish by the eye in its dark-adapted state, special photographic techniques can be used to display them. A realistic representation of the true colors of celestial bodies can reveal new relationships in familiar objects and add an important third dimension to the morphology and brightness information of the more usual monochrome representations.

Special photographic materials are necessary to accommodate the unusual requirements of photography in astronomy. Not only is the amount of incoming radiation to be detected extremely small, but it is accompanied by unwanted light from the night sky (the airglow). The materials must therefore combine extreme sensitivity at long exposures with high contrast. The ability to detect faint objects is ultimately more dependent on the contrast and resolution of the photographic material than on the light grasp of the telescope or available observing time. On the other hand, color films are designed for general use at levels of illumination where high contrast and low-light-level efficiency are unimportant. In addition, these films are intended primarily to reproduce the broadband colors of everyday life, and for this the rather uneven spectral response of their individual layers is unimportant. Unfortunately, gaseous nebulae emit most of their visible radiation in the form of monochromatic emission lines from the ionized elements present. Color films always show gaseous nebulae as red, largely irrespective of the contribution from the green oxygen line, whereas yellow (red + green) would be a more realistic representation in many cases. See NEBULA.

A further problem is the effect of long exposures on the relative sensitivity of the three layers, which are differently affected by low-intensity reciprocity failure. Changes in both sensitivity and contrast of the layers are found, and exposures which are long enough to be astronomically useful often produce severe color-balance distortion.

Low-intensity reciprocity failure of both color and monochrome films is reduced if the long exposure is made at a low temperature. Most experiments have been made with cameras designed for fairly small formats and cooled to about  $-103^{\circ}\text{F}$  ( $-75^{\circ}\text{C}$ ) with solid carbon dioxide.

Some of the techniques which are used for spectroscopic plates may also be applied to color films. Baking both in nitrogen and in forming gas, a 2–4% hydrogen-in-nitrogen mixture, is useful. Films are baked for several hours in a flow of the gas at  $150^{\circ}\text{F}$  ( $65^{\circ}\text{C}$ ) just prior to exposure and then (preferably) exposed in a nitrogen atmosphere.

These user-applied processes reduce some of the disadvantages of color films for astrophotography, and push development may be used in addition to the above, to increase both speed and contrast. However, the basic problem of uneven spectral response remains. As a result, color films can reproduce only realistic colors of the brighter, continuous-spectrum objects, such as planets, stars, and galaxies. Faint objects and emission nebulae are not well recorded.

An alternative approach is to use the oldest system of color photography, the three-color separation technique. In this system, three exposures are made with combinations of photographic emulsions and filters chosen to record the red, green, and blue parts of the spectrum on separate plates or film. Filter-emulsion passbands are chosen to ensure adequate overlap between adjacent colors so that hues intermediate between red, green, and blue are well recorded. With care in selection of these

parameters, coverage of the visible region is much more uniform than is possible with conventional color film.

The same principles are used with digital detectors such as charge-coupled devices, which are much more sensitive than hypersensitized silver-based photographic materials. As yet, they lack the essentially unlimited area and small pixels that give conventional materials their "photographic" characteristics that translate into a distinctive esthetic quality. Charge-coupled-device images are usually combined into three-color images with a computer, and similar methods can be used to combine digitized versions of photographic red, green, and blue exposures.

Two methods are possible to recover the color information in three-color separations. The subtractive process involves image-wise combinations of yellow, magenta, and cyan dyes or pigments and is now rarely practiced outside professional printing applications. Much more flexible in the astronomical application is the additive process, which allows several levels of image manipulation before the monochromes are combined. Additive color photography involves mixing colored light, rather than colored compounds, and its most common manifestation is the color television or computer screen image, which a magnifier shows to be made up of blue, green, and red dots or strips. When used photographically, monochrome positive copies are made by contact copying the three original separation negatives onto a suitable film material. A wide range of image-manipulation techniques can be applied to enhance small or faint features and to adjust the contrast of the original images. See ELECTRONIC DISPLAY. [D.F.M.]

**Astronomical spectroscopy** The use of spectroscopy (the analysis of light as a function of wavelength) as a tool for obtaining observational data on the chemical compositions, physical conditions, and radial velocities of astronomical objects. Astronomical applications of optical spectroscopy from ground-based observatories cover the electromagnetic spectrum from the near-ultraviolet (wavelengths around 0.3 micrometer) through the visible (0.4–0.7  $\mu\text{m}$ ) and into the near-infrared (2  $\mu\text{m}$ ). Space-based observatories extend spectroscopic observations from the far-ultraviolet (0.1  $\mu\text{m}$ ) to the far-infrared (100  $\mu\text{m}$ ). Work at shorter wavelengths (x-ray and gamma-ray spectroscopy) and longer wavelengths (submillimeter and radio wavelengths) requires techniques other than those discussed here. See GAMMA-RAY ASTRONOMY; RADIO ASTRONOMY; SATELLITE ASTRONOMY; ULTRAVIOLET ASTRONOMY; X-RAY ASTRONOMY.

Usually a spectrograph is fitted to a reflecting telescope, which serves as a light collector. The image of the celestial body being studied is focused on the spectrograph slit, which limits the region under study (thus improving the spectral resolution) and reducing the contribution by the night sky. The diverging light beam then passes from the slit to a collimator (either a lens or mirror). This produces parallel light, which is then dispersed by a diffraction grating or prism. The dispersed light enters a camera, which focuses the spectrum onto a detector, either a charge-coupled device (CCD) in the case of an optical spectrograph, or an electronic array sensitive to infrared light. See CHARGE-COUPLED DEVICES; DIFFRACTION GRATING; SPECTROGRAPH; SPECTROSCOPY; TELESCOPE.

It is often desirable to obtain spectroscopy of many of the objects within a telescope's field of view in a single exposure. A variety of methods are available to accomplish such surveys, including slitless spectroscopy, slitlet masks, and fiber-fed spectroscopy.

It is possible to take spectra of all of the brighter objects within the field of view by not using a spectrograph at all, but by combining a low-dispersing element directly with the telescope. For instance, an objective prism may be placed in front of the telescope, which is often a Schmidt camera. Slitless spectroscopy has been used for large stellar surveys. See ASTRONOMICAL CATALOGS.

In the technique of slitlet masks, a picture is usually taken of a region containing several astronomical objects of interest;

the exact locations of these objects are determined, and small slits (slitlets) are then milled in the corresponding locations in a metal plate. This plate is substituted for the slit in a conventional spectrograph.

Rather than milling slitlets in a plate, holes may be drilled, which are then plugged with optical fibers. (Such an arrangement is often referred to as a plugboard.) The light is then transported via the fibers to a spectrograph mounted on an optical bench in a laboratorylike environment adjacent to the telescope. Alternatively, robotics may be used to position fibers in the focal plane; the fibers are then anchored to a metal plate via magnets. At the spectrograph, the fibers are arrayed in a line and act as the spectrograph slit. Hundreds of objects can be observed simultaneously, leading to very effective use of the telescope. See OPTICAL FIBERS.

Normal spectrographs employ diffraction gratings that are intended to be used in low orders ( $n = 1, 2, \text{ or } 3$ ), with colored glass filters used to prevent overlap of adjacent orders. Echelle spectrographs differ from conventional systems in that they employ gratings intended to be used in very high orders ( $n > 10$ ), resulting in very high resolving power. Normally these orders would fall on top of one another, rendering the data useless. An echelle uses a second dispersal element, usually another grating but sometimes a prism, at right angles to the first, in order to separate the successive spectral strips from each other. A large range of wavelengths can be obtained in the format of nearly parallel segments, well suited for charge-coupled devices.

In integral field spectroscopy, a close-knit bundle of optical fibers is placed in the focal plane and is used to observe an extended astronomical object, such as a gaseous nebula or a galaxy. The light is transmitted via the fibers to a bench-mounted spectrograph. Although the fibers are in a linear array at the spectrograph, their locations in the focal plane are known, and sophisticated data reduction techniques allow the astronomer to reconstruct a spectral "image" of the object.

Fourier transform spectroscopy is used particularly in the near-infrared. Instead of being dispersed in a spectrograph, the light of a wide band of wavelengths is passed through a Michelson interferometer with variable spacing of its two apertures. The resulting interferogram, which is an electronic record of the interference signal produced by the interferometer as the separation of the apertures is varied, is converted into a record of intensity versus wavelength by a computer, and is of extremely high spectral resolution. See INFRARED SPECTROSCOPY; INTERFEROMETRY.

The application of astronomical spectroscopy extends from solar system objects (the Sun, planets, and comets) to Milky Way objects (stars, including binary stars, ordinary novae, and cataclysmic variables; and gaseous nebulae, such as supernova remnants, H II regions, and planetary nebulae) and to distant galaxies and quasars. [PMa.; L.H.AL.]

**Astronomical transit instrument** A telescope adapted to the observation of the passage, or transit, of an astronomical object across the meridian of the observer. The astronomical transit instrument is the classic instrument of positional astronomy, which is the study of the positions and motions of astronomical objects. The chief variants of the classic design include the vertical circle, the horizontal transit circle, the broken or prism transit, the photographic zenith tube and, most commonly, the meridian or transit circle.

The modern transit instrument has an objective (lens) with a diameter of 6–10 in. (15–25 cm) and a focal length of 72–90 in. (180–230 cm). The instrument consists of a telescope mounted on a single fixed horizontal axis of rotation. The horizontal axis has a central hollow cube (or sometimes a sphere) and two conical semi-axes ending in cylindrical pivots. The objective and imaging halves of the telescope are also fastened to the cube of the instrument, perpendicular to the horizontal axis. Rotation of the instrument in its bearings, or wyes, permits the optical axis to sweep only in the plane of the meridian. Because



Carlsberg Meridian Circle, La Palma, Canary Islands. (University of Copenhagen)

it is constrained to a single plane, it can be solidly mounted on massive piers, creating a stability not present in other telescope designs.

**Meridian or transit circle.** For many years, the major observatories of the world had astronomical transit instruments called meridian or transit circles. These instruments are similar to the transit instrument described above except that they are also capable of measuring the distance of the object along the meridian to obtain its declination, using a large, accurately calibrated circle attached to the horizontal axis. An accurate (atomic) clock is used as the scale for determining the right ascension of the object. See ATOMIC CLOCK.

Electronic detection systems, most commonly charge-coupled devices have improved the accuracy and efficiency of the observations, but they cannot be used far from the Equator due to the curved paths that the stars follow across the charge-coupled devices, and it is difficult to observe objects that are not point sources, such as the Sun and planets. See CHARGE-COUPLED DEVICES.

**Applications.** In 1997 the European Space Agency published the results of observations made with the *Hipparcos* satellite. The accuracy of the 100,000 star positions far exceeds anything obtainable with transit circles. In addition, modern astrophotographs with charge-coupled-device cameras can measure far more star positions than the transit circle and with greater accuracy. Nevertheless, transit circles still carry on specialized observing programs. The Carlsberg Meridian Telescope at La Palma in the Canary Islands is an example of a modern transit circle used to provide additional accurate star positions to improve the proper motions of previously measured stars and for the measurement of solar system bodies, especially asteroids (see illustration). It is completely automatic, being operated remotely via the Internet. Use of a charge-coupled device as the detector generally limits these instruments to areas near the Equator. See ASTEROID. [F.S.Ga.]

**Astronomical unit** The basic unit of length in the solar system. The astronomical unit (AU) is also used to a limited extent for interstellar distances through the definition of the parsec (1 pc = 206,265 AU). It is nearly equal to the mean distance  $a$  between the center of mass of the Sun and the center of mass of the Earth-Moon system ( $a = 1.00\,000\,23$  AU), and for that reason it is often convenient to think of it as the mean distance between the Sun and Earth. See PARSEC.

The most accurate determination of the length of the astronomical unit in physical units, such as meters, is obtained from

phase-modulated continuous-wave (CW) radio signals beamed to other planets. The round-trip travel times of the signals are determined by cross-correlating the returned signal from the planet with the transmitted signal, and as a result, planetary distances are measured directly. Continuous-wave signals returned from the National Aeronautics and Space Administration (NASA) landers on the surface of Mars resulted in a determination of the astronomical unit to an accuracy of 20 m (65 ft). With an adopted value of 299,792,458 m/s (186,282.397051 mi/s) for the speed of electromagnetic propagation in vacuum, the value of the astronomical unit from NASA's Viking and Pathfinder missions is 149,597,870,692 m (92,955,807.268 mi). [J.D.A.]

**Astronomy** The study of the universe and the objects in it through scientific investigation. Since much of contemporary astronomy uses the laws and methods of physics, the terms "astronomy" and "astrophysics" are usually used interchangeably. However, modern astronomy also uses techniques from many other scientific disciplines, including chemistry, geology, and biology, for which the terms astrochemistry, planetary science, and astrobiology are increasingly used.

The use of geological knowledge and methods in analyzing close-up observations from spacecraft of planets and their satellites and of comets and asteroids closely links the disciplines of astronomy and planetary science. Indeed, the discovery of planets around distant stars holds for even closer relations in the future. Methods of studying molecules in interstellar clouds involve chemical knowledge. Planetary science and astrochemistry come together with astronomy in the search for life outside the solar system, part of the search for extraterrestrial intelligence (SETI). The National Aeronautics and Space Administration (NASA), the United States space agency, has placed a priority on astrobiology, including the investigation of Mars and the bringing of samples back to Earth from Mars. See ASTEROID; COMET; COSMOCHEMISTRY; EXTRATERRESTRIAL INTELLIGENCE; INTERSTELLAR MATTER; PLANET; PLANETARY PHYSICS; SOLAR SYSTEM.

Astronomers often lead in employing new technologies, pushing them to the limit in exploring extremely faint signals in various parts of the electromagnetic spectrum. Nearly all astronomical research is now heavily dependent on computers. Astronomical imagery is now dominated by light-sensitive silicon chips known as charge-coupled devices (CCDs), which are approximately 100 times more sensitive than film. Fiber optics are used for a variety of astronomical purposes, including the taking of hundreds of galaxy images simultaneously from the field of view of a telescope and bringing the light to a spectrograph that can produce simultaneous spectra of all the objects. The technology of active optics, in which the shape of a mirror is changed slightly at a high rate (often faster than 1 Hz) to compensate for the blurring of astronomical images caused by the Earth's atmosphere, is being increasingly pursued to eliminate the twinkling of stars. See ADAPTIVE OPTICS; FIBER-OPTICS IMAGING.

The opening of the 5-m (200-in.) Hale telescope at the Palomar Observatory on Palomar Mountain, California, in 1948 marked the beginning of a great period of development in optical astronomy. The light-gathering power of this telescope allowed cosmological study that extended most of the way to the beginning of time in the universe. It was joined in the task by several 4-m-class (160-in.) telescopes and by one less successful larger telescope. In the 1990s, new techniques of telescope making allowed the completion of several telescopes in the 10-m (400-in.) class, twice the diameter and thus four times the collecting area of the Hale telescope. The large telescopes have proven useful in taking spectra of the optical counterparts of gamma-ray bursts, proving that they are very far away; and in analyzing the distances to faraway galaxies and in measuring the redshifts of their spectra, leading to the current cosmological models of the expansion of the universe and the tentative conclusion that the rate of expansion is accelerating. See COSMOLOGY; HUBBLE CONSTANT; TELESCOPE.

The 1990s saw the thorough use of the vantage points of space for astronomical observation, exemplified by NASA's series of Great Observatories. In 1991 the *Compton Gamma-Ray Observatory* was launched, and in the following years mapped about one gamma-ray burst per day in addition to many other objects and events. The Hubble Space Telescope was launched in 1990 to study the ultraviolet and visible parts of the spectrum. Its repair in 1993, with secondary mirrors compensating for a focusing problem with the main mirror, brought it to full working order, and a 1996 upgrade included an improved two-dimensional spectrograph and infrared capability. The *Chandra X-Ray Observatory*, launched in 1999, provides high-resolution x-ray images, and is the same size and scope as Hubble. It studies various types of celestial objects and processes, such as black holes of stellar and galactic sizes. The *Space Infrared Telescope Facility*, the fourth of this series of Great Observatories, was launched in 2004 and renamed the *Spitzer Space Telescope*. Smaller spacecraft have also made valuable contributions. See BLACK HOLE; INFRARED ASTRONOMY; X-RAY ASTRONOMY; X-RAY TELESCOPE.

The atmosphere blocks most of the electromagnetic spectrum from reaching the Earth's surface, leaving windows of transparency mostly in the optical and radio parts of the spectrum. Radio astronomers have made the most of their window of transparency with such telescopes as the 100-m (328-ft) fully steerable telescope outside Bonn, Germany; the 330-m (1083-ft) Arecibo dish in Puerto Rico, which has some limited tracking ability, the Very Large Array of radio telescopes in New Mexico, and the Very Long Baseline Array. The ozone layer and other constituents of the atmosphere block the shortest wavelengths from penetrating to the Earth's surface, so observations of gamma rays, x-rays, and most of the ultraviolet region require telescopes in space. See OZONE; RADIO ASTRONOMY; RADIO TELESCOPE.

Much of astronomy involves breaking down the incoming celestial radiation into its component wavelengths, a process known as spectroscopy. Spectroscopic studies can reveal the temperature of an object, the identity and proportions of its chemical elements, and the velocities of its constituents toward and away from the Earth. Light from the Sun and other objects is sometimes polarized, and studies of such polarization can tell about the magnetic fields present or about scattering processes. See ASTRONOMICAL SPECTROSCOPY; POLARIMETRY.

The expansive definition of a telescope includes anything used in astronomy to observe the sky. Several neutrino telescopes have been used to detect neutrinos from the Sun and, in one instance, from a supernova. The pace of observation of secondary cosmic rays as well as the few primary cosmic rays that reach the Earth is increasing. A pair of interferometers are being built on Earth to attempt direct detection of such gravitational waves, which should result from such distant events as the merger of two neutron stars. See COSMIC RAYS; NEUTRINO; SOLAR NEUTRINOS.

Theoretical calculations of the nature of astronomical objects or processes are known as theoretical astrophysics. The availability of supercomputers, powerful and fast computers capable of handling large amounts of data, has led to three-dimensional simulations of, for example, the formation of large-scale structure in the early universe. Models of the oscillations detectable on the Sun's surface through long-time-series observations are used to improve understanding of the solar interior, a process known as helioseismology. See HELIOSEISMOLOGY; SIMULATION; SUPERCOMPUTER; UNIVERSE.

Laboratory astrophysics involves the measurement of basic parameters that are used in calculations of physical or chemical processes relevant to astronomy, such as cross sections of atomic and molecular collisional excitation and ionization. See MOLECULAR STRUCTURE AND SPECTRA. [J.M.P.]

**Astrophysics, high-energy** The study of the universe as revealed by high-energy, invisible forms of light: x-rays

and gamma rays. These radiations are produced in the cosmos when gas is heated to millions of degrees Kelvin or electrons have been accelerated to near the speed of light by violent and extreme conditions. Exploding stars, neutron stars, black holes, and galaxy clusters, the most massive objects in the universe, are among the objects studied.

The high energies of x-rays and gamma rays have two important consequences for astronomical research. First, these forms of light are absorbed by the atmosphere, so telescopes to detect them must be placed on spacecraft above the atmosphere. Second, the telescopes must be constructed differently. Gamma rays have such high energy that they cannot be focused by traditional techniques, although indirect methods can give a rough estimate of their direction. See SATELLITE ASTRONOMY.

X-rays will reflect off mirrors, but only if they strike at grazing angles, like a stone skipping across a pond. For this reason, x-ray mirrors have to be carefully shaped and aligned nearly parallel to the incoming x-rays. These barrel-shaped mirrors are nested one inside the other to increase the collection area, and therefore the sensitivity, of the telescope.

The *Chandra X-ray Observatory*, launched by the National Aeronautics and Space Administration (NASA) in July 1999, is the premier focusing x-ray telescope. It is an assembly of four pairs of mirrors. *Chandra's* mirrors are the smoothest mirrors ever constructed. The largest of the mirrors is almost 4 feet (1.2 m) in diameter and 3 ft (0.9 m) long. See X-RAY TELESCOPE.

The European Space Agency's *XMM*, a powerful telescope launched in December 1999, has 58 mirrors. These mirrors are not as smooth as *Chandra's* mirrors, so *XMM* cannot make images of the same crispness, but it can detect fainter sources and measure the energies of x-rays very accurately.

The new era of gamma-ray astronomy was inaugurated by the launches of NASA's *Compton Gamma-Ray Observatory*, and *Granat*, a Russian-French mission. *Granat*, launched in 1989, has two instruments that cover the x-ray through the gamma-ray region. *Compton* was launched in 1991 as one of NASA's Great Observatories, along with the Hubble Space Telescope and the *Chandra X-ray Observatory*. It has four instruments on board that go from high-energy x-ray to high-energy gamma-ray energies. The capabilities of the instruments aboard these observatories are more than ten times that of any previous gamma-ray mission. See GAMMA-RAY ASTRONOMY.

**Supernovae.** A massive star explodes about once every 50 years in the Milky Way Galaxy. The shell of matter thrown off by the supernova creates a bubble of multimillion-degree gas called a supernova remnant. The hot gas expands and produces x-rays for thousands of years. Gamma rays from radioactive elements have also been detected from supernova remnants by gamma-ray telescopes such as those on the *Compton Gamma-Ray Observatory* and the *SIGMA* telescope on board *Granat*.

The study of remnants of exploded stars, or supernovae, is essential for understanding the origin of life on Earth. The cloud of gas and dust that collapsed to form the Sun, Earth, and other planets was composed mostly of hydrogen and helium, with a small amount of heavier elements such as carbon, nitrogen, oxygen, and iron. The only place where these and other heavy elements necessary for life are made is deep in the interior of a massive star. There they remain until a supernova explosion spreads them throughout space. See NUCLEOSYNTHESIS; SUPERNOVA.

**Neutron stars.** When a massive star explodes, most of it is flung into space, but the core of the star is compressed to form a rapidly rotating dense ball of neutrons that is about 12 mi (20 km) in diameter. The collapse and rapid rotation of the neutron star cause it to become highly magnetized. A magnetized, rapidly rotating neutron star can produce electric voltages of  $10^{16}$  v.

Neutron star gravity, which is more than  $10^{11}$  times stronger than gravity on Earth, is overwhelmed by the electric field, and particles are pulled off the neutron star and accelerated to speeds

near the speed of light. An intense shower of electrons and anti-matter electrons, or positrons, is produced by these particles. The pulsed emission from the Crab Nebula, observed at all wavelengths from radio through gamma rays, is thought to be caused by this process (see illustration). See CRAB NEBULA; PULSAR.

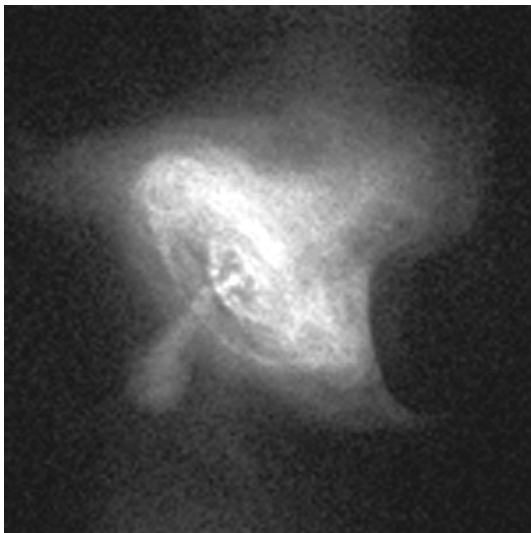

**Chandra X-ray Observatory image of the Crab Nebula, a supernova remnant and pulsar in the constellation Taurus. The image shows the central pulsar, a rapidly spinning neutron star, or pulsar that emits pulses of radiation 30 times a second, surrounded by tilted rings of high-energy particles that appear to have been flung outward over a distance of more than a light-year from the pulsar. (NASA/Chandra X-ray Observatory Center/ Smithsonian Astrophysical Observatory)**

**Black holes and quasars.** When a very massive star collapses, it forms a black hole. A black hole does not have a surface in the usual sense of the word. There is simply a region in space around a black hole beyond which nothing can be seen, because nothing can escape from inside this region. This region is called the event horizon.

Anything that passes beyond the event horizon is doomed to be crushed as it descends ever deeper into the gravitational well of the black hole. Neither visible light, nor x-rays, nor any other form of electromagnetic radiation given off by the particle can escape.

A black hole cannot be seen directly. The only way to find one is by observing the energy released by matter that is falling toward the black hole. As gas and dust particles swirl toward a black hole, they speed up and form a flattened disk. Friction caused by collisions between the particles heats them to extreme temperatures. Just before the particles pass beyond the event horizon, they produce x-rays and gamma rays as their temperatures approach  $10^8$  K.

Black holes grow when matter falls into them. A black hole in the center of a galaxy where stars are densely packed may grow to the mass of  $10^9$  suns. Energy released from large clouds of gas as they fall into these supermassive black holes can be stupendous. This is the accepted explanation for quasars, sources in which the power output at the center of a galaxy is a thousand times greater than an entire galaxy of  $10^{11}$  stars. See QUASAR.

One of the most intriguing features of supermassive black holes is that they do not suck up all the matter that falls within their sphere of influence. Some of the matter falls inexorably toward the black hole, and some explodes away from the black hole in high-energy jets that move at near the speed of light. These jets produce radio, optical, x-ray, and gamma radiation. The matter swirling around the black hole must somehow be producing enormous electric and magnetic fields that accelerate

electrons to extremely high energies. Exactly how this happens is unknown and is a major focus of research. See BLACK HOLE.

**Galaxy clusters and dark matter.** More than half of all galaxies in the universe are members of groups of galaxies or larger collections of galaxies, called clusters. X-ray observations have shown that most clusters of galaxies are filled with vast clouds of multimillion-degree gas. The mass of this gas, which was heated when it collapsed from a much larger size, is greater than all the stars in all the galaxies in a cluster of a thousand galaxies. Galaxy clusters are the largest and most massive gravitationally bound objects in the universe.

The x-ray-producing hot gas found in a typical cluster of galaxies presents a great mystery. Over time this extremely hot gas should escape the cluster, since the galaxies and gas do not provide enough gravity to hold it in. Yet the gas remains in clusters of all ages. Scientists have concluded that some unobserved form of matter, called dark matter, is providing the gravity needed to hold the hot gas in the cluster. An enormous amount of dark matter is needed—about three to ten times as much matter as that observed in the gas and galaxies. This means that most of the matter in the universe may be dark matter.

The dark matter could be collapsed stars, planet-like objects, black holes, or exotic subatomic particles that produce no light, and can be detected only through their gravity. Detailed measurements of the size and temperature of the hot gas clouds in galaxy clusters with x-ray telescopes could help solve the dark matter mystery. See COSMOLOGY; GALAXY, EXTERNAL; SATELLITE ASTRONOMY; UNIVERSE; X-RAY ASTRONOMY. [W.T.]

**Asymmetric synthesis** A reaction or series of reactions leading to predominant or exclusive formation of a single enantiomer, that is, a stereoisomer that is not superimposable on its mirror image. Among the organic compounds that are usually the target of asymmetric synthesis, the most common structural element that makes one exist as an enantiomer is a carbon atom with a single bond to four different atoms or groups (a stereogenic center), as the two enantiomers of 3-methylhexane, (R)-3-methylhexane (**1**) and (S)-3-methylhexane (**2**).

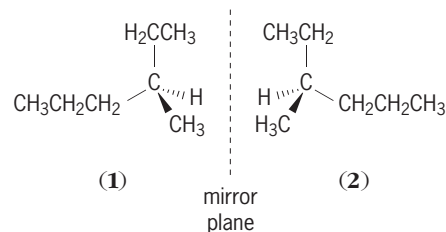

Enantiomers are said to be chiral. They are asymmetric; symmetric molecules, possessing a plane or point of symmetry, are superimposable on their mirror images. Not all molecules exist as enantiomers. See PROCHIRALITY.

Other structural elements can give rise to asymmetry, for example substituted allene functional groups, as in (S)-2,3-pentadiene (**3**) and (R)-2,3-pentadiene (**4**), and binaphthyl sys-

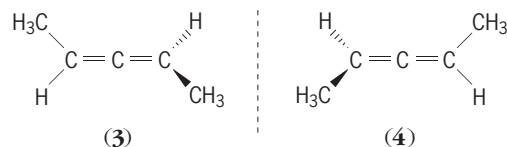

tems, as in (R)-1,1'-binaphthyl (**5**) and (S)-1,1'-binaphthyl (**6**),





**Athalamida** An order of Granuloreticulosa in which the naked amebas form branched, threadlike interconnected pseudopodia (reticulopodia; see illustration). Species are known from fresh, salt, and brackish water. General characteristics are difficult to select. Heterogeneity may extend even to a genus; described

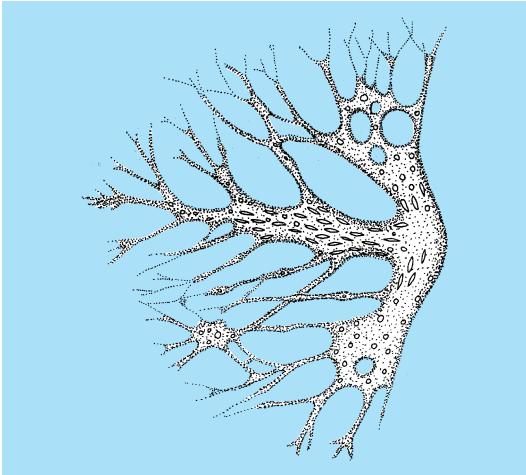

*Biomyxa vagans*. (After R. P. Hall, *Protozoology*, Prentice Hall, 1953)

species of *Biomyxa* differ appreciably in morphology and exhibit, for example, uninucleate and multinucleate conditions in different species (although these may represent young and mature stages in life cycles). In addition to *Biomyxa*, the genera *Arachnula*, *Gymnophrys*, and *Pontomyxa* have been assigned to this order. See GRANULORETICULOSIA; PROTOZOA; RHIZOPODEA; SARCODINA; SARCOMASTIGOPHORA. [R.P.H.]

**Athecanephria** An order of Pogonophora, a group of elongate, tentaculated, tube-dwelling, sedentary, nonparasitic marine worms lacking a digestive system. The coelom in the tentacular region is sac-shaped, with the two ducts set far apart from one another, and their excretory (osmoregulatory) sections lie close to the lateral cephalic blood vessels. The Athecanephria contain two families: Siboglinidae and Oligobrachiidae, with two and five genera respectively. See POGONOPHORA; THECANEPHRIA. [E.B.Cu.]

**Atheriniformes** An order of actinopterygian fishes that includes the flyingfishes, needlefishes, killifishes, silversides, and their allies. Atheriniform fishes date from the Upper Cretaceous. Modern forms are grouped in 3 suborders, 16 families, about 170 genera, and probably 700–800 species. They chiefly inhabit fresh, brackish, and oceanic surface waters of the tropics and subtropics, but some enter the temperate zones, both in fresh water and the sea. They are circumtropical in distribution,

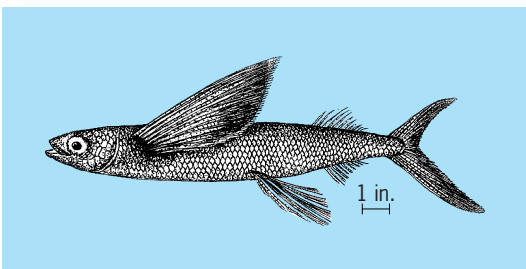

California flyingfish (*Cypselurus californicus*). (After G. B. Goode, *Fishery Industries of the U.S.*, 1884)

abounding in fresh waters of Africa and the Americas and in all warm seas. None lives in deep oceanic waters. Atheriniformes are mostly small, although some needlefishes reach 5 ft (1.5 m) or more in length; most have a single dorsal fin of soft rays, but the silversides have a short anterior spinous dorsal; the pectoral fin is placed high on the side; the pelvic fin, if present, is abdominal, subabdominal, or thoracic and has six (occasionally seven) or fewer rays, one of which may be a spine; scales are usually cycloid, sometimes ctenoid, and rarely absent. The most familiar families include flyingfishes (see illustration) and halfbeaks (Exocoetidae), the former with stiffened, elongated rays on the paired fins that permit gliding in air; killifishes (Cyprinodontidae); live-bearers (Poeciliidae), among them guppies, swordtails, platyfishes, and mosquito fishes; and silversides (Atherinidae), that abound on marine beaches and reefs. Viviparity is more frequent and better understood in Atheriniformes than in any other order of bony fishes, occurring in no fewer than eight families. See ACTINOPTERYGII; OSTEICHTHYES; TELEOSTEI. [R.M.B.]

**Atlantic Ocean** The large body of sea water separating the continents of North and South America in the west from Europe and Africa in the east and extending south from the Arctic Ocean to the continent of Antarctica. The Atlantic is the second largest ocean water body and in area covers nearly one-fifth of the Earth's surface. The two major divisions, North and South Atlantic oceans, have the Equator as the common boundary. The North Atlantic, because of projecting land areas and island arcs, has numerous subdivisions. These include three large mediterranean-type seas, the Mediterranean Sea, the Gulf of Mexico plus Caribbean Sea, and the Arctic Ocean; two small mediterranean-type seas, the Baltic Sea and Hudson Bay; and four marginal seas, the North Sea, English Channel, Irish Sea, and Gulf of St. Lawrence. Parts of the Atlantic are given special names but lack precise boundaries, such as the Bahama Sea, Irminger Sea, Labrador Sea, and Sargasso Sea.

The mean depth of the Atlantic Ocean is 12,960 ft (3868 m), and its volume is 76,300,000 mi<sup>3</sup> (318,000,000 km<sup>3</sup>). Broad shelves with depths less than 660 ft (200 m) are found in the region of the North Sea and the British Isles, on the Grand Banks of Newfoundland, and off the coasts of northeastern South America and Patagonia. The Mid-Atlantic Ridge, which extends from the Arctic Ocean to 55°S, is less than 9800 ft (3000 m) beneath the surface and is characterized by a pronounced relief. It separates the east and west Atlantic troughs, both of which have relatively uniform relief.

Three marked east-west ridges—the Greenland-Scotland Ridge in the North Atlantic and the Walvis and Rio Grande Ridges in the South Atlantic—and several less-conspicuous east-west rises separate the two Atlantic troughs into a series of basins including the West European, Canary, and Angola in the eastern Atlantic and the North American, Brazilian, and Argentine basins in the western Atlantic.

Islands in the Atlantic are mostly of volcanic origin. The Bermudas are the northernmost coral reefs, rising from an old submarine volcanic cone. Some islands, such as the British Isles, are continental in character. See OCEANIC ISLANDS; WEST INDIES.

The primary circulation of surface winds over the Atlantic Ocean is characterized by a zonal distribution pattern oriented in an east-west direction. The greatest storm frequency, more than 30% in winter, is in the zone of the prevailing westerlies. Air temperatures also follow a zonal pattern of distribution. They are lower in the South Atlantic than in the North Atlantic, and lower in the tropics and subtropics over the eastern Atlantic, than they are in the same latitudes over the western Atlantic. Maximum precipitation occurs in the doldrum zone (80 in. or 2000 mm/year). Precipitation also is relatively great in the zone of westerlies but is low in the trade-wind zones.

Sea ice is formed in the northernmost and southernmost parts of the Atlantic Ocean. From these areas drift ice moves equatorward into neighboring regions where it becomes a hazard to sea

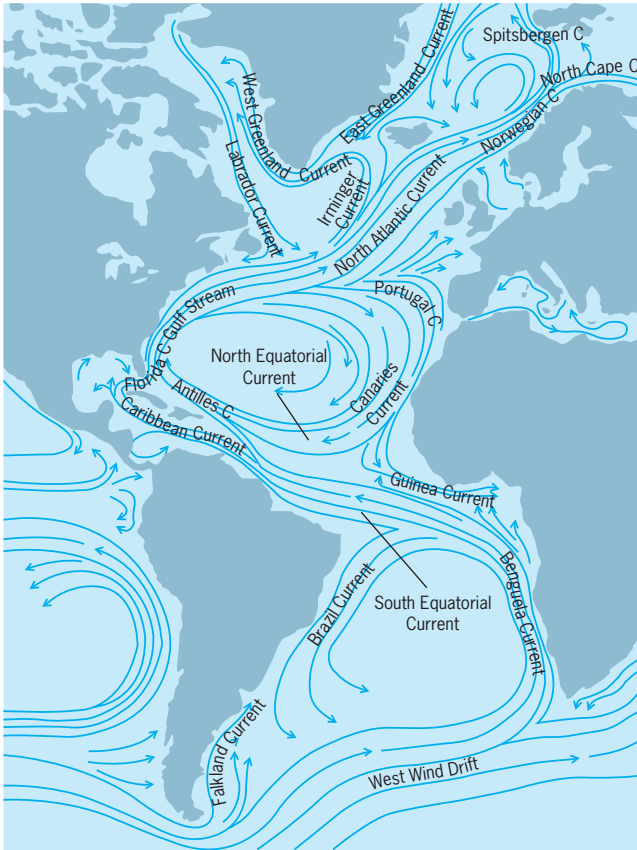

**Currents of the Atlantic Ocean.** (Adapted from J. Bartholomew *Advanced Atlas of Modern Geography*, McGraw-Hill, 3d ed., 1957)

traffic and limits fishing. Many icebergs drift southward into the sea lanes of the North Atlantic. Most of these have their origin in the valley glaciers of western Greenland. Icebergs generally drift south of the Grand Banks, and some are known to have drifted southeast of Bermuda. In the South Atlantic large, tabular icebergs separate from the Antarctic ice shelf and drift northward. See ICEBERG; SEA ICE.

Surface currents in the Atlantic Ocean flow in much the same direction as the prevailing surface winds (see illustration). Deflections from these directions are caused by the bottom topography and the latitude or increased effect of Coriolis forces. The fairly constant flow of the North and South Equatorial currents is sustained largely by the trade winds. As a result, warm water is piled up along the poleward borders of these currents and on the western sides of the Atlantic Ocean. See ANTARCTIC; OCEAN; ARCTIC; OCEAN; SEA; GULF OF; GULF; STREAM; OCEAN CIRCULATION.

The surface water in certain areas takes on a particularly high density in winter under the influence of climatic conditions. These water masses sink to a depth where the surrounding waters have a corresponding density and then spread out at that level. At the same time they are constantly mixing with the surrounding waters. In this way a multistoried stratification arises. Compared with that of the Indian and Pacific oceans, the deep circulation in the Atlantic Ocean is very vigorous, and the deeper water is therefore rich in oxygen. The abundance of nutrients permits a greater rate of organic production where the nutrient-rich waters nearly reach the surface, as in the Antarctic waters. See SEAWATER; SEAWATER FERTILITY.

The semidiurnal tidal form predominates in the Atlantic Ocean. The mean tidal range is about 3.3 ft (1 m) in the open ocean, but it decreases to 6.3 in. (16 cm) off Rio Grande do Sul in southern Brazil and to 3.5 in. (9 cm) off Puerto Rico. Tidal

ranges increase beyond broad shelves under favorable physical conditions. The tides of the mediterranean and marginal seas are cooscillations of the tides of the Atlantic Ocean. See TIDE.

The Atlantic Ocean, especially the North Atlantic, is by far the most important bearer of the world's sea traffic. Favorable trend include increased transportation capacities for handling bulk goods, regular weather observations for the safety of air and sea traffic by weather ships in selected positions, and the observation and reporting of drifting icebergs by the International Ice Patrol. Communication facilities, including telegraph and telephone cables and radio stations, have been improved and increased in number. [G.O.D.]

**Atmosphere** A gaseous layer that envelops the Earth and most other planets in the solar system. Earth, Venus, Mars, Jupiter, Saturn, Uranus, Neptune, and Titan (Saturn's largest satellite) are all known to possess substantial atmospheres that are held by the force of gravity. The structure and properties of the various atmospheres are determined by the interplay of physical and chemical processes. Structural features of Earth's atmosphere detailed below can often be identified in the atmospheres of other planetary bodies. See PLANETARY PHYSICS.

The composition of the Earth's atmosphere is primarily nitrogen ( $N_2$ ), oxygen ( $O_2$ ), and argon (Ar) [see table]. The concentration of water vapor ( $H_2O$ ) is highly variable, especially near the surface, where volume fractions can vary from nearly 0% to as high as 4% in the tropics. There are many minor constituents or trace gases, such as neon (Ne), helium (He), krypton (Kr), and xenon (Xe), that are inert, and active species such as carbon dioxide ( $CO_2$ ), methane ( $CH_4$ ), hydrogen ( $H_2$ ), nitrous oxide (NO), carbon monoxide (CO), ozone ( $O_3$ ), and sulfur dioxide ( $SO_2$ ), that play an important role in radiative and biological processes.

In addition to the gaseous component, the atmosphere suspends many solid and liquid particles. Aerosols are particulates usually less than 1 micrometer in diameter that are created by gas-to-particle reactions or are lifted from the surface by the wind. A portion of these aerosols can become centers of condensation or deposition in the growth of water and ice clouds. Cloud droplets and ice crystals are made primarily of water with some trace amounts of particles and dissolved gases. Their diameters range from a few micrometers to about  $100 \mu m$ . Water or ice particles larger than about  $100 \mu m$  begin to fall because of gravity and may result in precipitation at the surface. See AEROSOL; CLOUD PHYSICS; PRECIPITATION (METEOROLOGY).

One of the remarkable properties of the Earth's atmosphere is the large amount of free molecular oxygen in the presence of gases such as nitrogen, methane, water vapor, hydrogen, and others that are capable of being oxidized. The atmosphere is in a highly oxidizing state that is far from chemical equilibrium. This is in sharp contrast to the atmospheres of Venus and Mars, the planets closest to the Earth, which are composed almost entirely of the more oxidized state, carbon dioxide. The chemical disequilibrium on the Earth is maintained by a continuous source of reactive gases derived from biological processes. Life plays a vital role in maintaining the present atmospheric composition. See ATMOSPHERIC CHEMISTRY; MARS; VENUS.

The total mass of the Earth's atmosphere is about  $5.8 \times 10^{15}$  tons ( $5.3 \times 10^{15}$  metric tons). The vertical distribution of gaseous mass is maintained by a balance between the downward force of gravity and the upward pressure gradient force. The balance is known as the hydrostatic balance or the barometric law. Hence, the declining atmospheric pressure that is measured while ascending in the atmosphere is a result of gravity. The globally averaged pressure at mean sea level is 1013.25 millibars ( $101,325$  pascals).

Below about 60 mi (100 km) in altitude, the atmosphere's composition of major constituents is very uniform. This region is known as the homosphere to distinguish it from the heterosphere above 60 mi (100 km), where the relative amounts of the major

Composition of the atmosphere\*

Molecule	Fraction volume near surface	Vertical distribution
<b>Major constituents</b>		
N <sub>2</sub>	$7.8084 \times 10^{-1}$	Mixed in homosphere; photochemical dissociation high in thermosphere
O <sub>2</sub>	$2.0946 \times 10^{-1}$	Mixed in homosphere; photochemically dissociated in thermosphere, with some dissociation in mesosphere and stratosphere
Ar	$9.34 \times 10^{-3}$	Mixed in homosphere with diffusive separation increasing above
<b>Important radiative constituents</b>		
CO <sub>2</sub>	$3.5 \times 10^{-4}$	Mixed in homosphere; photochemical dissociation in thermosphere
H <sub>2</sub> O	Highly variable	Forms clouds in troposphere; little in stratosphere; photochemical dissociation above mesosphere
O <sub>3</sub>	Variable	Small amounts, $10^{-8}$ , in troposphere; important layer, $10^{-6}$ to $10^{-5}$ , in stratosphere; dissociated above
<b>Other constituents</b>		
Ne	$1.82 \times 10^{-5}$	
He	$5.24 \times 10^{-6}$	Mixed in homosphere with diffusive separation increasing above
Kr	$1.14 \times 10^{-6}$	
CH <sub>4</sub>	$1.15 \times 10^{-6}$	Mixed in troposphere; dissociated in upper stratosphere and above
H <sub>2</sub>	$5 \times 10^{-7}$	Mixed in homosphere; product of H <sub>2</sub> O photochemical reactions in lower thermosphere, and dissociated above
NO	$\sim 10^{-8}$	Photochemically produced in stratosphere and mesosphere

\*Other gases, for example, CO, N<sub>2</sub>O, NO<sub>2</sub>, and many by-products of atmospheric pollution also exist in small amounts.

constituents change with height. In the homosphere there are sufficient atmospheric motions and a short enough molecular free path to maintain uniformity in composition. Above the boundary between the homosphere and the heterosphere, known as the homopause or turbopause, the mean free path of the individual molecules becomes long enough that gravity is able to partially separate the lighter molecules from the heavier ones. The mean free path is the average distance that a particle will travel before encountering a collision. Hence the average molecular weight of the heterosphere decreases with height as the lighter atoms dominate the composition.

The vertical structure of the atmosphere is in large part determined by the transfer properties of the solar and terrestrial radiation streams. The energy of the smallest unit of radiation, the photon, is directly proportional to its frequency. The type of interaction that occurs between photons and the atmosphere depends on the energy of the photons. See PHOTON.

The most energetic of the photons are x-rays and extreme ultraviolet radiation of the electromagnetic spectrum, which are capable of dissociating and ionizing the gaseous molecules. The less energetic near-ultraviolet photons are able to excite molecules and atoms into higher electronic levels. As a result, most of the ultraviolet and x-ray radiation is attenuated by the upper atmosphere. A cloudless atmosphere, however, is relatively transparent to visible light, where most of the solar energy resides. At the opposite end of the spectrum toward the lower frequencies of radiation is the infrared part, which is capable of inducing various vibrational and rotational motions in triatomic and polyatomic molecules.

In order to maintain an energy balance, the Earth must emit about the same amount of radiation as it absorbs from the Sun. The terrestrial radiation occurs in the infrared part of the spectrum and hence is strongly affected by water vapor, clouds, carbon dioxide, and ozone and other trace gases. The ability of these gases to absorb and emit in the infrared allows them to effectively trap some of the outgoing radiation that is emitted by the surface, creating the so-called greenhouse effect. See INSULATION.

The atmospheric layer that extends from the surface to about 7 mi (11 km) is called the troposphere. The tropopause, which is the top of the troposphere, has an average altitude that varies from about 11 mi (18 km) near the Equator to about 5 mi (8 km) near the Poles. The actual tropopause height varies considerably on time scales from a few days to an entire year. The troposphere contains about 80% of the atmospheric mass and exhibits most

of the day-to-day weather fluctuations that are observed from the ground. Temperatures generally decrease with increasing altitude at an average lapse rate of about 17°F/mi (6°C/km), although this rate varies considerably, depending on time and location. See TROPOPAUSE; TROPOSPHERE.

The stratosphere is the atmospheric layer that extends from the tropopause up to the stratopause at about 30 mi (50 km) above the surface. It is characterized by a nearly isothermal layer in the first 6 mi (10 km) overlaid by a layer in which the temperature increases with height to a maximum of about 32°F (0°C) at the stratopause. The reversal in the temperature lapse rate is a result of direct absorption of solar radiation, mainly by ozone and oxygen at the ultraviolet frequencies. See STRATOSPHERE.

The reversal of the temperature lapse rate makes the stratosphere vertically stable. This stability limits the amount of vertical mixing and results in molecular residence times of many months to years. Another consequence of a stable stratosphere is that it acts as a lid on the troposphere, confining the strong vertical overturning and hence most of the surface-based weather phenomena. See WEATHER.

The mesosphere is the atmospheric layer extending from the stratopause up to the mesopause at an altitude of about 53 mi (85 km). The mesosphere is characterized by temperatures decreasing with height at a rate of about 12°F/mi (4°C/km). Although the mesosphere has less vertical stability than the stratosphere, it is still more stable than the troposphere and does not experience rapid overturning. The coldest temperatures of the entire atmosphere are encountered at the mesopause, with values as low as -150°F (-100°C). The temperature lapse rate found in the mesosphere is a result of the gradual weakening with height of the direct absorption of solar radiation by ozone. The radiative infrared cooling to space by the carbon dioxide molecules is responsible for the low temperatures near the mesopause. See MESOSPHERE.

The thermosphere is found above the mesopause. The thermosphere is characterized by rising temperatures with height up to an altitude of about 190 mi (300 km) and then is nearly isothermal above that. Although there is no clear upper limit to the thermosphere, it is convenient to consider it extending several thousand kilometers. Embedded within the thermosphere is the ionosphere, comprising those atmospheric layers in which the ionized molecules and atoms are dominating the processes.

Molecular species dominate the lower thermosphere, while atomic species are dominant above 190 mi (300 km). The distribution of the constituents is controlled by diffusive equilibrium in

which the concentration of each constituent decreases exponentially with height according to its molecular weight. Hence the concentration of the heavier constituents such as nitrogen, oxygen, and carbon dioxide will decrease with height faster than the lighter constituents such as helium and hydrogen. At an altitude of 560 mi (900 km) helium becomes the dominant constituent while hydrogen dominates above 1900 mi (3000 km).

The ionosphere can be defined operationally as that part of the atmosphere that is sufficiently ionized to affect the propagation of radio waves. In the ionosphere, the dominant negative ion is the electron, and the main positive ions include  $O^+$ ,  $NO^+$ , and  $O_2^+$ . The ionosphere is classified into four subregions. The D region extends from 40 to 60 mi (60 to 90 km) and contains complex ionic chemistry; most of the ionization is caused by ultraviolet ionization of NO and by galactic cosmic rays. This region is responsible for the daytime absorption of radio waves, which prevents distant propagation of certain frequencies. The E region extends from 60 to 90 mi (90 to 150 km) and is caused primarily by the x-rays from the Sun. The F1 region from 90 to 125 mi (150 to 200 km) is caused by the extreme ultraviolet radiation from the Sun and disappears at night. Finally, the F2 region includes all the ionized particles above 125 mi (200 km), with the peak ion concentrations occurring near 190 mi (300 km). See COSMIC RAYS; IONOSPHERE.

The exosphere is the atmosphere above 300 mi (500 km) where the probability of interatomic collisions is so low that some of the atoms traveling upward with sufficient velocity can escape the Earth's gravitational field. The dominant escaping atom is hydrogen since it is the lightest constituent. Calculations of the thermal escape of hydrogen (also known as the Jeans escape) yield a value of about  $3 \times 10^8$  atoms  $\cdot$  cm<sup>-2</sup>  $\cdot$  s<sup>-1</sup>. This is a very small amount since at this rate less than 0.5% of the oceans would disappear over the current age of the Earth.

The magnetosphere is the region surrounding the Earth where the movement of ionized gases is dominated by the geomagnetic field. The lower boundary of the magnetosphere, which occurs at an altitude of nearly 75 mi (120 km), can be roughly defined as the height where there are enough neutral atoms that the ion-neutral particle collisions dominate the ion motion. The dynamics of the magnetosphere is dictated in part by its interaction with the plasma of ionized gases that blows away from the Sun, the solar wind. The solar wind interacts with the Earth's magnetic field and severely deforms it, producing a magnetosphere around the Earth. It extends about 40,000 mi (60,000 km) toward the Sun but extends beyond the orbit of the Moon away from the Sun. See MAGNETOSPHERE; SOLAR WIND; VAN ALLEN RADIATION. [G.B.L.]

**Atmospheric acoustics** The science of sound in the atmosphere. The atmosphere has a structure that varies in both space and time, and these variations have significant effects on a propagating sound wave. In addition, when sound propagates close to the ground, the type of ground surface has a strong effect.

**Atmospheric sound attenuation.** As sound propagates in the atmosphere, several interacting mechanism attenuate and change the spectral or temporal characteristics of the sound received at a distance from the source. The attenuation means that sound propagating through the atmosphere decreases in level with increasing distance between source and receiver. The total attenuation, in decibels, can be approximated as the sum of three nominally independent terms, as given in the equation below,

$$A_{\text{total}} = A_{\text{div}} + A_{\text{air}} + A_{\text{env}}$$

where  $A_{\text{div}}$  is the attenuation due to geometrical divergence,  $A_{\text{air}}$  is the attenuation due to air absorption, and  $A_{\text{env}}$  is the attenuation due to all other effects and includes the effects of the ground,

refraction by a nonhomogeneous atmosphere, and scattering effects due to turbulence.

Sound energy spreads out as it propagates away from its source due to geometrical divergence. At distances that are large compared with the effective size of the sound source, the sound level decreases at the rate of 6 dB for every doubling of distance. The phenomenon of geometrical divergence, and the corresponding decrease in sound level with increasing distance from the source, is the same for all acoustic frequencies. In contrast, the attenuation due to the other two terms in the equation depends on frequency and therefore changes the spectral characteristics of the sound.

**Air absorption.** Dissipation of acoustic energy in the atmosphere is caused by viscosity, thermal conduction, and molecular relaxation. The last arises because fluctuations in apparent molecular vibrational temperatures lag in phase the fluctuations in translational temperatures. The vibrational temperatures of significance are those characterizing the relative populations of oxygen ( $O_2$ ) and nitrogen ( $N_2$ ) molecules. Since collisions with water molecules are much more likely to induce vibrational state changes than are collisions with other oxygen and nitrogen molecules, the sound attenuation varies markedly with absolute humidity. See MOLECULAR STRUCTURE AND SPECTRA; VISCOSITY.

The total attenuation due to air absorption increases rapidly with frequency. For this reason, applications in atmospheric acoustics are restricted to sound frequencies below a few thousand hertz if the propagation distance exceeds a few hundred meters. See SOUND ABSORPTION.

**Effects of the ground.** When the sound source and receiver are above a large flat ground surface in a homogeneous atmosphere, sound reaches the receiver via two paths. There is the direct path from source to receiver and the path reflected from the ground surface. Most naturally occurring ground surfaces are porous to some degree, and their acoustical property can be represented by an acoustic impedance. The acoustic impedance of the ground is in turn associated with a reflection coefficient that is typically less than unity. In simple terms, the sound field reflected from the ground surface suffers a reduction in amplitude and a phase change.

When the source and receiver are both relatively near the ground and are a large distance apart, the direct and reflected fields become nearly equal and cancel each other.

**Refraction of sound.** Straight ray paths are rarely achieved outdoors. In the atmosphere, both the wind and temperature vary with height above the ground. The velocity of sound relative to the ground is a function of wind velocity and temperature; hence it also varies with height, causing sound waves to propagate along curved paths.

The speed of the wind decreases with decreasing height above the ground because of drag on the moving air at the surface. Therefore, the speed of sound relative to the ground increases with height during downwind propagation, and ray paths curve downward. For propagation upwind, the sound speed decreases with height, and ray paths curve upward (see illustration). In the case of upward refraction, a shadow boundary forms near the ground beyond which no direct sound can penetrate. Some acoustic energy penetrates into a shadow zone via creeping waves that propagate along the ground and that continually shed diffracted rays into the shadow zones. The dominant feature of shadow-zone reception is the marked decrease in a sound's higher-frequency content. The presence of shadow zones explains why sound is generally less audible upwind of a source.

Refraction by temperature profiles is analogous. During the day, solar radiation heats the Earth's surface, resulting in warmer air near the ground. This condition is called a temperature lapse and is most pronounced on sunny days. A temperature lapse is the common daytime condition during most of the year, and also causes ray paths to curve upward. After sunset there is

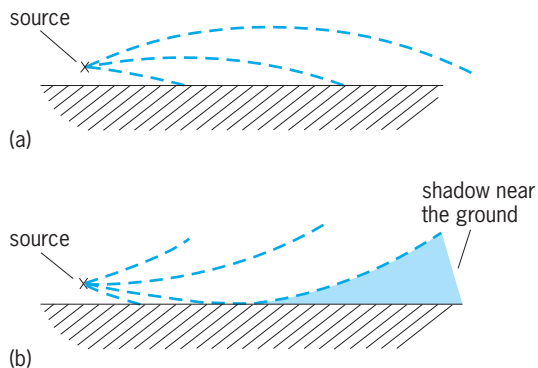

**Curved ray paths. (a) Refraction downward, during temperature inversion or downwind propagation. (b) Refraction upward, during temperature lapse or upwind propagation.**

often radiation cooling of the ground, which produces cooler air near the surface. In summer under clear skies, such temperature inversions begin to form about 2 hours after sunset. Within the temperature inversion, the temperature increases with height, and ray paths curve downward.

The effects of refraction by temperature and wind are additive and produce rather complex sound speed profiles in the atmosphere.

**Effects of turbulence.** Turbulence in the atmosphere causes the effective sound speed to fluctuate from point to point, so a nominally smooth wave front develops ripples. One result is that the direction of a received ray may fluctuate with time in random manner. Consequently, the amplitude and phase of the sound at a distant point will fluctuate with time. The acoustical fluctuations are clearly audible in the noise from a large aircraft flying overhead. Turbulence in the atmosphere also scatters sound from its original direction. *See* TURBULENT FLOW. [G.A.Da.]

**Atmospheric chemistry** A scientific discipline concerned with the chemical composition of the Earth's atmosphere. Topics include the emission, transport, and deposition of atmospheric chemical species; the rates and mechanisms of chemical reactions taking place in the atmosphere; and the effects of atmospheric species on human health, the biosphere, and climate.

A useful quantity in atmospheric chemistry is the atmospheric lifetime, defined as the mean time that a molecule resides in the atmosphere before it is removed by chemical reaction or deposition. The atmospheric lifetime measures the time scale on which changes in the production or loss rates of a species may be expected to translate into changes in the species concentration. The atmospheric lifetime can also be compared to the time scales for atmospheric transport to infer the spatial variability of a species in the atmosphere; species with lifetimes longer than a decade tend to be uniformly mixed, while species with shorter lifetimes may have significant gradients reflecting the distributions of their sources and sinks.

The principal constituents of dry air are nitrogen ( $N_2$ ; 78% by volume), oxygen ( $O_2$ ; 21%), and argon (Ar; 1%). The atmospheric concentrations of  $N_2$  and Ar are largely determined by the total amounts of N and Ar released from the Earth's interior since the origin of the Earth. The atmospheric concentration of  $O_2$  is regulated by a slow atmosphere-lithosphere cycle involving principally the conversion of  $O_2$  to carbon dioxide ( $CO_2$ ) by oxidation of organic carbon in sedimentary rocks (weathering), and the photosynthetic conversion of  $CO_2$  to  $O_2$  by marine organisms which precipitate to the bottom of the ocean to form new sediment. This cycle leads to an atmospheric lifetime for  $O_2$  of about 4 million years. *See* ATMOSPHERE, EVOLUTION OF; BIOSPHERE; LITHOSPHERE; PHOTOSYNTHESIS.

Water vapor concentrations in the atmosphere range from 3% by volume in wet tropical areas to a few parts per million by volume (ppmv) in the stratosphere. Water vapor, with a mean atmospheric lifetime of 10 days, is supplied to the troposphere by evaporation from the Earth's surface, and it is removed by precipitation. Because of this short lifetime, water vapor concentrations decrease rapidly with altitude, and little water vapor enters the stratosphere. Oxidation of methane represents a major source of water vapor in the stratosphere, comparable to the source contributed by transport from the troposphere.

The most abundant carbon species in the atmosphere is  $CO_2$ . It is produced by oxidation of organic carbon in the biosphere and in sediments. The atmospheric concentration of  $CO_2$  is rising, and there is concern that this may cause significant warming of the Earth's surface because of the ability of  $CO_2$  to absorb infrared radiation emitted by the Earth (the greenhouse effect). The total amount of carbon present in the atmosphere is small compared to that present in the other geochemical reservoirs, and therefore it is controlled by exchange with these reservoirs. Equilibration of carbon between the atmosphere, biosphere, soil, and surface ocean reservoirs takes place on a time scale of decades. *See* CARBON DIOXIDE; GREENHOUSE EFFECT.

Methane is the second most abundant carbon species in the atmosphere and an important greenhouse gas. It is emitted by anaerobic decay of biological carbon (for example, in wetlands, landfills, and stomachs of ruminants), by exploitation of natural gas and coal, and by combustion. It has a mean lifetime of 12 years against atmospheric oxidation by the hydroxyl (OH) radical, its principal sink. *See* METHANE.

Many hydrocarbons other than methane are emitted to the atmosphere from vegetation, soils, combustion, and industrial activities. The emission of isoprene [ $H_2C=C(CH_3)-CH=CH_2$ ] from deciduous vegetation is particularly significant. Non-methane hydrocarbons have generally short lifetimes against oxidation by OH (a few hours for isoprene), so that their atmospheric concentrations are low. They are most important in atmospheric chemistry as sinks for OH and as precursors of tropospheric ozone, organic nitrates, and organic aerosols.

Carbon monoxide (CO) is emitted to the atmosphere by combustion, and it is also produced within the atmosphere by oxidation of methane and other hydrocarbons. It is removed from the atmosphere by oxidation by OH, with a mean lifetime of 2 months. Carbon monoxide is the principal sink of OH and hence plays a major role in regulating the oxidizing power of the atmosphere.

Nitrous oxide ( $N_2O$ ) is of environmental importance as a greenhouse gas and as the stratospheric precursor for the radicals NO and  $NO_2$ . The principal sources of  $N_2O$  to the atmosphere are microbial processes in soils and the oceans; the main sinks are photolysis and oxidation in the stratosphere, resulting in an atmospheric lifetime for  $N_2O$  of about 130 years.

About 90% of total atmospheric ozone ( $O_3$ ) resides in the stratosphere, where it is produced by photolysis of  $O_2$ . The ultraviolet photons ( $\lambda < 240$  nm) needed to photolyze  $O_2$  are totally absorbed by ozone and  $O_2$  as solar radiation travels through the stratosphere. As a result, ozone concentrations in the troposphere are much lower than in the stratosphere. *See* PHOTOLYSIS; STRATOSPHERE; TROPOSPHERE.

Tropospheric ozone plays a central role in atmospheric chemistry by providing the primary source of the strong oxidant OH. It is also an important greenhouse gas. In surface air, ozone is of great concern because of its toxicity to humans and vegetation. Ozone is supplied to the troposphere by slow transport from the stratosphere, and it is also produced within the troposphere by a chain reaction involving oxidation of CO and hydrocarbons by OH in the presence of  $NO_x$ . Ozone production by this mechanism is particularly rapid in urban areas, where emissions of  $NO_x$  and of reactive hydrocarbons are high.

Sulfuric acid produced in the atmosphere by oxidation of sulfur dioxide ( $SO_2$ ) is a major component of aerosols in the

atmosphere and an important contributor to acid deposition. Sources of SO<sub>2</sub> to the atmosphere include emission from combustion, smelters, and volcanoes, and oxidation of oceanic dimethylsulfide [(CH<sub>3</sub>)<sub>2</sub>S] emitted by phytoplankton. It is estimated that about 75% of total sulfur emission to the atmosphere is anthropogenic. See AEROSOL; AIR POLLUTION. [D.J.J.]

**Atmospheric electricity** The electrical processes constantly taking place in the lower atmosphere. This activity is of two kinds, the intense local electrification accompanying storms, and the much weaker fair-weather electrical activity over the entire globe, which is produced by the many electrified storms continuously in progress over the Earth. The mechanisms by which storms generate electric charge are unknown, and the role of atmospheric electricity in meteorology has not been determined.

Almost all precipitation-producing storms throughout the year are accompanied by energetic electrical activity. The most intense of these are the thunderstorms, in which the electrification attains values sufficient to produce lightning. Electrical measurements show that most other storms, even though they do not give lightning, are also quite strongly electrified. The electric fields of thunderstorms cause three currents to flow, each of a few amperes: lightning, point discharge from the ground beneath, and conduction in the surrounding air. Because the external field and conductivity are greatest over the top of the cloud, most of the conduction current flows to the ionosphere, the upper, highly conductive layer of the atmosphere. See THUNDERSTORM.

Fair-weather measurements, irrespective of place and time, show the invariable presence of a weak negative electric field caused by the estimated several thousand electrified storms continually in progress. Together these storms cause a 2000-A current from the earth to the ionosphere that raises the ionosphere to a positive potential of about 300,000 V with respect to the earth. This potential difference is sufficient to cause a return flow of positive charge to the earth by conduction through the intervening lower atmosphere equal and opposite to the thunderstorm supply current. The fair-weather field is simply the voltage drop produced by the flow of this current through the atmosphere. Because the electrical resistance of the atmosphere decreases with altitude, the field is greatest near the Earth's surface and gradually decreases with altitude until it vanishes at the ionosphere.

No importance is presently attached to fair-weather atmospheric electricity except that according to some theories it is responsible for the initiation of the thunderstorm electrification process. See CLOUD PHYSICS; LIGHTNING; SFERICS; STORM DETECTION; TORNADO. [B.V.]

**Atmospheric entry** The motion of a body traveling from space through the atmosphere surrounding a planet. Entry bodies can be natural bodies, such as meteors or comets, or vehicles, such as ballistic missiles or the space shuttle orbiter. Entry begins when the body reaches the sensible atmosphere (defined as 400,000 ft or 122 km altitude for Earth).

The primary forces acting on an entry body are aerodynamic lift and drag, gravity, propulsion, and centrifugal acceleration. Of particular concern to the designer of entry vehicles is the control of the trajectory to minimize the effects of heating on the thermal protection system and aerodynamic loading on the vehicle structure. From Newton's law of motion, the forces on the vehicle determine the resulting trajectory as the body traverses the atmosphere.

Aerocapture vehicles use the atmosphere to deplete energy prior to orbit capture in order to significantly reduce the amount of propellant required and thus reduce the mass requirements.

For controllable vehicles, the concept of trajectory control refers to the management of the kinetic and potential energy so as to maneuver from the initial entry conditions to the de-

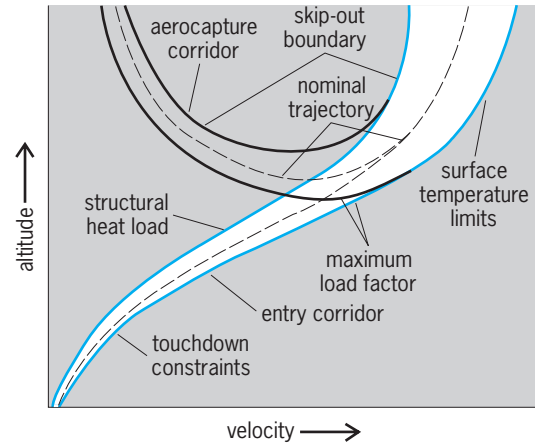

**Guidance corridor.** Constraints on the trajectory, which determine the boundaries of the corridor, are indicated.

sired final conditions with due regard to system constraints and dispersions. One manner of accomplishing this is to establish a guidance corridor (see illustration). Initially, the flight path is steep enough to prevent skipping out of the atmosphere but shallow enough to keep the maximum temperature and structural load factor within limits. Later in flight, the total heat load into the structure, which increases with time of flight, becomes a constraint.

The most dominant aerodynamic force is the vehicle drag, which provides the deceleration. High-drag bodies are characterized by large, blunt reference profiles. The lift force is perpendicular to the drag force, works perpendicular to the velocity vector, and is the primary force vector for trajectory control. The ratio of lift to drag ( $L/D$ ) determines the amount of trajectory control available. For the space shuttle this ratio is 1.1, while for the Apollo entry capsule this ratio was 0.3. See AERODYNAMIC FORCE.

Vehicles entering the atmosphere experience heat transferred from the hot air surrounding the spacecraft to the colder wall of the spacecraft. The transfer of heat or energy is accomplished by conduction, radiation, and convection. A vehicle traveling at supersonic or hypersonic velocities deflects the air and forms a shock wave. The air between the detached bow shock and the vehicle is heated to very high temperatures by molecular collisions converting the kinetic energy to thermal energy. Approximately 97–98% of this energy flows past the vehicle into the free stream. The remaining 2% has to be managed by the thermal protection system on the spacecraft. See AEROTHERMODYNAMICS; HYPERSONIC FLIGHT; SHOCK WAVE; SUPERSONIC FLIGHT.

The flow within the thin boundary layer next to the surface of the vehicle can be either laminar or turbulent. Turbulent flow has faster-moving particles and higher rates of heat transfer to the surface than laminar flow. Thus, it is desirable for entry vehicles to maintain laminar flow as long as possible to minimize the surface temperature. See FLUID FLOW.

Ablator materials, which were used on Mercury, Gemini, and Apollo spacecraft, accommodated the convective heating through absorption, vaporization, and the resultant char layer that radiated the heat to the atmosphere. Ablators, however, are not reusable. See NOSE CONE.

The reuse requirement for the shuttle orbiter necessitated development of new concepts of thermal protection. One concept is an external low-density insulator that can withstand high temperatures for multiple orbiter entries for at least 100 flights. The insulator is a tile fabricated from high-purity silica fibers reinforced with silica binder.

The temperature on the wing leading edges and on the nose of the shuttle orbiter was predicted to exceed 2300°F (1533 K). A

reinforced carbon-carbon system was developed to withstand up to 3000°F (1922 K). Reinforced carbon-carbon is a laminate of woven graphite cloth with a carbon binder and a silicon carbide coating which prevents oxidation. [R.L.Ba.; D.B.L.; J.D.Ga.]

**Atmospheric general circulation** The statistical description of atmospheric motions over the Earth, their role in transporting energy, and the transformations among different forms of energy. Through their influence on the pressure distributions that drive the winds, spatial variations of heating and cooling generate air circulations, but these are continually dissipated by friction. While large day-to-day and seasonal changes occur, the mean circulation during a given season tends to be much the same from year to year. Thus, in the long run and for the global atmosphere as a whole, the generation of motions nearly balances the dissipation. The same is true of the long-term balance between solar radiation absorbed and infrared radiation emitted by the Earth-atmosphere system, as evidenced by its relatively constant temperature. Both air and ocean currents, which are mainly driven by the winds, transport heat. Hence the atmospheric and oceanic general circulations form cooperative systems. See MARITIME METEOROLOGY.

Owing to the more direct incidence of solar radiation in low latitudes and to reflection from clouds, snow, and ice, which are more extensive at high latitudes, the solar radiation absorbed by the Earth-atmosphere system is about three times as great in the equatorial belt as at the poles, on the annual average. Infrared emission is, however, only about 20% greater at low than at high latitudes. Thus in low latitudes (between about 35°N and 35°S) the Earth-atmosphere system is, on the average, heated by radiation, and in higher latitudes cooled by radiation. The Earth's surface absorbs more radiative heat than it emits, whereas the reverse is true for the atmosphere. Therefore, heat must be transferred generally poleward and upward through processes other than radiation. At the Earth-atmosphere interface, this transfer occurs in the form of turbulent flux of sensible heat and through evapotranspiration (flux of latent heat). In the atmosphere the latent heat is released in connection with condensation of water vapor. See CLIMATOLOGY.

Considering the atmosphere alone, the heat gain by condensation and the heat transfer from the Earth's surface exceed the net radiative heat loss in low latitudes. The reverse is true in higher latitudes. The meridional transfer of energy, necessary to balance these heat gains and losses, is accomplished by air currents. These take the form of organized circulations, whose dominant features are notably different in the tropical belt (roughly the half of the Earth between latitudes 30°N and 30°S) and in extratropical latitudes. See METEOROLOGY; STORM.

Characteristic circulations over the Northern Hemisphere are shown in the illustration. In the upper troposphere, there are two principal jet-stream systems: the subtropical jet (STJ) near latitude 30°, and the polar-front jet (PFJ), with large-amplitude long waves and superimposed shorter waves associated with cyclone-scale disturbances. The long waves on the polar-front jet move slowly eastward, and the shorter waves move rapidly. At the Earth's surface, northeast and southeast trade winds of the two hemispheres meet at the intertropical convergence zone (ITCZ), in the vicinity of which extensive lines and large clusters of convective clouds are concentrated. Westward-moving waves and vortices form near the intertropical convergence zone and, in summer, within the trades. Heat released by condensation in convective clouds of the intertropical convergence zone, and the mass of air conveyed upward in them, drive meridional circulations (right side of the illustration), whose upper-level poleward branches generate the subtropical jet stream at their poleward boundaries.

In extratropical latitudes, the circulation is dominated by cyclones and anticyclones. Cyclones develop mainly on the polar front, where the temperature contrast between polar and trop-

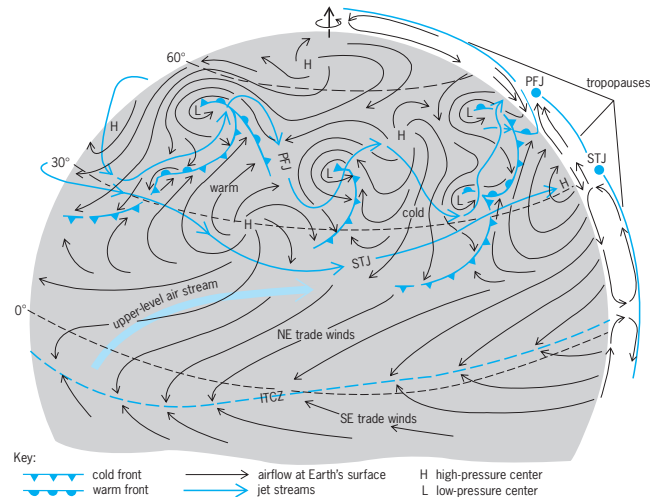

**Schematic circulations over the Northern Hemisphere in winter.** The intertropical convergence zone (ITCZ) lies entirely north of the Equator in the summer. Eastward acceleration in the upper-level tropical airstream is due to Earth rotation and generates the subtropical jet stream (STJ). The vertical section (right) shows the dominant meridional circulation in the tropics and shows airstreams relative to the polar front in middle latitudes.

ical air masses is concentrated, in association with upper-level waves on the polar-front jet stream. In winter, cold outbreaks of polar air from the east coasts of continents over the warmer oceans result in intense transfer of heat and water vapor into the atmosphere. Outbreaks penetrating the tropics also represent a sporadic exchange in which polar air becomes transformed into tropical air. Tropical airstreams, poleward on the west sides of the subtropical highs, then supply heat and water vapor to the extratropical disturbances. See CYCLONE; FRONT.

The characteristic flow in cyclones takes the form of slantwise descending motions on their west sides and ascent to their east in which extensive clouds and precipitation form. Heat that is released in condensation drives the ascending branch, and the descending branch consists of polar air that has been cooled by radiation in higher latitudes. When viewed relative to the meandering polar-front zone (right side of the illustration), the combined sinking of cold air and ascent of warm air represents a conversion of potential energy into kinetic energy. This process maintains the polar jet stream. The branches of the circulation transfer heat both upward, to balance the radiative heat loss by the atmosphere, and poleward, to balance the radiative heat deficit in high latitudes. [C.W.N.]

**Atmospheric tides** Those oscillations in any or all atmospheric fields whose periods are integral fractions of either lunar or solar days. Oscillations with a period of a day are called diurnal, with a period of a half day semidiurnal, and with a period of a third of a day terdiurnal. The sum of all tidal variations is referred to as the daily variation. As a practical matter, the subject of atmospheric tides is generally restricted to oscillations on a global spatial scale (thus excluding sea breezes). The bulk of attention is devoted to migrating tides, which are those tidal oscillations that depend only on local time.

Atmospheric tides tend to be rather small in the troposphere, although the tidal oscillations in rainfall are surprisingly large. Their importance stems from two primary factors: (1) Tidal oscillations tend to increase in amplitude with height and become major components of the total meteorology above about 50 km (30 mi). (2) The subject has played a prominent role in the intellectual history of meteorology, and it still provides a remarkable example of scientific methodology in an observational science. Tides are unique among meteorological systems in that they

have perfectly known periods and relatively well known sources of forcing.

The determination of an oscillation by means of data requires at least two measurements per period. Since most meteorological upper air soundings are taken only twice each day, such data can be used only to marginally determine diurnal oscillations. Occasionally, stations obtain soundings four times per day, which in turn permits determinations of semidiurnal oscillations. Rain gages assign rainfall to specific hours, and averages over many years allow the determination of the daily variation of rainfall. Surface pressure is monitored at a great many stations with effectively (from the point of view of tidal analyses) continuous time resolution. Therefore, surface pressure has traditionally been the field most thoroughly analyzed for tides.

The lunar semidiurnal tide in surface pressure is similar in distribution to the migrating part of the solar semidiurnal tide but only about one-twentieth its strength; maximum lunar semidiurnal surface pressure typically occurs about 1 lunar hour and 13 lunar hours after lunar transit. Clearly, the solar semidiurnal tide dominates the surface pressure. The solar diurnal component is not only smaller but also far more irregular.

Rainfall is commonly observed to have a daily variation. The diurnal component, though often quite large, has a very irregular phase; on the other hand, the solar semidiurnal component is surprisingly uniform, amounting to about 10–20% of the mean daily rainfall in the tropics with maximum rainfall at about 4 A.M. and 4 P.M. local time. Maximum semidiurnal rainfall appears to occur somewhat later in middle latitudes. See PRECIPITATION (METEOROLOGY).

Data become more sparse when attempts are made to analyze tides above the surface. Analyses of radiosonde wind measurements have shown that solar semidiurnal oscillations in horizontal wind are primarily in the form of migrating tides. Diurnal oscillations, on the other hand, are significantly affected by regional, nonmigrating components up to at least 20 km (12 mi). Above this height, the diurnal oscillations also tend to be dominated by migrating components. There is a tendency for the diurnal oscillations to have more phase variation with height, especially at low latitudes. As a rough rule of thumb, oscillations in temperature tend to have magnitudes in kelvins comparable to the amplitudes in wind in meters per second. There is also no longer a clear dominance of the semidiurnal oscillations over the diurnal oscillations once the upper-level fields are considered. The amplitude increase with height renders the detection of tidal oscillations at greater altitudes somewhat easier since the tides are becoming a larger feature of the total fields. See OSCILLATION.

While the classical theory of atmospheric tides is adequate for many purposes, recent years have seen a substantial development of theory well beyond the classical theory to include the effects of mean winds, viscosity, and thermal conductivity. See ATMOSPHERE; EARTH TIDES; TIDE. [R.S.L.]

**Atmospheric waves, upper synoptic** Horizontal wavelike oscillations in the pattern of wind flow aloft, usually with reference to the stronger portion of the westerly current in mid-latitudes. The flow is anticyclonically curved in the vicinity of a ridge line in the wave pattern, and is cyclonically curved in the vicinity of a trough line.

Any given hemispheric upper flow pattern may be represented by the superposition of sinusoidal waves of various lengths in the general westerly flow. Analysis of a typical pattern discloses the presence of prominent long waves, of which there are usually three or four around the hemisphere, and of distinctly evident short waves, of about half the length of the long waves.

Typically, each short-wave trough and ridge is associated with a particular cyclone and anticyclone, respectively, in the lower troposphere. The development and intensification of one of these circulations depends in a specific instance upon the details of this association, such as the relative positions and intensities

of the upper trough and the low-level cyclone. These circulations produce the rapid day-to-day weather changes which are characteristic of the climate of the mid-latitudes.

The long waves aloft do not generally correspond to a single feature of the circulation pattern at low levels. They are relatively stable, slowly moving features which tend to guide the more rapid motion of the individual short waves and of their concomitant low-level cyclones and anticyclones. Thus, by virtue of their position and amplitude the long waves can exert an indirect influence on the character of the weather over a given region for a period of the order of weeks.

A blocking situation is one in which waves do not progress through the latitude belt of the westerlies. Blocking situations are frequently accompanied by extreme meteorological events; precipitation and cool temperatures persist near upper-level cyclones, and dry, warm weather persists near upper-level anticyclones. A blocking pattern usually consists of a ridge (anticyclone) over a trough (cyclone), a high-amplitude ridge, or flow shaped like an uppercase Greek omega ( $\Omega$ ). Because of the preference for blocking off the west coasts of Europe and North America, it appears that topography must play an important role in blocking. See ATMOSPHERE; JET STREAM; STORM; VORTEX; WIND. [F.S.; H.B.B.]

**Atoll** An annular coral reef, with or without small islets, that surrounds a lagoon without projecting land area. Most atolls are isolated reefs rising from the deep sea, and vary considerably in size. Small rings, usually without islets, may be less than a mile in diameter, but many atolls have a diameter of about 20 mi (32 km) and bear numerous islets.

The reefs of the atoll ring are flat, pavementlike areas, large parts of which, particularly along the seaward margin, may be exposed at times of low tide. The reefs vary in width from narrow ribbons to broad bulging areas more than a mile (1.6 km) across. The structures form a most effective baffle that robs the incoming waves of much of their destructive power, and at the same time brings a constant supply of refreshing sea water with oxygen, food, and nutrient salts to wide expanses of the reef.

Atolls, like other types of coral reefs, require strong light and warm waters and are limited in the existing seas to tropical and near-tropical latitudes. A large percentage of the world's atolls are contained in an area known as the former Darwin Rise that covers much of the central and southwestern Pacific. Atolls are also numerous in parts of the Indian Ocean and a number are found, mostly on continental shelves, in the Caribbean area. See OCEANIC ISLANDS; REEF. [H.S.L.]

**Atom** A constituent of matter consisting of  $z$  negatively charged electrons bound predominantly by the Coulomb force to a tiny, positively charged nucleus consisting of  $Z$  protons and  $(A - Z)$  neutrons.  $Z$  is the atomic number, and  $A$  is the mass or nucleon number. The atomic mass unit is  $u = 1.6605397 \times 10^{-24}$  g. Electrically neutral atoms ( $z = Z$ ) with the range  $Z = 1$  (hydrogen) to  $Z = 92$  (uranium) make up the periodic table of the elements naturally occurring on Earth. Isotopes of a given element have different values of  $A$  but nearly identical chemical properties, which are fixed by the value of  $Z$ . Certain isotopes are not stable; they decay by various processes called radioactivity. Atoms with  $Z$  greater than 92 are all radioactive but may be synthesized, either naturally in stellar explosions or in the laboratory using accelerator techniques. See ATOMIC MASS UNIT; ELECTRON; ISOTOPE; MASS NUMBER; NUCLEAR STRUCTURE; RADIOACTIVITY; TRANSURANIUM ELEMENTS.

Atoms with  $Z - z$  ranging from 1 to  $Z - 1$  are called positive ions. Those having  $z - Z = 1$  are called negative ions; none has been found with  $z - Z$  greater than 1. See ION. [P.M.K.]

**Atom cluster** Clusters are aggregates of atoms (or molecules) containing between three and a few thousand atoms



that have properties intermediate between those of the isolated monomer (atom or molecule) and the bulk or solid-state material. The study of such species has been an increasingly active research field since about 1980. This activity is due to the fundamental interest in studying a completely new area that can bridge the gap between atomic and solid-state physics and also shows many analogies to nuclear physics. However, the research is also done for its potential technological interest in areas such as catalysis, photography, and epitaxy. A characteristic of clusters which is responsible for many of their interesting properties is the large number of atoms at the surface compared to those in the cluster interior. For many kinds of atomic clusters, all atoms are at the surface for sizes of up to 12 atoms. As the clusters grow further in size, the relative number of atoms at the surface scales as approximately  $4N^{-1/3}$ , where  $N$  is the total number of atoms. Even in a cluster as big as  $10^5$  atoms, almost 10% of the atoms are at the surface. Clusters can be placed in the following categories:

1. Microclusters have from 3 to 10–13 atoms. Concepts and methods of molecular physics are applicable.

2. Small clusters have from 10–13 to about 100 atoms. Many different geometrical isomers exist for a given cluster size with almost the same energies. Molecular concepts lose their applicability.

3. Large clusters have from 100 to 1000 atoms. A gradual transition is observed to the properties of the solid state.

4. Small particles or nanocrystals have at least 1000 atoms. These bodies display some of the properties of the solid state.

The most favored geometry for rare-gas (neon, argon, and krypton) clusters of up to a few thousand atoms is icosahedral. However, the preferred cluster geometry depends critically on the bonding between the monomers in the clusters. For example, ionic clusters such as those of sodium chloride  $[(\text{NaCl})_N]$  very rapidly assume the cubic form of the bulk crystal lattice, and for metallic clusters it is the electronic structure rather than the geometric structure which is most important. See CHEMICAL BONDING; CRYSTAL STRUCTURE.

There are two main types of sources for producing free cluster beams. In a gas-aggregation source, the atoms or molecules are vaporized into a cold, flowing rare-gas atmosphere. In a jet-expansion source, a gas is expanded under high pressure through a small hole into a vacuum.

In most situations, the valence electrons of the atoms making up the clusters can be regarded as being delocalized, that is, not attached to any particular atom but with a certain probability of being found anywhere within the cluster. The simplest and most widely used model to describe the delocalized electrons in metallic clusters is that of a free-electron gas, known as the jellium model. The positive charge is regarded as being smeared out over the entire volume of the cluster, while the valence electrons are free to move within this homogeneously distributed, positively charged background. [E.Ca.]

**Atom laser** A device that generates an intense coherent beam of atoms through a stimulated process. It does for atoms what an optical laser does for light. The atom laser emits coherent matter waves, whereas the optical laser emits coherent electromagnetic waves. Coherence means, for instance, that atom laser beams can interfere with each other. See COHERENCE.

Laser light is created by stimulated emission of photons, a light amplification process. Similarly, an atom laser beam is created by stimulated amplification of matter waves. The conservation of the number of atoms is not in conflict with matter-wave amplification: The atom laser takes atoms out of a reservoir and transforms them into a coherent matter wave similar to the optical laser, which converts energy into coherent electromagnetic radiation (but, in contrast, the number of photons need not be conserved). See LASER.

**Elements.** A laser requires a cavity (resonator), an active medium, and an output coupler (see table).

#### Analogies between an atom laser and the optical laser

Atom laser*	Optical laser
Atoms	Photons
Matter waves	Electromagnetic waves
Atom trap	Laser cavity
Atoms in the Bose condensate	Photons in the lasing mode
Thermal atoms	Gain medium
Evaporative cooling	Excitation of the gain medium
Stimulated scattering of atoms	Stimulated emission of photons
Critical temperature for Bose-Einstein condensation	Laser threshold

\* Based on evaporative cooling.

**Cavity.** Various analogs of laser cavities for atoms have been realized. The most important ones are magnetic traps (which use the force of an inhomogeneous magnetic field on the atomic magnetic dipole moment) and optical dipole traps (which use the force exerted on atoms by focused laser beams). See PARTICLE TRAP.

**Active medium.** The active medium is a reservoir of atoms which are transferred to one state of the confining potential, which is the analog of the lasing mode. The reservoir can be atoms confined in other quantum states of the atom cavity or an ultraslow atomic beam. The atoms are transferred to the lasing mode either by collisions or by optical pumping. The transfer of

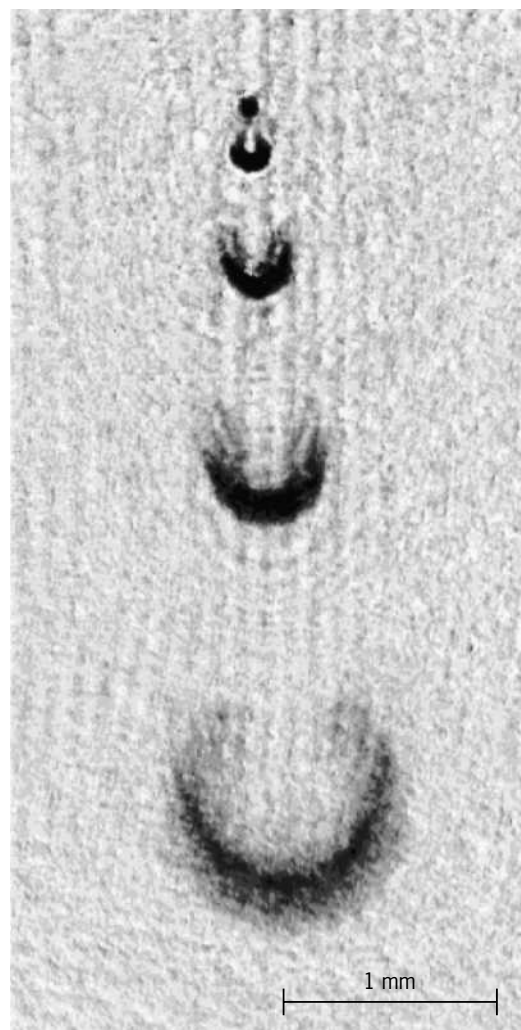

Pulsed atom laser in operation, with pulses of coherent sodium atoms coupled out from a Bose-Einstein condensate that is confined in a magnetic trap.

atoms is efficient only for an ultracold sample, which is prepared by laser cooling or evaporative cooling. This cooling ensures that the atoms in the reservoir occupy only a certain range of quantum states which can be efficiently coupled to the lasing mode.

**Output coupler.** The output coupler extracts atoms from the cavity, thus generating a pulsed or continuous beam of coherent atoms. A simple way to accomplish this step is to switch off the atom trap and release the atoms. This method is analogous to cavity dumping for an optical laser, and extracts all the stored atoms into a single pulse. A more controlled way to extract the atoms requires a coupling mechanism between confined quantum states and propagating modes.

Such a beam splitter for atoms can be realized by applying the Stern-Gerlach effect to atoms in a magnetic trap. Initially, all the atoms have their electron spin parallel to the magnetic field, say spin up, and in this state they are confined in the trap. A short radio-frequency pulse rotates (tilts) the spin of the atoms by a variable angle. Quantum-mechanically, a tilted spin is a superposition of spin up and spin down. Since the spin-down component experiences a repulsive magnetic force, the cloud of atoms is split into a trapped cloud and an out-coupled cloud. By using a series of radio-frequency pulses, a sequence of coherent atom pulses can be formed. These pulses are accelerated downward by gravity and spread out. See QUANTUM MECHANICS.

The illustration shows such a sequence of coherent pulses. In this case, sodium atoms are coupled out from a magnetic trap by radio-frequency pulses every 5 ms. The atom pulses are observed by illuminating them with resonant laser light and imaging their shadows, which are caused by absorption of the light. Each pulse contains  $10^5$ – $10^6$  sodium atoms.

**Potential applications.** Although a basic atom laser has now been demonstrated, major improvements are necessary before it can be used for applications, especially in terms of increased output power and reduced overall complexity. The atom laser provides ultimate control over the position and motion of atoms at the quantum level, and might find use where such precise control is necessary, for example, for precision measurements of fundamental constants, tests of fundamental symmetries, atom optics (in particular, atom interferometry and atom holography), and precise deposition of atoms on surfaces. See FUNDAMENTAL CONSTANTS; NANOTECHNOLOGY; SYMMETRY LAWS (PHYSICS). [W.Ket.]

**Atom optics** The use of laser light and nanofabricated structures to manipulate the motion of atoms in the same manner that rudimentary optical elements control light. The term refers to both an outlook in which atoms in atomic beams are thought of and manipulated like photons in light beams, and a collection of demonstrated techniques for doing such manipulation. Two types of atom optics elements have existed for some time: slits and holes used to collimate molecular beams (the analog of the pinhole camera), and focusing lenses for atoms and molecules (for example, hexapole magnets and quadrupole electrostatic lenses). However, in the 1980s the collection of optical elements for atoms expanded dramatically because of the use of near-resonant laser light and fabricated structures to make several types of mirrors as well as diffraction gratings. The diffraction gratings are particularly interesting because they exploit and demonstrate the (de Broglie) wave nature of atoms in a clear fashion. See LASER.

**Diffraction gratings.** Diffraction gratings for atoms have been made by using either a standing wave of light or a slotted membrane. The standing light wave makes a phase grating (that is, it advances or retards alternate sections of the incident wavefront but does not absorb any of the atom wave), so that the transmitted intensity is high. This approach requires the complexity of a single-mode laser, and introduces the complication that the light acts differently on the various hyperfine states of the

atom. The slotted membrane, however, absorbs (or backscatters) atoms which strike the grating bars, but does not significantly alter the phase of the transmitted atoms; it is therefore an amplitude grating. It works for any atom or molecule, regardless of internal quantum state, but with total transmission limited to about 40% by the opacity of the grating bars and requisite support structure. See DIFFRACTION GRATING.

**Atom interferometers.** Atom interferometers have been demonstrated through several different experimental routes, involving both microscopic fabricated structures and laser beams. These interferometers are the first examples of optical systems composed of the elements of atom optics like those discussed above. Atom interferometers, like optical interferometers, are well suited for application to a wide range of fundamental and applied scientific problems. Scientific experiments with atom interferometers divide naturally into three major categories: measurements of atomic and molecular properties, fundamental tests and demonstrations, and inertial effects. See FRAME OF REFERENCE; INTERFERENCE OF WAVES; INTERFEROMETRY; OPTICS. [D.E.P.]

**Atomic beams** Unidirectional streams of neutral atoms passing through a vacuum. These atoms are virtually free from the influence of neighboring atoms but may be subjected to electric and magnetic fields so that their properties may be studied. The technique of atomic beams is identical to that of molecular beams. For historical reasons the latter term is most generally used to describe the method as applied to either atoms or molecules.

The method of atomic beams yields extremely accurate spectroscopic data about the energy levels of atoms, and hence detailed information about the interaction of electrons in the atom with each other and with the atomic nucleus, as well as information about the interaction of all components of the atom with external fields. See MOLECULAR BEAMS. [PKu.]

**Atomic bomb** A device for suddenly producing an explosive neutron chain reaction in a fissile material such as uranium-235 ( $^{235}\text{U}$ ) or plutonium-239 ( $^{239}\text{Pu}$ ). In a wider sense, any explosive device that derives its energy from nuclear reactions, including not only the foregoing fission weapon but also a fusion weapon, which gets its energy largely from fusion reactions of heavy hydrogen isotopes, and a fission-fusion weapon, which derives its energy from both fission and fusion. Because an atomic bomb derives its energy from nuclear reactions, it is properly called a nuclear explosive or nuclear weapon. See NUCLEAR FISSION; NUCLEAR REACTION; PLUTONIUM; URANIUM.

Of the two principal fissile materials, the cheaper but less potent  $^{235}\text{U}$  is present in natural uranium usually in the proportion of 1 part to 139 parts of  $^{238}\text{U}$  and is separated from it by various enrichment processes. Weapons-grade plutonium is manufactured from  $^{238}\text{U}$  in a special military production reactor that has enough excess neutrons for the reaction below.

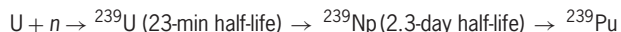

Weapon cores are made of very high fractions of fissile materials: highly enriched 93% uranium-235 or weapon-grade 94% plutonium-239. See ISOTOPE SEPARATION.

A fission bomb before ignition consists of a mass of fissile material and surrounding tamper—beryllium oxide or other reflector of neutrons intended ultimately to improve the neutron multiplication factor  $k$ —arranged in a geometry so favorable to neutron leakage that  $k$  is less than 1. These materials are suddenly compressed into a geometry where  $k$  substantially exceeds 1. This is done with chemical explosives that either implode a spherical subcritical mass of fission material or else drive two subcritical sections together in a gun-barrel type of arrangement. At the same time, enough neutrons are artificially introduced to start an explosively divergent (expanding) chain reaction. Fission-explosive devices intended for military application are highly

sophisticated combinations of pure materials, precise design, and reliable electronics.

The explosive energy (yield) of a nuclear weapon is usually expressed in kilotons or megatons. A kiloton is the amount of energy liberated in the explosion of 1000 tons of TNT ( $10^{12}$  calories or  $4.18 \times 10^{12}$  J), and a megaton is a thousand times as large. The fission bombs that destroyed Hiroshima (gun-barrel type) and Nagasaki (implosion type) had estimated explosive yields of 13 and 22 kilotons, respectively. Fractional kiloton yields can be obtained (tactical nuclear weapons). Fission weapons have been tested up to approximately 500 kilotons, overlapping the yield of multistage fusion explosives (strategic nuclear weapons).

The nuclear explosive energy is communicated by mechanical shock and radiative transport to the surrounding water, earth, or air, ionizing it out to a radius which, in the case of explosions in air, is known as the fireball radius (150 yd or 140 m in about 1 s after a 20-kiloton nuclear explosion). Energy goes out from such a fireball into the surrounding relatively transparent air, in not very different orders of magnitude in the form of a shock wave and in the form of heat radiation that may continue for a number of seconds. See NUCLEAR EXPLOSION; RADIOACTIVE FALLOUT. [A.DeV.]

**Atomic clock** A device that uses an internal resonance frequency of atoms (or molecules) to measure the passage of time. The terms atomic clock and atomic frequency standard are often used interchangeably. A frequency standard generates pulses at regular intervals. It can be made into a clock by the addition of an electronic counter, which records the number of pulses. See DIGITAL COUNTER.

Most methods of timekeeping rely on counting some periodic event, such as the rotation of the Earth, the motion of a pendulum in a grandfather clock, or the vibrations of a quartz crystal in a watch. An atomic clock relies on counting periodic events determined by the difference of two different energy states of an atom. A transition between two energy states with energies  $E_1$  and  $E_2$  may be accompanied by the absorption or emission of a photon (particle of electromagnetic radiation). The frequency  $\nu$  of this radiation is given by the equation

$$h\nu = |E_2 - E_1|$$

where  $h$  is Planck's constant. A basic advantage of atomic clocks is that the frequency-determining elements, atoms of a particular isotope, are the same everywhere. Thus, atomic clocks constructed and operated independently will measure the same time interval. See ATOMIC STRUCTURE AND SPECTRA; ENERGY LEVEL (QUANTUM MECHANICS); QUANTUM MECHANICS.

An atomic frequency standard can be either active or passive. An active standard uses as a reference the electromagnetic radiation emitted by atoms as they decay from a higher energy state to a lower energy state. A passive standard attempts to match the frequency of an electronic oscillator or laser to the resonant frequency of the atoms by means of a feedback circuit. Either kind of standard requires some kind of frequency synthesis to produce an output near a convenient frequency that is proportional to the atomic resonance frequency. See FEEDBACK CIRCUIT; LASER; MASER; OSCILLATOR.

Two different gages of the quality of a clock are accuracy and stability. The accuracy of a frequency standard is defined in terms of the deviation of its frequency from an ideal standard. The stability of frequency standard is defined in terms of the constancy of its average frequency from one interval of time to the next.

The three most commonly used types of atomic clock are the cesium atomic beam, the hydrogen maser, and the rubidium gas cell. The cesium clock has high accuracy and good long-term stability. The hydrogen maser has the best stability for periods of up to a few hours. The rubidium cell is the least expensive and most compact and also has good short-term stability.

The cesium atomic-beam clock uses a 9193-MHz transition between two hyperfine energy states of the cesium-133 atom. Both the atomic nucleus and the outermost electron have magnetic moments; that is, they are like small magnets, with a north and a south pole. The two hyperfine energy states differ in the relative orientations of these magnetic moments. The cesium atoms travel in a collimated beam through a series of evacuated regions, where they are exposed to microwave radiation near their resonance frequency and are deflected into different trajectories by nonuniform magnetic fields. See ELECTRON SPIN; HYPERFINE STRUCTURE; MAGNETIC MOMENT; MOLECULAR BEAMS; NUCLEAR MOMENTS.

Cesium has become the basis of the international definition of the second; the duration of 9,192,631,770 periods of the radiation corresponding to the transition between the two hyperfine states of the ground state of the cesium-133 atom. The cesium clock is especially well suited for applications such as timekeeping, where absolute accuracy without recalibration is necessary. Measurements from many cesium clocks throughout the world are averaged together to define an international time scale that is uniform to parts in  $10^{14}$ , or about 1 microsecond in a year. See ATOMIC TIME; DYNAMICAL TIME; PHYSICAL MEASUREMENT.

The hydrogen maser is based on the hyperfine transition of atomic hydrogen, which has a frequency of 1420 MHz. Atoms in the higher hyperfine energy state enter an evacuated storage bulb inside a microwave cavity, and are induced to make a transition to the lower hyperfine state by a process called stimulated emission.

The rubidium gas cell is based on the 6835-MHz hyperfine transition of rubidium-87. The rubidium atoms are contained in a glass cell together with a buffer gas, where they are subjected to optical pumping and microwave radiation at the hyperfine transition frequency; this results in a detectable decrease in the light transmitted through the cell.

Many other kinds of atomic clocks, such as thallium atomic beams and ammonia and rubidium masers, have been demonstrated in the laboratory. The first atomic clock, constructed at the National Bureau of Standards in 1949, was based on a 24-GHz transition in the ammonia molecule. Some laboratories have tried to improve the cesium atomic-beam clock by replacing the magnetic state selection with laser optical pumping and fluorescence detection. One such standard, called NIST-7, is in operation at the U.S. National Institute of Standards and Technology and is the primary frequency standard for the United States. Atomic frequency standards can also be based on optical transitions. One of the best-developed optical frequency standards is the 3.39-micrometer (88-THz) helium-neon laser, stabilized to a transition in the methane molecule. Frequency synthesis chains have been built to link the optical frequency to radio frequencies.

Atomic clocks are used in applications for which less expensive alternatives, such as quartz oscillators, do not provide adequate performance. In addition to maintaining a uniform international time scale, atomic clocks are used to keep time in the Global Positioning System, various digital communications systems, radio astronomy, and navigation of space probes. See ELECTRICAL COMMUNICATIONS; RADIO ASTRONOMY; SATELLITE NAVIGATION SYSTEMS; SPACE NAVIGATION AND GUIDANCE. [W.M.I.]

**Atomic mass** The mass of an atom or molecule on a scale where the mass of a carbon-12 ( $^{12}\text{C}$ ) atom is exactly 12.0. The mass of any atom is approximately equal to the total number of its protons and neutrons multiplied by the atomic mass unit,  $u = 1.6605397 \times 10^{-24}$  gram. (Electrons are much lighter, about 0.0005486 u.) No atom differs from this simple formula by more than 1%, and stable atoms heavier than helium all lie within 0.3%. See ATOMIC MASS UNIT.

This simplicity of nature led to the confirmation of the atomic hypothesis—the idea that all matter is composed of atoms, which are identical and chemically indivisible for each chemical element. In 1802, G. E. Fischer noticed that the weights of acids

needed to neutralize various bases could be described systematically by assigning relative weights to each of the acids and bases. A few years later, John Dalton proposed an atomic theory in which elements were made up of atoms that combine in simple ways to form molecules.

In reality, nature is more complicated, and the great regularity of atomic masses more revealing. Two fundamental ideas about atomic structure come out of this regularity: that the atomic nucleus is composed of charged protons and uncharged neutrons, and that these particles have approximately equal mass. The number of protons in an atom is called its atomic number, and equals the number of electrons in the neutral atom. The electrons, in turn, determine the chemical properties of the atom. Adding a neutron or two does not change the chemistry (or the name) of an atom, but does give it an atomic mass which is 1 u larger for each added neutron. Such atoms are called isotopes of the element, and their existence was first revealed by careful study of radioactive elements. Most naturally occurring elements are mixtures of isotopes, although a single isotope frequently predominates. Since the proportion of the various isotopes is usually about the same everywhere on Earth, an average atomic mass of an element can be defined, and is called the atomic weight. Atomic weights are routinely used in chemistry in order to determine how much of one chemical will react with a given weight of another. See ISOTOPE; RELATIVE ATOMIC MASS.

In contrast to atomic weights, which can be defined only approximately, atomic masses are exact constants of nature. All atoms of a given isotope are truly identical; they cannot be distinguished by any method. This is known to be true because the quantum mechanics treats identical objects in special ways, and makes predictions that depend on this assumption. One such prediction, the exclusion principle, is the reason that the chemical behavior of atoms with different numbers of electrons is so different. See QUANTUM MECHANICS. [F.L.P.; D.E.P.]

**Atomic mass unit** An arbitrarily defined unit in terms of which the masses of individual atoms are expressed. One atomic mass unit is defined as exactly  $1/12$  of the mass of an atom of the nuclide  $^{12}\text{C}$ , the predominant isotope of carbon. The unit, also known as the dalton, is often abbreviated amu, and is designated by the symbol u. The relative atomic mass of a chemical element is the average mass of its atoms expressed in atomic mass units. See RELATIVE ATOMIC MASS. [J.F.We.]

**Atomic nucleus** The central region of an atom. Atoms are composed of negatively charged electrons, positively charged protons, and electrically neutral neutrons. The protons and neutrons (collectively known as nucleons) are located in a small central region known as the nucleus. The electrons move in orbits which are large in comparison with the dimensions of the nucleus itself. Protons and neutrons possess approximately equal masses, each roughly 1840 times that of an electron. The number of nucleons in a nucleus is given by the mass number  $A$  and the number of protons by the atomic number  $Z$ . Nuclear radii  $r$  are given approximately by  $r = 1.2 \times 10^{-15} \text{ m } A^{1/3}$ . [H.E.D.]

**Atomic number** The number of elementary positive charges (protons) contained within the nucleus of an atom. It is denoted by the letter  $Z$ . Correspondingly, it is also the number of planetary electrons in the neutral atom.

The concept of atomic number emerged from the work of G. Moseley, done in 1913–1914. He measured the wavelengths of the most energetic rays ( $K$  and  $L$  lines) produced by using the elements calcium to zinc as targets in an x-ray tube. The square root of the frequency,  $\nu$ , of these x-rays increased by a constant amount in passing from one target to the next. These data, when extended, gave a linear plot of atomic number versus  $\nu$  for all elements studied, using 13 as the atomic number for aluminum and 79 for that of gold. See X-RAY SPECTROMETRY.

Moseley's atomic numbers were quickly recognized as providing an accurate sequence of the elements, which the chemical atomic weights had sometimes failed to do. Additionally, the atomic number sequence indicated the positions of elements that had not yet been discovered.

The atomic number not only identifies the chemical properties of an element but facilitates the description of other aspects of atoms and nuclei. Thus, atoms with the same atomic number are isotopes and belong to the same element, while nuclear reactions may alter the atomic number. See ISOTOPE; RADIOACTIVITY.

When specifically written, the atomic number is placed as a subscript preceding the symbol of the element, while the mass number ( $A$ ) precedes as a superscript, for example,  $^{27}_{13}\text{Al}$ ,  $^{238}_{92}\text{U}$ . See ELEMENT (CHEMISTRY); MASS NUMBER. [H.E.D.]

**Atomic physics** The study of the structure of the atom, its dynamical properties, including energy states, and its interactions with particles and fields. These are almost completely determined by the laws of quantum mechanics, with very refined corrections required by quantum electrodynamics. Despite the enormous complexity of most atomic systems, in which each electron interacts with both the nucleus and all the other orbiting electrons, the wavelike nature of particles, combined with the Pauli exclusion principle, results in an amazingly orderly array of atomic properties. These are systematized by the Mendeleev periodic table. In addition to their classification by chemical activity and atomic weight, the various elements of this table are characterized by a wide variety of observable properties. These include electron affinity, polarizability, angular momentum, multiple electric moments, and magnetism. See PERIODIC TABLE; QUANTUM ELECTRODYNAMICS; QUANTUM MECHANICS.

Each atomic element, normally found in its ground state (that is, with its electron configuration corresponding to the lowest state of total energy), can also exist in an infinite number of excited states. These are also ordered in accordance with relatively simple hierarchies determined by the laws of quantum mechanics. The most characteristic signature of these various excited states is the radiation emitted or absorbed when the atom undergoes a transition from one state to another. The systemization and classification of atomic energy levels (spectroscopy) has played a central role in developing an understanding of atomic structure. [B.B.]

**Atomic spectrometry** A branch of chemical analysis that seeks to determine the composition of a sample in terms of which chemical elements are present and their quantities or concentrations. Unlike other methods of elemental analysis, however, the sample is decomposed into its constituent atoms which are then probed spectroscopically.

In routine atomic spectrometry, a device called the atom source or atom cell is responsible for producing atoms from the sample; there are many different kinds of atom sources. After atomization of the sample, any of several techniques can determine which atoms are present and in what amounts, but the most common are atomic absorption, atomic emission, atomic fluorescence (the least used of these four alternatives), and mass spectrometry.

Most atomic spectrometric measurements (all those just mentioned except mass spectrometry) exploit the narrow-line spectra characteristic of gas-phase atoms. Because the atom source yields atomic species in the vapor phase, chemical bonds are disrupted, so valence electronic transitions are unperturbed by bonding effects. As a result, transitions among atomic energy levels yield narrow spectral lines, with spectral bandwidths commonly in the 1–5-picometer wavelength range. Moreover, because each atom possesses its unique set of energy levels, these narrow-band transitions can be measured individually, with little mutual interference. Thus, sodium, potassium, and scandium can all be monitored simultaneously and with minimal spectral influence on each other. This lack of spectral overlap remains

one of the most attractive features of atomic spectrometry. See ATOMIC STRUCTURE AND SPECTRA; LINE SPECTRUM; SPECTRUM.

In atomic absorption spectrometry, light from a primary source is directed through the atom cell, where a fraction of the light is absorbed by atoms from the sample. The amount of radiation that remains can then be monitored on the far side of the cell. The concentration of atoms in the path of the light beam can be determined by Beer's law, which can be expressed as the equation below, where  $P_0$  is the light intensity incident on the

$$\log \frac{P_0}{P} = kC$$

atom cell,  $P$  is the amount of light which remains unabsorbed,  $C$  is the concentration of atoms in the cell, and  $k$  is the calibration constant, which is determined by means of standard samples having known concentrations.

The two most common kinds of atom cells employed in atomic absorption spectrometry are chemical flames and electrical furnaces. Chemical flames are usually simple to use, but furnaces offer higher sensitivity.

The most common primary light source employed in atomic absorption spectrometry is the hollow-cathode lamp. Conveniently, the hollow-cathode lamp emits an extremely narrow line spectrum of one, two, or three elements of interest. As a result, the atomic absorption spectrometry measurement is automatically tuned to the particular spectral lines of interest.

In atomic emission spectrometry, atomic species are measured by their emission spectra. For such spectra to be produced, the atoms must first be excited by thermal or nonthermal means. Therefore, the atom sources employed in atomic emission spectrometry are hotter or more energetic than those commonly used in atomic absorption spectrometry. Although several such sources are in common use, the dominant one is the inductively coupled plasma. From the simplest standpoint, the inductively coupled plasma is a flowing stream of hot, partially ionized (positively charged) argon. Power is coupled into the plasma by means of an induction coil.

There are two common modes for observing emission spectra from an inductively coupled plasma. The less expensive and more flexible approach employs a so-called slew-scan spectrometer, which accesses spectral lines in rapid sequence, so that a number of chemical elements can be measured rapidly, one after the other. Moreover, because each viewed elemental spectral line can be scanned completely, it is possible to subtract spectral emission background independently for each element. The alternative approach is to view all spectral lines simultaneously, either with a number of individual photo-detectors keyed to particular spectral lines or with a truly multichannel electronic detector driven by a computer. This approach enables samples to be analyzed more rapidly and permits transient atom signals (as from a furnace-based atomizer) to be recorded. See EMISSION SPECTROCHEMICAL ANALYSIS.

Elemental mass spectrometry has been practiced for many years in the form of spark-source mass spectrometry and, more recently, glow-discharge-lamp mass spectrometry. However, a hybrid technique that combines the inductively coupled plasma with a mass spectrometer has assumed a prominent place.

At the high temperatures present in an inductively coupled plasma, many atomic species occur in an ionic form. These ions can be readily extracted into a mass spectrometer.

The advantages of the combination of inductively coupled plasma and mass spectrometry are substantial. The system is capable of some of the best detection limits in atomic spectrometry, typically  $10^{-3}$  to  $10^{-2}$  ng/ml for most elements. Also, virtually all elements in the periodic table can be determined during a single scan. The method is also capable of providing isotopic information, unavailable by any other atomic spectrometric method for such a broad range of elements. See MASS SPECTROMETRY.

[G.M.H.]

**Atomic structure and spectra** The idea that matter is subdivided into discrete building blocks called atoms, which are not divisible any further, dates back to the Greek philosopher Democritus. His teachings of the fifth century B.C. are commonly accepted as the earliest authenticated ones concerning what has come to be called atomism by students of Greek philosophy. The weaving of the philosophical thread of atomism into the analytical fabric of physics began in the late eighteenth and the nineteenth centuries. Robert Boyle is generally credited with introducing the concept of chemical elements, the irreducible units of which are now recognized as individual atoms of a given element. In the early nineteenth century John Dalton developed his atomic theory, which postulated that matter consists of indivisible atoms as the irreducible units of Boyle's elements, that each atom of a given element has identical attributes, that differences among elements are due to fundamental differences among their constituent atoms, that chemical reactions proceed by simple rearrangement of indestructible atoms, and that chemical compounds consist of molecules which are reasonably stable aggregates of such indestructible atoms. See CHEMISTRY.

**Electromagnetic nature of atoms.** The work of J. J. Thomson in 1897 clearly demonstrated that atoms are electromagnetically constituted and that from them can be extracted fundamental material units bearing electric charge that are now called electrons. The electrons of an atom account for a negligible fraction of its mass. By virtue of overall electrical neutrality of every atom, the mass must therefore reside in a compensating, positively charged atomic component of equal charge magnitude but vastly greater mass. See ELECTRON.

Thomson's work was followed by the demonstration by Ernest Rutherford in 1911 that nearly all the mass and all of the positive electric charge of an atom are concentrated in a small nuclear core approximately 10,000 times smaller in extent than an atomic diameter. Niels Bohr in 1913 and others carried out some remarkably successful attempts to build solar system models of atoms containing planetary pointlike electrons orbiting around a positive core through mutual electrical attraction (though only certain "quantized" orbits were "permitted"). These models were ultimately superseded by nonparticulate, matter-wave quantum theories of both electrons and atomic nuclei. See NONRELATIVISTIC QUANTUM THEORY; QUANTUM MECHANICS.

The modern picture of condensed matter (such as solid crystals) consists of an aggregate of atoms or molecules which respond to each other's proximity through attractive electrical interactions at separation distances of the order of 1 atomic diameter (approximately  $10^{-10}$  m) and repulsive electrical interactions at much smaller distances. These interactions are mediated by the electrons, which are in some sense shared and exchanged by all atoms of a particular sample, and serve as an interatomic glue that binds the mutually repulsive, heavy, positively charged atomic cores together. See SOLID-STATE PHYSICS.

**Bohr atom.** The hydrogen atom is the simplest atom, and its spectrum (or pattern of light frequencies emitted) is also the simplest. The regularity of its spectrum had defied explanation until Bohr solved it with three postulates, these representing a model which is useful, but quite insufficient, for understanding the atom.

Postulate 1: The force that holds the electron to the nucleus is the Coulomb force between electrically charged bodies.

Postulate 2: Only certain stable, nonradiating orbits for the electron's motion are possible, those for which the angular momentum associated with the motion of an electron in its orbit is an integral multiple of  $h/2\pi$  (Bohr's quantum condition on the orbital angular momentum). Each stable orbit represents a discrete energy state.

Postulate 3: Emission or absorption of light occurs when the electron makes a transition from one stable orbit to another, and the frequency  $\nu$  of the light is such that the difference in the orbital energies equals  $h\nu$  (A. Einstein's frequency condition for the photon, the quantum of light).

Here the concept of angular momentum, a continuous measure of rotational motion in classical physics, has been asserted to have a discrete quantum behavior, so that its quantized size is related to Planck's constant  $h$ , a universal constant of nature. Velocity  $v$ , in rotational motion about a central body, is defined as the product of the component.

Modern quantum mechanics has provided justification of Bohr's quantum condition on the orbital angular momentum. It has also shown that the concept of definite orbits cannot be retained except in the limiting case of very large orbits. In this limit, the frequency, intensity, and polarization can be accurately calculated by applying the classical laws of electrodynamics to the radiation from the orbiting electron. This fact illustrates Bohr's correspondence principle, according to which the quantum results must agree with the classical ones for large dimensions. The deviation from classical theory that occurs when the orbits are smaller than the limiting case is such that one may no longer picture an accurately defined orbit. Bohr's other hypotheses are still valid.

According to Bohr's theory, the energies of the hydrogen atom are quantized (that is, can take on only certain discrete values). These energies can be calculated from the electron orbits permitted by the quantized orbital angular momentum. The orbit may be circular or elliptical, so only the circular orbit is considered here for simplicity. Let the electron, of mass  $m$  and electric charge  $-e$ , describe a circular orbit of radius  $r$  around a nucleus of charge  $+e$  and of infinite mass. With the electron velocity  $v$ , the angular momentum is  $mvr$ , and the second postulate becomes Eq. (1). The integer  $n$  is called the principal quantum number.

$$mvr = n(h/2\pi) \quad (n = 1, 2, 3, \dots) \quad (1)$$

The possible energies of the nonradiating states of the atom are given by Eq. (2). Here  $\epsilon_0$  is the permittivity of free space, a constant included in order to give the correct units to the statement of Coulomb's law in SI units.

$$E = -\frac{me^4}{8\epsilon_0^2 h^2} \cdot \frac{1}{n^2} \quad (2)$$

The same equation for the hydrogen atom's energy levels, except for some small but significant corrections, is obtained from the solution of the Schrödinger equation, as modified by W. Pauli, for the hydrogen atom. See QUANTUM NUMBERS.

The frequencies of electromagnetic radiation or light emitted or absorbed in transitions are given by Eq. (3), where  $E'$  and  $E''$

$$\nu = \frac{E' - E''}{h} \quad (3)$$

are the energies of the initial and final states of the atom. Spectroscopists usually express their measurements in wavelength  $\lambda$  or in wave number  $\sigma$  in order to obtain numbers of a convenient size. The wave number of a transition is shown in Eq. (4).

$$\sigma = \frac{\nu}{c} = \frac{E'}{hc} - \frac{E''}{hc} \quad (4)$$

If  $T = E/(hc)$ , then Eq. (5) results. Here  $T$  is called the spectral term.

$$\sigma = T'' - T' \quad (5)$$

The allowed terms for hydrogen, from Eq. (2), are given by Eq. (6). The quantity  $R$  is the important Rydberg constant. Its

$$T = \frac{me^4}{8\epsilon_0^2 ch^3} \cdot \frac{1}{n^2} = \frac{R}{n^2} \quad (6)$$

value, which has been measured to a remarkable and rapidly improving accuracy, is related to the values of other well-known atomic constants, as in Eq. (6). See RYDBERG CONSTANT.

The effect of finite nuclear mass must be considered, since the nucleus does not actually remain at rest at the center of the atom. Instead, the electron and nucleus revolve about their common center of mass. This effect can be accurately accounted for and

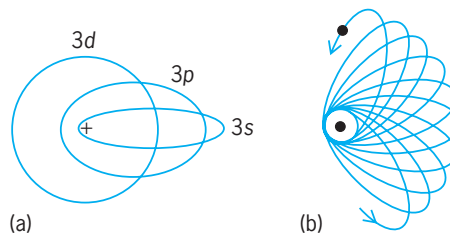

**Possible elliptical orbits, according to the Bohr-Sommerfeld theory. (a) The three permitted orbits for  $n = 3$ . (b) Precession of the 3s orbit caused by the relativistic variation of mass. (After A. P. Arya, *Fundamentals of Atomic Physics*, Allyn and Bacon, 1971)**

requires a small change in the value of the effective mass  $m$  in Eq. (6).

In addition to the circular orbits already described, elliptical ones are also consistent with the requirement that the angular momentum be quantized. A. Sommerfeld showed that for each value of  $n$  there is a family of  $n$  permitted elliptical orbits, all having the same major axis but with different eccentricities. Illustration *a* shows, for example, the Bohr-Sommerfeld orbits for  $n = 3$ . The orbits are labeled *s*, *p*, and *d*, indicating values of the azimuthal quantum number  $l = 0, 1, \text{ and } 2$ . This number determines the shape of the orbit, since the ratio of the major to the minor axis is found to be  $n/(l + 1)$ . To a first approximation, the energies of all orbits of the same  $n$  are equal. In the case of the highly eccentric orbits, however, there is a slight lowering of the energy due to precession of the orbit (illus. *b*). According to Einstein's theory of relativity, the mass increases somewhat in the inner part of the orbit, because of greater velocity. The velocity increase is greater as the eccentricity is greater, so the orbits of higher eccentricity have their energies lowered more. The quantity  $l$  is called the orbital angular momentum quantum number or the azimuthal quantum number. See RELATIVITY.

**Multielectron atoms.** In attempting to extend Bohr's model to atoms with more than one electron, it is logical to compare the experimentally observed terms of the alkali atoms, which contain only a single electron outside closed shells, with those of hydrogen. A definite similarity is found but with the striking difference that all terms with  $l > 0$  are double. This fact was interpreted by S. A. Goudsmit and G. E. Uhlenbeck as due to the presence of an additional angular momentum of  $\frac{1}{2}(h/2\pi)$  attributed to the electron spinning about its axis. The spin quantum number of the electron is  $s = \frac{1}{2}$ .

The relativistic quantum mechanics developed by P. A. M. Dirac provided the theoretical basis for this experimental observation. See ELECTRON SPIN.

Implicit in much of the following discussion is W. Pauli's exclusion principle, first enunciated in 1925, which when applied to atoms may be stated as follows: no more than one electron in a multielectron atom can possess precisely the same quantum numbers. In an independent, hydrogenic electron approximation to multielectron atoms, there are  $2n^2$  possible independent choices of the principal ( $n$ ), orbital ( $l$ ), and magnetic ( $m_l, m_s$ ) quantum numbers available for electrons belonging to a given  $n$ , and no more. Here  $m_l$  and  $m_s$  refer to the quantized projections of  $l$  and  $s$  along some chosen direction. The organization of atomic electrons into shells of increasing radius (the Bohr radius scales as  $n^2$ ) follows from this principle. See EXCLUSION PRINCIPLE.

The energy of interaction of the electron's spin with its orbital angular momentum is known as spin-orbit coupling. A charge in motion through either "pure" electric or "pure" magnetic fields, that is, through fields perceived as "pure" in a static laboratory, actually experiences a combination of electric and magnetic fields, if viewed in the frame of reference of a moving observer with respect to whom the charge is momentarily at rest. For example, moving charges are well known to be deflected by

magnetic fields. But in the rest frame of such a charge, there is no motion, and any acceleration of a charge must be due to the presence of a pure electric field from the point of view of an observer analyzing the motion in that reference frame. See RELATIVISTIC ELECTRODYNAMICS.

A spinning electron can crudely be pictured as a spinning ball of charge, imitating a circulating electric current. This circulating current gives rise to a magnetic field distribution very similar to that of a small bar magnet, with north and south magnetic poles symmetrically distributed along the spin axis above and below the spin equator. This representative bar magnet can interact with external magnetic fields, one source of which is the magnetic field experienced by an electron in its rest frame, owing to its orbital motion through the electric field established by the central nucleus of an atom. In multielectron atoms, there can be additional, though generally weaker, interactions arising from the magnetic interactions of each electron with its neighbors, as all are moving with respect to each other and all have spin. The strength of the bar magnet equivalent to each electron spin, and its direction in space are characterized by a quantity called the magnetic moment, which also is quantized essentially because the spin itself is quantized. Studies of the effect of an external magnetic field on the states of atoms show that the magnetic moment associated with the electron spin is equal in magnitude to a unit called the Bohr magneton.

The energy of the interaction between the electron's magnetic moment and the magnetic field generated by its orbital motion is usually a small correction to the spectral term, and depends on the angle between the magnetic moment and the magnetic field or, equivalently, between the spin angular momentum vector and the orbital angular momentum vector (a vector perpendicular to the orbital plane whose magnitude is the size of the orbital angular momentum). Since quantum theory requires that the quantum number  $j$  of the electron's total angular momentum shall take values differing by integers, while  $l$  is always an integer, there are only two possible orientations for  $s$  relative to  $l$ :  $s$  must be either parallel or antiparallel to  $l$ .

For the case of a single electron outside the nucleus, the Dirac theory gives Eq. (7) for the spin-orbit correction to the spectral

$$\Delta T = \frac{R\alpha^2 Z^4}{n^3} \times \frac{j(j+1) - l(l+1) - s(s+1)}{l(l+1)(l+1)} \quad (7)$$

terms. Here  $\alpha = e^2/(2\epsilon_0 hc) \cong 1/137$  is called the fine structure constant.

In atoms having more than one electron, this fine structure becomes what is called the multiplet structure. The doublets in the alkali spectra, for example, are due to spin-orbit coupling; Eq. (7), with suitable modifications, can still be applied.

When more than one electron is present in the atom, there are various ways in which the spins and orbital angular momenta can interact. Each spin may couple to its own orbit, as in the one-electron case; other possibilities are orbit-other orbit, spin-spin, and so on. The most common interaction in the light atoms, called *LS* coupling or Russell-Saunders coupling, is described schematically in Eq. (8). This notation indicates that the  $l$  are

$$\{(l_1, l_2, l_3, \dots)(s_1, s_2, s_3, \dots)\} = \{L, S\} = J \quad (8)$$

coupled strongly together to form a resultant  $L$ , representing the total orbital angular momentum. The  $s_i$  are coupled strongly together to form a resultant  $S$ , the total spin angular momentum. The weakest coupling is that between  $L$  and  $S$  to form  $J$ , the total angular momentum of the electron system of the atom in this state.

Coupling of the *LS* type is generally applicable to the low-energy states of the lighter atoms. The next commonest type is called *jj* coupling, represented in Eq. (9). Each electron has its

$$\{(l_1, s_1)(l_2, s_2)(l_3, s_3) \dots\} = \{j_1, j_2, j_3, \dots\} = J \quad (9)$$

spin coupled to its own orbital angular momentum to form a  $j_i$  for that electron. The various  $j_i$  are then more weakly coupled

together to give  $J$ . This type of coupling is seldom strictly observed. In the heavier atoms it is common to find a condition intermediate between *LS* and *jj* coupling; then either the *LS* or *jj* notation may be used to describe the levels, because the number of levels for a given electron configuration is independent of the coupling scheme.

**Nuclear magnetism and hyperfine structure.** Most atomic nuclei also possess spin, but rotate about 2000 times slower than electrons because their mass is on the order of 2000 or more times greater than that of electrons. Because of this, very weak nuclear magnetic fields, analogous to the electronic ones that produce fine structure in spectral lines, further split atomic energy levels. Consequently, spectral lines arising from them are split according to the relative orientations, and hence energies of interaction, of the nuclear magnetic moments with the electronic ones. The resulting pattern of energy levels and corresponding spectral-line components is referred to as hyperfine structure. See NUCLEAR MOMENTS.

Nuclear properties also affect atomic spectra through the isotope shift. This is the result of the difference in nuclear masses of two isotopes, which results in a slight change in the Rydberg constant. There is also sometimes a distortion of the nucleus, which can be detected by ultrahigh precision spectroscopy. See MOLECULAR BEAMS; PARTICLE TRAP.

**Doppler spread.** In most cases, a common problem called Doppler broadening of the spectral lines arises, which can cause overlapping of spectral lines and make analysis difficult. The broadening arises from motion of the emitted atom with respect to a spectrometer. Several ingenious ways of isolating only those atoms nearly at rest with respect to spectrometric apparatus have been devised. The most powerful employ lasers and either involve saturation spectroscopy, utilizing a saturating beam and probe beam from the same tunable laser, or use two laser photons which jointly drive a single atomic transition and are generated in lasers so arranged that the first-order Doppler shifts of the photons cancel each other. See DOPPLER EFFECT.

**Radiationless transitions.** It would be misleading to think that the most probable fate of excited atomic electrons consists of transitions to lower orbits, accompanied by photon emission. In fact, for at least the first third of the periodic table, the preferred decay mode of most excited atomic systems in most states of excitation and ionization is the electron emission process first observed by P. Auger in 1925 and named after him. For example, a singly charged neon ion lacking a 1s electron is more than 50 times as likely to decay by electron emission as by photon emission. In the process, an outer atomic electron descends to fill an inner vacancy, while another is ejected from the atom to conserve both total energy and momentum in the atom. The ejection usually arises because of the interelectron Coulomb repulsion. See AUGER EFFECT.

**Cooling and stopping atoms and ions.** Despite impressive progress in reducing Doppler shifts and Doppler spreads, these quantities remain factors that limit the highest obtainable spectroscopic resolutions. The 1980s and 1990s saw extremely rapid development of techniques for trapping neutral atoms and singly charged ions in a confined region of space, and then cooling them to much lower temperatures by the application of laser-light cooling techniques. Photons carry not only energy but also momentum; hence they can exert pressure on neutral atoms as well as charged ions. See LASER COOLING.

Schemes have been developed to exploit these light forces to confine neutral atoms in the absence of material walls, whereas various types of so-called bottle configurations of electromagnetic fields developed earlier remain the technique of choice for similarly confining ions. Various ingenious methods have been invented to slow down and even nearly stop neutral atoms and singly charged ions, whose energy levels (unlike those of most more highly charged ions) are accessible to tunable dye lasers. These methods often utilize the velocity-dependent light pressure from laser photons of nearly the same frequency as, but slightly

less energetic than, the energy separation of two atomic energy levels to induce a transition between these levels.

The magneto-optic trap combines optical forces provided by laser light with a weak magnetic field whose size goes through zero at the geometrical center of the trap and increases with distance from this center. The net result is a restoring force which confines sufficiently laser-cooled atoms near the center. Ingenious improvements have allowed cooling of ions to temperatures as low as  $180 \times 10^{-9}$  K.

For more highly ionized ions, annular storage rings are used in which radial confinement of fast ion beams (with speeds of approximately 10% or more of the speed of light) is provided by magnetic focusing. Two cooling schemes are known to work on stored beams of charged particles, the so-called stochastic cooling method and the electron cooling method. In the former, deviations from mean stored particle energies are electronically detected, and electronic "kicks" that have been adjusted in time and direction are delivered to the stored particles to compensate these deviations. In electron cooling, which proves to be more effective for stored heavy ions of high charge, electron beams prepared with a narrow velocity distribution are merged with the stored ion beams. When the average speeds of the electrons and the ions are matched, the Coulomb interaction between the relatively cold (low-velocity-spread) electrons and the highly charged ions efficiently transfers energy from the warmer ions, thereby reducing the temperature of the stored ions. [I.A.S.]

**Atomic theory** The study of the structure and properties of atoms based on quantum mechanics and the Schrödinger equation. These tools make it possible, in principle, to predict most properties of atomic systems. A stationary state of an atom is governed by a time-independent wave function which depends on the position coordinates of all the particles within the atom. To obtain the wave function, the time-independent Schrödinger equation, a second-order differential equation, has to be solved. The potential energy term in this equation contains the Coulomb interaction between all the particles in the atom, and in this way they are all coupled to each other. See DIFFERENTIAL EQUATION; NONRELATIVISTIC QUANTUM THEORY; QUANTUM MECHANICS.

A many-particle system where the behavior of each particle at every instant depends on the positions of all the other particles cannot be solved directly. This is not a problem restricted to quantum mechanics. A classical system where the same problem arises is a solar system with several planets. In classical mechanics as well as in quantum mechanics, such a system has to be treated by approximate methods. See CELESTIAL MECHANICS.

**Independent particle model.** As a first approximation, it is customary to simplify the interaction between the particles. In the independent particle model the electrons are assumed to move independently of each other in the average field generated by the nucleus and the other electrons. In this case the potential energy operator will be a sum over one-particle operators. The simplest wave function which will satisfy the resulting equation is a product of one-particle orbitals. To fulfill the Pauli exclusion principle, the total wave function must, however, be written in a form such that it will vanish if two particles are occupying the same quantum state. This is achieved with an antisymmetrized wave function, that is, a function which, if two electrons are interchanged, changes sign but in all other respects remains unaltered. The antisymmetrized product wave function is usually called a Slater determinant. See EXCLUSION PRINCIPLE.

**Hartree-Fock method.** In the late 1920s, only a few years after the discovery of the Schrödinger equation, D. Hartree showed that the wave function to a good approximation could be written as a product of orbitals, and also developed a method to calculate the orbitals. Important contributions to the method were also made by V. Fock and J. C. Slater (thus, the Hartree-

Fock method). The Hartree-Fock model thus gives the lowest-energy ground state within the assumption that the electrons move independently of each other in an average field from the nucleus and the other electrons.

To simplify the problem even further, it is common to add the requirement that the Hartree-Fock potential should be spherically symmetric. This leads to the central-field model and the so-called restricted Hartree-Fock method.

The Hartree-Fock method gives a qualitative understanding of many atomic properties. Generally it is, for example, able to predict the configurations occupied in the ground states of the elements. Electron binding energies are also given with reasonable accuracy.

**Electron correlation.** Correlation is commonly defined as the difference between the full many-body problem and the Hartree-Fock model. More specifically, the correlation energy is the difference between the experimental energy and the Hartree-Fock energy. There are several methods developed to account for electron correlation, including the configuration-interaction method, the multi-figuration Hartree-Fock method, and perturbation theory.

**Strongly correlated systems.** Although the Hartree-Fock model can qualitatively explain many atomic properties, there are systems and properties for which correlation is more important, such as negative ions, doubly-excited states, and some open-shell systems. If the interest is not in calculating the total energy of a state but in understanding some other properties, such as the hyperfine structure, effects beyond the central field model can be more important. See HYPERFINE STRUCTURE; NEGATIVE ION.

**Relativistic effects.** The Schrödinger equation is a nonrelativistic wave equation. In heavy elements the kinetic energy of the electrons becomes very large, and calculations are based on the relativistic counterpart to the Schrödinger equation, the Dirac equation. It is possible to construct a Hartree-Fock model based on the Dirac equation, where the electron-electron interaction is given by the Coulomb interaction, a magnetic contribution, and a term which corrects for the finite speed (retardation) with which the interaction propagates. See ANTIMATTER; RELATIVISTIC QUANTUM THEORY.

**Radiative corrections.** Radiative corrections, which arise when the electromagnetic field is quantized within the theory of quantum electrodynamics. For many-body systems, calculations of radiative effects are usually done within some independent-particle model, and the result is added to a correlated relativistic calculation based on the Dirac equation. See QUANTUM ELECTRODYNAMICS; ATOMIC STRUCTURE AND SPECTRA. [Eva Li.]

**Atomic time** Time based on the frequency determined by the energy of quantum transitions. Atomic time is obtained from the continuous operation of atomic clocks since mid-1955. The only relativistic correction to atomic time is for gravitational potential (related to height above sea level). See ATOMIC CLOCK.

An atom which drops from an energy level,  $E_2$ , to a lower one,  $E_1$ , emits radiation of frequency  $f = (E_1 - E_2)/h$ , where  $h$  is Planck's constant. The second in the International System of Units (SI) was defined in 1967 as the duration of 9,192,631,770 cycles of the radiation from a selected transition of cesium-133. See ATOMIC STRUCTURE AND SPECTRA; QUANTUM MECHANICS.

International Atomic Time (TAI) is generated by the International Bureau of Weights and Measures (BIPM) in Sèvres, France. It is based on approximately 200 commercial atomic clocks and up to 8 laboratory-built, cesium primary-frequency standards at approximately 44 laboratories around the world. The clock data are collected through use of the Global Positioning System (GPS) with a process called common-view time transfer. The primary physical frequency standards, with accuracy as good as 2.2 parts in  $10^{15}$ , provide the accuracy and long-term stability of TAI, which reproduces the SI second to better than 1 part in  $10^{14}$ . The highest-accuracy standards now use laser-cooled



atoms. The function of the commercial clocks is to provide redundancy and short-term stability. See ATOMIC CLOCK; SATELLITE NAVIGATION SYSTEMS.

TAI is a highly precise atomic time used, for example, in determining variations in the Earth's speed of rotation, computing orbits, and tracking celestial objects, including spacecraft. TAI provides not only the SI unit of time but also the unit of length, the meter, now defined as the distance that light travels in  $1/299,792,458$  of a second in vacuum. See PHYSICAL MEASUREMENT. [T.E.P.; M.We.]

**Atomization** The process whereby a bulk liquid is transformed into a multiplicity of small drops. This transformation, often called primary atomization, proceeds through the formation of disturbances on the surface of the bulk liquid, followed by their amplification due to energy and momentum transfer from the surrounding gas.

Spray formation processes are critical to the performance of a number of technologies and applications. These include combustion systems (gas turbine engines, internal combustion engines, incinerators, furnaces, rocket motors), agriculture (pesticide and fertilizer treatments), paints and coatings (furniture, automobiles), consumer products (cleaners, personal care products), fire suppression systems, spray cooling (materials processing, computer chip cooling), medicinal (pharmaceutical), and spray drying (foods, drugs, materials processing). Current concerns include how to make smaller drops (especially for internal combustion engines), how to make larger drops (agricultural sprays), how to reduce the number of largest and smallest drops (paints and coatings, consumer products, medicinals, spray drying), how to distribute the liquid mass more uniformly throughout the spray, and how to increase the fraction of liquid that impacts a target (paints and coatings, spray cooling, fire suppression).

Spray devices (that is, atomizers) are often characterized by how disturbances form. The most general distinction is between systems where one or two fluids flow through the atomizer. The most common types of single-fluid atomizers are pressure (also called plain-orifice, hydraulic, or pneumatic), pressure-swirl, rotary, ultrasonic (sometimes termed whistle or acoustic), and electrostatic. Twin-fluid atomizers include internal-mix and external-mix versions, where these terms describe the location where atomizing fluid (almost always a gas) first contacts fluid to be sprayed (almost always a liquid).

While primary atomization is important, because of its role in determining mean drop size and the spectrum of drop sizes, subsequent processes also play key roles in spray behavior. They include further drop breakup (termed secondary atomization), drop transport to and impact on a target, drop evaporation (and perhaps combustion), plus drop collisions and coalescence. In addition, the spray interacts with its surroundings, being modified by the adjacent gas flow and modifying it in turn. See AEROSOL; PARTICULATES. [PE.So.]

**Atropine** An alkaloid,  $C_{17}H_{23}NO_3$ , with the chemical structure below. The systematic chemical name is endo-(±)- $\alpha$ -(hydroxymethyl)phenylacetic acid 8-methyl-8-azabicyclo[3.2.1]oct-3-yl ester, and in pharmacy it is sometimes known as *dl*-hyoscyamine. It occurs in minute amounts in the leaves of *Atropa*

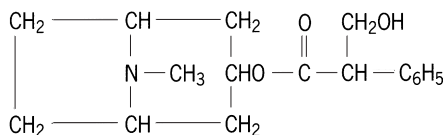

*belladonna*, *A. betica*, *Datura stramonium*, *D. innoxia*, and *D. sanguinea*, as well as many related plants. It is chiefly manufactured by racemization of *l*-hyoscyamine, which is isolated from the leaves and stems of the henbane, *Hyoscyamus niger*. It melts

at 114–116°C (237–241°F) and is poorly soluble in water. The nitrate and sulfate are used in medicine instead of the free base.

Atropine is used clinically as a mydriatic (pupil dilator). Dilation is produced by paralyzing the iris and ciliary muscles. Atropine is also administered in small doses before general anesthesia to lessen oral and air-passage secretions. Its ability to reduce these secretions is also utilized in several preparations commonly used for symptomatic relief of colds. See ALKALOID. [F.W.]

**Attention deficit hyperactivity disorder** A common psychiatric disorder of childhood characterized by attentional difficulties, impulsivity, and hyperactivity; known earlier as attention deficit disorder. Other older names for this disorder include minimal brain dysfunction, minimal brain damage, hyperactivity, hyperkinesis, and hyperactive child syndrome. Over time, these names were modified due to their implications about etiology and core symptoms: minimal brain dysfunction seemed to imply that children with this disorder were brain-damaged, while hyperactivity and its synonyms named a feature seen in many but not all of these children.

The three defining symptoms of attention deficit disorder are as follows:

(1) *Attentional deficits*. The child is described as having a short attention span. The child often fails to finish things he or she starts, does not seem to listen, and is easily distracted or disorganized. In more severe instances the child is unable to focus attention on anything, while in less severe cases attention can be focused on things of interest to the child.

(2) *Impulsivity*. The child is often described as acting before thinking, shifting excessively and rapidly from one activity to another, or having difficulty waiting for a turn in games or group activities.

(3) *Hyperactivity*. Many children with this disorder are hyperactive—and indeed, may have been noted to be so prior to birth. They may fidget, wiggle, move excessively, and have difficulty keeping still. This excessive activity is not noticeable when the children are playing; however, in the classroom or other quiet settings, the child cannot decrease his or her activity appropriately. Some affected children are active at a normal level or even sluggish. On the basis of the predominating symptoms, children with attention deficit hyperactivity disorder are subcategorized as having hyperactive symptoms (hyperactive type), lacking hyperactivity (inattentive type), and having both inattention and hyperactivity or impulsivity (combined type).

Many children with attention deficit hyperactivity disorder frequently show an altered response to socialization. They are often described by their parents as obstinate, impervious, stubborn, or negativistic. With peers, many affected children are domineering or bullying, and thus may prefer to play with younger children. Another characteristic often seen in children with the disorder is emotional lability. Their moods change frequently and easily, sometimes spontaneously, and sometimes reactively. Because of their behavioral difficulties, children with the disorder often have conflicts with parents, teachers, and peers. Commonly, difficulties in discipline and inadequacies in schoolwork lead to reproof and criticism. As a consequence, children with the disorder usually also have low self-esteem. Attention deficit hyperactivity disorder is frequently associated with other disorders, including disruptive behavior disorders, internalizing (mood and anxiety) disorders, and developmental disorders. See AFFECTIVE DISORDERS.

Formerly believed to be largely caused by brain damage, and more recently believed by some to be caused by food allergy, attention deficit hyperactivity disorder is now considered to be mainly hereditary. It is estimated that 3–10% of children of elementary school age (roughly 6–19 years) manifest significant symptoms of attention deficit hyperactivity disorder. About twice as many boys as girls are affected with the disorder. The girls are much less likely than the boys to be aggressive and have serious behavioral difficulties, making the girls vulnerable to

underidentification and undertreatment. It was formerly believed that attention deficit hyperactivity disorder was out-grown during adolescence. Although some signs of the disorder such as excessive activity may diminish or disappear in some affected children, other signs such as attentional difficulties, impulsivity, and interpersonal problems may persist. Despite the fact that this disorder is not uncommon in adults, the lower rates of hyperactivity in adults may result in the condition being frequently overlooked.

The treatment of the child or adult with this disorder involves three steps: evaluation, explanation of the problem to parents and child, and therapeutic intervention. Evaluation requires a detailed history of the child's psychological development and current functioning. Next, because the disorder is frequently associated with learning problems in school, it is desirable to obtain an individual intelligence test as well as a test of academic achievement. Since attention deficit hyperactivity disorder is often associated with other psychiatric disorders, it is important to carefully evaluate the presence of these other conditions. If a diagnosis of attention deficit hyperactivity disorder is confirmed, the parents or family should be educated regarding the nature of the condition and other associated conditions. Medication and guidance are the mainstays of the treatment. Approximately 70–80% of the children manifest a therapeutic response to one of the major stimulant drugs, such as amphetamines and methylphenidate. When effective, these medications increase attention, decrease impulsivity, and usually make the child more receptive to parental and educational requests and demands. Hyperactivity, when present, is usually diminished as well. Although usually less effective, other medications can be helpful to individuals who cannot tolerate or do not respond to stimulants. The common mechanism of action for such medications is their impact upon the neurotransmitters dopamine and norepinephrine. [J.Bi.]

**Attenuation** The reduction in level of a transmitted quantity as a function of a parameter, usually distance. It is applied mainly to acoustic or electromagnetic waves and is expressed as the ratio of power densities. Various mechanisms can give rise to attenuation. Among the most important are geometrical attenuation, absorption, and scattering.

For unconfined radiation from a point source in free space, the power density (watts per square meter) decreases in proportion to the square of the distance. The power densities,  $I_1$  and  $I_2$ , at distances  $r_1$  and  $r_2$  from the source, are related by Eq. (1).

$$I_2 = I_1 \left( \frac{r_1}{r_2} \right)^2 \quad (1)$$

See INVERSE-SQUARE LAW.

If the signal, in a parallel beam so that there is no geometrical attenuation, passes through a lossy medium, absorption reduces the power level,  $I$ , exponentially with distance,  $x$ , according to Eq. (2), where  $a$  is the attenuation coefficient.

$$I(x) = I(0)e^{-ax} \quad (2)$$

See ABSORPTION; ABSORPTION OF ELECTROMAGNETIC RADIATION; SOUND ABSORPTION.

Scattering is said to occur if the power is not absorbed in the medium but scattered from inhomogeneities. See SCATTERING OF ELECTROMAGNETIC RADIATION.

More complicated situations occur with guided waves, such as acoustic waves in pipes or electromagnetic waves in transmission lines or waveguides, where absorption may take place and irregularities may cause reflection of some power. See TRANSMISSION LINES; WAVEGUIDE.

In electric circuits, constituent elements are often described as attenuators when they reduce the level of signals passing through them. See ATTENUATION (ELECTRICITY).

Attenuation is usually measured in terms of the logarithm of the power ratio, the units being the neper or the decibel. See DECIBEL; NEPER. [A.E.Ba.]

**Attenuation (electricity)** The exponential decrease with distance in the amplitude of an electrical signal traveling along a very long uniform transmission line, due to conductor and dielectric losses. If the peak voltage at the sending end of the transmission line is denoted by  $V_0$ , the peak voltage at a distance  $x$  from the sending end is given by the equation below, where  $\alpha$  is the attenuation constant of the line.

$$V_x = V_0 e^{-\alpha x}$$

Attenuators find numerous applications, typical examples being: in a signal generator, to vary the amplitude of the output signal; and in the input line to a television receiver that is very close to a television transmitter, so that overloading can be avoided. See SIGNAL GENERATOR; TELEVISION RECEIVER.

Attenuators for the dc (steady voltage) to very high-frequency (VHF) range (frequencies from 0 to 300 MHz) often contain resistors arranged in  $T$  or  $\pi$  configurations.

Piston attenuators (sometimes called waveguide-beyond-cutoff attenuators) are used at both intermediate and microwave frequencies (see illustration). The attenuation is varied by altering the separation between the two coils. The circular tube acts as a waveguide beyond cutoff, and the launching system is designed so that only one mode is excited in it.

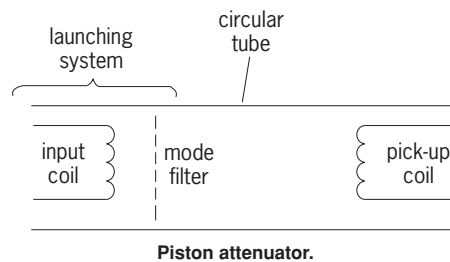

A variable waveguide attenuator can be produced by moving a lossy vane either sideways across the waveguide or into the waveguide through a longitudinal slot.

The rotary vane attenuator is a very popular instrument. At the input end, there is a rectangular-to-circular waveguide taper containing a fixed lossy vane perpendicular to the incident electric vector. The central section contains a lossy vane diametrically across a circular waveguide that can be rotated, and the output section is a mirror image of the input section.

Many different techniques for measuring attenuation have been devised. The power-ratio method is widely used. The simplest configuration requires only a stable well-matched filtered source and a well-matched low-drift power meter. Substitution methods of attenuation measurement are also very popular.

Low values of attenuation can be determined accurately by making reflection coefficient measurements on the device under test with a sliding short behind it. Several bridge techniques for measuring attenuation have been devised.

The attenuation in a waveguide can be found by making  $Q$  measurements on resonant sections of different lengths.

When only moderate accuracy (on the order of  $\pm 0.5$  dB) is required over a wide frequency range, a leveled swept source can be connected to the device under test, and the emerging signal can be fed to a diode detector that is followed by a logarithmic amplifier and oscilloscope. See AMPLITUDE-MODULATION DETECTOR.

Network analyzers yield both the magnitude and phase angle of the transmission and reflection coefficients of the device under test over a wide frequency range. By using ingenious calibration and computer-correction techniques, high accuracy can be achieved. See TRANSMISSION LINES. [F.L.W.]

**Audio amplifier** An electronic circuit for amplification of signals within or somewhat beyond the audio frequency range (generally regarded as 20 to 20,000 Hz). Audio amplifiers may function as voltage amplifiers (sometimes called preamplifiers), power amplifiers, or both. In the last case, they are often called integrated amplifiers. See POWER AMPLIFIER.

The function of integrated amplifiers (or of the combination of separate voltage amplifiers and power amplifiers used together) is to amplify a weak signal, such as from a microphone, phonograph pickup, tape player, radio tuner, or compact disc player, to a level capable of driving a loudspeaker or other type of transducer such as headphones at the desired sound level. Power amplifiers may have power ratings ranging from less than 1 W to several hundreds of watts. Stereo amplifiers consist of two identical, but electrically independent, amplifier circuits housed in a single chassis, often sharing a common power supply. Audio amplifiers are commonly constructed with solid-state devices (transistors and integrated circuits), although some amplifiers using vacuum tubes as the active, amplifying devices are still manufactured. See AMPLIFIER; INTEGRATED CIRCUITS; LOUDSPEAKER; TRANSISTOR; VACUUM TUBE.

The ideal amplifier delivers an output signal that, aside from its higher power level, is identical in relative spectral content to the input signal. Normally, various forms of distortion are generated by the amplifier, such as harmonic distortion (multiples of the desired signal frequency), intermodulation distortion (spurious sum or difference frequencies created when multiple tones are applied to the amplifier simultaneously, as in the case of music or speech amplification), and transient intermodulation distortion (caused by rapid fluctuations of the input signal level). All forms of distortion are measured as percentages of the desired signal amplitude. Generally, distortion levels of under 1% or 0.5% are considered to be low enough for high-fidelity applications. See FIDELITY.

Other parameters used to define an amplifier's characteristics include frequency response and signal-to-noise ratio (S/N). The frequency response is the range of frequencies that the amplifier can handle, usually quoted with a tolerance in decibels, for example: "frequency response: 20 to 20,000 Hz,  $\pm 0.5$  dB." Signal-to-noise ratio, also quoted in decibels, is indicative of the amount of residual noise generated by the amplifier itself, as compared with the desired output signal level. Signal-to-noise levels greater than 70 dB are generally considered to be acceptable, although some amplifiers offer much better values. See RESPONSE; SIGNAL-TO-NOISE RATIO. [L.Fel.]

**Audiometry** The quantitative assessment of individual hearing, either normal or defective. Three types of audiometric tests are used: pure tone, speech, and bone conduction tests. Such tests may serve various purposes, such as investigation of auditory fatigue under noise conditions, human engineering study of hearing aids and communication devices, screening of individuals with defective hearing, and diagnosis and treatment of defective hearing. In all of these situations, individual hearing is measured relative to defined standards of normal hearing.

The pure-tone audiometer is the instrument used most widely in individual hearing measurement. It is composed of an oscillator, an amplifier, and an attenuator to control sound intensity. For speech tests of hearing, word lists called articulation tests are reproduced on records or tape recorders. Measurements of detectability or intelligibility can be made by adjusting the intensity of the test words. To make bone conduction tests, sound vibrations from the audiometer activate a vibrator located on the forehead or mastoid bone.

Scientific advance in audiometry demands careful control of all environmental sound. Two types of rooms especially constructed for research and measurement of hearing are the random diffusion, or reverberation, chamber and the anechoic room. In the reverberation chamber, sounds are randomly reflected from heavy nonparallel walls, floor, and ceiling surfaces.

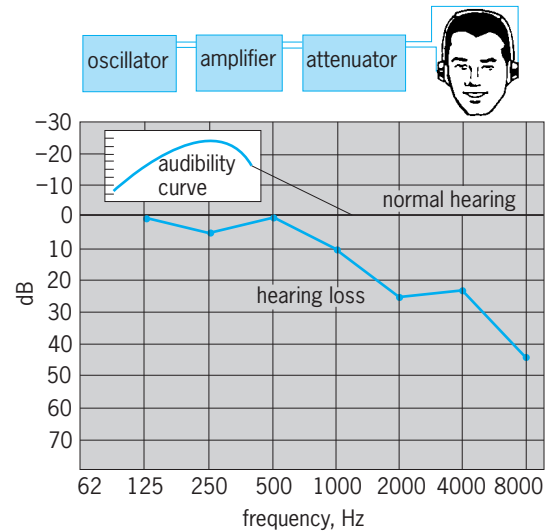

**Audiogram for determining the audibility curve for pure-tone hearing loss at various frequency levels.**

In the anechoic room, the fiber glass wedges absorb all but a small percent of the sound.

The measurement of hearing loss for pure tones in defective hearing is represented by the audiogram (see illustration). Sounds of different frequencies are presented separately to each ear of the individual, and the intensity levels of the absolute thresholds for each frequency are determined. The absolute threshold is the lowest intensity which can be detected by the individual who is being tested.

In clinical audiometry the status of hearing is expressed in terms of hearing loss at each of the different frequency levels. In the audiogram the normal audibility curve, representing absolute thresholds at all frequencies for the normal ear, is represented as a straight line of zero decibels. Amount of hearing loss is then designated as a decibel value below normal audibility. The audiogram in the illustration reveals a hearing loss for tones above 500 Hz. Automatic audiometers are now in use which enable individuals to plot an audiogram for themselves.

Articulation tests are speech perception or speech hearing tests used to assess hearing and loss of hearing for speech. The threshold of intelligibility for speech is defined as the intensity level at which 50% of the words, nonsense syllables, or sentences used in the articulation test are correctly identified. The hearing loss for speech is determined by computing the difference in decibels between the individual intelligibility threshold and the normal threshold for that particular speech test. Discrimination loss for speech represents the difference between the maximum articulation score at a high intensity level (100 dB), expressed in percent of units identified, and a score of 100%. The measure of discrimination loss is important in distinguishing between conduction loss and nerve deafness.

Bone conduction audiograms are compared with air conduction audiograms in order to analyze the nature of deafness. Losses in bone conduction hearing generally give evidence of nerve deafness, as contrasted to middle-ear or conduction deafness. See EAR; HEARING IMPAIRMENT. [K.U.S.]

**Auger effect** One of the two principal processes for the relaxation of an inner-shell electron vacancy in an excited or ionized atom. The Auger effect is a two-electron process in which an electron makes a discrete transition from a less bound shell to the vacant, but more tightly bound, electron shell. The energy gained in this process is transferred, via the electrostatic interaction, to another bound electron which then escapes from the atom. This outgoing electron is referred to as an Auger electron and is labeled by letters corresponding to the atomic shells involved in

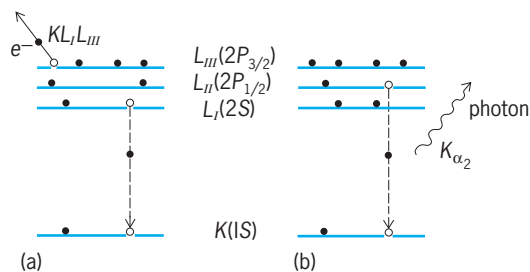

Two principal processes for the filling of an inner-shell electron vacancy. (a) Auger emission; a  $KL_I L_{III}$  Auger process in which an  $L_I$  electron fills the  $K$ -shell vacancy with the emission of a  $KL_I L_{III}$  Auger electron from the  $L_{III}$  shell. (b) Photon emission; a radiative process in which an  $L_{II}$  electron fills the  $K$ -shell vacancy with the emission of a  $K_{\alpha_2}$  photon.

the process. For example, a  $KL_I L_{III}$  Auger electron corresponds to a process in which an  $L_I$  electron makes a transition to the  $K$  shell and the energy is transferred to an  $L_{III}$  electron (illus. a). By the conservation of energy, the Auger electron kinetic energy  $E$  is given by  $E = E(K) - E(L_I) - E(L_{III})$  where  $E(K, L)$  is the binding energy of the various electron shells. Since the energy levels of atoms are discrete and well understood, the Auger energy is a signature of the emitting atom. See ELECTRON CONFIGURATION; ENERGY LEVEL (QUANTUM MECHANICS).

The other principal process for the filling of an inner-shell hole is a radiative one in which the transition energy is carried off by a photon (illus. b). Inner-shell vacancies in elements with large atomic number correspond to large transition energies and usually decay by such radiative processes; vacancies in elements with low atomic number or outer-shell vacancies with low transition energies decay primarily by Auger processes. [L.C.F.]

**Auger electron spectroscopy** Auger electron spectroscopy (AES) is a widely used technique that detects the elements in the first atomic layers of a solid surface. Although many elements can be detected, hydrogen usually cannot be observed. Excellent spatial resolution can be achieved. Auger electron spectroscopy is important in many areas of science and technology, such as catalysis, electronics, lubrication, and new materials, and also understanding chemical bonding in the surface region. Auger spectra can be observed with gas-phase species.

**Basic principles.** In Auger electron spectroscopy an electron beam, usually 2–20 kV in energy, impinges on a surface, and a core-level electron in an atom is ejected. An electron from a higher level falls into the vacant core level. Two deexcitation processes are possible: An x-ray can be emitted, or a third electron is ejected from the atom (see illustration). This electron is

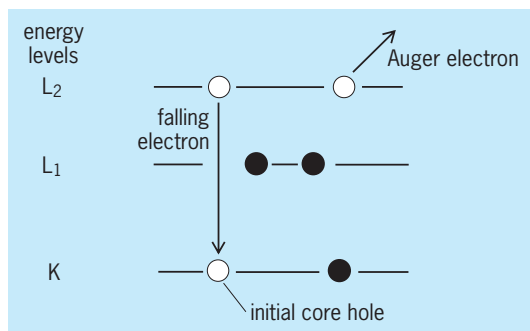

Schematic diagram of an Auger electron being ejected from a carbon atom for a  $KL_2 L_2$  transition. Round forms are electrons.

an Auger electron; the effect is named after its discoverer, Pierre Auger. Auger electrons for surface analysis can be created from other sources, such as, x-rays, ion beams, and positrons. K capture (radioactive decay) is another source of Auger electrons. The Auger yield (the ratio of Auger electrons to the number of core holes created) depends upon the element, the initial core level, and the excitation conditions. See AUGER EFFECT.

The surface sensitivity of Auger electron spectroscopy is based upon the fact that electrons with kinetic energy in the range of 30–2500 eV have an inelastic mean free path (IMFP) of about 0.5–3 nanometers for most materials. The inelastic mean free path is defined as the average distance that an electron will travel before it undergoes an inelastic collision with another electron or nucleus of the matrix constituent atoms. Very few Auger electrons created at depths greater than two to three times the IMFP will leave the bulk with their initial kinetic energy. Those electrons formed at greater depths undergo collisions with atoms and electrons in the bulk and lose part or all of the initial creation energy. In this energy range, all elements with an atomic number of 3 or more have detectable Auger electrons. Most elements can be detected to 1 atomic percent in the analysis volume, and relative atomic amounts usually can be determined.

X-ray notation is used to signify Auger transitions. For example, if a K (1s) electron in silicon is ejected and an  $L_3$  ( $2p_{3/2}$ ) electron falls into the K-level hole and another  $L_3$  is ejected as the Auger electron, the transition is  $KL_3 L_3$ . If a valence electron is involved, it often is denoted with a V. [N.H.T.]

**Augite** A group of monoclinic calcic pyroxenes which have the general chemical formula  $(Ca, Mg, Fe)(Mg, Fe)Si_2O_6$ , in which calcium is the dominant cation in the first cation position. Monoclinic pyroxene with substantial iron or magnesium in place of calcium is called pigeonite, and has a different crystal structure from augite. Augite is generally considered a combination of the four end members diopside ( $CaMgSi_2O_6$ ), hedenbergite ( $CaFe^{2+}Si_2O_6$ ), enstatite ( $Mg_2Si_2O_6$ ), and ferrosilite ( $Fe^{2+}_2Si_2O_6$ ), but it almost always has substantial aluminum and minor to substantial amounts of sodium, ferric iron, chromium, and titanium.

Augite occurs in both igneous and metamorphic rocks. It is nearly universal in basalts and gabbros, and occurs somewhat less frequently in less mafic igneous rocks. Magnesium-rich augite is a characteristic mineral in many ultramafic rocks and in rocks of the Earth's mantle. Augite and pigeonite are also rather common constituents of lunar basalts and basaltic meteorites. See DIOPSIDE; ECLOGITE; ENSTATITE; PIGEONITE; PYROXENE. [R.J.Tr.]

**Aurora** An optical manifestation of a large-scale electrical discharge process which surrounds the Earth. The discharge is powered by the so-called solar wind-magnetosphere generator. The Sun continuously blows out its upper atmosphere, the corona, with a supersonic speed. This fully ionized and magnetized gas flow interacts with the Earth's magnetic field, resulting in a comet-shaped cavity (the magnetosphere) carved around the Earth, while the lines of force of the Earth's magnetic field and of the solar wind magnetic field interconnect. Electric power of as much as  $10^{12}$  W is generated as the solar wind blows across the interconnected field lines near the comet-shaped boundary. A part of the electric current (carried mainly by electrons) thus generated flows between the magnetospheric boundary and an annular, ring-shaped region of the polar upper atmosphere along the lines of force of the Earth's magnetic field. See MAGNETOSPHERE.

As these electrons descend toward the Earth, they themselves develop an electrical potential drop of the order of a few kilovolts along the lines of force. As a result, the current-carrying electrons acquire energies of as much as a few kiloelectronvolts, sufficient to ionize and excite a few hundred atoms and molecules before they are stopped by the atmosphere at an altitude of about 60 mi (100 km).



Two curtain-shaped auroras stretching across the sky near Fairbanks, Alaska. (Courtesy of Lee Snyder)

Two ring-shaped glows, one in each hemisphere, are produced by upper atmospheric atoms and molecules which emit their own characteristic light after colliding with the current-carrying electrons. The most common light of the aurora (the greenish-white light) comes from excited oxygen atoms. Excited and ionized molecular nitrogen adds several band emissions. Imaging devices aboard satellites have successfully “photographed” both the northern and southern auroral rings. See SCIENTIFIC SATELLITES.

From a point on the ground, only a small part of the ring-shaped glow can be observed. It is seen as a curtain-shaped glow, stretching from horizon to horizon across the sky (see illustration). The bottom of the auroral curtain is sharply bounded and is located at about 60 mi (100 km) altitude. The upper boundary diffuses and extends to well above 180 mi (300 km).

The aurora becomes active during geomagnetic storms which occur often about 40 h after an intense solar flare. This is because the efficiency of the solar wind-magnetosphere generator becomes high and variable when the solar wind becomes gusty after a solar flare. During a great magnetic storm, the auroral ring expands from its usual latitude of about 67 to 50° or a little less. It is on such an occasion when the aurora can be seen widely across the continental United States. See ATMOSPHERE; ATOMIC STRUCTURE AND SPECTRA; GEOMAGNETISM; IONOSPHERE; PLASMA (PHYSICS). [S.I.A.]

**Australia** An island continent in the Southern Hemisphere with a total area of 2,941,526 mi<sup>2</sup> (7,618,552 km<sup>2</sup>). It is bounded on the west by the Indian Ocean and on the east by the Pacific Ocean and the Tasman Sea. Numerous small and several large islands lie off the coast, including Tasmania and New Zealand. Australia is generally of remarkably low elevation and moderate relief. Three-fourths of the land mass lies between 600 and 1500 ft (180 and 450 m) in the form of a huge plateau. A cross section from east to west shows first a narrow belt of coastal plain, then the steep escarpments of the eastern face of the Great Dividing Range, stretching 1200 mi (1900 km) from the north of Queensland to the south of Victoria. The descent on the western slope of the Dividing Range is gradual until often elevation in the inland basins is below sea level, rising gradually again across the great plateau until the low ranges of western Australia fringing the plateau are reached, and beyond these lies another coastal plain. With the exception of the Gulf of Carpentaria and Cape York peninsula in the north and the Great Australian Bight in the south, there are few striking features in the configuration of the coast. Australia may conveniently be divided into three great structural and landform regions.

The region called East Australian Highlands consists of a narrow plain extending north and south along the eastern coast. Flanking the plain are the series of ranges and tablelands making up the Great Dividing Range. The East Australian Highlands is the best-watered region in Australia, and some of the river systems are of considerable size. On the flanks of the East Australian Highlands are Australia's principal coal deposits—in the vicinity of Sydney and Newcastle and in the Bowen and Ipswich fields in Queensland. Petroliferous basins at Surat (Roma), flanking the divide in Queensland and off the coast of Victoria in Bass Strait, are Australia's most promising deposits of petroleum and natural gas.

The region known as the Interior Lowland Basins comprises a region of sedimentary rocks that occupy one-third of the continent between the western slope of the eastern highlands and the inner eastern margin of the ancient shield which forms the Western Plateau. Little land is over 500 ft (150 m), and some is below sea level. The rivers of the Murray-Darling Basin, draining the western slopes of the Great Dividing Range, have a marked seasonal variation in flow but never dry up in the lower reaches. South Australia's shallow lakes are more often dry expanses of encrusted white salt than bodies of water—the result of low rainfall and high evaporation. In most parts of the region water from deep artesian wells is available.

The region known as the Western Plateau is the largest area, occupying almost three-fifths of the continent, and is a great shield of ancient rocks standing 750–1500 ft (225–450 m) high. Much of it is buried in desert sand, and only a few ridges of ancient mountains (such as the Macdonnel and Musgrave ranges) break the monotony of the plateau surface. Only in the southwestern corner of the continent and along the northwestern coast is rainfall sufficient to support a sclerophyll forest of eucalypts and a monsoon woodland, respectively. In the north, coastal rivers are of considerable size but change from flooded torrents after rains to a succession of water holes in dry seasons.

Tasmania is a small mountainous island lying 150 mi (240 km) southeast of Australia across Bass Strait, with a total area of 26,383 mi<sup>2</sup> (68,332 km<sup>2</sup>). The island is structurally similar to the East Australian Highlands. The dominant feature is the central plateau, falling from a general level of 3500 ft (1070 m) in the northwest toward the southeast. A dense eucalyptus forest covers most of the island except along the wetter west coast, where beech forest predominates. The rivers have short, rapid courses with little seasonal variation in flow. See NEW ZEALAND. [K.B.C.]

**Australopithecine** Any of the seven extinct species that belong to the family Hominidae (comprising humans and their closest relatives). These species are not attributable to the genus *Homo*, but belong to at least three genera that existed between about 4.4 million years ago (Ma) and 1.2 Ma during the Pliocene and early Pleistocene epochs. All seven species are known only from Africa. Although some workers regard all of them as belonging to one genus, *Australopithecus*, it is clear that a second genus, *Ardipithecus*, should be recognized for the earliest known hominid fossils, and that the three “robust” species belong to a third genus, *Paranthropus*.

The name australopithecine comes from the taxon *Australopithecus* (“southern ape”) *africanus*, which was coined by Raymond Dart for a fossil skull discovered in 1924 in Taung, South Africa (see illustration). The Taung skull had several distinctly hominid, or humanlike, features, but the claim that *A. africanus* was a human forebear was disputed by many of the leading paleoanthropologists of that time. The hominid status of *A. africanus* became widely accepted more than a decade later, largely because of work on *Australopithecus* fossils from Sterkfontein. Specimens of *A. africanus* are known also from the sites of Makapansgat and Gladysvale in southern Africa. Faunal comparison with radiometrically dated sites in eastern Africa indicates that this species existed between about 3.0 and 2.3 Ma. The name *Paranthropus*



Lateral view of the Taung skull of *Australopithecus africanus*, the type specimen of *Australopithecus* and the first early hominid specimen to be discovered in Africa. (Courtesy of F. E. Grine)

(“beside human”) was coined in 1938 when fossils from Kromdraai, South Africa, were attributed to the taxon *P. robustus*. Fossils of this species are also known from the nearby sites of Swartkrans and Drimolen. These bones are dated, also by faunal comparisons with radiometrically dated sites in eastern Africa, to between about 1.8 and 1.5 Ma.

At least seven australopithecine species, belonging to at least three genera, can be recognized in the Pliocene and early Pleistocene of Africa: *Ardipithecus ramidus* (?5.0–4.4 Ma), *Australopithecus anamensis* (3.9–4.2 Ma), *Australopithecus afarensis* (?4.0–2.9 Ma), *Australopithecus africanus* (3.0–2.3 Ma), *Paranthropus aethiopicus* (2.8–2.3 Ma), *Paranthropus boisei* (2.3–1.2 Ma), and *Paranthropus robustus* (1.8–1.5 Ma). All are defined on the basis of craniodental morphology.

Paleoanthropologists disagree over the assignment of early hominid fossils to different genera and species. Such arguments over what is known as Alpha Taxonomy are to be expected, as different workers view the fossil record from different philosophical perspectives. Such differences also account for disagreements over the phylogenetic relationships of these species, including the issue of which (if any) is most closely related to the human genus, *Homo*. Every phylogenetic hypothesis that has been put forward since the 1950s has been either falsified outright or at least substantially altered by ongoing research and new discoveries.

At present, no scientifically rigorous phylogenetic analysis has been undertaken that incorporates all seven of the australopithecine species. The most comprehensive study of “australopithecine” evolutionary relationships to date does not include *Ar. ramidus* or *A. anamensis*. Nevertheless, it is evident from the descriptive account of *Ar. ramidus* that it very likely resembles the stem hominid taxon in its morphology. *Australopithecus anamensis* shares some evolved (derived) traits with later species such as *A. afarensis*, but retains some primitive features that are displayed also by *Ar. ramidus*. Thus, *A. anamensis* most likely evolved from a species that was at least morphologically similar to *Ar. ramidus* in some respects. For the moment, *Ar. ramidus* represents the best candidate for the ancestor of *A. anamensis*. *Australopithecus anamensis*, in turn, possesses some unique features that make it unlikely to be the immediate ancestor of *A. afarensis*, but it is probable that *A. afarensis* evolved from a species that had a strong morphological resemblance to *A. anamensis*.

*Australopithecus afarensis* likely gave rise to a lineage that provided the ancestry of both *A. africanus* and another lineage that included the common ancestor of the genera *Paranthropus* and *Homo*. Although *A. africanus* shares a number of derived morphological characters with species that are part of the *Paranthropus* and *Homo* lineage, it is not considered to be directly ancestral to that line because it exhibits derived morphology in several characters that are more primitive in both *A. afarensis* and *P. aethiopicus*. It is perhaps more likely that the derived traits which *A. africanus* shares with some species of *Paranthropus* and *Homo* were evolved in parallel. Other workers, however, have argued that *A. africanus* constitutes a reasonable morphotype for the last common ancestor of the lineage that leads to *Homo* and *Paranthropus*. In this case, the primitive features displayed by *P. aethiopicus* would represent evolutionary reversals. At present, then, it is safest to conclude that the phyletic position of *A. africanus* remains ambiguous.

*Paranthropus aethiopicus* is considered to be a likely candidate for the ancestry of both *P. boisei* and *P. robustus*. The reason is that *P. aethiopicus* shares a number of primitive features with *A. afarensis*, but at the same time it shares a host of derived features with the later species of *Paranthropus*, namely *P. robustus* and *P. boisei*.

The lineage leading to *Paranthropus* shares a number of morphological features with that leading to *Homo*. For example, all species of *Homo* and *Paranthropus* share a coronally oriented petrous temporal bone, a foramen magnum that is roughly horizontal in disposition, and a vertically oriented mandibular symphysis. Thus, it is most parsimonious to assume that these two lineages shared a common ancestor at some time prior to 2.8 Ma.

The apparent increase in cranial capacity that is shown by some species of *Paranthropus* (*P. robustus* and *P. boisei*) would appear to parallel the increase in brain size that characterized the evolutionary history of the lineage that led to *Homo sapiens*. Tools made of stone or bone are not known to be associated with *Ardipithecus* or the three species of *Australopithecus*. Stone tools are known from sites that contain *P. boisei* fossils, and both bone and stone tools are known from sites that preserve *P. robustus* remains. However, early members of the genus *Homo* are known also from these same localities. Thus, it is difficult to determine whether *Paranthropus* species may have been responsible for some of the late Pliocene and early Pleistocene archeological record. Indeed, it has been argued that the later species of *Paranthropus* may have been driven to extinction through competition with early *Homo*, because the latter possessed a distinct ecological advantage through the utilization of lithic technology in the procurement of food. While the evidence for this is not compelling, it is possible that ecological interactions between *Paranthropus* and early members of *Homo* may have influenced the evolutionary course of the human genus. See APES; FOSSIL HUMANS. [F.E.Gr.]

**Authigenic minerals** Minerals that are formed in sediment or a sedimentary rock. Their in-place origin distinguishes them from minerals that are formed elsewhere and transported to the site of deposition (detrital minerals). Authigenic minerals form at the Earth’s surface as well as during subsequent burial. The postdepositional processes are referred to as diagenesis, and the resulting minerals are important clues to postdepositional physical and chemical changes in the rock. See DIAGENESIS; SEDIMENTARY ROCKS.

Authigenic minerals precipitate from the overlying water column, pore fluids in the sediment, recrystallization or alteration of preexisting minerals, and structural transformation of one mineral to another. The minerals change in an attempt to equilibrate to the physical and chemical conditions present at any given time. Critical factors in their formation are initial mineral assemblage, temperature, pressure, ionic concentration, pH, electron availability, and the fluid flux through the rock.

In sedimentary rocks it is common to find a record of multiple diagenetic events based on the authigenic minerals. For example, in sediments near the surface, meteoric water may displace original marine pore water, resulting in distinct types of cements. Iron oxide can result from oxidizing fluid. Depletion of oxygen by bacteria may result in the formation of iron sulfides, such as pyrite. During burial, the sediments respond to increasing temperature (up to 200°C; 390°F), pressure (up to 2.5 kilobars; 250 megapascals), and fluid movement from compaction-driven waters or influx of water from the basin flanks. As a result, the sedimentary rock may contain authigenic minerals that record a sequence of events ranging from processes occurring near the sediment-water interface to those forming during deep burial. Unlike metamorphic rocks, the preexisting (detrital) mineral assemblage is at least partially retained, in part due to the sluggish reaction rates at diagenetic conditions. Early cementation processes often seal up the rock, preventing subsequent diagenetic reactions and preserving the original detrital mineral assemblage.

Authigenic minerals occur in all sedimentary rock and can vary from trace amounts to virtually the total rock (see table). The carbonate minerals calcite, dolomite, and siderite are some of the most common types. They form in a wide range of depositional environments and at varying burial depths. Calcite and dolomite form the principal minerals in limestones and dolostones, respectively, as well as cements in sandstones or shales. Carbonate cements result from recrystallization of detrital carbonates and from dissolution of other calcium, iron, and magnesium minerals with carbon dioxide from organic reactions. Much of the calcite in limestones initially consisted of aragonite or magnesium-rich calcite, whereas most dolomite has been formed by the chemical alteration of calcite. Recrystallization may change aragonite to calcite. Aragonite (orthorhombic) is a naturally unstable form of calcium carbonate. With the passage of geologic time, aragonite

normally inverts to the more stable calcite (hexagonal). The substitution of magnesium for calcium is responsible for the conversion of calcite or aragonite to dolomite, and it has been shown that dedolomitization (replacement of magnesium by calcium) is also possible. See ARAGONITE; CALCITE; CARBONATE MINERALS; CEMENT; DOLOMITE. [J.R.B.]

**Autistic disorder** A severe neuropsychiatric disorder of early childhood onset, historically regarded as a psychosis of childhood but now classified as a pervasive developmental disorder. While autism has been the most intensively studied pervasive developmental disorder, other conditions are now included in this class of conditions: Asperger's syndrome (sometimes referred to as autistic psychopathy), Rett's syndrome, and childhood disintegrative disorder (Heller's syndrome).

Symptoms of autism generally are apparent within the first 2 years of life and may occasionally be noted from the time of birth. Characteristic disturbances include disruption of social, cognitive, linguistic, motor, and perceptual development. Affected individuals fail to develop appropriate interpersonal relationships. In about half of the cases, language fails to develop; when it does develop, it is characterized by pronoun confusion (for example, the use of "you" for "I"), abnormal speech tone or rhythm, and an impaired ability to use abstract terms or communicate symbolic information. Unusual responses to the environment are common and may include resistance to change, exaggerated reactions to sensory stimuli or changes in the environment, ritualistic behavior, and peculiar attachments to inanimate objects. Motor abnormalities include unusual posturing and stereotyped (purposeless and repetitive) movements; self-injurious behavior (for example, head banging) is also common. Although some islets of unusual ability (in memory, drawing, or calculation) may be present, about 80% of individuals score in the mentally retarded range on tests of intelligence. Autistic individuals do not experience delusions and hallucinations; however, the metaphorical and bizarre language of verbal individuals may mistakenly suggest the kind of thought disturbance that is found in schizophrenia. See SCHIZOPHRENIA.

In Rett's syndrome, a short period of normal development is followed by loss of developmental skills and marked psychomotor retardation. A brief autisticlike phase may be observed during the preschool period, but the subsequent course and clinical features are markedly different from those of autism. Rett's syndrome has been observed only in females. The validity of Asperger's syndrome apart from autism has been more controversial. Individuals with Asperger's syndrome appear to have relatively much more preserved verbal and cognitive skills. Unusual circumscribed interests are common (for example, in maps, the weather, or train or bus schedules). In childhood disintegrative disorder, development in the first several years of life is unequivocally normal and is followed by a marked developmental regression (a child who previously had been speaking in sentences becomes totally mute), and various autistic features develop.

Autism is chronic and incapacitating. Only one autistic individual in six is able to make a good adjustment in adulthood and engage in regular, gainful employment. Approximately two-thirds of children remain severely handicapped as adults and need constant supervision and support. Even for those autistic individuals who make the best adjustment as adults, residual deficits in social, affective, and cognitive development remain. Factors related to better prognosis include the development of communication skills by age 5 and intellectual achievement. In Asperger's syndrome, the prognosis is apparently better than in autism, probably reflecting, in some part, the preservation of cognitive abilities in this condition. In Rett's syndrome and childhood disintegrative disorder, the prognosis is worse than in autism.

The "purest" form of autism, where the child has higher IQ, some islets of normal or near-normal behavior, and profound social detachment, affects only 1 child in 2000; however, the

Common authigenic minerals

Mineral	Formula
Albite	NaAlSi <sub>3</sub> O <sub>8</sub>
Anatase	TiO <sub>2</sub>
Anhydrite	CaSO <sub>4</sub>
Apatite*	Ca <sub>5</sub> (PO <sub>4</sub> ) <sub>3</sub> (F,Cl,OH)
Aragonite (orthorhombic)	CaCO <sub>3</sub>
Barite	BaSO <sub>4</sub>
Boehmite	AlO(OH)
Calcite (hexagonal)	CaCO <sub>3</sub>
Celestite	SrSO <sub>4</sub>
Clay minerals	
Chlorites*	(Mg,Fe <sup>2+</sup> ,Fe <sup>3+</sup> ) <sub>6</sub> - (Al,Si <sub>3</sub> )O <sub>10</sub> (OH) <sub>8</sub>
Illites*	K(Al) <sub>2</sub> (AlSi <sub>3</sub> )O <sub>10</sub> (OH) <sub>2</sub>
Kaolinite	Al <sub>2</sub> Si <sub>2</sub> O <sub>5</sub> (OH) <sub>4</sub>
Smectites*	(Na,0.5Ca) <sub>0.5</sub> (Al,Mg,Fe) <sub>2</sub> - (Al,Si <sub>3</sub> )O <sub>10</sub> (OH) <sub>2</sub> · nH <sub>2</sub> O
Dolomite	CaMg(CO <sub>3</sub> ) <sub>2</sub>
Gibbsite	Al(OH) <sub>3</sub>
Glauconite*	K(Al,Mg,Fe <sup>2+</sup> ,Fe <sup>3+</sup> ) <sub>2</sub> - (Al,Si <sub>3</sub> )O <sub>10</sub> (OH) <sub>2</sub>
Goethite	Fe <sub>2</sub> O <sub>3</sub> · n(H <sub>2</sub> O)
Gypsum	CaSO <sub>4</sub> · 2(H <sub>2</sub> O)
Halite	NaCl
Hematite	Fe <sub>2</sub> O <sub>3</sub>
Leucoxene	TiO <sub>2</sub>
Limonite	FeO(OH) · n(H <sub>2</sub> O)
Opal (amorphous)	SiO <sub>2</sub> · n(H <sub>2</sub> O)
Orthoclase	KAlSi <sub>3</sub> O <sub>8</sub>
Pyrite (isometric)	FeS <sub>2</sub>
Pyrolusite	MnO <sub>2</sub>
Quartz	SiO <sub>2</sub>
Siderite	FeCO <sub>3</sub>
Zeolites*	X <sub>y</sub> <sup>1+2+</sup> Al <sub>x</sub> Si <sub>1-x</sub> O <sub>z</sub> · nH <sub>2</sub> O
Clinoptilolite*	(Na,0.5Ca,K) <sub>3.5</sub> Al <sub>3.5</sub> Si <sub>14.5</sub> O <sub>36</sub> · nH <sub>2</sub> O
Analcime	NaAlSi <sub>2</sub> O <sub>6</sub> · H <sub>2</sub> O
Laumontite	CaAl <sub>2</sub> Si <sub>4</sub> O <sub>12</sub> · 4H <sub>2</sub> O

\*Group of minerals characterized by considerable chemical variation.

broader spectrum of communication and developmental disorders associated with autism and requiring similar care may affect 1 in every 750 children. Although males outnumber females (by four or five times), females with autism tend to be more severely affected. Predisposing factors include congenital infections (for example, maternal rubella) and metabolic and genetic illnesses (for example, phenylketonuria). A history of prenatal or perinatal complication is not uncommon, but in many cases no specific predisposing factor or associated mental condition is found. See PHENYLKETONURIA; RUBELLA.

For the majority of cases of autism, the cause remains unknown. Theoretical explanations have emphasized either a primary psychological or biological vulnerability in the child, the role of environmental factors, and an interaction between an inborn vulnerability and the child's environment. The high incidence of neurological signs, electroencephalographic abnormalities, and the fact that seizures develop in 25% of children during adolescence (especially in lower-IQ children) tend to support the role of a biological vulnerability. The final behavioral expression of the syndrome may be a function of multiple factors. Individuals with Rett's syndrome and childhood disintegrative disorder also are at increased risk for developing seizures, and exhibit other signs of central nervous system dysfunction. The history of a prolonged period of normal development in childhood disintegrative disorder often prompts extensive medical investigation, which usually does not reveal a specific medical condition that might account for the deterioration.

Treatment modalities that have been used in the management of individuals with autism and related conditions include psychotherapy, pharmacotherapy, behavior therapy, various somatic treatments, and educational interventions. Certain drugs may be effective in controlling certain maladaptive behavioral features, such as hyperactivity, aggression, and stereotyped behaviors. Behavior modification procedures may be quite useful. Educational interventions with highly structured, intensive remediation are of greatest overall benefit. However, even with the best of interventions there are no cures and most autistic individuals remain severely impaired. See PSYCHOTHERAPY; TRANQUILIZER. [D.J.C.; F.R.Vo.]

**Autogiro** A type of aircraft which utilizes a rotating wing (rotor) to provide lift. An autogiro is similar to a helicopter, but uses a conventional engine-propeller combination in addition to the rotor to pull the vehicle through the air like a fixed-wing aircraft (see illustration),

Unlike the helicopter, the autogiro rotor maintains its speed of rotation in the air because of the aerodynamic forces acting upon the rotor blades, and is without direct mechanical drive from the engine (autorotation). All the power required to maintain flight is supplied through the propeller of the autogiro at the front (tractor type) or rear (pusher type) of the fuselage. The rotor is thereby pulled through the air and creates a lifting force.

The autogiro has several inherent advantages. It is capable of takeoff and landing in a shorter distance than the fixed-wing airplane, and is capable of level controlled flight at extremely slow speed, on the order of 20 mi/h (30 km/h). It is mechanically simpler than the helicopter. An autogiro, unlike an

airplane, cannot be stalled. Among the disadvantages of the vehicle is that its speed performance is limited as compared to an airplane, although it is capable of flying slightly faster than the helicopter. It cannot hover as can a helicopter. See HELICOPTER.

[L.G.]

**Autoimmunity** The occurrence in an organism of an immune response to one of its own tissues, that is, a response to a self constituent. Efficient discrimination between self and nonself, the basis of normal immune function, depends upon a function known as immune tolerance (inertness to substances that could be capable of provoking an immune response). Failure of immune tolerance to self constituents results in an autoimmune response which is often, although not invariably, associated with autoimmune disease. Autoimmune disease occurs when the autoimmune response to self constituents has damaging effects of a structural or functional character.

Lymphocytes that participate in immune responses belong to two major groups. One group, which matures in the thymus gland, comprises thymic or T lymphocytes, of which there are several subsets. These subsets have different functions and carry unique surface molecules: (1) helper T lymphocytes, marked by the CD4 molecule, respond to antigens by releasing stimulatory cytokines (intercellular hormones) that can amplify the number and activity of lymphocytes participating in the immune response; (2) cytolytic T lymphocytes, marked by the CD8 molecule, can directly recognize and kill cellular targets, usually virus-infected cells; and (3) suppressor T lymphocytes, which also carry the CD8 molecule, release molecules that reduce the intensity of immune responses, or switch these off altogether. The other major group of lymphocytes, which mature in the bone marrow, are B lymphocytes. After stimulation with antigen molecules, and under the influence of factors released by helper T cells, B lymphocytes proliferate and later secrete the antibody molecules which, when circulating in the blood, provide for humoral immune responses. The normal immune system remains in a state of balance conditioned by positive signals and negative signals. Positive signals are provided by antigen in low dose and the amplifying factors released by activated helper T lymphocytes, while negative signals are provided by antigen present in excess, which causes an overload paralysis, and by suppressor T lymphocytes which are generated preferentially when self antigens are presented. There is still a lack of full understanding of the mechanism by which immune responses to self antigens are suppressed so as to provide for natural tolerance to self. The major processes are (1) permanent deletion, or functional inactivation in early life, of cells capable of responding to self antigens; and (2) regulatory controls, which inhibit the activity of self-reactive lymphocytes that escape the deletion process. The relative contribution of these two mechanisms for specific self antigens appears to differ, and both probably operate to control autoimmunity. There are low background levels of immunologic reactivity to many self antigens in healthy subjects, indicating that suppressor activity over immune responses to autoantigens must be continuously operative. See IMMUNITY.

Failure of immune regulation is responsible for autoimmune disease. Inheritance may account for 25–50% of the risk for autoimmune diseases. It is known that autoimmune disease, or at least the tendency to produce autoantibodies, runs in families. There are many genetic determinants, and they are poorly understood. One set is in some way associated with major histocompatibility complex (MHC; called HLA in humans), a gene complex that codes for cell-surface molecules which confer biological uniqueness on cells of an individual. Since products of HLA genes normally function to direct T lymphocytes to cells with which they should interact, it is not surprising that autoimmune diseases are associated with the presence of particular HLA types; examples include B8 (thyrotoxicosis), DR4 (rheumatoid arthritis, type 1 diabetes mellitus), and DR2

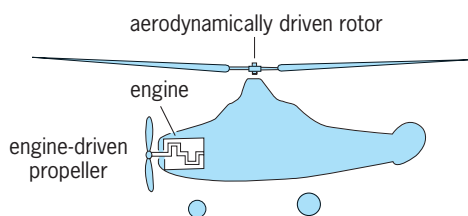

In-flight loaded dynamic components of a typical autogiro.



(multiple sclerosis). The reason may be that the autoantigen readily associates with the MHC (HLA) molecule on cells which present antigen to helper T lymphocytes. The MHC influences the occurrence of autoimmunity in other ways. Release of cytokines by T lymphocytes may induce aberrant expression of molecules on tissue cells which then can present their own antigens, and these become inducers of an autoimmune response. In addition to the MHC, there are other inherited determinants of autoimmunity, including genes specifying immunoglobulin structure and genes specifying weakness in the down-regulation of immune reactions. There may also be somatic genetic causes of autoimmunity (random mutations in later life) among genes that code for immunoglobulins that function as recognition structures on the surface of B lymphocytes; such a mutation may generate a cell with a receptor structure with exquisite specificity for a self antigen which is resistant to regulation. Environmental causes could include infection with microorganisms that carry antigenic structures closely resembling those of self; these could provoke an uncontrolled response to the related self structures of the body. See IMMUNOGENETICS.

Any autoimmune response must become self-sustaining, which implies coexisting failure of normal regulatory processes, either by reason of genetic predisposition or by an acquired disruption of immune function. Once self-sustaining, the autoimmune reaction can cause damage or dysfunction in one of several ways. First, autoantibody molecules circulate in the blood and, by attaching to self antigens on cell surfaces, either damage cells or interfere with important cell-surface receptor molecules. Second, antibodies can unite with their autoantigen, which results in the binding of a serum factor, complement, to form immune complexes that are capable of provoking inflammatory responses. Third, there may be generated T lymphocytes with the capacity for cellular destruction, and these may cause the progressive inflammatory damage that characterizes autoimmune reactions in solid organs. Many human diseases can be attributed to autoimmune reactions. Circulating autoantibodies are responsible for diseases in which there is intravascular destruction of elements of the blood, for example, the red blood cells in hemolytic anemia. T lymphocytes may be responsible for some types of thyroid goiter, such as Hashimoto's disease; a stomach mucosal degeneration that results in nonabsorption of vitamin B<sub>12</sub> and thus the blood disease pernicious anemia; the insulin-dependent or juvenile type of diabetes mellitus; and one type of chronic hepatitis. Immune complexes cause glomerulonephritis and most of the features of systemic lupus erythematosus, in which autoantibodies are formed to various constituents of cell nuclei. In Sjogren's disease, in which salivary and lacrimal glands are destroyed, damage by T lymphocytes within the glands may be accompanied by damage by immune complexes throughout the body. Some autoimmune diseases are caused by antibodies to cell receptors, which either block neuromuscular transmission, as in myasthenia gravis, or stimulate thyroid cells to overactivity, as in Graves' disease. Some important human diseases may be autoimmune disorders, although demonstration of an autoimmune basis is not yet adequate: these include rheumatoid arthritis, multiple sclerosis, and ulcerative colitis. See ANEMIA; ARTHRITIS; DIABETES; HEPATITIS; MULTIPLE SCLEROSIS; MYASTHENIA GRAVIS.

Autoimmune diseases are alleviated by treatment, though these diseases are seldom curable. At the simplest level, replacement of the specific secretions of tissues or organs damaged by autoimmune reactions may help. For multisystem autoimmune disease, such as lupus, there are drugs, particularly cortisone derivatives, that modify the harmful effects of humoral or cellular autoimmune attack on tissues and so allow the body to reestablish immunologic homeostasis. Also used are cytotoxic immunosuppressive drugs, which are given specifically to inhibit the activity of immunologically active cells responsible for autoantibody formation or for cytolytic damage to tissues. See IMMUNOLOGY.

[I.R.M.]

**Automata theory** A theory concerned with models (automata) used to simulate objects and processes such as computers, digital circuits, nervous systems, cellular growth, and reproduction. Automata theory helps engineers design and analyze digital circuits which are parts of computers, telephone systems, or control systems. It uses ideas and methods of discrete mathematics to determine the limits of computational power for models of existing and future computers. Among many known applications of finite automata are lexical analyzers and hardware controllers.

The concept now known as the automaton was first examined by A. M. Turing in 1936 for the study of limits of human ability to solve mathematical problems in formal ways. His automaton, the Turing machine, is too powerful for simulation of many systems. Therefore, some more appropriate models were introduced.

**Turing machines and intermediate automata.** The Turing machine is a suitable model for the computational power of a computer. A Turing machine has two main parts: a finite-state machine with a head, and a tape (see illustration). The tape is infinite in both directions and is divided into squares. The head sees at any moment of time one square of the tape and is able to read the content of the square as well as to write on the square. The finite-state machine is in one of its states. Each square of the tape holds exactly one of the symbols, also called input symbols or machine characters. It is assumed that one of the input symbols is a special one, the blank, denoted by *B*.

At any moment of time, the machine, being in one of its states and looking at one of the input symbols in some square, may act or halt. The action means that, in the next moment of time, the machine erases the old input symbol and writes a new input symbol on the same square (it may be the same symbol as before, or a new symbol; if the old one was not *B* and the new one is *B*, the machine is said to erase the old symbol), changes the state to a new one (again, it is possible that the new state will be equal to the old one), and finally moves the head one square to the

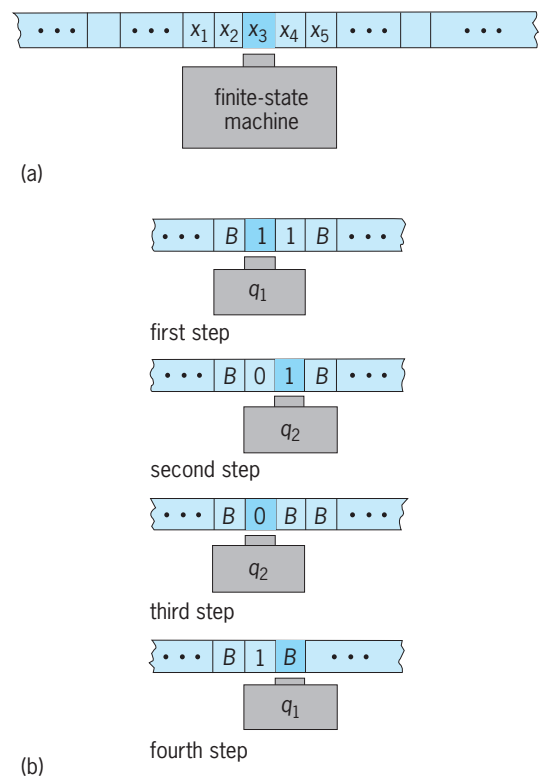

**Turing machine.** (a) General idea. (b) An example of a computation.

left, or one square to the right, or stays on the same square as before.

For some pairs of states and input symbols the action is not specified in the description of a Turing machine; thus the machine halts. In this case, symbols remaining on the tape form the output, corresponding to the original input, or more precisely, to the input string (or sequence) of input symbols. A sequence of actions, followed by a halt, is called a computation. A Turing machine accepts some input string if it halts on it. The set of all accepted strings over all the input symbols is called a language accepted by the Turing machine. Such languages are called recursively enumerable sets.

Another automaton is a nondeterministic Turing machine. It differs from an ordinary, deterministic Turing machine in that for a given state and input symbol, the machine has a finite number of choices for the next move. Each choice means a new input symbol, a new state, and a new direction to move its head.

A linear bounded automaton is a nondeterministic Turing machine which is restricted to the portion of the tape containing the input. The capability of the linear bounded automaton is smaller than that of a Turing machine.

A computational device with yet smaller capability than that of a linear bounded automaton is a push-down automaton. It consists of a finite-state machine that reads an input symbol from a tape and controls a stack. The stack is a list in which insertions and deletions are possible, both operations taking place at one end, called the top. The device is nondeterministic, so it has a number of choices for each next move. Two types of moves are possible. In the first type, a choice depends on the input symbol, the top element of the stack, and the state of the finite-state machine. The choice consists of selecting a next state of the finite-state machine, removing the top element, leaving the stack without the top element, or replacing the top element by a sequence of symbols. After performing a choice, the input head reads the next input symbol. The other type is similar to the first one, but now the input symbol is not used and the head is not moved, so the automaton controls the stack without reading input symbols. See ABSTRACT DATA TYPE.

**Finite-state machines.** A finite-state automaton, or a finite-state machine, or a finite automaton, is a computational device having a fixed upper bound on the amount of memory it uses (unlike Turing and related machines). One approach to finite automata is through the concept of an acceptor. The finite automaton examines an input string (that is, a sequence of input symbols, located on the tape) in one pass from left to right. It has a finite number of states, among which one is specified as initial. The assumption is that the finite automaton starts scanning of input standing in its initial state. Some of the states are called accepting states. The finite automaton has a transition function (or next-state function) which maps each state and input symbol into the next state. In each step the finite automaton computes the next state and reads the next input symbol. If after reading the entire input string the last state is accepting, the string is accepted; otherwise it is rejected. [J.W.G.B.]

**Automated decision making** The use of computers to automate decision tasks. A decision task is any task requiring the generation or selection of options.

Related to automated decision making (ADM) are techniques for automated control. The term "control" is usually applied to continuously operating systems that are constantly monitored and adjusted. The term "decision making" usually refers to comparatively high-level tasks with discrete decision points. For example, continuous monitoring and adjustment of operating factory equipment may be considered a control task, while the scheduling of factory operations may be considered a decision task. See CONTROL SYSTEMS; PROCESS CONTROL.

Another related area is decision support systems. Decision support systems are intended to support human decision making, while automated decision making concentrates on com-

pletely computer-automated decision making. Nevertheless, there is a close connection between these two areas since many decision support systems are designed as advisory systems, where the decision support system recommends decisions. To generate a recommendation, the decision support system invokes an ADM model. See DECISION SUPPORT SYSTEM.

Techniques for automated decision making are drawn from several disciplines, including optimization, artificial intelligence, and decision theory. Alternative approaches to automated decision making can be characterized in terms of a trade-off between power and generality. An ADM technique is general to the extent that it can be applied to diverse problems. It is powerful to the extent that it quickly generates good answers. See DECISION THEORY; OPTIMIZATION.

There is a trend toward integration of ADM techniques. Decision-theory approaches now strongly influence artificial intelligence research in automated decision making, and there has also been an active interest in integrating optimization and artificial intelligence problem-solving approaches. [P.E.L.]

**Automatic frequency control (AFC)** The automatic control of the intermediate frequency in a radio, television, or radar receiver, to correct for variations of the frequency of the transmitted carrier or the local oscillator. In high-fidelity broadcast receivers, AFC keeps distortion due to detuning to a low figure. In the reception of long-haul telegraph signals, AFC reduces the error rate due to signal pulse distortion or interference from lower-intensity signals in the same frequency band.

AFC techniques are varied but are mainly of two types. One uses a discriminator to furnish a voltage whose magnitude and polarity are determined by the frequency change. This voltage is used to adjust the frequency of the local oscillator of the receiver, thereby keeping the intermediate frequency constant. The other uses two-polarity pulse accumulation which furnishes a dc potential proportional to frequency error. [W.Lyo.]

**Automatic gain control (AGC)** The automatic maintenance of a nearly constant output level of an amplifying circuit by adjusting the amplification in inverse proportion to the input field strength, also called automatic volume control (AVC). Almost all radio receivers in use employ AGC. In broadcast receivers, AGC makes it possible to receive incoming signals of widely varying strength, yet have the sound remain at nearly the same volume. In communications receivers a type of AGC circuit called a squelch circuit is used to prevent noise during periods of no transmission, such as in the reception of on-off keying, frequency-shift keying (FSK), and phone. AGC is also useful in accelerating the switching action between receivers in diversity connection. See RADIO RECEIVER.

AGC action depends on the characteristic, possessed by most electronic tubes and transistors, of adjustment of gain by the variation of the applied bias voltage. If the dc voltage applied to the control grid of a vacuum tube is made more negative, the amplification of that stage will be reduced.

In most broadcast receivers the AGC voltage is taken from the detector. This dc voltage, proportional to the average level

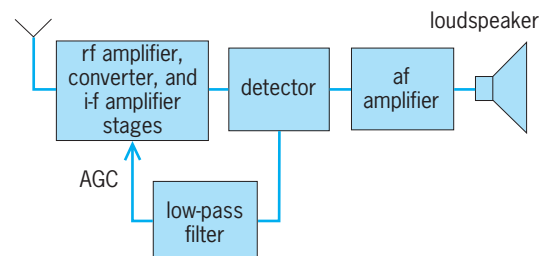

Block diagram of broadcast receiver using AGC.

of the carrier, adjusts the gain of the radio-frequency (rf) and intermediate-frequency (i-f) amplifiers and the converter, as shown in the illustration. AGC tends to keep the input signal to the audiofrequency (af) amplifier constant despite variations in rf signal strength. There are several modifications of this basic circuit.

AGC circuits are also used in dictation recording equipment, public address systems, and similar equipment where a constant output level is desirable. See AMPLIFIER. [W.Lyo.]

**Automatic horizon** A device that provides the pilot with symbols representative of the attitude of an aircraft relative to an artificial horizon. In an automatic or artificial horizon a vertical gyro moves a horizon bar relative to a fixed aircraft index. Motion of the bar simulates changes in pitch or roll of the aircraft. As the pilot views the indicator, the horizon is seen relative to the aircraft as the horizon would appear if the pilot could see it through the windscreen. See GYROSCOPE. [J.W.A.]

**Automatic landing system** The means for guiding and controlling aircraft from an initial approach altitude to a point where safe contact is made with the landing surface. Such systems differ from low-approach systems in three major respects: (1) They furnish not only guidance but control of the aircraft as well. (2) They furnish information on the aircraft's position with respect to the terrain below it, and the rate at which the landing surface is being approached. (3) They do not require the pilot to assume manual control near the ground.

Two automatic landing systems have been developed. One, a radar-beam type, detects the position and rate of change in position of the landing aircraft by means of a radar beam emitted from a ground derived-control complex. The other, a fixed-beam type, derives position and rate of change in position by instrumentation within the landing aircraft, but it makes use of instrument landing system (ILS) type equipment on the ground. In the aircraft are accelerometers (which may be part of an inertial navigation system) and a radio altimeter. Essential to both systems is an autopilot in the aircraft, commanded by a computer on the ground in the radar-beam system and by a computer in the aircraft for the fixed-beam system. See INSTRUMENT LANDING SYSTEM (ILS). [J.L.Lo.]

**Automatic sprinkler system** An integrated arrangement of fixed facilities for protection from combustion by use of water extinguishment. The system comprises an adequate water supply, hydraulically designed internal piping, and sprinklers connected in a systematic pattern over the protected area; the system is activated by a fire to discharge a fine spray of water over the heat.

Essential features of a system are its self-detection of fire, prior installation, and built-in activation. In these respects, the automatic sprinkler system is among the earliest-used architectural features that contribute actively to maintenance of the internal environment (in contrast to the passive fire-resistant contribution of the static structure). Auxiliary to an automatic sprinkler system may be a fire alarm. See FIRE DETECTOR.

The principal component of the system is a thermally sensitive sprinkler with a linkage assembly that holds closed the discharge opening. In various designs the assembly is disrupted through a low-melting-point chemical, a frangible bulb filled with liquid, a bimetallic disk, or—usually—a low-melting-point alloy link. The sprinkler abruptly opens to discharge water against a deflector so that water falls in a hemispherical spray across the area below.

Water reaches the sprinklers variously in five basic setups. In the usual wet-pipe system, for heated buildings, all pipes contain water under pressure for immediate release through any sprinkler that opens. In a dry-pipe system—for unheated buildings in freezing climates or for cold-storage rooms—branch lines and other distribution pipes contain dry air or nitrogen under pres-

sure. For occupancies where flash fires are possible, a deluge system is appropriate. All sprinklers are continuously open while the pipes are empty. In a preaction system, both heat-sensitive sprinklers and separate detectors guard the area; the separate detectors open a preaction valve and sound an alarm in the event of fire. Another adaptation is the recycling preaction system, applicable to unattended buildings, in which the water flow recycles if necessary to follow the fire cycle. See FIRE EXTINGUISHER; FIRE TECHNOLOGY. [F.H.R.]

**Automation** The process of having a machine or machines accomplish tasks hitherto performed wholly or partly by humans. As used here, a machine refers to any inanimate electromechanical device such as a robot or computer. As a technology, automation can be applied to almost any human endeavor, from manufacturing to clerical and administrative tasks. An example of automation is the heating and air-conditioning system in the modern household. After initial programming by the occupant, these systems keep the house at a constant desired temperature regardless of the conditions outside.

The fundamental constituents of any automated process are (1) a power source, (2) a feedback control mechanism, and (3) a programmable command (see illustration) structure. Programmability does not necessarily imply an electronic computer. For example, the Jacquard loom, developed at the beginning of the nineteenth century, used metal plates with holes to control the weaving process. Nonetheless, the advent of World War II and the advances made in electronic computation and feedback have certainly contributed to the growth of automation. While feedback is usually associated with more advanced forms of automation, so-called open-loop automated tasks are possible. Here, the automated process proceeds without any direct and continuous assessment of the effect of the automated activity. For example, an automated car wash typically completes its task with no continuous or final assessment of the cleanliness of the automobile. See CONTROL SYSTEMS; DIGITAL COMPUTER.

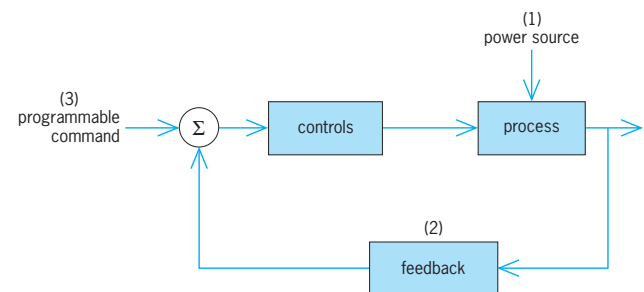

Elements of an automated system.

Because of the growing ubiquity of automation, any categorization of automated tasks and processes is incomplete. Nonetheless, such a categorization can be attempted by recognizing two distinct groups, automated manufacturing and automated information processing and control. Automated manufacturing includes automated machine tools, assembly lines, robotic assembly machines, automated storage-retrieval systems, integrated computer-aided design and computer-aided manufacturing (CAD/CAM), automatic inspection and testing, and automated agricultural equipment (used, for example, in crop harvesting). Automated information processing and control includes automatic order processing, word processing and text editing, automatic data processing, automatic flight control, automatic automobile cruise control, automatic airline reservation systems, automatic mail sorting machines, automated planet exploration (for example, the rover vehicle, *Sojourner*, on the *Mars Pathfinder* mission), automated electric utility distribution systems, and automated bank teller machines. See ASSEMBLY MACHINES; COMPUTER-AIDED DESIGN AND MANUFACTURING;

COMPUTER-INTEGRATED MANUFACTURING; FLEXIBLE MANUFACTURING SYSTEM; INSPECTION AND TESTING; SPACE PROBE; WORD PROCESSING.

A major issue in the design of systems involving both human and automated machines concerns allocating functions between the two. This allocation can be static or dynamic. Static allocation is fixed; that is, the separation of responsibilities between human and machine do not change with time. Dynamic allocation implies that the functions allocated to human and machine are subject to change. Historically, static allocation began with reference to lists of activities which summarized the relative advantages of humans and machines with respect to a variety of activities. For example, at present humans appear to surpass machines in the ability to reason inductively, that is, to proceed from the particular to the general. Machines, however, surpass humans in the ability to handle complex operations and to do many different things at once, that is, to engage in parallel processing. Dynamic function allocation can be envisioned as operating through a formulation which continuously determines which agent (human or machine) is free to attend to a particular task or function. In addition, constraints such as the workload implied by the human attending to the task as opposed to the machine can be considered. *See* HUMAN-FACTORS ENGINEERING.

It has long been the goal in the area of automation to create systems which could react to unforeseen events with reasoning and problem-solving abilities akin to those of an experienced human, that is, to exhibit artificial intelligence. Indeed, the study of artificial intelligence is devoted to developing computer programs that can mimic the product of intelligent human problem solving, perception, and thought. For example, such a system could be envisioned to perform much like a human copilot in airline operations, communicating with the pilot via voice input and spoken output, assuming cockpit duties when and where assigned, and relieving the pilot of many duties. Indeed, such an automated system has been studied and named a pilot's associate. Machines exhibiting artificial intelligence obviously render the sharp demarcation between functions better performed by humans than by machines somewhat moot. While the early promise of artificial intelligence has not been fully realized in practice, certain applications in more restrictive domains have been highly successful. These include the use of expert systems, which mimic the activity of human experts in limited domains, such as diagnosis of infectious diseases or providing guidance for oil exploration and drilling. Expert systems generally operate by (1) replacing human activity entirely, (2) providing advice or decision support, or (3) training a novice human in a particular field. *See* EXPERT SYSTEMS. [R.A.He.]

**Automobile** A self-propelled land vehicle, usually having four wheels and an internal combustion engine, used primarily for personal transportation. Other types of motor vehicles include buses, which carry large numbers of commercial passengers, and medium- and heavy-duty trucks, which carry heavy or bulky loads of freight or other goods and materials. Instead of being carried on a truck, these loads may be placed on a semitrailer, and sometimes also a trailer, forming a tractor-trailer combination which is pulled by a truck tractor. *See* BUS; TRUCK.

The automobile body is the assembly of sheet-metal, fiberglass, plastic, or composite-material panels together with windows, doors, seats, trim and upholstery, glass, and other parts that form enclosures for the passenger, engine, and luggage compartments. The assembled body structure may attach through rubber mounts to a separate or full frame (body-on-frame construction), or the body and frame may be integrated (unitized-body construction). In the latter method, the frame, body parts, and floor pan are welded together to form a single unit that has energy-absorbing front and rear structures, and anchors for the engine, suspension, steering, and power-train components. A third type of body construction is the space frame

which is made of welded steel stampings. Similar to the tube chassis and roll cage combination used in race-car construction, non-load-carrying plastic outer panels fasten to the space frame to form the body. *See* COMPOSITE MATERIAL; SHEET-METAL FORMING.

The frame is the main structural member to which all other mechanical chassis parts and the body are assembled to make a complete vehicle. In older vehicle designs, the frame is a separate rigid structure; newer passenger-car designs have the frame and body structure combined into an integral unit, or unitized body. Subframes and their assembled components attach to the side rails at the front and rear of the unitized body. The front subframe carries the engine, transmission or transaxle, lower front suspension, and other mechanical parts. The rear subframe, if used, carries the rear suspension and rear axle.

The suspension supports the weight of the vehicle, absorbs road shocks, transmits brake-reaction forces, helps maintain traction between the tires and the road, and holds the wheels in alignment while allowing the driver to steer the vehicle over a wide range of speed and load conditions. The action of the suspension increases riding comfort, improves driving safety, and reduces strain on vehicle components, occupants, and cargo. The springs may be coil, leaf, torsion bar, or air. Most automotive vehicles have coil springs at the front and either coil or leaf springs at the rear. *See* AUTOMOTIVE SUSPENSION.

The steering system enables the driver to turn the front wheels left or right to control the direction of vehicle travel. The rotary motion of the steering wheel is changed to linear motion in the steering gear, which is located at the lower end of the steering shaft. The linear motion is transferred through the steering linkage to the steering knuckles, to which the front wheels are mounted. Steering systems are classed as either manual steering or power steering, with power assist provided hydraulically or by an electric motor.

A brake is a device that uses a controlled force to reduce the speed of or stop a moving vehicle, or to hold the vehicle stationary. The automobile has a friction brake at each wheel. When the brake is applied, a stationary surface moves into contact with a moving surface. The resistance to relative motion or rubbing action between the two surfaces slows the moving surface, which slows and stops the vehicle.

The engine supplies the power to move the vehicle. The power is available from the engine crankshaft after a fuel, usually gasoline, is burned in the engine cylinders. Most automotive engines are located at the front of the vehicle and drive either the rear wheels or the front wheels through a drive train or power train made up of gears, shafts, and other mechanical and hydraulic components. Most automotive vehicles are powered by a spark-ignition four-stroke-cycle internal combustion engine. The inline four-cylinder engine and V-type six-cylinder engine are the most widely used, with V-8 engines also common. Other automotive engines have three, five, ten, and twelve cylinders. Some passenger cars and trucks have diesel engines. Some automotive spark-ignition and diesel engines are equipped with a supercharger or turbocharger. *See* AUTOMOTIVE ENGINE; DIESEL ENGINE; ENGINE; IGNITION SYSTEM; SUPERCHARGER; TURBOCHARGER.

Most automotive engines have electronic fuel injection instead of a carburetor. A computer-controlled electronic engine control system automatically manages various emissions devices and numerous functions of engine operation, including the fuel injection and spark timing. This allows optimizing power and fuel economy while minimizing exhaust emissions. *See* CARBURETOR; CONTROL SYSTEMS; FUEL INJECTION.

The power available from the engine crankshaft to do work is transmitted to the drive wheels by the power train, or drive train. In the front-engine rear-drive vehicle, the power train consists of a clutch and manual transmission, or a torque converter and an automatic transmission; driveshafts and Hooke (Cardan) universal joints; and rear drive axle that includes the final drive, differential, and wheel axle shafts. In the typical

front-engine front-drive vehicle, the power train consists of a clutch and manual transaxle, or a torque converter and an automatic transaxle. The final drive and differential are designed into the transaxle, and drive the wheels through half-shafts with constant-velocity (CV) universal joints. See CLUTCH; GEAR; UNIVERSAL JOINT.

The transmission is the device in the power train that provides different forward gear ratios between the engine and drive wheels, as well as neutral and reverse. The two general classifications of transmission are manual transmission, which the driver shifts by hand, and automatic transmission, which shifts automatically. To shift a manual transmission, the clutch must first be disengaged. However, some vehicles have automatic clutch disengagement for manual transmissions, while other vehicles have a limited manual-shift capability for automatic transmissions. See AUTOMOTIVE TRANSMISSION.

In the power train, the final drive is the speed-reduction gear set that drives the differential. The final drive is made up of a large ring gear driven by a smaller pinion, or pinion gear. This provides a gear reduction of about 3:1; the exact value can be tailored to the engine, transmission, weight of the vehicle, and performance or fuel economy desired.

In drive axles, the differential is the gear assembly between axle shafts that permits one wheel to rotate at a speed different from that of the other (if necessary), while transmitting torque from the final-drive ring gear to the axle shafts. When the vehicle is cornering or making a turn, the differential allows the outside wheel to travel a greater distance than the inside wheel; otherwise, one wheel would skid, causing tire wear and partial loss of control. See DIFFERENTIAL.

A wheel is a disc or a series of spokes with a hub at the center and a rim around the outside for mounting of the tire. The wheels of a vehicle must have sufficient strength and resiliency to carry the weight of the vehicle, transfer driving and braking torque to the tires, and withstand side thrusts over a wide range of speed and road conditions. Wheel size is primarily determined by the load-bearing strength of the tire.

The use of solid-state electronic devices in the automobile began during the 1960s, when the electromechanical voltage regulator of the alternator, was replaced by a transistorized voltage regulator. This was followed in the 1970s by electronic ignition, fuel injection, and cruise control. Since then, electronic devices and systems on the automobile have proliferated. These include engine and power train control, air bags, antilock braking, traction control, suspension and ride control, remote keyless entry, memory seats, driver information and navigation systems, cellular telephone and mobile communications systems, and on-board diagnostics. See ELECTRONIC DISPLAY; FEEDBACK CIRCUIT; SATELLITE NAVIGATION SYSTEMS.

The self-diagnostic capability of the vehicle computer, power-train or engine control module, or system controller may be aided by a memory that stores information about malfunctions that have occurred and perhaps temporarily disappeared. When recalled from the memory, this information can help the service technician diagnose and repair the vehicle more quickly, accurately, and reliably. [D.L.An.]

**Automotive brake** An energy conversion device used to slow a vehicle, stop it, or hold it in position. The two systems are the service brake and the parking brake, both of friction type. The service brake includes a hydraulically operated brake mechanism at each wheel. These wheel brakes are controlled by movement of the brake pedal, providing braking proportional to the applied pedal force. The parking brake is a mechanical brake operated through a separate hand lever or pedal; it applies parking-brake mechanisms usually at the two rear wheels. Most automotive vehicles have power-assisted braking, where a hydraulic or vacuum booster increases the force applied by the driver to the service-brake pedal. See BRAKE.

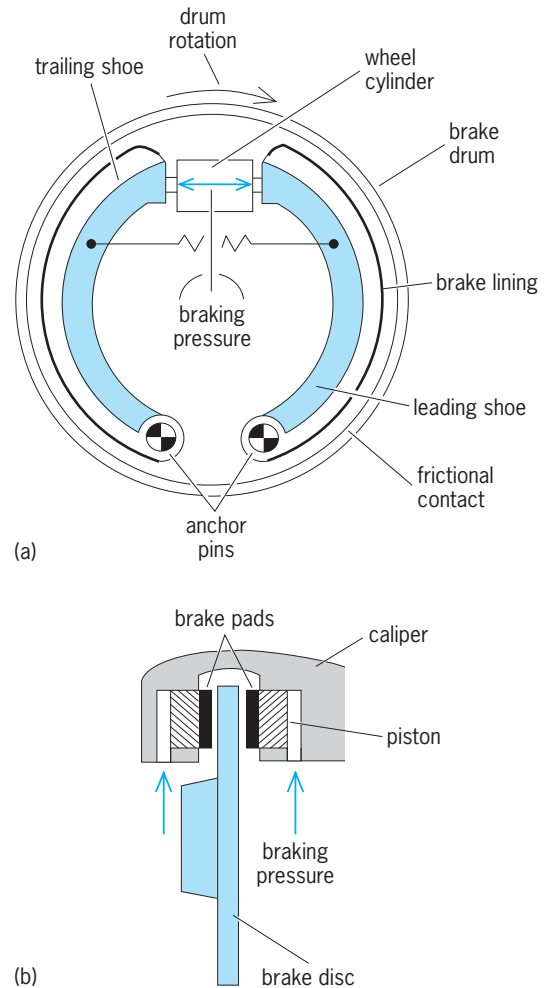

Friction brakes of (a) drum type and (b) disk type used in automotive vehicles. (Robert Bosch Corp.)

The two types of wheel-brake mechanisms are drum brakes and disk brakes (see illustration). Drum brakes are used at all four wheels on older vehicles, and at the rear wheels of many vehicles with front disk brakes. Some vehicles have disc brakes at all four wheels.

The four wheel brakes are hydraulically interconnected so they operate together from one control. When the driver depresses the brake pedal, pistons are forced into fluid chambers in the master cylinder. The resulting hydraulic pressure is transmitted through steel pipe and rubber hose to hydraulic cylinders in the wheel brakes. The pressure forces pistons in the cylinders to move outward, pushing brake friction material, or lining, into contact with the rotating drum or disk to apply the brakes. See HYDRAULICS.

In a drum brake, two nonrotating curved steel shoes, faced with heat- and wear-resistant lining, are forced against the inner surface of a rotating brake drum as the driver depresses the brake pedal. When the pedal is released, return springs pull the shoes away from the drum.

In a disk brake, a nonrotating caliper containing one or more pistons and carrying two brake pads, or lined flat shoes, straddles the rotating disk. As the driver depresses the brake pedal, the piston and hydraulic reaction push the brake pads against each side of the disk. When the brake pedal is released, the piston seal, which was deflected as the piston moved out, provides piston retraction. Two types of caliper are the fixed or nonmoving, and the floating or sliding. The floating or sliding type depends on slight inward movement of the caliper, resulting

from hydraulic reaction, to force the outer brake pad against the disk.

Power-assisted braking is provided by a hydraulic or vacuum booster. As the brake pedal is depressed, the booster furnishes most of the force to push a pushrod into the master cylinder. The power piston in the hydraulic booster is operated by oil pressure from the power-steering pump or from a separate pump driven by an electric motor. In the vacuum booster, a diaphragm usually is suspended in a vacuum supplied from the engine intake manifold or from a vacuum pump driven by the engine or an electric motor. Depressing the brake pedal allows atmospheric pressure to act against one side of the diaphragm. The resulting pressure differential moves the diaphragm and power piston, which forces the pushrod into the master cylinder. [D.L.An.]

**Automotive climate control** A system for providing a comfortable environment within the passenger compartment of a vehicle. Controlled ventilation is utilized, along with a heater, an air conditioner, or an integrated heater and air-conditioner system. Linked to the setup is a windshield defrosting and defogging system capable of clearing the windshield. Some vehicles have a ventilation-air filter which cleans the outside air that enters the passenger compartment through the fresh-air inlet. The increasing glass area of many passenger vehicles places an additional load on the air conditioner. Many vehicles incorporate solar-control glass to reduce solar transmission to the interior.

**Heating.** There are two types of passenger-compartment heaters: engine-dependent and engine-independent. The engine-dependent heater utilizes waste heat from the engine. The engine-independent heater includes a small combustion chamber in which fuel is burned.

Most vehicles have a liquid-cooled engine and an engine-dependent heater through which hot engine coolant flows. The coolant passes through the tubes of a tube-and-fin heater core (see illustration) while air flows between the fins. Heat output into the passenger compartment is regulated by controlling either the coolant flow or the airflow. An electric blower motor may run at various speeds to help move the air. When the heater is turned off, a coolant flow-control valve may close to stop the

flow of coolant through the heater core. See DEWAR FLASK; ENGINE COOLING.

**Air conditioning.** When the outside temperature is above 68°F (20°C), the passenger compartment may be uncomfortable for the occupants unless the inside air is cooled. Cooling is provided by a mobile, vehicle-mounted refrigeration system known as an automotive air conditioner. The automotive air conditioner combines the refrigeration system with an air-distribution system and a temperature-control system to cool, clean, dry, and circulate passenger-compartment air. Cooling is provided by a mechanical vapor-compression refrigeration system with five major components: compressor, condenser, refrigerant flow-control valve, evaporator, and a receiver or accumulator that includes a desiccant. See COMPRESSOR; DESICCANT; EVAPORATOR; FLUOROCARBON; HEAT EXCHANGER; REFRIGERATION.

Operation, air temperature, and air distribution through the passenger compartment may be controlled either automatically or manually by the driver. In some vehicles, conditioned air distribution can be controlled for each seat or seating position. See AIR CONDITIONING. [D.L.An.]

**Automotive drive axle** A theoretical or actual cross-bar or assembly which supports a motor vehicle and on which one or more wheels turn. The axle is either a live axle or a dead axle. A live axle, or drive axle, drives the wheels connected to it while supporting part of the weight of the vehicle. A dead axle, or nondrive axle, carries part of the weight of the vehicle but does not drive the wheels. See AUTOMOBILE.

A drive axle on which the wheels can pivot for steering, such as on the front axle of a four-wheel-drive truck, is a steerable drive axle. The rear axle in most automotive vehicles is a non-steering drive axle.

The rear drive axle is suspended from the vehicle body or frame by springs attached to the axle housing. The housing encloses the final-drive gears, differential gears, and wheel axle shafts. See AUTOMOTIVE SUSPENSION.

Most four-wheel-drive vehicles have a steerable front drive axle that is usually similar in construction and function to the rear drive axle. The principal difference is in the provisions made for steering. See AUTOMOTIVE STEERING.

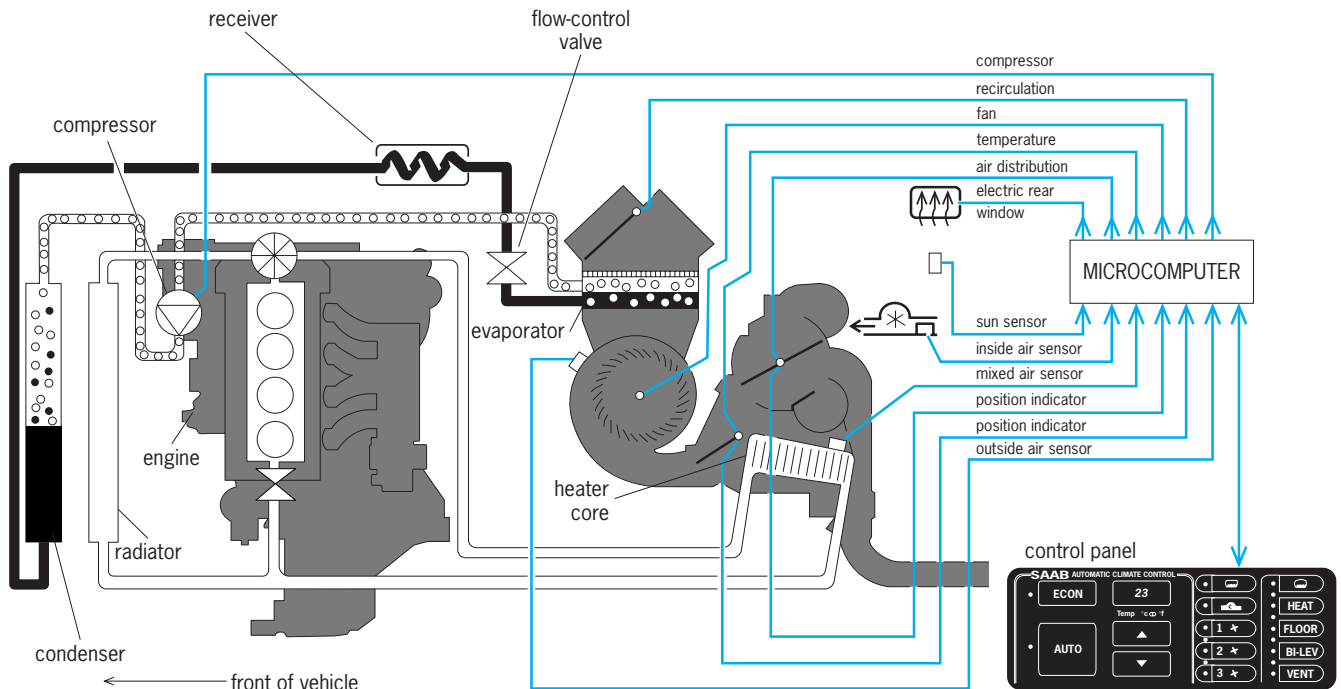

Schematic of an automotive air conditioner. (Saab Cars USA, Inc.)

Automobiles with front-engine and front-wheel drive have independent front suspension and do not use a front drive-axle housing. Instead, a separate transaxle combines the functions of the transmission and the drive axle. See AUTOMOTIVE TRANSMISSION. [D.L.An.]

**Automotive electrical system** The system in a motor vehicle that furnishes the electrical energy to crank the engine for starting, recharge the battery after cranking, create the high-voltage sparks to fire the compressed air-fuel charges, and power the headlamps, light bulbs, and electrical accessories.

The vehicle electrical system includes the battery, wiring, starting motor and controls, generator and voltage regulator, electronic ignition, and electronic fuel metering. Also included may be a computerized electronic engine control system, an electronically displayed driver information system, various types of radios and sound systems, and many other electrically operated and electronically controlled systems and devices. See ALTERNATING-CURRENT GENERATOR; BATTERY; COMMUTATION; COMMUTATOR; COMPUTER; CONDUCTOR (ELECTRICITY); CONTROL SYSTEMS; CURRENT MEASUREMENT; DIRECT CURRENT; DIRECT-CURRENT MOTOR; ELECTRIC SWITCH; ELECTRONIC DISPLAY; ELECTRONICS; FUSE (ELECTRICITY); GENERATOR; PARALLEL CIRCUIT; REGULATOR; SPARK PLUG; SPEEDOMETER; STEPPING MOTOR; VOLTAGE REGULATOR. [D.L.An.]

**Automotive engine** The component of the motor vehicle that converts the chemical energy in fuel into mechanical energy for power. The automotive engine also drives the generator and various accessories, such as the air-conditioning compressor and power-steering pump. See AUTOMOTIVE CLIMATE CONTROL; AUTOMOTIVE ELECTRICAL SYSTEM; AUTOMOTIVE STEERING.

**Otto-cycle engine.** An Otto-cycle engine, the dominant automotive engine in use today, is an internal combustion piston engine that may be designed to operate on either two strokes or four strokes of a piston that moves up and down in a cylinder. Generally, the automotive engine uses four strokes to convert chemical energy to mechanical energy through combustion of gasoline or similar hydrocarbon fuel. The heat produced is converted into mechanical work by pushing the piston down in the cylinder. A connecting rod attached to the piston transfers this energy to a rotating crankshaft. See GASOLINE; INTERNAL COMBUSTION ENGINE; OTTO CYCLE.

Engines having from 1 to 16 cylinders in in-line, flat, horizontally opposed, or V-type cylinder arrangements have appeared in production vehicles. Increased vehicle size and weight played a major role in this transition, requiring engines with additional displacement and cylinders to provide acceptable performance. See ENGINE.

In many automotive engines, the camshaft, which operates the intake and exhaust valves, has been moved from the cylinder block to the cylinder head. This overhead-camshaft arrangement allows the use of more than two valves per cylinder, with various multivalve engines having three to five. Some overhead-camshaft engines have only one camshaft, while others have two camshafts, one for the intake valves and one for the exhaust valves. A V-type engine may have four camshafts, two for each bank of cylinders.

Most engines have fixed valve timing, regardless of the number of camshafts or their location. Variable valve timing can improve fuel economy and minimize exhaust emissions, especially on multivalve engines. At higher speeds, volumetric efficiency can be increased by opening the intake valves earlier. One method drives the camshaft through an electrohydraulic mechanism that, on signal from the engine computer, rotates the intake camshaft ahead about  $10^\circ$ . Another system varies both valve timing and valve lift by having two cam lobes, each with a different profile, that the computer can selectively engage to operate each valve. Computer-controlled solenoids for opening and closing the valves will allow elimination of the complete valve train, in-

cluding the camshaft, from the automotive piston engine while providing variable valve timing and lift.

**Alternative engines.** Alternative engine designs have been investigated as replacements for the four-stroke Otto-cycle piston engine, including the two-stroke, diesel, Stirling, Wankel rotary, gas turbine, and steam engines, as well as electric motors and hybrid power plants. However, only two engines are in mass production as automotive power plants: the four-stroke gasoline engine described above, and the diesel engine. See DIESEL ENGINE; ROTARY ENGINE; STIRLING ENGINE. [D.L.An.]

**Automotive steering** The means by which a motor vehicle is controlled about the vertical axis. It allows the driver to control the course of vehicle travel by turning the steering wheel, which turns the input shaft in the steering gear. The steering system has three major components: (1) the steering wheel and attached shaft in the steering column which transmit the driver's movement to the steering gear; (2) the steering gear that increases the mechanical advantage while changing the rotary motion of the steering wheel to linear motion; and (3) the steering linkage (including the tie rod and tie-rod ends) that carries the linear motion to the steering-knuckle arms. See MECHANICAL ADVANTAGE.

When the only energy source for the steering system is the force that the driver applies to the steering wheel, the vehicle has manual steering. When the driver's effort is assisted by hydraulic pressure from an electric or engine-driven pump, or by an electric motor, the vehicle has power-assisted steering, commonly known as power steering. Power steering allows manual steering to always be available, even if the engine is not running or the power-assist system fails.

Two types of automotive steering gears are rack-and-pinion and recirculating-ball. In a rack-and-pinion steering gear (see illustration), a tubular housing contains the toothed rack and a pinion gear. The housing is mounted rigidly to the vehicle body or frame to take the reaction to the steering effort. The pinion gear is attached to the lower end of the steering shaft, and meshes with rack teeth. Tie rods connect the ends of the rack to the steering-knuckle arms at the wheels. As the steering wheel turns, the pinion gear moves the rack right or left. This moves the tie rods and steering-knuckle arms, which turn the wheels in or out for steering.

In a recirculating-ball steering gear, a worm gear is attached to the lower end of the steering shaft. The worm gear turns inside a ball nut which rides on a set of recirculating ball bearings. These

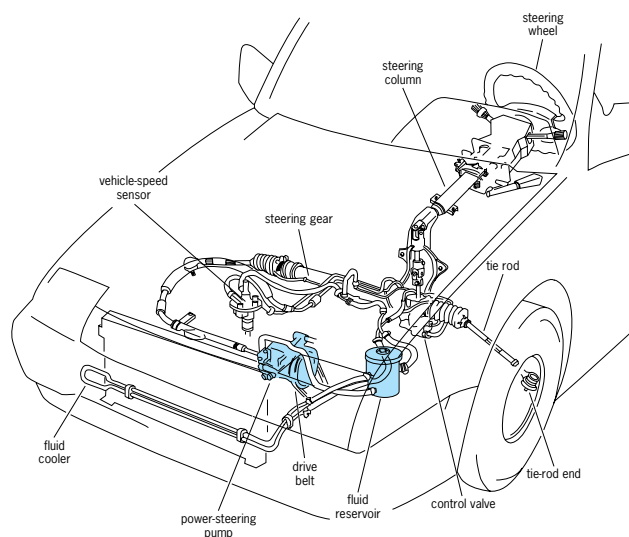

**Speed-sensitive rack-and-pinion power-steering system that provides variable assist. (American Honda Motor Co., Inc.)**

ball bearings roll in the grooves in the worm and inside the ball nut. Gear teeth on one outside flat of the ball nut mesh with a sector of teeth on the output or sector shaft to which the pitman arm is attached. As the steering wheel is turned, the rotary motion of the worm gear causes the ball nut to move up or down, forcing the sector shaft and pitman arm to rotate. This action moves the steering linkage to the right or left, turning the front wheels in or out for steering. See ANTI-FRICTION BEARING; GEAR. [D.L.An.]

**Automotive suspension** The springs and related parts intermediate between the wheels and the frame, subframe, or side rails of a unitized body. The suspension supports the weight of the upper part of a vehicle on its axles and wheels, allows the vehicle to travel over irregular surfaces with a minimum of up-and-down body movement, and allows the vehicle to corner with minimum roll or loss of traction between the tires and the road. See AUTOMOBILE; SPRING (MACHINES).

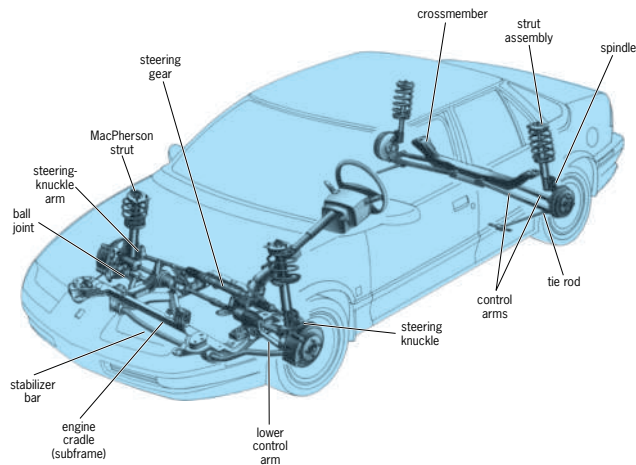

**Front-wheel-drive car with MacPherson-strut front suspension and strut-type independent rear suspension. (Saturn Corp.)**

In a typical suspension system for a vehicle with front-engine and front-wheel drive (see illustration), the weight of the vehicle applies an initial compression to the coil springs. When the tires and wheels encounter irregularities in the road, the springs further compress or expand to absorb most of the shock. The suspension at the rear wheels is usually simpler than for the front wheels, which require multiple-point attachments so the wheels can move up and down while swinging from side to side for steering.

A telescoping hydraulic damper, known as a shock absorber, is mounted separately or in the strut at each wheel to restrain spring movement and prevent prolonged spring oscillations. The shock absorber contains a piston that moves in a cylinder as the wheel moves up and down with respect to the vehicle body or frame. As the piston moves, it forces a fluid through an orifice, imposing a restraint on the spring. Spring-loaded valves open to permit quicker flow of the fluid if fluid pressure rises high enough, as it may when rapid wheel movements take place. Most automotive vehicles use gas-filled shock absorbers in which the air space above the fluid is filled with a pressurized gas such as nitrogen. The gas pressure on the fluid reduces the creation of air bubbles and foaming. See SHOCK ABSORBER.

Most automotive vehicles have independent front suspension, usually using coil springs as part of either a short-arm long-arm or a MacPherson-strut suspension system. A MacPherson-strut suspension (see illustration) combines a coil spring and shock absorber into a strut assembly that requires only a beam-type lower control arm.

Some vehicles with short-arm long-arm front suspension use either longitudinal or transverse torsion bars for the front springs.

One end of the torsion bar is attached to the lower control arm, and the other end is anchored to the vehicle body or frame. As the tire and wheel move up and down, the torsion bar provides springing action by twisting about its long axis. Turning an adjustment bolt at one end of the torsion bar raises or lowers the vehicle ride height. See TORSION BAR.

Most automobiles and many light trucks have coil springs at the rear. These may mount on the rear drive axle, on struts, or on various types of control or suspension arms in an independent suspension system. Some rear-drive vehicles have leaf springs at the rear. Others use transverse torsion bars. [D.L.An.]

**Automotive transmission** The device in the power train of a motor vehicle that provides different gear ratios between the engine and drive wheels, as well as neutral and reverse. An internal combustion engine develops relatively low torque at low speed and maximum torque at only one speed, with the crankshaft always rotating in the same direction. To meet the tractive-power demand of the vehicle, the transmission converts the engine speed and torque into an output speed and torque in the selected direction for the final drive. This arrangement permits a smaller engine to provide acceptable performance and fuel economy while moving the vehicle from standstill to maximum speed. The transmission may be a separate unit as in front-engine rear-drive vehicles or may be combined with the drive axle to form a transaxle as in most front-drive vehicles. See AUTOMOBILE; AUTOMOTIVE DRIVE AXLE; DIFFERENTIAL.

The two general classifications are manual transmissions that the driver shifts by hand after disengaging the foot-operated clutch, and automatic transmissions that shift with no action by the driver. However, manual transmissions can have a clutch that is automatically disengaged by an actuator when the driver moves the shift lever, and automatic transmissions can have manual-shift capability which allows the driver to select the shift to the next lower or higher gear ratio by movement of the shift lever. See CLUTCH.

The manual transmission is an assembly of gears, shafts, and related parts contained in a metal case or gearbox partially filled with lubricant. The transmission input shaft connects through the clutch and flywheel to the engine crankshaft (see illustration). The transmission output shaft connects through a driveshaft to the final-drive gearing in the drive axle. To get the vehicle into motion, reduction or underdrive gearing in the transmission allows the engine crankshaft to turn fast while the drive wheels turn much more slowly but with greatly increased torque. As the vehicle accelerates, and less torque and more speed are needed, the driver shifts the transmission into successively lower numerical gear ratios, known as higher gears. In a typical five-speed manual transmission, gear ratios are approximately 3.35:1 for first gear, 2:1 for second gear, 1.35:1 for third gear, 1:1 (direct drive) for fourth gear, and 0.75:1 (overdrive) for fifth gear. Most transmissions with four or more forward speeds are operated by a floor-mounted shift lever. See GEAR; GEAR TRAIN.

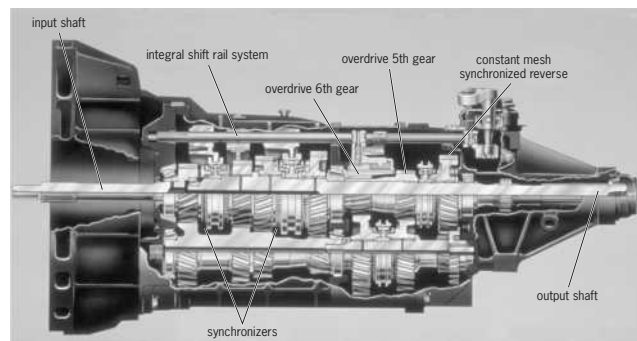

**Six-speed manual transmission for a rear-drive car. (Pontiac-GMC Division, General Motors Corp.)**



Automatic transmission provides automatic control of drive-away, gear-ratio selection, and gear shifting through four or five forward speeds. A typical automotive automatic transmission includes a hydrodynamic three-element torque converter with locking clutch, a planetary-gear system that provides overdrive in fourth or higher gear, and a hydraulic or electrohydraulic control system. Shifts are made without loss of tractive power. See HYDRAULICS; HYDRODYNAMICS; PLANETARY GEAR TRAIN; TORQUE CONVERTER. [D.L.An.]

**Autonomic nervous system** The part of the nervous system that innervates smooth and cardiac muscle and the glands, and regulates visceral processes including those associated with cardiovascular activity, digestion, metabolism, and thermoregulation. The autonomic nervous system functions primarily at a subconscious level. It is traditionally partitioned into the sympathetic system and the parasympathetic system, based on the region of the brain or spinal cord in which the autonomic nerves have their origin. The sympathetic system is defined by the autonomic fibers that exit thoracic and lumbar segments of the spinal cord. The parasympathetic system is defined by the autonomic fibers that either exit the brainstem via the cranial nerves or exit the sacral segments of the spinal cord. See PARASYMPATHETIC NERVOUS SYSTEM; SYMPATHETIC NERVOUS SYSTEM.

The defining features of the autonomic nervous system were initially limited to motor fibers innervating glands and smooth and cardiac muscle. This definition limited the autonomic nervous system to visceral efferent fibers and excluded the sensory fibers that accompany most visceral motor fibers. Although the definition is often expanded to include both peripheral and central structures (such as the hypothalamus), contemporary literature continues to define the autonomic nervous system solely as a motor system. However, from a functional perspective, the autonomic nervous system includes afferent pathways conveying information regarding the visceral organs and the brain areas (such as the medulla and the hypothalamus) that interpret the afferent feedback and exert control over the motor output back to the visceral organs. See HOMEOSTASIS. [S.W.P.]

**Autopilot** An automatic means for steering an aircraft or other vehicle. The original use of an autopilot, or automatic pilot, was to provide pilot relief during cruise modes. Autopilots now perform functions more rapidly and with greater precision than the human pilot. The functions, designs, and uses of autopilots vary widely depending on the type of vehicle. In addition to controlling various types of aircraft and spacecraft, autopilots are used to control ships or sea-based vehicles and in some cases land-based vehicles. This article discusses autopilots used in aircraft and space vehicles.

An autopilot is unique equipment in that it is expected to make the aircraft fly in the same manner as a highly trained, proficient pilot. It must provide smooth control and avoid sudden and erratic behavior. The intelligence for control must come from sensors such as gyroscopes, accelerometers, altimeters, air-speed indicators, automatic navigators, and various types of radio-controlled data links. The autopilot supplies the necessary scale factors, dynamics (timing), and power to convert the sensor signals into control surface commands. These commands operate the normal aerodynamic controls of the aircraft. See ACCELEROMETER; AIRCRAFT INSTRUMENTATION; ALTIMETER; GYROSCOPE; INERTIAL GUIDANCE SYSTEM.

Autopilots come in varying degrees of sophistication. A simple attitude hold (wing leveler) just barely justifies the term autopilot, while a top-of-the-line system that automatically takes the aircraft from one location to another exceeds the normal capabilities of an autopilot. Sophisticated autopilots are no longer limited to military aircraft but are now common in commercial aircraft and are available for general aviation. In modern fly-by-wire aircraft the autopilot and the flight control system often reside together in the same digital computer, and it is difficult to separate

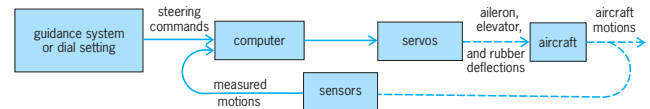

Basic elements of an autopilot system.

their functions. These advanced systems provide the pilot relief functions plus help to stabilize the aircraft, protect the aircraft from undesirable maneuvers, and provide automatic landings (in some cases on a moving ship). Research aircraft are being tested with backup automatic control concepts that continue to control the aircraft even if the primary controls are damaged and no longer function. See FLIGHT CONTROLS.

Aircraft motion is usually sensed by a gyro, which transmits a signal to a computer (see illustration). The computer commands a control servo to produce aerodynamic forces to remove the sensed motion. The computer may be a complex digital computer, an analog computer (electrical or mechanical), or a simple summing amplifier, depending on the complexity of the autopilot. The control servo can be a hydraulically powered actuator or an electromechanical type of surface actuation. Signals can be added to the computer that supply altitude commands or steering commands. For a simple autopilot, the pitch loop controls the elevators and the roll loop controls the aileron. A directional loop controlling the rudder may be added to provide coordinated turns. See AILERON; AMPLIFIER; ANALOG COMPUTER; CONTROL SYSTEMS; DIGITAL COMPUTER; ELEVON; GUIDANCE SYSTEMS; SERVOMECHANISM. [L.L.K.]

**Autoradiography** A photographic technique used to localize a radioactive substance within a solid specimen; also known as radioautography.

A photographic emulsion is placed in contact with the object to be tested and is left for several hours, days, or weeks, depending on the suspected concentration of the radioactive material to be measured. The emulsion, which is a gel containing silver halide, is then developed, fixed, and washed as in the usual photographic process. At sites where the emulsion was close enough to the radioactive substance, it appears dark because of the presence of silver grains. When the number of grains is insufficient to darken the film to the unaided eye, the film may be examined with the aid of a microscope. The individual silver grains may then be seen. The pattern formed by the grains depends on the type of radiation and the nature of the photographic emulsion. Alpha particles produce short, straight rows or tracks of grains. Beta particles as well as x-rays and gamma rays, which affect film by producing beta particles, produce tortuous tracks whose lengths and grain densities depend on the energy of the beta particles. Low-energy particles produce shorter tracks with higher grain densities. Very low energy particles like those from tritium (3-hydrogen) may produce only a single grain very close to the site of decay.

Autoradiography can be used to detect, and measure semi-quantitatively, the radioactive materials in almost any object that can be placed in contact with film or photographic emulsion in some form. However, in biological research the object may be (1) a whole plant or animal that can be flattened against a film; (2) the cut surface of a plant or animal, or one of its organs; (3) thin sections of tissues or cells; (4) squashed or otherwise flattened cells; (5) surface films produced by spreading on water the protein monolayers containing DNA or ribonucleic acid (RNA) that are picked up on grids for electron microscopy; (6) sheets of paper or other materials on which radioactive substances have been separated by chromatography or electrophoresis; or (7) acrylamide gels in which DNA, RNA, or proteins have been separated by electrophoresis. See RADIOGRAPHY. [J.H.T.]

**Autotransformer** A special form of transformer having one winding, a portion of which is common to both the primary and the secondary circuits. The current in the high-voltage circuit flows through the series and common windings (see illustration).

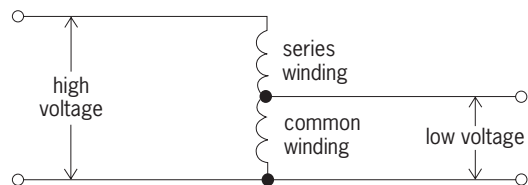

Typical autotransformer circuit.

The current in the low-voltage circuit flows through the common winding and adds vectorially to the current in the high-voltage circuit to give the common winding current. Thus, an electrical connection exists between high-voltage and low-voltage windings. Because of this sharing of parts of the winding, an autotransformer having the same kilovolt-ampere (kVA) output rating is generally smaller in weight and dimensions than a two-winding transformer. One possible disadvantage of autotransformers is that the windings are not insulated from each other and that the autotransformer provides no isolation of the primary and secondary circuits.

Autotransformers of large sizes are used for interconnecting high-voltage power systems. They are used in small sizes for intermittent-duty starting of motors. For this use the motor is connected for a short time to the common winding voltage, and then connected to the full line voltage. Small, variable-ratio autotransformers are used in testing and as components of other apparatus. [J.R.Su.]

**Autoxidation** The slow, flameless combustion of materials by reaction with oxygen; it is sometimes spelled autooxidation. Autoxidation is important because it is a useful reaction for converting compounds to oxygenated derivatives, and also because it occurs in situations where it is not desired (as in the destructive cracking of the rubber in automobile tires). See COMBUSTION; OXIDATION PROCESS.

Although virtually all types of organic materials can undergo air oxidation, certain types are particularly prone to autoxidation, including unsaturated compounds that have allylic hydrogens or benzylic hydrogens; these materials are converted to hydroperoxides by autoxidation.

Autoxidation is a free-radical chain process. Such reactions can be divided into three stages: initiation, propagation, and termination. In the initiation process, some event causes free radicals to be formed. For example, free radicals can be produced purposefully by the decomposition of a free-radical initiator, such as benzoyl peroxide. In some cases, initiation occurs by a process that is not well understood but is thought to be the spontaneous reaction of oxygen with a material with a readily abstractable hydrogen. Destructive autoxidation processes also are initiated by pollutants such as those in smog.

Once free radicals are formed, they react in a chain to convert the material to a hydroperoxide. The chain is ended by termination reactions in which free radicals collide and combine their odd electrons to form a new bond. See FREE RADICAL; ORGANIC REACTION MECHANISM.

Autoxidation is a process of enormous economic impact, since all foods, plastics, gasolines, oils, rubber, and other materials that must be exposed to air undergo continuous destructive reactions of this type. All plastics and rubber and most processed foods contain antioxidants to protect them against the attack of oxygen. See ANTIOXIDANT; FAT AND OIL (FOOD); FOOD MANUFACTURING; PLASTICS PROCESSING; RUBBER. [W.I.A.P.]

**Auxin** Any of a group of organic compounds which, when applied in low concentration, are able to promote elongation growth of plant shoots excised from a growing region of a young seedling. The ability to increase the rate of shoot elongation is a key to the designation of a synthetic or naturally occurring compound as an auxin. However, auxins, and the other plant hormones, influence a variety of plant processes during various stages of plant development.

The major naturally occurring auxin, indole-3-acetic acid (IAA) has been found in almost all plant tissues that have been studied. It occurs in minute quantity, usually in less than micromolar amounts. Auxins occur in plant tissue in several chemical forms. They may occur as the free active hormone (such as indoleacetic acid), and they may also be present in plant tissue as a number of so-called bound auxins. The bound forms are auxins linked by a covalent chemical bond to some other chemical compound. These bound forms are thought to be important reserve forms which function to regulate the levels of free hormone in tissue, especially during certain developmental stages such as seedling growth. In addition, it is possible that the compound to which the auxin is linked (usually a sugar or an amino acid) is important in the transport of the hormone within the plant. Conjugation also renders the auxin immune to many of the enzymes which would normally degrade the free auxin.

Auxin responses in plant tissue can be artificially divided into two groups, based on the time of their appearance. First, there are a number of very rapid responses which can be measured within minutes after the addition of auxin. Included in these responses are auxin-induced increases in protoplasmic streaming, cell elongation, and an increase in the acidity of the cell-wall free space. The second group of responses includes the long-term effects in which the observable response can be measured only after hours or even days of hormone treatment. Examples of these responses are auxin-induced increases in ribonucleic acid and protein synthesis, initiation of xylem differentiation, and an inhibition of lateral bud growth.

The generalized model for auxin action begins when a membrane receptor responds to auxin by releasing phosphoinositides from the pool of membrane-bound phospholipids. These signals are carried through the cytosol and initiate release of calcium stored in vacuole and endoplasmic reticulum compartments. This sudden increase in calcium initiates a response from at least two cell systems. First, the active removal of calcium from cytosol back to the vacuole is begun through the pumping of calcium in exchange for protons in the vacuole. These protons are in turn pumped out of the cytosol and into the cell-wall where acidification occurs. Second, the increase of calcium in cytosol acts to stimulate enzymes known as protein kinases which modify other proteins by phosphorylation. One protein that is modified by phosphorylation in this way is the proposed auxin-binding protein mediator that becomes receptive to auxin and can thus act on plant DNA to promote transcription of mRNAs that are critical for enzymes involved in cell growth.

The most widespread agricultural use of auxins is for weed and vegetation control. Synthetic auxins, such as 2,4-D and 2,4,5-trichlorophenoxy-acetic acid (2,4,5-T) and their homologs, are commonly used as herbicides. Synthetic auxins have found practical use for other agricultural needs as well. For example, auxin applications are effective for floral thinning of overproductive orchard trees. Synthetic auxins have also been used to prevent premature fruit drop and to improve fruit quality in tree crops. Auxin treatments have been used to enhance rooting of over 1000 different plant species, and have been applied on a practical scale to over 30 different species throughout the world. Auxin preparations designed to enhance root formation in cuttings are also available for home use. The production of large numbers of genetically identical (clonal) plants is now possible by use of plant cell culture techniques. Additions of auxins as well as another type of plant hormone, cytokinin, are usually necessary for the growth of such cultures. In addition, ongoing research

on the production of new varieties of agriculturally important plants, using the emerging techniques of molecular biology, rely on cell culture methods and a detailed knowledge of the role of auxins and other plant hormones in the developmental life of plants. See CYTOKININS; HERBICIDE; MOLECULAR BIOLOGY; PLANT GROWTH; PLANT HORMONES; TISSUE CULTURE. [J.D.Coh.; B.G.Ba.]

**Avalanche** In general, a large mass of snow, ice, rock, earth, or mud in rapid motion down a slope or over a precipice. In the English language, the term avalanche is reserved almost exclusively for snow avalanche. Minimal requirements for the occurrence of an avalanche are snow and an inclined surface, usually a mountainside. Most avalanches occur on slopes between 30 and 45°.

Two basic types of avalanches are recognized according to snow cover conditions at the point of origin. A loose-snow avalanche originates at a point and propagates downhill by successively dislodging increasing numbers of poorly cohering snow grains, typically gaining width as movement continues downslope. This type of avalanche commonly involves only those snow layers near the surface. The mechanism is analogous to dry sand. The second type, the slab avalanche, occurs when a distinct cohesive snow layer breaks away as a unit and slides because it is poorly anchored to the snow or ground below. A clearly defined gliding surface as well as a lubricating layer may be identifiable at the base of the slab, but the meteorological conditions which create these layers are complex.

In the case of the loose avalanche, release mechanisms are primarily controlled by the angle of repose, while slab releases involve complex strength-stress problems. A release may occur simply as a result of the overloading of a slope during a single snowstorm and involve only snow which accumulated during that specific storm, or it may result from a sequence of meteorological events and involve snow layers comprising numerous precipitation episodes. Most large snow slides are believed to be caused by an unstable layer of ice grains that develop deep in mountain snow. Called depth hoar by students of avalanche dynamics, these crystals owe their formation to heat from earth and rock which are buried by the snow, and which in late autumn are warmer than the surrounding air. Snow nearest the ground vaporizes, causing growth of angular ice grains that exhibit poor bonding qualities. Gravity combining with the weakness of the depth hoar crystals loosens the upper stable layers. Once the stable layers begin to slide, the depth hoar acts in a manner similar to ball bearings to speed the descent of the slide.

Where snow avalanches constitute a hazard, that is, where they directly threaten human activities, various defense methods have evolved. Attempts are made to prevent the avalanche from occurring by artificial supporting structures or reforestation in the zone of origin. The direct impact of an avalanche can be avoided by construction of diversion structures, dams, sheds, or tunnels. Hazardous zones may be temporarily evacuated while avalanches are released artificially, most commonly by explosives. Finally, attempts are made to predict the occurrence of avalanches by studying relationships between meteorological and snow cover factors. [R.L.A.]

**Aves** Modern birds are a class of vertebrates characterized by being feathered, warm-blooded (endothermic), and bipedal (two-legged); and by having very high metabolic rates and a forelimb modified into a wing which, together with a long tail, forms part of a flight mechanism. Such a definition, however, as with any group of vertebrates, characterizes the living forms and is blurred by the fossil record, which contains species with characteristics close to those of the reptilian ancestors of birds. The feathers of birds are filamentous, lightweight modifications of the outer skin that have remarkable aerodynamic qualities. They serve not only as flight structures by generating lift and thrust but also as insulation to maintain high body temperatures. In addition, birds have lightweight hollow bones, a well-

developed air-sac system and flow-through lungs, a wishbone or furcula (fused clavicles), and a hand reduced to three digits (comparable to digits 2, 3, and 4 of the human hand). Birds are known to have evolved from some group of reptiles within the larger group of ancient diapsid reptiles known as archosaurs. However, debate still centers on whether they are derived from a common ancestor with the theropod (meat-eating) dinosaurs (a group known as basal archosaurs), or later in time directly from the theropod dinosaurs.

Feathers are unique to birds. These lightweight structures made of keratin are the most complex appendages produced by the skin of any vertebrate. The bird wing comprises two sets of flight feathers, the outer primary feathers which are attached to the hand, and the inner secondary feathers which are attached to the ulna. The vanes of the wing feathers are asymmetric with a smaller outer vane and larger inner vane, producing lift in flight. The body feathers provide small aerodynamic contours which result in laminar airflow in flight. Most of the vane is stiff and tightly bound, like flight feathers. However, the basal portion can be fluffed up to trap body heat next to the skin. In warm conditions the body feathers can be flattened to allow heat to escape. Thus, feathers form an insulatory pelt to cover the surface of the avian body. The tail feathers resemble the flight feathers of the wing and provide lift in flight. The tail feathers of modern birds are attached to a specialized bone known as the pygostyle, which is formed by a number of fused tail vertebrae. The pygostyle (sometimes called the plowshare bone) also accommodates the uropygial gland, or oil gland, an essential part of the anatomy of birds that provides a rich waterproofing oil for preening the feathers. In addition to their primary functions of flight and insulation, feathers can serve other functions, ranging from the production of color patterns and structural forms that allow for species recognition and courtship displays, to color patterns that serve a cryptic purpose for protection. See FEATHER.

The once-toothed jaws of birds have evolved into the lighter beak in which the upper and lower jaws are covered by a horny rhamphotheca, which may vary in texture from the rock-solid beaks of predatory raptors to relatively soft beaks of shorebirds and ducks. Beaks have a great variety of adaptive forms, including the flesh-tearing hooked beaks of hawks and eagles, the filter-feeding straining beaks of flamingos and ducks, the fish-trapping beaks of pelicans, the climbing and nut-cracking beaks of parrots, the hammering beaks of woodpeckers, and the seed-eating beaks of finches. Birds have developed a muscular gizzard (also found in their relatives, crocodiles and dinosaurs) for grinding and processing food into small pieces. The grinding is often assisted by the addition of gizzard stones, which are ingested.

Birds have varied feet. The most primitive avian foot, found in the earliest known bird, *Archaeopteryx*, is the perching foot also found in most modern tree-dwelling birds. Three toes point forward, and a reversed first toe, or hallux, opposes them in perching on a branch. This type of foot is called anisodactyl. Other modifications include the zygodactyl feet of woodpeckers with two forward and two rearward pointing toes, and the webbed feet of ducks with the three forward pointing toes united by a web that serves as a paddle. The varied birds in the order Pelecaniformes have a foot in which all four toes are united by webbing, a totipalmate foot. Ostriches are unique in the bird world in having a foot with only two toes. The ankle and foot bones are fused and elongated in birds, so that the avian leg consists of a femur, tibiotarsus, and fibula, then a fusion of three bones into a tarsometatarsus, and finally the toes. Thus, birds walk on their toes, and the equivalent to the human foot is a long bone, the tarsometatarsus, which is off the ground.

Birds have keen senses of vision and hearing. The sense of smell (olfaction) is not particularly well developed, although in some birds there is a good sense of smell. Birds have developed a flow-through lung and an extensive air-sac system. Modern flying birds have a well-developed sternum with a keel, or carina, for the attachment of the large flight musculature.

Birds are found over the entire Earth. One of the most intriguing aspects of bird biology is the ability to migrate exceptional distances. Birds possess highly specialized directional senses for orientation, navigation, homing, and migration, including the ability to detect the Earth's magnetic field. These uncanny abilities permit birds to occupy distinctive wintering and nesting grounds, thus expanding their usable habitats. Some migrations, such as that of the Arctic tern, involve a circumatlantic migration from Alaska to the South Pole. See FLIGHT.

There are some 9700 species of birds living today, and most species are particularly well known. However, the relationships of the higher categories of birds are still debated. Of the 9700 species, some 5000 species belong to the order Passeriformes, the perching birds or songbirds. The number of avian orders is still controversial, and texts show different arrangements. Because the situation is in flux, a fairly conservative system is used below (fossil groups are designated by a dagger). See PASSERIFORMES.

#### Class Aves

##### Subclass Sauriurae

##### Infraclass Archaeopterygiformes<sup>†</sup>

Order Archaeopterygiformes (late Jurassic reptile-birds)<sup>†</sup>

Order Confuciusornithiformes (lower Cretaceous, beaked reptile-birds)<sup>†</sup>

##### Infraclass Enantiornithes (archaic Mesozoic land birds)

##### Subclass Ornithuriae

##### Infraclass Odontornithes (or Odontoholcae)<sup>†</sup>

Order Hesperornithiformes (Cretaceous toothed divers)<sup>†</sup>

##### Infraclass Neornithes (or Carinata)

##### Superorder Ambiortimorphae (gull-like, Mesozoic toothed birds)<sup>†</sup>

*Incertae sedis* (*Gansus*, *Chaoyangia*, etc., archaic modern-type birds)<sup>†</sup>

##### Palaeognathae (ostrich and allies)

##### Neognathae (modern birds)

##### Order: Sphenisciformes (penguins, 17 species)

Procellariiformes (tube-nose seabirds, 114)

Pelecaniformes (pelicans and allies, 66)

Ciconiiformes (storks and allies, 86)

Falconiformes (hawks, eagles, and vultures, 309)

Galliformes (chickens and allies, 282)

Gruiformes (rails, cranes and allies, 214)

Podicipediformes (grebes, 22)

Charadriiformes (shorebirds, gulls and allies, 349)

Pteroclidiformes (sand grouse, 16)

Threskiornithiformes (ibis, spoonbills, 33)

Anseriformes (waterfowl, 161)

Phoenicopteriformes (flamingos, 5 or 6)

Gaviiformes (loons, 5)

Columbiformes (pigeons and doves, 316)

Psittaciformes (parrots, 360)

Coliiformes (mousebirds, 6)

Musophagiformes (turacos, or plaitain-eaters, 23)

Cuculiformes (cuckoos, 142)

Opisthocomiformes (hoatzin, 1)

Strigiformes (owls, barn owls, 173)

Caprimulgiformes (nightjars and allies, 116)

Apodiformes (hummingbirds and swifts, 425)

Trogoniformes (trogons, quetzals, 39)

Coraciiformes (kingfishers, bee-eaters and allies, 219)

Piciformes (woodpeckers and allies, 407)

Passeriformes (perching birds, songbirds, passerines, 5739)

The classification system presented above coordinates with most major treatises on birds. The subclass Sauriurae contains the archaic birds of the Mesozoic Era, the Age of Reptiles, which

includes the toothed fossil *Archaeopteryx*, or *Urvogel*, the oldest known bird (150 million years ago). Other Mesozoic birds included the ancient ornithurine birds more closely allied with the modern radiation of birds, among them such forms as the hesperornithiforms, the Cretaceous toothed divers, which superficially resembled loons. They became extinct at the end of the Cretaceous along with their gull-like contemporaries, the Ambiortimorphae. Also included in this group is the Lower Cretaceous *Ambiortus* from Mongolia, which was a fully volant ornithurine bird about the size of a pigeon. It possessed a well-developed sternal keel and other features of the pectoral region typical of modern birds, indicating that true flying birds existed some 12 million years after the appearance of *Archaeopteryx*. See ARCHAEORNITHES; HESPERORNITHIFORMES; ICHTHYORNITHIFORMES.

The extinction of the dinosaurs 65 million years ago is now believed to have been due to the collision of a large extraterrestrial body, a meteor or some other object, with Earth, causing catastrophic effects, including the extinction of numerous bird species. It is likely that the very few types that survived, possibly related to shorebirds, were the wellspring of the modern evolution of birds; and modern birds, like their mammalian counterparts, probably evolved explosively during the early part of the Tertiary Period, perhaps over a period of some 5–10 million years. Among the first birds to appear were the strange *Diatrymas*, large, predatory, flightless birds that had a head the size of that of a horse. They are thought to have taken over the niche left vacant by predatory dinosaurs, and they fed on the small archaic mammals of the Paleocene and Eocene.

By the Eocene, approximately 50 million years ago, all the major orders of modern birds were present. By the Oligocene, most of the families were present, and by the Miocene, the genera of modern birds were well established. [A.Fe.]

**Avian leukosis** A complex of several related and unrelated viruses (both C-type retroviruses and herpesviruses) that are collectively responsible for a variety of benign and malignant neoplasms in chickens and, to a lesser extent, in other avian species. Although most neoplasms observed in avian species are induced by viruses, there are some of unknown etiology.

The neoplastic diseases induced by the leukosis-sarcoma group of retroviruses include lymphoid leukosis, myeloid or erythroid leukemias or solid tumors, tumors of connective tissue origin (for example, sarcomas, fibromas, and chondromas), epithelial carcinomas, and endothelial tumors. The many viral strains involved have similar physical and chemical characteristics and share a group-specific antigen; some can cause more than one type of neoplasm. The viruses are about 100 nanometers in diameter; have a core composed of ribonucleic acid; contain a reverse transcriptase; mature by budding from the cell membrane; and are divided into subgroups based on envelope glycoproteins. Some strains carry their own specific oncogenes that induce neoplasms within days or weeks. Others lack an oncogene and cause neoplasms less frequently and only after several months, probably by activating a specific cellular oncogene. See CANCER (MEDICINE); ONCOGENES; ONCOLOGY.

Lymphoid leukosis is the most important of the leukosis sarcoma diseases. The lymphoid leukosis virus is transmitted vertically from hen to chick through the egg. Infection can result in leukotic neoplasms in various visceral organs following metastasis from primary tumors in the bursa of Fabricius. Large-scale transmission of the lymphoid leukosis virus can be eradicated by eliminating individual infected breeders.

Reticuloendotheliosis virus strains constitute another retrovirus group, unrelated to the lymphoid-sarcoma group, and also may carry a specific oncogene. They can cause a chronic neoplastic form of reticuloendotheliosis or other neoplasms in turkeys, chickens, ducks, geese, quail, and pheasants, and a runting disease has been seen in chickens after accidental contamination of vaccines with reticuloendotheliosis virus.

Marek's disease in chickens is caused by an oncogenic, cell-associated, lymphotropic, highly contagious herpesvirus. Inhalation of the virus causes an active infection in lymphoid organs; after about 1 week, a latent infection develops in lymphocytes. T-cell lymphomas may develop within a few weeks or months, depending on age, genetic makeup, virus virulence, and other factors. Degenerative, inflammatory and lymphoproliferative lesions occur principally in the peripheral nerves (causing paralysis), lymphoid tissues, visceral organs, muscle, and skin. Eye involvement (gray eye) can cause blindness. The disease is of great economic importance in chickens, and several vaccines, injected at 1 day of age, have been in worldwide use since about 1970. See ANIMAL VIRUS; TUMOR VIRUSES. [B.W.C.]

**Aviation** A general term including the science and technology of flight through the air. Aviation also applies to the mode of travel provided by aircraft as carriers of passengers and cargo, and as such is part of the total transportation system. Aviation also describes the employment of aircraft in such fields as military aviation. The world of the airplane, including the people who manufacture, market, and repair aircraft or who work in allied industries, is frequently spoken of as aviation. See AIRPLANE; MILITARY AIRCRAFT.

Aviation is broadly grouped into three classes: general aviation, air transport aviation, and military aviation. General aviation comprises all aviation not included in military or air-transport aviation. Military aviation includes all forms of aviation in military activities, and air-transport aviation is primarily the operation of commercial airlines essentially as a public utility for the movement of persons and commodities. See GENERAL AVIATION. [L.A.B.]

**Avocado** A tropical and subtropical fruit tree, *Persea americana*, in the Lauraceae family. It originated in Central America or adjoining regions of North or South America. It has now spread to much of the near-tropical world.

The species is divided into three horticultural races with differing commercial qualities. The so-called West Indian race is least tolerant of cold, the Mexican most tolerant, and the Guatemalan intermediate. This same gradation is found in salt tolerance (West Indian highest) and oil content (West Indian lowest). But in some other respects the West Indian race is intermediate (skin thickness), or one of the races is different from the other two (the West Indian fruit is less tolerant of cold storage; the Mexican has smaller fruit with a unique aniselike odor; the Guatemalan has a smaller seed ratio, and takes twice as long to mature—14 months or more in California).

Mexico is the world's leading producer, followed by Brazil and California, then Colombia and Venezuela, countries of eastern South America, Central America, Caribbean Islands, Florida, Philippines, and Zaire (central West Africa). South Africa and Israel have important export industries, primarily to Europe. Many other countries have begun development. The California industry is expanding rapidly, and the avocado has become one of the state's leading fruit crops. See FRUIT; FRUIT, TREE. [B.O.B.]

**Avogadro number** The number of elementary entities in one mole of a substance. A mole is defined as an amount of a substance that contains as many elementary entities as there are atoms in exactly 12 g of  $^{12}\text{C}$ ; the elementary entities must be specified and may be atoms, molecules, ions, electrons, other particles, or specified groups of such particles. Experiments give  $6.0221367 \times 10^{23}$  as the value of the Avogadro number. In most calculations the coefficient is rounded off to 6.02. Thus, a mole of  $^{12}\text{C}$  atoms has  $6.02 \times 10^{23}$  carbon atoms, a mole of water molecules contains  $6.02 \times 10^{23}$   $\text{H}_2\text{O}$  molecules, a mole of electrons contains  $6.02 \times 10^{23}$  electrons, and so forth. See MOLE (CHEMISTRY).

The atomic weight (relative atomic mass) of  $^{12}\text{C}$  is exactly 12, by definition. Consider 12 g of  $^{12}\text{C}$  (which is one mole and contains the Avogadro number of atoms) compared with 4 g of He, whose atomic weight is 4. The 12 g to 4 g ratio of the masses of the two samples is the same as the 12 to 4 ratio of the masses of the atoms of  $^{12}\text{C}$  and He. Therefore the two samples must contain the same number of atoms, and 4 g of He contains the Avogadro number of atoms. The same argument holds for any element. Thus, for an element with atomic weight  $x$ , a sample with mass  $x$  grams contains the Avogadro number of atoms. Similarly, for a substance with molecular weight  $y$ , a sample whose mass is  $y$  grams must contain the Avogadro number of molecules. For example, 18 g of water contains  $6.02 \times 10^{23}$   $\text{H}_2\text{O}$  molecules.

The Avogadro number is a dimensionless number. The Avogadro constant is defined as the Avogadro number divided by the unit "mole." The Avogadro constant is usually symbolized by  $N_A$ ,  $N_0$ , or  $L$ . Since  $N_A$  gives the number of molecules per mole,  $N_A = N/n$ , where  $N$  is the number of molecules present in  $n$  moles of a substance.

The Avogadro number relates the mass of a mole of a substance to the mass of a single molecule. For example, for  $\text{H}_2\text{O}$  (whose molecular weight is 18) the mass of one mole is 18 g and the mass of one molecule is  $(18 \text{ g}) / (6.02 \times 10^{23}) \approx 3 \times 10^{-23}$  g. The mass  $m$  of one molecule of a substance with molar mass  $M$  is  $m = M/N_A$ .

The Avogadro constant  $N_A$  is related to other fundamental physical constants. The Faraday constant  $F$  is the absolute value of the charge on one mole of electrons. Therefore  $F = N_A e$ , where  $e$  is the absolute value of the charge on one electron. Also,  $R = N_A k$ , where  $R$  is the gas constant and  $k$  is the Boltzmann constant. See BOLTZMANN CONSTANT; GAS CONSTANT.

Widespread use of the mole concept began only around 1900. The nineteenth-century concept most closely related to the Avogadro number is the number of molecules per unit volume in a gas at  $0^\circ\text{C}$  and 1 atm. [The ideal-gas law  $PV = nRT = (N/N_A)RT$  gives  $N/V = N_A P/RT$ , so  $N/V$ , the number of gas molecules per unit volume, is proportional to the Avogadro constant  $N_A$  at fixed pressure  $P$  and temperature  $T$ .] Avogadro hypothesized in 1811 that at a fixed temperature and pressure the number of molecules per unit volume is the same for different gases, but he had no way of estimating this number. [I.N.L.]

**Avogadro's law** The principle that equal volumes of all gases and vapors, under the same conditions of temperature and pressure, contain identical number of molecules; also known as Avogadro's hypothesis. From Avogadro's law the converse follows that equal numbers of molecules of any gases under identical conditions occupy equal volumes. Therefore, under identical physical conditions the gram-molecular weights of all gases occupy equal volumes. See GAS; KINETIC THEORY OF MATTER. [I.C.W.]

**Axenic culture** The growth and maintenance of a single species in isolation, free from foreign or contaminating species. Isolation is usually achieved by growing the species in an environment that was previously sterilized, and was thereby rid of contaminating organisms. Since, from a practical viewpoint, the contaminating organisms usually encountered are microorganisms, axenic cultures, whether of invertebrates or vertebrates, are often referred to as germ-free. Indeed, the terms axenic and germ-free are occasionally used interchangeably. Gnotobiotic is also often used interchangeably with axenic; however, in common practice gnotobiotic specifically refers to germ-free conditions. See GNOTOBIOTICS.

A principal goal of early studies with axenic cultures was the establishment of nutritional requirements for individual species. Historically, axenic cultures have also been employed to

demonstrate that organisms growing in close association can have both direct and indirect effects on each other. Direct effects include competition for nutrients, attacks (for example, by a parasite), or production by one species of toxic compounds that affect a second species. Indirect effects include such phenomena as the production by intestinal microflora of vitamin K (germ-free animals therefore require it as a dietary supplement).

The two methodological challenges associated with developing axenic culture methods are formulating an appropriate culture medium and designing a functional habitat. Formulating a culture medium for small organisms, including microorganisms and many invertebrates, is the more difficult of the two challenges. For larger organisms, a culture medium is replaced by a carefully formulated diet, which is usually a relatively straightforward task. Initiating the axenic cycle and maintaining a sterile environment can, however, be a formidable endeavor for larger organisms.

For axenic culture of small organisms, such as bacteria, protozoa, and fungi, a typical strategy is to add to a minimal medium [which usually contains only a carbon source (such as glucose), nitrogen, sulfur, and phosphorus, as well as various salts and trace minerals] several supplements that are rich in a large number of growth factors. Such supplements often include water-soluble extracts of meat or yeast containing vitamins and other organic compounds. Once successful growth is achieved, it is usual to attempt to simplify the culture medium by deleting, in a stepwise fashion, each of the more esoteric ingredients (for example, individual vitamins).

Initiating the axenic cycle and designing an appropriate habitat for larger organisms require special effort. First, organisms free of contaminating species need to be obtained; in some cases, cesarean births are employed. Second, sterile containers that have entry and exit ports as well as a comfortable living environment must be constructed.

Axenic culture has been achieved for a broad range of organisms. The method employed to remove contaminating organisms in a starter culture or for the initiation of an experiment depends upon the type of organism to be decontaminated and the nature of the contaminating organism.

Since bacteria represent the single most important potential contaminant in axenic cultures, antibiotic therapy is usually employed to maintain the cultures. There is no single antibiotic that inhibits all bacteria, however, so combinations of up to four to six antibiotics are usually added either directly to the culture fluid for axenic stocks of protozoa, plant cells, or nematodes, or to the food or beverage for larger, germ-free animals such as small mammals. Axenic cultures need to be continually monitored for the presence of contaminating microorganisms. See BACTERIOLOGY.

One problem is that it is not always possible to be certain that viruses and mycoplasmas are not present as a contaminant in axenic cultures. Another limitation is that since axenic cultures are designed to be pure it is almost impossible to construct a holistic or comprehensive view of an organism with data from axenic cultures alone. Nevertheless, the benefits that have been obtained from the use of axenic cultures have far outweighed the limitations. Indeed, virtually all aspects of research on pharmaceuticals, nutrition, ecology, agricultural production, and parasitology have benefited enormously from the use of axenic cultures. [G.M.M.]

**Axinellida** An order of sponges of the class Demospongiae, subclass Tetractinomorpha, with monactinal or diactinal megascleres or both arranged in plumose tracts bearing more or less spongin (see illustration). The axial skeleton may be dense, with an abundance of spongin especially near the base of the sponge. Axinellidan sponges vary in form from branching or massive to cup-shaped or lamellate. Most occur in shallower



*Axinella polycapella*, a representative axinelline sponge.

waters down to 330 ft (100 m), but a few descend to abysmal depths of at least 14,500 ft (4400 m). See DEMOSPONGIAE. [W.D.H.]

**Aye-aye** A rare prosimian primate indigenous to eastern Madagascar. A single living species, *Daubentonia madagascariensis*, makes up the family Daubentoniidae (see illustration). The aye-aye is a nocturnal, arboreal animal. A single young is produced in early spring in a special nest, which is constructed by the female. The hindtoes are opposable, and the fingers are quite long and slender, especially the middle one. Using its middle finger or its sharp incisors, the aye-aye digs insect larvae out of tree bark or extracts the contents of sugarcane.



The aye-aye, *Daubentonia madagascariensis*.

The phylogenetic relationship of this species is obscure; however, the general consensus is that this animal is an aberrant or divergent form of a lemuroid ancestral stock. See MAMMALIA; PRIMATES. [C.B.C.]

**Azeotropic distillation** Any of several processes by which liquid mixtures containing azeotropes may be separated into their pure components with the aid of an additional substance (called the entrainer, the solvent, or the mass separating agent) to facilitate the distillation. Distillation is a separation technique that exploits the fact that when a liquid is partially vaporized the compositions of the two phases are different. By separating the phases, and repeating the procedure, it is often possible to separate the original mixture completely. However, many mixtures exhibit special states, known as azeotropes, at which the composition, temperature, and pressure of the liquid phase become equal to those of the vapor phase. Thus, further separation by conventional distillation is no longer possible. By adding a carefully selected entrainer to the mixture, it is often possible to "break" the azeotrope and thereby achieve the desired separation. See AZEOTROPIC MIXTURE; DISTILLATION.

Entrainers fall into at least four distinct categories that may be identified by the way in which they make the separation possible. These categories are: (1) liquid entrainers that do not induce liquid-phase separation, used in homogeneous azeotropic distillations, of which classical extractive distillation

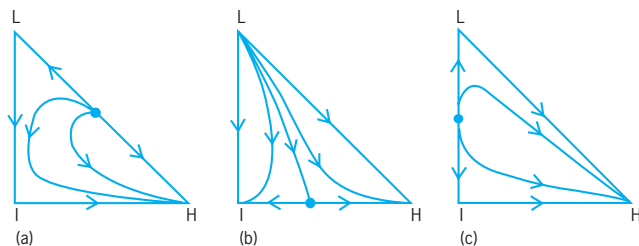

**Schematic representation of the residue curve maps for ternary mixtures with one minimum-boiling binary azeotrope. (a) Azeotrope between the lowest- (L) and highest-boiling (H) pure components. (b) Azeotrope between the intermediate- (I) and highest-boiling components. (c) Azeotrope between the intermediate- and lowest-boiling components.**

is a special case; (2) liquid entrainers that do induce a liquid-phase separation, used in heterogeneous azeotropic distillations; (3) entrainers that react with one of the components; and (4) entrainers that dissociate ionically, that is, salts. See SALT-EFFECT DISTILLATION.

Within each of these categories, not all entrainers will make the separation possible, that is, not all entrainers will break the azeotrope. In order to determine whether a given entrainer is feasible, a schematic representation known as a residue curve map for a mixture undergoing simple distillation is created. The path of liquid compositions starting from some initial point is the residue curve. The collection of all such curves for a given mixture is known as a residue curve map (see illustration). These maps contain exactly the same information as the corresponding phase diagram for the mixture, but they represent it in such a way that it is more useful for understanding and designing distillation systems.

Mixtures that do not contain azeotropes have residue curve maps that all look the same. The presence of even one binary azeotrope destroys the structure. If the mixture contains a single minimum-boiling binary azeotrope, three residue curve maps are possible, depending on whether the azeotrope is between the lowest- and highest-boiling components, between the intermediate- and highest-boiling components, or between the intermediate- and lowest-boiling components.

Nonazeotropic mixtures may be separated into their pure components by using a sequence of distillation columns because there are no distillation boundaries to get in the way. The situation is quite different when azeotropes are present, as can be seen from the illustration. It is possible to separate mixtures that have residue curve maps similar to those shown in illus. a and c by straightforward sequences of distillation columns. This is because these maps do not have any distillation boundaries. These, and other feasible separations for more complex mixtures, are referred to collectively as homogeneous azeotropic distillations. Without exploiting some other effect (such as changing the pressure from column to column), it is impossible to separate mixtures that have residue curve maps like illus. b.

A large number of mixtures have residue curve maps similar to illus. c, and therefore the corresponding distillation is given the special name extractive distillation.

Heterogeneous entrainers cause liquid-liquid phase separations to occur in such a way that the composition of each phase lies on either side of a distillation boundary. In this way, the entrainer allows the separation to "jump" over a boundary that would otherwise be impassable. [M.F.D.]

**Azeotropic mixture** A solution of two or more liquids, the composition of which does not change upon distillation. The composition of the liquid phase at the boiling point is identical to that of the vapor in equilibrium with it, and such mixtures or azeotropes form constant-boiling solutions. The exact composition of the azeotrope changes if the boiling point is altered by a change in the external pressure. A solution of two components which form an azeotrope may be separated by distillation into one pure component and the azeotrope, but not into two pure components. See DISTILLATION; SOLUTION. [F.J.J.]

**Azide** A compound containing the group  $-\text{N}_3$ , which can be represented as a resonance hybrid of two structures, as shown in expression (1). Sodium azide, from which most other azides are

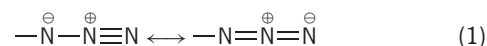

prepared, is manufactured by passing nitrous oxide over heated sodium amide, reaction (2). It is a water-soluble, stable com-



pound. Heavy-metal azides are highly explosive and very shock sensitive; lead azide,  $\text{Pb}(\text{N}_3)_2$ , is used as a detonator to set off explosives. Sodium azide, in combination with an oxidizing agent, may be used as a gas generator in motor-vehicle passive-restraint systems. See EXPLOSIVE.

A variety of organic azides are known. The most important of these are aryl azides ( $\text{ArN}_3$ ), azidoformates ( $\text{ROCON}_3$ ), and sulfonyl azides ( $\text{RSO}_2\text{N}_3$ ).

These lose  $\text{N}_2$  when heated or exposed to ultraviolet light to generate species known as nitrenes, which are so reactive that they will react with almost any organic compound to form amine derivatives, as shown in reaction (3). Aryl azides are widely

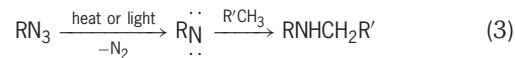

used to probe the active sites of biological targets by photoaffinity labeling. Difunctional aryl azides are used commercially to prepare photoresists, the nitrenes reacting with a polymer containing double bonds to insolubilize the polymer in the light-struck areas. The insoluble polymer protects the underlying metal from being attacked by an etching solution. Difunctional azidoformates and sulfonyl azides can be used to cross-link polymers, to prepare polymeric foams, and to adhere tire cord to rubber in the manufacture of automobile tires. Compounds containing a sulfonyl azide group and a hydrolyzable silane group, such as  $-\text{Si}(\text{OCH}_3)_3$ , in the same molecule are used to bond siliceous fillers (glass fibers, silica, mica, and so forth) to almost any organic polymer. Such coupled systems have much superior properties to simple mechanical mixtures.

Simple acyl azides ( $\text{R} = \text{alkyl or aryl}$ ) undergo a Curtius rearrangement on heating to form an isocyanate, reaction (4).

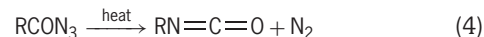

See NITROGEN; POLYMERIZATION; RUBBER.

[D.S.Br.]

**Azurite** A basic carbonate of copper with the chemical formula  $\text{Cu}_3(\text{OH})_2(\text{CO}_3)_2$ . Azurite is normally associated with copper ores and often occurs with malachite. Azurite is monoclinic. It may be massive or may occur in tabular, prismatic, or equant crystals. Invariably blue, azurite was originally used extensively as a pigment. Hardness is  $3\frac{1}{2}$ –4 (Mohs scale) and specific gravity is 3.8. Notable localities for azurite are at Tsumeb, Southwest Africa, and Bisbee, Arizona. See COPPER. [R.I.Ha.]





# B

**Bacillariophyceae** A class of nonflagellate unicellular algae, commonly called diatoms, with boxlike silicified walls. Diatoms range in maximum dimension from 4 micrometers to more than 1 millimeter. The diatom wall or frustule (illus. *a* and *b*) comprises several interlocking, usually elaborately sculptured, lightly or heavily silicified pieces overlying a thin polysaccharide layer. The two largest pieces are the upper and lower valves, which fit together like the top and bottom of a petri dish or shoe box. Between the valves (along the side or girdle of the cell), several smaller pieces—hooplike girdle bands—are intercalated. Depending upon which dimension is larger, breadth or depth, a diatom tends to lie on the valve side or on the girdle side.

Valves are honeycombed by perforate chambers arranged in patterns characteristic of individual species. The overall symmetry of the valves and details of their structure and ornamentation provide the basis for classification. More than 200 genera and 12,000 species of living diatoms have been described. Two main groups are recognized: those in which structural features of the valve are arranged with reference to a central pole (centric valve; illustration *c*) or to two or more poles (gonioid valve); and those in which the features are arranged with respect to a line, often symmetrically (pennate valve).

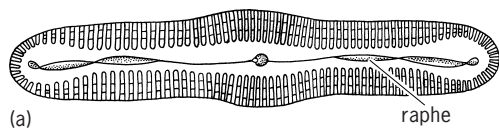

(a)

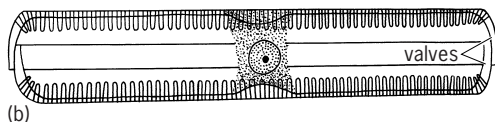

(b)

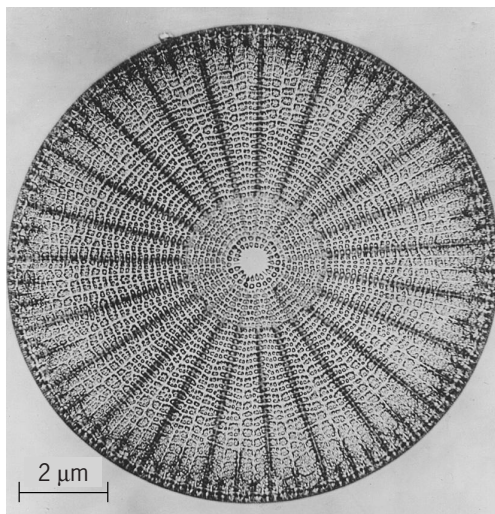

(c)

**Diatoms.** (a) *Pinnularia*, top view; (b) side view. (c) *Arachnoidiscus ehenbergii*.

Most diatoms are photosynthetic. Many, however, are auxotrophic, requiring an external source of certain vitamins. Diatoms are likely to occur wherever there is moisture. They are free-living or attached, solitary or colonial. Marine planktonic diatoms have been important primary producers for at least 100 million years, and over the millennia their frustules have accumulated on the ocean floor. From the abundant fossil record, it is known that centric diatoms evolved first (Cretaceous), followed by pennate diatoms (Paleocene). Uplifted deposits (diatomaceous earth) are mined at several locations. See ALGAE; CHRYSOPHYCEAE. [P.C.Si; R.L.Moe.]

**Bacillary dysentery** A highly contagious intestinal disease caused by rod-shaped bacteria of the genus *Shigella*. Bacillary dysentery is a significant infection of children in the developing world, where it is transmitted by the fecal-oral route. The global disease burden is estimated as 165 million episodes and 1.3 million deaths annually. Common-source outbreaks occasionally occur in developed countries, usually as a result of contaminated food. The most common species isolated in developed countries is *S. sonnei*, while *S. flexneri* serotypes predominate in endemic areas. Epidemics of *S. dysenteriae* 1 occur in equatorial regions, and these outbreaks can involve adults as well as children.

When ingested even in very small numbers, shigellae multiply in the intestine and invade the epithelial lining of the colon. Infection of this tissue elicits an acute inflammatory response (colitis) that is manifested as diarrhea or bloody, mucoid stools (dysentery). The virulence of all *Shigella* species, and *Shigella*-like enteroinvasive *Escherichia coli*, depends on an extrachromosomal genetic element (virulence plasmid) that encodes four invasion plasmid antigen (Ipa) proteins and a secretory system (Type III) for these proteins. Secreted Ipa proteins help shigellae to initiate colonic invasion through specialized endocytic intestinal cells (M cells). After shigellae pass through these M cells, they are phagocytized by tissue macrophages in the underlying lymphoid tissue. Ipa proteins then induce apoptosis (programmed cell death) in infected macrophages, releasing cytokines (primarily IL-1) that initiate an acute, localized inflammatory infiltrate. This infiltrate of polymorphonuclear leukocytes destabilizes tight junctions between absorptive epithelial cells (enterocytes), making the tissue more susceptible to additional *Shigella* invasion. Secreted Ipa proteins induce uptake of shigellae by the colonic enterocytes. The virulence plasmid also encodes an intercellular spread protein (IcsA) that recruits mammalian cytoskeletal elements (primarily actin) to the bacterial surface. This actin is organized into a cytoplasmic motor that facilitates spread of shigellae to adjacent enterocytes. See DIARRHEA; ESCHERICHIA.

In otherwise healthy individuals, bacillary dysentery is typically a short-term disease lasting less than a week. The symptoms can be truncated by appropriate antibiotic therapy (such as oral ampicillin or ciprofloxacin) that rapidly eliminates shigellae from the intestinal lumen and tissues. When *S. dysenteriae* 1 is the etiologic agent, however, hemolytic uremic syndrome can be manifested as a serious consequence of disease. This species produces a cytotoxin (Shiga toxin or Stx) that is functionally identical to the toxin of enterohemorrhagic *E. coli* (for example,

O157:H7). Stx inhibits protein synthesis, damaging endothelial cells of the intestinal capillary bed; the toxin may also damage renal tubules, causing acute renal failure with chronic sequela in up to one-third of hemolytic uremic syndrome patients. See MEDICAL BACTERIOLOGY. [T.L.Ha.]

**Background count** The number of counts recorded by a radiation detector from background radiation. The term background radiation refers to the natural ionizing radiation on the Earth. Ionizing radiation refers to all radiations, waves, and particles that are energetic enough to remove electrons from stable atoms; they are stronger than infrared radiation, radio waves, or visible light, which cannot separate electrons from stable atoms. Radiation strong enough to cause ionization of atoms is measured in electrical units which range from 32 electronvolts up to millions of electronvolts. See ELECTROMAGNETIC RADIATION.

A radiation detector at sea level would detect the radiation from both cosmic and terrestrial sources. The measurement of background radiation is in absorbed dose units known as sieverts (Sv). (Previously the unit was the millirem, and 100 millirem = 1 mSv.) The chief concern is with the amount of background radiation absorbed by people's tissues. Most people absorb about 0.3 mSv per year at sea level, roughly 1 microsievert per day. About 10% of this is external radiation from cosmic radiation, and 10% is external radiation from terrestrial sources. Internal radiation from inhaled and ingested radionuclides constitutes the rest. Some 13% of the background radiation comes from the natural terrestrial radionuclide (radioisotope) potassium-40, which is uniformly concentrated in all living cells and is present as 1 in every 2000 potassium atoms. The remaining two-thirds of the background dose comes from inhalation of radon daughter products. Radon is a radioactive noble gas which is derived from the decay of radium, a decay product of uranium. In regions where the geology is such that there is a relatively high concentration of uranium, the radon concentration may be elevated, and the background dose rate can be quite high. See ENVIRONMENTAL RADIOACTIVITY; RADIOACTIVITY; RADON; UNITS OF MEASUREMENT. [M.Gol.]

**Bacteria** Extremely small—usually 0.3 to 2.0 micrometers in diameter—and relatively simple microorganisms possessing the prokaryotic type of cell construction. Although traditionally classified within the fungi as Schizomycetes, they show no phylogenetic affinities with the fungi, which are eukaryotic organisms. The only group that is clearly related to the bacteria are the blue-green algae. Bacteria are found almost everywhere, being abundant, for example, in soil, water, and the alimentary tracts of animals. Each kind of bacterium is fitted physiologically to survive in one of the innumerable habitats created by various combinations of space, food, moisture, light, air, temperature, inhibitory substances, and accompanying organisms. Dried but often still living bacteria can be carried into the air. Bacteria have a practical significance for humans. Some cause disease in humans and domestic animals, thereby affecting health and the economy. Some bacteria are useful in industry, while others, particularly in the food, petroleum, and textile industries, are harmful. Some bacteria improve soil fertility. As in higher forms of life, each bacterial cell arises either by division of a pre-existing cell with similar characteristics or through a combination of elements from two such cells in a sexual process. See FOOD MICROBIOLOGY; INDUSTRIAL MICROBIOLOGY; PETROLEUM MICROBIOLOGY; SOIL MICROBIOLOGY.

Descriptions of bacteria are preferably based on the studies of pure cultures, since in mixed cultures it is uncertain which bacterium is responsible for observed effects. Pure cultures are sometimes called axenic, a term denoting that all cells had a common origin in being descendants of the same cell, without implying exact similarity in all characteristics. Pure cultures can be obtained by selecting single cells, but indirect methods achieving the same result are more common.

If conditions are suitable, each bacterium grows and divides, using food diffused through the gel, and produces a mass of cells called a colony. Colonies always develop until visible to the naked eye unless toxic products or deficient nutrients limit them to microscopic dimensions. See CULTURE.

The morphology, that is, the shape, size, arrangement, and internal structures, of bacteria can be distinguished microscopically and provides the basis for classifying the bacteria into major groups. Three principal shapes of bacteria exist, spherical (coccus), rod (bacillus), and twisted rod (spirillum). The coccus may be arranged in chains of cocci as in *Streptococcus*, or in tetrads of cocci as in *Sarcina*. The rods may be single or in filaments. Stains are used to visualize bacterial structures otherwise not seen, and the stain reaction with Gram's stain provides a characteristic used in classifying bacteria.

Many bacteria are not motile. Of the motile bacteria, however, some move by means of tiny whirling hairlike flagella extending from within the cell. Others are motile without flagella and have a creeping or gliding motion. Many bacteria are enveloped in a capsule, a transparent gelatinous or mucoid layer outside the cell wall. Some form within the cell a heat- and drought-resistant spore, called an endospore. Cytoplasmic structures such as reserve fat, protein, and volutin are occasionally visible within the bacterial cell.

The nucleus of bacteria is prokaryotic, that is, not separated from the rest of the cell by a membrane. It contains the pattern material for forming new cells. This material, deoxyribonucleic acid (DNA), carrying the information for synthesis of cell parts, composes a filament with the ends joined to form a circle. The filament consists of two DNA strands joined throughout their length. The joining imparts a helical form to the double strand. The double-stranded DNA consists of linearly arranged hereditary units, analogous and probably homologous with the "genes" of higher forms of life. During cell division and sexual reproduction, these units are duplicated and a complete set is distributed to each new cell by an orderly mechanism.

The submicroscopic differences that distinguish many bacterial genera and species are due to structures such as enzymes and genes that cannot be seen. The nature of these structures is determined by studying the metabolic activities of the bacteria. Data are accumulated on the temperatures and oxygen conditions under which the bacteria grow, their response in fermentation tests, their pathogenicity, and their serological reactions. There are also modern methods for determining directly the similarity in deoxyribonucleic acids between different bacteria. See FERMENTATION; PATHOGEN; SEROLOGY.

Bacteria are said to be aerobic if they require oxygen and grow best at a high oxygen tension, usually 20% or more. Microaerophilic bacteria need oxygen, but grow best at, or may even require, reduced oxygen tensions, that is, less than 10%. Anaerobic bacteria do not require oxygen for growth. Obligately anaerobic bacteria can grow only in the complete absence of oxygen. Some bacteria obtain energy from the oxidation of reduced substances with compounds other than oxygen (O<sub>2</sub>). The sulfate reducers use sulfate, the denitrifiers nitrate or nitrite, and the methanogenic bacteria carbon dioxide as the oxidizing agents, producing H<sub>2</sub>S, nitrogen (N<sub>2</sub>), and methane (CH<sub>4</sub>), respectively, as reduction products.

Interrelationships may be close and may involve particular species. Examples are the parasitic association of many bacteria with plant and animal hosts, and the mutualistic association of nitrogen-fixing bacteria with leguminous plants, of cellulolytic bacteria with grazing animals, and of luminous bacteria with certain deep-sea fishes. See NITROGEN FIXATION; POPULATION ECOLOGY. [R.E.H.]

Endospores are resistant and metabolically dormant bodies produced by the gram-positive rods of *Bacillus* (aerobic or facultatively aerobic), *Clostridia* (strictly anaerobic), by the coccus *Sporosarcina*, and by certain other bacteria. Sporeforming bacteria are found mainly in the soil and water and also in the

intestines of humans and animals. Some sporeformers are found as pathogens in insects; others are pathogenic to animals and humans. Endospores seem to be able to survive indefinitely. Spores kept for more than 50 years have shown little loss of their capacity to germinate and propagate by cell division. The mature spore has a complex structure which contains a number of layers. The unique properties of bacterial spores are their extreme resistance to heat, radiation from ultraviolet light and x-rays, organic solvents, chemicals, and desiccation. The capacity of a bacterial cell to form a spore is under genetic control, although the total number of genes specific for sporulation is not known. The actual phenotypic expression of the spore genome depends upon a number of external factors. For each species of sporeforming bacteria, there exist optimum conditions for sporogenesis which differ from the optimal conditions for vegetative growth. These conditions include pH, degree of aeration, temperature, metals, and nutrients. The three processes involved in the conversion of the spore into a vegetative cell are (1) activation (usually by heat or aging), which conditions the spore to germinate in a suitable environment; (2) germination, an irreversible process which results in the loss of the typical characteristics of a dormant spore; and (3) outgrowth, in which new classes of proteins and structures are synthesized so that the spore is converted into a new vegetative cell. [H.O.H.; K.Hu.; C.O.]

**Bacterial genetics** The study of gene structure and function in bacteria. Genetics itself is concerned with determining the number, location, and character of the genes of an organism. The classical way to investigate genes is to mate two organisms with different genotypes and compare the observable properties (phenotypes) of the parents with those of the progeny. Bacteria do not mate (in the usual way), so there is no way of getting all the chromosomes of two different bacteria into the same cell. However, there are a number of ways in which a part of the chromosome or genome from one bacterium can be inserted into another bacterium so that the outcome can be studied. See GENETICS.

All organisms have diverged from a common ancestral prokaryote whose precise location in the evolutionary tree is unclear. This has resulted in three primary kingdoms, the Archaeobacteria, the Eubacteria, and the Eukaryotae. All bacteria are prokaryotes, that is, the "nucleus" or nucleoid is a single circular chromosome, without a nuclear membrane. Bacteria also lack other membrane-bounded organelles such as mitochondria or chloroplasts, but they all possess a cytoplasmic membrane. Most bacteria have a cell wall that surrounds the cytoplasmic membrane, and some bacteria also contain an outer membrane which encompasses the cell wall. Duplication occurs by a process of binary fission, in which two identical daughter cells arise from a single parent cell. Every cell in a homogeneous population of bacterial cells retains the potential for duplication. Bacteria do not possess the potential for differentiation (other than spore formation) or for forming multicellular organisms. See ARCHAEBACTERIA; BACTERIA; PROKARYOTAE; RIBONUCLEIC ACID (RNA).

One of the most frequently used organisms in the study of bacterial genetics is the rod-shaped bacillus *Escherichia coli*, whose normal habitat is the colon. Conditions have been found for growing *E. coli* in the laboratory, and it is by far the best understood of all microorganisms. The single circular chromosome of *E. coli* contains about  $4.5 \times 10^6$  base pairs, which is enough to make about 4500 average-size genes (1000 base pairs each). In regions where mapping studies are reasonably complete, the impression is obtained of an efficiently organized genome. Protein coding regions are located adjacent to regulatory regions. There is no evidence for significant stretches of nonfunctional deoxyribonucleic acid (DNA), and there is no evidence for introns [regions that are removed by splicing the messenger RNA (mRNA) before it is translated into protein] in the coding regions. Very little repetitive DNA exists in the *E. coli* chromosome other

than the seven sequence-related rRNA genes that are dispersed at different locations on the chromosome. See CHROMOSOME; DEOXYRIBONUCLEIC ACID (DNA); GENETIC CODE.

The first step in performing genetic research on bacteria is to select mutants that differ from wild-type cells in one or more genes. Then crosses are made between mutants and wild types, or between two different mutants, to determine dominance-recessive relationships, chromosomal location, and other properties. Various genetic methods are used to select bacterial mutants, antibiotic-resistant cells, cells with specific growth requirements, and so on.

Certain genes that have the function of modulating the expression of other genes are known as regulatory genes. Mutations that affect the action of regulatory proteins are of two types: those that occur in the genes that encode the regulatory proteins, and those that affect the genetic loci where the regulatory protein interacts to modulate the level of gene expression. Some regulatory gene mutations cause overproduction and some cause underproduction of gene products. This is the hallmark of a mutation that influences the functioning of a regulatory protein or regulatory factor-binding site; it affects the quantity but not the quality of other gene products. Furthermore, regulatory gene mutations are frequently pleiotropic, that is, they influence the rate of synthesis of several gene products simultaneously. See GENE ACTION; PROTEIN.

Frequently, geneticists want to increase the number or types of mutants that can be obtained as a result of spontaneous mutagenesis. In such instances, they treat a bacterial population with a mutagenic agent to increase the mutation frequency. This is called induced mutagenesis. The simplest techniques of induced mutagenesis involve measured exposure of the bacteria to a mutagenic agent, such as x-rays or chemical mutagenic agents. Such procedures have a general effect on the increase in the mutation rate. More sophisticated procedures involve isolating the gene of interest and making a change in the desired location. This is called site-directed mutagenesis. The goal is usually to determine the effects of a change at a specific gene locus. The gene in question is isolated, modified, and reinserted into the organism. Discrete alterations can be made in a variety of ways on any DNA in cell-free culture, and the effect of such alterations can be subsequently tested in the organism. See GENETIC ENGINEERING; MUTAGENS AND CARCINOGENS.

Bacteria do not mate to form true zygotes, but they are able to exchange genetic information by a variety of processes in which partial zygotes (merozygotes) are formed. The first type of genetic exchange between bacteria to be observed was transformation. Naturally occurring transformation involves the uptake of DNA. This phenomenon is observed only for a limited number of bacterial species and is a relatively difficult technique to use for gene manipulation. In 1946 direct chromosomal exchange by conjugation between *E. coli* cells was discovered by J. Lederberg and E. Tatum, and in 1951 transduction, the virus-mediated transfer of bacterial genes, was discovered. Both conjugation and transduction provide facile, generally applicable methods for moving part of the bacterial chromosome from one cell to another. The discovery of bacterial transposons (a class of mobile genetic elements commonly found in bacterial populations) in the 1970s has been useful in marking and mobilizing genes of interest. The purely genetic approaches to mapping have been supplemented by the biochemical approaches of hybrid plasmid construction and DNA sequence analysis. See GENETIC MAPPING; TRANSFORMATION (BACTERIA); TRANSPOSONS.

At any given time, only a small percentage of the *E. coli* genome is being actively transcribed. The remainder of the genome is either silent or being transcribed at a very low rate. When growth conditions change, some active genes are turned off and other, inactive genes are turned on. The cell always retains its totipotency, so that within a short time (seconds to minutes), and given appropriate circumstances, any gene can be fully turned on. The maximal activity for transcription varies

from gene to gene. For example, a  $\beta$ -galactosidase gene makes about one copy per minute, and a fully turned-on biotin synthase gene makes about one copy per 10 min. In the maximally repressed state, both of these genes express less than one transcript per 10 min. The level of transcription for any particular gene usually results from a complex series of control elements organized into a hierarchy that coordinates all the metabolic activities of the cell. For example, when the rRNA genes are highly active, so are the genes for ribosomal proteins, and the latter are regulated in such a way that stoichiometric amounts of most of the ribosomal proteins are produced. When glucose is abundant, most genes involved in processing more complex carbon sources are turned off in a process called catabolite repression. If the glucose supply is depleted and lactose is present, the genes involved in lactose breakdown (catabolism) are expressed. In *E. coli* the production of most RNAs and proteins is regulated exclusively at the transcriptional level, although there are notable exceptions. [G.Z.]

**Bacterial growth** The processes of both the increase in number and the increase in mass of bacteria. Growth has three distinct aspects: biomass production, cell production, and cell survival. Biomass production depends on the physical aspects of the environment (water content, pH, temperature), the availability of resources (carbon and energy, nitrogen, sulfur, phosphorus, minor elements), and the enzymatic machinery for catabolism (energy trapping), anabolism (biosynthesis of amino acid, purines, pyrimidines, and so forth), and macromolecular synthesis [proteins, ribonucleic acid (RNA), and deoxyribonucleic acid (DNA)]. Cell production is contingent on biomass production and involves, in addition, the triggering of chromosome replication and subsequent cell division. The cells may or may not separate from each other, and the division may partition the cell evenly or unevenly. Alternatively, growth may occur by budding (unequal division). Most cells so produced are themselves capable of growing and dividing; consequently, viability is usually very high when growth conditions are favorable. Moreover, in many cases the incidence of death is surprisingly low in the absence of needed nutrients. Many bacteria differentiate into resistant resting forms (such as spores); others may simply reduce their rate of metabolism and persist in the vegetative state for long times. [A.L.Ko.]

**Bacterial luminescence** The production of visible light by bacteria; with very few exceptions this light is blue-green. The phenomenon is seen in many species of several genera, including *Vibrio*, *Photobacterium*, *Alteromonas*, and *Xenorhabdus*. Luminous bacteria are primarily marine, but there are some genera with terrestrial (*Xenorhabdus*) and fresh-water (*Vibrio*) species. In the marine environment the bacteria are found in various habitats, including planktonic (free-floating), saprophytic (on a variety of marine proteinaceous materials), parasitic (on a number of marine invertebrates), and symbiotic. The symbiotic habitat can take one of several forms. The symbiotic bacteria may be loosely associated as gut symbionts in many different marine organisms; they may be specifically and more tightly associated in the light organs of marine fishes and squids; or they may be very tightly associated as intracellular symbionts in luminous pyrosomes (light-emitting organelles). When associated as light-organ symbionts, the bacteria are used by the host fish or squid as a biological light bulb. Under these conditions the bacteria are maintained in specialized organs where they are cultured by the host organism, kept free from contaminants, and continuously emit light. The actual light emission is then controlled physically by the host's use of shutters, chromatophores, or other mechanisms. These symbiotic relationships are probably the most common habitats in which bacterial luminescence is observed in the ocean.

The chemistry of bacterial luminescence is unique among luminous organisms. The enzyme that catalyzes light emission is lu-

ciferase; it combines with a riboflavinlike substance called flavin mononucleotide (FMNH<sub>2</sub>). This complex then reacts with a long-chain aldehyde, and with molecular oxygen to form an excited state capable of emitting light. The molecule that actually emits the light is an altered form of the flavin. This unique biochemistry has been used as an indicator of the presence of luminous bacteria in cases where the symbiotic bacteria could not be obtained in pure culture or could not be grown free from their host. See BACTERIAL PHYSIOLOGY AND METABOLISM; BIOLUMINESCENCE; RIBOFLAVIN. [K.H.N.]

**Bacterial physiology and metabolism** The biochemical reactions that together enable bacteria to live, grow, and reproduce. Strictly speaking, metabolism describes the total chemical reactions that take place in a cell, while physiology describes the role of metabolic reactions in the life processes of a bacterium. The study of bacteria has significance beyond the understanding of bacteria themselves. Since bacteria are abundant, easily grown, and relatively simple in cellular organization, they have been used extensively in biological research. Functional analyses of bacterial systems have provided a foundation for much of the current detailed knowledge about molecular biology and genetics. Bacteria are prokaryotes, lacking the complicated cellular organization found in higher organisms; they have no nuclear envelope and no specialized organelles. Yet they engage in all the basic life processes—transport of materials into and out of the cell, catabolism and anabolism of complex organic molecules, and the maintenance of structural integrity. To accomplish this, bacteria must obtain nutrients and convert them into a form of energy that is useful to the cell. [M.R.J.S.]

**Enzymes.** A list of bacterial enzymes (organic catalysts) includes many of the enzymes found in mammalian tissues, as well as many enzymes not found in higher forms of life. By combining with such enzymes, many antibiotics are able to exert a selective killing or inhibition of bacterial growth without causing toxic reactions in the mammalian host. The great capability of the bacterial cell to metabolize a wide variety of substances, as well as to control to some extent the environment in which the cell lives, is reflected in its ability to form inducible enzymes. The majority of bacterial enzymes require cofactors for activity. These cofactors may be inorganic cations or organic molecules called coenzymes. See COENZYME; ENZYME.

Bacterial enzymes may be classified in numerous ways, for example, on the basis of (1) whether they are inducible or constitutive (constitutive enzymes are defined as those enzymes formed by the bacterial cell under any or all conditions of growth, whereas inducible enzymes are formed by the bacterial cell only in response to an inducer); (2) whether they are degradative (catabolic; resulting in the release of energy) or synthetic (anabolic; using energy to catalyze the formation of macromolecules); or (3) whether they are exoenzymes (enzymes secreted from the cell to hydrolyze insoluble polymers—wood, starch, protein, and so on—into smaller, soluble compounds which can be taken into the cytoplasm of the bacterium).

In addition, bacterial enzymes are involved in the transport of substrates across the cell wall, in the oxidation of inorganic molecules to provide energy for the cell, and in the destruction of a large number of antibiotics.

Many pathogenic microorganisms excrete enzymes which may play an important role in pathogenesis in some cases (see table). The  $\alpha$ -toxin (lecithinase) of *Clostridium perfringens* illustrates a highly active enzyme which is responsible for the necrotizing action associated with gas gangrene infections due to this microorganism. *Streptococcus pyogenes* excretes hyaluronidase which degrades ground substance (polymer of hyaluronic acid), and streptokinase, which activates plasmin resulting in a system that lyses fibrin. Other examples include coagulase of the *Staphylococcus*, which activates clotting of plasma, urease of *Proteus*

## Enzymes excreted by microorganisms of medical importance

Organism	Enzyme	Substrate	End products
<i>Clostridium</i>	Lecithinase Collagenase	Lecithin Collagen	Diglyceride, phosphoryl choline ?
<i>Streptococcus</i>	Hyaluronidase Streptodornase Streptokinase	Hyaluronic acid polymer Deoxyribonucleic acid Activates plasminogen to plasmin	Hyaluronic acid Nucleotides Results in lysis of fibrin clots
<i>Staphylococcus</i>	Coagulase	Coagulase reacting factor	Results in coagulation of plasma
<i>Proteus</i>	Urease	Urea	Ammonia and carbon dioxide
<i>Corynebacterium diphtheriae</i>	Diphtheria toxin	Nicotinamide dinucleotide (NAD)	Splits NAD and adds ADP-ribose to elongation factor 2 to prevent protein synthesis by freezing ribosome movement

*vulgaris*, which splits urea to ammonia and carbon dioxide, and collagenase of *Clostridium*, which hydrolyzes collagen. See DIPHTHERIA; GANGRENE; STAPHYLOCOCCUS.

Many bacteria are able to synthesize enzymes which will hydrolyze or modify an antibiotic so that it is no longer effective. Essentially all of these enzymes are coded by DNA that exists in bacterial plasmids. As a result, the ability to produce enzymes which destroy antibiotics can be rapidly passed from one organism to another either by conjugation in gram-negative organisms or by transduction in both gram-negative and gram-positive bacteria. [W.A.V.]

**Bacterial catabolism.** Bacterial catabolism comprises the biochemical activities concerned with the net breakdown of complex substances to simpler substances by living cells. Substances with a high energy level are converted to substances of low energy content, and the organism utilizes a portion of the released energy for cellular processes. Endogenous catabolism relates to the slow breakdown of nonvital intracellular constituents to secure energy and replacement building blocks for the maintenance of the structural and functional integrity of the cell. This ordinarily occurs in the absence of an external supply of food. Exogenous catabolism refers to the degradation of externally available food. The principal reactions employed are dehydrogenation or oxygenation (either represents biological oxidation), hydrolysis, hydration, decarboxylation, and intermolecular transfer and substitution. The complete catabolism of organic substances results in the formation of carbon dioxide, water, and other inorganic compounds and is known as mineralization. Catabolic processes may degrade a substance only part way. The resulting intermediate compounds may be reutilized in biosynthetic processes, or they may accumulate intra- or extracellularly. Catabolism also implies a conversion of the chemical energy into a relatively few energy-rich compounds or "bonds," in which form it is biologically useful; also, part of the chemical energy is lost as heat.

Bacterial intermediary metabolism relates to the chemical steps involved in metabolism between the starting substrates and the final product. Normally these intermediates, or precursors of subsequent products, do not accumulate inside or outside the bacterial cell in significant amounts, being transformed serially as rapidly as they are formed. The identification of such compounds, the establishment of the coenzymes and enzymes catalyzing the individual reaction steps, the identity of active forms of the intermediates, and other details of the reaction mechanisms are the objectives of a study of bacterial intermediary metabolism. [J.W.Fo./R.E.K.]

Many bacteria are able to decompose organic compounds and to grow in the absence of oxygen gas. Such anaerobic bacteria obtain energy and certain organic compounds needed for growth by a process of fermentation. This consists of an oxidation of a suitable organic compound, using another organic compound as an oxidizing agent in place of molecular oxygen. In most fermentations both the compounds oxidized and the compounds reduced (used as an oxidizing agent) are derived from a single fermentable substrate. In other fermentations, one substrate is oxidized and another is reduced. Different bacteria

ferment different substrates. Many bacteria are able to ferment carbohydrates such as glucose and sucrose, polyalcohols such as mannitol, and salts of organic acids such as pyruvate and lactate. Other compounds, such as cellulose, amino acids, and purines, are fermented by some bacteria. [H.A.B.]

**Bacterial anabolism.** Bacterial anabolism comprises the physiological and biochemical activities concerned with the acquisition, synthesis, and organization of the numerous and varied chemical constituents of a bacterial cell. Clearly, when a cell grows and divides to form two cells, there exists twice the amount of cellular components that existed previously. These components are drawn, directly or indirectly, from the environment around the cell, and (usually) modified extensively in the growth processes when new cell material is formed (biosynthesis). This build-up, or synthesis, begins with a relatively small number of low-molecular-weight building blocks which are either assimilated directly from the environment or produced by catabolism. By sequential and interrelated reactions, they are fashioned into different molecules (mostly of high molecular weight, and hence called macromolecules), for example, lipids, polysaccharides, proteins, and nucleic acids, and many of these molecules are in turn arranged into more complex arrays such as ribosomes, membranes, cell walls, and flagella. Other typical anabolic products, of lower molecular weight, include pigments, vitamins, antibiotics, and coenzymes. The enzymes responsible for the sequential reactions in any one biosynthetic pathway or assembly sequence are often located on or in cellular structures and thus in physical proximity to the preceding and succeeding enzymes, and their products, and to the site(s) where cellular structures are to be formed. Anabolism also includes the transport of molecules into cells, of building blocks to reaction sites, energetic activations, and the transfer and incorporation of the finished products to their ultimate sites in or outside the cell. [E.R.L.]

**Bacterial taxonomy** The classification, nomenclature, and identification of bacteria; sometimes used as a term to indicate the theory of classification. The bacteria are members of the kingdom Prokaryotae, which is defined in terms of the unique structural and biochemical properties of their cells; more specifically, the organization of the deoxyribonucleic acid (DNA) in the nucleus, the lack of a nuclear membrane, the lack of independent membrane-bounded cytoplasmic organelles, the lack of endocytosis and exocytosis, and the chemical nature of some components of plasma membrane and cell walls.

Classification involves the recognition of similarities and relationships as a basis for the arrangement of the bacteria into taxonomic groups or taxa. The basic taxon is the species. Identification involves the recognition of a bacterium as a member of one of the established taxa, appropriately named, by the comparison of a number of characters with those in the description. See BACTERIA; TAXONOMIC CATEGORIES.

A bacterial species is a conceptual entity that is hard to define, despite its role as the basic taxonomic grouping. Bacteriologists accept the imprecision and recognize that a species represents a cluster of clones exhibiting some variations in minor properties.

They have developed a formal approach to the description of the taxon while trying to solve the problems encountered in the process of recognizing and naming species. The description is an assembly of such structural, chemical, physiologic, genetic, and ecologic characteristics as can be determined for the available strains that closely resemble each other. A strain is any pure culture of an organism isolated from nature, and the collected strains may then be conserved as cultures in the laboratory for study and comparison. In addition to the description, one strain must be designated by the author and preserved in a culture collection as a type strain, or permanent example, of the species and available to all who study bacteria. If that type strain is lost or succumbs, a formal proposal of a substitute strain (neotype) must be published. In general, bacterial taxonomy is built around the living type specimen: a species consists of the type strain and, whenever available, all other strains sufficiently similar to the type strain to be considered as included in the species. There is a provision for the description and naming of a distinctive species that is not yet cultivable, with the requirement for a suitably preserved type specimen.

A new species, validly described, must be assigned to a genus in order to accord with the binomial system of nomenclature initiated by C. Linnaeus. Thus, a species assigned to the genus *Bacillus* would be referred to as, for example, *Bacillus subtilis*. Such formal names of taxa are italicized to indicate that they are considered to accord with the formal description. If there is no appropriate genus available, a new genus must be named in accord with the *International Code of Nomenclature of Bacteria* and provided with a description that circumscribes the included species, and a type species must be designated as the exemplary representative of the genus.

The lowest nomenclatural rank that is recognized by the *Code* is subspecies, which is a subdivision of the species recognizing consistent variations in otherwise stable characters in the species description, for example, *Bacillus cereus* ssp. *mycoides*. There are times, however, when even finer but unofficial subdivisions of the species are useful and contribute to science, for example, for the epidemiology of pathogenic species. Then, groups of strains may be recognized by some special character as a variety of the species. These may be based on a biological property (biovar), antigenic variation (serovar), pathogenicity (pathovar), or susceptibility to particular bacterial viruses (phagovar). These characters have no formal standing in nomenclature.

Several new techniques are presently used in modern approaches to taxonomy. Numerical taxonomy (taxometrics) is a first approach for the analysis of phenotype. It implies the existence of programs for computer-assisted identification, either as recognizable phenons or by relation into a computer-stored classification and key program. Either of these methods has found considerable application in dealing with masses of isolates (for example, in studies of pollution or of sediments), or in dealing with results of automated systems for identification of pathogens in clinical bacteriology. See NUMERICAL TAXONOMY.

Chemotaxonomy applies systematic data on the molecular architecture of components of the bacterial cell to the solution of taxonomic problems. This has been a powerful tool since the 1950s, and a number of chemotaxonomic markers have been identified, ranging from molecules unique to the Prokaryotae or specific groups of bacteria to mechanisms or products of metabolism that characterize genera or species. The availability, and relative simplicity of techniques for amino acid analysis, for sequential analysis of polymers, for gas and thin-layer chromatography, for fermentation products and lipids, and so on, have made the systematic studies possible. These have led to a more effective definition of taxonomic groups based on biochemical assessment of cell wall composition, lipid composition of membranes, the types of isoprenoid quinones, the amino acid sequences of select proteins, and the characterization of proteins,

such as the cytochromes and many other macromolecules. See CHEMOTAXONOMY.

Nucleic acid studies have been by far the most potent generators and arbiters of data on relatedness, with distinct capability for applications to the phylogenetic assessment of taxonomic arrangements. See DEOXYRIBONUCLEIC ACID (DNA); RIBONUCLEIC ACID (RNA). [R.G.E.M.]

**Bacteriology** The science and study of bacteria, and hence a specialized branch of microbiology. It deals with the nature and properties of the bacteria as living entities, their morphology and developmental history, ecology, physiology and biochemistry, genetics, and classification.

The major subjects that have consecutively occupied the forefront of bacteriological research have been the origin of bacteria, the constancy or variability of their properties, their role as causative agents of disease and of spoilage of foods, their significance in the cycle of matter, their classification, and their physiological, biochemical, and genetic features. See BACTERIA; MICROBIOLOGY. [C.B.V.N.]

**Bacteriophage** Any of the viruses that infect bacterial cells. They are discrete particles with dimensions from about 20 to about 200 nanometers. A given bacterial virus can infect only one or a few related species of bacteria; these constitute its host range. Bacteriophages consist of two essential components: nucleic acid, in which genetic information is encoded (this may be either ribonucleic acid or deoxyribonucleic acid), and a protein coat (capsid), which serves as a protective shell containing the nucleic acid and is involved in the efficiency of infection and the host range of the virus.

The description of a bacterial virus involves a study of its shape and dimensions by electron microscopy (see illustration), its host range, the serological properties of its capsid, the kind of nucleic acid it contains, and the characters of the plaques it forms on a given host. Both the nucleic acid and the capsid proteins are specific to the individual virus; in the case of the capsid proteins this specificity is the basis for serological identification of the virus.

The most striking form of phage infection is that in which all of the infected bacteria are destroyed in the process of the formation of new phage particles. This results in the clearing of a turbid liquid culture as the infected cells lyse. When lysis occurs in cells fixed as a lawn of bacteria growing on a solid

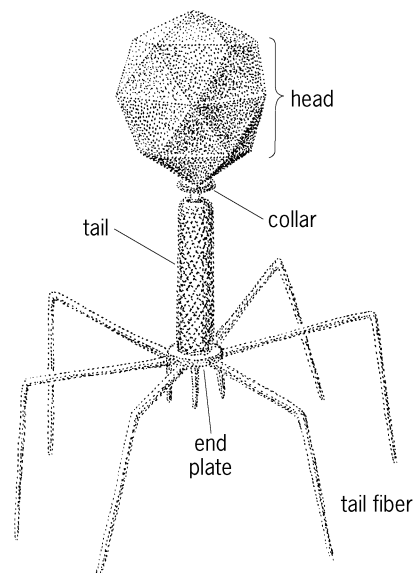

Diagram of a T4 bacteriophage.

medium, it produces holes, or areas of clearing, called plaques. These represent colonies of bacteriophage. The size and other properties of the plaque vary with individual viruses and host cells. See ACTINOPHAGE; COLIPHAGE; LYSOGENY; LYTIC INFECTION; VIRUS. [L.B.]

**Badger** The name for a number of species of heavily built omnivorous mammals assigned to the subfamily Melinae of the weasel family, Mustelidae. There are eight species in six genera (see table). *Taxidea taxus*, the American badger, is the only representative in North America. It tends to be more carnivorous with a diet consisting of small rodents, rabbits, prairie dogs, and ground squirrels in addition to vegetation. The American badger is more frequently found in open terrain than is the Eurasian species, which prefers wooded regions. Badgers live in burrows, called sets.

#### Names and geographic distribution of badgers

Species	Common name	Geographic distribution
<i>Taxidea taxus</i>	American badger	North America, especially United States
<i>Meles meles</i>	Eurasian or common badger	Europe, Asia
<i>Arctonyx collaris</i>	Hog or sand badger	Sumatra, southern Asia
<i>Suillotaxus marchei</i>	Philippines badger	Philippines
<i>Mydaus javanensis</i>	Malay or stinking badger, teledu	Malay Archipelago
<i>Melogale moschata</i>	Chinese ferret, badger	China, especially forested areas
<i>Melogale orientalis</i>	Javanese ferret, badger	Java, Borneo
<i>Melogale personata</i>	Burmese ferret, badger	Malayasia

Badgers are essentially nocturnal animals which have nonretractile claws on each of the five digits. Anal scent glands are present. The badgers walk on their feet and toes, and therefore are plantigrade. They have 38 teeth. Although little is known about the breeding behavior of the animal, the usual litter is three or four, and the gestation period for the Eurasian badger is known to be 7 months. In the colder regions of their range, badgers hibernate for varying periods from October on, with the exception of *Meles meles*, which is active during the winter. See CARNIVORA; HIBERNATION. [C.B.C.]

**Balance** An instrument used for the precise measurement of small weights or masses in amounts ranging from micrograms up to a few kilograms. See MASS; WEIGHT.

Balances are differentiated according to design, weighing principle, and metrological criteria (see table). For a given weighing task, a balance is selected primarily for its maximum weighing load (Max) and for the finest graduation or division (d) of its weight-reading device (scale dial, digital display, readout).

Balances can be roughly differentiated from scales by their resolution or number of scale divisions,  $n = \text{Max}/d$ . Balances typically have a resolution of more than 10,000 divisions, and scales for the most part have less.

A traditional mechanical balance consists of a symmetric lever called a balance beam, two pans suspended from its ends, and a pivotal axis (fulcrum) at its center (see illustration). The object

#### Classification of balances

Type	Division (d)	Typical capacity (Max)
Ultramicroanalytical	0.1 $\mu\text{g}$	3 g
Microanalytical	1 $\mu\text{g}$	3 g
Semimicroanalytical	0.01 mg	30 g
Macroanalytical	0.1 mg	160 g
Precision	$\geq 1$ mg	160 g–60 kg

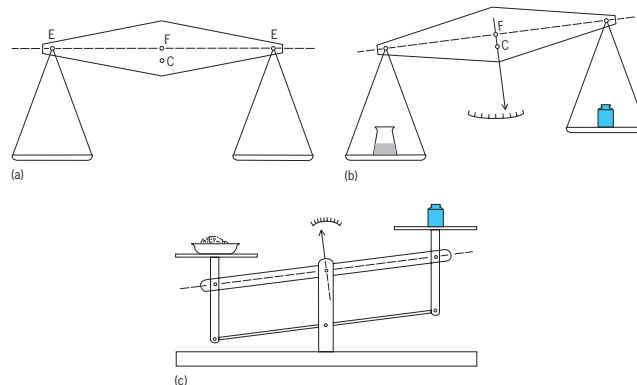

**Mechanical balance design.** (a) Critical design aspects for an equal-arm balance. (b) Weighing small weight differentials with an equal-arm balance. (c) Top-loading equal-arm balance. F, fulcrum; E, end pivot; C, center of gravity.

to be weighed is placed on one pan, whereupon the balance is brought into equilibrium by placing the required amount of weights on the opposite pan. Thus the weight of an object is defined as the amount represented by the calibrated standard masses that will exactly counterbalance the object on a classic equal-arm balance. Although this is not self-evident with modern balances and scales, the measurement of weight continues to be based on this original understanding.

The substitution principle represented the conclusive step in the evolution of the mechanical balance. Substitution balances have only one hanger assembly, incorporating both the load pan and a built-in set of weights on a holding rack. The hanger assembly is balanced by a counterpoise which is rigidly connected to the other side of the beam. The weight of an object is determined by lifting weights off the holding rack until the balance returns to an equilibrium position within its angular, differential weighing range. Small increments of weight in between the discrete dial weight steps are read from the projected screen image of a graduated optical reticle which is rigidly connected to the balance beam.

The evolution of electronic (more accurately, electromechanical) balances started in the late 1960s and has extended over several generations of electronic technology. Among a number of technical possibilities, one operating principle, electromagnetic force compensation, emerged early as the standard in high-precision weighing. First described by K. Ångström in 1895, the principle of electromagnetic force compensation became feasible for technical application as a result of the advancements in solid-state electronic components.

In every electromechanical weighing system, there are three basic functions: (1) The load-transfer mechanism, composed of the weighing platform or pan, levers, and guides, receives the weighing load on the pan as a randomly distributed pressure force and translates it into a measurable single force. (2) The electromechanical force transducer, often called load cell, converts the mechanical input force into an electrical output, for example, voltage, current, or frequency. (3) The electronic signal-processing part of the balance receives the output signal, converts it to numbers, performs computation, and displays the final weight data on the readout.

Besides improved accuracy, reliability, and speed of operation, the main benefits from this technology are human-engineered design for optimized interaction between operator and instrument, and numerous operating conveniences such as push-button zero setting, automatic calibration, built-in computing capabilities for frequently used work procedures, and data output to printers and computers. See PHYSICAL MEASUREMENT; WEIGHT MEASUREMENT. [W.E.Kup.]

**Balanomorpha** A suborder of the Thoracica. This group includes the common acorn barnacles. The mantle secretes a highly calcified test forming the bilaterally symmetrical conical shell, consisting typically of anterior rostrum, posterior carina, and one to three pairs of lateral plates. The broad basis is membranous or calcified. The shell (mantle) opening is closed by paired valves, each formed of two interlocking plates. These animals are hermaphroditic, and cross-fertilization is normal. Dwarf males have been recorded.

Balanomorph barnacles are found on almost every possible site for attachment, inanimate or living. They are most abundant intertidally and in shallow water. Some species occur at great depths. A few have become an economic problem as fouling organisms on ship hulls and in marine installations. See BARNACLE; THORACICA. [H.G.St.]

**Ball-and-race-type pulverizer** A grinding machine in which balls rotate under pressure to crush materials, such as coal, to a fine consistency. The material is usually fed through a chute to the inside of a ring of closely spaced balls. In most designs the upper spring-loaded race applies pressure to the balls, and the lower race rotates and grinds the coarse material between it and the balls (see illustration). Two or more rings of

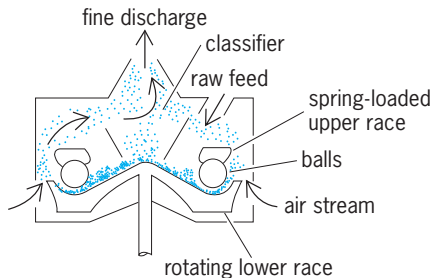

Coarse raw material is ground by crushing and attrition between balls and races and is then withdrawn from the pulverizer by an airstream.

balls can be cascaded in one machine to obtain greater capacity or output. Counterrotating top and bottom rings also are used to increase pulverizer capacity. Such pulverizers are compact and the power required per ton of material ground is relatively low. See CRUSHING AND PULVERIZING. [G.W.K.]

**Ballast resistor** A resistor that has the property of increasing in resistance as current flowing through it increases, and decreasing in resistance as current decreases. Therefore the ballast resistor tends to maintain a constant current flowing through it, despite variations in applied voltage or changes in the rest of the circuit. See RESISTOR.

The ballast action is obtained by using resistive material that increases in resistance as temperature increases. Any increase in current then causes an increase in temperature, which results in an increase in resistance and reduces the current. Ballast resistors may be wire-wound resistors. Other types, also called ballast tubes, are usually mounted in an evacuated envelope to reduce heat radiation.

Ballast resistors have been used to compensate for variations in line voltage, as in some automotive ignition systems, or to compensate for negative volt-ampere characteristics of other devices, such as fluorescent lamps and other vapor lamps. See FLUORESCENT LAMP; VAPOR LAMP; VOLTAGE REGULATOR. [D.L.An.]

**Ballistic missile** A weapon that consists of integral rocket propulsion, means of pointing or guiding the weapon's velocity vector to a prescribed orientation at the position and

time of rocket engine shutoff or burnout, and a warhead. In certain applications, means of deploying multiple warheads or submunitions may be incorporated. Ballistic missiles are conceptually simple weapons whose implementation becomes more complex with increasing accuracy, range, and defense penetration requirements.

The term ballistic means that part or most of the missile's trajectory is not subject to propulsion or control. In its ballistic phase of flight, a missile's motion is affected only by gravitation and uncontrolled aerodynamic interactions with the atmosphere.

The ballistic missile follows an elliptical path due to action of the Earth's gravitational field. If both the burnout velocity and burnout altitude are large, then an upwardly slanted flight path will cause the missile's trajectory to rise high above the sensible atmosphere, thereby eliminating the retarding and disturbing influences of the Earth's atmosphere for most of the trajectory. See BALLISTICS; CELESTIAL MECHANICS.

All ballistic missiles incorporate means of pointing or guiding their velocity vectors so that their trajectories end coincidentally with the intended target. The simplest instance involves launching a missile from a guide rail or tube which the weapon operator points toward the intended target and upward at predetermined elevation angle that will result in a missile impact in the target area. The Army's Multiple Rocket Launching System (MRLS) is a good example of simple pointing as the means of initial-conditions guidance. Intercontinental ballistic missiles (ICBMs) wherein propulsion durations of several minutes are typical and precise pointing of the velocity vector at propulsion burnout is essential to achieve the desired accuracy in hitting the target area after intercontinental flight. ICBMs and theater nuclear weapons typically employ control over the direction of thrust from their rocket motors to change the orientation of the missile in response to guidance commands. Guidance is based upon the principles of inertial navigation. See GUIDANCE SYSTEMS; INERTIAL GUIDANCE SYSTEM.

Ballistic missiles are either land-based or sea-based.

Land-based versions are commonly categorized according to the distance they can fly. See ARMY ARMAMENT.

1. Battlefield ballistic missiles can hit targets from 12 to 300 mi (20 to 500 km) from the launch point, and generally employ conventional (nonnuclear) or submunition warheads.

2. Intermediate-range ballistic missiles (IRBM), which are sometimes referred to as intermediate nuclear forces (INF) or theater nuclear weapons, come in a variety of sizes, and can hit targets 300 to 3000 mi (500 to 5000 km) from the launch site. These missiles invariably carry one to three nuclear warheads.

3. ICBMs have flyout ranges between 5500 and 7500 mi (9000 and 12,000 km). Modern ICBMs carry from one to ten nuclear warheads in reentry vehicles that are independently targetable (multiple independently targeted reentry vehicles, or MIRVs).

Sea-based ballistic missiles are invariably based on submarines (submarine-launched ballistic missiles, or SLBMs), providing considerable uncertainty as to their location as an important element of survivability. The flyout range of SLBMs has systematically increased from a few thousand kilometers to more than 5500 mi (9000 km), equaling the capability of ICBMs. SLBMs have employed MIRV warheads since the early 1970s, and accuracy enhancements of the 1980s provide SLBMs with effectiveness levels comparable to those of their land-based counterparts. See GUIDED MISSILE; MISSILE; NAVAL ARMAMENT; SUBMARINE. [M.M.Br.]

**Ballistic range** A long, instrumented enclosure wherein tests of gun-launched projectiles are conducted. Ballistic ranges were originally used for study of projectile flight characteristics such as the rate of velocity loss and the dispersion of trajectories, that is, the imperfect following of the bore sight line of the gun. Ballistic ranges are now used for the measurement of aerodynamic characteristics of projectiles and of scale models of



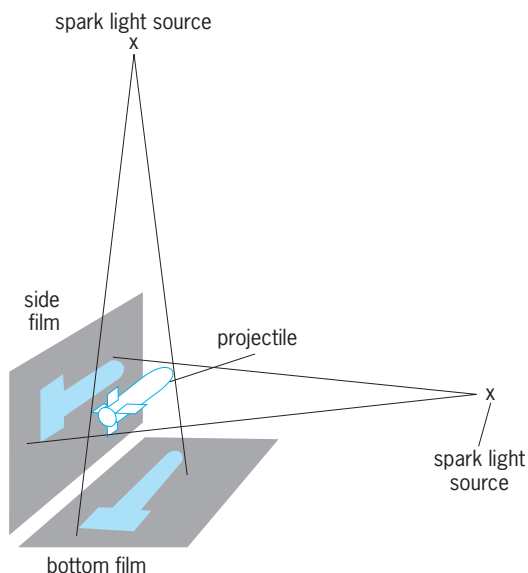

Fig. 1. Simple shadowgraph system.

vehicles intended for flight through the atmosphere, including missiles, aircraft, and space-flight capsules.

Ballistic ranges may vary in length from less than 10 ft (3 m), for limited investigations of small arms projectiles, to greater than 1000 ft (300 m), for detailed studies of projectiles from large-bore guns. Instrumentation may be as simple as a series of sheets of paper hung normal to the flight path (yaw cards) in which the projectile, by punching its outline, gives evidence of its vertical and lateral position and its angular orientation at the instant of penetration. The more refined instruments required in modern practice are usually photographic. A spark of extremely short duration (from 1 to 0.1 microsecond) is discharged when the projectile reaches a position between the spark and a piece of film (Fig. 1). The resulting shadow photograph (shadowgraph) records in projection two components of the linear position of the projectile and one component of angular orientation. Two orthogonal pictures, as in the simple system shown, completely define the position in space of the model. A number of shadowgraph stations placed in sequence along the flight path will define, as a function of distance flown, the history of position and attitude of the projectile in flight. Corollary timing apparatus is used to measure the precise times, frequently accurate within microseconds, at which the pictures are recorded.

The shadowgraph pictures further aid aerodynamic studies by making visible certain details of the airflow about the projectile (Fig. 2). Refraction, or bending, of light rays by the variable-air-density field about the model makes visible the shock waves, turbulence, boundary layers, and boundaries of expansion fans.

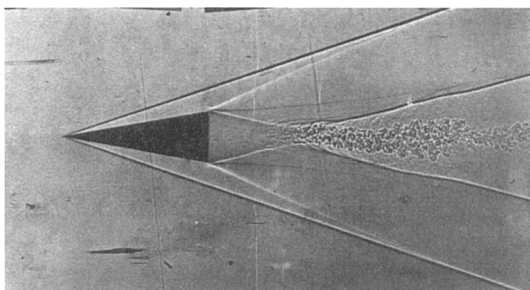

Fig. 2. Shadowgraph of a cone in supersonic flight. (NASA, Ames Research Center)

The flow visualization is most valuable for the study of aerodynamics.

In modern practice the velocity performance of ballistic ranges has sometimes been enhanced by placing the instrumented range within the test section of a supersonic wind tunnel, which provides a high-velocity airflow opposite in direction to the model's flight direction. The earliest facility of this type used a conventional supersonic wind tunnel with a very long test section, driven by a high-pressure reservoir of air at room temperature. Later devices have been driven by high-temperature air generated in a shock tube. See WIND TUNNEL. [A.Se.]

**Ballistics** That branch of applied physics which deals with the motion of projectiles and the conditions governing that motion. Commonly called the science of shooting, it is, for practical purposes, subdivided into exterior and interior ballistics. Exterior ballistics begins at the instant the projectile leaves the muzzle of the gun barrel; interior ballistics, logically, deals with the events preceding this instant, that is, the events inside the gun barrel. [W.L./D.Wo.]

**Balloon** A nonporous envelope of thin material filled with a lifting gas and capable of lifting any surrounding material and usually a suspended payload into the atmosphere. A balloon which is supported chiefly by buoyancy imparted by the surrounding air is often referred to as an aerostat. The balloon rises because of a differential displacement of air according to Archimedes' principle, which states that the total upward buoyant force is equal to the weight of the air displaced. The upper practical limit for useful ballooning is approximately 34 mi (55 km). Beyond this altitude, the exponential nature of the atmosphere would require balloons of enormous size and delicately thin skin. A record altitude of 32.2 mi (51.8 km) has been recorded.

Balloons have been configured in many geometrical shapes, but the most common are spheres, oblate spheroids, and aerodynamic configurations. The materials used in the manufacture of the balloon envelope have been paper, rubber, fabric, and various plastics. Several types of lifting gases have been used to inflate balloons, but the most common in use are helium, hydrogen, and heated air.

The many types of balloons in use fall into twin main categories: extensible (expandable) and nonextensible. There are three methods of balloon operation: free balloons which are released into the atmosphere, tethered or moored balloons, and powered or controlled free balloons. The various types of balloons in use are the hot-air balloon, meteorological balloon, zero-pressure balloon, superpressure balloon, tethered balloon, and powered balloon (airship). See AIRSHIP. [W.R.N.]

**Balsa** A fast-growing tree, *Ochroma lagopus*, widely distributed in tropical America, especially in Ecuador. The leaves are simple, angled, or lobed, and the flowers are large and yellowish-white or brownish, and they are terminal on the branches. See MALVALES.

With plenty of room for growth in a rich, well-drained soil at low elevations, the wood is very light and soft. However, under adverse conditions, the wood is heavier. Culture is important, for if the trees are injured only slightly, the wood develops a hard and fibrous texture, thereby losing its commercial value. To secure a uniform product the trees must be grown in plantations.

The wood decays easily in contact with the soil and is subject to sap stain if not promptly dried. Seasoned lumber absorbs water quickly, but this can be largely overcome by waterproofing.

Balsa owes most of its present commercial applications to its insulating properties. Balsa also has sound-deadening qualities, and is also used under heavy machinery to prevent transmission of vibrations. The heartwood of balsa is pale brown or reddish, whereas the sapwood is nearly white, often with a yellowish

or pinkish hue. Luster is usually rather high, and the wood is odorless and tasteless. [A.H.G./K.P.D.]

**Baltic Sea** A semienclosed brackish sea located in a humid zone, with a positive water balance relative to the adjacent ocean (the North Sea and the North Atlantic). The Baltic is connected to the North Sea by the Great Belt (70% of the water exchange), the Øresund (20% of the water exchange), and the Little Belt. The total area of the Baltic is 147,414 mi<sup>2</sup> (381,705 km<sup>2</sup>), its total volume 4982 mi<sup>3</sup> (20,764 km<sup>3</sup>), and its average depth 181 ft (55.2 m). The greatest depth is 1510 ft (459 m), in the Landsort Deep.

The topography of the Baltic is characterized by a sequence of basins separated by sills and by two large gulfs, the Gulf of Bothnia (40,100 mi<sup>2</sup> or 104,000 km<sup>2</sup>) and the Gulf of Finland (11,400 mi<sup>2</sup> or 29,500 km<sup>2</sup>). More than 200 rivers discharge an average of 104 mi<sup>3</sup> (433 km<sup>3</sup>) annually from a watershed area of 637,056 mi<sup>2</sup> (1,649,550 km<sup>2</sup>). The largest river is the Newa, with 18.5% of the total fresh-water discharge. From December to May, the northern and eastern parts of the Baltic are frequently covered with ice. On the average, the area of maximum ice coverage is 82,646 km<sup>2</sup> (214,000 km<sup>2</sup>). The mean maximum surface-water temperature in summer is between 59 and 63°F (15 and 17°C).

As the Baltic stretches from the boreal to the arctic continental climatic zone, there are large differences between summer and winter temperature in the surface waters, ranging from about 68 to 30°F (20 to -1°C) in the Western Baltic and 57 to 32°F (14 to -0.2°C) in the Gulf of Bothnia and the Gulf of Finland.

The salt content of the Baltic waters is characterized by two major water bodies; the brackish surface water and the more saline deep water. Salinities for the surface water range from 8 to 6‰ in the Western and Central Baltic and 6 to 2000 in the Gulf of Bothnia and the Gulf of Finland; salinities for the deep water range from 18 to 13‰ in the Western and Central Baltic and 10 to 4‰ in the Gulf of Bothnia and the Gulf of Finland.

The surface currents of the Baltic are dominated by a general counterclockwise movement and by local and regional wind-driven circulations. A complex system of small- and medium-scale gyres develops especially in the central parts of the Baltic. The currents in the Belt Sea are dominated by the topography; they are due to sea-level differences between the Baltic proper and the North Sea. Tides are of minor importance, ranging between 0.8 and 4.7 in. (2 and 12 cm). Water-level changes of more than 6 ft (2 m) occur occasionally as a result of onshore or offshore winds and the passage of cyclones over the Baltic Sea area. The frequency of longitudinal sea-level oscillations is about 13.5 h. See OCEAN CIRCULATION.

The flora and fauna of the Baltic are those of a typical brackish-water community, with considerably reduced numbers of species compared to an oceanic community. The productivity is relatively low compared to other shelf seas. The major commercially exploited species are cod, herring, sprat, flounder, eel, and salmon, and some fresh-water species such as whitefish, pike, perch, and trout. The total annual catch amounts to about 880,000 tons (800,000 metric tons). The Baltic is completely divided into fishery zones, with exclusive fishing rights belonging to the respective countries.

Other than fish the only major resources that have been exploited are sand and gravel in the Western Baltic Sea. It is believed that the deeper layer under the Gotland Basin contains mineral oil, but so far only exploratory drilling has been carried out in the near-coastal regions. Limited amounts of mineral oil have also been located in the Gulf of Kiel. [K.G.]

**Bamboo** The common name of various perennial, ornamental grasses (Gramineae). There are five genera with approximately 280 species. They have a wide distribution, but occur mainly in tropical and subtropical parts of Asia, Africa, and America, extending from sea level to an elevation of 15,000 ft

(4600 m). Their greatest development occurs in the monsoon regions of Asia. Most plants are woody; a few are herbaceous or climbing. The economic uses of bamboo are numerous and varied. The seeds and young shoots are used as food, and the leaves make excellent fodder for cattle. In varying sizes, the stems are used for pipes, timber, masts, bows, furniture, bridges, cooking vessels, buckets, wickerwork, paper pulp, cordage, and weaving. Entire houses are made of bamboo stems. Certain bamboos have been naturalized in California, Louisiana, and Florida. See CYPERALES. [P.D.St./E.L.C.]

**Banana** A large tropical plant of the family Musaceae; also its edible fruit, which occurs in hanging clusters, is usually yellow when ripe, and is about 6–8 in. (15–20 cm) long. The banana of commerce (*Musa sapientum*), believed to have originated in the Asian tropics, was one of the earliest cultivated fruits. For commercial production the plant requires a tropical climate within the temperature range 50–105°F (10–40°C) and a constant supply of moisture by rainfall or irrigation.

The plant portion above the ground is a false stem (pseudostem) consisting of several concentrically formed leaves, from the center of which develops the inflorescence stalk. The rhizome or true stem is underground. Near the tip of the flower stalk are several groups of sterile male flowers subtended by brilliant purple bracts. The lower female flower clusters on the same stalk give rise to the fruit and contain aborted stamens (male organs). The single fruits are called fingers, a single group of 8–12 fingers is termed a hand, and the several (6–18) hands of the whole inflorescence make up the stem.

The fruit bunch requires 75–150 days to mature and must be removed from the plant to ripen properly. Chilled banana fruits do not soften normally; hence for best edibility the fruit is kept well ventilated at room temperature. Banana fruits of commerce set without pollination, by parthenocarpy, and hence are seedless. When mature, most varieties are yellow, although fine red-skinned types are well known. There are several hundred varieties grown throughout the world. The Cavendish banana (*M. nana*, variety Valery) is becoming important in the American tropics. The more starchy bananas, known as plantains, must be cooked before they can be eaten. See FRUIT; FRUIT, TREE; ZINGIBERALES. [C.A.Sch.]

**Band spectrum** A spectrum consisting of groups or bands of closely spaced lines. Band spectra are characteristic of molecular gases or chemical compounds. When the light emitted or absorbed by molecules is viewed through a spectroscope with small dispersion, the spectrum appears to consist of very wide asymmetrical lines called bands. These bands usually have a maximum intensity near one edge, called a band head, and a gradually decreasing intensity on the other side. In some band systems the intensity shading is toward shorter waves, in others toward longer waves. Each band system consists of a series of nearly equally spaced bands called progressions; corresponding bands of different progressions form groups called sequences.

When spectroscopes with adequate dispersion and resolving power are used, it is seen that most of the bands obtained from gaseous molecules actually consist of a very large number of lines whose spacing and relative intensities, if unresolved, explain the appearance of bands of continua. For the quantum-mechanical explanations of the details of band spectra see MOLECULAR STRUCTURE AND SPECTRA. [W.F.M./W.W.W.]

**Band theory of solids** A quantum-mechanical theory of the motion of electrons in solids which predicts certain restricted ranges, or bands, for the electron energies.

If the atoms of a solid are separated from each other to such a distance that they do not interact, the energy levels of the electrons will then be those characteristic of the individual free atoms, and thus many electrons will have the same energy. As the distance between atoms is decreased, the electrons in the outer

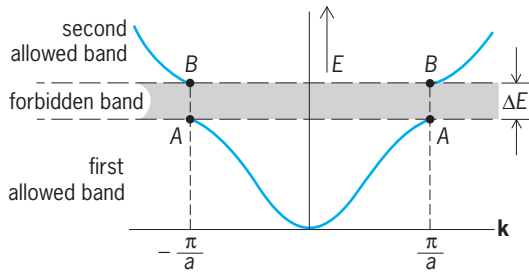

Electron energy  $E$  versus wave vector  $k$  for a monatomic linear lattice of lattice constant  $a$ . (After C. Kittel, *Introduction to Solid State Physics*, 7th ed., 1995)

shells begin to interact, thus altering their energy and broadening the sharp energy level out into a range of possible energy levels called a band. One would expect the process of band formation to be well advanced for the outer, or valence, electrons at the observed interatomic distances in solids. Once the atomic levels have spread into bands, the valence electrons are not confined to individual atoms, but may jump from atom to atom with an ease that increases with the increasing width of the band.

Although energy bands exist in all solids, the term energy band is usually used in reference only to ordered substances, that is, those having well-defined crystal lattices. In such a case, an electron energy state can be classified according to its crystal momentum  $\mathbf{p}$  or its electron wave vector  $\mathbf{k} = \mathbf{p}/\hbar$  (where  $\hbar$  is Planck's constant  $h$  divided by  $2\pi$ ). If the electrons were free, the energy of an electron whose wave vector is  $\mathbf{k}$  would be as shown in the equation below, where  $E_0$  is the energy of the lowest state of a

$$E(\mathbf{k}) = E_0 + \hbar^2 k^2 / 2m_0$$

valence electron and  $m_0$  is the electron mass. In a crystal, however, the electrons are not free because of the effect of the crystal binding and the forces exerted on them by the atoms; consequently, the relation  $E(\mathbf{k})$  between energy and wave vector is more complicated. The statement of this relationship constitutes the description of an energy band.

The bands of possible electron energy levels in a solid are called allowed energy bands. There are also bands of energy levels which it is impossible for an electron to have in a given crystal. Such bands are called forbidden bands, or gaps. The allowed energy bands sometimes overlap and sometimes are separated by forbidden bands. The presence of a forbidden band immediately above the occupied allowed states (such as the region A to B in the illustration) is the principal difference in the electronic structures of a semiconductor or insulator and a metal. In the first two substances there is a gap between the valence band or normally occupied states and the conduction band, which is normally unoccupied. In a metal there is no gap between occupied and unoccupied states. The presence of a gap means that the electrons cannot easily be accelerated into higher energy states by an applied electric field. Thus, the substance cannot carry a current unless electrons are excited across the gap by thermal or optical means.

Under external influences, such as irradiation, electrons can make transitions between states in the same band or in different bands. The interaction between the electrons and the vibrations of the crystal lattice can scatter the electrons in a given band with a substantial change in the electron momentum, but only a slight change in energy. This scattering is one of the principal causes of the electrical resistivity of metals. See ELECTRICAL RESISTIVITY.

An external electromagnetic field (for example, visible light) can cause transitions between different bands. Here momentum must be conserved. Because the momentum of a photon  $h\nu/c$  (where  $\nu$  is the frequency of the light and  $c$  its velocity) is quite small, the momentum of the electron before and after collision is nearly the same. Such a transition is called vertical in reference to an energy band diagram. Conservation of energy must also

hold in the transition, so absorption of light is possible only if there is an unoccupied state of energy  $h\nu$  available at the same  $\mathbf{k}$  as the initial state. These transitions are responsible for much of the absorption of visible and near-infrared light by semiconductors.

The results of energy-band calculations for ordinary metals usually predict Fermi surfaces and other properties that agree rather well with experiment. In addition, cohesive energies and values of the lattice constant in equilibrium can be obtained with reasonable accuracy, and, in the case of ferromagnetic metals, calculated magnetic moments agree with experiment. However, there are significant discrepancies between theoretical calculations and experiments for certain types of systems, including heavy-fermion systems (certain metallic compounds containing rare-earth or actinide elements), superconductors, and Mott-Hubbard insulator (compounds of 3d transition elements, for which band calculations predict metallic behavior). Also band calculations for semiconductors such as silicon, germanium and gallium arsenide (GaAs) predict values for the energy gap between valence and conduction bands in the range one-half to two-thirds of the measured values. In all these cases, the failures of band theory are attributed to an inadequate treatment of strong electron-electron interactions. [J.C.]

**Banded iron formation** Banded iron formation is a sedimentary rock that was commonly deposited during the Precambrian. It was probably laid down as a colloidal iron-rich chemical precipitate, but in its present compacted form it consists typically of equal proportions of iron oxides (hematite or magnetite) and silica in the finely crystalline form of quartz known as chert. Its chemical composition is 50% silicon dioxide ( $\text{SiO}_2$ ) and 50% iron oxides ( $\text{Fe}_2\text{O}_3$  and  $\text{Fe}_3\text{O}_4$ ), to give a total iron content of about 30%. Banding is produced by the concentration of these two chemical components into layers about 1–5 cm (1/2–2 in.) thick; typical banded iron formation consists of pale silica-rich cherty bands alternating with black to dark red iron-rich bands (see illustration). These contrasting layers are sharply defined, so that the rock has a striped appearance; banded iron formation is normally a hard, tough rock, highly resistant both to erosion and to breaking with a hammer.

The world's iron and steel industry is based almost exclusively on iron ores associated with banded iron formation. Banded iron formation itself may be the primary ore, from which hematite or magnetite is concentrated after crushing. But the main ore now

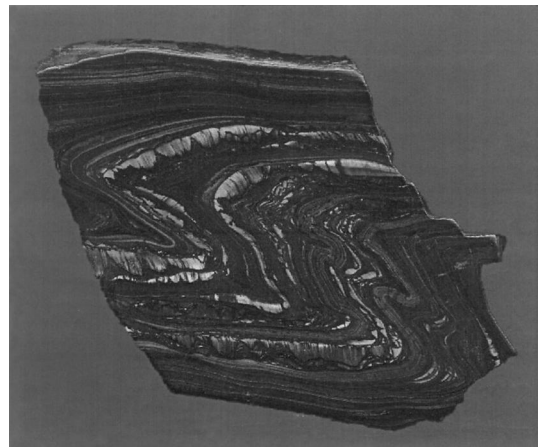

Folded banded iron formation from the Ord Range, Western Australia. The distance between top and bottom of the polished face of the sample is about 15 cm (6 in.). Chert jasper bands alternate with dark magnetite-rich bands. The thin pale layers of irregular thickness are bands of asbestiform amphibole, now replaced by silica, to give the semiprecious material "tiger-eye." (Photo courtesy of John Blockley)

mined globally is high-grade (greater than 60% iron) material that formed within banded iron formation by natural leaching of its silica content. [A.F.T.]

### Bandwidth requirements (communications)

The channel bandwidths needed to transmit various types of signals, using various processing schemes. Every signal observed in practice can be expressed as a sum (discrete or over a frequency continuum) of sinusoidal components of various frequencies. The plot of the amplitude versus frequency constitutes one feature of the frequency spectrum (the other being the phase versus frequency). The difference between the highest and the lowest frequencies of the frequency components of significant amplitudes in the spectrum is called the bandwidth of the signal, expressed in the unit of frequency, hertz. Every communication medium (also called channel) is capable of transmitting a frequency band (spectrum of frequencies) with reasonable fidelity. Qualitatively speaking, the difference between the highest and the lowest frequencies of components in the band over which the channel gain remains reasonably constant (or within a specified variation) is called the channel bandwidth. See FOURIER SERIES AND TRANSFORMS; WAVEFORM.

Clearly, to transmit a signal with reasonable fidelity over a communication channel, the channel bandwidth must match and be at least equal to the signal bandwidth. Proper conditioning of a signal, such as modulation or coding, however, can increase or decrease the bandwidth of the processed signal. Thus, it is possible to transmit the information of a signal over a channel of bandwidth larger or smaller than that of the original signal.

Amplitude modulation (AM) with double sidebands (DSB), for example, doubles the signal bandwidth. If the audio signal to be transmitted has a bandwidth of 5 kHz, the resulting AM signal bandwidth using DSB is 10 kHz. Amplitude modulation with a single sideband (SSB), on the other hand, requires exactly the same bandwidth as that of the original signal. In broadcast frequency modulation (FM), on the other hand, audio signal bandwidth is 15 kHz (for high fidelity), but the corresponding frequency-modulated signal bandwidth is 200 kHz. See FREQUENCY MODULATION; FREQUENCY-MODULATION RADIO; SINGLE SIDEBAND.

C. E. Shannon proved that over a channel of bandwidth  $B$  the rate of information transmission,  $C$ , in bits/s (binary digits per second) is given by the equation below, where SNR is the

$$C = B \log_2(1 + \text{SNR}) \quad \text{bits/s}$$

signal-to-noise power ratio. This result assumes a white gaussian noise, which is the worst kind of noise from the point of view of interference. See INFORMATION THEORY; SIGNAL-TO-NOISE RATIO.

It follows from Shannon's equation that a given information transmission rate  $C$  can be achieved by various combinations of  $B$  and SNR. It is thus possible to trade  $B$  for SNR, and vice versa.

A corollary of Shannon's equation is that, if a signal is properly processed to increase its bandwidth, the processed signal becomes more immune to interference or noise over the channel. This means that an increase in transmission bandwidth (broadbanding) can suppress the noise in the received signal, resulting in a better-quality signal (increased SNR) at the receiver. Frequency modulation and pulse-code modulation are two examples of broadband schemes where the transmission bandwidth can be increased as desired to suppress noise.

Broadbanding is also used to make communication less vulnerable to jamming and illicit reception by using the so-called spread spectrum signal. See ELECTRICAL COMMUNICATIONS; ELECTRONIC WARFARE; SPREAD SPECTRUM COMMUNICATION. [B.PL.; M.Wr.]

**Barbiturates** A group of drugs widely used for the suppression of anxiety, the induction of sleep, and the control of

seizures. Some of them, when injected intravenously, produce a general anesthesia. See ANESTHESIA.

Barbituric acid, from which the various barbiturate congeners come, is a malonyl urea. Following the synthesis of this compound, a dozen or more closely related compounds were synthesized by adding or substituting various radicals to the general formula. The names of many of them have become familiar; examples are Phenobarbital, Meberal, Seconal, Nembutal, Amytal, and Pentothal.

These drugs act by suppressing the excitability of all tissues; but all tissues are not equally sensitive. Low dosages induce drowsiness, and high dosages coma and death. The spread between the therapeutic and fatal doses varies with the different barbiturates.

The prolonged use of these drugs results in habituation; and insomnia, agitation, confusional psychosis, and seizures may occur within 24 to 36 hours of withdrawal. Overdose is one of the commonest means of suicide in Western countries, and life can be saved only by admission to a hospital where respiration can be maintained and cerebral anoxia prevented. [R.D.A.]

**Barite** An orthorhombic mineral with chemical composition  $\text{BaSO}_4$ . It possesses one perfect cleavage, and two good cleavages, as do the isostructural minerals. The mineral has a specific gravity of approximately 4.5, and is relatively soft, approximately 3 on Mohs scale. The color ranges through white to yellowish, gray, pale blue, or brown, and a thin section is colorless.

Barite is often an accessory mineral in hydrothermal vein systems, but frequently occurs as concretions or cavity fillings in sedimentary limestones. It also occurs as a residual product of limestone weathering and in hot spring deposits. It occasionally occurs as extensive beds in evaporite deposits. Occurrences of barite are extensive. It is found as a vein mineral associated with zinc and lead ores in Derbyshire, England. Large deposits occur at Andalusia, Spain. Commercial residual deposits occur in limestones throughout the Appalachian states such as Georgia, Tennessee, and Kentucky. It also occurred in substantial amounts in the galena ore deposits in Wisconsin and Missouri.

Since barite is dense and relatively soft, its principal use is as a weighting agent in rotary well-drilling fluids. It is the major ore of barium salts, used in glass manufacture, as a filler in paint, and, owing to the presence of a heavy metal and inertness, as an absorber of radiation in x-ray examination of the gastrointestinal tract. [P.B.M.]

**Barium** A chemical element, Ba, with atomic number 56 and atomic weight of 137.34. Barium is eighteenth in abundance in the Earth's crust, where it is found to the extent of 0.04%, making it intermediate in amount between calcium and strontium, the other alkaline-earth metals. Barium compounds are obtained from the mining and conversion of two barium minerals. Barite, barium sulfate, is the principal ore and contains 65.79% barium oxide. Witherite, sometimes called heavy spar, is barium carbonate and is 72% barium oxide. See BARITE; PERIODIC TABLE; WITHERITE.

The metal was first isolated by Sir Humphry Davy in 1808 by electrolysis. Industrially, only small amounts are prepared by aluminum reduction of barium oxide in large retorts. These are used in barium-nickel alloys for spark-plug wire (the barium increases the emissivity of the alloy) and in frary metal, which is an alloy of lead, barium, and calcium used in place of babbitt metal because it can be cast.

The metal reacts with water more readily than do strontium and calcium, but less readily than sodium; it oxidizes quickly in air to form a surface film that inhibits further reaction, but in moist air it may inflame. The metal is sufficiently active chemically to react with most nonmetals. Freshly cut pieces have a lustrous

## Properties of barium

Property	Value
Atomic number	56
Atomic weight	137.34
Isotopes (stable)	130, 132, 134, 135, 136, 137, 138
Atomic volume	36.2 cm <sup>3</sup> /g-atom
Crystal structure	Face-centered cubic
Electron configuration	2 8 18 18 8 2
Valence	2+
Ionic radius (Å)	1.35
Boiling point, °C	1140(?)
Melting point, °C	850(?)
Density	3.75 g/cm <sup>3</sup> at 20°C
Latent heat of vaporization at boiling point, kJ/g-atom	374

gray-white appearance, and the metal is both ductile and malleable. The physical properties of the elementary form are given in the table.

For the manufacture of barium compounds, soft (easily crushable) barite is preferred, but crystalline varieties may be used. Crude barite is crushed and then mixed with pulverized coal. The mixture is roasted in a rotary reduction furnace, and the barium sulfate is thus reduced to barium sulfide or black ash. Black ash is roughly 70% barium sulfide and is treated with hot water to make a solution used as the starting material for the manufacture of many compounds.

Lithopone, a white powder consisting of 20% barium sulfate, 30% zinc sulfide, and less than 3% zinc oxide, is widely used as a pigment in white paints. Blanc fixe is used in the manufacture of brilliant coloring compounds. It is the best grade of barium sulfate for paint pigments. Because of the large absorption of x-rays by barium, the sulfate is used to coat the alimentary tract for x-ray photographs in order to increase the contrast. Barium carbonate is useful in the ceramic industry to prevent efflorescence on claywares. It is used also as a pottery glaze, in optical glass, and in rat poisons. Barium chloride is used in purifying salt brines, in chlorine and sodium hydroxide manufacture, as a flux for magnesium alloys, as a water softener in boiler compounds, and in medicinal preparations. Barium nitrate, or the so-called baryta saltpeter, finds use in pyrotechnics and signal flares (to produce a green color), and to a small extent in medicinal preparations. Barium oxide, known as baryta or calcined baryta, finds use both as an industrial drying agent and in the case-hardening of steels. Barium peroxide is sometimes used as a bleaching agent. Barium chromate, lemon chrome or chrome yellow, is used in yellow pigments and safety matches. Barium chlorate finds use in the manufacture of pyrotechnics. Barium acetate and cyanide are used industrially as a chemical reagent and in metallurgy, respectively. [R.F.R.]

**Bark** A word generally referring to the surface region of a stem or a root. Sometimes part or all of the bark is called rind. Occasionally the word bark is used as a substitute for periderm or for cork only. Most commonly, however, it refers to all tissues external to the cambium. If this definition is applied to stems having only primary tissues, it includes phloem, cortex, and epidermis; the bark of roots of corresponding age would contain cortex and epidermis. In the more general usage the term bark is restricted to woody plants with secondary growth.

In most roots with secondary growth, the bark consists of phloem and periderm since the cortex and epidermis are sloughed off with the first cork formation in the pericycle that is beneath the cortex. In stems, the first cork cambium may be formed in any living tissue outside the vascular cambium, and the young bark may include any or all of the cortex in addition to the phloem and periderm. The region composed of the

successive layers of periderm and the enclosed dead tissues is called outer bark. The outer bark composed of dead phloem alternating with bands of cork is called, technically, rhytidome. Both stems and roots may have rhytidome. The inner bark is living, and consists of phloem only. See CORTEX (PLANT); EPIDERMIS (PLANT); PARENCHYMA; PERICYCLE; PERIDERM; PHLOEM; ROOT (BOTANY); STEM. [H.W.B.I.]

**Barkhausen effect** An effect, due to discontinuities in size or orientation of magnetic domains as a body of ferromagnetic material is magnetized, whereby the magnetization proceeds in a series of minute jumps. See FERROMAGNETISM; MAGNETIZATION.

Ferromagnetic materials are characterized by the presence of microscopic domains of some  $10^{12}$  to  $10^{15}$  atoms within which the magnetic moments of the spinning electrons are all parallel. In an unmagnetized specimen, there is random orientation of the various domains. When a magnetic field is applied to the specimen, the domains turn into an orientation parallel to the field, or if parallel to the field, the domains increase in size. During the steep part of the magnetization curve, whole domains suddenly change in size or orientation, giving a discontinuous increase in magnetization. If the specimen being magnetized is within a coil connected to an amplifier and loudspeaker, the sudden changes give rise to a series of clicks or, when there is a rapid change, a hissing sound. This is called the Barkhausen effect; it is an important piece of evidence in support of a domain theory of magnetism. [K.V.M.]

**Barley** A cereal grass plant whose seeds are useful to humans. It is grown in nearly all cultivated areas of the temperate



Barley spikes: (a) six-rowed *Hordeum vulgare*; (b) two-rowed *H. distichum* (USDA).

parts of the world, and is an important crop in Europe, North and South America, North Africa, much of Asia, and Australia. Barley is the most dependable cereal crop where drought, summer frost, and alkali soils are encountered. In the United States, barley is grown to some extent in 49 states, with the most important production areas in North Dakota, Montana, and California. Principal uses of barley grain are as livestock feed, for the production of barley malt, and as human food. It is also used in some areas for hay and silage.

Taxonomically barley belongs to the family Gramineae, subfamily Festucoideae, tribe Hordeae, and genus *Hordeum*. Most of the modern cultivated barleys are *H. vulgare* (six-rowed) or *H. distichum*. (two-rowed; see illustration). All cultivated barleys are annuals and are naturally self-pollinated. In the cultivated varieties, a wide diversity of morphological, physiological, and anatomical types are known. There are spring, facultative, and winter growth habits; hulled and naked grain; awned, awnless, and hooded lemmas; black, purple, and white kernels; and also a wide range of plant heights, spike densities, and resistances to a wide range of diseases and insects. There are in excess of 150 cultivars presently commercially grown in the United States and Canada alone, and many additional cultivars are grown in other parts of the world. New and improved varieties produced by barley breeders are constantly replacing older varieties. Several barley collections are being maintained in different countries as germplasm sources for breeding and research. These include both collections made by direct exploration in many barley-growing areas of the world and lines from barley-breeding programs. Among the largest of these collections is one maintained by the U.S. Department of Agriculture, which includes more than 17,000 individual strains. See CYPERALES.

[D.A.R.]

**Barnacle** The name popularly applied to two types of Crustacea, subclass Cirripedia, the goose barnacles and acorn barnacles. Both were formerly of importance to seafarers (and acorn barnacles are still so) because of their habit of adhering to ships hulls. Four orders of barnacles are recognized, of which one only, the Thoracica, fits the popular conception of barnacles. See CIRRIPIEDIA; THORACICA.

[H.G.St.]

**Baroclinic field** A distribution of atmospheric pressure and mass such that the specific volume, or density, of air is a function of both pressure and temperature, but not either alone. When the field is baroclinic, solenoids are present, there is a gradient of air temperature on a surface of constant pressure, and there is a vertical shear of the geostrophic wind. Significant development of cyclonic and anticyclonic wind circulations typically occurs only in strongly baroclinic fields. Fronts represent baroclinic fields which are locally very intense. See AIR PRESSURE; FRONT; GEOSTROPHIC WIND; SOLENOID (METEOROLOGY); STORM; WIND.

[F.S.; H.B.B.]

**Barometer** An absolute pressure gage specifically designed to measure atmospheric pressure. This instrument is a type of manometer with one leg at zero pressure absolute. See MANOMETER.

The common meteorological barometer (see illustration) is a liquid-column gage filled with mercury. The top of the column is sealed, and the bottom is open and submerged below the surface of a reservoir of mercury. The atmospheric pressure on the reservoir keeps the mercury at a height proportional to that pressure. An adjustable scale, with a vernier scale, allows a reading of column height. Aneroid barometers using metallic diaphragm elements are usually less accurate, though often more sensitive,

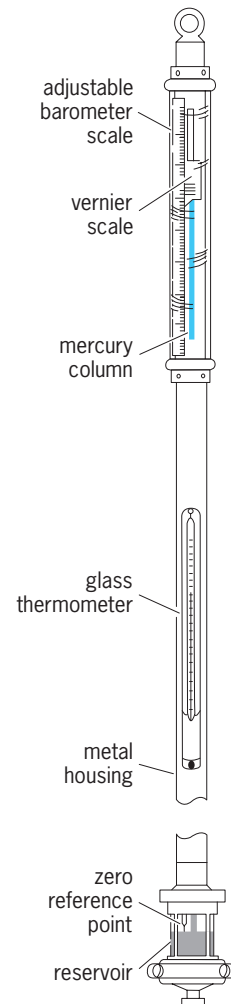

Mercury barometer.

devices, and not only indicate pressure but may be used to record it. See PRESSURE MEASUREMENT.

[J.H.Z.]

**Barotropic field** A distribution of atmospheric pressure and mass such that the specific volume, or density, of air is a function solely of pressure. When the field is barotropic, there are no solenoids, air temperature is constant on a surface of constant pressure, and there is no vertical shear of the geostrophic wind. Significant cyclonic and anticyclonic circulations typically do not develop in barotropic fields. Considerable success has been achieved, paradoxically, in prediction of the flow pattern at middle-tropospheric elevations by methods which are strictly applicable only to barotropic fields, despite the fact that the field in this region is definitely not barotropic. The subtropics, however, are to a large extent barotropic. See AIR PRESSURE; BAROCLINIC FIELD; GEOSTROPHIC WIND; SOLENOID (METEOROLOGY); WEATHER FORECASTING AND PREDICTION; WIND.

[F.S.; H.B.B.]

**Barracuda** The name for about 20 species of fish found in warm seas throughout the world. All species belong to the genus *Sphyraena* and are members of the order Perciformes. The larger species, such as the great barracuda (*Sphyraena barracuda*), are solitary and not found in schools. Generally, all species are good food fish.

The teeth, which occur both in the jaws and on the roof of the large mouth, are strong and pointed, resembling canine teeth. The jaws are long, with the lower projecting beyond the upper, and the upper incapable of being protracted. The head is large

and pointed, and the body is compressed and long, somewhat like the pike. The body is covered with cycloid scales, and the lateral line is well developed. Many of these fish weigh over 100 lb (45 kg) and reach a length of 10 ft (3 m). See PERCIFORMES.

[C.B.C.]

**Barretter** A bolometer element with a positive temperature coefficient of resistance, used to detect and measure power at radio, microwave, infrared, and optical frequencies. The temperature of the barretter increases when electromagnetic energy is absorbed. Barretters are made of metal; therefore, the electrical resistance increases when the temperature increases. The resulting resistance change of the barretter is measured by using direct-current or low-frequency instruments. See BOLOMETER.

The barretter resistance is selected to absorb most of the power when the barretter is mounted as a termination in a waveguide or coaxial transmission line. A barretter can be made to detect power at optical and infrared frequencies by using a very thin metal ribbon blackened to absorb light. See TRANSMISSION LINES; WAVEGUIDE.

Barretters with less sensitivity and accuracy for use at radio frequencies can be made by using low-current fuses made with fine wires. See FUSE (ELECTRICITY); INCANDESCENT LAMP.

A meter can be made to measure high-frequency signal amplitudes using a barretter. The temperature and hence the resistance of a barretter can change at audio-frequency rates, but the time constant of a barretter is too great for the resistance to vary at radio-frequency rates. A radio- or microwave-frequency current modulated at a low frequency will cause the barretter resistance to follow the low-frequency signal. If a direct-current voltage is applied to the barretter while the modulated radio-frequency current is also applied, the varying resistance will produce a current which follows the modulation. The low-frequency current can be coupled to the input of an audio amplifier tuned to the modulation frequency by using an audio transformer. The output of the audio amplifier may be rectified to drive a direct-current meter. The meter then indicates the relative amplitude of the radio-frequency or microwave signal.

[R.C.Po.]

**Barrier islands** Elongate, narrow accumulations of sediment which have formed in the shallow coastal zone and are separated from the mainland by some combination of coastal bays and marshes. They are typically several times longer than their width and are interrupted by tidal inlets. Although their origin has been widely discussed, at least three possibilities exist: longshore spit development and subsequent cutting of inlets; drowning of old coastal ridges; and upward shoaling of subtidal sediment accumulations. All three may have occurred; however, the last seems most likely and most prevalent.

Barrier islands must be considered in terms of the adjacent and closely related environments within the coastal system. Beginning offshore and proceeding landward, the sequence of environments crossed is shoreface, beach, dunes, back-island flats or marsh, coastal bay, marsh, and mainland. The barrier island proper consists of the beach, dunes, and back-island flats or marsh; however, of the remaining environments, at least the shoreface is closely integrated with the barrier island in terms of morphology, processes, and sediments. See DUNE.

A variety of physical processes exists along the coast. These processes act to shape and maintain the barrier-island system and also to enable the barrier to migrate landward as sea level continues to rise. The most important process in the barrier-island system is the waves, which also give rise to longshore currents. Waves and longshore currents dominate the outer portion of the barrier system, whereas tidal currents are dominant landward of the barrier, although small waves may also be present. Tidal currents are most prominent in and adjacent to the inlets. On the supratidal portion of the barrier island, the wind is the most dominant physical process.

Barrier-island sands represent one of the best sources of oil and gas, with the tight organic-rich source rocks being in the form of the bay and shelf muds and the barrier itself being the reservoir rock. These elongate sand bodies have been sought by exploration geologists for decades. The Tertiary sequences of the Texas Gulf coasts are an example of such barrier systems which have been very productive. See COASTAL LANDFORMS.

[R.A.D.]

**Baryon** The generic name for any hadronic particle with baryon number  $B = +1$ . By far the most common baryons are the proton and neutron, the two states of the nucleon doublet  $N = (p, n)$  [Table 1]. The baryon number of any particular state may be deduced from its production or decay processes, or both, since the total baryon number is conserved (with possible rare exceptions discussed below) and  $B = 0$  holds for all mesons and leptons. See LEPTON; MESON; NEUTRON; NUCLEON; PROTON.

It is now generally accepted that hadrons are composite, consisting of spin- $1/2$  quarks ( $q$ ), corresponding antiquarks ( $\bar{q}$ ), and some number of gluons, the last being the quanta of the intermediate field which binds the quarks and antiquarks to form hadrons.  $B = +\frac{1}{3}$  holds for a quark  $q$ ,  $B = -\frac{1}{3}$  for an antiquark  $\bar{q}$ , while  $B = 0$  holds for a gluon. Thus, a baryon consists of three ("valence") quarks, together with some number of quark-antiquark ( $q\bar{q}$ ) pairs (called the quark-antiquark sea) and of gluons. The quarks must be assigned fractional charge values, relative to the proton charge (Table 2). See GLUONS; HADRON; QUARKS.

**Color and quantum chromodynamics.** This quark theory of the hadrons has been proposed in a quite specific form, known as quantum chromodynamics (QCD). It is a gauge theory based on a symmetry hypothesized for the hadronic interactions of the quarks, which says that these interactions are invariant with respect to a local (gauge) group of unitary transformations with modulus unity,  $SU(3)_C$ , acting in an abstract complex three-dimensional space known as color space. Each quark type then has three color states, usually labeled by the suffixes  $r$  (red),  $g$  (green), and  $b$  (blue), corresponding to the three axes of this space. The gauge particle of this symmetry theory is the gluon, a neutral vector particle coupled universally with the currents of color, just as the photon, the gauge particle of quantum electrodynamics (QED), is coupled universally with the electromagnetic current. However, whereas the photon has no charge, the gluon has eight color components, so that it is a color octet. Consequently, there is a gluon contribution to the color currents, and so the gluon field must interact with itself, introducing a nonlinearity into quantum chromodynamics which has no parallel in quantum electrodynamics. This nonlinearity has important implications for quantum chromodynamics, leading to its asymptotic freedom, the property that the coupling of gluon to the color current approaches zero at short distances, which is essential for even qualitative agreement between quantum chromodynamics predictions and the empirical data on high-energy collision processes. See COLOR (QUANTUM MECHANICS); GAUGE THEORY; QUANTUM CHROMODYNAMICS; QUANTUM ELECTRODYNAMICS; SYMMETRY LAWS (PHYSICS).

An important element in quantum chromodynamics is the confinement dogma, the assertion that only color singlet states have finite energy. This assertion implies that neither a quark nor a gluon can exist in a free state, since the former is a color triplet and the latter a color octet, and indeed no observations of free gluons or quarks have yet been confirmed. However, no rigorous proof that the dogma follows from quantum chromodynamics has yet been given.

Quantitative predictions of the properties of baryonic states are currently made by using a simplified quark-quark ( $q-q$ ) potential with the following features: (1) an attractive long-range potential, increasing with separation to ensure confinement, and (2) a spin-dependent potential representing one-gluon exchange, effective at small separation, where the regime of

**Table 1. Known stable and semistable baryons and their properties**

Baryon	Mass, MeV	Spin parity	Flavors		Lifetime, s	Dominant decay modes	Magnetic moment, n.m.*
			Strangeness (s)	Charm (c)			
<i>p</i>	938.27200 ± 0.00004	1/2 <sup>+</sup>	0	0	>10 <sup>39</sup>	—	2.792847
<i>n</i>	939.56533 ± 0.00004	1/2 <sup>+</sup>	0	0	886 ± 1	<i>p</i> $\bar{\nu}_e e^-$	-1.91304
$\Lambda$	1115.683 ± 0.006	1/2 <sup>+</sup>	-1	0	2.63 ± 0.02 × 10 <sup>-10</sup>	<i>p</i> $\pi^-$ (64%) <i>n</i> $\pi^0$ (36%)	-0.613 ± 0.004
$\Sigma^+$	1189.37 ± 0.07	1/2 <sup>+</sup>	-1	0	8.02 ± 0.03 × 10 <sup>-11</sup>	<i>p</i> $\bar{\nu}_e e^-$ (0.083 ± 0.002)% <i>p</i> $\pi^0$ (52%) <i>n</i> $\pi^+$ (48%)	2.46 ± 0.01
$\Sigma^0$	1192.64 ± 0.03	1/2 <sup>+</sup>	-1	0	7.4 ± 0.7 × 10 <sup>-20</sup>	<i>p</i> $\gamma$ (0.123 ± 0.005)% $\Lambda\gamma$	—
$\Sigma^-$	1197.449 ± 0.030	1/2 <sup>+</sup>	-1	0	1.48 ± 0.01 × 10 <sup>-10</sup>	<i>n</i> $\pi^-$	-1.16 ± 0.03
$\Xi^0$	1314.8 ± 0.2	1/2 <sup>+</sup>	-2	0	2.9 ± 0.1 × 10 <sup>-10</sup>	<i>n</i> $\bar{\nu}_e e^-$ (0.102 ± 0.003)% $\Lambda\pi^0$	-1.25 ± 0.02
$\Xi^-$	1321.31 ± 0.13	1/2 <sup>+</sup>	-2	0	1.64 ± 0.02 × 10 <sup>-10</sup>	$\Lambda\pi^-$	-0.651 ± 0.003
$\Omega^-$	1672.4 ± 0.3	(3/2 <sup>+</sup> ?)	-3	0	0.82 ± 0.01 × 10 <sup>-10</sup>	<i>n</i> $\bar{\nu}_e e^-$ (0.056 ± 0.003)% $\Lambda K$ (68%) $\Xi^0\pi^-$ (24%) $\Xi^-\pi^0$ (9%)	-2.02 ± 0.05
$\Lambda_c^+$	2284.9 ± 0.6	(1/2 <sup>+</sup> ?)	0	1	2.0 ± 0.1 × 10 <sup>-13</sup>	<i>p</i> $K^+\pi^+$ (5 ± 1)%	—
$\Sigma_c^+$	2452 ± 1	(1/2 <sup>+</sup> ?)	0	1	hadronic	$\Lambda_c^+\pi$ (+, 0, -)	—
$\Xi_c^+$	2466 ± 2	(1/2 <sup>+</sup> ?)	-1	1	4.4 ± 0.3 × 10 <sup>-13</sup>	$\Xi^-\pi^+\pi^-$ , $\Lambda K^-\pi^+\pi^+$	—
$\Xi_c^0$	2472 ± 2	(1/2 <sup>+</sup> ?)	-1	1	1.0 ± 0.2 × 10 <sup>-13</sup>	$\Xi^-\pi^+$ , $\Xi^-\pi^+\pi^+$	—
$\Omega_c^0$	2698 ± 3	(1/2 <sup>+</sup> ?)	-2	1	0.6 ± 0.2 × 10 <sup>-13</sup>	$\Xi^-\pi^+\pi^-$	—
$\Lambda_b^0$	5624 ± 9	(1/2 <sup>+</sup> ?)	0	0	1.23 ± 0.08 × 10 <sup>-12</sup>	$\Lambda_c^+\pi^-$	—

\*The abbreviation n.m. denotes the unit  $e\hbar/2M_p c$  (nuclear magneton).

† $\Sigma_c$  is included here, although hadronically unstable, because  $\Lambda_c$ ,  $\Sigma_c$ ,  $\Xi_c$ , and  $\Omega_c$  belong to a common SU(3)<sub>f</sub> multiple t; see Fig. 2a.

asymptotic freedom holds and perturbation theory is valid. Such predictions have had a great deal of success.

The quark content of the nucleons is given by Eqs. (1).

$$p = (uud) \quad n = (udd) \quad (1)$$

The replacement of a *d* quark in the nucleon by an *s* quark produces a baryon state with spin parity 1/2<sup>+</sup> and strangeness number *s* = -1, the latter being given by  $[n(s) - n(u)]$ , where *n*(*q*) denotes the number of quarks of type *q* in the system considered. The states thus reached have the flavor structures of Eqs. (2), the

$$(\Sigma^+, \Sigma^0, \Sigma^-) = (uus, (ud + du)s/\sqrt{2}, dds) \quad (2a)$$

$$\Lambda = (ud - du)s/\sqrt{2} \quad (2b)$$

other factors in their wave functions being identical with those for the nucleons; thus the isotriplet  $\Sigma$  and isosinglet  $\Lambda$  states are obtained. If a *u* quark and a *d* quark are each replaced by an *s* quark in Eqs. (1), the isodoublet  $\Xi$  states of Eq. (3) are

$$(\Xi^0, \Xi^-) = (uss, dss) \quad (3)$$

obtained. The quark has *I* = 0, being unaffected by the SU(2)<sub>τ</sub> transformations in the (*u*, *d*) space. The flavor wave function (*sss*) is necessarily symmetric and cannot occur with total spin *S* = 1/2. Baryonic states with *s* ≠ 0 are collectively termed hyperons. See HYPERON; STRANGE PARTICLES.

**Table 2. Properties of established quarks and leptons\*, arranged in three families**

Quark type	<i>d</i> (down)	<i>u</i> (up)	<i>s</i> (strange)	<i>c</i> (charmed)	<i>b</i> (bottom)	<i>t</i> (top)
Charge ( <i>Q</i> / <i>e</i> <sub>p</sub> )	-1/3	2/3	-1/3	2/3	-1/3	2/3
Mass, GeV <sup>†</sup>	≈0.3	≈0.3	≈0.5	≈1.5	≈4.7	≈174
Flavor	<i>I</i> <sub>3</sub> = -1/2	<i>I</i> <sub>3</sub> = +1/2	<i>s</i> = -1	<i>c</i> = +1	<i>b</i> = -1	<i>t</i> = +1
Lepton type	$\nu_e$	$e^+$	$\mu^+$	$\nu_\mu$	$\tau^+$	$\nu_\tau$

\*To each quark and lepton, there exists an antiquark and antilepton with opposite flavor values and with opposite intrinsic parity.

†Quark masses are rough estimates of the "effective mass" of each quark in a hadron.

These eight baryon states (*p*, *n*,  $\Sigma^+$ ,  $\Sigma^0$ ,  $\Sigma^-$ ,  $\Lambda$ ,  $\Xi^0$ ,  $\Xi^-$ ) all have the spin parity 1/2<sup>+</sup> and the same internal wave functions. It is helpful to use the quantum number *Y* = (*B* + *s*), named hypercharge. Then, if the states are arrayed in the *I*<sub>3</sub> - *Y* plane (Fig. 1), the symmetry of their relationship is evident.

The mass difference  $\delta m = [m(s) - m(u, d)]$  is quite large, and so SU(3)<sub>f</sub> symmetry is much more strongly violated than SU(2)<sub>τ</sub> symmetry. The baryon mass values vary widely over the octet; the leading variation is that proportional to the strangeness *s*, which counts the *s*-quark content of each baryon. The approximately 75-MeV difference between the mean  $\Sigma$  mass ( $m(\Sigma)$ ) and *m*( $\Lambda$ ) has a more subtle origin, but is well accounted for on the basis of the quark-quark (*qq*) potential from quantum chromodynamics, described above. The small mass differences within each isospin multiplet are believed to be due to the intrinsic (*u*, *d*) mass difference and to electromagnetic effects.

The baryon-baryon interactions are of particular interest. That

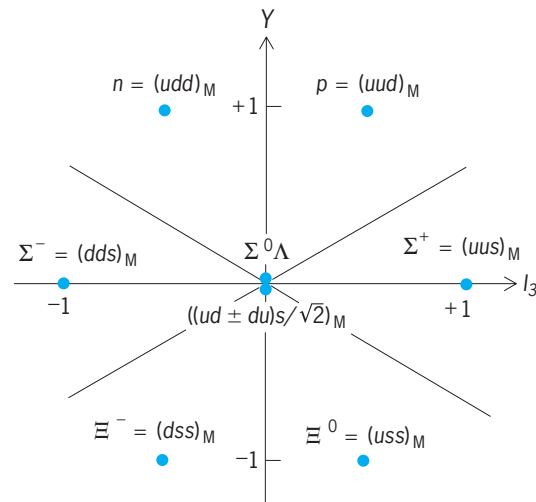

**Fig. 1. Baryon octet states, arrayed with respect to *I*<sub>3</sub> as ordinate and *Y* = (*B* + *s*) as abscissa. The charge number *Q* is given by *Q* = *I*<sub>3</sub> + *Y*/2. There are three axes of symmetry.**



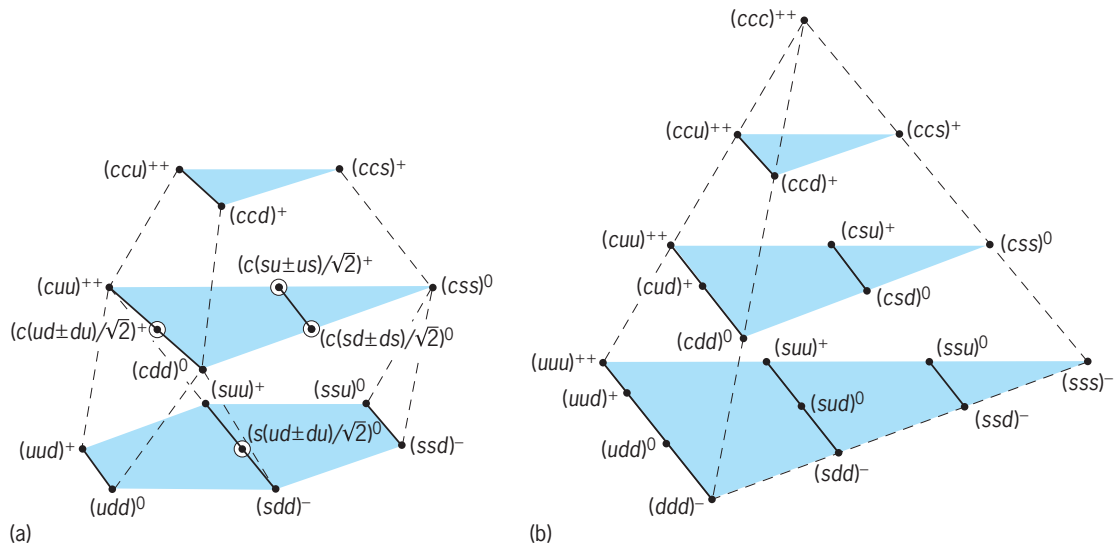

**Fig. 2.** Arrays of the states of baryons made from three quarks of the types  $u$ ,  $d$ ,  $s$ , and  $c$ , with no internal orbital angular momentum. The quark content and charge of each state is specified. The vertical axis specifies the number of  $c$  quarks. (a)  $1/2^+$  baryons. (b)  $3/2^+$  baryons. The former have flavor symmetry  $M$ ; the latter have symmetry  $S$ .

between nucleons gives rise to the existence of atomic nuclei, and has been particularly well studied, both empirically and theoretically. For large separations (greater than 0.8 femtometer), the  $NN$  force is due to the exchange of pions and of other known mesons with masses less than about 1 GeV; for small separations (less than 0.4 fm), a strong short-range repulsion is observed, possibly arising from the suppressive effects of the Pauli principle for quarks when the quark structures of the two nucleons overlap. At low energies, the outstanding feature of the  $NN$  interaction is its strong noncentral tensor component, which is due to one-pion exchange and is a direct consequence of the pseudoscalar nature of the pion. It also has a strong spin-orbit interaction, observed in  $NN$  interactions at higher energy and of much importance for the shell structure of nuclei. See NUCLEAR STRUCTURE.

Many further particle-unstable baryon states, with lifetimes in the range  $10^{-22}$  to  $10^{-23}$  s, have become established, up to mass values of order 2500 MeV, all consistent with the limitations of the three-quark model.

Further baryon states can be formed by replacing one or more of the  $u$ ,  $d$ , and  $s$  quarks of the states discussed above by a  $c$  quark. If the  $s$  and  $c$  quarks both had the same mass as the ( $u$ ,  $d$ ) quarks, the states formed would correspond to an  $SU(4)_f$  symmetry. Extensions of the  $1/2^+$  baryon octet (Fig. 2a) and the  $3/2^+$  baryon decuplet (Fig. 2b) to arrays in three dimensions are obtained in this way. The lowest plane of each such array consists of the charmless baryon states, in accord with the original octet or decuplet. In reality, the  $c$ -quark mass is so large that little quantitative detail of  $SU(4)_f$  symmetry can survive in the physical situation, and these arrays have value mainly for general comprehension and for the counting of states.

The fifth quark, named "bottom" (symbol  $b$ ), was discovered in 1978. The baryon  $\Lambda_b^0$  is well established, with decay mode  $\pi^- \Lambda_c^+$  and mass  $5624 \pm 9$  MeV. See UPSILON PARTICLES.

The sixth quark, named "top" (symbol  $t$ ), became established in 1994 through top-antitop pair production in proton-antiproton collisions at center-of-mass energy 1800 GeV. Its mass,  $174 \pm 5$  GeV, is remarkably large, far above the  $bW^+$  threshold at  $\approx 85$  GeV. The decay  $t \rightarrow bW^+$  is very rapid, its lifetime being  $4 \times 10^{-25}$  s and its decay width  $\Gamma_t \approx 1.5$  GeV. This decay is so much faster than hadronization that there is almost no time for top baryons to form.

No further quark-lepton families are expected. This conclusion comes from counting the number of neutrino species in  $Z^0$

decays, and from astrophysical arguments about light-nucleus formation in the early universe.

For every baryonic state mentioned above, there will exist an antibaryon state with opposite flavor quantum numbers, in particular with  $B = -1$ . The antiproton  $p$  was first identified in 1954, and antiproton beams at high-energy proton accelerators are a basic tool in elementary particle research. Most of the expected antibaryon states have been detected and studied in some detail.

In grand unification theories (GUT), which attempt to account for both quarks and leptons, together with their strong, electromagnetic, and weak interactions, quark  $\rightarrow$  lepton transitions generally exist, at some level, since such theories assign leptons and quarks to common multiplets. This violation of baryon conservation opens the possibility that the lightest baryon, the proton, might not be absolutely stable but may undergo decay processes such as  $p \rightarrow e^+ \pi^0$  at a very low rate. Indeed, cosmology appears to require the existence of nucleon decay processes in order to account for the baryon-antibaryon asymmetry of the universe. Empirically, the partial decay rate  $\Gamma(p \rightarrow e^+ \pi^0)$  is less than  $0.58 \times 10^{-40} \text{ s}^{-1}$  with 90% probability. In the simplest GUT [known as  $SU(5)$ ], this leads to a proton lifetime greater than  $1.7 \times 10^{32}$  years. Other GUTs may predict smaller decay rates, even zero. Since proton decay offers the possibility of discriminating between various GUTs, the detection of proton decay (and neutron decay involving baryon non-conservation, for example, when bound in a deuteron or alpha particle), or at least the improvement of the present empirical limits on its rate, is an important subject of investigation. See COSMOLOGY; ELEMENTARY PARTICLE; FUNDAMENTAL INTERACTIONS; GRAND UNIFICATION THEORIES. [R.H.D.]

**Basalt** An igneous rock characterized by small grain size (less than about 0.2 in. or 5 mm) and approximately equal proportions of calcium-rich plagioclase feldspar and calcium-rich pyroxene, with less than about 20% by volume of other minerals. Olivine, calcium-poor pyroxene, and iron-titanium oxide minerals are the most prevalent other minerals. Most basalts are dark gray or black, but some are light gray. Various structures and textures of basalts are useful in inferring both their igneous origin and their environment of emplacement. Basalts are the predominant surficial igneous rocks on the Earth, Moon, and probably other bodies in the solar system. Several chemical-mineralogical types of basalts are recognized. The nature of basaltic rocks

provides helpful clues about the composition and temperature within the Earth and Moon. The magnetic properties of basalts are responsible in large part for present knowledge of the past behavior of the Earth's magnetic field and of the rate of sea-floor spreading. Some meteorites are basaltic rocks. They differ significantly from lunar basalts and appear to have originated elsewhere in the solar system at a time close to the initial condensation of the solar nebula. See IGNEOUS ROCKS; METEORITE.

Basalt erupts out of fissures and cylindrical vents. Repeated or continued extrusion of basalt from cylindrical vents generally builds up a volcano of accumulated lava and tephra around the vent. Fissure eruptions commonly do not build volcanoes, but small cones of tephra may accumulate along the fissures. See VOLCANO; VOLCANOLOGY.

Basalts display a variety of structures mostly related to their environments of consolidation. On land, basalt flows form pahoehoe, aa, and block lava, while under water, pillow lava is formed. Basalt also occurs as pumice and bombs. Commonly, basaltic pumice is called scoria to distinguish it from the lighter-colored, more siliceous rhyolitic pumice.

The mineralogy and texture of basalts vary with cooling history and with chemical composition. As basalt crystallizes, both the minerals and the residual melt change in composition because of differences between the composition of the melt and the crystals forming from it. In basalts, because of the rapid cooling, there is little chance for crystals to react with the residual melt after the crystals have formed. Completely solid basalts generally preserve a record of their crystallization in the zoned crystals and residual glass.

Most basalts contain minor amounts of chromite, magnetite, ilmenite, apatite, and sulfides in addition to the minerals mentioned above. Magnetite in basalts contains a history of the strength and orientation of the Earth's magnetic field at the time of cooling. Therefore, although magnetite is minor in amount, it is probably the most important mineral in terrestrial basalts, because it enables earth scientists to infer both the magnetic history of the Earth and the rate of the production of basaltic ocean floor at the oceanic ridges.

Basalts occur in all four major tectonic environments: ridges in the sea floor, islands in ocean basins, island arcs and mountainous continental margins, and interiors of continents. The principal environment is the deep sea floor. Significant differences exist in the composition of basalt which relate to different tectonic environments (see table). Chemical analyses of basalts are now used instead of, or together with, the textural criteria as a basis of

classification. Geologists customarily recast the chemical analysis into a set of ideal minerals according to a set of rules. The result is called the norm of the rock. In general there is rather close correspondence between the normative minerals and the observed minerals in basaltic rocks. See PETROLOGY; MAGMA. [A.T.A.]

**Base (chemistry)** In the Brønsted-Lowry classification, any chemical species, ionic or molecular, capable of accepting or receiving a proton (hydrogen ion) from another substance. The other substance acts as an acid in giving up the proton. A substance may act as a base, then, only in the presence of an acid. The greater the tendency to accept a proton, the stronger the base. The hydroxyl ion acts as a strong base. Substances that ionize in aqueous solutions to produce the hydroxyl ion (OH<sup>-</sup>), such as potassium hydroxide (KOH) and barium hydroxide [Ba(OH)<sub>2</sub>], are also conventionally called bases.

Anions of weak acids such as acetic and formic, act as bases in reacting with solvent water to form the molecular acid and hydroxyl ion, for example, the acetate ion (CH<sub>3</sub>COO<sup>-</sup>). Ammonia (NH<sub>3</sub>) and amines react similarly in aqueous solutions. In these examples, the acetate ion and acetic acid (CH<sub>3</sub>COOH) and NH<sub>3</sub> and the ammonium ion are conjugate base-acid pairs. The basicity constant, *K<sub>b</sub>*, is the equilibrium constant for the proton transfer reaction, and it is a quantitative measure of base strength.

The Lewis classification involves the concept of a base as a substance that donates an electron pair to an acid acceptor. In the gas phase, NH<sub>3</sub> acts as a base contributing an electron pair to the formation of a covalent bond with the boron trifluoride (BF<sub>3</sub>) molecule. See ACID AND BASE. [F.J.J.]

**Basidiomycota** A phylum in the kingdom fungi; commonly known as basidiomycetes. Basidiomycetes traditionally included four artificial classes: Hymenomycetes, Gasteromycetes, Urediniomycetes, and Ustilaginomycetes. They are mostly filamentous fungi characterized by the production of basidia. These are microscopic, often club-shaped end cells in which nuclear fusion and meiosis usually take place prior to the maturation of external, typically haploid basidiospores, which are then disseminated. Common basidiomycetes are the rusts and smuts, which cause severe plant diseases, mushrooms (edible and poisonous), boletes, puffballs, stinkhorns, chanterelles, false truffles, jelly fungi, bird's-nest fungi, and conk or bracket fungi. Basidiomycetes are the most important decayers of wood, living or dead, in forests or buildings, causing either brown rot (for example, dry rot) or white rot. Many, especially mushrooms and boletes, are the primary fungal partners in symbiotic ectomycorrhizal associations with tree roots. Plant litter and soil are other major habitats. A few basidiomycetes are cultivated for food. Some are luminescent, hallucinogenic, lichenized, nematophagous, or aquatic. Some are cultivated by ants or termites, or are symbiotic with captured scale insects. Some can convert to a yeast (or single-cell) phase, one of which causes cryptococcosis in humans and animals. See MUSHROOM; MYCORRHIZAE; RUST (MICROBIOLOGY); WOOD DEGRADATION. [S.A.R.]

**Basil** An annual herb (*Ocimum basilicum*) of the mint family (Labiatae), grown from seed for its highly scented leaves. It is sold fresh or dried, and its essential oil is used in pharmaceuticals and flavoring. The genus *Ocimum* has approximately 150 species, many of which are also grown as "basil." See LAMI-ALES.

Growth habit varies with type, but it is usually upright and branching from a square central stem up to 24 in. (61 cm) in height. Leaf shape and odor vary considerably from type to type, with "sweet basil," the most popular, having broad, flat, shiny green leaves to 3 in. (7.5 cm) long. Wild forms of basil are found in South America, Africa, India, and Europe. Cultivated basil differs little from its wild forms, although breeding and selection

Chemical compositions of basalts, in weight percent

	1*	2	3	4	5	6
SiO <sub>2</sub>	49.92	49.20	49.56	51.5	45.90	45.5
TiO <sub>2</sub>	1.51	2.32	1.53	1.1	1.80	2.97
Al <sub>2</sub> O <sub>3</sub>	17.24	11.45	17.88	17.1	15.36	9.69
Fe <sub>2</sub> O <sub>3</sub>	2.01	1.58	2.78	n.d.	1.22	0.00
Cr <sub>2</sub> O <sub>3</sub>	0.04	n.d.	n.d.	n.d.	n.d.	0.50
FeO	6.90	10.08	7.26	8.9	8.13	19.7
MnO	0.17	0.18	0.14	n.d.	0.08	0.27
MgO	7.28	13.62	6.97	7.0	13.22	10.9
CaO	11.85	8.84	9.99	9.3	10.71	10.0
Na <sub>2</sub> O	2.76	2.04	2.90	4.3	2.29	0.33
K <sub>2</sub> O	0.16	0.46	0.73	0.80	0.67	0.06
P <sub>2</sub> O <sub>5</sub>	0.16	0.23	0.26	n.d.	0.62	0.10
Sum	100.00	100.00	100.00	100.00	100.00	100.02
H <sub>2</sub> O	0.4	0.3	n.d.	2	n.d.	0.0
CO <sub>2</sub>	0.02	0.01	n.d.	n.d.	n.d.	n.d.
F	0.02	0.03	n.d.	n.d.	n.d.	0.002
Cl	0.02	0.03	n.d.	0.09	0.01	0.0005
S	0.08	0.07	n.d.	0.19	n.d.	0.07

\* (1) Average of 10 basalts from oceanic ridges; (2) submarine basalt, Eastern Rift Zone, Kilauea Volcano, Hawaii; (3) average high-alumina basalt of Oregon Plateau; (4) initial melt of Pacaya Volcano, Guatemala; (5) alkali basalt, Hualalai Volcano, Hawaii; (6) average *Apollo 12* lunar basalt.

work have been performed on some of the varieties grown for essential oil production. Some of the more popular cultivated types are: sweet basil (used fresh or dehydrated), lemon-scented basil, opal basil (a purple-leaved type), and large- or lettuce-leaf basil. Many unusual types can be obtained which have a scent similar to camphor, lemon, licorice, or nutmeg. See SPICE AND FLAVORING. [S.Kir.]

**Basin** A low-lying area which is wholly or largely surrounded by higher land. An example is Hudson Bay in northeastern Canada, which was formed by depression beneath the center of a continental ice sheet 18,000 years ago. Another example, the Qattara depression, is 150 mi (240 km) long and the largest of several wind-excavated basins of northern Egypt. Depressions in the ocean floor are also basins, such as the Canary Basin, west of northern Africa, or the Argentine Basin, east of Argentina. These basins occur in regions where cold, dense oceanic crust lies between the topographically elevated ocean ridges and the continental margins. See CONTINENTAL MARGIN; MARINE GEOLOGY.

A drainage basin is the entire area drained by a river and its tributaries. Thus, the Mississippi Basin occupies most of the United States between the Rocky Mountains and the Appalachians. Interior drainage basins consist of depressions that drain entirely inward, without outlet to the sea. Examples may be quite small, such as the Salton Sea of southern California or the Dead Sea of central Asia. One of the most remarkable examples of an interior drainage basin is the Chad Basin in northern Africa, the center of which is occupied by Lake Chad. The fresh waters of the lake drain underground to feed oases in the lowlands 450 mi (720 km) to the northeast.

In the geologic sense, a basin is an area in which the continental crust has subsided and the depression has been filled with sediments. Such basins were interior drainage basins at the time of sediment deposition but need not be so today. As these basins subside, the layers of sediment are tilted toward the axis of maximum subsidence. Consequently, when the sedimentary layers are observed in cross section, their geometry is a record of the subsidence of the basin through time and contains clues about the origin of the basin.

The origin of geologic basins is a topic of continuing interest in both applied and basic geological studies. They contain most of the world's hydrocarbon reserves, and they are regarded as some of the best natural laboratories in which to understand the thermal and mechanical processes that operate deep in the interior of the Earth and that shape the Earth's surface. [G.Bo.; M.Ko.]

**Basommatophora** A superorder of the molluscan subclass Pulmonata containing about 2500 species that are grouped into 11–15 families. Only a few members of the family Ellobiidae are terrestrial, with the other species today being tidal to supratidal or estuarine in habitat. The families Siphonatiidae and Trimusculidae are marine limpets with cap-like shells. The families Otinidae and Amphibolidae also are marine taxa. The remaining families inhabit a great variety of fresh-water situations and are quite varied in shell structure and shape. Because of this great variation in habitat and form, it is difficult to find structures that are common to all taxa and thus diagnostic of the group, which indeed may not have a common origin. The most easily observable characters are having the eyespots normally located at the base of two slender tentacles that are neither contractile nor retractile, and usually having two external genital orifices. Most features of the anatomy are shared with other pulmonate superorders, or are specializations related to major changes in habitat or body form. See PULMONATA. [G.A.S.]

**Bass** The name for a number of fishes assigned to two families in the order Perciformes. Both marine and fresh-water species are included under this common name, and all are highly prized as game fish as well as for food. Members of the family Centarchidae are commonly referred to as the freshwater or black

basses, while the Serranidae are designated as the sea basses. See PERCIFORMES. [C.B.C.]

**Basswood** A member of the linden family in the order Malvales. One species, known as the American linden (*Tilia americana*), is a timber tree of the northeastern quarter of the United States and the adjacent area of Canada. *Tilia* is also an ornamental tree. *Tilia europea*, or lime tree of Europe, is often cultivated along the streets. The lindens are also important as bee trees. The leaves are heart-shaped, coarsely toothed, long, pointed, and alternate. All species of *Tilia* can be recognized by the winter buds, which have a large outer scale that gives the bud a humped, asymmetrical appearance, and by the small, spherical, nutlike fruits borne in clusters.

The wood of basswood, also known as whitewood, is white and soft and is used for boxes, venetian blinds, millwork, furniture, and woodenware. There are about 30 species in the temperate regions of the Northern Hemisphere in North America south to Mexico, but none in the western part. In Asia lindens grow south to central China and southern Japan. See MALVALES. [A.H.G./K.P.D.]

**Batales** A small order of flowering plants, division Magnoliophyta (Angiospermae), in the subclass Dilleniidae of the class Magnoliopsida (dicotyledons). It consists of two small families and fewer than 20 species, of no economic significance. The plants are trees, shrubs, or subshrubs with simple, entire leaves and small, unisexual flowers. The perianth consists of small, separate or fused sepals with no petals. The stamens are four to numerous; the pistil has (1)2-many carpels, fused to form a plurilocular, superior ovary. The fruit is a dry, dehiscent nutlet or a drupe. The taxonomic disposition of the Batales has long been disputed, and it is often included in the Caryophyllidae. However, the presence of mustard oils as well as certain morphological features suggest that the order is best included near the Capparales in the Dilleniidae. See CAPPARALES; DILLENIIDAE; MAGNOLIOPHYTA; PLANT KINGDOM. [T.M.Ba.]

**Bathynellacea** An order of syncarid crustaceans found in subterranean waters in central Europe and England. The body is elongate and segmented. Organs and limbs are primitive. Each of the thoracic limbs has two epipodites which function as gills.

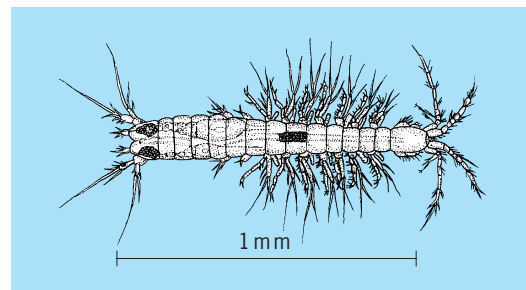

*Bathynellia natans*, female.

The thorax and abdomen have a similar form (see illustration). These animals have no metamorphosis. See SYNCARIDA. [H.J.]

**Batoidea** Skates and rays, one of the two Recent orders of the subclass Elasmobranchii. The order is also known as Rajiformes. The skates and rays differ from the sharks (order Selachii) in having ventral gill slits, the edge of the pectoral fin attached to the side of the head anterior to the gill clefts, and the upper margin of the orbit not free from the eyeball (see illustration). Guitarfishes, the most generalized rays, appeared in the Upper Jurassic, but most major groups of rays date from the Cretaceous.

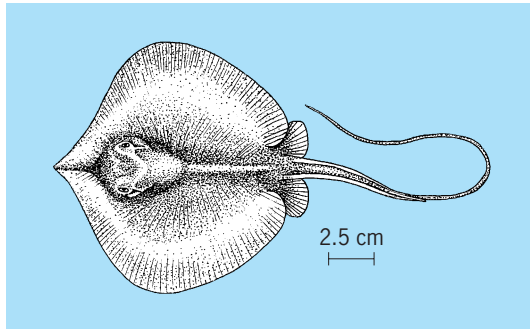

Atlantic stingray (*Dasyatis sabina*). (After G. B. Goode, *Fishery Industries of the United States*, 1884)

Rays have been classified in 5 suborders, 16 families, 47 genera, and 300–350 species. They occur in all oceans, and most are sluggish bottom inhabitants, although the mantas commonly swim at the surface. A few, especially stingrays and sawfishes, penetrate estuaries of tropical rivers or even live far upstream. Rays vary in size from less than 1 ft (0.3 m) in length as adults to a width of over 20 ft (6 m) in the giant mantas. There are some bizarre skates that live at depths of as much as 9000 ft (2750 m); however, none of these is luminescent. The torpedoes have a pair of enlarged electric organs located lateral to the eyes on the expansive pectoral fins; these can deliver a strong and temporarily disabling shock to bathers. More to be feared, however, are the stingrays, which lie in shallow water and if stepped on are able to inflict a dangerous or fatal wound with the serrated tail spine and its venom gland. Rays are carnivorous, feeding on a wide variety of marine worms, mollusks, crustaceans, and other invertebrates, as well as small fishes. Although rays are abundant in many seas, they are of minor commercial importance. See ELASMOBRANCHII. [R.M.B.]

**Batrachoidiformes** The toadfishes, which make up an order (or suborder) of actinopterygian fishes. This group is also known as the Haplodoci. The first vertebra of Batrachoidiformes is rigidly fused with the broad, flattened cranium; the short post-temporal is not forked and is suturally attached to the skull. There are no epiotics, intercalars, or ribs, and the four or five pectoral radials are elongate. There are only three gill arches, and the gill openings are reduced in size. The pelvic fins are on the throat; the spinous dorsal fin is short, and the soft dorsal and anal fins are long (see illustration).

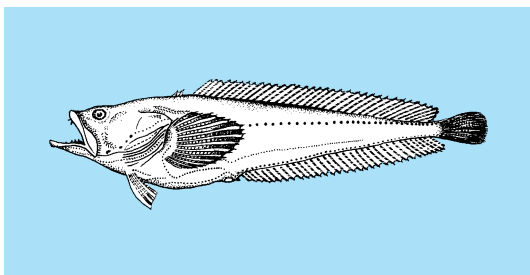

Atlantic midshipman (*Porichthys porosissimus*). (After D. S. Jordan and B. W. Evermann)

The single family, Batrachoididae, known from Miocene to Recent time, includes 10 genera and about 35 species. Most live in tropical and temperate oceanic shore waters or in moderate depths, but a few ascend tropical rivers. Some species are luminescent; some have hollow opercular and dorsal spines associated with venom glands. Toadfishes have powerfully muscled jaws and strong teeth and are predacious. See ACTINOPTERYGII; BIOLUMINESCENCE; OSTEICHTHYES. [R.M.B.]

**Battery** An electrochemical device that stores chemical energy which can be converted into electrical energy, thereby providing a direct-current voltage source. Although the term “battery” is properly applied to a group of two or more electrochemical cells connected together electrically, both single-cell and multicell devices are called battery. See ELECTROCHEMISTRY; ELECTROMOTIVE FORCE (CELLS).

The two general types are the primary battery and the secondary battery. The primary battery delivers current as the result of a chemical reaction that is not efficiently reversible. Practically, this makes the primary battery nonrechargeable. Only one intermittent or continuous discharge can be obtained before the chemicals placed in it during manufacture are consumed. Then the discharged primary battery must be replaced. The secondary or storage battery is rechargeable because it delivers current as the result of a chemical reaction that is easily reversible. When a charging current flows through its terminals in the direction opposite to the current flow during discharge, the active materials in the secondary battery return to approximately their original charged condition.

The cell is the basic electrochemical unit. It has three essential parts: (1) a negative electrode (the anode) and (2) a positive electrode (the cathode) that are in contact with (3) an electrolyte solution. The electrodes are metal rods, sheets, or plates that are used to receive electrical energy (in secondary cells), store electrical energy chemically, and deliver electrical energy as the result of the reactions that occur at the electrode-solution surfaces. Solid polymer or plastic active materials have been developed that can serve as the cathode in rechargeable batteries. The electrolyte is a chemical compound (salt, acid, or base) that when dissolved in a solvent forms a solution that becomes an ionic conductor of electricity, but essentially insulating toward electrons—properties that are prerequisites for any electrolyte. In the cell or battery, this electrolyte solution is the conducting medium in which the flow of electric current between electrodes takes place by the migration of ions. When water is the solvent, an aqueous solution is formed. Some cells have a nonaqueous electrolyte, for example, when alcohol is used as the solvent. Other cells have a solid electrolyte that when used with solid electrodes can form a leak-free solid-state cell or battery.

During charging of a secondary cell, the negative electrode becomes the cathode and the positive electrode becomes the

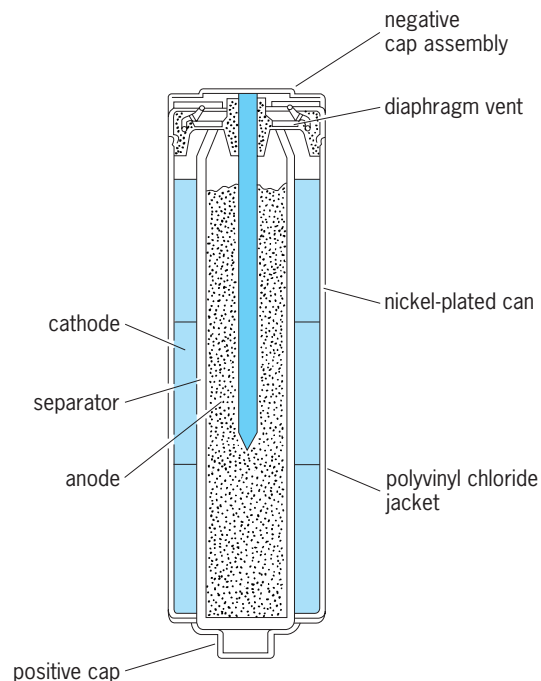

Diagram of a zinc-alkaline-manganese dioxide cylindrical cell.

anode. However, electrode designation as positive or negative is unaffected by the operating mode of the cell or battery. Two or more cells internally connected together electrically, in series or parallel, form a battery of a given voltage. Typical are the rectangular 9-V primary battery, which has six flat 1.5-V zinc-carbon or alkaline "dry" cells connected in series, and the 12-V automotive or secondary battery, which has six 2.1-V lead-acid "wet" cells connected in series.

A primary cell or battery is not intended to be recharged and is discarded when it has delivered all its electrical energy (see illustration). Several kinds of primary cell are widely used, particularly in portable devices and equipment, providing freedom from the dependence on alternating-current line power. They are convenient, lightweight, and usually relatively inexpensive sources of electrical energy that provide high energy density (long service life) at low-to-moderate or intermittent discharge rates, good shelf life, and ease of use while requiring little or no maintenance.

Primary cells are classified by their electrolyte, which may be described as aqueous, nonaqueous, aprotic, or solid. In most primary cells the electrolyte is immobilized by a gelling agent or mixed as a paste, with the term "dry cell" commonly applied to the zinc-carbon Leclanche cell and sometimes to other types. An aqueous electrolyte or electrolyte system is used in zinc-carbon, magnesium, alkaline-manganese dioxide, mercuric oxide, silver oxide, and zinc-air cells. Nonaqueous electrolyte systems are used in lithium cells and batteries. See ELECTROLYTE. [D.L.An.]

Secondary batteries (also known as accumulators) are rechargeable. This means that the electrochemical reactions in the cell must be reversible so that if the load in the external circuit is replaced by a power supply, the reactions in the cell can be forced to run in reverse, thereby restoring the driving force for reaction and hence recharging the cell. The paradigm of battery design is to identify a chemical reaction with a strong driving force and then to fashion a cell that requires the reaction to proceed by a mechanism involving electron transfer, thereby making electrons available to a load in the external circuit. The magnitude of the driving force will determine cell voltage; the kinetics of reaction will determine cell current.

Most batteries have solid electrodes and a liquid electrolyte. However, there are examples of batteries in which the anode and cathode are both liquid, and the electrolyte is solid.

The lead-acid battery is the dominant secondary battery, used in a wide variety of applications, including automotive SLI (starting, lighting, ignition), traction for industrial trucks, emergency power, and UPS (uninterruptible power supplies). The attributes of lead-acid batteries include low cost, high discharge rate, and good performance at subambient temperatures. The anode is metallic lead. The cathode active material is lead dioxide, which is incorporated into a composite electrode also containing lead sulfate and metallic lead. The electrolyte is an aqueous solution of sulfuric acid, 37% by weight when the battery is fully charged.

Other secondary types include the nickel-cadmium, nickel-metal hydride, silver-zinc, sodium-sulfur, zinc-air, lithium-ion, and lithium-solid polymer electrolyte battery. [D.R.Sa.]

**Bauxite** A rock mainly comprising minerals that are hydrous aluminum oxides. These minerals are gibbsite, boehmite, and diaspore. The major impurities in bauxite are clay minerals and iron oxides. Bauxite is a weathering product of aluminous rock that results from intense leaching in tropical and subtropical areas, a process called laterization. Bauxite deposits are generally found on plateaus in stable areas where they had sufficient geologic time to form and were protected from erosion. See ALUMINUM.

Bauxite is the primary ore of aluminum. The two types of bauxites that are used commercially as aluminum ores are laterite and karst. Lateritic bauxites constitute more than three-fourths of the world's bauxite resources. Karstic bauxites are formed on a carbonate terrain and are concentrated in sinkholes and solution depressions on the surface of carbonate rocks. See LATERITE.

Bauxite used to produce alumina is called metallurgical grade; approximately 90% of the world's production is for this purpose. Other major uses are in refractories, abrasives, chemicals, and aluminous cements. The compositional requirements are much more rigid for these uses. The alumina content must be higher, and the iron, silica, and titanium contents significantly lower, than for metallurgical-grade bauxite. World resources of bauxite are many tens of billions of tons, so an adequate supply is assured for hundreds of years. [H.H.Mu.]

**Bayesian statistics** An approach to statistics in which estimates are based on a synthesis of a prior distribution and current sample data. Bayesian statistics is not a branch of statistics in the way that, say, nonparametric statistics is. It is, in fact, a self-contained paradigm providing tools and techniques for all statistical problems. In the classical frequentist viewpoint of statistical theory, a statistical procedure is judged by averaging its performance over all possible data. However, the bayesian approach gives prime importance to how a given procedure performs for the actual data observed in a given situation. Further, in contrast to the classical procedures, the bayesian procedures formally utilize information available from sources other than the statistical investigation. Such information, available through expert judgment, past experience, or prior belief, is described by a probability distribution on the set of all possible values of the unknown parameter of the statistical model at hand. This probability distribution is called the prior distribution. The crux of the bayesian approach is the synthesis of the prior distribution and the current sample data into a posterior probability distribution from which all decisions and inferences are made. This synthesis is achieved by using a theorem proved by Thomas Bayes in the eighteenth century.

The posterior distribution combines the prior information about the unknown parameter  $\theta$  with the information contained in the observed data to give a composite picture of the final judgments about  $\theta$ . In order to arrive at a single number as the estimate of  $\theta$ , it may be necessary to bring in the notion of the loss suffered by the decision maker as a result of estimating the true value  $\theta$  by the number  $\theta$ . Depending on the choice of the loss function, the mode, the mean, and the median of the posterior distribution are all reasonable estimates of  $\theta$ .

The choice of the prior distribution for the unknown parameter  $\theta$  is of crucial importance in bayesian statistics. The selected prior distribution for  $\theta$  must be at least a reasonable approximation to the true beliefs about  $\theta$ . In addition, the prior distribution must be such that the posterior distribution is tractable.

**Noninformative and improper priors.** The bayesian approach remains applicable even when little or no prior information is available. Such situations can be handled by choosing a prior density giving equal weight to all possible values of  $\theta$ . Priors that seemingly impart no prior preference, the so-called noninformative priors, also arise when the prior is required to be invariant under certain transformations. Frequently, the desire to treat all possible values of  $\theta$  equitably leads to priors with infinite mass. Such noninformative priors are called improper priors.

**Criticism.** Proponents of the bayesian paradigm claim a number of significant and fairly convincing advantages over the classical non-bayesian approach. However, bayesian statistics is itself criticized for its apparent lack of objectivity. The use of a prior distribution introduces subjectivity into a bayesian analysis so that decision makers having different priors may come to different conclusions even when working on the same problem with the same observed data. This, however, is the price that must be paid in order to incorporate prior information or expert judgment. Moreover, the bayesian approach seems to be the most logical approach if the performance of a statistical procedure for the actual observed data is of interest, rather than its average performance over all possible data. See ESTIMATION THEORY; PROBABILITY; STATISTICS. [S.N.U.A.K.]

**Bdelloidea** A class (formerly order) of the phylum Rotifera. Bdelloid rotifers have a very characteristic appearance; the agile elongate body consists of several (typically 16) false segments or annuli which do not correspond to the true segmentation of the body. Of these, the shorter and smaller head, neck, and foot segments are telescopically retractile into the larger and longer trunk joints. In typical species the corona has the characteristic form of two trochal disks, raised on pedicels, and a single cingulum of smaller cilia. The corona can be completely withdrawn, to reveal the true anterior end of the body. The mouth is large and funnel-shaped, and leads via a ciliated buccal tube into the mastax (a gizzardlike structure) whose ramate trophi are in constant motion. The intestine is syncytial, often colored brown or red by its contents, and digestion appears to be extracellular, rapid, and occurring in an alkaline medium. No males are known, and reproduction is believed to be parthenogenetic. A few genera are viviparous, but most are oviparous.

The Bdelloidea are typically bottom dwellers and crawl over the substratum leech-fashion. They are the most common inhabitants of standing fresh waters throughout the world, occurring in the smallest pools, in the littoral zones of large lakes, and also in mosses, liverworts, and lichens, some of which may be wetted only intermittently. See ROTIFERA. [J.B.J.]

**Bdellonemertini** An order of the class Enopla in the phylum Rhynchocoela. The proboscis is unarmed. The alimentary system comprises the mouth, papillate foregut, sinuous intestine without diverticula, and anus. Members are characterized by the presence of a posterior adhesive disk and dorsoventral flattening of the body, which lacks eyes, cephalic slits, and cerebral organs. The order contains the single genus *Malacobdella*, with three species ectocommensal in the mantle cavity of marine bivalves and one in the pulmonary sac of a freshwater gastropod. See ENOPLA; RHYNCHOCOELA. [J.B.J.]

**Beam** A structural member that is fabricated from metal, reinforced or prestressed concrete, wood, fiber-reinforced plastic, or other construction materials and that resists loads perpendicular to its longitudinal axis. Its length is usually much larger than its depth or width. Usually beams are of symmetric cross section; they are designed to bend in this plane of symmetry, which is also the plane of their greatest strength and stiffness. This plane coincides with the plane of the applied loads. Beams are used as primary load-carrying members in bridges and buildings. [T.V.G.]

**Beam column** A structural member that is subjected to axial compression and transverse bending at the same time. A beam column differs from a column only by the presence of the eccentricity of the load application, end moment, or transverse load. Beam columns are found in frame-type structures where the columns are subjected to other than pure concentric axial loads and axial deformations, and where the beams are subjected to axial loads in addition to transverse loads and flexural deformations. See BEAM; COLUMN. [R.T.R.]

**Beam-foil spectroscopy** A technique used in atomic physics to study the structure and dynamics of atomic ions of any element in any state of ionization. For this purpose, a beam of fast ions is sent through a very thin foil. The ion-foil interaction shakes up the electronic shells of the projectile and, after leaving the foil, the ions shed surplus energy by emitting photons, and sometimes electrons. The energies and intensities of these particles yield spectral information on the projectile. See PARTICLE ACCELERATOR.

The multitude of collisions inside the foil changes the complement of electrons that travel with the projectile ion; some are ejected and others are captured from the target atoms. The ion beam therefore has a different charge-state composition after passage through the foil. (Higher exit charge states are produced at higher incident beam energies.) The beam-foil interaction

efficiently populates atomic levels with a high degree of excitation such as multiply excited and core-excited levels. The richness of the resulting spectra yields a great deal of information on atoms and ions, although it is often difficult to resolve the details of line-rich spectra that reflect the complexity of multiply excited systems.

The ion beam travels in a high vacuum before and after transiting the target foil. This environment minimizes collisional perturbation of the ions. The sudden termination of the ion-foil interaction provides an inherently good time resolution to beam-foil spectroscopy. This property of the source permits lifetime measurements as well as the observation of coherent-excitation phenomena such as quantum beats. Because the ion velocity is constant and measurable, it is sufficient to trace the change in intensity of the fluorescence from the ion beam as a function of distance from the foil in order to determine atomic level lifetimes. See FLUORESCENCE.

Beam-foil spectroscopy has developed into many variants which now go under the name of fast-beam spectroscopy. For example, a gas target may be used, a laser, a combination of gas or foil and laser, or a target of free electrons in a heavy-ion storage ring. The ion-foil interaction is capable of producing all ionization stages of all elements from negative ions to  $U^{91+}$ . The production of the highest ionization stages, however, requires a beam energy of about 500 MeV/nucleon, which can be reached only at the most energetic accelerators. However, since only the relative motion of electrons and ions is important, the same degree of ionization can be reached by use of 250-keV electrons in an electron-beam ion trap (EBIT). The device offers easier ways to attain high spectroscopic precision because the ions are practically at rest. In beam-foil spectroscopy the ions are rapidly moving, which shifts and broadens the spectral lines. This, in turn, causes problems in wavelength calibration and spectral resolution. However, the inherent time resolution of the foil-excited fast-ion-beam source is unique and remains a great asset in time-resolved spectroscopic measurements. See ATOMIC STRUCTURE AND SPECTRA; ION SOURCES; SPECTROSCOPY. [E.Tr.]

**Bean** Any of several leguminous plants, or their seeds, long utilized as food by humans or livestock. Some 14 genera of the legume family contain species producing seeds termed "beans" which are useful to humans. Twenty-eight species in 7 genera produce beans of commercial importance, which implies that the bean can be found in trade at the village level or up to and including transoceanic commerce.

The principal Asiatic beans include the edible soybeans, *Glycine* sp., and several species of the genus *Vigna*, such as the cowpea and mung, grams, rice, and adzuki beans. The broad bean (*Vicia faba*) is found in Europe, the Middle East, and Mediterranean region, including the North African fringe. Farther south in Africa occur *Phaseolus* beans, of the *vulgaris* (common bean) and *coccineus* (scarlet runner) species. Some *Phaseolus* beans occur in Europe also. The cowpea, used as a dry bean, is also found abundantly in Nigeria. See COWPEA; SOYBEAN.

In the Americas, the *Phaseolus* beans, *P. vulgaris* and *P. lunatus* (lima bean), are the principal edible beans, although the blackeye cowpea, mung bean, and chick pea or garbanzo (*Cicer arietinum*) are grown to some extent. *Phaseolus coccineus* is often grown in higher elevations in Central and South America, as is *Vicia faba*. The tepary bean (*P. acutifolius*) is found in the drier southwestern United States and northern Mexico. See ROSALES.

Bean plants may be either bush or vining types, with white, yellow, red, or purple flowers. The seed itself is the most differentiating characteristic of bean plants. It may be white, yellow, black, red, tan, cream-colored, or mottled, and range in weight from 0.0044 to over 0.025 oz (125 to over 700 mg) per seed. Seeds are grown in straight or curved pods (fruit), with 2–3 seeds per pod in *Glycine* to 18–20 in some *Vigna*.

Beans are consumed as food in several forms. Lima beans and snap beans are used as fresh vegetables, or they may be processed by canning or freezing. Limas are also used as a dry bean.

Mung beans are utilized as sprouts. Usage of dry beans (*P. vulgaris*) for food is highly dependent upon seed size, shape, color, and flavor characteristics, and is often associated with particular social or ethnic groups. See LEGUME. [M.W.A.]

**Bear** The name for a number of species of carnivorous mammals in the family Ursidae (see table). Bears are large and heavy bodied, with short, strong legs and short tails. They are completely plantigrade, walking with their metatarsal and metacarpal regions touching the ground, but are able to stand upright. The foot has five toes which terminate in nonretractile claws. The toes are separate with no membranes between them. The foot soles of the polar bear are covered with hair, lacking in other species, which aids in walking on ice. The eyes of bears are relatively small and vision is rather poor; however, hearing and smell are acute. The rounded ears are small, and the muzzle is elongate.

Depending upon the species, the female produces one to three young per litter; gestation varies from 180 to 250 days. The small, blind, toothless offspring weigh less than 1 lb (0.5 kg). The female cares for the cubs since the male usually does not remain with her.

Common name and geographic distribution of some Ursidae species

Scientific name	Common name	Distribution
<i>Tremarctos ornatus</i>	Spectacled bear, Andean bear	Pacific slopes of Andes from northern Chili to Colombia
<i>Selenarctos thibetanus</i>	Asiatic black bear, moon bear, Himalayan bear	Iran, China, Japan, Himalayas
<i>Ursus arctos</i>	Brown bear, many varietal names	Eastern Europe, Asia, North America, Pyrenees
<i>Ursus americanus</i>	American black bear	North American forested areas
<i>Thalarctos maritimus</i>	Polar bear	Arctic regions of Northern Hemisphere
<i>Helarctos malayanus</i>	Sun bear, honey bear, bruang, Malay bear	Sumatra, Borneo, southeastern Asia
<i>Melursus ursinus</i>	Sloth bear	Ceylon, southern India

Bears originated in the Northern Hemisphere and are now widely distributed throughout the world. The brown bear (*Ursus arctos*) is the commonest species, in North America as well as in other areas of the world. The grizzly bear is an example of a species that is on the verge of extinction. It is found in national park areas, Alaska, and the Yukon region. The spectacled bear (*Tremarctos ornatus*) is the only native bear in the Southern Hemisphere, where it is found in the forested foothills of the western slopes of the Andes. The Himalayan bear (*Selenarctos thibetanus*) occurs in China, Japan, Iran, and the Himalayas. The black bear (*Ursus americanus*) is still numerous across North America in forested areas. It is hunted for its fur and as a game animal in many parts of the United States. The sun bear (*Helarctos malayanus*) is found in the tropical forested areas of southern Asia, and thus differs from other bears in its habitat preference. It is the smallest of all bears. The polar bear (*Thalarctos maritimus*) occurs in the polar regions of the Northern Hemisphere. See CARNIVORA; HIBERNATION. [C.B.C.]

**Beat** A variation in the intensity of a composite wave which is formed from two distinct waves with different frequencies. Beats were first observed in sound waves, such as those produced by two tuning forks with different frequencies. Beats also can be produced by other waves. They can occur in the motion of two pendulums of different lengths and have been observed among the different-frequency phonons in a crystal lattice.

One important application of beat phenomena is to use one object with an accurately known frequency to determine the unknown frequency of another such object. The beat-frequency or heterodyne oscillator also operates by producing beats from two frequencies. See OSCILLATOR. [B.DeF.]

**Beaver** The common name for two different and unrelated species of rodents—*Aplodontia rufa*, the mountain beaver, and *Castor canadensis*, the common or true beaver.

The mountain beaver is the only living species of the family Aplodontidae. It is a medium-sized animal and resembles a muskrat. The eyes are small as are the external ears, an adaptation to its fossorial (digging) habits. The tail is a short stump, the body is short and stout, and the limbs are short and terminate in broad feet with five toes and long claws. The mountain beaver is a vegetarian. Although not strictly nocturnal, it is more active at night. The animals form colonies with a single family inhabiting a series of runways. The mountain beaver is found along the Pacific Coast and ranges from British Columbia, Canada, to California.

The common beaver, a member of the family Castoridae, is a large rodent (weighing up to 50 lb or 23 kg). It occurs across Europe, North America from Labrador southward, and Asia, and is a valuable fur-bearing animal. The tail is broad and spatulate and is used, together with the webbed hindfeet, for swimming. The beaver is aquatic and builds its lodge in water by using mud, sticks, and branches interwoven. These beavers are vegetarians. Mating occurs in February, and the average litter of four young is born in May. These beavers appear to be monogamous and mate for life. See RODENTIA. [C.B.C.]

**Bee** Insects of the superfamily Apoidea in the order Hymenoptera. There are some 3000 species of bees divided into 19 families. Present-day bees subsist almost entirely on pollen as a source of protein, and on the sugar in nectar as an energy source. They are now obligately dependent on flowers, although a few species can sometimes feed on “honeydew” secretions from aphids and scale insects. In turn, many plants have become obligately dependent on bees for pollination. See HYMENOPTERA.

Most of the world’s bee species are solitary. That is, a female builds a nest cell, provisions the cell with a nectar-pollen mixture, lays an egg on this food, and seals the nest cell, allowing the larva to develop and emerge as much as a year later. In primitively social bees such as some of the sweat bees (family Halictidae) and bumblebees (family Bombidae), an overwintered female (queen) that has mated the previous fall emerges from her underground hibernacula in the spring and attempts to start her own colony. A colony consists initially of sterile female offspring, who are her workers. Near the end of the colony cycle, in late summer or fall, the workers aid the queen in producing large numbers of sexuals, the drones and new queens. Colonies generally consist of several dozen and up to several hundred individuals at the height of the colony cycle in the summer. The workers, drones, and old queens all die off in the fall, and the new queens disperse and hibernate.

In the highly social bees, the honeybee (*Apis mellifera*) and stingless (*Trigona*) species, as many as 50,000 and 150,000 individuals, respectively, may be present in the colonies. In these bees the old queen lives several years, and the colonies are perennial rather than annual. The queens are nearly exclusively concerned with egg laying, and the workers are produced not only during times of food availability in the field, but also before major times of flowering by relying on large stores of pollen and honey. These bees reproduce by swarming, when the old queen leaves the hive accompanied by about half of the workers, which help her to initiate a new colony. See SOCIAL INSECTS.

The highly social organization of honeybees and stingless bees is orchestrated by scent, sound, and “dance” signals. The queen emits a chemical (pheromone) which inhibits the workers from developing and laying eggs. Absence or low concentrations of the queen pheromone cause the workers to rear a new queen. The workers also produce pheromones that act as signals to other workers. Honeybees indicate the direction, distance, and quality of rewarding food sources to hive mates by a symbolic dance language. Honeybees also buzz during the dance, which may serve to alert potential followers that then attempt to “read” the dancer’s message. Stingless bees also alert hive mates by

buzzing. The hive mates follow the scout bee (that has discovered the food) out of the hive; the scout then deposits a trail of scent droplets onto vegetation that aid the recruit to find the food. Bumblebees do not seem to have any way of communicating food found by successful hive mates.

By visiting flowers, bees serve as agents of cross-pollination. They are of inestimable importance in the pollination of crops and in pollination of the natural flora. Their activity is thus vital, not only directly for the human food supply, but also for land, water, and animal resources. See BEEKEEPING; POLLINATION. [B.He.]

**Beech** A genus, *Fagus*, of deciduous trees of the beech family Fagaceae, order Fagales. They can best be distinguished by their long (often more than 1 in. or 2.5 cm), slender, scaly winter buds; their thin, gray bark, smooth even in old trees; and their simple, toothed, ovate or ovate-oblong, deciduous leaves.

The American beech (*F. grandifolia*) is native in the United States east of the Mississippi River and in the lower Mississippi Valley. The hard, strong wood is used for furniture, handles, woodenware, cooperage, and veneer. The small, edible, three-sided nuts, called beechnuts, are valuable food for wildlife. The European beech (*F. sylvatica*) is more popular as an ornamental tree than the American species. Its leaves are smaller, with 5–9 pairs of primary veins compared with 9–14 pairs in the American beech. The leaf teeth are also shorter. Important ornamental varieties are *F. sylvatica purpurea*, the copper or purple beech; var. *incisa*, the cut-leaved or fern-leaved beech; and *F. pendula*, the weeping European beech. See FAGALES. [A.H.G./K.P.D.]

**Beekeeping** The management and maintenance of colonies of honeybees. Although the commonly known honeybee species is native to Europe and Africa only, humans have transported them to other continents, and in most places they have flourished. The natural home for a honeybee colony is a hollow tree, log, or cave. European strains of the honeybee build a nest only in locations which are dry and protected from the wind and sunlight. African bees are less selective and may nest in hollowed-out termite mounds, rock piles, and locations which are less well protected. See BEE.

The honey which beekeepers harvest is made from nectar, a sweet sap or sugar syrup produced by special glands in flowers, collected from both wild and cultivated plants. Nectar, the honeybees' source of sugar or carbohydrate, and pollen, their source of protein and fat, make up their entire diet. Nectar contains 50–90% water, 10–50% sugar (predominantly sucrose), and 1–4% aromatic substances, coloring material, and minerals. To transform nectar into honey, bees reduce its moisture content, so that the final honey produced contains between 14 and 19% water, and also add two enzymes which they produce in their bodies.

Scientific beekeeping started in 1851 when an American, L. L. Langstroth, discovered bee space and the movable frame hive. Bee space is the open space which is about 0.4 in. (1 cm) wide and maintained around and between the combs in any hive or natural nest and in which the bees walk. If this space is smaller or larger than 0.4 in. (1 cm), the bees will join the combs. When the combs are stuck together, the hive is not movable, and it is not possible for beekeepers to manipulate a colony or to examine a brood nest. It was found, in 1857, that bees could be forced to build a straight comb in a wooden frame by giving them a piece of wax, called foundation, on which the bases of the cells were already embossed. Bees use these bases to build honeycomb, the cells of which are used for both rearing brood and for storing honey. When a hive of bees is given a frame of foundation, they are forced to build the comb where the beekeeper wants it and not where they might otherwise be inclined to build it. Another discovery, made in 1865, was that honey can be removed from the comb by placing a comb full of honey in a centrifugal force machine, called an extractor. If the beekeeper can return an intact comb to a hive after removing the honey from it, the bees are saved the time and trouble of building a new

comb, and the honey harvest is increased. The next discovery, in 1873, was the modern smoker. When bees are smoked, they engorge with honey and become gentle. Without smoke to calm a hive, normal manipulation of the frames would not be possible. By 1880, honey, which had once been a scarce commodity, became abundant.

All beehives used in the industry today are made of wooden boxes with removable frames of comb. Beekeepers have standardized their equipment so that parts will be interchangeable within an apiary and from one commercial operation to another. To be successful in commercial beekeeping, beekeepers must locate in those areas where nectar-producing plants abound. The best-known honey in the United States is clover honey. Alfalfa and oranges are also good nectar-producing plants and are major sources of honey. Bees collect nectar from hundreds of kinds of flowers, and thus there are a great variety of honey flavors. Thousands of colonies of honeybees are rented each year by growers of crops needing cross pollination. As the plants come into bloom, the beekeeper moves the bees, usually at night when all the bees are in the hive, and places them in groups in groves, orchards, and fields. While beekeepers make most of their living producing honey, the real importance of their bees in the agricultural economy is as cross pollinators. Without cross pollination the abundance and variety of food and flowers would not exist. Commercial beekeepers feel they need to own 500 to 2000 colonies to make a living, depending on how they market their honey. Some beekeepers sell their honey on the wholesale market only, while others pack their honey themselves and devote a great deal of time to sales. [R.A.Mo.]

**Beet** The red or garden beet (*Beta vulgaris*), a cool-season biennial of Mediterranean origin belonging to the plant order Caryophyllales (Centrospermales). This beet is grown primarily for its fleshy root, but also for its leaves, both of which are cooked fresh or canned as a vegetable. Detroit Dark Red strains predominate. Cool weather favors high yields of dark red roots. Wisconsin, New York, and Texas are important beet producing states. See CARYOPHYLLALES; SUGARBEET. [H.J.C.]

**Behavior genetics** The study of the hereditary factors of behavior. Charles Darwin, who originated the theory that natural selection is the basis of biological evolution, was persuaded by Francis Galton that the principles of natural selection applied to behavior as well as physical characteristics. Members of a species vary in the expression of certain behaviors because of variations in their genes, and these behaviors have survival value in some environments. One example of such a behavior is curiosity—some organisms are more curious than others, and in some settings curiosity is advantageous for survival. The science of behavior genetics is an extension of these ideas and seeks (1) to determine to what extent the variation of a trait in a population (the extent of individual differences) is due to genetic processes, to what extent it is due to environmental variation, and to what extent it is due to joint functions of these factors (heredity-environment interactions and correlations); and (2) to identify the genetic architecture (genotypes) that underlies behavior.

Traditionally, some of the clearest and most indisputable evidence for a hereditary influence on behavior comes from selective-breeding experiments with animals. Behavior genetic research has utilized bacteria, paramecia, nematodes, fruit flies, moths, houseflies, mosquitoes, wasps, bees, crickets, fishes, geese, cows, dogs, and numerous other organisms. Breeding of these organisms allows genetically useful types of relationships, such as half-sibs, to be produced easily. Artificial selection (selective breeding) can be used to obtain a population that scores high or low on specific traits. Inbred strains of many animals, particularly rodents, are readily available, and the study of various types of crosses among them can provide a wealth of information. An experimental design using the recombinant



inbred-strain method shows great promise for isolating single-gene effects. This procedure derives several inbred strains from the F<sub>2</sub> generation (grandchildren) produced by a cross between two initial inbred strains. Since it is possible to exert a great deal of control over the rearing environments, the experimenter can manipulate both heredity and environment.

Other work has focused on the effects of the environment and genotype-environment interactions. For example, experiments with mice have shown that, with respect to several learning tasks, early environmental-enrichment effects and maternal effects were quite small, relative to the amount of normal genetic variation found in the strains of mice tested. Only a few genotype-environment interactions were found. Still other work has shown that early experiences affect later behavior patterns for some strains but not others (a genotype-environment interaction).

An increasing role for animals in genetic research is to provide models of human genetic diseases, many of which have behavioral features. Such animal models may occur naturally or may be engineered in the laboratory. Animal models are available for many neurobehavioral disorders, including narcolepsy, various epilepsies, and alcoholism. The availability of animal models allows researchers to obtain information about the development of genetic disorders and the effects of different environments on this development, as well as to explore treatment options. While it is not always prudent or desirable to generalize from animal results to humans, it is assumed that basic genetic systems work in similar ways across organisms, and it is likely that these types of animal studies will play a key role in elucidating the ways in which environment influences phenotypic variation. With advances in genetic technology, it is possible to observe genetic variation more directly by locating, identifying, and characterizing genes themselves.

The effects of a single gene on behavior have been most extensively studied in the domain of mental retardation. Research has shown that there are a large number of metabolic pathways which have defects due to a single gene. Over 100 of these defects influence mental ability. One such single-gene defect is classic phenylketonuria (PKU), an autosomal recessive disorder, which also illustrates the role that environment can play in the expression of a trait. Individuals who are homozygous (having two copies of the PKU allele) are unable to make the enzyme phenylalanine hydroxylase, which converts the essential amino acid phenylalanine to tyrosine, a nonessential amino acid. Instead, the excess phenylalanine builds up in the blood and is converted into phenylpyruvic acid, which is toxic to the developing nervous system in large amounts. The main effect of untreated PKU is severe mental retardation, along with a distinctive odor, light pigmentation, unusual gait and posture, and seizures. Many untreated individuals with PKU show fearfulness, irritability, and violent outbursts of temper. See MENTAL RETARDATION; PHENYLKETONURIA.

Every organism develops in a particular environment, and both genes and environment control development. It is, therefore, not possible to state that a particular behavioral trait is either genetic or environmental in origin. It is possible, however, to investigate the relative contributions of heredity and environment to the variation among individuals in a population. With humans, it is possible to obtain approximate results by measuring the similarity among relatives on the trait of interest. Twins are often used in such studies. One method compares the similarity within pairs of both identical twins and fraternal twins reared together. Identical twins have all their genes in common by descent, since they arise from a single fertilized egg. Fraternal twins arise from two fertilized eggs and so share on average one-half of their genes. If it is assumed that the effects of the shared environments of the two types of twins are equal (a testable assumption), greater resemblance between identical twins than fraternal twins should reflect the proportion of genes they share, and the difference between the correlations of

the two twin types should represent about one-half the genetic effect.

A second type of twin study compares not only twins reared together but twins who have been reared apart. The degree of similarity between identical twins reared in the same home would reflect the fact that all their genes are identical and that they share a common family environment. On the other hand, if identical twins can be located who had been adopted by different families chosen at random (an unlikely event, since adopted children tend to be selectively placed), a measure of their degree of similarity would reflect only the effect of their common genes. If it were true that an individual's level on a measure (for example, extroversion) is determined in large part by the characteristics of his or her family and the opportunities that the family makes available to him or her, reared-apart identical twins should be no more alike than pairs of individuals chosen at random. If they do exhibit some degree of similarity, it would reflect genetic effects alone. The existence of even very large genetic effects, however, would in no way imply that the environment was unimportant in the development of the trait; it would simply imply that environment was less important than genes in determining the variation among individuals on the trait in question at the time of measurement. That is, the individuals would differ more because of the genes they carry than because of the particular environments to which they were exposed. In another range of environments, the results might be different. See TWINS (HUMAN).

Developmental psychologists are finding that differences in children's behavioral phenotypes are due more to their different genotypes than to their different rearing environments, as long as those environments are within a normal range of experiences. Identifying environmental variables from this normal range that have an important effect on the behavioral phenotype may be even more difficult than identifying contributing genes. Advances in theory and new technologies, combined with information from more traditional methodologies, will continue to provide insight into the contributions of genes and environment to behavior. [K.J.W.; T.J.B.]

**Behavioral ecology** The branch of ecology that focuses on the evolutionary causes of variation in behavior among populations and species. Thus it is concerned with the adaptiveness of behavior, the ultimate questions of why animals behave as they do, rather than the proximate questions of how they behave. The principles of natural selection are applied to behavior with the underlying assumption that, within the constraints of their evolutionary histories, animals behave optimally by maximizing their genetic contribution to future generations. For example, animals must maintain their internal physiological conditions within certain limits in order to function properly, and often they do this by behavior. Small organisms may avoid desiccation by living under logs or by burrowing. Many insects must raise body temperatures to 86–95°F (30–35°C) for effective flight, and achieve this by muscular activity such as the shivering of butterflies in the early morning or by orienting to the Sun. Other adaptive behaviors that are studied may fall in the categories of habitat selection, foraging, territoriality, and reproduction. See BEHAVIOR GENETICS; ETHOLOGY; MIGRATORY BEHAVIOR; REPRODUCTIVE BEHAVIOR. [H.Di.; P.Fr.]

**Behavioral psychophysics** The use of behavioral methods to measure the sensory capacities of animals and non-verbal humans such as infants. The observations are analogous to those obtained from adult human subjects who are asked to observe appropriate stimuli and report what they see. The behavioral methods differ primarily in that stimulus-response associations are established by means other than verbal instructions, either as unlearned reflexes or through conditioning. Any sense or species may be studied, but most work has been done on the vision and hearing of primates, cats, pigeons, and rats. Typical investigations determine (1) the absolute threshold (the

minimum intensity needed to elicit a standard response); (2) the difference threshold (the minimum change in a stimulus needed to elicit a standard response); and (3) points of apparent equality (values of stimuli that elicit no response because a change in one aspect compensates for a change in another). A few investigations have determined stimulus scales that express quantitative relations between the physical stimulus and the perceptual effect over a range of stimulus values. These various measures provide a picture of the sensory function, such as visual acuity, color sensitivity, loudness or pitch perception, and odor discrimination. Efficiency and sensitivity to the sensory function of interest are the major factors that govern the choice of method in behavioral psychophysics.

Reflex methods are the most convenient since no training is required. An example is the preferential looking response in infants. Without training, infants spend more time looking at patterned stimuli than at blank fields. Two stimulus fields are placed before the infant, and the relative time spent looking at each is determined. A preference for one pattern according to this measure indicates that the infant can detect a difference between the two.

Unconditioned reflex methods are limited to sensory functions for which appropriate reflexes may be found; also, they usually impose severe limits on the specific stimulus conditions that may be used. Conditioning methods add considerable flexibility. In Pavlovian conditioning, the stimulus of interest becomes the conditioned stimulus through its association with a stimulus that elicits a clear-cut reflexive response (the unconditioned stimulus).

Operant conditioning offers still more flexibility. Typically the subject is rewarded for making an indicator response in the presence of one stimulus value; reward is withheld (or another response rewarded) in the presence of other stimulus values. The responses are selected to suit the species and the stimulus under study.

Interest in the development of sensory function has spurred the use of behavioral methods in infants and young children, while the effects of controlled sensory input during development have been extensively monitored in nonhuman subjects. Applications to the prevention and control of sensory disorders also are increasing. For example, a number of toxicants, drugs, and environmental stressors have been related to sensory disorders; the methods of behavioral psychophysics are used to follow the development of these disorders under controlled conditions, and to uncover potential preventive and therapeutic measures. See PSYCHOLOGY; SENSATION. [D.B.]

**Behavioral toxicology** The study of behavioral abnormalities induced by exogenous agents such as drugs, chemicals in the general environment, and chemicals encountered in the workplace. Just as some substances are hazardous to the skin or liver, some are hazardous to the function of the nervous system. In the case of permanent effects, changes in sensation, mood, intellectual function, or motor coordination would obviously be undesirable, but even transient alterations of behavior are considered toxic in some situations. For example, operating room personnel accidentally exposed to very small doses of anesthetic do not exhibit altered performance on an intelligence test, a dexterity test, or a vigilance task. However, significant decrements in performance occur in recognizing and recording visual displays, detecting changes in audiovisual displays, and recalling series of digits.

By comparing the behavior of exposed subjects and control subjects, behavioral toxicologists seek to identify agents capable of altering behavior and to determine the level of exposure at which undesirable effects occur. When the agent under study is one in common use, and there is no evidence of its being hazardous to health, experiments may be carried out on human volunteers, or comparisons may be made from epidemiologic data. More frequently, safety considerations dictate the use of laboratory animals in toxicology research.

Perhaps the best-known example of toxicity in humans is methyl mercury poisoning (Minimata disease), which occurred

in epidemic proportions in a Japanese coastal town where the inhabitants ate fish contaminated with mercury from industrial pollution. Although mercury affects a variety of behaviors, the most obvious symptoms are tremors and involuntary movements.

A different set of functional problems is exemplified by the effects of ethyl alcohol, a single agent with direct and indirect, short- and long-term consequences. The short-term, low-dose effects of alcohol include sensory disturbances, motor problems, and difficulties with processing information. Neurologically, alcohol is usually described as a central nervous system depressant which is general, in the sense that it disrupts many functions.

In some individuals, large quantities of alcohol consumed over a long period lead to permanent damage to the nervous system. Behaviorally, individuals with Korsakoff's syndrome exhibit severe memory deficits. Anatomically, their brains are found to have degenerative changes in the thalamus. This syndrome is not just an extension of the short-term effects. In fact, it is thought to arise from alcohol-induced malnutrition rather than as a direct effect of alcohol itself.

Lasting injuries to the nervous system have been reported to occur in children exposed to alcohol before birth. The behavioral problems associated with fetal alcohol syndrome do not appear to be related to either Korsakoff's syndrome or the immediate effects of alcohol. Rather, they constitute a third set of effects, including learning deficits, problems with inhibiting inappropriate behavior, and fine motor dysfunction, along with some visible physical abnormalities. While malnutrition may play a role in this congenital syndrome, the mechanism and locus of damage are not known. See ALCOHOLISM; CONGENITAL ANOMALIES; FETAL ALCOHOL SYNDROME.

When toxicity is considered only in terms of direct risk to survival, behavioral toxicity may seem to be of minor importance. However, survival is not the only criterion of good health. In a complex society that places heavy demands on an individual's educability, alertness, and emotional stability, even small deviations in behavior are potentially hazardous. Severe disabilities, as in the gross motor malfunctions of Minimata disease, have drawn attention to behavioral toxicology. Such incidents represent failures of control of toxic substances. Successes are difficult to measure, for they can be seen only in reduction of risk—the ultimate goal of toxicology. See TOXICOLOGY. [P.M.R.]

**Belemnoidea** An order of extinct dibranchiate cephalopods. These mollusks ranged from the Upper Mississippian through the Cretaceous. The oldest known representative is highly specialized, although the belemnoids are considered to be the most primitive of the dibranchiates. Belemnoids have a chambered shell or phragmocone which fits into a guard or rostrum, the apical portion of the shell (see illustration).

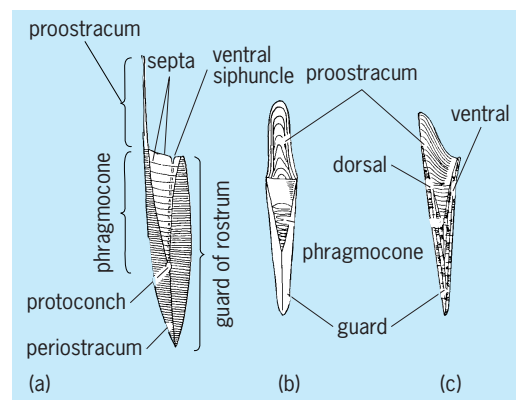

**Belemnoidea.** (a) Diagram of a belemnite shell. (b) Ventral aspect and (c) lateral aspect of a belemnite. (After R. R. Shrock and W. H. Twenhofel, *Principles of Invertebrate Paleontology*, 2d ed., McGraw-Hill, 1953)

*Belemnites* is an important index fossil. See CEPHALOPODA; INDEX FOSSIL. [C.B.C.]

**Bell** A hollow metallic cylinder closed at one end and flared at the other. A bell is used as a fixed-pitch musical instrument or a signaling device, frequently in clocks. A bell is set vibrating by a clapper or tongue which strikes the lip. The bell has two tones, the strike note or key, and the hum tone, which is a major sixth below the strike note. Both tones are rich in harmonics. The finer bells are made for carillons. Small carillons have two full chromatic octaves and large ones have four or more chromatic octaves, the bell with the lowest tone being called the bourdon. All bells of a carillon are shaped for homogeneity of timbre.

Bell metal is approximately four parts copper and one part tin, although zinc, lead, or silver may be used. The shape of a bell—its curves and full trumpet mouth—evolved from experience. A bell can be pitched slightly. The tone is raised by grinding the outer surface, effectively decreasing the diameter, or lowered by grinding the inner surface. Too much tuning of a well-shaped bell is apt to degrade its voice or timbre. [F.H.R.]

**Belladonna** The drug and also the plant known as the deadly nightshade, *Atropa belladonna*, which belongs to the nightshade family (Solanaceae). This is a coarse, perennial herb native to the Mediterranean regions of Europe and Asia Minor, but now grown extensively in the United States, Europe, and India. During the blooming period, the leaves, flowering tops, and roots are collected and dried for use. The plant contains several important medicinal alkaloids, the chief one being atropine, which is much used to dilate the pupil of the eye. See ATROPINE; SOLANACEAE. [P.D.St./E.L.C.]

**Belt drive** The lowest-cost means for transmitting power between shafts that are not necessarily parallel. Belts run smoothly and quietly, and they cushion motor and bearings against load fluctuations. Belts typically are not as strong or durable as gears or chains. However, improvements in belt construction and materials are making it possible to use belts where formerly only chains or gears would do.

Advantages of belt drive are: They are simple. They are economical. Parallel shafts are not required. Overload and jam protection are provided. Noise and vibration are damped out. Machinery life is prolonged because load fluctuations are cushioned (shock-absorbed). They are lubrication-free. They require only low maintenance. They are highly efficient (90–98%, usually 95%). Some misalignment is tolerable. They are very economical when shafts are separated by large distances. Clutch action may be obtained by relieving belt tension. Variable speeds may be economically obtained by step or tapered pulleys.

Disadvantages include: The angular-velocity ratio is not necessarily constant or equal to the ratio of pulley diameters, because of belt slip and stretch. Heat buildup occurs. Speed is limited to usually 7000 feet per minute (35 meters per second). Power transmission is limited to 370 kilowatts (500 horsepower). Operating temperatures are usually restricted to –31 to 185°F (–35 to 85°C). Some adjustment of center distance or use of an idler pulley is necessary for wear and stretch compensation. A means of disassembly must be provided to install endless belts.

There are four general types of belts: flat belts, V-belts, film belts, and timing belts. Each has its own special characteristics, limitations, advantages, and special-purpose variations for different applications.

Flat belts, in the form of leather belting, served as the basic belt drive from the beginning of the Industrial Revolution. They can transmit large amounts of power at high speeds. Flat belts find their widest application where high-speed motion, rather than power, is the main concern. Flat belts are very useful where large center distances and small pulleys are involved. They can engage pulleys on both inside and outside surfaces, and both endless and jointed construction are available.

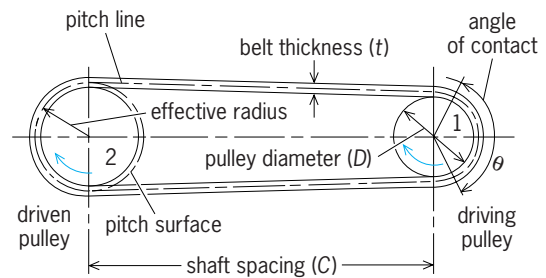

Fig. 1. Open belt drive.

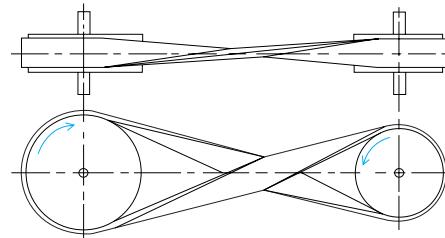

Fig. 2. Cross belt drive.

V-belts are the basic power-transmission belt, providing the best combination of traction, operating speed, bearing load, and service life. The belts are typically endless, with a trapezoidal cross section which runs in a pulley with a V-shaped groove. The wedging action of the belt in the pulley groove allows V-belts to transmit higher torque at less width and tension than flat belts. V-belts are far superior to flat belts at small center distances and high reduction ratios. V-belts require larger pulleys than flat belts because of their greater thickness. Several individual belts running on the same pulley in separate grooves are often used when the power to be transmitted exceeds that of a single belt. These are called multiple-belt drives.

Film belts are often classified as a variety of flat belt, but actually they are a separate type. Consisting of a very thin strip of material, usually plastic but sometimes rubber, their widest application is in business machines, tape recorders, and other light-duty service.

Timing belts have evenly spaced teeth on their bottom side which mesh with grooves cut on the periphery of the pulleys to produce a positive, no-slip, constant-speed drive. They are often used to replace chains or gears, reducing noise and avoiding the lubrication bath or oiling system requirement. They have also found widespread application in miniature timing applications. Timing belts, known also as synchronous or cogged belts, require the least tension of all belt drives and are among the most efficient.

The most common belt-pulley arrangement, by far, is the open belt drive (Fig. 1). Here both shafts are parallel and rotate in the same direction. The cross-belt drive of Fig. 2 shows parallel shafts rotating in opposite directions. Timing and standard V-belts are not suitable for cross-belt drives because the pulleys contact both the inside and outside belt surfaces.

Industrial belts are usually reinforced rubber or leather, the rubber type being predominant. Nonreinforced types, other than leather, are limited to light-duty applications.

Belts probably fail by fatigue more often than by abrasion. The fatigue is caused by the cyclic stress applied to the belt as it bends around the pulleys. Belt failure is accelerated when the following conditions are present: high belt tension; excessive slippage; adverse environmental conditions; and momentary overloads caused by shock, vibration, or belt slapping. See CHAIN DRIVE; GEAR DRIVE; PULLEY. [A.Erd.; R.G.]

**Bentonite** The term first applied to a particular, highly colloidal plastic clay found near Fort Benton in the Cretaceous beds

of Wyoming. This clay swells to several times its original volume when placed in water and forms thixotropic gels when small amounts are added to water. Later investigations showed that this clay was formed by the alteration of volcanic ash in place; thus, the term bentonite was redefined by geologists to limit it to highly colloidal and plastic clay materials composed largely of montmorillonite clay minerals, and produced by the alteration of volcanic ash in place. The term has been used commercially for any plastic, colloidal, and swelling clays without reference to a particular mode of origin. See CLAY; GEL; MONTMORILLONITE.

Bentonites have been found in almost all countries and in rocks of a wide variety of ages. They appear to be most abundant in rocks of Cretaceous age and younger. In the United States, bentonites are mined extensively in Wyoming, Arizona, and Mississippi. England, Germany, Yugoslavia, Russia, Algeria, Japan, and Argentina also produce large tonnages of bentonite. Many bentonites are of great commercial value. They are used in decolorizing oils, in bonding molding sands, in the manufacture of catalysts, in the preparation of oil well drilling muds, and in numerous other relatively minor ways. The properties of a particular bentonite determine its economic use. [R.E.Gr.; F.M.W.]

**Benzene** A colorless, liquid, inflammable, aromatic hydrocarbon of chemical formula  $C_6H_6$  which boils at  $80.1^\circ C$  ( $176.2^\circ F$ ) and freezes at  $5.4-5.5^\circ C$  ( $41.7-41.9^\circ F$ ). In the older American and British technical literature benzene is designated by the German name benzol. In current usage the term benzol is commonly reserved for the less pure grades of benzene.

Benzene is used as a solvent and particularly in Europe as a constituent of motor fuel. In the United States the largest uses of benzene are for the manufacture of styrene and phenol. Other important outlets are in the production of dodecylbenzene, aniline, maleic anhydride, chlorinated benzenes (used in making DDT and as moth flakes), and benzene hexachloride, an insecticide.

The six carbon atoms of benzene, each with a hydrogen atom attached, are arranged symmetrically in a plane, forming a regular hexagon. The hexagon symbol, commonly used to represent the structural formula for benzene, implies the presence of a carbon atom at each of the six angles and, unless substituents are attached, a hydrogen at each carbon atom. Whereas the three double bonds usually included in the formula are convenient in accounting for the addition reactions of benzene, present evidence is that all the carbon-to-carbon bonds are identical.

Nearly all commercial benzene is a product of petroleum technology. The gasoline fractions obtained by reforming or steam cracking of feedstocks from petroleum contain benzene and toluene which can be separated economically. Benzene may also be produced by the dealkylation of toluene.

Benzene is a toxic substance, and prolonged exposure to concentrations in excess of 35–100 parts per million in air may lead to symptoms ranging from nausea and excess fatigue to anemia and leukopenia. See AROMATIC HYDROCARBON. [C.K.B.]

**Benzoic acid** An organic acid, also known as benzene carboxylic acid, with the formula below. Melting point is  $250.2^\circ F$

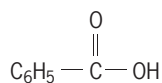

( $121.2^\circ C$ ), and the acid sublimates at  $212^\circ F$  ( $100^\circ C$ ). Benzoic acid is only slightly soluble in water but is soluble in most organic solvents, and reacts with bases to form the corresponding benzoate salts. Benzoic acid was first obtained by sublimation from gum benzoin. It occurs both free and combined in nature, being found in many berries (cranberries, prunes, cloves) and as the end product of phenylalanine metabolism.

Benzoic acid is prepared in the laboratory by the Grignard reaction, hydrolysis of benzonitrile ( $C_6H_5CN$ ), or prolonged oxidation of alkyl benzenes with potassium permanganate regardless

of the length of the alkyl group. Commercially it was previously prepared by the chlorination of toluene ( $C_6H_5CH_3$ ) with the subsequent hydrolysis of the benzotrithloride ( $C_6H_5CCl_3$ ), and by the monodecarboxylation of phthalic anhydride (from naphthalene). Modern preparation is by the catalytic oxidation of toluene at elevated temperatures with a cobalt catalyst, and purification by sublimation. See GRIGNARD REACTION.

Benzoic acid undergoes the normal reactions of the aromatic ring (nitration, sulfonation, halogenation, alkylation). Groups are inserted in the meta position due to the directive influence of the carboxyl group. Substitution occurs less readily than with ortho- or para-directing groups due to the deactivating effect of the meta-directing group. Ortho or para derivatives can be obtained with some starting materials other than the acid. Benzoic acid also undergoes the usual reactions of the carboxyl group, forming acyl halides, anhydrides, amides, esters, and salts. See HALOGENATION; NITRATION; SUBSTITUTION REACTION.

Sodium benzoate is the only salt of importance. It is water-soluble, has antipyretic and antiseptic properties, is useful as a corrosion inhibitor with sodium nitrite if used for iron, and is also used to modify alkyd resins by increasing hardness, adhesion, and gloss.

Esters of benzoic acid are also found in nature. They are almost universally fragrant. Methyl benzoate is the fragrant principle in tuberose. Some esters of benzoic acid are used in the perfume industry, for example, benzyl ester as a fixative. The butyl ester is used as a dye carrier because of its desirable biodegradable properties; and glycol esters are used as plasticizers. See ESTER.

Uses for both benzoic acid and its derivatives include the pharmaceuticals and synthetic polymers. Benzoic acid is used in preservatives and many cosmetics. The derivatives are used in the dyeing industry, with some applications in the cosmetic industry. Pure benzoic acid is a standard for bomb calorimetry because of its ease of purification by sublimation. See CALORIMETRY. [E.H.H.]

**Benzoyl peroxide** A chemical compound, sometimes called dibenzoyl peroxide, with the formula below. It is a col-

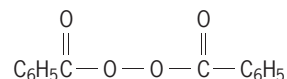

orless, crystalline solid, melting point  $106-108^\circ C$  ( $223-226^\circ F$ ), that is virtually insoluble in water but very soluble in most organic solvents. Benzoyl peroxide is an initiator, a type of material that decomposes at a controlled rate at moderate temperatures to give free radicals. See FREE RADICAL.

Benzoyl peroxide has a half-life (10 h at  $73^\circ C$  or  $163^\circ F$  in benzene) for decomposition that is very convenient for many laboratory and commercial processes. This, plus its relative stability among peroxides, makes it one of the most frequently used initiators. Its primary use is as an initiator of vinyl polymerization. It also is the preferred bleaching agent for flour; is used to bleach many commercial waxes and oils; and is the active ingredient in commercial acne preparations. See BLEACHING; POLYMERIZATION.

Benzoyl peroxide itself is neither a carcinogen nor a mutagen. However, when coapplied with carcinogens to mouse skin it is a potent promoter of tumor development. All peroxides should be treated as potentially explosive, but benzoyl peroxide is one of the least prone to detonate. See MUTAGENS AND CARCINOGENS. [W.I.A.P.]

**Bering Sea** A water body north of the Pacific Ocean,  $875,000 \text{ mi}^2$  ( $2,268,000 \text{ km}^2$ ) in area, bounded by Siberia, Alaska, and the Aleutian Islands. The Bering Sea is a biologically productive area, with large populations of marine birds and mammals. An active pollock fishery and a developing bottom-fish industry are evidence of its rich biological resources.

The Bering Sea consists of a large, deep basin in the southwest portion, where depths as great as 9900 ft (3000 m) are encountered. To the north and east, an extremely wide, shallow

continental shelf extends north to the Bering Strait. The two major regions are separated by a shelf break, the position of which coincides with the southernmost extent of sea ice in a cold season. Ice is a prominent feature of the Bering Sea shelf during the cold months. Coastal ice begins to form in late October, and by February coastal ice is found in the Aleutians. The sea ice may extend as far south as 58°N. Thus, the ice edge in the eastern Bering Sea advances and retreats seasonally over a distance as great as 600 mi (1000 km). Ice-free conditions can be expected throughout the entire region by early July. See SEA ICE.

The main water connections with the Pacific are in the west of the Aleutian Islands, the 6600-ft-deep (2000-m) pass between Attu and Komandorskiye Islands and the 14,000-ft-deep (4400-m) pass between the Komandorskiy and Kamchatka. Aleutian passes also serve to exchange water. The Bering Sea connection with the Arctic Ocean (Chukchi Sea) is the Bering Strait, 53 mi (85 km) wide and 30 mi (45 m) deep.

Tides in the Bering Sea are semidiurnal, with a strong diurnal inequality typical of North Pacific tides. Three water masses are associated with Bering sea water—Western Subarctic, Bering Sea, and the Alaskan Stream. The general circulation of the Bering Sea is counterclockwise, with many small eddies superimposed on the large-scale pattern. The currents in the Bering Sea are generally a few centimeters per second except along the continental slope, the coast of Kamchatka, and in certain eddies, where somewhat higher values have been found. See OCEAN CIRCULATION; TIDE. [V.A.]

**Berkelium** Element number 97, symbol Bk, the eighth member of the actinide series of elements. In this series the 5f electron shell is being filled, just as the 4f shell is being filled in the lanthanide (rare-earth) elements. These two series of elements are very similar in their chemical properties, and berkelium, aside from small differences in ionic radius, is especially similar to its homolog terbium. See PERIODIC TABLE; RARE-EARTH ELEMENTS; TERBIUM.

Berkelium does not occur in the Earth's crust because it has no stable isotopes. It must be prepared by means of nuclear reactions using more abundant target elements. These reactions usually involve bombardments with charged particles, irradiations with neutrons from high-flux reactors, or production in a thermonuclear device.

Berkelium metal is chemically reactive, exists in two crystal modifications, and melts at 986°C (1806°F). Berkelium was discovered in 1949 by S. G. Thompson, A. Ghiorso, and G. T. Seaborg at the University of California in Berkeley and was named in honor of that city. Nine isotopes of berkelium are known, ranging in mass from 243 to 251 and in half-life from 1 hour to 1380 years. The most easily produced isotope is <sup>249</sup>Bk, which undergoes beta decay with a half-life of 314 days and is therefore a valuable source for the preparation of the isotope <sup>249</sup>Cf. The berkelium isotope with the longest half-life is <sup>247</sup>Bk (1380 years), but it is difficult to produce in sufficient amounts to be applied to berkelium chemistry studies. See ACTINIDE ELEMENTS; TRANSURANIUM ELEMENTS. [G.T.S.]

**Bermuda grass** A long-lived perennial (*Cynodon* spp.) that originated in Africa. It is believed that in the early 1500s Spanish explorers unintentionally brought the first common Bermuda grass seeds to the Western Hemisphere with the hay that fed their horses. The weedy common type, *C. dactylon* (the type species), can now be found throughout the tropical and subtropical regions of the world. *Cynodon dactylon* is an extensively creeping grass with both stolons and rhizomes. It has short leaves borne on 8–12-in. (20–30-cm) upright culms with several slender seed-bearing spikes digitate at their summit. It is propagated by planting seed, stolons, rhizomes, or green stems cut at an advanced hay stage. It is well adapted to a wide range of soil types, tolerates a pH range from 4.0 to over 8.0, prefers well-drained soils, is very drought-tolerant, and responds well

to fertilization. It grows best during high summer temperatures, grows little at temperatures below 65°F (18°C), and goes dormant when temperatures drop below 30°F (–1°C). Although a weed in cultivated fields, it controls erosion, makes excellent turf, and supplies good grazing for all classes of livestock. See CYPERALES; LAWN AND TURF GRASSES.

Bermuda grass is a highly variable, heterozygous, cross-pollinated species. Breeding work, begun in 1936, has produced a number of superior F<sub>1</sub> hybrids that are sterile and must be propagated vegetatively. Vegetative propagation is facilitated by the rapid spread of the aboveground stolons of the new hybrids. The top turf Bermuda grasses, Tifgreen, Tifway, and Tifdwarf, are the best of a number of F<sub>1</sub> hybrids between selected plants of *C. dactylon* and *C. transvaalensis*. Tifdwarf, tolerant of daily mowing at 3/16 in. (0.5 cm), is unsurpassed for use as top-quality turf for golf greens and bowling greens. Tifgreen, also bred for golf greens, must be mowed at a higher cut. Tifway, more resistant to pests, weeds, and frost, is the best Bermuda grass for golf fairways and tees, lawns, and athletic fields. People suffering from asthma and hay fever find Bermuda grass pollen to be one of the worst offenders. The sterile turf Bermuda grass hybrids solve this problem by producing no pollen. See ASTHMA; GRASS CROPS; POLLEN. [G.M.Bu.]

**Bernoulli's theorem** An idealized algebraic relation between pressure, velocity, and elevation for flow of an inviscid fluid. Its most commonly used form is for steady flow of an incompressible fluid, and is given by the equation below, where  $p$  is

$$\frac{p}{\rho} + \frac{V^2}{2} + gz = \text{constant}$$

pressure,  $\rho$  is fluid density (assumed constant),  $V$  is flow velocity,  $g$  is the acceleration of gravity, and  $z$  is the elevation of the fluid particle. The relation applies along any particular streamline of the flow. The constant may vary across streamlines unless it can be further shown that the fluid has zero local angular velocity.

The above equation may be extended to steady compressible flow (where changes in  $\rho$  are important) by adding the internal energy per unit mass,  $e$ , to the left-hand side. See COMPRESSIBLE FLOW.

The equation is limited to inviscid flows with no heat transfer, shaft work, or shear work. Although no real fluid truly meets these conditions, the relation is quite accurate in free-flow or "core" regions away from solid boundaries or wavy interfaces, especially for gases and light liquids. Thus Bernoulli's theorem is commonly used to analyze flow outside the boundary layer, flow in supersonic nozzles, flow over airfoils, and many other practical problems. See AERODYNAMICS; BOUNDARY-LAYER FLOW. [F.M.Wh.]

**Beroïda** An order of the phylum Ctenophora comprising two genera, *Beroë* and *Neis*. These are the only ctenophores that lack tentacles throughout their life, and their origin relative to other ctenophores is uncertain. The conical or cylindrical body ranges in size from a few millimeters to about 40 cm (16 in.) and is strongly flattened in the tentacular plane. Beroïds range from clear to bluish, orange, pink, and red in color. Comb rows are well developed in all, and run the entire body length in some species. The mouth is large and extensible, lined with bundles of macrocilia that help to grip and swallow prey.

Beroïds are actively swimming predators that feed mainly on other ctenophores. On contact, they rapidly engulf the entire prey or bite off large pieces with the macrocilia. The single species of *Neis* is known only from Australia. Numerous species of *Beroë* have been described from all over the world. Many of these are simply variations in color, and there may be only about a dozen valid species. See CTENOPHORA. [L.P.M.]

**Beryciformes** An order of somewhat intermediate position among actinopterygian fishes. Beryciformes, or Berycomorphi, have fin spines (see illustration) and ctenoid scales, an

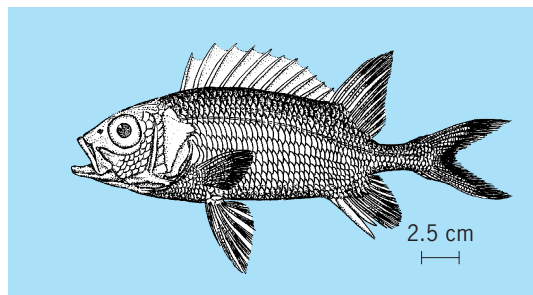

Squirrelfish (*Holocentrus ascensionis*). (After G. B. Goode, *Fishery Industries of the United States*, 1884)

upper jaw that is bordered by the premaxillae, and a ductless swim bladder and lack a mesocoracoid.

Beryciformes have a rich fossil history extending back to the Upper Cretaceous. Recent representatives are classified in 3 suborders, 12 families, some 30 genera, and about 135 species. They are cosmopolitan in tropical and temperate seas; many are restricted to deep water but some are pelagic and others live in shore waters. Most familiar of the beryciforms are the squirrelfishes and soldierfishes, family Holocentridae, nocturnal animals found in shallow tropical and subtropical reefs. Most are reddish in color. See ACTINOPTERYGII; OSTEICHTHYES; TELEOSTEI.

[R.M.B.]

**Beryl** The most common beryllium mineral. Beryl,  $\text{Al}_2[\text{Be}_3\text{Si}_6\text{O}_{18}]$ , crystallizes in the hexagonal system. The crystal structure consists of six-membered rings of corner-sharing silicon-oxygen ( $\text{SiO}_4$ ) tetrahedra cross-linked by corner-sharing beryllium-oxygen ( $\text{BeO}_4$ ) tetrahedra to make a three-dimensional honeycomb structure; aluminum-oxygen ( $\text{AlO}_6$ ) octahedra lie between the  $\text{Si}_6\text{O}_{18}$  rings. Beryl has a vitreous luster and is typically white to bluish- or yellowish-green, but it can also be shades of yellow, blue, and pink. Its hardness is 7.5–8 on Mohs scale; it has an imperfect basal cleavage and a specific gravity of 2.7–2.9 (increasing with alkali content). Weakly colored varieties can be confused with quartz or apatite. See CRYSTAL STRUCTURE; HARDNESS SCALES.

Beryl is a minor accessory mineral in many natural environments, most commonly in granites and associated hydrothermally altered rocks. Granitic pegmatites constitute the major source of beryl (used for beryllium and gemstones); rarely, single crystals weigh many tons. Alkali-rich beryl occurs in complex pegmatites which contain abundant rare-element minerals such as spodumene, lepidolite, and tourmaline. Alkali-poor beryl occurs in mineralogically simple pegmatites, tin and tungsten deposits, and hydrothermal veins. The gem varieties of beryl, aquamarine (blue), emerald (deep green), and morganite (pink to red), are produced from pegmatites (aquamarine, morganite, some emerald), veins (some aquamarine, most emerald), and, rarely, rhyolites (ruby-red morganite). See BERYLLIUM; BERYLLIUM MINERALS; PEGMATITE; SILICATE MINERALS.

[M.D.B.]

**Beryllium** A chemical element, Be, atomic number 4, with an atomic weight of 9.0122. Beryllium, a rare metal, is one of the lightest structural metals, having a density about one-third that of aluminum. Some of the important physical and chemical properties of beryllium are given in the table. Beryllium has a number of unusual and even unique properties. See PERIODIC TABLE.

The largest volume uses of beryllium metal are in the manufacture of beryllium-copper alloys and in the development of beryllium-containing moderator and reflector materials for nuclear reactors. Addition of 2% beryllium to copper forms a non-magnetic alloy which is six times stronger than copper. These

#### Physical and chemical properties of beryllium

<i>Atomic and mass properties</i>	
Mass number of stable isotopes	9
Atomic number	4
Outer electronic configuration	$1s^2 2s^2$
Atomic weight	9.0122
Atomic diameter	0.221 nm
Atomic volume	$4.96 \text{ cm}^3/\text{mole}$
Crystal structure	Hexagonal close-packed
Lattice parameters	$a = 0.2285 \text{ nm}$ $c = 0.3583 \text{ nm}$ $c/a = 1.568$
Axial ratio	17
Field of cation (charge/radius <sup>2</sup> )	
Density*, 25°, x-ray (theoretical)	$1.8477 \pm 0.0007 \text{ g/cm}^3$
Density, 1000°, x-ray	$1.756 \text{ g/cm}^3$
Radius of atom ( $\text{Be}^0$ )	0.111 nm
Radius of ion, $\text{Be}^{2+}$	0.034 nm
Ionization energy ( $\text{Be}^0 \rightarrow \text{Be}^{2+}$ )	27.4 eV
<i>Thermal properties</i>	
Melting point	1285°C (2345°F)
Boiling point <sup>†</sup>	2970°C (5378°F)
Vapor pressure ( $T = K^\circ$ )	$\log P \text{ (atm)} = 6.186 +$ $1.454 \times 10^{-4}T -$ $(16,700/T)$
Heat of fusion	250–275 cal/g
Heat of vaporization	53,490 cal/mole
Specific heat (20–100°)	0.43–0.52 cal/(g)(°C)
Thermal conductivity (20°)	$0.355 \text{ cal}/(\text{cm}^2)(\text{cm})(\text{s})(^\circ\text{C})$ (42% of copper)
Heat of oxidation	140.15 cal
<i>Electrical properties</i>	
Electrical conductivity	40–44% of copper
Electrical resistivity	4 microhms/cm (0°C) 6 microhms/cm (100°C)
Electrolytic solution potential, $\text{Be}/\text{Be}^\dagger$	$E^0 = -1.69 \text{ volts}$
Electrochemical equivalent	0.04674 mg/coulomb

\*Measured values vary from 1.79 to 1.86, depending on purity and method of fabrication.

<sup>†</sup>Obtained by extrapolation of vapor pressure data, not considered very reliable.

beryllium-copper alloys find numerous applications in industry as nonsparking tools, as critical moving parts in aircraft engines, and in the key components of precision instruments, mechanical computers, electrical relays, and camera shutters. Beryllium-copper hammers, wrenches, and other tools are employed in petroleum refineries and other plants in which a spark from steel against steel might lead to an explosion or fire. See ALKALINE-EARTH METALS; BERYLLIUM ALLOYS.

Beryllium has found many special uses in nuclear energy because it is one of the most efficient materials for slowing down the speed of neutrons and acting as a neutron reflector. Consequently, much beryllium is used in the construction of nuclear reactors as a moderator and as a support or alloy with the fuel elements. See NUCLEAR REACTOR.

The following list shows some of the principal compounds of beryllium. Many of the compounds listed are useful as intermediates in the processes for the preparation of ceramics, beryllium oxide, and beryllium metal. Other compounds are useful in analysis and organic synthesis.

Acetylacetonate	Fluoride, $\text{BeF}_2$
Ammonium beryllium fluoride	Hydroxide
Aurintricarboxylate	Nitrate,
Basic acetate,	$\text{Be}(\text{NO}_3)_2 \cdot 4\text{H}_2\text{O}$
$\text{BeO} \cdot \text{Be}_3(\text{CH}_3\text{COO})_6$	Nitride, $\text{Be}_3\text{N}_2$
Basic beryllium carbonate	Perchlorate,
Beryllate, $\text{BeO}_2^{2-}$	$\text{Be}(\text{ClO}_4)_2 \cdot 4\text{H}_2\text{O}$
Beryllium ammonium	Oxide, BeO
phosphate	Plutonium-beryllium, $\text{PuBe}_{13}$
Bromide, $\text{BeBr}_2$	Salicylate
Carbide, $\text{Be}_2\text{C}$	Silicates (emerald)
Chloride, $\text{BeCl}_2$	Sulfate, $\text{BeSO}_4 \cdot 4\text{H}_2\text{O}$
Dimethyl, $\text{Be}(\text{CH}_3)_2$	Uranium-beryllium, $\text{UBe}_{13}$

Beryllium is surprisingly rare for a light element, constituting about 0.005% of the Earth's crust. It is about thirty-second in order of abundance, occurring in concentrations approximating those of cesium, scandium, and arsenic. Actually, the abundances of beryllium and its neighbors, lithium and boron, are about  $10^{-5}$  times those of the next heavier elements, carbon, nitrogen, and oxygen. At least 50 different beryllium-bearing minerals are known, but in only about 30 is beryllium a regular constituent. The only beryllium-bearing mineral of industrial importance is beryl. Bertrandite substitutes for beryl as a domestic source in the United States. See BERYL. [J.Sch.]

**Beryllium alloys** Dilute alloys of base metals which contain a few percent of beryllium in a precipitation-hardening system. Although beryllium has some solid solubility in copper, silver, gold, nickel, cobalt, platinum, palladium, and iron and forms precipitation-hardening alloys with these metals, the copper-beryllium system and, to a considerably lesser degree, the nickel-beryllium alloys are the only ones used commercially. See BERYLLIUM.

In addition to these precipitation-hardening systems, small amounts of beryllium are used in alloys of the dispersion type wherein there is little solid solubility (Al and Mg). Various amounts of beryllium combine with most elements to form intermetallic compounds. Development of beryllium-rich alloys has been chiefly confined to the ductile matrix Be-Al, Be-Cu solid solution alloy with up to 4% Cu, and dispersed-phase-type alloys having relatively small amounts of compounds (0.25–6%), chiefly as BeO or intermetallics, for dimensional stability, elevated temperature strength, and elastic limit control. See ALLOY.

Primary applications of beryllium-copper alloys are found in the electronics, automotive, appliance, instrument, and temperature-control industries for electric current-carrying springs, diaphragms, electrical switch blades, and other devices. Applications in structural aerospace and nuclear fields are submarine repeater cable housings for transoceanic cable systems, wind tunnel throats, liners for magnetohydrodynamic generators for gas ionization, and scavenger tanks for propane-Freon bubble chambers in high-energy physics research.

Beryllium intermetallic compounds (beryllides) have high strength at high temperature, good thermal conductivity, high specific heat, and good oxidation resistance. Beryllides are formed with actinide and rare metals, as well as with the transition metals. They are of interest to the nuclear field, to power generation, and to aerospace applications. Evaluation of the intermetallics as refractory coatings, reactor hardware, fuel elements, turbine buckets, and high-temperature bearings has been carried out. [W.W.Be./W.D.T.]

**Beryllium metallurgy** Beryllium metallurgy involves two processes for the extraction of beryllium oxide or hydroxide from beryl ore. There are also two methods employed to reduce BeO to beryllium metal. The two extraction methods are based on dissolving beryl as either a fluoride or a sulfate. Reduction is accomplished thermally by means of magnesium with beryllium fluoride, and electrolytically with beryllium chloride. Over 90% of the metal is made from the thermal process.

Vacuum-cast beryllium ingots either are produced as raw material for the powder-metal process, which accounts for over 90% of the material being used, or are cast directly for fabrication. Machined parts are usually made from powder-metal products, while ingot beryllium is usually rolled or otherwise worked. See BERYLLIUM.

Beryllium can be welded, soldered, brazed, or plastically bonded, with brazing and plastic bonding, as well as mechanical fasteners, being the usual production methods. Surface protection of finished beryllium surfaces can be provided by anodizing, plating, optical polishing, or using conversion coatings. Chemical machining and chemical milling are used to provide patterned and low-damage surfaces.

Beryllium has had a long history of use in atomic energy as neutron sources, reflectors, and moderators in thermal and intermediate reactors. Applications of beryllium to aerospace usually provides weight saving up to 60% of that of a competing material on the same design basis. Extensive use of beryllium in reentry structures depends on high-temperature strength and thermal capacity. The metal's transparency to radiation (as used in x-ray windows) also is important to missile structures, which must withstand electromagnetic pulse conditions created by antimissile tactics. Finally, ability to machine to high tolerance coupled with dimensional stability has created almost exclusive employment of beryllium in inertial guidance navigation and control devices. [W.W.Be./W.D.T.]

**Beryllium minerals** Minerals containing beryllium as an essential component. Over 50 beryllium minerals have been identified, even though beryllium is a scarce element in the Earth's crust. The unusual combination of low charge (+2) and small ionic radius (0.035 nanometer) of the beryllium ion accounts for this diverse group of minerals and their occurrence in many natural environments. See BERYLLIUM.

Nearly all beryllium minerals can be included in one of three groups: compositionally simple oxides and silicates with or without aluminum; sodium- and calcium-bearing silicates; and phosphates and borates. The first group is by far the most abundant; it contains beryl, the most common beryllium mineral, plus the common minerals phenakite, bertrandite, chrysoberyl, and euclase. Of this group, only beryl shows a wide compositional variation.

The beryllium minerals have many structural characteristics similar to the major rock-forming silicate minerals, but are distinguished by containing large quantities of tetrahedrally coordinated beryllium ion ( $\text{Be}^{2+}$ ) in place of, or in addition to, tetrahedrally coordinated aluminum ion ( $\text{Al}^{3+}$ ) and silicon ion ( $\text{Si}^{4+}$ ). See SILICATE MINERALS.

Beryllium minerals occur in many geological environments, where they are generally associated with felsic (abundant feldspar  $\pm$  quartz) igneous rocks and related, metasomatically altered rocks.

Beryl and bertrandite, mined from granitic pegmatites and altered volcanic rocks, are the principal ores of beryllium; deposits of chrysoberyl and phenakite may become economically significant in the future. The colored varieties of beryl (emerald, aquamarine, morganite) are valued gemstones; chrysoberyl, phenakite, and a few of the other minerals are less common gemstones. See CHRYSOBERYL; EMERALD; GEM. [M.D.B.]

**Bessel functions** The solutions of Bessel's differential equation, Eq. (1). Bessel functions, also called cylinder functions,

$$z^2 d^2 y/dz^2 + z dy/dz + (z^2 - v^2)y = 0 \quad (1)$$

are examples of special functions which are introduced by a differential equation. Bessel functions are of great interest in purely mathematical concepts and in mathematical physics. They constitute additional functions which, like the elementary functions  $z^n$ ,  $\sin z$ ,  $e^z$ , can be used to express physical phenomena.

Applications of Bessel functions are found in such representative problems as heat conduction or diffusion in circular cylinders, oscillatory motion of a sphere in a viscous fluid, oscillations of a stretched circular membrane, diffraction of waves by a circular cylinder of infinite length or by a sphere, acoustic or electromagnetic oscillations in a circular cylinder of finite length or in a sphere, electromagnetic wave propagation in the waveguides of circular cross section, in coaxial cables, or along straight wires, and in the skin effect in conducting wires of circular cross section. In these problems Bessel functions are used to represent such quantities as the temperature, the concentration, the displacements, the electric and magnetic field strengths, and the current density as a function of space coordinates. The Bessel functions enter into all these problems because boundary values

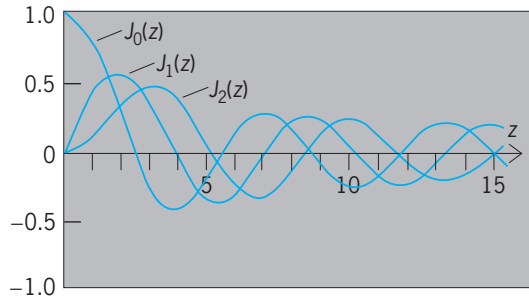

Fig. 1. Bessel functions  $J_0(z)$ ,  $J_1(z)$ ,  $J_2(z)$  for  $\nu = 0, 1, 2$  and for positive values of  $z$ .

on circles (two-dimensional problems), on circular cylinders, or on spheres are prescribed, and the solutions of the respective problems are sought either inside or outside the boundary, or both.

The independent variable  $z$  in Bessel's differential equation may in applications assume real or complex values. The parameter  $\nu$  is, in general, also complex. Its value is called the order of the Bessel function. Since there are two linearly independent solutions of a linear differential equation of second order, there are two independent solutions of Bessel's differential equation. They cannot be expressed in finite form in terms of elementary functions such as  $z^n$ ,  $\sin z$ , or  $e^z$  unless the parameter is one-half of an odd integer. They can, however, be expressed as power series with an exception for integer values of  $\nu$ . The function defined by Eq. (2) is designated as Bessel's function of the first

$$J_\nu(z) = \left(\frac{z}{2}\right)^\nu \sum_{l=0}^{\infty} \frac{(-z^2/4)^l}{l! \Gamma(\nu + l + 1)} \quad (2)$$

kind, or simply the Bessel function of order  $\nu$ .  $\Gamma(\nu + l + 1)$  is the gamma function. The infinite series in Eq. (2) converges absolutely for all finite values, real or complex, of  $z$ . Along with  $J_\nu(z)$ , there is a second solution  $J_{-\nu}(z)$ . It is linearly independent of  $J_\nu(z)$  unless  $\nu$  is an integer  $n$ . In this case  $J_{-n}(z) = (-1)^n J_n(z)$ . See GAMMA FUNCTION.

The Bessel function of the second kind, also called the Neumann function, is defined by Eq. (3).

$$Y_\nu(z) = \frac{\cos \nu \pi J_\nu(z) - J_{-\nu}(z)}{\sin \nu \pi} \quad (3)$$

If  $\nu = n$ , this expression is indeterminate, and the limit of the right member is to be taken. There are two Bessel functions of the third kind, designated as first and second Hankel functions.

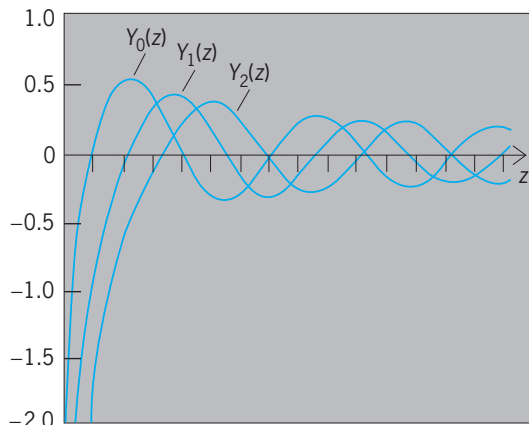

Fig. 2. Neumann functions  $Y_0(z)$ ,  $Y_1(z)$ ,  $Y_2(z)$  for  $\nu = 0, 1, 2$  and for positive values of  $z$ .

They are defined as Eqs. (4).

$$H_\nu^{(1)}(z) = J_\nu(z) + iY_\nu(z) \quad (4)$$

$$H_\nu^{(2)}(z) = J_\nu(z) - iY_\nu(z)$$

Figures 1 and 2 give the Bessel and Neumann functions for  $\nu = 0, 1, 2$  and positive values of  $z$ . [J.Meix.]

**Beta particles** The name first applied in 1897 by Ernest Rutherford to one of the forms of radiation emitted by radioactive nuclei. Beta particles can occur with either negative or positive charge (denoted  $\beta^-$  or  $\beta^+$ ) and are now known to be either electrons or positrons, respectively. Electrons and positrons are now referred to as beta particles only if they are known to have originated from nuclear beta decay. Their observed kinetic energies range from zero up to about 5 MeV in the case of naturally occurring radioactive isotopes, but can reach values well over 10 MeV for some artificially produced isotopes. See RADIOACTIVITY; ALPHA PARTICLES; ELECTRON; GAMMA RAYS; POSITRON.

When a nucleus beta-decays, it emits two particles at the same time: One is a beta particle; the other, a neutrino or antineutrino. With this emission, the nucleus itself undergoes a transformation, changing from one element to another. In the case of isotopes that  $\beta^+$ -decay, each decaying nucleus emits a positron and a neutrino, simultaneously reducing its atomic number by one unit; for those isotopes that  $\beta^-$ -decay, each nucleus emits an electron and an antineutrino while increasing its atomic number by one. In both classes of decay, the energy released by the nuclear transformation is shared between the two emitted particles. Though the energy released by a particular nuclear transformation is always the same, the fraction of this energy carried away by the beta particle is different for each decaying nucleus. (The neutrino always carries away the remainder, thus conserving energy overall.) When observed collectively, the decaying nuclei of a simple radioactive source emit their beta particles with a continuous distribution of kinetic energies covering the range from zero up to the total nuclear decay energy available.

Radioactive samples often contain several radioactive isotopes. Since each isotope has its own decay energy and beta-particle energy distribution, the energy spectrum of beta particles observed from such a sample would be the sum of a number of distributions, each with a different end-point energy. Indeed, many isotopes, especially those artificially produced with accelerators, can themselves beta-decay by additional paths that also release part of the energy in the form of gamma radiation.

As a beta particle penetrates matter, it loses its energy in collisions with the constituent atoms. Two processes are involved. First, the beta particle can transfer a small fraction of its energy to the struck atom. Second, the beta particle is deflected from its original path by each collision and, since any change in the velocity of a charged particle leads to the emission of electromagnetic radiation, some of its energy is lost in the form of low-energy x-rays (bremsstrahlung). Though the energy lost by a beta particle in a single collision is very small, many collisions occur as the particle traverses matter, causing it to follow a zigzag path as it slows down. See BREMSSTRAHLUNG.

The thickness of material that is just sufficient to stop all the beta particles of a particular energy is called the range of those particles. For the continuous energy distribution normally associated with a source of beta particles, the effective range is the one that corresponds to the highest energy in the primary spectrum. That thickness of material stops all of the beta particles from the source. The range depends strongly on the electron energy and the density of the absorbing material.

The slowing-down processes have the same effect on both  $\beta^-$  and  $\beta^+$  particles. However, as antimatter, the positron ( $\beta^+$ ) cannot exist for long in the presence of matter. It soon combines with an atomic electron, with which it annihilates, the masses of both particles being replaced by electromagnetic energy. Usually this annihilation occurs after the positron has come to rest and



formed a positronium atom, a bound but short-lived positron-electron system. In that case, the electromagnetic energy that is emitted from the annihilation takes the form of two 511-keV gamma rays that are emitted in opposite directions to conserve momentum. See POSITRONIUM.

Beta particles are detected through their interaction with matter. One class of detectors employs gas as the detection medium. Ionization chambers, proportional counters, and Geiger-Müller counters are of this class. In these detectors, after entering through a thin window, the beta particles produce positive ions and free electrons as they collide with atoms of the gas in the process of their slowing down. An electric field applied across the volume of gas causes these ions and electrons to drift along the field lines, causing an ionization current that is then processed in external electronic devices. See IONIZATION CHAMBER; PARTICLE DETECTOR.

More precise energy information can be achieved with scintillation detectors. In certain substances, the ion-electron pairs produced by the passage of a charged particle result in the emission of a pulse of visible or near-ultraviolet light. If a clear plastic scintillator is used, it can be mounted on a photomultiplier tube, which converts the transmitted light into a measurable electrical current pulse whose amplitude is proportional to the energy deposited by the incident beta particle. See SCINTILLATION COUNTER.

Even better energy information comes from semiconductor detectors, which are effectively solid-state ionization chambers. When a beta particle enters the detector, it causes struck electrons to be raised into the conduction band, leaving holes behind in the valence band. The electrons and holes move under the influence of an imposed electric field, causing a pulse of current to flow. Such detectors are useful mainly for low-energy beta particles. See JUNCTION DETECTOR.

Any one of these detectors can be combined with a magnetic spectrometer. Beta particles, like any charged particles, follow curved paths in a perpendicular magnetic field, their radius of curvature being proportional to the square of their energy. Their detected position on exiting the magnetic field can be precisely related to their energy. The best current measurement of the electron antineutrino mass comes from a spectrometer measurement of the tritium beta-decay spectrum. See NEUTRINO. [J.Hard.]

**Betatron** A device for accelerating charged particles in an orbit by means of the electric field  $E$  from a slowly changing magnetic flux  $\Phi$ . The electric field is given by  $E = -(1/2\pi r_o) d\Phi/dt$  (in SI or mks units), where  $r_o$  is the orbit radius. The name was chosen because the method was first applied to electrons. In the usual betatron both the accelerating core flux and a guiding magnetic field rise with similar time dependence, with the result that the orbit is circular. However, the orbit can have a changing radius as acceleration progresses. For the long path (usually more than 60 mi or 100 km), variations of axial and radial magnetic field components provide focusing forces, while space charge and space current forces due to the particle beam itself also contribute to the resulting betatron oscillations about the equilibrium orbit. In many other instances of particle beams, the term betatron oscillations is used for the particle oscillations about a beam's path.

Collective effects from self-fields of the beam have been found important and helpful in injecting. Circulating currents of about 3 amperes are contained in the numerous industrial and therapeutic betatrons, although the average currents are below  $10^{-7}$  A. See PARTICLE ACCELERATOR. [D.W.K.]

**Betel nut** The dried, ripe seed of the palm tree *Areca catechu* (Palmae), a native of Ceylon and Malaya. The nuts, slightly larger than a chestnut, have a faint odor when broken open and a somewhat acrid taste. Betel nuts are chewed by the inhabitants together with the leaves of the betel pepper, *Piper betle* (Piperaceae), and lime. The mixture discolors and eventually destroys the teeth. Frequently, habitual chewers of the nut are toothless by

the age of 25. The seeds contain a narcotic that produces some stimulation and a sense of well-being. See NARCOTIC; PIPERALE. [PD.St./E.L.C.]

**Betelgeuse** A cool and highly luminous star, prominently located in the right shoulder of the constellation Orion and noticeably red in color. Betelgeuse, or  $\alpha$  Orionis, is a supergiant star about 130 parsecs (430 light-years) from the Sun. Its spectral type of M2 indicates an effective temperature of approximately 3500 K (5800°F). This temperature would result in a low overall luminosity were it not for the enormous diameter of the star, about 1100 times that of the Sun. Replacing the Sun, Betelgeuse would fill the solar system to beyond the orbit of Mars. Betelgeuse is a supergiant star with approximately 150,000 times the Sun's luminosity. Its mean density is extremely low, less than one-millionth the density of water, and the low surface gravity of the rarefied outer layers results in a continual loss of matter, presently at the rate of 1 solar mass every 250,000 years. Observations at infrared and radio wavelengths show a complex system of dust and gas shells extending out as far as a few hundred stellar radii. See SPECTRAL TYPE; STELLAR EVOLUTION; SUPERGIANT STAR; VARIABLE STAR.

Speckle interferometry techniques have also produced the first images of the disk of a star and show asymmetric brightness variations over the surface that change with time and are possibly due to large-scale convection of material within the star's atmosphere. Betelgeuse has also been imaged by the Hubble Space Telescope at ultraviolet wavelengths showing the asymmetric inner atmosphere of the star and a central hot spot. See SPECKLE; STAR. [H.A.McA.]

**Bias (electronics)** The establishment of an operating point on the transistor volt-ampere characteristics by means of direct voltages and currents.

Since the transistor is a three-terminal device, any one of the three terminals may be used as a common terminal to both input and output. In most transistor circuits the emitter is used as the common terminal, and this common emitter, or grounded emitter, is indicated in illus. a. If the transistor is to be used as a linear device, such as an audio amplifier, it must be biased to operate in the active region. In this region the collector is biased in the reverse direction and the emitter in the forward direction. The area in the common-emitter transistor characteristics to the right of the ordinate  $V_{CE} = 0$  and above  $I_C = 0$  is the active region. Two more biasing regions are of special interest for those cases in which the transistor is intended to operate as a switch. These are the saturation and cutoff regions. The saturation region may be defined as the region where the collector current is independent of base current for given values of  $V_{CC}$  and  $R_L$ . Thus, the onset of saturation can be considered to take place at the knee of the common-emitter transistor curves. See AMPLIFIER; TRANSISTOR.

In saturation, the transistor current  $I_C$  is nominally  $V_{CC}/R_L$ . Since  $R_L$  is small, it may be necessary to keep  $V_{CC}$  correspondingly small in order to stay within the limitations imposed by the transistor on maximum-current and collector-power dissipation. In the cutoff region it is required that the emitter current  $I_E$  be zero, and to accomplish this it is necessary to reverse-bias the emitter junction so that the collector current is approximately equal to the reverse saturation current  $I_{CO}$ . A reverse-biasing voltage of the order of 0.1 V across the emitter junction will ordinarily be adequate to cut off either a germanium or silicon transistor.

The particular method to be used in establishing an operating point on the transistor characteristics depends on whether the transistor is to operate in the active, saturation or cutoff regions; on the application under consideration; on the thermal stability of the circuit; and on other factors.

In a fixed-bias circuit, the operating point for the circuit of illus. a can be established by noting that the required current  $I_B$  is constant, independent of the quiescent collector current  $I_C$ , which is why this circuit is called the fixed-bias circuit. Transistor

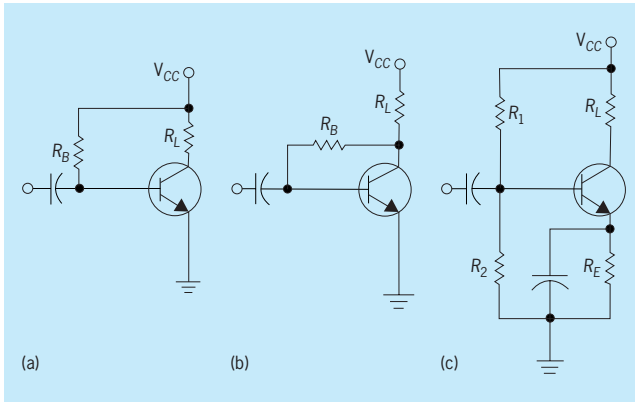

Translator circuits. (a) Fixed-bias. (b) Collector-to-base bias. (c) Self-bias.

biasing circuits are frequently compared in terms of the value of the stability factor  $S = \partial I_C / \partial I_{CO}$ , which is the rate of change of collector current with respect to reverse saturation current. The smaller the value of  $S$ , the less likely the circuit will exhibit thermal runaway.  $S$ , as defined here, cannot be smaller than unity. Other stability factors are defined in terms of dc current gain  $h_{FE}$  as  $\partial I_C / \partial h_{FE}$ , and in terms of base-to-emitter voltage as  $\partial I_C / \partial V_{BE}$ . However, bias circuits with small values of  $S$  will also perform satisfactorily for transistors that have large variations of  $h_{FE}$  and  $V_{BE}$ . For the fixed-bias circuit it can be shown that  $S = h_{FE} + 1$ , and if  $h_{FE} = 50$ , then  $S = 51$ . Such a large value of  $S$  makes thermal runaway a definite possibility with this circuit.

In collector-to-base bias, an improvement in stability is obtained if the resistor  $R_B$  in illus. *a* is returned to the collector junction rather than to the battery terminal. Such a connection is shown in illus. *b*. In this bias circuit, if  $I_C$  tends to increase (either because of a rise in temperature or because the transistor has been replaced by another), then  $V_{CE}$  decreases. Hence  $I_B$  also decreases and, as a consequence of this lowered bias current, the collector current is not allowed to increase as much as it would if fixed bias were used. The stability factor  $S$  is shown in Eq. (1).

$$S = \frac{h_{FE} + 1}{1 + h_{FE} R_L / (R_L + R_B)} \quad (1)$$

This value is smaller than  $h_{FE} + 1$ , which is the value obtained for the fixed-bias case.

If the load resistance  $R_L$  is very small, as in a transformer-coupled circuit, then the previous expression for  $S$  shows that there would be no improvement in the stabilization in the collector-to-base bias circuit over the fixed-bias circuit. A circuit that can be used even if there is zero dc resistance in series with the collector terminal is the self-biasing configuration of illus. *c*. The current in the resistance  $R_E$  in the emitter lead causes a voltage drop which is in the direction to reverse-bias the emitter junction. Since this junction must be forward-biased (for active region bias), the bleeder  $R_1$ - $R_2$  has been added to the circuit.

If  $I_C$  tends to increase, the current in  $R_E$  increases. As a consequence of the increase in voltage drop across  $R_E$ , the base current is decreased. Hence  $I_C$  will increase less than it would have had there been no self-biasing resistor  $R_E$ . The stabilization factor for the self-bias circuit is shown by Eq. (2), where  $R_B = R_1 R_2 / (R_1 + R_2)$ . The smaller the value of  $R_B$ , the better the stabilization.

$$S = (1 + h_{FE}) \frac{1 + R_B / R_E}{1 + h_{FE} + R_B / R_E} \quad (2)$$

Even if  $R_B$  approaches zero, the value of  $S$  cannot be reduced below unity.

In order to avoid the loss of signal gain because of the degeneration caused by  $R_E$ , this resistor is often bypassed by a very large capacitance, so that its reactance at the frequencies under consideration is very small.

The selection of an appropriate operating point ( $I_D$ ,  $V_{GS}$ ,  $V_{DS}$ ) for a field-effect transistor (FET) amplifier stage is determined by considerations similar to those given to transistors, as discussed previously. These considerations are output-voltage swing, distortion, power dissipation, voltage gain, and drift of drain current. In most cases it is not possible to satisfy all desired specifications simultaneously. [C.C.H.]

**Bicosoecida** An order of Zoomastigophorea (Protozoa). They are colorless, free-living cells, each with two flagella, one of which is used for attaching the organism to its exoskeleton (lorica). Although the attachment is normally from the front end, the flagellum emerges alongside the primary or vibrating one (see illustration). The anterior end in many species (*Codomonas annulata*, *Poteriodendron petiolatum*, and *Stephanocodon stellatum*) is ameboid, or at times appears to be formed into a lip which can turn in and engulf a bacterium.

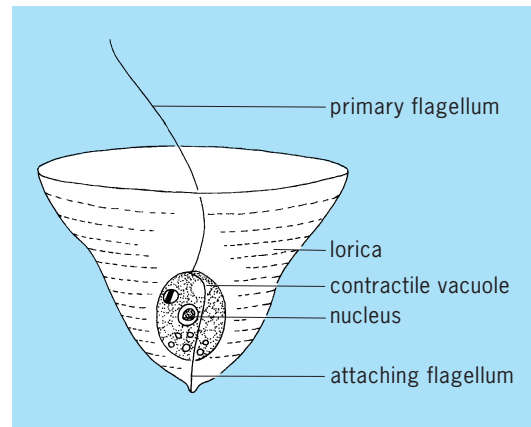

A bicosoecid, *Codomonas annulata*.

These Bicosoecida are common in fresh water and often seen attached to desmids or other algae. *Bicosocca mediterranea* is common at times in salt water, where assemblages of it are found on diatoms. The order has very few genera and species. See PROTOZOA; ZOOMASTIGOPHOREA. [J.B.L.]

**Big bang theory** The theory that the universe began in a state of extremely high density and has been expanding since some particular instant that marked the origin of the universe. The big bang is the generally accepted cosmological theory; the incorporation of developments in elementary particle theory has led to the inflationary universe version. The predictions of the inflationary universe and older big bang theories are the same after the first  $10^{-35}$  s. See INFLATIONARY UNIVERSE COSMOLOGY.

Two observations are at the base of observational big bang cosmology. First, the universe is expanding uniformly, with objects at greater distances receding at a greater velocity. Second, the Earth is bathed in the cosmic background radiation, an isotropic glow of radiation that has the characteristics expected from the remnant of a hot primeval fireball.

Tracing the expansion of the universe back in time shows that the universe would have been compressed to infinite density approximately  $8-16 \times 10^9$  years ago. In the big bang theory, the universe began at that time as a so-called big bang began the expansion. The big bang was the origin of space and time.

In 1917, Albert Einstein found a solution to his own set of equations from his general theory of relativity that predicted the nature of the universe. His universe, though, was unstable: it could only be expanding or contracting. This seemed unsatisfactory at the time, for the expansion had not yet been discovered, so Einstein arbitrarily introduced a special term—the cosmological constant—into his equations to make the universe static. The need for the cosmological constant seemed to disappear with

Hubble's discovery of the expansion, though the cosmological constant has subsequently reappeared in some models.

Further solutions to Einstein's equations, worked out in the 1920s, are at the basis of the cosmological models that are now generally accepted. These solutions indicate that the original "cosmic egg" from which the universe was expanding was hot and dense. This is the origin of the current view that the universe was indeed very hot in its early stages.

Modern theoretical work has been able to trace the universe back to the first instants in time. In the big bang theory and in related theories that also propose a hot, dense early universe, the universe may have been filled in the earliest instants with exotic elementary particles of the types now being studied by physicists with large accelerators. Individual quarks may also have been present. By 1 microsecond after the universe's origin, the exotic particles and the quarks had been incorporated in other fundamental particles. See ELEMENTARY PARTICLE; QUARKS.

Work in the early 1980s incorporated the effect of elementary particles in cosmological models. The research seems to indicate that the universe underwent a period of extremely rapid expansion in which it inflated by a factor of billions in a very short time. This inflationary universe model provides an explanation for why the universe is so homogeneous: Before the expansion, regions that now seem too separated to have been in contact were close enough to interact. After the inflationary stage, the universe is in a hot stage and is still dense; the models match the big bang models thereafter.

In the inflationary universe models, the universe need not have arisen from a single big bang. Rather, matter could have appeared as fluctuations in the vacuum.

It is not definitely known why there is an apparent excess of matter over antimatter, though attempts in elementary particle physics to unify the electromagnetic, the weak, and the strong forces show promise in explaining the origin of the matter-antimatter asymmetry. The asymmetry seems to have arisen before the first millisecond. The asymmetry in the decay of certain mesons may provide a clue to resolving this question. See ANTI-MATTER; FUNDAMENTAL INTERACTIONS.

By 5 s after the origin of the universe, the temperature had cooled to  $10^9$  K ( $2 \times 10^9$ °F), and only electrons, positrons, neutrinos, antineutrinos, and photons were important. A few protons and neutrons were mixed in, and they grew relatively more important as the temperature continued to drop. The universe was so dense that photons traveled only a short way before being reabsorbed. By the time 1 min had gone by, nuclei of the light elements had started to form.

After about a million years, when the universe cooled to 3000 K (5000°F) and the density dropped sufficiently, the protons and electrons suddenly combined to make hydrogen atoms, a process called recombination. Since hydrogen's spectrum absorbs preferentially at the wavelengths of sets of spectral lines rather than continuously across the spectrum, and since there were no longer free electrons to interact with photons, the universe became transparent at that instant. The average path traveled by a photon—its mean free path—became very large. The blackbody spectrum of the gas at the time of recombination was thus released and has been traveling through space ever since. As the universe expands, this spectrum retains its blackbody shape though its characteristic temperature drops. See BLACKBODY; HEAT RADIATION.

As the early universe cooled, the temperatures became sufficiently low for element formation to begin. By about 100 s, deuterium (comprising one proton plus one neutron) formed. When joined by another neutron to form tritium, the amalgam soon decayed to form an isotope of helium. Ordinary helium, with still another neutron, also resulted.

Big bang nucleosynthesis, although at first thought to be a method of forming all the elements, foundered for the heavy elements at mass numbers 5 and 8. Isotopes of these mass numbers are too unstable to form heavier elements quickly enough. The gap is bridged only in stars, through processes worked out

in 1957. Thus the lightest elements were formed as a direct result of the big bang while the heavier elements as well as additional quantities of most of the lighter elements were formed later in stars or supernovae. See NUCLEOSYNTHESIS.

The two extreme possibilities for the future of the universe are that the universe will continue to expand forever, or that it will cease its expansion and begin to contract. It can be shown that the case where the universe will expand forever corresponds to an infinite universe. The term applied is the open universe. The case where the universe will begin to contract corresponds to a finite universe. The term applied is the closed universe. The inflationary universe scenario has the universe on the boundary between open and closed, as signified by the parameter  $\Omega$  taking the value of 1. Such a universe will expand forever but at an ever-decreasing rate. See COSMOLOGY; UNIVERSE.

The inflationary universe model provides a natural explanation for the universe being on this dividing line. After expansion slows down at the close of the inflationary stage (thus causing a phase change, much like water boiling into steam), the universe necessarily approaches this line. Further work on inflationary scenarios is necessary to see whether certain problems, such as the inflationary model's predictions of the density fluctuations that lead to the coalescence of galaxies, can be accounted for. See COSMOLOGY; UNIVERSE. [J.M.P.]

**Bilirubin** The predominant orange pigment of bile. It is the major metabolic breakdown product of heme, the prosthetic group of hemoglobin in red blood cells, and other chromoproteins such as myoglobin, cytochrome, and catalase. The breakdown of hemoglobin from the old red cells takes place at a rapid rate in the reticuloendothelial cells of the liver, spleen, and bone marrow. The steps in this breakdown process include denaturation and removal of the protein globin, oxidation and opening of the tetrapyrrole ring, and the removal of iron to form the green pigment biliverdin, which is then reduced to bilirubin by the addition of hydrogen. The formed bilirubin is transported to the liver, probably bound to albumin, where it is conjugated into water-soluble mono- and diglucuronides and to a lesser extent with sulfate. See LIVER.

In mammalian bile essentially all of the bilirubin is present as a glucuronide conjugate. Bilirubin glucuronide is passed through the liver cells into the bile caniculi and then into the intestine. The bacterial flora further reduces the bilirubin to colorless urobilinogen. Most of the urobilinogen is either reduced to stercobilinogen or oxidized to urobilin. These two compounds are then converted to stercobilin, which is excreted in the feces and gives the stool its brown color. See HEMOGLOBIN. [M.K.S.]

**Binary star** Two stars held together by their mutual gravitational attraction in a permanent (or long-term) association. The stellar universe is hierarchical. Stars exist singly, in binary pairs, in multiple systems, and in clusters. On large scales, roughly  $10^5$  light-years, astronomical objects congregate into galaxies. In fact, most stars are in binary systems. The Sun, with its collection of planets, is an exception. Stars in binaries revolve around their common center of mass (which itself moves through space). This star-star gravitational interaction makes possible the measurement of stellar masses and other basic properties. Stellar evolution in some binary systems can lead to spectacularly energetic activity. See GALAXY, EXTERNAL; SOLAR SYSTEM.

Binary systems are observed in various ways. They may be classified as visual binaries, spectroscopic binaries, or spectroscopic-eclipsing binaries, according to the means of observation.

In visual binary systems the stars are widely separated compared to their sizes and appear as separate points of light in the telescope. Binary stars provide the only proof that has been found so far of gravitation's validity beyond the solar system. See CELESTIAL MECHANICS; GRAVITATION.

More detailed observations reveal the apparent orbit of each star relative to the center of mass, leading directly to the stellar

mass ratio of the two components. If the binary's parallax (distance) can be measured, individual stellar masses can be found. Without a knowledge of masses, stellar evolution cannot be understood.

There is a large class of nonvisual binaries in which the stars are separated by only a few stellar diameters. They cannot be resolved in telescopes, and are referred to as close binaries. The closeness of the stars profoundly affects their evolution. It also creates high orbital speeds (tens to hundreds of kilometers per second), rendering them easily detectable through Doppler shifts of their spectral lines.

If the two stars are of comparable luminosity, both stars contribute equally to their combined spectra and stellar lines are double over much of the orbital cycle. These are double-line spectroscopic binaries. The inverse ratio of their velocity amplitudes is the stellar mass ratio. See ASTRONOMICAL SPECTROSCOPY; DOPPLER EFFECT.

In spectroscopic-eclipsing binaries, the orbital plane of a close binary is nearly in the sight line. Mutual stellar eclipses occur, yielding a brightness-time variation called the light curve. Analysis of the light curve yields the inclination which, coupled with radial velocity curves of both stars, leads to both stellar masses and stellar sizes.

Stellar evolution in close binaries is drastically changed by the second star. The more massive star will exhaust its core hydrogen first and begin its evolution to a red giant. Its expansion is halted when the star's surface reaches the so-called inner lagrangian surface. This is a teardrop-shaped equipotential surface, usually called the Roche lobe, that touches the lagrangian surface of the less massive companion at the inner lagrangian point  $L_1$ .

Instead of expanding through this surface, matter flows along the Roche lobe to  $L_1$ , evaporates from  $L_1$ , and forms a stream that accelerates hypersonically toward the companion (see illustration). In other words, the post-main-sequence star transfers matter to its companion. One star loses mass (the loser) while the other gains mass (the gainer).

A visual binary, in which both stars are far from their Roche lobes, is referred to as detached. A system in which one star has evolved to fill its Roche lobe is called semidetached (see illustration). W Ursae Majoris stars are a class of main sequence binaries where both stars fill their lobes and share in effect a common envelope. Their periods are usually less than a day, and they are called contact binaries.

Algol eclipsing binaries illustrate evolution in close binaries. They contain a fairly massive main sequence gainer and a less massive, evolved subgiant (or giant) loser that fills its Roche lobe. Their existence posed the Algol paradox: how could the less massive star be the more evolved? The more evolved star must have originally been the more massive; mass transfer through  $L_1$  to the companion has reversed the mass ratio.

At some point the gainer will itself evolve from the main sequence. Its envelope expansion may well engulf the original loser, whose orbit will then decay because of friction with the envelope gas (the so-called common-envelope phase). See STELLAR EVOLUTION; SYMBIOTIC STAR.

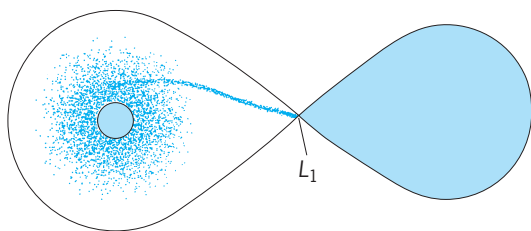

Roche lobes surrounding the stars in a binary system. The contact point is  $L_1$ . The less massive star on the right already fills its lobe. A mass-transferring stream supplies an accretion disk around the other star. (Matthew Senay)

Stellar evolution with a common-envelope stage may produce cataclysmic variables, in which a white dwarf is paired with a Roche-lobe-filling main-sequence loser. Orbital periods are typically less than a day. The mass-transferring stream from the loser supplies an accretion disk rotating around the white dwarf. Matter in the stream is rapidly accelerated toward the white dwarf, producing significant shock heating on impact with the disk. See WHITE DWARF STAR.

The cataclysmic binary zoo includes novae, dwarf novae, recurrent novae, and novalike variables. Much of their light comes from the thick accretion disk. Thermal instabilities in the disk may trigger mass dumps onto the white dwarf, producing eruptive brightenings. In some cases, hydrogen-rich matter from the loser slowly accumulates on the high-gravity surface of the white dwarf. At a critical density this matter becomes electron-degenerate, igniting a thermonuclear runaway that is a nova outburst. The explosion does not destroy the star, and outbursts may recur after many centuries of quiescence. See CATAclysmic VARIABLE; NOVA.

Neutron stars in close binary systems, where the companion fills its Roche lobe and transfers mass, can tap the enormous gravitation energy of in-falling matter. The strong magnetic field interferes with the formation of an accretion disk and funnels transferred mass onto the magnetic poles of the neutron star. This matter, enormously accelerated, strikes the surface at about half the speed of light and heats the poles to  $10^8$  K. Thermal radiation at such enormous temperatures (hotter than the solar core) is mainly x-rays. An x-ray binary results. See NEUTRON STAR.

High- and low-mass x-ray binaries are now recognized. The former are born with stars of comparable mass, totaling more than 20 solar masses. The more massive component explodes as a supernova and leaves a neutron star (or a black hole) remnant, but the binary is not disrupted. As the second star evolves and expands, it feeds mass to the neutron star. The resulting x-radiation may reach  $10^5$  solar luminosities, making these high-mass binaries among the most luminous objects in the Milky Way Galaxy. See BLACK HOLE; SUPERNOVA.

Low-mass x-ray binaries form with stars of differing mass (typically 10 and less than 2 solar masses). The more massive star suffers a supernova explosion and leaves a neutron star remnant. Mass accreted from the other star may spin up the neutron star to make a so-called millisecond pulsar. The enormous radiation from the neutron star may literally strip the companion to its degenerate helium core, as seems to be happening in the Black Widow Pulsar.

If the unseen x-ray source in a close binary has a mass significantly larger than about 3 solar masses, it cannot exist as a neutron star. According to current theory, it must have collapsed into a stellar-mass black hole. A handful of such candidates exist in the Milky Way Galaxy.

When the evolution of a moderate-mass binary results in two carbon-oxygen white dwarfs orbiting each other inside a common envelope, a remarkable event may occur. Viscous friction with the envelope causes the stars to spiral inward. If they merge into a total mass larger than about 1.4 solar masses (the Chandrasekhar limit), extremely intense thermonuclear reactions produce iron-peak elements, the structure abruptly runs out of thermonuclear energy, and an implosion-explosion occurs, producing a type Ia supernova. These highly luminous objects are seen in distant galaxies. They behave as standard candles (distance indicators), and are used to study the long-term evolution of the expansion rate of the universe. See COSMOLOGY; NUCLEOSYNTHESIS; UNIVERSE. [E.C.OI.]

**Binaural sound system** A sound-reproducing system in which sound is recorded or transmitted by using two microphones mounted at the ears of a dummy human head. To preserve the binaural effect, the sound must be monitored by a listener wearing a set of earphones identically spaced. In an ideal

binaural transmission system, both the amplitude and phase of the sound waves incident on the dummy's ears are duplicated at the listener's ears.

Binaural systems have been made so perfect that the listener is unable to distinguish the monitored sound from the real sound. For example, when a person walks around the dummy head, the listener, upon hearing the footsteps, has the compelling illusion of someone walking around him. No other sound system thus far devised can even approximate such an effect. See SOUND-REPRODUCING SYSTEMS; STEREOGRAPHIC SOUND. [H.F.O.]

**Binoculars** Optical instruments consisting of a parallel pair of matched telescopes, used to extend the range of stereoscopic vision to far distances. Each half of a binocular consists of a telescope objective, a prism for inverting the image, and an eyepiece (see illustration). See EYEPIECE; STEREOSCOPY; VISION.



Modern prism binocular. (Bausch and Lomb Optical Co.)

The characteristics of a binocular are stated by using a pair of numbers, such as  $7 \times 50$  (seven by fifty), where the first number is the magnifying power of the binocular and the second is the diameter of the objective of the binocular in millimeters.

Since a lens forms an inverted image, the straight-through combination of an objective and eyepiece would provide an inverted field of view to the eye, as in an astronomical telescope. Almost all binoculars use prisms with an odd number of reflecting surfaces to invert the image correctly. The choice of prisms must also provide for the adjustment in pupil separation by having the optical axes on either side of the prism displaced but parallel. The most frequently used prism is a Porro prism, which is a combination of two  $45^\circ$ - $90^\circ$  prisms. These lead to a bulky mechanical construction, so that many modern binoculars use straight-through prisms. See MIRROR OPTICS; OPTICAL PRISM.

Binoculars require some ability to change the separation between the eyepiece and the objective to provide focusing to accommodate different object distances and possible refractive errors in the eye. Most binoculars provide for a joint focus adjustment of both tubes with one eye having an additional focus range to compensate for users who have differing refractive errors in each eye. Another optical feature often available in binoculars is a variable magnification or zoom system. See ZOOM LENS.

Selection of binoculars should be made with some consideration of the intended use. A larger objective will permit use of the binoculars at lower light levels. However, binoculars with larger-diameter objectives and higher powers are heavier and less convenient to use. The jitter produced while holding the binoculars will be magnified by the binocular, so that very high power binoculars usually require a stable support, such as a tripod, to be used properly. A modest power such as 6 is usually more comfortable than a high power such as 10.

Opera glasses are a type of low-power binoculars which use simpler optics. The use of a negative lens as an eyepiece, as in a Galilean telescope, limits the power and the field of view but permits a lighter and less expensive instrument. See TELESCOPE.

[R.R.S.]

**Binomial theorem** One of the most important algebraic identities, with many applications in a variety of fields. The binomial theorem, discovered by Isaac Newton, expresses the result of multiplying a binomial by itself any number of times:

$$(a + b)^n = a^n + c_1 a^{n-1} b + c_2 a^{n-2} b^2 + c_3 a^{n-3} b^3 + \dots + c_r a^{n-r} b^r + \dots + b^n$$

where the coefficients  $c_1, c_2, c_3, \dots, c_r, \dots$  are

$$c_1 = \frac{n}{1} \quad c_2 = \frac{n(n-1)}{1 \cdot 2} \quad c_3 = \frac{n(n-1)(n-2)}{1 \cdot 2 \cdot 3}$$

$$c_r = \frac{n(n-1)(n-2) \dots (n-r+1)}{1 \cdot 2 \cdot 3 \dots r}$$

The standard notation for these coefficients is

$$c_1 = \binom{n}{1}, c_2 = \binom{n}{2}, \dots, c_r = \binom{n}{r}$$

Here  $\binom{n}{r}$  is the coefficient of the term containing  $b^r$  in the expansion of  $(a + b)^n$ . It is a fraction with the numerator and denominator each containing  $r$  factors; those in the denominator begin with 1 and increase by 1; those in the numerator begin with  $n$  and decrease by 1. It is easily shown that

$$\binom{n}{4} = \binom{n}{n-4}$$

Under suitable conditions the binomial formula is valid when  $n$  is not a positive integer. In this case the formula does not terminate, but generates an infinite series.

Much of the utility of the binomial theorem stems from the properties of the coefficients. In particular, the coefficient  $\binom{n}{r}$  gives the number of combinations of  $n$  distinct objects taken  $r$  at a time. The set of coefficients for any value of  $n$  forms a distribution that has fundamental importance in the study of probability and statistics. See ALGEBRA; SERIES. [H.R.C.]

**Bioacoustics, animal** The study of the role of sounds in the life history of animals. The field of animal bioacoustics can be subdivided into the acoustics of terrestrial animals and aquatic animals. Each field of study can be subdivided into (1) auditory capabilities and processes, (2) characteristics of sound emissions and mechanisms of sound production, and (3) the function and meaning of specific vocalizations.

Airborne acoustics, associated with terrestrial animals, and underwater acoustics, associated with aquatic animals, have three primary differences. First, the amount of acoustic energy that is absorbed and transformed into heat is much higher in air than underwater. Acoustic transmission loss in both media has a geometric spreading loss component plus an absorption loss component. The geometric spreading loss is dependent on the propagation geometry and not the medium, whereas absorption loss is directly dependent on the medium. Absorption loss in both media increases with frequency, although it is much higher in air than underwater. Therefore, the acoustic range of most aquatic animals is considerably larger than for terrestrial animals. Animals interested in long-range communications naturally use lower-frequency sounds. See SOUND ABSORPTION.

Second, airborne acoustics and underwater acoustics differ greatly in the respective values of the acoustic impedance,  $\rho c$ , where  $\rho$  is the density of the medium and  $c$  is the sound velocity in that medium. The density of water is approximately 1000 times greater than that of air, and the sound velocity in water is about 4.5 times greater than in air. Therefore, the acoustic impedance of water is approximately 3600 times greater than air. This difference in acoustic impedance has great ramifications on how sounds are produced and received in both media. For example, the middle-ear ossicular chain of terrestrial mammals serves as an impedance-matching transformer between the air in the external auditory meatus and the fluid in the cochlea, or inner ear. Such a chain is not needed for animals hearing

underwater since the impedance of water is already matched to the fluid of the inner ear. The impedance difference issue becomes rather complex with regard to hearing and sound production in amphibians and pinnipeds, which must have good in-air and underwater hearing. *See* ACOUSTIC IMPEDANCE; AMPHIBIA; PINNIPEDS.

Third, between airborne acoustics and underwater acoustics there is a large pressure difference. Pressure underwater increases by 1 atmosphere for approximately every 10-m (34-ft) increase in depth. As animals in an underwater environment swim deeper, the pressure they experience will be considerably higher than at the surface and will cause the air in body cavities to compress and increase in density, which in turn affects the production and reception of sounds. *See* ATMOSPHERIC ACOUSTICS; HYDROSTATICS; SOUND; UNDERWATER SOUND.

The hearing sensitivity of animals is determined by careful laboratory psychophysical experiments in which the subjects are trained to respond to an acoustic stimulus of varying frequency and amplitude. Intensity rather than pressure of the acoustic stimulus must be used to compare the hearing sensitivity of terrestrial and aquatic animals, because of the difference in the acoustic impedances of the respective media. A unit of acoustic pressure conveys different amounts of energy in the two media. Dolphins have the highest upper-frequency limit of hearing and have the most acute hearing sensitivity of all animals. Fishes tend to have a limited frequency range of hearing. *See* AUDIOMETRY; EAR (VERTEBRATE); PHONORECEPTION; PSYCHOACOUSTICS.

Animals use a wide variety of different sounds in different frequency ranges and for different purposes. Sounds can be very short events lasting less than 100 microseconds for some echolocating dolphins or can be very long duration events lasting several hours for singing humpback whales. The sounds can be infrasonic, with frequencies below the human hearing capability, or ultrasonic, with frequencies above the human hearing range. Most terrestrial animals, including mammals, birds, amphibians, and reptiles, produce sounds that are within the human frequency range, or sonic sounds. Many aquatic animals, including fishes and marine mammals, also produce sounds that are in the sonic range; however, some marine mammals also produce sounds that can extend either beyond (ultrasonic) or below (infrasonic) the human frequency range. Dolphins can produce very high frequency echolocation sounds having frequency components up to 200 kHz. *See* DECAPODA (CRUSTACEA); INFRASOUND; ULTRASOUND.

The mechanism of sound production in most animals is well known. Mammals and birds typically use their lungs as a source of air that is forced through a small orifice such as a larynx in mammals or a syrinx in birds. Amphibians such as frogs also use their lungs to force air through a larynx; however, the acoustic energy is coupled to an expandable air sac in the throats, which resonates to amplify sounds. Insects and crustaceans strike or rub certain appendages against other parts of their bodies. Some fishes produce sounds by inflating and compressing their swim bladder, causing vibrations in the water, while others may use the swim bladder as a resonator of sounds produced by stridulation between bony parts of their bodies.

The sound production mechanism of the odontocete, or toothed, whales baffled researchers for many years. In 1997, T. Cranford demonstrated that dolphins produce sounds with a pair of phonic lips previously called the monkey lips-dorsal bur-sae complex that are embedded in the nasal system. The simultaneous manipulation of these phonic lips and the production of echolocation clicks and whistles have been documented. Sperm whales probably use a similar set of phonic lips of the museau de singe, which are located in the forward portion of the animal's forehead. The exact mechanism of sound production by baleen whales is still a mystery.

Careful studies in the field are often required in order to determine the function and meaning of specific vocalizations to conspecifics and to other species. Birds sing to mark territory

and to attract potential mating partners. Some nonhuman primates use specific sounds as alarm calls indicating whether the threat is a predator bird or a mammal. Male frogs use their sound to attract females for mating. Dolphins and bats emit ultrasonic echolocation signals to detect and localize prey. Pinniped and dolphin mother-calf pairs use specific acoustic signals for identification purposes. Elephants use their infrasonic calls to maintain social contact and to coordinate family group movements. *See* ECHOLOCATION.

The meaning of many animal sounds still escapes human understanding. The infrasonic sounds of blue whales can propagate over hundreds of kilometers if trapped in a surface duct or in the deep sound channel of the ocean. Unfortunately, the aquatic environment has made it very difficult to study the behavior of blue whales and to determine how they respond to different sounds. Certain dolphins such as spinner and spotted dolphins often are found in groupings of up to several hundred animals. These dolphins may be swimming in the same direction but are spread out over hundreds of meters. Yet, some of these schools have been observed to suddenly change their course abruptly as a response to some kind of signal, probably acoustic in nature. However, the difficulty in conducting research in the ocean has made it next to impossible to determine the specific acoustic signals used in group coordination. Humpback whales have been known to "sing" for hours on end, yet there is no consensus on the role of the songs in their natural history. *See* ANIMAL COMMUNICATION. [W.W.L.A.]

**Bioarcheology** The study of skeletal remains from archeological sites by biological (or physical) anthropologists. Bioarcheology differs in several ways from traditional skeletal research. Previous work focused on individual case studies (for example, individuals with identifiable diseases), or on typological analyses of cranial form, the object of which was to classify collections into racial or ethnic groups. Bioarcheology looks at populations rather than individuals, often highlighting variation within groups as much as differences between them. In addition, it considers the interaction of biology with human culture and behavior, and the effects of the latter upon skeletal morphology or form. Technological advances in computers and methodology have opened up new fields of study, such as biomechanics and paleonutrition, while revolutionizing older interests, such as biological distance studies. *See* ANTHROPOLOGY; ARCHEOLOGY; BONE; PHYSICAL ANTHROPOLOGY.

The field of bioarcheology is built in large part upon the traditional study of human disease in prehistoric remains, or paleopathology. Bioarcheologists are more interested in the effect of disease on populations, and interrelationships between disease and social systems. For example, infectious diseases increase in frequency in agricultural communities due to a variety of factors, including population growth, increasing sedentism, and an expansion in trade contacts with other societies. *See* DISEASE; PATHOLOGY.

The study of prehistoric diet has been revolutionized by work on bone chemistry and isotopic variation. Essentially, this research focuses on the fact that some dietary ingredients leave a chemical or isotopic trace in bones. For example, carbon isotope analyses of bone indicate when maize (corn), the main component of historic Native American diets, was introduced into North America. Such studies have also uncovered differences in the level of reliance on maize within populations based on sex and status, and between societies.

Traumatic injuries and osteoarthritis (arthritis in the bony sections of joints) are extremely common in prehistoric populations. Bioarcheologists can identify examples of violent death in prehistory. Studies indicate that violence escalated in late prehistory in North America as societies became increasingly agricultural and population size rose. Osteoarthritis is common throughout prehistory and may be tied in part to levels of activities, although

it is also caused by other factors, including injuries and infections of the joints. See ARTHRITIS.

An area of research that has only recently become feasible through computer-aided technology is biomechanics. Like muscles, bones respond to higher-than-normal physical activities by increasing in mass, and can therefore indicate the usual level of physical exertion during life. Biomechanical studies have shown that physical activities changed as populations adopted agriculture, although the nature of the change varies in different regions of North America. See BIOMECHANICS.

With more sophisticated computer technology, biodistance studies, which seek to establish genetic relationships between populations, are increasingly complex. However, biodistance studies can be used productively to answer questions about the evolution of regional societies, as well as to illuminate such practices as residence patterns. [P.S.Br.]

**Bioassay** A method for the quantitation of the effects on a biological system by its exposure to a substance, as well as the quantitation of the concentration of a substance by some observable effect on a biological system. The biological material in which the effect is measured can range from subcellular components and microorganisms to groups of animals. The substance can be stimulatory, such as an ion increasing taxis behavior in certain protozoans, or inhibitory, such as an antibiotic for bacterial growth. Bioassays are most frequently used when there is a number of steps, usually poorly understood, between the substance and the behavior observed, or when the substance is a complex mixture of materials and it is not clear what the active components are. Bioassays can be replaced, in time, by either a more direct measure of concentration of the active principle, such as an analytical method (for example, mass spectrometry, high-pressure liquid chromatography, radioimmunoassay), or a more direct measurement of the effect, such as binding to a surface receptor in the case of many drugs, as the substance or its mechanism of action is better characterized.

Assays to quantitate the effects of an exposure model the effect of a substance in the real world. Complex biological responses can be estimated by laboratory culture tests, which use, for example, bacteria or cells cultured in a petri dish (usually to model an effect either on the organism of interest, such as bacteria, or on some basic cellular function); by tissue or organ culture, which isolates pieces of tissue or whole organs in a petri dish (usually to model organ function); or in whole animals (usually to model complex organismic relationships). [R.W.Har.; A.Tu.]

**Biocalorimetry** The measurement of the energetics of biological processes such as biochemical reactions, association of ligands to biological macromolecules, folding of proteins into their native conformations, phase transitions in biomembranes, and enzymatic reactions, among others. Two types of instruments have been developed to study these processes: differential scanning calorimeters and isothermal titration calorimeters. Differential scanning calorimeters measure the heat capacity at constant pressure of a sample as a continuous function of temperature. Isothermal titration calorimeters measure directly the energetics (through heat effects) associated with biochemical reactions or processes occurring at constant temperatures. In all cases, the uniqueness of calorimetry resides in its capability to measure directly and in a model-independent fashion the heat energy associated with a process. See CALORIMETRY; THERMOCHEMISTRY; TITRATION. [E.Fr.]

**Biochemical engineering** The application of engineering principles to conceive, design, develop, operate, or use processes and products based on biological and biochemical phenomena. Biochemical engineering, a subset of chemical engineering, impacts a broad range of industries, including health care, agriculture, food, enzymes, chemicals, waste treatment, and energy. Historically, biochemical engineering has been dis-

tinguished from biomedical engineering by its emphasis on biochemistry and microbiology and by the lack of a health care focus. However, now there is increasing participation of biochemical engineers in the direct development of health care products. Biochemical engineering has been central to the development of the biotechnology industry, especially with the need to generate prospective products (often using genetically engineered microorganisms) on scales sufficient for testing, regulatory evaluation, and subsequent sale. See BIOTECHNOLOGY.

In the discipline's initial stages, biochemical engineers were chiefly concerned with optimizing the growth of microorganisms under aerobic conditions at scales of up to thousands of liters. While the scope of the discipline has expanded, this focus remains. Often the aim is the development of an economical process to maximize biomass production (and hence a particular chemical, biochemical, or protein), taking into consideration raw-material and other operating costs. The elemental constituents of biomass (carbon, nitrogen, oxygen, hydrogen, and to a lesser extent phosphorus, sulfur, mineral salts, and trace amounts of certain metals) are added to the biological reactor (often called a fermentor) and consumed by the bacteria as they reproduce and carry out metabolic processes. Sufficient amounts of oxygen (usually supplied as sterile air) are added to the fermentor in such a way as to promote its availability to the growing culture. See BIOMASS; CHEMICAL REACTOR; FERMENTATION.

In some situations, microorganisms may be cultivated whose activity is adversely affected by the presence of dissolved oxygen. Anaerobic cultures are typical of fermentations in which organic acids and solvents are produced; these systems are usually characterized by slower growth rates and lower biomass yields. The largest application of anaerobic microorganisms is in waste treatment, where anaerobic digesters containing mixed communities of anaerobic microorganisms are used to reduce the quantity of solids in industrial and municipal wastes.

While the operation and optimization of large-scale, aerobic cultures of microorganisms is still of major importance in biochemical engineering, the capability of cultivating a wide range of cell types has become important also. Biochemical engineers are often involved in the culture of plant cells, insect cells, and mammalian cells, as well as the genetically engineered versions of these cell types. Metabolic engineering uses the tools of molecular genetics, often coupled with quantitative models of metabolic pathways and bioreactor operation, to optimize cellular function for the production of specific metabolites and proteins. Enzyme engineering focuses on the identification, design, and use of biocatalysts for the production of useful chemicals and biochemicals. Tissue engineering involves material, biochemical, and medical aspects related to the transplant of living cells to treat diseases. Biochemical engineers are also actively involved in many aspects of bioremediation, immunotechnology, vaccine development, and the use of cells and enzymes capable of functioning in extreme environments. [R.M.Ke.]

**Biochemistry** The study of the substances and chemical processes which occur in living organisms. It includes the identification and quantitative determination of the substances, studies of their structure, determining how they are synthesized and degraded in organisms, and elucidating their role in the operation of the organism.

Substances studied in biochemistry include carbohydrates (including simple sugars and large polysaccharides), proteins (such as enzymes), ribonucleic acid (RNA) and deoxyribonucleic acid (DNA), lipids, minerals, vitamins, and hormones. See CARBOHYDRATE; DEOXYRIBONUCLEIC ACID (DNA); ENZYME; HORMONE; LIPID; PROTEIN; RIBONUCLEIC ACID (RNA); VITAMIN.

**Metabolism and energy production.** Many of the chemical steps involved in the biological breakdown of sugars, lipids (fats), and amino acids are known. It is well established that living organisms capture the energy liberated from these reactions by forming a high-energy compound, adenosine triphosphate

(ATP). In the absence of oxygen, some organisms and tissues derive ATP from an incomplete breakdown of glucose, degrading the sugar to an alcohol or an acid in the process. In the presence of oxygen, many organisms degrade glucose and other food-stuff to carbon dioxide and water, producing ATP in a process known as oxidative phosphorylation. See BIOLOGICAL OXIDATION; CARBOHYDRATE METABOLISM; LIPID METABOLISM.

**Structure and function studies.** The relationship of the structure of enzymes to their catalytic activity is becoming increasingly clear. It is now possible to visualize atoms and groups of atoms in some enzymes by x-ray crystallography. Some enzyme-catalyzed processes can now be described in terms of the spatial arrangement of the groups on the enzyme surface and how these groups influence the reacting molecules to promote the reaction. It is also possible to explain how the catalytic activity of an enzyme may be increased or decreased by changes in the shape of the enzyme molecule. An important advance has been the development of an automated procedure for joining amino acids together into a predetermined sequence. This technology will permit the synthesis of slightly altered enzymes and will improve the understanding of the relationship between the structure and the function of enzymes. In addition, this procedure permits the synthesis of medically important polypeptides (short chains of amino acids) such as some hormones and antibiotics.

**Molecular genetics.** A subject of intensive investigation has been the explanation of genetics in molecular terms. It is now well established that genetic information is encoded in the sequence of nucleotides of DNA and that, with the exception of some viruses which utilize RNA, DNA is the ultimate repository of genetic information. The sequence of amino acids in a protein is programmed in DNA; this information is first transferred by copying the nucleotide sequence of DNA into that of messenger RNA, from which this sequence is translated into the specific sequence of amino acids of the protein. See GENETIC CODE; MOLECULAR BIOLOGY.

The biochemical basis for a number of genetically inherited diseases, in which the cause has been traced to the production of a defective protein, has been determined. Sickle cell anemia is a striking example; it is well established that the change of a single amino acid in hemoglobin has resulted in a serious abnormality in the properties of the hemoglobin molecule. See DISEASE.

**Regulation.** Increased understanding of the chemical events in biological processes has permitted the investigation of the regulation of these processes. An important concept is the chemical feedback circuit: the product of a series of reactions can itself influence the rates of the reactions. For example, the reactions which lead to the production of ATP proceed vigorously when the supply of ATP within the cell is low, but they slow down markedly when ATP is plentiful. These observations can be explained, in part, by the fact that ATP molecules bind to some of the enzymes involved, changing the surface features of the enzymes sufficiently to decrease their effectiveness as catalysts. It is also possible to regulate these reactions by changing the amounts of the enzymes; the amount of an enzyme can be controlled by modulating the synthesis of its specific messenger RNA or by modulating the translation of the information of the RNA molecule into the enzyme molecule. Another level of regulation involves the interaction of cells and tissues in multicellular organisms. For instance, endocrine glands can sense certain tissue activities and appropriately secrete hormones which control these activities. The chemical events and substances involved in cellular and tissue "communication" have become subjects of much investigation.

**Photosynthesis and nitrogen fixation.** Two subjects of substantial interest are the processes of photosynthesis and nitrogen fixation. In photosynthesis, the chemical reactions whereby the gas carbon dioxide is converted into carbohydrate are understood, but the reactions whereby light energy is trapped and converted into the chemical energy necessary for the synthesis of carbohydrate are unclear. The process of nitrogen fixation in-

volves the conversion of nitrogen gas into a chemical form which can be utilized for the synthesis of numerous biologically important substances; the chemical events of this process are not fully understood. See NITROGEN CYCLE; PHOTOSYNTHESIS. [A.S.L.H.]

**Biodegradation** The destruction of organic compounds by microorganisms. Microorganisms, particularly bacteria, are responsible for the decomposition of both natural and synthetic organic compounds in nature. Mineralization results in complete conversion of a compound to its inorganic mineral constituents (for example, carbon dioxide from carbon, sulfate or sulfide from organic sulfur, nitrate or ammonium from organic nitrogen, phosphate from organophosphates, or chloride from organochlorine). Since carbon comprises the greatest mass of organic compounds, mineralization can be considered in terms of CO<sub>2</sub> evolution. Radioactive carbon-14 (<sup>14</sup>C) isotopes enable scientists to distinguish between mineralization arising from contaminants and soil organic matter. However, mineralization of any compound is never 100% because some of it (10–40% of the total amount degraded) is incorporated into the cell mass or products that become part of the amorphous soil organic matter, commonly referred to as humus. Thus, biodegradation comprises mineralization and conversion to innocuous products, namely biomass and humus. Primary biodegradation is more limited in scope and refers to the disappearance of the compound as a result of its biotransformation to another product. See HUMUS.

Compounds that are readily biodegradable are generally utilized as growth substrates by single microorganisms. Many of the components of petroleum products (and frequent ground-water contaminants), such as benzene, toluene, ethylbenzene, and xylene, are utilized by many genera of bacteria as sole carbon sources for growth and energy.

The process whereby compounds not utilized for growth or energy are nevertheless transformed to other products by microorganisms is referred to as cometabolism. Chlorinated aromatic hydrocarbons, such as diphenyldichloroethane (DDT) and polychlorinated biphenyls (PCBs), are among the most persistent environmental contaminants; yet they are cometabolized by several genera of bacteria, notably *Pseudomonas*, *Alcaligenes*, *Rhodococcus*, *Acinetobacter*, *Arthrobacter*, and *Corynebacterium*. Cometabolism is caused by enzymes that have very broad substrate specificity. See BACTERIAL GROWTH; POLYCHLORINATED BIPHENYLS.

The use of microorganisms to remediate the environment of contaminants is referred to as bioremediation. This process is most successful in contained systems such as surface soil or ground water where nutrients, mainly inorganic nitrogen and phosphorus, are added to enhance growth of microorganisms and thereby increase the rate of biodegradation. The process has little, if any, applicability to a large open system such as a bay or lake because the nutrient level (that is, the microbial density) is too low to effect substantive biodegradation and the system's size and distribution preclude addition of nutrients.

Remediation of petroleum products from ground waters is harder to achieve than surface soil because of the greater difficulty in distributing the nutrients throughout the zone of contamination, and because of oxygen (O<sub>2</sub>) limitations. [D.D.Fo.]

**Biodiversity** The variety of all living things; a contraction of biological diversity. Biodiversity can be measured on many biological levels ranging from genetic diversity within a species to the variety of ecosystems on Earth, but the term most commonly refers to the number of different species in a defined area.

Recent estimates of the total number of species range from 7 to 20 million, of which only about 1.75 million species have been scientifically described. The best-studied groups include plants and vertebrates (phylum Chordata), whereas poorly



**Numbers of extant species for selected taxonomic groups**

Kingdom	Phylum	Number of species described	Estimated number of species	Percent described
Protista		100,000	250,000	40.0
Fungi	Eumycota	80,000	1,500,000	5.3
Plantae	Bryophyta	14,000	30,000	46.7
	Tracheophyta	250,000	500,000	50.0
Animalia	Nematoda	20,000	1,000,000	2.0
	Arthropoda	1,250,000	20,000,000	5.0
	Mollusca	100,000	200,000	50.0
	Chordata	40,000	50,000	80.0

\*With permission, modified from G. K. Meffe and C. R. Carroll, *Principles of Conservation Biology*, 1997.

described groups include fungi, nematodes, and arthropods (see table). Species that live in the ocean and in soils remain poorly known. For most groups of species, there is a gradient of increasing diversity from the Poles to the Equator, and the vast majority of species are concentrated in the tropical and subtropical regions.

Human activities, such as direct harvesting of species, introduction of alien species, habitat destruction, and various forms of habitat degradation (including environmental pollution), have caused dramatic losses of biodiversity; current extinction rates are estimated to be 100–1000 times higher than prehuman extinction rates.

Some measure of biodiversity is responsible for providing essential functions and services that directly improve human life. For example, many medicines, clothing fibers, and industrial products and the vast majority of foods are derived from naturally occurring species. In addition, species are the key working parts of natural ecosystems. They are responsible for maintenance of the gaseous composition of the atmosphere, regulation of the global climate, generation and maintenance of soils, recycling of nutrients and waste products, and biological control of pest species. Ecosystems surely would not function if all species were lost, although it is unclear just how many species are necessary for an ecosystem to function properly. [M.A.Ma.]

**Bioelectromagnetics** The study of the interactions of electromagnetic energy (usually referring to frequencies below those of visible light with biological systems. This includes both experimental and theoretical approaches to describing and explaining biological effects. Diagnostic and therapeutic uses of electromagnetic fields are also included in bioelectromagnetics.

The induction of cataracts has been associated with exposure to intense microwave fields. Although heating the lens of the eye with electromagnetic energy can cause cataracts, the threshold for cataract production is so high that, for many species, if the whole animal were exposed to the cataractogenic level of radiation, it would die before cataracts were produced. In 1961 it was reported that people can “hear” pulsed microwaves at very low averaged power densities (50 microwatts/cm<sup>2</sup>). It is now generally accepted that the perceived sound is caused by elastic-stress waves which are created by rapid thermal expansion of the tissue that is absorbing microwaves. There are reports that microwave irradiation at very low intensities can affect behavior, the central nervous system, and the immune system, but many of these reports are controversial. Most biological effects of microwaves can be explained by the response of the animal to the conversion of electromagnetic energy into thermal energy within the animal. However, a few experiments yield results that are not readily explained by changes of temperature.

In an industrial society, an appreciation of the effects of stationary electric and magnetic fields, and of extremely low-frequency fields are important because of the ubiquitous nature of electricity. The possibility of hazard from occupational exposure to 50- or 60-Hz electric and magnetic fields has not been documented and is a subject of debate. Epidemiological studies have been

undertaken to determine the health implications for workers and the general public exposed to these possible hazards. In addition, laboratory experiments have been designed to study the interactions of electric and magnetic fields with biological systems. See BIOMAGNETISM; MICROWAVE; RADIATION BIOLOGY.

The most common mechanism by which electromagnetic fields interact with biological systems is by inducing motion in polar molecules. Water and other polar molecules experience a torque when an electric field is applied. The excitation of water, or other polar molecules, in the form of increased rotational energy is manifest as increased kinetic energy (elevation of temperature), but molecular structure is essentially unaltered if elevations are not excessive. Electromagnetic energy absorbed by biological material can be converted into stress by thermal expansion. This phenomenon is caused by a rapid rise of temperature either deep within or at the surface of the material, and thus creates a time-varying thermal expansion that generates elastic stress waves in the tissue.

The therapeutic heating of tissue, diathermy, has been used by physicians for many years. Short-wave diathermy provides deeper, more uniform heating than does diathermy at higher frequencies. High-intensity radio-frequency fields have been used to produce hyperthermia in cancer patients. The development of bone tissue (osteogenesis) can be stimulated electrically either with implanted electrodes or by inductive coupling through the skin. This therapy has been used successfully to join fractures that have not healed by other means. Electromagnetic fields were first used for medical diagnosis in 1926 when the electrical resistance across the chest cavity was used to diagnose pulmonary edema (water in the lungs). Another diagnostic tool, magnetic resonance imaging, uses the behavior of protons, or other nuclei, in an electromagnetic field to obtain images of organs in the body. Internally generated fields associated with nerve activity (electroencephalography) and with muscle activity (electrocardiography, magnetocardiography) are used to monitor normal body functions. There may be other uses of electric currents or fields in growth differentiation or development which have not yet been explored. Electric fields now play a role in biotechnology. Intense, pulsed electric fields (about 60,000 V/m) produce short-lived pores in cell membranes by causing a reversible rearrangement of the protein and lipid components. This permits the entrance of deoxyribonucleic acid (DNA) fragments or other large molecules into the cell (electroporation). The fusion of cells using electric fields (electrofusion) is easy to control and provides high yields. See CARDIAC ELECTROPHYSIOLOGY; ELECTROENCEPHALOGRAPHY; ELECTROMAGNETIC RADIATION; ELECTROMYOGRAPHY; MEDICAL IMAGING; RADIOLOGY; THERMOTHERAPY. [E.P.]

**Bioelectronics** A discipline in which biotechnology and electronics are joined in at least three areas of research and development: biosensors, molecular electronics, and neuronal interfaces. Some workers in the field include so-called biochips and biocomputers in this area of carbon-based information technology. They suggest that biological molecules might be incorporated into self-structuring bioinformatic systems which display novel information processing and pattern recognition capabilities, but these applications—although technically possible—are speculative.

Of the three disciplines—biosensors, molecular electronics, and neuronal interfaces—the most mature is the burgeoning area of biosensors. The term biosensor is used to describe two sometimes very different classes of analytical devices—those that measure biological analytes and those that exploit biological recognition as part of the sensing mechanism—although it is the latter concept which truly captures the spirit of bioelectronics. Molecular electronics is a term coined to describe the exploitation of biological molecules in the fabrication of electronic materials with novel electronic, optical, or magnetic properties. Finally, and more speculatively, bioelectronics incorporates the development of functional neuronal interfaces which permit contiguity

between neural tissue and conventional solid-state and computing technology in order to achieve applications such as aural and visual prostheses, the restoration of movement to the paralyzed, and even expansion of the human faculties of memory and intelligence. The common feature of all of this research activity is the close juxtaposition of biologically active molecules, cells, and tissues with conventional electronic systems for advanced applications in analytical science, electronic materials, device fabrication, and neural prostheses. [C.R.Lo.]

**Biofilm** An adhesive substance, the glycocalyx, and the bacterial community which it envelops at the interface of a liquid and a surface. When a liquid is in contact with an inert surface, any bacteria within the liquid are attracted to the surface and adhere to it. In this process the bacteria produce the glycocalyx. The bacterial inhabitants within this microenvironment benefit as the biofilm concentrates nutrients from the liquid phase. However, these activities may damage the surface, impair its efficiency, or develop within the biofilm a pathogenic community that may damage the associated environment. Microbial fouling or biofouling are the terms applied to these actual or potentially undesirable consequences.

Microbial fouling affects a large variety of surfaces under various conditions. Microbial biofilms may form wherever bacteria can survive; familiar examples are dental plaque and tooth decay. Dental plaque is an accumulation of bacteria, mainly streptococci, from saliva. The process of tooth decay begins with the bacteria colonizing fissures in and contact points between the teeth. Dietary sucrose is utilized by the bacteria to form extracellular glucans that make up the glycocalyx and assist adhesion to the tooth. Within this microbial biofilm or plaque the metabolic by-products of the bacterial inhabitants are trapped; these include acids that destroy the tooth enamel, dentin, or cementum. [H.L.Sc.; J.W.C.]

**Biogeochemistry** The study of the cycling of chemicals between organisms and the surface environment of the Earth. The chemicals either can be taken up by organisms and used for growth and synthesis of living matter or can be processed to obtain energy. The chemical composition of plants and animals indicates which elements, known as nutrient elements, are necessary for life. The most abundant nutrient elements, carbon (C), hydrogen (H), and oxygen (O), supplied by the environment in the form of carbon dioxide (CO<sub>2</sub>) and water (H<sub>2</sub>O), are usually present in excess. The other nutrient elements, which are also needed for growth, may sometimes be in short supply; in this case they are referred to as limiting nutrients. The two most commonly recognized limiting nutrients are nitrogen (N) and phosphorus (P).

Biogeochemistry is concerned with both the biological uptake and release of nutrients, and the transformation of the chemical state of these biologically active substances, usually by means of energy-supplying oxidation-reduction reactions, at the Earth's surface. Emphasis is on how the activities of organisms affect the chemical composition of natural waters, the atmosphere, rocks, soils, and sediments. Thus, biogeochemistry is complementary to the science of ecology, which includes a concern with how the chemical composition of the atmosphere, waters, and so forth affects life. See ECOLOGY; OXIDATION-REDUCTION.

The two major processes of biogeochemistry are photosynthesis and respiration. Photosynthesis involves the uptake, under the influence of sunlight, of carbon dioxide, water, and other nutrients by plants to form organic matter and oxygen. Respiration is the reverse of photosynthesis and involves the oxidation and breakdown of organic matter and the return of nitrogen, phosphorus, and other elements, as well as carbon dioxide and water, to the environment. See PHOTOSYNTHESIS; PLANT RESPIRATION.

Biogeochemistry is usually studied in terms of biogeochemical cycles of individual elements. There are short-term cycles ranging

from days to centuries and long-term (geological) cycles ranging from thousands to millions of years.

There has been increasing interest in biogeochemistry because the human influence on short-term biogeochemical cycling has become evident. Perhaps the best-known example is the changes in the biogeochemical cycling of carbon due to the burning of fossil fuels and the cutting and burning of tropical rainforests. The cycles of nitrogen and phosphorus have been altered because of the use of fertilizer and the addition of wastes to lakes, rivers, estuaries, and the oceans. Acid rain, which results from the addition of sulfur and nitrogen compounds to the atmosphere by humans, affects biological systems in certain areas.

**Carbon cycle.** Carbon is the basic biogeochemical element. The atmosphere contains carbon in the form of carbon dioxide gas. There is a large annual flux of atmospheric carbon dioxide to and from forests and terrestrial biota, amounting to nearly 7% of total atmospheric carbon dioxide. This is because carbon dioxide is used by plants to produce organic matter through photosynthesis, and when the organic matter is broken down through respiration, carbon dioxide is released to the atmosphere. The concentration of atmospheric carbon dioxide shows a yearly oscillation because there is a strong seasonal annual cycle of photosynthesis and respiration in the Northern Hemisphere.

Photosynthesis and respiration in the carbon cycle can be represented by the reaction below. Breakdown of organic matter via

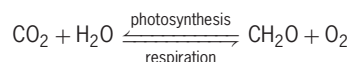

respiration is accomplished mainly by bacteria that live in soils, sediments, and natural waters. There is a very large reservoir of terrestrial carbon in carbonate rocks, which contain calcium carbonate (CaCO<sub>3</sub>), and in rocks such as shales which contain organic carbon. Major exchange of carbon between rocks and the atmosphere is very slow, on the scale of thousands to millions of years, compared to exchange between plants and the atmosphere, which can even be seasonal. See MICROBIAL ECOLOGY; SOIL MICROBIOLOGY.

The oceans taken as a whole represent a major reservoir of carbon. Carbon in the oceans occurs primarily as dissolved (HCO<sub>3</sub>)<sup>-</sup> and to a lesser extent as dissolved carbon dioxide gas and carbonate ion [(CO<sub>3</sub>)<sup>2-</sup>]. The well-mixed surface ocean (the top 250 ft or 75 m) rapidly exchanges carbon dioxide with the atmosphere. However, the deep oceans are cut off from the atmosphere and mix with it on a long-term time scale of about 1000–2000 years. Most of the biological activity in the oceans occurs in the surface (or shallow) water where there is light and photosynthesis can occur. See MARITIME METEOROLOGY.

The main biological process in seawater is photosynthetic production of organic matter by phytoplankton. Some of this organic matter is eaten by animals, which are in turn eaten by larger animals farther up in the food chain. Almost all of the organic matter along the food chain is ultimately broken down by bacterial respiration, which occurs primarily in shallow water, and the carbon dioxide is quickly recycled to the atmosphere. See FOOD WEB; NEARSHORE PROCESSES; PHYTOPLANKTON; SEAWATER.

Another major biological process is the secretion of shells and other hard structures by marine organisms. A biogeochemical cycle of calcium and bicarbonate exists within the oceans, linking the deep and shallow water areas. Bottom dwellers in shallow water, such as corals, mollusks, and algae, provide calcium carbonate skeletal debris. Since the shallow waters are saturated with respect to calcium carbonate, this debris accumulates on the bottom and is buried, providing the minerals that form carbonate rocks such as limestone and dolomite. Calcium carbonate is also derived from the shells of organisms inhabiting surface waters of the deep ocean; these are tiny, floating plankton such as foraminiferans, pteropods, and coccoliths. Much of the calcium carbonate from this source dissolves as it sinks into the deeper

ocean waters, which are undersaturated with respect to calcium carbonate. The undissolved calcium carbonate accumulates on the bottom to form deep-sea limestone. The calcium and the bicarbonate ions [ $\text{Ca}^{2+}$  and  $(\text{HCO}_3)^-$ ] dissolved in the deep ocean water eventually are carried to surface and shallow water, where they are removed by planktonic and bottom-dwelling organisms to form their skeletons. See CARBONATE MINERALS; LIMESTONE.

The long-term biogeochemical carbon cycle occurs over millions of years when the calcium carbonate and organic matter that are buried in sediments are returned to the Earth's surface. There, weathering occurs which involves the reaction of oxygen with sedimentary organic matter with the release of carbon dioxide and water (analogous to respiration), and the reaction of water and carbon dioxide with carbonate rocks with the release of calcium and bicarbonate ions. See WEATHERING PROCESSES.

Fossil fuels (coal and oil) represent a large reservoir of carbon. Burning of fossil fuels releases carbon dioxide to the atmosphere, and an increase in the atmospheric concentration of carbon dioxide has been observed since the mid-1950s. While much of the increase is attributed to fossil fuels, deforestation by humans accompanied by the decay or burning of trees is another possible contributor to the problem.

When estimates are made of the amount of fossil fuels burned from 1959 to 1980, only about 60% of the carbon dioxide released can be accounted for in the atmospheric increase in carbon dioxide. The remaining 40% is known as excess carbon dioxide. The surface oceans are an obvious candidate for storage of most of the excess carbon dioxide by the reaction of carbon dioxide with dissolved carbonate to form bicarbonate. Because the increase in bicarbonate concentration in surface waters due to excess carbon dioxide uptake would be small, it is difficult to detect whether such a change has occurred. Greater quantities of excess carbon dioxide could be stored as bicarbonate in the deeper oceans, but this process takes a long time because of the slow rate of mixing between surface and deep oceans.

An increase in atmospheric carbon dioxide is of concern because of the greenhouse effect. The carbon dioxide traps heat in the atmosphere; notable increases in atmospheric carbon dioxide should cause an increase in the Earth's surface temperature by as much as several degrees. This temperature increase would be greater at the poles, and the effects could include melting of polar ice, a rise in sea level, and changes in rainfall distribution, with droughts in interior continental areas such as the Great Plains of the United States. See DROUGHT; GREENHOUSE EFFECT.

**Nitrogen cycle.** Nitrogen is dominantly a biogenic element and has no important mineral forms. It is a major atmospheric constituent with a number of gaseous forms, including molecular nitrogen gas ( $\text{N}_2$ ), nitrogen dioxide ( $\text{NO}_2$ ), nitric oxide ( $\text{NO}$ ), ammonia ( $\text{NH}_3$ ), and nitrous oxide ( $\text{N}_2\text{O}$ ). As an essential component of plant and animal matter, it is extensively involved in biogeochemical cycling. On a global basis, the nitrogen cycle is greatly affected by human activities.

Nitrogen gas ( $\text{N}_2$ ) makes up 80% of the atmosphere by volume; however, nitrogen is unreactive in this form. In order to be available for biogeochemical cycling by organisms, nitrogen gas must be fixed, that is, combined with oxygen, carbon, or hydrogen. There are three major sources of terrestrial fixed nitrogen: biological nitrogen fixation by plants, nitrogen fertilizer application, and rain and particulate dry deposition of previously fixed nitrogen. Biological fixation occurs in plants such as legumes (peas and beans) and lichens in trees, which incorporate nitrogen from the atmosphere into their living matter; about 30% of worldwide biological fixation is due to human cultivation of these plants. Nitrogen fertilizers contain industrially fixed nitrogen as both nitrate and ammonium. See FERTILIZER.

Fixed nitrogen in rain is in the forms of nitrate [ $(\text{NO}_3)^-$ ] and ammonium [ $(\text{NH}_4)^+$ ] ions. Major sources of nitrate, which is derived from gaseous atmospheric nitrogen dioxide (and nitric oxide), include (in order of importance) combustion of fossil fuel, especially by automobiles; forest fires (mostly caused by

humans); and lightning. Nitrate in rain, in addition to providing soluble fixed nitrogen for photosynthesis, contributes nitric acid ( $\text{HNO}_3$ ), a major component of acid rain. Sources of ammonium, which is derived from atmospheric ammonia gas ( $\text{NH}_3$ ), include animal and human wastes, soil loss from decomposition of organic matter, and fertilizer release.

The basic land nitrogen cycle involves the photosynthetic conversion of the nitrate and ammonium ions dissolved in soil water into plant organic material. Once formed, the organic matter may be stored or broken down. Bacterial decomposition of organic matter (ammonification) produces soluble ammonium ion which can then be either taken up again in photosynthesis, released to the atmosphere as ammonia gas, or oxidized by bacteria to nitrate ion (nitrification).

Nitrate ion is also soluble, and may be used in photosynthesis. However, part of the nitrate may undergo reduction (denitrification) by soil bacteria to nitrogen gas or to nitrous oxide which are then lost to the atmosphere. Compared to the land carbon cycle, the land nitrogen cycle is considerably more complex, and because of the large input of fixed nitrogen by humans, it is possible that nitrogen is building up on land. However, this is difficult to determine since the amount of nitrogen gas recycled to the atmosphere is not known and any changes in the atmospheric nitrogen concentration would be too small to detect. See NITROGEN CYCLE.

The oceans are another major site of nitrogen cycling: the amount of nitrogen cycled biogenically, through net primary photosynthetic production, is about 13 times that on land. The main links between the terrestrial and the oceanic nitrogen cycles are the atmosphere and rivers. Nitrogen gases carried in the atmosphere eventually fall as dissolved inorganic (mainly nitrate) and organic nitrogen and particulate organic nitrogen in rain on the oceans. The flux of river nitrogen lost from the land is only about 9% of the total nitrogen recycled biogeochemically on land each year and only about 25% of the terrestrial nitrogen flux from the biosphere to the atmosphere.

River nitrogen is an important nitrogen source to the oceans; however, the greatest amount of nitrogen going into ocean surface waters comes from the upwelling of deeper waters, which are enriched in dissolved nitrate from organic recycling at depth. Dissolved nitrate is used extensively for photosynthesis by marine organisms, mainly plankton. Bacterial decomposition of the organic matter formed in photosynthesis results in the release of dissolved ammonium, some of which is used directly in photosynthesis. However, most undergoes nitrification to form nitrate, and much of the nitrate may undergo denitrification to nitrogen gas which is released to the atmosphere. A small amount of organic-matter nitrogen is buried in ocean sediments, but this accounts for a very small amount of the nitrogen recycled each year. There are no important inorganic nitrogen minerals such as those that exist for carbon and phosphorus, and thus there is no mineral precipitation and dissolution. See UPWELLING.

**Phosphorus cycle.** Phosphorus, an important component of organic matter, is taken up and released in the form of dissolved inorganic and organic phosphate. Phosphorus differs from nitrogen and carbon in that it does not form stable atmospheric gases and therefore cannot be obtained from the atmosphere. It does form minerals, most prominently apatite (calcium phosphate), and insoluble iron (Fe) and aluminum (Al) phosphate minerals, or it is adsorbed on clay minerals. The amount of phosphorus used in photosynthesis on land is large compared to phosphorus inputs to the land. The major sources of phosphorus are weathering of rocks containing apatite and mining of phosphate rock for fertilizer and industry. A small amount comes from precipitation and dry deposition. See PHOSPHATE MINERALS.

Phosphorus is lost from the land principally by river transport, which amounts to only 7% of the amount of phosphorus recycled by the terrestrial biosphere; overall, the terrestrial biosphere conserves phosphorus. Humans have greatly affected terrestrial phosphorus: deforestation and agriculture have doubled

the amount of phosphorus weathering; phosphorus is added to the land as fertilizers and from industrial wastes, sewage, and detergents. Thus, about 75% of the terrestrial input is anthropogenic; in fact, phosphorus may be building up on the land.

In the oceans, phosphorus occurs predominantly as dissolved orthophosphates [ $\text{PO}_4^{3-}$ ,  $(\text{HPO}_4)^{2-}$  and  $(\text{H}_2\text{PO}_4)^{-}$ ]. Since it follows the same cycle as do carbon and nitrogen, dissolved orthophosphate is depleted in surface ocean waters where both photosynthesis and respiration occur, and the concentration builds up in deeper water where organic matter is decomposed by bacterial respiration. The major phosphorus input to the oceans is from rivers, with about 5% coming from rain. However, 75% of the river phosphorus load is due to anthropogenic pollutants; humans have changed the ocean balance of phosphorus. Most of the dissolved oceanic orthophosphate is derived from recycled organic matter. The output of phosphorus from the ocean is predominantly biogenic: organic phosphorus is buried in sediments; a smaller amount is removed by adsorption on volcanic iron oxides. In the geologic past, there was a much greater inorganic precipitation of phosphorite (apatite) from seawater than at present, and this has resulted in the formation of huge deposits which are now mined.

**Nutrients in lakes.** Biogeochemical cycling of phosphorus and nitrogen in lakes follows a pattern that is similar to oceanic cycling: there is nutrient depletion in surface waters and enrichment in deeper waters. Oxygen consumption by respiration in deep water sometimes leads to extensive oxygen depletion with adverse effects on fish and other biota. In lakes, phosphorus is usually the limiting nutrient.

Many lakes have experienced greatly increased nutrient (nitrogen and phosphorus) input due to human activities. This stimulates a destructive cycle of biological activity: very high organic productivity, a greater concentration of plankton, and more photosynthesis. The result is more organic matter falling into deep water with increased depletion of oxygen and greater accumulation of organic matter on the lake bottom. This process, eutrophication, can lead to adverse water quality and even to the filling up of small lakes with organic matter. See EUTROPHICATION; LIMNOLOGY.

**Biogeochemical sulfur cycle.** A dominant flux in the global sulfur cycle is the release of 65–70 teragrams of sulfur per year to the atmosphere from burning of fossil fuels. Sulfur contaminants in these fuels are released to the atmosphere as sulfur dioxide ( $\text{SO}_2$ ) which is rapidly converted to aerosols of sulfuric acid ( $\text{H}_2\text{SO}_4$ ), the primary contributor to acid rain. Forest burning results in an additional release of sulfur dioxide. Overall, the broad range of human activities contribute 75% of sulfur released into the atmosphere. Natural sulfur sources over land are predominantly the release of reduced biogenic sulfur gases [mainly hydrogen sulfide ( $\text{H}_2\text{S}$ ) and dimethyl sulfide] from marine tidal flats and inland waterlogged soils and, to much lesser extent, the release of volcanic sulfur. The atmosphere does not have an appreciable reservoir of sulfur because most sulfur gases are rapidly returned (within days) to the land in rain and dry deposition. There is a small net flux of sulfur from the atmosphere over land to the atmosphere over the oceans.

Ocean water constitutes a large reservoir of dissolved sulfur in the form of sulfate ions [ $(\text{SO}_4)^{2-}$ ]. Some of this sulfate is thrown into the oceanic atmosphere as sea salt from evaporated sea spray, but most of this is rapidly returned to the oceans. Another major sulfur source in the oceanic atmosphere is the release of oceanic biogenic sulfur gases (such as dimethyl sulfide) from the metabolic activities of oceanic organisms and organic matter decay. Marine organic matter contains a small amount of sulfur, but sulfur is not a limiting element in the oceans.

Another large flux in the sulfur cycle is the transport of dissolved sulfate in rivers. However, as much as 43% of this sulfur may be due to human activities, both from burning of fossil fuels and from fertilizers and industrial wastes. The weathering of sulfur minerals, such as pyrite ( $\text{FeS}_2$ ) in shales, and the evaporite

minerals, gypsum and anhydrite, make an important contribution to river sulfate. The major mechanism for removing sulfate from ocean water is the formation and burial of pyrite in oceanic sediments, primarily nearshore sediments. (The sulfur fluxes of sea salt and biogenic sulfur gases do not constitute net removal from the oceans since the sulfur is recycled to the oceans.)

**Biogeochemical cycles and atmospheric oxygen.** The main processes affecting atmospheric oxygen are photosynthesis and respiration; however, these processes are almost perfectly balanced against one another and, thus, do not exert a simple effect on oxygen levels. Only the very small excess of photosynthesis over respiration, manifested by the burial of organic matter in sediments, is important in raising the level of oxygen. This excess is so small, and the reservoir of oxygen so large, that if the present rate of organic carbon burial were doubled and the other rates remained constant, it would take 5–10 million years for the amount of atmospheric oxygen to double. Nevertheless, this is a relatively short time from a geological perspective. See ATMOSPHERE; ATMOSPHERE, EVOLUTION OF; BIOSPHERE; GEOCHEMISTRY; HYDROSPHERE; MARINE SEDIMENTS. [E.K.B.; R.A.Ber.]

**Biogeography** A synthetic discipline that describes the distributions of living and fossil species of plants and animals across the Earth's surface as consequences of ecological and evolutionary processes. Biogeography overlaps and complements many biological disciplines, especially community ecology, systematics, paleontology, and evolutionary biology. See ZOOGEOGRAPHY.

Based on relatively complete compilations of species within well-studied groups, such as birds and mammals, biogeographers identified six different realms within which species tend to be closely related and between which turnovers in major groups of species are observed (see table). The boundaries between biogeographic realms are less distinct than was initially thought, and the distribution of distinctive groups such as parrots, marsupials, and southern beeches (*Nothofagus* spp.) implies that modern-day biogeographic realms have been considerably mixed in the past. See ANIMAL EVOLUTION; PALEOBOTANY; PALEOECOLOGY; PALEONTOLOGY; PLANT EVOLUTION; SPECIATION.

Two patterns of species diversity have stimulated a great deal of progress in developing ecological explanations for geographic patterns of species richness. The first is that the number of species increases in a regular fashion with the size of the geographic area being considered. The second is the nearly universal observation that there are more species of plants and animals in tropical regions than in temperate and polar regions.

In order to answer questions about why there are a certain number of species in a particular geographic region, biogeography has incorporated many insights from community ecology. Species number at any particular place depends on the amount of resources available there (ultimately derived from the amount of primary productivity), the number of ways those resources can be apportioned among species, and the different kinds of ecological requirements of the species that can colonize the region. The equilibrium theory of island biogeography arose as an

**Biogeographic realms**

Realm	Continental areas included	Examples of distinctive or endemic taxa
Palaearctic	Temperate Eurasia and northern Africa	Hynobiid salamanders
Oriental	Tropical Asia	Lower apes
Ethiopian	Sub-Saharan Africa	Great apes
Australian	Australia, New Guinea, and New Zealand	Marsupials
Nearctic	Temperate North America	Pronghorn antelope, ambystomatid salamanders
Neotropic	Subtropical Central America and South America	Hummingbirds, antbirds, marmosets

application of these insights to the distribution of species within a specified taxon across an island archipelago. This theory generated specific predictions about the relationships among island size and distance from a colonization source with the number and rate of turnover of species. Large islands are predicted to have higher equilibrium numbers of species than smaller islands; hence, the species area relationship can be predicted in principle from the ecological attributes of species. Experimental and observational studies have confirmed many predictions made by this theory. See ECOLOGICAL COMMUNITIES; ISLAND BIOGEOGRAPHY.

The latitudinal gradient in species richness has generated a number of explanations, none of which has been totally satisfactory. One explanation is based on the observation that species with more temperate and polar distributions tend to have larger geographic ranges than species from tropical regions. It is thought that since species with large geographic ranges tend to withstand a wider range of physical and biotic conditions, this allows them to penetrate farther into regions with more variable climates at higher latitudes. If this were true, then species with smaller geographic ranges would tend to concentrate in tropical regions where conditions are less variable. While this might be generally true, there are many examples of species living in high-latitude regions that have small geographic ranges. See ALTITUDINAL VEGETATION ZONES.

Biogeography is entering a phase where data on the spatial patterns of abundance and distribution of species of plants and animals are being analyzed with sophisticated mathematical and technological tools. Geographic information systems and remote sensing technology have provided a way to catalog and map spatial variation in biological processes with a striking degree of detail and accuracy. These newer technologies have stimulated research on appropriate methods for modeling and analyzing biogeographic patterns. Modern techniques of spatial modeling are being applied to geographic information systems data to test mechanistic explanations for biogeographic patterns that could not have been attempted without the advent of the appropriate technology. See GEOGRAPHIC INFORMATION SYSTEMS. [B.A.M.]

**Bioherm** A lenslike to moundlike structure of strictly organic origin. This term involves two concepts: shape and organic internal composition.

The term shape denotes original topographic relief above the sea floor as well as a three-dimensional quality: crudely conical (sugar loaf-shaped) or ellipsoidal (bread loaf-shaped). Such forms are massive or unbedded, their upbuilding resulting from the very rapid rate of accretion of organic carbonate once it starts in a favorable locality. There are size limitations: bioherms a meter or so in diameter are known, and some rise 300 ft (100 m) or more above the sea floor.

The second concept, organic internal composition, not only embraces sessile, bottom-dwelling organisms forming frame-building reefy bondstone but also includes piles of organically derived debris replete with organisms which encrust it and cement it in place. Even inorganic cement precipitated from marine and meteoric water is known to play a role in a buildup of massive, moundlike structures. When the internal material is coarse and identifiable, no problem is encountered in applying the term bioherm in its original sense. In some buildups, however, an appreciable amount of lime mud is present, and relatively few organisms are identifiable which could have secreted, bound, encrusted, or trapped carbonate mud (as in some early Carboniferous mounds). In such cases, problems arise in applying that part of the definition based on internal composition. In fact, as a field term, bioherm can hardly ever be completely diagnostic because careful petrographic study is commonly necessary for details of internal composition to be ascertained.

Bioherms may occur on shelves (where they are normally lens-shaped) or in shallow basins, often at the basin margin. In the latter position, they have been called reef knolls or pinnacle reef. See BIOSTROME; REEF; STROMATOLITE. [J.L.Wi.]

**Bioinorganic chemistry** The field at the interface between biochemistry and inorganic chemistry; also known as inorganic biochemistry or metallobiochemistry. This field involves the application of the principles of inorganic chemistry to problems of biology and biochemistry. Because most biological components are organic, that is, they involve the chemistry of carbon compounds, the combination of the prefix bio- and inorganic may appear contradictory. However, organisms require a number of other elements to carry out their basic functions. Many of these elements are present as metal ions that are involved in crucial biological processes such as respiration, metabolism, cell division, muscle contraction, nerve impulse transmission, and gene regulation. The characterization of the interactions between such metal centers and biological components is the heart of bioinorganic chemistry. See BIOCHEMISTRY.

Metal ions influence biological phenomena by interacting with organic functional groups on biomolecules, forming metal complexes. From this perspective, much of bioinorganic chemistry may be considered as coordination chemistry applied to biological questions. In general, bioinorganic chemists tackle such problems by first focusing on the elucidation of the structure of the metal complex of interest and then correlating structure with function. The attainment of solutions usually requires a combination of physical, chemical, and biological approaches. Biochemistry and molecular biology are often used to provide sufficient amounts of the system for investigation. Physical approaches such as crystallography and spectroscopy are useful in defining structural properties of the metal site. Synthetic methods can be used for the design and assembly of structural, spectroscopic, and functional models of the metal site. All these approaches then converge to elucidate how such a site functions. See COORDINATION CHEMISTRY; CRYSTALLOGRAPHY; SPECTROSCOPY.

**Low-molecular-weight compounds.** A number of coordination compounds found in organisms have relatively low molecular weights. Ionophores, molecules that are able to carry ions across lipid barriers, are polydentate ligands designed to bind alkali and alkaline-earth metal ions; they span membranes and serve to transport such ions across these biological barriers. Molecular receptors known as siderophores are also polydentate ligands; they have a very high affinity for iron. See IONOPHORE.

Other low-molecular-weight compounds are metal-containing cofactors that interact with macromolecules to promote important biological processes. Perhaps the most widely studied of the metal ligands found in biochemistry are the porphyrins; iron protoporphyrin IX (see illustration) is an example of the all-important complex in biology known as heme. Chlorophyll and vitamin B<sub>12</sub> are chemically related to the porphyrins. Magnesium is the central metal ion in chlorophyll, which is the green pigment in plants used to convert light energy into chemical energy. Cobalt is the central metal ion in vitamin B<sub>12</sub>; it is converted into coenzyme B<sub>12</sub> in cells, where it participates in a variety of enzymatic reactions. See CHLOROPHYLL; HEMOGLOBIN; PORPHYRIN.

**Metalloproteins and metalloenzymes.** These are metal complexes of proteins. In many cases, the metal ion is coordinated directly to functional groups on amino acid residues. In some cases, the protein contains a bound metallo-cofactor such as heme. In metalloproteins with more than one metal-binding site, the metal ions may be found in clusters. Examples include ferredoxins, which contain iron-sulfur clusters (Fe<sub>2</sub>S<sub>2</sub> or Fe<sub>4</sub>S<sub>4</sub>), and nitrogenase, which contains both Fe<sub>4</sub>S<sub>4</sub> units and a novel MoFe<sub>7</sub>S<sub>8</sub> cluster. See PROTEIN.

Some metalloproteins are designed for the storage and transport of the metal ions themselves—for example, ferritin and transferrin for iron and metallothionein for zinc. Others, such as the yeast protein Atx1, act as metallochaperones that aid in the insertion of the appropriate metal ion into a metalloenzyme. Still others function as transport agents. Cytochromes and ferredoxins facilitate the transfer of electrons in various metabolic processes.

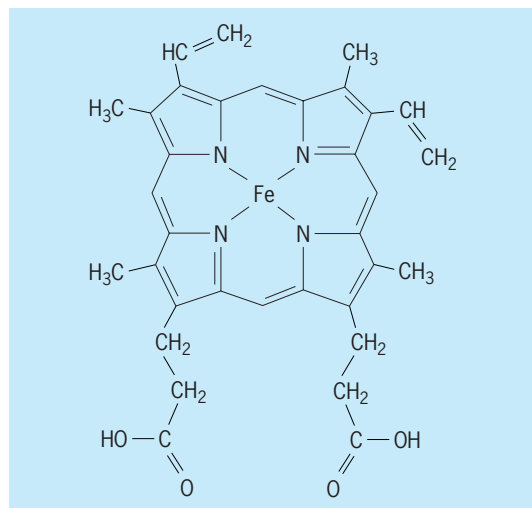

Iron complex of protoporphyrin IX, or heme.

Many metalloproteins catalyze important cellular reactions and are thus more specifically called metalloenzymes. For example, cytochrome oxidase is the respiratory enzyme in mitochondria responsible for disposing of the electrons generated by mammalian metabolism; it does so by reducing  $O_2$  to water with the help of both heme and copper centers. In contrast, the conversion of water to  $O_2$  is carried out in the photosynthetic apparatus by manganese centers. Other metalloenzymes are involved in the transformation of organic molecules in cells. For example, tyrosine hydroxylase (an iron enzyme) and dopamine  $\beta$ -hydroxylase (a copper enzyme) carry out oxidation reactions important for the biosynthesis of neurotransmitters. Alternatively, the metal center can serve as a Lewis acidic site to activate substrates for nucleophilic displacement reactions (that is, hydrolysis).

**Metals in medicine.** Metal complexes have also been found to be useful as therapeutic or diagnostic agents. Prominent among metal-based drugs is cisplatin, which is particularly effective in the treatment of testicular and ovarian cancers. Gold, gallium, and bismuth compounds are used for the treatment of rheumatoid arthritis, hypercalcemia, and peptic ulcers, respectively.

In clinical diagnosis, metal complexes can be used as imaging agents. The convenient half-life and radioemission properties of technetium-99 make its complexes very useful for a number of applications; by varying the ligands bound to the metal ion, diagnostic agents have been developed for imaging the heart, brain, and kidneys. Complexes of paramagnetic metal ions such as gadolinium(III), iron(III), and manganese(II) are also used as contrast agents to enhance images obtained from magnetic resonance imaging (MRI). See COORDINATION COMPLEXES; ORGANOMETALLIC COMPOUND. [L.Q.]

**Bioleaching** The dissolution of metals from their mineral source by certain naturally occurring microorganisms. Dozens of bacterial species have been identified as having bioleaching capabilities; those of commercial interest include species of *Thiobacillus*, *Leptospirillum*, *Sulfobacillus*, and *Sulfolobus*. *Thiobacillus ferrooxidans* is by far the most widely studied and commercially useful species. It is an aerobic rod-shaped microorganism that derives its energy from the oxidation of various sulfide minerals and soluble ferrous ion ( $Fe^{2+}$ ). The use of this organism is of considerable interest to the mining industry since many important metals are extracted and refined from sulfide minerals. *Thiobacillus ferrooxidans* thrives in acidic environments of pH 1–3, conditions that would be fatal to most other life forms, and can rapidly oxidize many sulfide minerals. This is of great commercial importance since most sulfide minerals are

inert and oxidize very slowly at room temperature and pressure. See SOLUTION MINING.

A typical bioleach reaction, using pyrite as the mineral source, is shown below; here pyrite is oxidized to produce soluble ferric

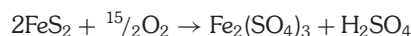

sulfate [ $Fe_2(SO_4)_3$ ] and sulfuric acid ( $H_2SO_4$ ). A considerable amount of oxygen is required in this reaction; it is extracted from the air.

Commercial applications of bioleaching have been developed for the solution mining of copper and uranium from low-grade ores and waste products. Uranium minerals are often found associated with the mineral pyrite. *Thiobacillus ferrooxidans* is used to oxidize pyrite and release the uranium according to the reaction discussed above. The ferric sulfate and sulfuric acid generated in this reaction then dissolve the uranium.

The use of sulfide oxidizing bacteria to enhance gold and silver recovery from ores that are difficult to treat is considered a major development in bioleaching technology. Bioleaching has gained acceptance because it offers a potentially inexpensive and nonpolluting way to pretreat these ores. The process consists essentially of two stages. In the first step, the ore is bioleached at acidic pH to oxidize the sulfide minerals. In the second step, the oxidized gold-bearing solids are mixed with lime to raise the pH to 10–11, and then subjected to conventional cyanide leaching to dissolve the precious metals. Often, overall gold or silver recovery can be improved to over 90%. See GOLD METALLURGY; HYDROMETALLURGY; LEACHING; SILVER METALLURGY; SOLVENT EXTRACTION. [R.Hac.]

**Biological clocks** Self-sustained circadian (approximately 24-hour) rhythms regulating daily activities such as sleep and wakefulness were described as early as 1729. By the midtwentieth century it had become clear that the period of self-sustained (free-running) oscillations usually does not match that of the Earth's rotation (environmental cycle), therefore the expression "approximately 24 hours." Moreover, the free-running period varies among species and also somewhat from one individual to another. Circadian rhythmicity is often referred to as the biological clock. See PHOTOPERIODISM.

Almost all organisms display circadian rhythms, indicating an evolutionary benefit, most likely facilitating adaptation to the cyclic nature of the environment. Physiological processes that occur with a circadian rhythm range from conidiation (spore production) in the bread mold, *Neurospora crassa*, and leaf movements in plants to rest-activity behavior in animals. Despite the diversity of these phenomena, the basic properties of the rhythms are the same—they synchronize to environmental cues, predominantly light, but are maintained in the absence of such cues, and they display a constant periodicity over a wide temperature range.

In humans, circadian rhythmicity is manifested in the form of sleep-wake cycles, and control of body temperature, blood pressure, heart rate, and release of many endocrine hormones. It is increasingly apparent that temporal ordering is a fundamental aspect of physiological processes. In fact, several disorders such as asthma, stroke, and myocardial infarction also tend to occur more frequently at certain times of the day. Awareness of circadian control has led to the concept of chronotherapeutics, which advocates drug delivery timed to the host's circadian rhythms.

In mammals the "master clock" controlling circadian rhythms is located in the hypothalamus, within a small group of neurons called the suprachiasmatic nucleus. Available data suggest that the suprachiasmatic nucleus transmits signals in the form of humoral factors as well as neural connections. For many years the suprachiasmatic nucleus was thought to be the only site of a clock in mammals. This was in contrast to several other vertebrates where clocks were known to be present in the pineal

gland and the eye as well. However, it is now clear that the mammalian eye also contains an oscillator (something that generates an approximately 24-h cycle) whose activity can be assayed by measuring melatonin release in isolated retinas. See NERVOUS SYSTEM (INVERTEBRATE); NERVOUS SYSTEM (VERTEBRATE).

The genetic basis of circadian rhythms was established through the identification of altered circadian patterns that were inherited. Such mutants were found first in *Drosophila* and then in *Neurospora* in the early 1970s. In addition, there is now an impetus to identify circadian abnormalities or naturally occurring variations in human populations. For instance, the difference between people that wake up and function most effectively in the early morning hours as opposed to those who prefer to sleep late into the morning may well lie in polymorphisms within clock genes.

It is now known that a feedback loop composed of cycling gene products that influence their own synthesis underlies overt rhythms in at least three organisms (*Drosophila*, *Neurospora*, and cyanobacteria) and most likely in a fourth (mammals). Similar feedback loops have also been found in plants, although it is not clear that they are part of the clock. [A.Se.]

**Biological oxidation** Oxidation occurs in over one-quarter of the known chemical reactions catalyzed by enzymes in living cells. In many cases this is accomplished by the transfer of hydrogen atoms or electrons from one molecule (hydrogen or electron donor) to another (the acceptor). Reactions of this type are the major source of energy for life processes. In other cases molecular oxygen is involved directly in the oxidation reaction. In all cases the enzymic oxidation reaction involves the participation of a cofactor which may merely serve as a second substrate (known as a coenzyme) or which may be an integral part of the enzyme, acting as a carrier of reducing equivalents (known as a prosthetic group). The principal sources of reducing equivalents are the numerous specific metabolic breakdown products of the major foodstuffs: carbohydrates, fats, and proteins. Energy release from these metabolites occurs in a stepwise series of hydrogen and electron transfers to molecular oxygen. See COENZYME; ENZYME. [V.Ma.]

**Biological productivity** The amount and rate of production which occur in a given ecosystem over a given time period. It may apply to a single organism, a population, or entire communities and ecosystems. Productivity can be expressed in terms of dry matter produced per area per time (net production), or in terms of energy produced per area per time (gross production = respiration + heat losses + net production). In aquatic systems, productivity is often measured in volume instead of area. See BIOMASS.

Ecologists distinguish between primary productivity (by autotrophs) and secondary productivity (by heterotrophs). Plants have the ability to use the energy from sunlight to convert carbon dioxide and water into glucose and oxygen, producing biomass through photosynthesis. Primary productivity of a community is the rate at which biomass is produced per unit area by plants, expressed in either units of energy [joules/(m<sup>2</sup>)(day)] or dry organic matter [kg/(m<sup>2</sup>)(year)]. The following definitions are useful in calculating production: Gross primary production (GPP) is the total energy fixed by photosynthesis per unit time. Net primary production (NPP) is the gross production minus losses due to plant respiration per unit time, and it represents the actual new biomass that is available for consumption by heterotrophic organisms. Secondary production is the rate of production of biomass by heterotrophs (animals, microorganisms), which feed on plant products or other heterotrophs. See PHOTOSYNTHESIS.

Productivity is not spread evenly across the planet. For instance, although oceans cover two-thirds of Earth's surface, they account for only one-third of the Earth's productivity. Further-

more, the factors that limit productivity in the ocean differ from those limiting productivity on land, producing differences in geographic patterns of productivity in the two systems. In terrestrial ecosystems, productivity shows a latitudinal trend, with highest productivity in the tropics and decreasing progressively toward the Poles; but in the ocean there is no latitudinal trend, and the highest values of net primary production are found along coastal regions. [D.C.C.; E.Gry.]

**Biological specificity** The orderly patterns of metabolic and developmental reactions giving rise to the unique characteristics of the individual and of its species. Biological specificity is most pronounced and best understood at the cellular and molecular levels of organization, where the shapes of individual molecules allow them to selectively recognize and bind to one another. The main principle which guides this recognition is termed complementarity. Just as a hand fits perfectly into a glove, molecules which are complementary have mirror-image shapes that allow them to selectively bind to each other.

This ability of complementary molecules to specifically bind to one another plays many essential roles in living systems. For example, the transmission of specific hereditary traits from parent to offspring depends upon the ability of the individual strands of a deoxyribonucleic acid (DNA) molecule to specifically generate two new strands with complementary sequences. Similarly, metabolism, which provides organisms with both the energy and chemical building blocks needed for survival, is made possible by the ability of enzymes to specifically bind to the substrates whose interconversions they catalyze. During embryonic development, individual cells associate with each other in precise patterns to form tissues, organs, and organ systems. These ordered interactions are ultimately dependent upon the ability of individual cells to recognize and specifically bind to other cells of a similar type. See DEOXYRIBONUCLEIC ACID (DNA); ENZYME; METABOLISM.

In addition to binding to one another, cells can interact by releasing hormones into the bloodstream. Though all of an organism's cells are exposed to hormones circulating in the bloodstream, only a small number of target cells respond to any particular hormone. This selectivity occurs because the specific receptor molecules to which hormones bind are restricted to certain cell types. Thus each hormone exerts its effects on a few selected cell types because only those cells contain the proper receptor. Specific receptors are also involved in interactions between neurotransmitters and the cells they stimulate or inhibit, between certain types of drugs and the cells they affect, and between viruses and the cells they infect. This last phenomenon has an important influence on the susceptibility of individuals to virally transmitted diseases. See ENDOCRINE MECHANISMS; HORMONE.

Although most examples of biological specificity are based upon interactions occurring at the molecular level, such phenomena affect many properties manifested at the level of the whole organism. The ability of individuals to defend against infectious diseases, for example, requires the production of antibody molecules which specifically bind to bacteria and viruses. The fertilization of an egg by a sperm is facilitated by specific recognition between molecules present on the surfaces of the sperm and egg cells. Even communication between organisms can be mediated by specific chemical signals, called pheromones. Such chemical signals are utilized in trail marking by ants and bees, in territory marking by certain mammals, and as sexual attractants. Specific molecular interactions thus exert influences ranging from the replication of genes to the behavior of organisms. See FERTILIZATION; IMMUNOLOGY; MOLECULAR BIOLOGY; PHEROMONE. [L.J.KI.]

**Biologicals** Biological products used to induce immunity to various infectious diseases or noxious substances of biological origin. The term is usually limited to immune serums, antitoxins, vaccines, and toxoids that have the effect of providing protective

substances of the same general nature that a person develops naturally from having survived an infectious disease or having experienced repeated contact with a biological poison. As a matter of governmental regulatory convenience, certain therapeutic substances which have little to do with conferring immunity have been classified as biological products primarily because they are derived from human or animal sources and are tested for safety by methods similar to those used for many biological products. See IMMUNITY.

One major class of biologicals includes the animal and human immune serums. All animals, including humans, develop protective substances in their blood plasma during recovery from many (but not all) infectious diseases or following the injection of toxins or killed bacteria and viruses. These protective substances, called antibodies, usually are found in the immunoglobulin fraction of the plasma and are specific since they react with and neutralize only substances identical or closely similar to those that caused them to be formed. See ANTIBODY; IMMUNOGLOBULIN; SERUM.

Antibody-containing serum from another animal is useful in the treatment, modification, or prevention of certain diseases of humans when it is given by intramuscular or intravenous injection. The use of these preformed "borrowed" antibodies is called passive immunization, to distinguish it from active immunization, in which each person develops his or her own antibodies. Passive immunization has the advantage of providing immediate protection, but it is temporary because serum proteins from other animals and even from other humans are rapidly destroyed in the recipient.

Serums which contain antibodies active chiefly in destroying the infecting virus or bacterium are usually called antiserums or immune serums; those containing antibodies capable of neutralizing the secreted toxins of bacteria are called antitoxins. Immune serums have been prepared to neutralize the venoms of certain poisonous snakes and black widow spiders; they are called antivenins.

Because all products used for passive immunization are immune serums, or globulin fractions from such serums, they are named to indicate the diseases that they treat or prevent, the substances that they inhibit or neutralize, the animal from which they came, and whether they are whole serums or the globulin fractions thereof. Thus there is, for example, antipertussis immune rabbit serum, measles immune globulin (human), diphtheria antitoxic globulin (horse), tetanus immune globulin (human), and anti-Rh<sub>0</sub> (D) gamma globulin (human).

The general methods of preparation of various immune serums and antitoxins differ only in details. Horses, cows, rabbits, or humans are injected with slowly increasing amounts of either the virus, bacterium, toxin, erythrocyte, or venom as antigens against which immunity is to be developed. Injections are given over several months and the animals respond by producing relatively large amounts of specific antibody against the injected material, which are then processed to obtain the concentrated antibody-globulin fraction free of albumin and other nonantibody fractions.

The use of animal immune serums for prevention of therapy in humans has certain disadvantages. The serum proteins themselves may cause the production of specific antibodies in the recipient of the immune serum, and thus the person may become allergically sensitized to the serum protein of this animal species. See ANAPHYLAXIS; HYPERSENSITIVITY.

A second and less acute type of reaction resulting from the injection of animal immune serum is so-called serum sickness. About 4–10 days after the administration of serum, the patient develops fever, urticarial (hivelike) rash, and sometimes joint pains. These reactions are not ordinarily fatal.

Products used to produce active immunity constitute the other large class of biological products. They contain the actual toxins, viruses, or bacteria that cause disease, but they are modified in a manner to make them safe to administer. Because the body does not distinguish between the natural toxin or infectious

agent and the same material when properly modified, immunity is produced in response to injections of these materials in a manner very similar to that which occurs during the natural disease. Vaccines are suspensions of the killed or attenuated (weakened) bacteria or viruses or fractions thereof. Toxoids are solutions of the chemically altered specific bacterial toxins which cause the major damage produced by bacterial infections. Biological products producing active immunity are usually named to indicate the disease they immunize against and the kind of substance they contain: thus typhoid vaccine, diphtheria toxoid, tetanus toxoid, measles vaccine, mumps vaccine, and poliomyelitis vaccine. See VACCINATION.

Another group of biological products consists of reagents used in the diagnosis of infectious diseases. These include immune serums for the serological typing and identification of pathogenic bacteria and viruses, and various antigens for the detection of antibodies in patients' serums as a means of assisting in diagnosis. In addition to these substances used in the laboratory diagnosis of disease, certain extracts of bacteria and fungi have been prepared for injection into the skin to detect allergic hypersensitivity. In certain diseases such as tuberculosis and brucellosis, the patient usually becomes hypersensitive to certain components of the infecting organism. Extracts of these organisms injected into the skin of such a person cause inflammation, whereas no reaction occurs in a person who has not been infected. These skin tests therefore are of assistance in the diagnosis of various infectious diseases. Allergenic products are administered to humans for the diagnosis, prevention, or treatment of allergies to various plant and animal substances. [L.F.S.]

**Biology** A natural science concerned with the study of all living organisms. Although living organisms share some unifying themes, such as their origin from the same basic cellular structure and their molecular basis of inheritance, they are diverse in many other aspects. The diversity of life leads to many divisions in biological science involved with studying all aspects of living organisms. The primary divisions of study in biology consist of zoology (animals), botany (plants), and protistology (one-celled organisms), and are aimed at examining such topics as origins, structure, function, reproduction, growth and development, behavior, and evolution of the different organisms. In addition, biologists consider how living organisms interact with each other and the environment on an individual as well as group basis. Therefore, within these divisions are many subdivisions such as molecular and cellular biology, microbiology (the study of microbes such as bacteria and viruses), taxonomy (the classification of organisms into special groups), physiology (the study of function of the organism at any level), immunology (the investigation of the immune system), genetics (the study of inheritance), and ecology and evolution (the study of the interaction of an organism with its environment and how that interaction changes over time).

The study of living organisms is an ongoing process that allows observation of the natural world and the acquisition of new knowledge. Biologists accomplish their studies through a process of inquiry known as the scientific method, which approaches a problem or question in a well-defined orderly sequence of steps so as to reach conclusions. The first step involves making systematic observations, either directly through the sense of sight, smell, taste, sound, or touch, or indirectly through the use of special equipment such as the microscope. Next, questions are asked regarding the observations. Then a hypothesis—a tentative explanation or educated guess—is formulated, and predictions about what will occur are made. At the core of any scientific study is testing of the hypothesis. Tests or experiments are designed so as to help substantiate or refute the basic assumptions set forth in the hypothesis. Therefore, experiments are repeated many times. Once they have been completed, data are collected and organized in the form of graphs or tables and the results are analyzed. Also, statistical tests may be performed to help



determine whether the data are significant enough to support or disprove the hypothesis. Finally, conclusions are drawn that provide explanations or insights about the original problem. By employing the scientific method, biologists aim to be objective rather than subjective when interpreting the results of their experiments. Biology is not absolute: it is a science that deals with theories or relative truths. Thus, biological conclusions are always subject to change when new evidence is presented. As living organisms continue to evolve and change, the science of biology also will evolve. See ANIMAL; BOTANY; CELL BIOLOGY; ECOLOGY; GENETICS; IMMUNOLOGY; MICROBIOLOGY; PLANT; TAXONOMY; ZOOLOGY. [L.Co.]

**Bioluminescence** The emission of light by living organisms that is visible to other organisms. The enzymes and other proteins associated with bioluminescence have been developed and exploited as markers or reporters of other biochemical processes in biomedical research. Bioluminescence provides a unique tool for investigating and understanding numerous basic physiological processes, both cellular and organismic.

Although rare in terms of the total number of luminous species, bioluminescence is phylogenetically diverse, occurring in many different groups (see table). Luminescence is unknown in higher plants and in vertebrates above the fishes, and is also absent in several invertebrate phyla. In some phyla or taxa, a substantial proportion of the genera are luminous (for example, ctenophores, about 50%; cephalopods, greater than 50%). Commonly, all members of a luminous genus emit light, but in some cases there are both luminous and nonluminous species.

Major groups having luminous species

Group	Features of luminous displays
Bacteria	Organisms glow constantly; system is autoinduced
Fungi	Mushrooms and mycelia produce constant dim glow
Dinoflagellates	Flagellated algae flash when disturbed
Coelenterates	Jellyfish, sea pansies, and comb jellies emit flashes
Annelids	Marine worms and earthworms exude luminescence
Mollusks	Squid and clams exude luminous clouds; also have photophores
Crustacea	Shrimp, copepods, ostracodes; exude luminescence; also have photophores
Insects	Fireflies (beetles) emit flashes; flies (Diptera) glow
Echinoderms	Brittle stars emit trains of rapid flashes
Fish	Many bony and cartilaginous fish are luminous; some use symbiotic bacteria; others are self-luminous; some have photophores

Bioluminescence is most prevalent in the marine environment; it is greatest at midocean depths, where some daytime illumination penetrates. In these locations, bioluminescence may occur in over 95% of the individuals. Where high densities of luminous organisms occur, their emissions can exert a significant influence on the communities and may represent an important component in the ecology, behavior, and physiology of the latter. Above and below midocean depths, luminescence decreases to less than 10% of all individuals and species; among coastal species, less than 2% are bioluminescent. Firefly displays of bioluminescence are among the most spectacular, but bioluminescence is rare in the terrestrial environment. Other terrestrial luminous forms include millipedes, centipedes, earthworms, and snails, but the display in these is not very bright.

While not metabolically essential, light emission can confer an advantage on the organism. The light can be used in diverse ways. Most of the perceived functions of bioluminescence fall into four categories: defense, offense, communication, and dispersal to enhance propagation.

Bioluminescence does not come from or depend on light absorbed by the organism. It derives from an enzymatically catalyzed chemiluminescence, a reaction in which the energy

released is transformed into light energy. One of the reaction intermediates or products is formed in an electronically excited state, which then emits a photon. See CHEMILUMINESCENCE.

Bioluminescence originated and evolved independently many times, and is thus not an evolutionarily conserved function. It has been estimated that present-day luminous organisms come from as many as 30 different evolutionarily distinct origins. In the different groups of organisms, the genes and proteins involved are unrelated, and it may be confusing that the substrates and enzymes, though chemically different, are all referred to as luciferin and luciferase, respectively. To be correct and specific, each should be identified with the organism.

Luminous bacteria typically emit a continuous light, usually blue-green. When strongly expressed, a single bacterium may emit  $10^4$  or  $10^5$  photons per second. A primary habitat where most species abound is in association with another (higher) organism, dead or alive, where growth and propagation occur. Luminous bacteria are ubiquitous in the oceans and can be isolated from most seawater samples. The most exotic specific associations involve specialized light organs (for example, in fish and squid) in which a pure dense culture of luminous bacteria is maintained. In teleost fishes, 11 different groups carrying such bacteria are known, an exotic example being the flashlight fish.

Of the approximately 70,000 insect genera, only about 100 are classed as luminous. But their luminescence is impressive, especially in the fireflies and their relatives. Fireflies possess ventral light organs on posterior segments; the South American railroad worm, *Phrixothrix*, has paired green lights on the abdominal segments and red head lights; while the click and fire beetles, Pyrophorini, have both running lights (dorsal) and landing lights (ventral). The dipteran cave glow worm, in a different group and probably different biochemically, exudes beaded strings of slime from its ceiling perch, serving to entrap minute flying prey, which are attracted by the light emitted by the animal. The major function of light emission in fireflies is for communication during courtship, typically involving the emission of a flash by one sex as a signal, to which the other sex responds, usually in a species-specific pattern. The time delay between the two may be a signaling feature; for example, it is precisely 2 s in some North America species. But the flashing pattern is also important in some cases, as is the kinetic character of the individual flash (duration; onset and decay kinetics).

The firefly system was the first in which the biochemistry was characterized. In 1947 it was discovered that adenosine triphosphate (ATP) functions to form a luciferyl adenylate intermediate from firefly luciferin. This then reacts with oxygen to form a cyclic luciferyl peroxy species, which breaks down to yield  $\text{CO}_2$  and an excited state of the carbonyl product (thus emitting a photon). Luciferase catalyzes both the reaction of luciferin with ATP and the subsequent steps leading to the excited product.

Bioluminescence and chemiluminescence have come into widespread use for quantitative determinations of specific substances in biology and medicine. Luminescent tags have been developed that are as sensitive as radioactivity, and now replace radioactivity in many assays. The biochemistry of different luciferase systems is different, so many different substances can be detected. One of the first, and still widely used, assays involves the use of firefly luciferase for the detection of ATP. The amount of oxygen required for bioluminescence in luminescent bacteria is small, and therefore the reaction readily occurs. Luminous bacteria can be used as a very sensitive test for oxygen, sometimes in situations where no other method is applicable. An oxygen electrode incorporating luminous bacteria has been developed.

Luciferases have also been exploited as reporter genes for many different purposes. Analytically, such systems are virtually unique in that they are noninvasive and nondestructive: the relevant activity can be measured as light emission in the intact cell and in the same cell over the course of time. Examples of the use of luciferase genes are the expression of firely and

bacterial luciferases under the control of circadian promoters; and the use of coelenterate luciferase expressed transgenically (in other organisms) to monitor calcium changes in living cells over time. Green fluorescent protein is widely used as a reporter gene for monitoring the expression of some other gene under study, and for how the expression may differ, for example at different stages of development or as the consequence of some experimental procedure. [J.W.H.]

**Biomagnetism** The production of a magnetic field by a living object. The living object presently most studied is the human body, for two purposes: to find new techniques for medical diagnosis, and to gain information about normal physiology. Smaller organisms studied include birds, fishes, and objects as small as bacteria; many scientists believe that biomagnetics is involved in the ability of these creatures to navigate. The body produces magnetic fields in two main ways: by electric currents and by ferromagnetic particles. The electric currents are the ion currents generated by the muscles, nerves, and other organs. For example, the same ion current generated by heart muscle, which provides the basis for the electrocardiogram, also produces a magnetic field over the chest; and the same ion current generated by the brain, which provides the basis for the electroencephalogram, also produces a magnetic field over the head. Ferromagnetic particles are insoluble contaminants of the body; the most important of these are the ferromagnetic dust particles in the lungs, which are primarily  $\text{Fe}_3\text{O}_4$  (magnetite). Magnetic fields can give information about the internal organs not otherwise available.

These magnetic fields are very weak, usually in the range of  $10^{-14}$  to  $10^{-9}$  tesla; for comparison, the Earth's field is about  $10^{-4}$  T (1 T =  $10^4$  gauss, the older unit of field). The fields at the upper end of this range, say stronger than  $10^{-4}$  T, can be measured with a simple but sensitive magnetometer called the fluxgate; the weaker fields are measured with the extremely sensitive cryogenic magnetometer called the SQUID (superconducting quantum interference device). The levels of the body's fields, whether they are fluctuating or steady, are orders of magnitude weaker than the fluctuating or steady background fields. They can, however, be measured by using either a magnetically shielded room or two detectors connected in opposition so that much of the background is canceled, or a combination of both methods. The organs producing magnetic fields which are of most interest are the brain, the lungs, and the liver. See BIOELECTROMAGNETICS; ELECTROENCEPHALOGRAPHY; MIGRATORY BEHAVIOR; SQUID. [D.C.]

**Biomass** The organic materials produced by plants, such as leaves, roots, seeds, and stalks. In some cases, microbial and animal metabolic wastes are also considered biomass. The term "biomass" is intended to refer to materials that do not directly go into foods or consumer products but may have alternative industrial uses. Common sources of biomass are (1) agricultural wastes, such as corn stalks, straw, seed hulls, sugarcane leavings, bagasse, nutshells, and manure from cattle, poultry, and hogs; (2) wood materials, such as wood or bark, sawdust, timber slash, and mill scrap; (3) municipal waste, such as waste paper and yard clippings; and (4) energy crops, such as poplars, willows, switchgrass, alfalfa, prairie bluestem, corn (starch), and soybean (oil). See BIOLOGICAL PRODUCTIVITY.

Biomass is a complex mixture of organic materials, such as carbohydrates, fats, and proteins, along with small amounts of minerals, such as sodium, phosphorus, calcium, and iron. The main components of plant biomass are carbohydrates (approximately 75%, dry weight) and lignin (approximately 25%), which can vary with plant type. The carbohydrates are mainly cellulose or hemicellulose fibers, which impart strength to the plant structure, and lignin, which holds the fibers together. Some plants also store starch (another carbohydrate polymer) and fats as sources

of energy, mainly in seeds and roots (such as corn, soybeans, and potatoes). See CELLULOSE; LIGNIN.

A major advantage of using biomass as a source of fuels or chemicals is its renewability. Utilizing sunlight energy in photosynthesis, plants metabolize atmospheric carbon dioxide to synthesize biomass. An estimated 140 billion metric tons of biomass are produced annually.

Major limitations of solid biomass fuels are difficulty of handling and lack of portability for mobile engines. To address these issues, research is being conducted to convert solid biomass into liquid and gaseous fuels. Both biological means (fermentation) and chemical means (pyrolysis, gasification) can be used to produce fluid biomass fuels. For example, methane gas is produced in China for local energy needs by anaerobic microbial digestion of human and animal wastes. Ethanol for automotive fuels is currently produced from starch biomass in a two-step process: starch is enzymatically hydrolyzed into glucose; then yeast is used to convert the glucose into ethanol. About 1.5 billion gallons of ethanol are produced from starch each year in the United States. See ALCOHOL FUEL; GASOLINE. [B.Y.Ta.]

**Biome** A major community of plants and animals having similar life forms or morphological features and existing under similar environmental conditions. The biome, which may be used at the scale of entire continents, is the largest useful biological community unit. In Europe the equivalent term for biome is major life zone, and throughout the world, if only plants are considered, the term used is formation. See ECOLOGICAL COMMUNITIES.

Each biome may contain several different types of ecosystems. For example, the grassland biome may contain the dense tall-grass prairie with deep, rich soil, while the desert grassland has a sparse plant canopy and a thin soil. However, both ecosystems have grasses as the predominant plant life form, grazers as the principal animals, and a climate with at least one dry season. Additionally, each biome may contain several successional stages. A forest successional sequence may include grass dominants at an early stage, but some forest animals may require the grass stage for their habitat, and all successional stages constitute the climax forest biome. See DESERT; ECOLOGICAL SUCCESSION; ECOSYSTEM; GRASSLAND ECOSYSTEM.

Distributions of animals are more difficult to map than those of plants. The life form of vegetation reflects major features of the climate and determines the structural nature of habitats for animals. Therefore, the life form of vegetation provides a sound basis for ecologically classifying biological communities. Terrestrial biomes are usually identified by the dominant plant component, such as the temperate deciduous forest. Marine biomes are mostly named for physical features, for example, for marine upwelling, and for relative locations, such as littoral. Many biome classifications have been proposed, but a typical one might include several terrestrial biomes such as desert, tundra, grassland, savanna, coniferous forest, deciduous forest, and tropical forest. Aquatic biome examples are fresh-water lotic (streams and rivers), fresh-water lentic (lakes and ponds), and marine littoral, neritic, upwelling, coral reef, and pelagic. See FRESH-WATER ECOSYSTEM; MARINE ECOLOGY; PLANTS, LIFE FORMS OF. [P.Ri.]

**Biomechanics** A field that combines the disciplines of biology and engineering mechanics and utilizes the tools of physics, mathematics, and engineering to quantitatively describe the properties of biological materials. One of its basic properties is embodied in so-called constitutive laws, which fundamentally describe the properties of constituents, independent of size or geometry, and specifically how a material deforms in response to applied forces. For most inert materials, measurement of the forces and deformations is straightforward by means of commercially available devices or sensors that can be attached to a test specimen. Many materials, ranging from steel to rubber, have linear constitutive laws, with the proportionality constant

(elastic modulus) between the deformation and applied forces providing a simple index to distinguish the soft rubber from the stiff steel. While the same basic principles apply to living tissues, the complex composition of tissues makes obtaining constitutive laws difficult.

Most tissues are too soft for the available sensors, so direct attachment not only will distort what is being measured but also will damage the tissue. Devices are needed that use optical, Doppler ultrasound, electromagnetic, and electrostatic principles to measure deformations and forces without having to touch the tissue.

All living tissues have numerous constituents, each of which may have distinctive mechanical properties. For example, elastin fibers give some tissues (such as blood vessel walls) their spring-like quality at lower loads; inextensible collagen fibers that are initially wavy and unable to bear much load become straightened to bear almost all of the higher loads; and muscle fibers contract and relax to dramatically change their properties from moment to moment. Interconnecting all these fibers are fluids, proteins, and other materials that contribute mechanical properties to the tissue.

The mechanical property of the tissue depends not only upon the inherent properties of its constituents but also upon how the constituents are arranged relative to each other. Thus, different mechanical properties occur in living tissues than in inert materials. For most living tissues, there is a nonlinear relationship between the deformations and the applied forces, obviating a simple index like the elastic modulus to describe the material. In addition, the complex arrangement of the constituents leads to material properties that possess directionality; that is, unlike most inert materials that have the same properties regardless of which direction is examined, living tissues have distinct properties dependent upon the direction examined. Finally, while most inert materials undergo small (a few percent) deformations, many living tissues and cells can deform by several hundred percent. Thus, the mathematics necessary to describe the deformations is much more complicated than with small deformations. [F.C.P.Y.]

The biomechanical properties and behaviors of organs and organ systems stem from the ensemble characteristics of their component cells and extracellular materials, which vary widely in structure and composition and hence in biomechanical properties. An example of this complexity is provided by the cardiovascular system, which is composed of the heart, blood vessels, and blood. See **CARDIOVASCULAR SYSTEM**.

Blood is a suspension of blood cells in plasma. The mammalian red blood cell consists of a membrane enveloping a homogeneous cytoplasm rich in hemoglobin, but it has no nucleus or organelles. While the plasma and the cytoplasm behave as fluids, the red blood cell membrane has viscoelastic properties; its elastic modulus in uniaxial deformation at a constant area is four orders of magnitude lower than that for areal deformation. This type of biomechanical property, which is unusual in nonbiological materials, is attributable to the molecular structure of the membrane: the lipid membrane has spanning proteins that are linked to the underlying spectrin network. The other blood cells (leukocytes and platelets) and the endothelial cells lining the vessel wall are more complex in composition and biomechanics; they have nuclei, organelles, and a cytoskeletal network of proteins. Furthermore, they have some capacity for active motility. See **BLOOD**; **CYTOSKELETON**.

Cardiac muscle and vascular smooth muscle cells have organized contractile proteins that can generate active tension in addition to passive elasticity. Muscle cells, like other cells, are surrounded by extracellular matrix, and cell-matrix interaction plays an important role in governing the biomechanical properties and functions of cardiovascular tissues and organs. The study of the overall performance of the cardiovascular system involves measurements of pressure and flow. The pressure-flow relationship results from the interaction of the biomechanical

functions of the heart, blood, and vasculature. To analyze the biomechanical behavior of cells, tissues, organs, and systems, a combination of experimental measurements and theoretical modeling is necessary. See **MUSCLE**.

Other organ systems present many quantitative and qualitative differences in biomechanical properties. For example, because the cardiovascular system is composed of soft tissues whereas bone is a hard tissue, the viscoelastic coefficients and mechanical behaviors are quite different. Cartilage is intermediate in stiffness and requires a poro-elastic theory to explain its behavior in lubrication of joints. In general, living systems differ from most physical systems in their nonhomogeneity, nonlinear behavior, capacity to generate active tension and motion, and ability to undergo adaptive changes and to effect repair. The biomechanical properties of the living systems are closely coupled with biochemical and metabolic activities, and they are controlled and regulated by neural and humoral mechanisms to optimize performance. While the biomechanical behaviors of cells, tissues, and organs are determined by their biochemical and molecular composition, mechanical forces can, in turn, modulate the gene expression and biochemical composition of the living system at the molecular level. Thus, a close coupling exists between biomechanics and biochemistry, and the understanding of biomechanics requires an interdisciplinary approach involving biology, medicine, and engineering.

[S.Chi.; R.Sk.]

**Biomedical chemical engineering** The application of chemical engineering principles to the solution of medical problems due to physiological impairment. A knowledge of organic chemistry is required of all chemical engineers, and many also study biochemistry and molecular biology. This training at the molecular level gives chemical engineers a unique advantage over other engineering disciplines in communication with life scientists and clinicians in medicine. Practical applications include the development of tissue culture systems, the construction of three-dimensional scaffolds of biodegradable polymers for cell growth in the laboratory, and the design of artificial organs. See **BIOCHEMISTRY**.

Cell transplantation is explored as a means of restoring tissue function. With this approach, individual cells are harvested from a healthy section of donor tissue, isolated, expanded in culture, and implanted at the desired site of the functioning tissue. Isolated cells cannot form new tissues on their own and require specific environments that often include the presence of supporting material to act as a template for growth. Three-dimensional scaffolds can be used to mimic their natural counterparts, the extracellular matrices of the body. These scaffolds serve as both a physical support and an adhesive substrate for isolated parenchymal cells during cell culture and subsequent implantation. The scaffold must be made of biocompatible materials. As the transplanted cell population grows and the cells function normally, they will begin to secrete their own extracellular matrix support. The need for an artificial support will gradually diminish; and thus if the implant is biodegradable, it will be eliminated as its function is replaced. The development of processing methods to fabricate reproducibly three-dimensional scaffolds of biodegradable polymers that will provide temporary scaffolding to transplanted cells will be instrumental in engineering tissues.

Chemical engineers have made significant contributions to the design and optimization of many commonly used devices for both short-term and long-term organ replacement. Examples include the artificial kidney for hemodialysis and the heart-lung machine employed in open heart surgery. The artificial kidney removes waste metabolites (such as urea and creatinine) from blood across a polymeric membrane that separates the flowing blood from the dialysis fluid. The mass transport properties and biocompatibility of these membranes are crucial to the functioning of hemodialysis equipment. The heart-lung machine

replaces both the pumping function of the heart and the gas exchange function of the lung in one fairly complex device. While often life saving, both types of artificial organs only partially replace real organ function. Long-term use often leads to problems with control of blood coagulation mechanisms to avoid both excessive clotting initiated by blood contact with artificial surfaces and excessive bleeding due to platelet consumption or overuse of anticoagulants. See DIALYSIS; MEMBRANE SEPARATIONS.

Other chemical engineering applications include methodology for development of artificial bloods, utilizing fluorocarbon emulsions or encapsulated or polymerized hemoglobin, and controlled delivery devices for release of drugs or of specific molecules (such as insulin) missing in the body because of disease or genetic alteration. See POLYMER. [L.V.M.; A.G.M.]

**Biomedical engineering** An interdisciplinary field in which the principles, laws, and techniques of engineering, physics, chemistry, and other physical sciences are applied to facilitate progress in medicine, biology, and other life sciences. Biomedical engineering encompasses both engineering science and applied engineering in order to define and solve problems in medical research and clinical medicine for the improvement of health care. Biomedical engineers must have training in anatomy, physiology, and medicine, as well as in engineering.

A wide variety of instrumentation is available to the physician and surgeon to facilitate the diagnosis and treatment of diseases and other malfunctions of the body. Instrumentation has been developed to extend and improve the quality of life. A primary objective in the development of medical instrumentation is to obtain the required results with minimal invasion of the body. Responsibility for the correct installation, use, and maintenance of all medical instrumentation in the hospital is usually assigned to individuals with biomedical engineering training. This phase of biomedical engineering is termed clinical engineering, and often involves providing training for physicians, nurses, and other hospital personnel who operate the equipment. Another responsibility of the clinical engineer is to ensure that the instrumentation meets functional specifications at all times and poses no safety hazard to patients. In most hospitals, the clinical engineer supervises one or more biomedical engineering technicians in the repair and maintenance of the instrumentation.

The application of engineering principles and techniques has a significant impact on medical and biological research aimed at finding cures for a large number of diseases, such as heart disease, cancer, and AIDS, and at providing the medical community with increased knowledge in almost all areas of physiology and biology. Biomedical engineers are involved in the development of instrumentation for nearly every aspect of medical and biological research, either as a part of a team with medical professionals or independently, in such varied fields as electrophysiology, biomechanics, fluid mechanics, microcirculation, and biochemistry. A number of fields, such as cellular engineering and tissue engineering, have evolved from this work.

A significant role for biomedical engineers in research is the development of mathematical models of physiological and biological systems. A mathematical model is a set of equations that are derived from physical and chemical laws and that describe a physiological or biological function. Modeling can be done at various physiological levels, from the cellular or microbiological level to that of a complete living organism, and can be of various degrees of complexity, depending on which kinds of functions they are intended to represent and how much of the natural function is essential for the purpose of the model. A major objective of biomedical engineering is to create models that more closely approximate the natural functions they represent and that satisfy as many of the conditions encountered in nature as possible. See MATHEMATICAL BIOLOGY; SIMULATION.

A highly important contribution of biomedical engineering is in the design and development of artificial organs and prosthetic devices which replace or enhance the function of missing, inoperative, or inadequate natural organs or body parts. A major goal in this area is to develop small, self-contained, implantable artificial organs that function as well as the natural organs, which they can permanently supersede. See PROSTHESIS.

The goal of rehabilitation engineering is to increase the quality of life for the disabled. One major part of this field is directed toward strengthening existing but weakened motor functions through use of special devices and procedures that control exercising of the muscles involved. Another part is devoted to enabling disabled persons to function better in the world and live more normal lives. Included in this area are devices to aid the blind and hearing-impaired. Human-factors engineering is utilized in modifying the home and workplace to accommodate the special needs of disabled persons. See BIOMECHANICS; HUMAN-FACTORS ENGINEERING. [F.J.W.]

**Biomedical ultrasonics** The applications to medicine and biology of sound waves that have a frequency higher than the audible spectrum. Biomedical applications of ultrasound range from cell sonicators using frequencies in the kilohertz range to ultrasonic imaging in the megahertz range. The best-known application, ultrasonic imaging, is the second most utilized diagnostic imaging modality, after x-rays. High-intensity ultrasound has been used for therapeutic applications.

Ultrasonic imaging possesses numerous advantages over other imaging modalities of similar capabilities such as x-ray computed tomography, radionuclide imaging, and magnetic resonance imaging. It uses radiation that is noninvasive to the human body at the diagnostic intensity level, produces images at a very fast rate of 30 frames per second, and can be used to yield blood flow information by applying the Doppler principle. It has been used in a variety of medical disciplines, including cardiology, obstetrics, and radiology. See MEDICAL IMAGING.

Notable disadvantages of ultrasound are that organs containing gases and bony structures cannot be adequately imaged, and only a limited acoustic window (space or opening between bones) is available for examination of organs such as the heart and the neonatal brain.

Ultrasound at high intensity levels has been used for hyperthermia treatment of tumors, frequently in combination with chemotherapy or radiotherapy, and for tissue ablation. See ONCOLOGY; THERMOTHERAPY.

**Ultrasonic wave propagation.** Ultrasound is a form of acoustic wave with a frequency higher than 20 kHz. Ultrasound velocity and wavelength in water are approximately  $1.48 \times 10^5$  cm/s and 0.03 cm at 5 MHz and 20°C (68°F). The sound speeds in soft biological tissues are similar to that in water. The sound speeds of shear and longitudinal waves are different. Biological tissues other than bone can be treated as fluidlike media, and as such they cannot support shear-wave propagation. See SOUND.

**Ultrasonic imaging.** An ultrasonic image is formed from echoes returned from tissues. Although there are a number of ways of displaying the image, the B (brightness) mode is the most common (see illustration). In this mode, the echo amplitude is displayed in gray scale as a function of the distance into the tissue. The center of the B-mode imaging system is an energy-conversion device, the ultrasonic transducer, which converts the electric signal into ultrasound and vice versa. See MEDICAL ULTRASONIC TOMOGRAPHY; TRANSDUCER.

**Transducers.** An ultrasonic transducer contains one or more elements made from a piezoelectric ceramic such as lead zirconate titanate. Depending upon how a transducer is driven, ultrasonic scanners are classified as mechanical-sector and electronic-array scanners. Electronic-array systems produce images of better quality and are faster. Mechanical-sector scanners are no longer used except for special applications. A typical array

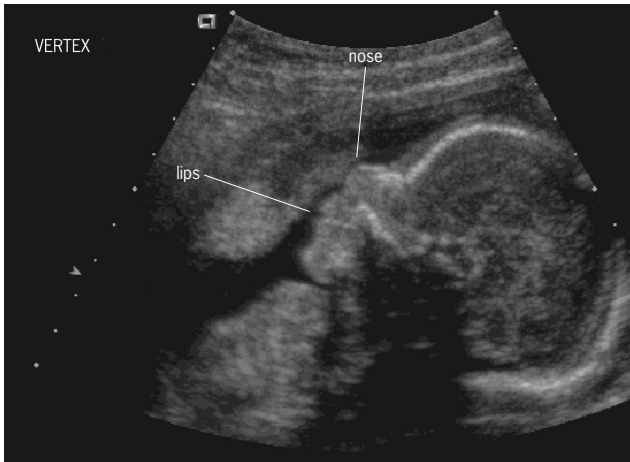

B-mode image of a fetus in the uterus.

consists of 128 or more small rectangular piezoelectric elements. In a linear sequenced array, or simply a linear array, a subaperture of 32 elements or more is fired simultaneously to form a beam. The beam is electronically focused and swept across the aperture surface from one end to the other. Electronic dynamic focusing can be achieved by appropriately controlling the timing of the signals to each individual element.

**Flow measurements.** The Doppler principle has been used to estimate blood flow in a blood vessel noninvasively. Two approaches have been used for ultrasonic Doppler flow measurements: continuous-wave and pulsed-wave Doppler. A probe consisting of two piezoelectric elements, one for transmitting the ultrasound signal and one for receiving the echoes returned from blood, is used in continuous-wave Doppler. A pulsed-wave Doppler may be used to alleviate the problem that a continuous-wave Doppler is unable to differentiate the origins of the Doppler signals produced within the ultrasound beam. Ultrasound bursts of 5–10 cycles are used, and the time of flight of the returned signal yields information about the signal's origin.

Color Doppler flow imaging scanners are capable of obtaining both B-mode images and Doppler blood flow data simultaneously in real time. The Doppler information is encoded in color. Red and blue are assigned to indicate flow toward and away from the transducer, respectively. The magnitude of the velocity is represented by the shade of the color. The color Doppler image is superimposed on the gray-scale B-mode image.

**Contrast media.** Ultrasonic contrast agents have been successfully developed to enhance the image contrast of anatomic structures that contain the agents. A majority of these agents utilize microscopic encapsulated gas bubbles, which are strong scatterers because of the acoustic impedance mismatch. Moreover, the bubbles can resonate when insonified by an ultrasonic wave, and therefore the echoes from the bubbles can be further enhanced if the incident wave is tuned to the resonant frequency of the bubbles. These bubbles have a mean diameter of less than 5 micrometers and can be injected intravenously.

**Biological effects of ultrasound.** Although ultrasound is known as a form of noninvasive radiation, biological effects inevitably result if its intensity is increased beyond some limit. Two types of ultrasound bioeffects can be produced: thermal and mechanical. No bioeffects have been found for ultrasound with a spatial peak temporal average intensity less than 100 mW/cm<sup>2</sup>. See CAVITATION. [K.K.S.]

**Biometeorology** A branch of meteorology and ecology that deals with the effects of weather and climate on plants, animals, and humans.

The principal problem for living organisms is maintaining an acceptable thermal equilibrium with their environment. Organ-

isms have natural techniques for adapting to adverse conditions. These techniques include acclimatization, dormancy, and hibernation, or in some cases an organism can move to a more favorable environment or microenvironment. Humans often establish a favorable environment through the use of technology. See DORMANCY; MICROMETEOROLOGY.

Homeotherms, that is, humans and other warm-blooded animals, maintain relatively constant body temperatures under a wide range of ambient thermal and radiative conditions through physiological and metabolic mechanisms. Poikilotherms, that is, cold-blooded animals, have a wide range in body temperature that is modified almost exclusively by behavioral responses. Plants also experience a wide range of temperatures, but because of their immobility they have less ability than animals to adapt to extreme changes in environment. See THERMOREGULATION.

Humans are physically adapted to a narrow range of temperature, with the metabolic mechanism functioning best at air temperatures around 77°F (25°C). There is a narrow range above and below this temperature where survival is possible. To regulate heat loss, warm-blooded animals developed hair, fur, and feathers. Humans invented clothing and shelter. The amount of insulation required to maintain thermal equilibrium is governed by the conditions in the atmospheric environment. There are a limited number of physiological mechanisms, controlled by the hypothalamus, that regulate body heat.

Clothing, shelter, and heat-producing objects can largely compensate for environmental cold, but with extensive exposure to cold, vasoconstriction in the peripheral organs can lead to chilblains and frostbite on the nose, ears, cheeks, and toes. This exposure is expressed quantitatively as a wind chill equivalent temperature that is a function of air temperature and wind speed. The wind chill equivalent temperature is a measure of convective heat loss and describes a thermal sensation equivalent to a lower-than-ambient temperature under calm conditions, that is, for wind speeds below 4 mi/h (1.8 m/s). Persons exposed to extreme cold develop hypothermia, which may be irreversible when the core temperature drops below 91°F (33°C.) See HYPOTHERMIA.

The combination of high temperature with high humidity leads to a very stressful thermal environment. The combination of high temperature with low humidity leads to a relatively comfortable thermal environment, but such conditions create an environment that has a very high demand for water.

Conditions of low humidity exist principally in subtropical deserts, which have the highest daytime temperatures observed at the Earth's surface. Human and animal bodies are also exposed to strong solar radiation and radiation reflected from the surface of the sand. This combination makes extraordinary demands on the sweat mechanism. Water losses of 1.06 quarts (1 liter) per hour are common in humans and may be even greater with exertion. Unless the water is promptly replaced by fluid intake, dehydration sets in. See DESERT; HUMIDITY; SOLAR RADIATION.

When humans are exposed to warm environments, the first physiological response is dilation of blood vessels, which increases the flow of blood near the skin. The next response occurs through sweating, panting, and evaporative cooling. Since individuals differ in their physiological responses to environmental stimuli, it is difficult to develop a heat stress index based solely on meteorological variables. Nevertheless, several useful indices have been developed.

Since wind moves body heat away and increases the evaporation from a person, it should be accounted for in developing comfort indices describing the outdoor environment. One such index, used for many years by heating and ventilating engineers, is the effective temperature. People will feel uncomfortable at effective temperatures above 81°F (27°C) or below 57°F (15°C); between 63°F (17°C) and 77°F (25°C) they will feel comfortable.

Both physiological and psychological responses to weather changes (meteorotropisms) are widespread and generally have their origin in some bodily impairment. Reactions to weather changes commonly occur in anomalous skin tissue such as scars and corns; changes in atmospheric moisture cause differential hygroscopic expansion and contraction between healthy and abnormal skin, leading to pain. Sufferers from rheumatoid arthritis are commonly affected by weather changes; both pain and swelling of affected joints have been noted with increased atmospheric humidity. Sudden cooling can also trigger such symptoms. Clinical tests have shown that in these individuals the heat regulatory mechanism does not function well, but the underlying cause is not understood.

Weather is a significant factor in asthma attacks. Asthma as an allergic reaction may, in rare cases, be directly provoked by sudden changes in temperature that occur after passage of a cold front. Often, however, the weather effect is indirect, and attacks are caused by airborne allergens, such as air pollutants and pollen. An even more indirect relationship exists for asthma attacks in autumn, which often seem to be related to an early outbreak of cold air. This cold air initiates home or office heating, and dormant dust or fungi from registers and radiators are convected into rooms, irritating allergic persons. See ALLERGY; ASTHMA.

A variety of psychological effects have also been attributed to heat. They are vaguely described as lassitude, decrease in mental and physical performance, and increased irritability. Similar reactions to weather have been described for domestic animals, particularly dogs; hence hot, humid days are sometimes known as dog days.

Meteorological and seasonal changes in natural illumination have a major influence on animals. Photoperiodicity is widespread. The daily cycle of illumination triggers the feeding cycle in many species, especially birds. In insectivores the feeding cycle may result from the activities of the insects, which themselves show temperature-influenced cycles of animation. Bird migration may be initiated by light changes, but temperature changes and availability of food are also involved. In the process of migration, especially over long distances, birds have learned to take advantage of prevailing wind patterns. In humans, light deprivation, as is common in the cold weather season in higher latitudes, is suspected as a cause of depression. Exposure to high-intensity light for several hours has been found to be an effective means of treating this depression. See AFFECTIVE DISORDERS; MIGRATORY BEHAVIOR; PHOTOPERIODISM.

Humans and animals often exhibit a remarkable ability to adapt to harsh or rapidly changing environmental conditions. An obvious means of adaptation is to move to areas where environmental conditions are less severe; examples are birds and certain animals that migrate seasonally, animals that burrow into the ground, and animals that move to shade or sunshine depending on weather conditions. Animals can acclimatize to heat and cold. The acclimatization process is generally complete within 2–3 weeks of exposure to the stressful conditions. For example, in hot climates heat regulation is improved by the induction of sweating at a lower internal body temperature and by the increase of sweating rates. The acclimatization to cold climates is accomplished by increase in the metabolic rate, by improvement in the insulating properties of the skin, and by the constriction of blood vessels to reduce the flow of blood to the surface. See BURROWING ANIMALS.

Unlike humans and animals, plants cannot move from one location to another; therefore, they must adapt genetically to their atmospheric environment. Plants are often characteristic for their climatic zone, such as palms in the subtropics and birches or firs in regions with cold winters. Whole systems of climatic classification are based on the native floras. See ALTITUDINAL VEGETATION ZONES; ECOLOGY; METEOROLOGY. [B.L.B.; H.E.L.]

**Bioorganic chemistry** The science that describes the structure, interactions, and reactions of organic compounds of biological significance at the molecular level. It represents the meeting of biochemistry, as attempts are made to describe the structure and physiology of organisms on an ever smaller scale, with organic chemistry, as attempts are made to synthesize and understand the behavior of molecules of ever-increasing size and complexity. Areas of research include enzymatic catalysis, the structure and folding of proteins, the structure and function of biological membranes, the chemistry of poly(ribonucleic acids) and poly(deoxyribonucleic acids), biosynthetic pathways, immunology, and mechanisms of drug action.

Being at the interface of two disciplines, bioorganic chemistry utilizes experimental techniques and theoretical concepts drawn from both. Important experimental techniques include organic synthesis, kinetics, structure-activity relationships, the use of model systems, methods of protein purification and manipulation, genetic mutation, cloning and overexpression (engineered enhancement of gene transcription), and the elicitation of monoclonal antibodies. Theoretical concepts important to bioorganic chemistry include thermodynamics, transition-state theory, acid-base theory, concepts of hydrophobicity and hydrophilicity, theories of stereocontrol, and theories of adaptation of organisms to selective pressures.

Historically, a major focus of bioorganic research has been the study of catalysis by enzymes. Enzymes have a dramatic ability to increase the rates at which reactions occur. One of the ways that enzymes increase the rates of bimolecular reactions is to overcome the entropic barrier associated with bringing two particles together to form one. See ENZYME.

Enzymes also catalyze reactions by facilitating proton transfers. Many of the reactions catalyzed by enzymes, such as the formation and hydrolysis of esters and amides, require the deprotonation of a nucleophile (base catalysis) or the protonation of an electrophile (acid catalysis).

Enzymes may act as preorganized solvation shells for transition states. If the active site of an enzyme has just the right size, shape, and arrangement of functional groups to bind a transition state, it will automatically bind the reactants less well. Selective binding of the transition state lowers the energy of the transition state relative to that of the reactants. Because the energy barrier between reactants and transition state is reduced, the reaction proceeds more rapidly.

The selectivity of enzymes makes them useful as catalysts for organic synthesis. Surprisingly, enzymes are able to catalyze not only the reactions that they mediate in living systems but also similar, selective transformations of unnatural substrates. Because of their selectivity, several enzyme-catalyzed reactions may run simultaneously in the same vessel. Thus, a reactant can undergo several reactions in series without the need for isolation of intermediates. Enzymes can be combined so as to reconstitute within a reaction vessel naturally occurring metabolic pathways or to create new, artificial metabolic pathways. Sequences of up

to 12 serial reactions have been executed successfully in a single reaction vessel. See CATALYSIS.

The biological activity of a protein, whether binding, catalytic, or structural, depends on its full three-dimensional or conformational structure. The linear sequence of amino acids that make up a protein constitutes its primary structure. Local regions of highly organized conformation ( $\alpha$ -helices,  $\beta$ -pleats,  $\beta$ -turns, and so on) are called secondary structure. Further folding of the protein causes regions of secondary structure to associate or come into correct alignment. This action establishes the tertiary structure of the native (active) protein. A goal of bioorganic chemistry is to achieve an understanding of the process of protein folding. See AMINO ACIDS; BIOCHEMISTRY; ORGANIC CHEMISTRY; PROTEIN. [H.K.C.]

**Biophysics** A hybrid science involving the overlap of physics, chemistry, and biology. A dominant aspect is the use of the ideas and methods of physics and chemistry to study and explain the structures of living organisms and the mechanisms of life processes. The recognition of biophysics as a separate field is relatively recent, having been brought about, in part, by the invention of physical tools such as the electron microscope, the ultracentrifuge, and the electronic amplifier, which greatly facilitate biophysical research. These tools are peculiarly adapted to the study of problems of great current importance to medicine, problems related to virus diseases, cancer, heart disease, and the like.

The major areas of biophysics are the following:

Molecular biophysics has to do with the study of large molecules and particles of comparable size which play important roles in biology. The most important physical tools for such research are the electron microscope, the ultracentrifuge, and the x-ray diffraction camera. See MOLECULAR BIOLOGY; ULTRACENTRIFUGE; X-RAY DIFFRACTION.

Radiation biophysics consists of the study of the response of organisms to ionizing radiations, such as alpha, beta, gamma, and x-rays, and to ultraviolet light. The biological responses are death of cells and tissues, if not of whole organisms, and mutation, either somatic or genetic.

Physiological biophysics, called by some classical biophysics, is concerned with the use of physical mechanisms to explain the behavior and the functioning of living organisms or parts of living organisms and with the response of living organisms to physical forces.

Mathematical and theoretical biophysics deals primarily with the attempt to explain the behavior of living organisms on the basis of mathematics and physical theory. Biological processes are being examined in terms of thermodynamics, hydrodynamics, and statistical mechanics. Mathematical models are being investigated to see how closely they simulate biological processes. See BIOMECHANICS; BIOPOTENTIALS AND IONIC CURRENTS; MATHEMATICAL BIOLOGY; MICROMANIPULATION; MICROSCOPE; MUSCLE PROTEINS; MUSCULAR SYSTEM; OXIMETRY; SKELETAL SYSTEM; SPACE BIOLOGY; THERMOREGULATION; THERMOTHERAPY. [M.A.L.]

**Biopolymer** A macromolecule derived from natural sources; also known as biological polymer. Some biopolymers are used as structural materials, food sources, or catalysts. Others have evolved as entities for information storage and transfer. Examples of biopolymers include polypeptides; polysaccharides; polypeptide/polysaccharide hybrids; polynucleotides, which are polymers derived from ribonucleic acid (RNA) and deoxyribonucleic acid (DNA); polyhydroxybutyrates, a class of polyesters produced by certain bacteria; and *cis*-1,4-polyisoprene, the major component of rubber tree latex. See POLYMER.

Amino acids are the monomers from which polypeptides are derived. Polypeptides alone, as well as multipolypeptide complexes or complexes with other molecules, are known as proteins, and each has a specific biological function. There are numerous

examples of biopolymers having a polysaccharide and polypeptide in the same molecule, usually with a polysaccharide as a side chain in a polypeptide, or vice versa. See PEPTIDE; POLYSACCHARIDE; PROTEIN. [G.E.W.]

**Biopotentials and ionic currents** The voltage differences which exist between separated points in living cells, tissues, organelles, and organisms are called biopotentials. Related to these biopotentials are ionic charge transfers, or currents, that give rise to much of the electrical changes occurring in nerve, muscle, and other electrically active cells. Electrophysiology is the science concerned with uncovering the structures and functions of bioelectrical systems, including the entities directly related to biological potentials and currents. According to their function, these structures are given descriptive names such as channels, carriers, ionophores, gates, and pumps.

The potential difference measured with electrodes between the interior cytoplasm and the exterior aqueous medium of the living cell is generally called the membrane potential or resting potential ( $E_{RP}$ ). This potential is usually in the order of several tens of millivolts and is relatively constant or steady. The range of  $E_{RP}$  values in various striated muscle cells of animals from insects through amphibia to mammals is about  $-50$  to  $-100$  mV (the voltage is negative inside with respect to outside). Nerve cells show a similar range in such diverse species as squid, cuttlefish, crabs, lobsters, frogs, cats, and humans. Similar potentials have been recorded in single tissue-culture cells.

Biopotentials arise from the electrochemical gradients established across cell membranes. In most animal cells, potassium ions are in greater concentration internally than externally, and sodium ions are in less concentration internally than externally. Generally, chloride ions are in less concentration inside cells than outside cells, even though there are abundant intracellular fixed negative charges. While calcium ion concentration is relatively low in body fluids external to cells, the concentration of ionized calcium internally is much lower (in the nanomolar range) than that found external to the cells.

**Sodium pump.** Measurements of ionic movements through cell membranes of muscle fibers by H. B. Steinbach and by L. A. Heppel in the late 1930s and early 1940s found that radioisotopically labeled sodium ion movement through the cell membrane from inside to outside seemed to depend upon the metabolism of the cell. I. M. Glynn showed that the sodium efflux from red cells depended on the ambient glucose concentration, and A. L. Hodgkin and R. D. Keynes demonstrated in squid and *Sepia* giant axons that the sodium efflux could be blocked by a variety of metabolic inhibitors (cyanide, 2,4-dinitrophenol, and azide). It was proposed that a metabolic process (sodium pump) located in the cell membrane extruded sodium from the cell interior against an electrochemical gradient. P. C. Caldwell's experiments on the squid's giant axon in the late 1950s indicated that there was a close relation between the activity of the sodium pump and the intracellular presence of high-energy compounds, such as adenosine triphosphate (ATP) and arginine phosphate. Caldwell suggested that these compounds might be directly involved in the active transport mechanism. Evidence by R. L. Post for red cells and by Caldwell for the giant axon also suggested that there was a coupling between sodium extrusion and potassium uptake. Convincing evidence has been presented that ATP breakdown to adenosine diphosphate and phosphorus (ADP + P) provides the immediate energy for sodium pumping in the squid giant axon. It seems that the sodium pump is a sufficient explanation to account for the high internal potassium and the low internal sodium concentrations in nerve, muscle, and red blood cells. See ABSORPTION (BIOLOGY); CELL PERMEABILITY.

**Channels.** In living cells there are two general types of ion transport processes. In the first, the transported ionic species flows down the gradient of its own electrochemical potential.

In the second, there is a requirement for immediate metabolic energy. This first category of bioelectrical events is associated with a class of molecules called channels, embedded in living cell membranes. It is now known that cell membranes contain many types of transmembrane channels. Channels are protein structures that span the lipid bilayers forming the backbones of cell membranes. The cell membranes of nerve, muscle, and other tissues contain ionic channels. These ionic channels have selectivity filters in their lumens such that in the open state only certain elementary ion species are admitted to passage, with the exclusion of other ion species. See CELL MEMBRANES.

There are two general types of channels, and these are classified according to the way in which they respond to stimuli. Electrically excitable channels have opening and closing rates that are dependent on the transmembrane electric field. Chemically excitable channels (usually found in synaptic membranes) are controlled by the specific binding of certain activating molecules (agonists) to receptor sites associated with the channel molecule.

Calcium channels are involved in synaptic transmission. When a nerve impulse arrives at the end of a nerve fiber, calcium channels open in response to the change in membrane potential. These channels admit calcium ions, which act on synaptic vesicles, facilitating their fusion with the presynaptic membrane. Upon exocytosis, these vesicles release transmitter molecules, which diffuse across the synaptic cleft to depolarize the postsynaptic membrane by opening ionic channels. Transmitter activity ceases from the action of specific transmitter esterases or by reabsorption of transmitter back into vesicles in the presynaptic neuron. Calcium channels inactivate and close until another nerve impulse arrives at the presynaptic terminal. Thus biopotentials play an important role in both the regulation and the genesis of synaptic transmission at the membrane channel level. See NERVE.

Ionic currents flow through open channels. The ion impermeable membrane lipid bilayer acts as a dielectric separating two highly conductive salt solutions. Ionic channels have the electrical property of a conductance between these solutions. The membrane conductance at any moment depends on the total number of channels, the type of channels, the fraction of channels found in the open state, and the unit conductances of these open channels. The most common channels directly giving rise to biopotentials are those admitting mainly sodium ions, potassium ions, chloride ions, or calcium ions. These channels are named after the predominant charge carrier admitted in the open state, such as potassium channels. It is now known that there are charged amino acid groups lining the channel lumen that determine the specificity of the channel for particular ions. These selectivity filters admit only ions of the opposite charge.

Hodgkin and A. F. Huxley proposed in 1952 that there were charged molecular entities responsible for the opening and closing of the ionic conductance pathways. These structures had to be charged to be able to move in response to changing electrical forces when the membrane voltage changed. Any movement of the gating structures would require a movement of charge and hence should have a detectable component of current flow across the membrane. It was not until 1973 that the existence of a gating current in squid axon sodium channels was demonstrated, and gating currents and their significance became a lively endeavor in membrane biophysics. [W.J.A.]

**Biopyribole** A member of a chemically diverse, structurally related group of minerals that comprise substantial fractions of both the Earth's crust and upper mantle. The term was coined by Albert Johannsen in 1911; it is a contraction of biotite (a mica), pyroxene, and amphibole.

The pyroxene minerals contain single chains of corner-sharing silicate ( $\text{SiO}_4$ ) tetrahedra, and the amphiboles contain double

chains. Likewise, the micas and other related biopyriboles (talc, pyrophyllite, and the brittle micas) contain two-dimensionally infinite silicate sheets, which result in their characteristic sheetlike physical properties. In the pyroxenes and amphiboles, the silicate chains are articulated to strips of octahedrally coordinated cations, such as magnesium and iron; and in the sheet biopyriboles, the silicate sheets are connected by two-dimensional sheets of such cations. In addition to the classical single-chain, double-chain, and sheet biopyriboles, several biopyriboles that contain triple silicate chains have been discovered. See BIOTITE; MICA; PYROXENE; SILICATE MINERALS.

Pyroxenes, amphiboles, and micas of various compositions can occur in igneous, metamorphic, and sedimentary rocks. Pyroxenes are the second most abundant minerals in the Earth's crust (after feldspars) and in the upper mantle (after olivine). Unlike the pyroxenes, amphiboles, and micas, the wide-chain biopyriboles do not occur as abundant minerals in a wide variety of rock types. However, some of them may be widespread in nature as components of fine-grain alteration products of pyroxenes and amphiboles and as isolated lamellae in other biopyriboles. See IGNEOUS ROCKS; METAMORPHIC ROCKS; SEDIMENTARY ROCKS. [D.R.V.]

**Biorheology** The study of the flow and deformation of biological materials. The behavior and fitness of living organisms depend partly on the mechanical properties of their structural materials. Thus, biologists are interested in biorheology from the point of view of evolution and adaptation to the environment. Physicians are interested in it in order to understand health and disease. Bioengineers devise methods to measure or to change the rheological properties of biological materials, develop mathematical descriptions of biorheology, and create new practical applications for biorheology in agriculture, industry, and medicine.

The rheological behavior of most biological materials is more complex than that of air, water, and most structural materials used in engineering. Air and water are viscous fluids; all fluids whose viscosity is similar to that of air and water are called newtonian fluids. Biological fluids such as protoplasm, blood, and synovial fluid behave differently, however, and they are called non-newtonian fluids. For example, blood behaves like a fluid when it flows, but when it stops flowing it behaves like a solid with a small but finite yield stress. See FLUID FLOW; NON-NEWTONIAN FLUID; VISCOSITY.

Most materials used in engineering construction, such as steel, aluminum, or rock, obey Hooke's law, according to which stresses are linearly proportional to strains. These materials deviate from Hooke's law only when approaching failure. A structure made of Hookean materials behaves linearly: load and deflection are a linearly proportional to each other in such a structure. Some biological materials, such as bone and wood, also obey Hooke's law in their normal state of function, but many others, such as skin, tendon, muscle, blood vessels, lung, and liver, do not. These materials, referred to as non-Hookean, become stiffer as stress increases. See BONE; ELASTICITY; STRESS AND STRAIN.

In biorheology, so-called constitutive equations are used to describe the complex mechanical behavior of materials in terms of mathematics. At least three kinds of constitutive equations are needed: those describing stress-strain relationships of material in the normal state of life; those describing the transport of matter, such as water, gas, and other substances, in tissues; and those describing growth or resorption of tissues in response to long-term changes in the state of stress and strain. The third type is the most fascinating, but there is very little quantitative information available about it except for bone. The second type is very complex because living tissues are nonhomogeneous, and since mass transport in tissues is a molecular phenomenon, it is accentuated by nonhomogeneity at the cellular level. The best-known constitutive equations are therefore of the first kind. See BIOMECHANICS. [Y.C.F.]



**Biosensor** An integrated device consisting of a biological recognition element and a transducer capable of detecting the biological reaction and converting it into a signal which can be processed. Ideally, the sensor should be self-contained, so that it is not necessary to add reagents to the sample matrix to obtain the desired response. There are a number of analytes (the target substances to be detected) which are measured in biological media: pH, partial pressure of carbon dioxide ( $p\text{CO}_2$ ), partial pressure of oxygen ( $p\text{O}_2$ ), and the ionic concentrations of sodium, potassium, calcium, and chloride. However, these sensors do not use biological recognition elements, and are considered chemical sensors. Normally, the biological recognition element is a protein or protein complex which is able to recognize a particular analyte in the presence of many other components in a complex biological matrix. This definition has since been expanded to include oligonucleotides. The recognition process involves a chemical or biological reaction, and the transducer must be capable of detecting not only the reaction but also its extent. An ideal sensor should yield a selective, rapid, and reliable response to the analyte, and the signal generated by the sensor should be proportional to the analyte concentration.

Biosensors are typically classified by the type of recognition element or transduction element employed. A sensor might be described as a catalytic biosensor if its recognition element comprised an enzyme or series of enzymes, a living tissue slice (vegetal or animal), or whole cells derived from microorganisms such as bacteria, fungi, or yeast. The sensor might be described as a bioaffinity sensor if the basis of its operation were a biospecific complex formation. Accordingly, the reaction of an antibody with an antigen or hapten, or the reaction of an agonist or antagonist with a receptor, could be employed. In the former case, the sensor might be called an immunosensor.

Since enzyme-based sensors measure the rate of the enzyme-catalyzed reaction as the basis for their response, any physical measurement which yields a quantity related to this rate can be used for detection. The enzyme may be immobilized on the end of an optical fiber, and the spectroscopic properties (absorbance, fluorescence, chemiluminescence) related to the disappearance of the reactants or appearance of products of the reaction can be measured. Since biochemical reactions can be either endothermic (absorbing heat) or exothermic (giving off heat), the rate of the reaction can be measured by microcalorimetry. Miniaturized thermistor-based calorimeters, called enzyme thermistors, have been developed and widely applied, especially for bioprocess monitoring.

In the case of affinity biosensors, as is true of catalytic biosensors, many physical techniques can be used to detect affinity binding: microcalorimetry (thermometric enzyme-linked immunosorbent assay, or *TELISA*), fluorescence energy transfer, fluorescence polarization, or bioluminescence.

The quality of the results obtained from sensors based on biological recognition elements depends most heavily on their ability to react rapidly, selectively, and with high affinity. Antibodies and receptors frequently react with such high affinity that the analyte does not easily become unbound. To reuse the sensor requires a time-consuming regeneration step. Nonetheless, if this step can be automated, semicontinuous monitoring may be possible. [G.S.W.]

**Biosphere** All living organisms and their environments at the surface of the Earth. Included in the biosphere are all environments capable of sustaining life above, on, and beneath the Earth's surface as well as in the oceans. Consequently, the biosphere overlaps virtually the entire hydrosphere and portions of the atmosphere and outer lithosphere. See *ATMOSPHERE*; *HYDROSPHERE*; *LITHOSPHERE*.

Neither the upper nor lower limits of the biosphere are sharp. Spores of microorganisms can be carried to considerable heights in the atmosphere, but these are resting stages that are not actively metabolizing. A variety of organisms inhabit the ocean

depths, including the giant tubeworms and other creatures that were discovered living around hydrothermal vents. Evidence exists for the presence of bacteria in oil reservoirs at depths of about 6600 ft (2000 m) within the Earth. The bacteria are apparently metabolically active, utilizing the paraffinic hydrocarbons of the oils as an energy source. These are extreme limits to the biosphere; most of the mass of living matter and the greatest diversity of organisms are within the upper 330 ft (100 m) of the lithosphere and hydrosphere, although there are places even within this zone that are too dry or too cold to support much life. Most of the biosphere is within the zone which is reached by sunlight and where liquid water exists.

The biosphere is characterized by the interrelationship of living things and their environments. Communities are interacting systems of organisms tied to their environments by the transfer of energy and matter. Such a coupling of living organisms and the nonliving matter with which they interact defines an ecosystem. An ecosystem may range in size from a small pond, to a tropical forest, to the entire biosphere. Ecologists group the terrestrial parts of the biosphere into about 12 large units called biomes. Examples of biomes include tundra, desert, grassland, and boreal forest. See *BIOME*; *ECOLOGICAL COMMUNITIES*; *ECOSYSTEM*.

Human beings are part of the biosphere, and some of their activities have an adverse impact on many ecosystems and on themselves. As a consequence of deforestation, urban sprawl, spread of pollutants, and overharvesting, both terrestrial and marine ecosystems are being destroyed or diminished, populations are shrinking, and many species are dying out. In addition to causing extinctions of some species, humans are expanding the habitats of other organisms, sometimes across oceanic barriers, through inadvertent transport and introduction into new regions. Humans also add toxic or harmful substances to the outer lithosphere, hydrosphere, and atmosphere. Many of these materials are eventually incorporated into or otherwise affect the biosphere, and water and air supplies in some regions are seriously fouled. See *HAZARDOUS WASTE*. [R.M.M.]

**Biostrume** An evenly bedded and generally horizontally layered stratum composed mostly of organic remains, normally considered to be those of sedentary organisms which lived, died, and were buried essentially in place.

The criterion of formation by in-place growth of organisms is subject to some interpretation. Crinoidal limestones obviously resulted from the accumulation of decayed pieces of millions of these stalked echinoderms, often with accompanying detritus of associated fenestrate bryozoans. Usually it is impossible to ascertain whether such debris dropped vertically a few centimeters or meters through the water column as the organisms died and collapsed (an essentially in-place deposit) or whether the layers of crinoidal grainstone were piled mechanically by currents. The same is true of coquinas of many other thin-shelled calcareous tests, such as those of brachiopods, bryozoans, and trilobites.

Biostromal layers need not have been horizontally deposited when they occur as flanking beds around organic buildups. Dips of up to 25 or 30° are possible here. Such biostromes are probably veneers of sessile organisms which lived somewhat above the realm of deposition and were buried as sediment cascaded down the flank of a mound. [J.L.Wi.]

**Biosynthesis** The synthesis of more complex molecules from simpler ones in cells by a series of reactions mediated by enzymes. The overall economy and survival of the cell is governed by the interplay between the energy gained from the breakdown of compounds and that supplied to biosynthetic reaction pathways for the synthesis of compounds having a functional role, such as deoxyribonucleic acid (DNA), ribonucleic acid (RNA), and enzymes. Biosynthetic pathways give rise to two distinct classes of metabolite, primary and secondary. Primary metabolites (DNA, RNA, fatty acids,  $\alpha$ -amino acids, chlorophyll in green plants, and so forth) are essential to the metabolic

functioning of the cells. Secondary metabolites (antibiotics, alkaloids, pheromones, and so forth) aid the functioning and survival of the whole organism more generally. Unlike primary metabolites, secondary metabolites are often unique to individual organisms or classes of organisms. See ENZYME; METABOLISM.

The selective pressures that drive evolution have ensured a diverse array of secondary metabolite structures. Secondary metabolites can be grouped to some extent by virtue of their origin from key biosynthetic pathways. It is often in the latter stages of these pathways that the structural diversity is introduced. All terpenes, for example, originate from the C<sub>5</sub> (five-carbon) intermediate isopentenyl pyrophosphate via mevalonic acid. The mammalian steroids, such as cholesterol, derive from the C<sub>30</sub> steroid lanosterol, which is constructed from six C<sub>5</sub> units. Alternatively, C<sub>10</sub> terpenes (for example, menthol from peppermint leaves) and C<sub>15</sub> terpenes (for example, juvenile hormone III from the silk worm) are derived after the condensation of two and three C<sub>5</sub> units, respectively, and then with further enzymatic customization in each case. See CHOLESTEROL; ORGANIC EVOLUTION; STEROID; TERPENE; TRITERPENE. [D.O'H.]

**Biot-Savart law** A law of physics which states that the magnetic flux density (magnetic induction) near a long, straight conductor is directly proportional to the current in the conductor and inversely proportional to the distance from the conductor. The field near a straight conductor can be found by application of Ampère's law. The magnetic flux density near a long, straight conductor is at every point perpendicular to the plane determined by the point and the line of the conductor. Therefore, the lines of induction are circles with their centers at the conductor. Furthermore, each line of induction is a closed line. This observation concerning flux about a straight conductor may be generalized to include lines of induction due to a conductor of any shape by the statement that every line of induction forms a closed path. See AMPÈRE'S LAW. [K.V.M.]

**Biotechnology** Generally, any technique that is used to make or modify the products of living organisms in order to improve plants or animals, or to develop useful microorganisms. In modern terms, biotechnology has come to mean the use of cell and tissue culture, cell fusion, molecular biology, and in particular, recombinant deoxyribonucleic acid (DNA) technology to generate unique organisms with new traits or organisms that have the potential to produce specific products. Some examples of products in a number of important disciplines are described below.

Recombinant DNA technology has opened new horizons in the study of gene function and the regulation of gene action. In particular, the ability to insert genes and their controlling nucleic acid sequences into new recipient organisms allows for the manipulation of these genes in order to examine their activity in unique environments, away from the constraints posed in their normal host. Genetic transformation normally is achieved easily with microorganisms; new genetic material may be inserted into them, either into their chromosomes or into extrachromosomal elements, the plasmids. Thus, bacteria and yeast can be created to metabolize specific products or to produce new products. See GENE; GENE ACTION; PLASMID.

Genetic engineering has allowed for significant advances in the understanding of the structure and mode of action of antibody molecules. Practical use of immunological techniques is pervasive in biotechnology. See ANTIBODY.

Few commercial products have been marketed for use in plant agriculture, but many have been tested. Interest has centered on producing plants that are resistant to specific herbicides. This resistance would allow crops to be sprayed with the particular herbicide, and only the weeds would be killed, not the genetically engineered crop species. Resistances to plant virus diseases have been induced in a number of crop species by transforming plants

with portions of the viral genome, in particular the virus's coat protein.

Biotechnology also holds great promise in the production of vaccines for use in maintaining the health of animals. Interferons are also being tested for their use in the management of specific diseases.

Animals may be transformed to carry genes from other species including humans and are being used to produce valuable drugs. For example, goats are being used to produce tissue plasminogen activator, which has been effective in dissolving blood clots.

Plant scientists have been amazed at the ease with which plants can be transformed to enable them to express foreign genes. This field has developed very rapidly since the first transformation of a plant was reported in 1982, and a number of transformation procedures are available.

Genetic engineering has enabled the large-scale production of proteins which have great potential for treatment of heart attacks. Many human gene products, produced with genetic engineering technology, are being investigated for their potential use as commercial drugs. Recombinant technology has been employed to produce vaccines from subunits of viruses, so that the use of either live or inactivated viruses as immunizing agents is avoided. Cloned genes and specific, defined nucleic acid sequences can be used as a means of diagnosing infectious diseases or in identifying individuals with the potential for genetic disease. The specific nucleic acids used as probes are normally tagged with radioisotopes, and the DNAs of candidate individuals are tested by hybridization to the labeled probe. The technique has been used to detect latent viruses such as herpes, bacteria, mycoplasmas, and plasmidia, and to identify Huntington's disease, cystic fibrosis, and Duchenne muscular dystrophy. It is now also possible to put foreign genes into cells and to target them to specific regions of the recipient genome. This presents the possibility of developing specific therapies for hereditary diseases, exemplified by sickle-cell anemia.

Modified microorganisms are being developed with abilities to degrade hazardous wastes. Genes have been identified that are involved in the pathway known to degrade polychlorinated biphenyls, and some have been cloned and inserted into selected bacteria to degrade this compound in contaminated soil and water. Other organisms are being sought to degrade phenols, petroleum products, and other chlorinated compounds. See GENETIC ENGINEERING; MOLECULAR BIOLOGY. [M.Z.]

**Biotelemetry** The use of telemetry methods for sending signals from a living organism over some distance to a receiver. Usually, biotelemetry is used for gathering data about the physiology, behavior, or location of the organism. Generally, the signals are carried by radio, light, or sound waves. Consequently, biotelemetry implies the absence of wires between the subject and receiver. See ANTENNA (ELECTROMAGNETISM); RADIO RECEIVER; RADIO TRANSMITTER.

Generally, biotelemetry techniques are necessary in situations when wires running from a subject to a recorder would inhibit the subject's activity; when the proximity of an investigator to a subject might alter the subject's behavior; and when the movements of the subject and the duration of the monitoring make it impractical for the investigator to remain within sight of the subject. Biotelemetry is widely used in medical fields to monitor patients and research subjects, and now even to operate devices such as drug delivery systems and prosthetics. Sensors and transmitters placed on or implanted in animals are used to study physiology and behavior in the laboratory and to study the movements, behavior, and physiology of wildlife species in their natural environments.

Biotelemetry is an important technique for biomedical research and clinical medicine. Perhaps cardiovascular research and treatment have benefited the most from biotelemetry. Heart rate, blood flow, and blood pressure can be measured in

ambulatory subjects and transmitted to a remote receiver-recorder. Telemetry also has been used to obtain data about local oxygen pressure on the surface of organs (for example, liver and myocardium) and for studies of capillary exchange (that is, oxygen supply and discharge). Biomedical research with telemetry includes measuring cardiovascular performance during the weightlessness of space flight and portable monitoring of radioactive indicators as they are dispersed through the body by the blood vessels. See SPACE BIOLOGY.

Telemetry has been applied widely to animal research, for example, to record electroencephalograms, heart rates, heart muscle contractions, and respiration, even from sleeping mammals and birds. Telemetry and video recording have been combined in research of the relationships between neural and cardiac activity and behavior. Using miniature electrodes and transmitters, ethologists have studied the influence of one bird's song on the heart rate and behavior of a nearby bird.

Many species of wildlife are difficult to find and observe because they are secretive, nocturnal, wide-ranging, or move rapidly. Most commonly, a transmitter is placed on a wild animal so that biologists can track or locate it by homing toward the transmitted signal or by estimating the location by plotting the intersection of two or more bearings from the receiver toward the signal. For some purposes, after homing to a transmitter-marked animal, the biologists observe its behavior. For other studies, successive estimates of location are plotted on a map to describe movement patterns, to delineate the amount of area the animal requires, or to determine dispersal or migration paths. Ecologists can associate the vegetation or other features of the environment with the locations of the animal.

There are usually two concerns associated with the use of biotelemetry: the distance over which the signal can be received, and the size of the transmitter package. Often, both of these concerns depend on the power source for the transmitter. Integrated circuits and surface mount technology allow production of very small electronic circuitry in transmitters, making batteries the largest part of the transmitter package. However, the more powerful transmitters with their larger batteries are more difficult to place on or implant in a subject without affecting the subject's behavior or energetics. See BATTERY. [M.R.F.]

**Biotin** A vitamin, widespread in nature. It is only sparingly soluble in water; it is stable in boiling water solutions, but can be destroyed by oxidizing agents, acids, and alkalis. Under some conditions, it can be destroyed by oxidation in the presence of rancid fats. Biotin's occurrence in nature is so widespread that it is difficult to prepare a natural deficient diet. Biotin deficiency in animals is associated with dermatitis, loss of hair, muscle incoordination and paralysis, and reproductive disturbances. Biotin deficiency produced in humans by feeding large amounts of egg white resulted in dermatitis, nausea, depression, muscle pains, anemia, and a large increase in serum cholesterol. See COENZYME. [S.N.G.]

**Biotite** An iron-magnesium-rich layer silicate; it is also known as black mica. Biotite is the most abundant of the mica group of minerals. The name is derived from that of the French chemist J. Biot. The formula for the ideal end member, phlogopite, is  $KMg_3AlSi_3O_{10}(OH)_2$ . The more general formula is  $AX_3Y_4O_{12}(Z)_2$ , where A (interlayer cation) = K, Na, Ca, Ba, or vacancies; X (octahedral cations) = Li, Mg,  $Fe^{2+}$ ,  $Fe^{3+}$ , Al, Ti, or vacancies; and Y (tetrahedral cation) =  $Fe^{3+}$ , Al, Si; Z = (OH), F, Cl,  $O^{2-}$ . This formula is more indicative of the wide range of compositions known for this mineral. Biotite has no commercial value, but vermiculite, an alteration product of magnesium-rich biotite, is used as insulation, as packing material, and as an ingredient for potting soils. See VERMICULITE.

Biotites are found commonly in igneous and metamorphic rocks. They are the common ferromagnesian phase in most granitic rocks, and are also found in some siliceous and interme-

diate volcanic rocks. In basaltic rocks biotite sometimes occurs in the crystalline groundmass, and is a common late interstitial phase in gabbroic rocks. It has been recognized in samples of the Earth's mantle found as inclusions in volcanic rocks. Biotites are not stable at the surface of the Earth, as they decompose by both hydrolysis and oxidation when exposed to the Earth's atmosphere. They alter to vermiculite, chlorite, and iron oxides, and thus are uncommon in sedimentary rocks. Biotites are important constituents of metamorphic rocks such as schist and gneiss, and the first appearance of biotite is an important marker in metamorphism. Biotite persists to very high grades of metamorphism, where it reacts with quartz to form granulites made up of potassium feldspar and orthopyroxene, garnet, or cordierite, in addition to quartz and plagioclase. Under conditions of ultrametamorphism, biotite reacts with quartz, plagioclase, and alkali feldspar to form siliceous melts. Biotite is also a common gangue mineral in ore deposits. The mineral has been used as an indicator of  $H_2O$ , HF,  $O_2$ , and  $S_2$  activities in both rock- and ore-forming processes. See IGNEOUS ROCKS; METAMORPHIC ROCKS; METAMORPHISM; MICA; SILICATE MINERALS. [D.R.W.]

**Birch** A deciduous tree of the genus *Betula* which is distributed over much of North America, in Asia south to the Himalaya, and in Europe. About 40 species are known. The birches comprise the family Betulaceae in the order Fagales. The sweet birch, *B. lenta*, the yellow birch, *B. alleghaniensis*, and the paper birch, *B. papyrifera*, are all important timber trees of eastern United States. The yellow and the paper species extend into Canada. The gray birch, *B. populifolia*, is a smaller tree of the extreme northeastern United States and adjacent Canada. Both sweet (black) and yellow birches can be recognized by the wintergreen taste of the bark of the young twigs. A flavoring similar to oil of wintergreen is obtained from the bark of the sweet birch. The paper and gray birches can be easily identified by their white bark. The bark of the paper birch peels off in thin papery sheets, a characteristic not true of the gray birch. The river birch, *B. nigra*, is a less common tree of wet soils and banks of streams and is important as an ornamental and for erosion control. The hard, strong wood of the yellow and the sweet birches is used for furniture, boxes, baskets, crates, and woodenware. The European birches, *B. pubescens* and *B. pendula*, are the counterparts of the paper and gray birches in the United States. European birches are also cultivated in America. See FAGALES. [A.H.G./K.P.D.]

**Birefringence** The splitting which a wavefront experiences when a wave disturbance is propagated in an anisotropic material; also called double refraction. In anisotropic substances the velocity of a wave is a function of displacement direction. Although the term birefringence could apply to transverse elastic waves, it is usually applied only to electromagnetic waves.

In birefringent materials either the separation between neighboring atomic structural units is different in different directions, or the bonds tying such units together have different characteristics in different directions. Many crystalline materials, such as calcite, quartz, and topaz, are birefringent. Diamonds, on the other hand, are isotropic and have no special effect on polarized light of different orientations. Plastics composed of long-chain molecules become anisotropic when stretched or compressed. Solutions of long-chain molecules become birefringent when they flow. This first phenomenon is called photoelasticity; the second, streaming birefringence. See CRYSTAL OPTICS; PHOTOELASTICITY; POLARIZED LIGHT; REFRACTION OF WAVES. [B.H.Bi.]

**Birth control** Methods of fertility control, including contraception, that are intended to prevent pregnancy, and means of interrupting early pregnancy. The efficacy of the various methods and consistency of use vary widely. Factors associated with degree of effectiveness include user age, income, marital status, and intention (that is, whether contraception is used to delay or to prevent pregnancy). The available methods consist

of hormonal methods (including oral contraceptives, subdermal implants, and injectable formulations), sterilization, intrauterine devices, barrier and chemical methods, and fertility awareness methods.

Oral contraceptives contain one or both of two compounds (estrogen and progestin) similar to the hormones that regulate the menstrual cycle. Each monthly series of pills either suppresses ovulation or alters the uterine lining and the cervical mucus, or both. See ESTROGEN; MENSTRUATION; PROGESTERONE.

Postcoital contraception is another hormonal method. In emergency situations (for example, rape) high dosages of oral contraception can be used. One dose is given within 72 h after the episode of unprotected intercourse, and an additional dose is given 12 h later.

The subdermal implant consists of small hollow rods that are placed under the skin of a woman's upper arm and release a low, continuous dose of a progestin. It is more effective than the oral contraceptives and, because it lacks estrogens, does not pose a risk of cardiovascular complications. It is reversible, lasts for 5 years, is nearly as reliable as sterilization, and is less expensive than birth control pills.

An injection of progestin suppresses ovulation and can be given every 3 months. It can be used by women who should not take estrogens. Women experience irregular bleeding in the first 6 months of use, often followed by cessation of menses with continuing use. It has been shown to be as safe and reliable as sterilization, yet is readily reversible.

The main mode of action for the intrauterine device (IUD) is considered to be prevention of fertilization. Of the two commercially available IUDs in the United States, the one containing copper is designed to remain in place for 10 years; for users over the age of 25, the pregnancy rate is less than 1%. The other one releases a daily dosage of the natural hormone progesterone to suppress the uterine lining and requires annual replacement.

Barrier methods include the male condom, female intravaginal pouch, diaphragm, cervical cap, vaginal contraceptive sponge, and various chemical preparations. The condom is a sheath of thin latex (sometimes coated with spermicide) or animal tissue that covers the penis. The intravaginal pouch, also known as a female condom, is a loose-fitting vaginal liner with an external rim designed to hold it in place. The diaphragm is a shallow rubber cup with a ring rim that fits securely in the vagina to cover the cervix. The cervical cap is a smaller, thimble-shaped latex device that fits over the cervix. The diaphragm and cervical cap are used with spermicides. The vaginal contraceptive sponge is a soft, synthetic, disposable sponge that fits over the cervix and, when moistened, continuously releases spermicide.

Fertility awareness methods enable a woman to estimate when she is fertile so that she can practice abstinence or use a barrier method during those times. Techniques used to determine fertility include cervical mucus observation, and body signs with temperature tracking. Such methods are often less effective for contraception.

Sterilization is the most commonly used method of birth control for women and men both in the United States and worldwide. The procedures do not adversely affect the production of male or female hormones, so that individual sexual characteristics such as sex drive and menses usually remain unchanged. Vasectomy is a minor male surgical procedure that occludes the vas deferens by various means (such as by cautery or suture). In the United States, tubal sterilization in the female is an operation commonly performed through the laparoscope. The instrument that performs the tubal occlusion may be either attached to the laparoscope or inserted through the lower abdomen. See FERTILIZATION; PREGNANCY.

[L.B.T.]

**Bismuth** The metallic element, Bi, of atomic number 83 and atomic weight 208.980 belonging in the periodic table to group V. Bismuth is the most metallic element in this group in both physical and chemical properties. The only stable isotope

is that of mass 209. It is estimated that the Earth's crust contains about 0.00002% bismuth. It occurs in nature as the free metal and in ores. The principal ore deposits are in South America. However, the primary source of bismuth in the United States is as a by-product in refining of copper and lead ores. See PERIODIC TABLE.

The main use of bismuth is in the manufacture of low-melting alloys which are used in fusible elements in automatic sprinklers, special solders, safety plugs in compressed gas cylinders, and automatic shutoffs for gas and electric water-heating systems. Some bismuth alloys, which expand on freezing, are used in castings and in type metal. Another important use of bismuth is in the manufacture of pharmaceutical compounds.

Bismuth is a gray-white, lustrous, hard, brittle, coarsely crystalline metal. It is one of the few metals which expand on solidification. The thermal conductivity of bismuth is lower than that of any metal, with the exception of mercury. The table cites the chief physical and mechanical properties of bismuth. Bismuth is inert in dry air at room temperature, although it oxidizes slightly in moist air. It rapidly forms an oxide film at temperatures above its melting point, and it burns at red heat, forming the yellow oxide,  $\text{Bi}_2\text{O}_3$ . The metal combines directly with halogens and with sulfur, selenium, and tellurium; however, it does not combine directly with nitrogen or phosphorus. Bismuth is not attacked at ordinary temperatures by air-free water, but it is slowly oxidized at red heat by water vapor.

Physical and mechanical properties of bismuth

Property	Value	Temperature
Melting point, °C	271.4	
Boiling point, °C	1559	
Heat of fusion, kcal/mole	2.60	
Heat of vaporization, kcal/mole	36.2	
Vapor pressure, mm Hg	1	917°C
	10	1067°C
	100	1257°C
Density, g/cm <sup>3</sup>	9.80	20° (solid)
	10.03	300° (liquid)
	9.91	400° (liquid)
	9.66	600° (liquid)
Mean specific heat, cal/g	0.0294	0–270°C
	0.0373	300–1000°C
Coefficient of linear expansion	$13.45 \times 10^{-6}/^\circ\text{C}$	
Thermal conductivity, cal/(s)(cm <sup>2</sup> )(°C)	0.018	100° (solid)
	0.041	300° (liquid)
	0.037	400° (liquid)
Electrical resistivity, $\mu\text{ohm-cm}$	106.5	0° (solid)
	160.2	100° (solid)
	267.0	269° (solid)
	128.9	300° (liquid)
	134.2	400° (liquid)
	145.3	600° (liquid)
Surface tension, dynes/cm	376	300°C
	370	400°C
	363	500°C
Viscosity, centipoise	1.662	300°C
	1.280	450°C
	0.996	600°C
Magnetic susceptibility, cgs units	$-1.35 \times 10^{-6}$	
Crystallography	Rhombohedral, $a_0 = 0.47457 \text{ nm}$	
Thermal-neutron absorption cross section, barns	$0.032 \pm 0.003$	
Modulus of elasticity, lb/cm <sup>2</sup>	$4.6 \times 10^6$	
Shear modulus, lb/cm <sup>2</sup>	$1.8 \times 10^6$	
Poisson's ratio	0.33	
Hardness, Brinell	4–8	

Almost all compounds of bismuth contain trivalent bismuth. However, bismuth can occasionally be pentavalent or monovalent. Sodium bismuthate and bismuth pentafluoride are perhaps the most important compounds of Bi(V). The former is a powerful oxidizing agent, and the latter a useful fluorinating agent for organic compounds.

[S.J.Y.]

**Bison** The name for two species of the Bovidae in the mammalian order Artiodactyla, found in North America and Europe. The European bison (*Bison bonasus*) is commonly known as the wisent. The American species (*B. bison*), shown in the illustration, is often called buffalo but should not be confused with the African buffalo.

The European bison was originally abundant in the forested areas of western Europe during the late Cenozoic Era. The wisent is a browsing, woodland animal which congregates in relatively small herds. It is almost extinct in its natural range and, although a few herds exist, it is known mainly from a few hundred specimens preserved in zoological gardens and zoos.



North American bison (*Bison bison*).

An intensive effort has been made to preserve the species by breeding and maintaining this animal in captivity.

Although there are differences, the wisent is closely allied to the American species. The wisent has a small head carried in a high position and a short mane, and is more graceful and less massive than the North American species. The hump is less noticeable, the legs are longer, the horns are more slender, and the body is not so shaggy.

Enormous herds of the American bison existed on the Plains area of North America in western Canada and the western United States during the 19th century. It is estimated that there are still about 20,000 bison in Canada and the United States on preserves and national parks. These bovines are massive, with the males attaining a length of 9 ft (2.7 m), a height of 6 ft (1.8 m) at the shoulder, and weight up to 3000 lb (1350 kg). They are herbivorous, and migrated originally when the grass or forage became scarce. The large head is held in a low position, and behind the neck region is a characteristic hump. The forequarters are shaggy with the hair more pronounced in the male than the female. The senses of smell and hearing are well developed, while vision is poor. Both the male and female have horns which are small and set far apart. See ARTIODACTYLA; BUFFALO; MAMMALIA. [C.B.C.]

**Bit** A binary digit. In the computer, electronics, and communications fields, "bit" is generally understood as a shortened form of "binary digit." In a numerical binary system, a bit is either a 0 or 1. Bits are generally used to indicate situations that can take one of two values or one of two states, for example, on and off, true or false, or yes or no. If, by convention, 1 represents a particular state, then 0 represents the other state. For example, if 1 stands for "yes," then 0 stands for "no." See BOOLEAN ALGEBRA.

In a computer system a bit is thought of as the basic unit of memory where, by convention, only either a 0 or 1 can be stored. In a computer memory, consecutive bits are grouped to form

smaller or larger "units" of memory. Depending upon the design of the computer, units up to 64 bits long have been considered. Although there is common agreement as to the number of bits that make up a byte, for larger memory units the terminology depends entirely on the convention used by the manufacturer. In all of these units the leftmost bit is generally called the most significant bit (msb) and the rightmost the least significant bit (lsb).

Bytes and larger units can be used to represent numerical quantities. In these cases the most significant bit is used to indicate the "sign" of the value being represented. By convention a 0 in the msb represents a positive quantity; a 1 represents a negative quantity. Depending on the convention used to represent these numbers, the remaining bits may then be used to represent the numerical value. In addition to numerical quantities, bytes are used to represent characters inside a computer. These characters include all letters of the English alphabet, the digits 0 through 9, and symbols such as comma, period, right and left parentheses, spaces, and tabs. Characters can be represented using ASCII (American Standard Code for Information Interchange) or EBCDIC (Extended Binary Coded Decimal Interchange Code). The latter is used by some mainframe computers. Computers are set up to handle only one of these two character codes. Generally, the internal representation of a character is different in the two codes. For instance, in ASCII the plus sign is represented by the numerical sequence 00101011, and in EBCDIC, by 01001110. [R.A.M.T.]

**Bitumen** A term used to designate naturally occurring or pyrolytically obtained substances of dark to black color consisting almost entirely of carbon and hydrogen with very little oxygen, nitrogen, and sulfur. Bitumen may be of variable hardness and volatility, ranging from crude oil to asphaltites, and is largely soluble in carbon disulfide. See ASPHALT AND ASPHALTITE. [I.A.B.]

**Bivalvia** One of the five classes in the phylum Mollusca, sometimes known as Pelecypoda. All bivalves are aquatic, living at all depths of the sea and in brackish and fresh waters. With about 25,000 living species, Bivalvia is second to class Gastropoda (over 74,000) in molluscan species diversity. However, the total biomass of bivalves is much greater, and certain bivalve species are numerically dominant in many benthic ecosystems. The most primitive bivalves are infaunal, burrowing into soft sediments, but many families are epifaunal, attached to rocks or shells or residing on the sediment surface. Bivalves are well represented in the fossil record from the early Paleozoic because of their calcareous shells.

In general, bivalves are bilaterally symmetrical and laterally compressed. They have a fleshy mantle that secretes the shell

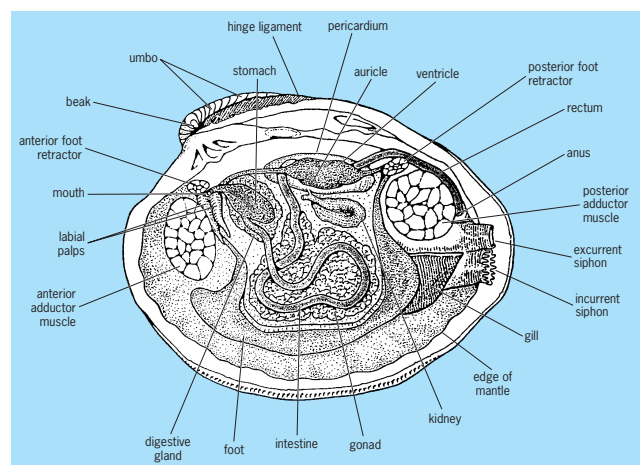

Bivalve anatomy.

enclosing the body (see illustration). The mouth is located anteriorly in bivalves; and in the Lamellibranchiata, the largest subclass, the mouth is flanked by paired labial palps that act to sort food prior to ingestion. Sensory organs are located on the outer mantle margin that has the closest contact with the environment. Frequently these sensory organs are borne on tentacles, and they are sensitive to tactile and chemical stimuli. Certain species of scallops have highly developed light-sensing organs or "eyes" on their mantle tentacles.

The shell consists of two valves with a noncalcified connecting ligament holding the valves together at a hinge plate. The shell layers consist of an outer horny periostracum (protective layer) that can be either absent or eroded in some species, a middle prismatic layer consisting of crystalline calcium carbonate, and an inner lamellar or nacreous layer. In some families such as the Mytilidae (mussels) or the Pteriidae (winged or pearl oysters), the nacreous layer can exhibit a beautiful iridescent sheen, whereas in most bivalves the inner layer is smooth but with a chalky appearance. Hinge ligament tension holds the valves in a gaping position, with valve closure effected by adductor muscles.

The ciliated molluscan gills, properly called ctenidia, are enlarged in the subclass Lamellibranchiata and occupy a substantial portion of the mantle cavity. The ctenidia consist of layered filaments which function primarily to pump water into the mantle cavity and to filter particulate food from the incurrent water stream. The ctenidia of bivalves of the subclass Protobranchia also serve to pump water, but they are smaller and less developed than in the lamellibranchs and do not serve to filter food particles. Protobranch bivalves are deposit feeders that gather food by extending thin muscular palp proboscides to probe soft sediments and entrap organic detrital particles. Bivalves of the subclass Septibranchia (sometimes called Anomalodesmata) have highly modified ctenidia that lack filaments. A septum divides the mantle cavity into dorsal and ventral chambers, and water is pumped by muscular contraction of the septum wall.

Some bivalves have a foot for locomotion. If present, the foot can be extended from the shell by blood pressure and dilated to act as an external anchor while movement is effected by contraction of retractor muscles. Some bivalves of the family Pectinidae (scallops) lack a foot but are highly active swimmers through clapping their valves and jetting water through orifices (openings) near the hinge. Some bivalves, such as oysters and giant clams, are sedentary and lack a foot as adults.

Bivalves exhibit a wide range of reproductive strategies. Most bivalves are dioecious or have separate sexes, while others exhibit various forms of hermaphroditism. For example, as mature adults, scallops carry both eggs and sperm, while oysters exhibit protandric hermaphroditism in which the oysters first develop as males and in subsequent years change sex to develop ovaries. Most species of bivalves shed eggs and sperm directly into the water, where fertilization occurs; in others, eggs may be held in a brood chamber, where they are fertilized by sperm in incurrent water, and released as well-developed larvae into the water. Most bivalves go through several planktonic stages prior to settlement and metamorphosis to their benthic form.

Many species of bivalves are actively farmed either for human consumption of the meats or for shell products. Most of the gem-quality pearls sold in the world originate from farmed pearl oysters of the genus *Pinctada* in Japan, Australia, and islands of the tropical Pacific. Fresh-water pearls are produced from fresh-water mussels in the United States, China, and Japan. Other species of bivalves are of economic concern by virtue of being pest organisms or biological invaders.

The fossil record of the Bivalvia can be traced to the Lower Cambrian *Fordilla*. The Ordovician was a major period of bivalve speciation, but throughout the Paleozoic the Bivalvia remained second to bivalves of the phylum Brachiopoda in species diversity and abundance. During the Mesozoic Era, the brachiopods declined in importance. It is probable that diverse adaptations of the Bivalvia to avoid predatory gastropods, arthropods, and

fish evolving during the Mesozoic were a major factor in the replacement of the more exposed brachiopods as the dominant bivalves. The evolutionary radiation occurring during the Mesozoic includes the emergence of many species of bivalves that bore into rocks, hard corals, and wood. The Mesozoic emergent family Ostreidae, which includes oysters, remains to the present. The transition from the Mesozoic to Cenozoic began with the extinction of many ancient families and the emergence of several modern families. See LAMELLIBRANCHIA; MOLLUSCA; PROTobranchia; SEPTIBRANCHIA. [M.A.Ric.]

**Black hole** One of the end points of gravitational collapse, in which the collapsing matter fades from view, leaving only a center of gravitational attraction behind. General relativity predicts that if a star of more than about 3 solar masses has completely burned its nuclear fuel, it should collapse to a configuration known as a black hole. The resulting object is independent of the properties of the matter that produced it and can be completely described by stating its mass, spin, and charge. The most striking feature of this object is the existence of a surface, called the horizon, which completely encloses the collapsed matter. The horizon is an ideal one-way membrane: that is, particles and light can go inward through the surface, but none can go outward. As a result, the object is dark, that is, black, and hides from view a finite region of space (a hole). See GRAVITATIONAL COLLAPSE; RELATIVITY.

The possible formation of black holes depends critically on what other end points of stellar evolution are possible. There can always be chunks of cold matter which are stable, but their mass must be considerably less than that of the Sun. For masses on the order of a solar mass, only two stable configurations are known for cold, evolved matter. The first, the white dwarf, is supported against gravitational collapse by the same quantum forces that keep atoms from collapsing. However, these forces cannot support a star which has a mass in excess of about 1.2 solar masses. The second stable configuration, the neutron star, is supported against gravitational collapse by the same forces that keep the nucleus of an atom from collapsing. There is also a maximum mass for a neutron star, estimated to be between 1 and 3 solar masses.

It would appear from the theory that if a collapsing star of over 3 solar masses does not eject matter, it has no choice but to become a black hole. There are, of course, many stars with mass larger than 3 solar masses, and it is expected that a significant number of them will reach the collapse stage without having ejected sufficient matter to take them below the 3-solar-mass limit. Further, more massive stars evolve more rapidly, enhancing the rate of formation of black holes. It seems reasonable to conclude that a considerable number of black holes should exist in the universe.

The black hole solutions of general relativity, ignoring quantum-mechanical effects, are completely stable. Once massive black holes form, they will remain forever; and subsequent processes, for example, the accumulation of matter, only increase their size. Steven Hawking showed that when quantum effects are properly taken into account, a black hole should emit thermal radiation, composed of all particles and quanta of radiation which exist. Since a radiating system loses energy and therefore loses mass, a black hole can shrink and decay if it is radiating faster than it is accumulating matter. However, for black holes formed from the collapse of stars, the ambient radiation incident on the black hole from other stars, and from the big bang itself, is much larger than the thermal radiation emitted by the black hole, implying that the black hole would not shrink. Even if the ambient radiation is shielded from the black hole, the time for the black hole to decay is much longer than the age of the universe, so that, in practice, black holes formed from collapse of a star are essentially as stable as they were thought to be before the Hawking radiation was predicted.

Because black holes themselves are unobservable, their existence must be inferred from their effect on other matter. Such is the case with the binary x-ray star system Cygnus X-1. There are a number of binary x-ray systems known. The model which best explains the data is one in which a fairly normal star is in mutual orbit about a very compact object. Because these two are so close, mass flows from the star onto an accreting disk about the compact object. As the mass in the disk spirals inward, it heats up by frictional forces. Because the central body is so compact, the matter heats to a temperature at which thermal x-rays are produced. The only compact objects known that could accomplish this are neutron stars and black holes. The existence of very short-time bursts of radiation also points to an object of small diameter, that is, compact. In some of these binary x-ray systems, there is also a regular pulsed component to the x-rays, indicating a rotating neutron star (by reasoning similar to that given for pulsars). In these systems, the compact object could not be a black hole because that would imply a more complicated structure than a black hole would allow. In other systems, however, there are only irregular pulsations or fluctuations; they are candidates for possible black holes.

The crucial evidence comes from the mass determination of the compact object. Because the inclination of the orbit is not known, a range of masses is found; however, there will be a typical mass obtained by assuming that the orbit is not in an extreme orientation. For three x-ray binaries, Cygnus X-1, LMC X-3, and A0620-00, the typical mass of the compact body is about 10 solar masses, much larger than the maximum mass of a neutron star. In fact, the compact objects in the first and third binary systems are more massive than the maximum mass of a neutron star, no matter what orientation the orbit is assumed to have. Assuming that general relativity is the correct theory of gravitation (and this assumption is now supported very well experimentally), there can be no compact objects of such a mass other than a black hole. In this sense it can now be said that black holes exist.

While the evidence is less direct and more model-dependent, there is growing acceptance of the idea that supermassive black holes exist at the cores of nuclei of active galaxies, including quasars and radio galaxies. Here, the black hole is assumed to interact with accreting matter in such a way as to provide a source of energy to power these ultraluminous objects.

Black holes are thought to exist in the nuclei of other galaxies as well, their presence not giving rise to amounts of radiation as spectacular as for active galactic nuclei only because of differing conditions near the black hole. In the Milky Way Galaxy, observations of the proper motions of stars within a fraction of a parsec of the galactic center demonstrate unambiguously that a central mass concentration of  $2 \times 10^6$  solar masses is present in a region so compact that no explanation other than that of a central black hole is feasible. Similar, although less convincing, observations of the presence of central black holes have been made for several nearby galaxies. The existence of supermassive black holes is virtually certain. See ASTROPHYSICS, HIGH-ENERGY; BINARY STAR; X-RAY ASTRONOMY. [P.C.P.; J.Si.]

**Black pepper** One of the oldest and most important of the spices. It is the dried, unripe fruit of a weak climbing vine, *Piper nigrum*, a member of the pepper family (Piperaceae), and a native of India or Indomalaysia. The fruits are small one-seeded berries which, in ripening, undergo a color change from green to red to yellow. When in the red stage, they are picked, sorted, and dried. The dry, wrinkled berries (peppercorns) are ground to make the familiar black pepper of commerce. White pepper is obtained by grinding the seed separately from the surrounding pulp. See PIPERALES. [P.D.St./E.L.C.]

**Black Sea** A semienlosed marginal sea with an area of 420,000 km<sup>2</sup> (160,000 mi<sup>2</sup>) bounded by Turkey to the south,

Georgia to the east, Russia and Ukraine to the north, and Romania and Bulgaria to the west. The physical and chemical structure of the Black Sea is critically dependent on its hydrological balance. As a result, it is the world's largest anoxic basin. It has recently experienced numerous types of environmental stress.

The Black Sea consists of a large basin with a depth of about 2200 m (7200 ft). The continental shelf is mostly narrow except for the broad shelf in the northwest region. Fresh-water input from rivers, especially the Danube, Dniester, and Don, and precipitation exceeds evaporation. Low-salinity surface waters are transported to the Mediterranean as a surface outflow. High-salinity seawater from the Mediterranean enters the Black Sea as a subsurface inflow through the Bosphorus. This estuarine circulation (seawater inflow at depth and fresh-water outflow at the surface) results in an unusually strong vertical density gradient determined mainly by the salinity. Thus the Black Sea has a two-layered structure with a lower-salinity surface layer and a higher-salinity deep layer.

The vertical stratification has a strong effect on the chemistry of the sea. Respiration of particulate organic carbon sinking into the deep water has used up all the dissolved oxygen. Thus, conditions favor bacterial sulfate reduction and high sulfide concentrations. As a result, the Black Sea is the world's largest anoxic basin and is commonly used as a modern analog of an environment favoring the formation of organic-rich black shales observed in the geological sedimentary record.

Before the 1970s the Black Sea had a highly diverse and healthy biological population. Its species composition was similar to that of the Mediterranean but with less quantity. The phytoplankton community was characterized by a large diatom bloom in May-June followed by a smaller dinoflagellate bloom. The primary zooplankton were copepods, and there were 170 species of fish, including large commercial populations of mackerel, bonito, anchovies, herring, carp, and sturgeon.

Since about 1970 there have been dramatic changes in the food web due to anthropogenic effects and invasions of new species. It is now characterized as a nonequilibrium, low-diversity, eutrophic state. The large increase in input of nitrogen due to eutrophication and decrease in silicate due to dam construction have increased the frequency of noxious algal blooms and resulted in dramatic shifts in phytoplankton from diatoms (siliceous) to coccolithophores and flagellates (nonsiliceous). The most dramatic changes have been observed in the northwestern shelf and the western coastal regions, which have the largest anthropogenic effects. The water overlying the sediments in these shallow areas frequently go anoxic due to this eutrophication. In the early 1980s the grazer community experienced major increases of previously minor indigenous species such as the omnivorous dinoflagellate *Noctiluca scintillans* and the medusa *Aurelia aurita*. The ctenophore *Mnemiopsis leidyi* was imported at the end of the 1980s from the east coast of the United States as ballast water in tankers and experienced an explosive unregulated growth. These changes plus overfishing resulted in a collapse of commercial fish stocks during the 1990s. [J.W.M.]

**Black Shale** A dark mud rock rich in organic carbon. Black shales are typically very fine-grained and contain pyrite, phosphate, and abnormally large amounts of heavy metals. They commonly display excellent fissility and well-preserved planktonic and nektonic faunas and plant debris. Benthic fossils are rare or absent. Some black shales are sources of hydrocarbons. See SHALE.

Black shales are enigmatic deposits. Although the large organic carbon content (3–15%) must have required reducing conditions of deposition, there are few unambiguous indicators of the specific environment, most especially of the depth of water. See MARINE SEDIMENTS; SEDIMENTOLOGY.

Black shales are typically well laminated on a scale of millimeters. Laminae are produced by variations in the supply of

sediment, such as seasonal alternations of clay and planktonic algae. Delicate laminae can be preserved only in the total absence of benthic life, for burrowing animals disrupt lamination, producing bioturbated texture. Hence it is possible to differentiate between totally anaerobic conditions of deposition and marginally oxygenated (dysaerobic) conditions by recognizing laminated or bioturbated fabrics in a shale. [C.W.By.]

**Blackberry** Any of several species of the genus *Rubus* (family Rosaceae) having fruit consisting of many drupelets attached to a common fleshy, elongated core (receptacle) which is removed with the fruit. Ripe fruit is usually black or dark purple, and often sweet and flavorful. The bushy plants have perennial roots from which arise long, often thorny, biennial stems (canes) with compound leaves. Many species are native to temperate regions, especially in the Northern Hemisphere, to which they are best adapted. They are commonly found on the edges of forests, along streams, and in clearings. Because of their thorns and prolific growth habit, blackberries are a nuisance in some areas. See ROSALES.

Commercial blackberry production occurs mainly in the United States, but appreciable quantities are grown in the United Kingdom and in New Zealand. In commercial plantings in the United States, harvesting is often done by machines which shake the canes and catch the ripe fruit, most of which is frozen or canned for use in bakery products and yogurt or made into jelly, jam, or wine. Some fruit is hand-harvested and sold fresh. The Pacific Coast states account for about 80% of the annual North American production, with Oregon the major producer. See FRUIT. [P.J.Br.]

**Blackbody** An ideal energy radiator, which at any specified temperature emits in each part of the electromagnetic spectrum the maximum energy obtainable per unit time from any radiator due to its temperature alone. A blackbody also absorbs all the energy which falls upon it. The radiation properties of real radiators are limited by two extreme cases—a radiator which reflects all incident radiation, and a radiator which absorbs all incident radiation. Neither case is completely realized in nature. Carbon and soot are examples of radiators which, for practical purposes, absorb all radiation. Both appear black to the eye at room temperature, hence the name blackbody. Often a blackbody is also referred to as a total absorber. See HEAT RADIATION. [H.G.S.; P.J.W.]

**Blackleg** An acute, usually fatal, disease of cattle and occasionally of sheep, goats, and swine. The infection is caused by *Clostridium chauvoei* (*C. fesceri*), a strictly anaerobic, sporeforming bacillus of the soil. The disease is also called symptomatic anthrax or quarter-evil. The characteristic lesions in the natural infection consist of crepitant swellings in involved muscles, which at necropsy are dark red, dark brown, or blue black. Artificial immunization is possible; animals surviving an attack of blackleg are permanently immune to recurrence of the disease. See IMMUNITY. [L.S.McC.]

**Blastoidea** A class of extinct Pelmatozoa in the subphylum Crinozoa, which arose in the Ordovician and flourished during Carboniferous times; they did not survive the Permian. The symmetrical bud-shaped theca comprised 13 rigid plates arranged in three horizontal rings of three basals, five radials, and five deltoids. There was often a jointed aboral stem. The ambulacral grooves were carried on five lancet plates lying in notches in the radial and deltoid plates. Series of lateral plates margined the lancet plates on either side, and each lateral plate supported a brachiolo (see illustration). Each brachiolo carried a branch of the ambulacral groove. Underneath the ambulacra the radial and deltoid plates were thrown into vertical pleats whose folds hung

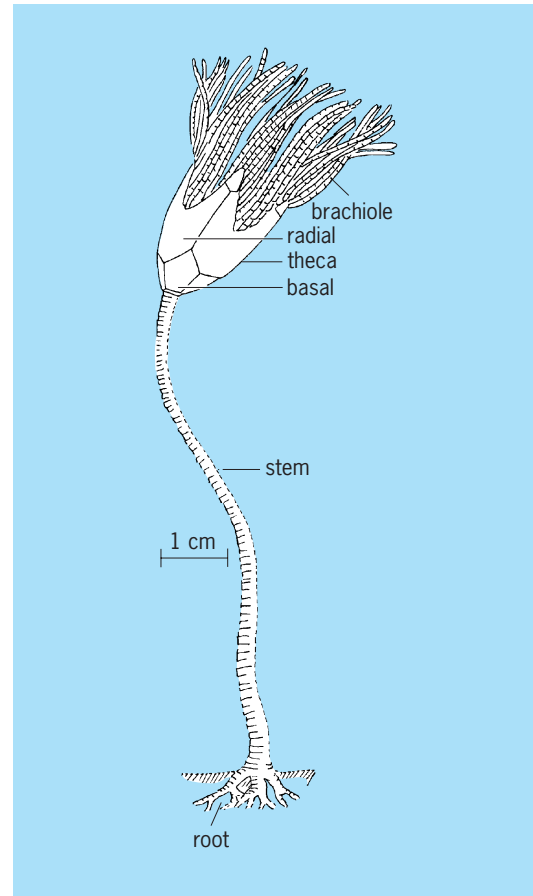

A blastoid, *Pentremites*.

into the coelom. The reverse folds on the upper side opened to the exterior via pores. See CRINOIDEA; CRINOZOA; ECHINODERMATA; PELMATOZOA. [H.B.F.]

**Blastomycetes** A class of the subdivision Deuteromycotina comprising anamorphic (asexual or imperfect) yeast fungi that lack fruit bodies (conidiomata), have no dikaryophase, and are usually unicellular rather than filamentous. The thallus consists of individual cells. Approximately 80 genera comprising about 600 species are recognized.

The Blastomycetes, like other groups of deuteromycetes, are artificial, composed entirely of anamorphic fungi of ascomycete or basidiomycete affinity. Taxa are referred to as form genera and form species because the absence of sexual, perfect, or meiotic states forces classification and identification by artificial rather than phylogenetic means. Black yeasts are distinguished from anamorphic yeasts by the presence of melanin in the cell walls, abundant production of septate mycelium (filamentous), and aerial dispersal of conidia. Unlike other deuteromycetes, the number of morphological and developmental features for classification of Blastomycetes, although useful, is limited. The emphasis in yeast systematics has therefore been on physiological and biochemical tests, supplemented extensively by serological, electrophoretic, and molecular techniques.

Anamorphic yeasts can be recovered from most ecological niches—animals, plants and their surfaces, fresh and marine water, soils, and environments such as manufacturing plants, tanning fluids, and mineral oils. Blastomycetes are of great economic importance in two respects: the production of products and the spoilage of raw materials and products. Selected strains of *Saccharomyces cerevisiae* are used in the baking, brewing, distilling, and wine industries.



Blastomycetes are also recognized pathogens in medicine. Both *Candida*, causing candidiasis or candidosis, and *Cryptococcus*, causing cryptococcosis, are opportunistic pathogens that cause systemic infections only in individuals with lowered resistance. Esophageal candidiasis and cryptococcosis of the central nervous system are both regarded as being particularly strong indicators of AIDS. See DEUTEROMYCOTINA; EUMYCOTA; FUNGI; YEAST. [B.C.S.]

**Blastulation** The formation of a segmentation cavity or blastocoele within a mass of cleaving blastomeres and rearrangement of blastomeres around this cavity in such a way as to form the type of definitive blastula characteristic of each species. The blastocoele originates as an intercellular space which sometimes arises as early as the four- or eight-cell stage. Thus blastulation is initiated during early cleavage stages, and formation of the definitive blastula is thought to terminate cleavage and to initiate gastrulation. Initially the diameter of the blastula is no greater than that of the activated egg; subsequently it increases. See GASTRULATION.

The blastula is usually a hollow sphere. Its wall may vary from one to several cells in thickness. In eggs which contain considerable amounts of yolk the blastocoele may be eccentric in position, that is, shifted toward the animal pole. The animal portion of its wall is always completely divided into relatively small cells, whereas the vegetative portion tends to be composed of relatively large cells and may be incompletely cellulated in certain species. The blastocoele contains a gelatinous or jellylike fluid, which originates in part as a secretion by the blastomeres and in part by passage of water through the blastomeres or intercellular material, or both, into the blastocoele.

The wall of the blastula is a mosaic of cellular areas, each of which will normally produce a certain structure during subsequent development. In other words, each area of cells in the wall of the blastula has a certain prospective fate which will be realized in normal development. [R.L.W.]

**Bleaching** The process in which natural coloring matter is removed from a fiber to make it white. The process may be used on fiber, yarn, or fabric. Prior to the bleaching of a fabric, preliminary purification processes should be used. These processes remove applied encrustants (desizing) and natural encrustants (scouring or boil-off) so that the bleaching agent may act uniformly on the material free of impediment.

Bleaching is also classified as a purification process and varies with the content of the substrate or fibrous content of the material. It should not be confused with the stripping process, which is the removal of applied color.

The fabric off the loom is called gray, grey, or greige goods to distinguish it from the partially or completely finished fabric.

The three most prominent commercial bleaching processes are the peroxide, the chlorine, and the chlorite, in that order.

In home bleaching the predominant bleach is the chlorine bleach, followed by the use of peroxygen compounds such as persulfates and perborates. The latter two are recommended for minimum care and permanent-press fabrics to preclude the yellowing of the whites and the stripping of colored fabrics, which are always potential problems when chlorine bleaches are used.

Optical bleaching uses organic compounds which are capable of absorbing waves shorter than visual waves and emitting waves within the visible range. The most notable of the short waves absorbed is the ultraviolet light present in daylight. These compounds absorb ultraviolet light which is less than 400 micrometers (0.02 in.) and emit blue light which is in the visible range of 400–700 micrometers (0.02–0.03 in.). This emitted blue light will counteract the yellow on the fabric surface and by the subtractive theory of color will produce a white. These agents are also characterized as brighteners and are extensively used in household detergents.

There are several bleaching systems which are classified as combination bleaches because two different bleaching agents are used together or in tandem. These have been projected to lower the cost, lower the degradation, or shorten the cycle as well as to preclude equipment damage in certain cases. See NATURAL FIBER; OXIDIZING AGENT; TEXTILE CHEMISTRY. [J.J.McD.]

**Blimp** A name originally applied to nonrigid airships and usually implying small size. Early blimps contained about 100,000 ft<sup>3</sup> (2800 m<sup>3</sup>) and were only a fraction of the size of the rigid airships of that period. The nonrigid pressure-type airship, however, did not stay small; each succeeding model built was substantially larger than its predecessor until ships with volumes of approximately 1,500,000 ft<sup>3</sup> (42,000 m<sup>3</sup>) were operational in the U.S. Navy. With the advent of these larger sizes it appeared that the name blimp would be replaced by the more general term airship. However, the principles of construction of these ships are basically the same regardless of the size. See AIRSHIP.

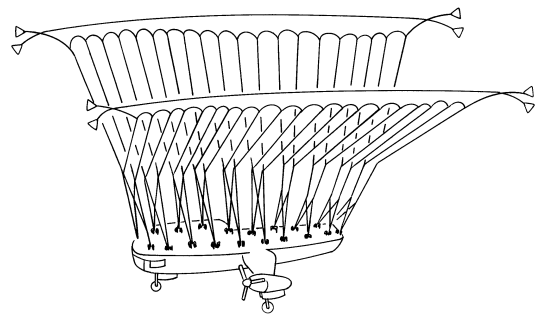

Typical internal rigging of nonrigid airships.

The fabric of the main envelope or pressure hull is usually made up of two or three plies of cloth impregnated with an elastomer; at least one of these plies is placed in a bias direction with respect to the others. This tends to make the fabric more resistant to shear loads and results in a stabilized structure. The materials used for the envelope must be lightweight, extremely strong, and resistant to gas diffusion. The airship envelope is a symmetrical airfoil in the form of a body of revolution, circular in cross section and elliptical along its longitudinal axis.

Inside the envelope are catenary curtains (see illustration). They support the weight of the car by distributing the loads imposed by it into the envelope fabric. This suspension system can be arranged in a number of ways, depending upon the particular airship configuration. Basically, however, they all consist of cable systems attached to the car which terminate in fabric curtains, which in turn are cemented and sewed or otherwise sealed to the envelope proper. The envelope also contains one or more air cells, fastened to the bottom or sides of the envelope, which are used to maintain the required pressure in the envelope without adding or valving of gas as the ship ascends or descends. These air cells are called ballonets and are usually made of a fabric much lighter in weight than that of the envelope, because they must merely retain gas tightness and do not have to withstand the normal envelope pressure.

Up until the late 1980s, the only commercial airships operating in the United States were the Goodyear Tire and Rubber Company advertising blimps of about 150,000 ft<sup>3</sup> (4200 m<sup>3</sup>). Fundamentally, they were communications platforms used for public service where airship characteristics are superior to other forms of flight. During the 1980s, several companies other than Goodyear began to produce blimps for advertising purposes, passenger operations, and even possible military missions. Typical of these was Airship Industries of England, which produces the Skyships 500 and 600, used in Europe, the United States, Australia, and Japan, primarily as advertising billboards. In 1988, Goodyear

introduced the GZ-22, the largest and most advanced blimp flying at the time, featuring a unique X-configuration tail and shrouded, swivable turboprop power plants. [R.S.R.]

**Bloch theorem** A theorem that specifies the form of the wave functions that characterize electron energy levels in a periodic crystal. Electrons that move in a constant potential, that is, a potential independent of the position  $\mathbf{r}$ , have wave functions that are plane waves, having the form  $\exp(i\mathbf{k} \cdot \mathbf{r})$ . Here,  $\mathbf{k}$  is the wave vector, which can assume any value, and describes an electron having momentum  $\hbar\mathbf{k}$ . (The quantity  $\hbar$  is Planck's constant divided by  $2\pi$ .) Electrons in a crystal experience a potential that has the periodicity of the crystal lattice. See BAND THEORY OF SOLIDS. [A.O.]

**Block and tackle** Combination of a rope or other flexible material and independently rotating frictionless pulleys; the pulleys are grooved or flat wheels used to change the direction of motion or application of force of the flexible member (rope or chain) that runs on the pulleys (see illustration). The block and

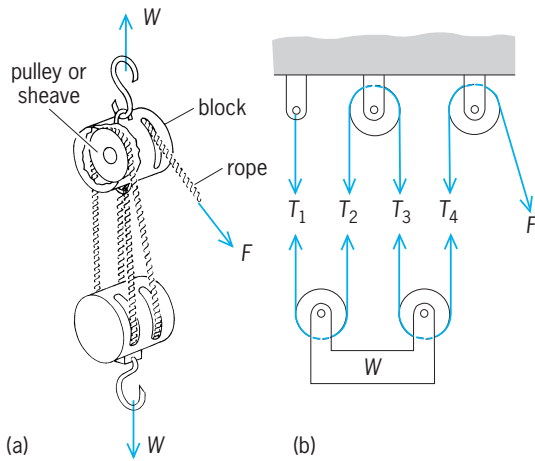

**Block and tackle.** (a) Actual view. (b) Schematic. Tension  $T_1 = T_2 = T_3 = T_4 = 1/4$  weight  $W$ ; applied force  $F = W/4$ .

tackle is used where a large multiplication of the applied forces is desirable. Examples are: lifting weights, sliding heavy machinery into position, and tightening fences. See PULLEY; SIMPLE MACHINE. [R.M.Ph.]

**Block diagram** A convenient graphical representation of input-output behavior of a system, where the signal into the block represents the input and the signal out of the block represents the output. The flow of information (the signal) is unidirectional from the input to the output. The primary use of the block diagram is to portray the interrelationship of distinct parts of the system.

A block diagram consists of two basic functional units that represent system operations. The individual block symbols portray the dynamic relations between the input and output signals. The second type of unit, called a summing point, is represented by a circle with arrows feeding into it. The operation that results is a linear combination of incoming signals to generate the output signal. The sign appearing alongside each input to the summing point indicates the sign of that signal as it appears in the output.

Block diagrams are widely used in all fields of engineering, management science, criminal justice, economics, and the physical sciences for the modeling and analysis of systems. In modeling a system, some parameters are first defined and equations governing system behavior are obtained. A block diagram is constructed, and the transfer function for the whole system is determined.

If a system has two or more input variables and two or more output variables, simultaneous equations for the output variables

can be written. In general, when the number of inputs and outputs is large, the simultaneous equations are written in matrix form. See MATRIX THEORY.

Block diagrams can be used to portray nonlinear as well as linear systems, such as a cascade containing a nonlinear amplifier and a motor. See COMPUTER PROGRAMMING; GAIN; NONLINEAR CONTROL THEORY; SYSTEMS ENGINEERING. [G.V.S.R.]

**Blood** The fluid that circulates in the blood vessels of the body. Blood consists of plasma and cells floating within it. The cells are derived from extravascular sites and then enter the circulatory system. They frequently leave the blood vessels to enter the extravascular spaces, where some of them may be transformed into connective tissue cells. The fluid part of the blood is in equilibrium with the tissue fluids of the body. The circulating blood carries nutrients and oxygen to the body cells, and is thus an important means of maintaining the homeostasis of the body. It carries hormones from their sites of origin throughout the body, and is thus the transmitter of the chemical integrators of the body. Blood plasma also circulates immune bodies and contains several of the components essential for the formation of blood clots. Finally, blood transports waste products to excretory organs for elimination from the body. Because of its basic composition (cells surrounded by a matrix), development, and ability to modify into other forms of connective tissues, blood can be regarded as a special form of connective tissue. See CONNECTIVE TISSUE.

**Formed elements.** The cells of the blood include the red blood cells and the white blood cells. In all vertebrates, except nearly all mammals, the red blood cells or corpuscles contain a nucleus and cytoplasm rich in hemoglobin. In nearly all mammals the nucleus has been extruded during the developmental stages.

In normal adult men the blood contains about 5,000,000 red blood corpuscles or erythrocytes per cubic millimeter; in normal adult women, about 4,500,000. Human erythrocytes are about 8 micrometers in diameter and about  $2 \mu\text{m}$  at their thickest and have a biconcave shape. They contain hemoglobin, which imparts to them their color, and possess an envelope. When circulating in the blood vessels, the red blood cells are not evenly dispersed. In the capillaries the erythrocytes are often distorted. In certain conditions they may be densely aggregated. This is known as a sludge. The erythrocytes respond to changes in osmotic pressure of the surrounding fluid by swelling in hypotonic fluids and by shrinking irregularly in hypertonic fluids. Shrunken red blood cells are referred to as crenated cells. The average life of the mature red blood cells is surprisingly long, having a span of about 120 days. See HEMATOLOGIC DISORDERS; HEMOGLOBIN.

In humans the white blood cells in the blood are fewer in number. There are about 5000–9000/mm<sup>3</sup>. In general, there are two varieties, agranular and granular. The agranular cells include the small, medium, and large lymphocytes and the monocytes

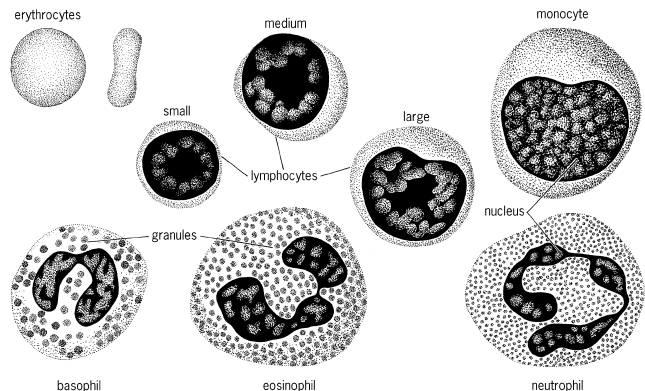

**Diagrammatic representation of human blood cells.**

(see illustration). The small lymphocytes are spherical, about the diameter of erythrocytes or a little larger, and constitute about 20–25% of the white blood cells. The medium and large lymphocytes are relatively scarce. In all lymphocytes the nucleus occupies nearly the whole volume of the cell, and the cytoplasm which surrounds it forms a thin shell. The typical monocyte is commonly as large as a large lymphocyte (12  $\mu\text{m}$ ), and constitutes 3–8% of the white blood cells. The nucleus is relatively small, eccentric, and oval or kidney-shaped. The cytoplasm is relatively larger in volume than that in lymphocytes.

The granular leukocytes are of three varieties: neutrophil, eosinophil, and basophil. Their structure varies somewhat in different species, and the following applies to those of humans. The neutrophils make up 65–75% of the leukocytes. They are about as large as monocytes with a highly variable nucleus, consisting of three to five lobes joined together by threads of chromatin. The cytoplasm contains numerous minute granules which stain with neutral dyes and eosin. The eosinophils (also called acidophils) are about the same size as the neutrophils but are less numerous, constituting about 1% of the leukocytes. The nucleus commonly contains but two lobes joined by a thin thread of chromatin. The granules which fill the cytoplasm are larger than those of the neutrophils and stain with acid dyes. The basophils are about the same size as the other granular leukocytes. The nucleus may appear elongated or with one or more constrictions. The granules are moderately large, stain with basic dyes, and are water-soluble.

The functions of the leukocytes while they are circulating in the blood are not known. However, when they leave the blood vessels and enter the connective tissue, they constitute an important part of the defense mechanism and of the repair mechanism. Many of the cells are actively phagocytic and engulf debris and bacteria. Lymphocytes are of two major kinds, T cells and B cells. They are involved in the formation of antibodies and in cellular immunity.

The blood platelets are small spindle-shaped or rodlike bodies about 3  $\mu\text{m}$  long and occur in large numbers in circulating blood. In suitably stained specimens they consist of a granular central portion (chromomere) embedded in a homogeneous matrix (hyalomere). They change their shape rapidly on contact with injured vessels or foreign surfaces and take part in clot formation. The platelets are not to be regarded as cells and are thought to be cytoplasmic bits broken off from their cells of origin in bone marrow, the megakaryocytes. [I.G.]

**Plasma.** Plasma is the residual fluid of blood left after removal of the cellular elements. Serum is the fluid which is obtained after blood has been allowed to clot and the clot has been removed. Serum and plasma differ only in their content of fibrinogen and several minor components which are in large part removed in the clotting process. See SERUM.

The major constituents of plasma and serum are proteins. The total protein concentration of human serum is approximately 7 g/ml, and most other mammals show similar levels. By various methods it can be demonstrated that serum protein is a heterogeneous mixture of a large number of constituents. Only a few are present in higher concentrations, the majority being present in trace amounts. More than 60 protein components have been identified and characterized. Albumin makes up more than one-half of the total plasma proteins and has a molecular weight of 69,000. Because of its relatively small molecular size and its high concentration, albumin contributes to 75–80% of the colloid osmotic pressure of plasma. The immunoglobulins, which represent approximately one-sixth of the total protein, largely constitute the  $\gamma$ -globulin fraction. The immunoglobulins are antibodies circulating in the blood, and therefore are also called humoral antibodies. They are of great importance in the organism's defense against infectious agents, as well as other foreign substances. See IMMUNOGLOBULIN.

In addition to the proteins, many other important classes of compounds circulate in the blood plasma. Most of these are

smaller molecules which diffuse freely through cell membranes and are, therefore, more similarly distributed throughout all the fluids of the body and not as characteristic for plasma or serum as the proteins. In terms of their concentration and their function, the electrolytes are most important. They are the primary factors in the regulation of the osmotic pressure of plasma, and contribute also to the control of the pH. The chief cations are sodium, potassium, calcium, and magnesium. The chief anions are chloride, bicarbonate, phosphate, sulfate, and organic acids. The circulating blood also contains the many small compounds which are transported to the sites of synthesis of larger molecules in which they are incorporated, or which are shifted as products of metabolic breakdown to the sites of their excretion from the body. [H.C.]

**Coagulation.** When mammalian blood is shed, it congeals rapidly into a gelatinous clot of enmeshed fibrin threads which trap blood cells and serum. Modern theories envision a succession of reactions leading to the formation of insoluble fibrin from a soluble precursor, fibrinogen (factor I). Blood also clots when it touches glass or other negatively charged surfaces, through reactions described as the intrinsic pathway. Several of the steps in this process are dependent upon the presence in blood of calcium ions and of phospholipids, the latter derived principally from blood platelets. The coagulation of blood can also be induced by certain snake venoms which either promote the formation of thrombin or clot fibrinogen directly, accounting in part for their toxicity.

Platelets, besides furnishing phospholipids for the clotting process, help to stanch the flow of blood from injured blood vessels by accumulating at the point of injury, forming a plug. Platelets participate in the phenomenon of clot retraction, in which the blood clot shrinks, expelling liquid serum. Although the function of retraction is unknown, individuals in whom this process is impaired have a bleeding tendency.

Hereditary deficiencies of the function of each of the protein-clotting factors have been described, notably classic hemophilia and Christmas disease, which are disorders of males and clinically indistinguishable. The various hereditary functional deficiencies are associated with a bleeding tendency with one inexplicable exception. Acquired deficiencies of clotting factors, sometimes of great complexity, are also recognized. Therapy for bleeding due to deficiencies of clotting factors often includes the transfusion of blood plasma or fractions of plasma rich in particular substances the patient may lack. See HUMAN GENETICS.

Clinical tests of the coagulability of the blood include (1) determination of the clotting time, that is, the time elapsing until shed blood clots; (2) the prothrombin time, the time elapsing until plasma clots in the presence of tissue thromboplastin (and therefore a measure of the extrinsic pathway of clotting); (3) the partial thromboplastin time, the time elapsing until plasma clots in the presence of crude phospholipid (and therefore a measure of the intrinsic pathway of clotting); (4) the enumeration of platelets; and (5) crude quantification of clot retraction and of the various plasma protein-clotting factors.

Heparin, a polysaccharide-sulfuric acid complex found particularly in the liver and lungs, impairs coagulation; its presence in normal blood is disputed. Both coumarin and heparin are used clinically to impede coagulation in thrombotic states, including thrombophlebitis and coronary heart disease. See FIBRINOGEN.

[O.D.R.]

**Blood groups** Genetically determined markers on the surface of cellular blood elements (red and white blood cells, platelets). In medicine, the matching of ABO and Rh groups of recipients and donors before blood transfusion is of paramount importance; other blood groups also can be implicated in incompatibility. Markers on white cells (histocompatibility antigens) are shared by a number of body tissue cells; these markers are important to the survival of transplanted organs and bone marrow. In law, the recognition of identity between bloodstains found

**Table 1. ABO blood group system**

Blood group	RBC antigens	Possible genotypes	Plasma antibody
A	A	<i>A/A</i> or <i>A/O</i>	anti-B
B	B	<i>B/B</i> or <i>B/O</i>	anti-A
O	—	<i>O/O</i>	Anti-A and anti-B
AB	A and B	<i>A/B</i>	—

at the scene of a crime and those on clothing of a suspect has resulted in many convictions, and blood typing has served to resolve paternity disputes. From an anthropologic standpoint, some blood groups are unique to specific populations and can be a reflection of tribal origin or migration patterns. Blood groups are also valuable markers in gene linkage analysis, and their study has contributed enormously to the mapping of the human genome.

**Antibodies.** Human blood can be classified into different groups based on the reactions of red blood cells with blood group antibodies (Table 1). Naturally acquired antibodies, such as anti-A and anti-B antibodies, are normally found in serum from persons whose red blood cells lack the corresponding antigen. It is thought that they are stimulated by antigens present in the environment, and are acquired by infants within months of birth. Because anti-A and anti-B antibodies can cause rapid, life-threatening destruction of incompatible red blood cells, blood for transfusion is always selected to be compatible with the plasma of the recipient. See ANTIBODY; ANTIGEN.

Most blood group antibodies, including Rh antibodies, are immune in origin and do not appear in serum or plasma unless the host is exposed directly to foreign red blood cell antigens. The most common stimulating event is blood transfusion or pregnancy. Because of the large number of different blood group antigens, it is impossible, when selecting blood for transfusion, to avoid transfusing antigens that the recipient lacks. However, these foreign antigens may or may not be immunogenic. A single-unit transfusion of Rh D-positive to an Rh D-negative recipient causes production of anti-D in about 85% of cases. Consequently, in addition to matching for ABO types, Rh D-negative blood is almost always given to Rh D-negative recipients. In pregnancy, fetal red blood cells cross the placenta and enter the maternal circulation, particularly at delivery. The fetal red blood cells may carry paternally derived antigens that are foreign to the mother and stimulate antibody production. These antibodies may affect subsequent pregnancies by destroying the

fetal red blood cells and causing a disease known as erythroblastosis fetalis.

**Antigens, genes, and blood group systems.** Approximately 700 distinct blood group antigens have been identified on human red blood cells. Biochemical analysis has revealed that most antigen structures are either protein or lipid in nature; in some instances, blood group specificity is determined by the presence of attached carbohydrate moieties. The human A and B antigens, for example, can be either glycoprotein or glycolipid, with the same attached carbohydrate structure. With few exceptions, blood group antigens are an integral part of the cell membrane.

A number of different concepts have been put forth to explain the genetics of the human blood groups. The presence of a gene in the host is normally reflected by the presence of the corresponding antigen on the red blood cells. Usually, a single locus determines antigen expression, and there are two or more forms of a gene or alleles (for example, *a* and *b*) that can occupy a locus. Each individual inherits one allele from each parent. For a given blood group, when the same allele (for example, allele *a*) is inherited from both parents, the offspring is homozygous for *a* and only the antigen structure defined by *a* will be present on the red blood cells. When different alleles are inherited (that is, *a* and *b*), the individual is heterozygous for *a* (and *b*), and both *a* and *b* antigens will be found on the red blood cells. In some blood group systems, several loci govern the expression of multiple blood group antigens within that system. These loci are usually closely linked, located adjacent to each other on the chromosome. Such complex loci may contain multiple alleles and are referred to as haplotypes.

Some 200 antigens have been assigned to 25 different blood group systems. Eight such systems are shown in the Table 2. For a system to be established, the genes involved must be distinct from other blood group system genes, and either they must be polymorphic (that is, two or more alleles, each with an appreciable frequency in a population) or the chromosome location must be known. Antigens that do not meet the criteria for assignment to a specific blood group system have been placed into collections, based primarily on biochemical data or phenotypic association, or into a series of either high- or low-frequency antigens.

ABO was the first human blood group system to be described. Three major alleles at the ABO locus on chromosome 9 govern the expression of A and B antigens. Gene A encodes for a protein ( $\alpha$ -N-acetylgalactosaminyl transferase) that attaches a blood group-specific carbohydrate ( $\alpha$ -N-acetyl-D-galactosamine) and

**Table 2. Human blood group systems**

System name	ISBT* symbol	System number	Antigens in system	Chromosome location <sup>†</sup>	Gene products
ABO	ABO	001	4	9q34.1-q34.2	<i>A</i> = $\alpha$ -N-acetylgalactosaminyl transferase <i>B</i> = $\alpha$ -galactosyl transferase
MNS	MNS	002	43	4q28-q31	<i>GYP A</i> = glycophorin A; 43-kDa single-pass glycoprotein <i>GYP B</i> = glycophorin B; 25-kDa single-pass glycoprotein
Rh	RH	004	45	1p36.13-p34	<i>RHD</i> and <i>RHCE</i> , 30–32-kDa multipass polypeptides
Lutheran	LU	005	18	19q13.2	78- and 85-kDa single-pass glycoproteins
Kell	KEL	006	23	7q33	93-kDa single-pass glycoprotein
Duffy	FY	008	6	1q22-q23	38.5-kDa multipass glycoprotein
Diego	DI	010	18	17q12-q21	95–105-kDa multipass glycoprotein
Xg	XG	012	1	Xp22.32	22–29-kDa single-pass glycoprotein

\*International Society of Blood Transfusion.

<sup>†</sup>Chromosome locations of genes/loci are identified by the arm (p = short; q = long), followed by the region, then by the band within the region, in both cases numbered from the centromere; ter = end.

confers blood group A activity to a preformed carbohydrate structure called H antigen. Gene *B* encodes for an  $\alpha$ -galactosyl transferase that attaches  $\alpha$ -D-galactose and confers blood group B activity to H antigen. In both instances, some H remains unchanged. The *O* gene has no detectable product; H antigen remains unchanged and is strongly expressed on red blood cells. These three genes account for the inheritance of four common phenotypes: A, B, AB, and O. A and O blood types are the most common, and AB the least common. The *A* and *B* genes are codominant; that is, when the gene is present the antigen can be detected. The *O* gene is considered an amorph since its product cannot be detected. When either *A* or *B* antigens are present on red blood cells, the corresponding antibody or antibodies should not be present in the serum or plasma. In adults, when *A* or *B* or both are absent from the red blood cells, the corresponding naturally acquired antibody is present in the serum. This reciprocal relationship between antigens on the red blood cells and antibodies in the serum is known as Landsteiner's law. Other ABO phenotypes do exist, but these are quite rare. Further, the *A* blood type can be subdivided, based on strength of antigen expression, with *A*<sub>1</sub> red blood cells having the most *A* antigen.

Currently 45 antigens are assigned to the Rh blood group system, although *D* is the most important. Red blood cells that carry *D* are called Rh-positive; red blood cells lacking *D* are called Rh-negative. Other important Rh antigens are *C*, *c*, *E*, and *e*. Rh antigen expression is controlled by two adjacent homologous structural genes on chromosome 1 that are inherited as a pair or haplotype. The *RhD* gene encodes *D* antigen and is absent on both chromosomes of most Rh-negative subjects. The *RhCE* gene encodes *CE* protein. Nucleotide substitutions account for amino acid differences at two positions on the *CE* protein, and result in the *Cc* and *Ee* polymorphisms.

**Biological role.** The function of blood group antigens has been increasingly apparent. Single-pass proteins such as the *LU* and *XG* proteins are thought to serve as adhesion molecules that interact with integrins on the surface of white blood cells. Multi-pass proteins such as band 3, which carries the *DI* system antigens, are involved in the transportation of ions through the red blood cell membrane bilipid layer. Some blood group antigens are essential to the integrity of the red blood cell membrane, for their absence results in abnormal surface shape; for example, absence of *KEL* protein leads to the formation of acanthocytes, and absence of *RH* protein results in stomatocytosis and hemolytic anemia. Many membrane structures serve as receptors for bacteria and other microorganisms. For example, the *FY* or Duffy protein is the receptor on red blood cells for invasion by *Plasmodium vivax*, the cause of benign tertian malaria. Particularly significant is the fact that *Fy(a-b-)* phenotype is virtually nonexistent among Caucasians but has an incidence of around 70% among African-Americans. Presumably, the *Fy(a-b-)* phenotype evolved as a selective advantage in areas where *P. vivax* is endemic. Similarly, the *S-s-U-red* blood cell phenotype in the *MNS* blood group system affords protection against *P. falciparum*, or malignant tertian malaria. Yet other blood group antigens can be altered in disease states; *A*, *B*, and *H* antigens are sometimes weakened in leukemia or may be modified by bacterial enzymes in patients with septicemia. See **BLOOD**; **IMMUNOLOGY**. [W.J.J.]

**Blood vessels** Tubular channels for blood transport, of which there are three principal types: arteries, capillaries, and veins. Only the larger arteries and veins in the body bear distinct names. Arteries carry blood away from the heart through a system of successively smaller vessels. Capillaries are the smallest but most extensive blood vessels, forming a network everywhere in the body tissues. Veins carry blood from the capillary beds back to the heart through increasingly larger vessels. In certain locations blood vessels are modified for particular functions, as the sinusoids of the liver and the spleen and the choroid plexuses of the brain ventricles. See **CAPILLARY (ANATOMY)**; **LYMPHATIC SYSTEM**. [W.J.B.]

**Blowout coil** A coil that produces a magnetic field in an electrical switching device for the purpose of lengthening and extinguishing an electric arc formed as the contacts of the switching device part to interrupt the current. The magnetic field produced

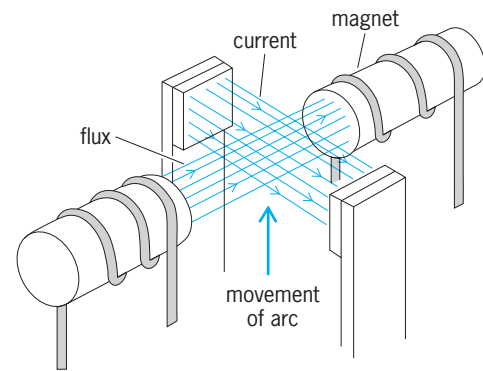

Relation of directions of current, magnetic flux, and movement of arc in a blowout coil.

by the coil is approximately perpendicular to the arc. The interaction between the arc and current and the magnetic field produces a force driving the arc in the direction perpendicular to both the magnetic flux and the arc current (see illustration). [T.H.L.]

**Blowpipe** In glass blowing, a long straight tube on which molten glass is gathered and worked, partly by blowing into the tube. The blowpipe is spun to shape the glass object further by centrifugal force, or by a tool, in which case the blowpipe acts as a spindle for turning.

In analytical chemistry, a blowpipe is a small, tapered, and frequently curved tube that directs a jet, usually of air, into a flame to concentrate the flame onto an unknown substance.

Coloration of the flame and other characteristic reactions in the reducing and in the oxidizing portions of the flame created by the blowpipe aid in identifying the substance. Such a blow-pipe may be blown directly by the analyst, from a bellows, or from a pressurized line. [F.H.R.]

**Blue straggler star** A star that is a member of a stellar association and is located at an unusual position on the association's color-magnitude diagram, above the turnoff from the main sequence. See **COLOR INDEX**; **HERTZSPRUNG-RUSSELL DIAGRAM**.

The blue stragglers were discovered by A. Sandage in 1953 in the galactic globular cluster *M3* (see illustration). They are located below the horizontal branch and above the turnoff from the main sequence. They form a new sequence extending from the extrapolation of the main sequence to higher luminosities on the left to the red giant branch on the right. While the majority of the cluster members fall rather precisely on the expected isochrones for the approximately  $15 \times 10^9$ -year age of the cluster, the 50 or so blue stragglers in *M3* are located on much younger isochrones. More than 1000 objects of this type have been found so far in every known type of stellar association, including dwarf spheroidal galaxies. See **GALAXY, EXTERNAL**.

The simplest explanation of the phenomenon is that the blue stragglers are younger than the rest of the cluster members, perhaps because of a recent burst of star formation. This delayed-formation scenario is possible in young open clusters and some dwarf spheroidal galaxies. However, there is no evidence at all for recent star formation episodes in the galactic globular clusters. For these systems, the scenario for the origin of blue stragglers favored by most astronomers in the field involves the merging of two low-mass stars to form a relatively unevolved more massive star. Two possibilities in this context have been discussed: merging of stars in a preexisting binary system by mass transfer, and

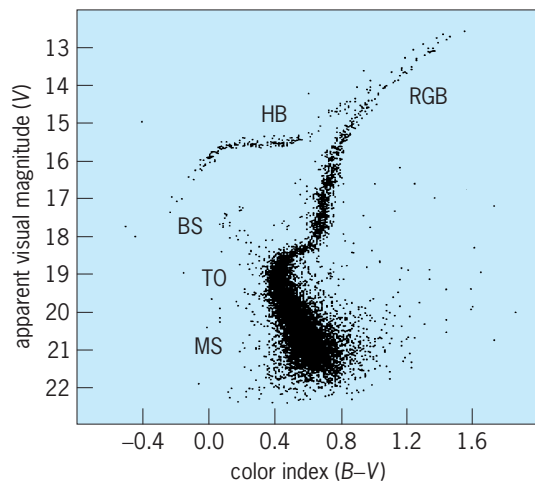

**Color-magnitude diagram** [apparent visual magnitude ( $V$ ) versus color index ( $B-V$ )] of 10,637 stars in the galactic globular cluster M3 (NGC 5272). The important evolutionary stages are marked by MS (main sequence), TO (turn-off), RGB (red giant branch), HB (horizontal branch), and BS (blue stragglers). (After R. Buonanno et al., *High precision photometry of 10,000 stars in M3*, *Mem. Soc. Astron. It.*, 57:391–393, 1986)

formation of a relatively unevolved massive star by direct collision of two stars. Both of these mechanisms are likely to occur simultaneously in globular clusters, giving rise to two different types of blue stragglers. The collisional stragglers should have been formed in the dense core where the stellar density, and thus the chance of a collision, is the highest, while the binary stragglers depend sensitively only on the number of primordial binaries and could be located anywhere in the cluster. See BINARY STAR; STAR CLUSTER; STELLAR EVOLUTION. [F.P.]

**Blueberry** Several species of the genus *Vaccinium*, plant order Ericales, ranging from low-growing, almost prostrate plants to vigorous shrubs reaching a height of 12–15 ft (3.7–4.6 m). The fruit, a berry, is usually black and covered with bluish bloom, generally occurring in clusters, and has numerous small seeds, a characteristic that distinguishes the blueberry from the huckleberry, which has 10 rather large, gritty seeds. Although there are blueberry species on other continents, all cultivated varieties in the United States are American in origin.

The dryland blueberry (*V. ashei*) is adapted to relatively dry soils and has been brought under cultivation in Florida and Georgia. In the Northeast the lowbush blueberry (*V. lamarkii*) grows wild over thousands of acres of dry hillsides, where it is harvested commercially, especially in Maine, but also in other New England states, Michigan, Minnesota, and a few others. In the Northwest fruit of the evergreen blueberry (*V. ovatum*) is harvested in the wild, and large tonnages of the leafy twigs are shipped for use as florists' greens. The highbush blueberry, represented by *V. australe* and *V. corymbosum*, provides most of the cultivated plants. The highbush blueberry is found in swampy land, usually on hummocks.

The fruit is sold fresh, canned, and frozen. The blueberry is becoming increasingly popular in home gardens, although its cultural requirements are rather exacting. For garden culture, mulching with sawdust or other organic matter is desirable because the roots are shallow. See ERICALES. [J.H.Cl.]

**Bluefish** A predatory and voracious species of fish that ranges throughout the tropical and temperate seas of the world, except for the eastern and central Pacific areas. A single species, *Pomatomus saltatrix*, makes up the family Pomatomidae. This fish, also known as the skipjack, is bluish gray with an average length of 3 ft (0.9 m) and weight of about 5 lb (2.3 kg). The

mouth is large with sharp, strong teeth. The bluefish form schools and migrate north along the Atlantic coast, following schools of smaller fish upon which they prey. The bluefish continue to kill and destroy their prey even after feeding. About June they reach the New England coast, where the young can be found in estuaries and bays. See PERCIFORMES. [C.B.C.]

**Bluegrass** Grass of genus *Poa* (also called meadowgrass), of the family Graminae (Poaceae). About 50 species are natural to the United States, and 4 are of economic importance: Kentucky bluegrass (*P. pratensis*), used in lawns and pasture; Canada bluegrass (*P. compressa*), used for erosion control; roughstalk bluegrass (*P. trivialis*), adapted for turf in cool wet shade; and annual bluegrass (*P. annua*), a weed of cool moist sites. Kentucky bluegrass was introduced from Europe to Illinois by French missionaries, and spread rapidly throughout the Midwest, thriving where mean July temperatures are below 68°F (20°C). See GRASS CROPS.

Kentucky bluegrass (June grass) provides nutritious spring pasture, but tends to semidormancy and sparse pasture in summer. Replaced by other grasses for pasture, it is now valued as grass for lawns in temperate North America. Bluegrass lawn turf is planted during fall or spring from sod or seed. Seed is sown at about 2 lb/1000 ft<sup>2</sup> (1 kilogram/are). In fertile soil, plants spread by rhizomes to form a dense sod, favoring a soil of pH 5.8–6.8, good levels of phosphorus and nitrogen, and a mowing of not lower than 2 in. (5 cm) with a sharp blade. Fertilizer needs depend on soil, length of growing season, and whether clippings are removed or left so nutrients are recycled. Irrigation is needed in regions of low rainfall or during periods of drought. [J.H.Ma.]

**Blueschist** Metamorphic rock formed at high pressure and low temperature, commonly above 5 kilobars (500 megapascals) and below 750°F (400°C). Metamorphic rocks of the relatively uncommon blueschist facies contain assemblages of minerals that record these high pressures and low temperatures. The name “blueschist” derives from the fact that at this metamorphic grade, rocks of ordinary basaltic composition are often bluish because they contain the sodium-bearing blue amphiboles glaucophane or crossite rather than the calcium-bearing green or black amphiboles actinolite or hornblende, which are developed in the more common greenschist- or amphibolite-facies metamorphism.

Blueschist metamorphic rocks are found almost exclusively in the young mountain belts of the circum-Pacific and Alpine-Himalayan chains. The rocks are usually metamorphosed oceanic sediments and basaltic oceanic crust. Previously continental rocks rarely exhibit blueschist metamorphism. The tectonic mechanism for blueschist metamorphism must move the rocks to depths of more than 6 to 12 mi (10 to 20 km) while maintaining relatively cool temperatures (390–750°F or 200–400°C). These temperatures are much cooler than for continental crust at those depths. For example, surface geothermal gradients of the order of 30°C per kilometer are common in continental crust and in thick sedimentary basins. In contrast, a steady-state surface gradient of about 44 to 58°F per mile (15 to 20°C per kilometer) would be required for typical blueschist metamorphism. Heat flow measurements above long-lived subduction zones, together with thermal models, suggest that the conditions of blueschist metamorphism exist today above subduction zones just landward of deep-sea trenches. This tectonic setting at the time of blueschist metamorphism is independently inferred for a number of metamorphic terranes.

What is not well understood is how the blueschist metamorphic rocks return to the surface; clearly the mechanism is not simple uplift and erosion of 12–18 mi (20–30 km) of the Earth's crust. Blueschist metamorphic rocks are usually in immediate fault contact with much less metamorphosed or unmetamorphosed sediments, indicating they have been tectonically displaced relative to their surroundings since metamorphism. See METAMORPHIC ROCKS; METAMORPHISM. [J.Sup.]

**Bluestem grass** The common generic name often applied to the genera *Andropogon*, *Dichanthium*, *Bothriochloa*, and *Schizachyrium* in the grass tribe Andropogoneae. They are adapted to environments with high light intensities and high temperatures during the growing season. The bluestems are medium to tall, warm-season, perennial grasses. The two most important forage species are big bluestem (*A. gerardi*) and little bluestem (*S. scoparius*).

Big bluestem is a tall (usually 3 to 6 ft or 1 to 2 m), deep-rooted grass with strong rhizomes; it occurs throughout the continental United States (except in the extreme western states), in southern Canada, and in northern Mexico. One of the most palatable of all grasses when it is actively growing, its nutritional value declines sharply with maturity. Because of its high palatability and tall growth habit, big bluestem has been reduced or eliminated by heavy grazing over much of its range.

Little bluestem is a medium-height bunchgrass (usually 1 to 2 ft or 30 to 60 cm, but taller in the south) which occurs in the same geographic area as big bluestem but extends farther north in the prairie provinces of Canada to the southern Yukon. It is an excellent grass for grazing and hay when actively growing, but nutritional value declines rapidly with maturity. This is the grass that provides the major aspect of the Flint Hills of Kansas and the Osage Hills of Oklahoma. See CYPERALES. [J.K.L.]

**Bluetongue** An arthropod-borne disease of ruminant species. Its geographic distribution is dependent upon a susceptible ruminant population and climatic conditions that favor breeding of the primary vector, a mosquito (*Culicoides* species).

Bluetongue virus is the prototype of the genus *Orbivirus* (family Reoviridae). The viral genome exists as 10 segments of the double-stranded ribonucleic acid (RNA) that encode for seven structural and three nonstructural proteins. The viral particle has a double capsid, with the outer coat (morphologically poorly defined) being composed of two proteins. Twenty-four serotypes of bluetongue virus have been defined, and their distribution throughout the world is varied. See ANIMAL VIRUS.

While multiple ruminant species can become infected, only sheep and deer typically display clinical bluetongue disease. Severity of the disease is dependent upon multiple factors, including virus strain, animal breed, and environmental conditions. Upon infection by a gnat bite, the virus apparently replicates in the local lymphatic system prior to the viral particles moving into the blood (viremia). Viral replication occurs in the endothelial cells of small vessels, resulting in narrowing of the vessel, release of proteinaceous material into the surrounding tissues, and possibly hemorrhage, with the respiratory tract, mucous membranes, cardiac and skeletal musculature, and skin being most affected. Animals experiencing acute clinical symptoms typically die from pneumonia or pulmonary failure; hemorrhage at the base of the pulmonary artery indicates the presence of a vascular lesion.

Control of bluetongue disease requires the application of vaccines and modulation of the farm environment. While bluetongue virus vaccines are available, efficacy is often incomplete and variable, in part because of the multiplicity of serotypes active throughout the world and limited cross-serotype protection. Furthermore, use of polyvalent (multiple-serotype) vaccines in the United States has been discouraged because of potential genetic reassortment between vaccine viruses and wild-type viruses, a process that could possibly lead to pathogenic variants. Relative to environment, elimination of vector breeding sites can also facilitate control of virus transmission. With the multiplicity of serotypes typically active in an endemic area, and the minimal cross-serotype protection observed, administration of vaccine in the face of an outbreak may be of limited value. See VACCINATION. [J.L.Sto.]

**Boat propulsion** The action of propelling a boat through water. A boat machinery plant consists principally of a propulsion

engine, propulsor (propeller or jet pump), and drive-line components. The engines are almost exclusively of the familiar internal combustion types: gasoline, diesel, or gas turbine. The gasoline engine has traditionally dominated the pleasure-boat field, while the diesel is favored for commercial and military craft. The gas turbine is comparatively rare and is found only in applications where high power from machinery of small weight and volume is essential.

Auxiliary items, such as bilge pumps, domestic water pumps and heaters, and electric generators and switchboards typically are found in the machinery plants of the larger boats. The generator (or alternator) is often driven by a belt from the propulsion engine, as in automotive practice, but is sometimes driven by a separate engine.

The marine gasoline engine appears in inboard and out-board forms. The outboard engine is a unit assembly of engine, propeller, and vertical drive shaft that is usually clamped to the boat transom. It is traditionally the power plant for the smallest motor boats, or an auxiliary for rowboats and sailboats. The inboard form is almost exclusively adapted from one of the mass-produced automotive engines. Inboard engines are compact, light, lower in first cost than any competitor, and familiar to untrained users, and so they predominate among pleasure boats and the smaller fishing boats.

The diesel engine is generally higher in first cost than the gasoline engine and is somewhat heavier for the same power, but it consumes less fuel. Fuel savings make the diesel attractive if the engine is to be used more than a few hundred hours a year or if the boat must have a long cruising range. Its principal market is thus in commercial and military craft, but some of the more compact models are used in pleasure craft.

The gas turbine engine is comparatively light and compact, making it attractive for high-speed, high-power boats. Its disadvantages are high first cost, high fuel consumption, and large exhaust and intake ducts. The last factor is due to its high rate of air consumption; the need for large volumes of air also makes it difficult, in a small vessel, to keep spray from being drawn into the engine, with consequent fouling and corrosion. See DIESEL ENGINE; GAS TURBINE; INTERNAL COMBUSTION ENGINE; MARINE ENGINE; MARINE MACHINERY. [J.B.W.]

**Bog** Nutrient-poor, acid peatlands with a vegetation in which peat mosses (*Sphagnum* spp.), ericaceous dwarf shrubs, and to a lesser extent, various sedges (Cyperaceae) play a prominent role. The terms muskeg, moor, heath, and moss are used locally to indicate these sites. See MUSKEG.

Bogs are most abundant in the Northern Hemisphere, especially in a broad belt including the northern part of the deciduous forest zone and the central and southern parts of the boreal forest zone. Farther south, and in drier climates farther inland, they become sporadic and restricted to specialized habitats. To the north, peatlands controlled by mineral soil water (aapa mires) replace them as the dominant wetlands.

Bogs are much less extensive in the Southern Hemisphere because there is little land in cold temperate latitudes. In these Southern Hemisphere peatlands, *Sphagnum* is much less important, and Epacridaceae and Restionaceae replace the Ericaceae and Cyperaceae of the Northern Hemisphere.

Bogs have a fibric, poorly decomposed peat consisting primarily of the remains of *Sphagnum*. Peat accumulation is the result of an excess of production over decomposition. Obviously, the very presence of bogs shows that production exceeded decay over the entire period of bog formation. However, in any given bog present production can exceed, equal, or be less than decomposition, depending on whether it is actively developing, in equilibrium, or eroding. In most bogs, production and decomposition appear to be in equilibrium at present.

Slow decay rather than high productivity causes the accumulation of peat. Decomposition of organic matter in peat bogs is slow due to the high water table, which causes the absence

of oxygen in most of the peat mass, and to the low fertility of the peat. Bogs, in contrast to other peatlands, can accumulate organic matter far above the groundwater table.

Bogs show large geographic differences in floristic composition, surface morphology, and development. Blanket bogs, plateau bogs, domed bogs, and flat bogs represent a series of bog types with decreasing climatic humidity. Concentric patterns of pools and strings (peat dams) become more common and better developed northward. Continental bogs are often forest-covered, whereas oceanic bogs are dominated by dwarf shrub heaths and sedge lawns, with forests restricted to the bog slope if the climate is not too severe.

Bogs have long been used as a source of fuel. In Ireland and other parts of western Europe, the harvesting of peat for domestic fuel and reclamation for agriculture and forestry have affected most of the peatlands, and few undisturbed bogs are left. Other uses are for horticultural peat, air layering in greenhouses, litter for poultry and livestock, and various chemical and pharmaceutical purposes. Mechanical extraction of peat for horticultural purposes has affected large bog areas worldwide. See BIOMASS; SWAMP, MARSH, AND BOG. [A.W.H.D.]

**Bohrium** A chemical element, symbol Bh, atomic number 107. Bohrium was synthesized and identified in 1981 by using the Universal Linear Accelerator (UNILAC) of the Gesellschaft für Schwerionenforschung (GSI) at Darmstadt, West Germany, by a team led by P. Armbruster and G. Müzenberg. The reaction used to produce the element was proposed and applied in 1976 by Y. T. Oganessian and colleagues at Dubna Laboratories in Russia. A  $^{209}\text{Bi}$  target was bombarded by a beam of  $^{54}\text{Cr}$  projectiles.

The best technique to identify a new isotope is its genetic correlation to known isotopes through a radioactive decay chain. These decay chains are generally interrupted by spontaneous fission. In order to apply decay chain analysis, those isotopes that are most stable against spontaneous fission should be produced, that is, isotopes with odd numbers of protons and neutrons. Not only does the fission barrier govern the spontaneous fission of a species produced, but also, in the deexcitation of the virgin nucleus, fission competing with neutron emission determines the final production probability. To keep the fission losses small, a nucleus should be produced with the minimum excitation energy possible. In this regard, reactions using relatively symmetric collision partners and strongly bound closed-shell nuclei, such as  $^{209}\text{Bi}$  and  $^{208}\text{Pb}$  as targets and  $^{48}\text{Ca}$  and  $^{50}\text{Ti}$  as projectiles, are advantageous.

Six decay chains were found in the Darmstadt experiment. All the decays can be attributed to  $^{262}\text{Bh}$ , an odd nucleus produced in a one-neutron reaction. The isotope  $^{262}\text{Bh}$  undergoes alpha-particle decay (10.38 MeV) with a half-life of about 5 ms.

Experiments at Dubna, performed in 1983 using the 157-in. (400-cm) cyclotron, established the production of  $^{262}\text{Bh}$  in the reaction  $^{209}\text{Bi} + ^{54}\text{Cr}$ . See NUCLEAR FISSION; NUCLEAR REACTION; PERIODIC TABLE; RADIOACTIVITY; TRANSURANIUM ELEMENTS. [P.Ar.]

**Boiler** A pressurized system in which water is vaporized to steam, the desired end product, by heat transferred from a source of higher temperature, usually the products of combustion from burning fuels. Steam thus generated may be used directly as a heating medium, or as the working fluid in a prime mover to convert thermal energy to mechanical work, which in turn may be converted to electrical energy. Although other fluids are sometimes used for these purposes, water is by far the most common because of its economy and suitable thermodynamic characteristics.

The physical sizes of boilers range from small portable or shop-assembled units to installations comparable to a multistory 200-ft-high (60-m) building equipped, typically, with a furnace

which can burn coal at a rate of 6 tons/min (90 kg/s). Boilers operate at positive pressures and offer the hazardous potential of explosions. Pressure parts must be strong enough to withstand the generated steam pressure and must be maintained at acceptable temperatures, by transfer of heat to the fluid, to prevent loss of strength from overheating or destructive oxidation of the construction materials.

The overall functioning of steam-generating equipment is governed by thermodynamic properties of the working fluid. By the simple addition of heat to water in a closed vessel, vapor is formed which has greater specific volume than the liquid, and can develop an increase of pressure to the critical value of 3208 psia (22.1 megapascals absolute pressure). If the generated steam is discharged at a controlled rate, commensurate with the rate of heat addition, the pressure in the vessel can be maintained at any desired value, and thus be held within the limits of safety of the construction. See STEAM.

Addition of heat to steam, after its generation, is accompanied by increase of temperature above the saturation value. The higher heat content, or enthalpy, of superheated steam permits it to develop a higher percentage of useful work by expansion through the prime mover, with a resultant gain in efficiency of the power-generating cycle. See SUPERHEATER.

If the steam-generating system is maintained at pressures above the critical, by means of a high-pressure feedwater pump, water is converted to a vapor phase of high density equal to that of the water, without the formation of bubbles. Further heat addition causes superheating, with corresponding increase in temperature and enthalpy. The most advanced developments in steam-generating equipment have led to units operating above critical pressure, for example, 3600–5000 psi (25–34 MPa). Superheated steam temperature has advanced from  $500 \pm ^\circ\text{F}$  ( $260 \pm ^\circ\text{C}$ ) to the present practical limits of  $1050\text{--}1100^\circ\text{F}$  ( $566\text{--}593^\circ\text{C}$ ). See MARINE ENGINEERING; NUCLEAR POWER; STEAM-GENERATING UNIT. [T.Ba.]

**Boiler economizer** A component of a steam-generating unit that absorbs heat from the products of combustion after they have passed through the steam-generating and super-heating sections. The name, accepted through common usage, is indicative of savings in the fuel required to generate steam.

An economizer is a forced-flow, once-through, convection heat-transfer device to which feedwater is supplied at a pressure above that in the steam-generating section and at a rate corresponding to the steam output of the unit. The economizer is in effect a feedwater heater, receiving water from the boiler feed pump and delivering it at a higher temperature to the steam generator or boiler. Economizers are used instead of additional steam-generating surface because the feedwater, and consequently the heat-receiving surface, is at a temperature below that corresponding to the saturated steam temperature; thus, the economizer further lowers the flue gas temperature for additional heat recovery. See BOILER FEEDWATER; THERMODYNAMIC CYCLE.

Generally, steel tubes, or steel tubes fitted with externally extended surface, are used for the heat-absorbing section of the economizer; usually, the economizer is coordinated with the steam-generating section and placed within the setting of the unit. See AIR HEATER; BOILER; STEAM-GENERATING UNIT. [G.W.K.]

**Boiler feedwater** Water supplied to a boiler unit for the generation of steam. Feedwater should be virtually free of impurities that are harmful to the boiler and its associated system. Generally, natural waters are unsuitable for direct use as feedwater because of their contamination by contact with the earth, the atmosphere, or other sources of pollution. These contaminants can be removed or altered by chemical treatment and other means to provide satisfactory feedwater. See RAW WATER; WATER TREATMENT. [G.W.K.]



**Boiler feedwater regulation** Addition of water to a steam-generating unit at a rate commensurate with the removal of steam from the unit. The addition of water to a boiler requires a feedwater pump or some other device that will develop a pressure higher than that of the steam generated. Means also are required to control the rate at which water is added. See BOILER.

Variations of water level in the steam unit usually are due to changes in the rate of steam generation because such changes affect the steam output and the volume of the steam below the water level. Changes in water level can be compensated by use of automatic control which, primarily, regulates the rate of feedwater flow to be equal to the rate of steam output, as determined by metering equipment; the control then readjusts the rate of feedwater flow to maintain the water level within the prescribed normal range. See BOILER FEEDWATER. [G.W.K.]

**Boiling** A process in which a liquid phase is converted into a vapor phase. The energy for phase change is generally supplied by the surface on which boiling occurs. Boiling differs from evaporation at predetermined vapor/gas-liquid interfaces because it also involves creation of these interfaces at discrete sites on the heated surface. Boiling is an extremely efficient process for heat removal and is utilized in various energy-conversion and heat-exchange systems and in the cooling of high-energy density components. See BOILER; EVAPORATION; HEAT EXCHANGER; HEAT TRANSFER.

Boiling is classified into pool and forced-flow. Pool boiling refers to boiling under natural convection conditions, whereas in forced-flow boiling the liquid flow over the heater surface is imposed by external means. Flow boiling is subdivided into external and internal. In external-flow boiling, liquid flow occurs over heated surfaces, whereas internal-flow boiling refers to flow inside tubes. Heat fluxes of  $2 \times 10^8 \text{ W/m}^2$ , or three times the heat flux at the surface of the Sun, have been obtained in flow boiling. See CONVECTION (HEAT).

**Pool boiling.** The illustration, a qualitative pool boiling curve, shows the dependence of the wall heat flux  $q$  on the wall superheat  $\Delta T$  (the difference between the wall temperature and the liquid's saturation temperature). The plotted curve is for

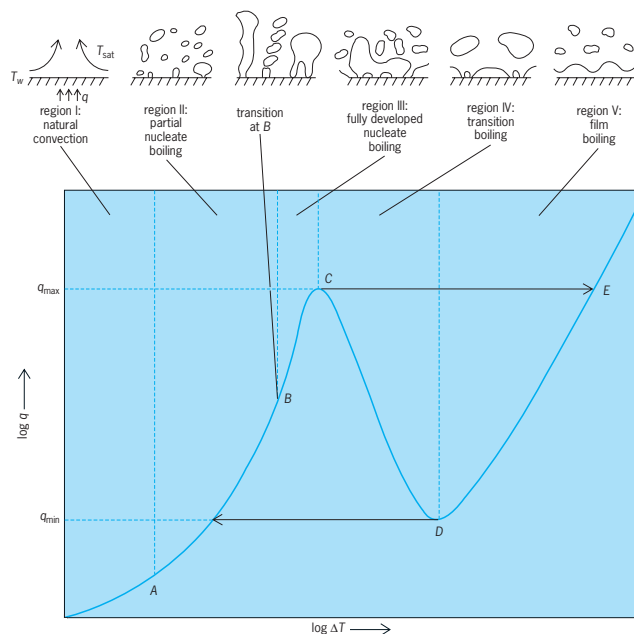

Typical boiling curve, showing qualitatively the dependence of the wall heat flux  $q$  on the wall superheat  $\Delta T$ . Schematic drawings show the boiling process in regions I–V, and transition points A–E.

a horizontal surface underlying a pool of liquid at its saturation temperature (the boiling point at a given pressure). See BOILING POINT.

Several heat transfer regimes can be identified on the boiling curve: single-phase natural convection, partial nucleate boiling, fully developed nucleate boiling, transition boiling, and film boiling.

**Forced-flow boiling.** Forced flow, both external and internal, greatly changes the boiling curve in the illustration. The heat flux is increased by forced convection at temperatures below boiling inception, and after that the nucleate boiling region is extended upward until a flow-enhanced higher maximum flux (corresponding to point C) is achieved. Forced flow boiling in tubes is used in many applications, including steam generators, nuclear reactors, and cooling of electronic components. See STEAM-GENERATING UNIT. [V.K.D.]

**Boiling point** The boiling point of a liquid is the temperature at which the liquid and vapor phases are in equilibrium with each other at a specified pressure. Therefore, the boiling point is the temperature at which the vapor pressure of the liquid is equal to the applied pressure on the liquid. The boiling point at a pressure of 1 atmosphere is called the normal boiling point.

For a pure substance at a particular pressure  $P$ , the stable phase is the vapor phase at temperatures immediately above the boiling point and is the liquid phase at temperatures immediately below the boiling point. The liquid-vapor equilibrium line on the phase diagram of a pure substance gives the boiling point as a function of pressure. Alternatively, this line gives the vapor pressure of the liquid as a function of temperature. The vapor pressure of water is 1 atm (101.325 kilopascals) at  $100^\circ\text{C}$  ( $212^\circ\text{F}$ ), the normal boiling point of water. The vapor pressure of water is 3.2 kPa (0.031 atm) at  $25^\circ\text{C}$  ( $77^\circ\text{F}$ ), so the boiling point of water at 3.2 kPa is  $25^\circ\text{C}$ . The liquid-vapor equilibrium line on the phase diagram of a pure substance begins at the triple point (where solid, liquid, and vapor coexist in equilibrium) and ends at the critical point, where the densities of the liquid and vapor phases have become equal. For pressures below the triple-point pressure or above the critical-point pressure, the boiling point is meaningless. Carbon dioxide has a triple-point pressure of 5.11 atm (518 kPa), so carbon dioxide has no normal boiling point. See TRIPLE POINT.

The normal boiling point is high for liquids with strong intermolecular attractions and low for liquids with weak intermolecular attractions. Helium has the lowest normal boiling point, 4.2 K ( $-268.9^\circ\text{C}$ ). Some other normal boiling points are 111.1 K ( $-162^\circ\text{C}$ ) for  $\text{CH}_4$ ,  $450^\circ\text{C}$  ( $842^\circ\text{F}$ ) for  $n\text{-C}_{30}\text{H}_{62}$ ,  $1465^\circ\text{C}$  ( $2669^\circ\text{F}$ ) for NaCl, and  $5555^\circ\text{C}$  ( $10031^\circ\text{F}$ ) for tungsten.

The rate of change of the boiling-point absolute temperature  $T_b$  of a pure substance with pressure is given by the equation below.  $\Delta H_{\text{vap,m}}$  is the molar enthalpy (heat) of vaporization, and  $\Delta V_{\text{vap,m}}$  is the molar volume change on vaporization.

$$\frac{dT_b}{dP} = \frac{T_b \Delta V_{\text{vap,m}}}{\Delta H_{\text{vap,m}}}$$

The quantity  $\Delta H_{\text{vap,m}}/T_b$  is  $\Delta S_{\text{vap,m}}$ , the molar entropy of vaporization. The molar entropy of vaporization at the normal boiling point (nbp) is given approximately by Trouton's rule:  $\Delta S_{\text{vap,m,nbp}} \approx 87 \text{ J/mol K}$  (21 cal/mol K). Trouton's rule fails for highly polar liquids (especially hydrogen-bonded liquids). It also fails for liquids boiling at very low or very high temperatures, because the molar volume of the vapor changes with temperature and the entropy of a gas depends on its volume.

When a pure liquid is boiled at fixed pressure, the temperature remains constant until all the liquid has vaporized. When a solution is boiled at fixed pressure, the composition of the vapor usually differs from that of the liquid, and the change in liquid composition during boiling changes the boiling point. Thus the boiling process occurs over a range of temperatures for a solution. An exception is an azeotrope, which is a solution that boils entirely at a constant temperature because the vapor in

equilibrium with the solution has the same composition as the solution. In fractional distillation, the variation of boiling point with composition is used to separate liquid mixtures into their components. See AZEOTROPIC MIXTURE; DISTILLATION. [I.N.L.]

**Bolometer** A device for detecting and measuring small amounts of thermal radiation. The bolometer is a simple electric circuit, the essential element of which is a slab of material with an electrical property, most often resistance, that changes with temperature. Typical operation involves absorption of radiant energy by the slab, producing a rise in the slab's temperature and thereby a change in its resistance. The electric circuit converts the resistance change to a voltage change, which then can be amplified and observed by various, usually conventional, instruments.

Although bolometers are useful in studying a variety of systems where detection of small amounts of heat is important, their primary application remains as the instrument of choice for measuring weak radiation signals in the infrared and far infrared, that is, at wavelengths from about 1 to 2000 micrometers, from stars and interstellar material. See BARRETTTER; INFRARED RADIATION; RADIOMETRY; THERMISTOR. [W.E.K.]

**Bolt** A cylindrical fastener with an integral head on one end and an external screw thread on the other end designed to be inserted through holes in assembled parts and to mate with an internally threaded block, called a nut, which is turned to tighten or loosen the bolt. Tensioning the fastener by turning the nut differentiates a bolt from a screw, which is tightened by turning its head. See BOLTED JOINT; NUT (ENGINEERING).

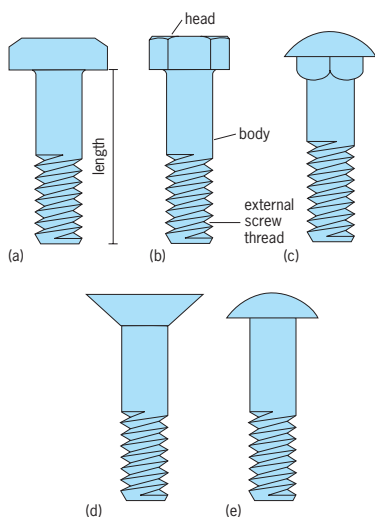

Examples of bolts inserted through clearance holes: (a) square bolt; (b) hex bolt; (c) round-head square-neck bolt for connecting wood to metal; (d) countersunk bolt; and (e) round-head bolt.

Bolts are generally manufactured from metals, but bolts made of other materials, such as nylon, are commercially available. The properties of some bolting metals are modified by heat treatment and other means to increase yield strength. Bolt heads have various shapes to suit different applications (see illustration). Hexagon-headed bolts (hex bolts) are available in two head widths for the same body diameter—regular hex bolts and heavy hex bolts, which have wider heads. The heavy-series bolts are normally supplied with heavy nuts that are wider and thicker than regular nuts.

Various types of bolts may be used for automobile, machinery, appliance, farm implement, and structural connections. For example, low-carbon-steel unfinished bolts with hex heads are used in machinery, and with square heads for structural steel connections. Heat-treated medium-carbon-steel finished hex-head bolts

are high-strength bolts used for connections in structures as well as machinery. However, there are two kinds of high-strength bolts made specifically for structural steel connections, both kinds are heavy hex structural bolts (dimensions differ slightly from those of heavy hex screws). Other kinds of bolts are medium-carbon-steel or atmospheric-corrosion-resistant-alloy-steel, quenched and tempered bolts; and alloy-steel or atmospheric-corrosion-resistant-alloy-steel, quenched and tempered bolts. See SCREW FASTENER; WASHER. [C.Bi.]

**Bolted joint** The assembly of two or more parts by a threaded bolt and nut or by a screw that passes through one member and threads into another. A bolted joint can be disassembled more readily than welded or riveted joints.

Structural members, such as I beams, H beams, angles, and plates, may be joined by bolting. When properly tightened, such joints are as strong and reliable as riveted ones. For joints of this type, high-strength alloy-steel bolts and nuts tightened with impact wrenches are generally used. No locking feature is necessary for properly selected and tightened bolts.

The strength of a bolted assembly depends to a great extent on the initial loading and stress placed on the bolt by the assembly torque. Devices such as torque wrenches are used to determine tension as a function of the torque applied to the assembly of nut and bolt or cap screw and machine part despite the uncertain coefficient of friction between nut, bolt, and assembled members. A better measure is to gage the elongation of the bolt as the tightening torque is applied. Bolt and nut assemblies often include special lock washers to prevent accidental loosening of the fastening by vibration. See SCREW FASTENER; STRUCTURAL CONNECTIONS; WELDED JOINT. [L.S.L.]

**Boltzmann constant** A constant occurring in practically all statistical formulas and having a numerical value of  $1.3807 \times 10^{-23}$  joule/K. It is represented by the letter  $k$ . If the temperature  $T$  is measured from absolute zero, the quantity  $kT$  has the dimensions of an energy and is usually called the thermal energy. At 300 K (room temperature)  $kT = 0.0259$  electronvolt.

The value of the Boltzmann constant may be determined from the ideal gas law. For 1 mole of an ideal gas Eq. (1a) holds, where

$$PV = RT \quad (1a)$$

$$PV = NkT \quad (1b)$$

$P$  is the pressure,  $V$  the volume, and  $R$  the universal gas constant. The value of  $R$ , 8.31 J/K mole, may be obtained from equation-of-state data. Statistical mechanics yields for the gas law Eq. (1b). Here  $N$ , the number of molecules in 1 mole, is called Avogadro's number and is equal to  $6.02 \times 10^{23}$  molecules/mole. Hence, comparing Eqs. (1a) and (1b), one obtains Eq. (2).

$$k = R/N = 1.3807 \times 10^{-23} \text{ J/K} \quad (2)$$

Almost any relation derived on the basis of the partition function or the Bose-Einstein, Fermi-Dirac, or Boltzmann distribution contains the Boltzmann constant. See BOLTZMANN STATISTICS; BOSE-EINSTEIN STATISTICS; FERMI-DIRAC STATISTICS; KINETIC THEORY OF MATTER; STATISTICAL MECHANICS. [M.Dr.]

**Boltzmann statistics** To describe a system consisting of a large number of particles in a physically useful manner, recourse must be had to so-called statistical procedures. If the mechanical laws operating in the system are those of classical mechanics, and if the system is sufficiently dilute, the resulting statistical treatment is referred to as Boltzmann or classical statistics. (Dilute in this instance means that the total volume available is much larger than the proper volume of the particles.) A gas is a typical example: The molecules interacting according to the laws of classical mechanics are the constituents of the system, and the pressure, temperature, and other parameters are the overall entities which determine the macroscopic behavior of the gas. In a case of this kind it is neither possible nor desirable to solve the complicated equations of motion of the molecules; one is not

interested in the position and velocity of every molecule at any time. The purpose of the statistical description is to extract from the mechanical description just those features relevant for the determination of the macroscopic properties and to omit others.

The basic notion in the statistical description is that of a distribution function. Suppose a system of  $N$  molecules is contained in a volume  $V$ . The molecules are moving around, colliding with the walls and with each other. Construct the following geometrical representation of the mechanical system. Introduce a six-dimensional space (usually called the  $\mu$  space), three of its coordinate axes being the spatial coordinates of the vessel  $x, y, z$ , and the other three indicating cartesian velocity components  $v_x, v_y, v_z$ . A molecule at a given time, having a specified position and velocity, may be represented by a point in this six-dimensional space. The state of the gas, a system of  $N$  molecules, may be represented by a cloud of  $N$  points in this space. In the course of time, this cloud of  $N$  points moves through the  $\mu$  space.

Note that the  $\mu$  space is actually finite; the coordinates  $x, y, z$  of the molecules' position are bounded by the finite size of the container, and the velocities are bounded by the total energy of the system. Imagine now that the space is divided into a large number of small cells, of sizes  $w_1, \dots, w_i, \dots$ . A certain specification of the state of the gas is obtained if, at a given time  $t$ , the numbers  $n_1(t), \dots, n_i(t), \dots$  of molecules in the cells  $1, \dots, i, \dots$  are given. To apply statistical methods, one must choose the cells such that on the one hand a cell size  $w$  is small compared to the macroscopic dimensions of the system, while on the other hand  $w$  must be large enough to allow a large number of molecules in one cell. If the cells are thus chosen, the numbers  $n_i(t)$ , the occupation numbers, will be slowly changing functions of time. The distribution functions  $f_i(t)$  are defined by Eq. (1).

$$n_i(t) = f_i(t)w_i \quad (1)$$

The distribution function  $f_i$  describes the state of the gas, and  $f_i$  of course varies from cell to cell. Since a cell  $i$  is characterized by a given velocity range and position range, and since for appropriately chosen cells  $f$  should vary smoothly from cell to cell,  $f$  is often considered as a continuous function of the variables  $x, y, z, v_x, v_y, v_z$ . The cell size  $w$  then can be written as  $dx dy dz dv_x dv_y dv_z$ .

Since a cell  $i$  determines both a position and a velocity range, one may associate an energy  $\epsilon_i$  with a cell. This is the energy a single molecule possesses when it has a representative point in cell  $i$ . This assumes that, apart from instantaneous collisions, molecules exert no forces on each other. If this were not the case, the energy of a molecule would be determined by the positions of all other molecules.

Most of the physically interesting quantities follow from a knowledge of the distribution function; the main problem in Boltzmann statistics is to find out what this function is. It is clear that  $n_i(t)$  changes in the course of time for three reasons: (1) Molecules located at the position of cell  $i$  change their positions and hence move out of cell  $i$ ; (2) molecules under the influence of outside forces change their velocities and again leave the cell  $i$ ; and (3) collisions between the molecules will generally cause a (discontinuous) change of the occupation numbers of the cells. Whereas the effect of (1) and (2) on the distribution function follows directly from the mechanics of the system, a separate assumption is needed to obtain the effect of collisions on the distribution function. This assumption, the collision-number assumption, asserts that the number of collisions per unit time, of type  $(i, j) \rightarrow (k, l)$  [molecules from cells  $i$  and  $j$  collide to produce molecules of different velocities which belong to cells  $k$  and  $l$ ], called  $A_{ij}^{kl}$ , is given by Eq. (2). Here  $a_{ij}^{kl}$  depends on the collision

$$A_{ij}^{kl} = n_i n_j a_{ij}^{kl} \quad (2)$$

configuration and on the size and kind of the molecules but not on the occupation numbers. Gains and losses of the molecules in, say, cell  $i$  can now be observed. If the three factors causing gains and losses are combined, the Boltzmann transport equa-

tion, written as Eq. (3), is obtained. Here  $\Delta_x f_i$  is the gradient of

$$\frac{\partial f_i}{\partial t} + (\mathbf{v}_i \cdot \Delta_x f_i) + (\mathbf{X}_i \cdot \Delta_v f_i) = \sum_{j,k,l} a_{ij}^{kl} w_j (f_k f_l - f_i f_j) \quad (3)$$

$f$  with respect to the positions,  $\Delta_v f_i$  refers similarly to the velocities, and  $\mathbf{X}_i$  is the outside force per unit mass at cell  $i$ . This nonlinear equation determines the temporal evolution of the distribution function. Exact solutions are difficult to obtain. Yet Eq. (3) forms the basis for the kinetic discussion of most transport processes. There is one remarkable general consequence, which follows from Eq. (3). If one defines  $H(t)$  as in Eq. (4), one finds by straight manipulation from Eqs. (3) and (4) that Eqs. (5)

$$H(t) = \sum_i n_i \ln f_i \quad (4)$$

$$\frac{dH}{dt} \dots 0 \quad \frac{dH}{dt} = 0 \quad \text{if } f_i f_j = f_k f_l \quad (5)$$

hold. Hence  $H$  is a function which in the course of time always decreases. This result is known as the  $H$  theorem. The special distribution which is characterized by Eq. (6) has the property

$$f_i f_j = f_k f_l \quad (6)$$

that collisions do not change the distribution in the course of time; it is an equilibrium or stationary distribution.

The form of the equilibrium distribution may be determined from Eq. (6), with the help of conservation laws. For a gas which as a whole is at rest, it may be shown that the only solution to functional Eq. (6) is given by Eqs. (7a) or (7b). Here  $A$  and

$$f_i = A e^{-\beta \epsilon_i} \quad (7a)$$

$$f(\mathbf{x}, \mathbf{v}) = A e^{(-1/2)\beta m v^2 - \beta U} \quad (7b)$$

$\beta$  are parameters, not determined by Eq. (6), and  $U$  is the potential energy at the point  $x, y, z$ . Equations (7a) and (7b) are the Maxwell-Boltzmann distribution. Actually  $A$  and  $\beta$  can be determined from the fact that the number of particles and the energy of the system are specified.

The indiscriminate use of the collision-number assumption leads, via the  $H$  theorem, to paradoxical results. The basic conflict stems from the irreversible results that appear to emerge as a consequence of a large number of reversible fundamental processes. A careful treatment of the explicit and hidden probability assumptions is the key to the understanding of the apparent conflict. The equilibrium distribution may be thought of as the most probable state of a system. If a system is not in equilibrium, it will most likely (but not certainly) go there; if it is in equilibrium, it will most likely (but not certainly) stay there. By using such probability statements, it may be shown that the paradoxes and conflicts may indeed be removed. A consequence of the probabilistic character of statistics is that the entities computed also possess this characteristic. For example, one cannot really speak definitively of the number of molecules hitting a section of the wall per second, but only about the probability that a given number will hit the wall, or about the average number hitting. In the same vein, the amount of momentum transferred to a unit area of the wall by the molecules per second (this, in fact, is precisely the pressure) is also to be understood as an average. This in particular means that the pressure is a fluctuating entity. The fluctuations in pressure may be demonstrated by observing the motion of a mirror, suspended by a fiber, in a gas. On the average, as many gas molecules will hit the back as the front of the mirror, so that the average displacement will indeed be zero. However, it is easy to imagine a situation where more momentum is transferred in one direction than in another, resulting in a deflection of the mirror. From the knowledge of the distribution function the probabilities for such occurrences may indeed be computed; the calculated and observed behavior agree very well. This clearly demonstrates the essentially statistical character of the pressure. See BROWNIAN MOVEMENT; BOLTZMANN TRANSPORT EQUATION; KINETIC THEORY OF MATTER; QUANTUM STATISTICS; STATISTICAL MECHANICS. [M.Dr.]

**Boltzmann transport equation** An equation which is used to study the nonequilibrium behavior of a collection of particles. In a state of equilibrium a gas of particles has uniform composition and constant temperature and density. If the gas is subjected to a temperature difference or disturbed by externally applied electric, magnetic, or mechanical forces, it will be set in motion and the temperature, density, and composition may become functions of position and time; in other words, the gas moves out of equilibrium. The Boltzmann equation applies to a quantity known as the distribution function, which describes this nonequilibrium state mathematically and specifies how quickly and in what manner the state of the gas changes when the disturbing forces are varied. See KINETIC THEORY OF MATTER.

Equation (1) is the Boltzmann transport equation shown be-

$$\frac{\partial f}{\partial t} = \left( \frac{\partial f}{\partial t} \right)_{\text{force}} + \left( \frac{\partial f}{\partial t} \right)_{\text{diff}} + \left( \frac{\partial f}{\partial t} \right)_{\text{coll}} \quad (1)$$

low, where  $f$  is the unknown distribution function which, in its most general form, depends on a position vector  $\mathbf{r}$ , a velocity vector  $\mathbf{v}$ , and the time  $t$ . The quantity  $\partial f/\partial t$  on the left side of Eq. (1) is the rate of change of  $f$  at fixed values of  $\mathbf{r}$  and  $\mathbf{v}$ . The equation expresses this rate of change as the sum of three contributions: first,  $(\partial f/\partial t)_{\text{force}}$  arises when the velocities of the particles change with time as a result of external driving forces; second,  $(\partial f/\partial t)_{\text{diff}}$  is the effect of the diffusion of the particles from one region in space to the other; and third,  $(\partial f/\partial t)_{\text{coll}}$  is the effect of the collisions of the particles with each other or with other kinds of particles.

The distribution function carries information about the positions and velocities of the particles at any time. The probable number of particles  $N$  at the time  $t$  within the spatial element  $dx dy dz$  located at  $(x, y, z)$  and with velocities in the element  $dv_x dv_y dv_z$  at the point  $(v_x, v_y, v_z)$  is given by Eq. (2) or, in vector notation, by Eq. (3). It is assumed that the particles are identical;

$$N = f(x, y, z, v_x, v_y, v_z, t) dx dy dz dv_x dv_y dv_z \quad (2)$$

$$N = f(\mathbf{r}, \mathbf{v}, t) d^3r d^3v \quad (3)$$

a different distribution function must be used for each species if several kinds of particles are present.

The Boltzmann equation is irreversible in time in the sense that if  $f(\mathbf{r}, \mathbf{v}, t)$  is a solution, then  $f(\mathbf{r}, -\mathbf{v}, -t)$  is not a solution. Thus if an isolated system is initially not in equilibrium, it approaches equilibrium as time advances; the time-reversed performance, in which the system departs farther from equilibrium, does not occur. This is paradoxical because actual physical systems are reversible in time when looked at on an atomic scale. From a mathematical point of view it is puzzling that one can begin with the exact equations of motion, reversible in time, and by making reasonable approximations arrive at the irreversible Boltzmann equation. The resolution of this paradox lies in the statistical nature of the Boltzmann equation. It does not describe the behavior of a single system, but the average behavior of a large number of systems.

The Boltzmann equation can be used to calculate the electronic transport properties of metals and semiconductors. For example, if an electric field is applied to a solid, one must solve the Boltzmann equation for the distribution function of the electrons. If the electric field is constant, the distribution function is also constant and is displaced in velocity space in such a way that fewer electrons are moving in the direction of the field than in the opposite direction. This corresponds to a current flow in the direction of the field. See FREE-ELECTRON THEORY OF METALS.

With the Boltzmann equation one can also calculate the heat current flowing in a solid as the result of a temperature difference, the constant of proportionality between the heat current per unit area and the temperature gradient being the thermal conductivity. In still more generality, both an electric field and a temperature gradient can be applied. The resulting equations describe thermoelectric phenomena, such as the Peltier and Seebeck effects. Finally, if a constant magnetic field is also

applied, it is found that the electrical conductivity usually decreases with increasing magnetic field, a behavior known as magnetoresistance. These equations also describe the Hall effect, as well as more complex thermomagnetic phenomena, such as the Ettingshausen and Nernst effects. See CONDUCTION (HEAT); GALVANOMAGNETIC EFFECTS; MAGNETORESISTANCE; THERMOELECTRICITY.

Nonequilibrium properties of atomic or molecular gases such as viscosity, thermal conduction, and diffusion have been treated with the Boltzmann equation. Although many useful results, such as the independence of the viscosity of a gas on pressure, can be obtained by simple approximate methods, the Boltzmann equation must be used in order to obtain quantitatively correct results. See DIFFUSION; VISCOSITY.

If one proceeds from a neutral gas to a charged gas or plasma, with the electrons partially removed from the atoms, a number of new phenomena appear. As a consequence of the long-range Coulomb forces between the charges, the plasma can exhibit oscillations in which the free electrons move back and forth with respect to the relatively stationary heavy positive ions at the characteristic frequency known as the plasma frequency. A plasma reflects an electromagnetic wave at a frequency lower than the plasma frequency, but transmits the wave at a higher frequency. This fact explains many characteristics of long-distance radio transmission, made possible by reflection of radio waves by the ionosphere, a low-density plasma. See PLASMA (PHYSICS).

If a magnetic field is applied to the plasma, its motion can become complex. In an Alfvén wave, which propagates in the direction of the magnetic field, the magnetic field lines oscillate like stretched strings, while waves that propagate in a direction perpendicular to the magnetic field have quite different properties. The outstanding problem in the attainment of a controlled thermonuclear reaction is to design a magnetic field configuration that can contain an extremely hot plasma long enough to allow nuclear reactions to take place. Plasmas in association with magnetic fields also occur in many astronomical phenomena. See MAGNETOHYDRODYNAMICS.

Many properties of plasmas can be calculated by studying the motion of individual particles in electric and magnetic fields, or by using hydrodynamic equations or the Vlasov equation, together with Maxwell's equations. However, subtle properties of plasmas, such as diffusion processes and the damping of waves, can best be understood by starting with the Boltzmann equation or the closely related Fokker-Planck equation. See MAXWELL'S EQUATIONS. [R.F.]

**Bond angle and distance** The angle between two bonds sharing a common atom is known as the bond angle. The distance between the nuclei of bonded atoms is known as bond distance. The geometry of a molecule can be characterized by bond angles and distances. The angle between two bonds sharing a common atom through a third bond is known as the torsional or dihedral angle (see illustration).

Certain pairs of atoms in a molecule are held together at distances of about 0.075–0.3 nanometer, with energies of about 150–1000 kilojoules/mol, because of a balance between electrostatic attraction and repulsion among the electrons and nuclei, subject to the electron distributions allowed by quantum mechanics. Such interactions are called chemical bonds.

Bond angles and distances are important because they determine the shape and size of a molecule and therefore affect many physical properties of a substance. The shape of a molecule influences its charge distribution, often determining whether a molecule is polar or nonpolar; polar molecules exhibit stronger intermolecular attraction and thus have higher boiling points. Molecular shapes also influence the packing density of molecules in solids and liquids.

Bond angles and distances depend on the identity of the atoms bonded together and the type of chemical bonding involved. For example, carbon-hydrogen bonds are remarkably similar in length in a wide range of compounds. Bonds vary in length

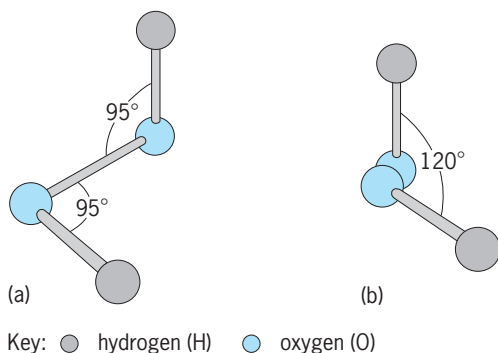

**Bond angle versus torsional angle.** (a) Two O—O—H bond angles in hydrogen peroxide ( $\text{H}_2\text{O}_2$ ). (b) The same molecule when viewed along the O—O bond, revealing the torsional angle, that is, the angle between the two O—H bonds.

depending on the bond multiplicity: they are shorter for a triple bond than for a single bond. Single bonds vary in length slightly, depending on whether they are adjacent to multiple bonds. Bond angles vary considerably from molecule to molecule; the variation in bond angles and distances depends primarily on the electronic structures of the molecules.

The bond lengths and angles of an electronically excited molecule usually differ from the ground-state values. For example, carbon dioxide is linear in its ground state but is bent in its lowest excited state; that is, the O—C—O angle is  $180^\circ$  in the ground state but is  $122 \pm 2^\circ$  in the first excited state. The C=O bond distance is 0.116 nm in the ground state but is 0.125 nm in the first excited state. [B.A.Ga.]

**Bone** The hard connective tissue that, together with cartilage, forms the skeleton of humans and other vertebrates. It is made of calcium phosphate crystals arranged on a protein scaffold. Bone performs a variety of functions: it has a structural and mechanical role; it protects vital organs; it provides a site for the production of blood cells; it serves as a reserve of calcium. See CONNECTIVE TISSUE; SKELETAL SYSTEM.

There are two types of bone in the skeleton: the flat bones (for example, the bones of the skull and ribs) and the long bones (for example, the femur and the bones of the hand and feet). Both types are characterized by an outer layer of dense, compact bone, known as cortical bone, and an inner spongy bone material made up of thin trabeculae, known as cancellous bone. Cortical bone consists of layers of bone (lamellae) in an orderly concentric cylindrical arrangement around tiny Haversian canals. These interconnecting canals carry the blood vessels, lymph vessels, and nerves through the bone and communicate with the periosteum and the marrow cavity. The periosteum is a thin membrane covering the outer surface of bone and consisting of layers of cells that participate in the remodeling and repair of bone. The cancellous bone is in contact with the bone marrow, in which much of the production of blood cells takes place. The interface between the cancellous bone and the marrow is called the endosteum, and it is largely at this site that bone is removed in response to a need for increased calcium elsewhere in the body.

Bone is formed by the laying down of an osteoid matrix by osteoblasts, the bone-forming cells, and the mineralization of the osteoid by the development and deposition of crystals of calcium phosphate (in the form of hydroxyapatite) within it. It is the mineral, organized in a regular pattern on a collagen scaffold, that gives bone its stiffness. Osteoid contains largely fibers of type I collagen and lesser amounts of numerous noncollagenous proteins. Although the role of these proteins in bone is not well understood, it is thought that their particular combination in bone gives this tissue the unique ability to mineralize. It is clear that these proteins interact with each other and that collagen and several of the noncollagenous proteins can bind to specialized

receptors on the surface of bone cells. This binding is important for the adhesion of the cells to the bone matrix, and also delivers behavioral signals to the cells. See APATITE; COLLAGEN.

The primary cell types in bone are those that result in its formation and maintenance (osteoblasts and osteocytes) and those that are responsible for its removal (osteoclasts). Osteoblasts form from the differentiation of multipotential stromal cells that reside in the periosteum and the bone marrow. Under the appropriate stimuli, these primitive stromal cells mature to bone-forming cells at targeted sites in the skeleton. Under different stimuli, they are also capable of developing into adipocytes (fat cells), muscle cells, and chondrocytes (cartilage cells). Osteocytes, which are osteoblasts that become incorporated within the bone tissue itself, are the most numerous cell type in bone. They reside in spaces (lacunae) within the mineralized bone, forming numerous extensions through tiny channels (canaliculi) in the bone that connect with other osteocytes and with the cells on the endosteal surface. Osteocytes are therefore ideally placed to sense stresses and loads placed on the bone and to convey this information to the osteoblasts on the bone surface, thus enabling bone to adapt to altered mechanical loading by the formation of new bone. Osteocytes are also thought to be the cells that detect and direct the repair of microscopic damage that frequently occurs in the bone matrix due to wear and tear. Failure to repair the cracks and microfractures that occur in bone, or when this microdamage accumulates at a rate exceeding its repair, can cause the structural failure of the bone, such as in stress fractures. A large number of molecules that regulate the formation and function of osteoblastic cells have been identified. Circulating hormones, such as insulin, growth hormone, and insulinlike growth factors, combine with growth factors within the bone itself, such as transforming growth factor beta ( $\text{TGF}\beta$ ) and bone morphogenetic proteins (BMPs), to influence the differentiation of osteoblasts.

Osteoclasts are typically large, multinucleated cells, rich in the intracellular machinery required for bone resorption. This is accomplished when the cells form a tight sealing zone by attachment of the cell membrane against the bone matrix, creating a bone-resorbing compartment. Into this space, the cell secretes acid to dissolve the bone mineral, and enzymes to digest the collagen and other proteins in the bone matrix. The removal of bone by osteoclasts is necessary to enable the repair of microscopic damage and changes in bone shape during growth and tooth eruption. Osteoclast-mediated bone resorption is also the mechanism for releasing calcium stored in bone for the maintenance of calcium levels in the blood. Most agents that promote bone resorption act on osteoblastic cells, which in turn convey signals to osteoclast precursors to differentiate into mature osteoclasts. These agents include the active form of vitamin D, parathyroid hormone, interleukin-1, interleukin-6, and interleukin-11, and prostaglandins such as prostaglandin  $\text{E}_2$ . Differentiation to fully functional osteoclasts also requires close contact between osteoclast precursors and osteoblastic cells. This is due to a molecule called osteoclast differentiation factor (ODF) which is located on the surface of osteoblasts, binds to receptors on the surface of osteoclast precursor cells, and induces their progression to osteoclasts.

Flat bones and long bones are formed by different embryological means. Formation of flat bones occurs by intramembranous ossification, in which primitive mesenchymal cells differentiate directly into osteoblasts and produce bony trabeculae within a periosteal membrane. The initial nature of this bone is relatively disorganized and is termed woven bone. Later, this woven bone is remodeled and replaced by the much stronger mature lamella bone, consisting of layers of calcified matrix arranged in orderly fashion. Long bones are formed by intracartilaginous development in which the future bone begins as cartilage. The cartilage template is gradually replaced by bone in an orderly sequence of events starting at the center of the growing bone. Cartilage remains at the ends of long bones during growth, forming a structure at each end termed the growth plate. Cartilage cells

(chondrocytes) that arise in the growth plates proliferate and add to the length of the bone. This occurs during a complex series of events, with expansion both away from and toward the center of the bone. When the bone achieves its final length in maturity, expansion from the growth plate ceases. Cartilage persists at the ends of the long bones in a specific form called articular cartilage, which provides the smooth bearing surfaces for the joints.

Bone is a dynamic tissue and is constantly being remodeled by the actions of osteoclasts and osteoblasts. After bone removal, the osteoclasts either move on to new resorption sites or die; this is followed by a reversal phase where osteoblasts are attracted to the resorption site. It is thought that growth factors that are sequestered in an inactive form in the bone matrix are released and activated by the osteoclast activity and that these in turn promote fresh osteoid production by the recruited osteoblasts. The new osteoid eventually calcifies, and in this way the bone is formed and replaced in layers (lamellae), which are the result of these repeated cycles. In growing bone, the activities of bone cells is skewed toward a net increase in bone. However, in healthy mature bone there is an equilibrium between bone resorption and bone formation. When the equilibrium between these two cell types breaks down, skeletal pathology results.

The most common bone disease is osteoporosis, in which there is a net loss of bone due to osteoclastic bone resorption that is not completely matched by new bone formation. The best-understood cause of osteoporosis is that which occurs in women due to the loss of circulating estrogen after menopause. Another cause of osteoporotic bone loss is seen in disuse osteoporosis. Just as bone can respond to increased loading with the production of additional bone, bone is also dependent on regular loading for its maintenance. Significant bone loss can occur during prolonged bed rest or, for example, in paraplegia and quadriplegia. Likewise, an unloading of the skeleton (due to a lack of gravitational pull) in space flight results in severe bone loss in astronauts unless the effects of gravity are simulated by special exercises and devices. See OSTEOPOROSIS.

Many metabolic and genetic diseases can affect the amount and quality of bone. Metabolic diseases such as diabetes, kidney disease, oversecretion of parathyroid hormone by the parathyroid glands, anorexia nervosa, and vitamin D-dependent rickets may cause osteopenias (the reduction in bone volume and bone structural quality). Immunosuppressive therapy in organ transplant patients can lead to reduced bone mass, as can tumors of bone and other sites. Tumors can produce substances that cause the activation of osteoclastic bone resorption. In the genetically based disease osteogenesis imperfecta, mutations in the gene for type I collagen result in the production of reduced amounts of collagen or altered collagen molecules by osteoblasts. Other common diseases of the skeleton are diseases of the joints, such as rheumatoid arthritis and osteoarthritis. See ARTHRITIS; CALCIUM METABOLISM; THYROID GLAND.

[D.M.Fi.]

**Bonsai** The construction of a mature, very dwarfed tree in a relatively small container. Although bonsai is formally an esoteric branch of horticulture, it is firmly based in the social, historical, and cultural ethic of Oriental peoples and its introduction to Western cultures is a development of the twentieth century; indeed, Westerners had not even seen bonsai plants prior to the early decades of this century. At the fundamental level, the word bonsai means merely “plant in a pot,” and its origin can be traced back to China’s Chou dynasty (900–250 B.C.), when emperors built miniaturized gardens in which soil, rocks, and plants from each province were installed as dwarfed representations of the lands held by the central government.

To a large extent, the technology of bonsai is derived from classical horticultural procedures which are the product of long tradition firmed up with considerations of many areas of plant physiology and ecology. There are, however, some techniques which are unique to bonsai. To maintain shape, not only must growth

be controlled, but the branching patterns must be planned. This is done by selective pruning and by pinching out of terminal buds to release axillary buds from apical dominance. Root prunings, done at intervals as short as 2 or 3 months in some species, promote the development of a tight root ball with large numbers of young lateral roots whose ability to take up water and minerals is great. Branch and stem position is controlled by selective pruning and by the wiring techniques developed by the Japanese in the eighteenth century. Weighting or tying is used for the same reasons.

[R.M.K.]

**Book manufacture** A series of professional operations including editing, designing, typography, platemaking, printing, and binding to transform a manuscript and its related illustrations into book form.

Books follow a distinctive technique in assembling and binding pages in sequential order and in fitting and sealing the pages into a separate cover. Those designed for relatively permanent usage are sealed into rigid or semirigid covers (called edition, case, or hardback binding), and those designed for less permanent usage are sealed into paper covers (called soft or paperback binding).

The basic cell of a book’s construction is called a signature or section and is composed of multiples of 4 pages. The folding of signatures printed on a web press is integrated with the printing units. In sheet-fed printing, folding is separate from presswork and is performed on special machines located in a book bindery.

Folding a sheet of paper once produces 4 pages, and each additional fold doubles the number of pages. A sheet folded three times yields a 16-page signature, the first page being the lowest numbered (a page number is called a folio). All right-hand pages are odd numbered, and left-hand pages are even numbered. A book of 160 pages has ten 16-page signatures, the first being folioed 1–16 and the last 145–160.

Signatures, assembled in sequence, are mechanically held together along one folded edge, called the binding edge or spine, by continuous thread sewing through the fold of each signature; or by thread stitching through the side of the book from front to back; or by wire stapling; or by cutting off the binding-edge folds and applying a coating of strong flexible adhesive, sometimes adding an additional locking device of wide mesh textiles or stretch papers.

Purely decorative features include colorful bits of textiles added to the head and tail of the spine (called headbands) and tinted or gilded edges. One spectacular technical breakthrough was the mechanical gilding of book edges; for centuries this had been a closely guarded handicraft process.

The book cover serves to protect the pages against disintegration, to announce the title of the book, and to stimulate the visual interest of the prospective buyer. The degree of usage and permanency influences the selection of raw materials for a book cover (as in reference sets and text and library books), and visual appeal is influenced by the book’s price and marketability. Permanent-type covers are made on special equipment in which the cover material and pulp-boards are assembled and joined with special adhesives. In embellishing the cover, the designer has numerous choices of special equipment and processes, such as flat ink, pigment or metal-foil stampings, embossing, silk-screening, and multicolor printing.

Preceding the final assembly of the book into its cover (called “casing in”), strong 4-page front and back end-sheets and one or more kinds of hinges (of textiles or paper) have been applied to strengthen the interlocking between book and cover (called “lining up”). The book also has acquired a concave and convex edge and a pair of ridges or joints along the binding edge (called “backing”). These features are added by special equipment and are specifically engineered to securely lock the book into its cover and to transmit the strains of opening the book throughout the entire body instead of only to the first and last pages.

For shelf display, a book is often wrapped in a colorful, eye-catching jacket (called dust wrapper), or in a transparent synthetic if the cover is highly decorative.

Books reach their markets packaged in many different ways. Single copies are packaged and mailed directly to the consumer; sets are assembled into cartons, one set per carton; textbooks and other single titles are bulk-cartoned or skid-packed and shipped to central warehouses. See PRINTING. [E.J.T.]

**Boolean algebra** A branch of mathematics that was first developed systematically, because of its applications to logic, by the English mathematician George Boole, around 1850. Closely related are its applications to sets and probability. Boolean algebra also underlies the theory of relations. A modern engineering application is to computer circuit design. See DIGITAL COMPUTER.

Most basic is the use of Boolean algebra to describe combinations of the subsets of a given set  $I$  of elements; its basic operations are those of taking the intersection or common part  $S \cap T$  of two such subsets  $S$  and  $T$ , their union or sum  $S \cup T$ , and the complement  $S'$  of any one such subset  $S$ . These operations satisfy many laws, including those shown in Eqs. (1), (2), and (3).

$$\begin{aligned} S \cap T &= T \cap S & S \cap T &= T \cap S \\ S \cap (T \cap U) &= (S \cap T) \cap U \end{aligned} \quad (1)$$

$$\begin{aligned} S \cup S &= S & S \cup T &= T \cup S \\ S \cup (T \cup U) &= (S \cup T) \cup U \end{aligned} \quad (2)$$

$$\begin{aligned} S \cap (T \cup U) &= (S \cap T) \cup (S \cap U) \\ S \cup (T \cap U) &= (S \cup T) \cap (S \cup U) \end{aligned} \quad (3)$$

If  $O$  denotes the empty set, and  $I$  is the set of all elements being considered, then the laws set forth in Eqs. (4) are also

$$\begin{aligned} O \cap S &= O & O \cup S &= S & I \cup S &= S &= I \\ I \cup S &= I & S \cap S' &= O & S \cup S' &= I \end{aligned} \quad (4)$$

fundamental. Since these laws are fundamentals, all other algebraic laws of subset combination can be deduced from them.

In applying Boolean algebra to logic, Boole observed that combinations of properties under the common logical connectives and, or, and not also satisfy the laws specified above. These laws also hold for propositions or assertions, when combined by the same logical connectives. See LOGIC CIRCUITS.

Boole stressed the analogies between Boolean algebra and ordinary algebra. If  $S \cap T$  is regarded as playing the role of  $st$  in ordinary algebra,  $S \cup T$  that of  $s + t$ ,  $O$  of 0,  $I$  of 1, and  $S'$  as corresponding to  $1 - s$ , the laws listed above illustrate many such analogies. However, as first clearly shown by Marshall Stone, the proper analogy is somewhat different. Specifically, the proper Boolean analog of  $s + t$  is  $(S' \cap T) \cup (S \cap T')$ , so that the ordinary analog of  $S \cup T$  is  $s + t - st$ . Using Stone's analogy, Boolean algebra refers to Boolean rings in which  $s^2 = s$ , a condition implying  $s + s = 0$ . See RING THEORY; SET THEORY.

In 1941 M. H. A. Newman developed a remarkable generalization which included Boolean algebras and Boolean rings. This generalization is based on the laws shown in Eqs. (5) and (6). From these assumptions, the idempotent, commutative, and associative laws (1) and (2) can be deduced.

$$a(b + c) = ab + ac \quad a + b)c = ac + bc \quad (5)$$

$$\begin{aligned} a1 &= 1 & a + 0 &= 0 + a = a & aa' &= 0 \\ a + a' &= 1 \end{aligned} \quad (6)$$

Such studies lead naturally to the concept of an abstract Boolean algebra, defined as a collection of symbols combined by operations satisfying the identities listed in formulas (1) to (4). Ordinarily, the phrase Boolean algebra refers to such an abstract Boolean algebra.

The class of finite (abstract) Boolean algebras is easily described. Each such algebra has, for some nonnegative integer  $n$ ,

exactly  $2^n$  elements and is algebraically equivalent (isomorphic) to the algebra of all subsets of the set of numbers  $1, \dots, n$ , under the operations of intersection, union, and complement.

The theory of infinite Boolean algebras is much deeper; it indirectly involves the whole theory of sets. One important result is Stone's representation theorem. Let a field of sets be defined as any family of subsets of a given set  $I$ , which contains with any two sets  $S$  and  $T$  their intersection  $S \cap T$ , union  $S \cup T$ , and complements  $S', T'$ . Considered abstractly, any such field of sets obviously defines a Boolean algebra. Stone's theorem asserts that, conversely, any finite or infinite abstract Boolean algebra is isomorphic to a suitable field of sets. His proof is based on the concepts of ideal and prime ideal, concepts which have been intensively studied for their own sake. [G.Bi.]

**Boötes** The Bear Driver, in astronomy, a northern and summer constellation. Boötes is one of the earliest recorded constellations. Arcturus, an orange, first-magnitude navigational star, dominates the constellation. Five prominent stars in this constellation form a pentagon, shaped much like an elongated kite, with Arcturus at the junction of the tail. Boötes is conventionally pictured as a driver of the Bear (Ursa Major) nearby. In a more recent version he is seen seated, smoking a pipe, his feet dangling and with one hand holding the leash of the Hunting Dogs (Canes Venatici). See CONSTELLATION. [C.S.Y.]

**Boracite** A borate mineral with chemical composition  $Mg_3B_7O_{13}Cl$ . It occurs in Germany, England, and the United States, usually in bedded sedimentary deposits of anhydrite, gypsum, and halite, and in potash deposits of oceanic type. The chemical composition of natural boracites varies, with  $Fe^{2+}$  or  $Mn^{2+}$  replacing part of the  $Mg^{2+}$  to yield ferroan boracite or manganian boracite. See BORATE MINERALS.

The hardness is  $7-7^{1/2}$  on Mohs scale, and specific gravity is 2.91–2.97 for colorless crystals and 2.97–3.10 for green and ferroan types. Luster is vitreous, inclining toward adamantine. Boracite is colorless to white, inclining to gray, yellow, and green, and rarely pink (manganian); its streak is white; and it is transparent to translucent. It is strongly piezoelectric and pyroelectric and does not cleave. [C.L.Ch.]

**Borane** One of a class of binary compounds of boron and hydrogen, often referred to as boron hydrides. The term borane is sometimes used to denote substances which may be considered to be derivatives of the boron-hydrogen compounds, such as boron trichloride ( $BCl_3$ ), and diiodododecaborane ( $B_{10}H_{12}I_2$ ).

The simplest borane is diborane ( $B_2H_6$ ); other boranes of increasingly higher molecular weight are known, one of the least volatile of which is an apparently polymeric solid of composition  $(BH)_x$ . Certain boranes, such as  $BH_3$ , and  $B_3H_7$ , are not known as such, but can be prepared in the form of adducts with electron-donor molecules.

The most spectacular projected large-scale use of the boranes and their derivatives is in the field of high-energy fuels for jet planes and rockets. The thermal decomposition of diborane (6) [ $B_2H_6$ ] has been used to produce coatings of pure elementary boron for neutron-detecting devices and for applications requiring hard, corrosion-resistant surfaces. Boranes can also be used as vulcanizing agents for natural and synthetic rubbers, and are especially effective in the preparation of silicone rubbers.

The molecular structures possessed by the boranes are exhibited by no other class of substances. Because of the lack of sufficient electrons for the formation of the requisite number of covalent bonds, normal covalently bonded structures of the hydrocarbon type are not possible. The boranes are sometimes referred to as electron-deficient substances. In no case are the simple chain and ring configurations of carbon chemistry encountered in the more complex boranes. Instead, the boron atoms are situated at the corners of polyhedrons. An example of such a structure is that of pentaborane (9) [ $B_5H_9$ ], as follows:

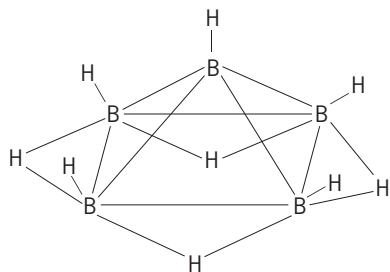

Boron nomenclature uses a prefix to designate the number of boron atoms in the molecule and a numeral suffix in parentheses to indicate the number of hydrogen atoms.

As a class, the boranes are quite reactive substances and are generally decomposed, at times explosively, on contact with air. Their reactivities with air and water decrease with increasing molecular weight. Because boranes react readily with air, laboratory investigations are almost invariably carried out in all-glass vacuum apparatus or in inert-atmosphere dry boxes. With the possible exception of decaborane (14) [B<sub>10</sub>H<sub>14</sub>], the known boranes are not indefinitely stable at room temperature. They decompose more or less rapidly to yield elementary hydrogen and boranes richer in boron.

The known derivatives of the boranes (other than BH<sub>3</sub>) are relatively few in number. Several halo, alkyl, and amino boranes have been reported but, in general, these have not been extensively characterized. See BORON; CARBORANE; METAL HYDRIDES.

[T.W.]

**Borate minerals** A large group of minerals in which boron is chemically bonded to oxygen. Boron is a fairly rare element. However, because of its chemical character, it is very susceptible to fractionation in earth processes and can become concentrated to a degree not found in other elements of similar abundance. Boron is symbolized B, carries atomic number 5, and has the ground-state electronic structure [He]2s<sup>2</sup>2p<sup>1</sup>. The very high ionization potentials for boron mean that the total energy required to produce the B<sup>3+</sup> ion is greater than the compensating structure energy of the resulting ionic solid, and hence bond formation involves covalent (rather than ionic) mechanisms. However, boron has only three electrons to contribute to covalent bonding involving four orbitals, (s, p<sub>x</sub>, p<sub>y</sub>, p<sub>z</sub>). This results in boron being a strong electron-pair acceptor (that is, a strong Lewis acid) with a very high affinity for oxygen. The structural chemistry of boron and silicon (Si), when associated with oxygen (O), is quite similar. The BO<sub>3</sub>, BO<sub>4</sub>, and SiO<sub>4</sub> groups have a marked tendency to polymerize in the solid state, and this aspect of their behavior gives rise to the structural complexity of both groups. However, subtle differences in chemical bonding do give rise to differences in the character of this polymerization, particularly when water is also involved. These differences result in the very different properties of the resultant minerals and their very different behavior in earth processes. See BORON.

Boron has an estimated primitive-mantle abundance of 0.6 part per million and a crustal abundance of 15 ppm. Despite this low abundance, fractionation in crustal processes results in concentration of boron to the extent that it forms an extensive array of minerals in which it is an essential constituent, and very complex deposits of borate minerals. Major concentrations of borate minerals occur in continental evaporite deposits (common in the desert regions of California and Nevada). Borate minerals are often very soluble in aqueous environments. In areas of internal drainage, saline lakes are formed, and continued evaporation leads to accumulation of large deposits of borate minerals. Borates may also occur in marine evaporites. Isolated-cluster borates are characteristic of metamorphosed boron-rich sediments and skarns. Most borosilicate minerals are character-

istic of granitic-pegmatite environments, either as a pegmatite phase or as a constituent of their exocontact zone. In particular, tourmaline is the most widespread of the mixed-anion borate minerals, occurring in a wide variety of igneous, hydrothermal, and metamorphic rocks. See SALINE EVAPORITES; ORE AND MINERAL DEPOSITS; PEGMATITE.

Despite its low crustal abundance, fractionation of boron in crustal processes leads to formation of deposits of borate minerals from which boron and (borates) can be easily extracted in large quantities. The easy availability and unique chemical properties result in boron being a major industrial material. It is widely used in soaps and washing powders. Boron combines well with silicon and other elements to form a wide variety of special-property glasses and ceramics; it also alloys with a variety of metals, producing lightweight alloys for specialty uses. Boron compounds usually have very low density; hence borates in particular are used as lightweight fillers in medicines, and also are used as insulation. The fibrous nature of some borate minerals results in their use in textile-grade fibers and lightweight fiber-strengthened materials. The mineral borax is used as a water softener and as a cleaning flux in welding and soldering. Boric acid has long been used as an antiseptic and a drying agent. Boron is also important as a constituent of inflammatory materials in fireworks and rocket fuel. Some mixed-anion borate minerals are used as gemstones. Tourmaline is of particular importance in this respect, forming pink (rubellite), blue-green (Paraiba tourmaline), green (chrome tourmaline), and pink + green (watermelon tourmaline) from a wide variety of localities. Kornerupine and sinhalite are also used as gemstones but are far less common. See BORON; TOURMALINE.

[FC.Ha.]

**Bordetella** A genus of gram-negative bacteria which are coccobacilli and obligate aerobes, and fail to ferment carbohydrates. These bacteria are respiratory pathogens. *Bordetella pertussis*, *B. parapertussis*, and *B. bronchiseptica* share greater than 90% of their deoxyribonucleic acid (DNA) sequences and would not warrant separate species designations except that the distinctions are useful for clinical purposes. *Bordetella pertussis* is an obligate human pathogen and is the causative agent of whooping cough (pertussis). *Bordetella parapertussis* causes a milder form of disease in humans and also causes respiratory infections in sheep. *Bordetella bronchiseptica* has the broadest host range, causing disease in many mammalian species, but kennel cough in dogs and atrophic rhinitis, in which infected piglets develop deformed nasal passages, have the biggest economic impact. *Bordetella avium* is more distantly related to the other species. A pathogen of birds, it is of major economic importance to the poultry industry.

Infection by all four species is characterized by bacterial adherence to the ciliated cells that line the windpipe (trachea), *B. pertussis* releases massive amounts of peptidoglycan, causing an exaggerated immune response that is ultimately deleterious, resulting in self-induced death of the ciliated cells. *Bordetella* also produces protein toxins. The best-characterized is pertussis toxin, made only by *B. pertussis*. This toxin interferes with the mechanisms used by host cells to communicate with one another.

*Bordetella pertussis* is spread by coughing and has no environmental reservoir other than infected humans. Culturing the organism is difficult. Erythromycin is the antibiotic used most frequently to treat whooping cough. Unfortunately, antibiotic treatment improves the patient's condition only if given early, when the disease is most difficult to diagnose, and does not help after whooping has begun. This is consistent with the concept that the early symptoms of the disease result from bacterial damage to the respiratory tract and the later symptoms are due to toxins released by the bacteria. Antibiotics can eradicate the microorganisms but cannot reverse the effects of toxins, which can cause damage far from the site of bacterial growth.



Vaccines have been developed for whooping cough and kennel cough. Multicomponent pertussis vaccines consisting of inactivated pertussis toxin and various combinations of filamentous hemagglutinin, pertactin, and fimbriae are now replacing the older whole-cell vaccines consisting of killed bacteria, which were suspected but not proven to cause rare but serious side effects. Vaccination programs have greatly reduced the incidence of whooping cough in affluent nations, but worldwide nearly half a million deaths occur each year, most of which are vaccine-preventable. See ANTIBIOTIC; MEDICAL BACTERIOLOGY. [A.We.]

**Boring bivalves** A variety of marine bivalve mollusks which penetrate solid substrata. They represent seven families and vary in the extent to which they are specialized, in the type of substrata they utilize, and in their method of boring.

Unlike other bivalves which use their shells as abrasive "tools," date mussels (*Lithophaga*, Mytilidae) penetrate calcareous rocks, corals, and shells by chemical means, possibly a weak carbonic acid. Larvae of *Botula* (another small, elongate mytilid), which settle in crevices of soft rock, corals, or wood, abrade their way into the substrate by continued movement of their shells and siphons. *Rupellaria* and *Petricola* (Petricolidae) are nonspecialized borers in peat, firm mud, and soft rock. *Platyodon* (Myidae), closely related to the soft-shelled clam, press their valves against the walls of the burrow by engorging the mantle and then abrade the soft rock by continued movement of their unspecialized valves. *Gastrochaena* and *Spengleria* (Gastrochaenidae) are specialized for boring by having a closed mantle cavity, a large pedal gape, and a truncate foot, allowing them to press the foot and shell against the burrow wall. The Pholadacea (Pholadidae and Teredinidae) are worldwide in distribution. The family Pholadidae (common name: piddocks) is composed of 17 genera, of which 5 are restricted to wood. All species of Teredinidae are obligate wood, nut, or plant-stem borers. The major difference between these two families is the presence of accessory plates in the pholads and pallets in the teredinids. See MOLLUSCA; SHIPWORM. [R.D.T.]

**Boring sponges** Sponges that excavate galleries in mollusk shells, corals, limestone, and other calcareous matter. Boring sponges are known in three families of the class Demospongiae; they are also called burrowing sponges. All species of the family Clionidae, order Hadromerida, excavate burrows in calcium carbonate substrata, as do some species of the genera *Anthosigmella* and *Spheciospongia* (family Spirastrellidae, order Hadromerida) and all species of *Siphonodictyon* (family Adocidae, order Haplosclerida).

Water currents are maintained through the tissues of these boring sponges exactly as in other Demospongiae. They do not obtain food from their hosts when the calcareous matter into which they burrow happens to be the shell or skeleton of a living organism. Instead, boring sponges feed on bacteria, flagellates, and other kinds of particulate organic matter. The burrowing process is similar in all genera and involves the excavation of numerous minute particles of calcium carbonate (20–70 micrometers in diameter) that pass out by way of the exhalant canals and oscula. In coral reef environments, up to 30–40% of fine sediment particles may be derived from the activities of burrowing sponges in low-energy environments; lesser proportions (5–22%) characterize sediments in high-energy environments.

Clionids are regarded as a nuisance in oyster beds because their excavations weaken the shells of these mollusks and thus hinder processing in canning factories. Boring sponges are also economically important when they attack limestone breakwaters.

Clionid boring sponges are found in all seas, chiefly in tidal and shallow waters. A few species reach a depth of at most 3000 ft (1000 m). Their excavations are known in fossil mollusk shells at least as far back as the Devonian Period. Burrowing species of the genera *Anthosigmella*, *Spheciospongia*, and

*Siphonodictyon* are found on coral reefs at depths of more than 200 ft (60 m). See DEMOSPONGIAE. [W.D.H.]

**Bornite** A sulfide of composition  $\text{Cu}_5\text{FeS}_4$ , specific gravity 5.07, and hardness 3 (Mohs scale), commonly occurring as a primary mineral in many copper ore deposits. Crystals are rare; bornite is usually massive or granular. The metallic and brassy color of a fresh surface rapidly tarnishes upon exposure to air to a characteristic iridescent purple, giving rise to the name "peacock ore." Though of lesser importance as an ore than chalcocite or chalcopyrite, masses of bornite have been mined in Chile, Peru, Bolivia, and Mexico and in the United States in Arizona and Montana. See CHALCOCITE; CHALCOPYRITE; COPPER. [B.J.Wu.]

**Boron** A chemical element, B, atomic number 5, atomic weight 10.811, in group III of the periodic table. It has three valence electrons and is nonmetallic in behavior. It is classified as a metalloid and is the only nonmetallic element which has fewer than four electrons in its outer shell. The free element is prepared in crystalline or amorphous form. The crystalline form is an extremely hard, brittle solid. It is of jet-black to silvery-gray color with a metallic luster. One form of crystalline boron is bright red. The amorphous form is less dense than the crystalline and is a dark-brown to black powder. In the naturally occurring compounds, boron exists as a mixture of two stable isotopes with atomic weights of 10 and 11. See PERIODIC TABLE.

Many properties of boron have not been sufficiently established experimentally as a result of the questionable purity of some sources of boron, as well as of the variations in the methods and temperatures of preparation. A summary of the physical properties is shown in the table.

Physical properties of boron

Property	Temp., °C	Value
Density		
Crystalline	25–27	2.31 g/cm <sup>3</sup>
Amorphous	25–27	2.3 g/cm <sup>3</sup>
Mohs hardness		
Crystalline		9.3
Melting point		2100°C
Boiling point		2500°C
Resistivity	25	$1.7 \times 10^{-6}$ ohm-cm
Coefficient of thermal expansion	20–750	$8.3 \times 10^{-6}$ cm <sup>3</sup> /°C
Heat of combustion	25	$302.0 \pm 3.4$ kcal/mole
Entropy		
Crystalline	25	1.403 cal/(mole)(deg)
Amorphous	25	1.564 cal/(mole)(deg)
Heat capacity		
Gas	25	4.97 cal/(mole)(deg)
Crystalline	25	2.65 cal/(mole)(deg)
Amorphous	25	2.86 cal/(mole)(deg)

Boron and boron compounds have numerous uses in many fields, although elemental boron is employed chiefly in the metal industry. Its extreme reactivity at high temperatures, particularly with oxygen and nitrogen, makes it a suitable metallurgical degassing agent. It is used to refine the grain of aluminum castings and to facilitate the heat treatment of malleable iron. Boron considerably increases the high-temperature strength characteristics of alloy steels. Elemental boron is used in the atomic reactor and in high-temperature technologies. The physical properties that make boron attractive as a construction material in missile and rocket technology are its low density, extreme hardness, high melting point, and remarkable tensile strength in filament form. When boron fibers are used in an epoxy (or other plastic) carrier material or matrix, the resulting composite is stronger and stiffer than steel and 25% lighter than aluminum. Refined borax,  $\text{Na}_2\text{B}_4\text{O}_7 \cdot 10\text{H}_2\text{O}$ , is an important ingredient of a variety of detergents, soaps, water-softening compounds, laundry

starches, adhesives, toilet preparations, cosmetics, talcum powder, and glazed paper. It is also used in fireproofing, disinfecting of fruit and lumber, weed control, and insecticides, as well as in the manufacture of leather, paper, and plastics.

Boron makes up 0.001% of the Earth's crust. It is never found in the uncombined or elementary state in nature. Besides being present to the extent of a few parts per million in sea water, it occurs as a trace element in most soils and is an essential constituent of several rock-forming silicate minerals, such as tourmaline and datolite. The presence of boron in extremely small amounts seems to be necessary in nearly all forms of plant life, but in larger concentrations, it becomes quite toxic to vegetation. Only in a very limited number of localities are high concentrations of boron or large deposits of boron minerals to be found in nature; the more important of these seem to be primarily of volcanic origin. See BORATE MINERALS. [F.H.M./V.V.L.]

**Borrelia** A genus of spirochetes that have a unique genome composed of a linear chromosome and numerous linear and circular plasmids. Borreliae are motile, helical organisms with 4–30 uneven, irregular coils, and are 5–25 micrometers long and 0.2–0.5  $\mu\text{m}$  wide. All borreliae are arthropod-borne. Of the 24 recognized species, 21 cause relapsing fever and similar diseases in human and rodent hosts; two are responsible for infections in ruminants and horses; and the remaining one, for borreliosis in birds. See BACTERIA.

The borreliae of human relapsing fevers are transmitted by the body louse or by a large variety of soft-shelled ticks of the genus *Ornithodoros*. The species *B. burgdorferi*, the etiologic agent of Lyme disease and related disorders, is transmitted by ticks of the genus *Ixodes*. *Borrelia anserina*, which causes spirochetosis in chickens and other birds, is propagated by ticks of the genus *Argas*. Various species of ixodid ticks are responsible for transmitting *B. theileri* among cattle, horses, and sheep. *Borrelia coriaceae*, isolated from *O. coriaceus*, is the putative cause of epizootic bovine abortion in the western United States. See RELAPSING FEVER.

Polyacrylamide gel electrophoresis of spirochetes has shown that the outer surface of the microorganisms contains numerous variable lipoproteins of which at least two are abundant. The antigenic variability is well known for the relapsing fever borreliae. A switch in the major outer-surface proteins leads to recurrent spirochetemias. Tetracyclines, penicillins, and doxycycline are the most effective antibiotics for treatment of spirochetes. Two vaccines consisting of recombinant *B. burgdorferi* have been evaluated in subjects of risk for Lyme disease. Both proved safe and effective in the prevention of this disease. See ANTIBIOTIC; MEDICAL BACTERIOLOGY. [W.Bu.; P.Ro.]

**Bose-Einstein condensation** When a gas of bosonic particles is cooled below a critical temperature, it condenses into a Bose-Einstein condensate. The condensate consists of a macroscopic number of particles, which are all in the ground state of the system. Bose-Einstein condensation is a phase transition, which does not depend on the specific interactions between particles. It is based on the indistinguishability and wave nature of particles, both of which are at the heart of quantum mechanics.

**Basic phenomenon in ideal gas.** In a simplified picture, particles in a gas may be regarded as quantum-mechanical wavepackets which have a spatial extent on the order of a thermal de Broglie wavelength, given by Eq. (1), where  $T$  is the

$$\lambda_{\text{dB}} = \left( \frac{2\pi^2 \hbar^2}{mk_B T} \right)^{1/2} \quad (1)$$

temperature,  $m$  the mass of the particle,  $k_B$  is the Boltzmann constant, and  $\hbar$  is Planck's constant divided by  $2\pi$ . The wavelength  $\lambda_{\text{dB}}$  can be regarded as the position uncertainty associated with

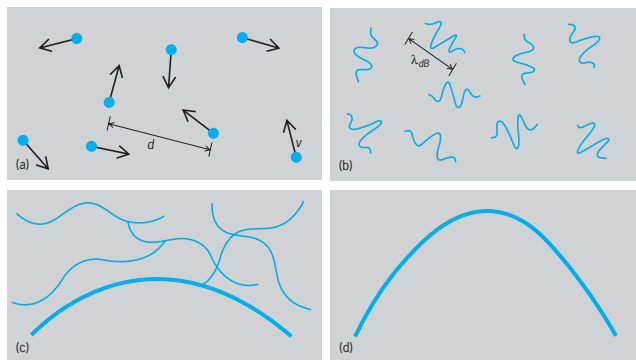

**Fig. 1. Criterion for Bose-Einstein condensation in a gas of weakly interacting particles.** (a) Gas at high temperature, treated as a system of billiard balls, with thermal velocity  $v$  and density  $d^{-3}$ , where  $d$  is the distance between particles. (b) Simplified quantum description of gas at low temperature, in which the particles are regarded as wave packets with a spatial extent of the order of the de Broglie wavelength,  $\lambda_{\text{dB}}$ . (c) Gas at the transition temperature for Bose-Einstein condensation, when  $\lambda_{\text{dB}}$  becomes comparable to  $d$ . The wave packets overlap and a Bose-Einstein condensate forms (in the case of bosonic particles). (d) Pure Bose condensate (giant matter wave), which remains as the temperature approaches absolute zero and the thermal cloud disappears. (After D. S. Durfee and W. S. Ketterle, *Experimental studies of Bose-Einstein condensation*, *Opt. Express*, 2:299–313, Optical Society of America, 1998)

the thermal momentum distribution of the particles. At high temperature,  $\lambda_{\text{dB}}$  is small, and the probability of finding two particles within this distance of each other is extremely low. Therefore, the indistinguishability of particles is not important, and a classical description applies (namely, Boltzmann statistics). When the gas is cooled to the point where  $\lambda_{\text{dB}}$  is comparable to the distance between particles, the individual wavepackets start to overlap and the indistinguishability of particles becomes crucial—an identity crisis can be said to occur. For fermions, the Pauli exclusion principle prevents two particles from occupying the same quantum state; whereas for bosons, quantum statistics (in this case, Bose-Einstein statistics) dramatically increases the probability of finding several particles in the same quantum state. The system undergoes a phase transition and forms a Bose-Einstein condensate, where a macroscopic number of particles occupy the lowest-energy quantum state (Fig. 1). See BOLTZMANN STATISTICS; EXCLUSION PRINCIPLE; PHASE TRANSITIONS; QUANTUM MECHANICS.

Bose-Einstein condensation can be described intuitively in the following way: When the quantum-mechanical wave functions of bosonic particles spatially overlap, the matter waves start to oscillate in concert. A coherent matter wave forms that comprises all particles in the ground state of the system. This transition from disordered to coherent matter waves can be compared to the step from incoherent light to laser light. Indeed, atom lasers based on Bose-Einstein condensation have been realized. See COHERENCE; LASER.

**Experimental techniques.** The phenomenon of Bose-Einstein condensation is responsible for the superfluidity of helium and for the superconductivity of an electron gas, which involves Bose-condensed electron pairs. However, these phenomena happen at high density, and their understanding requires a detailed treatment of the interactions. See SUPERCONDUCTIVITY; SUPERFLUIDITY.

The quest to realize Bose-Einstein condensation in a dilute weakly interacting gas focused on atomic gases. At ultralow temperatures, all atomic gases liquefy or solidify in thermal equilibrium. Keeping the gas at sufficiently low density can prevent this from occurring. Typical number densities of atoms between  $10^{12}$  and  $10^{15} \text{ cm}^{-3}$  imply transition temperatures for Bose-Einstein condensation in the nanokelvin or microkelvin regime.

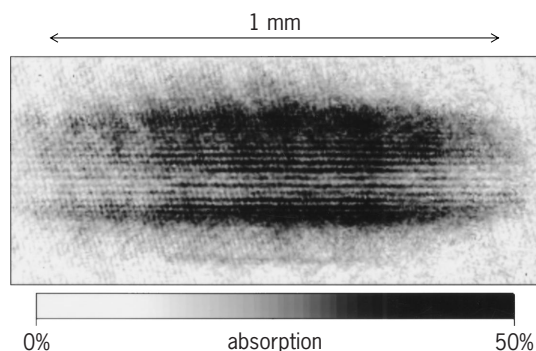

**Fig. 2. Interference pattern of two expanding condensates, demonstrating the coherence of Bose-Einstein condensates. This absorption image was observed after a 40-millisecond time of flight. Interference fringes have a spacing of  $15 \mu\text{m}$ . (After D. S. Durfee and W. S. Ketterle, *Experimental studies of Bose-Einstein condensation*, *Opt. Express*, 2:299–313, *Optical Society of America*, 1998)**

The realization of Bose-Einstein condensation in atomic gases required techniques to cool gases to such low temperatures, and atom traps to confine the gases at the required density and keep them away from the much warmer walls of the vacuum chamber. The experiments on alkali vapors (lithium, rubidium, and sodium) use several laser-cooling techniques as precooling, then hold the atoms in a magnetic trap and cool them further by forced evaporative cooling. For atomic hydrogen, the laser-cooling step is replaced by cryogenic cooling.

**Macroscopic wave function.** In superconductors and liquid helium, the existence of coherence and of a macroscopic wave function is impressively demonstrated through the Josephson effect. In the dilute atomic gases, the coherence has been demonstrated even more directly by interfering two Bose condensates (Fig. 2). The interference fringes typically have a spacing of  $15 \mu\text{m}$ , a huge length for matter waves. (In contrast, the matter wavelength of atoms at room temperature is only  $0.05 \text{ nm}$ , less than the size of the atoms.) [W.Ket.]

**Bose-Einstein statistics** The statistical description of quantum mechanical systems in which there is no restriction on the way in which particles can be distributed over the individual energy levels. This description applies when the system has a symmetric wave function. This in turn has to be the case when the particles described are of integer spin.

Suppose one describes a system by giving the number of particles  $n_i$  in an energy state  $\epsilon_i$ , where the  $n_i$  are called occupation numbers and the index  $i$  labels the various states. The energy level  $\epsilon_i$ , is of finite width, being really a range of energies comprising, say,  $g_i$ , individual (nondegenerate) quantum levels. If any arrangement of particles over individual energy levels is allowed, one obtains for the probability of a specific distribution Eq. (1a). In Boltzmann statistics, this same probability would be written as Eq. (1b). See BOLTZMANN STATISTICS.

$$W = \prod_i \frac{(n_i + g_i - 1)!}{n_i! (g_i - 1)!} \quad (1a)$$

$$W = \prod_i \frac{g_i^{n_i}}{n_i!} \quad (1b)$$

The equilibrium state is defined as the most probable state of the system. To obtain it, one must maximize Eq. (1a) under the conditions given by Eqs. (2a) and (2b), which express the

$$\sum n_i i = N \quad (2a)$$

$$\sum \epsilon_i n_i = E \quad (2b)$$

fact that the total number of particles  $N$  and the total energy

$E$  are fixed. One finds for the most probable distribution that Eq. (3) holds. Here,  $A$  and  $\beta$  are parameters to be determined

$$n_i = \frac{g_i}{\frac{1}{A} e^{\beta \epsilon_i} + 1} \quad (3)$$

from Eqs. (2a) and (2b); actually,  $\beta = 1/kT$ , where  $k$  is the Boltzmann constant and  $T$  is the absolute temperature.

An interesting and important result emerges when Eq. (3) is applied to a gas of photons, that is, a large number of photons in an enclosure. (Since photons have integer spin, this is legitimate.) The formula for the energy density (energy per unit volume) in a given frequency range is found to be the celebrated Planck radiation formula for blackbody radiation. Thus, black-body radiation must be considered as a photon gas, with the photons satisfying Bose-Einstein statistics. See HEAT RADIATION.

If an ideal Bose gas, consisting of a fixed number of material particles, is compressed beyond a certain point, some of the particles will condense in a zero state, where they do not contribute to the density or the pressure. If the volume is decreased, this curious condensation phenomenon results, yielding the zero state which has the paradoxical properties of not contributing to the pressure, volume, or density. There is now considerable evidence that many of the superfluid properties exhibited by liquid helium are in fact manifestations of an Einstein condensation. See FERMI-DIRAC STATISTICS; QUANTUM STATISTICS; STATISTICAL MECHANICS. [M.Dr.]

**Botanical gardens** A garden for the culture of plants collected chiefly for scientific and educational purposes. Such a garden is more properly called a botanical institution, in which the outdoor garden is but one portion of an organization including the greenhouse, the herbarium, the library, and the research laboratory. See HERBARIUM.

It was only in modern Europe, after the foundation of the great medieval universities, that botanical gardens for educational purposes began to be established in connection with the schools. The oldest gardens are those in Padua (established 1533) and at Pisa (1543). The botanical garden of the University of Leiden was begun in 1587, and the first greenhouse is said to have been constructed there in 1599. The Royal Botanical Gardens at Kew, England, were officially opened in 1841. This institution came to be known as the botanical capital of the world.

The first of the great tropical gardens was founded at Calcutta in 1787. The original name, Royal Botanic Garden, was changed in 1947 to Indian Botanic Garden. Another great tropical garden, the Jardin Botanique of Rio de Janeiro, was founded in 1808. The great tropical botanical garden of Buitenzorg (Bogor), Java, which originated in 1817, has an area of 205 acres (83 hectares) with an additional 150 acres (61 hectares) in the Mountain Garden.

The first great garden of the United States was founded by Henry Shaw at St. Louis in 1859, and is now known as the Missouri Botanical Garden. The New York Botanical Garden was chartered in 1891 and the Brooklyn Botanic Garden in 1910. The Jardin Botanique of Montreal, the leading garden of Canada, was opened in 1936. See ARBORETUM. [E.L.C.]

**Botany** That branch of biological science which embraces the study of plants and plant life. Botanical studies may range from microscopic observations of the smallest and obscurest plants to the study of the trees of the forest. One botanist may be interested mainly in the relationships among plants and in their geographic distribution, whereas another may be primarily concerned with structure or with the study of the life processes taking place in plants.

Botany may be divided by subject matter into several specialties, such as plant anatomy, plant chemistry, plant cytology, plant ecology (including autecology and synecology), plant embryology, plant genetics, plant morphology, plant physiology,

plant taxonomy, ethnobotany, and paleobotany. It may also be divided according to the group of plants being studied; for example, agostology, the study of grasses; algology (phycology), the study of algae; bryology, the study of mosses; mycology, the study of fungi; and pteridology, the study of ferns. Bacteriology and virology are also parts of botany in a broad sense. Furthermore, a number of agricultural subjects have botany as their foundation. Among these are agronomy, floriculture, forestry, horticulture, landscape architecture, and plant breeding. See AGRICULTURE; AGRONOMY; BACTERIOLOGY; CELL BIOLOGY; ECOLOGY; FLORICULTURE; GENETICS; LANDSCAPE ARCHITECTURE; PALEOBOTANY; PLANT ANATOMY; PLANT GROWTH; PLANT MORPHOGENESIS; PLANT PATHOLOGY; PLANT PHYSIOLOGY; PLANT TAXONOMY. [A.Gr.]

**Botulism** An illness produced by the exotoxin of *Clostridium botulinum* and occasionally other clostridia, and characterized by paralysis and other neurological abnormalities. There are seven principal toxin types involved (A–G); only types A, B, E, and F have been implicated in human disease. Types C and D produce illness in birds and mammals. Strains of *C. barati* and *C. butyricum* have been found to produce toxins E and F and have been implicated in infant botulism. See VIRULENCE.

The three clinical forms of botulism are classic botulism, infant botulism, and wound botulism. Classic botulism is typically due to ingestion of preformed toxin, infant botulism involves ingestion of *C. botulinum* spores with subsequent germination and toxin production in the gastrointestinal tract, and wound botulism involves production of toxin by the organism's infecting or colonizing a wound. The incubation period is from a few hours to more than a week (but usually 1–2 days), depending primarily on the amount of toxin ingested or absorbed.

There is classically acute onset of bilateral cranial nerve impairment and subsequent symmetrical descending paralysis or weakness. Commonly noted are dysphagia (difficulty in swallowing), dry mouth, diplopia (double vision), dysarthria (a neuromuscular disorder affecting speech), and blurred vision. Nausea, vomiting, and fatigue are common as well. Ileus (impaired intestinal motility) and constipation are much more typical than diarrhea; there may also be urinary retention and dry mucous membranes. Central nervous system function and sensation remain intact, and fever does not occur in the absence of complications. Fever may even be absent in wound botulism. See TOXIN.

In food-borne botulism, home-canned or home-processed foods (particularly vegetables) are commonly implicated, with commercially canned foods involved infrequently. Outbreaks usually involve only one or two people, but may affect dozens. In infant botulism, honey and corn syrup have been implicated as vehicles. Therapy involves measures to rid the body of unabsorbed toxin, neutralization of unfixed toxin by antitoxin, and adequate intensive care support. See FOOD POISONING; POISON. [S.M.F.]

**Boundary-layer flow** That portion of a fluid flow, near a solid surface, where shear stresses are significant and the inviscid-flow assumption may not be used. All solid surfaces interact with a viscous fluid flow because of the no-slip condition, a physical requirement that the fluid and solid have equal velocities at their interface. Thus a fluid flow is retarded by a fixed solid surface, and a finite, slow-moving boundary layer is formed. A requirement for the boundary layer to be thin is that the Reynolds number of the body be large,  $10^3$  or more. Under these conditions the flow outside the boundary layer is essentially inviscid and plays the role of a driving mechanism for the layer. See REYNOLDS NUMBER.

A typical low-speed or laminar boundary layer is shown in the illustration. Such a display of the streamwise flow vector variation near the wall is called a velocity profile. The no-slip condition requires that  $u(x, 0) = 0$ , as shown, where  $u$  is the velocity of flow in the boundary layer. The velocity rises monotonically with

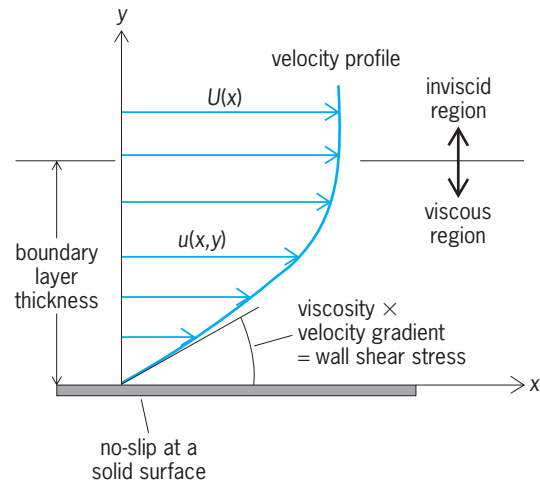

Typical laminar boundary-layer velocity profile.

distance  $y$  from the wall, finally merging smoothly with the outer (inviscid) stream velocity  $U(x)$ . At any point in the boundary layer, the fluid shear stress  $\tau$  is proportional to the local velocity gradient, assuming a newtonian fluid. The value of the shear stress at the wall is most important, since it relates not only to the drag of the body but often also to its heat transfer. At the edge of the boundary layer,  $\tau$  approaches zero asymptotically. There is no exact spot where  $\tau = 0$ ; therefore the thickness  $\delta$  of a boundary layer is usually defined arbitrarily as the point where  $u = 0.99U$ . See LAMINAR FLOW.

When a flow enters a duct or confined region, boundary layers immediately begin to grow on the duct walls. An inviscid core accelerates down the duct center, but soon vanishes as the boundary layers meet and fill the duct with viscous flow. Constrained by the duct walls into a no-growth condition, the velocity profile settles into a fully developed shape which is independent of the streamwise coordinate. The pressure drops linearly downstream, balanced by the mean wall-shear stress. This is a classic and simple case of boundary-layer flow which is well documented by both theory and experiment.

A classic incompressible boundary-layer flow is a uniform stream at velocity  $U$ , moving past a sharp flat plate parallel to the stream. In the Reynolds number range  $1 \times 10^3$  to  $5 \times 10^5$ , the flow is laminar and orderly, with no superimposed fluctuations. The boundary-layer thickness  $\delta$  grows monotonically with  $x$ , and the shape of the velocity profile is independent of  $x$  when normalized. The profiles are said to be similar, and they are called Blasius profiles.

The Blasius flat-plate flow results in closed-form algebraic formulas for such parameters as wall-shear stress and boundary-layer thickness as well as for temperature and heat-transfer parameters. These results are useful in estimating viscous effects in flow past thin bodies such as airfoils, turbine blades, and heat-exchanger plates.

The flat plate is very distinctive in that it causes no change in outer-stream velocity  $U$ . Most body shapes immersed in a stream flow, such as cylinders, airfoils, or ships, induce a variable outer stream  $U(x)$  near the surface. If  $U$  increases with  $x$ , which means that pressure decreases with  $x$ , the boundary layer is said to be in a favorable gradient and remains thin and attached to the surface. If, however, velocity falls and pressure rises with  $x$ , the pressure gradient is unfavorable or adverse. The low-velocity fluid near the wall is strongly decelerated by the rising pressure, and the wall-shear stress drops off to zero. Downstream of this zero-shear or separation point, there is backflow and the wall shear is upstream. The boundary layer thickens markedly to conserve mass, and the outer stream separates from the body, leaving a broad, low-pressure wake downstream. Flow separation may be

predicted by boundary-layer theory, but the theory is not able to estimate the wake properties accurately.

In most immersed-body flows, the separation and wake occur on the rear or lee side of the body, with higher pressure and no separation on the front. The body thus experiences a large downstream pressure force called pressure drag. This happens to all blunt bodies such as spheres and cylinders and also to airfoils and turbomachinery blades if their angle of attack with respect to the oncoming stream is too large. The airfoil or blade is said to be stalled, and its performance suffers.

All laminar boundary layers, if they grow thick enough and have sufficient velocity, become unstable. Slight disturbances, whether naturally occurring or imposed artificially, tend to grow in amplitude, at least in a certain frequency and wavelength range. The growth begins as a selective group of two-dimensional periodic disturbances, called Tollmien-Schlichting waves, which become three-dimensional and nonlinear downstream and eventually burst into the strong random fluctuations called turbulence. The critical parameter is the Reynolds number. The process of change from laminar to turbulent flow is called transition.

The turbulent flow regime is characterized by random, three-dimensional fluctuations superimposed upon time-mean fluid properties, including velocity, pressure, and temperature. The fluctuations are typically 3–6% of the mean values and range in size over three orders of magnitude, from microscale movements to large eddies of size comparable to the boundary-layer thickness. They are readily measured by modern instruments such as hot wires and laser-Doppler velocimeters. See ANEMOMETER.

The effect of superimposing a wide spectrum of eddies on a viscous flow is to greatly increase mixing and transport of mass, momentum, and heat across the flow. Turbulent boundary layers are thicker than laminar layers and have higher heat transfer and friction. The turbulent mean-velocity profile is rather flat, with a steep gradient at the wall. The edge of the boundary layer is a ragged, fluctuating interface which separates the nonturbulent outer flow from large turbulent eddies in the layer. The thickness of such a layer is defined only in the time mean, and a probe placed in the outer half of the layer would show intermittently turbulent and nonturbulent flow.

As the stream velocity  $U$  becomes larger, its kinetic energy,  $U^2/2$ , becomes comparable to stream enthalpy,  $c_p T$ , where  $c_p$  is the specific heat at constant pressure and  $T$  is the absolute temperature. Changes in temperature and density begin to be important, and the flow can no longer be considered incompressible. Liquids flow at very small Mach numbers, and compressible flows are primarily gas flows. See GAS; MACH NUMBER.

In a flow with supersonic stream velocity, the no-slip condition is still valid, and much of the boundary-layer flow near the wall is at low speed or subsonic. The fluid enters the boundary layer and loses much of its kinetic energy, of which a small part is conducted away although most is converted into thermal energy. Thus the near-wall region of a highly compressible boundary layer is very hot, even if the wall is cold and is drawing heat away. The basic difference between low and high speed is the conversion of kinetic energy into higher temperatures across the entire boundary layer.

In a low-speed (incompressible) boundary layer, a cold wall simply means that the wall temperature is less than the free-stream temperature. The heat flow is from high toward lower temperature, that is, into the wall. For a low-speed insulated wall, the boundary-layer temperature is uniform. For a high-speed flow, however, an insulated wall has a high surface temperature because of the viscous dissipation energy exchange in the layer.

Except for the added complexity of having to consider fluid pressure, temperature, and density as coupled variables, compressible boundary layers have similar characteristics to their low-speed counterparts. They undergo transition from laminar to turbulent flow but typically at somewhat higher Reynolds

numbers. Compressible layers tend to be somewhat thicker than incompressible boundary layers, with proportionally smaller wall-shear stresses. They tend to resist flow separation slightly better than incompressible flows.

In a supersonic outer stream, shock waves can always occur. Shocks may form in the boundary layer because of obstacles in the layer or downstream, or they may be formed elsewhere and impinge upon a boundary. In either case, the pressure rises sharply behind the shock, an adverse gradient, and this tends to cause early transition to turbulence and early flow separation. Special care must be taken to design aerodynamic surfaces to accommodate or avoid shockwave formation in transonic and supersonic flows. See COMPRESSIBLE FLOW.

As boundary layers move downstream, they tend to grow naturally and undergo transition to turbulence. Boundary layers encountering rising pressure undergo flow separation. Both phenomena can be controlled at least partially. Airfoils and hydrofoils can be shaped to delay adverse pressure gradients and thus move separation downstream. Proper shaping can also delay transition. Wall suction removes the low-momentum fluid and delays both transition and separation. Wall blowing into the boundary layer, from downward-facing slots, delays separation but not transition. Changing the wall temperature to hotter for liquids and colder for gases delays transition. Practical systems have been designed for boundary-layer control, but they are often expensive and mechanically complex. See AIRFOIL; FLUID-FLOW PRINCIPLES; STREAMLINING; VISCOSITY. [F.M.Wh.]

**Bovine virus diarrhea** A viral disease of cattle. The bovine viral diarrhea virus is common worldwide, infects cattle of all ages, and causes a variety of disease processes. In addition to cattle, the virus infects most even-toed ungulates, including sheep, swine, goats, deer, bison, llama, and antelope. See ANIMAL VIRUS.

The mature virion is spherical and 40–60 nanometers in diameter. It is composed of a spherical core that is surrounded by a lipid envelope. The viral genome consists of a single strand of positive-sense ribonucleic acid (RNA) about 12,300 nucleotides in length. Although all bovine viral diarrhea viruses are related serologically, variation is common among viral isolates in nucleotide sequence, antigenic sites on viral proteins, and biologic properties expressed in vitro or in vivo.

Cattle infected with bovine viral diarrhea virus usually develop a clinically mild, acute disease that is characterized by fever, low white blood cell count, mild depression, and transient loss of appetite. A clinically severe, acute disease occurs in cattle infected with some viruses. The clinical signs of severe disease include prolonged fever, pronounced depression, rapid respiration, ulceration of the mouth, esophagus, and intestines, hemorrhaging, diarrhea, dehydration, and death. The virus replicates in lymphoid cells and may suppress their immune function, potentially lowering resistance of the host to other infectious agents. Adverse effects on the fetus are common following infection of pregnant cattle with bovine viral diarrhea virus. Embryonic resorption, abortion, stillbirth, and congenital anomalies may result when the virus crosses the placenta and infects the fetus. A clinically severe disease, termed mucosal disease, occurs only in persistently infected cattle. The signs of mucosal disease are fever, low white blood cell count, diarrhea that is often bloody, mucosal ulcerations of the alimentary tract, inappetence, and death.

Oral or nasal exposure with virus is the primary mode of transmission of acute disease. Persistently infected cattle are important in viral transmission because they shed large quantities of virus in their saliva and nasal secretions. Contact with other cattle undergoing an acute infection is another important method of viral transmission. Biting insects and artificial insemination with semen contaminated with virus have been reported to transmit the virus. Because wild ruminants may be infected with bovine viral diarrhea virus, there is a possibility that disease may spread from farm to farm with movement of wildlife.

Treatment for bovine virus diarrhea primarily is based on supportive care. Prevention of disease can be achieved through use of vaccination. The vaccines usually are given first when calves are about 6 months of age. Vaccination is often repeated at regular intervals during the life of the animal. Identification and elimination of persistently infected cattle also is important for control of viral spread and for prevention of disease. [S.R.Bo.]

**Boyle's law** A law of gases which states that at constant temperature the volume of a gas varies inversely with its pressure. This law, formulated by Robert Boyle (1627–1691), can also be stated thus: The product of the volume of a gas times the pressure exerted on it is a constant at a fixed temperature. The relation is approximately true for most gases, but is not followed at high pressure. The phenomenon was discovered independently by Edme Mariotte about 1650 and is known in Europe as Mariotte's law. See GAS; KINETIC THEORY OF MATTER. [F.H.R.]

**Brachiopoda** A phylum of solitary, exclusively marine, coelomate, bivalved animals, with both valves symmetrical about a median longitudinal plane. They are typically attached to the substrate by a posteriorly located fleshy stalk or pedicle. Anteriorly, a relatively large mantle cavity is always developed between the valves, and the filamentous feeding organ, or lophophore, is suspended in it, projecting forward from the anterior body wall (see illustration).

There are two clearly defined groups within the phylum, a division that is particularly marked if only Recent animals are considered. These two groups are regarded as classes; several names have been given to them, but Inarticulata and Articulata are the most widely used and are based on one of the most readily observed differences between them, the presence or absence of articulation between the two valves of the shell. Among the Articulata the valves are typically hinged together by a pair of teeth with complementary sockets in the opposing valve; these hinge teeth are lacking in the Inarticulata, whose valves are held together only by the soft tissue of the living animal. The phylum is currently classified into the following groups:

Class Inarticulata	Class Articulata
Order: Lingulida	Order: Orthida
Acrotretida	Strophomenida
Obolellida	Pentamerida
Paterinida	Rhynchonellida
Class Incertae Sedis	Spiriferida
Order Kutorginida	Terebratulida

The pedicle is the only organ protruding outside the valves, while the remainder of the animal is enclosed in the space between them. This space is divided into two unequal parts, a smaller posteriorly located body cavity and an anterior mantle cavity. The two mantles approach each other and ultimately fuse along the posterior margin of articulate brachiopods; in contrast, the mantles are invariably discrete in the inarticulates and are separated by a strip of body wall.

The body cavity contains the musculature; the alimentary canal; the nephridia, which are paired excretory organs also functioning as gonoducts; the reproductive organs; and primitive circulatory and nervous systems. Except for the openings through the nephridia, the body cavity is enclosed, but the mantle cavity communicates freely with the sea when the valves are opened. The lophophore is suspended from the anterior body wall within the mantle cavity and is always symmetrically disposed about the median plane. The lophophore consists of a variably disposed, ciliated, filament-bearing tube, with the ciliary beat producing an ordered flow of water within the cavity, flowing across the filaments. The latter trap food particles which are carried along a groove in the lophophore to the medially situated mouth.

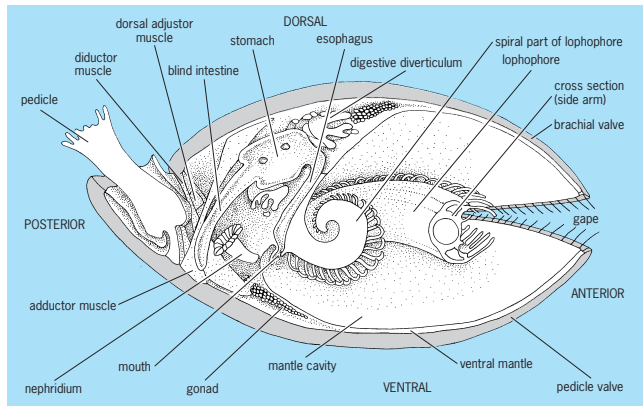

The principal organs of a brachiopod as typified by *Terebratulina*. (After R. C. Moore, ed., *Treatise on Invertebrate Paleontology*, pt. H, Geological Society of America, Inc., and University of Kansas Press, 1965)

All modern brachiopods are marine, and there is little doubt from the fossil record that brachiopods have always been confined to the sea. Recent brachiopods occur most commonly beneath the relatively shallow waters of the continental shelves, which seems to have been the most favored environment, but the bathymetric range of the phylum is large. A few modern species live intertidally and, at the other extreme, a limited number have been dredged from depths of over 16,000 ft (5000 m).

The majority of brachiopods form part of the sessile benthos and are attached by their pedicle during postlarval life. *Glotidia* and *Lingula* are exceptional in being infaunal and making burrows. A commoner modification involves loss of the pedicle, either complete suppression or atrophy early in the life history of the individual. Such forms either lie free on the sea floor, are attached by cementation of part or all of the pedicle valve, or are anchored by spines. The geographic distribution and geological setting of some fossil species suggest that they may have been eiplanktonic, attached to floating weed, but such a mode of life is unknown in modern faunas. See INARTICULATA. [A.J.R.]

**Bradyodonti** An order, perhaps composite in nature, of Paleozoic cartilaginous fishes (Chondrichthyes), presumably derived from primitive sharks. They are mainly represented by dentitions, which appear to have been adapted to the eating of mollusks and other shelled invertebrates; the body (seldom preserved) appears to have been broad and flattened, with large pectoral fins, as in the later skates and rays of similar habits. The first bradyodonts appeared at the end of the Devonian; they flourished during the Carboniferous, but declined and vanished by the end of the Permian, concomitantly with a reduction in the invertebrate fauna at that time. There are four families: Cochlodontidae, Petalodontidae, Psammodontidae, and Copodontidae. See CHIMAERIFORMES; CHONDRICHTHYES; ELASMOBRANCHII. [A.S.R.]

**Brain** A collection of specialized cells (neurons) in the head that regulates behavior as well as sensory and motor functions. The three main parts of the brain in vertebrates are the cerebrum, the cerebellum, and the brainstem that connects them with each other and with the spinal cord (see illustration). The two cerebral hemispheres are separated by a midline fissure that is bridged by a massive bundle of axons running in both directions, the corpus callosum. Each hemisphere has a core of groups of neurons (the basal ganglia); an outer shell of neurons in layers (the cerebral cortex); and massive bundles of axons for communication within the cerebrum and with the rest of the brain. These bundles are called white matter because of the waxy myelin sheaths surrounding the axons. See NEURON.

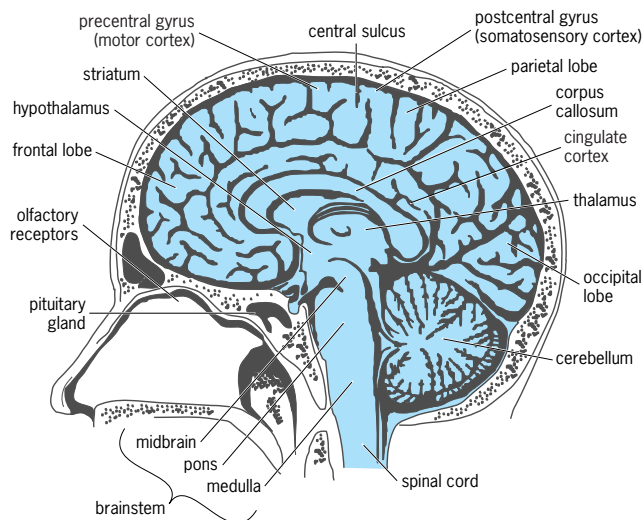

**Midsagittal (midline, medial) section through the human brain.** (After C. R. Noback, *The Human Nervous System*, 4th ed., McGraw-Hill, 1991)

The basal ganglia comprises three main groups. (1) The thalamus receives axons from all sensory systems and transmits information to the cortex. It also receives feedback from cortical neurons during sensory processing. (2) The striatum, comprising bundles of axons cutting through the groups of neurons, also has two-way communication with the cortex and assists in the organization of body movement. (3) The hypothalamus receives orders from the cortex and organizes the chemical systems that support body movement. One output channel is hormonal, and controls the pituitary gland (hypophysis) which in turn controls the endocrine system. The other channel is neural, comprising axons coursing through the brainstem and spinal cord to the motor neurons of the autonomic nervous system, which regulates the heart, blood vessels, lungs, gastrointestinal tract, sex organs, and skin. The autonomic and endocrine systems are largely self regulating, but they are subject to control by the cortex through the hypothalamus. See AUTONOMIC NERVOUS SYSTEM; ENDOCRINE SYSTEM (VERTEBRATE); NEUROBIOLOGY.

The cortex is also called gray matter because it contains the axons, cell bodies, and dendrites of neurons but there is very little myelin. An index of the capacity of a brain is cortical surface area. In higher mammals, the cortical surface increases more rapidly than the volume during fetal development; as a result the surface folds, taking the form of convexities (gyri) and fissures (sulci) that vary in their details from one brain to another. However, they are sufficiently reliable to serve as landmarks on the cerebral hemisphere that it can be subdivided into lobes. Four lobes make up the shell of each hemisphere, namely the frontal, parietal, temporal, and occipital lobes. Each lobe contains a motor or sensory map (an orderly arrangement of cortical neurons associated with muscles and sensory receptors on the body surface). The central sulcus delimits the frontal and parietal lobes. The precentral gyrus contains the motor cortex whose neurons transmit signals to motor neurons in the brainstem and spinal cord which control the muscles in the feet, legs, trunk, arms, face, and tongue of the opposite side of the body. The number of neurons for each section is determined by the fineness of control, not the size of the muscle; for example, the lips and tongue have larger areas than the trunk. Within the postcentral gyrus is the primary somatosensory cortex. Sensory receptors in the skin, muscles, and joints send messages to the somatosensory cortical cells through relays in the spinal cord and the thalamus to a map of the opposite side of the body in parallel to the map in the motor cortex. The lateral fissure separates the temporal lobe from the parietal and frontal lobes. The cortex on the inferior

border of the fissure receives input relayed through the thalamus from the ears to the primary auditory cortex. The occipital lobe receives thalamic input from the eyes and functions as the primary visual cortex.

In humans, the association cortex surrounds the primary sensory and motor areas that make up a small fraction of each lobe. The occipital lobe has many specialized areas for recognizing visual patterns of color, motion, and texture. The parietal cortex has areas that support perception of the body and its surrounding personal space. Its operation is manifested by the phenomenon of phantom limb, in which the perception of a missing limb persists for an amputee. Conversely, individuals with damage to these areas suffer from sensory neglect. The temporal cortex contains areas that provide recognition of faces and of rhythmic patterns, including those of speech, dance, and music. The frontal cortex provides the neural capabilities for constructing patterns of motor behavior and social behavior. It was the rapid enlargement of the frontal and temporal lobes in human evolution over the past half million years that supported the transcendence of humans over other species. This is where the capacity to create works of art, and also to anticipate pain and death, is located. Insight and foresight are both lost with bilateral frontal lobe damage, leading to reduced experience of anxiety, asocial behavior, and a disregard of consequences of actions.

A small part of frontal lobe output goes directly to motor neurons in the brainstem and spinal cord for fine control of motor activities, such as search movements by the eyes, head, and fingers, but most goes either to the striatum from which it is relayed to the thalamus and then back to the cortex, or to the brainstem from which it is sent to the cerebellum and then through the thalamus back to the cortex. In the cerebellum, the cortical messages are integrated with sensory input predominantly from the muscles, tendons, and joints, but also from the eyes and inner ears (for balance) to provide split-second timing for rapid and complex movements. The cerebellum also has a cortex and a core of nuclei to relay input and output. Their connections, along with those in the cerebral cortex, are subject to modification with learning in the formation of a working memory (the basis for learned skills). See MEMORY; MOTOR SYSTEMS.

The cerebellum and striatum do not set goals, initiate movements, store temporal sequences of sensory input, or provide orientation to the spatial environment. These functions are performed by parts of the cortex and striatum deep in the brain that constitute another loop, the limbic system. Its main site of entry is the entorhinal cortex, which receives input from all of the sensory cortices, including the olfactory system. The input from all the sensory cortices is combined and sent to the hippocampus, where it is integrated over time. Hippocampal output returns to the entorhinal cortex, which distributes the integrated sensory information to all of the sensory cortices, updates them, and prepares them to receive new sensory input. This new information also reaches the hypothalamus and part of the striatum (the amygdaloid nucleus) for regulating emotional behavior. Bilateral damage to the temporal lobe including the hippocampus results in loss of short-term memory. Damage to the amygdaloid nucleus can cause serious emotional impairment. The Papez circuit is formed by transmission from the hippocampus to the hypothalamus by the fornix, then to the thalamus, parietal lobe, and entorhinal cortex. The limbic system generates and issues goal-directed motor commands, with corollary discharge to the sensory systems that prepares them for the changes in sensory input caused by motor activity (for example, when one speaks and hears oneself, as distinct from another).

Each hemisphere has its own limbic, Papez, cortico-thalamic, cortico-striatal, and cortico-cerebellar loops, together with sensory and motor connections. When isolated by surgically severing the callosus, each hemisphere functions independently, as though two conscious persons occupied the same skull, but with differing levels of skills in abstract reasoning and language. The right brain (spatial)-left brain (linguistic) cognitive differences are

largely due to preeminent development of the speech areas in the left hemisphere in most right- and left-handed persons. Injury to Broca's area (located in the frontal lobe) and Wernicke's area (located in the temporal lobe) leads to loss of the ability, respectively, to speak (motor aphasia) or to understand speech (sensory aphasia). Studies of blood flow show that brain activity during intellectual pursuits is scattered broadly over the four lobes in both hemispheres. See APHASIA; CENTRAL NERVOUS SYSTEM; HEMISPHERIC LATERALITY. [W.J.F.]

**Brake** A machine element for applying a force to a moving surface to slow it down or bring it to rest in a controlled manner. In doing so, it converts the kinetic energy of motion into heat which is dissipated into the atmosphere. Brakes are used in motor vehicles, trains, airplanes, elevators, and other machines. Most brakes are of a friction type in which a fixed surface is brought into contact with a moving part that is to be slowed or stopped.

Friction brakes are classified according to the kind of friction element employed and the means of applying the friction forces. See FRICTION.

The single-block is the simplest form of brake. It consists of a short block fitted to the contour of a wheel or drum and pressed against its surface by means of a lever on a fulcrum, as widely used on railroad cars. The block may have the contour lined with friction-brake material, which gives long wear and a high coefficient of friction. The fulcrum may be located with respect to the lever in a manner to aid or retard the braking torque of the block. The lever may be operated manually or by a remotely controlled force (Fig. 1a).

In double-block brakes, two single-blocks brake in symmetrical opposition, where the operating force on the end of one lever is the reaction of the other, make up a double-block brake (Fig. 1b). External thrust loads are balanced on the rim of the rotating wheel.

An external-shoe brake operates in the same manner as the block brake, and the designation indicates the application of externally contracting elements. In this brake the shoes are appreciably longer, extending over a greater portion of the drum (Fig. 1c). This construction allows more combinations for special applications than the simple shoe, although assumptions of uniform pressure and concentrated forces are no longer possible. In particular, it is used on elevator installations for locking the hoisting sheave by means of a heavy spring when the electric current is off and the elevator is at rest. See ELEVATOR.

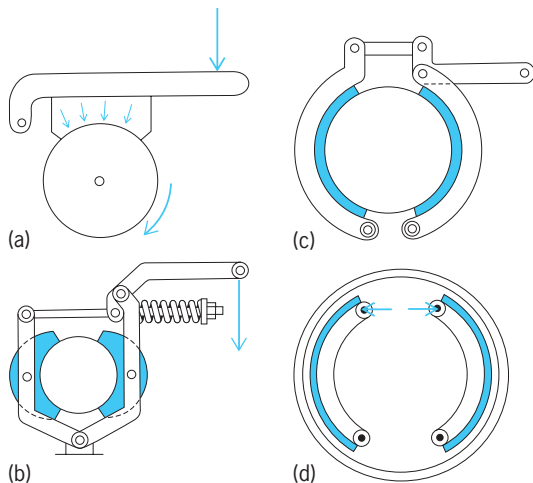

**Fig. 1. Brakes.** (a) Single-block brake. The block is fixed to the operating lever; force in the direction of the top arrow applies the brake. (b) Double-block brake. The blocks are pivoted on their levers; force in the direction of the arrow releases the brake. (c) External shoe brake. Shoes are lined with friction material. (d) Internal shoe brake with lining.

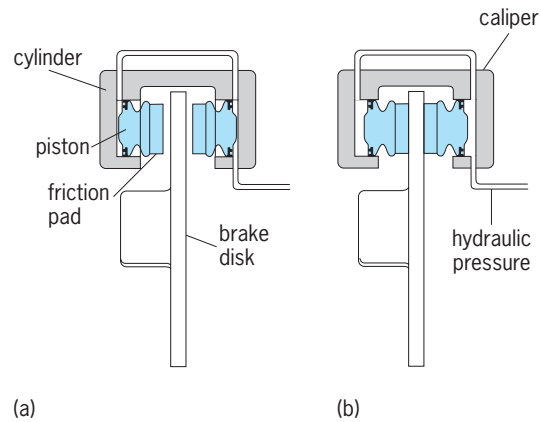

**Fig. 2. Caliper disk brake.** (a) Friction pads on either side of a disk that is free to rotate. (b) Brake applied, hydraulic pressure forces the pistons toward the disk to stop its rotation and hold it stationary. (Automotive & Technical Writing, Charlottesville, Virginia)

An internal shoe brake has several advantages over an external shoe. Because the internal shoe works on the inner surface of the drum, it is protected from water and grit (Fig. 1d). It may be designed in a more compact package, is easily activated, and is effective for drives with rotations in both directions. The internal shoe is used in the automotive drum brake, with hydraulic piston actuation. See AUTOMOTIVE BRAKE.

Hoists, excavating machinery, and hydraulic clutch-controlled transmissions have band brakes. They operate on the same principle as flat belts on pulleys. In the simplest band brake, one end of the belt is fastened near the drum surface, and the other end is then pulled over the drum in the direction of rotation so that a lever on a fulcrum may apply tension to the belt.

Disk brakes have long been used on hoisting and similar apparatus. Because more energy is absorbed in prolonged braking than in clutch startup, additional heat dissipation must be provided in equivalent disk brakes. Disk brakes are used for the wheels of aircraft, where segmented rotary elements are pressed against stationary plates by hydraulic pistons. Flexibility, self-alignment, and rapid cooling are inherent in this design. Another application is the bicycle coaster brake.

The caliper disk brake (Fig. 2) is widely used on automotive vehicles. It consists of a rotating disk which can be gripped between two friction pads. The caliper disk brake is hydraulically operated, and the pads cover between one-sixth and one-ninth of the swept area of the disk. See AUTOMOTIVE BRAKE.

Railway brakes are normally applied air brakes; if the air coupling to a car is broken, the brakes are applied automatically. To apply the brakes, the brake operator releases the compressed air that is restraining the brakes by means of a diaphragm and linkage. Over-the-road trucks and buses use air brakes. Another form of air brake consists of an annular air tube surrounding a jointed brake lining that extends completely around the outside of a brake drum. Air pressure expands the tube, pressing the lining against the drum. [D.L.An.]

**Branch circuit** The portion of an electrical wiring system that extends beyond the final, automatic overcurrent protective device (circuit breaker or fuse), which is recognized by the National Electrical Code for use as a branch-circuit overcurrent protector, and that terminates at the utilization device (such as a lighting fixture, motor, or heater). Thermal cutouts, motor overload devices, and fuses in luminaires or plug connections are not approved for branch-circuit protection and do not establish the point of origin of a branch circuit.

Branch circuits serving more than one outlet or load are limited by the National Electrical Code to three types:



1. Circuits of 15 or 20 A may serve lights and appliances; the rating of one portable appliance may not exceed 80% of the circuit capacity; the total rating of fixed appliances may not exceed 50% of circuit capacity if lights or portable appliances are also supplied.
2. Circuits of 30 A may serve fixed lighting units with heavy-duty lampholders in other than dwellings or appliances in any occupancy.
3. Circuits of 40 or 50 A may serve fixed lighting with heavy-duty lampholders in other than dwellings, fixed cooking appliances, or infrared heating units. [B.J.McP.; J.F.McP.]

**Branched polymer** A polymer chain having branch points that connect three or more chain segments. Examples of branched polymers include long chains having occasional and usually short branches comprising the same repeat units as the main chain (nominally termed a branched polymer); long chains having occasional branches comprising repeat units different from those of the main chain (termed graft copolymers); main chains having one long branch per repeat unit (referred to as comb polymers); and small core molecules with branches radiating from the core (star polymers). Starburst or dendritic polymers are a special class of star polymer in which the branches are multifunctional, leading to further branching with polymer growth. Star, comb, and starburst polymers (see illustration), especially the last, represent interesting

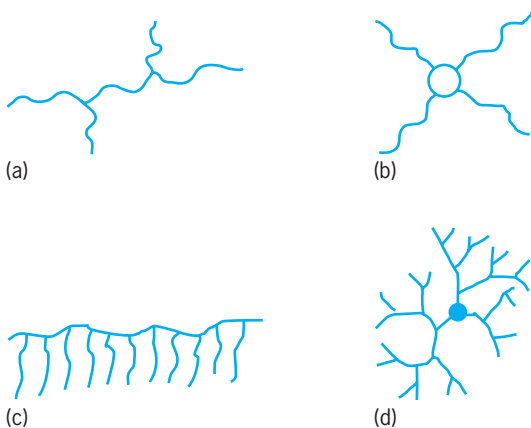

Examples of branched polymers. (a) Branched polymer (if arms are of composition similar to backbone) or graft polymer (if compositions are different). (b) Star polymer. (c) Comb polymer. (d) Dendritic polymer.

molecular structures that may lead to unusual supramolecular structures (for example, micelles and liposomes) that mimic the functions of complex biomolecules. See BIOPOLYMER; POLYMER; POLYMERIZATION. [G.E.W.]

**Branchiopoda** A class of crustaceans. The Conchostraca consist of two groups which, although superficially similar, differ in so many fundamental features that they have been placed in separate orders, Laevicaudata and Spinicaudata. See LAEVICAUDATA; SPINICAUDATA.

Living members of the Branchiopoda range from less than 0.5 mm (0.02 in.) to (exceptionally) 100 mm (4 in.) in length. Form is exceedingly diverse. The trunk may be abbreviated and of probably as few as 5 segments (although segmentation is sometimes obscure) or elongate and of more than 40 segments. Trunk limbs range from 5 to about 70 pairs. A carapace is often present, either as a dorsal shield or as a bivalved structure; anostracans lack a carapace.

Most species are microphagous. Microphagous forms collect their food either by direct scraping from surfaces, which may or

may not be followed by filtration, or by abstracting suspended particles by the use of complicated filtering devices.

Reproductive habits are diverse. Parthenogenesis is widespread, and the production of highly resistant resting eggs that can withstand freezing and drying and retain their viability for several years is highly characteristic. Almost all species live in fresh water, but a few are marine and some frequent highly saline situations. Branchiopods have a worldwide distribution. See CRUSTACEA. [G.Fr.]

**Branchiura** A subclass of the Crustacea known as the fish lice. They are ectoparasites of fresh-water and marine fish. *Argulus* is a common genus. They are a small homogeneous group, less than 100 species, with worldwide distribution, and very much alike in appearance. The disklike head and thorax (cephalothorax) is strongly flattened and bears a small unsegmented abdomen bilobed at its distal end. Larger species may exceed 1 in. (25 mm) in length.

The appendages, all on the cephalothorax, consist of two pairs of antennae, the mouthparts which are one pair of mandibles and two pairs of maxillae, and four pairs of swimming legs. The wafer-thin cephalothorax with its appendages appressed to the underside permits fish lice to flatten themselves against a fish's skin. The resulting highly streamlined contour serves to minimize the considerable force of frictional drag found in a dense medium like water.

Other adaptations for holding fast to a mucus-covered swimming fish include numerous spinules and strategically placed hooks on the underside of the body and utilization of specialized portions of the body as suction cups. Despite these elaborate specializations, fish lice never lose the ability to abandon a host and swim. At least some of this activity is associated with mating and spawning.

Branchiurans feed on tissue fluids, especially blood. The mouth, located at the end of a movable proboscis, is applied to the host's skin and the rasping mandibles make the necessary wound. Fish lice usually are no threat to fish populations. In restricted areas such as hatchery ponds, however, an infestation can increase to levels that bring about high fish mortality. Treatment may require such drastic measures as drainage and cleaning before restocking can be successful. See CRUSTACEA. [A.Fl.]

**Brass** An alloy of copper and zinc. In manufacture, lump zinc is added to molten copper, and the mixture is poured into either castings ready for use or into billets for further working by rolling, extruding, forging, or similar process. Brasses containing 75–85% copper are red-gold and malleable; those containing 60–70% are yellow and also malleable; and those containing 50% or less copper are white, brittle, and not malleable. Alpha brass contains up to 36% zinc; beta brass contains nearly equal proportions of copper and zinc. Specific brasses are designated as follows: gilding (95% copper: 5% zinc), red (85:15), low (80:20), and admiralty (70:29, with balance of tin). Naval brass is 59–62% copper with about 1% tin, less than that of lead and iron, and the remainder zinc. The nickel silvers contain 55–70% copper and the balance nickel. Leaded brass is used for castings.

Brass stains in moist air; however, the oxide so formed is sufficiently continuous and adherent to retard further oxidation. When brass is required to remain bright, it is either washed in nitric acid and then coated with clear lacquer, or it is regularly polished and waxed.

Brass is widely used in cartridge cases, plumbing fixtures, valves and pipes, screws, clocks, and musical instruments. See ALLOY; COPPER ALLOYS; ZINC. [F.H.R.]

**Brayton cycle** A thermodynamic cycle (also variously called the Joule or complete expansion diesel cycle) consisting of two constant-pressure (isobaric) processes interspersed with two reversible adiabatic (isentropic) processes.

The thermal efficiency for a given gas, air, is solely a function of the ratio of compression. This is also the case with the Otto cycle. For the diesel cycle with incomplete expansion, the thermal efficiency is lower.

The Brayton cycle, with its high inherent thermal efficiency, requires the maximum volume of gas flow for a given power output. The Otto and diesel cycles require much lower gas flow rates, but have the disadvantage of higher peak pressures and temperatures. These conflicting elements led to many designs, all attempting to achieve practical compromises. With the development of fluid acceleration devices for the compression and expansion of gases, the Brayton cycle found mechanisms which could economically handle the large volumes of working fluid. This is perfected in the gas turbine power plant. See GAS TURBINE; THERMODYNAMIC CYCLE. [T.Ba.]

**Brazil nut** A large broad-leaved evergreen tree, *Bertholettia excelsa*, that grows wild in the forests of the Amazon valley of Brazil and Bolivia. The fruit is a spherical capsule weighing 2–4 lb (1–2 kg) which, when mature, consists of an outer hard indehiscent husk enclosing an inner hard-shelled container or pod filled with about 20 rather triangular seeds or nuts.

Although there are a few plantations in Brazil, almost the entire production is gathered from wild trees. The nuts are mostly exported to Europe, Canada, and the United States. About one-fourth of the crop is shelled in Brazil before export.

Brazil nuts have a high oil and protein content and require careful handling and refrigeration to prevent spoilage. The nuts are used in confectionery, baked goods, and nut mixtures. See LECYTHIDALES. [L.H.MacD.]

**Brazing** A method of joining metals, and other materials, by applying heat and a brazing filler metal. The filler metals used have melting temperatures above 840°F (450°C), but below the melting temperature of the metals or materials being joined. They flow by capillary action into the gap between the base metals or materials and join them by creating a metallurgical bond between them, at the molecular level. The process is similar to soldering, but differs in that the filler metal is of greater strength and has a higher melting temperature.

When properly designed, a brazed joint will yield a very high degree of serviceability under concentrated stress, vibration, and temperature loads. It can be said that in a properly designed brazement, any failure will occur in the base metal, not in the joint. There are many design variables to be considered. First among them is the mechanical configuration of the parts to be joined, and the joint area itself. All brazements can be categorized as having one of two basic joint designs: the lap joint or the butt joint. Others are adaptations of these two.

Design considerations should include the informed selection of the base and filler metals. In addition to the basic mechanical requirements, the base metals used in the brazement must retain the integrity of their physical properties throughout the heat of the brazing cycle. No universal filler metal that will satisfy all design requirements is possible, but there are many types available, ranging from pure metals such as copper, gold, or silver to complex alloys of aluminum, gold, nickel, magnesium, cobalt, silver, and palladium.

There are 11 basic brazing processes. In torch brazing, heat is applied by flame, from some type of torch, directly to the base metal. A mineral flux is normally used. The brazing filler metal may be preplaced in the joint, or face-fed into the joint. In induction brazing, brazing temperatures are developed in the parts to be brazed by placing them in or near a source of high-frequency ac electricity. Flux and preplaced filler metals are normally employed. Resistance brazing employs electrodes, which are arranged so that the joint forms a part of an electric circuit. Heat is developed by the resistance of the parts to the flow of the electric current. In dip brazing, the brazing filler metal is preplaced in or at the joint, and the assembly is immersed in a bath

of molten salt or flux until the brazing temperature is achieved. In a variation of this process, the assembly is prefluxed and dipped into a bath of molten brazing filler metal. Infrared brazing is a process in which high-intensity quartz lamps are directed on the metals to be joined.

Furnace brazing is a widely used technique, especially useful where the parts to be brazed are machined or formed to their final dimensions, or constitute a complex assembly that has already been lightly joined or fixtured. The atmosphere within a brazing furnace is usually controlled, which permits a great deal of flexibility. An important advantage is that potential distortion of metal, created by heating and cooling, can be predicted and controlled and thereby minimized or eliminated. Also the capacity for automation is facilitated in the furnace brazing process.

Diffusion brazing, unlike furnace brazing, is defined not by the method of heating but rather by the degree of mutual filler metal solution and diffusion with the base metal resulting from the temperature used and the time interval at heat. In diffusion brazing, temperature, time, in some cases pressure, and selection of base and filler materials are so controlled that the filler metal is partially or totally diffused into the base metal. The joint properties then closely approach those of the base metal.

Other, less used processes include arc brazing, block brazing, flow brazing, and twin carbon arc brazing. [R.L.P.]

**Breadboarding** Assembling an electronic circuit in the most convenient manner on a board or other flat surface, without regard for final locations of components, to prove the feasibility of the circuit and to facilitate changes when necessary. Standard breadboards for experimental work are made with mounting holes and terminals closely spaced at regular intervals, so that parts can be mounted and connected without drilling additional holes.

Printed-circuit boards having similar patterns of punched holes, with various combinations of holes connected together by printed wiring on each side, are often used for breadboarding when the final version is to be a printed circuit. See PRINTED CIRCUIT. [J.Mar.]

**Breadfruit** The multiple fruit of an Indo-Malaysian tree, *Artocarpus altilis*, of the mulberry family (Moraceae), now cultivated in tropical lowlands around the world. The fruits vary considerably in size and are often borne in small clusters. Breadfruit is a wholesome food for both humans and animals, although it has a high carbohydrate content. It is eaten fresh or baked, boiled, roasted, fried, or ground up and made into bread. There are many varieties, both with and without seeds. [E.L.C.]

**Breakdown potential** The potential difference at which an electrically stressed gas is transformed from an insulator to a conductor. In an electrically stressed gas, as the voltage is increased, the free electrons present in the gas gain energy from the electric field. When the applied voltage is increased to such a level that an appreciable number of these electrons are energetically capable of ionizing the gas, the gas makes the transition from an insulator to a conductor; that is, it breaks down. The potential difference at which this transition occurs is known as the breakdown potential for the particular gaseous medium.

The breakdown potential depends on the nature, number density, and temperature of the gas; on the material, state, and geometry of the electrodes; on the type of voltage applied (steady, alternating, impulsive); and on the degree of preexisting ionization. Areas of surface roughness at the electrodes (especially the cathode) or the presence of conducting particles in the gas greatly reduces the breakdown potential because at such points the electric field is significantly enhanced, increasing the electron energies and thus gas ionization. The breakdown voltage varies considerably from one gaseous medium to another; it is very low for the rare gases, and very high for polyatomic, especially electronegative, gases such as sulfur hexafluoride (SF<sub>6</sub>).

The transition of a gas from an insulator to a conductor under an imposed electrical potential occurs in times ranging from milliseconds to nanoseconds, depending on the form of the applied field and the gas density. This transition depends on the behavior of electrons, ions, and photons in the gas, especially the processes which produce or deplete free electrons. Knowledge of these processes often allows prediction of the breakdown voltage of gases and the tailoring of gas mixtures which can withstand high electrical potentials for practical uses. See ELECTRICAL BREAKDOWN; ELECTRICAL CONDUCTION IN GASES.

The systematic development of gaseous dielectrics with high dielectric strength (that is, high breakdown potential) is most significant for high-voltage technology, which has a multiplicity of gas insulation needs. Dielectric gases are widely used as insulating media in high-voltage transmission lines, circuit breakers, transformers, substations, high-voltage research apparatus, and other electrical equipment. See CIRCUIT BREAKER; DIELECTRIC MATERIALS; TRANSMISSION LINES. [L.G.C.]

**Breast** The human mammary gland, usually well developed in the adult female but rudimentary in the male. Each adult female breast contains 15–20 separate, branching glands that radiate from the nipple. During lactation their secretions are discharged through separate openings at the base of the nipple.

In the female, hormonal changes in adolescence cause enlargement of breast tissue, but much of this is connective tissue although some glandular buds form. With the advent of full menstruation ovarian estrogenic hormones influence breast development. If pregnancy ensues, the glandular tissue reaches full development and full lactation begins shortly after birth. After cessation of lactation the breasts regress considerably and once again reflect cyclic regulation. See LACTATION. [W.J.B.]

Breast disorders may result from congenital or developmental abnormalities, inflammations, hormonal imbalances, and, most important, from tumor formation.

Congenital defects are usually unimportant except for their psychic or cosmetic implications. Supernumerary nipples and breasts or accessory breast tissue are common examples.

Inflammations are not encountered frequently and usually result from a staphylococcal or streptococcal invasion incurred during lactation. A special form of inflammation may result from fat necrosis. Although any age is susceptible, older women show a slightly higher incidence of fat necrosis, the commonest cause of which is injury from trauma. See STAPHYLOCOCCUS; STREPTOCOCCUS; SYPHILIS; TUBERCULOSIS.

Hormonal imbalances are believed to be responsible for the variants of the commonest nontumorous breast disorder of women, cystic hyperplasia. The changes are thought to result from exaggeration or distortion of the normal cyclic alterations induced during the menstrual interval. Although a wide range of clinical and pathologic variation is commonplace, three major types or tendencies prevail. The first, called fibrosis or mastodynia, is marked by an increase of connective tissue in the breast, without a proportionate increase in glandular epithelium. The second, cystic disease, is characterized by an increase in the glandular and connective tissues in local areas, with a tendency toward formation of cysts varying in size. The third major type is adenosis, in which glandular hyperplasia is predominant. Each major form of cystic hyperplasia has its own clinical characteristics, ages of highest incidence, and distribution. Each is important because the breast masses which occur require differentiation from benign and malignant tumors. These lesions also have been found to predispose to the subsequent development of carcinoma.

Breast cancer is the most significant lesion of the female breast, accounting for 25,000–30,000 deaths in the United States each year. It rarely occurs before the age of 25, but its incidence increases each year thereafter, with a sharper climb noted about the time of menopause. Early breast cancer may appear as a small, firm mass which is nontender and freely movable.

Diagnosis at this time carries a more favorable prognosis than later, when immobility, nipple retraction, lymph node involvement, and other signs of extension or spread are noted. Paget's disease of the nipple is a special form of breast cancer, in which there are early skin changes about the nipple. See CANCER (MEDICINE); HORMONE; ONCOLOGY. [E.G.St./N.K.M.]

**Breast disorders** Benign and malignant lesions of the human mammary glands. Benign breast disorders are often symptomatic and bothersome but do not have malignant potential. Malignant disorders have the potential to grow locally in the breast and spread through the bloodstream to other parts of the body.

**Physiologic changes.** The breast is an organ that changes in response to fluctuations in hormone levels. Physiologic changes in the breast are often confused with disease. Fibrocystic disease, chronic cystic mastitis, and mammary dysplasia are terms that have been used to describe cyclical pain, tenderness, and lumpiness in the breast. These terms are imprecise and represent the normal physiologic responses to hormonal changes in the body rather than distinct clinical entities. Cyclic breast pain can occur in response to estrogens endogenous in premenopausal women or supplemental in postmenopausal women. Diffuse, palpable irregularities or lumps in the breast are also associated with this cyclical pain. Unlike malignant masses, however, these irregularities fluctuate in size and tenderness with the menstrual cycle, and are better described as physiologic nodularity of the breast. See MENOPAUSE.

**Benign disorders.** Common benign disorders include breast masses, cysts, gynecomastia, nipple discharge, and breast infections. Breast masses or dominant lumps are different from lumpiness; they are persistent over time and are palpably distinct from the surrounding breast tissue. They can develop in any age group and should be carefully evaluated. Mammography and ultrasound can help to determine the character of the mass, depending on the age of the patient.

Dominant lumps include fibroadenomas, gross cysts, pseudolumps, and cancer. Fibroadenomas may occur in any age group but are most commonly seen in young women. They are benign tumors consisting of smooth, rounded masses that are easily palpable in the breast. The cause is unknown; however, there is evidence to support the presence of an imbalance in circulating hormone levels that might be responsible for tumor growth. Breast cysts may be difficult to identify by physical examination or mammography, but can be distinguished from solid masses by using ultrasound imaging. Treatment of a cyst involves draining it with a small needle and syringe. If the cyst completely disappears, no further treatments are required. However, if the cyst remains or recurs or the cyst fluid is bloody, further examinations are required to rule out an underlying carcinoma. See MAMMOGRAPHY.

Gynecomastia, a benign enlargement of the male breast which can occur at any age and in one or both breasts, is a physiologic response to hormones, drugs, or an underlying medical condition. Nipple discharge does not always indicate a pathologic process; the character of the discharge is significant. A watery bilateral discharge from multiple ducts is usually normal. A milky discharge (galactorrhea) is often physiologic but sometimes can be associated with a tumor of the pituitary gland, which secretes prolactin. Unilateral, and especially spontaneous, nipple discharge generally signifies underlying pathology. Bloody nipple discharge is of most concern. About 80% of the time, however, the underlying cause is a benign papilloma within a duct. Breast infections are a common problem seen in both lactating and nonlactating individuals. See LACTATION.

Proliferative breast disorders include ductal and lobular hyperplasias. It is thought that some of these disorders might represent precancerous changes since they signal an increased risk for the development of breast cancer. Women who have

hyperplasia without atypical cell changes have a mildly elevated risk for the subsequent development of breast cancer when they are compared with the general population. Women with atypical hyperplasia have a risk of developing breast cancer 4.4 times that of women without identifiable risk factors. This lesion is seen in only about 4–10% of breast biopsies. It does not characteristically form lumps or show up on mammography. Other benign neoplasms of the breast include adenomas, intraductal papillomas, adenosis, and radial sclerosing lesions.

**Precancer.** Ductal carcinoma is a precancer. It does not have the ability to disseminate throughout the body but can progress to an invasive carcinoma if left untreated. Once discovered, this lesion can be treated with breast conservation surgery, that is, excision of the tumor with a margin of normal tissue, with or without radiation, or with total mastectomy. Lobular carcinoma, however, is a misnomer since it is not a premalignant lesion but a marker for subsequent cancer. Women with lobular carcinoma who subsequently develop cancer do so in either breast with a relative risk 5.7 times that of the general population. Treatment options include close observation with physical examination and mammography, or bilateral mastectomies.

**Cancer.** Breast cancer is the most common cancer in women and is the second leading cause of cancer deaths among all American women, particularly in the fifth and sixth decades of life. Almost 80% of invasive carcinomas of the breast are of ductal origin; the remainder are lobular carcinomas or other special histologic types. Invasive ductal carcinomas can be subtyped if they have one or more characteristics of a specific histologic type, including tubular, medullary, papillary, or mucinous differentiation. When a large part of the tumor is differentiated into one of these subtypes, they generally carry a more favorable prognosis.

There are no significant differences in the rates of local recurrence and survival when breast conservation surgery is combined with radiation therapy to the breast as compared with total mastectomy. Removal of axillary lymph nodes continues to be an important tool in the staging and prognosis of invasive carcinomas of the breast. If axillary lymph node metastases are detected, systemic therapy is indicated to decrease the incidence of distant metastases, and will usually decrease the risk of mortality by one-third. Combination chemotherapy is generally recommended for premenopausal women, and its use has been extended to healthy postmenopausal women. Hormonal therapy is used to treat postmenopausal women with axillary lymph node metastases and hormone receptor positive tumors. Tamoxifen (an antiestrogen) is a hormonal agent which has been shown to decrease the risk of recurrence and the development of second primary tumors in postmenopausal women. See CANCER (MEDICINE); CHEMOTHERAPY.

Thirty percent of all women with negative lymph nodes will have developed micrometastases at the time of diagnosis and will eventually die of breast cancer. Chemotherapy or hormone therapy is therefore often recommended even for women with negative nodes. The use of chemotherapy or hormone therapy in women without axillary lymph node metastases is determined by multiple factors. The most important determinant is tumor size. Women with tumors greater than 2 cm (0.8 in.) in diameter, with negative axillary nodes, should receive systemic therapy. For individuals without axillary lymph node metastases and tumors less than 1 cm (0.4 in.) in diameter, the probability of relapse 10 years after diagnosis is less than 10%. Therefore, systemic chemotherapy is generally not recommended in this group.

**Screening.** Breast cancer screening is the most effective way of detecting breast cancer in its early stages. Screenings involve self-examination of the breast, physical examination, and mammography. The guidelines for when these examinations should be administered depend on the individual's age. A mammogram is the most reliable screening test for the early detection of breast cancer; mammograms are recommended every 2–3 years from age 40 to 50 and annually after age 50. As the density of

the breast parenchyma changes with increasing age, mammography is better able to detect abnormalities within the breast.

[K.K.H.; S.M.L.]

**Breccia** A clastic rock composed of angular gravel-size fragments; the consolidated equivalent of rubble. The designation gravel-size refers to a mean particle diameter greater than 0.08 in. (2 mm), which means that 50% or more of the particles (by volume) are this size or larger. Various classifications specify different values for the degree of angularity. One system specifies angular or subangular fragments (roundness  $\leq 0.25$ ), whereas another restricts the term breccia to aggregates with angular fragments (roundness  $\leq 0.10$ ). See GRAVEL.

Sedimentary breccias, also known as sharpstone conglomerates, are significant because the angularity of their fragments indicates either proximity to the source or transportation by a mechanism that does not cause significant rounding of the fragments. Examples of the first condition are talus breccia formed at the base of a scarp, and reef breccia deposited adjacent to a reef margin. Transport mechanisms that can preserve the angularity of clasts over significant distances include debris flows, slumps, and glacial transport, although rounded fragments may also be carried. All of these mechanisms incorporate a large proportion of fine sediment in the transporting medium, which effectively cushions interparticle collisions and inhibits rounding. See CONGLOMERATE; REEF; SEDIMENTOLOGY.

Intraformational or intraclastic breccias are an important class of sedimentary breccias. They are formed by the breakup and incorporation of sediment aggregates from within the same formation, which requires either early cementation (for example, the formation of nodules or duricrusts) or uncemented aggregates sufficiently cohesive to be transported a short distance without disaggregation. Thus, uncemented aggregates are basically limited to sediments that are rich in clay or clay-size carbonates (calcilitites). The mechanisms for formation of intraformational breccias include bank slumping or desiccation fracturing of mud in river or tidal channels, and erosion and incorporation of mud blocks in mass flows such as slumps or turbidity currents. See SEDIMENTARY ROCKS.

Igneous breccias are mainly of pyroclastic origin but may also form as intrusive breccias by forceful intrusion of magma. In the latter case the operative agent is fluid pressure; in the former it is the explosive escape of gas from solidifying viscous lava. These rocks, termed pyroclastic or volcanic breccias, are distinct from agglomerates, which accumulate mainly as lava bombs solidified during flight and which are commonly rounded. See PYROCLASTIC ROCKS.

Cataclastic breccias result from the fracture of rocks by tectonic or gravitational stresses. However, since many tectonic processes are at least partly gravitational, the two processes can be considered together. Tectonic breccias include fault and fold breccias, the latter formed by fracturing of brittle layers within incompetent plastic strata during folding. In one classification, landslide and slump breccias are included in the gravitational category, but here they are considered to be sedimentary, commonly intraformational. Solution or collapse breccias are a type of nontectonic gravitational breccia. They result from the creation by groundwater solution of unsupported rock masses which collapse under their own weight to form breccia.

[B.Rus.]

**Breeding (animal)** The application of genetic principles to improving heredity for economically important traits in domestic animals. Examples are improvement of milk production in dairy cattle, meatiness in pigs, feed requirements or growth rate in beef cattle, and egg production in chickens. Selection permits the best parents to leave more offspring in the next generation than do poor parents.

Selection is the primary tool for generating directed genetic changes in animals. It may be concentrated on one characteristic, may be directed independently on several traits, or may be

conducted on an index or total score which includes information on several traits. In general, the third method is preferable when several important heritable traits need attention. In practice, selection is likely to be a mixture of the second and third methods.

Heritability, the fraction of the total variation in a trait that is due to additive genetic differences, is a key parameter in making decisions in selection. Most traits are strongly to moderately influenced by environmental or managerial differences. Therefore, managing animals to equalize environmental influences on them, or statistically adjusting for environmental differences among animals, is necessary to accurately choose those with the best inheritance for various traits.

The improvement achieved by selection is directly related to the accuracy with which the breeding values of the subjects can be recognized. Accuracy, in turn, depends upon the heritabilities of the traits and upon whether they can be measured directly upon the subjects for selection (mass selection), upon their parents (pedigree selection), upon their brothers and sisters (family selection), or upon their progeny (progeny testing). For traits of medium heritability, the following sources of information are about equally accurate for predicting breeding values of subjects: (1) one record measured on the subject; (2) one record on each ancestor for three previous generations; (3) one record each on five brothers or sisters where there is no environmental correlation between family members; and (4) one record each on five progeny having no environmental correlations, each from a different mate.

Propagation of improved animal stocks is achieved primarily with purebred strains descended from imported or locally developed groups or breeds of animals which have been selected and interbred for a long enough period to be reasonably uniform for certain trademark characteristics, such as coat color. Because the number of breeding animals is finite and because breeders tend to prefer certain bloodlines and sires, some inbreeding occurs within the pure breeds, but this has not limited productivity in most of these breeds. Crossbreeding makes use of the genetic phenomenon of heterosis. Heterosis is improved performance of crossbred progeny, exceeding that of the average performance of their parents. Most commercial pigs, sheep, and beef cattle are produced by crossbreeding. See GENETICS.

Advances in a variety of technologies have application for improvement of domestic animals, including quantitative genetics, reproductive physiology, and molecular genetics. Quantitative geneticists use statistical and genetic information to improve domestic animals. Typically a statistical procedure is used to rank animals based on their estimated breeding values for traits of economic importance. The statistical procedures used allow ranking animals across herds or flocks, provided the animals in different herds or flocks have relatives in common. The primary contribution of reproductive physiology to genetic improvement is to reduce the generation interval. If genetic improvement is increasing at the same rate per generation, more generations can be produced for a fixed time, and thus more gain per unit of time. The most important development was artificial insemination, which allows extensive use of superior males. Another development was embryo transplantation, which allows more extensive use of females. Cloning is a relatively new technique, by which whole and healthy animals have been produced that have the same DNA as the animal from which the cells were taken.

Due to advances in molecular genetics, knowledge is increasing regarding the location of genes on chromosomes and the distance between the genes. In domestic animals, polymorphisms (changes in the order of the four bases) that are discovered in the DNA may be associated with economic traits. When the polymorphisms are associated with or code for economic traits, they are called quantitative trait loci (QTL). When a few or several quantitative trait loci are known that control a portion of the variability in a trait, increasing the frequencies of favorable alleles can enhance the accuracy of selection and augment production.

Another use of molecular genetics is to detect the genes that code for genetically predetermined diseases. An example is the bovine leukocyte deficiency gene, which does not allow white blood cells to migrate out of the blood supply into the tissues to fight infection. The calves perish at a young age. Screening all sires that enter artificial breeding organizations and not using sires that transmit the defect has effectively controlled this condition. [A.E.Fr.]

**Breeding (plant)** The application of genetic principles to improve cultivated plants. New varieties of cultivated plants can result only from genetic reorganization that gives rise to improvements over the existing varieties in particular characteristics or in combinations of characteristics. Thus, plant breeding can be regarded as a branch of applied genetics, but it also makes use of the knowledge and techniques of many aspects of plant science, especially physiology and pathology. Related disciplines, like biochemistry and entomology, are also important, and the application of mathematical statistics in the design and analysis of experiments is essential. See GENETICS.

The cornerstone of all plant breeding is selection, or the picking out of plants with the best combinations of agricultural and quality characteristics from populations of plants with a variety of genetic constitutions. Seeds from the selected plants are used to produce the next generation, from which a further cycle of selection may be carried out if there are still differences. Conventional breeding is divided into three categories on the basis of ways in which the species are propagated. First come the species that set seeds by self-pollination; that is, fertilization usually follows the germination of pollen on the stigmas of the same plant on which it was produced. The second category of species sets seeds by cross-pollination; that is, fertilization usually follows the germination of pollen on the stigmas of different plants from those on which it was produced. The third category comprises the species that are asexually propagated; that is, the commercial crop results from planting vegetative parts or by grafting. The procedures used in breeding differ according to the pattern of propagation of the species. Several innovative techniques have been explored to enhance the scope, speed, and efficiency of producing new, superior cultivars. Advances have been made in extending conventional sexual crossing procedures by laboratory culture of plant organs and tissues and by somatic hybridization through protoplast fusion.

The essential attribute of self-pollinating crop species, such as wheat, barley, oats, and many edible legumes, is that, once they are genetically pure, varieties can be maintained without change for many generations. When improvement of an existing variety is desired, it is necessary to produce genetic variation among which selection can be practiced. This is achieved by artificially hybridizing between parental varieties that may contrast with each other in possessing different desirable attributes. This system is known as pedigree breeding, and it is the method most commonly employed, and can be varied in several ways.

Another form of breeding often employed with self-pollinating species involves backcrossing. This is used when an existing variety is broadly satisfactory but lacks one useful and simply inherited trait that is to be found in some other variety. Hybrids are made between the two varieties, and the first hybrid generation is crossed, or backcrossed, with the broadly satisfactory variety which is known as the recurrent parent. Backcrossing has been exceedingly useful in practice and has been extensively employed in adding resistance to diseases, such as rust, smut, or mildew, to established and acceptable varieties of oats, wheat, and barley.

Natural populations of cross-pollinating species are characterized by extreme genetic diversity. No seed parent is true-breeding, first because it was itself derived from a fertilization in which genetically different parents participated, and second because of the genetic diversity of the pollen it will have received. In dealing with cultivated plants with this breeding structure, the

essential concern in seed production is to employ systems in which hybrid vigor is exploited, the range of variation in the crop is diminished, and only parents likely to give rise to superior offspring are retained.

Plant breeders have made use either of inbreeding followed by hybridization or of some form of recurrent selection. During inbreeding programs normally cross-pollinated species, such as corn, are compelled to self-pollinate by artificial means. Inbreeding is continued for a number of generations until genetically pure, true-breeding, and uniform inbred lines are produced. During the production of the inbred lines, rigorous selection is practiced for general vigor and yield and disease resistance, as well as for other important characteristics. To estimate the value of inbred lines as the parents of hybrids, it is necessary to make tests of their combining ability. The test that is used depends upon the crop and on the ease with which controlled cross-pollination can be effected.

Breeding procedures designated as recurrent selection are coming into limited use with open-pollinated species. In theory, this method visualizes a controlled approach to homozygosity, with selection and evaluation in each cycle to permit the desired stepwise changes in gene frequency. Experimental evaluation of the procedure indicates that it has real possibilities. Four types of recurrent selection have been suggested: on the basis of phenotype, for general combining ability, for specific combining ability, and reciprocal selection. The methods are similar in the procedures involved, but vary in the type of tester parent chosen, and therefore in the efficiency with which different types of gene action (additive and nonadditive) are measured.

Varieties of asexually propagated crops consist of large assemblages of genetically identical plants, and there are only two ways of introducing new and improved varieties: by sexual reproduction and by the isolation of somatic mutations. (A very few asexually propagated crop species are sexually sterile, like the banana, but the majority have some sexual fertility.) The latter method has often been used successfully with decorative plants, such as chrysanthemum, and new forms of potato have occasionally arisen in this way. When sexual reproduction is used, hybrids are produced on a large scale between existing varieties; the small number that have useful arrays of characters are propagated vegetatively until sufficient numbers can be planted to allow agronomic evaluation. [R.Ri.]

Cell technologies have been used to extend the range and efficiency of asexual plant propagation. For example, plant cell culture involves the regeneration of entire mature plants from single cells or tissues excised from a source plant and cultured in a nutrient medium. In micropropagation and cloning, tissues are excised from root, stem, petiole, or seedling and induced to regenerate plantlets. All regenerants from tissues of one source plant constitute a clone. Microspore or anther culture is the generation of plants from individual cells with but one set of chromosomes, haploid cells, as occurs in the development of pollen. Microspores are isolated from anthers and cultured on nutrient media, or entire anthers are cultured in this manner. Doubling of chromosomes that may occur spontaneously or can be induced by treatment with colchicine leads to the formation of homozygous dihaploid plants. See PLANT PROPAGATION; POLLEN; TISSUE CULTURE.

Breeding for new, improved varieties of crop plants is most often based on cross-pollination and hybrid production. Such breeding is limited to compatible plants, and compatibility lessens with increasing distance in the relationship between plants. Breeding would benefit from access to traits inherent in sexually noncompatible plants. Biotechnological techniques such as *in vitro* fertilization and embryo rescue (the excision and culture of embryos on nutrient media) have been employed to overcome incompatibility barriers, as have somatic hybridization and DNA technologies. Somatic hybridization involves enzymatic removal of walls from cells of leaves and seedlings to furnish individual naked cells, that is, protoplasts,

which can then be fused to produce hybrids. Similarity of membrane structure throughout the plant kingdom permits the fusion of distantly related protoplasts. Cell fusion may lead to nuclear fusion, resulting in amphi-diploid somatic hybrid cells. Fusion products of closely related yet sexually incompatible plants have been grown to flowering plants; the most famous example is the potato + tomato hybrid = pomato (*Solanum tuberosum* + *Lycopersicon esculentum*). DNA technologies enable the isolation of desirable genes from bacteria, plants, and animals (genes that confer herbicide resistance or tolerance to environmental stress, or encode enzymes and proteins of value to the processing industry) and the insertion of such genes into cells and tissues of target plants by direct or indirect uptake has led to the genetic transformation of plant cells. The regeneration of transformed plant cells and tissues results in new and novel genotypes (transgenic plants). Contrary to hybrids obtained by cross-pollination, such plants are different from their parent by only one or two single, defined traits. [F.Co.]

**Bremsstrahlung** In a narrow sense, the electromagnetic radiation emitted by electrons when they pass through matter. Charged particles radiate when accelerated, and in this case the electric fields of the atomic nuclei provide the force which accelerates the electrons. The continuous spectrum of x-rays from an x-ray tube is that of the bremsstrahlung; in addition, there is a characteristic x-ray spectrum due to excitation of the target atoms by the incident electron beam. The major energy loss of high-energy (relativistic) electrons (energy greater than about 10 MeV, depending somewhat upon material) occurs from the emission of bremsstrahlung, and this is the major source of gamma rays in a high-energy cosmic-ray shower. See COSMIC RAYS; ELECTROMAGNETIC RADIATION.

In a broader sense, bremsstrahlung is the radiation emitted when any charged particle is accelerated by any force. To a great extent, as a source of photons in the ultraviolet and soft x-ray region for the investigation of atomic structure (particularly in solids), bremsstrahlung from x-ray tubes has been replaced by synchrotron radiation. Synchrotron radiation is an analog to bremsstrahlung, differing in that the force which accelerates the electron is a macroscopic (large-scale) magnetic field. [C.G.]

**Brick** A construction material usually made of clay and extruded or molded as a rectangular block. Three types of clay are used in the manufacture of bricks: surface clay, fire clay, and shale. Adobe brick is a sun-dried molded mix of clay, straw, and water, manufactured mainly in Mexico and some southern regions of the United States. See CLAY.

The first step in manufacture is crushing the clay. The clay is then ground, mixed with water, and shaped. Then the bricks are fired in a kiln at approximately 2000°F (1093°C). Substances in the clay such as ferrous, magnesium, and calcium oxides impart color to the bricks during the firing process. The color may be uniform throughout the bricks, or the bricks may be manufactured with a coated face. The latter are classified as glazed, claycoat, or engobe.

The most commonly used brick product is known as facing brick. Decorative bricks molded in special shapes are used to form certain architectural details such as water tables, arches, copings, and corners. [M.Gu.]

**Bridge** A structure built to provide ready passage over natural or artificial obstacles, or under another passageway. Bridges serve highways, railways, canals, aqueducts, utility pipelines, and pedestrian walkways. In many jurisdictions, bridges are defined as those structures spanning an arbitrary minimum distance, generally about 10–20 ft (3–6 m); shorter structures are classified as culverts or tunnels. In addition, natural formations eroded into bridgelike form are often called bridges. This article covers only bridges providing conventional transportation passageways.

Bridges generally are considered to be composed of three separate parts: substructure, superstructure, and deck. The substructure or foundation of a bridge consists of the piers and abutments which carry the superimposed load of the superstructure to the underlying soil or rock. The superstructure is that portion of a bridge or trestle lying above the piers and abutments. The deck or flooring is supported on the bridge superstructure; it carries and is in direct contact with the traffic for which passage is provided.

Bridges are classified in several ways. Thus, according to the use they serve, they may be termed railway, highway, canal, aqueduct, utility pipeline, or pedestrian bridges. If they are classified by the materials of which they are constructed (principally the superstructure), they are called steel, concrete, timber, stone, or aluminum bridges. Deck bridges carry the deck on the very top of the superstructure. Through bridges carry the deck within the superstructure. The type of structural action is denoted by the application of terms such as truss, arch, suspension, stringer or girder, stayed-girder, composite construction, hybrid girder, continuous, cantilever, or orthotropic (steel deck plate).

The two most general classifications are the fixed and the movable. In the former, the horizontal and vertical alignment of the bridge are permanent; in the latter, either the horizontal or vertical alignment is such that it can be readily changed to permit the passage beneath the bridge of traffic. Movable bridges are sometimes called drawbridges in an anachronistic reference to an obsolete type of movable bridge spanning the moats of castles.

A singular type of bridge is the floating or pontoon bridge, which can be a movable bridge if it is designed so that a portion of it can be moved to permit the passage of water traffic.

The term trestle is used to describe a series of short spans supported by braced towers, and the term viaduct is used to describe a high structure of short spans, often of arch construction.

**Fixed bridges.** This type of construction is selected when the vertical clearance provided beneath the bridge exceeds the clearance required by the traffic it spans. For very short spans, construction may be a solid slab or a number of beams; for longer spans, the choice may be girders or trusses. Still longer spans may dictate the use of arch construction, and if the spans are even longer, stayed-girder bridges are used. Suspension bridges are used for the longest spans.

Beam bridges consist of a series of beams, usually of rolled steel, supporting the roadway directly on their top flanges. The beams are placed parallel to traffic and extend from abutment to abutment. Plate-girder bridges are used for longer spans than can be practically traversed with a beam bridge. In its simplest form, the plate girder consists of two flange plates welded to a web plate, the whole having the shape of an I. Box-girder bridges have steel girders fabricated by welding four plates into a box section. A conventional floor beam and stringer can be used on box-girder bridges, but the more economical arrangement is to widen the top flange plate of the box so that it serves as the deck. When this is done, the plate is stiffened to desired rigidity by closely spaced bar stiffeners or by corrugated or honeycomb-type plates. These stiffened decks, which double as the top flange of the box girders, are termed orthotropic. The wearing surface on such bridges is usually a relatively thin layer of asphalt.

Truss bridges, consisting of members vertically arranged in a triangular pattern, can be used when the crossing is too long to be spanned economically by simple plate girders. Where there is sufficient clearance underneath the bridge, the deck bridge is more economical than the through bridge because the trusses can be placed closer together, reducing the span of the floor beams.

The continuous bridge is a structure supported at three or more points and capable of resisting bending and shearing forces at all sections throughout its length. The bending forces in the center of the span are reduced by the bending forces acting oppositely at the piers. Trusses, plate girders, and box girders can be made continuous. The advantages of a continuous bridge over a

simple-span bridge (that is, one that does not extend beyond its two supports) are economy of material, convenience of erection (without need for falsework), and increased rigidity under traffic. The disadvantages are its sensitivity to relative change in the levels of supporting piers, the difficulty of constructing the bridge to make it function as it is supposed to, and the occurrence of large movements at one location due to thermal changes.

The cantilever bridge consists of two spans projecting toward each other and joined at their ends by a suspended simple span. The projecting spans are known as cantilever arms, and these, plus the suspended span, constitute the main span. The cantilever arms also extend back to shore, and the section from shore to the piers offshore is termed the anchor span. Trusses, plate girders, and box girders can be built as cantilever bridges. The chief advantages of the cantilever design are the saving in material and ease of erection of the main span. The cable-stayed bridge, a modification of the cantilever bridge which has come into modern use, resembles a suspension bridge. It consists of girders or trusses cantilevering both ways from a central tower and supported by inclined cables attached to the tower at the top or sometimes at several levels.

The suspension bridge is a structure consisting of either a roadway or a truss suspended from two cables which pass over two towers and are anchored by backstays to a firm foundation. If the roadway is attached directly to the cables by suspenders, the structure lacks rigidity, with the result that wind loads and moving live loads distort the cables and produce a wave motion on the roadway. When the roadway is supported by a truss which is hung from the cable, the structure is called a stiffened suspension bridge. The stiffening truss distributes the concentrated live loads over a considerable length of the cable.

Since the development of the prestressing method, bridges of almost every type are being constructed of concrete. Prior to the advent of prestressing, these bridges were of three types: (1) arches, which were built in either short or long spans; (2) slab bridges of quite short spans, which were simply reinforced concrete slabs extending from abutment to abutment; and (3) deck girder bridges, consisting of concrete slabs built integrally with a series of concrete girders placed parallel to traffic. The advent of prestressed concrete greatly extended the utility and economy of concrete for bridges, particularly by making the hollow box-girder type practicable. See PRESTRESSED CONCRETE.

**Movable bridges.** Modern movable bridges are either bascule, vertical lift, or swing; with few exceptions, they span waterways. They are said to be closed when set for the traffic they carry, and open when set to permit traffic to pass through the waterway they cross. Bascule and swing bridges provide unlimited vertical clearance in the open position. The vertical clearance of a lift bridge is limited by its design.

The bascule bridge consists primarily of a cantilever span, which may be either a truss or a plate girder, extending across the channel. Bascule bridges rotate about a horizontal axis parallel with the waterway. The portion of the bridge on the land side of the axis, carrying a counterweight to ease the mechanical effort of moving the bridge, drops downward, while the forward part of the leaf opens up over the channel much like the action of a playground seesaw. Bascule bridges may be either single-leaf, where rotation of the entire leaf over the waterway is about one axis on one side of the waterway, or double-leaf, where the leaves over the waterway rotate about two axes on opposite sides of the waterway.

The vertical-lift bridge has a span similar to that of a fixed bridge and is lifted by steel ropes running over large sheaves at the tops of its towers to the counterweights, which fall as the lift span rises and rise as it falls. If the bridge is operated by machinery on each tower, it is known as a tower drive. If it is driven by machinery located on the lift span, it is known as a span drive.

Swing bridges revolve about a vertical axis on a pier, called the pivot pier, in the waterway. There are three general classes

of swing bridges: the rim-bearing, the center-bearing, and the combined rim-bearing and center-bearing. Rim-bearing bridges are supported on circular girder drums on rollers, center-bearing on a single large bearing at the center of rotation.

**Substructure.** Bridge substructure consists of those elements that support the trusses, girders, stringers, floor beams, and decks of the bridge superstructure. Piers and abutments are the primary bridge substructure elements. Other types of substructure, such as skewbacks for arch bridges, pile bents for trestles, and various forms of support wall, are also commonly used for specific applications. [E.R.H.; H.W.F.; R.W.Ch.; B.H.]

**Degradation.** Many factors can cause bridges to degrade and become structurally deficient and in need of repair. Two environmental factors that cause significant damage to primarily concrete components in bridges are excessive changes in temperature and freeze-thaw cycles in the presence of moisture. Steel structures are vulnerable to corrosion, especially in prolonged moisture environments. Use of deicing salts on concrete pavements and bridge decks produces chemical reactions that accelerate the corrosion of reinforcing steel. A significant cause of bridge damage is vehicular impact and fatigue from repeated truck loads. Special loads, such as seismic, wind, and snow, also may produce dramatic degradation of bridge structures. See EARTHQUAKE; MECHANICAL VIBRATION.

**Strengthening techniques.** The strengthening of concrete bridges is generally achieved by replacing the damaged material, incorporating additional structural members, as in external prestressing, or increasing the size and capacity of existing members.

**Repair techniques.** Numerous repair techniques have evolved for concrete members in both bridges and buildings for replacing damaged concrete, repairing cracks, and repairing corroded reinforced steel bars. Steel bridges are most often strengthened by the addition of new steel members or smaller elements. Steel welding and bolting are well-developed techniques for steel connections. Thus, strengthening of steel bridges is perhaps more defined than for the concrete bridges. Techniques for repairing steel bridge elements include flame straightening, hot mechanical straightening, cold mechanical straightening, welding, bolting, partial replacement and complete replacement. [J.M.Pl.; O.He.; A.Pug.]

**Bridge circuit** A circuit composed of a source and four impedances that is used in the measurement of a wide range of physical quantities. The bridge circuit is useful in measuring impedances (resistors, capacitors, and inductors) and in converting signals from transducers to related voltage or current signals. See CAPACITOR; INDUCTOR; RESISTOR; TRANSDUCER.

The bridge impedances  $Z_1$ ,  $Z_2$ ,  $Z_3$ ,  $Z_4$ , shown in the illustration may be single impedances (resistor, capacitor, or inductor), combinations of impedances, or a transducer with varying impedance. For example, strain gages are resistive transducers whose resistance changes when they are deformed.

Bridge circuits are often used with transducers to convert physical quantities (temperature, displacement, pressure) to electrical

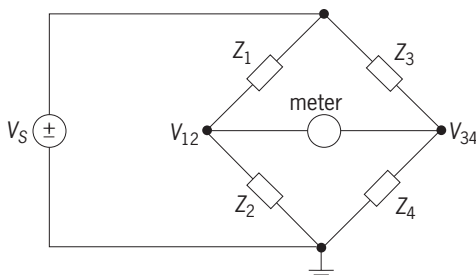

Bridge circuit with source and impedances.

quantities (voltage and current). High-accuracy voltmeters and ammeters are relatively inexpensive, and the voltage form of a signal is usually most convenient for information display, control decisions, and data storage. Another important advantage of the bridge circuit is that it provides greater measurement sensitivity than the transducer.

The bridge circuit is balanced when the output read by the meter is zero. In this condition the voltages on both sides of the meter are identical. The bridge is used in two forms. The null adjustment method requires adjustment of a calibrated impedance to balance it. In this case the meter is usually a highly sensitive current-measuring galvanometer. The null adjustment method is often used to measure impedances, with the output read from a dial attached to the adjustable impedance. The deflection method requires on accurate meter in the bridge to measure the deviation from the balance condition. The deviation is proportional to the quantity being measured.

There are many special forms of the bridge circuit. When all of the impedances are resistive, it is commonly called a Wheatstone bridge. Other common forms use a current source in place of the voltage source, a sinusoidal source in place of a constant (dc) source, or branch impedances which are specific combinations of single passive impedances. The bridge circuit is also used in a variety of electrical applications varying from oscillators to instrumentation amplifier circuits for extremely accurate measurements. See INSTRUMENTATION AMPLIFIER; OSCILLATOR; WHEATSTONE BRIDGE. [K.D.P.]

**Brillouin zone** In the propagation of any type of wave motion through a crystal lattice, the frequency is a periodic function of wave vector  $\mathbf{k}$ . This function may be complicated by being multivalued; that is, it may have more than one branch. Discontinuities may also occur. In order to simplify the treatment of wave motion in a crystal, a zone in  $\mathbf{k}$ -space is defined which forms the fundamental periodic region, such that the frequency or energy for a  $\mathbf{k}$  outside this region may be determined from one of those in it. This region is known as the Brillouin zone (sometimes called the first or the central Brillouin zone). It is usually possible to restrict attention to  $\mathbf{k}$  values inside the zone. Discontinuities occur only on the boundaries. If the zone is repeated indefinitely, all  $\mathbf{k}$ -space will be filled. Sometimes it is also convenient to define larger figures with similar properties which are combinations of the first zone and portions of those formed by replication. These are referred to as higher Brillouin zones.

The central Brillouin zone for a particular solid type is a solid which has the same volume as the primitive unit cell in reciprocal space, that is, the space of the reciprocal lattice vectors, and is of such a shape as to be invariant under as many as possible of the symmetry operations of the crystal. See CRYSTALLOGRAPHY. [J.C.]

**Brittleness** That characteristic of a material that is manifested by sudden or abrupt failure without appreciable prior ductile or plastic deformation. A brittle fracture occurs on a cleavage plane which has a crystalline appearance at failure because each crystal tends to fracture on a single plane. On the other hand, a shear fracture has a fibrous appearance because of the sliding of the fracture surfaces over each other. Brittle failures are caused by high tensile stresses, high carbon content, rapid rate of loading, and the presence of notches. Materials such as glass, cast iron, and concrete are examples of brittle materials. [J.B.S.]

**Broccoli** A cool-season biennial crucifer, *Brassica oleracea* var. *italica*, of Mediterranean origin, belonging to the plant order Papaverales. Broccoli is grown for its thick branching lower stalks which terminate in clusters of loose green flower buds. Stalks and buds are cooked as a vegetable or may be processed in either canned or frozen form. California and Texas are important broccoli-producing states. See PAPAVERALES. [H.J.C.]



**Bromegrass** A common name designating a number of grasses found in the North Temperate Zone that produce highly palatable and nutritious forage. Of these, smooth bromegrass (*Bromus inermis*) is the most important. Although first widely used in the eastern Great Plains and western Corn Belt regions, improved strains are now grown extensively for hay and rotation pastures north of the Mason-Dixon line, from the Plains to the Atlantic. Smooth bromegrass is a long-lived perennial, spreads by underground creeping stems, and is fairly deep rooted and drought-tolerant. Top growth is used for hay or pasture. Regional strains are available for Canada and the northern two-thirds of the United States. See CYPERALES. [H.B.S.]

**Bromeliales** An order of flowering plants, division Magnoliophyta (Angiospermae) in the subclass Zingiberidae of the class Liliopsida (monocotyledons). It consists of the single family Bromeliaceae, with about 45 genera and 2000 species, occurring chiefly in tropical and subtropical America. They are firm-leaved, terrestrial xerophytes, or very often epiphytes, with six stamens and regular or somewhat irregular flowers that usually have sepal nectaries and an inferior ovary. Spanish moss (*Tillandsia*) and the cultivated pineapple (*Ananas*) are familiar members of the Bromeliales, and many others attract attention as houseplants. See LILIOPSIDA; MAGNOLIOPHYTA. [A.Cr.; T.M.Ba.]

**Bromine** A chemical element, Br, atomic number 35, atomic weight 79.909, which normally exists as Br<sub>2</sub>, a dark-red, low-boiling but high-density liquid of intensely irritating odor. This is the only nonmetallic element that is liquid at normal temperature and pressure. Bromine is very reactive chemically; one of the halogen group of elements, it has properties intermediate between those of chlorine and iodine. See HALOGEN ELEMENTS; PERIODIC TABLE.

The most stable valence states of bromine in its salts are -1 and +5, although +1, +3, and +7 are known. Within wide limits of temperature and pressure, molecules of the liquid and vapor are diatomic, Br<sub>2</sub>, with a formula weight of 159.818. There are two stable isotopes (<sup>79</sup>Br and <sup>81</sup>Br) that occur naturally in nearly equal proportion, so that the atomic weight is 79.909. A number of radioisotopes are also known.

The solubility of bromine in water at 20°C (68°F) is 3.38 g/100 g (3.38 oz/100 oz) solution, but its solubility is increased tremendously in the presence of its salts and in hydrobromic acid. The ability of this inorganic element to dissolve in organic solvents is of considerable importance in its reactions. The table summarizes the physical properties of bromine.

Although it is estimated that from 10<sup>15</sup> to 10<sup>16</sup> tons of bromine are contained in the Earth's crust, the element is widely distributed and found only in low concentrations in the form of its salts. The bulk of the recoverable bromine, however, is found in the hydrosphere. Sea water contains an average of 65 parts per million (ppm) of bromine. The other major sources of bromine in the United States are underground brines and salt lakes, with commercial production in Michigan, Arkansas, and California.

While many inorganic bromides have found industrial use, the organic bromides have even wider application. Because of the ease of reaction of bromine with organic compounds and the ease of its subsequent removal or replacement, organic bromides have been much studied and used as chemical intermediates. In addition, any of the bromine reactions are so clean-cut that they can be used for the study of reaction mechanisms without complication of side reactions. The ability of bromine to add into unusual places on organic molecules has added to its value as a research tool.

Bromine and its compounds have found acceptance as disinfection and sanitizing agents in swimming pools and potable water. Certain bromine-containing compounds are safer to use than the analogous chlorine compounds due to certain persistent residuals found in the chlorine-containing materials. Other bromine chemicals are used as a working fluid in gases, as hy-

#### Physical properties of bromine

Property	Value		
Flash point	None		
Fire point	None		
Freezing point, °C	-7.27		
Density, 20°C	3.1226		
Pounds per gallon, 25°C	25.8		
Boiling point, 760 mm Hg, °C	58.8		
Refractive index, 20°C	1.6083		
Latent heat of fusion, cal/g	15.8		
Latent heat of vaporization, cal/g, bp	44.9		
Vapor density, g/liter, standard conditions (0°C, 1 atm)	7.139		
Viscosity, centistokes, 20°C	0.314		
Surface tension, dynes/cm, 20°C	49.5		
	30°C	47.3	
	40°C	45.2	
Dielectric constant, 10 <sup>5</sup> freq, 25°C	3.33		
Compressibility, vapors, 25°C	0.998		
Thermodynamic data, cal/(mole K)			
	T, K	Entropy	Heat capacity
Solid	265.9	24.786	14.732
Liquid	265.9	34.290	18.579

draulic fluids, as chemical intermediates in the manufacture of organic dyes, in storage batteries, and in explosion-suppressant and fire-extinguishing systems. Bromine compounds, because of their density, also find use in the gradation of coal and other minerals where separations are effected by density gradients. The versatility of bromine compounds is illustrated by the commercial use of over 100 compounds that contain bromine.

Bromine is almost instantaneously injurious to the skin, and it is difficult to remove quickly enough to prevent a painful burn that heals slowly. Bromine vapor is extremely toxic, but its odor gives good warning; it is difficult to remain in an area of sufficient concentration to be permanently damaging. Bromine can be handled safely, but the recommendations of the manufacturers should be respected. [R.C.S.]

**Bronze** Usually an alloy of copper and tin. Bronze is used in bearings, bushings, gears, valves, and other fittings both for water and steam.

The properties of bronze depend on its composition and working. Lead, zinc, silver, and other metals are added for special-purpose bronzes. Tin bronze, including statuary bronze, contains 2-20% tin; bell metal 15-25%; and speculum metal up to 33%. Gun metal contains 8-10% tin plus 2-4% zinc. Phosphor bronze is tin bronze hardened and strengthened with traces of phosphorus; it is used for fine tubing, wire springs, and machine parts. Lead bronze may contain up to 30% lead; it is used for cast parts such as low-pressure valves and fittings. Manganese bronze with 0.5-5% manganese plus other metals, but often no tin, has high strength. Aluminum bronze also contains no tin; its mechanical properties are superior to those of tin bronze, but it is difficult to cast. Silicon bronze, with up to 3% silicon, casts well and can be worked hot or cold by rolling, forging, and similar methods. Beryllium bronze (also called beryllium copper) has about 2% beryllium and no tin. The alloy is hard and strong and can be further hardened and strengthened by precipitation hardening; it is one of the few copper alloys that responds to heat treatment, approaching three times the strength of structural steel. See ALLOY; COPPER; TIN. [F.H.R.]

**Brown dwarf** A starlike body whose mass is too small to sustain nuclear fusion reactions in its core. All stars, including the Sun, shine because they engage in nuclear fusion in their hot and dense cores. In the early 1960s, S. S. Kumar noted that, if they existed, stars with mass less than 8% that of the Sun would not have the high temperatures in their cores necessary to sustain nuclear fusion reactions. These objects, called

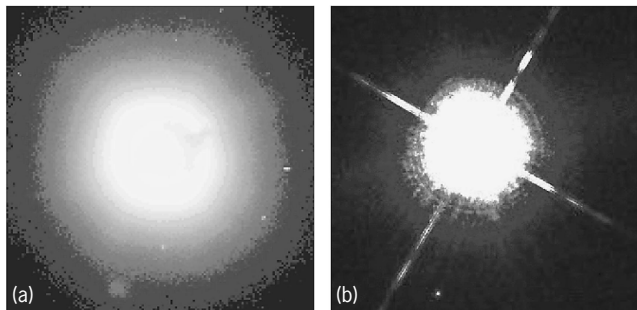

Images of the cool brown dwarf Gliese 229B. In each image, the bright primary star is at the center and the brown dwarf is the faint object near the bottom center. (a) Discovery image, taken with the Palomar 60-in. (1.5-m) telescope and an instrument designed to reduce the substantial glare of the nearby star. (b) Hubble Space Telescope image.

brown dwarfs, would not truly be normal stars because their lack of nuclear fusion would inhibit their ability to shine. Indeed, these brown dwarfs would grow dimmer as they aged. At even lower masses are the planets, such as Earth and Jupiter (which is approximately 0.1% the mass of the Sun). See PLANET; STAR; STELLAR EVOLUTION.

Calculations by several research groups have established that the lowest-mass star (8% the mass of the Sun) will shine with a luminosity of about  $10^{-4}$  times the luminosity of the Sun. (Luminosity here means the energy emitted per unit of time.) While young brown dwarfs can have luminosities larger than this value, they eventually cool to much smaller ranges of brilliance. These calculations also show that all brown dwarfs have essentially the same radius, about 10% that of the Sun. This is also approximately the radius of Jupiter. See RED DWARF STAR.

Because young brown dwarfs are hot and even more luminous than the oldest, lowest-mass stars, they are very difficult to distinguish from such stars. However, an important diagnostic exists. The fragile element lithium is transmuted in stars by high-temperature fusion reactions that are absent in most brown dwarfs' cores. This suggests that although the youngest brown dwarfs might look identical to low-mass stars they will exhibit signs of lithium, which stars will not.

Two searches for brown dwarfs in the Pleiades, which is one of the youngest nearby star clusters, were undertaken in 1995. Sensitive spectroscopic observations with the Keck Telescope in Hawaii revealed for the first time the telltale features of lithium in three low-luminosity objects. Since these discoveries, many more brown dwarfs have been identified in the Pleiades, other star clusters, and in interstellar space. The majority of these brown dwarfs have been found due to improved astronomical imaging and spectroscopy technology, in particular, large-scale surveys of the sky in infrared wavelengths. See ASTRONOMICAL SPECTROSCOPY; INFRARED ASTRONOMY; PLEIADES; TELESCOPE.

In 1995, Tadashi Nakajima and coworkers at the Palomar Observatory, California Institute of Technology, discovered an object in orbit around the nearby star Gliese 229, located only 17 light-years ( $1.0 \times 10^{14}$  mi or  $1.6 \times 10^{14}$  km) from the Sun (see illustration). With a luminosity of  $6 \times 10^{-6}$  that of the Sun, this was the first unambiguous discovery of an old brown dwarf, one that had absolutely no similarity to any star. Dozens of other stars of this type have now been identified. [B.R.O.; S.R.K.]

**Brownian movement** The irregular motion of a body arising from the thermal motion of the molecules of the material in which the body is immersed. Such a body will of course suffer many collisions with the molecules, which will impart energy and momentum to it. Because, however, there will be fluctuations in the magnitude and direction of the average momentum

transferred, the motion of the body will appear irregular and erratic.

In principle, this motion exists for any foreign body suspended in gases, liquids, or solids. To observe it, one needs first of all a macroscopically visible body; however, the mass of the body cannot be too large. For a large mass, the velocity becomes small. See KINETIC THEORY OF MATTER. [M.Dr.]

**Brucellosis** An infectious, zoonotic disease of various animals and humans caused by *Brucella* species. Each species tends to preferentially infect a particular animal, but several types can infect humans. *Brucella melitensis* (preferentially infects goats and sheep), *B. suis* (infects pigs), and *B. abortus* (infects cattle) are the most common causes of human brucellosis. *Brucella melitensis* is the most virulent for humans, followed by *B. suis* and *B. abortus*. *Brucella canis* and *B. ovis*, which infect dogs and sheep respectively, rarely infect humans. Although brucellosis is found all over the world, in many countries the disease has been eradicated. The brucellae are small, gram-negative coccobacilli which are defined as facultative intracellular parasites since they are able to replicate within specialized cells of the host.

In animals the brucellae often localize in the reproductive tract, mammary gland, and lymph node. They have a particular affinity for the pregnant uterus, leading to abortion and reduced milk production with resultant economic loss to the farmer. Wildlife, including elk, feral pigs, bison, and reindeer, can become infected and can spread the disease to domestic livestock.

Brucellosis in humans is characterized by undulant fever, cold sweats, chills, muscular pain, and severe weakness. Some individuals may have recurrent bouts of the disease in which a variety of organs may be affected, sometimes resulting in death. The disease can be contracted by consuming unpasteurized milk or cheese, or via the introduction of organisms through small skin lesions or as an aerosol through the conjunctiva and the respiratory system. Treatment with tetracycline and other antibiotics is most successful if started early after symptoms occur. Development of the disease can be prevented if treatment is initiated immediately after contact with potentially infected material.

At present there are no effective vaccines for humans. The disease can be eliminated only by eradicating it in animals. A major source of brucellosis in humans is the consumption of *B. melitensis*-infected milk and cheese from goats. Incidence can be reduced by pasteurizing milk. Animals can be vaccinated to increase their immunity against brucellosis and therefore reduce abortions and disease transmission. See EPIDEMIOLOGY; MEDICAL BACTERIOLOGY. [W.W.Sp.]

**Brucite** A magnesium hydroxide mineral,  $Mg(OH)_2$ , crystallizing in the trigonal system. It is a member of the important  $Cd(OH)_2$  structure type, consisting of hexagonal close-packed oxygen atoms with alternate octahedral layers occupied by Mg. The "brucite layer" is an important structural component in the clay, mica, and chlorite mineral groups. Brucite occurs as tabular crystals and as elongated fibers (as the variety nemalite), hardness  $2\frac{1}{2}$  (Mohs scale), color white to greenish, and specific gravity 2.4.  $Fe^{2+}$  and  $Mn^{2+}$  commonly substitute for  $Mg^{2+}$ .

Brucite often occurs in a low-temperature vein paragenesis, usually with serpentine and accessory magnesite. It is also derived by the action of water on periclase,  $MgO$ , which results from the thermal metamorphism of dolomites and limestones. Carbonate rocks rich in periclase and brucite are called predazzites. See DOLOMITE; MAGNESITE; SERPENTINE. [P.B.M.]

**Brussels sprouts** A cool-season biennial crucifer (*Brassica oleracea* var. *gemmifera*), which is of northern European origin and belongs to the plant order Capparales. The plant is grown for its small headlike buds formed in the axils of the leaves along the plant stem (see illustration). These buds are eaten as a cooked vegetable. Popular varieties (cultivars) are Half Dwarf



Brussels sprouts (*Brassica oleracea* var. *gemmifera*), Jade Cross. (Joseph Harris Co., Rochester, New York)

and Catskill; however, hybrid varieties are increasingly planted. California and New York are important producing states. See CAPPARALES. [H.J.C.]

**Bryales** An order of the subclass Bryidae. With 11 families and perhaps 44 genera, it is defined in terms of terminal inflorescences, with rare exceptions, and perfect, double peristomes which are papillose on the outer surface. The capsules are generally inclined and more or less pear-shaped. Erect capsules are associated with reduced peristomes.

These mosses often grow in disturbed places. They are perennial and grow in tufts, with stems erect and simple or forked and often densely covered with rhizoids. The leaves are generally bordered by elongate cells and often toothed. The midrib often ends in a hairpoint. The sporophytes are nearly always terminal. The setae are generally elongate, and the operculate capsules are usually symmetric but generally inclined to pendulous and commonly pyriform owing to the development of a sizable neck. The peristome is normally double, with a well-developed endostome. See BRYIDAE; BRYOPHYTA; BRYOPSIDA. [H.Cr.]

**Bryidae** A subclass of the class Bryopsida. Most genera of true mosses (Bryopsida) belong in the 16 orders of the Bryidae. The most characteristic feature is the peristome consisting of one or two series of teeth, derived from parts of cells rather than whole cells, as in the Tetrarhizidae, Dawsoniidae, and Polytrichidae. (The Buxbaumiiidae have some resemblance in peristome structure to Bryidae.) The stems may be erect and merely forked, or prostrate and freely branched, with sporophytes produced terminally or laterally, respectively. The leaves are inserted in many rows, though sometimes flattened together and appearing two-ranked, but only rarely actually in two rows. The costa may be single or double, sometimes very short, and rarely lacking. The setae are generally present and elongate. The capsules dehisce by means of an operculum except in a few genera that show extreme reduction. See ARCHIDIIDAE; BRYOPHYTA; BRYOPSIDA; BRYOXIPHIALES; DAWSONIIDAE; DICRANALES; ENCALYPTALES; FISSIDENTALES; FUNARIALES; GRIMMIALES; HOOKERIALES; HYPNALES; ISOBRYALES; MITTENIALES; ORTHOTRICHALES; POLYTRICHIDAE; POTIALES; SELIGERIALES; SPLACHNALES. [H.Cr.]

**Bryophyta** A division that consists of some 23,000 species of small and relatively simple plants commonly known as mosses, granite mosses, peat mosses, liverworts, and hornworts (see illustration). The bryophytes display a distinct alternation of sexual and asexual generations; the sexual gametophyte, with a haploid chromosome number, is the more diversified. The sporebearing, diploid sporophyte is reduced in size and structure, attached to the gametophyte, and partially or almost completely dependent on it.

The gametophytes may consist of leafy stems or flat thalli. They have no roots but are anchored to the substrate by hairlike rhizoids. Vascular tissue is at best poorly differentiated, with no lignification of cells. Growth results from the divisions of single cells (rather than meristematic tissues) located at stem tips or in notches at the margins of thalli. The sex organs are multicellular and have a jacket of sterile cells surrounding either the single egg produced in flask-shaped archegonia or the vast number of sperms produced in globose to cylindrical, stalked antheridia. The sperms swim by means of two flagella. The sporophyte commonly consists of a capsule that produces a large number of spores, a stalklike seta, and a swollen foot anchored in the gametophyte. The spores, nearly always single-celled, are dispersed in the air, except in the case of a small number of aquatics. They germinate directly or produce a juvenile stage called a protonema. See REPRODUCTION (PLANT).



Moss plant, *Polytrichum juniperinum* (General Biological Supply House).

The division can be divided into five classes: Sphagnopsida (peat mosses), Andreaeopsida (granite mosses), Bryopsida (true mosses), Hepaticopsida (liverworts), and Anthocerotopsida (hornworts). The mosses have radially organized leafy gametophytes that develop from a protonema and have multicellular rhizoids with slanted crosswalls. The liverworts and hornworts are mostly flat and dorsiventrally organized and have no protonematal stage; the rhizoids are unicellular. Though obviously related, as evidenced by similar sex organs and attachment of a simplified sporophyte to a more complex and independent gametophyte, the classes differ greatly in structural detail. See ANDREAEOPSIDA; ANTHOCEROTOPSIDA; BRYOPSIDA; HEPATICOPSIDA; PLANT KINGDOM; SPHAGNOPSIDA. [H.Cr.]

**Bryopsida** The largest class of the division Bryophyta, the true mosses. Members of the class are best characterized by operculate capsules and a peristome that aids in the dispersal of spores, and are generally perennial. The class consists of about 14,000 species distributed in six subclasses based primarily on the structure and developmental history of the sporophyte and especially the peristome. The orders and families are likewise based primarily on stable sporophytic details, whereas genera

and species are most often differentiated in terms of gametophytic features.

The filamentous, freely branched protonema of Bryopsida gametophytes produces an abundance of leafy plants which may be erect, simple or sparsely forked, and growing in tufts and producing archegonia at the stem tips; or, alternatively, plants may be prostrate, freely branched, growing in intertangled mats, and producing archegonia laterally. In large, erect-growing plants, the stems may have a central strand of vascular tissues similar to xylem and phloem but without lignification. In smaller plants, the vascular tissue is reduced or lacking. The rhizoids are multicellular, with slanted crosswalls. The inflorescences are usually enveloped in differentiated leaves, and the sex organs, of superficial origin, are often mingled with paraphyses, especially in the male inflorescence. The archegonia are flask-shaped; the antheridia are banana-shaped and stalked. See PHLOEM; XYLEM.

The long-lived sporophytes are abundantly green until maturity and largely self-supporting. They consist of foot and capsule, usually also a seta. The capsules dehisce by means of a lidlike operculum, or rarely irregularly by rupture. The capsule wall is usually spongy, especially in the neck portion below the spore sac. Stomata are usually present, especially in the neck or at the junction of capsule and seta. The spore sac is derived from the endothecium. The calyptra may be mitrate (conic and lobed) or cucullate (slit up one side and hoodlike). The chromosome numbers are exceedingly diverse; polyploidy is common, both within species and among related ones. See ARCHIDIIDAE; BRYIDAE; BRYOPHYTA; BUXBAUMIIDAE; DAWSONIIDAE; POLYTRICHIDAE; TETRAPHIDIDAE. [H.Cr.]

**Bryopsidales** An order of the green algae (Chlorophyceae), also called Caulerpales, Codiales, or Siphonales, in which the plant body (thallus) is a coenocytic filament (tube or siphon). The order comprises six families with about 24 genera. The filaments may be discrete with free or laterally coherent branches, or organized into a dense plexus exhibiting distinctive morphological features. Septa, which are generally infrequent and incomplete, are formed by centripetal deposition of wall material. A large, continuous central vacuole restricts the cytoplasm to a thin layer just beneath the wall. The cytoplasm contains innumerable nuclei, discoid plastids, and other organelles. Vegetative reproduction is common, usually by rhizomes or fragments. Reproductive cells may be formed in unmodified or slightly modified portions of the filament or in special organs. See ALGAE; CHLOROPHYCEAE. [P.C.Si.; R.L.Moe]

**Bryoxiphiales** An order of the class Bryopsida in the subclass Bryidae. The order consists of a single genus and species, *Bryoxiphium norvegicum*, the sword moss. This order is characterized by a swordlike appearance owing to leaves overlapping in two rows. The shiny, rigid leaves are keeled and conduplicate-folded. The apex is long-awned at the stem tip and progressively shorter-pointed downward. The midrib bears at back a low ridge of one to four rows of cells. The leaf cells are smooth and subquadrate within, longer and narrower toward the margins. The plants are dioecious with terminal archegonia. See BRYIDAE; BRYOPHYTA; BRYOPSIDA. [H.Cr.]

**Bryozoa** A phylum of sessile aquatic invertebrates (also called Polyzoa) which form colonies of zooids. Each zooid, in its basic form, has a lophophore of ciliated tentacles situated distally on an introvert, a looped gut with the mouth inside the lophophore and the anus outside, a coelomic body cavity, and (commonly) a protective exoskeleton. The colonies are variable in size and habit. Some are known as lace corals and others as sea mats, but the only general name is bryozoans (sea mosses).

The colony may be minute, or not more than a single feeding zooid and its immediate buds, or substantial, forming masses 3 ft (1 m) in circumference, festoons 1.6 ft (0.5 m) in length, or patches 2.7 ft<sup>2</sup> (0.25 m<sup>2</sup>) in area. Com-

monly the colonies form incrustations not more than a few square centimeters in area, small twiggy bushes up to about 1.2 in. (3 cm) in height, or soft masses up to about 0.3 ft (0.1 m) in the largest dimension. In many colonies much of the bulk consists of the zooid exoskeletons which may persist long after the death of the organism and account for the abundance of fossilized bryozoan remains.

Many bryozoans display polymorphism, having certain zooids adapted in particular ways to perform specialized functions, such as protection, cleaning the surface, anchoring the colony, or sheltering the embryo. The evolution of nonfeeding polymorphs is dependent upon some form of intercommunication between zooids.

Bryozoa is the name of a phylum for which Ectoprocta is generally regarded as a synonym, these names being used by zoologists according to personal preference. Entoprocta (synonym Callyssozoa) is likewise regarded as an independent phylum. A minority regard Ectoprocta and Entoprocta as subphyla within the Bryozoa, while others maintain Ectoprocta and Entoprocta as phyla but link them under Bryozoa as a name of convenience. See ENTOPROCTA.

The phylum contains some 20,000 described species, one-fifth of them living. These are distributed among three classes and a somewhat variable number of orders:

- Phylum Bryozoa
  - Class Phylactolaemata
    - Order Plumatellida
  - Class Gymnolaemata
    - Order Ctenostomata
      - Suborder Cheilostomata
  - Class Stenolaemata
    - Order Cyclostomata
      - Suborder Cystoporata (extinct)
      - Suborder Trepostomata
      - Suborder Cryptostomata
      - Suborder Hederellida

See GYMNOLAEMATA; PHYLACTOLAEMATA; STENOLAEMATA.

Fresh-water bryozoans are present on submerged tree roots and aquatic plants in most lakes, ponds, and rivers, especially in clear water of alkaline pH. Most other bryozoans are marine, although some gymnolaemates inhabit brackish water. They are common in the sea, ranging from the middle shore to a depth of over 26,000 ft (8000 m), and are maximally abundant in waters of the continental shelf. Most attach to firm substrata, so that their distribution is primarily determined by the availability of support. Mud is unfavorable and so is sand unless well provided with stone, dead shells, hydroids, or large foraminiferans.

Colony form in bryozoans is to some extent related to habitat. Encrusting and bushy flexible species are adapted to wave exposure; brittle twiglike and foliaceous species are found deeper; some erect branching species tolerate sediment deposition. One group of tiny discoid species lives on sand in warm seas, and in one genus the colonies are so small that they live actually among the sand grains; a few species live anchored in mud. A number of stolonate ctenostomes bore into the substance of mollusk shells; other species are associated only with hermit crabs, and a few are commensal with shrimps or polychaete worms.

Bryozoans have few serious predators. Nudibranch mollusks and pycnogonids (sea spiders) specialize in feeding on zooids but are rarely destructive of entire colonies. Loxosomatids (Entoprocta) and a hydroid (*Zanclaea*) are common commensals.

Life spans vary. Small algal dwellers complete their life cycle in a few months. Many species survive a year but have two overlapping generations; others are perennial, with one known to survive for 12 years.

Bryozoans may be a nuisance in colonizing ship hulls and the insides of water pipes, and one species has caused severe

dermatitis in fishers. Recently some delicate kinds have been used in costume jewelry, and green-dyed clumps of dried *Bugula* are often sold as “everlasting plants.” [J.S.R.]

Fossil Bryozoa have a long geological history, from early in the Ordovician Period [500 million years ago (Ma)] to the Recent. Individual fossils range in size from a few millimeters to several meters in maximum dimension. Various encrusting or erect growth forms are common, though some were free-living. Representatives of the marine orders that secreted calcareous skeletons (Cryptostomata, Cyclostomata, Cystoporata, Trepostomata, and Cheilostomata) commonly are abundant in sedimentary rocks formed where benthic organisms flourished. Skeletons generally are calcite, though some are aragonite or mixed calcite and aragonite. Ctenostomata have nonmineralized skeletons, so they have been preserved only as excavations or borings in marine shells or on the undersides of other organisms that overgrew them. The fresh-water Phylactolaemata have gelatinous skeletons, but their tough statoblasts (dormant reproductive bodies) have been reported from sediments as old as the Jurassic (at least 150 Ma). During the Ordovician, Carboniferous, and Permian periods, bryozoans were important parts of many fossil reefs, reef flanks, and other carbonate buildups in shallow (less than 100 m depth) tropical waters. Bryozoans commonly dominate and may reach very high diversities in post-Paleozoic cool-temperate carbonate deposits, indicating a shift in primary environment after the Paleozoic.

Although colonies of many bryozoan species are large, the individual skeletons of each zooid (unit of the colony) range from less than 0.1 to about 1 mm in diameter. The smaller diameters are typical for cross sections of elongate tubes that characterize zooids in stenolaemate bryozoans, and the larger diameters are typical for the more equidimensional zooids of cheilostomes. Identification is based on numerous external and, for most stenolaemates, internal features that require study with a microscope. Features of the colonial skeletons (zoaria) as well as the morphology of the individual zooidal skeletons (zooecia) are used to classify bryozoans. Many fossil bryozoans had only one type of zooid (autozooids), which apparently could feed and carry out all other necessary biological functions of the colony. Others were polymorphic, with various types of specialized zooids supplementing the autozooids. Number, types, and morphology of polymorphs is important in classification. Other characters important in classification of fossil bryozoans are wall structure, reproductive chambers, general growth habit or specific shape of colonies, and for some, surface topography of the colony. [F.K.McK.]

**Buckeye** A genus, *Aesculus*, of deciduous trees or shrubs belonging to the plant order Sapindales, buckeyes grow in North America, southeast Europe, and eastern Asia to India. The distinctive features are opposite, palmately compound leaves and a large fruit having a firm outer coat and containing usually one large seed with a conspicuous hilum.

The Ohio buckeye (*A. glabra*) is found mainly in the Ohio valley and in the southern Appalachians. It can be recognized by the glabrous winter buds, prickly fruits, and compound leaves having five leaflets. Another important species, the yellow buckeye (*A. octandra*), is native in the Central states, has five leaflets and smooth buds, but differs in its smooth, larger fruit. The horse chestnut (*A. hippocastanum*), which usually has seven leaflets and resinous buds, is a native of the Balkan Peninsula. It is planted throughout the United States and is a beautiful ornamental tree bearing cone-shaped flower clusters in early summer.

The seeds of all species contain a bitter and narcotic principle. The wood of the native tree species is used for furniture, boxes, crates, baskets, and artificial legs. See SAPINDALES. [A.H.G./K.P.D.]

**Buckwheat** A herbaceous, erect annual, the dry seed or grain of which is used as a source of food and feed. It is not a true cereal and is one of the very few plants, other than those of the

Gramineae family, used for their starchy seed, which is processed as a meal or flour. Buckwheat belongs to the Polygonaceae family, which also includes the common weeds dock, sorrel, knotweed, bindweed, smartweed, and climbing false buckwheat. Species of buckwheat that have been commercially grown are *Fagopyrum sagittatum* (*F. esculentum*), *F. emarginatum*, and *F. tataricum*. See POLYGONALES.

The plant grows to a height of 2–5 ft (0.6–1.5 m), with many broad heart-shaped leaves. It produces a single main stem which usually bears several branches, and is grooved, succulent, and smooth except for nodes. Buckwheat is an indeterminate species in response to photoperiod, and produces flowers and fruits (so-called seeds) until the beginning of frost. See PHOTOPERIODISM.

[H.G.M.]

The production of buckwheat flour requires cleaning, grinding, and fractionation in a manner similar to that used for wheat flour. Whole groats, splits, and farina are obtained by selective sieving and may be utilized as breakfast cereals and porridges or as thickening agents. When milled as flour, buckwheat will yield 60–75% extraction. The flour is typically more coarse and more highly colored than wheat flour. Buckwheat middlings, which include the layer immediately below the hull and the germ, provide valuable animal feed stock. In the United States, buckwheat flour is used primarily in pancake mix formulations, blended with wheat, corn, rice, or oat flour. See CEREAL; FOOD MANUFACTURING; GRAIN CROPS. [M.A.U.]

**Bud** An embryonic shoot containing the growing stem tip surrounded by young leaves or flowers or both, and the whole frequently enclosed by special protective leaves, the bud scales.

The bud at the apex of the stem is called a terminal bud (illus. a). Any bud that develops on the side of a stem is a lateral bud. The lateral bud borne in the axil (angle between base of leaf and stem) of a leaf is the axillary bud (illus. a and d). It develops concurrently with the leaf which subtends it, but usually such buds do not unfold and grow rapidly until the next season. Because of the inhibitory influence of the apical or other buds, many axillary buds never develop actively or may not do so for many years. These are known as latent or dormant buds. Above or beside the axillary buds, some plants regularly produce additional buds called accessory, or supernumerary, buds. Accessory buds which occur above the axillary bud are called superposed buds (illus. c), and those beside it collateral buds (illus. d). Under certain conditions, such as removal of terminal and axillary buds, other buds may arise at almost any point on the stem, or even on roots or leaves. Such buds are known as adventitious buds. See PLANT GROWTH.

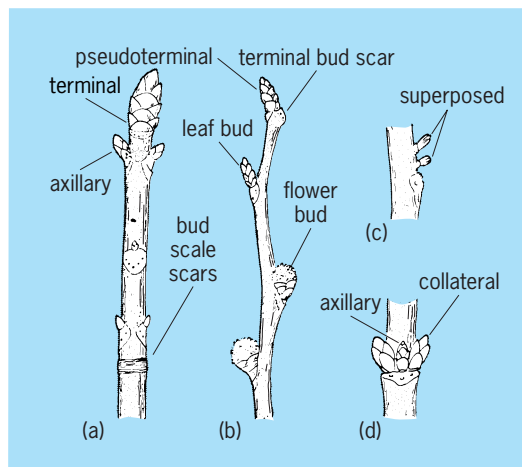

**Bud positions.** (a) Terminal and axillary (buckeye). (b) Pseudoterminal (elm). (c) Superposed (butternut). (d) Collateral (red maple).

Buds that give rise to flowers only are termed flower buds, or in some cases, fruit buds. If a bud grows into a leafy shoot, it is called a leaf bud, or more accurately, a branch bud. A bud which contains both young leaves and flowers is called a mixed bud.

Buds of herbaceous plants and of some woody plants are covered by rudimentary foliage leaves only. Such buds are called naked buds. In most woody plants, however, the buds are covered with modified protective leaves in the form of scales. These buds are called scaly buds or winter buds. In the different species of plants, the bud scales differ markedly. They may be covered with hairs or with water-repellent secretions of resin, gum, or wax. Ordinarily when a bud opens, the scales fall off, leaving characteristic markings on the stem (bud scale scars). See LEAF.

[N.A.]

**Buffalo** The name for members of the family Bovidae in the mammalian order Artiodactyla. The buffalo is an Old World species and resembles the oxen in general appearance. The North American bison is often called a buffalo, but is not related to the true buffalo.

The Asiatic buffalo (*Bubalus bubalis*), known as the Indian or water buffalo and also as the carabao, is found as a domestic animal in the Balkans, Asia Minor, and Egypt. These buffalo exist in the wild state in southern Asia and Borneo, where they are considered to be ferocious and dangerous. Water buffalo are stocky, heavy-built animals. They have very short hair and short, splayed horns. Like all buffalo, they have a liking for marshes, where they wallow and become caked with mud that affords protection against insects.

Two other Asiatic species related to, but smaller than, the water buffalo are the tamarau (*Anoa mindorensis*), which is indigenous to the Philippines, and the still smaller anoa (*A. depressicornis*), or wild dwarf buffalo, found in the Celebes.

The African buffalo, classed in the genus *Syncerus*, was very numerous until the turn of the century, when the infectious disease rinderpest caused many deaths. They are still abundant though widely hunted. There are several varieties of African buffalo, and it is thought that all may be subspecies of *S. caffer*, the Cape buffalo. They live in the open country of central, eastern, and southern Africa. Except for its size, this animal is difficult to distinguish from the rare dwarf or forest buffalo (*S. caffer nanus*). It lives in marshy, forested areas of western Africa, where it is known as the bush cow. See ARTIODACTYLA; BISON.

[C.B.C.]

**Buffers (chemistry)** A solution selected or prepared to minimize changes in hydrogen ion concentration which would otherwise tend to occur as a result of a chemical reaction. In general, chemical buffers are systems which, once constituted, tend to resist further change due to external influences. Thus it is possible, for example, to make buffers resistant to changes in temperature, pressure, volume, redox potential, or acidity. The commonest buffer in chemical solution systems is the acid-base buffer.

Chemical reactions known or suspected to be dependent on the acidity of the solution, as well as on other variables, are frequently studied by measurements in comixture with an appropriate buffer. For example, it may be desirable to investigate how the rate of a chemical reaction depends upon the hydrogen ion activity (pH). This is accomplished by measurements in several buffer systems, each of which provides a nearly constant, different pH. Alternatively, it may be desirable to measure the effects of other variables on a pH-sensitive system, by stabilizing the pH at a convenient value with a particular buffer. See pH.

Buffer action depends upon the fact that, if two or more reactions coexist in a solution, then the chemical potential of any species is common to all reactions in which it takes part, and

may be defined by specification of the chemical potentials of all other species in any one of the reactions. To be effective, a buffer must be able to respond to an increase as well as a decrease of the species to be buffered. In order to do so, it is necessary that the proton transfer step of the buffer be reversible with respect to the species involved, in the reaction to be buffered. In aqueous solution the proton transfer between most acids, their conjugate bases, and water, is so rapid and reversible that the dominant direct source of protons for a chemical reaction is  $\text{H}_3\text{O}^+$ , the hydronium ion.

Buffers are particularly effective in water, because of the unusual properties of water as a solvent. Its high dielectric constant tends to promote the existence of formally charged ions (ionization). Because it has both an acidic (H) and a basic (O) group, it may form bonds with ionic species leading to an organized sheath of solvent surrounding an ion (solvation). Water also tends to self-ionize to form its own conjugate acid-base system. See ACID AND BASE; ACID-BASE INDICATOR; IONIC EQUILIBRIUM; SOLVATION.

[A.M.H.]

**Buffers (electronics)** Electronic circuits whose primary function is to connect a high-impedance source to a low-impedance load without significant attenuation or distortion of the signal. Thus, the output voltage of a buffer replicates the input voltage without loading the source. An ideal voltage buffer is an amplifier with the following properties: unity gain,  $A_B = 1$ ; zero output impedance,  $Z_{\text{out}} = 0$ ; and infinite input impedance,  $Z_{\text{in}} = \infty$ . For example, if the voltage from a high-impedance source, say a strain-gage sensor with 100 k $\Omega$  output resistance, must be processed by further circuitry with an input impedance of, say, 500  $\Omega$ , the signal will be attenuated to only 500/100,500  $\approx$  0.5% of the sensor voltage if the two circuits are directly connected, whereas the full strain-gage voltage will be available if a buffer is used.

Buffers are generally applied in analog systems to minimize loss of signal strength due to excessive loading of output nodes (illus. a). Two kinds of circuits are frequently used: the operational-amplifier-based buffer and the transistor follower.

The operational-amplifier-based buffer circuit (illus. b) is based on an operational amplifier (op amp) with unity-gain feedback. The open-loop gain,  $A(s)$ , of the operational amplifier should be very high. To form the buffer, the amplifier is placed in a feedback loop. The buffer gain,  $A_B(s)$ , is then given by Eq. (1). Here,  $s = j\omega$

$$A_B(s) = \frac{V_{\text{out}}}{V_{\text{in}}} = \frac{A(s)}{1 + A(s)} \quad (1)$$

is the Laplace transform variable,  $j = -1$ ;  $\omega = 2\pi f$  is the radian frequency in radians per second (rad/s); and  $f$  is the frequency in hertz (Hz). The magnitude of  $A_B$  is approximately equal to unity, that is,  $|A_B|$  approaches 1, if  $|A|$  becomes very large. A common

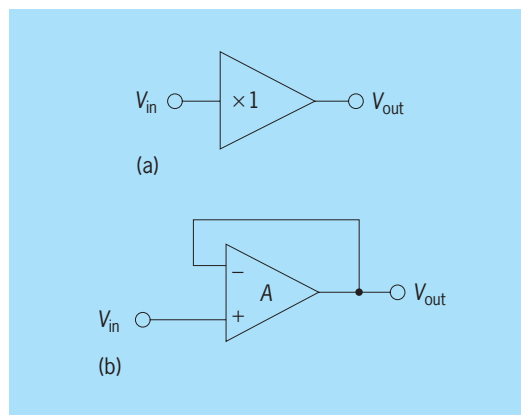

**Buffer circuit. (a) Circuit schematic symbol. (b) Operational-amplifier-based circuit.**

representation of the frequency dependence of the operational-amplifier gain is given by Eq. (2), where  $\omega_t$  is the operational

$$A(s) = \frac{\omega_t}{s} \quad (2)$$

amplifier's unity-gain frequency. By using this notation, Eq. (1) becomes Eq. (3), which shows that the buffer's bandwidth is

$$A_B = \frac{\omega_t}{s + \omega_t} \quad (3)$$

approximately equal to the unity-gain frequency of the operational amplifier, typically 1 MHz or higher.

Under the assumption that the frequency of interest is much less than  $\omega_t$ , it follows from Eq. (2) that the magnitude of the operational-amplifier gain,  $A(s)$ , is much greater than 1. In that case, it can be shown that, because of the feedback action, the buffer's input impedance is much larger than that of the operational amplifier itself [by a factor of  $A(s)$ ]. Similarly, the buffer's output impedance is much smaller than that of the operational amplifier [again, by a factor of  $A(s)$ ].

The very low output impedance of operational-amplifier-based buffers assures that a load impedance,  $Z_L(s)$ , does not affect the buffer's gain,  $A_B$ . Also, operational-amplifier-based buffers have no systematic offset. The high-impedance input node of a buffer may in practice have to be shielded to prevent random noise from coupling into the circuit. This shielding can be accomplished with a coaxial cable. To eliminate the capacitive loading of the source by the effective input capacitance of the cable, the shield can be driven with the output voltage of the buffer so that no voltage difference exists between the signal line and the shield. The driven shield is referred to as the guard. See AMPLIFIER; ELECTRICAL SHIELDING; ELECTROMAGNETIC COMPATIBILITY; OPERATIONAL AMPLIFIER.

The bipolar junction transistor (BJT) emitter follower and the field-effect transistor (FET) source follower are very simple but effective buffer circuits. Both consist of a single transistor and a bias-current source; they are used in applications where power consumption and circuit area must be reduced to a minimum or where specifications are not too demanding.

The performance of a transistor follower circuit depends strongly on the source and load impedances, that is, on the surrounding circuitry. In fact, the transistors are so fast that the frequency response is usually determined by loading. In general, follower circuits exhibit a systematic direct-current (dc) offset equal to the base-to-emitter voltage,  $V_{BE}$ , in BJTs and equal to the gate-to-source voltage,  $V_{GS}$ , for FET. Only followers made with depletion-mode field-effect transistors can be biased with zero  $V_{GS}$  to avoid this offset. See EMITTER FOLLOWER; TRANSISTOR.

Buffer circuits should have small dc offset voltages (dc outputs when no input is applied), small bias currents (to minimize the effect of high-impedance sources), large linear signal swing (to minimize distortion), and high slew rate (to handle fast transitions of the applied signals).

Buffers should have a low-frequency gain of unity and wide bandwidth (to reproduce the applied signals faithfully), low phase margins (to prevent peaking and overshoots), and low equivalent input-referred noise (to have wide dynamic range). Field-effect-transistor input buffers exhibit the lowest noise for high-impedance signal sources. See ELECTRICAL NOISE; GAIN.

[R.Sc.]

**Buhrstone mill** A mill for grinding or pulverizing, in which a flat siliceous rock, generally of cellular quartz, rotates against a stationary stone of the same material. Grooves in the stones facilitate the movement of the material. Fineness of the product is controlled by the pressure between the stones and by the grinding speed. A finely ground product is achieved by

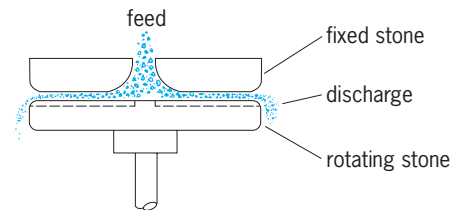

In a Buhrstone mill, material is fed at the center of the fixed stone and moves toward outer edge of the stones where product is discharge.

slowly rotating the stone at a high pressure against the materials and its mate (see illustration). See CRUSHING AND PULVERIZING. [G.W.K.]

**Buildings** Fixed permanent structures, more or less enclosed and designed to use as housing or shelter or to serve the needs of commerce and industry.

**Building materials.** Iron and steel building components are noncombustible, and their strength-to-weight ratio of steel is also good. Steel is equally strong in tension and compression and possesses excellent ductility, a highly desirable quality in building design. Contemporary applications of structural steel in building construction generally utilize rolled shapes in the form of wide flange and I beams, pipes and tubes, channels, angles, and plates. There are fabricated and erected into frameworks of beams, girders, and columns. Floors are usually concrete slabs cast of corrugated metal deck or on removable wood forms. See FLOOR CONSTRUCTION; STRUCTURAL STEEL.

Another important building material is concrete. The material is inherently weak in tension and must be reinforced by means of steel bars embedded in and bonded to the concrete matrix. This combination of nonhomogeneous materials, called reinforced concrete, is utilized in many areas of building construction, including foundations, walls, columns, beams, floors, and roofs. See COLUMN; CONCRETE; FOUNDATIONS; REINFORCED CONCRETE; ROOF CONSTRUCTION; WALL CONSTRUCTION.

In North America, where large softwood forests were plentiful, the milling of small-dimension lumber gave rise to the balloon frame house in the latter part of the nineteenth century. In this technique, closely spaced studs, joists, and rafters are fastened together with simple square cuts and nails. The balloon frame allowed relatively unskilled persons to erect simple frame houses. In the twentieth century, the balloon frame gave way to the platform frame, in which the studs were capped at each floor rather than running continuously for two stories.

Masonry is a widely used construction technique, and perhaps the oldest building material. The three most common masonry materials are stone (quarried from natural geologic formations), brick (manufactured from clay that is exposed to high temperature in kilns), and concrete masonry units (solid or hollow blocks manufactured from carefully controlled concrete mixes). These materials are used alone or in combination, with each unit separated from the adjacent one by a bed of mortar. See BRICK; MORTAR; STONE AND STONE PRODUCTS.

The strength of a masonry wall depends greatly on the quality of construction. Since quality varies widely, it is desirable to introduce a relatively large factor of safety into the design. Masonry has been used in structural supporting walls built as high as 20 stories. See MASONRY.

New materials include high-strength alloys of steel as well as products developed for space programs that have very high strength-to-weight ratios. Other desirable properties involve increased strength as well as resistance to corrosion, high temperature from fires, and fatigue. Plastics are used in many building applications. However, these materials require improvements in strength and stiffness, long-term dimensional stability, resistance to high temperature and the degrading effects of ultraviolet

radiation, and ease in being fastened and connected. Composite materials have been developed for application in buildings, and include sandwich panels in which the surfaces are bonded to a core. Combinations of steel and concrete, masonry and steel reinforcement or prestress, timber and concrete, and timber and steel are in use. Other novel materials include high-performance fabric for roof coverings, structural adhesives, carbon fiber, and glass-fiber products.

**Skyscrapers.** Skyscrapers were developed at the end of the nineteenth and early in the twentieth century to maximize the economic return on parcels of land in urban environments. Earlier heavy-masonry-bearing-wall buildings had walls up to 6 ft (2 m) thick at their base to support as much as 16 stories of load. These walls occupied valuable space that could otherwise be rented to tenants. This drawback provided stimulus to the development of the skeleton steel frame, in which the thin exterior cladding does not participate in the support of the building but functions as a weather enclosure and a visual expression. These external skins (curtain walls) are often constructed of light aluminum or steel supports infilled with glass or metal panels. Curtain walls may also be fabricated of masonry veneer or precast concrete panels. They are designed to resist water and wind pressure and infiltration, and they are attached to the building frame for their primary support.

The major structural problem that must be considered in the design of skyscrapers is the ability of the frame to resist lateral wind loads. The building must be strong enough to resist the applied forces and stiff enough to limit the lateral displacement. The simplest method of providing lateral rigidity is to ensure that the joints between girders and columns remain rigid, that is, their geometry remains unchanged. Rigid frame design is still the most economical method of framing buildings up to 20 stories tall. See STRUCTURAL ANALYSIS.

As buildings became taller than 20 stories, diagonal braces were introduced between the top of one column and the bottom of an adjacent one to form a truss type of framework. The diagonals were found to be very efficient for buildings up to about 60 stories. See TRUSS.

**Building services.** In order for buildings to be fully functional, they must be able to provide adequate levels of comfort and service. There are many methods used to supply the services of heating and cooling. Heating may be provided by radiation, conduction, or convection. Electrical systems are installed throughout buildings to provide lighting as well as power to operate appliances and machinery. Signal systems for telephones, computers, and alarms are also commonly specified and built. Finally, there is plumbing service, which delivers hot and cold water and carries away wastewater as well as storm water into disposal systems such as sewers or septic systems. See AIR CONDITIONING; COMFORT HEATING; SEWAGE.

**Building safety.** Buildings are designed to resist loads due to their own weight, to environmental phenomena, and from the occupants' usage. The self-weight of a building, called dead load, is relatively easy to calculate if the composition and thickness of all of the materials are known. Included in the dead load are the building frame, walls, floors, roof, ceilings, partitions, finishes, and service equipment—that is, everything that is fixed and immovable. Environmentally applied loads include rain, which may cause ponding, and snow and ice.

Another significant load to which buildings are subjected is the force of earthquakes. Seismic loads, unlike most other loads except for wind, are dynamic in character rather than static. Engineers have devised a number of methods by which buildings can resist significant seismic loads. One is to design a maximum of energy absorption into the building by providing ductility in the frame and its connections. A second method involves an attempt to separate the superstructure of the building from ground-induced vibration—a method called base isolation. In this system, shock-absorbent material is inserted between the foundation and the superstructure to prevent vibrations

from traveling up into the building. See EARTHQUAKE; SEISMIC RISK.

The danger of fire in buildings has several aspects. Of primary importance is the assurance that all occupants can exit safely and that firefighters can perform their work with minimal danger. The second consideration involves the protection of property, the building, and its contents. In the initial planning of a building, the location, number, and size of exits must be carefully considered in relation to the anticipated occupancy and the material of construction. Where it is not possible to provide sufficient access to exit doors at ground level, fire escapes (generally steel-bar platforms and stairs) are affixed to the sides of buildings.

Sophisticated fire detection systems can sense both smoke and heat. These sound audible alarms and directly contact municipal fire departments and building safety officers. In addition, the alarm may automatically shut down ventilation systems to prevent smoke from spreading, may cause elevators to return to the ground floor where they remain until the danger is passed, and may close fire doors and dampers to compartmentalize the spread of smoke or flames. Supplementing this passive detection are automatic sprinkler systems. See AUTOMATIC SPRINKLER SYSTEM; FIRE DETECTOR; FIRE TECHNOLOGY.

**Building codes and environmental concerns.** The process of building is often regulated by governmental authorities through the use of building codes that have the force of law. In the United States there is no national code; rather there are regional, state, or even city building codes. Codes establish classifications of buildings according to the proposed occupancy or use. Then, for any given type of construction (for example, wood, steel, or concrete), they establish minimum standards for exit and egress requirements, for height and area, and for fire resistance ratings. In addition, minimum loads are designated as well as requirements for natural light, ventilation, plumbing, and electrical services. Local codes are written to regulate zoning, stipulating items such as building type, occupancy, size, height, setbacks from property lines, and historic considerations.

The process of building raises large numbers of environmental issues. In many cases the owner must prepare an official environmental impact statement that considers the potential effect of the proposed building on traffic, air quality, sun and shadow, wind patterns, archeology, wildlife, and wetlands, as well as demands on existing utilities and services.

One of the primary environmental concerns is energy conservation. In the initial design of a building, all systems are studied to obtain maximum efficiency. Heating and cooling are two of the largest consumers of energy, and a great deal of effort is directed toward minimizing energy consumption by techniques such as building orientation, sun shading, insulation, use of natural ventilation and outside air, recapture of waste heat, cogeneration (using waste heat to generate electricity), use of solar energy both actively and passively, and limiting heat generation from lighting. Efforts at reducing electric power consumption by designing more efficient lighting, power distribution, and machinery are also of high priority. Consumption of water and disposal of liquid and solid waste are additional concerns. See COGENERATION; HEAT INSULATION; SOLAR HEATING AND COOLING; VENTILATION.

[R.Sil.]

**Bulk-handling machines** A diversified group of materials-handling machines specialized in design and construction for handling unpackaged, divided materials.

Solid, free-flowing materials are said to be in bulk. The handling of these materials requires that the machinery both support their weight and confine them either to a desired path of travel for continuous conveyance or within a container for handling in discrete loads. Wet or sticky materials may also be handled successfully by some of the same machines used for bulk materials. Characteristics of materials that affect the selection of equipment for bulk handling include (1) the size of component particles, (2) flowability, (3) abrasiveness, (4) corrosiveness, (5) sensitivity



to contamination, and (6) general conditions such as dampness, structure, or the presence of dust or noxious fumes.

Equipment that transports material continuously in a horizontal, inclined, or vertical direction in a predetermined path is a form of conveyor. The many different means used to convey bulk materials include gravity, belt, apron, bucket, skip hoist, flight or screw, dragline, vibrating or oscillating, and pneumatic conveyors. Wheel or roller conveyors cannot handle bulk materials.

Gravity chutes are the only unpowered conveyors used for bulk material. They permit only a downward movement of material.

Belt conveyors of many varieties move bulk materials. Fabric belt conveyors have essentially the same operating components as those used for package service; however, these components are constructed more ruggedly to stand up under the more rigorous conditions imposed by carrying coal, gravel, chemicals, and other similar heavy bulk materials. Belts may also be made of such materials as rubber, metal, or open wire. Their advantages include low power requirements, high capacities, simplicity, and dependable operation.

An apron conveyor is a form of belt conveyor, but differs in that the carrying surface is constructed of a series of metal aprons or pans pivotally linked together to make a continuous loop. This type of conveyor is suitable for handling large quantities of bulk material under severe service conditions. Apron conveyors are most suitable for heavy, abrasive, or lumpy materials.

Bucket conveyors are constructed of a series of buckets attached to one or two strands of chain or in some instances to a belt. These conveyors are most suitable for operating on a steep incline or vertical path, sometimes being referred to as elevating conveyors. This type of conveyor is most ideal for bulk materials such as sand or coal.

Flight conveyors employ the use of flights, or bars attached to single or double strands of chain. The bars drag or push the material within an enclosed duct or trough. These are frequently referred to as drag conveyors. This type of conveyor is commonly used for moving bulk material such as coal or metal chips from machine tools.

Spiral or screw conveyors rotate upon a single shaft to which are attached flights in the form of a helical screw. When the screw turns within a stationary trough or casing, the material advances. These conveyors are used primarily for bulk materials of fine and moderate sizes, and can move material on horizontal, inclined, or vertical planes.

Vibrating or oscillating conveyors employ the use of a pan or trough bed, attached to a vibrator or oscillating mechanism, designed to move forward slowly and draw back quickly. The inertia of the material keeps the load from being carried back so that it is automatically placed in a more advanced position on the carrying surface.

Pneumatic, or air, conveyors employ air as the propelling media to move materials. One implementation of this principle is the movement within an air duct of cylindrical carriers, into which are placed currency, mail, and small parts for movement from one point to discharge at one of several points by use of diverters. Pneumatic pipe conveyors are widely used in industry, where they move granular materials, fine to moderate size, in original bulk form without need of internal carriers.

Power cranes and shovels perform many operations moving bulk materials in discrete loads. When functioning as cranes and fitted with the many below-the-hook devices available, they are used on construction jobs and in and around industrial plants. Such fittings as magnets, buckets, grabs, skull-crackers, and pile drivers enable cranes to handle many products. The machines of the convertible, full-revolving type are mounted on crawlers, trucks, or wheels. Specialized front-end operating equipment is required for clamshell, dragline, lifting-crane, pile-driver, shovel, and hoe operations. Specialized equipment for mechanized pit mining has been developed. Power cranes, shovels, and scoops

are actively engaged in strip mines, quarries, and other earth-moving operations. See ELEVATING MACHINES; INDUSTRIAL TRUCKS; MATERIALS-HANDLING EQUIPMENT; MONORAIL. [A.M.P.]

**Buoy** An anchored or moored floating object, other than a lightship, intended as an aid to navigation. Buoys are the most numerous of all engineered aids to navigation.

Buoys are intended to serve as daymarks. Some buoys, particularly those at turning points in channels, are provided with lights of distinctive characteristics for location and identification at night. Some buoys are equipped with apparatus for providing distinctive sounds at intervals so they can be used as aids to navigation in fog and darkness. Some buoys are equipped with radio beacons, and some have reflectors to make them more conspicuous to radar.

Over the years, a number of different buoyage systems have been developed in various parts of the world. In an effort to reduce the differences, the International Association of Lighthouse Authorities (IALA) recommended a uniform system that has been adopted by most European, African, and Asian nations.

This system, identified as IALA system A, has one feature that has not been acceptable to most nations in the Western Hemisphere and some Asian countries: the use of red buoys to port while entering a channel from seaward. These nations have adopted IALA system B, similar to system A but with the red buoys on the opposite side of the channel. [A.B.M.]

**Buoyancy** The resultant vertical force exerted on a body by a static fluid in which it is submerged or floating. The buoyant force  $F_B$  acts vertically upward, in opposition to the gravitational force that causes it. Its magnitude is equal to the weight of fluid displaced, and its line of action is through the centroid of the displaced volume, which is known as the center of buoyancy. See AEROSTATICS; HYDROSTATICS.

By weighing an object when it is suspended in two different fluids of known specific weight, the volume and weight of the solid may be determined. See ARCHIMEDES' PRINCIPLE.

Another form of buoyancy, called horizontal buoyancy, is experienced by models tested in wind or water tunnels. Horizontal buoyancy results from variations in static pressure along the test section, producing a drag in closed test sections and a thrust force in open sections. These extraneous forces must be subtracted from data as a boundary correction. Wind tunnel test sections usually diverge slightly in a downstream direction to provide some correction for horizontal buoyancy. See WATER TUNNEL; WIND TUNNEL.

A body floating on a static fluid has vertical stability. A small upward displacement decreases the volume of fluid displaced, hence decreasing the buoyant force and leaving an unbalanced force tending to return the body to its original position. Similarly, a small downward displacement results in a greater buoyant force, which causes an unbalanced upward force.

A body has rotational stability when a small angular displacement sets up a restoring couple that tends to return the body to its original position. When the center of gravity of the floating body is lower than its center of buoyancy, it will always have rotational stability. Many a floating body, such as a ship, has its center of gravity above its center of buoyancy. Whether such an object is rotationally stable depends upon the shape of the body. See SHIP DESIGN. [V.L.S.]

**Burgess Shale** Part of a clay and silt sequence that accumulated at the foot of a colossal "reef" during the Cambrian explosion, a dramatic evolutionary radiation of animals beginning about 545 million years ago. Although this explosion is most obvious from the geologically abrupt appearance of

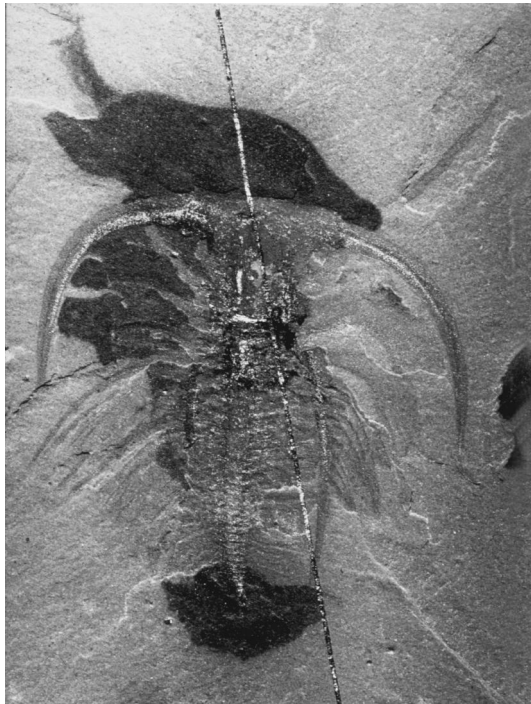

*Marrella splendens*, a characteristic Burgess Shale arthropod. The head shield bears two prominent pairs of spinose extensions; also visible are various appendages that include walking legs and gills. The prominent dark areas appear to represent body contents that oozed into the newly deposited sediment. This indicates that some decay occurred before an unknown factor intervened. (Copyright by Simon Conway Morris)

skeletons, the bulk of the radiation consisted of soft-bodied animals (see illustration). The Burgess Shale fauna, located near Field in southern British Columbia, is Middle Cambrian, approximately 520 million years old.

The Burgess Shale fauna is remarkably diverse, with about 120 genera. Its approximate composition is arthropods 37%, sponges 15%, brachiopods 4%, priapulids 5%, annelids 5%, chordates and hemichordates 5%, echinoderms 5%, cnidarians and ctenophores 2%, mollusks 3%, and "other fauna" 19%. Although arthropods are the most important group, the trilobites, normally dominant among Cambrian arthropods, are entirely overshadowed both in number of species and in absolute number of specimens by a remarkable variety of other arthropods with delicate exoskeletons. The priapulids, which today are a more or less relict group of marine worms, also show a wide diversity of anatomical form, as do the polychaete annelids. Only one species of polychaete annelids has a close parallel among the Recent assemblages.

The Burgess Shale has revealed many other aspects of the Cambrian explosion. First, a census of the collections reveals a marine ecology that is fundamentally unchanged to the present day. Predators, long thought to be insignificant in the Cambrian, are an important component. Second, groups with a minimal fossilization potential are preserved. One example is the gelatinous and delicate ctenophores, an important pelagic group in today's oceans but practically unknown as fossils. Third, although many of the species are a product of the Cambrian explosion, rare species are clear holdovers from the primitive Ediacaran faunas of late Precambrian age. Finally, some species are of particular evolutionary importance. Most significant is the worm *Pikaia*, which is interpreted as an early chordate, and as a predecessor of fish it lies near the beginning of the evolutionary path that ultimately leads to humans. See CAMBRIAN; FOSSIL; PALEONTOLOGY.

[S.C.M.]

**Burn** An injury to tissues caused by heat, chemicals, electricity, or irradiation effects.

The commonest type of burn is that due to thermal injury, in which some portion of the body surface is exposed to either moist or dry heat of sufficient temperature to cause local and systemic reactions. Clinically, the extent of such a burn is often expressed as first degree, second degree, and so forth. Different systems of classification exist.

First-degree burns result in some redness and swelling of the injured part, without necrosis of any tissue or the formation of blisters. Healing is completed in a few days without scarring.

Second-degree burns show a variable destruction of parts of the epidermis so that blistering occurs. Healing by regeneration in such superficial burns does not necessitate skin grafting, unless secondary infections ensue; no scarring results.

Third-degree burns are marked by complete destruction of the epidermis of a region, including the necrosis of accessory skin structures like hair and sweat glands. A brownish-black eschar marks the destroyed tissue. This is sloughed off and that defect becomes filled with granulation tissue that later consolidates and changes to form a dense, thick scar. Complications may occur without adequate care, and grafting is not unusual, sometimes being required because of contracture of the scar tissue.

In fourth-degree burns, tissue is destroyed to the level of or below the deep fascia lying beneath the subcutaneous fat and connective tissue of the body. Muscle, bone, deeper nerves, and even organs may be injured or destroyed by this severe degree of burn. Healing is usually a slow, involved process, requiring much reparative and reconstructive work by surgical specialists.

Electrical burns result from the amount of heat incident to the flow of a certain amount of electricity through the resistance offered by tissues. From a practical standpoint, most of the resistance offered to the passage of an electric current is that of the skin and the interface between the skin and the external conductor. Therefore, most electrothermal injuries are limited to the skin and immediately subjacent tissues, although deep penetration may follow large voltages.

Most chemical burns result from the action of corrosive agents which destroy tissues at the point of contact. Exposure of the skin, eyes, and gastrointestinal tract are commonest. [E.G.St./N.K.M.]

**Burrowing animals** Some terrestrial and aquatic animals are capable of excavating holes in the ground (burrowing) for protection from adverse environmental conditions, as well as for storing food. Burrows vary from temporary structures of simple design (for example, the nesting burrows of some birds) to more permanent underground networks that may be inhabited for several generations (for example, rabbit warrens, badger sets, fox earths, and prairie dog burrows). They vary in structure from blind burrows with a single opening to extensive systems with several openings. Some animals (for example, some species of moles) live permanently underground, and their burrows have no obvious large openings to the surface. Burrows may be shared by a number of species, and abandoned burrows may be used by other species. Animals with limbs usually excavate their burrows by using their legs, but many burrowing animals are limbless and the mechanism of progression is not always obvious.

Worms, slugs, many insects, and many vertebrates live in burrows. Earthworms are important soil organisms because their burrows improve drainage and aeration, their feeding habits enhance leaf decomposition, and their droppings increase soil fertility. Earthworms burrow by contracting circular muscles in their body wall to push forward, and contracting the longitudinal muscles to widen the burrow. Termites (Isoptera) and ants (Hymenoptera) are social insects, most of which live underground. Termites are major consumers of vegetation in warm climates, and many construct extensive underground galleries extending from the mound located on the surface. Most ants are predators or scavengers, but leaf-cutter ants feed on a fungus that grows

on the harvested pieces of leaf in carefully tended underground galleries.

Many marine animals, including flatfish, crabs, and shrimps, take temporary refuge or live more permanently in sand or mud by burying themselves just below the surface. Aquatic sand and mud pose several problems for burrowing animals. First, the particles are usually tightly packed together, restricting movement and requiring these organisms to expend 10–1000 times as much energy to move a given distance compared to other forms of locomotion. Second, burrows readily collapse unless reinforced or consolidated. The wall of burrows may simply be consolidated with mucus, but some animals make a more permanent, substantial tube of particles stuck together with mucus. Finally, all burrowing animals must be able to create a current of water through the burrow so that they can breathe. Many animals also feed partly or wholly on particles carried in such currents. [H.D.J.]

**Bursa** A simple sac or cavity with smooth walls and containing a clear, slightly sticky fluid interposed between two moving surfaces of the body to reduce friction. Subcutaneous bursae are found where the skin stretches around the greater curvature of a joint, as in the elbow or knee, and considerable chafing may occur; they may be single or multiple sacs. These bursae may enlarge as a result of continuous excessive irritation, as in housemaid's knee or miner's elbow. See BURSTITIS.

Synovial bursae are small closed sacs of fibrous tissue continuous with the joint cavity of a diarthrosis. They are lined with a complex membrane that secretes a clear lubricating fluid, serving to reduce friction between the opposing surfaces of the articulation. See JOINT (ANATOMY).

Bursae may exist in the form of elongated sheaths surrounding tendons or ligaments, where these moving bands are in contact with another structure, such as a bone, muscle, or another tendon or ligament. Tendon sheaths are especially common where tendons bend around the ends of two bones at an articulation. See MUSCULAR SYSTEM; SKELETAL SYSTEM. [W.J.B.]

**Bursitis** Any inflammation of a bursa. Bursae are synovial pouches, positioned to minimize friction between moving parts of the body. Bursitis most often occurs near the shoulder, hip, elbow, or knee. See BURSA; JOINT (ANATOMY).

Inflammatory changes in bursae produce acute or chronic swelling, an increase in the fluid content, and variable degrees of pain and tenderness. Acute bursitis may be septic (caused by microorganisms) or nonseptic. Nonseptic bursitis can be further subdivided into idiopathic (of unknown cause), traumatic, and crystal-induced bursitis. Septic bursitis may result from direct penetration by microorganisms through medical instrumentation or trauma; rarely, microorganisms may reach bursae through the blood. Most cases of bursitis are nonseptic; they may result from trauma or physical stress. In chronic bursitis, the wall of the bursa becomes thickened, shaggy, and irregular, with calcium deposits commonly being present.

The treatment depends on whether the bursitis is septic or nonseptic. Septic bursitis is most commonly due to *Staphylococcus aureus* and requires prompt administration of appropriate antibiotics and repeated drainage of fluid containing pus. Nonseptic bursitis can be treated conservatively by withdrawal of fluid and administration of nonsteroidal, anti-inflammatory drugs. Crystal-induced nonseptic bursitis is most frequently due to gout and usually responds well to drug therapy. Avoidance of trauma can help to prevent occupation-related cases of bursitis. Most cases of bursitis have a favorable prognosis. See CONNECTIVE TISSUE; GOUT. [R.P.S.]

**Bus** A motor vehicle for mass transit, built in various capacities and sizes, designed for carrying from 10 to 60 passengers or more on school, local, intercity, or interstate routes. A commercial bus usually operates on a regular schedule and travels

a fixed route, and each passenger pays a fare. In general, a bus has a long body with the passengers sitting on benches or seats. A double-deck bus has two separate passenger compartments, one above the other. The articulated bus has two connected passenger compartments that bend at their connecting point as the bus turns.

Most commercial buses have diesel engines, air conditioning, air suspension, and automatic transmission. Restroom facilities are usually included in buses for long-distance service. Basic bus design retains many passenger car and truck components. Gross weight is kept at a minimum for economic operation and for maximum utilization of space for entry, aisle, and exit areas. Seating and safety devices must comply with federal regulations. Heavy frames perform the same functions as those in other commercial vehicles for load-bearing capacity, rigidity, and resistance to impact. [D.L.An.]

**Bus-bar** An aluminum or copper conductor supported by insulators that interconnects the loads and the sources of electric power in an electric power system. A typical application is the interconnection of the incoming and outgoing transmission lines and transformers at an electrical substation. Bus-bars also interconnect the generator and the main transformers in a power plant. In an industrial plant such as an aluminum smelter, large bus-bars supply several tens of thousands of amperes to the electrolytic process. See ELECTRIC POWER SUBSTATION.

The major types are (1) rigid bus-bars, used at low, medium, and high voltage; (2) strain bus-bars, used mainly for high voltage; (3) insulated-phase bus-bars, used at medium voltage; and (4) sulfur hexafluoride (SF<sub>6</sub>)-insulated bus-bars, used in medium- and high-voltage systems. The rigid bus-bar is an aluminum or copper bar, which is supported by porcelain insulators. The strain bus-bar is a flexible, stranded conductor which is strung between substation metal structures and held by suspension-type insulators. The insulated-phase bus-bar is a rigid bar supported by insulators and covered by a grounded metal shield. The main advantage of this system is the elimination of short circuits between adjacent phases. The sulfur hexafluoride-insulated bus-bar is a rigid aluminum tube, supported by insulators and installed in a larger metal tube, which is filled with high-pressure sulfur hexafluoride gas. See CONDUCTOR (ELECTRICITY); ELECTRICAL INSULATION; WIRING. [G.G.K.]

**Bushing** A removable metal lining, usually in the form of a bearing to carry a shaft. Generally a bushing is a small bearing in the form of a cylinder and is made of soft metal or graphite-filled sintered material. Bushings are also used as cylindrical liners for holes to preserve the dimensional requirements, such as in the guide bearings in jigs and fixtures for drilling holes in machine parts. [J.J.R.]

**Butter** A food product made by churning cream. Butter is a water-in-fat emulsion. Cream is a fat-in-water emulsion. Cream consists of discrete fat globules, 6–16 micrometers in size, suspended in skim milk. Fat globules have a membrane or coating consisting of natural emulsifiers, lipoproteins, fat-soluble vitamins, cholesterol, and some other materials in lesser concentrations. The membrane provides stability for the globule and protects it from attack by lipase enzymes. See EMULSION; MILK.

Butter manufacturers first pasteurize the cream. This heat treatment destroys bacteria, inactivates enzymes, and gives the cream a cooked or heated flavor. See PASTEURIZATION.

Following pasteurization, rapid cooling promotes fat crystals on the exterior and liquid fat on the interior of the fat globules. If the cream were churned after this step, the loss of fat to the buttermilk would be high. Thus, a tempering step is used in which the cream is held at about 50°F (10°C) to allow rearrangement of

the fat crystals. Then, liquid fat is on the outside of the globules to allow rapid aggregation during churning.

Continuous churns produce as much as 15,000 lb (6800 kg) of butter per hour; they convert cream to butter in a few minutes. With the batch churn, about 45 min is needed to produce butter, and then at least 30 min to standardize the composition and get water dispersed in tiny droplets.

In the continuous churn the entering pasteurized and tempered cream is agitated vigorously by beater bars. This causes stripping of the fat globule membrane and aggregation of the fat globules into chunks 0.2–0.4 in. (0.5–1 cm) in diameter. At this point the emulsion has been inverted. The slope of the continuous churn allows the buttermilk to drain out the rear of the churn and the butter granules to continue through the churn barrel. The next flow-through position continues the kneading process to produce butter with finely dispersed droplets of moisture. If composition or color adjustment is required, it is done in this step; also, a salt solution is added to give the finished butter 1.2–1.5% salt. As the butter continues through the last step, more kneading is done with finer bars to complete the blending process and provide for fat crystallization that will yield optimum spreadability in the finished butter.

Butter in the package has a composition close to 80.0% milk fat, 1.2–1.5% salt, 17.5–17.8% water, and 1% milk solids. If

butter is salt-free, the moisture and fat contents are adjusted to a slightly higher value to compensate. [R.Bra.]

**Buxbaumiidae** A subclass of the class Bryopsida, the true mosses. It consists of a single family with four genera. The Buxbaumiidae is very distinctive in every way and most significantly in the structure of the peristome. The plants are small and occur especially on soil. The gametophyte is greatly reduced (*Buxbaumia*), with no stem and few leaves that are readily disappearing, or better developed with well-formed leaves having a single costa and short cells. The sporophytes are terminal. The capsules are disproportionately large and immersed or elevated on a seta (*Buxbaumia*). They are strongly inclined and asymmetric, tapered to a small mouth from a broad base. The operculum is small and conic. See BRYOPHYTA; BRYOPSIDA. [H.Cr.]

**Bytownite** A member of the plagioclase feldspar solid-solution series with a composition ranging from  $Ab_{30}An_{70}$  to  $Ab_{10}An_{90}$  ( $Ab = NaAlSi_3O_8$  and  $An = CaAl_2Si_2O_8$ ). Bytownite is very abundant in basic igneous rocks where it is the first plagioclase to crystallize under plutonic conditions; it forms the cores of zoned plagioclase phenocrysts in basaltic volcanics, and it sometimes occurs in anorthosites. See FELDSPAR. [L.Gr.]

# C

**C—H activation** The cleavage of carbon-hydrogen bonds in organic compounds, leading to subsequent functionalization to introduce useful chemical groups. For example, petroleum and natural gas, important energy resources for the modern world, are both alkanes,  $C_nH_{2n+2}$ , with many C—H bonds. One problem is to convert these alkanes to useful alcohols,  $C_nH_{2n+1}OH$ . This is particularly difficult because of the lack of reactivity of alkanes as indicated by their older name, paraffins (from Latin, meaning low affinity). In C—H activation, metal catalysts are often used to mediate the hydrocarbon conversion reactions. See ALCOHOL; ALKANE; CHEMICAL BONDING; ORGANIC CHEMISTRY.

A variety of  $ML_n$  fragments, consisting of a metal M and its associated ligands  $L_n$ , are capable of reaction with an alkane to give C—H bond breaking as shown in the first step of reaction (1). In principle, it should be possible to follow this with a

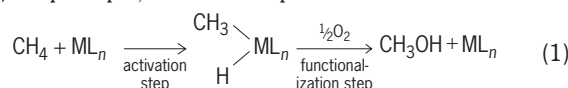

second step to give the functionalized alkane, but this has proved difficult in practice. R. G. Bergman showed as early as 1982 that  $(C_5Me_5)Ir(PMe_3)_3$ , formed photochemically, is suitable for the first reaction, for example. See COORDINATION CHEMISTRY; LIGAND.

Other cases are known where the first step of reaction (1) is followed by a functionalization reaction. H. Felkin, R. H. Crabtree, and A. S. Goldman showed reactions of this kind where the intermediate alkyl hydride decomposes to give alkene and free  $H_2$  or, in the presence of a second alkene as sacrificial oxidant, alkene and hydrogenated sacrificial oxidant [reaction (2)].

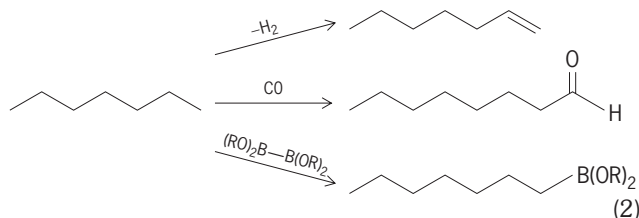

Y. Saito and M. Tanaka showed that the intermediate alkyl hydride can be trapped by carbon monoxide (CO) to give aldehyde (RCHO) as final product, and J. F. Hartwig trapped the alkyl with diborane derivatives to give alkyl boronic esters [reaction (2)]. In all of these cases, C—H activation preferentially occurs at the least hindered C—H bond, leading to products that are quite different from those formed in radical and acid pathways where the most substituted and most hindered C—H bonds are most reactive. In each case, appropriate transition-metal compounds are present and catalyze the reactions. These reactions do not yet form the basis of any practical process, but produce terminally functionalized products (the most desirable type) rather than the mixtures commonly found in other reactions. [R.H.Cr.]

**Cabbage** A hardy, cool-season crucifer (*Brassica oleracea* var. *capitata*) of Mediterranean origin and belonging to the plant order Capparales. Cabbage is grown for its head of overlapping leaves (see illustration), which are generally eaten raw in salads, cooked fresh, or processed into sauerkraut. Because it normally



**Cabbage** (*Brassica oleracea* var. *capitata*), cultivar Golden Acre 84. (Joseph Harris Co., Inc., Rochester, New York)

produces seed the second year, cabbage is considered to be a biennial by most authorities. Others regard it a perennial because it will remain vegetative unless subjected to cold weather.

Chinese cabbage is a related annual of Asiatic origin. Two species are grown in the United States, pe-tsai (*B. pekinensis*) and pakchoi (*B. chinensis*). See ORIENTAL VEGETABLES.

Cabbage varieties (cultivars) are generally classified according to season of maturity, leaf surface (smooth, savoyed, or wrinkled), head shape (flattened, round, or pointed), and color (green or red). Round, smooth-leaved, green heads are commonest. Varieties differ in their resistance to disease and in the tendency for heads to crack or split in the field.

Texas and Florida are important winter crop producing states; Georgia, Mississippi, and North Carolina produce large acreages in the spring; and New York, North Carolina, and Wisconsin are important for the summer and fall crops. New York and Wisconsin are the important kraut cabbage states. See CAPPARALES.

[H.J.C.]

**Cable television system** A system that receives and processes television signals from various sources and retransmits these signals through cables to subscribers' homes. The sources of the signals include broadcast transmissions, satellite-delivered programming, and local television studio productions. The facility that receives, processes, and retransmits the signals is called a headend.

Unlike broadcast television signals, which travel through free space, cable signals travel through coaxial cable or optical fiber, with different programs or channels traveling at different frequencies (much the same as frequency-division multiplex). In effect, the coaxial cable or optical fiber acts as a self-contained, closed, noninterfering frequency spectrum, created inside the cable by

the reuse of the spectrum already in use for other purposes. See MULTIPLEXING.

Cable television is made possible by the technology of coaxial and optical-fiber cable and is subject to the principles of transmission-line theory. The primary disadvantage of coaxial-cable distribution systems is their relatively high loss or attenuation regarding television signals at the frequencies normally used in cable television systems (50–550 MHz, extending up to 1 GHz in newer systems). Amplifiers are required to overcome this signal loss, and the farther the subscriber is from the cable headend the more amplifiers are needed. Noise and intermodulation distortions created by many cascaded amplifiers limit the practical length of any coaxial cable network. See COAXIAL CABLE.

Optical fiber does not have the same high attenuation or loss characteristics as coaxial cable, and optical-fiber networks can therefore be built without amplifiers. Most cable systems that use optical fibers do so in a hybrid fashion. Optical fiber is connected from the headend to some localized node or terminating location. The subscriber is then connected to the optical-fiber node by short distances of coaxial cable. See COMMUNICATION CABLES; OPTICAL COMMUNICATIONS; OPTICAL FIBERS.

The system design or architecture is known as a tree-and-branch design. The tree-and-branch architecture is the most efficient way to transmit a package of multiple channels of programming from a headend to all subscribers. See CLOSED-CIRCUIT TELEVISION; TELEVISION. [R.D.P.]

**Cacao** *Theobroma cacao*, a small tropical tree (see illustration) that is cultivated for the almond-shaped seeds which are used to make chocolate. The species is native to the rainforest of the Amazon basin, and two regions of distribution in pre-Columbian times are recognized. The crop was first cultivated in Central America and northern South America, the varieties found there being known as Criollos. The second region comprises the Amazon and Orinoco basins, where the cacao populations are known as Amazonian Forastero. The second type is more commonly cultivated, particularly in Brazil, Ivory Coast, Ghana, and Nigeria.

The produce is generally exported in the form of dry beans. The farmers' production is purchased by dealers and exported by registered exporters or government marketing boards. Sales are effected through contracts or futures markets, principally in



Cacao (*Theobroma cacao*). (USDA)

New York and London. The market distinguishes between bulk and fine cocoas. The latter have preferred flavor or other characteristics and receive a price premium. See THEALES. [P.DeTA.]

**Cachexia** The severe wasting syndrome that accompanies such diseases as cancer, infection, or parasitic infestation. The causes of cachexia are only partially understood. However, it is clear that most cachexia is caused by diminished consumption of nutrients rather than by a hypermetabolic state.

Anorexia, the proximal cause of this problem, is thought to be related to the expression of endogenous factors collectively termed cytokines, some of which have now been identified. For example, tumor necrosis factor, a protein (also known as cachectin), when administered to animals for a long period of time, causes a syndrome of cachexia indistinguishable from that produced by chronic disease. It is likely that other cytokines are also involved, and that together these agents cause wasting of such severity that it may lead to death in a wide variety of diseases. See ANOREXIA NERVOSA; CYTOKINE.

The cytokines that cause cachexia are produced mainly by cells of the immune system, especially macrophages. Synthesis is triggered by contact with molecules produced by microbial pathogens or tumor cells. Rational strategies for alleviation of cachexia include eradicating the underlying infection or tumor, blocking cytokine synthesis with agents that specifically interrupt the requisite signaling pathways, or inhibiting cytokine activity with specific antibodies or other antagonists. Oral or intravenous administration of nutrients is likely to be effective if the process has not advanced to a point at which utilization of nutrients is impaired. See ONCOLOGY. [B.Be.]

**Cactus** The common name for any member of the cactus family (Cactaceae). There are 120 genera with perhaps 1700 species, nearly all indigenous to America. The cacti are among the most extremely drought-resistant plants, and consequently they thrive in very arid regions. The group is characterized by a fleshy habit, presence of spines and bristles, and large, brightly colored, solitary flowers. There is a great variety of body shapes and patterns, and many of the species are grown as ornamentals or oddities. A few have edible fruits. The cochineal insect, which produces a valuable red dye, is cultivated chiefly on the cochineal cactus (*Nopalea coccinellifera*). The saguaro (*Cereus giganteus*) of Arizona and Sonora is the largest of the cacti, attaining a height of 70 ft (21 m). See CARYOPHYLLALES.

Cacti grow in many habitats, ranging from epiphytes living on trees in dense tropical forests to large, isolated plants in deserts. In all cases, various adaptations that lead to water conservation are apparent. For example, the stems of most cacti are massive and can store large amounts of water that sustain the plants during prolonged drought. Adaptations for water conservation also occur on a metabolic level. Cacti have a thick waxy cuticle on their stems, which acts as a waterproofing skin. Also, the pores (called stomata or stomates) in the cactus skin that are necessary for the uptake of carbon dioxide (CO<sub>2</sub>) from the atmosphere tend to open only at night. Much less water (generally 80–90% less) is lost by transpiration during the nocturnal opening of stomata by cacti compared with the daytime stomatal opening of most other plants. The opening of stomata at night presents a problem for photosynthesis, which requires light. Specifically, photosynthesis uses atmospheric carbon dioxide and the energy of sunlight to form sugars in the chloroplasts of the chlorenchyma. During the night malic acid accumulates in the large vacuoles of cactus chlorenchyma cells; during the next daytime, when the stomata have closed, carbon dioxide is released from the accumulated acid within the stems of cacti. Carbon dioxide is then fixed into sugars via photosynthesis when sunlight is available as the energy source. This process, known as crassulacean acid metabolism (CAM) because it was first discovered in the plant family Crassulaceae, is crucial for the adaptation of cacti to the dry conditions characteristic of deserts. Its

water-conserving attribute is also important in the increasing cultivation of cacti for their fruits and as fodder for livestock, particularly cattle. [PD.St.; E.L.C.; PS.N.; S.M.A.]

**Cadmium** A relatively rare chemical element, symbol Cd, atomic number 48, closely related to zinc, with which it is usually associated in nature. It is a silvery-white ductile metal with a faint bluish tinge. It is softer and more malleable than zinc, but slightly harder than tin. It has an atomic weight of 112.40 and a specific gravity of 8.65 at 20°C (68°F). Its melting point of 321°C (610°F) and boiling point of 765°C (1410°F) are lower than those of zinc. There are eight naturally occurring stable isotopes, and eleven artificial unstable radio isotopes have been reported. Cadmium is the middle member of group II (zinc, cadmium, and mercury) in the periodic table, and its chemical properties generally are intermediate between zinc and mercury. The cadmium ion is displaced by zinc metal in acidic sulfate solutions. Cadmium is bivalent in all its stable compounds, and its ion is colorless. See PERIODIC TABLE; TIN; ZINC.

Cadmium does not occur uncombined in nature, and the one true cadmium mineral, greenockite (cadmium sulfide), is not a commercial source of the metal. Almost all of the cadmium produced is obtained as a by-product of the smelting and refining of zinc ores, which usually contain 0.2–0.4% cadmium. The United States, Canada, Mexico, Australia, Belgium-Luxembourg, and the Republic of Korea are principal sources, although not all are producers.

At one time an important commercial use of cadmium was as an electrodeposited coating on iron and steel for corrosion protection. Nickel-cadmium batteries are the second-largest application, with pigment and chemical uses third. Sizeable amounts are used in low-melting-point alloys, similar to Wood's metal, and in automatic fire sprinklers, and relatively smaller uses are in brazing alloys, solders, and bearings. Cadmium compounds are used as stabilizers in plastics and the production of cadmium phosphors. Because of its great neutron-absorbing capacity, especially the isotope 113, cadmium is used in control rods and shielding for nuclear reactors. See ALLOY; CADMIUM METALLURGY.

[W.H.]

**Cadmium metallurgy** Most cadmium occurs in solid solution in the zinc sulfide mineral called sphalerite. Although cadmium may be recovered from some lead and copper ores, it is associated with the zinc which is also found in these ores. Since cadmium is entirely a by-product metal, the supply available is closely aligned with zinc production, averaging about 0.4% of zinc production.

All cadmium recovery processes involve the dissolution of cadmium-bearing feed material, followed by various purification and cadmium displacement steps. Methods of processing can be grouped conveniently into two basic categories, electrolytic and electromotive. In the former case, cadmium is recovered by electrolyzing purified solutions; in the latter case, cadmium in the form of a metallic sponge is displaced from purified solutions by a less noble metal, zinc being used in every known commercial application, and the sponge is melted or distilled, or both.

Major end uses for cadmium are in corrosion-resistant plating and in cadmium compounds for use as pigments in paints, ceramics, and plastics. Cadmium is also used in alloys, plastic stabilizers, batteries, and television picture tube phosphors. In view of the changing world energy situation, uses for cadmium are anticipated in applications such as solar energy cells and energy storage systems. See CADMIUM. [R.E.L.]

**Caffeine** An alkaloid, formerly synthesized by methylation of theobromine isolated from cacao, but now recovered from the solvents used in the manufacture of decaffeinated coffee. Chemically, caffeine is 1,3,7-trimethylxanthine, and has the formula shown here. It is widely used in medicine as a stimulant for

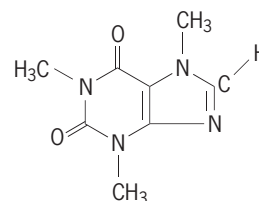

the central nervous system and as a diuretic. It occurs naturally in tea, coffee, and yerba maté, and small amounts are found in cola nuts and cacao. Caffeine crystallizes into long, white needlelike crystals that slowly lose their water of hydration to give a white solid that melts at 235–237.2°C (455–459.0°F). It sublimes without decomposition at lower temperatures. Caffeine has an intensely bitter taste, though it is neutral to litmus. See ALKALOID.

[F.W.]

**Cage hydrocarbon** A compound that is composed of only carbon and hydrogen atoms and contains three or more rings arranged topologically so as to enclose a volume of space. In general, the “hole” within a cage hydrocarbon is too small to accommodate even a proton. The carbon frameworks of many cage hydrocarbons are quite rigid. Consequently, the geometric relationships between substituents on the cage are well defined. This quality makes these compounds exceptionally valuable for testing concepts concerning bonding, reactivity, structure-activity relationships, and structure-property relationships. See CHEMICAL BONDING.

The carbocyclic analogs of the platonic solids that are tenable are tetrahedrane (structure **1**, where X = –H), cubane (**2**), and dodecahedrane. See ALICYCLIC HYDROCARBON.

An unsubstituted prismane has the general formula of (CH)<sub>n</sub>, and the carbon atoms are located at the corners of a regular prism. Prismane (**3**), cubane (**2**), pentaprismane, and hexaprismane are the simplest members of this family of cage hydrocarbons.

The monomer of the diamond carbon skeleton is adamantane (**4**, where X = –H).

Amantadine (**4**, where X = –NH<sub>2</sub>) was developed commercially as the first orally active antiviral drug for the prevention of respiratory illness due to influenza A2-Asian viruses.

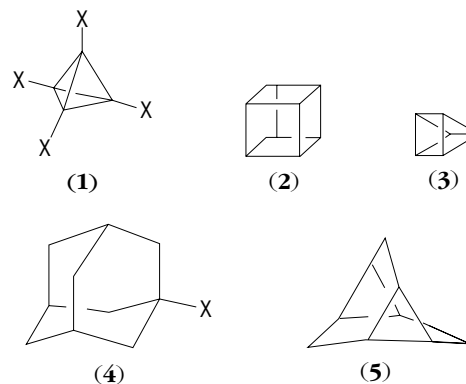

The other simple diamondoid hydrocarbons are diamantane and triamantane.

Organic chemists have prepared a wide variety of cage hydrocarbons that do not occur in nature. Among these compounds are triasterane (**5**), icane or wurtzitane, and pagodane. [R.K.Mu.]

**Caisson foundation** A permanent substructure that, while being sunk into position, permits excavation to proceed inside and also provides protection for the workers against water pressure and collapse of soil. The term caisson covers a wide range of foundation structures. Caissons may be open,

pneumatic, or floating type; deep or shallow; large or small; and of circular, square, or rectangular cross section. The walls may consist of timber, temporary or permanent steel shells, or thin or massive concrete. Large caissons are used as foundations for bridge piers, deep-water wharves, and other structures. Small caissons are used singly or in groups to carry such loads as building columns. Caissons are used where they provide the most feasible method of passing obstructions, where soil cannot otherwise be kept out of the bottom, or where cofferdams cannot be used. See BRIDGE; PILE FOUNDATION.

The bottom rim of the caisson is called the cutting edge (see illustration). The edge is sharp or narrow and is made of, or faced with, structural steel. The narrowness of the edge facilitates removal of ground under the shell and reduces the resistance of the soil to descent of the caisson.



Underside of open caisson for Greater New Orleans bridge over Mississippi River. (Dravo Corp.)

An open caisson is a shaft open at both ends. It is used in dry ground or in moderate amounts of water. A pneumatic caisson is like a box or cylinder in shape; but the top is closed and thus compressed air can be forced inside to keep water and soil from entering the bottom of the shaft. A pneumatic caisson is used where the soil cannot be excavated through open shafts or where soil conditions are such that the upward pressure must be balanced. A floating or box caisson consists of an open box with sides and closed bottom, but no top. It is usually built on shore and floated to the site where it is weighted and lowered onto a bed previously prepared by divers. See FOUNDATIONS. [R.D.Che.]

**Calamine** A term that may refer to either a zinc mineral,  $Zn_4Si_2O_7(OH)_2 \cdot H_2O$ , which is also known as hemimorphite, or to zinc oxide,  $ZnO$ , which is used in medicinal or pharmaceutical products and in cosmetics. See HEMIMORPHITE. [E.E.W.]

**Calanoida** An order of Copepoda that includes the larger and more abundant of the pelagic species. Some authorities consider the Calanoida an order of the subclass Copepoda. In the food cycles of the sea these copepods are the most important group of marine animals because of their overwhelming numbers, ubiquitous distribution, and position at the base of the animal food chain. See COPEPODA.

The anterior part of the body is cylindrical with five or six segments, and much broader than the posterior part. The first antennae are not for locomotion, but are stabilizers and sinking retarders, and also have an olfactory function. The second antennae and mandibular palps are biramous and create water currents for feeding and slow movement. The five pairs of swimming legs are biramous, but the last pair is sometimes reduced or absent in the female, and the male's right fifth leg may be modified for grasping the female (see illustration).

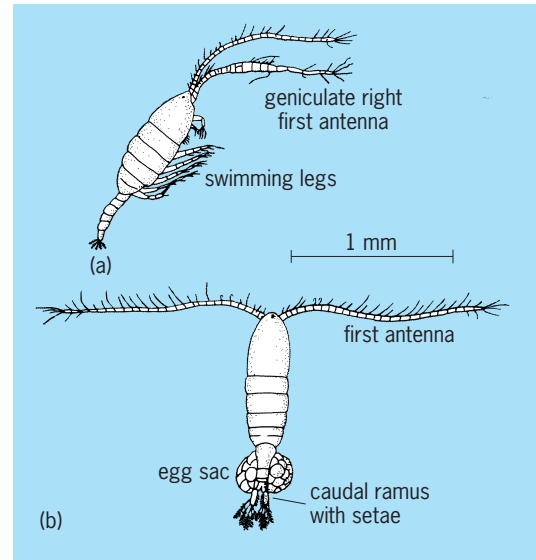

*Diaptomus*. (a) Lateral view of male. (b) Dorsal view of female.

Nearly all calanoids are planktonic and, as a group, occur in all parts of the oceans from the surface to abyssal depths. The geographic and bathymetric ranges of many species are, however, restricted by the nature of water currents and the chemical and physical conditions of the water. In their southernmost range the northern species are found at greater depths. [H.C.Y.]

**Calcarea** A class of the phylum Porifera, including sponges with a skeleton composed of spicules of calcium carbonate. Calcarea vary from radially symmetrical vase-shaped species to colonies made up of a reticulum of thin tubes to irregular massive forms. Calcareous sponges are mostly of small size and inhabit the shallow waters of all seas, from tidal areas to depths of 600 ft (200 m), with a few species extending down to at least 12,000 ft (4000 m).

Primitive calcareous sponges with an ascon grade of construction consist of colonies of upright tubes with unfolded walls made up of an outer epidermis of pinacocytes and an inner lining of choanocytes. Between these layers of cells is a stratum of mesoglea containing amebocytes and spicules. Cells called porocytes, each perforated by a tubular canal, pierce the walls at intervals and allow water to enter the central cavity or spongocoel. Water leaves by way of a terminal osculum.

A somewhat more complicated structure is seen in calcareous sponges of the sycon grade of construction. Syconoid sponges are usually individual vase-shaped forms with a thick wall enclosing a large central spongocoel opening out through a terminal osculum. In the simplest forms the wall is pushed out at intervals into fingerlike projections, called radial canals, in which the choanocytes are localized. Water enters the radial canals directly through pores without the intervention of special inhalant canals. In most syconoid species, however, a dermal membrane made up of pinacocytes and mesenchyme forms a cortex of greater or less thickness which joins the outer ends of the radial canals. Pores or ostia pierce the dermis and open into inhalant canals which are simply the spaces between the radial canals in some cases.

The leuconoid grade of construction has probably evolved independently among the several lines of calcareous sponges. In those with a syconoid ancestry, the radial canals subdivide into many small flagellated chambers which arise as outpocketings of the radial canal wall. [W.D.H.]

Fossils clearly referable to the class Calcarea do not appear before the Carboniferous, later than any other class of sponges.



The dominant Calcarea preserved from the late Paleozoic (Carboniferous and Permian periods) are the Sphinctozoa. In the Permian probable Calcinea with the pharetronid type of skeleton first appear. Both the Sphinctozoa and the pharetronids become highly varied and abundant in the Permian and Triassic periods. Calcareous sponges remained fairly abundant in shallow water and reefy deposits until the end of the Cretaceous. After that time the Sphinctozoa became extinct and the pharetronids became gradually less abundant. See PORIFERA. [R.M.F.]

**Calcichordates** Primitive fossil members of the phylum Chordata with a calcite skeleton of echinoderm type. They occur in marine rocks of Cambrian to Pennsylvanian age (530–300 million years old) and, because of their skeletons, have traditionally been placed in the phylum Echinodermata. They are shown to be chordates, however, by many chordate anatomical features. Their calcite skeletons merely confirm an old view—that echinoderms and chordates are closely related. There are three main groups of calcichordates—the Soluta, the Corenuta, and the Mitrata. See CHORDATA; ECHINODERMATA. [R.P.S.J.]

**Calcite** A mineral composed of calcium carbonate ( $\text{CaCO}_3$ ); one of the most common and widespread minerals in the Earth's crust. Calcite may be found in a great variety of sedimentary, metamorphic, and igneous rocks. It is also an important rock-forming mineral and is the sole major constituent in limestones, marbles, and many carbonatites. Calcite in such rocks is the main source of the world's quicklime and hydrated, or slaked, lime. It is also widely used as a metallurgical flux to a scavenge siliceous impurities by forming a slag in smelting furnaces. It provides the essential calcium oxide component in common glasses and cement. Limestones and marbles of lower purity may find uses as dimension stone, soil conditioners, industrial acid neutralizers, and aggregate in concrete and road building. Calcite in transparent well-formed crystals is used in certain optical instruments. See CRYSTAL OPTICS; GLASS; LIME (INDUSTRY); LIMESTONE; STONE AND STONE PRODUCTS.

When pure, calcite is either colorless or white, but impurities can introduce a wide variety of colors: blues, pinks, yellow-browns, greens, and grays have all been reported. Hardness is 3 on Mohs scale. The specific gravity of pure calcite is  $2.7102 \pm 0.0002$  at  $68^\circ\text{F}$  ( $20^\circ\text{C}$ ). Calcite has a very low solubility in pure water (less than 0.001% at  $77^\circ\text{F}$  or  $25^\circ\text{C}$ ), but the solubility increases considerably with  $\text{CO}_2$  added, as in natural systems from the atmosphere, when more bicarbonate ions and carbonic acid are formed. The solubility is also increased by falling temperature and rising total pressure. Shallow warm seas are supersaturated with calcite, while enormous quantities of calcite are dissolved in the unsaturated deep oceans. See CALCIUM; CARBONATE MINERALS. [R.I.Ha.]

**Calcium** A chemical element, Ca, of atomic number 20, fifth among elements and third among metals in abundance in the Earth's crust. Calcium compounds make up 3.64% of the Earth's crust. The physical properties of calcium metal are given in the table. The metal is trimorphous and is harder than sodium, but softer than aluminum. Like beryllium and aluminum, but unlike the alkali metals, it will not cause burns on the skin. It is less reactive chemically than the alkali metals and the other alkaline-earth metals. See PERIODIC TABLE.

Occurrence of calcium is very widespread; it is found in every major land area of the world. This element is essential to plant and animal life, and is present in bones, teeth, eggshell, coral, and many soils. Calcium chloride is present in sea water to the extent of 0.15%. See CARBONATE MINERALS.

Calcium metal is prepared industrially by the electrolysis of molten calcium chloride. Calcium chloride is obtained either by treatment of a carbonate ore with hydrochloric acid or as a waste product from the Solvay carbonate process. The pure metal may be machined in a lathe, threaded, sawed, extruded, drawn into

Properties of calcium metal

Property	Value
Atomic number	20
Atomic weight	40.08
Isotopes (stable)	40, 42, 43, 44, 46, 48
Atomic volume, $\text{cm}^3/\text{g-atom}$	25.9
Crystal form	Face-centered cubic
Valence	2+
Ionic radius, nm	0.099
Electron configuration	2882
Boiling point, $^\circ\text{C}$	1487(?)
Melting point, $^\circ\text{C}$	810(?)
Density, $\text{g}/\text{cm}^3$ at $20^\circ\text{C}$	1.55
Latent heat of vaporization at boiling point, kilojoules/g-atom	399

wire, pressed, and hammered into plates. See ELECTROMETALLURGY.

In air, calcium forms a thin film of oxide and nitride, which protects it from further attack. At elevated temperatures, it burns in air to form largely the nitride. The commercially produced metal reacts easily with water and acids, yielding hydrogen that contains noticeable amounts of ammonia and hydrocarbons as impurities.

The metal is employed as an alloying agent for aluminum-bearing metal, as an aid in removing bismuth from lead, and as a controller for graphitic carbon in cast iron. It is also used as a deoxidizer in the manufacture of many steels, as a reducing agent in preparation of such metals as chromium, thorium, zirconium, and uranium, and as a separating material for gaseous mixtures of nitrogen and argon.

Calcium oxide,  $\text{CaO}$ , is made by the thermal decomposition of carbonate minerals in tall kilns using a continuous-feed process. The oxide is used in high-intensity arc lights (lime-lights) because of its unusual spectral features and as an industrial dehydrating agent. The metallurgical industry makes wide use of the oxide during the reduction of ferrous alloys.

Calcium hydroxide,  $\text{Ca}(\text{OH})_2$ , is used in many applications where hydroxide ion is needed. During the slaking process for producing calcium hydroxide, the volume of the slaked lime [ $\text{Ca}(\text{OH})_2$ ] produced expands to twice that of quicklime ( $\text{CaO}$ ), and because of this, it can be used for the splitting of rock or wood. Slaked lime is an excellent absorbent for carbon dioxide to produce the very insoluble carbonate. See LIME (INDUSTRY).

Calcium silicide,  $\text{CaSi}$ , an electric-furnace product made from lime, silica, and a carbonaceous reducing agent, is useful as a steel deoxidizer. Calcium carbide,  $\text{CaC}_2$ , is produced by heating a mixture of lime and carbon to  $5432^\circ\text{F}$  ( $3000^\circ\text{C}$ ) in an electric furnace. The compound is an acetylide which yields acetylene upon hydrolysis. Acetylene is the starting material for a great number of chemicals important in the organic chemicals industry.

Pure calcium carbonate exists in two crystalline forms: calcite, the hexagonal form, which possesses the property of birefringence, and aragonite, the rhombohedral form. Naturally occurring carbonates are the most abundant of the calcium minerals. Iceland spar and calcite are essentially pure carbonate forms, whereas marble is a somewhat impure and much more compact variety which, because it may be given a high polish, is much in demand as a construction stone. Although calcium carbonate is quite insoluble in water, it has considerable solubility in water containing dissolved carbon dioxide, because in these solutions it dissolves to form the bicarbonate. This fact accounts for cave formation in which limestone deposits have been leached away by the acidic ground waters. See CARBONATE MINERALS.

The halides of calcium include the phosphorescent fluoride, which is the most widely distributed calcium compound and which has important applications in spectroscopy. Calcium chloride has in the anhydrous form important deliquescent properties

which make it useful as an industrial drying agent and as a dust quieter on roads. Calcium chloride hypochlorite (bleaching powder) is produced industrially by passing chlorine into slaked lime, and has been used as a bleaching agent and a water purifier. See BLEACHING; CHLORINE.

Calcium sulfate dihydrate is the mineral gypsum. It constitutes the major portion of portland cement, and has been used to help reduce soil alkalinity. A hemihydrate of calcium sulfate, produced by heating gypsum at elevated temperatures, is sold under the commercial name plaster of paris. See PLASTER OF PARIS.

Calcium is an invariable constituent of all plants because it is essential for their growth. It is contained both as a structural constituent and as a physiological ion. Calcium is found in all animals in the soft tissues, in tissue fluid, and in the skeletal structures. The bones of vertebrates contain calcium as calcium fluoride, as calcium carbonate, and as calcium phosphate. See CALCIUM METABOLISM. [R.FR.]

**Calcium metabolism** The calcium ion is essential to the normal function of all living cells. In the human, some 99% of total body calcium resides in the skeleton, and 1% is distributed in the soft tissues and extracellular fluids. The concentration of free calcium ions in the cytoplasm of resting cells and in the extracellular fluids is rigidly maintained, in keeping with the critical physiological importance of calcium to a wide variety of biological processes.

The calcium salts in bone provide structural integrity to the skeleton. They exist largely in the form of hydroxylapatite, a crystalline structure composed of calcium, phosphate, and hydroxyl ions. See BONE.

The total concentration of calcium in serum is approximately 10 milligrams per deciliter (2.5 millimoles per liter). Only about one-half of this concentration is represented by free calcium ions, the biologically important fraction, the remainder being bound to proteins and complexed to other ionic species. The concentration of free calcium ions in the extracellular fluids is involved in the maintenance of plasma membrane integrity and permeability, functions as a cofactor for certain clotting factors, and is of crucial importance to normal skeletal mineralization. See BLOOD; CELL MEMBRANES; CELL PERMEABILITY.

The concentration of calcium ions in the cytoplasm of resting cells is approximately  $10^{-6}$  molar, only about one-thousandth that present in the extracellular fluids. The cytosolic calcium concentration is tightly regulated by calcium transport mechanisms in the plasma membrane, mitochondria, and microsomes. Calcium ions play various roles in cellular physiology, including coupling of excitation and contraction in skeletal and heart muscle, participation in nerve excitation, regulation of cellular secretion and ion transport, and regulation of the activities of cytosolic enzymes. See BIOPOTENTIALS AND IONIC CURRENTS.

At a systemic level, the metabolism of calcium and phosphate ions is intimately related. The two most important hormones that are responsible for regulating the extracellular concentration of these ions are parathyroid hormone and 1,25-dihydroxyvitamin D [ $1,25-(OH)_2D$ ]. The secretion of parathyroid hormone is rigidly controlled by the extracellular concentration of calcium ions, and parathyroid hormone is responsible for the fine regulation of the serum calcium concentration on a minute-to-minute basis, by virtue of its effects on calcium mobilization from bone and the rate of calcium (and phosphate) excretion into the urine. 1,25-Dihydroxyvitamin D is primarily responsible for regulating the quantity of calcium absorbed in the small intestine, and it also participates with parathyroid hormone in the regulation of mineral mobilization from bone. The demonstration of prominent  $1,25-(OH)_2D$  effects requires hours rather than minutes, so that it may be more important to the long-term maintenance of systemic calcium balance than to the minute-to-minute regulation of the serum concentration of calcium ions. There are a large number of human disorders affecting

the parathyroid glands and vitamin D metabolism. See PARATHYROID HORMONE; PHOSPHATE METABOLISM; VITAMIN D. [A.E.Br.]

**Calculators** Desktop or, more often, portable electronic devices that are used to perform arithmetic, statistical, or other, more complex processing operations at the step-by-step direction of the user or by execution of a program (a stored sequence of processing operations) selected and initiated by the user. Models are offered with particular stored programs specialized to professional fields such as finance and science, and results are displayed in formats ranging from the still prevalent single line of alphanumeric characters to small viewing screens capable of graphical representations.

Calculator designs use either a customized integrated circuit or a microprocessor and a small number of peripheral integrated circuits to perform their operations. A customized integrated circuit will accept and interpret keystrokes made by the user, perform the requested operation, and generate signals to drive the display device, providing the user an indication of the processing result. Complex mathematical processing abilities are built into some calculator integrated circuits, and some accept plug-in memory modules that extend the available processing sequences. A single line of alphanumeric readout is usually coupled with a customized calculator integrated circuit. Microprocessor-based calculators are generally more complex, more flexible, more capable, and more costly. Some accept memory modules or programs selected from a library to meet the particular requirements of an application and downloaded to the unit. The peripheral integrated circuits effect interfacing of the microprocessor with data and program entry and display, readout, and printout devices. See MICROPROCESSOR. [W.W.Mo.]

**Calculus** The branch of mathematics dealing with two fundamental operations, differentiation and integration, which are carried out on functions. The subject, as traditionally developed in college textbooks, is partly an elementary development of the purely theoretical aspects of these operations and their interrelation, partly a development of rules and formulas for applying calculus to the standard functions which arise in algebra and trigonometry (with exponentials and logarithms included), and partly a collection of applications to problems of geometry, physics, chemistry, engineering, economics, and perhaps a few other subjects.

The fundamental concept of differential calculus is that of the derivative of a function of one variable. The classical physical prototype of this concept is that of instantaneous velocity, which is the derivative of distance as a function of time. The derivative also has a highly significant geometrical realization which depends upon the graphical representation of a function in rectangular coordinates  $(x, y)$ . If  $y$  is a differentiable function of  $x$ , perhaps as  $x$  increases from  $x_1$  to  $x_2$ , the graph of the function is a continuous curve with exactly one  $y$  for each  $x$ , and at each point the curve has a tangent line which is not parallel to the  $y$  axis. If  $\phi$  is the angle, measured counterclockwise, from the positive  $x$  direction to the tangent (Fig. 1), then  $\tan \phi$  is equal to the derivative of  $y$  with respect to  $x$ . (This is on the supposition

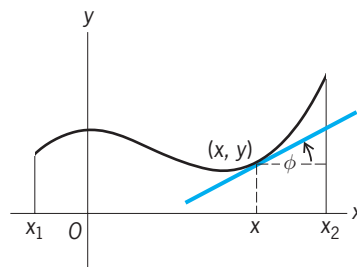

Fig. 1. Graphical representation of the derivative of  $f(x)$ .

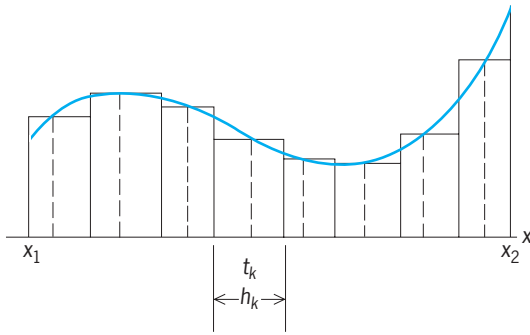

Fig. 2. The definite integral.

that the same unit of length is used along the two axes.) This  $\tan \phi$  is also called the slope of the curve.

The standard notation for the derivative of  $y$  with respect to  $x$  is  $dy/dx$ . If the functional notation  $y = f(x)$  is used, the derivative is often denoted by  $f'(x)$ . See DIFFERENTIATION.

If  $f$  is a function defined on the finite interval from  $x_1$  to  $x_2$  inclusive, the definite integral of  $f$  from  $x_1$  to  $x_2$ , denoted by

$$\int_{x_1}^{x_2} f(x) dx$$

is defined by applying to  $f$  a rather intricate process which entails the consideration of what are called approximating sums. When the function  $f$  is subjected to certain restrictions, this process culminates in the determination of a number as the limit of the approximating sums, and this number is called the definite integral of  $f$  from  $x_1$  to  $x_2$ . The integral is not defined unless the approximating sums do converge to a well-defined limit. A sufficient condition that this be so is that the function  $f$  be continuous.

There is a geometrical representation of the process of defining the definite integral, and it furnishes a plausible argument for the convergence of the approximating sums to a limit. Divide the interval from  $x_1$  to  $x_2$  into a finite number  $N$  of not necessarily equal parts. Let the lengths of these parts be  $h_1, h_2, \dots, h_N$  and let  $t_k$  be the value of  $x$  in the  $k$ th part (Fig. 2). Then the expression

$$f(t_1)h_1 + f(t_2)h_2 + \dots + f(t_N)h_N$$

is called an approximating sum. In Fig. 2, where the function is continuous and the function values are all positive, each term  $f(t_k)h_k$  in the approximating sum is equal to the area of a certain shaded rectangle, and the whole sum is an approximation of the area between the graph of the function and  $x$  axis, from  $x_1$  to  $x_2$  inclusive. The limiting process is carried on by the increasing  $N$  and making the largest of the  $h_k$ 's approach 0. It is then intuitively clear that the definite integral is the number which represents the exact area between the  $x$  axis and the graph. This geometrical interpretation of the integral is the basis of an important application of integral calculus, to the calculation of areas.

It would be tedious and difficult in practice to compute definite integrals by actually working out the limits of approximating sums. It is therefore fortunate that by purely mathematical reasoning it is possible to demonstrate a theorem which links derivatives and integrals and makes it possible, in many important instances, to compute definite integrals by an easier procedure. See INTEGRATION.

The two fundamental theorems of calculus are as follows:

1. For the calculation of

$$\int_{x_1}^{x_2} f(x) dx$$

find, if possible, a function  $F$  with continuous derivative  $F'$  such that  $F'(x) = f(x)$  when  $x_1 \leq x \leq x_2$ . Then Eq. (1) can be written.

$$\int_{x_1}^{x_2} f(x) dx = F(x_2) - F(x_1) \quad (1)$$

This is one of the two central theorems.

2. Suppose  $f$  is continuous, and consider the function  $F$  defined by Eq. (2).

$$F(x) = \int_{x_1}^{x_2} f(t) dt \quad (2)$$

Then  $F$  has a derivative given by  $F'(x) = f(x)$ .

[A.L.Ta.]

**Calculus of variations** An extension of the part of differential calculus which deals with maxima and minima of functions of a single variable. The functions of the calculus of variations depend in an essential way upon infinitely many independent variables. Classically these functions are usually integrals whose integrand depends on a function whose specification by any finite number of parameters is impossible. For example, let  $C$  be a smooth bounded region of a space of  $m$  variables,  $x_1, x_2, \dots, x_m$ , let  $y$  be any function of some smooth class on  $C$  and its boundary into real numbers or into  $n$ -tuples of real numbers and taking specified values on the boundary, and let  $f(x, y, p)$  be a smooth function of  $2m + 1$  variables  $x_1, x_2, \dots, x_m, y, p_1, p_2, \dots, p_m$ . Then the integral, shown below, is a function on

$$J = \int \dots \int_C f(x, y, y_x)$$

the space of functions  $y$  to the real numbers, and this space of functions is infinite dimensional unless excessive restrictions are placed on it. Here  $y_x$  denotes the derivatives  $\partial y / \partial x$ .

The calculus of variations studies such functions and their maxima and minima. The limitation of the competing functions is made realistically, and with sufficient restrictions it is possible to arrive at a rewarding theory; these restrictions do not always include the fixed boundary conditions stated above.

Principal applications may be to physical systems involving flexible components or time-dependent orbits; equilibrium positions or orbits may be determined by minimizing energy or action integrals. The problems are of mathematical interest because of intrinsic difficulties (largely related to lack of topological compactness of bounded regions in spaces of infinitely many dimensions) and possibly because more progress with difficult nonlinear problems has been made here than elsewhere. See HAMILTON'S PRINCIPLE; LEAST-ACTION PRINCIPLE.

Much of the work on the calculus of variations is devoted to meticulous detail with regard to the number of derivatives assumed to be available for various functions, particularly the competitive admissible functions  $y(x)$ . If too many derivatives are assumed, minima may not exist; if too few are assumed, the solution might not be sufficiently smooth to be acceptable in the light of the original statement of the problem. In an attempt to use fewer derivatives, different approaches are used depending on the number of independent variables  $x$ . [C.M.T.]

**Calculus of vectors** In its simplest form, a vector is a directed line segment. Physical quantities, such as velocity, acceleration, force, and displacement, are vector quantities, or simply vectors, because they can be represented by directed line segments. Vector analysis is a tool of the mathematical physicist, because many physical laws can be expressed in vector form.

Two vectors  $\mathbf{a}$  and  $\mathbf{b}$  are added according to the parallelogram law (Fig. 1). An equivalent definition is as follows: From the end point of  $\mathbf{a}$ , a vector is constructed parallel to  $\mathbf{b}$ , of the same magnitude and direction as  $\mathbf{b}$ . The vector from the origin of  $\mathbf{a}$  to the end point of  $\mathbf{b}$  yields the vector sum  $\mathbf{s} = \mathbf{a} + \mathbf{b}$  (Fig. 2). Any number of vectors can be added by this rule.

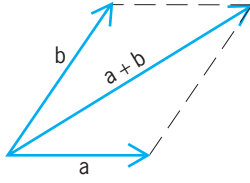

Fig. 1. Addition of two vectors.

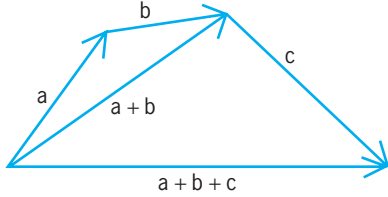

Fig. 2. Addition of three vectors.

Given a vector  $\mathbf{a}$ , a class of vectors can be formed which are parallel to  $\mathbf{a}$  but of different magnitudes. If  $x$  is a real number, the vector  $x\mathbf{a}$  is defined to be parallel to  $\mathbf{a}$  of magnitude  $|x|$  times that of  $\mathbf{a}$ . For  $x < 0$ , the two vectors  $\mathbf{a}$  and  $x\mathbf{a}$  have the same sense of direction, whereas for  $x < 0$  the vector  $x\mathbf{a}$  is in a reverse direction from that of  $\mathbf{a}$ . The vector  $-\mathbf{a}$  is the negative of the vector  $\mathbf{a}$ , such that  $\mathbf{a} + (-\mathbf{a}) = \mathbf{0}$ , with  $\mathbf{0}$  designated as the zero vector (a vector with zero magnitude). Subtraction of two vectors is defined by Eq. (1).

$$\mathbf{a} - \mathbf{b} = \mathbf{b} + (-\mathbf{b}) \quad (1)$$

The cartesian coordinate frame of analytic geometry is very useful for yielding a description of a vector (Fig. 3). The unit

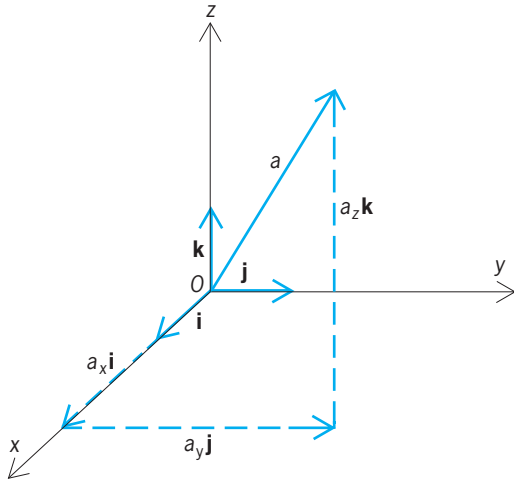

Fig. 3. Vectors in cartesian coordinate system.

vectors  $\mathbf{i}, \mathbf{j}, \mathbf{k}$  lie parallel to the positive  $x, y,$  and  $z$  axes, respectively. Any vector can be written as a linear combination of  $\mathbf{i}, \mathbf{j}, \mathbf{k}$ . From Fig. 3, it is noted that Eq. (2) holds. Furthermore, the

$$\mathbf{a} = a_x \mathbf{i} + a_y \mathbf{j} + a_z \mathbf{k} \quad (2)$$

scalars  $a_x, a_y, a_z$  are simply the projections of  $\mathbf{a}$  on the  $x, y,$  and  $z$  axes, respectively, and are designated as the components of  $\mathbf{a}$ . Thus,  $a_x$  is the  $x$  component of  $\mathbf{a}$ , and so on. If the vector  $\mathbf{b}$  is described by  $\mathbf{b} = b_x \mathbf{i} + b_y \mathbf{j} + b_z \mathbf{k}$ , then Eq. (3) holds.

$$\alpha \mathbf{a} + \beta \mathbf{b} = (\alpha a_x + \beta b_x) \mathbf{i} + (\alpha a_y + \beta b_y) \mathbf{j} + (\alpha a_z + \beta b_z) \mathbf{k} \quad (3)$$

From two vectors  $\mathbf{a}$  and  $\mathbf{b}$ , a scalar quantity is formed from the definition in Eq. (4), where  $\theta$  is the angle between the two

$$\mathbf{a} \cdot \mathbf{b} = |\mathbf{a}| \cdot |\mathbf{b}| \cos \theta \quad (4)$$

vectors when drawn from a common origin (Fig. 4).

In three-dimensional space, a vector can be formed from two vectors  $\mathbf{a}$  and  $\mathbf{b}$  in the following manner if they are non-parallel. Let  $\mathbf{a}$  and  $\mathbf{b}$  have a common origin defining a plane, and let  $\mathbf{c}$  be that vector perpendicular to this plane of magnitude  $|\mathbf{c}| = |\mathbf{a}| |\mathbf{b}| \sin \theta$ . If  $\mathbf{a}$  is rotated into  $\mathbf{b}$  through the angle  $\theta$ , a right-hand screw will advance in the direction of  $\mathbf{c}$  (Fig. 5). Thus Eq. (5) can be written.

$$\mathbf{c} = \mathbf{a} \times \mathbf{b} = |\mathbf{a}| |\mathbf{b}| \sin \theta \mathbf{n} \quad (5)$$

The distributive law can be shown to hold for the vector product so that Eq. (6) holds.

$$(\mathbf{a} + \mathbf{b}) \times (\mathbf{c} + \mathbf{d}) = \mathbf{a} \times \mathbf{c} + \mathbf{a} \times \mathbf{d} + \mathbf{b} \times \mathbf{c} + \mathbf{b} \times \mathbf{d} \quad (6)$$

It follows from

$$\begin{aligned} \mathbf{i} \times \mathbf{i} = \mathbf{j} \times \mathbf{j} = \mathbf{k} \times \mathbf{k} &= \mathbf{0} \\ \mathbf{i} \times \mathbf{c} = \mathbf{k}, \mathbf{j} \times \mathbf{k} = \mathbf{i}, \mathbf{k} \times \mathbf{i} = \mathbf{j} \end{aligned}$$

that for

$$\mathbf{a} = a_x \mathbf{i} + a_y \mathbf{j} + a_z \mathbf{k} \quad \mathbf{b} = b_x \mathbf{i} + b_y \mathbf{j} + b_z \mathbf{k}$$

Eq. (7) holds. The expression in Eq. (7) is to be expanded by the ordinary rules governing determinants.

$$\mathbf{a} \times \mathbf{b} = \begin{vmatrix} \mathbf{i} & \mathbf{j} & \mathbf{k} \\ a_x & a_y & a_z \\ b_x & b_y & b_z \end{vmatrix} \quad (7)$$

It is easy to verify that a reflection of the space coordinates given by  $x' = -x, y' = -y, z' = -z$ , reverses the sign of the components of a vector. Under a space reflection, however, the components of the vector  $\mathbf{a} \times \mathbf{b}$  do not change sign. This is seen from Eq. (7), for if  $a_x, a_y, a_z$  are replaced by  $-a_x, -a_y, -a_z$ , and if  $b_x, b_y, b_z$  are replaced by  $-b_x, -b_y, -b_z$ , the components of  $\mathbf{a} \times \mathbf{b}$  remain invariant. Hence,  $\mathbf{a} \times \mathbf{b}$  is not a true vector and therefore is given the title pseudovector. In electricity theory the magnetic field vector  $\mathbf{B}$  is a pseudovector, whereas the electric field vector is a true vector provided the electric charge is a true scalar under a reflection of axes.

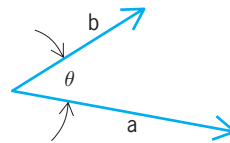

Fig. 4. Scalar product of two vectors.

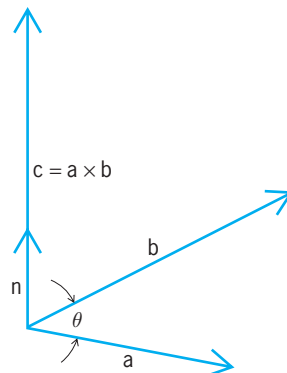

Fig. 5. Vector product of two vectors.

There are three differentiation processes that are of conceptual value in the study of vectors: the gradient of a scalar, the divergence of a vector, and the curl of a vector.

From the scalar  $\phi(x, y, z)$ , one can form the three partial derivatives  $\partial\phi/\partial x$ ,  $\partial\phi/\partial y$ ,  $\partial\phi/\partial z$ , from which the vector in Eq. (8) can

$$\left\{ \begin{array}{l} \text{gradient of } \phi \\ \text{grad } \phi \\ \text{del } \phi \equiv \nabla\phi \end{array} \right\} = \frac{\partial}{\partial x}\mathbf{i} + \frac{\partial}{\partial y}\mathbf{j} + \frac{\partial}{\partial z}\mathbf{k} \quad (8)$$

be formed. The vector,  $\text{grad } \phi$ , has two important properties.  $\text{Grad } \phi$  is a vector field normal to the surface  $\phi(x, y, z) = \text{constant}$  at every point of the surface. Moreover,  $\text{grad } \phi$  yields that unique direction such that  $\phi$  increases at its greatest rate.

The del operator defined by Eq. (9) plays an important role in the development of the differential vector calculus. For the

$$\nabla = \mathbf{i} \frac{\partial}{\partial x} + \mathbf{j} \frac{\partial}{\partial y} + \mathbf{k} \frac{\partial}{\partial z} \quad (9)$$

vector field of Eq. (10), the divergence of  $\mathbf{v}$  is defined by Eq. (11). The divergence of a vector is a scalar.

$$\mathbf{v} = v_1(x, y, z)\mathbf{i} + v_2(x, y, z)\mathbf{j} + v_3(x, y, z)\mathbf{k} \quad (10)$$

$$\text{div } \mathbf{v} = \nabla \cdot \mathbf{v} = \frac{\partial v_1}{\partial x} + \frac{\partial v_2}{\partial y} + \frac{\partial v_3}{\partial z} \quad (11)$$

By use of the del operator one obtains quite formally Eq. (12). The vector  $\nabla \times \mathbf{v}$  is called the curl of  $\mathbf{v}$  ( $\text{curl } \mathbf{v}$ ). Under

$$\nabla \times \mathbf{v} = \begin{vmatrix} \mathbf{i} & \mathbf{j} & \mathbf{k} \\ \frac{\partial}{\partial x} & \frac{\partial}{\partial y} & \frac{\partial}{\partial z} \\ v_1 & v_2 & v_3 \end{vmatrix} = \left( \frac{\partial v_3}{\partial y} - \frac{\partial v_2}{\partial z} \right) \mathbf{i} + \left( \frac{\partial v_1}{\partial z} - \frac{\partial v_3}{\partial x} \right) \mathbf{j} + \left( \frac{\partial v_2}{\partial x} - \frac{\partial v_1}{\partial y} \right) \mathbf{k} \quad (12)$$

a reflection of space coordinates,  $\partial v_3/\partial y \rightarrow \partial(-v_3)/\partial(-y) = \partial v_3/\partial y$ , and so on, so that the curl of  $\mathbf{v}$  is a pseudovector.

If a closed surface is decomposed into a large number of small surfaces, a vector field normal to the surface can be constructed, each normal element being represented by  $d\sigma$ . The magnitude of  $d\sigma$  is the area of the surface element  $dS$ ,  $d\sigma = \mathbf{N} dS$ .

If  $\mathbf{f}$  is a vector field defined at every point of the surface, then notation (13) represents the total flux of  $\mathbf{f}$  through the surface  $S$ .

$$\iint_S \mathbf{f} \cdot d\sigma \quad (13)$$

The elements  $d\sigma$  point outward from the interior of  $S$ .

The divergence theorem of Gauss states that Eq. (14) is true,

$$\iint_S \mathbf{f} \cdot d\sigma = \iiint_R (\nabla \cdot \mathbf{f}) d\tau \quad (14)$$

where  $R$  is the region enclosed by  $S$ ,  $d\tau$  a volume element of  $R$ . See GAUSS' THEOREM.

The line integral of a vector field is described as follows: Let  $\Gamma$  be a space curve, and let  $\mathbf{t}$  be the unit vector field tangent to  $\Gamma$  at every point of  $\Gamma$  in progressing from  $A$  to  $B$ , the initial and end points of the trajectory  $\Gamma$ .

The scalar integral in notation (15) is called the line integral

$$\int_A^B (\mathbf{f} \cdot \mathbf{t}) ds \quad (15)$$

of  $\mathbf{f}$  along  $\Gamma$ , with arc length  $s$  measured along  $\Gamma$ . If  $\mathbf{f}$  is a force field, notation (15) represents the work performed by the force field if a unit test particle is taken from  $A$  to  $B$  along  $\Gamma$ .

The value of the integral of notation (15) will generally depend on the path from  $A$  to  $B$ . However, if  $\mathbf{f} = \nabla\phi$ , then

$$\int_A^B (\mathbf{f} \cdot \mathbf{t}) ds = \int_A^B \nabla\phi \cdot d\mathbf{r} = \int_A^B d\phi = \phi(B) - \phi(A)$$

and the line integral is independent of the path of integration.

The theorem of Stokes states that Eq. (16) holds, where  $\Gamma$

$$\oint_{\Gamma} \mathbf{f} \cdot d\mathbf{r} = \iint_S (\nabla \times \mathbf{f}) \cdot d\sigma \quad (16)$$

is the boundary of the open surface  $S$ . See STOKES' THEOREM. [H.La.]

**Caldera** A large volcanic collapse depression, typically circular to slightly elongate in shape, the dimensions of which are many times greater than any included vent. Calderas range from a few miles to 37 mi (60 km) in diameter. A caldera may resemble a volcanic crater in form, but differs genetically in that it is a collapse rather than a constructional feature. The topographic depression resulting from collapse is commonly widened by slumping of the sides along concentric faults, so that the topographic crater wall lies outside the caldera wall. As originally defined, the term caldrón referred to volcanic subsidence structures, and caldera referred only to the topographic depression formed at the surface by collapse. However, the term caldera is now common as a synonym for caldrón, denoting all features of collapse, both topographic and structural. See PETROLOGY.

Calderas occur primarily in three different volcanic settings, each of which affects their shape and evolution: basaltic shield cones, stratovolcanoes, and volcanic centers consisting of preexisting clusters of volcanoes. These last calderas, associated with broad, large-volume andesitic to rhyolitic ignimbrite sheets, are generally the largest and most impressive, and are those generally denoted by the term. Calderas have been formed throughout much of the Earth's history, ranging in age from Precambrian (greater than 1.4 billion years old) to Holocene (for example, Krakatau in Indonesia, which erupted in 1883). See RHYOLITE; VOLCANO.

In addition to Earth, large calderas occur on Mars, Venus, and Jupiter's moon Io. The presence of calderas on four solar system bodies indicates that the underlying mechanisms of shallow intrusion and caldera collapse are basic processes in planetary geology. See MAGMA.

Collapse occurs because of withdrawal of magma from an underlying chamber some 2.4–3.6 mi (4–6 km) beneath the surface, resulting in foundering of the roof into the chamber. Withdrawal of magma may occur either by relatively passive eruption of lavas, as in the case of calderas formed on basaltic shield cones, or by catastrophic eruption of pyroclastic material, as accompanies formation of the largest calderas.

Caldera-forming eruptions probably last only a few hours or days. Eruption of pyroclastic material begins as gases (predominantly water) that are dissolved in the magma come out of solution at shallow depths. Magma is explosively fragmented into particles ranging in size from micrometers to meters. An eruption column develops, rising several miles into the atmosphere. This first and most explosive phase of the eruption, known as the Plinian phase, covers the area around the vent with pumice. Caldera subsidence occurs during eruption. As caldera subsidence proceeds and eruption becomes less explosive, the Plinian eruption column collapses. This collapse produces hot, ground-hugging pyroclastic flows that can travel as far as 93 mi (150 km) outward from the vent at speeds of 330 ft/s (100 m/s). Successive collapses of the column produce multiple flow units with an aggregate thickness that may be several hundreds of feet thick near the caldera.

The floors of many of the largest calderas (typically those with diameters exceeding 6 mi or 10 km) have been domed upward, resulting in a central massif or resurgent dome. Resurgence

results from the continued or renewed buoyant rise of magma after collapse.

Calderas typically contain or are associated with extensive hydrothermal systems, because of two factors: (1) the shallow magma chambers that underlie them provide a readily available source of heat; and (2) the floors of calderas may be extensively fractured, which, along with the main ring faults, allows meteoric water to penetrate deeply into the crust beneath calderas. Hydrothermal activity related to a caldera system can occur any time after magmas rise to shallow crustal levels, but it is dominant late in caldera evolution.

Many metals, including such base and precious metals as molybdenum, copper, lead, zinc, silver, gold, mercury, uranium, tungsten, and antimony, are mobile in hydrothermal circulation systems driven by the shallow intrusions which underlie and give rise to large calderas. Many economically important ore deposits in the western United States lie within calderas. See ORE AND MINERAL DEPOSITS. [W.S.Ba.]

**Calendar** A system that gives a name to each day. Ancient calendars were based on observations of phenomena such as the waxing and waning of the Moon, the change in seasons, or the movement of heavenly bodies. Modern calendars tend to be based solely on arithmetical rules, distanced from their motivation in nature.

Most calendars divide a year into an integral number of months and divide months into an integral number of days. However, these astronomical periods—day, month, and year—are incommensurate, so exactly how these time periods are coordinated and the accuracy with which they approximate their astronomical values are what differentiate one calendar from another. See DAY; EARTH ROTATION AND ORBITAL MOTION; MONTH; YEAR.

Dozens of calendars are still in use, in addition to the almost universally used Gregorian calendar. Many religious holidays and national events are determined by dates on these calendars. Solar calendars—including the Egyptian, Julian, Coptic, Ethiopic, Gregorian, and Persian—are based on the yearly solar cycle, whereas lunar calendars such as the Islamic and lunisolar calendars such as the Hebrew, Hindu, and Chinese take the monthly lunar cycle as the basic building block. Most solar calendars are divided into months, but these months are divorced from the lunar events; they are sometimes related to the movement of the Sun through the twelve signs of the zodiac.

Almost every calendar incorporates a notion of “leap” year to correct the cumulative error caused by approximating a year by an integral number of days and months. Solar calendars add a day every few years to keep up with the astronomical year.

The simplest naming convention would be to assign an integer to each day; fixing day 1 would determine the whole calendar. The Babylonians had such a day count, as did the Maya and the Hindus. Astronomers, especially those studying variable stars, use Julian day numbers to specify dates. The Julian period, introduced in 1583 by Joseph Justus Scaliger, was originally a counting of years in a cycle of 7980 years, starting from 4713 B.C.E. (before the common era; or B.C.); nineteenth-century astronomers adapted the system into a strict counting of days backward and forward from JD0 = noon on Monday, January 1, 4713 B.C.E. (Julian) = noon on Monday, November 24, –4713 (Gregorian). A fractional part of a Julian day gives the fraction of a day beyond noon. Computer scientists often use diurnal calendars as an intermediate device for converting from one calendar to another.

The Gregorian calendar, now in common use throughout the world, is based on a 12-month year that closely approximates the Earth's solar cycle. This calendar was designed by a commission assembled by Pope Gregory XIII in the sixteenth century; the main author of the new system was the Naples astronomer Aloysius Lilius. This calendar is based on a 365-day common year divided into 12 months, and on 366 days in leap years, the extra day being added to the second

month. A year is a leap year if it is divisible by 4 and is not a century year (multiple of 100) or if it is divisible by 400. For example, 1900 is not a leap year; 2000 is a leap year. The Gregorian calendar differs from its predecessor, the Julian calendar, only in that the Julian calendar did not include the century rule for leap years—all century years were leap years.

Since every fourth year on the Julian calendar was a leap year, a cycle of 4 years contained  $(4 \times 365) + 1 = 1461$  days, giving an average length of year of 365.25 days. This is somewhat more than the mean length of the tropical year, and over the centuries the calendar slipped with respect to the seasons. By the sixteenth century, the date of the spring equinox had shifted from around March 21 to around March 11. Pope Gregory XIII instituted only a minor change in the calendar: century years not divisible by 400 would no longer be leap years. (He also improved the rules for Easter.) Thus, three out of four century years are common years, giving a cycle of 400 years containing  $(400 \times 365) + 97 = 146,097$  days and an average year length of  $146,097/400 = 365.2425$  days. He also corrected the accumulated 10-day error in the calendar by proclaiming that Thursday, October 4, 1582 C.E., the last date in the old-style (Julian) calendar, would be followed by Friday, October 15, 1582, the first day of the new-style (Gregorian) calendar. Catholic countries followed his rule, but Protestant countries resisted. Turkey did not switch to the Gregorian calendar until 1927.

The Islamic calendar is an example of a strictly lunar calendar, with no intercalation of months (unlike lunisolar calendars). Its independence of the solar cycle means that its months do not occur in fixed seasons but migrate through the solar year.

Lunisolar calendars invariably alternate 12- and 13-month years. The so-called Metonic cycle is based on the observation that 19 solar years contain almost exactly 235 lunar months. This correspondence, named after the Athenian astronomer Meton and known much earlier to ancient Babylonian and Chinese astronomers, makes a relatively simple and accurate fixed solar/lunar calendar feasible. The  $235 = (12 \times 12) + (7 \times 13)$  months in the cycle are divided into 12 years of 12 months and 7 leap years of 13 months. The 7 leap years are evenly distributed within the 19-year cycle, with gaps of 1 or 2 years between them. The Metonic cycle is (currently) accurate to within 6.5 minutes a year and is still employed in the Hebrew calendar (instituted in 359 C.E.) and for the ecclesiastical calculation of Easter. [N.D.; E.M.Re.]

**Calibration** The process of determining the performance parameters of an artifact, instrument, or system by comparing it with measurement standards. Adjustment may be a part of a calibration, but not necessarily. A calibration assures that a device or system will produce results which meet or exceed some defined criteria with a specified degree of confidence.

Two important measurement concepts related to calibration are precision and accuracy. Precision refers to the minimum discernible change in the parameter being measured, while accuracy refers to the actual amount of error that exists in a calibration. All measurement processes used for calibration are subject to various sources of error. It is common practice to classify them as random or systematic errors. When a measurement is repeated many times, the results will exhibit random statistical fluctuations which may or may not be significant. Systematic errors are offsets from the true value of a parameter and, if they are known, corrections are generally applied, eliminating their effect on the calibration. If they are not known, they can have an adverse effect on the accuracy of the calibration. High-accuracy calibrations are usually accompanied by an analysis of the sources of error and a statement of the uncertainty of the calibration. Uncertainty indicates how much the accuracy of a calibration could be degraded as a result of the combined errors. See ANALYSIS OF VARIANCE; DISTRIBUTION (PROBABILITY); INSTRUMENT SCIENCE; PHYSICAL MEASUREMENT; PROBABILITY; PROBABILITY (PHYSICS); STATISTICS. [B.Br.]

**Caliche** A soil that is mineralogically an impure limestone. Such soils are also known as duricrust, kunkar, nari, kafkalla, Omdurman lime, croute, and race. Many soil profiles in semiarid climates (that is, those characterized by a rainfall of 4–20 in. or 10–50 cm per year) contain concentrations of calcium carbonate ( $\text{CaCO}_3$ ). This calcium carbonate is not an original feature of the soils but has been added during soil formation either by direct precipitation in soil pores or by replacement of preexisting material. Fossil analogs of caliche, which are widely reported in ancient sedimentary sequences, are referred to as calcrete or concretion. See LIMESTONE; SOIL.

The principal control on the formation of caliche is a hydrologic regime in which there is sufficient moisture to introduce calcium carbonate in solution to the soil but not enough to leach it through the system. As a result, calcium carbonate precipitates in the soil during periods of evaporation, and it will slowly increase in amount as long as the hydrologic setting remains stable. The source of the carbonate may be from the dissolution of adjacent limestones, from the hydrolysis of plagioclase and other silicates, or from carbonate loess.

Within the climatic constraints noted above, most caliche forms in river floodplains and near the surface of alluvial fans. In addition, caliche deposits may form within exposed marine and lacustrine limestones during periods of sea-level fall or lake desiccation. Caliche may also form at inert pediment (eroded rock) surfaces; in the geological record such surfaces will be seen as unconformities. In this context it is interesting that the first unconformity ever recognized as such, by James Hutton in 1787 on the Isle of Arran, western Scotland, is characterized by a development of caliche. See UNCONFORMITY.

The mineralogy of the host soil or rock in which a caliche develops may vary considerably; it is not essential for there to be any preexisting carbonate grains within the regolith. The most favorable medium is a clay-rich soil of limited permeability. Low permeability provides the residence time in the soil pores necessary for calcite to precipitate. See CALCITE; REGOLITH. [N.Do.]

**Caliciales** An order of the Ascolichenes. This order is characterized by an unusual apothecium. The hymenial layer originates normally, but by the time the spores are mature, the asci and paraphyses have partially disintegrated into a mass of spores and hymenial tissues known as a mazaedium. Two families, Caliciaceae and Roesleriaceae, are so close that some species in either one may or may not lichenize symbiotic algae. The family Cypheliaceae is more typically crustose, with sessile apothecia and a more fully developed thallus. The Sphaerophoraceae are fruticose but the thallus is solid. The apothecia are open or enclosed in a spherical chamber at the tips of branches. The largest genus, *Sphaerophorus*, is widespread in boreal zones and mountains of both hemispheres. [M.E.H.]

**Californium** A chemical element, Cf, atomic number 98, the ninth member of the actinide series of elements. Its discovery and production have been based upon artificial nuclear transmutation of radioactive isotopes of lighter elements. All isotopes of californium are radioactive, with half-lives ranging from a minute to about 1000 years. Because of its nuclear instability, californium does not exist in the Earth's crust. See ACTINIDE ELEMENTS; BERKELIUM; PERIODIC TABLE; RADIOACTIVITY.

The chemical properties are similar to those observed for other 3+ actinide elements: a water-soluble nitrate, sulfate, chloride, and perchlorate. Californium is precipitated as the fluoride, oxalate, or hydroxide. Ion-exchange chromatography can be used for the isolation and identification of californium in the presence of other actinide elements. Californium metal is quite volatile and can be distilled at temperatures of the order of 1100–1200°C (2010–2190°F). It is chemically reactive and appears to exist in three different crystalline modifications between room temperature and its melting point, 900°C (1600°F).

The most easily produced isotope for many purposes is  $^{252}\text{Cf}$ , which is obtained in gram quantities in nuclear reactors and has a half-life of 2.6 years. It decays partially by spontaneous fission, and has been very useful for the study of fission. It has also had an important influence on the development of counters and electronic systems with applications not only in nuclear physics but in medical research as well. See TRANSURANIUM ELEMENTS.

[G.T.S.]

**Caliper** An instrument with two legs used for measuring linear dimensions. Calipers may be fixed, adjustable, or movable. Fixed calipers are used in routine inspection of standard products; adjustable calipers are used similarly but can be reset to slightly different dimensions if necessary. Movable calipers can be set to match the distance being measured. The legs may pivot about a rivet or screw in a firm-joint pair of calipers; they may pivot about a pin, being held against the pin by a spring and set in position by a knurled nut on a threaded rod; or the legs may slide either directly (caliper rule) or along a screw (micrometer caliper) relative to each other. See MICROMETER.

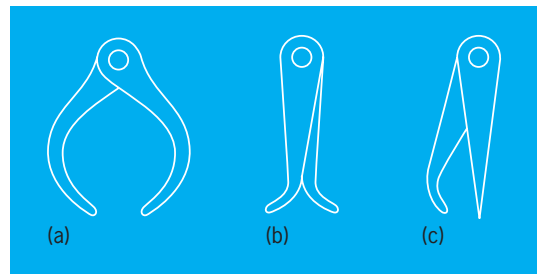

Some typical machinist's calipers. (a) Outside. (b) Inside. (c) Hermaphrodite. (After R. J. Sweeney, *Measurement Techniques in Mechanical Engineering*, John Wiley and Sons, Inc., 1953)

The legs may be shaped to facilitate measuring outside dimensions, inside dimensions, surface dimensions as between points on a plate, or from a surface into a hole as in a keyway (see illustration). See GAGE. [F.H.R.]

**Callitrichales** An order of flowering plants, division Magnoliophyta (Angiospermae), in the subclass Asteridae of the class Magnoliopsida (dicotyledons). The order consists of three small families with about 50 species, most of which are aquatics or small herbs of wet places, and have much reduced vascular systems. The flowers are small and solitary in the axils of leaves or bracts. The perianth is nearly or completely absent. The pistil consists of two carpels united to form a compound, unilocular or four-chambered ovary, or sometimes the pistil appears to be of a single carpel. The Callitrichales are placed in the Asteridae largely on the basis of their embryology and phytochemistry. The ovules are anatropous and tenuinucellar and have a single integument, and the plants generally produce iridoid substances. See ASTERIDAE; MAGNOLIOPHYTA; MAGNOLIOPSIDA; PLANT KINGDOM. [T.M.Ba.]

**Calobryales** An order of liverworts. They are characterized by prostrate, simple or branched, leafless stems and erect, leafy branches of a radial organization. The order consists of a single genus, *Calobryum*, and 12 species, most of them occupying restricted ranges in apparently relic areas indicative of an ancient origin and dispersal. The order is considered primitive in comparison with the Jungermanniales, in which the leafy axis tends to be prostrate and the underleaves reduced. The stems are thick and fleshy, with no differentiated outer layers. Rhizoids are lacking. The leaves may be small or lacking below, larger and more crowded above. They are three-ranked, with those of one

rank sometimes more or less reduced. They are broad, unlobed, and entire. See BRYOPHYTA; JUNGERMANNIALES; JUNGERMANNIACEAE.

[H.C.R.]

**Calomel** Mercury(I) chloride,  $\text{Hg}_2\text{Cl}_2$ , a covalent compound which is insoluble in water. The substance sublimes when heated. The formula weight is 472.086 and the specific gravity is 7.16 at 20°C (68°F). The material is a white, impalpable powder consisting of fine tetragonal crystals.

Calomel is used in preparing insecticides and medicines. It is well known in the laboratory as the constituent of the calomel reference electrodes which are commonly used in conjunction with a glass electrode to measure pH. See MERCURY (ELEMENT).

[E.E.W.]

**Calorimetry** The measurement of the quantity of heat energy involved in processes such as chemical reactions, changes of state, and mixing of substances, or in the determination of heat capacities of substances. The unit of energy in the International System of Units is the joule. Another unit still being used is the calorie, defined as 4.184 joules.

A calorimeter is an apparatus for measuring the quantity of heat energy released or absorbed during a process. Since there are many processes that can be studied over a wide range of temperature and pressure, a large variety of calorimeters have been developed.

Nonisothermal calorimeters measure the temperature change that occurs during the process. An aneroid-type nonisothermal calorimeter is normally constructed of a material having a high thermal conductivity, such as copper, so that there is rapid temperature equilibration. It is isolated from its surroundings by a high vacuum to reduce heat leaks. This type of calorimeter can be used for determining the heat capacity of materials when measurements involve low temperatures. Aneroid-type nonisothermal calorimeters have also been developed for measuring the energy of combustion for small samples of rare materials.

With most nonisothermal calorimeters, it is necessary to relate the temperature rise to the quantity of energy released in the process. This is done by determining the calorimeter constant, which is the amount of energy required to increase the temperature of the calorimeter itself by 1°. This value can be determined by electrical calibration or by measurement on a well-defined test system. For example, in bomb calorimetry the calorimeter constant is often determined from the temperature rise which occurs when a known mass of a very pure standard sample of benzoic acid is burned.

Isothermal calorimeters make measurements at constant temperature. The simplest example is a calorimeter containing an outer annular space filled with a liquid in equilibrium with a crystalline solid at its melting point, arranged so that any volume change will displace mercury along a capillary tube. The Bunsen ice calorimeter operates at 0°C (32°F) with a mixture of ice and water. Changes as a result of the process being studied cause the ice to melt or the water to freeze, and the consequent volume change is determined by measurement of the movement of the mercury meniscus in the capillary tube. While these calorimeters can yield accurate results, they are limited to operation at the equilibrium temperature of the two-phase system. Other types of isothermal calorimeters use the addition of electrical energy to achieve exact balance of the heat absorption that occurs during an endothermic process.

All calorimeters consist of the calorimeter proper and a jacket or a bath, which is used to control the temperature of the calorimeter and the rate of heat leak to the environment. For temperatures not too far removed from room temperature, the jacket or bath contains liquid at a controlled temperature. For measurements at extreme temperatures, the jacket usually consists of a metal block containing a heater to control the temperature. With nonisothermal calorimeters, where the jacket is kept at a constant temperature, there will be some heat leak to the jacket

when the temperature of the calorimeter changes. It is necessary to correct the temperature change observed to the value it would have been if there were no leak. This is achieved by measuring the temperature of the calorimeter for a time period both before and after the process and applying Newton's law of cooling. This correction can be avoided by using the technique of adiabatic calorimetry, where the temperature of the jacket is kept equal to the temperature of the calorimeter as a change occurs. This technique requires more elaborate temperature control, and its primary use is for accurate heat capacity measurements at low temperatures.

In calorimetric experiments it is necessary to measure temperature differences accurately; in some cases the temperature itself must be accurately known. Modern calorimeters use resistance thermometers to measure both temperatures and temperature differences, while thermocouples or thermistors are used to measure smaller temperature differences. See TEMPERATURE MEASUREMENT; THERMISTOR; THERMOCOUPLE; THERMOMETER.

Heat capacities of materials and heats of combustion are processes that are routinely measured with calorimeters. Calorimeters are also used to measure the heat involved in phase changes, for example, the change from a liquid to a solid (fusion) or from a liquid to a gas (vaporization). Calorimetry has also been applied to the measurement of heats of hydrogenation of unsaturated organic compounds, the heat of dissolution of a solid in a liquid, or the heat change on mixing two liquids. [K.M.M.]

**Calycerales** An order of flowering plants, division Magnoliophyta (Angiospermae), in the subclass Asteridae of the class Magnoliopsida (dicotyledons). The order consists of a single family with about 60 species native to tropical America. The plants are herbs with alternate, simple leaves that do not have stipules. The flowers are borne in involucre heads with centripetal flowering sequence. The calyx is reduced to small lobes or teeth, and the corolla consists of (4)5(6) fused lobes and is regular or somewhat irregular. The stamens are attached near the summit of the corolla tube, and the filaments are more or less connate. The pistil consists of two united carpels, forming a compound, inferior ovary with a single, pendulous ovule. The order Calycerales is sometimes included within the Dipsacales, and the order has attracted attention because of the overall resemblance of the inflorescence to that of the Asteraceae. See ASTERACEAE; ASTERIDAE; DIPSACALES; MAGNOLIOPHYTA; MAGNOLIOPSIDA; PLANT KINGDOM. [T.M.Ba.]

**Cam mechanism** A mechanical linkage whose purpose is to produce, by means of a contoured cam surface, a prescribed motion of the output link of the linkage, called the follower. Cam and follower are a higher pair. See LINKAGE (MECHANISM).

A familiar application of a cam mechanism is in the opening and closing of valves in an automotive engine. The cam rotates with the cam shaft, usually at constant angular velocity, while the follower moves up and down as controlled by the cam surface. A cam is sometimes made in the form of a translating cam. Other cam mechanisms, employed in elementary mechanical analog computers, are simple memory devices, in which the position of the cam (input) determines the position of the follower (output or readout).

Although many requisite motions in machinery are accomplished by use of pin-jointed mechanisms, such as four-bar linkages, a cam mechanism frequently is the only practical solution to the problem of converting the available input, usually rotating or reciprocating, to a desired output, which may be an exceedingly complex motion. No other mechanism is as versatile and as straightforward in design. However, a cam may be difficult and costly to manufacture, and it is often noisy and susceptible to wear, fatigue, and vibration.

Cams are used in many machines. They are numerous in automatic packaging, shoemaking, typesetting machines, and the like, but are often found as well in machine tools, reciprocating



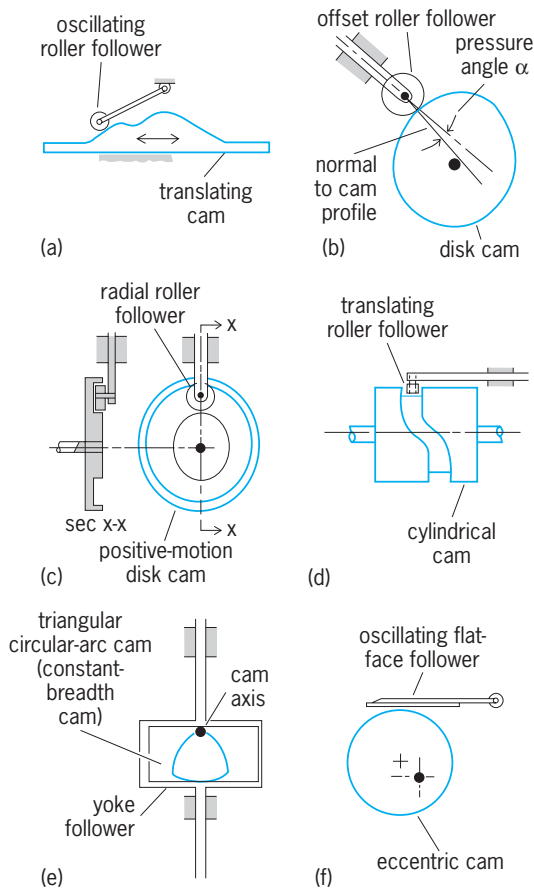

**Classification of cams. (a) Translating. (b) Disk. (c) Positive motion. (d) Cylindrical. (e) With yoke follower. (f) With flat-face follower.**

engines, and compressors. They are occasionally used in rotating machinery.

Cams are classified as translating, disk, plate, cylindrical, or drum (see illustration). The link having the contoured surface that prescribes the motion of the follower is called the cam. Cams are usually made of steel, often hardened to resist wear and, for high-speed application, precisely ground.

The output link, which is maintained in contact with the cam surface, is the follower. Followers are classified by their shape as roller, flat face, and spherical face. Followers are also described by the nature of their constraints, for example, radial, in which motion is reciprocating along a radius from the cam's axis of rotation; offset, in which motion is reciprocating along a line that does not intersect the axis of rotation (illus. *b*); and oscillating, or pivoted (illus. *a*). Three-dimensional cam-and-follower systems are coming into more frequent use, where the follower may travel over a lumpy surface. [D.PAd.]

**Cambrian** An interval of time in Earth history (Cambrian Period) and its rock record (Cambrian System). The Cambrian Period spanned about 60 million years and began with the first appearance of marine animals with mineralized (calcium carbonate, calcium phosphate) shells. The Cambrian System includes many different kinds of marine sandstones, shales, limestones, dolomites, and volcanics. Apart from the occurrence of an alkaline playa containing deposits of trona (hydrated basic sodium carbonate) in the Officer Basin of South Australia, there is very little provable record of nonmarine Cambrian environments. The best present estimates suggest that Cambrian time began about 545 million years ago (Ma) and ended at about 485 Ma. It is the longest of the Paleozoic periods and the fourth longest of the Phanerozoic periods.

The Cambrian world can be resolved into at least four major continents that were quite different from those of today (see illustration). These were (1) Laurentia, which is essentially North America, minus a narrow belt along the eastern coast from eastern Newfoundland to southern New England that belonged to a separate microcontinent, Avalonia. This microcontinent, which also included present-day England, and another microcontinent now incorporated in South Carolina were originally marginal to Gondwana; (2) Baltica, consisting of present-day northern Europe north of France and west of the Ural Mountains but excluding most of Scotland and northern Ireland, which are fragments of Laurentia; (3) Gondwana, a giant continent whose present-day fragments are Africa, South America, India, Australia, Antarctica, parts of southern Europe, the Middle East, and Southeast Asia; and (4) Siberia, including much of the north-eastern quarter of Asia. See CONTINENTAL MARGIN; CONTINENTS, EVOLUTION OF; PLATE TECTONICS.

For most practical purposes, rocks of Cambrian age are recognized by their content of distinctive fossils. On the basis of the successive changes in the evolutionary record of Cambrian life that have been worked out during the past century, the Cambrian System has been divided globally into three or four series, each of which has been further divided on each continent into stages, each stage consisting of several zones. Despite the amount of work already done, precise intercontinental correlation of series and stage boundaries, and of zones, is still difficult, especially in the Early Cambrian due to marked faunal provinciality. Refinement of intercontinental correlation of these ancient rocks is a topic of research.

The record preserved in rocks indicates that essentially all Cambrian plants and animals lived in the sea. The few places where terrestrial sediments have been preserved suggest that the land was barren of major plant life, and there are no known records of Cambrian insects or of terrestrial vertebrate animals of any kind.

The plant record consists entirely of algae, preserved either as carbonized impressions in marine black shales or as filamentous or blotchy microstructures within marine buildups of calcium carbonate, called stromatolites, produced by the actions of these organisms. Cambrian algal stromatolites were generally low domal structures, rarely more than a few meters high or wide, which were built up by the trapping or precipitation of calcium carbonate by one or more species of algae. Such structures, often composed of upwardly arched laminae, were common in regions of carbonate sedimentation in the shallow Cambrian seas. See STROMATOLITE.

The most abundant remains of organisms in Cambrian rocks are of trilobites. They are present in almost every fossiliferous Cambrian deposit and are the principal tools used to describe divisions of Cambrian time and to correlate Cambrian rocks. These marine arthropods ranged from a few millimeters to 20 in. (50 cm) in length, but most were less than 4 in. (10 cm) long. The

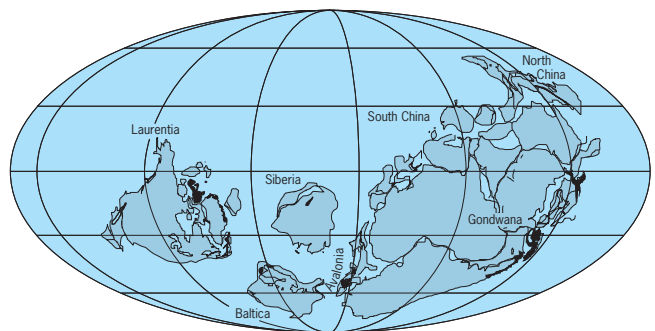

**Reconstruction of the Lower Cambrian world. (After W. S. McKerrow, C. R. Scotese, and M. D. Brasier, *Early Cambrian continental reconstructions*. *J. Geol. Soc.*, 149:599-606, 1992)**

next most abundant Cambrian fossils are brachiopods. These bivalved animals were often gregarious and lived on the sediment surface or on the surfaces of other organisms. Limestones of Early Cambrian age may contain large reeflike structures formed by an association of algae and an extinct phylum of invertebrates called *Archaeocyatha*. The Cambrian record of mollusks and echinoderms is characterized by many strange-looking forms. Some lived for only short periods of time and left no clear descendants. Except for rare jellyfish impressions, the Coelenterata were thought to be unrepresented in Cambrian rocks. Corals have now been discovered in early Middle Cambrian rocks in Australia. However, like clams, they are not seen again as fossils until Middle Ordovician time, many tens of millions of years later. See ARCHAEOCYATHA; BRACHIOPODA; COELENTERATA; ECHINODERMATA; MOLLUSCA; TRILOBITA.

Throughout Cambrian time, terrestrial landscapes were stark and barren. Life in the sea was primitive and struggling for existence. Only in post-Cambrian time did the shallow marine environment stabilize and marine life really flourish. Only then did vertebrates evolve and plants and animals invade the land. [A.R.P.; J.H.Sh.]

**Camel** The name given to two species of mammals which are members of the family Camelidae in the order Artiodactyla. These are the Bactrian camel (*Camelus bactrianus*) and the Arabian or dromedary camel (*C. dromedarius*). Both species are domesticated, but a few wild herds of Bactrian camels are still in existence in the Gobi desert. The legs of these animals are long and slender and terminate in two toes. The neck and head are elongate, and there is a cleft upper lip. The period of gestation is about 1 year and the female breeds every second year, producing one young (colt).

The Bactrian camel is stronger and more heavily built than the dromedary and is more suitable as a pack animal. There are two humps of fatty tissue, one over the shoulders and the other atop the hindquarters. This animal is economically important as it provides milk, meat, and leather for the nomads in central Asia.

The Arabian camel is taller than the Bactrian and has a single hump of fatty tissue, which can be used as a food reserve. There are two varieties of this species found in the desert. One is the baggage camel, used as a beast of burden. The other type is the more slightly built racing camel. The species is well suited to desert life with its broad feet adapted to walking on sand, its ability to close its nostrils completely, and its double row of interlocking eyelashes.

These two species have a most important physiological adaptation in their ability to conserve water. Camels do not store water but conserve it, since the body is well insulated by fur and has a temperature range of over 12°F (7°C) before it perspires sufficiently to prevent a further rise. The camel can lose over 40% of its body water without fear of dehydration. However, although able to survive for long periods without water, it may drink as much as 15 gal (57 liters) when water is available. See ARTIODACTYLA. [C.B.C.]

**Camel's hair** A fine hair known to the American consumer chiefly in the form of high-quality coat fabrics. This textile fiber is obtained from the two-humped Bactrian camel. Camel's-hair fabrics are ideal for comfort, particularly when used for overcoating, as they are especially warm and light in weight. Camel's hair is characterized by strength, luster, and smoothness. The best quality is expensive. It is often mixed with wool to improve the quality of the wool fabric. The price of such a mixed cloth is much less than that of a 100% camel's-hair fabric. See CAMEL; NATURAL FIBER; WOOL. [M.D.P.]

**Cameo** A type of carved gemstone in which the background is cut away to leave the subject in relief. Often cameos are cut from stones in which the coloring is layered, resulting in a figure

of one color and a background of another. The term cameo, when used without qualification, is usually reserved for those cut from a gem mineral, although they are known also as stone cameos. The commonly encountered cameo cut from shell is properly called a shell cameo.

Most cameos are cut from onyx or agate, but many other varieties of quartz, such as tiger's-eye, bloodstone, sard, carnelian, and amethyst, are used; other materials used include beryl, malachite, hematite, labradorite, and moonstone. See GEM; INTAGLIO (GEMOLOGY). [R.T.L.]

**Camera** A device for forming and recording images; the basic tool of photography. In its simplest form, a camera is a light-tight box in which an image is formed by a pinhole or lens at one end on a light-sensitive material at the opposite end. Most cameras contain an aperture and shutter for controlling the amount of light reaching the light-sensitive material (exposure). The receiving material, the film, is usually a plastic sheet or flexible strip coated with a photosensitive silver halide emulsion. It can also be an electronic device such as a charge-coupled device.

Cameras for still photography include box, point-and-shoot, view-and-press, roll film, 35-mm, instant-picture, stereo, underwater, and panoramic. Some categories overlap. Still video and digital cameras use electronic sensors instead of film, and store the image in solid-state memory or on magnetic media or optical disks. Motion picture or cine cameras record movement at regular intervals in a series of frames, which are projected on a screen to create an illusion of movement. Television and video cameras record movement electronically for broadcast and storage on magnetic media or optical disks. Camcorders are video cameras which contain both the image sensor and recording media in a single unit. See PHOTOGRAPHY. [L.R.Wh.]

**Camerata** An extinct subclass of stalked Crinoidea comprising about 210 Paleozoic genera ranging from the Lower Ordovician to the upper Permian. The calyx was composed of a rigid, boxlike structure of many small, polygonal plates. The lower arm plates (brachials) were solidly incorporated into the upper part of the calyx, and were separated by small interbrachial and interrachial plates. The tegmen was rigid and roofed over the mouth and proximal food grooves. Advanced forms had a long, slender, solid anal tube with the anal opening at the tip. All but a few primitive Ordovician forms had biserial arms, and the arms bore pinnules.

Both dicyclic forms with infrabasal plates (order Diplobathrida; 50 genera) and monocyclic forms without infrabasals (order Monobathrida; 160 genera) are known. The former became extinct during middle Mississippian time, the latter persisted to the close of the Paleozoic Era and flourished during Mississippian time. The origin of the Camerata is obscure but presumably occurred during Cambrian or earliest Ordovician time. Camerates are not closely related to the other two large subclasses of Paleozoic crinoids, the flexibles and the inadunates. See CRINOIDEA; ECHINODERMATA. [N.G.L.]

**Campanulales** An order of flowering plants, division Magnoliophyta in the subclass Asteridae of the class Magnoliopsida (dicotyledons). It consists of 7 families and about 2500 species. The order is distinguished in this subclass by its chiefly herbaceous habit, alternate leaves, inferior ovary, and stamens which are free from the corolla or attached at the base of the tube. About 2000 of the species belong to the single family Campanulaceae. Several familiar ornamentals, including the Canterbury bell (*Campanula medium*) and the cardinal flower (*Lobelia cardinalis*), belong to the Campanulaceae. See ASTERIDAE; MAGNOLIOPHYTA; MAGNOLIOPSIDA; ORNAMENTAL PLANTS; PLANT KINGDOM. [A.Cr.; T.M.Ba.]

**Camphor** A bicyclic, saturated terpene ketone. It exists in the optically active dextro and levo forms, and as the racemic

mixture of the two forms. All of these melt within a degree of 178°C (352°F). The principal form is *dextro*-camphor, which occurs in the wood and leaves of the camphor tree (*Cinnamomum camphora*). Camphor is also synthesized commercially on a large scale from pinene which yields mainly the racemic variety. The structural formula of the molecule is shown below.

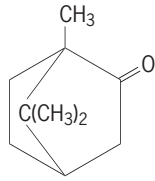

Camphor has a characteristic odor; it crystallizes in thin plates and sublimates readily at ordinary temperatures.

Camphor has use in liniments and as a mild rubefacient, analgesic, and antipruritic. It has a local action on the gastrointestinal tract, producing a feeling of warmth and comfort in the stomach. It is also used in photographic film and as a plasticizer in the manufacture of plastics. See KETONE; PINE TERPENE; TERPENE.

[E.L.S.]

**Camphor tree** The plant *Cinnamomum camphora*, a member of the laurel family (Lauraceae) and a native of China, Japan, and Taiwan. The tree is dense-topped and has shiny, dark, evergreen leaves. All parts of the tree contain camphor, an essential oil which is obtained from the finely ground wood and leaves by distillation with steam. See CAMPHOR; MAGNOLIALES.

[P.D.St./E.L.C.]

**Camptostromatoidea** A small class of primitive echinoderms (subphylum Echinozoa) known from the single species *Camptostroma roddyi* based on about 200 specimens from the Early Cambrian (*Bonnia-Olenellus* Zone) in southeastern Pennsylvania. *Camptostroma* was originally described as a hydrozoan or jellyfish, but it was recognized as an echinoderm and the new class Camptostromatoidea was set up for it. *Camptostroma* has been reinterpreted as an early edrioasteroid, and as a "stem echinoderm" ancestral to several other groups including edrioasteroids. Because of *Camptostroma's* puzzling morphology, different reconstructions of it have been made. Its unusual thecal plating is the main feature separating *Camptostroma* from later Edrioasteroidea, which it otherwise resembles, but this genus may also have been ancestral to other classes such as the Eocrinioidea. See ECHINODERMATA; ECHINOZOA.

[J.Sp.]

**Canal** An artificial open channel usually used to convey water or vessels from one point to another. Canals are generally classified according to use as irrigation, power, flood-control, drainage, or navigation canals or channels. All but the last type are regarded as water conveyance canals.

Canals may be lined or unlined. Linings may consist of plain or reinforced concrete, cement mortar, asphalt, brick, stone, buried synthetic membranes, or compacted earth materials. Linings serve to reduce water losses by seepage or percolation through pervious foundations or embankments and to lessen the cost of weed control. Concrete and other hard-surface linings also permit higher water velocities and, therefore, steeper gradients and smaller cross sections, which may reduce costs and the amount of right-of-way required.

Navigation canals are artificial inland waterways for boats, barges, or ships. A canalized river is one that has been made navigable by construction of one or more weirs or overflow dams to impound river flow, thereby providing navigable depths. Locks may be built in navigation canals and canalized rivers to enable vessels to move to higher or lower water levels. A lock is a chamber equipped with gates at both upstream and downstream ends. Water impounded in the chamber is used to raise or lower a vessel from one elevation to another. The lock chamber is filled and

emptied by means of filling and emptying valves and a culvert system usually located in the walls and bottom of the lock. See IRRIGATION (AGRICULTURE); TRANSPORTATION ENGINEERING; WATER SUPPLY ENGINEERING.

[C.E.; B.R.]

**Cancer (constellation)** The Crab, in astronomy, a winter constellation and the faintest of the zodiacal groups. Cancer, the fourth sign of the zodiac, is important because during early times it marked the northernmost limit of the ecliptic, when the zodiacal system was adopted. The Tropic of Cancer takes its name from this constellation. Four faint stars form a rough Y outline, which is suggestive of a crab. In the center of Cancer is a hazy object. This is a magnificent cluster of faint stars called Praesepe (the Beehive) or the Manger. See CONSTELLATION.

[C.-S.Y.]

**Cancer (medicine)** The common name for a malignant neoplasm or tumor. Neoplasms are new growths and can be divided into benign and malignant types, although in some instances the distinction is unclear. The most important differentiating feature is that a malignant tumor will invade surrounding structures and metastasize (spread) to distant sites whereas a benign tumor will not. Other distinctions between benign and malignant growth include the following: malignancies but not benign types are composed of highly atypical cells; malignancies tend to show more rapid growth than benign neoplasms, and are composed, in part, of cells showing frequent mitotic activity; and malignant tumors tend to grow progressively without self-limitation. See MITOSIS; TUMOR.

Malignant neoplasms that arise from cells of mesenchymal origin (for example, bone muscle, connective tissue) are called sarcomas. Those that develop from epithelial cells and tissues (for example, skin, mucosal membranes, and glandular tissues) are termed carcinomas. Carcinomas usually metastasize initially by way of lymphatic channels, whereas sarcomas spread to distant organs through the bloodstream.

The cause of most types of human cancers is unknown. However, a number of factors are thought to be operative in the development of some malignant neoplasms. Genetic factors are thought to be causally related to some human malignancies such as lung cancer in that the incidence of cancer among persons with a positive family history of cancer may be three times as high as in those who do not have a family history. A number of different neoplasms are known to be genetically related and may be due to damage or changes in chromosome structure. Radiation in various forms is thought to be responsible for up to 3% of all cancers. In the United States the carcinogens in tobacco account for up to one-third of all cancer deaths in men and 5–10% in women. The increasing incidence and death rate from cancer of the lung in women is alarming, and is directly related to the increasing prevalence of cigarette smoking by women. Cigarette smoking and the heavy consumption of ethyl alcohol appear to act synergistically in the development of oral, esophageal, and gastric cancers. There are several carcinogens to which people are exposed occupationally that result in the development of cancer, although the mechanisms by which they cause neoplasms are sometimes poorly understood. For example, arsenic is associated with lung, skin, and liver cancer and asbestos causes mesotheliomas (cancer of the pleural, peritoneal, and pericardial cavities). Certain drugs and hormones have been found to cause certain types of neoplasms. Postmenopausal women taking estrogen hormones have a much higher incidence of endometrial cancer (cancer of the lining of the uterine cavity). The role of diet and nutrition in the development of malignant tumors is controversial and still under investigation. Some epidemiologic studies have shown that certain diets, such as those high in saturated fats, are associated with an increased incidence of certain types of neoplasm, such as colon cancer. The role of viruses in the development of human cancers is being studied. See MUTAGENS AND CARCINOGENS; RADIATION BIOLOGY; TUMOR VIRUSES.

It is generally accepted that the neoplastic condition is caused by alterations in genetic mechanisms involved in cellular differentiation. In malignant cells, normal cellular processes are bypassed due to the actions of a select group of genes called oncogenes which regulate cellular activities. A group of these highly conserved genes exist in normal cells and are called proto-oncogenes. These genes appear to be important in regulating cellular growth during embryonic development. It is thought that in carcinogenesis these proto-oncogenes become unmasked or changed during the breakage or translocation of chromosomes. These genes that were previously suppressed in the cell then become functional, and in some instances lead to the excessive production of growth factors which could be important in the neoplastic state. See ONCOGENES.

The physical changes that cancer produces in the body vary considerably, depending on the type of tumor, location, rate of growth, and whether it has metastasized. The American Cancer Society has widely publicized cancer's seven warning signals: (1) a change in bowel or bladder habits; (2) a sore that does not heal; (3) unusual bleeding or discharge; (4) a thickening or lump in the breast or elsewhere; (5) indigestion or difficulty in swallowing; (6) an obvious change in a wart or mole; and (7) a nagging cough or hoarseness. In current medical practice, most cancers are staged according to tumor size, metastases to lymph nodes, and distant metastases. This type of staging is useful in determining the most effective therapy and the prognosis.

The progression, or lack thereof, of a given cancer is highly variable and depends on the type of neoplasm and the response to treatment. Treatment modalities include surgery, chemotherapy, radiation therapy, hormonal manipulation, and immunotherapy. In general, each type of cancer is treated very specifically, and often a combination of the various modalities is used, for example, surgery preceded or followed by radiation therapy. The response to treatment depends on the type of tumor, its size, and whether it has spread. See CHEMOTHERAPY; IMMUNOTHERAPY; ONCOLOGY; RADIOGRAPHY. [S.P.H.]

**Cancrinite** A family of minerals, related to the scapolite family, characteristically occurring in basic rocks such as nepheline syenites and sodalite syenites. Cancrinite is hexagonal. Four-, six-, and twelve-membered aluminosilicate rings can be discerned in the structure. Large anions such as  $[\text{SO}_4]^{2-}$  and  $[\text{CO}_3]^{2-}$  occur in the hexagonal channels of the structure. Four members of the cancrinite family are cancrinite, vishnevite, hauyne, and afghanite. The cancrinite member is white, yellow, greenish, or reddish. It has perfect prismatic cleavage, hardness is 5–6 on Mohs scale, and the specific gravity is 2.45. Localities include the Fen area, southern Norway; the Kola Peninsula, Russia; Bancroft, Ontario, Canada; and Litchfield, Maine, U.S.A. See NEPHELINE SYENITE; SILICATE MINERALS. [P.B.M.]

**Candlepower** Luminous intensity expressed in candelas. The term refers only to the intensity in a particular direction and by itself does not give an indication of the total light emitted. The candlepower in a given direction from a light source is equal to the illumination in footcandles falling on a surface normal to that direction, multiplied by the square of the distance from the light source in feet. The candlepower is also equal to the illumination of metercandles (lux) multiplied by the square of the distance in meters.

The apparent candlepower is the candlepower of a point source which will produce the same illumination at a given distance as produced by a given light source.

The mean horizontal candlepower is the average candlepower of a light source in the horizontal plane passing through the luminous center of the light source.

The mean spherical candlepower is the average candlepower in all directions from a light source as a center. Since there is

a total solid angle of  $4\pi$  (steradians) emanating from a point, the mean spherical candlepower is equal to the total luminous flux (in lumens) of a light source divided by  $4\pi$  (steradians). See LUMINOUS INTENSITY; PHOTOMETRY. [R.C.Pu.]

**Canine distemper** A fatal viral disease of dogs and other carnivores, with a worldwide distribution. Canine distemper virus has a wide host range; most terrestrial carnivores are susceptible to natural canine distemper virus infection. All animals in the families Canidae (such as dog, dingo, fox, coyote, wolf, jackal), Mustelidae (such as weasel, ferret, mink, skunk, badger, stoat, marten, otter), and Procyonidae (such as kinkajou, coati, bassariscus, raccoon, panda) may succumb to canine distemper virus infection. Members of other Carnivora families, including domestic cats and swine, may become subclinically infected. The virus has also been isolated from large cats (lions, tigers, leopards) that have died in zoological parks in North America, from wild lions in the Serengeti National Park (Tanzania), and from wild javelinas (collared peccaries). See CARNIVORA.

Canine distemper virus is classified as a morbillivirus within the Paramyxoviridae family, closely related to measles virus and rinderpest virus of cattle and the phocine (seal) and dolphin distemper virus. The virus is enveloped with a negative-sense ribonucleic acid and consists of six structural proteins: the nucleoprotein and two enzymes in the nucleocapsid, the membrane protein on the inside, and the hemagglutinating and fusion proteins on the outside of the lipoprotein envelope. See ANIMAL VIRUS; PARAMYXOVIRUS.

Canine distemper is enzootic worldwide. Aerosol transmission in respiratory secretions is the main route of transmission. Virus shedding begins approximately 7 days after the initial infection. Acutely infected dogs and other carnivores shed virus in all body excretions, regardless of whether they show clinical signs or not.

Great variations occur in the duration and severity of canine distemper, which may range from no visible signs to severe disease, often with central nervous system involvement, with approximately 50% mortality in dogs. The first fever 3–6 days after infection may pass unnoticed; the second peak (several days later and intermittent thereafter) is usually associated with nasal and ocular discharge, depression, and anorexia. A low lymphocyte count is always present during the early stages of infection. Gastrointestinal and respiratory signs may follow, often enhanced by secondary infection.

A specific antiviral drug having an effect on canine distemper virus in dogs is not presently available. Treatment of canine distemper, therefore, is nonspecific and supportive. Antibiotic therapy is recommended because of the common occurrence of secondary bacterial infections of the respiratory and alimentary tracts. Administration of fluids and electrolytes may be the most important therapy for canine distemper because diseased dogs with diarrhea are often dehydrated. [M.J.G.A.; B.A.S.]

**Canine parvovirus infection** Severe enteritis caused by a small nonenveloped single-stranded deoxyribonucleic acid (DNA) virus that is resistant to inactivation and remains infectious in the environment for 5–7 months. First observed in dogs in 1976, canine parvovirus may have originated by mutation of a closely related parvovirus of cats or wildlife. The original virus was designated as canine parvovirus, type 2 (CPV-2); however, since its discovery the virus has undergone two minor genetic alterations, designated CPV-2a and CPV-2b. These alterations may have enabled the virus to adapt to its new host, replicate, and spread more effectively. See ANIMAL VIRUS.

Canine parvovirus is transmitted between dogs by the fecal-oral route. The incubation period is 3–7 days. Virus is first shed in the feces on day 3, and shedding continues for an additional 10 days. Chronically infected dogs that shed virus intermittently

are rare. Most naturally occurring infections in dogs are subclinical or result in mild signs of the disease. Dogs with subclinical infections play an important role in the spread of the disease by shedding large amounts of virus into the environment. This shedding, along with the ability of the virus to persist in the environment, contributes to the endemicity of the disease. The development of disease following infection ranges from 20 to 90%, and mortality ranges 0 to 50%.

The goal of treatment is to support the animal until the infection runs its course. There are no specific antiviral therapies available. The intensity of treatment depends on the severity of signs. Dehydrated pups require intensive intravenous fluid therapy. Antimicrobial drugs are useful because of the risk of secondary bacterial infections, and antiemetic drugs help control vomiting and nausea. Good nursing care is essential. All food and water should be withheld until the pup is no longer vomiting, and the pup should be kept warm, clean, and dry. Because of the infectious nature of the disease, pups should be isolated from other dogs. [M.S.Co.]

**Canonical transformations** Transformations among the coordinates and momenta describing the state of a classical dynamical system which leave the canonical or Hamiltonian form of the equations of motion unchanged. See HAMILTON'S EQUATIONS OF MOTION; HAMILTON'S PRINCIPLE. [P.M.S.]

**Cantaloupe** In the United States the name applied to muskmelon cultivars belonging to *Cucumis melo* var. *reticulatus* of the family Cucurbitaceae. However, this is a misnomer, and the name cantaloupe should be restricted to cultivars of *C. melo* var. *cantalupensis*. The fruits of this group are rough and scaly, with deep vein tracts and a hard rind. Cultivars of the variety *cantalupensis* are grown in Europe and Asia, but seldom in the United States.

The fruits grown in the United States are round to oval; the surface is netted and has shallow vein tracts. At maturity the skin color changes from dark green or gray to light gray or yellow. The flesh is usually salmon-colored, but it may vary from green to deep salmon-orange. When mature the melon is sweet, averages 6–8% sugar, and has a distinct aroma and flavor. The flesh is high in potassium and vitamin C, and, when deep orange, rich in vitamin A. See MUSKMELON; VIOLALES. [O.A.L.]

**Cantilever** A linear structural member supported both transversely and rotationally at one end only; the other end of the member is free to deflect and rotate. Cantilevers are common throughout nature and engineered structures; examples are a bird's wing, an airplane wing, a roof overhang, and a balcony. See WING.

A horizontal cantilever must be counterbalanced at its one support against rotation. This requirement is simply achieved in the design of a playground seesaw, with its double-balanced cantilever. This principle of counterbalancing the cantilever is part of the basic design of a crane, such as a tower crane (see illustration). More commonly, horizontal cantilevers are resisted by being continuous with a backup span that is supported at both ends. This design is common for cantilever bridges; all swing bridges or drawbridges are cantilevers. See BRIDGE.

Vertical cantilevers primarily resist lateral wind loads and horizontal loads created by earthquakes. Common vertical cantilevers are chimneys, stacks, masts, flagpoles, lampposts, and railings or fences. All skyscrapers are vertical cantilevers. One common system to provide the strength to resist lateral loads acting on the skyscraper is the use of a truss (known as bracing). See BUILDINGS; SHEAR; TRUSS.

Some of the largest cantilevers are used in the roofs of airplane hangars. It has become common practice to include cantilevers in the design of theaters and stadiums, where an unobstructed view is desired; balconies and tiers are supported in the back and

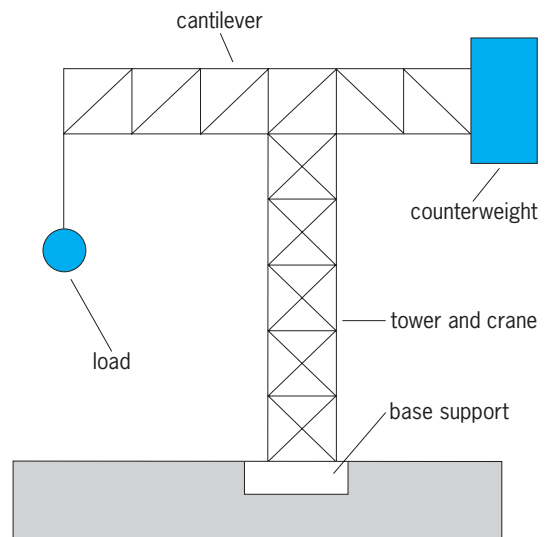

Cantilever configuration in the form of a tower support crane.

cantilevered out toward the stage or playing field so that the audience has column-free viewing. See BEAM; ROOF CONSTRUCTION. [I.P.L.]

**Capacitance** The ratio of the charge  $q$  on one of the plates of a capacitor (there being an equal and opposite charge on the other plate) to the potential difference  $v$  between the plates; that is, capacitance (formerly called capacity) is  $C = q/v$ .

In general, a capacitor, often called a condenser, consists of two metal plates insulated from each other by a dielectric. The capacitance of a capacitor depends on the geometry of the plates and the kind of dielectric used, since these factors determine the charge which can be put on the plates by a unit potential difference existing between the plates.

In an ideal capacitor, no conduction current flows between the plates. A real capacitor of good quality is the circuit equivalent of an ideal capacitor with a very high resistance in parallel or, in alternating-current (ac) circuits, of an ideal capacitor with a low resistance in series. See CAPACITOR; DIELECTRIC MATERIALS. [R.PWi.]

**Capacitance measurement** The measurement of the ratio of the charge induced on a conductor to the change in potential with respect to a neighboring conductor which induces the charge. In a multiconductor system there are capacitances between each pair of conductors. In general, these capacitances are functions of the total geometry, that is, the location of all of the conducting and dielectric bodies. When, as is usually true, only the capacitance between two conductors is of interest, the presence of other conductors is an undesirable complication. It is then customary to distinguish between two-terminal and three-terminal capacitors and capacitance measurements. In a two-terminal capacitor, either one of the conductors of primary interest surrounds the other (in which case the capacitance between them is independent of the location of other bodies except in the vicinity of the terminals); or the somewhat indefinite contributions of the other conductors to the capacitance of interest are accepted.

A three-terminal capacitor consists of two active electrodes surrounded by a third, or shield, conductor. The direct capacitance between the two active electrodes is the capacitance of interest, and, when shielded leads are used, it is independent of the location of all other conductors except the shield.

Every physically realizable capacitor has associated loss in the dielectric and in the metal electrodes. At a single frequency these

are indistinguishable, and the capacitor may be represented by either a parallel or series combination of pure capacitance and pure resistance. The measurement of capacitance, then, in general involves the simultaneous measurement of, or allowance for, an associated resistive element. See PERMITTIVITY.

Most capacitance measurements involve simply a comparison of the capacitor to be measured with a capacitor of known value. Methods which permit comparison of essentially equal capacitors by simple substitution of one for the other at the same point in a circuit are frequently possible and almost always preferable.

**Bridge comparison methods.** When capacitors must be compared with high accuracy, bridge methods must be adopted. See BRIDGE CIRCUIT; WHEATSTONE BRIDGE.

Resistance-ratio bridges are Wheatstone-bridge configurations in which the potential division of the capacitor being measured and either a parallel combination of a standard loss-free capacitor  $C_s$  and a conductance  $G_s$  or a series combination of  $C_s$  and a resistor  $R_s$  is equated, when the detector is nulled, to the ratio of potentials across resistors  $R_1$  and  $R_2$ . More commonly now, the reference potential division is that of a variable-ratio autotransformer known as an inductive voltage divider (IVD). See INDUCTIVE VOLTAGE DIVIDER.

The Schering bridge yields a measurement of the equivalent series-circuit representation of a capacitor.

The resistance-ratio and Schering bridges are useful for two-terminal capacitance measurements. Their use may be extended to three-terminal measurements and extended in accuracy and range by the introduction of shielding and the addition of the Wagner branch.

**Time-constant methods.** If a direct voltage is suddenly applied to the series combination of a resistor and an initially discharged capacitor, the charge and the voltage on the capacitor increase exponentially toward their full magnitudes with a time constant equal in seconds to the product of the resistance in ohms and the capacitance in farads. Similarly, when a charged capacitor is discharged through a resistor, the charge and the voltage decay with the same time constant. Various methods are available for the measurement of capacitance by measurement of the time constant of charge or discharge through a known resistor. See TIME CONSTANT.

In one such method the time required for the output voltage of an operational amplifier having a capacitor as a feedback component to increase to a value equal to the step-function input voltage applied through a resistor to its input is determined by an electronic voltage-comparison circuit and timer. With the assumption of ideal characteristics for the amplifier, such as infinite gain without feedback, infinite input impedance, and zero output impedance, the measured time interval is equal to the product of the values of the known resistance and the capacitance being measured. See OPERATIONAL AMPLIFIER.

[B.P.K.; FR.Ko.; G.H.Ra.]

**Capacitance multiplication** The generation of a capacitance which is some multiple of that of an actual capacitor. Capacitance multiplication circuits have an input impedance which is capacitive and which is proportional to that of an actual capacitor appearing somewhere in the circuit. In most applications, capacitance multiplication circuits are used to generate an equivalent input capacitance which is much larger than that of the actual capacitor. One scenario where capacitance multiplication might prove useful is where a physical capacitor of a required capacitance may be too large, too expensive, or unavailable. A second is where the capacitor must be reasonably large and capable of handling bidirectional signals, thus precluding the direct use of widely available electrolytic capacitors and hence making practical the utilization of a much smaller non-electrolytic capacitor in a capacitance multiplication circuit. See CAPACITANCE; CAPACITOR.

Capacitance multiplication circuits are often made from operational amplifiers and resistors along with the capacitor that is to be scaled, although transistors and other active devices can also be used. Capacitance multiplication circuits are closely related to classes of circuits termed generalized immittance converters and negative impedance converters. Generalized immittance converters are used to generate an equivalent input impedance that is proportional to products or quotients of specific impedances that appear in the circuit. Generalized immittance converters are often used for capacitance multiplication. Related applications of generalized immittance converters are synthetic inductance simulation and negative-resistance generation. Negative-impedance converters are also used for the generation of negative impedances. See ELECTRICAL IMPEDANCE; IMMITTANCE; INDUCTANCE; NEGATIVE-RESISTANCE CIRCUITS; OPERATIONAL AMPLIFIER.

[R.L.Ge.]

**Capacitor** An electrical device capable of storing electrical energy. In general, a capacitor consists of two metal plates insulated from each other by a dielectric. The capacitance of a capacitor depends primarily upon its shape and size and upon the relative permittivity  $\epsilon_r$  of the medium between the plates. In vacuum, in air, and in most gases,  $\epsilon_r$  ranges from one to several hundred. See CAPACITANCE; PERMITTIVITY.

One classification of capacitors comes from the physical state of their dielectrics, which may be gas (or vacuum), liquid, solid, or a combination of these. Each of these classifications may be subdivided according to the specific dielectric used. Capacitors may be further classified by their ability to be used in alternating-current (ac) or direct-current (dc) circuits with various current levels.

Capacitors are also classified as fixed, adjustable, or variable. The capacitance of fixed capacitors remains unchanged, except for small variations caused by temperature fluctuations. The capacitance of adjustable capacitors may be set at any one of several discrete values. The capacitance of variable capacitors may be adjusted continuously and set at any value between minimum and maximum limits fixed by construction. Trimmer capacitors are relatively small variable capacitors used in parallel with larger variable or fixed capacitors to permit exact adjustment of the capacitance of the parallel combination.

Made in both fixed and variable types, air, gas, and vacuum capacitors are constructed with flat parallel metallic plates (or cylindrical concentric metallic plates) with air, gas, or vacuum as the dielectric between plates. Alternate plates are connected, with one or both sets supported by means of a solid insulating material such as glass, quartz, ceramic, or plastic. Gas capacitors are similarly built but are enclosed in a leakproof case. Vacuum capacitors are of concentric-cylindrical construction and are enclosed in highly evacuated glass envelopes.

The purpose of a high vacuum, or a gas under pressure, is to increase the voltage breakdown value for a given plate spacing. For high-voltage applications, when increasing the spacing between plates is undesirable, the breakdown voltage of air capacitors may be increased by rounding the edges of the plates. Air, gas, and vacuum capacitors are used in high-frequency circuits. Fixed and variable air capacitors incorporating special design are used as standards in electrical measurements. See CAPACITANCE MEASUREMENT; ELECTRICAL UNITS AND STANDARDS.

Solid-dielectric capacitors use one of several dielectrics such as a ceramic, mica, glass, or plastic film. Alternate plates of metal, or metallic foil, are stacked with the dielectric, or the dielectric may be metal-plated on both sides.

A large capacitance-to-volume ratio and a low cost per microfarad of capacitance are chief advantages of electrolytic capacitors. These use aluminum or tantalum plates. A paste electrolyte is placed between the plates, and a dc forming voltage is applied. A current flows and by a process of electrolysis builds up a molecule-thin layer of oxide bubbles on the positive plate. This serves as the dielectric. The rest of the electrolyte and the other

plate make up the negative electrode. Such a device is said to be polarized and must be connected in a circuit with the proper polarity. Polarized capacitors can be used only in circuits in which the dc component of voltage across the capacitors exceeds the crest value of the ac ripple.

Another type of electrolytic capacitor utilizes compressed tantalum powder and the baking of manganese oxide (MnO<sub>2</sub>) as an electrolyte. Nonpolarized electrolytic capacitors can be constructed for use in ac circuits. In effect, they are two polarized capacitors placed in series with their polarities reversed.

Thick-film capacitors are made by means of successive screenprinting and firing processes in the fabrication of certain types of microcircuits used in electronic computers and other electronic systems. They are formed, together with their connecting conductors and associated thick-film resistors, upon a ceramic substrate. Their characteristics and the materials are similar to those of ceramic capacitors. See PRINTED CIRCUIT.

Thin-film dielectrics are deposited on ceramic and integrated-circuit substrates and then metallized with aluminum to form capacitive components. These are usually single-layer capacitors. The most common dielectrics are silicon nitride and silicon dioxide. See INTEGRATED CIRCUITS. [A.Mot.]

**Capparales** An order of flowering plants (Angiospermae) of approximately 15 families of dicotyledons with over 4000 species. In molecular phylogenetic classifications, it is placed near Malvales, Myrtales, and Sapindales. See MALVALES; MYR- TALES; PLANT KINGDOM; SAPINDALES.

The mustard family, Brassicaceae (Cruciferae), with about 3000 species, and the caper family, Capparaceae, with about 800 species, form the core of the order. An additional 200 or so species are treated in 13 families, including Caricaceae (papaya), Limnanthaceae (meadowfoam), Resedaceae (mignonette), and Tropaeolaceae (garden nasturtium). The plants are diverse in vegetative habit and in floral and fruit morphology. However, they commonly possess myrosin cells, containing the enzyme myrosinase, and produce mustard oil glucosides (glucosin- olates), the breakdown products of which are the pungent compounds of radish, wasabi, horseradish, and capers. Primitive members of the order have five-parted flowers, but the core fam- ilies have four-parted flowers. Common vegetables such as broc- coli, brussels sprouts, cabbage, kale, radish, rutabaga, turnip, and water cress belong to the Brassicaceae. Capparales are also important sources of seed oils and of several ornamental flow- ers. See BROCCOLI; BRUSSELS SPROUTS; CABBAGE; CAULIFLOWER; COLLARD; CRESS; HORSERADISH; KALE; KOHLRABI; MUSTARD; OR- NAMENTAL PLANTS; RADISH; RAPE; RUTABAGA; TURNIP. [J.E.Ro.]

**Caprellidea** A common crustacean suborder in marine and estuarine environments, belonging to the superorder Peracarida, order Amphipoda. As peracarids, female Caprellidea have a ventral brood pouch and eggs develop directly (that is, there are no planktonic larvae); as amphipods, Caprellidea have the second and third thoracic appendages formed into en- larged subchelate claws (gnathopods). The abdomen and ab- dominal appendages of caprellideans are reduced; thus caprel- lideans are restricted to a clinging and crawling life-style. Almost all caprellideans use other organisms as substrata. Family dis- tinctions within the Caprellidea are being reevaluated, but the classical divisions are the families Caprellidae and Cyamidae (whale lice). The ecology of both families is poorly understood. See AMPHIPODA; CRUSTACEA. [E.A.C.]

**Capricornus** The Sea Goat, in astronomy, an inconspic- uous zodiacal constellation in the southern sky lying between Aquarius and Sagittarius. Capricornus is the tenth sign of the zo- diac. The constellation has been described from the earliest times as a goat, or as a figure that is part goat with the tail of a fish (see illustration). The Tropic of Capricorn originates from this

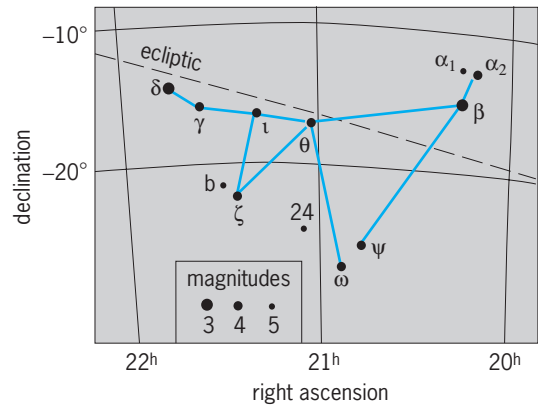

Line pattern of constellation Capricornus. Grid lines represent coordinates of the sky. Apparent brightness, or magnitudes, of stars are shown by size of dots, which are graded by appropriate numbers as indicated.

constellation, which marked the southern limit of the ecliptic in ancient times. See CONSTELLATION. [C.S.Y.]

**Caprimulgiformes** An order of crepuscular or mainly nocturnal birds collectively known as the goatsuckers. The group is apparently most closely related to the owls (Strigiformes) and is found worldwide, mainly in the tropics and warm temperate regions. Species breeding in the Arctic and cooler temperate regions are migratory. See STRIGIFORMES.

The order Caprimulgiformes is divided into the suborder Steatornithes, containing the single family Steatornithidae (oil- birds; 1 species), and the suborder Caprimulgi, including the families Podargidae (frogmouths; 13 species), Aegothelidae (owlet-frogmouths; 8 species), Nyctibiidae (potoos; 6 species), and Caprimulgidae (nightjars or goatsuckers; 77 species). The largest family, Caprimulgidae, is found worldwide; Steatornithi- dae are restricted to northern South America; Podargidae live in the Old World tropics from India to Australia; Aegothelidae are restricted to Australia and surrounding islands; and Nyctibiidae are found in the New World tropics.

The goatsuckers are primarily insectivorous, although the large frogmouths also feed on small vertebrates; the oilbird is unique in feeding on fruits, especially of palms. Goatsuckers have a huge, generally weak mouth with long, stout bristles surrounding it to make an effective trap for insects caught in flight. The wings are well developed, but the feet are weak and serve mainly for perch- ing. The plumage is soft and fluffy, and is mottled and barred brown and gray, serving as a cryptic protective coloration. White patches may exist on the wings, tail, and throat, which are visible only in flight. Goatsuckers are solitary but may migrate in loose flocks (nighthawks). Most species are highly vocal, using the calls to attract mates and defend territories. The English names of a number of species, such as the whipoorwill and chuck-will's- widow, are based on their calls. Goatsuckers nest on the ground or in trees, laying one to five eggs. Young are downy and remain in the nest until they are able to fly. A few species are known to hibernate.

The oilbirds are colonial nesters, placing their nest of seeds and droppings on ledges deep in caves. Paired adults remain together throughout the year, roosting on their breeding ledge. Oilbirds have excellent night vision, but inside their often totally dark caves they find their way by using echolocation based on pulses of sound of about 7000 Hz which are audible to the human ear. See AVES; ECHOLOCATION. [W.J.B.]

**Captorhinida** A moderately coherent group of primitive reptiles constituting an order of the subclass Anapsida. Most members are characterized by a closed cheek (temporal) region. The order is divided into four suborders: Captorhinomorpha,

Millerosauria, Procolophonia, and Pareiasauria. Except for the Procolophonia, which continue into the Late Triassic, Captorhinida are confined to the Permo-Carboniferous. They lived in lowlands, where they were associated with amphibians and synapsid reptiles. Some of the smaller animals of the Captorhinomorpha and the Millerosauria fed primarily on insects and small vertebrates, but the larger genera were exclusively herbivorous. Along with the caseid pelycosaurs, they were the dominant consumers of vegetation in the middle Permian ecosystems. See ANAPSIDA; REPTILIA; SYNAPSIDA. [E.C.O.]

**Carat** The unit of weight now used for all gemstones except pearls. It is also called the metric carat (m.c.). By international agreement, the carat weight is set at 200 milligrams. Pearls are weighed in grains, a unit of weight equal to 50 mg, or  $\frac{1}{4}$  carat. The application of the term carat as a unit of weight must not be confused with the term karat used to indicate fineness or purity of the gold in which gems are mounted. See GEM. [R.T.L.]

**Caraway** An important spice from the fruits of the perennial herb *Carum carvi*, of the family Umbelliferae. A native of Europe and western Asia, it is now cultivated in many temperate areas of both hemispheres. The small, brown, slightly curved fruits are used in perfumery, cookery, confectionery, in medicine, and for flavoring beverages. See APIALES. [P.D.St./E.L.C.]

**Carbohydrate** A term applied to a group of substances which include the sugars, starches, and cellulose, along with many other related substances. This group of compounds plays a vitally important part in the lives of plants and animals, both as structural elements and in the maintenance of functional activity. Plants are unique in that they alone in nature have the power to synthesize carbohydrates from carbon dioxide and water in the presence of the green plant chlorophyll through the energy derived from sunlight, by the process of photosynthesis. This process is responsible not only for the existence of plants but for the maintenance of animal life as well, since animals obtain their entire food supply directly or indirectly from the carbohydrates of plants. See CARBOHYDRATE METABOLISM; PHOTOSYNTHESIS.

The term carbohydrate originated in the belief that naturally occurring compounds of this class, for example, D-glucose ( $C_6H_{12}O_6$ ), sucrose ( $C_{12}H_{22}O_{11}$ ), and cellulose ( $C_6H_{10}O_5$ )<sub>n</sub>, could be represented formally as hydrates of carbon, that is,  $C_x(H_2O)_y$ . Later it became evident that this definition for carbohydrates was not a satisfactory one. New substances were discovered whose properties clearly indicated that they had the characteristics of sugars and belonged in the carbohydrate class, but which nevertheless showed a deviation from the required hydrogen-to-oxygen ratio. Examples of these are the important deoxy sugars, D-deoxyribose, L-fucose, and L-rhamnose, the uronic acids, and such compounds as ascorbic acid (vitamin C). The retention of the term carbohydrate is therefore a matter of convenience rather than of exact definition. A carbohydrate is usually defined as either a polyhydroxy aldehyde (aldose) or ketone (ketose), or as a substance which yields one of these compounds on hydrolysis. However, included within this class of compounds are substances also containing nitrogen and sulfur. See DEOXYRIBOSE; FRUCTOSE.

The properties of many carbohydrates differ enormously from one substance to another. The sugars, such as D-glucose or sucrose, are easily soluble, sweet-tasting, and crystalline; the starches are colloidal and paste-forming; and cellulose is completely insoluble. Yet chemical analysis shows that they have a common basis; the starches and cellulose may be degraded by different methods to the same crystalline sugar, D-glucose.

The carbohydrates usually are classified into three main groups according to complexity: monosaccharides, oligosaccharides, and polysaccharides. Monosaccharides are simple sugars

that consist of a single carbohydrate unit which cannot be hydrolyzed into simpler substances. These are characterized, according to their length of carbon chain, as trioses ( $C_3H_6O_3$ ), tetroses ( $C_4H_8O_4$ ), pentoses ( $C_5H_{10}O_5$ ), hexoses ( $C_6H_{12}O_6$ ), heptoses ( $C_7H_{14}O_7$ ), and so on. Oligosaccharides are compound sugars that are condensation products of two to five molecules of simple sugars and are subclassified into disaccharides, trisaccharides, tetrasaccharides, and pentasaccharides, according to the number of monosaccharide molecules yielded upon hydrolysis. Polysaccharides comprise a heterogeneous group of compounds which represent large aggregates of monosaccharide units, joined through glycosidic bonds. They are tasteless, nonreducing, amorphous substances that yield a large and indefinite number of monosaccharide units on hydrolysis. Their molecular weight is usually very high, and many of them, like starch or glycogen, have molecular weights of several million. They form colloidal solutions, but some polysaccharides, of which cellulose is an example, are completely insoluble in water. On account of their heterogeneity they are difficult to classify. See MONOSACCHARIDE; OLIGOSACCHARIDE; POLYSACCHARIDE.

The sugars are also classified into two general groups, the reducing and nonreducing. The reducing sugars are distinguished by the fact that because of their free, or potentially free, aldehyde or ketone groups they possess the property of readily reducing alkaline solutions of many metallic salts, such as those of copper, silver, bismuth, mercury, and iron. The most widely used reagent for this purpose is Fehling's solution. The reducing sugars constitute by far the larger group. The monosaccharides and many of their derivatives reduce Fehling's solution. Most of the disaccharides, including maltose, lactose, and the rarer sugars cellobiose, gentiobiose, melibiose, and turanose, are also reducing sugars. The best-known nonreducing sugar is the disaccharide sucrose. Among other nonreducing sugars are the disaccharide trehalose, the trisaccharides raffinose and melezitose, the tetrasaccharide stachyose, and the pentasaccharide verbascode.

The sugars consist of chains of carbon atoms which are united to one another at a tetrahedral angle of  $109^{\circ}28'$ . A carbon atom to which are attached four different groups is called asymmetric. A sugar, or any other compound containing one or more asymmetric carbon atoms, possesses optical activity; that is, it rotates the plane of polarized light to the right or left. See OPTICAL ACTIVITY. [W.Z.H.]

**Carbohydrate metabolism** Many aspects of biochemistry and physiology have to do with the breakdown and synthesis of simple sugars, oligosaccharides, and polysaccharides, and with the transport of sugars across cell membranes and tissues. The breakdown or dissimilation of simple sugars, particularly glucose, is one of the principal sources of energy for living organisms. The dissimilation may be anaerobic, as in fermentations, or aerobic, that is, respiratory. In both types of metabolism, the breakdown is accompanied by the formation of energy-rich bonds, chiefly the pyrophosphate bond of the coenzyme adenosine triphosphate (ATP), which serves as a coupling agent between different metabolic processes. In higher animals, glucose is the carbohydrate constituent of blood, which carries it to the tissues of the body. In higher plants, the disaccharide sucrose is often stored and transported by the tissues. Certain polysaccharides, especially starch and glycogen, are stored as endogenous food reserves in the cells of plants, animals, and microorganisms. Others, such as cellulose, chitin, and bacterial polysaccharides, serve as structural components of cell walls. As constituents of plant and animal tissues, various carbohydrates become available to those organisms which depend on other living or dead organisms for their source of nutrients. Hence, all naturally occurring carbohydrates can be dissimilated by some animals or microorganisms. See ADENOSINE TRIPHOSPHATE (ATP); CARBOHYDRATE; CELLULOSE; CHITIN; GLYCOGEN; STARCH.



Certain carbohydrates cannot be used as nutrients by humans. For example, cellulose cannot be digested by humans or other mammals and is a useful food only for those, such as the ruminants, that harbor cellulose-decomposing microorganisms in their digestive tracts. The principal dietary carbohydrates available to humans are the simple sugars glucose and fructose, the disaccharides sucrose and lactose, and the polysaccharides glycogen and starch. Lactose is the carbohydrate constituent of milk and hence one of the main sources of food during infancy. The disaccharides and polysaccharides that cannot be absorbed directly from the intestine are first digested and hydrolyzed by enzymes, glycosidases, secreted into the alimentary canal. See FRUCTOSE; LACTOSE.

The simple sugars reach the intestine or are produced there through the digestion of oligosaccharides. They are absorbed by the intestinal mucosa and transported across the tissue into the bloodstream. This process involves the accumulation of sugar against a concentration gradient and requires active metabolism of the mucosal tissue as a source of energy. The sugars are absorbed from the blood by the liver and are stored there as glycogen. The liver glycogen serves as a constant source of glucose in the bloodstream. The mechanisms of transport of sugars across cell membranes and tissues are not yet understood, but they appear to be highly specific for different sugars and to depend on enzymelike components of the cells.

The degradation of monosaccharides may follow one of several types of metabolic pathways. In the phosphorylative pathways, the sugar is first converted to a phosphate ester (phosphorylated) in a reaction with ATP. The phosphorylated sugar is then split into smaller units, either before or after oxidation. In the non-phosphorylative pathways, the sugar is usually oxidized to the corresponding aldonic acid. This may subsequently be broken down either with or without phosphorylation of the intermediate products. Among the principal intermediates in carbohydrate metabolism are glyceraldehyde-3-phosphate and pyruvic acid. The end products of metabolism depend on the organism and, to some extent, on the environmental conditions. Besides cell material the products may include carbon dioxide ( $\text{CO}_2$ ), alcohols, organic acids, and hydrogen gas. In the so-called complete oxidations,  $\text{CO}_2$  is the only excreted end product. In incomplete oxidations, characteristic of the vinegar bacteria and of certain fungi, oxidized end products such as gluconic, ketogluconic, citric, or fumaric acids may accumulate. Organic end products are invariably found in fermentations. The amount of biosynthesis and mechanical work that an organism can do at the expense of a given amount of sugar is many times greater in respiration than in fermentation. See FERMENTATION; RESPIRATION.

The principal phosphorylative pathway involved in fermentations is known as the glycolytic, hexose diphosphate, or Embden-Meyerhof pathway (see illustration). This sequence of reactions is the basis of the lactic acid fermentation of mammalian muscle and of the alcoholic fermentation of yeast. For every molecule of glucose fermented through the glycolytic sequence, two molecules of ATP are used for phosphorylation, while four are produced. Thus, fermentation results in the net gain of two energy-rich phosphate bonds as ATP at the expense of inorganic phosphate esterified. The excess ATP is converted back to ADP and inorganic phosphate through coupled reactions useful to the organism, such as the mechanical work done by the contraction of muscle or biosynthetic reactions associated with growth. See ADENOSINE DIPHOSPHATE (ADP); NICOTINAMIDE ADENINE DINUCLEOTIDE (NAD).

The oxidative or respiratory metabolism of sugars differs in several respects from fermentative dissimilation. First, the oxidative steps, that is, the reoxidation of NADH, are linked to the reduction of molecular oxygen. Second, the pyruvic acid produced through glycolytic or other mechanisms is further oxidized, usually to  $\text{CO}_2$  and  $\text{H}_2\text{O}$ . Third, in most aerobic organ-

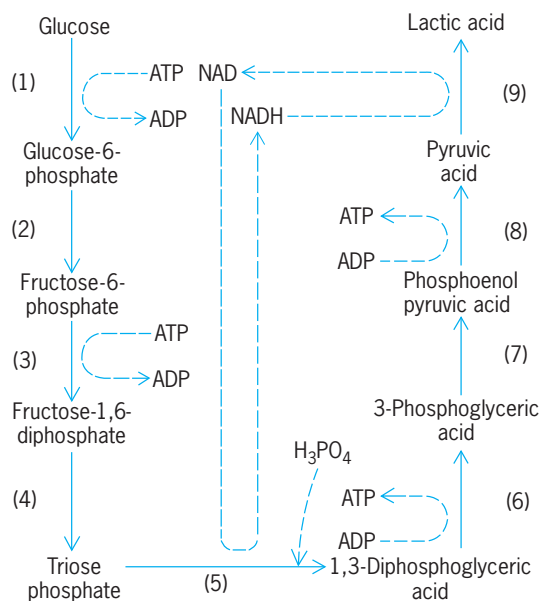

Glycolysis in lactic acid fermentation.

isms, alternative pathways either supplement or completely replace the glycolytic sequence of reactions for the oxidation of sugars. Where pyruvic acid appears as a metabolic intermediate, it is generally oxidatively decarboxylated to yield  $\text{CO}_2$  and the two-carbon acetyl fragment which combines with coenzyme A. The acetyl group is then further oxidized via the Krebs cycle. The principal alternative pathways by which sugars are dissimilated involve the oxidation of glucose-6-phosphate to the lactone of 6-phosphogluconic acid and are known as the hexose monophosphate pathways. See CITRIC ACID CYCLE.

The metabolism of simple sugars other than glucose usually involves the conversion of the sugar to one of the intermediates of the phosphorylative pathways described for glucose metabolism. For example, fructose may be phosphorylated to fructose-6-phosphate, which can then be degraded via the glycolytic pathway or converted to glucose-6-phosphate and oxidized through the hexose monophosphate pathway.

The dissimilation and biosynthesis of the oligosaccharides are effected through the enzymatic cleavage or formation of glycosidic bonds between simple monosaccharide constituents of the complex carbohydrates. The principal types of enzyme which split or synthesize glycosidic bonds are the hydrolases or glycosidases, phosphorylases, and transglycosylases. The enzymes are generally highly specific with respect to the glycosidic portion, or moiety, and the type of linkage of the substrates which they attack. The essential function of all three types of enzymes is the transfer of the glycosyl moiety of the substrate to an appropriate glycosyl acceptor. The phosphorylases catalyze the reversible phosphorylation of certain disaccharides, polysaccharides, and nucleosides by transferring the glycosyl moieties to inorganic phosphate. The breakdown of glycogen and starch by the enzymes known as amylophosphorylases is an example of biologically important phosphorylative reactions. [M.D.]

**Carbon** A chemical element, C, with an atomic number of 6 and an atomic weight of 12.01115. Carbon is unique in chemistry because it forms a vast number of compounds, larger than the sum total of all other elements combined. By far the largest group of these compounds are those composed of carbon and hydrogen. It has been estimated that there are at least 1,000,000 known organic compounds, and this number is increasing rapidly each year. Although the classification is not rigorous, carbon forms another series of compounds, classified as

inorganic, comprising a much smaller number than the organic compounds. See ORGANIC CHEMISTRY; PERIODIC TABLE.

Elemental carbon exists in two well-defined crystalline allotropic forms, diamond and graphite. Other forms, which are poorly developed in crystallinity, are charcoal, coke, and carbon black. Chemically pure carbon is prepared by the thermal decomposition of sugar (sucrose) in the absence of air. The physical and chemical properties of carbon are dependent on the crystal structure of the element. The density varies from 2.25 g/cm<sup>3</sup> (1.30 oz/in.<sup>3</sup>) for graphite to 3.51 g/cm<sup>3</sup> (2.03 oz/in.<sup>3</sup>) for diamond. For graphite, the melting point is 3500°C (6332°F) and the extrapolated boiling point is 4830°C (8726°F). Elemental carbon is a fairly inert substance. It is insoluble in water, dilute acids and bases, and organic solvents. At elevated temperatures, it combines with oxygen to form carbon monoxide or carbon dioxide. With hot oxidizing agents, such as nitric acid and potassium nitrate, mellitic acid, C<sub>6</sub>(CO<sub>2</sub>H)<sub>6</sub>, is obtained. Of the halogens, only fluorine reacts with elemental carbon. A number of metals combine with the element at elevated temperatures to form carbides.

Carbon forms three gaseous compounds with oxygen: carbon monoxide, CO; carbon dioxide, CO<sub>2</sub>; and carbon suboxide, C<sub>3</sub>O<sub>2</sub>. The first two oxides are the more important from an industrial standpoint. Carbon forms compounds with the halogens which have the general formula CX<sub>4</sub>, where X is fluorine, chlorine, bromine, or iodine. At room temperature, carbon tetrafluoride is a gas, carbon tetrachloride is a liquid, and the other two compounds are solids. Mixed carbon tetrahalides are also known. Perhaps the most important of them is dichlorodifluoromethane, CCl<sub>2</sub>F<sub>2</sub>, commonly called Freon. See CARBON DIOXIDE; HALOGENATED HYDROCARBON.

Carbon and its compounds are found widely distributed in nature. It is estimated that carbon makes up 0.032% of the Earth's crust. Free carbon is found in large deposits as coal, an amorphous form of the element which contains additional complex carbon-hydrogen-nitrogen compounds. Pure crystalline carbon is found as graphite and as diamonds.

Extensive amounts of carbon are found in the form of its compounds. In the atmosphere, carbon is present in amounts of up to 0.03% by volume as carbon dioxide. Various minerals such as limestone, dolomite, marble, and chalk all contain carbon in the form of carbonate. All plant and animal life is composed of complex organic compounds containing carbon combined with hydrogen, oxygen, nitrogen, and other elements. The remains of past plant and animal life are found as deposits of petroleum, asphalt, and bitumen. Deposits of natural gas contain compounds that are composed of carbon and hydrogen. See CARBONATE MINERALS.

The free element has many uses, ranging from ornamental applications of the diamond in jewelry to the black-colored pigment of carbon black in automobile tires and printing inks. Another form of carbon, graphite, is used for high-temperature crucibles, arc-light and dry-cell electrodes, lead pencils, and as a lubricant. Charcoal, an amorphous form of carbon, is used as an absorbent for gases and as a decolorizing agent. See CARBON BLACK; CHARCOAL; DIAMOND; GRAPHITE.

The compounds of carbon find many uses. Carbon dioxide is used for the carbonation of beverages, for fire extinguishers, and in the solid state as a refrigerant. Carbon monoxide finds use as a reducing agent for many metallurgical processes. Carbon tetrachloride and carbon disulfide are important solvents for industrial uses. Freon is used in refrigeration devices. Calcium carbide is used to prepare acetylene, which is used for the welding and cutting of metals as well as for the preparation of other organic compounds. Other metal carbides find important uses as refractories and metal cutters. [E.E.W.]

**Carbon black** An amorphous form of carbon produced commercially by thermal or oxidative decomposition of hydro-

carbons. It is used principally in rubber goods, pigments, and printer's ink. It is not an inert filler but enhances and reinforces various properties of rubber.

Manufacturing processes may be classed as contact, furnace, or thermal. In the channel (contact) process, natural gas is burned with insufficient air for complete combustion. The smoky flame from individual burners impinges on a cool channel iron, and carbon black deposited on the channel is removed by a scraper blade. In the furnace process, the hydrocarbon and air are fed into a reactor. Combustion of part of the hydrocarbon raises the temperature to 2000–3000°F (1100–1700°C), causing decomposition of the unburned hydrocarbon to carbon black. A water spray quickly cools the hot reaction products, and the finely divided black is recovered by cyclones and bag filters. In the thermal process, natural gas is decomposed to carbon and hydrogen by heated refractories. [C.J.He.]

**Carbon dioxide** A colorless, odorless, tasteless gas, formula CO<sub>2</sub>, about 1.5 times as heavy as air. Under normal conditions, it is stable, inert, and nontoxic. The decay (slow oxidation) of all organic materials produces CO<sub>2</sub>. Fresh air contains approximately 0.033% CO<sub>2</sub> by volume. In the respiratory action (breathing) of all animals and humans, CO<sub>2</sub> is exhaled.

Carbon dioxide gas may be liquefied or solidified. Solid CO<sub>2</sub> is known as dry ice. Carbon dioxide is obtained commercially from four sources: gas wells, fermentation, combustion of carbonaceous fuels, and as a by-product of chemical processing. Applications include use as a refrigerant, in either solid or liquid form, inerting medium, chemical reactant, neutralizing agent for alkalis, and pressurizing agent.

Most CO<sub>2</sub> is obtained as a by-product from steam-hydrocarbon reformers used in the production of ammonia, gasoline, and other chemicals; other sources include fermentation, deep gas wells, and direct production from carbonaceous fuels. Whatever the source, the crude CO<sub>2</sub> (containing at least 90% CO<sub>2</sub>) is compressed in either two or three stages, cooled, purified, condensed to the liquid phase, and placed in insulated storage vessels. Carbon dioxide is distributed in three ways; in high-pressure uninsulated steel cylinders; as a low-pressure liquid in insulated truck trailers or rail tank cars; and as dry ice in insulated boxes, trucks, or boxcars. [J.S.L.]

**Carbon-nitrogen-oxygen cycles** A group of nuclear reactions that involve capture of protons by carbon, nitrogen, and oxygen nuclei. These cycles are believed to be the source of energy in main-sequence stars which are more massive than the Sun. Completion of any one of the cycles results in consumption of four protons, synthesis of one helium nucleus (<sup>4</sup>He) and two neutrinos, and 26.73 MeV of energy. This energy *E* reflects the difference in mass *m* between the four protons and the helium nucleus and is equal to the mass difference times the square of the velocity of light *c*, as is known from Einstein's statement of mass-energy equivalence,  $E = mc^2$ . Because the nuclear fuel consumed in these processes is hydrogen, they are referred to as hydrogen burning by means of the carbon-nitrogen-oxygen (CNO) cycles. [G.R.C.]

**Carbon star** Any star whose spectrum shows a higher abundance of carbon than of oxygen. The carbon enhancements are easily recognizable from strong spectral absorption bands of carbon in molecular forms such as C<sub>2</sub>, CN, and CH.

Most stars with masses between 0.6 and 5 times the mass of the Sun must pass through a carbon-star phase. Stars like the Sun, called dwarf stars, derive their energy from nuclear fusion of hydrogen to produce helium. As a star evolves and its core supply of hydrogen disappears, it can begin to burn helium into carbon, becoming a giant star. Asymptotic giant branch (AGB) stars are further evolved stars where nuclear burning of helium surrounds

a dense carbon-oxygen core. The helium shell burning causes large temperature gradients and convection, which efficiently dredge up the processed, carbon-rich material toward the stellar surface. See NUCLEOSYNTHESIS.

Asymptotic giant branch carbon stars expel much of their carbon-rich envelopes as a wind. During a single year of its mass-losing phase, a carbon star may expel up to  $10^{-5}$  of a solar mass, about 3 Earth masses, of carbon-rich material. This material may form cool envelopes of ejected circumstellar dust that dim and redden its appearance. The expelled stellar envelopes eventually mix with the surrounding interstellar environment, so that much of the carbon throughout the Milky Way Galaxy comes from mass-losing carbon stars.

Matter expelled from asymptotic giant branch stars in binary star systems may fall onto and enhance the carbon abundance of a dwarf companion star. Since dwarf carbon stars are much fainter, only a few are yet known. The long lifetimes of dwarfs, however, all but ensure that many more currently exist than do carbon giants. See BINARY STAR; DWARF STAR; GIANT STAR; STAR; STELLAR EVOLUTION. [P.J.G.]

**Carbonate minerals** Mineral species containing the carbonate ion as the fundamental anionic unit. The carbonate minerals can be classified as (1) anhydrous normal carbonates, (2) hydrated normal carbonates, (3) acid carbonates (bicarbonates), and (4) compound carbonates containing hydroxide, halide, or other anions in addition to the carbonate. See CARBONATE.

Most of the common carbonate minerals belong to group (1), and can be further classified according to their structures. The rhombohedral carbonates are typified by calcite,  $\text{CaCO}_3$ , and by dolomite,  $\text{CaMg}(\text{CO}_3)_2$ . The other structural type within this group is that of aragonite, which has orthorhombic symmetry. See ANKERITE; ARAGONITE; CALCITE; CERUSSITE; DOLOMITE; MAGNESITE; RHODOCHROSITE; SIDERITE; SMITHSONITE; STRONTIANITE; WITHERITE.

The minerals in groups (2) and (3) all decompose at relatively low temperatures and therefore occur only in sedimentary deposits (typically evaporites) and as low-temperature hydrothermal alteration products. The only common mineral in these groups is trona,  $\text{Na}_3\text{H}(\text{CO}_3)_2 \cdot 2\text{H}_2\text{O}$ . See SALINE EVAPORATE.

Similarly, the group (4) minerals are relatively rare and are characteristically low-temperature hydrothermal alteration products. The commonest members of this group are malachite,  $\text{Cu}_2\text{CO}_3(\text{OH})_2$ , and azurite,  $\text{Cu}_3(\text{CO}_3)_2(\text{OH})_2$ , which are often found in copper ore deposits. See AZURITE; MALACHITE.

Important occurrences of carbonates include ultrabasic igneous rocks such as carbonatites and serpentinites, and metamorphosed carbonate sediments, which may recrystallize to form marble. The major occurrences of carbonates, however, are in sedimentary deposits as limestone and dolomite rock. See DOLOMITE ROCK; LIMESTONE; MARBLE; SEDIMENTARY ROCKS. [A.M.G.]

**Carbonatite** An igneous rock in which carbonate minerals make up at least half the volume. Individual occurrences of carbonatite are not numerous (about 330 have been recognized) and generally are small, but they are widely distributed. Carbonatites are scientifically important because they reveal clues concerning the composition and thermal history of the Earth's mantle. See CARBONATE MINERALS.

The carbonate minerals that dominate the carbonatites are, in order of decreasing abundance, calcite, dolomite, ankerite, and rarely siderite and magnesite. Sodium- and potassium-rich carbonate minerals have been confirmed in igneous rocks at only one locality, the active volcano Oldoinyo Lengai in Tanzania. Noncarbonate minerals that typify carbonatites are apatite, magnetite, phlogopite or biotite, clinopyroxene, amphibole,

monticellite, perovskite, and rarely olivine or melilite. Secondary minerals, produced by alteration of primary magmatic minerals, include barite, alkali feldspar, quartz, fluorite, hematite, rutile, pyrite, and chlorite. Minerals that are important in some carbonatites because they carry niobium, rare-earth elements, and other metals in concentrations high enough for profitable extraction are pyrochlore, bastnaesite, monazite, baddeleyite, and bornite.

Carbonatites, compared to the inferred composition of the Earth's mantle and to other igneous rocks, are greatly enriched in niobium, rare-earth elements, barium, strontium, phosphorus, and fluorine, and they are relatively depleted in silicon, aluminum, iron, magnesium, nickel, titanium, sodium, potassium, and chlorine. These extreme differences are attributed to strong fractionation between carbonate liquid on the one hand and silicate and oxide solid phases on the other during separation of the carbonate liquid from its source. Strontium and neodymium isotope ratios indicate that the sources of carbonatites are geologically old, inhomogeneous, and variably depleted in the radioactive parent elements rubidium and samarium.

Ultramafic xenoliths from lithospheric mantle commonly show textures and mineral assemblages that indicate modification of the original rock. This alteration typically results in strong enrichment in light rare-earth elements, uranium, thorium, and lead, but much less enrichment in titanium, zirconium, niobium, and strontium. These changes are commonly attributed to interaction of lithospheric mantle with an invading carbonate-rich magma. The wide geographic dispersal of these altered xenoliths suggests that carbonate-rich liquid has been more common in the upper mantle than the low abundance of carbonatites in the upper crust would suggest. According to the testimony of these samples, carbonatite magma, ascending through lithospheric mantle, commonly is trapped before it can invade the crust. In addition to the factors that can stop the rise of any magma (heat loss, increase of solidus temperature with decrease in pressure, decrease in density and increase in strength of wall rock), carbonatite magma can be halted by reaction with wall rock to form calcium and magnesium silicates plus carbon dioxide ( $\text{CO}_2$ ), and by less oxidizing conditions to reduce carbonate to elemental carbon (graphite or diamond) or to methane. Both of these changes subtract dissolved  $\text{CO}_2$  from the magma, causing crystallization. See EARTH INTERIOR.

Carbonatites are not restricted to a single tectonic regime. They occur in oceanic and continental crust and have formed in compressional fold belts and stable cratons as well as regions of crustal extension. Rather than indicating the stress field in the shallow crust in which they were emplaced, carbonatites are useful in modeling the long-term thermal and chemical development of the mantle. See IGNEOUS ROCKS.

Carbonatites yield a variety of mineral commodities, including phosphate, lime, niobium, rare-earth elements, anatase, fluorite, and copper. Agricultural phosphate for fertilizer is the most valuable single product from carbonatites; most is obtained from apatite in lateritic soils that have developed by tropical weathering of carbonatites, dissolving the carbonates and thereby concentrating the less soluble apatite. Lime for agriculture and for cement manufacture is obtained from carbonatites in regions where limestones are lacking. The carbonatites at Bayan Obo, China, and Mountain Pass, California, dominate the world suppliers of rare-earth elements, but many other carbonatites contain unexploited reserves. Tropical weathering at several carbonatites in Brazil has produced economically important concentrations of anatase ( $\text{TiO}_2$ ) from decomposition of perovskite ( $\text{CaTiO}_3$ ). [D.S.Ba.]

**Carboniferous** The fifth period of the Paleozoic Era. The Carboniferous Period spanned from about 355 million years to about 295 million years ago. The rocks that formed during this time interval are known as the Carboniferous System; they

include a wide variety of sedimentary, igneous, and metamorphic rocks. Sedimentary rocks in the lower portion of the Carboniferous are typically carbonates, such as limestones and dolostones, and locally some evaporites. The upper portions of the system are usually composed of cyclically repeated successions of sandstones, coals, shales, and thin limestones. See SEDIMENTARY ROCKS.

The economic importance of the Carboniferous is evident in its name, which refers to coal, the important energy source that fueled the industrialization of northwestern Europe in the early 1800s and led to the Carboniferous being one of the first geologic systems to be studied in detail. Carboniferous coals formed in coastal and fluvial environments in many parts of the world. Petroleum, another important energy resource, accumulated in many Carboniferous marine carbonate sediments, particularly near shelf margins adjacent to basinal black shale source rocks. In many regions the cyclical history of deposition and exposure has enhanced the permeability and porosity of the shelfal rocks to make them excellent petroleum reservoirs. The limestones of the Lower Carboniferous are extensively quarried and used for building stone, especially in northwestern Europe and the central and eastern United States. See COAL; PETROLEUM.

The base of the Carboniferous is placed at the first appearance of the conodont *Siphonodella sulcata*, a fossil that marks a widely recognized biozone in most marine sedimentary rocks. The reference locality for this base is an outcrop in Belgium. The top of the Carboniferous is placed at the first appearance of the conodont *Streptognathus isolatus* a few meters below the first appearance of the Permian fusulinacean foraminiferal zone of *Sphaeroschwagerina fusiformis*. The reference locality is in the southern Ural region in Kazakhstan. The equivalent biozone is at the base of *Pseudoschwagerina* in North America. See CONODONT; FUSULINACEA.

The International Subcommittee on Carboniferous Stratigraphy reached general agreement in the 1970s and 1980s that the Carboniferous would be divided into two parts: a Lower Carboniferous Mississippian Subsystem and an Upper Carboniferous Pennsylvanian Subsystem. The two Carboniferous subsystems are subdivided into a number of series and stages that are variously identified in different parts of the world, based on biostratigraphic evidence using evolutionary successions in fossils or overlapping assemblage zones.

Perhaps the strongest of the many ecological factors that controlled biotic distributions were the paleogeographic changes within the Carboniferous that were brought about by the initial assembling of the supercontinent Pangaea and the associated mountain-building activities, which greatly modified climate, ocean currents, and seaways. In the Early Carboniferous, a nearly continuous equatorial seaway permitted extensive tropical and subtropical carbonate sedimentation on the shelves and platforms in North America, northern and southern Europe, Kazakhstan, North and South China, and the northern shores of the protocontinent Gondwana (such as northern Africa).

The gradual collision of northern Gondwana against northern Europe-North America (also called Euramerica or Laurussia) started the formation of the supercontinent of Pangaea. See CONTINENTAL DRIFT; CONTINENTS, EVOLUTION OF; PALEO GEOGRAPHY; PLATE TECTONICS.

An additional ramification of the formation of Pangaea was the beginning of very extensive glaciation in the Southern Hemisphere polar and high-latitude regions of the supercontinent. Glacial deposits are also known from smaller continental fragments that were at high paleolatitudes in the Northern Hemisphere. The Earth's climate cooled, tropical carbonate-producing areas became restricted toward the Equator, and eustatic sea-level fluctuations became prominent in the sedimentary record. See GLACIAL EPOCH.

During the Carboniferous, life evolved to exploit fully the numerous marine and nonmarine aquatic environments and ter-

restrial and aerial habitats. Single-cell protozoan foraminifers evolved new abilities to construct layered, calcareous walls. Insects have remarkable evolutionary histories during the Carboniferous. They adapted to flight and dispersed into many terrestrial and fresh-water habitats. Vertebrates also evolved rapidly. Although acanthodian fish declined from their Devonian peak, sharklike fishes and primitive bony fishes adapted well to the expanded environments and the new ecological food chains of the Carboniferous. Some sharklike groups invaded fresh-water habitats, where they were associated with coal swamp deposits. Carboniferous amphibians evolved rapidly in several directions. The earliest were the labyrinthodont embolomeres, which had labyrinthodont teeth and were mainly aquatic. Another significant labyrinthodont group was the rhabditomeres, which originated in the Early Carboniferous and became abundant, commonly reaching about 1 m (3 ft) or more; they were widespread in terrestrial habitats during the Late Carboniferous and Permian. Primitive reptiles evolved from one of the embolomere amphibian lineages during the Late Carboniferous. They formed the basal stock from which all other reptiles have evolved including the earliest mammal-like reptiles in the Late Carboniferous. During the Late Carboniferous, early reptiles coexisted with several advanced amphibian groups which shared at least some, but probably not all, of their reptile-like characters.

Terrestrial plants also showed major diversification of habitats and the evolution of important new lineages during the Carboniferous. Initially, Early Carboniferous plants were predominantly a continuation of latest Devonian groups; however, they were distinguished in part by their large sizes with many arborescent lycopods and large articulates, and pteridosperms (seed ferns) and ferns became increasingly abundant and varied. By the Late Carboniferous, extensive swamps formed along the broad, nearly flat coastal areas; and these coal-forming environments tended to move laterally across the coastal plain areas as the sea level repeatedly rose. Other coal-forming marshes were common in the floodplains and channel fills of the broad rivers of upper delta distributary systems. During the Late Carboniferous, primitive conifers appeared and included araucarias, which became common in some, probably drier ecological habitats. See PALEOBOTANY; PALEOZOIC. [C.A.R.; J.R.P.R.]

**Carbonyl** A functional group found in organic compounds in which a carbon atom is doubly bonded to an oxygen atom:

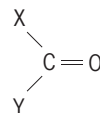

Depending upon the nature of the other groups attached to carbon, the most common compounds containing the carbonyl group are aldehydes (X and Y = H; X = H, Y = alkyl or aryl), ketones (X and Y = alkyl or aryl), carboxylic acids (X = OH, Y = H, alkyl, or aryl), esters (X = O-alkyl or aryl; Y = H, alkyl, or aryl), and amides (X = N-H, N-alkyl, or N-aryl; Y = H, alkyl, or aryl). Other compounds that contain the carbonyl group are acid halides, acid anhydrides, lactones, and lactams. See ACID ANHYDRIDE; ACID HALIDE; ALDEHYDE; AMIDE; ESTER; KETONE.

All the compounds containing this functional group are referred to in a general way as carbonyl compounds. It is important, however, to distinguish these compounds from a large group formed from metals and carbon monoxide, which are known as metal carbonyls. In these latter compounds, there is only one group attached to the carbon in addition to the oxygen, and the carbon atom is viewed as triply bonded to the oxygen. See METAL CARBONYL. [J.P.Fr.]

**Carborane** A cluster compound containing both carbon (C) and boron (B) atoms as well as hydrogen (H) atoms external to the framework of the cluster. A cluster compound is one with insufficient electrons to allow for classical two-center two-electron bonds between all adjacent atoms. Sometimes the term carborane is used as a synonym for *closo*-1,2- $C_2B_{10}H_{12}$ , commonly referred to as *ortho*-carborane. Carboranes are of interest because of their nonclassical bonding, their relatively high thermal stability, and their ability, when containing the  $^{10}B$  isotope, to capture neutrons efficiently. See BORANE.

The structures of carboranes are based upon a series of three-dimensional, cagelike geometric shapes possessing triangulated faces; such shapes are termed delta polyhedra. The structure for any given carborane may be predicted by determining the framework electrons, by determining the number of electrons involved in bonding the boron and carbon atoms of the cluster framework together, and by using Wade's rule. Wade's rule states that a cluster containing  $n$  framework electrons will be derived from a delta polyhedron containing  $(n - 2)/2$  vertices, the parent cluster. Once this parent cluster has been determined, the geometry of the cluster framework may be predicted by clipping off vertices from the parent cluster until a polyhedron whose number of vertices is equivalent to the sum of boron and carbon atoms in the cluster framework is obtained.

Carboranes are placed, according to their structure, into several classifications. The most common classifications are *closo* (closed), *nido* (nestlike), and *arachno* (cobweb) (see illustration).

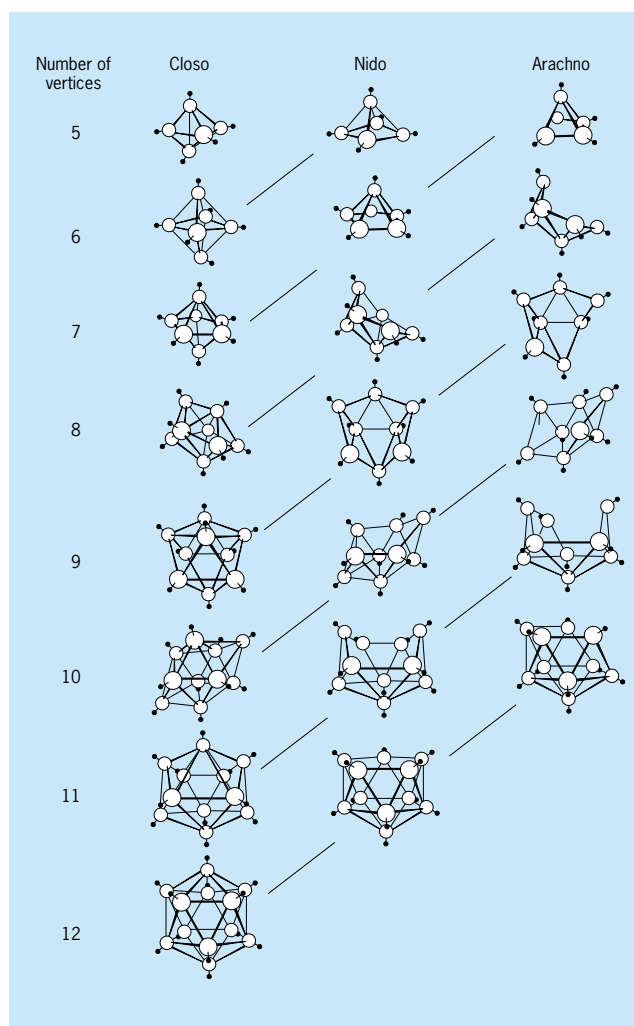

Parent clusters from which carborane structures are determined. The diagonal lines define series of related *closo*, *nido*, and *arachno* structures.

If a carborane's framework structure is that of a closed delta polyhedron, the carborane is said to be a *closo*-carborane. If a carborane's framework structure is that of a closed delta polyhedron minus one or two vertices, the carborane is said to be a *nido*- or *arachno*-carborane, respectively.

The bonding within a carborane can be thought of in terms of localized atomic orbitals forming both classical two-center two-electron bonds and nonclassical three-center two-electron bonds. Each vertex boron and carbon atom can be thought of as being  $sp^3$  hybridized, with three of these hybrid orbitals of each vertex atom employed in framework bonding. Employing this simple approach, the bonding within carboranes can be represented by employing resonance structures. For example, *nido*- $C_2B_4H_8$  exhibits three resonance structures. The existence of resonance structures implies a delocalization of electron density throughout the cluster framework. Indeed, carboranes exhibit a high degree of electron density delocalization, and their bonding can be described more accurately by employing molecular orbital theory. See CHEMICAL BONDING; DELOCALIZATION; MOLECULAR ORBITAL THEORY; RESONANCE (MOLECULAR STRUCTURE).

The typical synthesis of a carborane involves the reaction of a boron hydride cluster, containing only boron and hydrogen, with an alkyne. The resulting carborane contains two carbon atoms in its skeletal structure, a dicarbon carborane. The dicarbon carboranes, because of their relative ease of preparation, have been the most widely studied group of carboranes. In particular, *closo*-1,2- $C_2B_{10}H_{12}$ , the most readily available carborane, has been extensively studied. Other common groups of carboranes include the monocarbon and tetracarbon carboranes. See ALKYNE.

[T.D.G.]

**Carboxylic acid** One of a large family of organic substances widely distributed in nature, and characterized by the presence of one or more carboxyl groups ( $-COOH$ ). These groups typically yield protons in aqueous solution. In the type formula,  $R(CXY)_nCOOH$ , symbols R, X, and Y can be hydrogen, saturated or unsaturated groups, carboxyl, alicyclic, or aromatic groups, halogens, or other substituents, and  $n$  may vary from zero (formic acid,  $HCOOH$ ) to more than 100, provided that the normal carbon covalence of four is maintained.

Physical and chemical properties of carboxylic acids are represented, grossly, by the resultant of the various chemical groupings present in the molecule. A short-chain aliphatic acid, wherein the carboxyl is dominant, is a pungent, corrosive, water-soluble liquid of abnormally high boiling point (because of molecular association), with specific gravity close to 1 (higher for formic and acetic acids). With increasing molecular weight, the hydrocarbon grouping overbalances the carboxyl; sharpness of odor diminishes, boiling and melting points rise, the specific gravity falls toward that of the parent hydrocarbon, and the water solubility decreases. Thus the typical high-molecular-weight saturated acid is a bland, waxlike solid.

Acids are used in large quantities in the production of esters, acid halides, acid amides, and acid anhydrides. They find wide use in the manufacture of soaps and detergents, in thickening lubricating greases (stearate soaps), in modifying rigidity in plastics, in compounding buffing bricks and abrasives, and in the manufacture of crayons, dictaphone cylinders, and phonograph records. The solvent action of acids finds use in manufacture of carbon paper, inks, and in the compounding of synthetic and natural rubber. Because of the stability of saturated fatty acids toward oxidation, these are often used as solvents for carrying out oxidation reactions upon sensitive compounds. [E.B.R.]

**Carburetor** A device that controls the power output and fuel feed of internal combustion spark-ignition engines used for automotive, aircraft, and auxiliary services. Its duties include control of the engine power by the air throttle; metering, delivery, and mixing of fuel in the airstream; and graduating the

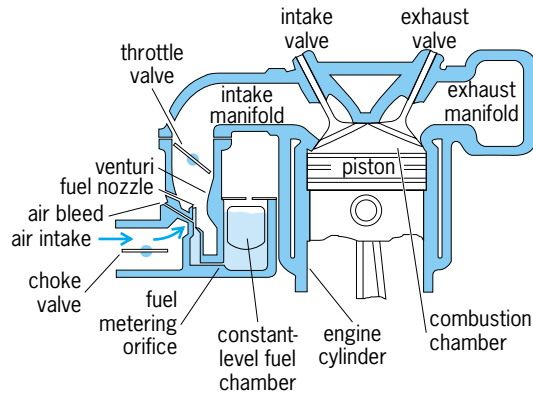

Elements that basically determine air and fuel charges received by the engine through the carburetor.

fuel-air ratio according to engine requirements in starting, idling, and load and altitude changes. The fuel is usually gasoline or similar liquid hydrocarbon compounds, although some engines with a carburetor may also operate on a gaseous fuel such as propane or compressed natural gas. A carburetor may be classified as having either a fixed venturi, in which the diameter of the air opening ahead of the throttle valve remains constant, or a variable venturi, which changes area to meet the changing demand. See AUTOMOBILE; ENGINE; FUEL SYSTEM; VENTURI TUBE.

A simple updraft carburetor with a fixed venturi illustrates basic carburetor action (see illustration). Intake air charge, at full or reduced atmospheric pressure as controlled by the throttle, is drawn into the cylinder by the downward motion of the piston to mix with the unscavenged exhaust remaining in the cylinder from the previous combustion. A cylinder is most completely filled with the fuel-air mixture when no other cylinder is drawing in through the same intake passage at the same time. The fuel is usually metered through a calibrated orifice, or jet, at a differential pressure derived from the pressure drop in a venturi in the intake air passage. [D.L.An.]

**Cardamon** The plant *Elettaria cardamomum* (Zingiberaceae), a perennial herb that is a native of India. The small, light-colored seeds, borne in capsules, have a delicate flavor. They are used in curries, cakes, pickles, and in general cooking, as well as in medicine. See ZINGIBERALES. [P.D.St./E.L.C.]

**Cardinal points** The four intersections of the horizon with the meridian and with the prime vertical circle, or simply prime vertical, the intersections with the meridian being designated north and south, and the intersections with the prime vertical being designated east and west (see illustration). The

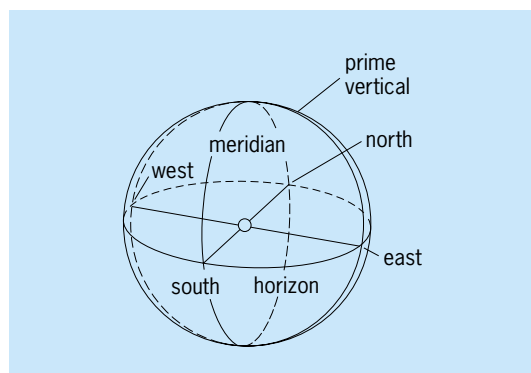

Cardinal points around the horizon.

cardinal points are  $90^\circ$  apart; they lie in a plane with each other and correspond to the cardinal regions of the heavens. The four intermediate points, northeast, southeast, northwest, and southwest, are the collateral points. [F.H.R.]

**Cardioid** A heart-shaped curve generated by a point of a circle that rolls (without slipping) on a fixed circle of the same diameter. In point-wise construction of the curve, let  $O$  be a fixed point of a circle  $C$  of diameter  $a$ , and  $Q$  a variable point of  $C$ . Lay off distance  $a$  along the secant  $OQ$ , in both directions from  $Q$ . The locus of the two points thus obtained is a cardioid (see illustration). If a rectangular coordinate system is chosen with  $O$

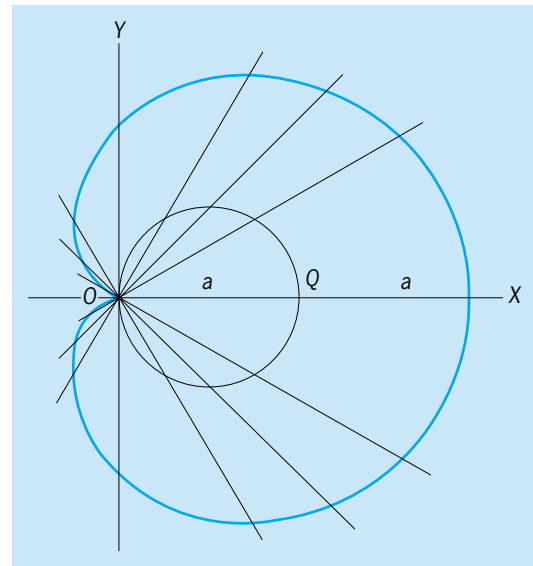

A cardioid (symbols are explained in the text).

for origin initially and  $y$  axis tangent to  $C$  at  $O$ , the cardioid has equation  $(x^2 + y^2 - ax)^2 = a^2(x^2 - y^2)$ . The equation in polar coordinates is  $p = a(1 + \cos \theta)$ . Its area is  $3/2\pi a^2$ , or six times the area of  $C$ , and its length is  $8a$ . See ANALYTIC GEOMETRY. [L.M.BI.]

**Cardiovascular system** Those structures, such as the heart, or pumping mechanism, and the arteries, veins, and capillaries, which provide channels for the flow of blood. The cardiovascular system is sometimes called the blood-vascular system. The circulatory system includes both the cardiovascular and lymphatic systems; the latter consists of lymph channels (lymphatics), nodes, and fluid lymph which finally empties into the bloodstream. See BLOOD; HEART (VERTEBRATE); HEMATOPOIESIS; LYMPHATIC SYSTEM. [C.K.W.]

Circulatory physiology describes the structure and operation of the circulation in living animals, and enquires as to how or why the circulatory system may have evolved. The circulatory system in all vertebrates has multiple functions, but all functions are involved in regulating the internal environment of the animal (promoting homeostasis). In all vertebrates the circulatory system consists of a central pump, the heart, which drives a liquid transport medium, the blood, continuously around a closed system of tubes, the vascular system. The arterial portion of this system is divided into larger elastic and smaller resistance vessels (arterioles) which distribute blood to specialized regions or organs where transfer of nutrients, oxygen, or waste products takes place across the walls of a fine network of microscopic capillaries. Blood from the capillaries passes through the venules (small venous vessels) into the main vein and returns to the heart. The

arterioles, venules, and capillaries make up the microcirculation, which is arguably the most important functional role of the vertebrate circulatory system from a functional point of view.

Cardiovascular system disorders are those disorders which involve the arteries, veins, and lymphatics. See ARTERIOSCLEROSIS; LYMPHADENITIS; PHLEBITIS. [D.R.J.]

**Carnauba wax** Product exuded from the leaves of the wax palm, *Copernicia cerifera*, a native of Brazil and other regions in tropical South America. It is the hardest, highest-melting natural wax and is used in making candies, shoe polish, high-luster wax, varnishes, phonograph records, and surface coating of automobiles. See WAX, ANIMAL AND VEGETABLE. [E.L.C.]

**Carnivora** One of the larger orders of placental mammals, including fossil and living dogs, raccoons, pandas, bears, weasels, skunks, badgers, otters, mongooses, civets, hyenas, seals, walruses, and many extinct groups organized into 12 families, with about 112 living genera and more than twice as many extinct genera. The subdivision of the order into three superfamilies has long been practiced and the following groups seem appropriate: Miacoidea, Canoidea, and Feloidea. The primary adaptation in this order was for predation on other vertebrates and invertebrates. A few carnivorans (for example, bear and panda) have secondarily become largely or entirely herbivorous, but even then the ancestral adaptations for predation are still clearly evident in the structure of the teeth and jaws. The Carnivora have been highly successful animals since their first appearance in the early Paleocene.

Structural adaptations involve the teeth and jaws. The dentition is sharply divided into three functional units. The incisors act as a tool for nipping and delicate prehension, and the large, interlocking upper and lower canines for heavy piercing and tearing during the killing of prey. The cheek teeth are divided into premolars (for heavy prehension) and molars (for slicing and grinding), which may be variously modified depending on the specific adaptation, but there is a constant tendency for the last (fourth) upper premolar and the first lower molar to enlarge and form longitudinal opposed shearing blades (the carnassials). In all carnivorans the jaw articulation is arranged in such a manner that movement is limited to vertical hinge motions and transverse sliding. The temporal muscle dominates the jaw musculature, forming at least one-half of the total mass of the jaw muscles.

The earliest fossil records are early Paleocene, but the earliest well-represented material comes from the middle Paleocene of North America. During the Paleocene and Eocene the stem-carnivorans or miacoids underwent considerable diversification in both the Old and New World. At the end of Eocene and beginning of Oligocene time throughout the Northern Hemisphere, a dramatic change took place within the Carnivora; this was the appearance of primitive representatives of modern carnivoran families. See BADGER; BEAR; CAT; CIVET; COATI; DOG; FERRET; FISHER; HYENA; MAMMALIA; MARTEN; MINK; MONGOOSE; OTTER; PANDA; PINNIPEDS; RACCOON; SKUNK; WEASEL; WOLVERINE. [R.H.T.]

**Carnot cycle** A hypothetical thermodynamic cycle used as a standard of comparison for actual cycles. The Carnot cycle shows that, even under ideal conditions, a heat engine cannot convert all the heat energy supplied to it into mechanical energy; some of the heat energy must be rejected.

In a Carnot cycle, an engine accepts heat energy from a high-temperature source, or hot body, converts part of the received energy into mechanical (or electrical) work, and rejects the remainder to a low-temperature sink, or cold body. The greater the temperature difference between the source and sink, the greater the efficiency of the heat engine.

The Carnot cycle (see illustration) consists first of an isentropic compression, then an isothermal heat addition, followed by an

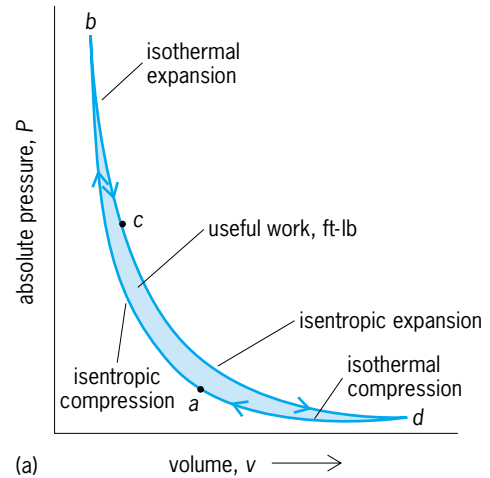

(a) Absolute pressure versus volume.

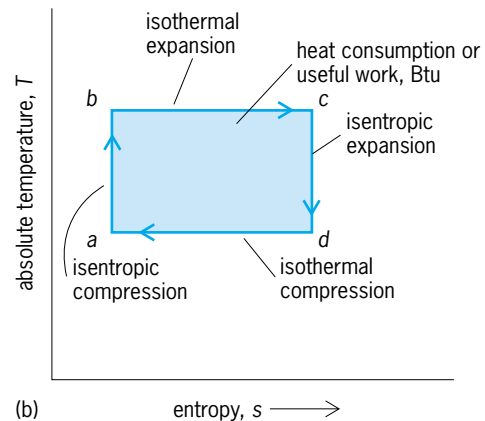

(b) Absolute temperature versus entropy.

**Carnot cycle for air. (a) Absolute pressure versus volume. (b) Absolute temperature versus entropy.**

isentropic expansion, and concludes with an isothermal heat rejection process. In short, the processes are compression, addition of heat, expansion, and rejection of heat, all in a qualified and definite manner. The net effect of the cycle is that heat is added at a constant high temperature, somewhat less heat is rejected at a constant low temperature, and the algebraic sum of these heat quantities is equal to the work done by the cycle.

A Carnot cycle consists entirely of reversible processes; thus it can theoretically operate to withdraw heat from a cold body and to discharge that heat to a hot body. To do so, the cycle requires work input from its surroundings. The heat equivalent of this work input is also discharged to the hot body. Just as the Carnot cycle provides the highest efficiency for a power cycle operating between two fixed temperatures, so does the reversed Carnot cycle provide the best coefficient of performance for a device pumping heat from a low temperature to a higher one. See HEAT PUMP; REFRIGERATION CYCLE.

Good as the ideal Carnot cycle may be, there are serious difficulties that emerge when one wishes to make an actual Carnot engine. The necessarily high peak pressures and temperatures limit the practical thermal efficiency that an actual engine can achieve. Although the Carnot cycle is independent of the working substance, and hence is applicable to a vapor cycle, the difficulty of efficiently compressing a vapor-liquid mixture renders the cycle impractical. See POWER PLANT; THERMODYNAMIC CYCLE; THERMODYNAMIC PRINCIPLES. [T.Ba.]

**Carnotite** A mineral that is a hydrous vanadate of potassium and uranium,  $K_2(UO_2)_2(VO_4)_2 \cdot nH_2O$ . The water content

varies at ordinary temperatures from one to three molecules. Carnotite generally occurs as a powder or as a slightly coherent microcrystalline aggregate. Color ranges from bright yellow to lemon- and greenish-yellow.

In the United States the principal region of carnotite mineralization is the Colorado Plateau and adjoining districts of Utah, New Mexico, and Arizona. Carnotite is found also in Wyoming and in Carbon County, Pennsylvania. Deposits are located at Radium Hill near Olary, Australia, and in Katanga (Zaire). Carnotite is the chief source of uranium in the United States. It is also a source of radium and vanadium. See RADIOACTIVE MINERALS; URANIUM; VANADIUM. [W.R.Lo.]

**Carotenoid** Any of a class of yellow, orange, red, and purple pigments that are widely distributed in nature. Carotenoids are generally fat-soluble unless they are complexed with proteins. In plants, carotenoids are usually located in quantity in the grana of chloroplasts in the form of carotenoprotein complexes. Carotenoprotein complexes give blue, green, purple, red, or other colors to crustaceans, echinoderms, nudibranch mollusks, and other invertebrate animals. Some coral coelenterates exhibit purple, pink, orange, or other colors due to carotenoids in the calcareous skeletal material. Cooked or denatured lobster, crab, and shrimp show the modified colors of their carotenoproteins.

The general structure of carotenoids is that of aliphatic and aliphatic-alicyclic polyenes, with a few aromatic-type polyenes. Most carotenoid pigments are tetraterpenes with a 40-carbon (C<sub>40</sub>) skeleton. More than 300 carotenoids of known structure are recognized, and the number is still on the rise. See TERPENE.

There are several biochemical functions in which the role of carotenoids is well understood. These include carotenoids in the photosynthetic apparatus of green plants, algae, and photosynthetic bacteria, where carotenoids function as a blue light-harvesting pigment (antenna or accessory pigment) for photosynthesis. Thus carotenoids make it possible for photosynthetic organisms more fully to utilize the solar energy in the visible spectral region. See CHLOROPHYLL; PHOTOSYNTHESIS.

Another function of carotenoids is to protect biological systems such as the photosynthetic apparatus from photodynamic damage. This is done by quenching the powerful photodynamic oxidizing agent, singlet oxygen, produced as an undesirable by-product of the exposure of pigmented organisms to light.

Perhaps the most important industrial application of carotenoids is in safe coloration of foods, as exemplified in the coloring and fortification of margarine and poultry feedstuff. [P.S.S., T.Y.L.]

**Carotid body** A special sensory organ (glomus caroticum) which is located in the angle between the bifurcation of the common carotid artery into the external and internal carotid arteries. The carotid body is a bilateral ovoid structure which in humans measures approximately 0.2 by 0.3 in. (5 by 7 mm) and is usually embedded within the outer connective tissue layer of the adjacent common carotid artery. The carotid bodies are termed chemoreceptors because they closely monitor the oxygen and carbon dioxide (CO<sub>2</sub>) content of the blood. See CHEMORECEPTION. [J.Ha.]

**Carp** The common name for a number of cypriniform fishes of the family Cyprinidae. The carp (*Cyprinus carpio*) is closely related to the goldfish (*Crassius auratus*). The fish originated in China, where for centuries it was raised for food. It was imported into the United States from Europe, where it also has been raised for years as a source of food.

The carp has pharyngeal teeth and a suckerlike mouth. A very long dorsal fin is preceded by a strong spine. The swim bladder

of the carp is associated with a group of small bones at the anterior end, the Weberian ossicles. This structural modification enables the carp to perceive sound quite well. See CYPRINIFORMES.

[C.B.C.]

**Carpal tunnel syndrome** A condition caused by the thickening of ligaments and tendon sheaths at the wrist with consequent compression of the median nerve at the palm. Affected individuals report numbness, tingling, and pain in the hand; the discomfort often becomes worse at night or after use of the hand. A physical examination of the injured hand during the early stages of the syndrome often reveals no abnormality. With more severe nerve compression, the individual experiences sensory loss over some or all of the digits innervated by the median nerve (thumb, index finger, middle finger, and ring finger) and weakness of thumb movement.

The incidence of carpal tunnel syndrome is greater among electronic-parts assemblers, frozen-food processors, musicians, and dental hygienists. Highly repetitive wrist movements, use of vibrating tools, awkward wrist positions, and movements involving great force seem to be correlated with the disorder. Awkward and repetitive wrist motions occur in many office tasks, such as typing and word processing.

Carpal tunnel syndrome probably accounts for a minority of the cases of overuse syndrome (cumulative trauma syndrome), which is a common problem in occupational settings. Overuse syndrome symptoms include muscle pain, tendinitis, fibrositis (inflammation of connective tissue in a joint region), and epicondylitis (inflammation of the eminence on the condyle of a bone). Although the causative relationship between the two disorders has not been conclusively proven, the incidence of both carpal tunnel syndrome and overuse syndrome appears to increase in tandem in individuals who are at risk.

The increase in pressure within the carpal canal is usually caused by nonspecific inflammation of flexor tendon sheaths. Diabetes, pregnancy, rheumatoid arthritis, and hypothyroidism are the most common medical conditions associated with carpal tunnel syndrome. A reduction in the flow of blood to the nerve can account for the intermittent tingling that occurs at night or with wrist flexion. See AMYLOIDOSIS; ARTHRITIS; DIABETES; THYROID GLAND DISORDERS.

Nonsurgical treatment includes avoidance of the use of the wrist, use of a splint to keep the wrist in a neutral position, and anti-inflammatory medications. These treatments are especially useful in individuals with an acute flare-up and in those with minimal and intermittent symptoms. Surgical treatment may be used if conservative approaches fail. The procedure is usually done on an outpatient basis with prognoses of good to excellent in 80% of the cases. Although 40% of the individuals regain normal function, the condition of 5% may worsen. [D.M.D.]

**Carpoids** The common name for four extinct classes of primitive echinoderms that have a flattened theca or body lacking radial symmetry. These enigmatic fossils were originally classified together in the class Carpoidea, but more recent echinoderm researchers have assigned them to four separate classes in the subphylum Homalozoa: the Stylophora (or Callichordates), Homoiostelea, Homostealea, and Ctenocystoidea. These four classes include about 50 genera that range from the Early or Middle Cambrian to the Late Carboniferous. Carpoids have a flattened theca that varies from asymmetrical to nearly bilaterally symmetrical (see illustration) and is made up of sutured, multiporous, single-crystal, calcite plates like those found in other echinoderms. Three of the classes have a long plated appendage attached to the theca that was used for locomotion and, in the Stylophora, also for feeding. Carpoids were apparently mobile, bottom-living or shallow-burrowing, detritus or suspension feeders, sifting out small food particles from the



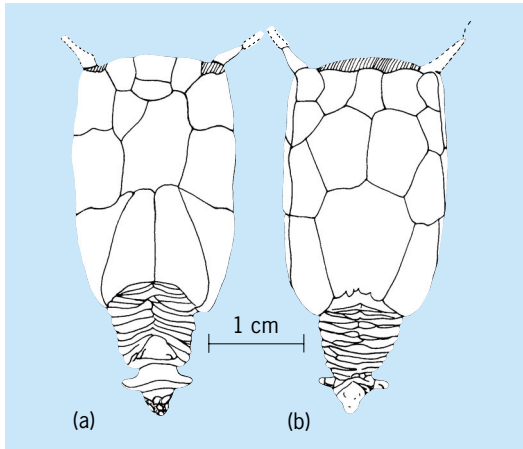

*Enoploura popei*, a stylophoran carpod from the Late Ordovician of Ohio. (a) Concave lower side and (b) convex upper side of the plated theca showing part of the attached, tapering appendage used for locomotion and feeding at the bottom.

top layer of soft sediment or from the surrounding seawater. Because of the distinctive skeletons, most researchers consider carpoids as true echinoderms, although they seem only distantly related to other fossil and living echinoderms that have well-developed pentamerous symmetry. See ECHINODERMATA; HOMALOOZOA. [J.Sp.]

**Carrageenan** A polysaccharide that is a major constituent of the cell walls of certain red algae (Rhodophyceae), especially members of the families Gigartinaceae, Hypneaceae, Phylloporaceae, and Solieriaceae. Extracted for its suspending, emulsifying, stabilizing, and gelling properties, it is one of three algal polysaccharides of major economic importance, the others being agar and alginates.

The main sources of carrageenan are *Chondrus crispus* (Gigartinaceae) from the Maritime Provinces of Canada and various species of *Eucheuma* (Solieriaceae) from the Philippines. *Chondrus*, popularly called Irish moss, is harvested from naturally occurring intertidal stands, while *Eucheuma* is successfully grown in mariculture on nets and lines.

About 80% of the refined carrageenan is used in food processing; the dairy industry is the chief consumer. The rest is used in the cosmetic, pharmaceutical, printing, and textile industries. See AGAR; ALGINATE; RHODOPHYCEAE. [P.C.Si.; R.L.Moe.]

**Carrier** A periodic waveform upon which an information-bearing signal is impressed. This process is known as modulation and comprises a variety of forms such as amplitude, phase, and frequency modulation. The most common type of carrier is the sinusoidal carrier, but any periodic waveform followed by a band-pass filter can serve as a carrier. See AMPLITUDE MODULATION; FREQUENCY MODULATION; MODULATION; PHASE MODULATION. [L.B.M.]

**Carrot** A biennial umbellifer (*Daucus carota*) of Asiatic and Mediterranean origin belonging to the plant order Apiales. The carrot is grown for its edible roots which are eaten raw or cooked. Varieties are classified according to length of root (long or short or stump-rooted) and use (fresh market or processing). Popular varieties for fresh market are Imperator and Gold Pak; for processing, Red Cored Chantenay and Royal Chantenay. Texas, California, and Arizona are important producing states. See APIALES. [H.J.C.]

**Cartilage** A firm, resilient connective tissue of vertebrates and some invertebrates. Isolated pieces act to provide support and anchor muscles, or with bone to contribute its resilience and interstitial growth to skeletal functions. Cartilage comprises a firm extracellular matrix synthesized by large, ovoid cells (chondrocytes) located in holes called lacunae. The matrix elements are water bound by the high negative charge of extended proteoglycan (protein-polysaccharide) molecules, and a network of fine collagen fibrils. The elements furnish mechanical stability, give, and tensile strength, but allow the diffusion of nutrients and waste to keep the cells alive. See BONE; COLLAGEN.

Cartilage is modified in several ways. In elastic cartilage, elastic fibers in the matrix increase resilience, as in cartilages supporting the Eustachian tube, mammalian external ear, and parts of the larynx. Where cartilage joins bones tightly at certain joints with limited mobility, for example, at the pubic symphysis and between vertebrae, the matrix of fibrocartilage contains prominent collagen fibers and has less proteoglycan than the typical hyaline variety. Hyaline cartilage, named for its glassy translucence, is the major support in the airway; and throughout the embryo, pieces of it develop as a precursor to the bony skeleton, except in the face and upper skull. See EAR (VERTEBRATE); LARYNX.

The primitive cartilaginous skeleton undergoes another modification, by locally calcifying its matrix. At sites of calcification, invading cells destroy the cartilage and mostly replace it by bone, leaving permanent hyaline cartilage only at the joint or articular surfaces, in some ribs, and, until maturity, at growth plates set back from the joints and perpendicular to the long axis of limb bones. The precarious physiological balance between chondrocytes and matrix materials in the heavily loaded articular cartilage breaks down in old age or in inflamed joints. See ARTHRITIS; CONNECTIVE TISSUE; JOINT (ANATOMY); SKELETAL SYSTEM. [W.A.Be.]

**Cartography** The techniques concerned with constructing maps from geographic information. Maps are spatial representations of the environment. Typically, maps take graphic form, appearing on computer screens or printed on paper, but they may also take tactile or auditory forms for the visually impaired. Other representations such as digital files of locational coordinates or even mental images of the environment are also sometimes considered to be maps, or virtual maps.

Maps are composed of two kinds of geographic information: attribute data and locational data. Attribute data are quantitative or qualitative measures of characteristics of the landscape, such as terrain elevation, land use, or population density. Locations of features on the Earth's surface are specified by use of coordinate systems; among these, the most common is the geographical coordinate system of latitudes and longitudes. See LATITUDE AND LONGITUDE.

Geographical coordinates describe positions on the spherical Earth. These must be transformed to positions on a two-dimensional plane before they can be depicted on a printed sheet or a computer screen. Hundreds of map projections—mathematical transformations between spherical and planar coordinates—have been devised, but no map projection can represent the spherical Earth in two dimensions without distorting spatial relationships among features on Earth's surface in some way. One specialized body of knowledge that cartographers bring to science is the ability to specify map projections that preserve the subset of geometric characteristics that are most important for particular mapping applications.

Although many broadly applicable map design principles have been established, the goal of specifying an optimal map for a particular task is less compelling than it once was. Instead, there is interest in the potential of providing map users with multiple, modifiable representations via dynamic media. Maps, graphs,

diagrams, movies, text, and sound can be incorporated in multimedia software applications that enable users to navigate through vast electronic archives of geographic information. Interactive computer graphics are eliminating the distinction between the mapmaker and the map user. Modern cartography's challenge is to provide access to geographic information and to cartographic expertise through well-designed user interfaces. See also MAP DESIGN; MAP PROJECTIONS. [D.DiB.]

**Caryophyllales** An order of flowering plants, division Magnoliophyta (Angiospermae), in the core eudicots. The order consists of 26 families and about 12,500 species. The order has been expanded from the traditional concept of 12 families (core Caryophyllales), which are characterized by P-type sieve-tube plastids, the presence of betalains (except in Caryophyllaceae) instead of anthocyanins, and frequent occurrence of succulent habit. The four largest families of core Caryophyllales are Aizoaceae (about 2500 species), Amaranthaceae (about 2300 species), Cactaceae (about 2000 species), and Caryophyllaceae (about 2000 species). The expanded order is more difficult to define on the basis of morphology, but anomalous secondary growth, multicellular glands (trichomes), ellagic acid, and naphthaquinones occur frequently. Many representatives grow in marginal environments such as saltmarshes and deserts.

Polygonaceae (about 1000 species) are among the additional families in the expanded order, many of the others being small, little-known groups. See MAGNOLIOPHYTA; PLANT KINGDOM. [M.FF.; M.W.C.]

**Caryophyllidae** A relatively small subclass of the class Magnoliopsida (dicotyledons) of the division Magnoliophyta (Angiospermae), the flowering plants, consisting of 3 orders, 14 families, and about 11,000 species. Most of these plants contain betalain pigments instead of anthocyanins, and the seeds very often have a perisperm. Most of the families and species of the subclass belong to the order Caryophyllales. The other orders (Plumbaginales and Polygonales) have only a single family each. See CARYOPHYLLALES; MAGNOLIOPHYTA; MAGNOLIOPSIDA; PLANT KINGDOM; PLUMBAGINALES; POLYGONALES. [A.Cr.; T.M.Ba.]

**Cascode amplifier** An amplifier stage consisting of a common-emitter transistor cascaded with a common-base transistor (see illustration). The common-emitter-common-base (CE-CB) transistor pair constitutes a multiple active device which essentially corresponds to a common-emitter stage with improved

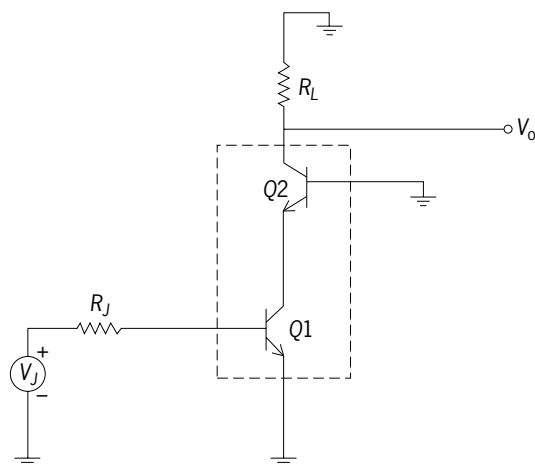

Cascode amplifier. Broken lines enclose a transistor pair consisting of a common-emitter transistor Q1 and a common-base transistor Q2.

high-frequency performance. In monolithic integrated-circuit design the use of such active compound devices is much more economical than in discrete designs. A similar compound device is the common-collector-common-emitter connection (CC-CE), also known as the Darlington pair. See INTEGRATED CIRCUITS.

The cascode connection is especially useful in wideband amplifier design as well as the design of high-frequency tuned amplifier stages. The improvement in high-frequency performance is due to the impedance mismatch between the output of the common-emitter stage and the input of the common-base stage.

Another important characteristic of the cascode connection is the higher isolation between its input and output than for a single common-emitter stage, because the reverse transmission across the compound device stage is much smaller than for the common-emitter stage. In effect, the second (common-base) transistor acts as an impedance transformer. This isolation effect makes the cascode configuration particularly attractive for the design of high-frequency tuned amplifier stages where the parasitic cross-coupling between the input and the output circuits can make the amplifier alignment very difficult. See AMPLIFIER; TRANSISTOR. [C.C.H.]

**Casein** The principal protein fraction of cows' milk. It accounts for about 80% of the protein content and is present in concentrations of 2.5–3.2%. Casein is a mixed complex of phosphoproteins existing in milk as colloiddally dispersed micelles 50 to 600 nanometers in diameter. Caseins can be separated from the whey proteins of cows' milk by gel filtration, high-speed centrifugation, salting-out with appropriate concentrations of neutral salts, acid precipitation at pH 4.3–4.6, and coagulation with rennet (or other proteolytic enzymes), and as a coprecipitate with whey proteins. The first three methods yield preparations in essentially their native micellar state, but are impractical for commercial exploitation. Thus, commercial caseins are produced by methods more amenable to industrial practices. See MICELLE.

The early production of casein isolates was stimulated by their application in industrial products such as paper, glue, paint, and plastics. These applications have been replaced by petroleum-based polymers. Thus the emphasis has shifted to their utilization in food systems, where they add enhanced nutritional and functional characteristics. They are widely used in the formulation of comminuted meat products, coffee whitener, processed cereal products, bakery products, and cheese analogs. See CHEESE; FOOD MANUFACTURING; MILK. [J.R.Bru.]

**Cashew** A medium-sized, spreading evergreen tree (*Anacardium occidentale*) native to Brazil, but now grown widely in the tropics for its edible nuts and the resinous oil contained in the shells. The fruit consists of a fleshy, red or yellow, pear-shaped receptacle, termed the apple, at the distal end of which is borne a hard-shelled, kidney-shaped ovary or nut. Although cashew trees are spread throughout the tropics, commercial production is centered in India, which handles 90% of the world trade.

Cashew nut kernels are eaten as nuts and used extensively in the confectionery and baking trade. The cashew shell liquid is a valuable by-product, containing 90% anacardic acid and 10% cardol, and is used in the varnish and plastic industries.

The cashew apples are too astringent for eating without being processed, but when processed may be used for jams, chutney, pickles, and wine. See SAPINDALES. [L.H.MacD.]

**Cashmere** The natural fiber obtained from the Cashmere goat, native to the Himalayan region of China and India. The fleece of this goat has long, straight, coarse outer hair of little value; but the small quantity of underhair, or down, is made into luxuriously soft woollike yarns with a characteristic highly napped finish. Cashmere is a much finer fiber than mohair or

wool fiber obtained from sheep. However, it is not as durable as wool. See MOHAIR; NATURAL FIBER; WOOL. [M.D.P.]

**Cassava** The plant *Manihot esculenta* (Euphorbiaceae), also called manioc. It is one of the 10 most important food plants, and the most important starchy root or tuber of the tropics. It originated in Central or South America, possibly Brazil, and was domesticated and widely distributed well before the time of Columbus. Subsequent distribution has established cassava as a major crop in eastern and western Africa, in India, and in Indonesia.

The cassava plant is a slightly woody, perennial shrub. The leaves are deeply palmately lobed; the flowers are inconspicuous, and the prominent capsules are three-seeded and explosive at maturity. The roots (see illustration) are enlarged by the deposition of starch and constitute the principal source of food from the plant. The leaves are also eaten (after cooking), and are noteworthy for their high protein content.

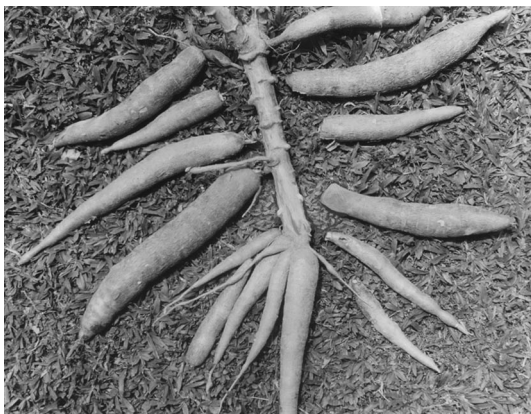

Tuberous roots from a single cassava plant.

The chief use of cassava is as a boiled vegetable. It is also a source of flour, called *farinha* in Brazil and *gari* in western Africa, and of toasted starch granules, the familiar tapioca. In spite of its popularity, however, cassava root is a poor food. Its protein content is extremely low, and its consumption as a staple food is associated with the protein deficiency disease kwashiorkor. See GERANIALES. [F.W.M.]

**Cassiopeia** A prominent northern circumpolar constellation as seen from the middle latitudes. The five main bright

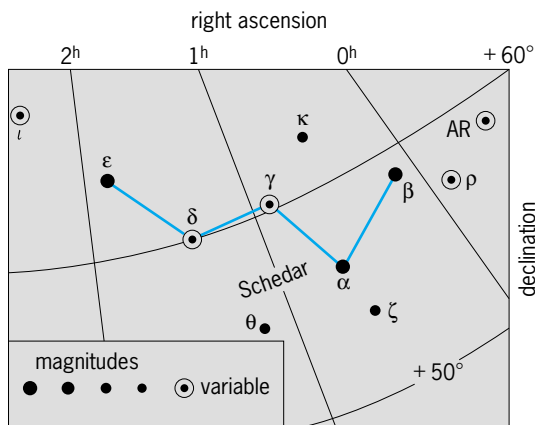

Line pattern of the constellation Cassiopeia. The grid lines represent the coordinate of the sky. Magnitudes of the stars are shown by the sizes of the "dots."

second- and third-magnitude stars of Cassiopeia form the rather distorted W or M by which the constellation is usually identified (see illustration). Cassiopeia and the Big Dipper lie across the opposite sides of the North Celestial Pole. See CONSTELLATION; URSA MAJOR. [C.S.Y.]

**Cassiterite** A mineral having the composition  $\text{SnO}_2$ . It is the principal ore of tin. Cassiterite is usually massive granular, but may be in radiating fibrous aggregates with reniform shapes (wood tin). The hardness is 6–7 (Mohs scale), and the specific gravity is 6.8–7.1 (unusually high for a nonmetallic mineral). The luster is adamantine to submetallic. Pure tin oxide is white, but cassiterite is usually yellow, brown, or black because of the presence of iron.

Cassiterite is most abundantly found as stream tin (rolled pebbles in placer deposits). The world's supply comes mostly from placer or residual deposits in the Malay Peninsula, Indonesia, Zaire, and Nigeria. It is also mined in Bolivia. See TIN. [C.S.Hu.]

**Cast iron** A generic term describing a family of iron alloys containing 1.8–4.5% carbon. Cast iron usually is made into specified shapes, called castings, for direct use or for processing by machining, heat treating, or assembly. In special cases it may be forged or rolled moderately. Generally, it is unsuitable for drawing into rods or wire, although to a limited extent it has been continuously cast into rods and shapes from a liquid bath or swaged from bars into smaller-dimensional units. Silicon usually is present in amounts up to 3%, but special compositions are made containing up to 6% (Sikal) and up to 12% (Duriron). Cast iron of the above composition range is often made into blocks or rough shapes and called pig iron. It is an intermediate form of cast iron used for remelting into iron castings. Cast iron may be purchased in several commercial grades called gray iron, chilled iron, mottled iron, white iron, malleable iron, ductile iron, spheroidal graphite iron, nodular iron, and austenitic cast iron. See ALLOY; IRON ALLOYS; WROUGHT IRON. [J.S.V.]

**Castor plant** A plant, *Ricinus communis*, belonging to the spurge family (Euphorbiaceae). Castor seeds are poisonous and also contain allergens.

Current distribution is in the warmer regions of the world, the plant often growing in waste places. The castor oil plant has been of utilitarian value since antiquity. Oil from the seeds is among the world's oldest nonfood products in commerce. Castor oil contains about 85% ricinoleic acid, used in making industrial products such as alkyde resins for surface coatings, blown oil used in plasticizers, cracked oil for production of synthetic perfumes, nylon, sebacic acid, synthetic detergents, drying oils, and special lubricating oils.

Production in the United States, mostly in west Texas, peaked in 1968 but declined to nil because of larger economic return from food and fiber crops. Brazil is the world's largest producer and exporter of castor seed and oil. [L.H.Z.]

**Casuarinales** An order of flowering plants, division Magnoliophyta (Angiospermae), in the subclass Hamamelidae of the class Magnoliopsida (dicotyledons). The order consists of a single family (Casuarinaceae) and genus (*Casuarina*), with about 50 species. Native to the southwestern Pacific region, especially Australia, they are sometimes called Australian pine. They are trees with much reduced flowers and green twigs that bear whorls of scalelike, much reduced leaves. Some species are grown as street trees in tropical and subtropical regions. See HAMAMELIDAE; MAGNOLIOPSIDA. [A.Cr.]

**Cat** The term used to describe any member of the mammalian family Felidae. Morecommonly, the term is restricted to

the domestic cat and those felids that resemble it in size, shape, and habits. Those that are larger in size are referred to as the big cats. All members of the cat family have a round head, are digitigrade (walk on their toes), have retractile claws (with the exception of the cheetah), and have 30 teeth. All species are carnivorous.

The origin of domestic cats is unknown, but it is established that they have been associated with humans for many centuries. Domestic mixed-breed cats are generally characterized by long, thin tails, straight ears, and short hair of a variety of colorations. The pure breeds, however, are notable exceptions to this general description. There is a long-haired race, apparently developed in Persia, which is represented by the Persian and the Angora. The Abyssinian breed, in contrast to the common domestic cat, is characterized by being ruddy brown in color and having a longer face and ears. There are at least two tailless breeds, of which the best known is the Manx from the Isle of Man. The other tailless variety is found in Japan. One of the most popular breeds is the Siamese cat. Its eyes are deep blue, it has a long, kinky tail, and its fur is short and cream to buff in color.

Wildcats include cats such as the lynx, bobcat, serval, ocelot, puma, leopard, lion, tiger, jaguar, and cheetah. In addition there are a few lesser known forms that are of interest. Among these are the Scottish wildcat and the caracal. See CARNIVORA. [C.B.C.]

**Cat scratch disease** In humans, typically a benign, subacute regional disease of the lymph nodes (lymphadenopathy) resulting from dermal inoculation of the causative agent, the bacterium *Bartonella henselae*. The domestic cat is the major reservoir of *B. henselae*, and the cat flea, *Ctenocephalides felis*, is the main vector of transmission from cat to cat. *Bartonella clarridgeiae* has been isolated from domestic cats. Recently, a new bacterium, *B. koehlerae*, has also been isolated from the blood of domestic cats.

Cat scratch disease occurs in immunocompetent patients of all ages, with 55–80% being less than 20 years of age. More than 90% of cases have a history of contact with cats, and 57–83% recall being scratched by a cat. Incidence varies by season; most cases occur in the fall and winter. More cases are observed in males than females.

In humans, 1–3 weeks may elapse between the scratch (or bite) and the appearance of clinical signs. In 50% of the cases, a small skin lesion, often resembling an insect bite, appears at the inoculation site (usually on the hand or forearm) and evolves from a pimple (papule) to a skin blister to partially healed ulcers. These lesions resolve within a few days to a few weeks. Inflammation of lymph nodes develops approximately 3 weeks after exposure. Swelling of the lymph node is usually painful and persists for several weeks or months. In 25% of the cases, a discharge of pus occurs. A large majority of the cases show signs of systemic infection, such as fever, chills, malaise, anorexia, or headaches. In general, the disease is benign and heals spontaneously without aftereffects.

No major clinical signs of cat scratch disease have been reported in cats, although enlargement of the lymph nodes caused by a cat scratch disease-like organism has been reported.

Most individuals with cat scratch disease experience mild illness and require minimal treatment. In severe forms, antibiotics such as ciprofloxacin, rifampin, or gentamicin have been recommended. Use of oral azithromycin for 5 days has shown significant clinical benefit in typical cat scratch disease. [B.B.Ch.]

**Cataclysmic variable** A type of close binary star system containing a cool star transferring material to its hotter, high-density, degenerate white dwarf companion. The mass transfer results in a large range of observed variability, including

cataclysmic events called outbursts, which can increase the brightness of the systems by 2–10 magnitudes (a logarithmic scale with each magnitude being a factor of 2.5 in brightness) from quiescence, equivalent to a factor of 6–10,000 times in intensity. The specific behavior of each system and the extent and cause of the variability are related to whether the transferred material accumulates in an accretion disk surrounding the white dwarf, or whether it flows in a ballistic stream directly from the cool star to the white dwarf surface. Which of these processes will occur depends on the magnetic field strength of the white dwarf and the separation of the two stars in the binary, properties which are determined during the formation of the system. See MAGNITUDE (ASTRONOMY).

If the white dwarf magnetic field is under 100 tesla (1 megagauss), an accretion disk will form and extend close to the white dwarf surface, while a hot spot will form where the mass stream from the cool star hits the disk. Systems in which the mass transfer occurs in this way constitute the most common type among the roughly 1000 known cataclysmic variables. They can be further classified as novae, dwarf novae, and novalike systems. These categories probably represent different phases of evolution of similar systems, and each is determined by the current mass-transfer rate.

Novae are the most spectacular cataclysmic variables, with 7–10-magnitude (factor of 630–10,000 times) outbursts caused by thermonuclear runaways triggered when a critical mass of hydrogen builds up in the atmosphere of the white dwarf. Usually this occurs every few thousand years, although a handful of novae with high-mass white dwarfs and mostly giant cool stars recur on time scales of tens of years. See NOVA.

Dwarf novae have much smaller outbursts of 2–5 magnitudes or a factor of 6–100 times (a small number may be as large as 9 magnitudes or a factor of 4000), and they recur much more frequently, on time scales of weeks or months. Their light curves and theoretical models indicate that their outbursts are probably due to accretion disk instabilities, resulting in increased accretion onto the white dwarf when the disk reaches a critical density.

Novalike systems have the highest mass-transfer rates, so that their disks dominate the light output of the system and do not undergo the instability of outbursts.

At very high magnetic fields, over 1000 T (10 MG), and small separations (short orbital periods), the mass-transfer stream follows the magnetic field lines of the white dwarf to the white dwarf surface. This type of magnetic cataclysmic variable is termed an AM Her star (after its prototype, AM Herculis) or as a polar (after its accretion mode). The approximately 60 known polars were primarily discovered by x-ray satellites due to their large x-ray emission, caused by an accretion shock (producing hard x-rays) as the material is channeled to the magnetic pole of the white dwarf and by the subsequent heating of the white dwarf surface (producing soft x-rays). See X-RAY ASTRONOMY; X-RAY TELESCOPE.

For magnetic fields of 100–1000 T (1–10 MG) and larger separations, the material will form an outer accretion disk ring and then flow from its inner edge to the white dwarf following the magnetic field lines. The dozen known systems that exhibit this behavior are termed DQ Her stars (after DQ Herculis) or intermediate polars (IPs). See BINARY STAR; STELLAR EVOLUTION; VARIABLE STAR; WHITE DWARF STAR. [P.Sz.]

**Catalysis** The phenomenon in which a relatively small amount of foreign material, called a catalyst, augments the rate of a chemical reaction without itself being consumed. A catalyst is material, and not light or heat. It increases a reaction rate. See ANTIOXIDANT; INHIBITOR (CHEMISTRY).

If the reaction  $A + B \rightarrow D$  occurs very slowly but is catalyzed by some catalyst (Cat), the addition of Cat must open new

channels for the reaction. In a very simple case,

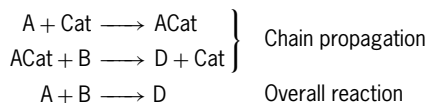

the two propagation processes, which are fast compared to the uncatalyzed reactions,  $A + B \rightarrow D$ , provide the new channel for the reaction. The catalyst reacts in the first step, but is regenerated in the second step to commence a new cycle. A catalytic reaction is thus a kind of chain reaction.

If a reaction is in chemical equilibrium under some fixed conditions, the addition of a catalyst cannot change the position of equilibrium without violating the second law of thermodynamics. Therefore, if a catalyst augments the rate of  $A + B \rightarrow D$ , it must also augment the reverse rate,  $D \rightarrow A + B$ . See CHEMICAL THERMODYNAMICS.

Catalysis is conventionally divided into three categories: homogeneous, heterogeneous, and enzyme. In homogeneous catalysis, reactants, products, and catalyst are all present molecularly in one phase, usually liquid. Homogeneous catalysis is important in the petrochemical and chemical industries. In heterogeneous catalysis, the catalyst is in a separate phase; usually the reactants and products are in gaseous or liquid phases and the catalyst is a solid. Heterogeneous catalysis plays a dominant role in chemical processes in the petroleum, petrochemical, and chemical industries. Transformations of matter in living organisms occur by an elaborate sequence of reactions, most of which are catalyzed by biocatalysts called enzymes. Enzyme catalysis plays a key role in all metabolic processes and in some industries, such as the fermentation industry. The mechanisms of these categories involve chemical interaction between the catalyst and one or more reactants. In phase-transfer catalysis the interaction is physical. Electrocatalysis and photocatalysis are more specialized forms of catalysis. See ENZYME; HETEROGENEOUS CATALYSIS; HOMOGENEOUS CATALYSIS; PHASE-TRANSFER CATALYSIS.

In most cases of catalysis, a given set of reactants could react in two or more ways. The degree to which just one of the possible reactions is favored over the other is called selectivity. The fraction of reactants that react by a specific path is called the selectivity by that path, and it will vary from catalyst to catalyst. Selectivity is a key property of a catalyst in any practical application of the catalyst.

The number of sets of molecules that react consequent to the presence of a catalytic site (heterogeneous or enzyme catalysis) or molecule of catalyst (homogeneous catalysis), the turnover number, is substantially greater than unity and may be very large. The turnover frequency is the number of sets of molecules that react per site or catalyst molecule per second. It must be greater than one or the reaction is stoichiometric, not catalytic.

In practical applications, catalyst life, that is, the time or number of turnovers before the reaction rate becomes uselessly low, is important. It will be reduced by the presence of molecules that adsorb at (react with) and block the active site (poisons). See ADSORPTION. [R.L.Bu.; G.L.H.]

**Catalytic antibody** An antibody that can cause useful chemical reactions. Catalytic antibodies are produced through immunization with a hapten molecule that is usually designed to resemble the transition state or intermediate of a desired reaction.

Antibodies are the recognition arm of the immune system. They are elicited, for example, when an animal is infected with a bacterium or virus. The animal produces antibodies with binding sites that are exactly complementary to some molecular feature of the invader. The antibodies can thus recognize and bind only to the invader, identifying it as foreign and leading to its destruction by the rest of the immune system. Antibodies are also elicited

in large quantity when an animal is injected with molecules, a process known as immunization. A small molecule used for immunization is called a hapten. Ordinarily, only large molecules effectively elicit antibodies via immunization, so small-molecule haptens must be attached to a large protein molecule, called a carrier protein, prior to the actual immunization. Antibodies that are produced after immunization with the hapten-carrier protein conjugate are complementary to, and thus specifically bind, the hapten. See ANTIBODY; ANTIGEN-ANTIBODY REACTION; IMMUNITY.

Ordinarily, antibody molecules simply bind; they do not catalyze reactions. However, catalytic antibodies are produced when animals are immunized with hapten molecules that are specially designed to elicit antibodies that have binding pockets capable of catalyzing chemical reactions. For example, in the simplest cases, binding forces within the antibody binding pocket are enlisted to stabilize transition states and intermediates, thereby lowering a reaction's energy barrier and increasing its rate. This can occur when the antibodies have a binding site that is complementary to a transition state or intermediate structure in terms of both three-dimensional geometry and charge distribution. This complementarity leads to catalysis by encouraging the substrate to adopt a transition-state-like geometry and charge distribution. Not only is the energy barrier lowered for the desired reaction, but other geometries and charge distributions that would lead to unwanted products can be prevented, increasing reaction selectivity. See CATALYSIS.

Making antibodies with binding pockets complementary to transition states is complicated by the fact that true transition states and most reaction intermediates are unstable. Thus, true transition states or intermediates cannot be isolated or used as haptens for immunization. Instead, so-called transition-state analog molecules are used. Transition-state analog molecules are stable molecules that simply resemble a transition state (or intermediate) for a reaction of interest in terms of geometry and charge distribution. To the extent that the transition-state analog molecule resembles a true reaction transition state or intermediate, the elicited antibodies will also be complementary to that transition state or intermediate and thus lead to the catalytic acceleration of that reaction.

Catalytic antibodies bind very tightly to the transition-state analog haptens that were used to produce them during the immunization process. The transition-state analog haptens only bind and do not react with catalytic antibodies. It is the substrates, for example, the analogous ester molecules, that react. For this reason, transition-state analog haptens can interfere with the catalytic reaction by binding in the antibody binding pocket, thereby preventing any substrate molecules from binding and reacting. This inhibition by the transition-state analog hapten is always observed with catalytic antibodies, and is used as a first level of proof that catalytic antibodies are responsible for any observed catalytic reaction.

The important feature of catalysis by antibodies is that, unlike enzymes, a desired reaction selectivity can be programmed into the antibody by using an appropriately designed hapten. Catalytic antibodies almost always demonstrate a high degree of substrate selectivity. In addition, catalytic antibodies have been produced that have regioselectivity sufficient to produce a single product for a reaction in which other products are normally observed in the absence of the antibody. Finally, catalytic antibodies have been produced by immunization with a single-handed version (only left- or only right-handed) of a hapten, and only substrates with the same handedness can act as substrates for the resulting catalytic antibodies. The net result is that a high degree of stereoselectivity is observed in the antibody-catalyzed reaction. See STEREOCHEMISTRY. [B.I.]

**Catalytic converter** An aftertreatment device used for pollutant removal from automotive exhaust. Since the 1975 model year, increasingly stringent government regulations for

the allowable emission levels of carbon monoxide (CO), hydrocarbons (HC), and oxides of nitrogen (NO<sub>x</sub>) have resulted in the use of catalytic converters on most passenger vehicles sold in the United States. The task of the catalytic converter is to promote chemical reactions for the conversion of these pollutants to carbon dioxide, water, and nitrogen.

For automotive exhaust applications, the pollutant removal reactions are the oxidation of carbon monoxide and hydrocarbons and the reduction of nitrogen oxides. Metals are the catalytic agents most often employed for this task. Small quantities of these metals, when present in a highly dispersed form (often as individual atoms), provide sites upon which the reactant molecules may interact and the reaction proceed.

Two types of catalyst systems, oxidation and three-way, are found in automotive applications. Oxidation catalysts remove only CO and HC, leaving NO<sub>x</sub> unchanged. Platinum and palladium are generally used as the active metals in oxidation catalysts. Three-way catalysts are capable of removing all three pollutants simultaneously, provided that the catalyst is maintained in a "chemically correct" environment that is neither overly oxidizing nor reducing. In both oxidation and three-way catalyst systems, the production of undesirable reaction products, such as sulfates and ammonia, must be avoided.

Maintaining effective catalytic function over long periods of vehicle operation is often a major problem. Catalytic activity will deteriorate due to two causes, poisoning of the active sites by contaminants, such as lead and phosphorus, and exposure to excessively high temperatures. To achieve efficient emission control, it is thus paramount that catalyst-equipped vehicles be operated only with lead-free fuel and that proper engine maintenance procedures be followed. See AUTOMOTIVE ENGINE; CATALYSIS. [N.O.]

**Cataract** Any clouding or opacity of the crystalline lens of the eye. The essential biochemical change in a cataractous lens is the coagulation of its protein. Cataracts vary markedly in degree of density and may be due to many causes, but the majority are associated with aging. Cataracts are the single leading cause of blindness in the world.

Senile cataract occurs with aging and is by far the most common type. Progressively blurred vision is the only symptom. There are a number of other varieties (congenital, metabolic, secondary, or traumatic) and causes (such as a reaction to certain drugs or irradiation). Cataracts may also be associated with systemic diseases such as hypoparathyroidism, myotonic dystrophy, atopic dermatitis, galactosemia, and Lowe's, Werner's, and Down syndromes.

At present the treatment for cataracts, when they are sufficiently advanced to impair the vision, is surgical removal. When a cataract is surgically removed, the crystalline lens of the eye is removed much as a lens would be removed from a camera. In order to restore normal vision after surgery, any of a number of methods may be followed: cataract glasses may be prescribed; contact lenses may be fitted; or intraocular lenses made of the plastic polymethylmethacrylate can be inserted into the eye to replace the cataractous lens. See EYE (VERTEBRATE). [J.Hart.]

**Catastrophe theory** A theory of mathematical structure in which smooth continuous inputs lead to discontinuous responses. Water suddenly boils, ice melts, a building crashes to the ground, or the earth unexpectedly buckles and quakes. The French mathematician René Thom conceived and developed an eclectic collection of ideas into catastrophe theory. His idea was to establish a new basis for a more mathematical approach to biology. Connotations of disaster are misleading, since Thorn's intention was to emphasize sudden, abrupt changes.

Advanced areas of modern mathematics, including algebraic geometry, differential topology, and dynamical system theory, contributed to the creation of catastrophe theory. A complete

mathematical theory exists for the elementary catastrophes, which can be written as the gradient of an energylike function. The physical, chemical, and engineering applications are less developed, although many are known in optics, laser theory, thermodynamics, elasticity, and chemical reaction theory. The Thom classification theorem gives exactly seven elementary catastrophes. Although a theory of generalized catastrophes exists, which extends the theory beyond gradient systems, it is not nearly as well developed mathematically or physically as that of elementary catastrophes. It does include remarkable examples of chaos (or stochastic behavior) in the solutions to nonlinear deterministic equations. These solutions include strange attractors and omega explosions among the examples of nonelementary catastrophes. See GEOMETRY; PERIOD DOUBLING; TOPOLOGY.

There are two important aspects of catastrophe theory which are frequently overlooked or misconstrued. One is that as a rigorous mathematical theory the characteristic catastrophe features can be proved. These features include: jumps in the response; hysteresis or a path dependence in the response, representing a storage of energy for some paths; divergence, where a small path change produces a large response change (as if a source or sink were crossed); and type changes in the response, where a smooth response occurs on one path which becomes discontinuous along a nearby path.

All of these features are topological, so that they are independent of the coordinates used to describe the potential. They are, therefore, qualitative features of the solutions. Some critics have concluded that because these aspects were qualitative, they could not be quantitative. This is contradicted by the solid and growing body of quantitative studies in catastrophe theory. (Problems in quantum optics, thermodynamics, and scattering theory have all been clarified by catastrophe theory.) [B.DeF.]

**Catenanes** Compounds that are made of interlocking macrocycles. The interlocking rings are said to be mechanically rather than chemically bound. Catenanes are named according to the number of interlocking rings. The simplest catenane, containing two interlocking rings, is called [2]-catenane. The most common catenanes consist of a linear arrangement of interlocking rings, so [2]-catenane is the first member of this series. Next is [3]-catenane, and so on. Catenanes involving necklace arrangements of beadlike rings have also been synthesized. [7]-Catenane combines linear and necklace topologies; it is the highest-order molecular catenane isolated so far.

Molecular catenanes are compounds of synthetic origin. However, natural deoxyribonucleic acid (DNA) macromolecules were shown to assemble, in certain conditions, into catenated structures, which were studied by electron microscopy.

The rings of the catenanes may be purely organic macrocycles or metallomacrocycles, that is, macrocycles including transition-metal ions in their bond sequences. Actually, the chemical nature of the ring is dictated by the method of synthesis. Basically, three methods have been developed for the synthesis of catenanes (see illustration): statistical, directed, and template syntheses.

Statistical synthesis relies on the probability that a macrocycle can be threaded onto a molecular string to afford an intermediate that will undergo the cyclization react (illus. a). Convincing approaches to the statistical method used the trick of stabilizing the threaded complex by stoppering the extremities of the string with bulky groups: a so-called rotaxane species is obtained (illus. b). Subsequently, conventional macrocycle synthesis is used to prepare the catenane, which is obtained after removal of the stoppers. This method produced the first hydrocarbon catenane, made of interlocked (CH<sub>2</sub>)<sub>28</sub> and (CH<sub>2</sub>)<sub>46</sub> macrocycles.

Directed synthesis uses a catechol-based acetal incorporated in a macrocycle (illus. c). Two pendent arms, as precursors to the second macrocycle, are anchored perpendicularly to the plane

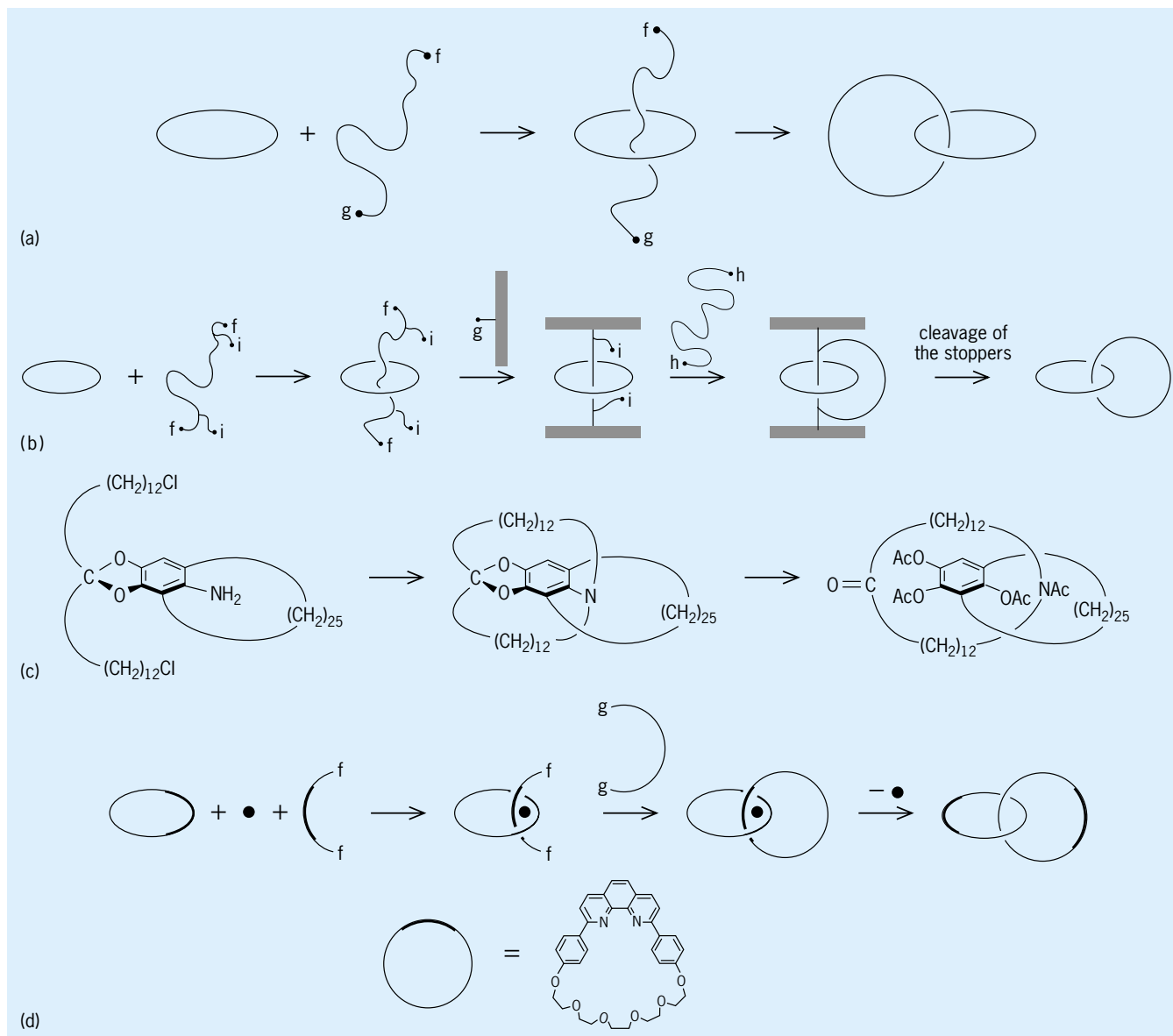

**Synthetic routes to catenanes. (a) Statistical; f and g are complementary functions that react to close the ring. (b) Statistical, using a rotaxane intermediate; f and g are complementary functions that react to anchor the stoppers; i and h are complementary functions that react to form the second, interlocked ring. (c) Directed. (d) Transition-metal-templated; the thick ring portions represent the coordination sites, and the black disk is the metal; f and g are complementary functions that react to close the second, interlocked ring.**

of the first macrocycle. Their functionalized extremities are compelled to react with a complementary function localized inside the first macrocycle, so that the construction of the second macrocycle is directed to take place inside the first one. The last key step is the cleavage of the bonds linking the two macrocyclic sequences of atoms. This multistep synthetic method was used to prepare [2]- and [3]-catenanes.

Template synthesis methods are highly directed and economical in terms of numbers of steps. In these methods, metal cations or molecules gather and preorganize reactive molecular fragments in a spatially controlled manner, so that the desired structure will be obtained preferentially over many others. In one method, the transition-metal-templated synthesis of catenanes, the metal [generally Cu(I)] gathers a macrocycle incorporating a chelating subunit and a linear fragment made up of the complementary chelate such that both components are more or less at

right angles to each other (illus. d). Cyclization of the linear fragment affords the metalloporphyrin, or catenane. Removal of the metal template by competitive complexation provides the catenane as a free ligand, or catenand. In the one-step alternative strategy, two open-chain chelates are assembled orthogonally at a metal center. A double cyclization reaction provides the catenane in one step.

Applications of catenanes are a research field in its infancy, and therefore they are more or less speculative. Promising approaches include incorporation of catenane structures into polymeric species to endow the polymers with peculiar rheological properties, because of the mechanical linking; and use of catenanes as elements of molecular machines—for example, the mechanical link of catenanes could be used for making a primitive rotary motor at the molecular level. See SUPRAMOLECULAR CHEMISTRY. [J.C.Ch.; C.O.D.B.; J.P.Sa.]

**Catenary** The curve formed by an ideal heavy uniform string hanging freely from two points of support. The lowest point *A* (see illustration) is the vertex. The portion *AP* is in equilibrium under the horizontal tension *H* at *A*, the tension *F* directed along the tangent at *P*, and the weight *W* of *AP*. If the weight of the string is *w* per unit length and *s* is the arc *AP*,  $W = ws$ ; and from the force triangle,  $\tan \psi = ws/H = s/c$ , where  $c = H/w$  is called the parameter of the catenary. Thus the catenary has the differential equation (1).

$$dy/dx = s/c \tag{1}$$

The horizontal line at a distance *c* below the vertex *A* is the directrix of the catenary. With the *x* axis as directrix and the *y* axis through the vertex, the integration of Eq. (1) yields Eqs. (2)

$$y = c \cosh \frac{x}{c} \quad s = c \sinh \frac{x}{c} \tag{2}$$

for the ordinate and arc of the catenary. All catenaries are geometrically similar to the hyperbolic cosine curve,  $y = \cosh x$ .

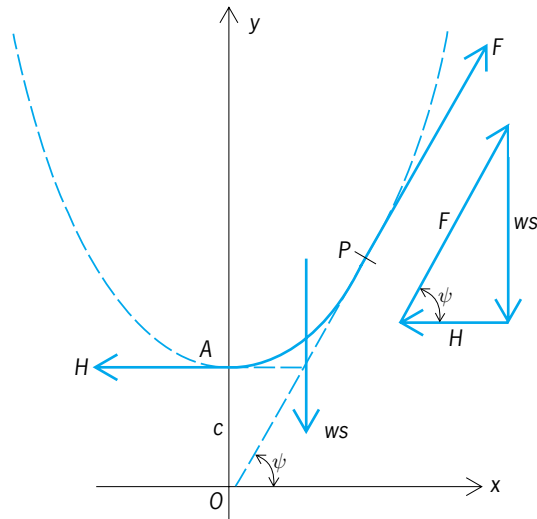

Catenary: force triangle.

The surface generated by revolving a catenary about its directrix is a minimal surface, the catenoid. The catenary is an extremal for the problem of finding a curve joining two given points so that the surface generated by revolving it about a given line has minimum area. See HYPERBOLIC FUNCTION. [L.Br.]

**Cathode-ray tube** An electron tube in which a beam of electrons can be focused to a small cross section and varied in position and intensity on a display surface. In common usage, the term cathode-ray tube (CRT) is usually reserved for devices in which the display surface is cathodoluminescent under electron bombardment, and the output information is presented in the form of a pattern of light. The character of this pattern is related to, and controlled by, one or more electrical signals applied to the cathode-ray tube as input information. See CATHODOLUMINESCENCE; ELECTRON TUBE.

Hundreds of millions of cathode-ray tubes were in service at the end of the twentieth century, and tens of thousands more were manufactured daily. These tubes were commonplace in television sets, computers, homes, hospitals, banks, and airplanes. Even so, the cathode-ray tube is being supplanted in many of its traditional uses by flat-panel electronic devices. This trend is expected to continue until, except for perhaps a few specialized applications, the cathode-ray tube will be primarily of historical interest.

The three elements of the basic cathode-ray tube are the envelope, the electron gun, and the phosphor screen (see illustration).

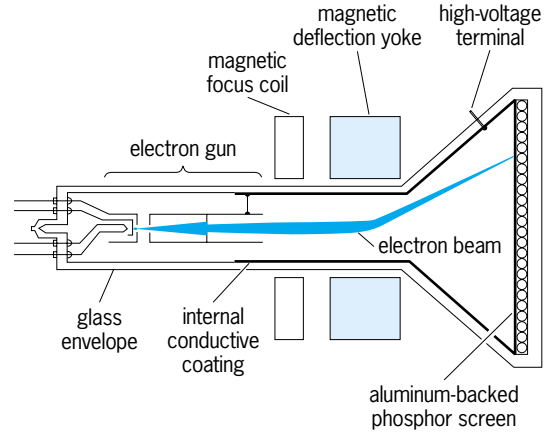

Elements of a cathode-ray tube.

The envelope is usually made of glass, although ceramic envelopes and metal envelopes have been used. It is typically funnel-shaped. The small opening is terminated by the stem, a disk of glass through which pass metal leads that apply voltages to the several elements of the electron gun. The electron gun is mounted within the neck portion of the envelope and is connected to the leads coming through the stem. The neck is often made sufficiently narrow to allow positioning of deflection and focusing components outside it.

The large end of the funnel is closed by a faceplate, on the inside of which the phosphor screen is deposited. The faceplate is made of high-quality clear glass in order to provide an undistorted view of the display on the phosphor screen.

The electron gun consists of an electrical element called a heater, a thermionic cathode, and an assemblage of cylinders, caps, and apertures which are all held in the proper orientation.

The cathode is a source of electrons when maintained at about 1750°F (1100 K) by thermal radiation from the heater. Electrons emitted by the cathode are formed into a beam, and controlled in intensity by other elements of the electron gun. Means are provided, either within the electron gun itself or externally, to focus the electron beam to a small cross section at its intersection with the phosphor screen and to deflect it to various locations on the screen. See CHARGED PARTICLE OPTICS; ELECTRON EMISSION.

In most cases, monochrome cathode-ray tubes employ a single electron gun. Nearly all color picture tubes employ the shadow-mask principle and use three electron guns.

The deflection path of the electron beam on the phosphor screen depends on the intended use of the cathode-ray tube. In oscillography, a horizontal trace is swept across the phosphor screen, with vertical excursions of the beam which coincide with variations in the strength of some electrical signal. In television, a raster of closely spaced horizontal lines is scanned on the phosphor screen by the electron beam, which is intensity-modulated to produce a visible picture. Radar makes use of a variety of specialized electron-beam scanning patterns to present information to an observer.

In the display of computer output information, two general approaches to beam deflection are used: The raster-scan technique may be identical in format to that used for television or may utilize a greater number of scanning lines for increased definition. The random-scan technique involves computer control to direct the electron beam to locations which may be anywhere on the tube face.

The phosphor screen consists of a layer of luminescent material coated on the inner surface of the glass faceplate. Monochrome cathode-ray tubes generally use a single layer of a homogeneous luminescent material. Color cathode-ray tubes typically utilize a composite screen made up of separate



red-, green-, and blue-emitting luminous materials. See LUMINESCENCE; PHOSPHORESCENCE.

Two basic types of deflection are electrostatic deflection and magnetic deflection.

With electrostatic deflection, it is possible to very quickly deflect the beam from one location to any other location on the screen. Operation is possible over a wide frequency range.

Magnetic deflection systems generally require more time, perhaps tens of microseconds, to deflect the electron beam from one location on the screen to another. This is because a change in position requires a change in the value of the current through an inductive coil. Magnetic deflection systems do have an important advantage in that they can deflect the beam through a much wider deflection angle with less distortion in the shape of the cross section of the beam than is possible with electrostatic deflection.

A wide variety of available envelopes, electron guns, and phosphor screens have been combined in different ways to fashion cathode-ray tubes specialized to meet the needs of different applications.

Direct view cathode-ray tubes involve either the presentation on the screen of an actual picture with a full black and white halftone range or with full color, such as is required for television, or the presentation of a computer-generated display which may consist of alphanumeric, graphics, or a variety of pictorial subjects. Tubes for the direct viewing of such presentations are required to have large display sizes, high brightness, high resolution, and in many cases a full halftone range and full color capability. Cathode-ray tubes for these presentations have always employed magnetic deflection and generally electrostatic-focus electron guns operating at high voltages from 15 to 36 kV.

Cathode-ray tubes for computer-generated data-display applications are very similar.

Projection tubes are not intended to be directly viewed. The display on the phosphor screen is projected by using an optical system, such as a lens, onto large screens. Screen sizes vary widely, the largest being those in theaters and sports arenas that are equipped for projection television.

Cathode-ray tubes for projection applications are usually of the general type described above but generally are optimized for extremely high brightness and resolution capability.

On a different scale, projection tubes used in avionics helmet-mounted displays make use of infinity optics to project images directly onto the retina of the aviators. Such cathode-ray tubes must be very small, light, low-voltage, low-power devices.

Another class of cathode-ray tubes which are not intended for direct viewing by human observers comprises photorecording tubes. The applications for these tubes require that the phosphor screen display be projected by an optical system, such as a lens, onto a photosensitive medium, such as photographic film. Applications include electronic phototypesetting and the storage of computer output information on microfilm. Photorecording cathode-ray tubes are required to have extremely high resolution capability, to be extremely stable over long periods of time, and to have accurate and precise display geometry. See PICTURE TUBE; TELEVISION. [N.W.P.]

**Cathode rays** The name given to the electrons originating at the cathodes of gaseous discharge devices. The term has now been extended to include low-pressure devices such as cathode-ray tubes. Furthermore, cathode rays are now used to designate electron beams originating from thermionic cathodes, whereas the term was formerly applied only to cold-cathode devices. See CATHODE-RAY TUBE. [G.H.M.]

**Cathodoluminescence** A luminescence resulting from the bombardment of a substance with an electron (cathode-ray) beam. The principal applications of cathodoluminescence are in television, computer, radar, and oscilloscope displays. In these a thin layer of luminescent powder (phosphor)

is evenly deposited on the transparent glass faceplate of a cathode-ray tube. After undergoing acceleration, focusing, and deflection by various electrodes in the tube, the electron beam originating in the cathode impinges on the phosphor. The resulting emission of light is observed through the glass faceplate, that is, from the unbombarded side of the phosphor coating. See CATHODE-RAY TUBE.

The luminescence of most phosphors comes from a few sites (activator centers) occupied by selected chemical impurities which have been incorporated into the matrix or host solid. Because of the complex mode of interaction of cathode rays with phosphors, the energy efficiency of light production by cathodoluminescence is lower than the best efficiencies obtainable with photoluminescence. Conversion efficiencies of currently used display phosphors are between 2 and 23%. See LUMINESCENCE.

[H.N.H.; J.S.H.]

**Cauliflower** A cool-season biennial crucifer (*Brassica oleracea* var. *botrytis*) of Mediterranean origin. Cauliflower belongs to the plant order Capparales. It is grown for its white head or curd, a tight mass of flower stalks, which terminates the main stem. Cauliflower is commonly cooked fresh as a vegetable; to a lesser extent, it is frozen or pickled and consumed as a relish. California and New York are important cauliflower-producing states. See CAPPARALES. [H.J.C.]

**Causality** In physics, the requirement that interactions in any space-time region can influence the evolution of the system only at subsequent times; that is, past events are causes of future events, and future events can never be the causes of events in the past. Causality thus depends on time orientability, the possibility of distinguishing past from future. Not all spacetimes are orientable.

The laws of a deterministic theory (for example, classical mechanics) are such that the state of a closed system (for example, the positions and momenta of particles in the system) at one instant determines the state of that system at any future time. Deterministic causality does not necessarily imply practical predictability. It was long implicitly assumed that slight differences in initial conditions would not lead to rapid divergence of later behavior, so that predictability was a consequence of determinism. Behavior in which two particles starting at slightly different positions and velocities diverge rapidly is called chaotic. Such behavior is ubiquitous in nature, and can lead to the practical impossibility of prediction of future states despite the deterministic character of the physical laws. See CHAOS.

Quantum mechanics is deterministic in the sense that, given the state of a system at one instant, it is possible to calculate later states. However, the situation differs from that in classical mechanics in two fundamental respects. First, conjugate variables, for example, position  $x$  and momentum  $p$ , cannot be simultaneously determined with complete precision. Second, the state variable  $\psi$  gives only probabilities that a given eigenstate will be found after the performance of a measurement, and such probabilities are also all that is calculable about a later state  $\psi'$  by the deterministic prediction. Despite its probabilistic character, the quantum state still evolves deterministically. However, which eigenvalue (say, of position) will actually be found in a measurement is unpredictable. See DETERMINISM; EIGENVALUE (QUANTUM MECHANICS); NONRELATIVISTIC QUANTUM THEORY; QUANTUM MECHANICS; QUANTUM THEORY OF MEASUREMENT; UNCERTAINTY PRINCIPLE.

Nonrelativistic mechanics assumes that causal action can be propagated instantaneously, and thus that an absolute simultaneity is definable. This is not true in special relativity. While the state of a system can still be understood in terms of the positions and momenta of its particles, time order, as well as temporal and spatial length, becomes relative to the observer's frame, and there is no possible choice of simultaneous events in the universe that is the same in all reference frames. Only space-time

intervals in a fused "spacetime" are invariant with respect to choice of reference frame. The theory of special relativity thus rejects the possibility of instantaneous causal action. Instead, the existence of a maximum velocity of signal transmission determines which events can causally influence others and which cannot. The investigation of a spacetime with regard to which events can causally influence (signal) other regions and which cannot is known as the study of the causal structure of the spacetime. See SPACE-TIME. [D.Sha.]

**Cave** A natural cavity located underground or in the side of a hill or cliff, generally of a size to admit a human. Caves occur in all types of rocks and topographic situations. They may be formed by many different erosion processes. The most important are created by ground waters that dissolve the common soluble rocks—limestone, dolomite, gypsum, and salt. Limestone caves are the most frequent, longest, and deepest. Lava-tube caves, sea caves created by wave action, and caves caused by piping in unconsolidated rocks are the other important types. The science of caves is known as speleology. See DOLOMITE; GYPSUM; HALITE; LIMESTONE.

Caves are important sediment traps, preserving evidences of past erosional, botanic, and other phases that may be obliterated aboveground. Chemical deposits are very important. More than 100 different minerals are known to precipitate in caves. Most abundant and significant are stalactites, stalagmites, and flowstones of calcite. These may be dated with uranium series methods, thus establishing minimum ages for the host caves. They contain paleomagnetic records. Their oxygen and carbon isotope ratios and trapped organic materials may record long-term changes of climate and vegetation aboveground that can be dated with great precision. As a consequence, cave deposits are proving to be among the most valuable paleoenvironmental records preserved on the continents. See STALACTITES AND STALAGMITES. [D.C.F.]

**Cavies** Rodents comprising the family Caviidae, which includes the guinea pig, rock cavies, mountain cavies, capybara, salt-desert cavy, and mara. All members of the group are indigenous to South America and comprise 15 species in six genera. Cavies have either rounded bodies with large heads and short ears and limbs, or rabbitlike bodies with long limbs and moderately long ears.

The guinea pig (*Cavia aperea*) originated in Peru, where there is still a wild stock. The domestic form (*C. porcellus*) has been produced by selective breeding and is a valuable laboratory animal with a life-span of 3–5 years. Closely related to the guinea pig is the mara or Patagonian cavy (*Dolichotis patagonum*) which resembles a large hare. The salt-desert cavy (*Pediolagus salinicola*) is a smaller species found in the salt deserts of southern Argentina. The largest of all rodents is the capybara or carpincho (*Hydrochoerus hydrochaeris*) which grows to the size of a small pig. It is essentially an aquatic animal which lives in small groups along the banks of lakes and streams in tropical South America. See RODENTIA. [C.B.C.]

**Cavitation** The formation of vapor- or gas-filled cavities in liquids. If understood in this broad sense, cavitation includes the familiar phenomenon of bubble formation when water is brought to a boil under constant pressure and the effervescence of champagne wines and carbonated soft drinks due to the diffusion of dissolved gases. In engineering terminology, the term cavitation is used in a narrower sense, namely, to describe the formation of vapor-filled cavities in the interior or on the solid boundaries created by a localized pressure reduction produced by the dynamic action of a liquid system without change in ambient temperature. Cavitation in the engineering sense is characterized by an explosive growth and occurs at suitable combinations of low pressure

and high speed in pipelines; in hydraulic machines such as turbines, pumps, and propellers; on submerged hydrofoils; behind blunt submerged bodies; and in the cores of vortical structures. This type of cavitation has great practical significance because it restricts the speed at which hydraulic machines may be operated and, when severe, lowers efficiency, produces noise and vibrations, and causes rapid erosion of the boundary surfaces, even though these surfaces consist of concrete, cast iron, bronze, or other hard and normally durable material.

Acoustic cavitation occurs whenever a liquid is subjected to sufficiently intense sound or ultrasound (that is, sound with frequencies of roughly 20 kHz to 10 MHz). When sound passes through a liquid, it consists of expansion (negative-pressure) waves and compression (positive-pressure) waves. If the intensity of the sound field is high enough, it can cause the formation, growth, and rapid recompression of vapor bubbles in the liquid. The implosive bubble collapse generates localized heating, a pressure pulse, and associated high-energy chemistry. See SOUND; ULTRASONICS.

Both experiments and calculations show that with ordinary flowing water cavitation commences as the pressure approaches or reaches the vapor pressure, because of impurities in the water. These impurities, called cavitation nuclei, cause weak spots in the liquid and thus prevent it from supporting higher tensions. The exact mechanism of bubble growth is generally described by mathematical relationships which depend upon the cavitation nuclei. Cavitation commences when these nuclei enter a low-pressure region where the equilibrium between the various forces acting on the nuclei surface cannot be established. As a result, bubbles appear at discrete spots in low-pressure regions, grow quickly to relatively large size, and suddenly collapse as they are swept into regions of higher pressure. [M.L.Bi.]

**Cavity resonator** An enclosure capable of resounding or resonating and thereby intensifying sound tones or electromagnetic waves. Resonance is the phenomenon which results when the frequency of the impressed driving force is the same as the natural vibration of the cavity. Vibrating rods, the tuning fork, musical instrument strings, radio and television channel tuners, and so forth, constitute resonating systems as well. The cavity resonator enclosure has a volume which stores energy oscillating between one form and another. In the case of sound, the oscillation is between displacement and velocity of particles. In the case of electromagnetic waves, the energy oscillates between the magnetic and the electric fields. See MUSICAL INSTRUMENTS; TUNING FORK; VIBRATION.

Cavity pipes are used as resonators in musical instruments such as pipe organs and flutes to increase their sonority. The frequency of resonance is determined (to a degree of approximation) by the length of the pipe, by the velocity of sound at the ambient temperature and pressure, by the intensity of the driving force, and by the condition at the ends of the pipe: closed or open. The resulting frequency is related to multiples of quarter-wavelengths or half-wavelengths (depending on the end conditions) contained in the length of pipe. The driving force, if sufficiently strong, can force oscillations to occur at overtone frequencies which are higher multiples of the lowest or fundamental frequency, as well as at the fundamental. See ACOUSTIC RESONATOR; SOUND.

At very high radio frequencies, losses due to radiation can be eliminated and resistive losses can be minimized by using closed resonant cavities instead of lumped-circuit resonators. A cavity resonator stores both magnetic and electric fields, the energy oscillating between the two, losing energy only to the conducting walls if a perfect dielectric fills the space. The resonant frequency of the cavity is determined by the shape of the cavity and the mode, or allowable field distribution, of the electromagnetic energy that the cavity contains. Microwave transmission devices use such cavities. See KLYSTRON; MAGNETRON. [D.J.A.]

**Cayley-Klein parameters** A set of four complex numbers used to specify the orientation of a body, or equivalently, the rotation  $R$  which produces that orientation, starting from some reference orientation. They can be expressed in terms of the Euler angles  $\psi$ ,  $\theta$ , and  $\phi$ , as in the equations below.

$$\begin{aligned}\alpha &= \cos \frac{\theta}{2} e^{-i(\psi - \phi)/2} & \beta &= -i \sin \frac{\theta}{2} e^{i(\psi - \phi)/2} \\ \gamma &= -i \sin \frac{\theta}{2} e^{-i(\psi - \phi)/2} & \delta &= \cos \frac{\theta}{2} e^{i(\psi - \phi)/2}\end{aligned}$$

Although these parameters have been used to simplify somewhat the mathematics of spinning top motion, their main use is in quantum mechanics. There they are related to the Pauli spin matrices and represent the change in the spin state of an electron or other particle of half-integer spin under the space rotation  $R$  ( $\psi$ ,  $\theta$ ,  $\phi$ ). See MATRIX THEORY; SPIN (QUANTUM MECHANICS). [B.G.]

**Caytoniales** A group of Mesozoic plants. The remains consist of palmately compound leaves with 3–6 lanceolate leaflets previously known as *Sagenopteris phillipsi*, pinnately branched microsporophylls (named *Caytonanthus arberi*) that bore winged pollen in four-chambered microsporangia, and fruit-bearing inflorescences, *Caytonia* (with two species), which bore a dozen or more globular, short-stalked fruits in subopposite rows. The Caytoniales appear related to the pteridosperms. They range from the Triassic to the Cretaceous. See PALEOBOTANY. [C.A.A.]

**Cedar** Any of a large number of evergreen trees having fragrant wood of great durability. Arborvitae is sometimes called northern white cedar. See ARBORVITAE.

*Chamaecyparis thyoides*, the southern white cedar, grows only in swamps near the eastern coast of North America, where it is also known as Atlantic white cedar. The wood is soft, fragrant, and durable in the soil and is used for boxes, crates, small boats, tanks, woodenware, poles, and shingles. The Port Orford cedar (*C. lawsoniana*), also known as Lawson cypress, is native to southwestern Oregon and northwestern California. It is the principal wood for storage battery separators, but is also used for venetian blinds and construction purposes. Alaska cedar (*C. nootkatensis*) is found from Oregon to Alaska. The wood is used for interior finish, cabinetwork, small boats, and furniture. It is also grown as an ornamental tree. Incense cedar (*Libocedrus decurrens*) is found from Oregon to western Nevada and Lower California. Incense cedar is one of the chief woods for pencils, and is also used for venetian blinds, rough construction, and fence posts and as an ornamental and shade tree.

Eastern red cedar (*Juniperus virginiana*) is distributed over the eastern United States and adjacent Canada. The very fragrant wood is durable in the soil and is used for fence posts, chests, wardrobes, flooring, and pencils. Cedarwood oil is used in medicine and perfumes. Cedar of Lebanon (*Cedrus libani*) and Atlas cedar (*C. atlantica*) resemble the larch, but the leaves are evergreen and the cones are much larger and erect on the branches. The cedar of Lebanon is a native of Asia Minor. See LARCH.

The cigarbox cedar (*Cedrela odorata*), also known as the West Indian cedar, belongs to the mahogany family, is a broadleaved tree with pinnate, deciduous leaves, and is related to the *Ailanthus* and sumac. The wood is very durable and fragrant and is valued in the West Indies for the manufacture of cabinets, furniture, and canoes. See PINALES. [A.H.G./K.P.D.]

**Celastrales** An order of flowering plants, division Magnoliophyta (Angiospermae), in the subclass Rosidae of the class Magnoliopsida (dicotyledons). The order consists of 11 families and more than 2000 species, with the families Celastraceae (about 800 species), Aquifoliaceae (about 400 species), Icaci-

naceae (about 400 species), and Hippocrateaceae (about 300 species) forming the core of the group. The order is marked by its simple leaves and regular flowers, varying from hypogynous (those with the perianth and stamens attached directly to the receptacle, beneath the ovary) to perigynous (those with the perianth and stamens united at the base into a hypanthium distinct from the ovary) and with a single set of stamens which alternate with the petals. Nearly all of the species are woody plants. Various species of holly (*Ilex*, family Aquifoliaceae) and *Euonymus* (Celastraceae) are often cultivated. See HOLLY; MAGNOLIOPHYTA; MAGNOLIOPSIDA; PLANT KINGDOM; ROSIDAE. [A.Cr.; T.M.Ba.]

**Celery** A biennial umbellifer (*Apium graveolens* var. *dulce*) of Mediterranean origin and belonging to the plant order Umbellales. Celery is grown for its petioles or leafstalks, which are most commonly eaten as a salad but occasionally cooked as a vegetable. California, Florida, and Michigan are important producing states. See APIALES. [H.J.C.]

**Celestial mechanics** The field of dynamics as applied to celestial bodies moving under their mutual gravitational influence in systems with few bodies. It usually describes and predicts motions in the solar system, both of natural bodies such as planets, satellites, asteroids, and comets, and of artificial bodies such as space probes. It can also be applied to small stellar systems.

Isaac Newton's law of universal gravitation is the foundation of most of the field. It states that the force produced by one particle upon another is attractive along the line connecting the bodies, is proportional to the product of the masses of the bodies, and is inversely proportional to the square of the distance between the bodies. The constant of proportionality is  $G$ , the universal constant of gravitation. Newton's second law of motion then says that the acceleration experienced by a body is equal to the force on that body divided by its mass. See FORCE; KINETICS (CLASSICAL MECHANICS); NEWTON'S LAWS OF MOTION.

The simplest and only exactly solvable problem in celestial mechanics is that of one particle moving about another. Since any body with spherical symmetry looks gravitationally like a point mass from the outside, the results from this problem may be used to describe approximately the relative motion of two finite bodies, such as a planet around the Sun or a satellite around a planet. The principal results from this problem had already been recognized empirically by Johannes Kepler and are embodied in his three laws of planetary motion. Usually the motion of the smaller body (the secondary) is described relative to the larger one (the primary). This relative motion is confined to a plane, and the path traced is a conic section such that the primary occupies one focus. If the bodies are gravitationally bound, the conic is an ellipse. The longest segment connecting opposite points on the ellipse is called the major axis, and half this length is called the semimajor axis  $a$  (see illustration). The departure of the ellipse from a circle is called the eccentricity  $e$ , which is usually quite small for planetary orbits. The tilt of the plane from some reference plane is called the inclination, and for the solar system that reference plane is the plane of the Earth's orbit, known as the ecliptic plane. Planetary inclinations are also usually quite small. The line of intersection of the plane of motion with the reference plane is called the line of nodes. The point on the orbit closest to the primary, which is at one end of the major axis, is called the pericenter (specifically for planetary orbits, the perihelion), and its angular distance from the node is called the argument of pericenter. The time at which the secondary passes through the pericenter is called the epoch of pericenter. A seventh parameter is the period of revolution, and the cube of the semimajor axis divided by the square of the period is proportional to the sum of the two masses. Since a planetary mass is small compared to that of the Sun, this ratio is essentially constant for the planets; this is Kepler's third law, also known as the harmonic law. See ELLIPSE.

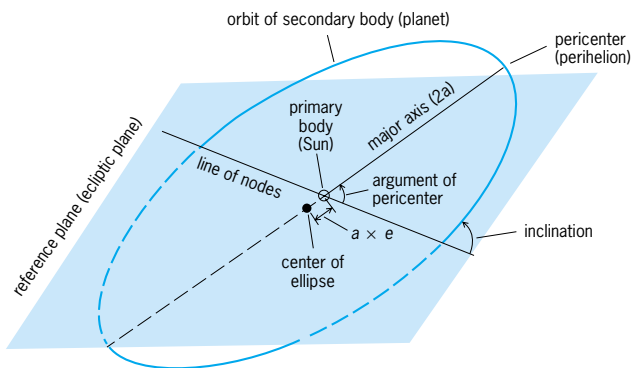

**Relative motion of one body about another when the bodies are gravitationally bound. Parameters used to describe the motion are shown. (Terms used to describe the motion of a planet about the Sun are given in parentheses.)  $e$  = eccentricity.**

A second result applies whenever the forces are directed along the line connecting the two bodies. Angular momentum is conserved, which causes the line connecting the two bodies to sweep out equal areas in equal times, a result stated in Kepler's second law. This results in the relative velocity in the orbit being inversely proportional to the square root of the separation. Ellipses are not the only type of relative motion permitted, and the type of conic depends on the total energy in the orbit. If there is just enough energy for the bodies to escape from each other, the relative orbit is a parabola. If there is more than enough energy for escape, such that some relative velocity would still remain, the orbit is a hyperbola. A hyperbola would also describe the relative motion of two independent bodies encountering each other, as in the case of two stars within the galaxy. See CONIC SECTION; ESCAPE VELOCITY; ORBITAL MOTION; PLANET.

One of the major operational problems of celestial mechanics is that of determining the orbit of a body in the solar system from observations of its position, or distance plus line-of-sight velocity, at various times. The objective is to determine the numerical values of the parameters characterizing the orbit, known as orbital elements. A minimum of three observations is required. Usually there are more than three observations, which means that best values must be estimated in some statistical sense. Once the orbit is known, the future locations of the object can be predicted. A table of predicted positions is called an ephemeris. See also EPHEMERIS.

Another important problem is determining the proper orbit to get from one point at one time to another point at another time. This may involve getting from one body to another (space flight) or from one point to another on the same body (ballistics). For space flight, the approach is to consider several two-body problems and then patch them together. For economy, an orbit with as little energy change as possible is desired. This dictates an elliptic heliocentric orbit that is just tangent to one planetary orbit at one extreme and just tangent to the other orbit at the other extreme. Such an orbit is known as a Hohmann transfer orbit, and it is unique for each pair of planets. See SPACE NAVIGATION AND GUIDANCE; SPACE PROBE.

Only slightly increased in complexity is this problem of the motion of a massless particle moving in the gravitational field of two bodies moving around each other in two-body motion. This problem has no general solution; the analytic and numerical study of the problem is concerned with stability, periodic orbits, and topology of solutions. There are five specific solutions—the fixed points or libration points. If the massless particle is placed at any of these points with zero velocity in the coordinate system rotating with the primaries, it will remain at that point in the rotating system. Three of these points are located along the line connecting the primaries, and the other two points form equilateral triangles with the primaries, one ahead and one be-

hind as they revolve. Unlike the linear points, these triangular points can be stable, in that a slight displacement of the massless particle away from the point will not produce unbounded motion but rather an oscillation (called a libration) about the point. There are asteroids, known as the Trojans, librating about both triangular points in the Sun-Jupiter system. See TROJAN ASTEROIDS.

If there are three or more bodies, all of which have mass and therefore all of which influence each other, the problem becomes almost hopeless. The degree of complexity is essentially independent of the number of bodies, so the problem is called the  $n$ -body problem. This is usually studied by purely numerical means, but in two extreme cases some analytical progress can be made. One is when the number of bodies,  $n$ , becomes so large that statistical approaches are possible; this leads into the dynamics of star clusters and galaxies and out of the field of celestial mechanics. The other is when relative geometries or masses are such that the situation becomes a series of two-body problems with small coupling influences, or perturbations. These perturbations can be treated in some approximate way, such as series expansions or iterative solutions. See GALAXY, EXTERNAL; MILKY WAY GALAXY; STAR CLUSTERS.

There are two classical areas of general perturbation theory. One is the development of lunar theory, the representation of the motion of the Moon about the Earth, under the influence of rather strong perturbations from the Sun. The other has been planetary theory, the description of the motion of planets (either major or minor) about the Sun, under the influence of (other) major planets. See MOON; PERTURBATION (ASTRONOMY).

The newtonian law of universal gravitation has been remarkably successful in explaining most astronomical dynamical phenomena. However, there have been some discrepancies, the most glaring being a small unexplainable motion in the perihelion of Mercury. The problem was resolved by Einstein's theory of general relativity. Philosophically, gravitation is quite different in the two theories, but the mathematical description of motion in general relativity shows that Newton's simple relationship is "almost" correct. The effects are, however, easily detectable in spacecraft trajectories, and thus now have to be routinely considered. See GRAVITATION; RELATIVITY. [R.S.H.]

**Celestial navigation** Navigation with the aid of celestial bodies, primarily for determination of position when landmarks are not available. In celestial navigation, position is not determined relative to the objects observed, as in navigation by piloting, but in relation to the points on the Earth having certain celestial bodies directly overhead.

Celestial bodies are also used for determination of horizontal direction on the Earth and for regulating time, which is of primary importance in celestial navigation because of the changing positions of celestial bodies in the sky as the Earth rotates daily on its axis.

The navigator, concerned less with the actual motions of celestial bodies than with their apparent motions as viewed from the Earth, pictures the heavens as a hollow celestial sphere of infinite radius, with the Earth at its center and the various celestial bodies on its inner surface. The navigator visualizes this sphere as rotating on its axis once in about 23 h 56 min—one sidereal day.

Several systems of coordinates are available to identify points on the celestial sphere. The celestial equator system of coordinates is an extension of the equatorial system commonly used on the Earth. The navigator also uses the horizon system of coordinates, in which the primary great circle is the horizon of the observer. See ASTRONOMICAL COORDINATE SYSTEMS.

Position determination in celestial navigation is primarily a matter of converting one set of coordinates to the other. This is done by solution of a spherical triangle called the navigational triangle.

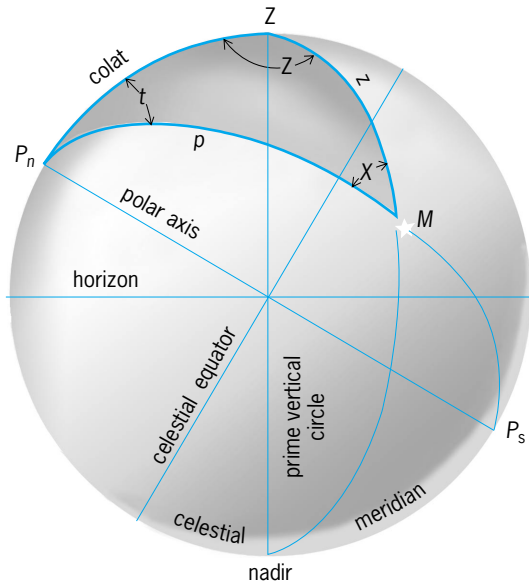

The navigational triangle.

The concept of the spherical navigational triangle is graphically shown in the illustration, a diagram on the plane of the celestial meridian. The celestial meridian passes through the zenith of the observer, and is therefore a vertical circle of the horizon system. Elements of both systems are shown in this illustration, indicating that an approximate solution can be made graphically.

The vertices of the navigational triangle are the elevated pole ( $P_n$ ), the zenith ( $Z$ ), and the celestial body ( $M$ ). The angles at the vertices are, respectively, the meridian angle ( $t$ ), the azimuth angle ( $Z$ ), and the parallax angle ( $X$ ). The sides of the triangle are the codeclination of the zenith or the colatitude (colat) of the observer, the coaltitude or zenith distance ( $z$ ) of the body, and the codeclination or polar distance ( $p$ ) of the body.

A navigational triangle is solved, usually by computation, and compared with an observed attitude to obtain a line of position by a procedure known as sight reduction. With the emergence of electronic computers and hand-held calculators, sight reduction has been performed increasingly with limited use or elimination of tables.

To establish a celestial line of position, the navigator observes the altitude of a celestial body, noting the time of observation. Observation is made by a sextant, so named because early instruments had an arc of one-sixth of a circle. By means of the double reflecting principle, the altitude of the body is double the amount of arc used. The marine sextant uses the visible horizon as the horizontal reference. An air sextant has an artificial, built-in horizontal reference based upon a bubble or occasionally a pendulum or gyroscope. The sextant altitude, however measured, is subject to certain errors, for which corrections are applied. See SEXTANT.

Time is repeatedly mentioned as an important element of a celestial observation because the Earth rotates at the approximate rate of 1 minute of arc each 4 s of time. An error of 1 s in the timing of an observation might introduce an error in the line of position of as much as one-quarter of a mile. Time directly affects longitude determination, but not latitude. The long search for a method of ascertaining longitude at sea was finally solved two centuries ago by the invention of the marine chronometer, a timepiece with a nearly steady rate. See NAVIGATION; PILOTING.

[A.B.M.]

**Celestial reference system** A system for specifying reference orientation coordinates for locating celestial objects. The International Celestial Reference System (ICRS) was

adopted by the International Astronomical Union in 1994 as the new fundamental reference system. The International Celestial Reference System is realized by the International Celestial Reference Frame (ICRF) made up from the positions of approximately 400 extragalactic radio sources observed with very long baseline interferometry. These sources are very distant, so they do not have any apparent proper motions, but they can have structure that changes with time. The resulting reference frame is accurate to about 0.3 milliarcsecond. The International Celestial Reference Frame replaces the historical use of fundamental star catalogs, such as the FK4 and FK5, which were based on optical observations of nearby bright stars. See RADIO ASTRONOMY; RADIO TELESCOPE; STAR.

There is a corresponding International Terrestrial Reference Frame (ITRF) consisting of coordinates on the surface of the Earth. These positions are subject to the variations due to geophysical effects such as plate tectonics and tidal effects. See ASTROMETRY; EARTH TIDES; GEODESY; PLATE TECTONICS. [P.K.S.]

**Celestial sphere** The imaginary sphere, on the inside surface of which the astronomical objects appear to be located. Its center is the center of the Earth. The sphere is so large in proportion to the size of the Earth that its center can be considered as the same point as the observer, wherever he or she may be on the Earth.

A section of the celestial sphere has been removed in the illustration to show the Earth at the center. The Earth's axis has been extended from the North Pole to intersect the celestial sphere in a point called the north celestial pole, which is only about 1° from Polaris, the North Star. See POLARIS.

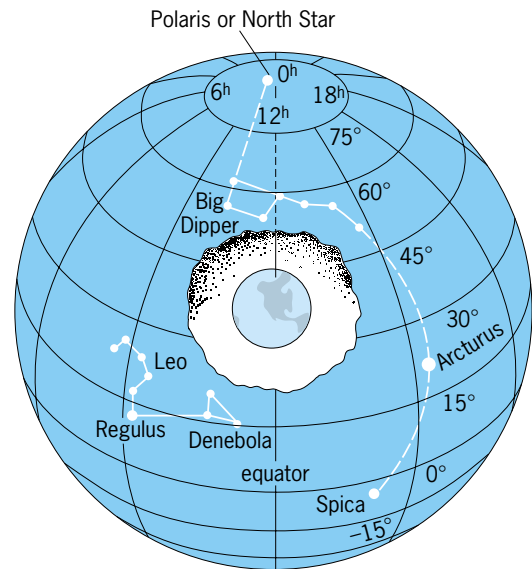

The celestial sphere and the Earth. (After C. H. Clemmshaw, *The Beginner's Guide to the Skies*, T. Y. Crowell, 1977)

Halfway between the north and south celestial poles is the celestial equator. Parallel to it are circles of declination. Declination is the angular distance north or south of the celestial equator, corresponding to latitude on the Earth.

Corresponding to the Earth's meridians, which run from pole to pole, are the hour circles on the celestial sphere. Similar to the way in which longitude is measured on Earth, right ascension is measured along the celestial equator in hours of time. See ASTRONOMICAL COORDINATE SYSTEMS; LATITUDE AND LONGITUDE. [C.H.C.]

**Celestite** A mineral with the chemical composition  $\text{SrSO}_4$ . Celestite occurs commonly in colorless to sky-blue, orthorhombic, tabular crystals. Fracture is uneven and luster is vitreous.

Hardness is 3–3.5 on Mohs scale and specific gravity is 3.97. It fuses readily to a white pearl. The strontium present in celestite imparts a characteristic crimson color to the flame.

Celestite occurs in association with gypsum, anhydrite, salt beds, limestone, and dolomite. Large crystals are found in vugs or cavities of limestone. It is deposited directly from sea water, by groundwater, or from hydrothermal solutions. Celestite is the major source of strontium: Although celestite deposits occur in Arizona and California, domestic production of celestite has been small and sporadic. Much of the strontium demand is satisfied by imported ores from England and Mexico. See STRONTIUM.

[E.C.T.C.]

**Cell (biology)** Cells can be separated into prokaryotic and eukaryotic categories. Eukaryotic cells contain a nucleus. They comprise protists (single-celled organisms), fungi, plants, and animals, and are generally 5–100 micrometers in linear dimension. Prokaryotic cells contain no nucleus, are relatively small (1–10  $\mu\text{m}$  in diameter), and have a simple internal structure. They include two classes of bacteria: eubacteria (including photosynthetic organisms, or cyanobacteria), which are common bacteria inhabiting soil, water, and larger organisms; and archaeobacteria, which grow under unusual conditions. See EUKARYOTAE; PROKARYOTAE.

**Prokaryotic (bacterial) cells.** All eubacteria have an inner (plasma) membrane which serves as a semipermeable barrier allowing small nonpolar and polar molecules such as oxygen, carbon dioxide, and glycerol to diffuse across (down their concentration gradients), but does not allow the diffusion of larger polar molecules (sugars, amino acids, and so on) or inorganic ions such as  $\text{Na}^+$ ,  $\text{K}^+$ ,  $\text{Cl}^-$ ,  $\text{Ca}^{2+}$  (sodium, potassium, chlorine, calcium). The plasma membrane, which is a lipid bilayer, utilizes transmembrane transporter and channel proteins to facilitate the movement of these molecules. Eubacteria can be further separated into two classes based on their ability to retain the dye crystal violet. Gram-positive cells retain the dye; their cell surface includes the inner plasma membrane and a cell wall composed of multiple layers of peptidoglycan. Gram-negative bacteria are surrounded by two membranes: the inner (plasma) membrane and an outer membrane that allows the passage of molecules of less than 1000 molecular weight through porin protein channels. Between the inner and outer membranes is the peptidoglycan-rich cell wall and the periplasmic space. See CELL PERMEABILITY.

Eubacteria contain a single circular double-stranded molecule of deoxyribonucleic acid (DNA), or a single chromosome. As prokaryotic cells lack a nucleus, this genomic DNA resides in a central region of the cell called the nucleoid. The bacterial genome contains all the necessary information to maintain the structure and function of the cell.

Many bacteria are able to move from place to place, or are motile. Their motility is based on a helical flagellum composed of interwoven protein called flagellin. The flagellum is attached to the cell surface through a basal body, and propels the bacteria through an aqueous environment by rotating like the propeller on a motor boat. The motor is reversible, allowing the bacteria to move toward chemoattractants and away from chemorepellants.

**Eukaryotic cells.** In a light microscopic view of a eukaryotic cell, a plasma membrane can be seen which defines the outer boundaries of the cell, surrounding the cell's protoplasm or contents. The protoplasm includes the nucleus, where the cell's DNA is compartmentalized, and the remaining contents of the cell (the cytoplasm). The eukaryotic cell's organelles include the nucleus, mitochondria, endoplasmic reticulum, Golgi apparatus, lysosomes, peroxisomes, cytoskeleton, and plasma membrane (Fig. 1). The organelles occupy approximately half the total volume of the cytoplasm. The remaining compartment of cytoplasm (minus organelles) is referred to as the cytosol or cytoplasmic ground substance. Eukaryotic cells also differ from prokaryotic cells in having a cytoskeleton that gives the cell its shape, its ca-

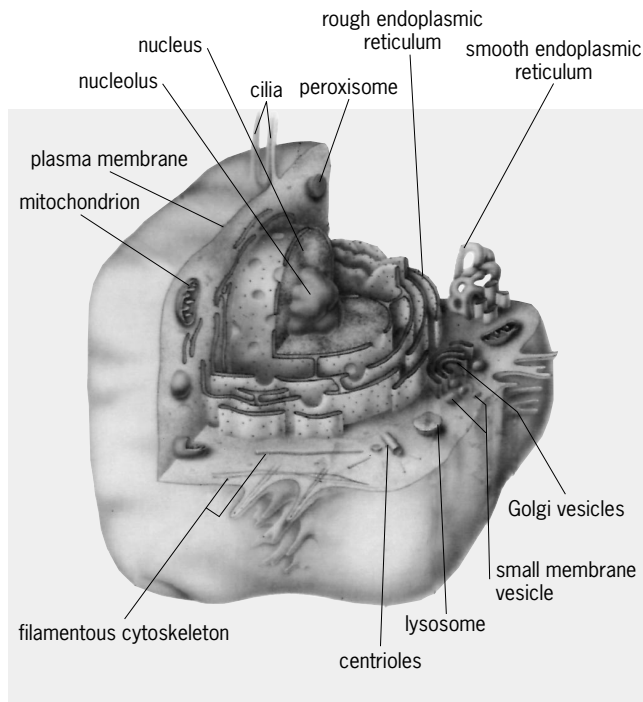

**Fig. 1.** Artist's rendition of a eukaryotic animal cell. (Modified from H. Lodish et al., *Molecular Cell Biology*, 3d ed., Scientific American, New York, 1995)

capacity to move, and its ability to transport organelles and vesicles from one part of the cell cytoplasm to another. Eukaryotic cells are generally larger than prokaryotic cells and therefore require a cytoskeleton and membrane skeleton to maintain their shape, which is related to their functions.

Eukaryotic cells contain a large amount of DNA (about a thousandfold more than bacterial cells), only approximately 1% of which encodes protein. The remaining DNA is structural (involved in DNA packaging) or regulatory (helping to switch on and off genes).

**Plasma membrane.** The plasma membrane serves as a selective permeability barrier between a cell's environment and cytoplasm. The fundamental structure of plasma membranes (as well as organelle membranes) is the lipid bilayer, formed due to the tendency of amphipathic phospholipids to bury their hydrophobic fatty acid tails away from water. Human and animal cell plasma membranes contain a varied composition of phospholipids, cholesterol, and glycolipids. See CELL MEMBRANES.

**Cytoskeleton.** The cytoskeleton is involved in establishing cell shape, polarity, and motility, and in directing the movement of organelles within the cell. The cytoskeleton includes microfilaments, microtubules, intermediate filaments, and the two-dimensional membrane skeleton that lines the cytoplasmic surface of cell membranes. See CYTOSKELETON.

**Nucleus.** One of the most prominent organelles within a eukaryotic cell is the nucleus. The nuclear compartment is separated from the rest of the cell by a specialized membrane complex built from two distinct lipid bilayers, referred to as the nuclear envelope. However, the interior of the nucleus maintains contact with the cell's cytoplasm via nuclear pores. The primary function of the nucleus is to house the genetic apparatus of the cell; this genetic machinery is composed of DNA (arranged in linear units called chromosomes), RNA, and proteins. Nuclear proteins aid in the performance of nuclear functions and include polypeptides that have a direct role in the regulation of gene function and those that give structure to the genetic material. See CELL NUCLEUS.

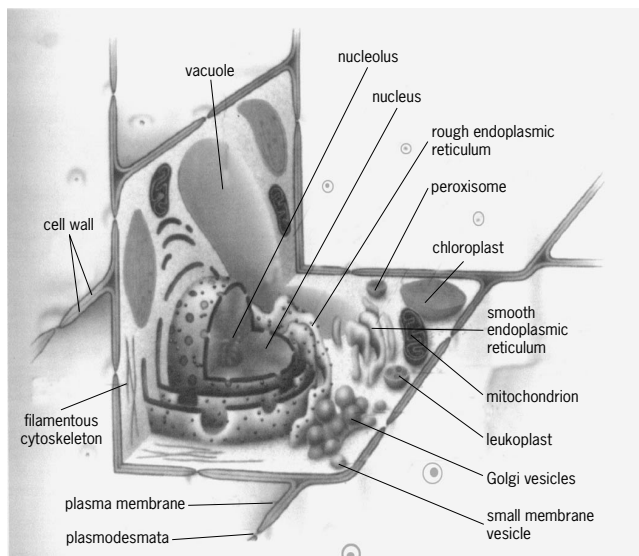

**Fig. 2.** Artist's rendition of a typical plant cell. (Modified from H. Lodish et al., *Molecular Cell Biology*, 3d ed., Scientific American, New York, 1999)

**Endoplasmic reticulum.** The endoplasmic reticulum is composed of membrane-enclosed flattened sacs or cisternae. The enclosed compartment is called the lumen. The endoplasmic reticulum is morphologically separated into rough (RER) and smooth (SER). RER is studded with ribosomes and SER is not. RER is the site of protein synthesis, while lipids are synthesized in both RER and SER. See ENDOPLASMIC RETICULUM.

**Golgi apparatus.** The final posttranslational modifications of proteins and glycolipids occur within a series of flattened membranous sacs called the Golgi apparatus. Vesicles which bud from the endoplasmic reticulum fuse with a specialized region of the cis Golgi compartment called the cis Golgi network. In the trans Golgi network, proteins and lipids are sorted into transport vesicles destined for lysosomes, the plasma membrane, or secretion. See GOLGI APPARATUS.

**Lysosomes.** Lysosomes are membrane-bound organelles with a luminal pH of 5.0, filled with acid hydrolyses. Lysosomes are responsible for degrading materials brought into the cell by endocytosis or phagocytosis, or autophagocytosis of spent cellular material. See ENDOCYTOSIS; LYSOSOME.

**Mitochondria.** The mitochondrion contains a double membrane: the outer membrane, which contains a channel-forming protein named porin, and an inner membrane, which contains multiple infolds called cristae. The inner membrane, which contains the protein complexes responsible for electron transport and oxidative phosphorylation, is folded into numerous cristae that increase the surface area per volume of this membrane. The transfer of electrons from nicotinamide adenine dinucleotide (NADH) or flavin adenine dinucleotide ( $\text{FADH}_2$ ) down the electron transfer chain to oxygen causes protons to be pumped out of the mitochondrial matrix into the intermembrane space. The resulting proton motive force drives the conversion of ADP plus inorganic orthophosphate ( $\text{P}_i$ ) to ATP by the enzyme ATP synthetase. See MITOCHONDRIA.

**Peroxisomes.** Within the peroxisome, hydrogen atoms are removed from organic substrates and hydrogen peroxide is formed. The enzyme catalase can then utilize the hydrogen peroxide to oxidize substrates such as alcohols, formaldehydes, and formic acid in detoxifying reactions. See PEROXISOME.

**Plant cells.** Plant cells are distinguished from other eukaryotic cells by various features. Outside their plasma membrane, plant cells have an extremely rigid cell wall. This cell wall is composed of cellulose and other polymers and is distinct in composition from the cell walls found in fungi or bacterial cells.

The plant cell wall expands during cell growth, and a new cell wall partition is created between the two daughter cells during cell division. Similar cell walls are not observed in animal cells (Fig. 2).

Most plant cells contain membrane-encapsulated vacuoles as major components of their cytoplasm. These vacuoles contain water, sucrose, ions, nitrogen-containing compounds formed by nitrogen fixation, and waste products.

Chloroplasts are the other major organelle in plant cells that is not found in other eukaryotic cells. Like mitochondria, they are constantly in motion within the cytoplasm. One of the pigments found in chloroplasts is chlorophyll, which is the molecule that absorbs light and gives the green coloration to the chloroplast. Chloroplasts, like mitochondria, have an outer and inner membrane. Within the matrix of the chloroplast there is an intricate internal membrane system. The internal membranes are made up of flattened interconnected vesicles that take on a disc-like structure (thylakoid vesicles). The thylakoid vesicles are stacked to form structures called grana, which are separated by a space called the stroma. Within the stroma, carbon dioxide ( $\text{CO}_2$ ) fixation occurs, in which carbon dioxide is converted to various intermediates during the production of sugars. Chlorophyll is found within the thylakoid vesicles; it absorbs light and, with the involvement of other pigments and enzymes, generates ATP during photosynthesis. See PLANT CELL. [S.R.G.]

**Cell, spectral analysis of** Living cells contain various substances, the concentrations and biological activity of which can be investigated by observing the spectrum of light passed through the cells. Such investigations take advantage of the fact that many substances absorb light in an individually characteristic manner. Thus, the spectrum of light passed through a green leaf has two black bands where red and blue light should appear. The absorption of red and blue light is characteristic of the chlorophylls, the photosynthetic pigments. Today, investigations of cells by optical methods go far beyond the routine analysis of brightly colored pigments that are found widespread and in high concentration, for example, hemoglobin and chlorophyll. Such methods allow the investigation of light-absorbing molecules within the cell whose concentration is 1000 times smaller than that of hemoglobin or of chlorophyll. See CHLOROPHYLL; HEMOGLOBIN.

Because the color of biological molecules changes when they undergo chemical reactions, such reactions in the cell can be monitored by spectral analyses. These analyses can be used to monitor reactions occurring in times ranging from  $10^{-15}$  s to minutes. In some cases, the spectral properties can also indicate the environment of the biological molecules in the cell, that is, whether they are rigidly held or free to move and how they react with one another within the cell.

Different parts of the spectrum provide different information about molecules in cells. Infrared spectra (700–5000 nanometers) give information about the structure of molecules; all molecules absorb in the infrared in a characteristic manner. Visible light spectra (400–700 nm) give information concerning those relatively few biological molecules that absorb light in this region. These molecules thus can be specifically studied in a cell that may contain tens of thousands of other types of molecules. Ultraviolet spectra (200–400 nm) give information on those molecules that absorb light in this region. Such spectra are not very useful when working with living cells or other light-scattering samples.

Fluorescence and phosphorescence spectra are produced by light emission. When some molecules absorb light in the ultraviolet and visible spectral regions, they can be energized into various electronic excited states. In many instances, the energy of the excited states is dissipated rapidly as heat, and the molecule returns to its original ground state. However, the appropriate excited state can also be dissipated relatively slowly by emitting light at wavelengths slightly longer than that of the excitation

light. The emitted light can take one of two forms: fluorescence, which occurs rapidly after excitation and lasts  $10^{-9}$  to  $10^{-6}$  s; and phosphorescence, which has a longer decay time and wavelength range than fluorescence and lasts on the order of  $10^{-6}$  to  $10^2$  s. Relatively few molecules emit light after absorption.

Light scattering is of two types. When light is scattered without changing wavelength (elastic scattering), the scattering reveals the size and shape of molecules. Another type is Raman scattering. In this case, molecules alter the light by slightly shifting the wavelength in a manner that is very specific for the particular molecule. See RAMAN EFFECT; SCATTERING OF ELECTROMAGNETIC RADIATION.

Spectral analysis by optical methods is limited to those substances which show characteristic peaks, or maxima, of absorption when light absorption is plotted as a function of light wavelength. Whether or not a given substance can be detected depends on the intensity of absorption relative to other substances present at a given absorption maximum. Substances of biological interest that are found in cells and that can be studied optically include pigments such as hemoglobin, flavoproteins, and the pyridine nucleotides. The spectral properties of these substances depend on their oxidation state.

There is a large group of proteins, the iron-sulfur proteins, which are of considerable biological importance. These substances, referred to individually as iron-sulfur clusters, do not have the properties that can be characterized by optical spectroscopy. However, they can be studied in detail by magnetic resonance spectroscopy, a technique where the spectrum involves magnetic fields and light in the microwave spectral region. This technique is also used to study the position of protein complexes relative to one another in biological membranes.

It is characteristic of biological processes that various proteins, enzymes, and coenzymes react with one another in cycles or sequences. In the processes of cellular respiration, there is a sequence of reactions which involve pyridine nucleotides, flavoproteins, iron-sulfur clusters, and cytochromes in processes involving energy transfer and oxygen consumption. Similarly, photosynthesis involves chlorophylls and accessory pigments, cytochromes, pyridine-nucleotides, and iron-sulfur clusters. It is particularly important to discover which components are included in various biological processes and the order in which they react with one another; spectral analysis provides the methods for such investigations.

Because of light-scattering problems and the limited numbers of single cells available, it is extraordinarily difficult to study specific processes within a single cell. Rather, it has proven much more profitable to investigate suspensions of subcellular organelles which can be isolated in a reasonably undamaged state, for example, mitochondria and chloroplasts. Such suspensions, prepared by destroying the cell structure, contain a variety of substances suitable for optical, fluorescent, and magnetic resonance analysis and in sufficient concentration to allow precise and quantitative study. Suspensions of mitochondria and chloroplasts have been used extensively in the development of the understanding of cellular respiration and of photosynthesis. See CELL (BIOLOGY); CELL PLASTIDS; MITOCHONDRIA.

Any spectral analysis, regardless of its application, utilizes the components in the illustration. These components consist of a light source from which the light is focused by means of a lens on a narrow slit. The narrow beam of light is then resolved into its component wavelengths by means of a prism or a grating. Lasers

have been used as a source of monochromatic light. A narrow band of such light is isolated by means of a second narrow slit and passes through the sample onto an appropriate detector. The signal produced on activation of the detector may be amplified and displayed or recorded on a suitable device.

[W.D.Bo.; J.M.V.]

**Cell biology** The study of the activities, functions, properties, and structures of cells. Cells were discovered in the middle of the seventeenth century after the microscope was invented. In the following two centuries, with steadily improved microscopes, cells were studied in a wide variety of plants, animals, and microorganisms, leading to the discovery of the cell nucleus and several other major cell parts. By the 1830s biologists recognized that all organisms are composed of cells, a realization that is now known as the Cell Doctrine. The Cell Doctrine constitutes the first major tenet upon which the contemporary science of cell biology is founded. By the late 1800s biologists had established that cells do not arise *de novo*, but come only by cell division, that is, division of a preexisting cell into two daughter cells. This is the second major tenet upon which the modern study of cells is based. See CELL DIVISION; MICROSCOPE.

By the end of the nineteenth century chromosomes had been discovered, and biologists had described mitosis—the distribution at cell division of chromosomes to daughter cells. Subsequent studies showed that the chromosomes contain genes and that mitosis distributes a copy of every chromosome and hence every gene to each daughter cell during cell division. This established the basis of cell heredity and ultimately the basis of heredity in multicellular organisms. See CHROMOSOME; MITOSIS.

Microscope studies established that some kinds of organisms are composed of a single cell and some, such as plants and animals, are made up of many cells—usually many billions. Unicellular organisms are the bacteria, protozoa, some fungi, and some algae. All other organisms are multicellular. An adult human, for example, consists of about 200 cell types that collectively amount to more than  $10^{14}$  cells.

All modern research recognizes that in both unicellular and multicellular organisms the cell is the fundamental unit, housing the genetic material and the biochemical organization that account for the existence of life. Many millions of different species of cells exist on Earth. Cells as different as a bacterium, an amoeba, a plant leaf cell, and a human liver cell appear to be so unrelated in structure and life-style that they might seem to have little in common; however, the study of cells has shown that the similarities among these diverse cell types are more profound than the differences. These studies have established a modern set of tenets that bring unity to the study of many diverse cell types. These tenets are: (1) All cells store information in genes made of deoxyribonucleic acid (DNA). (2) The genetic code used in the genes is the same in all species of cells. (3) All cells decode the genes in their DNA by a ribonucleic acid (RNA) system that translates genetic information into proteins. (4) All cells synthesize proteins by using a structure called the ribosome. (5) Proteins govern the activities, functions, and structures in all cells. (6) All cells need energy to operate; all use the molecule adenosine triphosphate (ATP) as the currency for transfer of energy from energy sources to energy needs. (7) All cells are enclosed by a plasma membrane composed of lipid and protein molecules. See CELL MEMBRANES; GENETICS; RIBOSOMES.

In the twentieth century the study of cells, which had been dominated for more than 200 years by microscopy, has been enormously expanded with many other experimental methods. The breaking open of a large mass of cells and the separation of released cell parts into pure fractions led to the discovery of functions contributed by different structures and organelles.

Contemporary research in cell biology is concerned with many problems of cell operation and behavior. Cell reproduction is of special concern because it is essential for the survival of all unicellular and multicellular forms of life. Cell reproduction is the

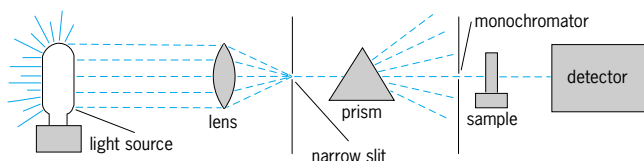

Basic components used for spectral analysis.



means by which a single cell, the fertilized egg, can give rise to the trillions of cells in an adult multicellular organism. Disrupted control of cell reproduction, resulting in accumulation of disorganized masses of functionally useless cells, is the essence of cancer. Indeed, all diseases ultimately result from the death or malfunctioning of one or another group of cells in a plant or animal. The study of cells pervades all areas of medical research and medical treatment. Great advances have been made in learning how cells of the immune system combat infection, and the nature of their failure to resist the acquired immune deficiency syndrome (AIDS) virus. See ACQUIRED IMMUNE DEFICIENCY SYNDROME (AIDS); CANCER (MEDICINE); CELL SENESCENCE AND DEATH.

The development of methods to grow plant and animal cells in culture has provided new ways to study cells free of the experimental complications encountered with intact plants and animals. Cell culture has greatly facilitated analysis of abnormal cells, including transformation of normal cells into cancer cells. Cultured cells are also used extensively to study cell differentiation, cell aging, cell movement, and many other cell functions. See TISSUE CULTURE. [D.M.Pr.]

**Cell constancy** The condition in which the entire body of an adult animal or plant consists of a fixed number of cells that is the same in all members of the species. This phenomenon is also called eutely. The largest group of animals exhibiting eutely are the nematode worms, one of the largest of all animal phyla, and of great medical and agricultural importance as parasites of plants, animals, and humans. A plant that exhibits eutely is usually called a coenobium. Many species of semimicroscopic aquatic green algae exist as coenobia, such as the common *Volvox* and *Pandorina*.

Numerical limitation occurs in certain organs and organ systems, notably the brain and muscles of annelid worms, mollusks, and vertebrates. A related but different phenomenon, observed for many animal cells when cultured, is that normal cells divide some specific number of times and then stop dividing. Thus the life-span, as measured by number of cell cycles, is limited; for many human cell types this is about 50 cell generations.

In annelids and vertebrates, cell proliferation is more or less continuous throughout life only in those tissues that are subject to wear. Thus, in adults, cell division may be found in the germinative zones of the skin, hair, finger and toe nails, the lining of the alimentary canal, and especially in the blood cell-forming tissues. The muscles and nervous system, however, appear to undergo no cell division after early embryonic or fetal stages. In both earthworms and mammals, including humans, it has been demonstrated that the number of muscle nuclei and muscle fibers, but not fibrils, is fixed early and does not increase with subsequent growth. An earthworm hatches from its egg cocoon with the adult number of muscle fibers and nuclei. A human fetus, about 5 in. (13 cm) from crown to rump, has as many muscle fibers and nuclei as an adult. It has been shown that the number of glomeruli in each kidney of a rat or human, and therefore presumably of any mammal, is fixed before birth, and that the subsequent growth of the glomeruli, either normally or resulting from compensatory hypertrophy after unilateral nephrectomy, is due entirely to the enlargement of cells already present. The same holds true for the cells of the ciliated nephrostomes of earthworms. [G.B.M.]

**Cell cycle** The succession of events that culminates in the asexual reproduction of a cell; also known as cell division cycle. In a typical cell cycle, the parent cell doubles its volume, mass, and complement of chromosomes, then sorts its doubled contents to opposite sides of the cell, and finally divides in half to yield two genetically identical offspring. Implicit in the term "cycle" is the idea that division brings the double-sized parent cell back to its original size and chromosome number, and ready to begin another cell cycle. This idea fits well with the behavior of many unicellular organisms, but for multicellular organisms the

daughter cells may differ from their parent cell and from each other in terms of size, shape, and differentiation state.

The time required for completion of a eukaryotic cell cycle varies enormously from cell to cell. Embryonic cells that do not need to grow between divisions can complete a cell cycle in as little as 8 min, whereas cycling times of 10–24 h are typical of the most rapidly dividing somatic cells. Many somatic cells divide much less frequently; liver cells divide about once a year, and mature neurons never divide. Such cells may be thought of as temporarily or permanently withdrawing from the cell cycle.

**Eukaryotic phases.** The cell cycle is divided into two main parts: interphase and mitosis (see illustration). During interphase, the cell grows and replicates its chromosomes. Interphase accounts for all but an hour or two of a 24-h cell cycle, and is subdivided into three phases: gap phase 1 (G1), synthesis (S), and gap phase 2 (G2). Interphase is followed by mitosis (nuclear division) and cytokinesis (cell division). This relatively brief part of the cell cycle includes some of the most dramatic events in cell biology.

**G1 phase.** Gap phase 1 begins at the completion of mitosis and cytokinesis and lasts until the beginning of S phase. This phase is generally the longest of the four cell cycle phases and is quite variable in length. During this phase, the cell chooses either to replicate its deoxyribonucleic acid (DNA) or to exit the cell cycle and enter a quiescent state (the G0 phase).

**S phase.** Replication of the chromosomes is restricted to one specific portion of interphase, called S phase (DNA synthesis phase), which typically lasts about 6 h. In mammalian cells, the start of S phase—the actual initiation of DNA synthesis—takes place several hours after the cell has committed to carrying out DNA synthesis. During S phase, each chromosome replicates exactly once to form a pair of physically linked sister chromatids. In animal cells, a pair of centrioles is also duplicated during S phase. See CHROMOSOME; GENETICS.

**G2 phase.** The portion of interphase that follows S phase is called gap phase 2. Some cells can exit the cell cycle from G2 phase, just as they can from G1 phase.

**M phase.** M phase includes the overlapping processes of mitosis and cytokinesis. Mitosis is divided into five stages: prophase, prometaphase, metaphase, anaphase, and telophase. Cytokinesis usually begins during anaphase and ends at a point after the completion of mitosis. At the end of cytokinesis, the parent cell has formed its two G1 phase progeny and the cell is ready to repeat the cycle. See CYTOKINESIS; MITOSIS.

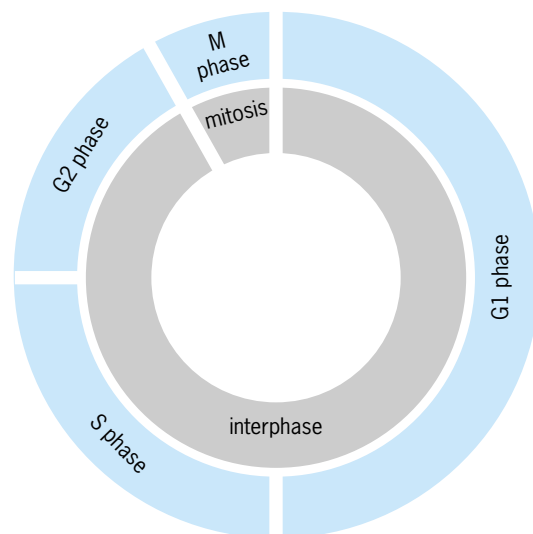

Phases of the eukaryotic cell cycle.

**Control of cell cycle.** The network of proteins that regulate DNA synthesis (G1/S), mitotic entry (G1/M), and mitotic exit (the transition from mitotic metaphase to anaphase and then out of mitosis) appears to be well conserved throughout eukaryotic evolution. At the heart of these cell cycle transitions is the periodic activation and inactivation of cyclin-dependent protein kinases. In addition, in multicellular eukaryotes, pathways regulating entry into and exit from the cell cycle entrain these central cyclin-dependent kinases to extrinsic signals. [J.E.F.]

**Cell differentiation** The mechanism by which cells in a multicellular organism become specialized to perform specific functions in a variety of tissues and organs. Specialized cells are the product of differentiation. The process can be understood only from a historical perspective, and the best place to start is the fertilized egg. Different kinds of cell behavior can be observed during embryogenesis: cells double, change in shape, and attach at and migrate to various sites within the embryo without any obvious signs of differentiation. Cleavage is a rapid series of cell cycles during which the large egg cell is divided into a ball of small cells that line the primitive body cavity as a single layer of embryonic cells. This blastula stage is followed by gastrulation, a complex coordinated cellular migration which not only shapes the embryo but segregates the single-cell layer of the blastula into the three germ layers: endoderm, mesoderm, ectoderm. They give rise to specific cell types; for example, skin and nerves from the ectoderm, the digestive tract from the endoderm, and muscle and connective tissue from the mesoderm. See BLASTULATION; CELL CYCLE; CLEAVAGE (EMBRYOLOGY); EMBRYOGENESIS; GASTRULATION.

The stable differentiated state is a consequence of multicellularity. A complex organism maintains its characteristic form and identity because populations of specialized cell types remain assembled in a certain pattern. Thus several kinds of cells make up a tissue, and different tissues build organs. The variable assortment of about 200 cell types allows for an almost infinite variety of distinct organisms.

Epithelia, sheets of cells of specific structure and function, cover the outer surface of the vertebrate body and line the lungs, gut, and vascular system. The stable form of a vertebrate is due to its rigid skeleton built from bone and cartilage, forming cells to which the skeletal muscles adhere. All other organs, such as liver and pancreas, are embedded in connective tissue that is derived from fibroblast cells which secrete large amounts of soft matrix material.

Some cells, like nerve cells, are so specialized that they need divide no longer in order to maintain a complex network. Their finite number decreases even during embryonic development. Other cell types are constantly worn out and must be replaced; for example, fibroblasts and pancreas cells simply divide as needed, proving that the differentiated state of cells is heritable, as the daughter cells remember and carry out the same special functions. The renewal of terminally differentiated cells that are unable to divide anymore, such as skin and blood cells, is carried out by stem cells. They are immortal and choose, as they double, whether to remain a stem cell or to embark on a path of terminal differentiation. Most stem cells are unipotent because they give rise to a single differentiated cell type. However, all cell types of the blood are derived from a single blood-forming stem cell, a pluripotent stem cell. A fertilized egg is a totipotent stem cell giving rise to all other cell types that make up an individual organism. See EMBRYONIC DIFFERENTIATION; EMBRYONIC INDUCTION; OOGENESIS. [H.Sa.]

**Cell lineage** A type of embryological study in which the history of individual blastomeres (cells formed during division of the zygote) or meristem cells is traced to their ultimate differentiation into tissues and organs.

The question of how the animal genome can be regulated to produce the various cell types found in the larval and adult

organism is a central concern in developmental biology. A possible approach to this problem would involve tracing the structural fates of the descendants of each of a population of progenitor cells, and then trying to determine which gene products are required for particular steps in the process of cell differentiation.

Some of the most promising cell lineage studies are conducted on a nematode worm, *Caenorhabditis elegans*, which is a small (1 mm or 0.04 in. in length), nearly transparent worm that lives in soil. Adults are either males or hermaphrodites; the hermaphrodites contain 959 somatic nuclei. The origin of each somatic cell can be traced back to a single blastomere, and the clonal history of each cell has been determined. A detailed genetic map for the 80,000-kilobase genome has been worked out. See CLEAVAGE (EMBRYOLOGY); FATE MAPS (EMBRYOLOGY). [S.J.B.]

Cell lineage analysis in plants, as in animals, involves tracing the origin of particular cells in the adult body back to their progenitor cells. The adult body of a typical plant consists primarily of leaves, stems, and roots. Cells arise continuously during plant life from specialized dividing cell populations called meristems. A shoot apical meristem produces the leaves and stem, and a root apical meristem produces root tissue. The shoot apical meristem will also produce specialized structures, such as cones, flowers, and thorns. Because plant cells do not move during development, and in many cases the plane of cell division is constant, lines of cells, called cell files, all derive from a single meristem cell at the base of the file. [V.W.]

**Cell membrane** The membrane that surrounds the cytoplasm of a cell; it is also called the plasma membrane or, in a more general sense, a unit membrane. This is a very thin, semifluid, sheetlike structure made of four continuous monolayers of molecules. The plasma membrane and the membranes making up all the intracellular membranous organelles display a common molecular architectural pattern of organization, the unit membrane pattern, even though the particular molecular species making up the membranes differ considerably. All unit membranes consist of a bilayer of lipid molecules, the polar surfaces of which are directed outward and covered by at least one monolayer of nonlipid molecules on each side, most of which are protein, packed on the lipid bilayer surfaces and held there by various intermolecular forces. Some of these proteins, called intrinsic proteins, traverse the bilayer and are represented on both sides. The segments of the polypeptide chains of these transverse proteins within the core of the lipid bilayer may form channels that provide low-resistance pathways for ions and small molecules to get across the membrane in a controlled fashion. Sugar moieties are found in both the proteins and lipids of the outer half of the unit membrane, but not on the inside next to the cytoplasm. The molecular composition of each lipid monolayer making up the lipid bilayer is different. The unit membrane is thus chemically asymmetric. See CELL ORGANIZATION.

**Unit membrane.** The unit membrane of a cell is a continuous structure having one surface bordered by cytoplasm and the other by the outside world. It appears in thin sections with the electron microscope as a triple-layered structure about 7.5–10 nanometers thick consisting of two parallel dense strata each about 2.5 nm thick separated by a light interzone of about the same thickness. The plasma membrane may become tucked into the cytoplasm and pinch off to make an isolated vesicle containing extracellular material by a process called endocytosis. During endocytosis the membrane maintains its orientation, with its cytoplasmic surface remaining next to cytoplasm. In this sense the contents of intracellular organelles, such as the endoplasmic reticulum, Golgi apparatus sacs, nuclear membrane, lysosomes, peroxisomes, and secretion granules, are material of the outside world, since at some time the space occupied by this material may become continuous directly or indirectly with the outside world. Hence the surface of the membrane bordering such ma-

terial and lying between it and cytoplasm is topographically an external membrane surface even though it may be contained completely within the cell. See ENDOCYTOSIS.

Eukaryotic cells are characterized by the triple-layered nature of the unit membrane. The genetic material is segregated into a central region bounded by the nuclear membrane that is penetrated by many pores containing special proteins. Bacteria (prokaryotes) do not contain such elaborate systems of internal membranes, but some have an external unit membrane separated from the plasma membrane by a special material called periplasm. The membrane does not normally flip over, so that the surface that borders the outside world, either at the cell surface or inside the cell, comes to border cytoplasm. This principle is maintained in all membranous organelles.

Mitochondria are a special case because the inner mitochondrial membrane is believed to be the membrane of a primitive one-celled organism that is symbiotically related to the cell and lies inside a cavity containing material of the outside world as defined above. The outer mitochondrial membrane is in this sense a membrane of the cell analogous to a smooth endoplasmic reticulum membrane, and the inner membrane of the mitochondrion is the plasma membrane of the included organism, which normally does not become continuous with the membrane of the cell. Thus it has its own unit membrane, and again the orientation of this unit membrane is always maintained, with one side directed toward the cytoplasm, in this case the cytoplasm of the mitochondrion. See MITOCHONDRIA.

**Function.** The cell membrane functions as a barrier that makes it possible for the cytoplasm to maintain a different composition from the material surrounding the cell. The unit membrane is freely permeable to water molecules but very impermeable to ions and charged molecules. It is permeable to small molecules in inverse proportion to their size but in direct proportion to their lipid solubility. It contains various pumps and channels made of specific transverse membrane proteins that allow concentration gradients to be maintained between the inside and outside of the cell. For example, there is a cation pump that actively extrudes sodium ions ( $\text{Na}^+$ ) from the cytoplasm and builds up a concentration of potassium ions ( $\text{K}^+$ ) within it. The major anions inside the cell are chlorine ions ( $\text{Cl}^-$ ) and negatively charged protein molecules, the latter of which cannot penetrate the membrane. The presence of the charged protein molecules leads to a buildup of electroosmotic potential across the membrane. Action potentials result from the transient opening of  $\text{Na}^+$  or calcium ion ( $\text{Ca}^{2+}$ ) channels depolarizing the membrane, followed by an opening of  $\text{K}^+$  channels leading to repolarization. This is one of the most important functions of membranes, since it makes it possible for the brain to work by sending or receiving signals sent over nerve fibers for great distances, as well as many other things. See BIOPOTENTIALS AND IONIC CURRENTS.

The plasma membrane contains numerous receptor molecules that are involved in communication with other cells and the outside world in general. These respond to antigens, hormones, and neurotransmitters in various ways. For example, thymus lymphocytes (T cells) are activated by attachment of antigens to specific proteins in the external surfaces of the T cells, an important part of the immune responses of an organism. Hormones such as epinephrine and glucagon attach to a receptor protein in the surfaces of cells and cause the activation of adenylate cyclase, which in turn causes the formation of cyclic adenosine monophosphate. Neurotransmitters attach to the postsynaptic membrane in synapses and mediate the transfer of information between neurons. There is a class of membrane proteins called cell adhesion molecules, components of the outer surfaces of cell membranes in the developing nervous system, that is thought to be involved in guiding embryonic development.

**Membrane lipids.** The major lipids of membranes are phospholipids with a glycerol backbone including phosphatidyl ethanolamine, phosphatidyl choline, phosphatidyl serine, phos-

phatidyl inositol, and cardiolipin. Cardiolipin is more complex because it contains two glycerols and four fatty acids. It is important in bacterial membranes and is also found in the mitochondrial inner membrane.

The sphingolipids are another class of membrane lipids having the compound sphingosine as their backbone structure instead of glycerol. Ceramide is a fatty acid derivative of sphingosine that is the parent substance of many important membrane lipids. Sphingomyelin is ceramide with phosphatidyl choline added. This molecule, like phosphatidyl choline and phosphatidyl ethanolamine, is a zwitterion at pH 7; that is, it is uncharged. Phosphatidyl serine is negatively charged.

The glycolipids are an important class of lipid not containing phosphorus and based on ceramide. These include the uncharged cerebrosides that have only one sugar group, either glucose or galactose, and the gangliosides that may contain branched chains of as many as seven sugar residues including sialic acid, which is charged.

Cholesterol is a very important membrane lipid. It is present only in eukaryotes and is a prominent constituent of red blood cells, liver cells, and nerve myelin. See CHOLESTEROL.

The different lipid molecules are not equally distributed on both sides of the bilayer. The amino lipids, glycolipids, and cholesterol are located primarily in the outer monolayer, and the choline and sphingolipids are located mainly in the internal monolayer. The fatty acids of the outer half of the bilayer tend to have longer, more saturated carbon chains than those of the inner half.

The lipid bilayer has a considerable degree of fluidity, with the lipid molecules tending to rotate and translate easily, but they do not ordinarily flipflop from one side of the bilayer to the other. Furthermore, some lipids are firmly attached to membrane proteins and translate laterally only as the proteins do so. Some membrane proteins form extended two-dimensional crystals, and their lateral movement is thus restricted. Nevertheless, there is a considerable degree of fluidity in membranes overall. See LIPID.

**Membrane proteins.** The ratio of protein to lipids in membranes is often about 1:1, but in some cases, such as nerve myelin, there is only about 20% protein. Usually polypeptide chains are folded into a globular structure with hydrophilic amino acid side chains to the outside and hydrophobic ones tucked inside. For this reason the common globular protein is hydrophilic. Sometimes stretches of hydrophobic amino acids occur in the chain and may divide it into two hydrophilic domains. If there is a stretch of hydrophobic amino acids long enough (about 20) to stretch across the hydrophobic interior of a membrane bilayer, the extrusion of the protein across the bilayer during protein synthesis may stop, leaving a hydrophilic part of the protein on the cytoplasmic side and another hydrophilic part on the outside. This protein then becomes an intrinsic amphiphilic transmembrane protein. Such proteins can be removed only with chaotropic agents that destroy the bilayer.

The classification of membrane proteins as intrinsic and extrinsic is not always easy. Some proteins clearly become attached to either the inside or outside of the bilayer by more specific interactions with the polar heads of the lipid molecules, and sometimes it is not clear whether such proteins should be called extrinsic or intrinsic. They are extrinsic in that they can be removed without using detergents to disrupt the lipid bilayer completely, but they are intrinsic in that they are permanent parts of the membrane and retain some tightly bound lipids when removed. Spectrin and anchorin in the erythrocyte membrane are firmly bound to the cytoplasmic surfaces presumably by polar head group interactions and can thus be regarded as intrinsic. See CELL (BIOLOGY); PLANT CELL; PROTEIN. [J.D.Ro.]

**Cell metabolism** The sum of chemical reactions which transpire within cells. The cell performs chemical, osmotic, mechanical, and electrical work, for which it needs energy. Plant

cells obtain energy from sunlight; using light energy, they convert simple compounds such as carbon dioxide and various nitrogen, phosphate, and sulfur compounds into more complex materials. The energy in light is thus "stored" as chemical substances, mostly carbohydrates, within plant cells. Animal cells cannot use sunlight directly, and they obtain their energy by breaking down the stored chemical compounds of plant cells. Bacterial cells obtain their energy in various ways, but again mostly by the degradation of some of the simple compounds in their environment. See BACTERIAL PHYSIOLOGY AND METABOLISM; PHOTOSYNTHESIS; PLANT METABOLISM.

Cells have definite structures, and even the chemical constituents of these structures are being constantly renewed. This continuing turnover has been called the dynamic state of cellular constituents. For example, an animal cell takes in carbohydrate molecules, breaks down some of them to obtain the energy which is necessary to replace the chemical molecules that are being turned over, while another fraction of these molecules is integrated into the substance of the cell or its extracellular coverings. The cell is constantly striving to maintain an organized structure in the face of an environment which is continuously striving to degrade that structure into a random mixture of chemical molecules.

All the large molecules of the cell have specific functions: Carbohydrates, fats, and proteins constitute the structures of the cells; these, particularly the former two, are also used for food, or energy, depots; the nucleic acids are the structures involved in the continuity of cell types from generation to generation. All these large molecules are really variegated polymers of smaller molecules. These smaller molecules interact with one another in chemical reactions which are catalyzed at cellular temperature by enzymes. All these reactions are very specific each enzyme only reacting with its own specified substrate or substrates. At present, about a thousand chemical reactions are known which occur within cells; thus, about a thousand specific enzymes are known. By studying how enzymes operate and what substrates they attack, the biochemist has learned in general, and in many cases in specific, how fats, carbohydrates, proteins, and nucleic acids are synthesized and degraded in cells. Mainly through the use of radioactive tracer atoms, the pathways of many chemical compounds within the cell have been realized. For example, it is known what part of the carbohydrate molecule is used for energy production, what part is used in fat storage, and what parts end up in proteins and nucleic acids. See CARBOHYDRATE METABOLISM; ENZYME; LIPID METABOLISM; NUCLEIC ACID; PROTEIN METABOLISM.

Via the vast array of enzymatic reactions which go on inside cells, the substances which a cell brings in are completely changed, becoming transformed into cell substance. This changeover needs energy for accomplishment. This energy comes from a chemical compound called adenosine triphosphate (ATP); it is synthesized enzymatically by the cell in a number of reactions in which various compounds coming from foodstuffs are oxidized, and the energy gained as a result is stored in ATP. Subsequently, all cellular reactions which require synthesis of cell-specific substances use this ATP as a source of energy. See ADENOSINE TRIPHOSPHATE (ATP).

Remarkably, even with these constant replacements going on, the cell never loses its own distinctive structure and function. The reason is that the ordering of the cell resides in a code of nucleic acids, which directs the syntheses of specific enzymes designed to do specific tasks; when these enzymes are degraded and have to be resynthesized, they are made again in exactly the same way as before. In this way continuity is ensured. See DEOXYRIBONUCLEIC ACID (DNA); GENETICS; RIBONUCLEIC ACID (RNA).

Although a great deal is known of the metabolism of a large variety of compounds (their degradation, syntheses, and interactions), little is known of how these multitudinous reactions are regulated within the cell to effect growth, particular size, and division into daughter cells having the same structure and functioning characteristics as those of the parent cells. It is known that

enzymatic reaction activities within cells are strictly governed so that in quite a few cases knowledge has been gained of how a cell shuts off the synthesis of a compound of which it has enough, or speeds up the syntheses of those in short supply. This is done by an enzyme so constructed that the compound which it synthesizes, say, can interact with the enzyme to inhibit its further activity.

Almost the sole justification for cell metabolism is the functioning of a vehicle whose major task is to reproduce as precise a replica of itself as possible. The efficiency of this metabolism has been maximized with this goal in view. See CELL (BIOLOGY).

[PSi.]

**Cell motility** The movement of cells, changes in cell shape including cell division, and the movement of materials within cells. Many free-living protozoa are capable of movement, as are sperm and ameboid cells of higher organisms. Coordinated movement of cells occurs during embryogenesis, wound healing, and muscle contraction in higher organisms. Cell division is observed in all organisms and is a requirement for reproduction, growth, and development. Many cells also undergo structural changes as they differentiate, such as the outgrowth of axonal and dendritic processes during nerve cell differentiation. A more subtle form of cell motility involves the active transport of membranous organelles within the cytoplasm. This form of movement is required for proper organization of the cytoplasmic contents, and the redistribution of metabolites, hormones, and other materials within the cell.

There are two basic molecular systems responsible for producing a variety of forms of movement in a wide range of cell types: one system involves filamentous polymers of the globular protein actin; the other involves hollow, tube-shaped polymers of the globular protein tubulin, known as microtubules. Associated with both actin filaments and microtubules are accessory enzymes that convert the chemical energy stored in adenosine triphosphate (ATP) into mechanical energy. Other proteins are responsible for regulating the arrangement, assembly, and organization of actin filaments and microtubules within the cell.

**Actin and myosin.** Muscle contraction represents one of the most extensively studied forms of cell movement, and it is from muscle that much basic knowledge of actin-based movement has been derived. Striated muscle cells found in skeletal muscle and heart muscle contain highly organized arrays of actin filaments interdigitating with filaments of the protein myosin. Myosin has an enzymatic activity that catalyzes the breakdown of ATP to adenosine diphosphate (ADP) and phosphate. The released energy is used to produce force against the actin filaments, which results in sliding between the actin and myosin filaments. See MUSCLE PROTEINS.

These proteins have by now been found in virtually all cell types. Actin is involved in a wide variety of movements in many cell types, such as ameboid movement, lamellipodial extension, cytoplasmic streaming, and cytokinesis. See CYTOKINESIS.

**Microtubules, dynein, and kinesin.** Like actin filaments, microtubules have by now been found within the cytoplasm of almost all eukaryotic cells. They are involved in a variety of forms of movement, including ciliary and flagellar movement in eukaryotes, organelle movement in cytoplasm, and chromosome movement during mitosis. See CILIA AND FLAGELLA; MITOSIS.

Two different molecules, dynein and kinesin, have been identified as enzymes that break down ATP to ADP and phosphate to produce force along microtubules. Dynein is a large enzyme complex that was initially identified in cilia and flagella. It has also been found associated with cytoplasmic microtubules. Kinesin is a force-producing enzyme that was initially found in microtubules prepared from neuronal cells. It is now also known to be widespread.

Despite the basic similarity in how the three force-producing enzymes (myosin, dynein, and kinesin) work, they differ from

each other in structure and enzymatic properties and there is no evidence that they are evolutionarily related. Kinesin and dynein differ from each other in another important way: they produce force in opposite directions along microtubules. This suggests that they play complementary roles in the cell. As yet, no enzyme has been identified that produces force along actin filaments in the direction opposite to myosin.

**Other motile proteins.** Other motile mechanisms certainly exist. For example, bacterial flagella are very fine helical hairs, unlike the more substantial flagella and cilia of eukaryotic cells. Bacterial flagella rotate about their axis and propel the bacterium by a corkscrewlike mechanism, unlike the bending and whiplashing movements of eukaryotic cilia and flagella. Bacterial flagella are hollow filamentous polymers, like microtubules, but are composed of the protein flagellin, which has no apparent relationship to tubulin. See BACTERIA.

Other forms of bacteria glide over solid substrata by using an excreted slime for propulsion; the mechanism of gliding is not understood. Gliding motility is also seen in a number of algae and blue-green algae.

The sperm cells of roundworms differ from other types of sperm cells in that they lack flagella and exhibit a form of ameboid movement. These cells, however, contain neither actin, which is involved in ameboid movement in other ameboid cells, nor tubulin. Movement may be produced by insertion of lipid in the forward region of the plasma membrane and rearward flow of the membrane.

A contractile protein, spasmin, has been identified in *Vorticella* and related ciliated protozoa. Spasmin is organized into a long, thick fiber within the stalk portion of the organism. In response to calcium, the fiber undergoes a rapid, drastic contraction. It is not known whether spasmin exists in other organisms. See CELL (BIOLOGY).

**Disease.** Understanding how cells move increases the ability to control abnormal cell behavior, such as the increased level of cell division responsible for cancer and the migration of cancer cells from their site of origin in the body. Errors in chromosome segregation are also known to be responsible for Down syndrome, and are prevalent during the progression of neoplastic tumors.

Because the normal functioning of cells is so dependent on proteins that compose and regulate microtubules and actin filaments, defects in these proteins are expected to have severe effects on cell viability. An example of a microtubule defect has been identified in Alzheimer's disease: a microtubule-associated protein (termed tau) is found to be a prominent component of abnormal neurofibrillary tangles seen in affected nerve cells. However, it remains unknown whether the defect involving tau is part of the cause of the disease or represents one of its effects. See ALZHEIMER'S DISEASE; CANCER (MEDICINE); DOWN SYNDROME.

[R.V.]

**Cell nucleus** The largest of the membrane-bounded organelles which characterize eukaryotic cells; it is thought of as the control center since it contains the bulk of the cell's genetic information in the form of deoxyribonucleic acid (DNA). The nucleus has two major functions: (1) It is the site of synthesis of ribonucleic acid (RNA), which in turn directs the formation of the protein molecules on which all life depends; and (2) in any cell preparing for division, the nucleus precisely duplicates its DNA for later distribution to cell progeny. See DEOXYRIBONUCLEIC ACID (DNA); EUKARYOTAE; RIBONUCLEIC ACID (RNA).

The diameter of nuclei ranges from 1 micrometer in intracellular parasites and yeast cells to several millimeters in some insect sperm. Spherical or ellipsoidal nuclei are found in most cell types, although occasionally spindle-shaped, lobulated, disc-shaped, or cup-shaped nuclei may be observed. Although nuclear size and shape are somewhat consistent features of a particular cell type, these features are more variable in cancer cells.

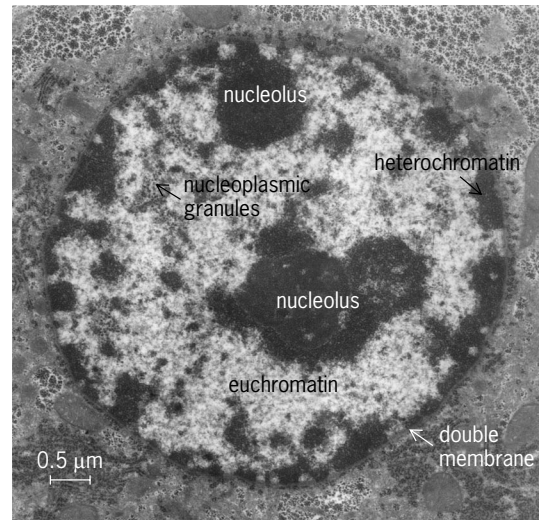

Transmission electron micrograph of a thin section of a rat liver cell nucleus.

In addition, tumor cell nuclei are characterized by indentation, furrowing, elongation, and budding.

The nucleus is bounded by a double membrane (the nuclear envelope) and contains several major components: chromatin, which is composed of DNA and chromosomal proteins; the nucleolus, which is the site of ribosomal RNA (rRNA) synthesis; and nucleoplasmic fibrils and granules, some of which are involved in the processing and transport of messenger RNA out of the nucleus (see illustration). The constituents of the nucleus are contained within a framework referred to as the nuclear matrix. [D.L.S.]

**Cell organization** Cells are divided into several compartments, each with a characteristic structure, biochemical composition, and function (see illustration). These compartments are called organelles. They are delimited by membranes composed of phospholipid bilayers and a number of proteins specialized for

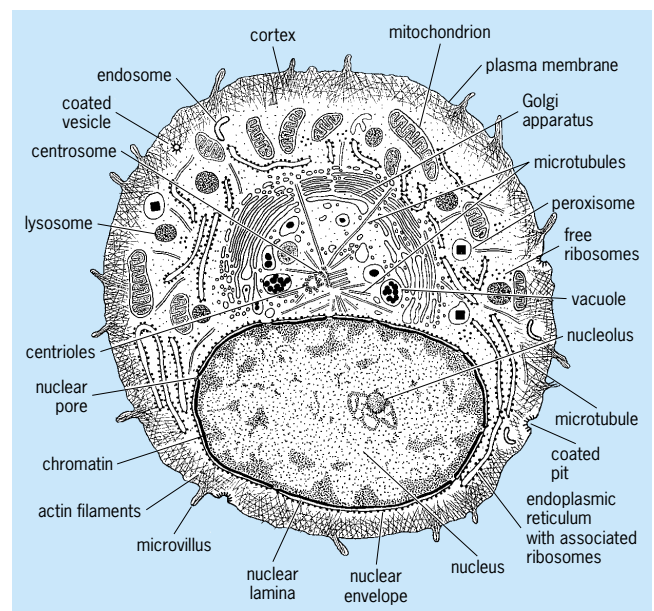

Section through an animal cell showing the major components visible by electron microscopy. To simplify, a few important components, including intermediate filaments, have been omitted.

each type of organelle. All eukaryotic cells have a nucleus surrounded by a nuclear envelope, and a plasma membrane that borders the whole cell. Most eukaryotic cells also have endoplasmic reticulum, a Golgi apparatus, lysosomes, mitochondria, and peroxisomes. Plant cells have chloroplasts for photosynthesis in addition to the organelles that both they and animal cells possess. These organelles are suspended in a gellike cytoplasmic matrix composed of three types of protein polymers called actin filaments, microtubules, and intermediate filaments. In addition to holding the cell together, the actin filaments and microtubules act as tracks for several different types of motor proteins that are responsible for cell motility and organelle movements within the cytoplasm.

A major challenge in the field of cell biology is to learn how each organelle and the cytoplasmic matrix are assembled and distributed in the cytoplasm. This is a very complex process since cells consist of more than 2000 different protein molecules together with a large number of lipids, polysaccharides, and nucleic acids, including both deoxyribonucleic acid (DNA) and many different types of ribonucleic acid (RNA). See NUCLEIC ACID.

The cell must possess enough information to specify which molecules are to be associated in a specific compartment, to route the appropriate groups of molecules to their compartments, and then to position each type of component appropriately in the cell. As a result of intense research on each of these topics, a number of specific chemical reactions that contribute to organizing cells are now recognized, but even more important, a small number of general principles that explain these complex processes of life can be appreciated.

Normal cells regulate the production and degradation of all of their constituent molecules so that the right balance of molecules is present at any given time. The genes stored in nuclear DNA are duplicated precisely once per cell cycle. The supply of each of thousands of proteins is usually regulated at the level of the genes at the time of biosynthesis and by the rate of degradation. These proteins serve as enzymes that determine the rate of synthesis of themselves as well as of other cellular components such as nucleic acids, carbohydrates, and lipids. Each of these processes is regulated by molecular feedback loops to assure the proper levels of each cellular constituent. See CELL CYCLE; CELL METABOLISM.

A large majority of cellular components are generated by the self-assembly of their constituent molecules. Self-assembly means that the information required for molecules to bind together in the proper orientation is contained in the molecules themselves. Some examples include the binding of histones to DNA, the formation of bilayers from phospholipids, and the polymerization of actin molecules into filaments. The molecules are usually brought together by diffusion. The energy required to hold them together derives from the exclusion of water from their complementary surfaces as well as from the formation of ionic bonds and hydrogen bonds. The variety of molecular structures found in proteins allows each type to self-assemble specifically, only with their correct partner molecules.

After biosynthesis, proteins and nucleic acids are routed to their proper cellular compartment by specific recognition signals consisting of parts of the molecule or, in the case of some proteins, by sugar side chains. These signals are recognized by compartment-specific receptors that guide the molecules to the correct compartment. For example, proteins destined for lysosomes have a specific sugar side chain added in the Golgi apparatus that guides them to lysosomes. Similarly, proteins destined for the nucleus all contain short sequences of amino acids that target the proteins for uptake by the nucleus. These so-called nuclear recognition sequences most likely bind to specific receptors associated with the nuclear pores, the channels through the nuclear envelope that connect the nucleus with the cytoplasm.

Most molecules move to their correct compartment by the process of diffusion down concentration gradients, but

organelles generally require transport systems composed of microtubules or actin filaments together with specific motor proteins to position them correctly in the cytoplasm. For example, a protein molecule destined to be part of a mitochondrion will diffuse from the site of biosynthesis through the cytoplasm to a mitochondrion, where it will bind to a receptor that guides its incorporation into the mitochondrion. On the other hand, the mitochondrion itself is too large to diffuse through the network of protein fibers in the cytoplasmic matrix, and so it must be pulled through the matrix by a motor protein that moves along microtubules to the correct place in the cell.

Some cellular components, such as ribosomes and the filaments in the cytoplasmic matrix, assemble afresh from their constituent molecules, but all organelles composed of membranes form only by the growth and division of preexisting organelles. The reason that these organelles require precursors is that biological membranes composed of phospholipids can grow only by expansion of preexisting bilayers. As a consequence, organelles such as mitochondria and the endoplasmic reticulum are inherited maternally starting from the egg and expanding into every cell in the body by continued growth and partition into both daughter cells at every cell division. Other membrane-bound organelles, such as lysosomes, form by budding off the Golgi apparatus.

Many of the individual self-assembly reactions required for normal cell growth can be reproduced in the test tube, but the cell is the only place known where the entire range of reactions, including biosynthesis, targeting, and assembly, can go to completion. Thus, cells are such a special environment that the chain of life has required an unbroken lineage of cells stretching from all living cells back through their ancestors to the earliest forms of life. This requirement for cellular continuity explains why extinction is an irreversible process. [T.Po.]

**Cell permeability** The permitting or activating of the passage of substances into, out of, or through cells, or from one cell to another. These materials traverse either the cell surface that demarcates the living cytoplasm from the extracellular space or the boundaries between adjacent cells. In many cases the materials also traverse the cell wall. See CELL WALLS (PLANT).

The cell can control many properties of its membranes, including those related to permeability. Control can be exerted in the following ways: (1) by varying the number and variety of membranes; (2) by varying the specific nature of the lipid components in the membrane; (3) by varying the glycocalyx proteins or lipid-associated sugar molecules on the outside of the cell, or the membrane-associated proteins on the inside; (4) by causing large areas of membrane to flow from one place to another, or to fold, indent, evert, or pinch off, carrying with these movements substances bound to one or the other surface of the membrane, or embedded in it; (5) by selectively moving integral membrane proteins in the plane of the membrane, allowing these proteins to carry with them substances, particles, molecules, or other materials bound to them; (6) by varying the properties of a single integral membrane protein or of a closely associated group of them so as to allow or prevent the passage across the membrane of substances such as ions or proteins of a specific character. See CELL MEMBRANES. [H.S.Be.]

**Cell plastids** Specialized structures found in the cytoplasm of plant cells, diverse in distribution, size, shape, composition, structure, function, and mode of development. A number of different types are recognized. Chloroplasts occur in the green parts of plants and are responsible for the green coloration, for they contain the chlorophyll pigments. These pigments, along with certain others, absorb the light energy that drives the processes of photosynthesis, by which sugars, starch, and other organic materials are synthesized. Amyloplasts, nearly or entirely colorless, are packed with starch grains and occur in cells of storage tissue. Proteoplasts are less common and contain crystalline,

fibrillar, or amorphous masses of protein, sometimes along with starch grains. In chromoplasts the green pigment is masked or replaced by others, notably carotenoids, as in the cells of carrot roots and many flowers and fruits. See CAROTENOID; CHLOROPHYLL.

All types of plastids have one structural feature in common, a double envelope consisting of two concentric sheets of membrane. The outer of these is in contact with the cytoplasmic ground substance; the inner with the plastid matrix, or stroma. They are separated by a narrow space of about 10 nanometers.

Another system of membranes generally occupies the main body of the plastid. This internal membrane system is especially well developed in chloroplasts, where the unit of construction is known as a thylakoid. In its simplest form this is a sac such as would be obtained if a balloon-shaped, membrane-limited sphere were to be flattened until the internal space was not much thicker than the membrane itself. It is usual, however, for thylakoids to be lobed, branched, or fenestrated.

The surface area of thylakoids is very large in relation to the volume of the chloroplast. This is functionally significant, for chlorophyll molecules and other components of the light-reaction systems of photosynthesis are associated with these membranes. A chloroplast, however, is much more than a device for carrying out photosynthesis. It can use light energy for uptake and exchange of ions and to drive conformational changes. The stroma contains the elements of a protein-synthesizing system—as much deoxyribonucleic acid (DNA) as a small bacterium, various types of ribonucleic acid (RNA), distinctive ribosomes, and polyribosomes. There is evidence to indicate that much of the protein synthesis of a leaf takes place within the chloroplasts. See PHOTOSYNTHESIS; PROTEIN; RIBOSOMES.

One of the most challenging problems in cell biology concerns the autonomy of organelles, such as the plastids. Chloroplasts, for instance, have their own DNA, DNA-polymerase, and RNA-polymerase; can make proteins; and, significantly, can mutate. All this suggests a measure of independence. It is known, however, that some nuclear genes can influence the production of molecules that are normally found only in chloroplasts, so their autonomy cannot be complete. It remains to be seen whether they control and regulate their own morphogenetic processes. [B.E.S.G.]

**Cell polarity (biology)** The highly organized condition in most cells that is characterized by a distinct apical-basal axis with an asymmetric distribution of cytoplasmic organelles. This phenomenon of polarization is critical for living organisms to function. For example, cells in secretory organs such as the gall bladder generally secrete only at one end where secretory vesicles are localized. Another example would be a cell in the intestinal wall that must collect nutrients on the side near the lumen and transport them through the cell to the opposite end, where they can be delivered to the blood supply for transport to the rest of the body. Clearly, this cell must exhibit a polarized distribution of membrane proteins so that those necessary for sugar uptake are concentrated in the membrane facing the lumen and those needed to move the sugar out of the cell are located at the opposite side.

Most organisms begin life as a rather symmetrical, spherical, single cell called an egg. During early development the fertilized egg divides many times and forms an embryo, which exhibits much more intricate patterns (such as the polarized intestine) than were initially expressed by the egg. Determining how the embryo controls the development of such patterns has been an area of active research, and there is evidence that the plasma (outer) membrane can influence the development of cell polarity by driving ionic currents through the cell which, in turn, can influence the polarization process by generating ion concentration gradients within the cell or voltage gradients between cells. See BIOPOTENTIALS AND IONIC CURRENTS; CELL (BIOLOGY); DEVELOPMENTAL BIOLOGY. [R.Nu.]

**Cell senescence and death** The limited capacity of all normal human and other animal cells to reproduce and function. The gradual decline in normal physiological function of the cells is referred to as aging or senescence. The aging process ends with the death of individual cells and then, generally, the whole animal. Aging occurs in all animals, except those that do not reach a fixed body size such as some tortoises and sharks, sturgeon, and several other kinds of fishes. These animals die as the result of accidents or disease, but losses in normal physiological function do not seem to occur. Examples of cells that do not age are those composing the germ plasm (sex cells) and many kinds of cancer cells. These cells are presumed to be immortal.

Although cultured normal human and other animal cells are mortal, they can be converted to a state of immortality. The conversion can be produced in human cells by the SV40 virus and in other animal cells by other viruses, chemicals, and irradiation. This conversion from mortality to immortality is called transformation, and is characterized by the acquisition of many profoundly abnormal cell properties, including changes in chromosome number and form, and the ability of the cells to grow unattached to a solid surface. These changes, and many more, are characteristic of most cancer cells. See CANCER (MEDICINE); ONCOLOGY; SENESCENCE; TUMOR VIRUSES. [L.H.]

**Cell-surface ionization** All living cells suspended in aqueous salt solutions at neutral pH values possess a negative charge. The charge is due to the dissociation of ionogenic, or charged, groups (carboxyl, amino, and others) in the cell surface. The charge carried by the cells can thus be measured electrophoretically to give information regarding the nature of the components in their surfaces. For example, studies have been used to measure the frequency distribution of bacterial variants in a mixed population and can assist in the selection of material for vaccine production. The occurrence and nature of tumor cells and the selection of yeasts for brewing have been also been studied electrophoretically. See BIOLOGICALS; ELECTROPHORESIS.

Factors which may affect the charge of cell surfaces are of three types: (1) biological factors—in bacterial and yeast cells, such things as sex, strain, age, growth conditions, presence of capsules or fimbriae, antibiotic resistance, virulence, and toxicity; in mammalian cells, such things as species, type of tissue, normal or pathological conditions, and the like; (2) nature of suspension medium, that is, ionic strength, pH, presence of dyes, drugs, or surface-active agents in the medium; and (3) chemical or enzymatic treatment of the surface. It is often possible to correlate alteration of charge with changes in the nature or number of ionogenic groups in the surface and hence with a particular biological property. [A.M.J.]

**Cell walls (plant)** The cell wall is the layer of material secreted by the plant cell outside its plasma membrane. All plants have cell walls that are generally very similar in chemical composition, organization, and development. The walls of the Chlorophyta (green algae) show characteristics virtually identical to those of flowering plants, an indication that flowering plants are derived evolutionarily from this division of algae. The wall serves as the first point of entry of materials into cells, functions in the movement of water throughout the plant, and is one of the major mechanical strengthening factors. In addition, the wall must be sufficiently flexible and plastic to withstand mechanical stresses while still permitting the growth of the cell. See CELL MEMBRANES.

The plant primary wall is initiated during the process of cell division. After chromosomes line up along the metaphase plate and begin to be pulled apart toward the poles of the cells by the spindle fibers (the anaphase portion of mitosis), a cell plate or phragmoplast can be observed at the equator of the dividing cell. Vesicles line up on both sides of the equator to form the proteinaceous cell plate. Elements of the endoplasmic reticulum

fuse with the cell plate, marking the location of plasmodesmatal pores and pits which will eventually provide the intercellular connections between adjacent cells. The cell plate forms the matrix within which the middle lamella and primary walls are formed. The middle lamella is composed of pectic substances which are polymers of pectins plus smaller amounts of other sugars. The middle lamella provides some of the observed plasticity and extensibility of cell walls during cell growth, and it has also been suggested that pectins are capable of hydrogen-bonding to the cellulose that forms the plant cell primary wall. During the early stages in cell wall formation, the cellulose wall is isotropic without any ordered orientation, but as cell walls continue to develop in area and in thickness and the cell grows to mature size, the walls become anisotropic, or highly ordered. See CYTOKINESIS.

Cellulose, like starch, is basically a polymer of glucose, a six-carbon monosaccharide. Each chain of cellulose may be as long as 8000 to 12,000 glucose monomers, or up to 4 micrometers long. These are arranged linearly, with no side branching. Cellulose chains are aggregated into bundles of approximately 40 chains each, the cellulose micelles, which are held together by hydrogen bonds. The micelle is a very regular, quasicrystalline structure.

The micelles are embedded in a matrix of other polysaccharides, the hemicelluloses. Hemicellulose serves to bind the micelle into a fairly rigid unit which retains a good deal of flexibility. Micelles, in bundles of variable number, are bound together into the cellulose microfibril, a unit sufficiently large to be seen under the electron microscope; these, in turn, are bound together into macrofibrils which are observable under the light microscope. See CELLULOSE; HEMICELLULOSE.

During the formation of the primary wall, at locations predetermined by attachments of endoplasmic reticulum to the middle lamella, cellulose microfibrillar deposition is minimal, leaving a thin place in the primary wall which forms the plasmodesmatal connections. Running through these pores are fine strands of protoplasm, the plasmodesmata proper, which contain a tube of endoplasmic reticulum-like material. The plasmodesmata provide a cytoplasmic connection between adjacent cells. Such connections are found among all the living cells of a plant, a fact which has led to the concept that all plant cells are so interconnected that the entire plant is a cytosymplast or single unit.

Although there are differences in nomenclature and terminology, secondary walls of plant cells are defined as those laid down after the primary wall has stopped increasing in surface area, essentially at that time when the plant cell has reached mature size. This is particularly true of those cells that, at maturity, have irreversibly differentiated into specialized cells, some of which are destined to lose their cytoplasm and become functional only as dead cells, including xylem vessels and tracheids, and sclereids. The secondary wall of most plants seems to have the same chemical structure and physical orientation of fibrils and hemicelluloses as do primary walls. While there may be little orientation of fibrils in young primary walls, the secondary walls are composed of fibrils that are highly ordered. In most secondary walls, and particularly those of the xylem, the fibrillar structure of the primary as well as the secondary walls may become impregnated with more substances, the most prominent of these being lignin. The chemical nature and biological role of lignin is of considerable interest because of the use of wood in the lumber and pulpwood-paper industries. The primary roles of the lignins include their ability to render walls mechanically strong, rigid, and—at least to some extent—water-impermeable. It has been suggested that lignins may also serve to make wood less subject to microbially caused decay. See LIGNIN; PLANT CELL; PLANT GROWTH; WOOD ANATOMY. [R.M.K.]

**Cellophane** A clear, flexible film made from cellulose. It first appeared commercially in the United States in 1924, and it revolutionized the packaging industry, which had been using opaque waxed paper or glassine as wrapping materials. Cellophane was also the first transparent mending tape. By 1960,

petrochemical-based polymers (polyolefins) such as polyethylene had surpassed cellophane for use as a packaging film. Nevertheless, cellophane is still often used for packaging because it is stiffer and more easily imprinted than are polyolefin films. See CELLULOSE.

Cellophane is manufactured in a process that is very similar to that for rayon. Special wood pulp, known as dissolving pulp, which is white like cotton and contains 92–98% cellulose, is treated with strong alkali in a process known as mercerization. The mercerized pulp is aged for several days. See TEXTILE CHEMISTRY.

The aged, shredded pulp is then treated with carbon disulfide, which reacts with the cellulose and dissolves it to form a viscous, orange solution of cellulose xanthate known as viscose. Rayon fibers are formed by forcing the viscose through a small hole into an acid bath that regenerates the original cellulose while carbon disulfide is given off. To make cellophane, the viscose passes through a long slot into a bath of ammonium sulfate which causes it to coagulate. The coagulated viscose is then put into an acidic bath that returns the cellulose to its original, insoluble form. The cellophane is now clear. See MANUFACTURED FIBER.

The cellophane is then treated in a glycerol bath and dried. The glycerol acts like a plasticizer, making the dry cellophane less brittle. The cellophane may be coated with nitrocellulose or wax to make it impermeable to water vapor; it is coated with polyethylene or other materials to make it heat sealable for automated wrapping machines. Cellophane is typically 0.03 mm (0.001 in.) thick, is available in widths to 132 cm (52 in.), and can be made to be heat sealable from 82 to 177°C (180 to 350°F). See POLYMER. [C.J.Bi.]

**Cellular adhesion** The process whereby cells interact and attach to other cells or to inanimate surfaces, mediated by interactions between the molecules on the surface of the cell. This process has been studied extensively in embryonic cells of higher organisms, where species and tissue specificity of adhesion has been shown. However, adhesion is a common feature in the life of most organisms.

Prokaryotic microorganisms do not frequently exhibit cell-to-cell interactions, but adhere to surfaces forming biofilms. In these interactions with a surface, some microorganisms cause corrosion of metal by adhering and producing corrosive acid by-products as a result of their metabolism. Adhesion of microorganisms to the cells of higher plants and animals is often a prerequisite for causing disease. Eukaryotic microorganisms often exhibit specific cell-to-cell interactions, allowing complex colonial forms and multicellular organisms to be constructed from individual or free-living cells. Adhesion between different plant cells is apparent in several cases, as in the interaction between a pollen grain and the stigma during fertilization.

Interactions between two cell surfaces may be quite specific, involving certain types of cell-surface protein molecules, or general, involving production of a sticky extracellular matrix that surrounds the cell, as frequently occurs in bacterial adhesion. Cellular adhesion is important in cellular recognition, in the generation of form or pattern, and possibly in regulation of cellular differentiation. See CELL (BIOLOGY); CELL DIFFERENTIATION.

All adhesion is mediated by the cell surface, either directly involving integral components of the plasma membrane, or indirectly through material excreted and deposited on the outside of the cell. Most theories of cellular adhesion suggest that cell-surface glycoproteins serve as ligands involved in attaching cell surfaces together. When a specific cell interacts with an identical cell, the attachment is said to be homotypic. Heterotypic adhesion involves interactions between different cell types. If the ligand-specific attachment involves interaction between identical cell-surface ligands, it is homophilic, and between two different ligands, heterophilic. The interaction between a pollen grain and the stigma cells described previously is an example of a heterotypic, heterophilic interaction.



Many studies of species and tissue specificity have been done with embryonic chick and mouse systems. In general, it would seem that homotypic adhesion is stronger than heterotypic adhesion. Also, tissue and species specific adhesion can be shown, but tissue specificity seems to be more frequent. For example, when dissociated embryonic neural retina of mouse and chick are mixed and allowed to aggregate, there is very little sorting, and mosaic tissue is formed. This is not true in all tissues, as heart and liver tissue show much greater species specificity than neural retina.

Throughout development, it is necessary for specific adhesion among cells to establish and maintain form. It is also important during development that cells change position, as occurs during gastrulation, or migrate, as with neural crest cells that move from the neural tube to various positions, forming ganglia. In these cases, it would seem to be necessary for certain cells to dissociate or alter their adhesive properties in response to the proper developmental cues. Throughout development, there are a series of primary and secondary inductions that affect cellular differentiation and pattern formation. These inductions depend on interactions between cell types having different histories, either due to being in different embryonic layers or due to interaction between cells derived from the same layer but previously differentiated. These changes in form are related to specific changes in cell-adhesion molecules. [M.Ha.]

**Cellular immunology** The field concerning the interactions among cells and molecules of the immune system, and how such interactions contribute to the recognition and elimination of pathogens. Humans (and vertebrates in general) possess a range of nonspecific mechanical and biochemical defenses against routinely encountered bacteria, parasites, viruses, and fungi. The skin, for example, is an effective physical barrier to infection. Basic chemical defenses are also present in blood, saliva, and tears, and on mucous membranes. True protection stems from the host's ability to mount responses targeted to specific organisms, and to retain a form of "memory" that results in a rapid, efficient response to a given organism upon a repeat encounter. This more formal sense of immunity, termed adaptive immunity, depends upon the coordinated activities of cells and molecules of the immune system.

**Cells involved.** Several types of cells play a role in protecting the body from infection, and they are found primarily in the blood and lymph. Specific immune responses mainly involve the activities of T-lymphocytes and B-lymphocytes, two types of white blood cells. A response is initiated when a pathogen triggers the activity of one or both of the two major types of T-cells: CD4+ cells, also known as helper T-cells ( $T_H$ ); and CD8+ cells, also known as cytotoxic T-lymphocytes (CTL) [see illustration].

When CD4+ T-cells are triggered, they release factors called cytokines, which in turn stimulate B-lymphocytes to make and secrete antibodies. See ANTIBODY; CYTOKINE.

When CD8+ T-cells are triggered, they release factors that kill a cell harboring an infectious agent, and they also release cytokines. Virus-infected cells commonly are the targets of cytotoxic T-lymphocytes, since viruses need to get inside a cell in order to reproduce.

**Antigen recognition.** The immune system must detect a pathogen before a response can be made. This phase of the response is shown in the interaction between a T-cell and an antigen-presenting cell (APC) [see illustration]. An antigen is a molecule, or portion of a molecule, that is recognized by a T-cell receptor (TCR) or antibody molecule. The cell surface molecules involved in antigen recognition by T-cells are the T-cell receptor and class I or class II molecules of the major histocompatibility complex (MHC). Each T-cell expresses a unique T-cell receptor that will interact specifically with a limited set of antigens. The antigens recognized by T-cell receptors are short peptides bound to MHC molecules. See HISTOCOMPATIBILITY.

**Co-stimulation.** Antigen recognition, as mediated by the T-cell receptor–MHC–peptide interaction, is necessary, but gen-

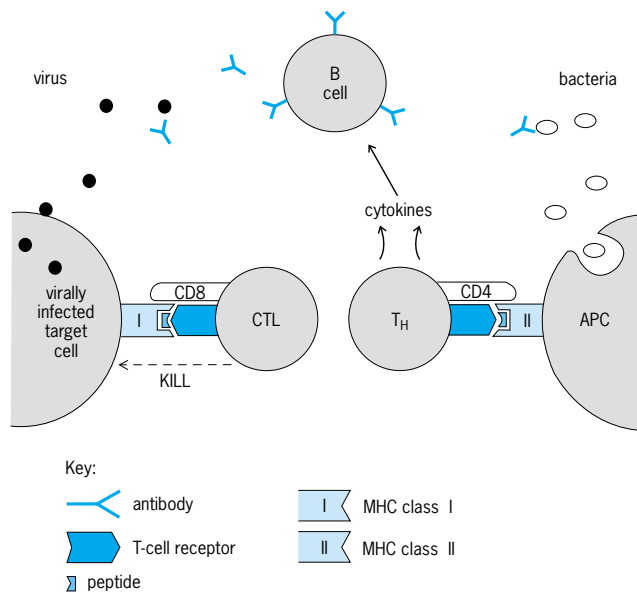

Key processes in a specific immune response.

erally it is not sufficient for the initiation of an immune response. Several other molecular interactions occur between molecules on the T-cell surface and those on the antigen-presenting cells. The co-stimulation provided by these additional interactions drives the production of cytokines by T-cells and induces their proliferation.

**Memory.** Once an immune response has been initiated, T-cells and B-cells proliferate and become mature responder cells. These cells do not have the same requirement for co-stimulation once a response is under way. As pathogen elimination nears completion, many of the T- and B-cells involved in the response die. However, a subset of cells remain as memory cells, which can be quickly called into action if the same pathogen is encountered on a future occasion. See ACQUIRED IMMUNOLOGICAL TOLERANCE; CELLULAR IMMUNOLOGY; IMMUNITY; IMMUNOLOGY. [D.J.L.]

**Cellulose** A linear polymer of (1→4)-linked  $\beta$ -D-glucopyranosyl units, and the most abundant of all naturally occurring substances. Cellulose constitutes approximately a third of all vegetable matter and thus it exists in far greater quantity than any other polysaccharide. It occurs as a principal structural component of the cell walls of mosses and seaweeds (25–30%), annual plants (25–35%), and trees (40–50%); cotton fiber contains 98% cellulose. Cellulose also is produced by some microorganisms, in a few cases reaching amounts of 20–30%. See CELL WALLS (PLANT).

Cellulose for chemical modification, particularly for derivatization, is often obtained from cotton linters by boiling them with 1% sodium hydroxide solution. High-quality cellulose may be obtained from bast fibers such as flax (80–90% cellulose), hemp (65–75%), jute (60–70%), and ramie (85%). Cellulose fibers used for paper, for cardboard, or for conversion to film and synthetic fiber are obtained from wood pulp. See PAPER.

While cellulose is a uniform, linear polymer of a  $\beta$ -D-glucopyranosyl units linked (1→4), the  $\beta$ -D-glucosidic bond causes alternate units to be positioned as shown in the structure here, so that the molecule is essentially a polymer of the

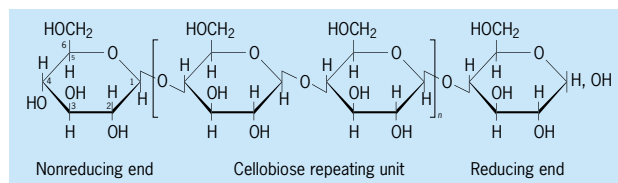

disaccharide, cellobiose, actually the cellobiosyl unit. The molecule has a nonreducing end and an aldehyde end, although at times the latter may be oxidized to a carboxyl group. Chain length varies with previous treatment, but native cellulose molecules have 7000 to 15,000 units, which are termed degrees of polymerization. See POLYMER; POLYSACCHARIDE.

[D.G.B.; R.L.Wh.]

**Cement** A material, usually finely divided, that when mixed with water forms a paste, and when molded sets into a solid mass. The term cement is sometimes used to refer to organic compounds used for adhering or for fastening materials, but these are more correctly known as adhesives. See ADHESIVE; ADHESIVE BONDING.

In the fields of architecture, engineering, and construction, the term portland cement is applied to most of the hydraulic cements used for concrete, mortars, and grouts. Portland cement sets and hardens by reacting chemically with water. In concrete, it combines with water and aggregates (sand and gravel, crushed stone, or other granular material) to form a stonelike mass. In grouts and mortars, cement is mixed with water and fine aggregates (sand) or fine granular materials. See CLAY, COMMERCIAL; CONCRETE; MORTAR.

Adjustments in the physical and chemical compositions allow for tailoring portland cements and other hydraulic cements to special applications. Blended hydraulic cements are produced with portland cements and materials that by themselves might not possess binding characteristics. Special cements are produced for mortars and architectural or engineering applications: white portland cement, masonry cement, and oil-well cement, expansive cement, and plastic cement. In addition to acting as the key ingredient in concrete, mortars, and grouts, portland cements are specified for soil-cement and roller-compacted concrete, used in pavements and in dams, and other water resource structures, and as reagents for stabilization and solidification of organic and inorganic wastes.

[D.Ma.]

**Cenozoic** Cenozoic (Cainozoic) is the youngest and the shortest of the three Phanerozoic geological eras. It represents the geological time (and rocks deposited during that time) extending from the end of the Mesozoic Era to the present day.

Traditional classifications subdivide the Cenozoic Era into two periods (Tertiary and Quaternary) and seven epochs (from oldest to youngest): Paleocene, Eocene, Oligocene, Miocene, Pliocene, Pleistocene, and Holocene. The older five epochs, which together constitute the Tertiary Period, span the time interval from 65 to 1.8 million years before present. The Tertiary is often separated into two subperiods, the Paleogene (Paleocene through Oligocene epochs, also collectively called the Nummulitic in older European literature) and the Neogene (Miocene and Pliocene epochs). These subperiods were introduced by M. Hornes in 1853. The Quaternary Period, which encompasses only the last 1.8 million years, includes the two youngest epochs (Pleistocene and Holocene). Holocene is also often referred to as the Recent, from the old Lyellian classification. Recent stratigraphic opinions are leaning toward abandoning the use of Tertiary and Quaternary (which are seen as the unnecessary holdovers from obsolete classifications) and in favor of retaining Paleogene and Neogene as the prime subdivisions of Cenozoic. See EOCENE; HOLOCENE; MIOCENE; OLIGOCENE; PALEOCENE; PLEISTOCENE; PLIOCENE.

Many of the tectonic events (mountain-building episodes or orogenies, changes in the rates of sea-floor spreading, or tectonic plate convergences) that began in the Mesozoic continued into the Cenozoic. The Laramide orogeny that uplifted the Rocky Mountains in North America, which began as early as Late Jurassic, continued into the Cretaceous and early Cenozoic time. In its post-Cretaceous phase the orogeny comprised a series of diastrophic movements that deformed the crust until some 50 million years ago, when it ended abruptly. The Alpine orogeny, which created much of the Alps, also began in the Mesozoic, but it

was most intense in the Cenozoic when European and African plates converged at an increased pace. See CRETACEOUS; JURASSIC; MESOZOIC; OROGENY.

Another major long-term affect of the tectonic uplift of Tibetan Plateau, which is dated to have been significant by 40 million years ago, may have been the initiation of the general global cooling trend that followed this event. The uplifted plateau may have initiated a stronger deflection of the atmospheric jet stream, strengthening of the summer monsoon, and increased rainfall and weathering in the Himalayas. Increased weathering and dissolution of carbonate rock results in greater carbon dioxide drawdown from the atmosphere. The decreased partial pressure of carbon dioxide levels may have ultimately led to the Earth entering into a renewed glacial phase.

The modern circulation and vertical structure of the oceans and the predominantly glacial mode that the Earth is in at present was initiated in the mid-Cenozoic time. The early Cenozoic was a period of transition between the predominantly thermospheric circulation of the Mesozoic and the thermohaline circulation that developed in the mid-Cenozoic. By the mid-Cenozoic the higher latitudes had begun to cool down, especially in the Southern Hemisphere due to the geographic isolation of Antarctica, leading to steeper latitudinal thermal gradients and accentuation of seasonality. The refrigeration of the polar regions gave rise to the cold high-latitude water that sank to form cold bottom water. The development of the psychrosphere (cold deeper layer of the ocean) and the onset of thermohaline circulation are considered to be the most significant events of Cenozoic ocean history, which ushered the Earth into its modern glacial-interglacial cyclic mode.

The Quaternary climatic history is one of repeated alternations between glacial and interglacial periods. At least five major glacial cycles have been identified in the Quaternary of northwestern Europe. The most recent glacial event occurred between 30,000 and 18,000 years ago when much of North America and northern Europe was covered with extensive ice sheets. The late Pliocene and Pleistocene glacial cyclicity led to repeated falls in global sea level as a result of sequestration of water as ice sheets in higher latitudes during the glacial intervals. For example, the sea level is estimated to have risen some 110 m (360 ft) since the end of the last glacial maximum. As a by-product of these repeated drops in sea level and movement of the shorelines toward the basins, large deltas developed at the mouths of the world's major drainage systems during the Quaternary. These bodies of sand and silt constitute ideal reservoirs for hydrocarbon accumulation. See DELTA; PALEOCLIMATOLOGY.

At the end of the Cretaceous a major extinction event had decimated marine biota and only a few species survived into the Cenozoic. The recovery, however, was relatively rapid. During the Paleocene through middle Eocene interval, the overall global sea-level rise enlarged the ecospace for marine organisms, and an associated climatic optimum led to increased speciation through the Paleocene, culminating in high marine diversities during the early and middle Eocene. Limestone-building coral reefs were also widespread in the tropical-temperate climatic belt of the early Cenozoic, and the tropical Tethyan margins were typified by expansive distribution of the larger foraminifera known as *Nummulites* (giving the Paleogene its informal name of the Nummulitic period). See NUMMULITES.

The late Eocene saw a rapid decline in diversities of marine phyto- and zooplankton due to a global withdrawal of the seas from the continental margins and the ensuing deterioration in climate. Marine diversities reached a new low in the mid-Oligocene, when the sea level was at its lowest, having gone through a major withdrawal of seas from the continental margins. The climates associated with low seas were extreme and much less conducive to biotic diversification. The late Oligocene and Neogene as a whole constitute an interval characterized by increasing partitioning of ecological niches into tropical, temperate, and higher-latitude climatic belts, and greater differentiation of marine fauna and flora.

Mammals evolved and spread rapidly to become dominant in the Cenozoic. The evolution of grasses in the early Eocene and the wide distribution of grasslands thereafter may have been catalytic in the diversification of browsing mammals. Marsupials and insectivores as well as rodents (which first appeared in the Eocene) diversified rapidly, as did primates, carnivores, and ungulates. The ancestral horse first appeared in the early Eocene in North America, where its lineage evolved into the modern genus *Equus*, only to disappear from the continent in the late Pleistocene. A complete evolution of the horse can be followed in North America during the Cenozoic. Increase in overall size, reduction in the number of toes, and increasing complexity of grinding surface of the molars over time are some of the obvious trends. Hominoid evolution began during the Miocene in Africa. Modern hominids are known to have branched off from the hominoids some 5 million years ago. Over the next 4.5 million years the hominids went through several evolutionary stages to finally evolve into archaic *Homo sapiens* about 1 million years ago. Truly modern *Homo sapiens* do not enter the scene until around 100 thousand years ago. See DINOSAUR; FOSSIL HUMANS; MAMMALIA; ORGANIC EVOLUTION. [B.U.H.]

**Centaurus** The Centaur, in astronomy; one of the most magnificent of the southern constellations. Two first-magnitude navigational stars, Alpha and Beta Centauri, mark the right and left front feet, respectively, of the centaur. The former is Rigil Kentaurus, or simply Rigil Kent, and the latter Hadar. Rigil Kent is the third brightest star in the whole sky, fainter than only Sirius and Canopus. The line joining Rigil Kent and Hadar points to the constellation Crux (Southern Cross). Thus they are also called the Southern Pointers, in contradistinction to the northern pointers of the Big Dipper. See CONSTELLATION. [C.-S.Y.]

**Center of gravity** A fixed point in a material body through which the resultant force of gravitational attraction acts. The resultant of all forces or attractions produced by the Earth's gravity on a body constitutes its weight. This weight is considered to be concentrated at the center of gravity in mechanical studies of a rigid body. The location of the center of gravity for a body remains fixed in relation to the body regardless of the orientation of the body. If supported at its center of gravity, a body would remain balanced in its initial position. See GRAVITY; RESULTANT OF FORCES. [N.S.F.]

**Center of mass** That point of a material body or system of bodies which moves as though the system's total mass existed at the point and all external forces were applied at the point. The Earth-Moon system moves in the Sun's gravitational field as though both masses were located at a center of mass some 3000 mi (4700 km) from the Earth's geometric center. The function of the center-of-mass concept is to permit analysis of the motion of an entire system as distinguished from that of its individual parts.

Consider a system of mass  $M$  composed of  $n$  bodies with masses  $m_1, m_2, \dots, m_n$ , and radius vectors  $r_1, r_2, \dots, r_n$  measured from some common reference point. Define a point with radius vector  $R$ , such that Eq. (1) holds. Then, it is possible to derive Eq. (2), an expression of Newton's second law, which states that

$$MR = \sum_j m_j r_j \quad (1)$$

$$\frac{d^2 R}{dt^2} = \frac{F}{M} \quad (2)$$

the center of mass at  $R$  moves as though it possessed the total mass of the system and were acted upon by the total external force.

A simplification of the description of collisions can be obtained by using a coordinate system which moves with the velocity of the center of mass before collision. See COLLISION (PHYSICS); RIGID-BODY DYNAMICS. [J.P.H.]

**Center of pressure** A point on a plane surface through which the resultant force due to pressure passes. Such a surface can be supported by a single mounting fixture at its center of pressure if no other forces act. For example, a water gate in a dam can be supported by a single shaft at its center of pressure. See RESULTANT OF FORCES. [N.S.F.]

**Central force** A force whose line of action is always directed toward a fixed point. The central force may attract or repel. The point toward or from which the force acts is called the center of force. If the central force attracts a material particle, the path of the particle is a curve concave toward the center of force; if the central force repels the particle, its orbit is convex to the center of force. Undisturbed orbital motion under the influence of a central force satisfies Kepler's law of areas. [R.L.Du.]

**Central heating and cooling** The use of a single heating or cooling plant to serve a group of buildings, facilities, or even a complete community through a system of distribution pipework that feeds each structure or facility. Central heating plants are basically of two types: steam or hot-water. The latter type uses high-temperature hot water under pressure and has become the more usual because of its considerable advantages. Steam systems are only used today where there is a specific requirement for high-pressure steam. Central cooling plants utilize a central refrigeration plant with a chilled water distribution system serving the air-conditioning systems in each building or facility.

Advantages of a central heating or cooling plant over individual ones for each building or facility in a group include reduced labor cost, lower energy cost, less space requirement, and simpler maintenance. Central cooling plants, using conventional, electrically driven refrigeration compressors, have the advantage of utilizing bulk electric supply, at voltages as high as 13.5 kV, at wholesale rates. Additionally, their flexible load factor, resulting from load divergency in the various buildings served, results in major operating economies.

The disadvantages of a central heating plant concern mainly the maintenance of the distribution system where steam is used. Corrosion of the condensate water return lines shortens their life, and the steam drainage traps need particular attention. These disadvantages do not occur with high-temperature hot-water installations. See AIR CONDITIONING; BOILER; COMFORT HEATING; REFRIGERATION; STEAM HEATING; WARM-AIR HEATING SYSTEM. [J.K.M.P.]

**Central nervous system** That portion of the nervous system composed of the brain and spinal cord. The brain is enclosed in the skull, and the spinal cord within the spinal canal of the vertebral column. The brain and spinal cord are intimately covered by membranes called meninges and bathed in an extracellular fluid called cerebrospinal fluid. Approximately 90% of the cells of the central nervous system are glial cells which support, both physically and metabolically, the other cells, which are the nerve cells or neurons. See MENINGES; NEURON.

Functionally similar groups of neurons are clustered together in so-called nuclei of the central nervous system. When groups of neurons are organized in layers (called laminae) on the outer surface of the brain, the group is called a cortex, such as the cerebral cortex and cerebellar cortex. The long processes (axons) of neurons course in the central nervous system in functional groups called tracts. Since many of the axons have a layer of shiny fat (myelin) surrounding them, they appear white and are called the white matter of the central nervous system. The nuclei and cortex of the central nervous system have little myelin in them, appear gray, and are called the gray matter of the central nervous system. See BRAIN; NERVOUS SYSTEM (VERTEBRATE); SPINAL CORD. [D.B.W.]

**Centrifugal force** A fictitious or pseudo outward force on a particle rotating about an axis which by Newton's third law is equal and opposite to the centripetal force. Like all such action-reaction pairs of forces, they are equal and opposite but do not act on the same body and so do not cancel each other. Consider a mass  $M$  tied by a string of length  $R$  to a pin at the center of a smooth horizontal table and whirling around the pin with an angular velocity of  $\omega$  radians per second. The mass rotates in a circular path because of the centripetal force  $F_C = M\omega^2R$  which is exerted on the mass by the string. The reaction force exerted by the rotating mass  $M$ , the so-called centrifugal force, is  $M\omega^2R$  in a direction away from the center of rotation. See CENTRIPETAL FORCE.

From another point of view, consider an experimenter in a windowless, circular laboratory that is rotating smoothly about a centrally located vertical axis. No object remains at rest on a smooth surface; all such objects move outward toward the wall of the laboratory as though an outward, centrifugal force were acting. To the experimenter partaking in the rotation, in a rotating frame of reference, the centrifugal force is real. An outside observer would realize that the inward force which the experimenter in the rotating laboratory must exert to keep the object at rest does not keep it at rest, but furnishes the centripetal force required to keep the object moving in a circular path. The concept of an outward, centrifugal force explains the action of a centrifuge. See CENTRIFUGATION. [C.E.H./R.J.S.]

**Centrifugal pump** A machine for moving fluid by accelerating it radially outward. More fluid is moved by centrifugal pumps than by all other types combined. Centrifugal pumps consist basically of one or more rotating impellers in a stationary casing which guides the fluid to and from the impeller or from one impeller to the next in the case of multistage pumps. Impellers may be single suction or double suction. Additional essential parts of all centrifugal pumps are (1) wearing surfaces or rings, which make a close-clearance running joint between the impeller and the casing to minimize the backflow of fluid from the discharge to the suction; (2) the shaft, which supports and drives the impeller; and (3) the stuffing box or seal, which prevents leakage between shaft and casing.

The rotating impeller imparts pressure and kinetic energy to the fluid pumped. A collection chamber in the casing converts much of the kinetic energy into head or pressure energy before the fluid leaves the pump. A free passage exists at all times through the impeller between the discharge and inlet side of the pump. Rotation of the impeller is required to prevent back-flow or draining of fluid from the pump. Because of this, only special forms of centrifugal pumps are self-priming. Most types must be filled with liquid, or primed, before they are started.

Every centrifugal pump has its characteristic curve, which is the relation between capacity or rate of flow and pressure or head against which it will pump. At zero pressure-difference, maximum capacity is obtained, but without useful work. As resistance to flow external to the pump increases, capacity decreases until, at a high pressure, flow ceases entirely. This is called shut-off head and again no useful work is done. Between these extremes, capacity and head vary in a fixed relationship at constant rpm. When the required head exceeds that practical for a single-stage pump, several stages are employed. Multistage pumps range from two-stage pumps to pumps built with as many as 20 or 30 stages for high lifts from relatively small-diameter wells. See PUMP; PUMPING MACHINERY. [E.F.W.]

**Centrifugation** A mechanical method of separating immiscible liquids or solids from liquids by the application of centrifugal force. This force can be very great, and separations which proceed slowly by gravity can be speeded up enormously in centrifugal equipment. See CENTRIFUGAL FORCE.

Centrifugal force is generated inside stationary equipment by introducing a high-velocity fluid stream tangentially into a cylindrical-conical chamber, forming a vortex of considerable intensity. Cyclone separators based on this principle remove liquid drops or solid particles from gases, down to 1 or 2  $\mu\text{m}$  in diameter. Smaller units, called liquid cyclones, separate solid particles from liquids. The high velocity required at the inlet of a liquid cyclone is obtained with standard pumps. Much higher centrifugal forces than in stationary equipment are generated in rotating equipment (mechanically driven bowls or baskets, usually of metal, turning inside a stationary casing). Rotating a cylinder at high speed induces a considerable tensile stress in the cylinder wall. This limits the centrifugal force which can be generated in a unit of a given size and material of construction. Very high forces, therefore, can be developed only in very small centrifuges.

There are two major types of centrifuges: sedimenters and filters. A sedimenting centrifuge contains a solid-wall cylinder or cone rotating about a horizontal or vertical axis. An annular layer of liquid, of fixed thickness, is held against the wall by centrifugal force; because this force is so large compared with that of gravity, the liquid surface is essentially parallel with the axis of rotation regardless of the orientation of the unit. Heavy phases "sink" outwardly from the center, and less dense phases "rise" inwardly. Heavy solid particles collect on the wall and must be periodically or continuously removed.

A filtering centrifuge operates on the same principle as the spinner in a household washing machine. The basket wall is perforated and lined with a filter medium such as a cloth or a fine screen; liquid passes through the wall, impelled by centrifugal force, leaving behind a cake of solids on the filter medium. The filtration rate increases with the centrifugal force and with the permeability of the solid cake. Some compressible solids do not filter well in a centrifuge because the particles deform under centrifugal force and the permeability of the cake is greatly reduced. The amount of liquid adhering to the solids after they have been spun also depends on the centrifugal force applied; in general, it is substantially less than in the cake from other types of filtration devices. See MECHANICAL SEPARATION TECHNIQUES. [J.C.Sm.]

**Centriole** A morphologically complex cellular organelle at the focus of centrosomes in animal cells and some lower plant cells. Prokaryotes, some lower animal cells, higher plant cells, and a few exceptional higher animal cells do not have centrioles in their centrosomes. Centrioles typically are not found singly; the centrosome of higher animal cells contains a pair of centrioles (together called the diplosome), arranged at right angles to each other and separated by a distance ranging from 250 nanometers to several micrometers. See CENTROSOME.

Centrioles are typically 300–700 nm in length and 250 nm in diameter. Although they can be detected by the light microscope, an electron microscope is required to resolve their substructure. At the electron microscopic level, a centriole consists of a hollow cylinder of nine triplet microtubules in a pinwheel arrangement (see illus.). Within each triplet, one microtubule (the A tubule) is a complete microtubule, while the others (the B and C tubules) share a portion of their wall with the adjacent tubule. In some cells these nine triplet microtubules are embedded in a densely staining cylindrical matrix that is spatially distinct from the pericentriolar material of the centrosome. Structures found in the lumen or core of the centriole include linkers between the triplets, granules, fibers, a cartwheel structure at one end of the centriole, and sometimes a small vesicle.

Centrioles have a close structural similarity to basal bodies, which organize the axoneme of cilia and flagella. In many types of mammalian somatic cells, the older of the two centrioles in the centrosome can act as a basal body during the interphase portion of the cell cycle. In such cases, tapered projections, called basal feet, are often observed on the external surface of the centriole

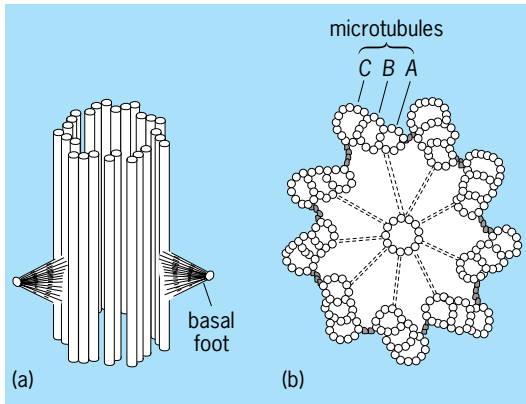

Diagrams of centriole showing (a) arrangement of microtubules and (b) cross section of proximal end, with nine triplet microtubules (A, B, and C) and central cartwheel structure.

that is acting as the basal body. Microtubules are attached to the globular tips of the basal feet and may serve to anchor this centriole in the cell.

During interphase the centrosome nucleates the array of cytoplasmic microtubules; later in the cell cycle the centrosome duplicates, and the daughter centrosomes form the poles of the mitotic (or meiotic) spindle. The terms “centriole” and “centrosome” are sometimes erroneously used interchangeably; centrioles are not the centrosome itself, but a part of it. The centrosome of higher animal cells has at its center a pair of centrioles, arranged at right angles to each other and separated by 250 nm or less.

The only clearly demonstrated role for the centriole is to organize the axoneme (central microtubular complex) of the primary cilium in cells having this structure, and the flagellar axoneme in sperm cells. Other possible functions for centrioles are a matter of debate. Some authorities assert that when present in the centrosome, centrioles contain activities that serve to organize the centrosome, determine the number of centrosomes in a cell, and control the doubling of the centrosome as a whole before mitosis. Others believe that centrioles have no role in the formation and doubling of the centrosomes but are associated with the centrosomes only to ensure the equal distribution of basal bodies during cell division. See CELL (BIOLOGY); CELL DIVISION.

[G.Stu.]

**Centripetal force** The inward force required to keep a particle or an object moving in a circular path. It can be shown that a particle moving in a circular path has an acceleration toward the center of the circle along a radius. See ACCELERATION.

This radial acceleration, called the centripetal acceleration, is such that, if a particle has a linear or tangential velocity  $v$  when moving in a circular path of radius  $R$ , the centripetal acceleration is  $v^2/R$ . If the particle undergoing the centripetal acceleration has a mass  $M$ , then by Newton's second law of motion the centripetal force  $F_C$  is in the direction of the acceleration. This is expressed by the equation below, where  $\omega$  is the constant angular velocity

$$F_C = Mv^2/R = MR\omega^2$$

and is equal to  $v/R$ . From Newton's laws of motion it follows that the natural motion of an object is one with constant speed in a straight line, and that a force is necessary if the object is to depart from this type of motion. Whenever an object moves in a curve, a centripetal force is necessary. In circular motion the tangential speed is constant but is changing direction at the constant rate of  $\omega$ , so the centripetal force along the radius is the only force involved.

[R.J.S.]

**Centrode** The path traced by the instantaneous center of a plane figure when it undergoes plane motion. If a plane rigid body is constrained to move in its own plane but is otherwise free to undergo an arbitrary translational and rotational motion, it is found that at any instant there exists a point, called the instantaneous center, about which the body is rotating. The path that this instantaneous center traces out in space as the motion unfolds is called the space centrode. The path that it would trace out in a coordinate system which is rigidly attached to the body is called the body centrode. The motion may therefore be specified, when the two centrodes are given, by allowing one curve to roll without slipping along the other. See FOUR-BAR LINKAGE; RIGID-BODY DYNAMICS.

[H.C.Co./B.G.]

**Centroheliida** An order of the Heliozoia. There is a central cell mass from which thin stiff arms radiate. In the majority of species, the body is coated with a layer of siliceous spines or spicules and measures from 20 to 50 micrometers. These organisms are found in fresh-water and marine habitats, feeding on other protozoa, which adhere to the arms after colliding with them. In addition to about five genera which certainly are closely related (of which *Acanthocystis* and *Raphidiophrys* are among the most widely represented), the group contains a variety of other Heliozoia of uncertain affinities. See ACTINOPODEA; HELIOZOIA; PROTOZOA; SARCODINA.

[D.J.Pa.]

**Centroids (mathematics)** Points positioned identically with the centers of gravity of corresponding homogeneous thin plates or thin wires. Centroids are involved in the analysis of certain problems of mechanics, for example, the phenomenon of bending.

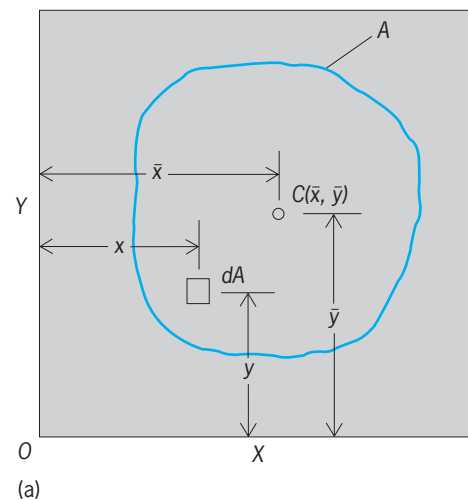

(a)

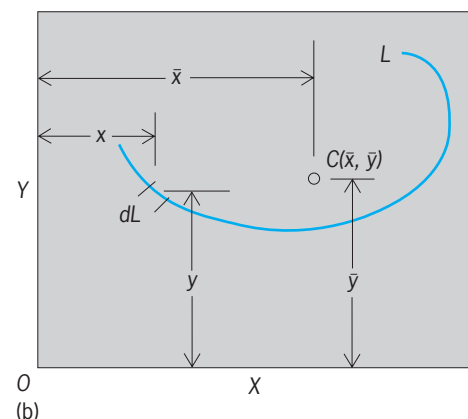

(b)

Notation of integral equations for centroids. (a) Centroid of area. (b) Centroid of line.

The centroid of plane area  $A$  is point  $C$  (illus.  $a$ ). Coordinates  $\bar{x}$  and  $\bar{y}$  of  $C$  as referred to the indicated  $X$  and  $Y$  coordinate axes are given by Eq. (1). Similarly, the centroidal coordinates of plane curve  $L$  (illus.  $b$ ) are given by Eq. (2). In these

$$\bar{x} = \frac{\int x dA}{\int dA} \quad \bar{y} = \frac{\int y dA}{\int dA} \quad (1)$$

$$\bar{x} = \frac{\int x dL}{\int dL} \quad \bar{y} = \frac{\int y dL}{\int dL} \quad (2)$$

equations  $\bar{x}$  and  $\bar{y}$  are the coordinate locations of infinitesimal area element  $dA$  and infinitesimal line element  $dL$ , respectively. [N.S.F.]

**Centrosome** An organelle located in the cytoplasm of all animal cells and many plants, fungi, and protozoa that controls the polymerization, position, and polar orientation of many of the cell's microtubules throughout the cell cycle. There is usually one centrosome per cell, located near the cell's center; it doubles during interphase, so there are two when the cell divides. At the onset of mitosis, each centrosome increases the number of microtubules it initiates. These mitotic microtubules are more labile and generally shorter than their interphase counterparts, and as they rapidly grow and shrink they probe the space around the centrosome that initiated them. When the nuclear envelope disperses, the microtubules extend from the centrosome into the former nucleoplasm where the chromosomes have already condensed. Some of these microtubules attach to the chromosomes, while others interact with microtubules produced by the sister centrosome, forming a mitotic spindle that organizes and segregates the chromosomes. During anaphase, sister centrosomes are forced apart as the spindle elongates, allowing each daughter cell to receive one centrosome to organize its microtubules in the next cell generation. See CELL CYCLE; CELL MOTILITY.

The shapes of centrosomes differ widely between organisms. The centrosomes of animal cells (see illustration) usually contain a pair of perpendicular centrioles including a parent centriole formed in an earlier cell generation and a daughter centriole formed during the most recent interphase. Centrioles can serve as basal bodies for the initiation of a cilium or flagellum in the cells that make them. They appear to be essential for the formation of these motile appendages, so centriole inheritance by both

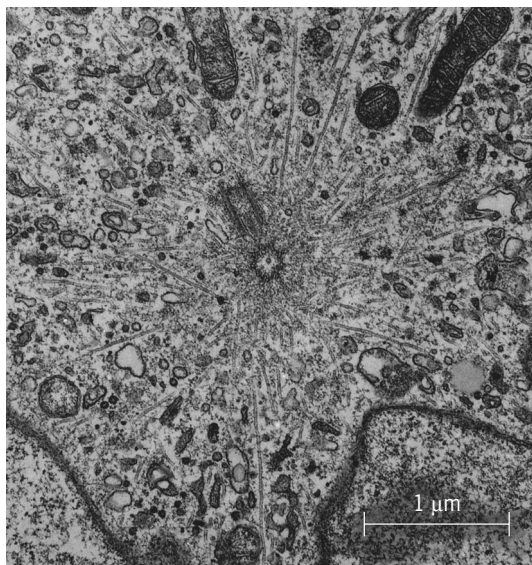

Centrosome of a mammalian cell. Many microtubules radiate from the cloud of pericentriolar material which surrounds one of the two centrioles. (Courtesy of Kent McDonald)

daughters at cell division is analogous to the transmission of a gene. See CENTRIOLE; CILIA AND FLAGELLA; CYTOSKELETON.

Centrosome action is regulated as a function of time in the cell cycle. The increase in microtubule number that occurs prior to mitosis is correlated with a significant increase in the extent of phosphorylation of several centrosomal proteins. The protein kinase  $p34^{cdc2}$ , which helps to regulate the cell cycle, is concentrated at the centrosome, together with cyclin-B, a positive regulator of this kinase. See MITOSIS. [J.R.Mc.]

**Cephalaspidomorpha** The subclass of Agnatha that includes the jawless vertebrates with a single median nostril. The Cephalaspidomorpha, sometimes called Monorhina, includes the superorder Hyperotreti, containing the modern Myxinoidea or hagfishes, and the superorder Hyperoartii, containing the living Petromyzonida or lampreys, as well as the extinct Osteostraci and Anaspida. See AGNATHA. [R.H.De.]

**Cephalobaenida** One of two orders in the class Pentastomida of the phylum Arthropoda. This order includes primitive pentastomids with six-legged larvae. The hooks are simple, lacking a fulcrum, and disposed in trapeziform pattern, with the anterior pair internal to the posterior pair. The mouth is anterior to the hooks. There are two families: Raillietiellidae, which contains two genera (*Raillietiella* and *Cephalobaena*); and Reighardiidae, which contains the single genus *Reighardia* with one species. See PENTASTOMIDA. [H.W.S.]

**Cephalocarida** A group of minute marine crustaceans of great interest to students of arthropod evolution because its members have been postulated to possess many primitive characters and to show relationships not only to various other groups of Crustacea but perhaps also to the trilobites. Nine species are recognized, placed in four genera. They have been found in flocculent surface deposits of mud or silty sand, from the intertidal zone down to depths of 5000 ft (1500 m), on the shores of all continents except Europe. Population densities up to an average of 16 individuals/ft<sup>2</sup> (177/m<sup>2</sup>) have been recorded.

The best-known species is *Hutchinsoniella macracantha*, from the east coast of North and South America, about 0.12–0.16 in. (3–4 mm) long, with a shovel-shaped head and a slender, very flexible body which is not covered by a carapace. Other species are similar. Among the features that appear to be primitive, most notable is the pronounced serial homology seen in the trunk limbs, the trunk musculature, the ventral nerve cord, and the heart. Other features in the anatomy of *Hutchinsoniella* that seem likely to be primitive are the uniramous, multisegmented antennules, the biramous antennae with both rami multisegmented, the large, flattened pleura on all the limb-bearing somites, and the telson freely articulated with the trunk and bearing a caudal furca. In the larval development, there is a primitive “nauplius” stage, followed by stages showing an unusually regular addition of new somites and limbs.

*Hutchinsoniella* is a nonselective deposit feeder, subsisting on the organic matter present in its habitat. Cephalocarids are non-swimming, bottom-creeping, nonselective deposit feeders. Distal claws on the endopods of the thoracopods scratch up particles that are passed into the median ventral food groove and moved forward to the mouth by metachronal beating of the thoracopods. See CRUSTACEA. [J.H.Lo.; P.McL.]

**Cephalochordata** A subphylum of the phylum Chordata comprising the lancelets, including *Branchiostoma* (amphioxus). They are also known as the Leptocardii. Lancelets are small fishlike animals, not exceeding 3.2 inches (80 mm) in length. They burrow in sand on the ocean bed or in estuaries in tropical and temperate regions throughout the world. Only two genera are recognized: *Branchiostoma* (23 species) and *Asymmetron* (6 species).

The structure of the lancelet is based on the same fundamental plan as all other chordates, but there is neither head nor paired fins. The skeletal rod of the back, or notochord, extends the entire length of the body. The animal is thus pointed at both ends and lanceolate in form.

The adults burrow in rather coarse sand or shell gravel and usually lie with the mouth open at the surface of the sand. Large numbers of lancelets congregate in small areas for spawning. The egg develops into a larva which at first is bottom-living, but later becomes planktonic. Metamorphosis takes place after about 11–12 weeks of life. The young adult sinks to the bottom and swims actively until a suitable sand in which it can burrow and remain undisturbed is found.

The importance of lancelets lies chiefly in their being one of the most primitive chordates. However, lancelets are eaten by the Chinese. See CHORDATA. [J.E.We.]

**Cephalopoda** The most highly evolved class of the phylum Mollusca. It consists of squids, cuttlefishes, octopuses, and the chambered nautilus. The earliest known cephalopods are small, shelled fossils from the Upper Cambrian rocks of north-east China that are 500 million years old. Cephalopods always have been marine, never fresh-water or land, animals. Most fossil cephalopods, among them the subclasses Nautiloidea and Ammonoidea, had external shells and generally were shallow-living, slow-moving animals. Of the thousands of species of such shelled cephalopods that evolved, all are extinct except for four species of the only surviving genus, *Nautilus*. All other recent cephalopods belong to four orders of the subclass Coleoidea, which also contains five extinct orders.

Living cephalopods are bilaterally symmetrical mollusks with a conspicuously developed head that has a crown of 8–10 appendages (8 arms and 2 tentacles) around the mouth. These appendages are lined with one to several rows of suckers or hooks. *Nautilus* is exceptional in having many simple arms. The mouth contains a pair of hard chitinous jaws that resemble a parrot's beak and a tongue-like, toothed radula (a uniquely molluscan organ). Eyes are lateral on the head; they are large and well developed. The "cranium" contains the highly developed brain, the center of the extensive, proliferated nervous system. The shell of ancestral cephalopods has become, in living forms, internal, highly modified, reduced, or absent; and is contained in the sac- or tubelike, soft muscular body, the mantle. A pair of fins may occur on the mantle as an aid to locomotion, but primary movement is achieved through jet propulsion in which water is drawn into the mantle cavity and then forcibly expelled through the nozzle-like funnel. Fewer than 1000 species of living cephalopods inhabit all oceans and seas.

The classification given here concentrates on the living groups and lists only the major fossil groups; see separate articles on each subclass and order.

- Class Cephalopoda
  - Subclass Nautiloidea
  - Subclass Ammonoidea
  - Subclass Coleoidea
    - Order Belemnoidea
    - Order Sepioidea
    - Order Teuthoidea
      - Suborder Myopsida
      - Suborder Oegopsida
    - Order Vampyromorpha
    - Order Octopoda
      - Suborder Cirrata
      - Suborder Incirrata

Species of cephalopods inhabit most marine habitats. Cephalopods inhabit tide pools, rocky patches, sandy bottoms, coral reefs, grass beds, mangrove swamps, coastal waters, and

the open ocean from the surface through the water column to depths on the abyssal bottom at over 16,000 ft (5000 m). See NERVOUS SYSTEM (INVERTEBRATE).

Cephalopods are high-level, active predators that feed on a variety of invertebrates, fishes, and even other cephalopods. The relatively sluggish nautilus feed primarily on slow-moving prey such as reed shrimps, and even are scavengers of the cast-off shells of molted spiny lobsters. Cuttlefishes prey on shrimps, crabs, and small fishes, while squids eat fishes, pelagic crustaceans, and other cephalopods. Benthic octopuses prey mostly on clams, snails, and crabs. Salivary glands secrete toxins that subdue the prey and, in octopuses, begin digestion.

To protect themselves from predators cephalopods would rather hide than fight. To this end they have become masters of camouflage and escape. Benthic forms especially (for example, *Sepia* and *Octopus*) have evolved an intricate, complex system of rapid changes in color and patterns via thousands of individually innervated chromatophores (pigment cells) that allow precise matching to the color and pattern of the background. In addition, they regulate the texture of their skins by erecting papillae, flaps, and knobs that simulate the texture of the background. Many midwater oceanic squids camouflage against predation from below by turning on photophores (light organs) that match the light intensity from the surface and eliminate their silhouettes. See CHROMATOPHORE; PHOTOPHORE GLAND; PROTECTIVE COLORATION.

Cephalopods have perfected jet propulsion for many modes of locomotion, from hovering motionless, to normal cruising, to extremely rapid escape swimming. Water enters the mantle cavity through an opening around the neck when the muscular mantle (body) expands. The mantle opening seals shut as the mantle contracts and jets the water out through the hoselike funnel, driving the cephalopod tail-first through the water.

The sexes are separate in cephalopods, and many species display complex courtship, mating, spawning, and parental care behavior. At mating, the male of most species transfers the spermatophores to the female with a specially modified arm, the hectocotylus. The spermatophores are implanted into the female's mantle cavity, around the neck, under the eyes, or around the mouth, depending on the species. Incubation takes a few weeks to a few months depending on the species.

Cephalopods are extremely important in the diets of toothed whales (sperm whales, dolphins), pinnipeds (seals, sea lions), pelagic birds (petrels, albatrosses), and predatory fishes (tunas, billfishes, groupers). For example, pilot whales in the North Atlantic feed almost exclusively on one species of squid, *Illex illecebrosus*, that aggregates for spawning in the summer. See MOLLUSCA. [C.F.E.R.]

**Cephalosporins** A group of antibiotics that are effective in eradicating streptococcal, pneumococcal, staphylococcal, *Klebsiella*, *Neisseria*, and enteric gram-negative rod bacteria that produce pulmonary, skin and soft tissue, bone and joint, endocardial, surgical, urinary, and bacteremic infections. They have been used most often in a preventive or prophylactic fashion at the time of various surgical procedures. All the third-generation cephalosporins penetrate well into tissues, and antibacterially active levels in various body fluids and tissues such as bone are excellent. The toxic potential of the agents, considering their broad antibacterial spectrum, has been minor. Toxicities which are seen are those of bleeding due to vitamin K depletion. See ANTIBIOTIC. [H.N.]

**Cepheids** A class of highly luminous yellow stars that vary periodically in brightness. The importance of Cepheids to astronomy comes both in their application to practical problems of distance determination (within the Milky Way Galaxy itself, and far beyond) and in their acting as critical tests of both stellar evolution and pulsation theory. From observations it is known that the luminosity of a Cepheid is closely predicted by the period

of oscillation, a relation known as the period-luminosity relation, discovered by Henrietta Leavitt in 1912. This relation provides a powerful tool for estimating distances, since the period can be determined without prior knowledge of the distance. Using the period to predict how bright a given star would appear at various distances, it is possible to calculate the distance of a Cepheid from the observer, given its apparent luminosity.

In the 1920s, Edwin Hubble conclusively ended the debate as to whether other galaxies existed in addition to the Milky Way when he discovered Cepheids in nebulae now considered to make up the Local Group of galaxies. Hubble went on to show that the distances of galaxies correlated with their apparent recession velocities, consistent with an expanding universe. See GALAXY, EXTERNAL; HUBBLE CONSTANT; LOCAL GROUP.

Cepheids are generally identified by the distinctive and periodic optical variations in their light output. The time period over which a complete cycle is executed ranges from a few days to a few hundred days. Analysis of spectroscopic properties, including the time variation of the radial velocities of Cepheids, led to the identification of the mechanism behind the changing light. The total light variation is the result of temperature changes in the stellar atmosphere, induced by, and combined with, an inward and outward motion of the surface of the star. Measurements of the color variation, interpreted as surface temperature variations, suggest that the surface temperature is changing by a few hundred kelvins during the pulsation cycle. The surface temperature changes the surface brightness and, especially at visible wavelengths, this is the primary cause of the large observed periodic light variation of a Cepheid. See ASTRONOMICAL SPECTROSCOPY; VARIABLE STAR.

The second helium ionization layer is the main driver of pulsation in Cepheid variables. If slightly perturbed in temperature, this zone can either add considerable energy to the flow of radiation from the center of the star, by recombining and releasing the ionization energy, or it can extract energy from the flow by ionizing new material. This situation is unstable to slight perturbations in temperature because there is an opportunity for a cycling between these two states of ionization to occur.

With the aid of the Hubble Space Telescope, Cepheids have been found in galaxies as far away as the Virgo cluster, more than 20 times farther away than the Andromeda galaxy, M31, in the Local Group. At these distances, the general expansion of the universe begins to dominate the radial velocities of the galaxies. (For nearby galaxies, the motions of galaxies can be perturbed by the interaction with neighbors, or motions due to bulk flows can be a significant component of the observed velocity.) Cepheids currently provide the most accurate zero point for the calibration of other (secondary) distance methods (for example, bright supernovae) which extend the range of distance measurements by over a factor of 10. At such distances, the observed velocities are representative of the overall expansion of the universe. See COSMOLOGY; STAR; UNIVERSE; VARIABLE STAR. [B.F.M.; W.L.F.]

**Ceramics** Inorganic, nonmetallic materials processed or consolidated at high temperature. This definition includes a wide range of materials known as advanced ceramics and is much broader than the common dictionary definition, which includes only pottery, tile, porcelain, and so forth. The classes of materials generally considered to be ceramics are oxides, nitrides, borides, carbides, silicides, and sulfides. Intermetallic compounds such as aluminides and beryllides are also considered ceramics, as are phosphides, antimonides, and arsenides. See INTERMETALLIC COMPOUNDS.

Ceramic materials can be subdivided into traditional and advanced ceramics. Traditional ceramics include clay-base materials such as brick, tile, sanitary ware, dinnerware, clay pipe, and electrical porcelain. Common-usage glass, cement, abrasives, and refractories are also important classes of traditional ceramics.

Typical properties for some ceramic materials

Property	Aluminum oxide	Silicon nitride	Silicon carbide	Partially stabilized zirconia
Density, g/cm <sup>3</sup>	3.9	3.2	3.1	5.7
Flexure strength, MPa	350	850	450	790
Modulus of elasticity, GPa	407	310	400	205
Fracture toughness ( $K_{IC}$ ), MPa · m <sup>1/2</sup>	5	5	4	12
Thermal conductivity, W/mK	34	33	110	3
Mean coefficient of thermal expansion ( $\times 10^{-6}/^{\circ}\text{C}$ )	7.7	2.6	4.4	10.2

Advanced materials technology is often cited as an enabling technology, enabling engineers to design and build advanced systems for applications in fields such as aerospace, automotive, and electronics. Advanced ceramics are tailored to have premium properties through application of advanced materials science and technology to control composition and internal structure. Examples of advanced ceramic materials are silicon nitride, silicon carbide, toughened zirconia, zirconia-toughened alumina, aluminum nitride, lead magnesium niobate, lead lanthanum zirconate titanate, silicon-carbide-whisker-reinforced alumina, carbon-fiber-reinforced glass ceramic, silicon-carbide-fiber-reinforced silicon carbide, and high-temperature superconductors. Advanced ceramics can be viewed as a class of the broader field of advanced materials, which can be divided into ceramics, metals, polymers, composites, and electronic materials. There is considerable overlap among these classes of materials. See CERMET; COMPOSITE MATERIAL; GLASS; POLYMER.

The general advantages of advanced structural ceramics over metals and polymers are high-temperature strength, wear resistance, and chemical stability, in addition to the enabling functions the ceramics can perform. Typical properties for some engineering ceramics are shown in the table.

Advanced ceramics are used in systems such as automotive engines, aerospace hardware, and electronics. The primary disadvantages of most advanced ceramics are in the areas of reliability, reproducibility, and cost. Major advances in reliability are being made through development of tougher materials such as partially stabilized zirconia and ceramic whiskers; and reinforced ceramics such as silicon-carbide-whisker-reinforced alumina used for cutting tools, and silicon-carbide-fiber-reinforced silicon carbide for high-temperature engine applications. [D.E.N.]

**Cerargyrite** A mineral with composition AgCl. Its structure is that of the isometric NaCl type, but well-formed cubic crystals are rare. The hardness is 2<sup>1/2</sup> on Mohs scale and specific gravity 5.5. Cerargyrite is colorless to pearl-gray but darkens to violet-brown on exposure to light. It is perfectly sectile and can be cut with a knife-like horn; hence the name horn silver. Bromyrite, AgBr, is physically indistinguishable from cerargyrite and the two minerals form a complete series. Both minerals are secondary ores of silver and occur in the oxidized zone of silver deposits. See HARDNESS SCALES; SILVER. [C.S.Hu.]

**Ceratophyllales** An order of flowering plants (angiosperms) previously thought to be related closely to the waterlilies because one genus of the latter, *Cabomba* (Nymphaeaceae), similarly has highly dissected leaves. Studies of deoxyribonucleic acid (DNA) sequences have revealed that the single genus of the order, *Ceratophyllum* (Ceratophyllaceae), has no close relationship to any other extant group of flowering plants. It is an old, highly specialized plant, modified for a fresh-water aquatic habitat. Fossil fruits attributed to it are more than 120 million years old, which makes it the oldest extant angiosperm genus. The plants are submersed, rootless aquatics with highly dissected, branching leaves; they have reduced,



separately sexed, petalless flowers. There are probably only six species distributed throughout fresh-water systems worldwide. See FLOWER; FOSSIL SEEDS AND FRUITS; MAGNOLIOPHYTA; PLANT EVOLUTION. [M.W.C.; M.F.F.]

**Cercaria** The larval generation which terminates the development of a digenetic trematode in the intermediate host, a mollusk or rarely an annelid. It becomes the adult fluke after entering the definitive host, a vertebrate. Access to the vertebrate may be either direct or indirect by entering a second intermediate, or vector, host which is ingested by the vertebrate. The intermediate host is usually aquatic and the cercaria has a tail used in swimming when it escapes from that host, but the tail may be inactive, reduced, or absent and the larva unable to swim. When the tail is absent, the organism is called a cercariaeum. Larvae with unknown life cycles are commonly described and named as species such as *Cercaria micrura* or *Cercariaeum helioides*.

The cercaria is important in taxonomy because that stage of closely related trematodes usually is less variable than the adult, and thus indicates kinships that may be masked in the adult by adaptations to parasitism of the vertebrate host. See DIGENEA; TREMATODA. [R.M.C.]

**Cereal** Any member of the grass family (Gramineae) which produced edible grains usable as food by humans and livestock. Common cereals are rice, wheat, barley, oats, maize (corn), sorghum, rye, and certain millets, with corn, rice, and wheat being the most important. Developed by scientists, triticale is a new cereal derived from crossing wheat and rye and then doubling the number of chromosomes in the hybrid. Occasionally, grains from other grasses (for example, teff) are used for food. Cereals provide more food for human consumption than any other crops.

Four general groups of foods are prepared from the cereal grains. (1) Baked products, made from flour or meal, include breads, pastries, pancakes, cookies, and cakes. (2) Milled grain products, made by removing the bran and usually the germ (or embryo of the seed), include polished rice, farina, wheat flour, cornmeal, hominy, corn grits, pearled barley, semolina (for macaroni products), prepared breakfast cereals, and soup, gravy, and other thickenings. (3) Beverages such as beer and whiskey, made from fermented grain products (distilled or undistilled) and from boiled, roasted grains. (4) Whole-grain products include rolled oats, brown rice, popcorn, shredded and puffed grains, and breakfast foods.

All cereal grains have high energy value, mainly from the starch fraction but also from the fat and protein. In general, the cereals are low in protein content, although oats and certain millets are exceptions. See GRAIN CROPS; GRASS. [L.P.R.]

**Cerebral palsy** A collection of syndromes (not a disease) of nonprogressive motor dysfunction arising from abnormal development of or damage to the brain, either prenatally, at birth, or postnatally. Most cases of cerebral palsy develop in utero. Premature birth is associated with an increased risk of cerebral palsy, with the lowest birth weights carrying the highest risk. A maximum of 15% of cases are related to birth injury or perinatal oxygen deprivation. See PREGNANCY DISORDERS.

Although the brain damage in cerebral palsy is nonprogressive and thus deterioration does not occur, the neurological manifestations of cerebral palsy may change with neurological maturation. The precise form of cerebral palsy rarely can be characterized prior to 6 months of age; often it cannot be characterized until the individual is 2 years old. Cerebral palsy is only rarely familial. Its incidence is stable at 0.1–0.3% of live births.

Cerebral palsy is classified by the form and distribution of the motor handicap. Spasticity, seen in 75% of cases, presents a clinical picture of muscle stiffness, weakness, and imbalance of muscle tone. Common findings are contractures of joints, result-

ing in shortened heel cords and thus toe walking. Tightness of the adductor muscles in the thigh may result in a scissors gait. Painful dislocation of the hip is a common problem associated with severe spasticity. Dyskinetic syndromes, occurring in 20% of cases, are characterized by a severe lack of voluntary muscle control. Unclear speech (dysarthria) can be quite severe. Ataxic syndromes, characterized by impaired coordination without altered motor tone, are uncommon. A fourth syndrome, characterized by severely decreased motor tone (hypotonia), is called atonic cerebral palsy. Distribution of the altered motor tone (that is, what parts of the body are involved) is of great importance in predicting the degree of handicap, especially in the spastic forms.

Treatment of cerebral palsy is aimed at maximizing lifetime independence within the limitations of the individual's handicap. Common treatment modalities include physical and occupational therapy to prevent contractures and facilitate optimal motor control. Speech therapy is used to improve feeding technique and communication skills. Surgical procedures to correct contractures and improve muscle balance are valuable in the spastic syndromes. Surgical and pharmacological approaches to reducing spasticity and dyskinesia remain largely experimental. [H.deC.P.]

**Cerenkov radiation** Light emitted by a high-speed charged particle when the particle passes through a transparent, nonconducting, solid material at a speed greater than the speed of light in the material. The blue glow observed in the water of a nuclear reactor, close to the active fuel elements, is radiation of this kind. The emission of Cerenkov radiation is analogous to the emission of a shock wave by a projectile moving faster than sound, since in both cases the velocity of the object passing through the medium exceeds the velocity of the resulting wave disturbance in the medium.

Particle detectors which utilize Cerenkov radiation are called Cerenkov counters. They are important in the detection of particles with speeds approaching that of light, such as those produced in large accelerators and in cosmic rays, and are used with photomultiplier tubes to amplify the Cerenkov radiation. These counters can emit pulses with widths of about  $10^{-10}$  s, and are therefore useful in time-of-flight measurements when very short times must be measured. They can also give direct information on the velocity of the passing particle. See PARTICLE DETECTOR.

[W.B.Fr.]

The properties of Cerenkov radiation have been exploited in the development of a branch of gamma-ray astronomy that covers the energy range of about  $10^5$ – $10^8$  MeV. A high-energy gamma ray from a source external to the Earth creates in the atmosphere a cascade of secondary electrons and positrons. This cascade is generated by the interplay of two processes: electron-positron pair production from gamma rays, and gamma-ray emission as the electrons and positrons are accelerated by the electric fields of nuclei in the atmosphere (bremsstrahlung). For a primary gamma ray having an energy of  $10^{12}$  eV (1 teraelectronvolt), as many as 1000 or more electrons and positrons will contribute to the cascade. The combined Cerenkov light of the cascade is beamed to the ground over an area a few hundred meters in diameter and marks the arrival direction of the initiating gamma ray to about  $1^\circ$ . On a clear, dark night this radiation may be detected as a pulse of light lasting a few nanoseconds, by using an optical reflector. See BREMSSTRAHLUNG; ELECTRON-POSITRON PAIR PRODUCTION.

This technique offers a means to study regions of the universe where charged particles are accelerated to extreme relativistic energies. Such regions involve highly magnetized, rapidly spinning neutron stars; supernova remnants; and active galactic nuclei. These same motivations drive the satellite observations of the EGRET instrument of the *Compton Gamma-Ray Observatory* at lower gamma-ray energies (up to about  $10^4$  MeV). See GAMMA-RAY ASTRONOMY. [R.C.La.]

**Ceres** The first asteroid discovered. It was found serendipitously by G. Piazzi on January 1, 1801. With a diameter of roughly 950 km (590 mi), Ceres is the largest asteroid but not the brightest since it reflects only 10% of the visual light it receives. Ceres' mass of  $9.5 \times 10^{20}$  kg ( $2.1 \times 10^{21}$  lb, that is,  $1.6 \times 10^{-4}$  that of the Earth) contains approximately one-third of the asteroid belt's total mass. See ASTEROID. [E.F.T.]

**Ceriantharia** An order of the Zoantharia, typified by *Cerianthus*, which lives in sandy marine substrata (illus. a and b). The animal is enclosed in a sheath formed by mucus secreted from gland cells of the column ectoderm, in which discharged nematocysts, sand grains, and other foreign objects are embedded.

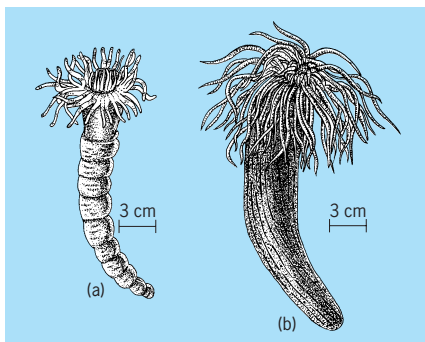

**Ceriantharia.** (a) *Cerianthus solitarius*. (b) *Pachycerlanthus multiplicatus*.

The polyp is a muscular, skeletonless, elongated, cylindrical body with a smooth wall. Long, slender, unbranching, freely retractile tentacles are arranged in two cycles and consist of smaller labial and larger marginal ones. See ZOANTHARIA. [K.At.]

**Cerium** A chemical element, Ce, atomic number 58, atomic weight 140.12. It is the most abundant metallic element of the rare-earth group in the periodic table. The naturally occurring element is made up of the isotopes  $^{136}\text{Ce}$ ,  $^{138}\text{Ce}$ ,  $^{140}\text{Ce}$ , and  $^{142}\text{Ce}$ . A radioactive  $\alpha$ -emitter,  $^{142}\text{Ce}$  has a half-life of  $5 \times 10^{15}$  years. Cerium occurs mixed with other rare earths in many minerals, particularly monazite and blastnasite, and is found among the products of the fission of uranium, thorium, and plutonium. See PERIODIC TABLE.

Although the common valence of cerium is 3, it also forms a series of quadrivalent compounds and is the only rare earth which occurs as a quadrivalent ion in aqueous solution. Although it can be separated from the other rare earths in high purity by ion-exchange methods, it is usually separated chemically by taking advantage of its quadrivalent state. [F.H.Sp.]

**Cermet** A group of composite materials consisting of an intimate mixture of ceramic and metallic components. Cermets can be fabricated by mixing the finely divided components in the form of powders or fibers, compacting the components under pressure, and sintering the compact to produce physical properties not found solely in either of the components. Cermets can also be fabricated by internal oxidation of dilute solutions of a base metal and a more noble metal. When heated under oxidizing conditions, the oxygen diffuses into the alloy to form a base metal oxide in a matrix of the more noble metal. See COMPOSITE MATERIAL; CORROSION; POWDER METALLURGY; SINTERING.

The combination of metallic and ceramic components can result in cermets characterized by increased strength and hardness, higher temperature resistance, improved wear resistance, and better resistance to corrosion, each characteristic depending on the variables involved in composition and processing. Friction

parts as well as cutting and drilling tools have been successfully made from cermets for many years. Certain nuclear reactor fuel elements, such as dispersion-type elements, are also made as cermets. See CERAMICS. [H.H.H.]

**Cerussite** The mineral form of lead carbonate,  $\text{PbCO}_3$ . Cerussite is common as a secondary mineral associated with lead ores. In the United States it occurs mostly in the central and far western regions. Cerussite is white when pure but is sometimes darkened by impurities. Hardness is  $3\frac{1}{4}$  on Mohs scale and specific gravity is 6.5. Crystals may be tabular, elongated, or arranged in clusters. See CARBONATE MINERALS. [R.I.Ha.]

**Cesium** A chemical element, Cs, with an atomic number of 55 and an atomic weight of 132.905, the heaviest of the alkali metals in group I of the periodic table (except for francium, the radioactive member of the alkali metal family). Cesium is a soft, light, very low-melting metal. It is the most reactive of the alkali metals and indeed is the most electropositive and the most reactive of all the elements. See PERIODIC TABLE.

Cesium reacts vigorously with oxygen to form a mixture of oxides. In moist air, the heat of oxidation may be sufficient to melt and ignite the metal. Cesium does not appear to react with nitrogen to form a nitride, but does react with hydrogen at high temperatures to form a fairly stable hydride. Cesium reacts violently with water and even with ice at temperatures as low as  $-116^\circ\text{C}$  ( $-177^\circ\text{F}$ ). Cesium reacts with the halogens, ammonia, and carbon monoxide. In general, cesium undergoes some of the same type of reactions with organic compounds as do the other alkali metals, but it is much more reactive. See SODIUM.

The physical properties of cesium metal are summarized in the table.

**Physical properties of cesium metal**

Property	Temp., $^\circ\text{C}$	Value
Density	20	$1.9 \text{ g/cm}^3$
Melting point	28.5	
Boiling point	705	
Heat of fusion	28.5	3.8 cal/g
Heat of vaporization	705	146 cal/g
Viscosity	100	4.75 millipoises
Vapor pressure	278	1 mm
	635	400 mm
Thermal conductivity	28.5	$0.044 \text{ cal/(s)(cm}^2\text{)}(^\circ\text{C)}$
Heat capacity	28.5	$0.06 \text{ cal/(g)}(^\circ\text{C)}$
Electrical resistivity	30	36.6 microhm-cm

Cesium is not very abundant in the Earth's crust, there being only 7 parts per million (ppm) present. Like lithium and rubidium, cesium is found as a constituent of complex minerals and not in relatively pure halide form as are sodium and potassium. Indeed, lithium, rubidium, and cesium frequently occur together in lepidolite ores, such as those from Rhodesia.

Cesium metal is used in photoelectric cells, spectrographic instruments, scintillation counters, radio tubes, military infrared signaling lamps, and various optical and detecting devices.

Cesium compounds are used in glass and ceramic production, as absorbers in carbon dioxide purification plants, as components of getters in radio tubes, and in microchemistry. Cesium salts have been used medicinally as antishock agents after administration of arsenic drugs. The isotope cesium-137 is supplanting cobalt-60 in the treatment of cancer. See ALKALI METALS. [M.Si.]

**Cestida** An order of the phylum Ctenophora comprising two genera, *Cestum* and *Velamen*. The morphology of these organisms is unusual; the transparent bodies are flattened in the

tentacular plane and greatly elongated in the stomodeal plane so that they have the shape of a belt or ribbon. Cestids are capable of rapid swimming by wriggling the body. *Cestum* is widely distributed in oceanic waters and are among the commonest and most spectacular of epipelagic ctenophores. See CTENOPHORA. [L.P.M.]

**Cestoda** A subclass of tapeworms including most of the members of the members of the class Cestoidea. All species are endoparasites of vertebrates, living in the intestine or related ducts.

Like other members of the class, the cestodes have no digestive tract or mouth. Nutrition presumably occurs by absorption of food through the body surface. The body is usually very elongated and tapelike and frequently divided into segments, or proglottids, with replication of the hermaphroditic reproductive systems. In a few species there is duplication of both male and female organs within a single segment. The anterior end is usually modified into a holdfast organ, the scolex. Since a digestive tract is completely absent, the scolex is of solid construction, typically highly muscular with sucking depressions and hooks (see illustration).

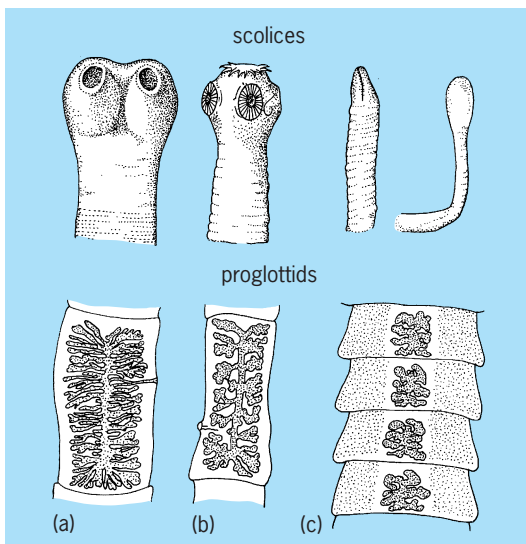

Scolices and mature proglottids of (a) *Taenia saginata*, (b) *T. solium*, and (c) *Dibothriocephalus*. (After T. I. Storer and R. L. Usinger, *General Zoology*, 3d ed. McGraw-Hill, 1957)

The worms require carbohydrate for growth and reproduction, and this requirement is satisfied only from the host ingesta. On the other hand, nitrogenous nutrients and many micronutrients may be obtained from the body stores of the host; deleting such materials from the host's diet has no appreciable effect on the worms.

Most authorities agree that the tapeworms are ancient parasites, probably evolving as parasites of the earliest fishes. It seems probable that the tapeworms did not evolve from trematodes or other present-day groups of parasitic flatworms. Their ancestry may be directly derived from the acoele or rhabdocoele turbellarians and represents a line of evolution which is completely independent of other parasitic flatworms. These relationships remain obscure in the absence of any fossil record. See CESTOIDEA; TURBELLARIA. [C.P.R.]

**Cestodaria** A subclass of worms belonging to the class Cestoidea. Only a few species are known. All are endoparasites of primitive fishes. The subclass is usually divided into two orders, Amphilinidea and Gyrocotylidea. These worms differ from

the other Cestoidea in being unsegmented, in not having the anterior end modified as a holdfast organ, and in frequently occurring as parasites of the coelomic cavity rather than the digestive tract. Some species have the posterior end modified into a holdfast organ. The animals are hermaphroditic and sexual reproduction occurs in the vertebrate host. See AMPHILINIDEA; CESTOIDEA; GYROCOTYLIDEA. [C.P.R.]

**Cestoidea** A class of the phylum Platyhelminthes commonly referred to as tapeworms. All members are endoparasites, usually in the digestive tract of vertebrates. The class has been subdivided as follows:

- Class Cestoidea
  - Subclass Cestodaria
    - Order: Amphilinidea
      - Gyrocotylidea
  - Subclass Cestoda
    - Order: Proteocephaloidea
      - Tetraphyllidea
      - Lecanicephaloidea
      - Trypanorhyncha
      - Diphylloidea
      - Pseudophyllidea
      - Cyclophyllidea
      - Nippotaeniidea

See separate articles on each group listed.

The tapeworms range from less than 0.04 in. (1 mm) to several feet in length. The class is differentially characterized by the presence of a cuticle rather than a cellular epidermis and by the total absence of a mouth and digestive tract. Food materials are presumed to be absorbed through the external surface. In most species of the class the body is divided into proglottids, each proglottid containing one or two hermaphroditic reproductive systems. The anterior end is usually modified into a holdfast organ, bearing suckers or sucking grooves, and frequently armed with hooks. Early embryonic development occurs in the parental body, usually in a uterus, to a hook-bearing stage, the oncosphere. The oncosphere leaves the parental body through a uterine pore or by liberation of the terminal segment from the main body of the worm. Further development of the worm always occurs within the body of a host, most often an invertebrate, which commonly ingests the larval form. Further larval growth and development of the holdfast may require a second host. Development of the sexual phase from the larva occurs in another host. Growth with strobilation and development of reproductive systems follow, the worm usually staying in the digestive tract. See PLATYHELMINTHES; PSEUDOPHYLLIDEA. [C.P.R.]

**Cetacea** A mammalian order comprising approximately 90 living species of whales, dolphins, and porpoises and their fossil relatives. Like all other mammals but unlike all fish, cetaceans nurse their young with milk produced by the mother, are endothermic (warm-blooded), breathe air, have a lower jaw that consists of a single bony element (the dentary), and have three small bones (hammer, anvil, and stirrup) subserving sound transmission within the ear.

Living cetaceans are aquatic animals that cannot live on land. They have streamlined bodies, with the nasal opening (blowhole) on top of the head (see illustration). Their forelimbs are modified into flippers, they lack external hindlimbs, and their tail forms a flat horizontal fluke. Modern cetaceans lack hair except for whiskers in the young of some species. Many of these features are common in aquatic vertebrates, and they have evolved convergently as adaptations for life in water.

The brain of cetaceans is large and highly developed, and they are thought to be very intelligent. The cetacean sense of smell is nearly or totally absent. In most species the nerve that

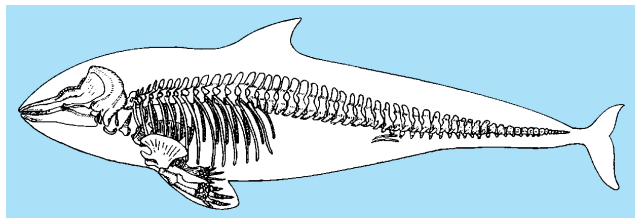

Skeleton of a porpoise, highly specialized for an aquatic life. (After *Guide to the Hall of Biology of Mammals, Amer. Mus. Nat. Hist. Guide Leaflet. Ser. 76, 1933*)

carries olfactory information to the brain is absent, which is very unusual among mammals. The eyes of most species are well developed. The ear is the most important sense organ. Toothed whales (Odontoceti) echolocate, emitting high-frequency sounds and using the echoes to determine shapes and distances in their surroundings. Odontocetes do not emit sounds with their voice box (larynx) like other mammals, but have modified nasal passages through which bursts of air are forced. Mysticetes (baleen whales) do not echolocate; rather, they produce low-frequency sounds with their larynx. These sounds can travel through the ocean for hundreds of miles and are used for communication. See ECHOLOCAION.

The two extant suborders of cetaceans, odontocetes and mysticetes, have different dietary specializations. Most odontocetes have simple, pronglike teeth which are used to grab and hold, but not chew, large prey items. Prey includes a variety of fish of all sizes, crustaceans, and squid and other mollusks. Some of the larger odontocetes, such as the killer whale (*Orcinus orca*), eat large prey, including sea lions and dolphins. A pod of killer whales will also hunt together, attacking much larger prey such as gray whales. Modern mysticetes do not have teeth and are filter feeders, straining water filled with clouds of marine organisms (krill) through a network of baleen. Baleen is a keratinlike substance that hangs down in plates from the upper jaws of the whale.

All modern cetaceans swim by swinging their horizontal tail fluke through the water, while their forelimbs are used for steering and navigating. The flippers of modern cetaceans resemble flat oars, although the bones for five fingers are present internally. The dorsal fin stabilizes the body during swimming. Under the skin of cetaceans is a layer of blubber, a fatty tissue that serves to insulate the animal and affects its buoyancy and streamlining. Some species are capable of diving to great depths [commonly more than 5000 ft (1500 m) in the sperm whale], yet all cetaceans must come to the surface to breathe. Whales have a number of adaptations for diving and staying underwater for long periods of time. They exhale before they dive, allowing them to submerge faster. They store oxygen in the muscle (myoglobin) and not in the lungs or blood (hemoglobin) and change circulation patterns of blood to save oxygen. Their chests can easily collapse under increasing pressure (with depth) without causing permanent damage. See ADIPOSE TISSUE; DIVING ANIMALS; HEMOGLOBIN.

A variety of social structures are found among cetaceans. Two examples are marine dolphins and sperm whales. Most marine dolphins live in schools that may contain dozens of animals, sometimes composed of multiple species. Herds of sperm whales consist of related females and juveniles. Clusters of young males form bachelor groups, and adult males, much larger than the females, are solitary.

Cetaceans are found in all oceans and seas. Some species are restricted to coastal environments (such as bottlenosed dolphins), whereas others live only in the open sea (such as sperm whales). Some species live in all seas and oceans of the world (such as killer whales). Many mysticetes and sperm whales are migratory. A number of dolphin species have left the sea and live permanently in rivers.

Cetaceans originated from a four-footed terrestrial ancestor. This predecessor, a mesonychian, may have resembled a wolf or a hyena and lived approximately 55 million years ago. Modern odontocetes are diverse, ranging from the enormous sperm whales [up to 20 m (66 ft) long and 52,000 kg (114,500 lb)] to the tiny porpoises [Phocaenidae, smallest around 9 kg (20 lb), length 1.5 m (5 ft)]. Dolphins (Delphinidae, which includes the killer whale), porpoises (Phocaenidae), and fresh-water dolphins (Iniidae, Pontoporidae, Platanistidae) are the smallest odontocetes. The largest animal ever to live on Earth is the blue whale (*Balaenoptera musculus*), a baleen whale that is 25 m (82 ft) long and weighs 130,000 kg (286,340 lb). Other examples of mysticetes are humpback whales, right whales, gray whales, and minke whales. See MAMMALIA. [J.G.M.B.]

**Cetane number** A number, usually between 30 and 60, that indicates the ability of a diesel engine fuel to ignite quickly after being injected into the cylinder. The higher the cetane number, the more easily the fuel can be ignited. In high-speed diesel engines, a fuel with a long ignition delay tends to produce rough operation. See DIESEL ENGINE; DIESEL FUEL. [D.An.]

**Cetomimiformes** An order of oceanic, mostly deep-water fishes that are structurally diverse and rare; most of the 41 species are known from one or a few specimens. Thus, their scientific study has been hindered, the anatomy is imperfectly known, and the relationships are in dispute. Five of the 10 families and 11 of the 21 genera currently placed in the order have been described since World War II. There is no fossil record.

Cetomimiforms are soft-rayed fishes. In most the mouth is large. Many are naked but a few have scales that are thin and deciduous or form an irregular mosaic; a few have the skin spinulose. Pelvic fins may be abdominal, thoracic, or jugular in position or, commonly, absent. In most forms the single dorsal and anal fins are placed rather well back and are opposed; an adipose fin is present in only one species.

Because of the diversity, the five currently recognized suborders may be mentioned separately. Best known are the Cetomimoidei (or Cetunculi) whalefishes, a group of 3 families and 15 rare species of small, red or black deep-sea fishes with whale-shaped bodies and enormous mouths; they are bioluminescent. The Atelepoidei (or Chondrobrachii) consist of 1 family, 3 genera, and 11 species of elongate fishes in which the long anal fin is continuous with the caudal and there is no dorsal fin. The Mirapinnatoidei (or Miripinnati) are tiny, perhaps larval fishes, all recently described. Three families, 4 genera, and 5 species are included. The Giganturoidei, with 2 families, 3 genera, and 6 species, are small mesopelagic fishes with large mouths and strong teeth; some have telescopic eyes. The Megalomyceroidei, or mosaic-scaled fishes, consist of 1 family, 4 genera, and 4 rare species of small, elongate deep-sea fishes with degenerate eyes and irregularly disposed scales. See ACTINOPTERYGII; OSTEICHTHYES; TELEOSTEI. [R.M.B.]

**Chabazite** A mineral belonging to the zeolite family of silicates. Hardness (on the Mohs hardness scale) is in the range of 4–5. Colors range from white to yellow, pink, and red. The ideal composition is  $\text{Ca}_2\text{Al}_2\text{Si}_4\text{O}_{12} \cdot 6\text{H}_2\text{O}$  (where Ca = calcium, Al = aluminum, Si = silicon, O = oxygen,  $\text{H}_2\text{O}$  = water), but there is considerable chemical substitution of Ca by sodium (Na) and potassium (K), as well as (Na,K)Si for CaAl. The internal structure of chabazite consists of a framework linkage of  $(\text{AlO}_4)$  and  $(\text{SiO}_4)$  tetrahedra, with large cagelike openings bounded by rings of tetrahedra. The cages are connected to each other by open structural channels that allow for the diffusion of molecules through the structure of a size comparable to that of the diameter of the channels (about 0.39 nanometer in diameter). For example, argon (0.384 nm in diameter) is quickly absorbed by the chabazite structure, but isobutane (0.56 nm in diameter) cannot

enter the structure. In this manner, chabazite can be used as a sieve on a molecular level. See MOLECULAR SIEVE; ZEOLITE. [C.K.]

**Chaetodermomorpha** A subclass of burrowing, vermiform mollusks in the class Aplacophora. They are covered by a spicular integument and recognizable by the presence of a sensory cuticular oral shield, lack of a foot, and presence of paired gills in a posterior mantle cavity. Chaetoderms range in size from less than 0.08 in. (2 mm) to more than 2.8 in. (70 mm) and are found from shelf depths to hadal depths over 22,400 ft (7000 m). There are three families with 10 genera and 84 species worldwide. Chaetoderm species are numerically dominant in certain deep-sea localities. See APLACOPHORA; MOLLUSCA. [A.H.S.]

**Chaetognatha** A phylum of abundant planktonic arrowworms. Their bodies are tubular and transparent, and divided into three portions: head, trunk, and tail. The head possesses one or two rows of minute teeth anterior to the mouth and usually 7–10 larger chaetae, or seizing jaws, on each side of the head. One or two pairs of lateral fins and a caudal fin are present.

Nine genera and about 42 species are recognized by some specialists. Most species belong to the genus *Sagitta*, which can be recognized by the presence of two pairs of teeth and two pairs of lateral fins.

Chaetognaths are cosmopolitan forms which live not only at the surface but also at great depths; however, no one species is found in all latitudes and at all depths. One of the Arctic species, *Eukrohnia hamata*, may extend to the Antarctic by way of deep water across the tropics. A few species are neritic and are not found normally beyond the continental shelf. Their food consists principally of copepods and other small planktonic crustaceans; however, they are very predacious and will even eat small fish larvae and other chaetognaths on rare occasions.

Studies have shown them to be useful as indicator organisms. Certain species appear to be associated with characteristic types or masses of water, and when this water is displaced into an adjacent water mass, the chaetognaths may be used as temporary evidence for such displacement. [E.L.P.]

**Chaetonotida** An order of the phylum Gastrotricha. Members have Y-shaped pharyngeal lumina. *Neodasyis* is a marine and macrodasyid-like form that reaches 0.8 mm (0.03 in.) in length and has front, side, and rear adhesive tubes. Others seldom exceed 0.3 mm (0.01 in.); they have only two rear adhesive tubes borne on a posterior furca, or none at all. The family Chaetonotidae comprises half of all gastrotrichs: *Musellifer* and *Halichaetonotus* are marine; *Polymerurus* is fresh-water; *Aspidiophorus*, *Chaetonotus*, *Heterolepidoderma*, *Ichthyidium*, and *Lepidodermella* have species in each habitat. *Musellifer* lives in mud; all others inhabit sands of streams, beaches, or offshore banks, or live in the surface detritus of ponds or lake bottoms. The other seven genera, in four families, are all fresh-water and either are rare or tend toward a semiplanktonic life, especially *Neogosseia* and *Stylochaeta*. See GASTROTRICHA. [W.D.Hu.]

**Chain drive** A flexible device of connected links used to transmit power. A drive consists of an endless chain which meshes with sprockets located on the shaft of a driving source, such as an electric motor/reducer and a driven source, such as the head shaft of a belt conveyor.

The roller chain (see illustration) meets the demands of heavy-duty oil well drilling equipment, high-production agricultural machinery, construction machinery, and similar equipment. It also meets the precise timing requirements of lighter-duty equipment such as printing, packaging, and vending equipment.

Another type of chain, the engineering steel chain, is usually identified by the offset/cranked link sidebar design. Generally, larger pitch sizes as compared to the roller chain and higher-strength chains characterize such chains. A third group used for chain drives is the inverted tooth/silent chains. A familiar appli-

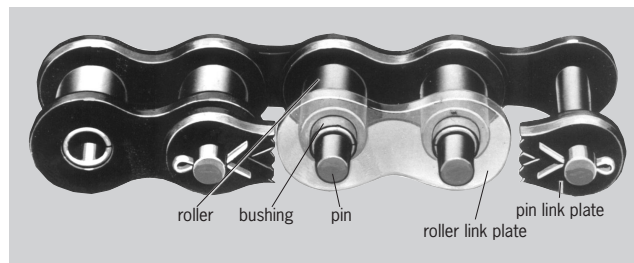

Single-strand roller chain.

cation is their use as automotive timing chains in automobile engines.

The use of chains for power transmission rather than another device, such as V-belts or a direct coupling to the power source, is usually based on the cost effectiveness and economy of chains and sprockets. Chains and sprockets offer the following advantages: large speed ratios; sufficient elasticity to absorb reasonable shocks; a constant speed ratio between the driving and driven shaft; long life without excessive maintenance; mechanical understandability regarding installation and functionality; coupling and uncoupling with simple tools; and a simple means to get power from its source to the location where needed. See BELT DRIVE. [V.D.P.]

**Chain reaction (chemistry)** A chemical reaction in which many molecules undergo chemical reaction after one molecule becomes activated. In ordinary chemical reactions, every molecule that reacts must first become activated by collision with other rapidly moving molecules. The number of these violent collisions per second is so small that the reaction is slow. After a chain reaction is started, it is not necessary to wait for more collisions with activated molecules to accelerate the reaction because the reaction now proceeds spontaneously.

A typical chain reaction is the photochemical reaction between hydrogen and chlorine as described by the following reactions.

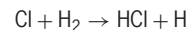
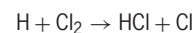
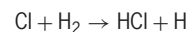

The light absorbed by a chlorine molecule dissociates the molecule into chlorine atoms; these in turn react rapidly with hydrogen molecules to give hydrogen chloride and hydrogen atoms. The hydrogen atoms react with chlorine molecules to give hydrogen chloride and chlorine atoms. The chlorine atoms react further with hydrogen and continue the chain until some other reaction uses up the free atoms of chlorine or hydrogen. The chain-stopping reaction may be the reaction between two chlorine atoms to give chlorine molecules, or between two hydrogen atoms to give hydrogen molecules. Again the atoms may collide with the walls of the containing vessel, or they may react with some impurity which is present in the vessel only as a trace.

Certain oxidations in the gas phase are known to be chain reactions. The carbon knock which occurs at times in internal combustion engines is caused by a too-rapid combustion rate caused by chain reactions. This chain reaction is reduced by adding tetraethyllead, which acts as an inhibitor.

The polymerization of styrene to give polystyrene and the polymerization of other organic materials to give industrial plastics involve chain reactions. The spoilage of foods, the precipitation of insoluble gums in gasoline, and the deterioration of certain plastics in sunlight involve chain reactions, which can be minimized with inhibitors. See CHEMICAL DYNAMICS; PHOTOCHEMISTRY. [F.D.]

**Chain reaction (physics)** A succession of generation after generation of acts of division (called fission) of certain heavy nuclei. The fission process releases about 200 MeV ( $3.2 \times 10^{-4}$  erg =  $3.2 \times 10^{-11}$  joule) in the form of energetic particles including two or three neutrons. Some of the neutrons from one generation are captured by fissile species ( $^{233}\text{U}$ ,  $^{235}\text{U}$ ,  $^{239}\text{Pu}$ ) to cause the fissions of the next generations. The process is employed in nuclear reactors and nuclear explosive devices.

[N.C.R.]

**Chalcanthite** A mineral with the chemical composition  $\text{CuSO}_4 \cdot 5\text{H}_2\text{O}$ . Chalcanthite commonly occurs in blue to greenish-blue triclinic crystals or in massive fibrous veins or stalactites. Fracture is conchoidal and luster is vitreous. Hardness is 2.5 on Mohs scale and specific gravity is 2.28. It has a nauseating taste and is readily soluble in water. It dehydrates in dry air to a greenish-white powder. Although deposits of commercial size occur in arid areas, chalcanthite is generally not an important source of copper ore. Its occurrence is widespread in the western United States.

[E.C.T.C.]

**Chalcedony** A fine-grained fibrous variety of quartz, silicon dioxide. The individual fibers that compose the mineral aggregate usually are visible only under the microscope. Subvarieties of chalcedony recognized on the basis of color differences, some valued since ancient times as semiprecious gem materials, include carnelian (translucent, deep flesh red to clear red in color), sard (orange-brown to reddish-brown), and chrysoprase (apple green). See GEM; QUARTZ.

Chalcedony occurs as crusts with a rounded, mammillary, or botryoidal surface and as a major constituent of nodular and bedded cherts. The hardness is 6.5–7 on Mohs scale. The specific gravity is 2.57–2.64.

Crusts of chalcedony generally are composed of fairly distinct layers concentric to the surface. Agate is a common and important type of chalcedony in which successive layers differ markedly in color and degree of translucency. In the most common kind of agate the layers are curved and concentric to the shape of the cavity in which the material formed. See AGATE.

[R.Si.]

**Chalcocite** A mineral having composition  $\text{Cu}_2\text{S}$  and crystallizing in the orthorhombic system (below 217°F or 103°C). Crystals are rare and small, usually with hexagonal outline because of twinning. Most commonly, the mineral is fine-grained and massive with a metallic luster and a lead-gray color which tarnishes to dull black on exposure. The Mohs hardness is 2.5–3, and the density 5.5–5.8. Chalcocite is an important copper ore found at Miami, Morenci, and Bisbee, Arizona; Butte, Montana; Kennecott, Alaska; and Tsumeb, South-West Africa.

[L.Gr.]

**Chalcopyrite** A mineral having composition  $\text{CuFeS}_2$ . Crystals are usually small and resemble tetrahedra. Chalcopyrite is usually massive with a metallic luster, brass-yellow color, and sometimes an iridescent tarnish. The Mohs hardness is 3.5–4.0, and the density 4.1–4.3. Chalcopyrite is a so-called fool's gold, but is brittle while gold is sectile. Pyrite, the most widespread fool's gold, is harder than chalcopyrite. See PYRITE.

Chalcopyrite is the most widespread primary copper ore mineral. It is commonly found in veins (Braden mine, Chile; Cornwall, England; Butte, Montana; Freiberg, Saxony; Tasmania; Rio Tinto, Spain). Chalcopyrite is also found in contact metamorphic deposits in limestone (Bisbee, Arizona) and as sedimentary deposits (Mansfeld, Germany). See COPPER.

[L.Gr.]

**Chalk** The term sometimes used in a broad sense for any soft, friable, or weathered fine-grained limestone; however the term is mostly restricted to pelagic (biogenic) limestones. Chalk is a uniformly fine-grained, typically light-colored marine limestone

primarily composed of the remains of calcareous nanofossils and microfossils. These minute pelagic organisms live in surface and near-surface oceanic waters and include coccolithophores (algae) and planktic foraminifers (Protozoa). Larger fossil constituents may be present, but only in subordinate amounts. The dominant pelagic skeletal remains are composed of low-magnesium calcite and have accumulated where the sea floor lies at a depth of less than about 4 km or 13,000 ft (the carbonate is redissolved at greater depths). Typical chalk sedimentation rates are 30 m (100 ft) per million years, so chalk accumulation is also dependent on the exclusion of diluting materials such as reefal detritus or terrigenous debris (clay, silt, or sand) transported from land areas by rivers. Chalks therefore form mainly in isolated outer shelf or deeper-water settings that are far from land areas. See CALCITE; LIMESTONE.

The unique combination of light color, compositional purity, softness, and fine texture led to many of the early uses of chalk for writing on blackboards. Chalks are also widely used in the manufacture of portland cement, as lime for fertilizers, and in powders, abrasives, and coatings.

[P.A.Sc.]

**Chameleon** The name for about 80 species of small-to-medium-sized lizards that make up the family Chamaeleontidae and occur mainly in Africa and Madagascar. The American chameleons (*Anolis*) belong to a different family of lizards, the Iguanidae.

*Chamaeleo chamaeleon* is the most common species and is a typical example of the group. Its body is flattened from side to side; it has a long, prehensile tail; and both the forelimbs and hindlimbs have two digits that oppose the other three. These feet and the tail make the chameleon well adapted for its arboreal habitat. The eyes are large and can move independently of each other in all directions. The tongue is also prehensile, being extensible for a great distance, about the length of the animal itself, and is a highly efficient organ for capturing insects. The head is triangular in profile and has a pointed crest. Chameleons are noted for their ability to change color. Color changes appear to be related to environmental temperatures as well as other external stimuli.

The chameleon is oviparous. The female digs out a hollow in the ground for a nest where several dozen eggs are laid and then covered with soil. The period of incubation varies inversely with the temperature and may be as short as 4 months or as long as 10 months. Parental care of the young has not been observed. See CHROMATOPHORE; SQUAMATA.

[C.B.C.]

**Chamois** One of several species of mammals included in the tribe Rupicaprini of the family Bovidae. The group is heterogeneous in form, but all are intermediate in characteristics between the goats and antelopes. The chamois is the only European species of the group and is indigenous to the mountainous areas, especially the Alps. About nine races are recognized, based on their geographical range. The chamois is, however, becoming rare.

The chamois (*Rupicapra rupicapra*) lives in small herds of both sexes in numbers from 10 to 50. The adult is almost 3 ft high and weighs about 90 lb (40 kg) maximum. Both sexes bear horns which are set close together on the forehead, project almost at right angles, and are straight except for the sharp curve backward at the top (see illustration). A soft, pliable leather, known as chamois cloth, is obtained from the skin of this animal.

The goral, serow, and Rocky Mountain goat are included in the same tribe of bovids as the chamois. Both the goral (genus *Naemorhedus*) and serow (genus *Capricornis*) are found in Asia. The goral is about 2 ft (0.6 m) high and has short horns. The male of the Rocky Mountain goat (*Oreamnos americanus*) is larger than the female, weighing between 200 and 300 lb (90 and 135 kg) and standing over 3 ft (1 m) high. Both sexes are

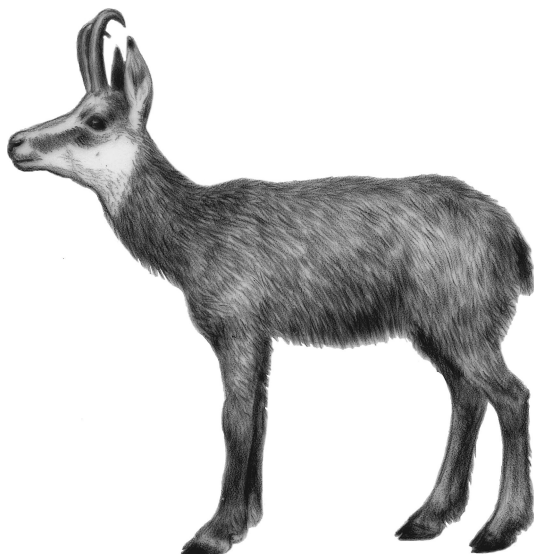

The chamois (*Rupicapra rupicapra*).

covered with thick, long white hair and have horns and beards. See ANTELOPE; MAMMALIA. [C.B.C.]

**Channel electron multiplier** A single-particle detector which in its basic form (see illustration) consists of a hollow tube (channel) of either glass or ceramic material with a semiconducting inner surface. The detector responds to one or more primary electron impact events at its entrance (input) by producing, in a cascade multiplication process, a charge pulse of typically  $10^4$ – $10^8$  electrons at its exit (output). Because particles other than electrons can impact at the entrance of the channel electron multiplier to produce a secondary electron, which is then subsequently multiplied in a cascade, the channel electron multiplier can be used to detect charged particles other than electrons (such as ions or positrons), neutral particles with internal energy (such as metastable excited atoms), and photons as well. As a result, this relatively simple, reliable, and easily applied device is employed in a wide variety of charged-particle and photon spectrometers and related analytical instruments, such as residual gas analyzers, mass spectrometers, and spectrometers used in secondary ion mass spectrometry (SIMS), electron spectroscopy for chemical analysis (ESCA), and Auger electron spectroscopy. See AUGER EFFECT; ELECTRON SPECTROSCOPY; MASS SPECTROMETRY; OPTICAL DETECTORS; PHOTOEMISSION; SECONDARY ION MASS SPECTROMETRY (SIMS); SPECTROSCOPY.

A related device is the channel electron multiplier array, often called a microchannel plate. The channel electron multiplier array is usually a disk-shaped device with a diameter between

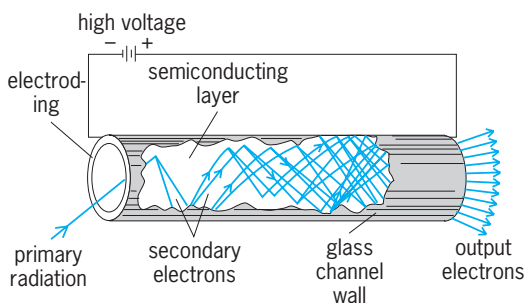

Cutaway view of a straight, single-channel electron multiplier, showing the cascade of secondary electrons resulting from the initial, primary radiation event, which produces an output charge pulse. (After J. L. Wiza, *Microchannel plate detectors*, *Nucl. Instrum. Meth.*, 162:587–601, 1979)

1 and 4 in. (2.5 and 10 cm) and a thickness of a fraction of a millimeter, and consists of millions of miniature channel electron multiplier devices arranged with channel axes perpendicular to the face of the disk. Channel electron multiplier arrays find application as image intensifiers in night vision devices, and are employed to add either large detection area or imaging capabilities, or both, to charged-particle detectors and spectrometers. See IMAGE TUBE (ASTRONOMY); LIGHT AMPLIFIER; PARTICLE DETECTOR. [S.B.E.]

**Channeling in solids** The steering of positively charged energetic particles between atomic rows or planes of a crystalline solid. The particles can be positive ions, protons, positrons, or muons. If the angle between the direction of the particle and a particular axis or plane in the crystal is within a small predictable limit (typically a few degrees or less), then the gradually changing electrostatic repulsion between the particle and each successive atomic nucleus of the crystal produces a smooth steering through the crystal lattice. See CRYSTAL STRUCTURE.

An obvious consequence of this steered motion is that it prevents violent collisions of the particles with atoms on the lattice sites. Hence, as compared with a randomly directed beam of particles, the channeled beam loses energy more slowly, penetrates more deeply, creates much less damage to the crystal along its track, and is prevented from participating in all close-encounter processes (nuclear reactions, Rutherford scattering, and so forth) with lattice atoms. See NUCLEAR REACTION; SCATTERING EXPERIMENTS (NUCLEI).

A related channeling phenomenon is the channeling of energetic electrons or other negative particles. In this case, the particles are attracted to the positively charged atomic nuclei, so that the probability of violent collisions with atoms on lattice sites is enhanced rather than being prevented, and the particles are steered along the rows or planes of nuclei rather than between them.

A closely related phenomenon is called blocking. In this case, the energetic positive particles originate from atomic sites within the crystal lattice by means of fission, alpha-particle decay, or by wide-angle scattering of a nonchanneled external beam in a very close encounter with a lattice atom. Those particles emitted almost parallel to an atomic row or plane will be deflected away from the row by a steering process. Consequently, no particles emerge from the crystal within a certain critical blocking angle of each major crystallographic direction. A piece of film placed some distance from the crystal provides a simple technique for recording blocking patterns. Theoretical considerations show that the same principle is involved in blocking as in channeling; hence, both phenomena exhibit an identical dependence on particle energy, nuclear charge, lattice spacing, and so forth. See NUCLEAR FISSION; RADIOACTIVITY.

Applications of channeling include the location of foreign atoms in a crystal, the study of crystal surface structure, and the measurement of nuclear lifetimes. The location of foreign (solute) atoms in a crystal is one of the simplest channeling applications. It is accomplished by measuring the yields of Rutherford back-scattered particles, characteristic x-rays, or nuclear reaction products produced by the interaction of channeled particles with the solute atoms. Such yields are enhanced for solute atoms that are displaced into channels of the crystal. This method has been used to determine the lattice positions of solute atoms that have been introduced into crystals, and to determine the amount of lattice damage created by ion implantation. These and similar applications have proved extremely useful in the development of semiconductor devices. See ION IMPLANTATION; LASER-SOLID INTERACTIONS. [J.A.Da.; M.L.Sw.]

**Chaos** System behavior that depends so sensitively on the system's precise initial conditions that it is, in effect, unpredictable and cannot be distinguished from a random process, even though it is deterministic in a mathematical sense.

Throughout history, sequentially using magic, religion, and science, people have sought to perceive order and meaning in a seemingly chaotic and meaningless world. This quest for order reached its ultimate goal in the seventeenth century when newtonian dynamics provided an ordered, deterministic view of the entire universe epitomized in P. S. de Laplace's statement, "We ought then to regard the present state of the universe as the effect of its preceding state and as the cause of its succeeding state."

But if the determinism of Laplace and Newton is totally accepted, it is difficult to explain the unpredictability of a gambling game or, more generally, the unpredictably random behavior observed in many newtonian systems. Commonplace examples of such behavior include smoke that first rises in a smooth, streamlined column from a cigarette, only to abruptly burst into wildly erratic turbulent flow (see illustration); and the unpredictable phenomena of the weather. See FLUID FLOW; TURBULENT FLOW.

At a more technical level, flaws in the newtonian view had become apparent by about 1900. The problem is that many newtonian systems exhibit behavior which is so exquisitely sensitive to the precise initial state or to even the slightest outside perturbation that, humanly speaking, determinism becomes a physically meaningless though mathematically valid concept. But even more is true. Many deterministic newtonian-system orbits are so erratic that they cannot be distinguished from a random process even though they are strictly determinate, mathematically speaking. Indeed, in the totality of newtonian-system orbits, erratic unpredictable randomness is overwhelmingly the most common behavior. See CLASSICAL MECHANICS; DETERMINISM; STOCHASTIC PROCESS.

One example of chaos is the evolution of life on Earth. Were this evolution deterministic, the governing laws of evolution would have had built into them anticipation of every natural crisis which has occurred over the centuries plus anticipation of every possible ecological niche throughout all time. Nature, however, economizes and uses the richness of opportunity available through chaos. Random mutations provide choices sufficient to

meet almost any crisis, and natural selection chooses the proper one. See ORGANIC EVOLUTION.

Another example concerns the problem that the human body faces in defending against all possible invaders. Again, nature appears to choose chaos as the most economical solution. Loosely speaking, when a hostile bacterium or virus enters the body, defense strategies are generated at random until a feedback loop indicates that the correct strategy has been found. A great challenge is to mimic nature and to find new and useful ways to harness chaos. See IMMUNITY.

Another matter for consideration is the problem of predicting the weather or the world economy. Both these systems are chaotic and can be predicted more or less precisely only on a very short time scale. Nonetheless, by recognizing the chaotic nature of the weather and the economy, it may eventually be possible to accurately determine the probability distribution of allowed events in the future given the present. At that point it may be asserted with mathematical precision that, for example, there is a 90% chance of rain 2 months from today. Much work in chaos theory seeks to determine the relevant probability distributions for chaotic systems. See WEATHER FORECASTING AND PREDICTION.

Finally, many physical systems exhibit a transition from order to chaos, as exhibited in the illustration, and much work studies the various routes to chaos. Examples include fibrillation of the heart and attacks of epilepsy, manic-depression, and schizophrenia. Physiologists are striving to understand chaos in these systems sufficiently well that these human maladies can be eliminated. See PERIOD DOUBLING.

Reduced to basics, chaos and noise are essentially the same thing. Chaos is randomness in an isolated system; noise is randomness entering this previously isolated system from the outside. If the noise source is included to form a composite isolated system, there is again only chaos. See ELECTRICAL NOISE. [J.Fo.]



Transition from order to chaos (turbulence) in a rising column of cigarette smoke. The initial smooth streamline flow represents order, while the erratic flow represents chaos.

**Chaparral** A vegetation formation characterized by woody plants of low stature (3.3–10 ft or 1–3 m tall), impenetrable because of tough, rigid, interlacing branches, with small, simple, waxy, evergreen, thick leaves. The term refers to evergreen oak, Spanish *chapparo*, and therefore is uniquely southwestern North American. This type of vegetation has its center in California and occurs continuously over wide areas of mountainous to sloping topography. The Old World Mediterranean equivalent is called maquis or macchie, with nomenclatural and ecological variants in the countries from Spain to the Balkans. Physiognomically similar vegetation occurs also in South Africa, Chile, and southwestern Australia in areas of Mediterranean climates, that is, with very warm, dry summers and maximum precipitation during the cool season. The floras of these five areas with Mediterranean climates are altogether different.

The characteristic species of the true chaparral of California include *Adenostema fasciculatum*, *Ceanothus cuneatus*, *Quercus dumosa*, *Heteromeles arbutifolia*, *Rhamnus californica*, *R. crocea*, and *Cercocarpus betuloides*, plus a host of endemic species of *Arctostaphylos* and *Ceanothus* and other Californian endemics, both shrubby and herbaceous. These plants determine the formation's physiognomy. It is a dense, uniform-appearing, evergreen, shrubby cover with sclerophyllous leaves and deep-penetrating roots.

Ecologically, chaparral occurs in a climate which is hot and dry in summer, cool but not much below freezing in winter, with little or no snow, and with excessive winter precipitation that leaches the soil of nutrients. The need for water and its supply are exactly out of phase.

Chaparral soils are generally rocky, often shallow, or of extreme chemistry such as those derived from serpentine, and are always low in fertility. In the very precipitous southern Californian mountains, soil erosion rates may be 0.04 in. (1 mm) per year over large watershed areas. [J.Ma.]



**Character recognition** The process of converting scanned images of machine-printed or handwritten text (numerals, letters, and symbols) into a computer-processable format; also known as optical character recognition (OCR). A typical OCR system contains three logical components: an image scanner, OCR software and hardware, and an output interface. The image scanner optically captures text images to be recognized. Text images are processed with OCR software and hardware. The process involves three operations: document analysis (extracting individual character images), recognizing these images (based on shape), and contextual processing (either to correct misclassifications made by the recognition algorithm or to limit recognition choices). The output interface is responsible for communication of OCR system results to the outside world.

Commercial OCR systems can largely be grouped into two categories: task-specific readers and general-purpose page readers. A task-specific reader handles only specific document types. Some of the most common task-specific readers read bank checks, letter mail, or credit-card slips. These readers usually utilize custom-made image-lift hardware that captures only a few predefined document regions. For example, a bank-check reader may scan just the courtesy-amount field (where the amount of the check is written numerically) and a postal OCR system may scan just the address block on a mail piece. Such systems emphasize high throughput rates and low error rates. Applications such as letter-mail reading have throughput rates of 12 letters per second with error rates less than 2%. The character recognizer in many task-specific readers is able to recognize both handwritten and machine-printed text.

General-purpose page readers are designed to handle a broader range of documents such as business letters, technical writings, and newspapers. These systems capture an image of a document page and separate the page into text regions and nontext regions. Nontext regions such as graphics and line drawings are often saved separately from the text and associated recognition results. Text regions are segmented into lines, words, and characters, and the characters are passed to the recognizer. Recognition results are output in a format that can be postprocessed by application software. Most of these page readers can read machine-written text, but only a few can read hand-printed alphanumeric. *See* COMPUTER; WORD PROCESSING. [S.N.Sh.; S.W.L.]

**Characteristic curve** A graphical display depicting complex nonlinear relationships in electronic circuits. A typical use is to show voltage-current relationships in semiconductor devices. Device amplification capabilities, for example, are exhibited by a characteristic plot which traces output current versus output voltage with a third controlling variable as a parameter. This control variable could be the base current of a bipolar junction transistor (BJT) or the gate-to-source voltage of a metal-oxide-semiconductor (MOS) transistor.

Other characteristics often included in transistor data sheets are displays of current gain versus bias current, gain versus frequency, and input and output impedances versus frequency. Less commonly, other graphical nonlinear relationships, such as the variation of thermocouple voltage with temperature or the dependence of electrical motor torque with current, also are known as characteristic curves.

In the past, characteristic curves were used as tools in the graphical solution of nonlinear circuit equations that are followed by relationships of this type. In current practice, this analysis is performed using computer packages for circuit simulation. Designers still use characteristic curves from data sheets, however, to evaluate relative performance capabilities when selecting devices, and to provide the information needed for a preliminary pencil-and-paper circuit design. *See* AMPLIFIER; ELECTRICAL MODEL; TRANSISTOR. [P.V.L.]

**Charadriiformes** A large, diverse, worldwide order of shore and aquatic birds. It may be closely related to the pigeons (Columbiformes) on the one side and to the cranes, rails, and their allies (Gruiformes) on the other. *See* COLUMBIFORMES; GRUIFORMES.

The order Charadriiformes is arranged into three suborders and 17 families as follows: (1) Charadrii, with superfamily Jacanoidea containing the families Jacanidae (jacanas; 8 species) and Rostratulidae (painted snipe; 2 species); superfamily Charadrioidea containing the families Graculavidae, Presbyornithidae, Haematopodidae (oyster catchers; 7 species), Charadriidae (plovers and lapwings; 64 species), Scolopacidae (sandpipers, curlews, phalaropes, and snipe; 86 species), Recurvirostridae (stilts and avocets; 10 species), Dromadidae (crab plovers; 1 species), Burhinidae (thick-knees; 9 species), and Glareolidae (pratincoles; 16 species); and superfamily Chionidoidea with the families Thinocoridae (seed snipe; 4 species) and Chionidae (sheathbills; 2 species). (2) Lari, with the families Stercorariidae (skuas, 5 species), Laridae (gulls and terns; 88 species), and Rynchopidae (skimmers; 3 species). (3) Alcae, with the single family Alcidae (auks, murre, and puffins; 23 species).

The three suborders of charadriiforms are quite different groups. The Charadrii are the typical shorebirds, usually found in marshy areas and along shores, but some are in dry areas, and a few, the phalaropes, are mainly aquatic. They can and fly well. Most live in flocks, although most breed solitarily in nests placed on the ground. Most feed on insects and other small animals; the seed snipes are mainly vegetarian. The Lari include the skuas, gulls, terns, and skimmers, predominantly aquatic birds that find their food by flying over the water. They are long-winged, excellent fliers with short legs, but they can walk well. The feet are webbed. Most species breed in large colonies. Alcae include only the alcids, which are true marine, swimming and diving birds found only in the Northern Hemisphere. They have webbed feet and reduced wings. Alcids are excellent divers, and swim underwater by using their wings, which are reduced to rather stiff, paddlelike structures. Alcids feed on fish and other aquatic animals. They breed in large colonies, on rocky ledges or in burrows. *See* AVES. [W.J.B.]

**Charcoal** A porous solid product containing 85–98% carbon produced by heating carbonaceous materials such as cellulose, wood, peat, and coals of bituminous or lower rank at 930–1100°F (500–600°C) in the absence of air.

Chars or charcoals from cellulose or wood are soft and friable. They are used chiefly for decolorizing solutions of sugar and other foodstuffs and for removing objectionable tastes and odors from water. Chars from nutshells and coal are dense, hard carbons. They are used in gas masks and in chemical manufacturing for many mixture separations. Another use is for the tertiary treatment of waste water. Residual organic matter is adsorbed effectively to improve the water quality. *See* ADSORPTION; CARBON. [J.H.Fi.]

**Charge-coupled devices** Semiconductor devices wherein minority charge is stored in a spatially defined depletion region (potential well) at the surface of a semiconductor, and is moved about the surface by transferring this charge to similar adjacent wells. The formation of the potential well is controlled by the manipulation of voltage applied to surface electrodes. Since a potential well represents a nonequilibrium state, it will fill with minority charge from normal thermal generation. Thus a charge-coupled device (CCD) must be continuously clocked or refreshed to maintain its usefulness. In general, the potential wells are strung together as shift registers. Charge is injected or generated at various input ports and then transferred to an output detector. By appropriate design to minimize the dispersive effects that are associated with the charge-transfer process, well-defined charge packets can be moved over relatively long distances through thousands of transfers.

There are several methods of controlling the charge motion, all of which rely upon providing a lower potential for the charge in the desired direction. When an electrode is placed in proximity to a semiconductor surface, the electrode's potential can control the near-surface potential within the semiconductor. The basis for this control is the same as for metal oxide semiconductor (MOS) transistor action. If closely spaced electrodes are at different voltages, they will form potential wells of different depths. Free charge will move from the region of higher potential to the one of lower potential.

An important property of a charge-coupled device is its ability to transfer almost all of the charge from one well to the next. Without this feature, charge packets would be quickly distorted and lose their identity. This ability to transfer charge is measured as transfer efficiency, which must be very good for the structure to be useful in long registers. Values greater than 99.9% per transfer are not uncommon. This means that only 10% of the original charge is lost after 100 transfers.

A second important property of a charge-coupled-device register is its lifetime. When the surface electrode is clocked high, the potential within the semiconductor also increases. Majority charge is swept away, leaving behind a depletion layer. If the potential is taken sufficiently high, the surface goes into deep depletion until an inversion layer is formed and adequate minority charge collected to satisfy the field requirements. The time it takes for minority charge to fill the well is the measure of well lifetime. The major sources of unwanted charge are: thermal diffusion of substrate minority charge to the edge of the depletion region, where it is collected in the well; electron-hole pair generation within the depletion region; and the emission of minority charge by traps. Surface-channel charge-coupled devices usually have a better lifetime, since surface-state trap emission is suppressed and the depletion regions are usually smaller. [M.R.Gu.]

The most significant current application of the charge-coupled-device concept is as an imaging device. Charge-coupled-device image sensors utilize the fact that silicon is sensitive to light. In fact, silicon is sensitive to wavelengths from about 400 to 1100 nanometers (from ultraviolet to near-infrared). When light photons penetrate the silicon surface, hole-electron pairs are created in the silicon. The number of hole-electron pairs created is a function of wavelength (photon energy), intensity (number of photons), and duration (length of time exposed to light).

In a charge-coupled-device image sensor, the light is focused upon an array of picture elements (pixels). These pixels collect the electrons as they are created. The number of electrons collected in each pixel is representative of the light intensity projected onto the sensor at that point. Periodically, the charges from all of the pixels are read out, and the image can then be reconstructed from the intensity and pixel location data.

There are two primary categories of image sensors. Linear image sensors have the pixels aligned along a central axis. Area image sensors have the pixels arranged in a rectangular (rows  $\times$  columns) array pattern. Linear image sensors require relative motion between the sensor and the object being scanned. The relative motion is precisely known so that, as the object is scanned one line at a time, it can then be reconstructed one line at a time. Area image sensors do not require this motion.

The resolution of area image sensors has become equivalent to photographic film, enabling the development of digital photography. Cameras with very large, very high resolution area image sensors provide professional photographers better final pictures than are obtainable with conventional film, while lower-resolution, lower-cost, digital charge-coupled-device cameras are available to consumers. See CAMERA.

A miniaturized charge-coupled-device camera allows a dentist to see inside a patient's mouth or a physician to see inside a patient's body. Charge-coupled-device area imagers are also used in intraoral dental x-ray systems. Charge-coupled-device-based systems with very large area image sensors have been

introduced in mammography, to image x-rays of the human breast.

Astronomers have long used charge-coupled device area image sensor cameras mounted on very high power telescopes. By synchronizing the motion of the telescope with the Earth's rotation, the camera can "stare" at one spot in space for hours at a time. The long integration times allow distant objects to be imaged that are otherwise invisible. To keep the sensor from being saturated with thermally generated charge, these cameras typically cool the charge-coupled-device chip down to  $-50^\circ$  to  $-100^\circ\text{C}$  ( $-58^\circ$  to  $-148^\circ\text{F}$ ). See ASTRONOMICAL PHOTOGRAPHY; INTEGRATED CIRCUITS; SEMICONDUCTOR. [S.O.]

**Charge-density wave** A possible ground state of a metal in which the conduction-electron charge density is sinusoidally modulated in space. The periodicity of this extra modulation is unrelated to the lattice periodicity. Instead, it is determined by the dimension of the conduction-electron Fermi surface in momentum space. See FERMI SURFACE.

In a quasi-one-dimensional metal, for which conduction electrons are mobile in one direction only, a charge-density wave can be caused by a Peierls instability. This mechanism involves interaction between the electrons and a periodic lattice distortion having a wave vector  $Q$  parallel to the conduction axis. The linear-chain metal niobium triselenide ( $\text{NbSe}_3$ ) is prototypical.

For isotropic metals, and quasi-two-dimensional metals, Coulomb interactions between electrons are the cause of a charge-density wave instability. The exchange energy, an effect of the Pauli exclusion principle, and the correlation energy, an effect of electron-electron scattering, both act to stabilize a charge-density wave. However, the electrostatic energy attributable to the charge modulation would suppress a charge-density wave were it not for a compensating charge response of the positive-ion lattice. See EXCHANGE INTERACTION; EXCLUSION PRINCIPLE.

A wavelike displacement of this lattice will generate a positive-ion charge density that almost cancels the electronic charge modulation of the charge-density wave. A typical value of the displacement amplitude is about 1% of the lattice constant. Ion-ion repulsive interactions must be small in order to permit such a distortion. Consequently, charge-density waves are more likely to occur in metals having small elastic moduli. See BAND THEORY OF SOLIDS; CRYSTAL STRUCTURE; SPIN-DENSITY WAVE. [A.W.O.]

**Charged particle beams** Unidirectional streams of charged particles traveling at high velocities. Charged particles can be accelerated to high velocities by electromagnetic fields. They are then able to travel through matter (termed an absorber), interacting with it, losing energy, and causing various effects important in many applications. Examples of charged particles are electrons, positrons, protons, antiprotons, alpha particles, and any ions (atoms with one or several electrons removed or added). In addition, some particles are produced artificially and may be short-lived (pions, muons).

In traveling through matter, charged particles interact with nuclei, producing nuclear reactions and elastic and inelastic collisions with the electrons (electronic collisions) and with entire atoms of the absorber (atomic collisions). Usually, in its travel through matter a charged particle makes few or no nuclear reactions or inelastic nuclear collisions, but many electronic and atomic collisions. The average distance between successive collisions is called the mean free path,  $\lambda$ . In solids, it is of the order of 10 cm (4 in.) for nuclear reactions. It ranges from the diameter of the atoms (about  $10^{-10}$  m) to about  $10^{-7}$  m for electronic collisions. The mean free path,  $\lambda$ , depends on the properties of the particle and, most importantly, on its velocity.

If a charged particle is accelerated, it can emit photons called bremsstrahlung. This process is of great importance for electrons as well as for heavy ions whose kinetic energies are much greater than their rest energies. It is used extensively for the production of x-rays in radiology. See BREMSSTRAHLUNG.

In gases, all electrons are bound to individual atoms or molecules in well-defined orbits. These electrons can be moved into other bound orbits (excitation) requiring a well-defined energy. Another possibility is the complete removal of the electron from the atom (ionization), requiring an energy equal to or greater than the ionization energy for the particular electron. In both processes, the charged particle will lose energy and will be deflected very slightly.

There are some major differences between electron beams and beams of heavier particles. In general, the path of an electron will be a zigzag. Angular deflections in the collisions will frequently be large. Electron beams therefore tend to spread out laterally, and the number of primary electrons in the beam at a depth  $x$  in the absorber decreases rapidly.

In general, for the same dose (the energy deposited per gram along the beam line) heavy charged particles will produce, because of their higher local ionization, larger biological effects than electrons (which frequently are produced by x-rays). See NUCLEAR RADIATION (BIOLOGY); RADIATION BIOLOGY; RADIATION INJURY (BIOLOGY).

Electron beams are used in the preservation of food. In medicine, electron beams are used extensively to produce x-rays for both diagnostic and therapeutic (cancer irradiation) purposes. Also, in radiation therapy, deuteron beams incident on Be and  $^3\text{H}$  targets are used to produce beams of fast neutrons, which in turn produce fast protons, alpha particles, and carbon, nitrogen, and oxygen ions in the irradiated tissue. Energetic pion, proton, alpha, and heavier ion beams can possibly be used for cancer therapy. See RADIOLOGY.

Charged particle beams are used in many methods of chemical and solid-state analysis. Nuclear activation analysis can be performed with heavy ions. See ACTIVATION ANALYSIS; ELECTRON DIFFRACTION; ELECTRON SPECTROSCOPY; SECONDARY ION MASS SPECTROMETRY (SIMS). [H.Bi.]

Beams of nuclei with lifetimes as short as  $10^{-6}$  s are used for studies in nuclear physics, astrophysics, biology, and materials science. Nuclear beams (or heavy-ion beams) are usually produced by accelerating naturally available stable isotopes. However, radioactive nuclei, most of which do not occur naturally on Earth, must be produced as required in nuclear reactions by using various accelerated beams. Because these radioactive nuclei are produced by the nuclear reactions of primary beams, they are called secondary particles and beams of such nuclei are called radioactive secondary beams. See RADIOACTIVITY.

Radioactive secondary beams have made possible the study of the structure of nuclei far from stability. Another important application occurs in the study of nuclear reactions of importance in hot stars and in supernovae, which are crucial for understanding nucleosynthesis in the universe. See NUCLEAR STRUCTURE; NUCLEOSYNTHESIS. [I.T.]

**Charged particle optics** The branch of physics concerned with the motion of charged particles under the influence of electric and magnetic fields. A positively charged particle that moves in an electric field experiences a force in the direction of this field. If the particle falls in the field from a potential of  $U$  volts to a potential zero, its energy gain, measured in electronvolts, is equal to the product of  $U$  and the particle's charge. For example, if a singly and a doubly charged particle are accelerated by a potential drop of 100 V, the two particles will gain energies of 100 eV and 200 eV, respectively. If both particles were initially at rest, they would have final velocities proportional to the square root of  $K/m$ , where  $K$  is the energy increase and  $m$  is the mass of the particle. This relation describes the velocities of energetic particles accurately as long as these velocities are small compared to the velocity of light  $c \approx 300,000$  km/s (186,000 mi/s), a speed that cannot be exceeded by any particle. See ELECTRIC FIELD; ELECTROSTATICS.

If an ensemble of ions of equal energies but of different masses is accelerated simultaneously, the ion masses can be determined

from their arrival times after a certain flight distance. Such time-of-flight mass spectrometers have successfully been used, for instance, to investigate the masses of large molecular ions, up to and beyond 350,000 atomic mass units. See TIME-OF-FLIGHT SPECTROMETERS.

If a homogeneous electric field is established between two parallel-plate electrodes at different potentials, a charged particle in the space between the electrodes will experience a force in the direction perpendicular to them. If initially the particle moved parallel to the electrodes, it will be deflected by the electric force and move along a parabolic trajectory. Magnetic fields also deflect charged particles. In contrast to electrostatic fields, however, magnetic fields change only the direction of a particle trajectory and not the magnitude of the particle velocity. Charged particles that enter a magnetic field thus move along circles whose radii increase with the products of their velocities and their mass-to-charge ratios,  $m/q$ . If initially all particles start at the same potential  $U$  and are accelerated to the potential zero, they will move along radii that are proportional to the square root of  $U(m/q)$ . Thus, particles of different mass-to-charge ratios can be separated in a magnetic sector field.

A sector-field mass analyzer can be used to determine the masses of atomic or molecular ions in a cloud of such ions. Such systems can also be used to purify a beam of ions that are to be implanted in semiconductors in order to fabricate high-performance transistors and diodes. Finally, such magnetic sector fields are found in large numbers in all types of particle accelerators. See ION IMPLANTATION; MASS SPECTROSCOPE.

An Einzel lens consists of three cylindrical tubes, the middle one of which is at a higher potential than the outer two. Positively charged particles entering such a device are first decelerated and then accelerated back to their initial energies. Axially symmetric magnetic lenses have also been constructed. Such lenses, also called solenoids, consist mainly of a coil of wire through which an electric current is passed. The charged particles are then constrained to move more or less parallel to the axis of such a coil. Axially symmetric electric and magnetic lenses are used extensively to focus low-energy particle beams. Particularly important applications are in television tubes and in electron microscopes. See CATHODE-RAY TUBE; ELECTRON MICROSCOPE; ELECTROSTATIC LENS; MAGNETIC LENS; PICTURE TUBE.

By passing charged particles through electrode or pole-face arrangements, a particle beam can also be focused toward the optic axis. In such quadrupole lenses the electric or the magnetic field strengths, and therefore the forces that drive the charged particles toward or away from the optic axis, increase linearly with the distance from the axis. While quadrupole lenses are found in systems in which low-energy particle beams must be focused, for instance, in mass spectrometers, such lenses have become indispensable for high-energy beams. Consequently, quadrupole lenses, especially magnetic ones, are found in many types of particle accelerators used in research in, for example, nuclear and solid-state physics, as well as in cancer irradiation treatment facilities. See CHARGED PARTICLE BEAMS; ELECTRON LENS; ELECTRON MOTION IN VACUUM; PARTICLE ACCELERATOR. [H.W.]

**Charles' law** A thermodynamic law, also known as Gay-Lussac's law, which states that at constant pressure the volume of a fixed mass or quantity of gas varies directly with the absolute temperature. Conversely, at constant volume the gas pressure varies directly with the absolute temperature. See GAS. [F.H.R.]

**Charm** A term used to describe a class of elementary particles. Ordinary atoms of matter consist of a nucleus composed of neutrons and protons and surrounded by electrons. Over the years, however, a host of other particles with unexpected properties have been found, associated with both electrons (leptons) and protons (hadrons). The hadrons number in the hundreds, and can be explained as composites of more fundamental constituents, called quarks. The originally simple situation of having

an up quark ( $u$ ) and a down quark ( $d$ ) has evolved as several more varieties or flavors have had to be added. These are the strange quark ( $s$ ) with the additional property or quantum number of strangeness to account for the unexpected characteristics of a family of strange particles; the charm quark ( $c$ ) possessing charm and no strangeness, to explain the discovery of the  $J/\psi$  particles, massive states three times heavier than the proton; and a fifth quark ( $b$ ) to explain the existence of the even more massive upilon ( $\gamma$ ) particles. See HADRONS; J PARTICLE; QUARKS.

The members of the family of particles associated with charm fall into two classes: those with hidden charm, where the states are a combination of charm and anticharm quarks ( $c\bar{c}$ ), charmonium; and those where the charm property is clearly evident, such as the  $D^+$  ( $c\bar{d}$ ) meson and  $\Lambda_c^+$  ( $cuu$ ) baryon. Although reasonable progress has been made in the study of charmed states, much work remains to be done. See ELEMENTARY PARTICLE. [N.P.S.]

**Charophyceae** A group of branched, filamentous green algae, commonly known as the stoneworts, brittleworts, or muskgrasses, that occur mostly in fresh- or brackish-water habitats. They are important as significant components of the aquatic flora in some locales, providing food for waterfowl and protection for fish and other aquatic fauna; as excellent model systems for cell biological research; and as a unique group of green algae thought to be more closely related to the land plants.

Charophytes are multicellular, branched, macroscopic filaments from a few inches to several feet in length. Colorless rhizoidal filaments anchor the plants to lake bottoms and other substrates. The main filaments are organized into short nodes forming whorls of branches, and much longer (up to 6 in. or 15 cm) internodal cells. The general morphology varies with environmental conditions such as depth of the water, light levels, and amount of wave action. Reproductive structures occur at the nodes and consist of egg cell-containing structures, the nucules, and sperm cell-containing structures called globules.

Based on the morphology of the vegetative filaments and the reproductive structures, six extant genera are recognized: *Chara*, *Nitella*, *Tolypella*, *Nitellopsis*, *Lamprothamnium*, and *Lychnothamnus*. There is no agreement on how many valid species exist, but the maximum number of living species is probably fewer than 100. Deoxyribonucleic acid (DNA) sequencing indicates that the charophytes are a distinct natural group that should be recognized at some taxonomic level (for example, as an order, Charales, or as a class, Charophyceae). See ALGAE; CHLOROPHYCOTA. [R.L.Cha.]

**Cheese** A product of milk, selectively concentrated from major milk components. It is generally rich in flavor and contains high-quality nutrients. There are many varieties of cheese, all produced in the following general manner. Raw or pasteurized milk is clotted by acid, rennet, or both. The curd is cut and shaped into the special form of the cheese with or without pressing. Salt is added, or the cheese is brined after pressing.

Acid is produced during manufacture of cheese by fermentation of the milk sugar, lactose. This fermentation is initiated by the addition of a culture of specially selected acid bacteria (starter culture) to the milk. Acid production in cheese curd retards growth of bacteria that cause undesirable fermentations in cheese. Moreover, it favors the expulsion of the whey and the fusion of the curd particles. Fresh cheese (cottage or cream cheese) does not require any ripening, and it is sold soon after it is made. Other varieties of cheese are cured or ripened to obtain the desirable consistency, flavor, or aroma. The flavor and aroma of cheese are obtained by a partial breakdown of mild proteins and fat by the action of microbial, milk, and rennet enzymes. In hard varieties (Cheddar, Gouda, Edam, Emmentaler or Swiss, and provolone) this is done by the microorganisms in the interior of cheese; in semisoft or soft types (Limburger, Camembert, and

Roquefort) by the organisms on, or in contact with, the surface of cheese.

Processed cheese is produced from cheeses of different ages by blending. The mixture, melted with the aid of emulsifying salts (citrate and phosphates), is packed in sealed containers (tins, paperboard, foil, or plastic). Few bacteria other than spore-formers survive the heat treatment. No substantial growth of flora occurs in well-preserved process cheese, but spoilage by anaerobic spore-formers may occur. [N.O.]

Key materials for cheesemaking include fresh or precultured milk, cultures, milk-coagulating enzyme preparations, special microorganisms, salt, and beta carotene or annatto color. The amounts used and the manner in which these materials are applied strongly influence the cheese character. Cheese may be made from the milk of the cow, sheep, goat, water buffalo, and other mammals, but the milk of the cow is most widely used despite some limitations. Sheep milk and water buffalo milk generally give more flavor to the cheeses, and the color is uniformly white because of a lack of carotene in such mammalian milks, but they are more expensive to make into cheese.

Two major classes of cheeses exist, fresh and ripened. Fresh cheeses are simpler to make than ripened, are more perishable, and do not develop as intense flavors, but give a mild acid, slightly aromatic flavor and soft, smooth texture. Three basic groups characterize fresh cheese types: group I—ricotta and Broccio; group II—cottage, Neufchatel, and cream; and group III—mozzarella. Most ripened cheeses are contained in one of six basic groups. The characteristic cheeses in each group include: group I—Cheddar and Monterey; group II—Swiss (Emmentaler) and Gruyère; group III—Edam and Gouda; group IV—Muenster, brick, and Limburger; group V—provolone; and group VI—Camembert, Brie, and bleu.

Processed cheese is made from natural types. Nearly any natural cheese can be processed, except that for blue cheese technical difficulties cause blackening of the blue mold due to the high heat. Processed cheese is produced by grinding selected lots of natural cheese and adding cream, color, salt, and emulsifying agents. Processed cheese foods and spreads are made similarly, but include more water and less protein, fat, and other solids. See MILK. [F.V.K.]

**Chelation** A chemical reaction or process involving chelate ring formation and characterized by multiple coordinate bonding between two or more of the electron-pair-donor groups of a multidentate ligand and an electron-pair-acceptor metal ion. The multidentate ligand is usually called a chelating agent, and the product is known as a metal chelate compound or metal chelate complex. Metal chelate chemistry is a subdivision of coordination chemistry and is characterized by the special properties resulting from the utilization of ligands possessing bridged donor groups, two or more of which coordinate simultaneously to a metal ion. See COORDINATION CHEMISTRY.

Many of the functional groups of both synthetic and naturally occurring organic compounds can form coordinate bonds to metal ions, producing metal-organic complexes or chelates, many of which are biologically active. Thus chelate compounds are frequently found in an interdisciplinary field of science called bioinorganic chemistry. The biological significance of chelates is demonstrated by the large number of biologically important compounds that are either metal chelates or chelating agents. Included in this group are the alpha amino acids, peptides, proteins, enzymes, porphyrins (such as hemoglobin), corrins (such as vitamin B<sub>12</sub>), catechols, hydroxypolycarboxylic acids (such as citric acid), ascorbic acid (vitamin C), polyphosphates, nucleosides and other genetic compounds, pyridoxal phosphate (vitamin B<sub>6</sub>), and sugars. The ubiquitous green plant pigment, chlorophyll, is a magnesium chelate of a tetradentate ligand formed from a modified porphyrin compound, and similarly the oxygen transport heme of red blood cells contains an Fe(II) chelate. See BIOINORGANIC CHEMISTRY; ORGANOMETALLIC COMPOUND.

The ability of chelating agents to reduce the chemical activity of metal ions has found extensive application in many areas of science and industry. Ethylenediaminetetraacetic acid (EDTA), a hexadentate chelating agent, has been employed commercially for water softening, boiler scale removal, industrial cleaning, soil metal micronutrient transport, and food preservation. Nitrilotriacetic acid (NTA) is a tetradentate chelating agent which, because of lower cost, has taken over some of the commercial applications of EDTA. Many commercially important dyes and pigments, such as copper phthalocyanines, are chelate compounds. Humic and fulvic acids are plant degradation products in lake and sea-water sediments that have been suggested as important chelating agents which regulate metal ion balance in natural waters. By virtue of its abundance, low toxicity, low cost, and good chelating tendencies for metal ions that produce water hardness, the tripolyphosphate ion (as its sodium salt) is used in large quantities as a builder in synthetic detergents. Both synthetic ion exchangers and the mineral zeolites are chelating ion-exchange resins which are used in analytical and water-softening applications. As final examples, less conventional chelating agents are the multidentate, cyclic ligands, termed collectively crown ethers, which are particularly suited for the complexation of the alkali and alkaline-earth metals. See ETHYLENEDIAMINETETRAACETIC ACID. [A.E.M.; R.J.Mo.]

**Chelicerata** A subphylum of the phylum Arthropoda. The Chelicerata can be defined as those arthropods with the anteriormost appendages as a pair of small pincers (chelicerae) followed usually by pedipalps and four pairs of walking legs, and with the body divided into two parts: the prosoma (corresponding approximately to the cephalothorax of many crustaceans) and the opisthosoma (or abdomen). There are never antennae or mandibles (lateral jaws). The Chelicerata comprise three classes: the enormous group Arachnida (spiders, ticks, mites, scorpions, and related forms); the Pycnogonida (sea spiders or nobody-crabs); and the Merostomata (including the Xiphosurida or horseshoe crabs). See ARACHNIDA; MEROSTOMATA; PYCNOGONIDA; XIPHOSURIDA.

Both Merostomata and Pycnogonida are marine, but the enormous numbers and varied forms of the Arachnida are almost entirely terrestrial. The respiratory structures of chelicerates include gills, book-lungs, and tracheae. Sexes are normally separate, with genital openings at the anterior end of the opisthosoma. Some mites and other small chelicerates are omnivorous scavengers, but the majority of species of larger chelicerates are predaceous carnivores at relatively high trophic levels in their particular ecotopes. See ARTHROPODA. [W.D.R.H.]

**Chelonia** An order of the Reptilia, subclass Anapsida, including the turtles, terrapins, and tortoises. This order is also known as the Testudines. The group first appeared in the Triassic, and its representatives are among the commonest fossils from that time on. Members of the order are most frequently found in fresh-water streams, lakes, and ponds or in marshy areas. However, a number of strictly terrestrial species are known, and several are marine. Turtles occur on all the major continents and continental islands in tropic and temperate regions. The marine forms are basically tropical in distribution, but some individuals stray into temperate waters. See ANAPSIDA.

The living turtles are usually divided into two major groups, the suborders Pleurodira and Cryptodira, based upon the structures of the head and neck. The pleurodires have spines on the most posterior cervicals (neck vertebrae) and the head is retractile laterally. In the cryptodires the cervical spines are uniformly reduced and the head is folded directly back to within the shell. In several cryptodires, notably in the marine turtles, the neck is secondarily nonretractile because of a reduction in the shell.

The Chelonia differ from most other vertebrates in possessing a hard bony shell which encompasses and protects the body. The shell is made up of a dorsal portion, the carapace, and a ventral

segment, the plastron, connected by soft ligamentous tissue or a bony bridge. The carapace is composed of the greatly expanded ribs and dorsal vertebrae overlain by a series of enlarged dermal ossifications and an outer covering of tough skin or horny scales. The plastron is similarly arranged with remnants of the interclavicle, clavicles, and gastralia fused with dermal ossifications and covered by skin or scales. Other peculiarities associated with the shell include the fusion of the ribs to the vertebrae and the reduction of trunk muscles, the presence of the pectoral girdle completely inside the ribs (found in no other animal), the highly modified short, thick humerus and femur, and the lungs attached dorsally to the shell. In addition, living turtles differ from the tuatara, snakes, lizards, and crocodilians in having an anapsid skull, no true teeth but horny beaks on the jaws, an immovable quadrate, and a single median penis in males.

The rigid bony shell of turtles imposes a basic body plan subject to relatively little variation. The principal obvious differences between them are in the shell shape, limbs, head, and neck. The general outline of the shell is variable, but in most forms the shell is moderately high-arched and covered with epidermal scales. The majority of turtles have limbs more or less adapted to aquatic or semiaquatic life with moderate to well-developed palmate webbed feet. However, in strictly terrestrial forms such as the tortoises, the limbs are elephantine with the weight of the body being borne on the flattened sole of the feet.

Associated with the tendency of most turtles toward a life in or near water is the auditory apparatus. Even though an eardrum is present, hearing is adapted to picking up sounds transmitted through the water or substratum. However, there is evidence that airborne sound can be heard. Vision is also important, and turtles have color vision. Most of the species are gregarious and diurnal, and territoriality is unknown in the order.

The courtship patterns of various turtles are distinctive. In general, aquatic forms mate in the water, but tortoises breed on land. The male mounts the female from above, and fertilization is internal. Sperm may be stored in the cloacal region of the female for extended periods before fertilization. Because of the presence of the large median penis in males, the sexes of many species can be distinguished by the longer and broader tail of the male. All turtles lay shelled eggs which are buried in sand or soil in areas where females congregate. The shell is calcareous in most forms, but the marine turtles have leathery shells. Eggs are rather numerous, as many as 200 being laid by a single individual in some species, and are highly valued as human food. Incubation takes 60–90 days, and the little turtle cuts its way out of the shell with a small horny egg caruncle at the end of the snout.

Turtles feed on all types of organisms. Aquatic species may eat algae, higher plants, mollusks, crustaceans, insects, or fishes; terrestrial forms are similarly catholic in tastes. Most species are omnivores, but some have very specialized diets. The edges and internal surfaces of the horny beaks of these reptiles are frequently denticulate and modified to form specialized mechanisms adapted to handle particular food items. [J.M.S.]

**Chemical bonding** The force that holds atoms together in molecules and solids. Chemical bonds are very strong. To break one bond in each molecule in a mole of material typically requires an energy of many tens of kilocalories.

It is convenient to classify chemical bonding into several types, although all real cases are mixtures of these idealized cases. The theory of the various bond types has been well developed and tested by theoretical chemists. See COMPUTATIONAL CHEMISTRY; MOLECULAR ORBITAL THEORY; QUANTUM CHEMISTRY.

The simplest chemical bonds to describe are those resulting from direct coulombic attractions between ions of opposite charge, as in most crystalline salts. These are termed ionic bonds. See COULOMB'S LAW; IONIC CRYSTALS; STRUCTURAL CHEMISTRY.

Other chemical bonds include a wide variety of types, ranging from the very weak van der Waals attractions, which bind neon atoms together in solid neon, to metallic bonds or metallike

bonds, in which very many electrons are spread over a lattice of positively charged atom cores and give rise to a stable configuration for those cores. See CRYSTAL STRUCTURE; INTERMOLECULAR FORCES.

The covalent bond, in which two electrons bind two atoms together, as in

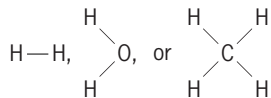

is the most characteristic link in chemistry. The theory that accounts for it is a cornerstone of chemical science. The physical and chemical properties of any molecule are direct consequences of its particular detailed electronic structure. Yet the theory of any one covalent chemical bond, for example, the H—H bond in the hydrogen molecule, has much in common with the theory of any other covalent bond, for example, the O—H bond in the water molecule. The current theory of covalent bonds both treats their qualitative features and quantitatively accounts for the molecular properties which are a consequence of those features. The theory is a branch of quantum theory. See NONRELATIVISTIC QUANTUM THEORY; QUANTUM CHEMISTRY.

The problem of the proper description of chemical bonds in molecules that are more complicated than H<sub>2</sub> has many inherent difficulties. The qualitative theory of chemical bonding in complex molecules preserves the use of many chemical concepts that predate quantum chemistry itself; among these are electrostatic and steric factors, tautomerism, and electronegativity. The quantitative theory is highly computational in nature and involves extensive use of computers and supercomputers.

The number of covalent bonds which an atom can form is called the valence and is determined by the detailed electron configuration of the atom. An extremely important case is that of carbon. In most of its compounds, carbon forms four bonds. When these connect it to four other atoms, the directions of the bonds to these other atoms normally make angles of about 109° to one another, unless the attached atoms are crowded or constrained by other bonds. That is, covalent bonds have preferred directions. However, in accord with the idea that carbon forms four bonds, it is necessary to introduce the notion of double and triple bonds. Thus in the structural formula of ethylene, C<sub>2</sub>H<sub>4</sub> (1), all lines denote covalent bonds, the double line connecting

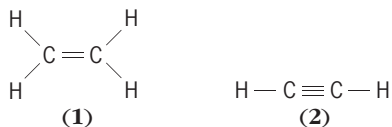

the carbon atoms being a double bond. Such double bonds are distinctly shorter, almost twice as stiff, and require considerably more energy to break completely than do single bonds. However, they do not require twice as much energy to break as a single bond. Similarly, acetylene (2) is written with a triple bond, which is still shorter than a double bond. A carbon-carbon single bond has a length close to  $1.54 \times 10^{-8}$  cm, whereas the triple bond is about  $1.21 \times 10^{-8}$  cm long. See BOND ANGLE AND DISTANCE; VALENCE.

Many substances have some bonds which are covalent and others which are ionic. Thus in crystalline ammonium chloride, NH<sub>4</sub>Cl, the hydrogens are bound to nitrogen by electron pairs, but the NH<sub>4</sub> group is a positive ion and the chlorine is a negative ion.

Both electrons of a covalent bond may come from one of the atoms. Such a bond is called a coordinate or dative covalent bond or semipolar double bond, and is one example of the combination of ionic and covalent bonding.

The hydrogen bond is a special bond in which a hydrogen atom links a pair of other atoms. The linked atoms are normally oxygen, fluorine, chlorine, or nitrogen. These four elements are

all quite electronegative, a fact which favors a partially ionic interpretation of this kind of bonding. See ELECTRONEGATIVITY; HYDROGEN BOND. [R.G.P]

**Chemical conversion** A chemical manufacturing process in which chemical transformation takes place, that is, the product differs chemically from the starting materials. Most chemical manufacturing processes consist of a sequence of steps, each of which involves making some sort of change in either chemical makeup, concentration, phase state, energy level, or a combination of these, in the materials passing through the particular step. If the changes are of a strictly physical nature (for example, mixing, distillation, drying, filtration, adsorption, condensation), the step is referred to as a unit operation. If the changes are of a chemical nature, where conversion from one chemical species to another takes place (for example, combustion, polymerization, chlorination, fermentation, reduction, hydrolysis), the step is called a unit process. Some steps involve both, for example, gas absorption with an accompanying chemical reaction in the liquid phase. The term chemical conversion is used not only in describing overall processes involving chemical transformation, but in certain contexts as a synonym for the term unit process. The chemical process industry as a whole has tended to favor the former usage, while the petroleum industry has favored the latter. See CHEMICAL PROCESS INDUSTRY; UNIT PROCESSES.

Another usage of the term chemical conversion is to define the percentage of reactants converted to products inside a chemical reactor or unit process. This quantitative usage is expressed as percent conversion per pass, in the case of reactors where unconverted reactants are recovered from the product stream and recycled to the reactor inlet. See CHEMICAL ENGINEERING. [W.F.F]

**Chemical dynamics** That branch of physical chemistry which seeks to explain time-dependent phenomena, such as energy transfer and chemical reaction, in terms of the detailed motion of the nuclei and electrons which constitute the system.

In principle, it is possible to prepare two reagents in specific quantum states and to determine the quantum-state distribution of the products. In practice, this is very difficult, and experiments have mostly been limited to preparing one reagent or to determining some aspect of the product distribution. This approach yields data concerning the detailed aspects of the dynamics.

**Energy distribution.** An important question regarding the dynamics of chemical reactions has to do with the product energy distribution in exothermic reactions. For example, because the hydrogen fluoride (HF) molecule is more strongly bound than the H<sub>2</sub> molecule, reaction (1) releases a considerable amount of



energy (more than 30 kcal/mol or 126 kJ/mol). The two possible paths for this energy release to follow are into translations, that is, with HF and H speeding away from each other, or into vibrational motion of HF.

In this case it is vibration, and this has rather dramatic consequences; the reaction creates a population inversion among the vibrational energy levels of HF—that is, the higher vibrational levels have more population than the lower levels—and the emission of infrared light from these excited vibrational levels can be made to form a chemical laser. A number of other reactions also give a population inversion among the vibrational energy levels, and can thus be used to make lasers.

**Most effective energy.** The rates of most chemical reactions are increased if they are given more energy. In macroscopic kinetics this corresponds to increasing the temperature, and most reactions are faster at higher temperatures. It seems reasonable, though, that some types of energy will be more effective in accelerating the reaction than others. For example, in reaction (2),



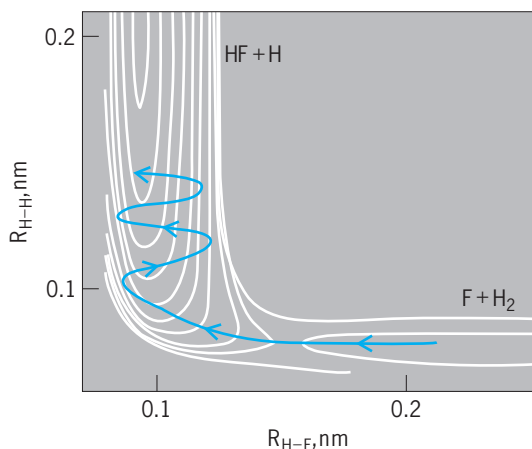

Contour plot of the potential energy surface for the reaction  $F + H_2 = HF + H$ , with a typical reactive trajectory indicated.

where potassium (K) reacts with hydrogen chloride (HCl) to form potassium chloride (KCl), studies have shown that if HCl is vibrationally excited (by using a laser), this reaction is found to proceed approximately 100 times faster, while the same amount of energy in translational kinetic energy has a smaller effect. Here, therefore, vibrational energy is much more effective than translational energy in accelerating the reaction.

For reaction (1), however, translational energy is more effective than vibrational energy in accelerating the reaction. The general rule of thumb is that vibrational energy is more effective for endothermic reactions (those for which the new molecule is less stable than the original molecule), while translational energy is most effective for exothermic reactions.

**Lasers.** Lasers are also important for probing the dynamics of chemical reactions. Because they are light sources with a very narrow wavelength, they are able to excite molecules to specific quantum states (and also to detect what states molecules are in), an example of which is reaction (2). For polyatomic molecules—that is, those with more than two atoms—there is the even more interesting question of how the rate of reaction depends on which vibration is excited.

For example, when the molecule allyl isocyanide,  $CH_2=CH-CH_2-NC$ , is given sufficient vibrational energy, the isocyanide part ( $-NC$ ) will rearrange to the cyanide ( $-CN$ ) configuration. A laser can be used to excite a C-H bond vibrationally. An interesting question is whether the rate of the rearrangement process depends on which C-H bond is excited. Only with a laser is it possible to excite different C-H bonds and begin to answer such questions. This question of mode-specific chemistry—whether excitation of specific modes of a molecule causes specific chemistry to result—has been a subject of great interest. (For the example above, the reaction is fastest if the C-H bond closest to the NC group is excited.) Mode-specific chemistry would allow much greater control over the course of chemical reactions, and it would be possible to accelerate the rate of some reactions (or reactions at one part of a molecule) and not others. See LASER.

**Theoretical methods.** The goal of chemical dynamics is to understand kinetic phenomena from the basic laws of molecular mechanics, and it is thus a field which sees close interplay between experimental and theoretical research. Many different theoretical models and methods have been useful in understanding and analyzing the phenomena described above. Probably the single most useful approach has been the calculation of classical trajectories. Assuming that the potential energy function or a reasonable approximation is known for the three atoms in reaction (1), for example, it is possible by use of electronic computers to calculate the classical motion of the three atoms. It is thus an easy matter to give the initial molecule more or less vibra-

tional or translational energy, and then compute the probability of reaction. Similarly, the final molecule and atom can be studied to see where the energy appears, that is, as translation or as vibration.

It is thus a relatively straightforward matter theoretically to answer the questions and to see whether or not mode-specific excitation leads to significantly different chemistry than simply increasing the temperature under bulk conditions.

The most crucial step in carrying out these calculations is obtaining the potential energy surface—that is, the potential energy as a function of the positions of the atoms—for the system. The illustration shows a plot of the contours of the potential energy surface for reaction (1). Even without carrying out classical trajectory calculations, it is possible to deduce some of the dynamical features of this reaction; for example, the motion of the system first surmounts a small potential barrier, and then it slides down a steep hill, turning the corner at the bottom of the hill. It is evident that such motion will cause much of the energy released in going down the hill to appear in vibrational motion of HF.

This and other theoretical methods have interacted strongly with experimental research in helping to understand the dynamics of chemical reactions. See CHEMICAL KINETICS; INORGANIC PHOTOCHEMISTRY. [P.R.B.; W.H.M.]

**Chemical ecology** The study of ecological interactions mediated by the chemicals that organisms produce. These substances, known as allelochemicals, serve a variety of functions. They influence or regulate interspecific and intraspecific interactions of microorganisms, plants, and animals, and operate within and between all trophic levels—producers, consumers, and decomposers—and in terrestrial, fresh-water, and marine ecosystems.

Function is an important criterion for the classification of allelochemicals. Allelochemicals beneficial to the emitter are called allomones; those beneficial to the recipient are called kairomones. An allomone to one organism can be a kairomone to another. For example, floral scents benefit the plant (allomones) by encouraging pollinators, but also benefit the insect (kairomones) by providing a cue for the location of nectar.

The chemicals involved are diverse in structure and are often of low molecular weight (<10,000). They may be volatile or nonvolatile; water-soluble or fat-soluble. Proteins, polypeptides, and amino acids are also found to play an important role.

Plant allelochemicals are often called secondary compounds or metabolites to distinguish them from those chemicals involved in primary metabolism, although this distinction is not always clear.

**Chemical defense in plants.** Perhaps to compensate for their immobility, plants have made wide use of chemicals for protection against competitors, pathogens, herbivores, and abiotic stresses. A chemically mediated competitive interaction between higher plants is referred to as allelopathy. Allelopathy appears to occur in many plants, may involve phenolics or terpenoids that are modified in the soil by microorganisms, and is at least partly responsible for the organization of some plant communities. See ALLELOPATHY.

Chemicals that are mobilized in response to stress or attack are referred to as active or inducible chemicals, while those that are always present in the plant are referred to as passive or constitutive. In many plants, fungus attack induces the production of defensive compounds called phytoalexins, a diverse chemical group that includes isoflavonoids, terpenoids, polyacetylenes, and furanocoumarins. See PHYTOALEXINS.

Defensive chemicals can be induced by herbivore attack. There has been increasing evidence that inducible defenses, such as phenolics, are important in plant-insect interactions.

Constitutive defenses include the chemical hydrogen cyanide. Trefoil, clover, and ferns have been found to exist in two genetically different forms, one containing cyanide (cyanogenic) and

one lacking it (acyanogenic); acyanogenic forms are often preferred by several herbivores. See ALKALOID; FLAVONOID; PHENOL.

Chemical defenses frequently occur together with certain structures which act as physical defenses, such as spines and hairs. While many chemicals protect plants by deterring herbivore feeding or by direct toxic effects, other defenses may act more indirectly. Chemicals that mimic juvenile hormones, the antijuvenile hormone substances found in some plants, either arrest development or cause premature development in certain susceptible insect species.

Plant chemicals potentially affect not only the herbivores that feed directly on the plant, but also the microorganisms, predators, or parasites of the herbivore. For example, the tomato plant contains an alkaloid, tomatine, that is effective against certain insect herbivores. The tomato hornworm, however, is capable of detoxifying this alkaloid and can thus use the plant successfully—but a wasp parasite of the hornworm cannot detoxify tomatine, and its effectiveness in parasitizing the hornworm is reduced. Therefore, one indirect effect of the chemical in the plant may be to reduce the effectiveness of natural enemies of the plant pest, thereby actually working to the disadvantage of the plant.

Most plant chemicals can affect a wide variety of herbivores and microorganisms, because the modes of action of the chemicals they manufacture are based on a similarity of biochemical reaction in most target organisms (for example, cyanide is toxic to most organisms). In addition, many plant chemicals may serve multiple roles: resins in the creosote bush serve to defend against herbivores and pathogens, conserve water, and protect against ultraviolet radiation.

It is argued that there are two different types of defensive chemicals in plants. The first type occurs in relatively small amounts, is often toxic in small doses, and poisons the herbivore. These compounds may also change in concentration in response to plant damage; that is, they are inducible. These kinds of qualitative defensive compounds are the most common in short-lived or weedy species that are often referred to as unapparent. They are also characteristic of fast-growing species with short-lived leaves. In contrast, the second type of defensive chemicals often occurs in high concentrations, is not very toxic, but may inhibit digestion by herbivores and is not very inducible. These quantitative defenses are most common in long-lived, so-called apparent plants such as trees that have slow growth rates and long-lived leaves. Some plants may use both types of defenses.

There is accumulating evidence that marine plants may be protected against grazing by similar classes of chemicals to those found in terrestrial plants. One interesting difference in the marine environment is the large number of halogenated organic compounds that are rare in terrestrial and fresh-water systems.

Through evolution, as plants accumulate defenses, herbivores that are able to bypass the defense in some way are selected for and leave more offspring than others. This in turn selects for new defenses on the part of the plant in a continuing process called coevolution.

Animals that can exploit many plant taxa are called generalists, while those that are restricted to one or a few taxa are called specialists. Specialists often have particular detoxification mechanisms to deal with specific defenses. Some generalists possess powerful, inducible detoxification enzymes, while others exhibit morphological adaptations of the gut which prevent absorption of compounds such as tannins, or provide reservoirs for microorganisms that accomplish the detoxification. Animals may avoid eating plants, or parts of plants, with toxins.

Some herbivores that have completely surmounted the plant toxin barrier use the toxin itself as a cue to aid in locating plants. The common white butterfly, *Pieris rapae*, for example, uses mustard oil glycosides, which are a deterrent and toxic to many organisms, to find its mustard family hosts.

**Chemical defense in animals.** Many animals make their own defensive chemicals—such as all of the venoms produced by social insects (bees, wasps, ants), as well as snakes and mites.

These venoms are usually proteins, acids or bases, alkaloids, or combinations of chemicals. They are generally injected by biting or stinging, while other defenses are produced as sprays, froths, or droplets from glands.

Animals frequently make the same types of toxins as plants, presumably because their function as protective agents is similar. Other organisms, particularly insects, use plant chemicals to defend themselves. Sequestration may be a low-cost defense mechanism and probably arises when insects specialize on particular plants.

**Microbial defenses.** Competitive microbial interactions are regulated by many chemical exchanges involving toxins. They include compounds such as aflatoxin, botulinus toxin, odors of rotting food, hallucinogens, and a variety of antibiotics. See ANTIBIOTIC; TOXIN.

Microorganisms also play a role in chemical interaction with plants and animals that range from the production of toxins that kill insects, such as those produced by the common biological pest control agent *Bacillus thuringiensis*, to cooperative biochemical detoxification of plant toxins by animal symbionts.

**Information exchange.** A large area of chemical ecology concerns the isolation and identification of chemicals used for communication. Pheromones, substances produced by an organism that induce a behavioral or physiological response in an individual of the same species, have been studied particularly well in insects. These signals are compounds that are mutually beneficial to the emitter and sender, such as sex attractants, trail markers, and alarm and aggregation signals. Sex pheromones are volatile substances, usually produced by the female to attract males. Each species has a characteristic compound that may differ from that of other species by as little as a few atoms.

Pheromones are typically synthesized directly by the animal and are usually derived from fatty acids. In a few cases the pheromone or its immediate precursors may be derived from plants, as in danaid butterflies.

Very little work has been done in identifying specific pheromones in vertebrates, particularly mammals. It is known, however, that they are important in marking territory, in individual recognition, and in mating and warning signals. Chemical communication may also occur among plants and microorganisms, although it is rarer and less obvious than in animals. See REPRODUCTIVE BEHAVIOR; SCENT GLAND; TERRITORIALITY.

[C.G.J.; A.C.L.]

**Chemical energy** A useful but obsolescent term for the energy available from elements and compounds when they react, as in a combustion reaction. In precise terminology, there is no such thing as chemical energy, since all energy is stored in matter as either kinetic energy or potential energy. See COMBUSTION; ENERGY.

When a chemical reaction takes place, the atoms of the reactants change their bonding pattern and become products. The breaking of bonds in the reactants requires energy, and the formation of bonds in the products releases energy. The net change in energy is commonly referred to as chemical energy. To be more precise, when a reaction takes place, there is an overall change in the enthalpy  $H$  of the system as bonds are broken and new bonds are formed. This change in enthalpy is denoted  $\Delta H$ . Under standard conditions [a pressure of 1 bar (100 kilopascals) and all substances pure], the change is noted  $\Delta H^\circ$  and called the standard enthalpy of reaction. Provided the pressure is constant, the standard enthalpy can be identified with the energy released as heat (when  $\Delta H^\circ < 0$ ) or gained as heat ( $\Delta H^\circ > 0$ ) when the reaction takes place. Reactions for which  $\Delta H^\circ < 0$  are classified as exothermic; those for which  $\Delta H^\circ > 0$  are classified as endothermic. All combustions are exothermic, the released heat being used either to provide warmth or to raise the temperature of a working fluid in an engine of some kind. There are very few common endothermic reactions; one example is the dissolution of ammonium nitrate in water (a process utilized in medical cold



packs). See CHEMICAL EQUILIBRIUM; CHEMICAL THERMODYNAMICS; ENTHALPY; THERMOCHEMISTRY.

The "chemical energy" available from a typical fuel (that is, the enthalpy change accompanying the combustion of the fuel, when carbon-hydrogen bonds are replaced by stronger carbon-oxygen and hydrogen-oxygen bonds) is commonly reported as either the specific enthalpy or the enthalpy density. The specific enthalpy is the standard enthalpy of combustion divided by the mass of the reactant. The enthalpy density is the standard enthalpy of combustion divided by the volume of the reactant. The former is of primary concern when mass is an important consideration, as in raising a rocket into orbit. The latter is of primary concern when storage space is a limitation. The specific enthalpy of hydrogen gas is relatively high (142 kilojoules/g), but its enthalpy density is low (13 kJ/L). The values for octane, a compound representative of gasoline, are 48 kJ/g and 38 MJ/L, respectively (note the change in units). The high enthalpy density of octane means that a gasoline tank need not be large to store a lot of "chemical energy." See AIRCRAFT FUEL; ENERGY SOURCES; GASOLINE; ROCKET PROPULSION. [P.W.A.]

**Chemical engineering** The application of engineering principles to conceive, design, develop, operate, or use processes and products based on chemical and physical phenomena. The chemical engineer is considered an engineering generalist because of a unique ability (among engineers) to understand and exploit chemical change. Drawing on the principles of mathematics, physics, and chemistry and familiar with all forms of matter and energy and their manipulation, the chemical engineer is well suited for working in a wide range of technologies.

Although chemical engineering was conceived primarily in England, it underwent its main development in America, propelled at first by the petroleum and heavy-chemical industries, and later by the petrochemical industry with its production of plastics, synthetic rubber, and synthetic fibers from petroleum and natural-gas starting materials. In the early twentieth century, chemical engineering developed the physical separations such as distillation, absorption, and extraction, in which the principles of mass transfer, fluid dynamics, and heat transfer were combined in equipment design. The chemical and physical aspects of chemical engineering are known as unit processes and unit operations, respectively.

Chemical engineering now is applied in biotechnology, energy, environmental, food processing, microelectronics, and pharmaceutical industries, to name a few. In such industries, chemical engineers work in production, research, design, process and product development, marketing, data processing, sales, and, almost invariably, throughout top management. See BIOCHEMICAL ENGINEERING; BIOMEDICAL CHEMICAL ENGINEERING; BIOTECHNOLOGY; CHEMICAL CONVERSION; CHEMICAL PROCESS INDUSTRY; ELECTROCHEMICAL PROCESS; FOOD ENGINEERING; UNIT OPERATIONS; UNIT PROCESSES. [W.F.F.]

**Chemical equilibrium** In a dynamic or kinetic sense, chemical equilibrium is a condition in which a chemical reaction is occurring at equal rates in its forward and reverse directions, so that the concentrations of the reacting substances do not change with time. In a thermodynamic sense, it is the condition in which there is no tendency for the composition of the system to change; no change can occur in the system without the expenditure of some form of work upon it. From the viewpoint of statistical mechanics, the equilibrium state places the system in a condition of maximum freedom (or minimum restraint) compatible with the energy, volume, and composition of the system. The statistical approach has been merged with thermodynamics into a field called statistical thermodynamics; this merger has been of immense value for its intellectual stimulus, as well as for its practical contributions to the study of equilibria. See CHEMICAL THERMODYNAMICS; STATISTICAL MECHANICS.

Of the three viewpoints, the thermodynamic approach is by far the most powerful and fruitful in treating the quantitative relationships between the position of equilibrium and the factors which govern it. Since thermodynamics is concerned with relationships among observable properties, such as temperature, pressure, concentration, heat, and work, the relationships possess general validity, independent of theories of molecular behavior.

**Chemical potential.** Thermodynamics attributes to each chemical substance a property called the chemical potential, which may be thought of as the tendency of the substance to enter into chemical (or physical) change. Although the chemical potential of a substance cannot be directly measured (except on a relative basis), differences in chemical potential are measurable. (The units are those of energy per mole.)

The importance of the chemical potential lies in its relation to the affinity or driving force of a chemical reaction. Consider general reaction (1). Let  $\mu_A$  be the chemical potential per mole of



substance A,  $\mu_B$  be the chemical potential per mole of B, and so on. Then, according to one of the fundamental principles of thermodynamics (the second law), the reaction will be spontaneous when the total chemical potential of the reactants is greater than that of the products. Thus, for spontaneous change (naturally occurring processes) notation (2) applies. When equilibrium is

$$[g\mu_G + h\mu_H] - [a\mu_A + b\mu_B] < 0 \quad (2)$$

reached, the total chemical potentials of products and reactants become equal; thus Eq. (3) holds at equilibrium. The difference

$$[g\mu_G + h\mu_H] - [a\mu_A + b\mu_B] = 0 \quad (3)$$

in chemical potentials in Eqs. (2) and (3) is called the driving force or affinity of the process or reaction; naturally, it is zero when the chemical system is in chemical equilibrium.

For reactions at constant temperature and pressure (the usual restraints in a chemical laboratory), the difference in chemical potentials becomes equal to the free energy change  $\Delta G$  for the process in Eq. (4). The decrease in free energy represents the

$$\Delta G = [g\mu_G + h\mu_H] - [a\mu_A + b\mu_B] \quad (4)$$

maximum net work obtainable from the process. When no more work is obtainable, the system is at equilibrium. Conversely, if the value of  $\Delta G$  for a process is positive, some useful work will have to be expended upon the process, or reaction, in order to make it proceed; the process cannot proceed naturally or spontaneously. (The term spontaneously as used here implies only that a process can occur. It does not imply that the reaction will be rapid or instantaneous. Thus, the reaction between hydrogen and oxygen is a spontaneous process in the sense of the term as used here, even though a mixture of hydrogen and oxygen can remain unchanged for years unless ignited or exposed to a catalyst.)

Since by definition a catalyst remains unchanged chemically through a reaction, its chemical potential does not appear in Eqs. (2), (3), and (4). A catalyst, therefore, can contribute nothing to the driving force of a reaction, nor can it, in consequence, alter the position of the chemical equilibrium in a system. See CATALYSIS.

In addition to furnishing a criterion for the equilibrium state of a chemical system, the thermodynamic method goes much further. In many cases, it yields a relation between the change in chemical potentials (or change in free energy) and the equilibrium concentrations of the substances involved in the reaction. To do this, the chemical potential must be expressed as a function

of concentration (and other properties of the substance). See CONCENTRATION SCALES.

**Activity and standard states.** It is often convenient to utilize the product  $fx$ , called the activity of the substance and defined by  $a = fx$ . The activity may be looked upon as an effective concentration of the substance, measured in the same units as the concentration  $x$  with which it is associated. The standard state of the substance is then defined as the state of unit activity (where  $a = 1$ ) and is characterized by the standard chemical potential  $\mu^\circ$ . Clearly, the terms  $\mu^\circ$ ,  $f$ , and  $x$  are not independent; the choice of the activity scale serves to fix the standard state. For example, for an aqueous solution of hydrochloric acid, the standard state for the solute (HCl) would be an (hypothetical) ideal 1 molar (or molal) solution, and for the solvent ( $\text{H}_2\text{O}$ ) the standard state would be pure water (mole fraction = 1). The reference state would be an infinitely dilute solution; here the activity coefficients would be unity for both solute and solvent. For the vapor of HCl above the solution, the standard state would be the ideal gaseous state at 1 atm (101.325 kilopascals) partial pressure; the reference state would be a state of zero pressure. (For gases, the term fugacity is used instead of activity.)

It should be noted that the reference state is a limiting state which in many cases can be reached only through an extrapolation from observed behavior. See FUGACITY.

**Equilibrium constant.** If general reaction (1) occurs at constant temperature  $T$  and pressure  $P$  when all of the substances involved are in their standard states of unit activity, Eq. (4) would become Eq. (5). The quantity  $\Delta G^\circ$  is known as the standard free

$$\Delta G^\circ = [g\mu_G^\circ + h\mu_H^\circ] - [a\mu_A^\circ + b\mu_B^\circ] \quad (5)$$

energy change for the reaction at that temperature and pressure for the chosen standard states. (Standard state properties are commonly designated by a superscript,  $\Delta G^\circ$ ,  $\mu^\circ$ .) Since each of the standard chemical potentials ( $\mu^\circ$ ) is a unique property determined by the temperature, pressure, standard state, and chemical identity of the substance concerned, the standard free energy change  $\Delta G^\circ$  is a constant (parameter) characteristic of the particular reaction for the chosen temperature, pressure, and standard states.

When the system has come to chemical equilibrium at constant temperature and pressure,  $\Delta G = 0$ , and  $\Delta G^\circ$  is given by Eq. (6), where the value of  $K^\circ$  is shown as Eq. (7), and the activities are

$$\Delta G^\circ = -RT \ln K^\circ \quad (6)$$

$$K^\circ = \left[ \frac{a_G^g a_H^h}{a_A^a a_B^b} \right] \quad (7)$$

the equilibrium values. The ratio of the activities at equilibrium,  $K^\circ$ , is called the equilibrium constant or, more precisely, the thermodynamic equilibrium constant. (The terms  $K^\circ$  and  $Q^\circ$  are written with superscripts to emphasize that they represent ratios of activities.) The equilibrium constant is a characteristic property of the reaction system, since it is determined uniquely in terms of the standard free energy change. The term  $-\Delta G^\circ$  represents the maximum net work which the reaction could make available when carried out at constant temperature and pressure with the substances in their standard states.

The kinetic concept of chemical equilibrium introduced by C. M. Guldberg and P. Waage (1864) led to the formulation of the equilibrium constant in terms of concentrations. Although the concept is correct in terms of the dynamic picture of opposing reactions occurring at equal speeds, it has not been successful in coping with the problems of activity coefficients. Conversely, the thermodynamic approach yields no relationship between the driving force of the reaction and the rate of approach to equilibrium. See CHEMICAL DYNAMICS.

The influence of temperature upon the chemical potentials, and hence upon the equilibrium constant, is given by the

Gibbs-Helmholtz equation, Eq. (8). The derivative on the left

$$\left[ \frac{d \ln K^\circ}{dT} \right]_P = \frac{\Delta H^\circ}{RT^2} \quad (8)$$

represents the slope of the curve obtained when values of  $\ln K^\circ$  for a reaction, obtained at different temperatures but always at the same pressure  $P$ , are plotted against temperature. The standard heat of reaction  $\Delta H^\circ$  for the temperature  $T$  at which the slope is measured is the heat effect which could also be observed by carrying out the reaction involving the standard states in a calorimeter at the corresponding temperature and pressure. See HEAT CAPACITY; THERMOCHEMISTRY.

**Homogeneous equilibria.** These involve single-phase systems: gaseous, liquid, and solid solutions. In most cases, solid solutions are so far from ideal that equilibrium constants cannot be evaluated, and such systems are treated in terms of the phase rule. A typical gas-phase equilibrium is the ammonia synthesis shown in reaction (9). A typical liquid-phase equilibrium is the dissociation of acetic acid in water, reaction (10).

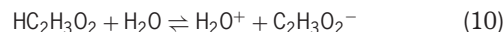

The solvent appears to be inert, since its chemical potential remains practically unchanged over the useful concentration range. As a result of this apparent inertness of the solvent, it is not possible to determine the extent of hydration of any dissolved species from equilibrium studies. Thus, whether the actual ion is  $\text{H}^+$ ,  $\text{H}_3\text{O}^+$ , or  $\text{H}_9\text{O}_4^+$ , it is the total stoichiometric concentration that is measured and used. See IONIC EQUILIBRIUM.

**Heterogeneous equilibria.** These are usually studied at constant pressure, since at least one of the phases will be a solid or liquid. The imposed pressure may be that of an equilibrium gaseous phase, or it may be an externally controlled pressure.

In describing such systems, the nature of each phase must be specified. In the following example, the terms  $s$ ,  $l$ , and  $g$  identify solid, liquid, and gaseous phases, respectively. For solutions or mixtures, the composition is needed, in addition to the temperature and pressure, to complete the specification of the system. If not obvious, the identity of the solvent must be given.

In the equilibrium shown as reaction (11), the relationship of Eq. (12) holds. Here  $K^\circ = p/N$ , the ratio of the vapor pressure



$$\Delta G^\circ = \mu_g^\circ - \mu_l^\circ = -RT \ln \frac{p}{N} \quad (12)$$

$p$  to the liquid mole fraction  $N$ . For pure water, the equilibrium constant is simply the standard vapor pressure  $p^\circ$ , and the Clausius-Clapeyron equation is just a special case of the Gibbs-Helmholtz equation, Eq. (8). Now when a small amount of solute is added, decreasing the mole fraction of solvent, the vapor pressure  $p$  must be lowered to maintain equilibrium (Raoult's law). The effect of the total applied pressure  $P$  upon the vapor pressure  $p$  of the liquid is given by the Gibbs-Poynting equation, Eq. (13). Here  $V_l$  and  $V_g$  are the molar volumes of liquid and

$$\left[ \frac{dp}{dP} \right]_T = \frac{V_l}{V_g} \quad (13)$$

vapor. The vapor pressure will increase as external pressure is applied (activity increases with pressure). If the external pressure is applied to a solution by a semipermeable membrane, an applied pressure can be found which will restore the vapor pressure (or activity) of the solvent to its standard state value. See OSMOSIS.

Other heterogeneous equilibria are solubility equilibria, reactions involving two immiscible phases, and reactions involving condensed and immiscible phases. See EXTRACTION; SOLUBILITY PRODUCT CONSTANT. [C.E.V.]

**Chemical fuel** The principal fuels used in internal combustion engines (automobiles, diesel, and turbojet) and in the furnaces of stationary power plants are organic fossil fuels. These fuels, and others derived from them by various refining and separation processes, are found in the earth in the solid (coal), liquid (petroleum), and gas (natural gas) phases.

Special fuels to improve the performance of combustion engines are obtained by synthetic chemical procedures. These special fuels serve to increase the specific impulse of the engine or to increase the heat of combustion available to the engine per unit mass or per unit volume of the fuel. A special fuel which possesses a very high heat of combustion per unit mass is liquid hydrogen. It has been used along with liquid oxygen in rocket engines. Because of its low liquid density, liquid hydrogen is not too useful in systems requiring high heats of combustion per unit volume of fuel ("volume-limited" systems).

A special fuel which produces high flame temperatures of the order of 5000°F (2800°C) is gaseous cyanogen. This is used with gaseous oxygen as the oxidizer. The liquid fuel hydrazine, and other hydrazine-based fuels, with the liquid oxidizer nitrogen tetroxide are used in many space-oriented rocket engines. The boron hydrides, such as diborane and pentaborane, are high-energy fuels which are used in advanced rocket engines.

For air-breathing propulsion engines (turbojets and ramjets), hydrocarbon fuels are most often used. For some applications, metal alkyl fuels which are pyrophoric (that is, ignite spontaneously in the presence of air), and even liquid hydrogen, are being used. See METAL-BASE FUEL.

Fuels which liberate heat in the absence of an oxidizer while decomposing either spontaneously or because of the presence of a catalyst are called monopropellants and have been used in rocket engines. Examples of these monopropellants are hydrogen peroxide and nitro-methane.

Liquid fuels and oxidizers are used in most large-thrust rocket engines. When thrust is not a consideration, solid-propellant fuels and oxidizers are frequently employed because of the lack of moving parts such as valves and pumps, and the consequent simplicity of this type of rocket engine. Solid fuels fall into two broad classes, double-base and composites. Double-base fuels are compounded of nitroglycerin (glycerol trinitrate) and nitrocellulose, with no separate oxidizer required. The double-base propellant is generally formed in a mold into the desired shape (called a grain) required for the rocket case. Composite propellants are made of a fuel and an oxidizer. The latter could be an inorganic perchlorate or a nitrate. Fuels for composite propellants are generally the asphalt-oil-type, thermosetting plastics or several types of synthetic rubber and gumlike substances. Metal particles such as boron, aluminum, and beryllium have been added to solid propellants to increase their heats of combustion and to eliminate certain types of combustion instability. See HYDROGEN PEROXIDE. [W.Ch.]

**Chemical kinetics** A branch of physical chemistry that seeks to measure the rates of chemical reactions, describe them in terms of elementary steps, and understand them in terms of the fundamental interactions between molecules.

**Reaction kinetics.** Although the ultimate state of a chemical system is specified by thermodynamics, the time required to reach that equilibrium state is highly dependent upon the reaction. For example, diamonds are thermodynamically unstable with respect to graphite, but the rate of transformation of diamonds to graphite is negligible. As a consequence, determining the rate of chemical reactions has proved to be important for practical reasons. Rate studies have also yielded fundamen-

tal information about the details of the nuclear rearrangements which constitute the chemical reaction.

Traditional chemical kinetic investigations of the reaction between species X and Y to form Z and W, reaction (1), sought a rate of the form given in Eq. (2), where  $d[Z]/dt$  is the rate of



$$d[Z]/dt = kf([X], [Y], [Z], [W]) \quad (2)$$

appearance of product Z,  $f$  is some function of concentrations of X, Y, Z, and W which are themselves functions of time, and  $k$  is the rate constant. Chemical reactions are incredibly diverse, and often the function  $f$  is quite complicated, even for seemingly simple reactions such as that in which hydrogen and bromine combine directly to form hydrogen bromide (HBr). This is an example of a complex reaction which proceeds through a sequence of simpler reactions, called elementary reactions. For reaction (3d), the sequence of elementary reactions is a chain mechanism known to involve a series of steps, reactions (3a)–(3c).



This sequence of elementary reactions was formerly known as the reaction mechanism, but in the chemical dynamical sense the word mechanism is reserved to mean the detailed motion of the nuclei during a collision.

An elementary reaction is considered to occur exactly as written. Reaction (3b) is assumed to occur when a bromine atom hits a hydrogen molecule. The products of the collision are a hydrogen bromide molecule and a hydrogen atom. On the other hand, the overall reaction is a sequence of these elementary steps and on a molecular basis does not occur as reaction (3d) is written. With few exceptions, the rate law for an elementary reaction  $A + B \rightarrow C + D$  is given by  $d[C]/dt = k[A][B]$ . The order (sum of the exponents of the concentrations) is two, which is expected if the reaction is bimolecular (requires only species A to collide with species B). The rate constant  $k$  for such a reaction depends very strongly on temperature, and is usually expressed as  $k = Z_{AB}\rho \exp(-E_a/RT)$ .  $Z_{AB}$  is the frequency of collision between A and B calculated from molecular diameters and temperature;  $\rho$  is an empirically determined steric factor which arises because only collisions with the proper orientation of reagents will be effective; and  $E_a$ , the experimentally determined activation energy, apparently reflects the need to overcome repulsive forces before the reagents can get close enough to react.

In some instances, especially for decompositions,  $AB \rightarrow A + B$ , the elementary reaction step is first-order, Eq. (4), which

$$d[A]/dt = d[B]/dt = k[AB] \quad (4)$$

means that the reaction is unimolecular. The species AB does not spontaneously dissociate; it must first be given some critical amount of energy, usually through collisions, to form an excited species  $AB^*$ . It is the species  $AB^*$  which decomposes unimolecularly. [P.R.B.]

**Relaxation methods.** Considerable use has been made of perturbation techniques to measure rates and determine mechanisms of rapid chemical reactions. These methods provide measurements of chemical reaction rates by displacing equilibria. In situations where the reaction of interest occurs in a system at equilibrium, perturbation techniques called relaxation methods have been found most effective for determining reaction rate constants.

A chemical system at equilibrium is one in which the rate of a forward reaction is exactly balanced by the rate of the corresponding back reaction. Examples are chemical reactions occurring in liquid solutions, such as the familiar equilibrium

in pure water, shown in reaction (5). The molar equilibrium

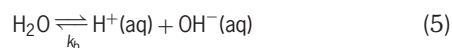

constant at 25°C (77°F) is given by Eq. (6), where bracketed quantities indicate molar concentrations. It arises naturally from the equality of forward and backward reaction rates, Eq. (7). Here  $k_f$  and  $k_b$  are the respective rate constants that depend on temperature but not concentrations. Furthermore, the combination of Eqs. (6) and (7) gives rise to Eq. (8). Thus

$$K_{\text{eq}} = \frac{[\text{H}^+][\text{OH}^-]}{[\text{H}_2\text{O}]} = \frac{10^{-14}}{55.5} = 1.8 \times 10^{-16} \quad (6)$$

$$k_f[\text{H}_2\text{O}] = k_b[\text{H}^+][\text{OH}^-] \quad (7)$$

$$K_{\text{eq}} = k_f/k_b = 1.8 \times 10^{-16} \quad (8)$$

a reasonable question might be what the numerical values of  $k_f$  in units of  $\text{s}^{-1}$  and  $k_b$  in units of  $\text{dm}^3 \text{mol}^{-1} \text{s}^{-1}$  must be to satisfy Eqs. (6) through (8) in water at room temperature. Stated another way, when a liter of 1 M hydrochloric acid is poured into a liter of 1 M sodium hydroxide (with considerable hazardous sputtering), how rapidly do the hydronium ions,  $\text{H}^+(\text{aq})$ , react with hydroxide ions,  $\text{OH}^-(\text{aq})$ , to produce a warm 0.5 M aqueous solution of sodium chloride? In the early 1950s it was asserted that such a reaction is instantaneous. Turbulent mixing techniques were (and still are) insufficiently fast (mixing time of the order of 1 ms) for this particular reaction to occur outside the mixing chamber. The relaxation techniques were conceived by M. Eigen, who accepted the implied challenge of measuring the rates of seemingly immeasurably fast reactions.

The essence of any of the relaxation methods is the perturbation of a chemical equilibrium (by a small change in temperature, pressure, electric-field intensity, or solvent composition) in so sudden a fashion that the chemical system, in seeking to reestablish equilibrium, is forced by the comparative slowness of the chemical reactions to lag behind the perturbation. [E.M.Eyr.]

**Gas-phase reactions.** The rates of thermal gas-phase chemical reactions are important in understanding processes such as combustion and atmospheric chemistry.

Chemical conversion of one stable, gas-phase molecule into another is an apparently simple process; yet it is highly unlikely to occur in just a single step, but as a web of sequential and parallel reactions involving many species. The oxidation of methane ( $\text{CH}_4$ ) to carbon dioxide ( $\text{CO}_2$ ) and water provides an excellent example. It occurs in combustion (for example, in burning natural gas, which is mostly methane) as well as in the atmosphere. In both cases, the net process may be written down as single reaction (9).



The reaction does not, however, result from collision of two oxygen ( $\text{O}_2$ ) molecules with one methane molecule. Rather, it involves many separate steps.

All elementary reactions fundamentally require a collision between two molecules. Even in the case of a unimolecular reaction, in which a single molecule breaks apart or isomerizes to another form, the energy required for the process comes from collision with other molecules. The species involved in many gas-phase elementary reactions are free radicals, molecules that have one or more unpaired electrons. Such species tend to be highly reactive, and they are responsible for carrying out most gas-phase chemistry.

A reaction rate is the rate at which the concentration of one of the reactants or products changes with time. The objective of a kinetics experiment is not to measure the reaction rate itself but to measure the rate coefficient, an intrinsic property of the reaction that relates the reactant concentrations to their time rates

of change. For example, the mathematical expression for the rate of a bimolecular reaction,  $\text{A} + \text{B} \rightarrow \text{products}$ , is differential equation (10). The square brackets denote the concentrations

$$-d[\text{A}]/dt = -d[\text{B}]/dt = k[\text{A}][\text{B}] \quad (10)$$

of A and B, and  $k$  is the rate coefficient described above. The dependence of the rate expression on reactant concentrations is determined experimentally, and it also arises from a fundamental tenet of chemistry known as the law of mass action. Once the rate constant is known, the rate of a reaction can be computed for any given set of concentrations.

Rate constants usually change with temperature because of the change in the mean energy of colliding molecules. The temperature dependence often follows an Arrhenius expression,  $k = A \exp(-E_A/RT)$ , where  $A$  is a preexponential factor that is related to the gas-phase collision rate,  $R$  is the universal gas constant, and  $T$  is the absolute temperature (in kelvins). The key quantity is the activation energy,  $E_A$ , the amount of energy required to induce a reaction. Pressure dependences are usually important only for association reactions,  $\text{A} + \text{B} \rightarrow \text{AB}$ , since collision of A with B will form an energized complex,  $\text{AB}^*$ , that will simply redissociate unless a subsequent collision carries away enough energy to stabilize the AB product. The probability of a stabilizing collision increases with the collision frequency and thus the total pressure.

In the simple case of a unimolecular reaction,  $\text{A} \rightarrow \text{P}$ , the rate expression is Eq. (11). Equation (11) is first-order since the rate

$$-d[\text{A}]/dt = d[\text{P}]/dt = k[\text{A}] \quad (11)$$

is proportional to the reactant concentration to the first power, and it leads to an expression for the change in the concentration of A or P with time (called an integrated rate expression), as in Eqs. (12). The subscripts denote the concentrations at zero time

$$[\text{A}]_t = [\text{A}]_0 \exp(-kt) \quad (12a)$$

$$[\text{P}]_t = [\text{A}]_0 \{1 - \exp(-kt)\} \quad (12b)$$

(initial concentration) and an arbitrary time  $t$ . The concentration of A decreases (because it is reacting away) as a function of time, while the concentration of P increases with time such that the sum of the concentrations of A and P is always constant and equal to the initial concentration of A. Because first-order reactions are mathematically simple, kineticists try to reduce all studied reactions (if at all possible) to this form. A second-order reaction, for example  $\text{A} + \text{B} \rightarrow \text{products}$ , has the rate expression given in Eq. (10). To reduce the second-order expression to the first-order expression, Eq. (11), one chooses one of the concentrations to be in large excess, for example  $[\text{B}] \gg [\text{A}]$ . The concentration of B is then approximately constant during the course of the reaction, and it may be combined with the rate constant to give an expression identical to Eq. (11) that depends on the concentration of A alone. [A.R.Ra.; S.S.B.]

**Chemical microscopy** A scientific discipline in which microscopes are used to solve chemical problems. The unique ability to form a visual image of a specimen, to select a small volume of the specimen, and to perform a chemical or structural analysis on the material in the selected volume makes chemical microscopy indispensable to modern chemical analysis. See ANALYTICAL CHEMISTRY; MICROSCOPE.

Microscopes can be combined with most analytical instruments. For example, a light microscope can be combined with a spectroscope, making it possible to determine the molecular composition of microscopic objects or structures. Similarly, an x-ray spectrometer can be combined with an electron microscope to determine the elemental composition of small objects. See ELECTRON MICROSCOPE; SPECTROSCOPY; X-RAY SPECTROMETRY.

Phase analyses can also be made microscopically. The boundaries of amorphous phases can usually be distinguished in the microscope, and an elemental or physical analysis can be used to identify the phase. An example of a physical analysis is the measurement of refractive index. Crystalline phases are even more amenable to microscopical analysis. For example, a polarizing microscope can be used to measure the optical properties of a crystalline phase and thus identify it. Or a transmission electron microscope can be used to select a tiny area of a crystalline phase and identify the crystal structure by means of electron diffraction. See ELECTRON DIFFRACTION.

The minimum volume that can be analyzed varies widely with the instrument used. Light microscopes can be used to identify particles as small as 1 micrometer in diameter and weighing about 1 picogram. A field ion microscope has been combined with a mass spectrometer and used to identify single atoms extracted from the surface of a specimen. See FIELD-EMISSION MICROSCOPY; MASS SPECTROMETRY; OPTICAL MICROSCOPE.

After a portion of a specimen has been selected microscopically, it can be analyzed in many ways. An experienced microscopist may learn to recognize various structures by studying known materials, using published atlases, or an atlas that the individual microscopist has constructed. If the object or structure cannot be recognized, many means of analysis are available. For example, a polarizing microscope may be employed to identify the object by using optical crystallographic methods. Other light microscopes useful for chemical analysis include phase-contrast and interference-contrast microscopes, microspectrophotometers, the confocal scanning laser microscope, and the laser Raman microscope. Physicochemical methods may be used to measure melting points, or mixed-melt phenomena and dispersion staining may also be used. See INTERFERENCE MICROSCOPE; LASER SPECTROSCOPY; PHASE-CONTRAST MICROSCOPE; RAMAN EFFECT.

Microscopes using other types of image-forming beams serve for chemical analysis. Scanning or transmission electron microscopes are powerful tools for chemical microscopy. Scanning electron microscopes are often fitted with x-ray spectrometers which are capable of both qualitative and quantitative analysis for most of the elements. Other electron microscopes capable of chemical analysis are the Auger electron microscope, field electron microscope, scanning tunneling microscope, and cathodoluminescence microscope. Microscopes which use ion beams, neutron beams, and x-ray beams also have analytical capabilities. See AUGER EFFECT; AUGER ELECTRON SPECTROSCOPY; NEUTRON SPECTROMETRY; SCANNING ELECTRON MICROSCOPE; X-RAY MICROSCOPE. [G.C.]

**Chemical process industry** An industry, abbreviated CPI, in which the raw materials undergo chemical conversion during their processing into finished products, as well as (or instead of) the physical conversions common to industry in general. In the chemical process industry the products differ chemically from the raw materials as a result of undergoing one or more chemical reactions during the manufacturing process. The chemical process industries broadly include the traditional chemical industries, both organic and inorganic; the petroleum industry; the petrochemical industry, which produces the majority of plastics, synthetic fibers, and synthetic rubber from petroleum and natural-gas raw materials; and a series of allied industries in which chemical processing plays a substantial part. While the chemical process industries are primarily the realm of the chemical engineer and the chemist, they also involve a wide range of other scientific, engineering, and economic specialists.

For a discussion of the more prominent chemical process industries, see ADHESIVE; BIOCHEMICAL ENGINEERING; BIOMEDICAL CHEMICAL ENGINEERING; CEMENT; CERAMICS; COAL CHEMICALS; COAL LIQUEFACTION; DYEING; ELECTROCHEMICAL PROCESS; EXPLOSIVE; FAT AND OIL; FERMENTATION; FERTILIZER; FUEL GAS; GLASS;

GRAPHITE; HYDROCRACKING; INSECTICIDE; LIME (INDUSTRY); NUCLEAR CHEMICAL ENGINEERING; PAPER; PETROCHEMICAL; PETROLEUM PROCESSING AND REFINING; PETROLEUM PRODUCTS; PLASTICS PROCESSING; POLYMER; RADIOACTIVE WASTE MANAGEMENT; RUBBER; WATER SOFTENING. [W.F.F.]

**Chemical reactor** A vessel in which chemical reactions take place. A combination of vessels is known as a chemical reactor network. Chemical reactors have diverse sizes, shapes, and modes and conditions of operation based on the nature of the reaction system and its behavior as a function of temperature, pressure, catalyst properties, and other factors.

Laboratory chemical reactors are used to obtain reaction characteristics. Therefore, the shape and mode of operation of a reactor on this scale differ markedly from that of the large-scale industrial reactor, which is designed for efficient production rather than for gathering information. Laboratory reactors are best designed to achieve well-defined conditions of concentrations and temperature so that a reaction model can be developed which will prove useful in the design of a large-scale reactor model.

Chemical reactions may occur in the presence of a single phase (liquid or gas), in which case they are called homogeneous, or they may occur in the presence of more than one phase and are referred to as heterogeneous. In addition, chemical reactions may be catalyzed. Examples of homogeneous reactions are gaseous fuel combustion (gas phase) and acid-base neutralization (liquid phase). Examples of heterogeneous systems are carbon dioxide absorption into alkali (gas-liquid); coal combustion and automobile exhaust purification (gas-solid); water softening (liquid-solid); coal liquefaction and oil hydrogenation (gas-liquid-solid); and cake reduction of iron ore (solid-solid).

Chemical reactors may be operated in batch, semibatch, or continuous modes. When a reactor is operated in a batch mode, the reactants are charged, and the vessel is closed and brought to the desired temperature and pressure. These conditions are maintained for the time needed to achieve the desired conversion and selectivity, that is, the required quantity and quality of product. At the end of the reaction cycle, the entire mass is discharged and another cycle is begun. Batch operation is labor-intensive and therefore is commonly used only in industries involved in limited production of fine chemicals, such as pharmaceuticals. In a semibatch reactor operation, one or more reactants are in the batch mode, while the coreactant is fed and withdrawn continuously. In a chemical reactor designed for continuous operation, there is continuous addition to, and withdrawal of reactants and products from, the reactor system.

There are a number of different types of reactors designed for gas-solid heterogeneous reactions. These include fixed beds, tubular catalytic wall reactors, and fluid beds. Many different types of gas-liquid-solid reactors have been developed for specific reaction conditions. The three-phase trickle-bed reactor employs a fixed bed of solid catalyst over which a liquid phase trickles downward in the presence of a cocurrent gas phase. An alternative is the slurry reactor, a vessel within which coreactant gas is dispersed into a liquid phase bearing suspended catalyst or coreactant solid particles. At high ratios of reactor to diameter, the gas-liquid-solid reactor is often termed an ebulating-bed (high solids concentration) or bubble column reactor (low solids concentration). Gas-liquid reactors assume a form virtually identical to the absorbers utilized in physical absorption processes. Solid-solid reactions are often conducted in rotary kilns which provide the necessary intimacy of contact between the solid coreactants. See GAS ABSORPTION OPERATIONS; KILN. [J.J.Ca.]

**Chemical senses** In vertebrates, the senses of smell (olfaction) and taste (gustation) plus the so-called common chemical sense constitute the external chemical senses (as contrasted with internal chemoreceptors). The olfactory cells of vertebrates,

usually located in the olfactory mucosa of the upper nasal passages, are specialized neural elements that are responsive to chemicals in the vapor phase. Taste buds of the oral cavity, especially the tongue, are composed of modified epithelial cells responsive to chemicals in solution. The common chemical senses are composed of free nerve endings in the mucous membrane of the eye, nose, mouth, and digestive tract and are responsive to irritants or other chemicals in either the vapor or liquid phase. See CHEMORECEPTION.

Among invertebrates, sense organs occur as specialized hairs and sensilla, or minute cones supplied with sensory nerves and nerve cells. Characteristic of male moths, for example, are their distinctive bushy antennae, by which they detect and locate females by sex pheromones. Rodents, ungulates, carnivores, and other mammals also show sexual attraction to female odors produced by specialized glands. Whether humans in general are susceptible to pheromonal influences from other humans is debatable. See PHEROMONE.

Taste plays an important role in selection and acceptance of food. Besides the protective, inborn aversion to bitter (many poisons, but not all, are bitter), a single experience with the particular taste of a toxic substance which caused illness may establish a strong and persistent learned taste aversion. By contrast, a compensatory salt hunger may occur in persons or animals suffering salt deficiency. See SALT (FOOD).

The limbic system of the brain, which modulates appetitive and emotional behavior and hedonic (pleasant vs. unpleasant) experiences, has both taste and olfactory neural pathways to it, providing the neural substrate for the pleasure or displeasure of sensations. See NEUROBIOLOGY; OLFACTION; SENSATION; TASTE. [C.P.]

**Chemical separation techniques** Methods used in chemistry to purify substances or to isolate them from other substances, for either preparative or analytical purposes. In industrial applications the ultimate goal is the isolation of a product of given purity, whereas in analysis the primary goal is the determination of the amount or concentration of that substance in a sample. There are three factors of importance to be considered in all separations: (1) the completeness of recovery of the substance being isolated, (2) the extent of separation from associated substances, and (3) the efficiency of the separation.

There are many types of separations based on a variety of properties of materials. Among the most commonly used properties are those involving solubility, volatility, adsorption, and electrical and magnetic effects, although others have been used to advantage. The most efficient separation will obviously be obtained under conditions for which the differences in properties between two substances undergoing separation are at a maximum.

The common aspect of all separation methods is the need for two phases. The desired substance will partition or distribute between the two phases in a definite manner, and the separation is completed by physically separating the two phases. The ratio of the concentrations of a substance in the two phases is called its partition or distribution coefficient. If two substances have very similar distribution coefficients, many successive steps may be required for a separation. The resulting process is called a fractionation.

Based on the nature of the second phase, the more commonly used methods of separation are classified as follows:

1. Methods involving a solid second phase include precipitation, electrodeposition, chromatography (adsorption), ion exchange, and crystallization.
2. The outstanding method involving a liquid second phase is solvent extraction, in which the original solution is placed in contact with another liquid phase immiscible with the first.
3. Methods involving a gaseous second phase include gas evolution, distillation, sublimation, and gas chromatography.

Mixtures of volatile substances can often be separated by fractional distillation. See EXTRACTION. [G.H.Mo.]

**Chemical symbols and formulas** A system of symbols and notation for the chemical elements and the combinations of these elements which form numerous chemical compounds. This system consists of letters, numerals, and marks that are designed to denote the chemical element, formula, or structure of the molecule or compound. These symbols give a concise and instantly recognizable description of the element or compound. In many cases, through the efforts of international conferences, the symbols are recognized throughout the scientific world, and they greatly simplify the universal language of chemistry.

**Elements.** At the present time, 109 chemical elements have been given symbols, usually derived from the name of the element. Examples of names and symbols are chlorine, Cl; fluorine, F; beryllium, Be; aluminum, Al; oxygen, O; and carbon, C. However, symbols for some elements are derived from Latin or other names for the element. Examples are Au, gold (from *aurum*); Fe, iron (from *ferrum*); Pb, lead (from *plumbum*); Na, sodium (from *natrium*); and K, potassium (from *kalium*). The symbols consist of one or, more commonly, two letters. The first letter is a capital, followed by a lowercase letter.

**Inorganic molecules and compounds.** Simple diatomic molecules of a single element are designated by the element symbol with a subscript 2, indicating that the molecule contains two atoms. Thus the hydrogen molecule is H<sub>2</sub>; the nitrogen molecule, N<sub>2</sub>; and the oxygen molecule, O<sub>2</sub>. Polyatomic molecules of a single element are designated by the element symbol with a subscript corresponding to the number of atoms in the molecule. Examples are the phosphorus molecule, P<sub>4</sub>; the sulfur molecule, S<sub>8</sub>; and the arsenic molecule, As<sub>4</sub>.

Diatomic covalent molecules containing unlike elements are given a similar designation. The formula for hydrogen chloride is HCl; for iodine monochloride, ICl; and for hydrogen iodide, HI. The more electropositive element is always designated first in the formula.

For polyatomic covalent molecules containing unlike elements, subscripts designate the number of atoms of each element that are present in the molecule. Examples are arsine, AsH<sub>3</sub>; ammonia, NH<sub>3</sub>; and water, H<sub>2</sub>O. Again, the more electropositive element is placed first in the formula.

Ionic inorganic compounds are designated by a similar notation. The positive ion is given first in the formula, followed by the negative ion; subscripts denote the number of ions of each element present in the compound. The formulas for several common compounds are sodium chloride, NaCl; ammonium nitrate, NH<sub>4</sub>NO<sub>3</sub>; and aluminum sulfate, Al<sub>2</sub>(SO<sub>4</sub>)<sub>3</sub>.

More complex inorganic compounds are designated in a similar manner. The positive ion is given first, but may contain attached or coordinated groups, and this is followed by the negative ion. Examples are hexammine-cobalt(III) chloride, [Co(NH<sub>3</sub>)<sub>6</sub>]Cl<sub>3</sub>; and potassium trioxalatoferate(III), K<sub>3</sub>[Fe(C<sub>2</sub>O<sub>4</sub>)<sub>3</sub>]. Hydrates of inorganic compounds, such as copper(II) sulfate pentahydrate, are designated by the formula of the compound followed by the formula for water, the number of water molecules being designated by a prefix. Thus the symbol for the last compound is CuSO<sub>4</sub> · 5H<sub>2</sub>O.

**Organic compounds.** Because there are many more organic than inorganic compounds, the designation or notation for the organic group becomes complex. Many different types of organic compounds are known; in the case of hydrocarbons, there are aromatic and aliphatic, saturated and unsaturated, cyclic and polycyclic, and so on. The system of notation must distinguish between the various hydrocarbons themselves as well as setting this group of compounds apart from others such as alcohols, ethers, amines, esters, and phenols. See CHEMISTRY; COORDINATION COMPLEXES; INORGANIC CHEMISTRY; ORGANIC CHEMISTRY. [W.W.We.]

**Chemical thermodynamics** The application of the thermodynamic principles to systems involving physical and chemical transformations in order to (1) develop quantitative relationships among the identifiable forms of energy and their conjugate variables, (2) establish the criteria for spontaneous change, for equilibrium, and for thermodynamic stability, and (3) provide the macroscopic base for the statistical-mechanical bridge to atomic and molecular properties. The thermodynamic principles applied are the conservation of energy as embodied in the first law of thermodynamics, the principle of internal entropy production as embodied in the second law of thermodynamics, and the principle of absolute entropy and its statistical thermodynamic formulation as embodied in the third law of thermodynamics.

The basic goal of thermodynamics is to provide a description of a system of interest in order to investigate the nature and extent of changes in the state of that system as it undergoes spontaneous change toward equilibrium and interacts with its surroundings. This goal implicitly carries with it the concept that there are measurable properties of the system which can be used to adequately describe the state of the system and that the system is enclosed by a boundary or wall which separates the system and its surroundings. Properties that define the state of the system can be classified as extensive and intensive properties. Extensive properties are dependent upon the mass of the system, whereas intensive properties are not. Typical extensive properties are the energy, volume, and numbers of moles of each component in the system, while typical intensive properties are temperature, pressure, density, and the mole fractions or concentrations of the components.

The concept of a boundary enclosing the system and separating it from the surroundings requires specification of the nature of the boundary and of any constraints the boundary places upon the interaction of the system and its surroundings. Boundaries that restrain a system to a particular value of an extensive property are said to be restrictive with respect to that property. A boundary which restrains the system to a given volume is a fixed wall. A boundary which is restrictive to one component of a system but not to the other components is a semipermeable wall or membrane. A system whose boundaries are restrictive to energy and to mass or moles of components is said to be an isolated system. A system whose boundaries are restrictive only to mass or moles of components is a closed system, whereas an open system has nonrestrictive walls and hence can exchange energy, volume, and mass with its surroundings. Boundaries can be restrictive with respect to specific forms of energy, and two important types are those restrictive to thermal energy but not work (adiabatic walls) and those restrictive to work but not thermal energy (diathermal walls).

Changes in the state of the system can result from processes taking place within the system and from processes involving exchange of mass or energy with the surroundings. After a process is carried out, if it is possible to restore both the system and the surroundings to their original states, the process is said to be reversible; otherwise the process is irreversible. All naturally occurring spontaneous processes are irreversible. The first law defines the internal energy as a state function or property of the state of a system, and restricts the system and its surroundings to those processes which conserve energy. The second law establishes which of the permissible processes can occur spontaneously.

According to the first law of thermodynamics, the total energy  $E$  of a system is the sum of its kinetic energy  $T$ , its potential energy  $V$ , and its internal energy  $U$ , Eq. (1). If a system has

$$E = T + V + U \quad (1)$$

constant mass and its center of mass is moving with uniform velocity in a uniform potential, then changes in the total energy of the system  $\delta E$  are equal to changes in its internal energy  $\delta U$ . Chemical thermodynamics concentrates on the internal energy

of the system, but kinetic and potential energy changes of the system as a whole can be important for chemical systems. The principle of conservation of energy requires that the change in the internal energy of a system be the result of energy transfer between the system and its surroundings. The internal energy  $U$  is a function of the set of extensive variables associated with the various forms of internal energy. Each form of internal energy is manifest by the product of an extensive variable and its conjugate intensive variable.

Thermal energy exchange or heat (that form of energy transferred as a result of temperature differences between a system and its surroundings) plays a central role in thermodynamics, and is singled out from the other forms of energy or work. This is expressed by Eq. (2), where  $\delta q$  is the differential thermal energy

$$dU = \delta q + \delta \omega \quad (2)$$

(heat) absorbed by the system from the surroundings and  $\delta \omega$  is the differential work performed on the system by the surroundings. It is convenient to write Eqs. (3), where  $T$  is temperature,  $S$

$$\delta q = TdS - \delta a \quad (3a)$$

$$dU = TdS + \delta \omega - \delta a \quad (3b)$$

is the entropy, and  $(-\delta a)$  is a sum of the nonthermal differential work terms. The term  $\delta a$  can be either zero or nonzero. If it is zero, the heat absorbed by the system is equal to  $TdS$ . In an adiabatic process  $\delta q$  is zero and  $TdS - \delta a$ , and hence if  $\delta a$  is nonzero, it must correspond to an internally generated thermal energy. This is frequently referred to as the uncompensated heat of a process, since it does not result from the transfer of heat from the surroundings. See HEAT.

The heat capacity of a system is of particular importance in such thermochemical calculations. The heat capacity is the amount of thermal energy that can be absorbed by a system for a unit rise in temperature. This is defined by Eq. (4), where

$$\delta q = C_{\text{process}}dT \quad (4)$$

$C_{\text{process}}$  is the heat capacity of a system for a given type of process. See HEAT CAPACITY.

There are many possible and essentially equivalent statements of the second law of thermodynamics. It will suffice to state the empirical result that in all spontaneous processes the uncompensated heat  $\delta a$  in Eqs. (3) is always positive. Equation (3a) can be rewritten as Eq. (5), where the term  $\delta q/T$  is the contribution to the

$$dS = \delta q/T + \delta a/T \quad (5)$$

entropy due to heat exchange with the surrounding ( $d_e S$ ), while  $\delta a/T$  is the contribution to the entropy produced as a result of the interconversion of work terms ( $d_i S$ ). The second law can then be summarized as Eqs. (6), where  $d_i S$  greater than zero applies

$$dS = d_e S + d_i S \quad (6a)$$

$$d_i S \geq 0 \quad (6b)$$

to irreversible process. When  $d_i S = 0$ , that is, for a reversible process, Eq. (7) holds. This is the basic equation for establishing

$$dS = \delta q_{\text{rev}}/T \quad (7)$$

the thermodynamic temperature scale based upon the theoretical limits of reversible cycles. The requirement that  $d_i S > 0$  for spontaneous processes provides the criteria for examining the specific conditions for spontaneous paths, and the criteria for establishing the equilibrium state of a system. See CARNOT CYCLE; TEMPERATURE.

Many chemical systems can be considered closed systems in which a single parameter  $\xi$  can be defined as a measure of the extent of the reaction or the degree of achievement of a process. If the reaction proceeds or the process advances spontaneously, entropy must be produced according to the second law and  $\delta a$  must be positive. In terms of the advancement parameter  $\xi$ , this

uncompensated heat  $\delta a$  can be given by Eq. (8), where  $\underline{A}$  is the

$$\delta a = \underline{A} d\xi = T d_i S \quad (8)$$

affinity of the process or reaction. The affinity is related to internal entropy production by Eq. (9). The condition that the entropy

$$\underline{A} = T d_i S / d\xi \geq 0 \quad (9)$$

production is zero represents equilibrium, and hence  $\underline{A} = 0$  is an equivalent condition for equilibrium in a closed system. For spontaneous processes, since the signs of  $A$  and  $d\xi$  must be the same, for positive  $\underline{A}$  the process must advance or go in a forward direction in the usual sense of chemical reactions or physical processes, while for negative  $\underline{A}$  the process must proceed in the reverse direction.

The affinity of a chemical reaction establishes the spontaneous direction of the reaction, and consequently methods for determining the affinity are important in thermochemical studies. The affinity is simply related to the stoichiometric coefficients of the reaction and the chemical potentials of the reactants and products in the reaction.

Classical equilibrium thermodynamics is primarily concerned with calculations for reversible processes, and deals with irreversibility in terms of inequalities. In the case of irreversible processes in systems slightly removed from equilibrium, the rate of internal entropy production  $d_i S/dt$  is related to the fluxes  $J_i$  associated with thermal, concentration, or other differences in intensive parameters or potentials  $X_i$ . This entropy production is then given by Eq. (10). The fluxes include heat conduction, diffusion, electric conduction, and other direct effects.

$$d_i S/dt = \sum_i J_i X_i \geq 0 \quad (10)$$

In addition, a flux of one type may be coupled to a potential difference of another type. For example, a thermal gradient can result in a mass flux (thermal diffusion), or a concentration gradient in any energy flux. Thermal conductivity, thermosmosis, and thermoelectric effects are all coupled effects.

Far removed from equilibrium, thermodynamics must be formulated somewhat differently and more cautiously. The interplay of thermodynamic stability and kinetics can give rise to macroscopic structures with both temporal and spatial coherence called dissipative structures. Much theoretical effort is being directed to these studies because of their apparent relevance to biological structures, but it is still too early to assess how far-reaching these theories will be in the future. See THERMODYNAMIC PRINCIPLES; THERMODYNAMIC PROCESSES. [R.A.Pi.]

**Chemiluminescence** The type of luminescence wherein a chemical reaction supplies the energy responsible for the emission of light (ultraviolet, visible, or infrared) in excess of that of a blackbody (thermal radiation) at the same temperature and within the same spectral range. Below 900°F (500°C), the emission of any light during a chemical reaction is a chemiluminescence. The blue inner cone of a bunsen burner or the Coleman gas lamp are examples. See BLACKBODY.

Many chemical reactions generate energy. Usually this exothermicity appears as heat, that is, translational, rotational, and vibrational energy of the product molecules; whereas, for a visible chemiluminescence to occur, one of the reaction products must be generated in an excited electronic state (designated by an asterisk) from which it can undergo deactivation by emission of a photon. Hence a chemiluminescent reaction, as shown in reactions (1) and (2), can be regarded as the reverse of a photochemical reaction.



The energy of the light quantum  $h\nu$  (where  $h$  is Planck's con-

stant, and  $\nu$  is the light frequency) depends on the separation between the ground and the first excited electronic state of  $C$ ; and the spectrum of the chemiluminescence usually matches the fluorescence spectrum of the emitter. Occasionally, the reaction involves an additional step, the transfer of electronic energy from  $C^*$  to another molecule, not necessarily otherwise involved in the reaction. Sometimes no discrete excited state can be specified, in which case the chemiluminescence spectrum is a structureless continuum associated with the formation of a molecule, as in the so-called air afterglow:  $\text{NO} + \text{O} \rightarrow \text{NO}_2 + h\nu$  (green light). See HEAT RADIATION; LUMINESCENCE; PHOTOCHEMISTRY.

Only very exothermic, or "exergonic," chemical processes can be expected to be chemiluminescent. Partly for this reason, most familiar examples of chemiluminescence involve oxygen and oxidation processes; the most efficient examples of these are the enzyme-mediated bioluminescences. See BIOLUMINESCENCE.

[T.Wi.]

Electrogenerated chemiluminescence, also known as electrochemiluminescence, is a luminescent chemical reaction in which the reactants are formed electrochemically. Electrochemical reactions are electron-transfer reactions occurring in an electrochemical cell. In such a reaction, light emission may occur as with chemiluminescence; however, the excitation is from the application of a voltage to an electrode. In chemiluminescence, the luminophore is excited to a higher energetic state by means of a chemical reaction initiated by mixing of the reagents. In electrogenerated chemiluminescence, the emitting luminophore is excited to a higher energy state by reactions of species that are generated at an electrode surface by the passage of current through the working electrode. Upon decay to the electronic ground state, light emitted by the luminophore (fluorescent or phosphorescent) can be detected. The luminophore is typically a polycyclic hydrocarbon, an aromatic heterocycle, or certain transition-metal chelates. See ELECTRON-TRANSFER REACTION.

Chief among the developments since the early research and discovery of electrogenerated chemiluminescence was the construction of instrumentation for detection of electrogenerated chemiluminescence. These instruments made it possible for the methodology to be used by practitioners other than electrochemists.

Measurement of the light intensity of electrogenerated chemiluminescence is very sensitive and is proportional to the luminophore concentration. Trace amounts of luminophore as low as  $10^{-13}$  mol/liter can be detected, making electrogenerated chemiluminescence very useful in analytical and diagnostic applications.

A commercial application of the phenomenon forms the basis of a highly sensitive technique for detection of biological analytes such as deoxyribonucleic acid (DNA), ribonucleic acid (RNA), proteins, antibodies, haptens, and therapeutic drugs in the clinical laboratory. The technique combines a binding assay method and a system for detecting electrogenerated chemiluminescence.

[J.K.Le.; L.Na.; H.Ya.]

**Chemiosmosis** The coupling of metabolic and light energy to the performance of transmembrane work through the intermediary of electroosmotic gradients. Processes include synthesis of adenosine triphosphate (ATP) by oxidative phosphorylation or by photosynthesis, production of heat, accumulation of small molecules by active transport, movement of bacterial flagella, uptake of deoxyribonucleic acid (DNA) during bacterial conjugation, genetic transformation and bacteriophage infection, and insertion or secretion of proteins into or through membranes.

Mitochondria are the powerhouses of the eukaryotic cell and the site of synthesis of ATP by oxidative phosphorylation. In the oxidation portion of ATP synthesis, reductants, such as reduced nicotinamide adenine dinucleotide (NADH) and succinate, are generated during metabolism of carbohydrates, lipids, and protein. These compounds are oxidized through the series



of redox reactions performed by membrane-bound complexes, called electron transport or respiratory chains. See ADENOSINE TRIPHOSPHATE (ATP); MITOCHONDRIA.

Bacteria do not contain mitochondria, but many of the functions of the mitochondrial membrane are carried out by the bacterial cytoplasmic membrane. Many bacteria also use respiratory chains. This resemblance to mitochondria is more than chance. The evidence, although mostly circumstantial, suggests that mitochondria, chloroplasts, and perhaps other eukaryotic organelles were originally free-living bacteria. These bacteria and larger proto-eukaryotic cells became mutually symbiotic, so that neither was complete or viable without the other. The animal and plant kingdoms arose from these endosymbiotic events.

Photosynthesis is the conversion of light energy into chemical energy. Overall photosynthetic bacteria and the chloroplasts of eukaryotic plants capture sunlight or other light and use that energy to generate both ATP and a reductant for use in biosynthesis. The mechanism of photophosphorylation, that is, the use of light energy to drive the phosphorylation of adenosine diphosphate (ADP) to ATP, resembles that of oxidative phosphorylation. See PHOTOSYNTHESIS.

Oxidative phosphorylation and photophosphorylation are but specialized examples of chemiosmotic energy coupling. Among the forms of useful energy are chemical energy, such as that derived from fossil fuels, and light energy in the case of solar cells. Electricity is transmitted to motors, which couple electrical energy to the performance of work. Bacterial cells, mitochondria, and chloroplasts have protonic generators and protonic motors. Respiratory and photosynthetic electron transport chains are generators of proton currents' proton motive forces, which then drive the various motors of the cell or organelle. When the H<sup>+</sup>-translocating ATPase is "plugged in," the proton current drives phosphorylation. There are other motors present in the cell. Most membranes contain specific transport systems for small molecules, such as ions, sugars, and amino acids. Many of these transport systems are protonic; that is, they use the energy of the proton motive force to drive the accumulation or extrusion of their substrate. [B.Ro.]

**Chemistry** The science that embraces the properties, composition, and structure of matter, the changes in structure and composition that matter undergoes, and the accompanying energy changes. It is important to distinguish chemical change, implicit in this definition, and changes in physical form. An example of the latter is the conversion of liquid water to solid or gas by cooling or heating; the water substance is unchanged. In chemical change, such as the rusting of iron, the metal is consumed as it reacts with air in the presence of water to form the new substance, iron oxide.

Modern chemistry grew out of the alchemy of the Middle Ages, and the attempts to transmute base metals into gold. Seminal observations were made in the early eighteenth century on the changes in volume of air during combustion in a closed vessel, and the French chemist Antoine Lavoisier in the 1770s interpreted these phenomena in essentially modern terms.

**Atoms and elements.** Underlying all of chemistry is the concept of elementary units of matter which cannot be subdivided. This idea was adumbrated in classical Greek writings, and was clearly expressed by the Englishman John Dalton in 1803, who called these units atoms. Different kinds of atoms were recognized, each corresponding to one of the chemical elements such as oxygen, sulfur, tin, iron, and a few other metals. By the mid-nineteenth century, about 80 elements had been characterized, and these were organized on the basis of regularities in behavior and properties, into a periodic table. See ELEMENT (CHEMISTRY); PERIODIC TABLE.

In the early twentieth century, observations of radiation from various sources and its impact on solid targets led to the recognition of three fundamental particles that are common to all elements; the electron, with negative charge; the proton, with

positive charge; and the neutron, with zero charge. An atom consists of a nucleus containing protons and neutrons, and a diffuse cloud of electrons, equal in number to the number of protons and arranged in orbitals of progressively higher energy levels as the distance from the nucleus increases. The atomic number of an element (*Z*) is defined as the number of protons in the nucleus; this is the sequence of ordering in the periodic table. The mass number corresponds to the total number of protons and neutrons. See ATOMIC NUMBER; ELECTRON; NEUTRON; PROTON.

**Isotopes.** Most elements exist as isotopes, which have differing numbers of neutrons. All isotopes of an element exhibit the same chemical behavior, although isotopes can be separated on the basis of differences in atomic mass. The known elements total 116; of these, 88 have been detected in one or more isotopic forms in the Earth's crust. The other elements, including all but one of those with atomic number above 92, are synthetic isotopes produced in nuclear reactions that take place in nuclear piles or particle accelerators. Most of the isotopes of these heavier elements and also some lighter ones are radioactive; that is, the nuclei are unstable and decay, resulting in the emission of radiation. See ISOTOPE; PARTICLE ACCELERATOR; RADIOACTIVITY.

**Molecules and chemical reactions.** Molecules are combinations of two or more atoms, bonded together in definite proportions and specific geometric arrangements. These entities are chemical compounds; a molecule is the smallest unit. The bonding of atoms in compounds involves the distribution of electrons, and is the central concern of chemistry.

Compounds result from chemical reactions of atoms or molecules. The process involves formation and breaking of bonds, and may be either exothermic, in which the net bond charges lead to a more stable (lower-energy) system and heat is evolved, or endothermic, in which energy must be added to overcome a net loss of bonding energy.

A simple case is the reaction of hydrogen and oxygen to give water, which can be expressed as reaction (1). The equation

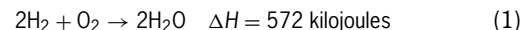

is balanced; no atoms are gained or lost in a chemical reaction. The symbols represent the nature of the initial and final materials and also the relative amounts. Thus H<sub>2</sub>O represents a molecule of water or a mole, which is the quantity in grams (or other mass units) equivalent to the molecular weight. The symbol  $\Delta H$  indicates the energy (enthalpy) change for the process. The reaction of hydrogen and oxygen is highly exothermic, and the sign of the energy charge is therefore negative since the system has lost heat to the surroundings. See ENTHALPY; MOLE (CHEMISTRY); STOICHIOMETRY.

**Bonds.** Bonds can be broadly classified as ionic or covalent. An ion is an atom or molecule which has an electric charge. Ionic compounds can be illustrated by salts such as sodium chloride, NaCl, in which a positive sodium ion, Na<sup>+</sup>, and negative chloride ion, Cl<sup>-</sup>, are associated by electrostatic attractions in regular locations of a crystal lattice. In solution the ions are solvated by water molecules and can conduct an electric current.

In covalent molecules, bonds are formed by the presence of pairs of electrons in overlapping orbitals between two atoms. Thus when two hydrogen atoms (H·) come within bonding distance, a molecule of hydrogen is formed in an exothermic reaction, by formation of a covalent bond. In this case the heat of reaction represents the energy of the H—H bond [reaction (2)].

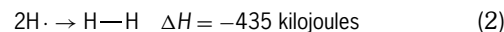

See CHEMICAL BONDING.

**Chemical compounds.** A compound is specified by the elements it contains, the number of atoms of each element, the bonding arrangement, and the characteristic properties. The number of unique compounds that have been isolated from natural sources or prepared by synthesis is enormous; as of 2000, over 15 million substances were registered in the file maintained

by Chemical Abstracts (American Chemical Society). Most of these are organic compounds, containing from a few to many hundred carbon atoms. The element carbon, unlike any others, can form long chains of covalently bonded atoms. Moreover, there can be many compounds, called isomers, with the same atomic composition. Thus a molecular formula such as  $C_8H_{16}O$  can represent many thousand different compounds. See CARBON; MOLECULAR ISOMERISM.

**Branches of chemistry.** Traditionally, five main subdivisions are designated for the activities, professional organizations, and literature of chemistry and chemists.

Analytical chemistry deals with the determination of the composition of matter and the amount of each component in mixtures of any kind. Analytical measurements are an integral and indispensable part of all chemical endeavor. Originally, analytical chemistry involved detection, separation, and weighing of the substances present in a mixture. Determination of the atomic ratio and thence the molecular formula of a compound is a prerequisite for any other investigation; the development of balances and techniques for doing this on milligram quantities of material had an enormous impact on organic chemistry. Advances have involved increasingly sophisticated instrumentation; mass spectrometers are a notable example. Other important methods include high-resolution chromatography and various applications of electrochemistry. A constant goal in analytical chemistry is the development of methods and instruments of greater sensitivity. It is now possible to detect trace compounds such as environmental pollutants at the picogram level. See ANALYTICAL CHEMISTRY.

Biochemistry is the study of living systems from a chemical viewpoint; thus it is concerned with the compounds and reactions that occur in plant and animal cells. Most of the substances in living tissues, including carbohydrates, lipids, proteins, nucleic acids, and hormones, are well-defined organic substances. However, the metabolic and regulatory processes of these compounds and their biological function are the special province of biochemistry. One of the major areas is the characterization of enzymes and their cofactors, and the mechanism of enzyme catalysis. Other topics of interest include the transport of ions and molecules across cell membranes, and the target sites of neurotransmitters and other regulatory molecules. Biochemical methods and thinking have contributed extensively to the fields of endocrinology, genetics, immunology, and virology. See BIOCHEMISTRY.

Inorganic chemistry is concerned with any material in which metals and metalloid elements are of primary interest. Inorganic chemistry is therefore concerned with the structure, synthesis, and bonding of a very diverse range of compounds. One of the early interests was the composition of minerals and the discovery of new elements; from this has grown the specialized area of geochemistry. Early synthetic work emphasized compounds of the main group elements, and particularly in the twentieth century, complex compounds of the transition metals. These studies have led to soluble transition-metal catalysts, and a greatly increased understanding of catalytic processes and the pivotal role of metal atoms in major biochemical processes, such as oxygen transport in blood, photosynthesis, and biological nitrogen fixation. Other contributions of inorganic chemistry are seen in advanced ceramics, high-performance composite materials, and the growing number of high-temperature superconductors. See CATALYSIS; CERAMICS; COMPOSITE MATERIAL; INORGANIC CHEMISTRY; PHOTOSYNTHESIS.

Organic chemistry is centered on compounds of carbon. Originally these were the compounds isolated from plant and animal sources, but the term was early broadened to include all compounds in which a linear or cyclic carbon chain is the main feature. Two of the major thrusts have been the elucidation of new structures and their preparation by synthesis; another long-standing interest has been study of the reaction mechanisms and rearrangements of organic compounds. Structure work on nat-

urally occurring compounds progressed over a 150-year period from simple straight-chain compounds with 2–10 carbon atoms, hydrogen, and 1 or 2 oxygen atoms to antibiotics and toxins with many rings and as many as 100 carbon atoms. In modern work, nuclear magnetic resonance spectroscopy and x-ray diffraction have become indispensable tools. Paralleling structural studies has been the synthesis of increasingly complex target molecules. Synthetic work is directed also to the preparation of large numbers of compounds for screening as potential drugs and agricultural chemicals. Plastics, synthetic fibers, and other high polymers are other products of organic chemistry. See NUCLEAR MAGNETIC RESONANCE (NMR); ORGANIC CHEMISTRY; X-RAY DIFFRACTION.

Physical chemistry deals with the interpretation of chemical phenomena and the underlying physical processes. One of the classical topics of physical chemistry involves the thermodynamic and kinetic principles that govern chemical reactions. Another is a description of the physical states of matter in molecular terms. Experimentation and theoretical analysis have been directed to the understanding of equilibria, solution behavior, electrolysis, and surface phenomena. One of the major contributions has been quantum chemistry, and the applications and insights that it has provided. The methods and instruments of physical chemistry, including such hardware as spectrometers and magnetic resonance and diffraction instruments, are an integral part of every other area. See CHEMICAL THERMODYNAMICS; PHYSICAL CHEMISTRY; QUANTUM CHEMISTRY.

Each broad area of chemistry embraces many specialized topics. There are also a number of hybrid areas, such as bioorganic and bioinorganic chemistry, analytical biochemistry, and physical organic chemistry. Each of these areas has borrowed extensively from and contributed to every other one. See BIOINORGANIC CHEMISTRY.

[J.A.Mo.]

**Chemometrics** A chemical discipline that uses mathematical and statistical methods to design or select optimal measurement procedures and experiments and to provide maximum chemical information by analyzing chemical data. Chemometrics is actually a collection of procedures, mathematics, and statistics that can help chemists perform well-designed experiments and proceed rapidly from data, to information, to knowledge of chemical systems and processes.

Medicinal chemists use chemometrics to relate measured or calculated properties of candidate drug molecules to their biological function; this subdiscipline is known as quantitative structure activity relations (QSAR). Environmental chemists use chemometrics to find pollution sources or understand the effect of point pollution sources on regional or global ecosystems by analyzing masses of environmental data. Forensic chemists analyze chemical measurements made on evidence (for example, gasoline in an arson case) or contraband to determine its source. Experimental physical chemists use chemometrics to unravel and identify physical or chemical states from spectral data acquired during the course of an experiment. See FORENSIC CHEMISTRY; PHYSICAL CHEMISTRY.

In analytical chemistry, chemometrics has seen rapid growth and widespread application, primarily due to the computerization of analytical instrumentation. Automation provides an opportunity to acquire enormous amounts of data on chemical systems. Virtually every branch of analytical chemistry has been impacted significantly by chemometrics; commercial software implementing chemometrics methods has become commonplace in analytical instruments. See ANALYTICAL CHEMISTRY.

Whether the analyst is concerned with a single sample or, as in process analytical chemistry, an entire chemical process (for example, the human body, a manufacturing process, or an ecosystem), chemometrics can assist in the experimental design, instrument response, optimization, standardization, and calibration as well as in the various steps involved in going from

measurements (data), to chemical information, to knowledge of the chemical system under study. [B.Ko.]

**Chemoreception** The ability of organisms to detect changes in the chemical composition of their exterior or interior environment. It is a characteristic of every living cell, from the single-celled bacteria and protozoa to the most complex multicellular organisms. Chemoreception allows organisms to maintain homeostasis, react to stimuli, and communicate with one another. See HOMEOSTASIS.

At the single-cell level, bacteria orient toward or avoid certain chemical stimuli (chemotaxis); algal gametes release attractants which allow sperm to find oocytes in a dilute aqueous environment; and unicellular slime molds are drawn together to form colonial fruiting bodies by use of aggregation pheromones. See CELLULAR ADHESION; TAXIS.

In multicellular organisms, both single cells and complex multicellular sense organs are used to homeostatically maintain body fluids (interoceptors) as well as to monitor the external environment (exteroceptors). The best-studied interoceptors are perhaps the carotid body chemoreceptors of higher vertebrates, which monitor the levels of oxygen, carbon dioxide, and hydrogen ions in arterial blood. The best-studied exteroceptors are those associated with taste (gustation) and smell (olfaction). Internal communication is also effected by chemical means in multicellular organisms. Thus both hormonal and neural control involve the perception, by cells, of control chemicals (hormones and neurotransmitters, respectively). See CAROTID BODY; CHEMICAL SENSES; OLFACTION; SENSE ORGAN; TASTE; TONGUE.

The basic mechanism underlying chemoreception is the interaction of a chemical stimulus with receptor molecules in the outer membrane of a cell. These molecules are believed to be proteins which, because of their three-dimensional shapes and chemical properties, will have the right spatial and binding "fit" for interaction with only a select group of chemicals (the same basic mechanism by which enzymes are specific for various substrates). The interaction between a chemical stimulus and a receptor molecule ultimately leads to structural changes in membrane channels. The net result is usually a change in membrane conductance (permeability) to specific ions which changes both the internal chemical composition of the cell and the charge distribution across the cell membrane. In single-celled organisms, this may be sufficient to establish a membrane current which may elicit responses such as an increase or decrease in ciliary movement. In multicellular organisms, it usually results in changes in the rate of release of hormones or the stimulation of neurons. See CELL MEMBRANES.

The basic characteristics of all chemoreceptors are specificity (the chemicals that they will respond to); sensitivity (the magnitude of the response for a given chemical stimulus); and range of perception (the smallest or largest level of stimulus that the receptor can discriminate). Specificity is a consequence of the types of proteins found in the membrane of a receptor cell. Each cell will have a mosaic of different receptor molecules, and each receptor molecule will show different combinations of excitatory or inhibitory responses to different molecules. In an excitatory response, there is a net flux of positive ions into the cell (depolarization); for an inhibitory response, there is a net flux of negative ions into the cell (hyperpolarization). The stronger the stimulus—that is, the more of the chemical present—the more receptors affected, the greater the change in conductance, and the larger the membrane current. In animals with nervous systems, these changes in conductance of primary sensory cells can lead to one of two events. In some receptors, if the current is excitatory and sufficient in magnitude (threshold), an action potential will be generated at a spike-initiating zone on the neuron. Other receptors respond by releasing a neurotransmitter that acts on a second-order neuron which is excitable and therefore can generate action potentials. See BIOPOTENTIALS AND IONIC CURRENTS.

The sensitivity of a chemoreceptor reflects both the amount of chemical substance required to initiate a change in membrane potential or discharge of the receptor cell, and the change in potential or discharge for any given change in the level of the chemical stimulus. There are real limits as to the extent of change in membrane conductance or firing frequency. Thus, for more sensitive cells, there is a smaller range over which they can provide information about the change in concentration of any given chemical before it has reached its maximum conductance or discharge rate and has saturated.

In animals, the responsiveness of some chemoreceptors can be either enhanced or attenuated by other neural input. These influences come in the form of efferent inputs from the central nervous system, from neighboring receptors, or even from recurrent branches of the chemoreceptor's own sensory axons. The net effect is either (1) to increase the acuity of the receptors (excitatory input brings the membrane potential of the receptor cell closer to threshold, requiring less chemical stimulus to elicit a response); or (2) to extend the range of responsiveness of the receptors (inhibitory input lowers the membrane potential of the receptor cell, requiring more chemical stimulus to bring the cell to threshold). For example, chemical sensitivity is greatly heightened in most animals when they are hungry.

Any given chemoreceptor cell can have any combination of receptor proteins, each of which may respond to different chemical molecules. Thus, chemoreceptor cells do not exhibit a unitary specificity to a single chemical substance, but rather an action spectrum to various groups of chemicals. The ability of animals to distinguish such a large number of different, complex, natural chemical stimuli resides in the ability of higher centers in the nervous system to "recognize" the pattern of discharge of large groups of cells. Sensory quality does not depend on the activation of a particular cell or group of cells but on the interaction of cells with overlapping response spectra.

Despite the common, basic mechanism underlying chemoreception in all organisms, there is a great diversity in the design of multicellular chemoreceptive organs, particularly in animals. The complex structures of most of these organs reflect adaptations that serve to filter and amplify chemical signals. Thus, the antennae in many insects, and the irrigated protective chambers, such as the olfactory bulb of fishes and nasal passages of mammals, increase the exposure of chemoreceptor cells to the environment. At the same time, they allow the diffusion distances between chemoreceptive cells and the environment to be reduced, thereby increasing acuity. In terms of filtering, they may serve to convert turbulent or dispersed stimuli into temporal patterns that can be more easily interpreted. The extent to which such structural adaptations are seen in various organisms tends to reflect the relative importance of chemoreception to the organism, which, to a large extent, reflects the habitat in which the organism lives. See CHEMICAL ECOLOGY. [W.Mil.]

**Chemostat** An apparatus (see illustration) for the continuous cultivation of microorganisms or plant cells. The nutrients required for cell growth are supplied continuously to the culture vessel by a pump connected to a medium reservoir. The cells in the vessel grow continuously on these nutrients. Residual nutrients and cells are removed from the vessel (fermenter) at the same rate by an overflow, thus maintaining the culture in the fermenter at a constant volume.

An important feature of chemostat cultivation is the dilution rate, defined as the volume of nutrient medium supplied per hour divided by the volume of the culture. During chemostat cultivation, an equilibrium is established (steady state) at which the growth rate of the cells equals the dilution rate. The higher the dilution rate, the faster the organisms are allowed to grow. Above a given dilution rate the cells will not be able to grow any faster, and the culture will be washed out of the fermenter. The chemostat thus offers the opportunity to study the properties of organisms at selected growth rates. See FERMENTATION.

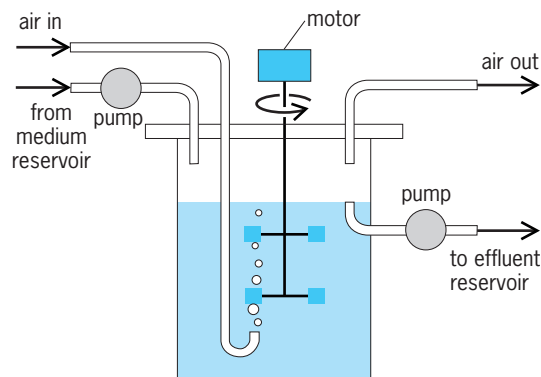

Schematic representation of chemostat apparatus.

The nutrient medium which is fed to the fermenter contains an excess of all growth factors except one, the growth-limiting nutrient. The concentration of the cells (biomass) in the fermenter is dependent on the concentration of the growth-limiting nutrient in the medium feed. Upon entering the fermenter, the growth-limiting nutrient is consumed almost to completion, and only minute amounts of it may be found in the culture and the effluent. Initially, when few cells have been inoculated in the growth vessel, even the growth-limiting nutrient is in excess. Therefore, the microorganisms can grow at a rate exceeding their rate of removal. This growth of cells causes a fall in the level of the growth-limiting nutrient, gradually leading to a lower specific growth rate of the microorganisms. Once the specific rate of growth balances the removal of cells by dilution, a steady state is established in which both the cell density and the concentration of the growth-limiting nutrient remain constant. Thus the chemostat is a tool for the cultivation of microorganisms almost indefinitely in a constant physiological state.

To achieve a steady state, parameters other than the dilution rate and culture volume must be kept constant (for example, temperature and pH). The fermenter is stirred to provide a homogeneous suspension in which all individual cells in the culture come into contact with the growth-limiting nutrient immediately, and to achieve optimal distribution of air (oxygen) in the fermenter when aerobic cultures are in use.

Laboratory chemostats usually contain 0.5 to 10.5 quarts (0.5 to 10 liters) of culture, but industrial chemostat cultivation can involve volumes up to 343,000 gal (1300 m<sup>3</sup>) for the continuous production of microbial biomass.

The chemostat can be used to grow microorganisms on very toxic nutrients since, when kept growth-limiting, the nutrient concentration in the culture is very low. The chemostat can be used to select mutants with a higher affinity to the growth-limiting nutrient or, in the case of a mixed population, to select the species that are optimally adapted to the growth limitation and culture conditions. The chemostat is of great use in such fields as physiology, ecology, and genetics of microorganisms. See BACTERIAL GENETICS; BACTERIAL PHYSIOLOGY AND METABOLISM; MICROBIOLOGY.

[J.Gi.]

**Chemostratigraphy** A subdiscipline of stratigraphy and geochemistry that involves correlation and dating of marine sediments and sedimentary rocks through the use of trace-element concentrations, molecular fossils, and certain isotopic ratios that can be measured on components of the rocks. The isotopes used in chemostratigraphy can be divided into three classes: radiogenic (strontium, neodymium, osmium), radioactive (radiocarbon, uranium, thorium, lead), and stable (oxygen, carbon, sulfur). Trace-element concentrations (that is, metals such as nickel, copper, molybdenum, and vanadium) and certain organic molecules (called biological markers or bio-markers) are also employed in chemostratigraphy. See DATING METHODS; ROCK AGE DETERMINATION.

Radiogenic isotopes are formed by the radioactive decay of a parent isotope to a stable daughter isotope. The application of these isotopes in stratigraphy is based on natural cycles of the isotopic composition of elements dissolved in ocean water, cycles which are recorded in the sedimentary rocks. See ISOTOPE; RADIOISOTOPE.

The elements hydrogen, carbon, nitrogen, oxygen, and sulfur owe their isotopic distributions to physical and biological processes that discriminate between the isotopes because of their different atomic mass. The use of these isotopes in stratigraphy is also facilitated by cycles of the isotopic composition of seawater, but the isotopic ratios in marine minerals are also dependent on water temperature and the mineral-forming processes. See SEAWATER.

Certain organic molecules that can be linked with a particular source (called biomarkers) have become useful in stratigraphy. The sedimentary distributions of biomarkers reflect the biological sources and inputs of organic matter (such as that from algae, bacteria, and vascular higher plants), and the depositional environment.

Certain trace metals, such as nickel, copper, vanadium, magnesium, iron, uranium, and molybdenum, are concentrated in organic-rich sediments in proportion to the amount of organic carbon. Although the processes controlling their enrichment are complex, they generally form in an oxygen-poor environment (such as the Black Sea) or at the time of global oceanic anoxic events, during which entire ocean basins become oxygen poor, resulting in the death of many organisms; hence large amounts of organic carbon are preserved in marine sediments. The trace-metal composition of individual stratigraphic units may be used as a stratigraphic marker, or "fingerprint." See GEOCHEMISTRY; MARINE SEDIMENTS; STRATIGRAPHY; URANIUM. [B.L.L.; D.J.DeP.]

**Chemotaxonomy** The use of biochemistry in taxonomic studies. Living organisms produce many types of natural products in varying amounts, and quite often the biosynthetic pathways responsible for these compounds also differ from one taxonomic group to another. The distribution of these compounds and their biosynthetic pathways correspond well with existing taxonomic arrangements based on more traditional criteria such as morphology. In some cases, chemical data have contradicted existing hypotheses, which necessitates a reexamination of the problem or, more positively, chemical data have provided decisive information in situations where other forms of data are insufficiently discriminatory. See ANIMAL SYSTEMATICS.

Modern chemotaxonomists often divide natural products into two major classes: (1) micromolecules, that is, those compounds with a molecular weight of 1000 or less, such as alkaloids, terpenoids, amino acids, fatty acids, flavonoid pigments and other phenolic compounds, mustard oils, and simple carbohydrates; and (2) macromolecules, that is, those compounds (often polymers) with a molecular weight over 1000, including complex polysaccharides, proteins, and the basis of life itself, deoxyribonucleic acid (DNA).

A crude extract of a plant can be separated into its individual components, especially in the case of micromolecules, by using one or more techniques of chromatography, including paper, thin-layer, gas, or high-pressure liquid chromatography. The resulting chromatogram provides a visual display or "fingerprint" characteristic of a plant species for the particular class of compounds under study.

The individual, separated spots can be further purified and then subjected to one or more types of spectroscopy, such as ultraviolet, infrared, or nuclear magnetic resonance or mass spectroscopy (or both), which may provide information about the structure of the compound. Thus, for taxonomic purposes, both visual patterns and structural knowledge of the compounds can be compared from species to species. See SPECTROSCOPY.

Because of their large, polymeric, and often crystalline nature, macromolecules (for example, proteins, carbohydrates, DNA)

can be subjected to x-ray crystallography, which gives some idea of their three-dimensional structure. These large molecules can then be broken down into smaller individual components and analyzed by using techniques employed for micromolecules. In fact, the specific amino acid sequence of portions or all of a cellular respiratory enzyme, cytochrome *c*, has been elucidated and used successfully for chemotaxonomic comparisons in plants and especially animals. See X-RAY CRYSTALLOGRAPHY.

Cytochrome *c* is a small protein or polypeptide chain consisting of approximately 103–112 amino acids, depending on the animal or plant under study. About 35 of the amino acids do not vary in type or position within the chain, and are probably necessary to maintain the structure and function of the enzyme. Several other amino acid positions vary occasionally, and always with the same amino acid substitution at a particular position. Among the remaining 50 positions scattered throughout the chain, considerable substitution occurs, the number of such differences between organisms indicating how closely they are related to one another. When such substitutional patterns were subjected to computer analysis, an evolutionary tree was obtained showing the degree of relatedness among the 36 plants and animals examined. This evolutionary tree is remarkably similar to evolutionary trees or phylogenies constructed on the basis of the actual fossil record for these organisms. Thus, the internal biochemistry of living organisms reflects a measure of the evolutionary changes which have occurred over time in these plants and animals. Since each amino acid in a protein is the ultimate product of a specific portion of the DNA code, the substitutional differences in this and other proteins in various organisms also reflect a change in the nucleotide sequences of DNA itself. See GENETIC CODE; PHYLOGENY.

In the case of proteins, it is often not necessary to know the specific amino acid sequence of a protein, but, rather, to observe how many different proteins, or forms of a single protein, are present in different plant or animal species. The technique of electrophoresis is used to obtain a pattern of protein bands of spots much like the chemical fingerprint of micromolecules. Because each amino acid in a protein carries a positive, negative, or neutral ionic charge, the total sum of charges of the amino acids constituting the protein will give the whole protein a net positive, negative, or neutral charge.

By using other techniques of molecular biology, such as DNA hybridization and genetic cloning, the specific gene function of individual fragments may be identified. Their nucleotide sequences can be determined and then compared for different taxa. Such data may prove useful at several different taxonomic levels. See GENETIC ENGINEERING.

While the organellar DNA does not contain the number of genetic messages of the organism that nuclear DNA does, and its transmission from parent to offspring may vary somewhat depending on the organism, the convenient size of organellar DNA and its potential for direct examination of the genetic code suggest that it is a potent macromolecular approach to chemosystematics. See GENETIC CODE. [D.E.G.]

**Chemotherapy** Chemotherapy is defined as the use of chemicals to treat any disease, but the term has come to be applied most commonly to the use of drugs to treat cancer. Cancer is an abnormal growth or proliferation of cells that tends to invade locally or spread to distant parts of the body. Several treatment modalities can be used for cancer. Surgery physically removes the abnormal growth, whereas radiation and chemotherapy are directed at killing, or slowing the growth of, cancerous cells.

Paul Ehrlich, a German physician and 1908 Nobel Laureate in Medicine, is generally credited with pioneering the field of chemotherapy and coining the word. However, his efforts were directed toward discovering antibiotics for infections rather than cancer drugs. The first extensively utilized chemotherapy was nitrogen mustard, which was used in the mid-1940s by Alfred

Gilman and Frederick S. Philips for the treatment of lymphomas and chronic leukemias. See LEUKEMIA.

The second group of useful anticancer drugs developed were folic acid antagonists. All actively growing cells require a chemical metabolite called folic acid to grow and divide. The antagonists were designed to inhibit a cancer cell's ability to produce folic acid, and therefore they are toxic. The third group of chemotherapeutic agents was designed to have a toxic effect on the cell's deoxyribonucleic acid (DNA). The development of these drugs was based on the theory that tumor growth might be stopped with chemicals that antagonize nucleic acids which are necessary for cancer cell growth and division. Antitumor antibiotics became recognized as potential chemotherapeutic agents in 1954, when actinomycin D was studied. They differ from antimicrobial antibiotics in that their spectrum of cytotoxicity includes human cells rather than bacteria and fungi. Since the mid-1950s, many new drugs have been developed. The availability of the techniques of molecular biology and a greater understanding of the genetic abnormalities of cancer are resulting in more effective therapies which tend to be more specific for cancer cells. Drugs which inhibit angiogenesis (blood vessel formation) or which target promoting (oncogenes) or suppressing (tumor suppressor) genes are being tested.

Chemotherapeutic drugs come from various sources. They may be extracted from nature, such as from bacteria, fungi, plants, or trees, or they may be chemically synthesized. They may also be semisynthetic, meaning that the process starts with a complex natural compound that is then modified chemically. They may also be produced using modern recombinant DNA technology.

Chemotherapy is used when a cancer has spread to multiple sites and cannot be removed surgically or treated with radiation therapy. It can also be used after all detectable tumor has been eradicated (complete remission) in order to destroy suspected undetectable residual tumor. This type of treatment is called adjuvant, intensification, or consolidation chemotherapy. Adjuvant therapy is effective in breast and colon cancer, and consolidation in acute leukemia, for example. Neoadjuvant chemotherapy is used to shrink a tumor prior to surgery or radiation. The results of treatment depend upon how much chemotherapy is given, how many times it is applied, and how effective it is against the tumor. These facts are derived from a basic principle of chemotherapy that a uniform dose of a drug will destroy a constant fraction rather than a constant number of tumor cells regardless of the size of the tumor or number of cells present (fractional cell kill hypothesis). Regrowth eventually occurs, but each subsequent dose of chemotherapy brings about a further decline in tumor cell number until eventually, in optimal circumstances, the number of tumor cells is low enough for the body to eliminate them by other mechanisms, resulting in a chemotherapy cure. See ONCOLOGY.

Although the different groups of chemotherapeutic agents have different mechanisms of toxicity for cells, the cellular death response is almost always apoptosis, or programmed cell death. In this process a death signal is generated from within the damaged cells. This initiates a series of energy-requiring choreographed cellular events leading to cellular suicide.

The goal of therapy should be determined in all patients who will receive chemotherapy. The possibilities include cure, prolongation of life but not a cure, or palliation (alleviating symptoms) but no prolongation of life. The choice of chemotherapy depends not only upon the type of tumor and the drug efficacy but, most importantly, upon the patient. Also, it must be decided whether the chemotherapy will improve the quality of life of the patient and not just shrink the tumor. Age and the general condition of the patient influence the outcome. Those patients who are more active are more likely to have a favorable outcome to chemotherapy.

The amount of chemotherapy given in each dose is usually based on the size of the body surface in square meters or

occasionally just on body weight. The dose must be appropriate for the size of the patient because toxicity often occurs at doses only slightly higher than those needed for therapy. The response of a cancer to a drug is determined by measuring the size of the cancer directly or the amount of marker substances produced by some tumors. A complete response is defined as disappearance of the tumor. A partial response is a decrease in the multiplication product of the two largest diameters by at least 50%. Less than this is considered a failure unless there is an improvement in symptoms. The ultimate measure of response is whether the patients have a prolongation of quality life, which may require observation over a long period of time.

Chemotherapeutic drugs have side effects that are specific for the agent and may include transient or permanent damage to almost any organ system of the body. Chemotherapeutic drugs cause side effects because in addition to destroying the actively dividing cancer cells they damage actively growing normal cells. Common sites of damage are the bone marrow resulting in increased risk for infection, anemia, and bleeding; the gastrointestinal tract resulting in vomiting and diarrhea; the hair follicles causing hair loss; and the kidneys resulting in renal failure. Today, cancer specialists have many ways of preventing or diminishing these toxicities, such as red blood cell transfusions for anemia, drugs to prevent nausea and vomiting, and growth factors which may improve anemia (erythropoietin) or shorten the time of either low white blood counts (granulocyte-colony stimulating factor) or of low platelet counts (thrombopoietin).

Cells can become resistant to drugs of different groups. The general mechanism is referred to as multiple drug resistance. This resistance is due to an acquired ability of the cells to pump these drugs out before they can cause irreversible damage. Most successful modern chemotherapeutic regimens are combinations of drugs. The use of more than one drug increases the chance of a cancer being sensitive to treatment since it is possible that a cancer cell resistant to one drug will be sensitive to another. Drugs can also be combined with other general types of treatment.

There has been a good deal of interest in the specific phase of the cell division cycle that is affected by chemotherapy in the hope that this information could be used to develop more effective cures for cancer. This may eventually lead to effective cell cycle-based drug strategies. Some of the proteins that control the cell cycle (for example, cyclins) might become targets for drug action. Techniques are being developed to ameliorate toxicity so that it may become possible to give higher doses of chemotherapeutic agents. See CANCER (MEDICINE); CELL CYCLE; CELL DIVISION.

[C.P.Bu.]

**Cherry** The two principal cherries of commerce are the sweet cherry (*Prunus avium*) and the sour cherry (*P. cerasus*). Both are of ancient origin and seem to have come from the region between the Black and Caspian seas. Cherries of minor importance are the dwarf or western sand cherries (*P. besseyi*) of the plains region of North America; the Duke cherries, which are supposedly natural hybrids between the sweet and sour cherry; and the Padus cherries, which bear their small fruits in long clusters or racemes rather than in short fascicles.

Sweet cherries may be divided into two groups: firm-fleshed types known as Bigarreaus, represented by the Napoleon (also called the Royal Anne), and soft-fleshed types known as Hearts, represented by the Black Tartarian. Sour cherries may also be divided into two groups, clear-juice or Amarelle types, represented by the Montmorency, and colored-juice or Morello types, represented by the English Morello.

In North America the principal sweet commercial varieties are the Napoleon (white), Bing, Lambert, Van, Schmidt, and Windsor (dark). The principal commercial variety of sour cherry is the Montmorency. See FRUIT; ROSALES.

[R.PL.]

**Chert** A hard, dense sedimentary rock composed of fine-grained silica (SiO<sub>2</sub>). Chert is characterized by a semivitreous to

dull luster and a splintery to conchoidal fracture, and is most commonly gray, black, reddish brown, or green. Chert is also used as a field term to describe silica-rich rocks which may be impure; common impurities include carbonates, iron and manganese oxides, and clay minerals. When impurities change the texture of the rock to the extent that it is less dense and hard than chert, and has the appearance of unglazed porcelain, the rock is then called porcellanite or siliceous shale. The term flint is synonymous with chert, but its use has become restricted to archeological artifacts and to nodular chert that occurs in chalk. The term chert, however, is preferred for the nodular deposits. Jasper refers to red or yellow quartz chert associated with iron ore or containing iron oxide. Novaculite is a white chert of great purity and uniform grain size, and is composed chiefly of quartz; the term is mostly restricted to descriptions of Paleozoic cherts in Oklahoma and Arkansas. Chert synonyms that have become obsolete include silexite, petrosilex, phthanite, and hornstone. See JASPER.

Chert occurs mainly in three forms: bedded sequences, nodular, and massive. Bedded chert (called ribbon chert if beds show pinch-and-swell structure) consists of rhythmically interlayered beds of chert and shale; chert and carbonates; or in some pre-Phanerozoic formations, alternations of chert and siderite or hematite. Bedded sequences can be hundreds of feet thick stratigraphically and cover areas of hundreds of square miles. Individual beds are commonly  $\frac{1}{2}$ –8 in. (1–20 cm) thick. Chert nodules and lenses occur primarily in chalk, limestone, and dolomite. Nodules and lenses vary in size from  $\frac{1}{2}$  in. to 30 ft (1 cm to 9 m). Fossils and sedimentary structures characteristic of the host rock are preserved within the nodules. Massive cherts occur in the interstices between basalt pillows, and as the basal member of bedded chert that overlies pillow basalts in ophiolites. See BASALT; CHALK; DOLOMITE ROCK; LIMESTONE.

When a supply of silica is available, chert forms in four ways: by replacement of mainly carbonate rock; by deposition from turbidity currents composed primarily of biogenic silica; by increasing the deposition of silica relative to terrigenous input, commonly by increased productivity of biogenic silica; and by precipitation of silica from water under either hydrothermal or low-temperature hypersaline conditions. See TURBIDITY CURRENT.

[J.R.He.]

**Chestnut** Any of seven species of deciduous, nut-bearing trees of the genus *Castanea* Corden Fagales native to the Northern Hemisphere and introduced throughout the world. The nuts are actually fruits, with the shells enclosing cotyledons. Trees bear both male and female flowers in late spring but must be cross-pollinated for nut production. Nuts are borne in a spiny involucre or bur that opens to release the nuts in late fall. See FAGALES.

Japanese chestnuts (*C. crenata*) and Chinese chestnuts (*C. mollissima*) are grown in Asia and the United States for their nuts, and many cultivars have been selected. European chestnuts (*C. sativa*) are an important food source, both cooked whole and ground into flour. They are native to the Caucasus mountains, and distributed throughout southern Europe. American chestnuts (*C. dentata*) have smaller nuts than Asian or European species and are usually sweeter. Only American trees served as an important source of lumber, because of the length of their unbranched trunks; all chestnut species have been used as a source of tannin for the leather-tanning industry. American and Chinese chinquapins (*C. pumila* and *C. henryi*) have very small nuts that are an important source of food for wildlife. All of the species can be crossed, and hybrids have been selected primarily as orchard cultivars.

[S.L.A.]

**Chevreil phases** A series of ternary molybdenum chalcogenide compounds. They were reported by R. Chevreil, M. Sergeant, and J. Prigent in 1971. The compounds have the general formula M<sub>x</sub>Mo<sub>6</sub>X<sub>8</sub>, where M represents any one of a large number

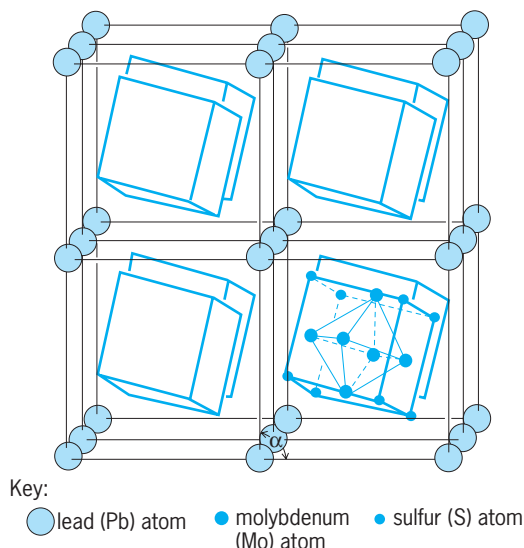

**Crystal structure of  $\text{PbMo}_6\text{S}_8$ . Each lead atom is surrounded by eight  $\text{Mo}_6\text{S}_8$  units, the structure of which is shown in the lower right-hand part of the figure. The rhombohedral angle  $\alpha$  is indicated.**

(nearly 40) of metallic elements throughout the periodic table;  $x$  has values between 1 and 4, depending on the M element; and X is a chalcogen (sulfur, selenium or tellurium). The Chevrel phases are of great interest, largely because of their striking superconducting properties.

Most of the ternary molybdenum chalcogenides crystallize in a structure in which the unit cell, that is, the repeating unit of the crystal structure, has the overall shape of a rhombohedron with a rhombohedral angle close to  $90^\circ$ . The building blocks of the Chevrel-phase crystal structure are the M elements and  $\text{Mo}_6\text{X}_8$  molecular units or clusters. Each  $\text{Mo}_6\text{X}_8$  unit is a slightly deformed cube with X atoms at the corners, and Mo atoms at the face centers. One of these structures, that of  $\text{PbMo}_6\text{S}_8$ , is shown in the illustration. See CRYSTAL; CRYSTALLOGRAPHY.

Several of the Chevrel-phase compounds have relatively high values of the superconducting transition temperature,  $T_c$ , the maximum being about 15 K ( $-433^\circ\text{F}$ ) for  $\text{PbMo}_6\text{S}_8$ . The Chevrel-phase  $\text{PbMo}_6\text{S}_8$  has a value of the upper critical magnetic field near absolute zero  $H_{c2}(0)$  of about 60 teslas (600 kilogauss), which was the largest value observed prior to the discovery of high-temperature ceramic superconductors in 1986. A number of Chevrel-phase compounds of the form  $\text{RMo}_6\text{X}_8$ , where R is a rare-earth element with a partially filled 4f electron shell and X is S or Se, display magnetic order at low temperatures in addition to superconductivity. See SUPERCONDUCTIVITY. [M.B.Ma.]

**Chevrotain** Any of four species of mammals which constitute the family Tragulidae in the order Artiodactyla. These animals, also known as mouse deer, are the smallest ruminants, growing to a maximum height of 12 in. (30 cm) at the shoulder. The chevrotain lacks horns or antlers. There are two well-developed toes on the feet, and the upper canines of the male are elongate and protrude from the mouth as small tusks. The chevrotain is a shy animal which leads a solitary life except during the breeding season. After a gestation period of 120 days, one or two young are born. The water chevrotain (*Hyemoschus aquaticus*) is found in west-central Africa along the banks of rivers in Sierra Leone through Cameroon to the Congo. The other species are all members of the genus *Tragulus*, and range through the forested areas of Sumatra into Borneo and Java. These are the Indian chevrotain (*T. meminna*), the larger Malay chevrotain (*T. napu*), and the lesser Malay chevrotain (*T. javanicus*). They are

differentiated by the pattern of markings (stripes or spots) on their coats. *Tragulus javanicus* has a coat of uniform color.

The Eocene fossil traguloid, *Archaeomeryx*, which was unearthed in Mongolia, shows many general similarities to the modern chevrotains. The main line of evolutionary development of the traguloids occurred in Eurasia. See ARTIODACTYLA. [C.B.C.]

**Chickenpox and shingles** Chickenpox (varicella) and shingles (herpes zoster) are two different forms of disease caused by the varicella-zoster virus, which is a deoxyribonucleic acid (DNA) virus closely related to herpes simplex and *Epstein-Barr viruses*. Initial infection causes varicella, a common childhood infection characterized by fever, malaise, and a rash consisting of dozens of hundreds of small fluid-filled lesions (vesicles) that are individually surrounded by reddened skin. Successive crops of lesions appear that eventually ulcerate and crust over during the two-week course of the disease. The virus is spread from person to person by the highly infectious respiratory secretions and lesion drainage. Varicella is rarely a serious disease in normal children but can be severe in immunocompromised individuals or in the rare adult who escaped childhood infection. Primary infection results in immunity to a new varicella-zoster virus, but the original virus lies dormant in nerve ganglia cells. See EPSTEIN-BARR VIRUS; HERPES.

At some time in their life, approximately 10% of the population suffers subsequent reactivation of latent virus, which spreads to the skin overlying the affected nerve and causes a localized eruption of vesicles called herpes zoster. The vesicles are similar in appearance and in infectiousness to varicella lesions. This syndrome is usually well tolerated, although elderly persons may develop chronic pain at the site of reactivation. Herpes zoster in immunocompromised individuals may be prolonged or may disseminate to vital organs.

Varicella or herpes zoster in a normal host is self-limited and does not typically require antiviral therapy. In individuals with underlying immune disorders, treatment with the antiviral drug acyclovir decreases the duration and severity of disease. See ANIMAL VIRUS; VIRUS INFECTION, LATENT, PERSISTENT, SLOW. [F.P.H.]

**Chicle** A gummy exudate used in the manufacture of chewing gum. It is contained in the bark of a tall evergreen tree, *Achras zapota* (Sapotaceae), a native of Mexico and Central America. The latex is collected and carefully boiled to remove excess moisture. When the water content is reduced to 33%, the chicle is poured off and molded into blocks. The product is an amorphous, pale-pink powder, insoluble in water, and forming a sticky paste when heated. In the manufacture of chewing gum, the chicle is cleaned, filtered, and sterilized, and various flavoring materials and sugar are added. [P.D.St./E.L.C.]

**Chicory** A perennial herb, *Cichorium intybus* (Compositae), with a long taproot, a coarse branching stem, and a basal rosette of numerous leaves. Although the plant is a native of Europe, it has become a common weed in the United States. It is used as a salad plant or for greens. The roasted root is also used as an adulterant of coffee. See CAMPANULALES. [P.D.St./E.L.C.]

**Child-Langmuir law** A law governing space-charge-limited flow of electron current between two plane parallel electrodes in vacuum when the emission velocities of the electrons can be neglected. It is often called the three-halves power law, and is expressed by the equation below.

$$j(\text{A}/\text{cm}^2) = 2.33 \times 10^{-6} \frac{V(\text{volts})^{3/2}}{d(\text{cm})^2}$$

Here  $V$  is the potential difference between the two electrodes,  $d$  their separation, and  $j$  the current density at the collector electrode, or anode. The potential difference  $V$  is the applied voltage reduced by the difference in work function of the collector and

emitter. The Child-Langmuir law applies, to a close approximation, to other electrode geometries as well. Thus for coaxial cylinders with the inner cylinder the cathode, it leads to a deviation from the true value of the current density of 13% at most. See SPACE CHARGE. [E.G.R.]

**Chilopoda** An order of the group Myriapoda commonly known as the centipedes. Like all myriapods, centipedes are ground dwellers whose spatial movements are restricted largely by a dependence upon high environmental moisture. Unlike the others, centipedes are evidently exclusively carnivorous and predatory, a way of life reflected in their great agility or fleetness and especially in the extraordinary modification of the first trunk appendages into a pair of usually massive raptorial pinners, the prehensors. Each prehensor contains a poison gland from which venom is conducted through a terminal claw into the victim's body. The poison immobilizes or kills arthropods and even some small vertebrates, but so far as is known it seems only harmlessly painful to human beings.

Excluding the last two or three trunk segments, each segment bears a single pair of functional legs. The genital ducts open at the posterior end of the body. Spiracles open laterally or dorsally; tracheal and circulatory systems are present and often elaborate. The antennae are unbranched; the eyes, when present, are either of the compound type or appear as simple ocelli. The mandibles have a partially free and movable gnathal portion. There are two pairs of maxillae.

In terms of families, genera, and individuals, the Diplopoda, or millipedes, are most abundant in the tropics, but this is not true of centipedes as a group, for whereas certain orders are basically tropical (Scutigeraomorpha, Scolopendromorpha), one order, the Lithobiomorpha, is essentially temperate, and the Geophilomorpha is abundant in both zones. In general, centipedes seem less affected by temperature and more sensitive to environmental moisture than are millipedes.

The class is divisible into two subclasses, the Notostigmophora and the Pleurostigmophora. The notostigmophorous centipedes comprise a single order, Scutigeraomorpha. Its members, which are peculiar in embodying primitive as well as highly advanced characters, are signalized by possession of dorsal respiratory openings (stomata), of compound-type eyes, of long flagellate, multisegmental antennae, and of long thin legs with multisegmental tarsi. The order includes the common house centipedes, *Scutigera coleoptrata*, one of which is shown in the illustration.

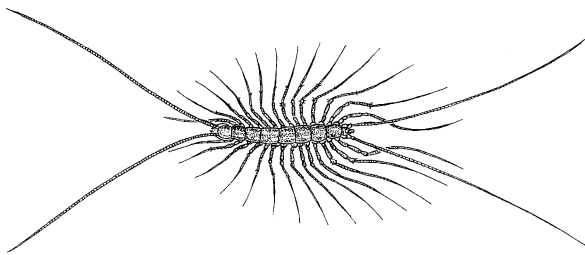

*Scutigera coleoptrata*, the house centipede. (After R. E. Snodgrass, *A Textbook of Arthropod Anatomy*, copyright 1952 by Cornell University Press; reprinted with permission)

The Pleurostigmophora, in contrast, have lateral respiratory openings, spiracles. They are reducible into four orders: Lithobiomorpha, Craterostigmomorpha, Scolopendromorpha, and Geophilomorpha. [R.E.Gr.]

**Chimaeriformes** The only order of the chondrichthyan subclass Holocephali. The chimaeriforms (ratfishes) are a distinctive group of marine bottom-feeding fishes that chiefly inhabit the deeper layers of the Atlantic and Pacific oceans. During the

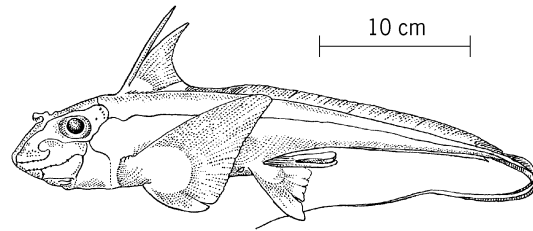

Modern chimaeriform *Chimaera*. (After H. B. Bigelow and W. C. Schroeder, *Fishes of the Western North Atlantic*, pt. 2, Sears Foundation for Marine Research, 1953)

winter months some species move into coastal waters, and a few species may be restricted to this environment.

Like the elasmobranchs, the ratfishes have a cartilaginous skeleton (partly calcified), a urea retention mechanism, and clasper organs in the male for internal fertilization. Unlike the elasmobranchs, however, they have the upper jaw fused to the braincase, a complete hyoid arch that is not involved in jaw suspension, four gill slits opening into a common outer chamber covered by an opercular skin fold, a single branchial opening on each side of the head, no spiracle in the adult, dental plates rather than teeth, a persistent notochord surrounded by calcified centra, and a narrow, tapering tail. See ELASMOBRANCHII.

The main line of chimaeriform evolution apparently began with Mississippian to Permian forms called menaspoids. By the beginning of the Jurassic the menaspoids had been replaced by their presumed descendants, the myracanthoids. Modern ratfishes (see illustration) appeared during the Middle Jurassic. They are characterized by a laterally compressed head with a variably developed rostrum, which is frequently exotically shaped, and an ethmoidal canal. The dorsal fin spine is made up almost entirely of lamellar bone. The pectoral fins are dibasal and fairly large, and the caudal fin is tapered to almost whiplike proportions. Placoid scales cover the body, in contrast to the more complicated compound scales of the primitive chimaeriforms.

The living ratfishes are divided into three families: the Chimaeridae, the Rhinochimaeridae, and the Callorhynchidae, which can be readily distinguished by the shape of the rostrum. Some 28 species are recognized. Most of them feed on mollusks and crustaceans and occasionally on smaller fishes. See CHONDRICHTHYES. [B.S.]

**Chimera** An individual animal or plant made up of cells derived from more than one zygote or otherwise genetically distinct.

**Animals.** Although some chimeras do arise naturally, most are produced experimentally, either by mixing cells of very early embryos or by tissue grafting in late embryos or adults. Experimental chimeras have been used to study a number of biological questions, including the origin and fate of cell lineages during embryonic development, immunological self-tolerance, tumor susceptibility, and the nature of malignancy.

Two techniques used to form chimeras by mixing embryo cells are aggregation and injection.

Aggregation chimeras are produced by a technique that involves removing the zonae pellucidae from around 8–16 cell embryos of different strains of mice and pushing the morulae together so that the cells can aggregate. After a short period of laboratory culture, during which the aggregate develops into a single large blastocyst, the embryo is returned to a hormone-primed foster mother. Chimeric offspring are recognized in several ways. If derived from embryos of pigmented and albino strains, they may have stripes of pigmented skin and patches of pigment in the eye. Internal chimerism can be detected by use of chromosomal markers or genetically determined enzyme



variants. Chimeras accept skin grafts from the two component strains, but reject grafts from third-party strains.

Injection chimeras are produced by a technique in which a blastocyst of the host mouse strain of mouse embryos is removed from its zona pellucida and held on a suction pipette. Cells of the donor strain are injected through a fine glass needle, either into the blastocoele cavity or into the center of the inner cell mass (the group of cells from which the fetus is derived). After a short period of culture, the blastocyst is returned to a foster mother.

Another kind of cell—the pluripotent stem cell of mouse teratocarcinomas—was found to give rise to normal tissues in adult chimeras after injection into the mouse blastocyst. Teratocarcinomas are tumors consisting of a disorganized mixture of adult and embryonic tissues. They develop spontaneously from germ cells in the gonads of certain mouse strains, or from cells in early embryos transplanted to ectopic sites. All the differentiated tissues in the tumor arise from pluripotent stem cells known as embryonal carcinoma (EC) cells. When embryonal carcinoma cells are injected into a genetically marked host blastocyst, they continue to divide and participate in normal development, and give rise to fully differentiated cells in all tissues of the adult, including skin, muscle, nerve, kidney, and blood. Embryonal carcinoma cells from several sources, including spontaneous and embryo-derived tumors and cultured lines selected to carry specific mutations or even human chromosomes, have contributed to normal chimeras. However, embryonal carcinoma cells from some other sources fail to integrate, but produce teratocarcinomas in the newborn animal or adult. The fact that certain embryonal carcinoma cells give rise to tumors when injected under the skin or into the body cavity, but behave normally in the blastocyst, has been used to support the idea that cancers can develop not only as a result of gene mutations but also as a result of disturbances in environmental factors controlling normal cell differentiation (epigenetic theory of cancer).

Animals that have accepted skin or organ grafts are technically chimeras. Radiation chimeras are produced when an animal is exposed to x-rays, so that blood-forming stem cells in the bone marrow are killed and then replaced by a bone marrow transplant from a genetically different animal. Lymphoid cells in the process of differentiating from stem cells in the donor marrow recognize the recipient as “self” and do not initiate an immune response against the host cells. See TRANSPLANTATION BIOLOGY.

Naturally occurring chimeras in humans are not rare and are most easily recognized when some cells are XX and others XY. Such individuals are usually hermaphrodite and probably result from fertilization of the egg by one sperm and the second polar body by another, with both diploid cells then contributing to the embryo (the small polar bodies normally degenerate). Blood chimeras are somewhat more common in animals such as cattle where the blood vessels in placentas of twins fuse, so that blood cells can pass from one developing fetus to the other. [B.Hog.]

**Plants.** In modern botanical usage a chimera is a plant consisting of two or more genetically distinct kinds of cells. Chimeras can arise either by a mutation in a cell in some part of the plant where cells divide or by bringing together two different plants so that their cells multiply side by side to produce a single individual. They are studied not only because they are interesting freaks or ornamental, but also because they help in the understanding of many of the developmental features of plants that would otherwise be difficult to investigate.

The first type of chimera to be used in this way resulted from grafting. Occasionally a bud forms at the junction of the scion and stock incorporating cells from both, and it sometimes happens that the cells arrange themselves so that shoots derived from the bud will contain cells from both plants forever.

Flowering plants have growing points (apical meristems) where the outer cells are arranged in layers parallel to the surface. This periclinal layering is due to the fact that the outer cells divide only anticlinally, that is, by walls perpendicular to the surface of the growing point. In many plants there are two such

tunica layers and, because cell divisions are confined to the anticlinal planes, each layer remains discrete from the other and from the underlying nonlayered tissue called the corpus. The epidermis of leaves, stems, and petals is derived from the outer layer of the growing point. See APICAL MERISTEM.

With a periclinal chimera it is possible to trace into stems, leaves, and flowers which tissues are derived from each layer in the growing point. For leaves, this can also be done with variegated chimeras where the genetic difference between the cells rests in the plastids resulting from mutation whose effect is to prevent the synthesis of chlorophyll. Tracts of cells whose plastids lack this pigment appear white or yellow. A common form of variegated chimera has leaves with white margins and a green center (see illustration). The white margin is derived from the second layer of the tunica, and the green center is derived from inner cells of the growing point. The white leaf tissue overlies the green in the center of the leaf, but does not mask the green color. Chimeras with green leaf margins and white centers are usually due to a genetically green tunica proliferating abnormally at the leaf margin in an otherwise white leaf.

Since the somatic mutation that initiates chimeras would normally occur in a single cell of a growing point or embryo, it often happens that it is propagated into a tract of mutant cells to form a sector of the plant. If the mutation resulted in a failure to form green pigment, the tract would be seen as a white stripe. Such chimeras are called sectorial, but they are normally unstable because there is no mechanism to isolate the mutant sector and, in the flux that occurs in a meristem of growing and dividing cells, one or other of the two sorts of cells takes over its self-perpetuating layer in the growing point. The sectorial chimera therefore becomes nonchimerical or else a periclinal chimera.

However, in one class of chimera an isolating mechanism can stabilize the sectorial arrangement. This propagates stripes of mutant tissue into the shoot, but because the tunica and corpus are discrete from each other, the plant is not fully sectored and is called a mericlinal chimera. Many chimeras of this type have



Variegated *Pelargonium*, a periclinal chimera whose second tunica layer is genetically white and whose corpus is genetically green.

a single tunica layer; those with green and white stripes in the leaves have the mutant cells in sectors of the corpus. They are always plants with leaves in two ranks, and consequently the lateral growth of the growing point occurs by cell expansion only in the plane connecting alternate leaves. This results in the longitudinal divisions of the corpus cells being confined to planes at right angles to the plane containing the leaves. A mutation in one cell therefore can result in a vertical sheet of mutant cells which, in the case of plastid defect, manifests itself as a white stripe in every future leaf.

The growing points of roots may also become chimerical, but in roots there is no mechanism to isolate genetically different tissues as there is in shoots, and so chimeras are unstable.

Since the general acceptance of the existence of organisms with genetically diverse cells, many cultivated plants have been found to be chimeras. Flecks of color often indicate the chimerical nature of such plants. Color changes in potato tubers occur similarly because the plants are periclinal chimeras. See SOMATIC CELL GENETICS. [F.A.L.C.]

**Chimney** A vertical hollow structure of masonry, steel, or reinforced concrete, built to convey gaseous products of combustion from a building or process facility. A chimney should be high enough to furnish adequate draft and to discharge the products of combustion without causing local air pollution. The height and diameter of a chimney determine the draft. For adequate draft, small industrial boilers and home heating systems depend entirely upon the enclosed column of hot gas. In contrast, stacks, which are chimneys for large power plants and process facilities, usually depend upon force-draft fans and induced-draft fans to produce the draft necessary for operation, and the chimney is used only for removal of the flue gas. See FAN.

For fire safety, chimneys for residential construction and for small buildings must extend at least 3 ft (0.9 m) above the level where they pass through the roof and at least 2 ft (0.6 m) higher than any ridge within 10 ft (3 m) of them. Some stacks extend as high as 500 ft (150 m) above ground level, thus providing supplementary natural draft.

A chimney or stack must be designed to withstand lateral loads from wind pressure or seismic forces (earthquakes), as well as vertical loads from its own weight. Small chimneys used in residential construction are commonly made of brick or unreinforced masonry, while stacks are usually made of steel. Tall steel chimneys of small diameter cannot economically be made self-supporting and must be guyed. Concrete chimneys may be plain or reinforced. Except for rectangular flues and chimneys commonly used in residential construction, masonry chimneys are usually constructed of perforated radial brick molded to suit the diameter of the chimney. See BRICK; LOADS, DYNAMIC; MASONRY; MORTAR; REINFORCED CONCRETE; STAINLESS STEEL; STEEL; TRUSS. [J.Ve.]

**Chinchilla** The name given to two species of rodents which, together with four species of viscachas, compose the family Chinchillidae. The two species of chinchilla are *Chinchilla brevicaudata* and *C. lanigar*. These animals resemble the squirrel in size and shape and are characterized by long, muscular hindlimbs, with elongate feet bearing four toes, and short forelimbs. Blunt claws occur on the flexible fingers. Chinchillas are gregarious, nocturnally active animals and are found in arid, mountainous regions where they feed principally on vegetation. They often seek shelter in burrows or rock crevices, so that their capture is difficult. The female, which is larger than the male, bears one to six offspring twice each year after a gestation period of 105–111 days.

These animals are native to several areas of South America and are widely bred on farms in North America and Europe for their fur, which is long, fine, and expensive. See RODENTIA. [C.B.C.]

**Chinook** A mild, dry, extremely turbulent westerly wind on the eastern slopes of the Rocky Mountains and closely adjoining plains. The term is an Indian word which means “snow-eater,” appropriately applied because of the great effectiveness with which this wind reduces a snow cover by melting or by sublimation. The chinook is a particular instance of a type of wind known as a foehn wind. Foehn winds, initially studied in the Alps, refer to relatively warm, rather dry currents descending the lee slope of any substantial mountain barrier. The dryness is an indirect result of the condensation and precipitation of water from the air during its previous ascent of the windward slope of the mountain range. The warmth is attributable to adiabatic compression, turbulent mixing with potentially warmer air, and the previous release of latent heat of condensation in the air mass and to the turbulent mixing of the surface air with the air of greater heat content aloft. In winter the chinook wind sometimes impinges upon much colder stagnant polar air along a sharp front located in the foothills of the Rocky Mountains or on the adjacent plain. Small horizontal oscillations of this front have been known to produce several abrupt temperature rises and falls of as much as 45–54°F (25–30°C) at a given location over a period of a few hours. Damaging winds sometimes occur as gravity waves, which are triggered along the interface between the two air masses. See FRONT; ISENTROPIC SURFACES; PRECIPITATION (METEOROLOGY); WIND; WIND STRESS. [F.S.; H.B.B.]

**Chipmunk** A member of the tribe Marmotini in the rodent family Sciuridae. There are 18 species. The eastern chipmunk (*Tamias striatus*) is found in wooded areas of eastern Canada and the United States. The western species, although quite similar to the eastern form, are included in the separate genus *Eutamias*.

These rodents are intermediate between the squirrels and marmots, having lost the typical bushy tail, tufted ears, and silky fur of the squirrel. They are diurnal animals, active in collecting food such as nuts, grains, and seeds. They fill their large cheek pouches with gathered food to carry it to storage places for the winter.

The animals construct extensive burrows of several chambers at the bottom of a downward sloping entry tunnel, which is about 3 ft (1 m) long. The chambers, used for hoarding food and for nesting, are below the frost line. While chipmunks are not true hibernators, they tend to remain in their underground chambers during the winter months. In the early spring they emerge from the burrows and mating occurs. After a gestation period of 5 weeks six or more young are born, blind and helpless. See RODENTIA. [C.B.C.]

**Chiroptera** An order of mammals (bats) in which the front limbs are modified as wings, thus making the chiropterans the only truly flying mammals. Bats form the second largest order of living mammals (16 families, 171 genera, some 840 species). They range from the limit of trees in the Northern Hemisphere to the southern tips of Africa, New Zealand, and South America, but most species are confined to the tropics. On many oceanic islands they are the only native land mammals.

The wing is formed by webs of skin running from the neck to the wrist (propatagium, or antebrachial membrane), between the greatly elongated second, third, fourth, and fifth fingers (chiropatagium), and from the arm and hand to the body (usually the side) and hindlegs (plagiopatagium). There is also usually a web between the hindlegs (uropatagium, or interfemoral membrane) in which the tail, if present, is usually embedded for at least part of its length (see illustration). The 16 living families may be briefly characterized as follows.

Pteropodidae are in general the most primitive of living bats and are placed in the suborder Megachiroptera, characterized by more primitive ears and shoulder joints. Most still retain a claw on the second digit (absent in all other bats, suborder Microchiroptera), and few have developed an echolocation (sonar) mechanism, found in all Microchiroptera. The teeth, however,

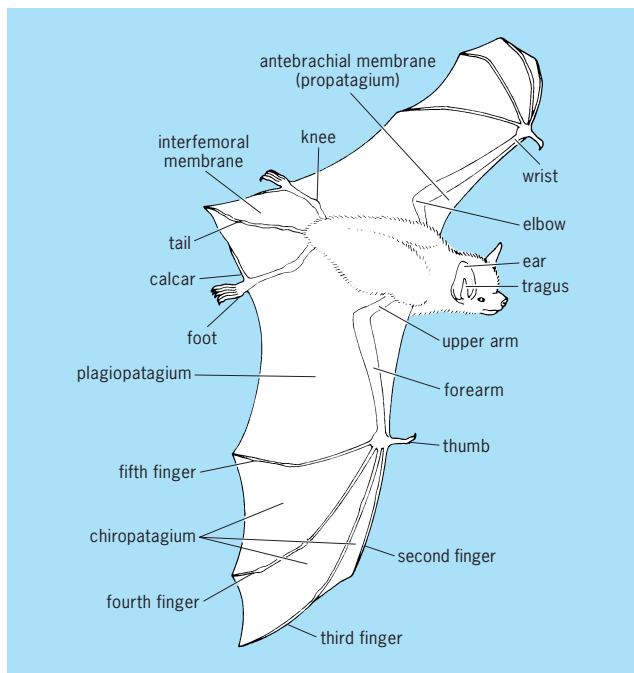

Features of the bat. (From R. Peterson, *Silently by Night*, McGraw-Hill, 1964)

are highly modified for eating fruit or nectar. The family, with 38 genera and 149 species, is widely distributed in the tropics and subtropics of the Eastern Hemisphere. While some species are quite small, the family includes the largest of all bats, with wingspreads of up to  $5\frac{1}{2}$  ft (1.65 m).

Rhinopomatidae is an insect-eating family, with one genus and two species, found chiefly in arid regions of northern Africa and southern Asia. These bats are characterized by long wirelike tails and rudimentary nose leaves.

Emballonuridae is an insectivorous family that includes 12 genera with 45 species found in the tropics of both Eastern and Western hemispheres. Like the Pteropodidae, these bats have well-developed bony processes behind the eye sockets. The tail extends only partly across the uropatagium.

Noctilionidae, a tropical American family, is represented by two species in one genus, including a highly specialized fish-eating species. Fish are detected by echolocation and gaffed by the long clawed feet.

Nycteridae are insect eaters, with 1 genus and 12 species found in Africa and southern Asia. These bats have an extensive basin behind the nose, which is partly bridged over by flaps of skin, leaving a mere slit between them.

The four genera of the Megadermatidae (with five species) occur in tropical Africa, southeastern Asia and adjoining islands, and northern Australia. Some species are insect-eating; others feed on small vertebrates, including other bats.

Rhinolophidae are insect-eating bats that are widely distributed in the Eastern Hemisphere. They are remarkable for their extremely complex nose leaves. There are 11 genera represented by 129 species.

Phyllostomatidae includes 120 species (in 50 genera) of tropical and subtropical bats. They possess simple nose leaves and a tremendous variety in structure, reflecting an equal diversity in food habits. Primitively insect-eating, many have become fruit or nectar feeders, and a few are predators on small vertebrates, including other bats.

Desmodontidae are the true vampires, essentially confined to the mainland of tropical America. The teeth and tongue are highly modified for taking of blood. This family includes three genera with three species.

Natalidae (one genus and four species) are tropical American insect-eating species with large funnellike ears.

Furipteridae is an insect-eating family, confined to tropical South America, and represented by two species in two genera. The thumb is reduced in size and largely enclosed in the wing membrane.

Thyropteridae includes two species (in one genus), confined to the tropical American mainland. The large suction disks on the thumbs and hindfeet enable them to roost on the smooth inner surfaces of large rolled-up leaves.

Myzopodidae, with a single species, is confined to Madagascar, eats insects, and has suckers on the thumbs and feet rather like those of the Thyropteridae.

Vespertilionidae, a nearly cosmopolitan family with 279 species in 34 genera, occur almost everywhere that bats occur. Almost all are insect-eating and a few catch fish. In all, the tail is long, extending to the edge of the uropatagium. Most have no special facial modifications. A few have very large ears or small simple nose leaves. In spite of its many species, the family shows little structural diversity. Echolocation, present in all families of bats except the Pteropodidae, is perhaps most highly developed here and is used for catching insects as well as avoiding obstacles.

Mystacinidae, with a single insect-eating species, is confined to New Zealand. It has a short tail, not reaching the edge of the uropatagium, and stout hindlegs and body.

Molossidae is widely distributed in the tropics and subtropics. Feeding on insects, they have long tails which extend beyond their uropatagia. The body and hindlegs are stoutly built. The family includes 81 species in 10 genera.

Bats have a poor fossil record, but have been distinct at least since the Eocene, some 50,000,000 years ago. See BAT; MAMMALIA. [K.F.K.]

**Chitin** A polysaccharide found abundantly in nature. Chitin forms the basis of the hard shells of crustaceans, such as the crab, lobster, and shrimp. The exoskeleton of insects is also chitinous, and the cell walls of certain fungi contain this substance.

Chitin is a long, unbranched molecule consisting entirely of *N*-acetyl-D-glucosamine units linked by  $\beta$ -1,4 bonds (see illustration). It may be thought of as cellulose in which the hydroxyl

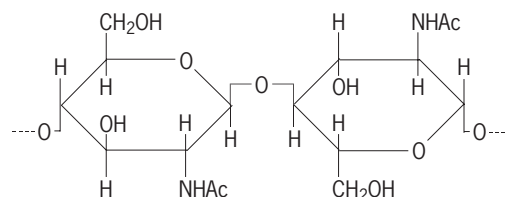

$\beta$ -*N*-acetyl-D-glucosamine unit of chitin.

groups on the second carbon are replaced with  $\text{NHCOCH}_3$  groups. Chitin is considered to be synthesized in nature by an enzyme which is capable of effecting a glycosyl transfer of the *N*-acetyl-D-glucosamine from uridinediphosphate-*N*-acetyl-D-glucosamine to a preformed chitodextrin acceptor, forming the polysaccharide. This stepwise enzymic transfer results in the production of the long chain of  $\beta$ -*N*-acetyl-D-glucosamine units, which is insoluble chitin. See CELLULOSE; OPTICAL ACTIVITY; POLYSACCHARIDE. [W.Z.H.]

**Chiton** A member of the class Polyplacophora in the phylum Mollusca. Chitons are also called loricates or coat-of-mail shells. All chitons are marine and, except for a few deep-sea forms, all live in the low intertidal and upper sublittoral, typically on wave-swept rocks. The flattened elliptical body bears eight articulated shell plates dorsally on the mantle and a ventral suctorial foot, features which are clearly adapted for life adhering to hard and uneven surfaces in the lower littoral zone (see illustration).

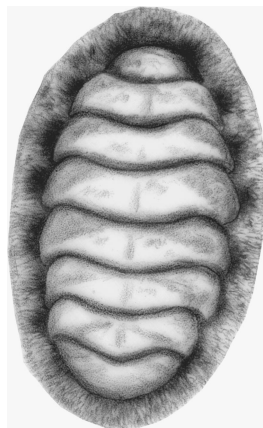

Dorsal view of a mossy chiton (*Mopalia muscosa*) showing the eight articulated plates of the shell and the pallial girdle with calcareous spicules.

Normally, chitons can resist the strongest surf action but, in the unlikely natural event of a chiton being washed off its rock (or if removed by a human collector), the articulated shell allows it to curl up to protect the soft foot and gills of its underside. Chiton species living on both sides of the Atlantic are relatively small (0.4–1.2 in. or 1–3 cm long) and unobtrusive. Only four genera have living species offshore and in deeper waters (to 20,000 ft or 6000 m), but they may be related to the earliest fossil chitons. See MOLLUSCA; POLYPLACOPHORA. [W.D.R.-H.]

**Chlamydia** A genus of bacteria with a growth cycle differing from that of all other microorganisms. Chlamydiae grow only in living cells and cannot be cultured on artificial media. Although capable of synthesizing macromolecules, they have no system for generating energy; the host cell's energy system fuels the chlamydial metabolic processes. The genome is relatively small; the genomes of *C. pneumoniae* and *C. trachomatis* have been completely sequenced.

The chlamydial infectious particle, called the elementary body, is round and about 350–450 nanometers in diameter. It enters a susceptible host cell and changes to a metabolically active and larger (approximately 800–1000 nm in diameter) reticulate body that divides by binary fission. The entire growth cycle occurs within a vacuole that segregates the chlamydia from the cytoplasm of the host cell. The reticulate bodies change back to elementary bodies, and then the cell lyses and the infectious particles are released. The growth cycle takes about 48 h.

Human diseases are caused by three species of *Chlamydia*. *Chlamydia trachomatis* is almost exclusively a human pathogen, and one of the most common. Infections occur in two distinct epidemiologic patterns. In many developing countries, *C. trachomatis* causes trachoma, a chronic follicular keratoconjunctivitis. It is the world's leading cause of preventable blindness, affecting approximately 500 million people. In areas where this condition is highly endemic, virtually the entire population is infected within the first few years of life. Most active infections are found in childhood. By age 60, more than 20% of a population can be blinded as a result of trachoma. See EYE DISORDERS.

*Chlamydia trachomatis* is the most common sexually transmitted bacterial pathogen; an estimated 3–4 million cases occur each year in the United States, and there are close to 90 million worldwide. The most common manifestation is nongonococcal urethritis in males. The cervix is the most commonly infected site in women. Ascending infections can occur in either sex, resulting in epididymitis in males or endometritis and salpingitis in females. Chlamydial infection of the fallopian tube can cause late consequences such as infertility and ectopic pregnancy, even though the earlier infection is asymptomatic. The infant passing through the infected birth canal can acquire the infection and

may develop either conjunctivitis or pneumonia. A more invasive form of *C. trachomatis* causes a systemic sexually transmitted disease called lymphogranuloma venereum. See SEXUALLY TRANSMITTED DISEASES.

*Chlamydia psittaci* is virtually ubiquitous among avian species and is a common pathogen among lower mammals. It is economically important in many countries as a cause of abortion in sheep, cattle, and goats. It causes considerable morbidity and mortality in poultry. *Chlamydia psittaci* can infect humans, causing the disease psittacosis. Psittacosis can occur as pneumonia or a febrile toxic disease without respiratory symptoms.

*Chlamydia pneumoniae* appears to be a human pathogen with no animal reservoir. It is of worldwide distribution and may be the most common human chlamydial infection. It appears to be an important cause of respiratory disease.

Azithromycin is the drug of choice for uncomplicated chlamydial infection of the genital tract. Two therapeutic agents require longer treatment regimens: doxycycline, a tetracycline antibiotic, is the first alternate treatment; erythromycin may be used for those who are tetracycline-intolerant, as well as for pregnant women or young children. See MEDICAL BACTERIOLOGY. [J.S.]

**Chlorine** A chemical element, Cl, atomic number 17 and atomic weight 35.453. Chlorine exists as a greenish-yellow gas at ordinary temperatures and pressures. It is second in reactivity only to fluorine among the halogen elements, and hence is never found free in nature, except at the elevated temperatures of volcanic gases. It is estimated that 0.045% of the Earth's crust is chlorine. It combines with metals, nonmetals, and organic materials to form hundreds of chlorine compounds, the most important of which are discussed here. See PERIODIC TABLE.

Chlorine and its common acid derivative, hydrochloric (or muriatic) acid, were probably noted by experimental investigators as early as the thirteenth century. C. W. Scheele identified chlorine as "dephlogisticated muriatic acid" in 1774, and H. Davy proved that a new element had been found in 1810. Extensive production started 100 years later. During the twentieth century, the amount of chlorine used has been considered a measure of industrial growth.

**Physical properties.** The atomic weight of naturally occurring chlorine is 35.453 (based on carbon at 12). It is formed of stable isotopes of mass 35 and 37; radioactive isotopes have been made artificially. The diatomic gas has a molecular weight of 70.906. The boiling point of liquid chlorine (golden-yellow in color) is  $-33.97^{\circ}\text{C}$  ( $-29.15^{\circ}\text{F}$ ) at 760 mm Hg ( $10^2$  kilopascals) and the melting point of solid chlorine (tetragonal crystals) is  $-100.98^{\circ}\text{C}$  ( $-149.76^{\circ}\text{F}$ ). The critical temperature is  $144^{\circ}\text{C}$  ( $292^{\circ}\text{F}$ ); the critical pressure is 78.7 atm; the critical volume is 1.745 ml/g; and density at the critical point is 0.573 g/ml. Thermodynamic properties include heat of sublimation at  $7370 \pm 10$  cal/mole at 0 K, heat of evaporation at 4882 cal/mole at  $-33.97^{\circ}\text{C}$ , heat of fusion at 1531 cal/mole, vapor heat capacity at a constant pressure of 1 atm of 8.32 cal/(mole  $^{\circ}\text{C}$ ) at  $0^{\circ}\text{C}$  ( $32^{\circ}\text{F}$ ) and 8.46 cal/(mole  $^{\circ}\text{C}$ ) at  $100^{\circ}\text{C}$  ( $212^{\circ}\text{F}$ ). Chlorine forms solid hydrates,  $\text{Cl}_2 \cdot 6\text{H}_2\text{O}$  (pale-green crystals) and  $\text{Cl}_2 \cdot 8\text{H}_2\text{O}$ . It hydrolyzes in water as shown in reaction (1).



**Chemical properties.** Chlorine is one of four closely related chemical elements which have been called the halogen elements. Fluorine is more active chemically, and bromine and iodine are less active. Chlorine replaces iodine and bromine from their salts. It enters into substitution and addition reactions with both organic and inorganic materials. Dry chlorine is somewhat inert, but moist chlorine unites directly with most of the elements. See HALOGEN ELEMENTS.

**Compounds.** Sodium chloride, NaCl, is used directly as mined (rock salt), or as found on the surface, or as brine. It may

also be dissolved, purified, and reprecipitated for use in foods or when chemical purity is required. Its main uses are in the production of soda ash and chlorine products. Farm use, refrigeration, dust and ice control, water treatment, food processing, and food preservation are other uses. Calcium chloride,  $\text{CaCl}_2$ , is usually obtained from brines or as a by-product of chemical processing. Its main uses are in road treatment, coal treatment, concrete conditioning, and refrigeration. See HALITE.

Wet chlorine reacts with metals to form chlorides, most of which are soluble in water. It also reacts with sulfur and phosphorus and with other halogens as in reactions (2).

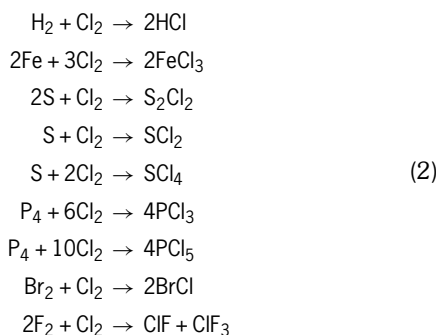

The oxides of chlorine, dichlorine monoxide,  $\text{Cl}_2\text{O}$ , chlorine monoxide,  $\text{ClO}$ , chlorine dioxide,  $\text{ClO}_2$ , chlorine hexoxide,  $\text{Cl}_2\text{O}_6$ , and chlorine heptoxide,  $\text{Cl}_2\text{O}_7$ , are all made indirectly.  $\text{Cl}_2\text{O}$  is commonly called chlorine monoxide also. Chlorine dioxide, a green gas, has become increasingly important in commercial bleaching of cellulose, water treatment, and waste treatment.

Hydrogen chloride,  $\text{HCl}$ , is a colorless, pungent, poisonous gas which liquefies at 82 atm at  $51^\circ\text{C}$  ( $124^\circ\text{F}$ ). It boils at  $-85^\circ\text{C}$  ( $-121^\circ\text{F}$ ) at 1 atm ( $10^2$  kPa). Its major production is as the by-product of many organic chlorinations. It can be made by direct reaction of chlorine and hydrogen in an open combustion chamber submerged in cooled, aqueous hydrochloric acid solution. It is used as a strong acid and as a reducing agent.

Aluminum chloride,  $\text{AlCl}_3$ , is an anhydrous, white, deliquescent, hexagonal crystalline substance. Either scrap aluminum or the oxide (bauxite) may be chlorinated. Aluminum chloride is a catalyst for production of cumene, styrene, and isomerized butane. Of the aluminum chloride uses in anhydrous form, ethylbenzene production uses 25%, dyes 30%, detergents 15%, ethyl chloride 10%, drugs 8%, and miscellaneous production 12%. Hydrated and liquid forms are also available, 50% of which are used in drug and cosmetic production.

Ferric chloride,  $\text{FeCl}_3$ , is a solid composed of dark, hexagonal crystals. Much chlorine from chemical processes is converted to ferric chloride, which is then used for the manufacture of salts, pigments, pharmaceuticals, and dyes and for photoengraving, preparation of catalysts, and waste and sewage treatment.

**Natural occurrence.** Because many inorganic chlorides are quite soluble in water, they are leached out of land areas by rain and ground water to accumulate in the sea or in lakes that have no outlets. Seawater contains 18.97 g of chloride ion per kilogram (3% sodium chloride). Solar evaporation produces large deposits of salts in landlocked areas. Similar evaporation in the past is responsible for vast underground deposits of rock salt and brines in Michigan, central New York, the Gulf Coast of Texas, Stassfurt in Germany, and elsewhere. These deposits are mainly of sodium chloride, the supply of which is unlimited for practical purposes. Other rocks and minerals in the Earth's surface average slightly over 0.03% chloride. See HALOGEN MINERALS; SALINE EVAPORITE.

**Manufacture.** The first electrolytic process was patented in 1851 by Charles Watt in Great Britain. In 1868 Henry Deacon produced chlorine from hydrochloric acid and oxygen at  $400^\circ\text{C}$  ( $750^\circ\text{F}$ ) with copper chloride absorbed in pumice stone as a

catalyst. The electrolytic cells now used may be classified for the most part as diaphragm and mercury types. Both make caustic ( $\text{NaOH}$  or  $\text{KOH}$ ), chlorine, and hydrogen. The economics of the chlor-alkali industry mainly involve the balanced marketing or internal use of caustic and chlorine in the same proportions as obtained from the electrolytic cell process.

**Uses.** Chlorine is an excellent oxidizing agent. Historically, the use of chlorine as a bleaching agent in the paper, pulp, and textile industries and as a germicide for drinking water preparation, swimming pool purification, and hospital sanitation has made community living possible. Chlorine is used to produce bromine from bromides found in brines and seawater. The automotive age increased the production of bromine tremendously for the manufacture of ethylene dibromide for use in gasoline. Compounds of chlorine are used as bleaching agents, oxidizing agents, solvents, and intermediates in the manufacture of other substances. See HERBICIDE. [J.Do.; FW.Ko.; R.W.B.]

**Chlorite** One of a group of layer silicate minerals, usually green in color, characterized by a perfect cleavage parallel to (001). The cleavage flakes are flexible but inelastic, with a luster varying from pearly or vitreous to dull and earthy. The hardness on the cleavage is about 2.5. The specific gravity of chlorite varies between 2.6 and 3.3 as a function of composition.

Chlorite is a common accessory mineral in low- to medium-grade regional metamorphic rocks and is the dominant mineral in chlorite schist. It can form by alteration of ferromagnesian minerals in igneous rocks and is found occasionally in pegmatites and vein deposits. It is a common constituent of altered basic rocks and of alteration zones around metallic ore bodies. Chlorite also can form by diagenetic processes in sedimentary rocks. See AUTHIGENIC MINERALS; CLAY MINERALS; DIAGENESIS; SILICATE MINERALS. [S.W.Ba.]

**Chloritoid** A hydrous iron aluminum silicate mineral with an ideal formula of  $\text{Fe}_2^{2+}\text{Al}_4\text{O}_2(\text{SiO}_4)_2(\text{OH})_4$ . Chloritoid occurs as platy, black or dark green crystals, rarely more than a few millimeters in size. Its density ranges from 3.46 to 3.80  $\text{g/cm}^3$ , and its hardness on the Mohs scale is 6.5. See HARDNESS SCALES.

Chloritoid is increasingly being recognized as a constituent in rocks that formed under high-pressure conditions. It is found in association with glaucophane in blueschist-facies metamorphic rocks, and with amphibole and pyroxene in eclogite-facies metamorphic rocks. These are rocks that formed under conditions thought to prevail at the base of the Earth's crust or in the mantle. Experimental studies of metamorphism of basalt under these conditions indicate the formation of chloritoid at pressures exceeding 2300 MPa (23 kbar) and at a temperature of  $650^\circ\text{C}$  ( $1200^\circ\text{F}$ ). In these high-pressure occurrences of chloritoid, the chloritoid is rich in magnesium, having a value of  $\text{Mg}/(\text{Mg} + \text{Fe})$  ranging from 0.38 to 0.40. See METAMORPHIC ROCKS. [T.C.L.]

**Chloromonadida** An order of the class Phytomastigophorea, also known as the Chloromonadina. These poorly known flagellates are grass-green or colorless, somewhat flattened, and have two equal flagella, one anterior, the other trailing. All known genera are free-swimming, although *Reckertia* and *Thaumatostix* form pseudopodia. They vary in size from 30 to 100 micrometers. Chromatophores are small disks, stigmas are lacking, and fat is the storage product. Trichocysts are found in three genera. The nucleus is large, with nucleoli and chromosomes visible during interphase. One or two anterior vacuoles are present and a reservoir seems to be present in *Trentonia* and *Gonyostomum*. Life cycles are unknown, but longitudinal division occurs. The taxonomic position of the class is poorly defined. See PHYTAMASTIGOPHOREA. [J.B.L.]

**Chlorophyceae** A large and diverse class of plants, commonly called green algae, in the chlorophyll *a-b* phyletic line (Chlorophycota). Estimated number of taxa varies widely;

560 genera and 8600 species are conservative estimates. See CHLOROPHYCOTA.

The green algae exhibit great morphological diversity while sharing fundamental biochemical and ultrastructural features. Their photosynthetic pigments are similar to those in higher plants and include chlorophyll *a* and *b*,  $\alpha$ -,  $\beta$ -, and  $\gamma$ -carotene, and various xanthophylls. Chloroplasts vary in number and shape, but always have two membranes, two to five thylakoids per lamella, and usually one or more pyrenoids. A cell wall, which may be calcified, is usually present, often contains cellulose, hydroxyproline glycosides, xylan, and mannan. The chief food reserve is starch, stored in the chloroplast as granules which often sheathe a pyrenoid. Motile cells usually have two or four apically inserted smooth flagella of approximately equal length. See CELL PLASTIDS; CHLOROPHYLL; PHOTOSYNTHESIS.

Almost all somatic cell types known for algae occur among the Chlorophyceae, the exceptions being rhizopodial unicells and complex multicellular thalli differentiated into macroscopic organs. Ultrastructural studies have revealed differences in details of nuclear and cell division, cell coverings, plasmodesmata, pyrenoids, and flagellar structure that are correlated among themselves and with certain traditional characters to a degree that strongly suggests that the ulotrichine line is polyphyletic, with desmoschisis having evolved at least four times. Moreover, these studies suggest that the ultimate ancestral green flagellate was prasinophycean (asymmetrical and covered with scales) rather than *Chlamydomonas*-like. Integration of these studies and inferences suggests four phyletic lines: chlorophycean, ulvophycean, charophycean, and pleurastrophycean.

In addition to the four phyletic lines, each of which includes monads as well as multicellular algae, there is a residual group of primitive green flagellates for which the name Micromonadophyceae has been proposed. These monads are scaly or secondarily naked and have one to four flagella arising from an apical pit or lateral depression. The interzonal mitotic spindle persists during cytokinesis. This group corresponds to the class Prasinophyceae in the present classification. For the sake of consistency, however, Prasinophyceae and Charophyceae are treated elsewhere in this work as separate classes. See ALGAE; CHAROPHYCEAE; PRASINOPHYCEAE. [P.C.Si.; R.L.Moe]

**Chlorophycota** A division of the plant kingdom (also known as Chlorophyta or Chlorophycophyta) comprising all algae that have chlorophyll *a* and *b* except the Euglenophyceae, and that in all other respects are so different as to suggest a separate origin of their photosynthetic pigments. Three classes, Charophyceae (charophytes), Chlorophyceae (green algae), and Prasinophyceae, are recognized. See ALGAE; CHAROPHYCEAE; CHLOROPHYCEAE; PRASINOPHYCEAE. [P.C.Si.; R.L.Moe]

**Chlorophyll** The generic name for the intensely colored green pigments which are the photoreceptors of light energy in photosynthesis. These pigments belong to the tetrapyrrole family of organic compounds.

Five closely related chlorophylls, designated *a* through *e*, occur in higher plants and algae. The principal chlorophyll (Chl) is Chl *a*, found in all oxygen-evolving organisms; photosynthetic bacteria, which do not evolve O<sub>2</sub>, contain instead bacteriochlorophyll (Bchl). Higher plants and green algae contain Chl *b*, the ratio of Chl *b* to Chl *a* being 1:3. Chlorophyll *c* (of two or more types) is present in diatoms and brown algae. Chlorophyll *d*, isolated from marine red algae, has not been shown to be present in the living cell in large enough quantities to be observed in the absorption spectrum of these algae. Chlorophyll *e* has been isolated from cultures of two algae, *Tribonema bombycinum* and *Vaucheria hamata*. In higher plants the chlorophylls and the above-mentioned pigments are contained in lipoprotein bodies, the plastids. See CAROTENOID; CELL PLASTIDS; PHOTOSYNTHESIS.

Chlorophyll molecules have three functions: They serve as antennae to absorb light quanta; they transmit this energy from one chlorophyll to another by a process of "resonance transfer;"

and finally, this chlorophyll molecule, in close association with enzymes, undergoes a chemical oxidation (that is, an electron of high potential is ejected from the molecule and can then be used to reduce another compound). In this way the energy of light quanta is converted into chemical energy.

The chlorophylls are cyclic tetrapyrroles in which four 5-membered pyrrole rings join to form a giant macrocycle. Chlorophylls are members of the porphyrin family, which plays important roles in respiratory pigments, electron transport carriers, and oxidative enzymes. See PORPHYRIN.

It now appears that the chlorophyll *a* group may be made up of several chemically distinct Chl *a* species. The structure of monovinyl chlorophyll *a*, the most abundant of the Chl *a* species, is shown in the illustration.

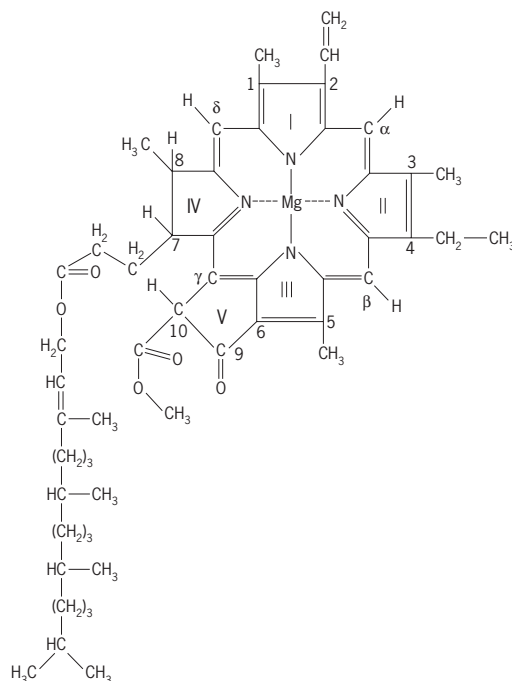

Structure of chlorophyll *a* (C<sub>55</sub>H<sub>72</sub>O<sub>5</sub>N<sub>4</sub>Mg).

The two major pigments of protoplasm, green chlorophyll and red heme, are synthesized from ALA ( $\delta$ -aminolevulinic acid) along the same biosynthetic pathway to protoporphyrin. ALA is converted in a series of enzymic steps, identical in plants and animals, to protoporphyrin. Here the pathway branches to form (1) a series of porphyrins chelated with iron, as heme and related cytochrome pigments; and (2) a series of porphyrins chelated with magnesium which are precursors of chlorophyll. See HEMOGLOBIN.

Chlorophylls reemit a fraction of the light energy they absorb as fluorescence. Irrespective of the wavelength of the absorbed light, the emitted fluorescence is always on the long-wavelength side of the lowest energy absorption band, in the red or infrared region of the spectrum.

The fluorescent properties of a particular chlorophyll are functions of the structure of the molecule and its immediate environment. Thus, the fluorescence spectrum of chlorophyll in the living plant is always shifted to longer wavelengths relative to the fluorescence spectrum of a solution of the same pigment. This red shift is characteristic of aggregated chlorophyll. [G.; S.Gr.; G.P.]

**Choanoflagellida** An order of the class Zoomastigophorea, superclass Mastigophora, subphylum Sarcomastigophora, in the phylum Protozoa. They are principally small, single-celled or colonial, structurally simple, colorless flagellates distinguished by having the anterior end surrounded by a thin protoplasmic collar, within which is an ingestive area for particu-

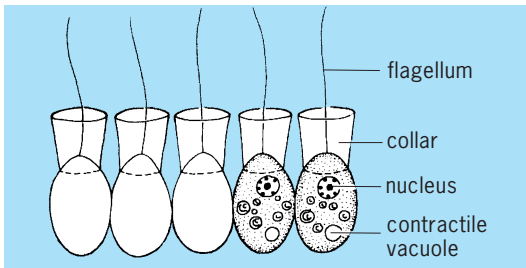

A linear colony of the choanoflagellate, *Desmarella moniliformis*.

late matter, for example, bacteria. A single flagellum arises from the center of this collar (see illustration). They are widespread in fresh and salt water and are common in inshore waters. See PROTOZOA; SARCOMASTIGOPHORA; ZOOMASTIGOPHOREA. [J.B.La.]

**Choke (electricity)** An inductor that is used to prevent electric signals and energy from being transmitted along undesired paths or into inappropriate parts of an electric circuit or system. Power-supply chokes prevent alternating-current components, inherent to a power supply, from entering the electronic equipment. Radio-frequency chokes (RFCs) prevent radio-frequency signals from entering audio-frequency circuits. The printed circuit boards used in virtually all electronic equipment such as computers, television sets, and high-fidelity audio systems typically have one or more chokes. The purposes of these chokes are the (1) attenuation of spurious signals generated in the equipment itself so that these signals will not be transmitted to other parts of the circuit or beyond the overall system to other electronic devices; (2) prevention of undesired signals or electrical noise generated in other parts of the system from adversely affecting circuit performance; and (3) prevention of ripple from the power supply from degrading system behavior. Waveguide chokes keep microwave energy from being transmitted to the wrong part of a waveguide system. See ELECTRICAL NOISE; ELECTRONIC POWER SUPPLY; PRINTED CIRCUIT; RIPPLE VOLTAGE; WAVEGUIDE.

In its simplest form, a choke or an inductor is a coil of wire (usually copper) wound around and insulated from a core, which may or may not be ferromagnetic. Ferromagnetic cores tend to increase inductance, reduce physical size, and reduce electromagnetic coupling between circuit elements, and they may increase power loss and resultant heating. Such cores often lead to nonlinear or swinging chokes, commonly found in power supplies, where the nonlinearity may be an advantage. See INDUCTANCE; INDUCTOR. [E.C.Jo.]

**Choked flow** Fluid flow through a restricted area whose rate reaches a maximum when the fluid velocity reaches the sonic velocity at some point along the flow path. The phenomenon of choking exists only in compressible flow and can occur in several flow situations. See COMPRESSIBLE FLOW.

**Through varying-area duct.** Choked flow can occur through a convergent flow area or nozzle attached to a huge reservoir. Flow exits the reservoir through the nozzle if the back pressure is less than the reservoir pressure. When the back pressure is decreased slightly below the reservoir pressure, a signal from beyond the nozzle exit is transmitted at sonic speed to the reservoir. The reservoir responds by sending fluid through the nozzle. Further, the maximum velocity of the fluid exists at the nozzle throat where the area is smallest.

When the back pressure is further decreased, fluid exits the reservoir more rapidly. Eventually, however, the velocity at the throat reaches the sonic velocity. Then the fluid velocity at the throat is sonic, and the velocity of the signal is also sonic. Therefore, further decreases in back pressure are not sensed by the reservoir, and correspondingly will not induce any greater

flow to exit the reservoir. The nozzle is thus said to be choked, and the mass flow of fluid is a maximum. See MACH NUMBER; NOZZLE; SOUND; SUPERSONIC DIFFUSER.

**With friction.** Choked flow can also occur through a long constant-area duct attached to a reservoir. As fluid flows through the duct, friction between the fluid and the duct wall reduces the pressure acting on the fluid. As pressure is reduced, other fluid properties are affected, such as sonic velocity, density, and temperature. The maximum Mach number occurs at the nozzle exit, and choked flow results when this Mach number reaches 1.

**With heat addition.** A reservoir with a constant-area duct attached may also be considered in the case that the flow through the duct is assumed to be frictionless but heat is added to the system along the duct wall. See FLUID FLOW; GAS DYNAMICS.

[W.S.J.]

**Cholera** A severe diarrheal disease caused by infection of the small bowel of humans with *Vibrio cholerae*, a facultatively anaerobic, gram-negative, rod-shaped bacterium. Cholera is transmitted by the fecal-oral route. Cholera has swept the world in seven pandemic waves. These involved the Western Hemisphere several times in the 1800s, and again in Peru in 1991. Whereas previous cholera outbreaks were associated with high mortality rates, through understanding of its pathophysiology it can now be said that no one should die of cholera who receives appropriate treatment soon enough.

Cholera produces a secretory diarrhea caused by the protein cholera enterotoxin (CTX). The toxin causes hypersecretion of chloride and bicarbonate and inhibition of sodium absorption in host membranes leading to the secretion of the large volumes of isotonic fluid which constitute the diarrhea of severe cholera. Treatment consists of replacing the fluids and electrolytes lost in the voluminous cholera stool. This can be done intravenously or orally. Appropriate antibiotics can also be used. The incubation period may be less than one day or up to several days; properly treated, the patient should recover in 4 or 5 days. The disease produces immunization, and convalescents rarely get cholera again. See DIARRHEA.

Despite the fact that the cholera bacteria were first discovered by Robert Koch in 1883 and a cholera vaccine was introduced 3 years later, there is still no effective, economical, and nonreactogenic vaccine. Use of a killed whole-cell vaccine administered parenterally (via injection) was eliminated because of expense, reactogenicity, and lack of efficacy. Experimental vaccines currently being evaluated include genetically engineered living attenuated preparations administered orally (or intranasally), killed whole-cell vaccines administered orally, and conjugated vaccines (polysaccharide and toxin antigens) administered parenterally. Efforts are also being made to include cholera antigens transgenically in edible plants.

A complicating feature is the fact that of approximately 150 recognized serogroups of *V. cholerae*, until 1992 only two, classical (first described by Koch) and El Tor (recognized later), of serogroup O1 have been responsible for all epidemic cholera. In 1992 a recently recognized serogroup, O139, caused epidemic cholera in India and Bangladesh and, for a time, replaced the resident El Tor vibrios. O139 and El Tor are antigenically distinct, so a new vaccine will be required for O139. The emergence of O139 raises the specter that other serogroups of *V. cholerae* may acquire virulence and epidemicity.

The best ways to avoid cholera are by chlorination of water, sanitary disposal of sewage, and avoidance of raw or improperly cooked seafood, which may have become infected by ingesting infected plankton in epidemic areas. [R.A.Fin.]

**Cholesterol** A cyclic hydrocarbon alcohol commonly classified as a lipid because it is insoluble in water but soluble in a number of organic solvents. It is the major sterol in all vertebrate cells and the most common sterol of eukaryotes. In vertebrates, the highest concentration of cholesterol is in the myelin sheath

that surrounds nerves and in the plasma membrane that surrounds all cells. See LIPID.

Cholesterol can exist either in the free (unesterified) form (see structure below) or in the esterified form, in which a fatty acid is

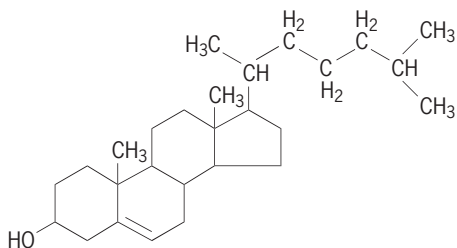

bound to the hydroxyl group of cholesterol by an ester bond. The free form is found in membranes. Cholesteryl esters are normally found in lipid droplets either within the cells of steroidogenic tissues, where it can be converted to free cholesterol and then to steroid hormones, or in the middle of spherical lipid-protein complexes, called lipoproteins, that are found in blood. See CELL MEMBRANES.

Cholesterol, together with phospholipids and proteins, is important in the maintenance of normal cellular membrane fluidity. At physiological temperatures, the cholesterol molecule interacts with the fatty acids of the membrane phospholipids and causes increased packing of the lipid molecules and hence a reduction of membrane fluidity. Thus, all vertebrate cells require cholesterol in their membranes in order for the cell to function normally. Cholesterol is also important as a precursor for a number of other essential compounds, including steroid hormones, bile acids, and vitamin D. See LIPID METABOLISM; STEROID.

Cellular cholesterol is obtained both from the diet, following its absorption in the intestine, and from synthesis within all cells of the body. Foods that are particularly high in cholesterol include eggs, red meat, and organs such as liver and brain. About 40–50% of the dietary cholesterol is absorbed from the intestine per day. In contrast, plant sterols are very poorly absorbed. Cholesterol synthesis occurs in all vertebrate cells but is highest in the liver, intestine, and skin, and in the brain at the time of myelination.

Cholesterol and cholesteryl esters are essentially insoluble in water. In order to transport these compounds around the body in the blood, the liver and intestine produce various lipid-protein complexes, called lipoproteins, which serve to solubilize them. Lipoproteins are large, complex mixtures of cholesterol, cholesteryl esters, phospholipids, triglycerides (fats), and various proteins. The major lipoproteins include chylomicrons, very low density lipoprotein (VLDL), low-density lipoprotein, and high-density lipoprotein (HDL).

Total plasma cholesterol levels of less than 200 mg/100 ml are considered desirable. Values of 200–239 or greater than 239 mg per 100 ml are considered, respectively, borderline high or high risk values, indicating the potential for a heart attack. High levels of low-density lipoprotein in the plasma are associated with increased risk of atherosclerosis, (“hardening of the arteries”), which involves deposition of cholesterol and other lipids in the artery wall. Diets low in cholesterol and saturated fats often result in a reduction in total plasma and LDL cholesterol levels. Such changes in blood cholesterol levels are thought to be beneficial and to reduce the incidence of heart attacks. See ARTERIOSCLEROSIS. [P.A.E.]

**Choline** A compound, trimethyl- $\beta$ -hydroxyethylammonium hydroxide, used by the animal organism as a precursor of acetylcholine and as a source of methyl groups. It is a strongly basic

hygroscopic substance with the formula

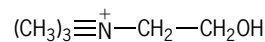

Choline deficiency in animals is associated with fatty livers, poor growth, and renal lesions. It is a lipotropic agent. There is no direct evidence of disease in humans due to choline deficiency, although there have been suggestions that some of the liver, kidney, or pancreas pathology seen in various nutritional deficiency states may be related to choline insufficiency. Choline is found in acetylcholine, which is necessary for nerve impulse propagation, and in phospholipids.

Humans eat 50–600 mg of choline per day, but only excrete 2–4 mg. Thus, conventional tests are of no value in studying choline requirements, and no knowledge of human choline requirements exists. See ACETYLCHOLINE. [S.N.G.]

**Chondrichthyes** A class of vertebrates comprising the cartilaginous, jawed fishes. The Chondrichthyes have traditionally included the subclasses Elasmobranchii (sharks, skates, and rays) and Holocephali (ratfishes). A classification scheme for the Chondrichthyes follows; for detailed information see separate articles on each group listed.

- Class Chondrichthyes
  - Subclass Elasmobranchii
    - Order: Cladoselachii
      - Pleurocanthodii
      - Selachii
      - Batoidea
  - Subclass Holocephali
    - Order Chimaeriformes

A group of Devonian armored fishes, the Placodermi, has usually been regarded as ancestral to the Chondrichthyes, but this derivation is not certain. Another group of primitive jawed fishes called acanthodians, which are considered by many as ancestral to the higher bony fishes, exhibit certain primitive elasmobranch-like features. In any case it is probable that the elasmobranchs and ratfishes arose independently of each other sometime during the Silurian or Early Devonian. See ACANTHODII; PLACODERMI.

The most distinctive feature shared by the elasmobranchs and ratfishes is the absence of true bone. In both groups the endoskeleton is cartilaginous; in some cases it may be extensively calcified. Because even calcified cartilage is rarely preserved, the fossil record of the Chondrichthyes is represented mainly by teeth and spines, with only occasional associated skeletons. See SKELETAL SYSTEM.

Other characteristics of the Chondrichthyes include placoid scales, clasper organs on the pelvic fins of males for internal fertilization, a urea-retention mechanism, and the absence of an air (swim) bladder. Both groups have primarily always been marine predators, although they have repeatedly invaded fresh water throughout their long history. The elasmobranchs have probably always fed as they do today, on other fishes as well as on soft and hard-bodied invertebrates. The ratfishes have most likely concentrated on invertebrates, although modern forms occasionally also feed on smaller fishes. See RAY; SCALE (ZOOLOGY); SHARK; SWIM BLADDER. [B.S.]

**Chondrostei** The most archaic of three organizational levels (infraclasses) of the subclass Actinopterygii, or rayfin fishes. Chondrosteans of the order Palaeonisciformes appeared first in the Lower Devonian, and by Middle Devonian were abundant contemporaries of the early crossopterygians and lungfishes, representative of the other two subclasses of bony fishes. Palaeonisciformes were diversified and abundant in sturgeons (order Acipenseriformes), which persist in the modern fauna as highly specialized and in some ways degenerate chondrosteans.



Even more like the palaeonisciforms than the sturgeons are the surviving African fishes of the order Polypteriformes, which are known only since the Eocene but are probably much older. See ACIPENSERIFORMES; PALAEONISCIFORMES; POLYPTERIFORMES.

Primitive chondrosteans were mostly small- or moderate-sized fishes with a heavy armor of rhomboidal, enameled scales. The heterocercal tail was preceded on the midline, above and below, by series of enlarged fulcral scales. There was usually a spiracle behind the eye. The head was heavily plated and relatively inflexible, with the maxilla firmly bound to the cheek bones. Feeding was accomplished largely by biting and gulping, aided by simple conical teeth. See ACTINOPTERYGII; SCALE (ZOOLOGY).

[R.M.B.]

**Chonotrichida** An order of the Holotrichia. This is a small group of curious, vase-shaped ciliates, commonly found as ectocommensals on marine crustaceans. They attach to their hosts by a short, secreted stalk, and their bodies are practically devoid

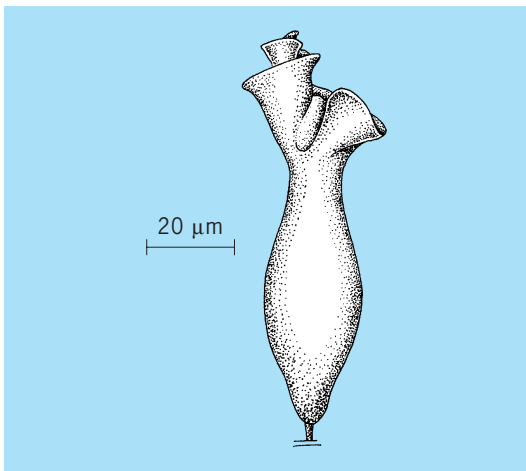

*Spirochona*, an example of a chonotrichid.

of ciliature. *Spirochona* (see illustration) is a common example of this order. See HOLOTTRICHIA; PROTOZOA.

[J.O.C.]

**Chopping** The act of interrupting an electric current, beam of light, or beam of infrared radiation at regular intervals. This can be accomplished mechanically by rotating a vibrating mirror in the path of the beam to deflect it away from its intended source at regular intervals. A current can be chopped with an electromagnetic vibrator having contacts on its moving armature. A current can also be chopped electronically by passing it through a multivibrator or other switching circuit. Chopping is generally used to change a direct-current signal into an alternating-current signal that can more readily be amplified. See MULTIVIBRATOR.

Chopping has been increasingly used inside analog integrated circuits. Solid-state switches and capacitors are used to chop operational amplifiers, greatly improving their offset voltages. Chopping is also used in analog large-scale-integrated switched-capacitor filters as a means for reducing their undesirable 1/f (inverse-frequency) noise. See AMPLIFIER; INTEGRATED CIRCUITS; OPERATIONAL AMPLIFIER; SWITCHED CAPACITOR.

[E.J.S.]

**Chordata** The highest phylum in the animal kingdom, which includes the lancelets or amphioxi (Cephalochordata), the tunicates (Urochordata), the acorn worms and pterobranchs (Hemichordata), and the vertebrates (Craniata) comprising the lampreys, sharks and rays, bony fish, amphibians, reptiles, birds, and mammals. Members of the first three groups, the lower chordates, are small and strictly marine. The vertebrates are free-living; the aquatic ones are primitively fresh-water types with marine groups being advanced; and the members include animals

of small and medium size, as well as the largest of all animals. See CEPHALOCHORDATA; HEMICHORDATA; TUNICATA; VERTEBRATA.

The typical chordate characteristics are the notochord, the dorsal hollow nerve cord, the pharyngeal slits, and a postanal tail. The notochord appears in the embryo as a slender, flexible rod filled with gelatinous cells and surrounded by a tough fibrous sheath, and contains, at least in some forms, transverse striated muscle fibers; it lies above the primitive gut. In lower chordates and the early groups of vertebrates, the notochord persists as the axial support for the body throughout life, but it is surrounded and gradually replaced by segmental vertebrae in the higher fish.

The dorsal hollow nerve cord grows from a specialized band of ectoderm along the middorsal surface of the embryo by a folding together of two parallel ridges. The anterior end enlarges slightly in larval tunicates and somewhat more in lancelets, but enlarges greatly in the vertebrates to form the brain. Vertebral evolution is characterized by continual enlargement of the brain. See NERVOUS SYSTEM (VERTEBRATE).

Paired slits develop as outpocketings of the posterior end of the mouth on the sides of the embryonic pharynx, a part of the digestive system, and are retained in all aquatic chordates. Pharyngeal slits originated as adaptations for filter feeding but soon became the primary respiratory organ, as blood vessels line the fine filaments on the margins of each slit. Water passing over the gills serves for gas exchange in addition to the original filter-feeding function, which was soon lost in the vertebrates. Internal gills were lost with the origin of tetrapods; larval and some adult amphibians possess external gills which are different structures. The pharyngeal slits in embryonic tetrapods close early in life, with the pharyngeal pouches becoming the site for development of glands, for example, the thyroid and the tonsils. See RESPIRATORY SYSTEM.

The chordate tail is part of the skeletal support, muscles, and nervous system which continues posteriad to the anus or posterior opening of the digestive system. It is a feature not found in any other animal group and serves to increase the force available to the animal for locomotion.

Much controversy still exists about the limits, origin, and affinities of the chordates. For example, opinions differ considerably as to whether the Hemichordata and the Pogonophora are related to the Chordata, although there is no question that the Hemichordata are closely related and part of the pharyngeal-slit filter-feeding radiation; the Hemichordata are here considered as members of the phylum Chordata, not as a separate phylum. Almost all workers agree that the Echinodermata are the closest relatives of the Chordata because of evidence ranging from embryonic development to biochemical resemblances, but there is dispute over which group is the more primitive. See ECHINODERMATA; POGONOPHORA.

The Chordata apparently arose from a group of elongated, segmented worms with three sets of body musculature (longitudinal, circular, and transverse) and transverse septa. The first change was the evolution of a segmented coelom, associated with improved locomotion; these animals possessed a hydrostatic skeleton and moved with a sinusoidal or peristaltic locomotion. The first chordate feature to appear was the notochord, which provided a stronger skeleton and permitted the reduction of the transverse and circular muscles. A notochord resulted in a fixed body length and the loss of peristaltic locomotion. The dorsal longitudinal muscles enlarged, and with this modification came the evolution of the dorsal hollow nerve cord. Having a notochord for support rather than a hydrostatic skeleton permitted the appearance of pharyngeal slits through the lateral walls of the anterior parts of the body, which served for increased filter feeding and subsequently for respiration. The presence of the notochord also permitted the appearance of a postanal tail and increased force for locomotion.

The earliest chordate with all of the typical features of the phylum probably looked much like the present-day lancelet or amphioxus (Cephalochordata), which burrows in shifting sands

and needs considerable force to move through the heavy sand. Presumably all other chordates developed from this ancestral type, with their differing characteristics evolving because of conditions of their differing habitats. [W.J.B.]

**Chorion** The outermost of the several extraembryonic membranes in amniotes (reptiles, birds, and mammals) enclosing the embryo and all of its other membranes. The chorion, or serosa, is composed of an outer layer of ectodermal cells and an inner layer of mesodermal cells, collectively the somatopleure. Both layers are continuous with the corresponding tissue of the embryo. The chorion arises in conjunction with the amnion, another membrane that forms the outer limb of the somatopleure which folds up over the embryo in reptiles, birds, and some mammals. The chorion is separated from the amnion and yolk sac by a fluid-filled space, the extraembryonic coelom, or body cavity. In those mammals in which the amnion forms by a process of cavitation in a mass of cells, instead of by folding, the chorion forms directly from the trophoblastic capsule, the extraembryonic ectoderm, which becomes gradually underlain by extraembryonic mesoderm.

In reptiles and birds the chorion fuses with another extraembryonic membrane, the allantois, to form the chorioallantois, which lies directly below the shell membranes. An extensive system of blood vessels develops in the mesoderm of this compound membrane which serves as the primary respiratory and excretory organ for gaseous interchanges. In all mammals above the marsupials, the chorion develops special fingerlike processes (chorionic villi) extending outward from its surface. To a varying degree in different species of mammals, the villous regions of the chorion come into more or less intimate contact with the uterine mucosa, or uterine lining, of the mother, thereby forming the various placental types. See ALLANTOIS; AMNIOTA; FETAL MEMBRANE; GERM LAYERS. [N.T.S.]

**Choristida** An order of sponges of the class Demospongiae, subclass Tetractinomorpha, in which at least some of the megascleres are tetraxons, usually triaenes. Monaxonid spicules may occur as well. Microsclere types are chiefly asters, strep-

tasters, or sigmas. A well-developed cortex comprising an outer gelatinous layer and an inner fibrous layer is often present.

Many choristidan sponges are radially symmetrical; spherical or ellipsoidal shapes are common. Others are encrusting or massive; very few form branching colonies. Some species have basal tufts or mats of long, thin spicules which anchor them in mud or sand on the sea bottom (see illustration). Choristidans are common in tidal regions and shallow waters of all seas, and some species extend down to depths of at least 11, 500 ft (3500 m). See DEMOSPONGIAE. [W.D.H.]

**Chromadorida** An order of nematodes in which the amphid manifestation is variable but within superfamilies some constancy is apparent. The various amphids are reniform, transverse elongate loops, simple spirals, or multiple spirals not seen in any other orders or subclasses. The cephalic sensilla are in one or two whorls at the extreme anterior. In all taxa the cuticle shows some form of ornamentation, usually punctations that are apparent whether the cuticle is smooth or annulated. When developed, the stoma is primarily esophagostome and is usually armed with a dorsal tooth, jaws, or protrusible rugae. The corpus of the esophagus is cylindrical; the isthmus is not seen; and the postcorpus, in which the heavily cuticularized lumen forms the crescentic valve, is distinctly expanded. The esophagointestinal valve is tri-radiate or flattened. The females usually have paired reflexed ovaries.

There are four chromadorid superfamilies: Choanolaimoidea, Chromadoroidea, Comesomatoidea, and Cyatholaimoidea. Choanolaimoidea are distinguished by a complex stoma in two parts. The group occupies marine habitats; some species are predaceous, but for many the feeding habits are unknown. Chromadoroidea comprise small to moderate-sized free-living forms that are mainly marine but are also found in fresh water and soil. Known species either are associated with algal substrates or are nonselective deposit feeders in softbottom sediments. Comesomatoidea, containing only the family Comesomatidae, are found in marine habitats, but the feeding habits are unknown. Cyatholaimoidea are found in marine, terrestrial, and fresh-water environments. See NEMATA. [A.R.M.]

**Chromatic aberration** The type of error in an optical system in which the formation of a series of colored images occurs, even though only white light enters the system. Chromatic aberrations are caused by the fact that the refraction law determining the path of light through an optical system contains the refractive index, which is a function of wavelength. Thus the image position and the magnification of an optical system are not necessarily the same for all wavelengths, nor are the aberrations the same for all wavelengths. See ABERRATION (OPTICS); REFRACTION OF WAVES. [M.J.H.]

**Chromatography** A physical separation method in which the components of a mixture are separated by differences in their distribution between two phases, one of which is stationary (stationary phase) while the other (mobile phase) moves through it in a definite direction. The substances must interact with the stationary phase to be retained and separated by it.

Retention results from a combination of reversible physical interactions that can be characterized as adsorption at a surface, absorption in an immobilized solvent layer, and electrostatic interactions between ions. When the stationary phase is a porous medium, accessibility to its regions may be restricted and a separation can result from size differences between the sample components. More than one interaction may contribute simultaneously to a separation mechanism. The general requirements are that all interactions must be reversible, and that the two phases can be separated (two immiscible liquids, a gas and a solid, and so forth) in such a way that a distribution of sample components between phases and mass transport by one phase can be established. See ABSORPTION; ADSORPTION.

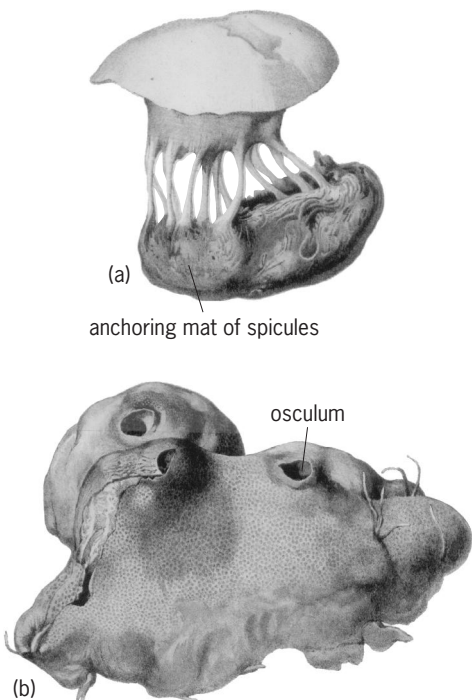

Choristidans. (a) *Thenea wyvilli*, with basal mat of spicules. (b) *Geodia gibberosa*. (After Sollas, 1888)

Reversibility of the interactions can be achieved by purely physical means, such as by a change in temperature or by competition; the latter condition is achieved by introducing substances into the mobile phase that have suitable properties to ensure reversibility for the interactions responsible for retention of the sample components. Since this competition with the sample components is itself selective, it provides a general approach to adjusting the outcome of a chromatographic experiment to obtain a desired separation. It is an absolute requirement that a difference in the distribution constants for the sample components in the chromatographic system exist for a separation to be possible.

**Methods.** A distinction between the principal chromatographic methods can be made in terms of the properties of the mobile phase and configuration of the stationary phase. In gas chromatography the mobile phase is an inert gas, in supercritical fluid chromatography the mobile phase is a fluid (dense gas above its critical pressure and temperature), and in liquid chromatography the mobile phase is a liquid of low viscosity. The stationary phase can be a porous, granular powder with a narrow particle-size distribution packed into a tube (called a column) as a dense homogeneous bed. This configuration is referred to as a packed column and is nearly always used in liquid chromatography and is commonly used in supercritical fluid and gas chromatography. Alternatively, the stationary phase can be distributed as a thin film or layer on the wall of an open tube of capillary dimensions, leaving an open space through the center of the column. This configuration is referred to as an open tubular column (or incorrectly as a capillary column); and it is commonly used in gas chromatography, frequently used in supercritical fluid chromatography, but rarely used in liquid chromatography.

Thin-layer chromatography is a form of liquid chromatography in which the stationary phase is spread as a thin layer over the surface of a glass or plastic supporting structure. The stationary phase must be immobilized on the support by using a binder to impart the desired mechanical strength and stability to the layer. The samples are applied to the layer as spots or bands near the bottom edge of the plate. The separation is achieved by contacting the bottom edge of the plate below the line of samples with the mobile phase, which proceeds to ascend the layer by capillary action. This process is called development and is performed in a chamber, with the lower edge of the layer in contact with the mobile phase and the remaining portion of the layer in contact with solvent vapors from the mobile phase. The chamber may be a simple device such as a covered jar or beaker or a more elaborate device providing control of the mobile-phase velocity and elimination or control of the vapor phase. Thin-layer chromatography is the most popular form of planar chromatography having virtually replaced paper chromatography in laboratory practice. See GAS CHROMATOGRAPHY; GEL PERMEATION CHROMATOGRAPHY; LIQUID CHROMATOGRAPHY; SUPERCRITICAL-FLUID CHROMATOGRAPHY.

**Uses.** Chromatographic methods provide a means of analyzing samples (to determine component identity and relative amount), of isolating significant quantities of purified material for further experimentation or commerce, and for determining fundamental physical properties of either the samples or the mobile or stationary phases (for example, diffusion coefficients, solubilities, or thermodynamic properties). There are virtually no boundaries to the sample types that can be separated. Examples include organic and inorganic compounds in the form of fixed gases, ions, polymers, as well as other species. Applications are found in all areas of technological development, making chromatography one of the most widely used laboratory procedures in chemistry. Depending on intent, chromatography can be applied to trace quantities at the limit of detector response (for example,  $10^{-15}$  g) or to kilogram amounts in preparative separations.

**Instrumentation.** Modern chromatographic methods are instrumental techniques in which the optimal conditions for the

separation are set and varied by electromechanical devices external to the column or layer. Separations are largely automated, with important features of the instrumentation being control of the flow and composition of the mobile phase, introduction of the sample onto the stationary phase, and on-line detection of the separated components. In column chromatography the sample components are detected in the presence of the mobile phase after they have exited the stationary phase. In thin-layer chromatography the sample components are detected in the presence of the stationary phase, resulting in different detection strategies.

Instrument requirements differ by the needs of the method employed. Gas chromatography, for example, employs a mobile phase of constant composition at a few atmospheres of column inlet pressure and variation in the temperature of the column to effect a separation. Liquid chromatography uses a pump to select or vary the composition of the mobile phase with a high column inlet pressure (typically a few hundred atmospheres) and a constant temperature for the separation. These differences in optimized separation conditions result in different equipment configurations for each chromatographic method.

**Interpretation.** The results of a chromatographic experiment are summarized in a chromatogram (see illustration), a

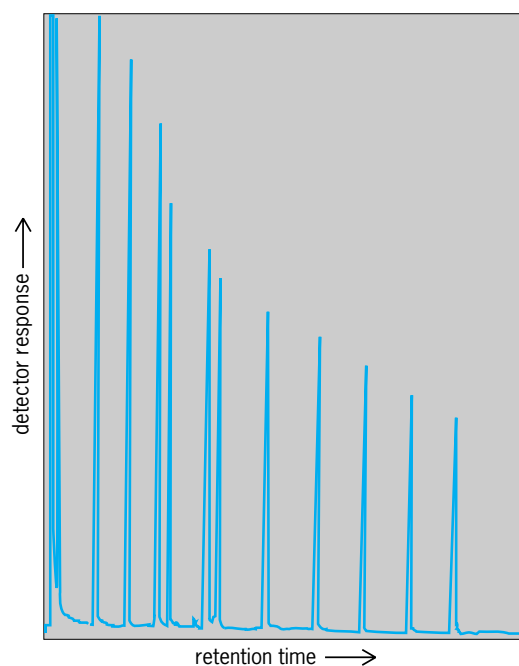

Typical chromatogram obtained by gas chromatography.

two-dimensional record of the detector response to the sample components (y axis) plotted against the residence time of the components in column chromatography or migration distance in planar chromatography (x axis). Individual compounds or mixtures of unseparated compounds appear as peaks in the chromatogram. These peaks are ideally symmetrical and occur at positions in the chromatogram that are characteristic of their identity, with a distribution around the mean position (apex of the peak) that is characteristic of the kinetic properties of the chromatographic system. The area inscribed by the peak is proportional to the amount of substance separated in the chromatographic system.

Information readily extracted from the chromatogram includes an indication of sample complexity (the number of observed peaks), qualitative substance identification (determined by peak position), relative composition of the sample (peak dimensions; area or height), and a summary of the kinetic characteristics of the chromatographic system (peak shapes). [C.F.P.]

**Chromatophore** A pigmented structure found in many animals, generally in the integument. The term is usually restricted to those structures that bring about changes in color or brightness. A majority of chromatophores are single cells that are highly branched and contain pigment granules that can disperse or aggregate within the cell. However, in coleoid cephalopod mollusks (all mollusks except *Nautilus*), the chromatophores function as miniature organs, and changes in the dispersion of pigment are brought about by muscles. Although the mode of action of the two types of chromatophore is completely different, the effect is the same: pigment either is spread out over a large area of the body or is retracted into a small area.

The movement of pigment takes place in many chromatophores simultaneously, so that the effect is a change in the quality of light reflected from the surface of the animal. The color change functions as a camouflage from predator or prey, but it may also serve for regulating temperature, protecting against harmful radiation, and in signaling. Light stimulates the responses of chromatophores, generally indirectly via the eyes and central nervous system.

Single-cell chromatophores are found in some annelids, insects, and echinoderms. They are much more conspicuous in crustaceans (shrimps and prawns), in fishes (especially in bony fish and teleosts), in anuran amphibians (frogs and toads), and in a few reptiles. The chromatophores may be uniformly distributed in the skin (chameleons), or they may occur in patches (flounders) or lines (around the abdomen in shrimps). Chromatophores of various colors may be distributed unevenly across the body, and occur at different depths in the skin.

Chromatophores produce their colors by reflection after absorption of light. Generally, the light comes from above, but it may come from below after reflection from an underlying structure. The most common type of chromatophore contains melanin (and is, therefore, often called a melanophore), which absorbs all wavelengths so that the chromatophore appears black; other types have red (erythrophores) or yellow (xanthophores) pigments. These pigments generally derive from carotenoids in vertebrates.

Chromatophores contain pigment granules that move within them, giving them an appearance that ranges from spotted to fibrous on the five-stage scale that is widely used to measure the degree of chromatophore expansion. If the pigment within the particular cell is black or brown, the integument takes on a dark appearance when most of the chromatophores are in the last stage of dispersion (stage 5). If the pigment color is yellow or cream, the animal tends to look paler if all the chromatophores are at that stage.

In crustaceans, elasmobranch fishes, anurans, and lizards, control of the chromatophores is thought to be exclusively hormonal. Such hormonal control is true also of some teleosts; in others the control is part hormonal and part neural; while in still others control is purely neural, as in the chameleon. Where nerves are involved, the speed of the response is faster, the chromatophores responding in minutes rather than hours. See NEUROSECRETION.

Each cephalopod chromatophore organ comprises an elastic sac containing pigment granules. Attached to the sac is a set of 15–25 radial muscles that are striated and contract rapidly. Associated with the radial muscles are axons from nerve cell bodies that lie within the brain. Active nerve cells cause the radial muscles to contract and the chromatophore sac expands; when the nerves are inactive, energy stored in the elastic sac causes the chromatophore to retract as the muscles relax. The chromatophores receive only nerve impulses, and there is no evidence that they are influenced by hormones. The chromatophores are ultimately controlled by the optic lobe of the brain under the influence of the eyes.

Two consequences follow from the fact that cephalopod chromatophores are under the direct control of the brain. First, color change is instantaneous. Second, patterns can be generated in

the skin in a way impossible in other animals. Thus, cephalopods can use the chromatophores not just to match the background in general color but to break up the body visually (disruptive coloration) so that a predator does not see the whole animal. Because the chromatophores are neurally controlled and patterns can be produced in the skin, they can also be used for signaling. See PIGMENTATION; PROTECTIVE COLORATION. [J.B.M.]

**Chromite** The only ore mineral of chromium. Chromite is jet black to brownish black, has a submetallic luster. It belongs to the spinel group of minerals and has cubic symmetry. Naturally occurring chromite has the general formula  $(\text{Mg,Fe}^{2+})(\text{Cr,Al,Fe}^{3+})_2\text{O}_4$  and ranges from 15 to 64 wt %  $\text{Cr}_2\text{O}_3$ , with minor amounts of nickel, titanium, zinc, cobalt, and manganese. The specific gravity of chromite ranges from 4 to 5, depending on its composition. Pure chromite,  $\text{Fe}^{2+}\text{Cr}_2\text{O}_4$ , is extremely rare in nature and has been found only in meteorites.

Chromite has a variety of uses. Chromium is extracted from it to make stainless steel and other alloys for which resistance to oxidation and corrosion is important. Chromium is also used as a plating and tanning agent. The mineral chromite is made into refractory lining for steel-making furnaces. See CHROMIUM; SPINEL; STAINLESS STEEL. [B.R.L.]

**Chromium** A chemical element, Cr, atomic number 24, and atomic weight 51.996, which is the weighted average for several isotopes weighing 50 (4.31%), 52 (83.76%), 53 (9.55%), and 54 (2.38%). The orbital arrangement of the electrons is  $1s^2, 2s^2, 2p^6, 3s^2, 3p^6, 3d^5, 4s^1$ . The stability of the half-filled *d* shell doubtless accounts for this rather unusual arrangement. In the crust of the Earth, chromium is the twenty-first element in abundance, which ranks it along with vanadium, zinc, nickel, and copper. Traces of chromium are present in the human body; in fact, it is essential to life. See PERIODIC TABLE.

The element was discovered in 1797 and isolated the following year by the French chemist L. N. Vauquelin. It was named chromium because of the many colors of its compounds. It occurs in nature largely as the mineral chromite ( $\text{FeO} \cdot \text{Cr}_2\text{O}_3$ ), which is a spinel, but the ore is usually contaminated with  $\text{Al}^{3+}$ ,  $\text{Fe}^{3+}$ ,  $\text{Mn}^{2+}$ , and  $\text{Mg}^{2+}$ . Smaller quantities are found as the yellow mineral crocoite ( $\text{PbCrO}_4$ ).

As a transition metal, chromium exists in all oxidation states from 2– to 6+. The chemistry of its aqueous solutions, at least in the 3+ (chromic) state, is complicated by the fact that the compounds exist in many isomeric forms, which have quite different chemical properties.

Pure chromium metal has a bluish-white color, reflects light well, and takes a high polish. When pure, it is ductile, but even small amounts of impurities render it brittle. The metal melts at about 1900°C (3452°F) and boils at 2642°C (4788°F). Chromium shows a wide range of oxidation states; the compounds in which the metal is in a low oxidation state are powerful reducing agents, whereas those in which it shows a high oxidation state are strong oxidizing agents.

The bright color and resistance to corrosion make chromium highly desirable for plating plumbing fixtures, automobile radiators and bumpers, and other decorative pieces. Unfortunately, chrome plating is difficult and expensive. It must be done by electrolytic reduction of dichromate in sulfuric acid solution. This requires the addition of six electrons per chromium ion. This reduction does not take place in one step, but through a series of steps, most of which are not clearly understood. The current efficiency is low (maybe 12%), and the chromium plate contains microscopic cracks and other flaws, and so it does not adequately protect the metal under it from corrosion. It is customary, therefore, to first plate the object with copper, then with nickel, and finally, with chromium.

In alloys with iron, nickel, and other metals, chromium has many desirable properties. Chrome steel is hard and strong and resists corrosion to a marked degree. Stainless steel contains

roughly 18% chromium and 8% nickel. Some chrome steels can be hardened by heat treatment and find use in cutlery; still others are used in jet engines. Nichrome and chromel consist largely of nickel and chromium; they have low electrical conductivity and resist corrosion, even at red heat, so they are used for heating coils in space heaters, toasters, and similar devices. Other important alloys are Hastelloy C (Cr, Mo, W, Fe, Ni), used in chemical equipment which is in contact with HCl, oxidizing acids, and hypochlorite. Stellite [Co, Cr, Ni, C, W (or Mo)], noted for its hardness and abrasion resistance at high temperatures, is used for lathes and engine valves, and Inconel (Cr, Fe, Ni) is used in heat treating and in corrosion-resistant equipment in the chemical industry. See ALLOY; HEAT TREATMENT (METALLURGY); STAINLESS STEEL.

Several chromium compounds are used as paint pigments—chrome oxide green (Cr<sub>2</sub>O<sub>3</sub>), chrome yellow (PbCrO<sub>4</sub>), chrome orange (PbCrO<sub>4</sub> · PbO), molybdate orange (a solution of PbSO<sub>4</sub>, PbCrO<sub>4</sub>, and PbMoO<sub>4</sub>), chrome green (a mixture of PbCrO<sub>4</sub> and Prussian blue), and zinc yellow (potassium zinc chromate). Several of these, particularly zinc yellow, are used to inhibit corrosion. The gems ruby, emerald, and alexandrite owe their colors to traces of chromium compounds. See CORROSION; EMERALD; PAINT; RUBY.

Dichromates are widely used as oxidizing agents, as rust inhibitors on steel, and as wood preservatives. In the last application, they kill fungi, termites, and boring insects. The wood can still be painted and glued, and retains its strength. Other chromium compounds find use as catalysts, as drilling muds, and in photochemical reactions. The last are important in the printing industry. A metal plate is coated with a colloidal material (for example, glue, shellac, or casein) containing a dichromate. On exposure to strong light under a negative image, the dichromate is reduced to Cr<sup>3+</sup>, which reacts with the colloid, hardening it and making it resistant to removal by washing. The unexposed material is washed off, and the metal plate is etched with acid to give a printing plate. See PRINTING.

Chromium is essential to life. A deficiency (in rats and monkeys) has been shown to impair glucose tolerance, decrease glycogen reserve, and inhibit the utilization of amino acids. It has also been found that inclusion of chromium in the diet of humans sometimes, but not always, improves glucose tolerance. Certain chromium(III) compounds enhance the action of insulin.

On the other hand, chromates and dichromates are severe irritants to the skin and mucous membranes, so workers who handle large amounts of these materials must be protected against dusts and mists. Continued breathing of the dusts finally leads to ulceration and perforation of the nasal septum. Contact of cuts or abrasions with chromate may lead to serious ulceration. Even on normal skin, dermatitis frequently results. Cases of lung cancer have been observed in plants where chromates are manufactured. [J.C.Ba.]

**Chromophycota** A division of the plant kingdom (also known as Chromophyta) comprising nine classes of algae: Bacillariophyceae (diatoms), Chrysophyceae (golden or golden-brown algae), Cryptophyceae, Dinophyceae (dinoflagellates), Eustigmatophyceae, Phaeophyceae (brown algae), Prymnesiophyceae, Raphidophyceae, and Xanthophyceae (yellow-green algae). Some of these classes are closely related, while others stand so far apart that they are sometimes assigned to their own divisions. The chief unifying character is the presence of chlorophyll *c* rather than chlorophyll *b* as a complement to chlorophyll *a* (although only chlorophyll *a* is present in Eustigmatophyceae). The chloroplasts are usually brown or yellowish because of large amounts of  $\beta$ -carotene and various xanthophylls, many of which are restricted to one or more classes. In most classes, motile cells bear two unequal flagella, one of which may be almost completely reduced and at least one of which bears two rows of hairlike appendages. Algae range in size and complexity from

unicellular flagellates to gigantic kelps. See ALGAE; BACILLARIOPHYCEAE; CHRYSOPHYCEAE; CRYPTOPHYCEAE; DINOPHYCEAE; EUSTIGMATOPHYCEAE; PHAEOPHYCEAE; PRYMNESIOPHYCEAE; RAPHIDOPHYCEAE; XANTHOPHYCEAE. [P.C.Si.; R.L.Moe]

**Chromosome** Any of the organized components of each cell which carry the individual's hereditary material, deoxyribonucleic acid (DNA). Chromosomes are found in all organisms with a cell nucleus (eukaryotes) and are located within the nucleus. Each chromosome contains a single extremely long DNA molecule that is packaged by various proteins into a compact domain. A full set, or complement, of chromosomes is carried by each sperm or ovum in animals and each pollen grain or ovule in plants. This constitutes the haploid (*n*) genome of that organism and contains a complete set of the genes characteristic of that organism. Sexually reproducing organisms in both the plant and animal kingdoms begin their development by the fusion of two haploid germ cells and are thus diploid (*2n*), with two sets of chromosomes in each body cell. These two sets of chromosomes carry virtually all the thousands of genes of each cell, with the exception of the tiny number in the mitochondria (in animal), and a few plant chloroplasts. See DEOXYRIBONUCLEIC ACID (DNA); GENE.

Chromosomes can change their conformation and degree of compaction throughout the cell cycle. During interphase, the major portion of the cycle, chromosomes are not visible under the light microscope because, although they are very long, they are extremely thin. However, during cell division (mitosis or meiosis), the chromosomes become compacted into shorter and thicker structures that can be seen under the microscope. At this time they appear as paired rods with defined ends, called telomeres, and they remain joined at a constricted region, the centromere, until the beginning of anaphase of cell division. See CELL CYCLE; MEIOSIS; MITOSIS.

Chromosomes are distinguished from one another by length and position of the centromere. They are metacentric (centromere in the middle of the chromosome), acrocentric (centromere close to one end), or telocentric (centromere at the end, or telomere). The centromere thus usually lies between two chromosome arms, which contain the genes and their regulatory regions, as well as other DNA sequences that have no known function. In many species, regional differences in base composition and in the time at which the DNA is replicated serve as the basis for special staining techniques that make visible a series of distinctive bands on each arm, and these can be used to identify the chromosome.

**Compaction.** Each nucleus in the cell of a human or other mammal contains some 6 billion base pairs of DNA which, if stretched out, would form a very thin thread about 6 ft (2 m) long. This DNA has to be packaged into the chromosome within a nucleus that is much smaller than a printed dot (Fig. 1). Each chromosome contains a single length of DNA comprising a specific portion of the genetic material of the organism. Tiny stretches of DNA, about 140 base pairs long and containing acidic phosphate groups, are individually wrapped around an octamer consisting of two molecules of each of the four basic histone proteins H2a, H2b, H3, and H4. This arrangement produces small structures called nucleosomes and results in a sevenfold compaction of the DNA strand. Further compaction is achieved by binding the histone protein H1 and several nonhistone proteins, resulting in a supercoiled structure in which the chromosome is shortened by about 1600-fold in the interphase nucleus and by about 8000-fold during metaphase and anaphase, where the genetic material must be fully compacted for transport to the two daughter cells. At the point of maximum compaction, human chromosomes range in size from about 2 to 10 micrometers in length, that is, less than 0.0004 in. See NUCLEOSOME.

**Number and size.** Each diploid (*2n*) organism has a characteristic number of chromosomes in each body (somatic) cell, which can vary from two in a nematode worm and one species of

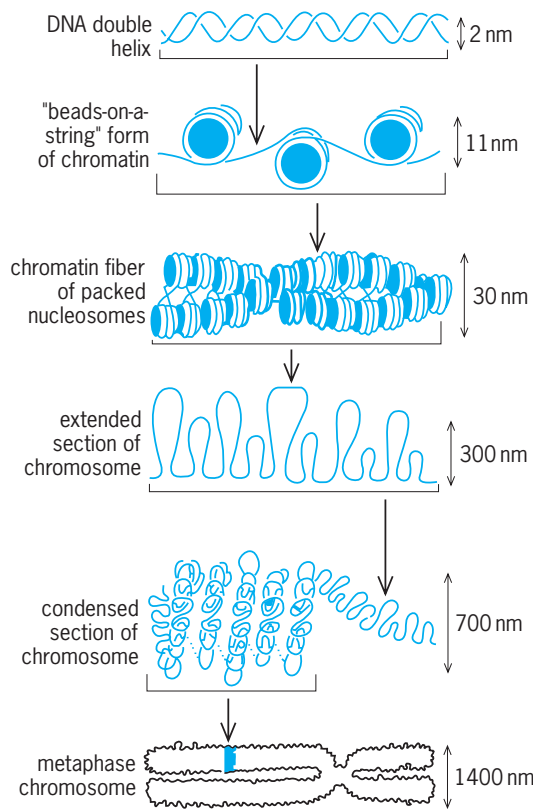

**Fig. 1. Organization of DNA into chromosomes.** (From B. Alberts et al., *Molecular Biology of the Cell*, 2d ed., Garland Publishing, 1989)

ant, to hundreds in some butterflies, crustaceans, and plants. The diploid number of chromosomes includes a haploid ( $n$ ) set from each parent. Many one-celled organisms are haploid throughout most of their life cycle. The human diploid number is 46.

There is some relationship between the number of chromosomes and their size. Some of the chromosomes in certain classes of organisms with large numbers of chromosomes are very tiny, and have been called microchromosomes. In birds and some reptiles, there are about 30–40 pairs of microchromosomes in addition to 5–7 or so pairs of regular-sized macrochromosomes. The number of microchromosomes is constant in any species carrying them, and only their size distinguishes them from the widespread macrochromosomes. At least seven microchromosomes in birds have been shown to contain genes, and all are thought to.

In some species of insects, plants, flatworms, snails, and rarely vertebrates (such as the fox), the number of chromosomes can vary because of the presence of a variable number of accessory chromosomes, called B chromosomes. It is not clear what role, if any, B chromosomes play, but they appear to be made primarily of DNA that neither contains functional genes nor has much effect on the animal or plant even when present in multiple copies.

**Structure.** A telomere caps each end of every chromosome and binds specific proteins that protect it from being digested by enzymes (exonucleases) present in the same cell. Most important, the telomere permits DNA replication to continue to the very end of the chromosome, thus assuring its stability. The telomere is also involved in attachment of the chromosome ends to the nuclear membrane and in pairing of homologous chromosomes during meiosis. The structure of telomeric DNA is very similar in virtually all eukaryotic organisms except the fruit fly (*Drosophila*). One strand of the DNA is rich in guanine and is oriented toward the end of the chromosome, and the other strand is rich in cyto-

sine and is oriented toward the centromere. In most organisms, the telomere consists of multiple copies of a very short DNA repeat.

The centromere is responsible for proper segregation of each chromosome pair during cell division. The chromatids in mitosis and each pair of homologous chromosomes in meiosis are held together at the centromere until anaphase, when they separate and move to the spindle poles, thus being distributed to the two daughter cells. The kinetochore, which is the attachment site for the microtubules that guide the movement of the chromosomes to the poles, is organized around the centromere. The molecular structures of centromeres in most species are still unclear. The repetitive DNA making up and surrounding the centromere is called heterochromatin because it remains condensed throughout the cell cycle and hence stains intensely.

One or more pairs of chromosomes in each species have a region called a secondary constriction which does not stain well. This region contains multiple copies of the genes that transcribe, within the nucleolus, the ribosomal RNA (rRNA). The number of active rRNA genes may be regulated, and an organism that has too few copies of the rRNA genes may develop abnormally or not survive. See RIBOSOMES.

**Staining.** Staining with quinacrine mustard produces consistent, bright and less bright fluorescence bands (Q bands) along the chromosome arms because of differences in the relative amounts of CG (cytosine-guanine) or AT (adenine-thymine) base pairs. The distinctive Q-band pattern of each chromosome makes it possible to identify every chromosome in the human genome. Quinacrine fluorescence can also reveal a difference in the amount or type of heterochromatin on the two members of a homologous pair of chromosomes, called heteromorphism or polymorphism. Such differences can be used to identify the parental origin of a specific chromosome, such as the extra chromosome in individuals who have trisomy 21. Two other methods involve treating chromosomes in various ways before staining with Giemsa. Giemsa or G-band patterns are essentially identical to Q-band patterns; reverse Giemsa or R-band patterns are the reverse, or reciprocal, of those seen with Q or G banding. In humans, most other mammals, and birds (macrochromosomes only), the Q-, G-, and R-banding patterns are so distinctive that each chromosome pair can be individually identified, making it possible to construct a karyotype, or organized array of the chromosome pairs from a single cell (Fig. 2). The chromosomes are identified on the basis of the banding patterns, and the pairs are arranged and numbered in some order, often based on length. In the human karyotype, the autosomes are numbered 1 through 22, and the sex chromosomes are called X and Y. The short arm of a chromosome is called the p arm, and the long arm is called the q arm; a number is assigned to each band on the arm.

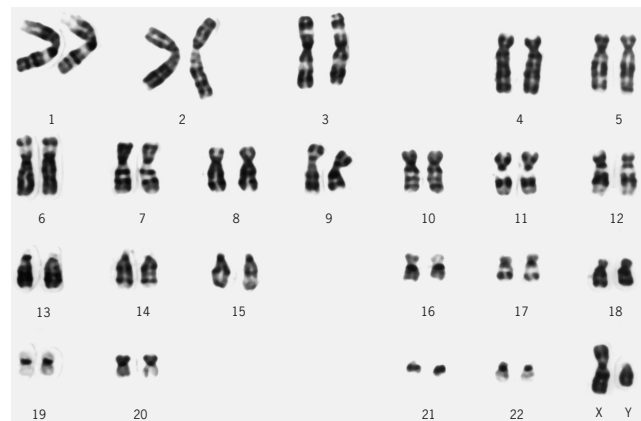

**Fig. 2. G-banded metaphase karyotype of a human male cell.** Every chromosome pair can be identified by its banding pattern. Chromosome 1 is about 12  $\mu\text{m}$  long.

Thus, band 1q23 refers to band 23 on the long arm of human chromosome 1.

**Imprinting.** A chromosome carries the same complement of genes whether it is transmitted from the father or the mother, and most of these genes appear to be functionally the same. However, a small number of mammalian genes are functionally different depending on whether they were transmitted by the egg or by the sperm. This phenomenon is known as imprinting. It appears to be caused by the inactivation of certain genes in sperm or ova, probably by methylation of cytosine residues within the regulatory (promotor) region of the imprinted gene. As a result of imprinting, normal development of the mammalian embryo requires the presence of both a maternal and a paternal set of chromosomes. Parthenogenesis, the formation of a normal individual from two sets of maternal chromosomes, is therefore not possible in mammals.

**Sex chromosomes.** In most mammals, the sex of an individual is determined by whether or not a Y chromosome is present because the Y chromosome carries the male-determining *SRY* gene. Thus XX and the rare XO individuals are female, while XY and the uncommon XXY individuals are male. In contrast, sex in the fruit fly depends on the balance of autosomes (non-sex chromosomes) and X chromosomes. Thus, in diploids, XX and the rare XXY flies are female, while XY and the rare XO flies are male. In both mammals and fruit flies, males are the heterogametic sex, producing gametes that contain either an X or a Y chromosome; and females are the homogametic sex, producing only gametes containing an X. In birds and butterflies, however, females are the heterogametic sex and males the homogametic sex. Other sex-determining systems are used by some classes of organisms, while sex in some species is determined by a single gene or even by environmental factors such as temperature (some turtles and alligators) or the presence of a nearby female (*Bonellia*, a marine worm) rather than by a chromosome-mediated mechanism.

More than 900 gene loci have been mapped to the human X chromosome. If the genes on both X chromosomes were fully expressed in female mammalian cells, then male cells, which have only one X, would exhibit only half as much gene product as female cells. However, dosage compensation is achieved, because genes on only one X chromosome are expressed, and genes on any additional X chromosomes are inactivated. This X inactivation randomly occurs during an early stage in embryonic development, and is transmitted unchanged to each of the daughter cells. Mammalian females are therefore mosaics of two types of cells, those with an active maternally derived X and those with an active paternally derived X. Species other than mammals do not show this type of dosage compensation mechanism for sex-linked genes, and some show none at all.

The Y chromosome is one of the smallest chromosomes in the genome in most mammalian species. Usually the mammalian Y chromosome has a very high proportion of heterochromatin, as does the large Y chromosome in *Drosophila*. Very few genes are located on the Y chromosome in mammals or in *Drosophila*, and most of these genes are concerned with either sex determination or the production of sperm. In some species of insects and other invertebrates, no Y chromosome is present, and sex in these species is determined by the X:autosome balance (XX female, XO male). See CELL NUCLEUS; GENETICS; HUMAN GENETICS; SEX DETERMINATION; SEX-LINKED INHERITANCE. [O.J.M.; D.A.Mi.]

**Chromosome aberration** Any numerical or structural change in the usual chromosome complement of a cell or organism.

**Heteroploidy.** Numerical changes (heteroploidy) are of two types, polyploidy and aneuploidy. Polyploidy is a change in the number of chromosome sets. Triploidy ( $3n$ ), for example, occurs in about 1% of human pregnancies, but it is almost always an embryonic lethal condition. See MEIOSIS; MITOSIS; POLYPOIDY.

Aneuploidy is a change in the number of chromosomes from the diploid ( $2n$ ) number (usually found in the somatic cells of

sexually reproducing organisms) or the haploid ( $n$ ) number (usually found in germ cells and the haplophase of some unicellular organisms.) It usually involves a single chromosome, and any chromosome in the complement can be involved. Aneuploidy is the result of aberrant segregation of one or more chromosomes during meiosis or mitosis. If malsegregation or nondisjunction occurs during meiosis, one daughter cell receives two copies of the chromosome and the other daughter cell receives none. Fertilization of such an aneuploid germ cell by a euploid gamete will produce a zygote that has either three copies (trisomy) or one copy (monosomy) of the chromosome. Malsegregation of a chromosome can also take place during a mitotic division in a somatic cell, producing trisomic or monosomic cells in an otherwise euploid individual. This outcome is important primarily in the origin and progression of some forms of cancer.

The most common trisomy of autosomes (non-sex chromosomes) in human liveborns is trisomy 21, or Down syndrome, which is a major cause of mental retardation and congenital heart disease. Individuals with trisomy 18 and trisomy 13 also occur but are much less common. Most autosomal trisomies are lethal to embryos, leading to spontaneous abortion. The incidence of trisomy for any autosome increases exponentially with maternal age. See CHROMOSOME; DOWN SYNDROME.

In humans, there are more types of aneuploidy involving the sex chromosomes than the autosomes. The most common is XO, occurring in about 1% of pregnancies. Although 99% of XO fetuses die early in pregnancy, the other 1% (about 1 in 10,000 liveborn females) survive. Adults who are XO tend to be short, with some webbing of the neck. They rarely develop secondary sexual characteristics or have children because the germ cells essential for ovarian development are usually absent. These features are characteristic of Turner syndrome. Trisomy for the human X chromosome, commonly called XXX, is not associated with embryonic death or congenital malformations. The reason is that in all mammals only a single X chromosome is active in each somatic cell. See HUMAN GENETICS.

In contrast to autosomal trisomy, sex chromosome aneuploidy increases only slightly with maternal age, and the extra X chromosome comes from the mother in only about 60% of the cases. An additional X chromosome can be present in either egg or sperm; additional Y chromosomes can be present only in sperm. The XXX and XXY individuals display minimal phenotypic manifestations of their increased number of chromosomes. Individuals who are XYY generally are indistinguishable from XY individuals. The presence of a Y chromosome leads to male sex differentiation no matter how many X chromosomes are present, because of the presence of a single, critical gene, called *SRY*, on the Y chromosome. A mutation of this gene has been found in some XY individuals who developed as females.

**Structural abnormalities.** Structural abnormalities (chromosome mutations) involve the gain, loss, or rearrangement of chromosome segments after the continuity of the deoxyribonucleic acid (DNA) strand in one or more chromosomes is disrupted. A deletion involves the loss of a chromosome segment and the genes it carries. A terminal deletion involves the loss of a segment extending from the point of disruption (breakpoint) to the end of the same arm of a chromosome, and it is relatively uncommon. An interstitial deletion involves the loss of the segment between two breakpoints in one arm of a chromosome. The effect of such a loss depends on the genes that are included in the missing segment.

When one break occurs in each arm of a chromosome, the broken ends of the internal centromeric fragment may join, resulting in the formation of a stable ring chromosome. Each of the two end segments lacks a centromere, and such acentric fragments are lost during cell division. Ring chromosomes are subject to reduction in size, as well as doubling. An individual who has a ring chromosome may thus show phenotypic effects not only of deletion but of duplication of part of the chromosome. A

duplication more commonly occurs in other ways. For example, a chromosome segment can undergo tandem or inverted duplication at the usual chromosome site, or the second copy of the segment may be carried on another chromosome.

An inversion is generated by disrupting the DNA strand in a chromosome at two breakpoints and rejoining the broken ends with the interstitial segment in the opposite orientation. This process will invert the order of the genes on the segment.

A translocation involves the interchange of one or more chromosome segments between two or more chromosomes. If a translocation breakpoint disrupts a gene, the gene's function will be blocked or abnormal, and such can have deleterious effects on development or function. Sometimes a normally silent gene is activated by a chromosome rearrangement that places it next to a strong promoter of gene expression, and this change is important as a cause of cancer. If a translocation does not block the function of an essential gene or activate a normally silent gene, the individual carrying the rearrangement will be normal.

Structural aberrations can occur spontaneously or be induced by agents that break chromosomes, such as x-rays, radioactive substances, ultraviolet rays, and certain chemicals. The most frequent cause may be the presence of enormous numbers of a few types of short interspersed elements (SINES), that is, DNA sequences that occur once every few thousand base pairs throughout the genome of most metazoans, including humans. These elements predispose to the occurrence of errors during DNA replication or genetic recombination at meiosis that can lead to the deletion or duplication of the region between two nearby interspersed repeats on one chromosome. They may also play a role in the formation of inversions and, possibly, translocations. See GENE AMPLIFICATION; MUTAGENS AND CARCINOGENS; MUTATION.

Another cause of structural aberrations is also inherent in the genome: the great abundance of short repeats of a 2-, 3-, or 4-base-pair unit. Some trinucleotide repeats, such as (CGG)<sub>n</sub> or (CAG)<sub>n</sub>, can undergo expansion during meiotic and mitotic cell divisions. This expansion sometimes affects gene function and leads to disease. The most common type of X-linked mental retardation in humans is the result of heritable expansions, in the *FMR-1* gene, of a specific trinucleotide repeat, (CGG)<sub>n</sub>, where the number of expansions (*n*) is increased from the normal 8–20 or so to 50–200 or more. For unknown reasons, this expanded region tends to undergo breakage under some conditions, and this particular form of mental retardation is called the fragile X syndrome. There are dozens, if not hundreds, of similar fragile sites in the human and other genomes. [O.J.M.; D.A.Mi.]

**Chromosphere** A complex structure of warm gas above the visible surface, or photosphere, of the Sun and most stars. The term "chromosphere" was first applied to the red ring and large prominences seen at the edge of the eclipsed Sun with the unaided eye. Emission in the Balmer-alpha line of hydrogen at 653-nanometer wavelength accounts for the red color. The chromosphere is transparent in visible light, but is opaque and bright in the ultraviolet continuum and in strong lines of abundant elements, including hydrogen, helium (first observed during the 1868 solar eclipse), oxygen, calcium, and magnesium. Gas temperatures range from 3500 to 30,000 K (5800 to 54,000°F) and densities are between 10<sup>9</sup> and 10<sup>12</sup> particles per cubic centimeter. See SUN.

The solar chromosphere extends from roughly 500 km (300 mi) above the photosphere to where hydrogen becomes fully ionized and the gas temperature rises rapidly to more than 10<sup>6</sup> K (1.8 × 10<sup>6</sup> °F) in the corona. High-resolution images of the Sun taken in strong emission lines reveal a filamentary structure consisting of many magnetic loops. In the chromospheric network at the edges of 30,000-km-wide (19,000-mi) supergranule cells, the magnetic field is strong, the gas is dense and hot, and the chromosphere may be only 500 km (300 mi) thick. Here the magnetic heating rate is 10 or more times higher than average.

Thin gas jets called spicules are clustered in the network. In the center of supergranule cells, where the magnetic field is weak, the chromospheric gas cools to 3500 K (5800°F) and extends upward several thousand kilometers. See SUPERGRANULATION.

Stars with effective temperatures less than about 8000 K (14,000°F; the Sun is 5770 K or 9930°F) show the same emission lines as the solar chromosphere and are thus thought to have analogous regions. [J.L.L.]

**Chronic fatigue immune dysfunction syndrome** A condition resulting in massive, debilitating fatigue accompanied by diverse symptoms including memory loss, diminished powers of concentration, sleep disorder, headaches, low-grade fever, muscle and joint pains, and intolerance to change of temperature. This condition is also known as postviral fatigue, chronic fatigue syndrome, and myalgic encephalomyelitis. It is often associated with stress.

The severity of the disease varies considerably: Some patients are bedridden while others suffer only mildly debilitating symptoms. The cause of the disease is unknown, although there are hypotheses relating it to an abnormal immune response due to concurrent stress and a previous infection, perhaps viral. The Epstein-Barr virus, Human Herpes virus 6, Cytomegaloinclusion virus, Coxsackie virus, various stealth viruses, and a retrovirus have been implicated. All of these viruses are common, and the general population is frequently exposed to them. The disease is not life-threatening and is not considered infectious. However, if a viral cause is proven, there would be an infective phase during or immediately after the initial incubation of the virus. There is no definitive diagnostic test for chronic fatigue immune dysfunction syndrome (CFIDS); thus it is necessary to rule out the possibility of another disease that produces fatigue. While the majority of individuals with confirmed CFIDS have a positive antibody to one or more of the implicated viruses, the viruses are so common that antibody titers may be suggestive but are not diagnostic. See ANTIBODY; EPSTEIN-BARR VIRUS; HERPES; INFECTION.

There is no standard method of treatment. However, some believe that treatment based on reversal of the abnormal immune response is helpful. Some individuals affected by CFIDS improve with time; most who are not treated remain functionally impaired for several years. [D.En.]

**Chronograph** A device for recording the epoch of an event. In its older form the astronomical chronograph includes a drum rotated at constant speed and a pen actuated by an electromagnet. A spiral line is traced on paper on the drum. Signals from a clock produce a set of time marks and signals made by an observer produce other marks, so that the epoch of the events observed can be determined.

Modern chronographs are of the digital printing type. In one form rotating type wheels carry numbers. In another form the time is accumulated electronically, and when a signal is given the output is printed by keys. See TIME-INTERVAL MEASUREMENT.

[W.M.]

**Chronometer** A large, strongly built watch especially designed for precise timekeeping on ships at sea. The name is sometimes loosely applied to any fine watch.

The features that distinguish a chronometer from a watch are (1) a heavy balance wheel, the axis of which is kept always vertical; (2) a balance spring wound in cylindrical shape, instead of a nearly flat helix; (3) a special escapement; and (4) a fusee, by means of which the power of the mainspring is made to work through a lever arm of continuously changing length, being shortest when the spring is tightly wound and longest when it has run down, thus regulating the transmitted power so that it is approximately constant at all times.

Oceangoing ships during a voyage formerly relied completely on chronometers keeping Greenwich mean time as a means for determining longitude. The broadcasting of radio time signals



that became widespread in the decade 1920–1930 has made Greenwich mean time available to mariners at almost any time of day, and chronometers are no longer indispensable for determining longitude at sea. See CLOCK. [G.M.C.]

**Chrysoberyl** A mineral having composition  $\text{BeAl}_2\text{O}_4$  and crystallizing in the orthorhombic system. The hardness is 8.5 (Mohs scale) and the specific gravity is 3.7–3.8. The luster is vitreous and the color various shades of green, yellow, and brown. There are two gem varieties of chrysoberyl. Alexandrite, one of the most prized of gemstones, is an emerald green but in transmitted or in artificial light is red. Cat's eye, or cymophane, is a green chatoyant variety with an opalescent luster. When cut en cabochon, it is crossed by a narrow beam of light. This property results from minute tabular cavities that are arranged in parallel position.

Chrysoberyl is a rare mineral found most commonly in pegmatite dikes and occasionally in granitic rocks and mica schists. Gem material is found in stream gravels in Ceylon and Brazil. The alexandrite variety is found in the Ural Mountains. In the United States chrysoberyl is found in pegmatites in Maine, Connecticut, and Colorado. See BERYLLIUM; GEM. [C.S.Hu.]

**Chrysocolla** A silicate mineral, composition  $\text{CuSiO}_3 \cdot 2\text{H}_2\text{O}$ . Small acicular crystals have been observed, but it ordinarily occurs in impure cryptocrystalline crusts and masses with conchoidal fracture. The hardness varies from 2 to 4 on Mohs scale, and the specific gravity varies from 2.0 to 2.4. The luster is vitreous and it is normally green to greenish-blue, but may be brown to black when impure. Chrysocolla is a secondary mineral occurring in the oxidized zones of copper deposits, where it is associated with malachite, azurite, native copper, and cuprite. It is a minor ore of copper. See SILICATE. [C.S.Hu.]

**Chryomonadida** An order of the class Phytomastigophorea. Chryomonads, also known as Chryomonadina, are usually small flagellates. They are yellow to brown because of phycocystin in the usual one or two chromatophores, but some lack chromatophores. Many species form diagnostic siliceous cysts. Palmelloid colonies (*Hydrurus*) consist of a tough, gelatinous matrix holding many nonflagellate cells. Starch is not formed, but fats are, and the refractive carbohydrate leucosin is common. The flagella are usually two, rarely three, and are subequal. Nuclei are small. See PHYTAMASTIGOPHOREA. [J.B.L.]

**Chrysophyceae** A relatively large and diverse class of algae in the chlorophyll *a-c* phyletic line (Chromophycota). In protozoological classification, these organisms constitute an order, Chryomonadida, of the class Phytomastigophora. Some workers align Chrysophyceae (golden or golden-brown algae) with Bacillariophyceae (diatoms) and Xanthophyceae (yellow-green algae) in the division Chrysophyta. See CHROMOPHYCOTA.

Chrysophytes typically are flagellate unicells, either free-living or attached, and solitary or colonial. There are, however, amoeboid and plasmodial forms, solitary or colonial nonflagellate cells, filaments, and blades. Fresh-water forms, which are usually found in cold clear water, are more common than marine forms.

Asexual reproduction in unicellular forms is by longitudinal binary fission, autospores (nonflagellate cells that are miniatures of the parent), or zoospores, and in multicellular forms by fragmentation or zoospores. See ALGAE; BACILLARIOPHYCEAE; BICOSOECIDA; CHOANOFAGELLIDA; CHRYSOMONADIDA; XANTHOPHYCEAE. [P.C.Si.; R.L.Moe]

**Chrysotile** Chrysotile is a fibrous mineral with a tubular morphology for each fibril. It is a member of the serpentine mineral group, as are antigorite and lizardite. Chrysotile aggregates make up serpentine asbestos, which is the most important type of commercially mined asbestos. Russia and Canada are the main producing countries. Chrysotile displays interesting prop-

erties such as being thermally and electrically insulating, sound insulating, chemically inert, fire-resistant, mechanical energy-absorbing, and flexible with enough high tensile strength to be woven. There are hundreds of applications for chrysotile including fire retarder in buildings, roofing tiles, brake pads, weavable material for refractory clothes, filters, and fibers in fibrocement and road surfaces. See ASBESTOS; SERPENTINE; SERPENTINITE.

Intensive inhalation of long and thin asbestos fibers over a considerable time period can induce pulmonary diseases such as asbestosis and lung cancers, as well as pleural diseases such as plaques, fibrosis, and mesothelioma. Such health hazards have drastically reduced the use of chrysotile, which is strictly regulated by law in western countries. See RESPIRATORY SYSTEM DISORDERS. [A.J.Ba.]

**Chytridiomycetes** A monophyletic group of true fungi in the subdivision Mastigomycotina. The zoospore has a single, posteriorly directed, whiplash-type of flagellum; a few species are polyflagellated. The Chytridiomycetes are generally regarded as primitive and are probably representative of the ancestral group for the true fungi, but they have also been classified within the Kingdom Protista and Kingdom Protoctista.

The thallus may be unicellular, colonial, or filamentous and consists of a single reproductive body (monocentric) or many reproductive bodies (polycentric). The asexual reproductive body comprises a zoosporangium that releases zoospores. The five orders are classified primarily on differences in zoospore ultrastructure and include the Chytridiales, Spizellomycetales, Blastocladales, Monoblepharidales, and Neocallimastigales.

Chytrids are cosmopolitan in distribution and are found in environments from the tundra to the equatorial rainforests, in alkaline or acid soil, in peat bogs, and in fresh or brackish water. Many are saprobes, but some are parasites of microflora and fauna such as algae and rotifers. Some are of interest because they destroy mosquitoes and others are parasites of vascular plants and are of economic concern as vectors of plant viruses. The Neocallimastigales are obligate anaerobes in the rumen and digestive tract of herbivores, where they are important in the breakdown of cellulose and hemicellulose fiber. See EUMYCOTA; FUNGI; MASTIGOMYCOTINA. [D.J.S.B.]

**Ciconiiformes** An order of predominantly long-legged, long-necked wading birds including herons, ibises, spoonbills, storks, and their allies, and also the hawklike New World vultures which were previously placed in the Falconiformes.

The order Ciconiiformes is divided into four suborders and seven families: Ardeae, with the family Ardeidae (herons; 62 species); Balaenicipites, with the family Balaenicipitidae (shoe-billed stork; 1 species); Ciconiae, with the families Scopidae (hammerhead; 1 species), Threskiornithidae (ibises and spoonbills; 33 species), and Ciconiidae (storks; 17 species); and Cathartae, containing the families Teratornithidae (Miocene to Pleistocene of South and North America) and Cathartidae (New World vultures; 7 species).

The herons, shoe-billed stork, hammerhead, ibises and spoonbills, and storks are mainly wading birds with strong legs, living in marshes and other wet areas. They feed on fish, amphibians, and other animals, which are caught in various ways depending on the structure of the bill. Some of the storks are scavengers. Most species are colonial and nest in mixed, often huge, colonies in trees or on the ground, as well as a few on cliff ledges. All are strong fliers, usually having to cover a long distance between the nesting site and feeding areas; some are excellent soarers.

The New World vultures are placed in a separate suborder to emphasize their specialization as scavengers. These vultures are large soaring birds; the Andean condor has the largest wing span of any living land bird. Vultures locate their food from the air either by sight or by smell; these abilities differ in the several species. Vultures may be solitary or hunt in loose flocks; larger concentrations may exist during the winter. They nest solitarily,

with the nest placed on the ground or on a cliff ledge. The one to three young remain in the nest until they can fly. See AVES.

[W.J.B.]

**Cilia and flagella** Centriole-based, motile cell extensions. These organelles are usually indistinguishable in fine structure as seen with the electron microscope, but quantitatively there are many (several hundred) cilia, and few or fewer (usually one or two) flagella, on one cell. Bacterial or prokaryotic flagella are entirely different organelles that are not considered in this article, which concerns only eukaryotic flagella.

Flagella move with undulatory motion in which successive bending waves progress along the length of the organelle, whereas cilia move with flexural motion consisting of a planar effective stroke, with the organelle extended perpendicular to the cell body, followed by a nonplanar curving recovery stroke, with the organelle pulled parallel to the cell body. Both organelles function to move water past the cell. Their action may bring food and oxygen into an animal, or it may propel the cell to a new environment.

The words cilium (eyelash) and flagellum (whip) are accurate descriptions of the appearance of these cell organelles when they are seen under the light microscope. Cilia are present on protozoa, such as *Paramecium*, and on metazoan cells of many different tissue types. A flagellum is present on human sperm; in fact, the sperm of most animals possess a flagellum, and, correspondingly, male gametes of many lower plants are flagellated. In addition, many ordinary types of cells of vertebrates, for example, from the thyroid, the kidney, or the pituitary gland, possess modified nonmotile derivatives that resemble cilia. See CILIOPHORA; EPITHELIUM; SPERM CELL.

Relative to cell size, both cilia and flagella are very long organelles. Flagella may be over 50 micrometers long. Certain compound cilia, such as the comb plates of ctenophores, are macroscopic structures, visible to the naked eye. Usually, however, cilia range from 10 to 15  $\mu\text{m}$  in length.

The electron microscope reveals that the cilium or flagellum is really an internal organelle since it is bounded by the cell membrane and enclosed at the tip. The main internal structure of the cilium is the axoneme. Under the electron microscope, a single axoneme appears to contain a fixed pattern of microtubules. The microtubules are not simple single units; rather, nine doublet microtubules are found on the periphery of the axoneme surrounding two central elements. This is the so-called 9 + 2 pattern (see illustration). Each peripheral doublet is composed of one complete and one partial microtubule. The microtubules



Electron micrograph of cilia showing 9 + 2 pattern of axoneme. (From P. Satir, *Studies on Cilia, II: Examination of the distal region of the ciliary shaft and the role of the filaments in motility*, *J. Cell Biol.*, 26:805-834, 1965)

are themselves composed of subunits arranged into microfibers or protofilaments.

At the base of the cilium or flagellum there is a basal body, or kinetosome, that is similar to, and sometimes derived from, a centriole. The basal body may have extensions of various sorts attached to it, notably a basal foot that indicates effective stroke direction and prominent striated rootlet fibers in many cilia. Ordinarily, the ciliary axoneme originates and grows in a membrane protrusion which forms just above the basal body, either at the cell surface or deeper inside the cytoplasm. The basal body remains attached to the cell membrane throughout morphogenesis by a structure that extends from the microtubules to the membrane, where it is seen as a ciliary necklace. See CENTRIOLE.

[P.S.; I.Gi.]

**Ciliata** The single class of the subphylum Ciliophora. This group has the characteristics of those defined for the subphylum. This protozoan class is divided into the subclasses Holotrichia, Peritrichia, Suctorina, and Spirotrichia. See CILIOPHORA; HOLOTRICHIA; PERITRICHIA; SPIROTRICHIA; SUCTORIA.

[J.O.C.]

**Ciliophora** A subphylum of the Protozoa. The ciliates are a fairly homogeneous group of highly differentiated, unicellular organisms. Over 5000 species have been described, and many more surely exist but remain to be discovered. Typically, ciliates are larger than most other protozoans, ranging from 10 to 3000 micrometers (about 1/2500 to 1/8 in.). Some larger species are easily visible to the naked eye. The majority of them are free-living forms, found abundantly in a variety of fresh- and salt-water habitats, although a few entire groups live in association with other organisms, generally as harmless ecto- or endocommensals. Their principal value to humans is as experimental animals in a host of biological investigations.

A classification scheme for the ciliates is given below. It is widely recognized as the most reasonable and useful classification currently available. Separate articles appear on each group listed. Subordinal divisions of some orders are commonly recognized by protozoologists.

- Subphylum Ciliophora
  - Class Ciliata
    - Subclass Holotrichia
      - Order: Gymnostomatida
        - Trichostomatida
        - Chonotrichida
        - Apostomatida
        - Astomatida
        - Hymenostomatida
        - Thigmatrichida
      - Subclass Peritrichia
        - Order Peritrichida
      - Subclass Suctorina
        - Order Suctorida
      - Subclass Spirotrichia
        - Order: Heterotrichida
          - Oligotrichida
          - Tintinnida
          - Entodiniomorphida
          - Odontostomatida
          - Hypotrichida

The usual ciliate life cycle is fairly simple. An individual feeds and undergoes binary fission, and the resulting filial products repeat the process. Some commensal or parasitic forms have a more complicated life history. Some ciliates, including free-living species, have a cystic stage in their cycle. As in other kinds of Protozoa this stage often serves as a protective phase during adverse environmental conditions, such as desiccation or lack of

food. It also may be important in distribution, and thus possibly in preservation, of the species.

Six major characteristics aid in distinguishing the Ciliophora from other protozoan groups. Not all of these are entirely unique, but when taken together they are definitely distinctive of ciliates: mouth, ciliation, infraciliature, nuclear apparatus, fission, and reproduction.

Most Ciliophora possess a true mouth or cytostome often associated with a buccal cavity containing compound ciliary organelles. However, some ciliates are completely astomatous, that is, mouthless. Nutrition is heterotrophic in ciliates.

The Ciliophora possess simple cilia or compound ciliary organelles, often in abundance, in at least one stage of their life cycle. Morphologically, cilia are relatively short and slender hair-like structures, whose ultrastructure is known, from electron microscope studies, to be composed of nine peripheral and two central fibrils. Membranes and membranelles are characteristically associated with the mouth or buccal areas and serve to bring food into the oral opening, although they sometimes aid in locomotion as well. See CILIA AND FLAGELLA.

Infraciliature is present, without exception, at a subpellicular level in the cortex. The infraciliature consists essentially of basal bodies, or kinetosomes, associated with cilia and ciliary organelles at their bases, plus certain more or less interconnecting fibrils.

Ciliophora possess two kinds of nuclei, and at least one of each is usually present. The smaller, or micronucleus, contains recognizable chromosomes and behaves much as the single nucleus in cells of metazoan organisms. The larger, or macronucleus, is considered indispensable in controlling metabolic functions, and is recognized as having genic control over all phenotypic characteristics of ciliates.

Ciliophora exhibit a type of binary fission commonly known as transverse division. In ciliates the splitting results in two filial organisms, the anterior or proter and the posterior or opisthe which, geometrically speaking, show homothety with respect to identical structures possessed by each. Thus, homothetogenic is both a broader and most exact descriptive term.

Ciliophora lack true sexual reproduction. Ciliates do not show syngamy, with fusion of free gametes. Processes such as conjugation are considered to be sexual phenomena, since meiosis and chromosome recombination are involved, but not sexual reproduction. In addition to conjugation, certain ciliates exhibit forms of sexual phenomena known as autogamy and cytogamy. See PROTOZOA; REPRODUCTION (ANIMAL). [J.O.C.]

**Cinchona** A genus of trees belonging to the madder family (Rubiaceae), occurring indigenously in the cool, cloud forests of the Andes from Colombia to Peru. Many species have been described, most of which may be variants of *Cinchona pubescens* or *C. officinalis*. The bark contains several alkaloids, the most important of which is quinine. This bitter substance is the most specific drug used in the treatment of malaria. The great demand for quinine and the wasteful methods used in collecting the materials threatened extinction of the plants; therefore cultivation was begun. Now there are extensive cinchona plantations in India, Java, Sri Lanka, Australia, and Jamaica. See QUININE; RUBIALES. [P.D.St.; E.L.C.]

**Cinematography** The process of producing the illusion of a moving picture. Cinematography includes two phases: the taking of the picture with a camera and the showing of the picture with a projector. The camera captures the action by taking a series of still pictures at regular intervals; the projector flashes these pictures on a screen at the same frequency, thus producing an image on the screen that appears to move. This illusion is possible only because of the persistence of vision of the human eye. The still pictures appear on the screen many times a second, and although the screen is dark equally as long as it is lighted by the projected image, they do not seem to be a

series of pictures but appear to the viewer to be one continuous picture. See CAMERA; MAGNETIC RECORDING; OPTICAL PROJECTION SYSTEMS; OPTICAL RECORDING; PHOTOGRAPHIC; PHOTOGRAPHY; STEREOPHONIC SOUND.

**Cameras.** Still photographs are taken by motion picture cameras (movie cameras) at the rate of 24 per second, even faster at times. The photographs are sharp and clear, and if they were superimposed on one another would be found to be extremely uniform with respect to position. This last feature is essential in order to have the image appear steady on the screen.

The lens on a motion picture camera collects the light from the scene being photographed and focuses it on the photographic emulsion in the camera aperture. The focal lengths most often used on 35-mm cameras are between 30 and 50 mm. Other lenses in common use vary from wide-angle (14.5 to 25 mm), through long-focal-length (60 to 250 mm), to telephoto (300 to 1000 mm). Variable-focal-length lenses (zoom lenses) are useful to cinematographers and directors and are used extensively not only for filming sport events but also in making feature films, documentaries, and television films. See FOCAL LENGTH; TELEPHOTO LENS; ZOOM LENS.

To protect the lens from extraneous light and prevent lens flare, a lens shade must be used. On a motion picture camera this shade is called a matte box. It completely surrounds the lens and acts as a lens shade, but it also has slots to hold various types of filters (such as diffusion, fog, color correcting, and polarizing), and optically flat glass for use when needed. These items are used by cinematographers for the many effects required in making a professional motion picture.

The shutter in a motion picture camera rotates and exposes the film according to its angle of opening. When the shutter is open to its widest angle, the film receives its maximum exposure. Many cameras have variable shutters; that is, the angle of opening can be changed while the camera is running. The shutter in a motion picture camera is almost always located between the lens and the film.

The aperture called the gate is the passageway through which the film is channeled while it is being exposed. It consists of the aperture plate, which is in front of the film and masks the frame, or picture; the pressure plate, which is in back of the film and holds it firmly against the aperture plate; and the edge guides, which keep the film stable laterally.

The film chamber holds the unexposed film at one end and collects the exposed film at the other. Although some motion picture cameras have an interior film chamber, it is usually a separate piece of equipment called the film magazine.

The part of the pull-down mechanism called the intermittent movement pulls the film down through the gate of the camera one frame at a time; in a conventional 35-mm camera, each frame is four perforations high. Some wide-screen cameras have frames five or six perforations high. The pull-down claw engages the perforations and pulls the film down into place to be exposed. Most modern cameras have registration pins which engage the film while the picture is being taken. This ensures that the film is perfectly still and is in exactly the same position as each frame is being exposed. This feature is especially important in special effects photography where independently photographed images are superimposed.

When sound is being recorded, cameras must be absolutely quiet. In the early days of sound, cameras were put in enclosures called blimps. Almost all modern cameras are self-blimped, which enhances their portability. The Mitchell BNC (Blimped News Camera) was the first such camera (see illustration), and remains the industry standard.

All sound is recorded on sprocketless 0.25-in. (6-mm) tape. Since tape is an elastic medium, some sort of "sync" pulse must be put on the tape in order to synchronize the recorded sound with the picture when they are put together in a "married" print. The sync pulse is usually an inaudible 1-V, 60-Hz (in Europe, 50 Hz) pulse put on the tape at the time of recording. This



Mitchell studio camera (BNC).

pulse can be one generated at the camera and sent to the sound recorder, which is exactly 60-Hz when the camera is running precisely 24 frames/s.

There are two types of sound tracks, optical and magnetic on the prints seen by the audience. All 35-mm have optical sound tracks. Until the mid-1990s, all sound tracks were recorded in analog fashion. Developments in the technology, however, have enabled optical sound tracks to be recorded digitally, permitting optical sound tracks to provide sound quality comparable to a digital compact disk.

**Film.** The film used in the standard motion-picture camera is 35 mm (wide) and is perforated along both edges. Motion-picture film consists of a cellulose acetate base approximately 0.006 in. (0.15 mm) thick and coated with a light-sensitive emulsion. In color film, several layers of emulsion are applied; each of three of the layers is sensitive to one of the three primary colors of light: blue, green, and red. The film is made in large rolls about 54 in. (1.37 m) wide and as long as several thousand feet. It is slit into 35-mm strips, perforated, and packed in lightproof bags and cans in rolls 100, 200, 400, and 1000 ft (30, 60, 120, and 300 m) in length.

There are two different types of film: negative film, from which a print is made in order to see the original subject in its true likeness, and reversal film, in which a negative is first formed in the original film and from this a positive is formed in the same piece of film. In the negative film two pieces of film are necessary to get a picture that can be projected; in the reversal film only one piece of film is required, making it a much less expensive process. In professional work, the original, that is, the film used in the camera, is never used for projection. A work print is made in order to edit the film and the original negative is assembled to conform to the edited work print. Master positives are then struck from the original negative, and the master positives are used, in turn, to produce duplicate negatives. The release prints are made from the duplicate negatives, and during this process the sound tracks are added. The original film is all-important and is kept in a vault at the laboratory; it is used only for making prints.

**Projectors.** The projector system in a modern motion picture theater has five main assemblies: the optical sound head, which reproduces optical (photographically recorded) sound; the projector head, which projects the image onto the screen; the lamphouse, which furnishes the illumination for the picture; the shutter; and the platter system, which feeds the film through the projector head. On some projectors, there is a sec-

ond sound head for the reproduction of magnetic (magnetically recorded) sound.

With the development of digital optical sound, most projectors are now equipped with a charge-coupled-device (CCD) line array to read the digital track. The analog optical track, which is still present as a backup system, is now read by a light-emitting diode (LED) array in lieu of the traditional exciter lamp. An alternate dual-system approach has a time-code track on the film that is read to synchronize the picture with the sound track played back from a compact disk machine. See CHARGE-COUPLED DEVICES; LIGHT-EMITTING DIODE.

**Current screen formats.** Films for theatrical release have now been standardized in two basic formats in the United States. With rare exceptions all films for theatrical presentation are now shot either in the 2.35:1 aspect ratio (ratio of film width to height), using the 35-mm frame, or in the 1.85:1 aspect ratio, which is achieved by cropping the standard 35-mm frame top and bottom. In Europe, the popular aspect ratio is 1.66:1. [E.M.DiG.]

**Cinnabar** A mineral of composition HgS, crystallizing in the hexagonal system. Crystals are rare, usually of rhombohedral habit and often in penetration twins. Cinnabar most commonly occurs in fine, granular, massive form. It has perfect prismatic cleavage, a Mohs hardness of 2.0–2.5, and a density of 8.09. It has either an adamantine luster and vermilion red color or a dull luster and brownish-red color.

Cinnabar is deposited from hydrothermal solutions in veins and as impregnations near recent volcanic rocks and hot springs. It is the principal ore of mercury. Notable occurrences are Almaden, Spain; Idria, Italy; near Belgrade, Yugoslavia; Kweichow and Hunan provinces, China; Soviet Turkistan; New Almaden and New Idria, California; Terlingua, Texas; and several localities in Utah, Nevada, New Mexico, Oregon, and Idaho. See MERCURY (ELEMENT). [L.Gr.]

**Cinnamon** An evergreen shrub or small tree, *Cinnamomum zeylanicum*, of the laurel family (Lauraceae). A native of Ceylon, the plant is now in cultivation in southern India, Burma, parts of Malaya, West Indies, and South America. The bark is removed from suckers that grow up from the roots, dried, and packaged for shipping. Cinnamon is a very important spice for flavoring foods. It is used in confectionery, gums, incense, dentrifices, and perfumes. Cinnamon oil is used in medicine and as a source of cinnamon extract. See MAGNOLIALES. [P.D.St./E.L.C.]

**Circle** The curve that is the locus of points in a plane with equal distance (radius) from a fixed point (center). In elementary mathematics, circle often refers to the finite portion of the plane bounded by a curve (circumference) all points of which are equidistant from a fixed point of the plane, that is, a circular disk. Circles are conic sections and are defined analytically by certain second-degree equations in cartesian coordinates. The ancient Greeks formulated the problem of “squaring the circle,” that is, to construct, with compasses and unmarked straightedge only, a square whose area is equal to that of a given circle. It was not until 1882 that this was shown to be impossible, when F. Lindemann proved that the ratio of the length of a circle to its diameter (denoted by  $\pi$ ) is not the root of any algebraic equation with integer coefficients. Electronic computers have calculated  $\pi$  to over  $10^{12}$  decimal places.

The area of a circle (circular disk) with radius  $r$  is  $\pi r^2$ ; the length (circumference) is  $2\pi r$ . The area enclosed by a circle is greater than that bounded by any other curve of the same length. See ANALYTIC GEOMETRY; CONIC SECTION. [L.M.Bl.]

**Circuit (electricity)** A general term referring to a system or part of a system of conducting parts and their interconnections through which an electric current is intended to flow. A circuit is made up of active and passive elements or parts and their interconnecting conducting paths. The active elements are

the sources of electric energy for the circuit; they may be batteries, direct-current generators, or alternating-current generators. The passive elements are resistors, inductors, and capacitors. The electric circuit is described by a circuit diagram or map showing the active and passive elements and their connecting conducting paths.

Devices with an individual physical identity, such as amplifiers, transistors, loudspeakers, and generators, are often represented by equivalent circuits for purposes of analysis. These equivalent circuits are made up of the basic passive and active elements listed above.

Electric circuits are used to transmit power as in high-voltage power lines and transformers or in low-voltage distribution circuits in factories and homes; to convert energy from or to its electrical form as in motors, generators, microphones, loudspeakers, and lamps; to communicate information as in telephone, telegraph, radio, and television systems; to process and store data and make logical decisions as in computers; and to form systems for automatic control of equipment.

Electric circuit theory includes the study of all aspects of electric circuits, including analysis, design, and application. In electric circuit theory the fundamental quantities are the potential differences (voltages) in volts between various points, the electric currents in amperes flowing in the several paths, and the parameters in ohms or mhos which describe the passive elements. Other important circuit quantities such as power, energy, and time constants may be calculated from the fundamental variables. For a discussion of these parameters See ADMITTANCE; CONDUCTANCE; ELECTRICAL IMPEDANCE; ELECTRICAL RESISTANCE; REACTANCE; SUSCEPTANCE; TIME CONSTANT.

Electric circuit theory is often divided into special topics, either on the basis of how the voltages and currents in the circuit vary with time (direct-current, alternating-current, nonsinusoidal, digital, and transient circuit theory) or by the arrangement or configuration of the electric current paths (series circuits, parallel circuits, series-parallel circuits, networks, coupled circuits, open circuits, and short circuits). Circuit theory can also be divided into special topics according to the physical devices forming the circuit, or the application and use of the circuit (power, communication, electronic, solid-state, integrated, computer, and control circuits). See ALTERNATING CURRENT; CIRCUIT (ELECTRONICS); COUPLED CIRCUITS; DIRECT-CURRENT; ELECTRIC TRANSIENT; INTEGRATED CIRCUITS; NEGATIVE-RESISTANCE CIRCUITS; OPEN CIRCUIT; PARALLEL CIRCUIT; SERIES CIRCUIT; SHORT CIRCUIT.

[C.F.G.]

**Circuit (electronics)** An interconnection of electronic devices, an electronic device being an entity having terminals which is described at its terminals by electromagnetic laws. Most commonly these are voltage-current laws, but others, such as photovoltaic relationships, may occur.

Some typical electronic devices are represented as shown in Fig. 1, where a resistor, a capacitor, a diode, transistors, an operational amplifier, an inductor, a transformer, voltage and current sources, and a ground are indicated. Other devices (such as vacuum tubes, switches, and logic gates) exist, in some cases as combinations of the ones mentioned. The interconnection laws are (1) the Kirchhoff voltage law, which states that the sum of voltages around a closed loop is zero, and (2) the Kirchhoff current law, which states that the sum of the currents into a closed surface is zero (where often the surface is shrunk to a point, the node, where device terminals join). Figure 2 represents an electronic circuit which is the interconnection of resistors ( $R$ ,  $R_{B1}$ ,  $R_{B2}$ ,  $R_E$ ,  $R_L$ ), capacitors ( $C$ ), a battery voltage source ( $V_{CC}$ ), a current source ( $i_s$ ), a bipolar transistor ( $T$ ), and a switch ( $S$ ). Functionally Fig. 2 represents a high-pass filter when  $S$  is open, and an oscillator when  $S$  is closed and the current source is removed. See AMPLIFIER; BATTERY; CAPACITOR; CURRENT SOURCES AND MIRRORS; DIODE; ELECTRIC FILTER; ELECTRONIC SWITCH; INDUCTOR; KIRCHHOFF'S LAWS OF ELECTRIC CIRCUITS; LOGIC CIRCUITS;

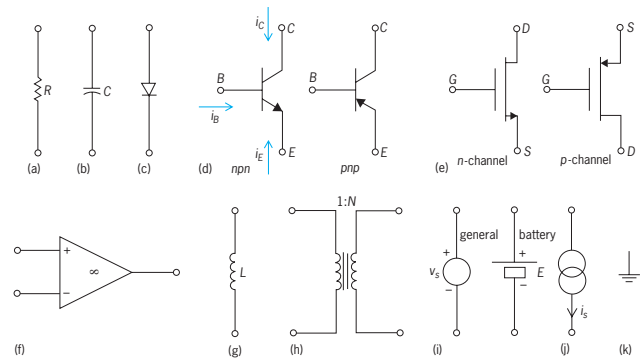
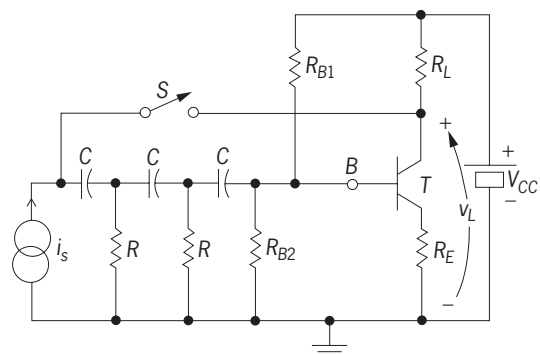

**Fig. 1. Representation of some typical electronic devices. (a) Resistor. (b) Capacitor. (c) Diode. (d) Bipolar junction transistors (BJTs). (e) Metal oxide semiconductor field-effect transistors (MOSFETs). (f) Operational amplifier. (g) Inductor. (h) Transformer. (i) Voltage sources. (j) Current source. (k) Ground.**

OPERATIONAL AMPLIFIER; OSCILLATOR; RESISTOR; TRANSFORMER; TRANSISTOR; VACUUM TUBE.

The devices in an electronic circuit are classified as being either passive or active. The passive devices change signal energy, as is done dynamically by capacitors and statically by transformers, or absorb signal energy, as occurs in resistors, which also act to convert voltages to currents and vice versa. The active devices, such as batteries, transistors, operational amplifiers, and vacuum tubes, can supply signal energy to the circuit and in many cases amplify signal energy by transforming power supply energy into signal energy. Often, though, they are used for other purposes, such as to route signals in logic circuits. Transistors can be considered the workhorses of modern electronic circuits, and consequently many types of transistors have been developed, among which the most widely used are the bipolar junction transistor (BJT), the junction field-effect transistor (JFET), and the metal oxide silicon field-effect transistor (MOSFET). See ELECTRONIC POWER SUPPLY.

Fortunately, most of these transistors occur in pairs, such as the *npn* and the *pnp* bipolar junction transistors, or the *n*-channel and the *p*-channel MOSFETs, allowing designers to work symmetrically with positive and negative signals and sources. This statement may be clarified by noting that transistors can be characterized by graphs of output current  $i$  versus output voltage  $v$  that are parametrized by an input current (in the case of the bipolar junction transistor) or input voltage (in the MOSFET and JFET cases). Typically, the curves for the *npn* bipolar junction transistor or an *n*-channel field-effect transistor are used in the first quadrant of the output  $i$ - $v$  plane, while for a *pnp* bipolar junction transistor or a *p*-channel field-effect transistor the same curves show up in the third quadrant. Mathematically, if  $i = f(v)$  for an *npn* bipolar junction transistor or *n*-channel field-effect



**Fig. 2. Diagram of electronic circuit.**

device, then  $i = -f(-v)$  for a *pn*p bipolar junction transistor or *p*-channel field-effect device when the controlling parameters are also changed in sign.

**Transistors.** Transistors are basic to the operation of electronic circuits. Bipolar transistors have three terminals, designated as the base *B*, the collector *C*, and the emitter *E*. These terminals connect to two diode junctions, *B-C* and *B-E*, these forming back-to-back diodes. The *B-E* junction is often forward-biased, in which case its voltage is about 0.7 V, while the *B-C* junction is reverse-biased for linear operation.

Besides biasing of the junctions for linear operation, any state of the two junctions can occur. For example, both junctions might be forward-biased, in which case the transistor is said to be in saturation and acts nearly as a short circuit between *E-C*, while if the junctions are simultaneously back-biased the transistor is said to be cut off and acts as an open circuit between all terminals. The transistor can be controlled between saturation and cutoff to make it act as an electronically controlled switch. This mode of operation is especially useful for binary arithmetic, as used by almost all digital computers, where 0 and 1 logic levels are represented by the saturation and cutoff transistor states.

MOSFETs have three regions of operation: cutoff, saturated, and resistive. The MOSFET also has three terminals, the gate *G*, the drain *D*, and the source *S*. A key parameter characterizing the MOSFET is a threshold voltage  $V_{th}$ . When the *G-S* voltage is below the threshold voltage, no drain current flows and the transistor is cut off.

The MOSFET is a versatile device, acting as a voltage-controlled current source in the saturation region and approximately as a voltage-controlled resistor in the resistive region. It can also be electronically controlled between cutoff and the resistive region to make it act as a switch, while for small signals around an operating point in the saturation region it acts as a linear amplifier. Another feature of the MOSFET is that, besides the categories of *n*-channel and *p*-channel devices, there are also enhancement- and depletion-mode devices of each category. In practice, for electronic circuit considerations, an *n*-channel device has  $V_{th} > 0$  for enhancement-mode devices and  $V_{th} < 0$  for depletion-mode devices, while the signs are reversed for *p*-channel devices.

**Biasing of circuits.** Since active devices usually supply signal energy to an electronic circuit, and since energy can only be transferred and not created, a source of energy is needed when active devices are present. This energy is usually obtained from batteries or through rectification of sinusoidal voltages supplied by power companies. When inserted into an electronic circuit, such a source of energy fixes the quiescent operation of the circuit; that is, it allows the circuit to be biased to a given operating point with no signal applied, so that when a signal is present it will be processed properly. To be useful, an electronic circuit produces one or more outputs; often inputs are applied to produce the outputs. These inputs and outputs are called the signals and, consequently, generally differ from the bias quantities, though often it is hard to separate signal and bias variables. Biasing of electronic circuits is an important, non-trivial, and often overlooked aspect of their operation. See BIAS (ELECTRONICS).

**Analog versus digital circuits.** Electronic circuits are also classified as analog or digital. Analog circuits work with signals that span a full range of values of voltages and currents, while digital circuits work with signals that are at prescribed levels to represent numerical digits. Analog signals generally are used for continuous-time processes, while digital ones most frequently occur where transistors are synchronized via a clock. However, there are situations where it is desirable to transfer between these two classes of signals, that is, where analog signals are needed to excite a digital circuit or where a digital signal is needed to excite an analog circuit. For example, it may be desired to feed a biomedically recorded signal, such as an electrocardiogram into

a digital computer, or it may be desired to feed a digital computer output into an analog circuit, such as a temperature controller. For such cases, there are special electronic circuits, called analog-to-digital and digital-to-analog converters. See ANALOG-TO-DIGITAL CONVERTER; DIGITAL-TO-ANALOG CONVERTER.

**Feedback.** An important concept in electronic circuits is that of feedback. Feedback occurs when an output signal is fed around a device to contribute to the input of the device. Consequently, when positive feedback occurs, that is, when the output signal returns to reinforce itself upon being fed back, it can lead to the generation of signals which may or may not be wanted. Circuit designers need to be conscious of all possible feedback paths that are present in their circuits so that they can ensure that unwanted oscillations do not occur. In the case of negative feedback, that is, when the output signal returns to weaken itself, then a number of improvements in circuit performance often ensue; for example, the circuit can be made less sensitive to changes in the environment or element variations, and deleterious nonlinear effects can be minimized. See CONTROL SYSTEMS; FEEDBACK CIRCUIT.

**Digital circuits.** The digital computer is based on digital electronic circuits. Although some of the circuits are quite sophisticated, such as the microprocessors integrated on a single chip, the concepts behind most of the circuits involved in digital computers are quite simple compared to the circuits used for analog signal processing. The most basic circuit is the inverter; a simple realization based upon the MOS transistor is shown in Fig. 3a. The upper (depletion-mode) transistor acts as a load "resistor" for the lower (enhancement-mode) transistor, which acts as a switch, turning on (into its resistive region) when the voltage at point *A* is above threshold to lower the voltage at point *B*. Adding the output currents of several of these together into the same load resistor gives a NOR gate, a two-input version of which is shown in Fig. 3b; that is, the output is high, with voltage at  $V_{DD}$ , if and only if the two inputs are low. Placing the drains of several of the enhancement-mode switches in series yields the NAND gate, a two-input version of which is shown in Fig. 3c; that is, the output is low if and only if both inputs are high. From the circuits of Fig. 3, the most commonly used digital logic circuits can be constructed. Because these circuits are so simple, digital circuits and digital computers are usually designed on the basis of negation logic, that is, with NOR and NAND rather than OR and AND circuits. See DIGITAL COMPUTER; INTEGRATED CIRCUITS; MICROPROCESSOR.

**Conversion.** Because most signals in the real world are analog but digital computers work on discretizations, it is necessary to convert between digital and analog signals. As mentioned above, this is done through digital-to-analog and analog-to-digital converters. Most approaches to digital-to-analog conversion use summers, where the voltages representing the digital bits are applied to input resistors, either directly or indirectly through switches gated on by the digital bits which change the input resistance fed by a dc source.

One means of doing analog-to-digital conversion is to use a clocked counter that feeds a digital-to-analog converter, whose output is compared with the analog signal to stop the count when the digital-to-analog output exceeds the analog signal. The counter output is then the analog-to-digital output. The comparator for such an analog-to-digital converter is similar to an open-loop operational amplifier (which changes saturation level when one of the differential input levels crosses the other). Other types of analog-to-digital converters, called flash converters, can do the conversion in a shorter time by use of parallel operations, but they are more expensive.

**Other circuits.** The field of electronic circuits is very broad and there are a very large number of other circuits besides those discussed above. For example, the differential is a key element in operational amplifier design and in biomedical data acquisition devices which must also be interfaced with specialized electronic sensors. Light-emitting and -detecting diodes allow

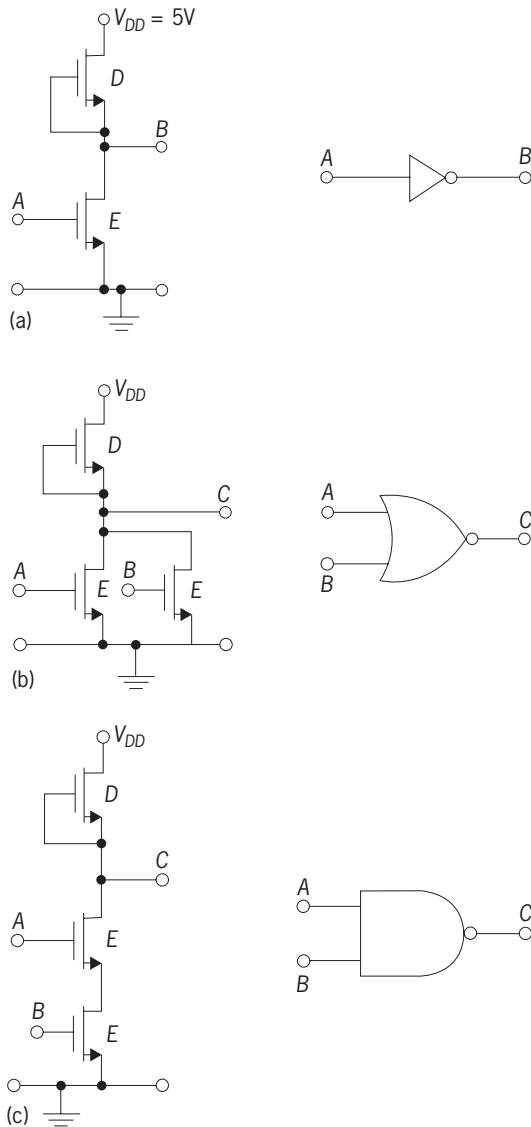

Fig. 3. Digital logic gates and their symbols. *D* = depletion-mode transistor; *E* = enhancement-mode transistor. (a) Inverter. (b) NOR gate. (c) NAND gate.

for signals to be transmitted and received at optical frequencies. Liquid crystals are controlled by electronic circuits and are useful in digital watches, flat-panel color television displays, and electronic shutters. See BIOMEDICAL ENGINEERING; ELECTRONIC DISPLAY; LIGHT-EMITTING DIODE; LIQUID CRYSTALS; OPTICAL DETECTORS; TRANSDUCER.

**Design.** Because some circuits can be very complicated, and since even the simplest circuits may have complicated behavior, the area of computer-aided design (CAD) of electronic circuits has been extensively developed. A number of circuit simulation programs are available, some of which can be run on personal computers with good results. These programs rely heavily upon good mathematical models of the electronic devices. Fortunately, the area of modeling of electronic devices is well developed, and for many devices there are models that are adequate for most purposes. But new devices are constantly being conceived and fabricated, and in some cases no adequate models for them exist. Thus, many of the commercial programs allow the designer to read in experimentally obtained data for a device from which curve fitting techniques are used to allow an engineer to proceed with the design of circuits incorporating the device. Reproducibility and acceptability of parts with tolerances are required

for the commercial use of electronic circuits. Consequently, theories of the reliability of electronic circuits have been developed, and most of the computer-aided design programs allow the designer to specify component tolerances to check out designs over wide ranges of values of the elements. Finally, when electronic circuits are manufactured they can be automatically tested with computer-controlled test equipment. Indeed, an area that will be of increasing importance is design for testability, in which decisions on what to test are made by a computer using knowledge-based routines, including expert systems. Such tests can be carried out automatically with computer-controlled data-acquisition and display systems. See CIRCUIT (ELECTRICITY); COMPUTER-AIDED DESIGN AND MANUFACTURING; EXPERT SYSTEMS; RELIABILITY, AVAILABILITY, AND MAINTAINABILITY; ROBOTICS. [R.W.Ne.]

**Circuit breaker** A device to open or close an electric power circuit either during normal power system operation or during abnormal conditions. A circuit breaker serves in the course of normal system operation to energize or deenergize loads. During abnormal conditions, when excessive current develops, a circuit breaker opens to protect equipment and surroundings from possible damage due to excess current. These abnormal currents are usually the result of short circuits created by lightning, accidents, deterioration of equipment, or sustained overloads.

Formerly, all circuit breakers were electromechanical devices. In these breakers a mechanism operates one or more pairs of contacts to make or break the circuit. The mechanism is powered either electromagnetically, pneumatically, or hydraulically. The contacts are located in a part termed the interrupter. When the contacts are parted, opening the metallic conductive circuit, an electric arc is created between the contacts. This arc is a high-temperature ionized gas with an electrical conductivity comparable to graphite. Thus the current continues to flow through the arc. The function of the interrupter is to extinguish the arc, completing circuit-breaking action.

In oil circuit breakers, the arc is drawn in oil. The intense heat of the arc decomposes the oil, generating high pressure that produces a fluid flow through the arc to carry energy away. At transmission voltages below 345 kV, oil breakers used to be popular. They are increasingly losing ground to gas-blast circuit breakers such as air-blast breakers and SF<sub>6</sub> circuit breakers.

In air-blast circuit breakers, air is compressed to high pressures. When the contacts part, a blast valve is opened to discharge the high-pressure air to ambient, thus creating a very-high-velocity flow near the arc to dissipate the energy. In SF<sub>6</sub> circuit breakers, the same principle is employed, with SF<sub>6</sub> as the medium instead of air. In the "puffer" SF<sub>6</sub> breaker, the motion of the contacts compresses the gas and forces it to flow through an orifice into the neighborhood of the arc. Both types of SF<sub>6</sub> breakers have been developed for ehv (extra high voltage) transmission systems.

Two other types of circuit breakers have been developed. The vacuum breaker, another electromechanical device, uses the rapid dielectric recovery and high dielectric strength of vacuum. A pair of contacts is hermetically sealed in a vacuum envelope. Actuating motion is transmitted through bellows to the movable contact. When the contacts are parted, an arc is produced and supported by metallic vapor boiled from the electrodes. Vapor particles expand into the vacuum and condense on solid surfaces. At a natural current zero the vapor particles disappear, and the arc is extinguished. Vacuum breakers of up to 242 kV have been built.

The other type of breaker uses a thyristor, a semiconductor device which in the off state prevents current from flowing but which can be turned on with a small electric current through a third electrode, the gate. At the natural current zero, conduction ceases, as it does in arc interrupters. This type of breaker does not require a mechanism. Semiconductor breakers have been built to carry continuous currents up to 10,000 A. [T.H.L.]

**Circuit testing (electricity)** The testing of electric circuits to determine and locate any of the following circuit conditions: (1) an open circuit, (2) a short circuit with another conductor in the same circuit, (3) a ground, which is a short circuit between a conductor and ground, (4) leakage (a high-resistance path across a portion of the circuit, to another circuit, or to ground), and (5) a cross (a short circuit or leakage between conductors of different circuits). Circuit testing for complex systems often requires extensive automatic checkout gear to determine the faults defined above as well as many quantities other than resistance.

In cable testing, the first step in fault location is to identify the faulty conductor and type of fault. This is done with a continuity tester, such as a battery and flashlight bulb or buzzer (Fig. 1), or an ohmmeter.

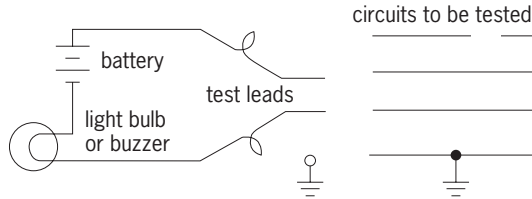

Fig. 1. Simple continuity test setup.

Useful for locating faults in relatively low-resistance circuits, the Murray loop is shown in Fig. 2 with a ground fault in the circuit under test. A known "good" conductor is joined to the faulty conductor at a convenient point beyond the fault but at a known distance from the test connection. One terminal of the test battery is grounded. The resulting Wheatstone bridge is then balanced by adjusting  $R_B$  until a null is obtained, as indicated by the detector in Fig. 2. Ratio  $R_A/R_B$  is then known. For a circuit having a uniform ratio of resistance with length, circuit resistance is directly proportional to circuit length. Therefore, the distance to the fault is determined from the producer given by Eqs. (1)–(3). From Eq. (3) and a knowledge of total length  $l$  of the circuit, once ratio  $r$  has been measured, the location of the fault  $x$  is determined.

$$R_C \propto l + (l - x) \quad R_D \propto x \quad (1)$$

$$R_A/R_B = r = R_C/R_D = (2l - x)/x \quad (2)$$

$$x = 2l/(r - 1) \quad (3)$$

The Varley loop test is similar to the Murray loop test except for the inclusion of the adjustable resistance  $R$ . The Varley loop is used for fault location in high-resistance circuits.

An alternating-current capacitance bridge can be used for locating an open circuit as shown in Fig. 3. One test terminal is connected to the open conductor and the other terminal to a conductor of known continuity in the cable. All conductors associated with the test are opened at a convenient point beyond the fault but at a known distance from the test connection. An

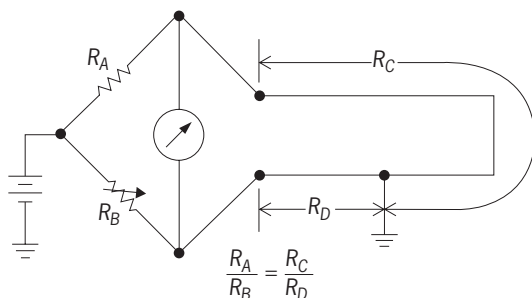

Fig. 2. Murray loop for location of ground fault.

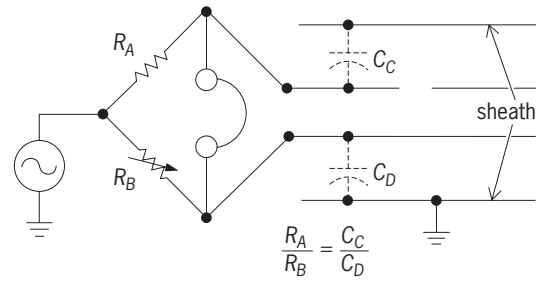

Fig. 3. Alternating-current capacitance bridge used in location of an open circuit in one conductor.

audio oscillator supplies the voltage to the bridge, which is balanced by adjusting  $R_B$  for a null as detected by the earphones. Measured ratio  $R_A/R_B$  equals the ratio of capacitances between the lines and the grounded sheath. Because each capacitance is proportional to the length of line connected to the bridge, the location of the open circuit can be determined from Eq. (4).

$$R_A/R_B = C_C/C_D \quad (4)$$

See CIRCUIT (ELECTRICITY).

[C.E.A.]

**Circulation** Those processes by which metabolic materials are transported from one region of an organism to another. Ultimately, the essential gases, nutrients, and waste products of metabolism are exchanged across cell membranes by diffusion. Diffusion is the movement of material, by random motion of molecules, from a region of high concentration to one of low concentration. The amount of material moved from one place to another depends on the difference in concentrations and on the distance between the two points. The greater the distance, the less movement of material per unit time for a given difference in concentration. Consequently, in all but the smallest animals, convection (or bulk circulation) of materials to the cell must be employed to supplement diffusion.

Protoplasmic movement aids diffusion at the intracellular level. In multicellular animals, however, either the external medium or extracellular body fluids, or both, are circulated. In sponges and coelenterates, water is pumped through definite body channels by muscular activity or, more often, by cilia or flagella on the cells lining the channels.

Coelenterates have a body wall derived from two cell layers; an outer ectoderm is separated from an inner endoderm by a noncellular gelatinous material (mesoglea). All higher animals have bodies consisting of three cell layers, with the ectoderm being separated from the endoderm by a cellular layer of mesoderm. The mesoderm proliferates and separates to develop a fluid-filled body cavity or coelom. The coelom separates the ectoderm (together with an outer layer of mesoderm) from the endoderm (which has an inner layer of mesoderm). Coelomic fluid is moved around by body movements or ciliary activity, but in larger animals this movement is usually inadequate to supply the metabolic requirements of the organs contained within the coelom. These needs are provided for by pumping a fluid, blood, to them through vessels, the blood vascular system. See BLOOD.

When the blood is in a separate compartment from the rest of the extracellular fluid, the vascular system is described as closed. The two principal components of such systems are hearts and blood vessels. In such a system, the blood is circulated by a pump, the heart, through special channels, blood vessels; it comes into close association with the tissues only in the capillaries, fine vessels with walls only one cell thick. In some tissues or regions, larger blood spaces may exist, called sinuses. A closed vascular system is found in most annelids (segmented worms and leeches), cephalopod mollusks (squids and octopods), holothurian echinoderms (sea cucumbers), and vertebrates. See BLOOD VESSELS; HEART (VERTEBRATE).



In vertebrates, a functional but anatomically closed connection exists between the extracellular spaces (between the cells) and the blood vascular system in the form of lymph channels. Lymph is derived from the noncellular component of blood (plasma), modified in its passage through the tissues, and is conducted to the veins by blind-ending lymphatic vessels, which are separate from blood vessels and coelomic space. See LYMPHATIC SYSTEM.

In most arthropods (crustaceans, insects), most mollusks (shellfish), and many ascidians (sea squirts), the extracellular spaces are confluent with the blood system. In these animals, blood is pumped through a limited network of vessels into a body cavity called a hemocoel. After bathing the tissues, blood (called hemolymph in these organisms) collects in sinuses and returns to the heart. This is the open vascular system. In animals with open circulatory systems, the coelom is much reduced. [D.R.J.]

**Circulation disorders** The function of the circulatory system is to transport and distribute substances either used or produced by cells or both. Excluded are those materials that are discharged directly from sweat glands, digestive glands, and renal tubule cells. Included, however, are nutritive and metabolic substances, hormones, waste products, water, and heat.

Disturbances in the normal pattern of circulation can either result in or from disease conditions. An example is edema, which is an abnormal accumulation of fluid in the cells, tissue spaces, or cavities of the body. There are three main factors in the formation of generalized edema and a fourth which plays a role in the formation of local edema. They are the permeability of the capillary wall, the colloid osmotic pressure of the plasma proteins, and the hydrostatic pressure in the capillaries. The fourth factor, which is of importance in local edema formation, is lymphatic obstruction.

Increased permeability of the capillary walls plays an important role in the formation of inflammatory edema, the edema of severe infections, metabolic intoxications, asphyxia, anaphylactic reactions, secondary shock, and acute nephritis. See EDEMA.

A deficiency of circulating blood volume, both cellular elements and fluid, is called oligemia. This may be the result of an acute blood loss or it may be of a chronic nature, such as an anemia combined with dehydration. Anemia, or oligochromemia, is a deficiency of circulating red cell volume or, more specifically, hemoglobin content. It can result from a variety of causes. See ANEMIA; BLOOD.

Pancytopenia, or oligocythemia, is a deficiency of all circulating blood cellular elements. This is usually the result of a deficiency of the blood-forming tissue, the bone marrow.

The decrease of blood flow to an organ or tissue is known as ischemia. This can be sudden as when a vessel is ligated, when a thrombus or blood clot forms, or when an embolus comes to lodge in the vessel. A gradual occlusion can follow arteriosclerotic changes in the vessel wall. The effect of a sudden occlusion depends to a great extent on the collateral circulation to the organ or tissue involved. If an adequate collateral circulation comes to be established, the tissue survives; if not, it dies and an infarct results. See INFARCTION.

An excess of blood is referred to as plethora. This increase may be the result of an increase in the size or the number of red blood cells. The increase in red cell volume may be a polycythemia vera, or true polycythemia, which is a primary increase in the number of red blood cells with no regard to the needs of the organism. Polycythemia, or erythrocytosis, is usually a secondary increase in red cells following conditions of chronic hypoxia. Serous plethora is an increase in the watery part of the blood.

Hyperemia, or congestion, refers to an excess of blood within an organ or tissue. This condition may be localized or generalized. Active hyperemia, caused by an active dilatation of arterioles and capillaries, occurs under certain physiological conditions, such as in the muscle when there is an increased need for blood during exercise. It also occurs in pathological states

such as inflammation. Passive hyperemia, a condition which results in an accumulation of blood in the venous system, may be generalized or localized and can result from any obstruction or hindrance to the outflow of blood from the venous circuit. Diseases of the lungs such as emphysema, fibrosis, or pulmonary hypertension of any origin can result in right ventricular failure and generalized congestion. Localized venous congestion results when a main vein from a region is occluded either by a thrombus or some extrinsic pressure such as a tumor or enlarged lymph nodes.

The escape of blood from within the vascular system is hemorrhage. This process can be the result of trauma to, or disease of, the vessel wall. The causes of hemorrhage other than trauma can be divided into three main groups. In the first group are those conditions in which there is a disease process affecting the vessel wall, such as arteriosclerosis or aneurysm formation. In the second group are conditions in which there is an acute process affecting the vessel wall such as in septicemia, poisoning by heavy metals, or even anoxia. The third group consists of those conditions in which there is a defect in the blood itself, which results in hemorrhage. Apoplexy, or stroke, is an acute vascular lesion of the brain. This can be the result of hemorrhage of, thrombosis in, or embolism to a cerebral vessel. See HEMORRHAGE.

Thrombosis is the formation of a thrombus, a solid body formed during life and composed of the elements of the blood: platelets, fibrin, red cells, and leukocytes. Thrombosis may occur on a vessel wall anywhere that the endothelium is damaged. However, because the platelets release thromboplastinogen, which activates the clotting mechanism, thrombosis and blood coagulation may occur together. See THROMBOSIS.

The sudden blocking of an artery or vein by a clot or other substance which has been brought to its place by the blood current is an embolism. The material carried in the circulation in this process is an embolus. Emboli may be composed of thrombi, fat, air, tumor cells, masses of bacteria or parasites, bone marrow, amniotic fluid, or atheromatous material from the vessel wall. See EMBOLISM. [R.A.V.]

**Cirque** A cliffed rock basin, shaped like half a bowl, at the head of a mountain valley. Cirques may be shallow if glacier erosion is slight, but may be 1600–2600 ft (500–800 m) from the top of the headwall to the cirque floor if erosion is deep. Cirques occur in glaciated mountains all over the world. Some cirques used repeatedly by glaciers over long periods of years are excavated profoundly. Many cirques contain small glaciers today that were inherited from a huge cirque cut by glaciers long ago. Well-formed cirques have steep rock walls and floors that slope down-valley or back toward the base of the headwall. Some cirques are cup-shaped rock basins holding rainwater; a lake formed in them is a tarn. If glacial deposits, such as till or a small moraine on the cirque floor, form a depression for a lake the lake is known as a moraine-dammed lake. [S.E.Wh.]

**Cirrhosis** A liver disease characterized by a marked increase in fibrous connective tissue, resulting in a firm, nodular, distorted liver.

There are numerous causes of cirrhosis. In the United States the majority of cases are caused by excessive alcohol consumption, and the condition is referred to as alcoholic cirrhosis. Cirrhosis may occur as a result of the healing of severe fulminant hepatitis or chronic active hepatitis. Some cases are caused by obstruction of the bile duct by calculi (stones) and are referred to as secondary biliary cirrhosis. Primary biliary cirrhosis is primarily a disease of middle-aged women and is caused by an autoimmune destruction of bile ducts. Autoimmune hepatitis, sometimes referred to as lupoid hepatitis and characteristically seen in young women and associated with serum autoantibodies, may progress to cirrhosis. Relatively few cases of cirrhosis are caused by genetically determined deficiencies in certain substances. See ALCOHOLISM; HEPATITIS.

The signs and symptoms of cirrhosis are nonspecific and frequently related to the complications. As the liver becomes fibrotic, there is obstruction of the blood flow through the liver. This results in portal hypertension, an increase in blood pressure within the portal vein and its tributaries. The obstructed hepatic blood flow also causes congestion of the spleen, leading to a markedly enlarged spleen (splenomegaly). Also, most people with cirrhosis eventually develop fluid in their abdomen (ascites) and are at an increased risk of developing a spontaneous intraabdominal infection. In addition to obstruction of blood flow, the bile ducts within the liver are distorted and frequently partially obstructed by the increased connective tissue. This results in jaundice, a yellow discoloration of all tissues and organs, including the skin. Some individuals with advanced cirrhosis develop renal failure, a condition referred to as hepatorenal syndrome. Also, there is a definite increase in liver cell cancer in cirrhotic persons. The liver may be slightly enlarged, but as the disease progresses it usually becomes smaller due to progressive loss of liver cells. See JAUNDICE.

The therapy of cirrhosis is aimed primarily at preventing or reducing the complications. Bleeding esophageal varices (collateral venous channels) are a frequent serious complication of cirrhosis. Various techniques are used to control the bleeding. In some individuals with severe portal hypertension, vascular shunts are made to reduce the pressure in the portal vein by bypassing the liver. Most frequently the portal vein is surgically connected to the inferior vena cava so that some of the blood in the portal vein does not pass through the liver. See CARDIOVASCULAR SYSTEM; LIVER DISORDERS. [S.P.H.]

**Cirripedia** A subclass of the Crustacea, permanently attached when adult, and called barnacles. The carapace forms a complete covering or mantle over the rest of the body and is

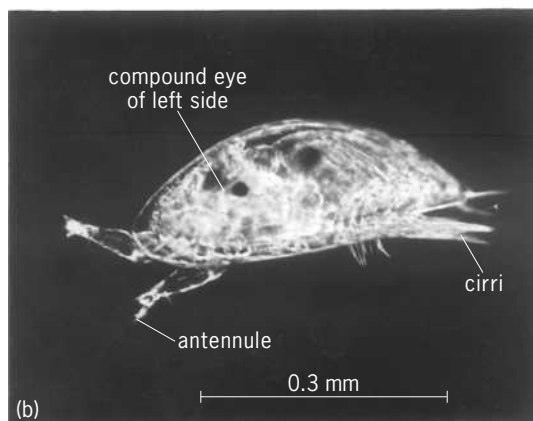
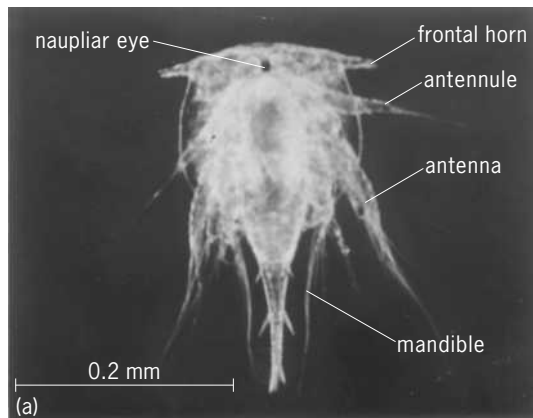

Larval stages of *Balanus*. (a) Nauplius. (b) Cypris. (Photographs by D. P. Wilson)

usually strengthened by calcareous plates. The body within the mantle consists of a mouth region and thorax. The abdomen is usually vestigial. Typically the mouth appendages are paired mandibles with palps, maxillulae, and maxillae. The thorax bears six pairs of biramous appendages (cirri) composed of numerous segments, each with a considerable armament of setae. Compound eyes occur only in the larvae, there is no heart, and typically adults are hermaphroditic. The eggs are incubated in the mantle cavity and hatch into free-swimming nauplius larvae (illus. a). By successive molts a further five nauplius larvae follow. The sixth nauplius (or metanauplius) molts into an entirely different larval form, the cypris (illus. b), which is characteristic of all Cirripedia. The Cirripedia are divided into four orders: Thoracica, Acrothoracica, Ascothoracica, and Rhizocephala. Only the Thoracica, the goose barnacles, and acorn barnacles are at all conspicuous, and only the latter of any economic significance. See ACROTHORACICA; ASCOTHORACICA; BARNACLE; RHIZOCEPHALA; THORACICA. [H.G.St.]

**Citric acid** A hydroxytricarboxylic acid, general formula  $C_6H_8O_7$ , with the structure shown here. It is available primar-

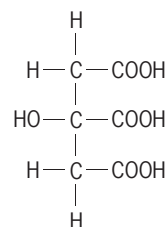

ily as anhydrous material but also as the monohydrate. The major commercial salts are sodium and potassium, with calcium, diammonium, and ferric ammonium (complex) also available. See ACID AND BASE.

Citric acid is a relatively strong organic acid, and is very soluble in water. Citric acid and its salts are widely used because they are nontoxic, safe to handle, and easily biodegraded.

Citric acid occurs in relatively large quantities in citrus fruits. It also occurs in other fruits, in vegetables, and in animal tissues and fluids either as the free acid or as citrate ion. It is an integral part of the Krebs (citric acid) cycle involving the metabolic conversion of carbohydrates, fats, and proteins in most living organisms. See CITRIC ACID CYCLE.

Today, essentially all of the commercial citric acid is produced by fermentation. Processes employed are surface or submerged fermentation by mold (*Aspergillus niger*) and submerged fermentation by yeast (*Candida guilliermondii*, *C. lipolytica*), using a variety of substrates including sucrose, molasses, corn syrup, enzyme-treated starch, and normal paraffins. Citric acid is recovered from the fermentation broth by solvent extraction or more commonly by precipitation as calcium citrate, followed by treatment with sulfuric acid to convert the calcium citrate to calcium sulfate and citric acid. The calcium sulfate is removed by filtration, and the citric acid solution is further purified. Crystallization of citric acid from a hot aqueous solution (above the transition temperature of 36.6°C or 97.9°F) yields anhydrous citric acid; crystallization from a cold solution yields the monohydrate. Although total chemical syntheses for citric acid have been published, they have never achieved commercial success. See FERMENTATION; INDUSTRIAL MICROBIOLOGY.

Citric acid is widely used in the food and pharmaceutical industries. In foods it is used primarily to produce a tart taste and to complement fruit flavors in carbonated beverages, beverage powders, fruit-flavored drinks, jams and jellies, candy, sherbets, water ices, and wine. It is also used to reduce pH in certain canned foods to make heat treatment more effective, and in conjunction with antioxidants to chelate trace metals and retard enzymatic activity. See FOOD MANUFACTURING.

In pharmaceuticals, citric acid provides the acid source in effervescent tablets in addition to being used to adjust pH, impart a tart taste, and chelate trace metals. It is also used as a blood anticoagulant. See PHARMACEUTICAL CHEMISTRY.

Citric acid, because of its low toxicity, relative noncorrosiveness, and biodegradability, is also being used for applications normally reserved for the strong mineral acids. These include preoperational and operational cleaning of iron and copper oxides from boilers, nuclear reactors, and heat exchangers; passivation of stainless steel tanks and equipment; and etching of concrete floors prior to coating. It is also used as a dispersant to retard settling of titanium dioxide slurries and as a sequestering and pH control agent in the textile industry. See TEXTILE CHEMISTRY. [F.Sa.]

**Citric acid cycle** In aerobic cells of animals and certain other species, the major pathway for the complete oxidation of acetyl coenzyme A (the thioester of acetic acid with coenzyme A); also known as the Krebs cycle or tricarboxylic acid cycle. Reduced electron carriers generated in the cycle are reoxidized by oxygen via the electron transport system; water is formed, and the energy liberated is conserved by the phosphorylation of adenosine diphosphate (ADP) to adenosine triphosphate (ATP). Reactions of the cycle also function in metabolic processes other than energy generation. The role of the cycle in mammalian tissues will be emphasized in this article. See ADENOSINE DIPHOSPHATE (ADP); COENZYME; ENZYME.

The first step in the cycle involves the condensation of the acetyl portion of acetyl coenzyme A (CoA) with the four-carbon compound oxaloacetate to form citrate, a tricarboxylate containing six carbons (see illustration). A shift of the hydroxyl group of citrate to an adjacent carbon results in the formation of D-threo-

isocitrate, which in turn is oxidized to the five-carbon compound  $\alpha$ -ketoglutarate and carbon dioxide ( $\text{CO}_2$ ). In a second oxidative decarboxylation reaction,  $\alpha$ -ketoglutarate, in the presence of CoA, is converted to succinyl CoA and another molecule of  $\text{CO}_2$ . In the subsequent formation of the four-carbon compound succinate and CoA, the energy in the thioester bond of succinyl CoA is conserved by the formation of guanosine triphosphate (GTP) from guanosine diphosphate (GDP) and inorganic phosphate. Fumarate is formed from succinate by the removal of two atoms of hydrogen, and the unsaturated compound is then hydrated to L-malate. The dehydrogenation of malate forms oxaloacetate, the starting four-carbon compound of the metabolic cycle. Thus, beginning with the two-carbon acetyl group, one completion of the cycle results in the formation of two molecules of carbon dioxide.

The oxidation of acetyl CoA to  $\text{CO}_2$  in the cycle occurs without direct reaction with molecular oxygen. The oxidations occur at dehydrogenation reactions in which hydrogen atoms and electrons are transferred from intermediates of the cycle to the electron carriers nicotinamide adenine dinucleotide ( $\text{NAD}^+$ ) and flavin adenine dinucleotide (FAD). The electrons from NADH and  $\text{FADH}_2$  are transferred to molecular oxygen via a series of electron transport carriers, with regeneration of  $\text{NAD}^+$  and FAD. The energy liberated in the electron transport chain is partially conserved by the formation of ATP from ADP and inorganic phosphate, by a process called oxidative phosphorylation. The energy generated as oxygen accepts electrons from the reduced coenzymes generated in one turn of the cycle results in the maximal formation of 11 molecules of ATP. Because GTP obtained by phosphorylation of GDP at the succinyl CoA to succinate step of the cycle is readily converted to ATP by nucleotide diphosphokinase, the yield is 12 molecules of ATP per molecule of acetyl CoA metabolized. See NICOTINAMIDE ADENINE DINUCLEOTIDE (NAD).

The electron transport and oxidative phosphorylation systems and the enzymes required for the citric acid cycle are located in the mitochondria of cells, which are the major source of ATP for energy-consuming reactions in most tissues. The citric acid cycle does not occur in all cells. For example, mature human red blood cells do not contain mitochondria and the cycle is absent. In these cells, ATP is formed by the anaerobic conversion of glucose to lactate (anaerobic glycolysis). See MITOCHONDRIA; PHOSPHATE METABOLISM.

Acetyl CoA is formed from carbohydrates, fats, and the carbon skeleton of amino acids. The origin of a precursor and the extent of its utilization depend on the metabolic capability of a specific tissue and on the physiological state of the organism. For example, most mammalian tissues have the capacity to convert glucose to pyruvate in a reaction called glycolysis. Pyruvate is then taken up from cellular cytosol by mitochondria and oxidatively decarboxylated to acetyl CoA and carbon dioxide by pyruvate dehydrogenase. Acetyl CoA is also the end product of fatty acid oxidation in mitochondria. However, the fatty acid oxidation pathway occurs in fewer tissues than does glycolysis or the citric acid cycle. The amino acids follow varied pathways for forming compounds that can enter the citric acid cycle. See AMINO ACIDS.

In addition to the cycle's role in yielding catabolic energy, portions of it can supply intermediates for synthetic processes, such as the synthesis of the fatty acid moiety of triglycerides from glucose (lipogenesis), and formation of glucose from the carbon skeletons of certain amino acids, lactate, or glycerol (gluconeogenesis). See BIOLOGICAL OXIDATION; CARBOHYDRATE METABOLISM; CELL (BIOLOGY); GLUCOSE; GLYCOGEN; LIPID METABOLISM; METABOLISM. [G.E.W.P.]

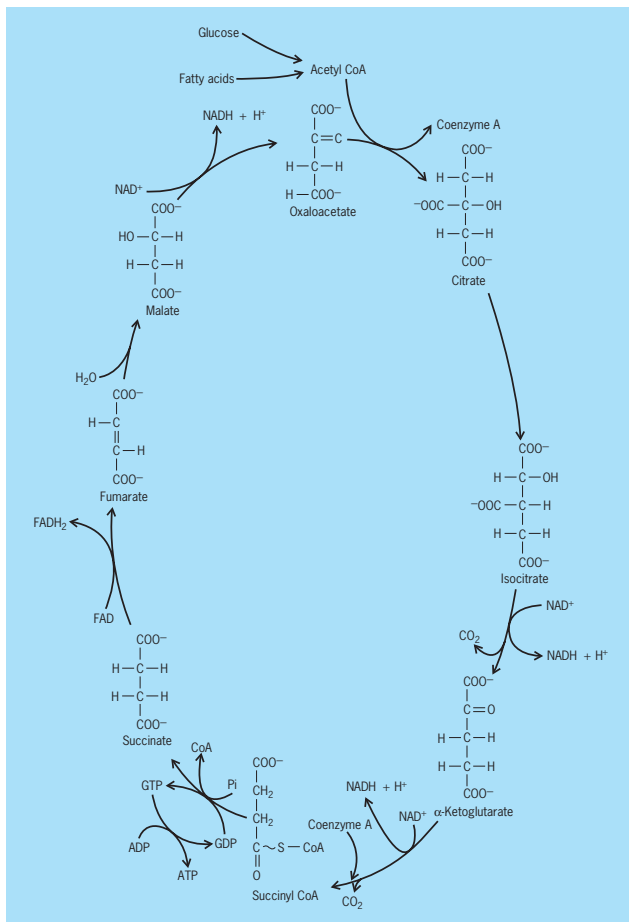

Citric acid cycle.

**Citron** *Citrus medica*, a species of true citrus. Commercially, citrons are grown almost exclusively in the Mediterranean area, principally in Italy, Sicily, Corsica, Greece, and Israel. The tree is

evergreen, as are all citrus, and frost-tender. It is thorny, straggly, shrubby, and tends to be short-lived.

The fruit is scarcely edible fresh, having a very thick skin with little flesh and that lacking in juice. However, it is very fragrant and was valued in ancient times for its aroma and its fragrant peel oil, used in perfumes and as a moth repellent. It is grown commercially only as a source of candied peel for use in cakes and confections. The actual candying is usually done in the importing country, the citron peel being exported in brine.

Confusion sometimes arises due to "citron" also being used for a small, wild, inedible melon in the United States and for lemons (*C. limon*) in France. See FRUIT, TREE. [W.G.]

**Citronella** A tropical grass, *Cymbopogon nardus*, from the leaves of which oil of citronella is distilled. This essential oil is pale yellow, inexpensive, and much used in cheap perfumes and soaps. It is perhaps best known as an insect repellent. A large acreage is devoted to the cultivation of this grass in Java and Ceylon. See CYPERALES. [P.D.St./E.L.C.]

**Civet** Any of 18 species of carnivores assigned to the family Viverridae. Also included in this family are genets, linsangs, and mongooses. See MONGOOSE.

Civets are small to medium size with a pointed muzzle, long head, slender body, and long, bushy tail. They have short limbs and nonretractile claws; they are digitigrade, that is, they walk on their toes. The Indian civet (*Viverra zibetha*) and the smaller African civet are two better-known species.

Civets are nocturnal and remain hidden in brush areas during the day. They have well-developed perianal glands, from which a scented substance used in perfumery is secreted. See CARNIVORA; SCENT GLAND. [C.B.C.]

**Civil engineering** A branch of engineering that encompasses the conception, design, construction, and management of residential and commercial buildings and structures, water supply facilities, and transportation systems for goods and people, as well as control of the environment for the maintenance and improvement of the quality of life. Civil engineering includes planning and design professionals in both the public and private sectors, contractors, builders, educators, and researchers.

The civil engineer holds the safety, health, and welfare of the public paramount. Civil engineering projects and systems should conform to governmental regulations and statutes; should be built economically to function properly with a minimum of maintenance and repair while withstanding anticipated usage and weather; and should conserve energy and allow hazard-free construction while providing healthful, safe, and environmentally sound utilization by society.

Civil engineers play a major role in developing workable solutions to construct, renovate, repair, maintain, and upgrade infrastructure. The infrastructure includes roads, mass transit, railroads, bridges, airports, storage buildings, terminals, communication and control towers, water supply and treatment systems, storm water control systems, wastewater collection, treatment and disposal systems, as well as living and working areas, recreational buildings, and ancillary structures for civil and civic needs. Without a well-maintained and functioning infrastructure, the urban area cannot stay healthy, grow, and prosper.

Because the desired objectives are so broad and encompass an orderly progression of interrelated components and information to arrive at the visually pleasing, environmentally satisfactory, and energy-frugal end point, civil engineering projects are actually systems requiring the skills and inputs of many diverse technical specialties, all of which are subsets of the overall civil engineering profession.

Some of the subsets that civil engineers can specialize in include photogrammetry, surveying, mapping, community and urban planning, and waste management and risk assessment. Various engineering areas that civil engineers can specialize in

include geotechnical, construction, structural, environmental, water resources, and transportation engineering. See CIVIL ENGINEERING; COASTAL ENGINEERING; CONSTRUCTION ENGINEERING; ENGINEERING; ENGINEERING GEOLOGY; ENVIRONMENTAL ENGINEERING; HIGHWAY ENGINEERING; LAND-USE PLANNING; PHOTOGRAMMETRY; RIVER ENGINEERING; SURVEYING; TOPOGRAPHIC SURVEYING AND MAPPING; TRANSPORTATION ENGINEERING. [G.Pa.]

**Cladding** An old jewelry art, now employed on an industrial scale to add the desirable surface properties of an expensive metal to a low-cost or strong base metal. In the process a clad metal sheet is made by bonding or welding a thick facing to a slab of base metal; the composite plate is then rolled to the desired thickness. The relative thickness of the layers does not change during rolling. Cladding thickness is usually specified as a percentage of the total thickness, commonly 10%.

Gold-filled jewelry has long been made by this process: the surface is gold, the base metal bronze or brass with the cladding thickness usually 5%. The process is used to add corrosion resistance to steel and to add electrical or thermal conductivity, or good bearing properties, to strong metals. Corrosion-resistant pure aluminum is clad to a strong duralumin base, and many other combinations of metals are widely used in cladding; a development includes a technique for cladding titanium to steel for jet-engine parts.

Cladding supplies a combination of desired properties not found in any one metal. A base metal can be selected for cost or structural properties, and another metal added for surface protection or some special property such as electrical conductivity. Thickness of the cladding can be made much heavier and more durable than obtainable by electroplating.

Cladding can be added to both sides of a sheet or strip of base metal. Tubing can be supplied with a clad surface on inside or outside; round and rectangular wire can be clad similarly (see illustration).

For some forms of electrical contacts, the composite materials are bonded side by side, or silver is inset as a stripe on one side or along the edges. This construction can place solid silver just where it is needed to form an electrical contact with no waste of costly metal.

A related form of cladding is found in thermostatic bimetals in which equal thicknesses of low- and high-expansion metals are bonded together. With a change in temperature, differing expansion rates of the two metals cause the composite material to bend and thus operate valves in automobile cooling systems, or electrical contacts in room thermostats.

Clad wires with properly chosen proportions of materials of different thermal-expansion rates can match the thermal expan-

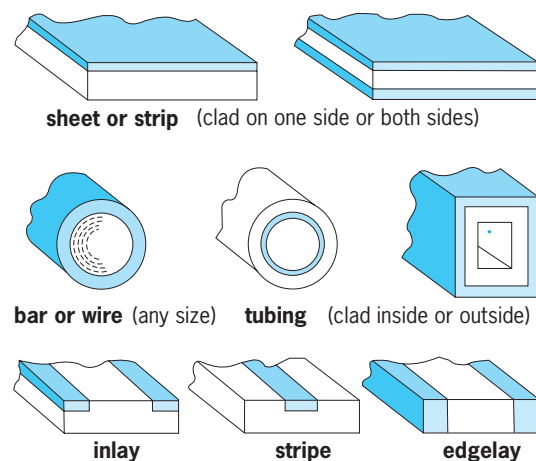

Types of cladding.

sion of types of glass used for vacuum-tight seals for conductors in lamp bulbs and hermetically sealed enclosures.

In making parts from clad metal, the composite material can be bent, drawn, spun, or otherwise formed just the same as the base metal without breaking the bond. The maximum service temperature is limited by the melting point of the material at the juncture of the two metals. See ELECTROPLATING OF METALS; METAL COATINGS. [R.W.C.]

**Cladoselachii** An order of extinct elasmobranch fishes including the oldest and most primitive of sharks. Best known is Cladoseleche (see illustration), of which complete specimens,

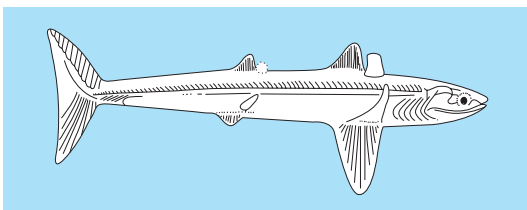

*Cladoseleche* of the Late Devonian.

including even muscle and other soft tissues, have been obtained from shales in the region of Cleveland, Ohio. Primitive features are broad-based paired fins, amphistylic jaw support, and absence of claspers. See ELASMOBRANCHII. [A.S.R.]

**Clarification** The removal of small amounts of fine, particulate solids from liquids. The purpose is almost invariably to improve the quality of the liquid, and the removed solids often are discarded. The particles removed by a clarifier may be as large as 100 micrometers or as small as 2 micrometers. Clarification is used in the manufacture of pharmaceuticals, beverages, and fiber and film polymers; in the reconditioning of electroplating solutions; in the recovery of dry-cleaning solvent; and for the purification of drinking water and waste water. The filters in the feed line and lubricating oil system of an internal combustion engine are clarifiers.

The methods of clarification include gravity sedimentation, centrifugal sedimentation, filtration, and magnetic separation. Clarification differs from other applications of these mechanical separation techniques by the low solid content of the suspension to be clarified (usually less than 0.2%) and the substantial completion of the particle removal. See FILTRATION; MAGNETIC SEPARATION METHODS; MECHANICAL SEPARATION TECHNIQUES; SEDIMENTATION (INDUSTRY); THICKENING. [S.A.M.]

**Classical field theory** The mathematical discipline that studies the behavior of distributions of matter and energy when their discrete nature can be ignored; also known as continuum physics or continuum mechanics. The discrete nature of matter refers to its molecular nature, and that of energy to the quantum nature of force fields and of the mechanical vibrations that exist in any sample of matter. The theory is normally valid when the sample is of laboratory size or larger, and when the number of quanta present is also very large. See PHONON; PHOTON; QUANTUM MECHANICS.

Classical field theories can be formulated by the molecular approach, which seeks to derive the macroscopic (bulk) properties by taking local averages of microscopic quantities, or by the phenomenological approach, which ignores the microscopic nature of the sample and uses properties directly measurable with laboratory equipment. Although the microscopic treatment sometimes yields profounder insights, the phenomenological approach can use partial differential equations since neglecting the microscopic structure allows quantities such as density and pressure to be expressed by continuously varying numbers.

Examples of classical field theories include the deformation of solids, flow of fluids, heat transfer, electromagnetism, and gravitation. Solving the equations has produced a vast body of mathematics. Computers have aided in special calculations, but many mathematicians are working on the analytical theory of partial differential equations, and new results continue to be produced. See DIFFERENTIAL EQUATION. [D.P.]

**Classical mechanics** The science dealing with the description of the positions of objects in space under the action of forces as a function of time. Some of the laws of mechanics were recognized at least as early as the time of Archimedes (287?–212 B.C.). In 1638, Galileo stated some of the fundamental concepts of mechanics, and in 1687, Isaac Newton published his *Principia*, which presents the basic laws of motion, the law of gravitation, the theory of tides, and the theory of the solar system. This monumental work and the writings of J. D'Alembert, J. L. Lagrange, P. S. Laplace, and others in the eighteenth century are recognized as classic works in the field of mechanics. Jointly they serve as the base of the broad field of study known as classical mechanics, or Newtonian mechanics. This field does not encompass the more recent developments in mechanics, such as statistical, relativistic, or quantum mechanics.

In the broad sense, classical mechanics includes the study of motions of gases, liquids, and solids, but more commonly it is taken to refer only to solids. In the restricted reference to solids, classical mechanics is subdivided into statics, kinematics, and dynamics. Statics considers the action of forces that produce equilibrium or rest; kinematics deals with the description of motion without concern for the causes of motion; and dynamics involves the study of the motions of bodies under the actions of forces upon them. For some of the more important areas of classical mechanics see BALLISTICS; COLLISION (PHYSICS); DYNAMICS; ENERGY; FORCE; GRAVITATION; KINEMATICS; LAGRANGE'S EQUATIONS; MASS; MOTION; PRECESSION; RIGID-BODY DYNAMICS; STATICS; WORK. [N.S.G.]

**Classification, biological** A human construct for grouping organisms into hierarchical categories. The most inclusive categories of any classification scheme are called kingdoms, which are delimited so that organisms within a single kingdom are more related to each other than to organisms grouped in the other kingdoms. Classification (grouping) is a part of biological systematics or taxonomy, science that involves naming and sorting organisms into groups.

Historically, organisms have been arranged into kingdoms based on practical characteristics, such as motility, medicinal properties, and economic value for food or fiber. In the nineteenth and twentieth centuries, advances such as electron and light microscopy, biochemistry, genetics, ethology, and greater knowledge of the fossil record provided new evidence upon which to construct more sophisticated classification schemes. Proposals were made to assign organisms into four, five, and even thirteen kingdoms. Earlier two-kingdom and three-kingdom systems were devised without awareness of the profound distinction between prokaryotes and eukaryotes, which Edouard Chatton (1937) recognized as a fundamental evolutionary discontinuity. Prokaryotic cells do not have either a nucleus or any other internal membrane-bounded structures, the so-called organelles. By contrast, eukaryotic cells have both a nucleus and organelles. The deoxyribonucleic acid (DNA) of eukaryotes is combined with protein to form chromosomes. All bacteria are prokaryotes. Plants, fungi, animals, and protoctists are eukaryotes. See EUKARYOTAE; PROKARYOTAE.

By the late 1990s, biologists widely accepted a system that classifies all organisms into five kingdoms based on key characteristics of function and structure. These are Superkingdom Prokarya [Kingdom Bacteria (Monera) with two subkingdoms, Archaea and Eubacteria] and Superkingdom Eukarya with four kingdoms, Protoctista (or Protozoa in some classification

schemes), Fungi, Animalia, and Plantae. Key characteristics used to classify organisms into these categories include the mode by which the organism obtains its nutrients; presence or absence of an embryo; and whether and how the organism achieves motility.

Cladistics may be defined as an approach to grouping organisms that classifies them according to the time at which branch points occur along a phylogenetic tree. Such a phylogenetic tree is represented by a diagram called a cladogram. In this approach, classification is based on a sequence of phylogenetic branching. In a cladogram, the phylogenetic tree branches dichotomously and repeatedly, reflecting cladogenesis (production of biological diversity by evolution of new species from parental species).

Modern classification is based on evidence derived from developmental pattern, biochemistry, molecular biology, genetics, and detailed morphology of extant organisms and their fossils. Because information is drawn from such diverse sources, and because 10–30 million (possibly 100 million) species are probably alive today, informed judgments must be made to integrate the information into classification hierarchies. Only about 1.7 million species have been formally classified in the taxonomic literature of biology to date. Thus, as new evidence about the evolutionary relationships of organisms is weighed, it must be anticipated that biological classification schemes will continue to be revised. See ANIMAL SYSTEMATICS; BACTERIAL TAXONOMY; PLANT TAXONOMY; VIRUS CLASSIFICATION. [K.V.S.]

**Clathrate compounds** Well-defined addition compounds formed by inclusion of molecules in cavities existing in crystal lattices or present in large molecules. The constituents are bound in definite ratios, but these are not necessarily integral. The components are not held together by primary valence forces, but instead are the consequence of a tight fit which prevents the smaller partner, the guest, from escaping from the cavity of the host. Consequently, the geometry of the molecules is the decisive factor.

Inclusion compounds can be subdivided into (1) lattice inclusion compounds (inclusion within a lattice which, as such, is built up from smaller single molecules); (2) molecular inclusion compounds (inclusion into larger ring molecules with holes); and (3) inclusion compounds of macromolecules. The best-known lattice inclusion compounds are the urea and thiourea channel inclusion compounds, which are formed by mixing hydrocarbons, carboxylic acids, or long-chain fatty alcohols with solutions of urea. Other representatives of lattice inclusion compounds are the choleic acids, which are adducts of deoxycholic acid with fatty acids, and other lipoic substances. Some aromatic compounds form an open crystal lattice which can accommodate smaller gas and solvent molecules (clathrates in the stricter sense of the word). The gas hydrates are inclusion compounds of gases in a somewhat expanded ice lattice. The gas or solvent molecules are inserted into definite places within the ice lattice and are surrounded by water molecules on all sides.

Crown ether compounds are cyclic or polycyclic polyether compounds capable of including another atom in the center of the ring. In this way, sodium or potassium compounds can be solubilized in organic solvents. Similarly, a series of ionophore antibiotics can complex inorganic cations.

Some clay minerals are made up of distinct silicate layers. Between these layers some free space may exist in the shape of channels. Smaller hydrocarbon molecules can be accommodated reversibly within these channels. This phenomenon is used in some technical separation processes for separating hydrocarbons (molecular sieves). Furthermore, ion-exchange processes used for water deionization are based on similar minerals. See CLAY MINERALS; MOLECULAR SIEVE.

Enzymes are believed to accommodate their substrates at active sites, pockets, or clefts prior to the chemical reaction which then changes the chemical structures of the substrates. These

binding processes are identical to those of low-molecular-weight inclusion compounds. [F.Cr.; W.S.; D.G.]

**Clathrinida** An order of sponges in the subclass Calcinea of the class Calcarea. These sponges have an asconoid structure and lack a true dermal membrane or cortex. The spongo-coel is lined with choanocytes. This order contains the family Clathrinidae; *Clathrina*, *Ascute*, and *Dendya* are examples. See CALCAREA. [W.D.H.]

**Clavaxinellida** An order of sponges of the class Demospongiae, subclass Tetractinomorpha, with monaxonid megascleres arranged in radial or plumose tracts. In the suborder Epipolagina, monactinal or diactinal megascleres are arranged in a radial pattern. Spongin is rare.

Clavaxinellidan sponges vary greatly in shape, from radially symmetrical species which are spherical in shape to encrusting or massive species and upright branching types. They occur in tidal and shallow waters of all seas and extend down to depths of at least 18,000 ft (5500 m). Sponges comparable to existing clavaxinellidans occur scattered through the fossil record from Cambrian strata upward. See DEMOSPONGIAE. [W.D.H.]

**Clay** The finest-grain particles in a sediment, soil, or rock. Clay is finer than silt, characterized by a grain size of less than approximately 4 micrometers. However, the term clay can also refer to a rock or a deposit containing a large component of clay-size material. Thus clay can be composed of any inorganic materials, such as clay minerals, allophane, quartz, feldspar, zeolites, and iron hydroxides, that possess a sufficiently fine grain size. Most clays, however, are composed primarily of clay minerals. See CLAY MINERALS; FELDSPAR; QUARTZ; ZEOLITE.

Although the composition of clays can vary, clays can share several properties that result from their fine particle size. These properties include plasticity when wet, the ability to form colloidal suspensions when dispersed in water, and the tendency to flocculate (clump together) and settle out in saline water. See COLLOID.

Clays, together with organic matter, water, and air, are one of the four main components of soil. Clays can form directly in a soil by precipitation from solution (neoformed clays); they can form from the partial alteration of clays already present in the soil (transformed clays); or they can be inherited from the underlying bedrock or from sediments transported into the soil by wind, water, or ice (inherited clays). See also SOIL.

The type of clays neoformed in a soil depends on the composition of the soil solution, which in turn is a function of climate, drainage, original rock type, vegetation, and time. Generally, neoformed clays that have undergone intense leaching, such as soils formed under wet, tropical climates, are composed of the least soluble elements, such as ferric iron, aluminum, and silicon. These soils contain clays such as gibbsite, kaolinite, goethite, and amorphous oxides and hydroxides of aluminum and iron. Clays formed in soils that are found in dry climates or in soils that are poorly drained can contain more soluble elements, such as sodium, potassium, calcium, and magnesium, in addition to the least soluble elements. These soils contain clays such as smectite, chlorite, and illite, and generally are more fertile than those formed under intense leaching conditions. See CHLORITE; GOETHITE; ILLITE; KAOLINITE.

Examples of clays formed by the transformation of other clays in a soil include soil chlorite and soil vermiculite, the first formed by the precipitation of aluminum hydroxide in smectite interlayers, and the second formed by the leaching of interlayer potassium from illite. Examples of inherited clays in a soil are illite and chlorite-containing soils formed on shales composed of these minerals. See SHALE.

Clays also occur abundantly in sediments and sedimentary rocks. For example, clays are a major component of many marine sediments. These clays generally are inherited from adjacent

continents, and are carried to the ocean by rivers and wind, although some clays (such as smectite and glauconite) are neofomed abundantly in the ocean. Hydrothermal clays can form abundantly where rock has been in contact with hot water or steam. Illite and chlorite, for example, form during the deep burial of sediments, and smectite and chlorite form by the reaction of hot, circulating waters at ocean ridges. See MARINE SEDIMENTS; SEDIMENTARY ROCKS.

Various clays possess special properties which make them important industrially. For example, bentonite, a smectite formed primarily from the alteration of volcanic ash, swells; is readily dispersible in water; and possesses strong absorptive powers, including a high cation exchange capacity. These properties lead to uses in drilling muds, as catalysts and ion exchangers, as fillers and absorbents in food and cosmetics, and as binders for taxonite and fertilizers. Other important uses for clays include the manufacture of brick, ceramics, molding sands, decolorizers, detergents and soaps, medicines, adhesives, liners for ponds and landfills, lightweight aggregate, desiccants, molecular sieves, pigments, greases, paints, plasticizing agents, emulsifying, suspending, and stabilizing agents, and many other products. See BENTONITE; CATALYSIS; CLAY, COMMERCIAL; ION EXCHANGE; REFRACTORY.

[D.D.E.]

**Clay, commercial** Clays utilized as raw material in manufacturing, which are among the most important nonmetallic mineral resources. The value of clays is related to their mineralogical and chemical composition, particularly the clay mineral constituents kaolinite, montmorillonite, illite, chlorite, and attapulgite. The presence of minor amounts of mineral or soluble salt impurities in clays can restrict their use. The more common mineral impurities are quartz, mica, carbonates, iron oxides and sulfides, and feldspar. In addition, many clays contain some organic material. See CLAY MINERALS.

**Kaolinitic clays.** Clays containing a preponderance of the clay mineral kaolinite are known as kaolinitic clays. Several commercial clays are composed predominantly of kaolinite. These are china clays, kaolines, ball clays, fireclays, and flint clays. The terms china clay and kaolin are used interchangeably in industry. See KAOLINITE.

China clays are high-grade white kaolins found in the southeastern United States, England, and many other countries. Many grades of kaolin are used in the manufacture of ceramics, paper, rubber, paint, plastics, insecticides, adhesives, catalysts, and ink. By far the largest consumer of white kaolins is the paper industry, which uses them to make paper products smoother, whiter, and more printable. The kaolin is used both as a filler in the sheet to enhance opacity and receptivity to ink and as a thin coating on the surface of the sheet to make it smoother and whiter for printing. See CERAMICS; PORCELAIN; POTTERY.

Ball clays are composed mainly of the mineral kaolinite but usually are much darker in color than kaolin. The term ball clay is used for a fine-grained, very plastic, refractory bond clay. Most ball clays contain minor amounts of organic material and the clay mineral montmorillonite, and are finer grained than china clays. This fineness, together with the montmorillonite and organic material, gives ball clays excellent plasticity and strength. For these reasons and because they fire to a light-cream color, ball clays are commonly used in whitewares and sanitary ware.

The term fireclay is used for clays that will withstand temperatures of 2730°F (1500°C) or higher. Such clays are composed primarily of the mineral kaolinite. Fireclays are generally light to dark gray in color, contain minor amounts of mineral impurities such as illite and quartz, and fire to a cream or buff color. Most fireclays are plastic, but some are nonplastic and very hard; these are known as flint clays. Fireclays are used primarily by the refractories industry. The foundry industry uses fireclay to bind sands into shapes in which metals can be cast. See REFRACTORY.

**Diaspore clay.** This clay is composed of the minerals diaspore and kaolinite. Diaspore is a hydrated aluminum oxide with

an  $Al_2O_3$  content of 85% and a water content of 15%. Diaspore clay is used almost exclusively by the refractories industry in making refractory brick. However, after calcination, it is sometimes used as an abrasive material.

**Mullite.** Mullite is a high-temperature conversion product of many aluminum silicate minerals, including kaolinite, pinite, topaz, dumortierite, pyrophyllite, sericite, andalusite, kyanite, and sillimanite. Mullite is used in refractories to produce materials of high strength and great refractoriness. Mullite does not spall, withstands the shock of heating and cooling exceptionally well, and is resistant to slag erosion. It is used in making spark plugs, laboratory crucibles, kiln furniture, saggars, and other special refractories.

**Bentonites.** Those clays that are composed mainly of the clay mineral montmorillonite and are formed by the alteration of volcanic ash are known as bentonites. The term bentonite is a rock term, but in industrial usage it has become almost synonymous with swelling clay. Bentonites are used in many industries; the most important uses are as drilling muds and catalysts in the petroleum industry, as bonding clays in foundries, as bonding agents for taconite pellets, and as adsorbents in many industries. See BENTONITE; MONTMORILLONITE; OIL AND GAS WELL DRILLING.

**Attapulgite clays.** Attapulgite is a hydrated magnesium aluminum silicate with a needlelike shape. Each individual needle is exceedingly small, about 1 micrometer in length and approximately 0.01 micrometer across. Attapulgite is used as a suspending agent, and gives high viscosity because of the interaction of the needles. Some commercial uses are as an oil well drilling fluid, in adhesives as a viscosity control, in oil base foundry sand binders, as thickeners in latex paints, in liquid suspension fertilizers, and as a suspending agent and thickener in pharmaceuticals.

**Properties.** Most clays become plastic when mixed with varying proportions of water. Plasticity of a material can be defined as the ability of the material to undergo permanent deformation in any direction without rupture under a stress beyond that of elastic yielding. Clays range from those which are very plastic, called fat clay, to those which are barely plastic, called lean clay. The type of clay mineral, particle size and shape, organic matter, soluble salts, adsorbed ions, and the amount and type of non-clay minerals are all known to affect the plastic properties of a clay.

Green strength and dry strength properties are very important because most structural clay products are handled at least once and must be strong enough to maintain shape. Green strength is the strength of the clay material in the wet, plastic state. Dry strength is the strength of the clay after it has been dried.

Both drying and firing shrinkages are important properties of clay used for structural clay products. Shrinkage is the loss in volume of a clay when it dries or when it is fired. Drying shrinkage is high in most very plastic clays and tends to produce cracking and warping. It is low in sandy clays or clays of low plasticity and tends to produce a weak, porous body. Firing shrinkage depends on the volatile materials present, the types of crystalline phase changes that take place during firing, and the dehydration characteristics of the clay minerals.

The temperature range of vitrification, or glass formation, is a very important property in structural products. Vitrification is due to a process of gradual fusion in which some of the more easily melted constituents begin to produce an increasing amount of liquid which makes up the glassy bonding material in the final fired product. The degree of vitrification depends on the duration of firing as well as on the temperature attained.

Color is important in most structural clay products, particularly the maintenance of uniform color. The color of a product is influenced by the state of oxidation of iron, the state of division of the iron minerals, the firing temperature and degree of vitrification, the proportion of alumina, lime, and magnesia in the clay material, and the composition of the fire gases during the burning operation.

[H.H.Mu.]

**Structural uses.** All types of clay and shale are used in the structural products industry but, in general, the clays that are used are considered to be relatively low grade. Clays that are used for conduit tile, glazed tile, and sewer pipe are underclays and shales that contain large proportions of kaolinite and illite. The semirefractory plastic clays found directly beneath the coal seams make the best raw material for the above mentioned uses. Brick and drain tile can be made from a wide variety of clays depending on their location and the quality of product desired. Clays used for brick and drain tile must be plastic enough to be shaped. In addition, color and vitrification range are very important. For common brick, drain tile, and terra-cotta, shales and surface clays are usually suitable, but for high-quality face bricks, shales and underclays are used. Geographic location is a prime factor in the type of clay used for structural clay products because, in general, these products cannot be shipped great distances without excessive transportation costs. Many raw materials of questionable quality are utilized in certain areas because no better raw material is available nearby. See BRICK; TILE.

The cement industry uses large quantities of impure clays and shales. Clays are used to provide alumina and silica to the charge for the cement kiln. Generally, a suitable clay can be found in the area in which the cement is being manufactured. See CEMENT; POTTERY; REFRACTORY.

**Clay minerals** Fine-grained, hydrous, layer silicates that belong to the larger class of sheet silicates known as phyllosilicates. Their structure is composed of two basic units. (1) The tetrahedral sheet is composed of silicon-oxygen tetrahedra linked to neighboring tetrahedra by sharing three corners to form a hexagonal network. The fourth corner of each tetrahedron (the apical oxygen) points into and forms a part of the adjacent octahedral sheet. (2) The octahedral sheet is usually composed of aluminum or magnesium in sixfold coordination with oxygen from the tetrahedral sheet and with hydroxyl. Individual octahedra are linked laterally by sharing edges. Tetrahedral and octahedral sheets taken together form a layer, and individual layers may be joined to each other in a clay crystallite by interlayer cations, by van der Waals and electrostatic forces, or by hydrogen bonding.

Clay minerals are classified by their arrangement of tetrahedral and octahedral sheets. Thus, 1:1 clay minerals contain one tetrahedral and one octahedral sheet per clay layer; 2:1 clay minerals contain two tetrahedral sheets with an octahedral sheet between them; and 2:1:1 clay minerals contain an octahedral sheet that is adjacent to a 2:1 layer.

Ionic substitutions may occur in any of these sheets, thereby giving rise to a complex chemistry for many clay minerals. For example, cations small enough to enter into tetrahedral coordination with oxygen, cations such as  $\text{Fe}^{3+}$  and  $\text{Al}^{3+}$ , can substitute for  $\text{Si}^{4+}$  in the tetrahedral sheet. Cations such as  $\text{Mg}^{2+}$ ,  $\text{Fe}^{2+}$ ,  $\text{Fe}^{3+}$ ,  $\text{Li}^+$ ,  $\text{Ni}^{2+}$ ,  $\text{Cu}^{2+}$ , and other medium-sized cations can substitute for  $\text{Al}^{3+}$  in the octahedral sheet. Still larger cations such as  $\text{K}^+$ ,  $\text{Na}^+$ , and  $\text{Cs}^+$  can be located between layers and are called interlayer cations.  $\text{F}^-$  may substitute for  $(\text{OH})^-$  in some clay minerals. See COORDINATION CHEMISTRY.

Clay minerals and related phyllosilicates are classified further according to whether the octahedral sheet is dioctahedral or trioctahedral. In dioctahedral clays, two out of three cation positions in the octahedral sheet are filled, every third position being vacant. This type of octahedral sheet is sometimes known as the gibbsite sheet, with the ideal composition  $\text{Al}_2(\text{OH})_6$ . In trioctahedral clay minerals, all three octahedral positions are occupied, and this sheet is called a brucite sheet, composed ideally of  $\text{Mg}_3(\text{OH})_6$ .

Clay minerals can be classified further according to their polytype, that is, by the way in which adjacent 1:1, 2:1, or 2:1:1 layers are stacked on top of each other in a clay crystallite. For example, kaolinite shows at least four polytypes: *b*-axis ordered kaolinite, *b*-axis disordered kaolinite, nacrite, and dickite. Serpentine

shows many polytypes, the best-known of which is chrysotile, a mineral that is used to manufacture asbestos products. See KAOLINITE; SERPENTINE.

Finally, clays are named on the basis of chemical composition. For example, two types of swelling clay minerals are the 2:1, dioctahedral smectites termed beidellite and montmorillonite. The important difference between them is in the location of ionic substitutions. In beidellite, charge-building substitutions are located in the tetrahedral sheet; in montmorillonite, the majority of these substitutions are located in the octahedral sheet.

Because clay minerals are composed of only two types of structural units (octahedral and tetrahedral sheets), different types of clay minerals can articulate with each other, thereby giving rise to mixed-layer clays. The most common type of mixed-layer clay is mixed-layer illite/smectite, which is composed of an interstratification of various proportions of illite and smectite layers. The interstratification may be random or ordered. The ordered mixed-layer clays may be given separate names. For example, a dioctahedral mixed-layer clay containing equal proportions of illite and smectite layers that are regularly interstratified is termed potassium rectorite. A regularly interstratified trioctahedral mixed-layer clay mineral containing approximately equal proportions of chlorite and smectite layers is termed corrensite.

A primary requirement for the formation of clay minerals is the presence of water. Clay minerals form in many different environments, including the weathering environment, the sedimentary environment, and the diagenetic-hydrothermal environment. Clay minerals composed of the more soluble elements (for example, smectite and sepiolite) are formed in environments in which these ions can accumulate (for example, in a dry climate, in a poorly drained soil, in the ocean, or in saline lakes), whereas clay minerals composed of less soluble elements (for example, kaolinite and halloysite) form in more dilute water such as that found in environments that undergo severe leaching (for example, a hilltop in the wet tropics), where only sparingly soluble elements such as aluminum and silicon can remain. Illite and chlorite are known to form abundantly in the diagenetic-hydrothermal environment by reaction from smectite. See CHLORITE; CLAY; CLAY, COMMERCIAL; HALLOYSITE; ILLITE; LITHOSPHERE; SEPIOLITE; SILICATE MINERALS. [D.D.E.]

**Clear-air turbulence** Turbulence above the boundary layer but not associated with cumulus convection. The atmosphere is a fluid in turbulent motion. That turbulence of a scale sensed by humans in aircraft is primarily associated with the boundary layer within a kilometer or so of the Earth, where it is induced by the surface roughness, or in regions of deep convection such as cumulus cloud development or thunderstorms. However, aircraft occasionally encounter turbulence when flying at altitudes well above the surface and far from convective clouds. This phenomenon has been given the rather unsatisfactory name of clear-air turbulence (CAT).

What is primarily sensed in CAT by the human is vertical acceleration. This acceleration will depend on the person's location in the plane, the speed of flight relative to the air, and the response characteristics of the airframe. A plane with a wing that generates aerodynamic lift more efficiently or an air-frame with less weight per unit wing area will respond more strongly to a given gust magnitude.

CAT is encountered in the atmosphere with a probability depending on flight altitude, geographical location, season of the year, and meteorological conditions. Given this variability and the small scale of the phenomenon, it is difficult to establish reliable statistics on the frequency of its occurrence. Although CAT may be encountered in unexpected meteorological contexts, there are highly favored locations for its occurrence. One is in the vicinity of the jet stream, particularly in ridges and troughs where the wind direction is turning sharply. A second and even more common location of occurrence is in the lee of a mountain range when a strong air flow is distorted by being forced over



the range. In this situation a gravity lee wave is generated, which propagates to stratospheric heights. At various altitudes and distances from the mountain, this wave may break, and as many as a dozen or more CAT patches, light to severe, may be formed. Despite knowledge of these favored meteorological areas, it is not possible to forecast with confidence the precise location of a CAT patch. Warning forecasts for substantial portions of routes are typically given to pilots when CAT conditions prevail. See JET STREAM.

Aside from the practical implications of CAT for air transport, this phenomenon plays a role of undetermined magnitude in the dissipation of the kinetic energy of the atmosphere. See UPPER ATMOSPHERE DYNAMICS. [M.G.W.; L.J.E.]

**Cleavage (embryology)** The subdivision of eggs into cells called blastomeres. It occurs in eggs activated by fertilization or parthenogenetic agents. Cleavages follow one another so rapidly that there is little opportunity for daughter cells to grow before they divide again. Consequently the size of blastomeres diminishes progressively, although many times unequally, during cleavage. By contrast, the nucleus of each daughter cell enlarges following each cleavage with the result that the ratio of the volume of the nucleus to the volume of cytoplasm (the nucleoplasmic ratio) progressively increases. The cleavage period is said by some authorities to terminate when the nucleoplasmic ratios of various blastomeres attain values characteristic of adult tissues. Cells continue to divide thereafter, but each daughter cell then undergoes a period of growth prior to its division with the result that the nucleoplasmic ratio tends to remain approximately constant for each cell type following termination of cleavage. According to others, cleavage terminates with formation of the definitive blastula. Cleavage appears to be an essential step in development. Although some differentiation occurs in eggs of certain animals when cleavage is blocked experimentally, it is limited and infrequent. See BLASTULATION.

Cleavage does more than merely subdivide the substance of the egg quantitatively into smaller units, the blastomeres, which are then of such a size that they can readily undergo the subsequent events of blastulation, gastrulation, and interaction that are involved in formation of tissues and organs. Sooner or later, cleavage segregates different cytoplasmic areas into different blastomeres, thus subdividing the substance of the egg qualitatively. These qualitative cytoplasmic differences among blastomeres are then sufficient to account for the initial establishment of different lines of differentiation in the progeny of different blastomeres, even though the genetic content of all blastomeres is identical. See CELL LINEAGE. [R.L.W.]

**Cleft lip and cleft palate** Two of the most common congenital anomalies in humans, resulting from incomplete closure of the lip and palate during early embryonic life. During the first trimester of pregnancy, the face and mouth are formed by the fusion of several different parts. The lip is fully fused 6 or 7 weeks after fertilization. The palate, which forms the roof of the mouth and separates the oral cavity from the nasal cavity, is fully fused 10 weeks after fertilization. If fusion fails to occur or breaks down, an opening, or cleft, occurs in the lip, the palate, or both. Although cleft lip and cleft palate are associated with separate embryologic events, that is, are separated by a long time on the embryonic time scale, both often occur in an affected individual.

Clefts of the lip may occur on one side (unilateral), or both sides (bilateral). When they occur in the exact midline of the lip, they are often associated with severe anomalies of the brain. The cleft usually extends through the lip and nostril floor. The underlying dental arch is also typically involved.

Clefts are the only major abnormality in approximately half of newborns who have them. In the other half, they occur as a part of a pattern of multiple anomalies (a syndrome). It has been

determined that most clefts are associated with genetic factors. See HUMAN GENETICS.

Because of the combination of esthetic, structural, and functional requirements for total repair of clefts, that is, surgical, dental, ear, hearing, and speech, the care of children with clefts has usually been managed by comprehensive teams of specialists, including plastic surgeons, speech pathologists, audiologists, geneticists, otolaryngologists, oral surgeons, orthodontists, and pediatricians. See CONGENITAL ANOMALIES. [R.Sh.]

**Clevis pin** A fastener with a head at one end and a hole at the other used to join a clevis to a rod. A clevis is a yoke with a hole formed or attached at one end of a rod (see illustration).

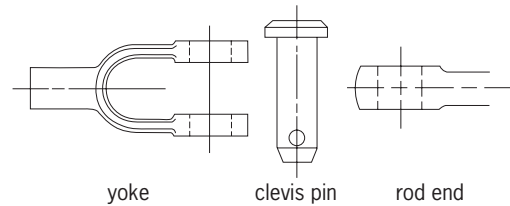

Clevis pin which joins yoke to rod end.

When an eye or hole of a second rod is aligned with the hole in the yoke, a clevis pin can be inserted to join the two. A cotter pin can then be inserted in the hole of the clevis pin to hold it in, yet the fastening is readily detachable. This joint is used for rods in tension where some flexibility is required. [P.H.B.]

**Client-server system** A computing system that is composed of two logical parts: a server, which provides services, and a client, which requests them. The two parts can run on separate machines on a network, allowing users to access powerful server resources from their personal computers. See LOCAL-AREA NETWORKS; WIDE-AREA NETWORKS.

Client-server systems are not limited to traditional computers. An example is an automated teller machine (ATM) network. Customers typically use ATMs as clients to interface to a server that manages all of the accounts for a bank. This server may in turn work with servers of other banks (such as when withdrawing money at a bank at which the user does not have an account). The ATMs provide a user interface and the servers provide services, such as checking on account balances and transferring money between accounts.

To provide access to servers not running on the same machine as the client, middleware is usually used. Middleware serves as the networking between the components of a client-server system; it must be run on both the client and the server. It provides everything required to get a request from a client to a server and to get the server's response back to the client. Middleware often facilitates communication between different types of computer systems. This communication provides cross-platform client-server computing and allows many types of clients to access the same data.

The server portion almost always holds the data, and the client is nearly always responsible for the user interface. The application logic, which determines how the data should be acted on, can be distributed between the client and the server. The part of a system with a disproportionately large amount of application logic is termed "fat"; a "thin" portion of a system is a part with less responsibility delegated to it. Fat server systems, such as groupware systems and web servers, delegate more responsibility for the application logic to the server, whereas fat client systems, such as most database systems, place more responsibility on the client. See HUMAN-COMPUTER INTERACTION.

The canonical client-server model assumes two participants in the system. This is called a two-tiered system; the application logic must be in the client or the server, or shared between the

two. It is also possible to have the application logic reside in a third layer separate from the user interface and the data, turning the system into a three-tier system. Complete separation is rare in actual systems; usually the bulk of the application logic is in the middle tier, but select portions of it are the responsibility of the client or the server.

The three-tier model is more flexible than the two-tier model because the separation of the application logic from the client and the server gives application logic processes a new level of autonomy. The processes become more robust since they can operate independently of the clients and servers. Furthermore, decoupling the application logic from the data allows data from multiple sources to be used in a single transaction without a breakdown in the client-server model. This advancement in client-server architecture is largely responsible for the notion of distributed data. See DISTRIBUTED SYSTEMS (COMPUTERS).

Standard web applications are the most common examples of three-tier systems. The first tier is the user interface, provided via interpretation of Hyper Text Markup Language (HTML) by a web browser. The embedded components being displayed by the browser reside in the middle tier, and provide the application logic pertinent to the system. The final tier is the data from a web server. Quite often this is a database-style system, but it could be a data-warehousing or groupware system. See WORLD WIDE WEB. [S.M.L.]

**Climate history** The long-term records of precipitation, temperature, wind, and all other aspects of the Earth's climate. The climate, like the Earth itself, has a history extending over several billion years. Climatic changes have occurred at time scales ranging from hundreds of millions of years to centuries and decades. Processes in the atmosphere, oceans, cryosphere (snow cover, sea ice, continental ice sheets), biosphere, and lithosphere (such as plate tectonics and volcanic activity) and certain extraterrestrial factors (such as the Sun) have caused these changes of climate.

The present climate can be described as an ice age climate, since large land surfaces are covered with ice sheets (for example, Antarctica and Greenland). The origins of the present ice age may be traced, at least in part, to the movement of the continental plates. With the gradual movement of Antarctica toward its present isolated polar position, ice sheets began to develop there about 30 million years ago. For the past several million years, the Antarctic ice sheet reached approximately its present size, and ice sheets appeared on the lands bordering the northern Atlantic Ocean. During the past million years of the current ice age, about 10 glacial-interglacial cycles have been documented. Changes in the Earth's orbital parameters, eccentricity, obliquity, and longitude of perihelion are thought to have initiated, or paced, these cycles through the associated small changes in the seasonal and latitudinal distribution of solar radiation. The most recent glacial period ended between about 15,000 and 6000 years ago with the rapid melting of the North American and European ice sheets and an associated rise in sea level, and the atmospheric concentration of carbon dioxide.

The climates of the distant geologic past were strongly influenced by the size and location of continents and by large changes in the composition of the atmosphere. For example, around 250 million years ago the continents were assembled into one supercontinent, Pangaea, producing significantly different climatic patterns than are seen today with widely distributed continents. In addition, based upon models of stellar evolution, it is hypothesized that the Sun's radiation has gradually increased by 10–20% over the past several billion years and, if so, this has contributed to a significant warming of the Earth. See CONTINENTS, EVOLUTION OF; GLACIAL EPOCH; PALEOClimatology.

Instrumental records of climatic variables such as temperature and precipitation exist for the past 100 years in many locations

and for as long as 200 years in a few locations. These records provide evidence of year-to-year and decade-to-decade variability, but they are completely inadequate for the study of century-to-century and longer-term variability. Even for the study of short-term climatic fluctuations, instrumental records are incomplete, because most observations are made from the continents (covering only 29% of the Earth's surface area). Aerological observations, which permit the study of atmospheric mass, momentum and energy budgets, and the statistical structure of the large-scale circulation, are available only since about the mid-1960s. Again there is a bias toward observations over the continents. It is only with the advent of satellites that global monitoring of the components of the Earth's radiation budget (clouds; planetary albedo, from which the net incoming solar radiation can be estimated; and the outgoing terrestrial radiation) became possible. See METEOROLOGICAL SATELLITES.

Evidence of climatic changes prior to instrumental records comes from a wide variety of sources. Tree rings, banded corals, and pollen and trace minerals retrieved from laminated lake sediments and ice sheets yield environmental records for past centuries and millennia. Advanced drilling techniques have made it possible to obtain long cores from ocean sediments that provide geologic records of climatic conditions going back hundreds of millions of years. See DENDROCHRONOLOGY; PALYNOLOGY.

Many extraterrestrial and terrestrial processes have been hypothesized to be possible causes of climatic fluctuations. These include solar irradiance, variations in orbital parameters, motions of the lithosphere, volcanic activity, internal variations of the climate system, and human activities. It is likely that all of the natural processes have played a role in past climatic changes. Also, the climatic response to some particular causal process may depend on the initial climatic state, which in turn depends upon previous climatic states because of the long time constants of lithosphere, oceans, and cryosphere. True equilibrium climates may not exist, and the climate system may be in a continual state of adjustment.

Because of the complexity of the real climate system, simplified numerical models of climate are being used to study particular processes and interactions. Some models treat only the global-average conditions, whereas others, particularly the dynamical atmosphere and ocean models, simulate detailed patterns of climate. These models will undoubtedly be of great importance in attempts to understand climatic processes and to assess the possible effects of human activities on climate. See CLIMATE MODELING; CLIMATIC PREDICTION; CLIMATOLOGY. [J.E.K.]

**Climate modeling** Construction of a mathematical model of the climate system of the Earth capable of simulating its behavior under present and altered conditions. The Earth's climate is continually changing over time scales ranging from millions of years to a few years. Since the climate is determined by the laws of classical physics, it should be possible in principle to construct such a model. The advent of a worldwide weather observing system capable of gathering data for validation and the development and widespread routine use of digital computers have made this undertaking possible.

The Earth's average temperature is determined mainly by the balance of radiant energy absorbed from sunlight and the radiant energy emitted by the Earth system. About 30% of the incoming radiation is reflected directly to space, and 72% of the remainder is absorbed at the surface. The radiation is absorbed unevenly over the Earth, which sets up thermal contrasts that in turn induce convective circulations in the atmosphere and oceans. Climate models attempt to calculate from mathematical algorithms the effects of these contrasts and the resulting motions in order to understand better and perhaps predict future climates in some probabilistic sense. See SOLAR RADIATION; TERRESTRIAL RADIATION.

Climate models differ in complexity, depending upon the

application. The simplest models are intended for describing only the surface thermal field at a fairly coarse resolution. These mainly thermodynamical formulations are successful at describing the seasonal cycle of the present climate, and have been used in some simulations of past climates, for example, for different continental arrangements millions of years ago. At the other end of the spectrum are the most complex climate models, which are extensions of the models in weather forecasts. These models aim at simulating seasonal and even monthly averages just shortly into the future, based upon conditions such as the temperatures of the tropical-sea surfaces. Intermediate to these extremes are models that attempt to model climate on a decadal basis, and these are used mainly in studies of the impact of hypothesized anthropogenically induced climate change. See WEATHER FORECASTING AND PREDICTION.

Attempts at modeling climate have demonstrated the extreme complexity and subtlety of the problem. This is due largely to the many feedbacks in the system. One of the simplest and yet most important feedbacks is that due to water vapor. If the Earth is perturbed by an increase in the solar radiation, for example, the first-order response of the system is to increase its temperature. But an increase in air temperature leads to more water vapor evaporating into the air; this in turn leads to increased absorption of space-bound long-wave radiation from the ground (greenhouse effect), which leads to an increased equilibrium temperature. Water vapor feedback is not the only amplifier in the system. Another important one is snowcover: a cooler planet leads to more snow and hence more solar radiation reflected to space, since snow is more reflecting of sunlight than soil or vegetation. Other, more subtle mechanisms that are not yet well understood include those involving clouds, oceans, and the biosphere.

While water vapor and snowcover feedback are fairly straightforward to model, the less understood feedbacks differ in their implementations from one climate model to another. These differences as well as the details of their different numerical formulations have led to slight differences in the sensitivity of the various models to such standard experimental perturbations as doubling carbon dioxide in the atmosphere. All models agree that the planetary average temperature should increase if carbon dioxide concentrations are doubled. However, the predicted response in planetary temperatures ranges from 4.5 to 9°F (2.5 to 5.0°C). Regional predictions of temperature or precipitation are not reliable enough for detailed response policy formulation. Many of the discrepancies are expected to decrease as model resolution increases (more grid points), since it is easier to include such complicated phenomena as clouds in finer-scale formulations and coupling with dynamic models of the ocean. Similarly, it is anticipated that some observational data (such as rainfall over the oceans) that are needed for validation of the models will soon be available from satellite sensors. See METEOROLOGICAL SATELLITES. [R.E.D.; E.S.S.]

**Climate modification** Alteration of the Earth's climate by human activities. This can occur on various scales. For example, conventional agriculture alters the microclimate in the lowest few meters of air, causing changes in the evapotranspiration and local heating characteristics of the air-surface interface. These changes lead to different degrees of air turbulence over the plants and to different moisture and temperature distributions in the local air. An example at a larger scale is that the innermost parts of cities are several degrees warmer than the surrounding countryside, and have slightly more rainfall. These changes are brought about by the differing surface features of urban land versus natural countryside and the ways that cities dispose of water (for example, storm sewers). The urban environment prevents evaporation cooling of surfaces in the city. The modified surface texture of cities (horizontal and vertical planes of buildings and streets versus gently rolling surfaces over natural forest or

grassland) leads to a more efficient trapping of solar heating of the near-surface air. The scales of buildings and other structures also lead to a different pattern of atmospheric boundary-layer turbulence, modifying the stirring efficiency of the atmosphere. See MICROMETEOROLOGY; URBAN CLIMATOLOGY.

At the next larger scale, human alteration of regional climates is caused by changes in the Earth's average reflectivity to sunlight. For example, the activities of building roads and highways and deforestation alter the amount of sunshine that is reflected to space as opposed to being absorbed by the surface and thereby heating the air through contact. Such contact heating leads to temperature increases and evaporation of liquid water at the surface. Vapor wakes from jet airplanes are known to block direct solar radiation near busy airports by up to 20%. Human activities also inject dust, smoke, and other aerosols into the air, causing sunlight to be scattered back to space. Dust particles screen out sunlight before it can enter the lower atmosphere and warm the near-surface air. See AIR POLLUTION; SMOG. [G.R.N.]

One of the most important and best understood features of the atmosphere is the process that keeps the Earth's surface much warmer than it would be with no atmosphere. This process involves several gases in the air that trap infrared radiation, or heat, emitted by the surface and reradiate it in all directions, including back to the surface. The heat-trapping gases include water vapor, carbon dioxide (CO<sub>2</sub>), methane (CH<sub>4</sub>), and nitrous oxide (N<sub>2</sub>O). These gases constitute only a small fraction of the atmosphere, but their heat-trapping properties raise the surface temperature of the Earth by a large amount, estimated to be more than 55°F (30°C). Human activities, however, are increasing the concentrations of CO<sub>2</sub>, CH<sub>4</sub>, and N<sub>2</sub>O in the atmosphere, and in addition industrially synthesized chemicals—chlorofluorocarbons (CFCs) and related compounds—are being released to the air, where they add to the trapping of infrared radiation. Carbon dioxide is released to the air mainly from fossil fuel use, which also contributes to the emissions of CH<sub>4</sub> and N<sub>2</sub>O. Agricultural and industrial processes add to the emissions of these gases. These concentration increases add to the already powerful heat-trapping capability of the atmosphere, raising the possibility that the surface will warm above its past temperatures, which have remained roughly constant, within about 3°F (1.7°C) for the past 10,000 years. Treaties are in existence that control internationally the production and use of many of the CFCs and related compounds, so their rate of growth has slowed, and for some a small decrease in atmospheric concentration has been observed. Large emissions of sulfur dioxide in industrial regions are thought to result in airborne sulfate particles that reflect sunlight and decrease the amount of heating in the Northern Hemisphere. See ATMOSPHERE; GREENHOUSE EFFECT. [J.Fi.]

**Climatology** The scientific study of climate. Climate is the expected mean and variability of the weather conditions for a particular location, season, and time of day. The climate is often described in terms of the mean values of meteorological variables such as temperature, precipitation, wind, humidity, and cloud cover. A complete description also includes the variability of these quantities, and their extreme values. The climate of a region often has regular seasonal and diurnal variations, with the climate for January being very different from that for July at most locations. Climate also exhibits significant year-to-year variability and longer-term changes on both a regional and global basis.

The goals of climatology are to provide a comprehensive description of the Earth's climate over the range of geographic scales, to understand its features in terms of fundamental physical principles, and to develop models of the Earth's climate for sensitivity studies and for the prediction of future changes that may result from natural and human causes. See CLIMATE HISTORY; CLIMATE MODELING; CLIMATE MODIFICATION; CLIMATIC PREDICTION; WEATHER. [D.L.Ha.]

**Clinical immunology** A branch of clinical pathology concerned with the role of the immune defense system in disease. The subject encompasses diseases where a malfunction of the immune system itself is the basic cause, together with diseases where some external agent is the initiating factor but an excessive response by the immune system produces the actual tissue damage. It also extends to the monitoring of the normal immune response in infectious diseases and to the use of immunological techniques in disease diagnosis. See ALLERGY; AUTOIMMUNITY; CLINICAL PATHOLOGY; HYPERSENSITIVITY; IMMUNOLOGICAL DEFICIENCY.

Many features of the immune system make it prone to shift from protecting the body to damaging it. This complex system not only must distinguish between the body's own cells and a foreign invader but must also recognize and eliminate the body's own cells if they are damaged or infected with a virus. The recognition receptors used to make this fine distinction between "self" and "not self" are not encoded in the genes. Rather, they are assembled following random rearrangement of information carried in small gene segments. During their development, immune system cells are subjected to a selective process, those bearing potentially useful receptors being preserved while those bearing dangerous, self-reactive receptors are eliminated. This process is closely balanced, and some potentially self-reactive cells often persist. See CELLULAR IMMUNOLOGY.

There are several approaches to suppressing excessive immune reactivity. Desensitization, or modifying the nature of the response by injecting small amounts of the foreign antigen, is sometimes used to treat allergic states. In contrast, there are few therapies for enhancing immune responses. Bone marrow transplantation is used to restore the immune system in some immunodeficiency diseases. Passive transfer of preformed antibody protects against some infections, and transfusion of immunoglobulin is used to treat immunoglobulin deficiencies. However, vaccination or immunization is one of the most effective of all medical procedures. See IMMUNOSUPPRESSION. [K.Sh.]

**Clinical microbiology** The adaptation of microbiological techniques to the study of the etiological agents of infectious disease. Clinical microbiologists determine the nature of infectious disease and test the ability of various antibiotics to inhibit or kill the isolated microorganisms. In addition to bacteriology, a contemporary clinical microbiologist is responsible for a wide range of microscopic and cultural studies in mycology, parasitology, and virology. The clinical microbiologist is often the most competent person available to determine the nature and extent of hospital-acquired infections, as well as public-health problems that affect both the hospital and the community. See ANIMAL VIRUS; HOSPITAL INFECTIONS; MEDICAL BACTERIOLOGY; MEDICAL MYCOLOGY; MEDICAL PARASITOLOGY; VIRUS.

**Bacteriology.** Historically, the diagnosis of bacterial disease has been the primary job of clinical microbiology laboratories. Many of the common ailments of humans are bacterial in nature, such as streptococcal sore throat, diphtheria, and pneumococcal pneumonia. The bacteriology laboratory accepts specimens of body fluids, such as sputum, urine, blood, and respiratory or genital secretions, and inoculates the specimens onto various solid and liquid growth media. Following incubation at body temperature, the microbiologist examines these agar plates and tubes and makes a determination as to the relative numbers of organisms growing from the specimen and their importance in the disease process. The microbiologist then identifies these alleged causes of disease and determines their pattern of antibiotic susceptibility to a few chosen agents.

Clinical microbiologists also microscopically examine these body fluids. They report on the presence of bacteria in body fluids and the cellular response to infection, such as the numbers or types of white blood cells observed in the specimen. [R.C.T.]

**Nonculture methods.** While direct microscopy and culture continue to be methodological mainstays in diagnostic microbi-

ology laboratories, nonculture methods are growing in the variety of applications and the sophistication of the technology. For example, polyclonal antibodies raised in animals such as mice, sheep, goats, and rabbits, and monoclonal antibodies produced by hybridization technology are used to detect bacteria, fungi, parasites, or virus-infected cells by using direct or indirect fluorescent techniques. Additional methods include latex agglutination tests to detect particulate antigens and enzyme immunoassays to detect soluble antigens. See IMMUNOASSAY; MONOCLONAL ANTIBODIES.

Probes for deoxyribonucleic acid (DNA) or messenger ribonucleic acid (mRNA) are available for various applications. Probes are used for direct detection of organisms in clinical material and for culture confirmation.

Further increases in analytical sensitivity have been achieved by nucleic acid amplification techniques. In polymerase chain reaction (PCR), double-stranded DNA is denatured; oligonucleotide probes bind to homologous strands of single-stranded DNA, and the enzyme polymerase extends the probes using deoxyribonucleotides in the milieu. In ligase chain reaction (LCR), the enzyme ligase fills the 3-nucleotide gap between two probes that attach to homologous, target, single-stranded DNA. In nucleic acid sequence-based amplification (NASBA), reverse transcriptase is used to make double-stranded complementary DNA (cDNA) and the target RNA is digested by ribonuclease H.

Analysis of lipopolysaccharides and proteins by sodium dodecyl sulfate-polyacrylamide gel electrophoresis (SDS-PAGE) and cellular fatty acid analysis by gas-liquid chromatography have given way to nucleic acid-based methods. Restriction enzymes, which cut DNA at a constant position within a specific recognition site usually composed of four to six base pairs, are used to cut chromosomal DNA; the resulting fragments are compared by pulse field gel electrophoresis (PFGE) or ribotyping. Electrophoresis of isolated plasmid DNA is another method for comparing organisms. DNA sequencing can also compare segments of the DNA of organisms from the same genus and species.

DNA chip or microarray technology is expected to have a greater effect on medicine than either DNA sequencing or PCR. Over 30,000 small cDNA clones of expressed fragments of individual genes are spotted onto a thumbnail-sized glass chip. Fluorescein-labeled genomic or cDNA from the sample being evaluated is passed over the chip to allow hybridization. A laser measures the fluorescent emissions and a computer analyzes the data. [C.A.Sp.]

**Clinical pathology** The branch of general pathology directed to the diagnosis and monitoring of diseases through the examination of blood, body fluids, secretions, and tissue biopsy specimens for chemical, morphological, microbiological, and immunological abnormalities. A variety of test procedures and microscopic examinations are performed in clinical pathology laboratories, located within hospitals, clinics, and stand-alone facilities, either privately owned or operated under the auspices of local, state, and federal public health agencies. Clinical laboratories function to confirm a clinical impression, establish or rule out a diagnosis, monitor therapy, and help establish a prognosis. Under guidelines established by the Clinical Laboratory Improvement Act of 1988, laboratory services are divided into several levels of activities. Many of the less complicated waived tests may be performed in physicians' office laboratories; more complex tests can be performed only within hospital laboratories or in laboratories where sophisticated state-of-the-art equipment is available.

The clinical pathology laboratory is commonly divided into four major subdisciplines or sections: chemical pathology, hematology, immunohematology (blood bank), and microbiology. Each includes several subsections of activity.

**Chemical pathology.** The chemical constituents of serum, urine, and other body fluids are analyzed in the chemical pathology section of the laboratory. Chemical tests are then clustered into functional groups to help diagnose diseases of the heart, kidney, liver, gastrointestinal tract, and other organ systems. Simple and high-volume tests are usually performed in the routine chemistry laboratory; more complicated, labor-intensive tests are carried out in a special chemistry section.

In the toxicology subsection of the chemical pathology laboratory, the blood, urine, and other body fluids are analyzed for the presence of drugs and substances of abuse. An equally important application of toxicology testing is to measure the blood levels of therapeutic drugs to assure that concentrations are adequate to treat the disease but not so high as to cause toxic side effects.

Radioimmunoassay allows trace quantities of substances to be measured. This procedure involves adding radioactive chemical markers to properly prepared specimens and detecting their binding to the substances being measured.

Because the use of radioactive substances requires licensure of personnel presents problems in disposal of biohazard waste, and requires expensive analytic instruments, most laboratories have substituted one or more enzyme-linked immunoassay (ELISA) techniques, in which specific enzymes instead of radioisotopes are linked to protein markers.

Electrophoresis is used to separate and identify proteins and lipoproteins.

Urinalysis is still carried out by manual procedures in many laboratories, relying on reagent-impregnated filter paper strips for the detection of protein, glucose, ketones, hemoglobin, bilirubin, and other substances, and microscopic observations for casts, crystals, red and white blood cells, and bacteria. However, automated instruments are used in higher-volume laboratories. Specific gravity is measured by a mass gravity meter, and urine chemistries by standard reflectance spectrophotometry; microscopic analysis is facilitated with an automated intelligent microscopy system. *See* ELECTROPHORESIS; IMMUNOASSAY; RADIOIMMUNOASSAY; SEROLOGY; TOXICOLOGY; URINALYSIS.

**Hematology.** The cornerstone of clinical laboratory work in hematology is the assessment of the cellular elements (red blood cells, white blood cells, and platelets) in blood samples. The blood cells may be enumerated, either by manual cell-counting techniques or by automated particle-sensing and -sizing instruments. Microscopic observation of stained peripheral blood smears is limited to assessing the morphology of atypical cells as they may appear in cases of dysplastic syndromes and overt leukemias. In complicated cases where the diagnosis of a hematologic disorder cannot be made by study of the peripheral blood smear, a bone marrow examination may be necessary. Special procedures are available by which specific markers on the surfaces of blood cells can be detected by using specific reactants, thereby providing a means for classifying leukemias and other hematologic disorders.

Flow cytometry is an extension of the particle-sensing principles used in the automated blood counting instruments. In the flow cytometer, cells are dispersed in fluid suspension and channeled through a narrow-bore tube; as each cell passes by a narrow laser light beam, an optical signal is translated into electronic pulses that are measured and analyzed in the computer processor. Signals may be scattered light that relates to the mass of each cell, or to the magnitude and type of fluorescence produced, which reflects the internal structures of cells depending upon the dyes used to stain the cells. Coagulation is an important subdiscipline of hematology involving the study of clotting and bleeding disorders. People especially prone to developing blood clots often receive anticoagulant drugs in order to "thin" the blood. The amount of anticoagulant given must be regulated, based on the results of a clotting test known as the prothrombin time. A test known as the partial thromboplastin time is also frequently performed in clinical laboratories to assist in the

assessment of patients who have one of various bleeding disorders. The evaluation of platelets in the peripheral blood is also an important step in evaluating patients with coagulopathies. *See* BLOOD.

**Immunoematology (blood bank).** The primary function of the blood bank is to ensure that blood taken from a donor will be safe to give to a recipient (that is, will not produce a transfusion reaction or transmit an infectious disease). Blood from a recipient must be subjected to compatibility testing against the blood of each donor to ensure that no atypical reaction occurs. Donor-recipient blood compatibility must be established for both the ABO blood group system and the Rh system. The recipient's plasma must also be subjected to an antibody screen to detect any atypical antibodies. If an atypical antibody is found, donor units must be carefully screened to select for transfusion only those with red cells lacking the antigens corresponding to the recipient's atypical antibody. Transfusion therapy has become a highly advanced discipline. It requires the separation of whole blood into a variety of components—packed red blood cells, platelet concentrates, fresh-frozen plasma, and cryoprecipitate.

Donor recruitment programs to maintain an adequate supply of blood are provided by many blood banks. Other services include outpatient therapeutic transfusions; phlebotomy of individuals who have too many red blood cells; and plasmapheresis, a procedure where plasma or platelets can be separated from the withdrawn blood and the formed elements (red cells and platelets) can be immediately retransfused, eliminating the chance for inducing anemia or deficiencies of other blood components. *See* BLOOD GROUPS.

**Microbiology.** The primary task of the clinical microbiologist is to identify as quickly as possible any microorganism in a specimen that represents the possible causative agent of an infectious disease. Presumptive identification of microbes can be made by microscopically examining direct mounts of an appropriate portion of the specimen or thin smears that have been stained with one of a variety of dyes. Rapid presumptive diagnoses can also be made by directly testing specimens with a variety of immunological reagents.

The practice of general bacteriology still follows traditional culture methods that were introduced by Robert Koch before the turn of the century. Specimens are applied to the surface of a variety of agar culture media for the purpose of recovering in pure culture any bacterial species that may be clinically significant. Gram stains may determine the cellular morphology and staining characteristics of the bacteria, and a variety of rapid, direct tests can be performed to provide an early identification.

Bacterial identifications and antibiotic susceptibility tests may be performed in a variety of packaged systems. These systems typically use lyophilized, dried chemical substrates or antibiotics at various concentrations that are contained within microwells that are stamped into plastic polystyrene cards or trays. These cards or trays are placed in a 95°F (35°C) incubator after the microwells have been inoculated with a suspension of a pure culture of the bacterium to be identified.

The availability of monoclonal antibodies and nucleic acid probes, in which a highly specific portion of antigen or a small segment of nucleic acid can be tagged with either a fluorescent or an enzyme-linked detector, revolutionized the ability to detect specific microbes in biologic specimens and rapidly confirm the results of a culture.

The laboratory identification of fungi and the diagnosis of fungal infections is similar to that described for the bacteria. Specimens are inoculated on special fungal media, the plates are incubated for periods as long as 4 weeks, and the growth of any mold or yeast is identified morphologically and biochemically. Nucleic acid probes are available to quickly confirm any fungus colony suspected of being one of the dangerous pathogens. The laboratory identification of parasites involves detecting microscopically the typical forms in body fluids and

secretions. Viruses can live only in viable cells and, for the most part, can survive briefly outside human or animal hosts. Therefore, culture techniques must use embryonated eggs, cell culture suspensions, thin cell sheets called monolayers, or laboratory animals. Species of viruses are identified by observing their ability to produce certain cytopathic effects in the cells where they are growing or to cause recognizable diseases in laboratory animals.

Clinical immunology is that discipline in which infectious diseases are diagnosed by detecting antibodies in serum and other body fluids. In practice, immunologic and serologic techniques are used to diagnose an infectious disease when the agent may be too difficult to recover in culture. See CLINICAL MICROBIOLOGY; CULTURE; MONOCLONAL ANTIBODIES. [E.W.Ko.]

**Clock** A device for indicating the passage of time. Most clocks contain a means for producing a regularly recurring action. This article describes only mechanical clocks. See ATOMIC CLOCK; QUARTZ CLOCK; WATCH.

The recurring action of a mechanical clock depends on the swing of a pendulum, or the oscillation of a balance wheel and balance spring or hairspring, or the vibration of a tuning fork, mechanisms capable of repeating their cyclic movements with great regularity. A counting mechanism, consisting of a gear train with calibrated dial and indicating hands, sometimes with a striking mechanism, marks the number of oscillations that have occurred, although the graduations are in seconds, minutes, and hours. A weight or spring ordinarily supplies power to operate the oscillating and the counting mechanisms. However, temperature changes, accelerations, automatic windings, or electricity may provide the power.

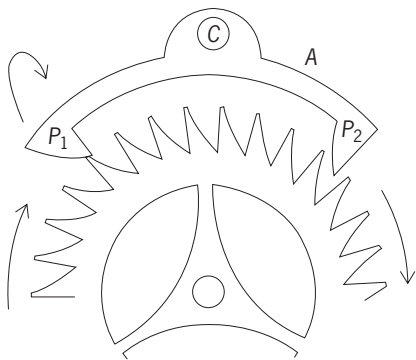

**Anchor escapement, common in domestic pendulum clocks. This escapement tends to compensate for changes in amplitude of the swing because of irregularly cut gears and varying lubrication.**

Usually an escapement transmits power from the counting mechanism to the oscillating mechanism. The accuracy of a clock depends primarily on the escapement. The illustration depicts an anchor or recoil escapement. Anchor *A* is connected loosely to the pendulum and swings about *C*. At some time after midswing, a tooth of the wheel escapes from pallet *P*<sub>1</sub> or *P*<sub>2</sub>, giving the pallet a push to maintain oscillation. The other pallet then checks another tooth, the curve of the pallet forcing the wheel slightly backward. The reaction helps to reverse the pendulum swing and to correct for circular error. [R.D'E.A.]

**Clock paradox** The phenomenon occurring in the special theory of relativity wherein two observers who start together with identical clocks and then undergo different motions can have different total elapsed time on their clocks when they rejoin later. This effect is a well-defined, mathematically consistent prediction of special relativity which has been verified by experiment but, historically, it has been referred to as a paradox

because of erroneous reasoning in the manner in which the effect is commonly analyzed. The clock-paradox phenomenon arises because there is no notion of absolute simultaneity in the theory of special relativity.

The clock-paradox effect is illustrated by the following hypothetical example. (In the context of the example the effect usually is referred to as the twin paradox.) Two identical twins are separated as young adults. One of the twins remains on Earth and, for the purposes of the discussion, is assumed to undergo inertial motion. (In fact, in the context of general relativity, the twin on Earth would be viewed as accelerating—only freely falling observers would be viewed as inertial—but in this example the corrections made to the effect by performing a proper, general-relativistic analysis would be negligible.) The other twin is placed in a rocket ship which accelerates very rapidly away from Earth until it is receding from Earth at nearly the speed of light. After coasting for a while at this speed, the rocket ship turns around and accelerates very rapidly back toward Earth, so that it soon is traveling at nearly the speed of light. The rocket ship then lands on Earth and the twins rejoin. The twin on Earth is old (and everything else on Earth has aged considerably), but the twin in the rocket ship (and everything else therein) has barely aged at all.

The clock-paradox phenomenon has been observed directly in an experiment performed in 1971 by J. C. Hafele and R. E. Keating, who observed differences in elapsed times of atomically stabilized clocks flown in airplanes as compared with ones on the ground. In this experiment the special relativistic effect is so small, since the velocities achieved by airplanes are much smaller than *c*, that the tiny corrections due to general relativity cannot be neglected, so the experiment actually must be viewed as verifying the analogous clock effect in general relativity rather than purely the clock effect of special relativity. See RELATIVITY; SPACE-TIME. [R.M.Wal.]

**Closed-caption television** A service, primarily for deaf people, that allows individual viewers to display the dialog of a television program in a readable form on the television screen. In the United Kingdom the service is called subtitled. Closed-caption television was introduced in the United States in 1980. Legislative and regulatory actions are spurring the worldwide introduction and growth of captioned television service.

Captions for television programs can be prepared in three ways. (1) Off-line captioning is used when the television program has been prerecorded. (2) Live television broadcasts that are scripted in advance, such as presidential State of the Union speeches, employ a live display captioning method. Here the script is stored in a computer in advance of the broadcast. During the broadcast the script appears as roll-up captions at the bottom of the screen. (3) In live broadcasts, where a script is not available, real-time captions have to be generated during the broadcast. Highly skilled court reporters using a stenograph keyboard and an associated computer create the captions.

Prior to being broadcast, the captions are digitally encoded and inserted into the vertical blanking interval (VBI) of the television picture.

The world's terrestrial television systems are in the process of converting from analog to digital broadcasting. The International Telecommunications Union (ITU) recommendation on a digital video, audio, and ancillary data multiplex model has been adopted worldwide. Captions have been classified as an ancillary service and will be multiplexed with other ancillary services such as text services. See TELEVISION. [J.E.D.B.]

**Closed-circuit television** Television transmitted to a particular audience at specific locations via coaxial cables, telephone wires, fiber-optic strands, microwave radio systems, or

communications satellites, as compared to open-circuit (broadcast) television intended for the general public. See COAXIAL CABLE; COMMUNICATIONS CABLE; COMMUNICATIONS SATELLITE; MICROWAVE; OPTICAL COMMUNICATIONS; TELEPHONE SERVICE.

Closed-circuit television applications include information display, remote monitoring, instruction, cable television programming, and teleconferences and special events. See CABLE TELEVISION SYSTEM; TELECONFERENCING.

Many types of closed-circuit television systems produce pictures intended for distant viewing. These images may include those taken from a space probe passing close to a distant planet, or pictures of blast furnaces or other industrial operations that could be hazardous to human observers. The low cost of modern video equipment makes practical the use of small cameras to observe sleeping children at home and to enjoy video images of people far away while chatting with them on the Internet.

Many universities and school systems employ television for teaching. Classrooms may be equipped with closed-circuit television cameras, recorders, and receivers. Lesson material is often presented via video tape recordings, CD-ROMs, or DVD recordings. In other cases, classroom receivers are supplied with signals from specially reserved broadcast channels, cable television channels, or satellite channels. Audio circuits installed at viewing locations sometimes allow two-way conversations between lecturer and students. See COMPACT DISK; MAGNETIC RECORDING.

The standardized television broadcast system used at present in the United States, Canada, Mexico, Japan, and some other countries was devised in the 1950s by the National Television Systems Committee (NTSC). Closed-circuit television systems are not required to use NTSC signals, but many do, mainly for economic reasons. If the transmission path to the viewer is of low quality, however, the signal can be modified to meet more closely the characteristics of the transmission system. For example, channel bandwidth can be reduced without loss of image resolution if the user accepts a rate lower than the normal 30 frames per second in the representation of image motion. This is called slow-scan closed-circuit television. Still-frame video images sometimes suffice.

Other applications require high image resolution, great sensitivity to light, the ability to respond to infrared or ultraviolet light, or very rugged system components. Closed-circuit television requirements for high-resolution display can be satisfied by increasing the number of image scanning lines and the overall video channel bandwidth. Industrial standards exist for high-resolution closed-circuit systems.

The digital revolution has affected the design of all kinds of television equipment. Video signals can be converted into digital form and processed by specialized computers, called digital signal processors. In closed-circuit television applications, digital processing can make transmission via the Internet practical and can also provide image enhancement. The advanced television systems now entering service make use of the advantages of digital signal processing to provide high-quality images to the home, to the classroom, and to industrial locations. See DATA COMPRESSION; IMAGE PROCESSING; TELEVISION. [FM.Re.]

**Clostridium** A genus of bacteria comprising large anaerobic spore-forming rods that usually stain gram-positive. Most species are anaerobes, but a few will grow minimally in air at atmospheric pressure.

The clostridia are widely distributed in nature, and are present in the soil and in the intestinal tracts of humans and animals. They usually live a saprophytic existence, and play a major role in the degradation of organic material in the soil and other nature environments. A number of clostridia release potent exotoxins and are pathogenic for humans and animals. Among the human pathogens are the causative agents of botulism (*Clostridium botulinum*), tetanus (*C. tetani*), gas gangrene (*C. perfringens*), and

an antibiotic-associated enterocolitis (*C. difficile*). See ANAEROBIC INFECTION; BOTULISM; TETANUS; TOXIN.

Clostridial cells are straight or slightly curved rods, 0.3–1.6 micrometers wide and 1–14  $\mu\text{m}$  long. They may occur singly, in pairs, in short or long chains, or in helical coils. The length of the cells of the individual species varies according to the stage of growth and growth conditions. Most clostridia are motile with a uniform arrangement of flagella. See CILIA AND FLAGELLA.

The endospores produced by clostridia are dormant structures capable of surviving for prolonged periods of time, and have the ability to reestablish vegetative growth when appropriate environmental conditions are provided. The spores of clostridia are oval or spherical and are wider than the vegetative bacterial cell. Among the distinctive forms are spindle-shaped organisms, club-shaped forms, and tennis racket-shaped structures:

Clostridia are obligate anaerobes: they are unable to use molecular oxygen as a final electron acceptor and generate their energy solely by fermentation. Clostridia exhibit varying degrees of intolerance of oxygen. Some species are sensitive to oxygen concentrations as low as 0.5%, but most species can tolerate concentrations of 3–5%. The sensitivity of clostridia to oxygen restricts their habitat to anaerobic environments; habitats that contain large amounts of organic matter provide optimal conditions for their growth and survival.

A primary property of all species of *Clostridium* is their inability to carry out a dissimilatory reduction of sulfate. Most species are chemoorganotrophic. The substrate spectrum for the genus as a whole is very broad and includes a wide range of naturally occurring compounds. Extracellular enzymes are secreted by many species, enabling the organism to utilize a wide variety of complex natural substrates in the environment. [H.P.W.]

**Cloud** Suspensions of minute droplets or ice crystals produced by the condensation of water vapor (the ordinary atmospheric cloud). Other clouds, less commonly seen, are composed of smokes or dusts. See AIR POLLUTION; DUST STORM.

If water vapor is cooled sufficiently, it becomes saturated, that is, in equilibrium with a plane surface of liquid water (or ice) at the same temperature. Further cooling in the presence of such a surface causes condensation upon it. In the atmosphere, even in the apparent absence of any surfaces, there are invisible motes upon which the condensation proceeds at barely appreciable cooling beyond the state of saturation. Consequently, when atmospheric water vapor is chilled sufficiently, such motes, or condensation nuclei, swell into minute water droplets and form a visible cloud.

The World Meteorological Organization (WMO) uses a classification which divides clouds into low-level (base below about 1.2 mi or 2 km), middle-level (about 1.2–4 mi or 2–7 km), and high-level (4–8 mi or 7–14 km) forms within the middle latitudes. The names of the three basic forms of clouds are used in combination to define 10 main characteristic forms, or “genera.”

1. Cirrus are high white clouds with a silken or fibrous appearance.
2. Cumulus are detached dense clouds which rise in domes or towers from a level low base.
3. Stratus are extensive layers or flat patches of low clouds without detail.
4. Cirrostratus is cirrus so abundant as to fuse into a layer.
5. Cirrocumulus is formed of high clouds broken into a delicate wavy or dappled pattern.
6. Stratocumulus is a low-level layer cloud having a dappled, lumpy, or wavy structure.
7. Altostratus is similar to stratocumulus but lies at intermediate levels.
8. Altostratus is a thick, extensive, layer cloud at intermediate levels.

9. Nimbostratus is a dark, widespread cloud with a low base from which prolonge drain or snow falls.
10. Cumulonimbus is a large cumulus which produces a rain or snow shower.

See CLOUD PHYSICS.

[F.H.Lu.]

**Cloud physics** The study of the physical and dynamical processes governing the structure and development of clouds and the release from them of snow, rain, and hail (collectively known as precipitation).

The factors of prime importance are the motion of the air, its water-vapor content, and the numbers and properties of the particles in the air which act as centers of condensation and freezing. Because of the complexity of atmospheric motions and the enormous variability in vapor and particle content of the air, it seems impossible to construct a detailed, general theory of the manner in which clouds and precipitation develop. However, calculations based on the present conception of laws governing the growth and aggregation of cloud particles and on simple models of air motion provide reasonable explanations for the observed formation of precipitation in different kinds of clouds.

Clouds are formed by the lifting of damp air which cools by expansion under continuously falling pressure. The relative humidity increases until the air approaches saturation. Then condensation occurs on some of the wide variety of aerosol particles present; these exist in concentrations ranging from less than 2000 particles/in.<sup>3</sup> (100/cm<sup>3</sup>) in clean, maritime air to perhaps 10<sup>7</sup>/in.<sup>3</sup> (10<sup>6</sup>/cm<sup>3</sup>) in the highly polluted air of an industrial city. A portion of these particles are hygroscopic and promote condensation at relative humidities below 100%; but for continued condensation leading to the formation of cloud droplets, the air must be slightly supersaturated. Among the highly efficient condensation nuclei are the salt particles produced by the evaporation of sea spray, but it appears that particles produced by human-made fires and by natural combustion (for example, forest fires) also make a major contribution. Condensation onto the nuclei continues as rapidly as the water vapor is made available by cooling of the air and gives rise to droplets of the order of 0.0004 in. (0.01 mm) in diameter. These droplets, usually present in concentrations of several thousand per cubic inch, constitute a non-precipitating water cloud.

Cloud droplets are seldom of uniform size. Droplets arise on nuclei of various sizes and grow under slightly different conditions of temperature and supersaturation in different parts of the cloud. A droplet appreciably larger than average will fall faster than the smaller ones, and so will collide and fuse (coalesce) with some of those which it overtakes.

The second method of releasing precipitation can operate only if the cloud top reaches elevations where temperatures are below 32°F (0°C) and the droplets in the upper cloud regions become supercooled. At temperatures below -40°F (-40°C) the droplets freeze automatically or spontaneously; at higher temperatures they can freeze only if they are infected with special, minute particles called ice nuclei. As the temperature falls below 32°F (0°C), more and more ice nuclei become active, and ice crystals appear in increasing numbers among the supercooled droplets. Such a mixture of supercooled droplets and ice crystals is unstable. After several minutes the growing crystals will acquire definite falling speeds, and several of them may become joined together to form a snowflake. In falling into the warmer regions of the cloud, however, the snowflake may melt and reach the ground as a raindrop.

The deep, extensive, multilayer-cloud systems, from which precipitation of a usually widespread, persistent character falls, are generally formed in cyclonic depressions (lows) and near fronts. Although the structure of these great raincloud systems, which are being explored by aircraft and radar, is not yet well understood, radar signals from these clouds usually take a char-

acteristic form which has been clearly identified with the melting of snowflakes.

Precipitation from shower clouds and thunderstorms, whether in the form of raindrops, pellets of soft hail, or true hailstones, is generally of greater intensity and shorter duration than that from layer clouds and is usually composed of larger particles. The clouds themselves are characterized by their large vertical depth, strong vertical air currents, and high concentrations of liquid water, all these factors favoring the rapid growth of precipitation elements by accretion.

The development of precipitation in convective clouds is accompanied by electrical effects culminating in lightning. The mechanism by which the electric charge dissipated in lightning flashes is generated and separated within the thunderstorm has been debated for more than 200 years, but there is still no universally accepted theory. However, the majority opinion holds that lightning is closely associated with the appearance of the ice phase, and the most promising theory suggests that the charge is produced by the rebound of ice crystals or a small fraction of the cloud droplets that collide with the falling hail pellets. See LIGHTNING.

The various stages of the precipitation mechanisms raise a number of interesting and fundamental problems in classical physics. Worthy of mention are the supercooling and freezing of water; the nature, origin, and mode of action of the ice nuclei; and the mechanism of ice-crystal growth which produces the various snow crystal forms.

The maximum degree to which a sample of water may be supercooled depends on its purity, volume, and rate of cooling. The freezing temperatures of waterdrops containing foreign particles vary linearly as the logarithm of the droplet volumes for a constant rate of cooling. This relationship, which has been established for drops varying between 10 micrometers and 1 centimeter in diameter, characterizes the heterogeneous nucleation of waterdrops and is probably a consequence of the fact that the ice-nucleating ability of atmospheric aerosol increases logarithmically with decreasing temperature.

Measurements made with large cloud chambers on aircraft indicate that the most efficient nuclei, active at temperatures above 14°F (-10°C), are present in concentrations of only about 10 in a cubic meter of air, but as the temperature is lowered, the numbers of ice crystals increase logarithmically to reach concentrations of about 1 per liter at -4°F (-20°C) and 100 per liter at -22°F (-30°C). Since these measured concentrations of nuclei are less than one-hundredth of the numbers that apparently are consumed in the production of snow, it seems that there must exist processes by which the original number of ice crystals are rapidly multiplied. Laboratory experiments suggest the fragmentation of the delicate snow crystals and the ejection of ice splinters from freezing droplets as probable mechanisms.

The most likely source of atmospheric ice nuclei is provided by the soil and mineral-dust particles carried aloft by the wind. Laboratory tests have shown that, although most common minerals are relatively inactive, a number of silicate minerals of the clay family produce ice crystals in a supercooled cloud at temperatures above -4°F (-18°C). A major constituent of some clays, kaolinite, which is active below 16°F (-9°C), is probably the main source of highly efficient nuclei.

The fact that there may often be a deficiency of efficient ice nuclei in the atmosphere has led to a search for artificial nuclei which might be introduced into supercooled clouds in large numbers. In general, the most effective ice-nucleating substances, both natural and artificial, are hexagonal crystals in which spacings between adjacent rows of atoms differ from those of ice by less than 16%. The detailed surface structure of the nucleus, which is determined only in part by the crystal geometry, is of even greater importance.

Collection of snow crystals from clouds at different temperatures has revealed their great variety of shape and form. This multiple change of habit over such a small temperature range



is remarkable and is thought to be associated with the fact that water molecules apparently migrate between neighboring faces on an ice crystal in a manner which is very sensitive to the temperature. The temperature rather than the supersaturation of the environment is primarily responsible for determining the basic shape of the crystal, though the supersaturation governs the growth rates of the crystals, the ratio of their linear dimensions, and the development of dendritic forms.

The presence of either ice crystals or some comparatively large water droplets (to initiate the coalescence mechanism) appears essential to the natural release of precipitation. Rainmaking experiments are conducted on the assumption that some clouds precipitate inefficiently, or not at all, because they are deficient in natural nuclei; and that this deficiency can be remedied by "seeding" the clouds artificially with dry ice or silver iodide to produce ice crystals, or by introducing water droplets or large hygroscopic nuclei. See PRECIPITATION (METEOROLOGY); WEATHER MODIFICATION. [B.J.M.]

**Clove** The unopened flower bud of a small, conical, symmetrical, evergreen tree, *Eugenia caryophyllata*, of the myrtle family (Myrtaceae). The cloves are picked by hand and dried. Cloves, one of the most important and useful spices, are strongly aromatic and have a pungent flavor. They are used as a culinary spice for flavoring pickles, ketchup, and sauces, in medicine, and for perfuming the breath and air. The essential oil distilled from cloves has even more uses. The chief clove-producing countries are Tanzania, Indonesia, Mauritius, and the West Indies. See MYRTALES. [P.D.St./E.L.C.]

**Clover** A common name used loosely to designate the true clovers, sweet clovers, and other members of the plant family Leguminosa.

**True clovers.** The true clovers are herbaceous annual or perennial plants of the genus *Trifolium*, order Rosales. There are approximately 250 species in the world. Collectively they represent the most important genus of forage legumes in agriculture. Most clovers are highly palatable and nutritious to livestock. The name clover is often applied to members of legume genera other than *Trifolium*. See ROSALES.

Clovers are used for hay, pasture, silage, and soil improvement. Certain kinds may be used for all purposes whereas others, because of their low growth, are best suited for grazing. All kinds, when well grown in thick stands, are good for soil improvement. Thoroughly inoculated plants add 50–200 lb of nitrogen per acre (62–252 kg per hectare) when plowed under for soil improvement, the amount added depending on growth, thickness of stand, and length of growing season. See NITROGEN CYCLE.

All the clover species of agricultural importance in the United States are introduced (exotic) plants. Some of the species most widely used are: red clover (*T. pratense*), alsike clover (*T. hybridum*), white clover (*T. repens*), crimson clover (*T. incarnatum*), subclover (*T. subterraneum*), strawberry clover (*T. fragiferum*), persian clover (*T. resupinatum*), and large hop clover (*T. campestre*, or *procumbens*). Other clovers of regional importance, mostly adapted to specific environmental conditions, are rose clover (*T. hirtum*), berseem clover (*T. alexandrinum*), ball clover (*T. nigrescens*), lappa clover (*T. lappaceum*), big-flower clover (*T. michelianum*), and arrowleaf clover (*T. vesiculosum*).

Red clover is composed of two forms, medium and mammoth, producing two and one hay cuts, respectively. The large purplish-red flower heads are round. An upright-growing perennial, red clover generally persists for 2 years in the northern United States, but behaves as a winter annual in the South. There are several varieties and strains of red clover such as Kenland, Pennscoot, Lakeland, Dollard, and Chesapeake. These produce higher yields of forage and are more persistent than common red clover.

Alsike clover is an upright-growing species that behaves like a biennial. The growth pattern, seeding methods, mixtures, and

uses are similar to those of red clover. The flower heads are much like those of white clover in shape and size, but are slightly more pinkish. Alsike clover is more tolerant of wet, poorly drained soils than red clover and occurs widely in mountain meadows of the West.

White clover, an inhabitant of lawns and closely grazed pastures, is the most important pasture legume in the humid states. The flowers are generally white, but sometimes they are tinged with pink. There are three main types, large, intermediate, and small, with all gradations between. All types are nutritious and are relished by all classes of livestock and poultry. White clover is mainly grown with low-growing grasses, not being tolerant of the tall-growing kinds. For best growth of the clover, grass-clover mixtures should be grazed or cut frequently.

Crimson clover is used principally as a winter annual for pasture and as a soil-improving crop from the latitude of the Ohio River southward, and along the West Coast. Crimson clover is seeded alone, with small grains and grasses, or on grass turf. During the winter it may be grazed, although if it is too heavily grazed, regrowth is slow. The greatest return for soil improvement is obtained when the largest growth is plowed under. There are several varieties of crimson clover, including Dixie, Auburn, Autauga, Chief, Talladega, and many local strains. When used with Bermuda or other perennial summer-growing grasses, the fall growth of the grass must be closely grazed or clipped.

Subclover, a winter annual extensively used for grazing in the coastal sections of the Western states, is the basic pasture crop of the sheep and cattle industry of Australia. The Australian varieties Mount Barker, Tallarook, and Nangeela have proved to be best adapted to most conditions in the United States. Subclover appears to have considerable promise as a pasture legume under many conditions in the southern United States, but better adapted varieties are needed.

**Sweet clover.** Sweet clover is the common name for all but one species of legumes of the genus *Melilotus*, order Rosales. The exception is sour clover (*M. indica*). There are approximately 20 species of sweet clover. Some of the biennial species have an annual form. Sweet clovers are native to the Mediterranean region and adjacent countries, but several are widely scattered throughout the world, generally by chance introduction.

Sweet clover is used as a field crop in regions of the United States and Canada where the rainfall is 17 in. (42 cm) or more during the growing season, where the soil is neutral, or where limestone and other needed minerals are applied. It is grown either alone or in rotations with small grains and corn, and is used for grazing, soil improvement, and hay. Except for those of certain improved varieties, the plants are somewhat bitter because of the presence of coumarin. [E.A.H.]

**Clupeiformes** An order of teleost fishes of the subclass Actinopterygii that includes the herrings, sardines, anchovies, and their allies. The Recent clupeiforms are classified in 2 suborders, 3 (by some authorities as many as 6) families, 71 genera, and about 300 species.

The Clupeiformes are generalized teleosts. They are mostly silvery and compressed. A distinctive feature is the extension of the cephalic canal system onto the operculum; the lateral line is undeveloped on the trunk except in *Denticeps*. They lack fin spines, adipose fin, and gular plate. The middle of the belly often bears one or a series of strong scutes. The pelvic fin is abdominal in position, free from the shoulder girdle, and the pectoral fin is placed low on the side. The cycloid scales are usually thin and loosely attached. The upper jaw is bordered by premaxillae and maxillae, but the dentition is usually feeble.

Clupeiform fishes have left a rich fossil record, especially from the Upper Cretaceous to the early Tertiary, but appeared first in the Upper Jurassic. Some herrings and a few anchovies live in lowland rivers and lakes, and others such as the shad and alewife enter rivers to reproduce; but the majority of clupeiforms occur in bays or shore waters of tropical, temperate, or even northern

seas, where they commonly make up enormous schools. None inhabits deep water. Most feed on plankton or other minute organisms. Thus they are efficient converters from the base of the food chain to fish flesh.

Some of the great fisheries of the world are based on the conversion of plankton by clupeiform fishes: the tremendous anchovy fishery off western South America; the California fisheries for anchovy and (until depleted) Pacific sardine; the menhaden fisheries of the western Atlantic; and the herring and sardine fisheries of northern seas. The catch is processed variously into oil, fertilizer, or fish meal or is prepared directly for human consumption. See ACTINOPTERYGII. [R.M.B.]

**Clutch** A machine element for the connection and disconnection of shafts in equipment drives. If both shafts to be connected can be stopped or made to move relatively slowly, a positive-type mechanical clutch may be used. If an initially stationary shaft is to be driven by a moving shaft, friction surfaces must be interposed to absorb the relative slippage until the speeds are the same. Likewise, friction slippage allows one shaft to stop after the clutch is released.

When positive connection of one shaft with another in a given position is needed, a positive clutch is used. This clutch is the simplest of all shaft connectors, sliding on a keyed shaft section or a splined portion and operating with a shift lever on a collar element. Because it does not slip, no heat is generated in this clutch. Interference of the interlocking portions prevents engagement at high speeds; at low speeds, if connection occurs, shock loads are transmitted to the shafting. Positive clutches may be of the square jaw type (Fig. 1) with two or more jaws of square section meshing together in the opposing clutches, or the spiral jaw type, a modification of the square-jaw clutch that permits more convenient engagement and provides a more gradual movement of the mating faces toward each other.

When the axial pressure of the clutch faces on each other serves to transmit torque instead of the mating shape of their parts, the clutch operates by friction. This friction clutch is usually placed between an engine and a load to be driven; when the friction surfaces of the clutch are engaged, the speed of the driven load gradually approaches that of the engine until the two speeds are the same. A friction clutch is necessary for connecting a rotating shaft of a machine to a stationary shaft so that it may be brought up to speed without shock and transmit torque for the development of useful work. The three common designs for friction clutches, combining axial and radial types, are cone clutches (Fig. 2), disk clutches, and rim clutches. In a cone clutch, the surfaces are sections of a pair of cones. The disk clutch consists essentially of one or more friction disks connected to a driven shaft by splines. A rim clutch has surface elements that apply pressure to the rim externally or internally.

In the overrunning type of clutch, the driven shaft can run faster than the driving shaft. This action permits freewheeling as the driving shaft slows down or another source of power is ap-

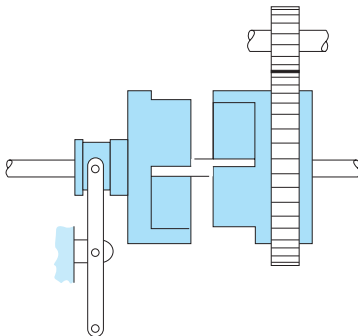

Fig. 1. Square-jaw-type positive clutch.

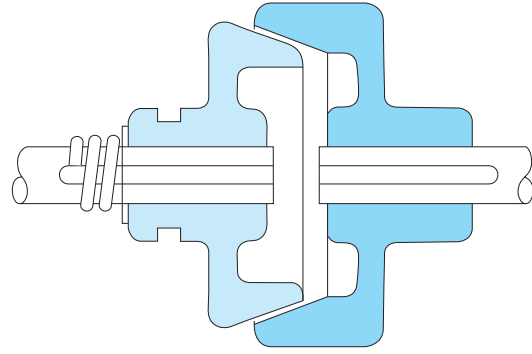

Fig. 2. Cone-type friction clutch.

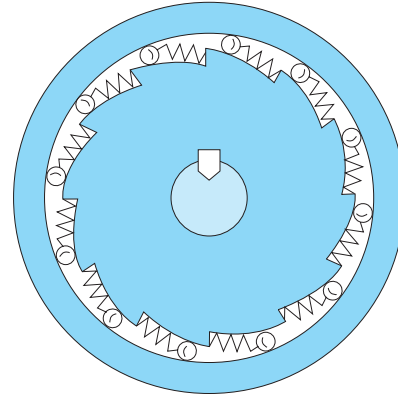

Fig. 3. Overrunning clutch with spring-constrained rollers or balls.

plied. Effectively this is a friction pawl-and-ratchet drive, wherein balls or rollers become wedged between the sleeve and recessed pockets machined in the hub (Fig. 3). The clutch does not slip when the second shaft is driven, and is released automatically when the second shaft runs faster than the driver. The centrifugal clutch employs centrifugal force from the speed of rotation. This type of clutch is not normally used because it becomes unwieldy and unsafe with increasing size. Clutch action is also produced by hydraulic couplings, with a smoothness not possible with a mechanical clutch. Automatic transmissions in automobiles represent a fundamental use of hydraulic clutches. See FLUID; COUPLING; TORQUE CONVERTER.

Magnetic coupling between conductors provides a basis for several types of clutches. The magnetic attraction between a current-carrying coil and a ferromagnetic clutch plate serves to actuate a disk-type clutch. Slippage in such a clutch produces heat that must be dissipated and wear that reduces the life of the clutch plate. Thus the electromagnetically controlled disk clutch is used to engage a load to its driving source. See BRAKE; COUPLING. [J.E.G.; J.J.R.]

**Cnidospore** A subphylum of spore-producing Protozoa containing the two classes Myxosporideia and Microsporideia. Cnidospore are parasites of cells and tissues of invertebrates, fishes, a few amphibians, and turtles. See MICROSPORIDEA; MYXOSPORIDEA.

A distinctive structure of this subphylum is the spore, which contains one or more protoplasmic masses called sporoplasms. The spore also contains one or more filaments which lie coiled within the spore proper or within one or more polar capsules.

When the spore is ingested by a new host, the filaments are extruded and at the same time the sporoplasm is released. The sporoplasm, now called an amebula, reaches the specific site of infection directly through the intestinal wall or by way of the bloodstream. The amebula becomes a stage in the life cycle

which feeds and grows at the expense of the host. Asexual reproduction by repeated binary fission, multiple fission, internal and external budding, or plasmotomy results in cells which develop into sporonts and eventually into sporoblasts, producing one or more spores. See PROTOZOA; SPOROZOA. [R.F.N.]

**Coal** A brown to black combustible rock that originated by accumulation and subsequent physical and chemical alteration of plant material over long periods of time, and that on a moisture-free basis contains no more than 50% mineral matter. The plant debris accumulated in various wet environments, commonly called peat swamps, where dead plants were largely protected from decay by a high water table and oxygen-deficient water. The accumulating spongy, water-saturated, plant-derived organic material known as peat is the precursor of coal. Over time, many changes of the original vegetable matter are brought about by bacteria, fungi, and chemical agents. The process progressively transforms peat into lignite or brown coal, subbituminous coal, bituminous coal, and anthracite. This progression is known as the coalification series. The pressure exerted by the weight of the overlying sediment and the heat that increases with depth, as well as the length of exposure to them, determine the degree of coalification reached. See FOSSIL FUEL; KEROGEN; LIGNITE; PEAT.

Minable coal seams occur in many different shapes and compositions. Some coal seams can be traced over tens, even hundreds, of miles in relatively uniform thickness and structure. The extensively mined Herrin coal bed of the Illinois Basin and the Pittsburgh coal bed of the northern Appalachian Basin are examples. They are 6–8 ft (2–2.5 m) thick over thousands of square miles. These coals originated in peat swamps that developed on vast coastal plains during the Pennsylvanian Period. The German brown coal deposits near Cologne are characterized by very thick coal deposits (300 ft or 100 m). However, their lateral extent is much more limited than are the two examples from the United States. These peat deposits formed in a gradually subsiding structural graben bounded by major faults. Land lay to the south and the sea to the north. Only a relatively small portion of the subsiding graben block provided optimal conditions for peat accumulation over a long period of time. Thus each coal

bed has its own depositional history that determined many of its characteristics. See CARBONIFEROUS; CRETACEOUS; PENNSYLVANIAN; TERTIARY.

Coal seams are commonly composed of a number of benches of alternating coal and more or less carbonaceous shale. The shale represents periods when the peat accumulation was interrupted by flooding from a river or the sea, or, more rarely, interrupted by volcanic ash deposition (tonsteins). The individual benches of a coal bed vary laterally in thickness and composition, sometimes quite rapidly. The degree of variability is related to the stability of conditions during accumulation. Fluvial and lacustrine depositional environments produce greater lateral variability than deltaic or coastal plain environments. See SHALE.

Both physical (pressure, heat) and chemical (biochemical, thermochemical) factors are influential in the transformation of peat into the other members of the coalification series. The boundaries between the members of the series are transitional and must be chosen somewhat arbitrarily. The term rank is used to identify the stage of coalification reached in the course of coal metamorphism. Rank is a fundamental property of coal, and its determination is essential in the characterization of a coal. Classification of coal by rank generally is based upon the chemical composition of the coal's ash-free or mineral-matter-free organic substance (see table), but parameters derived from empirical tests indicative of technological properties, such as agglomerating characteristics, are commonly used in several countries outside the United States in addition to coal rank parameters. See METAMORPHISM.

Coal rank increases with depth at differing rates from place to place, depending primarily on the rate of temperature increase with depth (geothermal gradient) at the time of coalification. Coal rank also changes laterally, even in the same coal seam, as former depth of burial and thus exposure to different pressure and temperature vary. Originally established vertical and regional coalification patterns can be significantly altered by various kinds of geologic events, such as the intrusion of large magma bodies at depth (plutonism), or renewed subsidence of a region. Volcanic activity may cause significant local anomalies in coal rank, but rarely leads to regional changes in coalification pattern. See MAGMA.

American Society for Testing and Materials classification of coals by rank (in box, ASTM standard D 388) and other related coal properties

ASTM class	ASTM group	1000 Btu/lb <sup>1</sup>	Agglomerating <sup>2</sup>	Volatile matter, <sup>3</sup> %	MJ/kg <sup>1</sup>	Maximum reflectance, <sup>4</sup> %	Moisture, <sup>1</sup> %	C, <sup>3</sup> %	O, <sup>3</sup> %	H, <sup>3</sup> %
	Peat	1.0–6.0	No	72–62	2.3–14.0	0.2–0.4	95–50	50–65	42–30	7–5
Lignite	Lignite B	>6.3 <sup>5</sup>	No	65–40	<14.7 <sup>5</sup>	0.2–0.4	60–40 <sup>5</sup>	55–73	35–23	7–5
	Lignite A	6.3–8.3 <sup>5</sup>	No	65–40	14.7–19.3 <sup>5</sup>	0.2–0.4	50–31 <sup>5</sup>	55–73	35–23	7–5
Subbituminous	Subbituminous C	8.3–9.5 <sup>5</sup>	No	55–35	19.3–22.1 <sup>5</sup>	0.3–0.6	38–25 <sup>5</sup>	60–80 <sup>6</sup>	28–15 <sup>6</sup>	6.0–4.5
	Subbituminous B	9.5–10.5 <sup>5</sup>	No	55–35	22.1–24.4 <sup>5</sup>	0.3–0.6	30–20 <sup>5</sup>	60–80 <sup>6</sup>	28–15 <sup>6</sup>	6.0–4.5
	Subbituminous A	10.5–11.5 <sup>5</sup>	No	55–35	24.4–26.7 <sup>5</sup>	0.3–0.7	25–18 <sup>5</sup>	60–80 <sup>6</sup>	28–15 <sup>6</sup>	6.0–4.5
Bituminous	High volatile C	10.5–13.0 <sup>5</sup>	Yes	55–35	24.4–30.2 <sup>5</sup>	0.4–0.7	25–10 <sup>5</sup>	76–83 <sup>6</sup>	18–8 <sup>6</sup>	6.0–4.5
	High volatile B	13.0–14.0 <sup>5</sup>	Yes	50–35	30.2–32.6 <sup>5</sup>	0.5–0.8 <sup>6</sup>	12–5 <sup>5</sup>	77–84 <sup>6</sup>	12–7 <sup>6</sup>	6.0–4.5
	High volatile A	≥14.0	Yes	45–31	≥32.6	0.6–1.2 <sup>6</sup>	7–1 <sup>5</sup>	78–88 <sup>6</sup>	10–6 <sup>6</sup>	6.0–4.5
	Medium volatile	>14.0	Yes	31–22 <sup>5</sup>	>32.6	1.0–1.7 <sup>5</sup>	<1.5	84–91	9–4	6.0–4.5
	Low volatile	>14.0	Yes	22–14 <sup>5</sup>	>32.6	1.4–2.2 <sup>5</sup>	<1.5	87–92	5–3	6.0–4.5
Anthracite	Semianthracite	>14.0	No	14–8 <sup>5</sup>	>32.6	2.0–3.0 <sup>5</sup>	<1.5	89–93 <sup>6</sup>	5–3 <sup>6</sup>	5–3 <sup>5</sup>
	Anthracite	>14.0	No	8–2 <sup>5</sup>	>32.6	2.6–6.0 <sup>5</sup>	0.5–2	90–97 <sup>6</sup>	4–2 <sup>6</sup>	4–2 <sup>5</sup>
	Meta-anthracite	>14.0	No	≤2	>32.6	>5.5 <sup>3</sup>	1–3	>94 <sup>6</sup>	2–1 <sup>6</sup>	2–1 <sup>5</sup>

<sup>1</sup>Moist, mineral-matter-free.

<sup>2</sup>Agglomerating coals form a button of cokelike residue in the standard volatile-matter determination that shows swelling or cell structure or supports a 500-g weight without pulverizing. The residue of nonagglomerating coal lacks these characteristics.

<sup>3</sup>Dry, mineral-matter-free.

<sup>4</sup>Reflectance of virinite under oil immersion.

<sup>5</sup>Well suited for rank discrimination in range indicated.

<sup>6</sup>Moderately well suited for rank discrimination.

SOURCE: Modified from Damberger et al., in B. R. Cooper and W. A. Ellingson (eds.), *The Science and Technology of Coal and Coal Utilization*, 1984.

Coal is used primarily for producing steam in electric power plants. Other important uses are by industry for producing steam and heat, and by the steel industry for coke making. Conversion of coal to synthetic liquid or gaseous fuels does not constitute a major use of coal worldwide or in most countries. See COAL CHEMICALS; COAL GASIFICATION. [H.H.D.]

**Coal balls** Various shaped nodules consisting of fossilized peat in which the individual cells and tissue systems of the plant parts are infiltrated by minerals, principally calcium carbonate, along with pyrite, dolomite, and occasionally silica. This type of fossilization, in which the cell walls are filled with minerals, is termed permineralization. Coal balls occur principally in Pennsylvanian (upper Carboniferous) bituminous and anthracite coals, but permineralized plants have also been reported in coals from as early as the Devonian and extending well into the Paleocene.

How coal balls formed is not well understood, but some are believed to represent accumulations of peat in which the plants were growing in low-lying swampy areas close to the sea. According to this model, seawater provided the high source of calcium carbonate in the permineralization processes.

Because the individual plant cells in coal balls have not been crushed, they offer a wealth of information to paleobiologists about the structure, morphology, and biology of the plants. See COAL PALEOBOTANY; PALEOBOTANY. [T.N.T.]

**Coal chemicals** For about 100 years, chemicals obtained as by-products in the primary processing of coal to metallurgical coke have been the main source of aromatic compounds used as intermediates in the synthesis of dyes, drugs, antiseptics, and solvents. Although some aromatic hydrocarbons, such as toluene and xylene, are now obtained largely from petroleum refineries, the main source of others, such as benzene, naphthalene, anthracene, and phenanthrene, is still the by-product coke oven. Heterocyclic nitrogen compounds, such as pyridines and quinolines, are also obtained largely from coal tar. Although much phenol is produced by hydrolysis of monochlorobenzene and by decomposition of cumene hydroperoxide, much of the phenol, cresols, and xylenols are still obtained from coal tar.

Coke oven by-products are gas, light oil, and tar. Coke oven gas is a mixture of methane, carbon monoxide, hydrogen, small amounts of higher hydrocarbons, ammonia, and hydrogen sulfide. Most of the coke oven gas is used as fuel. Although several hundred chemical compounds have been isolated from coal tar, a relatively small number are present in appreciable amounts. These may be grouped as in the table. All the compounds in the table except the monomethylnaphthalenes are of some commercial importance.

The direct utilization of coal as a source of bulk organic chemicals has been the objective of much research and development.

Coal tar chemicals

Compound	Fraction of whole tar, %	Use
Naphthalene	10.9	Phthalic acid
Monomethylnaphthalenes	2.5	
Acenaphthenes	1.4	Dye intermediates
Fluorene	1.6	Organic syntheses
Phenanthrene	4.0	Dyes, explosives
Anthracene	1.0	Dye intermediates
Carbazole (and other similar compounds)	2.3	Dye intermediates
Phenol	0.7	Plastics
Cresols and xylenols	1.5	Antiseptics, organic syntheses
Pyridine, picolines, lutidines, quinolines, acridine, and other tar bases	2.3	Drugs, dyes, antioxidants

Oxidation of aqueous alkaline slurries of coal with oxygen under pressure yields a mixture of aromatic carboxylic acids. Because of the presence of nitrogen compounds and hydroxy acids, this mixture is difficult to refine. Hydrogenation of coal at elevated temperatures and pressures yields much larger amounts of tar acids and aromatic hydrocarbons of commercial importance than are obtained by carbonization. However, this operation is more costly than other sources of these chemicals. See COKE; DESTRUCTIVE DISTILLATION; PYROLYSIS. [H.W.W.]

**Coal gasification** The conversion of coal or coal char to gaseous products by reaction with steam, oxygen, air, hydrogen, carbon dioxide, or a mixture of these. Products consist of carbon monoxide, carbon dioxide, hydrogen, methane, and some other gases in proportions dependent upon the specific reactants and conditions (temperatures and pressures) employed within the reactors, and the treatment steps which the gases undergo subsequent to leaving the gasifier. Similar chemistry can also be applied to the gasification of coke derived from petroleum and other sources. The reaction of coal or coal char with air or oxygen to produce heat and carbon dioxide could be called gasification, but it is more properly classified as combustion. The principal purposes of such conversion are the production of synthetic natural gas as a substitute gaseous fuel and synthesis gases for production of chemicals and plastics. See COMBUSTION.

In all cases of commercial interest, gasification with steam, which is endothermic, is an important chemical reaction. The necessary heat input is typically supplied to the gasifier by combusting a portion of the coal with oxygen added along with the steam. From the industrial viewpoint, the final product is either chemical synthesis gas (CSG), medium-Btu gas (MBG), or a substitute natural gas (SNG).

Each of the gas types has potential industrial applications. In the chemical industry, synthesis gas from coal is a potential alternative source of hydrogen and carbon monoxide. This mixture is obtained primarily from the steam reforming of natural gas, natural gas liquids, or other petroleum liquids. Fuel users in the industrial sector have studied the feasibility of using medium-Btu gas instead of natural gas or oil for fuel applications. Finally, the natural gas industry is interested in substitute natural gas, which can be distributed in existing pipeline networks. See NATURAL GAS.

There has also been some interest by the electric power industry in gasifying coal by using air to provide the necessary heat input. This could produce low-Btu gas (because of the nitrogen present), which can be burned in a combined-cycle power generation system. See ELECTRIC POWER GENERATION.

In nearly all of the processes, the general process is the same. Coal is prepared by crushing and drying, pretreated if necessary to prevent caking, and then gasified with a mixture of air or oxygen and steam. The resulting gas is cooled and cleaned of char fines, hydrogen sulfide, and carbon dioxide before entering optional processing steps to adjust its composition for the intended end use. [W.R.Ep.]

**Coal liquefaction** The conversion of most types of coal (with the exception of anthracite) primarily to petroleumlike hydrocarbon liquids which can be substituted for the standard liquid or solid fuels used to meet transportation, residential, commercial, and industrial fuel requirements. Coal liquids contain less sulfur, nitrogen, and ash, and are easier to transport and use than the parent (solid) coal. These liquids are suitable refinery feedstocks for the manufacture of gasoline, heating oil, diesel fuel, jet fuel, turbine fuel, fuel oil, and petrochemicals.

Liquefying coal involves increasing the ratio of hydrogen to carbon atoms (H:C) considerably—from about 0.8 to 1.5–2.0. This can be done in two ways: (1) indirectly, by first gasifying the coal to produce a synthesis gas (carbon monoxide and

hydrogen) and then reconstructing liquid molecules by Fischer-Tropsch or methanol synthesis reactions; or (2) directly, by chemically adding hydrogen to the coal matrix under conditions of high pressure and temperature. In either case (with the exception of methanol synthesis), a wide range of products is obtained, from light hydrocarbon gases to heavy liquids. Even waxes, which are solid at room temperature, may be produced, depending on the specific conditions employed. [W.R.Ep.]

**Coal mining** The technical and mechanical activities involved in removing coal from the earth and preparing it for market. Coal mining in the industrialized countries is characterized by the integration of a number of complex systems into a production methodology that varies for surface versus underground mining. See COAL.

The basic systems of the production methodology are the following. (1) Extraction systems: the methods and techniques used to break out or "win" the coal. (2) Materials-handling systems: the transport of coal and waste products away from the active production area, and the transport of the necessary materials, equipment, supplies, and workers to service the extraction system. (3) Ventilation: the development and operation of an air distribution system to provide the quantity, quality, and velocity of air where and when needed, to meet health and safety requirements. (4) Ground control: the control of the behavior of underground and surface openings developed by the extraction of coal. (5) Reclamation: the restoration of the mined area to its approximate original state or to an approved state.

To properly plan, design, and engineer a production system, knowledge of the geology of the deposit and the chemical and physical properties of the coal must be assembled and assessed. Basic information on the geology of the deposit is obtained from surface prospecting and mapping, and borehole drilling. This information is used to determine the size and shape of the coal area, the geologic column above and below all minable seams, the continuity and persistence of geologic features throughout the deposit, the presence of water or methane gas, and other special conditions. Proximate chemical analyses are made to determine coal characteristics, which affect its utilization. Tests are made to determine the cleaning, grinding, and handling properties of the coal. Ultimate chemical analyses are made to determine the fundamental chemical constituents of the coal. Maps are drawn to summarize this information, and are used for scheduling and sequencing production. See ANALYTICAL CHEMISTRY; ENGINEERING GEOLOGY; PROSPECTING; ROCK MECHANICS; SOIL MECHANICS; SPECTROSCOPY.

When a coal seam lies close to the ground surface, a surface mining method is employed. Surface coal mines involve area mining or modified open pit mining, contour mining and mountaintop removal, and auger mining. Removal of overburden is called stripping, and hence the term "strip mining" is often applied to surface coal operations. Area mining is applicable in relatively flat to gently undulating terrain where coal seams are of considerable area and may be at various dips. Contour mining and mountaintop removal are used in hilly and mountainous country and can be modified to handle coal seams at any dip. Auger mining follows the other surface methods when overburden removal becomes uneconomic, and is generally limited to more or less horizontal coal seams. See SURFACE MINING.

When a coal seam does not lie close to the surface, it must be extracted by underground methods. The methods may be classified as room-and-pillar, longwall, and others. In each method, modifications to the basic techniques are needed to cope with varying geologic conditions and seam factors. Irregular seam thickness, steep dips, changing rock quality, seam partings, and other factors have a marked influence on the mine geometry and equipment specifications. In developing a particular extraction system, development openings and production openings must be driven. Development openings provide the

primary access to various parts of the coal deposit and are called mains. In room-and-pillar mining, the production openings are the rooms driven in the panel and the extraction cuts made during pillar retrieval. In longwall mining, the production openings are the longwall faces. In general, the term "development" includes all openings and other work which precedes production. See MINING; UNDERGROUND MINING. [M.T.W.; T.M.Y.]

**Coal paleobotany** A special branch of the paleobotanical sciences concerned with the origin, composition, mode of occurrence, and significance of the fossil plant materials that occur in, or are associated with, coal seams. Information developed in this field of science provides knowledge useful to the biologist in attempting to describe the development of the plant world, aids the geologist in unraveling the complexities of coal measure stratigraphy in order to reconstruct the geography of past ages and to describe ancient climates, and has practical application in the coal, coke, and coal chemical industries. See PALEOBOTANY.

All coal seams consist of countless fragments of fossilized plant material admixed with varying percentages of mineral matter. The organic and inorganic materials initially accumulate in some type of swamp environment. In some instances, the fossilized plant fragments can be recognized as remnants of a plant of some particular family, genus, or species. When this is possible, information can be obtained on the vegetation extant at the time the source peat was formed, and such data aid greatly in reconstructing paleogeographies and paleoclimatic patterns.

Pollen grains and spores are more adequately preserved in coals than are most other plant parts. Recognition of this fact, coupled with an appreciation of the high degree to which these fossils are diagnostic of floral composition, has led to the rapid development of the paleobotanical subspecialty of palynology. Fruits, seeds, and identifiable woods also occur as coalified fossils. Occasionally, coal seams contain fossil-rich coal balls. Essentially all types of plant fossil, including entire leaves, cones, and seeds, are encountered in these discrete nodular masses. See COAL BALLS; PALYNOLOGY.

Coal seams generally are composed of several superposed sedimentary layers, each having formed under somewhat different environmental conditions. The coal petrologist and paleobotanist recognize these layers because of their distinctive textural appearance and because each consists of a particular association of organic and inorganic materials. Accordingly, each coal seam usually contains several types of coal. These coal types, or lithotypes, possess characteristic suites of physical properties, and knowledge of these properties is very profitably employed in manipulating coal composition in coal preparation and beneficiation plants. [W.Sp.]

**Coalbed methane** Coalbed methane production, sometimes referred to as coal degasification, is the process of extracting natural gas from underground coal formations (coal seams). This extraction is accomplished with production technology similar to that used in the conventional natural gas industry. The objectives of producing the natural gas from a coal seam are to improve mine safety, to sell the natural gas, or both. See COAL; NATURAL GAS.

Coalbed methane production is a leading form of unconventional production in terms of annual gas production and reserves. Other unconventional gas resources include low-permeability sandstones, Devonian shales, geopressured aquifers, and gas-hydrate reservoirs.

In 2001, coalbed methane production accounted for approximately 7.9% of the United States annual natural gas production and 9.6% of its total proven natural gas reserves. In addition, natural gas production from all of the unconventional gas resources accounted for approximately 26% of the total United States annual production.

The natural gas associated with coal is a by-product of the coalification process. Therefore, coal-seam reservoirs are different from conventional natural gas reservoirs; the coal seam is both the source rock and reservoir rock for the gas. The natural gas associated with coal is composed of low-molecular-weight hydrocarbon gases, predominantly methane, and inorganic gases, such as carbon monoxide, carbon dioxide, hydrogen sulfide, and oxygen.

The drilling technology used for coalbed methane wells is identical to the technology used for conventional natural gas wells. The production technologies do, however, differ in well completions. The well completion is the portion of the well that connects the wellbore to the reservoir. Specialized well completions are required for coalbed methane wells because of the unique mechanical properties of coal.

There are two well completions commonly used in coalbed methane wells: open-hole cavity completions and hydraulically stimulated completions. In the open-hole cavity completion, the well is injected with high-pressure gas and water and is then rapidly depressurized. This process is repeated several times to break down the coal in order to create a large effective well radius, or cavity, in the coal seam.

In the hydraulic stimulation process, a high-pressure fluid (usually a gelled liquid, foam, or gas) is injected into the well along with a proppant (generally sand). The injection of the fracturing fluid either creates and propagates a fracture from the well into the coal seam, or opens preexisting, near-wellbore fractures. The proppant is used to keep the fractures open once the well is put onto production. [G.R.K.]

**Coastal engineering** A branch of civil engineering concerned with the planning, design, construction, and maintenance of works in the coastal zone. The purposes of these works include control of shoreline erosion; development of navigation channels and harbors; defense against flooding caused by storms, tides, and seismically generated waves (tsunamis); development of coastal recreation; and control of pollution in nearshore waters. Coastal engineering usually involves the construction of structures or the transport and possible stabilization of sand and other coastal sediments.

The successful coastal engineer must have a working knowledge of oceanography and meteorology, hydrodynamics, geomorphology and soil mechanics, statistics, and structural mechanics. Tools that support coastal engineering design include analytical theories of wave motion, wave-structure interaction, diffusion in a turbulent flow field, and so on; numerical and physical hydraulic models; basic experiments in wave and current flumes; and field measurements of basic processes such as beach profile response to wave attack, and the construction of works. Postconstruction monitoring efforts at coastal projects have also contributed greatly to improved design practice.

Coastal structures can be classified by the function they serve and by their structural features. Primary functional classes include seawalls, revetments, and bulkheads; groins; jetties; breakwaters; and a group of miscellaneous structures including piers, submerged pipelines, and various harbor and marina structures.

Seawalls, revetments, and bulkheads are structures constructed parallel or nearly parallel to the shoreline at the land-sea interface for the purpose of maintaining the shoreline in an advanced position and preventing further shoreline recession. Seawalls are usually massive and rigid, while a revetment is an armoring of the beach face with stone rip-rap or artificial units. A bulkhead acts primarily as a land-retaining structure and is found in a more protected environment such as a navigation channel or marina. See REVETMENT.

A groin is a structure built perpendicular to the shore and usually extending out through the surf zone under normal wave and surge-level conditions. It functions by trapping sand from the alongshore transport system to widen and protect a beach or by retaining artificially placed sand.

Jetties are structures built at the entrance to a river or tidal inlet to stabilize the entrance as well as to protect vessels navigating the entrance channel.

The primary purpose of a breakwater is to protect a shoreline or harbor anchorage area from wave attack. Breakwaters may be located completely offshore and oriented approximately parallel to shore, or they may be oblique and connected to the shore where they often take on some of the functions of a jetty. [R.M.So.]

**Coastal landforms** The characteristic features and morphology of the land in the coastal zone. They are subject to processes of erosion and deposition as produced by winds, waves, tides, and river discharge. The interactions of these processes and the coastal environments produce a wide variety of landforms. Processes directed seaward from the land are dominated by the transport of sediment by rivers, but also include gravity processes such as landslides, rockfalls, and slumping. The dominant processes on the seaward side are wind, waves, and wave-generated currents. Mixed among these locations are tidal currents which also carry large volumes of sediment.

Subcontinental- to continental-scale coastal landform patterns are related to plate tectonics. The three major tectonic coastal types are leading-edge, trailing-edge, and marginal sea coasts. Leading-edge coasts are associated with colliding plate boundaries where there is considerable tectonic activity. Trailing-edge coasts are on stable continental margins, and marginal seas have fairly stable coasts with plate margins, commonly characterized by island arcs and volcanoes, that form their seaward boundaries. See CONTINENTAL MARGIN; PLATE TECTONICS.

The primary characteristics of leading-edge coasts is the rugged and irregular topography, commonly displaying cliffs or bluffs right up to the shoreline. Seaward, the topography reflects this with an irregular bottom and deep water near the shoreline. The geology is generally complex with numerous faults and folds in the strata of the coastal zone. These coasts tend to be dominated by erosion with only local areas of deposition, typically in the form of small beaches or spits between headlands. Waves tend to be large because of the deep nearshore water, and form wave-cut platforms, terraces, notches, sea stacks, and caves. See FRAME OF REFERENCE.

The most diverse suite of coastal landforms develops along trailing-edge coasts. These coasts are generally developed along the margin of a coastal plain, they are fed by well-developed and large river systems, and they are subjected to a low-to-modest wave energy because of the gently sloping adjacent continental shelf. The overall appearance is little topographic relief dominated by deposition of mud and sand. The spectrum of environments and their associated landforms includes deltas, estuaries, barrier islands, tidal inlets, tidal flats, and salt marshes. See BARRIER ISLANDS; COASTAL PLAIN; DELTA; FLOODPLAIN; SALT MARSH.

Marginal coastal settings are along a stable continental mass and are protected from open ocean processes, commonly an island arc system or other form of a plate boundary. The consequence is a coastal zone that tends to be subjected to small waves and where considerable mud is allowed to accumulate in the coastal zone. Many coastal landforms are present in much the same fashion as on the trailing-edge coasts. Marginal sea coasts tend to have large river deltas. Examples are the eastern margin of Asia along the Gulf of Korea and the China Sea, the entire Gulf of Mexico, and the Mediterranean Sea. See DEPOSITIONAL SYSTEMS AND ENVIRONMENTS; NEARSHORE PROCESSES. [R.A.D.]

**Coastal plain** An extensive, low-relief area that is bounded by the sea on one side and by some type of relatively high-relief province on the landward side. The geologic province of the coastal plain actually extends beyond the shoreline across the continental shelf. It is only during times of glacial melting and high sea level that much of the coastal plain is drowned. See CONTINENTAL MARGIN.

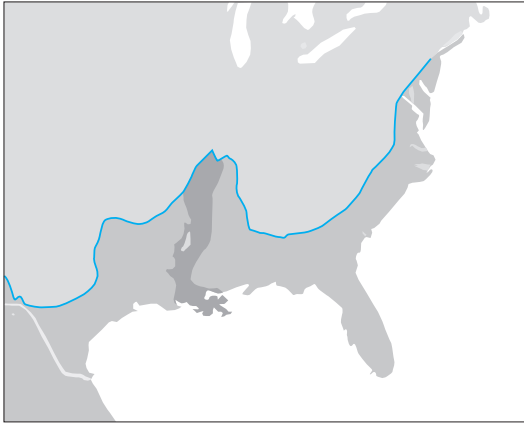

Coastal plains of the United States.

The coastal plain is a geologic province that is linked to the stable part of a continent on the trailing edge of a plate. The extent and nature of the coastal plains of the world range widely. Some are very large and old, whereas others are small and geologically young. For example, the Atlantic and Gulf coasts of the United States are among the largest in the world. (see illustration). In some areas the coastal plain is hundreds of kilometers wide and extends back about 100 million years. By contrast, local coastal plains in places like the east coast of Australia and New Zealand are only 1 or 2 million years old and extend only tens of kilometers landward from the shoreline.

The typical character of a coastal plain is one of strata that dip gently and uniformly toward the sea. There may be low ridges that are essentially parallel to the coast and that have developed from erosion of alternating resistant and nonresistant strata. These strata are commonly a combination of mudstone, sandstone, and limestone, although the latter is typically a subordinate amount of the total. These strata resulted from deposition in fluvial, deltaic, and shelf environments as sea level advanced and retreated over this area. Coastal plain strata have been a source of considerable oil and gas as well as various economic minerals. Although the coastal plain province is typically stable tectonically, there may be numerous normal faults and salt dome intrusions. See COASTAL LANDFORMS; DELTA; GEOMORPHOLOGY; PLAINS. [R.A.D.]

**Coati** The name for three species of carnivorous mammals assigned to the raccoon family Procyonidae. The common or

Common coati (*Nasua nasua*).

ring-tailed coati (*Nasua nasua*) ranges through the forests of Central and South America, the mountain coati (*Nasuella oviceae*) is found only in South America, while *Nasua nelsoni* is confined to Cozumel Island in Central America.

The coatis are characterized by their elongated snouts, body, and tail, which is held erect when they walk (see illustration). They are adept at climbing trees in search of birds and lizards, and their diet also includes fruit, insects, and larvae. *Nasua nasua* roams in bands of females and young during the day in search of food. The males are excluded from the band except during the brief breeding season, when a single male is allowed to join. After mating, the male leaves and the female builds an isolated nest in a tree. Here, following a gestation period of 11 weeks, a litter of about five young are born and are cared for by the female away from the group. After about 1 month the female and her young rejoin the band. See CARNIVORA. [C.B.C.]

**Coaxial cable** An electrical transmission line comprising an inner, central conductor surrounded by a tubular outer conductor. The two conductors are separated by an electrically insulating medium which supports the inner conductor and keeps it concentric with the outer conductor. One version of coaxial cable has periodically spaced polyethylene disks supporting the inner conductor. This coaxial is a building block of multicoaxial cables used in L-carrier systems (see illustration). See TRANSMISSION LINES.

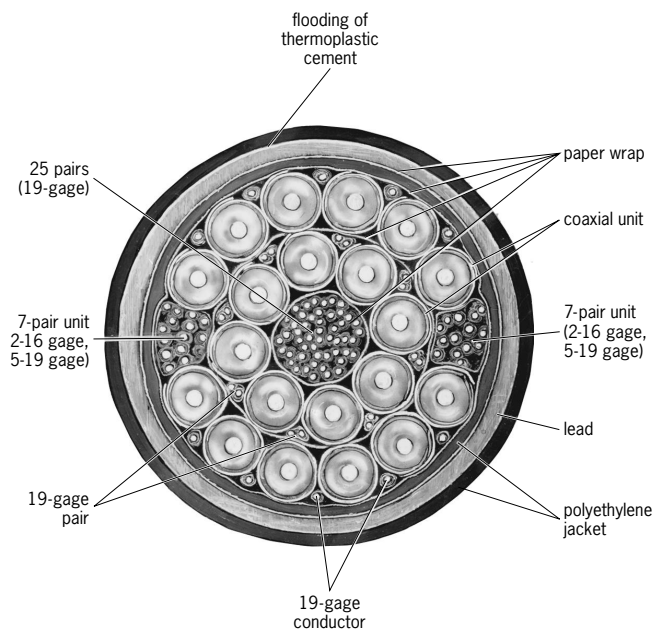

Construction of multicoaxial transmission line with twenty 0.375-in. (9.5-mm) coaxial units.

The symmetry of the coaxial cable and the fact that the outer conductor surrounds the inner conductor make it a shielded structure. At high frequencies, signal currents concentrate near the inside surface of the outer conductor and the outer surface of the inner conductor. This is called skin effect. The depth to which currents penetrate decreases with increasing frequency. Decreased skin depth improves the cable's self-shielding and increases transmission loss. This loss (expressed in decibels per kilometer) increases approximately as the square root of frequency because of the skin effect. See ELECTRICAL SHIELDING; SKIN EFFECT (ELECTRICITY).

Coaxial cables can carry high power without radiating significant electromagnetic energy. In other applications, coaxial cables carry very weak signals and are largely immune to interference from external electromagnetic fields.

A coaxial cable's self-shielding property is vital to successful use in broadband carrier systems, undersea cable systems, radio and TV antenna feeders, and community antenna television (CATV) applications.

Coaxial units are designed for different mechanical behavior depending upon the application. Widely used coaxials are classified as flexible or semirigid. [S.T.B.]

**Cobalt** A lustrous, silvery-blue metallic chemical element, Co, with an atomic number of 27 and an atomic weight of 58.93. Metallic cobalt was isolated in 1735 by the Swedish scientist G. Brandt, who called the impure metal cobalt rex, after the ore from which it was extracted. The metal was shown to be a previously unknown element by T. O. Bergman in 1780.

Cobalt is a transition element in the same group as rhodium and iridium. In the periodic table it occupies a position between iron and nickel in the third period. Cobalt resembles iron and nickel in both its free and combined states, possessing similar tensile strength, machinability, thermal properties, and electrochemical behavior. Constituting 0.0029% of the Earth's crust, cobalt is widely distributed in nature, occurring in meteorites, stars, lunar rocks, seawater, fresh water, soils, plants, and animals. See PERIODIC TABLE; TRANSITION ELEMENTS.

Cobalt and its alloys resist wear and corrosion even at high temperatures. The most important commercial uses are in making alloys for heavy-wear, high-temperature, and magnetic applications. Small amounts of the element are required by plants and animals. The artificially produced radioactive isotope of cobalt,  $^{60}\text{Co}$ , has many medical and industrial applications.

Cobalt, with a melting point of  $1495^{\circ}\text{C}$  ( $2723^{\circ}\text{F}$ ) and a boiling point of  $3100^{\circ}\text{C}$  ( $5612^{\circ}\text{F}$ ), has a density ( $20^{\circ}\text{C}$ ;  $68^{\circ}\text{F}$ ) of  $8.90\text{ g}\cdot\text{cm}^{-3}$ , an electrical resistivity ( $20^{\circ}\text{C}$ ) of  $6.24\text{ microhm}\cdot\text{cm}$ , and a hardness (diamond pyramid, Vickers;  $20^{\circ}\text{C}$ ) of 225. It is harder than iron and, although brittle, it can be machined. The latent heat of fusion is  $259.4\text{ joules/g}$ , and the latent heat of vaporization is  $6276\text{ J/g}$ ; the specific heat ( $15\text{--}100^{\circ}\text{C}$ ;  $59\text{--}212^{\circ}\text{F}$ ) is  $0.442\text{ J/g}\cdot^{\circ}\text{C}$ . Cobalt is ferromagnetic, with the very high Curie temperature of  $1121^{\circ}\text{C}$  ( $2050^{\circ}\text{F}$ ). The electronic configuration is  $1s^2 2s^2 2p^6 3s^2 3p^6 3d^7 4s^2$ . At normal temperatures the stable crystal form of cobalt is hexagonal close-packed, but above  $417^{\circ}\text{C}$  ( $783^{\circ}\text{F}$ ) face-centered cubic is the stable structure. Although the finely divided metal is pyrophoric in air, cobalt is relatively unreactive and stable to oxygen in the air, unless heated. It is attacked by sulfuric, hydrochloric, and nitric acids, and more slowly by hydrofluoric and phosphoric acids, ammonium hydroxide, and sodium hydroxide. Cobalt reacts when heated with the halogens and other nonmetals such as boron, carbon, phosphorus, arsenic, antimony, and sulfur. Dinitrogen, superoxo, peroxo, and mixed hydride complexes also exist. In its compounds, cobalt exhibits all the oxidation states from  $-I$  to  $IV$ , the most common being  $II$  and  $III$ . The highest oxidation state is found in cesium hexafluorocobaltate( $IV$ ),  $\text{Cs}_2\text{CoF}_6$ , and a few other compounds.

There are over 200 ores known to contain cobalt; traces of the metal are found in many ores of iron, nickel, copper, silver, manganese, and zinc. However, the commercially important cobalt minerals are the arsenides, oxides, and sulfides. Zaire is the chief producer, followed by Zambia. Russia, Canada, Cuba, Australia, and New Caledonia produce most of the rest. Zaire and Zambia together account for just over 50% of the world's cobalt reserves. Nickel-containing laterites (hydrated iron oxides) found in the soils of the Celebes, Cuba, New Caledonia, and many other tropical areas are being developed as sources of cobalt. The manganese nodules found on the ocean floor are another large potential reserve of cobalt. They are estimated to contain at least 400 times as much cobalt as land-based deposits. See MANGANESE NODULES.

Since cobalt production is usually subsidiary to that of copper, nickel, or lead, extraction procedures vary according to which of these metals is associated with the cobalt. In general, the ore is roasted to remove stony gangue material as a slag, leaving a

speiss of mixed metal and oxides, which is then reduced electrolytically, reduced thermally with aluminum, or leached with sulfuric acid to dissolve iron, cobalt, and nickel, leaving metallic copper behind. Lime is used to precipitate iron, and sodium hypochlorite is used to precipitate cobalt as the hydroxide. The cobalt hydroxide can be heated to give the oxide, which in turn is reduced to the metal by heating with charcoal.

Cobalt ores have long been used to produce a blue color in pottery, glass, enamels, and glazes. Cobalt is contained in Egyptian pottery dated as early as 2600 B.C. and in the blue and white porcelain ware of the Ming Dynasty in China (1368–1644).

An important modern industrial use involves the addition of small quantities of cobalt oxide during manufacture of ceramic materials to achieve a white color. The cobalt oxide counteracts yellow tints resulting from iron impurities. Cobalt oxide is also used in enamel coatings on steel to improve the adherence of the enamel to the metal. Cobalt arsenates, phosphates, and aluminates are used in artists' pigments, and various cobalt compounds are used in inks for full-color jet printing and in reactive dyes for cotton. Cobalt blue (Thenard's blue), one of the most durable of all blue pigments, is essentially cobalt aluminate. Cobalt linoleates, naphthenates, oleates, and ethylhexoates are used to speed up the drying of paints, lacquers, varnishes, and inks by promoting oxidation. In all, about a third of the world's cobalt production is used to make chemicals for the ceramic and paint industries. See CERAMICS; DYE; INK; METAL COATINGS.

Cobalt catalysts are used throughout the chemical industry for various processes. These include hydrogenations and dehydrogenations, halogenations, aminations, polymerizations (for example, butadiene), oxidation of xylenes to toluic acid, production of hydrogen sulfide and carbon disulfide, carbonylation of methanol to acetic acid, olefin synthesis, denitrogenation and desulfurization of coal tars, reductions with borohydrides, and nitrile syntheses, and such important reactions as the Fisher-Tropsch method for synthesizing liquid fuels and the hydroformylation process. Cobalt catalysts have also been used in the oxidation of poisonous hydrogen cyanide in gas masks and in the oxidation of carbon monoxide in automobile exhausts. See CATALYTIC CONVERTER.

Although cobalt was not used in its metallic state until the twentieth century, the principal use of cobalt is as a metal in the production of alloys, chiefly high-temperature and magnetic types. Superalloys needed to stand high stress at high temperatures, as in jet engines and gas turbines, typically contain 20–65% cobalt along with nickel, chromium, molybdenum, tungsten, and other elements.

In parts of the world where soil and plants are deficient in cobalt, trace amounts of cobalt salts [for example, the chloride and nitrate of  $\text{Co(II)}$ ] are added to livestock feeds and fertilizers to prevent serious wasting diseases of cattle and sheep, such as pining, a debilitating disease especially common in sheep. Symptoms of cobalt deprivation in animals include retarded growth, anemia, loss of appetite, and decreased lactation.

The principal biological role of cobalt involves corrin compounds (porphyrin-like macrocycles). The active forms contain an alkyl group (5'-deoxyadenosine or methyl) attached to the cobalt as well as four nitrogens from the corrin and a nitrogen from a heterocycle, usually 5,6-dimethylbenzimidazole. These active forms act in concert with enzymes to catalyze essential reactions in humans. However, the corrin compounds are not synthesized in the body; they must be ingested in very small quantities. Vitamin  $\text{B}_{12}$ , with cyanide in place of the alkyl, prevents pernicious anemia but is itself inactive. The body metabolizes the vitamin into the active forms. Although the cobalt in corrins is usually  $\text{Co(III)}$ , both  $\text{Co(II)}$  and  $\text{Co(I)}$  are involved in enzymic processes. Roughly one-third of all enzymes are metalloenzymes. Cobalt( $II$ ) substitutes for zinc in many of these to yield active forms. Such substitution of zinc may account, in part, for the toxicity of cobalt. See ENZYME; VITAMIN  $\text{B}_{12}$ . [L.Ma.; P.A.Mar.]



**Cobaltite** A mineral having composition (Co,Fe)AsS. Cobaltite is one of the chief ores of cobalt. It crystallizes in the isometric system, commonly in cubes or pyritohedrons, resembling crystals of pyrite. There is perfect cubic cleavage. The luster is metallic and the color silver-white but with a reddish tinge. The hardness is 5.5 (Mohs scale) and the specific gravity is 6.33. Notable occurrences of cobaltite are at Skutterud, Norway; Lunaberg, Sweden; Ravensthorpe, Australia; and Cobalt, Ontario, Canada. See COBALT. [C.S.Hu.]

**Coca** Shrubs of the genus *Erythroxylum* in the coca family (Erythroxylaceae). The genus contains over 200 species, most in the New World tropics. Two species, *E. coca* and *E. novogranatense*, are cultivated for their content of cocaine and other alkaloids. Leaves of cultivated coca contain 14 alkaloids, chiefly cocaine, and significant amounts of vitamins and minerals. The cocaine content averages 0.5%, rarely exceeding 1.0%.

South American Indians "chew" coca as a mild stimulant by placing dried leaves in the mouth and masticating with various alkalies such as lime or plant ashes to promote the release of the alkaloids, which are swallowed. Coca is important in the folk medicine of Andean Indians, especially as a treatment for gastrointestinal disorders. It may regulate carbohydrate metabolism in a useful way and supplement an otherwise deficient diet. See COCAINE; COLA; LINALES. [A.T.W.]

**Cocaine** The principal alkaloid of coca leaves, a topical anesthetic and stimulant, and popular illicit drug. In 1884 C. Koller demonstrated cocaine's efficacy as an anesthetic in eye surgery, introducing the age of local anesthesia. For the next decade cocaine enjoyed the status of a wonder drug and panacea. It fell into disfavor with increasing reports of acute toxicity and long-term dependence. Today it is used as a topical anesthetic in the eye, nose, mouth, and throat; for injection anesthesia it has been replaced by synthetic drugs with fewer central nervous system effects. See COCA.

Cocaine increases heart rate and blood pressure and causes feelings of alertness and euphoria. It does not produce physical dependence, as alcohol and opiates do, but many people find it hard to use in a stable and moderate fashion if they have access to it in quantity. Although it is quite active orally, most users of illicit cocaine take it intranasally by snuffing; few inject it intravenously. Aside from local irritation of the nasal membranes, moderate users suffer few adverse effects. The soluble hydrochloride salt is the common form. Insoluble cocaine free base may be smoked, a practice that may be more harmful. See ALKALOID. [A.T.W.]

**Coccidia** A subclass of the class Telosporae. These protozoa are typically intracellular parasites of epithelial tissues in both vertebrates and invertebrates. The group is divided on the basis of life cycles into two orders, the Protococcidia (in which there is only sexual reproduction) and the Eucoccidia (in which there is both sexual and asexual reproduction). There are only a few species in Protococcidia, and all are parasites in marine invertebrates. See EUCCOCIDIA; PROTOCCOCIDIA; TELOSPORAE. [E.R.B./N.D.L.]

**Coccolithophorida** A group of unicellular, biflagellate, golden-brown algae characterized by a covering of extremely small interlocking calcite plates called coccoliths. The Coccolithophorida are mainly classified by the shape of their coccoliths into two groups: the holococcoliths, with simple rhombic or hexagonal crystals arranged like a mosaic, and the heterococcoliths, with complex crystals arranged into boat, trumpet, basket, or collar-button shapes (see illustration). The Coccolithophorida are usually considered plants but possess also some animal characteristics. Botanists assign them to the class Haptophyceae of the phylum Chrysochyta, and zoologists to the

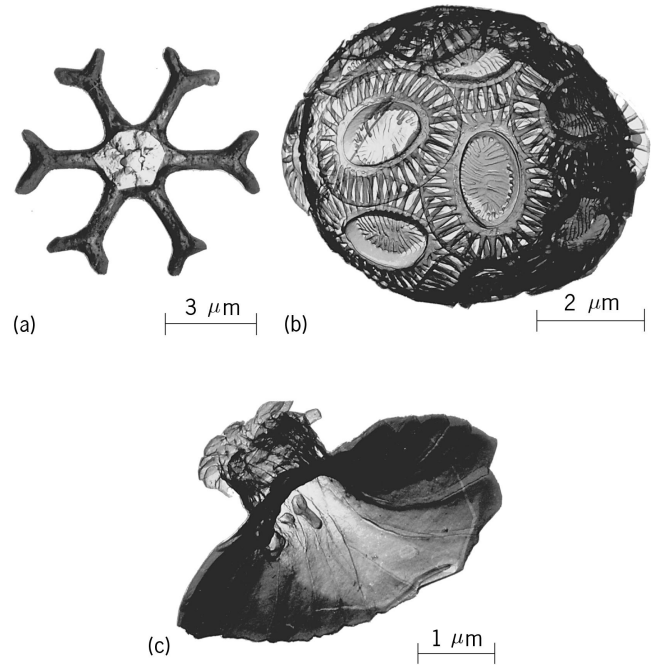

Coccolithophorida: (a) *Discoaster*; (b) a coccosphere; (c) a heterococcolith. (A. McIntyre, Lamont-Doherty Geological Observatory of Columbia University)

class Phytomastigophorea of the phylum Protozoa. See PHYTOMASTIGOPHOREA; PROTOZOA.

Chiefly photosynthetic, although epiphytism, phagotrophism, and saprophytism have also been shown, the Coccolithophorida form a significant percentage of the nanoplankton of the tropic through subarctic-subantarctic waters of all oceans; a few brackish and fresh-water species also exist. Together with the diatoms they constitute the primary producers of the open ocean food chain. See PHYTOPLANKTON.

Coccoliths preserve well and have a fossil record dating back into the Jurassic, 180,000,000 years ago. Their long and involved evolutionary record makes them useful to geologists for dating ancient sediments. Because they live in surface waters, coccoliths are under direct climatic control. Thus many modern species with relatively long fossil records are excellent temperature indicators. See MICROPALAEONTOLOGY. [A.McI.]

**Cockroach** Any of a group of insects (approximately 2500 species) of the family Blattidae, order Dictyoptera. This group is among the most primitive of the living and oldest of the fossilized insects, being found in abundance in the Carboniferous age. In general, cockroaches have a flat oval body, a darkened cuticle, and a thoracic shield which extends dorsally over the head. A pair of sensory organs, the whiplike antennae, are located on the head, and a much shorter pair of sensory organs, the cerci, are located at the end of the abdomen. Although some species are wingless, most have two pairs of wings but seldom fly. Most species are nocturnal and primarily live in narrow crevices and under stones and debris. Cockroaches are omnivorous, and a few species have adapted to the human environment, becoming household pests since they can chew foodstuffs, clothing, paper, and even plastic insulation. They also can emit a highly disagreeable odor.

Females deposit egg cases almost anywhere; each case contains several eggs from which the young nymphs hatch and go through several molts as they grow. At the final molt a winged, sexually mature adult will emerge. The time from egg to adult varies from species to species but can be longer than a year.

Cockroaches have been claimed as vectors for numerous human diseases. There is little evidence to support this claim; however, there is evidence that they can produce allergenic reactions in humans. Because of their large size, cockroaches have proved to be very useful animals for scientific research on general problems of insect behavior, physiology, and biochemistry. [C.R.F.]

**Cocoa powder and chocolate** Products derived from the seeds of the tropical tree *Theobroma cacao*, which grows within a narrow belt along both sides of the Equator. There are three basic varieties: Criollo, which was native to Central and South America; Forastero, which constitutes the bulk of the world supply and is mostly cultivated in West Africa and Brazil; and Trinitario, consisting of various hybrids. See CACAO.

The seeds, contained in pods which grow on the trunks and lower branches of the trees, are surrounded by a mucilaginous pulp. They are whitish in color and have no normal chocolate flavor. Each mature bean is about  $\frac{3}{4}$ –1 in. (2–2.5 cm) in length with an average weight not less than 0.04 oz (1 g). Good-quality beans show a brown or purplish-brown color and striations in the sliced cotyledon. Unfermented beans have a dense structure and slaty color. See SEED.

To develop a chocolate flavor, the beans are first subjected to a fermentation process. The next process is roasting in which the chocolate flavor is fully developed from the precursors, the shell loosened from the nib (cotyledon), and the moisture content reduced. After roasting, the shell is separated from the nib. The roasted nibs are ground at a temperature above the melting point of the cocoa butter constituent (93–95°F or 34–35°C) to produce a dark brown liquid called liquor, mass, or unsweetened chocolate. Finely ground liquor is the basis for manufacture of cocoa powder and chocolate.

To manufacture cocoa powder, liquor is subjected to hydraulic pressing, which separates some of the cocoa butter from the solid cocoa matters, resulting in compressed cocoa cakes. To make cocoa powder, these cakes are first mechanically broken into small pieces called kibbled cake and then put through pulverizers which, in conjunction with air separators, produce a very fine powder. Such cocoa powder is called natural cocoa. Commercial cocoa powders may have a residual cocoa butter content of 10–22%. They are used extensively as ingredients in cookies, biscuits, chocolate syrups and spreads, and vegetable fat coatings.

Dark, bitter, or sweet chocolate is manufactured from liquor (or nibs), sugar, and cocoa butter—the cocoa butter being obtained from cocoa powder manufacture. Cocoa butter is a very stable, natural fat; it melts just below body temperature and has a narrow melting range. It displays good contraction on solidifying from the liquid state, which enables chocolate to be molded into various shapes. Its melting properties impart good texture in the mouth and flavor release.

Milk chocolate is made from liquor, sugar, milk solids, and cocoa butter. The milk solids are derived from liquid milk, usually by a spray-drying process. Another milk product often used, called milk crumb, is prepared by concentrating and drying liquid milk in the presence of sugar and liquor. This gives a caramelized milk flavor. See MILK. [B.W.M.]

**Coconut** A large palm, *Cocos nucifera*, widely grown throughout the tropics and valuable for its fruit and fiber. Usually found near the seacoast, it requires high humidity, abundant rainfall, and mean annual temperature of about 85°F (29°C). Southern Florida, with mean temperature of 77°F (25°C), is at the limit of successful growth.

The fruit, 10 in. (25 cm) or more in length, is ovoid and obtusely triangular in cross section. The tough, fibrous outer husk encloses a spherical nut consisting of a hard, bony shell within which is a thin layer of fleshy meat or kernel. The meat is high in oil and protein and, when dried, is the copra of commerce.

Although many trees grow without special care, the crop lends itself to plantation culture with control of weeds, fertilization, and protection from diseases, insects, and animal pests. Palms begin to bear nuts the sixth year after planting and reach full bearing about the eighth year. Individual nuts mature about a year after blossoming and normally fall to the ground.

The oil from the dried coconut meats (copra) is widely used for margarine, soap, and industrial purposes. High-quality copra may be shredded for confectionery and the baking trade. The residue, after oil removal, is used for animal feed. Coconut husks are an important source of fiber called coir. Various grades of coir are used for ropes, mats and matting, and upholstery filling. See COIR.

The coco palm is the most useful of all tropical plants to the native population. An important source of food and drink, it also furnishes building material, thatch, hats, dishes, baskets, and many other useful items. See ARECALES. [L.H.MacD.]

**Codfish** Fish of a subfamily of the Gadidae in the order Gadiformes. Important commercially, these fish are found in cold waters, such as the Baltic and the North Atlantic. *Gadus morhua* is extensively fished off the Newfoundland banks and a circumpolar species, *Boreogadus saida*, the Arctic cod, is found around the ice pack during the summer. *G. macrocephalus*, a related species, occurs in the northern Pacific.

The cod is covered with cycloid scales, has a barbel under the chin, and has pelvic fins on the throat; there are two anal and three dorsal fins. Codfish average about 3 ft (0.9 m) in length and weigh 10–35 lb (4.5–15.7 kg). They live at depths of 100–1500 ft (30–450 m), where they feed on mollusks, small fish, crustaceans, and worms. Spawning occurs from January on to spring. The livers are processed for cod liver oil, which is rich in vitamins, and the swim bladder is made into isinglass. See GADIFORMES. [C.B.C.]

**Coelacanthiformes** An order of lobefin fishes placed in the subclass Crossopterygii and well known as fossils. Members are easily recognized by the two dorsal fins, by the paired pectoral and pelvic fins, and the anal fin, and by their symmetrical caudal fin with small central prolongation (see illustration). The only living fish with such features is *Latimeria chalumnae*; it is also the only extant fish with an intracranial joint, which otherwise occurs only in fossil rhipidistians. In 1952 its habitat was discovered to be the deep waters around the Comoro Islands. A new population of *Latimeria* was discovered in 1998 north of Sulawesi in the Indonesian archipelago.

The Coelacanthiformes (or Actinistia) are the only fishes with a special rostral organ, a deep postcoronoid in the lower jaw, a tandem double articulation of the lower jaw, a postspiracular bone, and an additional bone, the extracleithrum, in the shoulder girdle. Like lungfish, coelacanth lack the marginal upper jaw bone, the maxilla, and possess a short dentary. Except for two Devonian (*Miguashaia* and *Gavinia* with heterocercal tail) and a Carboniferous (*Allenopterus* with diphycercal tail) genus, coelacanth have a caudal fin with equal-sized upper and lower

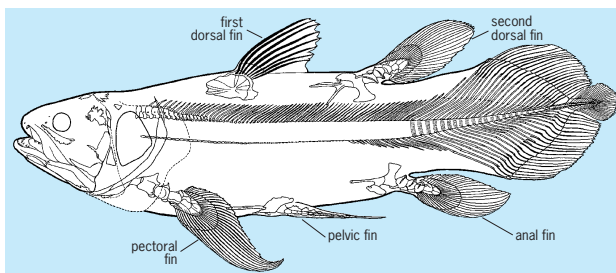

Overall shape and internal structures of *Latimeria chalumnae*.

lobe of unbranched fin rays separated by an axial notochordal lobe (triphyccercal tail).

*Latimeria* shows sexual dimorphism; the female is longer than the male. Reproduction is by internal fertilization even though the male has no intermittent organ. *Latimeria* has the largest eggs of any bony fish. It is ovoviviparous; up to 30 developing juveniles have been found in one female.

Coelacanth is known since the Middle Devonian. They reach high diversity in the Early Triassic and Late Jurassic. Coelacanth acquired their common structure in the Carboniferous. The number of morphological changes is minor thereafter. There is no fossil record for the last 80 million years. Most fossil records refer to marine forms; nevertheless, some coelacanth were able to enter fresh water. See FOSSIL.

The phylogenetic position of the coelacanthiforms within sarcopterygian fishes is debated. Within extant fishes, they may be closer to tetrapods than to the lungfish, or vice versa. The living coelacanth is not, as often written, a survivor of human ancestry. See CROSSOPTERYGII; OSTEICHTHYES; SARCOPTERYGII. [H.P.S.]

**Coelenterata** That group of the Radiata whose members typically bear tentacles and possess intrinsic nematocysts. The name Cnidaria is also used for this phylum and is preferred by some because the name Coelenterata, as first used, included the sponges (Porifera) and the comb jellies (Ctenophora), as well as the animals called coelenterates. See CTENOPHORA; PORIFERA.

The coelenterates are mainly marine organisms and are best known as jellyfish or medusae, sea anemones, corals, the Portuguese man-of-war, small polypoid forms called hydroids, and the fresh-water hydras. Taken together, the phylum is divisible into three classes as follows: (1) Hydrozoa, the hydroids, hydras, and hydrozoan or craspedote jellyfish (hydromedusae); (2) Scyphozoa, the acraspedote jellyfish; and (3) Anthozoa, the sea anemones, corals, sea fans, sea pens, and sea pansies. See ANTHOZOA; HYDROZOA; SCYPHOZOA.

It is convenient to recognize two basic body forms in this phylum, the polyp and the medusa, into which all coelenterates can be classified. The polyp and the medusa, however, have many features in common (see illustration).

The polyp is a radially, biradially, or radiobilaterally symmetrical individual having a longitudinal oral-aboral axis and is usually sessile. The mouth is at the free end and is surrounded by one to many whorls or sets of tentacles which may be hollow or solid. The aboral end is commonly developed as an adhesive device for attachment and is conveniently referred to as a base. The central body cavity is the gastrovascular cavity, also called the enteron or coelenteron.

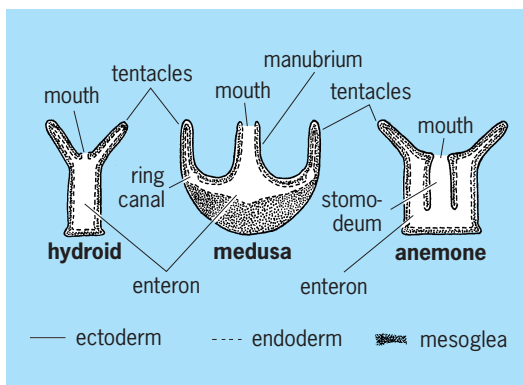

Comparison of hydroid polyp, medusa (inverted), and anthozoan polyp. (After T. I. Storer and R. L. Usinger, *General Zoology*, 3d ed., McGraw-Hill, 1957)

The medusa is a tetramerously or polymerously radial individual and is free-swimming. The body is usually bell- or bowl-shaped with the mouth suspended in the center of the underside of the bell on a stalk. Instead of directly surrounding the mouth as in the polyp, the tentacles are located at the margin of the bell. The outer or aboral part of the bell is recognized as the exumbrella and the under or oral part as the subumbrella. The mouth leads to the central stomach which in turn gives rise to four or more radial canals. These radial canals run through the umbrella, on the subumbrellar side, and commonly lead to a ring canal at the margin which is continuous around the margin.

The unique and most distinctive feature of coelenterates is the possession of intracellular, independent effector organelles called nematocysts, but also known as stinging cells or nettle cells. A coiled thread tube in each cell may be rapidly everted under proper stimulation and used for food gathering and for defense against predators, intruders, or enemies. Nematocysts are produced within cells called cnidoblasts. The morphologically simplest coelenterates, the Hydrozoa, have nematocysts limited to their outer epidermis whereas the more complex Scyphozoa and Anthozoa bear nematocysts in both the outer epidermis and inner gastrodermis.

The body systems of coelenterates may be divided into the following categories for the purpose of description: epithelial, nervous, muscular, mesogleal, skeletal, digestive, and reproductive. There is no analog of a circulatory system and the functions of respiration and excretion are carried out by each cell.

The epidermis is usually ciliated in polyps so that the net effect of the ciliary beat is to move material away from the mouth toward the margin of the oral disk and toward the tips of the tentacles. The gastrodermis, or inner epithelial layer, is also abundantly ciliated. These cilia move food materials about within the gastric cavity and circulate the contained water. One of the prime functions of the gastrodermis is digestion, and essentially every cell of the gastrodermis is capable of ingesting small food particles.

The coelenterate nervous system can be defined as consisting basically of an unpolarized network of bipolar and multipolar neurons. The nervous system is subepithelial in location, both subepidermal and subgastrodermal, and may in some forms consist of two networks in only limited contact with one another and with each specialized either for rapid through conduction or for slower, more general spread of conduction.

The muscular system varies considerably among coelenterates. In simple polyps there is an epidermal, longitudinal muscle sheath of epitheliomuscular cells and a gastrodermal, circular sheath. In medusae and in members of the classes Scyphozoa and Anthozoa, the musculature has become separated from the epithelial tissue as a subepithelial system. In many anthozoans a large sphincter muscle develops in the gastrodermal surface, at the top of the column. In medusae, where the primary swimming muscles are subumbrellar, large muscle bands, both circular and radial, develop.

The mesogleal system is represented by a layer between epidermis and gastrodermis which varies from the thin structureless cementing layer of hydrozoan polyps to the highly complex cellular, fibrous, gelatinous matrix of the scyphomedusans and anthozoans. Where the mesoglea is well developed, as in medusae and some anthozoans, it serves as a type of internal skeleton, against which muscles may act.

Two different types of skeleton occur in the phylum. The first is of an internal nature and is either the mesoglea against which the muscles operate or the contained hydroskeleton of most polyps. Of a quite different nature is the exoskeleton, seen in most hydrozoan polyps, some scyphozoan polyps, and corals, which supports and protects the organisms. Still another skeletal type known in the coelenterates is an axial skeleton composed of sclerified proteins. It is exceedingly tough and flexible and is characteristic of such anthozoans as gorgonians.

The digestive system in coelenterates is developed as a function of the gastrodermis. In hydrozoans, both polyps and medusae, glandular, enzyme-producing cells are abundant throughout the gastrodermis. These cells secrete proteolytic enzymes into the coelenteron which reduce food objects to a fine particulate state. In scyphozoans and anthozoans, although glandular cells are common throughout the gastrodermis, they tend to be most abundant along the free edges of the mesenteries of anthozoans and on the gastric tentacles of scyphozoans. These glandular cells are also the source of proteolytic enzymes which act in the extracellular environment of the coelenteron.

The phylum is characterized by its carnivorous diet, made possible first by the possession of nematocysts which make the predaceous habit successful. After food has been trapped, movements of the tentacles carry it to the mouth, where with the help of ciliary and muscular devices the food is moved to the coelenteron. Here extracellular proteases prepare the way for final intracellular digestion. No herbivorous coelenterates are known.

The reproductive system of coelenterates consists of specialized areas of epithelia, the gonads, which periodically appear and produce gametes. There are no ducts for the sex products or any accessory sexual structures. Fertilization usually occurs in the water surrounding the animal, although a few coelenterates have their eggs fertilized in place and may then brood their young.

The ability to regenerate lost parts is characteristic of coelenterates. Pieces cut from almost any part of polyps will in time grow into new polyps. The regenerative powers of medusae are much less well developed, and not only will the excised piece not develop but it may not even be replaced by the medusa. Gradients of regenerative ability in polyps exist with the ability for a piece to reconstitute a new whole organism decreasing from the mouth to the base. See REGENERATION (BIOLOGY). [C.H.]

The Coelenterata have a long and impressive fossil record stretching from the present into the Precambrian, about 700,000,000 years ago. Thus, the known duration of this phylum equals or exceeds that of other animal phyla. Forms with skeletons, primarily the Conulata, Tabulata, Rugosa, and Scleractinia, have left fairly complete fossil records, whereas soft-bodied forms, such as most of the Hydrozoa, Scyphomedusae, and Alcyonaria, are represented by very few fossils. [C.H.St.]

**Coelom** The mesodermally lined body cavity of most animals above the flatworms and nonsegmented roundworms. Its manner of origin provides one basis for classifying the major higher groups.

Annelids, arthropods, and mollusks have a coelom which develops from solid mesodermal bands. Within the trochophore larva of annelids, a single pole cell proliferates two strips of mesoblast lying on either side of the ventral midline. These bands subdivide transversely into bilateral solid blocks, the somites. Each somite then splits internally to form a hollow vesicle, the cavity of which is the coelom. The mollusks also form bands of mesoderm from a single pole cell, but these bands do not segment. They split internally to form single right and left coelomic sacs, but the cavities are soon reduced and the surrounding mesoblast disperses as separate cells, many of which become muscle. The only remnants of the coelom in the adult are the pericardial cavity and the cavities of the gonads and their ducts. In arthropods paired bands of mesoblast may proliferate from a posterior growth center or may separate inward from a blastoderm, a superficial layer of cells, on the ventral surface of the egg. These bands divide into linear series of somites which then hollow out. Their cavities represent the coelom.

Echinoderms and chordates constitute a second major group, characterized by the origin of the coelom from outpocketings of the primitive gut wall. In echinoderms one pair of bilateral pouches evaginates and separates from the archenteron or primitive digestive cavity. Each pouch constricts into three portions, not homologous to the metameres of other animals.

The protochordates of the groups Hemichordata and Cephalochordata have three coelomic pouches formed by separate evaginations of the archenteral roof. In hemichordates the head cavity remains single as the cavity of the proboscis and has a pore to the exterior on each side. The second pouches form cavities within the collar and also acquire external pores. The third pair is contained within the trunk and forms the major perivisceral cavity.

In cephalochordates the head cavity divides into lateral halves. The left side communicates, by a pore, to an ectodermal pit called the wheel organ. The second pair of pouches forms the pair of mesoblastic somites, and the third pouches subdivide transversely to give rise to the remainder of the linear series of somites. The upper or myotomic portion of each somite remains metameric and forms the segmental muscles. As it enlarges, the coelomic space is displaced ventrally and expands above and below the gut to form the perivisceral cavities and mesenteries, as described for annelids.

In vertebrates the mesoderm arises as a solid sheet from surface cells that have been involuted through the blastopore. Lateral to the notochord, beginning at about the level of the ear, the mesoderm subdivides into three parts: (1) the somites; (2) the nephrotomic cord, temporarily segmented in lower vertebrates, which will form excretory organs and ducts; and (3) the unsegmented lateral plate. The coelom arises as a split within the lateral plate. See ANIMAL KINGDOM; GASTRULATION. [H.L.H.]

**Coelomycetes** Mitosporic or anamorphic (asexual or imperfect) fungi (Deuteromycotina) with sporulation occurring inside fruit bodies (conidiomata) that arise from a thallus consisting of septate hyphae. About 1075 genera containing more than 10000 species are recognized.

The Coelomycetes, like other groups of deuteromycetes, is artificial, comprising almost entirely anamorphic fungi of ascomycete affinity. Some are known anamorphs of Ascomycotina, although there are a few (*Fibulocoela*, *Cenangiomycetes*) with Basidiomycotina affinities because they have clamp connections or dolipore septa. Taxa are referred to as form genera and form species because the absence of a teleomorph (sexual or perfect) state means that they are classified and identified by artificial rather than phylogenetic means. The unifying feature of the group is the production of conidia inside cavities lined by fungal tissue, or by a combination of fungal and host tissue which constitutes the conidioma. See ASCOMYCOTA; BASIDIOMYCOTA.

Differences in conidiomatal structure traditionally have been used to separate three orders: the Melanconiales, the Sphaeropsidales, and the Pycnothyriales. However, differences in the ways that conidia are produced are now used in classification and identification.

Coelomycetes are known mainly from temperate and tropical regions. They grow, reproduce, and survive in a wide range of ecological situations and can be categorized as either stress-tolerant or combative species. They are commonly found in and recovered from soils, leaf litter and other organic debris from both natural and manufactured sources (as biodegraders and biodegradative organisms), and saline and fresh water; and on other fungi and lichens. Several are of medical importance, associated with acute conditions in humans and animals, often as opportunistic organisms causing infection in immunocompromised patients. Coelomycetes are consistently isolated from or associated with disease conditions in all types of vascular plants, often in association with other organisms. See PLANT PATHOLOGY.

[B.C.S.]

**Coenopteridales** True ferns which span the Late Devonian through Permian time between the recognizable beginnings of fernlike morphology and the earliest-appearing extant filicalean families (Gleicheniaceae, Osmundaceae). A true fern is a relatively advanced type of vascular land plant with distinct stem, fronds, roots, and foliar-borne annulate sporangia.

Coenopterid ferns are mostly small and simple in contrast to late Paleozoic tree ferns of the Marattiales.

There are two major distinct groups. Zygopterid ferns are the most ancient and diverse, and apparently a dead-end evolutionary line; they differ the most from other ferns. Coenopterid ferns are usually placed in the Anachoropteridaceae and Botryopteridaceae, or in one of several extinct families assigned to the Filicales. Coenopterid ferns *sensu stricto* are probably ancestral to, and consequently form an imperceptible transition with, the Filicales.

The Zygopteridaceae appear in Late Devonian time, the Botryopteridaceae in Visean (Mississippian), the Anachoropteridaceae in the lower Westphalian A (Pennsylvanian), and all families extend into the Permian. See PALEOBOTANY. [T.L.P.]

**Coenothecalia** An order of the class Alcyonaria. The Coenothecalia have no spicules but form colonies with a massive skeleton composed of fibrocrystalline aragonite fused into lamellae. The skeleton is perforated by both numerous wide cylindrical cavities occupied by the polyps, and narrow ones containing the solenial systems. The order includes a few genera, of which *Heliopora*, or the blue coral, is often found on coral reefs. See ALCYONARIA. [K.At.]

**Coenurosis** The infection by the larval stage of several species of *Taenia* from canids, such as *T. multiceps*, *T. serialis*, and *T. brauni*. It is rare in humans. Symptoms are the result of toxic and allergenic metabolites and pressure effects. Surgery may be attempted; chemotherapy may be effective, but secondary effects still render a poor prognosis. Herbivores feeding on grass contaminated by the parasite's eggs also develop coenurosis. If the central nervous system is involved (as is frequent in sheep) neurological signs appear and the animal staggers and circles. Economic losses in sheep-raising regions due to coenurosis are considerable. The disease could be controlled by treatment of shepherd dogs. See CYCLOPHYLLEIDA. [J.F.M.]

**Coenzyme** An organic cofactor or prosthetic group (non-protein portion of the enzyme) whose presence is required for the activity of many enzymes. The prosthetic groups attached to the protein of the enzyme (the apoenzyme) may be regarded as dissociable portions of conjugated proteins. Neither the apoenzyme nor the coenzyme moieties can function singly. In general, the coenzymes function as acceptors of electrons or functional groupings, such as the carboxyl groups in  $\alpha$ -keto acids, which are removed from the substrate. See PROTEIN.

Well-known coenzymes include the pyridine nucleotides, nicotinamide adenine dinucleotide (NAD) and nicotinamide adenine dinucleotide phosphate (NADP); thiamine pyrophosphate (TPP); flavin mononucleotide (FMN) and flavinadenine dinucleotide (FAD); iron protoporphyrin (hemin); uridine diphosphate (UDP) and UDP-glucose; and adenosine triphosphate (ATP), adenosine diphosphate (ADP), and adenosine monophosphate (AMP). Coenzyme A (CoA), a coenzyme in certain condensing enzymes, acts in acetyl or other acyl group transfer and in fatty acid synthesis and oxidation. Folic acid coenzymes are involved in the metabolism of one carbon unit. Biotin is the coenzyme in a number of carboxylation reactions, where it functions as the actual carrier of carbon dioxide. See ADENOSINE DIPHOSPHATE (ADP); ADENOSINE TRIPHOSPHATE (ATP); BIOTIN; ENZYME; HEMOGLOBIN; NICOTINAMIDE ADENINE DINUCLEOTIDE (NAD); NICOTINAMIDE ADENINE DINUCLEOTIDE PHOSPHATE (NADP); URIDINE DIPHOSPHOGLUCOSE (UDPG). [M.B.McC.]

**Coesite** Naturally occurring coesite, a mineral of wide interest and the high-pressure polymorph of SiO<sub>2</sub>, was first discovered and identified from shocked Coconino sandstone of the Meteor Crater in Arizona in 1960. Since then coesite has been identified from the Wabar (meteorite) Crater in Saudi Arabia, from the Ries Crater in Bavaria in southern Germany, from the Lake

Bosumtwi Crater in Ashanti, Ghana, Africa, and from Lake Mien in Sweden. Coesite has also been identified from some Thailand tektites which are considered to have been formed also by an impact cratering process. The finding of natural coesite elevates it as a true mineral species. Because it requires a unique physical condition, extremely high pressure, for its formation, its occurrence is diagnostic of a special natural phenomenon, in this case, the hypervelocity impact of a meteorite. See METEORITE.

Synthetic coesite was first produced in the laboratory by L. Coes, Jr., as a chemical compound at pressures of about 35 kilobars ( $3.5 \times 10^9$  pascals) in the temperature range of 500–800°F (246–404°C). Coesite has also been found in synthetic diamonds and has been formed by transformation from alpha quartz by the application of shearing stress. See DIAMOND.

Coesite occurs in grains that are usually less than 0.0002 in. (5 micrometers) in size and are generally present in small amounts. The properties of the mineral are known mainly from studies of synthesized crystals. It is colorless with vitreous luster and has no cleavage. It has a specific gravity of  $2.915 \pm 0.015$  and a hardness of about 8 on Mohs scale.

Coesite has as yet no evident commercial use and therefore has no obvious economic value. As a stepping-stone in scientific research, it serves in at least two ways: where it occurs naturally, coesite is diagnostic of a past history of high pressure; the occurrence of coesite from Meteor Crater clearly suggests that shock as a process can transform a low-density ordinary substance to one of high density and unique properties. Coesite has been found in materials ejected from craters formed by the explosion of 500,000 tons (450,000 metric tons) of TNT. Research on the occurrence of coesite from rocks deformed by other energy sources, such as volcanic explosions and deep-seated tectonic movement, is continuing. The study of coesite and craters may be useful in understanding the impact craters on the Earth as well as those on the Moon. [E.C.T.C.]

**Coffee** A tropical evergreen shrub or small tree of the genus *Coffea* (Rubiaceae), a native of northeast Africa and adjacent southwest Asia. The beverage known as coffee is made by the hot-water extraction of solubles from the ground roasted beans (seeds) of the shrub. *Coffea* grows mainly between the Tropic of Cancer and Tropic of Capricorn at elevations of 2000–6000 ft (600–1800 m) above sea level, at temperatures near 70°F (21°C), and with annual rains near 60 in. (150 cm).

Annual international commerce is about 75 million bags (standard of 130 lb or 60 kg per bag) of green coffee beans, that is, coffee beans that have been cultivated, harvested, and are ready for commercial processing. The supply generally is a third each from Brazil, Africa, and all other countries. The United States and Europe consume 85% of all world exports. Coffee beverage has no nutritive value and is consumed for its flavor and stimulating effects. The stimulating ingredient in coffee is caffeine. The two main coffee varieties are Arabica with about 1.1% caffeine and Robusta with 2.2%. See CAFFEINE.

The coffee plant is a shrub or relatively small tree, often controlled to a height of 15–18 ft (4.5–5.5 m). *Coffea arabica* (milds) accounts for 69% of world production; *C. canephora* (robustas), 30%; and all others, 1%. Each species includes several varieties.

After the spring rains, the plant produces white flowers. About 6 months later the flowers are replaced by fruit the size of a small cherry. The cherries can be selectively picked to harvest only ripe ones, or strip-picked to yield mostly ripe but also some over- or underripe fruit. The green coffee beans are the two halves of the seed derived from the processed cherries.

Coffee cherries are processed by either dry or wet methods. In the dry method, the cherries from strip picking are spread on open drying ground and turned frequently to permit thorough drying by the sun and wind. Some producing areas use hot air, indirect steam, and other machine-drying devices. When the coffee cherries are thoroughly dry, they are transferred to hulling machines that remove the skin, pulp, parchment shell, and silver

skin in a single operation. In the wet method, freshly picked ripe coffee cherries are fed to a tank for initial washing and removal of stones and other foreign material. The cherries are then transferred to depulping machines that remove the outer skin and most of the pulp, although some pulp mucilage clings to the parchment shells that encase the coffee beans. This is removed in fermentation tanks, usually containing water. The beans are then dried, either in the sun or in mechanical dryers. After drying, the coffee is further processed in machines that remove silver skins, producing green coffee beans. The coffee beans are then machine graded. After processing, the green beans have 10–12% moisture and maintain acceptable quality for about a year.

A series of basic bean processing steps is required to produce the major types of commercial coffee products. First, the green beans are weighed and cleaned, and then they are stored in silos, each containing a single bean type. Green coffee beans to be used for decaffeinated coffee products are processed separately to remove the required amount of caffeine (usually 97% in the United States) and then stored in special silos before further processing.

Roasting and grinding are key steps in producing all coffee products. The roasting step is the most important operation in defining the final product characteristics. Roasting is usually conducted by use of hot combustion gases in rotating cylinders or fluidized-bed systems. When the bean temperature reaches 375–475°F (190–246°C), roasting is terminated by rapidly adding a water quench. The final roast temperature is the critical control point that fixes the flavor and color of the product, and it must be consistent for good quality control. The quenched beans are air cooled and conveyed to storage bins for moisture and temperature equilibration prior to grinding. Residual foreign material (mostly stones) that has passed through the initial cleaning step is removed in transit to the storage bins by means of a high-velocity air lift, which leaves the heavier debris behind. Grinding of the roasted coffee beans is tailored to the requirements of the intended beverage preparation. For example, only coarse cracking of the beans is needed for instant coffee, whereas finer grinds are required for packaged roast and ground coffee. The most commonly used grinder is a multistep steel roll mill. Particle size is controlled by regulation of roll separation.

Instant coffee comprises the dried solids made from water extraction of the soluble solids in roasted and partially ground (cracked) coffee. The extraction process follows the same principle as home brewing using a filter-drip percolator, except that it is much more efficient and results in very high solid-extraction yields. The coffee extract is concentrated from about 20–35% to 50% by using multiple-effect vacuum evaporators or freeze concentration, or a combination of both. The flavor of the final dry product can be enhanced by recovering the aroma and flavor compounds prior to, or as part of, the concentration process and then introducing these to the concentrated extract just before drying. The method of drying defines the instant coffee as either spray dried or freeze dried. Spray drying involves spraying the concentrated aroma-enhanced extract into a concurrently flowing stream of hot combustion gases. Freeze drying uses special high-vacuum equipment to remove water from the frozen extract by sublimation. Freeze-dried coffee is more expensive to produce and requires a much higher investment than the spray-dried product. See DRYING; EXTRACTION.

Decaffeinated coffees represent about 18% of the total coffee consumption in the United States. Decaffeinated coffee was commercially developed in Europe about 1900. The early process involved direct contact of water-moistened beans with a solvent. The principle of moisturizing green coffee before decaffeination remains a key process step for all decaffeination processes, because it facilitates transport of caffeine through the cell walls. A water extraction process was developed in the United States in 1943 which provided a decaffeinated coffee with improved flavor and with very low solvent residues. Natural decaffeination processes were invented and commercialized from

the mid-1970s through the 1980. Three processes for natural decaffeinated products are commercially available. The water process is in many ways the same as the earlier water extraction process. However, instead of using a solvent to remove caffeine from a green coffee extract, the extract is decaffeinated by adsorption using activated carbon. The supercritical CO<sub>2</sub> processes use carbon dioxide (CO<sub>2</sub>) above its critical temperature (supercritical CO<sub>2</sub>) to remove caffeine from green coffee beans. Other so-called natural processes are similar to older solvent processes but use solvents (such as ethyl acetate) considered to be natural, based on the designation “generally regarded as safe” (GRAS) by the U.S. Food and Drug Administration. See ACTIVATED CARBON; ADSORPTION. [FKr.]

**Cofferdam** A temporary, wall-like structure to permit dewatering an area and constructing foundations, bridge piers, dams, dry docks, and like structures in the open air. A dewatered area can be completely surrounded by a cofferdam structure or by a combination of natural earth slopes and cofferdam structure. The type of construction is dependent upon the depth, soil conditions, fluctuations in the water level, availability of materials, working conditions desired inside the cofferdam, and whether the structure is located on land or in water (see illustration). An important consideration in the design of cofferdams is the hydraulic analysis of seepage conditions, and erosion of the bottom when in streams or rivers.

Where the cofferdam structure can be built on a layer of impervious soil (which prevents the passage of water), the area within the cofferdam can be completely sealed off. Where the soils are pervious, the flow of water into the cofferdam cannot be completely stopped economically, and the water must be pumped out periodically and sometimes continuously.

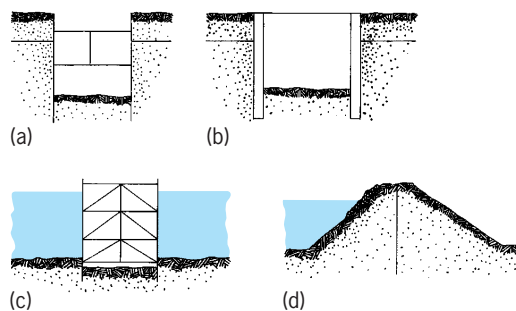

Types of cofferdams for use on land: (a) cross-braced sheet piles, (b) cast-in-place concrete cylinder; and in water: (c) cross-braced sheet piles, (d) earth dam.

A nautical application of the term cofferdam is a watertight structure used for making repairs below the waterline of a vessel. The name also is applied to void tanks which protect the buoyancy of a vessel. [E.J.Q.]

**Cogeneration** The sequential production of electricity and thermal energy in the form of heat or steam, or useful mechanical work, such as shaft power, from the same fuel source. Cogeneration projects are typically represented by two basic types of power cycles, topping or bottoming. The topping cycle has the widest industrial application.

The topping cycle utilizes the primary energy source to generate electrical or mechanical power. Then the rejected heat, in the form of useful thermal energy, is supplied to the process. The cycle consists of a combustion turbine-generator, with the turbine exhaust gases directed into a waste-heat-recovery boiler that converts the exhaust gas heat into steam which drives a steam turbine, extracting steam to the process while driving an electric generator. This cycle is commonly

referred to as a combined cycle arrangement. Combustion turbine-generators, steam turbine-generator sets, and reciprocating internal-combustion-engine generators are representative of the major equipment components utilized in a topping cycle. See GENERATOR; STEAM TURBINE; TURBINE.

A bottoming cycle has the primary energy source applied to a useful heating process. The reject heat from the process is then used to generate electrical power. The typical bottoming cycle directs waste heat from a process to a waste-heat-recovery boiler that converts this thermal energy to steam which is supplied to a steam turbine, extracting steam to the process and also generating electrical power. See ELECTRIC POWER GENERATION.

Cogeneration for building and district space heating and cooling purposes consists of producing electricity and sequentially utilizing useful energy in the form of steam, hot water, or direct exhaust gases. The two most common heating, ventilating, and air-conditioning cycles are the vapor compression cycle and the absorption cycle. See AIR CONDITIONING; CENTRAL HEATING AND COOLING; COMFORT HEATING; DISTRICT HEATING. [C.Bu.]

**Cognition** The internal structures and processes that are involved in the acquisition and use of knowledge, including sensation, perception, attention, learning, memory, language, thinking, and reasoning. Cognitive scientists propose and test theories about the functional components of cognition based on observations of an organism's external behavior in specific situations.

Cognition throughout life can be broadly described as an interaction between knowledge-driven processes and sensory processes; and between controlled processes and automatic processes. Over time, there is a trade-off between the amount of surface information that is retained in the internal representation of objects or events (bottom-up processing) and the amount of meaning that is incorporated (top-down processing). Following exposure to a stimulus, a sensory representation (sometimes called an image, icon, or echo) is constructed that encodes nearly all the surface characteristics of the stimulus (for example, color, shape, location, pitch, and loudness). The information is short lived, lasting less than a second. Much evidence suggests that extraction of information from this representation takes place in two stages, a feature analysis stage and an object recognition stage. It is during the latter stage that attention (controlled processing) and previous knowledge come into play. See MEMORY; PERCEPTION.

Conceptual knowledge is needed to classify objects and events in the world. Some aspects of conceptual knowledge are innate or emerge very early in development, while others are acquired through learning and inference.

A primary cognitive function of all social species is communication, which can be accomplished by a combination of vocal, gestural, and even hormonal signals. Of all species on Earth, only humans have developed a communication system based on abstract signs. This evolutionary development is closely tied to the greater reasoning capacity of humans as well. All reasoning can be broadly described as pattern recognition and search. Conceptual knowledge base are searched for relevant information in order to draw a conclusion, solve a problem, or guide behavior. Thinking often takes the form of a chain of associations among concepts in long-term memory, with one thought retrieving others to which it is related. The most common reasoning strategies include direct retrieval, imaging, means-ends analysis, analogy, classification, deduction, and formal procedures.

Reasoning by direct retrieval involves retrieving a known fact from memory to solve a problem. Reasoning imagistically involves constructing or retrieving images from conceptual memory and examining or manipulating them to solve a problem. For example, individuals reason imagistically when they determine how many windows there are in their living rooms by retrieving an image of the room and counting the windows in the image.

Means-ends analysis is typically employed when solving problems in unfamiliar domains. When a solution is not immediately

apparent, reasoners typically compare the goal to the current situation and select means with which to reduce the differences between the two situations.

The restructuring of a problem representation that allows an available means to be used in a novel way or a seemingly unrelated bit of knowledge to be accessed to solve the problem is called insight.

Reasoning by analogy is used when a current situation allows an individual to recall another, similar situation that has a known solution or other information relevant to the task at hand. It is a technique that is powerful but error prone.

Reasoning by classification involves making inferences about an object or event based on its category membership.

Deductive reasoning involves drawing a conclusion based on its logical relation to one or more premises. A second common use for deduction is testing hypotheses.

Formal procedures for reasoning and for solving problems include logic, mathematics, probability theory and statistics, and scientific investigation. Understanding of the behavior and properties of physical, biological, and cognitive systems has been greatly enhanced through the use of these techniques. See PSYCHOLINGUISTICS.

By using noninvasive techniques such as positron emission tomography (PET scan), magnetic resonance imaging, electrical skin conductance, invasive surgical and chemical investigations of animal brains, and data from clinically observed syndromes associated with brain injury, cognitive neuroscientists have pieced together information concerning the role that specific brain regions play in the processing of emotional and cognitive events. High-level visual processing, such as object recognition, takes place in the occipital lobes of the cortex, although recognition of certain highly complex visual stimuli, such as faces, is handled by the right cerebral hemisphere. Auditory stimuli in general are processed by the temporal lobes of the cortex, and written and spoken word recognition and syntactical components of language processing are handled by certain regions of the left hemisphere of the cerebral cortex, notably Broca's and Wernicke's areas; while emotional, idiomatic, and prosodic aspects of language are handled by corresponding regions in the right hemisphere. Higher cognition, such as reasoning and problem solving, involves the frontal lobes of the cortex. Memory and the processing of emotional stimuli are handled by the combined effort of the cortex (notably the anterior and frontal regions) and subcortical structures (notably the limbic system).

One particular subcortical structure—the hippocampus—plays a major role in the formation of new explicit memories. It is believed that an intact hippocampus is needed to temporarily bind together distributed sites of activation in the cortex that together make up a whole, explicit memory for an event. See BRAIN; COMPUTERIZED TOMOGRAPHY.

Theories of cognition are often tested by building computer models that embody the theories and then comparing the model's performance with human performance on selected tasks. These models tend to be of two types. Rule-based models consist of a long-term memory containing rules which specify actions to take in the presence of particular input patterns, a short-term memory that encodes input patterns and temporarily stores data structures constructed by the rules, and a control structure that guides the process and resolves conflicts when more than one rule applies to the current input. Neural network models simulate cognition as a strengthening and weakening of associations among cognitive events. They consist of a network of interconnected nodes, a mathematical formula for modifying the connections, and a mathematical formula for propagating activation through the network. See EXPERT SYSTEMS; INFORMATION PROCESSING (PSYCHOLOGY); INTELLIGENCE; PROBLEM SOLVING (PSYCHOLOGY). [D.D.C.]

**Coherence** The attribute of two or more waves, or parts of a wave, whose relative phase is constant during the resolving

time of the observer. The concept has been developed most extensively in optics, but is applicable to all wave phenomena.

Consider two waves, with the same mean angular frequency  $\omega$ , given by Eqs. (1) and (2). It is convenient, and no restric-

$$\Psi_A(x,t) = A \exp \{i[k(\omega)x - \omega t - \delta_A(t)]\} \quad (1)$$

$$\Psi_B(x,t) = B \exp \{i[k(\omega)x - \omega t - \delta_B(t)]\} \quad (2)$$

tion, to choose both  $A$  and  $B$  real. These expressions as they stand could describe de Broglie waves in quantum mechanics. For real waves, such as components of the electric field in light or radio beams, or the pressure oscillations in sound, it is necessary to retain only the real parts of these and subsequent expressions. The frequency spectrum is assumed to be narrow, in the sense that a Fourier analysis of expressions (1) and (2) gives appreciable contributions only for angular frequencies close to  $\omega$ . This assumption means that, on the average,  $\delta_A(t)$  and  $\delta_B(t)$  do not change much per period. See ELECTROMAGNETIC RADIATION; QUANTUM MECHANICS; SOUND.

Suppose that the waves are detected by an apparatus with resolving time  $T$ , that is,  $T$  is the shortest interval between two events for which the events do not seem to be simultaneous. For the human eye and ear,  $T$  is about 0.1 s, while a fast electronic device might have a  $T$  of  $10^{-10}$  s. If the relative phase  $\delta(t)$ , given by Eq. (3), does not, on the average, change noticeably during

$$\delta(t) = \delta_B(t) - \delta_A(t) \quad (3)$$

$T$ , then the waves are coherent. If during  $T$  there are sufficient random fluctuations for all values of  $\delta(t)$ , modulus  $2\pi$ , to be equally probable, then the waves are incoherent. If during  $T$  there are noticeable random fluctuations in  $\delta(t)$ , but not enough to make the waves completely incoherent, then the waves are partially coherent. These distinctions are not useful unless  $T$  is specified. On the one hand, only waves that have existed forever and that fill all of space can have absolutely fixed frequency and phase. On the other hand, two independent sound waves in the phases change appreciably in 0.01 s would seem incoherent to the human ear, but would seem highly coherent to a fast electronic device.

The degree of coherence is related to the interference patterns that can be observed when the two beams are combined. See INTERFERENCE OF WAVES.

Coherence is also used to describe relations between phases within the same beam. Suppose that a wave represented by Eq. (1) is passing a fixed observer characterized by a resolving time  $T$ . The phase  $\delta_A$  may fluctuate, perhaps because the source of the wave contains many independent radiators. The coherence time  $\Delta t_w$  of the wave is defined to be the average time required for  $\delta_A(t)$  to fluctuate appreciably at the position of the observer. If  $\Delta t_w$  is much greater than  $T$ , the wave is coherent; if  $\Delta t_w$  is of the order of  $T$ , the wave is partially coherent; and if  $\Delta t_w$  is much less than  $T$ , the wave is incoherent. These concepts are very close to those developed above.

Extended sources give partial coherence and produce interference fringes with visibility  $V$  less than unity. A. A. Michelson exploited this fact with his stellar interferometer, a modified double-slit arrangement with movable mirrors that permit adjustment of the effective separation  $D'$  of the slits. It can be shown that if the source is a uniform disk of angular diameter  $\theta$ , then the smallest value of  $D'$  that gives zero  $V$  is  $1.22\lambda/\theta$ . The same approach has also been applied in radio astronomy. A different technique, developed by R. Hanbury Brown and R. Q. Twiss, measures the correlation between the intensities received by separated detectors with fast electronics. See INTERFEROMETRY.

Because they are highly coherent sources, lasers and masers provide very large intensities per unit frequency. See LASER.

[R.G.Wi.]

Photon statistics is concerned with the probability distribution describing the number of photons incident on a detector,

or present in a cavity. By extension, it deals with the correlation properties of beams of light.

According to the quantum theory of electromagnetism, quantum electrodynamics, light is made up of particles called photons, each of which possesses an energy  $E$  of  $\hbar\omega$ , where  $\hbar$  is Planck's constant divided by  $2\pi$  and  $\omega$  is the angular frequency of the light (the frequency multiplied by  $2\pi$ ). In general, however, the photon number is an intrinsically uncertain quantity. It is impossible to precisely specify both the phase  $\phi = \omega t$  of a wave and the number of photons  $n \approx E/(\hbar\omega)$  that it contains; the uncertainties of these two conjugate variables must satisfy  $\Delta n \Delta \phi \geq \frac{1}{2}$ . For a beam to be coherent in the sense of having a well-defined phase, it must not be describable in terms of a fixed number of particles. (Lacking a fixed phase, a single photon may interfere only with itself, not with other photons.) See PHOTON; QUANTUM ELECTRODYNAMICS.

The most familiar example of this uncertainty is shot noise, the randomness of the arrival times of individual photons. There is no correlation between photons in the coherent state emitted by a classical source such as an ideal laser or radio transmitter, so the number of photons detected obeys Poisson statistics, displaying an uncertainty equal to the square root of the mean. The shot noise constitutes the dominant source of noise at low light levels, and may become an important factor in optical communications as well as in high-precision optical devices (notably those that search for gravitational radiation). See DISTRIBUTION (PROBABILITY); ELECTRICAL NOISE. [A.M.S.]

**Cohesion (physics)** The tendency of atoms or molecules to coalesce into extended condensed states. This tendency is practically universal. In all but exceptional cases, condensation occurs if the temperature is sufficiently low; at higher temperatures, the thermal motions of the constituents increase, and eventually the solid assumes gaseous form. The cohesive energy is the work required to separate the condensed phase into its constituents or, equivalently, the amount by which the energy of the condensed state is lower than that of the isolated constituents. The science of cohesion is the study of the physical origins and manifestations of the forces causing cohesion, as well as those opposing it. It is thus closely related to the science of chemical bonding in molecules, which treats small collections of atoms rather than extended systems. See CHEMICAL BONDING; INTERMOLECULAR FORCES.

The origin and magnitude of the attractive forces depend on the chemical nature of the constituent atoms or molecules. Strong attractive interactions are usually associated with constituents having valence electron shells which are partly filled or open; if the valence electron shells are completely filled or closed, the interactions are weaker. See VALENCE.

For open-shell constituents, as the atoms approach, the electron energy levels on different atoms begin to interact, forming a complex of energy levels in the solid. Some of these are below the atomic energy levels and some above. Since the atomic shells are partly filled, the lower energy levels in the solid are filled, but at least some of the higher levels are empty. Thus the average energy of the occupied levels in the solid is lower than that in the isolated atoms, resulting in an attractive force. Bonding in open-shell systems can be approximately divided into three categories, although most cases involve a combination. See BAND THEORY OF SOLIDS; FERMI-DIRAC STATISTICS; SOLID-STATE PHYSICS; VALENCE BAND.

1. *Covalent bonding.* This type of bonding is most similar to the molecular bond. The electron energy levels in the solid are split into a lower and a higher portion, with the states in the lower one filled and the higher one empty. Covalent bonds are strongly directional, with electron charge accumulating around the bond centers. Materials bonded in this fashion typically form structures with low coordination numbers, prototypical materials elements in group IV of the periodic table, the insulator carbon,



and the semiconductors silicon and germanium. See PERIODIC TABLE; SEMICONDUCTOR.

2. *Metallic bonding.* In this case, there is no split between the lower and higher states of the electrons in the solid; rather, they occupy levels from the bottom up to a cutoff point known as the Fermi level. For example, in transition metals, the electron states in the solid derived from the atomic *d* orbitals form a complex which is gradually filled with increasing atomic number. The bulk of the cohesive energy is due to this complex. The metallic bond is less directional than the covalent bond, with a more uniform distribution of electronic charge. Metals usually form closely packed structures. See FERMİ SURFACE; FREE-ELECTRON THEORY OF METALS.

3. *Ionic bonding.* This occurs in compounds having at least two distinct types of atoms. One or more of the species of atoms (the cations) have only a small number of electrons in their valence shells, whereas at least one species (the anions) has a nearly filled valence shell. As the atoms approach each other, electrons drop from the cation valence states into holes in the anion valence shell, forming a closed-shell configuration in the solid. The different types of atoms in the solid have net charges; a strong attractive force results from the interaction between unlike charges. For example, in sodium chloride (NaCl), the sodium atoms acquire positive charges, and the chlorine atoms acquire negative charges. The closest interatomic separations in the solid are between sodium and chlorine, so that the attractive electrostatic interactions outweigh the repulsive ones. See IONIC CRYSTALS; SOLID-STATE CHEMISTRY.

In closed-shell constituents, the above effects are greatly reduced because the atomic or molecular shells are basically inert. The constituents retain their separate identities in the solid environment. If the constituents are atomic, as in rare-gas solids, the cohesion is due to the van der Waals forces. The positions of the electrons in an atom fluctuate over time, and at any given time their distribution is far from spherical. This gives rise to fluctuating long-ranged electric fields, which average zero over time, but can still have appreciable effects on neighboring atoms. The electrons on these atoms move in the direction of the force exerted by the electric field. The net result is that the interactions between unlike charges (electrons and nuclei) are increased in the solid, whereas the interactions between like charges are reduced. Thus the solid has a lower energy than the isolated atoms.

In solids made up of molecules, there are additional electrostatic interactions due to the nonspherical components of the molecular charge density. These interactions are strongest if the molecules are polar. This means that the center of the positive charge on the molecule is at a different point in space from that of the negative charge. Polar molecules, such as water (H<sub>2</sub>O), form structures in which the positive charge on a molecule is close to the negative charges of its neighbors. For nonpolar molecules, the electrostatic interactions are usually weaker than the van der Waals forces. The nonspherical interactions in such cases are often so weak that the molecules can rotate freely at elevated temperatures, while the solid is still held together by the van der Waals forces.

The repulsive forces in the condensed phase are a dramatic illustration of the combined action of two quantum-mechanical principles, the exclusion principle and the uncertainty principle.

The exclusion principle states that the quantum-mechanical wave function for the electrons in the solid must be antisymmetric under the interchange of the coordinates of any two electrons. Consequently, two electrons of the same spin are forbidden from being very close to each other. See EXCLUSION PRINCIPLE.

The uncertainty principle states that if the motion of an electron is confined, its kinetic energy must rise, resulting in a repulsive force opposing the confinement. The kinetic energy due to the confinement is roughly inversely proportional to the square of the radius of the region of confinement. According to the exclusion principle, the motion of an electron in a solid is partially confined because it is forbidden from closely approaching other

electrons of the same spin. Thus the uncertainty principle in turn implies a repulsive force. See UNCERTAINTY PRINCIPLE. [A.E.Ca.]

**Coil** One or more turns of wire used to introduce inductance into an electric circuit. At power line and audio frequencies a coil has a large number of turns of insulated wire wound close together on a form made of insulating material, with a closed iron core passing through the center of the coil. This is commonly called a choke and is used to pass direct current while offering high opposition to alternating current.

At higher frequencies a coil may have a powdered iron core or no core at all. The electrical size of a coil is called inductance and is expressed in henries or millihenries. In addition to the resistance of the wire, a coil offers an opposition to alternating current, called reactance, expressed in ohms. The reactance of a coil increases with frequency. See INDUCTOR; REACTOR (ELECTRICITY). [J.Mar.]

**Coining** A cold metalworking process in a press-type die. Coining is used to produce embossed parts, such as badges and medals, and for minting of coins. It is also used on portions of a blank or workpiece to form corners, indentations, or raised sections, frequently as part of a progressive die operation. The work is subjected to high pressure within the die cavity and thereby forced to flow plastically into the die details. The absence of overflow of excess metal from between the dies is characteristic of coining and is responsible for the fine detail achieved. See METAL FORMING. [R.L.Fr.]

**Coir** A natural fiber, also known as coco fiber, obtained from the husks of the coconut (*Cocos nucifera*). The outstanding characteristic of coir fiber is its resistance to rot. For example, a coir fiber doormat can stay out in the weather for years. Coir is only intermediate in strength among the vegetable fibers, but its elongation at break is greater than any of the bast or hard fibers. More than 95% of coir exports are from Sri Lanka and India; small amounts are exported from Thailand, Tanzania, Mexico, the Philippines, Malaysia, Kenya, and Trinidad and Tobago.

There are three main types of coir—yarn fiber, bristle fiber, and mattress fiber. Only the finest and longest fiber is suitable for spinning into yarn. It is obtained from the husks of unripe nuts and is the main cash crop rather than a by-product. The bristle fiber and most of the mattress fiber come from mature nuts and are by-products of copra production. Coir fiber ranges in color from light tan to dark brown. Bristles are sorted according to length and graded on the basis of length, stiffness, color, and cleanliness. Long, clean fibers and light color are desirable for any purpose, but stiffness is desirable in bristles and undesirable for yarn.

In developed countries, yarn fiber is used chiefly in mats and mattings; in the United States, for instance, its best-known use is in light-brown tufted doormats. In Asia it is used extensively for ropes and twines, and locally for hand-made bags. The principal outlet for bristle fiber has been in brush making, but the market has declined and most bristle fiber is now used in upholstery padding. Mattress fiber is used chiefly in innerspring mattresses, though it has found uses as an insulating material. See COCONUT; NATURAL FIBER. [E.G.N.]

**Coke** A coherent, cellular, carbonaceous residue remaining from the dry (destructive) distillation of a coking coal. It contains carbon as its principal constituent, together with mineral matter and residual volatile matter. The residue obtained from the carbonization of a noncoking coal, such as subbituminous coal, lignite, or anthracite, is normally called a char. Coke is produced chiefly in chemical-recovery coke ovens, but a small amount is also produced in beehive or other types of nonrecovery ovens.

Coke is used predominantly as a fuel reductant in the blast furnace, in which it also serves to support the burden. As the

fuel, it supplies the heat as well as the gases required for the reduction of the iron ore. It also finds use in other reduction processes, the foundry cupola, and house heating.

Coke is formed when coal is heated in the absence of air. During the heating in the range of 660–930°F (350–500°C), the coal softens and then fuses into a solid mass. The degree of softening attained during heating determines to a large extent the character of the coke produced. In order to produce coke having desired properties, two or more coals are blended before charging into the coke oven. In addition to the types of coals blended, the carbonizing conditions in the coke oven influence the characteristics of the coke produced. Oven temperature is the most important of these and has a significant effect on the size and the strength of the coke. In general, for a given coal, the size and shatter strength of the coke increase with decrease in carbonization temperature.

The important properties of coke that are of concern in metallurgical operations are its chemical composition, such as moisture, volatile-matter, ash, and sulfur contents, and its physical character, such as size, strength, and density. The moisture and the volatile-matter contents are a function of manner of oven operation and quenching, whereas ash and sulfur contents depend upon the composition of the coal charged. See CHARCOAL; COAL; DESTRUCTIVE DISTILLATION. [M.P.]

**Coking (petroleum)** In the petroleum industry, a process for converting nondistillable fractions (residua) of crude oil to lower-boiling-point products and coke. Coking is often used in preference to catalytic cracking because of the presence of metals and nitrogen components that poison catalysts. See CRACKING.

The liquid products from the coker, after cleanup via commercially available hydrodesulfurization technology, can provide large quantities of low-sulfur liquid fuels (less than 0.2 wt% sulfur). Another major application for the processes is upgrading heavy low-value crude oils into lighter products.

Petroleum coke is used principally as a fuel or, after calcining, for carbon electrodes. The feedstock from which the coke is produced controls the coke properties, especially in terms of sulfur, nitrogen, and metals content. A concentration effect tends to deposit the majority of the sulfur, nitrogen, and metals in the coke. Cokes exceeding around 2.5% sulfur content and 200 parts per million vanadium are mainly used, environmental regulations permitting, for fuel or fuel additives. The properties of coke for nonfuel use include low sulfur, metals, and ash as well as a definable physical structure. See PETROLEUM PRODUCTS. [J.G.S.]

**Cola** A tree, *Cola acuminata*, of the sterculia family (Sterculiaceae) and a native of tropical Africa. Its fruit is a star-shaped follicle containing eight hard seeds, the cola nuts of commerce. These nuts are an important masticatory in many parts of tropical Africa. They have a caffeine content twice that of coffee. The nuts also contain an essential oil and a glucoside, kolanin, which is a heart stimulant. Cola nuts, in combination with an extract from coca, are used in the manufacture of the beverage Coca-Cola. Cola is now cultivated in Angola, Jamaica, Brazil, India, and other parts of tropical Asia. See COCA; MALVALES. [P.D.St./E.L.C.]

**Colchicine** The major alkaloid obtained from the seed capsules, corms, and bulbs of the meadow saffron (autumn crocus; *Colchicum autumnale*). The use of the colchicum plant to relieve the pain of gout has been known since medieval times, and colchicine is still the standard treatment for gout, although it is an extremely toxic substance. An important property of colchicine is its ability to interrupt the mitotic cycle before cell division occurs. This effect leads to cells with multiple chromosomes, which are of value in plant breeding. See ALKALOID; LILIALES; MITOSIS; POLYPLIIDY. [J.A.Mo.]

**Cold hardiness (plant)** The ability of temperate zone plants to survive subzero temperatures. This characteristic is a predominant factor that determines the geographical distribution of native plant species and the northern limits of cultivation of many important agronomic and horticultural crops. Further, freezing injury is a major cause of crop loss resulting from early fall frosts, low midwinter temperatures, or late spring frosts. Problems of cold hardiness are of concern to farmers in diverse areas of agriculture. As a result, the development of varieties of cultivated plants with improved cold hardiness is of long-standing concern.

Within the plant kingdom there is a wide range of diversity in low-temperature tolerance—from low levels of hardiness in herbaceous species such as potatoes, to intermediate levels of hardiness for winter annuals such as wheat and rye, to extremely hardy deciduous trees and shrubs such as black locust and red osier dogwood that can withstand temperatures of liquid nitrogen. Within a given species, the range in hardiness can be substantial. Within a given plant there is a wide range in the cold hardiness of different tissues and organs. For example, roots are much less tolerant of subzero temperatures than shoots; flower buds are more sensitive than vegetative buds.

The cold hardiness of a given species is an inherent genetic trait that requires certain environmental cues for its expression. With the shorter days and cooler nights of autumn, temperate zone plants become dormant and increase their cold hardiness. This process is referred to as cold acclimation. In the spring, increasing daylength and warmer temperatures result in the resumed growth and development of the plant and a corresponding decrease in cold hardiness. Cold hardiness may be influenced by radiation, temperature, photoperiod, precipitation, and stage of development of the plant, with different optimum conditions for different species or cultivars and ecotypes within a species. The various environmental cues serve to synchronize plant development with the environment. This synchronization has taken centuries to evolve, and freezing injury in cultivated species can result from any factor that disrupts this synchrony.

Temperature is the key environmental parameter for increasing a plant's capacity to withstand freezing temperatures. Low, above-freezing temperatures are conducive to an increase in hardiness in the fall, and warm temperatures are responsible for the decrease in the spring. Generally, it is considered that most plants will acclimate as temperatures are gradually lowered below 50°F (10°C). However, during acclimation, the progressive decline in temperatures is extremely important. The development of cold hardiness may take 4 to 6 weeks.

Photoperiod is the second major factor influencing cold acclimation, but only in those species that are photoperiodically responsive in relation to growth cessation or induction of dormancy (a true physiological rest period). In other species, light is important only in providing sufficient photosynthetic reserves required for the cold acclimation process. In some cases (for example, germinating seeds), sufficient energy reserves are already present and acclimation can occur in the dark. See PHOTOPERIODISM.

There are conflicting reports on the role of moisture in relation to cold hardiness. High soil moisture may reduce the degree of cold acclimation; however, severe winter injury of evergreens will occur if soil moisture levels are too low. Most often tissue moisture levels will influence the survival to a given freeze-thaw cycle rather than directly influencing the process of cold acclimation. Thus, whereas temperature and light effects on hardiness are probably mediated through the development of hardiness (cold acclimation), tissue moisture content directly affects the stresses that are incurred during a freeze-thaw cycle. In addition, various cultural practices can influence the cold hardiness of a given plant. For example, late fall applications of fertilizer or improper pruning practices may stimulate flushes of growth that do not have sufficient time to acclimate. Conversely, insufficient

mineral nutrition can also impair the development of maximum cold hardness.

The process of cold acclimation results in numerous biochemical changes within the plant. These include increases in growth inhibitors and decreases in growth promoters; changes in nucleic acid metabolism; alterations in cellular pigments such as carotenoids and anthocyanins; the accumulation of carbohydrates, amino acids, and water-soluble proteins; increases in fatty acid unsaturation; changes in lipid composition; and the proliferation of cellular membrane systems. Some of these are merely changes in response to slower growth rates and decreased photosynthate utilization; others are changes associated with growth at low, above-zero temperatures; and still others are associated with other developmental phenomena, such as vernalization or the induction of dormancy, that also occur during the period of cold acclimation.

Large increases in cellular solute concentrations are one of the most universal manifestations of cold acclimation. A doubling of the intracellular solute concentration, most notably sugars, is not uncommon. Such increases have several beneficial effects. First, they serve to depress the freezing point of the intracellular solution. More important, a doubling of the initial intracellular solute concentration will decrease the extent of cell dehydration at any subzero temperature by 50%. An increase in intracellular solutes will also decrease the concentration of toxic solutes at temperatures below 32°F (0°C), because less water will be removed. Following cold acclimation there are also substantial changes in the lipid composition of the plasma membrane. This includes an increase in free sterols with corresponding decreases in steryl glucosides and acylated steryl glucosides, a decrease in the glucocerebroside content, and an increase in the phospholipid content. The complexity of the plasma membrane lipid composition and the numerous changes that occur during cold acclimation preclude the possibility of any simple correlative analysis; however, studies have demonstrated that differential behavior of the plasma membrane observed in protoplasts isolated from nonacclimated and cold-acclimated leaves is a consequence of alterations in the lipid composition. See ALTITUDINAL VEGETATION ZONES; PLANT PHYSIOLOGY; PLANT-WATER RELATIONS. [P.L.S.]

**Cold storage** The storage of perishables at low temperatures, usually above freezing, by the use of refrigeration to increase the storage life. In general, the lower the temperature, the longer the storage life. If temperatures are maintained below the freezing point of the product stored, it is called freezer storage. Most fruits and many other products, however, are damaged by freezing and cannot be kept in freezer storage. A cold-storage plant is a large insulated building, with its attendant refrigeration equipment, for storage of commodities at low temperatures. Facilities are often included for quick-freezing fruits, vegetables, meats, and a variety of precooked foods and bakery products for the consumer convenience market. See REFRIGERATION. [C.F.K.]

**Colemanite** One of the more common minerals of the borate group (in which boron is chemically bonded to oxygen), colemanite is a hydroxy-hydrated calcium borate with the chemical formula  $\text{Ca}[\text{B}_3\text{O}_4(\text{OH})_3](\text{H}_2\text{O})$  [Ca = calcium, B = boron, O = oxygen, OH = hydroxyl,  $\text{H}_2\text{O}$  = water].

Colemanite is white to gray with a white streak, is transparent to translucent, and has a vitreous luster. It occurs either as short highly modified prismatic crystals or as massive to granular aggregates. It has perfect cleavage in one direction, parallel to the sheet nature of its crystal structure. Colemanite has hardness of 4–4½ on Mohs scale and a specific gravity of 2.42. See HARDNESS SCALES.

Colemanite typically occurs in lacustrine (lake) evaporite deposits of Tertiary age. It forms by thermal diagenesis of primary borate minerals, such as ulexite,  $\text{NaCa}[\text{B}_5\text{O}_6(\text{OH})_6](\text{H}_2\text{O})_6$ , and

borax,  $\text{Na}_2[\text{B}_4\text{O}_5(\text{OH})_4](\text{H}_2\text{O})_8$  (Na = sodium). See BORATE MINERALS; DIAGENESIS; SALINE EVAPORITES.

Colemanite is a principal source of boron, together with borax and ulexite, and is mined extensively in California and Nevada, Turkey, and Argentina. Boron is used in a wide variety of industrial commodities: soaps and washing powders, glasses and ceramics, specialty alloys, and fillers in many products. See BORON. [F.C.Ha.]

**Coleoidea** A subclass of the Cephalopoda that appeared in the middle Paleozoic (Early Devonian Period) and presumably evolved from the nautiloid stalk. Of the five orders of fossil coleoids, the belemnites are conspicuous with their fossilized shells termed lightning bolts. All these forms became extinct by the end of the Mesozoic, 65 million years ago. The surviving four orders that developed in the Late Triassic to Late Cretaceous represent all the living cephalopods today, except *Nautilus* (subclass Nautiloidea).

Coleoids are characterized by an internal chitinous or calcareous shell; 8–10 appendages around the mouth (8 arms and 2 tentacles when present) lined with suckers or hooks; one pair of gills; highly developed eyes; a fused, tubelike funnel; an ink sac (lost in some species); chromatophores; and fins on the body (lost in some octopuses).

The living coleoids are the order Sepioidea (cuttlefishes, like *Sepia*; bobtail squids, *Spirula*); the order Teuthoidea (squids—nearshore myopsids, like *Loligo*; open-ocean oegopsids, like *Ommastrephes*); the order Vampyromorpha (the black, deep-sea vampire squid); and the order Octopoda (octopuses, argonauts, deep-sea finned or cirrate octopods). Living coleoids generally are fast, mobile predators with an advanced brain and central nervous system. See BELEMNOIDEA; CEPHALOPODA; MOLLUSCA; NAUTILOIDEA; SEPIOIDEA; TEUTHOIDEA; VAMPYROMORPHA. [C.F.E.R.]

**Coleoptera** An order of Insecta (generally known as beetles) with a complete metamorphosis (with larva and pupa stages), the forewings forming hard protective elytra under which the hindwings are normally folded in repose, and the indirect flight muscles of the mesothorax having been lost. The head capsule is characterized by a firm ventral (gular) closure, the antennae are basically 11-segmented, and mouthparts are of the biting type with 4-segmented maxillary palpi. The prothorax is large and free. The abdomen has sternite I normally absent, sternite II usually membranous and hidden, and segment X vestigial, with cerci absent. The female has one pair of gonapophyses, on segment IX. There are four or six malpighian tubules, which are often cryptonephric. True labial glands are nearly always absent.

**General biological features.** The order has well over 250,000 described species, more than any comparable group, showing very great diversity in size, form (see illustration), color, habits, and physiology. Beetles have been found almost everywhere on Earth (except as yet for the Antarctic mainland) where any insects are known, and species of the order exploit almost every habitat and type of food which is used by insects. Many species are economically important.

A common feature is for the exoskeleton to form an unusually hard and close-fitting suit of armor, correlated with a tendency for the adults to be less mobile but longer-lived than those of other orders of higher insects. It seems to be common in a number of groups for adults to survive and breed in 2 or more successive years, a rare occurrence in other Endopterygota. Adult beetles tend to be better runners than most other Endopterygota, and some (such as Cicindelidae) are among the fastest of running insects. The flight of most beetles is not very ready or frequent, often requiring prior climbing up onto some eminence, and in many beetles occurs only once or twice in an average life.

Apart from a tendency for the sclerotized layers to be thicker, the cuticle of beetles differs little from that of other insects in constitution or ultrastructure. The black coloring which is prevalent

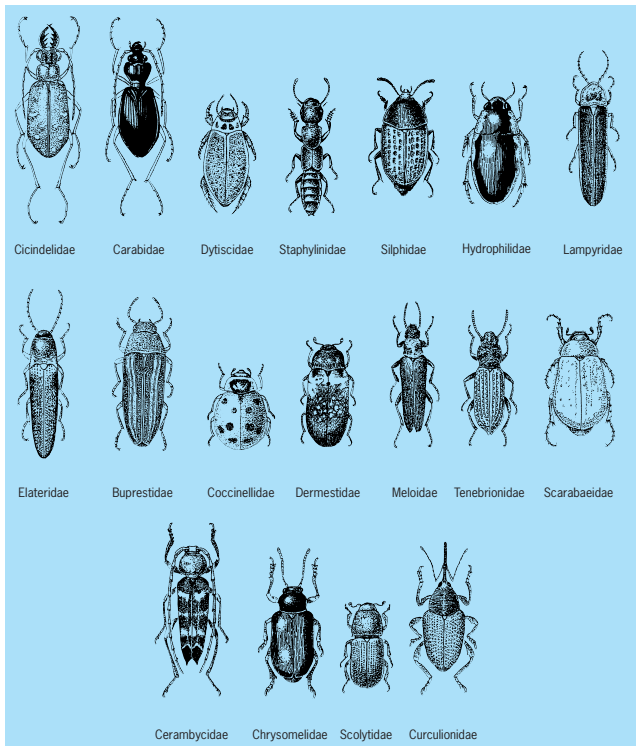

Coleoptera. (After T. I. Storer et al., *General Zoology*, 6th ed., McGraw-Hill, 1979)

in many groups of beetles is produced by deposition of melanin in the process of cuticle hardening. In many groups with adults active by day, the black is masked by a metallic structural color produced by interference in the surface cuticle layers. Pigmentary colors, mainly ommochromes, giving reddish to yellowish colors, occur in the cuticle of many species.

Special defenses against predation are common in species with long-lived adults, particularly the ground-living species of Carabidae, Staphylinidae, and Tenebrionidae. These groups commonly possess defensive glands, with reservoirs opening on or near the tip of the abdomen, secreting quinones, unsaturated acids, and similar toxic substances. In some cases, the secretion merely oozes onto the body surface, but in others may be expelled in a jet, as in the bombardier beetles (Brachinini). Other common defensive adaptations include cryptic and mimetic appearances. The most frequent behavioral adaptations are the drop-off reflex and appendage retraction, in which adults will react to visual or tactile stimuli by dropping off the plant foliage on which they occur, falling to the ground with retracted appendages, and lying there for some time before resuming activity. In death feigning, the appendages are tightly retracted, often into grooves of the cuticle, and held in this position for some time. In such conditions, beetles often resemble seeds and are difficult for predators to perforate or grasp.

Sound production (stridulation) is widespread in beetles and may be produced by friction between almost any counterposed movable parts of the cuticle. Stridulatory organs may show sex dimorphism, and in some species may play an important role in the interrelations of the sexes.

**Anatomy.** The head of beetles rarely has a marked posterior neck, and the antennal insertions are usually lateral, rather than dorsal as in most other Endopterygota, a feature possibly related to an original habit of creeping under bark. Antennal forms are very various, with the number of segments often reduced, but rarely increased, from the basic 11. Mandible forms are very diverse and related to types of food.

The prothorax commonly has lateral edges which separate the dorsal part from the ventral part of the tergum. The mesothorax is the smallest thoracic segment. Dorsally, its tergum is usually exposed as a small triangular sclerite between the elytral bases, and ventrally, its sternite may have a median pit receiving the tip of the prosternum. The form of the metathorax is affected by far-forward insertions of the hind-wings and far-posterior ones of the hindlegs, so that the pleura are extremely oblique and the sternum usually long.

The tarsi of beetles show all gradations from the primitive five-segmented condition to total disappearance. The number of segments may differ between the legs of an individual or between the sexes of a species.

Most beetles have the entire abdomen covered dorsally by the elytra in repose, and ventrally only five or six sternites (of segments III to VII or VIII) exposed; segment IX is retracted inside VIII in repose. Tergites I-VI are usually soft and flexible, those of VII and VIII more or less sclerotized. A feature developed in several groups of Coleoptera, but particularly in Staphylinidae, is the abbreviation of the elytra to leave part of the abdomen uncovered in repose, but usually still covering the folded wings. One advantage of this may be to give greater overall flexibility to the body. Perhaps surprisingly, many beetles with short elytra fly readily.

Internally, the gut varies greatly in length and detailed structure. The foregut commonly ends in a distended crop whose posterior part usually has some internal setae and may be developed into a complex proventriculus; the midgut may be partly or wholly covered with small papillae (regenerative crypts) and sometimes has anterior iceca. The four or six malpighian tubules open in various ways into the beginning of the hindgut and in many Polyphaga have their apices attached to it (cryptonephric). The central nervous system shows all degrees of concentration of the ventral chain, from having three thoracic and eight abdominal ganglia distinct to having all of these fused into a single mass.

The sense organs of beetles, adult or larval, are generally similar in type and function to those of other insects. For vision, some types are adapted for high visual acuity in bright light, others to high sensitivity in poor light, and many show light-dark adaptations of screening pigment. Color vision seems to be restricted to certain groups. In certain beetles, there is evidence of specialized infrared sensitivity. Antennae are mainly receptors for smell and touch, but detection of aerial vibrations (by Johnston's organ in the pedicel) may be important in some. The olfactory sensilla, which commonly are setae, are often concentrated on expanded apical segments, forming a club. Taste, or contact chemoreception, is usually mediated by sensilla with a single large apical opening. These sensilla are concentrated on the palpi and other mouthparts and are often found on tibiae or tarsi of the front legs.

Taste, or contact chemoreception, is usually mediated by sensilla with a single large apical opening. These sensilla are concentrated on the palpi and other mouthparts and are often found on tibiae or tarsi of the front legs.

Specialized sound receptors, other than Johnston's organ, have not been much studied in Coleoptera, though many species produce sounds and in some cases these play a significant part in courtship. A gravitational sense is evident in many burrowing beetles, which are able to sink accurately vertical burrows despite inclinations of the surface started from. A temperature sense is clearly present in some beetles and larvae, but little is known of the sensilla concerned. What might be called a time sense (otherwise known as a biological clock) clearly operates in many beetles that react specifically to changing daylight lengths marking the seasons in nontropical latitudes.

**Food specialization.** The biting mouthparts of many adult and larval beetles are adaptable to many types of food, and fairly widely polyphagous habits are not uncommon in the order, though most species can be assigned to one or another of

a few main food categories: fungivores, carnivores, herbivores, or detritivores. Included in the last category are species feeding on decaying animal or vegetable matter and on dung. Most parasites could be included with carnivores, but those myrmecophiles and termitophiles which are fed by their hosts, and those Meloidae which develop on the food stores of bees, form special categories.

**Water beetles.** Beetles are unusual among the higher insects in that aquatic habits, where present, usually affect adults as well as larvae. The elytra may have been preadaptive to the invasion of water. Almost any type of fresh or brackish water body is liable to contain some types of water beetles, though very few species can live permanently in full marine salinities. Almost all aquatic beetles maintain an air reservoir, into which the second thoracic and abdominal spiracles open, under their elytra; and some, mainly small, species may have plastrons or physical gills. Aquatic larvae tend to have a last pair of abdominal spiracles that is large and effectively terminal, or tend to develop tracheal gills. Pupae are terrestrial in the large majority of water beetles, and eggs, when deposited underwater, are commonly laid in contact with airspaces in the stems of water plants, or in an air-filled egg cocoon. Most water beetles are confined to shallow waters, and many of them are ready colonists of temporary pools, through adult flight.

**Special habitats and adaptations.** More or less unusual adaptations and modes of life are manifest in dung and carrion beetles, ambrosia beetles, cave and subterranean beetles, desert beetles, and luminous beetles. Dung and carrion beetles exploit sporadic and very temporary food resources in which competition (particularly with Diptera larvae) tends to be fierce. Many dung beetles avoid the difficulties by burying dung stores in underground cells where their larvae can develop safely, and some beetles (Necrophorinae) adopt a similar strategy for carrion. They may also develop phoretic and symbiotic relations with specific mites preying on fly eggs.

In ambrosia beetles, the adults usually excavate burrows in wood, carrying with them spores of special fungi, which proceed to develop along the walls of the burrows and are fed on by larvae developing from eggs laid there. This type of relation between beetles, fungi, and trees exists in various forms in a number of families and may be of ecological importance if the fungi concerned are liable to kill trees.

More than one family of beetles contains highly adapted types living exclusively in deeper cave systems (cavernicolous) or the deeper layers of the soil (hypogeous). Such species are usually flightless and eyeless, poorly pigmented, and slow-moving, and of very restricted geographical distribution. Another marginal habitat in which beetles are the principal insect group represented is the desert. Here, too, wings are usually lost, but the cuticle tends to be unusually thick, firm, and black. Also beetles may be found in hot springs. A few water beetles are adapted to underground (phreatic) waters, showing parallel features with the cavernicolous and hypogeous terrestrial ones.

More or less parasitic relations to animals of other groups have developed in a number of lines of Coleoptera. The closest parallels to Hymenoptera-Parasitica are to be seen in the families Stylopidae (Strepsiptera of many authors) and Rhipiphoridae. Stylopid larvae are exclusively endoparasites of other insects, while the adult females are apterous, often legless, and remain in the host's body, while males have large fanlike hind-wings and the elytra reduced to halter-like structures. A considerable variety of Coleoptera develop normally in the nests of termites and social or solitary Hymenoptera-Aculeata, some being essentially detritivores or scavengers, but most feed either on the young or the food stores of their hosts. Ectoparasitism on birds or mammals is a rare development in beetles.

The beetles are notable in that some of them manifest the highest developments of bioluminescence known in nonmarine animals, the main groups concerned being Phengodidae, Lampyridae, and Elateridae-Pyrophorini, the glowworms and fireflies. In

luminous beetles, the phenomenon always seems to be manifest in the larvae and often in the pupae, but not always in the adults. In luminous adult beetles, there is often marked sex dimorphism, and a major function of the lights seems to be the mutual recognition of the sexes of a species.

Another possible function of adult luminosity, and the only seriously suggested for that of larvae, is as an aposematic signal. There is definite evidence that some adult fireflies are distasteful to some predators, and the luminous larvae of Phengodidae have dorsal glandular openings on the trunk segments that probably have a defensive function. See BIOLUMINESCENCE.

**Phylogenetic history.** Coleoptera are older than the other major endopterygote orders. The earliest fossils showing distinctively beetle features were found rather before the middle of the Permian Period. By the later Permian, fossils indicate that beetles had become numerous and diverse, and during the Mesozoic Era they appear as a dominant group among insect fossils. Fossils in Triassic deposits have shown features indicative of all four modern suborders, and the Jurassic probably saw the establishment of all modern superfamilies. By early Cretaceous times, it is likely that all "good" modern families had been established as separate lines. In the Baltic Amber fauna, of later Paleogene age (about 40,000,000 years ago), about half the fossil beetle genera appear to be extinct, and the other half have still-living representatives (often in remote parts of the world). Beetle fossils in Quaternary (Pleistocene) deposits are very largely of still-living species.

**Geographical distribution.** Almost every type of continuous or discontinuous distribution pattern which is known in any animal group could be matched in some taxon of Coleoptera, and every significant zoogeographical region or area could be characterized by endemic taxa of beetles. In flightless taxa, distributional areas are generally more limited than those of comparable winged taxa. Distinct distributional categories can be seen in those small, readily flying groups (in Staphylinidae and Nitidulidae, for example) which are liable to form part of "aerial plankton," and in those wood borers which may survive for extended periods in sea-drifted logs, both of which are liable to occur in oceanic islands beyond the ranges of most other beetle taxa. Climatic factors often seem to impose limits on the spread of beetle species (and sometimes of genera or families), and beetle remains in peats have been found to be sensitive indicators of climatic changes in glacial and postglacial times. See INSECTA.

[R.A.Cr.]

**Coliiformes** A small order of birds containing only the family Coliidae with six species (the mousebirds) restricted to Africa. The mousebirds are small, grayish to brownish, with a long tail. The legs are short and the feet strong, with the four toes movable into many positions from all four pointing forward to two reversed backward. Mousebirds perch, climb, crawl, and scramble agilely in bushes and trees. They are largely vegetarian but eat some insects. They are nonmigratory and gregarious, and sleep in clusters, but they are monogamous as breeders. The nest is an open cup in a tree or bush, and the two to four young remain in the nest, cared for by both adults until they can fly. The relationships of the mousebirds to other birds are obscure. Mousebirds have a surprisingly good fossil record from the Miocene of France and Germany. See AVES.

[W.J.B.]

**Coliphage** Any bacteriophage able to infect the bacterium *Escherichia coli*; many are able to attack more than one strain of this organism. The T series of phage (T1-T7), propagated on a special culture of *E. coli*, strain B, have been used in extensive studies, from which most of the knowledge of phages is derived. See BACTERIOPHAGE; LYSOGENY.

[P.B.C.]

**Collagen** The major fibrous protein in animals, present in all types of multicellular animals and probably the most abundant animal protein in nature. It is estimated that collagen accounts

for about 30% of the total human body protein. Collagen is located in the extracellular matrix of connective tissues. It is part of the interacting network of proteoglycans and proteins that provides a structural framework for both soft and calcified connective tissues. By self-associating into fibrils and by binding to proteoglycans and other matrix components, collagen contributes to tissue integrity and mechanical properties. Collagen interacts with cells through the integrin cell receptors and mediates cellular adhesion and migration. Important roles for collagen have been identified in development, wound healing, platelet aggregation, and aging. Its commercial importance in leather and the production of gelatin and glue have long been recognized. More recently, it is being used as a basis for biomaterials. Examples of its biomedical applications include injectable collagen to lessen facial wrinkles and defects; surgical collagen sponges to increase blood clotting; and artificial skin for the treatment of burns. See GELATIN; LEATHER AND FUR PROCESSING.

The classification of an extracellular matrix protein as a collagen is based on the presence of a domain with a distinctive triple-helical conformation. The collagen triple helix consists of three polypeptide chains supercoiled about a common axis and linked by hydrogen bonds. At least 19 distinct molecules have been classified as collagens, and specific types are associated with particular tissues. The most prevalent and well-studied collagens belong to the fibril-forming or interstitial collagen family. The molecules in a fibril are covalently cross-linked by an enzymatic mechanism to strengthen and stabilize them. Inhibition of the enzyme involved in cross-linking results in a dramatic decrease in the tensile strength of tissues, a condition known as lathyrism.

Type I is the most common fibril-forming collagen. Its fibrils make up the mineralized matrix in bone, the strong parallel bundles of fibers in tendon, and the plywoodlike alternating layers in the transparent cornea. Type II is the major fibril-forming collagen in cartilage, while type III is found in blood vessels and skin, together with type I. Basement membranes, which serve to separate cell layers and act as filtration barriers, contain a distinctive group of collagens, denoted as type IV collagens, which are organized into a network or meshlike sheet structure. In the kidney glomerulus, the network based on type IV collagen acts as a filter to determine which molecules will pass from the blood into the urine. See BONE; CONNECTIVE TISSUE; FIBROUS PROTEIN.

An orderly breakdown of collagen is necessary during development and tissue remodeling. For instance, following childbirth, the uterus reduces in size, which involves a massive degradation of collagen. An abnormal increase in the degradation of cartilage collagen is seen in osteoarthritis. Collagen breakdown also appears to be essential for tumor metastases. A number of hereditary diseases have been shown to be due to mutations in specific collagen genes. Osteogenesis imperfecta (brittle bone) disease is characterized by fragile bones and is due to mutations in type I collagen. Some cartilage disorders are caused by mutations in type II collagen. Ruptured arteries are found in Ehlers-Danlos syndrome type IV, which arises from mutations in type III collagen. [B.Bro.]

**Collard** A cool-season biennial crucifer, *Brassica oleracea* var. *acephala*, similar to nonheading cabbage. Collard is of Mediterranean origin and is grown for its rosette of leaves, which are cooked fresh as a vegetable. Important production centers are in the southern United States, where collards are an important nutritious green, especially during winter months. See CABBAGE; CAPPARALES; KALE. [H.J.C.]

**Collembola** An order of primitive insects, commonly called springtails, belonging to the subclass Apterygota. These tiny insects do not undergo a metamorphosis. They have six abdominal segments, some of which may be ankylosed to give an apparently smaller number (see illustration). Appended to the fourth abdominal segment in most of the species is a spring,

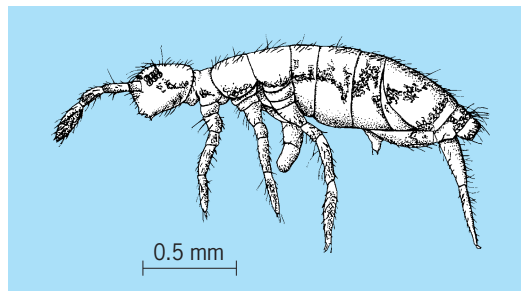

A collembolan, *Entomobrya cubensis*. (After J. W. Folsom, Proc. U.S. Nat. Mus., 72(6), plate 6, 1927)

or furcula. This consists of a basal piece and two apical parallel structures which end in hooks. Another pair of structures, united at the base, occur ventrally on the third abdominal segment. These bear teeth which engage with the furcula and hold it beneath the body. When released, the spring flies backward, catapulting the insect.

Collembola live in humid places, often in leaf mold. Some species are active at cool temperatures, hence another common name, snowflea, is used. The earliest known insect fossil, *Rhyniella praecursor*, is thought to belong to this order. See INSECTA. [H.B.Mi.]

**Collenchyma** A primary, or early differentiated, supporting tissue of young shoot parts appearing while these parts are still elongating. It is located near the surface, usually just under the epidermis. When observed in transverse sections, it is characterized structurally by cell walls that are intermittently thickened, generally in the corners or places of juncture of three or more cells. Collenchyma is typically formed in the petioles and vein ribs of leaves, the elongating zone of young stems, and the pedicels of flowers. See CELL WALLS (PLANT).

As in parenchyma, the cells in collenchyma are living and may contain chloroplasts and starch grains. The cell wall of a collenchyma cell is its most striking feature structurally and functionally. It is composed of cellulose and pectic compounds plus a very high proportion of water. The cytoplasm is very rich in ribosomes and ribonucleic acids in the early stages of development. Another striking feature of collenchyma cell walls is their plasticity. They are capable of great elongation during the period of growth in length of the plant. The plasticity of collenchyma is associated with a tensile strength comparable to that shown by fibers of sclerenchyma. The combination of strength and plasticity makes the collenchyma effective as a strengthening tissue in developing stems and leaves having no other supporting tissue at that time. See CELLULOSE; EPIDERMIS (PLANT); PARENCHYMA; PECTIN. [R.L.Hu.]

**Collision (physics)** Any interaction between particles, aggregates of particles, or rigid bodies in which they come near enough to exert a mutual influence, generally with exchange of energy. The term collision, as used in physics, does not necessarily imply actual contact.

In classical mechanics, collision problems are concerned with the relation of the magnitudes and directions of the velocities of colliding bodies after collision to the velocity vectors of the bodies before collision. When the only forces on the colliding bodies are those exerted by the bodies themselves, the principle of conservation of momentum states that the total momentum of the system is unchanged in the collision process. This result is particularly useful when the forces between the colliding bodies act only during the instant of collision. The velocities can then change only during the collision process, which takes place in a short time interval. Under these conditions the forces can be treated as impulsive forces, the effects of which can be expressed

in terms of an experimental parameter known as the coefficient of restitution. See CONSERVATION OF MOMENTUM; IMPACT.

The study of collisions of molecules, atoms, and nuclear particles is an important field of physics. Here the object is usually to obtain information about the forces acting between the particles. The velocities of the particles are measured before and after collision. Although quantum mechanics instead of classical mechanics should be used to describe the motion of the particles, many of the conclusions of classical collision theory are valid. See SCATTERING EXPERIMENTS (ATOMS AND MOLECULES); SCATTERING EXPERIMENTS (NUCLEI).

Collisions can be classed as elastic and inelastic. In an elastic collision, mechanical energy is conserved; that is, the total kinetic energy of the system of particles after collision equals the total kinetic energy before collision. For inelastic collisions, however, the total kinetic energy after collision is different from the initial total kinetic energy.

In classical mechanics the total mechanical energy after an inelastic collision is ordinarily less than the initial total mechanical energy, and the mechanical energy which is lost is converted into heat. However, an inelastic collision in which the total energy after collision is greater than the initial total energy sometimes can occur in classical mechanics. For example, a collision can cause an explosion which converts chemical energy into mechanical energy. In molecular, atomic, and nuclear systems, which are governed by quantum mechanics, the energy levels of the particles can be changed during collisions. Thus these inelastic collisions can involve either a gain or a loss in mechanical energy.

[P.W.S.]

**Colloid** A state of matter characterized by large specific surface areas, that is, large surfaces per unit volume or unit mass. The term colloid refers to any matter, regardless of chemical composition, structure (crystalline or amorphous), geometric form, or degree of condensation (solid, liquid, or gas), as long as at least one of the dimensions is less than approximately 1 micrometer but larger than about 1 nanometer. Thus, it is possible to distinguish films (for example, oil slick), fibers (spider web), or colloidal particles (fog) if one, two, or three dimensions, respectively, are within the submicrometer range.

A colloid consists of dispersed matter in a given medium. In the case of finely subdivided particles, classification of a number of systems is possible, as given in the table. In addition to the colloids listed in the table, there are systems that do not fit into any of the listed categories. Among these are gels, which consist of a network-type internal structure loaded with larger or smaller amounts of fluid. Some gels may have the consistency of a solid, while others are truly elastic bodies that can reversibly deform. Another colloid system that may occur is termed coacervate, and is identified as a liquid phase separated on coagulation of hydrophilic colloids, such as proteins. See GEL.

It is customary to distinguish between hydrophobic and hydrophilic colloids. The former are assumed to be solvent-repellent, while the latter are solvent-attractant (dispersed matter is said to be solvated). In reality there are various degrees of hy-

drophilicity for which the degree of solvation cannot be determined quantitatively.

Certain properties of matter are greatly enhanced in the colloidal state due to the large specific surface area. Thus, finely dispersed particles are excellent adsorbents; that is, they can bind various molecules or ions on their surfaces. This property may be used for removal of toxic gases from the atmosphere (in gas masks), for elimination of soluble contaminants in purification of water, or decolorization of sugar, to give just a few examples. See ADSORPTION.

Colloids are too small to be seen by the naked eye or in optical microscopes. However, they can be observed and photographed in transmission or scanning electron microscopes. Owing to their small size, they cannot be separated from the medium (liquid or gas) by simple filtration or normal centrifugation. Special membranes with exceedingly small pores, known as ultrafilters, can be used for collection of such finely dispersed particles. The ultracentrifuge, which spins at very high velocities, can also be employed to promote colloid settling. See ELECTRON MICROSCOPE; SCANNING ELECTRON MICROSCOPE; ULTRACENTRIFUGE; ULTRAFILTRATION.

Colloids show characteristic optical properties. They strongly scatter light, causing turbidity such as in fog, milk, or muddy water. Scattering of light (recognized by the Tyndall beam) can be used for the observation of tiny particles in the ultramicroscope. Colloidal state of silica is also responsible for iridescence, the beautiful effect observed with opals. See SCATTERING OF ELECTROMAGNETIC RADIATION; TYNDALL EFFECT.

Since the characteristic dimensions of colloids fall between those of simple ions or molecules and those of coarse systems, there are in principle two sets of techniques available for their preparation: dispersion and condensation. In dispersion methods the starting materials consist of coarse units which are broken down into finely dispersed particles, drawn into fibers, or flattened into films. For example, colloid mills grind solids to colloid sizes, nebulizers can produce finely dispersed droplets from bulk liquids, and blenders are used to prepare emulsions from two immiscible liquids (such as oil and water). See EMULSION.

In condensation methods, ions or molecules are aggregated to give colloidal particles, fibers, or films. Thus, insoluble monolayer films can be developed by spreading onto the surface of water a long-chain fatty acid (for example, stearic acid) from a solution in an organic liquid (such as benzene or ethyl ether). Colloidal aggregates of detergents (micelles) form by dissolving the surface-active material in an aqueous solution in amounts that exceed the critical micelle concentration. See MICELLE; MONOMOLECULAR FILM.

The most common procedure to prepare sols is by homogeneous precipitation of electrolytes. Thus, if aqueous silver nitrate and potassium bromide solutions are mixed in proper concentrations, colloidal dispersions of silver bromide will form, which may remain stable for a long time. Major efforts have focused on preparation of monodispersed sols, which consist of colloidal particles that are uniform in size, shape, and composition. See PRECIPITATION (CHEMISTRY).

[E.Ma.]

**Types of colloid dispersions**

Medium	Dispersed matter	Technical name	Examples
Gas	Liquid	Aerosol	Fog, sprays
	Solid	Aerosol	Smoke, atmospheric or interstellar dust
Liquid	Gas	Foam	Head on beer, lather
	Liquid	Emulsion	Milk, cosmetic lotions
	Solid	Sol	Paints, muddy water
Solid	Gas	Solid foam	Foam rubber
	Liquid	Solid emulsion	Opal
	Solid	Solid sol	Steel

**Colloidal crystals** Periodic arrays of suspended colloidal particles. Common colloidal suspensions (colloids) such as milk, blood, or latex are polydisperse; that is, the suspended particles have a distribution of sizes and shapes. However, suspensions of particles of identical size, shape, and interaction, the so-called monodisperse colloids, do occur. In such suspensions, a new phenomenon that is not found in polydisperse systems, colloidal crystallization, appears: under appropriate conditions, the particles can spontaneously arrange themselves into spatially periodic structures. This ordering is analogous to that of identical atoms or molecules into periodic arrays to form atomic or molecular crystals. However, colloidal crystals are distinguished from molecular crystals, such as those formed by very large protein

molecules, in that the individual particles do not have precisely identical internal atomic or molecular arrangements. On the other hand, they are distinguished from periodic stackings of macroscopic objects like cannonballs in that the periodic ordering is spontaneously adopted by the system through the thermal agitation (brownian motion) of the particles. These conditions limit the sizes of particles which can form colloidal crystals to the range from about 0.01 to about 5 micrometers. See BROWNIAN MOVEMENT; KINETIC THEORY OF MATTER.

The most spectacular evidence for colloidal crystallization is the existence of naturally occurring opals. The ideal opal structure is a periodic close-packed three-dimensional array of silica microspheres with hydrated silica filling the spaces not occupied by particles. Opals are the fossilized remains of an earlier colloidal crystal suspension. Another important class of naturally occurring colloidal crystals are found in concentrated suspensions of nearly spherical virus particles, such as *Tipula* iridescent virus and tomato bushy stunt virus. Colloidal crystals can also be made from the synthetic monodisperse colloids, suspensions of plastic (organic polymer) microspheres. Such suspensions have become important systems for the study of colloidal crystals, by virtue of the controllability of the particle size and interaction. See COLLOID; CRYSTAL; OPAL; VIRUS. [N.A.C.]

**Colon** The portion of the intestine that runs from the cecum to the rectum; in some mammals, it may be separated from the small intestine by an ileocecal valve. It is also known as the large intestine. The colon is usually divided into ascending, transverse, and descending portions. In the human a fourth section, the sigmoid, is found. The colon is longer in herbivores and shorter in carnivores, and is about 4 to 6 ft (1.2 to 1.8 m) long in humans. No digestive enzymes are secreted in the colon. Much digestion (for example, all breakdown of cellulose) occurs by bacteria, of which *Escherichia coli* is the most common. Most of the fluid added to the food during digestion is reabsorbed into the body in the colon. All digestive action, water absorption, and so on, is completed before the food materials pass out of the colon into the rectum. See DIGESTIVE SYSTEM. [W.J.B.]

**Color** That aspect of visual sensation enabling a human observer to distinguish differences between two structure-free fields of light having the same size, shape, and duration. Although luminance differences alone permit such discriminations to be made, the term color is usually restricted to a class of differences still perceived at equal luminance. These depend upon physical differences in the spectral compositions of the two fields, usually revealed to the observer as differences of hue or saturation.

Color discriminations are possible because the human eye contains three classes of cone photoreceptors that differ in the photopigments they contain and in their neural connections. Two of these, the R and G cones, are sensitive to all wavelengths of the visible spectrum from 380 to 700 nanometers. (Even longer or shorter wavelengths may be effective if sufficient energy is available.) R cones are maximally sensitive at about 570 nm, G cones at about 540 nm. The ratio R/G of cone sensitivities is minimal at 465 nm and increases monotonically for wavelengths both shorter and longer than this. This ratio is independent of intensity, and the red-green dimension of color variation is encoded in terms of it. The B cones, whose sensitivity peaks at about 440 nm, are not appreciably excited by wavelengths longer than 540 nm. The perception of blueness and yellowness depends upon the level of excitation of B cones in relation to that of R and G cones. No two wavelengths of light can produce equal excitations in all three kinds of cones. It follows that, provided they are sufficiently different to be discriminable, no two wavelengths can give rise to identical sensations.

Different complex spectral distributions usually, but not always, look different. Suitable amounts of short-, middle-, and long-wavelength lights, if additively mixed, can for example ex-

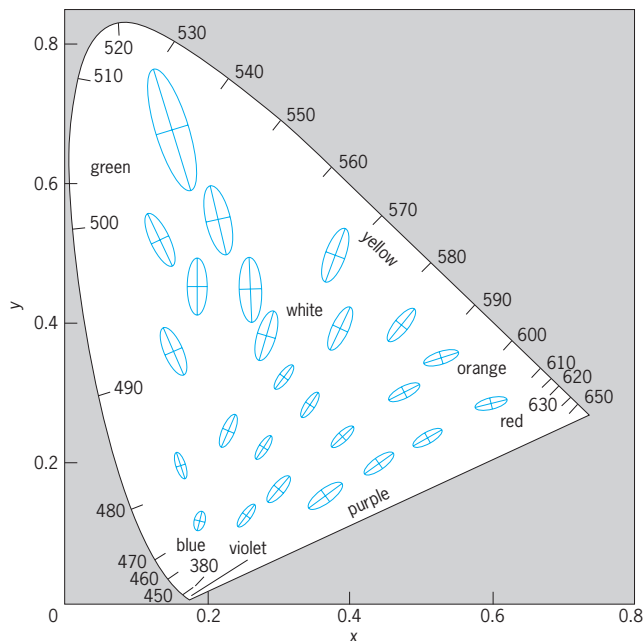

The 1931 CIE chromaticity diagram showing discrimination ellipses enlarged 10 times.

cite the R, G, and B cones exactly as does a light containing equal energy at all wavelengths. As a result, both stimuli look the same. This is an extreme example of the subjective identity of physically different stimuli known as chromatic metamerism. Additive mixture is achievable by optical superposition, rapid alternation at frequencies too high for the visual system to follow, or (as in color television) by the juxtaposition of very small elements which make up a field structure so fine as to exceed the limits of visual acuity. See EYE (VERTEBRATE); LIGHT.

Although colors are often defined by appeal to standard samples, the trivariant nature of color vision permits their specification in terms of three values. Ideally these might be the relative excitations of the R, G, and B cones. Because too little was known about cone action spectra in 1931, the International Commission on Illumination (CIE) adopted at that time a different but related system for the prediction of metamers (the CIE system of colorimetry). This widely used system permits the specification of tristimulus values  $X$ ,  $Y$ , and  $Z$ , which make almost the same predictions about color matches as do calculations based upon cone action spectra. If, for fields 1 and 2,  $X_1 = X_2$ ,  $Y_1 = Y_2$ , and  $Z_1 = Z_2$ , then the two stimuli are said to match (and therefore have the same color) whether they are physically the same (isometric) or different (metameric).

Colors are often specified in a two-dimensional chart known as the CIE chromaticity diagram, which shows the relations among tristimulus values independently of luminance. In this plane,  $y$  is by convention plotted as a function of  $x$ , where  $y = Y/(X + Y + Z)$  and  $x = x/(x + y + z)$ . [The value  $z = Z/(X + Y + Z)$  also equals  $1 - (x + y)$  and therefore carries no additional information.] Such a diagram is shown in the illustration, in which the continuous locus of spectrum colors is represented by the outermost contour. All nonspectral colors are contained within an area defined by this boundary and a straight line running from red to violet. The diagram also shows discrimination data for 25 regions, which plot as ellipses represented at 10 times their actual size. A discrimination unit is one-tenth the distance from the ellipse's center to its perimeter. Predictive schemes for interpolation to other regions of the CIE diagram have been worked out.

A chromaticity diagram has some very convenient properties. Chief among them is the fact that additive mixtures of colors plot along straight lines connecting the chromaticities of the colors being mixed. Although it is sometimes convenient to visualize colors



in terms of the chromaticity chart, it is important to realize that this is not a psychological color diagram. Rather, the chromaticity diagram makes a statement about the results of metameric color matches, in the sense that a given point on the diagram represents the locus of all possible metamers plotting at chromaticity coordinates  $x, y$ . However, this does not specify the appearance of the color, which can be dramatically altered by preexposing the eye to colored lights (chromatic adaptation) or, in the complex scenes of real life, by other colors present in nearby or remote areas (color contrast and assimilation). Nevertheless, within limits, metamers whose color appearance is thereby changed continue to match.

For simple, directly fixated, and unstructured fields presented in an otherwise dark environment, there are consistent relations between the chromaticity coordinates of a color and the color sensations that are elicited. Therefore, regions of the chromaticity diagram are often denoted by color names, as shown in the illustration.

Although the CIE system works rather well in practice, there are important limitations. Normal human observers do not agree exactly about their color matches, chiefly because of the differential absorption of light by inert pigments in front of the photoreceptors. Much larger individual differences exist for differential colorimetry, and the system is overall inappropriate for the 4% of the population (mostly males) whose color vision is abnormal. The system works only for an intermediate range of luminances, below which rods (the receptors of night vision) intrude, and above which the bleaching of visual photopigments significantly alters the absorption spectra of the cones. See COLOR VISION.

[R.M.Bo.]

**Color (quantum mechanics)** A term used to refer to a hypothetical quantum number carried by the quarks which are thought to make up the strongly interacting elementary particles. It has nothing to do with the ordinary, visual use of the word color.

The quarks which are thought to make up the strongly interacting particles have a spin angular momentum of one-half unit of  $h$  (Planck's constant). According to a fundamental theorem of relativity combined with quantum mechanics, they must therefore obey Fermi-Dirac statistics and be subject to the Pauli exclusion principle. No two quarks within a particular system can have exactly the same quantum numbers. See EXCLUSION PRINCIPLE; FERMI-DIRAC STATISTICS.

However, in making up a baryon, it often seemed necessary to violate this principle. The  $\Omega^-$  particle, for example, is made of three strange quarks, and all three had to be in exactly the same state. O. W. Greenberg is responsible for the essential idea for the solution to this paradox. In 1964 he suggested that each quark type ( $u, d,$  and  $s$ ) comes in three varieties identical in all measurable qualities but different in an additional property, which has come to be known as color. The exclusion principle could then be satisfied and quarks could remain fermions, because the quarks in the baryon would not all have the same quantum numbers. They would differ in color even if they were the same in all other respects. See BARYON; ELEMENTARY PARTICLE; MESON; QUARKS.

[T.Ap.]

**Color centers** Atomic and electronic defects of various types which produce optical absorption bands in otherwise transparent crystals such as the alkali halides, alkaline earth fluorides, or metal oxides. They are general phenomena found in a wide range of materials. Color centers are produced by gamma radiation or x-radiation, by addition of impurities or excess constituents, and sometimes through electrolysis. A well-known example is that of the  $F$ -center in alkali halides such as sodium chloride, NaCl. The designation  $F$ -center comes from the German word *Farbe*, which means color.  $F$ -centers in NaCl produce a band of optical absorption toward the blue end of the visible spectrum; thus the colored crystal appears yellow under

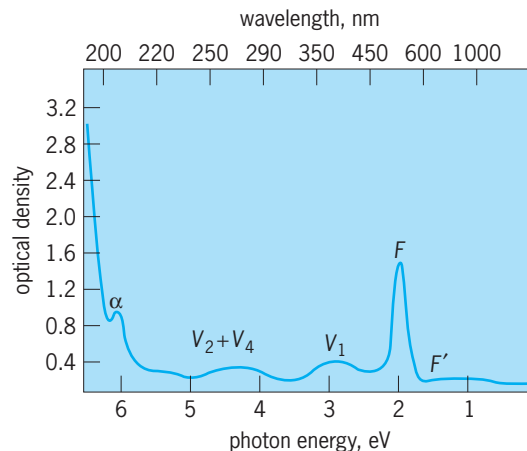

**Absorption bands produced in a KBr crystal by exposure to x-rays at 81 K. Bands are designated by letters. Optical density is equal to  $\log_{10} (I_0/I)$ , where  $I_0$  is the intensity of incident light and  $I$  the intensity of transmitted light. Steep rise in optical density at far left is due to intrinsic absorption in crystals (modified slightly by existence of  $F$ -centers).**

transmitted light. On the other hand, KCl with  $F$ -centers appears magenta, and KBr appears blue. See CRYSTAL.

Color centers have been under investigation for many years. Theoretical studies guided by detailed experimental work have yielded a deep understanding of specific centers. The crystals in which color centers appear tend to be transparent to light and to microwaves. Consequently, experiments which can be carried out include optical spectroscopy, luminescence and Raman scattering, magnetic circular dichroism, magnetic resonance, and electromodulation. Color centers find practical application in radiation dosimeters; schemes have been proposed to use color centers in high-density memory devices; and tunable lasers have been made from crystals containing color centers.

The illustration shows the absorption bands due to color centers produced in potassium bromide by exposure of the crystal at the temperature of liquid nitrogen (81 K) to intense penetrating x-rays. Several prominent bands appear as a result of the irradiation. The  $F$ -band appears at 600 nanometers and the so-called  $V$ -bands appear in the ultraviolet.

Color bands such as the  $F$ -band and the  $V$ -band arise because of light absorption at defects dispersed throughout the lattice. This absorption is caused by electronic transitions at the centers. On the other hand, colloidal particles, each consisting of many atoms, dispersed through an optical medium also produce color bands. In this case, if the particles are large enough, the extinction of light is due to both light scattering and light absorption. Colloidal gold is responsible for the color of some types of ruby glass. Colloids may also form in alkali halide crystals—for example, during heat treatment of an additively colored crystal with an excess of alkali metal.

Atomically dispersed centers such as  $F$ -centers are part of the general phenomena of trapped electrons and holes in solids. The accepted model of the  $F$ -center is an electron trapped at a negative ion vacancy. Many other combinations of electrons, holes, and clusters of lattice vacancies have been used to explain the various absorption bands in ionic crystals.

Impurities can play an important role in color-center phenomena. Certain impurities in ionic crystals produce color bands characteristic of the foreign ion. For example, hydrogen can be incorporated into the alkali halides with resultant appearance of an absorption band (the  $U$ -band) in the ultraviolet. In this case, the  $U$ -centers interact with other defects. The rate at which  $F$ -centers are produced by x-irradiation is greatly increased by the incorporation of hydrogen, the  $U$ -centers being converted into  $F$ -centers with high efficiency.

[F.C.Br.]

**Color filter** An optical element that partially absorbs incident radiation, often called an absorption filter. The absorption is selective with respect to wavelength, or color, limiting the colors that are transmitted by limiting those that are absorbed. Color filters absorb all the colors not transmitted. They are used in photography, optical instruments, and illuminating devices to control the amount and spectral composition of the light.

Color filters are made of glass for maximum permanence, of liquid solutions in cells with transparent faces for flexibility of control, and of dyed gelatin or plastic (usually cellulose acetate) for economy, convenience, and flexibility. The plastic filters are often of satisfactory permanence, but they are sometimes cemented between glass plates for greater toughness and scratch resistance. They do not have as good quality as gelatin filters.

Color filters are sometimes classified according to their type of spectral absorption: short-wavelength pass, long-wavelength pass or band-pass; diffuse or sharp-cutting; monochromatic or conversion. The short-wavelength pass transmits all wavelengths up to the specified one and then absorbs. The long-wavelength pass is the opposite. Every filter is a band-pass filter when considered generally. Even an ordinary piece of glass does not transmit in the ultraviolet or infrared parts of the spectrum. Color filters, however, are usually discussed in terms of the portion of the visible part of the spectrum. Sharp and diffuse denote the sharpness of the edges of the filter band pass. Monochromatic filters are very narrow band-pass filters. Conversion filters alter the spectral response or distribution of one selective detector or source to that of another, for example, from that of a light bulb to that of the Sun. *See* ABSORPTION OF ELECTROMAGNETIC RADIATION; COLOR; SUN. [W.L.Wo.]

**Color index** A quantitative measure of a star's color. Such color is closely related to temperature. Stars are reddish at around 3000 K (5000°F), orange about 4500 K (7500°F), yellowish about 6000 K (10,300°F), white about 10,000 K (17,500°F), and bluish above 10,000 K. With proper calibration, color provides a means by which the temperature and spectral class can be evaluated. *See* SPECTRAL TYPE; STAR.

Color is defined through the star's magnitude  $m$ , which indicates brightness. The original magnitudes were visual, being estimated with the unaided eye, and depended on the eye's response, which is maximized for yellow light. Early photographic emulsions, however, were sensitive primarily to blue light. As a result, blue stars look relatively brighter to the photographic plate than they do the eye, and red stars considerably fainter. It was then necessary to establish a separate magnitude system for photography, called  $m_{\text{pig}}$ . The original visual magnitudes were distinguished by calling them  $m_v$ . The two magnitudes were set equal for white stars with temperatures of 9300 K (16,280°F). Color can then be quantified by taking the difference between the two magnitudes, the color index becoming  $m_{\text{pig}} - m_v$ . Blue stars have slightly negative color indices, red stars positive ones. *See* ASTRONOMICAL PHOTOGRAPHY.

Photoelectric photometry allowed the establishment of the more precise UBV system, wherein V (yellow) and B (blue) filters respectively mimic the response of the human eye and the untreated photographic plate, and a U filter is added in the ultraviolet. The traditional color index is then replaced by  $B - V$ , and the addition of U allows a second color index,  $U - B$ . *See* HERTZSPRUNG-RUSSELL DIAGRAM; INTERSTELLAR EXTINCTION.

The standard system has been expanded into the red and the infrared with other filters. Numerous color indices are then available to examine stars that radiate primarily in the infrared. Other photometric schemes, such as the Strömgren four-color system (uvby, for ultraviolet, violet, blue, and yellow), allow more sophisticated color indices that are responsive not only to temperature but to a variety of other parameters. *See* INFRARED ASTRONOMY. [J.B.Ka.]

**Color vision** The ability to discriminate light on the basis of wavelength composition. It is found in humans, in other primates, and in certain species of birds, fishes, reptiles, and insects. These animals have visual receptors that respond differentially to the various wavelengths of visible light. Each type of receptor is especially sensitive to light of a particular wavelength composition. Evidence indicates that primates, including humans, possess three types of cone receptor, and that the cones of each type possess a pigment that selectively absorbs light from a particular region of the visible spectrum. The trichromatic system of colorimetry, using only three primary colors, is based on the concept of cone receptors with sensitivities having their peaks, respectively, in the long, middle, and short wavelengths of the spectrum. *See* COLOR; COLORIMETRY.

Color is usually presented to the individual by the surfaces of objects on which a more or less white light is falling. A red surface, for example, is one that absorbs most of the short-wave light and reflects the long-wave light to the eye. A set of primary colors can be chosen so that any other color can be produced from additive mixtures of the primaries in the proper proportions. Thus, red, green, and blue lights can be added together in various proportions to produce white, purple, yellow, or any of the various intermediate colors. Three-color printing, color photography, and color television are examples of the use of primaries to produce plausible imitations of colors of the original objects. *See* PHOTOGRAPHY; PRINTING.

Colors lying along a continuum from white to black are known as the gray, or achromatic, colors. They have no particular hue. Whiteness is a relative term; white paper, paint, and snow reflect some 80% or more of the light of all visible wavelengths, while black surfaces typically reflect less than 10% of the light. The term white is also applied to a luminous object, such as a gas or solid, at a temperature high enough to emit fairly uniformly light of all visible wavelengths.

Color blindness is a condition of faulty color vision. It appears to be the normal state of animals that are active only at night. It is also characteristic of human vision when the level of illumination is quite low or when objects are seen only at the periphery of the retina. Under these conditions, vision is mediated not by cone receptors but by rods, which respond to low intensities of light. In rare individuals, known as monochromats, there is total color blindness even at high light levels. Such persons are typically deficient or lacking in cone receptors, so that their form vision is also poor.

Dichromats are partially color-blind individuals whose vision appears to be based on two primaries rather than the normal three. Dichromatism occurs more often in men than in women because it is a sex-linked, recessive hereditary condition. One form of dichromatism is protanopia, in which there appears to be a lack of normal red-sensitive receptors. Red lights appear dim to protanopes and cannot be distinguished from dim yellow or green lights. A second form is deuteranopia, in which there is no marked reduction in the brightness of any color, but again there is a confusion of the colors normally described as red, yellow, and green. A third and much rarer form is tritanopia, which involves a confusion among the greens and blues. *See* HUMAN GENETICS.

Many so-called color-blind individuals might better be called color-weak. They are classified as anomalous trichromats because they have trichromatic vision of a sort, but fail to agree with normal subjects with respect to color matching or discrimination tests. Protanomaly is a case of this type, in which there is subnormal discrimination of red from green, with some darkening of the red end of the spectrum. Deuteranomaly is a mild form of red-green confusion with no marked brightness loss. Nearly 8% of human males have some degree of either anomalous trichromatism or dichromatism as a result of hereditary factors; less than 1% of females are color-defective.

Color blindness is most commonly tested by the use of color plates in which various dots of color define a figure against a background of other dots. The normal eye readily distinguishes

the figure, but the colors are so chosen that even the milder forms of color anomaly cause the figure to be indistinguishable from its background.

Techniques of microspectrophotometry have been used to measure the absorption of light by single cone receptors from the eyes of primates, including humans. The results confirm that three types of cone receptors are specialized to absorb light over characteristic ranges of wavelength, with maximum absorption at about 420, 530, and 560 nanometers. In addition there are rod receptors sensitive to low intensities of light over a broad range of wavelengths peaking at about 500 nm. In each of the four types of receptor there is a photosensitive pigment that is distinguished by a particular protein molecule. This determines the range and spectral location of the light which it absorbs.

Central nervous system factors are also evident. Color vision, like other forms of perception, is highly dependent on the experience of the observer and on the context in which the object is perceived. See EYE (INVERTEBRATE); EYE (VERTEBRATE); NERVOUS SYSTEM (VERTEBRATE); PERCEPTION; PHOTORECEPTION; VISION.

[L.A.R.]

**Colorimetry** Any technique by which an unknown color is evaluated in terms of known colors. Colorimetry may be visual, photoelectric, or indirect by means of spectrophotometry. These techniques are widely used in scientific studies involving the appearance of objects and lights, but are of greatest importance in the color specification of the raw materials and finished products of industry.

In visual colorimetry, the unknown color is presented beside a comparison field into which may be introduced any one of a range of known colors from which the operator chooses the one matching the unknown. To be generally applicable, the comparison field must not only cover a sufficient color range but must also be continuously adjustable in color.

In indirect colorimetry, the light leaving the unknown specimen is split into its component spectral parts by means of a prism or diffraction grating, and the amount of each component part is separately measured by a photometer. The quantity evaluated is spectral radiance of a light source, spectral transmittance of a filter (glass, plastic, gelatin, or liquid), or spectral reflectance of an opaque body. See SPECTROPHOTOMETRIC ANALYSIS.

In photoelectric colorimetry, the light leaving the specimen is measured separately by three photocells. The spectral sensitivity of these photocells is adjusted, usually by color filters, to conform as closely as possible to the three color-mixture functions for the average normal human eye (CIE standard observer). The responses of the photocells give directly the amounts of red, green, and blue primaries required to produce the color of the unknown specimen for the kind of vision represented by the three photocells.

If two objects have the same color because the light leaving one of them toward the eye is spectrally identical to that leaving the other, any type of colorimetry serves reliably to establish the fact of color match. If, however, the two lights are spectrally dissimilar, they may still color-match for any one observer; such pairs of lights are called metamers. Normal color vision differs sufficiently from person to person so that a metameric color match for one observer may be seriously mismatched for another. On this account, the question of color match of spectrally dissimilar lights can be reliably settled only by the indirect method which uses spectrophotometry combined with a precisely defined standard observer. See COLOR; COLOR FILTER; COLOR VISION.

[D.B.J./J.L.L.]

**Columbiformes** An order of birds containing three families, the largest of which is the worldwide pigeons and doves (Columbidae). The members of this order are characterized by an ability to drink water by sucking instead of the sip-and-tilt method of most birds. However, some other groups of birds are able to suck water by various methods.

The order Columbiformes is divided into the suborder Pterocletes, with the single family Pteroclididae (sandgrouse; 16 species), and the suborder Columbidae with the families Raphidae (dodos; 3 species) and Columbidae (pigeons and doves; 303 species). Relationships of Columbiformes appear to be to the Charadriiformes in one direction and to the Psittaciformes in another. Possibly the Columbiformes are a central stock in the evolution of birds. See CHARADRIIFORMES; PSITTACIFORMES.

Pigeons are found mainly in the tropics, but a number of species are common in temperate regions. They have a sleek plumage ranging from browns and grays to the brilliant greens, yellows, and reds of the tropical fruit pigeons. They feed on seeds, fruit, and other vegetarian food. Most pigeons live in flocks but breed solitarily. Almost all are nonmigratory.

The sandgrouse live in flocks in dry grasslands and deserts of the Old World, but depend on ponds of water to which flocks come in large numbers. The nest is generally a long distance from water, which is transported to the young by soaking specialized belly feathers. The young drink only from these moistened feathers, and will refuse water in pans placed before them.

The three species of dodos and solitaires were found only in the several Macarene Islands and were completely exterminated by the seventeenth century by sailors and released pigs. See AVES.

[W.J.B.]

**Columbite** A mineral with the composition  $(\text{Fe}, \text{Mn})\text{Nb}_2\text{O}_6$ . Tantalum may substitute in all proportions for the niobium; and a complete series extends to the pure end-member tantalite  $[(\text{Fe}, \text{Mn})\text{Ta}_2\text{O}_6]$ , a relatively rare mineral. With a complete solid solution of iron and manganese, four end-member compositions are possible:  $\text{FeNb}_2\text{O}_6$  (ferrocolumbite),  $\text{MnNb}_2\text{O}_6$  (manganocolumbite),  $\text{FeTa}_2\text{O}_6$  (ferrotantalite), and  $\text{MnTa}_2\text{O}_6$  (manganotantalite).

Physical properties vary with composition. The specific gravity may range from 5.0 for  $\text{MnNb}_2\text{O}_6$  to 5.4 for  $\text{FeNb}_2\text{O}_6$ ;  $\text{FeTa}_2\text{O}_6$  has a specific gravity of 7.9. The hardness of columbite on the Mohs scale is 6, while that of tantalite is 6.5. When the mineral is studied as a hand specimen, the color is black; however, the streak may be dark red to black. Manganoan varieties, end-member compositions rich in manganese, are often reddish brown. The luster is submetallic to weakly vitreous.

Columbite is a common accessory mineral in granitic pegmatites, and it may occur as a heavy mineral in placer deposits in streams. Minerals of the columbite-tantalite series are the most abundant and widespread of the natural columbates and tantalates, and columbite is the chief ore mineral of niobium. Niobium is used chiefly as an alloying element in the manufacture of specialty steels and alloys with nuclear and aerospace applications. See MINERALOGY; NIOBIUM; PEGMATITE; TANTALITE; TANTALUM.

[R.C.Ew.]

**Column** A structural member that carries its load in compression along its length. Most frequently, as in a building, the column is in a vertical position transmitting gravity loads from its top down to its base. Columns are present in other structures as well, such as in bridges, towers, cranes, airplanes, machinery, and furniture. Other terms used by both engineers and lay persons to identify a column are pillar, post, and strut. Columns of timber, stone, and masonry have been constructed since the dawn of civilization; modern materials also include steel, aluminum, concrete, plastic, and composite material. See COMPOSITE MATERIAL; LOADS, TRANSVERSE; STRUCTURAL MATERIALS; STRUCTURAL STEEL.

Modern steel columns are made by rolling, extruding, or forming hot steel into predetermined cross-sectional shapes in the manufacturing facility. Reinforced concrete columns are fabricated either in their final locations (cast-in-place concrete) or in a precast plant (precast concrete) with steel reinforcing rods embedded in the concrete. Masonry columns are usually built in their final locations; they are made of brick or concrete

masonry blocks; sometimes steel reinforcing rods are embedded within the masonry. See BRICK; CONCRETE; MASONRY; PRECAST CONCRETE; REINFORCED CONCRETE.

According to their behavior under load, columns are classified as short, slender, or intermediate. A short column is one whose length is relatively short in comparison to its cross-sectional dimensions and, when loaded to its extreme, fails by reaching the compressive strength of its material. This is called failure in axial compression. A slender column is one whose length is large in comparison to its cross-sectional dimensions and, when loaded to its extreme, fails by buckling (abruptly bending) out of its straight-line shape and suddenly collapsing before reaching the compressive strength of its material. This is called a condition of instability. An intermediate column falls between the classifications of short and slender. When loaded to its extreme, the intermediate column falls by a combination of compression and instability. [R.T.R.]

**Combinatorial chemistry** A method in which very large numbers of chemical entities are synthesized by condensing a small number of reagents together in all combinations defined by a small set of reactions. The main objective of combinatorial chemistry is synthesis of arrays of chemical or biological compounds called libraries. These libraries are screened to identify useful components, such as drug candidates. Synthesis and screening are often treated as separate tasks because they require different conditions, instrumentation, and scientific expertise. Synthesis involves the development of new chemical reactions to produce the compounds, while screening aims to identify the biological effect of these compounds, such as strong binding to proteins and other biomolecular targets.

Combinatorial chemistry is sometimes referred to as matrix chemistry. If a chemical synthesis consists of three steps, each employing one class of reagent to accomplish the conversion, then employing one type of each reagent class will yield  $1 \times 1 \times 1 = 1$  product as the result of  $1 + 1 + 1 = 3$  total reactions. Combining 10 types of each reagent class will yield  $10 \times 10 \times 10 = 1000$  products as the result of as few as  $10 + 10 + 10 = 30$  total reactions; 100 types of each reagent will yield 1,000,000 products as the result of as few as 300 total reactions. While the concept is simple, considerable strategy is required to identify 1,000,000 products worth making and to carry out their synthesis in a manner that minimizes labor and maximizes the value of the resulting organized collection, called a chemical library. See MATRIX THEORY.

The earliest work was motivated by a desire to discover novel ligands (that is, compounds that associate without the formation of covalent bonds) for biological macromolecules, such as proteins. Such ligands can be useful tools in understanding the structure and function of proteins; and if the ligand meets certain physicochemical constraints, it may be useful as a drug. For this reason, pharmaceutical applications provided early and strong motivation for the development of combinatorial chemistry. See LIGAND. [A.W.Cz.]

In combinatorial chemistry, attention has been focused on the problem of how to identify the set of molecules that possess a desired combination of properties. In a drug-discovery effort, the library members that strongly bind to a particular biological receptor are of interest. In a search for new materials that behave as superconductors at relatively high temperatures, the special combination of elements yielding the best electrical properties is a goal. In each case, the library might consist of up to a million members, while the subset of target molecules might consist of several thousand contenders or just a single highly selective binder. This subset could then be studied in more detail by conventional means.

Several emerging strategies promise to address this problem. In the first case, a library is constructed in a spatial array such that the chemical composition of each location in the array is noted during the construction. The binding molecules, usually

labeled with a fluorescent tag, are exposed to the entire assay. The locations that light up can then be immediately identified from their spatial location. This approach is being actively developed for libraries of proteins and nucleotides. A problem is that the chemistry required to attach various molecules to the solid surface, usually silicon, is quite tricky and difficult to generalize. The assaying strategy is intertwined with the available procedures for synthesizing the libraries themselves.

A conceptually straightforward approach is to first synthesize the library by using polystyrene beads as the solid support. The product molecules are then stripped from the support and pooled together into a master solution. This complex mixture consisting of a potentially large selection of ligand molecules could then be exposed to an excess of a target receptor. The next step is to devise a method for identifying the ligand-receptor pairs that point to molecularly specific binding. One approach is to examine a part of the mixture *en masse* by using affinity capillary electrophoresis. With this technique, the migration times of the ligand-receptor pair are significantly longer than the unreactive ligands, and can be interrogated by electrospray mass spectrometry.

The mass spectrometric method often provides a direct structural identification of the ligand, either by determination of its molecular weight or by collision-induced dissociation experiments. In the latter case, the molecular ion is selected by a primary mass spectrometer and is driven into a region of high-pressure inert gas for fragmentation. The fragment ions are then used to reconstruct the original molecular structure. This direct approach to screening and assaying has the advantage that the screening is carried out in solution rather than on a solid support, and it avoids steric problems associated with resin-bound molecules. At present the approach seems limited to libraries of about 1000 compounds because of interference from unbound ligands, and limited by sensitivity issues. New strategies using mass spectrometry may eliminate this limit.

A different tack involves assaying the polystyrene beads one by one after the resin-bound molecules are exposed to a receptor. With this approach, active beads may be identified by color or by fluorescence associated with the receptor, and are subsequently indexed in standard 96-well titer plates. Identification is then possible by using a variety of spectroscopic techniques; at present, the most popular methods are electrospray mass spectrometry and matrix-assisted laser desorption ionization mass spectrometry. See MASS SPECTROMETRY. [N.W.]

Dynamic combinatorial chemistry integrates library synthesis and screening in one process, potentially accelerating the discovery of useful compounds. In the dynamic approach the libraries are not created as arrays of individual compounds, but are generated as mixtures of components, similar to natural pools of antibodies. One important requirement is that the mixture components exist in dynamic equilibrium with each other. According to basic laws of thermodynamics (Le Chatelier's principle), if one of the components ( $A_i$ ) is removed from the equilibrated mixture, the system will respond by producing more of the removed component to maintain the equilibrium balance in the mixture. See CHEMICAL EQUILIBRIUM; LE CHATELIER'S PRINCIPLE.

The dynamic mixture, as any other combinatorial library, is so designed that some of the components have potentially high affinity to a biomolecular target. These high-affinity (effective) components can form strong complexes with the target. If the target is added to the equilibrated mixture, when the effective components form complexes with the target they are removed from the equilibrium. This forces the system to make more of these components at the expense of other ones that bind to the target with less strength. As a result of such an equilibrium shift, the combinatorial library reorganizes to increase the amount of strong binders and decrease the amount of the weaker ones. This reorganization leads to enrichment of the library with the effective components and simplifies their identification. [A.V.E.]

**Combinatorial synthesis** A method for preparing a large number of chemical compounds, commonly known as a combinatorial library, which are then screened to identify compounds having a desired function, such as a particular biological or catalytic activity. Combinatorial synthesis is an aspect of combinatorial chemistry, which allows for the simultaneous generation and rapid testing for a desired property of large numbers of chemically related compounds. One could regard combinatorial chemistry as the scientist's attempt to mimic the natural principles of random mutation and selection of the fittest. Combinatorial chemistry has already become an invaluable tool in the areas of molecular recognition, materials science, drug discovery and optimization, and catalyst development. See COMBINATORIAL CHEMISTRY; ORGANIC SYNTHESIS.

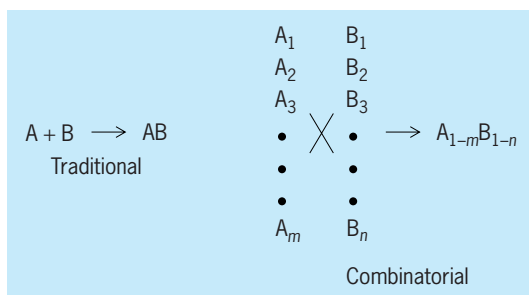

Traditional synthesis versus combinatorial synthesis.

Combinatorial synthesis was developed to prepare libraries of organic compounds containing from a few dozen to several million members simultaneously, in contrast to traditional organic synthesis where one target compound is prepared at a time in one reaction (see illustration). Thus, a target compound AB, for example, would be prepared by coupling of the substrates A and B in a traditional (orthodox) synthesis and would be isolated after reaction processing (workup) and purification (such as crystallization, chromatography, or distillation). Combinatorial synthesis offers the potential to prepare every combination of substrates, type  $A_{1-m}$  and type  $B_{1-n}$ , providing a set of compounds,  $A_{(1-m)}B_{(1-n)}$ . [Y.U.]

**Combinatorial theory** The branch of mathematics which studies arrangements of elements (usually a finite number) into sets under certain prescribed constraints. Problems combinatorialists attempt to solve include the enumeration problem (how many such arrangements are there?), the structure problem (what are the properties of these arrangements and how efficiently can associated calculations be made?), and, when the constraints become more subtle, the existence problem (is there such an arrangement?). [T.Br.]

**Combining volumes, law of** The principle that when gases take part in chemical reactions the volumes of the reacting gases and those of the products, if gaseous, are in the ratio of small whole numbers, provided that all measurements are made at the same temperature and pressure. The law is illustrated by the following reactions:

1. One volume of chlorine and one volume of hydrogen combine to give two volumes of hydrogen chloride.
2. Two volumes of hydrogen and one volume of oxygen combine to give two volumes of steam.
3. One volume of ammonia and one volume of hydrogen chloride combine to give solid ammonium chloride.
4. One volume of oxygen when heated with solid carbon gives one volume of carbon dioxide.

The law of combining volumes is similar to the other gas laws in that it is strictly true only for an ideal gas, though most

gases obey it closely at room temperatures and atmospheric pressure. Under high pressures used in many large-scale industrial operations, such as the manufacture of ammonia from hydrogen and nitrogen, the law ceases to be even approximately true. See GAS. [T.C.W.]

**Combustion** The burning of any substance, in gaseous, liquid, or solid form. In its broad definition, combustion includes fast exothermic chemical reactions, generally in the gas phase but not excluding the reaction of solid carbon with a gaseous oxidant. Flames represent combustion reactions that can propagate through space at subsonic velocity and are accompanied by the emission of light. The flame is the result of complex interactions of chemical and physical processes whose quantitative description must draw on a wide range of disciplines, such as chemistry, thermodynamics, fluid dynamics, and molecular physics. In the course of the chemical reaction, energy is released in the form of heat, and atoms and free radicals, all highly reactive intermediates of the combustion reactions, are generated. See FLAME; FREE RADICAL; REACTIVE INTERMEDIATES.

The physical processes involved in combustion are primarily transport processes: transport of mass and energy and, in systems with flow of the reactants, transport of momentum. The reactants in the chemical reaction are normally a fuel and an oxidant. In practical combustion systems the chemical reactions of the major chemical species, carbon and hydrogen in the fuel and oxygen in the air, are fast at the prevailing high temperatures (greater than 1200 K or 1700°F) because the reaction rates increase exponentially with temperature. In contrast, the rates of the transport processes exhibit much smaller dependence on temperature are, therefore, lower than those of the chemical reactions. Thus in most practical flames the rate of evolution of the main combustion products, carbon dioxide and water, and the accompanying heat release depends on the rates at which the reactants are mixed and heat is being transferred from the flame to the fresh fuel-oxidant mixture injected into the flame. However, this generalization cannot be extended to the production and destruction of minor species in the flame, including those of trace concentrations of air pollutants such as nitrogen oxides, polycyclic aromatic hydrocarbons, soot, carbon monoxide, and submicrometer-size inorganic particulate matter. See TRANSPORT PROCESSES.

Combustion applications are wide ranging with respect to the fields in which they are used and to their thermal input, extending from a few watts for a candle to hundreds of megawatts for a utility boiler. Combustion is the major mode of fuel utilization in domestic and industrial heating, in production of steam for industrial processes and for electric power generation, in waste incineration, and in propulsion in internal combustion engines, gas turbines, or rocket engines. [J.M.Be.]

**Combustion chamber** The space at the head end of an internal combustion engine cylinder where most of the combustion takes place. See COMBUSTION.

In the spark-ignition engine, combustion is initiated in the mixture of fuel and air by an electrical discharge. The resulting reaction moves radially across the combustion space as a zone of active burning, known as the flame front. The velocity of the flame increases nearly in proportion to engine speed so that the distance the engine shaft turns during the burning process is not seriously affected by changes in speed. See INTERNAL COMBUSTION ENGINE; SPARK PLUG.

Occasionally a high burning rate, or too rapid change in burning rate, gives rise to unusual noise and vibration called engine roughness. Roughness may be reduced by using less squish or by shaping the combustion chamber to control the area of the flame front. A short burning time is helpful in eliminating knock because the last part of the charge is burned by the flame before it has time to ignite spontaneously. See SPARK KNOCK.

In compression-ignition (diesel) engines, the fuel is injected late in the compression stroke into highly compressed air. Mixing must take place quickly, especially in smaller high-speed engines, if the fuel is to find oxygen and burn while the piston remains near top center. After a short delay, the injected fuel ignites from contact with the hot air in the cylinder. There is no flame front travel to limit the combustion rate.

If mixing of fuel and air is too thorough by the end of the delay period, high rates of pressure rise result, and the operation of the engine is rough and noisy. To avoid this condition, the auxiliary chamber in most compression-ignition engines operates at high temperature so that the fuel ignites soon after injection begins. This reduces the amount of fuel present and the degree of mixing at the time that ignition takes place. High rates of pressure rise can also be reduced by keeping most of the fuel separated from the chamber air until the end of the delay period. Rapid mixing must then take place to ensure efficient burning of the fuel while the piston is near top center. See DIESEL ENGINE. [A.R.R.; D.L.An.]

**Comet** One of the major types of objects that move in closed orbits around the Sun. Compared to the orbits of planets and asteroids, comet orbits are more eccentric and have a much greater range of inclinations to the ecliptic (the plane of the Earth's orbit). Physically, a comet is a small, solid body which is roughly 2 mi (3 km) in diameter, contains a high fraction of icy substances, and shows a complex morphology, often including the production of an extensive atmosphere and tail, as it approaches the Sun. See ASTEROID; PLANET.

Astronomers consider comets to be worthy of detailed study for several reasons: (1) They are intrinsically interesting, involving a large range of physical and chemical processes. (2) They are valuable tools for probing the solar wind. (3) They are considered to be remnants of the solar system's original material and, hence, prime objects to be studied for clues about the nature of the solar system in the distant past. (4) Comets may be required to explain other solar system phenomena.

Present knowledge of comets is heavily influenced by the Halley's Comet campaign in 1986, which included images of the nucleus obtained by spacecraft sent to intercept the comet, and by the extensive studies of the very large Comet Hale-Bopp in 1997. While the data obtained from these comets are invaluable, comets are believed to be highly individualistic. See HALLEY'S COMET.

As seen from Earth, comets are nebulous in appearance, and the tail is usually the most visually striking feature. This tail can in some cases stretch along a substantial arc in the sky (see illustration). Some fainter comets, however, have little or no tail.

The coma or head of a comet is seen as the ball of light from which the tail or tails emanate. Within the coma is the nucleus, the origin of the material in the tail and coma.

The main components of a comet are the nucleus, coma, hydrogen cloud, and tails. Strong evidence points to the existence of a central nuclear body or nucleus for all comets from which all cometary material, both gas and dust, originates. In the early 1950s, F. L. Whipple proposed a model of the nucleus in which it is a single mass of ice with embedded dust particles, commonly called a dirty snowball. Such a nucleus could supply an adequate amount of gas to explain cometary phenomena and last through many apparitions because only a relatively thin surface layer would be eroded away (by sublimation) during each passage near the Sun.

The nucleus of Halley's Comet has been directly observed. Its shape was highly irregular, the surface exhibited features and structure, and the albedo (fraction of reflected light) was very low. While the confirmation of the existence of a single, nuclear body is important, Halley is just one comet and generalizations from it may not be valid. See ALBEDO.

The coma is observed as an essentially spherical cloud of gas and dust surrounding the nucleus. The principal gaseous constituents are neutral molecules. As the gas flows away from

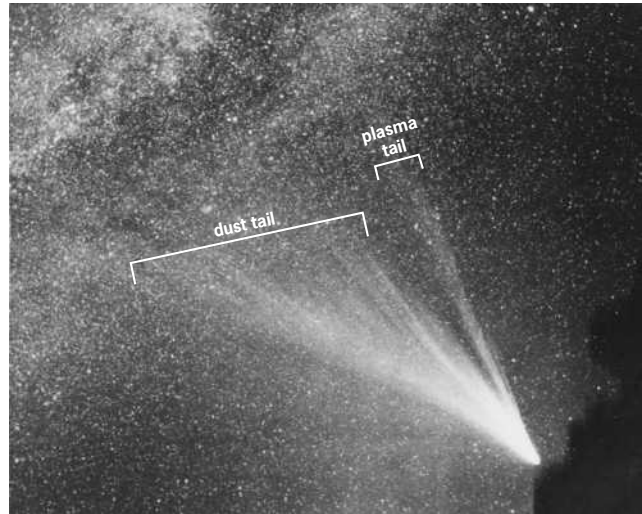

Comet West as photographed on March 9, 1976, showing the general appearance of a bright comet. The fan-shaped structure emanating from the head or coma is the dust tail, while the single straight structure is the plasma tail. The tails are some  $30^\circ$  in length. (S. M. Larson, Lunar and Planetary Laboratory, University of Arizona)

the nucleus, the dust particles are dragged along. In 1970, observations of Comet Tago-Sato-Kosaka and Comet Bennett from orbiting spacecraft showed that these comets were surrounded by a giant hydrogen cloud that extends to distances on the order of  $10^7$  km, or a size larger than the Sun.

Photographs of bright comets generally show two distinct types of tails (see illustration): the dust tails and the plasma tails. They can exist separately or together in the same comet. The plasma tails are generally straight and the plasma in these tails is composed of electrons and molecular ions. The dust tails are usually curved and the dust particles are probably silicate in composition.

The Oort Cloud, postulated by J. Oort in 1950, is the source of the long-period comets. The evidence from the statistics of cometary orbits indicates that it is an essentially spherical cloud of comets with dimensions in the range  $10^4$  to  $10^5$  AU. Gravitational perturbations from passing stars and gas clouds have several effects on the cloud. They limit its size and tend to make the orbits random (as observed). Most importantly, the perturbations continually send new comets from the cloud into the inner solar system, where they are observed. Thus, the Oort Cloud can be considered as a steady-state reservoir for new comets. Evidence is mounting for the view that the Oort Cloud is supplied by an inner cloud of comets.

The current consensus on the origin of comets holds that they condensed from the solar nebula at the same time as the formation of the Sun and planets, and their material may be little altered from the era of condensation to the present time. Generally accepted models of the solar nebula have temperature and density conditions suitable for the condensation of cometary materials at solar distances around the orbits of Uranus and Neptune. The condensate could coalesce to produce a ring of comets or cometesimals. Gravitational perturbations by the major planets would disperse the ring of comets, sending some into the inner cloud or Oort's Cloud and sending some inward to become short-period comets. See SOLAR SYSTEM. [J.C.B.]

**Comfort heating** The maintenance of the temperature in a closed volume, such as a home, office, or factory, at a comfortable level during periods of low outside temperature. Two principal factors determine the amount of heat required to maintain a comfortable inside temperature: the difference between

inside and outside temperatures and the ease with which heat can flow out through the enclosure.

The first step in planning a heating system is to estimate the heating requirements. This involves calculating heat loss from the space, which in turn depends upon the difference between outside and inside space temperatures and upon the heat transfer coefficients of the surrounding structural members. Outside and inside design temperatures are first selected. Ideally, a heating system should maintain the desired inside temperature under the most severe weather conditions. The design temperature selected depends upon the heat capacity of the structure, amount of insulation, wind exposure, proportion of heat loss due to infiltration or ventilation, nature and time of occupancy or use of the space, difference between daily maximum and minimum temperatures, and other factors. Usually the outside design temperature used is the median of extreme temperatures. The selected inside design temperature depends upon the use and occupancy of the space. Generally it is between 66 and 75°F (19 and 24°C).

In localities where outdoor temperatures are often below 36°F (2°C), it is advisable to provide means for adding moisture in heated spaces to improve comfort. The colder the outside air is, the less moisture it can hold. When it is heated to room temperature, the relative humidity in the space becomes low enough to dry out nasal membranes, furniture, and other hygroscopic materials. This results in discomfort as well as deterioration of physical products. Various types of humidifiers are available. The most satisfactory type provides for the evaporation of the water to take place on a mold-resistant treated material which can be easily washed to get rid of the resultant deposits.

Good insulating material has air cells or several reflective surfaces. A good vapor barrier should be used with or in addition to insulation, or serious trouble may result. Air inside a space in which moisture has been added from cooking, washing, drying, or humidifying has a much higher vapor pressure than cold outdoor air. Therefore, moisture in vapor form passes from the high vapor pressure space to the lower pressure space and will readily pass through most building materials. When this moisture reaches a subfreezing temperature in the structure, it may condense and freeze. When the structure is later warmed, this moisture will thaw and soak the building material, which may be harmful. Good vapor barriers include asphalt-impregnated paper, metal foil, and some plastic-coated papers. Heat loss due to infiltration is the most difficult item to estimate accurately and depends upon how well the house is built. If a masonry or brick-veneer house is not well caulked or if the windows are not tightly fitted and weather-stripped, this loss can be quite large. See AIR REGISTER; CENTRAL HEATING AND COOLING; HOT-WATER HEATING SYSTEM; RADIATOR; STEAM HEATING; WARM-AIR HEATING SYSTEM.

[G.B.P.]

**Commelinales** An order of flowering plants, division Magnoliophyta (Angiospermae), which is included in the subclass Commelinidae in the class Liliopsida (monocotyledons). It consists of 4 families and about 1000 species, the bulk of which is in the families Commelinaceae (about 700 species) and Xyridaceae (about 200 species). The order is marked by its flowers that ordinarily have the perianth well differentiated into sepals and petals but do not have nectaries or nectar. The ovary is consistently superior and the fruit capsular. The wandering Jew (species of *Tradescantia* and *Zebrina* in the Commelinaceae) belongs to this order. See COMMELINIDAE; LILIOPSIDA; MAGNOLIOPHYTA; PLANT KINGDOM.

[A.Cr.; T.M.Ba.]

**Commelinidae** A subclass of the class Liliopsida (monocotyledons) of the division Magnoliophyta (Angiospermae), the flowering plants, consisting of 7 orders, 16 families, and nearly 15,000 species. The orders include Commelinales, Eriocaulales, Restionales, Juncales, Cyperales, Hydatellales, and Typhales. For further information see separate articles on each order.

These monocotyledons are syncarpous (the carpels are united in a compound ovary) or pseudomonomerous (reduced to a single carpel from a syncarpous ancestry). The endosperm is usually starchy, and the perianth is either well differentiated into sepals and petals or more or less reduced and not petallike. The stomates have two or more subsidiary cells, the pollen is either binucleate or more often trinucleate, and the endosperm may be nuclear. Many of the families have well-developed vessels in all vegetative organs. Several of the orders of Commelinidae have often been treated as a single order Farinosae or Farinales. See LILIOPSIDA; MAGNOLIOPHYTA; PLANT KINGDOM.

[A.Cr.; T.M.Ba.]

**Common cold** An acute infectious disorder characterized by nasal obstruction and discharge that may be accompanied by sneezing, sore throat, headache, malaise, cough, and fever. The disorder involves all human populations, age groups, and geographic regions; it is more common in winter than in summer in temperate climates. Most people in the United States experience at least one disabling cold (causing loss of time from work or school or a physician visit) per year. Frequencies are highest in children and are reduced with increasing age.

Most, or possibly all, infectious colds are caused by viruses. More than 200 different viruses can induce the illness, but rhinoviruses, in the picornavirus family, are predominant. Rhinoviruses are small ribonucleic acid-containing viruses with properties similar to polioviruses. Other viruses commonly causing colds include corona, parainfluenza, influenza, respiratory syncytial, entero, and adeno. See ADENOVIRIDAE; ENTEROVIRUS; PARAINFLUENZA VIRUS; RHINOVIRUS.

Cold viruses are spread from one person to another in either of two ways: by inhalation of infectious aerosols produced by the sneezing or coughing of ill individuals, or by inoculation with virus-containing secretions through direct contact with a person or a contaminated surface. Controlled experiments have not shown that chilling produces or increases susceptibility to colds. Infection in the nasopharynx induces symptoms, with the severity of the illness relating directly to the extent of the infection. Recovery after a few days of symptoms is likely, but some individuals may develop a complicating secondary bacterial infection of the sinuses, ear, or lung (pneumonia).

Colds are treated with medications designed to suppress major symptoms until natural defense mechanisms terminate the infection. Immunity to reinfection follows recovery and is most effective in relation to antibody in respiratory secretions. There is no established method for prevention of colds; however, personal hygiene is recommended to reduce contamination of environmental air and surfaces with virus that may be in respiratory secretions. See PNEUMONIA.

[R.B.C.]

**Communications cable** A cable that transmits information signals between geographically separated points. The heart of a communications cable is the transmission medium, which may be optical fibers, coaxial conductors, or twisted wire pairs. A mechanical structure protects the heart of the cable against handling forces and the external environment. The structure of a cable depends on the application.

Optical communications cables are used in both terrestrial and undersea systems. Optical communications cables for terrestrial use may be installed aerially, by direct burial, or in protective ducts. The terrestrial cable requires only enough longitudinal strength to support its own weight over relatively short pole-to-pole spans, or to allow installers to pull the cable into ducts or lay it in a trench. For the undersea cable, the high-strength steel strand allows it to be laid and recovered in ocean depths up to 4.5 mi (7315 m). See OPTICAL COMMUNICATIONS; SUBMARINE CABLE.

Optical communications cables are often used to carry input and output data to computers, or to carry such data from one computer to another. Then they are generally referred to as optical data links or local-area networks. The links are generally

short enough that intermediate regeneration of the signals is not needed. See FIBER-OPTIC CIRCUIT; LOCAL-AREA NETWORKS.

Signals in these cables are carried by light pulses which are guided down the optical fiber. In most applications, two fibers make up a complete two-way signal channel. The guiding effect of the fiber confines light to the core of the glass fiber and prevents interference between signals being carried on different fibers. The guiding effect also delivers the strongest possible signal to the far end of the cable. Exceptionally pure silica glass in the fiber minimizes light loss for signals passing longitudinally through the glass fiber. See OPTICAL FIBERS.

Optical cable systems are usually digital. Thus, information is coded into a train of off-or-on light pulses. These are detected by a photodetector at the far end of a cable span and converted into electronic pulses which are amplified, retimed, recognized in a decision circuit, and finally used to drive an optical transmitter. In the transmitter, a laser converts the electric signals back into a train of light pulses which are strong enough to traverse another cable span. By placing many spans in tandem, optical cable systems can carry signals faithfully for thousands of miles.

Rather than undersea regenerators, current optical-fiber cable systems use erbium-doped fiber amplifiers (EDFAs) to boost the optical signal on long spans. Conversion from optical to electronic modes and back again is then not needed in the undersea repeaters.

Coaxial communication systems evolved before optical systems. Most of these systems are analog in nature. Signals are represented by the amplitude of a wave representing the signal to be transmitted. In a multichannel system, each voice, data, or picture signal occupies its unique portion of a broadband signal which is carried on a shared coaxial conductor or "pipe." In the transmitting terminal, various signals are combined in the frequency-division transmitting multiplex equipment. At the receiving end of a link, signals are separated in the receiving demultiplex equipment. This combining and separation operates much as broadcast radio and television do, and the principles are identical. See AMPLITUDE MODULATION; COAXIAL CABLE; ELECTRICAL COMMUNICATIONS; FREQUENCY MODULATION; TELEPHONE SERVICE; TELEPHONE SYSTEMS CONSTRUCTION. [S.T.B.]

**Communications satellite** A spacecraft in orbit around the Earth to receive and retransmit radio signals. Communications satellites amplify and sort or route these signals. In earlier days they functioned much like ground microwave repeaters but with greatly increased coverage. Whereas a ground repeater relays signals between two fixed locations, a communications satellite interconnects many locations, fixed and mobile, over a wide area. With the advent of on-board processing, switching and rerouting of signals has been added to the functionality of some communications satellites, making them "switchboards in the sky."

**Choice of orbit.** The height of a satellite in a circular orbit determines both the period and the great-circle-arc distance which can be covered.

At an altitude of 22,280 mi (35,860 km) the orbital period corresponds to a sidereal day (23 h 56 min 4 s), and if the plane of the orbit coincides with the equatorial plane the satellite appears geostationary. It hovers at a fixed point with respect to the rotating Earth. With coverage of about two-fifths of the entire Earth's surface from a single satellite, three geostationary spacecraft could, in principle, provide worldwide coverage. Satellites in geosynchronous equatorial (geostationary earth) orbit (GEO) currently provide most of the world's satellite communications, for both fixed and mobile services. See ORBITAL MOTION.

However, very high latitude regions cannot be covered from the geostationary orbit. To cover high latitudes, inclined orbits are used. For its domestic communications satellite system initiated in 1965, the Molniya system, the Soviet Union chose orbits inclined 63.5° with respect to the equatorial plane, with perigee at 300 mi (500 km), apogee at 25,000 mi (40,000 km), and

orbital period of 12 h. For the above-mentioned orbit inclination, no rotation of the line of the apsides (otherwise induced by the Earth's oblateness) occurs, and the need for orbit maneuvers and corrections is reduced. It is necessary, however, to track the satellites, and several are required for continuous communications, together with tracking and handover equipment at earth stations. Tundra orbits are also highly inclined and elliptical, but with 24-h periods. The Molniya principle is not limited to high northern latitudes, and satellite communications systems that provide Molniya- and Tundra-type coverage to other regions, such as the contiguous United States, are being implemented.

As technology has progressed, low-altitude earth orbits (LEOs; less than 600 mi or 1000 km) and medium-altitude earth orbits (MEOs; less than 8000 mi or 14,400 km) have acquired some distinct advantages for mobile services. The lower-altitude satellites have much shorter paths from base stations (fixed earth stations) and mobile earth terminals as compared with satellites in geostationary orbit. Thus rf power requirements and path delay are much smaller. The consequence is that the mobile earth terminals can use low-gain antennas that need little or no tracking while still using low-power transmitters, and the system does not degrade from delay with multiple hops.

However, since the duration of an interconnection is limited to the interval of satellite visibility to the mobile earth terminals and base stations to be connected, constellations of satellites must be orbited to provide continuous communications. Typically, a system has several orbital planes, all inclined, with multiple satellites in each orbit. The satellites travel around the orbits in succession so that the next satellite rises over the horizon before the currently used satellite sets, and satellites hand over coverage (and users) in an orderly way. As the Earth rotates under the orbit planes, or, to the Earth-based observer, the orbit planes rotate around the Earth, a new orbit rotates into the field of view as the previously used orbit plane rotates out. Depending on altitude, 12–66 satellites are needed to maintain continuous worldwide communications. The orbits of choice for these constellations are below the lower Van Allen belt (that is, in LEOs) or between the Van Allen belts (that is, in MEOs). These regions are chosen to reduce the effects of radiation on solid-state components aboard, as compared to orbits inside the Van Allen belts. See VAN ALLEN RADIATION.

**Uses.** Geostationary commercial communications satellites carry less than one-half of the long-distance international telephone traffic. Other services include television, satellite news gathering, private business networks, data, facsimile, electronic mail, and Internet interconnection. Worldwide television would be impossible without satellites, because no other pervasive wide-band transmission system exists. See DATA COMMUNICATIONS; FACSIMILE; INTERNET; TELEPHONE SERVICE; TELEVISION; TELEVISION NETWORKS.

In addition to these fixed-point satellite communications services (fixed satellite service; FSS), GEO satellites provide worldwide mobile communications services (mobile satellite service; MSS) of high quality and reliability. Mobile communications include ship-to-shore maritime communication (maritime mobile satellite service; MMSS), aircraft-to-ground (aeronautical mobile satellite service; AMSS), and land vehicle-to-base (land mobile satellite service; LMSS). Services provided include data, voice, paging, facsimile, and emergency services such as search and rescue for ships and aircraft and terrestrial emergency services (forest fire, flood, and earthquake). See RADIO PAGING SYSTEMS.

Broadcasting via satellites to individual homes and community antenna television (CATV) cable heads has been in use since 1983 employing medium-power satellites. The advent of high-power satellites in the late 1980s created the direct broadcast satellite (DBS) industry, which has experienced worldwide growth. Satellites are being built to provide direct radio services (in the same manner as broadcast radio stations) to vehicles;



this is called the digital audio radio service (DARS). See DIRECT BROADCASTING SATELLITE SYSTEMS.

Satellites are also widely used for military communications between fixed stations and mobile terminals on ships, airplanes, and land vehicles. See MILITARY SATELLITES.

Satellites in Molniya- and Tundra-type orbits provide much the same type of services, since the constellation appears quasi-geostationary for the region over which the very slow moving satellites hover near apogee.

In the latter half of the 1990s, satellite systems (constellations) were planned and some were launched to provide services from MEO and LEO. The planned and implemented services include paging, messaging, meter reading, and other low-data-rate services from the little LEO systems, to voice, data, private business networks, and Internet communication via the other LEO and MEO systems.

**Basic configuration.** Satellites represent a very significant step in the evolution of radio communications systems, whose progress can be largely attributed to the use of ever-higher carrier frequencies to obtain wider signaling bandwidths. Terrestrial ultrahigh-frequency (UHF) and superhigh-frequency (SHF) radio relay systems have high communications capacity, but are range-limited. Clearly, when terminals are separated by oceans, electronic equipment on an orbiting spacecraft provides a solution with which only fiber-optic cables can compete, and then only on trunk routes. See MICROWAVE; OPTICAL COMMUNICATIONS.

In a satellite communications system, the spacecraft carries the power subsystem, station-keeping and orientation devices, and the payload, the communications subsystem. Wideband linear receivers amplify the uplink signals. After a process of frequency conversion, the signals are further amplified in separate channels (to minimize intermodulation noise) and fed to the downlinks. Transmitter power output of individual channels falls in the range 5–40 W in satellites for fixed services. Travelling-wave tube amplifiers (TWTAs) are commonly used as power amplifiers, but solid-state power amplifiers (SSPAs) based upon field-effect transistors are competitive at 4 GHz and will become competitive at 12 GHz. Mobile satellites in geostationary orbit require higher effective radiated powers, and typically use solid-state matrix amplifiers and 20-ft (6-m) antennas to achieve them. Their Ku-band feeder links employ 100-W TWTAs on board. Broadcasting satellites, serving a multitude of users having small, inexpensive receivers and receive-only antennas (typically 1–3 ft or 0.3–1 m in diameter), require transmitter power up to a few hundred watts provided by TWTAs. The total power generated by solar-cell arrays has gradually climbed to over 10 KW. See AMPLIFIER; MICROWAVE SOLID-STATE DEVICES; TRANSISTOR.

**Spacecraft antennas.** Parabolic reflector spacecraft antennas provide spot beam coverage down to about 1°. The allocated frequency bands are reused many times by means of orthogonal polarizations (vertical–horizontal linear or clockwise–counterclockwise circular) and spatially separated beams. Beams have been synthesized to follow the contours of geographical areas such as continents and national or regional boundaries, using suitably arranged feed horns, excited with proper amplitude and phase, whose radiated energy impinges upon a reflector and illuminates desired areas on Earth.

In such frequency reuse systems, adequate isolation (up to 30 dB) must be maintained between dually polarized and spatially separated beams. Until the 1980s, parabolic reflectors with offset feed assemblies in the focal region were adequate. However, when more beams and higher frequency reuse factors are desired, dual-offset reflectors with gregorian or cassegrainian feeds provide better control of the illumination and permit the use of larger reflectors without the need for excessive focal lengths. These are usually fed by feed arrays backed by beam-forming networks to provide the multiplicity of beams or beam shaping required. Arrays of up to 160 feed horns have been employed, backed by three layers of beam-forming networks to provide reconfigurability while on station.

Antennas used on LEO and MEO satellite systems must radiate families of beams to provide coverage cells that resemble in some respects terrestrial coverage patterns. This has led to deployment of multibeam arrays in some configurations and constellations. As the satellites proceed along their orbital paths, these clusters of beams sweep out coverage swaths that move over the Earth. See ANTENNA (ELECTROMAGNETISM).

**Transponders.** Transponders are microwave repeaters carried by communications satellites. Transparent transponders can handle any signal whose format can fit in the transponder bandwidth. No signal processing occurs other than that of heterodyning (frequency changing) the uplink frequency bands to those of the downlinks. Such a satellite communications system is referred to as a bent-pipe system. Connectivity among earth stations, which is maximum with global-coverage antennas, is reduced when multiple narrow beams are used. Hence, the evolution proceeded from the transparent transponder to transponders that can perform signal switching and format processing.

On-board processing has increased in other areas as well, including (1) radio-frequency and intermediate-frequency signal switching, (2) baseband processing and switching, (3) phased-array antenna and feed-array control and beam forming, and (4) bus function support processing. The first two relate to the traffic through the transponder. The function of the antennas is growing ever more complex, especially on some LEO and MEO systems, and thus requires on-board processing and control. Similarly, control of the satellite bus functions (power systems, attitude, station-keeping, telemetry and the like) requires significant on-board processing. [G.Hy.; P.L.Ba.; C.E.Ma.]

**Communications scrambling** The methods for ensuring the privacy of voice, data, and video transmissions. Various techniques are commonly utilized to perform such functions.

Analog voice-scrambling methods typically involve splitting the voice frequency spectrum into a number of sections by means of a filter bank and then shifting or reversing the sections for transmission in a manner determined by switch settings similar to those of a combination lock; the reverse process takes places at the receive end. Digital methods first convert the analog voice to digital form and then scramble or encrypt the digital voice data by one of the methods discussed below. See ANALOG-TO-DIGITAL CONVERTER; ELECTRIC FILTER.

A simple data-scrambling method involves the addition of a pseudorandom number sequence to the data at the transmit end. Devices using this method are known as stream ciphers. A second method partitions the data into blocks. Data within a block may be permuted bit by bit or substituted by some other data in a manner determined by the switch setting, which is often called a key. Devices using this method are known as block ciphers. See CRYPTOGRAPHY.

Typical video scrambling devices used for cable television applications involve modifying the amplitude or polarity of the synchronization signals, thereby preventing the normal receiver from detecting the synchronization signals. A more sophisticated technique, used in satellite transmission, introduces a random delay to the active video signal on a line-by-line basis. An even more advanced technique called cut-and-rotate has been proposed. Video signals can also be digitized by a number of coding techniques and then scrambled by any of the data-scrambling techniques discussed above to achieve high security. See CLOSED-CIRCUIT TELEVISION; TELEVISION. [L-N.L.]

**Communications systems protection** The protection of wire and optical communications systems equipment and service from electrical disturbances. This includes the electrical protection of lines, terminal equipment, and switching centers, and inductive coordination, or the protection against interference from nearby electric power lines.

The principal sources of destructive electrical disturbances on wire communications systems are lightning and accidental

energization by power lines. Lightning that directly strikes aerial or buried communication cable may cause localized thermal damage and crushing. Simultaneously, it energizes the communication line with a high-level voltage transient that is conducted to terminal equipment. Indirect strikes are more common than direct strikes and, although they normally do not cause mechanical damage, they propagate electrical transients along the line. See LIGHTNING.

During fault conditions on commercial power lines, high voltages may occur in nearby communication lines by several mechanisms. The most common is magnetically induced voltage caused by the high unbalanced currents of a phase-to-ground power-line fault. During such an event, an aerial or buried communication line that is parallel to the faulted power line intercepts its time-varying magnetic field, incurring a high longitudinal voltage.

In city centers, the diversion of lightning strikes by steel-framed buildings, and the shielding effect of the many underground metallic utility systems, considerably reduce the probability of high-voltage transients from lightning or induction from power lines. Since communication and power facilities are routed in separate conduits, the possibility of a power contact is remote. See ELECTRICAL INTERFERENCE; ELECTRICAL NOISE.

Metallic communication lines often are made up of many closely spaced pairs of wires arranged as a cable. A grounded circumferential metallic shield on the cable reduces the magnitude of electrical transients from nearby lightning strikes, and also can intercept a low-current direct strike, minimizing damage to the internal conductors. The effectiveness of the shield is improved if its resistance per unit length is low and if the dielectric strength of the insulation between the shield and the internal conductors is high.

Damage to cable plant from a power-line contact is minimized by providing frequent bonds between the cable shield or aerial support strand and the neutral conductor of the power line. These bonds create low-resistance paths for fault currents returning to the neutral, and hasten deenergization by power-line fault-clearing devices. Closely spacing the bonds limits the length of communication cable that is damaged by the contact.

The outer metallic shields of belowground cables may be attacked by electrolytic action and require protective measures against corrosion. See CORROSION.

Optical-fiber communication lines are enclosed in cables that may contain metallic components to provide mechanical strength, water-proofing, local communications, or a rodent barrier. Though the cables otherwise would be immune to the effects of lightning or nearby power lines, such metallic components introduce a measure of susceptibility that is made all the more important by the high information rates carried by the fibers. A direct lightning strike to a metallic component of buried optical-fiber cable can cause localized thermal damage, arcing, and crushing that together may damage the fibers. Electrical protection is provided by cable designs that withstand these effects. As with metallic lines, the probability of this damage can be reduced by burying one or more shield wires at least 1 ft (0.3 m) above the cable.

Alternating currents may be conducted on the metallic sheath components of optical-fiber cables during an accidental contact with power-line conductors. Cable damage is minimized in extent by bonding the sheath to the neutral conductor of the power line, and by providing enough conductivity to carry the currents without damage to the fibers. See OPTICAL COMMUNICATIONS; OPTICAL FIBERS.

To protect the users, their premises, and terminal equipment, communication lines that are exposed to lightning or contacts with power lines are usually provided with surge protectors. Article 800 of the National Electrical Code requires that communication lines exposed to contact with power lines of voltages greater than 300 V be equipped with a protector at the entrance to the served premises. Interbuilding lines that are ex-

posed to lightning also have protectors. Although not required, it is common practice to minimize equipment damage by so equipping communication lines in an area of significant lightning exposure even if there is no power-contact hazard. Article 830 extends similar requirements to coaxial circuits that provide network-powered broadband communications. See ELECTRICAL CODES.

Switching centers contain electronic equipment that routes communications to their proper destinations. This equipment is protected from the effects of electrical transients appearing at interfaces with external communication lines in a similar way as for terminal equipment.

Inductive coordination refers to measures that reduce the magnitudes and effects of steady-state potentials and currents induced in metallic communication lines from paralleling power facilities. See INDUCTIVE COORDINATION. [M.Pa.]

**Commutation** The process of transferring current from one connection to another within an electric circuit. Depending on the application, commutation is achieved either by mechanical switching or by electronic switching.

Commutation was conceived over a century ago through the invention of the direct-current (dc) motor. When direct current is supplied to a winding on a rotor that is subjected to a stationary magnetic field, it experiences a rotational force and resulting output torque. As the stator north and south poles are reversed relative to the rotating winding, the rotor current is reversed by a commutator in order to maintain the unidirectional torque required for continuous motor action. See DIRECT-CURRENT MOTOR; WINDINGS IN ELECTRIC MACHINERY.

The principle is illustrated in Fig. 1. In its simplest form, a single rotor winding is connected between two segments of a cylindrical copper commutator which is mounted axially on the rotor. Connection to the external dc supply is through sliding carbon contacts (brushes). The segments have small insulated gaps at A and B. As A and B pass the brushes, the current in the rotor winding reverses. In the short interval where the brushes short-circuit the segments, the rotor current decays before building up in the reverse direction. The angular position of the brushes is selected to reverse the current at the appropriate rotor position. See COMMUTATOR.

The same principle of commutation applies to the ac commutator motor and universal ac/dc motor, which are common in variable-speed kitchen appliances and electric hand tools. See ALTERNATING-CURRENT MOTOR; UNIVERSAL MOTOR.

The equivalent of mechanical commutation occurs in solid-state converter circuits such as those used for rectifying ac to dc or inverting dc to ac. Figure 2 shows a three-phase converter widely used in industry. For simplicity, the ac supply network is represented by equivalent phase voltages in series with the effective supply inductance. (Often this inductance is mainly the inductance per phase of a converter transformer that interfaces

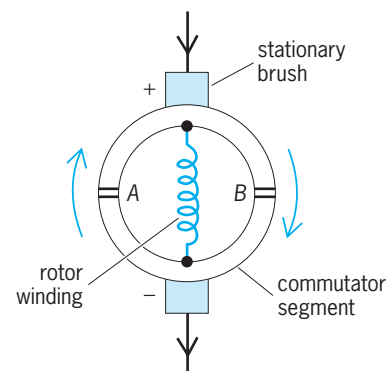

Fig. 1. Basic commutator for a dc motor.

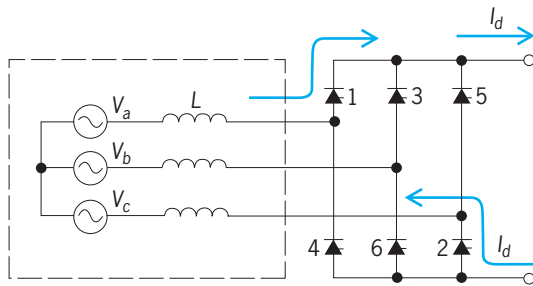
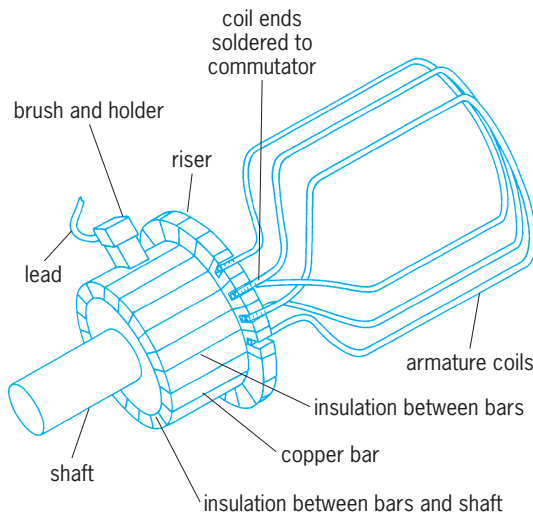

Fig. 2. Three-phase converter.

the converter and the three-phase supply.) Usually, supply resistance is relatively low and plays a negligible role in the converter action. As shown, thyristors 1 and 2 are conducting the dc current from phase *a* to phase *c*. A smooth dc current does not produce a voltage across the inductance *L* in each phase. In the cyclic conduction sequence, the dc current is commutated from phase *a* and thyristor 1 to phase *b* and thyristor 3. To achieve this, thyristor 3 is gated in a region of the ac waveform when its forward voltage is positive. Turning it on applies a reverse voltage to thyristor 1 (phase *b* being more positive than phase *a*), which ceases conduction to complete the commutation of the dc current. This is repeated in sequence for the other thyristors in each ac cycle. See CONVERTER; SEMICONDUCTOR RECTIFIER. [J.Re.]

**Commutator** That part of a dc motor or generator which serves the dual function, in combination with brushes, of providing an electrical connection between the rotating armature winding and the stationary terminals, and of permitting the reversal of the current in the armature windings. For explanation of the necessity of this function See COMMUTATION.



Commutator and brush assembly with coil connections for lap winding.

A commutator (see illustration) is composed of copper bars assembled to form a drumlike cylinder which is concentric with the axis of rotation. Insulation, commonly mica, to provide exceptional mechanical and electrical stability, is placed between commutator bars and between the bars and the shaft. Conducting brushes, commonly carbon, sufficient in size and number to carry the current, are spaced at intervals of 180 electrical degrees about the surface of the commutator and held in contact with the surface of the commutator by spring tension. See DIRECT-CURRENT GENERATOR; DIRECT-CURRENT MOTOR; ELECTRIC ROTATING MACHINERY. [A.R.E.]

**Compact disk** A system for data storage in which digitally encoded information in the form of microscopic pits on a rotating disk is accessed by optical readout. The compact disk was originally developed as a music carrier providing high fidelity, random access, convenience, durability, and low cost. Its attributes made it suitable for storing diverse data such as video programs and computer software, and improvements allowed recordability and erasability. Greater storage capacity and more sophisticated integration of features is provided in the DVD (digital video disk or digital versatile disk) format.

An acoustic signal waveform is stored on the disk in the form of a binary code, as a series of 0's and 1's. This is done by forming pits along spiral tracks on a transparent plastic disk, overlaying this with a reflective coating, and covering this coating with a protective layer. The light from a semiconductor laser is focused onto the pits from below (see illustration). The presence or absence of pits within the laser spot changes the intensity of the reflected beam (pits diffract the light, reducing reflected intensity). The reflected light strikes a light-detecting photodiode that converts the varying-intensity light beam into a binary electrical signal. See LASER.

In the disk mastering and replication process, a glass disk is covered by a uniform coating of photoresist material. A laser exposes portions of the photoresist where pits are to be formed. The photoresist is then developed and washed, leaving the master recording. A nickel mother is derived from this master and is then used as a mold to produce multiple copies of the disk in transparent polycarbonate plastic. These substrates are coated with a thin metallic reflecting layer (usually aluminum), with a protective plastic coating on top of that.

Since the information that is read off the disk is in digital form, as a sequence of 0's and 1's, it can be processed in many ways that are not possible with analog systems. To enable this, information can be passed through a buffer memory, and then output at a rate that is controlled by the player's quartz-crystal (oscillator) clock, hence entirely eliminating the wow and flutter of conventional systems.

To recreate the original music signal, the binary data on the disk must be passed through a digital-to-analog (D/A) converter and a low-pass filter. The digital-to-analog converter accepts each 16-bit sample and outputs a voltage corresponding to its value. The series of samples forms a staircase waveform that is applied to a low-pass filter that removes all frequencies above the half-sampling frequency. In this way, the filter reconstructs the original waveform. A steep (high-order) analog filter can be

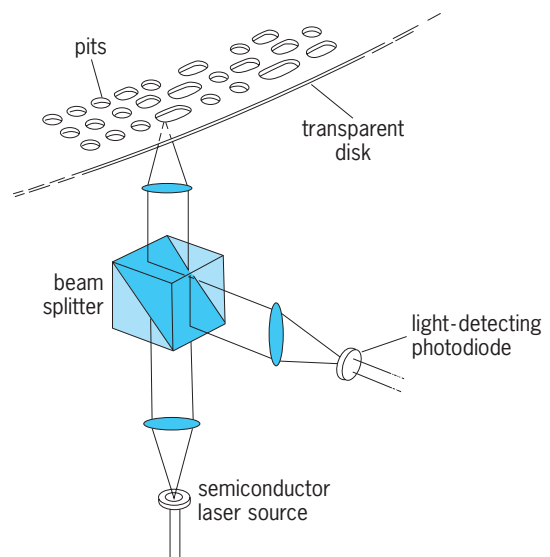

Optical readout system for an audio compact disk.

used, with a flat amplitude to the half-sampling frequency, at which point the amplitude falls to zero. See DIGITAL-TO-ANALOG CONVERTER; ELECTRIC FILTER.

Subsequent to its origin as a music carrier, the compact disk's format was extended to include the CD-ROM (read-only memory) format for computer applications. Newer formats that use the compact disk as their basis include the recordable CD-R and erasable CD-RW formats, and the multimedia DVD format. [K.C.Po.]

**Comparator** An electronic circuit that produces an output voltage or current whenever two input levels simultaneously satisfy predetermined amplitude requirements. A comparator circuit may be designed to respond to continuously varying (analog) or discrete (digital) signals, and its output may be in the form of signaling pulses which occur at the comparison point or in the form of discrete direct-current (dc) levels.

A linear comparator operates on continuous, or nondiscrete, waveforms. Most often one voltage, referred to as the reference voltage, is a variable dc or level-setting voltage and the other is a time-varying waveform. When the signal voltage becomes equal to the reference voltage, a discrete output level is obtained. If the time-varying (signal) voltage approaches the reference voltage from a more negative level the output voltage is of one polarity; if it approaches the reference from a more positive value the output is of the opposite polarity.

A very high-gain operational amplifier whose output is inverting with respect to one input terminal and noninverting with respect to the other and whose output voltage is limited at upper and lower levels (usually at voltages near the supply voltage levels) may be used as a voltage comparator. The high-gain operational-amplifier comparator used in the open-loop mode is designated as a nonregenerative comparator because there is no positive feedback path from the output back to the input.

An operational-amplifier comparator connected in a positive-feedback mode is referred to as a regenerative comparator. If the voltage gain is very high, then there is a difference between the input levels which will cause the output to switch.

This difference in input levels is referred to as the hysteresis of the circuit. Such regenerative comparators are generically referred to as Schmitt triggers. Historically, they were first implemented as discrete two-vacuum-tube devices, which were later replaced by transistors and then by the operational amplifier feedback circuit. See AMPLIFIER; FEEDBACK CIRCUIT; HYSTERESIS; OPERATIONAL AMPLIFIER.

The term digital comparator has historically been used when the comparator circuit is specifically designed to respond to a combination of discrete level (digital) signals, for example, when one or more such input signals simultaneously reach the reference level which causes the change of state of the output. Among other applications, such comparators perform the function of the logic gate such as the AND, OR, NOR, and NAND functions. More often, the term digital comparator describes an array of logic gates designed specifically to determine whether one binary number is less than or greater than another binary number. Such digital comparators are sometimes called magnitude or binary comparators. [G.M.G.]

**Complement** A group of proteins in the blood and body fluids that play an important role in humoral immunity and the generation of inflammation. When activated by antigen-antibody complexes, or by other agents such as proteolytic enzymes (for example, plasmin), complement kills bacteria and other microorganisms. In addition, complement activation results in the release of peptides that enhance vascular permeability, release histamine, and attract white blood cells (chemotaxis). The binding of complement to target cells also enhances their phagocytosis by white blood cells. The most important step in complement system function is the activation of the third compo-

nent of complement (C3), which is the most abundant of these proteins in the blood.

Genetic deficiencies of certain complement subcomponents have been found in humans, rabbits, guinea pigs, and mice. Certain deficiencies lead to immune-complex diseases, such as systemic lupus erythematosus; other deficiencies result in increased susceptibility to bacterial infections, particularly those of the genus *Neisseria* (for example, gonorrhea and meningococcal meningitis), and hereditary angioneurotic edema. See COMPLEMENT-FIXATION TEST; IMMUNITY. [F.S.R.]

**Complement-fixation test** A sensitive reaction used in serology for the detection of either antigen or antibody, as in the diagnosis of many bacterial, viral, and other diseases, including syphilis. It involves two stages: Stage I is the binding or fixation of complement if certain antigen-antibody reactions occur, and stage II is detection of residual unbound complement, if any, by its hemolytic action on the sensitized erythrocytes subsequently added (see illustration).

In the first stage either the antigen or the antibody must be supplied as a reagent, with the other of the pair as the test unknown. Fresh guinea pig serum is normally used as a complement source. Sheep erythrocytes which are coated with their corresponding antibody (amboceptor or hemolysin) are used in the second stage. See COMPLEMENT.

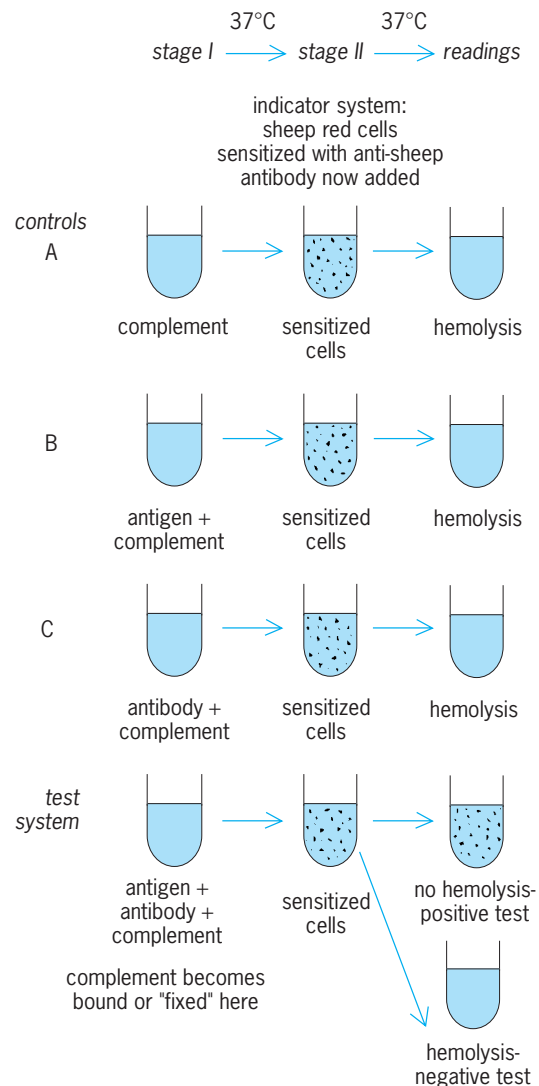

Diagram of the complement-fixation reaction.

The controls A, B, and C in the diagram demonstrate that sufficient complement is present to effect hemolysis of the sensitized indicator cells and that neither antigen or antibody added alone will interfere with this by binding complement. In the test system the combination of a suitable antigen and antibody in the presence of complement will bind the complement to the complex so that the complement becomes unavailable for the hemolysis of the indicator cells added in stage II. If either antigen or antibody is added as a reagent in stage I, then the presence of the other in the test unknown added can be detected through its ability to complete the antigen-antibody system. A lack of hemolysis denotes that the complement is bound. See IMMUNOLOGY; LYTIC REACTION. [H.P.T.]

**Complementation (genetics)** The complementary action of different genetic factors. The term usually implies two homologous chromosomes or chromosome sets, each defective because of mutation and unable by itself to promote the normal development or metabolism of the organism, but able to do so jointly when brought together in the same cell. See CHROMOSOME; MUTATION.

S. Benzer proposed the term cistron for the unit within which mutants do not complement each other. The word gene is often used in the same sense. The usual biochemical function of a cistron, or gene, is to determine the structure of a specific polypeptide component of a protein. Full complementation between different genes is the rule except when, as sometimes in bacteria, the genes form part of a functionally coordinated complex (operon). Allelic mutants (mutants within one gene) show limited complementation in some cases, for example, when certain pairs of mutant polypeptides correct each other's defects through coaggregation in a complex protein. See GENETICS; OPERON. [J.R.S.F.]

**Complex numbers** A natural and extremely useful extension of the familiar real numbers. They can be introduced formally as follows. Consider the two-dimensional real vector space consisting of all ordered pairs  $(a_1, a_2)$  of real numbers. Geometrically this space can be identified with the ordinary euclidean plane, viewing the real numbers  $a_1, a_2$  as the coordinates of a point in the plane.

The addition of vectors is defined by  $(a_1, a_2) + (b_1, b_2) = (a_1 + b_1, a_2 + b_2)$  and is just the usual addition of vectors by the parallelogram law. The multiplication of a vector  $(a_1, a_2)$  by a real number  $c$  is defined by  $c(a_1, a_2) = (ca_1, ca_2)$ , and is just the uniform dilation of the plane by the factor  $c$ . It may be asked whether it is possible to define a multiplication of one vector by another in such a manner that this multiplication is linear and satisfies the same formal rules as multiplication of real numbers. There does exist such a multiplication, given by the equation below, and it is

$$(a_1, a_2) \cdot (b_1, b_2) = (a_1 b_1 - a_2 b_2, a_1 b_2 + a_2 b_1)$$

essentially unique in the sense that any multiplication satisfying all the desired properties can be reduced to this equation by a suitable choice of coordinates in the plane. The plane with the ordinary addition and scalar multiplication of vectors and with the vector multiplication given above is the complex number system.

The above multiplication law can most easily be interpreted geometrically by introducing polar coordinates in the plane and writing  $(a_1, a_2) = (r \cos \theta, r \sin \theta)$ , where  $r$  is the length of the vector  $(a_1, a_2)$ , or the modulus of the complex number  $(a_1, a_2)$ , defined by  $r^2 = a_1^2 + a_2^2$ , and  $\theta$  is the angle between the vector  $(a_1, a_2)$  and the first coordinate axis, or the argument of the complex number  $(a_1, a_2)$ , defined by  $\tan \theta = a_2/a_1$ . Then multiplication of complex numbers amounts to multiplying their moduli and adding their arguments (see illustration).

Introducing the basis vectors  $l = (1, 0)$  and  $i = (0, 1)$ , any vector  $(x, y)$  can be written uniquely as the sum  $(x, y) = xl + yi$ . It follows readily from the multiplication law that  $l \cdot l = l$ ,  $l \cdot i = i$ ,  $i \cdot l = i$ , and

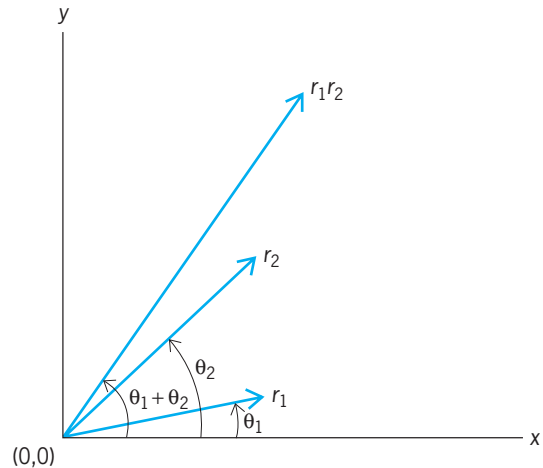

Multiplication of complex numbers.

$i \cdot i = -1$ , so that in particular the vector  $l$  is the identity element for the multiplication of complex numbers. The complex number  $l$  can be identified with the ordinary real number 1, and reflecting this identification can be simplified by writing a complex number  $z = (x, y) = xl + yi$  merely as  $z = x + iy$ . The component  $x$  is called the real part of the complex number  $z$ , and the component  $y$  is called the imaginary part. The modulus of the complex number  $z$  is denoted by  $|z|$ . [R.C.G.]

**Composite beam** A structural member composed of two or more dissimilar materials joined together to act as a unit. An example in civil structures is the steel-concrete composite beam in which a steel wide-flange shape (I or W shape) is attached to a concrete floor slab (see illustration). The many other kinds of composite beam include steel-wood, wood-concrete, and plastic-concrete or advanced composite materials-concrete. Composite beams as defined here are different from beams made from fiber-reinforced polymeric materials. See COMPOSITE MATERIAL.

There are two main benefits of composite action in structural members. First, by rigidly joining the two parts together, the resulting system is stronger than the sum of its parts. Second, composite action can better utilize the properties of each constituent material. In steel-concrete composite beams, for example, the concrete is assumed to take most or all of the compression while the steel takes all the tension.

Steel-concrete composite beams have long been recognized as one of the most economical structural systems for both multistory

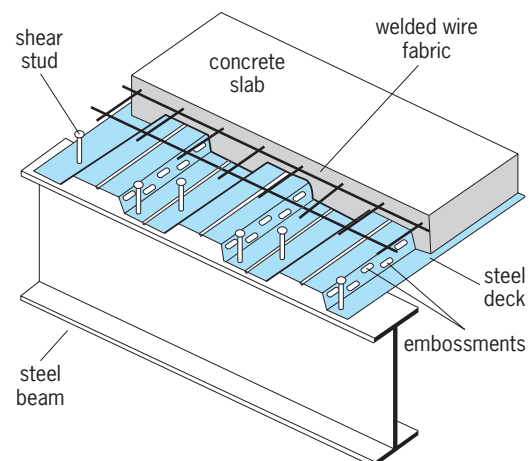

Typical composite floor system.

steel buildings and steel bridges. Buildings and bridges require a floor slab to provide a surface for occupants and vehicles, respectively. Concrete is the material of choice for the slab because its mass and stiffness can be used to reduce deflections and vibrations of the floor system and to provide the required fire protection. The supporting system underneath the slab, however, is often steel because it offers superior strength-weight and stiffness-weight ratio, ease of handling, and rapid construction cycles. Since both the steel and concrete are already present in the structures, it is logical to connect them together to better utilize their strength and stiffness. See CONCRETE; CONCRETE SLAB; STEEL. [R.Leo.]

**Composite laminates** Assemblages of layers of fibrous composite materials (see illustration) which can be tailored to provide a wide range of engineering properties, including in-plane stiffness, bending stiffness, strength, and coefficients of thermal expansion.

The individual layers consist of high-modulus, high-strength fibers in a polymeric, metallic, or ceramic matrix material. Fibers currently in use include graphite, glass, boron, and silicon carbide. Typical matrix materials are epoxies, polyimides, aluminum, titanium, and alumina. Layers of different materials may be used, resulting in a hybrid laminate. The individual layers generally are orthotropic (that is, with principal properties in orthogonal directions) or transversely isotropic (with isotropic properties in the transverse plane) with the laminate then exhibiting anisotropic (with variable direction of principal properties), orthotropic, or quasi-isotropic properties. Quasi-isotropic laminates exhibit isotropic (that is, independent of direction) inplane response but are not restricted to isotropic out-of-plane (bending) response. Depending upon the stacking sequence of the individual layers, the laminate may exhibit coupling between inplane and out-of-plane response. An example of bending-stretching coupling is the presence of curvature developing as a result of inplane loading. See COMPOSITE MATERIAL; METAL MATRIX COMPOSITE; POLYMERIC COMPOSITE.

Classical lamination theory describes the mechanical response of any composite laminate subjected to a combination of inplane and bending loads. The laminate in Fig. 1 uses a global  $x$ - $y$ - $z$  coordinate system with  $z$  perpendicular to the plane of the laminate and positive downward. The origin of the coordinate system is located on the laminate midplane. The laminate has  $N$  layers numbered from top to bottom. Each layer has a distinct fiber orientation denoted  $\theta_k$ . The  $z$  coordinate to the bottom of the  $k$ th layer is designated  $z_k$  with the top of the layer being  $z_{k-1}$ . The thickness,  $t_k$ , of any layer is then  $t_k = z_k - z_{k-1}$ . The top surface of the laminate is denoted  $z_0$ , and the total thickness is  $2H$ .

It is assumed that (1) there is perfect bonding between layers; (2) each layer can be represented as a homogeneous ma-

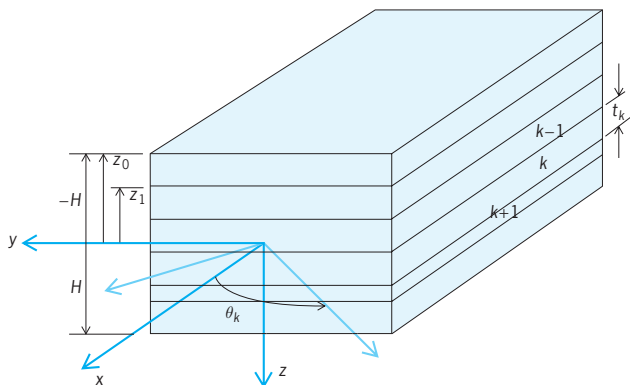

**Composite laminate consisting of layers with varying thickness.**

terial with known effective properties which may be isotropic, orthotropic, or transversely isotropic; (3) each layer is in a state of plane stress; and (4) the laminate deforms according to the Kirchhoff (1850) assumptions for bending and stretching of thin plates: (a) normals to the midplane remain straight and normal to the deformed midplane after deformation, and (b) normals to the midplane do not change length.

The wide variety of coefficients of thermal expansion are possible through changes in the stacking arrangement of a given carbon/epoxy. The coefficient of thermal expansion is the strain associated with a change in temperature of  $1^\circ$ . Most materials have positive coefficients of expansion and thus expand when heated and contract when cooled. The effective axial coefficient of thermal expansion of the carbon/epoxy can be positive, negative, or zero, depending upon the laminate configuration. Laminates with zero coefficient of thermal expansion are particularly important because they do not expand or contract when exposed to a temperature change. Composites with zero (or near zero) coefficient of thermal expansion are therefore good candidates for application in space structures where the temperature change can be  $500^\circ\text{F}$  (from  $-250$  to  $+250^\circ\text{F}$ ) [ $278^\circ\text{C}$  (from  $-157$  to  $+121^\circ\text{C}$ )] during an orbit in and out of the Sun's proximity. There are many other applications where thermal expansion is a very important consideration. [C.T.H.]

**Composite material** A material system composed of a mixture or combination of two or more constituents that differ in form or material composition and are essentially insoluble in each other. In principle, composites can be constructed of any combination of two or more materials—metallic, organic, or inorganic; but the constituent forms are more restricted. The matrix is the body constituent, serving to enclose the composite and give it bulk form. Major structural constituents are fibers, particles, laminae or layers, flakes, fillers, and matrices. They determine the internal structure of the composite. Usually, they are the additive phase.

Because the different constituents are intermixed or combined, there is always a contiguous region. It may simply be an interface, that is, the surface forming the common boundary of the constituents. An interface is in some ways analogous to the grain boundaries in monolithic materials. In some cases, the contiguous region is a distinct added phase, called an interphase. Examples are the coating on the glass fibers in reinforced plastics and the adhesive that bonds the layers of a laminate together. When such an interphase is present, there are two interfaces, one between the matrix and the interphase and one between the fiber and the interface.

Interfaces are among the most important yet least understood components of a composite material. In particular, there is a lack of understanding of processes occurring at the atomic level of interfaces, and how these processes influence the global material behavior. There is a close relationship between processes that occur on the atomic, microscopic, and macroscopic levels. In fact, knowledge of the sequence of events occurring on these different levels is important in understanding the nature of interfacial phenomena. Interfaces in composites, often considered as surfaces, are in fact zones of compositional, structural, and property gradients, typically varying in width from a single atom layer to micrometers. Characterization of the mechanical properties of interfacial zones is necessary for understanding mechanical behavior.

Advanced composites comprise structural materials that have been developed for high-technology applications, such as airframe structures, for which other materials are not sufficiently stiff. In these materials, extremely stiff and strong continuous or discontinuous fibers, whiskers, or small particles are dispersed in the matrix. A number of matrix materials are available, including carbon, ceramics, glasses, metals, and polymers. Advanced composites possess enhanced stiffness and lower density compared to fiber-glass and conventional monolithic materials. While

composite strength is primarily a function of the reinforcement, the ability of the matrix to support the fibers or particles and to transfer load to the reinforcement is equally important. Also, the matrix frequently dictates service conditions, for example, the upper temperature limit of the composite. [PSa.]

The use of fiber-reinforced materials in engineering applications has grown rapidly. Selection of composites rather than monolithic materials is dictated by the choice of properties. The high values of specific stiffness and specific strength may be the determining factor, but in some applications wear resistance or strength retention at elevated temperatures is more important. A composite must be selected by more than one criterion, although one may dominate.

Components fabricated from advanced organic-matrix-fiber-reinforced composites are used extensively on commercial aircraft as well as for military transports, fighters, and bombers. The propulsion system, which includes engines and fuel, makes up a significant fraction of aircraft weight (frequently 50%) and must provide a good thrust-to-weight ratio and efficient fuel consumption. The primary means of improving engine efficiency are to take advantage of the high specific stiffness and strength of composites for weight reduction, especially in rotating components, where material density directly affects both stress levels and critical dynamic characteristics, such as natural frequency and flutter speed.

Composites consisting of resin matrices reinforced with discontinuous glass fibers and continuous-glass-fiber mats are widely used in truck and automobile components bearing light loads, such as interior and exterior panels, pistons for diesel engines, drive shafts, rotors, brakes, leaf springs, wheels, and clutch plates.

The excellent electrical insulation, formability, and low cost of glass-fiber-reinforced plastics have led to their widespread use in electrical and electronic applications ranging from motors and generators to antennas and printed circuit boards.

Composites are also used for leisure and sporting products such as the frames of rackets, fishing rods, skis, golf club shafts, archery bows and arrows, sailboats, racing cars, and bicycles.

Advanced composites are used in a variety of other applications, including cutting tools for machining of superalloys and cast iron and laser mirrors for outer-space applications. They have made it possible to mimic the properties of human bone, leading to development of biocompatible prostheses for bone replacements and joint implants. In engineering, composites are used as replacements for fiber-reinforced cements and cables for suspension bridges. See MATERIALS SCIENCE AND ENGINEERING. [M.M.S.]

**Composition board** A wood product in which the grain structure of the original wood is drastically altered. Composition board may be divided into several types. When wood serves as the raw material for chemical processing, the resultant product may be insulation board, hardboard, or other pulp product. When the wood is broken down only by mechanical means, the resultant product is particle board. Because composition board can use waste products of established wood industries and because there is a need to find marketable uses for young trees, manufacture of composition board is one of the most rapidly developing portions of the wood industry. See PAPER.

Fiberboard is produced from wood chips. Synthetic resin may be added as a binder before the board is formed. After the board is formed, it may be impregnated with drying oils and heated in a kiln until the oils are completely polymerized to produce tempered board. If insulating board is required instead of hardboard, the material is less compacted, the degree of compaction being described by the specific gravity of the finished board.

When formed from wood particles that retain their woody structure, the product is termed particle board. Properties of such boards depend on the size and orientation of the particles, which may be dimensioned flakes, random-sized shavings,

or splinters. After the particular type of particles are produced, they are screened to remove fines and to return oversizes for further reduction. Graded particles are dried, mixed with synthetic adhesive and other additives such as preservatives, and delivered to the board-forming machine.

Development of adhesives specifically for composition boards is extending their utilitarian value, and variety of textures is increasing their esthetic appeal. See WOOD PRODUCTS. [F.H.R.]

**Compound (chemistry)** Substances composed of two or more elements which do not vary in composition from sample to sample, and which have fixed and definite physical properties, such as density and refractive index. The elements in compounds cannot be separated by simple physical or mechanical means, but only by chemical treatment. When compounds are formed from their elements, heat is generated or absorbed. These properties distinguish them from mixtures. See ELEMENT (CHEMISTRY); MIXTURE.

Most chemical compounds are formed in fixed and definite proportions by weight from their elements, and they obey the laws of chemical combination. However, a number of solid compounds, known as nonstoichiometric compounds, exhibit departures from the law of definite proportions. See DEFINITE COMPOSITION, LAW OF; MULTIPLE PROPORTIONS, LAW OF; NONSTOICHIOMETRIC COMPOUNDS. [T.C.W.]

**Compressible flow** Flow in which density changes are significant. Pressure changes normally occur throughout a fluid flow, and these pressure changes, in general, induce a change in the fluid density. In a compressible flow, the density changes that result from these pressure changes have a significant influence on the flow. The changes in the flow that result from the density changes are often termed compressibility effects. All fluids are compressible. However, compressibility effects are more frequently encountered in gas flows than in liquid flows.

An important dimensionless parameter in compressible flows is the Mach number,  $M$ . This is defined by Eq. (1), where  $a$  is the

$$M = \frac{V}{a} \quad (1)$$

speed of sound and  $V$  is the velocity of the flow. For a gas, the speed of sound is given by Eq. (2), where  $R$  is the gas constant,

$$a = \sqrt{kRT} \quad (2)$$

$k = c_p/c_v$ ,  $c_p$  and  $c_v$  being the specific heats at constant pressure and constant volume respectively, and  $T$  is the temperature. If  $M < 0.3$  in a flow, the density changes in the flow will usually be negligible; that is, the flow can be treated as incompressible. Compressible flows are, therefore, as a rough guide, associated with Mach numbers greater than 0.3.

When  $M < 1$ , the flow is said to be subsonic; when  $M = 1$ , the flow is said to be sonic; when  $M$  varies from slightly below 1 to slightly above 1, the flow is said to be transonic; and if  $M > 1$ , the flow is said to be supersonic. When the Mach number is very high, this usually being taken to mean  $M > 5$ , the flow is said to be hypersonic.

Compressible flows can have features that do not occur in low-speed flows. For example, shock waves and expansion waves can occur in supersonic flows. Another important phenomenon that can occur due to compressibility is choking, where the mass flow rate through a duct system may be limited as a result of the Mach number being equal to 1 at some point in the flow. See CHOKED FLOW; SHOCK WAVE; SONIC BOOM.

Another effect of compressibility is associated with the acceleration of a gas flow through a duct. In incompressible flow, an increase in velocity is associated with a decrease in the cross-sectional area of the duct, this in fact being true as long as  $M < 1$ . However, when  $M > 1$ , that is, when the flow is supersonic, the opposite is true; that is, an increase in the velocity is associated with an increase in the cross-sectional area. Therefore, in order

to accelerate a gas flow from subsonic to supersonic velocities in a duct, it is necessary first to decrease the area and then, once the Mach number has reached 1, to increase the area, that is, to use a so-called convergent-divergent nozzle. An example is the nozzle fitted to a rocket engine. See FLUID FLOW; MACH NUMBER; NOZZLE; SUPERSONIC FLOW. [P.H.Oc.]

**Compression ratio** In a cylinder, the piston displacement plus clearance volume, divided by the clearance volume. This is the nominal compression ratio determined by cylinder geometry alone. In practice, the actual compression ratio is appreciably less than the nominal value because the volumetric efficiency of an unsupercharged engine is less than 100%, partly because of late intake valve closing. In spark ignition engines the allowable compression ratio is limited by incipient knock at wide-open throttle. See COMBUSTION CHAMBER; INTERNAL COMBUSTION ENGINE; VOLUMETRIC EFFICIENCY. [N.Mac.]

**Compressor** A machine that increases the pressure of a gas or vapor (typically air), or mixture of gases and vapors. The pressure of the fluid is increased by reducing the fluid specific volume during passage of the fluid through the compressor. When compared with centrifugal or axial-flow fans on the basis of discharge pressure, compressors are generally classed as high-pressure and fans as low-pressure machines.

Compressors are used to increase the pressure of a wide variety of gases and vapors for a multitude of purposes. A common application is the air compressor used to supply high-pressure air for conveying, paint spraying, tire inflating, cleaning, pneumatic tools, and rock drills. The refrigeration compressor is used to compress the gas formed in the evaporator. Other applications of compressors include chemical processing, gas transmission, gas turbines, and construction. See GAS TURBINE; REFRIGERATION.

Compressor displacement is the volume displaced by the compressing element per unit of time and is usually expressed in cubic feet per minute (cfm). Where the fluid being compressed flows in series through more than one separate compressing element (as a cylinder), the displacement of the compressor equals that of the first element. Compressor capacity is the actual quantity of fluid compressed and delivered, expressed in cubic feet per minute at the conditions of total temperature, total pressure, and composition prevailing at the compressor inlet. The capacity is always expressed in terms of air or gas at intake (ambient) conditions rather than in terms of arbitrarily selected standard conditions.

Air compressors often have their displacement and capacity expressed in terms of free air. Free air is air at atmospheric conditions at any specific location. Since the altitude, barometer, and temperature may vary from one location to another, this term does not mean air under uniform or standard conditions. Standard air is at 68°F (20°C), 14.7 lb/in.<sup>2</sup> (101.3 kilopascals absolute pressure), and a relative humidity of 36%. Gas industries usually consider 60°F (15.6°C) air as standard.

Compressors can be classified as reciprocating, rotary, jet, centrifugal, or axial-flow, depending on the mechanical means used to produce compression of the fluid, or as positive-displacement or dynamic-type, depending on how the mechanical elements act on the fluid to be compressed. Positive-displacement compressors confine successive volumes of fluid within a closed space in which the pressure of the fluid is increased as the volume of the closed space is decreased. Dynamic-type compressors use rotating vanes or impellers to impart velocity and pressure to the fluid. [T.G.H.; D.L.An.]

**Compton effect** The increase in wavelength of electromagnetic radiation, observed mainly in the x-ray and gamma-ray region, on being scattered by material objects. This increase in wavelength is caused by the interaction of the radiation with the weakly bound electrons in the matter in which the scattering takes place. The Compton effect illustrates one of the most

fundamental interactions between radiation and matter and displays in a very graphic way the true quantum nature of electromagnetic radiation. Together with the laws of atomic spectra, the photoelectric effect, and pair production, the Compton effect has provided the experimental basis for the quantum theory of electromagnetic radiation. See ANGULAR MOMENTUM; ATOMIC STRUCTURE AND SPECTRA; ELECTRON-POSITRON PAIR PRODUCTION; LIGHT; PHOTOEMISSION; QUANTUM MECHANICS; UNCERTAINTY PRINCIPLE.

Perhaps the greatest significance of the Compton effect is that it demonstrates directly and clearly that in addition to its wave nature with transverse oscillations, electromagnetic radiation has a particle nature and that these particles, the photons, behave quite like material particles in collisions with electrons. This discovery by A. H. Compton and P. Debye led to the formulation of quantum mechanics by W. Heisenberg and E. Schrödinger and provided the basis for the beginning of the theory of quantum electrodynamics, the theory of the interactions of electrons with the electromagnetic field.

The Compton effect has played a significant role in several diverse scientific areas. Compton scattering (often referred to as incoherent scattering, in contrast to Thomson scattering or also Rayleigh scattering, which are called coherent scattering) is important in nuclear engineering (radiation shielding), experimental and theoretical nuclear physics, atomic physics, plasma physics, x-ray crystallography, elementary particle physics, and astrophysics, to mention some of these areas. In addition the Compton effect provides an important research tool in some branches of medicine, in molecular chemistry and solid-state physics, and in the use of high-energy electron accelerators and charged-particle storage rings. [E.N.H.]

The development of high-resolution silicon and germanium semiconductor radiation detectors opened new areas for applications of Compton scattering. Semiconductor detectors make it possible to measure the separate probabilities for Rayleigh and Compton scattering. An effective atomic number has been assigned to compounds that appears to successfully correlate theory with Rayleigh-Compton ratios.

Average density can be measured by moving to higher energies where Compton scattering does not have to compete with Rayleigh scattering. At these energies, Compton scattering intensity has been successfully correlated with mass density. An appropriate application is the measurement of lung density in living organisms.

The ability to put large detectors in orbit above the Earth's atmosphere has created the field of gamma-ray astronomy. This field is now based largely on the data from the *Compton Gamma-Ray Observatory*, all of whose detectors made use of the Compton effect (although not exclusively). See GAMMA-RAY ASTRONOMY; GAMMA-RAY DETECTORS; GAMMA RAYS; X-RAYS. [I.K.M.]

**Computational chemistry** A branch of theoretical chemistry that uses a digital computer to model systems of chemical interest. In this discipline, the computer itself is the primary instrument of research. The use of computers for analysis of experimental data, and for the storage and display of results obtained with other tools, is distinct from computational chemistry. The latter permits calculation of quantities which can be measured experimentally, such as molecular geometries of ground and excited states, heats of formation, and ionization potentials. Alternatively, quantities not readily accessible by existing experimental techniques, such as geometries of transition states and detailed structure of liquids, may be evaluated. See DIGITAL COMPUTER.

Because of the increasing power and availability of computers, and the simultaneous development of well-tested and reliable theoretical methods, the use of computational chemistry as an adjunct to experimental research has increased rapidly. Calculations ranging from a few seconds to many hours of computer time can serve as a guide to exclude less favorable reactions or unstable products, or to select several more fruitful



procedures from the many possible ones. In addition, modeling of chemical systems with a computer enables the researcher to examine them on a scale of space or time as yet unmeasurable by experimental techniques. This can give insight into a chemical system beyond that provided by experiment. Examples are examination of the dynamics of a chemical reaction or of detailed changes in conformation of a polymer in solution. Examination of the molecular orbitals occupied by the electrons of the molecule can provide insight into chemical bonding and the electronic interactions which determine specific geometric configurations. Thus computational chemistry can yield information which may not be experimentally available. See CHEMICAL DYNAMICS.

Computational chemistry may be the application of existing theory and numerical methods to new molecules, or it may be the development of new computational methods. The latter may include incorporating more physics into the mathematical model in order to provide a better theoretical description of the system being studied, for example, inclusion of interactions between individual electrons in molecular orbital calculations. These more complete studies, for "large" molecules, usually need to be performed on a supercomputer, or on a mid-size computer with an array processor. Another approach is to devise simpler methods which will approximate the accuracy of more complex calculations. These include semiempirical methods in which values of hard-to-calculate terms are derived from experiment. Such an approach allows fruitful work with a mid-size or even a desk-top computer, avoiding the need for expensive computer resources. See MICROCOMPUTER; SUPERCOMPUTER. [Z.R.W.]

**Computational fluid dynamics** The numerical approximation to the solution of mathematical models of fluid flow and heat transfer. Computational fluid dynamics is one of the tools (in addition to experimental and theoretical methods) available to solve fluid-dynamic problems. With the advent of modern computers, computational fluid dynamics evolved from potential-flow and boundary-layer methods and is now used in many diverse fields, including engineering, physics, chemistry, meteorology, and geology. The crucial elements of computational fluid dynamics are discretization, grid generation and coordinate transformation, solution of the coupled algebraic equations, turbulence modeling, and visualization.

Numerical solution of partial differential equations requires representing the continuous nature of the equations in a discrete form. Discretization of the equations consists of a process where the domain is subdivided into cells or elements (that is, grid generation) and the equations are expressed in discrete form at each point in the grid by using finite difference, finite volume, or finite element methods. The finite difference method requires a structured grid arrangement (that is, an organized set of points formed by the intersections of the lines of a boundary-conforming curvilinear coordinate system), while the finite element and finite volume methods are more flexible and can be formulated to use both structured and unstructured grids (that is, a collection of triangular elements or a random distribution of points). See FINITE ELEMENT METHOD.

There are a variety of approaches for resolving the phenomena of fluid turbulence. The Reynolds-averaged Navier-Stokes (RANS) equations are derived by decomposing the velocity into mean and fluctuating components. An alternative is large-eddy simulation, which solves the Navier-Stokes equations in conjunction with a subgrid turbulence model. The most direct approach to solving turbulent flows is direct numerical simulation, which solves the Navier-Stokes equations on a mesh that is fine enough to resolve all length scales in the turbulent flow. Unfortunately, direct numerical simulation is limited to simple geometries and low-Reynolds-number flows because of the limited capacity of even the most sophisticated supercomputers. See TURBULENT FLOW.

The final step is to visualize the results of the simulation. Powerful graphics workstations and visualization software permit generation of velocity vectors, pressure and velocity contours, streamline generation, calculation of secondary quantities (such as vorticity), and animation of unsteady calculations. Despite the sophisticated hardware, visualization of three-dimensional and unsteady flows is still particularly difficult. Moreover, many advanced visualization techniques tend to be qualitative, and the most valuable visualization often consists of simple x-y plots comparing the numerical solution to theory or experimental data. See COMPUTER GRAPHICS.

Computational fluid dynamics has wide applicability in such areas as aerodynamics, hydraulics, environmental fluid dynamics, and atmospheric and oceanic dynamics, with length and time scales of the physical processes ranging from millimeters and seconds to kilometers and years. Vehicle aerodynamics and hydrodynamics, which have provided much of the impetus in the development of computational fluid dynamics, are primarily concerned with the flow around aircraft, automobiles, and ships. See AERODYNAMIC FORCE; AERODYNAMICS; CLIMATE MODELING; DYNAMIC METEOROLOGY; FLUID FLOW; FLUID-FLOW PRINCIPLES; HYDRAULICS; HYDRODYNAMICS; OCEAN CIRCULATION; RIVER; SIMULATION; WATER POLLUTION. [E.Pa.; F.Ste.]

**Computer** A device that receives, processes, and presents information. The two basic types of computers are analog and digital. Although generally not regarded as such, the most prevalent computer is the simple mechanical analog computer, in which gears, levers, ratchets, and pawls perform mathematical operations—for example, the speedometer and the watt-hour meter (used to measure accumulated electrical usage). The general public has become much more aware of the digital computer with the rapid proliferation of the hand-held calculator and a large variety of intelligent devices and especially with exposure to the Internet and the World Wide Web. See CALCULATORS; INTERNET; WORLD WIDE WEB.

An analog computer uses inputs that are proportional to the instantaneous value of variable quantities, combines these inputs in a predetermined way, and produces outputs that are a continuously varying function of the inputs and the processing. These outputs are then displayed or connected to another device to cause action, as in the case of a speed governor or other control device. Small electronic analog computers are frequently used as components in control systems. If the analog computer is built solely for one purpose, it is termed a special-purpose electronic analog computer. In any analog computer the key concepts involve special versus general-purpose computer designs, and the technology utilized to construct the computer itself, mechanical or electronic. See ANALOG COMPUTER.

In contrast, a digital computer uses symbolic representations of its variables. The arithmetic unit is constructed to follow the rules of one (or more) number systems. Further, the digital computer uses individual discrete states to represent the digits of the number system chosen. A digital computer can easily store and manipulate numbers, letters, images, sounds, or graphical information represented by a symbolic code. Through the use of the stored program, the digital computer achieves a degree of flexibility unequalled by any other computing or data-processing device.

The advent of the relatively inexpensive and readily available personal computer, and the combination of the computer and communications, such as by the use of networks, have dramatically expanded computer applications. The most common application now is probably text and word processing, followed by electronic mail. See ELECTRONIC MAIL; LOCAL-AREA NETWORKS; MICROCOMPUTER; WORD PROCESSING.

Computers have begun to meet the barrier imposed by the speed of light in achieving higher speeds. This has led to research and development in the areas of parallel computers (in order to accomplish more in parallel rather than by serial

computation) and distributed computers (taking advantage of network connections to spread the work around, thus achieving more parallelism). Continuing demand for more processing power has led to significant changes in computer hardware and software architectures, both to increase the speed of basic operations and to reduce the overall processing time. See COMPUTER SYSTEMS ARCHITECTURE; CONCURRENT PROCESSING; DISTRIBUTED SYSTEMS (COMPUTERS); MULTIPROCESSING; SUPERCOMPUTER. [B.A.G.; J.H.Sa.]

### Computer-aided design and manufacturing

The application of digital computers in engineering design and production. Computer-aided design (CAD) refers to the use of computers in converting the initial idea for a product into a detailed engineering design. The evolution of a design typically involves the creation of geometric models of the product, which can be manipulated, analyzed, and refined. In CAD, computer graphics replace the sketches and engineering drawings traditionally used to visualize products and communicate design information. See COMPUTER GRAPHICS.

Engineers also use computer programs to estimate the performance and cost of design prototypes and to calculate the optimal values for design parameters. These programs supplement and extend traditional hand calculations and physical tests. When combined with CAD, these automated analysis and optimization capabilities are called computer-aided engineering (CAE). See COMPUTER-AIDED ENGINEERING; OPTIMIZATION.

Computer-aided manufacturing (CAM) refers to the use of computers in converting engineering designs into finished products. Production requires the creation of process plans and production schedules, which explain how the product will be made, what resources will be required, and when and where these resources will be deployed. Production also requires the control and coordination of the necessary physical processes, equipment, materials, and labor. In CAM, computers assist managers, manufacturing engineers, and production workers by automating many production tasks. Computers help to develop process plans, order and track materials, and monitor production schedules. They also help to control the machines, industrial robots, test equipment, and systems which move and store materials in the factory.

CAD/CAM can improve productivity, product quality, and profitability. Computers can eliminate redundant design and production tasks, improve the efficiency of workers, increase the utilization of equipment, reduce inventories, waste, and scrap, decrease the time required to design and make a product, and improve the ability of the factory to produce different products. Today most manufacturers employ CAD/CAM to varying degrees. See PRODUCTIVITY.

The fact that CAD, CAE, and CAM work best together has led to the breakdown of many of the traditional barriers between functional and manufacturing units. The goal of computer-integrated manufacturing (CIM) is a database, created and maintained on a factory-wide computer network, that will be used for design, analysis, optimization, process planning, production scheduling, robot programming, materials handling, inventory control, maintenance, and marketing. Although many technical and managerial obstacles must be overcome, computer-integrated manufacturing appears to be the future of CAD/CAM. See COMPUTER-INTEGRATED MANUFACTURING; DATABASE MANAGEMENT SYSTEM; FLEXIBLE MANUFACTURING SYSTEM; MATERIALS HANDLING; ROBOTICS. [K.P.W.]

**Computer-aided engineering** Any use of computer software to solve engineering problems. With the improvement of graphics displays, engineering workstations, and graphics standards, computer-aided engineering (CAE) has come to mean the computer solution of engineering problems with the assistance of interactive computer graphics. See COMPUTER GRAPHICS.

CAE software is used on various types of computers, such as mainframes and superminis, engineering workstations, and even personal computers. The choice of a computer system is frequently dictated by the computing power required for the CAE application or the level (and speed) of graphics interaction desired. The trend is toward more use of engineering workstations, especially a new type known as supergraphics workstations. See DIGITAL COMPUTER; MICROCOMPUTER.

Design engineers use a variety of CAE tools, including large, general-purpose commercial programs and many specialized programs written in-house or elsewhere in the industry. Solution of a single engineering problem frequently requires the application of several CAE tools. Communication of data between these software tools presents a challenge for most applications. Data are usually passed through proprietary neutral file formats, data interchange standards, or a system database.

A typical CAE program is made up of a number of mathematical models encoded by algorithms written in a programming language. The natural phenomena being analyzed are represented by an engineering model. The physical configuration is described by a geometric model. The results, together with the geometry, are made visible via a user interface on the display device and a rendering model (graphics image). See ALGORITHM; COMPUTER PROGRAMMING; PROGRAMMING LANGUAGES.

Computer-aided design and manufacturing (CAD/CAM) systems were created by the aerospace industry in the early 1960s to assist with the massive design and documentation tasks associated with producing airplanes. CAD/CAM systems have been used primarily for detail design and drafting along with the generation of numerical control instructions for manufacturing. Gradually, more CAE functions are being added to CAD/CAM systems. Modeling with CAD/CAM systems has become fairly sophisticated. Most popular commercial systems support 2D and 3D wireframe, surface models and solid models. Rendered surface models differ from solid models in that the latter have full information about the interior of the object. For solid models a combination of three types of representation is commonly used: constructive solid geometry, boundary representation, and sweep representation. See COMPUTER-AIDED DESIGN AND MANUFACTURING.

The CAE methods for electrical and electronics engineering are well developed. The geometry is generally two-dimensional, and the problems are primarily linear or can be linearized with sufficient accuracy. Chemical engineering makes extensive use of CAE with process simulation and control software. The fields of civil, architectural, and construction engineering have CAE interests similar to mechanical CAE with emphasis on structures. Aerospace, mechanical, industrial, and manufacturing engineering all make use of mechanical CAE software together with specialized software. [A.My.]

**Computer-based systems** Complex systems in which computers play a major role. While complex physical systems and sophisticated software systems can help people to lead healthier and more enjoyable lives, reliance on these systems can also result in loss of money, time, and life when these systems fail. Much of the complexity of these systems is due to integration of information technology into physical and human activities. Such integration dramatically increases the interdependencies among components, people, and processes, and generates complex dynamics not taken into account in systems of previous generations. Engineers with detailed understanding both of the application domain and computer electronics, software, human factors, and communication are needed to provide a holistic approach to system development so that disasters do not occur.

**Engineering activities.** The computer-based systems engineer develops a system within a system; the properties of the former have pervasive effects throughout the larger system. The computer-based system consists of all components necessary to capture, process, transfer, store, display, and manage

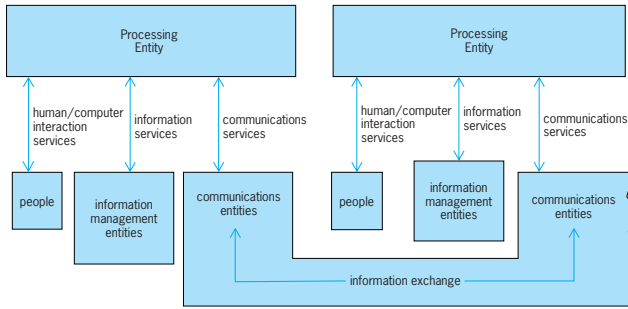

Model of a distributed computer-based system.

information. Components include software, processors, networks, buses, firmware, application-specific integrated circuits, storage devices, and humans (who also process information). Embedded computer-based systems interact with the physical environment through sensors and actuators, and also interact with external computer-based systems (see illustration). The computer-based systems engineer must have a thorough understanding of the system in which the computer-based system is embedded, for example an automobile, medical diagnostic system, or stock exchange.

**Model-based development.** Models are necessary in systems engineering as they support interdisciplinary communication, formalize system definition, improve analysis of trade-offs and decision making, and support optimization and integration. The use of models can reduce the number of errors in the design and thus the system, reduce engineering effort, and preserve knowledge for future efforts. Maintaining models with up-to-date knowledge is a major problem as most systems are not generated from models, although this should be an industry goal. During the later stages of system development and testing, significant schedule pressure makes it difficult to keep the models and manually developed software consistent. [S.M.W.]

**Computer graphics** A branch of computer science that deals with the theory and techniques of computer image synthesis. Computers produce images by analyzing a collection of dots, or pixels (picture elements). Computer graphics is used to enhance the transfer and understanding of information in science, engineering, medicine, education, and business by facilitating the generation, production, and display of synthetic images of natural objects with realism almost indistinguishable from photographs. Computer graphics facilitates the production of images that range in complexity from simple line drawings to three-dimensional reconstructions of data obtained from computerized axial tomography (CAT) scans in medical applications. User interaction can be increased through animation, which conveys large amounts of information by seemingly bringing to life multiple related images. Animation is widely used in entertainment, education, industry, flight simulators, scientific research, and heads-up displays (devices which allow users to interact with a virtual world). Virtual-reality applications permit users to interact with a three-dimensional world, for example, by “grabbing” objects and manipulating objects in the world. Digital image processing is a companion field to computer graphics. However, image processing, unlike computer graphics, generally begins with some image in image space, and performs operations on the components (pixels) to produce new images. See IMAGE PROCESSING.

Computers are equipped with special hardware to display images. Several types of image presentation or output devices convert digitally represented images into visually perceptible pictures. They include pen-and-ink plotters, dot-matrix plotters, electrostatic or laser-printer plotters, storage tubes, liquid-crystal displays (LCDs), active matrix panels, plasma panels, and cathode-ray-tube (CRT) displays. Images can be displayed by a

computer on a cathode-ray tube in two different ways: raster scan and random (vector) scan. See CATHODE-RAY TUBE; COMPUTER PERIPHERAL DEVICES.

Interaction with the object takes place via devices attached to the computer, starting with the keyboard and the mouse. Each type of device can be programmed to deliver various types of functionality. The quality and ease of use of the user interface often determines whether users enjoy a system and whether the system is successful. Interactive graphics aids the user in the creation and modification of graphical objects and the response to these objects in real-time. The most commonly used input device is the mouse. Other kinds of interaction devices include the joystick, trackball, light pen, and data tablet. Some of these two-dimensional (2D) devices can be modified to extend to three dimensions (3D). The data glove is a device capable of recording hand movements. The data glove is capable of a simple gesture recognition and general tracking of hand orientation.

In the production of a computer-generated image, the designer has to specify the objects in the image and their shapes, positions, orientations, and surface colors or textures. Further, the viewer's position and direction of view (camera orientation) must be specified. The software should calculate the parts of all objects that can be seen by the viewer (camera). Only the visible portions of the objects should be displayed (captured on the film). (This requirement is referred to as the hidden-surface problem.) The rendering software is then applied to compute the amount and color of light reaching the viewer eye (film) at any point in the image, and then to display that point. Some modern graphics work stations have special hardware to implement projections, hidden-surface elimination, and direct illumination. Everything else in image generation is done in software.

Solid modeling is a technique used to represent three-dimensional shapes in a computer. The importance of solid modeling in computer-aided design and manufacturing (CAD/CAM) systems has been increasing. Engineering applications ranging from drafting to the numerical control of machine tools increasingly rely on solid modeling techniques. Solid modeling uses three-dimensional solid primitives (the cube, sphere, cone, cylinder, and ellipsoid) to represent three-dimensional objects. Complex objects can be constructed by combining the primitives. See COMPUTER-AIDED DESIGN AND MANUFACTURING; COMPUTER-AIDED ENGINEERING.

The creation of images by simulating a model of light propagation is often called image synthesis. The goal of image synthesis is often stated as photorealism, that is, the criterion that the image look as good as a photograph. Rendering is a term used for methods or techniques that are used to display realistic-looking three-dimensional images on a two-dimensional medium such as the cathode-ray-tube screen (see illustration). The display of a wire-frame image is one way of rendering the object. The most common method of rendering is shading. Generally, rendering includes addition of texture, shadows, and the color of light that reaches the observer's eye from any point in the image.

Computer-generated images are used extensively in the entertainment world and other areas. Realistic images have become essential tools in research and education. Conveying realism in

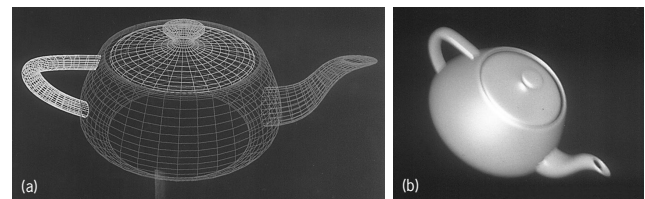

Image renderings of a teapot. (a) Wire-frame model with 512 polygons. (b) Smooth shading (non-shiny). (A. Tokuta, Technical Report, Department of Computer Science and Engineering, University of South Florida)

these images may depend on the convincing generation of natural phenomena. A fundamental difficulty is the complexity of the real world. Existing models are based on physical or biological concepts. The behavior of objects can be determined by physical properties or chemical and microphysical properties. [A.O.T.]

**Computer-integrated manufacturing** A system in which individual engineering, production, and marketing and support functions of a manufacturing enterprise are organized into a computer-integrated system. Functional areas such as design, analysis, planning, purchasing, cost accounting, inventory control, and distribution are linked through the computer with factory floor functions such as materials handling and management, providing direct control and monitoring of all process operations.

Computer-integrated manufacturing (CIM) may be viewed as the successor technology which links computer-aided design (CAD), computer-aided manufacturing (CAM), robotics, numerically controlled machine tools (NCMT), automatic storage and retrieval systems (AS/RS), flexible manufacturing systems (FMS), and other computer-based manufacturing technology. Computer-integrated manufacturing is also known as integrated computer-aided manufacturing (ICAM). Autofacturing includes computer-integrated manufacturing, but also includes conventional machinery, human operators, and their relationships within a total system. See COMPUTER-AIDED DESIGN AND MANUFACTURING; FLEXIBLE MANUFACTURING SYSTEM; ROBOTICS.

**Agile manufacturing and lean manufacturing.** The CIM factory concept includes both soft and hard technology. Soft technology can be thought of as the intellect or brains of the factory, and hard technology as the muscles of the factory. The type of hard technology employed depends upon the products or family of products made by the factory. For metalworking, typical processes would include milling, turning, forming, casting, grinding, forging, drilling, routing, inspecting, coating, moving, positioning, assembling, and packaging. For semiconductor device fabrication, typical processes would include layout, etching, lithography, striping, lapping, polishing, and cleaning, as well as moving, positioning, assembling, and packaging. More important than the list of processes is their organization.

Whatever the products, the CIM factory is made up of a part fabrication center, a component assembly center, and a product assembly center. Centers are subdivided into work cells, cells into stations, and stations into processes. Processes comprise the basic transformations of raw materials into parts which will be assembled into products. In order for the factory to achieve maximum efficiency, raw material must come into the factory at the left end and move smoothly and continuously through the factory to emerge as a product at the right end. No part must ever be standing; each part is either being worked on or is on its way to the next workstation.

In the part fabrication center, raw material is transformed into piece parts. Some piece parts move by robot carrier or automatic guided vehicle to the component fabrication center. Other piece parts (excess capacity) move out of the factory to sister factories for assembly. There is no storage of work in process and no warehousing in the CIM factory. To accomplish this objective, part movement is handled by robots or conveyors of various types. These materials handlers serve as the focus or controlling element of work cells and workstations. Each work cell contains a number of workstations. The station is where the piece part transformation occurs from a raw material to a part, after being worked on by a particular process.

Components, also known as subassemblies, are created in the component assembly center. Here materials handlers of various types, and other reprogrammable automation, put piece parts together. Components may then be transferred to the product assembly center, or out of the factory (excess capacity) to sister factories for final assembly operations there. Parts from other factories may come into the component assembly center of this

factory, and components from other factories may come into the product assembly center of this factory. The final product moves out of the product assembly center to the product distribution center or in some cases directly to the end user. See AUTOMATION.

The premise of CIM is that a network is created in which every part of the enterprise works for the maximum benefit of the whole enterprise. Independent of the degree of automation employed, for example, whether it is robotic or not, the optimal organization of computer hardware and software is essential. The particular processes employed by the factory are specific to the product being made, but the functions performed can be virtually unchanged in the CIM factory no matter what the product. These typical functions include forecasting, designing, predicting, controlling, inventorying, grouping, monitoring, releasing, planning, scheduling, ordering, changing, communicating, and analyzing. [D.E.Wi.]

**Computer numerical control** The method of controlling machines by the application of digital electronic computers and circuitry. Machine movements that are controlled by cams, gears, levers, or screws in conventional machines are directed by computers and digital circuitry in computer numerical control (CNC) machines.

Computer numerical control provides very flexible and versatile control over machine tools. Most machining operations require that a cutting tool be fed at some speed against a workpiece. In a conventional machine such as a turret lathe, the turning tool is mounted on a slide with hand-operated infeed and crossfeed slides. The operator manually turns a crank that feeds the cutting tool into the workpiece (infeed) to the desired diameter. Another crank then moves the turning tool along the longitudinal axis of the machine and produces a cylindrical cut along the workpiece. The feed rate of the turning tool is sometimes controlled by selecting feed gears. These gears move the axis slide at the desired feed. A CNC machine replaces the hand cranks and feed gears with servomotor systems. See SERVOMECHANISM.

Computer numerical controls allow the desired cut depths and feed rates to be "dialed in" rather than controlled by cranks, cams, and gears. This provides precise, repeatable machine movements that can be programmed for optimal speeds, feeds, and machine cycles. All cutting-tool applications, whether on a lathe, drill press, or machining center, have optimum speeds and feeds, which are determined by carefully weighing the economics of tool life, required production rates, and operator attentiveness. With computer numerical control these parameters are set once, and then they are repeated precisely for each subsequent machine cycle.

In computer-aided manufacturing (CAM), computers are used to assist in programming CNC machines. In sophisticated CNC manufacturing operations, machined parts are first designed on computer-aided-design (CAD) equipment. The same electronic drawing is then used to create the CNC part program automatically. A less advanced version of CAM is the use of high-level part programming languages to write part programs. See COMPUTER-AIDED DESIGN AND MANUFACTURING.

Computer numerical control machines are used mainly when flexibility is required or variable and complex part geometries must be created. They are used to produce parts in lot sizes of a few pieces to several thousand. Extremely large manufacturing lot sizes frequently call for more product-specific machines, which can be optimized for large production runs. [J.R.C.B.]

**Computer peripheral devices** Any device connected internally or externally to a computer and used in the transfer of data. A personal computer or workstation processes information and, strictly speaking, that is all the computer does. Data (unprocessed information) must get into the computer, and the processed information must get out. Entering and displaying information is carried out on a wide variety of accessory

devices called peripherals, also known as input/output (I/O) devices. Some peripherals, such as keyboards, are only input devices; other peripherals, such as printers, are only output devices; and some are both. See DIGITAL COMPUTER; MICROCOMPUTER.

The monitor is the device on which images produced by the computer operator or generated by the program are displayed on a cathode-ray tube (CRT). Electron guns—one in a monochrome monitor, three in a color monitor—irradiate phosphors on the inside of the vacuum tube, causing them to glow. The flat-panel displays on most portable computers, known as liquid-crystal displays (LCDs), use two polarizing filters with liquid crystals between them to produce the image. See ELECTRONIC DISPLAY; LIQUID CRYSTALS.

The computer keyboard, based on the typewriter keyboard, contains keys for entering letters, numbers, and punctuation marks, as well as keys to change the meaning of other keys. The function keys perform tasks that vary from program to program. See TYPEWRITER.

The mouse is a device that is rolled on the desktop to move the cursor on the screen. A ball on the bottom of the mouse translates the device's movements to sensors within the mouse and then through the connecting port to the computer. There are also mice that substitute optical devices for mechanical balls, and mice that use infrared rather than physical connections.

The trackball is essentially an upside-down mouse, with the ball that is used to move the cursor located on the top rather than on the bottom.

The joystick is a pointing device used principally for games.

The light pen performs the same functions as a mouse or trackball, but it is held up to the screen, where its sensors detect the presence of pixels and send a signal through a cable to the computer.

The graphics, or digitizing, tablet is a pad with electronics beneath the surface which is drawn upon with a pointed device, called a stylus. The shapes drawn appear on the monitor's screen.

The most common input, or storage, device in personal computers or workstations is a hard disk drive, a stack of magnetized platters on which information is stored by heads generating an electrical current to represent either 1 or 0 in the binary number system. The device is called hard because the platters are inflexible, and is called a drive because it spins at 3600 revolutions or more a minute, within a sealed case. Diskettes, made of flexible film like that used in recording tape, are usually stored within a hard shell and are spun by their drives at about 360 revolutions per minute. See COMPUTER STORAGE TECHNOLOGY.

Data can also be stored and retrieved with light, the light of a laser beam reading a pattern of pits on an optical disk. The most familiar type of optical disk is the CD-ROM (compact disk-read only memory). Another kind of optical disk is the WORM (write once read many times). See COMPACT DISK; MULTIMEDIA TECHNOLOGY; OPTICAL RECORDING.

As a consequence of their greater efficiency and speed, disk drives have quickly replaced tape drives as the primary means of data and program storage. Tape drives are still in use for backup storage, copying the contents of a hard disk as insurance against mechanical failure or human error. See MAGNETIC RECORDING.

The scanner converts an image of something outside the computer, such as text, a drawing, or a photograph, into a digital image that it sends into the computer for display or further processing. The image is viewed as a graphics image, not a text image, so it can be altered with a graphics program but cannot be edited with a word-processing program, unless the scanner is part of a character-recognition system. To digitize photographs, a scanner may dither the image (put the dots a varying amount of space apart), or use the tagged image file format (TIFF), storing the image in 16 gray values. Some scanners can use standard video cameras to capture images for the computer. See CHARACTER RECOGNITION.

The printer puts text or other images produced with a computer onto paper or other surfaces. Printers are either impact or nonimpact devices.

Daisy-wheel or thimble printers are so called from the shape of the elements bearing raised images of the characters. Their speed, perhaps 30 characters per second, is now considered unacceptably slow. Dot-matrix printers produce their images by striking a series of wire pins, typically, 9, 18, or 24, through the ribbon in the pattern necessary to form the letter, number, line, or other character.

Ink-jet printers carry their ink in a well, where it is turned into a mist by heat or vibration and sprayed through tiny holes to form the pattern of the character on paper. Laser printers are similar to photocopying machines. The quality of laser-printer output is the highest generally available. See PHOTOCOPYING PROCESSES; PRINTING.

The modem connects one computer to another, ordinarily through the telephone lines, to exchange information. See MODEM. [L.R.S.]

**Computer programming** Designing and writing computer programs, or sequences of instructions to be executed by a computer. A computer is able to perform useful tasks only by executing computer programs. A programming language or a computer language is a specialized language for expressing the instructions in a computer program.

**Problem solving.** In this stage, the programmer gains a full understanding of the problem that the computer program under development is supposed to solve, and devises a step-by-step procedure (an algorithm) that, when followed, will solve the problem. Such a procedure is then expressed in a fairly precise yet readily understandable notation such as pseudo code, which outlines the essentials of a computer program using English statements and programming language-like key words and structures. See ALGORITHM.

A useful example concerns the problem of finding the greatest common divisor (gcd) of two given positive integers. After an analysis of the problem, a programmer may choose to solve the problem by the procedure described by the following pseudo code. (In the pseudo code, the modulus operator produces the remainder that results from the division of one integer by another; for example, 15 modulus 6 yields 3.)

1. Let  $x$  and  $y$  be the two given integers
2. As long as  $x$  and  $y$  are greater than 0, repeat lines 3–5
3.   if  $x$  is greater than  $y$
4.     then replace  $x$  by the value of  $x$  modulus  $y$
5.     else replace  $y$  by the value of  $y$  modulus  $x$
6. If  $x$  is 0
7.   then  $y$  is the gcd
8.   else  $x$  is the gcd

See NUMBER THEORY.

Lines 3–5 and 6–8 are examples of the selection control structure, which specifies alternative instructions and enables a computer to choose one alternative for execution and ignore the other. Lines 2–5 form a repetitive control structure (commonly called a loop), which causes the computer to execute certain instructions (lines 3–5) repeatedly.

Programmers indent to show the structural relationship among the statements and to enhance the readability of the program. In the example, indentation makes it clear that lines 4 and 5 are part of the selection structure beginning at line 3, that lines 3–5 are part of the loop that begins at line 2, and that lines 7 and 8 are part of the selection structure that begins at line 6.

An algorithm developed to solve a given problem should be verified to ensure that it will function correctly. The following list shows how the above procedure derives the gcd of 48 and 18 by successively modifying the values of  $x$  and  $y$ .

```

x y
48 18 (Let x be equal to 48 and y equal to 18)
48 18 (48 modulus 18 is 12, which replaces 48)
12 18 (18 modulus 12 is 6, which replaces 18)
12 6 (12 modulus 6 is 0, which replaces 12)
0 6 (since x is 0, the loop ends and 6 is the gcd)

```

**Implementation.** In this stage the pseudocode procedure developed in the problem-solving stage will be expressed in a programming language. There are numerous programming languages, in two broad classes: low-level languages, which are difficult for human programmers to understand and use but can be readily recognized by a physical computer; and high-level languages, which are easier for human programmers to use but cannot be directly recognized by a physical computer. Currently most computer programs are first written in a high-level language and then translated into an equivalent program in a low-level language so that a physical computer can recognize and obey the instructions in the program. The translator itself is usually a sophisticated computer program called a compiler. See PROGRAMMING LANGUAGES.

Shown below is the gcd-finding procedure written in a widely used high-level language called C++.

```

/*****
 *The function findgcd computes the greatest*
 *common divisor of two int parameters, and *
 *returns the result as an int value\hspace *
 *****/
int findgcd (int x, int y)
{
    while (x > 0 && y < 0)
        if (x > y)
            x = x % y;
        else y = y % x;
        if (x = 0)
            return y;
        else return x;
}

```

The text beginning with `/*` and ending with `*/` (the first five lines above) is a program comment. Program comments are not executable instructions and do not affect the functioning of a computer program in any way, but are intended as a way to document a computer program. Appropriate program comments enhance program readability and are considered an important part of a computer program. A more readable program is usually easier to enhance or modify when such needs arise later. The rest of the above text is C++ code (instructions in the language C++) to compute the gcd of two given integers. Indentation in C++ code serves the same purpose as in pseudo code. It is obvious that the above C++ code closely parallels the pseudo code developed previously, as they both express the same abstract procedure.

**Object-oriented programming.** Object-oriented programming is a way to structure a computer program. The object-oriented paradigm has gained widespread acceptance and is supported by such widely used languages as C++ and Java. An object includes relevant data and operations on the data as a self-contained entity. Interaction with an object can be made by invoking the object's operations. Each object is an instance of an object class. Object classes may be related by inheritance; one class may be a subclass (specialization) of another class. At the center of an object-oriented program design is a collection of objects that represent entities in the application domain. Identifying the objects and object classes, the relationship among the object classes, and the interactions among the objects is a major issue

in designing an object-oriented program. See OBJECT-ORIENTED PROGRAMMING.

**Language processors.** Although many widely used programming languages are processed by compilation into machine-executable instructions, some programming languages (for example, LISP and Prolog) are usually interpreted instead of being compiled. When a computer program is interpreted, it is directly executed by another program called an interpreter without being translated into low-level, machine-executable instructions. Some other languages are processed by a hybrid approach. For example, a program in the language Java is first compiled into an equivalent program in an intermediate-level language, which is executed by an interpreter. See COMPUTER; DIGITAL COMPUTER.

[S.C.Hs.]

**Computer security** The process of ensuring confidentiality, integrity, and availability of computers, their programs, hardware devices, and data. Lack of security results from a failure of one of these three properties. The lack of confidentiality is unauthorized disclosure of data or unauthorized access to a computing system or a program. A failure of integrity results from unauthorized modification of data or damage to a computing system or program. A lack of availability of computing resources results in what is called denial of service.

An act or event that has the potential to cause a failure of computer security is called a threat. Some threats are effectively deflected by countermeasures called controls. Kinds of controls are physical, administrative, logical, cryptographic, legal, and ethical. Threats that are not countered by controls are called vulnerabilities.

**Encryption.** Encryption is a very effective technique for preserving the secrecy of computer data, and in some cases it can also be employed to ensure integrity and availability. An encrypted message is converted to a form presumed unrecognizable to unauthorized individuals. The principal advantage of encryption is that it renders interception useless. See CRYPTOGRAPHY.

**Access control.** Computer security implies that access be limited to authorized users. Therefore, techniques are required to control access and to securely identify users. Access controls are typically logical controls designed into the hardware and software of a computing system. Identification is accomplished both under program control and by using physical controls.

Typically, access within a computing system is limited by an access control matrix administered by the operating system or a processing program. All users are represented as subjects by programs executing on behalf of the users; the resources, called the objects of a computing system, consist of files, programs, devices, and other items to which users' accesses are to be controlled. The matrix specifies for each subject the objects that can be accessed and the kinds of access that are allowed.

Access control as described above relates to individual permissions. Typically, such access is called discretionary access control because the control is applied at the discretion of the object's owner or someone else with permission. With a second type of access control, called mandatory access control, each object in the system is assigned a sensitivity level, which is a rating of how serious would be the consequences if the object were lost, modified, or disclosed, and each subject is assigned a level of trust.

Access control is not necessarily as direct as just described. Unauthorized access can occur through a covert channel. One process can signal something to another by opening and closing files, creating records, causing a device to be busy, or changing the size of an object. All of these are acceptable actions, and so their use for covert communication is essentially impossible to detect, let alone prevent.

**Security of programs.** Computer programs are the first line of defense in computer security, since programs provide

logical controls. Programs, however, are subject to error, which can affect computer security.

A computer program is correct if it meets the requirements for which it was designed. A program is complete if it meets all requirements. Finally, a program is exact if it performs only those operations specified by requirements.

Simple programmer errors are the cause of most program failures. Fortunately, the quality of software produced under rigorous design and production standards is likely to be quite high. However, a programmer who intends to create a faulty program can do so, in spite of development controls. *See* SOFTWARE ENGINEERING.

A salami attack is a method in which an accounting program reduces some accounts by a small amount, while increasing one other account by the sum of the amounts subtracted. The amount reduced is expected to be insignificant; yet, the net amount summed over all accounts is much larger.

Some programs have intentional trapdoors, additional undocumented entry points. If these trapdoors remain in operational systems, they can be used illicitly by the programmer or discovered accidentally by others.

A Trojan horse is an intentional program error by which a program performs some function in addition to its advertised use. For example, a program that ostensibly produces a formatted listing of stored files may write copies of those files on a second device to which a malicious programmer has access.

A program virus is a particular type of Trojan horse that is self-replicating. In addition to performing some illicit act, the program creates a copy of itself which it then embeds in other, innocent programs. Each time the innocent program is run, the attached virus code is activated as well; the virus can then replicate and spread itself to other, uninfected programs. Trojan horses and viruses can cause serious harm to computing resources, and there is no known feasible countermeasure to halt or even detect their presence.

**Security of operating systems.** Operating systems are the heart of computer security enforcement. They perform most access control mediation, most identification and authentication, and most assurance of data and program integrity and continuity of service.

Operating systems structured specifically for security are built in a kernelized manner, embodying the reference monitor concept. A kernelized operating system is designed in layers. The innermost layer provides direct access to the hardware facilities of the computing system and exports very primitive abstract objects to the next layer. Each successive layer builds more complex objects and exports them to the next layer. The reference monitor is effectively a gate between subjects and objects. *See* OPERATING SYSTEM.

**Security of databases.** Integrity is a much more encompassing issue for databases than for general applications programs, because of the shared nature of the data. Integrity has many interpretations, such as assurance that data are not inadvertently overwritten, lost, or scrambled; that data are changed only by authorized individuals; that when authorized individuals change data, they do so correctly; that if several people access data at a time, their uses will not conflict; and that if data are somehow damaged, they can be recovered.

Database systems are especially prone to inference and aggregation. Through inference, a user may be able to derive a sensitive or prohibited piece of information by deduction from nonsensitive results without accessing the sensitive information itself. Aggregation is the ability of two or more separate data items to be more (or less) sensitive together than separately. Various statistical methods make it very difficult to prevent inference, and aggregation is also extremely difficult to prevent, since users can access great volumes of data from a database over long periods of time and then correlate the data independently. *See* DATABASE MANAGEMENT SYSTEMS.

**Security of networks.** As computing needs expand, users interconnect computers. Network connectivity, however, increases the security risks in computing. Whereas users of one machine are protected by some physical controls, with network access, a user can easily be thousands of miles from the actual computer. Furthermore, message routing may involve many intermediate machines, called hosts, each of which is a possible point where the message can be modified or deleted, or a new message fabricated. A serious threat is the possibility of one machine's impersonating another on a network in order to be able to intercept communications passing through the impersonated machine.

The principal method for improving security of communications within a network is encryption. Messages can be encrypted link or end-to-end. With link encryption, the message is decrypted at each intermediate host and reencrypted before being transmitted to the next host. End-to-end encryption is applied by the originator of a message and removed only by the ultimate recipient. *See* LOCAL-AREA NETWORK; WIDE-AREA NETWORK.

[C.PP]

To benefit from sharing access to computing systems that are not all located together, organizations have established virtual private networks (VPNs). These networks approach the security of a private network at costs closer to those of shared public resources. The primary security technique used is encryption.

The Internet, or any similar public network, is subject to threats to its availability, integrity, and confidentiality. A complicating feature is that there is effectively no control on transmissions over the Internet. Consequently, a system connected to the Internet is exposed to any malicious attack that any other Internet user wants to launch.

**Security perimeter.** A security perimeter is a logical boundary surrounding all resources that are controlled and protected. The protected resources are called a domain (or enclave or protected subnetwork). There may be overlapping domains of varying protection, so that the most sensitive resources are in the innermost domain, which is the best protected. Protecting the security perimeter may be physical controls, identification and authentication, encryption, and other forms of access control. Two controls that relate especially to the security perimeter are network vulnerability scanning and firewalls.

A network vulnerability scan is the process of determining the connectivity of the subnetwork within a security perimeter, and then testing the strength of protection at all the access points to the subnetwork. With a network domain, if a forgotten access point is not secured, its weakness can undermine the protection of the rest of the domain. A network scanner maps the connectivity of a domain, typically by probing from outside the domain, to determine what resources are visible from the outside. Once all outside connections are identified, each is tested with a range of attacks to determine the vulnerabilities to which it is susceptible and from which it needs to be better protected.

A firewall is a host that functions as a secured gateway between a protected enclave and the outside. The firewall controls all traffic according to a predefined access policy. For example, many firewalls are configured to allow unhindered communication outbound (from the protected domain to a destination outside the domain) but to allow only certain kinds of inbound communication. A firewall can be a separate computer, or firewall functionality can be built into the communications switch connecting the enclave to the external network.

**Intrusion detection.** It is most effective to eliminate vulnerabilities, but if that is not possible, it is then desirable to recognize that an attack is occurring or has occurred, and take action to prevent future attacks or limit the damage from the current one. Intrusion detection can be either anomaly detection, which seeks to identify an attack by behavior that is out of the norm, or misuse detection, to identify an attack by its attempted effect on sensitive resources. Intrusion detection systems monitor a

computing system in order to warn of an attack that is imminent, is under way, or has occurred. [C.P.P.]

**Computer storage technology** The techniques, equipment, and organization for providing the memory capability required by computers in order to store instructions and data for processing at high electronic speeds.

**Memory hierarchy.** Memory hierarchy refers to the different types of memory devices and equipment configured into an operational computer system to provide the necessary attributes of storage capacity, speed, access time, and cost to make a cost-effective practical system. The fastest-access memory in any hierarchy is the main memory in the computer. In most computers, random-access memory (RAM) chips are used because of their high speed and low cost. The secondary storage in the hierarchy usually consists of disks. The last, or bottom, level (sometimes called the tertiary level) of storage hierarchy is made up of magnetic tape transports and mass-storage tape systems. Performance is usually measured by two parameters: capacity and access time. (Speed or data rate is a third parameter, but it is not so much a function of the device itself as of the overall memory design.) Capacity refers to the maximum on-line user capacity of a single connectable memory unit. Access time is the time required to obtain the first byte of a randomly located set of data. See BIT.

**Memory organization.** The efficient combination of memory devices from the various hierarchy levels must be integrated with the central processor and input/output equipment, making this the real challenge to successful computer design. The resulting system should operate at the speed of the fastest element, provide the bulk of its capacity at the cost of its least expensive element, and provide sufficiently short access time to retain these attributes in its application environment. Another key ingredient of a successful computer system is an operating system (that is, software) that allows the user to execute jobs on the hardware efficiently. Operating systems are available which achieve this objective reasonably well. See COMPUTER SYSTEMS ARCHITECTURE.

The computer system hardware and the operating system software must work integrally as one resource. In many computer systems, the manufacturer provides a virtual memory system. It gives each programmer automatic access to the total capacity of the memory hierarchy without specifically moving data up and down the hierarchy and to and from the central processing unit (CPU). See COMPUTER PROGRAMMING; DATABASE MANAGEMENT SYSTEM; OPERATING SYSTEM; PROGRAMMING LANGUAGES.

A cache memory is a small, fast buffer located between the processor and the main system memory. Cache memory is used to speed up the flow of instructions and data into the central processing unit from main memory. This cache function is important because the main memory cycle time is typically slower than the central processing unit clocking rates.

**Main memory.** Random access memory (RAM) chips come in a wide variety of organizations and types. Computer main memories are organized into random addressable words in which the word length is fixed to some power-of-2 bits (for example, 4, 8, 16, 32, or 64 bits). But there are exceptions, such as 12-, 18-, 24-, 48-, and 60-bit word-length machines. Usually RAMs contain  $NK \cdot 1$  (for example,  $64 \cdot 1$ ) bits, so the main memory design consists of a stack of chips in parallel with the number of chips corresponding to that machine's word length. There are two basic types of RAMs, static and dynamic. The differences are significant. Dynamic RAMs are those which require their contents to be refreshed periodically. They require supplementary circuits on-chip to do the refreshing and to assure that conflicts do not occur between refreshing and normal read-write operations. Even with those extra circuits, dynamic RAMs still require fewer on-chip components per bit than do static RAMs (which do not require refreshing).

Static RAMs are easier to design, and compete well in applications in which less memory is to be provided, since their higher cost then becomes less important. They are often chosen for minicomputer memory, or especially for microcomputers. Because they require more components per chip, making higher bit densities more difficult to achieve, the introduction of static RAMs of any given density occurs behind that of dynamic versions.

There is another trade-off to be made with semiconductor RAMs in addition to the choice between static and dynamic types, namely that between MOS and bipolar chips. Bipolar devices are faster, but have not yet achieved the higher densities (and hence the lower costs) of MOS. Within each basic technology, MOS and bipolar, there are several methods of constructing devices, and these variations achieve a variety of memory speeds and access times, as well as power consumption and price differences. Within the basic MOS technologies there are several types, such as the *n*-channel MOS referred to as NMOS and the complementary MOS solid-state structure referred to as CMOS. For bipolar there are several types such as transistor-to-transistor logic (TTL) and the emitter-coupled logic (ECL). See LOGIC CIRCUITS.

**Secondary memory.** High-capacity, slower-speed memory consists of two major functional types: random-access, which has been provided primarily by disk drives, and sequential-access, which has been provided primarily by tape drives. Since tape drives provide removability of the medium from the computer, tape is used for the majority of off-line, archival storage, although some disks are removable also. The on-line random-access disk devices are classed as secondary, and tape-based systems are classed as tertiary.

Conventional magnetic-disk memories consist of units which vary in capacity from the small floppy disks to gigabyte and higher capacity disk drives. The major area of development in disks has been the progressive and even spectacular increases in capacity per drive, particularly in terms of price per byte.

Optical recording is a nonmagnetic disk technology that uses a laser beam to burn pits in the recording medium to represent the bits of information, and a lower-power laser to sense the presence or absence of pits for reading.

CD-ROM (compact disk-read-only memory) and WORM (write once, read many) are special types of optical disks. CD-ROM resembles the related audio compact disk technology in that users of CD-ROM can read only prerecorded data on the disk. A 5-in. (125-mm) CD-ROM can hold 500 to 600 megabytes, which is equivalent to 1400 to 1700 (360-kilobyte) diskettes. See COMPACT DISK.

Bubble memories are chips rather than disks, but are different from semiconductor memories in that they are magnetic devices, in which the absence or presence of a magnetic domain is the basis for a binary 1 to 0. The performance characteristics of these devices makes them competitive as small-capacity secondary storage. For portable and other special applications, bubbles have definite advantages such as nonvolatility, low power, and high compactness. Performance capabilities relative to floppy disks are 100 kilobits per second for bubbles versus 200–250 kilobits per second for floppies, and 40 milliseconds average access time for bubbles versus 200–250 milliseconds for floppies.

**Magnetic tape units.** In magnetic tape units, the tape maintains physical contact with the fixed head while in motion, allowing high-density recording. The long access times to find user data on the tape are strictly due to the fact that all intervening data have to be searched until the desired data are found. This is not true of rotating disk memories or RAM word-addressable main memories. The primary use of tape storage is for seldom-used data files and as back-up storage for disk data files. Half-inch (12.5-mm) tape has been the industry standard since it was first used commercially in 1953. Half-inch magnetic tape drive transports are reel-to-reel recorders with extremely high



tape speeds (up to 200 in. or 5 m per second), and fast start, stop (on the order of 1 millisecond), reverse, and rewind times. Performance and data capacity of magnetic tape have improved by orders of magnitude.

**Mass storage systems.** With the gradual acceptance of virtual memory and sophisticated operating systems, a significant operational problem arose with computer systems, particularly the large-scale installations. The expense and attendant delays and errors of humans storing, mounting, and demounting tape reels at the command of the operating system began to become a problem. Cartridge storage facilities are designed to alleviate this problem.

Their common attributes are: capacity large enough to accommodate a very large database on-line; access times between those of movable-head disks and tapes; and operability, without human intervention, under the strict control of the operating system. The cartridge storage facility is included within the virtual address range. All such configurations mechanically extract from a bin, mount on some sort of tape transport, and replace in a bin, following reading or writing, a reel or cartridge of magnetic tape.

Cartridge storage systems are hardware devices that need operating system and database software in order to produce a truly integrated, practical hardware-software system. Users require fast access to their files, and thus there is a definite need to queue up (stage) files from the cartridge storage device onto the disks. The database software must function efficiently to make this happen. In general, users base their storage device selection on the file sizes involved and the number of accesses per month. Magnetic tape units are used for very large files accessed seldom or infrequently. Mass-storage devices are for intermediate file sizes and access frequencies. Disk units are used for small files or those which are accessed often. [P.P.C.; M.Ple.; D.Th.]

**Computer-system evaluation** The evaluation of performance, from the perspectives of both developers and users, of complex systems of hardware and software. Modern computer-based information systems have become increasingly complex because of networking, distributed computing, distributed and heterogeneous databases, and the need to store large quantities of data. People are relying increasingly on computer systems to support daily activities. When these systems fail, significant breakdowns may ensue. See DISTRIBUTED SYSTEMS (COMPUTERS); LOCAL-AREA NETWORKS.

A computer system can fail in two major ways. First, functional failure occurs when the system fails to generate the correct results for a set of inputs. For example, if an information system fails to retrieve records that match a set of keywords, or if an air-missile tracking system fails to distinguish between a friendly and enemy missile, a functional failure has occurred. Second, performance failure occurs when the system operates correctly but fails to deliver the results in a timely fashion. For example, if an information system takes a longer time than users are willing to wait for the records they requested, the system is said to fail performance-wise even though it may eventually retrieve the correct set of records. Also, if the air-missile tracking system fails to detect an enemy missile in sufficient time to launch a counterattack, the system manifests performance failure.

Therefore, in designing a computer system it is necessary to guarantee that the end product will display neither functional nor performance failure. It is then necessary to predict the performance of computer systems when they are under design and development, as well as to predict the impact of changes in configurations of existing systems. This requires the use of predictive performance models.

The input parameters of performance models include workload intensity parameters, hardware and system parameters, and resource demand parameters. The outputs generated by performance models include response times, throughputs, utilization of

devices, and queue lengths. There are analytic, simulation, and hybrid performance models. Analytic models are composed of a set of equations, or computational algorithms, used to compute the outputs from the input parameters. Simulation models are based on computer programs that emulate the behavior of a system by generating arrivals of so-called customers through a probabilistic process and by simulating their flow through the system. As these simulated entities visit the various system elements, they accumulate individual and system statistics. Hybrid models combine both analytic and simulation approaches by, for example, replacing an entire subsystem in an analytic model by an equivalent device whose input-output behavior is obtained by simulating the subsystem. Analytic models can be exact or approximate. See SIMULATION.

Approximations are needed either when there is no known mathematically tractable exact solution or when the computation of an exact solution is very complex. Modern computer systems are very complex because of ubiquitous networking, distributed processing using client-server architectures, multiprocessor, and sophisticated input-output subsystems using network-attached storage devices. For this reason, most computer system performance models are approximate models. See CLIENT-SERVER SYSTEM; MULTIPROCESSING.

The design and development of complex software systems is a time-consuming and expensive task. Performance modeling techniques must be integrated into the software development methodology. This integrated approach is called software performance engineering. One goal is to estimate the resource consumption of software under development so that performance models can be used to influence the architecture of the software under development. Better estimates on the resource consumption are obtained as the software development process evolves. See INFORMATION SYSTEMS ENGINEERING; SOFTWARE ENGINEERING.

[D.A.Men.]

**Computer systems architecture** The discipline that defines the conceptual structure and functional behavior of a computer system. It is analogous to the architecture of a building, determining the overall organization, the attributes of the component parts, and how these parts are combined. It is related to, but different from, computer implementation. Architecture consists of those characteristics which affect the design and development of software programs, whereas implementation focuses on those characteristics which determine the relative cost and performance of the system. The architect's main goal has long been to produce a computer that is as fast as possible, within a given set of cost constraints. Over the years, other goals have been added, such as making it easier to run multiple programs concurrently or improving the performance of programs written in higher-level languages.

A computer system consists of four major components (see illustration): storage, processor, peripherals, and input/output (communication). The storage system is used to keep data and programs; the processor is the unit that controls the operation of the system and carries out various computations; the peripheral devices are used to communicate with the outside world; and the input/output system allows the previous components to communicate with one another.

**Storage.** The storage or memory of a computer system holds the data that the computer will process and the instructions that indicate what processing is to be done. In a digital computer, these are stored in a form known as binary, which means that each datum or instruction is represented by a series of bits. Bits are conceptually combined into larger units called bytes (usually 8 bits each) and words (usually 8 to 64 bits each). A computer will generally have several different kinds of storage devices, each organized to hold one or more words of data. These types include registers, main memory, and secondary or auxiliary storage. See BIT.

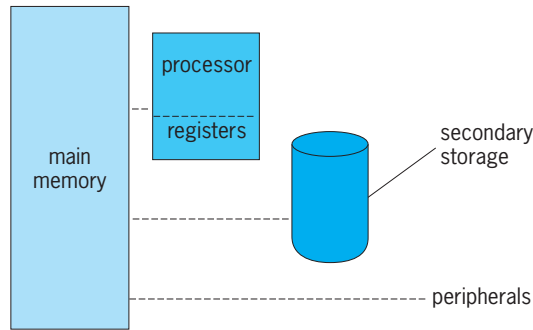

**Overview of a computer system.** Storage is made up of registers, main memory, and secondary storage. Broken lines indicate input/output.

Registers are the fastest and most costly storage units in a computer. Normally contained within the processing unit, registers hold data that are involved with the computation currently being performed.

Main memory holds the data to be processed and the instructions that specify what processing is to be done. A major goal of the computer architect is to increase the effective speed and size of a memory system without incurring a large cost penalty. Two prevalent techniques for increasing effective speed are interleaving and cacheing, while virtual memory is a popular way to increase the effective size. Interleaving involves the use of two or more independent memory systems, combined in a way that makes them appear to be a single, faster system. With cacheing, a small, fast memory system contains the most frequently used words from a slower, larger main memory.

Virtual memory is a technique whereby the programmer is given the illusion of a very large main memory, when in fact it has only a modest size. This is achieved by placing the contents of the large, "virtual" memory on a large but slow auxiliary storage device, and bringing portions of it into main memory, as required by the programs, in a way that is transparent to the programmer.

Auxiliary memory (sometimes called secondary storage) is the slowest, lowest-cost, and highest-capacity computer storage area. Programs and data are kept in auxiliary memory when not in immediate use, so that auxiliary memory is essentially a long-term storage medium. There are two basic types of secondary storage: sequential and direct-access. Sequential-access secondary storage devices, of which magnetic tape is the most common, permit data to be accessed in a linear sequence. A direct-access device is one whose data may be accessed in any order. Disks and drums are the most commonly encountered devices of this type.

Memory mapping is one of the most important aspects of modern computer memory designs. In order to understand its function, the concept of an address space must be considered. When a program resides in a computer's main memory, there is a set of memory cells assigned to the program and its data. This is known as the program's logical address space. The computer's physical address space is the set of memory cells actually contained in the main memory. Memory mapping is simply the method by which the computer translates between the computer's logical and physical address spaces. The most straightforward mapping scheme involves use of a bias register. Assignment of a different bias value to each program in memory enables the programs to coexist without interference.

Another strategy for mapping is known as paging. This technique involves dividing both logical and physical address spaces into equal-sized blocks called pages. Mapping is achieved by means of a page map, which can be thought of as a series of bias registers. See COMPUTER STORAGE TECHNOLOGY.

**Processing.** A computer's processor (processing unit) consists of a control unit, which directs the operation of the system,

and an arithmetic and logic unit, which performs computational operations. The design of a processing unit involves selection of a register set, communication paths between these registers, and a means of directing and controlling how these operate. Normally, a processor is directed by a program, which consists of a series of instructions that are kept in main memory.

Although the process of decoding and executing instructions is often carried out by logic circuitry, the complexity of instruction sets can lead to very large and cumbersome circuits for this purpose. To alleviate this problem, a technique known as microprogramming was developed. With microprogramming, each instruction is actually a macrocommand that is carried out by a microprogram, written in a microinstruction language. The microinstructions are very simple, directing data to flow between registers, memories, and arithmetic units.

It should be noted that microprogramming has nothing to do with microprocessors. A microprocessor is a processor implemented through a single, highly integrated circuit. See MICROPROCESSOR.

**Peripherals and communication.** A typical computer system includes a variety of peripheral devices such as printers, keyboards, and displays. These devices translate electronic signals into mechanical motion or light (or vice versa) so as to communicate with people.

There are two common approaches for connecting peripherals and secondary storage devices to the rest of the computer: The channel and the bus. A channel is essentially a wire or group of wires between a peripheral device and a memory device. A multiplexed channel allows several devices to be connected to the same wire. A bus is a form of multiplexed channel that can be shared by a large number of devices. The overhead of sharing many devices means that the bus has lower peak performance than a channel; but for a system with many peripherals, the bus is more economical than a large number of channels.

A computer controls the flow of data across buses or channels by means of special instructions and other mechanisms. The simplest scheme is known as program-controlled input/output (I/O). Direct memory access I/O is a technique by which the computer signals the device to transmit a block of data, and the data are transmitted directly to memory, without the processor needing to wait.

Interrupts are a form of signal by which a peripheral device notifies a processor that it has completed transmitting data. This is very helpful in a direct memory access scheme, for the processor cannot always predict in advance how long it will take to transmit a block of data. Architects often design elaborate interrupt schemes to simplify the situation where several peripherals are active simultaneously. See COMPUTER; DIGITAL COMPUTER. [D.J.F.]

**Computer vision** The technology concerned with computational understanding and use of the information present in visual images. In part, computer vision is analogous to the transformation of visual sensation into visual perception in biological vision. For this reason the motivation, objectives, formulation, and methodology of computer vision frequently intersect with knowledge about their counterparts in biological vision. However, the goal of computer vision is primarily to enable engineering systems to model and manipulate the environment by using visual sensing. See VISION.

Computer vision begins with the acquisition of images. A camera produces a grid of samples of the light received from different directions in the scene. The position within the grid where a scene point is imaged is determined by the perspective transformation. The amount of light recorded by the sensor from a certain scene point depends upon the type of lighting, the reflection characteristics and orientation of the surface being imaged, and the location and spectral sensitivity of the sensor.

One central objective of image interpretation is to infer the three-dimensional (3D) structure of the scene from images that are only two-dimensional (2D). The missing third dimension

necessitates that assumptions be made about the scene so that the image information can be extrapolated into a three-dimensional description. The presence in the image of a variety of three-dimensional cues is exploited. The two-dimensional structure of an image or the three-dimensional structure of a scene must be represented so that the structural properties required for various tasks are easily accessible. For example, the hierarchical two-dimensional structure of an image may be represented through a pyramid data structure which records the recursive embedding of the image regions at different scales. Each region's shape and homogeneity characteristics may themselves be suitably coded. Alternatively, the image may be recursively split into parts in some fixed way (for example, into quadrants) until each part is homogeneous. This approach leads to a tree data structure. Analogous to two dimensions, the three-dimensional structures estimated from the imaged-based cues may be used to define three-dimensional representations. The shape of a three-dimensional volume or object may be represented by its three-dimensional axis and the manner in which the cross section about the axis changes along the axis. Analogous to the two-dimensional case, the three-dimensional space may also be recursively divided into octants to obtain a tree description of the occupancy of space by objects.

A second central objective of image interpretation is to recognize the scene contents. Recognition involves identifying an object based on a variety of criteria. It may involve identifying a certain object in the image as one seen before. A simple example is where the object appearance, such as its color and shape, is compared with that of the known, previously seen objects. A more complex example is where the identity of the object depends on whether it can serve a certain function, for example, drinking (to be recognized as a cup) or sitting (to be recognized as a chair). This requires reasoning from the various image attributes and the derivative three-dimensional characteristics to assess if a given object meets the criteria of being a cup or a chair. Recognition, therefore, may require extensive amounts of knowledge representation, reasoning, and information retrieval.

Visual learning is aimed at identifying relationships between the image characteristics and a result based thereupon, such as recognition or a motor action.

In manufacturing, vision-based sensing and interpretation systems help in automatic inspection, such as identification of cracks, holes, and surface roughness; counting of objects; and alignment of parts. Computer vision helps in proper manipulation of an object, for example, in automatic assembly, automatic painting of a car, and automatic welding. Autonomous navigation, used, for example, in delivering material on a cluttered factory floor, has much to gain from vision to improve on the fixed, rigid paths taken by vehicles which follow magnetic tracks prelaid on the floor. Recognition of symptoms, for example, in a chest x-ray, is important for medical diagnosis. Classification of satellite pictures of the Earth's surface to identify vegetation, water, and crop types, is an important function. Automatic visual detection of storm formations and movements of weather patterns is crucial for analyzing the huge amounts of global weather data that constantly pour in from sensors. See CHARACTER RECOGNITION; COMPUTER GRAPHICS; INTELLIGENT MACHINE; ROBOTICS. [N.Ah.]

**Computerized tomography** An imaging technique which uses an array of detectors to collect information from a beam that has passed through an object (for example, a portion of the human body). The information collected is then used by a computer to reconstruct the internal structures, and the resulting image can be displayed—for example, on a television screen. The technique relies on the fact that wave phenomena can penetrate into regions where it is impossible or undesirable to introduce ordinary probes. Since wave attenuation and velocity are affected by material properties, such as temperature and density, information concerning these properties is accumulated

by a wave packet as it travels along its path. The intensities and travel times of such pulses measured at a receiver represent such accumulations. Although a single such datum does not allow point-to-point variation to be inferred, when many rays crisscross a region the corresponding interrelated data contain constraints that allow an inversion to determine interior structures. Considerable computational power and mathematical sophistication are needed in dealing with indirect, incomplete, and imperfect measurements, notably the branch of mathematics called inverse theory. The term computerized tomography for this technology arose in medicine, where x-ray attenuation data along many straight paths confined to a plane were used to obtain a map of density structure in a body section. The term tomography refers to methods that display only thin slices or sections through an object or a human body. See INVERSE SCATTERING THEORY.

Examining a person or object in the laboratory requires the use of a gantry, composed of an x-ray tube, an array of detectors opposite the tube, and a central aperture in which the person or object is placed. The rigid gantry maintains the proper alignment between the x-ray tube and the detectors. An electron beam is used, which is focused on stationary anode rings located in the gantry surrounding the patient, making it possible to generate considerable x-ray output within a very short time and to acquire images while the patient is advancing through the gantry. Up to 34 scans or slices can be obtained within 1 s. The computer reconstructs the image from the information collected by the detectors. In order to obtain enough information to calculate one image, at least 90,000 readings (300 pulses and 300 detectors) are needed.

In medicine, computerized tomography represents a noninvasive way of seeing internal structures. In the brain, for example, computerized tomography can readily locate tumors and hemorrhages, thereby providing immediate information for evaluating neurological emergencies. Another advantage of computerized tomography is three-dimensional reconstruction. It is most useful in cases of fracture of the hip or facial bones, helping the surgeon to do reconstructive surgery. Other medical imaging techniques that make use of computerized tomographic methods include magnetic resonance imaging, positron emission tomography, and single-photon emission tomography. See MEDICAL IMAGING; RADIOGRAPHY. [N.F.B.]

After the success of computerized tomography in medicine, its possibilities in other fields were quickly realized. In the earth, atmospheric, and ocean sciences it has supplemented, but by no means replaced, older methods of remote sensing. Seismic tomography is now an important tool for investigating the deep structure of the Earth, testing theories such as plate tectonics, and exploring for oil. Ocean acoustic tomography is applied to physical oceanography, climatology, and antisubmarine warfare. Atmospheric tomography finds applications to weather, climate, and the environment. See OCEANOGRAPHY; PLATE TECTONICS; SEISMOLOGY. [T.J.E.; R.N.]

**Concentration scales** Concentration is a very important property of mixtures, because it defines the quantitative relation of the components. In solutions the concentration is expressed as the mass, volume, or number of moles of solute present in proportion to the amount of solvent or of total solution.

The simplest scale to measure is percentage; hence it is often used for medicinal or household solutions. Weight percent is the number of parts of weight of solute per hundred parts of solution (total). For example, a 10% saline solution contains 10 g of salt in 90 g of water, that is, 100 g total weight. Gaseous mixtures, being difficult to weigh, are often expressed as volume percent. Thus, air is said to contain 78% nitrogen by volume. Solutions of liquids in liquids (say, alcohol in water) may also be expressed in volume percent.

To the chemist, the number of moles of solute is of more significance than the number of grams. The molarity (abbreviated *M*)

is the number of moles of solute per liter of total solution. Thus, 12 M HCl means that the solution contains 12 formula weights ( $12 \times 36.5$ ), or 438 g, of HCl/liter. (As used here, the mole is an amount of substance whose weight in grams is numerically the same as the molecular weight.)

Molality (abbreviated *m*) relates the number of moles of solute to the weight of solvent rather than to the volume of solution. This scale indicates the number of moles of solute/1000 g of solvent. Thus 34.2 g of sucrose ( $C_{12}H_{22}O_{11}$ , mol wt 342), if dissolved in 200 g of water, has the concentration of 0.5 mole of sucrose/1000 g of water, and hence is 0.5 *m*.

When it is important to know the reactive capacities of reagents, as in volumetric analysis, the normality scale is used. Normality (abbreviated *N*) is found by multiplying molarity by the number of active units in the formula.

In recent years many chemists have sought to avoid the molarity scale lest it imply that electrolyte solutes exist as molecules rather than ions. The formality scale (abbreviated *F*) represents formula weights per liter. Its values are identical with the molarities of un-ionized solutes.

Many properties of solutions (for example, vapor pressure of one component) are dependent on the ratio of the number of moles of solute to the number of moles of solvent, rather than on the ratios of respective volumes or masses. The mole fraction (abbreviated  $N_A$  or  $X_A$  for component *A*) is the ratio of the number of moles of solute to the total number of moles of all components. Thus for 16 g of methanol (0.5 mole) dissolved in 18 g of water (1 mole), the mole fraction of methanol is 0.5/1.5, or 1/3; the mole percent is 33.3. For gases the mole percent is identical with the volume percent. See GRAM-MOLECULAR WEIGHT; SOLUTION; TITRATION. [A.L.H.]

**Concrete** Any of several manufactured, stonelike materials composed of particles, called aggregates, that are selected and graded into specified sizes for construction purposes and that are bonded together by one or more cementitious materials into a solid mass.

The term concrete, when used without a modifying adjective, ordinarily is intended to indicate the product formed from a mix of portland cement, sand, gravel or crushed stone, and water. There are, however, many different types of concrete. The names of some are distinguished by the types, sizes, and densities of aggregates—for example, wood-fiber, lightweight, normal-weight, or heavyweight concrete. The names of others may indicate the type of binder used—for example, blended-hydraulic cement, natural-cement, polymer, or bituminous (asphaltic) concrete.

Concretes are similar in composition to mortars, which are used to bond unit masonry. Mortars, however, are normally made with sand as the sole aggregate, whereas concretes contain much larger aggregates and thus usually have greater strength. As a result, concretes have a much wider range of structural applications, including pavements, footings, pipes, unit masonry, floor slabs, beams, columns, walls, dams, and tanks. See CONCRETE BEAM; CONCRETE COLUMN; CONCRETE SLAB; MASONRY; MORTAR.

Because ordinary concrete is much weaker in tension than in compression, it is usually reinforced or prestressed with a much stronger material, such as steel, to resist tension. Use of plain, or unreinforced, concrete is restricted to structures in which tensile stresses will be small, such as massive dams, heavy foundations, and unit-masonry walls. For reinforcement of other types of structures, steel bars or structural-steel shapes may be incorporated in the concrete. Prestress to offset tensile stresses may be applied at specific locations by permanently installed compressing jacks, high-strength steel bars, or steel strands. Alternatively, prestress may be distributed throughout a concrete component by embedded pretensioned steel elements. Another option is use of a cement that tends to expand concrete while enclosures prevent

that action, thus imposing compression on the concrete. See PRESTRESSED CONCRETE; REINFORCED CONCRETE.

There are various methods employed for casting ordinary concrete. For very small projects, sacks of prepared mixes may be purchased and mixed on the site with water, usually in a drum-type, portable, mechanical mixer. For large projects, mix ingredients are weighed separately and deposited in a stationary batch mixer, a truck mixer, or a continuous mixer. Concrete mixed or agitated in a truck is called ready-mixed concrete. In general, concrete is placed and consolidated in forms by hand tamping or puddling around reinforcing steel or by spading at or near vertical surfaces. Another technique, vibration or mechanical puddling, is the most satisfactory one for achieving proper consolidation.

Finishes for exposed concrete surfaces are obtained in a number of ways. Surfaces cast against forms can be given textures by using patterned form liners or by treating the surface after forms are removed, for instance, by brushing, scrubbing, floating, rubbing, or plastering. After the surface is thoroughly hardened, other textures can be achieved by grinding, chipping, bush-hammering, or sandblasting. Unformed surfaces, such as the top of pavement slabs or floor slabs, may be either broomed or smoothed with a trowel. Brooming or dragging burlap over the surface produces scoring, which reduces skidding when the pavement is wet.

Adequate curing is essential to bring the concrete to required strength and quality. The aim of curing is to promote the hydration of the cementing material. This is accomplished by preventing moisture loss and, when necessary, by controlling temperature. Moisture is a necessary ingredient in the curing process, since hydration is a chemical reaction between the water and the cementing material. Unformed surfaces are protected against moisture loss immediately after final finishing by means of wet burlap, soaked cotton mats, wet earth or sand, sprayed-on sealing compounds, waterproof paper, or waterproof plastic sheets. Formed surfaces, particularly vertical surfaces, may be protected against moisture loss by leaving the forms on as long as possible, covering with wet canvas or burlap, spraying a small stream of water over the surface, or applying sprayed-on sealing compounds. The length of the curing period depends upon the properties desired and upon atmospheric conditions, such as temperature, humidity, and wind velocity, during this period. Short curing periods are used in fabricating concrete products such as block or precast structural elements. Curing time is shortened by the use of elevated temperatures. [F.S.M.]

**Concrete beam** A structural member of reinforced concrete placed horizontally to carry loads over openings. Because both bending and shear in such beams induce tensile stresses, steel reinforcing tremendously increases beam strength. Usually, beams are designed under the assumption that tensile stresses have cracked the concrete and the steel reinforcing is carrying all the tension. See STRESS AND STRAIN. [F.S.M.]

**Concrete column** A structural member subjected principally to compressive stresses. Concrete columns may be unreinforced, or they may be reinforced with longitudinal bars and ties (tied columns) or with longitudinal bars and spiral steel (spiral-reinforced columns). Sometimes the columns may be a composite of structural steel of cast iron and concrete.

Unreinforced concrete columns are seldom used because of transverse tensile stresses and the possibility of longitudinal tensile stresses being induced by buckling or unanticipated bending. Because concrete is weak in tension, such stresses are generally avoided. When plain concrete columns are used, they usually are limited in height to five or six times the least thickness. Under axial loading, the load divided by the cross-sectional area of the concrete should not exceed the allowable unit compressive stress for the concrete. See CONCRETE; REINFORCED CONCRETE; STEEL. [F.S.M.]

**Concrete slab** A shallow, reinforced-concrete structural member that is very wide compared with depth. Spanning between beams, girders, or columns, slabs are used for floors, roofs, and bridge decks. If they are cast integrally with beams or girders, they may be considered the top flange of those members and act with them as a T beam. See CONCRETE; CONCRETE BEAM.

A one-way slab is supported on four sides and has a much larger span in one direction than in the other may be assumed to be supported only along its long sides. It may be designed as a beam spanning in the short direction. For this purpose a 1-ft width can be chosen and the depth of slab and reinforcing determined for this unit. Some steel is also placed in the long direction to resist temperature stresses and distribute concentrated loads. The area of the steel generally is at least 0.20% of the concrete area.

A slab supported on four sides and with reinforcing steel perpendicular to all sides is called a two-way slab. Such slabs generally are designed by empirical methods. A two-way slab is divided into strips for design purposes.

When a slab is supported directly on columns, without beams and girders, it is called a flat plate or flat slab. Although thicker and more heavily reinforced than slabs in beam-and-girder construction, flat slabs are advantageous because they offer no obstruction to passage of light (as beam construction does); savings in story height and in the simpler formwork involved; less danger of collapse due to overload; and better fire protection with a sprinkler system because the spray is not obstructed by beams. See CONCRETE COLUMN; REINFORCED CONCRETE. [F.S.M.]

**Concretion** A loosely defined term used for a sedimentary mineral segregation that may range in size from inches to many feet. Concretions are usually distinguished from the sedimentary matrix enclosing them by a difference in mineralogy, color, hardness, and weathering characteristics. Some concretions show definite sharp boundaries with the matrix, while others have gradational boundaries. Most concretions are composed dominantly of calcium carbonate, with or without an admixture of various amounts of silt, clay, or organic material. Coal balls are calcareous concretions found in or immediately above coal beds. Concretions are normally spherical or ellipsoidal; some are flattened to disklike shapes. Frequently a concretion is dumbbell-shaped, indicating that two separate concretionary centers have grown together. See COAL BALLS; SEDIMENTARY ROCKS. [R.Si.]

**Concurrent processing** The simultaneous execution of several interrelated computer programs. A sequential computer program consists of a series of instructions to be executed one after another. A concurrent program consists of several sequential programs to be executed in parallel. Each of the concurrently executing sequential programs is called a process. Process execution, although concurrent, is usually not independent. Processes may affect each other's behavior through shared data, shared resources, communication, and synchronization.

Concurrent programs can be executed in several ways. Multiprogramming systems have one processing unit and one memory bank. Concurrent process execution is simulated by randomly interleaving instructions of the sequential programs. All processes have access to a common pool of data. In contrast, multiprocessing systems have several processing units and one memory bank. Processes are executed in parallel on the separate processing units while sharing common data. In distributed systems, or computer networks, each process is executed on its own processor with its own memory bank. Interaction between processes occurs by transmission of data from one process to another along a communication channel. See DISTRIBUTED SYSTEMS (COMPUTERS); MULTIPROCESSING.

One of the first uses of concurrent processing was in operating systems. If the computer is to support a multiuser environment, the operating system must employ concurrent program-

ming techniques to allow several users to access the computer simultaneously. The operating system should also permit several input/output devices to be used simultaneously, again utilizing concurrent processing. See MULTIACCESS COMPUTER; OPERATING SYSTEM.

Concurrent programming is also used when several computers are joined in a network. An airline reservation system is one example of concurrent processing on a distributed network of computers. See LOCAL-AREA NETWORKS; WIDE-AREA NETWORK.

A simple example of a task that can be performed more efficiently by concurrent processing is a program to calculate the sum of a large list of numbers. Several processes can simultaneously compute the sum of a subset of the list, after which these sums are added to produce the final total.

Concurrent programs can be created explicitly or implicitly. Explicit concurrent programs are written in a programming language designed for specifying processes to be executed concurrently. Implicit concurrent programs are created by a compiler that automatically translates programs written in a sequential programming language into programs with several components to be executed in parallel. See DATA-FLOW SYSTEMS; PROGRAMMING LANGUAGES. [J.Wi.]

**Concussion** A state following injury in which there is temporary functional impairment without physical evidence of damage to the impaired tissues. The term usually refers to cerebral concussion produced by any type of trauma.

From a clinical point of view cerebral concussion is produced by a head injury which causes temporary unconsciousness but with complete recovery within 24 h. This temporary alteration is believed to result from one of several mechanisms. In all of these a sudden acceleration or deceleration appears to be a prerequisite. The sudden movement is thought to cause an unequal shifting of tissues of different specific gravities within the skull, between skull and brain, or between different brain tissues. See BRAIN. [E.G.St./N.K.M.]

**Condensation** A phase-change process in which vapor converts into liquid when the temperature of the vapor is reduced below the saturation temperature corresponding to the pressure in the vapor. For a pure vapor this pressure is the total pressure, whereas in a mixture of a vapor and a noncondensable gas it is the partial pressure of the vapor. Sustaining the process of condensation on a cold surface in a steady state requires cooling of the surface by external means. Condensation is an efficient heat transfer process and is utilized in various

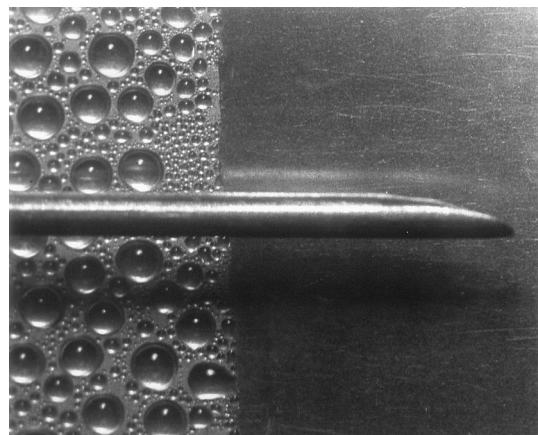

Steam at atmospheric pressure condensing on a vertical copper surface. Film condensation is visible on the right side, and dropwise condensation in the presence of a promoter is visible on the left side. The horizontal tube is a thermocouple. (J. F. Welch and J. W. Westwater, Department of Chemical Engineering, University of Illinois, Urbana)

industrial applications. Condensation of vapor on a cold surface can be classified as filmwise or dropwise. Direct-contact condensation refers to condensation of vapor (bubbles or a vapor stream) in a liquid or condensation on liquid droplets entrained in the vapor. If vapor temperature falls below its saturation temperature, condensation can occur in the bulk vapor. This phenomenon is called homogeneous condensation (formation of fog) and is facilitated by foreign particles such as dust. See GAS; HEAT TRANSFER.

In film condensation, a thin film of liquid forms upon condensation of vapor on a cold surface that is well wetted by the condensate. The liquid film flows downward as a result of gravity.

In dropwise condensation, on surfaces that are not well wetted, vapor may condense in the form of droplets (see illustration). The droplets form on imperfections such as cavities, dents, and cracks on the surface. The droplets of 10–100  $\mu\text{m}$  diameter contribute most to the heat transfer rate. As a droplet grows to a size that can roll down the surface because of gravity, it wipes the surface of the droplets in its path. In the wake behind the large droplet, numerous smaller droplets form and the process repeats. The heat transfer coefficients with dropwise condensation can be one to two orders of magnitude greater than that for film condensation.

Direct-condensation involves condensation of vapor bubbles in a host liquid and condensation on droplets entrained in vapor. Both are also very efficient heat transfer processes, especially when the vapor-liquid interface oscillates. [V.K.D.]

**Conditioned reflex** A learned response performed by a trained animal to a signal that was previously associated with an event of consequence for that animal. Conditioned reflex (CR) was first used by the Russian physiologist I. P. Pavlov to denote the criterion measure of a behavioral element of learning, that is, a new association between the signal and the consequential event, referred to as the conditioned stimulus (CS) and unconditioned stimulus (US), respectively. In Pavlov's classic experiment, the conditioned stimulus was a bell and the unconditioned stimulus was sour fluid delivered into the mouth of a dog restrained by harness; the conditioned stimulus was followed by the unconditioned stimulus regardless of the dog's response. After training, the conditioned reflex is manifested when the dog salivates to the sound of the bell.

Ideally, certain conditions must be met to demonstrate the establishment of a conditioned reflex according to Pavlov's classical conditioning method. Before conditioning, the bell conditioned stimulus should attract the dog's attention or elicit the orienting reflex (OR), but it should not elicit salivation, the response to be conditioned. That response should be specifically and reflexively elicited by the sour unconditioned stimulus, thus establishing its unlearned or unconditioned status. After conditioned pairings of the conditioned stimulus and the unconditioned stimulus, salivation is manifested prior to the delivery of the sour unconditioned stimulus. Salivation in response to the auditory conditional stimulus is now a "psychic secretion" or the conditioned reflex.

To this day, Pavlov's methods provide important guidelines for basic research upon brain mechanisms in learning and memory. Scientists all over the world have paired a vast array of stimuli with an enormous repertoire of reflexes to test conditioned reflexes in representative species of almost all phyla, classes, and orders of animals. As a result, classical conditioning is now considered a general biological or psychobiological phenomenon which promotes adaptive functioning in a wide variety of physiological systems in various phylogenetic settings. See COGNITION; MEMORY. [J.G.]

**Conductance** The real part of the admittance of an alternating-current circuit. The admittance  $Y$  of an alternating-

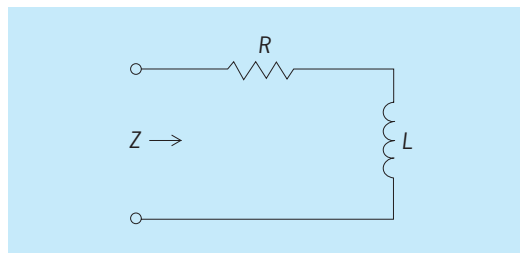

Circuit with a resistor and inductor in series.

current circuit is a complex number given by Eq. (1).

$$Y = G + jB \quad (1)$$

The real part  $G$  is the conductance. The units of conductance, like those of admittance, are called siemens or mhos. Conductance is a positive quantity. The conductance of a resistor  $R$  is given by Eq. (2).

$$G = \frac{1}{R} \quad (2)$$

In general the conductance of a circuit may depend on the capacitors and inductors in the circuit as well as on the resistors. For example, the circuit in the illustration has impedance at frequency  $\omega$  given by Eq. (3) and admittance given by Eq. (4), so that the conductance, given by Eq. (5), depends on

$$Z = R + jL\omega \quad (3)$$

$$Y = \frac{1}{R + jL\omega} \quad (4)$$

$$G = \frac{R}{R^2 + L^2\omega^2} \quad (5)$$

the inductance  $L$  as well as the resistance  $R$ . See ADMITTANCE; ALTERNATING-CURRENT CIRCUIT THEORY; ELECTRICAL IMPEDANCE. [J.O.S.]

**Conduction (electricity)** The passage of electric charges due to a force exerted on them by an electric field. Conductivity is the measure of the ability of a conductor to carry electric current; it is defined as the ratio of the amount of charge passing through unit area of the conductor (perpendicular to the current direction) per second divided by the electric field intensity (the force on a unit charge). Conductivity is the reciprocal of resistivity and is therefore commonly expressed in units of siemens per meter, abbreviated S/m. See ELECTRICAL RESISTIVITY.

In metals and semiconductors (such as silicon, of which transistors are made) the charges that are responsible for current are free electrons and holes (which, as missing electrons, act like positive charges). These are electrons or holes not bound to any particular atom and therefore able to move freely in the field. Conductivity due to electrons is known as  $n$ -type conductivity; that due to holes is known as  $p$ -type. See HOLE STATES IN SOLIDS; SEMICONDUCTOR.

The conductivity of metals is much higher than that of semiconductors because they have many more free electrons or holes. The free electrons or holes come from the metal atoms. Semiconductors differ from metals in two important respects. First, the semiconductor atoms do not contribute free electrons or holes unless thermally excited, and second, free electrons or holes can also arise from impurities or defects.

An exception to some of the rules stated above has been found in conjugated polymers. Polyacetylene, for example, although a semiconductor with extremely high resistance when undoped, can be doped so heavily with certain nonmetallic impurities (iodine, for example) that it attains a conductivity comparable to that of copper. See ORGANIC CONDUCTOR.

In metals, although the number of free carriers does not vary with temperature, an increase in temperature decreases conductivity. The reason is that increasing temperature causes the lattice atoms to vibrate more strongly, impeding the motion of the free carriers in the field. This effect also occurs in semiconductors, but the increase in number of free carriers with temperature is usually a stronger effect. At low temperatures the thermal vibrations are weak, and the impediment to the motion of free carriers in the field comes from imperfections and impurities, which in metals usually does not vary with temperature. At the lowest temperatures, close to absolute zero, certain metals become superconductors, possessing infinite conductivity. See ELECTRICAL CONDUCTIVITY OF METALS; SUPERCONDUCTIVITY.

Electrolytes conduct electricity by means of the positive and negative ions in solution. In ionic crystals, conduction may also take place by the motion of ions. This motion is much affected by the presence of lattice defects such as interstitial ions, vacancies, and foreign ions. See ELECTROLYTIC CONDUCTANCE; IONIC CRYSTALS.

Electric current can flow through an evacuated region if electrons or ions are supplied. In a vacuum tube the current carriers are electrons emitted by a heated filament. The conductivity is low because only a small number of electrons can be "boiled off" at the normal temperatures of electron-emitting filaments. See ELECTRON EMISSION; ELECTRON MOTION IN VACUUM; VACUUM TUBE. [E.M.Co.]

**Conduction (heat)** The flow of thermal energy through a substance from a higher- to a lower-temperature region. Heat conduction occurs by atomic or molecular interactions. Conduction is one of the three basic methods of heat transfer, the other two being convection and radiation. See CONVECTION (HEAT); HEAT RADIATION; HEAT TRANSFER.

Steady-state conduction is said to exist when the temperature at all locations in a substance is constant with time, as in the case of heat flow through a uniform wall. Examples of essentially pure transient or periodic heat conduction and simple or complex combinations of the two are encountered in the heat-treating of metals, air conditioning, food processing, and the pouring and curing of large concrete structures. Also, the daily and yearly temperature variations near the surface of the Earth can be predicted reasonably well by assuming a simple sinusoidal temperature variation at the surface and treating the Earth as a semi-infinite solid. The widespread importance of transient heat flow in particular has stimulated the development of a large variety of analytical solutions to many problems. The use of many of these has been facilitated by presentation in graphical form.

For an example of the conduction process, consider a gas such as nitrogen which normally consists of diatomic molecules. The temperature at any location can be interpreted as a quantitative specification of the mean kinetic and potential energy stored in the molecules or atoms at this location. This stored energy will be partly kinetic because of the random translational and rotational velocities of the molecules, partly potential because of internal vibrations, and partly ionic if the temperature (energy) level is high enough to cause dissociation. The flow of energy results from the random travel of high-temperature molecules into low-temperature regions and vice versa. In colliding with molecules in the low-temperature region, the high temperature molecules give up some of their energy. The reverse occurs in the high-temperature region. These processes take place almost instantaneously in infinitesimal distances, the result being a quasi-equilibrium state with energy transfer. The mechanism for energy flow in liquids and solids is similar to that in gases in principle, but different in detail. [W.H.Gi.]

**Conduction band** The electronic energy band of a crystalline solid which is partially occupied by electrons. The electrons in this energy band can increase their energies by going to higher energy levels within the band when an electric field

is applied to accelerate them or when the temperature of the crystal is raised. These electrons are called conduction electrons, as distinct from the electrons in filled energy bands, which, as a whole, do not contribute to electrical and thermal conduction. In metallic conductors the conduction electrons correspond to the valence electrons (or a portion of the valence electrons) of the constituent atoms. In semiconductors and insulators at sufficiently low temperatures, the conduction band is empty of electrons. Conduction electrons come from thermal excitation of electrons from a lower energy band or from impurity atoms in the crystal. See BAND THEORY OF SOLIDS; ELECTRIC INSULATOR; SEMICONDUCTOR; VALENCE BAND. [H.Y.F.]

**Conductor (electricity)** Metal wires, cables, rods, tubes, and bus-bars used for the purpose of carrying electric current. (The most common forms are wires, cables, and bus-bars.) Although any metal assembly or structure can conduct electricity, the term conductor usually refers to the component parts of the current-carrying circuit or system.

Wires employed as electrical conductors are slender rods or filaments of metal, usually soft and flexible. They may be bare or covered by some form of flexible insulating material. They are usually circular in cross section; for special purposes they may be drawn in square, rectangular, ribbon, or other shapes. Conductors may be solid or stranded, that is, built up by a helical lay or assembly of smaller solid conductors.

Insulated stranded conductors in the larger sizes are called cables. Small, flexible, insulated cables are called cords. Assemblies of two or more insulated wires or cables within a common jacket or sheath are called multiconductor cables.

Bus-bars are rigid, solid conductors and are made in various shapes, including rectangular, rods, tubes, and hollow squares. Bus-bars may be applied as single conductors, one bus-bar per phase, or as multiple conductors, two or more bus-bars per phase. The individual conductors of a multiple-conductor installation are identical.

Most wires, cables, and bus-bars are made from either copper or aluminum. Copper, of all the metals except silver, offers the least resistance to the flow of electric current. Both copper and aluminum may be bent and formed readily and have good flexibility in small sizes and in stranded constructions. Aluminum, because of its higher resistance, has less current-carrying capacity than copper for a given cross-sectional area. However, its low cost and light weight (only 30% that of the same volume of copper) permit wide use of aluminum for bus-bars, transmission lines, and large insulated-cable installations.

For overhead transmission lines where superior strength is required, special conductor constructions are used. Typical of these are aluminum conductors, steel reinforced, a composite construction of electrical-grade aluminum strands surrounding a stranded steel core. Other constructions include stranded, high-strength aluminum alloy and a composite construction of aluminum strands around a stranded high-strength aluminum alloy core.

For extra-high-voltage transmission lines, conductor size is often established by corona performance rather than current-carrying capacity. Thus special "expanded" constructions are used to provide a large circumference without excessive weight. Typical constructions use helical lays of widely spaced aluminum strands around a stranded steel core. The space between the expanding strands is filled with paper twine, and outer layers of conventional aluminum strands are applied. [H.W.Be.]

**Cone** The solid of revolution obtained by revolving a right triangle about one of its shorter sides is called a cone, or more precisely a right circular cone (see illustration). More generally, the term cone is used in solid geometry to describe a solid bounded by a plane and a portion of one nappe of a conical surface. In analytic geometry, however, the term cone refers not to a solid but to a conical surface. This is a surface generated by a straight

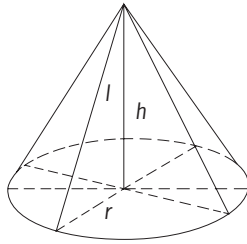

Right circular cone.

line which moves so that it always intersects a given plane curve, called the directrix, and passes through a point, called the vertex, not in the plane of the directrix. The generating line in each of its positions is called an element of the cone. The vertex divides the surface into two parts, called nappes.

If the elements of a cone make equal angles with a line through the vertex, the cone is called a cone of revolution. Plane sections of a cone of revolution are called conic sections.

The volume of a solid cone is  $V = Bh/3$ , where  $B$  is the base area included within the directrix, and  $h$  is the altitude (or height) measured from the vertex to the plane of the base. The volume  $V$  and surface area  $S$  of a right circular cone are  $V = \pi r^2 h/3$  and  $S = 2\pi rl + 2\pi r^2$ , where  $r$  denotes the radius of the base and  $l = \sqrt{r^2 + h^2}$  denotes the slant height, measured from vertex to base along an element of the cone. See CONIC SECTION; EUCLIDEAN GEOMETRY; SURFACE AND SOLID OF REVOLUTION. [J.S.F.]

**Confocal microscopy** A technique that creates high-resolution images of very small objects but differs from conventional optical microscopy in that it uses a condenser lens to focus the illuminating light from a point source into a very small, diffraction-limited spot within the specimen, and an objective lens to focus the light emitted from that spot onto a small pinhole in an opaque screen. Located behind the screen is a detector capable of quantifying how much light passes through the hole at any instant. Because only light from within the illuminated spot is properly focused to pass through the pinhole and reach the detector, any stray light from structures above, below, or to the side of the spot is filtered out. The image quality is therefore greatly enhanced.

Only the smallest possible spot is illuminated at any one time, and so a coherent image must be built up by scanning point by point over the desired field of view and recording the intensity of the light emitted from each spot. The size of the spot is equal to the ultimate resolution of the instrument and is typically about 0.25 micrometer in diameter and about  $0.5 \mu\text{m}$  deep, although the dimensions vary with the wavelength of the light and the lens system used. [R.J.Ta.]

**Conformal mapping** A special operation in mathematics in which a set of points in one coordinate system is mapped or transformed into a corresponding set in another coordinate system, preserving the angle of intersection between pairs of curves.

A mapping or transformation of a set  $E$  of points in the  $xy$  plane onto a set  $F$  in the  $uv$  plane is a correspondence that is defined for each point  $(x, y)$  in  $E$  and sends it to a point  $(u, v)$  in  $F$ , so that each point in  $F$  is the image of some point in  $E$ . A mapping is one to one if distinct points in  $E$  are transformed to distinct points in  $F$ . A mapping is conformal if it is one to one and it preserves the magnitudes and orientations of the angles between curves. Conformal mappings preserve the shape but not the size of small figures.

If the points  $(x, y)$  and  $(u, v)$  are viewed as the complex numbers  $z = x + iy$  and  $w = u + iv$ , the mapping becomes a function of a complex variable:  $w = f(z)$ . It is an important fact that a

one-to-one mapping is conformal if and only if the function  $f$  is analytic and its derivative  $f'(z)$  is never equal to zero.

Conformal mappings are important in two-dimensional problems of fluid flow, heat conduction, and potential theory. They provide suitable changes of coordinates for the analysis of difficult problems. For example, the problem of finding the steady-state distribution of temperature in a conducting plate requires the calculation of a harmonic function with prescribed boundary values. If the region can be mapped conformally onto the unit disk, the transformed problem is readily solved by the Poisson integral formula, and the required solution is the composition of the resulting harmonic function with the conformal mapping. The method works because a harmonic function of an analytic function is always harmonic. See CONDUCTION (HEAT); FLUID-FLOW PRINCIPLES; POTENTIALS.

The term conformal applies in a more general context to the mapping of any surface onto another. A problem of great importance for navigation is to produce conformal mappings of a portion of the Earth's surface onto a portion of the plane. The Mercator and stereographic projections are conformal in this sense. See MAP PROJECTIONS. [P.L.D.]

**Conformal optics** Conformal optical systems have outer surfaces whose shape is chosen to optimize the interaction with the environment in which the optical system is being used. The imaging through such conformal optical windows is likely to suffer from extreme aberration, requiring special techniques for correction. Computer-intensive methods of design, fabrication, and testing of optics have reached a level where the development of cost-effective methods for insertion of these conformal

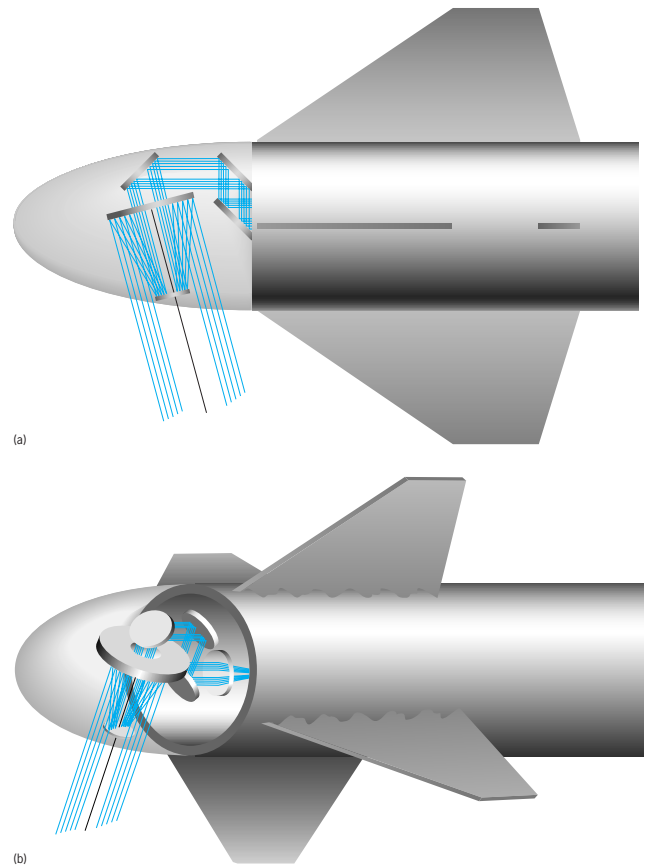

Geometric optics of an optical tracker behind a conformal window that is shaped to provide an improved drag profile for a missile. Paths of rays through the optical system are shown. (a) Side view. (b) Oblique view. (Optical Research Associates)



optics concepts into operational systems appears to be practical. See ABERRATION (OPTICS).

Important applications of conformal optics are found in missile and aircraft systems. Missiles and aircraft carry optical sensors for imaging, detection, and ranging that must look at the world through the outer skin of the vehicle. Traditionally, the windows for viewing through the skin of missiles and aircraft have had simple optical forms, such as flats or spheres, that enable the optical tracking systems to operate by using well-known technology. But these optically advantageous windows degrade the performance of the vehicle through increased drag, aerodynamic heating, or other undesirable effects. One example is the use of an optical tracker or seeker on the front end of a missile. The use of a conformal window, whose shape conforms more closely to the optimal, pointed ogival shape, reduces the drag of the missile and provides significant gains in the missile's performance. Such ogival shapes produce considerable optical aberration, however (see illustration).

The approach to design with conformal optics does not call for complete abandonment of current understanding of the image-formation process. Optical design methods are based on the description of the wavefront passing through surfaces by use of numerical ray tracing. The understanding of the aberrations arising at surfaces is obtained from an analytic method for describing the surface and the wavefront to stated levels of accuracy. The aberrations produced by general aspheric surfaces defy simple analytic descriptions but can be obtained by fitting of the numerical ray-tracing results. See GEOMETRICAL OPTICS. [R.R.S.]

**Conformational analysis** The study of the energies and structures of conformations of organic molecules and their chemical and physical properties. Organic molecules are not static entities. The constituent atoms vibrate and groups rotate about the bond axes. See STEREOCHEMISTRY.

**Linear structures.** Rotation about the C-C bond in ethane, for example, results in an infinite number of slightly different structures called conformations; one of these is indicated below. In conformation (1) of ethane, the pairs of C-H bonds on the

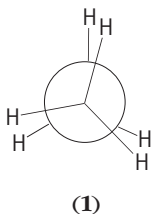

two carbon atoms reside in a plane, and are termed eclipsed. (The circle represents the front-most carbon atom, and the long bonds those from that carbon atom to the hydrogen atoms. The bonds from the circle represent those bonds from the rearward carbon to its hydrogen atoms.) Conformation (1) is called the eclipsed conformation. In conformation (2), the C-H bonds on one carbon reside between the C-H bonds on the other carbon. Conformation (2) is called the staggered conformation. An infinite number of conformations between (1) and (2) are possible; however, conformations (1) and (2) are of greatest interest because they are the maximum and minimum energy structures. In conformation (1), the electrons in the C-H bonds and the nuclear charges of the hydrogen atoms repel each other, resulting in a higher energy state. In conformation (2), the electrons and hydrogen atoms are at their greatest possible separation and the repulsion is at a minimum. The conversion of (2) to (3) by rotation of one of the methyl groups by  $120^\circ$  requires the input of energy, approximately 3.0 kcal (13 kilojoules) per mole, in order to pass through the eclipsed conformation. This amount is small compared to the thermal energy at room temperature, and the rotation about the C-C bond in ethane occurs at about  $10^9$ – $10^{10}$  times per second.

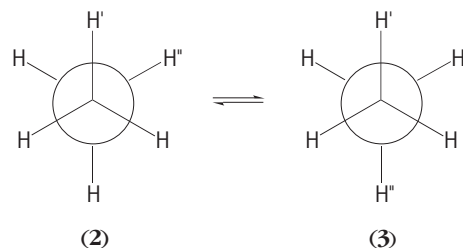

Butane provides a more complicated case. There are two different eclipsed (4 and 6) and two staggered (5 and 7)

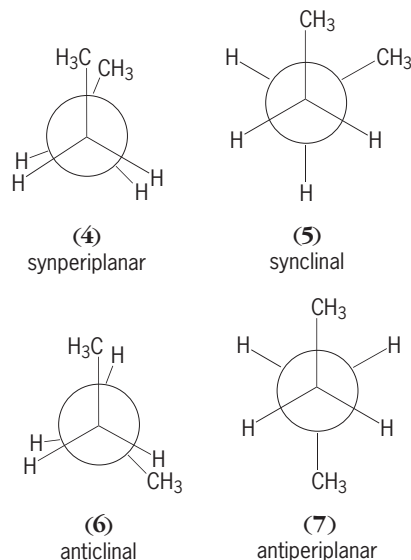

conformations which are designated by the names below the structures. As the methyl group is larger than a hydrogen atom, (4) is higher in energy than (6), and (5) is higher in energy than (7). As the molecular weight of an alkane increases, the number of molecular conformations (combinations of all possible individual bond conformations) increases dramatically, although the antiperiplanar conformations are always favored.

**Cyclic structures.** These also exist in various conformations. Cyclopropane, a planar structure, can exist in only one conformation. In cyclobutane, slight twisting about the C-C bonds can occur which relieves some of the C-H eclipsing strain energy. Cyclobutane exists in rapidly interconverting so-called butterfly conformations (8). Cyclopentane exists in two types of

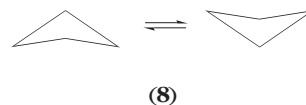

nonplanar conformations: the envelope conformation (9) and the half-chair (or twist) conformation (10). The flap atom of (9),



the atom out of the plane of the other four, can migrate around the ring, as can also the twist in (10). These motions, called pseudorotation, require very little energy, and cyclopentane presents a very complex conformational system.

Cyclohexane exists predominantly in the chair conformation (11), in which all C-C bond conformations are of the staggered type. Interconversion between chair conformations occurs rapidly at room temperature, passing through the high-energy, boat conformation (12). In the chair conformation, there are two

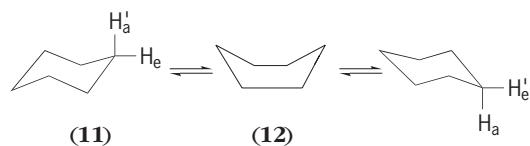

distinctly different types of hydrogen atoms; one set oriented perpendicular to the general plane of the ring, called axial (a) hydrogens, and one set oriented parallel to the plane of the ring, called equatorial (e) hydrogens. These hydrogens interchange orientation on chair interconversion. Axial and equatorial hydrogens possess different chemical and physical properties, although at room temperature the interconversion occurs very rapidly ( $\sim 10^5$  per second), and it is in general not possible to detect the differences. It is easy to design molecules in which the interconversion is not possible and the differences in properties become readily apparent. [D.J.Pa.]

**Congenital anomalies** Structural abnormalities of the body that develop during embryogenesis and the fetal period; also called birth defects. Children with significant birth defects need more medical care than other children do, require more frequent hospitalizations, need community support services, and often require special education programs. Among children, over half of all visits to subspecialty medical clinics and admissions to hospitals are for treatment of disorders resulting from errors in embryonic development, chromosomal abnormalities, and genetic and familial disorders. Two-thirds of the deaths of infants and children in pediatric hospitals in developed countries are caused by underlying congenital anomalies.

Screening programs are available to identify fetuses and newborns likely to have disorders such as congenital malformations and genetic diseases. Examples of screening include amniocentesis to detect fetal chromosomal abnormalities in mothers over 35 years of age; measurement of maternal serum alpha-fetoprotein levels at 15–16 weeks' gestation to help identify fetuses with certain malformations; and screening of newborns for phenylketonuria, sickle cell disease, thalassemia, galactosemia, and congenital hypothyroidism. See ALPHA FETOPROTEIN; PHENYLKETONURIA; SICKLE CELL DISEASE.

Birth defects can be caused by genetic factors, exposure to malformation-causing agents (teratogens), or a combination of both. Dysmorphology is the area of medicine and science concerned with the cause of congenital anomalies resulting from errors in embryonic development (dysmorphogenesis). The study of normal and abnormal embryonic development allows identification of the latest time in embryogenesis when a malformation could occur. Examples of such times include 28 days of gestation for neural tube defects, 36 days for cleft lip, and 10 weeks for cleft palate.

To facilitate study, birth defects are divided into malformations, disruptions, deformations, and dysplasias. Malformations are structural defects that are caused by primary errors in morphogenesis. They are classified as major and minor. Major malformations require medical or surgical intervention or are of substantial cosmetic importance. Minor malformations do not require such treatment or do not greatly affect appearance. Disruptions are structural defects resulting from interruption of normal morphogenesis, with consequent destruction of previously existing structures and incomplete development of tissues. Deformations are congenital anomalies resulting from external compression of a normally formed part of the fetus. Dysplasias are disorders that result from an abnormal organization of cells into tissues; the morphological result is called dyshistogenesis.

Some individuals have various major and minor congenital anomalies that together form a recognizable pattern, called a syndrome. Syndromes can have both genetic and environmental causes.

Tetatology is the study of the effect of environmental agents on the developing embryo and fetus. Teratogens are agents that

interfere with normal embryonic development. They can cause miscarriages, retard prenatal growth, and produce congenital anomalies or mental retardation. There are five general groups of teratogens: (1) infectious diseases and agents; (2) physical agents, such as radiation; (3) drugs and chemical agents; (4) maternal metabolic and genetic factors, such as diabetes; and (5) paternal factors, although rare.

Treatment of congenital anomalies is specific for each individual. Individuals with severe or numerous abnormalities usually require multidisciplinary treatment, including such measures as medical management, surgical correction, nursing care, special diets, rehabilitation, prosthetic devices, special education, and community support. Measures that help reduce the risk of having a child with congenital anomalies include avoidance of teratogenic exposures, medical treatment of maternal illnesses, good nutrition, and routine obstetrical care. See PREGNANCY. [M.I.V.A.]

**Conglomerate** The consolidated equivalent of gravel. Conglomerates are aggregates of more or less rounded particles greater than 0.08 in. (2 mm) in diameter. Frequently they are subdivided on the basis of size of particles into pebble (fine), cobble (medium), and boulder (coarse) conglomerates. The common admixture of sand-sized and gravel-sized particles in the same deposit leads to further subdivisions, into conglomerates (50% or more pebbles), sandy conglomerates (25–50% pebbles), and pebbly or conglomeratic sandstones (less than 25% pebbles). The pebbles of conglomerates are always somewhat rounded, giving evidence of abrasion during transportation; this distinguishes them from some tillites and from breccias, whose particles are sharp and angular (see illustration).

Conglomerates fall into two general classes: the well-sorted, matrix-poor conglomerates with homogeneous pebble lithology, and the poorly sorted, matrix-rich conglomerates with heterogeneous pebble lithology. The well-sorted class includes

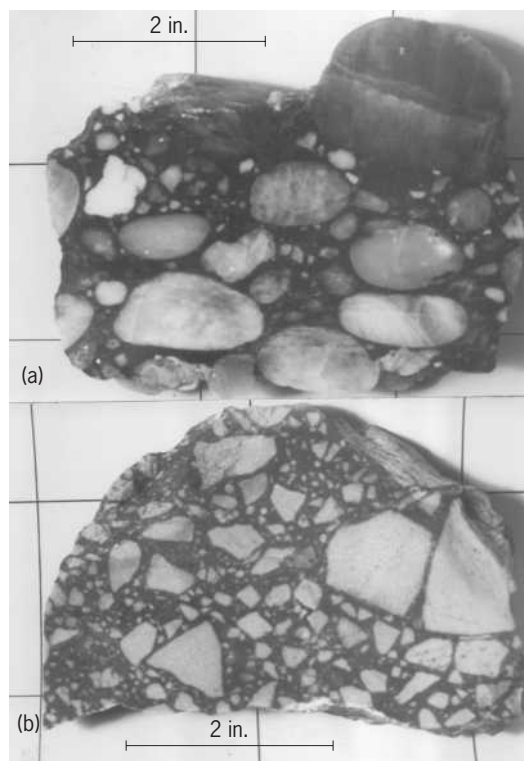

Lithified gravels. (a) Conglomerate, composed of rounded pebbles. (b) Breccia, containing many angular fragments. 2 in. = 5.2 cm. (Specimens from Princeton University Museum of Natural History; photo by Willard Starks)

quartz-pebble, chert-pebble, and limestone-pebble conglomerates which tend to be distributed in thin, widespread sheets, normally interbedded with well-sorted, quartzose sandstones. The poorly sorted conglomerates include many different types, all related in having very large amounts of sandy or clayey matrix and pebbles of many different rock classes. The graywacke conglomerates are the outstanding representatives. All poorly sorted conglomerates tend to occur in fairly thick sequences, and some of them, typically the fanglomerates (conglomerates formed on alluvial fans) are wedge-shaped accumulations. See SEDIMENTARY ROCKS.

Special types of conglomerates, such as volcanic conglomerates and agglomerates and some intraformational conglomerates composed of shale pebbles or deformed limestone pebbles, do not seem to fall easily into either class. See BRECCIA; GRAVEL; GRAYWACKE; TILL. [R.Si.]

**Conglutination** A term used in serology to describe the completion or enhancement of an incomplete agglutinating system by the addition of certain substances. Some bacteria or erythrocyte suspensions do not exhibit the visible agglutination ordinarily expected after they have been coated with their specific antibodies and complement. Further addition of a conglutinating agent—normal bovine serum—however, initiates visible agglutination. Complement is an essential component of the system. The conglutination reagent is itself without effect in the absence of antibody and complement. Similar overall actions, such as agglutination of Rh<sup>+</sup> cells, occur when human serum, gelatin, or bovine serum albumin are added to the incomplete Rh antibodies found in some sera, but since this enhancing effect occurs also in the absence of complement, these reactions probably are to be distinguished in mechanism from that of the traditional conglutination. The conglutination reaction can be used for a variety of serological diagnostic reactions in bacterial and viral infections. See AGGLUTINATION REACTION; BLOOD GROUPS; COMPLEMENT; COMPLEMENT-FIXATION TEST. [H.P.T.]

**Conic section** One of the class of curves in which a plane may cut a cone (surface) of revolution. The section is a parabola if the plane is parallel to an element of the cone, an ellipse or circle if the plane cuts all elements of one nappe (but does not go through the apex), and a hyperbola if the plane cuts elements of both nappes (for example, the plane parallel to the cone's axis of revolution) and does not go through the apex (see illustration).

After the advent of analytic geometry, the synthetic method used by the Greeks to develop the properties of conics gave way

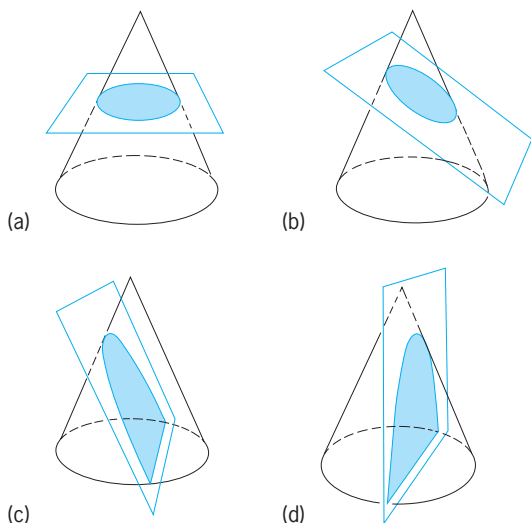

Four conic sections illustrated. (a) Circle. (b) Ellipse. (c) Parabola. (d) Hyperbola.

to algebraic procedures which, using other definitions, divorced these curves from their original relationship to cones and regarded them as graphs of second-degree equations in cartesian coordinates  $x, y$ . The third phase in the study of conic sections began with the development of projective geometry. See ANALYTIC GEOMETRY; CONE; ELLIPSE; HYPERBOLA; PARABOLA; PROJECTIVE GEOMETRY. [L.M.Bi.]

**Conjugation and hyperconjugation** A higher-order bonding interaction between electron orbitals on three or more contiguous atoms in a molecule, which leads to characteristic changes in physical properties and chemical reactivity. One participant in this interaction can be the electron pair in the  $\pi$ -orbital of a multiple (that is, double or triple) bond between two atoms, or a single electron or electron pair or electron vacancy on a single atom. The second component will be the pair of  $\pi$ -electrons in an adjacent multiple bond in the case of conjugation, and in the case of hyperconjugation it will be the pair of electrons in an adjacent polarized  $\sigma$ -bond (that is, a bond where the electrons are held closer to one atom than the other due to electronegativity differences between the two atoms). See CHEMICAL BONDING.

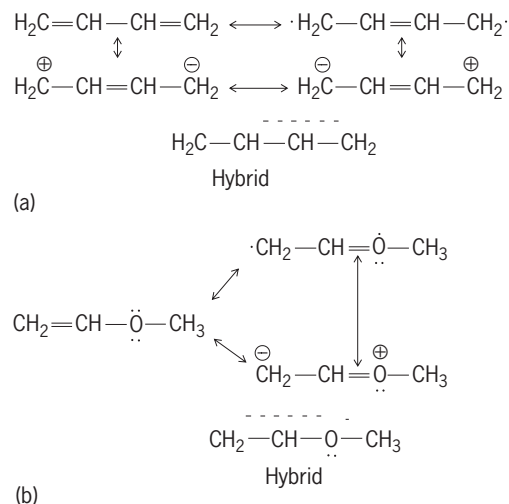
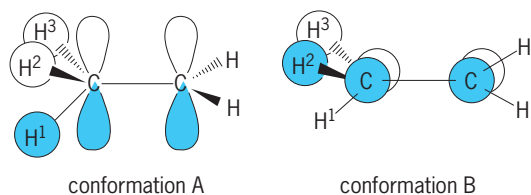

Fig. 1. Conjugated molecules. Broken overbars indicate the effects of conjugation. (a) 1,3-Butadiene. (b) Methyl vinyl ether.

The conjugated orbitals reside on atoms that are separated by a single bond in the classical valence-bond molecular model, and the conjugation effect is at a maximum when the axes of the component orbitals are aligned in a parallel fashion because this allows maximum orbital overlap. Conjugation thus has a stereoelectronic requirement, or a restriction on how the participating orbitals must be oriented with respect to each other. Two simple examples are shown in Fig. 1; in 1,3-butadiene ( $\text{H}_2\text{C}=\text{HC}-\text{CH}=\text{CH}_2$ ) conjugation occurs between the  $p$  orbitals ( $\pi$ -bonds) of the two double bonds, and in methyl vinyl ether ( $\text{H}_2\text{C}=\text{HC}-\text{O}-\text{CH}_3$ ) the nonbonding  $sp^3$  orbital on oxygen is conjugated with the  $p$  orbitals of the double bond. This interaction is manifest in an effective bond order between single and double for the underlined single bond.

Hyperconjugation, the conjugation of polarized  $\sigma$ -bonds with adjacent  $\pi$ -orbitals, was introduced in the late 1930s by R. S. Mulliken. This rationale was used to explain successfully a wide variety of chemical phenomena; however, the confusing adaptation of the valence-bond model necessary to depict it and its inappropriate extension to some phenomena led to difficulties. The advent of the molecular orbital treatment has eliminated many of these difficulties.

Early on, hyperconjugation was used to explain the stabilization by alkyl groups of carbocations, or positively charged



**Fig. 2.** Diagram showing hyperconjugative effect of orbitals of the  $\sigma$ -bonds of a methyl group ( $\text{H}_3\text{C}$ ) on a neighboring  $p$  orbital of a methylene group ( $\text{CH}_2$ ). Algebraic phase is indicated by the presence or absence of tint.

trivalent carbon. Figure 2 shows how the orbitals of the  $\sigma$ -bonds of a methyl group ( $\text{H}_3\text{C}$ ) exert a hyperconjugative stabilizing effect upon a neighboring  $p$  orbital on a methylene group ( $\text{CH}_2$ ). The bonding molecular orbitals of the methyl group utilize aspects of its carbon  $p$  orbitals; in both of the conformations or rotations the methyl group has such an orbital which overlaps in phase with the neighboring  $p$  orbital on  $\text{CH}_2$ . As hydrogen is an electropositive atom, the methyl group acts as an electron donor to stabilize an empty  $p$  orbital and to destabilize a filled  $p$  orbital on the right-hand carbon. This is in accord with empirical observations. If  $\text{H}^1$  is replaced with some other atom  $\text{X}$ , the hyperconjugative effect of  $\text{X}$  will be at a maximum in conformation A, where there is orbital density on  $\text{X}$ , and it will be at a minimum in conformation B, where  $\text{X}$  is in the nodal or null plane. If  $\text{X}$  is a more electropositive atom such as silicon, the  $\text{C-X}$  bond is a donor bond and will stabilize an adjacent empty  $p$  orbital, such as in a cation. If  $\text{X}$  is a more electronegative element such as fluorine, the  $\text{C-X}$  bond is an acceptor bond and will stabilize an adjacent filled  $p$  orbital such as in an anion; this result accords with experiment as well. The donor and acceptor effects are also important where the single  $p$  orbital is replaced by a multiple bond. See MOLECULAR ORBITAL THEORY; REACTIVE INTERMEDIATES.

A number of scientific phenomena depend on the properties of conjugated systems; these include vision (the highly tuned photoreceptors are triggered by molecules with extended conjugation), electrical conduction (organic semiconductors such as polyacetylenes are extended conjugated systems), color (most dyes are conjugated molecules designed to absorb particular wavelengths of light), and medicine (a number of antibiotics and cancer chemotherapy agents contain conjugated systems which trap enzyme sulfhydryl groups by conjugate addition). See VALENCE. [M.F.S.]

**Connecting rod** A link in several kinds of mechanisms. Usually one end of a connecting rod is intended to follow a circular path, while the other end follows a path along a straight line or curve of large radius. The term is sometimes applied, however, to any straight link that transmits motion or power from one linkage to another within a mechanism. The illustration shows some conventional arrangements.

The connecting rod of the four-bar linkage, often called the coupler, has special significance. The motion of its plane can now be synthesized to furnish desired paths for points, or desired positions of the entire connecting-rod plane. The connecting rod is then not primarily used for transmission of force or motion from input to output crank, but the entire mechanism is employed to

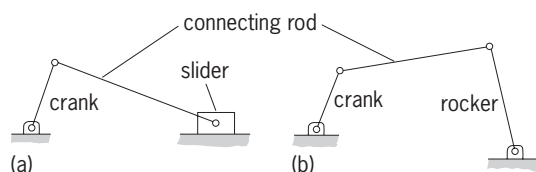

**Connecting rod in (a) slider-crank mechanism and (b) crank-and-rocker mechanism.**

impart to the connecting-rod plane certain displacements, and sometimes velocities and accelerations. See FOUR-BAR LINKAGE; MECHANISM. [D.PAD.]

**Connective tissue** One of the four primary tissues of the body. It differs from the other three tissues in that the extracellular components (fibers and intercellular substances) are abundant. It cannot be sharply delimited from the blood, whose cells may give rise to connective tissue cells, and whose plasma components continually interchange with and augment the ground substance of connective tissue. Bone and cartilage are special kinds of connective tissue.

The functions of connective tissues are varied. They are largely responsible for the cohesion of the body as an organism, of organs as functioning units, and of tissues as structural systems. The connective tissues are essential for the protection of the body both in the elaborate defense mechanisms against infection and in repair from chemical or physical injuries. Nutrition of nearly all cells of the body and the removal of their waste products are both mediated through the connective tissues. Connective tissues are important in the development and growth of many structures. Constituting the major environment of most cells, they are probably the major contributor to the homeostatic mechanisms of the body so far as salts and water are concerned. They act as the great storehouse for the body of salts and minerals, as well as of fat. The connective tissues determine in most cases the pigmentation of the body. Finally, the skeletal system (cartilage and bones) plus other kinds of connective tissue (tendons, ligaments, fasciae, and others) make motion possible.

The connective tissues consist of cells and extracellular or intercellular substance (see illustration). The cells include many varieties, of which the following are the most important: fibroblasts, macrophages (histiocytes), mast cells, plasma cells, melanocytes, and fat cells. Most of the cells of the connective tissue are developmentally related even in the adult; for example, fibroblasts may be developed from histiocytes or from undifferentiated mesenchymal cells.

The extracellular components of connective tissues may be fibrillar or nonfibrillar. The fibrillar components are reticular fibers, collagenous fibers, and elastic fibers. The nonfibrillar component of connective tissues appears amorphous with the light microscope and is the matrix in which cells and fibers are embedded. It consists of two groups of substances: (1) those probably derived from secretory activity of connective tissue cells including mucoproteins, protein-polysaccharide complexes, tropocollagen, and antibodies; and (2) those probably derived from the

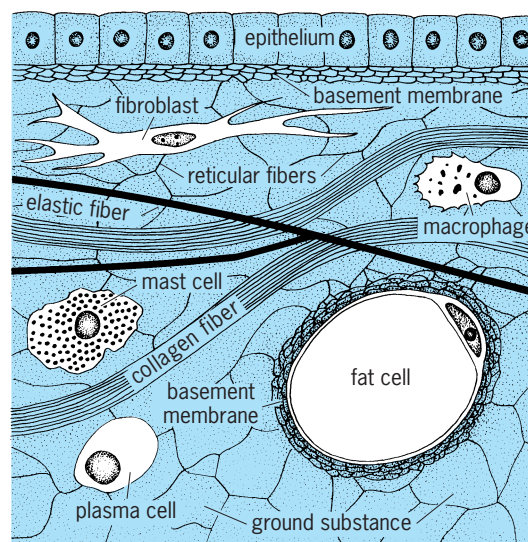

**Components of connective tissue.**

blood plasma, including albumin, globulins, inorganic and organic anions and cations, and water. In addition, the ground substance contains metabolites derived from, or destined for, the blood.

All the manifold varieties of connective tissue may contain all the cells and fibers discussed above in addition to ground substance. They differ from each other in the relative occurrence of one or another cell type, in the relative proportions of cells and fibers, in the preponderance and arrangement of one or another fiber, and in the relative amount and chemical composition of ground substance. They are classified as:

1. Irregularly arranged connective tissue—which may be loose (subcutaneous connective tissue) or dense (dermis). The dominant fiber type is collagen.

2. Regularly arranged connective tissue—primarily collagenous—with the fibers arranged in certain patterns depending on whether they occur in tendons or as membranes (dura mater, capsules, fasciae, aponeuroses, or ligaments).

3. Mucous connective tissue—ground substance especially prominent (umbilical cord).

4. Elastic connective tissue—predominance of elastic fibers or bands (ligamentum nuchae) or lamellae (aorta).

5. Reticular connective tissue—fibers mostly reticular, moderately rich in ground substance, frequently numerous undifferentiated mesenchymal cells.

6. Adipose connective tissue—yellow or brown fat cells constituting chief cell type, reticular fibers most numerous.

7. Pigment tissue—melanocytes numerous.

8. Cartilage—cells exclusively of one type, derived from mesenchymal cells.

9. Bone—cells are predominantly osteocytes, but also include fibroblasts, mesenchymal cells, endothelial cells, and osteoclasts.

See ADIPOSE TISSUE; BLOOD; BONE; CARTILAGE; COLLAGEN; HISTOLOGY; LIGAMENT; TENDON. [I.G.]

**Connective tissue disease** Any of a group of diseases involving connective tissue; formerly termed collagen vascular disease. These diseases are clinically and pathologically discrete from each other but have overlapping features. The group includes lupus erythematosus, systemic vasculitis, polymyositis, scleroderma (and systemic sclerosis), and Sjögren's syndrome. Each of the diseases can involve multiple organ systems and is often coupled with various immunologic abnormalities. See CONNECTIVE TISSUE.

The set of diseases known as lupus erythematosus includes limited, primarily cutaneous disorders (discoid lupus and subacute cutaneous lupus) and a diffuse systemic illness (systemic lupus erythematosus), all of which are of unknown cause. Also, a lupuslike reaction known as drug-induced lupus can be caused by certain therapeutic agents.

Systemic vasculitis comprises a series of different clinical illnesses that are all characterized by intense inflammation in the walls of blood vessels, especially arteries (that is, arteritis). These illnesses differ clinically, pathologically, and with respect to therapeutic responsiveness and outcome. Even the age and sex of the typical affected person varies from one to another. The clinical pattern of illness varies with the sites of blood vessel involvement and the character of vascular injury. Tissue death in the vessel wall can lead to narrowing, or even blockage, of the vessel or weakening of the wall with formation of an aneurysm. Impaired circulation and altered blood flow result. Symptoms, therefore, can arise not only from the tissue inflammation itself but also from the lack of adequate blood supply. See ANEURYSM; CIRCULATION DISORDERS.

Polymyositis involves intense inflammation in skeletal muscle that, if untreated, can lead to destruction of muscle fibers. When typical skin lesions are present, the term dermatomyositis is applied. The cause of polymyositis, or dermatomyositis, is not known in most cases. These conditions can occur alone or in association with other connective tissue disorders (that is,

systemic lupus, scleroderma, and Sjögren's syndrome). In older persons, they sometimes accompany malignant tumors. If diagnosed early, before loss of muscle fibers and replacement by fibrous scarring is extensive, myositis is reversible; recovery with minimal residual loss of strength is to be expected in almost all patients.

The term scleroderma means "hard skin," designating a disorder in which increased deposition of collagen fibers in the deeper dermis leads to thickened, leathery, bound-down skin. When organ involvement is associated with such skin changes, the term systemic sclerosis is used. Raynaud's phenomenon, a hyperreactivity to cold exposure with blanching and discoloration of the fingers and toes, is the common initial manifestation and may precede sclerodermatous skin changes by decades. Systemically, the gastrointestinal tract is most commonly involved. Difficulty in swallowing and mid-chest discomfort result from loss of peristalsis in the esophagus. Diarrhea, inability to absorb nutrients, abdominal pain, and distention can occur with bowel involvement and lead to weight loss and wasting. Scarring of the lungs and decreased pulmonary function occur frequently. The most serious lesions are those of the heart and kidney, which may result from vascular abnormalities related to Raynaud's phenomenon. Joint inflammation is mild and uncommon; but advanced skin changes, especially in the hands, may restrict joint mobility.

Sjögren's syndrome is characterized primarily by dryness of the membranes due to excretory gland failure, especially dryness of the eyes (xerophthalmia) and mouth (xerostomia) from loss of tears and saliva, respectively. This sicca (dryness) syndrome reflects the infiltration of lacrimal and salivary glands by immunologically competent cells (lymphocytes). Sjögren's syndrome may be primary or secondary; that is, superimposed on another disorder like rheumatoid arthritis or systemic lupus. See IMMUNOLOGY; INFLAMMATION. [M.B.S.]

**Conodont** A group of extinct marine animals that are often abundant in strata of Late Cambrian to Late Triassic age, a time span of about 300 million years. Only the mineralized elements, which are usually 0.2 to 2 mm (0.008 to 0.08 in.) in dimension (the largest known reach 14 mm or 0.6 in.), are normally preserved. They are routinely extracted as isolated discrete specimens by chemical degradation of the rock in which they occur. In the earliest euconodonts ("true" conodonts, as opposed to the more primitive, and possibly unrelated, protoconodonts and paraconodonts), the elements comprise an upper crown and a basal body. The basal body occupies a cavity in the base of the crown, but is not present in the majority of post-Devonian species. In advanced conodonts the crown incorporates regular patches of opaque, finely crystalline, white matter.

For many years, conodont taxonomists treated individual element types as separate species. There are three major shape categories, coniform, ramiform, and pectiniform (see illustration). Coniform elements were dominant in the Cambrian to Early Ordovician and common until the Devonian. Ramiform (comb-like) elements extend into elongate processes with various arrangements of denticles. Pectiniform elements include straight and arched blades, and may be expanded laterally to form a platform.

In the absence of preserved soft parts, the nature of the affinities of conodonts was the subject of considerable speculation and debate. Since the first discovery of isolated elements in 1856, conodonts have been variously aligned with algae, higher plants, several wormlike phyla, mollusks, arthropods, lophophorates, chaetognaths, and chordates, or have been assigned to a separate phylum, Conodonta. It was not until 1983 that evidence of the soft parts was described by D. E. G. Briggs, E. N. K. Clarkson, and R. J. Aldridge, on the basis of the first of several specimens discovered in lower Carboniferous rocks near Edinburgh, Scotland. The evidence of the soft-part morphology indicates that the conodonts belong within the chordates; it is no longer

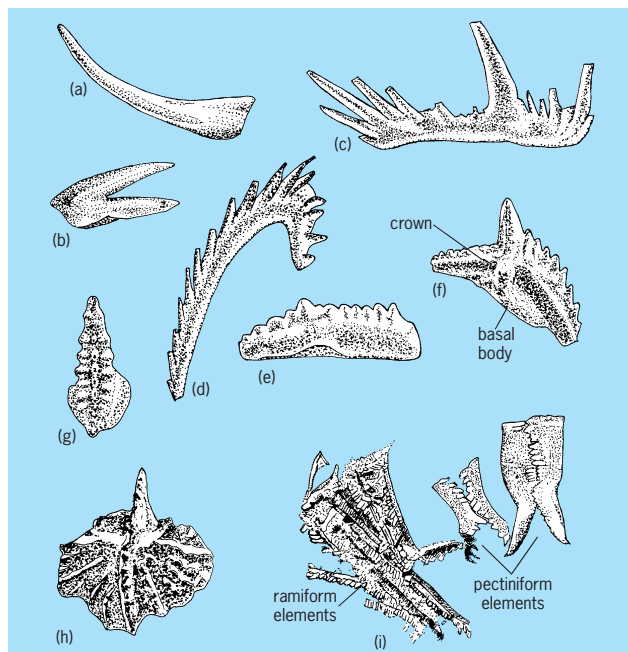

**Conodont elements:** (a, b) coniform elements, (c, d) ramiform elements, (e, f) pectiniform blade elements, (g, h) pectiniform platform elements, (i) bedding-plane assemblage.

possible to justify their separation as a phylum, Conodonta. See CHORDATA.

Although the biological affinities of conodonts and the function of the elements were essentially unknown until recently, they have nonetheless been extensively studied because of their important geological applications. Most significant of these is the use of conodont elements in biostratigraphy. See STRATIGRAPHY.

[R.J.A.L.; D.E.G.B.]

**Conservation laws (physics)** Principles which state that the total values of specified quantities remain constant in time for an isolated system. Conservation laws occupy enormously important positions both at the foundations of physics and in its applications.

**Realization in classical mechanics.** There are three great conservation laws of mechanics: the conservation of linear momentum, often referred to simply as the conservation of momentum; the conservation of angular momentum; and the conservation of energy.

The linear momentum, or simply momentum, of a particle is equal to the product of its mass and velocity. It is a vector quantity. The total momentum of a system of particles is simply the sum of the momenta of each particle considered separately. The law of conservation of momentum states that this total momentum does not change in time. See CONSERVATION OF MOMENTUM; MOMENTUM.

The angular momentum of a particle is more complicated. It is defined by the vector product of the position and momentum vectors. The law of conservation of angular momentum states that the total angular momentum of an isolated system is constant in time. See ANGULAR MOMENTUM.

The conservation of energy is perhaps the most important law of all. Energy is a scalar quantity, and takes two forms: kinetic and potential. The kinetic energy of a particle is defined to be one-half the product of its mass and the square of its velocity. The potential energy is loosely defined as the ability to do work. The total energy is the sum of the kinetic and potential energies, and according to the conservation law it remains constant in time for an isolated system.

The essential difficulty in applying the conservation of energy law can be appreciated by considering the problem of two colliding bodies. In general, the bodies emerge from the collision moving more slowly than when they entered. This phenomenon seems to violate the conservation of energy, until it is recognized that the bodies involved may consist of smaller particles. Their random small-scale motions will require kinetic energy, which robs kinetic energy from the overall coherent large-scale motion of the bodies that are observed directly. One of the greatest achievements of nineteenth-century physics was the recognition that small-scale motion within macroscopic bodies could be identified with the perceived property of heat. See CONSERVATION OF ENERGY; ENERGY; KINETIC THEORY OF MATTER.

**Position in modern physics.** As physics has evolved, the great conservation laws have likewise evolved in both form and content, but have never ceased to be important guiding principles.

In order to account for the phenomena of electromagnetism, it was necessary to go beyond the notion of point particles, to postulate the existence of continuous electric and magnetic fields filling all space. To obtain valid conservation laws, energy, momentum, and angular momentum must be ascribed to the electromagnetic fields. See ELECTROMAGNETIC RADIATION; MAXWELL'S EQUATIONS; POYNTING'S VECTOR.

In the special theory of relativity, energy and momentum are not independent concepts. Einstein discovered perhaps the most important consequence of special relativity, that is, the equivalence of mass and energy, as a consequence of the conservation laws. The "law" of conservation of mass is understood as an approximate consequence of the conservation of energy. See CONSERVATION OF MASS; RELATIVITY.

A remarkable, beautiful, and very fruitful connection has been established between symmetries and conservation laws. Thus the law of conservation of linear momentum is understood as a consequence of the homogeneity of space, the conservation of angular momentum as a consequence of the isotropy of space, and the conservation of energy as a consequence of the homogeneity of time. See SYMMETRY LAWS (PHYSICS).

The development of general relativity, the modern theory of gravitation, necessitates attention to a fundamental question for the conservation laws: The laws refer to an "isolated system," but it is not clear that any system is truly isolated. This is a particularly acute problem for gravitational forces, which are long range and add up over cosmological distances. It turns out that the symmetry of physical laws is actually a more fundamental property than the conservation laws themselves, for the symmetries remain valid while the conservation laws, strictly speaking, fail.

In quantum theory, the great conservation laws remain valid in a very strong sense. Generally, the formalism of quantum mechanics does not allow prediction of the outcome of individual experiments, but only the relative probability of different possible outcomes. One might therefore entertain the possibility that the conservation laws were valid only on the average. However, momentum, angular momentum, and energy are conserved in every experiment. See QUANTUM MECHANICS; QUANTUM THEORY OF MEASUREMENT.

**Conservation laws of particle type.** There is another important class of conservation laws, associated not with the motion of particles but with their type. Perhaps the most practically important of these laws is the conservation of chemical elements. From a modern viewpoint, this principle results from the fact that the small amount of energy involved in chemical transformations is inadequate to disrupt the nuclei deep within atoms. It is not an absolute law, because some nuclei decay spontaneously, and at sufficiently high energies it is grossly violated. See RADIOACTIVITY.

Several conservation laws in particle physics are of the same character: They are useful even though they are not exact because, while known processes violate them, such processes

are either unusually slow or require extremely high energy. See ELEMENTARY PARTICLE. [FWil.]

**Conservation of energy** The principle of conservation of energy states that energy cannot be created or destroyed, although it can be changed from one form to another. Thus in any isolated or closed system, the sum of all forms of energy remains constant. The energy of the system may be interconverted among many different forms—mechanical, electrical, magnetic, thermal, chemical, nuclear, and so on—and as time progresses, it tends to become less and less available; but within the limits of small experimental uncertainty, no change in total amount of energy has been observed in any situation in which it has been possible to ensure that energy has not entered or left the system in the form of work or heat. For a system that is both gaining and losing energy in the form of work and heat, as is true of any machine in operation, the energy principle asserts that the net gain of energy is equal to the total change of the system's internal energy. See THERMODYNAMIC PRINCIPLES.

There are many ways in which the principle of conservation of energy may be stated, depending on the intended application. Of particular interest is the special form of the principle known as the principle of conservation of mechanical energy which states that the mechanical energy of any system of bodies connected together in any way is conserved, provided that the system is free of all frictional forces, including internal friction that could arise during collisions of the bodies of the system.

J. P. Joule and others demonstrated the equivalence of heat and work by showing experimentally that for every definite amount of work done against friction there always appears a definite quantity of heat. The experiments usually were so arranged that the heat generated was absorbed by a given quantity of water, and it was observed that a given expenditure of mechanical energy always produced the same rise of temperature in the water. The resulting numerical relation between quantities of mechanical energy and heat is called the Joule equivalent, or is also known as mechanical equivalent of heat.

In view of the principle of equivalence of mass and energy in the restricted theory of relativity, the classical principle of conservation of energy must be regarded as a special case of the principle of conservation of mass-energy. However, this more general principle need be invoked only when dealing with certain nuclear phenomena or when speeds comparable with the speed of light ( $1.86 \times 10^5$  mi/s or  $3 \times 10^8$  m/s) are involved.

[D.E.R./L.N.]

**Conservation of mass** The notion that mass, or matter, can be neither created nor destroyed. According to conservation of mass, reactions and interactions which change the properties of substances leave unchanged their total mass; for instance, when charcoal burns, the mass of all of the products of combustion, such as ashes, soot, and gases, equals the original mass of charcoal and the oxygen with which it reacted.

The special theory of relativity of Albert Einstein, which has been verified by experiment, has shown, however, that the mass of a body changes as the energy possessed by the body changes. Such changes in mass are too small to be detected except in subatomic phenomena. Furthermore, matter may be created, for instance, by the materialization of a photon (quantum of electromagnetic energy) into an electron-positron pair; or it may be destroyed, by the annihilation of this pair of elementary particles to produce a pair of photons. See ELECTRON-POSITRON PAIR PRODUCTION; RELATIVITY. [L.N.]

**Conservation of momentum** The principle that, when a system of masses is subject only to forces that masses of the system exert on one another, the total vector momentum of the system is constant. Since vector momentum is conserved, in problems involving more than one dimension the component of

momentum in any direction will remain constant. The principle of conservation of momentum holds generally and is applicable in all fields of physics. In particular, momentum is conserved even if the particles of a system exert forces on one another or if the total mechanical energy is not conserved. Use of the principle of conservation of momentum is fundamental in the solution of collision problems. See COLLISION (PHYSICS); MOMENTUM. [P.W.S.]

**Conservation of resources** Management of the human use of natural resources to provide the maximum benefit to current generations while maintaining capacity to meet the needs of future generations. Conservation includes both the protection and rational use of natural resources.

Earth's natural resources are either nonrenewable, such as minerals, oil, gas, and coal, or renewable, such as water, timber, fisheries, and agricultural crops. The combination of growing populations and increasing levels of resource consumption is degrading and depleting the natural resource base. The world's population stood at 850 million at the onset of the industrial age. The global population has grown to nearly seven times as large (6 billion), and the level of consumption of resources is far greater. This human pressure now exceeds the carrying capacity of many natural resources.

Nonrenewable resources, such as fossil fuels, are replaced over geologic time scales of tens of millions of years. Human societies will eventually use up all of the economically available stock of many nonrenewable resources, such as oil. Conservation entails actions to use these resources most efficiently and thereby extend their life as long as possible. By recycling aluminum, for example, the same piece of material is reused in a series of products, reducing the amount of aluminum ore that must be mined. Similarly, energy-efficient products help to conserve fossil fuels since the same energy services, such as lighting or transportation, can be attained with smaller amounts of fuel. See HUMAN ECOLOGY.

It may be expected that the biggest challenge of resource conservation would involve nonrenewable resources, since renewable resources can replenish themselves after harvesting. In fact, the opposite is the case. Historically, when nonrenewable resources have been depleted, new technologies have been developed that effectively substitute for the depleted resources. Indeed, new technologies have often reduced pressure on these resources even before they are fully depleted. Fiber optics, for example, has substituted for copper in many electrical applications, and it is anticipated that renewable sources of energy, such as photovoltaic cells, wind power, and hydropower, will ultimately take the place of fossil fuels when stocks are depleted. Renewable resources, in contrast, can be seriously depleted if they are subjected to excessive harvest or otherwise degraded, and no substitutes are available for, say, clean water or food products such as fish or agricultural crops. Moreover, when the misuse of biological resources causes the complete extinction of a species or the loss of a particular habitat, there can be no substitute for that diversity of life.

"Conservation" is sometimes used synonymously with "protection." More appropriately, however, it refers to the protection and sustainable use of resources. Critical elements of the effective conservation of natural resources include sustainable resource management, establishment of protected areas, and ex situ (off-site) conservation.

**Resource management.** Some of the most pressing resource conservation problems stem directly from the mismanagement of important biological resources. Many marine fisheries are being depleted, for example, because of significant overcapacity of fishing vessels and a failure of resource managers to closely regulate the harvest. In theory, a renewable resource stock could be harvested at its maximum sustainable yield and maintain constant average annual productivity in perpetuity. In practice, however, fishery harvest levels are often set too high and, in many regions, enforcement is weak, with

the result that fish stocks are driven to low levels. A similar problem occurs in relation to the management of timber resources. Short-term economic incentives encourage cutting as many trees as quickly as possible. See FISHERIES ECOLOGY; FOREST MANAGEMENT.

A number of steps are being taken to improve resource conservation in managed ecosystems. (1) Considerable scientific research has been undertaken to better understand the natural variability and productivity of economically important resources. (2) Many national and local governments have enacted regulations for resource management practices on public and private lands. (3) In some of regions, programs recently have been established either to involve local communities who have a greater incentive to manage for long-term production more directly in resource management decisions or to return to them resource ownership rights. (4) Efforts are under way to manage resources on a regional or ecosystem scale using methods that have come to be known as ecosystem management or bioregional management. Since the actions taken in one location often influence species and processes in other locations, traditional resource conservation strategies were often focused too narrowly to succeed.

**Protected areas.** One of the most effective strategies to protect species from extinction is the establishment of protected areas designed to maintain populations of a significant fraction of the native species in a region. Worldwide, 9832 protected areas, totaling more than 9.25 million square kilometers (24 million square miles), cover about 8% of land on Earth. Although these sites are not all managed exclusively for the conservation of species, they play an essential role in protecting species from extinction.

Many problems remain, however, in ensuring effective protected-area conservation networks. For example, several regions with important biodiversity still lack effective protected-area networks. In addition, where protected areas have been designated, human and financial resources are not always available to effectively manage the areas. Particularly in developing countries, the establishment of protected areas has resulted in conflicts with local communities that had been dependent upon the areas for their livelihood. These challenges are now being addressed through international efforts, such as the International Convention on Biological Diversity, which aims to increase the financing available for protected areas and to integrate conservation and development needs.

**Ex situ conservation.** The most effective and efficient means for conserving biological resources is to prevent the loss of important habitats and to manage resources for their long-term productivity of goods and services. In many cases, effective conservation in the field is no longer possible. For example, some species have been so depleted that only a few individuals remain in their natural habitat. In these cases, there is no alternative to the ex situ conservation of species and genetic resources in zoos, botanical gardens, and seed banks. Ex situ collections play important conservation roles as well as serving in public education and research. Worldwide, zoos contain more than 3000 species of birds, 1000 species of mammals, and 1200 species of reptiles, and botanic gardens are believed to hold nearly 80,000 species of plants. These collections hold many endangered species, some of which have breeding populations and thus could potentially be returned to the wild. Genebanks hold an important collection of the genetic diversity of crops and livestock. See LAND-USE PLANNING; MINERAL RESOURCES; SOIL CONSERVATION; WATER CONSERVATION. [W.Re.]

**Constellation** One of the 88 areas into which the sky is divided. Each constellation has a name that reflects its earliest recognition. Though pictures are associated with the constellations, they have no official status, and constellations have been depicted differently by different artists.

The catalog of Ptolemy, in Hellenic Alexandria in the second century of the Christian Era, included over 1000 stars grouped into 48 constellations. Johann Bayer's *Uranometria* (1603) included the constellations listed by Ptolemy and also named 12 new ones containing stars observed on expeditions to the Southern Hemisphere. Bayer originated the scheme of labeling individual stars in constellations with Greek and other letters, roughly in order of brightness, and the genitive form of the constellation name. In some cases, Bayer labeled stars in order around figures in the sky, as for the Big Dipper.

Johannes Hevelius added nine more southern constellations in his 1690 star atlas, *Firmamentum Sobiescianum sive Uranographia*. Nicolas Louis de Lacaille added 14 constellations in 1763 from his expedition to the Cape of Good Hope.

In 1928, the International Astronomical Union formally accepted the division of the sky into 88 constellations, with the final list provided 2 years later; each star now falls in only one constellation. The boundaries follow north-south or east-west celestial coordinates (right ascension and declination lines) from the year 1875; because of precession, the current boundaries do not match rounded values of celestial coordinates. See ASTRONOMICAL COORDINATE SYSTEMS; PRECESSION OF EQUINOXES.

Some of the most familiar patterns in the sky are asterisms rather than constellations. For example, the asterism known as the Big Dipper is part of the constellation Ursa Major. The asterism known as the Great Square of Pegasus has three of its corners in Pegasus but the fourth in Andromeda. The Northern Cross is made of stars in Cygnus. [J.M.P.]

**Constraint** A restriction on the natural degrees of freedom of a system. If  $n$  and  $m$  are the numbers of the natural and actual degrees of freedom, the difference  $n - m$  is the number of constraints. In principle  $n = 3N$ , where  $N$  is the number of particles, for example, atoms. In practice  $n$  is determined by the number of effectively rigid components.

A holonomic system is one in which the  $n$  original coordinates can be expressed in terms of  $m$  independent coordinates and possibly also the time. It is characterized by frictionless contacts and inextensible linkages. The new coordinates are called generalized coordinates. See LAGRANGE'S EQUATIONS.

Nonholonomic systems cannot be reduced to independent coordinates because the constraints are not on the  $n$  coordinate values themselves but on their possible changes. For example, an ice skate may point in all directions but at each position it must point along its path. See DEGREE OF FREEDOM (MECHANICS). [B.G.]

**Construction engineering** A specialized branch of civil engineering concerned with the planning, execution, and control of construction operations for such projects as highways, buildings, dams, airports, and utility lines. Planning consists of scheduling the work to be done and selecting the most suitable construction methods and equipment for the project. Execution requires the timely mobilization of all drawings, layouts, and materials on the job to prevent delays. Control consists of analyzing progress and cost to ensure that the project will be done on schedule and within the estimated cost. See CONSTRUCTION EQUIPMENT; CONSTRUCTION METHODS. [W.Her.]

**Construction equipment** A wide variety of relatively heavy machines which perform specific construction (or demolition) functions under power. The power plant is commonly an integral part of an individual machine, although in some cases it is contained in a separate prime mover, for example, a towed wagon or roller. It is customary to classify construction machines in accordance with their functions such as hoisting, excavating, hauling, grading, paving, drilling, or pile driving. There have been few changes for many years in the basic types of machines available for specific jobs, and few in the basic configurations of those that have long been available. Design emphasis



for new machines is on modifications that increase speed, efficiency, and accuracy (particularly through more sophisticated controls); that improve operator comfort and safety; and that protect the public through sound attenuation and emission control. The selection of a machine for a specific job is mainly a question of economics and depends primarily on the ability of the machine to complete the job efficiently, and secondarily on its availability.

Hoisting equipment is used to raise or lower materials from one elevation to another or to move them from one point to another over an obstruction. The main types of hoisting equipment are derricks, cableways, cranes, elevators, and conveyors. See BULK-HANDLING MACHINES; HOISTING MACHINES.

Excavating equipment is divided into two main classes: standard land excavators and marine dredges; each has many variations. The standard land excavator comprises machines that merely dig earth and rock and place it in separate hauling units, as well as those that pick up and transport the materials. Among the former are power shovels, draglines, backhoes, cranes with a variety of buckets, front-end loaders, excavating belt loaders, trenchers, and the continuous bucket excavator. The second group includes such machines as bulldozers, scrapers of various types, and sometimes the front-end loader.

Usually called a dredge, the marine excavator is an excavating machine mounted on a barge or boat. Two common types are similar to land excavators, the clamshell and the bucket excavator. The suction dredge is different; it comprises a movable suction pipe which can be lowered to the bottom, usually with a fast-moving cutter head at the bottom end.

Excavated materials are moved great distances by a wide variety of conveyances. The most common of these are the self-propelled rubber-tired rear-dump trucks, which are classed as over-the-road or off-the-road trucks. Wagons towed by a rubber-tired prime mover are also used for hauling dirt. These commonly have bottom dumps which permit spreading dirt as the vehicle moves. In special cases side-dump trucks are also used. Conveyors, while not commonly used on construction jobs for hauling earth and rock great distances, have been used to good advantage on large jobs where obstructions make impractical the passage of trucks.

Graders are high-bodied, wheeled vehicles that mount a leveling blade between the front and rear wheels. The principal use is for fine-grading relatively loose and level earth. Pavers place, smooth, and compact paving materials. Asphalt pavers embody tamping pads that consolidate the material; concrete pavers use vibrators for the same purpose. Drilling equipment is used to drill holes in rock for wells and for blasting, grouting, and exploring. Drills are classified according to the way in which they penetrate rock, namely, percussion, rotary percussion, and rotary. Specialized construction equipment includes augers, compactors, pile hammers, road planers, and bore tunneling machines. See CONSTRUCTION ENGINEERING. [E.M.Y.]

**Construction methods** The procedures and techniques utilized during construction. Construction operations are generally classified according to specialized fields. These include preparation of the project site, earth-moving, foundation treatment, steel erection, concrete placement, asphalt paving, and electrical and mechanical installations. Procedures for each of these fields are generally the same, even when applied to different projects, such as buildings, dams, or airports. However, the relative importance of each field is not the same in all cases. For a description of tunnel construction, which involves different procedures, see TUNNEL. [W.Her.]

**Contact aureole** The zone of alteration surrounding a body of igneous rock caused by heat and volatiles given off as the magma crystallized. Changes can be in mineralogy, texture, or elemental and isotopic composition of the original enclosing (country or wall) rocks, and progressively increase closer to

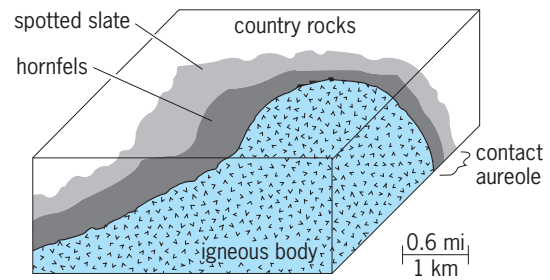

Zoned contact aureole developed around an igneous body.

the igneous contact. The contact aureole is the shell of metamorphosed or metasomatized rock enveloping the igneous body (see illustration). The ideal contact aureole forms locally around a single magma after it is emplaced. Metamorphism over a much larger area can result from coalescing of several contact aureoles. This is termed a contact-regional metamorphic aureole and is thought responsible for the regional metamorphism of several mountain areas. Other contact aureoles develop at greater depths and may be physically emplaced to shallower levels along with the igneous body. These are termed dynamothermal aureoles. See IGNEOUS ROCKS; MAGMA; METAMORPHIC ROCKS; METAMORPHISM; METASOMATISM; PLUTON.

The aureole extends from the igneous contact, where the metamorphic effects are the greatest, out into the country rocks to where the temperature or heat energy is insufficient to effect any changes. This temperature lies between 400 and 750°F (200 and 400°C), and actual widths of contact aureoles range from several inches to miles.

Contact metamorphism can occur over a wide range of temperatures, pressures, or chemical gradients in rocks of any composition. Thus any mineral assemblage or facies of metamorphic rocks can be found. However, the nature of contact aureoles results in minerals characteristic of low to moderate pressures and moderate to high temperatures usually in common rock types: shales, basalt, limestone, and sandstone. Characteristic minerals developed in shales are andalusite, sillimanite, cordierite, biotite, orthopyroxene, and garnet. At the highest temperatures, tridymite, sanidine, mullite, and pigeonite form; whereas in limestone unusual calcium silicates form, including tilleyite, spurrite, rankinite, larnite, merwinite, akermanite, monticellite, and melilite. See FACIES (GEOLOGY).

Compositional changes in a contact aureole range from none to great, but as a rule, contact metamorphism entails relatively little change in bulk rock composition. Because metamorphic changes are largely brought about by heat, contact aureoles are often termed thermal aureoles. However, there is a tendency for volatiles (water, carbon dioxide, oxygen) and alkalis (sodium, potassium) to be lost from rocks in the aureole. Stable isotope compositions (oxygen, sulfur) change in response to the thermal gradient and flow of fluids through the rocks. In some cases, volatiles (boron, fluorine, and chlorine) and other elements from the crystallizing magma are gained.

Some wall rock compositions, such as limestone, can be greatly changed and form rocks termed skarn. These contact aureoles are economically important because they often contain ore deposits of iron, copper, tungsten, graphite, zinc, lead, molybdenum, and tin. Conversely, the magma can incorporate material from the wall rocks by assimilation or mixing with any partial melts formed. Mixing results in elemental and isotopic contamination of the magma, crystallization of different minerals from the melt, and hybrid rock types at the margin of the igneous body. See ORE AND MINERAL DEPOSITS; PNEUMATOLYSIS; SKARN. [J.A.Sp.]

**Contact condenser** A device in which a vapor is brought into direct contact with a cooling liquid and condensed

## 544 Contact potential difference

by giving up its latent heat to the liquid. In almost all cases the cooling liquid is water, and the condensing vapor is steam. Contact condensers are classified as jet, barometric, and ejector condensers. In all three types the steam and cooling water are mixed in a condensing chamber and withdrawn together. Noncondensable gases are removed separately from the jet condenser, entrained in the cooling water of the ejector condenser, and removed either separately or entrained in the barometric condenser. The jet condenser requires a pump to remove the mixture of condensate and cooling water and a vacuum breaker to avoid accidental flooding. The barometric condenser is self-draining. The ejector condenser converts the energy of high-velocity injection water to pressure in order to discharge the water, condensate, and noncondensables at atmospheric pressure. See VAPOR CONDENSER. [J.F.Se.]

**Contact potential difference** An electrostatic potential that exists between samples of two dissimilar electrically conductive materials (metals or semiconductors with different electron work functions) that have been brought into thermal equilibrium with each other, usually through a physical contact. Although normally measured between two surfaces which are not in contact, this potential is called the contact potential difference. Initially it is expected that mobile charge carriers (electrons or holes) will migrate from one sample to the other. If there is a net flow of electrons from material A to material B (see illustration), material B will become negatively charged and material A will become positively charged, assuming that they were originally

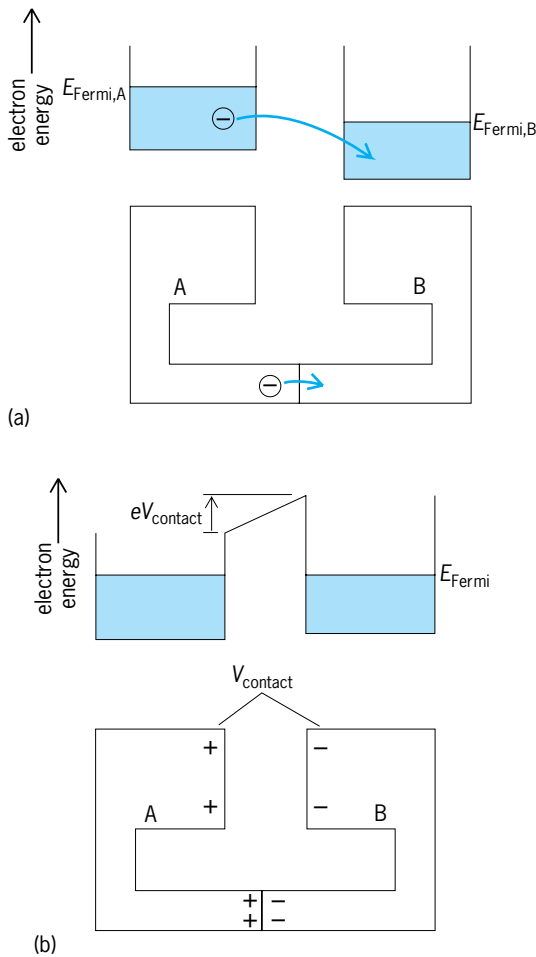

**Development of a contact potential as two conductive materials are brought into thermal equilibrium. (a) Initial charge transfer. (b) Thermal equilibrium. Diagrams show corresponding electron energy distributions.  $E_{\text{Fermi}}$  = Fermi level;  $V_{\text{contact}}$  = contact potential difference;  $e$  = electron charge.**

neutral. This process is self limiting because a potential difference between the two samples will develop due to the charge separation and will grow to a value sufficient to stop further motion of the electrons from A to B.

In a metal or a semiconductor, the electrons are distributed in energy such that virtually all of them exist at or below a level called the Fermi level. When any combination of metals and semiconductors are put into equilibrium with one another, the Fermi levels in all will coincide. The contact potential difference between materials is that value necessary to raise or lower the potential energies of the electrons to produce a common Fermi level. Since they are then at the same energy, electrons in either material will have no net force on them, that is, no reason to travel to the other material. Because it causes no net force on the equilibrium distribution of electrons, contact potential difference cannot be directly measured with an ordinary voltmeter. Nevertheless, it profoundly affects the behavior of a number of electronic devices. See FREE-ELECTRON THEORY OF METALS; SCHOTTKY BARRIER DIODE; SEMICONDUCTOR; WORK FUNCTION (ELECTRONICS). [J.E.No.]

**Continent** A protuberance of the Earth's crustal shell with an area of several million square miles and with sufficient elevation above neighboring depressions (the ocean basins) so that much of it is above sea level.

The great majority of maps now in use imply that the boundaries of continents are their shorelines. From the geological point of view, however, the line of demarcation between a continent and an adjacent ocean basin lies offshore, at distances ranging from a few to several hundred miles, where the gentle slope of the continental shelf changes somewhat abruptly to a steeper declivity. This change occurs at depths ranging from a few to several hundred fathoms (1 fathom = 6 feet) at different places around the periphery of various continents. See CONTINENTAL MARGIN.

On such a basis, numerous offshore islands, including the British Isles, Greenland, Borneo, Sumatra, Java, New Guinea, Tasmania, Taiwan, Japan, and Sri Lanka, are parts of the nearby continent. Thus, there are six continents: Eurasia (Europe, China, and India are parts of this largest continent), Africa, North America, South America, Australasia (including Australia, Tasmania, and New Guinea), and Antarctica.

All continents have similar structural features but display great variety in detail. Each includes a basement complex (shield) of metamorphosed sedimentary and volcanic rocks of Precambrian age, with associated igneous rocks, mainly granite. Originally formed at considerable depths below the surface, this shield was later exposed by extensive erosion, then largely covered by sediments of Paleozoic, Mesozoic, and Cenozoic age, chiefly marine limestones, shales, and sandstones. In at least one area on each continent, these basement rocks are now at the surface (an example is the Canadian Shield of North America). In some places they have disappeared beneath a sedimentary platform occupying a large fraction of the area of each continent, such as the area in the broad lowland drained by the Mississippi River in the United States. In each continent there are long belts of mountains in which thick masses of sedimentary rocks have been compressed into folds and broken by faults. See CONTINENTS, EVOLUTION OF.

Continents are the less dense, subaerially exposed portion of the plates that make up the Earth's lithosphere, or outer shell of rigid rock material. As such, continents together with part of the ocean's floor are intimately joined portions of the lithospheric plates. As plates rip apart and migrate horizontally over the Earth's surface, so too do continents rip apart and migrate, sometimes colliding with other continental segments scores of millions of years later. Mountain systems, such as the Appalachian-Ouachita, the Arbuckle-Wichita, and the Urals systems, are now believed to represent the sutures of former continents attached to their respective plates which collided long ago.

The Red Sea and the linear rift-volcano-lakes district of Africa are also believed by many to manifest continental ripping and early continental drifting. Such continental collision and accretion are believed to have occurred throughout most of the Earth's history. See AFRICA; ANTARCTICA; ASIA; EUROPE; ISOSTASY; LITHOSPHERE; NORTH AMERICA; PLATE TECTONICS; SEISMOLOGY; SOUTH AMERICA.

[D.L.J.]

**Continental drift** The concept that the world's continents once formed part of a single mass and have since drifted into their present positions. Although it was outlined by Alfred Wegener in 1912, the idea was not particularly new. Paleontological studies had already demonstrated such strong similarities between the flora and fauna of the southern continents between 300,000,000 and 150,000,000 years ago that a huge supercontinent, Gondwana, containing South America, Africa, India, Australia, and Antarctica, had been proposed. However, Gondwana was thought to be the southern continents linked by land bridges, rather than contiguous units.

Wegener's ideas were almost universally rejected in 1928; the fundamental objection was the lack of a suitable mechanism. Almost simultaneously with the temporary eclipse of Wegener's theory, Arthur Holmes was considering a mechanism that is still widely accepted. Holmes conceived the idea of convective currents within the Earth's mantle which were driven by the radiogenic heat produced by radioactive minerals within the mantle. At that time, Holmes's ideas, like those of Wegener, were largely ignored. Nonetheless, several geologists, particularly those living in the Southern Hemisphere, continued to believe the theory and accumulate more data in its support.

By the 1950s, convincing evidence had accumulated, with studies of the magnetization of rocks, paleomagnetism, beginning to provide numerical parameters on the past latitude and orientation of the continental blocks. Early work in North America and Europe clearly indicated how these continents had once been contiguous and had since separated. The discovery of the midoceanic ridge system also provided further evidence for the geometric matching of continental edges, but the discovery of magnetic anomalies parallel to these ridges and their interpretation in terms of sea-floor spreading finally led to almost universal acceptance of continental drift as a reality.

In the 1970s and 1980s, the interest changed from proving the reality of the concept to applying it to the geologic record, leading to a greater understanding of how the Earth has evolved through time. The fundamental change in concept was that not only have the continents drifted, but the continents are merely parts of thicker tectonic plates comprising both oceanic and continental crust, with 50–300 km (31–186 mi) of the Earth's mantle moving along with them. See CONTINENTS, EVOLUTION OF; EARTH, CONVECTION IN; PALEOMAGNETISM; PLATE TECTONICS; GEODYNAMICS.

[D.H.T.]

**Continental margin** The submerged portions of the continental masses on crustal plates, including the continental shelf, the continental slope, and the continental rise. All continental masses have some continental margin, but there is great variety in the size, shape, and geology depending upon the tectonic setting.

The most common settings are the trailing-edge margin and the leading-edge margin. The former is associated with tectonic stability, as exemplified by the Atlantic side of the North American landmass (see illustration). Here the margin is wide and geologically relatively uncomplicated, with thick sequences of coastal plain to shallow marine strata dipping slightly toward the ocean basin. By contrast, the leading-edge margin (for example, the Pacific side of the United States) is narrow, rugged, and geologically complicated. The global distribution of these widespread continental margin types is controlled by the plate tectonic setting in which the landmass resides. Some major landmasses, such as Australia, are surrounded by wide margins, but

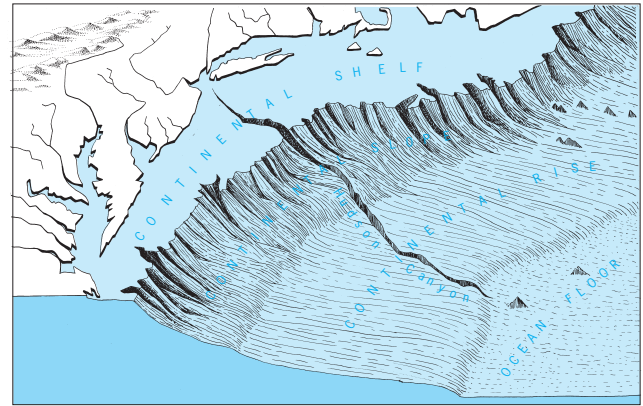

Continental margin off the northeastern United States.

most, such as North and South America, have some of both types. See PLATE TECTONICS.

Any consideration of the continental margin must include a general understanding of global sea-level history over the past few million years. As glaciers expanded greatly just over 2 million years ago, sea level was lowered more than 300 ft (100 m). The cyclic growth and decay of glaciers during this period caused the shoreline to move from near its present position to near the edge of the present continental shelf on multiple occasions. These sea-level changes had a profound effect on the entire continental margin, particularly the shelf and the rise. During times of glacial advance, the coast was near the shelf edge, causing large volumes of river-borne sediment to flow down the continental slope and pile up on the rise; deltas were poorly developed for lack of place for sediment to accumulate. During times of high sea-level stand similar to the present time, little sediment crossed the shelf and large volumes of riverine sediment accumulated in large fluvial deltas. See DELTA.

The continental shelf is simply an extension of the adjacent landmass. It is characterized by a gentle slope and little relief except for shelf valleys (see illustration), which are old rivers that were active during times of low sea level. The outer limit of the shelf shows a distinct change in gradient to the much steeper slope.

The continental slope and rise of the outer continental margin includes the relatively steep slope and the rise that accumulates at the base of the slope. This continental material has the same general composition as the landmass.

The leading-edge continental margin that is commonly associated with a crustal plate boundary displays a very different geology, geomorphology, and bathymetry than the outer continental margin. In this type there is no distinct shelf, slope, and rise. Like the trailing-edge margin, the leading-edge margin exhibits the same characteristics as the adjacent landmass, in this case a structurally complex geology with numerous fault basins and high relief. The borderland is narrow and overall steep. Its geomorphology consists of numerous local basins that receive sediment through numerous submarine canyons. The canyons commonly extend nearly to the beach; there is no shelf as such. See SUBMARINE CANYON.

The continental margin contains a vast amount and array of natural fishing resources, most of which are being harvested. The primary fishing grounds around the globe are in shelf waters. The Grand Banks off northeastern North America and the North Sea adjacent to Europe are among the most heavily fished. There are also many mineral resources that are taken from shelf sediments, including heavy minerals that are sources of titanium, phosphate, and even placer gold. Important commodities such as sand, gravel, and shell are also taken in large quantities from the inner shelf. Salt domes that underlie the shelf, especially in the northern Gulf of Mexico, provide salt and sulfur.

Probably the most important resource obtained from the continental margin is petroleum, in the form of both oil and gas. Production is extremely high in some places, ranging from the deltas at the coast across the entire shelf and onto the outer margin, and reserves are high. See MARINE GEOLOGY; OIL AND GAS, OFFSHORE. [R.A.D.]

Shelf circulation is the pattern of flow over continental shelves. An important part of this pattern is any exchange of water with the deep ocean across the shelf-break and with estuaries or marginal seas at the coast. The circulation transports and distributes materials dissolved or suspended in the water, such as nutrients for marine life, fresh-water and fine sediments originating in rivers, and domestic and industrial waste. Water movements over continental shelves include tidal motions, wind-driven currents, and long-term mean circulation. The inflow of fresh water from land also contributes to shelf circulation, because such water would tend to spread out on the surface on account of its low density. Rapid nearshore mixing reduces the density contrast, and the Earth's rotation deflects the offshore flow into a shore-parallel direction, leaving the coast to the right. A compensating shoreward flow at depth is deflected in the opposite direction, adding to the complexity of shelf circulation. See NEARSHORE PROCESSES; OCEAN CIRCULATION. [G.T.C.]

**Continents, evolution of** The process that led to the formation of the continents. The Earth's crust is distinctively bimodal in thickness. Oceanic crust is normally about 4 mi (7 km) thick, varying mainly with the temperature of the mantle beneath the sea-floor spreading ridges when the crust was formed. In contrast, the typical 22–25-mi (35–40-km) thickness of continental crust is controlled ultimately—through the agents of erosion, sedimentation, and isostatic adjustment—by sea level. Oceanic crust is formed at spreading ridges, continental crust at subduction zones. Both are recycled to the mantle, but oceanic crust, being less buoyant, is recycled about 30 times faster than continental crust. Consequently, continents, having a mean age of almost 2 billion years and a maximum age of 4 billion years, provide the only directly accessible record spanning most of Earth history. They are, however, structurally more complex than ocean basins because of their great antiquity and weak rheology. See EARTH CRUST; MID-OCEANIC RIDGE.

**Constructive processes.** Subduction zones are the main factories for making continental crust (see illustration). The primary constructive processes are trench accretion, arc magmatism, and arc-continent collision. Mantle plumes and lithospheric stretching cause secondary magmatic additions to continental crust. See LITHOSPHERE; MAGMA; SUBDUCTION ZONES.

Trench accretion occurs where an oceanic plate sinks beneath a continental plate or another oceanic plate; sediment scraped off the top of the descending plate accumulates as an accretionary prism at the leading edge of the overriding plate; Trench accretion is dominantly a process of crustal reworking, not crustal growth, because the bulk of the sediment is derived from the erosion of preexisting crust.

A volcanic arc is a surface manifestation of partial melting near the tip of the mantle wedge above the subducting slab. Melting in the wedge is induced by the infiltration of aqueous fluids, which lower the temperature required for melting to begin (hydration melting). Although the main source of arc magmas is the mantle wedge, sediment and ablated crust entrained in the slab make subordinate contributions to arc magmas. The mantle-derived fraction represents new crustal addition.

Where subduction occurs beneath continental lithosphere, trench accretion and arc magmatism add crust to the continent directly. Continental-type protocrust is also formed at subduction zones (often having complex developmental histories) situated entirely within oceanic lithosphere. Incorporation of such protocrust in a continent is accomplished by arc-continent collision.

Plumes are jets of anomalously hot mantle that partially melts as it reaches the lithosphere, causing the volcanism of Hawaiian-type islands and related seamount chains. Plumes also cause volcanism on continents, for example, Yellowstone in North America. In addition to surface volcanism, the melts may pond at or near the base of the crust, causing magmatic underplating. Seamounts and oceanic plateaus are fragmentarily accreted to continents at trenches. See BASALT; OCEANIC ISLANDS; SEAMOUNT AND GUYOT; VOLCANOLOGY.

**Destructive processes.** Subduction zones may also cause destruction of continental crust (see illustration). The destructive processes are sediment subduction and subduction ablation. Constructive and destructive processes may be at work simultaneously, and the net balance may swing one way or the

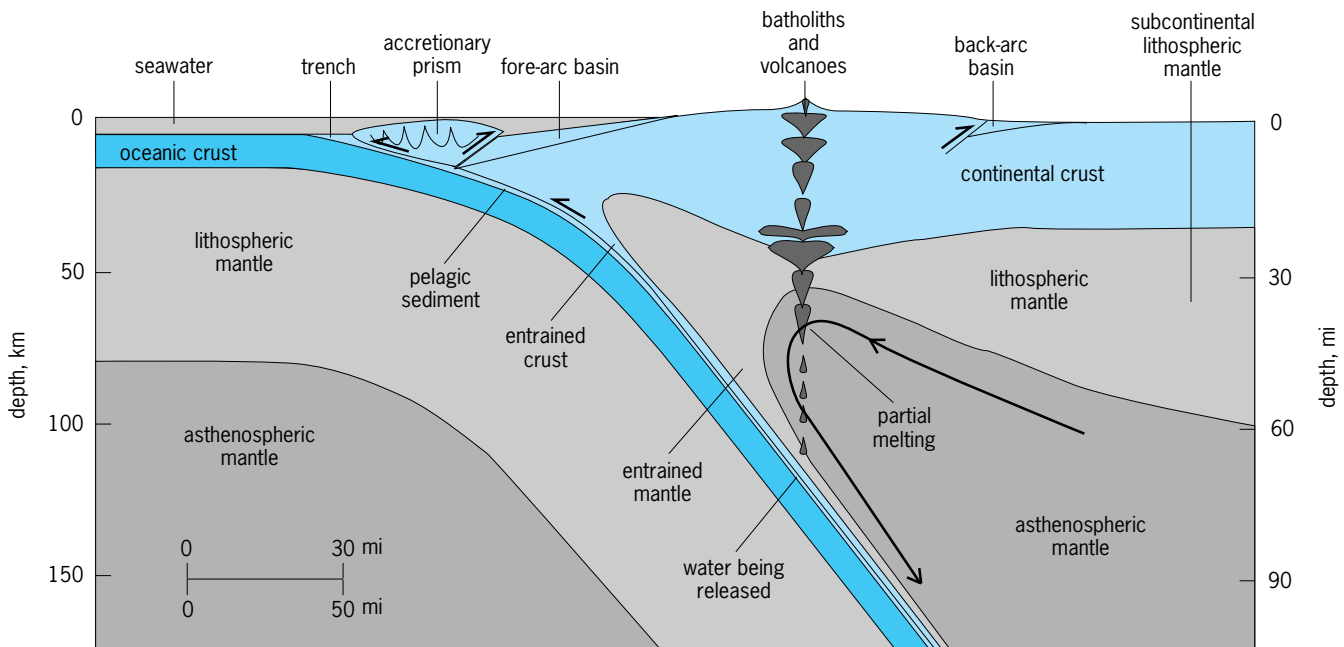

Recycling of continental crust at a subduction zone. Arrows show direction of movement.

other with time. Selective destruction of lower crust may occur in continent-continent collision zones as a result of convective dripping of tectonically thickened lithosphere.

Even at subduction zones with well-developed accretionary prisms, some of the sediments disappear beneath the deformation front of the prism. Some is accreted structurally to the base of the prism, and some is transferred to the magmatic arc by melting. Some escapes melting and sinks deeply into the mantle, where it constitutes an isotopically recognizable component in the source of plume basalts. Sediment subduction, being fed by surface erosion, preferentially destroys the upper crust.

It is postulated that crust and lithospheric mantle from the overriding plate may become entrained in the subducting slab, causing tectonic ablation. Like subducted sediment, ablated crust is potentially capable of melting as it passes beneath the convecting mantle wedge. Unlike subducted sediment, ablated material may include lower crust and lithospheric mantle as well as upper crust.

Where continental lithosphere is tectonically thickened, cold lithospheric mantle is forced downward into hotter convecting mantle. Lithospheric thickening generates lateral thermal gradients, which drive mantle convection. The thickened lithospheric mantle is therefore unstable and may drip away. Unlike sediment subduction, upper crust is not lost by dripping; and unlike subduction ablation, continental drips are not susceptible to hydration melting.

**Continents and Earth history.** The mean age of extant continental crust is about 2 billion years. The conventional interpretation is that there was little continental crust following a period of high impact flux and that continental growth was slow at first, then rose to a peak 2–3 billion years ago, after which it slowly tapered off. An alternative interpretation, however, holds that the volume of continental crust has been in a near steady state since the impact flux waned. The present age distribution is explained by assuming a secular decline in the rate of crustal recycling, presumably modulated by the decreasing vigor of mantle convection as the Earth cooled. The difference in interpretation hinges on the importance assigned to recycling of continental crust. In crustal growth models, there is little crust older than 3 billion years, because little was formed. In steady-state models, much crust was formed early on but little of it survives. The steady-state interpretation is consistent with isotopic data showing that the oldest crustal relics contain highly evolved as well as juvenile components, and that the contemporaneous mantle was also heterogeneous and included strongly depleted regions. Furthermore, the near steady-state alternative is supported by comparative planetology, which indicates that for the hot young mantle not to be thoroughly differentiated by near-surface melting is physically implausible. See CONTINENTAL DRIFT; EARTH; EARTH, AGE OF; EARTH, CONVECTION IN; FAULT AND FAULT STRUCTURES; MARINE GEOLOGY; GEOPHYSICS; PLATE TECTONICS; SEISMOLOGY. [PHo.]

**Continuous-wave radar** A radar in which the transmitter output is uninterrupted, in contrast to pulse radar, where the output consists of short pulses. Among the advantages of continuous-wave (CW) radar is its ability to measure velocity with extreme accuracy by means of the Doppler shift in the frequency of the echo. The detected, reflected wave is shifted in frequency by an amount which is a function of the relative velocity between the target and the transmitter-receiver. Range data are extracted from the change in Doppler frequency with time. See DOPPLER RADAR.

In order to measure the range of targets, some form of frequency modulation (FM) of the continuous-wave output must be used. In one very effective form of modulation, the carrier frequency of the transmitted signal is varied at a uniform rate. Range is determined by comparing the frequency of the echo with that of the transmitter, the difference being proportional

to the range of the target that produced the echo. Systems in which this is done are known as FM-CW radars. See FREQUENCY MODULATION.

A modified form of FM-CW radar employs long, but not continuous, transmission. This might be regarded as the same as transmitting extremely long pulses on an FM carrier. Systems of this type are referred to as pulse compression radars.

Design objectives for continuous-wave radar include: protecting the receiver from the transmitter output and close-by return echoes when a single antenna is used; resolving side-lobe ambiguity; resolving range ambiguity; distinguishing between approaching and receding targets; eliminating noise and clutter; simultaneously measuring both target range and velocity; determining the shapes of targets; handling multiple targets; measuring target acceleration; communicating with targets; and increasing the received signal-to-noise ratio.

One disadvantage of continuous-wave radar is that when a single antenna is used for both reception and transmission it is difficult to protect the receiver against the transmitter because, in contrast to pulse radar, both are on all the time. Use of isolation circuitry gives the receiver protection from a transmitter output up to 200 W. Use of magnetically biased yttrium-iron-garnet (YIG) provides three tuned, tandem-connected power-limiter stages in one X-band FM-CW radar. See FERRIMAGNETIC GARNETS.

Applications of continuous-wave radar include missile guidance; detection of hostile targets; terrain clearance indication and ground surveillance; laser radar systems; atmospheric studies; automobile safety; surveillance of personnel; ice studies; remote sensing; and reproduction of the shape of a patient's pulse.

The principal use of continuous-wave radar is in short-range missile guidance. Typically the missile's course is tracked from the ground while the missile is simultaneously illuminated. Continuous-wave radar, in some cases the same radar, can be used for both tracking and illumination, although it is more common for pulse Doppler radar to be used for tracking.

A variant of continuous-wave radar is used to illuminate persons under surveillance by techniques employing semiconductor tracer diodes. These devices are secreted on or implanted in the subject's body without his or her knowledge, or else concealed in objects that are to be protected against theft. Despite the fact that pulsed X-band sources could provide the needed power levels more conveniently, the requirement to reduce clutter makes it desirable to use continuous-wave power. [J.M.C.]

**Contour** The locus of points of equal elevation used in topographic mapping. Contour lines represent a uniform series of elevations, the difference in elevation between adjacent lines being the contour interval of the given map. Thus, contours represent the shape of terrain on the flat map surface (see illustration). Closely spaced contours indicate steep ground; sparseness or absence of contours indicates gentle slope or flat ground.

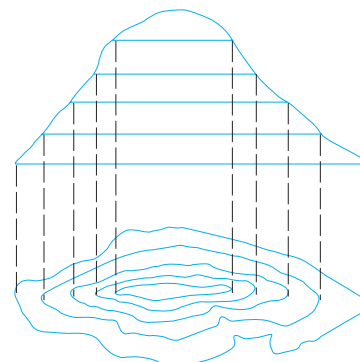

Contour representation.

Contours do not cross each other unless there is an overhang. See TOPOGRAPHIC SURVEYING AND MAPPING. [R.H.Do.]

**Control chart** A graphical technique for determining whether a process is or is not in a state of statistical control. Being in statistical control means that the extent of variation of the output of the process does not exceed that which is expected on the basis of the natural statistical variability of the process. Several main types of control charts are used, based on the nature of the process and on the intended use of the data.

Every process has some inherent variability due to random factors over which there is no control and which cannot be eliminated economically. For instance, in a metal fabrication process random factors may include the distribution of impurities and structural faults among the metal molecules, vibrations of the fabrication equipment, fluctuations in the power supply that affect the speed and torque of the equipment, and variations in the operator performance from one cycle to the next. The inherent variability of the process is the aggregate result of many individual causes, each having a small impact.

The control chart technique is applicable to processes that produce a stream of discrete output units. Control charts are designed to detect excessive variability due to specific assignable causes that can be corrected. Assignable causes result in relatively large variations, and they usually can be identified and economically removed. Examples of assignable causes of variations that may occur in the example of metal fabrication include a substandard batch of raw material, a machine malfunction, and an untrained or poorly motivated operator.

A control chart is a two-dimensional plot of the evolution of the process over time. The horizontal dimension represents time, with samples displayed in chronological order, such that the earliest sample taken appears on the left and each newly acquired sample is plotted to the right. The vertical dimension represents the value of the sample statistic, which might be the sample mean, range, or standard deviation in the case of measurement by variables, or in the case of measurement by attributes, the number of nonconforming units, the fraction nonconforming, the number of nonconformities, or the average number of nonconformities per unit.

Typically a control chart includes three parallel horizontal lines (see illustration): a center line and two control limits. The center line (CL) intersects the vertical dimension at a value that represents the level of the process under stable conditions (natural variability only). The process level might be based on a given standard or, if no standard is available, on the current level of the process calculated as the average of an initial set of samples. The two lines above and below the center-line are called the upper control limit (UCL) and lower control limit (LCL) respectively, and they both denote the normal range of variation for the sample statistic. The control limits intersect the vertical axis such that if only the natural variability of the process is present, then the probability of a sample point falling outside the control

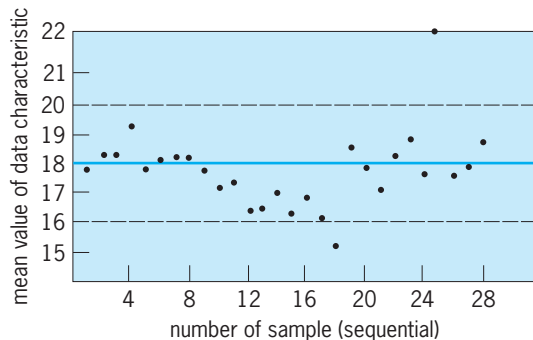

Control chart, showing changes in average of process.

limits and causing a false alarm is very small. Typically, control limits are located at three standard deviations from the center line on both sides. This results in a probability of a false alarm being equal to 0.0027.

The principle of operation of control charts is rather simple and consists of five general steps:

1. Samples are drawn from the process output at regular intervals.
2. A statistic is calculated from the observed values of the units in the sample; a statistic is a mathematical function computed on the basis of the values of the observations in the sample.
3. The value of the statistic is charted over time; any points falling outside the control limits or any other nonrandom pattern of points indicate that there has been a change in the process, either its setting or its variability.
4. If such change is detected, the process is stopped and an investigation is conducted to determine the causes for the change.
5. Once the causes of the change have been ascertained and any required corrective action has been taken, the process is resumed.

The main benefit of control charts is to provide a visual means to identify conditions where the process level or variation has changed due to an assignable cause and consequently is no longer in a state of statistical control. The visual patterns that indicate either the out-of-control state or some other condition that requires attention are known as outliers, runs of points, low variability, trends, cycles, and mixtures. See CONTROL SYSTEMS; QUALITY CONTROL. [T.Ra.]

**Control systems** Interconnections of components forming system configurations which will provide a desired system response as time progresses. The steering of an automobile is a familiar example. The driver observes the position of the car relative to the desired location and makes corrections by turning the steering wheel. The car responds by changing direction, and the driver attempts to decrease the error between the desired and actual course of travel. In this case, the controlled output is the automobile's direction of travel, and the control system includes the driver, the automobile, and the road surface. The control engineer attempts to design a steering control mechanism which will provide a desired response for the automobile's direction control. Different steering designs and automobile designs result in rapid responses, as in the case of sports cars, or relatively slow and comfortable responses, as in the case of large autos with power steering.

**Open- and closed-loop control.** The basis for analysis of a control system is the foundation provided by linear system theory, which assumes a cause-effect relationship for the components of a system. A component or process to be controlled can be represented by a block. Each block possesses an input (cause) and output (effect). The input-output relation represents the cause-and-effect relationship of the process, which in turn represents a processing of the input signal to provide an output signal variable, often with power amplification. An open-loop control system utilizes a controller or control actuator in order to obtain the desired response (Fig. 1).

In contrast to an open-loop control system, a closed-loop control system utilizes an additional measure of the actual output

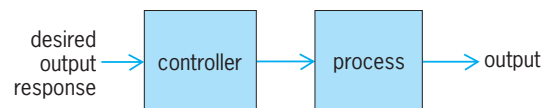

Fig. 1. Open-loop control system.

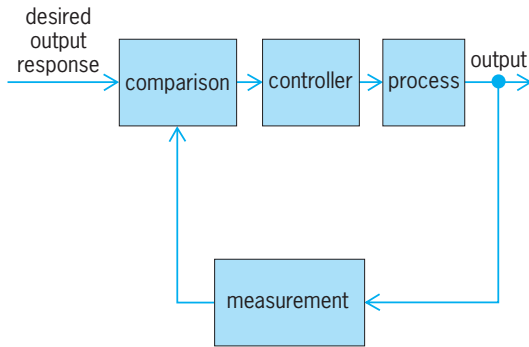

Fig. 2. Closed-loop control system.

in order to compare the actual output with the desired output response (Fig. 2). A standard definition of a feedback control system is a control system which tends to maintain a prescribed relationship of one system variable to another by comparing functions of these variables and using the difference as a means of control. In the case of the driver steering an automobile, the driver uses his or her sight to visually measure and compare the actual location of the car with the desired location. The driver then serves as the controller, turning the steering wheel. The process represents the dynamics of the steering mechanism and the automobile response.

A feedback control system often uses a function of a prescribed relationship between the output and reference input to control the process. Often, the difference between the output of the process under control and the reference input is amplified and used to control the process so that the difference is continually reduced. The feedback concept has been the foundation for control system analysis and design.

**Applications for feedback systems.** Familiar control systems have the basic closed-loop configuration. For example, a refrigerator has a temperature setting for desired temperature, a thermostat to measure the actual temperature and the error, and a compressor motor for power amplification. Other examples in the home are the oven, furnace, and water heater. In industry, there are controls for speed, process temperature and pressure, position, thickness, composition, and quality, among many others. Feedback control concepts have also been applied to mass transportation, electric power systems, automatic warehousing and inventory control, automatic control of agricultural systems, biomedical experimentation and biological control systems, and social, economic, and political systems. See BIOMEDICAL ENGINEERING; ELECTRIC POWER SYSTEMS; MATHEMATICAL BIOLOGY; SYSTEMS ANALYSIS; SYSTEMS ENGINEERING.

**Advantages of feedback control.** The addition of feedback to a control system results in several important advantages. A process, whatever its nature, is subject to a changing environment, aging, ignorance of the exact values of the process parameters, and other natural factors which affect a control process. In the open-loop system, all these errors and changes result in a changing and inaccurate output. However, a closed-loop system senses the change in the output due to the process changes and attempts to correct the output. The sensitivity of a control system to parameter variations is of prime importance. A primary advantage of a closed-loop feedback control system is its ability to reduce the system's sensitivity.

One of the most important characteristics of control systems is their transient response, which often must be adjusted until it is satisfactory. If an open-loop control system does not provide a satisfactory response, then the process must be replaced or modified. By contrast, a closed-loop system can often be adjusted to yield the desired response by adjusting the feedback loop parameters.

A second important effect of feedback in a control system is the control and partial elimination of the effect of disturbance sig-

nals. Many control systems are subject to extraneous disturbance signals which cause the system to provide an inaccurate output. Feedback systems have the beneficial aspect that the effect of distortion, noise, and unwanted disturbances can be effectively reduced.

**Costs of feedback control.** While the addition of feedback to a control system results in the advantages outlined above, it is natural that these advantages have an attendant cost. The cost of feedback is first manifested in the increased number of components and the complexity of the system. The second cost of feedback is the loss of gain. Usually, there is open-loop gain to spare, and one is more than willing to trade it for increased control of the system response. Finally, a cost of feedback is the introduction of the possibility of instability. While the open-loop system is stable, the closed-loop system may not be always stable.

**Stability of closed-loop systems.** The transient response of a feedback control system is of primary interest and must be investigated. A very important characteristic of the transient performance of a system is the stability of the system. A stable system is defined as a system with a bounded system response. That is, if the system is subjected to a bounded input or disturbance and the response is bounded in magnitude, the system is said to be stable.

The concept of stability can be illustrated by considering a right circular cone placed on a plane horizontal surface. If the cone is resting on its base and is tipped slightly, it returns to its original equilibrium position. This position and response is said to be stable. If the cone rests on its side and is displaced slightly, it rolls with no tendency to leave the position on its side. This position is designated as neutral stability. On the other hand, if the cone is placed on its tip and released, it falls onto its side. This position is said to be unstable.

The stability of a dynamic system is defined in a similar manner. The response to a displacement, or initial condition, will result in a decreasing, neutral, or increasing response.

**Design.** A feedback control system that provides an optimum performance without any necessary adjustments is rare indeed. Usually one finds it necessary to compromise among the many conflicting and demanding specifications and to adjust the system parameters to provide a suitable and acceptable performance when it is not possible to obtain all the desired optimum specifications.

It is often possible to adjust the system parameters in order to provide the desired system response. However, it is often not possible to simply adjust a system parameter and thus obtain the desired performance. Rather, the scheme or plan of the system must be reexamined, and a new design or plan must be obtained which results in a suitable system. Thus, the design of a control system is concerned with the arrangement, or the plan, of the system structure and the selection of suitable components and parameters. For example, if one desires a set of performance measures to be less than some specified values, one often encounters a conflicting set of requirements. If these two performance requirements cannot be relaxed, the system must be altered in some way. The alteration or adjustment of a control system, in order to make up for deficiencies and inadequacies and provide a suitable performance, is called compensation.

In redesigning a control system in order to alter the system response, an additional component or device is inserted within the structure of the feedback system to equalize or compensate for the performance deficiency. The compensating device may be an electric, mechanical, hydraulic, pneumatic, or other-type device or network, and is often called a compensator.

**Digital computer systems.** The use of a digital computer as a compensator device has grown since 1970 as the price and reliability of digital computers have improved.

Within a computer control system, the digital computer receives and operates on signals in digital (numerical) form, as contrasted to continuous signals. The measurement data are

converted from analog form to digital form by means of a converter. After the digital computer has processed the inputs, it provides an output in digital form, which is then converted to analog form by a digital-to-analog converter. See ANALOG-TO-DIGITAL CONVERTER; DIGITAL-TO-ANALOG CONVERTER.

Automatic handling equipment for home, school, and industry is particularly useful for hazardous, repetitious, dull, or simple tasks. Machines that automatically load and unload, cut, weld, or cast are used by industry in order to obtain accuracy, safety, economy, and productivity. Robots are programmable computers integrated with machines. They often substitute for human labor in specific repeated tasks. Some devices even have anthropomorphic mechanisms, including what might be recognized as mechanical arms, wrists, and hands. Robots may be used extensively in space exploration and assembly. They can be flexible, accurate aids on assembly lines. See ROBOTICS. [R.C.D.]

**Controlled rectifier** A three-terminal semiconductor junction device with four regions of alternating conductivity type ( $p-n-p-n$ ), also called a thyristor. This switching device has a characteristic such that, once it conducts, the voltage in the circuit in which it conducts must drop below a threshold before the controlled rectifier regains control. Such devices are useful as high-current switches and may be used to drive electromagnets and relays.

The principle of operation can be understood by referring to the illustration. The central junction is reverse-biased (positive collector, grounded emitter). The wide  $n$  region between collector and base regions prevents holes injected at the collector junction from reaching the collector-to-base barrier by diffusion. The junction between emitter and base is the emitter. When operated as a normal transistor, this device shows a rapid increase of current gain with collector current. This effect may be due to a field-induced increase of transport efficiency across the floating  $n$  region, or to increased avalanching in the high-field barrier region, or to increased injection efficiency at the two forward-biased junctions, or to a combination of these phenomena.

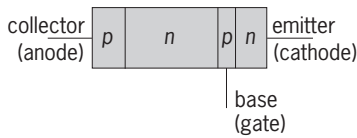

Diagram of a controlled rectifier.

If this device is operated as a three-terminal device, the switching between the nonconducting and conducting states can be controlled by the base. See SEMICONDUCTOR RECTIFIER. [L.P.H.]

**Conularida** A small group of extinct invertebrates showing a fourfold symmetry and a narrow pyramidal shape; the cross section commonly is square. Specimens are chitinous and frequently impregnated with calcium phosphate. The four side walls are characteristically ornamented by numerous transverse lines. The posterior tip may bear an attachment disk or may be broken off and sealed with a septum. Internal structures are rare; the few known show fourfold symmetry. Conularida are regarded as a subclass of the Coelenterata because of the characteristic symmetry. See COELENTERATA.

Specimens are worldwide in occurrence and are known from rocks of Cambrian through Triassic age. They have been found in sandstone, shales, and limestones. About 20 genera and 150 species are known. Except for a few local occurrences, Conularida are rare fossils. [E.L.Y.]

**Convection (heat)** The transfer of thermal energy by actual physical movement from one location to another of a substance in which thermal energy is stored. A familiar example is the free or forced movement of warm air throughout a

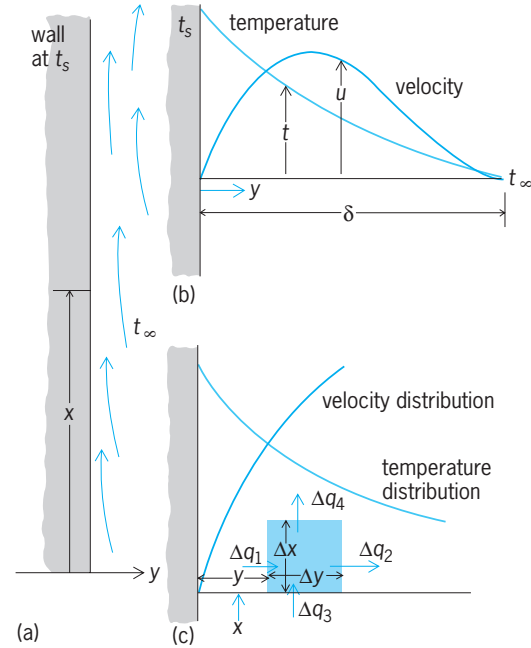

Temperature and velocity distributions in air near a heated vertical surface at arbitrary vertical location. The distance  $\delta$  is that distance at which the velocity and the temperature reach ambient surrounding conditions.

room to provide heating. Technically, convection denotes the nonradiant heat exchange between a surface and a fluid flowing over it. Although heat flow by conduction also occurs in this process, the controlling feature is the energy transfer by flow of the fluid—hence the name convection. Convection is one of the three basic methods of heat transfer, the other two being conduction and radiation. See CONDUCTION (HEAT); HEAT RADIATION; HEAT TRANSFER.

Natural convection is exemplified by the cooling of a vertical surface in a large quiescent body of air of temperature  $t_\infty$ . The lower-density air next to a hot vertical surface moves upward because of the buoyant force of the higher-density cool air farther away from the surface. At any arbitrary vertical location  $x$ , the actual variation of velocity  $u$  with distance  $y$  from the surface will be similar to that in the illustration *b*, increasing from zero at the surface to a maximum, and then decreasing to zero as ambient surrounding conditions are reached. In contrast, the temperature  $t$  of the air decreases from the heated wall value  $t_s$  to the surrounding air temperature. These temperature and velocity distributions are clearly interrelated, and the distances from the wall through which they exist are coincident because, when the temperature approaches that of the surrounding air, the density difference causing the upward flow approaches zero.

The region in which these velocity and temperature changes occur is called the boundary layer. Because velocity and temperature gradients both approach zero at the outer edge, there will be no heat flow out of the boundary layer by conduction or convection. See BOUNDARY-LAYER FLOW.

When air is blown across a heated surface, forced convection results. Although the natural convection forces are still present in this latter case, they are clearly negligible compared with the imposed forces. The process of energy transfer from the heated surface to the air is not, however, different from that described for natural convection. The major distinguishing feature is that the maximum fluid velocity is at the outer edge of the boundary layer. This difference in velocity profile and the higher velocities provide more fluid near the surface to carry along the heat conducted normal to the surface. Consequently, boundary layers are very thin.



Heat convection in turbulent flow is interpreted similarly to that in laminar flow. Rates of heat transfer are higher for comparable velocities, however, because the fluctuating velocity components of the fluid in a turbulent flow stream provide a macroscopic exchange mechanism which greatly increases the transport of energy normal to the main flow direction. Because of the complexity of this type of flow, most of the information regarding heat transfer has been obtained experimentally. See LAMINAR FLOW; TURBULENT FLOW.

Convection heat transfer which occurs during high-speed flight or high-velocity flow over a surface is known as aerodynamic heating. This heating effect results from the conversion of the kinetic energy of the fluid as it approaches a body to internal energy as it is slowed down next to the surface. In the case of a gas, its temperature increases, first, because of compression as it passes through a shock and approaches the stagnation region, and second, because of frictional dissipation of kinetic energy in the boundary layer along the surface.

The phenomena of condensation and boiling are important phase-change processes involving heat release or absorption. Because vapor and liquid movement are present, the energy transfer is basically by convection. Local and average heat-transfer coefficients are determined and used in the Newton cooling-law equation for calculating heat rates which include the effects of the latent heat of vaporization. [W.H.Gi.]

**Convective instability** A state of fluid flow in which the distribution of body forces along the direction of the net body force is unstable and will thus break down. Fluid flows are subject to a variety of instabilities, which may be broadly viewed as the means by which relatively simple flows become more complex. Instabilities are an important step in the transition between smooth and turbulent flow, and in the atmosphere they are responsible for phenomena ranging from thunderstorms to low- and high-pressure systems. Meteorologists and oceanographers divide instabilities into two broad classes: convective and dynamic. See DYNAMIC INSTABILITY.

In the broadest terms, convective instabilities arise when the displacement of a small parcel of fluid causes a force on that parcel which is in the same direction as the displacement. The parcel of fluid will then continue to accelerate away from its initial position, and the fluid is said to be unstable. In most geophysical flows, the convective motions that result from convective instabilities operate very quickly compared with the processes acting to destabilize the fluid; the result is that such fluids seem to be nearly neutrally stable to convection.

The simplest type of convective instability arises when a fluid is heated from below or cooled from above. Warm air rises and cold air sinks; thus a fluid whose temperature decreases with altitude is convectively unstable, while one in which the temperature increases with height is convectively stable. A fluid at constant temperature is said to be convectively neutral.

The above description assumes that density depends on temperature alone and that density is conserved in parcels of fluid, so that when the parcels are displaced their density does not change. However, in the Earth's atmosphere, neither of these assumptions is true. In the first place, the density of air depends on pressure and on the amount of water vapor in the air, in addition to temperature. Second, the density will change when the parcel is displaced because both its pressure and its temperature will change. Because of these conditions it is convenient to define a quantity known as virtual potential temperature ( $\theta_v$ ) that both is conserved and reflects the actual density of air. This quantity is given by the equation below, where  $T$  is the temperature

$$\theta_v \equiv T \left( \frac{1 + (r/0.622)}{1 + r} \right) \left( \frac{1000}{p} \right)^{0.287}$$

in kelvins,  $p$  is the pressure in millibars, and  $r$  is the number of grams of water vapor in each gram of dry air. When  $\theta_v$  decreases

with height in the atmosphere, it is convectively unstable, while  $\theta_v$  increasing with height denotes stability.

In the oceans, density is a function of pressure, temperature, and salinity; convection there is driven by cooling of the ocean surface by evaporation of water into the atmosphere and by direct loss of heat when the air is colder than the water. It is also driven by salinity changes resulting from precipitation and evaporation. In many regions of the ocean, a convectively driven layer exists near the surface in analogy with the atmospheric convective layer. This oceanic mixed layer is also nearly neutral to convection.

Convective instabilities are also responsible for convection in the Earth's mantle, which among other things drives the motion of the plates, and for many of the motions of gases within other planets and in stars. [K.A.Em.]

**Converter** A device for processing alternating-current (ac) or direct-current (dc) power to provide a different electrical waveform. The term converter denotes a mechanism for either processing ac power into dc power (rectifier) or deriving power with an ac waveform from dc (inverter). Some converters serve both functions, others only one. See ALTERNATING CURRENT; DIRECT CURRENT; RECTIFIER.

Converters are used for such applications as (1) rectification from ac to supply electrochemical processes with large controlled levels of direct current; (2) rectification of ac to dc followed by inversion to a controlled frequency of ac to supply variable-speed ac motors; (3) interfacing dc power sources (such as fuel cells and photoelectric devices) to ac distribution systems; (4) production of dc from ac power for subway and streetcar systems, and for controlled dc voltage for speed-control of dc motors in numerous industrial applications; and (5) transmission of dc electric power between rectifier stations and inverter stations within ac generation and transmission networks. See ALTERNATING-CURRENT MOTOR; DIRECT-CURRENT TRANSMISSION.

The introduction of the thyristor (silicon-controlled rectifier) in the 1960s had an immediate effect on converter applications because of its ruggedness, reliability, and compactness. Power semiconductor devices for converter circuits include (1) thyristors, controlled unidirectional switches that, once conducting, have no capability to suppress current; (2) triacs, thyristor devices with bidirectional control of conduction; (3) gate turn-off devices with the properties of thyristors and the further capability of suppressing current; and (4) power transistors, high-power transistors operating in the switching mode, somewhat similar in properties to gate turn-off devices. Thyristors are available with ratings from a few watts up to the capability of withstanding several kilovolts and conducting several kiloamperes. See SEMICONDUCTOR RECTIFIER. [J.Re.]

**Convertiplane** An aircraft combining vertical takeoff and landing capabilities as in the helicopter with forward-flight effectiveness and high-speed potentials of the airplane. In forward flight a convertiplane relies, at least partially, on the fixed wing, while for vertical takeoffs, landings, and hovering, a separate vertical thrust generator is provided. Between vertical and forward-flight regimes, the aircraft goes through a conversion. See AIRPLANE; HELICOPTER; VERTICAL TAKEOFF AND LANDING (VTOL).

Of many systems suitable as vertical-thrust generators, those applied to practical convertiplanes will probably be either of the direct type, in which combustion products are used directly for thrust generation (turbojets and rockets), or of the indirect type, in which all or a part of the available combustion energy is used to drive a mechanical system, functioning as an actuator disk to accelerate the ambient air. The actuator disks may be either free (helicopter rotors and propellers) or shrouded (shrouded propellers and ducted fans).

The principle of the convertiplane can be applied to many types of aircraft. The first practical attempts were directed toward rotary-wing aircraft. In the so-called compounds as much lift as



Fig. 1. NASA-Army-Bell XV-15 in airplane configuration after conversion from helicopter mode. (Bell Helicopter Textron)

possible is transferred in forward flight from the rotor (which is either put into autorotation or slowed down) to more efficient fixed wings, while a propeller (or propellers) provides the forward thrust.

To achieve high speeds the helicopter-type rotor must be eliminated from the forward-flight configuration, which should be as close as possible to that of conventional aircraft. Configurations have been studied wherein rotors are stopped, folded, and retracted into the fuselage or into nacelles.

In the nonhelicopter-type convertiplane, the same device can be used both as a vertical-thrust generator and as a means of forward propulsion. Two basic solutions are technically feasible: (1) the wing remains fixed, while either the entire thrust generator or only the thrust vector tilts from the vertical to the horizontal position, and (2) both the wing and the thrust generator tilt as a unit.



Fig. 2. Bell-Boeing V-22 Osprey tilt-rotor aircraft. (Bell Helicopter Textron)



Fig. 3. Harrier fighter aircraft, manufactured by Hawker Siddeley, now British Aerospace, and McDonnell Douglas. Close ground support and reconnaissance are provided through use of vectored-thrust turbofans.

In the fixed-wing, free-airscrew group, the NASA-Army-Bell XV-15, a flight research aircraft with 375 mi/h (167 m/s) speed capabilities, went through complete conversion in 1979 (Fig. 1). In the ensuing years of extensive flight testing, the XV-15 proved the feasibility of the tilt-rotor concept, thus paving the way for the development of an operational aircraft, the Bell-Boeing V-22 Osprey (Fig. 2), for the U.S. military forces, especially the Marine corps.

The Harrier (manufactured by Hawker Siddeley, now British Aerospace, and McDonnell Douglas), with Pegasus vectored-thrust turbofan engines (manufactured by British Siddeley, now Rolls Royce), is a fighter that is produced for the military forces (including the U.S. Marines) of several Western countries and was an important factor for the British in the 1982 Falkland Islands conflict (Fig. 3). The Yakovlev, a Russian single-seat, carrier-based combat aircraft, is similar in concept. [W.Z.S.]

**Conveyor** A horizontal, inclined, declined, or vertical machine for moving or transporting bulk materials, packages, or objects in a path predetermined by the design of the device and having points of loading and discharge fixed or selective. Included in this category are skip hoist and vertical reciprocating and inclined reciprocating conveyors; but in the strictest sense this category does not include those devices known as industrial trucks, tractors and trailers, cranes, hoists, monorail cranes, power and hand shovels or scoops, bucket drag lines, platform elevators, or highway or rail vehicles. See BULK-HANDLING MACHINES.

Gravity conveyors provide the most economical means for lowering articles and materials. Chutes depend upon sliding friction to control the rate of descent; wheel and roller conveyors use rolling friction for this purpose.

Gravity chutes may be made straight or curved and are fabricated from sheet metal or wood, the latter being sometimes covered with canvas to prevent slivering. The bed of the chute can be shaped to accommodate the products to be handled. In spiral chutes centrifugal force is the second controlling factor. Spirals with roller beds or wheels provide smooth descent of an article and tend to maintain the position of the article in its original starting position. Rollers may be constructed of metals, wood, or plastic and can be arranged in an optimum position, depending upon the articles to be carried.

To move loads on level or inclined paths, or declining paths that exceed the angle of sliding or rolling friction of the particular material to be conveyed, powered conveyors must be employed. There are various types of powered conveyors. Belt conveyors move loads on a level or inclined path by means of power-driven belts. Belt conveyors with rough-top belts make possible inclines up to 28°; cleated belts are limited on degree of incline only by the position of the center of gravity of the conveyed item.

Live-roller conveyors move objects over series of rollers by the application of power to all or some of the rollers. The power-transmitting medium is usually belting or chain. [A.M.P.]

Vibrating conveyors are designed to move bulk materials along a horizontal, or almost horizontal, path in a controlled system. They can be used to simply transport material from one point to another or to perform various functions en route, such as cooling, drying, blending, metering, spreading, and, by installing a screen, or dedusting. [R.F.M.]

**Cooling tower** A tower- or building-like device in which atmospheric air (the heat receiver) circulates in direct or indirect contact with warmer water (the heat source) and the water is thereby cooled (see illustration). A cooling tower may serve as the heat sink in a conventional thermodynamic process, such as refrigeration or steam power generation, or it may be used in any process in which water is used as the vehicle for heat removal, and when it is convenient or desirable to make final heat rejection to atmospheric air. Water, acting as the heat-transfer fluid, gives up heat to atmospheric air, and thus cooled, is recir-



Counterflow natural-draft cooling tower at Trojan Power Plant in Spokane, Washington. (*Research-Cottrell*)

culated through the system, affording economical operation of the process.

Two basic types of cooling towers are commonly used. One transfers the heat from warmer water to cooler air mainly by an evaporation heat-transfer process and is known as the evaporative or wet cooling tower. Evaporative cooling towers are classified according to the means employed for producing air circulation through them: atmospheric, natural draft, and mechanical draft. The other transfers the heat from warmer water to cooler air by a sensible heat-transfer process and is known as the nonevaporative or dry cooling tower. Nonevaporative cooling towers are classified as air-cooled condensers and as air-cooled heat exchangers, and are further classified by the means used for producing air circulation through them. These two basic types are sometimes combined, with the two cooling processes generally used in parallel or separately, and are then known as wet-dry cooling towers.

Evaluation of cooling tower performance is based on cooling of a specified quantity of water through a given range and to a specified temperature approach to the wet-bulb or dry-bulb temperature for which the tower is designed. Because exact design conditions are rarely experienced in operation, estimated performance curves are frequently prepared for a specific installation, and provide a means for comparing the measured performance with design conditions.

[J.F.Se.]

**Coordinate systems** Schemes for locating points in a given space by means of numerical quantities specified with respect to some frame of reference. These quantities are the coordinates of a point. To each set of coordinates there corresponds just one point in any coordinate system, but there are useful coordinate systems in which to a given point there may correspond more than one set of coordinates.

A coordinate system is a mathematical language that is used to describe geometrical objects analytically; that is, if the coordinates of a set of points are known, their relationships and the properties of figures determined by them can be obtained by numerical calculations instead of by other descriptions. It is the province of analytic geometry, aided chiefly by calculus, to investigate the means for these calculations.

The most familiar spaces are the plane and the three-dimensional euclidean space. In the latter a point  $P$  is determined by three coordinates  $(x, y, z)$ . The totality of points for which  $x$  has

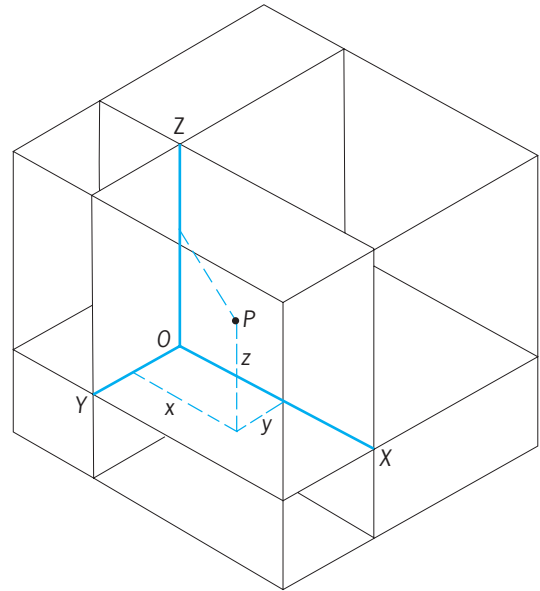

Fig. 1. Cartesian coordinate system.

a fixed value constitutes a surface. The same is true for  $y$  and  $z$  so that through  $P$  there are three coordinate surfaces. The totality of points for which  $x$  and  $y$  are fixed is a curve and through each point there are three coordinate lines. If these lines are all straight, the system of coordinates is said to be rectilinear. If some or all of the coordinate lines are not straight, the system is curvilinear. If the angles between the coordinate lines at each point are right angles, the system is rectangular.

A cartesian coordinate system is one of the simplest and most useful systems of coordinates. It is constructed by choosing a point  $O$  designated as the origin. Through it three intersecting directed lines  $OX$ ,  $OY$ ,  $OZ$ , the coordinate axes, are constructed. The coordinates of a point  $P$  are  $x$ , the distance of  $P$  from the plane  $YOZ$  measured parallel to  $OX$ , and  $y$  and  $z$ , which are determined similarly (Fig. 1). Usually the three axes are taken to be mutually perpendicular, in which case the system is a rectangular cartesian one. Obviously a similar construction can be made in the plane, in which case a point has two coordinates  $(x, y)$ .

A polar coordinate system is constructed in the plane by choosing a point  $O$  called the pole and through it a directed straight

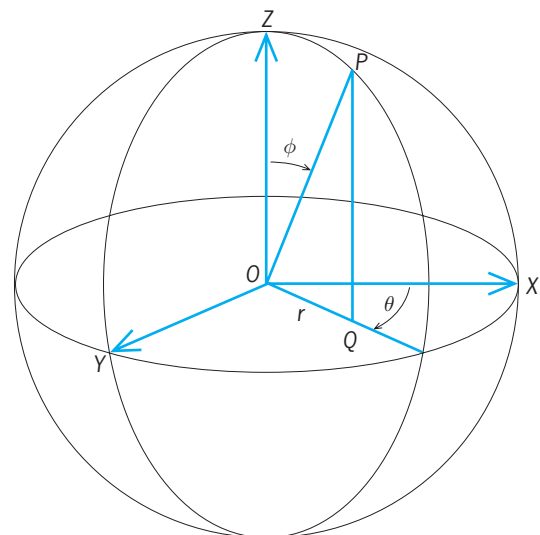

Fig. 2. Spherical coordinate system.

line, the initial line. A point  $P$  is located by specifying the directed distance  $OP$  and the angle through which the initial line must be turned to coincide with  $OP$  in position and direction. The coordinates of  $P$  are  $(r, \theta)$ . The radius vector  $r$  is the directed line  $OP$ , and the vectorial angle  $\theta$  is the angle through which the initial line was turned, + if turned counterclockwise, - if clockwise.

Spherical coordinates are constructed in three-dimensional euclidean space by choosing a plane and in it constructing a polar coordinate system. At the pole  $O$  a polar axis  $OZ$  is constructed at right angles to the chosen plane. A point  $P$ , not on  $OZ$ , and  $OZ$  determine a plane. The spherical coordinates of  $P$  are then the directed distance  $OP$  denoted by  $p$ , the angle  $\theta$  through which the initial line is turned to lie in  $ZOP$  and the angle  $\phi = ZOP$  (Fig. 2).

Cylindrical coordinates are constructed by choosing a plane with a pole  $O$ , an initial line in it, and a polar axis  $OZ$ , as in spherical coordinates. A point  $P$  is projected onto the chosen plane. The cylindrical coordinates of  $P$  are  $(r, \theta, z)$  where  $r$  and  $\theta$  are the polar coordinates of  $Q$  and  $z = QP$  (Fig. 2).

By means of a system of equations the description of a geometrical object in one coordinate system may be translated into an equivalent description in another coordinate system. See ANALYTIC GEOMETRY; CALCULUS; CONFORMAL MAPPING; CURVE FITTING; SPHERICAL HARMONICS. [M.S.Kn.]

**Coordination chemistry** A field which, in its broadest usage, is acid-base chemistry as defined by G. N. Lewis. However, the term coordination chemistry is generally used to describe the chemistry of metals and metal ions in their interactions with other molecules or ions. For example, reactions (1)–(3)

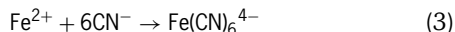
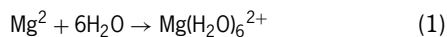

show acid-base-type reactions; the products formed are coordination ions or compounds, and this area of chemistry is known as coordination chemistry.

Thus, it follows that coordination compounds are compounds that contain a central atom or ion and a group of ions or molecules surrounding it. Such a compound tends to retain its identity, even in solution, although partial dissociation may occur. The charge on the coordinated species may be positive, zero, or negative, depending on the charges carried by the central atom and the coordinated groups. These groups are called ligands, and the total number of attachments to the central atom is called the coordination number. Other names commonly used for these compounds include complex compounds, complex ions, Werner complexes, coordinated complexes, chelate compounds, or simply complexes. See ACID AND BASE; CHELATION.

Experimental observations as early as the middle of the 18th century reported the isolation of coordination compounds, but valence theory could not adequately account for such materials. The correct interpretation of these compounds was given by Alfred Werner in 1893. He introduced the concept of residual or secondary valence, and suggested that elements have this type of valence in addition to their normal or primary valence. Thus, platinum(IV) has a normal valence of 4 but a secondary valence or coordination number of 6. This then led to the formulation of  $\text{PtCl}_4 \cdot 6\text{NH}_3$  as  $[\text{Pt}(\text{NH}_3)_6]^{4+}$ ,  $4\text{Cl}^-$  and of  $\text{PtCl}_4 \cdot 5\text{NH}_3$  as  $[\text{Pt}(\text{NH}_3)_5\text{Cl}]^{3+}$ ,  $3\text{Cl}^-$ . The compound with five ammonias has only three ionic chlorides, the fourth is inside the coordination sphere, and therefore is not readily precipitated upon the addition of silver ion. Although the exact nature of the coordinate bond between metal and ligand remains the subject of considerable discussion, it is agreed that the formulations of Werner are essentially correct.

Three theories have been used to explain the nature of the coordinate bond. These are the valence bond theory, the electrostatic theory, including crystal field corrections, and the

molecular orbital theory. Currently, the theory used almost exclusively is the molecular orbital theory. The valence bond theory for metal complexes considers that the pair of electrons on the ligand enter the hybridized atomic orbitals of the metal and that the bond is either essentially covalent or essentially ionic. Several of the properties of these substances can be explained on the basis of this theory. The electrostatic theory, plus the crystal field theory for the transition metals, assumes that the metal-ligand bond is caused by electrostatic interactions between point charges and dipoles and that there is no sharing of electrons. In addition to explaining the structure and magnetic properties, the crystal field theory affords an adequate interpretation of the visible spectra of metal complexes. The molecular orbital theory assumes that the electrons move in molecular orbitals which extend over all the nuclei of the metalligand system. In this manner, it serves to make use of both the valence bond theory and crystal field theory. The molecular orbital theory is therefore the best approximation to the nature of the coordinate bond because it is sufficiently flexible to permit both covalent and ionic bonding as well as the splitting of  $d$  orbitals into various energy levels. See MOLECULAR ORBITAL THEORY.

The stability of metal complexes depends both on the metal ion and the ligand. In general the stability of metal complexes increases if the central ion increases in charge, decreases in size, and increases in electron affinity. Several characteristics of the ligand are known to influence the stability of complexes: (1) basicity of the ligand, (2) the number of metal-chelate rings per ligand, (3) the size of the chelate ring, (4) steric effects, (5) resonance effects, and (6) the ligand atom. Since coordination compounds are formed as a result of acid-base reactions where the metal ion is the acid and the ligand is the base, it follows that generally the more basic ligand will tend to form the more stable complex. The size of the chelate ring is likewise an important factor. For saturated ligands such as ethylenediamine, five-membered rings are the most stable for chelates containing one or more double bonds.

Steric factors often have a very large effect on the stability of metal complexes. This is most frequently observed with ligands having a large group attached to the ligand atom or near it. Thus complexes, of the type shown in the illustration, with alkyl groups  $R$  in the position designated are much less stable than the parent complex where  $R = \text{H}$ . This results from the steric strain introduced by the size of the alkyl group on or adjacent to the ligand atom. In contrast to this, alkyl substitution at any other position results in the formation of more stable complexes because the ligand becomes more basic, and the bulky group is now removed from a position near the coordination site.

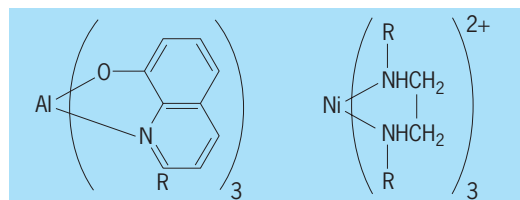

Structural formulas of metal complexes which are affected by steric factors.

Finally, the ligand atom itself plays a significant role in controlling the stability of metal complexes. For most of the metal ions, the smallest ligand atom with the largest electron density will form the most stable complex.

Often the most stable complex is also the least reactive or most inert. Several factors, such as the electronic configuration of the central metal ion, its coordination number, and the extent of chelation, all have a marked effect on the rate of reaction of a given compound. See CHEMICAL BONDING; MAGNETOCHEMISTRY; SOLID-STATE CHEMISTRY; STEREOCHEMISTRY. [F.Ba.]

**Coordination complexes** A group of chemical compounds in which a part of the molecular bonding is of the coordinate covalent type. For a discussion of the nature of the coordinate bond, and the stability and reactivity of complex compounds. See CHELATION; COORDINATION CHEMISTRY.

Coordination complexes contain a central atom or ion and a group of ions or molecules surrounding it. Many simple hydrates, such as  $\text{MgCl}_2 \cdot 6\text{H}_2\text{O}$ , are best formulated as  $[\text{Mg}(\text{H}_2\text{O})_6]\text{Cl}_2$  because it is known that the 6 molecules of water surround the central magnesium ion. Therefore,  $[\text{Mg}(\text{H}_2\text{O})_6]^{2+}$  is a complex ion, and  $[\text{Mg}(\text{H}_2\text{O})_6]\text{Cl}_2$  is a complex compound. The charge on this complex ion is +2, because this is the charge on the magnesium ion and the coordinated water molecules are neutral. However, if the coordinated groups are charged, then the charge on the complex is represented by the sum of the charge on the metal and that of the coordinated ions. See, for example, the progression of charges on the platinum(IV) complexes listed below.

$[\text{Pt}(\text{NH}_3)_6]\text{Cl}_4$	Hexaammineplatinum(IV) chloride
$[\text{Pt}(\text{NH}_3)_5\text{Cl}]\text{Cl}_3$	Chloropentaammineplatinum(IV) chloride
$[\text{Pt}(\text{NH}_3)_4\text{Cl}_2]\text{Cl}_2$	Dichlorotetraammineplatinum(IV) chloride
$[\text{Pt}(\text{NH}_3)_3\text{Cl}_3]\text{Cl}$	Trichlorotriammineplatinum(IV) chloride
$[\text{Pt}(\text{NH}_3)_2\text{Cl}_4]$	Tetrachlorodiammineplatinum(IV)
$\text{K}[\text{Pt}(\text{NH}_3)\text{Cl}_5]$	Potassium pentachloroammineplatinate(IV)
$\text{K}_2[\text{PtCl}_6]$	Potassium hexachloroplatinate(IV)

Thus the charge is +4 for  $[\text{Pt}(\text{NH}_3)_6]^{4+}$  because Pt is +4 and  $\text{NH}_3$  is neutral. But the charge is -2 for  $[\text{PtCl}_6]^{2-}$  because of the 6 for  $\text{Cl}^-$ , that is,  $+4 - 6 = -2$ .

Metal complexes exhibit various types of isomerism. In many ways, inorganic stereochemistry is similar to that observed with organic compounds. Geometrical isomers are common among the inert complexes of coordination numbers 4 and 6. See STEREOCHEMISTRY.

The synthesis of metal complexes containing only one kind of ligand generally involves just the reaction of the metal salt in aqueous solution with an excess of the ligand reagent, as shown below.

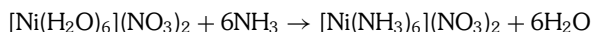

The desired complex salt can then be isolated by removal of water until it crystallizes, or by addition of a water-miscible organic solvent to cause it to separate. For the inert complexes (those slow to react), prolonged treatment at more drastic conditions is often necessary. The preparation of geometrical isomers is much more difficult, and in most cases, the approach used is rather empirical. Generally, reactions yield a mixture of cis-trans products, and these are separated on the basis of their differences in solubility. See AMMINE; HYDRATE. [FBa.]

**Copepoda** A subclass of Crustacea with eight orders. There are over 6000 species, most of which are free-living in aqueous environments, though many are parasitic or symbiotic with other aquatic animals. The free-living forms are the most abundant of all animals in the sea and directly constitute the main food for vast numbers of fishes, many invertebrates, and also at times for baleen whales.

The structure of copepods, although similar in basic pattern, varies greatly (see illustration). In free-living forms the body is composed externally of a series of small chitinous cylinders, or segments, some of which may be more or less fused. The head bears two pairs of antennae. The feeding appendages are one pair of mandibles, two pairs of maxillae, and one pair of maxillipeds. The thorax, consisting of six segments, bears the swimming feet. The abdomen consists of one to five segments and bears no appendages except a pair of terminal processes known as caudal rami. The sexes are separate and sexual dimorphism is frequently evidenced. Free-living species usually range in size

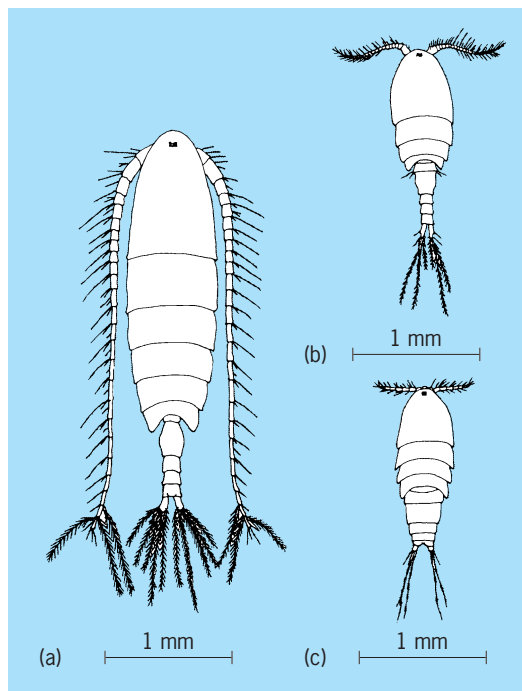

Free-living copepods. (a) *Calanus finmarchicus*, a calanoid. (b) *Cyclops*, a cyclopooid. (c) *Harpacticus*, a harpacticoid.

from less than 0.02 in. (0.5 mm) to about 0.4 in. (10 mm) in length.

Three orders, Calanoida, Cyclopoida, and Harpacticoida, are wholly or primarily free-living and because of overwhelming numbers are of greatest general interest.

In the adult state the remaining orders (Poecilostomatoida, Siphonostomatoida, Monstrilloida, Misophrioida, and Mormonilloida) are parasitic at least part of their lives. Their numbers are relatively small, but they may be conspicuous and important as "fish lice," burrowing deep into the flesh or feeding externally upon the skin and gills. See CALANOIDA; CYCLOPOIDA; MISOPHRIOIDA; MONSTRILLOIDA; MORMONILLOIDA; POECILOSTOMATOIDA; SIPHONOSTOMATOIDA.

Copepod habitats are extremely varied, but the vast majority of species live in the sea. They are mostly planktonic throughout their lives, some occurring only in coastal waters while others live in the open sea. Many frequent only the upper layers to about 650–1000 ft (200–300 m) depth. Others are bathypelagic at great depths. The harpacticoids, however, are primarily a benthic, or bottom-dwelling, group, though many are truly planktonic.

The role of copepods in the economy of the sea consists mainly of converting plant into animal substance. Many species are adapted to graze directly upon the chief synthesizers of organic material, the microscopic diatoms and dinoflagellates that constitute the great pasturage of the sea. Some species are predatory on other copepods, fish larvae, and other small animals, such as protozoa. Commonly copepods constitute about 70% of the zooplankton, and at times their numbers are so great as to impart a pinkish color to the sea. See MARINE ECOLOGY. [H.C.Y.]

**Copolymer** A macromolecule in which two or more different species of monomer are incorporated into a polymer chain. The properties of copolymers depend on both the nature of the monomers and their distribution in the polymer. Thus, monomers A and B can polymerize randomly to form ABBAABA; they can alternate to give ABAB; they can form

blocks AAABBB; or one monomer can be grafted onto a polymer of the other:

AAAA  
B  
B

Copolymers can be prepared by all the known methods of polymerization: addition polymerization of vinyl monomers (by free-radical, anionic, cationic, or coordination catalysis), ring-opening polymerization, or condensation polymerization. See POLYMERIZATION.

In the polymerization of two monomers,  $M_1$  and  $M_2$ , the monomers can add to a growing chain ending in either monomer, designated as  $M_1^*$  and  $M_2^*$ . To a first approximation, only the terminal group of the growing chain is important, so two reactivity ratios can be defined:  $r_1$  is the relative reactivity of chain end  $M_1^*$  to monomers  $M_1$  and  $M_2$ , and  $r_2$  is the relative reactivity of chain end  $M_2^*$  to monomers  $M_2$  and  $M_1$ . The reactivity ratios can be determined experimentally by analyzing polymer compositions at different monomer feeds. See ACRYLONITRILE; POLYACRYLONITRILE RESINS; POLYMER. [D.S.Br.]

**Copper** A chemical element, Cu, atomic number 29, atomic weight 63.546. Copper, a nonferrous metal, is the twentieth most abundant element present in the Earth's crust, at an average level of 68 parts per million (0.22 lb/ton or 0.11 kg/metric ton). Copper metal and copper alloys have considerable technological importance due to their combined electrical, mechanical, and physical properties. The discoveries that mixed-valence Cu(II)/Cu(III) oxides exhibit superconductivity (zero electrical resistance) at temperatures as high as 125 K ( $-234^\circ\text{F}$ ; liquid nitrogen, a cheap coolant, boils at 90 K or  $-297^\circ\text{F}$ ) have generated intense international competition to understand these new materials and to develop technological applications. Although some pure copper metal is present in nature, commercial copper is obtained by reduction of the copper compounds in ores followed by electrolytic refining. The rich chemistry of copper is restricted mostly to the valence states Cu(I) and Cu(II); compounds containing Cu(0), Cu(III), and Cu(IV) are uncommon. Soluble copper salts are potent bacteriocides and algicides at low levels and toxic to humans in large doses. Yet copper is an essential trace element that is present in various metalloproteins required for the survival of plants and animals. See COPPER ALLOYS.

Copper is located in the periodic table between nickel and zinc in the first row of transition elements and in the same subgroup as the other so-called coinage metals, silver and gold. The electronic configuration of elemental copper is  $[1s^2 2s^2 2p^6 3s^2] 3d^{10} 4s^1$  or [argon] $3d^{10} 4s^1$ . At first glance, the sole 4s electron might suggest chemical similarity to potassium, which has the [argon] $4s^1$  configuration. However, metallic copper, in sharp contrast to metallic potassium, is relatively unreactive. The higher nuclear charge of copper relative to that of potassium is not fully shielded by the 10 additional  $d$  electrons, with the result that the copper 4s electron has a higher ionization potential than that of potassium (745.5 versus 418.9 kilojoules/mole, respectively). Moreover, the second and third ionization potentials of copper (1958.1 and 3554 J/mole, respectively) are considerably lower than those of potassium, and account for the higher valence-state accessibility associated with transition-metal chemistry as opposed to alkali-metal chemistry. See PERIODIC TABLE; TRANSITION ELEMENTS; VALENCE.

Copper is a comparatively heavy metal. The density of the pure solid is  $8.96 \text{ g/cm}^3$  ( $5.18 \text{ oz/in.}^3$ ) at  $20^\circ\text{C}$  ( $68^\circ\text{F}$ ). The density of commercial copper varies with method of manufacture, averaging  $8.90\text{--}8.92 \text{ g/cm}^3$  ( $5.14\text{--}5.16 \text{ oz/in.}^3$ ) in cast refinery shapes,  $8.93 \text{ g/cm}^3$  ( $5.16 \text{ oz/in.}^3$ ) for annealed tough-pitch copper, and  $8.94 \text{ g/cm}^3$  ( $5.17 \text{ oz/in.}^3$ ) for oxygen-free copper. The density of liquid copper is  $8.22 \text{ g/cm}^3$  ( $4.75 \text{ oz/in.}^3$ ) near the freezing point.

The melting point of copper is  $1083.0 \pm 0.1^\circ\text{C}$  ( $1981.4 \pm 0.2^\circ\text{F}$ ). Its normal boiling point is  $2595^\circ\text{C}$  ( $4703^\circ\text{F}$ ).

The coefficient of linear expansion of copper is  $1.65 \times 10^{-5}/^\circ\text{C}$  at  $20^\circ\text{C}$ .

The specific heat of the solid is  $0.092 \text{ cal/g}$  at  $20^\circ\text{C}$  ( $68^\circ\text{F}$ ). The specific heat of liquid copper is  $0.112 \text{ cal/g}$ , and of copper in the vapor state about  $0.08 \text{ cal/g}$ .

The electrical resistivity of copper in the usual volumetric unit, that of a cube measuring 1 cm in each direction, is  $1.6730 \times 10^{-6} \text{ ohm}\cdot\text{cm}$  at  $20^\circ\text{C}$  ( $68^\circ\text{F}$ ). Only silver has a greater volumetric conductivity than copper. On a relative basis in which silver is rated 100, copper is 94, aluminum 57, and iron 16.

The mass resistivity of pure copper for a length of 1 m weighing 1 g at  $20^\circ\text{C}$  ( $68^\circ\text{F}$ ) is  $0.14983 \text{ ohm}$ . The conductivity of copper on the mass basis is surpassed by several light metals, notably aluminum. The relative values are 100 for aluminum, 50 for copper, and 44 for silver.

By far the largest use of copper is in the electrical industry, and therefore high electrical conductivity is its most important single property, although for industrial use this property must be accompanied by suitable characteristics in other respects. See CONDUCTOR (ELECTRICITY); ELECTRICAL CONDUCTIVITY OF METALS.

Copper-containing proteins provide diverse biochemical functions, including copper uptake and transport (ceruloplasmin), copper storage (metallothionein), protective roles (superoxide dismutase), catalysis of substrate oxygenation (dopamine  $\beta$ -monooxygenase), biosynthesis of connective tissue (lysyl oxidase), terminal oxidases for oxygen metabolism (cytochrome  $c$  oxidase), oxygen transport (hemocyanin), and electron transfer in photosynthetic pathways (plastocyanin). See BIORGANIC CHEMISTRY; ENZYME. [H.Sc.]

**Copper alloys** Solid solutions of one or more metals in copper. Many metals, although not all, alloy with copper to form solid solutions. Some insoluble metals and nonmetals are intentionally added to copper alloy to enhance certain characteristics. See SOLID SOLUTION.

Copper alloys form a group of materials of major commercial importance because they are characterized by such useful mechanical properties as high ductility and formability and excellent corrosion resistance. Copper alloys are easily joined by soldering and brazing. Like gold alloys, copper alloys have decorative red, pink, yellow, and white colors. Copper has the second highest electrical and thermal conductivity of any metal. All these factors make copper alloys suitable for a wide variety of products.

Copper and zinc melted together in various proportions produce one of the most useful groups of copper alloys, known as the brasses. Brasses containing 5–40% zinc constitute the largest volume of copper alloys. One important alloy, cartridge brass (70% copper, 30% zinc), has innumerable uses, including cartridge cases, automotive radiator cores and tanks, lighting fixtures, eyelets, rivets, screws, springs, and plumbing products.

Lead is added to both copper and the brasses, forming an insoluble phase which improves machinability of the material. Free cutting brass (61% copper, 3% lead, 36% zinc) is the most important alloy in the group. It is machined into parts on high-speed (10,000 rpm) automatic screw machines for a multiplicity of uses. Increased strength and corrosion resistance are obtained by adding up to 2% tin or aluminum to various brasses.

Alloys of copper, nickel, and zinc are called nickel silvers. Nickel is added to the copper-zinc alloys primarily because of its influence upon the color of the resulting alloys; color ranges from yellowish-white, to white with a yellowish tinge, to white. Because of their tarnish resistance, these alloys are used for table flatware, zippers, camera parts, costume jewelry, nameplates, and some electrical switch gear.

Three copper-base alloys containing 10%, 20%, and 30% nickel, with small amounts of manganese and iron added to enhance casting qualities and corrosion resistance, have gained commercial importance. These alloys are known as

cupronic-kels and are well suited for application in industrial and marine installations as condenser and heat-exchanger tubing because of their high corrosion resistance and particular resistance to impingement attack.

Copper-tin alloys (3–10% tin), deoxidized with phosphorus, form an important group known as phosphorus bronzes. Tin increases strength, hardness, and corrosion resistance. These alloys are widely used for springs and screens in papermaking machines. *See* ALLOY; COPPER. [R.E.R.]

**Copper loss** The power loss due to the flow of current through copper conductors. When an electric current flows through a copper conductor (or any conductor), some energy is converted to heat. The heat, in turn, causes the operating temperature of the device to rise. This happens in transformers, generators, motors, relays, and transmission lines, and is a principal limitation on the conditions of operation of these devices. Excessive temperature rises lead to equipment failure.

Much research has been undertaken to reduce the loss in machines and thus to increase the output capability and efficiency for a given amount of conductor. For large machines and for transmission lines, the concept of superconductivity appears to hold much promise for substantial improvements in operating efficiencies. *See* SUPERCONDUCTING DEVICES. [E.C.Jo.]

**Copper metallurgy** The economic production of pure copper metal, suitable for fabrication and use, from copper ores containing as little as 0.5% Cu. Over 90% of the consumption of primary copper in the Western world is produced from ores containing sulfide minerals (chalcopyrite,  $\text{CuFeS}_2$ ; chalcocite,  $\text{Cu}_2\text{S}$ ; and bornite,  $\text{Cu}_5\text{FeS}_4$ ) that can be economically treated only by pyrometallurgical processes. *See* PYROMETALLURGY, NONFERROUS.

In the main processes used in the production of copper from sulfide ores, the mined ore (0.5–2.0% Cu) is finely ground, and then concentrated by flotation to form copper concentrates containing 20–30% Cu. The concentrates are then smelted at high temperatures (about 2280°F or 1250°C) to form a molten mixture of copper and iron sulfides called matte. The molten matte is converted to blister copper (about 99% Cu) by oxidizing the remaining iron and sulfur. After removing the residual sulfur and oxygen in an anode furnace, copper anodes are cast and then refined electrolytically to produce high-purity cathode copper (99.99% Cu), which is suitable for most uses. *See* ORE DRESSING.

Smelting and converting a typical copper concentrate generates over 0.50 ton  $\text{SO}_2$  per ton concentrate (0.50 metric ton  $\text{SO}_2$  per metric ton concentrate), and the resulting  $\text{SO}_2$  emissions must be controlled to meet local environmental standards. This is generally achieved by converting the  $\text{SO}_2$  to sulfuric acid in a contact acid plant, as long as the  $\text{SO}_2$  concentration exceeds 4% and a viable market for acid exists. *See* SULFUR.

Electrorefining is used to remove the remaining impurities in the anode copper (principally As, Bi, Ni, Pb, Sb, and Se) and produce a pure cathode copper (99.99+% Cu). Also, many copper ores contain appreciable amounts of precious metals (Ag, Au, Pt, and so on), which are concentrated into the anode copper during smelting and are recovered as valuable by-products in electrorefining. The impure anodes are suspended alternately with pure copper cathodes in tanks through which an electrolyte of copper sulfate and free sulfuric acid is continuously circulated. When direct current is applied, the copper in the anodes is electrochemically dissolved and then plated as pure copper on the cathodes. Some of the anode impurities, such as arsenic and nickel, are less noble than copper and dissolve in the electrolyte, but they do not plate out at the cathode as long as their concentrations are controlled. The other impurities, such as silver, lead, and selenium, are virtually insoluble in the electrolyte and fall as slimes to the bottom of the tank. These slimes are recovered and processed for eventual recovery of selenium and the precious-metal values. *See* ELECTROCHEMICAL PROCESS; ELECTROMETALLURGY.

Oxidized copper ores are more effectively treated by hydrometallurgical processes. The ore is crushed, ground if necessary, and leached with dilute sulfuric acid, either by percolation through heaps of ore or by agitation in tanks. Copper is recovered from the resulting solution by either cementation or solvent extraction-electrowinning. In cementation, copper is precipitated by contact with scrap iron to form an impure cement copper, which is smelted, then refined. Solvent extraction-electrowinning has become the preferred process. In solvent extraction special organic reagents are used to selectively extract copper from solution. The resulting copper-containing organic phase is then stripped to give a pure and more concentrated aqueous copper solution for electrowinning. Electrowinning is similar to electrorefining except that an inert anode is used and more energy is required. Although electrowon cathode copper is generally not as pure as electrorefined copper, it is still suitable for many applications. *See* COPPER; HYDROMETALLURGY; SOLVENT EXTRACTION. [J.G.Pe.]

**Copulatory organ** An organ utilized by certain male vertebrates for insemination, that is, to deposit spermatozoa directly into the female reproductive tract. In fish, internal fertilization is restricted to certain groups. The pelvic fin of male elasmobranchs and holocephalians is modified for the transmission of sperm and is known as the clasper or clasp organ. A pair of anterior claspers (illus. a) and a frontal clasper which protrudes from the head occur among holocephalians in addition to the modified pelvic clasper of elasmobranchs. The anal fin of teleosts, in which copulation occurs, may be elongated to form a gonopodium.

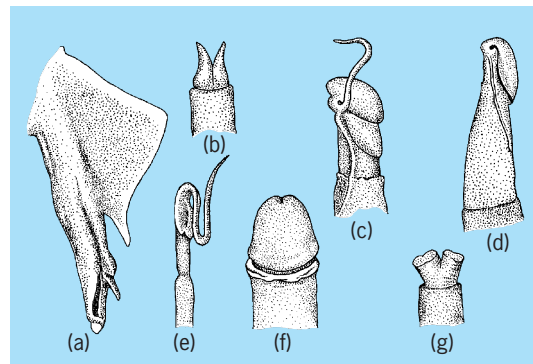

**Vertebrate copulatory organs.** (a) Clasper of dogfish (*Squalus*). Glans penis of (b) opossum, (c) ram, (d) bull, (e) short-tailed shrew, (f) man, (g) Echidna.

Hemipenes which can be everted during copulation are common to both snakes and lizards; however, these structures lack erectile tissue. Turtles and crocodiles possess a single penis with associated erectile tissue, the corpora cavernosa, which becomes distended with blood. A few species of birds have a penis; among these are the ostriches and anseriforms. The penis is present in all mammals.

The copulatory organ (illus. b–g) is variously modified morphologically. Among certain mammals such as rodents, bats, whales, some carnivores, and lower primates, a penis bone, the os priapi or baculum, occurs, increasing the rigidity of the penis. *See* PENIS. [C.B.C.]

**Coquina** A calcarenite or clastic limestone whose detrital particles are chiefly fossils, whole or fragmented. The term is most frequently used for an aggregate of large shells more or less cemented by calcite. If the rock consists of fine-sized shell debris, it is called a microcoquina. Some coquinas show little evidence of any transportation by currents. *See* LIMESTONE. [R.S.]

**Coraciiformes** A diverse order of land birds that is found mainly in the tropics. The relationships of these families have been disputed, with no resolution; the closest affinities may be with other land birds, such as the Piciformes and Passeriformes. See PASSERIFORMES; PICIFORMES.

The Coraciiformes are divided into four suborders and families: Alcedines, including the families Alcedinidae (kingfishers; 91 species), Todidae (todies; 5 species), and Momotidae (motmots; 9 species); Meropes, with the single family Meropidae (bee-eaters; 24 species); Coracii, containing the families Coraciidae (rollers; 11 species), Brachypteraciidae (ground-rollers; 5 species), Leptosomatidae (cuckoo-rollers; 1 species), Upupidae (hoopoes; 1 species), and Phoeniculidae (wood hoopoes; 8 species); and Bucerotes, with the single family Bucerotidae (hornbills; 45 species). Several of these families, such as the different groups of rollers, are sometimes merged into a single family, and several families, such as the kingfishers and hornbills, are divided into subfamilies.

Coraciiform birds are characterized by a syndactyl foot in which the three anterior toes are joined together at the base, although the cuckoo rollers have a zygodactyl foot. Most groups are tropical or warm temperate and are brilliantly colored. Except for bee eaters and wood hoopoes, coraciiforms are generally solitary. Most temperate species are migratory; the tropical ones are permanent residents. Most coraciiforms feed on insects and other animal prey, including fish; hornbills are omnivorous and some feed mainly on fruit. All nest, either solitarily or in colonies in holes burrowed in earthen banks or in tree cavities. See AVES.

[W.J.B.]

**Corallimorpharia** An order of the subclass Zoantharia or Hexacorallia. These sea anemones resemble corals in their weak musculature, capitate (spherically tipped) tentacles, and complex nematocysts. They do not possess a skeleton, however. The tentacles are arranged in radial rows, not cycles, on the disk, and the base has no musculature. The group occurs in shallow water from the temperate zone to the tropics. The species are solitary, although they may occur in large, asexually produced aggregations. Examples are *Corallimorphus* and *Corynactis*. See ANTHOZOA.

[C.H.]

**Corallinales** An order of red algae (Rhodophyceae), commonly called coralline algae. Only one family is recognized, the Corallinaceae, which formerly was assigned to the order Cryptonemiales. These algae are distinguished by the impregnation of cell walls with calcite, a form of calcium carbonate, which causes the thallus to be stony or brittle. See RHODOPHYCEAE.

Coralline algae, comprising about 40 genera and 500 species, are widespread, abundant, and ecologically important. They are divisible into two groups on the basis of the presence or absence of uncalcified, moderately flexible joints (genicula) between calcified segments (intergenicula). The most simple nonarticulated coralline algae are individual crusts of varying extent and thickness (to 8 in. or 20 cm thick). These often become confluent and cover large expanses of substrate. Many crusts bear rounded or pointed, branched or unbranched protuberances that can break off and continue to grow as free nodules known collectively as maerl.

Coralline algae are exclusively marine, although some species can tolerate a reduction in salinity to 13 parts per thousand. Some species thrive only where light is intense, as at the crest of a coral reef, while others grow only in shaded habitats or in deep water. Most species require constant immersion.

The ecosystem in which coralline algae are most important is the coral reef, where they are primary producers, adding carbon to the ecosystem, adding new material to the reefs, and cementing together other calcareous organisms. They have been engaged in similar activities through the millennia, with modern genera recognizable in limestones at least as old as 150 million years (Jurassic).

[P.C.Si.; R.L.Moe]

**Corbino disk** A conducting disk with concentric inner and outer electrical contacts, which can be placed in a magnetic field parallel to its axis. In zero applied field the lines of current are simply radial, but in the presence of an axial magnetic field they lengthen by spiraling. This spiraling occurs because the geometry of the disk is such that the Lorentz force acting on the charge carriers is not counterbalanced by a Hall-effect electric field. The resistance of the disk increases as the field increases, largely as a result of the geometrical magnetoresistance effect associated with the lengthening of the current path. Corbino disks have been used only rarely in practical devices since they have a low overall resistance and correspondingly large power dissipation. See HALL EFFECT; MAGNETORESISTANCE.

[J.F.H.]

**Cordaitales** An extinct order of the class Pinopsida comprising a natural grouping of Paleozoic forest trees or shrubs that first appeared in the Lower Pennsylvanian. They became an important component of the tropical vegetation during the Middle and Upper Pennsylvanian and diminished during the basal Permian. The Cordaitales were divided into three families, Cordaitaceae, Pityaceae, and Poroxylaceae. However, members of the Pityaceae and Poroxylaceae are now known to be either seed ferns or progymnosperms, so only the Cordaitaceae remain. Detailed information about these prominent Paleozoic gymnosperms comes from impression-compression fossils and sandstone casts. However, coal balls, which are mineral nodules in which the plants are preserved with three-dimensional anatomy, have been essential to establishing whole-plant concepts of cordaitan species. See COAL BALLS; PALEOBOTANY.

[M.L.T.]

**Cordierite** An orthorhombic magnesium aluminosilicate mineral of composition  $Mg_2[Al_4Si_5O_{18}]$ . The crystal structure is related to beryl. Limited amounts of  $Fe^{2+}$  may substitute for  $Mg^{2+}$ , and  $Fe^{3+}$  for  $Al^{3+}$ . The hardness is 7 (Mohs scale); specific gravity 2.6; luster vitreous; cleavage poor; and color greenish-blue, lilac blue, or dark blue, often strongly pleochroic colorless to deep blue. Transparent pleochroic crystals are used as gem material. The disordered cordierite structure,  $Mg_2[(Al,Si)_9O_{18}]$ , is called indialite and is hexagonal, isotypic with beryl. Osumilite,  $KMg_2Al_3[(Al,Si)_{12}O_{30}] \cdot H_2O$ , is also related but has a structure built of double six-membered rings of tetrahedrons. Cordierite, indialite, and osumilite are difficult to distinguish. Pale colored varieties are often misidentified as quartz, since these minerals have many physical properties in common. See BERYL; SILICATE MINERALS.

Cordierite possesses unusually low thermal expansion, and synthetic material has been applied to thermal-shock-resistant materials, such as insulators for spark plugs and low-expansion concrete.

Cordierite frequently occurs associated with thermally metamorphosed rocks derived from argillaceous sediments. It may occur in aluminous schists, gneisses, and granulites; though usually appearing in minor amounts, cordierite occurs at many localities throughout the world.

[P.B.M.]

**Cordilleran belt** A mountain belt or chain which is an assemblage of individual mountain ranges and associated plateaus and intermontane lowlands. A cordillera is usually of continental extent and linear trend; component elements may trend at angles to its length or be nonlinear.

The term cordillera is most frequently used in reference to the mountainous regions of western South and North America, which lie between the Pacific Ocean and interior lowlands to the east. Farther north, the extensive and geologically diverse mountain terrane of western North America is formally known as the Cordilleran belt or orogen. This belt includes such contrasting elements within the United States as the Sierra Nevada, Central Valley of California, Cascade Range, Basin and Range



Province, Colorado Plateau, and Rocky Mountains. See MOUNTAIN SYSTEMS.

Cordilleras represent zones of intense deformation of the Earth's crust produced by the convergence and interaction of large, relatively stable areas known as plates. Mountain belts have been analyzed in terms of different modes of plate convergence. Cordilleran-type mountain belts, such as the North American Cordillera, are contrasted with collision-type belts, such as the Himalayas. The former develop during long-term convergence of an oceanic plate toward and beneath a continental plate, whereas the latter are produced by the convergence and collision of one continental plate with another or with an island arc. Characteristics of cordilleran-type mountain belts include their position along a continental margin, their widespread volcanic and plutonic igneous activity, and their tendency to be bordered on both sides by zones of low-angle thrust faulting directed away from the axis of the belt. See OROGENY.

[G.A.D.]

**Core loss** The rate of energy conversion into heat in a magnetic material due to the presence of an alternating or pulsating magnetic field. It may be subdivided into two principal components, hysteresis loss and eddy-current loss. See EDDY CURRENT.

The energy consumed in magnetizing and demagnetizing magnetic material is called the hysteresis loss. It is proportional to the frequency and to the area inside the hysteresis loop for the material used. Most rotating machines are stacked with silicon steel laminations, which have low hysteresis losses. The cores of large units are sometimes built up with cold-reduced, grain-oriented, silicon iron punchings having exceptionally low hysteresis loss, as well as high permeability when magnetized along the direction of rolling. See MAGNETIZATION.

Induced currents flow within the magnetic material because of variations in the flux; this is called eddy-current loss. For 60-cycle rotating machines, core laminations of 0.014–0.018 in. (0.35–0.45 mm) are usually used to reduce this eddy-current loss. See ELECTRIC ROTATING MACHINERY.

[L.T.R.]

**Coriander** A strong-scented annual herb. Coriander is cultivated in many places throughout the world for both seeds and leaves. The two forms are quite different in taste from one another, and both are used for flavor in a variety of foods. Only one species, *Coriandrum sativum*, is cultivated. Coriander is a member of the carrot family, Apiaceae (Umbelliferae), and is closely related to other spice seed plants such as cumin, caraway, anise, dill, and fennel. A number of distinct cultivars have been developed. Some, with longer maturity times and resulting higher leaf yield, are grown for cilantro, also called Chinese parsley. See APIALES; SPICE AND FLAVORING.

[S.Kir.]

**Coriolis acceleration** An acceleration which arises as a result of motion of a particle relative to a rotating system. Only the components of motion in a plane parallel to the equatorial plane are influenced. Coriolis accelerations are important to the circulation of planetary atmospheres, and also in ballistics. See ACCELERATION; BALLISTICS.

Newton's second law of motion is valid only when the motions and accelerations are those observed in a coordinate system that is not itself accelerating, that is, an inertial reference frame. In order to utilize familiar concepts in mathematical treatment, the Earth is commonly treated as if it were fixed, as it appears to one observing from a point on the surface, and the Coriolis force is introduced to balance the acceleration observed by virtue of the observer's motion in the rotating frame. As with the influenced components of motion, the Coriolis force is directed perpendicularly to the Earth's axis, that is, in a plane parallel to the equatorial plane. Since the direction of its action is also perpendicular to the particle velocity itself, the Coriolis force affects

only the direction of motion, not the speed. This is the basis for referring to it as the deflecting force of the Earth's rotation.

A simple illustration of a Coriolis effect in the Northern Hemisphere is afforded by a turntable in counterclockwise rotation, and an external observer who moves a marker steadily in a straight line from the axis to the rim of the turntable. The trace on the turntable is a right-turning curve, and obviously this is also the nature of the path apparent to an observer who rotates with the table. Now consider the contrasting case of an air parcel near the North Pole that moves directly south (away from the Earth's axis of rotation) so that its motion to an observer on the Earth is in a straight line. To a nonrotating observer in space, this same motion appears curved toward the east because of the increased linear velocity of the meridian at lower latitudes. The force necessary to produce the eastward acceleration in the inertial frame is equal to the Coriolis force and would be produced by a gradient of air pressure from west to east, and shown by north-south-oriented isobars. In the absence of the pressure gradient force, the Coriolis force would cause the trajectory of the southward-moving air to curve westward on the Earth's surface. Then an air parcel moving uniformly away from the North Pole along a line which appears straight to an observer in space would appear to earthbound observers to curve westward. See GEOSTROPHIC WIND; ISOBAR (METEOROLOGY).

[E.Ke.]

**Corn** *Zea mays* occupies a larger area than any other grain crop in the United States, where 60% of the world production is grown. Although corn is grown in the United States primarily for livestock feed, about 10% is used for the manufacture of starch, sugar, corn meal, breakfast cereals, oil, alcohol, and several other specialized products. In many tropical countries, corn is used primarily for human consumption.

**As a crop.** The origin of corn is still unsettled, but the most widely held hypothesis assumes that corn developed from its wild relative teosinte (*Z. mexicana*) through a combination of favorable mutations, recognized and selectively propagated by early humans. Corn migrated from its center of origin, presumed to be Mexico or Central America, and was being cultivated by the Indians as far north as New England upon the arrival of the first European colonists, whose survival was due largely to the use of corn as food.

Botanically, corn is a member of the grass family. Each form (botanical variety) is conditioned by fairly few genetic differences, and each may exhibit the full range of differences in color, plant type, maturity, and so on, characteristic of the species. All types have the same number of chromosomes (10 pairs), and all may be intercrossed to produce fertile progeny. Dent corns are the most important in the United States. Sweet corn is grown more extensively in the United States than in any other country. It is eaten as fresh corn or canned or frozen. In other countries, flint, dent, or flour corns may be eaten fresh, but at a much more mature stage than the sweet corn eaten in the United States. The commercial production of popcorn is almost exclusively American. See CYPERALES; GENETICS; REPRODUCTION (PLANT).

Corn is a cross-pollinated plant; the staminate (male) and pistillate (female) inflorescences (flower clusters) are borne on separate parts of the same plant (see illustration). Plants of this type are called monoecious. The staminate inflorescence is the tassel; it produces pollen that is carried by the wind to the silks produced on the ears.

The development of varieties and strains of corn made possible the extension of its culture under diverse soil and climatic conditions. However, modern research methods led to the present widespread use of hybrid corn. Hybrid corn is the first generation of cross involving inbred lines. Inbred lines are developed by controlled self-pollination. When continued for several generations, self-pollination leads to reduction in vigor but permits the isolation of types which are genetically pure or homozygous. Intense



A corn plant in full tassel and silk. The tassel produces pollen that is blown by wind to the silks. (Courtesy of J. W. McManis)

selection is practiced during the inbreeding phase to identify and maintain genotypes having the desired plant and ear type and maturity characteristics, and relative freedom from insect and disease attacks. Crosses involving any two unrelated lines will exhibit heterosis, that is, yields above the means of the two parents. See BREEDING (PLANT); HETEROSIS.

Planting dates depend upon temperature and soil conditions. Germination is very slow at soil temperatures of 50°F (10°C), and seedling growth is limited at temperatures of 60°F (16°C) or below. Planting rates are influenced by water supply, soil type, and fertility and by the maturity characteristics of the hybrid grown. With planting rates above 16,000 plants per acre (40,000 per hectare), drilling in rows 24–36 in. (60–90 cm) apart has become common practice. The use of nitrogen fertilizer has increased greatly; lesser amounts of phosphorus and potash are applied as needed. See AGRICULTURAL SOIL AND CROP PRACTICES.

In the 1930s most corn was husked by hand, and the ears were stored in slatted cribs. The mechanical picker supplanted hand harvesting. The mechanical picker, in turn, has been replaced by the picker-sheller or corn combine, which harvests the crop as shelled grain. When harvested as shelled grain, at a relatively high moisture content (20–30%), the grain must be dried artificially for safe storage. High-moisture corn to be used for livestock feed may be stored in airtight silos or may be treated with certain chemical preservatives such as propionic acid. Corn stored under either of these systems is not suitable either for industrial processing or for seed. See AGRICULTURAL MACHINERY.

[G.F.S.]

Corn is highly productive largely because it can use solar energy so efficiently. The corn plant grows vegetatively until about silking, after which all weight increase is in the form of grain. Almost the entire grain yield results from photosynthesis during the grain growth period, which runs from silking to maturity. Contrary to much popular opinion, grain yields are highest under cool conditions, when the lengthened grain growth period more than compensates for the slower growth rate. Relationships among solar radiation, temperature, growing-season length, soil moisture, day length, soil fertility, and corn genotype in producing grain yields are complex and not well understood. Attempts to study the system as a whole, using simulation models on

digital computers, may add considerably to knowledge of the subject.

[W.G.D.]

**Processing.** Corn kernels (seeds) are subjected to both wet and dry milling. The goal of both processes is to separate the germ, the endosperm, and the pericarp (hull).

Wet milling separates the chemical constituents of corn into starch, protein, oil, and fiber fractions, the primary objective being to produce refined corn starch. Worldwide, the production of nutritive sweeteners is the largest use for the starch obtained from corn. The manufacture of corn sweeteners begins with the wet milling process. The starch is first cooked, or pasted. Then, the starch polymers are hydrolyzed (depolymerized) using an acid, an enzyme, a combination of enzymes, or an acid-enzyme combination. The resulting solutions are refined and concentrated to 70–80% solids. These syrups are known worldwide as glucose syrups, but in the United States are often called corn syrups. When starch is completely hydrolyzed, that is, converted into its monomer units, the only product is D-glucose (dextrose), which can be crystallized from concentrated solutions. Isomerization of some of the D-glucose in a high-glucose hydrolyzate to D-fructose produces high-fructose corn syrups (HFCS), which are known simply as high-fructose syrups (HFS) outside the United States. Fructose is approximately 20% sweeter than sucrose on an equal weight basis.

Corn starch is less extensively depolymerized to make products other than sweeteners. Very slight hydrolysis makes products known as acid-modified or thin-boiling starches. A little more modification with an acid produces dextrans. One application is as remoistenable adhesives on envelopes. Hydrolysis catalyzed by acid or enzymes produces starch oligomers, which are known as maltooligosaccharides or maltodextrins. Maltodextrins are used extensively in foods for their bulking and binding properties and the protection they give to frozen foods. Hydrolysis gives mixtures of breakdown products that, when dried, are known as corn syrup solids. Corn syrup solids dissolve rapidly, are mildly sweet, and are used as bulking materials in food.

Most of the processing of dry-milled corn is done by tempering-degerming systems. Cleaned kernels are transferred to a tempering bin, where they are held for various times at various temperatures depending on the miller and the desired product. Tempered kernels are passed through a degerminator, which removes the bran (pericarp) and germ while leaving the endosperm intact. The endosperm may be converted into as many as 16 different fractions. The main products are regular grits, coarse grits, flaking grits, and corn flour. Other products are corn cones and corn meal.

Nixtamalization is the process of cooking and soaking corn kernels in water containing calcium hydroxide (lime) to soften the pericarp and hydrate the protein matrix and starch of the endosperm. The cooked, steeped product, called nixtamal, is then ground, using stone attrition mills. The product, masa, is sheeted, cut into pieces, and baked, producing tortillas, tortilla chips, taco shells, and corn chips. See FOOD ENGINEERING; FOOD MANUFACTURING.

[J.N.BeM.]

**Cornales** An order of flowering plants, division Magnoliophyta (Angiospermae), in the superordinal Asteridae group of Eudicotyledon. The order consists of 5 families (Cornaceae, Grubbiaceae, Hydrangeaceae, Hydrostachyaceae, and Loasaceae), approximately 50 genera, and about 600 species. The order is mostly characterized by opposite leaves and flowers with four or five perianth parts that usually grow from the top of the ovary (epigynous). The fruit is either a fleshy berry or dehiscent capsule. The various species of dogwoods (*Cornus*) and sour gum (*Nyssa sylvatica*, family Cornaceae) are well known. Various species of Hydrangeaceae (deutzia, hydrangea, mock-orange) are important cultivated shrubs. See ASTERIDAE; DOGWOOD; PLANT KINGDOM; TUPELO.

[K.J.Sy.]

**Corner reflector antenna** A directional antenna consisting of the combination of a reflector comprising two conducting planes forming a dihedral angle and a driven radiator or dipole which usually is in the bisecting plane (see illustration).

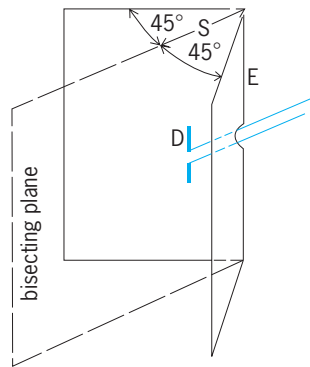

A 90° corner reflector antenna.

It is widely used both singly and in arrays, gives good gain in comparison with cost, and covers a relatively wide band of frequency. The distance  $S$  from the driven radiator  $D$  to edge  $E$  need not be critically chosen with respect to wavelength. See ANTENNA (ELECTROMAGNETISM). [J.C.S.]

**Corona discharge** A type of electrical conduction that generally occurs at or near atmospheric pressure in gases. A relatively strong electric field is needed. External manifestations are the emission of light and a hissing sound. The particular characteristics of the discharge are determined by the shape of the electrodes, the polarity, the size of the gap, and the gas or gas mixture. See ELECTRICAL CONDUCTION IN GASES.

In some cases corona discharge may be desirable and useful, whereas in others it is harmful and attempts are made to minimize it. The effect is used for voltage division and control in direct-current nuclear particle accelerators. On the other hand, the corona discharge that surrounds a high-potential power transmission line represents a power loss and limits the maximum potential which can be used. Because the power loss due to Joule heating decreases as the potential difference is increased, it is desirable to use the maximum possible voltage.

In the potential current characteristic, the corona region is found above the dark current region and is field-sustained. Near the upper end it goes into a glow discharge or a brush discharge, depending on pressure. Higher pressure favors the brush discharge. See GLOW DISCHARGE.

For still higher potential difference, breakdown occurs and a continuously ionized path forms. See ELECTRIC SPARK. [G.H.M.]

**Coronagraph** A specialized astronomical telescope substantially free from instrumentally scattered light, used to observe the solar corona, the faint atmosphere surrounding the Sun. Coronagraphs can record the emission component of the corona (spectral lines emitted by high-temperature ions surrounding the Sun) and the white-light component (solar photospheric light scattered by free electrons surrounding the Sun) routinely from high mountain sites under clear sky conditions. The emission

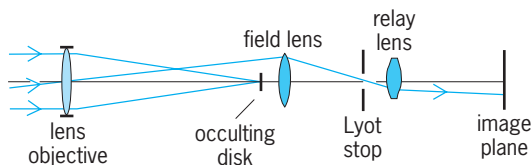

Basic designs of Lyot coronagraph with lens objective.

and white-light components are typically only a few millionths the brightness of the Sun itself. Hence, the corona is difficult to observe unless the direct solar light is completely rejected, and unless instrumentally diffracted and scattered light that reaches the final image plane of the coronagraph is small relative to the coronal light. See SOLAR CORONA; SUN.

The basic design (see illustration), as invented by B. Lyot, has an occulting disk in the primary image plane of the telescope to block the image of the Sun itself. In addition, the primary objective (a lens or superpolished mirror) is specially fabricated to minimize scattered light. Also, light diffracted by the objective rim must be suppressed. For this, an aperture (Lyot stop) is placed at an image of the objective as produced by a field lens, with the aperture diameter slightly smaller than that of the objective image. A relay lens behind the Lyot stop forms the coronal image at the final image plane.

The development of superpolished mirror technology allowed the construction of coronagraphs based on mirror objectives, with significant advantages compared with the singlet-lens objectives used in traditional Lyot coronagraphs. [R.N.Sm.]

**Coronatae** An order of the class Scyphozoa which includes mainly abyssal species. The exumbrella is divided by a circular or coronal furrow into two parts, an upper central disk and a lower coronal part. The central disk is usually domelike, but in *Periphylla* (see illustration) it often narrows toward the top. The

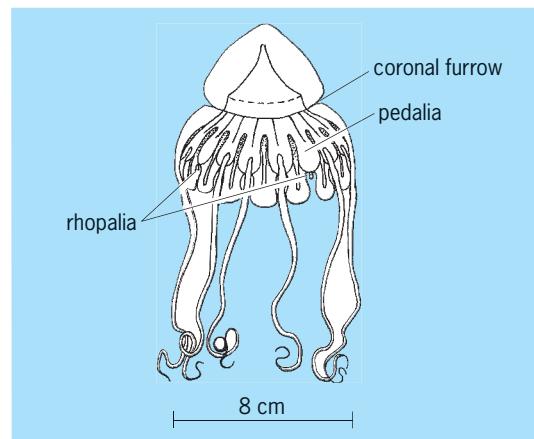

*Periphylla*. (After L. H. Hyman, *The Invertebrates*, vol. 1, McGraw-Hill, 1940)

coronal part has gelatinous thickenings (pedalia) situated on the radii running from the center of the umbrella to the tentacles and the sensory organs. The pedalia are separated from one another by clefts, running down the radii, that are half-way between each tentacle and rhopalium (a sensory organ). Abyssal forms of this group are dark brown or reddish-purple. The littoral species of *Nausithoë* is reported to show alternation of generations, but the life history of abyssal forms remains unknown. See SCYPHOZOA. [T.U.]

**Coronoidea** A small class of "arm"- and brachiole-bearing, stemmed echinoderms in the subphylum Crinozoa, based on five genera known from the Middle Ordovician to Late Silurian of Europe and North America. Coronoids have a crested theca or body with well-developed pentamerous symmetry and plate arrangement very similar to that found in blastoids. A thin stem supported the theca above the sea floor, allowing coronoids to live as attached, low- to medium-level suspension feeders. Coronoids had previously been assigned to the blastoids, eocrinoids, or crinoids by different researchers, but they have been elevated in rank to a separate class. Coronoids appear to be most closely related to the Blastoidea and may have been the

ancestors of this class. See BLASTOIDEA; CRINOZOA; ECHINODERMATA; EOCHRINOIDEA. [J.Sp.]

**Correspondence principle** A fundamental hypothesis according to which classical mechanics can be understood as a limiting case of quantum mechanics; or conversely, many characteristic features in quantum mechanics can be approximated on the basis of classical mechanics, provided classical mechanics is properly reinterpreted. This idea was first proposed by N. Bohr in the early 1920s as a set of rules for understanding the spectra of simple atoms and molecules.

The classical motions in simple dynamical systems can be understood as composed of independent partial motions, each with its own degree of freedom. Each degree of freedom accumulates its own classical action-integral. The frequency of the classical motion for any particular degree of freedom is given by the partial derivative of the energy function with respect to the corresponding action. Bohr noticed that this classical result yields the correct quantum-theoretical result for the light frequency in a transition from one energy level to another, provided the derivative is replaced by the difference in the energies. Moreover, precise information about the possibility of such transitions and their intensities is obtained by analyzing the related classical motion. This information becomes better as the quantum numbers involved become larger. The apparent inconsistencies in Bohr's quantum theory are thereby overcome by a set of rules that came to be called the correspondence principle. See ACTION.

After 1925, the success of the new quantum mechanics, particularly wave mechanics, reduced the correspondence principle to a somewhat vague article of faith among physicists. However, the appeal to classical mechanics is still convenient for some rather crude estimates such as the total number of levels below a given energy. Such estimates help in finding the approximate shape of large atoms and large nuclei in the Thomas-Fermi model.

The correspondence principle, however, has assumed a more profound significance. Experimental techniques in atomic, molecular, mesoscopic, and nuclear physics have improved dramatically. High-precision data for many thousands of energy levels are available where the traditional methods of quantum mechanics are not very useful or informative. However, the basic idea behind the correspondence principle must still be valid: Quantum mechanics must be understandable in terms of classical mechanics for the highly excited states, even in difficult cases like the three-body problem, where the overall behavior seems unpredictable and chaotic. The wider application of Bohr's correspondence principle allows many basic but difficult problems to be seen in a new light. See ATOMIC STRUCTURE AND SPECTRA; CHAOS; MESOSCOPIC PHYSICS; MOLECULAR STRUCTURE AND SPECTRA; QUANTUM MECHANICS. [M.C.G.]

**Corrosion** In broad terms, the interaction between a material and its environment that results in a degradation of the physical, mechanical, or even esthetic properties of that material. More specifically, corrosion is usually associated with a change in the oxidation state of a metal, oxide, or semiconductor.

Electrolytic corrosion consists of two partial processes: an anodic (oxidation) and cathodic (reduction) reaction (see illustration). In the absence of any external voltages, the rates of the anodic and cathodic reactions are equal, and there is no external flow of current. The loss of metal that is the usual manifestation of the corrosion process is a result of the anodic reaction, and can be represented by reaction (1).



This reaction represents the oxidation of a metal (M) from the elemental (zero valence) state to an oxidation state of  $M^{n+}$  with the generation of  $n$  moles of electrons ( $e^{-}$ ). The anodic reaction may occur uniformly over a metal surface or may be localized to a specific area. If the dissolved metal ion can react

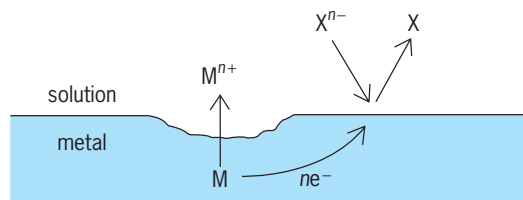

Diagram of a corrosion cell showing the anodic and cathodic partial processes.  $X^{n-}$  = cathodic reactant,  $X$  = cathodic product,  $X^{n-} + ne^{-} \rightarrow X$ .

with the solution to form an insoluble compound, then a buildup of corrosion products may accumulate at the anodic site. See OXIDATION-REDUCTION.

In the absence of any applied voltage, the electrons generated by the anodic reaction (1) are consumed by the cathodic reaction. For most practical situations, the cathodic reaction is either the hydrogen-evolution reaction or the oxygen-reduction reaction. The hydrogen-evolution reaction can be summarized as reaction (2).



In this case, protons ( $H^{+}$ ) combine with electrons to form molecules of hydrogen ( $H_2$ ). This reaction is often the dominant cathodic reaction in systems at low pH. The hydrogen-evolution reaction can itself cause corrosion-related problems, since atomic hydrogen (H) may enter the metal, causing embrittlement, a phenomenon that results in an attenuation of the mechanical properties and can cause catastrophic failure. See EMBRITTLEMENT.

The second important cathodic reaction is the oxygen-reduction, given by reactions (3) and (4). These represent the

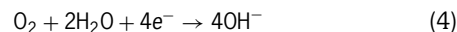
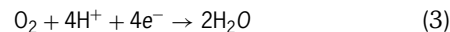

overall reactions in acidic and alkaline solutions, respectively. This cathodic reaction is usually dominant in solutions of neutral and alkaline pH. In order for this reaction to proceed, a supply of dissolved oxygen is necessary; hence the rate of this reaction is usually limited by the transport of oxygen to the metal surface.

Reactions (2)–(4) represent the overall reactions which, in practice, may occur by a sequence of reaction steps. In addition, the reaction sequence may be dependent upon the metal surface, resulting in significantly different rates of the overall reaction. The cathodic reactions are important to corrosion processes since many methods of corrosion control depend on altering the cathodic process. Although the cathodic reactions may be related to corrosion processes which are usually unwanted, they are essential for many applications such as energy storage and generation.

Corrosion rates are usually expressed in terms of loss of thickness per unit time. General corrosion rates may vary from on the order of centimeters per year to micrometers per year. Relatively large corrosion rates may be tolerated for some large structures, whereas for other structures small amounts of corrosion may result in catastrophic failure. For example, with the advent of technology for making extremely small devices, future generations of integrated circuits will contain components that are on the order of nanometers ( $10^{-9}$  m) in size, and even small amounts of corrosion could cause a device failure.

In some situations, corrosion may occur only at localized regions on a metal surface. This type of corrosion is characterized by regions of locally severe corrosion, although the general loss of thickness may be relatively small.

Pitting corrosion is usually associated with passive metals, although this is not always the case. Pit initiation is usually related

to the local breakdown of a passive film and can often be related to the presence of halide ions in solution.

Crevice corrosion occurs in restricted or occluded regions, such as at a bolted joint, and is often associated with solutions that contain halide ions. Crevice corrosion is initiated by a depletion of the dissolved oxygen in the restricted region. As the supply of oxygen within the crevice is depleted, because of cathodic oxygen reduction, the metal surface within the crevice becomes activated, and the anodic current is balanced by cathodic oxygen reduction from the region adjacent to the crevice. The ensuing reactions within the crevice are the same as those described for pitting corrosion: halide ions migrate to the crevice, where they are then hydrolyzed to form metal hydroxides and hydrochloric acid.

Corrosion can also be accelerated in situations where two dissimilar metals are in contact in the same solution. This form of corrosion is known as galvanic corrosion. The metal with the more negative potential becomes the anode, while the metal with the more positive potential sustains the cathodic reaction. In many cases the table of equilibrium potential can be used to predict which metal of galvanic couple will corrode. For example, aluminum-graphite composites generally exhibit poor corrosion resistance since graphite has a positive potential and aluminum exhibits a highly negative potential. As a result, in corrosive environments the aluminum will tend to corrode while the graphite remains unaffected.

Stress corrosion cracking and hydrogen embrittlement are corrosion-related phenomena associated with the presence of a tensile stress. Stress corrosion cracking results from a combination of stress and specific environmental conditions so that localized corrosion initiates cracks that propagate in the presence of stress. Mild steels are susceptible to stress corrosion cracking in environments containing hydroxyl ions ( $\text{OH}^-$ ; often called caustic cracking) or nitrate ions ( $\text{NO}_3^-$ ). Austenitic stainless steels are susceptible in the presence of chloride ions ( $\text{Cl}^-$ ) and hydroxyl ions ( $\text{OH}^-$ ). Other alloys that are susceptible under specific conditions include certain brasses, aluminum and titanium alloys. Hydrogen embrittlement is caused by the entry of hydrogen atoms into a metal or alloy, resulting in a loss of ductility or cracking if the stress level is sufficiently high. The source of the hydrogen is usually from corrosion (that is, cathodic hydrogen evolution) or from cathodic polarization. In these cases the presence of certain substances in the metal or electrolyte can enhance the amount of hydrogen entry into the alloy by poisoning the formation of molecular hydrogen. Metals and alloys that are susceptible to hydrogen embrittlement include certain carbon steels, high-strength steels, nickel-based alloys, titanium alloys, and some aluminum alloys. See ALLOY; STAINLESS STEEL; STEEL.

A reduction in the rate of corrosion is usually achieved through consideration of the materials or the environment. Materials selection is usually determined by economic constraints. The corrosion resistance of a specific metal or alloy may be limited to a certain range of pH, potential, or anion concentration. As a result, replacement metal or alloy systems are usually selected on the basis of cost for an estimated service lifetime. See ELECTROCHEMISTRY. [R.M.L.; P.C.Se.]

**Cortex (plant)** The mass of primary tissue in roots and stems extending inward from the epidermis to the phloem. The cortex may consist of one or a combination of three major tissues: parenchyma, collenchyma, and sclerenchyma. In roots the cortex almost always consists of parenchyma, and is bounded, more or less distinctly, by the hypodermis (exodermis) on the periphery and by the endodermis on the inside.

Cortical parenchyma is composed of loosely arranged thin-walled living cells. Prominent intercellular spaces usually occur in this tissue. In stems the cells of the outer parenchyma may appear green due to the presence of chloroplasts in the cells (see

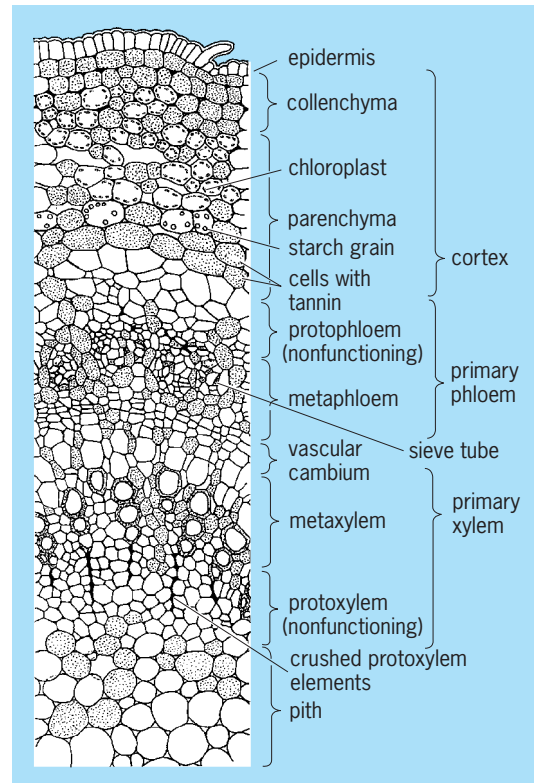

Transverse section of the *Prunus* stem showing the cortex which is composed of collenchyma and parenchyma. (After K. Esau, *Plant Anatomy*, 2d ed., 1967)

illustration). This green tissue is sometimes called chlorenchyma, and it is probable that photosynthesis takes place in it.

In some species the cells of the outer cortex are modified in aerial stems by deposition of hemicellulose as an additional wall substance, especially in the corners or angles of the cells. This tissue is called collenchyma, and the thickening of the cell walls gives mechanical support to the shoot.

The cortex makes up a considerable proportion of the volume of the root, particularly in young roots, where it functions in the transport of water and ions from the epidermis to the vascular (xylem and phloem) tissues. In older roots it functions primarily as a storage tissue.

In addition to being supportive and protective, the cortex functions in the synthesis and localization of many chemical substances; it is one of the most fundamental storage tissues in the plant. The kinds of cortical cells specialized with regard to storage and synthesis are numerous.

Because the living protoplasts of the cortex are so highly specialized, patterns and gradients of many substances occur within the cortex, including starch, tannins, glucosides, organic acids, crystals of many kinds, and alkaloids. Oil cavities, resin ducts, and laticifers (latex ducts) are also common in the midcortex of many plants. [D.S.V.F.]

**Corundum** A mineral with the ideal composition  $\text{Al}_2\text{O}_3$ . It is one of a large group of isostructural compounds including hematite ( $\text{Fe}_2\text{O}_3$ ) and ilmenite ( $\text{FeTiO}_3$ ), all of which crystallize in the hexagonal crystal system, trigonal subsystem. Corundum has the high hardness of 9 on Mohs scale and is therefore commonly used as an abrasive, either alone or in the form of the rock called emery, which consists principally of the minerals corundum and magnetite. Crystals occurring in igneous rocks usually have an elongated barrellike shape, while crystals from metamorphic rocks are generally tabular. The specific gravity is approximately 3.98. See HEMATITE; ILMENITE.

Pure corundum is transparent and colorless, but most specimens contain some transition elements substituting for aluminum, resulting in the presence of color. Substitution of chromium results in a deep red color; such red corundum is known as ruby. The term "sapphire" is used in both a restricted sense for the "cornflower blue" variety containing iron and titanium, and in a general sense for gem-quality corundums of any color other than red. Star ruby and star sapphire contain tiny needles of the mineral rutile. See RUBY; SAPPHIRE.

Corundum occurs as a rock-forming mineral in both metamorphic and igneous rocks, but only in those which are relatively poor in silica, and never in association with free silica. Igneous rocks which most commonly contain corundum include syenites, nepheline syenites, and syenite pegmatites. Both contact and regionally metamorphosed silica-poor rocks may contain corundum. See IGNEOUS ROCKS; METAMORPHIC ROCKS. [D.R.P.]

**Cosmic background radiation** A nearly uniform flux of microwave radiation that is believed to permeate all of space. The discovery of this radiation in 1965 by A. Penzias and R. W. Wilson has had a profound impact on understanding the nature and history of the universe. The interpretation of this radiation as the remnant fireball from the big bang by P. J. E. Peebles, R. H. Dicke, R. G. Roll, and D. T. Wilkinson, and their correct prediction of the spectrum to be that of a blackbody, was one of the great triumphs of cosmological theory. The flight of the *Cosmic Background Explorer (COBE)* satellite has both verified the basic nature of the radiation and given deep insight into the mechanism of formation of galaxy clusters in the early universe and the presence of dark matter.

In the theory of the big bang, the universe began with an explosion 10–15 billion years ago. This big bang was not an explosion of matter into empty space but an explosion of space itself. The early universe was filled with dense, hot, glowing matter; there was no region of space free of matter or radiation. (This state is reflected in the present universe by the fact that space is more or less uniformly filled with galaxies; galaxy clusters and holes between clusters are believed to have grown from gravitational instabilities during the expansion.) The explosion of space increased the volume of the matter and radiation and thus reduced the density and temperature. The initial temperature was so high that even for several hundred thousand years after the initial explosion the universe was still as hot as the surface of the present-day Sun. At this temperature the matter of the universe was in the form of a plasma of electrons, protons, alpha particles (helium nuclei), and photons. The photons were strongly absorbed and reemitted by the electrons, and their spectrum was similar to that of the Sun. About 500,000 years after the initial explosion, the expansion caused the temperature to drop enough that the electrons and protons recombined to form hydrogen atoms. Unlike the previous plasma, which was opaque to light, neutral hydrogen is transparent. From that time (called the time of the decoupling or of recombination) until now, the cosmic photons have been traveling virtually unscattered, carrying information about the nature of the universe at the time of the decoupling. See BIG BANG THEORY.

To an observer moving with the plasma, the photons have a blackbody spectrum with a characteristic temperature of a few thousand kelvins. (A blackbody spectrum is the characteristic emission from a perfectly absorbing object heated to the characteristic temperature. The orange glow emitted from a heated pan is approximately blackbody, as is the light emitted from the filament of a light bulb or from the surface of the Sun.) Although the glow from the plasma is in the visible region, as a result of the recessional velocity of the plasma from the Earth the radiation is redshifted from the visible into the microwave region, with a characteristic temperature of 3 K (5°F above absolute zero, -459.67°F). Detection of the radiation is really the observation of the shell of matter that last scattered the radiation. See HEAT RADIATION; REDSHIFT.

The microwave radiation is coming from the most distant region of space ever observed, and was emitted earlier in time than any other cosmological signal. The radiation was originally termed cosmic background radiation because the discoverers foresaw that it would cause a background interference with satellite communications, but the term has taken on a vivid new meaning: the radiating shell of matter forms the spatial background in front of which all other astrophysical objects, such as quasars, lie. Until methods are devised to detect the neutrinos or gravity waves that were decoupled earlier, there will be no direct means of viewing beyond this background. See GRAVITATIONAL RADIATION; NEUTRINO.

Subsequent to its discovery, experimental work on the microwave background has been concerned primarily with the measurement of the radiation's color (its spectrum of intensity at different frequencies) and with its isotropy (its intensity as a function of direction in the sky). Results from the *COBE* satellite showed that the spectrum is that of a blackbody, at a temperature above absolute zero of  $2.735 \pm 0.060$  K, to better than 1% accuracy. The lack of deviations places strong limits on the nature of material present at the time of decoupling, just a half million years after the creation of the universe.

Measurements showed that the radiation was isotropic to better than 1%. This uniformity posed a difficult problem for cosmological theory, since according to the simple big bang theory the different parts of the sky that gave rise to the microwave background had not been close enough together to reach an equilibrium temperature. Thus there was no way to understand how the intensity could be uniform. This theoretical problem was solved by a variation on the big bang theory called the inflationary universe model. In this picture the early universe was much smaller than had previously been supposed, giving it time to attain a uniform temperature; the rapid expansion of the universe occurred at a later time, the period of inflation. See INFLATIONARY UNIVERSE COSMOLOGY.

A map of intensity produced by the *COBE* satellite displays a smooth yin-yang pattern, which is the cosine variation from the 600-km/s (370-mi/s) motion of the Milky Way Galaxy. The variation is only about 3.4 mK, or about 0.1% as large as the constant 2.7-K past. The velocity of the Milky Way Galaxy is believed to result from its gravitational acceleration toward the center of a large local supercluster of galaxies. See DOPPLER EFFECT; GALAXY, EXTERNAL; UNIVERSE.

In 1992 the *COBE* team announced that they had found small variations in the microwave map that appear to be cosmological in origin. The map of intensity with the cosine term removed displays a bright horizontal band which comes from synchrotron emission in the Milky Way Galaxy. The most exciting regions of the plot are the marbled areas above and below the synchrotron stripe, which the *COBE* team called ripples in the radiation. These ripples are believed to be the first indications that the early universe was not completely uniform. The structure has a magnitude of approximately 15–30  $\mu$ K, a factor of 200,000 times smaller than the 2.7-K radiation itself.

The inflationary universe model accounts for the uniformity of the radiation but still leaves the puzzle that the present universe is highly nonuniform, with most of the mass clumped into stars, galaxies, and clusters of galaxies. Most astrophysicists believe that the clumping came about from the mutual gravitational attraction of the matter created in the big bang. The cosmological anisotropy observed by the *COBE* satellite is interpreted as the early sign of the clumping, taking place a half million years after the creation of the universe.

Theories of galaxy formation must postulate large amounts of dark, unseen matter in order to provide the strong gravitational fields necessary for sufficient clumping. The nature of this matter is unknown, but the matter must be more massive than all that observed in stars and galaxies. The radiation coming from the otherwise unseen clumps undergoes a gravitational redshift, according to the general theory of relativity, and it is this effect

that *COBE* is believed to be observing. These residual lumps are consistent in magnitude and form with that predicted by the inflationary universe version of the big bang theory. Thus the ripples observed in the radiation are in fact a map of the distribution of dark matter in the very early universe. See COSMOLOGY; GRAVITATIONAL REDSHIFT. [R.A.Mu.]

**Cosmic rays** Electrons and the nuclei of atoms—largely hydrogen—that impinge upon Earth from all directions of space with nearly the speed of light. These nuclei with relativistic speeds are often referred to as primary cosmic rays, to distinguish them from the cascade of secondary particles generated by their impact against air nuclei at the top of the terrestrial atmosphere. The secondary particles shower down through the atmosphere and are found all the way to the ground and below.

The primary cosmic rays provide the only direct sample of matter from outside the solar system. Measurement of their composition can aid in understanding which aspects of the matter making up the solar system are typical of the Milky Way Galaxy as a whole and which may be so atypical as to yield specific clues to the origin of the solar system. Cosmic rays are electrically charged; hence they are deflected by the magnetic fields which are thought to exist throughout the Galaxy, and may be used as probes to determine the nature of these fields far from Earth. Outside the solar system the energy contained in the cosmic rays is comparable to that of the magnetic field, so the cosmic rays probably play a major role in determining the structure of the field. Collisions between the cosmic rays and the nuclei of the atoms in the tenuous gas which permeates the Galaxy change the cosmic-ray composition in a measurable way and produce gamma rays which can be detected at Earth, giving information on the distribution of this gas.

**Cosmic-ray detection.** All cosmic-ray detectors are sensitive only to moving electrical charges. Neutral cosmic rays (neutrons, gamma rays, and neutrinos) are studied by observing the charged particles produced in the collision of the neutral primary with some type of target. At low energies the ionization of the matter through which they pass is the principal means of detection. A single measurement of the ionization produced by a particle is usually not sufficient both to identify the particle and to determine its energy. However, since the ionization itself represents a significant energy loss to a low-energy particle, it is possible to design systems of detectors which trace the rate at which the particle slows down and thus to obtain unique identification and energy measurement.

At energies above about 500 MeV per nucleon, almost all cosmic rays will suffer a catastrophic nuclear interaction before they slow appreciably. An ionization measurement is commonly combined with measurements of physical effects which vary in a different way with mass, charge, and energy. Cerenkov detectors and the deflection of the particles in the field of large superconducting magnets or the magnetic field of the Earth itself provide the best means of studying energies up to a few hundred GeV per nucleon. Detectors employing the phenomenon of x-ray transition radiation promise to be useful for measuring composition at energies up to a few thousand GeV per nucleon. See CERENKOV RADIATION; SUPERCONDUCTING DEVICES.

Above about  $10^{12}$  eV, direct detection of individual particles is no longer possible since they are so rare. Such particles are studied by observing the large showers of secondaries they produce in Earth's atmosphere. These showers are detected either by counting the particles which survive to strike ground-level detectors or by looking at the flashes of light the showers produce in the atmosphere with special telescopes and photomultiplier tubes. See PARTICLE DETECTOR; PHOTOMULTIPLIER.

**Atmospheric cosmic rays.** The primary cosmic-ray particles coming into the top of the terrestrial atmosphere make inelastic collisions with nuclei in the atmosphere. When a high-energy nucleus collides with the nucleus of an air atom, a number of things usually occur. Rapid deceleration of the incoming

nucleus leads to production of pions with positive, negative, or neutral charge. A few protons and neutrons (in about equal proportions) may be knocked out with energies up to a few GeV. They are called knock-on protons and neutrons.

All these protons, neutrons, and pions generated by collision of the primary cosmic-ray nuclei with the nuclei of air atoms are the first stage in the development of the secondary cosmic-ray particles observed inside the atmosphere. Since several secondary particles are produced by each collision, the total number of energetic particles of cosmic-ray origin will increase with depth, even while the primary density is decreasing.

The uncharged  $\pi^0$  mesons decay into two gamma rays with a life of about  $8 \times 10^{-17}$  s. The two gamma rays each produce a positron-electron pair. Upon passing sufficiently close to the nucleus of an air atom deeper in the atmosphere, the electrons and positrons convert their energy into bremsstrahlung. The bremsstrahlung in turn create new positron-electron pairs, and so on. This cascade process continues until the energy of the initial  $\pi^0$  has been dispersed into a shower of positrons, electrons, and photons with insufficient individual energies ( $\leq 1$  MeV) to continue the pair production. The electrons and photons of such showers are referred to as the soft component of the atmospheric (secondary) cosmic rays. See ELECTRON-POSITRON PAIR PRODUCTION.

The  $\pi^\pm$  mesons produced by the primary collisions have a life of about  $2.6 \times 10^{-8}$  s before they decay into muons. Most low-energy  $\pi^\pm$  decay into muons before they have time to undergo nuclear interactions. Except at very high energy (above 500 GeV), muons interact relatively weakly with nuclei, and are too massive (207 electron masses) to produce bremsstrahlung. They lose energy mainly by the comparatively feeble process of ionizing an occasional air atom as they progress downward through the atmosphere. Because of this ability to penetrate matter, they are called the hard component.

The high-energy nucleons—the knock-on protons and neutrons—produced by the primary-particle collisions and a few pion collisions proceed down into the atmosphere. They produce nuclear interactions of the same kind as the primary nuclei, though of course with diminished energies. This cascade process constitutes the nucleonic component of the secondary cosmic rays.

**Solar modulation.** The cosmic-ray intensity is lower during the years of high solar activity and sunspot number, which follow an 11-year cycle. This effect has been extensively studied with ground-based and spacecraft instruments.

The primary cause of solar modulation is the solar wind, a highly ionized gas (plasma) which boils off the solar corona and propagates radially from the Sun at a velocity of about 250 mi/s (400 km/s). The wind is mostly hydrogen, with typical density of 80 protons per cubic inch (5 protons per cubic centimeter). This density is too low for collisions with cosmic rays to be important. Rather, the high conductivity of the medium traps part of the solar magnetic field and carries it outward.

In addition to the bulk sweeping action, another effect of great importance occurs in the solar wind, adiabatic deceleration. Because the wind is blowing out, only those particles which chance to move upstream fast enough are able to reach Earth. However, because of the expansion of the wind, particles interacting with it lose energy. Thus, particles observed at Earth with energy of 10 MeV per nucleon actually started out with several hundred MeV per nucleon in nearby interstellar space, and those with initial energy of only 100–200 MeV per nucleon probably never reach Earth at all.

**Composition of cosmic rays.** Nuclei ranging from protons to lead have been identified in the cosmic radiation. The relative abundances of the elements may be compared with the best estimate of the “universal abundances” obtained by combining measurements of solar spectra, lunar and terrestrial rocks, meteorites, and so forth. Most obvious is the similarity between the two distributions. However, a systematic deviation is quickly

apparent: the elements lithium-boron and scandium-manganese as well as most of the odd-charged nuclei are vastly overabundant in the cosmic radiation. This effect has a simple explanation: the cosmic rays travel great distances in the galaxy and occasionally collide with atoms of interstellar gas—mostly hydrogen and helium—and fragment. This fragmentation, or spallation as it is called, produces lighter nuclei from heavier ones but does not change the energy per nucleon very much. Thus the energy spectra of the secondaries are similar to those of the primaries. Calculations involving reaction probabilities determined by nuclear physicists show that the overabundances of the secondary elements can be explained by assuming that cosmic rays pass through an average of about 1 oz per square inch (5 g per square centimeter) of material on their way to Earth.

When spallation has been corrected for, differences between cosmic-ray abundances and solar-system or universal abundances still remain. The most important question is whether these differences are due to the cosmic rays having come from a special kind of material (such as would be produced in a supernova explosion), or simply to the fact that some atoms might be more easily accelerated than others.

Cosmic-ray electron measurements pose other problems of interpretation, partly because electrons are nearly 2000 times lighter than protons, the next lightest cosmic-ray component. Protons with kinetic energy above 1 GeV are about 100 times as numerous as electrons above the same energy, with the relative number of electrons decreasing slowly at higher energies. But it takes about 2000 GeV to give a proton the same velocity as a 1-GeV electron. Viewed in this way electrons are several thousand times more abundant than protons. It is thus quite possible that cosmic electrons have a different source entirely from the nuclei.

**Age.** Another important result which can be derived from detailed knowledge of cosmic-ray isotopic composition is the “age” of cosmic radiation. Certain isotopes are radioactive, such as beryllium-10 with a half-life of  $1.6 \times 10^6$  years. Since Be is produced entirely by spallation, study of the relative abundance of  $^{10}\text{Be}$  to the other Be isotopes, particularly as a function of energy to utilize the relativistic increase in this lifetime, will yield a number related to the average time since the last nuclear collision. Measurements show that  $^{10}\text{Be}$  is nearly absent at low energies and yield an estimate of the age of the cosmic rays of approximately  $10^7$  years. An implication of this result is that the cosmic rays propagate in a region in space which has an average density of 1.5–3 atoms per cubic inch (0.1–0.2 atom per cubic centimeter). This is consistent with some astronomical observations of the immediate solar neighborhood.

**Origin.** Although study of cosmic rays has yielded valuable insight into the structure, operation, and history of the universe, their origin has not been determined. The problem is not so much to devise processes which might produce cosmic rays, but to decide which of many possible processes do in fact produce them.

It is thought that cosmic rays are produced by mechanisms operating within galaxies and are confined almost entirely to the galaxy of their production, trapped by the galactic magnetic field. The intensity in intergalactic space would only be a few percent of the typical galactic intensity, and would be the result of a slow leakage of the galactic particles out of the magnetic trap. [PE.]

**Cosmic spherules** Solidified droplets of extraterrestrial materials that melted either during high-velocity entry into the atmosphere or during hypervelocity impact of large meteoroids onto the Earth's surface. Cosmic spherules are rounded particles that are millimeter to microscopic in size and that can be identified by unique physical properties. Although great quantities of the spheres exist on the Earth, they are ordinarily found only in special environments where they have concentrated and are least diluted by terrestrial particulates. See METEOR.

The most common spherules are ablation spheres produced by aerodynamic melting of meteoroids as they enter the atmosphere. Typical ablation spheres are produced by melting of sub-millimeter asteroidal and cometary fragments that enter the atmosphere at velocities ranging from 6.5 to 43 mi (11 to 72 km) per second. The spheres are formed near 48 mi (80 km) altitude, where deceleration, intense frictional heating, melting, partial vaporization, and solidification all occur within a few seconds. During formation, the larger particles can be seen as luminous meteors or shooting stars.

Ablation spheres fall to Earth at a rate of one 0.1-mm-diameter sphere per square meter per year, and every rooftop contains these particles. Unfortunately they are usually mixed in with vast quantities of terrestrial particulates, and they are very difficult to locate. They can, however, be easily found in special environments, such as the ocean floor, that do not contain high concentrations of terrestrial particles that could be confused with cosmic spheres larger than 0.004 in. (0.1 mm) in diameter. See MARINE SEDIMENTS.

Impact spheres constitute a second and rarer class of particles that are produced when giant meteoroids impact the Earth's surface with sufficient velocity to produce explosion craters that eject molten droplets of both meteoroid and target materials. They are very abundant on the Moon, but they are rare on the Earth, and they have been found in only a few locations. Impacts large enough to produce explosion craters occur on the Earth every few tens of thousands of years, but the spheres and the craters themselves are rapidly degraded by weathering and geological processes. Meteoritic spherules have been found around a number of craters. Silica-rich glass spheroids (microtektites) are found in thin layers that are contemporaneous with the conventional tektites. Microtektites are believed to be shock-melted sedimentary materials that were ejected from large impact craters. They were ejected as plumes that covered substantial fractions of the surface of the Earth. Microspherules of a different composition have been found in the thin iridium-rich layer associated with the global mass extinctions at the Cretaceous–Tertiary boundary. See TEKTITE.

Cosmic spherules are of particular scientific interest because they provide information about the composition of comets and asteroids and also because they can be used as tracers to identify debris resulting from the impact of large extraterrestrial objects. In general, cosmic spherules can be confidently identified on the basis of their elemental and mineralogical compositions, which are radically different from nearly all spherical particles of terrestrial origin. [D.E.Br.]

**Cosmic string** A hypothetical object that may account for large-scale structure in the universe. The problem of the form and origin of such structure is one of the major challenges in science. The hot big bang theory provides a remarkably simple and successful description of the broad features of the universe, but it provides no mechanism through which structure could have formed. See BIG BANG THEORY.

Cosmic strings were the earliest theory of the formation of structure in the universe to emerge from high-energy particle theory in the early 1980s. It was realized that certain grand unified theories and superstring theories, which seek to unify the disparate forces of nature within a single theoretical framework, automatically lead to the production of a network of cosmic strings in the very early universe. Eventually, disturbances produced by the strings would lead to the formation of structures like galaxies and galaxy clusters.

Cosmic strings are analogous to defects that form when water is suddenly frozen to form ice. Freezing is an important example of a phase transition in which symmetry is broken. The water is symmetric under rotations; it looks the same from any angle. However, the crystalline structure of ice is not; its crystalline planes pick out definite directions. As the water freezes, at each point in space the crystalline structure of the solid picks an



orientation in which to form, but this orientation varies from place to place. At some points, there is a mismatch between the orientation of neighboring crystalline regions. The resulting topological defects can take the form of sheets, lines, or points.

All unified field theories are based on the concept of symmetry breaking. The idea is that at high energies and temperatures the forces of nature should be indistinguishable and matter should exist in a highly symmetric state. However, at low energies the symmetry is broken and the forces are distinct. But the symmetry breaking that occurred as the very hot early universe cooled would have produced defects, just as symmetry breaking produces defects in ice when water freezes. Cosmic strings are closely analogous to the linelike defects in ice, often called dislocation lines. See CRYSTAL DEFECTS; INFLATIONARY UNIVERSE COSMOLOGY; SYMMETRY BREAKING.

Cosmic strings are very thin, approximately  $10^{-15}$  the radius of a proton. They are also very massive; 1 m of grand-unified cosmic string would weigh  $10^{20}$  kg. They can take the form of closed loops, or infinite strings that wander on forever. When the cosmic strings form, around  $10^{-34}$  s after the big bang, most of the string is in very long strings, which wander right across the universe. In effect, the universe is filled with a random, tangled network of spaghetti. As the universe expands, the string network chops itself up into tiny loops, which lose energy by radiating gravity waves until they shrink and disappear. However, the long strings cannot be eliminated, and would survive right up to the present. See COSMOLOGY; GRAVITATIONAL RADIATION; UNIVERSE. [N.T.]

**Cosmochemistry** The science of the chemistry of the universe, particularly that beyond the Earth. As currently practiced, cosmochemistry is concerned primarily with inferences on pre-solar-system events, solar nebular processes, and early planetary processes as deduced from minerals in meteorites and from chemical and isotopic compositions of meteorites and their parts. See ISOTOPE; METEORITE.

**Minerals in meteorites.** Meteorites provide a great deal of otherwise unobtainable information about the formation and early history of the solar system. The solar system formed from the solar nebula, a large cloud of gas and dust. The chemical composition of the solar system, which can be assumed to be the same as that of the solar nebula, is known in detail from spectroscopic analysis of the Sun, which contains 99.9% of its mass. From a combination of this knowledge, an estimate of temperature and pressure from hydrodynamic models, and thermodynamic data for all possible gas, liquid, and solid species, it can be determined which minerals would have become stable as the gas cloud underwent gravitational collapse, spun down into a disk, and cooled. Pressure in the solar nebula was probably so low that condensation occurred at temperatures below the melting points of the minerals, and they condensed as solids. Different minerals became stable at different temperatures, giving rise to a condensation sequence, which can be calculated. See ASTRONOMICAL SPECTROSCOPY; ELEMENTS, COSMIC ABUNDANCE OF; HYDRODYNAMICS; PROTOSTAR; SOLAR SYSTEM; SUN; THERMODYNAMIC PRINCIPLES.

Detailed chemical information, however, requires samples, and the Earth is too geologically active to provide samples dating to its formation. Meteorites are therefore studied because, in general, they have undergone much less modification than terrestrial rocks.

A certain type of meteorite, the carbonaceous chondrite, contains millimeter-sized rocklets, or refractory inclusions, that are composed of the very minerals (especially hibonite, perovskite, melilite, spinel, and fassaite) believed to have been among the first to condense from the solar nebula. This finding indicates that assumptions used to calculate the condensation sequence are reasonably accurate. See CORUNDUM; MELILITE; PEROVSKITE; SPINEL.

Some meteorites also contain trace amounts of grains of carbon-rich minerals (silicon carbide, diamond, and graphite)

whose condensation requires a gas with a carbon/oxygen ratio greater than 1, whereas that of the Sun is 0.6. This finding, along with very large isotopic anomalies for many elements, provides strong evidence that these grains are interstellar in origin, predating the Sun by as much as about  $2.4 \times 10^9$  years. These grains should have disappeared by reacting with the solar nebular gas, however; why they did not and how they survived long enough to be incorporated into meteorites are not yet understood. See DIAMOND; GRAPHITE; INTERSTELLAR MATTER; SILICON. [S.B.S.]

**Chemical compositions of meteorites.** The chemical composition of meteorites and independently formed objects within them have taught much about pre-solar-system events, solar nebular processes, and early planetary processes.

As mentioned above, several types of interstellar grains have been separated from primitive meteorites. Presolar grains identified include silicon carbide, graphite, diamond, titanium carbide, zirconium carbide, molybdenum carbide, aluminum oxide, titanium oxide, hibonite, and spinel. While chemistry alone has not unambiguously identified any of these grains as presolar, chemistry does help to understand the formation conditions of objects whose isotopic composition proves a presolar origin. A good example is silicon carbide, most of which is believed, on the basis of isotopic arguments, to come from the circumstellar envelopes of asymptotic giant branch stars. The silicon carbide with isotope anomalies that is separated from meteorites is enriched in a number of trace elements that are predicted to condense at high temperatures as carbides in reducing environments, such as zirconium, titanium, molybdenum, strontium, barium, and the rare-earth elements. These enrichments are entirely consistent with the proposed origin of silicon carbide by high-temperature condensation in the circumstellar envelopes of carbon-rich stars. See GIANT STAR.

Chemistry has been used to infer a number of important processes in the solar nebula. These include high-temperature condensation and vaporization, melting and crystallization of millimeter- to centimeter-sized objects in the solar nebula, separation of metal from silicate grains, and reaction of condensed grains with solar nebular gas. Investigation of these processes helps determine important properties of the solar nebula, such as its temperature, how long it lasted, and what the planets, which formed from the nebula, are made of.

A number of important planetary processes, such as separation and differentiation of a metallic core and differentiation of the silicate portion of a planet into mantle and crust, can be studied through the chemical compositions of meteorites. [A.M.D.]

**Isotopic compositions of meteorites.** Studies of the relative abundances of isotopes in meteorites provide a unique source of information about the age of the solar system, the time scales for formation of the first solid bodies in the solar system and the growth and evolution of small planets, the prehistory (nucleosynthesis) of the material out of which the solar system formed, and the interaction of solar and galactic cosmic rays with matter. See NUCLEOSYNTHESIS.

The oldest meteoritic samples are the refractory, calcium-aluminum-rich inclusions found in carbonaceous chondrites. The 4.566-billion-year age of these objects provides the best estimate for the condensation of the first solid material in the solar system. Chondrules, millimeter-size spherules of glass and crystals, began to form a few million years after refractory inclusions as the solar nebula cooled. The oldest basaltic meteorites crystallized from molten lavas on small asteroids within roughly 10 million years of this time (that is, ages of 4.562–4.552 billion years). Most chondritic meteorites have less precisely determined ages encompassing the range covered by chondrules and basaltic achondrites. The tight clustering of ages of the oldest meteorites reflects a period of rapid growth during the first 10 million years of solar system history, as millimeter-to-centimeter-size objects collided and coalesced to form meter-to-kilometer-size planetesimals. The younger ages of some meteorites indicate that disturbances due to shock and thermal metamorphism began as

early as 4.5 billion years ago and continued for 100–200 million years. Collisions between planetesimals led to coagulation, the growth of larger bodies, and the eventual formation of the terrestrial planets, including the Earth-Moon system, 50–100 million years after most meteorites. See EARTH, AGE OF; ROCK AGE DETERMINATION.

One unusual group, the SNC meteorites, whose appearance and composition is similar to that of terrestrial basalts, is the exception to the rule with much younger crystallization ages of approximately 1.3 billion years. The young ages require an origin on a planetary body larger than the Moon, on which radioactive heating could sustain igneous activity for at least 3 billion years. It is generally believed that this group of meteorites originated on Mars, an argument strengthened by recent evidence that the isotopic compositions of hydrogen, nitrogen, and noble gases in the SNC meteorites and the Martian atmosphere are strikingly similar and distinct from those in the Earth and other meteorites.

Nine short-lived species with half-lives ranging from 0.10 to 103 million years are known to have existed at the birth of the solar system. The evidence of short-lived radionuclides is distributed across all classes of meteorites and provides a compelling argument not only that meteorites are the oldest objects in the solar system but that they formed rather quickly over a very short interval. Although these nuclides can no longer be observed directly, evidence that they were present during the earliest epoch of solar system history is preserved as variations in the relative abundances of the daughter isotopes of the extinct radionuclides. For example, large excesses of  $^{26}\text{Mg}$ , produced by the decay of  $^{26}\text{Al}$  (half-life of 0.72 million years), are found in aluminum-rich, magnesium-poor minerals in refractory inclusions in carbonaceous chondrites.

The short-lived nuclides are not restricted to primitive chondritic meteorites but are also prominent in meteorites believed to have been produced by planetary-scale melting. The widespread presence of short-lived nuclides indicates that the time interval between nucleosynthesis and the formation of the solar system must be short. Refractory inclusions containing  $^{41}\text{Ca}$ , an isotope with a half-life of only 100,000 years, must have formed within a few mean lives, that is, a few hundred thousand years of  $^{41}\text{Ca}$  production. This time scale is so short that it suggests the formation of the solar system may have been triggered by a shock wave from a nearby exploding star containing freshly synthesized nuclear material.

Except for the variations in isotopic abundances related to decay of radionuclides discussed above, for the most part there is a close similarity between the isotopic compositions of meteorites, the Moon, and the Earth. For many years this apparent homogeneity was taken as evidence that the solar nebula was chemically and physically well mixed before the formation of the first solid bodies. The development of new analytical techniques permitting the determination of isotopic compositions in small (<0.01 mm) constituents of meteorites has, however, led to the discovery of large differences in isotopic abundances for many elements which cannot be explained in terms of radioactive decay or cosmic-ray interactions. These isotope anomalies provide unequivocal evidence that dust grains that condensed around a variety of different stars were incorporated into primitive meteorites and offer a window through which nucleosynthesis and stellar evolution are revealed with unprecedented clarity.

The isotope anomalies found in refractory inclusions represent a mixture of exotic stardust from other stars diluted with normal solar system material; the inclusions themselves clearly are not presolar material. A major new discovery in meteorite research is the identification in primitive chondrites of whole interstellar grains, formed outside the solar system in stellar atmospheres and incorporated into primitive meteorites essentially intact. These grains survived the formation of the solar system and preserve the isotope compositions of the stellar nuclear sources for both major and trace elements. Presolar grains show isotope

anomalies for all elements, and the size of the anomalies is at least a factor of 100 times larger than that of anomalies found in refractory inclusions.

Studies of isotope anomalies and presolar grains in primitive meteorites have yielded important new clues to nucleosynthesis and the types of stars contributing material to the nascent solar nebula. The very large range of isotope abundances measured in presolar grains cannot be generated by a single stellar source, and is ample proof that the solar system is the product of contributions from disparate stars. Hydrogen and the bulk of the helium in the solar system are relicts of big bang nucleosynthesis, while the elements carbon through iron were produced dominantly in charged particle reactions in massive stars. The radionuclides  $^{129}\text{I}$ ,  $^{232}\text{Th}$ ,  $^{235}\text{U}$ ,  $^{238}\text{U}$ , and  $^{244}\text{Pu}$  are all produced by neutron-rich nucleosynthesis in supernovae. The abundance of short-lived radionuclides requires the late addition of fresh nucleosynthetic material, possibly from a massive, red-giant star, to the solar nebula less than a few million years prior to the formation of the first meteorites. See BIG BANG THEORY; SUPERNOVA.

[I.D.H.]

**Cosmogenic nuclide** A rare nuclide produced by nuclear reactions between high-energy cosmic radiation and terrestrial or extraterrestrial material. Cosmogenic nuclides may be used to examine the history of exposure to cosmic rays, and have numerous applications in earth science and archeology.

Primary cosmic radiation is present in space and consists of nuclear particles (mostly protons and alpha particles) with energies that are greater than typical nuclear binding energies. Collisions between cosmic-ray particles and atomic nuclei produce fragments, including cosmogenic nuclides, and also alter the characteristics of the cosmic radiation. As cosmic radiation enters the atmosphere, its flux decreases and its composition becomes dominated by neutrons rather than protons and alpha particles (which react with atmospheric gases). This reduction in flux continues through the atmosphere; at ground level, small but measurable quantities of cosmogenic nuclides are produced in solid material within about 1 m (3.3 ft) of the Earth's surface. The cosmogenic nuclides produced in these two reservoirs (atmosphere and lithosphere) may be employed for examination of different geological processes. Because of their wide range of half-lives and chemical properties, cosmogenic nuclides have a wide range of applications in geological, geomorphological, and biogeochemical studies. See ALPHA PARTICLES; COSMIC RAYS; COSMOCHEMISTRY; PROTON.

Numerous nuclides are produced in measurable quantities in the atmosphere. Their half-lives and their chemical reactivities determine their applications in earth science.

Short-lived nuclides, including beryllium-7 ( $^7\text{Be}$ ), sodium-22 ( $^{22}\text{Na}$ ), phosphorus-32 ( $^{32}\text{P}$ ), and phosphorus-33 ( $^{33}\text{P}$ ), have been employed in studies of atmospheric circulation, particularly stratospheric-tropospheric exchange. Because of its highly successful applications in dating, carbon-14 ( $^{14}\text{C}$ ; radiocarbon) is the best-known cosmogenic nuclide. Essentially all atmospheric  $^{14}\text{C}$  is in the form of gaseous carbon dioxide ( $^{14}\text{CO}_2$ ); it thus has an atmospheric residence time long enough for the ratio of  $^{14}\text{C}$  to  $^{12}\text{C}$  (the stable isotope) to become homogeneous throughout the atmosphere. Living organisms and inorganic carbonates incorporate carbon with an isotope ratio reflecting that of the atmosphere. Upon removal from contact with the atmosphere, the ratio  $^{14}\text{C}/^{12}\text{C}$  decreases through radioactive decay of  $^{14}\text{C}$ . With knowledge of the initial ratio and the half-life of  $^{14}\text{C}$ , measurement of  $^{14}\text{C}/^{12}\text{C}$  allows calculation of the age of a sample. This technique has been extensively used in archeology and geology for samples as old as  $4 \times 10^4$  years. High-precision  $^{14}\text{C}$  dates of inorganic carbon dissolved in seawater are also used to deduce global oceanic circulation rates and patterns by determining the time since a particular water mass had contact with the atmosphere. See also OCEAN CIRCULATION; RADIOCARBON DATING; RADIOISOTOPE (GEOCHEMISTRY); SEAWATER.

A small but significant flux of cosmic rays is present at ground level. This radiation produces cosmogenic nuclides within mineral lattices of exposed rock. In-situ-produced cosmogenic nuclides are used to examine geological problems. In-situ-produced cosmogenic nuclides are useful for dating periods of surface exposure. Their production rates decrease by a factor of 2 for every  $\gg 40$  cm (16 in.) depth below an exposed rock surface, so accumulation of cosmogenic nuclides can date geological events that bring material to the Earth's surface. For example, the theoretical evolution of the concentration of  $^{10}\text{Be}$  as a function of time for various erosion rates can be calculated. The method has been used to date exposure of rocks brought to the surface by processes including glaciation, volcanic activity, and meteor impact. It has also been used to date the formation of geomorphological features (such as alluvial fans or glacial moraines) deposited over active faults and subsequently offset by fault movement. This provides a quantitative approach to determine slip rates on faults and earthquake recurrence intervals. Such results could not have been obtained by conventional methods. See GEOMORPHOLOGY.

Because cosmic rays penetrate just a few meters of solid matter, cosmogenic nuclides cannot form deep in the interiors of large bodies such as asteroids. The accumulation of cosmogenic nuclides begins when a collision lifts deep-seated material to the surface or ejects it into space as part of a small body. When a meteorite hits the Earth, the accumulation of cosmogenic nuclides effectively stops. The reason is that the Earth's atmosphere and magnetic field screen out most cosmic rays. The total amounts of the cosmogenic nuclides in a meteorite are related to its exposure age. They also indicate the size of the meteoroid. To get this information, it is necessary to be able to identify cosmogenic nuclides as such and measure their concentrations. [G.F.H.]

**Cosmology** The study of the structure and the origin of the universe, including the origin of galaxies, the elements, and matter itself.

**Structure of the universe.** Modern cosmology began in the early twentieth century with theoretical work on the cosmological implications of A. Einstein's theory of general relativity and with the astronomical debate over the nature of spiral nebulae.

Some astronomers contended that these faint nebulae were regions of star formation that were part of the Milky Way Galaxy, while others argued that they were distant galaxies much like the Milky Way. This debate was settled in 1923 by E. Hubble's discovery of 12 Cepheid variable stars in M31, the Andromeda Nebula. There is a simple empirical relationship between the period of the Cepheids and their luminosity. Thus, Hubble's observations allowed him to determine that the Andromeda Nebula was at a very large distance and was a galaxy much like the Milky Way. See ANDROMEDA GALAXY; CEPHEIDS; GALAXY, EXTERNAL; MILKY WAY GALAXY.

Hubble continued his study of galaxies and found that most were receding from the Earth. Hubble proposed a simple linear relationship between the distance to a galaxy and its recessional velocity, given by Eq. (1), where  $v$  is the recessional velocity of the galaxy, usually measured in kilometers per second, and  $r$  is the distance to the galaxy, usually measured in megaparsecs (1 Mpc =  $3.26 \times 10^6$  light-years =  $3.1 \times 10^{19}$  km =  $1.9 \times 10^{19}$  mi). Astronomers are still trying to accurately measure  $H$ , the Hubble constant. The Hubble Space Telescope has observed Cepheids in the Virgo and Fornax clusters. These observations suggest that the Hubble constant is about 72 (km/s)/Mpc. See HUBBLE CONSTANT; SPACE TELESCOPE, HUBBLE.

$$v = Hr \quad (1)$$

locity of the galaxy, usually measured in kilometers per second, and  $r$  is the distance to the galaxy, usually measured in megaparsecs (1 Mpc =  $3.26 \times 10^6$  light-years =  $3.1 \times 10^{19}$  km =  $1.9 \times 10^{19}$  mi). Astronomers are still trying to accurately measure  $H$ , the Hubble constant. The Hubble Space Telescope has observed Cepheids in the Virgo and Fornax clusters. These observations suggest that the Hubble constant is about 72 (km/s)/Mpc. See HUBBLE CONSTANT; SPACE TELESCOPE, HUBBLE.

**Age of the universe.** The universe ought to be older than any visible star; thus, the inferred ages of the stars in the Milky Way Galaxy place a lower limit on age of the universe. The oldest known stars are in globular clusters, dense concentrations of roughly 100,000 stars, believed to be  $12\text{--}20 \times 10^9$  years old.

These age estimates are based on models of stellar evolution that predict when a star of a given mass becomes a red giant. See STAR CLUSTERS; STELLAR EVOLUTION.

**Big bang model.** When Einstein proposed his theory of general relativity, the universe was believed to be static. Einstein had to modify his equations so that general relativity would allow a static universe by adding a cosmological constant term. Hubble's observations of the expanding universe then implied that these modifications were unnecessary. In the 1920s, G. Lemaître and A. Friedmann independently proposed a general relativistic model of the expanding universe. One of the simplest solutions to Einstein's relativity equation, it assumes that the universe is homogeneous and expanding. When Lemaître and Friedmann made their proposal, there was no real evidence for their simplifying assumptions. Only since the late 1980s have observations become sensitive enough to confirm their assumptions. See RELATIVITY.

The Friedmann-Lemaître model, often called the big bang model, implies that the universe began in an extremely dense state and expanded and cooled. In this model, the Hubble law is predicted as an approximate description of the expansion valid for galaxies within a few hundred megaparsecs of the Milky Way Galaxy. The model implies that radiation is redshifted as the universe expands. Thus, radiation from distant objects should appear at lower frequencies than those at which it was emitted. Observations of atomic lines from distant quasars confirm that radiation is redshifted just as predicted. See QUASAR; REDSHIFT.

The Friedmann-Lemaître model, while fully relativistic, can be described in the language of newtonian physics. The Hubble law implies that a shell of galaxies of radius  $R$  and mass  $m$  expands with velocity  $HR$ . Thus, the kinetic energy of the shell is  $m(HR)^2/2$ . If  $M$  is the mass interior to the shell, then the gravitational binding energy of the shell is  $GMm/R$ , where  $G$  is the newtonian constant of gravitation. The total energy  $E$  of the shell is therefore given by Eq. (2). Since it has been assumed

$$E = \frac{m(HR)^2}{2} - \frac{GMm}{R} \quad (2)$$

that the universe is uniform, the mass  $M$  within the shell can be replaced with the quantity  $4\pi\rho R^3/3$ , where  $\rho$  is the density of the universe and  $4\pi R^3/3$  is the volume of a shell of radius  $R$ . Then Eq. (2) can be rewritten as Eq. (3), where  $\Omega$  is the ratio of

$$\frac{E}{mR^2} = \frac{H^2}{2} \left( 1 - \frac{8\pi G\rho}{3H^2} \right) = \frac{H^2}{2} (1 - \Omega) \quad (3)$$

the density of the universe to the critical density of the universe,  $3H^2/(8\pi G)$ . If  $\Omega < 1$ , the total energy of the shell is positive, and the universe will continue to expand forever. If  $\Omega > 1$ , the total energy of the shell is negative, gravity will eventually stop the expansion, and the universe will eventually collapse. Some physicists speculate that this so-called big crunch will be followed by a future big bang. If  $\Omega = 1$ , the total energy is zero, and the universe stands on the balance between open and closed and corresponds to a special solution called the Einstein-de Sitter model. See GRAVITATION.

This simple newtonian model, while accurately describing the dynamics of the expanding universe, can lead to a conceptual error. The newtonian shell has a center, since newtonian theory cannot deal with a uniform mass density. General relativity, however, allows the universe to be isotropic and expanding uniformly without having a special center point. In the Friedmann-Lemaître model, the Milky Way Galaxy is not a special place in the universe.

The density of the universe determines not only the final fate of the universe but also its geometry. If  $\Omega > 1$ , the universe is closed and its geometry is that of a three-dimensional sphere. If the universe is closed, two light rays sent off in opposite directions from the same starting point will eventually bend toward each other. If  $\Omega = 1$ , the universe is flat and the

two light rays will continue to move away from each other. If  $\Omega < 1$ , the geometry of the universe is hyperbolic, much like that of a saddle. A common misconception is that if the universe is open it must be spatially infinite. This need not be true, as general relativity does not constrain the topology of the universe. If  $\Omega < 1$ , the universe could be either infinite or finite and periodic.

Astronomical observations could also potentially measure the geometry of the universe. If the universe is closed, there is less volume associated with a given redshift than if it is open. The implication is that fewer galaxies should be detectable at large distances than in an open universe. The current observational situation is confused; galaxy counts using infrared techniques favor a flat or closed universe, while galaxy counts using optical techniques favor an open universe.

Observations of supernovae are another potential probe of the geometry of the universe. It is suspected that all type Ia supernovae, supernovae produced by the explosive burning of a white dwarf star, have the same luminosity. Thus, observations of distant supernovae can potentially determine the distances to galaxies at high redshift. Since the relation between distance and redshift differs in different cosmologies, this test can be used to measure the geometry of the universe. Current data suggest that the universe is accelerating and has a cosmological constant. Because of uncertainties in dust and evolutionary corrections, these results are uncertain.

One of the most dramatic discoveries of modern physics was the detection of the microwave background radiation by A. Penzias and R. Wilson. Most cosmologists believe that this radiation is the leftover heat from the big bang.

In the hot big bang model, the universe started in an extremely hot dense state. In this state, the universe was composed of electrons, positrons, quarks, neutrinos, and photons. As the universe expanded, most of the matter annihilated with antimatter into photons. These photons then cooled as the universe expanded. Thermal physics predicts that the spectrum of radiation from the big bang would be similar to that emitted by a blackbody, a so-called Planck spectrum. The Friedmann-Lemaître model predicts that this radiation should be uniform since the big bang started in a uniform state. See HEAT RADIATION.

The observations of the *Cosmic Background Explorer* (COBE) satellite, launched in 1989, provided strong confirmation of the hot big bang model. The observed spectrum of the microwave background radiation agrees closely with the predicted Planck spectrum. The COBE experiment also confirmed that the microwave background radiation is uniform to nearly 1 part in 50,000, consistent with the homogeneity assumption of the hot big bang model. See COSMIC BACKGROUND RADIATION.

Within the context of the hot big bang model, the conditions in the universe now can be extrapolated back to the first moments after the big bang. The temperature of the cosmic background radiation now is 2.73 kelvins above absolute zero. When the universe was half its present size, the background temperature was twice as high. One second after the big bang, the universe was only  $3 \times 10^{-11}$  of its present size and the temperature of the microwave background was roughly  $10^{10}$  K ( $1.8 \times 10^{10}$  °F). At this high temperature, the universe consisted of a thermal sea of photons, electrons, positrons, and neutrinos. In addition, there was a handful of protons and neutrons. There was approximately 1 baryon (proton or neutron) for every  $10^{10}$  photons. See BARYON; ELECTRON; NEUTRINO; NEUTRON; POSITRON; PROTON.

As the universe cooled, the protons and neutrons combined to make deuterium. Most of this deuterium then interacted to make helium, while trace amounts combined to make lithium. Most of the deuterium and helium in the early universe is believed to have been produced in the first minutes of the big bang. One of the successes of the big bang model is its ability to account for the observed abundances of light elements. The universe today consists of roughly 28% helium, 70% hydrogen, and 2% other elements. Nucleosynthesis in stars produces roughly equal amounts of helium and heavier elements from hydrogen. Thus, it

is difficult to understand the helium abundances without big bang nucleosynthesis. See DEUTERIUM; HELIUM; HYDROGEN; LITHIUM.

The amounts of deuterium, helium, and lithium produced in the big bang depend sensitively on the number of baryons per photon in the early universe and on the number of neutrino flavors. Based on the observed abundances of these elements in old stars, it was predicted that there should be only three flavors of neutrinos. Experiments at particle accelerators have confirmed this prediction based on the first moments of the early universe. See FLAVOR.

The observed light-element abundances also lead to a prediction for the density of protons and neutrons. The current best estimates suggest that if the universe is made only of protons, neutrons, and electrons, then  $\Omega$  is between 0.01 and 0.1. Thus, unless there exists some exotic form of matter, big bang nucleosynthesis suggests that the universe is open. See BIG BANG THEORY; NUCLEOSYNTHESIS.

**Alternatives to the hot big bang.** There have been a variety of models proposed as alternatives to the hot big bang. Historically, the most important alternative model is the steady-state model, which assumes a homogeneous expanding universe that is not evolving because matter is continuously being created out of the vacuum. This model has great difficulty accounting for the observed shape of the microwave background radiation and cannot account for the observed abundance of helium. Another alternative is the cold big bang model in which the universe began in a big bang that started at absolute zero. It has been suggested that in this model the microwave background radiation could be due to reemitted light from iron needles. This model requires special dust grains and also cannot explain the abundances of light elements.

**Dark-matter problem.** Astronomers have been in an embarrassing situation for several decades: the amount of mass measured dynamically in galaxies by observing stellar and gas motions is roughly 10 times the mass observed in dust, gas, and known stars. This discrepancy suggests that either there is a basic flaw in newtonian physics or 90% of the mass in galaxies is in some yet unknown form, usually referred to as the dark matter.

Some of the strongest evidence for existence of dark matter comes from radio observations of hydrogen gas and optical observations of star motions in spiral galaxies like the Milky Way Galaxy. Observations of hot x-ray-emitting gas in elliptical galaxies provide a method for measuring their mass distribution. Since the gas pressure gradients must balance the force of gravity, gas density and temperature profiles can be directly related to the elliptical galaxy mass profiles. Data from x-ray satellites suggest that the galactic dark-matter problem is ubiquitous: all galaxies, whether spiral or elliptical, dwarf or normal, seem to have halos of dark matter. See X-RAY ASTRONOMY.

Candidates for the dark matter range in mass from micro-electronvolt axions to  $10^6$ -solar-mass black holes. Yet another possibility is that the dark matter consists of some as yet undetected particle. Particle physicists have suggested several possible candidates for the dark matter. The most popular of these particles is predicted in an extension of standard physics called supersymmetry. This particle, named a WIMP (weakly interacting massive particle), could potentially be detected in deep underground experiments. See BLACK HOLE; ELEMENTARY PARTICLE; SUPERSYMMETRY; WEAKLY INTERACTING MASSIVE PARTICLE (WIMP).

**Origin of large-scale structure.** One of the most active areas of research in cosmology has been the attempt to understand the formation of galaxies and the origin of large-scale structure. Most popular models of structure formation are based on gravitational instability. These models assume that there was some initial source of weak density fluctuation. In the expanding universe, these weak density fluctuations grow gravitationally.

The details of the gravitational formation scenario depend upon the nature of the dark matter. If the dark matter is in the form of either baryons or neutrinos, small-scale density

fluctuations are erased. In these models, the first objects to form are the rich clusters. Galaxies form later through the fragmentation of rich clusters. If the dark matter is in the form of WIMPs, it can cluster more easily. In these cold dark-matter models, the first structures to form are usually subgalactic objects, which later condense to form galaxies. Galaxies can then agglomerate gravitationally and form clusters. Observations of quasars at high redshifts suggest that at least some small objects must have formed in the early universe and appear to favor models in which small objects formed before very large objects.

Observations of the microwave background radiation probe conditions in the early universe. In most cosmology models, the microwave photons that are detected on Earth last interacted with electrons when the universe was one-thousandth its present size. Thus, fluctuations in the microwave background temperature reflect the density fluctuations in the early universe.

While the gravitational instability picture can explain how initial weak fluctuations grew to form large-scale structure, it does not explain the initial source of these fluctuations. There are several competing theories.

The inflationary universe model is an attractive scenario for simultaneously explaining the homogeneity of the universe on large scales and the fluctuations in density observed on the smaller scales. In this scenario, the universe in its first few moments underwent a period of exponential expansion. This rapid expansion, which took place before nucleosynthesis, stretched out any initial density variations and eliminated any monopoles or other unwanted objects that formed before the inflationary epoch. During this inflationary epoch, quantum fluctuations generated new density fluctuations that are predicted to be the initial source of structure. The inflationary scenarios predict that the density parameter  $\Omega$  should be extremely close to 1. See INFLATIONARY UNIVERSE COSMOLOGY.

Maps of the microwave background fluctuations may eventually reveal the source of the initial fluctuations. Different models make different predictions for the amplitude of microwave fluctuations on different scales. The inflationary model predicts that there should be fluctuations of roughly the same amplitude on all angular scales on the sky. The model also suggests that the fluctuations should be random and show no large-scale coherent edges or peaks. Microwave background observations appear to favor the inflationary structure formation scenario. [D.N.S.]

**Cotton** A fiber obtained from the cotton plant *Gossypium*, of the order Malvales. It has been used for more than 3000 years, and is the most widely used natural fiber, because of its versatility and comparatively low cost to produce and to manufacture into finished products. Cotton traditionally has been used alone in textile products, but blends with artificial fibers are also important. Chemically, cotton is essentially pure cellulose. The natural waxes occurring on the original fiber surface act as a finish which facilitates spinning. See CELLULOSE; MALVALES; NATURAL FIBER; TEXTILE.

To mature, cotton requires about 180 days of continuously warm weather with adequate moisture and sunlight; frost is harmful and may kill the plant. The plants begin to bloom about 4 months after planting. When the flowers fall off, seed pods grow and become cotton capsules or bolls, which must be protected against the boll weevil or other insects. When fully grown, the bolls burst, exposing the fleecy white fiber. When the raw cotton is harvested, it contains seeds, leaf fragments, and dirt that must be removed before baling. Cotton seeds alone constitute approximately two-thirds of the weight of the picked cotton.

After harvesting, the fiber, or lint as it is then called, is separated from the seed by gins. The lint is compressed into bales, covered with jute bagging, and bound with metal bands. After baling, the lint is sampled, graded, and sent to cotton mills, where the lint is blended, cleaned, carded, and spun into yarns. In the oil mill processing industry, the cottonseed is separated into fuzz

or linters, hulls, oil, and protein cake. Each of these products is converted to several subproducts.

The cotton plant is one of the world's major agricultural crops. It is grown in all countries lying within a wide band around the Earth. The limits of this band in the New World are at about 37°N latitude and at about 32°S latitude. In addition to the effects of latitude, suitability of climate for the growth of cotton is also regulated by elevation, wind belts, ocean currents, and mountain ranges. The regions of more intensive culture comprise the Cotton Belt of the United States, the northern valleys of Mexico, India, Pakistan, eastern China, central Asia, Australia, the Nile River valley, eastern Africa, South Africa, northeastern and southern Brazil, northern Argentina, and Peru. Within these regions and outlying districts, 44 countries report data on cotton production. [E.G.N.]

**Cotton effect** The characteristic wavelength dependence of the optical rotatory dispersion curve or the circular dichroism curve or both in the vicinity of an absorption band.

When an initially plane-polarized light wave traverses an optically active medium, two principal effects are manifested: a change from planar to elliptic polarization, and a rotation of the major axis of the ellipse through an angle relative to the initial direction of polarization. Both effects are wavelength dependent. The first effect is known as circular dichroism, and a plot of its wavelength (or frequency) dependence is referred to as a circular dichroism (CD) curve. The second effect is called optical rotation and, when plotted as a function of wavelength, is known as an optical rotatory dispersion (ORD) curve. In the vicinity of absorption bands, both curves take on characteristic shapes, and this behavior is known as the Cotton effect, which may be either positive or negative (see illustration). There is a Cotton effect associated with each absorption process, and hence a partial CD curve or partial ORD curve is associated with each particular absorption band or process. See OPTICAL ROTATORY DISPERSION; POLARIZED LIGHT.

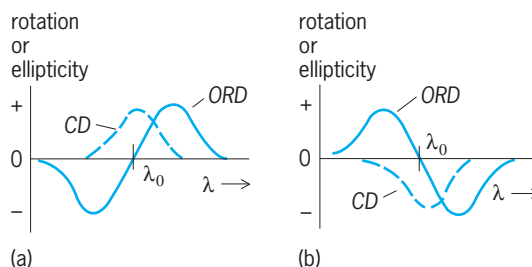

Behavior of the ORD and CD curves in the vicinity of an absorption band at wavelength  $\lambda_0$ , (idealized). (a) Positive Cotton effect. (b) Negative Cotton effect.

The rotational strengths actually observed vary over quite a few orders of magnitude; this variation in magnitude is useful in stereochemical interpretation of molecular structure. [A.Mo.]

**Coulomb excitation** Nuclear excitation caused by the time-dependent long-ranged electric field acting between colliding nuclei. Theoretically, the Coulomb force between the positively charged colliding nuclei is well understood, and the interaction is exactly calculable. Coulomb excitation usually is the dominant reaction in nuclear scattering, and even occurs at low bombarding energies where the separation of the nuclei is sufficiently large that the short-ranged nuclear force does not act. See also COULOMB'S LAW.

Coulomb excitation plays a vital role in probing the response of both shape and volume collective modes of motion as well as the interplay of single-particle degrees of freedom of the nuclear many-body system. The goal of this work is to develop better

models of nuclear structure and to elucidate the underlying nuclear force. See NUCLEAR STRUCTURE. [D.Cl.]

**Coulomb explosion** A process in which a molecule moving with high velocity strikes a solid and the electrons that bond the molecule are torn off rapidly in violent collisions with the electrons of the solid; as a result, the molecule is suddenly transformed into a cluster of charged atomic constituents that then separate under the influence of their mutual Coulomb repulsion. See COULOMB'S LAW.

Coulomb explosions are most commonly studied using a particle accelerator, normally employed in nuclear physics research (Van de Graaff generator, cyclotron, and so forth), to produce a beam of fast molecular ions that are directed onto a solid-foil target. The Coulomb explosion of the molecular projectiles begins within the first few tenths of a nanometer of penetration into the foil, continues during passage of the projectiles through the foil, and runs to completion after emergence of the projectiles into the vacuum downstream from the foil. Detectors located downstream make precise measurements of the energies and charges of the molecular fragments together with their angles of emission relative to the beam direction. The Coulomb explosion causes the fragment velocities to be shifted in both magnitude and direction from the beam velocity. See PARTICLE ACCELERATOR.

Coulomb explosion experiments serve two main purposes. First, they yield valuable information on the interactions of fast ions with solids. For example, it is known that a fast ion generates a polarization wake that trails behind it as it traverses a solid. This wake can be studied in detail by using diatomic molecular-ion beams, since the motion of a trailing fragment is influenced not only by the Coulomb explosion but also by the wake of its partner. Second, Coulomb-explosion techniques can be used to determine the stereochemical structures of molecular-ion projectiles. See ELECTRON WAKE; MOLECULAR STRUCTURE AND SPECTRA; STEREOCHEMISTRY. [D.S.Ge.]

**Coulomb's law** For electrostatics, Coulomb's law states that the direct force  $F$  of point charge  $q_1$  on point charge  $q_2$ , when the charges are separated by a distance  $r$ , is given by  $F = k_0 q_1 q_2 / r^2$ , where  $k_0$  is a constant of proportionality whose value depends on the units used for measuring  $F$ ,  $q$ , and  $r$ . It is the basic quantitative law of electrostatics. In the rationalized meter-kilogram-second (mks) system of units,  $k_0 = 1/(4\pi\epsilon_0)$ , where  $\epsilon_0$  is called the permittivity of empty space and has the value  $8.85 \times 10^{-12}$  farad/m. Thus, Coulomb's law in the rationalized mks system is as in the equation below, where

$$F = \frac{1}{4\pi\epsilon_0} \frac{q_1 q_2}{r^2}$$

$q_1$  and  $q_2$  are expressed in coulombs,  $r$  is expressed in meters, and  $F$  is given in newtons. See ELECTRICAL UNITS AND STANDARDS.

The direction of  $F$  is along the line of centers of the point charges  $q_1$  and  $q_2$ , and is one of attraction if the charges are opposite in sign and one of repulsion if the charges have the same sign. For a statement of Coulomb's law as applied to point magnet poles see MAGNETOSTATICS.

Experiments have shown that the exponent of  $r$  in the equation is very accurately the number 2. Lord Rutherford's experiments, in which he scattered alpha particles by atomic nuclei, showed that the equation is valid for charged particles of nuclear dimensions down to separations of about  $10^{-12}$  cm. Nuclear experiments have shown that the forces between charged particles do not obey the equation for separations smaller than this. See ELECTROSTATICS. [R.P.Wi.]

**Coulometer** Electrolysis cell in which a product is obtained with 100% efficiency as a result of an electrochemical reaction. The quantity of electricity, that is, the number of coulombs of electricity ( $Q$ ), can be determined very accurately by weighing the product that is deposited on an electrode in the course of the

electrochemical reaction. The relationship between the weight of the product formed in the coulometer and the quantity of electricity used is given by Faraday's laws of electrolysis. When a constant current of  $i$  amperes flows through the electrolyte in the coulometer for  $t$  seconds, the number of coulombs passed is given by Eq. (1).

$$Q = it \quad (1)$$

If the current varies in the course of the electrolysis, the simple current-time product in Eq. (1) is replaced by the current-time integral, Eq. (2).

$$Q = \int_0^t i dt \quad (2)$$

When  $Q$  coulombs of electricity are passed through the electrolyte, the weight in grams of the material that is deposited on the electrode ( $w$ ) is given by Eq. (3), where  $n$  is the number

$$w = \frac{QM}{Fn} \quad (3)$$

of electrons transferred per mole of material deposited,  $M$  is its molecular weight, and  $F$  is the Faraday constant,  $96,487 \pm 1.6$  coulombs.

Equation (3) is fundamental in coulometry and is a mathematical statement of Faraday's laws. This equation is used for the accurate determination of  $Q$ , the current-time integral, by weighing or measuring a product that is formed at an electrode by an electrochemical reaction that occurs with 100% current efficiency. The electrolysis cell that is used for this purpose is a coulometer.

Only a few electrode reactions proceed with the 100% current efficiency that is required for the use of Eq. (3). The deposition of silver or copper (in a silver or copper coulometer), the evolution of oxygen and hydrogen (in a gas coulometer), and the oxidation of iodide to iodine (in an iodine coulometer) are examples of electrode reactions that have been successfully employed. One coulomb of electricity will deposit 1.1180 mg of silver at the cathode in a silver coulometer or liberate 1.315 mg of iodine at the anode in an iodine coulometer. Although these classical chemical coulometers are capable of measuring the quantity of electricity with high precision and accuracy, their use is time-consuming and inconvenient; and they have been largely replaced by operational amplifier integrator circuits or digital circuits that display in a direct readout the number of coulombs passed during electrolysis. See ELECTROCHEMICAL EQUIVALENT; ELECTROLYSIS. [Q.F.]

**Countercurrent exchange (biology)** Engineers have known for decades that efficient, almost complete heat or other exchange could be achieved between two fluids flowing in opposite directions in separate tubes. Such countercurrent systems have evolved numerous times in living organisms for all types of exchange function. They are most commonly found in the circulatory, respiratory, and excretory (kidney) systems, serving in heat, oxygen, and ion exchange. Biological countercurrent systems can be classified into two main types: downhill exchanges and hairpin multipliers. In both cases, the basic mechanism is the same—exchange of substance between fluids flowing in opposite directions—but the consequences are very different.

Downhill exchange systems are commonest in the circulatory system where their morphological structure is a rete (network) of closely oppressed sets of small arteries and veins. They are also found in gills of fish and in the minute air tubules of the avian lung. In downhill exchanges, fluids flow in opposite directions in separate tubes with the possibility of exchange, for example, heat flow or diffusion of oxygen, between them. The fluid entering one tube is warmest at that end, while that entering the second tube is coolest at the other end. Heat flows from higher to lower temperature. Although the temperature differential between the two fluids is small at any point along the length of the countercurrent system, almost all the heat contained in the

warmer tube is transferred to the cooler tube. Exchange of heat or oxygen occurs by passive diffusion. Most of the heat that entered the countercurrent system at one end leaves the system at the same end.

Retia of blood vessels thus serve as thermal isolating mechanisms within the body. Downhill exchange systems in the gills of fish and in the air tubules of birds permit maximum exchange of oxygen from the environment into the blood. Blood in respiratory capillaries flows against the water or air current and thus can pick up most of the oxygen contained in the external fluid. The advantage of downhill exchangers is that they achieve greater efficiency without extra energy cost simply by arranging flow in a countercurrent rather than in a concurrent fashion.

Hairpin multiplier systems take their name from the structure of the tubes, which have a hairpin turn between the afferent (descending) and the efferent (ascending) limbs. Hairpin countercurrent systems are found in the nephron (the loop of Henle) of the kidney and in the capillary system of the gas gland in the swim bladder of many fish. In contrast to downhill systems, which operate by passive transport, hairpin multipliers must employ active transport of materials. These are always materials pumped out of the efferent limb of the system. See KIDNEY; RESPIRATORY SYSTEM; SWIM BLADDER. [W.J.B.]

**Countercurrent transfer operations** Industrial processes in chemical engineering or laboratory operations in which heat or mass or both are transferred from one fluid to another, with the fluids moving continuously in very nearly steady state or constant manner and in opposite directions through the unit. Other geometrical arrangements for transfer operations are the parallel or concurrent flow, where the two fluids enter at the same end of the apparatus and flow in the same direction to the other end, and the cross-flow apparatus, where the two fluids flow at right angles to each other through the apparatus.

In heat transfer there can be almost complete transfer in countercurrent operation. The limit is reached when the temperature of the colder fluid becomes equal to that of the hotter fluid at some point in the apparatus. At this condition the heat transfer is zero between the two fluids. Most heat transfer equipment has a solid wall between the hot fluid and the cold fluid, so the fluids do not mix. Heat is transferred from the hot fluid through the wall into the cold fluid. Another type of equipment does use direct contact between the two fluids—for example, the cooling towers used to remove heat from a circulating water stream. See COOLING TOWER; HEAT BALANCE; HEAT EXCHANGER; HEAT TRANSFER.

Mass transfer involves the changing compositions of mixtures, and is done usually by physical means. A material is transferred within a single phase from a region of high concentration to one of lower concentration by processes of molecular diffusion and eddy diffusion. In typical mass transfer processes, at least two phases are in direct contact in some state of dispersion, and mass (of one or more substances) is transferred from one phase across the interface into the second phase. Mass transfer takes place between two immiscible phases until equilibrium between the two phases is attained. In mass transfer there is seldom an equality of concentration in the two equilibrium phases. This means that a component may be transferred from a phase at low concentration (but at a concentration higher than that at equilibrium) to a second phase of greater concentration. The approach to equilibrium is controlled by diffusion transport across phase boundaries.

Although the two phases may be in concurrent flow or cross-flow, usual arrangements have the phases moving in Countercurrent directions. The more dense phase enters near the top of a vertical cylinder and moves downward under the influence of gravity. The less dense phase enters near the bottom of the cylinder and moves upward under the influence of a small pressure gradient. See ADSORPTION; CHEMICAL SEPARATION TECHNIQUES; DISTILLATION; ELECTROPHORESIS; EXTRACTION; LEACHING. [F.J.L.]

**Couple** A system of two parallel forces of equal magnitude and opposite sense. Under a couple's action a rigid body tends only to rotate about a line normal to the couple's plane. This tendency reflects the vector properties of a couple.

The total force of a couple is zero. The total moment  $\mathbf{C}$  of a couple is identical about any point. Accordingly,  $\mathbf{C}$  is the moment of either force about a point on the other and is perpendicular to the couple's plane. See RESULTANT OF FORCES; STATICS.

The moment of a couple about a directed line is the component of its total moment in the line's direction. Couples are equivalent whose total moments are equal. [N.S.F.]

**Coupled circuits** Two or more electric circuits are said to be coupled if energy can transfer electrically or magnetically from one to another. If electric charge, or current, or rate of change of current in one circuit produces electromotive force or affects the voltage between nodes in another circuit, the two circuits are coupled.

Between coupled circuits there is mutual inductance, resistance, or capacitance, or some combination of these. The concept of a mutual parameter is based on the loop method of analysis. A mutual parameter can be one that carries two or more loop currents; such a network has conductive coupling because electricity can flow from one circuit to the other.

Also, there can be purely inductive coupling, which appears if the magnetic field produced by current in one circuit links the other circuit. A two-winding transformer is an application of inductive coupling, with energy transferred through the magnetic field only.

It is also possible to have mutual capacitance, with energy transferred through the electric field only. Examples are the mutual capacitance between grid and plate circuits of a vacuum tube, or the capacitive interference between two transmission lines, as a power line and a telephone line, that run for a considerable distance side by side.

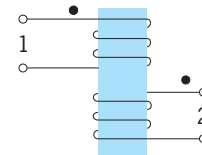

Fig. 1. Polarity of coils.

There are several ways to show the relative polarities of inductive coupling. Figure 1 shows two coils wound on the same core. Current flowing into the upper end of coil 1 would produce magnetic flux upward in the core, and so also would current flowing into the upper end of coil 2. For this reason the upper ends of the two coils are said to be corresponding ends. Dots are placed on a diagram at the corresponding ends of coupled coils. Such dots are shown in Fig. 1, though they are not needed in

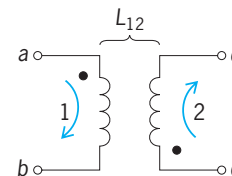

Fig. 2. Mutual inductance  $L_{12}$ . Letters  $a$ ,  $b$ ,  $c$ , and  $d$  label terminals.

this figure. Dots are also shown in Fig. 2, where they give the only means of identifying corresponding ends of the coils shown. [H.H.Sk.]

**Coupling** The mechanical fastening that connects shafts together for power transmission, often to form long sections of shafting or to connect the shaft of a machine to an external drive. Couplings are classified with respect to the kind of alignment and the centerline position of the connecting shafts. Rigid couplings are used where the axes of the shafts are directly in line, flexible couplings where the axes may be at a slight angle and slightly displaced, and universal joint couplings for large angularity or large displacement.

A rigid coupling is suitable for shafts in close alignment or held in alignment without inducing destructive forces in shafts or bearings. For commercial shafting, the coupling may be a sleeve with the shafts pressed into each end, or it may be a clamping sleeve. The sleeve on each shaft end may have an external flange with bolt holes. Couplings for large power machines are bolted together to hold the shafts rigidly; hence the shafts must be accurately aligned before assembly.

Flexible coupling provides the mechanical connection for shafts at a slight angle and displaced somewhat, particularly where power machines may set up vibratory forces. Such couplings are used when alignment is difficult to obtain, when a nonrigid support makes alignment impossible to maintain, or if shaft position changes because of operation. Flexible couplings consist of symmetrical hubs on each end of the joined shafts with a flexible connecting member between. This member may take such forms as the floating gear, the embedded spring, the flexible pin, and the flexible disk. Flexible couplings not only provide for lateral and angular misalignment, but also reduce the transmission of shock loads and change the vibration characteristics and critical speeds of the shafts. Oldham's coupling is the original flexible coupling, and presents the basic principle from which most flexible couplings are derived.

A flexible coupling for connecting shafts that have appreciable permanent angularity is termed a universal joint. See CLUTCH; FLUID COUPLING; SHAFTING; UNIVERSAL JOINT. [J.J.R.]

**Covellite** A mineral having composition CuS and crystallizing in the hexagonal system. It is usually massive or occurs in disseminations through other copper minerals. The luster is metallic and the color indigo blue. The hardness is 1.5 (Mohs scale), the specific gravity 4.7. Covellite is a common though not abundant mineral in most copper deposits. It is a supergene mineral and is thus found in the zone of sulfide enrichment associated with other copper minerals, principally chalcocite, chalcopyrite, bornite, and enargite, and is derived by their alteration. See BORNITE; CHALCOCITE; CHALCOPYRITE; COPPER; ENARGITE. [C.S.Hu.]

**Cover crops** Unharvested crops grown to improve soil quality or enhance pest management. Increasing numbers of farmers plant cover crops as a means of conserving soil, enhancing production, and reducing off-farm inputs. The sustainable agriculture movement has been a driving force for the increased use of cover crops. Cover cropping can accomplish a wide range of desired benefits, although there can be some drawbacks.

Cover crops play a vital role in controlling erosion by (1) shielding the soil surface from the impact of falling raindrops; (2) holding soil particles in place; (3) preventing crust formation; (4) improving the soil's capacity to absorb water; (5) slowing the velocity of runoff; and (6) removing subsurface water between storms through transpiration. Cover crops also improve soil structure by adding organic matter. Legume cover crops add nitrogen to the soil, which can then be used by crops. Insect, weed, and nematode management can be affected by cover cropping, as cover crops provide a food source to many beneficial insect species. In turn, these beneficial insects may feed on adjacent crop pests.

Cover crops require knowledge and management to attain the desired benefit. If they are not properly selected or managed, there are drawbacks to their use, including depletion of soil moisture, competition with the adjacent crop (when present)

for soil moisture and nutrients, increased frost hazard in orchards and vineyards, increased insect, nematode, and weed pests, and added costs to purchase and plant seeds.

Cover crops can be readily grown in humid climates and in arid and semiarid climates where irrigation provides sufficient water that cover crops do not rob the soil of needed moisture. Cover crops that reseed themselves are often sown on rangeland. Long-lived grasses have been widely seeded on many different soil types in the Great Plains.

In cold climates, many common spring-sown crops can be advantageously used as cover crops. Buckwheat (*Fagopyrum esculentum*) can be used as a cover crop to protect the soil and as a smother crop to control weeds; it also improves the soil upon incorporation.

Cover cropping in orchard and vineyard middles is often easier than in annual crops because they are grown between the crop spatially rather than temporally. A wide range of species, mixes, and management systems are used in orchards and vineyards. See AGRICULTURAL SOIL AND CROP PRACTICES; NITROGEN FIXATION; SOIL CONSERVATION. [C.In.; P.J.Z.]

**Cowpea** The legume *Vigna unguiculata* ssp. *unguiculata*, also called southern pea, blackeye pea, or blackeye bean (United States), or niébé (French-speaking Africa). It is an important source of dietary protein for human consumption and of animal feed in the tropics, especially in Africa, Brazil, and India where cowpeas are grown mostly as a subsistence crop for home consumption and are not sold in markets. The cowpea is adapted to hotter, more arid climates and more infertile soils than other food legume crops. Its symbiotic nitrogen-fixing abilities help maintain soil fertility in peasant cropping systems.

The cowpea was domesticated in Africa from one of several wild taxa that belong to the same species as the cultivars and are classified as *V. unguiculata* ssp. *dekintiana*. Cultivars generally have dark-green, glabrous, shiny leaves. Growth habits include climbing, prostrate, and bush types. Flowers are white or violet with various color patterns. Most cultivars are self-pollinating. Seeds can be kidney or egg shaped, spherical or rhomboid. Pigmentation covers the entire seed (self-colored) or surrounds the hilum (eye). Colors are mottled, speckled, or solid and include white, cream, brown, red, pink, green, and black.

The most important utilization of cowpeas is that of seeds, whether mature (dry seeds or blackeye bean) or immature (southern pea). Seeds are marketed as a dry pack or as a canned or frozen product. Other uses, such as for the yard-long beans, are becoming more available, especially in specialty food markets. See LEGUME. [PGe.]

**Coxsackievirus** A large subgroup of the genus *Enterovirus* in the family Picornaviridae. The coxsackieviruses produce various human illnesses, including aseptic meningitis, herpangina, pleurodynia, and encephalomyocarditis of newborn infants. See ENTEROVIRUS; PICORNAVIRIDAE.

Coxsackieviruses measure about 28 nanometers in diameter; they resemble other enteroviruses in many biological properties, but differ in their high pathogenicity for newborn mice. At least 23 antigenically distinct types in group A are now recognized, and 6 in group B.

After incubation for 2–9 days, during which the virus multiplies in the enteric tract, clinical manifestations appear which vary widely. Diagnosis is by isolation of virus in tissue culture or infant mice. Stools are the richest source of virus. Neutralizing and complement-fixing antibodies form during convalescence and are also useful in diagnosis. See ANTIBODY; COMPLEMENT-FIXATION TEST; NEUTRALIZING ANTIBODY; TISSUE CULTURE.

The coxsackieviruses have worldwide distribution. Infections occur chiefly during summer and early fall, often in epidemic proportions. Spread of virus, like that of other enteroviruses, is associated with family contact and contacts among young children. See ANIMAL VIRUS; VIRUS CLASSIFICATION. [J.L.Me.; M.E.Re.]



**CPT theorem** A fundamental ingredient in quantum field theories, which dictates that all interactions in nature, all the force laws, are unchanged (invariant) on being subjected to the combined operations of particle-antiparticle interchange (so-called charge conjugation, *C*), reflection of the coordinate system through the origin (parity, *P*), and reversal of time, *T*. In other words, the *CPT* operator commutes with the hamiltonian. The operations may be performed in any order; *TCP*, *TPC*, and so forth, are entirely equivalent. If an interaction is not invariant under any one of the operations, its effect must be compensated by the other two, either singly or combined, in order to satisfy the requirements of the theorem. See QUANTUM FIELD THEORY.

The *CPT* theorem appears implicitly in work by J. Schwinger in 1951 to prove the connection between spin and statistics. Subsequently, G. Lüders and W. Pauli derived more explicit proofs, and it is sometimes known as the Lüders-Pauli theorem. The proof is based on little more than the validity of special relativity and local interactions of the fields. The theorem is intrinsic in the structure of all the successful field theories. See QUANTUM STATISTICS; RELATIVITY; SPIN (QUANTUM MECHANICS).

*CPT* assumed paramount importance in 1957, with the discovery that the weak interactions were not invariant under the parity operation. Almost immediately afterward, it was found that the failure of *P* was attended by a compensating failure of *C* invariance. Initially, it appeared that *CP* invariance was preserved and, with the application of the *CPT* theorem, invariance under time reversal. Then, in 1964 an unmistakable violation of *CP* was discovered in the system of neutral *K* mesons. See PARITY (QUANTUM MECHANICS).

One question immediately posed by the failure of parity and charge conjugation invariance is why, as one example, the  $\pi^+$  and  $\pi^-$  mesons, which decay through the weak interactions, have the same lifetime and the same mass. It turns out that the equality of particle-antiparticle masses and lifetimes is a consequence of *CPT* invariance and not *C* invariance alone. See ELEMENTARY PARTICLE; MESON; SYMMETRY LAWS (PHYSICS). [V.F.]

**Crab** The name applied to arthropods in sections Anomura and Brachyura of the reptantian suborder of the order Decapoda, class Crustacea. The term crab is also sometimes used for two species of sucking lice (order Anoplura) which prey upon humans. *Phthirus pubis* is the crab louse which inhabits the pubic region.

Section Anomura includes over 1400 species in 12 different families. Commonly called hermit, king, sand, or mole crabs, the anomurans have lobsterlike abdomens which bend beneath the cephalothorax in crablike manner, setting them apart in a somewhat ill-defined group.

Section Brachyura encompasses the so-called true crabs, with reduced abdomens folded snugly beneath the cephalothorax. More than 4500 species making up 28 families have been grouped into subsections. In addition to subsections Dromiacea, Gymnopleura, and Oxystomata, the Hapalocarcinidea has one family of the same name containing three genera of small crabs with elongated abdomens. Subsection Brachygnatha is the largest group of brachyurans and includes the most typical crabs. It has 20 families encompassing over 3700 species which occupy a variety of habitats, undergo different types of development, and exhibit contrasting patterns of behavior. See CRUSTACEA; DECAPODA (CRUSTACEA). [M.S.K.]

**Crab Nebula** The Crab Nebula is the remnant of a tremendous stellar explosion witnessed by Chinese astronomers in 1054. The explosion, called a supernova, occurred at a distance of about 2000 parsecs from the Earth (1 parsec =  $1.9 \times 10^{13}$  mi =  $3.1 \times 10^{13}$  km = 3.26 light-years). See SUPERNOVA.

The Crab now consists of three components. At the heart of the nebula is what is left of the core of the Crab's giant stellar progenitor. This neutron star has twice the mass of the Sun concentrated into an object only about 20 km (12 mi) across,

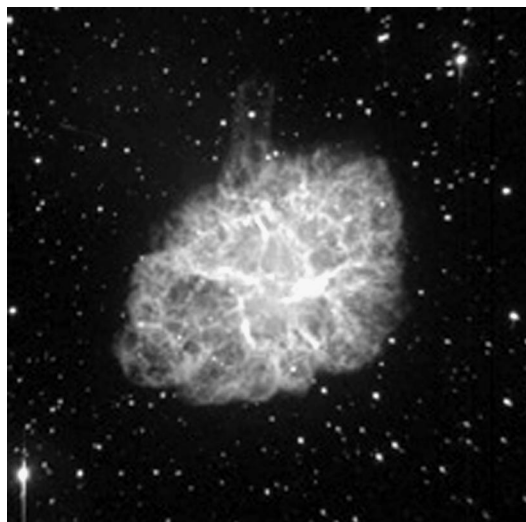

Crab Nebula, the 900-year-old remnant of a cataclysmic stellar explosion.

giving it a density of  $10^9$  tons per cubic centimeter. The neutron star is spinning at 30 times a second, whipping its powerful ( $10^8$  tesla) magnetic field around with it. Radiation formed in this extreme environment is concentrated into two intense beams directed away from the neutron star's two magnetic poles. As these beams sweep past the direction of the Earth like the beam from a lighthouse, the star appears to wink on and off, earning it the name "pulsar." The Crab pulsar has been seen in all parts of the electromagnetic spectrum from gamma rays through radio waves. See GAMMA-RAY ASTRONOMY; NEUTRON STAR; PULSAR; RADIO ASTRONOMY; X-RAY ASTRONOMY.

The Crab pulsar's rotational period is slowing by 34 nanoseconds a day, and as it slows it loses 100,000 times more power than is radiated away by the Sun. Most of this energy is carried away from the pulsar by a wind of electrons and positrons moving at close to the speed of light. The wind feeds a vast cloud of highly relativistic particles. This cloud is called the Crab synchrotron nebula because, as the particles spiral through the nebula's magnetic field, they give off the sort of radiation emitted by a synchrotron particle accelerator. See SYNCHROTRON RADIATION.

The third component of the Crab is a complex of filaments made up of gas ejected by the explosion itself (see illustration). The filaments are ionized by ultraviolet radiation from the synchrotron nebula, causing them to glow like the gas in a fluorescent light bulb. See ASTROPHYSICS, HIGH-ENERGY; FLUORESCENCE.

[J.He.]

**Crabapple** A fruit, represented commercially by such varieties as Martha, Hyslop, and Transcendent, comprising hybrids between *Malus baccata* (Siberian crabapple) and *M. domestica* (cultivated apple).

Trees are very hardy. At one time the fruit of the crabapple was esteemed because of its high pectin content and its usefulness in jam and jelly manufacture. With the introduction of commercial pectin preparations, demand for the crabapple declined sharply. Except for its use as a pickled product, there is little commercial interest in this fruit. See APPLE; FRUIT, TREE; PECTIN; ROSALES.

[H.B.T.]

**Cracking** A process used in the petroleum industry to reduce the molecular weight of hydrocarbons by breaking molecular bonds. Cracking is carried out by thermal, catalytic, or hydrocracking methods. Increasing demand for gasoline and other middle distillates relative to demand for heavier fractions makes cracking processes important in balancing the supply of petroleum products.

Thermal cracking depends on a free-radical mechanism to cause scission of hydrocarbon carbon-carbon bonds and a reduction in molecular size, with the formation of olefins, paraffins, and some aromatics. Side reactions such as radical saturation and polymerization are controlled by regulating reaction conditions. In catalytic cracking, carbonium ions are formed on a catalyst surface, where bond scissions, isomerizations, hydrogen exchange, and so on, yield lower olefins, isoparaffins, isoolefins, and aromatics. Hydrocracking is based on catalytic formation of hydrogen radicals to break carbon-carbon bonds and saturate olefinic bonds. It converts intermediate- and high-boiling distillates to middle distillates high in paraffins and low in cyclics and olefins. See HYDROCRACKING. [E.C.L.]

**Cranberry** The large-fruited American cranberry, *Vaccinium macrocarpon*, a member of the heath family, Ericaceae, is a native plant of open, acid peat bogs in northeastern North America. Well-tended cranberry bogs continue to produce annual crops for a century or more without replanting. Selections from the wild have been cultivated since the early 19th century. It is an evergreen perennial vine producing runners and upright branches with conspicuous terminal flower buds.

Commercial cranberry growing is confined to Massachusetts, New Jersey, Wisconsin, Washington, and Oregon and to several provinces in Canada. Most of the fruit destined for processing is harvested in flood waters, either by machines which pick and deliver the fruit into towed plastic boats or by water reels which detach the berries to float and be driven by wind to shore where they are elevated into bulk trucks. Berries for juice manufacture are usually vine-ripened and deep-frozen for a month or more prior to thawing and extraction.

Good-quality fresh cranberries can be stored for several months, refrigerated, with very little loss to decay. Good-quality cranberries can be kept in deep-freeze storage for several years with only minor moisture loss. Frozen berries on thawing are soft and juicy, unlike the firm fresh berry, and must be utilized promptly.

The special requirements of the cranberry plant for low fertility, acid soil, and winter protection make it a poor choice for home garden cultivation. [C.E.C.]

**Cranial nerve** Any peripheral nerve which has its central nervous system connection with the brain, as opposed to the

spinal cord, and reaches the brain through a hole (foramen) in the skull. Nerve fibers are sensory if they carry information from the periphery to the brain, and motor if they carry information from the brain to the periphery. Sensory fibers are classified as (1) somatic sensory (ss) if they come from the skin or muscle sense organs, (2) visceral sensory (vs) if they come from the viscera, and (3) special sensory (sp.s) if they come from special sense organs such as the eye and ear. Motor fibers are classified as (1) somatic motor (sm) if they carry information to somatic striated muscles, (2) general visceral motor (gvm) if they carry information to glands, smooth muscle, or cardiac muscle, and (3) special visceral motor (svm) if they carry information to visceral striated muscle. A cranial nerve may have only one fiber type or several; cranial nerves with several fiber types are called mixed nerves.

In mammals, 12 pairs of cranial nerves, numbered I through XII, are usually described. However, mammals also have an anterior unnumbered nerve, the terminal nerve. Many vertebrates also have two pairs of lateral line nerves (unnumbered), and lack discrete nerves XI and XII. The table summarizes the cranial nerves of vertebrates. See BRAIN. [D.B.W.]

**Crank** In a mechanical linkage or mechanism, a link that can turn about a center of rotation. The crank's center of rotation is in the pivot, usually the axis of a crankshaft, that connects the crank to an adjacent link. A crank is arranged for complete rotation (360°) about its center; however, it may only oscillate

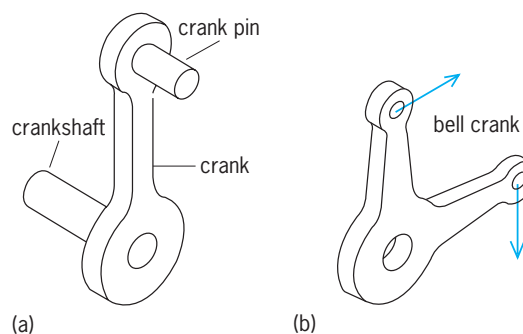

Cranks (a) for changing radius of rotation, and (b) for changing direction of translation.

or have intermittent motion. A bell crank is frequently used to change direction of motion in a linkage (see illustration). See LINKAGE (MECHANISM). [D.PAd.]

**Craton** A large, relatively stable portion of the Earth's crust. Although ocean basins originally were considered low cratons, today the term applies only to continents. Continental (high) cratons are the broad heartlands of continents with subdued topography, encompassing the largest areas of most continents. Cratons experience only broad (epeirogenic) warping and occasional faulting in contrast to the much more structurally mobile or unstable zones of continents, which include mountain ranges, such as the Himalaya, and rift zones, such as those of East Africa. The terminology used today to express these contrasts was first proposed by the German geologist L. Kober in 1921. *Kratogen* referred to stable continental platforms, and *orogen* to mountain or orogenic belts. Later authors shortened the former term to kraton or craton. A complementary term, taphrogen, coined in the 1940s, encompasses the rift structures.

The present North American craton comprises the low continental interior extending from the young Rocky Mountains east to the older Paleozoic Appalachian Mountains, and north to the Paleozoic Franklin mountain belt along the Arctic margin of Canada and Greenland. The Canadian shield is that part of the craton where pre-Paleozoic rocks are widely exposed

#### Cranial nerves of vertebrates

No.	Name (type)	Peripheral origin or destination
—	Terminal (ss)	Anterior nasal epithelium
I	Olfactory (sp.s)	Olfactory mucosa
—	Vomerolateral (sp.s)	Vomerolateral mucosa
II	Optic (sp.s)	Retina of eye
III	Oculomotor (sm)	Four extrinsic eye muscles
IV	Trochlear (sm)	One extrinsic eye muscle
V	Trigeminal (svm)	Muscles of mandibular arch derivative
	(ss)	Most of head
VI	Abducens (sm)	One extrinsic eye muscle
—	Anterior lateral line (sp.s)	Lateral line organs of head
VII	Facial (svm)	Muscles of hyoid arch derivative
	(gvm)	Salivary glands
	(ss)	Small part of head
	(vs)	Anterior pharynx
	(sp.s)	Taste, anterior tongue
VIII	Vestibulocochlear (sp.)	Inner ear
—	Posterior lateral line (sp.s)	Lateral line organs of trunk
IX	Glossopharyngeal (svm)	Muscles of third branchial arch
	(gvm)	Salivary gland
	(ss)	Skin near ear
	(vs)	Part of pharynx
	(sp.s)	Taste, posterior tongue
X	Vagus (svm)	Muscles of arches 4–6
	(gvm)	Most viscera of entire trunk
	(vs)	Larynx and part of pharynx
	(sp.s)	Taste, pharynx
XI	Spinal accessory (svm)	Some muscles of arches 4–6
XII	Hypoglossal (sm)	Muscles of tongue and anterior throat

today. In contrast, the remainder of the craton in the plains of western Canada and most of the central United States has little-deformed younger strata at the surface. Most continents have similar large Phanerozoic cratons. See CONTINENTS, EVOLUTION OF; EARTH CRUST.

Cratons are believed to comprise bits of old continental crust, which have had long and complex histories involving the overprinting of many tectonic events. Continents can be viewed as great collages of tectonic elements amalgamated together at different times and in different ways. Therefore, the delineation of both cratons and orogens has an important temporal element: What is now a craton may be made up of interlaced orogens of differing ages, each of which may include bits of mangled older cratons within them. Refined studies of seismic waves that have penetrated the Earth's deep interior indicate that beneath cratons there is anomalous mantle with distinctive compositional or thermal characteristics. Such roots imply a long-term linkage between the evolution of early continental crust and underlying mantle, which somehow contributed to the survival of fragments of cratons older than 2.5–3 billion years. See OROGENY; PLATE TECTONICS. [R.H.Dot.]

**Creep (materials)** The time-dependent strain occurring when solids are subjected to an applied stress. See STRESS AND STRAIN.

Some of the different kinds of creep phenomena that can be exhibited by materials are shown in the illustration. The strain  $\epsilon = \Delta L/L_0$ , in which  $L_0$  is the initial length of a body and  $\Delta L$  is its increase in length, is plotted against the time  $t$  for which it is subjected to an applied stress. The most common kind of creep response is represented by the curve A. Following the loading strain  $\epsilon_0$ , the creep rate, as indicated by the slope of the curve, is high but decreases as the material deforms during the primary creep stage. At sufficiently large strains, the material creeps at a constant rate. This is called the secondary or steady-state creep stage. Ordinarily this is the most important stage of creep since the time to failure  $t_f$  is determined primarily by the secondary creep rate  $\dot{\epsilon}_s$ . In the case of tension creep, the secondary creep stage is eventually interrupted by the onset of tertiary creep, which is characterized by internal fracturing of the material, creep acceleration, and finally failure. The creep rate is usually very temperature-dependent. At low temperatures or applied stresses the time scale can be thousands of years or longer. At high temperatures the entire creep process can occur in a matter of seconds. Another kind of creep response is shown by curve B. This is the sort of strain-time behavior observed when the applied stress is partially or completely removed in the course of creep. This results in time-dependent or anelastic strain recovery.

Creep of materials often limits their use in engineering structures. The centrifugal forces acting on turbine blades cause them to extend by creep. In nuclear reactors the metal tubes that

contain the fuel undergo creep in response to the pressures and forces exerted on them. In these examples the occurrence of creep is brought about by the need to operate these systems at the highest possible temperatures. Creep also occurs in ordinary structures. An example is found in prestressed concrete beams, which are held in compression by steel rods that extend through them. Creep and stress relaxation in the steel rods eventually leads to a reduction of the compression force acting in the beam, and this can result in failure. See PRESTRESSED CONCRETE.

The mechanism of creep invariably involves the sliding motion of atoms or molecules past each other. In amorphous materials such as glasses, almost any atom or molecule within the material is free to slide past its neighbor in response to a shear stress. In plastics, the long molecular chains can slide past each other only to a limited extent. Such materials typically show large anelastic creep effects (curve B in the illustration).

For crystalline materials, creep deformation also involves the sliding of atoms past each other, but here the sliding can occur only within the cores of crystal dislocations. Thus, creep of metals and ceramics is usually governed by the motion of dislocations.

It is possible to design materials with superior creep resistance. When solute atoms are added to metals, they are attracted to the strain fields of the dislocations. There they inhibit dislocation motion and in this way improve the creep resistance. Many of the aluminum alloys used for aircraft structures are strengthened in this way. The addition of second-phase particles to alloys is another way to improve the creep resistance. The most effective strengthening phases are oxides, carbides, or intermetallic phases, because they are usually much stronger than the host metal and therefore create strong obstacles to dislocation motion. Materials containing finely dispersed, strong particles of a stable phase are usually very creep-resistant. Nickel-based superalloys, used in gas-turbine engines, derive their creep resistance from these effects. See ALUMINUM ALLOYS; CRYSTAL DEFECTS; DIFFUSION; HIGH-TEMPERATURE MATERIALS; METAL, MECHANICAL PROPERTIES OF; PLASTICITY; RHEOLOGY. [W.D.N.; J.G.C.; K.J.He.]

**Creeping flow** Fluid at very low Reynolds number. In the flow of fluids, a Reynolds number (density · length · velocity/viscosity) describes the relative importance of inertia effects to viscous effects. In creeping flow the Reynolds number is very small (less than 1) such that the inertia effects can be ignored in comparison to the viscous resistance. Creeping flow at zero Reynolds number is called Stokes flow.

Mathematically, viscous fluid flow is governed by the Navier-Stokes equation. In creeping flow the nonlinear momentum terms are unimportant, and the Navier-Stokes equation can be linearized. See FLUID FLOW; FLUID-FLOW PRINCIPLES; FLUID MECHANICS; NAVIER-STOKES EQUATION; REYNOLDS NUMBER; VISCOSITY.

Examples of creeping flow include very small objects moving in a fluid, such as the settling of dust particles and the swimming of microorganisms. Other examples include the flow of fluid (ground water or oil) through small channels or cracks, such as in hydrodynamic lubrication or the seepage in sand or rock formations. The flow of high-viscosity fluids may also be described by creeping flow, such as the extrusion of melts or the transport of paints, heavy oils, or food-processing materials. [C.Y.W.]

**Creodonta** An extinct order of mammals containing the dominant carnivores in North America, Europe, Asia, and Africa during much of the Cenozoic. Its members roamed the Earth for more than 50 million years, then became extinct less than 9 million years ago. Creodonts were not part of the order Carnivora, but they independently evolved carnivorous specializations in their teeth and limbs. They ranged from tiny (*Isohyaenodon* from Africa was the size of a small weasel) to gigantic (*Hyainailouros* from Europe and Asia was one of the largest land-dwelling mammalian carnivores ever). The wolflike genus *Hyaenodon* is probably the most familiar creodont among the more than 180 known species. Most lived in North America and

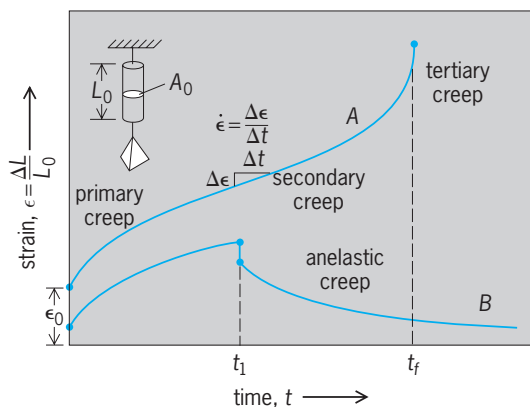

Typical creep curves for materials.

Europe, but new species from Africa and Asia are being described at an incredible rate. See DENTITION.

There are two major families within Creodonta: Hyaenodontidae and Oxyaenidae. Hyaenodontids are the more diverse, with more than 140 known species. Oxyaenids were less diverse (only about 40 species are known).

The formal classification of Creodonta has changed considerably. Improved knowledge about the relationships of placental mammals has resulted in many former creodont families being moved to other orders so that only oxyaenids and hyaenodontids remain. It is unclear how Hyaenodontidae and Oxyaenidae are related to one another, and their grouping as Creodonta may turn out to be unjustified.

It was long thought that the extinction of the creodonts was caused by competition from better-adapted members of the order Carnivora. However, the timing of creodont evolution does not support this theory. It is more likely that chance and changing conditions, including the evolution and extinction of creodont prey species, explain their slow demise. See CARNIVORA; MAMMALIA. (P.D.P.)

**Cress** A prostrate hardy perennial crucifer of European origin belonging to the plant order Capparales. Watercress (*Nasturtium officinale*) is generally grown in flooded soil beds and used for salads and garnishing. Virginia is an important producing state. Garden cress (*Lepidium sativum*) is a cool-season annual crucifer of western Asian origin grown for its flavorful leaves. Of lesser commercial importance is upland or spring cress (*Barbarea verna*), a biennial crucifer of European origin. See CAPPARALES. (H.J.C.)

**Cretaceous** In geological time, the last period of the Mesozoic Era, preceded by the Jurassic Period and followed by the Tertiary Period. The rocks formed during Cretaceous time constitute the Cretaceous System. Omalius d'Halloys first recognized the widespread chalks of Europe as a stratigraphic unit. W. O. Conybeare and W. Phillips (1822) formally established the period, noting that whereas chalks were remarkably widespread deposits at this time, the Cretaceous System includes rocks of all sorts and its ultimate basis for recognition must lie in its fossil remains. See CHALK; FOSSIL; JURASSIC; ROCK AGE DETERMINATION; STRATIGRAPHY; TERTIARY.

The parts of the Earth's crust that date from Cretaceous time include three components: a large part of the ocean floor, formed by lateral accretion; sediments and extrusive volcanic rocks that accumulated in vertical succession on the ocean floor and on the continents; and intrusive igneous rocks such as the granitic batholiths that invaded the crust of the continents from below or melted it in situ. The sedimentary accumulations contain, in fossils, the record of Cretaceous life. The plutonic and volcanic rocks are the chief source of radiometric data from which actual ages can be estimated, and suggest that the Cretaceous Period extended from 144 million years to  $65 \pm 0.5$  million years before present (see illustration).

There are 12 globally recognized subdivisions, or stages, in the Cretaceous, based on species development (see illustration). In marine sediments the appearance and disappearance of individual, widely distributed species allows further time resolution by so-called zones. Initially these zones were largely based on ammonites, a now extinct group of cephalopods, closest to the squids and octopuses but resembling the pearly nautilus. Due to the provinciality of some ammonite species and the rarity of many, the dating of Cretaceous marine sediments now mainly devolves on microscopic fossils of calcareous plankton. The most important of these are protozoans. Their shells, in the range of 0.1–1 mm, occurring by hundreds if not thousands in a handful of chalk, have furnished about 38 pantropical zones. Next in importance are the even tinier (0.01-mm) armor plates of "nanoplanktonic" coccolithophores. Thousands may be present in a pinch of chalk, and 24 zones

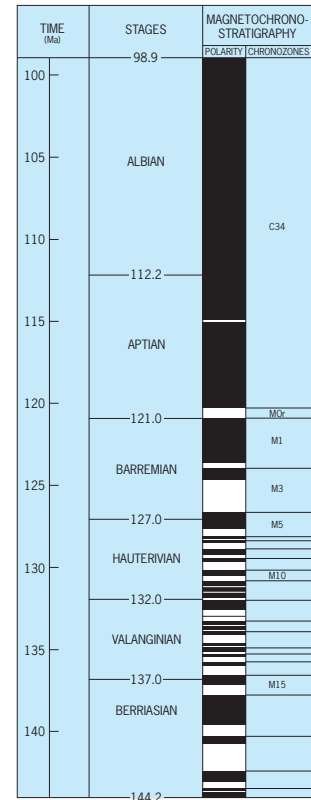
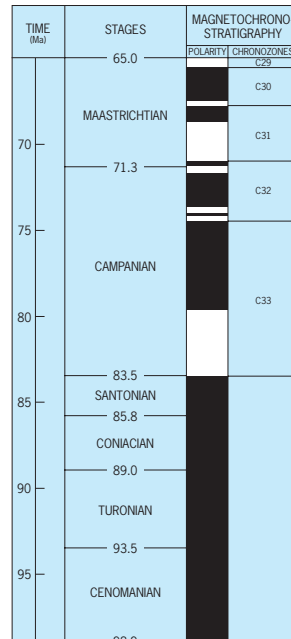

**Stages of the Cretaceous Period, their estimated ages in years before present, and polarity chrons representing the alternation between episodes of normal (black) and reversed (white) orientations of the Earth's magnetic field. (After F. M. Gradstein et al., in W. A. Berggren et al., eds., *Geochronology, Time Scales and Global Stratigraphic Correlations*, SEPM Spec. Publ., no. 54, 1995)**

have been recognized. See CEPHALOPODA; COCCOLITHOPHORIDA; FORAMINIFERIDA; MARINE SEDIMENTS; MICROPALAEONTOLOGY; PALEONTOLOGY; PHYTOPLANKTON; PROTOZOA; ZOOPLANKTON.

The Earth's magnetic field reversed about 60 times during Cretaceous time, and the resulting polarity chrons have been recorded in the remanent magnetism of many rock types (illustration). The actual process of reversal occurs in a few thousand years and affects the entire Earth simultaneously, providing geologically instantaneous time signals by which the continental and volcanic records can be linked to marine sequences and their fossil zonation. Noteworthy here is the occurrence of a very long (32-million-year) interval during which the field remained in normal polarity. See PALEOMAGNETISM.

During Cretaceous time the breakup of Gondwana, the great late Paleozoic-Triassic supercontinent, became complete. Laurasia had already separated from Africa by the development of Tethys and became split into North America and Eurasia by the opening of the North Atlantic. These new, deep oceanic areas continued to grow in Cretaceous time. India broke away from Australia and Australia from Antarctica. South America tore away from Africa by the development of the South Atlantic Ocean, while India brushed past Madagascar on its way north to collide with southeast Asia. As these new oceanic areas grew, comparable areas of old ocean floor plunged into the mantle in subduction zones such as those that still ring the Pacific Ocean, marked by deep oceanic trenches and by the development of mountain belts and volcanism on adjacent continental margins. See ALSO CONTINENTS, EVOLUTION OF; PLATE TECTONICS; SUBDUCTION ZONES.

The face of the globe was also affected by changes in sea level. Sea level at times in the early Cretaceous stood at levels

comparable to the present, but subsequently the continents were flooded with relatively shallow seas to an extent probably not attained since Ordovician-Silurian times. Maximal flooding, in the Turonian Stage, inundated at least 40% of present land area. Cretaceous seas covered most of western Europe, though old mountain belts such as the Caledonides of Scandinavia and Scotland remained dry and archipelagos began to emerge in the Alpine belt. In America, seas flooded the southeastern flank of the Appalachian Mountains, extended deep into what is now the Mississippi Valley, and advanced along the foredeep east of the rising Western Cordillera to link at times the Gulf of Mexico with the Arctic Ocean.

Large seas extended over parts of Asia, Africa, South America, and Australia. The wide spread of the chalk facies is essentially due to this deep inundation of continents, combined with the trapping of detrital sediments near their mountain-belt sources, in deltas or in turbidite-fed deep-water fans. At the same time, carbonate platforms were still widespread, and the paratropical dry belts were commonly associated with evaporite deposits. See PALEOGEOGRAPHY; SALINE EVAPORITES.

In parts of early Cretaceous time, ice extended to sea level in the polar regions. But during most of Cretaceous time, climates were in the hothouse or greenhouse mode, showing lower latitudinal temperature gradients. Tropical climates may have been much like present ones, and paratropical deserts existed as they do now, but terrestrial floras and faunas suggest that nearly frost-free climates extended to the polar circles as did abundant rainfall, and no ice sheets appear to have reached sea level.

On land, flowering plants (angiosperms) first appeared in early Cretaceous time, as opportunistic plants in marginal settings, and then spread to the understorey of woodlands, replacing cycads and ferns. In late Cretaceous time, evergreen angiosperms, including palms, thus came to dominate the tropical rainforests. Evergreen conifers maintained dominance in the drier mid-latitude settings, while in the moist higher latitudes forests of broad-leaved deciduous trees dominated. Insects became highly diverse, and many modern families have their roots in the Cretaceous. Amphibians and small reptiles were present. Larger land animals included crocodiles and crocodilelike reptiles, turtles, and dinosaurs. The mammals remained comparatively minor elements in the Cretaceous faunas. In early Cretaceous time, egg-laying and marsupial mammals were joined by placentals, but Cretaceous mammals were in general small, and lack of color vision in most modern mammals suggests a nocturnal ancestry and a furtive existence in a dinosaurian world. Birds had arisen, from dinosaurs in Jurassic time, but their fossil record from the Cretaceous is poor and largely one of water birds. More common are the remains of flying reptiles, the pterosaurs. See DINOSAUR; MAMMALIA; MARSUPIALIA; PTEROSAURIA.

About 65 million years ago, during the reversed magnetic interval known as chron 29R, a collision with an asteroid or comet showered the entire Earth with impact debris, preserved in many places as a thin "boundary clay" enriched in the trace element iridium. This event coincided with the great wave of extinctions—the K/T crisis—which serve to bound the Cretaceous (Kreide) Period against the Tertiary.

Global effects of the impact must have included earthquake shock many orders of magnitude greater than any found in human history; associated land slips and tidal waves; a dust blackout of sunlight that must have taken many months to clear; a sharp drop in temperatures that would have brought frost to the tropics; changes in atmospheric and water chemistry; and disturbance of existing patterns of atmospheric and oceanic circulation. It is possible that earthquakes influenced volcanic eruptions. Different biotic communities were affected to different degrees. The pelagic community, sensitive to photosynthetic productivity, was severely struck, with coccolithophores and planktonic foraminiferans reduced to a few species, while ammonites, belemnites, plesiosaurs, and mosasaurs were eliminated. Dinoflagellates, endowed with the capacity to encyst

under stress, suffered no great loss. Benthic life was only moderately damaged, excepting destruction of the reef community. While North American trees underwent far more extinction at the specific level than formerly believed, land floras escaped with little damage, presumably because they were generally equipped to handle stress by dormancy and seed survival. The plant-fodder-dependent dinosaurs perished, as did their predators and scavengers. The fresh-water community, buffered by ground water against temperature change and food-dependent mainly on terrestrial detritus, was little affected. While a great many individual organisms must have been killed by the immediate effects of the impact, the loss of species and higher taxa must have occurred on land and in shallowest waters mainly in the aftermath of darkness, chill, and starvation, and in the deeper waters in response to changed regimes in currents, temperatures, and nutrition. The Cretaceous crash led above all to an evolutionary outburst of the mammals, which in the succeeding tens of millions of years not only filled and multiplied the niches left by dinosaurs but also invaded the seas. [A.G.F.]

**Criminalistics** Criminalistics is the science and profession dealing with the recognition, collection, identification, individualization, and interpretation of physical evidence, and the application of the natural sciences to law-science matters. It is not possible for a single person to become proficient in the examination and analysis of all types of physical evidence. Increasingly, criminalists and other workers in forensic science laboratories are specializing in the examination of one or a few types of physical evidence. For example, forensic biologists analyze the biological or genetic properties of evidence, trace evidence analysts identify material that is transferred between two objects and determine its origin, and firearms and toolmark experts examine firearms, ammunition components, and tools and marks left by them. See FORENSIC MEDICINE.

A wide variety of techniques are used by criminalists for the location and collection of evidence at crime scenes as well as for the examination and analysis of that evidence in the laboratory. Crime scene techniques may involve the use of lasers or other light sources to locate biological stains or minute fibers or paint particles, chemical tests for lead around suspected bullet holes, electrostatic devices to recover a dusty shoe sole impression from a floor, or special reagents for the development of latent fingerprints.

Many techniques used in the forensic laboratory are the same ones that are used by analytical chemists, molecular biologists, materials scientists, and so on. Often these techniques are adapted to the special requirements of the forensic science laboratory. Infrared spectroscopy, mass spectrometry, gas chromatography, optical and electron microscopy, and a host of other standard analytical chemistry techniques find common use by criminalists.

Routine techniques and procedures have been developed by forensic scientists which have little or no application outside the forensic laboratory. Examples are the determination of genetic markers in minute fragments of dried biological material, the determination of the refractive index of microscopic glass fragments, the microscopic comparison of individual human hairs, and the microscopic comparison of markings on the surface of bullets. [P.D.B.]

**Crinoidea** A class of exclusively suspension-feeding echinoderms with long, slender arms arranged radially around the calyx, a rigid cuplike structure composed of calcareous plates. The radial arm arrangement gives crinoids a flowerlike appearance (see illustration). Two basic adult body types are recognized: the sea lilies, with a long, anchored stem vertically supporting the calyx and arms above the sea bottom; and the stemless feathery stalks, or comatulids, with a whorl of flexible appendages on the calyx. Crinoids have a worldwide distribution and can be found in all seas except the Black and Baltic. They occupy depths

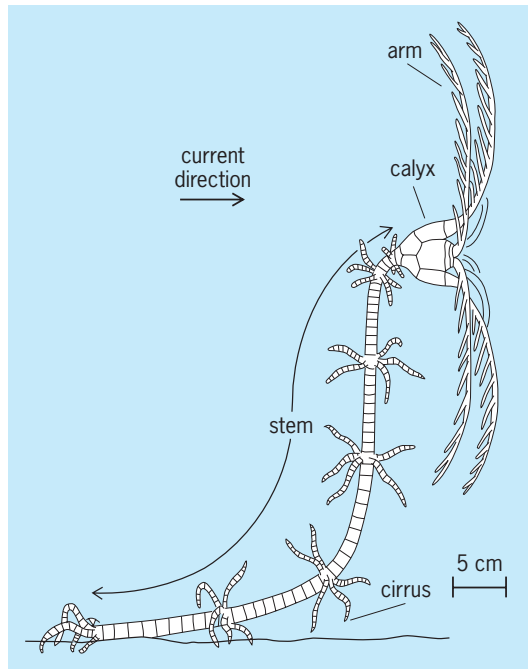

Schematic diagram of a stemmed crinoid in feeding posture.

ranging from just below sea level to a depth of over 9000 m (29,500 ft). Sea lilies are found only at depths greater than 100 m (330 ft), whereas comatulids are most abundant and diverse in shallow, tropical coral reef environments. See BLASTOIDEA; PELMATOZOA.

Over 500 species of living comatulids have been described, and many of these can be extremely abundant locally, yet fewer than 100 species of living sea lilies are known. These patterns contrast starkly with the fossil record of crinoids, which is dominated by stemmed crinoids: of the more than 5000 described fossil species, more than 90% have stems.

Living crinoids have no economic importance and are not used for food by humans. However, their fossil remains are often the dominant constituent of building limestone (for example, Indiana limestone) which is highly valued.

Adult crinoids range in size from a few centimeters for some of the stemless forms to several meters from base of the stem to tip of the arms for the largest stemmed crinoids. They also vary in color from the largely bland whites and grays of the deep-water forms to the brilliantly reds, yellows, and purples of the shallow-water tropical featherstars. In spite of the size range, color differences, and stemmed or stemless condition as adults, all crinoids share a suite of morphological traits that can be traced back to the Ordovician age, nearly 500 million years ago. See ORDOVICIAN.

Crinoids are exclusively passive suspension feeders, extracting food particles from the ambient water. Crinoids are indiscriminate feeders, and the tube feet capture organic and inorganic particles with a median size of about 50 micrometers and rarely larger than 500  $\mu\text{m}$ . The organic food component consists primarily of phytoplankton, protozoa, and crustacea. Crinoid morphology and behavior strongly reflect their total reliance on water movement for nutrient supply. Crinoids avoid slack-water environments, living in areas dominated by currents, wave action, or multidirectional flows.

Crinoids have a long and rich fossil record, and at times in Earth history they were numerically one of the dominant members of the benthic marine ecosystem. The first undisputed crinoids were found in rocks of the Ordovician Period. The Mississippian Period, known as the Age of Crinoids, represents the peak in their abundance and diversity. Crinoids remained an

important component of marine communities until the Permian-Triassic extinction event that signaled the end of the Paleozoic Era. This event led to a great reduction in crinoid diversity. A single genus, *Holocrinus*, found in Lower Triassic rocks, is the most primitive member of the Articulata, a subclass that includes all post-Paleozoic crinoids. See ARTICULATA (ECHINODERMATA); CRINOZOA; ECHINODERMATA. [T.K.B.]

**Crinozoa** A subphylum of the Echinodermata including radially symmetrical echinoderms showing a partly meridional pattern of growth. This tends to produce an aboral cup-shaped theca and a partly radially divergent pattern of growth, forming appendages, called brachioles or arms and bearing ambulacral grooves. Included in the subphylum are the blastoids, cystoids, edrioblastoids, eocrinoids, parablattoids, and paracrinoids. See BLASTOIDEA; CRINOIDEA; ECHINODERMATA; EOCHRINOIDEA. [H.B.F.]

**Critical care medicine** The treatment of acute, life-threatening disorders, usually in intensive care units. Critical care medicine has been practiced informally for many decades in trauma centers, postanesthesia recovery rooms, coronary care units, delivery rooms, emergency rooms, and postoperative areas. The facilities and trained personnel available in the intensive care unit (ICU) permit extensive monitoring of physiological variables, organization of complex, multidisciplinary diagnostic and therapeutic plans, administration of therapy to predetermined goals, and expert nursing care.

Critical care thus runs counter to the traditional division of specialties by organ or organ system. Specialists in critical care undergo training beyond a primary qualification (internal medicine, surgery, anesthesia, or pediatrics), and must be able to manage acute respiratory, cardiovascular, metabolic, cerebral, and renal problems, as well as infections. The patients may be newborns, children, or adults suffering from trauma or acute life-threatening disease. Patients having failure of multiple organs, complicated medical problems, disorders falling into several medical specialties, or a need for 24-h care often become the responsibility of the critical care specialist.

The intensive care unit is the most labor-intensive, technically complex, and expensive part of hospital care. The intensive care unit, however, may be crucial to the patient's survival. Perhaps the single most useful function of the intensive care unit is to provide life-support systems for desperately ill patients who would not survive without them. Such systems include mechanical ventilation; cardiopulmonary resuscitation; peritoneal dialysis and hemodialysis; circulatory support with intraaortic balloon pumping; and extracorporeal membrane oxygenation.

Another aspect of critical care is the provision of life-sustaining therapy. Components include administration of intravenous fluids, provision of nutritional support, and control of infections.

[W.C.Sh.]

**Critical mass** The amount of fissile material (uranium-233, uranium-235, or plutonium-239) that supports a self-sustaining nuclear chain reaction. Critical mass is a definitive feature of nuclear reactors and nuclear explosives. It is increased by the presence of such neutron-absorptive materials as admixed uranium-238, aluminum pipes for flow of coolant, zirconium fuel-element cladding, and boron, cadmium, or gadolinium control rods. It is reduced by a moderator, such as graphite, heavy water, or light water, which slows down the neutrons, inhibits their escape, and thus improves the probability of producing fission in the fuel. Without a moderator, natural uranium cannot reach criticality. See CHAIN REACTION.

Critical mass also depends on the density of the fissile component, its geometry, and the immediate surroundings. In a reactor the critical mass is not a static quantity because specific nuclear phenomena activate and influence the chain reaction. See NUCLEAR REACTOR.

An explosive, supercritical condition can be deliberately created by rapid introduction of reactivity in excess of the requirements for a critical mass. This is the basis for nuclear explosions, which rely on sudden explosively driven densification of a subcritical fissile component. See ATOMIC BOMB; HYDROGEN BOMB; NUCLEAR EXPLOSION. [A.DeV.]

**Critical phenomena** The unusual physical properties displayed by substances near their critical points. The study of critical phenomena of different substances is directed toward a common theory.

Ideally, if a certain amount of water ( $\text{H}_2\text{O}$ ) is sealed inside a transparent cell and heated to a high temperature  $T$ , for instance,  $T > 647 \text{ K}$  ( $374^\circ\text{C}$  or  $705^\circ\text{F}$ ), the enclosed water exists as a transparent homogeneous substance. When the cell is allowed to cool down gradually and reaches a particular temperature, namely the boiling point, the enclosed water will go through a phase transition and separate into liquid and vapor phases. The liquid phase, being more dense, will settle into the bottom half of the cell. This sequence of events takes place for water at most moderate densities. However, if the enclosed water is at a density close to  $322.2 \text{ kg} \cdot \text{m}^{-3}$ , rather extraordinary phenomena will be observed. As the cell is cooled toward  $647 \text{ K}$  ( $374^\circ\text{C}$  or  $705^\circ\text{F}$ ), the originally transparent water will become increasingly turbid and milky, indicating that visible light is being strongly scattered. Upon slight additional cooling, the turbidity disappears and two clear phases, water and vapor, are found. This phenomenon is called the critical opalescence, and the water sample is said to have gone through the critical phase transition. The density, temperature, and pressure at which this transition happens determine the critical point and are called respectively the critical density  $\rho_c$ , the critical temperature  $T_c$ , and the critical pressure  $P_c$ . For water  $\rho_c = 322.2 \text{ kg} \cdot \text{m}^{-3}$ ,  $T_c = 647 \text{ K}$  ( $374^\circ\text{C}$  or  $705^\circ\text{F}$ ), and  $P_c = 2.21 \times 10^7$  pascals. See OPALESCENCE.

Different fluids, as expected, have different critical points. Although the critical point is the end point of the vapor pressure curve on the pressure-temperature ( $P$ - $T$ ) plane (see illustration), the critical phase transition is qualitatively different from that of the ordinary boiling phenomenon that happens along the vapor pressure curve. In addition to the critical opalescence, there are other highly unusual phenomena that are manifested near the critical point; for example, both the isothermal compressibility and heat capacity diverge to infinity as the fluid approaches  $T_c$ . See THERMODYNAMIC PROCESSES.

Many other systems, for example, ferromagnetic materials such as iron and nickel, also have critical points. The ferromag-

netic critical point is also known as the Curie point. As in the case of fluids, a number of unusual phenomena take place near the critical point of ferromagnets, including singular heat capacity and divergent magnetic susceptibility. The study of critical phenomena is directed toward describing the various anomalous and interesting types of behavior near the critical points of these diverse and different systems with a single common theory. See CURIE TEMPERATURE; FERROMAGNETISM. [M.H.W.C.]

**Crocodile** The common name used for 14 species of large reptiles included in the family Crocodylidae (order Crocodylia) which also includes the alligators, caimans, and the gharial (also known as the gavial). Like all crocodylians, the crocodiles are primarily distributed throughout the tropical regions of the world. Species occur in both saltwater and freshwater habitats. Crocodiles are generally omnivorous, feeding on invertebrates, fish, other reptiles and amphibians, birds, and mammals—practically any animal they can overpower. A few, very narrow-snouted species are believed to subsist primarily on fish. Crocodiles are primarily aquatic and nocturnal, leaving the water only to bask by day or to build their nests. Some species construct burrows into the banks of rivers or lakes where they spend part of their time.

These animals are powerful predators with large teeth and strong jaws. Large adults of some species may exceed 20 ft (6 m) in length and are capable of overpowering and eating large grazing mammals, even occasionally humans. The webbed feet, flattened tail, and placement of the nostrils, eyes, and ears on raised areas of the head are adaptations for an aquatic existence. The raised nostrils, eyes, and ears allow the animals to float almost completely submerged while still monitoring their environment.

Reproduction in crocodiles is the most elaborate of the reptiles. Courtship and mating occur in the water. The female digs a hole in the soil for the 30 or so eggs. Nests are often guarded by the female. The young may remain together as a pod with the female for a year or more. Hearing and vocal communication are well developed in the crocodiles, and a variety of bellows, snarls, and grunts are utilized in their elaborate social behavior.

Crocodiles are considered very valuable for the leather obtained from their hides, and all species are becoming very rare owing to hunting and to the loss of their habitats through land development for other uses. Most countries with native crocodile populations are implementing conservation measures, and international efforts are being made to regulate trade in a crocodile products. See ALLIGATOR; CROCODYLIA; REPTILIA. [H.W.C.]

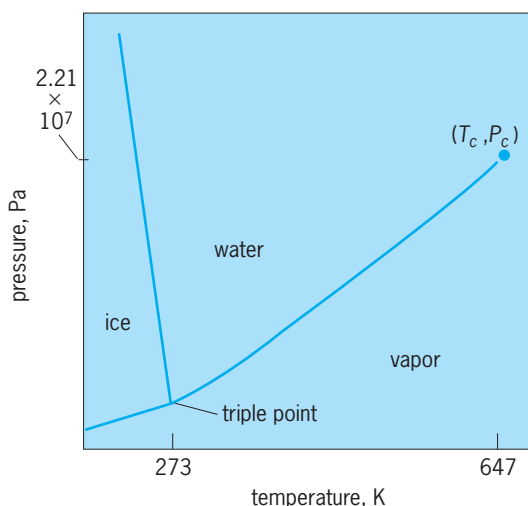

Phase diagram of water ( $\text{H}_2\text{O}$ ) on pressure-temperature ( $P$ - $T$ ) plane.

**Crocodylia** An order of the class Reptilia (subclass Archosauria) which is composed of large, voracious, aquatic species which include the alligators, caimans, crocodiles, and gavials. The group has a long fossil history from Late Triassic times and its members are the closest living relatives of the extinct dinosaurs and the birds. The 21 or 22 living species are found in tropic areas of Africa, Asia, Australia, and the Americas. One form, the salt-water crocodile (*Crocodylus porosus*), has traversed oceanic barriers from the East Indies as far east as the Fiji Islands. See ARCHOSAURIA.

The order is distinguished from other living reptiles in that it has two temporal foramina, an immovable quadrate, a bony secondary palate, no shell, a single median penis in males, socketed teeth, a four-chambered heart, and an oblique septum that completely separates the lung cavities from the peritoneal region. Certain of these unique features and other salient characteristics of the Crocodylia are intimately associated with their aquatic life. For example, there is a special pair of fleshy flaps at the posterior end of the mouth cavity which form a valvular mechanism which separates the mouth from the region where the air passage opens into the throat. This complex arrangement allows crocodylians to breathe even though most of the head is under water, or the mouth is open holding prey or full of water.

During the breeding season male crocodylians set up territories on land which they defend against intruders of the same species. Fertilization is internal and the hard-shelled eggs are deposited in excavations in the sand or in large nests of decaying vegetation, depending upon the species.

The living species are placed in two families and eight genera. The family Crocodylidae contains two subgroups: the true crocodiles, Crocodylinae, including the genera *Crocodylus* found in all tropic areas, *Osteolaemus* in central Africa, and the false gavia (*Tomistoma*) in Malaya and the East Indies; the alligators and caimans, Alligatorinae, including the genera *Alligator* of the southeastern United States and near Shanghai, China, the *Caiman* from Central and South America, and *Melanosuchus* and *Paleosuchus* of South America. The gavia (*Gavialis gangeticus*) of India and north Burma is the only living member of the family Gavialidae. Crocodiles differ most obviously from alligators and caimans in head shape and in the position of the teeth, although other technical details also separate them. See ALLIGATOR; CROCODILE; GAVIAL.

Crocodylians first appear in deposits of Late Triassic or possibly Early Jurassic age in North America and South Africa. They formerly were much more widely distributed in temperate latitude than today; abundant paleobotanical evidence confirms a warmer climate in mid-latitudes at this time. It seems probable that the restriction of crocodylians to the tropics was a direct result of cooling climate in the late Cenozoic. See REPTILIA. [J.T.G.]

**Crocoite** A mineral with the chemical composition  $PbCrO_4$ . Crocoite occurs in yellow to orange or hyacinth red, monoclinic, prismatic crystals with adamantine to vitreous luster; it is also massive granular. Hardness is 2.5–3 on Mohs scale and specific gravity is 6.0. Streak, or color of the mineral powder, is orangish-yellow. It fuses easily.

Crocoite is a secondary mineral associated with other secondary minerals of lead such as pyromorphite and of zinc such as cerussite. It has been found in mines in California and Colorado. See LEAD. [E.C.T.C.]

**Crossing-over (genetics)** The process whereby one or more gene alleles present in one chromosome may be exchanged with their alternative alleles on a homologous chromosome to produce a recombinant (crossover) chromosome which contains a combination of the alleles originally present on the two parental chromosomes. Genes which occur on the same chromosome are said to be linked, and together they are said to compose a linkage group. In eukaryotes, crossing-over may occur during both meiosis and mitosis, but the frequency of meiotic crossing-over is much higher. See ALLELE; CHROMOSOME; GENE; LINKAGE (GENETICS).

Crossing-over is a reciprocal recombination event which involves breakage and exchange between two nonsister chromatids of the four homologous chromatids present at prophase I of meiosis; that is, crossing-over occurs after the replication of chromosomes which has occurred in premeiotic interphase. The result is that half of the meiotic products will be recombinants, and half will have the parental gene combinations. Using maize chromosomes which carried both cytological and genetic markers, H. Creighton and B. McClintock showed in 1931 that genetic crossing-over between linked genes was accompanied by exchange of microscopically visible chromosome markers. See RECOMBINATION (GENETICS).

In general, the closer two genes are on a chromosome, that is, the more closely linked they are, the less likely it is that crossing-over will occur between them. Thus, the frequency of crossing-over between different genes on a chromosome can be used to produce an estimate of their order and distances apart; this is known as a linkage map. See GENETIC MAPPING.

Since each chromatid is composed of a single deoxyribonucleic acid (DNA) duplex, the process of crossing-over involves the breakage and rejoining of DNA molecules. Although the precise

molecular mechanisms have not been determined, it is generally agreed that the following events are necessary: (1) breaking (nicking) of one of the two strands of one or both nonsister DNA molecules; (2) heteroduplex (hybrid DNA) formation between single strands from the nonsister DNA molecules; (3) formation of a half chiasma, which is resolved by more single-strand breakages to result in either a reciprocal crossover, a noncrossover, or a nonreciprocal crossover (conversion event). [C.B.G.]

**Crossopterygii** An infraclass of the bony fishes (class Osteichthyes), also known as fringe-finned fishes, that forms one of the two major divisions of the lobe-finned fishes (Sarcopterygii). The group first appeared as fossils in the Early Devonian; in the Paleozoic they were mostly small to medium-sized carnivorous fish living in shallow tropical seas, estuaries, and fresh waters. There were two principal groups: a diverse set of fishes termed Rhipidista and the Coelacanthini. Their principal radiations were in the Devonian, and by the Mississippian they were in sharp decline. The Rhipidista were wholly extinct by the Middle Permian, but the coelacanths underwent a second, smaller, Mesozoic radiation and managed to survive to the present day as the most famous lobe-fin of all, the living species *Latimeria chalumnae*. Crossopterygii are characterized by a unique hinge in the skull that allowed the front portion to be raised and lowered during feeding and respiratory movements. See SARCOPTERYGII.

Members of the order Rhipidistia were principally fusiform, fast-swimming carnivores that flourished in the rivers and lakes of the Late Devonian. They could breathe air, and the use of lungs as well as gills gave them an advantage in warm, shallow-water environments where dissolved oxygen was often low. Members of the order Coelacanthini are characterized by a special trifold tail and scales ornamented with tubercles. They are not thought to be close to the ancestors of tetrapods. See OSTEICHTHYES. [K.T.]

**Crosstalk** Interference in a communications channel (disturbed channel) caused by activity in other communications channels (disturbing channels). The term was originally used to denote the presence in a telephone receiver of unwanted speech signals from other conversations, but its scope has been extended by common usage to include like effects in other types of communications.

The cause of crosstalk is some form of coupling mechanism between the disturbed channel and the disturbing channels. Communications channels are normally segregated by space, frequency, time, code, or polarization division, or by some combination of the five, to avoid such coupling, but economic and other constraints often preclude complete segregation.

In space-division segregation, each communication channel is assigned its own transmission medium, for example, a pair of wires is a multipair cable or a separate radio propagation path. Coupling between channels is caused by the physical proximity and relative orientation of the transmission media. The coupling is usually electromagnetic, a linear phenomenon that is independent of signal level in the channels. See ELECTROMAGNETIC COMPATIBILITY.

Crosstalk is classified in a variety of ways. The type of coupling (electromagnetic, intermodulation, or common impedance) indicates the mechanism. The terms near-end crosstalk (NEXT) and far-end crosstalk (FEXT) indicate the relative directions of signal propagation in the disturbed and disturbing channels. The terms direct crosstalk, where the disturbing channel couples directly to the disturbed channel, and indirect crosstalk, where the coupling path between disturbing and disturbed channels involves a third, or tertiary, channel, are often used to further describe crosstalk caused by electromagnetic coupling. Interaction crosstalk (IXT) is a term used to further describe indirect crosstalk that couples from the disturbing channel to the tertiary channel at one place, propagates along the tertiary channel, and subsequently couples into the disturbed channel at another place. Transverse crosstalk is a term that includes all direct and indirect



crosstalk that is not interaction crosstalk. Intelligible crosstalk is understood by the receiver of the disturbed channel, whereas nonintelligible crosstalk is not.

Most remedies for reducing crosstalk entail some technique for decreasing coupling among the communications channels involved. The use of twisted pairs in multipair cables, of shielding for each pair, or of coaxial conductors and optical fibers in place of pairs are common techniques for reducing electromagnetic coupling where space division alone is not adequate. Improved control of signal levels and improved linearity in amplifiers are effective for frequency-division systems. Often such improvements are made possible by advances in technology. Selection of the appropriate type of modulation (AM, FM, PM) is also important. Crosstalk within multichannel digital systems that transport digital versions of analog signals can be reduced with the help of a separate coder-decoder for each analog channel in place of a common, time-shared coder-decoder for all channels. Signal processing in the disturbed channel can sometimes be effective in reducing crosstalk. See ELECTRICAL COMMUNICATIONS; ELECTRICAL INTERFERENCE; ELECTRICAL SHIELDING; OPTICAL FIBERS; TELEPHONE SERVICE. [J.W.S.]

**Crown gall** A neoplastic disease of primarily woody plants, although the disease can be reproduced in species representing more than 90 plant families. The disease results from infection of wounds by the free-living soil bacterium *Agrobacterium tumefaciens* which is commonly associated with the roots of plants.

The first step in the infection process is the site-specific attachment of the bacteria to the plant host. Up to half of the bacteria become attached to host cells after 2 h. At 1 or 2 weeks after infection, swellings and overgrowths take place in tissue surrounding the site of infection, and with time these tissues proliferate into large tumors (see illustration). If infection takes place around the main stem or trunk of woody hosts, continued tumor proliferation will cause girdling and may eventually kill the host. Crown gall is therefore economically important, particularly in nurseries

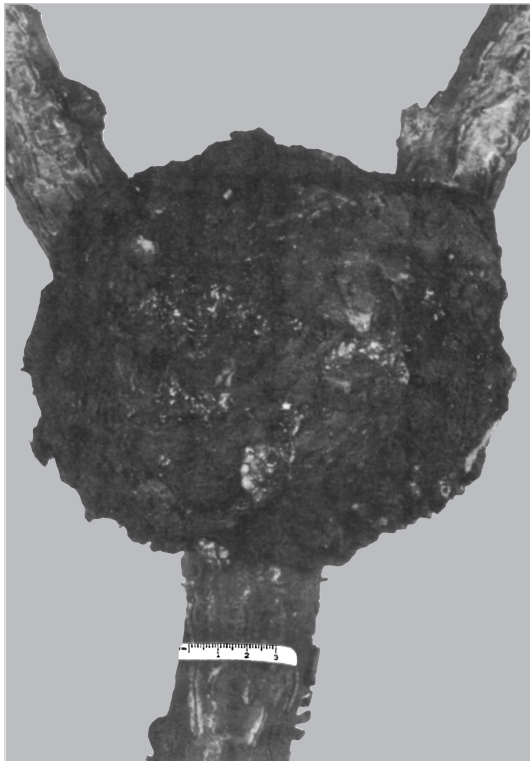

Crown gall on peach.

where plant material for commercial use is propagated and disseminated.

Unlike healthy normal cells, crown gall tumor cells do not require an exogenous source of phytohormones (auxins and cytokinin) for growth in culture because they readily synthesize more than sufficient quantities for their own growth. They also synthesize basic amino acids, each conjugated with an organic acid, called opines. The tumor cells also grow about four times faster and are more permeable to metabolites than normal cells.

These cellular alterations, such as the synthesis of opines and phytohormone regulation, result from bacterial genes introduced into host plant cells by *A. tumefaciens* during infection. Although it is not understood how these genes are introduced into the plant cell, the genes for the utilization of these opines and for regulating phytohormone production have been found to be situated on an extrachromosomal element called the pTi plasmid. This plasmid, harbored in all tumor-causing *Agrobacterium* species, also carries the necessary genetic information for conferring the tumor-inducing and host-recognition properties of the bacterium.

Crown gall is consequently a result of this unique bacteria-plant interaction, whereby *A. tumefaciens* genetically engineers its host to produce undifferentiated growth in the form of a large tumor, in which there is the synthesis of a unique food source in the form of an opine for specific use by the bacterial pathogen. See BACTERIAL GENETICS; GENETIC ENGINEERING; PLANT HORMONES; PLANT PATHOLOGY. [C.J.Ka.]

**Crushing and pulverizing** The reduction of materials such as stone, coal, or slag to a suitable size for their intended uses such as road building, concrete aggregate, or furnace firing. Reduction in size is accomplished by five principal methods: (1) crushing, a slow application of a large force; (2) impact, a rapid hard blow as by a hammer; (3) attrition, a rubbing or abrasion; (4) sudden release of internal pressure; and (5) ultrasonic forces. The last two methods are not in common use.

Crushing and pulverizing are processes in ore dressing needed to reduce valuable ores to the fine size at which the valueless gangue can be separated from the ore. These processes are also used to reduce cement rock to the fine powder required for burning, to reduce cement clinker to the very fine size of portland cement, to reduce coal to the size suitable for burning in pulverized form, and to prepare bulk materials for handling in many processes. See MATERIALS-HANDLING EQUIPMENT.

Equipment suitable for crushing large lumps as they come from the quarry or mine cannot be used to pulverize to fine powder, so the operation is carried on in three or more stages called primary crushing, secondary crushing, and pulverizing. The three stages are characterized by the size of the feed material, the size of the output product, and the resulting reduction ratio of the material. The crushing-stage output may be screened for greater uniformity of product size.

There are four principal types of primary crushers. The Blake jaw crusher uses a double toggle to move the swinging jaw and is built in a variety of sizes from laboratory units to large sizes having a feed inlet 84 by 120 in. (213 by 305 cm). The Dodge jaw crusher uses a single toggle or eccentric and is generally built in smaller sizes. The Gates gyratory crusher has a cone or mantle that does not rotate but is moved eccentrically by the lower bearing sleeve. The Symons cone crusher also has a gyratory motion, but has a much flatter mantle or cone than does the gyratory crusher. The top bowl is spring-mounted. It is used as a primary or secondary crusher.

Secondary crushers include the single-roll crusher and the double-roll crusher which have teeth on the roll surface and are used mainly for coal. Smooth rolls without teeth are sometimes used for crushing ores and rocks. The hammer crusher is the type of secondary crusher most generally used for ore, rock, and coal. The reversible hammer mill can run alternately in either direction, thus wearing both sides of the hammers.

In open-circuit pulverizing, the material passes through the pulverizer once with no removal of fines or recirculation. In closed-circuit pulverizing, the material discharged from the pulverizer is passed through an external classifier where the finished product is removed and the oversize is returned to the pulverizer for further grinding.

Ball and tube mills, rod mills, hammer mills, and attrition mills are pulverizers operating by impact and attrition. In ball race and roller pulverizers, crushing and attrition are used. See BALL-AND-RACE-TYPE PULVERIZER; BUHRSTONE MILL; PEBBLE MILL; TUMBLING MILL. [R.M.H.]

**Crustacea** A highly variable, species-rich group of arthropods that have inhabited marine environments since the beginning of the Cambrian Period. Within the marine realm the crustaceans occupy as diverse a spectrum of habitats as the insects inhabit on land.

The hierarchical rank of the Crustacea is a matter of continuing debate. The Crustacea are regarded as a phylum, distinct from other arthropods, by proponents of the concept of polyphyly in the Arthropoda. Alternatively, they are given the rank of subphylum or superclass by those who view the Arthropoda as a monophyletic taxon.

Species of Crustacea such as the shrimp, prawn, crab, or lobster are familiar. However, there are many more with less common vernacular names such as the water fleas, beach fleas, sand hoppers, fish lice, wood lice, sow bugs, pill bugs, barnacles, scuds, slaters, and krill or whale food. The Crustacea are one of the most difficult animal groups to define because of their great diversity of structure, habit, habitat, and development. No one character or generalization will apply equally well to all.

Crustaceans have segmented, chitin-encased bodies; articulated appendages; mouthparts known as mandibles during some stage of their life, however modified they may be for cutting, chewing, piercing, sucking, or licking; and two pairs of accessory feeding organs, the maxillules and maxillae. One or the other pair is sometimes vestigial or may be lacking. The Crustacea are unique in having two pairs of antennae: the first pair, or antennules, and the second pair, the antennae proper. The latter, are almost always functional at some stage of every crustacean's life.

**Taxonomy.** Not only is there a lack of agreement on the rank of the Crustacea per se, but there is no consensus on hierarchical levels of subordinate taxa. The classification presented here is restricted to extant taxa and is, at best, a compromise among opposing opinions.

- Superclass Crustacea
  - Class Cephalocarida
  - Class Branchiopoda
    - Order: Anostraca
      - Spinicaudata
      - Laevicaudata
      - Ctenopoda
      - Anomopoda
      - Onychopoda
    - Order: Haplopoda
      - Notostraca
  - Class Remipedia
  - Class Ostracoda
    - Subclass Myodocopa
      - Order: Myodocopida
      - Halocyprida
    - Subclass Podocopa
      - Order: Platycopida
      - Podocopida
  - Class Maxillopoda
    - Subclass Mystacocarida
    - Subclass Cirripedia

- Order: Ascothoracica
  - Thoracica
  - Acrothoracica
  - Rhizocephala
- Subclass Copepoda
  - Order: Calanoida
    - Harpacticoida
    - Cyclopoida
    - Poecilostomatoida
    - Siphonostomatoida
    - Monstrilloida
    - Misosphrioida
    - Mormonilloida
  - Subclass Branchiura
  - Subclass Tantulocarida
- Class Malacostraca
  - Subclass Phyllocarida
    - Order: Leptostraca
  - Subclass Hoplocarida
    - Order: Stomatopoda
  - Subclass Eumalacostraca
    - Superorder Syncarida
      - Order: Bathynellacea
      - Anaspidacea
    - Superorder Peracarida
      - Order: Spelaeogriphacea
        - Mysidacea
        - Mictacea
        - Amphipoda
        - Isopoda
        - Tanaidacea
        - Cumacea

See BRANCHIOPODA; CEPHALOCARIDA; MALACOSTRACA; MAXILLOPODA; OSTRACODA; REMIPEDIA.

**General morphology.** The true body segments, the somites or metameres, are usually somewhat compressed or depressed. Each typically includes one pair of biramous appendages. The linear series of somites making up the body of a crustacean are more or less distinctly organized into three regions or tagmata: the head, thorax, and abdomen. Where regional organization of the postcephalic somites is not clearly marked, they collectively form the trunk. The somites are variously fused with one another in diagnostic combinations in different groups of the Crustacea.

**Body.** A dorsal shield or carapace of variable length arises from the dorsum of the third cephalic somite and covers the cephalon and cephalothorax to varying extent. The carapace reaches its greatest development in the malacostracan Decapoda (shrimps, lobsters, and crabs). See DECAPODA (CRUSTACEA).

The chitinous cuticle covering the crustacean body is its external skeleton (exoskeleton). The chitin is flexible at the joints, in foliaceous appendages, and throughout the exoskeletons of many small and soft-bodied species, but it is often thickened and stiff in others. It becomes calcified in many species as a result of the deposition of lime salts.

The paired appendages are typically biramous and consist of two branches: the endopod and exopod. The endopod is definitely segmented in the higher Crustacea. The endopods are variously modified to serve a variety of functions and needs such as sensory perception, respiration, locomotion, prehension and comminution of food, cleansing, defense, offense, reproduction, and sex recognition and attraction. If retained in the adult, the exopod may remain leaf- or paddlelike, or become flagellated structures, facilitating swimming or aiding respiration.

The digestive system is a relatively straight tube that curves dorsally from the mouth, which is situated on the underside of the head between the mandibles. In the alimentary tract three regions are recognizable: the foregut, midgut, and hindgut. The anterior part of the foregut often is esophageal in nature, whereas the posterior and greater part usually consists of two parts. In

the anterior portion in the Eucarida, a complex and elaborate grinding mechanism, the gastric mill, is developed. The posterior chamber is divided into dorsal and ventral filtering compartments for the straining of food. The midgut in most cases is provided with several ceca or diverticula which produce digestive secretions or serve as organs for the absorption of food. When these ceca are present in considerable number, they become organized into a sizable gland, the midgut gland of higher Crustacea. The hindgut is typically short and terminates in a muscular anus on the underside of the telson.

Most crustaceans have a heart perforated by openings, or ostia, which admit venous blood from the pericardial sinus in which it is located. The heart may be elongated and tubular and extend through the greater part of the body, but generally it is a more compact organ. It pumps blood through an arterial system or through connecting sinuses or lacunae within the body tissues. Some lower Crustacea do not have a heart, and the muscular movements of the animal or its alimentary tract circulate the blood through the body cavities or sinuses. The blood of the great majority of the crustaceans is bluish because it contains the respiratory pigment hemocyanin. A few crustaceans have red blood as a result of the presence of erythrocrurin. See RESPIRATORY PIGMENTS (INVERTEBRATE).

Crustacea take up oxygen by means of gills, the general body surface, or special areas of it. Some of the few species that have become more or less terrestrial in their habits have developed modifications of their branchial mechanism such as water-retaining recesses which when sufficiently moist enable them to breathe air. Some sow or pill bugs have special tracheal developments in their abdominal appendages for the same purpose.

In the crustacean nervous system a supraesophageal ganglion somewhat larger than the other ganglia is considered to be the brain. It is connected by circumesophageal commissures to a double ventral nerve cord with segmentally arranged ganglia. These become reduced in number and, in the brachyuran crabs, form a large ganglionic mass centered in the thorax.

The organs of special sense are the eyes, the antennules, and the antennae. Crustacean eyes (photoreceptors) are of two types: the median (nauplius eye) and simple eyes (frontal organs); and compound eyes. Simple and median eyes and lateral eyes consist only of light sensory cells. In contrast, compound eyes are composed of many subunits (ommatidia), each having separate optical elements. Compound eyes, therefore, provide varying amounts of actual vision, and in at least some species color differentiation. The antennules and antennae are provided with a variety of sensory structures for the reception of chemical and mechanical stimuli. Taste chemoreceptors are usually found on the mouthparts and the pereopods, or walking legs. Many of the hairs (setae) and bristles found on the crustacean body and appendages act as mechanoreceptors. Organs of balance (statocysts) are also present on basal segments of the antennules in many crustaceans. See CHEMORECEPTION; EYE (INVERTEBRATE); PHOTORECEPTION.

Those glands recognized as definite excretory organs are the maxillary and antennal glands in the adult crustaceans. They are located in the cephalon and rarely are both present at the same time. Many crustaceans, especially deep-sea forms, have phosphorescent or luminous organs. The barnacles and some other crustaceans have cement glands. Species that produce encysted or drought-resistant eggs have other glands of special secretion. The most studied crustacean gland is the sinus gland of the eyestalks. This gland is part of a neurosecretory system producing hormones that control color change and pattern, molting cycle, oogenesis, and egg development within the ovary. See ENDOCRINE SYSTEM (INVERTEBRATE); NEUROSECRETION.

**Reproductive system.** The sexes are separate in most Crustacea and usually can be differentiated from each other by secondary sex characters. Chief among these characters are the size and shape of the body, appendages, or both, and placement of the genital apertures. Hermaphroditism is the rule in the

Cephalocarida, Remipedia, some ostracods, sessile Cirripedia (barnacles), in isolated cases in other crustaceans, and in certain parasitic forms. Parthenogenesis (eggs developing and hatching without prior fertilization) occurs frequently in some of the lower crustaceans that have what might be called an alternation of generations. The parthenogenetic generations alternate with a generation produced by fertilized eggs. See CIRRIPIEDIA.

The eggs of most crustaceans are carried attached to the female until hatched. Some females develop brood pouches in which the young are retained for a time. A nutrient secretion which sustains the young until they are released is produced in some species having a brood chamber. Penaeid shrimp and a few of the lower Crustacea deposit their eggs in the medium in which they live, in some cases attaching them to aquatic vegetation.

**Development.** The nauplius larva is characteristic of Crustacea. This first larval stage is common in the lower forms, but in many of the higher forms it occurs during development in the egg, and the young are hatched as a different and more advanced larva or, as in many Malacostraca, in a form similar to the adult. Life histories vary from the simple to the complex within the different groups of Crustacea.

**Molting (ecdysis).** This process involves several steps: (1) preparation, which includes some degree of resorption of the old cuticle; (2) the formation of a new, temporarily soft and thin one within it; (3) the accumulation and storing of calcium in the midgut gland or as lenticular deposits (gastroliths). The preparatory period is less complicated in the thinly chitinous forms. The actual molt follows. The old shell or cuticle splits at predetermined places, permitting the crustacean within, already enclosed in new but still soft exoskeleton, to withdraw. A temporary absorption of water enables the animal to split or crack its housing. Upon withdrawal of the entire animal, absorption of water again rapidly takes place with a pronounced increase in body size. The chitinous lining of the foregut and hindgut as well as the endophragmal skeleton are shed along with the exoskeleton. In the immediate postmolt period the crustacean is quite helpless and, if unsheltered, is at the mercy of its enemies. The tender new cuticle is reinforced rapidly by the resorbed chitin, and hardened by whatever reserves of calcium the animal may have stored, supplemented and extended by the far more plentiful supplies in solution in the sea which may be absorbed or ingested by the growing crustacean. Molting takes place quite frequently in the larval stages when growth is rapid, but becomes less frequent as the animal ages. In many species there is a terminal molt at maturity. Hormones from the sinus gland play an important role in both initiating and inhibiting molting. See GASTROLITH.

**Autotomy and regeneration.** The mechanisms of autotomy and regeneration are developed in the crustaceans to minimize injury or loss to an enemy. When an appendage is broken, it is cast off or broken at the fracture or breaking plane. This sacrifice often enables the victim to escape. Even more remarkable is the fact that crustaceans, by voluntary muscular contraction, can part with a limb which may be injured. Crustacea also have the ability to regenerate lost parts. Although the regenerated parts are not always the same size as the original in the first molt after injury, increase in size in successive molts soon restores a lost limb to virtually its former appearance.

**Geologic history.** Exceptionally well-preserved arthropods have been discovered in Late Cambrian rocks. The oldest true crustaceans are ostracods, dating from 570 million years ago (Ma). Although the ostracods are not the most primitive crustaceans, their remains constitute the oldest authentic record of the Crustacea. The appearance of more primitive crustaceans later in geologic history, the reverse of what would be expected, is more related to their preservation potential than to their evolutionary history. The more advanced classes, the Maxillopoda and the Malacostraca, appeared in the fossil record, respectively, in the Middle Cambrian, about 530 Ma, and the Late Devonian, about 370 Ma. See CEPHALOCARIDA.

**Bionomics and economics.** Crustacea are ubiquitous. They live at almost all depths and levels of the sea, in fresh waters at elevations up to 12,000 ft (3658 m), in melted snow water, in the deepest of the sea's abysses more than 6 mi (9 km) down, and in waters of 0°C (32°F) temperature. Some species live on land, although most must descend to salt water areas again to spawn their young. Some live in strongly alkaline waters and others in salt water which is at the saturation point, still others in hot springs and hydrothermal vents with temperatures in excess of 55°C (131°F).

Crustacea are of all sizes, ranging from copepods 0.01 in. (0.25 mm) long to huge spider crabs of Japan, which span 12 ft (3.7 m) from tip to tip of the laterally extended legs. The American lobster, the heaviest so far known, tops all crustaceans at 44½ lb (20 kg).

Most crustaceans are omnivorous and essentially scavengers. Many are filter feeders and screen particulate life, plankton, and organic detritus from the waters in which they live; others are largely carnivorous, still others vegetarian. Among the vegetarians are the grazers of the ocean meadows which convert the microscopic plant life (diatoms) into flesh and food for larger animals which in turn are harvested as food for humans.

[W.L.S.; P.A.McL.; R.M.Fe.]

**Crux** The Southern Cross in astronomy, the most celebrated of the constellations of the far south. The four principal bright stars of the group,  $\alpha$ ,  $\gamma$ ,  $\beta$  and  $\delta$  form the figure of a cross,

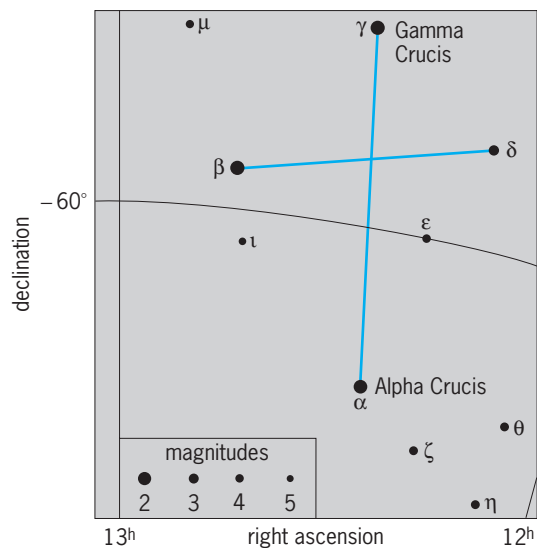

Line pattern of the constellation Crux. The grid lines represent the coordinates of the sky. The apparent brightness, or magnitude, of the stars is shown by the sizes of dots, graded by appropriate numbers as indicated.

giving the constellation its name (see illustration). The brightest star in Crux is Alpha Crucis at the foot of the cross, which has received the artificial name Acrux. This is a navigational star. See CONSTELLATION; CYGNUS. [C.-S.Y.]

**Cryobiology** The use of low-temperature environments in the study of living plants and animals. The principal effects of cold on living tissue are destruction of life and preservation of life at a reduced level of activity. Both of these effects are demonstrated in nature. Death by freezing is a relatively common occurrence in severe winter storms. Among cold-blooded animals winter weather usually results in a comalike sleep that may last for a considerable length of time.

In cryobiological applications much lower temperatures are

used than are present in natural environments. The extreme cold of liquid nitrogen (boiling at -320°F or -196°C) can cause living tissue to be destroyed in a matter of seconds or to be preserved for years and possibly for centuries with essentially no detectable biochemical activity. The result achieved when heat is withdrawn from living tissue depends on processes occurring in the individual cells. Basic knowledge of the causes of cell death, especially during the process of freezing, and the discovery of methods which circumvent these causes have led to practical applications both for long-term storage of living cells or tissue (cryopreservation) and for calculated and selective destruction of tissue (cryosurgery).

The biochemical constituents of a cell are either dissolved or suspended in water. During the physical process of freezing, water tends to crystallize in pure form, while the dissolved or suspended materials concentrate in the remaining liquid. In the living cell, this process is quite destructive. In a relatively slow freezing process ice first begins to form in the fluid surrounding the cells, and the concentration of dissolved materials in the remaining liquid increases. A concentration gradient is established across the cell wall, and water moves out of the cell in response to the osmotic force. As freezing continues, the cell becomes quite dehydrated. Salts may concentrate to extremely high levels. In a similar manner the acid-base ratio of the solution may be altered during the concentration process. Dehydration can affect the gross organization of the cell and also the molecular relationships, some of which depend on the presence of water at particular sites. Cellular collapse resulting from loss of water may bring in contact intracellular components normally separated to prevent destructive interaction. Finally, as the ice crystals grow in size, the cell walls may be ruptured by the ice crystals themselves or by the high concentration gradients which are imposed upon them.

By speeding the freezing process to the point that temperature drop is measured in degrees per second, some of these destructive events can be modified. However, most of the destructive processes will prevail. To prevent dehydration, steps must be taken to stop the separation of water in the form of pure ice so that all of the cell fluids can solidify together. The chief tools used to accomplish this are agents that lower the freezing point of the water. Glycerol, a polyalcohol which is compatible with other biochemical materials in living cells, is frequently used in cell preservation. Besides the antifreeze additive, refrigeration procedures are designed to control the rate of decline in temperature to the freezing point, through the liquid-solid transition, and below, to very low temperatures.

**Cryopreservation.** The earliest commercial application of cryopreservation was in the storage of animal sperm cells for use in artificial insemination. The microorganisms used in cheese production can be frozen, stored, and transported without loss of lactic acid-producing activity. Pollen from various plants can be frozen for storage and transport, facilitating plant-breeding experiments. Among the most valuable applications of cryopreservation is the storage of whole blood or separated blood cells.

**Cryosurgery.** Cellular destruction from freezing can be used to destroy tissue as a surgical procedure. One of the significant advantages of cryosurgery is that the apparatus can be employed to cool the tissue to the extent that the normal or the aberrant function is suppressed; yet at this stage the procedure can be reversed without permanent effect. When the surgeon is completely satisfied that he or she has located the exact spot to destroy, the temperature can be lowered enough to produce irreversible destruction. This procedure is of particular assistance in neurosurgery.

A second major advantage of cryosurgery is that the advancing front of reduced temperatures tends to cause the removal of blood and the constriction of blood vessels in the affected area. This means that little or no bleeding results from cryosurgical procedures.

A third major advantage of cryosurgery is that cryosurgery equipment currently employs a freezing apparatus that can be placed in contact with area to be destroyed with a minimum incision to expose the affected area. [A.W.F.]

**Cryogenics** The science and technology of phenomena and processes at low temperatures, defined arbitrarily as below 150 K (−190°F). Phenomena that occur at cryogenic temperatures include liquefaction and solidification of ambient gases; loss of ductility and embrittlement of some structural materials such as carbon steel; increase in the thermal conductivity to a maximum value, followed by a decrease as the temperature is lowered further, of relatively pure metals, ionic compounds, and crystalline dielectrics (diamond, sapphire, solidified gases, and so forth); decrease in the thermal conductivity of metal alloys and plastics; decrease in the electrical resistance of relatively pure metals; decrease in the heat capacity of solids; decrease in thermal noise and disorder of matter; and appearance of quantum effects such as superconductivity and superfluidity. See ELECTRICAL RESISTIVITY; SPECIFIC HEAT OF SOLIDS; SUPERCONDUCTIVITY; SUPERFLUIDITY; THERMAL CONDUCTION IN SOLIDS.

Low-temperature environments are maintained with cryogenes (liquefied gases) or with cryogenic refrigerators. The temperature afforded by a cryogen ranges from its triple point to slightly below its critical point. Commonly used cryogenes are liquid helium-4 (down to 1 K), liquid hydrogen, and liquid nitrogen. Less commonly used because of their expense are liquid helium-3 (down to 0.3 K) and neon. The pressure maintained over a particular cryogen controls its temperature. Heat input—both the thermal load and the heat leak due to imperfect insulation—boils away the cryogen, which must be replenished. See LIQUID HELIUM; THERMODYNAMIC PROCESSES; TRIPLE POINT.

A variety of techniques are available for prolonged refrigeration. Down to about 1.5 K, refrigeration cycles involve compression and expansion of appropriately chosen gases. At lower temperatures, liquid and solids serve as refrigerants. Adiabatic demagnetization of paramagnetic ions in solid salts is used in magnetic refrigerators to provide temperatures from around 4 K down to 0.003 K. Nuclear spin demagnetization of copper can achieve  $5 \times 10^{-8}$  K. Helium-3/helium-4 dilution refrigerators are frequently used for cooling at temperatures between 0.3 and 0.002 K, and adiabatic compression of helium-3 (Pomeranchuk cooling) can create temperatures down to 0.001 K. See ADIABATIC DEMAGNETIZATION.

Both the latent heat of vaporization and the sensible heat of the gas (heat content of the gas) must be removed to liquefy a gas. Of the total heat that must be removed to liquefy the gas, the latent heat is only 1.3% for helium and 46% for nitrogen. Consequently, an efficient liquefier must supply refrigeration over the entire temperature range between ambient and the liquefaction point, not just at the liquefaction temperature. The Collins-Claude refrigeration cycle forms the basis (with a multitude of variations) of most modern cryogenic liquefiers. Gas is compressed isothermally and cooled in a counterflow heat exchanger by the colder return stream of low-pressure gas. During this cooling, a fraction of the high-pressure stream (equal to the rate of liquefaction) is split off and cooled by the removal of work (energy) in expansion engines or turbines. This arrangement provides the cooling for the removal of the sensible heat. At the end of the counterflow cooling, the remaining high-pressure stream is expanded in either a Joule-Thomson valve or a wet expander to give the liquid product and the return stream of saturated vapor. See LIQUEFACTION OF GASES.

The work input required to produce refrigeration is commonly given in terms of watts of input power per watt of cooling, that is, W/W. Cooling with a refrigerator is more efficient (that is, requires a lower W/W) than cooling with evaporating liquid supplied from

a Dewar because the refrigerator does not discard the cooling available in the boil-off gas. See REFRIGERATION; REFRIGERATION CYCLE; THERMODYNAMIC CYCLE. [D.E.D.]

**Cryolite** A mineral with chemical composition  $\text{Na}_3\text{AlF}_6$ . It crystallizes in the monoclinic system. Hardness is  $2\frac{1}{2}$  on Mohs scale and the specific gravity is 2.95. Crystals are usually snow-white but may be colorless and more rarely brownish, reddish, or even black. The mean refraction index is 1.338, approximately that of water, and thus fragments become invisible when immersed in water.

Cryolite was once used as a source of metallic sodium and aluminum, but now is used chiefly as a flux in the electrolytic process in the production of aluminum from bauxite. See ALUMINUM. [C.S.Hu.]

**Cryotron** A current-controlled switching device based on superconductivity for use primarily in computer circuits. The early version has been superseded by the tunneling cryotron, which consists basically of a Josephson junction. In its simplest form the device has two electrodes of a superconducting material (for example, lead) which are separated by an insulating film only about 10 atomic layers thick. Switching is accomplished by a magnetic field generated by sending a current through the control line on top of the junction. The tunneling cryotron is still in the research stage, but various computer circuits have already been realized. See SUPERCONDUCTING DEVICES; SUPERCONDUCTIVITY. [P.Wo.]

**Cryptobiosis** A state of life in which the metabolic rate of an organism is reduced to an imperceptible level. The several kinds of cryptobiosis ("hidden life") include anhydrobiosis (life without water), cryobiosis (life at low temperatures), and anoxybiosis (life without oxygen). The most is known about anhydrobiosis.

States of anhydrobiosis occur in early developmental stages of various organisms, including seeds of plants, spores of bacteria and fungi, cysts of certain crustaceans, and larvae of certain insects; they occur in both developmental and adult stages of certain soil-dwelling micrometazoans (rotifers, tardigrades, and nematodes), mosses, lichens, and certain ferns.

A central question in the study of anhydrobiosis has been whether metabolism actually ceases. Available evidence strongly suggests that dry anhydrobiotes are ametabolic. In that case, a philosophical question immediately arises concerning the nature of life. This philosophical quandary can be avoided by applying the definition of life adopted by most students of anhydrobiosis: an organism is alive, provided its structural integrity is maintained. When that integrity is violated, it is dead. See METABOLISM. [J.H.Cr.]

**Cryptography** The various methods for writing in secret code or cipher. As society becomes increasingly dependent upon computers, the vast amounts of data communicated, processed, and stored within computer systems and networks often have to be protected, and cryptography is a means of achieving this protection. It is the only practical method for protecting information transmitted through accessible communication networks such as telephone lines, satellites, or microwave systems. Cryptographic procedures can also be used for message authentication, personal identification, and digital signature verification for electronic funds transfer and credit card transactions. See DATA COMMUNICATIONS; DIGITAL COMPUTER; ELECTRICAL COMMUNICATIONS.

Cryptography helps resist decoding or deciphering by unauthorized personnel; that is, messages (plaintext) transformed into cryptograms (codetext or ciphertext) have to be able to withstand intense cryptanalysis. Transformations can be done by using either code or cipher systems. Code systems rely on code books to transform the plaintext words, phrases, and sentences into

ciphertext code groups. To prevent cryptanalysis, there must be a great number of plaintext passages in the code book and the code group equivalents must be kept secret, making it difficult to utilize code books in electronic data-processing systems.

Cipher systems are more versatile. Messages are transformed through the use of two basic elements: a set of unchanging rules or steps called a cryptographic algorithm, and a set of variable cryptographic keys. The algorithm is composed of enciphering (**E**) and deciphering (**D**) procedures which usually are identical or simply consist of the same steps performed in reverse order, but which can be dissimilar. The keys, selected by the user, consist of a sequence of numbers or characters. An enciphering key ( $K_e$ ) is used to encipher plaintext ( $X$ ) into ciphertext ( $Y$ ) as in Eq. (1), and a deciphering key ( $K_d$ ) is used to decipher ciphertext ( $Y$ ) into plaintext ( $X$ ) as in Eq. (2).

$$E_{K_e}(X) = Y \tag{1}$$

$$D_{K_d}[E_{K_e}(X)] = D_{K_d}(Y) = X \tag{2}$$

Algorithms are of two types—conventional and public-key. The enciphering and deciphering keys in a conventional algorithm either may be easily computed from each other or may be identical [ $K_e = K_d = K$ , denoting  $E_k(X) = Y$  for encipherment and  $D_k(Y) = X$  for decipherment]. In a public-key algorithm, one key (usually the enciphering key) is made public, and a different key (usually the deciphering key) is kept private. In such an approach it must not be possible to deduce the private key from the public key.

When an algorithm is made public, for example, as a published encryption standard, cryptographic security completely depends on protecting those cryptographic keys specified as secret.

**Unbreakable ciphers.** Unbreakable ciphers are possible. But the key must be randomly selected and used only once, and its length must be equal to or greater than that of the plaintext to be enciphered. Therefore such long keys, called one-time tapes, are not practical in data-processing applications. To work well, a key must be of fixed length, relatively short, and capable of being repeatedly used without compromising security. In theory, any algorithm that uses such a finite key can be analyzed; in practice, the effort and resources necessary to break the algorithm would be unjustified.

**Strong algorithms.** Fortunately, to achieve effective data security, construction of an unbreakable algorithm is not necessary. However, the work factor (a measure, under a given set of assumptions, of the requirements necessary for a specific analysis or attack against a cryptographic algorithm) required to break the algorithm must be sufficiently great. Included in the set of assumptions is the type of information expected to be available for cryptanalysis. For example, this could be ciphertext only; plaintext (not chosen) and corresponding ciphertext; chosen plaintext and corresponding ciphertext; or chosen ciphertext and corresponding recovered plaintext.

A strong cryptographic algorithm must satisfy the following conditions: (1) The algorithm's mathematical complexity prevents, for all practical purposes, solution through analytical methods. (2) The cost or time necessary to unravel the message or key is too great when mathematically less complicated methods are used, because either too many computational steps are involved (for example, in trying one key after another) or because too much storage space is required (for example, in an analysis requiring data accumulations such as dictionaries and statistical tables).

To be strong, the algorithm must satisfy the above conditions even when the analyst has the following advantages: (1) Relatively large amounts of plaintext (specified by the analyst, if so desired) and corresponding ciphertext are available. (2) Relatively large amounts of ciphertext (specified by the analyst, if so desired) and corresponding recovered plaintext are available.

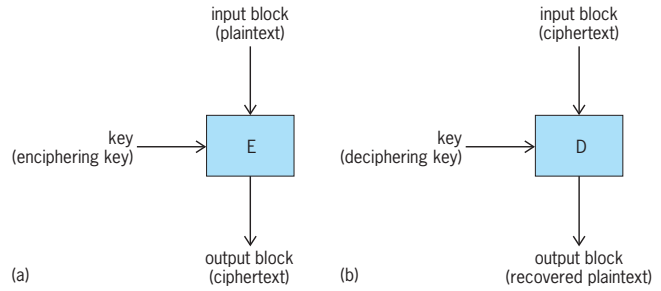

Fig. 1. Block cipher. (a) Enciphering. (b) Deciphering.

(3) All details of the algorithm are available to the analyst; that is, cryptographic strength cannot depend on the algorithm remaining secret. (4) Large high-speed computers are available for cryptanalysis.

**Digital signatures.** Digital signatures authenticate messages by ensuring that: the sender cannot later disavow messages; the receiver cannot forge messages or signatures; and the receiver can prove to others that the contents of a message are genuine and that the message originated with that particular sender. The digital signature is a function of the message, a secret key or keys possessed by the sender of the message, and sometimes data that are nonsecret or that may become nonsecret as part of the procedure (such as a secret key that is later made public).

Digital signatures are more easily obtained with public-key than with conventional algorithms. When a message is enciphered with a private key (known only to the originator), anyone deciphering the message with the public key can identify the originator. The latter cannot later deny having sent the message. Receivers cannot forge messages and signatures, since they do not possess the originator's private key.

Since enciphering and deciphering keys are identical in a conventional algorithm, digital signatures must be obtained in some other manner. One method is to use a set of keys to produce the signature. Some of the keys are made known to the receiver to permit signature verification, and the rest of the keys are retained by the originator in order to prevent forgery.

**Data Encryption Standard.** Regardless of the application, a cryptographic system must be based on a cryptographic algorithm of validated strength if it is to be acceptable. The Data Encryption Standard (DES) is such a validated conventional algorithm already in the public domain. This procedure enciphers a 64-bit block of plaintext into a 64-bit block of ciphertext under the control of a 56-bit key. The National Bureau of Standards accepted this algorithm as a standard, and it became effective on July 15, 1977.

**Block ciphers.** A block cipher (Fig. 1) transforms a string of input bits of fixed length (termed an input block) into a string of output bits of fixed length (termed an output block). In a strong block cipher, the enciphering and deciphering functions are such that every bit in the output block jointly depends on every bit

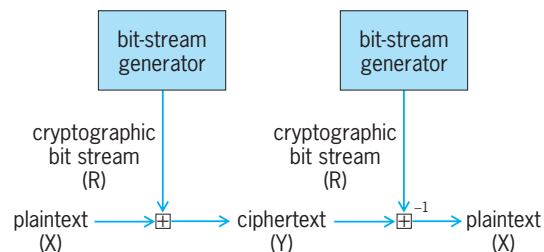
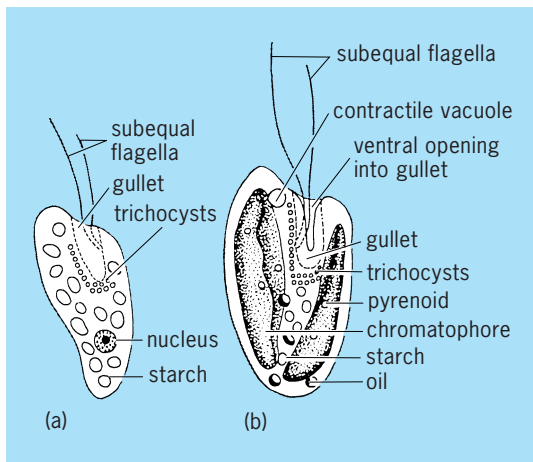

Fig. 2. Stream cipher concept. (After C.H. Meyer and S. M. Matyas, *Cryptography: A New Dimension in Computer Data Security*, 1980).

in the input block and on every bit in the key. This property is termed intersymbol dependence.

**Stream ciphers.** A stream cipher (Fig. 2) employs a bit-stream generator to produce a stream of binary digits (0's and 1's) called a cryptographic bit stream, which is then combined either with plaintext (via the  $\oplus$  operator) to produce ciphertext or with ciphertext (via the  $\oplus^{-1}$  operator) to recover plaintext. [C.H.M.; S.M.M.]

**Cryptomonadida** An order of the class Phytomastigophorea, also known as the Cryptomonadina. Cryptomonads are considered to be protozoans by zoologists and algae by botanists. Most species occur in fresh water. They are olivegreen, blue, red, brown, or colorless. All flagellated members have two subequal flagella inserted in a gullet opening through an obliquely truncate anterior end (see illustration).



Examples of cryptomonads. (a) *Chilomonas paramecium*. (b) *Cryptomonas erosa*.

Although few in genera and species, Cryptomonadida form extensive marine and fresh-water blooms. See PROTOZOA. [J.B.L.]

**Cryptophyceae** A small class of biflagellate unicellular algae (cryptomonads) in the chlorophyll  $a-c$  phyletic line (Chromophycota). In protozoological classification, these organisms constitute an order, Cryptomonadida, of the class Phytomastigophora. Cryptomonads are 4-80 micrometers long, ovoid or bean-shaped, and dorsiventrally flattened. The cell is bounded by a moderately flexible periplast comprising the plasmalemma and underlying rectangular or polygonal proteinaceous plates. A tubular invagination (gullet, groove, or furrow) traverses the ventral cytoplasm and opens just below the apex of the cell. A pair of subequal flagella, which are covered with hairs and small scales, arise from the center or apical end of the gullet. Cryptomonads may be photosynthetic, osmotrophic, or phagotrophic. In photosynthetic species, chloroplasts occur singly or in pairs.

Photosynthetic pigments include chlorophyll  $a$  and  $c$ ,  $\alpha$ -carotene and  $\beta$ -carotene (the former being predominant, an unusual ratio for algae), and red and blue phycobiliproteins closely related to those in red algae but occurring in the intrathylakoidal space rather than forming phycobilisomes. The color of the chloroplasts, and thus the color of the cryptomonad, depends upon pigment composition and may be green, olive, brown, yellow, red, or blue. Pigment composition is affected by environmental conditions.

Cryptomonads are found in fresh, brackish, marine, and hypersaline bodies of water, sometimes in great abundance. Several species are endosymbionts of marine ciliates and inver-

tebrates, and of fresh-water dinoflagellates. See ALGAE; CHROMOPHYCOTA; CRYPTOMONADIDA. [P.C.Si.; R.L.Moe]

**Cryptostomata** An extinct order of Bryozoa in the class Stenolaemata. Cryptostomes had basally attached, erect, calcified colonies made of sheets or delicate branches composed of short tubular or box-shaped feeding zooids (individual units that constitute these colonial organisms) and commonly extra-zooidal skeletal deposits. Overall colony morphology is the basis for dividing cryptostomes into four subgroups that commonly are treated as orders: Rhabdomesina, Ptilodictyina, Fenestellina, and Timanodictyina.

Cryptostomes were exclusively marine and lived in a wide variety of relatively low-energy environments on continental shelves and seas. They were important contributors to the growth of organic mounds during the Late Ordovician and early Carboniferous.

Phylogenetic relationships among the four subgroups are not clear. Probably the Rhabdomesina is paraphyletic and gave rise to the other three groups, each of which apparently is monophyletic. See BRYOZOA; STENOLAEMATA. [FK.McK.]

**Crystal** A solid in which the atoms or molecules are arranged periodically. Within a crystal, many identical parallelepiped unit cells, each containing a group of atoms, are packed together to fill all space (see illustration). In scientific nomenclature, the term crystal is usually short for single crystal, a single periodic arrangement of atoms. Most gems are single crystals. However, many materials are polycrystalline, consisting of many small grains, each of which is a single crystal. For example, most metals are polycrystalline. See SINGLE CRYSTAL.

In electronics, the term crystal is restricted to mean piezoelectric crystal. Piezoelectric crystals contract or expand under application of electric voltages, and conversely they generate voltages when compressed. They are used for oscillators, pressure sensors, and position actuators. See PIEZOELECTRICITY.

The anisotropic microscopic structure of a crystal is often reflected in its external form, consisting of flat faces and sharp edges. Crystal structure is generally determined via diffraction of x-rays, neutrons, or electrons. Unlike disordered materials such as glasses or liquids, the diffraction pattern of a periodic array of atoms consists of individual sharp spots. The symmetry and structure of the crystal can be inferred from the symmetry of the diffraction pattern and the intensities of the diffracted

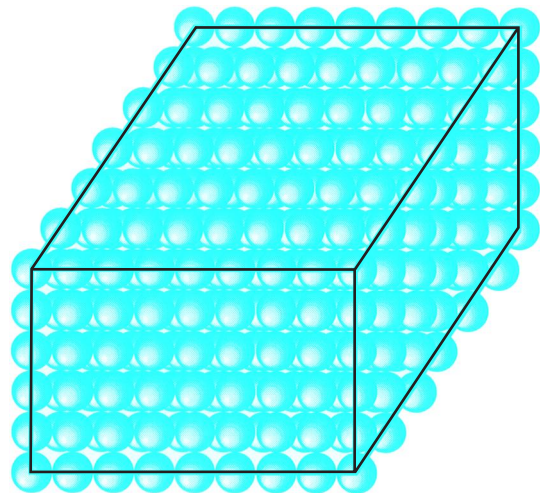

Structure of a simple crystal. Spheres, representing atoms, are packed together into a cubic lattice. This crystal has 4-fold symmetry axes passing through the front face; after a 90° rotation the structure appears unchanged.

beams. See ELECTRON DIFFRACTION; NEUTRON DIFFRACTION; X-RAY DIFFRACTION.

A crystal can be characterized by the symmetry operations that leave its structure invariant. These can include rotation about an axis through a specific angle, reflection through a plane, inversion through a point, translations by a unit cell dimension, and combinations of these. For a periodic structure, the only allowable rotational symmetries are 2-fold, 3-fold, 4-fold, and 6-fold. A quasicrystal is a solid which yields a sharp diffraction pattern but has rotational symmetries (such as 5-fold or 10-fold) which are inconsistent with a periodic arrangement of atoms. See QUASICRYSTAL.

A plastic crystal is generally composed of organic molecules which are rotationally disordered. The centers of the molecules lie at well-defined, periodically spaced positions, but the orientations of the molecules are random. Plastic crystals are often very soft and may flow under their own weight.

A liquid crystal is a material which is intermediate in structure between a liquid and a solid. Liquid crystals usually flow like liquids but have some degree of internal order. They are generally composed of rodlike organic molecules, although in some cases they are composed of disklike molecules. In a nematic liquid crystal, the rods all have the same general orientation, but the positions of the rods are disordered. In a smectic liquid crystal, rodlike molecules are ordered into sheets, within which there is only liquidlike order. A smectic can thus be thought of as being crystalline in one dimension and liquid in the other two. In a discotic liquid crystal, disklike molecules are ordered into columnar arrays; there is short-range liquidlike order within the columns, but the columns form a two-dimensional crystal. See CRYSTAL DEFECTS; CRYSTAL GROWTH; CRYSTAL STRUCTURE; CRYSTALLOGRAPHY; LIQUID CRYSTALS. [P.A.He.]

**Crystal absorption spectra** The wavelength or energy dependence of the attenuation of electromagnetic radiation as it passes through a crystal, due to its conversion to other forms of energy in the crystal. When atoms are grouped into an ordered array to form a crystal, their interaction with electromagnetic radiation is greatly modified. Free atoms absorb electromagnetic radiation by transitions between a few electronic states of well-defined energies, leading to absorption spectra consisting of sharp lines. In a crystal, these states are broadened into bands, and the cores of the atoms are constrained to vibrate about equilibrium positions. The ability of electromagnetic radiation to transfer energy to bands and ionic vibrations leads to broad absorption spectra that bear little resemblance to those of the free parent atoms. See ABSORPTION OF ELECTROMAGNETIC RADIATION; ATOMIC STRUCTURE AND SPECTRA; BAND THEORY OF SOLIDS; LATTICE VIBRATIONS. [D.E.As.]

**Crystal counter** A device, more correctly described as a crystal detector, that detects ionizing radiation of all types and is adaptable to measuring neutrons. The sensitive element is a single crystal with a dc resistance normally higher than  $10^{12}$  ohms. The crystals are small and are cut or grown to volumes ranging from less than  $1 \text{ mm}^3$  to approximately  $200 \text{ mm}^3$ .

Crystal detectors fall into two categories: Certain crystals act as thermoluminescent detectors, of which lithium fluoride (LiF), lithium borate ( $\text{Li}_2\text{B}_4\text{O}_7$ ), and calcium sulfate ( $\text{CaSO}_4$ ) are among the best known. Other crystals, for example, cadmium telluride (CdTe) and mercury iodide ( $\text{HgI}_2$ ), act as conduction detectors, delivering either pulses or a dc signal, depending upon the associated electronic circuitry. See IONIZATION CHAMBER; THERMOLUMINESCENCE.

Diamond is a unique crystal that functions as a thermoluminescent detector or, if suitable contacts are made, as a conduction detector. The efficiency of the diamond detector in the thermoluminescent or conduction mode is strongly dependent on the impurity atoms included within the crystal lattice, with nitrogen and boron playing dominant roles. Not all diamonds are good

detectors; only the rare and expensive natural types IB or IIA are appropriate. Besides being stable and nontoxic, diamond has an additional attractive feature as a detector. As an allotrope of carbon, it has the atomic number  $Z = 6$ . Human soft tissue has an effective  $Z = 7.4$ , so that diamond is a close tissue-equivalent material, an essential characteristic for biological dosimetry, for example, in measurements in living organisms. See DIAMOND.

Good crystal detectors are insulators and therefore have significant band-gap energies. A large band gap impedes the spontaneous excitation of charge carriers between the valence and conduction bands, thus lowering leakage currents and movement of charge carriers to trapping centers. Room temperature devices are consequently possible. See BAND THEORY OF SOLIDS; ELECTRIC INSULATOR; TRAPS IN SOLIDS.

In thermoluminescent detectors, the crystal is heated at a controlled rate on a metal tray by means of an electric current. The photon emission from the crystal is monitored by a photomultiplier the output of which is directed toward an appropriate recording device. The result is a "glow curve", the area of which correlates with the number of traps depopulated, which are in turn directly related to the radiation-field intensity. The integrated light output therefore becomes a direct measure of the total radiation dose. See DOSIMETER; PHOTOMULTIPLIER.

In a conduction detector, a charged particle entering the crystal transfers its kinetic energy to the bulk of the crystal by creating charge carriers (electron-hole pairs). A photon of sufficient energy interacts with the crystal atoms, losing all or part of its energy through the photoelectric effect, the Compton effect, or pair production. In each of these processes, electrons are either liberated or created, and they in turn have their energy dissipated in the bulk of the crystal by creating charge carriers. When the carrier pair is created, the individual carriers move under the influence of the electric field toward the oppositely charged contacts. On arriving at the contacts, the charges can be measured at the output point either as a dc or as a pulse signal, depending upon the circuitry. It is, however, necessary for full efficiency of the counting system that both types of carriers are collected equally. See COMPTON EFFECT; ELECTRON-POSITRON PAIR PRODUCTION; GAMMA-RAY DETECTORS; PHOTOEMISSION.

In the thermoluminescent mode the crystals measure the total dose of the applied radiation, whereas in the conduction mode they measure the instantaneous dose rate; in both cases it is ultimately the crystal itself that limits the sensitivity and resolution of the system. Present methods of synthesis for crystals permit the detection of radiation fields down to nearly background values ( $0.1 \text{ microgray/h}$  or  $10^{-5} \text{ rad/h}$ ) even with crystals as small as  $1 \text{ mm}^3$ . Small crystals make detectors possible that are capable of very high spatial resolution. This feature is important in electron radiation therapy. See PARTICLE DETECTOR; RADIATION BIOLOGY; RADIOLOGY. [R.J.K.]

**Crystal defects** Departures of a crystalline solid from a regular array of atoms or ions. A "perfect" crystal of NaCl, for example, would consist of alternating  $\text{Na}^+$  and  $\text{Cl}^-$  ions on an infinite three-dimensional simple cubic lattice, and a simple defect (a vacancy) would be a missing  $\text{Na}^+$  or  $\text{Cl}^-$  ion. There are many other kinds of possible defects, ranging from simple and microscopic, such as the vacancy and other structures shown in the illustration, to complex and macroscopic, such as the inclusion of another material, or a surface.

Natural crystals always contain defects, due to the uncontrolled conditions under which they were formed. The presence of defects which affect the color can make these crystals valuable as gems, as in ruby (Cr replacing a small fraction of the Al in  $\text{Al}_2\text{O}_3$ ). Crystals prepared in the laboratory will also always contain defects, although considerable control may be exercised over their type, concentration, and distribution.

The importance of defects depends upon the material, type of defect, and properties which are being considered. Some properties, such as density and elastic constants, are proportional to



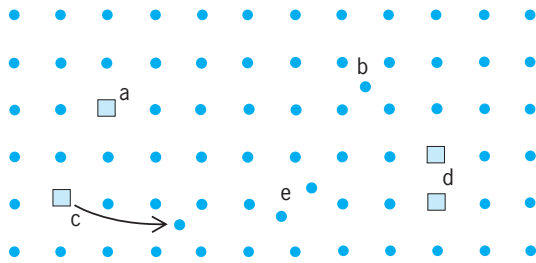

Key:

- a = vacancy (Schottky defect)
- b = interstitial
- c = vacancy-interstitial pair (Frenkel defect)
- d = divacancy
- e = split interstitial
- = vacant site

Some simple defects in a lattice.

the concentration of defects, and so a small defect concentration will have a very small effect on these. Other properties, such as the conductivity of a semiconductor crystal, may be much more sensitive to the presence of small numbers of defects. Indeed, while the term defect carries with it the connotation of undesirable qualities, defects are responsible for many of the important properties of materials, and much of solid-state physics and materials science involves the study and engineering of defects so that solids will have desired properties. A defect-free silicon crystal would be of little use in modern electronics; the use of silicon in devices is dependent upon small concentrations of chemical impurities such as phosphorus and arsenic which give it desired electronic properties.

An important class of crystal defect is the chemical impurity. The simplest case is the substitutional impurity, for example, a zinc atom in place of a copper atom in metallic copper. Impurities may also be interstitial; that is, they may be located where atoms or ions normally do not exist. In metals, impurities usually lead to an increase in the electrical resistivity. Impurities in semiconductors are responsible for the important electrical properties which lead to their widespread use. The energy levels associated with impurities and other defects in nonmetals may also lead to optical absorption in interesting regions of the spectrum.

Even in a chemically pure crystal, structural defects will occur. These may be simple or extended. One type of simple defect is the vacancy, but other types exist (see illustration). The atom which left a normal site to create a vacancy may end up in an interstitial position, a location not normally occupied. Or it may form a bond with a normal atom in such a way that neither atom is on the normal site, but the two are symmetrically displaced from it. This is called a split interstitial. The name Frenkel defect is given to a vacancy-interstitial pair, whereas an isolated vacancy is a Schottky defect.

The simplest extended structural defect is the dislocation. An edge dislocation is a line defect which may be thought of as the result of adding or subtracting a half-plane of atoms. A screw dislocation is a line defect which can be thought of as the result of cutting partway through the crystal and displacing it parallel to the edge of the cut. Dislocations are of great importance in determining the mechanical properties of crystals. A dislocation-free crystal is resistant to shear, because atoms must be displaced over high-potential-energy barriers from one equilibrium position to another. It takes relatively little energy to move a dislocation (and thereby shear the crystal), because the atoms at the dislocation are barely in stable equilibrium. Such plastic deformation is known as slip. See PLASTICITY.

For both scientific and practical reasons, much of the research on crystal defects is directed toward the dynamic properties of defects under particular conditions, or defect chemistry. Much

of the motivation for this arises from the often undesirable effects of external influences on material properties, and a desire to minimize these effects. Examples of defect chemistry abound, including one as familiar as the photographic process, in which incident photons cause defect modifications in silver halides or other materials. Properties of materials in nuclear reactors is another important case. [W.B.F.]

**Crystal growth** The growth of crystals, which can occur by natural or artificial processes. Crystal growth generally comes about by means of the following processes occurring in series: (1) diffusion of the atoms (or molecules, in the case of molecular crystals such as hydrocarbons or polymers) of the crystallizing substance through the surrounding environment (or solution) to the surface of the crystal, (2) diffusion of these atoms over the surface of the crystal to special sites on the surface, (3) incorporation of atoms into the crystal at these sites, and (4) diffusion of the heat of crystallization away from the crystal surface. The rate of crystal growth may be limited by any of these four steps. The initial formation of the centers from which crystal growth proceeds is known as nucleation. See CRYSTALLIZATION; NUCLEATION.

During its growth into a fluid phase, a crystal often develops and maintains a definite polyhedral form which may reflect the characteristic symmetry of the microscopic pattern of atomic arrangement in the crystal. The bounding faces of this form are those which are perpendicular to the directions of slowest growth. How this comes about is illustrated in Fig. 1, in which it is seen that the faces *b*, normal to the faster-growing direction, disappear, and the faces *a*, normal to the slower-growing directions, become predominant. Growth forms, like that shown, are not necessarily equilibrium forms, but they are likely to be most regular when the departures from equilibrium are not large. See also CRYSTAL STRUCTURE.

The atomic binding sites on the surface of a crystal can be of several kinds. Thus an atom must be more weakly bound on a perfectly developed plane of atoms at the crystal surface (site A) than at a ledge formed by an incomplete plane one atom thick (site B). Atom A binds with only three neighboring atoms, whereas atom B binds to five neighbors. (An atom in the middle of the island monolayer has bonds with nine neighbors.) Therefore, the binding of atoms in an island monolayer on the crystal surface will be less per atom than it would be within a completed surface layer.

The potential energy of a crystal is most likely to be minimum in forms containing the fewest possible ledge sites. This means that, in a regime of regular crystal growth, dilute fluid, and moderate departure from equilibrium, the crystal faces of the growth form are likely to be densely packed and atomically smooth. There will be a critical size of monolayer, which will be a decreasing function of supersaturation, such that all monolayers smaller than the critical size tend to shrink out of existence, and

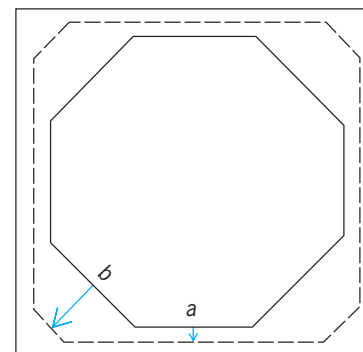

Fig. 1. Schematic representation of cross section of crystal at three stages of regular growth.

those which are larger will grow to a complete layer. The critical monolayers form by a fluctuation process. Kinetic analyses indicate that the probability of critical fluctuations is so small that in finite systems perfect crystals will not grow, except at substantial departures from equilibrium. That, in ordinary experience, finite crystals do grow in a regular regime only at infinitesimal departures from equilibrium is explained by the screw dislocation theory. According to this theory, growth is sustained by indestructible surface ledges which result from the emergence of screw dislocations in the crystal face. See CRYSTAL DEFECTS.

When the departures from equilibrium (supersaturation or undercooling) are sufficiently large, the more regular growth shapes become unstable and cellular (grasslike) or dendritic (treelike) morphologies develop. Essentially, the development of protuberances on an initially regular crystal permits more efficient removal of latent heat or of impurities, but at the cost of higher interfacial area and the associated excess surface energy. When the supersaturation becomes so great that the energy associated with the increase in interfacial area is unimportant, protuberances proliferate and the crystal grows in a multibranching form that is even more complicated; its shape is characterized by fractal geometry. See FRACTALS. [M.J.A.; D.T.]

The advent of semiconductor-based technology generated a demand for large, high-quality single crystals, not only of semiconductors but also of associated electronic materials. With increasing sophistication of semiconductor devices, an added degree of freedom in materials properties was obtained by varying the composition of major components of the semiconductor crystal over very short distances. Thin, multilayered single-crystal structures, and even structures that vary in composition both normal and lateral to the growth direction, are often required.

Bulk single crystals are usually grown from a liquid phase. The liquid may have approximately the same composition as the solid; it may be a solution consisting primarily of one component of the crystal; or it may be a solution whose solvent constitutes at most a minor fraction of the crystal's composition. The most important bulk crystal growth technique is the crystal-pulling or Czochralski method, in which a rotating seed crystal is dipped into the melt (Fig. 2). Rotation reduces radial temperature gradients, and slow withdrawal of the rotating seed results in growth of a cylinder of single-crystal material. Crystal diameter and length depend upon the details of the temperature and

pulling rate, and the dimensions of the melt container. Crystal quality depends very critically upon minimization of temperature gradients that enhance the formation of dislocations. Pulled silicon crystals 6 in. (15 cm) in diameter are important for the semiconductor industry. Ruby, sapphire, and group 13–15 compound semiconductor crystals are among the many crystals that are routinely grown by the Czochralski technique.

The evolution of methods for the growth of very thin but very high-quality epitaxial layers has resulted largely from the need for such layers of semiconductors and magnetic garnets. The technique most closely related to the methods used for bulk crystal growth is liquid-phase epitaxy. For a typical binary semiconductor, growth is done onto a substrate single-crystal wafer from a solution rich in the component with the lowest partial pressure. For a binary compound, the grown layers may differ only in impurity concentrations to modify their electrical characteristics. More often, multilayered structures with layers differing in major component composition but having the same crystal structure and lattice parameter are required. The simplest example of liquid-phase epitaxy with major composition changes in layers is the growth of layers of aluminum gallium arsenide ( $\text{Al}_x\text{Ga}_{1-x}\text{As}$ ;  $1 > x > 0$ ) on a gallium arsenide (GaAs) substrate.

Growth by liquid-phase epitaxy is done in an apparatus in which the substrate wafer is sequentially brought into contact with solutions that are at the desired compositions and may be supersaturated or cooled to achieve growth. For crystalline solid solutions other than  $\text{Al}_x\text{Ga}_{1-x}\text{As}$ , very precise control over solution compositions is required to achieve a lattice match. Typically, structures grown by liquid-phase epitaxy have four to six layers ranging widely in composition and having thickness from  $10^{-7}$  to  $10^{-6}$  m.

The desirability of highly reproducible growth and even thinner epitaxial layers of 13–15 compounds on large wafer areas has led to the development of molecular-beam epitaxy and several forms of chemical-vapor deposition. Molecular-beam epitaxy is an ultrahigh-vacuum technique in which beams of atoms or molecules of the constituent elements of the crystal provided by heated effusion ovens, impinge upon a heated substrate crystal. It has been used for epitaxial layers as thin as 0.5 nanometer. Molecular-beam epitaxy has also been used for group 12–16 compounds and for silicon. See ARTIFICIALLY LAYERED STRUCTURES; MOLECULAR BEAMS; SEMICONDUCTOR; SEMICONDUCTOR HETEROSTRUCTURES; VAPOR DEPOSITION. [M.B.P.]

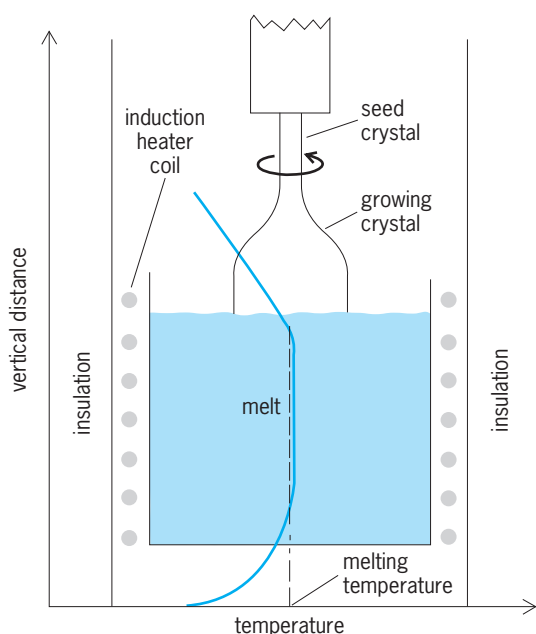
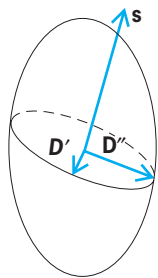

Fig. 2. Czochralski crystal growth and temperature distribution.

**Crystal optics** The study of the propagation of light, and associated phenomena, in crystalline solids. For a simple cubic crystal the atomic arrangement is such that in each direction through the crystal the crystal presents the same optical appearance. The atoms in anisotropic crystals are closer together in some planes through the material than in others. In anisotropic crystals the optical characteristics are different in different directions. In classical physics the progress of an electromagnetic wave through a material involves the periodic displacement of electrons. In anisotropic substances the forces resisting these displacements depend on the displacement direction. Thus the velocity of a light wave is different in different directions and for different states of polarization. The absorption of the wave may also be different in different directions. See DICHOISM; TRICHOISM.

In an isotropic medium the light from a point source spreads out in a spherical shell. The light from a point source embedded in an anisotropic crystal spreads out in two wave surfaces, one of which travels at a faster rate than the other. The polarization of the light varies from point to point over each wave surface, and in any particular direction from the source the polarization of the two surfaces is opposite. The characteristics of these surfaces can be determined experimentally by making measurements on a given crystal.

In the most general case of a transparent anisotropic medium, the dielectric constant is different along each of three orthogonal



**Index ellipsoid, showing construction of directions of vibrations of  $D$  vectors belonging to a wave normal  $s$ .** (After M. Born and E. Wolf, *Principles of Optics*, 7th ed., Cambridge University Press, 1999)

axes. This means that when the light vector is oriented along each direction, the velocity of light is different. One method for calculating the behavior of a transparent anisotropic material is through the use of the index ellipsoid, also called the reciprocal ellipsoid, optical indicatrix, or ellipsoid of wave normals. This is the surface obtained by plotting the value of the refractive index in each principal direction for a linearly polarized light vector lying in that direction (see illustration). The different indices of refraction, or wave velocities associated with a given propagation direction, are then given by sections through the origin of the coordinates in which the index ellipsoid is drawn. These sections are ellipses, and the major and minor axes of the ellipse represent the fast and slow axes for light proceeding along the normal to the plane of the ellipse. The length of the axes represents the refractive indices for the fast and slow wave, respectively. The most asymmetric type of ellipsoid has three unequal axes. It is a general rule in crystallography that no property of a crystal will have less symmetry than the class in which the crystal belongs.

Accordingly, there are many crystals which, for example, have four- or sixfold rotation symmetry about an axis, and for these the index ellipsoid cannot have three unequal axes but is an ellipsoid of revolution. In such a crystal, light will be propagated along this axis as though the crystal were isotropic, and the velocity of propagation will be independent of the state of polarization. The section of the index ellipsoid at right angles to this direction is a circle. Such crystals are called uniaxial and the mathematics of their optical behavior is relatively straightforward.

In crystals of low symmetry the index ellipsoid has three unequal axes. These crystals are termed biaxial and have two directions along which the wave velocity is independent of the polarization direction. These correspond to the two sections of the ellipsoid which are circular. See CRYSTALLOGRAPHY.

The normal to a plane wavefront moves with the phase velocity. The Huygens wavelet, which is the light moving out from a point disturbance, will propagate with a ray velocity. Just as the index ellipsoid can be used to compute the phase or wave velocity, so can a ray ellipsoid be used to calculate the ray velocity. The length of the axes of this ellipsoid is given by the velocity of the linearly polarized ray whose electric vector lies in the axis direction. See PHASE VELOCITY.

The refraction of a light ray on passing through the surface of an anisotropic uniaxial crystal can be calculated with Huygens wavelets in the same manner as in an isotropic material. For the ellipsoidal wavelet this results in an optical behavior which is completely different from that normally associated with refraction. The ray associated with this behavior is termed the extraordinary ray. At a crystal surface where the optic axis is inclined at an angle, a ray of unpolarized light incident normally on the surface is split into two beams: the ordinary ray, which proceeds through the surface without deviation; and the extraordinary ray, which is deviated by an angle determined by a line drawn from the center of one of the Huygens ellipsoidal wavelets to the point

at which the ellipsoid is tangent to a line parallel to the surface. The two beams are oppositely linearly polarized. [B.H.Bi]

**Crystal structure** The arrangement of atoms, ions, or molecules in a crystal. Crystals are solids having, in all three dimensions of space, a regular repeating internal unit of structure.

Crystals have been studied using x-rays, which excite signals from the atoms. The signals are of different strengths and depend on the electron density distribution about atomic cores. Light atoms give weaker signals and hydrogen is invisible to x-rays. However, the mutual atomic arrangements that are called crystal structures can be derived once the chemical formulas and physical densities of solids are known, based on the knowledge that atomic positions are not arbitrary but are dictated by crystal symmetry, and that the diffraction signals received are the result of systematic constructive interference between the scatterers within the regularly repeating internal unit of pattern. See CRYSTALLOGRAPHY; POLYMORPHISM (CRYSTALLOGRAPHY); X-RAY CRYSTALLOGRAPHY; X-RAY DIFFRACTION.

Crystals are defined in terms of space, population, and mutual arrangement. Crystal space is represented as an indefinitely extended lattice of periodically repeating points. The periodicity of the lattice is defined by the lengths and mutual orientations of three lattice vectors that enclose the pattern. Population is defined as the total number and kind of fundamental units of structure that form the pattern. The order and periodicity of crystals must extend to about 100 nanometers in all three dimensions of space to give the sharply defined diffraction signals required for mapping structural details by x-rays. Intermediate states of order are seen in liquid crystals, which have long molecules as fundamental units of structure. These are arranged with their lengths parallel to each other, but without periodicity, in the nematic state. In the smectic state there is orientation in equally spaced planes but no sideways periodicity, like traffic moving freely on a multilane highway. See LIQUID CRYSTALS.

In reality crystal space is not, in general, perfect. The growth process is characterized by constraints and turbulences, and by the dynamic interaction between the crystal and its environment. The process is reflected within the structures formed as an assemblage of atoms is collected and made relatively immobile by releasing the energy known as the heat of crystallization. The resulting crystal lattices resemble a mosaic of slightly misaligned adjacent regions. This is fortunate for research in x-ray crystallography. Perfect alignment would result in subtraction of energy by interference with the primary beam, due to a  $180^\circ$  phase reversal of the reflected beam (primary extinction). Internally diffracted beams would also be attenuated by internal reflection from regions above them (secondary extinction). See CRYSTAL GROWTH.

Each of the spatially misaligned mosaic blocks of a single crystal is assumed to maintain lattice periodicity within it. This assumption is confirmed by the sharp diffraction patterns observed. There are some "wrong" atoms, vacant lattice sites, trapped gas atoms, and so forth, and the atomic occupants jiggle about while also vibrating cooperatively and synchronously in complex internal modes of motion. Intricate patterns of electron exchange are enacted, and systematic changes in spin orientations can occur for an atom with a magnetic moment. Details like these are important for understanding the relationships between structure determination on the atomic and molecular levels and the cooperative behavior that determines bulk properties and functions. See CRYSTAL DEFECTS; LATTICE VIBRATIONS.

A rectangular space lattice with two possible cells is outlined in the illustration. These have the same cell volumes but different symmetries. Since crystallographic unit cells are completely defined by three lattice vectors, the crystal symmetry referenced to this lattice can be no higher than orthorhombic:  $a \neq b \neq c$  ( $OA \neq OB \neq OC$ ), and all angles equal to  $90^\circ$ . This and a possible monoclinic cell, with the same vectors  $a$  and  $b$  ( $OA$  and

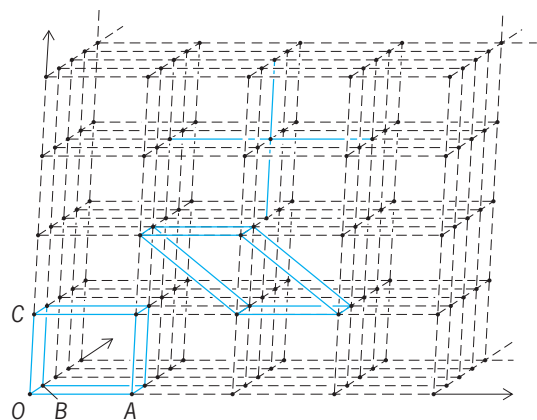

A space lattice, two possible unit cells, and the environment of a point.

$OB$ ) and one angle not equal to  $90^\circ$ , are outlined. If the  $OAB$  plane is rotated and the vector  $a$  ( $OA$ ) is extended to terminate at the next lattice point, then all angles differ from  $90^\circ$  and the crystal symmetry represented becomes triclinic. The mutual arrangement and atom coordinates of the cell population must be such that the environment, seen from every point of the space lattice, remains the same.

Screw axes combine the rotation of an ordinary symmetry axis with a translation parallel to it and equal to a fraction of the unit distance in this direction. If screw axes are present in crystals, it is clear that the displacements involved are of the order of a few tenths of nanometer and that they cannot be distinguished macroscopically from ordinary symmetry axes. The same is true for glide mirror planes, which combine the mirror image with a translation parallel to the mirror plane over a distance that is half the unit distance in the glide direction. The handedness of screw axes is a very important feature of many biological and mineral structures. See STEREOCHEMISTRY.

Space groups are indefinitely extended arrays of symmetry elements disposed on a space lattice. A space group acts as a three-dimensional kaleidoscope: An object submitted to its symmetry operations is multiplied and periodically repeated in such a way that it generates a number of interpenetrating identical space lattices. Space groups are denoted by the Hermann-Mauguin notation preceded by a letter indicating the Bravais lattice on which it is based. For example,  $P 2_1 2_1 2_1$  is an orthorhombic space group; the cell is primitive and three mutually perpendicular screw axes are the symmetry elements. J. D. H. Donnay and D. Harker have shown that it is possible to deduce the space group from a detailed study of the external morphology of crystals.

In general, metallic structures are relatively simple, characterized by a close packing and a high degree of symmetry. Manganese, gallium, mercury, and one form of tungsten are exceptions. A characteristic of metallic structures is the frequent occurrence of allotropic forms; that is, the same metal can have two or more different structures which are most frequently stable in a different temperature range. The forces which link the atoms together in metallic crystals are nondirectional. This means that each atom tends to surround itself by as many others as possible. This results in a close packing, similar to that of spheres of equal radius, and yields three distinct systems: close-packed (face-centered) cubic, hexagonal close-packed, and body-centered cubic.

Simple crystal structures are usually named after the compounds in which they were first discovered (diamond or zinc sulfide, cesium chloride, sodium chloride, and calcium fluoride). Many compounds of the types  $A^+X^-$  and  $A^{2+}X_2^-$  have such structures. They are highly symmetrical, the unit cell is cubic, and the atoms or ions are disposed at the corners of the unit cell

and at points having coordinates that are combinations of 0, 1,  $\frac{1}{2}$ , or  $\frac{1}{4}$ .

The sodium chloride structure is an arrangement in which each positive ion is surrounded by six negative ions, and vice versa. The centers of the positive and the negative ions each form a face-centered cubic lattice. Systematic study of the dimensions of the unit cells of compounds having this structure has revealed that:

1. Each ion can be assigned a definite radius. A positive ion is smaller than the corresponding atom and a negative ion is larger.
2. Each ion tends to surround itself by as many others as possible of the opposite sign because the binding forces are nondirectional.

In the cesium chloride structure each of the centers of the positive and negative ions forms a primitive cubic lattice; the centers are mutually shifted. Contact of the ions of opposite sign here is along the cube diagonal. In the diamond structure, each atom is in the center of a tetrahedron formed by its nearest neighbors. The 4-coordination follows from the well-known bonds of the carbon atoms.

The calcium fluoride structure is divided into eight equal cubelets, calcium ions are situated at corners and centers of the faces of the cell. The fluorine ions are at the centers of the eight cubelets. [D.Ev.]

**Crystal whiskers** Single crystals that have grown in filamentary form. Some grow from their base: either these are extruded to relieve pressure in the base material or they grow as a result of a chemical reaction at the base. In both cases, the growth occurs at a singularity in the base material. Other crystal whiskers grow at their tip, into a supersaturated medium, and the filamentary growth results from a strong anisotropy in the growth rate. See SINGLE CRYSTAL; SUPERSATURATION.

Great interest in whiskers developed after it was discovered that the strength exhibited by some whiskers approached that expected theoretically for perfect crystals. This great strength results from the internal and surface perfection of the whiskers, whereas the strength of most materials is limited by defects. The interest in the high strength of the whiskers centered on the possibility of using them in composites to increase the strength of more ductile matrix materials. Fibers of silica, boron, and carbon, which are much easier to fabricate in large quantity than whiskers, exhibit similarly high strengths, and are now used in composites. See COMPOSITE MATERIAL; CRYSTAL DEFECTS. [K.A.J.; R.S.Wa.]

**Crystallization** The formation of a solid from a solution, melt, vapor, or a different solid phase. Crystallization from solution is an important industrial operation because of the large number of materials marketed as crystalline particles. Fractional crystallization is one of the most widely used methods of separating and purifying chemicals. In fractional crystallization it is desired to separate several solutes present in the same solution. This is generally done by picking crystallization temperatures and solvents such that only one solute is supersaturated and crystallizes out. By changing conditions, other solutes may be crystallized subsequently. Repeated crystallizations are necessary to achieve desired purities when many inclusions are present or when the solid solubility of other solutes is significant. For a discussion of crystallization in glass, a supercooled melt, see GLASS. Polymer crystals obtained from solutions are used to study the properties of these crystals, while crystallization of polymer melts dramatically influences polymer properties; see POLYMER. For methods of preparing large crystals see SINGLE CRYSTAL. For crystallization from vapors see SUBLIMATION. For solubility and other relationships between solid and liquid phases see PHASE EQUILIBRIUM; SOLUTION. See also CRYSTAL; CRYSTALLOGRAPHY; NUCLEATION. [W.R.W.]

**Crystallography** The branch of science that deals with the geometric forms of crystals. How to describe, classify, and measure such forms are the first questions of crystallography. Revealing the forces that made them and the activities within them are the modern directions of the field. Crystallography is essential to progress in the applied sciences and technology and developments in all materials areas, including metals and alloys, ceramics, glasses, and polymers, as well as drug design. It is equally vital to progress in fundamental physics and chemistry, mineralogy and geology, and computer science, and to understanding of the dynamics and processes of living systems. See CRYSTAL STRUCTURE; POLYMORPHISM (CRYSTALLOGRAPHY).

The external morphology of crystals reflects their growth rates in different directions. These directions remain constant during the course of the growth process, and are represented mathematically as the normals to sets of parallel planes that are imagined as being added on as growth proceeds. The faces that meet and define an edge belong to a zone, a zone being a set of planes that share one common direction, the zone axis. The invariance of interfacial angles, measured by rotation about an axis that is defined by the zone direction, was discovered in the seventeenth century. See CRYSTAL GROWTH.

Interfacial angles are calculated from spherical geometry. Figure 1 illustrates the procedure for a crystal having well-developed faces of which three are mutually perpendicular. The normals to these faces are the natural directions for constructing an orthogonal frame of reference for measurement. The crystal is imagined to be shrunk and placed at the center of a sphere with coordinates (0,0,0). The face normals, labeled [100], [010], and [001], define the directions of an orthogonal reference system. Normals to the same set of planes, but oppositely directed, are labeled  $\bar{1}00$ ,  $0\bar{1}0$ ,  $00\bar{1}$ . The reversal of sign indicates that the crystal must be rotated 180° to obtain the same view. Rotation about the [001] direction interchanges the positions of [100] and  $\bar{1}00$  faces and their bounding edges. Rotation about [010] turns these faces upside down. Correct designations for group movements and symmetry operations are clearly essential for establishing and maintaining orientation in crystal space. The directions of face normals determine points at which the imagined sphere is pierced. The solid angles between an array of such points, all lying on the same great circle of the sphere, belong to a zone.

Optical measurements and stereographic projections established the constancy of interfacial angles, independent of how well developed the faces are. Such properties as the cleavage of large rhombohedral crystals of calcite (CaCO<sub>3</sub>) into

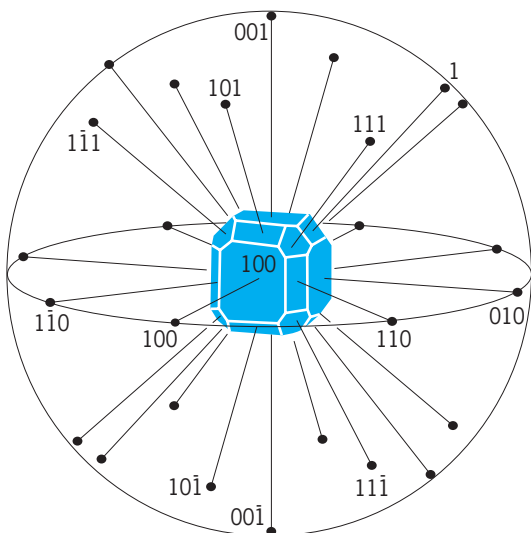

Fig. 1. Spherical projection of normals to crystal faces.







Bravais lattice cells	Axes and interaxial angles	Examples
 Cubic P    Cubic I    Cubic F	Three axes at right angles; all equal: $a = b = c$ ; $\alpha = \beta = \gamma = 90^\circ$	Copper (Cu), silver (Ag), sodium chloride (NaCl)
 Tetragonal P    Tetragonal I	Three axes at right angles; two equal: $a = b \neq c$ ; $\alpha = \beta = \gamma = 90^\circ$	White tin (Sn), rutile (TiO <sub>2</sub> ), $\beta$ -spodumene (LiAlSi <sub>2</sub> O <sub>6</sub> )
 Orthorhombic	Three axes at right angles; all unequal: $a \neq b \neq c$ ; $\alpha = \beta = \gamma = 90^\circ$	Gallium (Ga), perovskite (CaTiO <sub>3</sub> )
 Monoclinic P    Monoclinic C	Three axes, one pair not at right angles, of any lengths: $a \neq b \neq c$ ; $\alpha = \gamma = 90^\circ \neq \beta$	Gypsum (CaSO <sub>4</sub> · 2H <sub>2</sub> O)
 Triclinic P	Three axes not at right angles, of any lengths: $a \neq b \neq c$ ; $\alpha \neq \beta \neq \gamma \neq 90^\circ$	Potassium chromate (K <sub>2</sub> CrO <sub>7</sub> )
 Trigonal R (rhombohedral)	Rhombohedral: three axes equally inclined, not at right angles; all equal: $a = b = c$ ; $\alpha = \beta = \gamma \neq 90^\circ$	Calcite (CaCO <sub>3</sub> ), arsenic (As), bismuth (Bi)
 Trigonal and hexagonal C (or P)	Hexagonal: three equal axes coplanar at 120°, fourth axis at right angles to these: $a_1 = a_2 = a_3 \neq c$ ; $\alpha = \beta = 90^\circ$ , $\gamma = 120^\circ$	Zinc (Zn), cadmium (Cd), quartz (SiO <sub>2</sub> ) [P]

Fig. 2. The 14 Bravais lattices, derived by centering of the seven crystal classes (P and R) defined by symmetry operators.

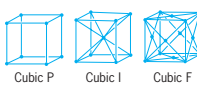
little rhombs suggested that the large crystal could be represented by geometrically identical smaller units stacked together, to fill space. The 14 lattices of Bravais (Fig. 2) enlarged the seven crystal systems of optical mineralogy by adding centering points to them: body (I), face (F), and base (C) centers. The 14 lattices define three-dimensional distributions of mathematical points such that the environments of all points of the lattice are identical. They also define the symmetries of frameworks for constructing mathematical models to represent the observed and measured realities—models made from cells of the smallest volume, but also highest symmetry, that stack together by translation to fill space.

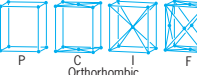
Stacking of model cells does not imply that a crystal grows by stacking identical bricks; a lattice of identically surrounded mathematical points does not imply that any real objects, atoms or molecules, are located at the points; and filling space by translation of identical cells does not imply that the space defined by the cells is filled. Rather, the Bravais lattices are a formalism for representing observed geometries and symmetries of real crystals by three-dimensional lattices of identically surrounded points.

The lattices also provide the means to identify imaginary planes within the cell; these are called Miller indices ( $h, k, l$ ). They consist of small whole numbers. For example, each of the six faces of a simple cube, with the origin of a coordinate frame of reference at the cube body center, is normal to one of the reference axes and parallel to the plane defined by the two others. The six faces are indexed as their normals in Fig. 1—(100), ( $\bar{1}00$ ), (010), ( $0\bar{1}0$ ), (001), and ( $00\bar{1}$ )—to represent a face that intercept the  $x, x$  axis but not the  $y$  and  $z$ ; the  $y, y$  axis but not the  $x$  and  $z$ ; and so forth. Hypothetical parallel planes with 1/2 the interplanar spacing are represented as (200), ( $\bar{2}00$ ), (020), and so forth.

A complete mathematical formalism exists for modeling an external morphological form and the symmetry relations between imagined units of structure within it. The symmetry operators include rotation axes, glide and mirror planes, and left- and right-handed screw axes which will simultaneously rotate and translate a three-dimensional object to create its clone in a different spatial position and orientation. The operators minimize the detail required to specify the spatial arrangements of patterns and objects that fill two-dimensional and three-dimensional space. The so-called color space groups of crystallography greatly

increase the number of distinguishably different symmetries beyond the classical 230 by adding a fourth coordinate to the three space coordinates. This is done to encode a real difference that will be manifested in some property. The different directions of the magnetic moments of chemically identical atoms of an element such as iron provide an example of the need for representing a difference on the atomic level between cells that are otherwise identical.

The sharp x-ray line spectra characteristic of the bombarded element are the primary probes for determining interior structural detail of crystals. Cameras with cylindrical film and enclosed powdered samples record all diffraction lines as arcs of concentric circles. This fundamental powder method has endured since 1917 and is now employed with improved beam purity and optics, improved diffractometers which couple sample and detector rotation, electronic detection, rapid sequential recording, and computer indexing programs that provide patterns of compounds, mixtures of phases, and dynamic changes that occur when crystals are subjected and respond to external stress. The method is applied to single crystals, polycrystalline aggregates, and multiple-phase mixtures, randomly disposed either in space or in geometrically designed composite materials. See X-RAY CRYSTALLOGRAPHY; X-RAY POWDER METHODS.

The dynamics of living systems, the difficulties in distinguishing light elements, and the inherent ambiguities of measuring, decoding, and mapping crystal structures are continuing challenges. Major achievements of crystallography include the determination of the structures of deoxyribonucleic acid (DNA), proteins, other biological compounds, and boranes; the development of direct methods of phase determination; and the determination of the structure and mechanism of a photosynthetic center. See BORANE; DEOXYRIBONUCLEIC ACID (DNA); PHOTOSYNTHESIS; PROTEIN. [D.E.v.]

**Ctenophora** A phylum of exclusively marine organisms, formerly included in the jellyfish and polyps as coelenterates. These animals, the so-called comb jellies, possess a biradial symmetry of organization and have eight rows of comblike plates as the main locomotory structures. Most are pelagic, but a few genera are creeping. Many are transparent and colorless; others are faintly to brightly colored. Almost all are luminescent. Many of these organisms are hermaphroditic. Development is biradially symmetrical, with a cydippid larval stage. Five orders constitute this phylum as follows:

- Phylum Ctenophora
- Order: Cydippida
  - Lobata
  - Cestida
  - Platyctenida
  - Beroida

The body is gelatinous and extremely fragile; its form may be globular, pyriform, or bell- or helmet-shaped. Some species resemble a ribbon. Their size ranges from  $\frac{1}{8}$  to 20 in. (3 mm to 50 cm). The axis of symmetry is determined by the mouth and the organ of equilibrium, or statocyst (see illustration). The mouth leads into the flattened, elongated pharynx. The sagittal plane is thus referred to as the stomodeal plane. The other plane of symmetry is perpendicular to the sagittal plane and is marked (Beroida excepted) by tentacles. Eight meridional comb-plate rows or ribs stretch from the aboral pole on the surface of the body. The comb plates, which are used as oars during locomotion, are the most characteristic structure of the ctenophores, possessed by all members of the phylum. Each plate consists of a great number of very long related cilia.

Fertilization usually occurs in seawater. Pelagic ctenophores are self-fertile, but cross-fertilization might also take place inside a swarm of ctenophores. Ctenophores have high powers of re-

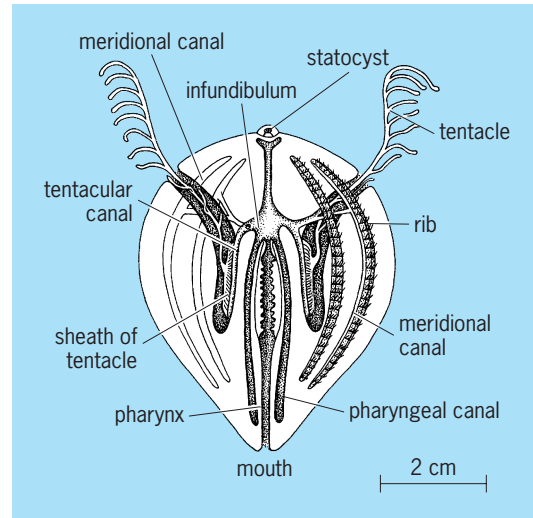

Structure of a cydippid ctenophore.

generation. Asexual reproduction (in a few platyctenid genera) is by regeneration of an entire organism from a small piece of the adult body.

The ctenophores feed on zooplankton. They are themselves important plankton organisms. They are quite common and have a worldwide distribution in all seas, where they can appear in enormous swarms. Some genera stand great changes in the seawater salinity. Because of their voracity as predators of zooplankton, they play an important role in plankton equilibrium and in fisheries. [J.M.F.]

**Ctenopoda** An order of branchiopod crustaceans formerly included in the order Cladocera. The body is up to about 4 mm (0.2 in.) in length. Although superficially similar to the large order Anomopoda in the protection of the trunk and its limbs by a functionally bivalved carapace, in the nature of the eye, in the use of antennae for swimming, and in the possession of a somewhat similar postabdomen, ctenopods differ in various ways. See ANOMOPODA.

The six trunk limbs are all constructed on a similar plan but differ in detail among themselves. They beat with a metachronal rhythm and by so doing draw in suspended food particles. Some species have become planktonic; *Holopedium* surrounds itself by a sphere of jelly to assist flotation. Others are sedentary; *Sida* attaches itself by a sucker at the back of the head.

Reproduction is mostly by parthenogenesis. Most species occur in fresh water, where they are widely distributed, but *Penilia* is marine. See BRANCHIOPODA. [G.Fr.]

**Ctenostomata** A paraphyletic order of Bryozoa in the class Gymnolaemata. Ctenostomes have entirely cuticular body walls, and colonies consist of feeding zooids only or of feeding zooids plus spine- or stolon-shaped zooids. See GYMNOLEAMATA.

Feeding zooids possess tentacles that collectively form a circular, feeding, bell-shaped lophophore centered on the mouth. Most ctenostomes grow as encrusting or erect, ramifying, thin branches that consist entirely of zooids or of individual zooids or zooid groups connected by stolons. Others grow as densely packed zooids that form flexible encrustations or thick, erect, branched growths. A few branching ctenostomes are endolithic borers.

Colonies are hermaphroditic. Fertilized eggs are usually brooded as embryos in the space normally occupied by the retracted tentacles of feeding zooids. In other species, brooding may be within specialized invaginations or within the coelom. A few species release fertilized eggs directly into the sea. The free-swimming larvae attach to a substrate for metamorphosis.

Then is formed the first feeding zooid of the colony, from which all subsequent zooids within the developing colony are budded.

Most ctenostomes are marine, although several species are tolerant to lower salinity than any other marine bryozoans and a few live in fresh water.

The fossil record of endolithic ctenostomes extends back to the Late Ordovician. The lack of a mineralized skeleton diminishes chances of preservation of nonboring ctenostomes. Ctenostome bryozoans are relatively primitive in their lack of calcification, small number of zooid types, lack of brooding in some species, and other features. The oldest known Cheilostomata are Late Jurassic and have zooidal shapes and encrusting colony growth habits that are close to morphologies known in extant ctenostomes and apparently are derived from ctenostomes. The class Stenolaemata may have originated from ctenostomes. See BRYOZOA; STENOLAEMATA. [F.K.McK.]

**Ctenothrissiformes** A small order of teleostean fishes that are of particular interest because they seem to be on or near the main evolutionary line leading from the generalized, soft-rayed salmoniforms to the spiny-rayed beryciforms and perciforms, dominant groups among higher bony fishes. Ctenothrissiformes lack fin spines but they share many characters with primitive beryciforms. The few fishes confidently assigned to the

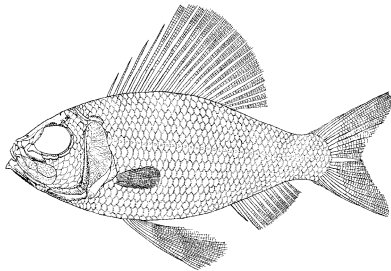

Cretaceous ctenothrissid, *Ctenothrissus radians*. (After C. Patterson, *Phil. Trans. Roy. Soc. London, Ser. B, Biol. Sci.*, no. 739, vol. 247, 1964)

Ctenothrissiformes, *Ctenothrissus* (Ctenothrissidae; see illustration) and *Aulolepis* and *Pateroperca* (Aulolepidae), are known as Upper Cretaceous marine fossils from Europe and southwestern Asia. Two little-known genera of Recent oceanic fishes, *Macristium* and *Macristiella* (Macristiidae), are assigned by some authors to the order but some doubt attends this placement. See BERYCIFORMES; PERCIFORMES; SALMONIFORMES. [R.M.B.]

**Cube** A parallelepiped whose six faces are all squares. The cube is one of the five regular solids known to the ancient Greeks. A cube has eight vertices and twelve edges. Each vertex is on three edges and three faces, each edge is on two vertices and two faces, and each plane is on four vertices and four edges. See POLYHEDRON; REGULAR POLYTOPES. [L.M.B.I.]

**Cubeb** The dried, nearly ripe fruit (berries) of a climbing vine, *Piper cubeba*, of the pepper family (Piperaceae). This species is native to eastern India and Indomalaysia. The crushed berries are smoked, and the inhaled smoke produces a soothing effect in certain respiratory ailments. Cubebs are used in medicine as a stimulant, expectorant, and diuretic. Medicinal properties of cubeb are due to the presence of a volatile oil which formerly was thought to stimulate healing of mucous membranes. See PIPERALEA. [PD.St./E.L.C.]

**Cubomedusae** An order of the class Scyphozoa. Their distribution is mostly tropical. The umbrella is cubic, and a pedalia, a gelatinous leaf-shaped body, is present at the base of each ridge of the exumbrella (see illustration). A well-developed

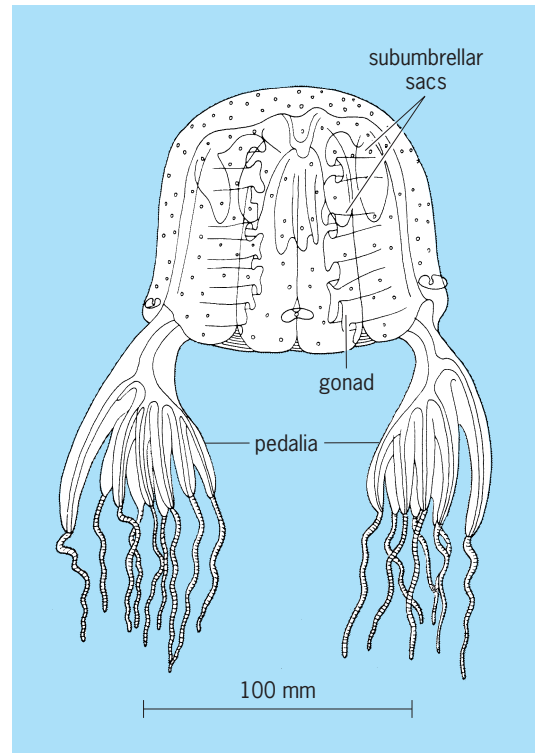

Cubomedusan, *Chiropsalmus quadrumanni*. (After L. Hyman, *The Invertebrates*, vol. 1, McGraw-Hill, 1940)

tentacle, or a cluster of tentacles, arises from each pedalia. No connecting stage between polyp and medusa is known. See SCYPHOZOA. [T.U.]

**Cuculiformes** An order of birds with zygodactyl feet in which the outer fourth toe is reversed. The order is divided into the suborder Musophagi, containing the single family Musophagidae (touracos; 18 species), and the suborder Cuculi, with the lone family Cuculidae (cuckoos; 129 species).

Touracos are African woodland birds with a loose green, gray, or brown plumage with patches of bright yellow, red, or violet. The nest is a bulky platform placed in a tree, with incubation and care of the chicks shared by the parents. The young leave the nest at an early age (about 10 days) and crawl about the trees before being able to fly.

Cuckoos are diverse. They are mostly arboreal, but some are terrestrial, and some, such as the American roadrunners (*Geococcyx*) are fast runners with top speeds of about 15 mi/h (25 km/h) and fly rarely. Most cuckoos are secretive, sulking in heavy vegetation. They are strong fliers but do not fly often. Temperate species are migratory. Cuckoos feed on insects, small vertebrates, other animals, and rarely on fruit. Most are solitary, but the anis (Crotophaginae) live in flocks and build a cooperative nest housing several females. Many Old World species (Cuculinae) are nest parasites. See AVES. [W.J.B.]

**Cucumber** A warm-season annual cucurbit (*Cucumis sativus*) native to India and belonging to the plant order Campanulales. The cucumber is grown for its immature fleshy fruit which is used primarily for pickling and for slicing as a salad. The development of gynoeious (bearing only female flowers) and hybrid varieties (cultivars) with increased disease resistance is resulting in a continuing change in the varieties of both pickling and slicing cucumbers. Important producing states are Florida and South Carolina for fresh market and Michigan and Wisconsin for pickling. See CAMPANULALES. [H.J.C.]

**Culture** The cultivation of cells in the laboratory. Bacteria and yeasts may be grown suspended in a liquid medium or as colonies on a solid medium; molds grow on moist surfaces; and animal and plant cells (tissue cultures) usually adhere to the glass or plastic beneath a liquid medium. Cultures must provide sources of energy and raw material for biosynthesis, as well as a suitable physical environment.

The materials supplied determine which organisms can grow out from a mixed inoculum. Some bacteria (prototrophic) can produce all their constituents from a single organic carbon source; hence they can grow on a simple medium. Other cells (auxotrophic) lack various biosynthetic pathways and hence require various amino acids, nucleic acid bases, and vitamins. Obligatory or facultative anaerobes grow in the absence of  $O_2$ ; many cells require elevated  $CO_2$ . Cultures isolated from nature are usually mixed; pure cultures are best obtained by subculturing single colonies. Viruses are often grown in cultures of a host cell, and may be isolated as plaques in a continuous lawn of those cells. In diagnostic bacteriology, species are ordinarily identified by their ability to grow on various selective media and by the characteristic appearance of their colonies on test media. See BACTERIAL GROWTH.

Laboratory cultures are often made in small flasks, test tubes, or covered flat dishes (petri dishes). Industrial cultures for antibiotics or other microbial products are usually in fermentors of 10,000 gallons (37,850 liters) or more. The cells may be separated from the culture fluid by centrifugation or filtration.

Specific procedures are employed for isolation, cultivation, and manipulation of microorganisms, including viruses and rickettsia, and for propagation of plant and animal cells and tissues. A relatively minute number of cells, the inoculum, is introduced into a sterilized nutrient environment, the medium. The culture medium in a suitable vessel is protected by cotton plugs or loose-fitting covers with overlapping edges so as to allow diffusion of air, yet prevent access of contaminating organisms from the air or from unsterilized surfaces. The transfer, or inoculation, usually is done with the end of a flamed, then cooled, platinum wire. Sterile swabs may also be used and, in the case of liquid inoculum, sterile pipets.

The aqueous solution of nutrients may be left as a liquid medium or may be solidified by incorporation of a nutritionally inert substance, most commonly agar or silica gel. Special gas requirements may be provided in culture vessels closed to the atmosphere, as for anaerobic organisms. Inoculated vessels are held at a desired constant temperature in an incubator or water bath. Liquid culture media may be mechanically agitated during incubation. Maximal growth, which is visible as a turbidity or as masses of cells, is usually attained within a few days, although some organisms may require weeks to reach this stage. See CHEMOSTAT; EMBRYONATED EGG CULTURE; TISSUE CULTURE. [B.D.D.]

**Cumacea** An order of the class Crustacea, subclass Malacostraca. All have a well-developed carapace which is fused dorsally with at least the first three thoracic somites and which overhangs the sides to enclose a branchial cavity. The telson may be free or may appear lacking because it is fused with the last abdominal somite. Eyes are sessile and, except for a few genera, are coalesced in a single median organ or wholly wanting. There are eight pairs of thoracic appendages. There is no free larval stage. In the few species whose life history has been investigated there are five to seven molts after release from the brood pouch. There is always some sexual dimorphism in adults, but immature males resemble females until the later stages.

The order is rather uniform and classification is based on trivial characters. Seven families are recognized. Affinities are probably closer to the Mysidacea than to the Tanaidacea. A few fossils are now known.

Cumacea are found in all seas and in some estuaries and areas of brackish water, including the Caspian Sea. Most inhabit water shallower than 660 ft (200 m), but many occur in great

depths. They normally burrow in sand or mud with the front protruding. They feed on organic detritus or very small organisms and may themselves form part of the diet of various fishes. See MALACOSTRACA. [N.S.J.]

**Cumin** *Cuminum cyminum*, a plant for which the whole or ground dried ripe fruit, commonly called seed, is a popular spice. It is a major ingredient in both chili powder and curry, and is added to meat sauces, rice, bread, pickles, soups, and other foods. Roman caraway is another common name for this member of the parsley family (Apiaceae). The only species in its genus, cumin exhibits a variety of plant types depending on the seed source. A small annual herb about 1–2 ft (0.3–0.6 m) tall, cumin grows upright as a single slender stem with many branches. See APIALES.

The strong, pungent green-spicy odor and flavor of cumin is attributable largely to cuminaldehyde, the main constituent of the essential oil, and other aldehydes.

This herb is native to the Mediterranean region. Presently cumin is commercially grown in Iran, southern Russia, China, India, Morocco, and Turkey. The three major types of cumin seed, Iranian, Indian, and Middle Eastern, vary in seed color, essential oil quantity, and flavor. Upon distillation cumin seed yields 2.5–5% essential oil, used in both perfumery and flavoring liqueurs. Cumin is also used medicinally. See SPICE AND FLAVORING. [S.Kir.]

**Cumingtonite** An amphibole (a double-chain silicate mineral) with the idealized chemical formula  $Mg_7Si_8O_{22}(OH)_2$  that crystallizes with monoclinic symmetry. Naturally occurring samples generally are solid solutions between  $Mg_7Si_8O_{22}(OH)_2$  and the corresponding iron (Fe)-end member with the general formula  $(Mg,Fe)_7Si_8O_{22}(OH)_2$ . The name cumingtonite (derived from the location Cumington, Massachusetts) is applied to all solid solutions with  $Mg/(Mg + Fe^{2+}) \geq 0.5$ , whereas those with  $Mg/(Mg + Fe^{2+}) < 0.5$  are termed grunerite. Up to a total of 1.0 (Ca + Na) atom per formula unit may also be present in cumingtonite.

Cumingtonite commonly occurs as aggregates of fibrous crystals, often in radiating clusters. It is transparent to translucent, varies in color from white to green to brown, and may be pale to dark depending primarily on the iron content. Hardness is 5–6 on Mohs scale; density is 3.1–3.6 g/cm<sup>3</sup> (1.8–2.1 oz/in.<sup>3</sup>), increasing with increasing iron content.

Cumingtonite is generally considered to be a metamorphic mineral, but it has been found in silicic volcanic rocks and, rarely, plutonic igneous rocks. It occurs in a variety of metamorphic rock types (amphibolite, schist, gneiss, granulite) that have undergone medium- to high-grade metamorphism. It commonly occurs in the calcium- and aluminum-poor environment of metamorphosed iron formation. It can also be a constituent of metamorphosed mafic and ultramafic igneous rocks, where it may coexist with other amphibole minerals such as hornblende, tremolite, and anthophyllite. With increasing intensity of metamorphism, cumingtonite is commonly replaced by pyroxene-bearing mineral assemblages. See AMPHIBOLE; HORNBLLENDE; IGNEOUS ROCKS; METAMORPHIC ROCKS; TREMOLITE. [R.K.P.]

**Cuprite** A mineral having composition  $Cu_2O$  and crystallizing in the isometric system. Cuprite is commonly in crystals showing the cube, octahedron, and dodecahedron. It is various shades of red and a fine ruby red in transparent crystals which have a metallic to adamantine luster. The hardness is 3.5–4 (Mohs scale) and the specific gravity is 6.1.

Cuprite is a widespread supergene copper ore. Fine crystals have been found at Cornwall, England, and Chessy, France. It has served as an ore in the Congo, Chile, Bolivia, and Australia. In the United States it has been found at Clifton, Morenci, Globe, and Bisbee, all in Arizona. See COPPER. [C.S.Hu.]



**Curie temperature** The critical or ordering temperature for a ferromagnetic or a ferrimagnetic material. The Curie temperature  $T_c$  is the temperature below which there is a spontaneous magnetization  $M$  in the absence of an externally applied magnetic field, and above which the material is paramagnetic. In the disordered state above the Curie temperature, thermal energy overrides any interactions between the local magnetic moments of ions. Below the Curie temperature, these interactions are predominant and cause the local moments to order or align so that there is a net spontaneous magnetization.

In the ferromagnetic case, as temperature  $T$  increases from absolute zero, the spontaneous magnetization decreases from  $M_0$ , its value at  $T = 0$ . At first this occurs gradually, then with increasing rapidity until the magnetization disappears at the Curie temperature. In ferrimagnetic materials the course of magnetization with temperature may be more complicated, but the spontaneous magnetization disappears at the Curie temperature.

In antiferromagnetic materials the corresponding ordering temperature is termed the Néel temperature. Below the Néel temperature the magnetic sublattices have a spontaneous magnetization, though the net magnetization of the material is zero. Above the Néel temperature the material is paramagnetic. See ANTIFERROMAGNETISM.

The ordering temperatures for magnetic materials vary widely. The ordering temperature for ferroelectrics is also termed the Curie temperature, below which the material shows a spontaneous electric moment. See FERROMAGNETISM; PYROELECTRICITY.

[J.F.Di.]

**Curie-Weiss law** A relation between magnetic or electric susceptibilities and the absolute temperature which is followed by ferromagnets, antiferromagnets, nonpolar ferroelectrics and antiferroelectrics, and some paramagnets. The Curie-Weiss law is usually written as the equation below, where  $\chi$  is the suscepti-

$$\chi = C/(T - \theta)$$

bility,  $C$  is a constant for each material,  $T$  is the absolute temperature, and  $\theta$  is called the Curie temperature. Antiferromagnets and antiferroelectrics have a negative Curie temperature. The Curie-Weiss law refers to magnetic and electric behavior above the transition temperature of the material in question. It is not always precisely followed, and it breaks down in the region very close to the transition temperature. Often the susceptibility will behave according to a Curie-Weiss law in different temperature ranges with different values of  $C$  and  $\theta$ . See CURIE TEMPERATURE; ELECTRIC SUSCEPTIBILITY; MAGNETIC SUSCEPTIBILITY.

[E.A.; F.Ke.]

**Curium** A chemical element, Cm, in the actinide series, with an atomic number of 96. Curium does not exist in the terrestrial environment, but may be produced artificially. The chemical properties of curium are so similar to those of the typical rare earths that, if it were not for its radioactivity, it might easily be mistaken for one of these elements. The known isotopes of curium include mass numbers 238–250. The isotope  $^{244}\text{Cm}$  is of particular interest because of its potential use as a compact, thermoelectric power source, through conversion to electrical power of the heat generated by nuclear decay. See PERIODIC TABLE.

Metallic curium may be produced by the reduction of curium trifluoride with barium vapor. The metal has a silvery luster, tarnishes in air, and has a specific gravity of 13.5. The melting point has been determined as  $2444 \pm 72^\circ\text{F}$  ( $1340 \pm 40^\circ\text{C}$ ). The metal dissolves readily in common mineral acids with the formation of the tripositive ion.

A number of solid compounds of curium have been prepared and their structures determined by x-ray diffraction. These include  $\text{CmF}_4$ ,  $\text{CmF}_3$ ,  $\text{CmC}_3$ ,  $\text{CmBr}_3$ ,  $\text{CmI}_3$ ,  $\text{Cm}_2\text{O}_3$ , and  $\text{CmO}_2$ . Isostructural analogs of the compounds of curium are observed in the lanthanide series of elements. See ACTINIDE ELEMENTS; TRANSURANIUM ELEMENTS.

[G.T.S.]

**Currant** A fruit (berry) in the genus *Ribes* in the family Saxifragaceae. Cultivated black and red currants and gooseberries all belong to this genus. *Ribes* species having prickles or spines are called gooseberries, and those that do not are called currants. The berries are produced in clusters on bushes, and cultivars ripen in midsummer.

*Ribes* are not widely grown commercially for fruit in the United States, but red currants and gooseberries are popular in home gardens for use in jellies and pies. Several *Ribes* species, particularly golden currant (*R. aureum*) and fuchsia-flowered gooseberry (*R. speciosum*), are used as shrubs in landscaping. In Europe cultivars of the black currant (*R. nigrum*) are extensively grown commercially for juice concentrate. Wild *Ribes* species occur widely in the United States, and desirable, edible types are sometimes gathered during the season when the fruit is locally abundant. See GOOSEBERRY; ROSALES.

[R.H.Co.]

**Current comparator** An instrument for determining the ratio of two currents, based on Ampère's laws. The application of the current comparator, unlike the voltage ratio transformer, is not limited to alternating currents but can be used with direct currents as well. See INSTRUMENT TRANSFORMER.

The current comparator is based on Ampère's circuital law, which states that the integral of the magnetizing force around a closed path is equal to the sum of the currents which are linked with that path. Thus, if two currents are passed through a toroid by two windings of known numbers of turns, and the integral of the magnetizing force around the toroid is equal to zero, the current ratio is exactly equal to the inverse of the turns ratio. See AMPÈRE'S LAW.

For alternating-current comparators, the ampere-turn unbalance is given by the voltage at the terminals of a uniformly distributed detection winding on a magnetic core. Direct-current comparators use two magnetic cores which are modulated by alternating current in such a way that the dc ampere-turn unbalance is indicated by the presence of even harmonics in the voltage. Neither method is an exact measure of the integral of the magnetizing force, and various design features are added to overcome this deficiency. The most important of these are the magnetic shields, which are configured as hollow toroids. They protect the magnetic core and detection winding from the leakage fluxes of the current-carrying windings and ambient magnetic fields, and they are responsible for an improvement in accuracy of about three orders of magnitude. The copper shields supplement this action at higher frequencies and also provide mechanical protection for the magnetic steels.

Applications of the ac comparator include current and voltage transformer calibration, measurement of losses in large capacitors, inductive reactors and power transformers, resistance measurement, and the calibration of active and reactive power and energy meters. Further, the current comparator, like the current transformer, has the advantage of being applicable to measurements involving high-voltage, high-power circuits as well as being the basis for very accurate high-current-transconductance amplifiers.

In dc applications, the current comparator provides the means to resolve the first three or four most significant digits of a balance by turns-count, thus eliminating problems associated with switch contact resistance and thermal electromotive forces. Its uses include eight-decade resistance and thermometry bridges, a seven-decade potentiometer, and high current ratio standards. It also provides the means for generating highly accurate direct-current voltages and currents. See CURRENT MEASUREMENT; ELECTRICAL MEASUREMENTS.

[W.J.M.M.; N.L.K.; E.So.]

**Current density** A vector quantity equal in magnitude to the instantaneous rate of flow of electric charge, perpendicular to a chosen surface, per unit area per unit time. If a wire of cross-sectional area  $A$  carries a current  $I$ , the current density  $J$  is  $I/A$ .

The units of  $J$  in the rationalized meter-kilogram-second system are amperes per square meter. [J.W.St.]

**Current measurement** The measurement of the rate of passage of electric charges in a circuit. The unit of measurement, the ampere (A), is one of the base units of the International System of Units (SI). It is defined as that constant current which, if maintained in two straight parallel conductors of infinite length, of negligible circular cross section, and placed 1 m apart in vacuum, would produce between these conductors a force equal to  $2 \times 10^{-7}$  newton per meter of length.

In order to establish an electrical unit in accordance with the SI definition, it is necessary to carry out an experimental determination. The ampere cannot be realized exactly as defined. Electromagnetic theory has to be used to relate a practical experiment to the definition. See CURRENT BALANCE.

Since January 1, 1990, working standards of voltage and resistance have provided the foundations of practical electrical measurements. The standard of voltage is based on the alternating-current (ac) Josephson effect, in which voltage is related to frequency. By international agreement the value 483 597.9 GHz/V for the Josephson constant is now used throughout the world. The working unit of resistance is maintained through the quantum Hall effect, with an agreed value of 25 812.807 ohms for the voltage-to-current ratio obtained under certain defined experimental conditions. These values have been chosen to provide the best known approximations to the SI units and have the advantage of reproducibility at the level of 1 part in  $10^8$ . The working standard of current is derived from measurements of voltage across a known resistor. See ELECTRICAL UNITS AND STANDARDS; HALL EFFECT; JOSEPHSON EFFECT.

The moving-coil (d'Arsonval) meter measures direct currents (dc) from 10 microamperes to several amperes. The accuracy is likely to be a few percent of the full-scale indication, although precision instruments can achieve 0.1% or even better. Above 1 milliampere a shunt usually carries the major part of the current; only a small fraction is used to deflect the meter. Since the direction of deflection depends on the direction of the current, the d'Arsonval movement is suitable for use only with unidirectional currents. Rectifiers are used to obtain dc and drive the meter from an ac signal. The resulting combination is sensitive to the rectified mean value of the ac waveform.

In the moving-iron meter, two pieces of soft magnetic material, one fixed and one movable, are situated inside a single coil. When current flows, both pieces become magnetized in the same direction and accordingly repel each other. The moving piece is deflected against a spring or gravity restoring force, the displacement being indicated by a pointer. As the repulsive force is independent of current direction, the instrument responds to low-frequency ac as well as dc. The natural response of such a movement is to the root-mean-square (rms) value of the current. The accuracy of moving-iron meters is less than that of moving-coil types. See AMMETER.

For radio-frequency applications it is essential that the sensing element be small and simple to minimize inductive and capacitive effects. In a thermocouple meter the temperature rise of a short, straight heater wire is measured by a thermocouple and the corresponding current is indicated by a d'Arsonval movement. In a hot-wire ammeter the thermal expansion of a wire heated by the current is mechanically enhanced and used to deflect a pointer. Both instruments, based on heating effects, respond to the rms value of the current. Above 100 MHz, current measurements are not made directly, as the value of current is likely to change with position owing to reflections and standing waves. See MICROWAVE MEASUREMENTS; THERMOCOUPLE.

Above 50 A the design of shunts becomes difficult. For ac, current transformers can be used to reduce the current to a level convenient for measurement. At the highest accuracy, current comparators may be used in which flux balance is detected when the magnetizing ampere-turns from two signals are equal and

opposite. Direct-current comparators are available in which dc flux balance is maintained and any unbalance is used to servo a second, or slave, current signal. For the highest accuracy, second-harmonic modulators are used, and for lower precision, Hall effect sensors. Electronically balanced ac and dc current comparators make clip-around ammeters possible, in which an openable magnetic core can be closed around a current-carrying conductor. This allows the meter to be connected into and removed from the circuit without breaking it or interrupting the current. See CURRENT COMPARATOR; INSTRUMENT TRANSFORMER.

The obvious method for measuring a very small current is to determine the voltage drop across a large resistor. A sensitive voltage detector having very low offset current is required, for example, an electrometer. Electrometers based on MOSFET (metal-oxide-semiconductor field-effect transistor) devices have overtaken other designs where the very highest resolution is required, as they can have offset current drifts less than  $10^{-16}$  A. In order to provide a low impedance to the measured current, it is preferable to use the electrometer device in an operational-amplifier configuration. The input becomes a virtual ground, and so stray capacitance across the input connection does not degrade the rate of response of the circuit as seriously as in the simple connection. See TRANSISTOR. [R.B.D.K.]

**Current sources and mirrors** A current source is an electronic circuit that generates a constant direct current which flows into or out of a high-impedance output node. A current mirror is an electronic circuit that generates a current which flows into or out of a high-impedance output node, which is a scaled replica of an input current, flowing into or out of a different node.

Most specifications of analog integrated circuits depend almost uniquely on the technological parameters of the devices, and on the direct or alternating current that flows through them. The voltage drop over the devices has much less impact on performance, as long as it keeps the devices in the appropriate mode of operation (linear or saturation). High-performance analog integrated-circuit signal processing requires that currents be generated and replicated (mirrored) accurately, independent of supply voltage and of those device parameters that are least predictable (such as current gain  $\beta$  in a bipolar transistor). Hence, current sources and mirrors occupy a large portion of the total die area of any analog integrated circuit. They are also used, but less often, in discrete analog circuits. See INTEGRATED CIRCUITS; TRANSISTOR. [P.M.VanP]

**Curve fitting** A procedure in which the basic problem is to pass a curve through a set of points, representing experimental data, in such a way that the curve shows as well as possible the relationship between the two quantities plotted. It is always possible to pass some smooth curve through all the points plotted, but since there is assumed to be some experimental error present, such a procedure would ordinarily not be desirable. See INTERPOLATION.

The first task in curve fitting is to decide (1) how many degrees of freedom (number of unspecified parameters, or independent variables) should be allowed in fitting the points, and (2) what the general nature of the curve should be. Since there is no known way of answering these questions in a completely objective way, curve fitting remains something of an art. It is clear, however, that one must make good use of any background knowledge of the quantities plotted in order to answer the two questions. Thus, if one knew that a discontinuity might occur at some value of the abscissa, one would try to fit the points above and below that value by separate curves.

Against this background knowledge of what the curve should be expected to look like, one may observe the way the points fall on the paper. One may even find it advantageous to make a few rough attempts to draw a reasonable curve "through" the points.

A knowledge of the accuracy of the data is needed to help answer the question of the number of degrees of freedom to be permitted in fitting the data. If the data are very accurate, one may use as many degrees of freedom as there are points. The curve can then be made to pass through all the points, and it serves only the function of interpolation. At the opposite extreme when the data are very rough, one may attempt to fit the data by a straight line representing a linear relation, Eq. (1), between

$$y = ax + b \quad (1)$$

$y$  and  $x$ . Using the above information and one's knowledge of the functions that have been found useful in fitting various types of experimental curves, one selects a suitable function and tries to determine the parameters left unspecified. At this point there are certain techniques that have been worked out to choose the optimum value of the parameters.

One of the most general methods used for this purpose is the method of least squares. In this method one chooses the parameters in such a way as to minimize the sum, Eq. (2), where

$$S = \sum_{i=1}^n [y_i - f(x_i)]^2 \quad (2)$$

$y_i$  is the ordinate of  $i$ th point and  $f(x_i)$  the ordinate of the point on the curve having the same abscissa  $x_i$  as this point. See LEAST-SQUARES METHOD. [K.S.K.]

**Cutaneous sensation** The sensory quality of skin. The skin consists of two main layers, the epidermis and the dermis. Sensory receptors in or beneath the skin are peripheral nerve-fiber endings that are differentially sensitive to one or more forms of energy. The sensory endings can be loosely categorized into three morphological groups: endings with expanded tips, such as Merkel's disks found at the base of the epidermis; encapsulated endings, such as Meissner's corpuscles (particularly plentiful in the dermal papillae), and other organs located in the dermis or subcutaneous tissue, such as Ruffini endings, Pacinian corpuscles, Golgi-Mazzoni corpuscles, and Krause's end bulb; and bare nerve endings that are found in all layers of the skin (some of these nerve endings are found near or around the base of hair follicles).

There is a remarkable relationship between the response specificities of cutaneous receptors and five primary qualities of cutaneous sensation, the latter commonly described as touch-pressure (mechanoreceptors), cold and warmth (thermoreceptors), pain, and itch. Each quality is served by a specific set of cutaneous peripheral nerve fibers. More complex sensations must result from an integration within the central nervous system of information from these sets of nerve fibers. Exploration of the skin surface with a rounded metal point reveals that there exist local sensory spots on the skin, stimulation of which evokes only one of the five qualities of sensation. Thus, there may be plotted maps of pressure, warm, cold, pain, or itch spots. See MECHANORECEPTORS; PAIN; SKIN; SOMESTHESIS. [R.LaM.]

**Cyanamide** A term used to refer to the free acid hydrogen cyanamide,  $H_2NCN$ , or commonly to the calcium salt of this acid, calcium cyanamide,  $CaCN_2$ . Calcium cyanamide is manufactured by the cyanamide process, in which nitrogen gas is passed through finely divided calcium carbide at a temperature of  $1832^\circ F$  ( $1000^\circ C$ ). Most calcium cyanamide is used in agriculture as a fertilizer; some is used as a weed killer, as a pesticide, and as a cotton defoliant.

Hydrogen cyanamide is prepared from calcium cyanamide by treating the salt with acid. It is used in the manufacture of dicyandiamide and thiourea. [E.E.W.]

**Cyanate** A compound containing the  $-OCN$  group, typically a salt or ester of cyanic acid ( $HO-CN$ ). The cyanate ion is ambidentate, that is, it has two reactive sites, because it can bind

through the oxygen (O) or the nitrogen (N). Cyanate is commonly N-bonded with most nonmetallic elements, presumably because of the small charge density on the oxygen. Cyanic acid has the structure  $H-O-C\equiv N$ , but it may exist in an isomeric form known as isocyanic acid,  $H-N=C=O$ . The cyanates are isomeric with fulminates, where the carbon and the nitrogen are transposed ( $-ONC$ ).

Cyanic acid is a volatile liquid, and it polymerizes upon standing to form cyamelide acid and cyanuric acid. In water cyanic acid undergoes hydrolysis to ammonia and carbon dioxide. However, dilute solutions in ice water may be kept for several hours. Both cyanic acid and isocyanic acid are prepared from cyanuric acid. The linear  $-OCN$  ion may be prepared by mild oxidation of aqueous cyanide ion ( $CN^-$ ) using lead oxide ( $PbO$ ) and potassium cyanide ( $KCN$ ).

The primary use for cyanates is in the synthesis of a number of organic compounds such as unsubstituted carbamates ( $R-NH-C=OOR'$ ). These compounds are used as derivatives of alcohols. Other important reactions include addition to amines to give substituted ureas. See CARBON; CYANIDE; NITROGEN; THIO-CYANATE. [T.J.Me.]

**Cyanide** A compound containing the  $-CN$  group, for example, potassium cyanide,  $KCN$ ; calcium cyanide,  $Ca(CN)_2$ ; and hydrocyanic (or prussic) acid,  $HCN$ . Chemically, the simple inorganic cyanides resemble chlorides in many ways. Organic compounds containing this group are called nitriles, for example, acrylonitrile,  $CH_2=CHCN$ . See ACRYLONITRILE.

$HCN$  is a weak acid. In the pure state, it is a highly volatile liquid, boiling at  $26^\circ C$  ( $78.8^\circ F$ ).  $HCN$  and the cyanides are highly toxic to animals and humans.

The cyanide ion forms a variety of coordination complexes with transition-metal ions, a property responsible for several of the commercial uses of cyanides. The cyanide process  $T$  is the most widely used method for extracting gold and silver from the ores. In silver-plating, a smooth adherent deposit is obtained on a metal cathode when electrolysis is carried out in the presence of an excess of cyanide ion. See ELECTROPLATING OF METALS; GOLD METALLURGY; SILVER METALLURGY.

$Ca(CN)_2$  is extensively used in pest control and as a fumigant in the storage of grain. In finely divided form, it reacts slowly with the moisture in the air to liberate  $HCN$ .

In case hardening of metals, an iron or steel article is immersed in a bath of molten sodium or potassium cyanide containing sodium chloride or carbonate. The cyanide decomposes at the surface, forming a deposit of carbon which combines with and penetrates the metal. See COORDINATION CHEMISTRY. [F.J.J.]

**Cyanobacteria** A large and heterogeneous group of photosynthetic microorganisms, formerly referred to as blue-green algae. They had been classified with the algae because their mechanism of photosynthesis is similar to that of algal and plant chloroplasts; however, the cells are prokaryotic, whereas the cells of algae and plants are eukaryotic. The name cyanobacteria is now used to emphasize the similarity in cell structure to other prokaryotic organisms. See ALGAE; CELL PLASTIDS.

All cyanobacteria can grow with light as an energy source through oxygen-evolving photosynthesis; carbon dioxide ( $CO_2$ ) is fixed into organic compounds via the Calvin cycle, the same mechanism used in green plants. Thus, all species will grow in the absence of organic nutrients. However, some species will assimilate organic compounds into cell material if light is available, and a few isolates are capable of growth in the dark by using organic compounds as carbon and energy sources. Some cyanobacteria can shift to a different mode of photosynthesis, in which hydrogen sulfide rather than water serves as the electron donor. Molecular oxygen is not evolved during this process, which is similar to that in purple and green photosynthetic sulfur bacteria. The photosynthetic pigments of cyanobacteria include

chlorophyll *a* (also found in algae and plants) and phycobiliproteins. See CHLOROPHYLL; PHOTOSYNTHESIS.

Cyanobacteria are extremely diverse morphologically. Species may be unicellular or filamentous. Both types may aggregate to form macroscopically visible colonies. The cells range in size from those typical of bacteria (0.5–1 micrometer in diameter) to 60  $\mu\text{m}$ .

When examined by electron microscopy, the cells of cyanobacteria appear similar to those of gram-negative bacteria. Many species produce extracellular mucilage or sheaths that promote the aggregation of cells or filaments into colonies.

The photosynthetic machinery is located on internal membrane foldings called thylakoids. Chlorophyll *a* and the electron transport proteins necessary for photosynthesis are located in these lipid membranes, whereas the water-soluble phycobiliprotein pigments are arranged in particles called phycobilisomes which are attached to the lipid membrane.

Several other types of intracellular structures are found in some cyanobacteria. Gas vesicles, which may confer buoyancy on the organisms, are often found in cyanobacteria that grow in the open waters of lakes. Polyhedral bodies, also known as carboxysomes, contain large amounts of ribulose biphosphate carboxylase, the key enzyme of  $\text{CO}_2$  fixation via the Calvin cycle. Several types of storage granules may be found.

Cyanobacteria can be found in a wide variety of fresh-water, marine, and soil environments. They are more tolerant of environmental extremes than are eukaryotic algae. For example, they are the dominant oxygenic phototrophs in hot springs (at temperatures up to  $72^\circ\text{C}$  or  $176^\circ\text{F}$ ) and in hypersaline habitats such as may occur in marine intertidal zones.

Cyanobacteria are often the dominant members of the phytoplankton in fresh-water lakes that have been enriched with inorganic nutrients such as phosphate. It is now known that high population densities of small, single-celled cyanobacteria occur in the oceans, and that these are responsible for 30–50% of the  $\text{CO}_2$  fixed into organic matter in these environments. About 8% of the lichens involve a cyanobacterium, which can provide both fixed nitrogen and fixed carbon to the fungal partner. See LICHENS; PHYTOPLANKTON.

Cyanobacteria are thought to be the first oxygen-evolving photosynthetic organisms to develop on the Earth, and hence responsible for the conversion of the Earth's atmosphere from anaerobic to aerobic about 2 billion years ago. This development permitted the evolution of aerobic bacteria, plants, and animals. See BACTERIA; CYANOPHYCEAE; PREBIOTIC ORGANIC SYNTHESIS. [A.Ko.]

**Cyanocarbon** A derivative of hydrocarbon in which all of the hydrogen atoms are replaced by the  $-\text{C}\equiv\text{N}$  group. However, the term cyanocarbon has been applied to compounds which do not strictly follow the above definition: tetracyanoethylene oxide, tetracyanothiophene, tetracyanofuran, tetracyanopyrrole, tetracyanobenzoquinone, tetracyanoquinodimethane, tetracyano-dithiin, pentacyanopyridine, diazomalnonitrile, and diazotetracyanocyclopentadiene.

Tetracyanoethylene (with the formula below), the simplest

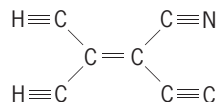

olefinic cyanocarbon, is a colorless, thermally stable solid, having a melting range of  $198\text{--}200^\circ\text{C}$  ( $388\text{--}392^\circ\text{F}$ ), and readily forming stable complexes with most aromatic systems. Cyanocarbon acids are among the strongest protonic organic acids known and are usually isolated only as the cyanocarbon anion salt. [O.W.W.]

**Cyanogen** A colorless, highly toxic gas having the molecular formula  $\text{C}_2\text{N}_2$ . Structurally, cyanogen is written  $\text{N}\equiv\text{C}-\text{C}\equiv\text{N}$ . Cyanogen belongs to a class of compounds known as pseu-

dohalogens, because of the similarity of their chemical behavior to that of the halogens. Liquid cyanogen boils at  $-21.17^\circ\text{C}$  ( $-6.11^\circ\text{F}$ ) and freezes at  $-27.9^\circ\text{C}$  ( $-18.2^\circ\text{F}$ ) at 1 atm (101.325 kilopascals).

Cyanogen reacts with hydrogen at elevated temperatures in a manner analogous to the halogens, forming hydrogen cyanide, HCN. With hydrogen sulfide,  $\text{H}_2\text{S}$ , cyanogen forms thiocyanofornamide or dithiooxamide. Cyanogen burns in oxygen, producing one of the hottest flames known from a chemical reaction. It is considered to be a promising component of high-energy fuels. See CYANIDE. [F.J.J.]

**Cyanophyceae** A class of prokaryotic organisms coextensive with the division Cyanophycota of the kingdom Monera. Because these organisms have chlorophyll *a* and carry out oxygen-evolving photosynthesis, they have traditionally been aligned with algae and, with regard for their characteristic color, called blue-green algae. Microbiologists have emphasized the prokaryotic structure of these organisms and aligned them with bacteria, as the Cyanobacteria. Other names applied to these organisms include Cyanophyta at the level of division and Myxophyceae or Schizophyceae at the level of class. Blue-greens range in form from unicells 1–2 micrometers in diameter to filaments 10 cm (4 in.) long. See CYANOBACTERIA.

Unicellular forms, which may aggregate in colonies or loosely constructed filaments and which reproduce by binary fission or spores, constitute the order Chroococcales, from which two additional orders, Chamaesiphonales and Pleurocapsales, are sometimes segregated. Filamentous forms, which reproduce by hormogonia, constitute the order Nostocales (= Hormogonales or Oscillatoriales). The Nostocales may be restricted to unbranched or falsely branched forms (in which the ends of a trichome adjacent to a rupture grow out as a pair of branches), while those forms in which cells divide in more than one plane (true branching) constitute the order Stigonematales.

Geographically and ecologically, blue-green algae are nearly as ubiquitous as bacteria. They are especially abundant in the plankton of neutral or alkaline eutrophic fresh waters and tropical seas, often forming blooms. Habitats for benthic forms include hot springs, snow and ice, soil, rocks, tree trunks, and buildings. Cyanophyceae live symbiotically with a large variety of animals and plants. They constitute the phycobiont of many lichens.

In addition to contributing to food chains, blue-green algae play specific beneficial roles. Nitrogen-fixing forms greatly enrich rice paddies. On the other hand, blue-green algae are often a nuisance. They clog filters, impart undesirable tastes and odors to domestic water supplies, and make unusable or at least unattractive many swimming pools, aquariums, and fountains. Cyanophycean blooms are often toxic to fish, birds, and livestock.

Blue-green algae were pioneers on Earth and are known from rocks at least as old as 2.3 billion years. They are believed to have been responsible for the accumulation of oxygen in the primeval atmosphere and to have been involved in the formation of laminated reeflike structures called stromatolites. See ALGAE; STROMATOLITE. [P.C.Si.; R.L.Moe.]

**Cybernetics** The study of communication and control within and between humans, machines, organizations, and society. This is a modern definition of the term cybernetics, which was first utilized by N. Wiener in 1948 to designate a broad subject area he defined as "control and communication in the animal and the machine." A distinguishing feature of this broad field is the use of feedback information to adapt or steer the entity toward a goal. When this feedback signal is such as to cause changes in the structure or parameters of the system itself, it appears to be self-organizing. See ADAPTIVE CONTROL.

Wiener developed the statistical methods of autocorrelation, prediction, and filtering of time-series data to provide a mathematical description of both biological and physical phenomena.

The use of filtering to remove unwanted information or noise from the feedback signal mimics the selectivity shown in biological systems in which imprecise information from a diversity of sensors can be accommodated so that the goal can still be reached. See ESTIMATION THEORY; HOMEOSTASIS; STOCHASTIC CONTROL THEORY. [D.W.Bo.]

**Cycadales** An order of the class Cycadopsida of the division Pinophyta (gymnosperms) consisting of four families, Cycadaceae, Stangeriaceae, Zamiaceae, and Boweniaceae, with perhaps 100 species. The order dates from the upper Carboniferous and has few living representatives. The cycads were distributed worldwide in the Mesozoic, but today are restricted to subtropical and tropical regions, with the plants occurring in small colonies; few have broad distributions.

The cycads, often incorrectly referred to as palms, range from a few inches (*Zamia*) to 65 ft (20 m; *Macrozamia*) tall. The stems are cylindrical and often branched; in some the stem is subterranean, in others it is mainly above the ground. The pinnate (or bipinnate in *Bowenia*) leaves are borne at the apex of the stems. Microsporophylls and megasporophylls are borne in cones of highly varied appearance. Male and female cones appear on separate plants (dioecious). See CYCADOPSIDA; PINOPHYTA; PLANT KINGDOM. [T.A.Z.]

**Cycadeoidales** An order of extinct plants that formed a conspicuous part of the landscape during the Triassic, Jurassic, and Cretaceous periods. The Cycadeoidales (or Bennettitales) had unbranched or sparsely branched trunks with a terminal crown of leaves (family Cycadeoidaceae; see illustration), or they were branched, at times profusely (family Williamsoniaceae).

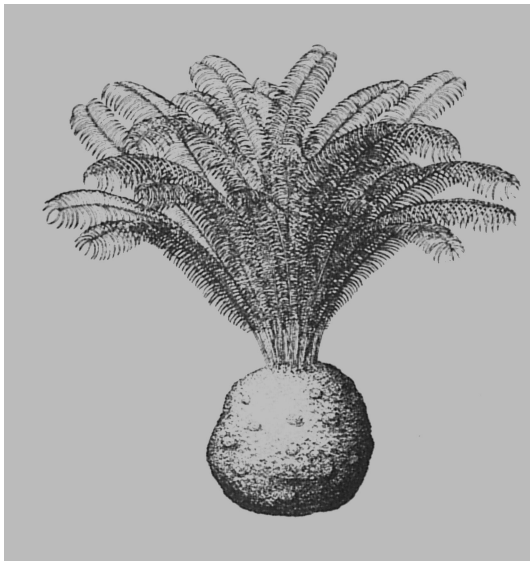

Reconstruction of a plant of the genus *Cycadeoidea*, showing terminal crown of leaves, persistent leaf bases, and positions of the fruiting structures. (Courtesy of T. Delevoryas)

No known relatives of the Cycadeoidales exist at the present time, although members of the order Cycadales show some resemblances to the extinct group. See CYCADALES; EMBRYOBIONTA. [T.D.]

**Cycadopsida** A class of the division Cycadophyta consisting of a single order, Cycadales, dating back to the Triassic and most abundant in the Jurassic. There are 100–150 living species of cycads in two families, Cycadaceae with one genus and Zamiaceae with ten genera. Most cycads are tropical, but some

extend into warm temperate regions. Wild cycads are threatened by collection for horticulture so they are protected by international treaties. They were used as traditional foods in some places but contain potent carcinogens and neurotoxins. See CYCADALES; GNETALES; WELWITSCHIALES.

Pinnately compound leaves on massive, usually unbranched trunks emerge in flushes, sometimes with the rachis or leaflets coiled like fiddleheads. Large pollen and seed cones crown different individuals. Pollen cones have numerous wedge-shaped scales, each covered below with clustered microsporangia. Seed cones of Zamiaceae are similar, with two seeds on each scale, but megasporophylls of Cycadaceae are leaflike, with two to eight seeds. As in *Ginkgo*, fertilization is by swimming sperm. See PINOPHYTA; PLANT KINGDOM. [J.E.E.]

**Cyclanthales** An order of flowering plants, division Magnoliophyta (Angiospermae), sometimes called Synanthae or Synanthales, in the subclass Arecidae of the class Liliopsida (monocotyledons). The order consists of the single tropical American family Cyclanthaceae, with about 180 species. They are herbs or, seldom, more or less woody plants, with characteristic leaves that have a basal sheath, a petiole, and an expanded, usually bifid (cleft into two equal parts) blade which is often folded lengthwise (plicate) like that of a palm leaf. One of the species, *Carludovicia palmata*, is a principal source of fiber for panama hats. See ARECIDAE. [A.Cr.]

**Cyclic nucleotides** Derivatives of nucleic acids that control the activity of several proteins within cells to regulate and coordinate metabolism. They are members of a group of molecules known as intracellular second messengers; their levels are regulated by hormones and neurotransmitters, which are the extracellular first messengers in a regulatory pathway. Cyclic nucleotides are found naturally in all living cells.

Two major forms of cyclic nucleotides are characterized: 3',5'-cyclic adenosine monophosphate (cyclic AMP or cAMP) and 3',5'-cyclic guanosine monophosphate (cyclic GMP or cGMP). Like all nucleotides, cAMP and cGMP contain three functional groups: a nitrogenous aromatic base (adenine or guanine), a sugar (ribose), and a phosphate. Cyclic nucleotides differ from other nucleotides in that the phosphate group is linked to two different hydroxyl (3' and 5') groups of the ribose sugar and hence forms a cyclic ring. This cyclic conformation allows cAMP and cGMP to bind to proteins to which other nucleotides cannot.

An increase in cAMP or cGMP triggered by hormones and neurotransmitters can have many different effects on any individual cell. The type of effect is dependent to some extent on the cellular proteins to which the cyclic nucleotides may bind. Three types of effector proteins are able to bind cyclic nucleotides: protein kinases, ion channels, and cyclic nucleotide phosphodiesterases.

Protein kinases are enzymes which are able to transfer a phosphate group to (phosphorylate) individual amino acids of other proteins. This action often changes the function of the phosphorylated protein. Ion channels are proteins found in the outer plasma membrane of some cells; binding of cyclic nucleotides to them can alter the flow of sodium ions across the cell membranes. Cyclic nucleotide phosphodiesterases are enzymes responsible for the degradation of cyclic nucleotides.

In bacteria, cAMP can bind to a fourth type of protein, which can also bind to deoxyribonucleic acid (DNA). This catabolite gene activator protein (CAP) binds to specific bacterial DNA sequences, stimulating the rate at which DNA is copied into ribonucleic acid (RNA) and increasing the amount of key metabolic enzymes in the bacteria.

In humans, cyclic nucleotides acting as second messengers play a key role in many vital processes and some diseases. For example, in the brain, cAMP and possibly cGMP are critical in the formation of both long-term and short-term memory. In the liver, cAMP coordinates the function of many metabolic enzymes

to control the level of glucose and other nutrients in the bloodstream. See ADENOSINE TRIPHOSPHATE (ATP); ENZYME; NUCLEIC ACID; NUCLEOPROTEIN; NUCLEOTIDE; PROTEIN. [M.D.U.]

**Cycliophora** A recently described phylum in the animal kingdom. Only one microscopic species, *Symbion pandora*, has been described. Its sessile stage is approximately 0.3 mm in length and 0.1 mm wide. All known occurrences are from the mouth limbs of the Norwegian lobster, which can be totally encrusted with thousands of the sessile stage of the animal (see illustration).

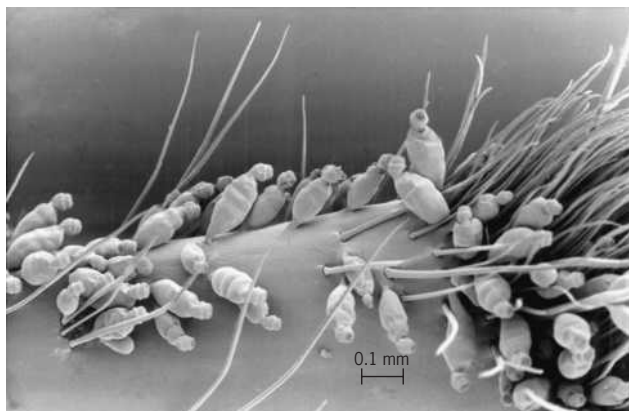

Scanning electron micrograph of the Norwegian lobster's mouthpart with numerous feeding stages of *Symbion pandora*. (Courtesy of P. Funch and R. M. Kristensen)

The sessile animal has a circular mouth surrounded by a ring of cilia, which is used for filtering small food particles, such as bacteria or algae. The anatomy is relatively simple, with a U-shaped gut, similar to what is found in bryozoans or some sessile rotiferans. It is the extremely complex life cycle of *S. pandora* that makes the phylum unique. The life cycle consists of an asexual and a sexual generation with no less than two types of free-swimming larva, dwarf male and female; two stages of sessile feeding animals, which brood the male and female; and one type of larva (Pandora larva) inside a brooding chamber (called a marsupium). Furthermore, the sessile animal has internal budding, whereby it grows by loss of the head itself and replacement of the old gut and feeding system with a new bud coming from embryonic cells in the basal part of the body. [R.M.Kr.]

**Cycloamylose** Any of a group of cyclic oligomers of glucose in the normal C-1 conformation in which the individual glucose units are connected by 1,4 bonds. They are called Schardinger dextrans (after the discoverer), cyclodextrins (to emphasize their cyclic character), or cycloamyloses (to emphasize both their cyclic character and their amylose origin). The most common ones are cyclohexaamylose (which has six glucose units in a cyclic array) and cycloheptaamylose (which has seven glucose units in a cyclic array). The toroidal shape of these molecules has been determined by x-ray analysis (see illustration). The molecular weights are around 1000.

In water or in a mixture of water and dimethyl sulfoxide, cycloamyloses form 1:1 complexes with many organic molecules and most benzenoid derivatives. X-ray and spectroscopic evidence indicates that the guest molecule (usually a small organic molecule) is bound tightly in the cavity of the host molecule (the cycloamylose) just like a key fitting into a lock. The result is an inclusion complex, which is what is formed by enzymes when they first bind the molecules whose reactions they subsequently catalyze. Inclusion complex formation is probably the most important similarity between cycloamyloses and enzymes.

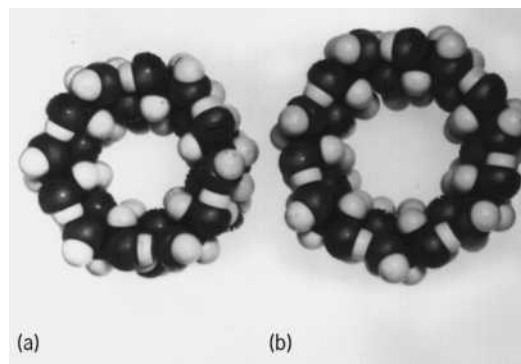

Molecular models of cycloamyloses viewed from the secondary hydroxyl side of the torus. (a) Cyclohexaamylose. (b) Cycloheptaamylose. (From M. L. Bender and M. Komiyama, *Cyclodextrin Chemistry*, Springer, 1978)

Cycloamyloses have been used to mimic many enzymes, such as ribonuclease, transaminase, and carbonic anhydrase. They have also been used to effect selectivity in several chemical reactions. Cycloamyloses are the premier example of chemical compounds that act like enzymes in inclusion complex formation followed by reaction. See CATALYSIS; CLATHRATE COMPOUNDS; ENZYME; STEREOSPECIFIC CATALYST. [M.L.Be.]

**Cyclocystoidea** A class of small, disk-shaped echinozoans in which the lower surface of the body probably consisted of a suction cap for adhering to substrate, and the upper surface was covered by separate plates arranged in concentric rings. The mouth lay at the center of the upper surface, and the anus, also on the upper surface, lay some distance between the margin and the mouth. Little is known of the habits of cyclocystoids. They occur in rocks of middle Ordovician to middle Devonian age in Europe and North America. See ECHINODERMATA; ECHINOZOA. [H.B.F.]

**Cycloid** A curve traced in the plane by a point on a circle that rolls, without slipping, on a line. If the line is the  $x$  axis of a rectangular coordinate system, at whose origin  $O$  the moving point  $P$  touches the axis, parametric equations of the cycloid are  $x = a(\theta - \sin \theta)$ ,  $y = a(1 - \cos \theta)$ , when  $a$  is the radius of the

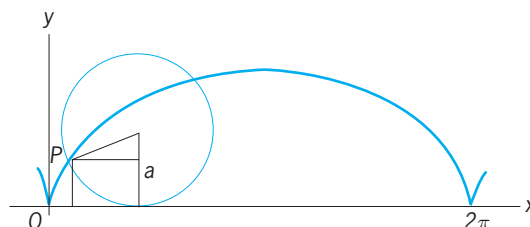

Diagram of a cycloid.

rolling circle, and the parameter  $\theta$  is the variable angle through which the circle rolls (see illustration). See ANALYTIC GEOMETRY. [L.M.Bl.]

**Cyclone** An atmospheric circulation system in which the sense of rotation of the wind about the local vertical is the same as that of the Earth's rotation. Thus, a cyclone rotates clockwise in the Southern Hemisphere and counterclockwise in the Northern Hemisphere. In meteorology the term cyclone is reserved for circulation systems with horizontal dimensions of hundreds (tropical cyclones) or thousands (extratropical cyclones) of kilometers. For such systems the Coriolis force due to the Earth's

rotation, which is directed to the right of the flow in the Northern Hemisphere, and the pressure gradient force, which is directed toward low pressure, are in opposite directions. Thus, there must be a pressure minimum at the center of the cyclone, and cyclones are sometimes simply called lows. See AIR PRESSURE.

Extratropical cyclones are the common weather disturbances which travel around the world from west to east in mid-latitudes. They are generally associated with fronts, which are zones of rapid transition in temperature. Extratropical cyclones arise due to the hydrodynamic instability of the upper-level jet stream flow. See FRONT; JET STREAM.

Tropical cyclones, by contrast, derive their energy from the release of latent heat of condensation in precipitating cumulus clouds. Over the tropical oceans, where moisture is plentiful, tropical cyclones can develop into intense vortical storms (hurricanes and typhoons), which can have wind speeds in excess of 200 mi/h ( $100 \text{ m} \cdot \text{s}^{-1}$ ). See HURRICANE; STORM; WIND. [J.R.H.]

**Cyclone furnace** A water-cooled horizontal cylinder in which fuel (coal, gas, or oil) is fired and heat is released at extremely high rates. When firing coal, the crushed coal is introduced tangentially into the burner at the front end of the cyclone (see illustration). About 15% of the combustion air is used as primary and tertiary air to impart a whirling motion to the particles of coal. The whirling, or centrifugal, action on the fuel is further increased by the tangential admission of high-velocity secondary air into the cyclone.

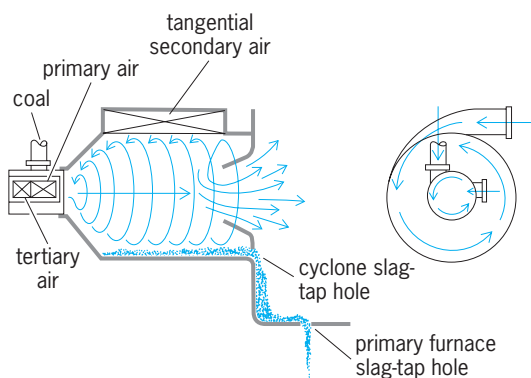

Schematic diagram of cyclone furnace. (From T. Baumeister, ed., *Standard Handbook for Mechanical Engineers*, 8th ed., McGraw-Hill, 1978)

The products of combustion are discharged through a water-cooled reentrant throat at the rear of the cyclone into the boiler furnace. Essentially, the fundamental difference between cyclone furnaces and pulverized coal-fired furnaces is the manner in which combustion takes place. In pulverized coal-fired furnaces, particles of coal move along with the gas stream; consequently, relatively large furnaces are required to complete the combustion of the suspended fuel. With cyclonic firing, the coal is held in the cyclone and the air is passed over the fuel. Thus, large quantities of fuel can be fired and combustion completed in a relatively small volume, and the boiler furnace is used to cool the products of combustion. See BOILER; STEAM-GENERATING FURNACE; STEAM-GENERATING UNIT. [G.W.K.]

**Cyclophane** A molecule composed of two building blocks: an aromatic ring (most frequently a benzene ring) and an aliphatic unit forming a bridge between two (or more) positions of the aromatic ring. Those cyclophanes that contain heteroatoms in the aromatic part are generally called phanes, as "cyclo" in cyclophanes more strictly means that only benzene rings are present in addition to aliphatic bridges. Phane molecules containing hetero atoms in the aromatic ring (for example,

nitrogen or sulfur) are called heterophanes, while in heterophanes they are part of the aliphatic bridge.

Cyclophanes usually are not at all planar molecules; they exhibit an interesting stereochemistry (arrangement of atoms in three-dimensional space); molecular parts are placed and sometimes fixed in unusual orientations toward each other, and often the molecules are not rigid but (conformationally) flexible. Ring strain and, as a consequence, deformation of the benzene rings out of planarity are often encountered. Electronic interactions between aromatic rings fixed face to face can take place. In addition, influence on substitution reactions in the aromatic rings results; that is, substituents in one ring induce transannular electronic effects in the other ring, often leading to unexpected products. See CHEMICAL BONDING; CONFORMATIONAL ANALYSIS; STEREOCHEMISTRY.

Cyclophanes have become important in host-guest chemistry and supramolecular chemistry as they constitute host compounds for guest particles because of their cavities. Recognition processes at the molecular level are understood to mean the ability to design host molecules to encompass or attach selectively to smaller, sterically complementary guests in solution—by analogy to biological receptors and enzymes. For this reason, water-soluble cyclophanes were synthesized; they have the ability to include nonpolar guest molecules in aqueous solution. See CAGE HYDROCARBON; MOLECULAR RECOGNITION; POLAR MOLECULE.

Cyclophanes also exist in nature as alkaloids, cytotoxic agents, antibiotics, and many cyclopeptides. With the possibility of locating groups precisely in space, cyclophane chemistry has provided building units for molecular niches, nests, hollow cavities, multifloor structures, helices, macropolycycles, macro-hollow tubes, novel ligand systems, and so on. Cyclophane chemistry has become a major component of supramolecular chemistry, molecular recognition, models for intercalation, building blocks for organic catalysts, receptor models, and variation of crown ethers and cryptands. See MACROCYCLIC COMPOUND; SUPRAMOLECULAR CHEMISTRY. [F.Vo.; M.Boh.]

**Cyclophyllidea** The order which includes most tapeworms that inhabit the gut of warm-blooded vertebrates. They are frequently referred to as the Taenioidea. Each worm has a head, or scolex, and a segmented body, called the strobila. The scolex typically has an apical rostellum, or muscular pad and hooks, and two pairs of lateral suckers. New segments are produced immediately posterior to the scolex, so that the oldest segment is at the hind end. As a segment is pushed further from the scolex, the male and female reproductive organs mature and open on the lateral margin. Ova, fertilized by sperm from the same or another segment, gather in a uterus. The ripe terminal segments containing infectious eggs are shed into gut contents of the host.

A number of tapeworms occur in humans and domestic animals, either as adults or immature stages, the metacestodes, but rarely in both stages. See COENUROSIS; PLATYHELMINTHES. [R.S.F.]

**Cyclopoida** An order of small copepod Crustacea. The abundant fresh-water and salt-water species form an important link in the food chains of aquatic life, consuming tiny plants, animals, and detritus and, in turn, furnishing food for small fish, some large fish, and other organisms. Some species are important intermediate hosts for human parasites.

The front part of the body is oval and sharply separated from the tubular hind end, which bears two caudal rami with distinctly unequal setae (see illustration). Usually 10 body segments are present in the male, and 9 in the female because of fusion of two to form a genital segment.

Cyclopoids are intermediate hosts of the parasitic guinea worm (*Drucunculus medinensis*), and sometimes the fish tapeworm (*Dibothriocephalus latus*). Most fresh-water species live

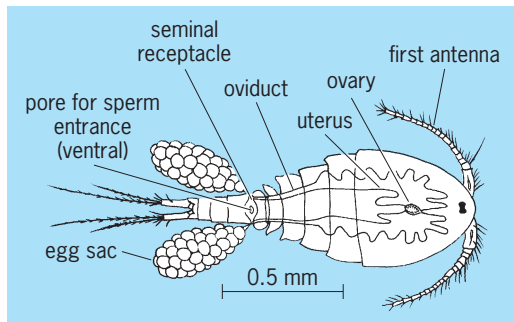

*Cyclops vernalis*, female, dorsal view.

in shallow water, swimming from plant to plant, but salt-water species are generally water-treaders. Food is not secured by filtration, but is seized and eaten with the biting mouthparts. Many species have a world wide distribution. See COPEPODA. [H.C.Y.]

**Cyclostomata (Bryozoa)** An order of bryozoans in the class Stenolaemata. Cyclostomes tend to have delicate colonies composed of relatively isolated, loosely bundled, or tightly packed, comparatively simple, long, slender, and tubular zoecia, with thin, highly porous, calcareous walls. Cyclostome colonies most commonly are small and delicate, but some are moderately large and massive. They may be inconspicuous encrusting threadlike networks, thin encrusting sheets, nodular masses, or erect tufflike, twiglike, or frondlike growths. Individual cyclostome zoecia are straight to slightly curved long tubes. The walls of adjacent zoecia may be either distinctly separate or fused together.

Exclusively marine, cyclostomes (occasionally termed Stenostomata) are known first from the Late Ordovician, when they may possibly have evolved from cystoporates (which were formerly included in the Cyclostomata). Rare and inconspicuous throughout the rest of the Paleozoic and Triassic, cyclostomes became moderately common in Jurassic and Cretaceous seas, but have since (including today) been less numerous. See BRYOZOA; CYSTOPORATA; STENOLAEMATA. [R.J.Cu.]

**Cyclothem** A vertical sequence of several different kinds of distinctive sedimentary rock units that is repeated upward through the stratigraphic succession. Originally defined in the rock succession of Pennsylvanian age in the Illinois Basin in the 1930s, the rock types include coal, limestone, sandstone, and several types of shale and mudstone. Cyclothem were soon recognized elsewhere in rocks of this age in the central and eastern United States. Those in the Midcontinent (Kansas and states to the northeast) are dominated by several types of limestone and shale, with less coal and sandstone. Those in the Appalachian region are dominated by coal, mudstone, shale, and sandstone, with less limestone. One proposed reason for the Pennsylvanian cyclothem is the periodic rise and fall of sea level (eustasy) that was driven by repeated episodes of continental glaciation in the southern continents of that time. See PENNSYLVANIAN; SEDIMENTARY ROCKS; STRATIGRAPHY.

Cyclothem were first noticed in the United States because of the many distinctive rock types involved. These resulted from the interplay between the then tropical to equatorial humid climate with ready access to detrital sand and mud and the marine circulation changes caused by the changing water depth of the sea. Coal-rich cyclothem were soon recognized in strata of the same age in western Europe. Currently, cyclothem without coal are being identified in late Paleozoic strata elsewhere in the world. See PALEOZOIC. [P.H.H.]

**Cyclotron resonance experiments** The measurement of charge-to-mass ratios of electrically charged particles from the frequency of their helical motion in a magnetic field. Such experiments are particularly useful in the case of conducting crystals, such as semiconductors and metals, in which the motions of electrons and holes are strongly influenced by the periodic potential of the lattice through which they move. Under such circumstances the electrical carriers often have "effective masses" which differ greatly from the mass in free space; the effective mass is often different for motion in different directions in the crystal. Cyclotron resonance is also observed in gaseous plasma discharges and is the basis for a class of particle accelerators. See BAND THEORY OF SOLIDS; PARTICLE ACCELERATOR.

Cyclotron resonance is most easily understood as the response of an individual charged particle; but, in practice, the phenomenon involves excitation of large numbers of such particles. Their net response to the electromagnetic radiation may significantly affect the overall dielectric behavior of the material in which they move. Thus, a variety of new wave propagation mechanisms may be observed which are associated with the cyclotron motion, in which electromagnetic energy is carried through the solid by the spiraling carriers. These collective excitations are generally referred to as plasma waves. In general, for a fixed input frequency, the plasma waves are observed to travel through the conducting solid at magnetic fields higher than those required for cyclotron resonance. The most easily observed of these excitations is a circularly polarized wave, known as a helicon, which travels along the magnetic field lines. It has an analog in the ionospheric plasma, known as the whistler mode and frequently detected as radio interference. There is, in fact, a fairly complete correspondence between the resonances and waves observed in conducting solids and in gaseous plasmas. Cyclotron resonance is more easily observed in such low-density systems since collisions are much less frequent there than in solids. In such systems the resonance process offers a means of transferring large amounts of energy to the mobile ions, a necessary condition if nuclear fusion reactions are to occur. See NUCLEAR FUSION; PLASMA (PHYSICS). [W.M.W.]

**Cydippida** The largest order of the phylum Ctenophora, comprising 5 families (Bathycytenidae, Haeckelidae, Lampeidae, Mertensidae, and Pleurobrachiidae) and 11 genera. The body of cydippids is usually globular or cylindrical in shape; sizes range from a few millimeters to about 15 cm (6 in.). Most cydippids are colorless and transparent, but some deep-sea species are pigmented dark red. Adult cydippids retain the larval morphology common to all ctenophores (except Beroida) and are usually thought to be the most primitive order. All forms have two main tentacles. Cydippids catch prey on the outstretched tentacles, contracting them to bring it to the mouth. The well-known genus *Pleurobrachia* is widely distributed in temperate coastal waters and estuaries, where it can be a major predator of copepods and larval fish. Many other species of cydippids occur in oceanic waters, from the surface to mesopelagic depths. See BEROIDA; CTENOPHORA. [L.P.M.]

**Cygnus** The Swan, in astronomy, is a conspicuous northern summer constellation. The five major stars of the group,  $\alpha$ ,  $\gamma$ ,  $\beta$ ,  $\epsilon$ , and  $\delta$ , are arranged in the form of a cross (see illustration). Hence Cygnus is often called the Northern Cross, to distinguish it from the Southern Cross of the constellation Crux. The constellation is represented by a swan with widespread wings flying southward. The bright star Deneb is the tail of the swan; it lies at the head of the cross. Albireo, a beautiful double star of contrasting orange and blue colors, is the head of the swan. The



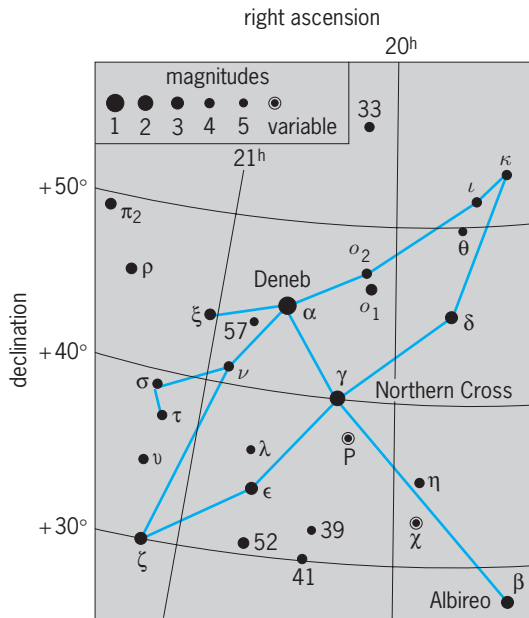

Line pattern of constellation Cygnus. Grid lines represent coordinates of sky. Apparent brightness, or magnitudes, of stars is shown by sizes of "dots," which are graded by appropriate numbers as indicated.

whole constellation lies in, and parallel to, the path of the Milky Way. See CONSTELLATION; CRUX. [C.-S.Y.]

**Cylinder** The solid of revolution obtained by revolving a rectangle about a side is called a cylinder, or more precisely a right circular cylinder. More generally the word cylinder is used in solid geometry to describe any solid bounded by two parallel planes and a portion of a closed cylindrical surface. In analytic geometry, however, the word cylinder refers not to a solid but to a cylindrical surface (see illustration). This is a surface generated



Cylindrical surface.

by a straight line which moves so that it always intersects a given plane curve called the directrix, and remains parallel to a fixed line that intersects the plane of the directrix. Cylinders whose right sections are circles, ellipses, parabolas, or hyperbolas are called circular cylinders, elliptic cylinders, parabolic cylinders, or hyperbolic cylinders, respectively. All these are quadric cylinders. See EUCLIDEAN GEOMETRY. [J.S.F.]

**Cyperales** An order of flowering plants, division Magnoliophyta (Angiospermae), in the subclass Commelinidae of the class Liliopsida (monocotyledons). The names Glumiflorae, Graminales, and Poales have also been used for this order. There are only two families, the Poaceae (Gramineae), with about 8000 species, and the Cyperaceae, with nearly 4000. The Cyperales are Commelinidae with reduced, mostly wind-pollinated or self-pollinated flowers that have a unilocular, two- or three-carpellate

ovary bearing a single ovule. The flowers are arranged in characteristic spikes or spikelets representing reduced inflorescences. The perianth is represented only by a set of bristles or tiny scales, or is completely missing. The leaves generally have a well-defined sheath and a narrow blade, often with a small adaxial appendage (the ligule) at the junction of the two.

The Cyperaceae, or sedge family, includes the bulrushes (*Scirpus*) and the papyrus (*Cyperus papyrus*) of Egypt, as well as the sedges (*Carex*). The Poaceae, or grass family, embraces all true grasses, including bamboos and the cereal grains such as wheat, maize, oats, and rye. The two families differ in a number of more or less consistent technical characters of the inflorescence, fruits, stems, and leaves. See COMMELINIDAE; FLOWER; GRASS CROPS; LILIOPSIDA; MAGNOLIOPHYTA. [A.Cr.; T.M.Ba.]

**Cypress** The true cypress (*Cupressus*), which is very close botanically to the cedars (*Chamaecyparis*). All of the species of *Cupressus* in the United States are western and are found from Oregon to Mexico. The Arizona cypress (*Cupressus arizonica*) of the southwestern United States and the Monterey cypress (*Cupressus macrocarpa*) of California are medium-sized trees and are chiefly of ornamental value. The Italian cypress (*Cupressus sempervirens*) and its varieties are handsome ornamentals, but usually do well only in the southern parts of the United States. Other trees are also called cypress, such as the Port Orford cedar (*Chamaecyparis lawsoniana*) known also as the Lawson cypress, and the Alaska cedar (*Chamaecyparis nootkatensis*), known also as the Nootka cypress or cedar.

The bald cypress (*Taxodium distichum*) is an entirely different tree that is found in the swamps of the South Atlantic and Gulf coastal plains and in the lower Mississippi Valley. The soft needle-like leaves and short branches are deciduous; hence, they drop off in winter and give the tree its common name. Also known as the southern or red cypress, this tree yields a valuable decay-resistant wood used principally for building construction, especially for exposed parts or where a high degree of resistance to decay is required as in ships, boats, greenhouses, railway cars, and railroad ties. See CEDAR; PINALES. [A.H.G./K.P.D.]

**Cypriniformes** An order of actinopterygian fishes which ranks second in size only to the Perciformes. The order Cypriniformes (or Eventognathi) includes the characins, minnows, and their allies. The Weberian apparatus of the Cypriniformes involves only the first four vertebrae. The body is typically invested in cycloid scales, although these are sometimes lost. In further contrast to catfishes, the Cypriniformes have parietal, suboperculum, symplectic, and intercalary bones; they lack a pectoral spine (present in most catfishes); and they have intermuscular bones.

The 8 families of the Cypriniformes, numbering about 3000 species, may be arranged in 3 suborders: Characoidei, Gymnotoidei, and Cyprinoidei. The suborder Characoidei includes the single family Characidae (split by some authors into several smaller families) or characins. They are primarily fresh-water fishes that abound in South America, where they have undergone an extensive adaptive radiation resulting in perhaps 850 species. The Gymnotoidei includes a single family, Gymnotidae, consisting of about 16 genera and perhaps 40 or 45 species that inhabit fresh waters of South and Central America. They are eel-shaped fishes that seem to be capable of producing an electric shock. The electric eel is the largest species. Cyprinoidei includes about 6 families of primarily fresh-water fishes. The Cyprinidae, including minnows and carps, are the largest family of fishes, with about 275 genera and more than 1500 species. The center of abundance and diversity of form of this group is in southeastern Asia. The family is well represented in Africa, Europe, Asia, and North America (about 230 species), but there are none in Central or South America, Madagascar, Australia, or in that part of the East Indies lying east of Lombok.

In the mountainous regions of southeastern Asia are found 3 other small families of the Cyprinoidei: the Homalopteridae, the Gastromyzontidae with 16 genera, and the Gyri-nocheilidae. All are adapted to life in torrential streams. See ACTINOPTERYGII; CARP; EEL; SILURIFORMES. [R.M.B.]

**Cyrtosoma** A subphylum of the Mollusca comprising members of the classes Monoplacophora, Gastropoda, and Cephalopoda. Each class has, in turn, been the most diverse molluscan group. In the Ordovician the cephalopods succeeded the monoplacophorans as the most diverse molluscan class, and they held this position until the close of the Mesozoic. They were followed by the gastropods, which by then had diversified into a great variety of aquatic and terrestrial habitats.

Primitive members of the Cyrtosoma have, or had, a conical univalved shell, often twisted into a spiral. Although primitive cyrtosomes, including the only living shelled cephalopod, *Nautilus*, are shell-bearing animals, many advanced cyrtosomes have either lost or greatly reduced their shells (examples include slugs, nudibranchs, squids, and octopuses). Consequently, it is not any particular shell form which unites all members of the Cyrtosoma; rather, it is a knowledge of their evolutionary history. See CEPHALOPODA; GASTROPODA; MOLLUSCA; MONOPLACOPHORA. [B.Ru.]

**Cystoporata** An extinct order of bryozoans in the class Stenolaemata. Cystoporates tend to have robust colonies composed of relatively simple, long, slender, and tubular zooecia, separated by blisterlike vesicles stacked upon one another. See BRYOZOA; STENOLAEMATA.

Cystoporate colonies range from small and delicate to large and massive; they can be thin encrusting sheets, tubular or nodular masses, or erect twiglike or frondlike growths.

The cystoporates may possibly have evolved from the earliest ctenostomes. Cystoporates first appeared late in the Early Ordovician, somewhat earlier than representatives of other stenolaemate orders; thus, the cystoporates may possibly have in turn given rise to those orders, although all these forms may simply share a common ancestor further back in time. Apparently marine, the cystoporates became moderately common by Mid-Ordovician time—contributing to building small reefs, as well as to level-bottom communities—and remained so until they died out in the latest Permian. See BRYOZOA; STENOLAEMATA. [R.J.Cu.]

**Cytochalasin** A class of lipophilic antibiotics produced by fungi. The cytochalasins elicit in animal and plant cells a puzzling diversity of membrane phenomena. There is evidence that numerous chemicals, including cytochalasins, interact directly with plasma membrane components, modulate activity of membrane-bound enzymes, and often produce changes in membrane structure.

In animals, cytochalasins inhibit cytokinesis, cell movement, and embryonic morphogenesis, as well as intracellular movement such as the transport of melanin granules. In addition, nuclear extrusion is induced; lymphocyte-mediated destruction of target cells is inhibited; and there is selective “pulverization” of certain chromosomes, which are converted to the unraveled, interphase form, while the other chromosomes in the cell remain in the condensed, metaphase form.

In plants, intracellular movements such as cytoplasmic streaming and chloroplast movements are inhibited. Cytochalasins also inhibit root growth and water uptake in onion seedlings; cells become more spherical in shape.

The great value of the cytochalasins as research tools is that they appear to achieve their reversible impact on cell behavior with a minimum of undesirable side effects such as inhibition of respiration or protein synthesis. Cytochalasin is extensively applied as a chemical “scalpel” to enucleate mammalian cells

rapidly, precisely, and efficiently in studies of nuclear-cytoplasmic relations and in cell hybridization and nuclear transplant work. Another major application is in examining the consequences of arrested cytoplasmic movement. [D.D.S.T.]

**Cytochemistry** The science concerned with the chemistry of cells. Specifically, the macromolecules of subcellular structures can be treated chemically to form microscopically visible end products. For example, proteins, enzymes, lipids, carbohydrates, and nucleic acids can be directly visualized in cell nuclei, membranes, and organelles by cytochemical methods which generate images that can be viewed by either bright field or light, fluorescence, confocal, or electron microscopes. See ELECTRON MICROSCOPE; FLUORESCENCE MICROSCOPE; INTERFERENCE MICROSCOPE; PHASE-CONTRAST MICROSCOPE; SCANNING ELECTRON MICROSCOPE.

Enzyme cytochemical methods detect enzymes associated with subcellular structures. The method employs a substrate specifically cleaved by an enzyme in the cell to liberate a product which is transformed into a visible precipitate. For example, to localize the enzyme acid phosphatase in lysosomes, a subcellular organelle, a lead sulfide precipitate is produced by splitting a phosphate (product) from cytidine monophosphate (substrate) and transforming the phosphate product initially into lead phosphate and subsequently into lead sulfide; the latter is visible as a brown-black precipitate in the light microscope. Other methods employ azo dye or formazan precipitates rather than lead to produce a visible product. The number of enzymes that can be detected are limited by the availability and specificity of substrates. See ENZYME.

Immunocytochemical methods are used to detect specific proteins associated with subcellular structures. The methods are based on the immunologic principle of the built-in specificity of antibody-antigen interactions. An antigen in a tissue or a cell is detected by employing either a direct or indirect method. The direct method requires a specific antibody linked to a molecule that produces a visible signal; the antibody-molecule complex is applied to a tissue or cells for antigen binding. The indirect method employs an unlabeled primary antibody which is applied to a tissue or cells. The antibody binds to the antigen. The bound primary antibody is then detected by application of a secondary antibody that yields a visible signal. Second antibodies can be labeled with fluorescent probes, enzymes, metals, and high-affinity complexes that are detectable with the appropriate microscope (such as bright-field light, fluorescence, confocal, and electron), in some cases, after application of other reagents to generate a visible product.

Double or triple label immunocytochemistry methods allow multiple antigens to be localized within a tissue or cells. Multiple antigens can be detected at the same time by using different antibodies labeled with probes that fluoresce at different wavelengths. Multiple antibodies can also be labeled with different enzymes or with different size gold particles. Fluorescent probes are detected with conventional fluorescence microscopy or with confocal microscopy using either appropriate filters or lasers. Enzyme probes and gold probes are detected with light and electron microscopy. See IMMUNOCHEMISTRY; IMMUNOFLUORESCENCE; PROTEIN.

Autoradiographic methods employ radioactive labeled molecules to identify sites within cells where synthesis of macromolecules occurs. This method is based on the property that an isotope emits ionizing particles during radioactive decay. Radioactive labeled precursor molecules (building blocks of molecules) become incorporated into specific cellular sites after injection into living organisms or cells, producing a radioactive product. To establish the location of the radioactive product in tissues or cells, a photographic emulsion is placed over tissues or cells in the dark for a period of time, followed by a photographic developer solution to reveal sites containing the radioactive product. [P.M.N.]

**Cytochrome** Any of a group of proteins that carry as prosthetic groups various iron porphyrins called hemes. Hemes also constitute prosthetic groups for other proteins, but the function of prosthetic groups in the cytochromes is largely restricted to oxidation to the ferric heme, with the iron in the  $3^+$  valence state, and reduction to ferrous heme with a  $2^+$  iron. Thus, by alternate oxidation and reduction the cytochromes can transfer electrons to and from each other and other substances, and can operate in the oxidation of substrates. The energy released in their oxidation reactions is conserved by using it to drive the formation of the energy-rich compound adenosine triphosphate (ATP) from adenosine diphosphate (ADP) and inorganic phosphate. This process of coupling the oxidation of substrates to phosphorylation of ADP is called oxidative phosphorylation. In cells of eukaryotic organisms, the cytochromes have rather uniform properties; they are part of the respiratory chain and are located in the mitochondria. In contrast, prokaryotes exhibit much more varied cytochromes. Cytochromes are found even in metabolic pathways that employ oxidants other than oxygen. See ADENOSINE DIPHOSPHATE (ADP); ADENOSINE TRIPHOSPHATE (ATP); MITOCHONDRIA; PROTEIN.

**Respiratory chain.** There are four cytochromes in the respiratory chain of eukaryotes, termed respectively  $a_3$ ,  $b$ ,  $c$ , and  $c_1$ . Cytochrome  $a_3$ , also called cytochrome oxidase, functions by oxidizing reduced cytochrome  $c$  (ferrocytochrome  $c$ ) to the ferric form. It then transfers the reducing equivalents acquired in this reaction to molecular oxygen, reducing it to water. The cytochrome oxidase reaction is probably the most important reaction in biology since it drives the entire respiratory chain and takes up over 95% of the oxygen employed by organisms, thus providing nearly all of the energy needed for living processes. See RESPIRATION.

The energy released during oxidation is utilized to actively pump protons ( $H^+$ ) from the matrix of the mitochondrion through the inner membrane into the intermembrane space. This creates a proton gradient across the membrane, with the matrix space having a lower proton concentration and the outside having a higher proton concentration. This chemical and potential gradient can be released by allowing protons to flow down the gradient and back into the mitochondrial matrix, thereby driving the formation of ATP. A pair of electrons flowing down the respiratory chain yields three molecules of ATP, a remarkable feat of energy conservation. This is called the chemiosmotic mechanism of oxidative phosphorylation, which is generally considered a true picture of respiratory chain function.

**Cytochrome oxidase.** The cytochrome oxidase of eukaryotes is a very complex protein assembly containing from 8 to 13 polypeptide subunits, two hemes,  $a$  and  $a_3$ , and two atoms of copper. The two hemes are chemically identical but are placed in different protein environments, so that heme  $a$  can accept an electron from cytochrome  $c$  and heme  $a_3$  can react with oxygen. When cytochrome oxidase has accepted four electrons, one from each of four molecules of reduced cytochrome  $c$ , both its hemes and both its copper atoms are in reduced form, and it can transfer the electrons in a series of reactions to a molecule of oxygen to yield two molecules of water.

Cytochrome oxidase straddles the inner membrane of mitochondria, part of it on the matrix side, part within the membrane, and part on the outer surface or cytochrome  $c$  side of the inner membrane. See CELL MEMBRANES.

**Cytochrome  $c$ .** Cytochrome  $c$  is the only protein member of the respiratory chain that is freely mobile in the mitochondrial intermembrane space. It is a small protein consisting of a single polypeptide chain of 104 to 112 amino acid residues, wrapped around a single heme prosthetic group. The cytochromes  $c$  of eukaryotes are all positively charged proteins, with strong dipoles, while the systems from which cytochrome  $c$  accepts electrons, cytochrome reductase, and to which cytochrome  $c$  delivers electrons, cytochrome oxidase, are negatively charged. There is good evidence that this electrostatic arrangement correctly orients cy-

tochrome  $c$  as it approaches the reductase or the oxidase, so that electron transfer can take place very efficiently, even though the surface area at which the reaction occurs is less than 1% of the total surface of the protein.

The amino acid sequences of the cytochromes  $c$  of eukaryotes have been determined for well over 100 different species, from yeast to humans, and have provided some very interesting correlations between protein structure and the evolutionary relatedness of different taxonomic groups. The extensive degree of similarity over the entire range of extant organisms has been taken as evidence that this is an ancient structure, developed long before the divergence of plants and animals, which in the course of its evolutionary descent has been adapted to serve a variety of electron transfer functions in different organisms. See PROTEINS, EVOLUTION OF.

**Cytochrome reductase.** Like cytochrome oxidase, the cytochrome reductase complex is an integral membrane protein system. There are numerous subunits, consisting of two molecules of cytochrome  $b$ , one molecule of a nonheme iron protein, and one molecule of cytochrome  $c_1$ . As in the case of the oxidase, the two cytochrome  $b$  hemes are chemically identical, but are present in somewhat different protein environments. The reductase complex is reduced by reaction with the reduced form of the fat-soluble coenzyme Q, dissolved within the inner mitochondrial membrane, which is itself reduced by the succinate dehydrogenase, the NADH dehydrogenase, and other systems. See COENZYME.

**Other cytochromes.** In addition to the mitochondrial respiratory chain cytochromes, animals have a heme protein, termed cytochrome P450, located in the liver and adrenal gland cortex. In the liver it is part of a mono-oxygenase system that can utilize oxygen and the reduced coenzyme NADPH, to hydroxylate a large variety of foreign substances and drugs and thus detoxify them; in the adrenal it functions in the hydroxylation of steroid precursors in the normal biosynthesis of adrenocortical hormones. See ADRENAL GLAND; LIVER.

Two varieties of cytochrome  $b$ , termed  $b_{563}$  and  $b_{559}$ , and one of cytochrome  $c$ ,  $c_{552}$ , are involved in the photosynthetic systems of plants. Other plant cytochromes occur in specialized tissues and certain species. See BIOLOGICAL OXIDATION; PHOTOSYNTHESIS.

[E.Ma.]

**Cytokine** Any of a group of soluble proteins that are released by a cell to send messages which are delivered to the same cell (autocrine), an adjacent cell (paracrine), or a distant cell (endocrine). The cytokine binds to a specific receptor and causes a change in function or in development (differentiation) of the target cell. Cytokines are involved in reproduction, growth and development, normal homeostatic regulation, response to injury and repair, blood clotting, and host resistance (immunity and tolerance). Unlike cells of the endocrine system, many different types of cells can produce the same cytokine, and a single cytokine may act on a wide variety of target cells. Further, several cytokines may produce the same effect on a target, so the loss of one type of cytokine may have few if any consequences for the organism; this situation is called redundancy. Finally, the response of a target cell may be altered by the context in which it receives a cytokine signal. The context includes other cytokines in the milieu, and extracellular matrix. Thus has developed the concept of cytokines as alphabet letters that combine to spell words which make up a molecular language.

**Types of cytokines.** Cytokines may be divided into six groups: interleukins, colony-stimulating factors, interferons, tumor necrosis factor, growth factors, and chemokines.

Interleukins are proteins that are produced by one type of lymphocyte or macrophage and act on other leukocytes. At least 18 types of this important class, with varying origin and function, exist. Production of interleukins is now known not to be confined to lymphocytes or macrophages.

Colony-stimulating factors are produced by lymphoid and nonlymphoid cells. These factors provide a mechanism whereby cells that are distant from bone marrow can call for different types of hemopoietic progeny. There are also growth-promoting actions of locally produced colony-stimulating factors within the bone marrow to stimulate progenitors to differentiate into macrophages, granulocytes, or colonies containing both cell types.

Interferons classically interfere with the virus replication mechanisms in cells. Interferon- $\alpha$  (produced by leukocytes) and interferon- $\beta$  (produced by fibroblasts) activate cytotoxicity in natural killer cells. Interferon- $\gamma$  also activates natural killer cells, and is a potent activator of macrophages as well.

Tumor necrosis factor- $\alpha$  (TNF- $\alpha$ ) is produced by a variety of cell types, but activated macrophages represent the dominant source. TNF- $\alpha$  activates natural killer cell cytotoxicity, enhances generation of cytotoxic T-lymphocytes, and activates natural killer cells to produce interferon- $\gamma$ . TNF- $\alpha$  also acts on vascular endothelium to promote inflammation and thrombosis. TNF- $\alpha$  may also induce apoptosis in cells such as trophoblasts. TNF- $\beta$  is a product of Th1 T-cells; in addition to providing help in proinflammatory cell-mediated immune responses, these cells produce delayed-type hypersensitivity reactions where macrophages are locally recruited and activated to kill intracellular pathogens, such as certain bacteria. TNF- $\beta$  has interferon-type activity and a narrower spectrum of action than TNF- $\alpha$ .

Transforming growth factors (TGFs) have the ability to promote unrestrained proliferation of cells which otherwise has a benign behavior phenotype. These factors have therefore been implicated in development of cancer. There are two groups of transforming growth factors. TGF- $\alpha$  is a 5-kilodalton peptide produced by a variety of cells and collaborates with TGF- $\beta$ , a 25-kD peptide, in promoting unrestrained tumorlike growth. TGF- $\beta$  has potent pleiotropic effects on a wide variety of tissues and is a potent fibrogenic and immunosuppressive agent.

Chemokines are chemoattractant cytokines of small (7–14 kD) heparin-binding proteins that are subdivided into four families: CXC, CC, C, and CX<sub>3</sub>C. Chemokines are produced by macrophages stimulated by bacterial endotoxins, and control the nature and magnitude of cell infiltration in inflammation.

**Wound healing.** Wound healing is probably the most common phenomenon in which the importance of cytokines is seen. Cytokines ensure that the restorative sequences are carried out in the appropriate order by signaling blood cells and vascular endothelium to coagulate and fill in a wound opening, recruiting and signaling macrophages and neutrophils to engulf microbes, and guiding protective skin epidermal cells to grow over the wounded area. If the damage is more extensive, cytokines stimulate production of new skin cells, blood vessels (angiogenesis), connective tissue, and bone. See CELLULAR IMMUNOLOGY. [D.A.C.]

**Cytokinesis** The physical partitioning of a plant or animal cell into two daughter cells during cell reproduction. There are two modes of cytokinesis: by a constriction (the cleavage furrow in animal cells and some plant cells) or from within by an expanding cell plate (the phragmoplast of many plant cells). In either mode, cytokinesis requires only a few minutes, beginning at variable times after the segregation of chromosomes during mitosis (nuclear division). In the vast majority of cases the resulting daughter cells are completely separated. Since they are necessarily smaller cells as a result of cytokinesis, most cells grow in volume between divisions.

Occasionally, cytokinesis is only partial, permitting nutrients and metabolites to be shared between cells. Should cytokinesis fail to occur at all, mitosis may cause more than one nucleus to accumulate. Such a cell is a syncytium. Some tissues normally contain syncytia, for example, binucleate cells in the liver and multinucleate plant endosperm. Some whole organisms such as slime molds are syncytial.

Cytokinesis is precisely and indispensably linked to mitosis, yet the timing and actual mechanisms are distinct. The plane of cell partitioning is perpendicular to the axis of mitosis and coincides with the plane previously occupied by the chromosomes at metaphase. Despite the reliability of this correlation, the chromosomes themselves are not essential for cytokinesis. Experiments performed upon living cells have shown that it is the cell's machinery for chromosome separation, the mitotic apparatus, that provides the essential positional signal to other parts of the cytoplasm which initiates cytokinesis. Subsequently, the mitotic apparatus is no longer involved in cytokinesis and can be destroyed or even sucked out without affecting cytokinesis. See CHROMOSOME; MITOSIS.

A cleavage furrow develops by circumferential contraction of the peripheral cytoplasm, usually at the cell's equator. The mechanism of furrowing is very similar among a wide diversity of cell types in lower and higher animals and certain plants. The physical forces of contraction exhibited by a cleavage furrow are evidently greater than the forces of resistance elsewhere. Electron microscopic analysis of the peripheral cytoplasm beneath the cleavage furrow consistently reveals a specialization called the contractile ring. This transient cell organelle is composed of numerous long, thin protein fibers oriented circumferentially within the plane of furrowing. These microfilaments are about 5 nanometers in thickness, appear to attach to the cell membrane, and are known to be composed of actin intermixed with myosin. Both of these proteins are intimately involved in force generation in muscle cells. Thus, the present theory of cytokinesis by furrowing implicates the contractile ring as a transient, localized intracellular "muscle" that squeezes the cell in two. See MUSCLE PROTEINS.

In plant cells the dominant mode of cytokinesis involves a phragmoplast, a structure composed of fibrous and vesicular elements that resemble parts of the mitotic apparatus. Microtubules (the fibers) appear to convey a stream of small membranous vesicles toward the midline where they fuse into a pair of partitioning cell membranes. Cellulose cell walls are subsequently secreted between these membranes to solidify the separation between daughter cells. This mode of cytokinesis is well suited to plant cells whose stiff cell walls cannot participate in furrowing. Surprisingly, however, there are instances among the algae where cleavage furrows are the normal mode of cytokinesis. Occasionally, both cleavage furrows and phragmoplasts are employed in the same cell. See CELL WALLS (PLANT); PLANT CELL. [T.E.S.]

**Cytokinins** A group of plant hormones (phytohormones) that, together with other plant hormones, induces plant growth and development. Since the isolation of the first naturally occurring cytokinin, zeatin, from corn seeds in 1961, more than 25 different cytokinins have been isolated from plants. In addition, more than 150 different analogs have been synthesized from kinetin, the first nonplant substance found (in 1954) to stimulate plant cell division.

Oversynthesis of cytokinins in plant tissue causes abnormal growth: crown gall tumor disease caused by the bacterium *Agrobacterium tumefaciens* is an example of excessive production of cytokinins in local tumor tissue. Tissue from crown gall tumors can grow on a simple medium lacking plant hormones because the tumor tissue overproduces both cytokinin and auxin. This is due to the insertion of a piece of bacterial plasmid DNA into the plant nuclear genomes causing activation of the gene responsible for the regulation of cytokinin production. Roots have been shown to be the major site of cytokinin biosynthesis, but stems and leaves are also capable of synthesizing cytokinins. It is possible that all actively dividing cells are capable of cytokinin biosynthesis. See CROWN GALL.

Cytokinins exhibit a wide range of physiological effects when applied externally to plant tissues, organs, and whole plants. Exogenous applications of this hormone induce cell division in tissue culture in the presence of auxin. The formation of roots

or shoots depends on the relative concentrations of auxin and cytokinin added to the culture medium. High auxin and low cytokinin concentrations lead to root formation, while low auxin and high cytokinin concentrations give shoots. Tissue culture techniques have been employed by plant biotechnologists to grow genetically engineered plant cells into whole plants. Cytokinins appear to be necessary for the correlated phenomena of mitosis and nucleic acid synthesis. Cytokinins delay the aging process in detached leaves by slowing the loss of chlorophyll. Cytokinin effects also include breaking of dormancy, promotion of seed germination, stimulation and nutrient mobilization, enhanced anthocyanin and flavanoid synthesis, increased resistance to disease, and stimulation of the opening of stomates. See AUXIN; DORMANCY; PLANT PHYSIOLOGY; TISSUE CULTURE.

The mechanism of action of cytokinin on plant growth and development is poorly understood. It has been demonstrated that specific proteins are induced, enhanced, reduced, or suppressed by the hormone. Some of the enzymes or proteins regulated by cytokinins have been identified. Initial evidence suggests that cytokinins regulate, at least in part, the transcriptional process of gene expression by turning on or off specific genes and stimulating or suppressing the synthesis of specific mRNAs. Another possible action of cytokinins is the regulation of a posttranscriptional process such as stabilization of mRNA. Scientists also demonstrated that cytokinins specifically increase the rate of protein synthesis and the effect seems to be on the translation of mRNA into proteins. See PLANT GROWTH; PLANT HORMONES. [C.M.C.]

**Cytolysis** An important immune function involving the dissolution of certain cells. There are a number of different cytolytic cells within the immune system that are capable of lysing a broad range of cells. The most thoroughly studied of these cells are the cytotoxic lymphocytes, which appear to be derived from different cell lineages and may employ a variety of lytic mechanisms. Cytotoxic cells are believed to be essential for the elimination of oncogenically or virally altered cells, but they can also play a detrimental role by mediating graft rejection or autoimmune disease. There are two issues regarding cytotoxic lymphocytes that are of concern: one is the target structure that is being recognized on the target cell, that is, the cell that is killed, which triggers the response; and the other is the lytic mechanism. See CELLULAR IMMUNOLOGY.

When freshly isolated, large granular lymphocytes from peripheral blood are tested in cytotoxicity assays, they spontaneously lyse certain tumor cells. These cytotoxic cells are called natural killer cells, and they are important mediators of innate immunity as a first line of defense against invading pathogens. They are unique in that no previous sensitization is required for them to kill. It now appears that a number of different receptors on natural killer cells are capable of activating the lytic machinery. Recently, it has been found that these cells also express inhibitory receptors that actually inhibit cell lysis, thus adding another level of complexity to the regulation of cytolysis by these cells.

Another killer cell, called the lymphokine-activated killer cell can lyse any target cell, including cells from freshly isolated tumors, and are employed in cancer therapy. Lymphokine-activated killer cells may also be important in mounting a vigorous response under conditions of extreme immunological stress. Very little is known about the mechanisms by which these cells recognize and lyse the target cell.

The last group of cytotoxic cells is the cytotoxic T lymphocyte. These are T cells that can lyse any target cell in an antigen-specific fashion. That is, as a population they are capable of lysing a wide range of target cells, but an individual cytotoxic T lymphocyte is capable of lysing only those target cells which bear the appropriate antigen. These are truly immune cells in that they require prior sensitization in order to function. These cells are thought to mediate graft rejection, mount responses against

viral infections and intracellular bacterial infections, and play a major role in tumor destruction.

Cytotoxic cell-mediated lysis is divided into three distinct steps. The first step is conjugation, when the killer cell determines if the target cell expresses the appropriate antigen and binds to it via a complex array of adhesion molecules. The second step involves the programming for lysis in which the lytic event is triggered. The third step is the destruction of the target cell.

Direct cell contact between the target cell and the killer cell is absolutely required for initiating the lytic mechanism. Killer cells remain unscathed during the lytic event, suggesting that the killer cell must either employ a unidirectional lytic mechanism or be resistant to the lytic mechanism. Also, when many, but not all, target cells die after cytotoxic T-lymphocyte interaction, nuclear damage with rapid DNA fragmentation precedes detectable plasma membrane damage. See ANTIGEN; HISTOCOMPATIBILITY.

It is becoming clear that cytotoxic lymphocytes employ multiple mechanisms designed to initiate target cell destruction. If cytolysis exists to protect the organism from invading pathogens, there should be redundancies in the system so that, if the pathogen has a mechanism for escaping one cytolytic pathway, alternative mechanisms would still be functional. Two mechanisms are the degranulation of cytolytic granules and the triggering of death receptors found on target cells. In the degranulation mechanism of killing, cytotoxic cells release the contents of cytotoxic granules after specific interaction with the target cell. This results in the leakage of salts, nucleotides, and proteins from the target cell, leading to cell death.

On virtually all cells of the body a number of receptors have been identified that are able to trigger apoptosis when engaged. These receptors are called death receptors. The most studied, and relevant to cytolytic cells, is a receptor called Fas. Fas, when engaged by its ligand (FasL), triggers the caspase cascade leading to the hallmark signs of apoptosis, which include membrane blebbing, chromosomal condensation, nuclear disintegration, DNA fragmentation, and cell death. [H.L.O.; M.M.Ba.]

**Cytomegalovirus infection** A common asymptomatic infection caused by cytomegalovirus, which can produce life-threatening illnesses in the immature fetus and in immunologically deficient subjects.

Cytomegalovirus is a member of the herpesvirus group, which asymptotically infects 50–100% of the normal adult population. Such infections usually take place during the newborn period when the virus can be transmitted from the mother to the baby if the virus is present in the birth canal or in breast milk. Toddlers may also acquire the infection in nurseries. Later in life, the virus may be transmitted by heterosexual or male homosexual activity. After infection, cytomegalovirus remains latent in the body because it cannot be completely eradicated even by a competent immune system. It may be activated and cause illnesses when there is a breakdown of the immune system.

Congenital or transplacental cytomegalovirus infection is also a fairly common event. With rare exceptions, it too is usually asymptomatic. Congenital cytomegalovirus disease results from transplacental transmission of the virus, usually from a mother undergoing initial or primary cytomegalovirus infection, during pregnancy. Its manifestations range from subtle sensory neural hearing loss detectable only later in life, to a fulminating multisystem infection and eventual death of the newborn. This important congenital disease occurs in about 1 in 1000 pregnancies.

The only cytomegalovirus illness clearly described in mature, immunologically normal subjects is cytomegalovirus mononucleosis. This is a self-limited illness like infectious mononucleosis, the main manifestation of which is fever. See INFECTIOUS MONONUCLEOSIS.

Otherwise, cytomegalovirus illnesses are usually seen only when cellular immunity is deficient. They constitute the most important infection problem after bone marrow and organ

transplantations. Manifestations vary from the self-limited cytomegalovirus mononucleosis to more serious organ involvement such as pneumonia, hepatitis, gastrointestinal ulcerations, and widespread dissemination. The virus causing these illnesses may come from activation of the patient's own latent infection, or it may be transmitted from an outside source, usually from latent cytomegalovirus infecting the graft from a donor. See IMMUNOLOGICAL DEFICIENCY; TRANSPLANTATION BIOLOGY.

Cytomegalovirus illnesses are also serious, fairly frequent complications of the acquired immunodeficiency syndrome (AIDS). One reason is that most individuals with human immunodeficiency virus (HIV) infection are already infected with cytomegalovirus. Disease manifestations are similar to what is seen in transplant cases, except they may be more severe. Cytomegalovirus retinitis is a typical problem associated with advanced AIDS. Without treatment, the retina is progressively destroyed such that blindness of one or both eyes is inevitable. See ACQUIRED IMMUNE DEFICIENCY SYNDROME (AIDS).

Cytomegalovirus diseases can be treated with two antivirals, ganciclovir or foscarnet, with varying degrees of success. Cytomegalovirus pneumonia in the bone marrow transplant recipient cannot be cured by antivirals alone because it probably has an immunopathologic component. Cytomegalovirus diseases in persons with AIDS can be contained but not cured by specific treatment. For example, ganciclovir treatment of cytomegalovirus retinitis is effective only as long as maintenance therapy is continued. See ANIMAL VIRUS. [Mo.H.]

**Cytoplasm** That portion of living cells bordered externally by the plasma membrane (cell membrane) and internally by the nuclear envelope. In the terminology of classical cytology, the substance in living cells and in living organisms not compartmentalized into cells was called protoplasm. It was assumed at the time that the protoplasm of various cells was similar in structure and chemistry. Results of research on cell chemistry and ultrastructure after about 1960 showed that each cell type had a recognizably different "protoplasm." Primarily for that reason, the term protoplasm gradually fell into disuse in contemporary biology. The terms cytoplasm and nucleoplasm have been retained and are used descriptively; they are used almost synonymously with the terms cytosome (body of cytoplasm) and nucleus, respectively.

Many cells, especially the single-celled organisms or protists, have regional cytoplasmic differentiation. The outer region is the cortex or ectoplasm, and the inner region is the endoplasm. In many cases the cortical layer is a gel made up of a meshwork of cytoskeletal fibers.

Cytoplasm contains mostly water, from 80 to 97% in different cells, except for spores and other inactive forms of living material, in which water may be present in lesser amounts. The dry mass of cells consists mainly of macromolecules: proteins, carbohydrates, nucleic acids, and lipids associated with membranes. The small molecules present in cells are mainly metabolites or metabolic intermediates. The principal ions other than the hydrogen and hydroxyl ions of water are the cations of potassium, sodium, magnesium, and calcium, and the anions chloride and bicarbonate. Many other elements are present in cytoplasm in smaller amounts. Iron is found in cytochrome pigments in mitochondria; magnesium is present in chlorophyll in chloroplasts; copper, zinc, iodine, bromine, and several other elements are present in trace quantities. See CYTOCHEMISTRY.

Sedimentation of cells by centrifugation shows that organelles and inclusions can be separated from the ground cytoplasm, the fluid phase of the cytoplasm in which they are suspended. The ground cytoplasm in turn has been shown to consist of a cytoskeletal network and the cytosol, the fluid in which the cytoskeleton is bathed. The cytoskeleton consists of several

biopolymers of wide distribution in cells. Microtubules have been observed in electron micrographs of a vast number of different cell types. They consist of the protein tubulin, and are frequently covered by a fuzzy layer of microtubule-associated proteins. See CYTOSKELETON.

In most cells the smaller particles exhibit Brownian motion due to thermal agitation. In some cells lacking extensive cytoskeletal structure, particles can be moved freely around the cell by Brownian motion. In others they are restricted by their surrounding cytoskeletal elements. Particles of various types may also undergo saltatory motions which carry them farther than Brownian motion possibly could. Such excursions result from the interaction of a particle with an element of the cytoskeleton such as one or more microtubules or microfilaments. See CELL (BIOLOGY). [R.D.A.]

**Cytoskeleton** A system of filaments found in the cytoplasm of cells and responsible for the maintenance of and changes in cell shape, cell locomotion, movement of various elements in the cytoplasm, integration of the major cytoplasmic organelles, cell division, chromosome organization and movement, and the adhesion of a cell to a surface or to other cells.

Three major classes of filaments have been resolved on the basis of their diameter and cytoplasmic distribution: actin filaments (or microfilaments) each with an average diameter of 6 nanometers, microtubules with an average diameter of 25 nm, and intermediate filaments whose diameter of 10 nm is intermediate to that of the other two classes. The presence of this system of filaments in all cells, as well as their diversity in structure and cytoplasmic distribution, has been recognized only in the modern period of biology.

A technique that has greatly facilitated the visualization of these filaments, as well as the analysis of their chemical composition, is immunofluorescence applied to cells grown in tissue culture. See IMMUNOFLUORESCENCE.

Actin is the main structural component of actin filaments in all cell types, both muscle and nonmuscle. Actin filaments assume a variety of configurations depending on the type of cell and the state it is in. They extend a considerable distance through the cytoplasm in the form of bundles, also known as stress fibers since they are important in determining the elongated shape of the cell and in enabling the cell to adhere to the substrate and spread out on it. Actin filaments can exist in forms other than straight bundles. In rounded cells that do not adhere strongly to the substrate (such as dividing cells and cancer cells), the filaments form an amorphous meshwork that is quite distinct from the highly organized bundles. The two filamentous states, actin filament bundles and actin filament meshworks, are interconvertible polymeric states of the same molecule. Bundles give the cell its tensile strength, adhesive capability, and structural support, while meshworks provide elastic support and force for cell locomotion.

Microtubules are slender cylindrical structures that exhibit a cytoplasmic distribution distinct from actin filaments. Microtubules originate in structures that are closely associated with the outside surface of the nucleus known as centrioles. The major structural protein of these filaments is known as tubulin. Unlike the other two classes of filaments, microtubules are highly unstable structures and appear to be in a constant state of polymerization-depolymerization. See CENTRIOLE.

Intermediate filaments function as the true cytoskeleton. Unlike microtubules and actin filaments, intermediate filaments are very stable structures. They have a cytoplasmic distribution independent of actin filaments and microtubules. In the intact cell, they anchor the nucleus, positioning it within the cytoplasmic space. During mitosis, they form a filamentous cage around the mitotic spindle which holds the spindle in a fixed place during chromosome movement. [E.L.]

# D

**Dacite** Aphanitic (very finely crystalline or glassy) rock of volcanic origin, composed chiefly of sodic plagioclase (oligoclase or andesine) and free silica (quartz or tridymite) with subordinate dark-colored (mafic) minerals (biotite, amphibole, or pyroxene). If alkali feldspar exceeds 5% of the total feldspar, the rock is a quartz latite. As quartz decreases in abundance, dacite passes into andesite. Thus, dacite is roughly intermediate between andesite and quartz latite. *See* ANDESITE. [C.A.C.]

**D'Alembert's paradox** A theorem in fluid mechanics which states that no forces act on a body moving at constant velocity in a straight line through a large mass of incompressible, inviscid fluid which was initially at rest (or in uniform motion). This seemingly paradoxical theorem can be understood by first realizing that inviscid fluids do not exist. If such fluids did exist, there would be no internal physical mechanism for dissipating energy into heat; hence there could be no force acting on the body, because work would then be done on the fluid with no net increase of energy in the fluid. *See* FLUID FLOW. [A.E.Br.]

**D'Alembert's principle** The principle that the resultant of the external forces  $\mathbf{F}$  and the kinetic reaction acting on a body equals zero. The kinetic reaction is defined as the negative of the product of the mass  $m$  and the acceleration  $\mathbf{a}$ . The principle is therefore stated as  $\mathbf{F} - m\mathbf{a} = 0$ . While D'Alembert's principle is merely another way of writing Newton's second law, it has the advantage of changing a problem in kinetics into a problem in statics. The techniques used in solving statics problems may then provide relatively simple solutions to some problems in dynamics; D'Alembert's principle is especially useful in problems involving constraints. *See* CONSTRAINT. [P.W.S.]

**Dalitz plot** Pictorial representation in high-energy nuclear physics for data on the distribution of certain three-particle configurations. Many elementary-particle decay processes and high-energy nuclear reactions lead to final states consisting of three particles (which may be denoted by  $a, b, c$ , with mass values  $m_a, m_b, m_c$ ). Well-known examples are provided by the  $K$ -meson decay processes, Eqs. (1) and (2), and by the  $K^-$  and  $\bar{K}$ -meson reactions with hydrogen, Eqs. (3) and (4). For definite total

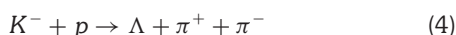
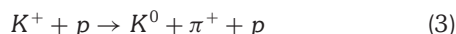
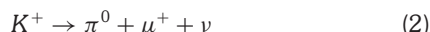
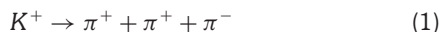

energy  $E$  (measured in the barycentric frame), these final states have a continuous distribution of configurations, each specified by the way this energy  $E$  is shared among the three particles. (The barycentric frame is the reference frame in which the observer finds zero for the vector sum of the momenta of all the particles of the system considered.) *See* ELEMENTARY PARTICLE.

If the three particles have kinetic energies  $T_a, T_b$ , and  $T_c$  (in the barycentric frame), Eq. (5) is obtained. As shown in the illustra-

$$T_a + T_b + T_c = E - m_a c^2 - m_b c^2 - m_c c^2 = Q \quad (5)$$

tion, this energy sharing may be represented uniquely by a point

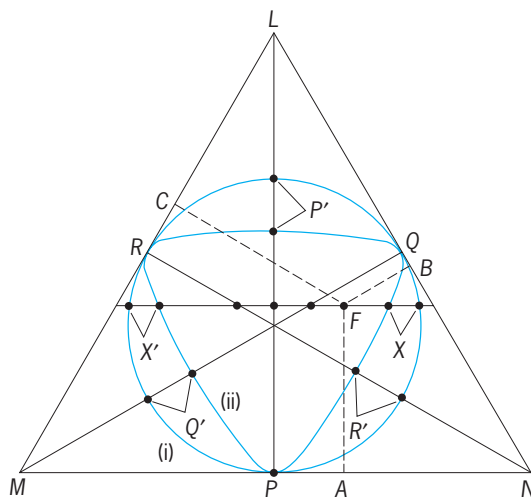

Configuration of a three-particle system ( $abc$ ) in its barycentric frame is specified by a point  $F$  such that the three perpendiculars  $FA, FB$ , and  $FC$  to the sides of an equilateral triangle  $LMN$  (of height  $Q$ ) are equal in magnitude to the kinetic energies  $T_a, T_b, T_c$ , where  $Q$  denotes their sum.

$F$  within an equilateral triangle  $LMN$  of side  $2Q/\sqrt{3}$ , such that the perpendiculars  $FA, FB$ , and  $FC$  to its sides are equal in magnitude to the kinetic energies  $T_a, T_b$ , and  $T_c$ . The most important property of this representation is that the area occupied within this triangle by any set of configurations is directly proportional to their volume in phase space.

Not all points  $F$  within the triangle  $LMN$  correspond to configurations realizable physically, since the  $a, b, c$  energies must be consistent with zero total momentum for the three-particle system. With nonrelativistic kinematics and with equal masses  $m$  for  $a, b, c$ , the only allowed configurations are those corresponding to points  $F$  lying within the circle inscribed within the triangle, shown as (i) in the illustration. More generally, with relativistic kinematics, the limiting boundary is distorted as illustrated by the boundary curve (ii), drawn for the  $\omega \rightarrow 3\pi$  decay process, where the final masses are equal. [R.H.D.]

**Dallis grass** A general term for a genus of grasses of which the most important species is the deeply rooted perennial *Paspalum dilatatum*. Dallis grass is widely used in the southern United States, mostly for pasture, and remains productive indefinitely if well managed. Dallis grass does best on fertile soils and responds to lime and fertilizer. On heavier soils it remains green throughout the winter unless checked by heavy frosts. Ergot-bearing seed heads are very toxic to livestock, and Dallis grass must be so managed as to prevent consumption of infected heads by livestock. *See* CYPERALES; ERGOT. [H.B.S.]

**Dalton's law** The total pressure of a mixture of gases is the sum of the partial pressures of each gas in the mixture. The law was established by John Dalton (1766–1844). In his original formulation, the partial pressure of a gas is the pressure of the

gas if it alone occupied the container at the same temperature. Dalton's law may be expressed as  $P = P_A + P_B + \dots$ , where  $P_J$  is the partial pressure of the gas  $J$ , and  $P$  is the total pressure of the mixture; this formulation is strictly valid only for mixtures of ideal gases. For real gases, the total pressure is not the sum of the partial pressures (except in the limit of zero pressure) because of interactions between the molecules.

In modern physical chemistry the partial pressure is defined as  $P_J = x_J P$ , where  $x_J$  is the mole fraction of the gas  $J$ , the ratio of its amount in moles to the total number of moles of gas molecules present in the mixture. With this definition, the total pressure of a mixture of any kind of gases is the sum of their partial pressures. However, only for an ideal gas is the partial pressure (as defined here) the pressure that the gas would exert if it alone occupied the container. See GAS; KINETIC THEORY OF MATTER; THERMODYNAMIC PRINCIPLES. [P.W.A.]

**Dam** A barrier or structure across a stream, river, or waterway for the purpose of confining and controlling the flow of water. Dams vary in size from small earth embankments for farm use to high, massive concrete structures for water supply, hydropower, irrigation, navigation, recreation, sedimentation control, and flood control. As such, dams are cornerstones in the water resources development of river basins. Dams are now built to serve several purposes and are therefore known as multipurpose. The construction of a large dam requires the relocation of existing highways, railroads, and utilities from the river valley to elevations above the reservoir. The two principal types of dams are embankment and concrete. Appurtenant structures of dams include spillways, outlet works, and control facilities; they may also include structures related to hydropower and other project purposes. See ELECTRIC POWER GENERATION; IRRIGATION (AGRICULTURE); WATER SUPPLY ENGINEERING.

Dams are built for specific purposes. In ancient times, they were built only for water supply or irrigation. Early in the development of the United States, rivers were a primary means of transportation, and therefore navigation dams with locks were constructed on the major rivers. Dams have become more complex to meet large power demands and other needs of modern countries.

In addition to the standard impounded reservoir and the appurtenant structures of a dam (spillway, outlet works, and control facility), a dam with hydropower requires a powerhouse, penstocks, generators, and switchyard. The inflow of water into the reservoir must be monitored continuously, and the outflow must be controlled to obtain maximum benefits. Under normal operating conditions, the reservoir is controlled by the outlet works, consisting of a large tunnel or conduit at stream level with control gates. Under flood conditions, the reservoir is maintained by both the spillway and outlet works. See RESERVOIR.

All the features of a dam are monitored and operated from a control room. The room contains the necessary monitors, controls, computers, emergency equipment, and communications systems to allow project personnel to operate the dam safely under all conditions. Standby generators and backup communications equipment are necessary to operate the gates and other reservoir controls in case of power failure. Weather conditions, inflow, reservoir level, discharge, and downstream river levels are also monitored. In addition, the control room monitors instrumentation located in the dam and appurtenant features that measures their structural behavior and physical condition.

All dams are designed and constructed to meet specific requirements. First, a dam should be built from locally available materials when possible. Second, the dam must remain stable under all conditions, during construction, and ultimately in operation, both at the normal reservoir operating level and under all flood and drought conditions. Third, the dam and foundation must be sufficiently watertight to control seepage and maintain the desired reservoir level. Finally, it must have sufficient spill-

way and outlet works capacity as well as freeboard to prevent floodwater from overtopping it.

Dams are classified by the type of material from which they are constructed. In early times, the materials were earth, large stones, and timber, but as technology developed, other materials and construction procedures were used. Most modern dams fall into two categories: embankment and concrete. Embankment dams are earth or rock-fill; other gravity dams and arch and buttress dams are concrete. See ARCH; CONCRETE.

The type of dam for a particular site is selected on the basis of technical and economic data and environmental considerations. In the early stages of design, several sites and types are considered. Drill holes and test pits at each site provide soil and rock samples for testing physical properties. In some cases, field pumping tests are performed to evaluate seepage potential. Preliminary designs and cost estimates are prepared and reviewed by hydrologic, hydraulic, geotechnical, and structural engineers, as well as geologists. Environmental quality of the water, ecological systems, and cultural data are also considered in the site-selection process.

Factors that affect the type are topography, geology, foundation conditions, hydrology, earthquakes, and availability of construction materials. The foundation of the dam should be as sound and free of faults as possible. Narrow valleys with shallow sound rock favor concrete dams. Wide valleys with varying rock depths and conditions favor embankment dams. Earth dams are the most common type. See ENGINEERING GEOLOGY; FAULT AND FAULT STRUCTURES.

The designers of a dam must consider the stream flow around or through the damsite during construction. Stream flow records provide the information for use in determining the largest flood to divert during the selected construction period. One common practice for diversion involves constructing the permanent outlet works, which may be a conduit or a tunnel in the abutment, along with portions of the dam adjacent to the abutments, in the first construction period. The stream is diverted into the outlet works by a cofferdam high enough to prevent overtopping during construction. A downstream cofferdam is also required to keep the damsite dry. See COFFERDAM.

Personnel responsible for operation and maintenance of the dam are familiar with the operating instructions and maintenance schedule. A schedule is established for collection and reporting of data for climatic conditions, rainfall, snow cover, stream flows, and water quality of the reservoir, as well as the downstream reaches. All these data are evaluated for use in reservoir regulation. Another schedule is established for the collection of instrumentation data used to determine the structural behavior and physical condition of the dam. These data are evaluated frequently. Routine maintenance and inspection of the dam and appurtenant structures are ongoing processes. The scheduled maintenance is important to preserve the integrity of the mechanical equipment.

The frequency with which instrumentation data are obtained is an extremely important issue and depends on operating conditions. Timely collection and evaluation of data are critical for periods when the loading changes, such as during floods and after earthquakes. Advances in applications of remote sensing to instrumentation have made real-time data collection possible. This is a significant improvement for making dam safety evaluations.

Throughout history there have been instances of dam failure and discharge of stored water, sometimes causing considerable loss of life and great damage to property. Failures have generally involved dams that were designed and constructed to engineering standards acceptable at the time. Most failures have occurred with new dams, within the first five years of operation. [A.H.Wa.]

**Damping** A term broadly used to denote either the dissipation of energy in, and the consequent decay of, oscillations of all types or the extent of the dissipation and decay. The energy



losses arise from frictional (or analogous) forces which are unavoidable in any system or from the radiation of energy to space or to other systems. For sufficiently small oscillations, the analogous forces are proportional to the velocity of the vibrating member and oppositely directed thereto; the ratio of force to velocity is  $-R$ , the mechanical resistance. For the role of damping in the case of forced oscillations, where it is decisive for the frequency response, see FORCED OSCILLATION; RESONANCE (ACOUSTICS AND MECHANICS). See also HARMONIC MOTION; MECHANICAL VIBRATION; OSCILLATION; VIBRATION.

An undamped system of mass  $m$  and stiffness  $s$  oscillates at an angular frequency  $\omega_0 = (s/m)^{1/2}$ . The effect of a mechanical resistance  $R$  is twofold: It produces a change in the frequency of oscillation, and it causes the oscillations to decay with time. If  $u$  is one of the oscillating quantities (displacement, velocity, acceleration) of amplitude  $A$ , then Eq. (1) holds in the damped case, whereas in the undamped case Eq. (2) holds. The reciprocal time

$$u = Ae^{-\alpha t} \cos \omega_d t \quad (1)$$

$$u = A \cos \omega_0 t \quad (2)$$

$1/\alpha$  in Eq. (1) may be called the damping constant.

The damped angular frequency  $\omega_d$  in Eq. (1) is always less than  $\omega_0$ . According to Eq. (1), the amplitude of the oscillation decays exponentially; the time required for the amplitude to decrease to the fraction  $1/e$  of its initial value is equal to  $1/\alpha$ .

A common measure of the damping is the logarithmic decrement  $\delta$ , defined as the natural logarithm of the ratio of two successive maxima of the decaying sinusoid. If  $T$  is the period of the oscillation, then Eq. (3) holds. Then  $1/\delta$  is the number of cycles

$$\delta = \alpha T \quad (3)$$

required for the amplitude to decrease by the factor  $1/e$  in the same way that  $1/\alpha$  is the time required.

The  $Q$  of a system is a measure of damping usually defined from energy considerations. The  $Q$  is  $\pi$  times the ratio of peak energy stored to energy dissipated per cycle and is equal to  $\pi/\delta$ .

If  $\alpha$  in Eq. (1) exceeds  $\omega_0$ , then the system is not oscillatory and is said to be overdamped. If the mass is displaced, it returns to its equilibrium position without overshoot, and the return is slower as the ratio  $\alpha/\omega_0$  increases. If  $\alpha = \omega_0$  (that is,  $Q = 1/2$ ), the oscillator is critically damped. In this case, the motion is again nonoscillatory, but the return to equilibrium is faster than for any overdamped case. [M.Gr.]

**Daphniphyllales** An order of flowering plants, division Magnoliophyta (Angiospermae), in the subclass Hamamelidae of the class Magnoliopsida (dicotyledons). The order consists of a single family with but one genus, *Daphniphyllum*, containing about 35 species. All are dioecious trees or shrubs native to eastern Asia and the Malay region. The plants produce a unique type of alkaloid (daphniphylline group); they often accumulate aluminum and sometimes produce iridoid compounds. The leaves are simple and entire, alternate or sometimes closely clustered at the ends of the branches. The flowers are small and inconspicuous, unisexual, regular, and hypogynous. Usually there are 2–6 sepals, or sometimes the sepals are absent; petals are lacking. *Daphniphyllum* has sometimes been included in the Euphorbiales of the subclass Rosidae, but structural details such as the very tiny embryo make it highly aberrant there. See HAMAMELIDAE; MAGNOLIOPSIDA; PLANT KINGDOM. [T.M.Ba.]

**Dark current** An ambiguous term used in connection with both gaseous-discharge devices and photoelectric cells or tubes. In gaseous-conduction tubes it refers to the region of operation known as the Townsend discharge. When applied to photoelectric devices, the term refers to background current. This is current which may be present as the result of thermionic emission or other effects when there is no light incident on the photosen-

sitive cathode. See ELECTRICAL CONDUCTION IN GASES; TOWNSEND DISCHARGE. [G.H.M.]

**Darmstadtium** The eighteenth of the synthetic transuranium elements. Element 110 should be a heavy homolog of the elements platinum, palladium, and nickel (group 10). It is the eighth element in the 6d shell. The various isotopes of element 110 have been reliably documented by the observation of at least two atoms with half-lives in the range of milliseconds, a time too short for the application of chemical methods, verifying its position in the periodic system. See HALF-LIFE; NICKEL; PALLADIUM; PERIODIC TABLE; PLATINUM; RADIOISOTOPE.

Searches for this element began in 1985. With the finding of the isotope  $^{269}110$  (the isotope of element 110 with mass number 269) in late 1994 at Gesellschaft für Schwerionenforschung (GSI), Darmstadt, Germany, its discovery became conclusive.

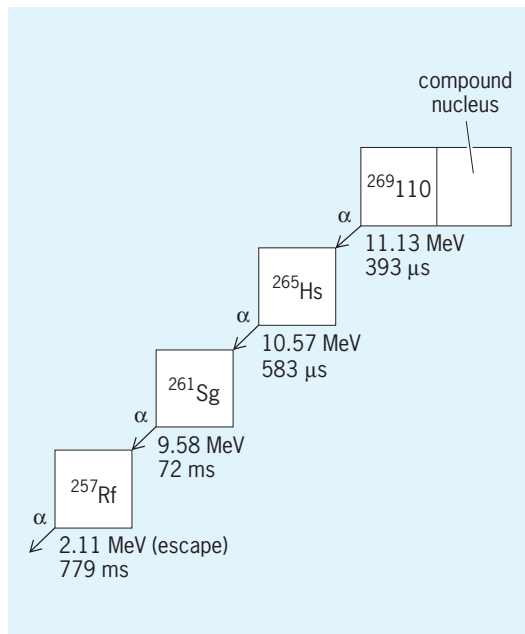

Sequence of decay chains that document the discovery of element 110. Numbers below boxes are alpha energies and correlation times. Element 110 is produced in the reaction  $^{62}\text{Ni} + ^{208}\text{Pb} \rightarrow ^{269}110 + 1n$ .

After an extensive search for the optimum bombarding energy on November 9, 1994, a decay chain was observed which proved the existence of the isotope  $^{269}110$ . The isotopes were produced in a fusion reaction of a nickel-62 projectile with a lead-208 target nucleus. The fused system, with an excitation energy of 13 MeV, cooled down by emitting one neutron and forming  $^{269}110$ , which by sequential alpha decays transformed to hassium-265, seaborgium-261, rutherfordium-257, and nobelium-253. All of these daughter isotopes were already known, and four decay chains observed in the following 12 days corroborated without any doubt the discovery of the element. The illustration shows the first decay chain observed, which ended in  $^{257}\text{Rf}$ . The isotope  $^{269}110$  has a half-life of 0.2 ms, and is produced with a cross section of about  $3 \times 10^{-36} \text{ cm}^2$ . See ALPHA PARTICLES; NEUTRON; NUCLEAR STRUCTURE; RUTHERFORDIUM. [PAr.]

**Dasheen** Common name for the plant *Colocasia esculenta*, including the variety *antiquorum* (taro). These plants are among the few edible members of the aroid family (Araceae). Native to southeastern Asia and Malaysia, the plants supply the people with their most important food. A main dish in the Polynesian menu is poi, a thin, pasty gruel of taro starch, often fermented, which is frequently formed into cakes for baking or toasting. The

raw corms (underground stems) are baked or boiled to eliminate an irritating substance present in the cells. See ARALES.

[P.D.St./E.L.C.]

**Dasycladales** An order of green algae (Chlorophyceae) in which the plant body (thallus) is composed of a nonseptate axis, attached by rhizoids and bearing whorls of branches. The walls utilize a partially crystalline mannan (polymer of mannose) as the skeletal component and usually are impregnated with aragonite, a form of calcium carbonate, causing these algae to be easily fossilized. Among green algae, only the Dasycladales have a fossil record sufficient to permit meaningful phylogenetic speculation. About 140 extinct genera have been described from limestones as old as the Ordovician, with three peaks of abundance and diversity—Carboniferous, Jurassic-Cretaceous, and Eocene. Only about 11 genera comprising 50 species are extant, with 3 of the genera extending from the Cretaceous. All are confined to warm marine waters except *Batophora*, which occurs as a relict in brackish sinkholes in New Mexico in addition to having a normal Caribbean distribution.

The extant Dasycladales are usually placed in a single family, Dasycladaceae, but those forms in which fertile and sterile whorls alternate or only one fertile whorl is produced may be segregated as the Acetabulariaceae (or Polyphysaceae). See ALGAE; CHLOROPHYCEAE.

[P.C.Si.; R.L.Moe]

**Data communications** The conveyance of information from a source to a destination. Data means the symbolic representation of information, generally in a digital (that is, discrete) form. (Analog information refers to information encoded according to a continuous physical parameter, such as the height or amplitude of a waveform, while digital information is encoded into a discrete set of some parameter.) Usually, this digital information is composed of a sequence of binary digits (ones and zeros), called bits. The binary system is used because its simplicity is universally recognizable and because digital data have greater immunity to so-called noise than analog information and allow flexible processing of the information. Groups of eight bits create a data byte or character. These characters make up the so-called alphabets (including alphabetic, numeric, and special symbols) which are used in data communications. The most common data sources and destinations are computers and computer peripherals, and the data represent groups of characters to form text, hypertext (text organized according to topic rather than linear sequence), or multimedia information, including audio, graphics, animation, and video information. See BIT; COMPUTER; COMPUTER GRAPHICS; COMPUTER PERIPHERAL DEVICES; DIGITAL COMPUTER; MULTIMEDIA TECHNOLOGY.

Data communications may be accomplished through two principal functions, data transmission and data switching.

Data transmission always involves at least three elements: a source of the information, a channel for the transmission of the information, and a destination for the information. In addition, sometimes the data are encoded. The codes can be used for error detection and correction, compression of the digital data, and so forth. See DATA COMPRESSION.

The communications channel is carried over a transmission medium. Such media can be wired, as in the cases of twisted-pair telephone wires, coaxial cables, or fiber-optic cables, or they can be wireless, where the transmission is not confined to any physical medium, such as in radio, satellite, or infrared optical transmission. Sometimes, even when the source of the information is digital, the transmission medium requires analog signaling, and modems (modulators-demodulators) are required to convert the digital signals to analog, and vice versa. For example, data communication between personal computers transmitted over telephone lines normally uses modems. See COAXIAL CABLE; COMMUNICATIONS CABLE; COMMUNICATIONS SATELLITE; MODEM; OPTICAL COMMUNICATIONS; OPTICAL FIBERS; RADIO; TELEPHONE SERVICE.

The directionality of the information can be either one-way (simplex communications) or two-way. Two-way communications can be either half-duplex (information goes both ways over the communications link, but not at the same time) or full-duplex (information goes both ways at the same time).

The data channel can be a serial channel, in which the bits are transmitted one after another across a single physical connection; or a parallel channel, in which many bits are transmitted simultaneously (for instance, over parallel wires). Generally, parallel channels are used for short-distance links (less than 300 ft or 100 m), whereas serial links are used for larger distances and high data rates.

At low data rates (less than a few hundred kilobits per second) communications channels are typically dedicated, whereas at higher data rates, because of the cost of high-speed transmitters and receivers, shared channels are used by multiplexing the data streams. For example, two independent data streams with constant data rates of 10 megabits per second (Mb/s) could use a shared channel having a data-rate capability of 20 Mb/s. The multiplexing system would select one bit from each of the two channels to time-multiplex the data together. See MULTIPLEXING AND MULTIPLE ACCESS.

In many cases, the source, the destination, and the path taken by the data may vary; thus switching is required.

The two primary types of switching employed in data communications are circuit switching and packet switching. In circuit-switched data communications, an end-to-end connection is established prior to the actual transmission of the data and the communications channel is open (whether or not it is in use) until the connection is removed.

A packet is a group of data bytes which represents a specific information unit with a known beginning and end. The packet can be formed from either a fixed or variable number of bytes. Some of these bytes represent the information payload, while the rest represent the header, which contains address information to be used in routing the packet. In packet switching, unlike circuit switching, the packets are sent only when information transmission is required. The channel is not used when there is no information to be sent. Sharing the channel capacity through multiplexing is natural for packet-switched systems. Furthermore, the packet switches allow for temporary loading of the network beyond the transmission capacity of the channel. This information overload is stored (buffered) in the packet switches and sent on when the channel becomes available.

In order to transfer information from a sender to a receiver, a common physical transmission protocol must be used. Protocols can range from very simple to quite complex. The Open Systems Interconnect (OSI) model, developed by the International Standards Organization, reduces protocol complexity by breaking the protocol into smaller functional units which operate in conjunction with similar functional units at a peer-to-peer level. Each layer performs functions for the next higher layer by building on the functions provided by the layer below. The advantage of performing communications based on this model is that at the application layers (user processes) there is no concern with the communications mechanisms. See ELECTRICAL COMMUNICATIONS; INTEGRATED SERVICES DIGITAL NETWORK (ISDN); PACKET SWITCHING; SWITCHING SYSTEMS (COMMUNICATIONS); TELEPROCESSING.

[M.S.Go.]

**Data compression** The process of transforming information from one representation to another, smaller representation from which the original, or a close approximation to it, can be recovered. The compression and decompression processes are often referred to as encoding and decoding. Data compression has important applications in the areas of data storage and data transmission. Besides compression savings, other parameters of concern include encoding and decoding speeds and workspace requirements, the ability to access and decode partial files, and error generation and propagation.

The data compression process is said to be lossless if the recovered data are assured to be identical to the source; otherwise the compression process is said to be lossy. Lossless compression techniques are requisite for applications involving textual data. Other applications, such as those involving voice and image data, may be sufficiently flexible to allow controlled degradation in the data.

Data compression techniques are characterized by the use of an appropriate data model, which selects the elements of the source on which to focus; data coding, which maps source elements to output elements; and data structures, which enable efficient implementation.

Information theory dictates that, for efficiency, fewer bits be used for common events than for rare events. Compression techniques are based on using an appropriate model for the source data in which defined elements are not all equally likely. The encoder and the decoder must agree on an identical model. See INFORMATION THEORY.

A static model is one in which the choice of elements and their assumed distribution is invariant. For example, the letter "e" might always be assumed to be the most likely character to occur. A static model can be predetermined with resulting unpredictable compression effect, or it can be built by the encoder by previewing the entire source data and determining element frequencies. The benefits of using a static model include the ability to decode without necessarily starting at the beginning of the compressed data.

An alternative dynamic or adaptive model assumes an initial choice of elements and distribution and, based on the beginning part of the source stream that has been processed prior to the datum presently under consideration, progressively modifies the model so that the encoding is optimal for data distributed similarly to recent observations. Some techniques may weight recently encountered data more heavily. Dynamic algorithms have the benefit of being able to adapt to changes in the ensemble characteristics. Most important, however, is the fact that the source is considered serially and output is produced directly without the necessity of previewing the entire source.

In a simple statistical model, frequencies of values (characters, strings, or pixels) determine the mapping. In the more general context model, the mapping is determined by the occurrence of elements, each consisting of a value which has other particular adjacent values. For example, in English text, although generally "u" is only moderately likely to appear as the "next" character, if the immediately preceding character is a "q" then "u" would be overwhelmingly likely to appear next.

The use of a model determines the intended sequence of values. An additional mapping via one coding technique or a combination of coding techniques is used to determine the actual output. Several data coding techniques are in common use.

[D.S.Hi.]

**Digitized audio and video signals.** The information content of speech, music, and television signals can be preserved by periodically sampling at a rate equal to twice the highest frequency to be preserved. This is referred to as Nyquist sampling. However, speech, music, and television signals are highly redundant, and use of simple Nyquist sampling to code them is inefficient. Reduction of redundancy and application of more efficient sampling results in compression of the information rate needed to represent the signal without serious impairment to the quality of the remade source signal at a receiver. For speech signals, redundancy evident in pitch periodicity and in the format (energy-peaks) structure of the signal's spectrum along with aural masking of quantizing noise is used to compress the information rate. In music, which has much wider bandwidth than speech and far less redundancy, time-domain masking and frequency-domain masking are principally used to achieve compression. For television, redundancy evident in the horizontal and vertical correlation of the pixels of individual frames and in the frame-to-frame correlation of a moving

picture, combined with visual masking that obscures quantizing noise resulting from the coding at low numbers of bits per sample, is used to achieve compression. See SPEECH; TELEVISION.

Compression techniques may be classified into two types: waveform coders and parametric coders. Waveform coders replicate a facsimile of a source-signal waveform at the receiver with a level of distortion that is judged acceptable. Parametric coders use a synthesizer at the receiver that is controlled by signal parameters extracted at the transmitter to remake the signal. The latter may achieve greater compression because of the information content added by the synthesizer model at the receiver.

Waveform compression methods include adaptive differential pulse-code modulation (ADPCM) for speech and music signals, audio masking for music, and differential encoding and sub-Nyquist sampling of television signals. Parametric encoders include vocoders for speech signals and encoders using orthogonal transform techniques for television. [S.J.C.]

**Data mining** The development of computational algorithms for the identification or extraction of structure from data. This is done in order to help reduce, model, understand, or analyze the data. Tasks supported by data mining include prediction, segmentation, dependency modeling, summarization, and change and deviation detection. Database systems have brought digital data capture and storage to the mainstream of data processing, leading to the creation of large data warehouses. These are databases whose primary purpose is to gain access to data for analysis and decision support. Traditional manual data analysis and exploration requires highly trained data analysts and is ineffective for high dimensionality (large numbers of variables) and massive data sets. See DATABASE MANAGEMENT SYSTEM.

A data set can be viewed abstractly as a set of records, each consisting of values for a set of dimensions (variables). While data records may exist physically in a database system in a schema that spans many tables, the logical view is of concern here. Databases with many dimensions pose fundamental problems that transcend query execution and optimization. A fundamental problem is query formulation: How is it possible to provide data access when a user cannot specify the target set exactly, as is required by a conventional database query language such as SQL (Structured Query Language)? Decision support queries are difficult to state. For example, which records are likely to represent fraud in credit card, banking, or telecommunications transactions? Which records are most similar to records in table A but dissimilar to those in table B? How many clusters (segments) are in a database and how are they characterized? Data mining techniques allow for computer-driven exploration of the data, hence admitting a more abstract model of interaction than SQL permits.

Data mining techniques are fundamentally data reduction and visualization techniques. As the number of dimensions grows, the number of possible combinations of choices for dimensionality reduction explodes. For an analyst exploring models, it is infeasible to go through the various ways of projecting the dimensions or selecting the right subsamples (reduction along columns and rows). Data mining is based on machine-based exploration of many of the possibilities before a selected reduced set is presented to the analyst for feedback. [U.F.]

**Data reduction** The transformation of information, usually empirically or experimentally derived, into corrected, ordered, and simplified form.

The term data reduction generally refers to operations on either numerical or alphabetical information digitally represented, or to operations which yield digital information from empirical observations or instrument readings. In the latter case data reduction also implies conversion from analog to digital form either by human reading and digital symbolization or by mechanical means. See ANALOG-TO-DIGITAL CONVERTER; DIGITAL COMPUTER.

In applications where the raw data are already digital, data reduction may consist simply of such operations as editing, scaling, coding, sorting, collating, and tabular summarization.

More typically, the data reduction process is applied to readings or measurements involving random errors. These are the indeterminate errors inherent in the process of assigning values to observational quantities. In such cases, before data may be coded and summarized, the most probable value of a quantity must be determined. Provided the errors are normally distributed, the most probable (or central) value of a set of measurements is given by the arithmetic mean or, in the more general case, by the weighted mean. See STATISTICS.

Data reduction may also involve operations of smoothing and interpolation, because the results of observations and measurements are always given as a discrete set of numbers, while the phenomenon being studied may be continuous in nature.

[R.J.Ne.]

**Data structure** A means of storing a collection of data. Computer science is in part the study of methods for effectively using a computer to solve problems, or in other words, determining exactly the problem to be solved. This process entails (1) gaining an understanding of the problem; (2) translating vague descriptions, goals, and contradictory requests, and often unstated desires, into a precisely formulated conceptual solution; and (3) implementing the solution with a computer program. This solution typically consists of two parts: algorithms and data structures.

**Relation to algorithms.** An algorithm is a concise specification of a method for solving a problem. A data structure can be viewed as consisting of a set of algorithms for performing operations on the data it stores. Thus algorithms are part of what constitutes a data structure. In constructing a solution to a problem, a data structure must be chosen that allows the data to be operated upon easily in the manner required by the algorithm.

Data may be arranged and managed at many levels, and the variability in algorithm design generally arises in the manner in which the data for the program are stored, that is (1) how data are arranged in relation to each other, (2) which data are calculated as needed, (3) which data are kept in memory, and (4) which data are kept in files, and the arrangement of the files. An algorithm may need to put new data into an existing collection of data, remove data from a collection, or query a collection of data for a specific purpose. See ALGORITHM.

**Abstract data types.** Each data structure can be developed around the concept of an abstract data type that defines both data organization and data handling operations. Data abstraction is a tool that allows each data structure to be developed in relative isolation from the rest of the solution. The study of data structure is organized around a collection of abstract data types that includes lists, trees, sets, graphs, and dictionaries. See ABSTRACT DATA TYPE.

**Primitive and nonprimitive structures.** Data can be structured at the most primitive level, where they are directly operated upon by machine-level instructions. At this level, data may be character or numeric, and numeric data may consist of integers or real numbers.

Nonprimitive data structures can be classified as arrays, lists, and files. An array is an ordered set which contains a fixed number of objects. No deletions or insertions are performed on arrays. At best, elements may be changed. A list, by contrast, is an ordered set consisting of a variable number of elements to which insertions and deletions can be made, and on which other operations can be performed. When a list displays the relationship of adjacency between elements, it is said to be linear; otherwise it is said to be nonlinear. A file is typically a large list that is stored in the external memory of a computer. Additionally, a file may be used as a repository for list items (records) that are accessed infrequently.

**File structures.** Not all information that is processed by a computer necessarily resides in immediately accessible memory because some programs and their data cannot fit into the main memory of the computer. Large volumes of data or records and archival data are commonly stored in external memory as entities called files. Any storage other than main memory may be loosely defined as external storage. This includes tapes, disks, and so forth. See COMPUTER STORAGE TECHNOLOGY.

**Virtual memory.** This is a system that provides an extension to main memory in a logical sense. In a virtual system, all currently active programs and data are allocated space or virtual addresses in virtual memory. The program and data may not in fact reside in main memory but in an external storage. References to virtual addresses are translated dynamically by the operating system into real addresses in main memory. See DIGITAL COMPUTER. [A.O.T.]

**Database management system** A collection of interrelated data together with a set of programs to access the data, also called database system, or simply database. The primary goal of such a system is to provide an environment that is both convenient and efficient to use in retrieving and storing information.

A database management system (DBMS) is designed to manage a large body of information. Data management involves both defining structures for storing information and providing mechanisms for manipulating the information. In addition, the database system must provide for the safety of the stored information, despite system crashes or attempts at unauthorized access. If data are to be shared among several users, the system must avoid possible anomalous results due to multiple users concurrently accessing the same data.

Examples of the use of database systems include airline reservation systems, company payroll and employee information systems, banking systems, credit card processing systems, and sales and order tracking systems.

A major purpose of a database system is to provide users with an abstract view of the data. That is, the system hides certain details of how the data are stored and maintained. Thereby, data can be stored in complex data structures that permit efficient retrieval, yet users see a simplified and easy-to-use view of the data. The lowest level of abstraction, the physical level, describes how the data are actually stored and details the data structures. The next-higher level of abstraction, the logical level, describes what data are stored, and what relationships exist among those data. The highest level of abstraction, the view level, describes parts of the database that are relevant to each user; application programs used to access a database form part of the view level.

The overall structure of the database is called the database schema. The schema specifies data, data relationships, data semantics, and consistency constraints on the data.

Underlying the structure of a database is the logical data model: a collection of conceptual tools for describing the schema.

The entity-relationship data model is based on a collection of basic objects, called entities, and of relationships among these objects. An entity is a "thing" or "object" in the real world that is distinguishable from other objects. For example, each person is an entity, and bank accounts can be considered entities. Entities are described in a database by a set of attributes. For example, the attributes account-number and balance describe one particular account in a bank. A relationship is an association among several entities. For example, a depositor relationship associates a customer with each of her accounts. The set of all entities of the same type and the set of all relationships of the same type are termed an entity set and a relationship set, respectively.

Like the entity-relationship model, the object-oriented model is based on a collection of objects. An object contains values stored in instance variables within the object. An object also contains bodies of code that operate on the object. These bodies of code are called methods. The only way in which one object

can access the data of another object is by invoking a method of that other object. This action is called sending a message to the object. Thus, the call interface of the methods of an object defines that object's externally visible part. The internal part of the object—the instance variables and method code—are not visible externally. The result is two levels of data abstraction, which are important to abstract away (hide) internal details of objects. Object-oriented data models also provide object references which can be used to identify (refer to) objects.

In record-based models, the database is structured in fixed-format records of several types. Each record has a fixed set of fields. The three most widely accepted record-based data models are the relational, network, and hierarchical models. The latter two were widely used once, but are of declining importance. The relational model is very widely used. Databases based on the relational model are called relational databases.

The relational model uses a collection of tables (called relations) to represent both data and the relationships among those data. Each table has multiple columns, and each column has a unique name. Each row of the table is called a tuple, and each column represents the value of an attribute of the tuple.

The size of a database can vary widely, from a few megabytes for personal databases, to gigabytes (a gigabyte is 1000 megabytes) or even terabytes (a terabyte is 1000 gigabytes) for large corporate databases.

The information in a database is stored on a nonvolatile medium that can accommodate large amounts of data; the most commonly used such media are magnetic disks. Magnetic disks can store significantly larger amounts of data than main memory, at much lower costs per unit of data.

To improve reliability in mission-critical systems, disks can be organized into structures generically called redundant arrays of independent disks (RAID). In a RAID system, data are organized with some amount of redundancy (such as replication) across several disks. Even if one of the disks in the RAID system were to be damaged and lose data, the lost data can be reconstructed from the other disks in the RAID system. *See* COMPUTER STORAGE TECHNOLOGY.

Logically, data in a relational database are organized as a set of relations, each relation consisting of a set of records. This is the view given to database users. The underlying implementation on disk (hidden from the user) consists of a set of files. Each file consists of a set of fixed-size pieces of disk storage, called blocks. Records of a relation are stored within blocks. Each relation is associated with one or more files. Generally a file contains records from only one relation, but organizations where a file contains records from more than one relation are also used for performance reasons.

One way to retrieve a desired record in a relational database is to perform a scan on the corresponding relation; a scan fetches all the records from the relation, one at a time.

Accessing desired records from a large relation using a scan on the relation can be very expensive. Indices are data structures that permit more efficient access of records. An index is built on one or more attributes of a relation; such attributes constitute the search key. Given a value for each of the search-key attributes, the index structure can be used to retrieve records with the specified search-key values quickly. Indices may also support other operations, such as fetching all records whose search-key values fall in a specified range of values.

A database schema is specified by a set of definitions expressed by a data-definition language. The result of execution of data-definition language statements is a set of information stored in a special file called a data dictionary. The data dictionary contains metadata, that is, data about data. This file is consulted before actual data are read or modified in the database system. The data-definition language is also used to specify storage structures and access methods.

Data manipulation is the retrieval, insertion, deletion, and modification of information stored in the database. A data-

manipulation language enables users to access or manipulate data as organized by the appropriate data model. There are basically two types of data-manipulation languages: Procedural data-manipulation languages require a user to specify what data are needed and how to get those data; nonprocedural data-manipulation languages require a user to specify what data are needed without specifying how to get those data.

A query is a statement requesting the retrieval of information. The portion of a data-manipulation language that involves information retrieval is called a query language. Although technically incorrect, it is common practice to use the terms query language and data-manipulation language synonymously.

Database languages support both data-definition and data-manipulation functions. Although many database languages have been proposed and implemented, SQL has become a standard language supported by most relational database systems. Databases based on the object-oriented model also support declarative query languages that are similar to SQL.

SQL provides a complete data-definition language, including the ability to create relations with specified attribute types, and the ability to define integrity constraints on the data.

Query By Example (QBE) is a graphical language for specifying queries. It is widely used in personal database systems, since it is much simpler than SQL for nonexpert users.

Forms interfaces present a screen view that looks like a form, with fields to be filled in by users. Some of the fields may be filled automatically by the forms system. Report writers permit report formats to be defined, along with queries to fetch data from the database; the results of the queries are shown formatted in the report. These tools in effect provide a new language for building database interfaces and are often referred to as fourth-generation languages (4GLs). *See* HUMAN-COMPUTER INTERACTION.

Often, several operations on the database form a single logical unit of work, called a transaction. An example of a transaction is the transfer of funds from one account to another. Transactions in databases mirror the corresponding transactions in the commercial world.

Traditionally database systems have been designed to support commercial data, consisting mainly of structured alphanumeric data. In recent years, database systems have added support for a number of nontraditional data types such as text documents, images, and maps and other spatial data. The goal is to make databases universal servers, which can store all types of data. Rather than add support for all such data types into the core database, vendors offer add-on packages that integrate with the database to provide such functionality. [H.F.Ko.; A.Si.; S.Su.]

**Date** The fruit of the date palm (*Phoenix dactylifera*), one of the oldest cultivated tree crops. It provides a staple food for many populations in the Middle East and North Africa, and also is highly valued for feed, fiber, and shelter.

The date palm is in the family Palmaceae. *Phoenix* is distinguished from other palm species by the production of offshoots, columnar-circular trunks, pinnate leaves, and distinctively furrowed seeds. Date palms are monocotyledons and have a single bud or growing point. The date trunk also lacks the cambium growth layer typically found in dicotyledon fruit trees, which is important for true secondary growth.

The date palm species is dioecious: male palms produce staminate flowers and female palms produce pistillate flowers. Both male and female flower clusters are enclosed in protective sheaths. Bees and insects go to the male flowers but not to the female blooms. The date palm is dependent on humans for pollination. Pollen from the staminate flowers must be collected and manually applied to the pistillate inflorescence every season for commercial date production. Windblown pollination results in poor fruit set and in fruit that do not mature properly. One male tree can provide enough pollen for 30–40 female trees. Because the inner layer of the fruit wall is fleshy, the date fruit is

classified as a berry, like a tomato. See ARECALES; FRUIT; FRUIT, TREE. [J.L.A.]

**Dating methods** Relative and quantitative techniques used to arrange events in time and to determine the numerical age of events in history, geology, paleontology, archeology, paleoanthropology, and astronomy. Relative techniques allow the order of events to be determined, whereas quantitative techniques allow numerical estimates of the ages of the events. Most numerical techniques are based on decay of naturally occurring radioactive nuclides, but a few are based on chemical changes through time, and others are based on variations in the Earth's orbit. Once calibrated, some relative techniques also allow numerical estimates of age. See ARCHEOLOGY; ASTRONOMY; GEOLOGY; RADIOISOTOPE.

Relative dating methods rely on understanding the way in which physical processes in nature leave a record that can be ordered. Once the record of events is ordered, each event is known to be older or younger than each other event. In most cases the record is contained within a geological context, such as a stratigraphic sequence; in other cases the record may be contained within a single fossil or in the arrangement of astronomical bodies in space and time. The most important relative dating methods are stratigraphic dating and paleontologic dating. Other relative dating methods include paleomagnetic dating, dendrochronology, and tephrostratigraphy. See DENDROCHRONOLOGY; PALEOMAGNETISM; SEQUENCE STRATIGRAPHY; STRATIGRAPHY.

Several chemical processes occur slowly, producing changes over times of geological interest; among these are the hydration of obsidian, and the conversion of L- to D-amino acids (racemization or epimerization). Determination of age requires measurement of a rate constant for the process, knowledge of the temperature history of the material under study, and (particularly for amino acid racemization) knowledge of the chemical environment of the materials. See AMINO ACID DATING; OBSIDIAN; RACEMIZATION.

Unlike chemical methods, in which changes depend both on time and on environmental conditions, isotopic methods which are based on radioactive decay depend only on time. A parent nuclide may decay to one stable daughter in a single step by simple decay [for example, rubidium decays to strontium plus a beta particle ( $^{87}\text{Rb} \rightarrow ^{87}\text{Sr} + \beta$ )]; to two daughters by branched decay through different processes [for example, potassium captures an electron to form argon, or loses a beta particle to form calcium ( $^{40}\text{K} + e^- \rightarrow ^{40}\text{Ar}$ ;  $^{40}\text{K} \rightarrow ^{40}\text{Ca} + \beta$ )]; to one stable daughter through a series of steps (chain decay); or into two unequal-sized fragments by fission. In all cases, the number of parent atoms decreases as the number of daughter atoms increases, so that for each method there is an age-sensitive isotopic ratio of daughter to parent that increases with time. Many different isotopes have been exploited for measuring the age of geological and archeological materials. For example, the table shows parent isotopes, their half-lives, and the resulting daughter products. See GERONTOLOGY; HALF-LIFE.

Astronomers have estimated the age of the universe, and of the Milky Way Galaxy, by various methods. It is well known that the universe is expanding equally from all points, and that the

velocity of recession of galaxies observed from Earth increases with distance. The rate of increase of recession velocity with distance is called the Hubble constant; and knowing the recession rate and distance of galaxies at some distance, it is simple to find how long it took them to get there. Initial estimates for the age of the universe were approximately 20 billion years; but as the rate of expansion decreases with time, revised estimates are nearer 13 billion years. By contrast, the Earth and other bodies in the solar system are only about 4.5 billion years old. Comparison of present-day osmium isotope ratios with theoretically estimated initial ratios yields estimates of 8.6–15.7 billion years for the age of the Galaxy. See COSMOCHEMISTRY; COSMOLOGY; MILKY WAY GALAXY; UNIVERSE. [F.S.B.]

**Datolite** A mineral nesosilicate, composition  $\text{CaBSiO}_4(\text{OH})$ , crystallizing in the monoclinic system. It usually occurs in crystals showing many faces and having an equidi-mensional habit. It may also be fine granular or compact and massive. Hardness is  $5-5\frac{1}{2}$  on Mohs scale; specific gravity is 2.8–3.0. The luster is vitreous, the crystals colorless or white with a greenish tinge. Datolite is found in the Harz Mountains, Germany; Bologna, Italy; and Arendal, Norway. In the United States fine crystals have come from Westfield, Massachusetts; Bergen Hill, New Jersey; and various places in Connecticut. In Michigan, in the Lake Superior copper district, datolite occurs in fine-grained porcelain-like masses which may be coppery red because of inclusions of native copper. See SILICATE MINERALS. [C.S.Hu.]

**Dawsoniidae** A subclass of the true mosses (Bryopsida) largely limited to the South Pacific. The subclass consists of a single genus, *Dawsonia*, of nine species. The plants are coarse and rigid in loose dark green or brownish tufts. They are simple or occasionally forked, grow erect from a procumbent base, and sometimes achieve a height of 26 in. (65 cm), much more than any other mosses. The stems may have a central strand of homogeneous fiberlike cells or both xylemlike and phloemlike cells. The leaves are long-linear or long-lanceolate from a relatively short, oblong-sheathing base. The limb, which may be as long as 1.6 in. (40 mm), is concave-tubulose and spreading or flat and spirally twisted when dry. It is coarsely toothed at the margins and at back. The inflorescences are dioecious and terminal. Male plants repeatedly form new growth through the perigonal bud. See BRYOPHYTA; BRYOPSIDA; POLYTRICHIDAE. [H.Cr.]

**Day** A unit of time equal to the period of rotation of Earth. Different sorts of day are distinguished, according to how the period of rotation is reckoned with respect to one or another direction in space. A day is normally defined as 86,400 SI (Système International) seconds [ $86,400 \text{ s/d} = (60 \text{ s/min}) \times (60 \text{ min/h}) \times (24 \text{ h/d})$ ], where SI seconds are measured by atomic processes. See PHYSICAL MEASUREMENT.

The apparent solar day is the interval between any two successive meridian transits of the Sun. It varies through the year, reaching about 24 h 30 s of ordinary clock time in December and about 23 h 59 min 39 s in September.

The mean solar day is the interval between any two successive meridian transits of an imagined point in the sky that moves along the celestial equator with a uniform motion equal to the average rate of motion of the Sun along the ecliptic. Ordinary clocks are regulated to advance 24 h during a mean solar day. Because of irregularities in the Earth's rotation, leap seconds are occasionally added to keep the day in terms of seconds of atomic time (Coordinated Universal Time, or UTC) in step with the day based on rotation (UT1).

The sidereal day is the interval between any two successive upper meridian transits of the vernal equinox. Similarly, as for

Principal parent and daughter isotopes used in radiometric dating

Radioactive parent isotope	Stable daughter isotope	Half-life, years
Carbon-14	Nitrogen-14	5730
Potassium-40	Argon-40	$1.25 \times 10^9$
Rubidium-87	Strontium-87	$4.88 \times 10^{10}$
Samarium-147	Neodymium-143	$1.06 \times 10^{11}$
Lutetium-176	Hafnium-176	$3.5 \times 10^{10}$
Rhenium-187	Osmium-187	$4.3 \times 10^{10}$
Thorium-232	Lead-208	$1.4 \times 10^{10}$
Uranium-235	Lead-207	$7.04 \times 10^8$
Uranium-238	Lead-206	$4.47 \times 10^9$

the solar day, a distinction is made between the apparent sidereal day and the mean sidereal day which, however, differ at most by a small fraction of a second. The difference between sidereal time and solar time arises from the Earth's revolution around the Sun, which results in a year containing one more sidereal day than solar day. A mean sidereal day comprises 23 h 56 min 4.09053 s of a mean solar day.

The mean solar day and the sidereal day vary together in consequence of variations in the speed of rotation of Earth, which are of three sorts: seasonal, irregular, and secular. See EARTH ROTATION AND ORBITAL MOTION; TIME. [G.M.C.; J.M.P.]

**Dead reckoning** A form of navigation that determines position of a craft by advancing a previous position to a new one on the basis of assumed distance and direction moved. The parameters of dead reckoning are direction of motion and distance traveled. The intended direction of travel, the course, may differ from the direction steered because of the anticipated off-setting effect of wind (called leeway) or current, or both. When it is desired to distinguish between the two directions, mariners call the second the course steered, or heading, while aviators refer to it as the heading. A compass is used to indicate direction. Distance is usually determined indirectly by measurement of speed and time, but it may be measured directly.

In addition to several magnetic compasses, nearly all naval vessels and ocean liners are equipped with one or more north-seeking gyrocompasses. Gyrocompasses have replaced magnetic compasses as the primary source of directional information on many modern vessels. See GYROCOMPASS; MAGNETIC COMPASS.

Aboard ship, distance or speed is measured by means of a log or by an engine revolution counter. The pitometer log uses a pitot-static tube. The Forbes log uses a small rotor in a tube projecting below the bottom of the vessel. An electromagnetic log has a sensing element which produces a voltage directly proportional to speed through the water.

In aircraft, speed through the air is measured by means of an airspeed indicator or Mach meter. The latter provides an indication of speed in units of the speed of sound, which varies with density of the atmosphere. For measurement of air speed a pitot-static tube is generally used with a suitable registering device.

To determine position by dead reckoning, air and land navigators, and some marine navigators, use the best estimate of direction and distance traveled over the surface. Many marine navigators, however, prefer to use course steered and estimated speed through the water, without allowance for leeway, for their dead reckoning; they consider positions determined by allowance of estimated effects of wind and current as estimated positions.

The uncertainty of a dead-reckoning position, however determined, increases with time and, if there is an error in direction measurement, it also increases with distance traveled. From time to time an independent determination of position is made by means of external references. When a reliable position, called a fix, is so obtained, a new dead reckoning is started from this point.

In many large naval vessels and commercial ships the dead reckoning is performed automatically by a device that receives inputs of direction from a gyrocompass and speed from a log and continuously computes dead-reckoning position, which is displayed on dials or traced on a chart or plotting sheet.

The Doppler effect, a frequency shift that is proportional to the speed of relative motion between transmitter and receiver or reflector of radiant energy, either acoustic or electromagnetic, is used in a system to accomplish dead reckoning, automatically. In the ship version, called a Doppler sonar navigator, ultrasonic energy is transmitted obliquely downward (typically 30° from the vertical) and the frequency of the return echo is noted. By using four beams separated 90° laterally, the system provides an indi-

cation of vessel speed in both the fore-and-aft and athwartship directions, so that total speed and direction of motion can be determined if the device is properly oriented. When reflections are from the sea bottom (bottom return mode), true ground speed (speed relative to the solid Earth) is measured. When reflections are from suspended particulate matter in the water (volume reverberation mode), the speed is relative to the water. In either mode the speed is integrated to determine distance from a starting point. Doppler sonar navigation has proved particularly useful in survey and geophysical exploration vessels. See SONAR.

Similar systems called Doppler navigators, which use electromagnetic energy, have been used in aircraft, but these systems have largely been replaced by inertial navigators. See DOPPLER EFFECT; DOPPLER RADAR.

Most aircraft that are used for long overwater flights, and some others, as well as some ships, notably submarines, are equipped with one or more inertial navigators. This device, when properly aligned, provides a continuous indication of speed, position, and heading by means of appropriate inertial sensors. Gyroscopes are used to sense angular motions of the craft and maintain accelerometers in the correct orientation to sense linear accelerations, or changes in speed. Single integration of the accelerations provides a measure of speed, and double integration produces a measure of distance. An inertial navigator is free from effects of wind and current, but like all dead-reckoning systems its output degrades with elapsed time and distance traveled, and must be reset periodically. Its use is particularly attractive in aircraft because of their high speed and hence relatively short time in transit. See INERTIAL GUIDANCE SYSTEM.

Knowledge of the real-time present position of a craft is generally considered essential to safe navigation. The Global Positioning System, using NAVSTAR artificial earth satellites, or an integrated system, using a computer and appropriate filter to synthesize outputs of several independent positioning systems, may provide an essentially continuous fix, which would then eliminate the need for dead reckoning. See CELESTIAL NAVIGATION; ELECTRONIC NAVIGATION SYSTEMS; PILOTING; SATELLITE NAVIGATION SYSTEMS. [A.B.M.]

**Death** Cessation of life functions. This can involve the whole organism (somatic death), individual organs (organ death), individual cells (cellular death), and individual parts of cells (organelle death). Although the next smaller level of organization, the macromolecules which make up the cell organelles, may also cease to function, their disintegration is ordinarily not spoken of as death.

**Pathogenesis.** A normal animal, cell, or organelle exists in a normal state of homeostasis, or a normal "steady state." Following a disturbance of the normal steady state, referred to as an "injury," the living system can be assumed to undergo a change in steady-state level, that is, to exhibit an altered steady state. Such altered steady states can be regarded as having increased, decreased, or unaltered levels of ability to maintain homeostasis. An altered steady state with increased homeostatic ability might include the hypertrophy of a muscle cell resulting from continued exercise; and altered steady state with decreased homeostatic ability is the atrophy or shrinking of cells that occurs following disuse or lack of stimulation by hormones or suitable nutrients. In the case of injuries that do not result in the death of the living system, the system may persist in one of the new or altered steady states for long periods up to many years; that is, although the system differs significantly from the normal steady state, it is able to continue its existence and to maintain homeostasis. On the other hand, certain severe injurious stimuli result in an altered state that ultimately passes a point beyond which recovery of homeostatic ability is impossible even if the injurious stimulus or situation is removed. This point may be considered as a point of no return or the point of death of the living system. Following this point, the system undergoes exponential decay, leading to complete equilibrium with its environment. This period of decay,

which is characterized by reactions resulting in the breakdown of structural components of the system, is referred to as necrosis. See HOMEOSTASIS.

**Somatic death.** In the biological sense, somatic death refers to the cessation of characteristic life functions. In higher organisms it can be assumed to result from an interplay between the genetic background of the individual and the effects of the environment. Death is, in a sense, the price of differentiation; in another sense, protoplasm is immortal and all life springs from preexisting life. The undifferentiated amebas need never die, only divide. It would appear that death is inevitable for higher organisms such as mammals and, in a sense, life is a series of little deaths.

Developments in medicine and associated technology involving supportive therapy, resuscitation, hypothermia, extracorporeal circulation, and organ transplantation have reopened serious questions regarding the definition of when an individual is "dead." The vagueness and inconsistency in previous legal and medical definitions have led to serious dilemmas. These are of particular importance in the selection of donors for transplantation of vital organs such as the heart.

Medical techniques have shown that individuals can be sustained for prolonged periods without spontaneous respiratory or cardiac movements as well as without electrical evidence of central nervous system activity. These techniques have also achieved the resuscitation of individuals who would formerly have been considered dead and have clearly shown the survival of transplanted organs from cadavers. Just as organs may survive after the death of the organism, the organism, properly supported by mechanical or other means, can survive the death of organs, including the brain.

The following are changes that occur in the body after somatic death: 1. Cooling (*algor mortis*) of the body occurs postmortem. 2. Rigidity (*rigor mortis*) or stiffening of the musculature usually begins within 5–10 h and begins to disappear after 3 or 4 days. 3. Staining (*livor mortis*) occurs, that is, there is reddish-blue discoloration in the dependent portions of the body resulting from the gradual gravitational flow of unclotted blood. 4. Blood begins to clot shortly after death and sometimes prior to cessation of cardiac function. 5. Autolysis (necrosis) occurs in the cells of the body following somatic death. 6. Putrefaction, bacterial and enzymatic decomposition, begins shortly after death, caused by microorganisms which enter the body.

**Organ death.** Following somatic death, all organs do not die at the same rate. Length of survival can be prolonged by reducing the temperature of the organs to near 32°F (0°C), which appreciably retards metabolic function and extends survival time. This survival of organs after the death of the host forms the basis for organ transplantation from cadavers.

**Cellular death.** Death and subsequent necrosis of cells form an important part of many reactions of cells to injury in disease states. The death and disintegration of cells within a living animal incite a vascular reaction called an inflammatory reaction on the part of the host. It is characterized by a series of vascular phenomena which include the migration of leukocytes (white blood cells) from the blood capillaries into the area of tissue damage with subsequent digestion and phagocytosis of the cellular debris resulting from cellular necrosis. [B.F.T.]

**Issues.** The advancements of modern medicine have brought significant changes in the ways of life and death, and challenge former concepts and definitions of death. As the determination of death becomes increasingly complex in a technological society, the definition of death becomes correspondingly more complex. The meaning of death is a philosophical concept which lies outside the scientific point of view. Although dying is a process which may continue over a considerable period of time, for all practical purposes death occurs at that point where there is an irreversible loss of one's essential human characteristics. Such loss indicates the death of the organism as a whole, the death of a person.

An interdisciplinary committee at the Harvard Medical School examined possible new criteria for determining death. In 1968 they cited four criteria as determinative of a permanently non-functioning brain: unreceptivity and unresponsivity to externally applied stimuli and inner need; absence of spontaneous movements of breathing; absence of reflexes other than spinal column reflexes, and fixed dilated pupils; and a flat electroencephalogram (EEG) to be used as a confirmatory but not mandatory test.

These tests were to be repeated after 24 h, and in the absence of hypothermia or depressant drugs, were to be considered a confirmation of brain death. It has since been conclusively demonstrated that when the flow of blood to the brain has been interrupted for approximately 15 min there is a uniform necrosis and liquefaction of the brain. This definition appears to be a major milestone in determining new criteria for making the determination that death has occurred.

With regard to the issue of organ transplantation, it is contrary to moral intuitions that a dying person might be prematurely defined as dead in order that someone else might harvest the organs. A moral obligation exists to treat the living as such until death occurs. To avoid a conflict in the role of the physician, it has become common practice that the physician for the recipient of an organ donation is not party to the judgment that the donor has died. The needs of a patient for a viable organ must not contaminate the judgment that another person has died.

The ability to define death with more precision is important in cases involving the comatose patient. It is generally accepted as both a moral and legal right that competent persons have the right to refuse medical treatment. Increasingly, dying patients claim a more active role in self-determination regarding medical treatment in the final stage of life.

One of the more radical issues is that of actively ending the life of a suffering person or helping another to die through a positive action. Some ethicists see no moral distinction between removing life-support systems or life-saving medications which allow a patient to die and taking a direct action which causes a patient to die, since the intention and the consequence are the same in both cases. Others disagree, claiming that there is indeed a morally significant difference if a person dies of the underlying disease and is not made to endure still greater suffering by prolonging the dying process than if the person dies because another has caused the death through an intentional and fatal action. [T.R.McC.]

**De Broglie wavelength** The wavelength  $\gamma = h/p$  associated with a beam of particles (or with a single particle) of momentum  $p$ ;  $h = 6.626 \times 10^{34}$  joule-second is Planck's constant. The same formula gives the momentum of an individual photon associated with a light wave of wavelength  $\gamma$ . This formula, along with the profound proposition that all matter has wavelike properties, was first put forth by Louis de Broglie in 1924, and is fundamental to the modern theory of matter and its interaction with electromagnetic radiation. See QUANTUM MECHANICS. [E.G.]

**Decapoda (Crustacea)** One of the more highly specialized orders of the class Crustacea. This order includes the shrimps, lobsters, hermit crabs, and true crabs. The order is so diverse that satisfactory definition is difficult, but a few characters are common to nearly all decapods. The most obvious is a head shield, or carapace, which covers and coalesces with all of the thoracic somites and which overhangs the gills on each side. The first three of the eight pairs of thoracic appendages are specialized as maxillipeds and closely associated with the true mouthparts. The gills are usually well developed and arranged in several series.

Decapods vary in size from less than 1/2 in. (1.25 cm) in length to that of the giant Japanese crab, the largest living arthropod, a spider crab which may span more than 12 ft (3.6 m) between



the tips of the outstretched claws. Although most decapods are found in the sea, they are by no means restricted to that habitat. Crayfishes are well-known inhabitants of freshwater streams and ponds, as are several kinds of shrimps and some true crabs. A number of crabs and hermit crabs have become well adapted to a terrestrial existence far from water; they return to the sea only seasonally to hatch their eggs. Many crayfishes burrow in the ground, and one species of crab spends its entire life in the tops of lofty trees.

In a general way, the decapods may be divided into two groups: the long-tailed and the short-tailed forms. The long-tailed species, such as the shrimps and lobsters, have a more or less cylindrical, or laterally compressed, carapace that often bears a head spine or rostrum. The large, muscular abdomen permits the shrimp, or lobster, to dart quickly backward out of danger, but the succulence of this tail makes the animals prey to numerous enemies, including humans. In the short-tailed species, the crabs, the carapace is often broadened and flattened dorsally and usually does not form a rostrum. The much-reduced and feeble abdomen is tucked under the thorax, where it serves the female as a brood pouch for eggs.

**Physiology.** The nervous system is somewhat variable. Although usually fewer, there may be as many as 11 ganglia, 5 thoracic and 6 abdominal, in the ventral nerve chain posterior to the subesophageal ganglion. The sense organs include eyes, statocysts, olfactory filaments, and tactile setae. The eyes are well developed in most decapods, but they may be reduced or entirely absent in species living in the deep sea, in caves, or in burrows. Luminous organs of various kinds occur in a number of deep-sea decapods, and some shrimps have the ability to eject a luminous fluid.

As in most crustaceans, the alimentary tract is a more or less straight tube divided into three parts: the foregut, the midgut, and the hindgut. The first and last have a chitinous, and sometimes calcified, lining. The foregut, in most decapods, is dilated to form a stomach. Its anterior, or cardiac, portion is at least partially lined with movably articulated, calcified ossicles, controlled by a complex system of muscles called the gastric mill. The posterior, or pyloric, part is provided with hairy ridges which combine to form a straining apparatus. The midgut is variously furnished with blind tubes, and a mass of minutely ramified tubules, known as the hepatopancreas or liver, empties through one or more ducts into the anterior end of the midgut.

The heart is short, polygonal, and situated under the posterior part of the carapace. It has three or more pairs of venous ostia, and two pairs of arteries lead from it, in addition to the median anterior and posterior arteries. The blood collects in a venous sinus in the midventral line, passes to the gills, and then back to the pericardial sinus surrounding the heart.

In practically all decapods, respiration is accomplished by a series of gills, attached to the lateral walls of the thoracic somites and to the basal segments of the thoracic appendages. A continuous current of water is drawn through the branchial chamber and over the gills by the fluttering motion of the outer lobe of the second maxilia. The current usually moves forward, but this direction may be periodically reversed in burrowing species. In those crabs best adapted for life on land, the action of the gills is supplemented by the lining membrane of the branchial chamber. This chamber is covered with minute villi and is unusually well supplied with blood vessels, and thus functions as a lung.

The antennal gland is the chief excretory organ in all decapods. Maxillary glands are often present in the larval stages, but they never persist in the adult. The antennal gland is compact and more complex than in any other crustacean group. It consists of three divisions: the saccule, which is usually partitioned or ramose; the labyrinth, a spongy mass with a complex system of canals; and the bladder with a duct leading to the exterior.

The sexes are separate in most decapods, although protandric hermaphroditism occurs in some shrimps. The testes most often lie partly in the thorax and partly in the abdomen, and they are

usually connected across the midline. The ovaries resemble the testes in shape and position.

**Development.** In only one group of shrimps are all of the presumably primitive larval stages represented. The first stage is a typical crustacean nauplius with an unprotected oval body bearing a median eye and three pairs of appendages. This stage is followed by a metanauplius in which four more appendage rudiments appear. The third pair of the original appendages becomes less of a swimming organ and more like a pair of primitive mandibles. In the third stage, the protozoa, the seven pairs of appendages become more highly developed, a carapace covers the anterior part of the body, the abdomen is clearly formed though unsegmented at first, the rudiments of paired eyes appear, and the heart is formed. In the next stage, the zoea, the eyes become movable and the carapace develops a rostrum. All thoracic appendages are present, at least in rudimentary form, and those of the abdomen appear, especially the uropods. In the last larval stage, the mysis, the well-developed thoracic appendages replace the antennae as the chief swimming organs. The abdomen increases markedly in size and takes on a form similar to that of the adult.

**Phylogeny.** No true decapod fossils are known with certainty from Paleozoic deposits, but decapod shrimps are not uncommon in Triassic and, especially, Jurassic rocks. Lobsterlike forms related to Recent deep-sea species also appeared in the Triassic; true lobsters are known from the Jurassic, and crayfishes from the Cretaceous. Crabs are well known as fossils, with primitive groups appearing in the Jurassic; several more specialized groups are found in the Cretaceous, and all of the major existing groups were represented in the Tertiary.

The evolution of the decapods has not been satisfactorily worked out and may never be known completely. The presence of a nauplius larva in the development of some shrimps suggests a link with the primitive crustaceans, but it can hardly be doubted that the Decapoda, as a group, are highly specialized. They are certainly closely related to the Euphausiacea, and fusion of the two groups has been suggested by some authors.

**Classification.** The classification of the 8500 living species of decapods presents a difficult problem that has not yet been entirely solved. The chief disparity seems to lie between the shrimps (Natantia) and all of the other decapods (Reptantia). The classification listing is

- Order Decapoda
  - Suborder Natantia
    - Section Penaeidea
    - Section Caridea
    - Section Stenopodidea
  - Suborder Reptantia
    - Section Macrura
    - Section Anomura
    - Section Brachyura

**Penaeidea.** The primitive section of the Decapoda, penaeideans, is distinguished by the following characters: The pleura of the first abdominal somite overlap those of the second; the third legs are nearly always chelate, but are no stouter than the first pair; the first pleopods of the male bear a complicated flaplike appendix, the petasma; and the females have a spermatophore receptacle, the thelycum, on the ventral surface of the posterior thoracic somites. The best-known penaeideans, including most of the commercially important shrimps or prawns of the warmer seas (Penaeidae), live on muddy bottoms in shallow or moderate depths. However, they also occur both in the deep sea and as pelagic organisms in the mid-depths. There are more than 300 species of living penaeideans.

**Caridea.** This is the largest and most diverse group of shrimps and prawns. The pleura of the second abdominal somite overlap those of the first; the third legs are never chelate; there is no

petasma or thelycum. The sexes can usually be distinguished by the presence, in the male, of two stylets on the inner edge of the inner branch of the second pleopods. Carideans occur in all parts of the sea, often in association with other marine animals. Members of at least two families, Atyidae and Palaemonidae, are also widespread in fresh water. The edible shrimps and prawns of northern Europe and of northwestern North America, of the genera *Crangon* and *Pandalus*, belong to the Caridea, as do the large fresh-water prawns of the tropical genus *Macrobrachium*. Most shrimps and prawns are favorite foods of fishes. Some carideans maintain "service stations" where they remove parasites from the outer skin, mouths, and gills of the fish. More than 1500 species of Caridea are known.

**Stenopodidea.** This is a small group of shrimps which superficially resemble the Penaeidea. The third pereopods are chelate but are much longer and stouter than the first pair; the pleura of the second abdominal somite do not overlap those of the first; and there is no petasma or thelycum. All of the 20 or more living species are marine; some are closely associated with other animals, such as sponges.

**Macrura.** This long-tailed group of the Reptantia includes the deep-water and fossil eryonids, the spiny lobsters, the true lobsters, and the mud shrimps (Fig. 1). The abdomen is extended and bears a well-developed tail fan. There are about 700 known living species.

The Eryoniidea are rather thin-shelled, blind inhabitants of the depths of the sea. The carapace is flattened dorsally and considerably expanded laterally. The first four, or all five, pairs of pereopods are chelate, with the first pair much elongated. There are about 40 living species; the group was probably more numerous in ancient seas.

The Scyllaridea include the spiny lobsters or langoustes (Palinuridae) and the Spanish, or shovel-nosed, lobsters (Scyllaridae). They are heavily armored like the true lobsters but are distinguished by the absence of a rostrum and of chelae, except occasionally on the last pereopod of the female. They are abundant in shallow and moderate depths of warm and temperate seas, where they are often of considerable commercial importance. There are about 85 Recent species.

The true lobsters and crayfishes, Nephropidea, also have a firm shell but are also characterized by a rostrum and by chelae on the first three pairs of pereopods, with the first pair being noticeably larger than the others. Most lobsters (*Nephropidae*) are found in cool seas or in the cool, off-shore waters of the tropics. The most familiar lobsters (*Homarus*) are those found along the Atlantic coasts of Europe and North America. The Norway lobster of Europe (*Nephrops*) is also of some commercial importance but is smaller and less meaty. The crayfishes (Cambaridae, Astacidae, Parastacidae) are widespread in fresh waters of the temperate regions of all continents except Africa. They are of commercial importance in southern Europe and Australia. More than 300 living species of lobsters and crayfishes are known, more than half of them being from the fresh waters of the United States.

The mud shrimps, Thalassinidea, are usually thin-shelled, burrowing crustaceans with large, chelate or subchelate first pereopods, and no chelae on the third pereopods. More than 250 living species are found in shallow and deep seas throughout the world, especially in tropical and warm temperate regions.

**Anomura.** This intermediate, and possibly unnatural, group lies between the Macrura and the Brachyura. It includes the galatheids, the porcelain crabs or rock sliders, the hermit crabs, the king crabs, and the mole crabs or hippas. In nearly all of these diverse crustaceans, the first, and sometimes the last, pereopods are chelate or subchelate. The abdomen is usually bent forward ventrally or is asymmetrical, soft, and twisted. There are about 1300 Recent species.

**Brachyura.** These are the true crabs (Fig. 2). The abdomen is symmetrical, without a tail fan, and bent under the thorax. The first pereopods are always chelate or subchelate. The true crabs are as numerous as all other decapods combined, num-

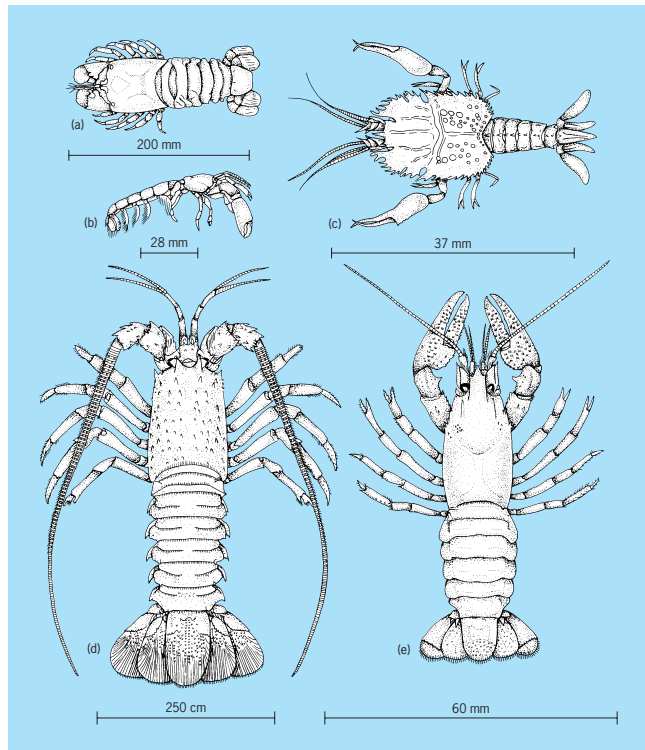

Fig. 1. Reptantian decapods. (a) Spanish lobster, *Scyllarides aequinoctialis*. (b) Mud shrimp, *Callinidea laevicauda*. (c) Eryonid, *Polycheles crucifer*. (d) Spiny lobster, *Panulirus interruptus*. (e) Crayfish, *Orconectes limosus*. (Smithsonian Institution)

bering nearly 4500 Recent species. They are divided into four subsections.

The Gymnopleura include about 30 species of primitive burrowing crabs; their carapaces are more or less trapezoidal or elongate, the first pereopods are subchelate, and some or all of the remaining pereopods are flattened and expanded for burrowing.

The Dromiacea is a primitive group of about 200 species. The first pereopods are chelate; the last pair is dorsal in position and modified for holding objects, such as sponges, tunicates, and bivalve mollusk shells, over the crab.

In Oxystomata the first pair of pereopods are chelate and the last pair are either normal or modified as in the Dromiacea. The oxystomes include the mask crabs (Dorippidae), the box

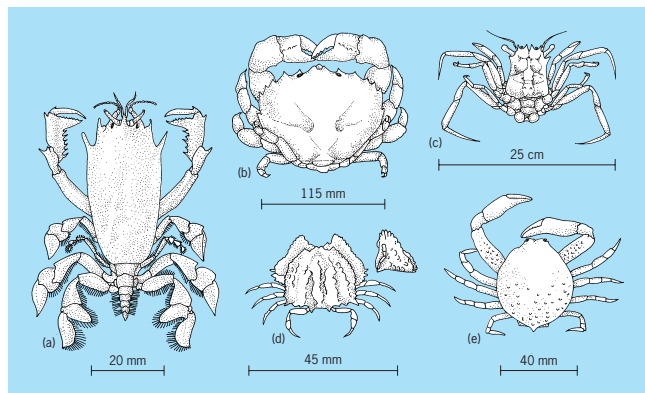

Fig. 2. Common brachyuran crabs. (a) Gymnopleuran crab, *Raninoides louisianensis*. (b) Dromiid crab, *Dromia erythropus*. (c) Mask crab, *Ethusa mascarone americana*. (d) Box crab, *Calappa sulcata*. (e) Purse crab, *Persephona punctata*. (Smithsonian Institution)

crabs (Calappidae), and the purse crabs (Leucosiidae). There are nearly 500 Recent species.

Most of the crabs, more than 3700 living species, belong to the Brachygnatha, in which the last pereopods are rarely reduced or dorsal in position. To this group belong the swimming crabs (Portunidae). Also worthy of mention are freshwater crabs (Potamidae, Pseudothelphusidae, and Trichodactylidae), found in tropical and some temperate regions, usually in areas not inhabited by crayfishes. The crabs of the genus *Cancer* are large and abundant enough to be of commercial importance in northern Europe and North America. The rock, or Jonah, crabs of New England and the Dungeness crab of the Pacific Coast are familiar edible crabs of this genus. The ubiquitous little mud crabs (Xanthidae) are well known to every visitor to rocky shores. One of them, the stone crab (*Menippe*), is highly esteemed by connoisseurs of seafood. The pea crabs (Pinnotheridae) are often found in oysters and other bivalve mollusks. The square-backed crabs (Grapsidae) are characteristic of warm, marshy areas but are not restricted to that habitat; they mark the trend toward the true land crabs (Gecarcinidae), the depreciations and intrusions of which are familiar to all who live in the tropics. The ghost crabs (*Ocypode*), which scuttle almost unseen over sandy beaches, and the fiddler crabs (*Uca*) of muddy shores, are closely related. The end of the list is reached with the spider, or decorator, crabs (Majidae), slow-moving animals that often conceal themselves by attaching seaweeds and various sessile animals to their carapaces. One of them (*Macrocheira*) is the largest arthropod now alive. See ARTHROPODA; CRAB; CRUSTACEA. [FA.Ch.]

**Decibel** A logarithmic unit used to express the magnitude of a change in level of power, voltage, current, or sound intensity. A decibel (dB) is 1/10 bel.

In acoustics a step of 1 bel is too large for most uses. It is therefore the practice to express sound intensity in decibels. The level of a sound of intensity  $I$  in decibels relative to a reference intensity  $I_R$  is given by notation (1). Because sound intensity

$$10 \log_{10} \frac{I}{I_R} \quad (1)$$

is proportional to the square of sound pressure  $P$ , the level in decibels is given by Eq. (2). The reference pressure is usually

$$10 \log_{10} \frac{P^2}{P_R^2} = 20 \log_{10} \frac{P}{P_R} \quad (2)$$

taken as 0.0002 dyne/cm<sup>2</sup> or 0.0002 microbar. (The pressure of the Earth's atmosphere at sea level is approximately 1 bar.) See BEL; SOUND PRESSURE.

The neper is similar to the decibel but is based upon natural (napierian) logarithms. One neper is equal to 8.686 dB. See NEPER; VOLUME UNIT (VU). [K.D.K.]

**Deciduous plants** Plants that regularly lose their leaves at the end of each growing season. Dropping of the leaves occurs at the inception of an unfavorable season characterized by either cold or drought or both. Most woody plants of temperate climates have the deciduous habit, and it may also occur in those of tropical regions having alternating wet and dry seasons. Many deciduous trees and shrubs of regions with cold winters become evergreen when grown in a warm climate. Conversely, such trees as magnolias, evergreen in warm areas, become deciduous when grown in colder climates. See LEAF; PLANT PHYSIOLOGY; PLANT TAXONOMY. [N.A.]

**Decision analysis** An applied branch of decision theory. Decision analysis offers individuals and organizations a methodology for making decisions; it also offers techniques for modeling decision problems mathematically and finding optimal decisions numerically. Decision models have the capacity for accepting and quantifying human subjective inputs: judgments of experts and preferences of decision-makers. Implementation of models can take the form of simple paper-and-pencil procedures

or sophisticated computer programs known as decision aids or decision systems.

The methodology is rooted in postulates of rationality—a set of properties which preferences of rational individuals must satisfy. One such property is transitivity: if an individual prefers action  $a$  to action  $b$  and action  $b$  to action  $c$ , he or she should prefer  $a$  to  $c$ . From the rationality postulates, principles of decision-making are derived mathematically. The principles prescribe how decisions ought to be made, if one wishes to be rational. In that sense, decision analysis is normative.

The methodology is broad and must always be adapted to the problem at hand. An illustrative adaptation to a class of problems known as decision-making under uncertainty (or risk) is outlined in the illustration and consists of seven steps:

1. The problem is structured by identifying feasible actions, one of which must be decided upon; possible events, one of which occurs thereafter; and outcomes, each of which results from a combination of decision and event. Problem structuring can be facilitated by displays such as decision trees and decision matrices.

2. At the time of decision-making, the event that will actually occur cannot be predicted perfectly. The degree of certainty about the occurrence of an event, given all information at hand, is quantified in terms of the probability of the event. See PROBABILITY.

3. Preferences are personal: the same outcome may elicit different degrees of desirability from different individuals. The subjective value that a decision-maker attaches to an outcome is quantified and termed the utility of outcome.

4. The preceding steps conform to the principle of decomposition: probabilities of events and utilities of outcomes must be measured independently of one another. They are next

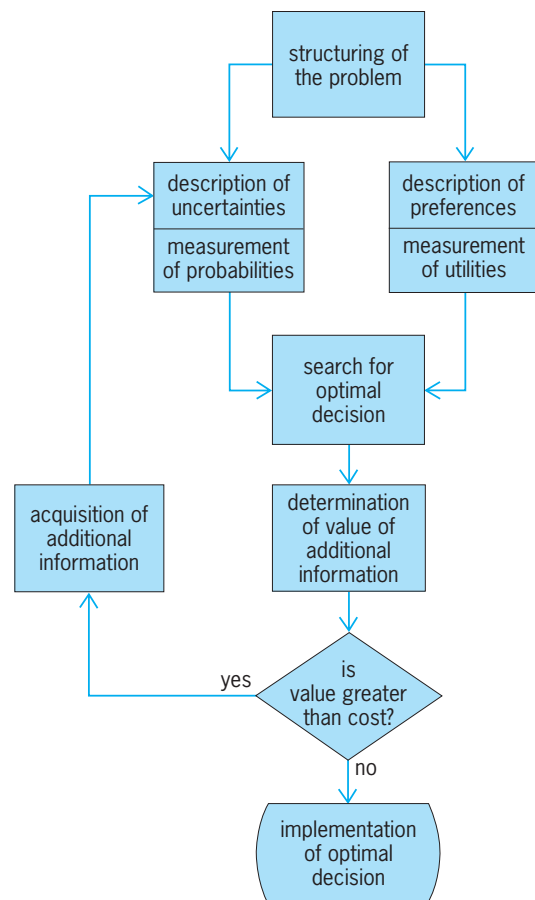

A methodology of decision analysis.

combined in a criterion for evaluating decisions. The utility of a decision is defined as the expected utility of the outcome. The optimal, or the most preferred, decision is one with the maximum utility.

5. The probability encodes the current state of information about a possible event. Often, additional information can be acquired in the hope of reducing the uncertainty. The monetary value of such information is computed before purchase and compared with the cost of information. Thus, one can determine whether or not acquiring information is economically rational.

6. The source of information may be a real-world experiment, a laboratory test, a mathematical model, or the knowledge of an expert. The informativeness of the source is described in terms of a probabilistic relation between information and event. This relation, known as the likelihood function, makes it possible to revise the prior probability of the event and to obtain a posterior probability of the event, conditional on additional information. The revision is carried out via Bayes' rule.

7. Given the additional information, prior probabilities can be replaced by posterior probabilities, and the analysis can be repeated from step 4 onward. Steps 4–6 may be cycled many times, until the cost of additional information exceeds its value, at which moment the optimal decision is implemented.

Measurement of probability and utility functions is guided by principles of decision theory, statistical estimation procedures, and empirical laws provided by behavioral decision theory—a branch of cognitive psychology. See COGNITION; DECISION THEORY. [R.Krz.]

**Decision support system** A system that supports technological and managerial decision making by assisting in the organization of knowledge about ill-structured, semistructured, or unstructured issues. A structured issue has a framework comprising elements and relations between them that are known and understood. Structured issues are generally ones about which an individual has considerable experiential familiarity. A decision support system (DSS) is not intended to provide support to humans about structured issues since little cognitively based decision support is generally needed.

Emphasis in the use of a decision support system is upon provision of support to decision makers in terms of increasing the effectiveness of the decision-making effort. This support involves the systems engineering steps of formulation of alternatives, the analysis of their impacts, and interpretation and selection of appropriate options for implementations. See SYSTEMS ENGINEERING.

Decisions may be described as structured or unstructured, depending upon whether or not the decision-making process can be explicitly described prior to its execution. Generally, operational performance decisions are more likely than strategic planning decisions to be prestructured. Thus, expert systems are usually more appropriate for operational performance and operational control decisions, while decision support systems are more appropriate for strategic planning and management control. See EXPERT SYSTEMS.

The primary components of a decision support system are a database management system (DBMS), a model-base management system (MBMS), and a dialog generation and management system (DGMS). An appropriate database management system must be able to work with both data that are internal to the organization and data that are external to it. Model-base management systems provide sophisticated analysis and interpretation capability. The dialog generation and management system is designed to satisfy knowledge representation, and control and interface requirements. See DECISION THEORY. [A.P.Sa.]

**Decision theory** A broad range of concepts which have been developed to both describe and prescribe the process of decision making, where a choice is made from a finite set of possible alternatives. Normative decision theory describes how

decisions should be made in order to accommodate a set of axioms believed to be desirable; descriptive decision theory deals with how people actually make decisions; and prescriptive decision theory formulates how decisions should be made in realistic settings. Thus, this field of study involves people from various disciplines: behavioral and social scientists and psychologists who generally attempt to discover elaborate descriptive models of the decision process of real humans in real settings; mathematicians and economists who are concerned with the axiomatic or normative theory of decisions; and engineers and managers who may be concerned with sophisticated prescriptive decision-making procedures.

**Categories of problems.** Efforts in decision theory may be divided into five categories:

1. Decision under certainty issues are those in which each alternative action results in one and only one outcome and where that outcome is sure to occur.

2. Decision under probabilistic uncertainty issues are those in which one of several outcomes can result from a given action depending on the state of nature, and these states occur with known probabilities. There are outcome uncertainties, and the probabilities associated with these are known precisely. See PROBABILITY.

3. Decision under probabilistic imprecision issues are those in which one of several outcomes can result from a given action depending on the state of nature, and these states occur with unknown or imprecisely specified probabilities. There are outcome uncertainties, and the probabilities associated with the uncertainty parameters are not all known precisely.

4. Decision under information imperfection issues are those in which one of several outcomes can result from a given action depending on the state of nature, and these states occur with imperfectly specified probabilities. There are outcome uncertainties, and the probabilities associated with these are not all known precisely. Imperfections in knowledge of the utility of the various event outcomes may exist as well.

5. Decision under conflict and cooperation issues are those in which there is more than a single decision maker, and where the objectives and activities of one decision maker are not necessarily known to all decision makers. Also, the objectives of the decision makers may differ.

Problems in any of these groupings may be approached from a normative, descriptive, or prescriptive perspective. Problems in category 5 are game theory-based problems. Most decision theory developments are concerned with issues in category 2. See GAME THEORY.

**Bases of normative decision theory.** The general concepts of axiomatic or normative decision theory formalize and rationalize the decision-making process. Normative decision theory depends on the following assumptions:

1. Past preferences are valid indicators of present and future preferences.

2. People correctly perceive the values of the uncertainties that are associated with the outcomes of decision alternatives.

3. People are able to assess decision situations correctly, and the resulting decision situation structural model is well formed and complete.

4. People make decisions that accurately reflect their true preferences over the alternative courses of action, each of which may have uncertain outcomes.

5. People are able to process decision information correctly.

6. Real decision situations provide people with decision alternatives that allow them to express their true preferences.

7. People accept the axioms that are assumed to develop the various normative theories.

8. People make decisions without being so overwhelmed by the complexity of actual decision situations that they would necessarily use suboptimal decision strategies.

Given these necessary assumptions, there will exist departures between normative and descriptive decision theories. A principal task of those aiding others in decision making is to retain those features from the descriptive approach which enable an acceptable transition from normative approaches to prescriptive approaches. The prescriptive features should eliminate potentially undesirable features of descriptive approaches, such as flawed judgment heuristics and information processing biases, while retaining acceptable features of the normative approaches. See DECISION ANALYSIS; DECISION SUPPORT SYSTEM.

**Determination of utility.** When choosing among alternatives, the decision maker must be able to indicate preferences among decisions that may result in diverse outcomes. In simple situations when only money is involved, an expected-value approach might be suggested, in which a larger expected amount of money is preferred to a smaller amount. However, in many situations the utility associated with money is not a linear function of the amount of money involved.

According to expected utility theory, the decision maker should seek to choose the alternative  $a_i$  which makes the resulting expected utility the largest possible. The utility  $u_{ij}$ , of choosing decision  $a_i$  and obtaining outcome event  $e_j$ , will also depend upon the particular value of the probabilistically uncertain random variable  $e_j$  as conditioned on the decision path that is selected. So, the best that the decision maker can do here is to maximize some function, such as the expected value or utility (EU), as shown below, where the maximization is carried out over all

$$\max_i EU\{a_i\} = \max_i \sum_{j=1}^n u_{ij} P(e_j | a_i)$$

alternative decisions, and  $P(e_j | a_i)$  is the probability that the state of nature is  $e_j$  given that alternative  $a_i$  is implemented. The notation  $EU\{a_i\}$  is often used to mean the expected utility of taking action  $a_i$ . Generally, this is also called the subjective expected utility (SEU). "Subjective" denotes the fact that the probabilities may be based on subjective beliefs and the utilities may reflect personal consequences. [A.P.Sa.]

**Decomposition potential** The electrode potential at which the electrolysis current begins to increase appreciably. Decomposition potentials are used as an approximate characteristic of industrial electrode processes. See ELECTROCHEMICAL PROCESS; ELECTROLYSIS.

Decomposition potentials are obtained by extrapolation of current-potential curves. Extrapolation is not precise because there is a progressive increase of current as the electrode potential is varied. The decomposition potential, for a given element, depends on the range of currents being considered. The cell voltage at which electrolysis becomes appreciable is approximately equal to the algebraic sum of the decomposition potentials of the reactions at the two electrodes and the ohmic drop, or voltage drop, in the electrolytic cell. The ohmic drop term is quite negligible for electrolytes with high conductance. For a discussion of current-potential curves see OVERVOLTAGE. See ELECTROLYTIC CONDUCTANCE. [PDe.]

**Decompression illness** Symptoms in humans which result from a sudden reduction in atmospheric pressure. It is also called dysbarism, caisson disease, the bends, and compressed-air illness. It is most commonly seen in two groups of subjects, (1) those who rapidly ascend in nonpressurized air-planes to altitudes in excess of 18,000 ft (5500 m), and (2) divers, scuba divers, sandhogs, and professional workers in hyperbaric chambers who work under increased ambient pressures and are decompressed. See DIVING.

This condition is caused by the formation of nitrogen bubbles in the tissues and blood vessels. These bubbles plug vessels and expand in tissue spaces producing the characteristic symptoms and signs of this illness. Helium, when present in high concen-

trations utilized by divers or found in some spacecraft, can also produce a similar condition.

The onset of symptoms may occur at any time from a few minutes to several hours after decompression. The most common manifestation is pain in the joints and muscles. However, skin, respiratory, and neurologic symptoms are not uncommon. The skin manifestations are itching, discoloration, and edema (swelling). Respiratory symptoms are coughing and dyspnea (difficulty in breathing). The neurologic symptoms vary from mild paresthesia (sensations of tingling, crawling, or burning of the skin) and weakness to total paralysis; loss of bladder and rectal sphincter control is common. The severe forms of this illness are followed by circulatory failure, paralysis, coma, and death.

Treatment is recompression, followed by gradual decompression to normal atmospheric pressure. Prognosis is generally good except in those subjects who show central nervous system damage. [McC.G.]

### Decontamination of radioactive materials

The removal of radioactive contamination which is deposited on surfaces or spread throughout a work area.

Decontamination methods are mechanical or chemical. Commonly used mechanical methods are vacuum cleaning, sand blasting, blasting with solid carbon dioxide, flame cleaning, scraping, ultrasonic cleaning, vibratory finishing, and using lasers to vaporize contaminants.

Chemical methods are used primarily to decontaminate components and tools that are immersed in a tank, either by means of a chemical solvent to dissolve the contaminant, or by using electropolishing techniques to remove the surface layer, including contaminants, from metals. Chemical decontamination methods are also used to remove radioactive deposits from the interior surfaces of piping, pumps, heat exchangers, and boilers. For these applications, the solvent is pumped or flushed through the system, dissolving the radioactive deposits. The solution itself is then radioactive, and the contaminants are typically removed using filters or ion-exchange resins. The use of this approach to clean the coolant systems of nuclear reactors has become common. Dilute chemical reagents, including organic acids, are used to decontaminate the primary coolant systems of operating nuclear power plants to minimize radiation exposure of the workers.

Personnel decontamination methods differ from those used for materials primarily because of the possibilities of injury to the subject. Soap and water (sequestrants and detergents) normally remove more than 99% of the contaminants. If it is necessary to remove the remainder, chemical methods which remove the outer layers of skin can be used. These chemicals, such as citric acid, potassium permanganate, and sodium bisulfite, should be used with caution and preferably under medical supervision because of the risk of injury to the skin surface. It is very difficult to remove radioactive material once it is fixed inside the body, and the safest and most reliable way to prevent radiation exposure from contamination is the application of health physics procedures to prevent entry of radioactive material into the body. [C.J.W.]

**Deep inelastic collisions** Either highly energetic collisions of elementary particles, namely, leptons and nucleons, which probe the nucleons' internal structure; or collisions between two heavy ions in which the two nuclei interact strongly while their nuclear surfaces overlap.

**Elementary-particle collisions.** Deep inelastic collisions of elementary particles are very energetic collisions between leptons such as electrons or neutrinos and nucleons (that is, protons or neutrons, typically in a nucleus) in which the target nucleon breaks up into many particles and the lepton is scattered through a large angle in the center-of-mass frame. These collisions are akin to the Rutherford scattering experiments in which most alpha particles went through a thin gold foil undeflected but some were deflected through large angles. In both cases, the

explanation for large deflections is that the incident particle encounters not a uniform sphere of material but a few hard or pointlike objects inside the target. The alpha particles encounter gold nuclei, while leptons strike quarks inside the nucleons. See ALPHA PARTICLES; LEPTON; NUCLEON; QUARKS; SCATTERING EXPERIMENTS (NUCLEI).

Deep inelastic scattering experiments are conducted to study the structure of protons and neutrons. In each collision the fraction  $x$  of the nucleon's momentum carried by the struck quark is measured, and thus the  $x$  distributions of quarks inside a proton are directly measured. These are known as structure functions. Studies of these have shown, among other things, that the momentum of a proton is not carried entirely by quarks. In fact, only about half the momentum can be ascribed to quarks. The other half is believed to be carried by gluons, which are carriers of the strong force which binds the quarks within nucleons and other hadrons. See GLUONS.

Modern-day experiments in deep inelastic scattering often use neutrinos or muons as probes. Neutrinos have the advantage that they are not affected by the electric charge of the target nucleus and hence scatter directly off the quarks. Muons are easy to detect and identify. However, the highest-energy deep inelastic collisions are carried out by using an electron-proton collider. These experiments aim to study structure functions at very low values of  $x$  where some models predict new behavior. The highest-energy deep inelastic collisions use electrons as probes to search for quark substructure. [M.V.P.]

**Heavy-ion collisions.** Deep inelastic collisions of heavy ions are characterized by features that are intermediate between those of comparatively simple quasielastic, few-nucleon transfer reactions and those of highly complex compound-nucleus reactions. These deep inelastic or damped collisions often occur for heavy-ion reactions at center-of-mass energies less than 5 MeV per nucleon above the Coulomb barrier. During the brief encounter of the two nuclei, large amounts of kinetic energy of radial and orbital motion can be dissipated. The lifetime of the dinuclear complex (analogous to a chemical molecule) corresponds to the time required for the intermediate system to make a partial rotation ( $10^{-22}$  s to  $5 \times 10^{-21}$  s). On separation, the final total kinetic energies of the two reaction fragments can be well below those corresponding to the Coulomb repulsion of spheres, indicating that the fragments are highly deformed in the exit channel, as is known to be the case for fission fragments. See NUCLEAR FISSION. [J.R.Hu.]

**Deep-marine sediments** The term "deep marine" refers to bathyal sedimentary environments occurring in water deeper than 200 m (656 ft), seaward of the continental shelf break, on the continental slope and the basin (see illustration). The continental rise, which represents that part of the continental margin between continental slope and abyssal plain, is included under the broad term "basin." On the slope and basin environments, sediment-gravity processes (slides, slumps, debris flows, and turbidity currents) and bottom currents are the dominant depositional mechanisms, although pelagic and hemipelagic deposition is also important. See BASIN; CONTINENTAL MARGIN; GULF OF MEXICO; MARINE SEDIMENTS.

**Types of processes.** The mechanics of deep-marine processes is critical in understanding the nature of transport and deposition of sand and mud in the deep sea. In deep-marine environments, gravity plays the most important role in transporting and depositing sediments. Sediment failure under gravity near the shelf edge commonly initiates gravity-driven deep-marine processes, such as slides, slumps, debris flows, and turbidity currents (see illustration). Sedimentary deposits reflect only depositional mechanisms, not transportational mechanisms. See SEDIMENTOLOGY.

A slide is a coherent mass of sediment that moves along a planar glide plane and shows no internal deformation. Slides represent translational movement. Submarine slides can travel

hundreds of kilometers. For example, the runout distance of Nuanu Slide in offshore Hawaii is 230 km (143 mi). Long runout distances of 50–100 km (31–62 mi) of slides are common.

A slump is a coherent mass of sediment that moves on a concave-up glide plane and undergoes rotational movements causing internal deformation.

A downslope increase in mass disaggregation results in the transformation of slumps into debris flows. Sediment is now transported as an incoherent viscous mass, as opposed to a coherent mass in slides and slumps. A debris flow is a sediment-gravity flow with plastic rheology (that is, fluids with yield strength) and laminar state. Deposition from debris flows occurs through freezing. The term "debris flow" is used here for both the process and the deposit of that process. The terms "debris flow" and "mass flow" are used interchangeably because each exhibits plastic flow behavior with shear stress distributed throughout the mass. Although only muddy debris flows (debris flows with mud matrix) received attention in the past, recent experimental and field studies show that sandy debris (debris flows with sand matrix) flows are equally important. Rheology is more important than grain-size distribution in controlling sandy debris flows, and the flows can develop in slurries of any grain size (very fine sand to gravel), any sorting (poor to well), any clay content (low to high), and any modality (unimodal and bimodal). See RHEOLOGY.

With increasing fluid content, plastic debris flows tend to become turbidity currents. Turbidity currents can occur in any part of the system (proximal and distal), and can also occur above debris flows due to flow transformation in density-stratified flows. A turbidity current is a sediment-gravity flow with newtonian rheology (that is, fluids without yield strength) and turbulent state. Deposition from turbidity currents occurs through suspension settling. Deposits of turbidity currents are called turbidites. Although turbidity currents have received a lot of emphasis in the past, other processes are equally important in the deep sea (see illustration). In terms of transporting coarse-grained sediment into the deep sea, sandy debris flows and other mass flows appear to play a greater role than turbidity currents.

**Bottom currents.** In large modern ocean basins, such as the Atlantic, thermohaline-induced geostrophic bottom currents within the deep and bottom water masses commonly flow approximately parallel to bathymetric contours (that is, along the slope (see illustration). They are generally referred to as contour currents. However, because not all bottom currents follow regional bathymetric contours, it is preferred that the term "contour current" be applied only to currents flowing parallel to bathymetric contours, and other currents be termed bottom currents. For example, wind-driven surface currents may flow in a circular motion (see illustration) and form eddies that reach the deep-sea floor, such as the Loop Current in the Gulf of Mexico, and the Gulf Stream in the North Atlantic. Local bottom currents that move up- and downslope can be generated by tides and internal waves, especially in submarine canyons. These currents are quite capable of erosion, transportation, and redeposition of fine-to-coarse sand in the deep sea. See also GULF STREAM; OCEAN CIRCULATION.

**Pelagic and hemipelagic settling.** Pelagic and hemipelagic processes generally refer to settling of mud fractions derived from the continents and shells of microfauna down through the water column throughout the entire deep-ocean floor (see illustration). Hemipelagites are deposits of hemipelagic settling of deep-sea mud in which more than 25% of the fraction coarser than 5 micrometers is of terrigenous, volcanogenic, or neritic origin. Although pelagic mud and hemipelagic mud accumulate throughout the entire deep-ocean floor, they are better preserved in parts of abyssal plains (see illustration). Rates of sedimentation vary from millimeters to greater than 50 cm (20 in.) per 1000 years, with the highest rates on the upper continental margin.

**Submarine slope environments.** Submarine slopes are considered to be of the sea floor between the shelf-slope break

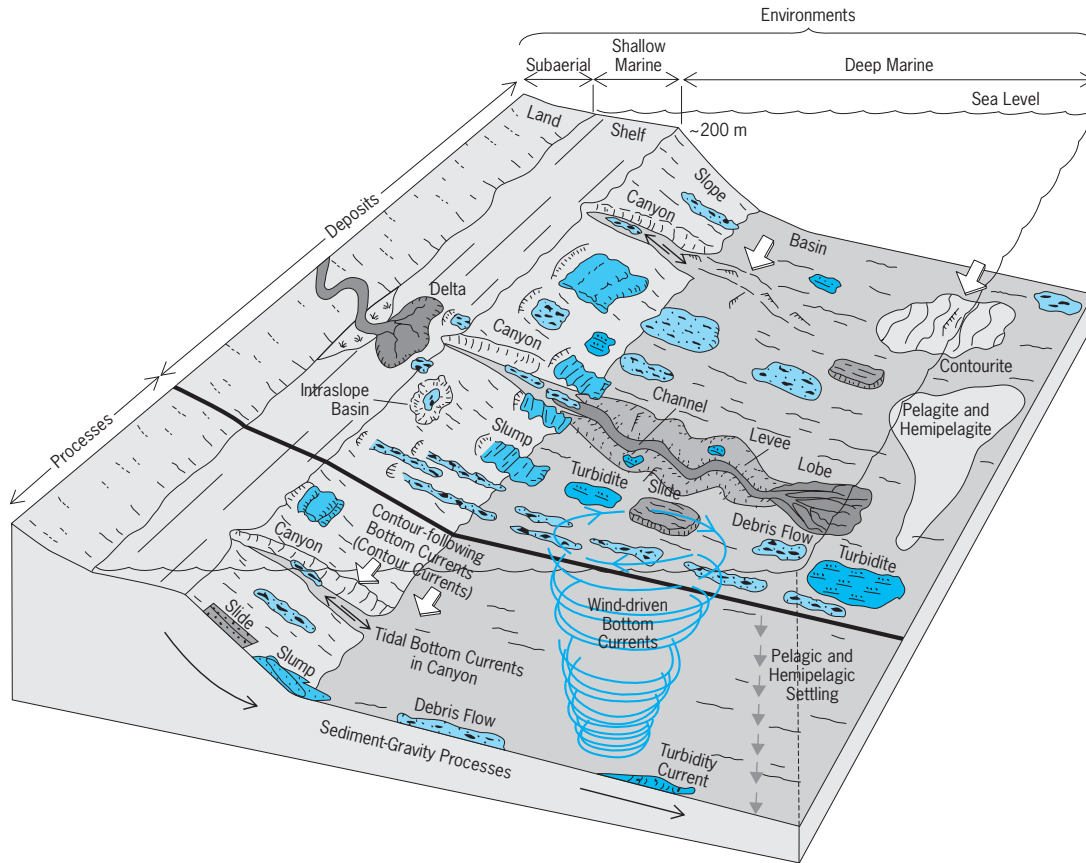

**Slope and basinal deep-marine sedimentary environments occurring at water depths greater than 200 m (656 ft). Slides, slumps, debris flows, turbidity currents, and various bottom currents are important processes in transporting and depositing sediment in the deep sea. Note the complex distribution of deep-marine deposits.**

and the basin floor (see illustration). Modern continental slopes around the world average  $4^\circ$ , but slopes range from less than  $1^\circ$  to greater than  $40^\circ$ . Slopes of active margins (for example, California and Oregon, about  $2^\circ$ ) are relatively steeper than those of passive margins (for example, Louisiana, about  $0.5^\circ$ ). On constructive continental margins with high sediment input, gravity tectonics involving salt and shale mobility and diapirism forms intraslope basins of various sizes and shapes (for example, Gulf of Mexico). Erosional features, such as canyons and gullies, characterize intraslope basins. Deposition of sand and mud occurs in intraslope basins. Slope morphology plays a major role in controlling deep-marine deposition through (1) steep versus gentle gradients, (2) presence or absence of canyons and gullies, (3) presence or absence of intraslope basins, and (4) influence of salt tectonics. See DIAPIR; EROSION.

**Submarine canyon and gully environments.** Submarine canyons and gullies are erosional features that tend to occur on the slope. Although canyons are larger than gullies, there are no standardized size criteria to distinguish between them. Submarine canyons are steep-sided valleys that incise the continental slope and shelf. They serve as major conduits for transporting sediment from land and the continental shelf to the basin floor. Modern canyons are relatively narrow, deeply incised, steeply walled, often sinuous valleys with predominantly V-shaped cross sections. Most canyons originate near the continental shelf break and generally extend to the base of the continental slope. Canyons commonly occur off the mouths of large rivers such as the Hudson and Mississippi, although many others, such as the Bering Canyon in the southern Bering Sea, have developed along structural trends. See BERING SEA.

Modern submarine canyons vary considerably in their dimensions. Their average length of canyons has been estimated to be about 55 km (34 mi), although the Bering Canyon, the world's longest, is nearly 1100 km (684 mi). The shortest canyons are those off the Hawaiian Islands, with average lengths of about 10 km (6.2 mi). [G.Sh.]

**Deep-sea fauna** The deep sea may be regarded as that part of the ocean below the upper limit of the continental slopes (see illustration). Its waters fill the deep ocean basins, cover about two-thirds of the Earth's surface, have an average depth of about 12,000 ft (4000 m), and provide living space for communities of animals that are quite different from those inhabiting the land-fringing waters which overlie the continental shelves (neritic zone). See ECOLOGICAL COMMUNITIES.

The deep-sea fauna consists of pelagic animals (swimming and floating forms between the surface and deep-sea floor) and below these the benthos, or bottom dwellers, which live on or near the ocean bottom. Pelagic animals can be divided into the usually smaller forms that tend to drift with the currents (zooplankton) and the larger and more active nekton, such as squids, fishes, and cetaceans. Pelagic, deep-sea animals are frequently termed bathypelagic in contrast to the epipelagic organisms of the surface waters (see illustration). See ZOOPLANKTON.

All animal life in the sea, pelagic and benthic, depends on the growth of microscopic plants (phytoplankton). From the surface down to a maximum depth of about 300 ft (100 m) there is sufficient light for photosynthesis and vigorous phytoplanktonic growth. This layer is known as the photic zone. See PHYTOPLANKTON.

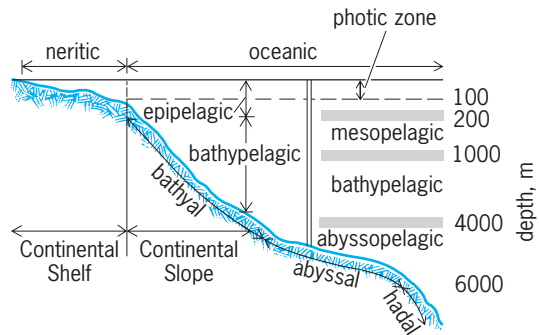

**Classification of marine environments.** Right side of diagram illustrates the proposal to divide the bathypelagic zone into mesopelagic, bathypelagic, and abyssopelagic zones. Division of benthic region into bathyal, abyssal, and hadal zones also is shown. 1 m = 3.3 ft.

**Bathypelagic fauna.** The typical bathypelagic animals begin to appear below depths of about 600 ft (200 m). The bathypelagic fauna is most diverse in the tropical and temperate parts of the ocean. Numerous species are found in all three temperature zones, but many appear to have a more limited distribution. Each species also has a definite vertical occurrence. Findings suggest that there are three main vertical zones, each with a characteristic community. Here the term bathypelagic is used for the fauna between about 3000 and 6000 ft (1000 and 2000 m), that above (between 600 and 3000 ft or 200 and 1000 m) being called mesopelagic and that below 6000 ft (2000 m) abyssopelagic (see illustration). The typical forms of the mesopelagic fauna (stomiatoids and lantern fishes) live in the twilight zone of the deep sea (between the 68 and 50°F or 20 and 10°C isotherms), while the bathypelagic species (ceratioid angler fishes and *Vampyroteuthis*) occur in the dark, cooler parts below the 50°F (10°C) isotherm.

Perhaps the most conspicuous feature of pelagic deep-sea life is the widespread occurrence of luminescent species bearing definite light organs (photophores). Many of the squids and fishes have definite patterns of such lights, as do some of the larger crustaceans (hoplophorid and sergestid prawns and euphausiids). Investigations have shown that flashes from luminescent organisms could be detected down to depths of 12,300 ft (3750 m). See BIOLUMINESCENCE; PHOTOPHORE GLAND.

**Benthic fauna.** There are two main ecological groups of bottom-living animals in the ocean: organisms that attach to the bottom and those that freely move over the bottom. The benthic fauna is most diverse in the temperate and tropical ocean, although the arctic and antarctic areas have their characteristic species. As in the pelagic fauna, certain species occur in all three oceanic zones, while others appear to have a more restricted occurrence. While a number of species—particularly among the polychaete worms, gastropod mollusks, and the brittle stars (Ophiuroidea)—range from littoral to abyssal regions, most forms tend to live within smaller ranges of depth. Data suggest that there are typical communities of animals over the continental slopes (see illustration) extending down to about 9000 ft (3000 m; bathyal zone); others occur below this in the abyssal zone. See MARINE ECOLOGY. [N.B.M.]

**Deep-sea trench** A long, narrow, very deep, and asymmetrical depression of the sea floor, with relatively steep sides. Oceanic trenches characterize active margins at the ocean-basin-continent or ocean-basin-island-arc boundaries. They contain the greatest oceanic depths and are associated with the most active volcanism, largest negative gravity anomalies, most frequent shallow seismicity, and almost all of the intermediate and deep-focus earthquake activity. As the surface expression of the widely accepted process of subduction by which oceanic crustal

material is returned to the upper mantle, they are key elements in current models of plate tectonic evolution on Earth and possibly on Venus. See PLATE TECTONICS; VOLCANOLOGY.

Deep-sea trenches are the signature relief form of the Pacific; in a counterclockwise direction, they occur from southern Chile to just northeast of North Island, New Zealand. A secondary or outer branch trends southward from near Tokyo Bay in a festoon of arcs to south of Palau. The principal gaps in the circum-Pacific chain are from Baja California to south-eastern Alaska, and off the northern coast of New Guinea. From eastern New Guinea to southern Vanuatu the trenches lie southwest, or "inside," the island chains; otherwise their characteristics are like those facing the Pacific. The Indian Ocean contains only the very long contorted Sunda Trench that appears near the northwestern end of Sumatra and extends southeast and east past Timor, to curve north and west near Aru and end adjacent to Buru. In the Atlantic, the Puerto Rico–Antillean trench system extends outside the island arc from eastern Hispaniola around to Trinidad; but south of 14°N, off Barbados, the trench is filled with sediment. In the far South Atlantic a typical island-arc-trench complex extends from near South Georgia through the South Sandwich Archipelago.

A series of pioneering gravity observations with pendulum instruments on Dutch submarines during the 1920s and 1930s established that the East Indian trenches, and several others, were characterized by a belt of negative gravity anomalies of 150–200+ milligals, that is, values 150–200 parts per million less than normal, interpretable as deficiency of mass near and at their axes.

It was established that oceanic crust is thin, that crust under island arcs is thicker, and its layers display different sound transmission velocities, indicating different composition. Shipboard studies in the Middle America, Tonga, Cedros, Aleutian, Peru-Chile, and Sunda trenches established that the characteristic oceanic crustal layer [that is, 6.8–7.0 km/s (4.1–4.2 mi/s) compressional wave velocity] does not end or thin under the trench; rather, it may thicken slightly but does deepen steeply as it passes beneath the island arc or continental slope by the process of subduction. See EARTH, GRAVITY FIELD OF; EARTH, HEAT FLOW IN; EARTH CRUST; FAULT AND FAULT STRUCTURES; OCEANIC ISLANDS; SEISMOLOGY; SUBDUCTION ZONES. [R.L.F.]

**Deer** The name for 41 species of even-toed ungulates (artiodactylids) that comprise the distinct and homogeneous family Cervidae. The males have antlers, which are bony out-growths on their heads that do not contain horn, are generally branched, and are shed yearly. The feet have four toes and, as such, are less developed than those of other ruminants. The third and fourth digits are well developed, while the second and fifth are small and do not touch the ground.

Musk deer occur in the mountains of central Asia at high altitudes in Tibet, Korea, Mongolia, and Siberia. They are solitary animals and are active nocturnally. The male has a scent gland, known as a pod or musk gland, in the skin of the abdomen in front of the navel that secretes musk, used as a fixative in the perfume industry.

A number of species of deer that occur throughout Eurasia are called European deer. The red deer (*Cervus elaphus*), one of the best-known species, is still common throughout Europe and also is found in southwestern Asia and northwestern Africa. These deer are closely related to the wapiti of North America.

One of the best-known species of American deer is the white-tailed deer (*Odocoileus virginianus*), which is also known as the Virginia deer. This animal is found to range in North America and into South America as far as Peru, where it prefers woods and thickets to heavily forested areas. In the western states the mule deer (*O. hemionus*) may be distinguished from the white-tailed deer by the long ears, black-tipped tail, and greater tendency to occur in herds. These animals range from Alaska to New Mexico and prefer more open habitats. The wapiti or North American



elk (*Cervus canadensis*) is more common in Canada than in the United States. The Key deer of the Florida Keys (*O. virginianus clavium*) is in danger of extinction because of the destruction of its habitat. See ARTIODACTYLA; MOOSE; REINDEER. [C.B.C.]

**Definite composition, law of** The law that a given chemical compound always contains the same elements in the same fixed proportions by weight. Thus, whatever its source, silver chloride always contains 100 g (3.53 oz) of silver to every 32.85 g (1.159 oz) of chlorine. If a compound is formed by the union of  $m$  atoms of one element, each weighing  $a$ , with  $n$  atoms of another element, each weighing  $b$ , the composition by weight of one molecule of the compound is in the ratio  $ma:nb$ . This must be the composition of any mass of the compound, provided that all atoms of the same kind have the same weight. It is now known that this is not usually the case but that the atoms of an element may consist of a number of isotopes, having different masses. However, as long as any sample of the element always contains the same relative proportions of the isotopes, the law still holds. Much more widespread and serious departures from the law of definite composition occur in a large variety of solid compounds (the nonstoichiometric compounds). See ISOTOPE; NONSTOICHIOMETRIC COMPOUNDS; STOICHIOMETRY. [T.C.W.]

**Defoliant and desiccant** Defoliants are chemicals that cause leaves to drop from plants; defoliation facilitates harvesting. Desiccants are chemicals that kill leaves of plants; the leaves may either drop off or remain attached; in the harvesting process the leaves are usually shattered and blown away from the harvested material. Defoliants are desirable for use on cotton plants because dry leaves are difficult to remove from the cotton fibers. Desiccants are used on many seed crops to hasten harvest; the leaves are cleaned from the seed in harvesting. Defoliants and desiccants have also been used during war to destroy vegetation. [A.S.C.]

**Degaussing** Neutralization of the magnetization of a ship by properly located and oriented current-carrying coils which produce a magnetic field of desired strength and direction. See DEMAGNETIZATION.

A steel ship has structural components of many different ferromagnetic characteristics. Many parts become magnetized during the construction, and retain that magnetization for a long time. Other parts are “soft” iron and do not retain a magnetized condition permanently but become magnetized by induction in the magnetic field of the Earth. The ship then has a magnetic field. This magnetization of the ship causes deviation of the magnetic compass and may trigger magnetic mines or other explosive devices when the ship passes near them. See MAGNETIZATION.

One method for neutralizing the magnetic field of the ship is to install coils in which currents are maintained to produce components of the field that will neutralize the field due to the magnetization of the ship. These coils are called degaussing coils. [K.V.M.]

**Degeneracy (quantum mechanics)** A term referring to the fact that two or more stationary states of the same quantum-mechanical system may have the same energy even though their wave functions are not the same. In this case the common energy level of the stationary states is degenerate. The statistical weight of the level is proportional to the order of degeneracy, that is, to the number of states with the same energy; this number is predicted from Schrödinger’s equation. In quantum mechanics and in other branches of mathematical physics, the term degeneracy is employed also to characterize the eigenvalues of operators other than the energy operator. See EIGENVALUE (QUANTUM MECHANICS). [E.G.]

**Degree-day** A unit used in estimating energy requirements for building heating and, to a lesser extent, for building cooling. It is applied to all fuels, district heating, and electric heating. Origin

of the degree-day was based on studies of residential gas heating systems. These studies indicated that there existed a straight-line relation between gas used and the extent to which the daily mean outside temperature fell below 65°F (18°C).

The number of degree-days to be recorded on any given day is obtained by averaging the daily maximum and minimum outside temperatures to obtain the daily mean temperature. The daily mean so obtained is subtracted from 65°F and tabulated. Monthly and seasonal totals of degree-days obtained in this way are available from local weather bureaus.

A frequent use of degree-days for a specific building is to determine before fuel storage tanks run dry when fuel oil deliveries should be made. Number of Btu which the heating plant must furnish to a building in a given period of time is

$$\text{Btu required} = \text{heat rate of building} \times 24 \times \text{degree-days}$$

where “Btu required” is the heat supplied by the heating system to maintain the desired inside temperature. “Heat rate of building” is the hourly building heat loss divided by the difference between inside and outside design temperatures. When the estimating procedure is applied to buildings with high levels of internal heat gains, as in a well-lighted office building, then degree-day data on other than a 65°F basis are required. See AIR CONDITIONING; COMFORT HEATING; PSYCHROMETRICS. [C.G.S.]

**Degree of freedom (mechanics)** Any one of the number of independent ways in which the space configuration of a mechanical system may change. A material particle confined to a line in space can be displaced only along the line, and therefore has one degree of freedom. A particle confined to a surface can be displaced in two perpendicular directions and accordingly has two degrees of freedom. A particle free in physical space has three degrees of freedom corresponding to three possible perpendicular displacements. A system composed of two free particles has six degrees of freedom, and one composed of  $N$  free particles has  $3N$  degrees. If a system of two particles is subject to a requirement that the particles remain a constant distance apart, the number of degrees of freedom becomes five. Any requirement which diminishes by one the degrees of freedom of a system is called a holonomic constraint. See CONSTRAINT. [R.A.Fi.]

**De Haas–van Alphen effect** An oscillatory behavior of the magnetic moment of a pure metal crystal with changes in the applied magnetic field  $B$ , at very low temperatures. It is named after its discoverers, W. J. de Haas and P. M. van Alphen. This effect has its origin in the Bohr-Sommerfeld quantization of the orbits of conduction electrons under the influence of the magnetic field.

A measurement of the temperature dependence of the oscillation amplitude permits a determination of the cyclotron frequency, or equivalently the electron mass. In a metal, as in a semiconductor, electrons behave with an effective mass  $m^*$  rather than the free electron mass, and the de Haas–van Alphen effect thus allows a measurement of  $m^*$  in metals. See KINETIC THEORY OF MATTER.

Application of the Bohr-Sommerfeld quantization rules shows that the “period” of the de Haas–van Alphen oscillations (it is a period in magnetic field, not time) is given by the equation below. Here  $a_p$  is the area of the orbit in momentum space of

$$\Delta \left( \frac{1}{B} \right) = \frac{2\pi \hbar e}{a_p}$$

an electron at the Fermi level, that is, the cross section of the Fermi surface;  $e$  is the charge of the electron; and  $\hbar$  is Planck’s constant divided by  $2\pi$ . By studying the dependence of  $a_p$  on the direction  $B$  of the magnetic field, sufficient information can be obtained to construct the detailed shape of the Fermi surfaces of a metal.

Virtually all metals available in sufficient purity have been studied by the de Haas-van Alphen effect. The effect is also the most powerful probe of Fermi surface properties in alloys and intermetallic compounds. See BAND THEORY OF SOLIDS; FERMI SURFACE. [J.B.K.]

**Dehumidifier** Equipment designed to reduce the amount of water vapor in the atmosphere. There are three methods by which water vapor may be removed: (1) the use of sorbent materials, (2) cooling to the required dew point, and (3) compression with aftercooling. See DEW POINT.

Sorbents are materials which are hygroscopic to water vapor. Solid sorbents include silica gels, activated alumina, and aluminum bauxite. Liquid sorbents include halogen salts such as lithium chloride, lithium bromide, and calcium chloride, and organic liquids such as ethylene, diethylene, and triethylene glycols and glycol derivatives.

Solid sorbents may be used in static or dynamic dehumidifiers. Bags of solid sorbent materials within packages of machine tools, electronic equipment, and other valuable materials subject to moisture damage constitute static dehumidifiers. A dynamic dehumidifier for solid sorbent consists of a main circulating fan, one or more beds of sorbent material, reactivation air fan, heater, mechanism to change from dehumidifying to reactivation, and aftercooler.

The liquid-sorbent dehumidifier consists of a main circulating fan, sorbent-air contactor, sorbent pump, and reactivator including contactor, fan, heater, and cooler. This unit will control the effluent dew point at a constant level because dehumidification and reactivation are continuous operations with a small part of the sorbent constantly bled off from the main circulating system and reactivated to the concentration required for the desired effluent dew point.

A system employing the use of cooling for dehumidifying consists of a circulating fan and cooling coil. The cooling coil may use cold water obtained from wells or a refrigeration plant, or may be a direct-expansion refrigeration coil. In place of a coil, a spray washer may be used in which the air passes through two or more banks of sprays of cold water or brine, depending upon the dew-point temperature required.

Dehumidifying by compression and aftercooling is used when the reduction of water vapor in a compressed-air system is required. This is particularly important, for example, if the air is used for automatic control instruments or cleaning of delicate machined parts. The power required for compression systems is so high compared to power requirements for dehumidifying by either the sorbent or refrigeration method that the compression system is not an economical one if dehumidifying is the only end result required. [J.E.]

**Dehydrogenation** A reaction in which hydrogen is detached from a molecule. The reaction is strongly endothermic, and therefore heat must be supplied to maintain the reaction temperature. When the detached hydrogen is immediately oxidized, two benefits accrue: (1) the conversion of reactants to products is increased because the equilibrium concentration is shifted toward the products (law of mass action); and (2) the added exothermic oxidation reaction supplies the needed heat of reaction. This process is called oxidative dehydrogenation. On the other hand, excess hydrogen is sometimes added to a dehydrogenation reaction in order to diminish the complete breakup of the molecule into many fragments.

The primary types of dehydrogenation reactions are vapor-phase conversion of primary alcohols to aldehydes, vapor-phase conversion of secondary alcohols to ketones, dehydrogenation of a side chain, and catalytic reforming of naphthas and naphthenes in the presence of a platinum catalyst. All four of these types of dehydrogenation reactions are of major industrial importance. They account for the production of billions of pounds of organic compounds that enter into the manufacture of lu-

bricants, explosives, plastics, plasticizers, and elastomers. See HYDROGENATION; OXIDATION PROCESS. [J.W.Fu.]

**Delay line** A transmission line (as nearly dissipationless as possible) or an electric network approximation of it which, if terminated in its characteristic impedance, will reproduce at its output a waveform applied to its input terminals with little distortion but at a time delayed by an amount dependent upon the electrical length of the line.

Delay lines are also used for establishing a time sequence for the occurrence of events. A delay line with a total length equal to the greatest time delay required in a system may be used as a basic element. Pulses occurring at intermediate times may be obtained from taps at various points along the line. A specific application is found in the synchronizing signal generator of the television system. Also, the lumped-circuit delay line is an essential element of the wide-band distributed amplifier.

When a signal is digital in nature, or consists of a series of pulses, the series of pulses may be delayed by using a shift register, which might, for example, consist of a chain of cascaded type D flip-flops. If the register has  $n$  stages, the pulse series will appear at the output delayed by a time  $(n - 1)T$ , where  $T$  is the interval between consecutive pulses of the system timing clock. The same function can be realized by using switched-capacitor circuits or an array of charge-coupled devices. See CHARGE-COUPLED DEVICES; SWITCHED CAPACITOR; TRANSMISSION LINES. [G.M.G.]

**Delayed neutron** A neutron emitted spontaneously from a nucleus as a consequence of excitation remaining from a preceding radioactive decay event. Analogously, delayed emission of protons and alpha particles is also observed, but the known delayed neutron emitters are more numerous, and some of them have practical implications. In particular, they are of importance in the control of nuclear chain reactors.

In a  $^{235}\text{U}$  nuclear reactor, about 0.7% of the neutrons are delayed, the others being prompt. In a conventional, moderated reactor, the prompt neutrons are born, slowed down, and reabsorbed to produce the next fissions in a cycling time of about 1 millisecond. (In a fast-neutron reactor, the time is much shorter.) Consequently, if the reactor were to become overcritical (more neutrons generated per millisecond than are absorbed or leak out), the chain reaction would exponentiate or "run away," and the reactor might overheat itself and possibly cause a dangerous accident unless the control rods could respond within a few milliseconds to correct the situation. The fortunate presence of the delayed neutrons eases the situation, because so long as the reactor operates within the margin of 0.7% ("delayed critical"), the control rods can take as long as several seconds to respond, and thus the chain reaction comes within the range of easy and leisurely control. See NEUTRON; NUCLEAR FISSION; REACTOR PHYSICS. [A.H.Sn.]

**Deliquescence** The absorption of atmospheric water vapor by a crystalline solid until the crystal eventually dissolves into a saturated solution. This behavior is well known for certain salts such as hydrated calcium chloride,  $\text{CaCl}_2 \cdot 6\text{H}_2\text{O}$ , and zinc chloride,  $\text{ZnCl}_2$ , but it is a property of all soluble salts in air of sufficiently high humidity.

Thermodynamically, the condition for deliquescence is that the partial pressure of the water vapor in the air exceeds the vapor pressure (aqueous tension) of the water in the saturated solution of the salt. The speed at which the process takes place depends upon the rate of diffusion of water vapor into the crystal lattice, crystal size, and other factors. The process will stop when the water vapor in the atmosphere is depleted to the point at which its partial pressure equals that of the saturated solution.

Crystalline solids also may absorb water by increasing their water of hydration if the dissociation pressure of the hydrated species to be formed is less than the partial pressure of the water

vapor. It is this process, not deliquescence, which is the opposite of efflorescence.

Deliquescent substances can be used to remove water vapor from air, although they have no special advantage over substances which merely add water of hydration and remain crystalline. See DESICCANT; EFFLORESCENCE; VAPOR PRESSURE. [R.L.S.]

**Delocalization** A phenomenon in which the most loosely held bonding electrons of some molecules serve to bind not two but several atoms. This contrasts with localization, a characteristic of ordinary single bonds, as in the normal paraffins, for example, methane ( $\text{CH}_4$ ); in ethane, ( $\text{C}_2\text{H}_6$ ); or in the molecules water ( $\text{H}_2\text{O}$ ) and ammonia ( $\text{NH}_3$ ). See CHEMICAL BONDING.

The prototype completely delocalized system is the ideal crystalline metal, in which the valence electrons are spaced uniformly over a periodic lattice of positive-ion cores. This confers a special stability to the metal, and it also accounts for its high electrical conductivity and other metallic properties. See METAL.

The aromatic and conjugated molecules of organic chemistry contain delocalized electronic systems. The benzene molecule ( $\text{C}_6\text{H}_6$ ) is considered the archetypal aromatic molecule. Benzene possesses an underlying single-bonded planar framework ( $\text{C}_6\text{H}_6$ )<sup>6+</sup> plus six additional electrons. Available for these electrons are six 2p orbitals, one on every carbon atom, each perpendicular to the molecular plane. The six electrons, called pi electrons, are ascribable to the six carbon atoms in such a way that neither structure (1) nor structure (2) is an accurate repre-

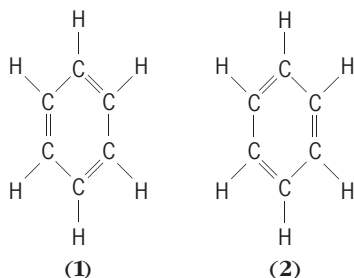

sentation, but instead a structure that can be described in the valence bond language as a resonance hybrid of the two, schematically written as (3), where the circle stands for the delocalized

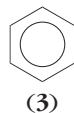

electrons. All molecules containing such rings possess an extra stability associated with the delocalization phenomenon. As a consequence, they also have a low propensity for chemical reactivity. See AROMATIC; MOLECULAR ORBITAL THEORY; RESONANCE (MOLECULAR STRUCTURE). [R.G.P.]

**Delta** A deposit of sediment at the mouth of a river or tidal inlet. It is also used for storm washovers of barrier islands and for sediment accumulations at the mouths of submarine canyons. See FLOODPLAIN.

The shape and internal structure of a delta depend on the nature and interaction of two forces: the sediment-carrying stream from a river, tidal inlet, or submarine canyon, and the current and wave action of the water body in which the delta is building. This interaction ranges from complete dominance of the sediment-carrying stream (still-water deltas) to complete dominance of currents and waves, resulting in redistribution of the sediment over a wide area (no deltas). This interaction has a large effect on the shape and structure of the delta body.

Most of the sediment carried into the basin is deposited when the inflowing stream decelerates. If there is little density contrast, this deceleration is sudden and most sediment is deposited near the mouth of the river. If the inflowing water is much lighter

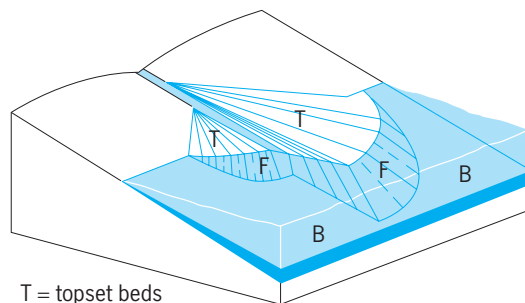

T = topset beds  
F = foreset beds  
B = bottomset beds

Schematic diagram showing two stages of growth and a Gilbert-type delta. (After P. H. Kuenen, *Marine Geology*, John Wiley, 1950).

than the basin water, for example, fresh water flowing into a colder sea, the outflow spreads at the surface over a large distance away from the outlet. If the inflow is very dense, for instance, cold muddy water in a warm lake, it may form a density flow on or near the bottom, and the principal deposition may occur at great distance from the outlet.

Three principal components make up the bodies of most deltas in varying proportions: topset, foreset, and bottomset beds (see illustration). As defined for most deltas, the topset beds comprise the sediments formed on the subaerial delta: channel deposits, natural levees, floodplains, marshes, and swamp and bay sediments. The foreset beds are those formed in shallow water, mostly as a broad platform fronting the delta shore, and the bottomset beds are the deep-water deposits beyond the deltaic bulge. In marine deltas the fluvial influence decreases and the marine influence increases from the topset to the bottomset beds.

In a different way, deltas can be viewed as being composed of three structural elements: (1) a framework of elongate coarse bodies (channels, river-mouth bars, levee deposits), which radiate from the apex to the distributary mouths (sand fingers); (2) a matrix of fine-grained floodplain, marsh, and bay sediments; and (3) a littoral zone, usually of beach and dune sands which result from sorting and longshore transport of river-mouth deposits by waves, currents, tides, and wind. The relative proportions of these components vary widely. The Mississippi delta consists almost entirely of framework and matrix; its rapid seaward growth is the result of deposition of river-mouth bars and extension of levees, and the areas in between are filled later with matrix. This gives the delta its characteristic bird-foot outline. A different makeup is presented by the Rhone delta, where the supply of coarse material at the distributary mouths is slow, and dispersal by wave action and longshore drift fairly efficient, so that nearly all material is evenly redistributed as a series of coastal bars and dunes across a large part of the delta front. This delta advances as a broad lobate front, while the present Mississippi delta grows at several localized and sharply defined points.

Despite difficult engineering problems, many cities, such as Calcutta, Shanghai, Venice, Alexandria (Egypt), and New Orleans, were constructed on deltas. These problems include shifting and extending shipping channels; lack of firm footing for construction except on levees; steady subsidence; poor drainage; and extensive flood danger. Moreover, in certain deltas the tendency of the main flow to shift away to entirely different areas, with resulting disappearance of the main channels for water traffic, is a constant problem that is difficult and costly to counter. See ESTUARINE OCEANOGRAPHY. [T.H.V.A.]

**Delta electrons** Energetic electrons ejected from atoms in matter by the passage of ionizing particles. In every primary ionizing collision between a charged particle and an atom, one or more electrons are ejected. Delta electrons are, by definition, that small fraction of these emitted electrons having energies

which are large compared to the ionization potential. The name is a traditional one—comparable to alpha particles, for energetic helium nuclei, and beta particles, for energetic electrons emitted in radioactive decays. See ALPHA PARTICLES; BETA PARTICLES; IONIZATION.

Delta electrons are responsible for the “hairy” appearance of charged particle tracks when they are observed in cloud chambers or in photographic emulsions. In studies of super-high-energy particles in cosmic radiation and from the highest-energy accelerators, observation of the number of delta electrons per centimeter of path length has been shown to lead to a reliable determination of the charge of the energetic particle. [D.A.B.]

**Delta resonance** A member of a class of subatomic particles called baryons, which exists in four electric charge states and has a total spin of  $J = 3/2$ . In the underlying quark model, the delta resonance ( $\Delta$ ) consists of three quarks whose intrinsic spins of  $1/2$  are lined up in the same direction. The  $\Delta$  is closely related to the more familiar nucleon constituents of atomic nuclei, the neutrons ( $n$ ) and protons ( $p$ ). See NUCLEON; QUARKS.

The  $\Delta$  was first observed as a resonant interaction of a beam of pi mesons ( $\pi$ ) with a proton target. The probability of a scattering interaction between the  $\pi$  and the proton is strongly dependent on energy, attaining a maximum at the  $\Delta$  mass of 1236 MeV/ $c^2$  (where  $c$  is the speed of light). The formation of the very short-lived  $\Delta$  (with a lifetime on the order of  $10^{-23}$  s) followed immediately by its decay back into pion and nucleon. See MESON; SCATTERING EXPERIMENTS (NUCLEI).

The  $\Delta$  plays an important role in a wide variety of nuclear phenomena, even under conditions of low energy and momentum transfer. The study of these phenomena reveals much about the presence of pions in nuclei, in addition to neutrons and protons. See BARYON; ELEMENTARY PARTICLE; NUCLEAR STRUCTURE. [C.D.]

**Demagnetization** The reduction or elimination of the magnetic moment in an object; that is, the reverse of magnetization. It is commonly encountered as a procedure for eliminating the inadvertent magnetization of iron (or other ferromagnetic) parts of a sensitive mechanical device that would otherwise result in a malfunction. A suitably intense magnetic field applied in a direction opposite to that of the existing magnetization will serve to reduce or destroy that magnetization. (Alternatively, the material could, if practical, be heated to a temperature above its Curie point, then returned to room temperature, in the absence of any external magnetic field.) The adiabatic (isentropic) demagnetization of paramagnetic materials is a technique used to produce temperatures very near absolute zero. It has been used to cool and study a magnetic substance itself or, through thermal contact, a secondary substance (refrigeration). See ADIABATIC DEMAGNETIZATION; FERROMAGNETISM; MAGNETIZATION. [R.P.Hu.]

**Demodulator** A device used to recover the original modulating signal from a modulated wave. A demodulator is also known as a detector.

In communications systems and in some automatic control systems, the information to be transmitted is first impressed upon a periodic wave called a carrier. The carrier is then said to be modulated. After reception of the modulated carrier, the original modulating signal is recovered by the process of demodulation or detection.

The amplitude, frequency, or phase of a carrier may be changed in the modulation process. Therefore, the process of demodulation and the practical circuits for accomplishing it differ in each case. However, all demodulators require the use of a nonlinear device in order to recover the original modulating frequencies, because these frequencies are not present in the modulated carrier and new frequencies cannot be produced by a linear device. See AMPLITUDE MODULATION; FREQUENCY MODULATION; PHASE MODULATION.

A semiconductor diode is frequently used to demodulate an amplitude-modulated (AM) carrier. A simple filter consisting of capacitance and resistance is used to eliminate the carrier and other undesired frequencies from the output of the demodulator. Another common AM detector uses a multiplier circuit, available as a semiconductor chip. A square-law detector is often used to demodulate single-sideband (SSB) signals. A multiplier chip with both inputs tied together serves nicely as a squaring circuit and may be used as a low-distortion demodulator for SSB signals. See AMPLITUDE-MODULATION DETECTOR; ELECTRIC FILTER; RECTIFIER; SEMICONDUCTOR DIODE; SINGLE SIDEBAND.

Frequency-modulated (FM) signals and phase-modulated (PM) signals may generally be demodulated by the same type of circuits, the only difference being the filter circuits in their respective outputs.

There are two basic classes of FM or PM demodulators. The first type, known as discriminators, use tuned circuits to change frequency or phase variations into amplitude variations and then use amplitude-demodulating devices such as diodes or a multiplier to recover the modulating frequencies. The second class or type of FM demodulator is the phase-locked loop, which includes a phase detector that may be a multiplier, a low-pass filter, and a voltage-controlled oscillator that produces a frequency proportional to its control voltage. The output of the phase detector is proportional to the phase difference between the incoming FM or PM signal and the voltage-controlled oscillator output. This phase detector output, after filtering, is the desired original modulating signal and also provides the control voltage needed to keep the voltage-controlled oscillator locked to the incoming signal frequency. These phase-locked loops are available as integrated semiconductor circuits, or chips. See FREQUENCY-MODULATION DETECTOR; PHASE-MODULATION DETECTOR.

Amplitude modulation and demodulation may be accomplished with the same device. For example, a multiplier performs both of these functions. In addition, phase-locked loops incorporate all the basic circuits needed for the modulation and demodulation of FM, PM, and AM signals. Therefore, circuits have been devised that will either modulate or demodulate FM, PM, and AM signals. These circuits are known as modems and are commonly used in modern communications systems. See MODEM.

A carrier wave may be modulated in both amplitude and phase simultaneously when a digital signal is being transmitted. The commonly used system employing this technique uses a  $90^\circ$  phase modulation and a two-level amplitude modulation and is called quadrature amplitude modulation (QAM).

The development of optical demodulators came with the advent of optical-frequency communications systems. See MODULATION; MODULATOR; OPTICAL COMMUNICATIONS; OPTICAL DETECTORS. [C.L.A.]

**Demospongiae** A class of the phylum Porifera, including sponges with a skeleton of one- to four-rayed siliceous spicules or of spongin fibers or both. Several genera lack a skeleton. The Demospongiae constitute the most abundant and widely distributed group of sponges, occurring in the sea from the tidal zone down to abyssal depths (at least 18,000 ft or 5500 m). One family has invaded fresh water. The species vary in size from thin encrustations several centimeters in diameter to huge cake-shaped forms which may measure up to as much as 6.5 ft (2 m) in diameter. See PORIFERA.

Comparative studies of the embryology and early attached stages of sponges of the class Demospongiae suggest at least two evolutionary lines within this group: the subclass Ceractinomorpha and the subclass Tetractinomorpha. [W.D.H.]

**Dendritic macromolecule** A large molecule having a well-defined three-dimensional structure. Dendritic macromolecules play a crucial role in the chemistry of living systems. In contrast to the high level of structural precision that characterizes

many biologically active macromolecules, the sizes and shapes of macromolecules made by polymer chemists are usually far less controlled. Most synthetic polymers are best described as statistical mixtures. However, chemists have sought to develop ways to prepare large molecules with more control over their architecture. If properly designed, such molecules might be capable of performing chemical or physical functions reminiscent of the macromolecules found in living systems.

Dendritic macromolecules are characterized by a highly branched molecular connectivity, whereby each repeat unit forms a branch juncture. The monomers used to prepare dendrimers possess three or more functional groups, and are of the type  $AB_2$ ,  $AB_3$ , and so forth, where A and B represent a functionality (a site of chemical activity) that can combine to form a new covalent bond. Monomer chemistry is thus similar to that used to make condensation polymers except that the functionality is higher (there are more sites of chemical activity). See POLYMER.

The architectures of dendritic macromolecules are dramatically different from those of conventional macromolecules. Variations in molecular size, shape, and flexibility are all possible, depending on the monomer's chemical structure and geometry, the branch-point multiplicity, and the number of repetitive cycles carried out. The architecture most typical of dendritic macromolecules is a globular shape where segment density increases in going from the core to the periphery. The unusual structure of dendritic macromolecules, yet to be fully investigated, results in rheological and solubility characteristics that are dramatically different from linear macromolecules. [J.S.Mo.]

**Dendroceratida** A small order of sponges of the class Demospongiae. Members of this order either have a skeleton of spongin fibers or lack a skeleton. The spongin fibers, when present, are typically dendritic in form, seldom anastomosing to form a network, and arise from a basal plate of spongin adherent to the substratum. The fibers, which in most genera lack foreign inclusions such as sand grains, are made up of concentric layers of spongin, new layers apparently being added throughout the life of the sponge. The flagellated chambers are large and sac-shaped and open directly into the exhalant canals without the intervention of a special channel. Dendroceratid sponges occur chiefly in tidal and shallow coastal regions of all seas. [W.D.H.]

**Dendrochronology** The science that uses annual tree rings dated to their exact year of formation for dating historical and environmental events and processes. Trees, like most plants, are sensitive to both natural (precipitation and temperature patterns) and human-related (air and water pollution) events that trigger certain responses in the vigor of the tree as seen in its growth rate. In most geographic regions, climate patterns in any year cause a response by trees in the volume of wood the tree produces, and often leave indelible "fingerprints" in certain physical and chemical properties of the wood. These fingerprints can be seen in the varying widths of tree rings. In some years, environmental conditions may be favorable for tree growth, allowing trees to produce greater volumes of wood. In other years, climate conditions may be generally unfavorable for tree growth, causing a reduction in the volume of wood produced. See DENDROLOGY; TREE; TREE GROWTH.

Crossdating is the primary guiding principle in dendrochronology, and concerns the matching of patterns of ring widths from one tree with corresponding patterns for the same years from another tree. Crossdating allows scientists to accurately assign calendar dates to tree rings by matching the sequence of tree-ring widths against a known reference chronology. Crossdating is possible because climate is largely a regional phenomenon, affecting trees in a like manner, so that similar patterns of ring widths are produced among many trees. Furthermore, crossdating helps identify false and locally absent rings that may otherwise be recorded as true rings.

Dendrochronology has become a useful tool in many areas of research. Dendroarchaeology uses tree rings to date wood material from archeological sites or artifacts, and is most often applied in the southwestern United States and Europe. In dendroclimatology climatic information is mathematically extracted from the tree-ring record and reconstructed back in time for the length of the tree-ring record. Dendroclimatologists also use tree-ring records to quantify the rising levels of atmospheric carbon dioxide to better understand global warming. Dendroecology analyzes changes in ecological processes over time using tree-ring information. Dendropyrochronology reconstructs the history of wildfires from tree rings. Dendrogeomorphology studies earth surface processes using tree-ring data. Dendrohydrology uses tree-ring data to investigate and reconstruct hydrologic properties, such as streamflow and riverflow, runoff, and past lake levels. Dendrochemistry is an important, emerging field of dendrochronology that analyzes the chemical composition of tree rings, especially the mineral elements. See ANALYTICAL CHEMISTRY; ARCHEOLOGY; ECOLOGY; GEOMORPHOLOGY; HYDROLOGY. [H.D.G.M.]

**Dendrology** The division of forestry concerned with taxonomy of trees and other woody plants. Dendrology, called forest botany in some countries, usually is limited to taxonomy of trees but may also include shrubs and woody vines. This basic subject in the training of foresters teaches how trees are named (nomenclature), described (morphology), and grouped (classification); how to find the name of an unknown tree and recognize important forest species (identification); and where trees occur both by geographic ranges of species and by forest types (distribution). Forest stands of similar composition, appearance, and structure are grouped together into areas characterized by major forest types or formation, and are named from the predominant or characteristic species. See FOREST AND FORESTRY; PLANT TAXONOMY. [E.L.L.]

**Density** The mass per unit volume of a material. The term is applicable to mixtures and pure substances and to matter in the solid, liquid, gaseous, or plasma state. Density of all matter depends on temperature; the density of a mixture may depend on its composition, and the density of a gas on its pressure. Common units of density are grams per cubic centimeter, and slugs or pounds per cubic foot. The specific gravity of a material is defined as the ratio of its density to the density of some standard material, such as water at a specified temperature, for example, 60°F (15.6°C), or, for gases the basis may be air at standard temperature and pressure. Another related concept is weight density, which is defined as the weight of a unit volume of the material. See DENSITY MEASUREMENT; MASS; WEIGHT. [L.N.]

**Density matrix** A matrix which is constructed as the most general statistical description of the states of a many-particle quantum-mechanical system. The state of a quantum system is described by a normalized wave function  $\psi(x, t)$  [where  $x$  stands for all coordinates of the system, and  $t$  for the time], which satisfies the Schrödinger equation (1), where  $H$  is the hamiltonian of the system, and  $\hbar$  is Planck's constant divided by  $2\pi$ . Furthermore,  $\psi(x, t)$  may be expanded in terms of a complete orthonormal set  $\{\varphi(x)\}$ , as in Eq. (2). Then, the density matrix is defined by Eq. (3), and this density matrix describes a pure

$$H\psi(x, t) = \frac{\hbar}{i} \frac{\partial \psi(x, t)}{\partial t} \quad (1)$$

$$\psi(x, t) = \sum_n a_n(t) \varphi_n(x) \quad (2)$$

$$\rho_{mn}(t) = a_n^*(t) a_m(t) \quad (3)$$

state. Examples of pure states are a beam of polarized electrons and the photons in a coherent beam emitted from a laser. See LASER; QUANTUM MECHANICS.

In quantum statistics, one deals with an ensemble of  $N$  systems which have the same hamiltonian. If the  $\alpha$ th member of the ensemble is in the state  $\psi^\alpha$  in Eq. (4), the density matrix is defined as the ensemble average, Eq. (5). In general, this density matrix

$$\psi^\alpha(x, t) = \sum_n a_n^\alpha(t) \varphi_n(x) \quad (4)$$

$$\rho_{mn}(t) = \frac{1}{N} \sum_\alpha [a_n^\alpha(t)]^* a_m^\alpha(t) \quad (5)$$

describes a mixed state, for example, a beam of unpolarized electrons or the photons emitted from an incoherent source such as an incandescent lamp. The pure state is a special case of the mixed state when all members of the ensemble are in the same state. See STATISTICAL MECHANICS. [S.H.L.]

**Density measurement** Determination of the mass per unit volume of a substance. The term density is equally applicable to solids (including powders), liquids, and gases. Usually values of density are given in terms of grams per cubic centimeter or pounds per cubic foot. The density of all substances depends on temperature; in the case of gases, on temperature and pressure. The temperature used as a base for determining or reporting values of density is not the same for all substances. For solids 32°F (0°C) is the preferred temperature, although some tables give values at average room temperature because the effect of temperature on density is relatively small for most solids. The effect of temperature on density is more pronounced in liquids, so that the temperature must always be stated along with the density value. For many liquids the reference temperature is 60°F (15.6°C). For gases 32°F and a pressure of 29.921 in. of mercury (or 0°C and 760 mm of mercury or 101.325 kilopascals) are used for most scientific work and for tables of gas data. For fuel gases 60°F (15.6°C) and a pressure of 14.73 lb/in.<sup>2</sup> absolute (29.99 in. mercury or 101.56 kPa) are the values used in the United States.

In the case of a solid, if the sample is of regular shape, such as a cube or a cylinder, its volume may be determined by linear measurement. The mass of the sample is determined by weighing it on a suitable scale or balance; then this weight divided by the volume gives the density. Ordinarily the weighing is done in air, and the density value is the density in air, or apparent density. By adjusting for the buoyant effect of the air upon the weight of the sample, the real density is obtained.

A second procedure, applicable to irregular as well as regular shaped samples, is to weigh the sample in air and then to suspend it in a liquid of known density. The volume of the sample is equal to its loss of weight in the liquid divided by the density of the liquid. This is the method of hydrostatic weighing.

One method to determine the density of a gas is to completely evacuate a light but strong vessel of suitable size, the interior volume of which is known. The evacuated vessel is weighed, filled with a sample of the gas, and then weighed again. Of course the pressure and temperature of this sample of gas must be obtained.

A densitometer or gravitometer may be used to indicate and record the density of a flowing stream of a liquid or a gas. In a densitometer, a spinning propeller produces a pressure difference between inlet and outlet chambers of the device, which is proportional to the density of the gas flowing through it. [H.S.B.]

Two precision methods, the oscillator or vibrator method and the magnetic method, have emerged which allow more rapid and accurate determinations on liquid systems.

In the oscillator method, the density of a sample is related to the change in resonance frequency of a laterally vibrating tube. This frequency is inversely proportional to the square root of the mass of the tube and its contents. By calibrating the tube with media of known density at a given temperature, the density of unknown solutions may be determined if the volumes are strictly identical. It is now established, that the accuracy of

this method decreases as the viscosity of the medium increases. Hence, accurate viscosity measurements must accompany the density calibrations for a given instrument.

The instruments used in the magnetic method are called magnetic densimeters. This densimeter is a device whereby a tiny ferromagnetic cylinder, encased in a glass or plastic jacket, is held at a precise height within a medium by virtue of a solenoid controlled by a servo system in circuit with a height sensor. The jacket and ferromagnetic material constitute a buoy or float. The solenoid induces a magnetic moment  $M$  at the buoy which is proportional to the electric current  $I$  to the solenoid. The total magnetic force on the buoy is the product of this moment and the field gradient,  $dH/dz$ , where  $H$  is the magnetic intensity and  $z$  is the vertical distance from the center of the solenoid. The field gradient varies with  $z$  and is also proportional to the current. Thus the total magnetic force at a particular distance  $z$  in the solution which compensates for the difference in the opposing forces of gravity (downward) and the buoyancy (upward) exerted by the medium, through Archimedes' principle, is  $M(dH/dz)$ . The magnetic force, under proper conditions, is directly proportional to the square of the current, which can be measured very accurately. Thus  $M(dH/dz) = kI^2$ , where  $k$  is a constant. If the buoyant force on the buoy is sufficient to make it float on the liquids of interest, the force generated by the solenoid must be downward to add to the force of gravity. The equation relating these forces is shown below, where,  $V_B$  is the volume of the buoy,  $g$  is

$$M \left( \frac{dH}{dz} \right) = gV_B \rho - gV_B \rho_B = gV_B (\rho - \rho_B)$$

the acceleration of gravity, and  $\rho$  and  $\rho_B$  are the densities of the solution and the buoy, respectively. By means of a precision resistor and an accurate differential voltmeter, the measurements consist simply of reading or recording the voltage, which is a parabolic function of the density. [D.W.Ku.]

**Dental anthropology** The scientific study of people, with their living and extinct primate relatives, using the evidence of teeth. Dental anthropologists include not only those trained in anthropology but also practicing dentists, anatomists, radiologists, forensic scientists, biochemists and geneticists, archeologists, paleontologists, and zoologists.

The deciduous (milk) teeth and permanent (adult) teeth make up the dentition. They have their own distinctive patterns of development, physiology, size and shape, disease, and changes with age, all very different from the bones of the skeleton. In particular, the three tissues of the teeth—enamel, dentine, and cement—do not turn over continuously as do bone and most other tissues of the body. This means that, even in adults, tooth form is more clearly related to the gene-mediated control of development than a structure such as a bone, which is modified throughout life in response to changing physiological factors and mechanical loadings. Another effect of this conservation of original tooth structure is that the layered pattern of growth in dental tissues is preserved throughout life, so that childhood development can be studied even in adults. For archeologists and paleoanthropologists, there is a further advantage in the study of teeth—they are exposed in the mouth. Their adaptation to this harsh, abrasive environment in life ensures that they are the toughest part of the body, and survive relatively unchanged in a wide variety of burial environments. The majority of fossils are teeth and jaws. In addition, teeth bear many traces of the diet and life-style of their owners. Furthermore, teeth are easily studied in living people and animals by direct observation, by taking dental impressions (casts), or by examining teeth extracted in dental surgeries.

For many dental anthropologists, the core of the subject is tooth morphology. Identification of different primate species is most readily done from tooth form in archeological and fossil material. Among the higher primates as a whole, males tend

to have larger teeth than females, particularly the canine teeth. Even modern humans show this to a small extent, and it helps to distinguish between the sexes in archeological and forensic remains. The cusps, ridges, and furrows that decorate the crown surface also vary within different species of primates, together with the number and form of tooth roots. The different forms have characteristic frequencies for different populations of living people, and are used to investigate their relationships and history in comparison with archeological groups. See DENTISTRY; TOOTH.

[S.Hi.]

**Dental caries** A disease in which the mineralized tissues of the tooth undergo progressive destruction from the surface of the tooth. It is caused by bacteria that colonize the tooth surface and, under certain conditions, produce sufficient acids to demineralize the enamel covering of the tooth crown or the cementum covering the root, and then the underlying dentin. As the destruction of the dentin progresses, along with breakdown of the organic components, the bacteria invade the dead tissue and enter the pulp chamber. The pulpal tissue becomes infected and the typical toothache may ensue. The infection can ultimately destroy the pulpal tissue and extend through the apical openings of the roots and into the surrounding peri-odontal tissues.

The sites of caries development have been correlated with the presence of dental plaque containing one of a number of mutans streptococci—notably in humans. *Streptococcus mutans* and *S. sobrinus*. These microorganisms are cariogenic because of their ability to generate a considerable amount of acid as a result of their metabolism of carbohydrates, and to survive in an acid environment. The acid environment is only slowly neutralized since its dilution is hindered by the fact that the acid is within the dental plaque and thereby shielded from the saliva. Each time a carbohydrate-rich substance is ingested, acid is formed. Therefore, the frequency of ingestion and physical consistency of fermentable carbohydrates are important factors in caries formation. See MICROBIOLOGY; TOOTH.

Dental caries can be prevented by making the tooth less susceptible to acid attack, removing cariogenic bacteria from the teeth, and limiting ingestion of cariogenic substrate.

The most effective and least expensive means of rendering the tooth less susceptible to the caries attack is through fluoridation, either by systemic means such as water fluoridation, or by topical application of fluoride to the tooth surfaces. Water fluoridation (approximately 1 part per million) by itself reduces the incidence of caries by 50–60%. Topical fluoridation can be instituted by many means, ranging from professional applications in the dental office to self-applied fluoride in the form of toothpastes, mouth rinses, and gels. The mode of action of fluoridation is not fully understood, but the benefit to the tooth structure is probably a result of a number of actions. It is believed that fluoride, when incorporated into the mineral phase of enamel and the other hard tissues, results in a better crystalline structure that is less susceptible to acid dissolution. Alternatively, the anticaries effect of fluoride may be due to its ability to inhibit demineralization and promote remineralization. Other means of improving the tooth's resistance to dental caries include the application of plastic pit and fissure sealants which eliminate retentive areas on the biting surfaces of the posterior teeth that are more susceptible to carious lesions.

[M.R.R.]

**Dentistry** An autonomous branch of biomedical science that is concerned with the prevention, diagnosis, and treatment of diseases and abnormalities of the teeth, jaws, oral cavity, and adjacent structures.

Dental caries (tooth decay) is one of the most prevalent diseases affecting humans, and the greatest portion of the dentist's time and efforts is expended on treating dental decay and its consequences. In addition to caries, teeth can be damaged by trauma, erosion, and abrasion. Restorative dentistry encom-

passes efforts to conserve and restore decayed, defective, missing, and traumatically injured teeth.

Significant advances have been made in the practice of restorative dentistry. Development of high-speed, air-driven turbines combined with rotary cutting instruments fashioned from diamonds and ultrahard steel permits the rapid removal of tooth structure with little discomfort to the patient. In addition, many new materials for restorations and impression taking have become available. Especially important is the availability of composite resins which have sufficient strength to withstand biting and chewing pressures.

Seven branches of specialization are recognized by the American Dental Association: oral surgery, orthodontics, pedodontics, periodontics, prosthodontics, oral pathology, and public health dentistry. Other subspecialties such as oral medicine, dental radiology, and periodontal prosthetics exist but are not recognized.

Oral surgery treats diseases and abnormalities of the maxillofacial region by surgical means. Oral surgeons treat a wide variety of problems by removing teeth, reducing bone fractures, removing cysts, tumors, and growths, and correcting congenital anomalies and malformation of the structures of the maxillofacial region.

Orthodontists deal with abnormalities in tooth position and jaw relationships that result in facial disharmony and malfunction. The objective of orthodontic treatment is to establish normal occlusion and facial harmony. The teeth are repositioned and the jaws modified through the use of mechanical force applied with fixed or removable appliances. Successful treatment results in normal shape and expression of the mouth and lips, aids in enunciation and the sounding of words, and permits proper mastication.

Pedodontics is the branch of dentistry concerned with the detection, prevention, and treatment of oral and dental diseases and abnormalities in children. The deciduous or primary teeth are very small and have shapes which differ from those of adult teeth; special procedures and materials are required for their conservation and restoration.

Periodontics is the branch of dentistry devoted to the study, prevention, diagnosis, and treatment of diseases of the tissues supporting the teeth: gingiva (gum tissue), alveolar bone, periodontal ligament, and cementum. Periodontal diseases include gingivitis, periodontitis (sometimes called pyorrhea), primary and secondary occlusal traumatism, gingival hyperplasia, and periodontal atrophy. Several types of anaerobic gram-negative microorganisms are thought to be associated with chronic periodontitis. See ANAEROBIC INFECTIONS; PERIODONTAL DISEASE.

Prosthodontics is the branch of dentistry devoted to the construction and replacement of oral structures with artificial substitutes. The replacement of teeth and other oral structures is necessitated by congenital abnormalities, loss of teeth from disease or trauma, and destruction of teeth or jaws or other parts of the mouth by surgical management of neoplasms or trauma.

Oral pathology is concerned with the detection and diagnosis of the diseases of the teeth, oral cavity, and jaws, and also with the oral manifestations of systemic diseases. See PATHOLOGY.

Public health dentistry is defined as the science and art of preventing and controlling dental diseases and promoting dental health through organized community efforts. It comprises research, education, prevention, diagnosis, prescription, treatment of problems related to dentistry, and evaluation of community dental care. See TOOTH DISORDERS.

[R.C.P.]

**Dentition** The arrangement, type, and number of teeth which are variously located in the oral or in the pharyngeal cavities, or in both. Teeth are found in areas where there is an underlying supporting structure of cartilage or bone and where stomodeal ectoderm is present.

Attachment of teeth is variable among vertebrates. They may be inserted in sockets in the jawbones (thecodont condition), fused to the edge of the bone proper (acrodont condition), or

Dental formulas of some mammals

Animal	Teeth				Total
	I	C	Pm	M	
Human	2/2	1/1	2/2	3/3	32
Cony	3/3	1/1	4/4	4/4	48
Beaver	1/1	0/0	1/1	3/3	20
Cat	3/3	1/1	3/2	1/1	30
Dog	3/3	1/1	4/4	2/3	42
Sheep	0/3	0/1	3/3	3/3	32
Lynx	3/3	1/1	2/2	1/1	28
Rat	1/1	0/0	0/0	3/3	16
Horse	3/3	1/1	4/4	3/3	44
Mole	3/3	1/1	4/4	3/3	44
Squirrel	1/1	0/0	2/1	3/3	22
Reindeer	0/3	0/1	3/3	3/3	32
Pig	3/3	1/1	4/4	3/3	44
Common seal	3/2	1/1	4/4	1/1	34
Skunk	3/3	1/1	3/3	1/2	34
Raccoon	3/3	1/1	4/4	2/2	40
Bear	3/3	1/1	4/4	2/3	42

attached to the inner surface of the jawbone (pleurodont condition). In polyphyodont animals, teeth may be constantly replaced. The polyphyodont condition is characteristic of the fishes and the lower tetrapods in which the teeth are replaced as they are worn out. Most mammals have two sets of teeth during their lifetime, which is the diphyodont condition. These sets are the deciduous, or milk, teeth and the permanent dentition. Monophyodont dentition is the development of only one set of teeth.

Teeth may have a similar form in all regions where they occur (homodont), as distinct from those that are variable in shape (heterodont). The homodont condition is characteristic of non-mammalian vertebrates, although the anterior teeth may differ from those lying in the cheek region of the jaws. A heterodont dentition began to evolve in the reptilian ancestors of mammals, but became fully developed in the mammals. The mammalian heterodont condition is frequently described by a dental formula expressing both the number and kind of teeth in each half jaw, both upper and lower (see table). For humans the formula is I 2/2 C 1/1 Pm 2/2 M 3/3. This can be read for either the right or left side of the jaw; there are 2 upper and 2 lower incisors, 1 upper and 1 lower canine, and 2 premolars and 3 molars in both the upper and lower jaws. According to this formula, humans have a total of 32 teeth, 8 located in each half of the upper jaw and 8 in each half of the lower jaw. See TOOTH.

[F.S.S.]

**Denudation** All the weathering and erosional processes that contribute to the lowering of the land surface. Denudation is, thus, the complement of deposition, which is the accumulation of the products of denudation in sedimentation basins. See BASIN; DEPOSITIONAL SYSTEMS AND ENVIRONMENTS; EROSION; WEATHERING PROCESSES.

Contemporary records of sediment and solute flux through river systems, representing the mass removed from the continental surfaces, have been used to estimate rates of denudation since the mid-nineteenth century. These are usually expressed as an average rate of lowering of the land surface, in units of millimeters per thousand years (mm/ka).

In recent decades methods which allow the definition of denudation rates over geologic time scales have been developed. Attempts to invert sedimentary and stratigraphic records, and so define rates of erosion on the contributing continental surface, have greatly benefitted from improved seismic surveys, core extraction, and modeling of sedimentation basin processes. On the land surface itself, estimates of denudation rates based on the dissection of surfaces of known age have improved with the use of digital terrain models and absolute dating techniques. Equivalent estimates show that very rapid rates of bedrock denudation (up to 15 mm/yr) have been maintained in the west-

ern Himalaya during the past few million years. See DATING METHODS.

Developments in the dating of bedrock surfaces and surficial material in the 1990s represent the greatest improvement in defining rates of denudation during the late Cenozoic era. Potassium-argon (K-Ar) dating of lavas and the magnitude of dissection on volcanic cones had been used earlier to define erosion rates. More recently, exposure dating of bedrock through the accumulation of cosmogenic nuclides produced within them is a development that allows the estimation of average surface lowering rates over long time intervals. Cosmogenic nuclides have also been used to define rates of regolith production and erosion, contributing to denudation, over more recent time periods. Fission track analysis of apatite is another recent development that has had success in defining the long-term tectonic and denudational history of continental margins and mountain systems. See APATITE; CENOZOIC; COSMOGENIC NUCLIDE; FISSION TRACK DATING; REGOLITH. [N.C.]

**Deoxyribonucleic acid (DNA)** The material that carries genetic information in all organisms, except for some families of viruses that use ribonucleic acid (RNA). The set of DNA molecules that contains all genetic information for an organism is called its genome. DNA is found primarily in the nuclei of eukaryotic cells and in the nucleoid of bacteria. Small amounts of DNA are also found in mitochondria and chloroplasts and in autonomously maintained DNAs called plasmids. See NUCLEIC ACID.

DNA is composed of two long polymer strands of the sugar 2-deoxyribose, phosphate, and purine and pyrimidine bases. The backbone of each strand is composed of alternating 2-deoxyribose and phosphate linked together through phosphodiester bonds. A DNA strand has directionality; each phosphate is linked to the 3' position of the preceding deoxyribose and to the 5' position of the following deoxyribose (Fig. 1). The four bases found in DNA are adenine, thymine, guanine, and cytosine. Each 2-deoxyribose is linked to one of the four bases via a covalent glycosidic bond, forming a nucleotide. The sequence of these four bases allows DNA to carry genetic information. Bases can form hydrogen bonds with each other. Adenine forms

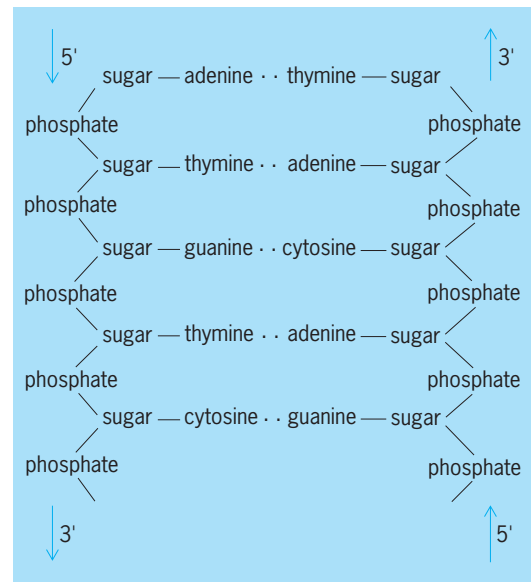

Fig. 1. Diagram of the nucleic acid backbone, a repeating sugar-phosphate polymer chain with base side chains. The two chains are antiparallel, as shown by arrows. The dots between the bases represent hydrogen bonding. Although the chains are drawn flat, they are actually wound around each other in the molecule.



two bonds with thiamine, and cytosine forms three bonds with guanine. These two sets of base pairs have the same geometry, allowing DNA to maintain the same structure regardless of the specific sequence of base pairs. See DEOXYRIBOSE; PURINE; PYRIMIDINE.

**Structure.** DNA is composed of two strands that wrap around each other to form a double helix. The two strands are held together by base pairing and are antiparallel. Thus if one strand is oriented in the 5' to 3' direction, the other strand will be 3' to 5'. This double-helical structure of DNA was first proposed in 1954 by J. D. Watson and F. H. C. Crick. The most common form of DNA is the B-form, which is a right-handed double helix with 10.4 base pairs per turn. Less common forms of DNA include A-form, which is a right-handed double helix that has 11 base pairs per turn and has wider diameter than B-form, and Z-form, which is a narrow, irregular left-handed double helix.

For cells to live and grow, the genetic information in DNA must be (1) propagated and maintained from generation to generation, and (2) expressed to synthesize the components of a cell. These two functions are carried out by the processes of DNA replication and transcription, respectively. See GENETIC CODE.

**Replication.** Each of the two strands of a DNA double helix contains all of the information necessary to make a new double-stranded molecule (Fig. 2). During replication the two parental strands are separated, and each is used as a template for the synthesis of a new strand of DNA. Synthesis of the nascent DNA strands is carried out by a family of enzymes called DNA polymerases. Base incorporation is directed by the existing DNA strand; nucleotides that base-pair with the template are added to the nascent DNA strand. The product of replication is two complete double-stranded helices, each of which contains all of the genetic information (has the identical base sequence) of the parental DNA. Each progeny double helix is composed of one parental and one nascent strand. DNA replication is very accurate. In bacteria the mutation rate is about 1 error per 1000 bacteria per generation, or about 1 error in  $10^9$  base pairs replicated. This low error rate is due to a combination of the high accuracy of the replication process and cellular pathways which repair misincorporated bases. See MUTATION.

**Transcription.** In transcription, DNA acts as a template directing the synthesis of RNA. RNA is single-stranded polymer similar to DNA except that it contains the sugar ribose instead of 2-deoxyribose and the base uracil instead of thymidine. The two strands of DNA separate transiently, and one of the two single-stranded regions is used as a template to direct the synthesis of an RNA strand. As in DNA replication, base pairing between the incoming ribonucleotide and the template strand determines the sequence of bases incorporated into the nascent RNA. Thus, genetic information in the form of a specific sequence of bases is directly transferred from DNA to RNA in transcription. After the RNA is synthesized, the DNA reverts to double-stranded form. Transcription is carried out by a family of enzymes called RNA polymerases. Following transcription, newly synthesized RNA is often processed prior to being used to direct protein synthesis by ribosomes in a process called translation. See PROTEIN; RIBONUCLEIC ACID (RNA); RIBOSOMES.

**Genetic variation.** There is a great deal of variation in the DNA content and sequences in different organisms. Because of base pairing, the ratios of adenine to thiamine and cytosine to guanine are always the same. However, the ratio of adenine and thymine to guanine and cytosine in different organisms ranges from 25 to 75%. There is also large variation in the amount of DNA in the genome of various organisms. The simplest viruses have genomes of only a few thousand base pairs, while complex eukaryotic organisms have genomes of billions of base pairs. This variation partially reflects the increasing number of genes necessary to encode more complex organisms, but mainly reflects an increase in the amount of DNA that does not encode proteins (known as introns). A large percentage of the DNA in multicellular eukaryotes is in introns or is repetitive DNA (se-

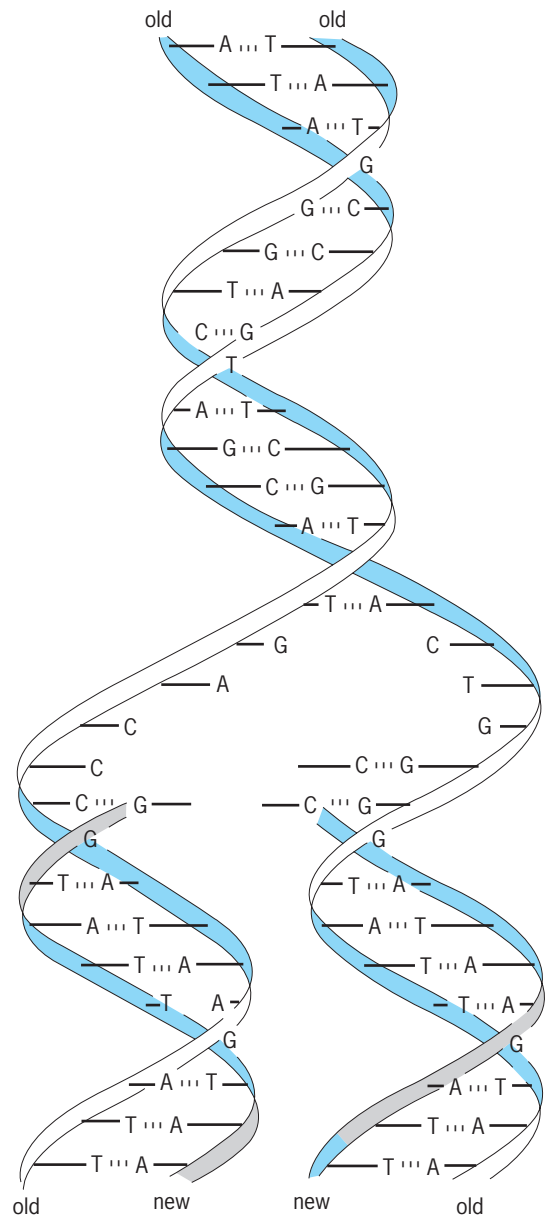

**Fig. 2. Replication of DNA:** A = adenine, C = cytosine, G = guanine, and T = thymine. (After J. D. Watson, *Molecular Biology of the Gene*, W. J. Benjamin, 1965)

quences that are repeated many times). In most eukaryotes the DNA sequences that encode proteins (known as exons) are not continuous but have introns interspersed within them. The initial transcript synthesized by RNA polymerase contains both exons and introns and can be many times the length of the actual coding sequence. The RNA is then processed and the introns are removed through a mechanism called RNA splicing to yield messenger RNA (mRNA), which is translated to make protein.

**Recombinant technology.** Techniques have been developed to allow DNA to be manipulated in the laboratory. These techniques have led to a revolution in biotechnology. This revolution began when methods were developed to cleave DNA at specific sequences and to join pieces of DNA together. Another major component of this technology is the ability to determine the sequence of the bases in DNA. There are two general approaches for determining DNA sequence. Either chemical reactions are carried out which specifically cleave the sugar-phosphate bond at sites which contain a certain base, or

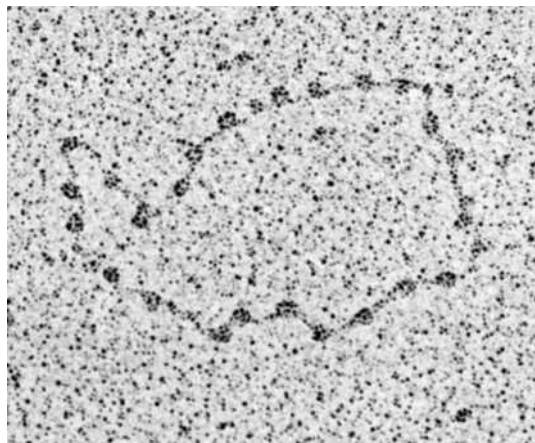

Fig. 3. Electron micrograph of the minichromosome of a virus that infects monkey cells. The circular viral DNA can be seen to be organized in nucleosome "beads." (From L. Lutter et al., *Mol. Cell. Biol.*, 12:5004-5014, 1992)

DNA is synthesized in the presence of modified bases that cause termination of synthesis after the incorporation of a certain base. These methods can now be automated so that it is practical to determine the DNA sequences of the entire genome of an organism. Currently, the complete sequences of several bacterial and fungal genomes are known, drafts exist for the complete mouse and rat genomes, and 99% of the gene-containing part of the human sequence has been determined. See HUMAN GENOME PROJECT. [M.C.Wo.]

**In the cell.** The full genome of DNA must be substantially compacted to fit into a cell. For example, the full human genome has a total length of about 3 m (10 ft). This DNA must fit into a nucleus with a diameter of  $10^{-5}$  m. This immense reduction in length is accomplished in eukaryotes via multiple levels of compaction in a nucleoprotein structure termed chromatin. The first level involves spooling about 200 base pairs of DNA onto a complex of basic proteins called histones to form a nucleosome. Nucleosomes are connected like beads on a string (Fig. 3) to form a 10-nanometer diameter fiber, and this is further coiled to form a 30-nm fiber. The 30-nm fibers are further coiled and organized into loops formed by periodic attachments to a protein scaffold. This scaffold organizes the complex into the shape of the metaphase chromosome seen at mitosis. See NUCLEOPROTEIN.

The nucleosome is the fundamental structural unit of DNA in all eukaryotes. Nucleosomes reduce the accessibility of the DNA to DNA-binding proteins such as polymerases and other protein factors essential for transcription and replication. Consequently, nucleosomes tend to act as general repressors of transcription. See NUCLEOSOME. [L.C.L.]

**Deoxyribose** A nucleic acid constituent (see illustration) of all animal, microbial, and plant cells; also known as 2-D-deoxyribose. Deoxyribose is enzymically formed in living cells

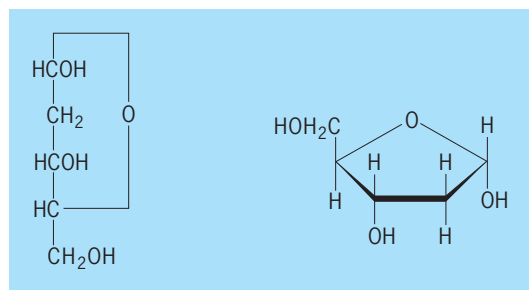

Formulas of 2-D-deoxyribose ( $\alpha$ -D-2-deoxyribofuranose).

by reduction of ribonucleoside di- or triphosphate. The four deoxyribose nucleotides, containing adenine, guanine, cytosine, and thymine, are the major constituents of the deoxyribonucleic acids (DNA), which control the hereditary characteristics of every living organism. See DEOXYRIBONUCLEIC ACID (DNA); NUCLEIC ACID; RIBOSE. [W.Z.H.]

**Dependovirus** Any of a group (genus) of defective viruses which seem unable to reproduce without help from adenoviruses. They were formerly known as adeno-associated viruses and belong to the family Parvoviridae. These 20-nanometer virus particles were found during electron microscopic studies (see illustration) in several preparations of adenovirus from both human and monkey sources, and have since been observed in many adenovirus stocks. See ADENOVIRIDAE.

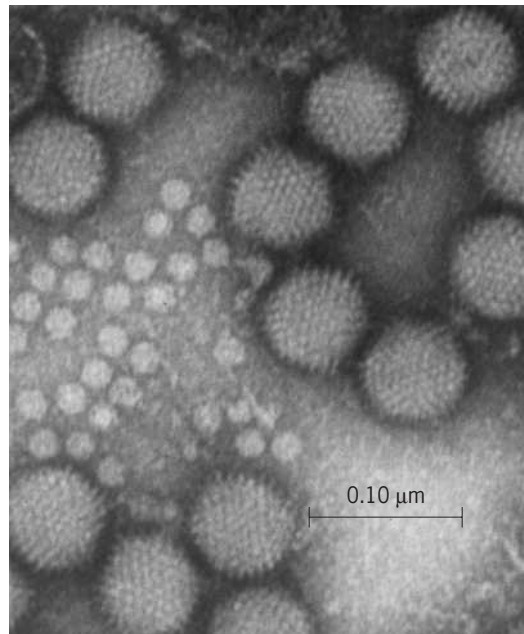

Electron micrograph showing adenovirus particles (70-nm diameter;  $0.10 \mu\text{m} = 100 \text{ nm}$ ) and dependoviruses (20-nm diameter).

Like adenovirus, the dependovirus has a deoxyribonucleic acid (DNA) core. However, the dependovirus, although dependent upon adenovirus for its growth, does not appear to be structurally related to its "helper." Its genetic content, as well as its size, is much smaller than that of adenovirus, and its protein coat is completely different from that of adenovirus. These particles contain single-stranded DNA and a protein coat with icosahedral symmetry. The single-stranded DNA has been shown to be present within the dependovirus virion as either plus or minus complementary strands in separate particles. Upon extraction, the minus and plus strands unite to form a double-stranded helix.

The genetic material of dependovirus not only can persist in cultured cells for long periods without giving evidence of its presence but also can survive within human beings in a latent state, becoming detectable only in specimens taken when the person is concurrently infected with adenovirus. This characteristic permits survival of a defective virus in nature, even though it cannot regularly replicate or be passed in infective form from host to host. See VIRUS CLASSIFICATION.

[J.L.Me.; M.E.Re.]

**Depositional systems and environments** Depositional systems are descriptions of the interrelationships of form and the physical, chemical, or biological processes involved

in the development of stratigraphic sequences. Depositional environments are the locations where accumulations of sediment have been deposited by either mechanical or chemical processes.

**Depositional systems.** Traditional stratigraphic analysis, which emphasized the physically descriptive aspects of strata, has changed; a critical genetic dimension has been added. Where once, for example, a formation may have been described in physical terms as a fine- to medium-grained quartzose sandstone, overlying a thick dark-gray shale sequence and underlying a coal-bearing sequence with discontinuous sands, the same sandstone may now be recognized as a delta-front sandstone, the underlying shale as a prodelta facies, and the overlying coal-bearing formation as the product of deposition on a delta plain. In this interpretation, the three distinct stratigraphic units become part of a genetically related sequence, each a component facies of a prograding delta system. *See* STRATIGRAPHY.

In a modern setting, a particular system of deposition is directly observable and known, whether it is a major delta, an alluvial fan, a meandering river, a barrier bar, a carbonate platform, or the like. Through specific observation, description, and delineation, it may be determined that a variety of depositional processes are active. At the terminus of rivers, sands may be deposited as bars in river mouths, creating the delta front; muds may be carried by suspension into the oceanic waters and deposited through flocculation, creating the prodelta; on the delta plain, a distributary channel may be depositing bed-load sands and, during flooding, may be carrying suspended muds to flanking flood basins or breaching the natural levee to form crevasse splays. Each process or combination of processes gives rise to distinct, specific environments of deposition, with each resulting in a deposit which can be characterized by such features as lithologic composition, texture, sedimentary structures, geometry, size, and relationship to other deposits. *See* DELTA; FLOOD-PLAIN; RIVER.

Distinct physical, or in some cases biologic or chemical, products of deposition can be related directly to definable, operative processes. Such data permit the development of models of modern deposition in which processes and resulting deposits or facies are linked. By recognizing comparable physical, chemical, and biologic attributes of ancient strata, modern depositional analogs can be applied, and the original processes forming the ancient deposit can be inferred. Such an ancient deposit is called a genetic facies. It contains the sedimentary record and constitutes a three-dimensional stratigraphic (ancient) depositional system. *See* FACIES (GEOLOGY).

An ancient depositional system is a three-dimensional, genetically defined, physical stratigraphic unit that consists of a contiguous set of process-related sedimentary facies. Several corollaries have evolved from the application of this concept. Depositional systems, such as delta, fluvial, and shelf systems, (1) are the stratigraphic equivalents of major physical geographic units; (2) form the principal building blocks of the sedimentary basin fill; and (3) can be applied where principal boundaries of the systems are preserved and where the geometry of the framework facies can be mapped.

The major realms of deposition may be classed broadly as terrigenous clastic depositional systems and biogenic-chemical depositional systems. Each of these major systems is subdivided according to particular systems of deposition, and within each of the subdivisions is an assemblage of genetic facies, which are the fundamental units of depositional systems.

Terrigenous clastic systems, composed chiefly of sands and shales, embrace eight major systems: (1) fluvial or river systems; (2) delta systems; (3) strike coastal systems; (4) fan or clastic wedge systems; (5) lacustrine systems; (6) continental eolian systems; (7) shelf systems; and (8) slope and abyssal systems.

The biogenic-chemical systems consist of three major systems: (1) carbonate systems; (2) glauconitic and authigenic shelf systems; and (3) evaporite systems. [W.L.Fi.]

**Depositional environments.** Depositional environments may be distinguished from erosional environments, in which erosion of the Earth's surface is taking place. Both depositional and erosional environments are of interest to geomorphologists. However, most attention to depositional environments has come from sedimentologists, particularly in order to understand the origin of sedimentary rocks. *See* EROSION.

Sediment is derived mainly from source areas that are actively undergoing uplift and erosion, and is deposited mainly in areas that are undergoing subsidence. Location of the source and basin of deposition is mainly controlled by large-scale geophysical processes acting within the Earth's mantle, so a major factor affecting the nature and distribution of sedimentary environments is the overall structural development, or tectonics, of the area. *See* PLATE TECTONICS.

Tectonics determines the major geological structure or setting of an environment of deposition, including the location and nature of the main areas undergoing uplift or subsidence. Areas with high relief, such as mountains and volcanoes, suffer rapid erosion and supply much more sediment to basins of deposition than larger areas of low relief. One investigation, for example, found that 82% of the suspended solids (mud) discharged by the Amazon River were supplied by the 12% of the drainage basin located within the Andes Mountains.

A second important major control is climate. This includes the average temperature, the range of temperature variation, the aridity or humidity (ratio of evaporation to precipitation), and the magnitude and frequency of floods and storms. Climate in turn has an important influence on such physical factors as the salinity and energy of the environment (wind and water speeds and degree of turbulence, for example), as well as on the abundance and types of plants and animals.

In areas of subsidence and sedimentation, topography results from and controls sedimentary environments. Along a coastline of low relief, for example, spits and barrier islands are produced by waves generated in the open sea. Shallow lagoons on the landward side of barrier islands are protected from wave action by the islands themselves. The distinctive features of the lagoon environment are a result of a topography which has been produced by the accumulation of sediment in another sedimentary environment (the barrier island). *See* BARRIER ISLANDS.

Sedimentary environments can be classified into three categories: terrestrial, including alluvial fans, fluvial plains, sandy deserts, lakes, and glacial regions; mixed (shore-related), including deltas, estuaries, barrier island complexes, and glacial marine environments; and marine, including terrigenous shelves or shallow seas, carbonate shelves or platforms, continental slopes, continental rises, basin plains, ocean ridges, and ocean trenches.

Although the importance of tectonics and climate in controlling sedimentary environments is widely recognized, most classifications are based mainly on topography. Almost all distinguish terrestrial (sub-aerial or fresh-water) from marine environments, and also recognize an important group of mixed or shore-related environments.

A number of major processes operate within environments and determine the types of sediment deposited in the environment, including water depth, energy (waves and current), temperature, and salinity. Biological factors also exert a very strong influence. There would be little or no oxygen in the atmosphere if it were not for the photosynthetic activity of plants. Deposition of calcium carbonate and silica in lakes and the oceans takes place largely through the action of plants and animals, and organic matter deposited along with mineral particles is largely responsible for the development of reducing conditions within sediments after deposition. Vegetable material accumulates in swamps to form peat and coal, and fine organic detritus settles with marine muds and is the ultimate source of oil and gas. Both terrestrial and aquatic plants exert a trapping and binding action that tends to immobilize sedimentary particles, as, for example, when coastal sand dunes or tidal flats become stabilized by the

growth of salt-tolerant grasses. Terrestrial vegetation plays an important role in rock weathering. [G.V.M.]

**Dermaptera** An order of insects commonly known as earwigs, in reference to an unfounded superstition that they crawl into the ears of sleeping persons. Earwigs are elongate and flattened, with a pair of forcepslike appendages, or cerci, at the end of the abdomen (see illustration). They are 0.4–1.2 in. (10–30 mm) long, and have chewing mouthparts, gradual metamorphosis, long legs, and shortened, leathery forewings. Some species are flightless, while others are active fliers with well-developed hindwings that fold elaborately under the forewings when the insect is at rest. Most earwigs are brown or black.

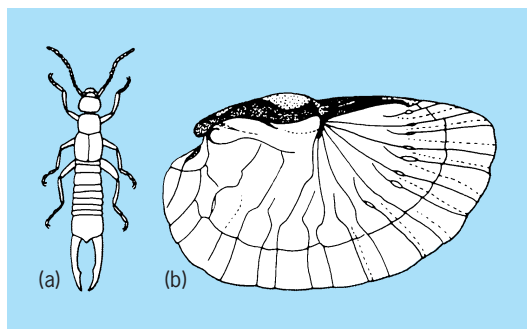

Some features of Dermaptera. (a) Adult of *Labidura*. (b) Hindwing of *Forficula*. (After C. P. Brues, A. L. Melander, and F. M. Carpenter, *Classification of Insects*, Harvard University Press, 1954)

Earwigs are usually nocturnal and spend the daylight hours under bark or stones, in moist cracks and crevices, or in leaf litter at the soil surface. Most species scavenge on decaying animal or vegetable matter. A few species are predators on smaller insects. The widely introduced European earwig, *Forficula auricularia*, is an occasional pest of buildings, and crop plants, especially seedlings and floral crops.

Worldwide, there are about 1100 species of earwigs, and most of these species are tropical. Fossil earwigs are known from the Jurassic Period. See INSECTA. [D.J.Hor.]

**Dermatitis** Inflammation of the skin with redness and scaling, or if acute, with blisters, edema, and formation of a crust; also known as eczema. Of the several distinct types of dermatitis, each has unique etiology, clinical characteristics, pathology, and treatment.

**Atopic dermatitis.** Atopic dermatitis usually begins in infancy and may continue into adult life. The eruption is characterized by red patches accompanied by intense itching. The lesions often become secondarily infected, leading to moist discharge and crusting. Although any anatomic site may be affected, the classic locations in infants are the extremities, face, and scalp. In older children and adults, the inside of the elbows, the back of the knees, wrists, eyelids, and neck are most often involved.

Treatment of atopic dermatitis includes oral antihistamines, emollients, topical corticosteroids (particularly ointments), and for more severe cases, systemic corticosteroids. Avoidance of irritants (wool, chemicals, harsh soaps and detergents, perfumes), extremes in temperature and humidity, overbathing, and certain foods is imperative. Mild cleansers are preferred. See ANTIHISTAMINE; STEROID.

**Contact dermatitis.** Contact dermatitis is a reaction that causes acute itching, redness, swelling, large blisters, and in chronic cases, red, scaly papules (raised bumps) and plaques (abnormal flat areas). The two forms are irritant contact dermatitis and allergic contact dermatitis. In irritant contact dermatitis the eruption is caused by a nonallergic reaction resulting from exposure to an irritating substance. Allergic contact dermatitis is an immunologic reaction in persons who have been previously

exposed (sensitized) to the allergen. The lesions occur 24–48 h after exposure to an irritant or allergen. The key to treatment is removal of the offending agent. Antihistamines, emollients, and topical and systemic corticosteroids are helpful. See ALLERGY.

**Seborrheic dermatitis.** Seborrheic dermatitis is characterized by reddish to yellow greasy scale that frequently forms on the face (eyebrows, nasolabial folds, forehead), ears, scalp, upper back, central chest, and anogenital region. In contrast to atopic and contact dermatitis, itching is uncommon.

Topical corticosteroids are the mainstay of treatment for seborrheic dermatitis. In cases in which *Pityrosporum ovale* is involved, topical antifungal agents (such as ketoconazole cream) are useful. Topical or oral antibiotics are required in cases with secondary bacterial infection. In generalized or recurring cases, systemic corticosteroids may be necessary.

**Exfoliative erythroderma.** Exfoliative erythroderma is characterized by widespread, warm redness and scaling. Nail degeneration and loss, hair loss, fever, chills, and enlargement of the lymph nodes may also occur. The eruption may be due to an underlying primary skin disorder, such as dermatitis (seborrheic, contact, or atopic) or psoriasis; drug allergy; or leukemia or lymphoma, particularly cutaneous T-cell lymphoma. See LEUKEMIA; LYMPHATIC SYSTEM; LYMPHOMA.

Individuals with exfoliative erythroderma are best managed in a hospital setting. Because heat, water, and protein losses occur through damaged skin, careful monitoring of fluid balance, protein losses, and body temperature is imperative. The application of wet dressings or topical corticosteroids and administration of oral antihistamines are important aspects of treatment. See INFECTIO. [L.M.Co.; K.A.A.]

**Flea allergy dermatitis.** Flea allergy dermatitis, sometimes called flea-bite dermatitis, affects the skin of small pets (dogs, cats, and ferrets), and results from an allergic reaction to protein substances deposited on (or under) the surface of the skin at the time of flea feeding. It is by far the most common cause of allergic dermatitis in pet animals and a major cause of itchy skin in geographic regions where fleas are found. [J.M.MacD.]

**Dermaptera** An ancient order of somewhat primate-like herbivorous (plant-eating) and frugivorous (fruit-eating) gliding mammals, now confined to the extreme southeast corner of Asia and parts of the East Indies and the Philippines. Colugos, or flying lemurs, as they are often called, are the only extant members of the group. Modern dermapterans are usually placed in a single genus, though two genera may exist.

The patagium, a flap of skin used in gliding, extends from behind the ears to the hands, then to the feet, and finally to the tip of the tail. The extent of the patagium and the gliding ability, of course, are not known in fossil forms, nor are certain features of the soft anatomy. Skeletal features not related to their gliding adaptations point to distant connections with primitive primate-like insectivores that were no doubt living in southeastern Asia as long ago as the Cretaceous. Colugos probably were restricted to southeastern Asia by the contraction of the tropics that occurred during the Oligocene and later Cenozoic. See EUTHERIA; INSECTIVORA; MAMMALIA. [M.C.McK.]

**Derrick** A hoisting machine consisting usually of a vertical mast, a slanted boom, and associated tackle. Derricks have a wide variety of forms. The mast may be no more than a base for the boom; it may be a tripod, an A-frame, a fixed column, and so on. Fixed stays may guy it in place. The boom may be fixed, it may pivot at the base of the mast, it may swing horizontally from near the top of the mast, or it may be omitted. The derrick may be permanently fixed, temporarily erected, or mobile on a cart or truck.

Derricks are widely used in construction, in cargo handling, and in shops. A manual or powered winch provides the lifting action by coiling in the running tackle, the load swinging free as it rises. See HOISTING MACHINES. [D.O.H./F.H.R.]

**Derris** A genus of tropical shrubs belonging to the legume family (Leguminosae). These plants, with their long branches climbing over other vegetation, occur as members of the jungle undergrowth in Malaysia. Extracts of the roots of *Derris elliptica* long been used by the natives as an arrow poison and to stupefy fish so they can be caught more easily. Derris root is an excellent insecticide, being harmful to both chewing and sucking insects, but not poisonous to human beings. The insecticidal ingredient of derris root is a white, crystalline substance, which is called rotenone. See ROSALES. [PD.St.; E.L.C.]

**Descriptive geometry** A mathematical-graphical procedure for the visualization of structures and their exact representation in drawings. After analysis of the structure, each element is shown in the drawing in its exact geometrical relation to the other elements. There are two basic methods of descriptive geometry: the projection method and the direct method. The two methods differ as regards the attitude of mind toward the structure and toward the drawing that represents the structure.

**Projection method.** In the projection method the horizontal projection plane *H* and the vertical projection plane *V* intersect in the line *GL*, which is called the ground line (Fig. 1). These two projection planes divide space into four quadrants, or angles, as numbered in Fig. 1. Point *A*, in the first quadrant, is projected

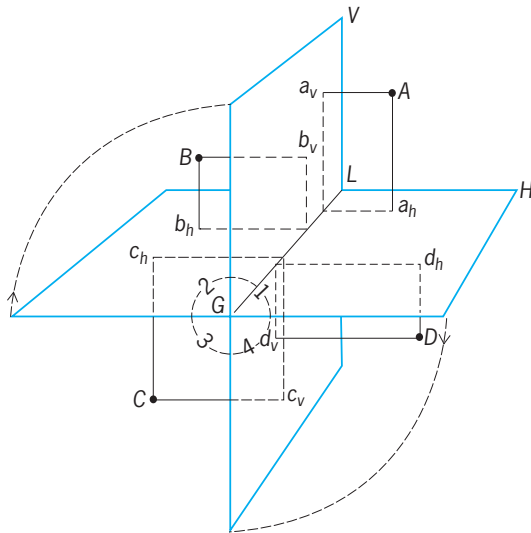

Fig. 1. Planes of projection. (After G. J. Hood and A. S. Palmerlee, *Geometry of Engineering Drawing*, 4th ed., McGraw-Hill, 1958)

onto the horizontal plane at *a<sub>h</sub>* by means of a projection line perpendicular to the *H* plane, and onto the vertical plane at *a<sub>v</sub>* by means of a projection line perpendicular to the *V* plane. The projections of the points *B*, *C*, and *D* in the other quadrants are located in a similar manner. Right-angle projection, as described above, is called orthographic projection.

To represent horizontal and vertical projections on a flat sheet of paper, the planes are conceived as being hinged along the ground line and brought together by closing the second and fourth quadrants. Projections of *A*, *B*, *C*, and *D* then appear in a single plane (Fig. 2). The *H* and *V* projections of a point are always in the same perpendicular to the ground line.

There are two general types of views, perspective and orthographic (Fig. 3). A perspective view of an object is observed from a fixed station point, or point of view, by means of converging rays of light that meet at the eye of the observer. An orthographic view of an object is observed in a chosen direction by means of parallel rays of light.

**Direct method.** In the direct method the attention is focused on the visualized structure or object. Each view of the object is obtained by looking at the object in a definite direction. The view

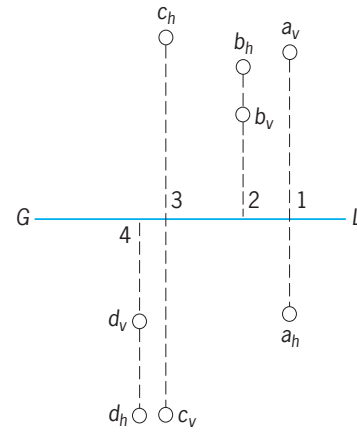

Fig. 2. Projection of points onto projection planes. (After G. J. Hood and A. S. Palmerlee, *Geometry of Engineering Drawing*, 4th ed., McGraw-Hill, 1958)

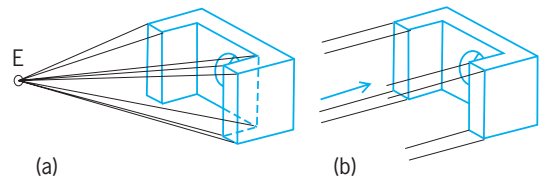

Fig. 3. Methods of viewing objects. (a) Perspective viewpoint (converging rays). (b) Orthographic viewpoint (parallel rays). (After G. J. Hood and A. S. Palmerlee, *Geometry of Engineering Drawing*, 4th ed., McGraw-Hill, 1958)

is orthographic. A view never is considered as two-dimensional or as projected or drawn on a plane. This is the way the engineer who makes and reads the drawings thinks of views.

Orthographic views may be classified into three types: principal views, auxiliary views, and oblique views. The object can be viewed from any direction around three rings—horizontal, frontal, and profile (Fig. 4). The rings represent three mutually perpendicular planes. The intersections of the rings define three mutually perpendicular directions from which six principal views are observed: front and rear, top and bottom, right and left sides.

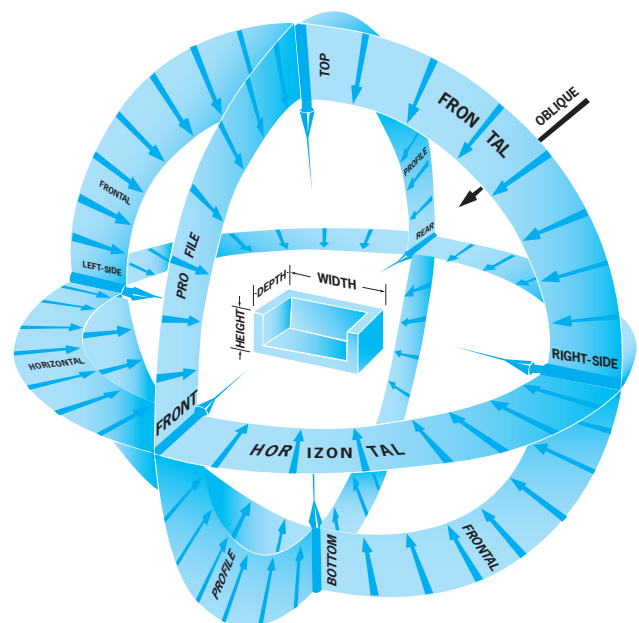

Fig. 4. A series of viewing positions for auxiliary views. (After G. J. Hood and A. S. Palmerlee, *Geometry of Engineering Drawing*, 4th ed., McGraw-Hill, 1958)

An auxiliary view can be observed around any ring in a direction perpendicular to one, and only one, of the directions in which principal views are observed. All views other than principal or auxiliary views are oblique. In Fig. 4 a single arrow, marked oblique, indicates one of the infinite number of directions in which oblique views are observed. See DRAFTING; ENGINEERING DRAWING. [A.S.P./C.J.B.]

**Desert** No precise definition of a desert exists. From an ecological viewpoint the scarcity of rainfall is all important, as it directly affects plant productivity which in turn affects the abundance, diversity, and activity of animals. It has become customary to describe deserts as extremely arid where the mean precipitation is less than 2.5–4 in. (60–100 mm), arid where it is 2.5–4 to 6–10 in. (60–100 to 150–250 mm), and semiarid where it is 6–10 to 10–20 in. (150–250 to 250–500 mm). However, mean figures tend to distort the true state of affairs because precipitation in deserts is unreliable and variable. In some areas, such as the Atacama in Chile and the Arabian Desert, there may be no rainfall for several years. It is the biological effectiveness of rainfall that matters and this may vary with wind and temperature, which affect evaporation rates. The vegetation cover also alters the evaporation rate and increases the effectiveness of rainfall. Rainfall, then, is the chief limiting factor to biological processes, but intense solar radiation, high temperatures, and a paucity of nutrients (especially of nitrogen) may also limit plant productivity, and hence animal abundance. Of the main desert regions of the world, most lie within the tropics and hence are hot as well as arid. The Namib and Atacama coastal deserts are kept cool by the Benguela and Humboldt ocean currents, and many desert areas of central Asia are cool because of high latitude and altitude.

The diversity of species of animals in a desert is generally correlated with the diversity of plant species, which to a considerable degree is correlated with the predictability and amount of rainfall. There is a rather weak latitudinal gradient of diversity with relatively more species nearer the Equator than at higher latitudes. This gradient is much more conspicuous in wetter ecosystems, such as forests, and in deserts appears to be overridden by the manifold effects of rainfall. Animals, too, may affect plant diversity: the burrowing activities of rodents create niches for plants which could not otherwise survive, and mound-building termites tend to concentrate decomposition and hence nutrients, which provide opportunities for plants to colonize.

Each desert has its own community of species, and these communities are repeated in different parts of the world. Very often the organisms that occupy similar niches in different deserts belong to unrelated taxa. The overall structural similarity between American cactus species and African euphorbias is an example of convergent evolution, in which separate and unrelated groups have evolved almost identical adaptations under similar environmental conditions in widely separated parts of the world. Convergent structural modification occurs in many organisms in all environments, but is especially noticeable in deserts where possibly the small number of ecological niches has necessitated greater specialization and restriction of way of life. The face and especially the large ears of desert foxes of the Sahara and of North America are remarkably similar, and there is an extraordinary resemblance between North American sidewinding rattlesnakes and Namib sidewinding adders. See ECOLOGY; PHYSIOLOGICAL ECOLOGY (PLANT); PRECIPITATION (METEOROLOGY).

[D.F.Ow.]

**Desert erosion features** A distinctive topography carved by erosion in regions of low rainfall and high evaporation where vegetation is scanty or absent. Although rainfall is low, it is the most important climatic factor in the formation of desert erosion features. Desert rains commonly occur as torrential downpours of short duration with a consequent high percentage of runoff. As a result of the dryness, wind and mechanical

weathering also play an important part in desert erosion. See SEDIMENTOLOGY; WEATHERING PROCESSES.

When storms of the so-called cloudburst type occur in the desert, sudden rushes of water, or flash floods, sweep down the normally dry washes or the narrow canyons in the mountains bordering the basins. The comparatively large volume of water combined with a high velocity due to the steepness of the slopes give the short-lived streams power to carry large amounts of fine and coarse rock fragments. As a result, the streams have great erosive power.

When intermittent streams leave the canyons and spread out at the foot of a desert mountain, they lose velocity and quickly drop the coarsest of the transported material to build an alluvial fan. Some of the water sinks into the fan, and some evaporates, but whatever remains may follow one of the channels on the fan or spread out in the form of a sheetflood, in either case carrying coarse sand, silt, and clay, and perhaps rolling some larger rock fragments along.

When the water reaches the toe of the fan, it spreads still more, dropping all but the finest silt and clay. Any excess water follows shallow washes to the lowest part of the basin, where it may form a playa lake. This evaporates in a few hours or a few days, depositing the silt and clay, mixed perhaps with soluble salts. The flat-surfaced area resulting from the silt and clay deposition is a playa. See PLAYA.

The lack of moisture during most of the year and the scanty vegetation make the wind a more potent agent of erosion in deserts than in humid lands. The finest material is blown high in the air and may be carried entirely out of the area, a process known as deflation. The larger sand grains are rolled along the surface, bouncing into the air when they strike an obstacle, knocking more grains into the air as they hit the ground again, until eventually a sheet of sand is moving along in the 3 or 4 ft (1 or 1.3 m) above the surface. This moving sand abrades rocks and other objects with which it comes in contact; at the same time the grains themselves become rounded and frosted. If movement is impeded by vegetation or other obstacles, sand accumulates to form dunes. See DUNE.

Desert landscapes evolve in three stages. In the early, or youthful, stage, alluvial fans are built, washes develop, playas form, and the basins slowly fill with detritus. As this stage progresses, some alluvial fans coalesce to form bajadas or piedmont alluvial plains along the mountain fronts, and individual basins may become deeply filled with waste to form bolsons. Desert flats develop between alluvial fans (or bajadas) and playas, and isolated dunes accumulate on the lee sides of the latter. If the original highlands are flat-topped rather than tilted mountain blocks, mesas develop. As the mountain fronts slowly retreat under the attack of the atmosphere and running water, small bare rock surfaces or pediments form at the canyon mouths, the result of lateral cutting by the intermittent streams. The general tendency during youth is for relief to decrease.

The middle, or mature, stage is initiated by the development of exterior drainage or the capture of higher basins by lower ones as drainage channels erode headward through low divides. The fill deposited during youth undergoes erosion, and pediments become more widely developed. The mountains are worn still lower, and more and more channels extend completely through them, cut by the streams engaged in draining and dissecting the higher basins. Playa deposits or other easily eroded sediments are cut into badlands before being entirely removed, and mesas are reduced to buttes. Undissected remnants of older deposits become covered with desert pavement (flat-lying, interlocking, angular stones left after finer particles are removed by deflation). Where winds are turbulent and large supplies of sand are available, complex dune areas develop. Relief shows some net increase during maturity.

At the late, or old-age, stage of desert evolution, the original mountains are so reduced in elevation that the winds sweep over them with little or no condensation of moisture, and rains

become still more infrequent. Great expanses of wind-scoured bare rock, or hammada, are exposed, with here and there a more resistant remnant standing above the general level as an inselberg. Buttes are reduced to smaller bornhardts and finally disappear. Those parts of the flat surface floored by earlier deposits are covered and protected by extensive areas of desert pavement. The rock fragments may be colored brown to black by desert varnish, a coating of manganese and iron oxides. Sand blown from the bare rock surfaces and from the sediments may form large dune areas. If there are no obstacles to obstruct movement or cause wind turbulence, the sand may move as a sheet, forming large expanses of flat or gently undulating sand surfaces. Relief slowly decreases in old age. See DESERT.

[T.C.]

**Desertification** Land degradation in low-rainfall and seasonally dry areas of the Earth. It can be viewed as both a process and the resulting condition. Desertification involves the impoverishment of vegetation and soil resources. Key characteristics include the degradation of natural vegetation cover and undesirable changes in the composition of forage species, deterioration in soil quality, decreasing water availability, and increased soil erosion from wind and water. Various stages of desertification can be seen in most of the world's drylands. In rare cases, desertification leads to abandoned, desertlike landscapes.

It is generally agreed that human activities, particularly excessive resource use and abusive land-use practices, are the primary cause of desertification. Specific activities leading to desertification include clearing and cultivation of low-rainfall areas where such cultivation is not sustainable, overgrazing of rangelands, clearing of woody plant species for fuelwood and building materials, and mismanagement of irrigated cropland leading to the buildup of mineral salts in the soil (salinization). Drought is often cited as a basic cause of desertification; however, it merely accelerates or accentuates land degradation processes already under way. See DROUGHT.

Consequences of desertification include reduced biological productivity, reduction of biodiversity, a gradual loss of agricultural potential and resource value, loss of food security, reduced carrying capacity for humans and livestock, increased risks from drought and flooding, and in extreme cases, barren lands that are effectively beyond restoration. Paleostudies, supported by model simulations, have shown that the intensity of Northern Hemisphere desert conditions has waxed and waned over the past 9000 years in response to the precession of the Earth's orbit about the Sun. Thus, it may be that the causal factors of desertification, whether climate change or human activities, depend on the time scale being addressed. See CLIMATE MODIFICATION; DESERT.

[W.Swe.]

**Desiccant** A substance (adsorbant) used to withdraw moisture from other materials. Although the removal of large quantities of water is done by evaporation, aided by moving air currents and by elevated temperature, the last traces of moisture are often held very tightly and do not evaporate readily. Furthermore, evaporation ceases when the moisture content of the material is reduced to that of the drying-air current. For final drying, a desiccant is used. It may react with water chemically or retain water through capillarity of adsorption. The drying agent is placed directly into the gas or liquid to be dried; solid materials are placed in a desiccator, a closed vessel in which moisture diffuses to the desiccant through the dry desiccator atmosphere. A desiccant loses potency as it takes on water; often it can be renewed by heating. Desiccants which form hydrates can be selected to maintain certain levels of low humidity in a closed vessel. See ADSORPTION; DELIQUESCENCE.

Among the more important types of solid desiccants are silica gel, activated alumina, anhydrous calcium sulfate, magnesium perchlorate, oxides (of barium and calcium), and activated carbon.

[A.L.H.]

**Design standards** Specifications of materials, physical measurements, processes, performance of products, and characteristics of services rendered. Design standards may be established by individual manufacturers, trade associations, and national or international standards organizations. The general purpose is to realize operational and manufacturing economies, to increase the interchangeability of products, and to promote uniformity of definitions of product characteristics.

Individual firms often maintain extensive and detailed standards of parts that are available for use in their product designs. Usually the standards have the effect of restricting the variety of parts to certain sizes and materials. In this way the production lots required for inventory purposes are increased, and production economies may thereby be realized through the wider use of mass production. However, even if the larger quantities needed of the relatively few sizes do not in themselves lead to a cheaper manufacturing process, the costs of carrying inventory and setting up for production runs are reduced. A further development of this design approach may lead to the modularization of the entire product line, by reducing it to certain major subassemblies that are common to as many products as possible. Special jobs then typically require only a few added features, and cost savings may be realized.

A possible disadvantage is that the extensive use of general-purpose parts may jeopardize the space parts business, especially where outside manufacturers can skim off the market for the more commonly used and profitable spare parts once the original patents, if any, have expired, and then leave the more complex and slow-moving spares to the original manufacturer. However, it is precisely this aspect of standardization which is often welcomed by the users of the product.

Standardization also determines the nature of design practice. Especially when the specifications also give data on strength and performance as well as the usual dimensions, it is only necessary to compute loads approximately and then select the nearest standard sizes. Much design effort is thereby saved, especially on detail drawings, bills of material, and so forth. This approach also simplifies programming when computer-aided design is used. See COMPUTER-AIDED DESIGN AND MANUFACTURING.

Trade associations are the principal sources of American industrial standards. These involve standardization over an entire product line. In general, their scope is considerably less than that within firms with extensive standardization programs, but the technical and policy considerations in the two levels of standardization are quite similar. Trade standards are primarily concerned with specifying overall dimensions, so that products of different manufacturers may be used interchangeably; with performance, so that customers know what they are buying; and with certain design features, such as major materials, in order to assure proper function. In some cases, dimensional standards particularly must be related to standards in other industries; for instance, an American butter dish must accommodate the standard 4-oz (113.6-g) sticks in which butter is packed. Like national standards to which they are closely related, trade association standards should be established on the basis of as broad a consensus as possible within the industry. If standards were established such that any required burden of retooling and product change would fall in a discriminatory fashion upon only certain members of the industry, legal remedy would certainly be sought under the American antitrust laws.

The principal industrial countries have official agencies that approve, consolidate, and in some cases establish standards. Among them are the British Standards Institution (BSS), German Institute for Norms (DIN), and the American National Standards Institute (ANSI, formerly ASA). The national standardization agencies are members of a wide variety of international groupings and United Nations agencies. The principal ones are the International Organization of Standardization (ISO) and the International Electrotechnical Commission (IEC). These attempt to coordinate national activities and promote

cooperation in the area of standardization. Several of the more than 50 organizations deal with weights and measures; others engage in transnational or international activities in the standardization of many products or cover specific regional issues and requirements. Some, like the European Economic Community (EEC), the International Telecommunications Union (ITU), the International Civil Aviation Organization (ICAO), or the administration of the General Agreement on Tariffs and Trade (GATT) mainly have other political, economic, and scientific concerns but must necessarily take note of standardization as part of their work. See ENGINEERING DESIGN; PHYSICAL MEASUREMENT.

[J.E.U.]

**Desmodorida** An order of nematodes in which the variable stoma may be armed with a dorsal tooth which may be opposed by subventral denticles. The variable amphids range from reniform-to-elongate loops to simple or multiple spirals. The cephalic sensilla are generally in three whorls; however, the second and third whorls may be combined. Distinguishing the order is the cephalic capsule or helmet and the conspicuous somatic annuli. In some groups, anterior and posterior adhesion tubes are utilized in locomotion.

There are five desmodorid superfamilies: Ceramonematoidea comprise marine forms with distinctive cuticular ornamentation that takes the form of crested annuli; nothing is known of the feeding habits. Most species of Desmodoroidea are found in the marine environment. Draconematoidea are an unusual superfamily of marine forms; when relaxed, the body is dorsally and then ventrally arched into a shallow sigmoid shape. Epsilonematoidea and Monoposthoidea comprise marine forms. See NEMATA.

[A.R.M.]

**Desmoscolecida** An order of nematodes in which the taxa are readily recognized by their conspicuous body annulation. The annuli may be covered with concretion rings, or the cuticle may be ornamented with scales, warts, or bristles. The cephalic sensilla reportedly are reduced in number. The internal whorl is absent, the second whorl is papilliform, and the fourth sensilla of the third cirlet are setiform. The vesiculate amphids are oval to circular and occupy much of the cephalic region. The somatic setae are tubular, and the open distal ends are often elaborate. The posterior esophagus is only slightly expanded. When pigment spots or ocelli are present, they are just posterior to the esophagus. Females are amphidelphic, and the ovaries are generally outstretched. The male spicules are generally accompanied by a gubernaculum. Both sexes have three caudal glands.

There are two desmoscolecid superfamilies: Most species of Desmoscolecoida are found in the marine environment, although some species have also been collected from brackish waters. Greeffilloidea are free-living nematodes found primarily in marine or, rarely, estuarine habitats. See NEMATA.

[A.R.M.]

**Desmostylia** An extinct order of large, hippopotamus-like, amphibious, gravi-grade, shellfish-eating mammals that frequented shallow bays and coastal margins during the Oligocene

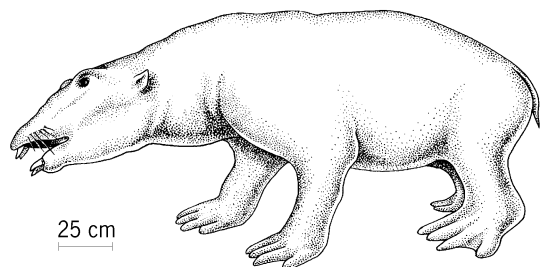

A restoration of *Desmostylus* from the Miocene of California. (After F. A. Stirton, 1959)

and Miocene (see illustration). Their main distribution was northern trans-Pacific, but discoveries in Florida indicate a much broader distribution. There are two families, the Desmostylidae and the Paleoparadoxidae. These animals probably descended from an ancestral stock that also gave rise to the Proboscidea and Sirenia. See MAMMALIA; PROBOSCIDEA; SIRENIA.

[G.T.J.]

**Desmothoracida** An order of Heliozoa. These ameboid organisms live in a stalked perforated organic or inorganic lorica. Stiffened pseudopodia extend from the perforations to capture food which collides with them. The best-known species is *Clathrulina elegans*, found in fresh-water environments. This species has a spherical organic test. Unlike most Heliozoa it has a life cycle which involves motile flagellated cells which arise from the sessile form and then may settle, transforming into amebas with thin pseudopodia. These ameboid forms secrete the stalk and lorica to give rise to the typical sessile (trophic) organism. See HELIOZOA; PROTOZOA; SARCODINA.

[D.J.Pa.]

**Desorption** A process in which atomic and molecular species residing on the surface of a solid leave the surface and enter the surrounding gas or vacuum. In stimulated desorption studies, species residing on a surface are made to desorb by incident electrons or photons. Measurements of these species provide insight into the ways that radiation affects matter, and are useful analytical probes of surface physics and chemistry. In thermal desorption studies, adsorbed surface species are caused to desorb as the sample is heated under controlled conditions. These measurements can provide information on surface-bond energies, the species present on the surface and their coverage, the order of the desorption process, and the number of bonding states or sites.

**Stimulated desorption.** Stimulated desorption from surfaces is initiated by electronic excitation of the surface bond by incident electrons or photons. The classical model of desorption is an adaptation of the theory of gas-phase dissociation, in which desorption results from excitation from a bonding state to an antibonding state.

Another model which is more applicable to the phenomenon of ion desorption was first observed in studies of the desorption of positively ionized oxygen ( $O^+$ ) from the surface of titanium(IV) oxide ( $TiO_2$ ). Here it is found that  $O^+$  is desorbed not by valence level excitation, but by ionization of the titanium and oxygen core levels. These levels, of course, have little to do with bonding. Furthermore, the fact that the oxygen is desorbed as an  $O^+$  ion (whereas it is nominally at  $O^{2-}$  on the surface) implies a large (three-electron) charge-transfer preceding desorption. This mechanism for desorption can also be effective for covalently bonded surface species.

Stimulated desorption studies are finding wide use. First, they can show the ways in which radiation affects the structure of solids. This will have important applications in the areas of radiation-induced damage and chemistry. Second, as an analytical tool, they offer a unique new way to study the physics and chemistry of atoms on surfaces which, when combined with the many other surface techniques based largely on electron spectroscopy, can provide new insight. Finally, models of the surface bond are put to a much sterner test in attempting to explain desorption phenomena. See RADIATION DAMAGE TO MATERIALS.

An additional important discovery is that ion angular distributions from stimulated desorption are not isotropic, but show that ions are emitted in relatively narrow cones which project along the nominal ground-state bond directions. Thus this technique provides a direct display of the surface-bonding geometry.

**Thermal desorption.** Thermal desorption mass spectroscopy is possibly the oldest technique for the study of adsorbates on surfaces. Three primary forms of the thermal desorption experiment involve measurement of (1) the rate of desorption from a surface during controlled heating



(temperature-programmed thermal desorption), (2) the rate of desorption at constant temperature (isothermal desorption), and (3) surface lifetimes and diffusion under exposure to a pulsed beam of adsorbates (molecular-beam experiments). Of the three, temperature-programmed thermal desorption is by far the most widely applied. The most straightforward information provided is the nature of the desorbed species from mass analysis, and a determination of the absolute coverage by the adsorbate, which is very difficult to obtain with other techniques. The technique can also provide important kinetic parameters of the desorption process.

While the thermal desorption techniques are among the simplest of surface probes, they remain indispensable because of their directness and the variety of information they convey. Thus while surface science moves to detailed methods involving extremely sophisticated apparatus, the simple thermal desorption methods remain an important part of the overall picture. See SURFACE PHYSICS. [M.L.K.]

**Destructive distillation** The primary chemical processing of materials such as wood, coal, oil shale, and some residual oils from refining of petroleum. It consists in heating material in an inert atmosphere at a temperature high enough for chemical decomposition. The principal products are (1) gases containing carbon monoxide, hydrogen, hydrogen sulfide, and ammonia, (2) oils, and (3) water solutions of organic acids, alcohols, and ammonium salts.

Crude shale oil may be obtained by destructive distillation of carboniferous shales. It may be subjected to a destructive, or coking, distillation to reduce its viscosity and increase its hydrogen content. Residual oils from petroleum refinery operations are subjected to coking distillation to reduce the carbon content. The coke is used for the manufacture of electrode carbon. The main product of the destructive distillation of wood is 40–45% charcoal used in metallurgical processes in which the low content of ash, sulfur, and phosphorus is important. See CHARCOAL; COAL CHEMICALS; COKE; COKING (PETROLEUM); OIL SHALE; PYROLYSIS; WOOD CHEMICALS. [H.H.St./H.W.W.]

**Detergent** A substance used to enhance the cleansing action of water. A detergent is an emulsifier, which penetrates and breaks up the oil film that binds dirt particles, and a wetting agent, which helps them to float off. Emulsifier molecules have an oillike nonpolar portion which is drawn into the oil, and a polar group that is water-soluble; by bridging the oilwater interface, they break the oil into dispersible droplets (emulsion). As a surfactant, a detergent decreases the surface tension of water and helps it penetrate soil.

Soap, the sodium salt of long-chain acids, was the principal detergent until superseded in 1954 by synthetic detergents (syndets) which, unlike soap, do not form insoluble products with the calcium in hard water. Most syndets are of the anionic type, that is, sodium salts of alkyl sulfates or sulfonates. Alkyl benzene sulfonates (ABS) with branched carbon chains were found to persist in wastewater and have been replaced by linear alkyl benzene sulfonates (LAS), which are biodegradable by bacterial action. Anionic detergents are best for water-absorbing fibers such as cotton, wool, and silk. Nonionic detergents are polyethers made by combining ethylene oxide with a 12-carbon lauryl alcohol. They are used for water-repelling “permanent press” fabrics, and their low-foaming property is desirable for automatic washers. Cationic syndets are quarternary base compounds. They are more expensive, but some are germicidal; some are used as fabric softeners and as good metal cleaners.

Detergents must contain alkaline “builders” to bind dissolved metal ions and support emulsification. Sodium pyrophosphate or polyphosphate were preferred because of low cost and high cleansing effectiveness. However, when discharged with laundry wastewater, these compounds supply nutrient to phosphate-deficient lakes and streams and thus lead to eutrophication, and

their use is now banned by law. Less harmful, but less effective, builders such as sodium carbonate are now widely used in detergents. See EUTROPHICATION.

Many additives are used in detergents to provide scent, brightening (usually through fluorescent action), or bleaching action. Biodegradability is essential for detergents; it ensures that components of detergents will be broken down by bacterial action before undesirable aftereffects can occur. Nonbiodegradable detergents can prevent effective bacterial action in septic tanks and sewage treatment plants, and can cause undesirable persistent foaming in rivers. See SOAP. [A.L.H.]

**Determinant** The theory of determinants had its origin in the solution of linear systems of equations. Determinants occur in virtually all branches of mathematics and related fields. See LINEAR SYSTEMS OF EQUATIONS; MATRIX THEORY; POLYNOMIAL SYSTEMS OF EQUATIONS.

The concept of a determinant can best be explained with reference to a matrix  $A$ .

$$\text{Let } A = \begin{pmatrix} a_{11} & a_{12} & \cdots & a_{1n} \\ a_{21} & a_{22} & \cdots & a_{2n} \\ \cdots & \cdots & \cdots & \cdots \\ a_{n1} & a_{n2} & \cdots & a_{nn} \end{pmatrix}$$

be an  $n$  by  $n$  square array of numbers. Such an array is called an  $n$  by  $n$  square matrix, and the numbers  $a_{ij}$  in the array are called elements of the matrix. The determinant of the matrix  $A$ , as indicated by Eq. (1), is a number which is the value of a certain function of the elements of  $A$ .

$$|A| = \begin{vmatrix} a_{11} & a_{12} & \cdots & a_{1n} \\ a_{21} & a_{22} & \cdots & a_{2n} \\ \cdots & \cdots & \cdots & \cdots \\ a_{n1} & a_{n2} & \cdots & a_{nn} \end{vmatrix} \quad (1)$$

The determinant of Eq. (1) is called a determinant of order  $n$ , and it can be defined by induction on  $n$ . For explanatory purposes, determinants of orders  $n = 1, 2$ , and  $3$  are defined as follows:

$$\begin{aligned} \text{For } n = 1, & \quad |a_{11}| = a_{11} \\ \text{For } n = 2, & \quad \begin{vmatrix} a_{11} & a_{12} \\ a_{21} & a_{22} \end{vmatrix} = a_{11}|a_{22}| - a_{12}|a_{21}| = a_{11}a_{22} - a_{12}a_{21} \\ \text{For } n = 3, & \quad \begin{vmatrix} a_{11} & a_{12} & a_{13} \\ a_{21} & a_{22} & a_{23} \\ a_{31} & a_{32} & a_{33} \end{vmatrix} \\ & = a_{11} \begin{vmatrix} a_{22} & a_{23} \\ a_{32} & a_{33} \end{vmatrix} - a_{12} \begin{vmatrix} a_{21} & a_{23} \\ a_{31} & a_{33} \end{vmatrix} + a_{13} \begin{vmatrix} a_{21} & a_{22} \\ a_{31} & a_{32} \end{vmatrix} \\ & = a_{11}(a_{22}a_{33} - a_{23}a_{32}) - a_{12}(a_{21}a_{33} - a_{23}a_{31}) \\ & \quad + a_{13}(a_{21}a_{32} - a_{22}a_{31}) \end{aligned}$$

The determinants of order 2 and 3 are defined in terms of determinants of order 1 and 2, respectively. Suppose now that a determinant of order  $n - 1$  has been defined. In Eq. (1), denote by  $A_{1j}$ ,  $j = 1, 2, \dots, n$ , the determinant of order  $n - 1$  formed by deleting from Eq. (1) the first row and the  $j$ th column. Equation (2) then, by definition, holds.

$$\begin{aligned} |A| = & a_{11}A_{11} - a_{12}A_{12} + a_{13}A_{13} + (-1)^{n-2}a_{1n-1}A_{1n-1} \\ & + (-1)^{n-1}a_{1n}A_{1n} \end{aligned} \quad (2)$$

This definition is seen to agree with the definitions for determinants of order 2 and 3 and, by the principle of mathematical induction, defines a determinant of order  $n$  for every  $n$ . There are many other definitions of a determinant of order  $n$  which can be proved to be equivalent to the definition given here. See EQUATIONS, THEORY OF. [R.A.B.]

**Determinism** The principle that nature follows exact laws, so that what will happen in the future is a necessary consequence of the state of the world at any given moment in the past. This view, if fully adopted, implies that events which seem to occur by chance would be fully understood if more was known about them, and that apparently free thoughts and choices are explainable and in principle predictable in terms of neuroscience. In a looser sense, determinism refers to claims that mental freedom is much more restricted than people are inclined to suppose.

The question of determinism in physical science cannot be considered apart from the philosophical problem; this gives it added importance and forces its consideration in a very critical spirit.

The idea that the world is composed of atoms moving under the influence of certain forces according to certain laws can be traced back to the Greek philosopher Leucippus. Deterministic philosophy was prominent in the work of the seventeenth-century thinker René Descartes, and became widely known through his influence. Isaac Newton carried out a large part of the cartesian program. His theory explained so many natural processes that it began to appear that the universe since the time of Creation might actually have run its course in a deterministic fashion like a machine, without divine intervention. A century after Newton, Pierre Simon de Laplace argued that an Omniscient Calculator, provided with exact knowledge of the state of the universe at present, would be able to predict the entire future. See CLASSICAL MECHANICS; NEWTON'S LAWS OF MOTION.

The quantum mechanics of the 1920s introduced the paradox of particles which are, at the same time, waves. A wave of length  $\lambda$  was supposed to accompany, or describe, a particle of momentum  $p = h/\lambda$ , where  $h$  is Planck's constant. The probability of finding a free particle is expressed by a (complex) wave packet (see illustration), and the particle has appreciable probability of being found only where the wave function is large; that is, within a region of size roughly  $\Delta x$  on each side of  $x_0$  in the illustration. A theorem of Fourier analysis shows that  $\Delta p$ , the range of momenta present in the wave packet, is related to  $\Delta x$  as shown below. This means that the more precisely the specification of a

$$\Delta x \Delta p \geq h/(2\pi)$$

particle's position  $x$  is attempted by means of a localized wave function, the less precisely can its momentum be specified. W. Heisenberg's principle of uncertainty, or indeterminacy, states that it is impossible to measure, and therefore to know,  $x$  and  $p$  any more accurately than is allowed by this relation, and there are also other pairs of dynamical variables similarly related. See FOURIER SERIES.

There remains the question as to whether Heisenberg's principle is merely an unfortunate limitation on an experimenter's ability to know or whether it goes deeper. The general opinion of physicists is that of N. Bohr: the principle expresses a limitation of the precision with which concepts such as position and momentum can be applied at all. Therefore Laplace's Omniscient Calculator cannot predict the future. See QUANTUM MECHANICS; UNCERTAINTY PRINCIPLE.

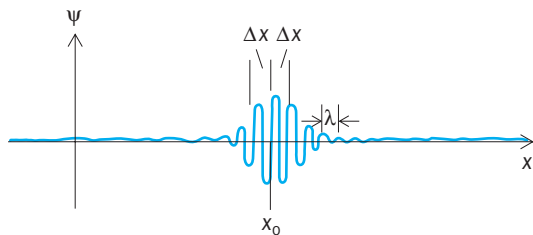

A wave packet—of wavelength approximately  $\lambda$ , and produced perhaps by opening and closing a shutter—traveling through space.

Perceptive mathematicians have warned that determinism is not as obvious a consequence of newtonian physics as it might appear. A series of mathematical results have been proven whose general effect is that for the vast majority of dynamical systems any error in the initial conditions, however small, will be amplified, in general exponentially, and so quickly that the predicted result will soon bear no relation to reality. Thus unless it is assumed that initial conditions are known with perfect accuracy, and perfectly accurate computation takes place thereafter, the Omniscient Calculator will wind up getting everything wrong. See CHAOS.

Very few people now think that all events in the natural world are exactly determined. Experiments suggest that some human and animal behavior can reliably be predicted and controlled, but nobody knows the limits within which this can be done. [D.P.]

**Deuterium** The isotope of the element hydrogen with atomic weight 2.0144 and symbols  $^2\text{H}$  or D. The terrestrial natural abundance of deuterium is 1 part in 6700 parts of ordinary hydrogen (protium). Small variations in natural sources are found as a result of fractionation by geological processes.

Deuterium is a gas ( $\text{D}_2$ ) at room temperature. It is prepared from heavy water,  $\text{D}_2\text{O}$ , either by electrolysis or by reaction of  $\text{D}_2\text{O}$  with metals such as zinc, iron, calcium, and uranium. It is also prepared directly by the fractional distillation of liquid hydrogen.

Deuterium is used mainly in the form of heavy water. In the uncombined state it finds uses as a research tool. Liquid deuterium is used in bubble chambers to study the reactions of elementary particles with the deuterium nucleus, the deuteron. Deuterons are frequently accelerated in cyclotrons to study their reactions with other nuclei and also to produce radioactive nuclides. Deuterium gas is used in the direct synthesis of organic compounds for tracer studies. See DEUTERON; HEAVY WATER; HYDROGEN; NUCLEAR FUSION; NUCLEAR REACTION; TRITIUM. [J.Big.]

**Deuteromycotina** A heterogeneous group of anamorphic (asexual or imperfect) fungi in which sporulation may occur on separate hyphae or composite fruit bodies (conidiomata). The diagnostic feature of the group is the lack of a teleomorphic (sexual or perfect) state. There are more than 2500 accepted genera containing 21,000 species.

Traditionally, Deuteromycotina are separated into two classes: Hyphomycetes, which are mycelial forms bearing conidia on separate hyphae or aggregations of hyphae; and Coelomycetes, which are forms that produce conidia in pycnidial, pycnothyrial, acervular, cupulate, or stromatic conidiomata. A third class is sometimes recognized, the Agonomycetes (*Mycelia Sterilia*); these fail to produce conidia and thus lack conidiomata, although they do form somatic survival propagules. Currently, no ranks are distinguished within the Deuteromycotina, and the subdivisional name itself is no longer in use, the preferred term being Mitotic Fungi or Fungi Anamorphici. See AGONOMYCETES; COELOMYCETES; HYPHOMYCETES.

Deuteromycetes are ubiquitous and occupy most conceivable ecological niches. Deuteromycetes such as *Penicillium*, *Aspergillus*, and *Saccharomyces* have been used extensively in manufacturing processes of different kinds. Increasingly important is the use of deuteromycetes in biological control of insects, nematodes, pathogenic fungi, and weeds. See DISTILLED SPIRITS; FOOD MANUFACTURING.

Fungal infections (mycoses) are almost always the result of abnormal host immunity. Even before the association of the human immunodeficiency virus (HIV) with acquired immune deficiency syndrome (AIDS), criteria used in defining the syndrome relied heavily on the existence of certain opportunistic infections in the absence of any of the established predisposing conditions. A significant number of these deep-seated infections are caused by deuteromycetes such as *Aspergillus*, *Candida*, *Cryptococcus*, and *Histoplasma*. See ACQUIRED IMMUNE

DEFICIENCY SYNDROME (AIDS); MEDICAL MYCOLOGY; MYCOTOXIN; OPPORTUNISTIC INFECTIONS. [B.C.S.]

**Deuteron** The nucleus of the atom of heavy hydrogen,  $^2\text{H}$  (deuterium). The deuteron  $d$  is composed of a proton and a neutron; it is the simplest multinucleon nucleus. Its binding energy is 2.227 MeV; that is, this is the amount of energy which must be added to a deuteron for it to dissociate into a proton and a neutron. Deuterons are much used as projectiles in nuclear bombardment experiments. See DEUTERIUM; NUCLEAR REACTION. [H.E.D.]

**Developmental biology** A large field of investigation that includes the study of all changes associated with an organism as it progresses through the life cycle. The life cycles of all multicellular organisms exhibit many similarities. That is, as an organism progresses from one generation to the next there is a series of common processes: for example, gametogenesis, fertilization, embryogenesis, cell differentiation, tissue differentiation, organogenesis, maturation, growth, reproduction, senescence, and death. [D.Ru.]

Analysis of all of the events associated with an organism as it progresses through its life cycle employs a multiplicity of approaches. Tremendous strides have been made in describing at the molecular level the developmental process of cell differentiation. However, the molecular control mechanisms which regulate cell differentiation are not known. Tissue and organ differentiation, as well as morphogenesis, are processes which have been described in detail for many situations, but little is known about the physical and chemical nature of the mechanisms involved. A complete understanding of the development of an organism will require an appreciation and comprehension of the changes which occur at all levels of organization as an organism traverses its life cycle.

The major unifying theme in biology is evolution. Not only has evolution led to the wide variety of organisms now present on Earth, but also evolution has modified the initial processes and patterns of development to the diversity of types currently encountered. This evolution of developmental parameters in multicellular organisms began as single-celled organisms became multicellular. The development of a multicellular organism entails a host of problems not faced by a single-celled organism. For example, cells in one part of the aggregate must coordinate their activities with cells in other parts, nutrients and oxygen must be provided to all cells, and water balance must be maintained.

Developmental biologists have focused on two central areas: the processes and associated mechanisms by which cells become different, that is, cell differentiation; and the processes and associated mechanisms by which patterns are created, that is, morphogenesis.

Current theories state that cells become different by expressing different genes. Thus, a liver cell is different from a muscle cell, not because it contains different genes or genetic information, but because it expresses different sets of genes. This explanation of cell differences is based upon the results of three types of experimental analysis. (1) Some plant cells are totipotent; that is, for tobacco, carrot, and a few other plant species, it has been demonstrated that a single cell (not a gamete) can divide and undergo morphogenesis to form a fertile plant. (2) Nuclei from some differentiated animal cells are totipotent. That is, a nucleus from a differentiated cell can be injected into a mature egg which has had its nucleus removed or destroyed, and the injected nucleus can direct normal development of the organism. (3) The sequences of nucleotides in the DNA of all cells in an organism appear to be the same; that is, DNA-DNA hybridization of DNA from different cell types indicates that the different cell types do not have unique DNA base sequences. Since these results indicate that all cells contain the complete genome for an organism, different cell types appear to arise as a result of the

expression of unique sets of genes in each cell type. See CELL DIFFERENTIATION; DEVELOPMENTAL GENETICS; GENE ACTION; SOMATIC CELL GENETICS.

Initially the cells of a developing embryo are not restricted in their developmental potential or fate, but as embryogenesis proceeds, a cell's developmental potential becomes restricted or fixed. Restriction of developmental fate is called determination. Two mechanisms have been identified that bring about determination. The first involves the presence of unique factors, called cytoplasmic determinants, which are products of the maternal genome and are located in specific areas of some animal eggs. The cells which come to contain these determinants differentiate along specific pathways. The second mechanism is induction, a process by which two tissues interact so that one or both differentiate along specific pathways. A classic example of induction is the action of mesoderm on the overlying ectoderm in the frog embryo at the time of gastrulation. The mesoderm acts on the ectoderm, causing it to form the neural plate. Only ectoderm of a certain developmental age is capable of responding to the mesoderm, and this ectoderm is said to be competent. See EMBRYONIC INDUCTION.

Developmental biologists have gained substantial insights into the molecular bases for determination in model organisms such as *Drosophila*. At least three sets of cytoplasmic determinants (maternal gene products) are present in the fly egg: determinants for germ-cell formation, determinants controlling dorsal-ventral polarity, and determinants for the anterior-posterior polarity. Some of these determinants are messenger ribonucleic acids (mRNAs) coding for proteins which are transcriptional regulators (that is, proteins that regulate gene activity).

Morphogenesis involves the production of form and structure by integrating the differentiation of many different cells and cell types into specific spatial patterns. This higher level of organization has been difficult to investigate in terms of establishing mechanisms. The processes of determination, competence, and induction are involved. One of the greatest challenges faced by developmental biologists is to bridge the gap between genes and patterns. It is clear that patterns are a result of gene activity, but the relationship between genes and patterns in most organisms is not well understood. See ANIMAL MORPHOGENESIS; PLANT MORPHOGENESIS. [C.N.M.]

**Developmental genetics** The study of how genes control development. Advances in the field have emphasized the degree of conservation of the genes controlling development throughout evolution. Thus, such distant organisms as insects and vertebrates share a number of very homologous genes controlling early development. For example, homeobox genes (*Hox* genes) are used in both insects and mammals to provide information for anterior-posterior positioning. The conservation of the genes is so great that the human version of a *Hox* gene can sometimes substitute for the mutant *Drosophila* gene and correct abnormalities of early development.

Most genes involved in sex determination have not been conserved, but a gene has been cloned in the nematode *Caenorhabditis elegans* which is highly homologous to a gene involved in the *Drosophila* sex determination cascade and to a gene in mammals whose role in sex determination has yet to be fully elucidated. Another organism which is elucidating these genes and has become of great interest is the zebrafish. Its small size and clear embryo allow easy screening of many developmental mutations, and many of the above-mentioned evolutionary conservations have been confirmed in the zebrafish.

Determination is a stage during the developmental process when genes become committed to a particular expression pattern leading to a differentiated state. At the time of this stage, the differentiated state is not yet visible. This aspect can be confirmed by transplantation of determined but not yet differentiated tissues to ectopic sites and observing the transplant's

development. Advances have shown that some cell types are not as highly determined as was previously thought. Brain cells have given rise to blood cells, and bone marrow cells have given rise to bone and muscle. This apparent lack of determination in cells previously believed to be determined suggests greater potential for plasticity and the possibility of manipulating cells to new fates to create organs for human transplantation, for example.

Another area of research has involved maternal inheritance. Many of the genes responsible for the determination of cell fate in *C. elegans* larva are laid down in the egg; that is, they are maternal-effect genes. In this case, it is not the genotype of the zygote which influences development but that of the mother. Thus, homozygosity for a recessive mutation in the mother leads to altered development, even though the sperm is from a homozygous wild-type male and the resulting zygote was heterozygous. The percentage of maternal-effect genes is also high in *Drosophila*. See GENE ACTION.

Another general phenomenon under genetic control during development is induction—the action of one cell or tissue on other cells in order to determine altered gene expression in them.

Homeotic mutations change one paired structure to another of a more anterior or posterior compartment (for example, a leg to an antenna). The study of their structure and function has provided a paradigm for the role of genes in conveying positional information during development. In *Drosophila*, seven homeotic genes are grouped in two complexes. Their role in establishing segmental identities is well defined, and the DNA sequence of the genes shows a highly conserved element called the homeobox. This conserved sequence is also found in some pair-rule and polarity genes, and the search for genes homologous to these led to the identification of other genes that are highly conserved in animal evolution. Although *Drosophila* uses one set of homeobox genes (separated into two clusters on two different chromosomes), mammals have amplified the set of genes to a minimum of four clusters of the size of the single cluster in *Drosophila*. These genes maintain the same patterns of expression in both mammals and *Drosophila*. They are expressed 5' to 3' in order of transcription, and the 5'-to-3' order in the cluster is also reflected in the posterior-to-anterior limits of expression of the gene products. Most mutations in homeobox genes are recessive, and embryonic stem-cell knockouts have disclosed that, because there is sufficient redundancy in the mammalian homeobox clusters, the homozygous absence of one homeobox gene does not always result in an apparent phenotype. Paired box genes are another highly conserved family of genes, first identified for their important developmental roles in *Drosophila*. Mutations in these genes frequently cause dominantly inherited birth defects in mammals.

Imprinting, a developmentally important phenomenon that was first discovered in insects, is also important for mammalian development and human disease. In imprinting, genes transmitted through the testis sometimes function differently from those transmitted through the ovary. Many portions of the genome have been found to be imprinted, including the reciprocal imprinting of insulinlike growth factor and its receptor. Some major human diseases occur when both a paternal and a maternal copy of a gene are not present. The Prader-Willi syndrome, a disorder of mental retardation, poor appetite regulation, and mild dysmorphic features, is an example. Advances have strongly implicated gametogenesis-specific methylation of key controlling regions in the imprinting process. Such imprints seem to be erased from the migrating germ cells enroute to the developing gonad, and then are established differentially during oogenesis and spermatogenesis, presumably by proteins uniquely expressed in the two different gonads and with specificity for the particular DNA sequences. The actual expression of imprinting differences frequently involves (1) competition between cis-linked genetic elements and (2) a nontranslated RNA species. See DEVELOPMENTAL BIOLOGY; GENETICS. [R.P.E.]

**Developmental psychology** The study of age-related changes in behavior from birth to death. Developmental psychologists attempt to determine the causes of such changes. Most research has concentrated on the development of children, but there is increasing interest in the elderly, and to a lesser extent in other age groups. Although most developmental work examines humans, there has been some work on primates and other species that would be considered unethical with human beings. Thus the sensory deprivation of kittens and the separation of monkeys from their mothers have provided information about abnormal perceptual and emotional development, respectively.

**Method.** Developmental psychologists who study children rely more upon careful observation in natural settings than upon laboratory experiments. Under these circumstances, only partial conclusions can be drawn about the causes of development. The field has been dominated by descriptive research, with increasing attempts to explain developmental phenomena by the use of animal experiments or by statistical methods. In longitudinal research, a group of individuals is studied at regular intervals over a relatively long period of time. This contrasts with cross-sectional research, where individuals of different ages are studied at the same time. Conclusions from the two types of research may differ. Finally, case studies, that is, close and extensive observations of a few subjects, have been relied upon by important developmental theorists such as S. Freud and J. Piaget.

**Theories.** An explanation of developmental changes requires a judgment as to the relative importance of genetically programmed maturation and environmental influences. Although most developmentalists believe that genetic endowment and environmental experience interact to account for behavior, the degree to which either affects a particular behavior is still often debated. This issue has important implications for the success of environmental intervention in the face of genetic constraints. For example, the influence on children of parental speech versus genetic programming in language acquisition is much debated, as is the origin of gender differences in behavior. See BEHAVIOR GENETICS.

Developmental psychology is divided roughly between those who study personal-social (emotional) development and those who study intellectual and linguistic development, although there is a small but growing interest in the overlap between these two aspects of personality, known as social cognition. The study of personal-social development in childhood is dominated by the theory of attachment formulated by J. Bowlby and extended by M. Ainsworth. In adolescence and adulthood, E. Erikson's theory of psychosocial development is prominent. The study of intellectual development at all ages is dominated by Piaget's theory of cognitive constructivism.

**Emotional development.** Ainsworth defines attachment as "an affectional tie that one person forms to another specific person, binding them together in space, and enduring over time . . . [It] is discriminating and specific." It is not present at birth, but is developed. In a word, attachment means love. Attachment behaviors such as crying, smiling, physical contact, and vocalizing are the means by which attachment is forged but are not to be equated with the more abstract, underlying construct of attachment. Attachment theory is strongly based on ethological notions. Thus, attachment is seen as serving a biological function, that is, the protection of infants by ensuring their proximity to (attached) adults. The common goal of attached individuals is proximity. Bowlby was influenced by Freud's psychoanalytic theory of development, but argues that there is a primary biological need to become attached to at least one adult, whereas Freud argued that love for a mother was secondary to her satisfaction of an infant's hunger.

**Intellectual development.** For Piaget, intelligence is defined as the ability to adapt to the environment, an ability that depends upon physical and psychological (cognitive) organization. The adaptation process has two complementary components,

assimilation and accommodation. Assimilation refers to the tendency to process new information, sometimes with distortion, in terms of existing cognitive structures. Accommodation refers to the opposite process, that is, the modification of existing cognitive structures in response to new information. An individual strives for equilibrium between assimilation and accommodation, with thought being neither unrealistic (excessive assimilation) nor excessively realistic and hence disorganized (excessive accommodation). See COGNITION; INTELLIGENCE.

For Piaget, cognition gradually becomes abstracted from perception over the course of 12 years. Infants begin cognitive exploration by actively perceiving and reflexively manipulating objects, giving the name sensorimotor period to the first phase of intellectual development. Perception is a key form of early cognitive activity, especially with newborns. The newborn infant can see, hear, smell, taste, and feel much better than previously thought, though sensitivity in these areas improves throughout the first year of life. Between the ages of 18 and 24 months, infants become capable of symbolic representation, occasionally solving problems just by thinking about them. The major accomplishment of the sensorimotor period is object permanence, the realization that objects continue to exist even when not observable. During the next 5 years, sometimes termed the preoperational period, children work on concrete operations such as classifying objects into categories, arranging things in serial order, figuring out causes and effects, or understanding a one-to-one correspondence of numbers to objects counted. They also eventually manipulate reality enough to overcome perceptual illusions such as that an amount of water changes when it is poured from a short wide glass into a tall narrow glass. From 7 to 11 years, children further consolidate their concrete mental operations. At about 12 years, many adolescents enter the final stage of intellectual development: formal operations. They become capable of abstract, logical thought. They understand reality as a subset of possible worlds, and are able to form multiple, systematic hypotheses, involving all possible combinations of relevant variables, in order to explain things.

Many quarrel with Piaget's age assessments of children, but most people accept his sequence of stages as useful for classifying children.

**Moral development.** L. Kohlberg's work on moral development spans the chasm between intellectual and emotional development. He studied reasoning about hypothetical moral dilemmas, such as whether a person should steal an unaffordable drug in order to save someone's life. He classified such reasoning in six stages. At birth children are considered to be pre-moral. By the age of 7, most children are in stage 1, chiefly characterized by the belief that people should act in certain ways in order to avoid physical or other punishment. In 2 or 3 years, children reason primarily in terms of doing things for rewards; this is stage 2. Stage 3 involves reasoning focused less on rewards than on maintaining the approval of others. Stage 4 involves reasoning that unquestioningly accepts conventional rules. Actions are judged by a rigid set of regulations, religious, legal, or both. Most individuals do not develop past this point. A few, however, do reach postconventional moral reasoning, stage 5. These individuals think in terms of moral principles. Rarely, a step higher to stage 6 is reached, governed by original abstract moral principles such as articulation of the golden rule. Kohlberg argued that moral development is progressive, without regression to earlier stages.

**Developmental psychopathology.** Traditionally, child clinical psychology (abnormal development) and the study of normal development were separate. However, effort is being made to integrate them. Abnormal development is informative about normal processes. The serious disorders of childhood include autism, attention-deficit disorder with hyperactivity, and depression. Viewed another way, abnormal children are either overcontrolled (obsessive-compulsive) or undercontrolled (impulsive,

aggressive). Developmental psychopathologists, however, are interested not just in disordered development in childhood, but in abnormal individuals over their lifetime. Such studies can shed light on the effectiveness of treatments and on the way in which disorders such as hyperactivity may be displayed differently at different ages. [A.McC.]

**Devonian** The fourth period of the Paleozoic Era, encompassing an interval of geologic time between 418 and 362 million years before present based on radiometric data. The Devonian System encompasses all rocks deposited or formed during the Devonian Period. See PALEOZOIC.

The base of the Devonian System has been fixed, by international agreement, at an outcrop of sedimentary rocks at Klonk in the Czech Republic, where it corresponds to the base of the *Monograptus uniformis* graptolite zone. The top of the Devonian System, corresponding to the base of the Carboniferous System, was fixed at LaSerre in southern France, recognized by the base of the *Siphonodella sulcata* conodont zone. The Devonian is customarily divided into Lower, Middle, and Upper series and their corresponding epochs.

Devonian fossils are found to be distributed in three realms. Within each realm there is taxonomic similarity, which indicates that there was reproductive interchange among members of the same phyletic groups, but between each two realms there are various degrees of taxonomic dissimilarity, which indicates that there were various degrees of reproductive isolation among members of the same phylogenetic groups. The largest realm covered Australia, Asia, Europe, western North America, and the Morocco-India fringe of Gondwana, and is termed the Old World Realm. It was unified by relatively free flowage of the warm equatorial currents and their immediate branches among the continental masses throughout this tropical to subtropical region. The Appalachian Realm covered most of eastern North America and the Colombia-Venezuela-Amazon part of northern South American Gondwana, which was adjacent to Appalachian North America during the Devonian. This region was bathed by the temperate southern west-wind current, which crossed a sufficiently broad stretch of ocean so that many Old World larvae could not make the journey, allowing endemic Appalachian forms to develop locally. The Malvinokaffric Realm covered central Gondwana, including southern South America, southern Africa, and Antarctica.

Devonian mountain building was particularly noticeable along the margins of Euramerica. The Acadian orogeny formed mountainous highlands accompanied by a chain of granitic intrusions from Nova Scotia to Pennsylvania during much of Devonian time. These mountains formed a barrier that prevented mixing between organisms of the Appalachian Realm and those of the Old World Realm at the same latitude in central Europe. Erosion from the Acadian mountains produced the thick Catskill deltaic complex of New York and Pennsylvania, which spread its fine-grained sediments far into the interior of eastern North America during later Devonian time. Simultaneously, along the Arctic margin of Canada, the Ellesmerian orogeny was producing folded mountains whose erosional products formed a clastic wedge that was a mirror image of the Catskill deposits. During latest Devonian time, the Roberts Mountains thrust, of the Antler orogeny in Nevada and Idaho, formed at the top of a subduction zone along which continental crust and overlying sediments were descending beneath oceanic sediments. A Late Devonian orogeny also affected eastern Australia. See OROGENY; PLATE TECTONICS.

Among the marine invertebrates, trilobites (Arthropoda) were much less abundant than during the Cambrian. The planktic members of the extinct graptolites died out during the Early Devonian, at about the same time as the pelagic ammonoid cephalopods first evolved. The externally two-shelled brachiopods were at their greatest diversity. Lime-secreting corals and stromatoporoids were important and widespread in

warm-water environments, and formed reefs during the Middle and Late Devonian. The extinct microfossil group known as conodonts was abundant, widespread, and rapidly evolving during the Devonian, so that conodont fossils are now regarded as the principal tools to be used for international correlation and relative age determination. See BRACHIOPODA; CONODONT; GRAPTOLITHINA; MICROPALAEONTOLOGY; STROMATOPOROIDEA; TRILOBITA.

The great diversification and radiation of fish in the Devonian has led to the term "Age of Fishes" for the period. Placoderm fish, among the most primitive of the jawed vertebrates, were successful predators in Devonian waters, and some grew to lengths up to 8 m (25 ft) just before their extinction at the end of the Devonian. The sharks, with a cartilaginous skeleton but lacking a swimbladder, may have evolved from an early placoderm. Bony fishes or Osteichthyes, a class that includes all modern fish other than sharks and agnathans, were represented in the Devonian by the primitive acanthodians, but more modern groups of bony fishes appeared in the Early Devonian. Lobe-finned bony fishes, or sarcopterygians, include both the lungfish (Dipnoi) and crossopterygians in the Devonian. The oldest known amphibians, including *Acanthostega* and *Ichthyostega*, occur in strata thought to be high Upper Devonian. See CROSSOPTERYGII; DIPNOI; OSTEICHTHYES; PLACODERMI; SARCOPTERYGII.

Land plants began to flourish near the beginning of Devonian time, and were exemplified by the vascular genus *Psilophyton* of the phylum Psilopsida. The latter gave rise in the Devonian to the Lycopsidea (scale trees) and Pteropsida (true ferns). See LYCOPHYTA; PALEOBOTANY; PSILOTOPHYTA; PTEROPSIDA.

[J.G.J.; P.H.H.; D.J.Ov.]

**Dew** The deposit of liquid water resulting from condensation of atmospheric water vapor to exposed surfaces that cool during the night. Dewfall is noticeable in the early morning after a calm, cool, clear night, usually as beads of liquid water on the outside and upward-facing surfaces of trees, buildings, and so forth. If the ground is moist, some of the condensed water can be evaporated surface moisture. Dew forms when the surface temperature drops sufficiently to saturate air in contact with the surface (that is, when the surface drops to below atmospheric dew-point temperature); when the surface cools to below freezing temperature, frost occurs. See DEW POINT; FROST.

Hygroscopic particles on surfaces can act as sites for condensation at temperatures higher than the atmospheric dew-point temperature. Thus, if a surface is not clean, the first deposit of moisture from the air can occur well before the surface cools to dew-point temperature. For some chemicals, such as common salt, condensation can start to occur when the local relative humidity reaches 80%; the humidity must be 100% in the case of a clean surface. Some desert plants exude hygroscopic salts from the interior of leaves which provide preferred sites for condensation and thereby create a supply of water for the plant. See HUMIDITY.

[B.Hi.]

**Dew point** The temperature at which air becomes saturated when cooled without addition of moisture or change of pressure. Any further cooling causes condensation; fog and dew are formed in this way.

Frost point is the corresponding temperature of saturation with respect to ice. At temperatures below freezing, both frost point and dew point may be defined because water is often liquid (especially in clouds) at temperatures well below freezing; at freezing (more exactly, at the triple point,  $+0.01^{\circ}\text{C}$ ) they are the same, but below freezing the frost point is higher. For example, if the dew point is  $-9^{\circ}\text{C}$ , the frost point is  $-8^{\circ}\text{C}$ . Both dew point and frost point are single-valued functions of vapor pressure. See DEW; EVAPORATION; FOG; HUMIDITY; VAPOR PRESSURE.

[J.R.F.]

**Dewar flask** A vessel having double walls, the space between being evacuated and the surfaces facing the vacuum be-

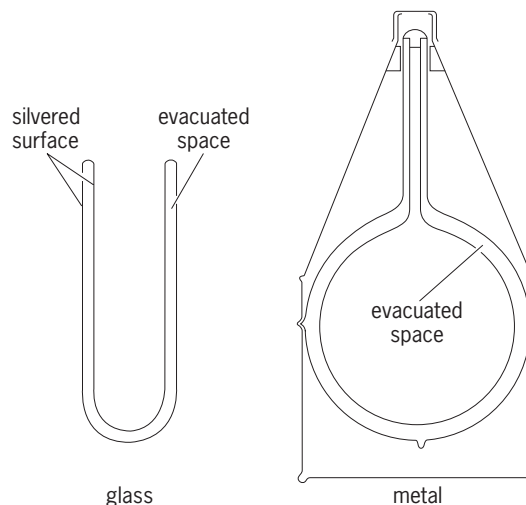

A typical Dewar container.

ing heat reflective. It was invented in 1892 by James Dewar as a container for liquid oxygen.

Dewar's original flasks were made of glass with a coating of mirror silver; this type is still used in the laboratory. But for shipment and storage of liquid gases, metal vacuum vessels are used (see illustration). Thermos Bottle is a trademark for a Dewar vessel for hot and cold foods.

[H.W.Ru./G.R.H.]

**Dewaxing of petroleum** The process of separating hydrocarbons which solidify readily (waxes) from petroleum fractions. Removal of wax is usually necessary to produce lubricating oil which will remain fluid down to the lowest temperature of use. The wax removed may be purified further to produce commercial paraffin or microcrystalline waxes.

Most commercial dewaxing processes utilize solvent dilution, chilling to crystallize the wax, and filtration. Wax crystals are formed by chilling through the walls of scraped surface chillers, and wax is separated from the resultant wax-oil-solvent slurry by using fully enclosed rotary vacuum filters. In a process modification, most of the chilling is accomplished by multistage injection of very cold solvent into the waxy oil with vigorous agitation, resulting in more uniform and compact wax crystals which filter faster.

Complex dewaxing requires no refrigeration, but depends upon the formation of a solid urea-*n*-paraffin complex which is separated by filtration and then decomposed. The catalytic dewaxing process is based on selective hydrocracking of the normal paraffins; it uses a molecular sieve-based catalyst in which the active hydrocracking sites are accessible only to the paraffin molecules. See PETROLEUM; PETROLEUM PROCESSING; WAX, PETROLEUM.

[S.F.P.]

**Dextran** A polyglucose biopolymer characterized by preponderance of  $\alpha$ -1,6 linkage, and generally produced by enzymes from certain strains of *Leuconostoc* or *Streptococcus*. While formerly its principal utility was as blood plasma substitute, dextran is also employed as packing material in column chromatography and as pharmaceutical agents; its average molecular weight determines usage to a great extent. Dextran's chemical and physical properties depend upon the strain of microorganism employed and the environmental conditions imposed upon the bacterium during growth, or the reaction conditions where an enzymatic method of dextran production is employed. *Leuconostoc* and *Streptococcus* species primarily convert sucrose to dextran and fructose. *Acetobacter* species convert dextrin to dextran. See DEXTRIN; POLYMERIZATION; POLYSACCHARIDE.

[H.M.Ts.]

**Dextrin** A polymer of D-glucose which is intermediate in complexity between starch and maltose. The dextrans are usually obtained by hydrolysis of starch with diastase (amylases). The higher dextrans resemble starch, while the lower dextrans more nearly resemble the sugars. Compared with the original starch, the dextrans produce less viscous solutions. They are soluble in water but insoluble in alcohol. Dextrans may be obtained from starch by controlled hydrolysis with acids. They are used commercially as adhesives. Tapioca, waxy maize, and sweet potato starch represent the best material for their manufacture. See GLUCOSE. [W.Z.H.]

**Diabetes** A condition in which excessive amounts of some substances are excreted from the body. The term may refer to either of two unrelated diseases, diabetes mellitus and diabetes insipidus. In common usage, the term diabetes is synonymous with diabetes mellitus.

**Diabetes mellitus.** This is a disease of abnormal carbohydrate metabolism in which glucose cannot enter the body's cells and be utilized, and therefore remains in the blood in high concentrations. In diabetes mellitus the excess sugar in the blood (hyperglycemia) leads to the excretion of sugar in the urine (glycosuria), a cardinal diagnostic symptom. Glycosuria in turn causes the excretion of large amounts of urine (polyuria), which results in dehydration and intense thirst (polydipsia). Although blood glucose is high, it cannot enter the appetite-regulating cells of the hypothalamus; hunger is therefore great, and the diabetic person tends to eat constantly (polyphagia). But because glucose cannot enter and nourish the cells, body tissues are subjected to the equivalent of starvation; rapid weight loss occurs, part of which is due to the excretion of water in urine. See CARBOHYDRATE METABOLISM.

Diabetes mellitus appears in two varieties, each with its own cause: diabetes mellitus type I (formerly known as juvenile onset diabetes), caused by deficiency of the pancreatic hormone insulin (whose chief function is to promote the entry of glucose into cells); and diabetes mellitus type II (formerly known as maturity onset diabetes), in which insulin is available but cannot be properly utilized. See INSULIN; PANCREAS.

Three factors that are believed to be important in the causation of this disease are heredity, viral infections, and immunological damage to the pancreas. Heredity does operate in determining one's risk of diabetes, but only as a predisposing factor, not as an absolute determinant. The two types of diabetes mellitus have entirely different patterns of inheritance. Virus infection is strongly implicated as one causative factor in the beta-cell destruction that characterizes type I diabetes, but it is not involved in type II diabetes. Some of the viruses that have been implicated are the agents of mumps and rubella (German measles) and coxsackievirus B. Autoimmune reactions, wherein the body's immune defense system attacks its own pancreatic tissue as though it were a foreign substance, are also suggested as a cause for the beta-cell destruction of type I diabetes. See ANIMAL VIRUS; AUTOIMMUNITY; HUMAN GENETICS.

Dietary management has been part of diabetic therapy since preinsulin days, when starvation diets were used to prolong the life of type I diabetics. More recently, weight reduction for victims of type II diabetes and complex carbohydrate liberalization for those of both types of diabetes mellitus have been the cornerstone of therapy. Some other dietary measures besides reducing caloric intake are now believed beneficial for type II diabetics. The ingestion of foods high in fiber content, for example, has been shown to reduce hyperglycemia in type II diabetics. For type I diabetics, the traditional diet is high in protein and quite restricted in carbohydrates. Since most type I diabetics are thin, weight reduction is not part of their program.

**Diabetes insipidus.** Diabetes insipidus is caused by a deficiency of, or resistance to the action of, vasopressin, the antidiuretic hormone produced by the posterior lobe of the pituitary gland. If the pituitary fails to produce vasopressin, the condition

is called central diabetes insipidus. If the kidneys do not respond to the vasopressin and fail to concentrate urine, the condition is labeled nephrogenic diabetes insipidus. Symptoms include increased thirst and frequent urination. Permanent damage to the kidneys can result if the condition is not treated.

A low level of vasopressin can be corrected with desmopressin acetate, a synthetic analog of 8-arginine vasopressin, which can be administered in the form of a nasal spray. Desmopressin acetate is ineffective in the treatment of nephrogenic diabetes insipidus. See NEUROHYPOPHYSIS HORMONE. [J.Da.; P.E.Br.]

**Diadematacea** A superorder of Euechinoidea having a rigid or flexible test, perforate tubercles, aulodont lantern, and branchial slits. The group arose in the Late Triassic and differentiated into four stocks, the Diadematoidea, Pedinoidea, Echinothurioida, and Pygasteroidea. See DIADEMATOIDEA; ECHINOIDEA; ECHINOTHURIOIDEA; PEDINOIDEA; PYGASTEROIDEA. [H.B.F.]

**Diadematoidea** An order of Diadematacea with hollow primary radioles and diademoid ambulacral plates. The tubercles are normally crenulate and the anus remains within the apical system. Three families compose this order: Diademataidae, Micropygidae, and Aspidodiademataidae. See DIADEMATACEA. [H.B.F.]

**Diagenesis** All the chemical, biochemical, and physical changes that sediments undergo from the time of deposition until the stage of metamorphism is reached. Diagenetic changes are gradational, with metamorphism at elevated temperatures or pressures, and with atmospheric weathering effects when sedimentary rocks become exposed at the surface. Sandstones, shales, and carbonate sediments are particularly susceptible to diagenetic modifications. See CARBONATE MINERALS; SANDSTONE; SHALE.

Diagenetic processes include purely physical ones that involve rearrangement of the sediments such as compaction, slumping, bioturbation by organisms, infiltration, and soft sediment deformation; biochemical or organic processes such as particle accretion, flocculation, boring, and decomposition; and physiochemical processes such as cementation, authigenesis (formation of new minerals), inversion, recrystallization, grain growth, replacement, and interstratal solution. Most of these processes involve a reduction in porosity and permeability, which are two important sediment properties in considering the migration of subsurface fluids and the accumulation of oil and gas and certain types of mineral deposits in subsurface rock units. However, one diagenetic process, interstratal solution, is of major importance in creating secondary porosity. See AUTHIGENIC MINERALS.

There have been attempts to group diagenetic processes into phases (or stages) in order to develop a comprehensive model for diagenetic evolution. The boundary limits of phases are a function of chemical as well as physical conditions and include pH, oxidation potential (Eh), ionic adsorption phenomena, temperature, pressure, depth of burial, and geologic time. In one model, three diagenetic phases are recognized: syndiagenesis, anadiagenesis, and epidiagenesis. Syndiagenesis includes sediment modifications that take place during and immediately following deposition. Anadiagenesis refers to the diagenesis processes that are characterized by expulsion and upward migration of connate water and other fluids, such as petroleum. Epidiagenesis includes those sediment-modifying processes that take place during and after uplift and emergence. See SEDIMENTARY ROCKS. [F.G.Et.]

**Dialysis** A process of selective diffusion through a membrane by dissolved solutes in liquid solution. As dialysis is usually carried out, the membrane permits the diffusion of low-molecular-weight solutes (crystalloids) but prevents the passage of colloidal and high-molecular-weight solutes (macromolecules). Membranes suitable for this purpose include

vegetable parchment, animal parchment, goldbeater's skin (peritoneal membranes of cattle), fish bladders, dialyzing cellophane (Visking sausage casing), and collodion (nitrocellulose deposited from alcohol-ether solution).

The solution is contained within such a membrane. The low-molecular-weight solutes are removed by placing pure solvent outside the membrane. This solvent is changed periodically or continuously until the concentration of diffusible solutes in the solution is reduced to near zero. The technique is used extensively in separating and purifying macro-molecules of biological origin. [Q.V.W.]

**Diamagnetism** That branch of magnetism which treats of diamagnetic phenomena and of the properties of diamagnetic bodies. Diamagnetism is a property exhibited by substances with a negative magnetic susceptibility, that is, by substances which magnetize in a direction opposite to that of an applied magnetic field. A diamagnetic substance has a magnetic permeability less than 1, and is repelled when placed near a magnet. The magnetization of diamagnetic substances is associated with the currents induced on application of a magnetic field. See MAGNETIC SUSCEPTIBILITY.

Although all matter exhibits diamagnetism, only those substances in which paramagnetism is absent are referred to as diamagnetic. This is because paramagnetism, if present, usually predominates, and the gross magnetic response of the material is paramagnetic. Important exceptions are the alkali and alkaline earth metals. The condition for pure diamagnetism is that all electronic spins be paired and all orbital moments either be zero or effectively cancel one another. See PARAMAGNETISM.

As stated previously, the diamagnetic response of a substance is small; only a very small fraction of the applied magnetic field is shielded from the interior of the substance by the induced diamagnetic currents. There is one case, however, in which the inducing field is completely shielded (except for small surface effects). This is the perfect diamagnetism exhibited by superconductors, and is known as the Meissner effect. See MEISSNER EFFECT; SUPERCONDUCTIVITY. [E.A.; F.Ke.]

**Diamond** A mineral composed entirely of carbon; the hardest substance known. Diamond is a polymorph of carbon; lonsdaleite, another polymorph, is sometimes referred to as hexagonal diamond. Diamond is found on all continents except Antarctica, which has not yet been explored for it. It occurs in nature as single crystals of gem or industrial quality, and as polycrystalline masses referred to as boart, framesite, or carbonado. It has also been found as minute black grains in some meteorites. Diamond can be synthesized in the laboratory and is produced commercially in large amounts for industrial uses. See CARBON; GRAPHITE.

Diamond has a cubic (isometric) crystal structure in which all carbon atoms have covalent ( $sp^3$ ) bonds. It is this strong bonding that makes diamond hard. Nevertheless, if diamond is struck in specific directions it will readily cleave—a property utilized in the preparation of polished gem diamonds. The combination of refractive index and dispersion gives diamond its brilliance and so-called fire when cut and polished. The thermal conductivity of diamond is the highest of any material (five times that of copper). This property, plus hardness, makes diamond an ideal material for use as a cutting tool in industry and also as a heat sink in electronics. See CRYSTAL STRUCTURE.

Although diamond consists of carbon, at least 58 other elements have been found (for example, aluminum, 10 parts per million; hydrogen, 1000 ppm; silicon, 80 ppm) as impurities in natural diamond. However, only two, nitrogen and boron, replace carbon atoms in the diamond lattice. Nitrogen is the major impurity and may substitute for carbon in a number of ways, commonly as either isolated or paired nitrogen atoms, and as

discrete platelets of nitrogen within the diamond structure. The presence or absence of nitrogen and the manner of its substitution leads to different physical properties, such as thermal conductivity, electrical resistivity, and infrared spectra.

Diamond is resistant to chemical attack, other than by strong oxidizing agents. In vacuum or an inert atmosphere, a clear, colorless gem diamond transforms to a gray-black mass of graphite at about 1500°C (2700°F). In air, diamond oxidizes (burns) to carbon dioxide at and above 800°C (1500°F). At high temperature, some metals (for example, tungsten, titanium, and tantalum) react with diamond to form metal carbides. Metals, such as iron, nickel, cobalt, and platinum, in the molten state are solvents for carbon and dissolve diamond; this phenomenon is used as a basis for the synthesis of diamond.

Most natural diamond, apart from that in meteorites, crystallizes at depths of approximately 110 mi (180 km) in the Earth's upper mantle at temperatures in the range 900–1200°C (1650–2200°F). The host rock in which diamond forms is either a magnesian-rich silica-deficient ultramafic (peridotitic) rock or an ultrabasic eclogitic rock. Minerals that constitute the ultramafic type of diamond-host rock are magnesian rich and include varieties of olivine, pyroxene, and pyrope garnet. The eclogitic rock consists of sodium-bearing pyroxene and an almandine garnet. These various constituent minerals may also occur as inclusions in diamond and result in the host being identified as either an ultramafic (peridotitic) or eclogitic diamond. Diamonds in each group have formed in a distinct and different geochemical environment in the upper mantle. See ECLOGITE; LITHOSPHERE; METEORITE; PERIDOTITE.

Diamond is eventually transported to the Earth's surface by unique types of volcanic eruption in which gases play a major role. The eruptions drill narrow (much less than 3000 ft or 1000 m) explosive vents or pipes through the crust of the Earth. Two different rock types, each containing diamond, may result and infill the volcanic neck or pipe. The first type is known as kimberlite, and the second as lamproite. The most productive mine in the world based on the number of diamonds produced per unit of host rock is based on lamproite—the Argyle mine in Western Australia. In general, diamonds are considerably older than the volcanic eruption that transported them to the surface. Thus diamonds that are 3.2 billion years old reached the surface only 85 million years ago. Diamond-bearing kimberlites occur in South Africa, Botswana, Angola, Sierra Leone, Guinea, Tanzania, Brazil, Venezuela, the United States, Canada, Russia, Siberia, China, India, and Australia. Only lamproites in Western Australia and one in Arkansas in the United States are diamond bearing.

The major production of diamond is from the primary sources in South Africa, Botswana, Zaire, Australia, and Siberia, with minor amounts coming from Tanzania and China. The diamond mines in all these countries are based on kimberlite, except for the Argyle mine in Australia, where the source rock is lamproite. Although Botswana and South Africa produce the most gem diamonds, as well as Russia whose production is difficult to assess, the major worldwide production is from the Argyle mine in Australia, albeit mostly industrial diamonds. Diamond production from secondary (alluvial or placer) deposits, apart from the extensive mining of the marine gravels off the west coast of southern Africa, is relatively small compared to the output from mines based on kimberlite and lamproite. Alluvial deposits in Guinea, Ghana, Russia, and Australia are mined by large companies or government agencies. All other alluvial diamond deposits are worked by small local groups or individual miners. See PLACER MINING.

Rough diamonds occur in a variety of shapes, including octahedra, dodecahedra, twinned octahedra (macle), and broken or cleavage fragments. The largest diamond found, the Cullinan, was a cleavage fragment. After the rough is sorted into cuttable (gem and near gem) and industrial stones, the decision is made as to how a specific diamond will be shaped and made into a



polished gem. The cutting and polishing process can result in the loss of as much as 60% of the original diamond.

Polished diamonds are graded on the basis of the 4 C's—carat, cut, clarity, and color. The carat is the unit of weight in the diamond industry and is standardized as 0.2 gram (0.0071 oz or 200 milligrams) and is divided into 100 points. Thus a 10-point diamond weighs 0.1 ct (0.00071 oz or 20 mg). The largest diamond, the Cullinan, weighed about 3000 ct (4.27 oz or 600 g) and was the size of an average human fist. The grading cut is based on how well the facets and the shape of a polished diamond compare to a standard model. See GEM.

Diamonds, although commonly considered to be mostly colorless, actually exist in all the colors of the rainbow. Colored stones are known as fancies, and if of excellent uniform color they are most desirable.

Diamonds were first synthesized in Sweden in 1953. These early experiments used the principle that carbon dissolves in the transition elements of groups 8–10 (such as iron or nickel). At high pressures (50–60 kilobars or 5–6 gigapascals) and temperatures (1500°C or 2700°F), the dissolved carbon nucleates and crystallizes as diamond. Direct conversion of graphite to diamond was achieved in 1961 in shock-wave experiments in which transient high pressures in excess of 300 kb (30 GPa) and temperatures of about 1100°C (2000°F) existed.

Synthetic diamonds generally are not large; most are produced in sizes below 0.004 in. (0.1 mm). These are used extensively as grit for industrial grinding purposes. Colorless gem-quality diamond can also be synthesized, but the cost of synthesis has proved to be greater than the cost of the natural product.

Diamond films can be grown in several ways. For example, diamond crystals up to 0.02 in. (0.5 mm) in size can be formed from a mixture of methane and hydrogen at about 50 torr (6.7 kPa) pressure and 1000°C (1900°F) on a silicon substrate. This method is known as thermally induced chemical vapor deposition, but other techniques may be used, including plasma chemical vapor ion deposition and electron-beam deposition. The diamond films display properties similar to those of natural diamond and have similar hardness and thermal conductivity, both significant properties for the uses of diamond films. See VAPOR DEPOSITION.

Diamond, apart from its use as a gem, has numerous applications in industry, and it is designated a strategic mineral. Many of the uses of natural and synthetic diamond are equivalent. Originally, natural diamond, including boart, carbonado, and frame-site, was crushed to various sizes of powder and used as grinding and polishing agents for glasses, ceramics, and nonferrous metals. Diamonds, as single crystals or powders, are also bonded in metal drills and bits. Small drills are used in applications such as dental work; large drills are used in drilling for oil and other minerals. Diamond-impregnated wheels are used for cutting many hard materials, including concrete and dimension stone for architectural purposes. Synthetic diamond is sometimes preferred for various uses, as it is grown to the specific grain size rather than crushed as in the case of natural diamond. Diamonds are used in eye surgery, and also as heat sinks and semiconductors in the electronics industry. Diamond films have potential uses as scratchproof coatings on optical lenses, compact discs, and even on nondiamond jewelry; bearings in machines; heat sinks and semiconductors in electronics; and general inert coatings or surfaces in areas of high chemical corrosion. Natural diamond has also been used as optical windows in spacecraft. [H.O.A.M.]

**Diapensiales** An order of flowering plants, division Magnoliophyta (Angiospermae), in the subclass Dilleniidae of the class Magnoliopsida (dicotyledons). The order has only a single family, the Diapensiaceae, with about 18 species of herbs and dwarf shrubs in temperate and arctic regions of the Northern Hemisphere. Within its subclass the order is marked by sympetalous flowers (flowers with the petals joined to each other by

their margins, at least toward the base, forming a basal tube, cup, or saucer), separate pollen grains, and ovules that have a single integument (unitegmic). *Shortia* and *Galax* genera are sometimes cultivated. See DILLENIIDAE; FLOWER. [A.Cr.]

**Diapir** A buoyant mass of ductile rock or sediment that has pierced, or appears to have pierced, overlying rock, known as overburden. The overburden can yield by ductile processes or by brittle faulting. Diapirs form by lateral and vertical intrusion of buoyant or nonbuoyant rock.

Diapirs are composed of salt, gypsum, shale, mud, sand, peat, coal, limestone, ice, serpentinite, granite, gneiss, and migmatite. Salt diapirs are typically several miles wide and high, but sheetlike varieties that have spread or coalesced laterally can be as much as 200 mi (300 km) wide. This type of diapir is economically important. Gneiss and migmatite diapirs are typically 6–13 mi (10–20 km) wide but locally approach 60 mi (100 km) in width. Diapirs doming the sea floor form large islands of salt in the Persian Gulf and islands of shale in the Caspian and Banda seas. See GNEISS; GRANITE; MIGMATITE. [M.P.A.J.]

**Diapsida** A subclass of reptiles characterized by two pairs of temporal openings and a suborbital fenestra, or features derived from this condition. This subclass includes lizards, snakes, tuatara, and crocodiles of the modern fauna, as well as the Mesozoic ancestors of these groups—dinosaurs, flying pterosaurs, aquatic nothosaurs, plesiosaurs, and placodonts—and their ancestors from the late Paleozoic Era. Birds evolved from bipedal theropod dinosaurs and are part of the diapsid radiation, but are placed in a separate class, Aves. See AVES; DINOSAUR.

The earliest adequately documented diapsid is *Petrolacosaurus* from the Upper Pennsylvanian Series of Kansas. It is about 8 in. (20 cm) in length, with a relatively long neck and distal limb elements. Aside from these differences in proportions and the presence of the diagnostic temporal openings, the skeleton of *Petrolacosaurus* strongly resembles that of the most primitive amniotes of the family Protorothyridae.

Fossils from the upper Permian and Lower Triassic are examples of the early stages of a great radiation that has continued to the present. Some Permian and Mesozoic groups, including the coelurosauravids (gliding reptiles from the upper Permian and Lower Triassic series) and the aquatic thalattosaurs, placodonts, and possibly the ichthyosaurs, may have evolved from reptiles at the beginning of the diapsid radiation. All other advanced diapsids can be grouped in two large infraclasses, the Lepidosauria and the Archosauria, represented in the modern fauna by the lizards and snakes on one hand and the crocodiles (and birds) on the other. See ARCHOSAURIA; LEPIDOSAURIA. [R.L.C.]

**Diarrhea** The passage of loose or watery stools, usually at more frequent than normal intervals. Diarrhea is a symptom of many diseases and may be accompanied by nausea, vomiting, griping, tenesmus, and other general or specific indications of a disease.

The more common specific disorders which may produce diarrhea include intestinal infections, such as dysentery, cholera, typhoid fever, food poisonings, and parasitic infestations; food sensitivities; drug and chemical irritation; and vitamin deficiency states.

Emotional and psychic disturbances frequently produce diarrhea and other visceral derangements. The poorly understood entities of regional enteritis and ulcerative colitis are perhaps related to these disturbances, as are other psychosomatic disorders.

Diarrhea is a common symptom in gastrointestinal obstruction or in inflammations from local infections or tumor invasion. See BACILLARY DYSENTERY; FOOD POISONING; MEDICAL PARASITOLOGY.

[E.G.St./N.K.M.]

**Diastem** A break in the stratigraphic record produced by local erosion or nondeposition and representing a short interval of geologic time. The breaks in deposition are those that would occur within a particular sedimentary environment, rather than those associated with a major change in environment. See STRATIGRAPHY; UNCONFORMITY.

Nondeposition can result either from excessive turbulence in the environment or from a lack in sediment supply. Discontinuity in sedimentation occurs on many scales. Short breaks, from seconds to days, are associated with migration of bedforms, variation in wave or current energy, and tidal cyclicity. Seasonal deposition occurs due to floods, storms, and plankton blooms. Sedimentation by major floods or hurricanes may occur on a scale of decades to centuries. In the deep ocean, the interval between successive turbidity current flows can be thousands of years. See MARINE SEDIMENTS; SEDIMENTOLOGY; TURBIDITY CURRENT. [C.W.By.]

**Diazotization** The process by which an aromatic primary amine is converted to a diazonium compound. The preparation and reactions of diazonium salts were discovered in 1858 and were the basis of the synthetic dye industry and the development of other industrial chemistry in Europe. In diazotization, sodium nitrite is added to a solution of the amine in aqueous acid solution at 0–5°C (32–41°F). Reaction of the amine with nitrous acid gives a nitrosamine. Tautomerization and loss of water lead to the diazonium ion, which is stabilized by delocalization of the positive charge at the ortho and para carbon atoms of the ring, as in the reaction below.

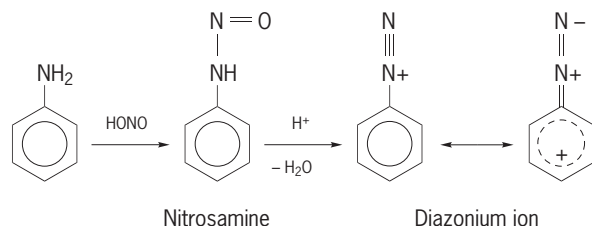

See AMINE; AROMATIC HYDROCARBON; DELOCALIZATION; TAUTOMERISM.

The overall reaction is simple and very general. Substituents of all types—alkyl, halogen, nitro, hydroxyl, sulfonic acid—can be present at any position. Heterocyclic amines such as aminothiazole or aminopyridines can also be diazotized. Aromatic diamines are converted to *bis*-diazonium compounds. Diazonium salts are generally used and handled in aqueous solution; they are explosive if isolated and dried.

The great importance of diazonium compounds in dye technology lies in the coupling reactions that occur with an activated aromatic ring, such as that in phenols or aromatic amines. Coupling, or electrophilic substitution by  $\text{ArN}_2^+$ , gives compounds with an arylazo group at the position para or ortho to  $-\text{OH}$  or  $-\text{NH}_2$ . Reaction with amines occurs in weak acid solution. With phenols the phenoxide ion is the reactive species, and slightly basic solution is used. See CHEMICAL EQUILIBRIUM.

The azo dyes obtained in these coupling reactions are one of the important types of synthetic dyes. The color of the dye can be varied widely by choice of diazonium and coupling components. The coupling reaction lends itself to an important method of applying the dye to fabrics. In this process the coupling reagent, such as a naphtholsulfonic acid, is absorbed onto the fiber, and the coupling reaction is then carried out directly on the fiber by passing the fabric through a bath of the diazonium solution. See DYE; DYEING; TEXTILE CHEMISTRY. [J.A.Mo.]

**Dichroism** In certain anisotropic materials, the property of having different absorption coefficients for light polarized in different directions. There are few natural materials which exhibit strong dichroism. One of the first to be discovered was tourma-

line. Light transmitted by thin plates of dark forms of tourmaline is almost completely polarized. See POLARIZED LIGHT.

If the absorption in a dichroic material is different for different linear states of polarization, the material is termed linear dichroic. If it is different for right and left circularly polarized light, it is termed circular dichroic. Similarly, there can be elliptically dichroic crystals. [B.H.Bi.]

The study of dichroism allows conclusions as to the submicroscopic fine structure of cells. In visible light only a few cellular components, such as chloroplasts, show absorption. An absorption can, however, be produced by staining. The dichroic staining of plant fibers is especially simple. The elongate stain particles of benzidine dyes, for example, congo red, are deposited in an oriented manner in the spaces between the microfibrils and produce an intrinsic dichroism of the fiber: colored for a vibration plane parallel, colorless for a plane perpendicular to the stain particles and fibrils. Therefore, the direction of strongest absorption indicates the course (parallel or helical) of the microfibrils in the fiber.

Ultraviolet dichroism gives direct information as to the orientation of the absorbing molecules or molecular groups in cell structures. The method has been especially helpful for studies of orientation of deoxyribonucleic acid in nuclei and chromosomes. Lignified plant cell walls show ultraviolet dichroism. It is pure form dichroism, a fact which eliminates the possibility that lignin is in an anisotropic state in the wall.

By irradiation with ultraviolet light, various compounds of the cell are caused to fluoresce. The fluorescent light is polarized if the object is anisotropic. This phenomenon, called difluorescence, is observable in lignified cell walls, and leads to the same conclusions as to lignin deposition as emerge from dichroism studies. [FRu.]

**Dichroism (biology)** In absorbing, anisotropic objects, the reference index and the absorption vary with direction. There are two main directions of anisotropy, which are perpendicular to each other. This phenomenon is called dichroism and may be studied in the polarizing microscope with one polarizer. By rotating the microscope stage the object is brought in different directions to the vibration plane of the polarized light, and the change of light absorption is observed. Study of dichroism thus allows conclusions as to the submicroscopic fine structure of cells.

In visible light only a few cellular components, such as chloroplasts, show absorption. An absorption can, however, be produced by staining. The dichroic staining of plant fibers is especially simple. The elongate stain particles of benzidine dyes are deposited in an oriented manner in the spaces between the microfibrils and produce an intrinsic dichroism of the fiber: colored for a vibration plane parallel, colorless for a plane perpendicular to the stain particles and fibrils. Therefore, the direction of strongest absorption indicates the course (parallel or helical) of the microfibrils in the fiber. Dichroic staining may also be carried out with animal tissue. Such studies have been made mainly with fibrous protein structures (collagenous fibers, myofibrils, neurofibrils) and with anisotropic nuclei of certain sperms.

In ultraviolet light many cell components show absorption. Ultraviolet dichroism gives direct information as to the orientation of the absorbing molecules or molecular groups in cell structures. The method has been especially helpful for studies of orientation of deoxyribonucleic acid in nuclei and chromosomes. The maximum absorption here is perpendicular to the molecular direction. Lignified plant cell walls show ultraviolet dichroism. It is pure form dichroism, a fact which eliminates the possibility that lignin is in an anisotropic state in the wall. See CELL WALLS (PLANT).

By irradiation with ultraviolet light, various compounds of the cell are caused to fluoresce. The fluorescent light is polarized if the object is anisotropic. This phenomenon, called difluorescence, is observable in lignified cell walls, and leads to the same conclusions as to lignin deposition as emerge from dichroism studies. See DICHROISM. [FRu.]

**Dicotyledons** A large group of flowering plants (angiosperms) that for many years has been considered one of the two main categories of plants, the other being monocotyledons. Dicotyledons have two seedling leaves as opposed to the single one in most monocotyledons. Several deoxyribonucleic acid (DNA) sequence studies subsequently demonstrated that there are two groups of angiosperms, but these correspond not to the number of seed leaves but to the two major pollen types. Thus, the term "dicotyledon" is no longer meaningful because some plants of this type are more closely related to monocotyledons. The group of former dicotyledons, which have pollen with a single aperture, includes magnolia, avocado, black pepper, and pipeworts; they are now termed magnoliids and include monocotyledons. The other category of dicotyledons, those with three (and often more) apertures in their pollen, are called eudicotyledons (true dicotyledons). See AVOCADO; EUDICOTYLEDONS; FLOWER; MAGNOLIOPHYTA; MONOCOTYLEDONS; PLANT KINGDOM. [M.W.C.]

**Dicranales** A large and diverse order of the true mosses (Bryopsida), containing 13 families. Plants in the Dicranales generally have long, narrow leaves, and the peristome (rarely lacking) commonly consists of 16 papillose or vertically pitted-striate teeth. The plants are erect and simple or merely forked and often woolly because of a dense covering of rhizoids among the leaves. See BRYIDAE; BRYOPHYTA; BRYOPSIDA. [H.Cr.]

**Dictyoceratida** An order of sponges of the class Demospongiae which includes the bath sponges of commerce. Dictyoceratida are mostly of considerable size, and form massive, lobate, or branching colonies. Some are leaflike in shape or vase-shaped. A reticulate skeleton of spongin fibers is always present. In many species some or all the fibers enclose foreign bodies, such as sand grains, shell fragments, or spicules of other sponges. There are three families, Spongiidae, Thorectidae, and Dysideidae.

Dictyoceratid sponges are most abundant in tidal and shallow waters of tropical and subtropical regions. Relatively few species occur in Arctic and Antarctic seas, and most occur above the continental slope. A few species are found down to 3300 ft (1000 m). See DEMOSPONGIAE. [W.D.H.]

**Dicyemida** An order of Mesozoa comprising minute, wormlike parasites of the renal organs of cephalopod mollusks. They are composed of a single layer of large, ciliated epithelial cells enclosing one or more elongate axial cells (see illustration).

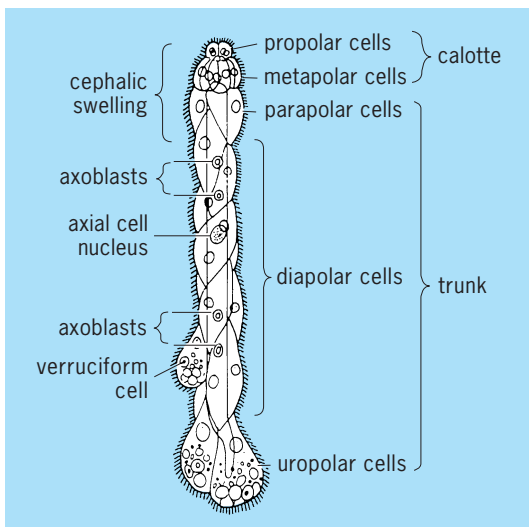

Morphology of a young dicyemid.

Each axial cell contains, in addition to its own nucleus, reproductive cells and developing larvae. These larvae, when fully developed, escape from the parent organism.

There are two reproductive phases termed the nematogens and rhombogens, respectively. During the nematogen phase vermiform larvae are formed asexually from the germ cells. They increase the infection in the same cephalopod. This is succeeded by the rhombogen phase in which infusoriform, or swarm, larvae are liberated. These are discharged into the sea with their host's urine and their fate is unknown. Zoologists are not in agreement regarding many points in the life cycle, particularly in respect to the interpretation of the infusorigen and its products. See MESOZOA. [B.H.McC.]

**Didymelales** An order of flowering plants, division Magnoliophyta (Angiospermae), in the subclass Hamamelidae of the class Magnoliopsida (dicotyledons). The order contains a single family with but one genus, *Didymeles*, with two species. These dioecious, evergreen trees are restricted to Madagascar. The wood has vessels with scalariform perforations, which is a putatively primitive feature. The leaves are alternate, simple, and entire. The flowers are small; the staminate ones are in open clusters, without perianth, with two stamens, and the pollen grains have three germinal furrows. The pistillate flowers are commonly paired in spikelike clusters; they are hypogynous and sometimes have 1-4 scalelike sepals but no petals. The pistil has but one carpel. This curious genus has often been included in the Hamamelidales; however, the primitive nature of the wood and of the pistil make it anomalous there. See HAMAMELIDAE; MAGNOLIOPSIDA; PLANT KINGDOM. [T.M.Ba.]

**Dielectric heating** The heating of a nominally electrical insulating material due to its own electrical (dielectric) losses, when the material is placed in a varying electrostatic field.

The material to be heated is placed between two electrodes (which act as capacitor plates) and forms the dielectric component of a capacitor (see illustration). The electrodes are connected to a high-voltage source of 2-90-MHz power, produced by a high-frequency vacuum-tube oscillator.

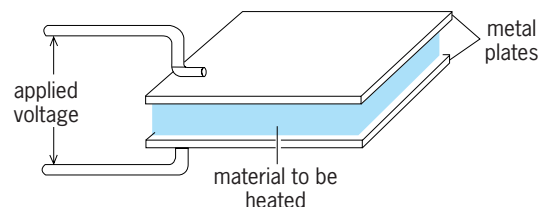

Basic assembly for dielectric heating.

The resultant heat is generated within the material, and in homogeneous materials is uniform throughout. Dielectric heating is a rapid method of heating and is not limited by the relatively slow rate of heat diffusion present in conventional heating by external surface contact or by radiant heating.

This technique is widely employed industrially for preheating in the molding of plastics, for quick heating of thermosetting glues in cabinet and furniture making, for accelerated jelling and drying of foam rubber, in foundry core baking, and for drying of paper and textile products. Its advantages over conventional methods are the speed and uniformity of heating, which offset the higher equipment costs. Because of the absence of high thermal gradients, an improved end-product quality is usually obtained. [G.F.B.]

**Dielectric materials** Materials which are electrical insulators or in which an electric field can be sustained with a minimal dissipation of power. Dielectrics are employed as insulation for wires, cables, and electrical equipment, as polarizable media for capacitors, in apparatus used for the propagation or reflection

of electromagnetic waves, and for a variety of artifacts, such as rectifiers and semiconductor devices, piezoelectric transducers, dielectric amplifiers, and memory elements. The term dielectric, though it may be used for all phases of matter, is usually applied to solids and liquids.

The ideal dielectric material does not exhibit electrical conductivity when an electric field is applied. In practice, all dielectrics do have some conductivity, which generally increases with increase in temperature and applied field. If the applied field is increased to some critical magnitude, the material abruptly becomes conducting, a large current flows (often accompanied by a visible spark), and local destruction occurs to an extent dependent upon the amount of energy which the source supplies to the low-conductivity path. This critical field depends on the geometry of the specimen, the shape and material of the electrodes, the nature of the medium surrounding the dielectric, the time variation of the applied field, and other factors. Temperature instability can occur because of the heat generated through conductivity or dielectric losses, causing thermal breakdown. Breakdown can be brought about by a variety of different causes, sometimes by a number of them acting simultaneously. Nevertheless, under carefully specified and controlled experimental conditions, it is possible to measure a critical field which is dependent only on the inherent insulating properties of the material itself in those conditions. This field is called the intrinsic electric strength of the dielectric. See ELECTRICAL BREAKDOWN.

Many of the traditional industrial dielectric materials are still in common use, and they compete well in some applications with newer materials regarding their electrical and mechanical properties, reliability, and cost. For example, oil-impregnated paper is still used for high-voltage cables. Various types of pressboard and mica, often as components of composite materials, are also in use. Elastomers and press-molded resins are also of considerable industrial significance. However, synthetic polymers such as polyethylene, polypropylene, polystyrene, polytetrafluoroethylene, polyvinyl chloride, polymethyl methacrylate, polyamide, and polyimide have become important, as has polycarbonate because it can be fabricated into very thin films. Generally, polymers have crystalline and amorphous regions, increasing crystallinity causing increased density, hardness, and resistance to chemical attack, but often producing brittleness. Many commercial plastics are amorphous copolymers, and often additives are incorporated in polymers to achieve certain characteristics or to improve their workability. [J.H.Ca.]

**Dielectric measurements** Measurements of the dielectric properties of a material, which are characterized by its complex relative permittivity  $\epsilon_r$ . For all materials except ferroelectrics, this quantity does not depend on applied field; the general behavior is linear, and so voltage of any convenient magnitude can be used for measurement. See FERROELECTRICS; PERMITTIVITY.

**Bridge methods.** The most commonly used apparatus for measuring  $\epsilon_r$  is the alternating-current (ac) bridge. These bridges are readily available in the operating range 10–10<sup>6</sup> Hz, and sometimes outside it; ultralow-frequency bridges can go as low as 10<sup>-3</sup> Hz. Most specimen holders for solids are essentially parallel-plate capacitors with the specimen filling all the space between the plates; for liquids, a test cell with cylindrical electrodes is usually employed. The bridges most commonly used are of the Wheatstone type, the most versatile for dielectric measurements being the Schering bridge.

**Resonance methods.** Resonance methods, useful for frequencies greater than 1 MHz, involve the injection of voltage or current by one of several methods into an LC (inductance-capacitance) resonant circuit. Measurements over a range of frequencies may be made by using coils with different inductance values, but ultimately the inductance required becomes impractically small, and in the range 10<sup>8</sup>–10<sup>9</sup> Hz reentrant cavities are often used. These are hybrid devices in which the plates holding the specimen still form a lumped capacitor, but the inductance

and capacitances are distributed along a coaxial line. At higher frequencies, the wavelength is comparable to the dimensions of the apparatus, and transmission methods in coaxial lines and waveguides must be used.

**Transmission methods.** Coaxial lines are used in the frequency range 300 MHz–3 GHz, and waveguides in the range 3–30 GHz. The transmission characteristics are determined by the complex permittivity of the material filling the line or guide. Many different measurement techniques have been devised, but all derive values of the complex relative permittivity  $\epsilon_r$  from its relationship to the complex propagation factor  $\gamma$ . See TRANSMISSION LINES; WAVEGUIDE.

In practice, traveling waves are rarely used as the basis of measurement, except for high-loss materials. Usually, reflections from terminations set up standing waves, the amplitude of which in the case of a liquid-filled line can be measured by a suitable probe. The ratios of the field magnitudes at adjacent maxima, and the distance between them, give the information required. See ATTENUATION (ELECTRICITY); WAVELENGTH.

**Submillimeter measurements.** Dielectric measurements are difficult to carry out in the frequency range 30–300 GHz, for which  $\lambda_0$  is in the range 1 cm–1 mm, but for  $\lambda_0$  less than 1 mm, methods related to infrared spectroscopy are used. Broadband continuous spectra result from Fourier transform spectroscopy, which in its simplest form is equivalent to normal infrared spectroscopy, with the specimen in one of the two passive arms of the interferometer, between the beam divider and either the source or the detector. In the more sophisticated dispersive Fourier transform spectroscopy, the specimen is in one of the active arms, that is, between the beam divider and either mirror. Discrete-point spectra also may be obtained by the use of a Mach-Zehnder interferometer and a laser source. By using interferometric techniques, the frequency range can be extended up to about 5 THz. See INFRARED SPECTROSCOPY; INTERFEROMETRY; SPECTROSCOPY.

**Time-domain methods.** If a constant direct-current (dc) voltage is suddenly applied to a dielectric specimen, in principle the charging current is related through the Fourier integral transformation to the steady-state ac current which would flow if the applied voltage were sinusoidal at any particular frequency. If the dc voltage is suddenly removed, a similar relationship holds between the discharge current and ac current. Thus the variation of complex permittivity with frequency can in principle be derived from a transient signal in the time domain. Because of various limitations, the method is not capable of giving results of an accuracy at all frequencies comparable to those obtainable from a single frequency measurement. Nevertheless, with the aid of computer analysis, the response over a large frequency range can be obtained much more quickly than would be possible by using point-by-point measurement methods. [J.H.Ca.]

**Diels-Alder reaction** The 1,4-addition of an alkene (the dienophile) to a conjugated diene. The reaction, also known as the diene synthesis, is one of the most valuable and versatile

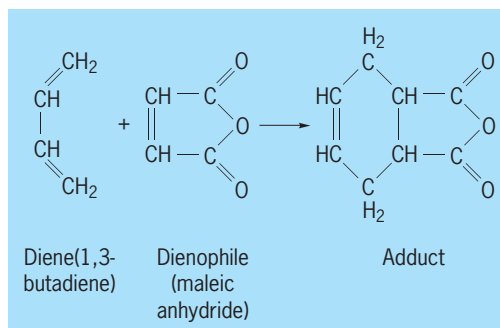

Example of Diels-Alder reaction.

methods for the preparation of compounds containing a six-membered ring, and proceeds most rapidly when the dienophile is substituted by electron-attracting groups. An example is in the illustration. The Diels-Alder reaction does not require a catalyst, nor is the reaction retarded by the presence of oxidation inhibitors with which dienes are commonly treated to prevent formation of peroxides.

Industrially the diene synthesis is used in the production of the insecticides aldrin and dieldrin. The adduct of butadiene and maleic anhydride is used in the synthesis of the important fungicide captan. [P.E.F.]

**Diesel cycle** An internal combustion engine cycle in which the heat of compression ignites the fuel. Compression-ignition engines, or diesel engines, are thermodynamically similar to spark-ignition engines. The sequence of processes for both types is intake, compression, addition of heat, expansion, and exhaust. Ignition and power control in the compression-ignition engine are, however, very different from those in the spark-ignition engine. See THERMODYNAMIC CYCLE.

Usually, a full-unthrottled charge of air is drawn in during the intake stroke of a diesel engine. A compression ratio between 12 and 20 is used, in contrast to a ratio of 4 to 10 for the Otto spark-ignition engine. This high compression ratio of the diesel raises the temperature of the air during the compression stroke. Just before top center on the compression stroke, fuel is sprayed into the combustion chamber. The high temperature of the air ignites the fuel, which burns almost as soon as it is introduced, adding heat. The combustion products expand to produce power, and exhaust to complete the cycle.

In an actual engine with a given compression ratio, the Otto engine has the higher efficiency. However, fuel requirements limit the Otto engine to a compression ratio of about 10, whereas a diesel engine can operate at a compression ratio of about 15 and consequently at a higher efficiency.

In addition, heat can be added earlier in the cycle by injecting fuel during the latter part of the compression process. This mode of operation is the dual-combustion or semidiesel cycle.

With most of the heat added near peak compression, semidiesel efficiency approaches Otto cycle efficiency at a given compression ratio. See DIESEL ENGINE. [T.Ba.]

**Diesel engine** An internal combustion engine operating on a thermodynamic cycle in which the ratio of compression of the air charge is sufficiently high to ignite the fuel subsequently injected into the combustion chamber. Compared to an engine operating on the Otto cycle, the diesel engine utilizes a wider variety of fuels with a higher thermal efficiency and consequent economic advantage under many service applications. See DIESEL CYCLE; OTTO CYCLE.

The true diesel engine, as represented in most low-speed engines, uses a fuel-injection system where the injection rate is delayed and controlled to maintain constant pressure during combustion. Adaptation of this injection principle to higher engine speeds has necessitated departure from the constant-pressure specification, because the time available for fuel injection is so short (often 2 ms or less). Nonvolatile (distillate) fuels are burned to advantage in these engines, which cannot be rigorously identified as true diesels but properly should be called commercial diesels. However, all such engines are ordinarily classified as diesels. Diesel engines give high intrinsic and actual thermal efficiency (20–40%).

The diesel engine in the automobile is usually a four-stroke engine with indirect injection into an auxiliary combustion chamber (see illustration). Most automobile diesel engines use a distributor-type injection pump. The fuel system often includes a fuel-conditioner assembly, which combines a water-in-fuel detector, water-fuel separator, fuel filter, fuel heater, and hand-priming pump in a single unit. See COMBUSTION CHAMBER.

Diesel engines in trucks and buses are usually larger and operate at lower speeds than diesel engines in passenger cars. Most truck diesel engines operate on the four-stroke cycle, although many buses and some trucks have two-stroke-cycle engines. These usually have intake ports in the cylinder and exhaust valves in the cylinder head, with scavenging air provided by a crankshaft-driven blower mounted on the crankcase.

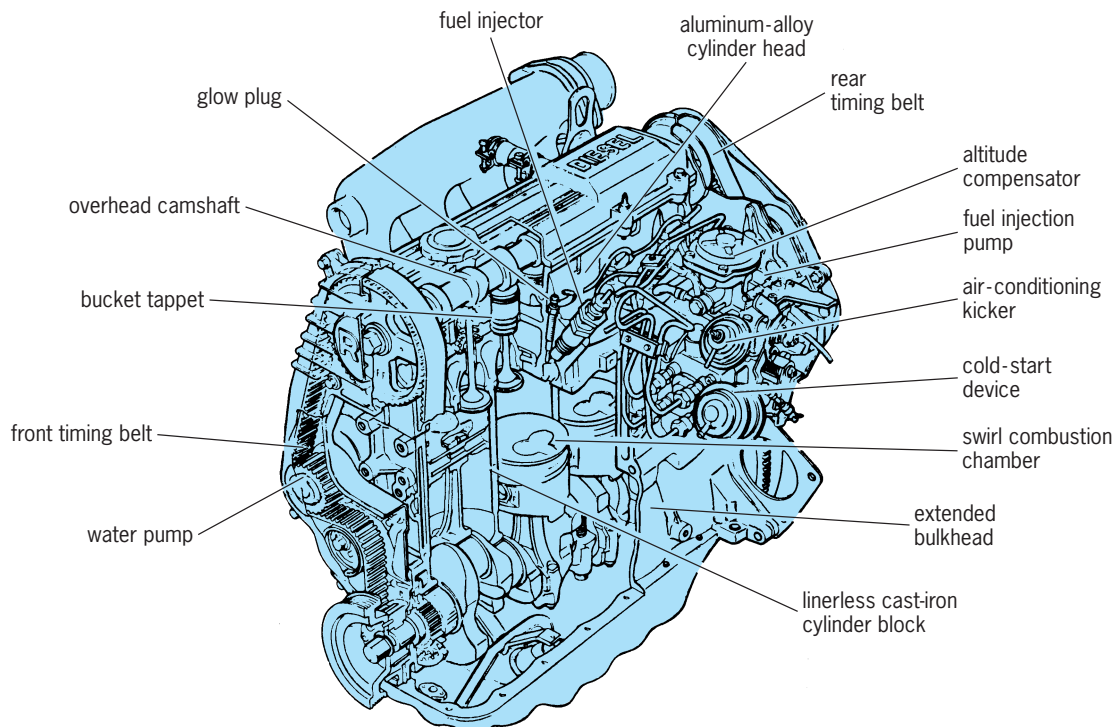

A 2.0-liter, four-cylinder, four-stroke-cycle passenger-car diesel engine which has a distributor-type injection pump and indirect injection. (Ford Motor Co.)

A unit fuel injector operated by the engine camshaft meters and injects the fuel into the combustion chamber at high pressure at the proper time.

In addition to a noticeable odor, the exhaust gas from the diesel engine contains gaseous and particulate emissions which contribute to air pollution. The particles, or soot, may be removed by a trap oxidizer that consists of a filter and a regeneration system, which burns the trapped particles and cleans the filter. Gaseous emissions of unburned hydrocarbons (HC), carbon monoxide (CO), and oxides of nitrogen (NO<sub>x</sub>) may be controlled through the use of electronically controlled fuel injection, exhaust-gas recirculation, and charge-air cooling. Operating the engine on low-sulfur fuel reduces sulfur and particulate emissions. See AIR POLLUTION; DIESEL FUEL; FUEL INJECTION. [D.L.An.]

**Diesel fuel** A broad mixture of hydrocarbons produced as distillates, as residual materials, or as blends of the two during the refining of crude petroleum. Diesel fuel usually has a distillation range of 390–715°F (200–380°C) and a specific gravity range of 0.760–0.935 [equivalent to 61.2–19.8° on the American Petroleum Institute (API) scale]. In addition to these properties, diesel fuel must have <1 wt % sulfur, <0.1 wt % ash, <0.5 vol % water and sediment, and a high flash point (greater than 131°F or 55°C).

Diesel fuel quality is defined by the cetane number, which usually falls into the range 30–60. A high cetane number indicates the potential for easy starting and smooth operation of the engine. The cetane number is the analog of the automobile engine octane number, with cetane (*n*-hexadecane, C<sub>16</sub>H<sub>34</sub>) having the arbitrarily assigned number of 100. At the other end of the scale, heptamethylnonane, an isomer of cetane, has the assigned cetane number of 0. The cetane number of a diesel fuel is determined by comparison with blends of cetane and heptamethylnonane. It corresponds to the number of parts by volume of cetane in a cetane-heptamethylnonane blend which has the same ignition quality as the fuel. See CETANE NUMBER.

The American Society for Testing and Materials (ASTM) has categorized diesel fuels into three general groups. The need to categorize these fuels results from the varied uses of diesel engines, which are designed to operate efficiently on one of the standard diesel fuels. See DIESEL ENGINE.

No. 1-D is a light distillate, similar to kerosine, for engines where frequent load changes and speed changes (truck, tractor engines) are essential. This fuel has a flash point greater than 100°F (38°C), with a minimum cetane number of 40. This fuel is believed to be particularly suitable for cold-weather operation. See Kerosine.

No. 2-D is a medium distillate fuel with a lower volatility and higher density than No. 1-D. This fuel finds use in heavier-duty engines, for example, railroad engines, which operate at uniform speeds but with heavier loads than encountered during the use of No. 1-D. The flash point is greater than 125°F (52°C) and the minimum cetane number is 40.

No. 3-D is a heavy distillate fuel with the highest density and lowest volatility of the three diesel fuels. It finds use in low- and medium-speed engines such as marine engines and electric power generation engines, which operate under sustained loads. The flash point is greater than 130°F (54°C) and the minimum cetane rating is 30. [J.G.S.]

**Difference equation** A relationship between one or more independent variables, one or more dependent variables, and differences of those variables. Difference equations arise in the analysis of discrete systems (for example, a string loaded along its length with small masses), in the solution of differential equations by means of digital computers, in the implementation of digital filters, and in the discrete-time control of systems. An ordinary difference equation expresses a relationship between an independent variable *t* and one or more dependent vari-

ables, *y(t)*, *w(t)*, and so forth, and any successive differences of *y, w, ...*. The first forward difference of *y*, relative to the increment *h*, is defined by Eq. (1). The second forward difference can be obtained by applying the above definition to itself, as in Eq. (2).

$$\Delta y(t) = y(t+h) - y(t) \quad (1)$$

$$\begin{aligned} \Delta^2 y(t) &= \Delta[\Delta y(t)] \\ &= \Delta y(t+h) - \Delta y(t) \\ &= [y(t+2h) - y(t+h)] \\ &\quad - [y(t+h) - y(t)] \\ &= y(t+2h) - 2y(t+h) + y(t) \end{aligned} \quad (2)$$

A difference equation is linear if it is of the first degree with respect to all the quantities  $\Delta y(t)$ ,  $\Delta^2 y(t)$ ,  $\Delta^3 y(t)$ , ... The general solution of difference equations is possible only for the case where they are linear with constant coefficients. However, nonlinear difference equations arise naturally in the solution of nonlinear differential equations. Likewise, the numerical solution of a partial differential equation leads to a partial difference equation. Methods exist for approximating governing equations for linear continuous-time systems by difference equations.

**Linear constant-coefficients equations.** The independent variable of a difference equation will usually have discrete values. Then the notation can be simplified by making the substitution in Eq. (3). In this case, the arguments of the independent

$$\begin{aligned} t_k &= t_0 + kh \\ k &= 0, 1, 2, \dots \end{aligned} \quad (3)$$

variables, if more than one, can be replaced by the subscript *k*. Then, the forward difference operators given by Eqs. (1) and (2) can be written as Eqs. (4), where the shifting operator *E* has

$$\begin{aligned} \Delta y_k &= y_{k+1} - y_k = E y_k - y_k \\ \Delta^2 y_k &= E^2 y_k - 2E y_k + y_k \end{aligned} \quad (4)$$

been defined, incrementing the index on the dependent variable by 1 each time it is applied.

The general homogeneous, linear, constant-coefficient difference equation of order *n* can be written in terms of the shifting operator as Eq. (5). From the solution of linear, constant-

$$\begin{aligned} E^n y_k + A_1 E^{n-1} y_k + \dots + A_{n-1} E y_k + A_n y_k &= 0 \\ k &\geq 0 \end{aligned} \quad (5)$$

coefficient differential equations, the solution is assumed to be of the form  $e^{rk} = \beta^k$ , where *r* is a suitably chosen constant and  $\beta = e^r$ . From the definition of the shifting operator, Eqs. (6)

$$\begin{aligned} E \beta^k &= \beta^{k-1} = \beta(\beta^k) \\ E^2 \beta^k &= \beta^{k-2} = \beta^2(\beta^k) \end{aligned} \quad (6)$$

follow, as well as similar equations for higher powers of *E*. When these equations are substituted into Eq. (5), the result is Eq. (7).

$$\beta^n + A_1 \beta^{n-1} + \dots + A_{n-1} \beta + A_n = 0 \quad (7)$$

Hence,  $y_k = \beta^k$  will satisfy Eq. (5) if  $\beta$  is a root of Eq. (7). If all roots are real and distinct, the most general expression satisfying Eq. (5) is Eq. (8), where  $\beta_1, \beta_2, \dots, \beta_n$  are the roots to Eq. (7) and

$$\begin{aligned} y_k &= c_1 \beta_1^k + c_2 \beta_2^k + \dots + c_n \beta_n^k \\ k &\geq 0 \end{aligned} \quad (8)$$

$c_1, c_2, \dots, c_n$  are constants to be determined by the initial conditions. See ALGEBRA.

**Nonhomogeneous linear equations.** The general solution of a nonhomogeneous, linear, constant-coefficient difference equation, given by Eq. (9), is of the form given by Eq. (10),

$$E^n y_k + A_1 E^{n-1} y_k + A_{n-1} E y_k + A_n y_k = x_k \quad (9)$$

$$k \geq 0$$

$$y_k = y_{k,h} + y_{k,p} \quad (10)$$

where  $y_{k,h}$  is the solution of the homogeneous equation [ $x_k = 0$  in Eq. (9)], and  $y_{k,p}$  is the particular solution of Eq. (9). With constant coefficients on Eq. (9), the method of undetermined coefficients can be used to find the particular solution. The solution of constant-coefficient, linear difference equations is facilitated greatly by use of the  $z$  transform. See DIFFERENTIAL EQUATION; DIGITAL FILTER; INTERPOLATION; LAPLACE'S DIFFERENTIAL EQUATION; LINEAR SYSTEM ANALYSIS; NUMERICAL ANALYSIS. [R.E.Z]

**Differential** A mechanism which permits a rear axle to turn corners with one wheel rolling faster than the other. An automobile differential is located in the case carrying the rear axle drive gear (see illustration).

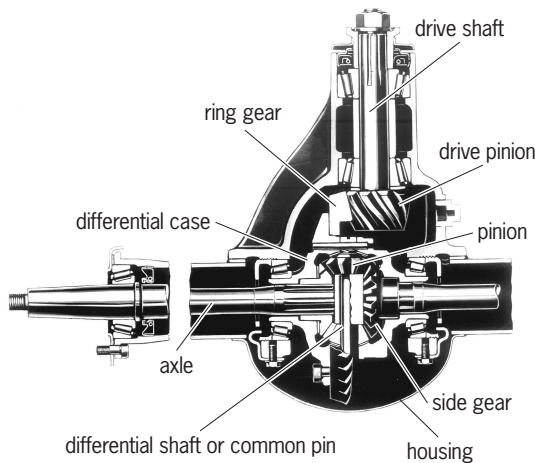

A rear-axle differential. (Chrysler)

The differential gears consist of the two side gears carrying the inner ends of the axle shafts, meshing with two pinions mounted on a common pin located in the differential case. The case carries a ring gear driven by a pinion at the end of the drive shaft. This arrangement permits the drive to be carried to both wheels, but at the same time as the outer wheel on a turn overruns the differential case, the inner wheel lags by a like amount.

Special differentials permit one wheel to drive the car by a predetermined amount even though the opposite wheel is on slippery pavement; they have been used on racing cars for years and are now used by a number of car manufacturers. See AUTOMOTIVE TRANSMISSION. [H.Fi.]

**Differential amplifier** An electronic circuit that is designed to amplify the difference between two voltages measured with respect to a common reference, usually designated as ground. By convention, the net difference of two voltages measured with respect to a common reference is called the differential-mode voltage, while the sum of the voltages, usually divided by two to give an average value, is called the common-mode voltage.

An ideal differential amplifier thus has exactly the same gain from each input to its output, and the amplifier produces an output that is directly proportional to its differential-mode voltage. The amplifier delivers zero output in response to common-mode voltages. If these gains are not exactly equal, then equal (common-mode) voltages applied at each input terminal will not

be equal at the amplifier output and their difference will not cancel completely. The common-mode gain, the ratio of the output response of a real differential amplifier to the input signal applied equally to each input terminal, is a measure of this gain mismatch.

Differential amplification is very useful when the signal to be amplified exists in an electrically noisy environment, since the noise voltage is usually a common component of both input voltages and, hence, will cancel when the difference of the amplifier inputs is taken. See AMPLIFIER.

For a physical differential amplifier to work properly, the electrical paths of each input signal through the amplifier must be nearly identical. Thus, the most important requirement for a differential amplifier is that it be constructed with transistors with closely matched electrical characteristics. Integrated circuits with amplifier transistors physically close to each other meet the required close matching requirement and are ideally suited for the production of differential amplifiers. See INTEGRATED CIRCUITS.

Differential-amplifier circuits that are suitable for integrated-circuit fabrication can use either metal oxide semiconductor field-effect transistors (MOSFETs) or bipolar junction transistors (BJTs). The input transistor pair must be matched closely. For best performance, the two load transistors also should be matched. See TRANSISTOR. [P.E.A.]

**Differential equation** A relationship between a function and its derivatives.

If there is one independent variable, the differential equation is called an ordinary differential equation. The general form of such an equation is shown in (1), where  $t$  is the independent

$$F(t, u, u', u'', \dots, u^{(n)}) = 0 \quad (1)$$

variable;  $u$  is a function of  $t$ ;  $u' = du/dt$ ,  $u'' = d^2u/dt^2$ ,  $\dots$ ,  $u^{(n)} = d^n u/dt^n$  are the derivatives of  $u$ ; and  $F(t, u_0, u_1, \dots, u_n)$  is a given function of the  $n+2$  variables  $t, u_0, \dots, u_n$ . The positive integer  $n$  is called the order of the differential equation; that is, the order of the differential equation is the order of the highest derivative that occurs in the equation. As an example, consider Eq. (2),

$$u'' + u = 0 \quad (2)$$

which is an ordinary differential equation of order 2. A function  $u$  is said to be a solution to Eq. (1) if, when  $u$  and its derivatives up to order  $n$  are substituted into  $F$ , the identity expressed in Eq. (1) is valid for  $t$  in some interval  $a < t < b$ . In Eq. (2),  $u = \cos t$  and  $u = \sin t$  are solutions for  $-\infty < t < \infty$ , as can be immediately verified.

If there are two or more independent variables, the equation is called a partial differential equation. Again, the order of the equation is the order of the highest partial derivative that occurs in the equation. Thus, the general form of a partial differential equation of order 2, with two independent variables, is given by Eq. (3), where  $x$  and  $y$  are the independent variables;  $u =$

$$F(x, y, u, u_x, u_y, u_{xx}, u_{xy}, u_{yy}) = 0 \quad (3)$$

$u(x, y)$  is a function:  $u_x = \partial u/\partial x$ ,  $u_y = \partial u/\partial y$ ,  $u_{xx} = \partial^2 u/\partial x^2$ ,  $u_{xy} = \partial^2 u/\partial x \partial y$ , and  $u_{yy} = \partial^2 u/\partial y^2$  are the derivatives of  $u$ ; and  $F(x, y, u, p, q, r, s, t)$  is a given function of eight variables. For example, Eq. (4) is a partial differential equation of order 2. It

$$u_{xy} = 0 \quad (4)$$

is easily verified that  $u = h(x) + g(y)$  is a solution of Eq. (4) for any choice of functions  $h$  and  $g$ .

A differential equation is linear if the function  $u$  and its derivatives appear linearly in the equation, and is nonlinear otherwise.

Partial differential equations occur with more than two independent variables. Another possibility is a system of differential equations. This consists of two or more equations involving one

or more unknown functions which are to be solved simultaneously. The Cauchy-Riemann equations, Eqs. (5), are a first-order

$$\begin{aligned} u_x - v_y &= 0 \\ u_y + v_x &= 0 \end{aligned} \tag{5}$$

linear system of partial differential equations. See COMPLEX NUMBERS. [J.C.P.]

**Differential geometry** A branch of mathematics that deals with intrinsic properties of curves and surfaces in three-dimensional euclidean space. The intrinsic properties are those which are independent of the geometrical objects orientation or location in space. The subject is also concerned with nets of curves and families of surfaces, these having wide application in the arts.

The space is referred to a rectangular cartesian coordinate system  $(x,y,z)$ . A space curve may be defined by a pair of independent equations,  $f(x,y,z) = 0$  and  $g(x,y,z) = 0$ , or, more meaningfully, by parametric equations,  $x = x(t)$ ,  $y = y(t)$ ,  $z = z(t)$ . In this case the arc length between two points  $t_0$  and  $t$  is given by Eq. (1).

$$s = \int_{t_0}^t \sqrt{\left(\frac{dx}{dt}\right)^2 + \left(\frac{dy}{dt}\right)^2 + \left(\frac{dz}{dt}\right)^2} dt \tag{1}$$

Obviously, if  $s$  is chosen as parameter, Eq. (2) holds. In this

$$\left(\frac{dx}{ds}\right)^2 + \left(\frac{dy}{ds}\right)^2 + \left(\frac{dz}{ds}\right)^2 = 1 \tag{2}$$

case  $dx/ds$ ,  $dy/ds$ ,  $dz/ds$  at a point  $P$  are the direction cosines of the tangent to the curve at  $P$ .

Consider three nearby points  $P, P_1, P_2$ . Through them, in general, one plane may be constructed. The limiting position of this plane as  $P_1$  and  $P_2$  approach  $P$  is the osculating plane of the curve at  $P$ . The limiting position of the circle through  $P, P_1, P_2$  as  $P_1$  and  $P_2$  approach  $P$  is the osculating circle. Its center is the center of curvature and its radius is the radius of curvature  $\rho$ . The reciprocal of the radius of curvature  $\kappa$  is the curvature; its value is shown in expression (3). The perpendicular to the tan-

$$\sqrt{\left(\frac{d^2x}{ds^2}\right)^2 + \left(\frac{d^2y}{ds^2}\right)^2 + \left(\frac{d^2z}{ds^2}\right)^2} \tag{3}$$

gent at  $P$  in the osculating plane is the principal normal and the perpendicular at  $P$  to the osculating plane is the binormal.

A surface in three-dimensional euclidean space may be given by  $f(x,y,z) = 0$  or, more conveniently, by Eqs. (4). For a fixed

$$x = x(u,v) \quad y = y(u,v) \quad z = z(u,v) \tag{4}$$

value of  $v$ , Eqs. (4) describe a curve in the surface, a  $u$  line, and similarly for a fixed value of  $u$ . Thus  $(u,v)$  are curvilinear coordinates of a point in the surface. The most important quantity in the study of surfaces is the arc length of a curve. This is given by Eq. (5), where  $E, F, G$  are functions of partial derivatives of

$$ds^2 = E du^2 + 2F du dv + G dv^2 \tag{5}$$

$(x,y,z)$ . In the real domain  $E, G$ , and  $EG - F^2$  are nonnegative and may be zero only at singular points of the surface, or at points where the matrix of the partial derivatives of  $(x,y,z)$  is of rank less than two. The right-hand side of Eq. (5) is called the first fundamental form of the surface, where  $E, F, G$  are the first fundamental quantities of the surface. All applicable surfaces have the same first fundamental form. Thus any cylinder or cone which is developable (applicable to a plane) has the fundamental form  $du^2 + dv^2$ , where  $(u,v)$  are rectangular cartesian coordinates. Under an arbitrary transformation of the surface coordinates  $(u,v)$  the fundamental quantities  $E, F, G$  transform linearly so that many problems in the study of surfaces reduce

to the question whether a coordinate system exists on the surface in which  $E, F, G$  satisfy desired conditions. See COORDINATE SYSTEMS; RIEMANNIAN GEOMETRY. [M.S.Kn.]

**Differential transformer** An iron-core transformer with movable core. A differential transformer produces an electrical output voltage proportional to the displacement of the core. It is used to measure motion and to sense displacements. It is also used in measuring devices for force, pressure, and acceleration which are based on the conversion of the measured variable to a displacement.

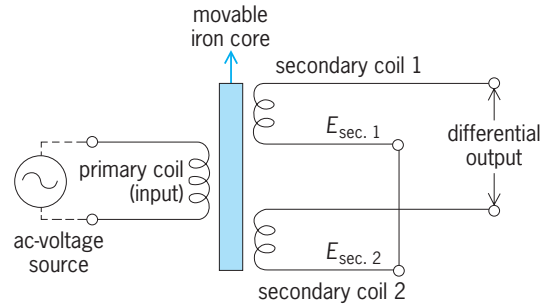

Basic circuit of differential transformer.  $E$  refers to  $E$  pickoff (from E-shaped iron core).

Various available configurations, some translational and others rotational, all employ the basic circuit shown in the illustration: a primary winding, two secondary windings, and a movable core. The primary winding is energized with alternating voltage. The two secondary windings are connected in series opposition, so that the transformer output is the difference of the two secondary voltages. When the core is centered, the two secondary voltages are equal and the transformer output is zero. This is the balance or null position. When the core is displaced from the null point, the two secondary voltages are no longer alike and the transformer produces an output voltage. With proper design, the output voltage varies linearly with core position over a small range. Motion of the core in the opposite direction produces a similar effect with  $180^\circ$  phase reversal of the alternating output voltage. See TRANSDUCER; TRANSFORMER. [G.W.]

**Differentiation** A mathematical operation performed on a function to determine the effect of a change in the value of the independent variable. Functions of one variable are considered in this article. For differentiation of functions of several variables see PARTIAL DIFFERENTIATION.

If  $f$  is a function of  $x$ , defined on an interval containing  $x_0$ , the derivative at  $x_0$  is, by definition, that shown in Eq. (1). For

$$f'(x_0) = \lim_{x \rightarrow x_0} \frac{f(x) - f(x_0)}{x - x_0} \tag{1}$$

generalities about derivatives and calculus see CALCULUS.

In the quotient on the right, in the definition of  $f'(x_0)$ ,  $x$  is restricted to the interval on which  $f$  is defined. If  $y = f(x)$ ,  $f'(x_0)$  is also denoted by

$$\left(\frac{dy}{dx}\right)_{x=x_0}$$

The limit defining  $f'(x_0)$  may not exist. If it does,  $f$  is called differentiable at  $x_0$ .

The derivative of  $f'(x)$ , called the second derivative, is denoted by

$$f''(x) \text{ or } \frac{d^2y}{dx^2}$$



A function  $f$  is called continuous at  $x_0$  if  $x_0$  is in the domain of  $f$  and

$$\lim_{x \rightarrow x_0} f(x) = f(x_0)$$

The precise formulation of the limit concept used here is the following: Let  $g$  be a function and let  $A$  be a number. Then Eq. (2) means that to each positive number  $\epsilon$  corresponds to

$$\lim_{x \rightarrow x_0} g(x) = A \tag{2}$$

some positive number  $\delta$  such that  $|g(x) - A| < \epsilon$  whenever  $x$  is a number in the domain of  $g$  such that  $x \neq x_0$  and  $|x - x_0| < \delta$ . It is required of  $g$  that its domain shall contain numbers  $x$  as close to  $x_0$  as desired, but different from  $x_0$ . The domain of  $g$  may also contain  $x_0$ , but this is irrelevant.

It is a theorem that, if  $f$  is differentiable at  $x_0$ , then  $f$  is continuous at  $x_0$ . However, a function can be continuous at  $x_0$ , but not differentiable there. An example is  $f(x) = |x|$  at  $x_0 = 0$ . It is even possible for a function to be continuous on an interval and yet not differentiable at any point of this interval.

The chief elementary applications of differentiation are (1) in expressing rates of change (velocity, acceleration), and in solving problems where, through functional relationship, the rate of change of one variable is calculated when the rate of change of another variable is known; (2) in studying graphs of functions and, more generally, in studying curves in the plane or in space of three dimensions; (3) in expressing scientific laws or principles in the form of differential equations; and (4) in the expression of various extensions and applications of the law of the mean, including such topics as l'Hospital's rule and Taylor's formula or series.

The general technique of differentiation is built upon the rules for differentiating combinations of differentiable functions. If  $u = f(x)$  and  $v = g(x)$  are functions differentiable for the same values of  $x$ , then  $u + v$  and  $uv$  are differentiable and so is  $u/v$  if  $v \neq 0$ . The formulas are shown in Eqs. (3). If  $u$  is constant in

$$\begin{aligned} \frac{d}{dx}(u + v) &= \frac{du}{dx} + \frac{dv}{dx} \\ \frac{d}{dx}(uv) &= u \frac{du}{dx} + v \frac{du}{dx} \\ \frac{d}{dx} \left( \frac{u}{v} \right) &= \frac{v \frac{du}{dx} - u \frac{dv}{dx}}{v^2} \end{aligned} \tag{3}$$

value, then  $du/dx = 0$ . A very powerful instrument of technique is furnished in the chain rule for composite functions. If  $y$  is a differentiable function of  $u$  and  $u$  is a differentiable function of  $x$ , then  $y$  is a differentiable function of  $x$ , and

$$\frac{dy}{dx} = \frac{dy}{du} \frac{du}{dx}$$

In functional notation, if  $y = f(u)$  and  $u = h(x)$ , then  $y = F(x)$ , where  $F(x) = f[h(x)]$ , and then  $F'(x) = f'[h(x)]h'(x)$ . [A.E.Ta.]

**Diffraction** The bending of light, or other waves, into the region of the geometrical shadow of an obstacle. More exactly, diffraction refers to any redistribution in space of the intensity of waves that results from the presence of an object that causes variations of either the amplitude or phase of the waves. Most diffraction gratings cause a periodic modulation of the phase across the wavefront rather than a modulation of the amplitude. Although diffraction is an effect exhibited by all types of wave motion, this article will deal only with electromagnetic waves, especially those of visible light. For discussion of the phenomenon as encountered in other types of waves see ELECTRON DIFFRACTION; NEUTRON DIFFRACTION; SOUND.

Diffraction is a phenomenon of all electromagnetic radiation, including radio waves; microwaves; infrared, visible, and ultra-

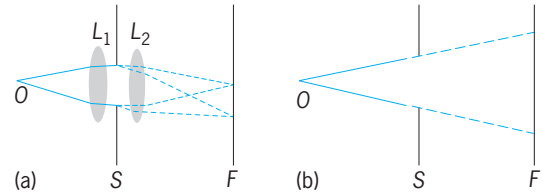

Fig. 1. Observation of the two principal types of diffraction, in the case of a circular aperture. (a) Fraunhofer and (b) Fresnel diffraction.

violet light; and x-rays. The effects for light are important in connection with the resolving power of optical instruments. See RADIO-WAVE PROPAGATION; X-RAY DIFFRACTION.

There are two main classes of diffraction, which are known as Fraunhofer diffraction and Fresnel diffraction. The former concerns beams of parallel light, and is distinguished by the simplicity of the mathematical treatment required and also by its practical importance. The latter class includes the effects in divergent light, and is the simplest to observe experimentally.

To illustrate the difference between the methods of observation of the two types of diffraction, Fig. 1 shows the experimental arrangements required to observe them for a circular hole in a screen  $S$ . The light originates at a very small source  $O$ , which can conveniently be a pinhole illuminated by sunlight. In Fraunhofer diffraction, the source lies at the principal focus of a lens  $L_1$  which renders the light parallel as it falls on the aperture. A second lens  $L_2$  focuses parallel diffracted beams on the observing screen  $F$ , situated in the principal focal plane of  $L_2$ . In Fresnel diffraction, no lenses intervene. The diffraction effects occur chiefly near the borders of the geometrical shadow, indicated by the broken lines. An alternative way of distinguishing the two classes, therefore, is to say that Fraunhofer diffraction concerns the effects near the focal point of a lens or mirror, while Fresnel diffraction concerns those effects near the edges of shadows. Photographs of diffraction patterns are shown in Fig. 2.

**Fraunhofer diffraction.** This class of diffraction is characterized by a linear variation of the phases of the Huygens secondary waves with distance across the wavefront, as they arrive at a given point on the observing screen. At the instant that the incident plane wave occupies the plane of the diffracting screen, it may be regarded as sending out, from each element of its surface, a multitude of secondary waves, the joint effect of which is to be evaluated in the focal plane of the lens  $L_2$ . The analysis of these secondary waves involves taking account of both their amplitudes and their phases. The simplest way to do this is to use a graphical method, the method of the so-called vibration curve, which can readily be extended to cases of Fresnel diffraction. See HUYGENS' PRINCIPLE.

The vibration curve results from the addition of a large (really infinite) number of infinitesimal vectors, each representing the

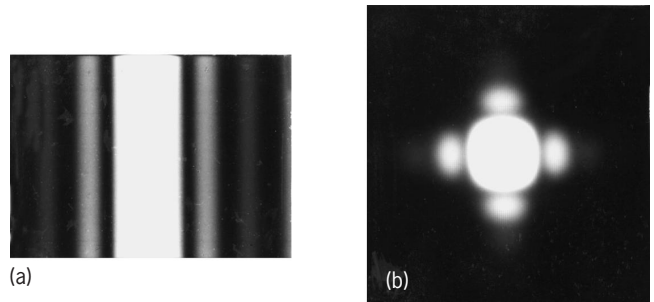
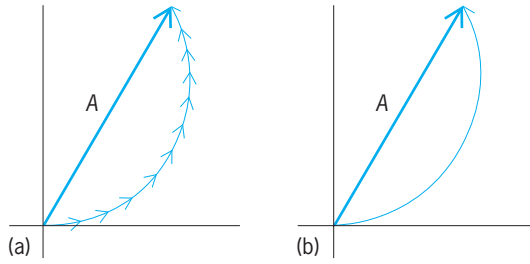

Fig. 2. Diffraction patterns, photographed with visible light. (a) Fraunhofer pattern, for a slit; (b) Fresnel pattern, circular aperture.



**Fig. 3. Vibration curves. (a) Addition of many equal amplitudes differing in phase by equal amounts. (b) Equivalent curve, when amplitudes and phase differences become infinitesimal.**

contribution of the Huygens secondary waves from an element of surface of the wavefront. If these elements are assumed to be of equal area, the magnitudes of the amplitudes to be added will all be equal. They will, however, generally differ in phase, so that if the elements were small but finite each would be drawn at a small angle with the preceding one, as shown in Fig. 3a. The resultant of all elements would be the vector *A*. When the individual vectors represent the contributions from infinitesimal surface elements (as they must for the Huygens wavelets), the diagram becomes a smooth curve, the vibration curve, shown in Fig. 3b. The intensity on the screen is then proportional to the square of this resultant amplitude. In this way, the distribution of the intensity of light in any Fraunhofer diffraction pattern may be determined.

The intensity distribution for Fraunhofer diffraction by a slit as a function of the angle  $\theta$  from the center may be simply calculated by the method of the vibration curve. The intensity at any angle is given by Eq. (1), where  $I_0$  is the intensity at the center of the pattern, and  $\beta$  is given by Eq. (2), where  $b$  is the width of the

$$I = I_0 \frac{\sin^2 \beta}{\beta^2} \quad (1)$$

$$\beta = (\pi b \sin \theta) \lambda \quad (2)$$

slit and  $\lambda$  is the wavelength. The central maximum is twice as wide as the subsidiary ones, and is about 21 times as intense as the strongest of these. A photograph of this pattern is shown in Fig. 2a.

Fraunhofer diffraction by a circular aperture determines the resolving power of instruments such as telescopes, cameras, and microscopes, in which the width of the light beam is usually limited by the rim of one of the lenses. The method of the vibration curve may be extended to find the angular width of the central diffraction maximum for this case. An exact construction of the curve or, better, a mathematical calculation shows that the extreme phase differences required are  $\pm 1.220\pi$ , yielding Eq. (3)

$$\sin \theta \approx \theta = \pm \frac{1.220\lambda}{d} \quad (3)$$

for the angle  $\theta$  at the first zero of intensity. Here  $d$  is the diameter of the circular aperture. This pattern has circular symmetry and consists of a diffuse central disk, called the Airy disk, surrounded by faint rings. The angular radius of the disk, given by Eq. (3), may be extremely small for an actual optical instrument, but it sets the ultimate limit to the sharpness of the image, that is, to the resolving power. See RESOLVING POWER (OPTICS).

**Fresnel diffraction.** The diffraction effects obtained when the source of light or the observing screen are at a finite distance from the diffracting aperture or obstacle come under the classification of Fresnel diffraction. This type of diffraction requires for its observation only a point source, a diffracting screen of some sort, and an observing screen. The latter is often advantageously replaced by a magnifier or a low-power microscope. The observed diffraction patterns generally differ according to the radius of curvature of the wave and the distance of the point

of observation behind the screen. If the diffracting screen has circular symmetry, such as that of an opaque disk or a round hole, a point source of light must be used. If it has straight, parallel edges, it is desirable from the standpoint of brightness to use an illuminated slit parallel to these edges. In the latter case, it is possible to regard the wave emanating from the slit as a cylindrical one. For the purpose of deriving the vibration curve, the appropriate way of dividing the wavefront into infinitesimal elements is to use annular rings in the first case, and strips parallel to the axis of the cylinder in the second case.

The zone plate is a special screen designed to block off the light from every other half-period zone, and represents an interesting application of Fresnel diffraction. The Fresnel half-period zones are drawn, with radii proportional to the square roots of whole numbers, and alternate ones are blackened. The drawing is then photographed on a reduced scale. When light from a point source is sent through the negative, an intense point image is produced, much like that formed by a lens. [F.A.J./W.W.W.]

**Diffraction grating** An optical device consisting of an assembly of narrow slits or grooves, which by diffracting light produces a large number of beams which can interfere in such a way as to produce spectra. Since the angles at which constructive interference patterns are produced by a grating depend on the lengths of the waves being diffracted, the waves of various lengths in a beam of light striking the grating will be separated into a number of spectra, produced in various orders of interference on either side of an undeviated central image. By controlling the shape and size of the diffracting grooves when producing a grating and by illuminating the grating at suitable angles, a beam of light can be thrown into a single spectrum whose purity and brightness may exceed that produced by a prism. Gratings can now be made with much larger apertures than prisms, and in such form that they waste less light and give higher intrinsic dispersion and resolving power. See DIFFRACTION.

Transmission gratings consist of a large number of narrow transparent and opaque slits alternating side by side in regular order and with uniform separation, through which a beam of light will appear as a series of spectra in various orders of interference. Reflection gratings, either plane or concave, are used in most spectrographs. Such a grating may consist of an original ruling or of a metal-coated replica from an original. Large grating replicas can now be made which are practically indistinguishable in performance or permanence from an original.

Gratings are engraved by highly precise ruling engines, which use a diamond tool to press into a highly polished mirror surface a series of many thousands of fine shallow burnished grooves. If a grating is to give resolution approaching the theoretical limit, its grooves must be ruled straight, parallel, and equally spaced to within a few tenths of the shortest incident wavelength. Scattered light and false images may arise from local spacing error and groove shape variations of only a few hundredths of the diffracted wavelength.

A grating spectroscope usually consists of a slit, a lens or mirror to collimate the light sent through the slit into a parallel beam, a transmission or reflection grating to disperse the light, a lens or mirror to focus the light into spectrum lines (which are monochromatic images of the slit in the light of each wavelength passing through it), and an eyepiece for viewing the spectrum. If a camera is substituted for the telescope, the instrument becomes a grating spectrograph. If a photoelectric cell, a thermocouple, or other radiation-detecting device is used instead of a camera or telescope, the device becomes a grating spectrometer. See INFRARED SPECTROSCOPY. [G.R.H.]

**Diffuser** A device in which the kinetic energy of a flow is recovered, thus giving a static pressure rise. A simple example is a diverging passage (see illustration) with flow entering the small end and leaving the large end. For an incompressible flow (density,  $\rho$ , is constant) the mass conservation principle,

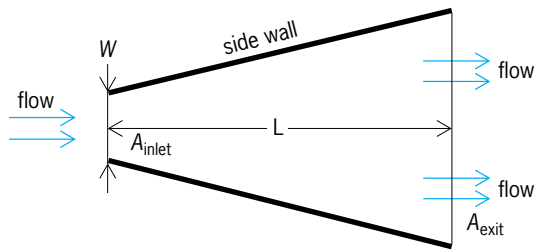

Standard diffuser geometry.

Eq. (1), indicates that the velocity ( $V$ ) will decrease through the

$$m = \rho V A$$

diffuser as the area ( $A$ ) increases, since the mass flow rate ( $m$ ) is constant. It follows from the Bernoulli principle, Eq. (2), and

$$p_0 = p + \frac{1}{2}\rho V^2$$

from the fact that the total pressure ( $p_0$ ) changes but slightly, that the static pressure ( $p$ ) rises in the diffuser. All subsonic diffusers, whether incompressible or not, experience stream-tube area increase as kinetic energy is converted to static pressure rise. Supersonic diffusers operate differently since changes in density become very significant. Many different geometries are possible for diffusers. See BERNOULLI'S THEOREM; CONSERVATION OF MASS; SUPERSONIC DIFFUSER.

Diffusers serve many vital roles. Many fluid-dynamic processes exhibit excessive kinetic energy at some point in their operating cycle. This kinetic energy can be recovered as a useful static pressure rise by the implementation of a diffuser. For example, hydraulic turbines installed for hydroelectric plant operation invariably use a draft tube, that is, an exhaust diffuser. Likewise, ground-based gas turbines for electric power production or general-purpose expansion turbines for waste-gas expansion generally employ an exhaust diffuser for extra pressure recovery. Compressors and pumps invariably generate excessive kinetic energy as work is done by their rotors, and diffusers are required to recover the kinetic energy as a static pressure rise. The basic elements of fluid transfer include pipes, elbows, valves, and diffusers. See COMPRESSOR; GAS TURBINE; HYDRAULIC TURBINE; PUMP.

[D.Ja.]

**Diffusion** The transport of matter from one point to another by random molecular motions. It occurs in gases, liquids, and solids.

Diffusion plays a key role in processes as diverse as permeation through membranes, evaporation of liquids, dyeing textile fibers, drying timber, doping silicon wafers to make semiconductors, and transporting of thermal neutrons in nuclear power reactors. Rates of important chemical reactions are limited by how fast diffusion can bring reactants together or deliver them to reaction sites on enzymes or catalysts. The forces between molecules and molecular sizes and shapes can be studied by making diffusion measurements. See CELL PERMEABILITY; EVAPORATION; INTEGRATED CIRCUITS; SEMICONDUCTOR; THERMAL NEUTRONS.

Molecules in fluids (gases and liquids) are constantly moving. Even in still air, for example, nitrogen and oxygen molecules ricochet off each other at bullet speeds. Molecular diffusion is easily demonstrated by pouring a layer of water over a layer of ink in a narrow glass tube. The boundary between the ink and water is sharp at first, but it slowly blurs as the ink diffuses upward into the clear water. Eventually, the ink spreads evenly along the tube without any help from stirring.

**Gases.** A number of techniques are used to measure diffusion in gases. In a two-bulb experiment, two vessels of gas are connected by a narrow tube through which diffusion occurs. Diffusion is followed by measuring the subsequent changes in the composition of gas in each vessel. Excellent results are also ob-

tained by placing a lighter gas mixture on top of a denser gas mixture in a vertical tube and then measuring the composition along the tube after a timed interval.

Rates of diffusion in gases increase with the temperature ( $T$ ) approximately as  $T^{3/2}$  and are inversely proportional to the pressure. The interdiffusion coefficients of gas mixtures are almost independent of the composition.

Kinetic theory shows that the self-diffusion coefficient of a pure gas is inversely proportional to both the square root of the molecular weight and the square of the molecular diameter. Interdiffusion coefficients for pairs of gases can be estimated by taking averages of the molecular weights and collision diameters. Kinetic-theory predictions are accurate to about 5% at pressures up to 10 atm (1 megapascal). Theories which take into account the forces between molecules are more accurate, especially for dense gases. See KINETIC THEORY OF MATTER.

**Liquids.** The most accurate diffusion measurements on liquids are made by layering a solution over a denser solution and then using optical methods to follow the changes in refractive index along the column of solution. Excellent results are also obtained with cells in which diffusion occurs between two solution compartments through a porous diaphragm. Many other reliable experimental techniques have been devised.

Room-temperature liquids usually have diffusion coefficients in the range  $0.5\text{--}5 \times 10^{-5} \text{ cm}^2 \text{ s}^{-1}$ . Diffusion in liquids, unlike diffusion in gases, is sensitive to changes in composition but relatively insensitive to changes in pressure. Diffusion of high-viscosity, syrupy liquids and macromolecules is slower. The diffusion coefficient of aqueous serum albumin, a protein of molecular weight 60,000 atomic mass units, is only  $0.06 \times 10^{-5} \text{ cm}^2 \text{ s}^{-1}$  at  $25^\circ\text{C}$  ( $77^\circ\text{F}$ ).

When solute molecules diffuse through a solution, solvent molecules must be pushed out of the way. For this reason, liquid-phase interdiffusion coefficients are inversely proportional to both the viscosity of the solvent and the effective radius of the solute molecules. Accurate theories of diffusion in liquids are still under development. See VISCOSITY. [D.G.L.]

**Solids.** Diffusion in solids is an important topic of physical metallurgy and materials science since diffusion processes are ubiquitous in solid matter at elevated temperatures. They play a key role in the kinetics of many microstructural changes that occur during the processing of metals, alloys, ceramics, semiconductors, glasses, and polymers. Typical examples of such changes include nucleation of new phases, diffusive phase transformations, precipitation and dissolution of a second phase, recrystallization, high-temperature creep, and thermal oxidation. Direct technological applications concern diffusion doping during the fabrication of microelectronic devices, solid electrolytes for battery and fuel cells, surface hardening of steels through carburization or nitridation, diffusion bonding, and sintering. See CREEP (MATERIALS); FUEL CELL; HEAT TREATMENT (METALLURGY); METAL, MECHANICAL PROPERTIES OF; PHASE TRANSITIONS; PLASTIC DEFORMATION OF METAL; SINTERING; SOLID-STATE BATTERY; SURFACE HARDENING OF STEEL.

The atomic mechanisms of diffusion are closely connected with defects in solids. Point defects such as vacancies and interstitials are the simplest defects and often mediate diffusion in an otherwise perfect crystal. Dislocations, grain boundaries, phase boundaries, and free surfaces are other types of defects in a crystalline solid. They can act as diffusion short circuits because the mobility of atoms along such defects is usually much higher than in the lattice. See CRYSTAL DEFECTS. [H.Me.]

**Digenea** A group of parasitic flatworms or flukes constituting a subclass or order of the class Trematoda, in the phylum Platyhelminthes. The name Digenea refers to the two types of generations in the life cycle: (1) the germinal sacs which parasitize the intermediate host (a mollusk or rarely an annelid) and reproduce asexually; and (2) the adult which is primarily endoparasitic in vertebrates and reproduces sexually. The adult

usually is hermaphroditic, but many of the blood flukes and a few others are dioecious. Vertebrates of all classes, except the Cyclostomata, serve as definitive hosts. Those feeding on aquatic plants and animals harbor the greatest variety of digenetic trematodes, but several species occur in strictly terrestrial hosts. Effects on the vertebrate vary from no apparent harm to severe and even fatal injury. Control of flukes is by preventive measures, including interruption of their life cycles and treatment with drugs. See TREMATODA.

The adult differs from other trematodes in several respects, the most obvious being the absence of a posterior adhesive organ with sclerotized hooks, plates, or multiple suckorial structures. Usually the mouth is anterior and opens into an oral sucker. A second sucker, the ventral one, is at the posterior end of amphistomes, on the ventral surface of distomes, or absent in monostomes. Adult digenetic trematodes occur in any part of the vertebrate that provides egress for their eggs and also in the circulatory system, from which eggs work through the tissues and escape in the feces or urine.

There is no general agreement concerning the classification of the Digenea. The scheme of G. La Rue proposes two superorders, the Anepitheliocystidia and Epitheliocystidia. See PLATYHELMINTHES. [R.M.C.]

**Digestive system** The vertebrate digestive system consists of the digestive tract and ancillary organs that serve for the acquisition of food and assimilation of nutrients required for energy, growth, maintenance, and reproduction. Food is ingested, reduced to particles, mixed with digestive fluids and enzymes, and propelled through the digestive tract. Enzymes produced by the host animal and microbes indigenous to the digestive tract destroy harmful agents and convert food into a limited number of nutrients, which are selectively absorbed. The digestive systems of vertebrates show numerous structural and functional adaptations to their diet, habitat, and other characteristics. Carnivores, which feed exclusively on other animals, and species that feed on plant concentrates (seeds, fruit, nectar, pollen) tend to have the shortest and simplest digestive tract. The digestive tract tends to be more complex in omnivores, which feed on both plants and animals, and most complex in herbivores, which feed principally on the fibrous portions of plants.

Gut structure and function can also vary with the habitat and other physiological characteristics of a species. The digestive tract of fish has adaptations for a marine or fresh-water environment. The basal metabolic rate per gram of body weight increases with a decrease in the body mass. Therefore, small animals must process larger amounts of food per gram of body weight, thus limiting their maximum gut capacity and digesta retention time.

**Anatomy.** Because of wide species variations, the digestive system of vertebrates is best described in terms of the headgut, foregut, midgut, pancreas, biliary system, and hindgut. The headgut consists of the mouthparts and pharynx, which serve for the procurement and the initial preparation and swallowing of food. The foregut consists of an esophagus for the swallowing of food and, in most species, a stomach that serves for its storage and initial stages of digestion. The esophagus of most vertebrates is lined with a multilayer of cells that are impermeable to absorption. In most birds it contains the crop, an out-pocketing of its wall that provides for the temporary storage of food. A stomach is present in all but the cyclostomes and some species of advanced fish and in the larval amphibians. In most vertebrates it consists of a dilated segment of the gut that is separated from the esophagus and midgut by muscular sphincters or valves. This is often referred to as a simple stomach. However, in birds these functions are carried out by the crop (storage), proventriculus (secretion), and gizzard (grinding or mastication). In most vertebrates, a major portion of the stomach is lined with a proper gastric mucosa (epithelium), which secretes mucus, hydrochloric acid (HCl), and pepsinogen. The distal (pyloric) part of the stomach secretes mucus and bicarbonate ions ( $\text{HCO}_3^-$ ),

and its muscular contractions help reduce the size of food particles and transfer partially digested food into the midgut. The stomach of reptiles and most mammals has an additional area of cardiac mucosa near its entrance, which also secretes mucus and bicarbonate ions. See ESOPHAGUS; STOMACH.

The midgut or small intestine is the principal site for the digestion of food and the absorption of nutrients. It is lined with a single layer of cells that secrete mucus and fluids, contain enzymes that aid in the final stages of carbohydrate and protein digestion, and absorb nutrients from the lumen into the circulatory system. The surface area of the lumen can be increased by a variety of means, such as folds and pyloric ceca (blind sacs) in fish. In higher vertebrates the lumen surface is increased by the presence of villi, which are macroscopic projections of the epithelial and subepithelial tissue.

The lumen surface is also expanded by a brush border of microvilli on the lumen-facing (apical) surface of the midgut absorptive cells in all vertebrates. The brush border membranes contain enzymes that aid in the final digestion of food and mechanisms that provide for the selective absorption of nutrients. The luminal surface area of the human small intestine is increased 10-fold by the presence of villi and an additional 20-fold by the microvilli, resulting in a total surface area of 310,000 in.<sup>2</sup> (2,000,000 cm<sup>2</sup>).

Digestion in the midgut is aided by secretions of digestive enzymes and fluid by pancreatic tissue, and secretion of bile by the liver. Pancreatic tissue is distributed along the intestinal wall, and even into the liver, of some species of fish. However, the pancreas is a compact organ in sharks, skates, rays, many teleosts, and all other vertebrates. The liver is a compact organ in all vertebrates. One of its many functions is the secretion of bile. In most vertebrates, the bile is stored in the gallbladder and released into the intestine as needed, but a gallbladder is absent in some species of fish and mammals. Bile salts serve to emulsify lipids and increase their surface area available for digestion by the water-soluble lipase. See GALLBLADDER; LIVER; PANCREAS.

The hindgut is the final site of digestion and absorption prior to defecation or evacuation of waste products. The hindgut of fish, amphibian larvae, and a few mammals is short and difficult to distinguish from the midgut. However, the hindgut of adult amphibians and reptiles, birds, and most mammals is a distinct segment, which is separated from the midgut by a muscular sphincter or valve. It also tends to be larger in diameter. Thus, the midgut and hindgut of these animals are often referred to as the small intestine and the large intestine. See INTESTINE.

The hindgut of some reptiles and many mammals includes a blind sac or cecum near its junction with the midgut. A pair of ceca are present in the hindgut of many birds and a few mammalian species. The remainder of the hindgut consists of the colon and a short, straight, terminal segment, which is called the rectum in mammals. The digestive and urinary tracts exit separately from the body of most species of fish and mammals. However, in adult amphibians and the reptiles, birds, and some mammals, this segment terminates in a chamber called the cloaca, which also serves as an exit for the urinary and reproductive systems. The hindgut or, where present, the cloaca terminates in the anus. See COLON; URINARY SYSTEM.

The hindgut is similarly lined with a single layer of absorptive and mucus-secreting cells. However, it lacks villi, and (with the exception of the cecum of birds) its absorptive cells lack digestive enzymes and the ability to absorb most nutrients. One major function of the hindgut is to reabsorb the fluids secreted into the upper digestive tract and (in animals that have a cloaca) excreted in the urine. It also serves as the principal site for the microbial production of nutrients in the herbivorous reptiles and birds and in most herbivorous mammals. Thus, the hindgut tends to be longest in animals that need to conserve water in an arid environment, and has a larger capacity in most herbivores.

**Musculature.** The digestion of food, absorption of nutrients, and excretion of waste products require the mixing of ingesta with digestive enzymes and the transit of ingesta and digesta through the digestive tract. In all vertebrates other than the cyclostome the contents are mixed and moved by an inner layer of circular muscle and an outer layer of muscle that runs longitudinally along the tract. The initial act of deglutition (swallowing) and the final act by which waste products are defecated from the digestive tract are effected by striated muscle. This type of muscle is characterized by rapid contraction and is controlled by extrinsic nerves. However, the esophagus of amphibians, reptiles, and birds, and the entire gastrointestinal tract of all vertebrates are enveloped by smooth muscle. This smooth muscle contracts more slowly, and its rate of contraction is partly independent of external stimulation. See **MUSCLE**.

**Nerve and endocrine tissue.** The initial act of deglutition and final act of defecation are under the voluntary control of the central nervous system. However, the remainder of the digestive system is subject to the involuntary control of nerves which release a variety of neurotransmitting or neuromodulating agents that either stimulate or inhibit muscular contractions and the secretions of glands and cells. The motor and secretory activities of the digestive system are also under the control of a wide range of other substances produced by endocrine cells that are released either distant from (hormones) or adjacent to (paracrine agents) their site of action. Although there are some major variations in the complement and activities of the neurotransmitters, neuromodulators, hormones, and paracrine agents, their basic patterns of control are similar.

The anatomy of the human digestive system is similar to that of other mammalian omnivores (see illustration). The teeth and salivary glands are those of a mammalian omnivore, and the initial two-thirds of the esophagus is enveloped by striated muscle. A simple stomach is followed by an intestine, whose length consists of approximately two-thirds small bowel and one-third large bowel. The structures of the pancreas and biliary system show no major differences from those of other mammals. During early fetal development, a distinct, conical cecum is present and continues to grow until the sixth month of gestation. However, unlike other primates, the cecum recedes to become little more than a bulge in the proximal colon by the time of birth. The colon continues to lengthen after the birth and is sacculated throughout its length like that of the apes and a few monkeys but few other mammals.

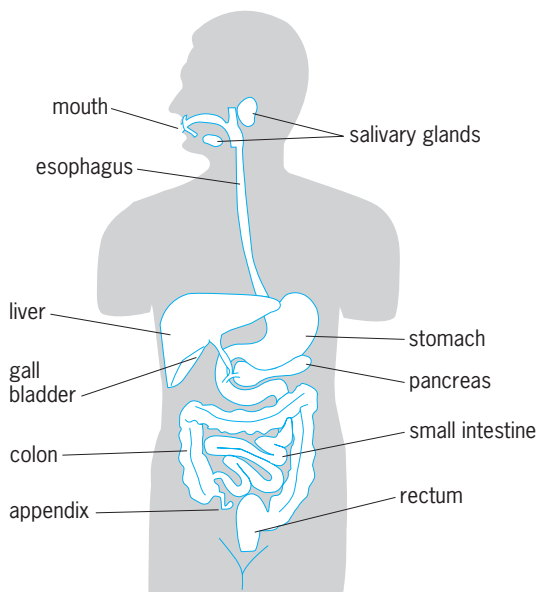

**Human digestive system.** (After A. C. Guyton, *Textbook of Medical Physiology*, 8th ed., Saunders, 1991)

**Physiology.** The major physiological activities of the digestive system are motility, secretion, digestion, and absorption. Each activity can be affected by diet and, in the cold-blooded species, is reduced with a decrease in body temperature.

**Motility.** The mastication of food and the movement of ingesta and digesta through the digestive tract are controlled by the motor activity of muscular contractions. Pressure of food against the palate and back of the mouth stimulates a nerve reflex that passes through a deglutition center in the brain. This reflex closes the entrance into the respiratory system and stops respiration, to prevent the inspiration of food into the lungs, and initiates muscular contractions that pass food into the esophagus. The food (bolus) is then passed down the esophagus and into the stomach by a moving wave of muscular contractions (peristalsis) accompanied by inhibition of the esophageal sphincters. The multicompartamental forestomach of ruminants undergoes a continuous series of complex, repetitive contractions that are controlled by the central nervous system. However, the gastric motility of most species and the intestinal motility of all vertebrates are controlled partially by the intrinsic characteristics of their smooth muscle cells. The result is production of either stationary (mixing) contractions of the stomach and intestine or a series of peristaltic contractions that carry digesta on through the tract.

**Digestion.** Digestion is accomplished by enzymes produced by the digestive system (endogenous enzymes) or by bacteria that are normal residents of the digestive tract. Plant and animal starches are converted to oligosaccharides (short-chain structures) and disaccharides by amylase, which is secreted by the salivary glands of some species and the pancreas of all vertebrates. The end products of starch digestion, plus the dietary disaccharides, are converted to monosaccharides by enzymes in the brush border of the absorptive epithelial cells lining the small intestine. Vertebrates do not produce enzymes capable of digesting the structural polysaccharides of plants.

Lipids are digested into alcohols, monoglycerides, and fatty acids by lipases and esterases, which are secreted predominantly by the pancreas. However, the lipases are water-soluble enzymes that can attack their substrate only at a lipid-water interface. Therefore, the lipids must be emulsified in order to provide the surface area required for efficient digestion. Emulsification is accomplished by the release of bile salts secreted by the liver and released into the midgut.

Dietary protein is first broken down into long chains of amino acids (polypeptides) by gastric pepsin and pancreatic trypsin. The polypeptides are then attacked by other pancreatic proteases (chymotrypsin, carboxypeptidase, elastase) to form tripeptides, dipeptides, and amino acids. All of these enzymes are secreted in an inactive form to prevent the self-digestion of the secretory cells prior to their release. Pepsin is activated by the acidity resulting from the secretion of hydrochloric acid (HCl) into the stomach, and trypsin is activated by an enzyme (enterokinase) that is secreted by intestinal epithelium. Tri- and dipeptides are digested into amino acids by enzymes in the brush border and contents of midgut absorptive cells. Nucleic acids are digested by pancreatic ribonucleases into pentose sugars, purines, and pyrimidines.

Substantial numbers of bacteria can be found in all segments of the gastrointestinal tract, but the highest numbers are present in those segments in which digesta are retained for prolonged periods of time at a relatively neutral pH. Indigenous bacteria help protect the animal from pathogenic microorganisms by stimulating immunity and competing for substrates. They also convert dietary and endogenous substances that are not digested by endogenous enzymes into absorbable nutrients. Many species of indigenous bacteria can ferment sugars, starches, and structural carbohydrates into short-chain fatty acids. The short-chain fatty acids, which are predominantly acetic, propionic, and butyric acids, are readily absorbed and serve as an additional source of energy. These bacteria also synthesize microbial protein and

the B-complex vitamins that may be useful to their host. The contributions of indigenous bacteria to the production and conservation of nutrients are greatest in herbivores. Although it has been estimated that short-chain fatty acid absorption provides 4% of total maintenance energy requirement by dogs and 6–10% of the maintenance energy required by humans, they can account for 30% of the maintenance energy of rabbits and up to 70% of maintenance energy of horses and ruminants. See BACTERIAL PHYSIOLOGY AND METABOLISM.

**Absorption.** The epithelial cells that line the gastrointestinal tract are closely attached to one another at their lumen-facing border by tight junctions, which are relatively impermeable to most substances other than water. Therefore, the major restriction for the absorption of most substances from the lumen into the blood is the apical and basolateral membranes of these cells. Lipid-soluble substances can be transported across the apical cell membranes by passive diffusion down their concentration gradient. The short- and medium-chain fatty acids that result from lipid digestion in the small intestine pass directly into the blood. However, the monoglycerides and long-chain fatty acids are resynthesized into triglycerides by the epithelial cells in the midgut and incorporated into small spheres (chylomicrons), which are transported across the basolateral membrane into the lymphatic system. Fat-soluble vitamins, long-chain alcohols, and other lipids also appear to be incorporated into chylomicrons and to enter the lymphatic system.

The intestinal cell membranes are relatively impermeable to the passive diffusion of water-soluble monosaccharides, amino acids, vitamins, and minerals that constitute a major portion of the required nutrients. These nutrients are selectively transferred across the intestinal cell membranes by carrier-mediated transport. Membrane carriers combine with the nutrient at one membrane surface and pass it across the membrane for release at the opposing surface. Some simply facilitate the diffusion of a substance down its concentration gradient; others are capable of transporting a nutrient against its concentration gradient, which requires either a direct or indirect investment of cellular energy. See CELL MEMBRANES.

The metabolic processes of the body require a number of different minerals. Some such as iron, calcium, sodium, and chloride are required in relatively large quantities. Others such as manganese and zinc are labeled trace minerals because they are required in only minute amounts.

The nutrient that is required in largest quantity for digestion, absorption, metabolism, and excretion of waste products is water. Because it readily diffuses across cell membranes down its concentration gradient, the net secretion or absorption of water is determined by the net secretion or absorption of all other substances. Sodium, chloride, and bicarbonate are the principal ions that are present in the extracellular fluids that bathe the body cells of all vertebrates and that are transported across cell membranes. Therefore, the transport of these electrolytes is the major driving force for the secretion or absorption of water. [C.E.St.]

**Digital computer** A device that processes numerical information; more generally, any device that manipulates symbolic information according to specified computational procedures. The term digital computer—or simply, computer—embraces calculators, computer workstations, control computers (controllers) for applications such as domestic appliances and industrial processes, data-processing systems, microcomputers, microcontrollers, multiprocessors, parallel computers, personal computers, network servers, and supercomputers. See CALCULATORS; DIGITAL CONTROL; MICROCOMPUTER; PROGRAMMABLE CONTROLLERS; SUPERCOMPUTER.

A digital computer is an electronic computing machine that uses the binary digits (bits) 0 and 1 to represent all forms of information internally in digital form. Every computer has a set of instructions that define the basic functions it can perform. Sequences of these instructions constitute machine-language pro-

grams that can be stored in the computer and used to tailor it to an essentially unlimited number of specialized applications. Calculators are small computers specialized for mathematical computations. General-purpose computers range from pocket-sized personal digital assistants (notepad computers), to medium-sized desktop computers (personal computers and workstations), to large, powerful computers that are shared by many users via a computer network. The vast majority of digital computers now in use are inexpensive, special-purpose microcontrollers that are embedded, often invisibly, in such devices as toys, consumer electronic equipment, and automobiles. See BIT; COMPUTER PROGRAMMING; EMBEDDED SYSTEMS.

The main data-processing elements of a computer reside in a small number of electronic integrated circuits (ICs) that form a microprocessor or central processing unit (CPU). Electronic technology allows a basic instruction such as “add two numbers” to be executed many millions of times per second. Other electronic devices are used for program and data storage (memory circuits) and for communication with external devices and human users (input-output circuits). Nonelectronic (magnetic, optical, and mechanical) devices also appear in computers. They are used to construct input-output devices such as keyboards, monitors (video screens), secondary memories, printers, sensors, and mechanical actuators.

Information is stored and processed by computers in fixed-sized units called words. Common word sizes are 8, 16, 32, and 64 bits. Four-bit words can be used to encode the first 16 integers. By increasing the word size, the number of different items that can be represented and their precision can be made as large as desired. A common word size in personal computers is 32 bits, which allows  $2^{32} = 4,294,967,296$  distinct numbers to be represented.

Computer words can represent many different forms of information, not just numbers. For example, 8-bit words called characters or bytes are used to encode text symbols (the 10 decimal digits, the 52 upper- and lowercase letters of the English alphabet, and punctuation marks). A widely used code of this type is ASCII (American Standard Code for Information Interchange). Visual information can be reduced to black and white dots (pixels) corresponding to 0's and 1's. Audio information can be digitized by mapping a small element of sound into a binary word; for example, a compact disk (CD) uses several million 16-bit words to store an audio recording. Logical quantities encountered in reasoning or decision making can be captured by associating 1 with true and 0 with false. Hence, most forms of information are readily reduced to a common, numberlike binary format suitable for processing by computer. See COMPACT DISK; IMAGE PROCESSING; LOGIC.

**Logic components.** The operation of a digital computer can be viewed at various levels of abstraction, which are characterized by components of different complexity. These levels range from the low, transistor level seen by an electronic circuit designer to the high, system level seen by a computer user. A useful intermediate level is the logic level, where the basic components process individual bits. By using other basic components called gates, logic circuits can be constructed to perform many useful operations. See LOGIC CIRCUITS.

**System organization.** An accumulator is a digital system that constitutes a simple processor capable of executing a few instructions. By introducing more data-processing circuits and registers, as well as control circuits for a larger set of instructions, a practical, general-purpose processor can be constructed. Such a processor forms the “brain” of every computer, and is referred to as its central processing unit. A CPU implemented on a single integrated-circuit chip is called a microprocessor. See MICROPROCESSOR.

A typical computer program is too large to store in the CPU, so another component called the main memory is used to store a program's instructions and associated data while they are being executed (Fig. 1). Main memory consists of high-speed

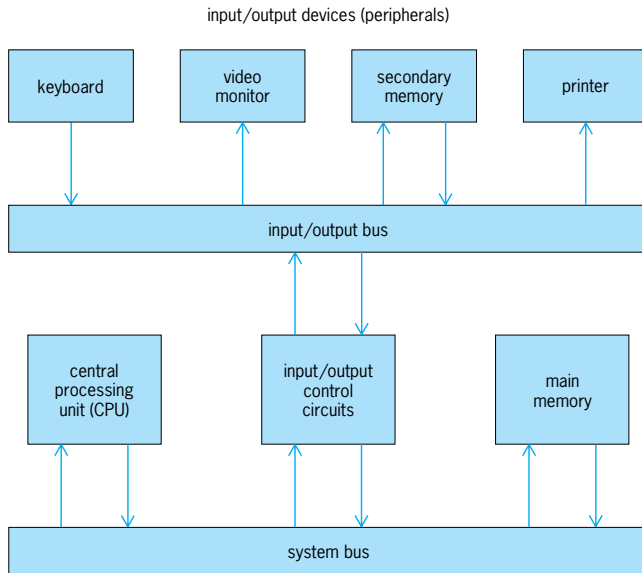

Fig. 1. General organization of a computer.

integrated circuits designed to allow storage and retrieval of information one word at a time. All words in main memory can be accessed with equal ease; hence this is also called a random-access memory (RAM).

A computer program is processed by loading it into main memory and then transferring its instructions and data one word (or a few words) at a time to the CPU for processing. Hence, there is a continual flow of instructions and data words between the CPU and its main memory. As millions of words must be transferred per second, a high-speed communication link is needed between the CPU and main memory. The system bus (Fig. 1) fills this role.

A computer has input-output (I/O) control circuits and buses to connect it to external input-output devices (also called peripherals). Typical input-output devices are a keyboard, which is an input device, and a printer, which is an output device. Because most computers need more storage space than main memory can supply, they also employ secondary memory units which form part of the computer's input-output subsystem. Common secondary memory devices are hard disk drives, flexible (floppy) disk drives, and magnetic tape units. Compared to main memory, secondary memories employ storage media (magnetic disks and tapes) that have higher capacity and lower cost. However, secondary memories are also significantly slower than main memory. See COMPUTER PERIPHERAL DEVICES; COMPUTER STORAGE TECHNOLOGY.

No explicit instructions are needed for input-output operations if input-output devices share with main memory the available memory addresses. This is known as memory-mapped input-output, and allows load and store instructions to be used to transfer data between the CPU and input-output devices. In general, a computer's instruction set should include a selection of instructions of the following three types: (1) Data-transfer instructions that move data unchanged between the CPU, main memory, and input-output devices. (2) Data-processing instructions that perform numerical operations such as add, subtract, multiply, and divide, as well as nonnumerical (logical) operations, such as NOT, AND, EXCLUSIVE-OR, and SHIFT. (3) Program-control instructions that can change the order in which instructions are executed, for example branch, branch-on-zero, call procedure, and return from procedure.

The instruction unit (I unit) of a CPU (Fig. 2), also called the program control unit, is responsible for fetching instructions from main memory, using the program counter as the instruction address register. The opcode of a newly fetched instruction

$I$  is placed in the instruction register. The opcode is then decoded to determine the sequence of actions required to execute  $I$ . These may include the loading or storing of data assigned to main memory, in which case the I unit computes all needed addresses and issues all needed control signals to the CPU and the system bus. Data are processed in the CPU's execution unit (E unit), also called the datapath, which contains a set of registers used for temporary storage of data operands, and an arithmetic logic unit (ALU), which contains the main data-processing circuits.

**Performance measures.** A simple indicator of a CPU's performance is the frequency  $f$  of its central timing signal (clock), measured in millions of clock signals issued per second or megahertz (MHz). The clock frequency depends on the integrated-circuit technology used; frequencies of several hundred megahertz are achievable with current technology. Each clock signal triggers execution of a basic instruction such as a fixed-point addition; hence, the time required to execute such an instruction (the clock cycle time) is  $1/f$  microseconds. Complex instructions like multiplication or operations on floating-point numbers require several clock cycles to complete their execution. Another measure of CPU performance is the (average) instruction execution rate, measured in millions of instructions per second (MIPS).

Instruction execution time is strongly affected by the time to move instructions or data between the CPU and main memory. The time required by the CPU to access a word in main memory is typically about five times longer than the CPU's clock cycle time. This disparity in speed has existed since the earliest computers despite efforts to develop memory circuits that would be fast enough to keep up with the fastest CPUs. Maximum performance requires the CPU to be supplied with a steady flow of instructions that need to be executed. This flow is disrupted by branch instructions, which account for 20% or more of the instructions in a typical program.

To deal with the foregoing issues, various performance-enhancing features have been incorporated into the design of computers. The communication bottleneck between the CPU and main memory is reduced by means of a cache, which is a special memory unit inserted between the two units. The cache is smaller than main memory but can be accessed more rapidly, and is often placed on the same integrated-circuit chip as the

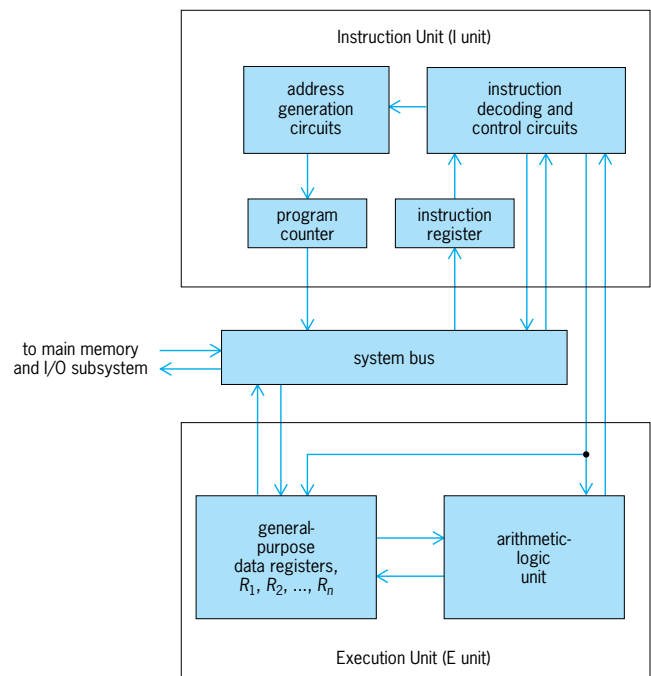

Fig. 2. Internal organization of a CPU.

CPU. Its effect is to reduce the average time required by the CPU to send information to or receive information from the memory subsystem. Special logic circuits support the complex flow of information among main memory, the cache, and the registers of the CPU. However, the cache is largely invisible to the programs being executed.

The instruction execution rate can be increased by executing several instructions concurrently. One approach is to employ several E units that are tailored to different instruction types. Examples are an integer unit designed to execute fixed-point instructions and a floating-point unit designed for floating-point instructions. The CPU can then execute a fixed-point instruction and a floating-point instruction at the same time. Processors that execute several instructions in parallel in this way are called superscalar. See CONCURRENT PROCESSING.

Another speedup technique called pipelining allows several instructions to be processed simultaneously in special circuits called pipelines. Execution of an instruction is broken into several consecutive steps, each of which can be assigned to a separate stage of the pipeline. This makes it possible for an  $n$ -stage E unit to overlap the execution of up to  $n$  different instructions. A pipeline processing circuit resembles an assembly line on which many products are in various stages of manufacture at the same time. The ability of a CPU to execute several instructions at the same time by using multiple or pipelined E units is highly dependent on the availability of instructions of the right type at the right time in the program being executed. A useful measure of the performance of a CPU that employs internal parallelism is the average number of clock cycles per instruction (CPI) needed to execute a representative set of programs.

**CISCs and RISCs.** A software implementation of a complex operation like multiply is slower than the corresponding hardware implementation. Consequently, as advances in IC technology lowered the cost of hardware circuits, instruction sets tended to increase in size and complexity. By the mid-1980s, many microprocessors had instructions of several hundred different types, characterized by diverse formats, memory addressing modes, and execution times. The heterogeneous instruction sets of these complex instruction set computers (CISCs) have some disadvantages. Complex instructions require more processing circuits, which tend to make CISCs large and expensive. Moreover, the decoding and execution of complex instruction can slow down the processing of simple instructions.

To address the defects of CISCs, a new class of fast computers referred to as reduced instruction set computers (RISCs) was introduced. RISCs are characterized by fast, efficient—but not necessarily small—instruction sets. The following features are common to most RISCs: (1) All instructions are of fixed length and have just a few opcode formats and addressing modes. (2) The only instructions that address memory are load and store instructions; all other instructions require their operands to be placed in CPU registers. (3) The fetching and processing of most instructions is overlapped in pipelined fashion. [J.P.Hay.]

**Digital control** The use of digital or discrete technology to maintain conditions in operating systems as close as possible to desired values despite changes in the operating environment. Traditionally, control systems have utilized analog components, that is, controllers which generate time-continuous outputs (volts, pressure, and so forth) to manipulate process inputs and which operate on continuous signals from instrumentation measuring process variables (position, temperature, and so forth). In the 1970s, the use of discrete or logical control elements, such as fluidic components, and the use of programmable logic controllers to automate machining, manufacturing, and production facilities became widespread. In parallel with these developments has been the accelerating use of digital computers in industrial and commercial applications areas, both for logic-level control and for replacing analog control systems. The development of inexpensive mini- and microcomput-

ers with arithmetic and logical capability orders of magnitude beyond that obtainable with analog and discrete digital control elements has resulted in the rapid substitution of conventional control systems by digital computer-based ones. With the introduction of microcomputer-based control systems into major consumer products areas (such as automobiles and video and audio electronics), it is clear that the digital computer will be widely used to control objects ranging from small, personal appliances and games up to large, commercial manufacturing and production facilities. See MICROCOMPUTER; PROGRAMMABLE CONTROLLERS.

The object that is controlled is usually called a device or, more inclusively, process. A characteristic of any digital control system is the need for a process interface to mate the digital computer and process, to permit them to pass information back and forth.

Measurements of the state of the process often are obtained naturally as one of two switch states; for example, a part to be machined is in position (or not), or a temperature is above (or below) the desired temperature. Control signals sent to the process often are expressed as one of two states as well; for example, a motor is turned on (or off), or a valve is opened (or closed). Such binary information can be communicated naturally to and from the computer, where it is manipulated in binary form. For this reason the binary or digital computer/process interface usually is quite simple.

Process information also must be dealt with in analog form; for example, a variable such as temperature can take on any value within its measured range, or, looked at conceptually, it can be measured to any number of significant figures by a suitable instrument. Furthermore, analog variables generally change continuously in time. Digital computers are not suited to handle arbitrarily precise or continuously changing information; hence, analog process signals must be reduced to a digital representation (discretized), both in terms of magnitude and in time, to put them into a useful digital form.

The magnitude discretization problem most often is handled by transducing and scaling each measured variable to a common range, then using a single conversion device—the analog-to-digital converter (ADC)—to put the measured value into digital form. See ANALOG-TO-DIGITAL CONVERTER.

Discretization in time requires the computer to sample the signal periodically, storing the results in memory. This sequence of discrete values yields a “staircase” approximation to the original signal, on which control of the process must be based. Obviously, the accuracy of the representation can be improved by sampling more often, and many digital systems simply have incorporated traditional analog control algorithms along with rapid sampling. However, newer control techniques make fundamental use of the discrete nature of computer input and output signals. Analog outputs from a computer most often are obtained from a digital-to-analog converter (DAC), a device which accepts a digital output from the computer, converts it to a voltage in several microseconds, and latches (holds) the value until the next output is converted. Usually a single DAC is used for each output signal. See DIGITAL-TO-ANALOG CONVERTER.

In order to be used as the heart of a control system, a digital computer must be capable of operating in real time. Except for very simple microcomputer applications, this feature implies that the machine must be capable of handling interrupts, that is, inputs to the computer’s internal control unit which, on change of state, cause the computer to stop executing some section of program code and begin executing some other section. The ability to initiate operations on schedule and to respond to process interrupts in a timely fashion is the very basis of real-time computing; this feature must be available in any digital control system.

Computer control systems for large or complex processes may involve complicated programs with many thousands of computer instructions. Several routes have been taken to mitigate the difficulty of programming control computers. One approach



is to develop a single program which utilizes data supplied by the user to specify both the actions to be performed on the individual process elements and the schedule to be followed. Another approach is to develop a rather sophisticated operating system to supervise the execution of user programs, scheduling individual program elements for execution as specified by the user or needed by the process. See DIGITAL COMPUTER.

Many applications, particularly machining, manufacturing, and batch processing, involve large or complex operating schedules. Invariably, these can be broken down into simple logical sequences. Some applications—in the chemical process industries, in power generation, and in aerospace areas—require the use of traditional automatic control algorithms.

Attempts to expand the digital control medium through development of strictly digital control algorithms is an important and continuing trend. Such algorithms typically attempt to exploit the sampled nature of process inputs and outputs, significantly decreasing the sampling requirements of the algorithm. See CONTROL SYSTEMS. [D.A.Me.]

**Digital counter** An instrument which, in its simplest form, provides an output that corresponds to the number of pulses applied to its input. Counters may be categorized into two types: the Moore machine or the Mealy machine. The simpler counter type, the Moore machine, has a single count input (also called the clock input or pulse input), while the Mealy machine has additional inputs that alter the count sequence. Digital counters take many forms, including geared mechanisms (tape counters and odometers are examples), relays (old pinball machines and old telephone switching systems), vacuum tubes (old test equipment), and solid-state semiconductor circuits (most modern electronic counters).

Most digital counters operate in the binary number system, since binary is easily implemented with electronic circuitry. Binary allows any integer (whole number) to be represented as a series of binary digits, or bits, where each bit is either a 0 or 1 (off or on, low or high, and so forth).

Digital counters are found in much modern electronic equipment, especially equipment that is digitally controlled or has digital numeric displays. A frequency counter, as a test instrument or a channel frequency display on a radio tuner, consists simply of a string of decade counters that count the pulses of an input signal for a known period of time, and display that count on a seven-segment display. A digital voltmeter operates by using nearly the same idea, except that the counter counts a known frequency for a period of time proportional to the input voltage. See ANALOG-TO-DIGITAL CONVERTER.

A digital watch contains numerous counter/dividers in its large-scale integration (LSI) chip, usually implemented with complementary metal oxide semiconductor (CMOS) technology.

Digital computers may contain counters in the form of programmable interval timers that count an integral number of clock pulses of known period, and then generate an output at the end of the count to signal that the time period has expired. Most of the counters in a microprocessor consist of arithmetic logic units that add one many-bit number to another, storing the results in a memory location. The program and data counters are examples of this kind of counter. See DIGITAL COMPUTER; MICROPROCESSOR.

Counters have progressed from relays to light-wavelength-geometry very-large-scale-integrated circuits. There are several technologies for building individual digital counters. Single counters are available as integrated circuit chips in emitter-coupled logic, transistor-transistor logic, and CMOS. [M.E.W.]

**Digital filter** Any digital computing means that accepts as its input a set of one or more digital signals from which it generates as its output a second set of digital signals. While being strictly correct, this definition is too broad to be of any practical

use, but it does demonstrate the possible extent of application of digital-filter concepts and terminology.

**Capabilities.** Digital filters can be used in any signal-manipulating application where analog or continuous filters can be used. Because of their utterly predictable performance, they can be used in exacting applications where analog filters fail because of time- or other parameter-dependent coefficient drift in continuous systems. Because of the ease and precision of setting the filter coefficients, adaptive and learning digital filters are comparatively simple and particularly effective to implement. As digital technology becomes more ubiquitous, digital filters are increasingly acknowledged as the most versatile and cost-effective solutions to filtering problems.

The number of functions that can be performed by a digital filter far exceeds that which can be performed by an analog, or continuous, filter. By controlling the accuracy of the calculations within the filter (that is, the arithmetic word length), it is possible to produce filters whose performance comes arbitrarily close to the performance expected of the perfect models. For example, theoretical designs that require perfect cancellation can be implemented with great fidelity by digital filters.

**Linear difference equation.** The digital filter accepts as its input signals numerical values called input samples and produces as its output signal numerical values called output samples. Each output sample at any particular sampling instant is a weighted sum of present and past input samples, and past output samples. If the sequence of input samples is  $x_n, x_{n+1}, x_{n+2}, \dots$ , then the corresponding sequence of output samples would be  $y_n, y_{n+1}, y_{n+2}, \dots$ . See DIFFERENCE EQUATION.

From this simple time-domain expression, a considerable number of definitions can be constructed. If the filter coefficients (the  $a$ 's and the  $b$ 's) are independent of the  $x$ 's and  $y$ 's, this digital filter is a linear filter. If the  $a$ 's and  $b$ 's are fixed, this is a linear time-invariant (LTI) filter. The order of the filter is given by the largest of the subscripts among the  $a$ 's and  $b$ 's, that is, the larger of  $M$  and  $N$ . If the  $b$ 's are all zero (that is, if the output is the weighted sum of present and past input samples only), the digital filter is referred to as a nonrecursive (having no feedback) or finite impulse response (FIR) filter because the response of the filter to an impulse (actually a unit pulse) input is simply the sequence of the " $a$ " coefficients. If any value of  $b$  is nonzero, the filter is recursive (having feedback) and is generally an infinite impulse response (IIR) filter.

If the digital filter under consideration is not a linear, time-invariant filter, the transfer function cannot be used.

**Transfer functions.** Although the time-domain difference equation is a useful description of a filter, as in the continuous-domain filter case, a powerful alternative form is the transfer function. The information content of the transfer function is the same as that of the difference equation as long as a linear, time-invariant system is under consideration. A difference equation is converted to transfer-function form by use of the  $z$  transform. The  $z$  transform is simply the Laplace transform adapted for sampled systems with some shorthand notation introduced. See LAPLACE TRANSFORM; Z TRANSFORM.

**Adaptive filters.** So far only LTI filters have been discussed. An important class of variable-parameter filter change their coefficients to minimize an error criterion. These filters are called adaptive because they adapt their parameters in response to changes in the operating environment. An example is an FIR digital filter whose coefficients are continually adjusted so that the output will track a reference signal with minimum error. The performance criterion will be the minimization of some function of the error. See ELECTRIC FILTER. [S.A.Wh.]

**Digital-to-analog converter** A device for converting information in the form of combinations of discrete (usually binary) states or a signal to information in the form of the value or magnitude of some characteristics of a signal, in relation to a standard or reference. Most often, it is a device which has

electrical inputs representing a parallel binary number, and an output in the form of voltage or current.

Digital-to-analog (D/A) converters (sometimes called DACs) are used to present the results of digital computation, storage, or transmission, typically for graphical display or for the control of devices that operate with continuously varying quantities. D/A converter circuits are also used in the design of analog-to-digital converters that employ feedback techniques, such as successive-approximation and counter-comparator types. In such applications, the D/A converter may not necessarily appear as a separately identifiable entity.

The fundamental circuit of most D/A converters involves a voltage or current reference; a resistive "ladder network" that derives weighted currents or voltages, usually as discrete fractions of the reference; and a set of switches, operated by the digital input, that determines which currents or voltages will be summed to constitute the output.

The output of the D/A converter is proportional to the product of the digital input value and the reference. In many applications, the reference is fixed, and the output bears a fixed proportion to the digital input. In other applications, the reference, as well as the digital input, can vary; a D/A converter that is used in these applications is thus called a multiplying D/A converter. It is principally used for imparting a digitally controlled scale factor, or "gain," to an analog input signal applied at the reference terminal. See AMPLIFIER; ANALOG COMPUTER.

Except for the highest resolutions (beyond 18 bits), commercially available D/A converters are generally manufactured in the form of integrated circuits, using bipolar, MOS, and hybrid technologies. A single chip may include just the resistor network and switches; it may also include a reference circuit, output amplifier, and one or more sets of registers (with control logic suitable for direct microprocessor interfacing). See INTEGRATED CIRCUITS. [D.H.S.]

**Digitalis** A genus of the figwort family (Scrophulariaceae) ranging from the Canary Islands to central Asia. Foxglove (*Digitalis purpurea*), a native of western Europe, is the source of the important drug digitalis, much used in the treatment of heart disorders. The active ingredient, digitalin, slows and regulates the heartbeat, improving the tone and rhythm, and making the contractions more effective. See SCROPHULARIALES. [P.D.St./E.LC.]

**Dill** An annual culinary herb of the carrot family, Apiaceae (Umbelliferae). It supplies four products: dill seed oil, dill leaf oil, dill seed, and dill leaf. Although all of the dill grown in the United States is one species, *Anethum graveolens*, a slightly different species, *A. sowa*, is grown in Asia. In the United States, two cultivars are grown, Mammoth and Bouquet. Other varieties exist, such as those developed in India and Russia, but are not extensively grown here. Dill can be grown in most soil types in all areas of the United States, but most of the production is centered in Oregon, Washington, Florida, and California.

Most of the production of dill seed oil is for use in the pickle industry for flavoring dill pickles. Dill leaf oil is little used, and relatively little dill is grown for this purpose. Dill seed is used as a spice, and large quantities of it are imported into the United States. India is the primary producer of dill seed for culinary use. See APIALES; FAT AND OIL (FOOD). [S.Kir.]

**Dilleniales** An order of flowering plants, division Magnoliophyta (Angiospermae), subclass Dilleniidae, class Magnoliopsida (dicotyledons). It consists of two families: the Dilleniaceae, with about 350 species; and the Paeoniaceae, with a single genus of some 30 species. Within its subclass the order is marked by separate carpels; numerous stamens; bitegmic (having two integuments), crassinucellate (having a nucellus that is more than one cell thick) ovules; and seeds that have a well-developed endosperm and are provided with an aril (a partial or complete covering or appendage,



The garden peony (*Paeonia lactiflora*), of the family Paeoniaceae. (F. E. Westlake, National Audubon Society)

usually derived from the funiculus of the ovule). The garden peony (*Paeonia lactiflora*) is a familiar member of the order (see illustration). See DILLENIIDAE; MAGNOLIOPHYTA. [A.Cr.; T.M.Ba.]

**Dilleniidae** A large subclass of the class Magnoliopsida (dicotyledons) of the division Magnoliophyta (Angiospermae), the flowering plants, consisting of 13 orders, 78 families, and nearly 25,000 species. The subclass is morphologically ill-defined, but most of the orders and species have the carpels united to form a compound pistil. The petals are either separate or joined into a sympetalous corolla. The stamens, when numerous, are initiated in centrifugal sequence. Many of the species have numerous ovules on parietal placentas; that is, the placentas are borne along the walls of an ovary which is usually with a single chamber.

The largest orders included in the subclass are the Violales, Capparales, Malvales, Theales, and Ericales. Other orders include the Dilleniales, Lecythidales, Nepenthales, Salicales, Diapensiales, Ebenales, Primulales, and Batales. See separate articles on each order. See MAGNOLIOPHYTA. [A.Cr.; T.M.Ba.]

**Dimensional analysis** A technique that involves the study of dimensions of physical quantities. Dimensional analysis is used primarily as a tool for obtaining information about physical systems too complicated for full mathematical solutions to be feasible. It enables one to predict the behavior of large systems from a study of small-scale models. It affords a convenient means of checking mathematical equations. Finally, dimensional formulas provide a useful cataloging system for physical quantities.

All the commonly used systems of units in physical science have the property that the number representing the magnitude of any quantity (other than purely numerical ratios) varies inversely with the size of the unit chosen. Thus, if the length of a given piece of land is 300 ft, its length in yards is 100. The ratio of the magnitude of 1 yd to the magnitude of 1 ft is the same as that of any length in feet to the same length in yards, that is, 3. The ratio of two different lengths measured in yards is the same as the ratio of the same two lengths measured in feet, inches, miles, or any other length units. This universal property of unit systems, often known as the absolute significance of relative magnitude,

determines the structure of all dimensional formulas. See UNITS OF MEASUREMENT.

In defining a system of units for a branch of science such as mechanics or electricity, certain quantities are chosen as fundamental and others as secondary, or derived. The choice of the fundamental units is always arbitrary and is usually made on the basis of convenience in maintaining standards. In mechanics the fundamental units most often chosen are mass, length, and time.

It can be proved that every secondary quantity which satisfies the condition of the absolute significance of relative magnitude is expressible as a product of powers of the primary quantities. Such an expression is known as the dimensional formula of the secondary quantity. There is no requirement that the exponents be integral.

The technique of dimensional analysis has several important applications. It is intuitively obvious that only terms whose dimensions are the same can be equated. The equation  $10 \text{ kg} = 10 \text{ m/s}$ , for example, makes no sense. A necessary condition for the correctness of any equation is that the two sides have the same dimensions. This is often a help in the verification of complicated analytic expressions. Of course, an equation can be correct dimensionally and still be wrong by a purely numerical factor.

The application of dimensional analysis to the derivation of unknown relations depends upon the concept of completeness of equations. An expression which remains formally true no matter how the sizes of the fundamental units are changed is said to be complete. Assume a group of  $n$  physical quantities  $x_1, x_2, \dots, x_n$ , for which there exists one and only one complete mathematical expression connecting them, namely,  $\phi(x_1, x_2, \dots, x_n) = 0$ . Some of the quantities  $x_1, x_2, \dots, x_n$  may be dimensional constants. Assume further that the dimensional formulas of the  $n$  quantities are expressed in terms of  $m$  fundamental quantities  $\alpha, \beta, \gamma, \dots$ . Then it will always be found that this single relation  $\phi$  can be expressed in terms of some arbitrary function  $F$  of  $n - m$  independent dimensionless products  $\pi_1, \pi_2, \dots, \pi_{n-m}$ , made up from among the  $n$  variables, as in the equation below.

$$F(\pi_1, \pi_2, \dots, \pi_{n-m}) = 0$$

This is known as the  $\pi$  theorem. It was first rigorously proved by E. Buckingham. The main usefulness of the  $\pi$  theorem is in the deduction of the form of unknown relations. The procedure is particularly useful in hydraulics and aeronautical engineering, where detailed solutions are often extremely complicated.

A further application of dimensional analysis is in model design. Often the behavior of large complex systems can be deduced from studies of small-scale models at a great saving in cost. In the model each parameter is reduced in the same proportion relative to its value in the original system. See MODEL THEORY.

Dimensional formulas also provide a convenient shorthand notation for representing the definitions of secondary quantities and are helpful in changing units from one system to another. [J.W.St.]

**Dimensionless groups** A dimensionless group is any combination of dimensional or dimensionless quantities possessing zero overall dimensions. Dimensionless groups are frequently encountered in engineering studies of complicated processes or as similarity criteria in model studies. A typical dimensionless group is the Reynolds number (a dynamic similarity criterion),  $N_{Re} = VD\rho/\mu$ . Since the dimensions of the quantities involved are velocity  $V$ :  $[L/\theta]$ ; characteristic dimension  $D$ :  $[L]$ ; density  $\rho$ :  $[M/L^3]$ ; and viscosity  $\mu$ :  $[M/L\theta]$  (with  $M$ ,  $L$ , and  $\theta$  as the fundamental units of mass, length, and time), the Reynolds number reduces to a dimensionless group and can be represented by a pure number in any coherent system of units. See DYNAMIC SIMILARITY.

Many important problems in applied science and engineering are too complicated to permit completely theoretical solutions to be found. However, the number of interrelated variables involved can be reduced by carrying out a dimensional analysis to group the variables as dimensionless groups. See DIMENSIONAL ANALYSIS.

The advantages of using dimensionless groups in studying complicated phenomena include:

1. A significant reduction in the number of "variables" to be investigated; that is, each dimensionless group, containing several physical variables, may be treated as a single compound "variable," thereby reducing the number of experiments needed as well as the time required to correlate and interpret the experimental data.
2. Predicting the effect of changing one of the individual variables in a process (which it may be impossible to vary much in available equipment) by determining the effect of varying the dimensionless group containing this parameter (this must be done with some caution, however).
3. Making the results independent of the scale of the system and of the system of units being used.
4. Simplifying the scaling-up or scaling-down of results obtained with models of systems by generalizing the conditions which must exist for similarity between a system and its model.
5. Deducing variation in importance of mechanisms in a process from the numerical values of the dimensionless groups involved; for instance, an increase in the Reynolds number in a flow process indicates that molecular (viscous) transfer mechanisms will be less important relative to transfer by bulk flow ("inertia" effects), since the Reynolds number is known to represent a measure of the ratio of inertia forces to viscous forces. See FROUDE NUMBER; KNUDSEN NUMBER; MACH NUMBER; REYNOLDS NUMBER. [J.Ca.; G.D.F.]

**Dimensions (mechanics)** Length, mass, time, or combinations of these quantities serving as an indication of the nature of a physical quantity. Quantities with the same dimensions can be expressed in the same units. For example, although speed can be expressed in various units such as miles/hour, feet/second, and meters/second, all these speed units involve the ratio of a length unit to a time unit; hence, the dimensions of speed are the ratio of length  $L$  to time  $T$ , usually stated as  $LT^{-1}$ . The dimensions of all mechanical quantities can be expressed in terms of  $L$ ,  $T$ , and mass  $M$ . The validity of algebraic equations involving physical quantities can be tested by a process called dimensional analysis; the terms on the two sides of any valid equation must have the same dimensions. See DIMENSIONAL ANALYSIS; UNITS OF MEASUREMENT. [D.Wi.]

**Dimethyl sulfoxide** A versatile solvent (formula  $C_2H_6OS$ ) abbreviated DMSO, used industrially and in chemical laboratories as a medium for carrying out chemical reactions. Its uses have been extended to that of a chemical reagent where DMSO itself is involved in a chemical change. It is the simplest member of a class of organic compounds which are typified by the polar sulfur-oxygen bond represented in the resonance hybrid shown below. The molecule is pyramidal in shape with the

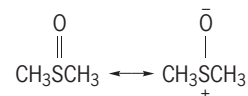

oxygen and the carbons at the corners.

DMSO is a colorless, odorless (when pure), and very hygroscopic stable liquid (bp  $189^\circ\text{C}$ , mp  $19.5^\circ\text{C}$ ). It is manufactured commercially by reacting the black liquor from digestion in the kraft pulp process, with molten sulfur to form dimethyl sulfide which is then oxidized with nitrogen tetroxide. This highly polar

aprotic solvent is water- and alcohol-miscible and will dissolve most polar organic compounds and many inorganic salts.

As an aprotic solvent, DMSO strongly solvates cations, leaving a highly reactive anion. Thus in DMSO, basicity and nucleophilicity is enhanced, and it is a superior solvent for many elimination, nucleophilic substitution, and solvolysis reactions in which nucleophile and base strength are important. Nucleophilic substitution reactions in which halogens or sulfonate esters are displaced by anions such as cyanide, alkoxide, thiocyanate, azide, and others are accelerated 1000 to 10,000 times in DMSO over the reaction in aqueous alcohol. Dimethyl sulfoxide is also superior to protic solvents as a media for elimination reactions. Its high dielectric constant makes DMSO a useful solvent for dissolving resins, polymers, and carbohydrates. It is employed commercially as a spinning solvent in the manufacture of synthetic fibers.

The apparent low toxicity and high skin permeability have led to extensive studies in numerous biological systems, including humans. Inorganic salts or small-molecular-weight organic compounds dissolved in DMSO can be transported across skin membrane, indicating a potential hazard in commercial use.

[W.W.E./F.W.Sw.]

**Dinocerata** An extinct order of large herbivorous mammals, often called uinatheres, from early Cenozoic deposits of North America and northern Asia. Members of this group have semigraviportal limbs, that is, adapted to bearing considerable weights, with hooved, five-toed feet (see illustration). A saber-like canine tooth and protective lower jaw flange are present in all forms except the aberrant *Gobiatherium*. Horns are absent or very small on the most primitive forms. Middle and late Eocene uinatheres in North America developed an imposing array of six horns. One pair was on the tips of the nasal bones, another was above the root of the saberlike canine tooth, and a third pair above the ear region.

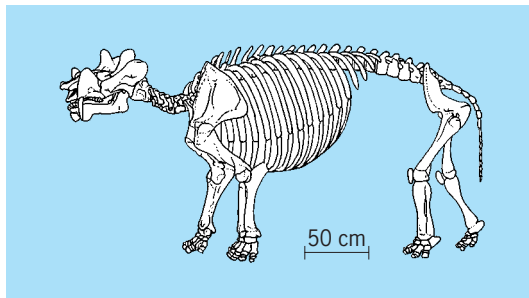

Skeleton of *Uintatherium*, a middle Eocene member of the Dinocerata.

The order Dinocerata consists of one family, the Uinatheridae, which is divided into three subfamilies: Prodinoceratinae, Uinatheriinae, and Gobiatheriinae. The Dinocerata left no descendants. They are believed to have arisen from the arctocyonid condylarths but from a different subfamily than that which gave rise to the order Pantodonta. See MAMMALIA; PANTODONTA.

[M.C.McK.]

**Dinoflagellida** An order of the class Phytomastigophorea; also known as the Dinoflagellata. Although primarily marine, some dinoflagellates occur in fresh water. Some possess brown chromatophores, some are variously colored, and others are colorless. All types of nutrition exist, and some species are parasitic. Two flagella emerge laterally from a longitudinal depression or sulcus. An encircling flagellum in a groove or girdle divides the body into epicone and hypocone; the other, extending backward, propels the organism forward. The nucleus is very large.

*Ceratium hirundinella* blooms in fresh water, causing tastes and odors. Marine blooms of *Gymnodinium breve* produce the

fish-killing red tides along the Gulf Coast of the southern United States. See PHYTAMASTIGOPHOREA.

[J.B.L.]

**Dinophyceae** A large and extremely diverse class of biflagellate algae (dinoflagellates) in the chlorophyll *a-c* phyletic line (Chromophycota). In protozoological classification, these organisms constitute an order, Dinoflagellida, of the class Phytomastigophora. Many taxonomists emphasize the distinctness of dinoflagellates by placing them in a separate division (Pyrrophyta or Pyrrhophyta) or even in a separate kingdom (Mesokaryota). More than 1200 species are known, classified into 18 orders and 54 families. Most are microscopic, but a few reach a diameter of 2 mm (0.08 in.). Cell shape is highly variable, with many planktonic species having elaborately modified surfaces. Dinoflagellates occur in marine, brackish, and fresh waters, frequently producing algal blooms. They may be benthic as well as planktonic, and a few are colonial. Ameboid, palmelloid, coccoid (with or without a gelatinous sheath), and filamentous forms are also known. See DINOFLAGELLIDA.

Dinoflagellates span the spectrum of nutritional diversity. About half of the species are photosynthetic, and some of these are facultatively osmotrophic (absorbing nutrients) or phagotrophic (engulfing food). Symbiosis involving dinoflagellates is a common occurrence in marine environments. The phenomenon is most important in coral reefs, where up to half of the carbonate in calcified structures is derived by way of photosynthesis carried out by endosymbiotic dinoflagellates.

Several dinoflagellates contain substances that are toxic to other organisms. Blooms of some of these dinoflagellates cause "red tides" that are lethal to fishes or invertebrates. See ALGAE.

[P.C.Si.; R.L.Moe]

**Dinosaur** The term Dinosauria (Greek, "terrible lizards") was coined by the British comparative anatomist Richard Owen in 1842 to represent three partly known, impressively large fossil reptiles from the English countryside: the carnivore *Megalosaurus*, the duckbilled *Iguanodon*, and the armored *Hylaeosaurus*.

As dinosaurs became better known, their taxonomy and classification developed, as well as their diversity. In 1888 H. G. Seeley recognized two quite different hip structures in dinosaurs and grouped them accordingly. Saurischia, including the carnivorous Theropoda and the giant, long-necked Sauropoda, retained the generalized reptilian hip structure in which the pubis points down and forward and the ischium points down and backward. The remaining dinosaurs have a pubis that also points down and backward, and lies parallel to the ischium; this reminded Seeley of the configuration in birds, and so he named this group Ornithischia. However, the ornithischian pubis is only superficially similar to that of birds, which are descended from, and are thus formally grouped in, Saurischia. Seeley's discovery, in fact, only recognized the distinctness of Ornithischia, but he concluded that Saurischia and Ornithischia were not particularly closely related. Even within Saurischia, there were general doubts that Sauropoda and Theropoda had any close relationship. In 1974 it was argued that there were a great many unique features, including warm-bloodedness, that diagnosed the dinosaurs as a natural group, including their descendants the birds. A 1986 analysis listed nine uniquely derived features of the skull, shoulder, hand, hip, and hindlimb that unite Dinosauria as a natural group; this analysis has been since modified and improved, and today Dinosauria is universally accepted as a natural group, divided into Ornithischia and Saurischia. See ORNITHISCHIA; SAURISCHIA.

Dinosaurs are archosaurs, a group that includes crocodiles, birds, and all the descendants of their most recent common ancestor. The closest relatives of dinosaurs, which evolved with them in the Middle and Late Triassic (about 225 million years ago), include the flying pterosaurs and agile, rabbit-sized forms such as *Lagosuchus* and *Lagerpeton*. The common ancestor of all these forms was small, lightly built, bipedal, and probably

an active carnivore or omnivore. Somewhat larger, with skulls ranging 15–30 cm (6–12 in.) in length, were *Eoraptor* and *Herrerasaurus* from the Late Triassic of Argentina, and *Staurikosaurus* from the early Late Triassic of Brazil. They were thought to be primitive saurischian dinosaurs, but it was later determined that they were outside the group formed by Saurischia plus Ornithischia, a view generally followed. In reconsidering these genera plus the more recently discovered *Eoraptor*, it has been argued that all three are both saurischians and theropods. However, they lack some features of both groups, so their position remains controversial. This testifies to a burst of evolutionary change at this very interesting time in vertebrate history, and it shows that there are a variety of taxa that are very close to the origin of dinosaurs. The first definite ornithischians and saurischians appear at almost the same time as these taxa, though dinosaurs remained generally rare and not very diverse components of terrestrial faunas until the beginning of the Jurassic Period (about 200 million years ago). See JURASSIC; TRIASSIC.

An area of great interest is how the dinosaurs and their closest relatives differ from their contemporaries. Their posture and gait hold some important clues. Like pterosaurs, *Lagosuchus*, *Lagerpeton*, and their other close relatives, the first dinosaurs stood upright on their back legs. The head of the thigh bone angled sharply inward to the hip socket, which was slightly perforated. The femur moved like a bird's, in a nearly horizontal plane; the shin bone (tibia) swung back and forth in a wide arc, and the fibula (the normally straplike bone alongside the tibia) was reduced because the lower leg did not rotate about the knee, like a crocodile's or lizard's does. The ankle, too, had limited mobility: it formed a hinge joint connecting the leg to long metatarsals (sole bones), which were raised off the ground. All these features can be seen today in birds, the living descendants of Mesozoic dinosaurs. Because the first dinosaurs were bipedal, their hands were free for grasping prey and other items, and the long fingers bore sharp, curved claws. The neck was long and S-shaped, the eyes large, and the bones lightly built and relatively thin-walled. And all dinosaurs, even the Jurassic giants, walked on their toes.

**Ornithischia.** Ornithischians (Fig. 1) are a well-defined group diagnosed by several unique evolutionary features; the entire group was analyzed cladistically in 1986, and a phylogeny was described that has been the basis of all later work. Ornithischians have a predentary bone, a toothless, beaklike addition to the front of the lower jaw that, like the front of the upper jaw, probably had a horny covering in life. This appears to have been an adaptation for plant eating. Even the earliest ornithischians lacked at least a pair of their front teeth, and some later members lost all of them. The jaw joint was set below the occlusal plane, nutcrackerlike, an arrangement interpreted as serving for increased leverage and for crushing plant material. The teeth were set in from the side of the jaw, suggesting the presence

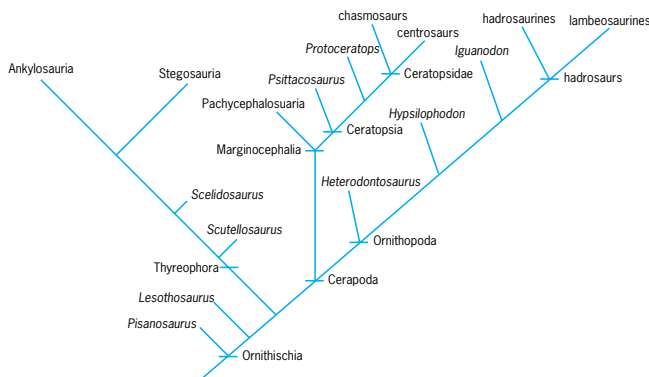

Fig. 1. Relationships of the ornithischian dinosaurs. (After P. C. Sereno, *Phylogeny of the bird-hipped dinosaurs (Order Ornithischia)*, *Nat. Geogr. Soc. Res.*, 2:234–256, 1986)

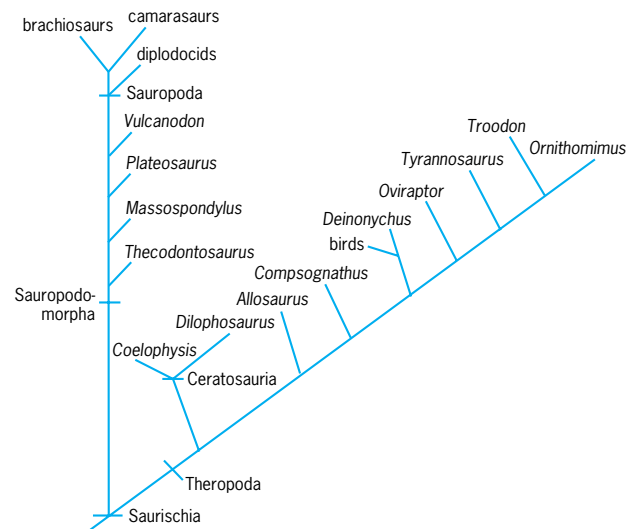

Fig. 2. Relationships of the saurischian dinosaurs. (After J. A. Gauthier, *Saurischian monophyly and a new class of vertebrates*, *Mem. Calif. Acad. Sci.*, 8:1–55, 1986; and T. R. Holtz, Jr., *The phylogenetic position of the Tyrannoidea*, *J. Paleont.*, 78:1100–1117, 1994)

of fleshy cheeks to help sustain chewing. The cheek teeth were broad, closely set, and leaf-shaped, and were often ground down to a shearing surface. In the hip, the pubis pointed backward. In all but the most generalized ornithischians, a new prong on the pubis was developed from the hip socket, upward, forward, and outward. This may have provided a framework to support the guts or to anchor the hindlimb muscles.

The most generalized ornithischians known are the fragmentary *Pisanosaurus* from the Late Triassic of Argentina and the small *Lesothosaurus* from the Early Jurassic of South Africa. In the major ornithischian radiation, Thyreophora branch off first, and Cerapoda are divided into Ornithopoda and Marginocephalia. All known ornithischians are herbivores.

**Saurischia.** Saurischia (Fig. 2) includes Sauropodomorpha and Theropoda. For many years it was doubted that Saurischia formed a natural group because its two subgroups are so different, but in 1986 Jacques Gauthier demonstrated its validity cladistically. Uniquely derived features of Saurischia include the long neck vertebrae; the long asymmetrical hand in which the second digit is the longest; the slightly offset thumb with its short basal metacarpal, robust form, and large claw; and several other features of the skull and vertebrae. Unlike ornithischians, saurischians are fairly well represented in Late Triassic faunas as well as in the later Mesozoic. See MESOZOIC.

**Paleobiology.** Dinosaurs laid eggs, and many nests have been found, but matching nests and eggs to their makers is difficult unless embryos are preserved. It appears that the young stayed around the nest and were fed by the parents until their bones fully calcified and they could fend for themselves. It is not clear how widespread either of these behaviors (or others) was among dinosaurs, but birds (living dinosaurs) are known for their extended parental care, and crocodiles, their closest living relatives, also care for their young, so it may be a general behavior among archosaurs.

If their bones are any indication, dinosaurs grew rapidly. Microscopic studies of their long bones show that the tissue was as well vascularized as in birds and mammals and that it was rapidly replaced. The texture of the bone is predominantly fibrolamellar, as in birds and mammals, and juvenile bone also shows a highly woven pattern reflecting rapid growth.

Footprints provide strong evidence that many kinds of dinosaurs traveled in groups, at least occasionally, and this is supported by records of mass burials. Whether traveling in family

groups or (at least occasionally) in large herds, all dinosaurs of any appreciable size would have had to migrate to exploit food sources successfully, if only in a local area. Annual migrations may have followed seasonal patterns of weather and vegetation.

A general picture of dinosaurian social behavior—no doubt highly variable among groups—is drawn from inferences about mass remains of trackways and bones, parental care, and the great variety of skeletal features conspicuously related to intraspecific interactions. The diversity of horns, crests, domes, knobs, and frills in many dinosaur groups contrasts starkly with the relative uniformity of their postcranial skeletons. Communicating, recognizing members of the same species, attracting mates, and repelling rivals, as well as delivering similar signals to members of different species, are all behavioral functions of such structures in living animals.

Dinosaurs evolved from within Reptilia, but they are as unlike living reptiles as bats and whales are unlike horses among living mammals (and they may have been just as diverse metabolically). The physiology of extinct animals can be assessed only indirectly. The evolution of thermal strategies in dinosaurs was probably mosaic, depending on the adaptations of individual groups, and should not be considered an all-or-nothing proposition of hot-bloodedness. Many lines of evidence suggest that Mesozoic dinosaurs were similar in behavior and activity to mammals and birds; no evidence seems to ally them physiologically to crocodiles and lizards. But dinosaurs should be taken on their own terms, not shoehorned into models of reptile or mammal physiology based on available living analogs.

For 160 million years during the Mesozoic Era, dinosaurs are represented by some 550 named genera and 800 named species, of which perhaps around 300 are valid, and nearly half of which are based on single (often partial) specimens. Through time, dinosaurian diversity increased, but the difference between preserved diversity and some estimates of projected diversity is traced in part to varying availability of the rock record, plus differential exploration. Known diversity ranged from about five genera in the Norian (Late Triassic) to over 75 in the Maastrichtian (latest Cretaceous). Evolution in dinosaurs was rapid: few dinosaurian genera survive more than the temporal span of a typical geologic formation (a few million years), and close relatives are often observed in succeeding formations. At the beginning of the Age of Dinosaurs, the continents were just beginning to drift apart. Dinosaurs are known from every continent and are often used to establish land connections, such as between North America and Asia in the Late Cretaceous, or the isolation of South America during much of the Cretaceous.

Many causes have been proposed for dinosaur extinction at the end of the Mesozoic Era, but most (for example, reproductive sterility, plant toxin poisoning, cataracts, supernova explosion, glaciation) have no supporting evidence. The apparent sudden decline of dinosaurs is surprising in view of their long dominance. In the last few million years of the Cretaceous, known dinosaur diversity, based mainly on excellent exposures from the United States Western Interior, declined precipitously until, in the meters of sediment just below the Cretaceous-Tertiary boundary, only *Triceratops* and *Tyrannosaurus* survive. An explanation is needed for this drop in diversity. In 1980, it was proposed that a giant asteroid had struck the Earth at the end of the Cretaceous, causing widespread marine and terrestrial extinctions. As valid as the proposal of a giant asteroid impact now appears, some of the proposed biotic effects are clearly overdrawn. Dinosaurs were all but extinct by that time. Apparently the birds survived the impact's effects, and so did most groups of fishes, sharks, amphibians, lizards, snakes, crocodiles, and mammals. Many of these groups are notoriously sensitive to environmental disturbances. Hence any catastrophic scenarios for the terrestrial biota at the end of the Mesozoic must account both for the latest Cretaceous decline in dinosaurian diversity and the survival

of any proposed environmental catastrophes by other terrestrial animals and plants. See AVES; EXTINCTION (BIOLOGY); REPTILIA. [K.P.]

**Diode** A two-terminal electron device exhibiting a nonlinear current-voltage characteristic. Although diodes are usually classified with respect to the physical phenomena that give rise to their useful properties, in this article they are more conveniently classified according to the functions of the circuits in which they are used. This classification includes rectifier diodes, negative-resistance diodes, constant-voltage diodes, light-sensitive diodes, light-emitting diodes, and capacitor diodes.

A circuit element is said to rectify if voltage increments of equal magnitude but opposite sign applied to the element produce unequal current increments. An ideal rectifier diode is one that conducts fully in one direction (forward) and not at all in the opposite direction (reverse). This property is approximated in junction and thermionic diodes. Processes that make use of rectifier diodes include power rectification, detection, modulation, and switching. See RECTIFIER.

Negative-resistance diodes, which include tunnel and Gunn diodes, are used as the basis of pulse generators, bistable counting and storage circuits, and oscillators. See NEGATIVE-RESISTANCE CIRCUITS; OSCILLATOR; TUNNEL DIODE.

Breakdown-diode current increases very rapidly with voltage above the breakdown voltage; that is, the voltage is nearly independent of the current. In series with resistance to limit the current to a nondestructive value, breakdown diodes can therefore be used as a means of obtaining a nearly constant reference voltage or of maintaining a constant potential difference between two circuit points, such as the emitter and the base of a transistor. Breakdown diodes (or reverse-biased ordinary junction diodes) can be used between two circuit points in order to limit alternating-voltage amplitude or to clip voltage peaks. See LIMITER CIRCUIT.

Light-sensitive diodes, which include phototubes, photovoltaic cells, photodiodes, and photoconductive cells, are used in the measurement of illumination, in the control of lights or other electrical devices by incident light, and in the conversion of radiant energy into electrical energy. Light-emitting diodes (LEDs) are used in the display of letters, numbers, and other symbols in calculators, watches, clocks, and other electronic units. See LIGHT-EMITTING DIODE; PHOTOCONDUCTIVE CELL; PHOTODIODE; PHOTOELECTRIC DEVICES; PHOTOTUBE; PHOTOVOLTAIC EFFECT.

Semiconductor diodes designed to have strongly voltage-dependent shunt capacitance between the terminals are called varactors. The applications of varactors include the tuning and the frequency stabilization of radio-frequency oscillators. See JUNCTION DIODE; MICROWAVE SOLID-STATE DEVICES; SEMICONDUCTOR DIODE; VARACTOR. [H.J.R.]

**Diopside** The monoclinic pyroxene mineral which in pure form has the formula  $\text{CaMgSi}_2\text{O}_6$ . Pure diopside melts congruently at  $1391^\circ\text{C}$  ( $2536^\circ\text{F}$ ) at atmospheric pressure. Diopside has no known polymorphs. Its structure consists of chains of  $\text{SiO}_4$  tetrahedrons in which each silicon ion shares an oxygen with each of its two nearest silicon neighbors. These chains are linked together by Ca and Mg ions in octahedral coordination.

Diopside forms gray to white, short, stubby, prismatic, often equidimensional, crystals. Small amounts of iron impart a greenish color to the mineral. Pure diopside is common and occurs as a metamorphic alteration of impure dolomites in medium and high grades of metamorphism.

Natural diopsidic pyroxenes which show extensive solid solution with jadeite and to a lesser extent with aegirite are called omphacite. Omphacite is a principal constituent of eclogites, rocks of basaltic composition which have formed at high pressure. See DOLOMITE; ECLOGITE; PYROXENE. [F.R.B.]

**Dioptr** A measure of the power of a lens or a prism. The diopter (also called dioptrie) is usually abbreviated D. Its dimension is a reciprocal length, and its unit is the reciprocal of 1 m (3.28 ft). See FOCAL LENGTH; LENS (OPTICS).

The dioptric power of a prism is defined as the measure of the deviation of a ray going through a prism measured at the distance of 1 m. A prism that deviates a ray by 1 cm in a distance of 1 m is said to have a power of one prism diopter. See OPTICAL PRISM.

Spectacle lenses in general consist of thin lenses, which are either spherical, to correct the focus of the eye for near and far distances, or cylindrical or toric, to correct the astigmatism of the eye. An added prism corrects a deviation of the visual axis. The diopter thus gives a simple method for prescribing the necessary spectacle for the human eye. [M.J.H.]

**Diorite** A phaneritic (visibly crystallized) plutonic rock having intermediate SiO<sub>2</sub> content (53–66%), composed mainly of plagioclase (oligoclase or andesine) and one or more ferromagnesian minerals (hornblende, biotite, or pyroxene), and having a granular texture. Diorite is the plutonic equivalent of andesite (a volcanic rock). This dark gray rock is used occasionally as a building stone and is known commercially as black granite. See IGNEOUS ROCKS.

Gray or white plagioclase feldspar is the dominant mineral. Rocks with more calcic plagioclases and more abundant ferromagnesian minerals are gabbros. Rocks with greater proportions of alkali feldspar are called monzonite. Those with more quartz are called quartz-diorite or tonalite.

The texture of diorites is notably variable. Most often diorites are equigranular, with coarse, partly or mostly anhedral plagioclase and hornblende crystals, subordinate biotite, and interstitial quartz and orthoclase.

Diorite is found as isolated small bodies such as dikes, sills, and stocks, but it is also found in association with other plutonic rocks in batholithic bodies. It is closely associated with convergent plate boundaries where calc-alkalic magmatism and mountain building are taking place. See MAGMA. [W.I.R.]

**Dioscoreales** A widespread order of lilioid monocotyledons composed of four or five families, the most important of which is Dioscoreaceae (650 species). These families contain some of the most peculiar plants among the monocots. Two families, Thismiaceae and Burmanniaceae (with 35 and 140 species, respectively), are largely composed of nonphotosynthetic herbaceous species that parasitize fungi, whereas other members, such as the bat plant (*Tacca*, Taccaceae) and the yams (*Dioscorea*) have net-veined leaves similar to dicots. Most of the 600 species of *Dioscorea* are vines, and all contain diosgenin, a precursor of progesterone and cortisone, leading to their being commercially collected in some parts of the world. See MAGNOLIOPHYTA. [M.W.C.]

**Diphtheria** An acute infectious disease of humans caused by *Corynebacterium diphtheriae*. Classically, the disease is characterized by low-grade fever, sore throat, and a pseudomembrane covering the tonsils and pharynx. Complications such as inflammation of the heart, paralysis, and even death may occur due to exotoxins elaborated by toxigenic strains of the bacteria. The upper respiratory tract is the most common portal of entry for *C. diphtheriae*. It can also invade the skin and, more rarely, the genitalia, eye, or middle ear. The disease has an insidious onset after a usual incubation period of 2–5 days.

The only specific therapy is diphtheria antitoxin, administered in doses proportional to the severity of the disease. Antitoxin is produced by hyperimmunizing horses with diphtheria toxoid and toxin. It is effective only if administered prior to the binding of circulating toxin to target cells. Antibiotics do not alter the course, the incidence of complications, or the outcome of diphtheria, but are used to eliminate the organism from the patient.

Persons with protective antitoxin titers may become infected with diphtheria but do not develop severe disease. Since the 1920s, active immunization with diphtheria toxoid has proved safe and effective in preventing diphtheria in many countries. Diphtheria toxoid is produced by incubating the toxin with formalin. Active immunization requires a primary series of four doses, usually at 2, 4, 6, and 18 months of age, followed by a booster at school entry. See IMMUNITY; MEDICAL BACTERIOLOGY; TOXIN; VACCINATION. [R.Ch.; C.V.]

**Diphylleida** An order of tapeworms of the subclass Cestoda. Species of this order belong to a single genus and live in the intestine of elasmobranch fishes. The scolex has a large muscular rostellum armed with hooks and two fused pairs of suckers; the neck is armed with T-shaped hooks. Larval stages have been found parasitizing marine mollusks and crustaceans, but the life history is not known. See CESTODA. [C.PR.]

**Diplogasterida** An order of nematodes in which the labia are seldom well developed; however, a hexaradiate symmetry is distinct. The external circle of labial sensilla may appear setose, but they are always short, never long or hair-like. The stoma may be slender and elongate, or spacious, or any gradation between. The stoma may be armed or unarmed; the armature may be movable teeth, fossors, or a pseudostylet. The corpus is always muscled and distinct from the postcorpus, which is divisible into an isthmus and glandular posterior bulb. The metacarpus is almost always valved. The female reproductive system may have one or two ovaries, and males may or may not have caudal alae; however, a gubernaculum is always present. The male tail commonly has nine pairs of caudal papillae; three are preanal and six are caudal.

There are two superfamilies: The members of Diplogasteroidea are predators, bacterial feeders, and omnivores; they are often found in association with insects or the fecal matter of herbivores. Cylirocorporoidea include both free-living forms and intestinal parasites of amphibians, reptiles, and certain mammals. See NEMATODA. [A.R.M.]

**Diplomonadida** An order of the class Zoomastigophorea, phylum Protozoa. These are small, colorless flagellates, some of which are free-living, some parasitic. The body is bilaterally symmetrical, composed of two mirror halves, each with a nucleus and a full set of kinetic organelles. There are four flagella to a side, not all of the same length.

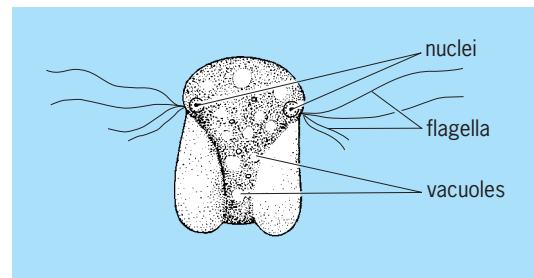

A diplomonad, *Trepomonas rotans*. (After McCracken)

*Trepomonas rotans* is probably the most common of the free-living species (see illustration), and usually occurs in water of high organic, low (or no) oxygen content, such as sewage. It occurs in ocean water also. This genus also is found as a parasite or symbiont in other animals, such as amphibians. *Hexamita* is another genus containing both free-living and parasitic representatives; *Spironucleus* is parasitic; and *Giardia* has several species which parasitize vertebrates. In humans giardiasis results in severe dysentery; however, adequate medication is available. See ZOOMASTIGOPHOREA. [J.B.L.]

**Diplopoda** A class of terrestrial, tracheate, oviparous arthropods. Diplopods (millipeds) are largely cryptic in habits, are saprophytic feeders, and are characterized by the development of a compact head with a pair of short, simple, eight-jointed antennae, and powerful mandibles. The body is not differentiated into thorax and abdomen, but is composed of a variable number of similar, cylindrical diplosomites, each of which (except the first two or three) bears two pairs of walking legs (see illustration). The body wall is chitinous, with a thick impregnation of calcium carbonate in the majority of species. Most millipeds are variously adapted for rolling into a closed spiral or nearly perfect sphere when threatened.

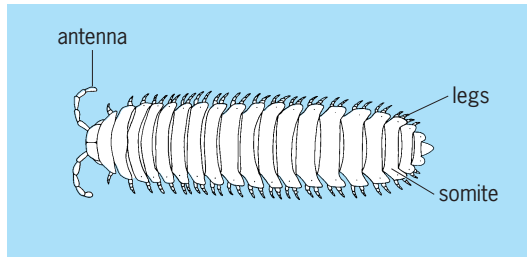

**A diplopod.** (After R. E. Snodgrass, *A Textbook of Arthropod Anatomy*, Cornell University Press, 1952)

The sexes are separate and fertilization is internal, following prolonged clasping behavior. Eggs may be laid in a cluster and "brooded" by the mother, scattered singly in the humus environment, or enclosed in an igloo-shaped mud nest built by the mother. Postembryonic development is gradual, without major changes in appearance, and may require a year or more for completion.

More than 8000 species have been described, although so far only the fauna of Europe is well known. In general, about 11 orders and more than 111 families are recognized. Probably as many as 25,000 species will eventually be recognized. Classification is based to a large extent upon shape of the male gonopods, which are quite constant and characteristic for each species.

Most species are local in distribution, because millipeds generally remain close to the parental habitat, and some may be restricted to a few square miles. Even genera are limited in distribution, and only a few occur on more than one continent.

The diplopods have a long geological history; they arose in the Early Devonian and were well developed by the Late Pennsylvanian. See ARTHROPODA. [R.L.Ho.]

**Diplura** An order of ancestrally wingless Hexapoda comprising about 800 species and variously considered as apterygotan insects or as their independent sister group. These insects are equipped with three pairs of thoracic legs and a pair of antennae on the head. They are slender and white, but unlike typical insects they have intrinsic muscles in the antennal segments beyond the basal one. All diplurans lack eyes, and have paired mandibles and maxillae largely enclosed by fused folds of the head so that only the tips are exposed for retrieving food. The dipluran body size is usually small, under 0.4 in. (1 cm) long, but some Australian *Heterojapyx* species reach 2 in. (5 cm).

Their habitat is normally cryptic in soil, under stones, and in rotten wood, where Campodeidae feed on vegetable matter, while other families apparently are predaceous. Campodeidae are found worldwide and are common in temperate and tropical regions, while the other eight families are mainly restricted to warmer climates and are often discontinuous or local in distribution. See APTERYGOTA. [W.L.Bro.]

**Dipnoi** The lungfishes, one of the three subclasses of Osteichthyes. In comparison with Devonian lungfishes, extant species have reduced the number of median fins, changed the shape of

the tail, and decreased ossification of the braincase and other endochondral bones.

The recent family Lepidosirenidae includes five species from Africa and South America. Lepidosirenids have eellike bodies, filamentous paired fins, two lungs, tooth plates with three cutting blades, a greatly reduced skull roof, and an elongated ceratohyal important in suction feeding and respiration. Lepidosirenids are obligate air breathers, and the heart, arterial tree, and gills are highly specialized. To breathe air, the fish protrudes its snout from the water surface, gulps air into the mouth, and then forces it into the lung by closing the mouth and raising the floor of the oral cavity.

The family Ceratodontidae is represented by the single species *Neoceratodus forsteri* from Australia. They are stout-bodied with large scales, leaf-shaped paired fins, and tooth plates with flattened crushing surfaces. Adults reach more than 3 ft (1 m) in length. The diet includes plants, crustaceans, and soft-bodied invertebrates. [W.Be.]

Early dipnoans were marine; fresh-water adaptations occur in Paleozoic and most post-Paleozoic dipnoans. Burrowing habits developed independently in late Paleozoic gnathorhizids and extant lepidosirenids. Dipnoans were common worldwide from the Early Devonian to the end of the Triassic, but are rare since. They are restricted to the southern continents in the Cenozoic. See OSTEICHTHYES. [H.P.S.]

**Dipole** Any object or system that is oppositely charged at two points or poles, such as a magnet, a polar molecule, or an antenna element. The properties of a dipole are determined by its dipole moment, that is, the product of one of the charges by their separation directed along an axis through the centers of charge. See DIPOLE MOMENT.

An electric dipole consists of two electric charges of equal magnitude but opposite polarity, separated by a short distance (see illustration); or more generally, a localized distribution of positive and negative electricity without net charge whose mean positions of positive and negative charge do not coincide.

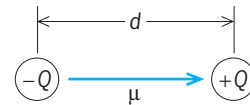

**Electric dipole with moment  $\mu = Qd$ .**

Molecular dipoles which exist in the absence of an applied field are called permanent dipoles, while those produced by the action of a field are called induced dipoles. See POLAR MOLECULE.

The term magnetic dipole originally referred to the fact that a magnet has two poles and, because of these two poles, experiences a torque in a magnetic field if its axis is not along a magnetic flux line of the field. It is now generalized to include electric circuits which, because of the current, also experience torques in magnetic fields. See MAGNET.

An electric dipole whose moment oscillates sinusoidally radiates electromagnetic waves and is known as a hertzian dipole; it is of interest in developing the theory of electromagnetic radiation. For practical purposes, a half-wave dipole, consisting of two collinear conducting rods, fed at the center, whose combined length equals half the wavelength of the radiation to be transmitted or received, is often used as an antenna element, either by itself or in an array, or as a feed for a reflector. See ANTENNA (ELECTROMAGNETISM); ELECTROMAGNETIC RADIATION; ELECTROMAGNETIC WAVE TRANSMISSION. [A.E.Ba.]

**Dipole-dipole interaction** The interaction of two atoms, molecules, or nuclei by means of their electric or magnetic dipole moments. This is the first term of the multipole-multipole series of invariants. More precisely, the interaction occurs when



one dipole is placed in the field of another dipole. The interaction energy depends on the strength and relative orientation of the two dipoles, as well as on the distance between the centers and the orientation of the radius vector connecting the centers with respect to the dipole vectors. The electric dipole-dipole interaction and magnetic dipole-dipole interaction must be distinguished.

The center of the negative charge distribution of a molecule may fail to coincide with its center of gravity, thus creating a dipole moment. An example is the water molecule. If such molecules are close together, there will be a (electric) dipole-dipole interaction between them. Atoms do not have permanent dipole moments, but a dipole moment may be induced by the presence of another atom nearby; this is called the induced dipole-dipole interaction. Induced dipole-dipole forces between atoms and molecules are known by many different names: van der Waals forces, London forces, or dispersion forces. These induced dipole-dipole forces are responsible for cohesion and surface tension in liquids. They also act between unlike molecules, resulting in the adsorption of atoms on macroscopic objects. See ADSORPTION; COHESION (PHYSICS); INTERMOLECULAR FORCES; SURFACE TENSION; VAN DER.

The magnetic dipole-dipole interaction is found both on a macroscopic and on a microscopic scale. Two compass needles within reasonable proximity of each other illustrate clearly the influence of the dipole-dipole interaction. In quantum mechanics, the magnetic moment is partially due to a current arising from the motion of the electrons in their orbits, and partially due to the intrinsic moment of the spin. The same interaction exists between nuclear spins. Magnetic dipole-dipole forces are particularly important in low-temperature solid-state physics, the interaction between the spins of the ions in paramagnetic salts being a crucial element in the use of such salts as thermometers and as cooling substances. See ADIABATIC DEMAGNETIZATION; DIPOLE; ELECTRON; LOW-TEMPERATURE THERMOMETRY; MAGNET; MAGNETIC THERMOMETER; NUCLEAR MOMENTS. [P.H.E.M.]

**Dipole moment** A mathematical quantity characteristic of a dipole unit equal to the product of one of its charges times the vector distance separating the charges. The dipole moment  $\mu$  associated with a distribution of electric charges  $q_i$  is given by

$$\mu = \sum_i q_i \mathbf{r}_i$$

where  $\mathbf{r}_i$  is the vector to the charge  $q_i$ . For systems with a net charge (for example, positive), the origin is taken at the mean position of the positive charges (and vice versa). Dipole moments have the dimensions coulomb-meters. Molecular dipole moments were previously expressed in debye units, where 1 debye =  $3.336 \times 10^{-30}$  C · m. See DIPOLE. [R.D.W.]

**Dipsacales** An order of flowering plants (angiosperms) in the asterid I group of the eudicotyledons consisting of around 6 families and almost 1000 species. Like many asterids of the asterid II group, Dipsacales have an inferior ovary and opposite leaves. They also have fewer stamens than petals (or petal lobes), and the flowers are often bilaterally symmetric or of irregular symmetry. Family limits have changed recently as a result of deoxyribonucleic acid (DNA) sequence studies, but the species content of the order is still similar to previous systems of classification. The flowers are typically arranged in heads, similar to those of their close relatives in Asterales and Apiales, but the ovary often contains more than one seed (reduced to a single seed in Dipsacaceae and Valerianaceae). Familiar members of Dipsacales include elderberry (*Sambucus*, Adoxaceae), honeysuckle (*Lonicera*, Caprifoliaceae), and teasel (*Dipsacus*, Dipsacaceae). *Viburnum* (Adoxaceae) and *Abelia* (Linnaeaceae) are commonly planted ornamental shrubs. See ASTERALES; MAGNOLOPHYTA; PLANT KINGDOM. [M.W.C.]

**Diptera** An order of the class Insecta known as the true flies and so named because they possess only two wings. This characteristic, together with a pair of balancers or halteres, distinguishes flies from all other orders of the Insecta. The three names for members of the order, known commonly as flies, gnats, or midges, form a part of the common names of most families, genera, and species of the order. The term fly also forms a part of the compound names of the insects in many other orders, such as butterfly, mayfly, and chalcid fly, but when used alone it is correctly applied only to the members of the Diptera. The forms most commonly known as maggots are actually dipterous larvae, and keds (Hippoboscidae) are parasitic forms of flies that have lost their wings. The Diptera are the most important group of insects considered in medical entomology. Many, especially the mosquitoes, are the vectors for numerous parasites and diseases.

In number of species, it is the third largest order; only the Coleoptera and Lepidoptera are larger. There are approximately 100,000 kinds of flies in the world, of which over 18,500 inhabit America north of Mexico.

The order is ubiquitous and is more widespread than any other of the insects. Diptera are found on every continent and most islands of the world, except for the coldest parts of the Arctic and Antarctic, and at the tops of extremely high mountain ranges. They occur in almost all available ecological niches. Specimens have been taken at altitudes of many thousands of feet by specially constructed traps attached to airplanes.

**Taxonomy.** For convenience, the families of Diptera may be divided into the Nematocera and the Brachycera, and the latter group further divided into the Orthorrhapha and the Cyclorrhapha. Adults of the Nematocera are characterized by their slow flight and long antennae. These are the more primitive Diptera, and the major groups are represented in fossil deposits as old as Jurassic and Cretaceous age.

The Brachycera are generally swift fliers, and their antennae are no longer than the head. In the Orthorrhapha, the adult fly emerges from the pupa through a T-shaped anterior opening, while in the Cyclorrhapha it emerges from a circular opening at the anterior end of the puparium.

Following is a list of scientific and vernacular names of the more common families of flies.

#### Nematocera

- Trichoceridae (winter crane flies)
- Ptychopteridae (phantom crane flies)
- Tipulidae (crane flies)
- Psychodidae (moth flies and sand flies)
- Blepharoceridae (net-winged midges)
- Chironomidae (midges)
- Ceratopogonidae (biting midges)
- Simuliidae (black flies)
- Chaoboridae (phantom midges)
- Culicidae (mosquitoes)
- Dixidae (dixid midges)
- Anisopodidae (wood gnats)
- Bibionidae (march flies)
- Scatopidae (scatopsid flies)
- Mycetophilidae (fungus gnats)
- Sciaridae (black fungus gnats)
- Cecidomyiidae (gall midges)
- Brachycera—Orthorrhapha
  - Stratiomyidae (soldier flies)
  - Rhagionidae (snipe flies)
  - Tabanidae (horse flies and deer flies)
  - Bombyliidae (bee flies)
  - Asilidae (robber flies)
  - Empididae (dance flies)
  - Dolichopodidae (long-legged flies)
- Brachycera—Cyclorrhapha
  - Lonchopidae (spear-winged flies)

Phoridae (hump-backed flies)  
 Platypezidae (flat-footed flies)  
 Syrphidae (syrphid flies)  
 Pipunculidae (big-headed flies)  
 Lonchaeidae (lonchaeid flies)  
 Lauxaniidae (lauxaniid flies)  
 Drosophilidae (pomace or fruit flies)  
 Ephydriidae (shore flies)  
 Anthomyiidae (anthomyiid flies)  
 Muscidae (house flies)  
 Calliphoridae (blow flies)  
 Sarcophagidae (flesh flies)  
 Oestridae (bot flies)  
 Tachinidae (tachinid flies)  
 Hippoboscidae (louse flies)  
 Micropezidae (stilt-legged flies)  
 Diopsidae (stalk-eyed flies)  
 Sciomyzidae (marsh or snail-killing flies)  
 Sepsidae (black scavenger flies)  
 Heleomyzidae (heleomyzid flies)  
 Sphaeoceridae (small dung flies)  
 Agromyzidae (leaf-miner flies)  
 Tethinidae (tethinid flies)  
 Chloropidae (frit flies)  
 Conopidae (thick-headed flies)  
 Tephritidae (fruit flies)  
 Piophilidae (skipper flies)

**Morphology.** Adult flies vary from somewhat less than 1 mm (0.04 in.) to over 25 mm (1 in.) in body length. The head is vertical, usually with three ocelli at the dorsal vertex and the mouthparts ventral. In some cases, however, the head is distinctly longer than high when viewed laterally. The compound eyes are usually large and prominent.

The mouthparts are modified for either lapping or piercing, but never with the mandibles apposable and capable of chewing. The structure of the mouthparts varies greatly throughout the order so that their homologies are often rather difficult to determine. Throughout the Orthorrhapha there tends to be a retention of mandibles for piercing, especially in those flies that require blood meals. In the Cyclorrhapha, on the other hand, mandibles tend to be reduced or lost entirely, and with few exceptions the work of the mouthparts is largely sucking, with the maxillae and labium taking over the large share of work. Since all adult flies imbibe fluids only, the presence of a pharyngeal “pump” to transfer fluids from the external substrate to the gut is characteristic.

Each antenna typically has two basal segments and one or more additional segments called the flagellum. In the Nematocera the flagellum consists of a variable number of quite similar segments. In all remaining flies that are three distinct antennal segments. The third segment, representing the flagellum, is usually longer than the two basal ones and sometimes complex.

The prothorax and metathorax are small and closely united with the large mesothorax which contains the musculature for the single pair of wings. The legs are usually alike, except in species in which the prothoracic pair are raptorial and species in which the fore, mid, or hind legs of the males are modified by secondary sexual characters.

Only the first pair of wings, the mesothoracic pair, is developed. The second pair is reduced to a pair of club-shaped organs, or halteres, which serve as balancing organs in flight. They are present in most species, even when the mesothoracic wings are absent. In many species, especially those of the Nematocera, abundant scalelike setae clothe the veins and sometimes the margins of the wings. The wings of some of the higher Diptera bear yellow, brown, or black markings that aid in species identification.

In certain families of Diptera, some of the setae covering the

head and body are greatly enlarged and are used for identification. The location and relative size of these bristles are often characteristic of species, genera, or families.

**Life cycle.** The adult stage in the life history may be regarded as a reproductive and dispersal phase, during which these insects increase both in number and often in geographic range. Females select suitable oviposition sites and lay a variable number of eggs, after which they usually die. The eggs, after a period of incubation of varying length, give rise to larvae, which represent a growth phase. During this period, the insect does almost nothing but nourish itself, thus providing the tissues necessary for a later transformation into an adult. This growth period is divided into stages, or instars, each of which terminates with the molting of the larval skin to allow increase in size for the stage that follows. In the Diptera there are four larval instars. In most of the Orthorrhapha, especially those with aquatic immature forms, all four instars are active; but in the Cyclorrhapha, at the third larval molt, a hard puparium is formed inside which a quiescent fourth larval stage occurs. At the conclusion of the final larval instar, there is a dramatic reorganization in tissue structure initiated by the action of appropriate hormones on the so-called “imaginal buds,” a process that eventually results in the formation of an adult insect. During this time, the insect is called a pupa because its external form is now altered and any external activity virtually ceases.

When the adult tissues are almost fully formed, the fly emerges from its pupal case and spends some time in drying, hardening, and expanding its wings, attaining color, and reaching sexual maturity. It is then ready to start its cycle once again.

**Economic importance.** Diptera have probably more economic importance than any other insect order. This importance comes from the relatively few species that affect domestic animals and plants. The vast majority of forms have no direct importance although a number are beneficial in one way or another.

Only a relatively few dipteran species cause severe economic loss to humans. Perhaps of most concern is the role played by them in disease transmission. About 70 species of *Anopheles* mosquitoes transmit an estimated 500,000 cases of malaria each year. Yellow fever is transmitted principally by a single mosquito, *Aedes aegypti*. Dengue, or breakbone fever, a usually nonfatal disease of worldwide distribution that leaves its victims debilitated for several weeks, is transmitted by *Aedes aegypti* and *A. albopictus*. Filariasis, primarily a disease of peoples of Africa, the Orient, and the Pacific islands, is caused by a minute roundworm whose larvae are transmitted by a few species of *Anopheles*, *Mansonia*, *Culex*, and *Aedes*. With modern methods used by bacteriologists and virologists, a large number of virus diseases known to be transmitted by mosquitoes have been found in humans. Many of these, such as Sindbis virus of Egypt, may not produce clinical symptoms of disease, but others, such as the equine encephalitides, which include western, eastern, St. Louis, Japanese, and others, may be quickly fatal in humans. With the exception of the viruses, none of the diseases mentioned above are transmitted by any insects other than members of the order Diptera.

A few less well-known diseases are transmitted by other flies. Black flies transmit *Onchocerca volvulus*, the causative agent of onchocerciasis, a disease affecting the eyes of natives of Central and parts of South America. Sandflies of the genus *Phlebotomus* transmit organisms that cause kala azar, Oriental sore, pappataci fever, and Oroya fever. Even today large parts of Africa remain underdeveloped because of the presence of sleeping sickness, a fatal disease transmitted by tsetse flies. Species of the genus *Chrysops* (Tabanidae) are instrumental in carrying tularemia, primarily a disease of rodents.

Domestic animals, hides, meat, and dairy products are affected by disease transmission or by direct attack by flies. Anthrax, tularemia, botulism, many virus diseases, and nagana, a form of sleeping sickness, are some of the diseases transmitted by members of the Diptera that take an annual toll amounting

to millions of dollars. Some flies wreak their damage by direct attack. The primary screwworm fly deposits eggs on hides of animals, and the larvae, upon hatching, burrow through the skin and into the flesh. The secondary screwworm gains entrance through holes, often infected, already present on the skin surface. *Hypoderma lineata* and *H. bovis* are botflies of special importance. Eggs of both species are laid on hairs of cattle, and the hatching larvae bore through the skin into the connective tissue. During their development they wander through the tissues of the animal, and when mature they escape through holes which they make along the spine of their host and drop to the ground to pupate. Horses are afflicted by a species of *Gasterophilus*. They lick the eggs from their bodies, and the larvae settle and dwell in their stomachs, often in large numbers. Sheep are victims of the sheep botfly, whose larvae live in their nasal passages and sinuses. All of these insects affect the meat, milk, and wool production of animals through debilitation and irritation, and hides may be rendered completely useless by their entrance and exit holes. An interesting dipteran is the bee louse, which is a wingless, ectoparasite of the honeybee.

Economic losses as a result of damage by flies to crops are perhaps not as great as those caused by other insects, yet their presence has necessitated the expenditure of large sums of money for control. Among these, perhaps the most important are members of the family Tephritidae, the larvae of which feed upon and ruin the succulent flesh and seeds of their hosts. The most important of these are the European and American cherry fruit flies; their relatives in the genus *Rhagoletis* that attack walnuts in North America; six or seven species of the genus *Anastrepha* which attack many kinds of fruit in the New World; the Mediterranean fruit fly which is a limiting factor in the production of many fruits, especially citrus; and several species of the genus *Dacus*, which attack olives, citrus fruits, many kinds of vegetables, and other edible plants and plant parts in Europe, the Orient, and Pacific islands.

Larvae of some flies mine the leaves of ornamentals thereby defacing them, reducing their growth potentials, and affecting their production and sale by nurseries. The larvae of some species of Muscidae are known as root maggots and burrow into the underground parts of plants with considerable loss to growers of truck crops over the world. See ARTHROPODA; INSECTA.

[R.J.G.]

**Dipteriformes** The single order of the subclass Dipnoi, the lungfishes. Some authorities divide the lungfishes into a series of orders. See DIPNOI.

Dipteriformes are classified in some nine families, of which two very dissimilar types have living representatives. The Ceratodontidae, well known as Mesozoic fossils from all continents, differ but little from the Recent Australian species, *Neoceratodus forsteri*. This is a heavy-bodied lungfish with large scales and paddlelike paired fins; it reaches a length of 6 ft (2 m). It has a single dorsal lung with a ventral connection to the gut and can survive in deoxygenated waters by breathing air, but does not

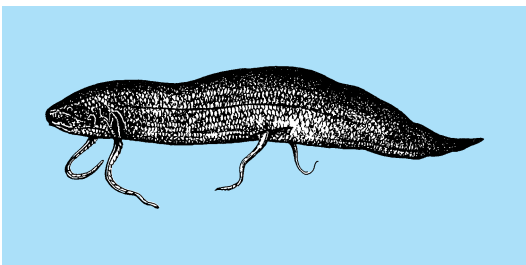

African lungfish (*Protopterus annectens*), length to 32 in. (80 cm). (After G. A. Boulenger, *Catalogue of the Fresh Water Fishes of Africa in the British Museum*, vol. 1, 1909)

estivate. The Lepidosirenidae, with a fossil history going back to the Permian, survive today in South America (*Lepidosiren paradoxo*) and Africa (four species of *Protopterus*). These are slender, eel-like fishes with small, thin scales and slender, ribbonlike paired fins (see illustration). They have paired ventral lungs like tetrapods and are obligate air breathers. They can survive desiccation by encasing themselves in a protective capsule of mud as swamps dry, and they breathe atmospheric air until freed by seasonal rains. The young of the Lepidosirenidae have external gills which disappear with age. See HIBERNATION AND ESTIVATION.

[R.M.B.]

**Direct broadcasting satellite systems** Systems for transmitting television and other program material via satellite directly to individual homes and businesses. Direct broadcasting satellite (DBS) systems operate at microwave frequencies, in a portion of the Ku band; in North and South America these systems operate in the frequency range 12.2–12.7 GHz. See RADIO SPECTRUM ALLOCATIONS.

Although direct broadcasting satellites had been operating in Europe and Japan for a number of years, the first United States direct broadcasting satellite was launched on December 17, 1993, and the second in July 1994, followed by additional satellites in subsequent years.

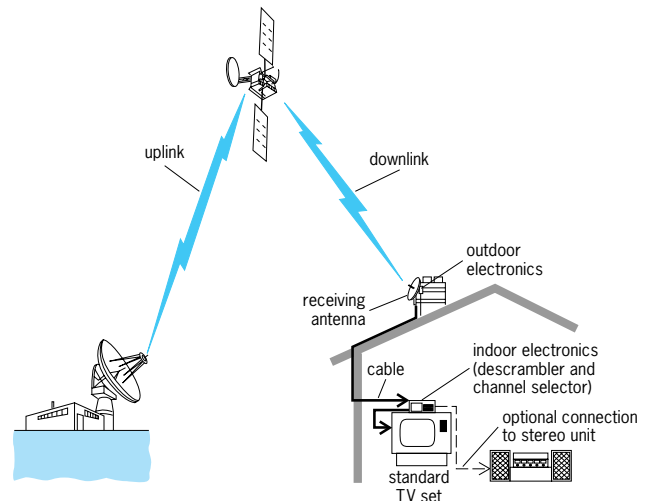

Direct broadcasting satellite system.

DBS systems use a satellite in geostationary orbit to receive television signals sent up from the Earth's surface, amplify them, and transmit them back down to the surface. The satellite also shifts the signal frequency, so that a signal sent up to the satellite in the 17.3–17.8-GHz uplink band is transmitted back down in the 12.2–12.7-GHz downlink band. The downlink signal is picked up by a receive antenna located atop an individual home or office; these antennas are usually in the form of a parabolic dish, but flat square phased-array antennas are sometimes used, and may eventually become commonplace. The receive antenna may be permanently pointed at the satellite, which is at a fixed point in the sky, in a geostationary orbit. See ANTENNA (ELECTROMAGNETISM).

It is difficult to build receivers to operate at the microwave downlink frequencies, so the signal from the dish antenna is first passed to a downconverter, usually mounted outdoors on the antenna, that shifts it to (typically) the 0.95–1.45-GHz band. This signal is then conducted by cable to the receiver atop the television set. The receiver contains the channel selector, as well as a decoder to permit the user to view authorized channels. The receiver is connected by an additional cable to the television set (see illustration).

A typical direct broadcasting satellite contains 16 transponders, or amplifiers, the maximum permitted under present regulations, each with a radio-frequency power output in the range 120–240 W. Two or more direct broadcasting satellites may be located at any of the orbital locations assigned to the United States, for a maximum of 32 transponders.

DBS satellites in the United States typically use digital signals; a single 24-MHz satellite transponder can carry an error-corrected digital signal of 30 megabits per second or greater. A wide variety of communications services can be converted to digital form and carried as part of this digital signal, including television, high-definition television (HDTV), stereo audio, one-way videoconference, information services (such as news retrieval services), and digital data.

Modern digital signal compression technology greatly increases the capacity of a satellite transponder. It is possible to compress up to perhaps 10 television signals into the bandwidth of a DBS transponder, depending on the amount of motion in the picture and the amount of screen resolution required. Since some common programming (for example, sports) contains a good deal of motion, the average compression factor for a DBS system will typically be lower than 10. *See* DATA COMPRESSION.

DBS systems, like all satellite systems operating in the  $K_u$  band, are subject to attenuation of their signals by rain. The combination of satellite power and receive-dish antenna size is chosen to enable reception for all but the heaviest rainfall periods of the year, corresponding to an outage period of perhaps 7 h per year at any particular location. The DBS customer can further reduce this expected outage period by purchasing a slightly larger dish antenna. *See* COMMUNICATIONS SATELLITE; TELEVISION.

[H.W.Ra.]

**Direct-coupled amplifier** A device for amplifying signals with direct-current components. There are many different situations where it is necessary to amplify signals having a frequency spectrum which extends to zero. Some typical examples are amplifiers in electronic differential analyzers (analog computers), certain types of feedback control systems, medical instruments such as the electrocardiograph, and instrumentation amplifiers. Amplifiers which have capacitor coupling between stages are not usable in these cases, because the gain at zero frequency is zero. Therefore, a special form of amplifier, called a dc (direct-current) or direct-coupled amplifier, is necessary. These amplifiers will also amplify alternating-current (ac) signals. *See* AMPLIFIER; ANALOG COMPUTER; BIOMEDICAL ENGINEERING; CONTROL SYSTEMS; INSTRUMENTATION AMPLIFIER.

Some type of coupling circuit must be used between successive amplifier stages to prevent the relatively large supply voltage of one stage from appearing at the input of the following stage. These circuits must pass dc signals with the least possible amount of attenuation.

Interstage direct-coupling in transistor dc amplifiers must be implemented with special care. The use of both *nnp* and *pnp* transistors is a possible solution. However, the *pnp* transistors available in monolithic form have relatively poor current-gain and frequency-response characteristics. If a dc amplifier is formed by a cascade of *nnp* stages, there is a positive dc level buildup toward the positive supply voltage. This voltage buildup limits the linearity and amplitude of the available output swing. The problem can be overcome by using a level-shift stage between each stage to shift the output dc level toward the negative supply with minimum attenuation of the amplified signal. Practical dc level-shift stages suitable for monolithic circuit applications can use Zener diodes, a series of diodes, or a  $V_{BE}$  multiplier circuit.

It is generally recognized that the differential amplifier is the most stable dc amplifier circuit available. This is true because in this circuit the performance depends on the difference of the device parameters, and transistors can be manufactured using

the planar epitaxial technique with very close matching of their parameters.

A method of amplifying dc (or slowly varying) signals by means of ac amplifiers is to modulate a carrier signal by the signal to be amplified, amplifying the modulated signal, and demodulating at the output.

The offset voltage of matched transistor pairs of differential amplifiers can be a source of serious problems in precision analog dc amplifier applications. Typically the offset voltage of matched metal oxide semiconductor (MOS) transistor pairs can be reduced to within  $\pm 20$  mV by careful processing. However, even this low offset voltage in many applications is unacceptable. It is possible to reduce the effective input offset voltage to below  $\pm 1$  mV by using chopper-stabilized amplifiers employing offset-nulling or auto-zero techniques. These techniques are essentially sampled-data methods and are based on the concept of measuring periodically the offset voltage and subsequently storing it as a voltage across a holding capacitor and then subtracting it from the signal plus the offset. [C.C.H.]

**Direct current** Electric current which flows in one direction only through a circuit or equipment. The associated direct voltages, in contrast to alternating voltages, are of unchanging polarity. Direct current corresponds to a drift or displacement of electric charge in one unvarying direction around the closed loop or loops of an electric circuit. Direct currents and voltages may be of constant magnitude or may vary with time.

Direct current is used extensively to power adjustable-speed motor drives in industry and in transportation. Very large amounts of power are used in electrochemical processes for the refining and plating of metals and for the production of numerous basic chemicals.

Direct current ordinarily is not widely distributed for general use by electric utility customers. Instead, direct-current (dc) power is obtained at the site where it is needed by the rectification of commercially available alternating-current (ac) power to dc power. *See* DIRECT-CURRENT TRANSMISSION; ELECTRIC POWER SYSTEMS. [D.D.R.]

**Direct-current generator** A rotating electric machine which delivers a unidirectional voltage and current. An armature winding mounted on the rotor supplies the electric power output. One or more field windings mounted on the stator establish the magnetic flux in the air gap. A voltage is induced in the armature coils as a result of the relative motion between the coils and the air gap flux. Faraday's law states that the voltage induced is determined by the time rate of change of flux linkages with the winding. Since these induced voltages are alternating, a means of rectification is necessary to deliver direct current at the generator terminals. Rectification is accomplished by a commutator mounted on the rotor shaft. Carbon brushes, insulated from the machine frame and secured in brush holders, transfer the armature current from the rotating commutator to the external circuit. *See* COMMUTATION; ELECTRIC ROTATING MACHINERY; GENERATOR; WINDINGS IN ELECTRIC MACHINERY.

The field windings of dc generators require a direct current to produce a magnetomotive force (mmf) and establish a magnetic flux path across the air gap and through the armature. Generators are classified as series, shunt, compound, or separately excited, according to the manner of supplying the field excitation current.

In the separately excited generator, the field winding is connected to an independent external source. Separately excited generators are among the most common of dc generators, for they permit stable operation over a very wide range of output voltages.

Using the armature as a source of supply for the field current, dc generators are also capable of self-excitation. Residual magnetism in the field poles is necessary for self-excitation. Series, shunt, and compound-wound generators are self-excited, and

each produces different voltage characteristics. The armature winding and field winding of a series generator are connected in series. The field winding of a shunt generator is connected in parallel with the armature winding. A compound generator has both a series field winding and a shunt field winding. Both windings are on the main poles with the series winding on the outside. The shunt winding furnishes the major part of the mmf. The series winding produces a variable mmf, dependent upon the load current, and offers a means of compensating for voltage drop. [R.T.W.]

**Direct-current motor** An electric rotating machine energized by direct current and used to convert electric energy to mechanical energy. It is characterized by its relative ease of speed control and, in the case of the series-connected motor, by an ability to produce large torque under load without taking excessive current. See ELECTRIC ROTATING MACHINERY.

The principal parts of a dc motor are the frame, the armature, the field poles and windings, and the commutator and brush assemblies. The frame consists of a steel yoke of open cylindrical shape mounted on a base. Salient field poles of sheet-steel laminations are fastened to the inside of the yoke. Field windings placed on the field poles are interconnected to form the complete field winding circuit. The armature consists of a cylindrical core of sheet-steel disks punched with peripheral slots, air ducts, and shaft hole. These punchings are aligned on a steel shaft on which is also mounted the commutator. The commutator, made of hard-drawn copper segments, is insulated from the shaft. Segments are insulated from each other by mica. Stationary carbon brushes in brush holders make contact with commutator segments. Copper conductors placed in the insulated armature slots are interconnected to form a reentrant lap or wave style of winding. See COMMUTATION; WINDINGS IN ELECTRIC MACHINERY.

Rotation of a dc motor is produced by an electromagnetic force exerted upon current-carrying conductors in a magnetic field. For basic principles of motor action see MOTOR.

Direct-current motors may be categorized as shunt, series, compound, or separately excited.

The field circuit and the armature circuit of a dc shunt motor are connected in parallel. The field windings consist of many turns of fine wire. The entire field resistance, including a series-connected field rheostat, is relatively large. The field current and pole flux are essentially constant and independent of the armature requirements. The torque is therefore essentially proportional to the armature current. Typical applications are for load conditions of fairly constant speed, such as machine tools, blowers, centrifugal pumps, fans, conveyors, wood- and metal-working machines, steel, paper, and cement mills, and coal or coke plant drives.

The field circuit and the armature circuit of a dc series motor are connected in series. The field winding has relatively few turns per pole. The wire must be large enough to carry the armature current. The flux of a series motor is nearly proportional to the armature current which produces it. Therefore, the torque of a series motor is proportional to the square of the armature current, neglecting the effects of core saturation and armature reaction. An increase in torque may be produced by a relatively small increase in armature current. Typical applications of this motor are to loads requiring high starting torques and variable speeds, for example, cranes, hoists, gates, bridges, car dumpers, traction drives, and automobile starters.

A compound motor has two separate field windings. One, generally the predominant field, is connected in parallel with the armature circuit; the other is connected in series with the armature circuit. The field windings may be connected in long or short shunt without radically changing the operation of the motor. They may also be cumulative or differential in compounding action. With both field windings, this motor combines the effects of the shunt and series types to an extent dependent upon the degree of compounding. Applications of this motor are to loads

requiring high starting torques and somewhat variable speeds, such as pulsating loads, shears, bending rolls, plunger pumps, conveyors, elevators, and crushers. See DIRECT-CURRENT GENERATOR.

The field winding of a separately excited motor is energized from a source different from that of the armature winding. The field winding may be of either the shunt or series type, and adjustment of the applied voltage sources produces a wide range of speed and torque characteristics. Small dc motors may have permanent-magnet fields with armature excitation only. Such motors are used with fans, blowers, rapid-transfer switches, electromechanical activators, and programming devices. [L.F.C.]

**Direct-current transmission** The conveyance of electric power by conductors carrying unidirectional currents. See DIRECT CURRENT.

A dc line with two conductors is cheaper to construct and often has lower power losses than a three-phase ac line rated for the same power. Moreover, the same dc line is often considered as equal in reliability of service to a double-circuit three-phase line. The economic advantages are proportional to the line length but are offset by the substantial cost of the converting equipment. However, several other factors influence the selection of dc.

If the ac frequencies at the converting stations are nominally the same but controlled separately, their frequency independence is maintained by the dc link. In other words, the dc system is an asynchronous link. This is the justification of many back-to-back schemes such as the ties between regions in the United States and between European countries.

Although North America operates at 60 Hz and most other parts of the world operate at 50 Hz, on occasion there is a need to interconnect ac systems having different nominal frequencies. The asynchronous nature of dc serves as a frequency changer with the control action of each converter synchronized to its local ac frequency. The Sakuma frequency changer in Japan is a back-to-back scheme, connecting two regions which, for historical reasons, have frequency standards of 50 and 60 Hz.

The electrical shunt capacitance of cables is charged and discharged at the frequency of the voltage. Since the capacitance is proportional to distance, an ac cable longer than a few tens of miles is loaded to its thermal rating by a capacitor charging current, with no power being conveyed to the remote termination. Unless the cable can be sectioned for intermediate compensating measures, dc is obligatory for many cable applications. This is especially the case for submarine links where overhead lines are not an option.

All parts of an ac system function at the same nominal frequency. A system is designed to ensure that the generators do not lose synchronism despite load variations and large fault disturbances. The system is then considered to be dynamically stable. This becomes more of a challenge when the generating stations are geographically dispersed and remote from load centers, as opposed to the relatively tightly knit systems found in Europe. Should an ac connection to another system be contemplated, the combined system is intended to operate in synchronism, although the dynamic stability in either system may deteriorate below acceptable security. In comparison, a dc interconnection maintains the dynamic independence of each system. For example, remote hydroelectric generation at Churchill Falls in Labrador and on rivers entering James Bay prevents Hydro-Quebec from establishing synchronous connections with neighboring power companies for reasons of potential instability. Mutual interties and export contracts for electric power to the New York power pool and New England utilities have been implemented by several dc links.

The automatic control circuits at the converting stations permit the dc power to be accurately set at a value determined by the system control center. Furthermore, the dc power is maintained during dynamic ac frequency disturbances and can be rapidly changed (modulated) in as little as a few milliseconds,

on demand. The same control permits the direction of dc power to be reversed equally quickly. This ability to ride through disturbances and to permit precise power scheduling and modulation responsive to dynamic needs has become of increasing value in the operation of power systems. The power flow in an individual ac line cannot be independently controlled to the degree offered by dc transmission.

A typical dc converter station contains conventional ac equipment in its ac switchyard supplemented by equipment specific to the ac-dc conversion. Solid-state converters are connected on the dc side with a center neutral point which is usually connected to a remote ground electrode. Balanced dc currents are circulated on each pole at plus and minus dc voltages with respect to ground. See CONVERTER; ELECTRIC POWER SUBSTATION.

[J.Re.]

**Direction-finding equipment** Equipment used for determining the direction from which a received signal is being radiated. Direction finders serve a variety of applications. In navigation, a direction finder on a moving vehicle, such as an aircraft or a ship can be used to provide either a transmitter's bearing to yield relative positioning information if the transmitter's location and range are known, or the vehicle's heading for guidance along a desired route toward a given destination. A direction finder may also be a ground station used to obtain bearing information on a moving source. This information, when passed on, can be useful for the moving source in navigating. Surveillance uses of direction finders include uncovering covert transmitters in espionage, locating the emitter in search-and-rescue missions, and tracking crewless objects in scientific missions.

Most direction-finding systems are based on two principles, one exploiting antenna gain characteristics and the other using phase-frequency relationships observed by a moving or a multiple-element antenna.

Direction-finding systems based on antenna gain sometimes take advantage of variations where the received signal amplitude is either a maximum or a minimum. Signal-minimum systems exploit the distinct null found in an antenna's gain pattern. Some of the earliest direction-finding equipment using loop antennas was conceived on this principle. The advent of higher-frequency systems and highly directive antennas, such as phased arrays and parabolic dishes, provided the basis for signal-maximum systems, which can pinpoint the direction in which the signal is strongest. See ANTENNA (ELECTROMAGNETISM).

The principle of induced Doppler frequency modulation requires movement of the antenna to cause additional Doppler shift to the original signal. The frequency of the signal received by the moving antenna will vary in relation to that received by a fixed antenna. The antenna motion most suited for omnidirectional purposes is circular. For this, the induced Doppler is zero at the instant when the antenna motion is perpendicular to the bearing of the received signal. See DOPPLER EFFECT.

Airborne automatic direction finders (ADFs) are constrained by size and weight. For their simplicity, signal-minimum systems with loop antennas are widely used. See AIR NAVIGATION; ELECTRONIC NAVIGATION SYSTEMS.

[PHw.]

**Directional coupler** A four-port waveguide device (see illustration) in which an incoming wave at any one port (for example, A) appears at two others (C and D) but not at the fourth (B). This device finds numerous applications in waveguide networks such as microwave waveguides, integrated optics, and optical fibers. It is the equivalent of the hybrid induction coil used in conventional wire circuit telephony to provide side-tone balance. See TELEPHONE.

Directional couplers are usually made by introducing some form of lumped or continuous coupling among several guides so that the coupled waves interfere constructively in some directions while canceling one another in other directions. A simple two-hole coupler consists of two identical microwave waveguides running adjacent to each other with two small holes of

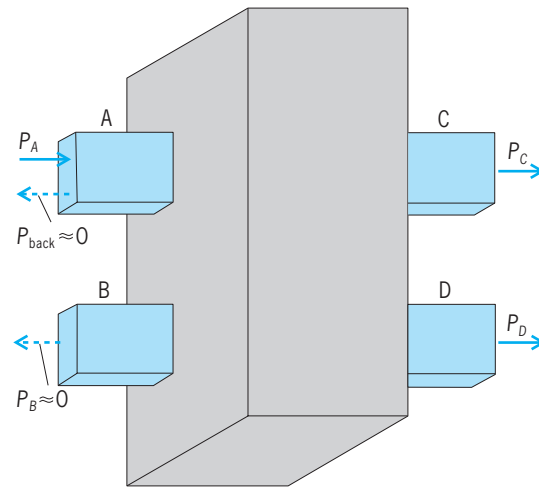

Four-port directional waveguide coupler.  $P_A$  is the input power, and  $P_B$ ,  $P_C$ , and  $P_D$  are the powers of the output waves at ports B, C, and D respectively.

the same size and shape coupling between them. It is limited by a narrow-frequency band over which the directivity is high, and a small coupling factor which is on the order of 10–30 dB. To alleviate these problems, multipath couplers are used, where the backward cancellation is obtained through destructive interference among waves excited by three or more coupling elements (such as holes), usually spaced a quarter-wavelength apart. The coupling holes are not necessarily equal. A natural extension to the multipath coupler is the slot coupler, where the coupling element is a continuous slot that is several wavelengths long and often tapered, and the coupling is continuously distributed along the length of the interaction.

Holes and slots are appropriate coupling elements for closed metallic waveguides, where the propagating field is completely enclosed within the walls of the guide. Other design alternatives exist for open waveguides such as microwave striplines, diffused dielectric optical guides used in integrated optics, and optical fibers. In these guides, the propagating field extends beyond the physical dimensions of the guiding structure (for example, the metallic plates of the stripline or the core of the fiber), and proximity coupling becomes possible. For example, the electromagnetic field of a single-mode optical fiber has an exponentially decreasing, evanescent, nonradiating tail in the first few micrometers of the cladding. Fusion, etching, and mechanical polishing techniques may be used to bring two fiber cores close enough to each other to make possible the transfer of power from one core to the other through the interaction of the corresponding evanescent fields.

Weak directional couplers can selectively monitor either the forward or backward power flow in waveguides, and medium-to-strong couplers serve as amplitude combiners and splitters in various resonators and sensors. All of these applications require high directivity, low insertion loss, and negligible back reflections. Many other useful junctions are also based on the same physical principles. See INTEGRATED OPTICS; MICROWAVE MEASUREMENTS; MICROWAVE POWER MEASUREMENT; OPTICAL COMMUNICATIONS; OPTICAL FIBERS; WAVEGUIDE.

[M.Tu.]

**Directivity** The general property of directional discrimination displayed by systems that receive or emit waves. Thus, loudspeakers, microphones, radio antennas, underwater sound projectors, hydrophones, and even telescopes all have the common property that their effectiveness depends upon the direction from which the wave is either emitted or received. The manner in which a sender or receiver is directional depends largely upon its geometrical shape and, in particular, upon its dimensions compared to those of the wavelength involved.

Directivity is a desirable property of a receiver because it permits the identification of the direction from which a signal comes and because noise from other directions is eliminated. It is desirable in a sender because the available energy can be concentrated in a given direction. A simple example of directivity is furnished by the megaphone, which effectively increases the size of the emitting area, thus increasing directivity. [W.S.Cr.]

**Disasteroidea** A paraphyletic grouping of extinct irregular echinoids, members of which gave rise to the Holasteroidea and Spatangoida in the Lower Cretaceous. Disasteroids have a split apical disc; the posterior two ocular plates and their associated ambulacra are separated from the remainder of the apical disc (and the anterior three ambulacra) by intercalated interambulacral plates. Disasteroids have a strong bilateral symmetry. Larger pore pairs, arranged in phyllodes around the mouth, suggest that disasteroids were deposit feeders with penicillate feeding tube feet. Most species probably lived infaunally, though not burrowing deeply.

Five families are included: Acrolusiidae, Collyritidae, Disasteridae, Pygorhytidae, and Tithoniidae, separated principally on apical disc plating. Approximately 75 species have been named, arranged in 17 genera. The oldest species is late Bajocian (Middle Jurassic) and the youngest Albian (Lower Cretaceous). The group achieved its greatest diversity during the Upper Jurassic. See ATELOSTOMATA; ECHINODERMATA. [A.B.S.]

**Discomycetes** A class in the phylum Ascomycota, commonly known as cup fungi. They form a well-developed mycelium which bears the sexual (ascus) and asexual (conidium) states. The ascocarp (apothecium) is generally cup or saucer shaped. In general, the asci are exposed when they mature, except in one group (truffles) that forms the ascocarps underground (hypogeous ascocarps). The ascocarp arises as coiled or intertwined initials that can be distinguished as male (antheridium) and female (ascogonium) in some species. Layers of hyphae develop around these initials to form the tissue of the ascocarp. As this development occurs, the initial coil forms a system of ascogenous hyphae that transform into asci. The asci form in a broad layer (hymenium) on the apothecium. They have a single rigid wall (unitunicate), with two basic types of apex, operculate and inoperculate. Operculate asci have a hinged cap (operculum) at the tip that opens to allow discharge of ascospores. In inoperculate asci, the apex has a pore or a small slit through which the spores are discharged. In most species, ascospores are forcibly discharged. Their shape is variable, but they are usually one celled and hyaline.

The Discomycetes occur on soil and on living and dead plants, either as saprobes or as parasites. The operculate discomycetes includes the largest of all ascomycetes: the edible morels (*Morchella*), prized for their flavor; those with large, showy red or orange apothecia (*Cookeina*, *Sarcoscypha*, *Scutellinia*); and truffles (*Tuber*). Among the inoperculate Discomycetes are numerous plant pathogens, such as *Monilinia fructicola* (brown rot of peach), which forms small, brown, cup-shaped ascocarps with long stalks, and the needle cast fungus (*Lophodermium pinastri*), which forms narrow, elongate ascocarps that open by a slit on pine needles. See ASCOMYCOTA; EUMYCOTA; FUNGI. [R.T.H.]

**Discriminant** For a polynomial  $f(x) = a_n x^n + a_{n-1} x^{n-1} + \dots + a_1 x + a_0$ , the discriminant is given by the expression

$$D = a_n^{2n-1} (x_1 - x_2)^2 (x_1 - x_3)^2 \dots (x_1 - x_n)^2 (x_2 - x_3)^2 \dots (x_2 - x_n)^2 \dots (x_{n-1} - x_n)^2$$

where  $x_1, x_2, \dots, x_n$  are the roots of the equation  $f(x) = 0$ .

The importance of the discriminant  $D$  lies in the fact that  $D$  vanishes if, and only if, the equation  $f(x) = 0$  has equal roots. Since the value of the discriminant is unchanged if any two letters

$x_i$  and  $x_j$  are interchanged, it is a symmetric function of the roots, and can be expressed in terms of the coefficients of  $f(x)$ . The discriminant of a quadratic polynomial  $f(x) = a_2 x^2 + a_1 x + a_0$  is  $D = a_1^2 - 4a_2 a_0$ . The discriminant of a cubic polynomial  $f(x) = a_3 x^3 + a_2 x^2 + a_1 x + a_0$  is

$$D = 18a_3 a_2 a_1 a_0 - 4a_2^3 a_0 + a_2^2 a_1^2 - 4a_3 a_1^2 - 27a_3^2 a_0^2$$

See EQUATIONS, THEORY OF; POLYNOMIAL SYSTEMS OF EQUATIONS. [R.A.B.]

**Disease** A deleterious set of responses which occurs at the subcellular level, stimulated by some injury, and which is often manifested in altered structure or functioning of the affected organism. With advances in understanding and the development of sensitive probes, it has become clear that the fundamental causes of diseases are based on biochemical and biophysical responses within the cell. These responses are now being categorized and, slowly, the mechanisms are being understood.

The term homeostasis refers to functional equilibrium in an organism and to the processes that maintain it. There is a range of responses that is considered normal. If cells are pushed to respond beyond these limits, there may be an increase, a decrease, or a loss of normal structure or function. These changes may be reversible or irreversible. If irreversible, the cells may die. Thus, subcellular changes may be reflected in altered tissues, organs, and consequently organisms, and result in a condition described as diseased. See HOMEOSTASIS.

Lesions are the chemical and structural manifestations of disease. Subjective manifestations of a disease process such as weakness, pain, and fatigue are called symptoms. The objective measurable manifestations such as temperature, blood pressure, and respiratory rate changes are called signs or physical findings. Changes in the chemical or cellular makeup of an organ, tissue, or fluid of the body or its excretory products are called laboratory findings. To make a diagnosis is to determine the nature of the pathologic process by synthesizing information from these sources evaluated in the light of the patient's history and compared with known patterns of signs and symptoms. In common usage, the term disease indicates a constellation of specific signs and symptoms attributable to altered reactions in the individual which are produced by agents that affect the body or its parts.

Etiology is the study of the cause or causes of a disease process. Although a disease may have one principal etiologic agent, it is becoming increasingly apparent that there are several factors involved in the initiation of a disease process. Susceptibility of the individual is an ever present variable. The etiologic factors can conveniently be divided into two categories (see table). One group consists of endogenous (internal; within the body) factors, and may originate from errors in the genetic material. The other category of etiologic factors is exogenous (environmental). These account for the majority of disease reactions. Exogenous factors include physical, chemical, and biotic agents.

Pathogenesis refers to the mechanisms by which the cell, and consequently the body, responds to an etiologic agent. It involves biochemical and physiological responses which are reflected in ultrastructural, microscopic, or gross anatomic lesions. There are a limited number of ways in which cells respond to injury. The nature of the response is modified by the nature of the agent, dose, portal of entry, and duration of exposure, as well as many host factors such as age, sex, nutritional state, and species and individual susceptibility.

The diseases which are important in causing human death have changed in the last 80 years. In 1900 six of the ten leading causes of death in the United States were infectious (biotic) agents. At present, only one of the ten leading causes of death in the United States, influenza and pneumonia, is due to biotic agents. While most of the biotic causes of diseases were being brought under control, continued population growth (in large part, a consequence of the control of infectious disease) and

## Common exogenous and endogenous causes of disease

Causative agent	Disease
EXOGENOUS FACTOR	
<i>Physical</i>	
Mechanical injury	Abrasion, laceration, fracture
Nonionizing energy	Thermal burns, electric shock, frostbite, sunburn
Ionizing radiation	Radiation syndrome
<i>Chemical</i>	
Metallic poisons	Intoxication from methanol, ethanol, glycol
Nonmetallic inorganic poisons	Intoxication, from phosphorous, borate, nitrogen dioxide
Alcohols	Intoxication from methanol, ethanol, glycol
Asphyxiants	Intoxication from carbon monoxide, cyanide
Corrosives	Burns from acids, alkalis, phenols
Pesticides	Poisoning
Medicinals	Barbiturism, salicylism
Warfare agents	Burns from phosgene, mustard gas
Hydrocarbons (some)	Cancer
<i>Nutritional deficiency</i>	
Metals (iron, copper, zinc)	Some anemias
Nonmetals (iodine, fluorine)	Goiter, dental caries
Protein	Kwashiorkor
<i>Vitamins:</i>	
A	Epithelial metaplasia
D	Rickets, osteomalacia
K	Hemorrhage
Thiamine	Beriberi
Niacin	Pellagra
Folic acid	Macrocytic anemia
B <sub>12</sub>	Pernicious anemia
Ascorbic acid	Scurvy
<i>Biological</i>	
Plants (mushroom, fava beans, marijuana, poison ivy, tobacco, opium)	Contact dermatitis, systemic toxins, cancer, hemorrhage
Bacteria	Abscess, scarlet fever, pneumonia, meningitis, typhoid, gonorrhoea, food poisoning, cholera, whooping cough, undulant fever, plague, tuberculosis, leprosy, diphtheria, gas gangrene, botulism, anthrax
Spirochetes	Syphilis, yaws, relapsing fever, rat bite fever
Virus	Warts, measles, German measles, smallpox, chickenpox, herpes, roseola, influenza, psittacosis, mumps, viral hepatitis, poliomyelitis, rabies, encephalitis, trachoma
Rickettsia	Rocky Mountain spotted fever, typhus
Fungus	Ringworm, thrush, actinomycosis, histoplasmosis, coccidiomycosis
Parasites (animal)	
Protozoa	Amebic dysentery, malaria, toxoplasmosis, trichomonas vaginitis
Helminths (worms)	Hookworm, trichinosis, tapeworm, filariasis, ascariasis
ENDOGENOUS FACTOR	
<i>Hereditary</i>	
	Phenylketonuria, alcaptonuria, glycogen storage disease, Down's syndrome (trisomy 21), Turner's syndrome, Klinefelter's syndrome, diabetes, familial polyposis
<i>Hypersensitivity</i>	
	Asthma, serum sickness, eczema drug idiosyncrasy

the remarkable growth of industrialization have been associated with an increased prevalence of diseases caused by physical and chemical agents. These include cancer, cirrhosis, and cardiovascular disease.

General principles of the organism's response to toxic substances, some of which occur naturally in the environment, have evolved from a great number of investigations of agent-host interaction. They are: (1) All substances entering the organism are toxic; none is harmless. Dose rate of exposure and route of entry into the body determine whether a toxic response will occur or not. (2) All agents evoke multiple responses. (3) Most of the biological responses are undesirable, leading to the development of pathological changes. (4) A given dose of an agent does not produce the same degree of response in all individuals. Thus, when disease is viewed as interaction between the environment and the individual, the control of disease is largely the management of the environmental causes of disease.

[N.K.M.; C.Qu]

**Disease ecology** The interaction of the behavior and ecology of hosts with the biology of pathogens, as it relates to the impact of diseases on populations.

**Threshold theorem.** For a disease to spread, on average it must be successfully transmitted to a new host before its current host dies or recovers. This observation lies at the core of the most important idea in epidemiology: the threshold theorem. The threshold theorem states that if the density of susceptible hosts is below some critical value, then on average the transmission of a disease will not occur rapidly enough to cause the number of infected individuals to increase. In other words, the reproductive rate of a disease must be greater than 1 for there to be an epidemic, with the reproductive rate being defined as the average number of new infections created per infected individual. Human immunization programs are based on applying the threshold theorem of epidemiology to public health; specifically, if enough individuals in a population can be vaccinated, then the density of susceptible individuals will be sufficiently lowered that epidemics are prevented. See EPIDEMIOLOGY; VACCINATION.

In general, the rate of reproduction for diseases is proportional to their transmissibility and to the length of time that an individual is infectious. For this reason, extremely deadly diseases that kill their hosts too rapidly may require extremely high densities of hosts before they can spread. All diseases do not behave as simply as hypothesized by the threshold theorem, the most notable exceptions being sexually transmitted diseases. Because organisms actively seek reproduction, the rate at which a sexually transmitted disease is passed among hosts is generally much less dependent on host density.

**Population effects.** Cycles in many animal populations are thought to be driven by diseases. For example, the fluctuations of larch bud moths in Europe are hypothesized to be driven by a virus that infects and kills the caterpillars of this species. Cycles of red grouse in northern England are also thought to be driven by disease, in this case by parasitic nematodes. It is only when grouse are laden with heavy worm burdens that effects are seen, and those effects take the form of reduced breeding success or higher mortality during the winter. This example highlights a common feature of diseases: their effects may be obvious only when their hosts are assaulted by other stresses as well (such as harsh winters and starvation).

The introduction of novel diseases to wild populations has created massive disruptions of natural ecosystems. For example, the introduction of rinderpest virus into African buffalo and wildebeest populations decimated them in the Serengeti. African wild ungulates have recovered in recent years only because a massive vaccination program eliminated rinderpest from the primary reservoir for the disease, domestic cattle. But the consequences of the rinderpest epidemic among wild ungulates extended well beyond the ungulate populations. For example, human sleeping



sickness increased following the rinderpest epidemic because the tsetse flies that transmit sleeping sickness suffered a shortage of game animals (the normal hosts for tsetse flies) and increasingly switched to humans to obtain meals.

It is widely appreciated that crop plants are attacked by a tremendous diversity of diseases, some of which may ruin an entire year's production. Diseases are equally prevalent among wild populations of plants, but their toll seems to be reduced because natural plant populations are so genetically variable that it is unlikely that any given pathogen strain can sweep through and kill all of the plants—there are always some resistant genotypes. But when agronomists have bred plants for uniformity, they have often depleted genetic diversity and created a situation in which a plant pathogen that evolves to attack the crop encounters plants with no resistance (all the plants are the same). For example, when leaf blight devastated the United States corn crop, 70% of that crop shared genetically identical cytoplasm, and the genetic uniformity of the host exacerbated the severity of the epidemic. See PLANT PATHOLOGY.

**Disease emergence.** Humans are dramatically altering habitats and ecosystems. Sometimes these changes can influence disease interactions in surprising ways. Lyme disease in the eastern United States provides a good example of the interplay of human habitat modifications and diseases. Lyme disease involves a spirochete bacterium transmitted to humans by ticks. However, humans are not the normal hosts for this disease; instead, both the ticks and the bacterium are maintained primarily on deer and mouse populations. Human activities influence both deer and mice populations, and in turn tick populations, affecting potential exposure of humans to the disease. Much less certain are the impacts of anticipated global warming on diseases. There is some cause for concern about the expansion of tropical diseases into what are now temperate regions in those cases where temperature sets limits to the activity or distribution of major disease vectors. See LYME DISEASE; POPULATION ECOLOGY. [PKa.]

**Dispersion (radiation)** The separation, by refraction, interference, scattering, or diffraction, of acoustic and electromagnetic radiation or energy into its constituent wavelengths or frequencies. For a refracting, transparent substance, such as a prism of glass, the dispersion is characterized by the variation of refractive index with change in wavelength of the radiation. Refractive index ( $n$ ) is defined as the ratio of the velocity of the radiation in free space (air at standard temperature and pressure for sound, and a vacuum for electromagnetic radiation) to the velocity in the substance in question. I. Newton used a small hole in a window shade and a glass prism to disperse sunlight into a visible spectrum, from violet through red. Using a second prism, he showed that no further decomposition of any of the spectral colors could be achieved. See OPTICAL PRISM; REFRACTION OF WAVES.

The condition where the refractive index decreases as wavelength increases is termed normal dispersion. The opposite condition is termed anomalous dispersion, and almost always occurs in regions outside the range of visible wavelengths. [R.A.Buc.]

**Dispersion relations** Relations between the real and imaginary parts of a response function. A response function relates a cause and its effect through an integral equation. The term dispersion refers to the fact that the index of refraction of a medium is a function of frequency. In 1926 H. A. Kramers and R. Kronig showed that the imaginary part of an index of refraction (that is, the absorptivity) determines the real part (that is, the refractivity); this is called the Kramers-Kronig relation. The term dispersion relation is now used for the analogous relation between the real and imaginary parts of the values of any response function. See COMPLEX NUMBERS. [C.J.G.]

**Displacement current** The name given by J. C. Maxwell to the term  $\partial\mathbf{D}/\partial t$  which must be added to the cur-

rent density  $\mathbf{i}$  to extend to time-varying fields the magnetostatic result of A. M. Ampère that  $\mathbf{i}$  equals the curl of the magnetic intensity  $\mathbf{H}$ . In integral form this result is given by the equation below, where the unit vector  $\mathbf{n}$  is perpendicular to the surface

$$\oint \mathbf{H} \cdot d\mathbf{s} = \int_S \left( \mathbf{i} + \frac{\partial\mathbf{D}}{\partial t} \right) \cdot \mathbf{n} dS$$

$dS$ . The concept of displacement current has important consequences for insulators and for free space where  $\mathbf{i}$  vanishes. For conductors, however, the difference between the above equation and Ampère's result is negligible. See AMPÈRE'S LAW; MAXWELL'S EQUATIONS.

If one defines current as a transport of charge, the term displacement current is certainly a misnomer when applied to a vacuum where no charges exist. If, however, current is defined in terms of the magnetic fields it produces, the expression is legitimate. [W.R.Sm.]

**Displacement pump** A pump that develops its action through the alternate filling and emptying of an enclosed volume. There are five basic types: reciprocating, direct-acting steam, rotary, vacuum, and air-lift.

Positive-displacement reciprocating pumps have cylinders and plungers or pistons with an inlet valve, which opens the cylinder to the inlet pipe during the suction stroke, and an outlet valve, which opens to the discharge pipe during the discharge stroke. Reciprocating pumps may be power-driven through a crank and connecting rod or equivalent mechanism, or direct-acting, driven by steam or compressed air or gas. Power-driven reciprocating pumps are highly efficient over a wide range of discharge pressures. Except for some special designs with continuously variable stroke, reciprocating power pumps deliver essentially constant capacity over their entire pressure range when driven at constant speed.

A reciprocating pump is readily driven by a reciprocating engine; a steam or power piston at one end connects directly to a fluid piston or plunger at the other end. Steam pumps can be built for a wide range of pressure and capacity by varying the relative size of the steam piston and the liquid piston or plunger. The delivery of a steam pump may be varied at will from zero to maximum simply by throttling the motive steam, either manually or by automatic control. Reciprocating pumps are used for low to medium capacities and medium to highest pressures. They are useful for low- to medium-viscosity fluids, or high-viscosity fluids at materially reduced speeds. Specially fitted reciprocating pumps are used to pump fluids containing the more abrasive solids.

Another form of displacement pump consists of a fixed casing containing gears, cams, screws, vanes, plungers, or similar elements actuated by rotation of the drive shaft. Most forms of rotary pumps are valveless and develop an almost steady flow rather than the pulsating flow of a reciprocating pump.

Although vacuum pumps actually function as compressors, displacement pumps are used for certain vacuum pump applications. Simplex steam pumps with submerged piston pattern fluid ends are used as wet vacuum pumps in steam heating and condensing systems. Sufficient liquid remains in the cylinder to fill the clearance volume and drive the air or gas out ahead of the liquid. See VACUUM PUMP.

In handling abrasive or corrosive waters or sludges, where low efficiency is of secondary importance, air-lift pumps are used. The pump consists of a drop pipe in a well with its lower end submerged and a second pipe which introduces compressed air near the bottom of the drop pipe. The mixture of air and water in the drop pipe is lighter than the water surrounding the pipe. As a result, the mixture of air and water is forced to the surface by the pressure of submergence. See COMPRESSOR; PUMP.

[E.F.W.]

**Distance-measuring equipment** An internationally standardized navigation system which allows an aircraft to measure its distance from a selected ground-based beacon. Such beacons are used throughout the world by all airliners, most of the military aircraft of the West, and a large number of general-aviation aircraft. The range of service is line-of-sight up to 300 mi (480 km) and system accuracy is usually 0.1 mi (0.16 km) but precision equipment, intended for use during landing, has accuracy of 100 ft (30 m).

The airborne equipment, called an interrogator, transmits pulses of 1 kW peak power on 1 of 126 frequencies. These are in the 1025–1150-MHz band and are spaced 1 MHz apart. Each pulse is of 3.5 microseconds duration and is paired with another, spaced 12 or 36 microseconds later. The combination of frequencies and pulse spacings therefore provides 252 operating channels.

The beacon on the ground, called a transponder, receives these pulses, delays them by 50  $\mu$ s, and then retransmits them, usually with a power of 1 kW, on 252 frequencies lying between 962 and 1213 MHz. The pulse-pair spacing is 12  $\mu$ s on those frequencies not used by the interrogator, and 30  $\mu$ s on those frequencies shared with the interrogator. The transponder transmission is called the reply. The frequency difference between interrogation and reply is always 63 MHz. This arrangement allows each transmitter frequency to act as the local oscillator for its associated superheterodyne receiver, the intermediate frequency of which is 63 MHz. For landing purposes, some transponders have powers as low as 100 W.

In the aircraft the replies to its own interrogations are recognized by their phase coherence with their own transmissions, and by the elapsed time measured between transmissions and reception (minus the 50- $\mu$ s transponder delay), usually by means of a crystal clock. This elapsed time is about 12  $\mu$ s for each nautical mile (7  $\mu$ s for each kilometer), and is displayed in the cockpit on a digital meter, which is usually calibrated in miles and tenths of miles. See ELECTRONIC NAVIGATION SYSTEMS; INSTRUMENT LANDING SYSTEM (ILS); RHO-THETA SYSTEMS; TACAN. [S.H.D.]

**Distillation** A method for separating homogeneous mixtures based upon equilibration of liquid and vapor phases. Substances that differ in volatility appear in different proportions in vapor and liquid phases at equilibrium with one another. Thus, vaporizing part of a volatile liquid produces vapor and liquid products that differ in composition. This outcome constitutes a separation among the components in the original liquid. Through appropriate configurations of repeated vapor-liquid contactings, the degree of separation among components differing in volatility can be increased many fold. See PHASE EQUILIBRIUM.

Distillation is by far the most common method of separation in the petroleum, natural gas, and petrochemical industries. Its many applications in other industries include air fractionation, solvent recovery and recycling, separation of light isotopes such as hydrogen and deuterium, and production of alcoholic beverages, flavors, fatty acids, and food oils.

**Simple distillations.** The two most elementary forms of distillation are a continuous equilibrium distillation and a simple batch distillation.

In a continuous equilibrium distillation, a continuously flowing liquid feed is heated or reduced in pressure (flashed) so as to cause partial vaporization. The vapor and liquid disengage while flowing through an open drum, and the products emerge as vapor and liquid streams. The vapor product can be condensed to form a liquid distillate. It is also possible to use a vapor feed, subjected to cooling and thereby partial condensation, again followed by disengagement of the resultant vapor and liquid in an open drum. See VAPOR CONDENSER.

In a simple batch distillation, an entire batch of liquid is initially charged to a vessel and is then heated, typically by condensation of steam inside a metal coil within the vessel. Vapor is thereby

continuously generated, and may be condensed to form a liquid distillate, which is collected. In the batch distillation, increments of vapor are formed in equilibrium with all liquid compositions ranging from the original to the final, whereas the continuous equilibrium distillation gives vapor in equilibrium with only the final liquid composition. Since the distillate consists primarily of the more volatile components and the feed liquid contains more of these substances than does the final liquid, the simple batch distillation gives a more enriched distillate than does the continuous equilibrium distillation.

**Fractional distillation.** Unless the vapor pressures of the species being separated are very dissimilar, a simple distillation does not produce highly purified products. Product purities can be increased by repeated partial vaporizations and condensations. The liquid from an initial continuous equilibrium distillation can be partially vaporized by additional heating. The remaining liquid can again be heated and partially vaporized, forming another liquid and so forth. Each liquid is progressively enriched in the less volatile substances. Similarly, successive partial condensations of the vapor fraction from the initial continuous equilibrium distillation produce vapor products successively enriched in the more volatile components. See VAPOR PRESSURE.

The process involved in successive partial vaporizations and condensations would lead to only very small amounts of the most enriched products, along with numerous streams having intermediate compositions. A logical step is to recycle each of these intermediate streams to the prior vessel in the sequence of contactors. Recycling of the intermediate vapors and liquids has another highly beneficial effect in that it negates the need for intermediate heaters and coolers. The resultant process is known as continuous fractional distillation. It is usually carried out in a distillation column, which is a simpler, more compact form of equipment than the cascade of vessels used in the process of recycling intermediate vapors and liquids. See DISTILLATION COLUMN.

**Vapor-liquid equilibria.** The separation accomplished in a distillation relates to the difference in composition of vapor and liquid phases at equilibrium. These relationships are the subject matter of phase-equilibrium thermodynamics. See CHEMICAL THERMODYNAMICS; GAS; LIQUID.

The dependence of liquid-phase activity coefficients upon liquid composition is complex; consequently vapor-liquid equilibrium relationships can have quite different characteristics. For example, the two-component benzene-toluene system (curve A in the illustration) is a relatively ideal system, for which the activity coefficients are close to 1.0 over the liquid composition range. The mole fraction of benzene in the vapor is therefore always greater than that in the liquid, and the relative volatility has a nearly constant value of 2.4. Such a system can be separated readily into products of high purity by continuous fractional distillation.

In the acetone-carbon disulfide system (curve B), there are positive deviations from ideality, meaning that the activity coefficients are greater than 1.0 and increase for either component as that component becomes more dilute in the mixture. The result is that the relative volatility is greatest at low concentrations of the more volatile component (acetone) and decreases at higher concentrations. Because of hydrogen bonding between the two components, the acetone-chloroform system (curve C) exhibits negative deviations from ideality, meaning that the activity coefficients are less than 1.0. The isobutanol-water system (curve D) exhibits sufficiently extreme positive deviations from ideality so that two immiscible liquid phases form over much of the composition range. Continuous fractional distillation cannot produce two products of high purity for such a system.

**Distillation pressure.** The pressure under which a distillation is performed is a matter of choice, although operation at pressures more removed from atmospheric becomes more costly.

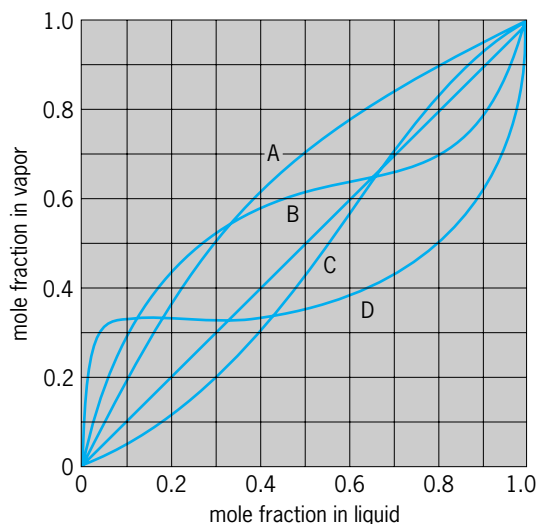

**Types of binary vapor-liquid equilibrium relationship; equilibrium vapor mole fraction of the more volatile (first named) component as a function of the liquid mole fraction of the more volatile component. The pressure is constant at 1 atm (101 kilopascals) for all systems. Curve A, benzene-toluene; B, acetone-carbon disulfide; C, acetone-chloroform; D, isobutyl alcohol-water.**

Altering the pressure of a distillation can serve to alter the vapor-liquid equilibrium relationship, a feature that can be used to advantage.

Because of the relationship between vapor pressure and temperature, the temperatures within a distillation column are lower for lower pressures. Vacuum distillation is an effective means of maintaining lower temperatures for separations involving heat-sensitive materials.

Steam distillation is an alternative to vacuum distillation for separations of organic substances. In this process, steam is fed directly to the bottom of a column and passes upward, composing a substantial fraction of the vapor phase. The combined partial pressures of the organic substances being distilled are thereby lessened, giving the lower temperatures characteristic of a vacuum distillation. [C.J.Ke.]

**Distillation column** An apparatus used widely for countercurrent contacting of vapor and liquid to effect separations by distillation or absorption. In general, the apparatus consists of a cylindrical vessel with internals designed to obtain multiple contacting of ascending vapor and descending liquid, together with means for introducing or generating liquid at the top and vapor at the bottom.

In a column that can be applied to distillation (see illustration), a vapor condenser is used to produce liquid (reflux) which is returned to the top, and a liquid heater (reboiler) is used to generate vapor for introduction at the bottom. In a simple absorber, the absorption oil is the top liquid and the feed gas is the bottom vapor. In all cases, changes in composition produce heat effects and volume changes, so that there is a temperature gradient and a variation in vapor, and liquid flows from top to bottom of the column. These changes affect the internal flow rates from point to point throughout the column and must be considered in its design.

Distillation columns used in industrial plants range in diameter from a few inches to 40 ft (12 m) and in height from 10 to 200 ft (3 to 60 m). They operate at pressures as low as a few millimeters of mercury and as high as 3000 lb/in.<sup>2</sup> (2 megapascals) at temperatures from -300 to 700°F (-180 to 370°C). They are made of steel and other metals, of ceramics and glass, and even of such materials as bonded carbon and plastics.

A variety of internal devices have been used to obtain more efficient contacting of vapor and liquid. The most widely used devices are the bubble-cap plate, the perforated or sieve plate, and the packed column.

The bubble-cap plate is a horizontal deck with a large number of chimneys over which circular or rectangular caps are mounted to channel and distribute the vapor through the liquid. Liquid flows by gravity downward from plate to plate through separate passages known as downcomers.

The perforated or sieve plate is a horizontal deck with a multiplicity of round holes or rectangular slots for distribution of vapor through the liquid. The sieve plate can be designed with downcomers similar to those used for bubble-cap trays, or it can be made without downcomers so that both liquid and vapor flow through the perforations in the deck.

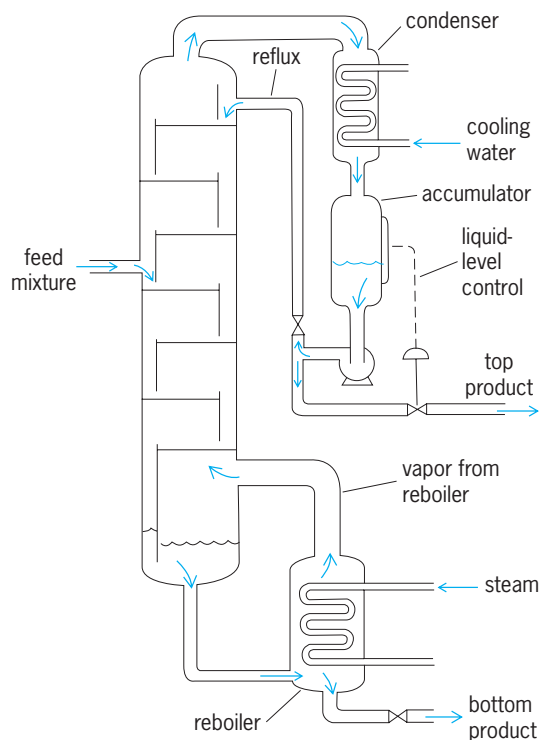

**Elements of a distillation column.**

The packed column is a bed or succession of beds made up of small solid shapes over which liquid and vapor flow in tortuous countercurrent paths. Expanded metal or woven mats are also used as packing. The packed column is used without downcomers, but in larger sizes usually has horizontal redistribution decks to collect and redistribute the liquid over the bed at successive intervals of height. The packed column is widely used in laboratories. It is often used in small industrial plants, especially where corrosion is severe and ceramic or glass materials must be chosen. See DISTILLATION; GAS ABSORPTION OPERATIONS. [M.Sou.]

**Distortion (electronic circuits)** The behavior of an electrical device or communications system whose output is not identical in form to the input signal. In a distortionless communications system, freedom from distortion implies that the output must be proportional to a delayed version of the input, requiring a constant-amplitude response and a phase characteristic that is a linear function of frequency. See RESPONSE.

In practice, all electrical systems will produce some degree of distortion. The art of design is to see that such distortion is maintained within acceptable bounds, while the signal is otherwise modified in the desired fashion. In general, distortion can be grouped into four forms: amplitude (nonlinear), frequency, phase, and cross modulation.

**Amplitude distortion.** All electronic systems are inherently nonlinear unless the input signal is maintained at an incrementally small level. Once the signal level is increased, the effects of device nonlinearities become apparent as distorted output waveforms. Such distortion reduces the output voltage capability of operational amplifiers and limits the power available from power amplifiers. Amplitude distortion may be reduced in amplifier stages by the application of negative feedback. *See* AMPLIFIER; FEEDBACK CIRCUIT; OPERATIONAL AMPLIFIER.

**Frequency distortion.** No practical device or system is capable of providing constant gain over an infinite frequency band. Hence, any nonsinusoidal input signal will encounter distortion since its various sinusoidal components will undergo unequal degrees of amplification. The effects of such distortion can be minimized by designing transmission systems with a limited region of constant gain. Thus, in high-fidelity systems, the amplifier response is made wide enough to capture all the harmonic components to which the human ear is sensitive.

**Phase distortion.** Since the time of propagation through a system varies with frequency, the output may differ in form from the input signal, even though the same frequency components exist. This can easily be demonstrated by noting the difference between the addition of two in-phase sine waves and two whose phase relationship differs by several degrees. In digital systems, such changes can be significant enough to cause timing problems. Hence, the phase-frequency response must be made linear to obtain distortionless transmission. *See* EQUALIZER.

**Cross modulation.** Sometimes referred to as intermodulation, this occurs because of the nonlinear nature of device characteristics. Thus, if two or more sinusoidal inputs are applied to a transistor, the output will contain not only the fundamentals but also signal harmonics, sums and differences of harmonics, and various sum or difference components of fundamental and harmonic components. While these effects are generally undesirable, they may be utilized to advantage in amplitude modulation and diode detection (demodulation). *See* AMPLITUDE-MODULATION DETECTOR; AMPLITUDE MODULATOR. [F.W.S.]

**Distributed systems (computers)** A distributed system consists of a collection of autonomous computers linked by a computer network and equipped with distributed system software. This software enables computers to coordinate their activities and to share the resources of the system hardware, software, and data. Users of a distributed system should perceive a single, integrated computing facility even though it may be implemented by many computers in different locations. This is in contrast to a network, where the user is aware that there are several machines whose locations, storage replications, load balancing, and functionality are not transparent. Benefits of distributed systems include bridging geographic distances, improving performance and availability, maintaining autonomy, reducing cost, and allowing for interaction. *See* LOCAL-AREA NETWORKS; WIDE-AREA NETWORKS.

The object-oriented model for a distributed system is based on the model supported by object-oriented programming languages. Distributed object systems generally provide remote method invocation (RMI) in an object-oriented programming language together with operating systems support for object sharing and persistence. Remote procedure calls, which are used in client-server communication, are replaced by remote method invocation in distributed object systems. *See* OBJECT-ORIENTED PROGRAMMING.

The state of an object consists of the values of its instance variables. In the object-oriented paradigm, the state of a program is partitioned into separate parts, each of which is associated with an object. Since object-based programs are logically partitioned, the physical distribution of objects into different processes or computers in a distributed system is a natural extension. The Object Management Group's Common Object Request Broker (CORBA) is a widely used standard for distributed object sys-

tems. Other object management systems include the Open Software Foundation's Distributed Computing Environment (DCE) and Microsoft's Distributed Common Object Manager (DCOM).

CORBA specifies a system that provides interoperability among objects in a heterogeneous, distributed environment in a way that is transparent to the programmer. Its design is based on the Object Management Group's object model.

This model defines common object semantics for specifying the externally visible characteristics of objects in a standard and implementation-independent way. In this model, clients request services from objects (which will also be called servers) through a well-defined interface. This interface is specified in Object Management Group Interface Definition Language (IDL). The request is an event, and it carries information including an operation, the object reference of the service provider, and actual parameters (if any). The object reference is a name that defines an object reliably.

The central component of CORBA is the object request broker (ORB). It encompasses the entire communication infrastructure necessary to identify and locate objects, handle connection management, and deliver data. In general, the object request broker is not required to be a single component; it is simply defined by its interfaces. The core is the most crucial part of the object request broker; it is responsible for communication of requests.

The basic functionality provided by the object request broker consists of passing the requests from clients to the object implementations on which they are invoked. In order to make a request, the client can communicate with the ORB core through the Interface Definition Language stub or through the dynamic invocation interface (DII). The stub represents the mapping between the language of implementation of the client and the ORB core. Thus the client can be written in any language as long as the implementation of the object request broker supports this mapping. The ORB core then transfers the request to the object implementation which receives the request as an up-call through either an Interface Definition Language (IDL) skeleton (which represents the object interface at the server side and works with the client stub) or a dynamic skeleton (a skeleton with multiple interfaces).

Many different ORB products are currently available; this diversity is very wholesome since it allows the vendors to gear their products toward the specific needs of their operational environment. It also creates the need for different object request brokers to interoperate. Furthermore, there are distributed and client-server systems that are not CORBA-compliant, and there is a growing need to provide interoperability between those systems and CORBA. In order to answer these needs, the Object Management Group has formulated the ORB interoperability architecture.

The interoperability approaches can be divided into mediated and immediate bridging. With mediated bridging, interacting elements of one domain are transformed at the boundary of each domain between the internal form specific to this domain and some other form mutually agreed on by the domains. This common form could be either standard (specified by the Object Management Group, for example, Internet Inter-ORB Protocol or IIOP), or a private agreement between the two parties. With immediate bridging, elements of interaction are transformed directly between the internal form of one domain and the other. The second solution has the potential to be much faster, but is the less general one; it therefore should be possible to use both. Furthermore, if the mediation is internal to one execution environment (for example, TCP/IP), it is known as a full bridge; otherwise, if the execution environment of one object request broker is different from the common protocol, each object request broker is said to be a half bridge. [M.Y.E.]

**Distributed systems (control systems)** Collections of modules, each with its own specific function, interconnected to carry out integrated data acquisition and control.

Industrial control systems have evolved from totally analog systems through centralized digital computer-based systems to multilevel, distributed systems. Originally, industrial control systems were entirely analog, with each individual process variable controlled by a single feedback controller. Although analog control systems were simple and reliable, they lacked integrated information displays for the process operator.

In supervisory control, the analog portion of the system is implemented in a traditional manner (including analog display in the central operating room), but a digital computer is added which periodically scans, digitizes, and inputs process variables to the computer. The computer is used to filter the data, compute trends, generate specialized displays, plot curves, and compute unmeasurable quantities of interest such as efficiency or quality measures. Once such data are available, optimal operation of the process may be computed and implemented by using the computer to output set-point values to the analog controllers. This mode of control is called supervisory control because the computer itself is not directly involved in the dynamic feedback. See DIGITAL COMPUTER.

Direct digital control replaces the analog control with a periodically executed equivalent digital control algorithm carried out in the central digital computer. A direct digital control system periodically scans and digitizes process variables and calculates the change required in the manipulated variable to reduce the difference between the set point and the process variable to zero. See ALGORITHM.

The advantages of direct digital control are the ease with which complex dynamic control functions can be carried out and the elimination of the cost of the analog controllers themselves. To maintain the attractive display associated with analog control systems, the display portion of the analog controller is usually provided. Thus operation of the process is identical to operation of digital supervisory control systems with analog controllers, except that "tuning" of the controllers (setting of gains) can be done through operator consoles.

The cost reduction which resulted from the introduction of direct digital control was offset by a number of disadvantages. The most notable of these were the decrease in reliability and the total loss of graceful degradation. Failure of a sensor or transmitter had the same effect as before, but failure of the computer itself threw the entire control system into manual operation. Hence it was necessary to provide analog controllers to back up certain critical loops which had to function even when the computer was down.

Increasing demand for ever-higher levels of supervisory control highlighted two disadvantages of centralized digital computer control of processes. First, process signals were still being transmitted from the process sensor to the central control room in analog form, meaning that separate wires had to be installed for every signal going to or from the computer. Second, the digital computer system itself evolved into a very complex unit because of the number of devices attached to the computer and because of the variety of different programs needed to carry out the myriad control and management functions. The latter resulted in the need for an elaborate real-time operating system for the computer which could handle resources, achieve desired response time for each task, and be responsible for error detection and error recovery in a highly dynamic real-time environment. Design coding, installation, and checkout of centralized digital control systems was so costly and time-consuming that application of centralized digital control was limited.

Low-cost electronic hardware utilizing large-scale integrated circuits provided the technology to solve both of these problems while retaining the advantages of centralized direct digital and supervisory control. The solution, distributed control, involved distributing control functions among hardware modules to eliminate the critical central computer. See INTEGRATED CIRCUITS.

The combination of reliable, responsive distributed control and general-purpose communication networks leads to a sys-

tem which can be adapted to critical control applications in a very flexible manner, with potential for increased productivity in plants, increased safety, and decreased energy consumption. Technology for higher-speed computation, data communication, and object-oriented software organization allows the integration of distributed control systems into plant-wide and enterprise-wide systems. See CONTROL SYSTEMS; DIGITAL CONTROL; MULTI-LEVEL CONTROL THEORY; OBJECT-ORIENTED PROGRAMMING. [J.D.S.]

**Distribution (probability)** The results of a series of independent trials, random variables, or errors often occur in fairly regular and predictable patterns that can be expressed mathematically. The most important of them are called the binomial, normal, and Poisson distributions.

Consider  $n$  independent trials, each of which results in success  $S$  or failure  $F$ , with corresponding probabilities  $p$  and  $q = 1 - p$ . Denote by  $S_n$  the number of successes. Because there are  $\binom{n}{k}$  possible ways to select  $k$  places for  $S$  and  $n - k$  places for  $F$ , the probability distribution of the random variable  $S_n$  is given by

$$P\{S_n = k\} = \binom{n}{k} p^k q^{n-k}$$

where  $k = 0, 1, \dots, n$ . This is the binomial distribution. Its expectation is  $np$ , its variance  $npq$ . See PROBABILITY.

The standard normal density is defined for  $-\infty < x < \infty$  by

$$\phi(x) = (2\pi)^{-1/2} e^{-x^2/2}$$

The standard normal distribution function or error function  $\Phi(x)$  is its integral from  $-\infty$  to  $x$ . The normal distribution function with mean  $m$  and variance  $s^2$  is  $\Phi[(x - m)/s]$ ; its density is  $2\pi^{-1/2} s^{-1} e^{-(x-m)^2/(2s^2)}$ . As  $x$  goes from  $-\infty$  to  $\infty$ , the function increases from 0 to 1. It plays an important role in many fields. In particular,  $u(t, x; \xi) = 2\pi^{-1/2} t^{-1/2} e^{-(x-\xi)^2/(4t)}$  is the fundamental solution of the heat (or diffusion) equation  $u_t = u_{xx}$  and represents the heat distribution on the  $x$  axis at time  $t$  caused by a unit heat source initially concentrated at  $x = \xi$ . Probabilistically, this represents the transition probabilities in the Wiener process. A random variable whose distribution is normal is called normal or Gaussian. Many empirical quantities (for example, the amount of water in a reservoir, certain inherited characteristics such as height, and the experimental error of physical measurements) represent the cumulative effect of many small components, and the statistical fluctuations of such quantities may be expected to follow the normal distribution.

The Poisson distribution with parameter  $\lambda$  is the probability distribution of a random variable assuming the values  $0, 1, 2, \dots$  with probabilities  $p_k(\lambda) = e^{-\lambda} \lambda^k / k!$  Both its expectation and variance equal  $\lambda$ . This is one of the most important distributions; it plays a basic role in the theory of stochastic processes and in many applications.

Consider a large number  $n$  of independent trials, each of which results in success or failure with probabilities  $p$  and  $q = 1 - p$ . Ordinarily, interest is restricted to the case where  $p$  is very small, but the expected number of successes  $np = \lambda$  is of moderate size. Typical examples may be obtained by considering centenarians, color-blind people, or triplets in a large population. The number of successes in the  $n$  trials is a random variable with the binomial distribution, but under the present circumstances the binomial is close to the Poisson distribution and may be replaced by it. In fact, the probability of no success is  $q^n = (1 - \lambda/n)^n$ , which is close to  $e^{-\lambda}$ , the first term of the Poisson distribution.

In other circumstances the Poisson distribution appears, not as an approximation, but as the exact expression of a law of nature. This is true in particular of processes where certain events, such as radioactive disintegrations, mutations, power failures, and accidents, occur in time in such a way that (1) the probability that an event occurs during any given time interval of length  $dt$  is, asymptotically,  $\lambda dt$  and (2) there is no interaction or aftereffect between nonoverlapping time intervals. A similar argument applies to random distributions of points in space, with  $t$  interpreted

as volume; typical examples are stars, flaws of material, raisins in a cake, and animal litters in a field. See ANALYSIS OF VARIANCE; STATISTICS. [W.F.]

**District heating** The supply of heat, either in the form of steam or hot water, from a central source to a group of buildings. Most district heating systems in the United States rely on separate steam generation facilities close to load centers. In some cities, notably New York, high-pressure district steam is used extensively to feed turbines that drive pumps and refrigerant compressors. Although some district heating plants serve detached residences, the cost of underground piping and the small quantities of heating service required makes this service generally unfeasible. District heating, apart from utility-supplied systems in downtown areas of cities, is accepted as efficient practice in many colleges, universities, and government complexes.

In Europe, a substantial part of the heat distribution is by hot water from plants combining power and heat generation. Hot water distribution systems have the advantage of high thermal mass (hence, storage for peak periods) and freedom from problems of condensate return. On the other hand, pumping costs are high and two mains are required, supply and return. See COMFORT HEATING. [R.L.K.]

**Diving** Skin diving, scuba diving, saturation diving, and "hard hat" diving are techniques used by scientists to investigate the underwater environment. Skin diving is usually without breathing apparatus and is done with fins and faceplate. The diver's underwater observation is limited to the time that breath can be held (1–2 min). Diving with scuba (self-contained underwater breathing apparatus) and "hard hat" provide the diver with a breathable gas, thus expanding the submerged time and the depth range of underwater observations. This type of diving is limited by human physiology and the diver's reaction to the pressure and nature of the breathing gas. Saturation diving permits almost unlimited time down to depths of 100 ft (30 m).

**Scuba diving.** Scuba is used by trained personnel as a tool for direct observation in marine research and underwater engineering. This equipment is designed to deliver through a demand-type regulator a breathable gas mixture at the same pressure as that exerted on the diver by the overlying water column. The gas which is breathed is carried in high-pressure cylinders (at starting pressures of 2000–3000 psi or 14–20 megapascals) worn on the back.

Scuba can be divided into three types: closed-circuit, semiclosed-circuit, and open-circuit. In the first two, which use pure oxygen or various combinations of oxygen, helium, and nitrogen, exhaled gas is retained and passed through a canister containing a carbon dioxide absorbent for purification and then recirculated to a bag worn by the diver. During inhalation additional gas is supplied to the bag by various automatic devices from the high-pressure cylinders. These two types of equipment are much more efficient than the open-circuit system, in which the exhaled gas is discharged directly into the water after breathing. Most open-circuit systems use compressed air because it is relatively inexpensive and easy to obtain. Although open-circuit scuba is not as efficient as the other types, it is preferred because of its safety, the ease in learning its use, and its relatively low cost.

For physiological reasons scuba diving is limited to about 165 ft (50 m) of water depth. Below this depth when using compressed air as a breathing gas, the diver is limited, not by equipment, but by the complex temporary changes which take place in the body chemistry while breathing gas (air) under high pressure.

**Saturation diving.** This type of diving permits long periods of submergence (1–2 weeks). It allows the diver to take advantage of the fact that at a given depth the body will become fully saturated with the breathing gas and then, no matter how long

the submergence period, the decompression time needed to return to the surface will not be increased. Using this method, the diver can live on the bottom and make detailed measurements and observations, and work with no ill effects. This type of diving requires longer periods of decompression in specially designed chambers to free the diver's body of the high concentration of breathing gas. Decompression times of days or weeks (the time increases with depth) are common on deep dives of over 200 ft (60 m). [R.F.Di.]

**Physiology.** Environmental effects on the submerged diver are quite different from those experienced at sea level. Two elements are very evident during the dive. As the depth of surrounding water increases, pressure on the air the diver breathes also increases. In addition, as the pressure increases, the solubility of the gases in the diver's tissues increases. The tissues, therefore, accumulate certain gases which are not metabolized. The increased presence of certain gases causes specific and often dangerous physiological effects.

The total pressure of the atmosphere at sea level is approximately 760 mmHg or 30.4 in. Hg. Pressure increases underwater at the rate of 1 atm (10 kilopascals) for each 33 ft (10 m) that the diver descends. The total pressure applied to the body and to the breathing gas increases proportionately with depth. As pressure of the gas increases, the amount of gas that is absorbed by the body increases. This is particularly evident if the diver is breathing air within a caisson since the percentage of nitrogen in the breathing gas increases proportionately to the amount of oxygen that is removed. Likewise, the amount of carbon dioxide in the body increases during the dive, particularly if the exhaled air is not separated from the inhaled air.

One of the more obvious effects of gases on divers is caused by nitrogen. This gas makes up about 78% of the air that is normally breathed, and its solubility in the tissues increases as atmospheric pressure increases. When nitrogen is dissolved in the body, more than 50% is contained in the fatty tissues; this includes the myelin sheaths which surround many nerve cells. When divers undergo increased pressure, amounts of nitrogen in nerve tissue increase and lead to nitrogen narcosis or "rapture of the deep." Nitrogen narcosis can occur at 415 ft (130 m) or 5 atm (500 kPa), and increases in severity as the diver descends below this depth. The irrational behavior and euphoria often seen in nitrogen narcosis can result in serious, even deadly mistakes during a dive. The maximum time that divers can remain underwater without showing symptoms decreases with increasing depth.

One of the earlier recognized problems associated with human diving is known as decompression sickness, the bends, or caisson disease. If a diver is allowed to stay beneath the surface for long periods of time, the volume of dissolved gases in the tissues will increase. This is particularly true of nitrogen in the case of air breathing. When nitrogen accumulates in the tissues, it remains in solution as long as the pressure remains constant. However, when pressure decreases during the ascent, bubbles form in the tissues. Nitrogen bubbles can occur in nerves or muscles and cause pain, or they can occur in the spinal cord or brain and result in paralysis, dizziness, blindness, or even unconsciousness. Bubbles forming in the circulatory system result in air embolism. If the embolism occurs in the circulation of the lungs, a condition known as the chokes occurs. See DECOMPRESSION ILLNESS.

A method of prevention of decompression sickness was suggested by J. S. Haldane in 1907. Haldane introduced the method of stage decompression, in which the diver is allowed to ascend a few feet and then remain at this level until the gases in the tissues have been allowed to reequilibrate at the new pressure. This stepwise ascent is continued until the diver finally reaches the surface. A modern variation of this method consists of placing the diver in a decompression chamber after the surface is reached, to allow for periods of decompression which simulate ocean depths. [J.H.F.]

**Diving animals** Truly aquatic animals have no need for a specialized diving response, because they are able to obtain oxygen directly from the water and thus sustain themselves indefinitely in the aquatic medium. Terrestrial or land animals, on the other hand, have in many cases gone back to the aquatic mode of living in varying degrees. In all of these has arisen the problem of obtaining the necessary gas exchange in an aquatic environment with only the physical attributes of a terrestrial animal. Many of these terrestrial animals have adapted so well as to achieve almost perfect freedom in the water.

All classes of terrestrial vertebrates (birds, mammals, and reptiles) have species which spend part of their lives under water or seek food or shelter by becoming submerged for a period of time. One example, a fresh-water mammalian species, is the North American beaver. One of the first changes noted in these and other animals that normally dive beneath the surface of the water is a reduction in heart rate, called bradycardia. However, those animals which traditionally utilize an aquatic habitat show a more pronounced reduction in heart rate in a much shorter time. In the other two classes of animals which contain divers, the reptiles and birds, some excellent examples reflect reductions in heart rate similar to the rates seen in mammals.

Warm-blooded animals show a more rapid response to submergence than do reptilian species. Those mammals, such as seals, which are traditionally found in open-ocean environments show the most dramatic responses of all. The reptiles in general utilize less oxygen than do warm-blooded animals and have slower resting heart rates, so that their response would be expected to be less spectacular. Also, reptilian reaction times are generally slower than those seen in mammals, and are usually modified by the temperature of the water in which they dive, so that a slower response to the diving stimulus is expected.

Specifically, the diving response enables the animal to remain underwater for longer periods of time. Not only does the heart rate slow down, but blood flow to specific muscles is decreased or stopped altogether. Lactic acid produced as a result of anaerobic glycolysis in muscles thus isolated is less likely to enter the systemic circulation and alter the functions of vital organs such as the brain and heart. This response also reduces the likelihood that hydrogen ions will build up in the blood and stimulate chemoreceptors (receptors which respond to changes in blood carbon dioxide levels and hydrogen ion concentration) which control breathing. Blood flow thus remains constant and unrestricted to the most essential organs, such as brain, heart, and lungs, during the dive, and arterial pressure to these organs remains at the normal level, so that perfusion of the capillaries with blood is not altered.

Other changes in the bodies of divers are also apparent, but are seen as changes in total body chemistry. For instance, glycogen and adenosinetriphosphate, which are the principal energy sources of muscles, are in more than ample supply in divers, and appear to have been stored for that time when they are most needed. Oxygen stores are essential to the length of time that a diver may stay submerged, and diving animals have concentrations of myoglobin in their muscles which gives them a remarkable ability to store oxygen. See DIVING. [J.H.F.]

**Division** In arithmetic and algebra, the process of finding one of two factors of a number (or polynomial) when their product and one of the factors are given. The symbol  $\div$  is used in elementary English and American arithmetics to denote division. Division is more often symbolized by the double dot  $:$ , the bar  $\overline{\quad}$ , or the solidus  $/$ ; thus  $x \div y$ ,  $\frac{x}{y}$ , or  $x/y$  indicates division of a number  $x$  by a number  $y$ . Considered as an operation inverse to multiplication,  $x/y$  is a symbol denoting a number whose product with  $y$  is  $x$ . Another way to base division upon multiplication is provided by the concept of the reciprocal of a number. If  $y$  is any number (real or complex) other than 0, there is a number, denoted by  $1/y$  and called the reciprocal of  $y$ , whose product with

$y$  is 1. Then  $x/y$  is the symbol for the product of  $x$  and  $1/y$ . This view of division furnishes a means of extending the concept to objects other than real or complex numbers. See ALGEBRA; MULTIPLICATION. [L.M.B.]

**Docodonta** One of the most primitive mammalian orders known, found in the Jurassic of North America and England and possibly in Rhaetic deposits. In docodonts the main jaw articulation was formed by the dentary and squamosal bones, but the articular and quadrate bones formed a secondary jaw articulation. Early members of other Mesozoic orders possessed the same double articulation, but by Late Jurassic time only the docodonts still retained this transitional reptile-mammal condition. See MAMMALIA. [M.C.McK.]

**Dogs** All breeds of domestic dogs, the wild dogs, and related species belong to the family Canidae. Despite the various breeds of domestic dogs which are known, the scientific name for all is *Canis familiaris*. The origin of domestic dogs is obscure, but they seem to be most closely related to the wolf. In many respects the dog is structurally primitive and shows a genetic plasticity which accounts for the many varieties.

**Domestic breeds.** There are more than 100 breeds of domestic dogs, and their classification is based principally on their uses. The domestic breeds are the sporting breeds, hounds, terriers, working breeds, and the toy breeds.

The sporting breeds are trained and employed for retrieving or finding game. The largest group in this class is the spaniels, of which there are about 10 types. The spaniels have been trained to retrieve and to flush game, and they hunt both birds and fur-bearing animals. Retrievers are specially trained to locate and return game to hunters and are used most commonly in hunting waterfowl. There are four varieties: the curly, the Chesapeake Bay, the golden retriever, and the Labrador. Pointers and setters, used for hunting upland game birds, range ahead of the hunter, point the game until the hunter arrives, and retrieve the fowl after it has been flushed and shot. Among the varieties that are used in these pursuits are the Weimeraner, the English and Irish setters, and the German short-haired pointer.

The hound group includes the basset, the bloodhound, the whippet, the dachshund, the wolfhound, and the beagle. The greyhound, one of the oldest breeds, is built for speed with its thin body and long legs. The bloodhounds and foxhounds (smaller, stockier dogs) are used for hunting, mostly by scent. The beagle, now more a pet than a hunter, can also follow a scent and is easier to follow on foot.

The terriers originally were bred for hunting burrowing animals, such as the badger and fox. The Boston terrier is the only breed to have originated in the United States. The fox terrier, typical of the group, may have been derived from the foxhound. It was originally bred for fox hunting but is an excellent ratter. Other terriers are the Airedale, largest of the group, and the Scottish and Skye terriers.

Most of the working breeds are large animals used as draught animals, for police work, for herding, and as guide dogs for the blind. Other draught breeds are the Alaskan malamute, the Eskimo, and the Samoyed. Among the animals used as guard dogs and for police work are the Doberman, the German shepherd, and the Great Dane. The collies, Belgian sheep dogs, and English sheep dogs are outstanding sheep herders. The bulldog is now more of a pet and house dog than a guard dog, but it is pugnacious if set on an intruder and will not release the person. The poodle, said to be the most intelligent dog, can be trained as a gun dog and was originally used for duck shooting.

Some of the toy breeds have been known for centuries and are principally household pets which may develop an instinct for protecting the premises of the owner. They are all quite small, some being miniatures of the larger breeds. The chihuahua is the smallest. Some of the more popular varieties are the Pomeranian, Pekingese, and pug.

**Wild species.** The wild species of the family, numbering about 36 and having a wide distribution, include several wild dogs, wolves, coyotes, foxes, and jackals. There are a number of wild dogs which have never been domesticated, unlike the dingo of Australia (*Canis dingo*) that is believed to have been a domestic dog introduced into Australia during prehistoric times and then reverted to its wild state. The Asiatic wild dog occurs throughout Asia, Java, and Sumatra and is considered to be three distinct species by some authorities while others regard it as two subspecies of *Cuon alpinus*, which is also known as the Siberian wild dog. The Cape hunting dog (*Lycaon pictus*) ranges throughout the grasslands of eastern and southern Africa but has become reduced in numbers.

The common European wolf (*Canis lupus*) is the species that once ranged throughout the temperate forested regions of Europe, Asia, and North America. This species has been exterminated in the British Isles and almost so in France, but they do occur in other European countries such as Italy, Spain, and the Balkans and are still plentiful in the Scandinavian countries. The gray wolf or timber wolf, originally extremely common in North America, is now restricted to Alaska and the subarctic regions of Canada.

The coyote (*Canis latrans*) is sometimes called the prairie wolf and is a close relative of the true wolf, although it is smaller than the wolves. They inhabit the prairies, open plains, and desert areas of North America.

Jackals are scavengers as well as menaces to domestic poultry. Both the oriental jackal (*Canis aureus*), the most widely distributed jackal, and the black-backed jackal (*C. mesomelas*) can be easily tamed. *Canis aureus* has spread from southeastern Europe and northern Africa through Asia as far south as Burma. It prefers higher elevations in contrast to *C. mesomelas*, which is found in the grasslands of eastern and southern Africa.

Foxes have relatively short legs and long bodies, big erect ears, pointed snouts, and long bushy tails. The Old World red fox (*Vulpes vulpes*) is closely related to, but is smaller than, the American red fox (*V. fulva*), which is found throughout North America. The American species has undergone many color phases and mutations and includes other varieties such as the silver fox and the cross fox. Scent glands are present in the anal region, which account for the characteristic odor of these animals. See CARNIVORA; MAMMALIA; SCENT GLAND. [C.B.C.]

**Dogwood** A tree, *Cornus florida*, also known as flowering dogwood, which may reach a height of 40 ft (12 m) and is found in the eastern half of the United States and in southern Ontario, Canada. It has opposite, simple, deciduous leaves with entire margins. When this tree is in full flower, the four large, white, notched bracts or petallike growths surrounding the small head of flowers give an ornamental effect. Pink, rose, and cream-colored varieties are commonly planted. The wood is very hard and is used for roller skates, carpenters' planes, and other articles in which hardness is desired. The Pacific dogwood (*C. nuttalli*), which grows in Idaho and from southwestern British Columbia to southern California, is similar to the eastern dogwood, but has rounded bracts. The Japanese dogwood (*C. kousa*) is a similar small tree with pointed bracts and blooms in June. Other shrubby species of dogwood are used as ornamentals. See CORNALES; FOREST AND FORESTRY; TREE. [A.H.G.; K.P.D.]

**Dolerite** A fine-textured, dark-gray to black igneous rock composed mostly of plagioclase feldspar (labradorite) and pyroxene and exhibiting ophitic texture. It is commonly used for crushed stone. Its resistance to weathering and its general appearance make it a first-class material for monuments. See STONE AND STONE PRODUCTS.

The most diagnostic feature is the ophitic texture, in which small rectangular plagioclase crystals are enclosed or partially wrapped by large crystals of pyroxene. As the quantity of pyrox-

ene decreases, the mineral becomes more interstitial to feldspar. The rock is closely allied chemically and mineralogically with basalt and gabbro. As grain size increases, the rock passes into gabbro; as it decreases, diabase passes into basalt. See BASALT; GABBRO.

Diabase forms by relatively rapid crystallization of basaltic magma (rock melt). It is a common and extremely widespread rock type. It forms dikes, sills, sheets, and other small intrusive bodies. The Palisades of the Hudson, near New York City, are formed of a thick horizontal sheet of diabase. In the lower part of this sheet is a layer rich in the mineral olivine. This concentration is attributed by some investigators to settling of heavy olivine crystals through the molten diabase and by others to movement of early crystals away from the walls of the passageway along which the melt flowed upward from depth, before it spread horizontally to form the sill. See MAGMA.

As defined, diabase is equivalent to the British term dolerite. The British term diabase is an altered diabase in the sense defined here. See BASALT; GABBRO; IGNEOUS ROCKS. [C.A.C.]

**Dolomite** The carbonate mineral  $\text{CaMg}(\text{CO}_3)_2$ . Often small amounts of iron, manganese, or excess calcium replace some of the magnesium; cobalt, zinc, lead, and barium are more rarely found. Dolomite is normally white or colorless with a specific gravity of 2.9 and a hardness of 3.5–4 on Mohs scale. It can be distinguished from calcite by its extremely slow reaction with cold dilute acid. Dolomite is a very common mineral, occurring in a variety of geologic settings. It is often found in ultrabasic igneous rocks, notably in carbonatites and serpentinites, in metamorphosed carbonate sediments, where it may recrystallize to form dolomite marbles, and in hydrothermal veins. The primary occurrence of dolomite is in sedimentary deposits, where it constitutes the major component of dolomite rock and is often present in limestones. See DOLOMITE ROCK; LIMESTONE; SEDIMENTARY ROCKS. [A.M.G.]

**Dolomite rock** Sedimentary rock containing more than 50% by weight of the mineral dolomite [ $\text{CaMg}(\text{CO}_3)_2$ ]. The term dolostone is used synonymously. Since dolomites usually form by replacement of preexisting limestones, it is often possible to see relict grains, fossils, and sedimentary structures preserved in dolomite rocks. More often, however, original textures are obliterated. See DOLOMITE; LIMESTONE.

Field differentiation of dolomite from calcite ( $\text{CaCO}_3$ ) is most easily accomplished by application of dilute hydrochloric acid. Calcite is strongly effervescent in acid, whereas dolomite is usually very weakly effervescent unless scratched or ground into a fine powder. Dolomite also often weathers to a brown color on outcrop because of the common substitution of iron for magnesium in the dolomite structure. X-ray diffraction analysis is the most reliable method for the differentiation of dolomite from calcite, and also the best method for characterization of the degree of ordering of a particular dolomite sample. See X-RAY DIFFRACTION.

Dolomite rocks are predominantly monomineralic. The most common noncarbonate minerals are quartz (either authigenic or detrital), clay minerals, pyrite, and glauconite. Evaporite minerals or their replacements are also common.

Geologists have been unable to decipher the exact conditions of dolomite formation. This so-called dolomite problem revolves around several questions relating to the stoichiometry of the reaction in which dolomite is formed, the fact that dolomite is not common in young marine sediments, and the type of geological setting in which ancient dolomites formed.

The relative proportions of dolomite and calcite have changed through geologic time. Dolomitic rocks are dominant in the Precambrian and early Paleozoic, whereas calcitic rocks become dominant in the late Mesozoic and continue to dominate through



the present. Several alternative hypotheses have been offered to explain this.

In a few geological settings, dolomite is forming within the sediments at the present time. One general setting includes a wide variety of supratidal ponds, lagoons, tidal flats, and sabkhas such as the Solar Lake in Israel, the Coorong Lagoon in Australia, the bank tops of Andros Island in the Bahamas, and the Sabkha of Abu Dhabi. Each of these environments is hot, more saline than seawater, and rich in organic matter. A second general setting of modern dolomite formation is in continental margin sediments underlying productive coastal oceanic upwelling zones. Examples include the Peru-Chile margin, the southern California borderlands, the Gulf of California, and the Walvis Ridge west of Namibia (southwestern Africa). This second set of geological environments is characterized by lower water temperature and normal marine salinity. Like the first set, these environments are rich in organic matter. The association of dolomite formation with abundant organic carbon seems to be the one common thread linking each dolomite occurrence and possibly controlling dolomite precipitation.

Dolomites are extremely important oil reservoir rocks. This is partly a result of the high porosity of many dolomite rocks and partly the result of the association between dolomite formation and the presence of sedimentary organic matter.

Dolomites are also the main host rocks for lead and zinc ore deposits. Rocks of this type are known as Mississippi Valley ore deposits. Neither the origin of the ore-forming solutions nor the association between the lead-zinc ores and the dolomite rocks has been satisfactorily explained. See PETROLEUM GEOLOGY; SEDIMENTARY ROCKS. [P.A.B.]

**Domain (electricity and magnetism)** A region in a solid within which elementary atomic or molecular magnetic or electric moments are uniformly aligned.

Ferromagnetic domains are regions of parallel-aligned magnetic moments. Each domain may be thought of as a tiny magnet pointing in a certain direction. The relatively thin boundary region between two domains is called a domain wall. Within a wall the magnetic moments rotate from the direction of one of the domains to the direction in the adjacent domain.

A ferromagnet generally consists of a large number of domains. For example, a sample of pure iron at room temperature contains many domains whose directions are distributed randomly, making the sample appear to be unmagnetized as a whole. Iron is called magnetically soft since the domain walls move easily if a magnetic field is applied. In a magnetically hard or permanent magnet material a net macroscopic magnetization is introduced by exposure to a large external magnetic field, but thereafter domain walls are difficult to either form or move, and the material retains its overall magnetization.

Antiferromagnetic domains are regions of antiparallel-aligned magnetic moments. They are associated with the presence of grain boundaries, twinning, and other crystal inhomogeneities.

Ferroelectric domains are electrical analogs of ferromagnetic domains. See ANTIFERROMAGNETISM; FERROELECTRICS; FERROMAGNETISM; MAGNETIC MATERIALS; MAGNETIZATION; TWINNING (CRYSTALLOGRAPHY). [J.F.He.]

**Dominance** The expression of a trait in both the homozygous and the heterozygous condition. In experiments with the garden pea, the Austrian botanist Gregor Mendel crossed plants from true-breeding strains containing contrasting sets of characters. For seed shape, round and wrinkled strains were used. When plants with round seeds were crossed to plants with wrinkled seeds ( $P_1$  generation), all offspring had round seeds. When the offspring ( $F_1$  generation) were self-crossed, 5474 of the resulting  $F_2$  offspring were round and 1850 were wrinkled. Thus, the round trait is expressed in both the  $F_1$  and  $F_2$  generations, while the wrinkled trait is not expressed in the  $F_1$  but is reexpressed in

the  $F_2$  in about one-fourth of the offspring. In reporting these results in a paper published in 1866, Mendel called the trait which is expressed in the  $F_1$  generation a dominant trait, while the trait which is unexpressed in the  $F_1$  but reappears in the  $F_2$  generation was called a recessive trait. See MENDELISM.

Traits such as round or wrinkled are visible expressions of genes. This visible expression of a gene is known as the phenotype, while the genetic constitution of an individual is known as its genotype. The alternate forms of a single gene such as round or wrinkled seed shape are known as alleles. In the  $P_1$  round plants, both alleles are identical (since the plant is true-breeding), and the individual is said to be homozygous for this trait. The  $F_1$  round plants are not true-breeding, since they give rise to both round and wrinkled offspring, and are said to be heterozygous. In this case, then, the round allele is dominant to the wrinkled, since it is expressed in both the homozygous and heterozygous condition. Dominance is not an inherent property of a gene or an allele, but instead is a term used to describe the relationship between phenotype and genotype. See ALLELE; GENE ACTION.

The production of phenotypes which are intermediate between those of the parents is an example of partial or incomplete dominance. The phenomenon of incomplete dominance which results in a clear-cut intermediate phenotype is relatively rare. However, even in cases where dominance appears to be complete, there is often evidence for intermediate gene expression.

The separate and distinct expression of both alleles of a gene is an example of codominance. This is a situation unlike that of incomplete dominance or complete dominance. In humans, the MN blood group is characterized by the presence of molecules called glycoproteins on the surface of red blood cells. These molecules or antigens contribute to the immunological identity of an individual. In the MN blood system, persons belong to blood groups M, MN, or N. These phenotypes are produced by two alleles, M and N, each of which controls the synthesis of a variant glycoprotein. In the heterozygote MN, there is separate and complete expression of each allele. This is in contrast to incomplete dominance, where there is an intermediate or blending effect in heterozygotes. Codominance usually results in the production of gene products of both alleles. See BLOOD GROUPS.

Individuals in which the phenotype of the heterozygote is more extreme than in either of the parents are said to exhibit overdominance. The concept of overdominance is important in understanding the genetic structure of populations and is usually related to characteristics associated with fitness, such as size and viability.

The production of superior hybrid offspring by crossing two different strains of an organism is known as heterosis. The hybrid superiority may take the form of increased resistance to disease or greater yield in grain production. The mechanism which results in heterosis has been widely debated but is still unknown. See BREEDING (PLANT); HETEROISIS.

A physiological explanation of dominance was put forward by S. Wright in 1934. He argued that variations in metabolic activity brought about by the heterozygous condition are likely to have little effect on the phenotype because enzymes are linked together in pathways so that the substrate of one enzyme is the product of another. Recessive mutations, when homozygous, may halt the activity of one enzyme and thus bring the entire pathway to a halt, producing a mutant phenotype. Heterozygotes, on the other hand, are likely to have only a reduction in activity of one enzyme which will be averaged out over the entire metabolic pathway, producing little phenotypic effect. Molecular studies of dominance have extended Wright's ideas by exploring the kinetic structure of metabolic pathways and enzyme systems. The results obtained thus far tend to support the thrust of his hypothesis, and have established that the dominant phenotype seen in heterozygotes for a recessive allele can be explained without the need to invoke the existence of modifiers. See GENETICS; MOLECULAR BIOLOGY; MUTATION. [M.R.C.]

**Donkeys and allies** Donkeys, asses, and mules are included in the family Equidae along with the horses and zebras. These are odd-toed ungulates and therefore belong to the mammalian order Perissodactyla.

Donkeys (*Equus asinus*) originated in Africa, and their only relatives in the wild state are found in Ethiopia and Somaliland. They have been domesticated and are used principally as pack animals throughout Asia and Europe. They are hardy animals but better suited to hot climates since they are sensitive to cold.

The wild ass of Asia (*E. hemionus*) is known by a variety of common names, and because of its extensive distribution it has been divided into a number of races or subspecies. In the central regions of Mongolia is the kulan (*E. h. hemionus*), the onager (*E. h. onager*) occurs in Persia and India, while the kiang (*E. h. kiang*), largest of all the races, is restricted to Tibet and the Sikkim. The Syrian wild ass (*E. h. hemippus*) is extremely rare and possibly extinct. The Asian wild asses are the most abundant of the wild Equidae after the zebras. The African wild ass (*E. asinus*) is also becoming rare in its natural habitat, being found only between the Sudan and Somaliland.

The mule is a hybrid resulting from the cross of the male ass (*E. asinus*) and the mare or female horse (*E. caballus*). When the female ass is bred to a stallion, the cross is called a hinny. These crosses do not occur naturally and both mule and hinny are usually sterile. See PERISSODACTYLA. [C.B.C.]

**Donnan equilibrium** The distribution of diffusible ions on either side of a semipermeable membrane in the presence of macro-ions that are too large to pass through the membrane. The Donnan equilibrium thus is the result of (1) external constraints (boundary conditions) that enforce an unequal distribution of mobile ions and (2) a corresponding electrical potential on the membrane as a balance. This equilibrium is named for F. G. Donnan, the first to describe it and formulate the theory.

Typically, within a solution system that consists of two communicating compartments (for example, an inner and outer compartment), the polyions of a macromolecular polyelectrolyte (a colloidal electrolyte) are confined to one compartment (for example, the inner one) by the semipermeable membrane, which allows the exchange of solvent and low-molecular-weight electrolytes by diffusion between the compartments. Since electrical neutrality must obtain in either compartment, and since the macro-ions are confined to one side, the concentration of the diffusible ions in the two compartments cannot be the same. At thermodynamic equilibrium—assuming for simplicity an electrolyte of which both ions are small, carry a charge of 1, and diffuse readily throughout the system in which they are dissolved—the chemical potential (activities) for the outer ionic pair must equal that of the diffusible ion pair on the inside. This condition is fulfilled when the products of the activities are equal, as shown in Eq. (1), where  $m_o$  and  $m_i$  are the molalities and  $\gamma_o$  and  $\gamma_i$  are

$$m_o^+ m_o^- \gamma_o^\pm = m_i^+ m_i^- \gamma_i^\pm \quad (1)$$

the activity coefficients within the outer and inner compartments, respectively. In dilute solution, the molalities are approximately equal to the molarities, and the activity coefficients are practically equal to 1. The equilibrium of the solvent (whether the nondiffusible species is ionized or not) follows upon flux of the solvent into the (closed) cell that holds the macromolecular solute, until osmotic pressure equalizes the activities of the solvent in both cells. See ACTIVITY (THERMODYNAMICS).

The inequality of the individual ionic concentrations on either side of the membrane means that, at equilibrium, the membrane must carry a charge whose free energy is equal in magnitude and opposite in sign to the free energy that results from the unequal individual activities of the diffusible ions. This is shown

in Eq. (2) for a negatively charged nondiffusible polyelectrolyte,

$$\begin{aligned} E &= \frac{RT}{F} \ln \frac{[Na_i^+]}{[Na_o^-]} \\ &= \frac{RT}{F} \ln \frac{[Cl_o^-]}{[Cl_i^-]} \end{aligned} \quad (2)$$

where  $E$  is the potential difference. In other words, the presence of the nondiffusing species on one side of the membrane and the resulting differences in salt concentration enforce a polarization of the membrane (which is independent of the nature of the diffusible ions).

Equation (1) permits the determination of the concentration (activity) of the ions of the same charge as the macro-ions within the inside cell, which is equal to the activity of the ions that have diffused in from the outer cell. It can also be seen that the osmotic pressure of a closed inner cell must be larger than the osmotic pressure that would be caused by the macro-ions alone, by an amount that corresponds to the number of ions that compensate the charges on the macro-ions, plus that of the ions that diffused in; that is, the osmotic pressure depends on the average molecular weight of the nonsolvent components of the inner cell. Therefore, if the salt concentration of the outer cell, and along with it the concentration in the inner cell, is raised, the contribution to the osmotic pressure by the macro-ions becomes relatively smaller and eventually becomes constant, amounting to the osmotic pressure of the macro-ions in their uncharged state. At the same time, the concentrations of the diffusible ions inside and outside approach one another. The same situation obtains in the absence of a membrane, when microscopic gel particles possess covalently bound ionized groups in their interior. Suspended microscopic gel particles, or dense polyelectrolyte coils, may thus carry a charge due to the effect of the Donnan equilibrium. See OSMOSIS.

The Donnan equilibrium is a frequent contributor to membrane potentials, but differential adsorption or, as in living systems, differences in the rates of passive or active ion transport through biological membranes are usually the main sources of membrane potentials of living cells. See COLLOID; ION-SELECTIVE MEMBRANES AND ELECTRODES. [F.R.E.]

**Donor atom** An impurity atom in a semiconductor which can contribute or donate one or more conduction electrons to the crystal by becoming ionized and positively charged. For example, an atom of column 5 of the periodic table substituting for a regular atom of a germanium or silicon crystal is a donor because it has one or more valence electrons which can be detached and added to the conduction band of the crystal. Donor atoms thus tend to increase the number of conduction electrons in the semiconductor. The ionization energy of a donor atom is the energy required to dissociate the electron from the atom and put it in the conduction band of the crystal. See ACCEPTOR ATOM; SEMICONDUCTOR. [H.Y.F.]

**Dopamine** A catecholamine neurotransmitter that is synthesized by certain neurons in the brain and interacts with specific receptor sites on target neurons.

Dopamine is manufactured inside dopamine neurons in a controlled manner from the amino acid precursor L-tyrosine, which mammals obtain through the normal diet. Dopamine is then stored in vesicles within the nerve terminals, which may fuse with the cell membrane to release dopamine into the synapse.

The release of neurotransmitter is controlled by a variety of factors, including the firing rate of the dopamine nerve cell (termed impulse-dependent release) and the release- and synthesis-modulating presynaptic dopamine receptors located on the dopamine nerve terminals. Since presynaptic dopamine receptors are sensitive to the cell's own neurotransmitter, they are called dopamine autoreceptors. Once released, dopamine

also acts at postsynaptic receptors to influence behavior. The actions of dopamine in the synapse are terminated primarily by the reuptake of neurotransmitter into the presynaptic terminal by means of an active dopamine transporter. Dopamine may then be either repackaged into synaptic vesicles for rerelease or degraded by the enzyme monoamine oxidase. The dopamine transporter is an important site of action of the drugs cocaine and amphetamine. *See SYNAPTIC TRANSMISSION.*

Although it was first thought that dopamine occurred only as an intermediate product formed in the biosynthesis of two other catecholamine neurotransmitters, norepinephrine and epinephrine, dopamine is now recognized as a neurotransmitter in its own right. Several distinct dopamine neuronal systems have been identified in the brain. These include systems within the hypothalamus and the pituitary gland; systems within the midbrain that project to a variety of cortical and limbic regions and basal ganglia; the retinal system; and the olfactory system. *See BRAIN; EPINEPHRINE; NORADRENERGIC SYSTEM.*

The midbrain dopamine neurons which project to a variety of forebrain structures are critically involved in normal behavioral attention and arousal; abnormalities in the normal functioning of these systems have been implicated in a variety of disorders. For example, Parkinson's disease involves a degeneration of the midbrain dopamine neurons. This condition is often successfully treated by providing affected individuals with L-dopa, which is readily converted to dopamine in the brain. Attention deficit disorder, which is usually first diagnosed in childhood, is thought to involve dopamine systems, because the treatment of choice, methylphenidate, binds to the dopamine transporter and alters dopamine levels in the synapse. *See PARKINSON'S DISEASE.*

Drugs used to treat the major symptoms of schizophrenia are potent dopamine receptor antagonists. It is possible that certain schizophrenias are the result of increased activity in dopamine neuronal systems, but this has not as yet been conclusively demonstrated. A similar involvement of midbrain dopamine systems has been implicated in the multiple tic disorder Tourette's syndrome, which is treated, often successfully, with dopamine receptor antagonists. *See NEUROBIOLOGY; SCHIZOPHRENIA.* [L.A.C.]

**Doppler effect** The change in the frequency of a wave observed at a receiver whenever the source or the receiver of the wave is moving relative to the other or to the carrier of the wave (the medium). The effect was predicted in 1842 by C. Doppler, and first verified for sound waves in 1845 from experiments conducted on a moving train.

The Doppler effect for sound waves is now a commonplace experience: If one is passed by a fast car or a plane, the pitch of its noise is considerably higher in approaching than in parting. The same phenomenon is observed if the source is at rest and the receiver is passing it. The linear optical Doppler effect was first observed in 1905 from a shift of spectral lines emitted by a beam of fast ions (canal rays) emerging from a hole in the cathode of a gas discharge tube run at high voltage. Still, their velocity was several orders of magnitude below that of light in vacuum. The precise interferometric experiments of A. A. Michelson and E. W. Morley (1887) showed clearly that the velocity of light is not bound to any ether, but is measured to be the same in any moving system. This result was a crucial check for A. Einstein's theory of special relativity (1905), which also makes a clear prediction for the optical Doppler effect.

The Doppler effect has important applications in remote-sensing, high-energy physics, astrophysics, and spectroscopy.

Let a wave from a sound source or radar source, or from a laser, be reflected from a moving object back to the source, which may itself move as well. Then a frequency shift is observed by a receiver connected to the source. The measurement provides an excellent means for the remote sensing of velocities of any kind of object, including cars, ships, planes, satellites, flows of fluids, or winds. *See DOPPLER RADAR; REMOTE SENSING.*

The light from distant stars and galaxies shows a strong Doppler shift to the red, indicating that the universe is rapidly expanding. However, this effect can be mixed up with the gravitational redshift that results from the energy loss which a light quantum suffers when it emerges from a strong gravitational field.

The Doppler width and Doppler shift of spectral lines in sunlight (Fraunhofer lines) are important diagnostic tools for the dynamics of the Sun's atmosphere, indicating its temperature and turbulence. *See ASTRONOMICAL SPECTROSCOPY; COSMOLOGY; GRAVITATIONAL REDSHIFT; REDSHIFT; SUN.* [E.W.O.]

**Doppler radar** A radar system used to measure the relative velocity of the system and the radar target. The operation of these systems is based on the fact that the Doppler frequency shift in the target echo is proportional to the radial component of target velocity. *See DOPPLER EFFECT.*

Airborne systems are used to determine the velocity of the vehicle relative to the Earth for such purposes as navigation, bombing, and aerial mapping, or relative to another vehicle for fire control or other purposes. Ground or ship equipment is used to determine the velocity of vehicular targets for fire control, remote guidance, intercept control, traffic control, and other uses.

Doppler navigation radar is a type of airborne Doppler radar system for determining aircraft velocity relative to the Earth's surface. It is generally used with a navigation computer. The signal from a single beam can provide only the velocity component in the direction of that beam. Complete velocity determination requires, therefore, the use of at least three beams. Most systems use four beams for symmetry.

A preferred technique for obtaining coherent detection is to employ sinusoidal frequency modulation. A sideband of the detected beat between echo and transmitter signal is used. Modulation index and rate and the sideband order are chosen such that echoes from nearby objects are rejected, while those from distant objects are accepted. Leakage noise is reduced at the expense of lowered efficiency. [F.B.B.]

Pulse Doppler radars are useful tools for the observation of the movements of precipitation particles. The Doppler frequency shift associated with the velocity of atmospheric targets, such as precipitation particles or artificial chaff, is always a very small fraction ( $10^{-6}$  to  $10^{-8}$ ) of the radar operating frequency. The observation and measurement of such small frequency shifts require excellent radar system frequency-stability characteristics that are not usually found in conventional radars but can be added without a drastic increase in equipment cost. *See RADAR.* [R.Lh.]

**Doppler VOR** A vhf omnidirectional radio range (VOR) employing the Doppler principle. If VOR beacons are installed in the vicinity of obstructions, or when aircraft using VOR signals fly over mountainous terrain, the bearing accuracy is deteriorated by reflections (site and enroute errors). The Doppler VOR solves this problem by two fundamental principles maintaining full compatibility of the radiated information with existing airborne receivers. It uses (1) a wide-base antenna array for suppressing the effects of multipath propagation and (2) the Doppler principle for determination of bearing. *See DOPPLER EFFECT.*

Disturbances by multipath propagation can be reduced by wide-aperture systems because of integration or averaging between the information transferred over the direct and the reflected propagation path. Wide-base systems, however, have the drawback that their directional information becomes ambiguous as soon as the aperture is larger than half a wavelength, approximately.

By applying the Doppler principle, one can overcome these limitations. A dipole rotating eccentrically on an orbit periodically changes the distance between transmitter and receiver, thus modulating the frequency of the radiated carrier by a deviation

$f_D$  according to the equation below. Here  $D$  is the diameter of

$$f_D = \frac{\text{velocity}}{\text{wavelength}} = \frac{\pi D f_{\text{rot.}}}{\lambda}$$

the array and  $f_{\text{rot.}}$  is the number of rotations, or revolutions, per second. The resulting Doppler effect produces a sinusoidal frequency modulation of the carrier frequency; the phase of this FM contains the bearing information (variable phase).

The Doppler VOR presents two essential advantages over conventional VOR: the improvement of absolute accuracy in good and poor terrain, and the spectacular radial stability and smoothness even over mountains. [E.Kr.]

**Dormancy** In the broadest sense, the state in which a living plant organ (seed, bud, tuber, bulb) fails to exhibit growth, even when environmental conditions are considered favorable. In a stricter context, dormancy pertains to a condition where the inhibition of growth is internally controlled by factors restricting water and nutrient absorption, gas exchange, cell division, and other metabolic processes necessary for growth. By utilizing the latter definition, dormancy can be distinguished from other terms such as rest and quiescence which reflect states of inhibited development due to an unfavorable environment.

Physically induced dormancy can be separated into two distinct classes, based on external conditions imposed by the environment (light, temperature, photoperiod) and restraints induced by structural morphology (seed-coat composition and embryo development).

The physical environment plays a key role in dormancy induction, maintenance, and release in several plant species.

1. *Temperature.* The onset of dormancy in many temperate-zone woody species coincides with decreasing temperature in the fall. However, it is the chilling temperature of the oncoming winter which is more crucial, particularly in regard to spring budbreak.

2. *Light duration and quality.* Possibly the single most important environmental variable affecting dormancy is day length or photoperiod. See PHOTOPERIODISM.

3. *Water and nutrient status.* Dormancy is affected by the availability of water and nutrients as demonstrated by many grasses, desert species, and subtropical fruits which go into dormancy when confronted by drought or lack of soil fertility. See FERTILIZER; PLANT MINERAL NUTRITION; PLANT-WATER RELATIONS.

4. *Environmental interactions.* Several of the factors previously discussed do not simply act independently, but combine to influence dormancy.

Examples of dormancy imposed by physical restrictions are most evident in the structural morphology of dormant seeds. These restrictions specifically pertain to the physical properties of the seed coat and developmental status of the embryo.

1. *Seed-coat factors.* The seed-coat material surrounding embryos of many plants consists of several layers of tissue, termed integuments, which are infiltrated with waxes and oils. In effect these waterproofing agents enable the seed coat to inhibit water absorption by the embryo. This results in a type of seed dormancy very characteristic of legume crops (clover and alfalfa). The environment itself can break this type of seed-coat dormancy through alternating temperature extremes of freezing and thawing. The extreme heat induced by forest fires is especially effective.

Seed-coat-induced dormancy can also result from mechanical resistance due to extremely hard, rigid integuments commonly found in conifer seeds and other tree species with hard nuts.

2. *Embryonic factors.* The morphological state of the embryo is yet another physical factor affecting dormancy. Often the embryo is in a rudimentary stage when the seed is shed from the maternal plant; dormancy will usually cease in those plants as the embryos reach an adequate state of maturation.

Studies dealing with dormancy have resulted in searches for endogenous plant hormones which regulate the process. Studies involving dormant buds of ash (*Fraxinus americana*) and birch

(*Betula pubescens*) revealed the presence of high concentrations of a growth inhibitor or dormancy-inducing and -maintaining compound. This compound was later identified as abscisic acid. As buds of these trees began to grow and elongate, the levels of abscisic acid fell appreciably, supporting the role for abscisic acid in the regulation of dormancy. Abscisic acid is also important in the regulation of seed dormancy, as exemplified by seeds of ash in which abscisic acid levels are high during the phase of growth inhibition, but then decline rapidly during stratification, resulting in germination. See ABSCISIC ACID.

In conjunction with decreased levels of abscisic acid, the endogenous supply of many growth promoters, such as gibberellins, cytokinins, and auxins, have been reported to rise during budbreak in sycamore (*Acer pseudoplatanus*) as well as in Douglas fir (*Pseudotsuga menziesii*). Levels of these dormancy-releasing compounds also correlate well with the breaking of seed dormancy. The hormonal regulation of dormancy can best be perceived as a balance between dormancy inducers or maintainers and dormancy-releasing agents. See AUXIN; CYTOKININS; GIBBERELLIN; PLANT HORMONES.

In addition to endogenous hormones, there are a variety of compounds that can break dormancy in plant species when they are applied exogenously. Many of these substances are synthetic derivatives or analogs of naturally occurring, dormancy-releasing agents.

The physical environment exerts a marked influence on dormancy. The plant, however, needs a receptor system to perceive changes in the environment so it can translate them into physiological responses which in most cases are under hormonal control. In the case of changing day length or photoperiod, phytochrome may serve as a receptor pigment. Phytochrome essentially favors the production of either abscisic acid (short days) or gibberellic acid (long days). Stress conditions, such as limited water or nutrient availability, favor the production of abscisic acid, whereas a period of chilling often promotes synthesis of gibberellic acid and other compounds generally considered as growth promoters. See PHYTOCHROME.

The mode of action of endogenous growth regulators can only be postulated at this time. Whatever the specific mechanism, it probably involves the regulation of gene action at the level of deoxyribonucleic acid (DNA) and ribonucleic acid (RNA), which subsequently controls protein synthesis. In this framework, abscisic acid is believed to repress the functioning of nucleic acids responsible for triggering enzyme and protein synthesis needed for growth. Gibberellic acid, on the other hand, promotes synthesis of enzymes essential for germination as in the case of  $\alpha$ -amylase production that is crucial for barley seed growth. See BUD; NUCLEIC ACID; PLANT GROWTH; SEED. [C.S.M.]

**Dormouse** The name applied to the 31 species of Old World rodents of the family Gliridae. These animals are



The fat dormouse *Glis glis*.

intermediate between squirrels and rats; they are vegetarians and arboreal like the former, but most have a general appearance like the latter.

The fat dormouse (*Glis glis*; see illustration), the largest member of the family, is found throughout Europe and western Asia. The only species of dormouse native to Britain is the common dormouse (*Muscardinus avellanarius*), which is about the size of a house mouse. Another species, found in central and southern Europe, is the garden dormouse (*Eliomys quercinus*), which is smaller than the fat dormouse but has similar habits. See RODENTIA. [C.B.C.]

**Dorylaimida** An order of nematodes in which the labia are generally well developed; however, many taxa exhibit a smoothly rounded anterior. The labial region is often set off from the general body contour by a constriction. The cephalic sensilla are all located on the labial region. When there is no constriction, the labial region is defined as that region anterior to the amphids. The amphidial pouch is shaped like an inverted stirrup, and the aperture is ellipsoidal or a transverse slit. The stoma is armed with a movable mural tooth or a hollow axial spear. The anterior portion of the tooth or spear is produced by a special cell in the anterior esophagus. The esophagus is divided into a slender, muscular anterior region and an elongated or pyriform glandular/muscular posterior region. There are generally five esophageal glands with orifices posterior to the nerve ring. In some taxa there are three glands, and in others seven have been reported. The esophagointestinal valve is well developed. The mesenteron is often clearly divided into an anterior intestine and a prerectum. Females have one or two reflexed ovaries; when there is only one, the vulva may shift anteriorly. Males have paired equal spicules that are rarely accompanied by a gubernaculum. The males often have the ventromedial preanal supplements preceded by paired adanal supplements.

There are seven dorylaimid superfamilies: Actinolaimoidea, Belonidiroidea, Diphtherophoroidea, Dorylaimoidea, Encholaimoidea, Nygolaimoidea, and Trichodoroidea. See NEMATODA. [A.R.M.]

**Dosimeter** A device used to measure the dose of ionizing radiation received by an individual. There are many types of dosimeters with varying characteristics and capabilities appropriate for different applications. They differ in sensitivity, energy range, and species of radiation to which they respond. Some can be read out directly by the wearer, while others must be sent to a specially equipped facility to determine the dose.

The air ionization chamber dosimeter is usually about the size and shape of a fountain pen with a clip suitable for carrying in a pocket, and is sometimes referred to as a pen meter or pocket dosimeter. The outside housing is usually made of plastic. Inside, a conductive cylinder and an insulated central electrode form an air-filled capacitor which is charged by connecting to a charging voltage supply. X-rays or gamma rays absorbed in the air space ionize the air, discharging the capacitor in proportion to the dose received. The dose is read by connecting the dosimeter to a quartz fiber or other type of electrometer which reads the charge remaining on the capacitor. See CAPACITOR; ELECTROMETER; GAMMA-RAY DETECTORS; IONIZATION CHAMBER; X-RAYS.

The housing of the film badge dosimeter is of plastic or metal, typically 50 mm square (2 in.) by 12 mm (0.5 in.) thick and equipped with a clip for attaching to clothing. It contains one or more film packets, usually standard dental x-ray film packets. The film is developed in a standardized procedure, and the optical density is measured and correlated to exposure, greater exposure being darker. The side of the badge housing is equipped with one or more filters of lead, aluminum, copper, silver, or cadmium which cover different parts of the film and leave part uncovered. These filters modify the response of different areas of the film and thereby provide more information to correct the response to approximate that of tissue. See RADIOGRAPHY.

The physical packaging of a thermoluminescent dosimeter can be similar to a film badge with filters incorporated, but the film is replaced by pieces of thermoluminescent materials. Absorbed radiation energy excites electrons of the thermoluminescent material, creating excited metastable states. These states remain excited until the material is subsequently heated to a sufficient temperature, when they deexcite, emitting visible light. The intensity of the emitted light is proportional to the absorbed radiation energy. The exposed material is placed in an automated instrument which heats it in a controlled manner, and the light is measured with a photomultiplier tube and the resulting signal is converted to a dose. If the exposed material is heated sufficiently to anneal all excited states, the dosimeter can be reused. Lithium fluoride is extensively used for thermoluminescent dosimeters, activated with manganese and titanium. See PHOTOMULTIPLIER; THERMOLUMINESCENCE.

Usually rectangular in shape, the electronic dosimeter ranges in size from a transistor radio to a pocket pager, though some devices resemble a fountain pen. It contains as sensing element a Geiger-Müller tube along with high-voltage supply, counting and control electronics, and a digital display, all powered by a battery. A wide variety of features are available. For example, a dose alarm can sound when a preset accumulated dose is reached, or a dose-rate alarm can sound when a preset dose rate is exceeded. An electrical connection can be made with a computer for dose recordkeeping. See GEIGER-MÜLLER COUNTER.

The active element of a track etch dosimeter is a piece of CR-39 plastic (from Columbia resin 39), made by polymerization of allyl diglycol carbonate. When a high-energy charged particle, such as a proton recoiling from a fast neutron, traverses the material, it gives up energy and leaves a trail of chemical damage. The material is subsequently exposed to a suitable etchant such as sodium hydroxide (NaOH), and damage sites are preferentially etched, leaving pits which can be observed and counted under a microscope. This dosimeter is sensitive only to high-energy neutrons, so it is usually used in conjunction with other dosimeters. See PARTICLE TRACK ETCHING.

The operation of the bubble detector dosimeter is based on the change to gas bubbles of superheated liquid (at a temperature above its boiling point) triggered by fast neutron interactions. A commercial bubble detector personal neutron dosimeter consists of a clear plastic tube with an aluminum fitting at one end, about the size of a large pen. It holds about 8 cm<sup>3</sup> (0.5 in.<sup>3</sup>) of clear, solid elastic polymer containing about 10,000 superheated liquid droplets. On exposure to fast neutrons, small uniform-sized bubbles form. The bubbles are counted visually and a fast neutron dose calculated using a calibration factor determined for that dosimeter. See HEALTH PHYSICS. [PRy.]

**Double diffusion** A type of convective transport in fluids that depends on the difference in diffusion rates of at least two density-affecting components. This phenomenon was discovered in 1960 in an oceanographic context, where the two components are heat and dissolved salts. Besides different diffusivities, it is necessary to have an unstable or top-heavy distribution of one component.

In the oceanographic context, if the unstable component is the slower-diffusing one (salt), with the overall gravitational stability maintained by the faster-diffusing component (heat), then "salt fingers" will form. Since warm, salty tropical waters generally overlie colder, fresher waters from polar regions, this is a very common stratification in the mid- to low-latitude ocean. Salt fingers arise spontaneously when small parcels of warm, salty water are displaced into the underlying cold, fresh water. Thermal conduction then removes the temperature difference much quicker than salt diffusion can take effect. The resulting cold, salty water parcel continues to sink because of its greater density. Conversely, a parcel of cold, fresh water displaced upward gains heat but not salt, becoming buoyant and continuing

to rise. The fully developed flow has intermingled columns of up- and downgoing fluid, with lateral exchange of heat but not salt, carrying advective vertical fluxes of salt and to a lesser extent heat.

Another form of double-diffusive convection occurs when the faster-diffusing component has an unstable distribution. In the ocean, this happens when cold, fresh water sits above warmer, saltier and denser water. Such stratifications are common in polar regions and in local areas above hot springs at the bottom of the deep sea. See OCEAN CIRCULATION; OCEANOGRAPHY; SEAWATER.

The importance of double diffusion lies in its ability to affect water mass structure with its differential transport rates for heat and salt. This is believed to play a significant role in producing certain oceanic water types with well-defined relationships between temperature and salinity. See OCEAN CIRCULATION; SEAWATER.

[R.W.Sc.]

**Douglas-fir** A large coniferous tree, *Pseudotsuga menziesii* (formerly *P. taxifolia*), known also as red fir, belonging to the pine family (Pinaceae). It is one of the most widespread and most valuable tree species of western North America and ranks among the world's most important. In the United States, this species is first in total stand volume, lumber production, and veneer for plywood. It is the most common Christmas tree in the West and is the state tree of Oregon. See PINALES.

Douglas-fir is a large to very large evergreen tree with narrow pointed crown of slightly drooping branches; at maturity it reaches a height of 80–200 ft (24–60 m) and a trunk diameter of 2–5 ft (0.6–1.5 m). The bark is dark or reddish brown, very thick, deeply furrowed, and often corky. The needlelike leaves spreading mostly in two rows are flat, and flexible, with a very short leafstalk. Buds are distinctive, conical pointed, scaly, and dark red. The cones are elliptical and light brown, with many thin rounded cone-scales, each above a longer distinctive three-pointed bract.

The natural distribution of Douglas-fir extends from southwestern Canada (British Columbia and Alberta) south through the western United States (Washington, Oregon, the Sierra Nevada, and the Rocky Mountains), and south to central Mexico. This species has been introduced into the eastern United States, Europe, and elsewhere.

Two varieties are distinguished: coast Douglas-fir of the Pacific region and Rocky Mountain or inland Douglas-fir. The latter has shorter cones with bracts bent backward. Though not so large, it is hardier and grows better in the East. See FOREST AND FORESTRY; TREE.

[E.L.L.]

**Down syndrome** A developmental disability due to abnormal chromosome number or structure. It is characterized by physical and behavioral features and has been considered the most common form of genetic aberration. Incidence among the newborn is estimated at 3 in 1000, in the general population approximately 1 in 1000. The difference reflects the early mortality.

The most common type (trisomy 21) is due to a nondisjunction of chromosome 21 during the original cell division, resulting in an extra chromosome 21. These children have a total of 47 chromosomes instead of the usual 46. However, the extra material from chromosome 21 can also be attached to another chromosome through translocation; such children have Down syndrome but only 46 chromosomes. More rarely, the trisomy 21 breaks up, giving some cells with 47 chromosomes and some with 46 (mosaicism).

The characteristic physical features include almond-shaped eyes; a rounded, brachycephalic skull with flattened occipital region; a broad, flattened bridge of the nose; an enlarged fissured tongue; broad hands with stubby fingers; often a single "simian" palmar crease; hypotonic muscle development; thick, everted, and cracked lips; dry, rough skin; subnormal height; and infantile genitalia. Not all of these physical signs are present in every

case, and some may be observed in individuals without Down syndrome. However, Down syndrome is diagnosed when most of the anomalies are present.

The degree of mental defect is not directly related to the number or gravity of the physical signs, but rather to a combination of those anomalies and the specific chromosomal defect. Few children with Down syndrome are classified today as severely retarded. Most are moderately to mildly retarded and are often educable and highly trainable. They tend to be curious, observant, skillful at mimicry, and usually, very affectionate. Aggression and hostility are rare; however, they are often stubborn and compulsive and are not easily frustrated. They are excellent candidates for vocational training.

Pathological research suggests nonspecific, generalized defective brain development. There is a tendency toward thyroid dysfunction and congenital heart defects. There may also be vision problems, but below-average dental caries. Medication has little effect on the physical condition or on the mental retardation. See ALZHEIMER'S DISEASE; CONGENITAL ANOMALIES.

Although there are some reports of more than one child with Down syndrome in a single family, it is not a classical hereditary disease. Incidence is increased if the mother is under 16 or over 35 years old or the father is of advanced age. Furthermore, the Down syndrome child may result from a late or problem pregnancy or the last of numerous pregnancies. Thyroid deficiency, hypopituitarism, and pathology of the ovary have been observed in the mothers, and the probability of upset in their endocrine balance may increase with age. However, the basic etiology is still very much in doubt.

Prenatal identification of Down syndrome in the fetus is possible through amniocentesis. See HUMAN GENETICS; MENTAL RETARDATION.

[H.Le.]

**Drafting** The making of drawings of objects, structures, or systems that have been visualized by engineers, scientists, or others. Such drawings may be executed in the following ways: manually with drawing instruments and other aids such as templates and appliqué, freehand with pencil on paper, or with automated devices.

Engineers often draft their own designs to determine whether they are workable, structurally sound, and economical. However, much routine drafting is done under the supervision of engineers by technicians specifically trained as drafters. See COMPUTER GRAPHICS; DESCRIPTIVE GEOMETRY; ENGINEERING DRAWING.

Graphic symbols have replaced pictorial representations leading to the introduction of templates that carry frequently used symbols, from which the draftsman quickly traces the symbols in the required positions on the drawing.

[C.J.B.]

Where the design procedures from which drawings are developed are repetitive, computers can be programmed to perform the design and to produce their outputs as instructions to automatic drafting equipment. Essentially, automated drafting is a method for creating an engineering drawing or similar document consisting of line delineation either in combination with, or expressed entirely by, alphanumeric characters.

The computer receives as input a comparatively simplified definition of the product design in a form that establishes a mathematical or digital definition of the object to be described graphically. The computer then applies programmed computations, standards, and formatting to direct the graphics-producing device. This method provides for close-tolerance accuracy of delineation and produces at speeds much greater than possible by manual drafting. In addition, the computer can be programmed to check the design information for accuracy, completeness, and continuity during the processing cycle.

[T.C.P.]

**Dragonfly** A member of the suborder Anisoptera of the order Odonata of the class Insecta. The adults are large, attractive insects characterized by four similar-appearing elongate, membranous wings with numerous characteristic veins; very large

compound eyes; tiny antennae; chewing mouthparts; and a long, slender abdomen terminating in a short pair of cerci. Adults are strong, agile fliers and are all predacious. In flight, their legs are held to form a "basket" which entraps small insects. Dragonflies are considered very beneficial since they consume large numbers of mosquitoes, flies, gnats, and similar pests. Dragonflies are most commonly found near permanent water. Eggs are laid in the water or on the banks. The nymphs are all aquatic and predacious. See ODONATA. [F.R.V.]

**Drawing of metal** An operation wherein the work-piece is pulled through a die, resulting in a reduction in outside dimensions. This article deals only with bar and wire drawing and tube drawing. See SHEET-METAL FORMING.

Among the variables involved in the drawing of wires and bars are properties of the original material, percent reduction of cross-sectional area, die angle and geometry, speed of drawing, and lubrication. The operation usually consists of swaging the end of a round rod to reduce the cross-sectional area so that it can be fed into the die; the material is then pulled through the die at high speeds. Most wire drawing involves several dies in tandem to reduce the diameter to the desired dimension. Die materials are usually alloy steels, carbides, and diamond. Diamond dies are used for drawing fine wires. The purpose of the die land is to maintain dimensional accuracy (see illustration).

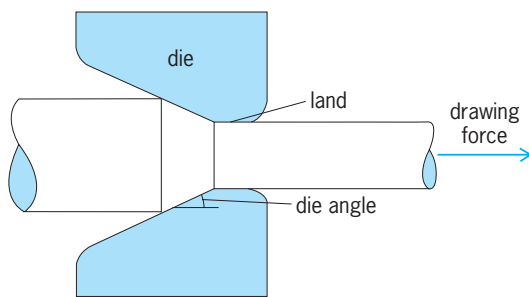

Cross section of drawing die.

Tubes are also drawn through dies to reduce the outside diameter and to control the wall thickness. The thickness can be reduced and the inside surface finish can be controlled by using an internal mandrel (plug). Various arrangements and techniques have been developed in drawing tubes of many materials and a variety of cross sections. Dies for tube drawing are made of essentially the same materials as those used in rod drawing. [S.Ka.]

**Drier (paint)** A material added to paint formulations to facilitate the oxidation of oils. Driers are salts of metals. Acids used to render metals soluble in oil, and therefore useful as driers, may be fatty acids, rosin, or naphthenic or octoic acids derived from petroleum. Cobalt, the most reactive of drier metals, is generally regarded as a surface drier, and it is widely used as the only additive in thin-film paint formulations. Lead, while less reactive than cobalt, may have increasing restrictions in its applications because of ecological requirements. Numerous other metals, including cerium and vanadium, have been used occasionally, and are effective driers. Certain organic compounds also catalyze the drying of oils and have been used for this purpose when freedom from all metallic contamination is required.

In general, small amounts of drier are essential to the formation of a satisfactory paint film within a reasonable time. Addition of large amounts of drier, however, can lead to premature embrittlement and failure of the paint film. See DRYING OIL; PAINT. [C.R.Ma.; C.W.Si.]

**Drilling, geotechnical** The drilling of holes for gathering and evaluating earth materials in order to design and monitor construction projects. Geotechnical data are required for the accurate, safe, and efficient design and construction of buildings, bridges, highways, dams, and mining sites. The data are derived from analysis of soil and rock samples obtained by drilling. Soil sampling usually is done with a split-spoon sampler, a tube that opens lengthwise to remove the sample. Rock cores are obtained by diamond drilling, using a hollow, diamond-embedded drill bit to cut an intact rock sample. The samples are tested in laboratories for compressive and shear strength, grain size, weathering properties, moisture content, and consolidation projections. The results are used to determine the materials' supporting characteristics, ability to resist transmission of fluids as with dams, and ability to stand without lateral support as in highway cuts or quarries. In addition, tunneling and mining are accomplished safely only with an understanding of the properties of the soil and rock above and below the projected opening. In-hole or in-situ testing through boreholes drilled in a formation is done to determine the material's permeability, water yield, movement (with inclinometers), and settlement over time (with settlement indicators). See ENGINEERING GEOLOGY; ROCK MECHANICS; SOIL MECHANICS. [T.B.St.]

**Drone** A pilotless aircraft capable of performing a nondestructive mission; when used destructively it is properly termed a missile. See GUIDED MISSILE; MISSILE.

There are three basic types of drones: the preprogrammed, the smart, and the remotely piloted drone.

A preprogrammed drone responds to an on-board timer or scheduler and has no sensor contact with the ground. The drone follows a set routine of maneuvers, altitude changes, speed changes, and course changes that are programmed through an autopilot to the drone's control surfaces and engine throttle. The drone is usually recovered by a parachute at the end of the mission.

A smart drone carries various sensors and is equipped with an on-board computer. The ability of a smart drone to make decisions governing course and altitude changes is limited only by its computer and sensor capacity. For example, a smart drone could probably take off on its own from a given airport, navigate a circuitous route, make decisions en route based on weather or enemy radar action, fly to a second airport, and make a safe landing. See GUIDANCE SYSTEMS; NAVIGATION.

The remotely piloted vehicle (RPV), probably the most common type of drone, is under the constant control of an operator or pilot through radio links. The pilot or pilots can be located on the ground, in other aircraft, or on ships. Typical missions for remotely piloted vehicles include reconnaissance or surveillance of enemy activities, target acquisition, relay of friendly communications, and jamming of enemy communications.

Advanced remotely piloted vehicles are equipped with low-light-level television and infrared sensors that allow over-the-horizon reconnaissance imagery to be transmitted to ground commanders as it is being acquired. See INFRARED IMAGING DEVICES. [R.Stro.]

**Drought** A general term implying a deficiency of precipitation of sufficient magnitude to interfere with some phase of the economy. Agricultural drought, occurring when crops are threatened by lack of rain, is the most common. Hydrologic drought, when reservoirs are depleted, is another common form. The Palmer index is used by agriculturalists to express the intensity of drought as a function of rainfall and hydrologic variables.

The meteorological causes of drought are usually associated with slow, prevailing, subsiding motions of air masses from continental source regions. These descending air motions, of the order of 660–1000 ft (200 or 300 m) per day, result in compressional warming of the air and therefore reduction in the relative humidity. Since the air usually starts out dry, and the relative humidity

declines as the air descends, cloud formation is inhibited—or if clouds are formed, they are soon dissipated. [J.N.]

**Drug delivery systems** The engineering of physical, chemical, and biological components into systems for delivering controlled amounts of a therapeutic agent over a prolonged period, thereby maintaining plasma or tissue drug levels at a constant level. Controlled drug delivery systems can take a variety of forms, such as mechanical pumps, polymer matrices or microparticulates, and externally applied transdermal patches.

The most obvious approach for controlled drug delivery involves miniaturization of the familiar infusion system. Mechanical pumps, either totally implantable or requiring percutaneous catheters, have been used to deliver insulin, anticoagulants, analgesics, and cancer chemotherapy. Drugs are maintained in a liquid reservoir prior to delivery, so only agents that are stable in solution at body temperature can be used. Because pumps deliver precisely controlled amounts of therapeutic agents, they may find additional important applications, particularly when coupled with implanted biosensors for feedback control. See BIOELECTRONICS.

Many disadvantages of controlled drug delivery via pumps can be avoided by using controlled-release polymers as delivery vehicles. For a specific therapeutic agent, the rate, pattern, and duration of drug release can be modified by selecting the appropriate biocompatible polymer and method of device fabrication. See PHARMACOLOGY; POLYMER.

The best example of controlled-release polymer systems are the cylindrical silicone-based subdermal implants that release contraceptive steroids at a constant rate for years following implantation and provide economical, reliable, long-term protection against unwanted pregnancy. An intrauterine device with a controlled-release poly(ethylene-covinyl acetate) coating delivers contraceptive steroids directly to the reproductive tract; local release of certain agents can reduce the overall drug dose and, therefore, reduce or eliminate side effects produced by drug toxicity in other tissues. See BIRTH CONTROL.

Transdermal controlled-delivery devices are similar in design to implantable reservoir systems. A single flat polymer membrane is placed between a drug reservoir and the skin. The polymer membrane is designed to control the rate of drug permeation into the skin over a period of several hours to 1 day. Transdermal delivery systems have been produced for agents that can penetrate the skin easily, such as nitroglycerin, scopolamine, clonidine, estradiol, and nicotine.

When nondegradable polymers are used for implanted delivery systems, the polymer must be surgically removed at the end of therapy. This procedure can be eliminated by the use of biodegradable polymers, which dissolve following implantation. Biodegradable polymers, which were first developed as absorbable sutures in the 1960s, are usually employed as matrix devices. Of the polymers tested, poly(lactide-co-glycolide) has been used most frequently. Most importantly, small microspheres of biodegradable polymers can be produced as injectable or ingestible delivery systems; injectable poly(lactide-co-glycolide) microspheres that release a peptide are used for the treatment of prostate cancer in humans. The chemistry of the biodegradable polymers can be exploited in other ways to achieve controlled delivery, for example, by linking drugs to the polymer matrix through degradable covalent bonds. [W.M.Sa.]

**Drug resistance** The ability of an organism to resist the action of an inhibitory molecule or compound. Examples of drug resistance include disease-causing bacteria evading the activity of antibiotics, the human immunodeficiency virus resisting antiviral agents, and human cancer cells replicating despite the presence of chemotherapy agents. There are many ways in which cells or organisms become resistant to drugs, and some organisms have developed many resistance mechanisms, each specific to a different drug. Drug resistance is best understood as it ap-

plies to bacteria, and the increasing resistance of many common disease-causing bacteria to antibiotics is a global crisis.

**Genetic basis.** Some organisms or cells are innately or inherently resistant to the action of specific drugs. In other cases, the development of drug resistance involves a change in the genetic makeup of the organism. This change can be either a mutation in a chromosomal gene or the acquisition of new genetic material from another cell or the environment.

Organisms may acquire deoxyribonucleic acid (DNA) that codes for drug resistance by a number of mechanisms. Transformation involves the uptake of DNA from the environment. Once DNA is taken up into the bacterial cell, it can recombine with the recipient organism's chromosomal DNA. This process plays a role in the development and spread of antibiotic resistance, which can occur both within and between species.

Transduction, another mechanism by which new DNA is acquired by bacteria, is mediated by viruses that infect bacteria (bacteriophages). Bacteriophages can integrate their DNA into the bacterial chromosome.

Conjugation is the most common mechanism of acquisition and spread of resistance genes among bacteria. This process, which requires cell-to-cell contact, involves direct transfer of DNA from the donor cell to a recipient cell. While conjugation can involve cell-to-cell transfer of chromosomal genes, bacterial resistance genes are more commonly transferred on nonchromosomal genetic elements known as plasmids or transposons. See DEOXYRIBONUCLEIC ACID (DNA).

**Mechanisms of resistance.** The four most important antibiotic resistance mechanisms are alteration of the target site of the antibiotic, enzyme inactivation of the antibiotic, active transport of the antibiotic out of the bacterial cell, and decreased permeability of the bacterial cell wall to the antibiotic (see illustration).

By altering the target site to which an antibiotic must bind, an organism may decrease or eliminate the activity of the antibiotic. Alteration of the target site is the mechanism for one of the most problematic antibiotic resistances worldwide, methicillin resistance among *Staphylococcus aureus*. See BACTERIAL GENETICS.

The most common mechanism by which bacteria are resistant to antibiotics is by producing enzymes that inactivate the drugs. For example,  $\beta$ -lactam antibiotics (penicillins and cephalosporins) can be inactivated by enzymes known as  $\beta$ -lactamases.

Active transport systems (efflux pumps) have been described for the removal of some antibiotics (such as tetracyclines, macrolides, and quinolones) from bacterial cells. In these situations, even though the drug can enter the bacterial cell, active

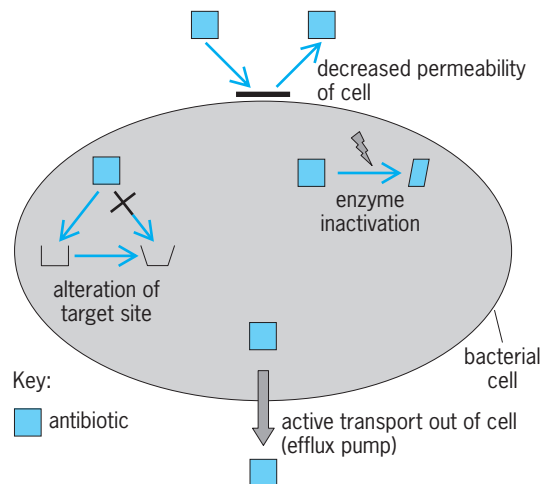

Four common mechanisms of antibiotic resistance.



efflux of the agent prevents it from accumulating and interfering with bacterial metabolism or replication.

Bacteria are intrinsically resistant to many drugs based solely on the fact that the drugs cannot penetrate the bacterial cell wall or cell membrane. In addition, bacteria can acquire resistance to a drug by an alteration in the porin proteins that form channels in the cell membrane. The resistance that *Pseudomonas aeruginosa* exhibits to a variety of penicillins and cephalosporins is mediated by an alteration in porin proteins.

**Promoters.** In the hospital environment, many factors combine to promote the development of drug resistance among bacteria. Increasing use of powerful new antibiotics gives selective advantage to the most resistant bacteria. In addition, advances in medical technology allow for the survival of sicker patients who undergo frequent invasive procedures. Finally, poor infection control practices in hospitals allow for the unchecked spread of already resistant strains of bacteria.

Outside the hospital environment, other important factors promote antibiotic resistance. The overuse of antibiotics in outpatient medicine and the use of antibiotics in agriculture exert selective pressure for the emergence of resistant bacterial strains. The spread of these resistant strains is facilitated by increasing numbers of children in close contact at day care centers, and by more national and international travel.

**Control.** A multifaceted worldwide effort will be required to control drug resistance among disease-causing microorganisms. Ongoing programs to decrease the use of antibiotics, both in the clinics and in agriculture, will be necessary. The increased use of vaccines to prevent infection can help limit the need for antibiotics. Finally, the development of novel classes of antibiotics to fight emerging resistant bacteria will be required. See ANTIBIOTIC; BACTERIA. [D.J.D.]

**Drumlin** A streamlined, oval-shaped hill which has been shaped by flowing glacial ice. The long axis is parallel to the direction of ice flow, the up-glacier slope is usually steeper than the lee slope, and composition includes a variety or combination of materials—till, outwash, or bedrock. Drumlins are highly localized, but where present, they occur in large numbers. Some drumlins are clearly erosional in origin, but in others till deposition appears to have been synchronous with drumlin formation. Thus, one or both processes must be operative at some time in the subglacial environment where drumlins form. [W.H.J.]

**Dry ice** A solid form of carbon dioxide, CO<sub>2</sub>, which finds its largest application as a cooling agent in the transportation of perishables. It is nontoxic and noncorrosive and sublimates directly from a solid to a gas, leaving no residue. At atmospheric pressure it sublimates at  $-109.6^{\circ}\text{F}$  ( $-78.7^{\circ}\text{C}$ ). Slabs of dry ice can easily be cut and used in shipping containers for frozen foods, in refrigerated trucks, and as a supplemental cooling agent in refrigerator cars. See CARBON DIOXIDE; REFRIGERATION. [C.F.K.]

**Drydocking** A technique used to remove a ship from the water so that the underwater portion may be inspected, repaired, maintained, or altered. Occasionally underwater repairs may be undertaken while a ship is afloat; however, at regular intervals, or as dictated by emergency, it may be necessary to expose all of the underwater portion, regardless of whether the ship is a small harbor tug or a large transoceanic liner.

The four types of dry docks are known as marine railways, floating dry docks, graving docks, and mechanical lift docks. The size of the ship usually determines which type is used.

The marine railway consists of a cradle of wood or steel with rollers on which the ship may be hauled out of the water along a fixed inclined track leading up the bank of a waterway. The advantages of a marine railway lie in the economy of the original construction and the relative low cost of maintenance. A marine railway is ideal for ships up to 5000 tons.

The floating dry dock may be constructed of wood, steel, or concrete. The dock is submerged, to provide the required depth of water over the keel blocks, by partially filling its tanks with water. The ship to be drydocked is then positioned within, the tanks of the dock are rapidly pumped out by powerful pumps located within the dock walls, and the ship is lifted out of the water.

The graving dock consists of an excavation in the ground with a thick concrete base supported, if necessary, by piling and surrounded on three sides by earth held back by timbers, stone, cement, or steel supports, or a combination of these materials. The entrance, or seaward end of the dock, is usually closed by a caisson of the pontoon type which, when flooded, is trimmed down into position. The dock is flooded, the caisson is floated, and the ship enters the dry dock and is positioned over the keel blocks. The caisson is then replaced and submerged, the dock is pumped out, and the ship settles on the keel blocks. This process is reversed when the ship is ready to leave the dock.

The mechanical lift dock is somewhat similar in action to the floating dry dock. The vessel, after taking up on the keel and bilge blocks in the dock, is bodily lifted clear of the water. The mechanical platform dock has much more flexibility than other types and has increased greatly in size and use. [L.C.R.]

**Drying** An operation in which a liquid, usually water, is removed from a wet solid in equipment termed dryers. The use of heat to remove liquids distinguishes drying from mechanical dewatering methods such as centrifugation, decantation or sedimentation, and filtration, in which no change in phase from liquid to vapor is experienced. Drying is preferred to the term dehydration, which usually implies removal of water accompanied by a chemical change. Drying is a widespread operation in the chemical process industries. It is used for chemicals of all types, pharmaceuticals, biological materials, foods, detergents, wood, minerals, and industrial wastes. Drying processes may evaporate liquids at rates varying from only a few ounces per hour to 10 tons per hour in a single dryer. Drying temperatures may be as high as  $1400^{\circ}\text{F}$  ( $760^{\circ}\text{C}$ ), or as low as  $-40^{\circ}\text{F}$  ( $-40^{\circ}\text{C}$ ) in freeze drying. Dryers range in size from small cabinets to spray dryers with steel towers 100 ft (30 m) high and 30 ft (9 m) in diameter. The materials dried may be in the form of thin solutions, suspensions, slurries, pastes, granular materials, bulk objects, fibers, or sheets. Drying may be accomplished by convective heat transfer, by conduction from heated surfaces, by radiation, and by dielectric heating. In general, the removal of moisture from liquids (that is, the drying of liquids) and the drying of gases are classified as distillation processes and adsorption processes, respectively, and they are performed in special equipment usually termed distillation columns (for liquids) and adsorbers (for gases and liquids). Gases also may be dried by compression. See ADSORPTION; DISTILLATION.

**Drying of solids.** In the drying of solids, the desirable end product is in solid form. Thus, even though the solid is initially in solution, the problem of producing this solid in dry form is classed under this heading. Final moisture contents of dry solids are usually less than 10%, and in many instances, less than 1%.

The mechanism of the drying of solids is reasonably simple in concept. When drying is done with heated gases, in the most general case, a wet solid begins to dry as though the water were present alone without any solid, and hence evaporation proceeds as it would from a so-called free water surface, that is, as water standing in an open pan. The period or stage of drying during this initial phase, therefore, is commonly referred to as the constant-rate period because evaporation occurs at a constant rate and is independent of the solid present. The presence of any dissolved salts will cause the evaporation rate to be less than that of pure water. Nevertheless, this lower rate can still be constant during the first stages of drying.

A fundamental theory of drying depends on a knowledge of the forces governing the flow of liquids inside solids. Attempts

have been made to develop a general theory of drying on the basis that liquids move inside solids by a diffusional process. However, this is not true in all cases. In fact, only in a limited number of types of solids does true diffusion of liquids occur. In most cases, the internal flow mechanism results from a combination of forces which may include capillarity, internal pressure gradients caused by shrinkage, a vapor-liquid flow sequence caused by temperature gradients, diffusion, and osmosis. Because of the complexities of the internal flow mechanism, it has not been possible to evolve a generalized theory of drying applicable to all materials. Only in the drying of certain bulk objects such as wood, ceramics, and soap has a significant understanding of the internal mechanism been gained which permits control of product quality.

Most investigations of drying have been made from the so-called external viewpoint, wherein the effects of the external drying medium such as air velocity, humidity, temperature, and wet material shape and subdivision are studied with respect to their influence on the drying rate. The results of such investigations are usually presented as drying rate curves, and the natures of these curves are used to interpret the drying mechanism.

When materials are dried in contact with hot surfaces, termed indirect drying, the air humidity and air velocity may no longer be significant factors controlling the rate. The "goodness" of the contact between the wet material and the heated surfaces, plus the surface temperature, will be controlling. This may involve agitation of the wet material in some cases.

Drying equipment for solids may be conveniently grouped into three classes on the basis of the method of transferring heat for evaporation. The first class is termed direct dryers; the second class, indirect dryers; and the third class, radiant heat dryers. Batch dryers are restricted to low capacities and long drying times. Most industrial drying operations are performed in continuous dryers. The large numbers of different types of dryers reflect the efforts to handle the larger numbers of wet materials in ways which result in the most efficient contacting with the drying medium. Thus, filter cakes, pastes, and similar materials, when preformed in small pieces, can be dried many times faster in continuous through-circulation dryers than in batch tray dryers. Similarly, materials which are sprayed to form small drops, as in spray drying, dry much faster than in through-circulation drying.

**Drying of gases.** The removal of 95–100% of the water vapor in air or other gases is frequently necessary. Gases having a dew point of  $-40^{\circ}\text{F}$  ( $-40^{\circ}\text{C}$ ) are considered commercially dry. The more important reasons for the removal of water vapor from air are (1) comfort, as in air conditioning; (2) control of the humidity of manufacturing atmospheres; (3) protection of electrical equipment against corrosion, short circuits, and electrostatic discharges; (4) requirement of dry air for use in chemical processes where moisture present in air adversely affects the economy of the process; (5) prevention of water adsorption in pneumatic conveying; and (6) as a prerequisite to liquefaction.

Gases may be dried by the following processes: (1) absorption by use of spray chambers with such organic liquids as glycerin, or aqueous solutions of salts such as lithium chloride, and by use of packed columns with countercurrent flow of sulfuric acid, phosphoric acid, or organic liquids; (2) adsorption by use of solid adsorbents such as activated alumina, silica gel, or molecular sieves; (3) compression to a partial pressure of water vapor greater than the saturation pressure to effect condensation of liquid water; (4) cooling below dew point of the gas with surface condensers or coldwater sprays; and (5) compression and cooling, in which liquid desiccants are used in continuous processes in spray chambers and packed towers—solid desiccants are generally used in an intermittent operation that requires periodic interruption for regeneration of the spent desiccant.

Desiccants are classified as solid adsorbents, which remove water vapor by the phenomena of surface adsorption and capillary condensation (silica gel and activated alumina); solid ab-

sorbents, which remove water vapor by chemical reaction (fused anhydrous calcium sulfate, lime, and magnesium perchlorate); deliquescent absorbents, which remove water vapor by chemical reaction and dissolution (calcium chloride and potassium hydroxide); or liquid absorbents, which remove water vapor by absorption (sulfuric acid, lithium chloride solutions, and ethylene glycol).

The mechanical methods of drying gases, compression and cooling and refrigeration, are used in large-scale operations, and generally are more expensive methods than those using desiccants. Such mechanical methods are used when compression or cooling of the gas is required.

Liquid desiccants (concentrated acids and organic liquids) are generally liquid at all stages of a drying process. Soluble desiccants (calcium chloride and sodium hydroxide) include those solids which are deliquescent in the presence of high concentrations of water vapor.

Deliquescent salts and hydrates are generally used as concentrated solutions because of the practical difficulties in handling, replacing, and regenerating the wet corrosive solids. The degree of drying possible with solutions is much less than with corresponding solids; but, where only moderately low humidities are required and large volumes of air are dried, solutions are satisfactory. See DESICCANT; EVAPORATION; FILTRATION; HEAT TRANSFER; HUMIDIFICATION; UNIT OPERATIONS; VAPOR PRESSURE. [W.R.M.]

**Drying oil** An oil that readily undergoes autoxidation and polymerization to form a hard, dry film on exposure to air. Drying oils are relatively highly unsaturated; that is, they are composed of triglycerides constructed from unsaturated fatty acids. The best drying oils contain several nonconjugated double bonds per molecule.

Raw (untreated) drying oils are not suitable for paints and varnishes because they polymerize too slowly, and various methods have been introduced to improve the polymerization process. One method involves boiling the oil after addition of soluble resin-acid salts. Boiled oil dries in approximately one-fifth the time in which raw oil dries. Blown oil, produced by blowing air through the oil (to which driers have been added) at about  $120^{\circ}\text{C}$  ( $248^{\circ}\text{F}$ ), is said to have superior wetting or surface-covering properties. Stand oil has been partially polymerized, with admixture of driers, by heating to  $260\text{--}280^{\circ}\text{C}$  ( $500\text{--}536^{\circ}\text{F}$ ). This material is used extensively in antifouling paints, printing inks, and linoleum, as well as in varnishes and enamels. Linseed oil is the most widely used drying oil in paints and varnishes. See DRIER (PAINT). [E.B.R.]

**Dryolestida** An extinct order of mammals related to the living marsupials and eutherian (placental) mammals; formerly known as the Pantoheria or Eupantoheria. Along with the closely related symmetrodonts, they were the most diverse group of mammals during the Jurassic. They are often found in some of the same quarries that yield the giant sauropod dinosaurs. Most were about the size and shape of a shrew or mouse, with teeth adapted for chopping up a diet of insects, and they apparently were adapted for living in trees like squirrels. See EUTHERIA; MARSUPIALIA; SYMMETRODONTA.

For over a century, dryolestoids were placed in the order Pantoheria, a taxonomic wastebasket for Mesozoic mammals that were not members of other groups. Recent research has shown that the dryolestoids were primitive in many features but highly advanced in others. Their complex mosaic of features showed the transition from archaic mammals such as the platypus and some extinct Mesozoic mammals (which still retain reptilian characteristics) to the marsupials and placentals. In addition, their unique specializations (such as seven to nine highly unusual molars) show that they were not ancestral to marsupials or placentals, but an early side branch of mammalian evolution that lived before and then contemporaneously with the earliest marsupials and placentals. See THERIA. [D.R.Pr.]

**Duality (physics)** The state of having two natures, which is often applied in physics. The classic example is wave-particle duality. The elementary constituents of nature—electrons, quarks, photons, gravitons, and so on—behave in some respects like particles and in others like waves.

Duality is often used in a more precise sense. It indicates that two seemingly different, theoretical descriptions of a physical system are actually mathematically equivalent. Such an occurrence is very useful. Various properties and phenomena are clearer in one or the other of the descriptions, and calculations that are difficult or impossible in one description may be simple in the other. In the case of wave-particle duality, the wave description corresponds to a theory of quantized fields, where the field variables are governed by an uncertainty principle. The particle description corresponds to a Feynman integral over all particle paths in spacetime. The quantized-field and path integral theories sound very different but are mathematically equivalent, making identical predictions. See FEYNMAN INTEGRAL; NONRELATIVISTIC QUANTUM THEORY; QUANTUM FIELD THEORY; QUANTUM MECHANICS; UNCERTAINTY PRINCIPLE; WAVE MECHANICS.

**Weak-strong duality.** In some systems, there is weak-strong duality, meaning that when the coupling constant  $g$  of the original description is large that of the dual description,  $g'$ , is small; for example  $g' = 1/g$ . When  $g$  is large, so the interactions in the original description are strong and the perturbation theory in this description is highly inaccurate, then perturbation theory in the dual description gives a very accurate description.

**Duality in superstring theory.** It is believed that a complete theory of all particles and interactions must be based on quantization of one-dimensional objects (loops) rather than points: this is superstring theory. In superstring theory there is again the problem that perturbation theory is the main tool, giving an incomplete description of the physics. The situation has greatly improved with the discovery that weak-strong duality is a general property of string theory. In fact, there are five known string theories, and all are dual to one another. A notable feature in string theory is that in addition to strings and solitons, duality requires certain other objects as well: D-branes, which are local disturbances to which strings become fixed. Remarkably, the same methods have also been used to solve some long-standing problems regarding the quantum mechanics of black holes. See BLACK HOLE; QUANTUM GRAVITATION; SUPERSTRING THEORY. [J.Pol.]

**Dubnium** A chemical element, symbol Db, atomic number 105. It was synthesized and identified unambiguously in March 1970 at the heavy-ion linear accelerator (HILAC) at the Lawrence Radiation Laboratory, Berkeley, University of California. The discovery team consisted of A. Ghiorso and colleagues. See PERIODIC TABLE.

The dubnium isotope, with a half-life of 1.6 s, decayed by emitting alpha particles with energies of 9.06 (55%), 9.10 (25%), and 9.14 (20%) MeV. It was shown to be of mass 260 by identifying lawrencium-256 as its daughter by two different methods.

Previous work on dubnium was reported in 1968 by G. N. Flerov and colleagues at Dubna Laboratories in Russia. They claimed to have discovered two isotopes of dubnium produced by the bombardment of  $^{243}\text{Am}$  by  $^{22}\text{Ne}$  ions. However, the Lawrence Radiation Laboratory work did not confirm these findings (due to energy and decay differences). See NUCLEAR CHEMISTRY. [A.Gh.]

**Ducted fan** A propeller or multibladed fan inside a coaxial duct or cowling, also called a ducted propeller or a shrouded propeller, although in a shrouded propeller the ring is usually attached to the propeller tips and rotates. The duct serves to protect the fan blades from adjacent objects and to protect objects from the revolving blades, but more importantly, the duct prevents radial flow of the fluid at the blade tips. Fan efficiency remains high over a wider speed range with a properly shaped

duct than without. However, fan efficiency is sensitive to duct shape at off-center design conditions. See DUCTED FLOW; FAN.

Ducted fans are used in axial-flow blowers or compressors of several stages for turbine engines. A ducted fan engine is a gas turbine arranged to move a larger mass of air than passes through the turbine, the additional air leaving at lower exit velocity and hence higher jet propulsion efficiency for moderate-speed aircraft than obtainable with a simple turbojet. See GAS TURBINE; TURBOFAN; TURBOJET. [F.H.R.]

**Dumortierite** A nesosilicate mineral with composition  $\text{Al}_7(\text{BO}_3)_3\text{SiO}_4)_3\text{O}_3$ . Dumortierite crystallizes in the orthorhombic system but well-formed crystals are rare; the mineral usually occurs in parallel or radiating fibrous aggregates. There is one direction of poor cleavage. The hardness is 7 on Mohs scale, and the specific gravity is 3.26–3.36. The mineral has a vitreous luster and a color that varies not only from one locality to another but in a single specimen. It may be pink, green, blue, or violet. Dumortierite is found in schists and gneisses and more rarely in pegmatites. In the United States it occurs at Dehesa, California, and at Rochester, Nevada, where it has been mined for the manufacture of high-grade porcelain. See SILICATE MINERALS. [C.S.Hu.]

**Dune** Mobile accumulation of sand-sized material that occurs along shorelines and in deserts because of wind action. Dunes are typically located in areas where winds decelerate and undergo decreases in sand-carrying capacity. Dunefields are composed of rhythmically spaced mounds of sand that range from about 3 ft (1 m) to more than 650 ft (200 m) in height and may be spaced as much as 5000 ft (1.5 km) apart. Smaller accumulations of windblown sand, typically ranging in height from 0.25 to 0.6; in. (5 to 15 mm) and in wavelength from 3 to 5 in. (7 to 12 cm), are known as wind ripples. Dunes and ripples are two distinctly different features. The lack of intermediate forms shows that ripples do not grow into dunes. Ripples commonly are superimposed upon dunes, typically covering the entire upwind (stoss) surface and much of the downwind (leeward) surface as well.

Virtually any kind of sand-sized material can accumulate as dunes. The majority of dunes are composed of quartz, an abundant and durable mineral released during weathering of granite or sandstone. Dunes along subtropical shorelines, however, are commonly composed of grains of calcium carbonate derived in part from the breakdown of shells and coral. Along the margins of seasonally dry lakes, dunes may be composed of gypsum (White Sands, New Mexico) or sand-sized aggregates of clay minerals (Laguna Madre, Texas). See CLAY MINERALS; GYPSUM; QUARTZ.

The leeward side of most dunes is partly composed of a slip face, that is, a slope at the angle of repose. For dry sand, this angle is approximately  $33^\circ$ . When additional sand is deposited at the top of such a slope, tongue-like masses of sand avalanche to the base of the slope. The dune migrates downwind as material is removed from the gently sloping stoss side of the dune and deposited by avalanches along the slip face. Much of the sand on the leeward side of the dune is later reworked by side winds into wind ripple deposits. Because the coarsest grains preferentially accumulate at the crests of wind ripples, the layering in wind ripple deposits is distinctive and relatively easily recognized—each thin layer is coarser at its top than at its base.

Dunes can be classified on the basis of their overall shape and number of slip faces. Three kinds of dunes exist with a single slip face; each forms in areas with a single dominant wind direction. Barchans are crescent-shaped dunes; their arms point downwind. They develop in areas in which sand is in small supply. If more sand is available, barchans coalesce to form sinuous-crested dunes called barchanoid ridges. Transverse dunes with straight crests develop in areas of abundant sand supply. The axis of each of these dune types is oriented at right angles to the dominant wind, and the dunes migrate rapidly relative to other



Linear dune, Imperial County, California.

dune types. The migration rate of individual dunes is quite variable, but in general, the larger the dune, the slower the migration rate. In the Mojave Desert of southern California, barchans having slip faces 30 ft (10 m) long migrate about 50 ft (15 m) per year.

Dunes having more than one slip face develop in areas with more complex wind regimes. Linear dunes, sometimes called longitudinal or self dunes, possess two slip faces which meet along a greatly elongated, sharp crest (see illustration). Some linear dunes in Saudi Arabia reach lengths of 120 mi (190 km). Experimental evidence has shown that linear dunes are the result of bidirectional winds that differ in direction by more than 90°. The trend of these dunes is controlled by wind direction, strength, and duration, but the nature of the wind regime cannot be deduced from a knowledge of dune trends. Star dunes bear many slip faces and consist of a central, peaked mound from which several ridges radiate. Because they do not migrate appreciably, they grow in height as sand is delivered to them, some reaching 1000 ft (300 m).

Plant growth appears to be important to the growth and maintenance of two types of dunes. Coppice dunes are small mounds of sand that are formed by the wind-baffling and sand-trapping action of desert plants. The crescentic shape of parabolic dunes gives them a superficial resemblance to barchan dunes, but their arms point upward. Plants commonly colonize and anchor only the edges of a dune, leaving the body of the dune free to migrate. The retarded migration rate of the dune margin leads to the formation of the trailing arms of a parabolic dune. See DUNE VEGETATION.

Other dune types are dependent on special topographic situations for their formation. Climbing dunes develop on the upwind side of mountains or cliffs; falling dunes are formed at the sheltered, downward margin of similar features. [D.B.Lo.]

**Dune vegetation** Plants occupying sand dunes and the slacks, or swales, and flats between them. The density and diversity of dune vegetation are greater on coastal dunes than on desert dunes. See DUNE.

A zonation pattern is evident in the vegetation of the coastal dunes (see illustration). A wrack, or debris, line occurs at the upper limit of the beach. Seeds caught in decaying plant material and other debris washed in on the high tides germinate here

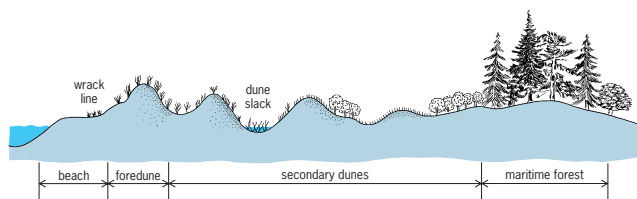

A coastal dune profile.

and trap windblown sand, initiating the formation of a dune. The foredunes, also called the primary dunes, are those closest to the water and lie behind the wrack line. The plants on these dunes, mostly grasses, are tolerant to sea spray, high winds, and sand accretion. Behind the primary dunes are the secondary dunes, sometimes called the dune field. In this more favorable environment, the vegetation is denser and more diverse; the foredunes block sea spray and reduce wind velocity. The dune slacks are the low areas between dunes and are frequently a result of a blowout, an area where sand has been blown away down to where the sand is moist and close to the water table. Plants typical of wetlands often vegetate these areas. Shrub communities also inhabit the dune field and often form dense patches of vegetation. A maritime forest may be found behind the secondary dunes. In coastal barrier beach or island locations, a salt marsh adjacent to a bay or sound may lie behind the forest.

Although the plant species occupying the sand dunes of the United States vary from coast to coast, their functions and adaptations are essentially the same. Plants growing on sand dunes are adapted to the environment. The plants closest to the sea are usually the most tolerant of salt spray. The plants in the wrack line must be tolerant to salinity, wind, and burial by sand.

The foredune plants must be tolerant of sand burial, sea spray, and a nutrient-poor substrate. By a system of underground stems called rhizomes, they overcome burial by sand and spread throughout the dune with new shoots arising from buds on the rhizomes. The roots and rhizomes of these dune grasses are important in stabilizing the dune sand and preventing wind erosion. The foredune plants participate in dune formation; by slowing the wind, they favor sand deposition. Furthermore, some of these plants have specialized bacterium named *Azotobacter* associated with their roots, and these bacteria fix atmospheric nitrogen into a form usable by the plant.

The plants in the dune slacks have morphological and physiological adaptations for growth in flooded areas. For example, the sedge American three-square contains large air spaces (aerenchyma) in its stems and roots, which provide an oxygen pathway from the shoots above the water to the oxygen-deprived roots in the flooded soil. When these plants are flooded, they increase their production of the hormone ethylene, which may stimulate the production of aerenchymatous tissue. [D.M.Se.]

**Dunite** An ultramafic igneous rock composed of at least 90% olivine. Important accessory minerals (abundances usually less than 1%) found in different occurrences of dunite include chromian spinel, low- or high-calcium pyroxenes (enstatite and diopside), and plagioclase. If these minerals constitute greater than 10% of the rock, it is called chromitite, peridotite, or troctolite, respectively. Low-temperature alteration (less than 750°F or 400°C) causes hydration of olivine to the mineral serpentine and, where extensive, may transform dunite to the metamorphic rock serpentinite. The dun color is a characteristic feature of the weathered rock. See CHROMITE; OLIVINE; PERIDOTITE; PYROXENE; SERPENTINITE.

Dunite is ultrabasic in composition, meaning that it is low in silica compared to most crustal rocks (<45% silica) and is generally very high in magnesium (up to 54%). In some occurrences, notably in continental layered intrusions, however, the olivine may be very iron rich (variety hortonolite), and the rock can contain as much as 40% iron. Dunite is notably poor in alumina, soda, and lime; and while it may be relatively nickel rich, many other critical trace elements are nearly missing. Thus, weathering of dunite forms soils to which most terrestrial plants are poorly adapted, and such soils often host unusual plant species such as the carnivorous cobra lily and the miniature rhododendron *Kalmiopsis leachiana* found in the coast ranges of Oregon and California.

The most important occurrence of dunite is in its association with rocks believed to have come from the Earth's mantle (principally peridotite) where it marks the location of former conduits

through which magmas have been transported out of the Earth to the crust. In the oceans, it is infrequently dredged from the great oceanic transform faults cutting the ocean ridges, exposed in tectonic windows in disrupted and uplifted ocean crust in association with serpentized mantle peridotite. Important dunite bodies crosscutting tectonically exposed mantle sections on the walls and floors of rift valleys have been found in the central Atlantic and eastern Pacific oceans far from transform faults. The suggestion is that the flow of magma out of the mantle upwelling beneath ocean ridges is not uniform, and is therefore important in controlling the formation and structure of the two-thirds of the Earth's crust that is formed in the oceans. See EARTH; MID-OCEANIC RIDGE; RIFT VALLEY; TRANSFORM FAULT.

Dunite has been extensively quarried as a building stone because of its unusual pale water-green color, but is little used now because of its high susceptibility to acid rain. Dunite is also used for refractory materials for furnaces. Olivine in dunite is occasionally of gem quality. Dunite is also the principal host of deposits of the mineral chromite. The hortonolite-dunite pipes found in the Bushveld Complex of South Africa have also been mined for platinum-group minerals. See GEM; IGNEOUS ROCKS; PETROLOGY; REFRACTORY. [H.J.B.D.]

**Dust and mist collection** The physical separation and removal of solid or liquid particles from a gas in which they are suspended. Such separation is required for one or more of the following purposes: (1) to collect a product which has been processed or handled in gas suspension, as in spray-drying or pneumatic conveying; (2) to recover a valuable product inadvertently mixed with processing gases, as in kiln or smelter exhausts; (3) to eliminate a nuisance, as a fly-ash removal; (4) to reduce equipment maintenance, as in engine intake air filters; (5) to eliminate a health, fire, explosion, or safety hazard, as in bagging operations or nuclear separations plant ventilation air; and (6) to improve product quality, as in cleaning of air used in processing pharmaceutical or photographic products.

All particle collection systems depend upon subjecting the suspended particles to some force which will drive them mechanically to a collecting surface. The known mechanisms by which such deposition can occur may be classed as gravitational, inertial, physical or barrier, electrostatic, molecular or diffusional, and thermal or radiant. There are also mechanisms which can be used to modify the properties of the particles or the gas to increase the effectiveness of the deposition mechanisms. For example, the effective size of particles may be increased by condensing water vapor upon them or by flocculating particles through the action of a sonic vibration. Usually, larger particles simplify the control problem. To function successfully, any collection device must have an adequate means for continuously or periodically removing collected material from the equipment.

Devices for control of particulate material may be considered, by structural or application similarities, in seven principal categories as follows: gravity setting chamber, inertial device, packed bed, cloth collector, scrubber, electrostatic precipitator, and air filter. See AIR FILTER; CHEMICAL SEPARATION TECHNIQUES; ELECTROSTATIC PRECIPITATOR; MECHANICAL SEPARATION TECHNIQUES; UNIT OPERATIONS. [C.E.La.]

**Dust storm** A strong, turbulent wind carrying large clouds of dust. In a large storm, clouds of fine dust may be raised to heights well over 10,000 ft (3000 m) and carried for hundreds or thousands of miles (1 mi = 1.6 km).

Sandstorms differ by the larger mass, more rapid setting speeds of the particles involved, and the stronger transporting winds required. The sand cloud seldom rises above 3.3–6.6 ft (1–2 m) and is not carried far from the place where it was raised.

Dust storms cause enormous erosion of the soil, as in the dust bowl disasters of 1933–1937 in the Great Plains of the United States. Besides causing acute physical discomfort, they present a severe hazard to transportation by reducing the visibility to very

low ranges. Conditions required are an ample supply of fine dust or loose soil, surface winds strong enough to stir up the dust, and sufficient atmospheric instability for marked vertical turbulence to occur.

Small dust particles increase scattering of light, mainly in short (blue) wavelengths. The Sun often appears a deep orange or red when seen through a dust cloud; however, optical effects are variable. Large particles are effective reflectors, and an observer in an aircraft above a dust storm may see a solid sheet with an apparent dust horizon. [C.W.N.]

**Dwarf star** A star whose state of evolution resembles that of the Sun. The term "dwarf star" derives from the work of Ejnar Hertzsprung and Henry Norris Russell, who distinguished two kinds of stars, large ones called giants (or supergiants) and smaller ones called dwarfs. The term "dwarf" is synonymous with "main sequence star" (luminosity class V) and implies not so much size as evolutionary condition. Dwarfs are stars that, like the Sun, fuse hydrogen into helium in their cores, the thermonuclear reactions providing energy and support. Dwarfs range over the entire spectral sequence. At the cool limit (where spectral class M converts to L), they have effective temperatures around 2000 K (3100°F), absolute visual magnitudes of +20, and bolometric luminosities of about  $10^{-4}$  times the solar luminosity. At the hot O3 limit, the values are respectively 55,000 K (100,000°F), -7, and over  $10^6$  solar. The Sun, a G2 dwarf, falls in the middle at 5780 K (9950°F) and an absolute visual magnitude of +4.83. These properties are produced by a mass range from 0.08 solar mass for warm L dwarfs, below which full hydrogen fusion cannot be turned on, to over 100 solar masses at class O3. See GIANT STAR; HERTZSPRUNG-RUSSELL DIAGRAM; MAGNITUDE (ASTRONOMY); SUN.

At the high-mass end, above about 10 solar masses, the dwarf stage lasts 2–20 million years, and O stars turn into supergiants and supernovae. At class G8 and a mass of 0.8 solar, the lifetime equals the age of the Milky Way Galaxy, and dwarfs between this limit and 10 solar masses become white dwarfs. See SPECTRAL TYPE; STAR; STELLAR EVOLUTION; STELLAR ROTATION; SUPERGIANT STAR; SUPERNOVA; WHITE DWARF STAR. [J.B.Ka.]

**Dwarfism and gigantism** Underdevelopment and overdevelopment of the skeleton, respectively. Skeletal growth is a complex process and can be distributed in many ways. For example, overstimulation by excessive growth-hormone production during childhood can produce gigantism. This is usually due to a pituitary tumor. Insufficient stimulation of skeletal growth, resulting from hormonal, metabolic, or nutritional disturbances, leads to reduced height with normal body proportions. The shortness of stature depends on the degree of the disturbance; the designation proportionate dwarfism is used in severe cases. Proportionate dwarfism may or may not be genetic. See PITUITARY GLAND.

Commonly, the term dwarfism is applied to short individuals with abnormal body proportions resulting from disturbances of bone growth itself. The bones of either limbs or trunk can be most affected. The disorders, called chondrodysplasias, number well over 100 and show a wide variation in clinical features: some appear at birth, others become evident in later childhood. The severity ranges from conditions in which infants die at birth to conditions compatible with normal life. In most instances, however, the abnormal skeleton creates medical problems.

Almost all of the chondrodysplasias are inherited as mendelian or single-gene traits. However, because of reduced fertility and a high incidence of new mutations for certain traits, most individuals with these disorders are born to parents of average stature. See HUMAN GENETICS; SKELETAL SYSTEM DISORDERS. [W.A.Ho.]

**Dyadic** A mathematical abstraction corresponding to an expression of the type  $\beta\gamma + \delta\epsilon + \dots$ , in which the elements (dyad

symbols) consist of two vector symbols in juxtaposition without the intervention of either the dot (·) or cross (×). Essentially, a dyad is an ordered pair of vectors subject to certain rules of operation. The first symbolic factor in a dyad ( $\beta$  in  $\beta\gamma$ , for example) is called the antecedent and the second the consequent. See CALCULUS OF VECTORS. [H.V.C.]

**Dye** A colored substance, also called a dyestuff, which imparts more or less permanent color to other materials. See DYEING.

Customarily, colored water-insoluble substances are called pigment. Dyes are generally water-soluble, although some are soluble only during application, after which they become insoluble. See PIGMENT.

The mechanism by which soluble colored substances enter the internal structure of fibers and there become fixed has been variously explained in terms of the physical and chemical concepts of the times when the explanations were given. It is said to be an adsorption phenomenon, a salt formation, a quasi-chemical union caused by hydrogen bonding, or an ether linkage, and in some cases it is considered to be a true solution effect. The end result, however, is that the dye has imparted a color (not necessarily that of the solid dye itself) to the fiber which is more or less resistant to washing or removal by similar mechanical operations. The dye is said to be fixed on and to have affinity for the material it has colored. The material is designated as the substrate. If the color is quite resistant to washing and light, it is called a fast color; if the color is easily removed or fades quickly, it is a fugitive dye.

Dyestuffs may be classified in various ways: according to color (blue, red, and so on); origin (natural—from vegetable and animal matter—or synthetic); chemical structure (the most precise); kinds of material to which they are applied (cloth, paper, leather, plastic, food, and biological specimens); and method of application (used most frequently by the practical dyer). [W.Mi.]

Dyes that form a covalent bond with the substrate during the dyeing process are known as reactive dyes. They offer improved washfastness, improved brightness, and improved rubbing fastness and shade range. Reactive dyes are one of the more important single types of cellulosic dye. To a lesser degree, they are used for polyamide fibers. The simplicity of continuous application and the brightness of reactive dyes make them useful in printing as well as dyeing. [D.R.B.; D.H.A.]

**Dyeing** The application of color-producing agents to material, usually fibrous or film, in order to impart a degree of color permanence demanded by the projected end use. True dyeing covers mechanisms in which molecules of material to be dyed become involved by various means with the molecules of the coloring matter, or small aggregates thereof. There is some overlapping between true dyeing and other methods of coloring, which are called dyeing in the industry. Products which are commonly dyed include textile fibers, plastic films, anodized aluminum, fur, wood, paper, leather, and some foodstuffs. See DYE.

Dyeing is accomplished by dissolving or dispersing the colorant in a suitable vehicle (usually water) and bringing this system into contact with the material to be dyed. Although many dye molecules or aggregates may adhere to the material surface when they meet, dyeing does not occur until the adhering dye particles migrate within the fibers or films. All dyeing processes are designed to accomplish ultimately penetration of the undyed substance by the colorant.

Assistants are materials which do not impart color to the product to be dyed but promote or retard dyeing. Usually, they affect the dye molecule.

Swelling agents are assistants which open up the structure of the fiber temporarily so that dye molecules or aggregates may enter more freely and reach otherwise inaccessible dye sites.

Carriers are agents (often solvents of low water solubility) which accelerate dyeing by breaking up or dissolving dye ag-

gregates and bringing them to the fiber-water interface in a size small enough to be absorbed by the material.

Dye retarders are a class of dyeing assistants, usually inorganic or organic salts, which slow up the dyeing process by forming evanescent compounds with the dye, by buffering or depressing the ionization of an acid assistant, or by temporarily occupying the more active or more accessible dye sites on the fiber, later to be dislodged therefrom by the dye.

Aftertreating agents are salts, resins, or other products (more frequently applied to cellulosic fibers) to render the colored fabric more resistant to the effects of washing, perspiration, or fading by ozone or combustion gases. More often than not, their application causes a loss in light fastness of the dyed material.

**Textiles.** Cellulose fibers, such as cotton and rayon, are most commonly dyed by immersion of the fibers in a solution of direct dyes using an electrolyte such as common salt as assistant and then boiling this dyebath. Such dyeings usually exhibit only commercial (minimum) resistance to washing. Treatment of the properly dyed fibers with resins and copper, for example, increases the resistance to washing with minimum loss of light resistance.

Synthetic fibers, such as cellulose acetates and triacetate (Aronel), are dyed in a suspension of solvent-soluble dyes by immersion. Polyamide synthetic fibers are dyed like wool with acid, metallized acid, neutral metallized, or fiber-reactive mordant dyes, azoics, and selected direct dyes from an acid bath. Special processes have also been developed for acrylic, polyester, and propylene fibers. See TEXTILE CHEMISTRY.

**Nontextile materials.** Anodized aluminum is readily dyed by many textile dyes. Light and weather resistance undreamed of in textile applications of some of these same dyes is achieved.

Paper pulp is usually dyed in the paper beater by dyes normally employed for cotton; on occasion, it is tinted by wool dyes, and it is frequently tinted by addition of pigments to the beater. Finished paper is also colored by passing it over rollers which supply dye or colored coatings to its surface (calender staining).

Leather is dyed at low temperatures with the classes of dyes normally used for wool and cotton. Formic acid is normally used to exhaust the dye. For dress gloves, leather is usually colored by applying the dye on the grain surface, leaving the flesh side undyed. Leather is also dyed with natural dyes such as logwood, fustic, and quercitron. Leather fresh from tanning and containing considerable moisture is dyed in Europe by tumbling with dry water-soluble dye.

Most food products which are artificially colored are not actually dyed. Maraschino cherries, however, are dyed for several hours with food dyes, then washed and placed in flavored syrup.

Many plastic materials may be dyed by processes similar to those employed for textiles. Nylon, cellulose acetate, polyethylene, polypropylene, and polyester resins are dyeable with dyes which color these materials in yarn form. See MANUFACTURED FIBER; NATURAL FIBER. [J.E.Lo.]

**Dynamic braking** A technique for braking in which mechanical energy is converted to heat or electrical energy in order to slow or stop motion. An all-mechanical dynamic brake consists of rotating vanes that circulate a viscous fluid in a manner that generates heat. This is one way that the power of the wind is harnessed for space heating. An electric dynamic brake consists of an electric dynamo in which the mechanical energy is converted to electric form, and either converted to heat in a resistor or returned to the supply lines. Typically, electric braking is accomplished with the same machine that serves as the drive motor. Electric dynamic braking is employed in electric vehicles, elevators, and other electrically driven devices that start and stop frequently. See WIND POWER.

The most common type of dynamic braking will be explained for a direct-current (dc) motor. To accomplish braking action, the supply voltage is removed from the armature of the motor but not from the field. The armature is then connected across a

resistor. The electromotive force generated by the machine, now acting as a generator driven by the mechanical system, forces current in the reverse direction through the armature. Thus a torque is produced to oppose rotation, and the load decelerates as its energy is dissipated, mostly in the external resistor, but to some extent in core and copper losses of the machine. See DIRECT-CURRENT MOTOR.

Electric braking can also be accomplished by causing the energy of the rotating system to be converted in the armature to electrical energy and then returned to the supply lines. This mode of operation, called regenerative braking, occurs when the counterelectromotive force exceeds the supply voltage.

Interchanging two of the lines supplying a three-phase alternating-current (ac) induction motor also produces braking. In this case, called plugging, the direction of the electromagnetic torque on the rotor is reversed to cause deceleration. Both the energy of the system and the energy drawn from the supply lines are expended in copper and core losses in the machine as heat. The power lines must be disconnected when the rotor comes to rest. See ALTERNATING-CURRENT GENERATOR; ELECTRIC POWER GENERATION; ELECTRIC ROTATING MACHINERY; INDUCTION MOTOR; TRANSMISSION LINES. [A.R.E.]

**Dynamic instability** A state of fluid flow in which the distribution of mass and momentum is unstable. Fluid flows are subject to a variety of instabilities which generally cause the flow to become more complex and which often lead to turbulent, chaotic flow. Instabilities are responsible for a variety of phenomena in natural flows, including cyclones, hurricanes, and thunderstorms in the atmosphere; mantle convection in the Earth's interior; and granules and supergranules in stellar atmospheres. A great deal of research in the geophysical and astrophysical sciences has focused on flow instabilities; and instability plays an important role in engineering problems ranging from naval engineering and aeronautics to the design of efficient heating and cooling systems. See FLUID FLOW; TURBULENT FLOW.

Fluid instabilities may be broadly divided into two classes: convective and dynamic. While convective instabilities can be understood rather easily in terms of forces acting on displaced parcels of fluid, dynamic instabilities are more varied and more challenging to understand. This broad class of fluid instabilities is responsible for the cyclones and anticyclones that dominate the weather in middle and high latitudes, as well as meanders and rings in ocean currents such as the Gulf Stream. These instabilities are ultimately responsible for the lack of predictability of complex flows such as are found in the atmosphere. See CONVECTIVE INSTABILITY; CYCLONE; WIND.

Many, but not all, dynamic instabilities can be understood with the aid of a vorticity principle and an invertibility principle. The vorticity of a fluid can be thought of as the rate of rotation of a rigid paddle wheel embedded in the flow (see illustration). [Mathematically, it is the curl of the vector velocity field.] The rotation can be brought about by shear (a change in the speed of the flow in the direction across the flow) and by the curvature

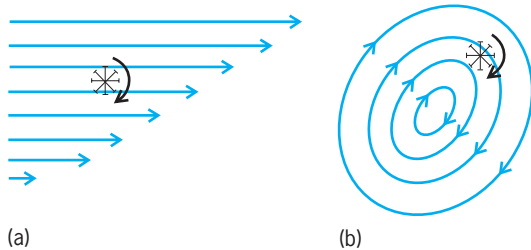

The vorticity of a fluid is related to the rate at which a rigid paddle wheel would rotate if placed in the flow. (a) The paddle wheel rotates because the velocity of the fluid varies in a direction perpendicular to the flow. (b) Rotation is generated by the curvature of the flow.

of the flow. Vorticity is important for two reasons. First, in two-dimensional flows, vorticity is conserved; that is, if the paddle wheel is followed around it is observed that its rate of rotation remains constant. Second, in such flows, it is possible to work backward from knowledge of the vorticity at every point in the fluid to find the flow field at every point. This is called the invertibility principle. Basically, a clockwise vorticity at a point in the fluid will induce a clockwise rotation of the fluid nearby; the total velocity field in the fluid can then be found by adding the velocities induced by all the vorticities at each point. See CALCULUS OF VECTORS.

The flow of the Earth's atmosphere is three-dimensional. Under this circumstance, vorticity is not conserved because fluid converging on or diverging from a point in the fluid causes it to spin faster or slower. (The principle at work here is the conservation of angular momentum.) Fortunately, the Earth's atmosphere is usually stably stratified; that is, a parcel displaced upward will be colder than its environment and will accelerate downward toward its original position. In this sense the atmosphere is convectively stable. It is possible to identify a quantity that reflects the air's density and at the same time is conserved as long as no heat is added to or subtracted from the air. This quantity is called the potential temperature ( $\theta$ ) and is related to temperature and pressure by the expression below, where  $T$  is the temperature in

$$\theta = T \left( \frac{1000}{p} \right)^{0.287}$$

kelvins and  $p$  is the pressure in millibars. Generally,  $\theta$  increases upward in the atmosphere: slowly in the troposphere (a layer of air that extends upward to roughly 6 mi or 10 km) and more rapidly in the stratosphere (a layer of air between about 6 and 18 mi, or 10 and 30 km). See STRATOSPHERE.

The criterion for the dynamic instability of large-scale three-dimensional flows is analogous to barotropic instability of two-dimensional flows. The necessary condition for this kind of instability is that potential vorticity must be a maximum or minimum somewhere on a surface of constant  $\theta$ . The type of instability that results from maxima or minima of potential vorticity in a fluid is called internal baroclinic instability. This type of instability can draw on both the kinetic energy of the original flow and the potential energy that occurs when there are horizontal variations of density.

Observations of the Earth's atmosphere show that the potential vorticity of the troposphere in middle and high latitudes is nearly uniform. But when a gently sloping  $\theta$  surface is followed into the stratosphere, a large increase of potential vorticity occurs. Even so, there is no localized maximum or minimum of potential vorticity, but just a large gradient of the quantity, concentrated near the boundary between the troposphere and stratosphere. (Many meteorologists define the stratosphere as a region of large potential vorticity.) For this reason, internal baroclinic instability seldom occurs in the atmosphere. See ATMOSPHERE. [K.A.Em.]

**Dynamic meteorology** The study of those motions of the atmosphere that are associated with weather and climate. Atmospheric motions span an enormous range of spatial and temporal scales; dynamic meteorology concentrates mainly on large-scale and mesoscale motions. Large-scale motions are those with horizontal scales in excess of a few hundred kilometers and time scales longer than a day. Such motions are strongly influenced by the rotation of the Earth and by the vertical thermal stratification of the atmosphere. Mesoscale motions have horizontal scales in the range of a few kilometers to a few hundred kilometers; they are often associated with convective clouds and precipitation.

The mechanics and thermodynamics of the unsaturated atmosphere are governed by three fundamental conservation laws: (1) conservation of mass, expressed by the mass continuity equation; (2) conservation of momentum, expressed by Newton's

second law of motion; and (3) conservation of thermodynamic energy, expressed by the first law of thermodynamics. For saturated conditions, conservation of water substance must also be considered. See CONSERVATION OF MASS; CONSERVATION OF MOMENTUM; CORIOLIS ACCELERATION; NEWTON'S LAWS OF MOTION; THERMODYNAMIC PRINCIPLES.

**Statics.** The vertical structure of the atmosphere is determined by the equation of state for an ideal gas and by the hydrostatic relationship. The former expresses the relationship among pressure, density, and temperature at any point; the latter expresses the balance between the upward-directed component of the pressure-gradient force (associated with the approximate exponential decrease of pressure with height) and the downward-directed gravity force. The equation of state and hydrostatic equation may be combined to form the hypsometric equation (1), which relates the geopotential height differences

$$Z_2 - Z_1 = \frac{R}{g} \int_{p_2}^{p_1} T \, d \ln p \quad (1)$$

( $Z_2 - Z_1$ ) between two pressure surfaces  $p_2$  and  $p_1$  to the mean temperature  $T$  in the layer between the two surfaces; and where  $R$  (the gas constant for dry air) =  $287 \text{ J} \cdot \text{kg}^{-1} \cdot \text{K}^{-1}$  and  $g$  (the acceleration of gravity) =  $9.81 \text{ m} \cdot \text{s}^{-2}$ . Thus, pressure decreases more rapidly with height in cold air than in warm air. See GAS; HYDROSTATICS.

Except in regions of active precipitation, where the heating rate due to latent heat of condensation is large, temperature changes following the motion of individual parcels of air are controlled primarily by adiabatic expansion and compression as the air parcels move to lower or higher pressure. The thermodynamic state of such parcels can be characterized by the potential temperature  $\theta$ , as in Eq. (2), where  $p_0$  [=  $10^5$  pascals

$$\theta = t \left( \frac{p_0}{p} \right)^{R/C_p} \quad (2)$$

(1000 millibars)] is a reference pressure and  $c_p$  (=  $1004 \text{ J} \cdot \text{kg}^{-1} \cdot \text{K}^{-1}$ ) is the specific heat at constant pressure. The potential temperature is the temperature that a parcel of air at pressure  $p$  and temperature  $T$  would acquire if it were moved adiabatically to pressure  $p_0$ . When all diabatic heat sources can be neglected,  $\theta$  remains constant in time for each air parcel. Normally,  $\theta$  increases with altitude in the atmosphere, so that an air parcel displaced upward (downward) has a value of  $\theta$  less (greater) than that of its environment, and hence experiences a net buoyancy force that tends to return it to its equilibrium level. The atmosphere is then said to be statically stable. When  $\theta$  is constant with height, a condition that occurs when the temperature decreases with height at a rate  $10^\circ\text{C} \cdot \text{km}^{-1}$  ( $30^\circ\text{F} \cdot \text{mi}^{-1}$ ), the atmosphere is said to be neutrally stable; if  $\theta$  decreases with height, the atmosphere is absolutely unstable and convective motion develops spontaneously. If an air parcel is saturated, upward displacement causes water vapor to condense and release its latent heat of condensation; the potential temperature is then no longer conserved.

The hydrostatic relationship implies that pressure decreases monotonically with altitude. Pressure may thus be substituted for height as the independent vertical coordinate. If the atmosphere is everywhere statically stable so that  $\theta$  increases monotonically with height, potential temperature can also be used as a vertical coordinate. Potential temperature coordinates are useful for analysis of adiabatic motions, since in that reference frame prediction of adiabatic flow is reduced to a two-dimensional problem of following the motion on  $\theta$  surfaces. Isobaric coordinates, in which pressure is the vertical coordinate, have the advantage of eliminating any explicit reference to the density field. These are the most commonly used vertical coordinates in dynamic meteorology. See CONVECTIVE INSTABILITY; DYNAMIC INSTABILITY; HYDROSTATICS; ISOBAR (METEOROLOGY).

**Baroclinic instability.** Baroclinic energy conversion processes are responsible for the growth and maintenance of most large-scale weather disturbances.

In midlatitudes in the troposphere, potential temperature normally decreases from Equator to pole on isobaric surfaces. This decrease does not occur uniformly, but tends to be concentrated in the jet stream, a narrow band of strong westerly winds in the upper troposphere that encircles the globe in midlatitudes. See JET STREAM.

When the shear of the zonal wind is sufficiently strong so that the meridional gradient of potential vorticity on a constant potential temperature surface is locally reversed, or when there is a nonvanishing gradient of potential temperature at the surface of the Earth, the linearized equations have solutions in the form of exponentially growing disturbances. These baroclinically unstable modes have growth rates, structures, and scales similar to those observed in developing extratropical cyclones. Baroclinic instability provides a mode whereby infinitesimal disturbances may amplify into large-amplitude storms. However, in many cases it appears that storms in the atmosphere grow through nonlinear interactions involving preexisting disturbances. Such processes must generally be studied by numerical simulations on high-speed computers.

**Mesoscale convective systems.** For horizontal scales less than several hundred kilometers, the major energy source is not baroclinic instability; it is latent heat release by cumulonimbus clouds. The convective storms associated with such clouds can occur only when the atmosphere is conditionally unstable [see Eq. (2)], sufficient moisture is present, and there is an initial disturbance strong enough to lift air parcels high enough to release the conditional instability. Mesoscale convective systems take a variety of forms. Among these are hurricanes, squall lines, and mesoscale convective complexes. See HURRICANE; MESOMETEOROLOGY; SQUALL LINE.

**Numerical weather prediction.** In current global weather prediction models, a mixture of techniques is often employed. Nearly all models use finite difference representations for the vertical coordinate and time; the horizontal variation is generally represented either by a network of grid points at uniform intervals of latitude and longitude or by a finite set of spherical harmonics. See SPHERICAL HARMONICS.

To predict the weather dynamically, it is necessary to solve the dynamics equations by integrating in time, starting from an initial state of the atmospheric variables determined from observations. In practice, observational errors and poor data coverage, particularly over the oceans, make it impossible to exactly determine the initial state of the atmosphere. Moreover, the state determined from observations generally does not properly represent the true dynamical balance among the pressure and wind fields. This imbalance introduces noise that is interpreted as high-frequency inertia-gravity waves. If a prediction is attempted from such an initial state, the noise rapidly dominates the true, slowly evolving weather disturbances. In order to prevent the growth of such spurious noise, the analysis must be initialized by processing it in a manner that assures a dynamical balance between the pressure and wind fields while preserving the actual observations as closely as possible. However, even if the initial state were known perfectly, there still would be a limit beyond which errors would dominate the forecast. See WEATHER FORECASTING AND PREDICTION.

**Global climate modeling.** In addition to their role in weather prediction, dynamical models can also be used to simulate global climate. Climate is the study of the average state of the atmosphere and its seasonal and interannual variability. Climate is determined by the joint influence of energy sources and sinks at the Earth's surface, and the transformation and transport of energy in the atmosphere and the oceans. Models that simulate these processes are usually referred to as general circulation models. Such models must contain accurate representations of all the important physical processes that influence the



circulation. See ATMOSPHERE; CLIMATE MODELING; METEOROLOGY; WIND. [J.R.H.]

**Dynamic nuclear polarization** The creation of assemblies of nuclei whose spin axes are not oriented at random, and which are in a steady state that is not a state of thermal equilibrium. Under commonly occurring conditions, the spin axes of nuclei (with nonzero spin) are oriented at random; where this is not so, the nuclei are said to be polarized. Assemblies of polarized nuclei are not in a state of thermal equilibrium except under rather extreme conditions (for example, temperatures below 10 millikelvins and magnetic fields greater than several teslas), and therefore schemes have been devised to produce polarized assemblies, in a steady state which is not a state of thermal equilibrium, under less extreme conditions of temperature and so forth. Such schemes constitute dynamic nuclear polarization.

Among the many applications of polarized nuclei are the following. Nuclear forces are spin-dependent, and although the spin-dependent part can be found by using unpolarized assemblies, the experiments are simpler and their interpretation is clearer if polarized nuclei are used. Assemblies of polarized nuclei have a lower geometrical symmetry than assemblies of randomly oriented nuclei, and so these have been used to investigate the fundamental symmetries of nature. Polarized nuclei have been used to enhance the signal in free precession magnetometers and similar instruments, and the use of an assembly of polarized nuclei as a gyroscope has also been suggested. See MAGNETOMETER; NUCLEAR ORIENTATION; PARITY (QUANTUM MECHANICS); SPIN (QUANTUM MECHANICS). [J.M.D.]

**Dynamic similarity** A relationship existing between two fluid flows when they have identical types of forces that are parallel at all corresponding points, with magnitudes related by a constant scale factor. Dynamic similarity makes it possible to scale results from model tests to predict corresponding results for the full-scale prototype.

Dynamic similarity requires faithful reproduction of detail on the model (geometric similarity); the same flow pattern, including boundary shapes (kinematic similarity); and test conditions that match relevant dimensionless ratios between model and prototype. Dynamically similar flows are said to be homologous. It may not be possible in a practical test to match all dimensionless parameters. It is most important to match parameters that represent the dominant physical effects. Thus, correct simulation of viscous effects requires that Reynolds number be matched; Mach number may be ignored if compressibility effects are not important. In ship model tests, Froude number must be matched to duplicate wave patterns; the effect of Reynolds number on viscous drag may be predicted analytically. See DIMENSIONAL ANALYSIS; DIMENSIONLESS GROUPS; FLUID MECHANICS; FROUDE NUMBER; MACH NUMBER; MODEL THEORY; REYNOLDS NUMBER. [A.T.McD.]

**Dynamical Time** The independent variable in the differential equations of motion of orbiting celestial bodies in a theory of relativity. The bodies move in accord with Newton's laws of motion and gravitation. Several types of dynamical time have been defined for different origins and theories of relativity. Integration of the equations, combined with observed positions, leads to an ephemeris, which lists coordinates as a function of dynamical time. See EPHEMERIS.

Dynamical Time is a uniform scale of time, unlike the mean solar scale Universal Time (UT), based on the Earth's rotation, which has variations in rotational speed. In 1952 the International Astronomical Union (IAU) defined a dynamical scale and named it Ephemeris Time (ET). See EARTH ROTATION AND ORBITAL MOTION.

Also, in 1952 the U.S. Naval Observatory began a program to obtain Ephemeris Time rapidly by photographing the Moon and nearby stars of known position. In 1958 a joint program with the National Physical Laboratory at Teddington, England,

gave 9,192,631,770 cycles per second of Ephemeris Time as the frequency of its cesium-beam atomic clock. See ATOMIC TIME.

Comparisons between Ephemeris Time and Atomic Time (AT) showed no definite systematic difference other than a constant. Therefore, Ephemeris Time could be obtained from Atomic Time with very high accuracy, and immediately.

In 1976 the IAU defined two timelike arguments based on International Atomic Time (French acronym, TAI). Terrestrial Dynamical Time (TDT) was for use with geocentric ephemerides. In effect,  $TDT = TAI + 32.184 \text{ s}$ . Barycentric Dynamical Time (TDB) was the argument to be used when the origin was at the barycenter of the solar system. TDT and TDB differ only by periodic relativistic terms. Thus, Dynamical Time, which was based formerly on motions of bodies in the solar system, was now derived from Atomic Time in the form of timelike arguments.

The use of the word dynamical for scales that do not involve dynamics caused some problems. In 1991 the IAU replaced TDT by Terrestrial Time (TT). Also, it introduced terminologies Geocentric Coordinate Time (TCG) and Barycentric Coordinate Time (TCB). See CELESTIAL MECHANICS; RELATIVITY; TIME. [W.M.]

**Dynamics** That branch of mechanics which deals with the motion of a system of material particles under the influence of forces, especially those which originate outside of the system under consideration. From Newton's third law of motion, namely, to every action there is an equal and opposite reaction, the internal forces cancel in pairs and do not contribute to the motion of the system as a whole, although they determine the relative motion, if any, of the several parts.

Particle dynamics refers to the motion of a single particle under the influence of external forces, particularly electromagnetic and gravitational forces. The dynamics of a rigid body is the study of the motion, under given forces, of a system of particles, the distances between which are postulated to be constant throughout the motion.

In classical dynamics the basic relation that enables the motion to be determined once the force is known is Newton's second law of motion, which states that the resultant force on a particle is equal to the product of the mass of the particle times its acceleration. For a many-particle system it becomes impracticable to write and solve this equation for each individual particle and, in general, the motion may be computed only on a statistical basis (that is, by the methods of statistical mechanics) unless, as for a few particles or a rigid body, the number of degrees of freedom is sufficiently small. See DEGREE OF FREEDOM (MECHANICS); KINEMATICS; KINETICS (CLASSICAL MECHANICS); NEWTON'S LAWS OF MOTION; RIGID-BODY DYNAMICS; STATISTICAL MECHANICS. [H.C.Co./B.G.]

**Dynamometer** A device for measuring the torque, force, or power available from a rotating shaft. The shaft speed is measured with a tachometer, while the turning force or torque of the shaft is measured with a scale or by another method. Power may be read from the instrumentation or calculated from shaft speed and torque. See TACHOMETER.

The two types are the transmission dynamometer and the absorption dynamometer. The transmission dynamometer transmits the force while measuring the elastic twist of the output shaft. An absorption dynamometer absorbs the power and dissipates it as heat by restraining the output shaft mechanically with a friction brake, hydraulically with a water brake, or electrically with an electromagnetic force. Since the restraining element tends to rotate with the output shaft, the force of the shaft can be determined by measuring the force required to arrest the rotation of the restraining element. Torque is then calculated by multiplying the force times the length of the lever arm, or the distance through which the force acts. See TORQUE.

One type of electric dynamometer consists of a direct-current (dc) machine with the stator cradle-mounted in antifriction bearings. The rotor is connected to the shaft of the machine under test. The field current is introduced through flexible leads.

The stator is constrained from rotating by a radial arm of known length to which is attached a scale for measuring the force required to prevent rotation. The torque of the connected machine is found from the product of the lever arm length and the scale reading, after correcting the scale reading by the amount of the zero torque reading.

The most common use of the dynamometer is in determining the power of an electric motor or engine of a car, truck, or other vehicle. A dynamometer that connects to the engine crankshaft is an engine dynamometer. One that has rollers turned by the vehicle drive wheels is a chassis dynamometer; this type is widely used in the automotive industry for mileage accumulation, emissions, fuel economy, and performance testing of cars and trucks.

[D.L.An.]

**Dysprosium** A metallic rare-earth element, Dy, atomic number 66 and atomic weight 162.50. The naturally occurring element is composed of seven stable isotopes. Dysprosium forms a white oxide,  $Dy_2O_3$ , which dissolves in acid to give a yellowish-green solution. For properties of the metal see RARE-EARTH ELEMENTS; See also PERIODIC TABLE.

The metal is attacked readily by air at high temperatures, but at room temperatures, in massive blocks, it is fairly stable in the atmosphere and remains shiny for long periods of time. Dysprosium is paramagnetic, but as the temperature is lowered, it becomes antiferromagnetic at the Néel point (178 K or  $-139^\circ\text{F}$ ) and ferromagnetic at the Curie point (85 K or  $-306.4^\circ\text{F}$ ). At very low temperatures, the metal shows strong anisotropic magnetic properties.

[FH.Sp.]

# E

**e (mathematics)** The number  $e$  is usually defined as the limit approached by the expression

$$\left(1 + \frac{1}{n}\right)^n$$

as  $n$  approaches infinity. If the given expression is expanded by the binomial theorem, and if one uses the theorem that the limit of the quotient of two polynomials of equal degree as the variable tends to infinity is equal to the ratio of the coefficients of highest degree, one obtains the expansion in relation (1). It can be shown

$$e = 1 + \frac{1}{1} + \frac{1}{1 \cdot 2} + \frac{1}{1 \cdot 2 \cdot 3} + \cdots + \frac{1}{1 \cdot 2 \cdot 3 \cdots n} + \cdots \quad (1)$$

by elementary methods that  $e$  is irrational; that is, it cannot be represented as the quotient of two integers. Furthermore,  $e$  is transcendental; it does not satisfy any algebraic equation with integral coefficients.

By the method outlined above, it may be shown that the limit of

$$\left(1 + \frac{x}{n}\right)^n$$

as  $n$  tends to infinity is  $e^x$ , and moreover that relation (2) holds.

$$e^x = 1 + \frac{x}{1} + \frac{x^2}{1 \cdot 2} + \cdots + \frac{x^n}{1 \cdot 2 \cdot 3 \cdots n} + \cdots \quad (2)$$

The function  $e^x$  is of great importance in mathematical analysis and is encountered in numerous problems in applied mathematics. See BINOMIAL THEOREM; CALCULUS; LOGARITHM. [A.N.L.; S.Bo.]

**Ear (vertebrate)** The organ which sends information about sound to the brain, constituting the sense of hearing, as well as vestibular information about the orientation of the head in space. The vertebrate ear is generally divided into three regions that have discrete functions: The inner ear is found in all vertebrates, and it subsumes both hearing and balance (functions). The external ear and the middle ear, not found in all vertebrates, enhance hearing. See HEARING (VERTEBRATE).

**Ear structure.** The inner ear is embedded in the ear (or otic) capsule and has a common embryological development in all vertebrate groups. In comparing the inner ears of different vertebrates, the major structural differences are associated with the auditory part of the ear. With few exceptions, the vestibular portion of the inner ear is developmentally, structurally, and functionally nearly the same in all vertebrates.

The middle ear and external ear are not found in the fishes. All tetrapods (amphibians, reptiles, birds, and mammals) have a middle ear with a tympanic membrane. Reptiles, birds, and mammals also have an external auditory meatus (or canal) which extends from the tympanic membrane to the external surface of the head. Mammals generally have an external structure, the pinna, that helps "collect" and carry the sound to the ear canal and then to the tympanum. The major difference in the middle ear among tetrapods is that it has a single ear bone, or ossicle (often called the columella or stapes), in amphibians, reptiles, and birds, while mammals have three middle-ear bones (malleus, incus, and stapes).

The basic sensory unit in the inner ear is the sensory hair cell. These specialized cells are morphologically similar in all of the epithelial structures of the ear in all vertebrates (and in the lateral line of fishes and amphibians), but they may have either auditory or vestibular functions depending upon the associated superstructure. The superstructure serves to facilitate the transmission of vibrations from the environment to the hair cells. For the vestibular apparatus, the superstructure blocks external vibratory energy, but sensitizes the sensory hair cells to the pull of gravity and to acceleratory and deceleratory movements of the head. See LATERAL LINE SYSTEM.

The sensory hair cell is a columnar, polarized structure from whose apex extend thin cilia that resemble hairs. Each hair cell has many such cilia, making up a ciliary bundle which bends in response to motional energy. The cilia in each bundle include many stereocilia and a single, eccentrically positioned kinocilium. The cilia extend into an extracellular fluid-filled space, with their tips embedded in a gelatinous membrane. See CILIA AND FLAGELLA.

The sensory hair cell is the detector of motion, either produced by compression and rarefaction of molecules due to sound waves, or imparted by movement of the head against gravity. This motion produces bending of the ciliary bundles, and this in turn results in a change in configuration of the membrane overlying the stereocilia and opening of channels in the membrane. It is generally thought that these channels admit calcium into the cell, and this in turn interacts with other components of the cell. Ultimately, the energy generated by these interactions causes release of neurotransmitter at the base of the cell, and results in stimulation of afferent neurons which contact the cell. See NEUROBIOLOGY; SYNAPTIC TRANSMISSION.

**Fishes.** In elasmobranchs and bony fishes the inner ear is located in the brain (cranial) cavity somewhat behind the eye. The inner ear has several regions, including three semicircular canals and otolith organs. Other than the very primitive jawless fishes which have one or two semicircular canals, all other vertebrates have three canals. All fishes, amphibians, reptiles, and birds have three otolith organs—the saccule, utricle, and lagena—while mammals do not have the lagena (Fig. 1).

At one end of each endolymph-filled semicircular canal is a widened area, the ampulla, which has a sensory area called the crista (or crista ampullaris). The crista contains large numbers of sensory hair cells, as well as other cells which provide support for the hair cells. At the base of the hair cells are nerve endings from the vestibular branch of the eighth cranial nerve. Each of the otolith organs also has a sensory area, called a macula, that contains hair cells and supporting cells. The cilia of the otolith organs are embedded in a thin gelatinous membrane that also contains very dense calcium carbonate crystals. In elasmobranchs, primitive fishes, and all tetrapods, these crystals are called otoconia. In most bony fishes the crystals are fused into a single mass in each otolith organ called the otolith.

Fishes are able to detect a wide range of sound using their inner ear. Tetrapods detect sounds that impinge on the tympanic membrane and then are carried by the middle-ear bones to the inner ear, where the sounds set the fluids of the ear into motion and thus stimulate the sensory hair cells. In fishes, however, this kind of pathway is not needed since sound is already traveling through

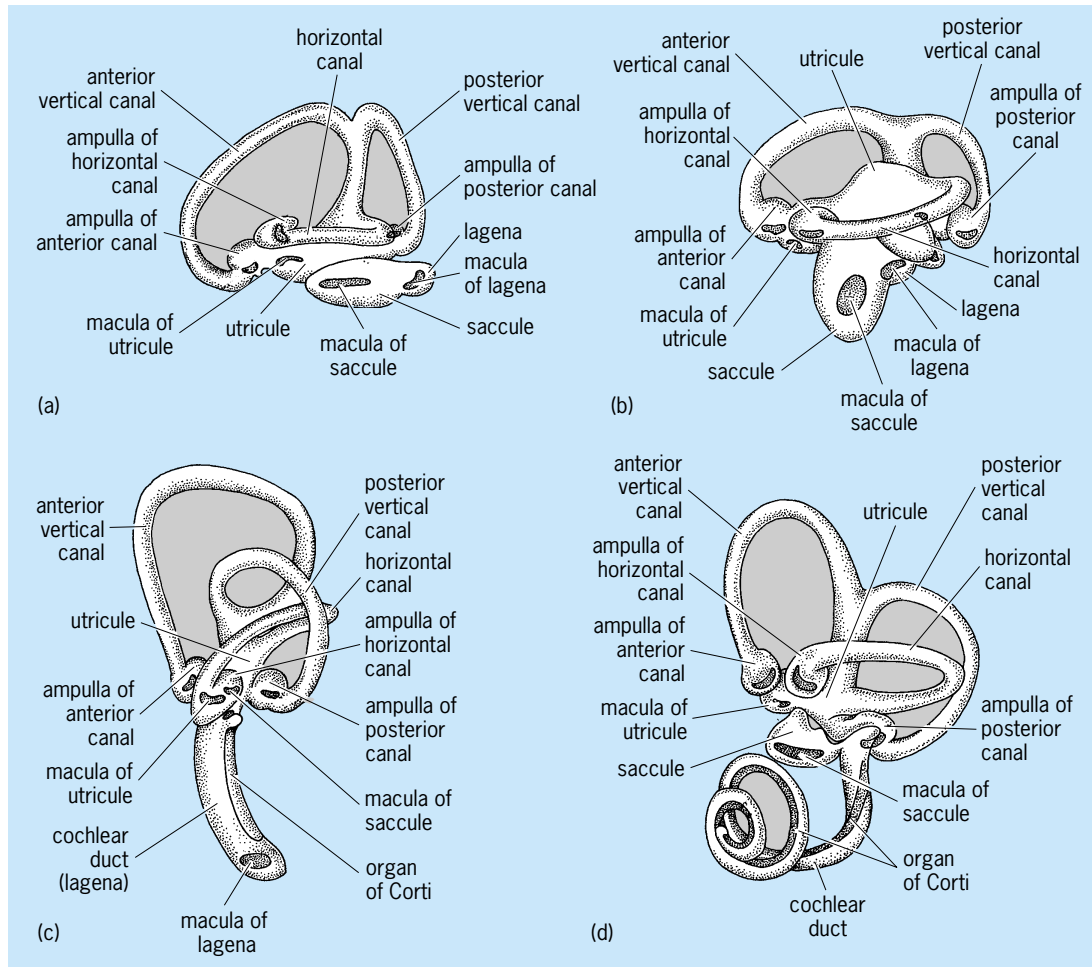

Fig. 1. Left-ear external view of the membranous labyrinths of (a) teleost, (b) frog, (c) bird, and (d) mammal. (After A. S. Romer, *The Vertebrate Body*, 3d ed., Saunders, 1962)

water. Indeed, since the fish's body is the same density as that of water, sound would travel right through the fish were it not for the otoconia or otoliths. Since these structures are much denser than the fish's body and the water, they stay still while the fish's body and the attached sensory hair cells move with the sound field. Since the stereocilia are attached to both the top of the hair cells and to the otoconia or otolith, they are bent as their base moves with the macula and their tops stand still with the otoliths. This bending sends signals to the nerves and then to the brain, indicating the presence of a sound. Most fishes detect sounds from 30 to 800 or 1000 Hz, with best hearing from 200 to 500 Hz. However, some fishes, called hearing specialists, have evolved special mechanisms to enhance hearing to 3000 or 4000 Hz. The hearing specialists use a secondary structure, the swim bladder, to enhance hearing capabilities. The swim bladder is a bubble of gas found in the abdominal cavity of most bony fishes, and it is used primarily for buoyancy control, though it may also be used in sound production in some species. Since the swim bladder is filled with gas, its density is different from that of the rest of the fish, and in a sound field the walls of the swim bladder are set into vibration and act as a small sound source to send sounds to the ear. See SWIM BLADDER.

**Tetrapods.** Many structural and functional features of the fish inner ear are also found in the tetrapod ear. The inner ear of tetrapods is embedded in the otic bones of the skull, with the membranous labyrinth attached to the bony labyrinth by connective tissue but suspended in perilymphatic fluid. There are three semicircular canals, with cristae, and, except in mammals which do not have a lagena, the three otolithic organs (Fig. 1b,

c, d). In their morphology and physiology the vestibular parts of fish and tetrapod ears are nearly the same. For the most part, the tetrapod otolithic organs function only as vestibular organs rather than playing an auditory role as they do in fishes.

**Amphibians.** The tympanic membrane of frogs and toads is located on the lateral surface of the head. Attached to its inner aspect is a small rodlike bone, the stapes, or columella, which runs through the air space of the middle-ear cavity and plugs a small hole, the oval window, beyond which are the inner-ear fluids. The frog's tympanic membrane collects sound energy and transmits it through the columella to the inner-ear fluids. In the lagena portion of the amphibian's membranous labyrinth are two areas of hair cells, the amphibian and basilar papillae, that are found in no other vertebrate group. The basilar papilla lies on the posterior wall of the saccule between the oval window and the round window, another membrane-covered opening between middle ear and inner ear. Vibratory energy enters the inner ear at the oval window, passes through the basilar and amphibian papillae causing them to vibrate, and then dissipates at the round window. See AMPHIBIA.

**Birds and reptiles.** In most reptiles and birds the tympanic membrane lies not on the surface of the head but internally, at the end of the tube called the external auditory meatus. A middle-ear cavity (with its eustachian tube to the mouth) lies medial to the tympanic membrane. A single ossicle, the columella, crosses this cavity from the tympanic membrane to the oval window at the inner ear. While both birds and reptiles have saccule, utricle, and lagena, as well as semicircular canals, they also have a newly evolved end organ, the basilar papilla, which is the part of

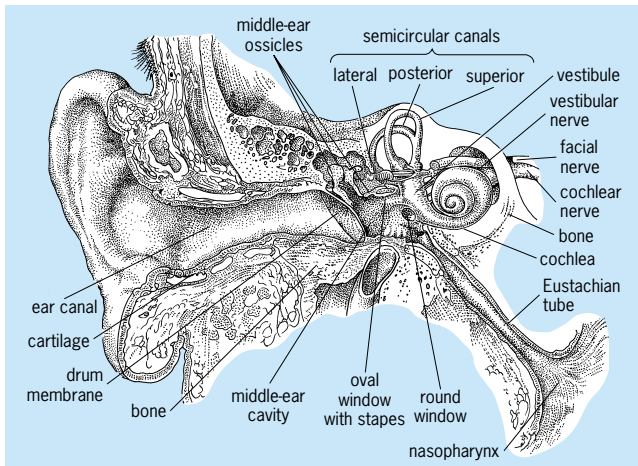

**Fig. 2. Schematic drawing of the human ear. (After M. Brödel, *Three Unpublished Drawings of the Anatomy of the Human Ear*, Saunders)**

the ear used for hearing in both groups of animals. (The avian and reptilian basilar papilla is thought to be a totally different structure, in terms of evolution and embryonic origin, than the basilar papilla found in amphibians.) The basilar papilla in birds and reptiles is often also called the cochlea, and there is some evidence to suggest that this end organ is directly related to the mammalian cochlea. The basilar papilla in reptiles is generally somewhat shorter than that found in birds, and there is considerable variation in the specific structure of this end organ in different species. The basilar papilla contains sensory hair cells. In birds, the basilar papilla sensory hair cells are differentiated into short and tall hair cells, which may have different functions in hearing. See AVES; REPTILIA.

**Mammals.** The mammalian ear consists of three parts: the external ear which receives the sound waves; the middle ear which transmits the vibrations by a series of three small bones; and the inner, or internal, ear, a complex bony chamber placed deep in the skull (Fig. 2). The external auditory meatus plus the newly evolved pinna, a cartilaginous structure projecting from the ear, compose the external ear. The shape and size of the pinna vary greatly. The auditory function of the pinna varies widely in different species. In some species the pinna is moved in the direction of a sound source and helps the animal focus sound to the external auditory meatus and then down the ear canal. In other species, such as humans, the pinna may have a lesser function, but even in humans the pinna helps to discriminate between sounds coming from the front and back of the head so that the person can better tell the direction of a sound source. See MAMMALIA.

As in other tetrapods, the first gill slit is modified as a middle-ear cavity, communicating with the pharynx by way of the eustachian tube. In other tetrapods this tube is permanently open, while in mammals it is usually closed. Instead of the single columella of other tetrapods, the mammalian middle ear has three bones, closely articulated with one another. The innermost is the stapes, which fits into the oval window of the inner ear and is homologous with the columella. Attached to the tympanic membrane is the malleus, and lying between the malleus and stapes is the incus. In spite of having additional bones, the mammalian middle ear functions basically as do those of amphibians, reptiles, and birds in transforming aerial vibrations into fluid vibrations within the inner ear.

In the mammalian inner ear the vestibular apparatus is much like that of other tetrapods. The auditory portion, however, is elongated and coiled into a snail shape. This structure is called the cochlea. The epithelium of the basilar papilla, called the organ of Corti, is more differentiated in mammals than in other

tetrapods. The number of turns in the cochlea varies. At the base of the cochlea is the oval window, which carries sound energy into the inner ear, and the round window, where this energy is dissipated after traveling in the cochlea.

Running the length of the coiled cochlea are three channels; the uppermost, the scala vestibule, and the lowest, the scala tympani, are filled with perilymph. In the center is the scala media, or cochlear duct. The cochlear duct is filled with endolymph, and it is separated from the scala vestibule above by the thin Reissner's membrane and from the scala tympani below by the basilar membrane.

The basilar membrane is suspended on both sides by ligaments or bone. The basilar membrane varies regularly in width, being narrow at the base (where it is most responsive to high frequencies) and wide at the apex (where it is most responsive to low frequencies). Resting upon the basilar membrane is the organ of Corti. The organ of Corti contains several cell types in addition to the auditory hair cells. The hair cells lying on the internal side of the pillar cells are called the inner hair cells, and those lying on the external side are called the outer hair cells. There may be up to 20,000 sensory hair cells in a cochlea of a normal young human, although the number of hair cells declines with age as a result of normal cell death, damage due to some medications, and trauma caused by loud sounds. A healthy teenager may hear sounds from below 20 Hz to upward of 20,000 Hz, while an adult 40 or 50 years old may hear sounds only to 14,000 Hz (or even less). This loss of hearing is associated with death of sensory hair cells.

Sounds entering the mammalian inner ear at the oval window travel along the basilar membrane from basal to apical ends, causing vibrations of the membrane. Different frequencies maximally excite different regions of the basilar membrane based on differences in the stiffness of the membrane itself. The response of the different regions of the organ of Corti to specific frequencies is also thought to be enhanced by the sensory hair cells themselves. Whereas early investigations suggested that both inner and outer hair cells were involved in detection of sound *per se*, recent evidence suggests that the inner hair cells have the major role in hearing, while the outer hair cells modify the function of the ear and help to enhance the sensitivity of the inner hair cells. See HEARING (HUMAN).

[A.N.P.; D.B.W.]

**Ear protectors** Objects or devices which insert into the ear canal (called earplugs) or cover the outer ear (called earmuffs) and which have a variety of applications. They may protect the ears from exposure to caustic materials, extremely cold temperatures, or excessive noise; serve as a barrier against solid particles collecting on the surface of the outer ear (auricle); prevent accidental injuries from flying objects in industrial activities, from contact during physical activities, or from excessive heat or fire; prevent moisture or solid particles from entering the ear canal; reduce noise to acceptable levels so signals are heard better through earphones; and protect the outer ear from direct sun rays. The purpose for wearing ear protectors determines the characteristics of the device to be used.

The most common use of ear protectors is to protect hearing from excessive noise; therefore "hearing protector" is a most appropriate term. Advances in materials used to construct hearing protection devices have led to significant improvements in both attenuation and comfort for users. The use of hearing protectors can prevent both temporary (auditory fatigue) and permanent noise-induced hearing losses, and may actually enhance a person's ability to hear in the presence of excessive noise. See HEARING (HUMAN).

[D.C.Ga.]

**Early modern humans** The earliest representatives of people anatomically similar to living humans evolved from more archaic humans approximately 100,000 years ago. The process by which they emerged from and eventually replaced those late archaic humans remains unclear. It is likely that they evolved

locally from such predecessors in northeastern Africa. Over the succeeding 50,000 years, their range expanded and contracted with changing global climatic cycles to include at times the Mediterranean Near East and portions of northern Africa. Early modern humans and their biology and way of life, therefore, initially had little advantage over late archaic humans. See NEANDERTALS.

Early modern humans were biologically the same as modern peoples and would blend in with living peoples. They differed from living people primarily in their tendency to have a rugged, athletic build. These populations were generally tall, males being 175–180 cm (5 ft 10 in.) and females 160–165 cm (5 ft 4 in.) on average. As a result of these tall bodies and muscularity, their brains were relatively large, averaging about 1500 cm<sup>3</sup> (90 in.<sup>3</sup>) as opposed to averages of about 1350 cm<sup>3</sup> (80 in.<sup>3</sup>) common for recent humans. Yet, when their brain sizes are scaled against estimated body weights, their brains were relatively the same size as those of living humans.

Early modern humans were successful hunters and gatherers, occupying most of the inhabitable regions of the Old World. They lived by hunting small to medium-size animals, especially antelopes, deer, goats, and occasional horses and cattle, and by gathering wild plants, fish, and shellfish for food. Their effectiveness as hunters and gatherers was due in part to their technology. They developed elaborate stone tool technologies, producing long blades that became blanks for tools with replaceable cutting edges and points. They were also the first to fire clay into ceramics, and they wove carrying bags with a variety of techniques. Yet, their ability to live effectively as hunters and gatherers depended upon their extensive knowledge of the environment. This knowledge was communicated through the first elaborate symbolic systems known, which consisted of a variety of geometric notational systems and the first representational art. They were also the first humans to commonly wear jewelry, and hence to modify their personal social images, suggesting more complex social roles than were previously known. Although these behavioral advances are associated with early modern humans, most of them appear only after about 50,000 years ago and hence are associated with the dispersal of modern humans. See FOSSIL HUMAN. [E.T.]

**Earphones** A class of energy transducers capable of receiving alternating current and generating acoustic waves resembling very closely the characteristics of that current. The movement of an element (diaphragm) is accomplished by magnetic attraction, electrostatic attraction, or the piezoelectric effect (the expansion or contraction of certain crystalline substances in response to electric charges). Earphone systems include the driver element with its diaphragm and arrangements for magnetic flux, or electrostatic or direct electric charge, plus a casing, one or more acoustic cavities and ports, acoustic damping and insulation, and some arrangement for coupling the driver to the human ear. The wiring connecting the precedent amplifier to the driver, which may be incorporated into the earphone system, may in modern systems be a complicated circuit which feeds, for each of two stereophonic channels, some part of the current to each ear. The time delays and energy ratios at the two earphones (each of which may contain two drivers) can be appropriately adjusted so that the listener is given the illusion that the sound sources are not “within the head” but are externalized appropriately in all three planes of space. The various types of earphones are described below. See TRANSDUCER.

The magnetic type is a permanently magnetized diaphragm that is moved in and out by an electromagnet energized by alternating current. Dynamic earphones are actually small dynamic loudspeakers. In some, a small coil fed by the sound source is bonded to the membranous diaphragm. Alternating current in the coil thus drives the diaphragm toward and away from a permanent magnet in the rear of the casing. In another configuration, the coil is relatively large and is attached to the diaphragm

only at its edge. A miniature magnetic earphone is a small unit of which the output port fits snugly into a plastic olive in the ear canal. These are widely used with small radios, with the more powerful hearing aids, by television commentators, in business transcription devices, and in many other communications situations. See HEARING AID.

Efficiency is increased if the mass of the diaphragm is reduced to a minimum. The electrostatic earphone utilizes a thin (2.5–12 micrometers) metallized plastic film, on which a large constant electrostatic charge is placed by an auxiliary unit. The motion of the diaphragm is controlled by the audio signal impressed on perforated wire mesh plates on either side. The assembly is mounted in a relatively large cavity and coupled to the head by a circumaural cushion. Such earphones are light and comfortable and have excellent frequency-response and transient-distortion characteristics.

The diaphragm of a dynamic-electrostatic (or orthodynamic) earphone is a permanently polarized electret of fluorocarbon. Consequently the need for an added source of polarization voltage (a drawback inherent to electrostatic earphones) is eliminated. See ELECTRET TRANSDUCER.

Certain crystalline substances expand and contract when alternating voltage is applied. In some piezoelectric earphones, a crystal element is coupled mechanically to the center of a small (about 2.5 cm diameter) cone. Such earphones can be lightweight and cheap and may be acceptable for speech communication. See PIEZOELECTRICITY.

Any single-channel recording of a real acoustic event will, when played back to an earphone in one ear, sound “in the head.” Even stereo recordings from two channels played back to earphones on two ears, while furnishing the illusion of movement, still are not externally localized by the listener. Externalization is improved if some of the signal from the left channel is time-delayed and applied also to the right earphone (the same, of course, for the right channel to the left earphone), and it is also improved if a realistic ratio is achieved between the acoustic energy density ratio from the “direct” versus the “indirect” sound sources (as from reflective walls). Stereophonic earphone systems have been built which incorporate these time delays and ratios, and which furthermore feed the signal from the right channel of an artificial-head stereophonic recording to the left earphone (and the left channel to the right earphone) through frequency filters which simulate the differential acoustic effects at various frequencies of the head and external ears in the original recording situation. Thus the eardrums under earphones are presented with the exact acoustic conditions generated by a loudspeaker or other sound source in an actual room, and such earphone systems very materially advance the important psychoacoustic feature of externalization of sound and of acoustic realism generally. See LOUDSPEAKER; MICROPHONE; SOUND-REPRODUCING SYSTEMS; STEREOPHONIC SOUND. [J.D.H.]

**Earth** The third planet from the Sun and the largest of the four inner, or terrestrial, planets. The Sun is an average-sized, middle-aged star situated toward the outer edge of one of the spiral arms of the Milky Way Galaxy. So far as is known, Earth is unique in the solar system in having life. Whether life exists in the universe beyond the solar system is unknown. See GALAXY, EXTERNAL; MILKY WAY GALAXY; PLANET; SOLAR SYSTEM; STAR; SUN; UNIVERSE.

Earth has one natural satellite, the Moon. Otherwise, Earth's nearest neighbors in space are Venus, which is about  $108 \times 10^6$  km ( $67 \times 10^6$  mi) from the Sun, and Mars, about  $228 \times 10^6$  km ( $141 \times 10^6$  mi) from the Sun. Earth is about  $150 \times 10^6$  km ( $93 \times 10^6$  mi) from the Sun. See MARS; MERCURY (PLANET); MOON; VENUS.

Earth completes an orbit around the Sun in 365 days, 5 h, 48 min, 46 s; the orbit defines the length of the year. The length of the day is determined by the period of Earth's rotation about

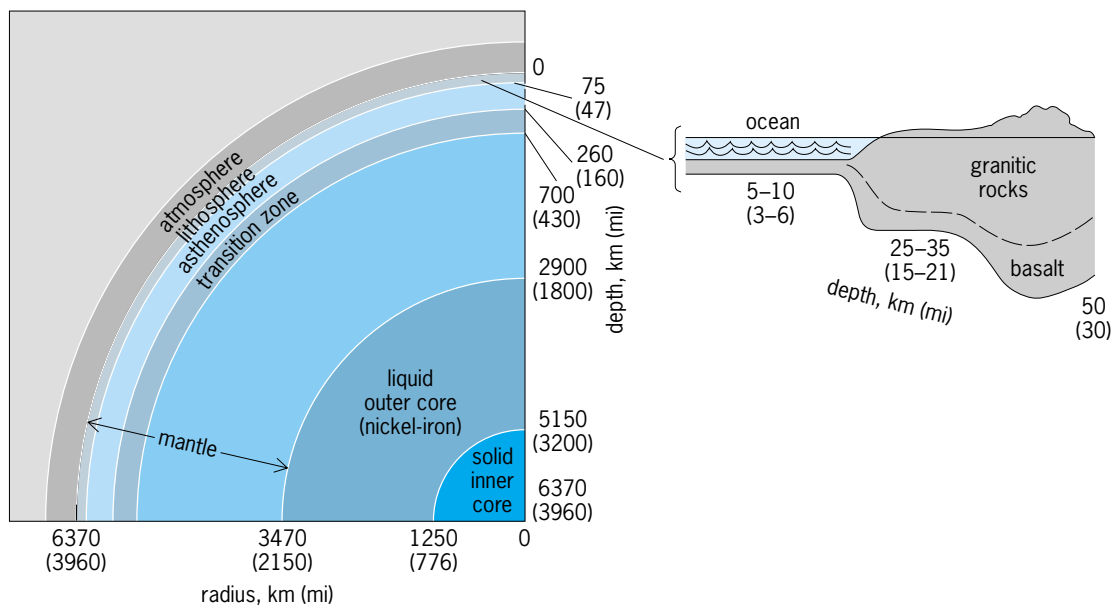

Principal layers of Earth.

its axis. The fact that the year is not a whole number of days has affected the development of the calendar. See CALENDAR.

Earth rotates on its axis once each day. The axis of rotation is perpendicular to the Equator, and the Equator is inclined at about  $23.5^\circ$  to the plane of Earth's orbit around the Sun. As Earth moves in its orbit, the north spin axis, or north geographic pole, points in the direction of the star Polaris, making it the North Star or polestar. One result of the tilt of the Equator relative to the orbital plane is that different parts of Earth receive differing amounts of sunlight through the year; this is the primary cause of seasons. See EQUATOR; POLARIS; ROTATIONAL MOTION.

Earth is an oblate spheroid. The mean equatorial radius is 6378.139 km (3963.37 mi), and the polar radius is 6356.779 km (3950.10 mi), the difference being 21.360 km (13.27 mi).

Earth's mass is  $5.976 \times 10^{27}$  g ( $0.2108 \times 10^{27}$  oz), being the sum of  $5.974 \times 10^{27}$  g ( $0.2107 \times 10^{27}$  oz) for solid Earth,  $1.4 \times 10^{24}$  g ( $0.049 \times 10^{24}$  oz) for the ocean, and  $5.1 \times 10^{21}$  g ( $0.18 \times 10^{21}$  oz) for the atmosphere. Earth's average density is  $5.518 \text{ g/cm}^3$ , which is just about double the density of the common rocks that form at Earth's surface, indicating that Earth's interior is more dense than the surface. Seismic studies have confirmed that Earth is layered both compositionally and mechanically (see illustration). See ATMOSPHERE; DENSITY; EARTH INTERIOR; OCEANOGRAPHY; SEISMOLOGY.

The deepest compositional layer is the core, which is divided into a solid inner core and a liquid outer core. Both the inner and outer core have the same composition, believed to be nickel-iron plus a small amount of lighter elements such as sulfur and silicon. Electric currents moving in the molten metal outer core are believed to be the origin of Earth's magnetic field. Above the core is the mantle which, on the basis of density of rare rock samples brought up from deep in the mantle in kimberlite pipes, and other evidence, is believed to be composed of silicate minerals, and in particular olivine and pyroxene. A rock composed largely of olivine and pyroxene is called a peridotite. See OLIVINE; PERIDOTITE; PYROXENE; SILICATE MINERALS.

Above the mantle is Earth's crust, and between the crust and the mantle there is a pronounced seismic discontinuity known as the Mohorovičić discontinuity, or Moho. The crust is of two kinds, both of which are less dense and compositionally different from the peridotitic mantle below. Beneath the ocean the crust is basaltic in composition and about 8 km (5 mi) thick. The crust beneath the continents is granitic in composition and averages 35 km (21.7 mi) in thickness but ranges up to 80 km (49.7 mi), as

beneath Tibet. The oceanic crust is geologically young because it is continually created and destroyed through the process of plate tectonics. No part of the oceanic crust that is older than about  $180 \times 10^6$  years has yet been discovered. The continental crust is much older than the oceanic crust. Continental rocks as old as  $4 \times 10^9$  years have been discovered in Canada, and the fact that they are highly deformed indicates a long and eventful history. See EARTH CRUST; GRANITE; MOHO (MOHOROVİČIĆ DISCONTINUITY); PLATE TECTONICS.

The surface of solid Earth has a bimodal distribution of elevations. If the water from the ocean could be removed, it would be apparent that continents stand high (average elevation is 840 m or 2755 ft above sea level), while the ocean floor sits low (average elevation is 3800 m or 12,464 ft below sea level). This difference in elevation arises because rigid lithosphere floats on the weak asthenosphere, and because the density of oceanic lithosphere (that is, lithosphere capped by oceanic crust) is greater than the density of continental lithosphere.

On the continents, mountain belts are the most dramatic features. They range in elevation from Mount Everest, 8848 m (29,030 ft), in the Himalaya Mountains to older, deeply eroded ranges that are now barely above sea level. Granitic and metamorphic rocks are generally exposed in the cores of mountain ranges. The overlying rocks that cover most of the Earth's surface are sedimentary, mainly of shallow marine origin, that may or may not have been deformed. The deformation is the result of compression and tension that causes folding and faulting, and may be accompanied by intrusion and metamorphism. Movements and collisions of tectonic plates are the principal cause of mountain building. Mountains generally are formed over several tens of millions of years. The rocks deformed in the process are generally marine sedimentary rocks formed along the margins of continents. See DEEP-MARINE SEDIMENTS; MARINE SEDIMENTS; METAMORPHIC ROCKS; OROGENY; SEDIMENTARY ROCKS.

The topographic features underlying the oceans are similarly diverse and reveal more evidence of a dynamic Earth. The continental shelf, an area covered by shallow water, generally less than 150 m (500 ft) deep, surrounds the continents at most places. Such areas are generally underlain by continental, granitic rocks, and are submerged parts of the continents. Continental slopes are the transition between the continental shelf and the ocean floors. Their tops are generally less than 150 m below sea level, and they slope down to about 4400 m (14,000 ft). They are narrow, steep features, with slopes generally between  $2$  and  $6^\circ$ ,

but some are up to  $45^\circ$ . They are generally underlain by thick accumulations of sedimentary rocks. See SEA-FLOOR IMAGING.

Submarine trenches and their associated volcanic island arcs are formed as a result of a tectonic plate of lithosphere sinking into the mantle beneath the edge of an overriding plate. The deepest place on Earth is in the Mariana Trench, 11,022 m (36,152 ft) below sea level.

The ocean floor is the most widespread surface feature of Earth. Beneath an average of 4.4 km (2.75 mi) of seawater are about 2.3 km (1.4 mi) of sedimentary rocks with some intercalated basalt, and below that is the oceanic crust, consisting of 4–6 km (2.5–3.7 mi) of basaltic rocks. Interrupting the ocean floor at many places are submarine mountains formed by basaltic volcanoes. Some of these volcanoes are very large and form oceanic islands such as the Hawaiian Islands.

New oceanic lithosphere capped by basaltic crust is created at the mid-ocean ridges, and this newly formed plate moves away from the ridges. The tectonic plates formed in this way may carry continents on them, and are the mechanism of continental drift. Paleomagnetic data from the continents indicate that the continents have moved relative to each other. The tectonic plates capped by basaltic crust plates are consumed at the trench-volcanic island arc areas. See PALEOMAGNETISM; SUBDUCTION ZONES.

As well as the ridge and the trench, a third type of plate boundary occurs where two plates slide past each other at a transform fault. Such collisions account for the deformed rocks found in the crust. See TRANSFORM FAULT.

The evidence for continental drift in the geological past includes matching of rock types, ages, fossils, climates, and structures (mountain ranges), as well as the paleomagnetic data. Evidence showing or suggesting present movements consists of shallow earthquakes along mid-ocean ridges and transform faults that offset them; deep earthquakes associated with deep-sea trench-volcanic island arc areas; direct measurement of movement; volcanic activity at mid-ocean ridges; and volcanic activity at trench-island arc areas. See GEODESY.

Earth's temperature and gravitation are such that an atmosphere is present. The major constituents are nitrogen and oxygen. A thin ozone layer in the atmosphere shields the Earth from lethal ultraviolet radiation from the Sun. The atmosphere, especially oxygen, and the presence of water, both at the surface and in the atmosphere, make life possible. Precipitation, mainly rain, results in running water such as streams and rivers on the continents. Running water is the main cause of erosion of the continents, and most of the landscapes have been eroded by water, although some are eroded by wind or ice (glaciers). See EROSION; GLACIOLOGY; GRAVITY; NITROGEN; OXYGEN; OZONE; WATER.

Earth, along with the rest of the solar system, is believed to have formed about  $4.55 \times 10^9$  years ago. This age is determined by dating radioactive isotopes in meteorites. Meteorites are believed to be fragments produced by collisions among small bodies formed by the same process that created the solar system. Theoretical studies of the Sun and other studies of radioactive isotopes also suggest a similar age. See EARTH, AGE OF. [B.J.S.]

**Earth, gravity field of** The field of gravitational attraction of the Earth. Since, at the Earth's surface, the small centrifugal force due to the Earth's rotation is inseparably superimposed on the attraction, the gravity field is usually understood to include also the effect of the centrifugal force.

The resultant of gravitation (pure attraction) and centrifugal force is called gravity. Gravity is the force that acts on the body at rest with respect to the Earth since the effects of attraction and of centrifugal force cannot be separated because of the equivalence of gravitational and inertial mass; thus gravity determines the weight of a body. The gravity potential  $W$  is the sum of the

gravitational potential  $V$  and the potential of centrifugal force, which is given by a simple analytical expression and may be considered as known.

A body moving with respect to the Earth is also affected by the Coriolis force. Like centrifugal force, the Coriolis force is an inertial force due to the Earth's rotation, but unlike centrifugal force, it does not possess a potential and hence cannot be easily incorporated into the gravity field. Therefore Coriolis force is not considered in the context of terrestrial gravitation. This is perfectly adequate since this force is zero for bodies at rest with respect to the Earth, and almost all measuring systems are at rest. See CORIOLIS ACCELERATION; GRAVITATION.

The gravity vector  $\mathbf{g}$  represents the force of gravity on a unit mass. It is the gradient vector of the gravity potential,  $\mathbf{g} = \text{grad } W$ . The magnitude of the gravity vector is the intensity of gravity, or briefly, gravity  $g$ . The dimension of  $g$  is force per unit mass, or acceleration. The SI unit is  $\text{m} \cdot \text{s}^{-2}$ . The cgs unit gal ( $1 \text{ gal} = 1 \text{ cm} \cdot \text{s}^{-2}$ ), named after Galileo, is still frequently used, especially the milligal ( $1 \text{ mgal} = 10^{-3} \text{ gal} = 10^{-5} \text{ m} \cdot \text{s}^{-2}$ ). Gravity  $g$  on the Earth's surface varies from about 978 gals at the Equator to about 983 gals at the poles. The direction of the gravity vector defines the vertical, or plumb line.

The surfaces of constant gravity potential,  $W = \text{const}$ , are called equipotential surfaces or level surfaces. The surface of a quiet lake is part of a level surface. So is the surface of the oceans, after some obvious idealization; the whole level surface so defined is called the geoid. After C. F. Gauss, the geoid is considered as the mathematical surface of the Earth, as opposed to the visible topographical surface. The plumb lines intersect the level surfaces orthogonally; they are not quite straight but very slightly curved.

The quantity that is measured most commonly is the gravity  $g$ . The determination of  $g$  as such is called an absolute gravity measurement. Usually only relative gravity measurements are performed, determining the difference between, or the quotient of, the gravity values at two different points. The direction of the gravity vector, which gives the plumb line in space, is measured by astronomical methods. Differences in the gravity potential  $W$  are obtained by geodetic leveling. Finally, certain derivatives of  $g$  and similar quantities are measured by instruments such as the torsion balance.

Satellite methods have enormously improved knowledge of the gravity field. In the future, new satellite technologies will advance gravity-related measurements, to be studied along with classical theoretical measurements, which will fully retain their importance. See GRAVITY.

For most purposes, the Earth's gravitational field may be considered invariable in time. However, it is subject to extremely small periodic variations due to tidal effects. These are caused by the attraction of the Sun and Moon. The attraction acts directly by superimposing itself onto the Earth's gravitational attraction; and it acts also indirectly by slightly deforming the Earth and shifting the waters of the oceans, so that the attracting terrestrial masses themselves are modified.

The lunar effect on gravity attains a maximum of 0.20 mgal, and the solar effect, a maximum of 0.09 mgal; both are well within the measuring accuracy of modern gravimeters. The results of stationary gravimeters recording variations of gravity may be used to draw conclusions as to the elastic behavior of the Earth under the influence of tidal stresses. See EARTH TIDES.

Anomalies of the terrestrial gravitational field are caused by mass irregularities. These may be the visible irregularities of topography such as mountains; or they may be invisible subsurface density anomalies. This is the reason why it is possible to use gravity measurements for investigating the underground structure of the Earth's crust. Thus analysis of gravity is applied by geophysicists and geologists for studying general features of the crust, and by exploration geophysicists for searching for shallow density irregularities that might indicate the presence of mineral deposits.



Geodetic instruments employ spirit levels and other devices to orient them with respect to the horizontal or, what amounts to the same thing, to the plumb line. Since the plumb line is defined by the gravitational field, it can be understood why this field enters essentially into almost all geodetic measurements, even into apparently purely geometric ones. In return, geodetic techniques are among the most efficient means for determining the gravitational field. The “mathematical figure of the Earth” for the purpose of geodesists, the geoid, is defined as a surface of constant potential  $W$ . “Heights above the sea level” are heights above the geoid; their determination is therefore a physical as well as a geometric problem. (Geodetic theories have been developed which employ only quantities referred to the Earth’s topographical surface; but here the gravitational field enters in an even more complicated way.) Thus geodesy is essentially concerned with the Earth’s gravitational field and its determination; the theory of the figure of the Earth is to a large extent equivalent to the theory of terrestrial gravitation. See GEODESY. [H.Mor.]

**Earth, heat flow in** The Earth’s heat flow is defined as the amount of heat escaping per unit time from the interior across each unit area of the Earth’s solid surface. The movement of heat within the Earth and its eventual loss through the surface are central elements in the modern theory of plate tectonics. The plate movements over the surface of the Earth are seen as one manifestation of a heat engine at work in the interior, and the heat flow at the surface as the exhaust from the engine. See EARTH INTERIOR; PLATE TECTONICS.

Because heat flows from the warmer to the cooler parts of a body, the observation that the Earth’s temperature increases with depth clearly implies that heat is escaping from the interior by conduction through the rocky crust. William Thomson (Lord Kelvin) used the heat flow in estimating the age of the Earth. He argued that as the Earth cooled, following its formation and solidification from molten rock, the rate at which the temperature increased with depth (the geothermal gradient) lessened over time, and thus by measuring the geothermal gradient the length of time that the Earth had been cooling could be estimated. Such an estimate is based on the assumption that all the heat being lost is drawn from the endowment of heat that the Earth possessed at the time of its initially molten condition. This assumption was later shown to be untenable because a significant fraction of the Earth’s heat flow is derived not from the initial heat but from the decay of radioactive elements present in trace amounts within the Earth. Thus the Earth’s heat should be thought of not as a finite quantity acquired at the time of formation and gradually dissipated over time, but as a quantity that in large part has been continually produced, albeit in diminishing amounts throughout the history of the Earth. See EARTH, AGE OF; EARTH, CONVECTION IN.

The most significant empirical relationship to emerge from heat flow studies is that heat flow generally decreases with increasing crustal age at the site of the measurement. In the oceans the significant age is the time of magmatic emplacement of the basaltic crust at a mid-ocean ridge. On the continents it is usually the age of the last major tectonic, magmatic, or thermal metamorphic event to have affected the measurement site. The pattern of the decrease in heat flow with age differs from ocean to continent. While both settings show a heat flow in the older segments of about 40–45 milliwatts per square meter, the oceanic heat flow shows a greater range over a shorter time interval than does the continental heat flow.

The heat production from radioactive decay contributes significantly to the heat flow from the Earth’s interior. In fact, the entire surface heat flow on continents could arise within the crust if the surface concentrations of the important heat-producing isotopes such as are found in granites and gneisses persisted throughout the full thickness of the crust. However, probable lower crustal rocks such as granulites and migmatites have lesser concentrations of these isotopes, and so radiogenic heat production ap-

parently decreases with depth in some manner. The principal heat-producing isotopes are thorium-232 ( $^{232}\text{Th}$ ), uranium-238 ( $^{238}\text{U}$ ), potassium-40 ( $^{40}\text{K}$ ), and uranium-235 ( $^{235}\text{U}$ ) with respective half-lives of 14.0, 4.47, 1.25, and  $0.70 \times 10^9$  years. Other radioactive isotopes do not presently contribute significant heat because their decay chains are not sufficiently energetic, or their abundances are insignificant, or their half-lives are too short. The concentrations of uranium and thorium in rocks are generally in trace amounts measured in parts per million, while potassium is much more abundant, in the range of a few percent, of which a small but well-known fraction is  $^{40}\text{K}$ . A range of values for the upper mantle is characteristic of various possible mantle rocks as inferred from xenoliths brought to the surface by igneous and tectonic processes. If the entire mantle had the lesser concentrations, then crustal and mantle radiogenic heat production would be less than half the present-day heat loss; whereas if the greater concentrations were representative of the mantle as a whole, radiogenic heat production would be about equal to the present-day heat loss.

The average heat flow over the entire Earth is  $87 \text{ mW} \cdot \text{m}^{-2}$  and is comparatively a trickle; it is sufficient to bring a thimbleful of water to a boil in about 2 years, or if collected over the area of a football field, would be adequate to light four 100-watt incandescent bulbs. The radiant energy from the Sun intercepted by the Earth is some 4000 times greater than the geothermal flux. The absorption and reradiation of the incident solar energy are the principal processes that determine the surface temperature of the Earth. The geothermal energy is of little significance to the surface temperature but is of paramount importance in considering the Earth’s internal thermal condition. See GEOLOGIC THERMOMETRY; GEOTHERMAL POWER. [H.N.P.]

**Earth crust** The low-density outermost layer of the Earth above the Mohorovičić discontinuity (the Moho), a global boundary that is defined as the depth in the Earth where the compressional-wave seismic velocity increases rapidly or discontinuously to a value in excess of 4.7 mi/s (7.6 km/s; the upper mantle). The crust is also the cold, upper portion of the Earth’s lithosphere, which in terms of plate tectonics is the mobile, outer layer that is underlain by the hot, convecting asthenosphere. See ASTHENOSPHERE; LITHOSPHERE; MOHO (MOHOROVİČIĆ DISCONTINUITY); PLATE TECTONICS.

**Continental crust.** The Earth’s continental crust has evolved over the past 4 billion years, and is highly variable in geologic composition and internal structure. The worldwide mean thickness of continental crust is 24 mi (40 km), with a standard deviation of 5.4 mi (9 km). The thinnest continental crust (found in the Afar Triangle, northeast Africa) is about 9 mi (15 km) thick, and the thickest crust (the Himalayan Mountains in China) is about 47 mi (75 km) thick. Ninety-five percent of all continental crust has a thickness within two standard deviations of the mean thickness, between 13 mi (22 km) and 37 mi (58 km). The Antarctic continent has a crustal thickness of 24 mi (40 km) in the ancient, stable (cratonic) region of East Antarctica, and about 12 mi (20 km) in the recently stretched (extended) crust of West Antarctica. Continental margins, which mark the transition from oceanic to continental crust, range in thickness from about 9 mi (15 km) to 18 mi (30 km). See CONTINENTAL MARGIN.

Despite its geologic complexity, the continental crust may generally be divided into four layers: an uppermost sedimentary layer, and an upper, middle, and lower crust composed of crystalline rocks. The sedimentary cover of the continental crust is an important source of natural resources. This cover averages 0.6 mi (1 km) in thickness, and varies in thickness from zero (for example, on shields) to more than 9 mi (15 km) in deep basins. In stable continental crust of average thickness (25 mi or 40 km), the crystalline upper crust is commonly 6–9 mi (10–15 km) thick and has an average composition equivalent to a granite. The middle crust is 3–9 mi (5–15 km) thick and has a composition equivalent to a diorite; and the lower crust is 3–12 mi (5–20 km)

thick and has a composition equivalent to a gabbro. Due to increasing temperature and pressure with depth, the metamorphic grade of rocks increases with depth, and the rocks within the deep continental crust generally are metamorphic rocks, even if they originated as sedimentary or igneous rocks. See DIORITE; GABBRO; GRANITE; METAMORPHIC ROCKS.

Crustal properties vary systematically with geologic setting, which may be divided into six groups: orogens (mountain belts), shields and platforms, island arcs (volcanic arcs), continental magmatic arcs, rifts, extended (stretched) crust, and forearcs. Orogens are typified by thick crust [average thickness is 29 mi (46 km), but the maximum thickness is as much as 47 mi (75 km) in the Himalayas]. Shields and platforms, such as the Canadian Shield and the Russian Platform, commonly have an approximately 26-mi-thick (42-km) crust, including a 3–6 mi-thick (5–10 km) lower crust. In comparison with shields, island arcs (such as Japan) have thinner crusts and significantly shallower middle and lower crustal layers due to the intrusion of mafic (that is, low silica content) plutons. Continental magmatic arcs, such as the Cascades volcanoes of the northwestern United States, intrude preexisting continental crust, and therefore they are generally 3–9 mi (10–15 km) thicker than island arcs. Continental rifts, such as the East African and Rio Grande rifts, have an average crustal thickness of about 22 mi (36 km). Extended continental crust, such as the Basin and Range Province of the western United States, averages 18 mi (30 km) in thickness. Forearcs are regions that were formed oceanward of volcanic arcs, such as much of the west coast of North America. They typically have thin crust, about 15 mi (25 km), and have a thick (9 mi or 15 km) upper crustal section that consists of relatively low-density metasedimentary rocks. See NORTH AMERICA; OCEANIC ISLANDS; PLUTON; RIFT VALLEY; SEDIMENTARY ROCKS; VOLCANO.

At least three processes provide new continental crust. The first is the accretion and consolidation of island arcs, such as Japan or the Aleutian Islands, onto a continental margin. The second process is the tectonic underplating of oceanic crust at active subduction zones. In this process, the continental crust grows from below as oceanic crust is welded to the base of the continental margin, either when subduction stops or when subduction steps oceanward and a new trench is formed. This process has been identified in western Canada and southern Alaska. The third process is the magmatic inflation of the crust at continental arcs, rifts, and regions of crustal extension. This process has been identified in many regions. See GEODYNAMICS.

[W.D.Mo.]

**Oceanic crust.** The surface of the ocean crust, except for some locally high volcanoes and plateaus, resides some 1–3 mi (2–5 km) below sea level, and about another kilometer below the average level of the continents. The ocean crust represents the youngest and geologically most dynamic portion of the Earth's surface. Most of it was produced at mid-ocean ridges during the process of sea-floor spreading. The ridges define the trailing edges, or accreting boundaries, of the major lithospheric plates that are moving about the surface of the Earth at present. Thus, the oldest rocks of the ocean crust date back no earlier than the rifting episodes that created most of these plates and initiated the most recent phase of continental drift, the Pangaeian breakup, in Late Jurassic times. See JURASSIC; MID-OCEANIC RIDGE.

There are fault slices of types of ocean crust on land, known as ophiolites, where nearly or entirely complete cross sections through the crust can be mapped and sampled. These strongly indicate that the ocean crust consists in downward sequence of submarine extrusives (usually pillow basalts), feeder dikes (often vertically sheeted), or sills, gabbros, and peridotites. There is much uncertainty, however, about the extent to which typical ophiolites, most of which formed in island-arc or backarc environments, can represent abyssal ocean crust, which is produced at the major accreting plate boundaries. Moreover, the physical correspondence of the rocks in ophiolites to ocean crust is often complicated by their complex structure and extent of alteration

and metamorphism, particularly in the ultramafic sections. See OPHIOLITE.

[J.H.Na.]

**Earth interior** All of the Earth beneath the land surface and the ocean bottom, including the crust, the mantle, and the core. The interior is not accessible to direct observation. Nevertheless, a rather detailed model has been constructed on the basis of measurements made at or above the surface. Measurements of gravity, the geomagnetic field, surface heat flow, and surface deformation can all be used to put constraints on the Earth model, but the most detailed information about the interior is provided by seismic measurements. In the exploration of the Earth's interior, the seismic waves being analyzed are usually generated by earthquakes, and measurements are made of waves propagating through the interior of the body, waves propagating along the surface, and standing waves bringing the whole Earth into a state of oscillation. Such measurements, when properly interpreted, provide information about seismic-wave velocities in the Earth. Seismic-wave velocities can also be measured in laboratory experiments where rock samples are subjected to the high pressures and temperatures typical of conditions in the deep interior.

Several standard Earth models have been constructed in the past. One of the more comprehensive models was constructed in 1981 by A. Dziewonski and D. Anderson, the Preliminary Reference Earth Model (PREM). The principal regions of this model are listed in the table. See EARTH.

Principal regions of a standard Earth model

Layer	Approximate depth range,* mi (km)	
(1) Ocean layer	0–1.8	(0–3)
(2) Upper and lower crust	1.8–15	(3–24)
(3) Lithosphere below the crust	15–50	(24–80)
(4) Asthenosphere (low-velocity zone)	50–140	(80–220)
(5) Upper mantle above phase or compositional changes near 240 mi (400 km)	140–240	(220–400)
(6) Transition region between phase or compositional changes near 240 and 416 mi (400 and 670 km)	240–416	(400–670)
(7) Lower mantle above core-mantle boundary layer	416–1703	(670–2741)
(8) Core-mantle boundary layer (D'')	1703–1796	(2741–2891)
(9) Outer core	1796–3200	(2891–5150)
(10) Inner core	3200–3959	(5150–6371)

\*Depth ranges are uncertain, especially in the crust and upper mantle.

**Seismic structure.** The seismic structure of the Earth is studied by analyzing body waves, surface waves and free oscillations, and anisotropy. Body waves are generated by earthquakes or large (nuclear) explosions and are recorded by many seismic stations throughout the world. Body waves are characterized as P (primary) and S (secondary) waves. Both wave types are supported by a solid, but P waves have a higher velocity and arrive first. It is routine practice that the stations report the arrival time of the first P wave to an earthquake information center, where these data are used to locate the earthquake and determine its origin time. By subtracting the origin time from the arrival times, the travel times of waves from the earthquake to the stations are determined, and these travel times can be used to determine the seismic velocity structure of the Earth's interior. See EARTHQUAKE; SEISMOLOGY.

Surface waves and free oscillations are also generated by earthquakes. The velocity with which surface waves propagate is a function of the frequency of the waves, that is, the surface waves are dispersive. The dispersion depends on the seismic velocity structure of the surface layers. The free oscillations of the Earth resonate only at certain discrete frequencies (the

eigenfrequencies), that is, the free oscillation spectrum would be a line spectrum (in practice the lines are somewhat smeared because of dissipation of the oscillations). The eigenfrequencies depend on the velocity structure of the whole Earth. Thus surface waves and free oscillations provide an alternative data set for constructing velocity models. PREM is based on both travel times and free-oscillation data. See OSCILLATION.

Anisotropy refers to the directional dependence of the wave velocity. Anisotropy in the Earth's interior may be induced by flow of material containing noncubic crystals or elongated grains. Anisotropy has been observed in the lithosphere, especially under the oceans, and has been postulated for the asthenosphere. This anisotropy has been explained in terms of alignment of olivine crystals, which are thought to be the dominant material in these layers. Anisotropy may occur in deeper regions of the Earth as well, but is difficult to resolve. However, to account for the differences in travel time between P waves passing through the inner core in the equatorial and polar directions, respectively, it has been proposed that the inner core is anisotropic, although the physical mechanism is not understood. See LITHOSPHERE; OLIVINE.

**Composition and state.** The Earth comprises a crust, a mantle, and a core, so there is a compositional differentiation into at least three regions. Each of these regions is differentiated again, both vertically and, at least for the crust and upper part of the mantle, laterally. See ELEMENTS, GEOCHEMICAL DISTRIBUTION OF.

The Earth's crust is on average about 12 mi (20 km) thick but is thinner under oceans and thicker under continents. Thickness under some high mountain ranges may be up to 36 mi (60 km; the so-called mountain roots). The boundary between the crust and the underlying mantle is called the Mohorovičić discontinuity or, more usually, the Moho. The continental and oceanic portions of the crust have different compositions. Continental crust can be divided into a lighter, granitic upper crust and a lower crust that is more basaltic, like the oceanic crust. Despite the striking heterogeneity of the crust, some generalizations can be made. Both the crust and the mantle are rich in silicates, but the mantle has much more magnesium, and the crust has proportionally more of the relatively light elements such as calcium, aluminum, sodium, and potassium in the form of oxides. See EARTH CRUST; MOHO (MOHORVIČIĆ DISCONTINUITY).

The mantle is the region between the crust and the core. It is common to make a distinction between the upper mantle and lower mantle, which are separated by the so-called 670-km discontinuity at a depth of 416 mi. The upper mantle includes the lithosphere below the crust, the asthenosphere, and the region of phase transformations (the transition zone). It contains also the subducting slabs of oceanic lithosphere. The difference between continental and oceanic crust extends to at least the bottom of the lithosphere and probably to the bottom of the asthenosphere. It is believed that the stiff lithosphere and the soft asthenosphere differ mainly in mechanical strength, not in composition. The shallow part of the upper mantle is likely to be relatively depleted in the light elements typical of the crust. On the other hand, the light elements do not seem to be underrepresented in estimates of the composition of the deeper parts of the upper mantle. It has been suggested that this region contains more eclogite, the high-pressure form of basalt, which is subducted with the oceanic lithosphere. Olivine is probably the most abundant upper-mantle mineral. At pressures prevailing near 240 mi (400 km) depth, it transforms to a denser structure (spinel). See BASALT; ECLOGITE; SPINEL.

The lower mantle, the mantle below 416 mi (670 km), appears to have a homogeneous composition down to the boundary layer above the core. Experimental results seem to indicate that mineralogy is dominated by ferromagnesium oxides (wüstite) and silicates (perovskite). The high-pressure perovskite phase of ferromagnesium silicate is thought to be the most abundant mineral of the Earth. See PEROVSKITE.

The core is the central region of the Earth. Its seismic and density structure are well matched by a solid inner core of iron or nickel iron and a liquid outer core of iron mixed with about 10% lighter material. Candidate light elements are sulfur and oxygen, with some preference for the former. The outer core can be taken as homogeneous for all practical purposes.

Core-mantle coupling is believed to be responsible for decade-long variations in the length of the day of up to about 5 milliseconds. The idea is that fluid flow in the outermost regions of the core is coupled to the mantle, so that the rotation rate of the mantle can fluctuate in response to time variations of the flow in the core. This view is supported by an observed correlation between the decade variations in the length of the day and certain variations of the geomagnetic field (the latter being associated with core flow). The coupling may be electromagnetic or topographic. It has been suggested that topographic coupling can be quite effective, provided that there is indeed topography on the core-mantle boundary (of the order of a few hundred meters). See GEOMAGNETISM. [D.J.D.]

**Earth rotation and orbital motion** The rotation of the Earth about its axis is demonstrated by the classical Foucault pendulum experiment. Its revolution in its orbit around the Sun is shown by (1) the annual parallactic displacement of relatively nearby stars against the background of more distant stars, and (2) the aberration of light, causing an apparent annual displacement of all stars on the celestial sphere. However, because the Earth is not truly a rigid symmetric body and because it interacts with other members of the solar system gravitationally, these motions vary with time. See ABERRATION (ASTRONOMY); FOUCAULT PENDULUM; ORBITAL MOTION; PARALLAX (ASTRONOMY).

**Rotation of the Earth.** Until recent times the rotation of the Earth has served as the basis for timekeeping. The assumption was made that the rotational speed of the Earth was essentially constant and repeatable, and that the length of the day which resulted from this constant rotational speed was naturally useful as a measure of the passage of time. Astronomical observations, however, have shown that the speed with which the Earth is rotating is not constant with time. The variations in rotational speed may be classified into three types: secular, irregular, and periodic. The secular variation of the rotational speed refers to the apparently linear increase in the length of the day due chiefly to tidal friction. This effect causes slowing of the Earth's rotational speed and lengthening of the day by about 0.0005 to 0.0035 s per century.

The irregular changes in speed have caused the length of the day to vary by as much as 0.01 s over the past 200 years. Irregular changes consist of so-called decade fluctuations with characteristic periods of 5–10 years as well as variations that occur at shorter time scales. The decade fluctuations are apparently related to processes occurring within the Earth. The higher-frequency variations are now known to be largely related to the changes in the total angular momentum of the atmosphere. See ATMOSPHERIC GENERAL CIRCULATION.

Periodic variations are associated with periodically repeatable physical processes affecting the Earth. Tides raised in the solid Earth by the Moon and the Sun produce periodic variations in the length of the day of the order of 0.0005 s with periods of 1 year,  $\frac{1}{2}$  year, 27.55 days, and 13.66 days. Seasonal changes in global weather patterns occurring with approximately annual and semiannual periods also cause variations in the length of the day of this order. See EARTH TIDES; TIME.

**Revolution about the Sun.** The motion of the Earth about the Sun is seen as an apparent annual motion of the Sun along the ecliptic. A large number of astronomical observations of the positions of the Sun and other solar system objects have been made and are being made continuously. This information is required to determine the nature of the motion of the Earth about the Sun. Observations are analyzed using the mathematical methods of celestial mechanics to provide improved

estimates of the motions of the solar system objects in the future and to describe the past motions of the objects. The description of the apparent motion of the Sun in the sky provides the determination of the orbit of the Earth. *See* CELESTIAL MECHANICS.

The true period of the revolution of the Earth around the Sun is determined by the time interval between successive returns of the Sun to the direction of the same star. This interval is the sidereal year of 365 days 6 h 9 min 9.51 s of mean solar time or 365.25636 mean solar days. The period between successive returns to the moving vernal equinox is known as the tropical year of 365 days 5 h 48 min 45.2 s or 365.24219 days. The length of the tropical year is regarded as the length of the year in common usage for calendars. The period of time between successive passages at perihelion (the closest approach of the Earth to the Sun) is called the anomalistic year of 365 days 6 h 13 min 53.26 s or 365.25964 days. The lengths of the years listed above are given for the year 2000. These values vary slowly as a consequence of the long-period perturbations of the Earth's orbit by other planets. *See* CALENDAR; PERTURBATION (ASTRONOMY).

The mean distance from the Earth to the Sun, or the semi-major axis of the Earth's orbit, was the original definition of the astronomical unit (AU) of distance in the solar system. Its absolute value fixes the scale of the solar system and the whole universe in terms of terrestrial standards of length. The distance between the Earth and the Sun can be determined by a variety of methods. The most precise method relies on measurement of the travel time of electromagnetic signals reflected from objects in the solar system or received from artificial interplanetary probes. The currently adopted value of the astronomical unit is  $1.495978706 \times 10^{11}$  m (92,955,807 mi). *See* ASTRONOMICAL UNIT.

The eccentricity of the Earth's orbit can be accurately determined from the variable speed of the Sun's apparent motion along the ecliptic and the laws of elliptic motion. The adopted value of the eccentricity is 0.0167086171540.

The fact that the Equator of the Earth is inclined in space by about  $23.5^\circ$  to the orbital plane of the Earth (the ecliptic) causes the Northern Hemisphere to be exposed to the more direct rays of the Sun during part of the Earth's revolution around the Sun. The Southern Hemisphere receives the more direct rays 6 months, or a half revolution, later. This effect causes the seasons. *See* SEASONS.

**Other motions.** In addition to the rotation of the Earth and its orbital motion about the Sun, the Earth experiences various small motions about its center of mass. Precession and nutation are examples, and these are caused by the gravitational attraction of the Sun and Moon on the nonspherical Earth. *See* NUTATION (ASTRONOMY AND MECHANICS); PRECESSION OF EQUINOXES.

Because the axis of symmetry of the Earth is not aligned precisely with the axis of rotation, the Earth also executes a motion about its center of mass known as polar motion. This motion, caused by geophysical and meteorological effects on and within the Earth, is not predictable with accuracy, and must be observed continuously to provide the most precise information on the orientation of the Earth. Polar motion is characterized mainly by an approximately 435-day and a 365-day periodic circular motion of the axis of rotation on the surface of the Earth. The radius of the circular motion is of the order of 16 ft (5 m), but this may vary. *See* EARTH; PLANET; PLANETARY PHYSICS. [D.D.McC.]

**Earth sciences** Sciences that involve attempts to understand the nature, origin, evolution, and behavior of the Earth or of its parts and to comprehend its place in the universe, especially in the solar system. Understanding has advanced primarily through improved appreciation of the complex, usually cyclical interactions that take place among distinct parts of the Earth such as the lithosphere, atmosphere, hydrosphere, and biosphere. Geophysics is the study of the physics of the Earth, emphasizing its physical structure and dynamics. Geochemistry is the study of the chemistry of the Earth, dealing with its composition and

chemical change. Geology is the study of the solid Earth and of the processes that have formed and modified it throughout its 4.5-billion-year history. *See* GEOCHEMISTRY; GEODESY; GEOLOGY; GEOPHYSICS; SOLAR SYSTEM.

Many branches of geology are considered separate sciences. Mineralogy is the study of the composition, structure, and properties of minerals. Petrology involves understanding how rocks originate and evolve, as well as rock description and classification. Specialties related to petrology include sedimentology and volcanology. Stratigraphy is the study of the origin, age, and development of layered, generally sedimentary rocks. Paleontology is the study of ancient (fossil) life. Historical geology is the study of the evolution of the Earth and its life. Geomorphology is the study of landscapes and their evolution. Seismology is the study of earthquakes and their effects. Structural geology is the study of deformed rocks. Engineering geology relates to the support of human constructions by underlying rock. *See* ENGINEERING GEOLOGY; GEOLOGY; GEOMORPHOLOGY; HYDROLOGY; MINERALOGY; PALEONTOLOGY; PETROGRAPHY; PETROLOGY; SEISMOLOGY; STRATIGRAPHY; STRUCTURAL GEOLOGY; VOLCANOLOGY.

Oceanography is the study of the oceans; limnology, the study of lakes; hydrology, the study of underground and surface water; and glaciology, the study of glaciers, ice caps, and ice sheets. These disciplines address the study of water in and on the Earth. The gaseous outer parts of the planet are the province of the atmospheric sciences, including meteorology, which is concerned with the weather and weather forecasting; climatology, which deals with longer-term and regional variations; and aeronomy which, because it deals with the outermost ionized region of the atmosphere, is much concerned with solar terrestrial interactions, including the aurora borealis and aurora australis. The biosphere embodies all life on Earth, and its study includes molecular biology, zoology, botany, and ecology. Geography, the study of all that happens at the Earth's surface, has been distinct insofar as it has encompassed not only physical and biological sciences but also the social sciences, including aspects of political science and economics. This distinction is fading rapidly as other earth sciences become more involved with social considerations.

[K.Bu.]

**Earth tides** Cyclic motions of the Earth, sometimes over a foot or so in height, depending on latitude, caused by the same lunar and solar forces which produce tides in the sea. These forces also react on the Moon and Sun, and thus are significant in astronomy in evaluations of the dynamics of the three bodies. For example, the secular spin-down of the Earth due to lunar tidal torques is best computed from the observed acceleration of the Moon's orbital velocity. In oceanography, earth tides and ocean tides are very closely related. *See* GEODESY; TIDE.

By far the most widely used earth tide instruments are the tiltmeter and the gravimeter. Both instruments have the merits of portability, high potential precision, and low cost. Thus they are able to advance economically an important mission—the global mapping of earth tides and ocean tides. [L.B.S./J.T.K.]

**Earthquake** The sudden movement of the Earth caused by the abrupt release of accumulated strain along a fault in the interior. The released energy passes through the Earth as seismic waves (low-frequency sound waves), which cause the shaking. Seismic waves continue to travel through the Earth after the fault motion has stopped. Recordings of earthquakes, called seismograms, illustrate that such motion is recorded all over the Earth for hours, and even days, after an earthquake.

Earthquakes are not distributed randomly over the globe but tend to occur in narrow, continuous belts of activity. Approximately 90% of all earthquakes occur in these belts, which define the boundaries of the Earth's plates. The plates are in continuous motion with respect to one another at rates on the order of centimeters per year; this plate motion is responsible for most geological activity.

Plate motion occurs because the outer cold, hard skin of the Earth, the lithosphere, overlies a hotter, soft layer known as the asthenosphere. Heat from decay of radioactive minerals in the Earth's interior sets the asthenosphere into thermal convection. This convection has broken the lithosphere into plates which move about in response to the convective motion. As the plates move past each other, little of the motion at their boundaries occurs by continuous slippage; most of the motion occurs in a series of rapid jerks. Each jerk is an earthquake. This happens because, under the pressure and temperature conditions of the shallow part of the Earth's lithosphere, the frictional sliding of rock exhibits a property known as stick-slip, in which frictional sliding occurs in a series of jerky movements, interspersed with periods of no motion—or sticking. In the geologic time frame, then, the lithospheric plates chatter at their boundaries, and at any one place the time between chatters may be hundreds of years. See PLATE TECTONICS.

The periods between major earthquakes is thus one during which strain slowly builds up near the plate boundary in response to the continuous movement of the plates. The strain is ultimately released by an earthquake when the frictional strength of the plate boundary is exceeded. See FAULT AND FAULT STRUCTURES.

Most great earthquakes occur on the boundaries between lithospheric plates and arise directly from the motions between the plates. These may be called plate boundary earthquakes. There are many earthquakes, sometimes of substantial size, that cannot be related so simply to the movements of the plates. At many plate boundaries, earthquakes occur over a broad zone—often several hundred miles wide—adjacent to the plate boundary. These earthquakes, which may be called plate boundary-related earthquakes, are secondarily caused by the stresses set up at the plate boundary. Some earthquakes also occur, although infrequently, within plates. These earthquakes, which are not related to plate boundaries, are called intraplate earthquakes. The immediate cause of intraplate earthquakes is not understood.

In addition to the tectonic types of earthquakes described above, some earthquakes are directly associated with volcanic activity. These volcanic earthquakes result from the motion of underground magma that leads to volcanic eruptions.

Earthquakes often occur in well-defined sequences in time. Tectonic earthquakes are often preceded, by a few days to weeks, by several smaller shocks (foreshocks), and are nearly always followed by large numbers of aftershocks. Foreshocks and aftershocks are usually much smaller than the main shock. Volcanic earthquakes often occur in flurries of activity, with no discernible main shock. This type of sequence is called a swarm.

Earthquakes range enormously in size, from tremors in which slippage of a few tenths of an inch occurs on a few feet of fault, to the greatest events, which may involve a rupture many hundreds of miles long, with tens of feet of slip.

The size of an earthquake is given by its moment: average slip times the fault area that slipped times the elastic constant of the Earth. The units of seismic moment are dyne-centimeters. An older measure of earthquake size is magnitude, which is proportional to the logarithm of moment. Magnitude 2.0 is about the smallest tremor that can be felt. Most destructive earthquakes are greater than magnitude 6; the largest shock known was the 1960 Chile earthquake, with a moment of  $10^{30}$  dyne-centimeters ( $10^{23}$  newton-meters) or magnitude 9.5. It involved a fault 600 mi (1000 km) long slipping 30 ft (10 m).

The intensity of an earthquake is a measure of the severity of shaking and its attendant damage at a point on the surface of the Earth. The same earthquake may therefore have different intensities at different places. The intensity usually decreases away from the epicenter (the point on the surface directly above the onset of the earthquake), but its value depends on many factors and generally increases with moment. Intensity is usually higher in areas with thick alluvial cover or landfill than in areas of shallow soil or bare rock. Poor building construction leads to high intensity ratings because the damage to structures is high.

Intensity is therefore more a measure of the earthquake's effect on humans than an innate property of the earthquake.

Many additional effects may be produced by earthquake shaking, including landslides and tsunamis. See LANDSLIDE; TSUNAMI.

Earthquake prediction research has been going on for nearly a century. Unfortunately, successful earthquake predictions are extremely rare. There are two basic categories of earthquake predictions: forecasts (months to years in advance) and short-term predictions (hours or days in advance). Forecasts are based a variety of research, including the history of earthquakes in a specific region, the identification of fault characteristics (including length, depth, and segmentation), and the identification of strain accumulation. Data from these studies are used to provide rough estimates of earthquake sizes and recurrence intervals. [C.H.S.; K.M.S.]

**East Indies** A loosely defined region in southeast Asia comprising the countries of Malaysia, Brunei, and Indonesia. The islands of the East Indies extend for about 2800 mi (4500 km) from western Sumatra to New Guinea. They form part of a region of great geological and biological diversity.

Three broad geographic subdivisions can be made: (1) Sundaland, which comprises the shallow marine Sunda Shelf, peninsular southeast Asia, and the islands west of the Makassar and Lombok straits; (2) northern Australia, which includes the shallow marine Sahul and Arafura shelf areas and islands surrounding northern Australia and New Guinea; and (3) Wallacea, which comprises the islands south of the Philippines between Sundaland and northern Australia. Each division is an important geomorphological and biological region. The boundaries of Sundaland and northern Australia can be drawn at the 660-ft (200-m) bathymetric contour. Deep trenches with depths averaging 5 mi (8 km) border the margins of Sundaland with the Indian Ocean, and northern Australia with the Pacific Ocean. In contrast, within the area of Wallacea there are a number of deep troughs, and there are large variations in relief with volcanic and nonvolcanic mountains, typically up to 6600–9900 ft (2000–3000 m) in height, separated by deep marine basins underlain by extended continental and oceanic crust with depths of several kilometers. See ASIA; AUSTRALIA.

At present, almost all the islands lie in a belt close to the Equator within the Intertropical Convergence Zone (ITCZ). An equatorial climate prevails, with high rainfall and, except at higher elevations, high temperatures throughout the year. Diurnal variations are greater than the difference of mean temperatures of the hottest and coldest months. High relative humidity is normal in most lowland regions. Regionally, there are significant variations in rainfall, reflecting topography and position with respect to major landmasses and oceans, and each island's climate can be different. Borneo is the only large island within which there is broadly an ever-wet tropical climate. See CLIMATOLOGY; TROPICAL METEOROLOGY.

The shallow seas with narrow deep-water passages of Wallacea mean that the region is particularly important for oceanic circulation. The Indonesian throughflow is a current to the Indian Ocean which transports large amounts of warm water from the Pacific, influencing sea surface temperatures, salinity, and rainfall. The magnitude and variations of this current are important controls on the thermohaline balance of the Pacific and Indian oceans, and perhaps on global thermohaline circulation. Most water passes from the North Pacific via the Celebes Sea, Makassar Strait, Flores Sea, and Banda Sea. See EQUATORIAL CURRENTS; OCEAN CIRCULATION.

The East Indies are characterized by intensely active seismicity and volcanic activity. The correlation of seismicity, volcanicity, deep trenches, and strong negative gravity anomalies along the Sunda and Banda arcs was noted long before the formulation of the theory of plate tectonics; these are now known to be features characteristic of the subduction of oceanic lithosphere. The history of convergence of the Pacific, Indian-Australian, and Asian

plates offers a broad explanation of the geological development and complexity of the region, but many small plates also need to be considered. However, the full details of the development of the region are still far from understood because of its size, relative inaccessibility, and the nature of the terrain. See CONTINENTAL DRIFT; GEODYNAMICS; PLATE TECTONICS.

The entire region is immensely rich in natural resources, in particular petroleum, minerals, and timber. Petroleum has been produced in large quantities on land in Sumatra, Borneo, and the Bird's Head of New Guinea since the mid-twentieth century. Most oil and gas provinces are in Cenozoic basins, and in the late 1990s the East Indies provided about 5% of annual world oil production. In recent years, exploration and production has moved offshore and is increasingly moving into deeper waters. Many parts of the region have considerable potential for geothermal energy production. Mineral production has been historically important, with major discoveries of tin, gold, and nickel. The late-twentieth-century discovery of major mineral deposits in the northern New Guinea margin suggests that the young island arcs of the region will continue to be targets for exploration, and large deposits are likely to be found both on and off shore. See EARTH RESOURCE PATTERNS. [R.Hai.]

**Eating disorders** Disorders characterized by abnormal eating behaviors and beliefs about eating, weight, and shape. The three major diagnoses are anorexia nervosa, bulimia nervosa, and binge eating disorder. In addition, there are many cases of abnormal eating that have only some of the features required for an eating disorder diagnosis; these cases are classified as eating disorders not otherwise specified. Obesity is classified as a general medical condition and not as an eating disorder (a psychiatric condition) because it is not consistently associated with psychological or behavioral problems.

There are also three childhood eating disorders: (1) Pica is a persistent pattern of eating nonnutritive substances in infants or young children. (2) Rumination disorder involves repeated regurgitation and rechewing of food. This behavior is not the result of a gastrointestinal or medical condition; the partially digested food comes back into the mouth without any observable nausea, disgust, or attempt to vomit. (3) Feeding disorder of infancy or early childhood is the persistent failure to eat adequately, as reflected in insufficient weight gain for age. Pica and rumination disorder are thought to be uncommon and frequently associated with developmental delays and mental retardation. Perhaps half of the pediatric hospitalizations for inadequate weight gain (which constitute 1–5% of all pediatric hospitalizations) may be due to feeding disorder of infancy or early childhood.

**Anorexia nervosa.** Anorexia nervosa is characterized by a refusal to maintain a minimal normal body weight (defined as 15% below average weight for height), an intense fear of becoming fat, and, if female, amenorrhea for at least 3 months. The majority of cases of anorexia nervosa are classified as restricting type; these individuals achieve abnormally low weight by severely dieting, fasting, and often by exercising compulsively. In severe cases, patients refuse to eat and can die of starvation or severe medical complications. Another subtype of anorexia nervosa is binge eating/purging type. Despite being emaciated or dangerously thin, persons with anorexia nervosa perceive themselves as overweight (distorted body image), deny the seriousness of their condition, and have an intense fear of becoming fat.

Anorexia nervosa occurs in roughly 1% of adolescent and young adult females. Most cases (90%) are female, and the majority are Caucasian and come from middle-class or higher socioeconomic groups. Anorexia nervosa is more prevalent in industrialized countries that share western views regarding thinness as an ideal. It develops most frequently during adolescence.

Persons with anorexia nervosa frequently manifest symptoms of depression and anxiety. The restricting type of anorexia nervosa is associated with obsessionality, rigidity, perfectionism, and

overcontrol, whereas the binge/purge subtype is associated with greater mood instability and impulsivity across a wide range of areas, including substance abuse.

Although some cases of anorexia nervosa show no evidence of medical problems, prolonged starvation affects most organ systems, and a wide array of medical problems tend to be present. Long-term mortality from anorexia nervosa is estimated at 5–10% with most deaths resulting from starvation, cardiac events, or suicide.

The causes of anorexia nervosa are not yet understood but are likely to involve a complex combination of genetic, familial, psychological, and sociocultural factors. The onset of anorexia nervosa tends to follow a period of dieting and is frequently triggered by a stressful life events or transitions.

Since the starvation and weight loss can be life-threatening, initial treatment efforts need to focus on weight gain and the reestablishment of regular eating patterns. Inpatient hospitalization is frequently necessary. Although significant psychological issues tend to be present, it is generally ineffective to address these until weight has been stabilized. Once weight gain is achieved, psychotherapies can become useful. Relapse rates are high. See ANOREXIA NERVOSA; PSYCHOTHERAPY.

**Bulimia nervosa.** Bulimia nervosa is characterized by recurrent episodes of binge eating (eating large amounts of food while experiencing a subjective sense of lack of control over the eating), the regular use of extreme weight compensatory methods (for example, self-induced vomiting), and dysfunctional beliefs about weight and shape that unduly influence self-evaluation or self-worth.

Bulimia nervosa occurs in roughly 2% of adolescents and adults. It is most common in females (90% of cases), Caucasians, and middle-class or higher socioeconomic groups. The prevalence of bulimia has increased over the past few decades, and is also becoming more common in non-Caucasian groups.

Persons with bulimia nervosa have high rates of depression, anxiety, and substance abuse problems. Although this condition is less dangerous than anorexia nervosa, medical complications can occur. Dental erosion and periodontal problems are common. Electrolyte imbalance and dehydration can result in serious medical complications, including cardiac arrhythmias. In rare cases, esophageal bleeding and gastric ruptures occur.

Bulimia nervosa is likely to result from a combination of genetic, familial, psychological, and sociocultural factors. Although many persons have weight and diet concerns, the development of bulimia is thought to arise only in vulnerable individuals and usually after a stressful event. Bulimia nervosa is a self-maintaining vicious cycle.

Bulimia nervosa can often be treated successfully with outpatient therapies. Cognitive behavioral therapy and interpersonal psychotherapy have been found to be most effective for reducing binge eating and vomiting and improving associated concerns such as depression, self-esteem, and body image. These two therapies also have the best results over the long term. Certain types of pharmacotherapy, notably antidepressant medications, are also effective.

**Binge eating disorder.** Binge eating disorder is characterized by recurrent episodes of binge eating but, unlike bulimia nervosa, no extreme weight control behaviors (purging, laxatives, fasting) are present. Persons with binge eating disorder have chaotic eating patterns and frequently overeat as well as binge.

Although obesity is not required for the diagnosis, many people with binge eating disorder are overweight. Binge eating disorder is estimated to occur in 3% of the general population but in roughly 30% of obese persons. Binge eating disorder occurs most frequently in adulthood, affects men nearly as often as women, and occurs across different ethnic groups.

Obese binge eaters are characterized by higher levels of psychiatric problems (depression, anxiety, substance abuse) and psychological problems (poor self-esteem, body image

dissatisfaction) than non-binge eaters and closely resemble persons with bulimia nervosa. Overweight persons with binge eating disorder are at high risk for further weight gain and weight fluctuations and associated medical complications. The etiology of binge eating disorder is unknown.

Cognitive behavioral therapy is effective for reducing binge eating and improving associated concerns such as depression, self-esteem, and body image, but does not seem to result in weight loss. There is some evidence that behavioral weight control treatment can reduce binge eating and facilitate weight loss. Antidepressant medications appear to reduce binge eating but do not produce weight loss; relapse is rapid after discontinuation of the medication. See AFFECTIVE DISORDERS. [C.M.G.]

**Ebenales** An order of flowering plants, division Magnoliophyta (Angiospermae) in the subclass Dilleniidae of the class Magnoliopsida (dicotyledons). The order consists of 5 families and about 1750 species, the Sapotaceae (about 800 species) and Ebenaceae (about 450 species) being the largest and most familiar families. The Ebenales are woody, chiefly tropical, sympetalous plants (those with flowers have the petals joined by their margins, at least toward the base, forming a basal tube, cup, or saucer) with usually twice as many stamens (including staminodes) as corolla lobes. Chicle (from *Manilkara sapota*, in the Sapotaceae) and ebony (*Diospyros ebenum*) are obtained from members of the Ebenales. See CHICLE; DILLENIIDAE; EBONY; MAGNOLIOPHYTA. [A.Cr.]

**Ebola virus** Ebola viruses are a group of exotic viral agents that cause a severe hemorrhagic fever disease in humans and other primates. The four known subtypes or species of Ebola viruses are Zaire, Sudan, Reston, and Côte d'Ivoire (Ivory Coast), named for the geographic locations where these viruses were first determined to cause outbreaks of disease. Ebola viruses are very closely related to, but distinct from, Marburg viruses. Collectively, these pathogenic agents make up a family of viruses known as the Filoviridae.

Filoviruses have an unusual morphology, with the virus particle, or virion, appearing as long thin rods. A filovirus virion is composed of a single species of ribonucleic acid (RNA) molecule that is bound together with special viral proteins, and this RNA-protein complex is surrounded by a membrane derived from the outer membrane of infected cells. Infectious virions are formed when the virus buds from the surface of infected cells and is released. Spiked structures on the surface of virions project from the virion and serve to recognize and attach to specific receptor molecules on the surface of susceptible cells, allowing the virion to penetrate the cell. The genetic information contained in the RNA molecule directs production of new virus particles by using the cellular machinery to drive synthesis of new viral proteins and RNA. See RIBONUCLEIC ACID (RNA); VIRUS.

Although much is known about the agents of Ebola hemorrhagic fever disease, the ecology of Ebola viruses remains a mystery. The natural hosts of filoviruses remain unknown, and there has been little progress at unraveling the events leading to outbreaks or identifying sources of filoviruses in the wild. Fortunately, the incidence of human disease is relatively rare and has been limited to persons living in equatorial Africa or working with the infectious viruses. The virus is spread primarily through close contact with the body of an infected individual, his or her body fluids, or some other source of infectious material.

Ebola virus hemorrhagic fever disease in humans begins with an incubation period of 4–10 days, which is followed by abrupt onset of illness. Fever, headache, weakness, and other flulike symptoms lead to a rapid deterioration in the condition of the individual. In severe cases, bleeding and the appearance of small red spots or rashes over the body indicate that the disease has affected the integrity of the circulatory system. Individuals with Ebola virus die as a result of a shock syndrome that usually occurs 6–9 days after the onset of symptoms. This shock is due to the

inability to control vascular functions and the massive injury to body tissues.

It appears that the immune response is impaired and that a strong cellular immune response is key to surviving infections. This immunosuppression may also be a factor in death, especially if secondary infections by normal bacterial flora ensue. See IMMUNOSUPPRESSION.

Outbreaks of Ebola virus disease in humans are controlled by the identification and isolation of infected individuals, implementation of barrier nursing techniques, and rapid disinfection of contaminated material. Diagnosis of Ebola virus cases is made by detecting virus proteins or RNA in blood or tissue specimens, or by detecting antibodies to the virus in the blood.

Dilute hypochlorite solutions (bleach), 3% phenolic solutions, or simple detergents (laundry or dish soap) can be used to destroy infectious virions. No known drugs have been shown to be effective in treating Ebola virus (or Marburg virus) infections, and protective vaccines against filoviruses have not been developed. [A.San.]

**Ebony** A genus, *Diospyros*, of the ebony family, containing more than 250 species. Some species are important for their succulent fruits, such as date plum, kaki plum, and persimmon, and several for their timber, particularly the heartwood, which is the true ebony of commerce. See EBENALES.

Although it is popularly supposed to be a black wood, most species have a heartwood that is only streaked and mottled with black. The heartwood is very brittle, and is difficult to work, but it has long been in demand. The sapwood is white, becoming bluish or reddish when cut.

Black ebony is used for knife handles, piano keys, finger boards of violins, hairbrush backs, inlays, and marquetry. Some of the woods called ebony, however, belong to different families, especially the pulse family, Leguminosae.

Persimmon (*D. virginiana*), of the southeastern United States, is one of numerous tropical or subtropical species. The species in tropical America are too small or rare to be of economic value, although several of them have black heartwood used locally for making walking sticks, inlays, and miscellaneous articles of turnery and carving. [A.H.G./K.P.D.]

**Ebriida** An order of flagellate Protozoa, subphylum Sarcomastigophora, class Phytamastigophorea. Two genera, *Ebria* and *Hermesinum*, remain of the once numerous order, as determined by fossil remains. They possess an internal solid siliceous skeleton forming a shallow flattened or slightly arched structure that is enclosed by clear cytoplasm. Skeleton form and structure are distinctive. These phytoflagellates do not have chromatophores.

The organisms are common in the inshore waters of the Atlantic Ocean and the Gulf of Mexico. However, numbers sufficient to influence the general ecology have not been observed. Their only occurrence seems to be marine, although somewhat lowered salinities are certainly tolerated. See PHYTAMASTIGOPHOREA; PROTOZOA. [J.B.L.]

**Ecdysone** The molting hormone of insects. It is a derivative of cholesterol. The most striking physiological activity of ecdysone is the induction of puffs (zones of gene activity) in giant chromosomes of the salivary glands and other organs of the midge *Chironomus*. The induction of puffs has been visualized as primary action of the hormone, indicating that ecdysone controls the activity of specific genes. It has been shown that ecdysone stimulates the synthesis of messenger RNA, among which is the messenger for dopa decarboxylase. This enzyme is involved in the biosynthesis of the sclerotizing agent *N*-acetyldopamine. See INSECTA. [P.K.]

**Echinacea** A superorder of Euechinoidea, having a rigid test, the periproct within the apical system, keeled teeth, a

complete perignathic girdle, and branchial slits. J. Durham and R. Melville (1957) include five orders in this group. These were formerly distributed among the Stirodonta and Camarodonta in the classification of R. Jackson (1912). See ECHINODERMATA; ECHINOIDA; EUECHINOIDEA; HEMICIDAROIDA; PHYMOSOMATOIDA; SALENIOIDA; TEMNOLEUROIDA. [H.B.F.]

**Echinodermata** A unique group of exclusively marine animals with a peculiar body architecture. They are headless with a fivefold radial symmetry. The body wall contains the endoskeleton, made of numerous independent calcareous plates which frequently support spines. The plates may be tightly interlocked or loosely associated. The spines may protrude through the outer epithelium, and are often used for defense. The skeletal plates of the body wall, together with their associated muscles and connective tissue, form a tough and sometimes rigid test which encloses the large coelom. A unique water-vascular system is involved in locomotion, respiration, food gathering, and sensory perception. This shows outside the body as rows of fluid-filled tube feet in conspicuous double lines or ambulacra. Within the body wall lie the ducts and fluid reservoirs necessary to protract and retract the tube feet by hydrostatic pressure. The nervous system arises from the embryonic ectoderm and consists of a ring around the mouth with connecting nerve cords associated with each ambulacrum. There may also be diffuse nerve plexuses lying below the outer epithelium. The coelom houses the alimentary canal and associated organs and in most groups the reproductive organs.

The larvae are usually planktonic with a bilateral symmetry, but the adults are usually sedentary and benthic. They inhabit all seas and oceans, ranging from the shores to the ocean depths.

The phylum comprises about 6000 existing species and many fossils, providing a good fossil record. Echinoderms first appeared in the Early Cambrian and have been evolving over 600 million years. During this vast time several divergent patterns have arisen. The surviving groups show few resemblances to the original stock. The existing representatives fall into three subphyla: Crinozoa (class Crinoidea: sea lilies and feather stars); Asterozoa (class Asteroidea: starfishes, and class Ophiuroidea: brittle stars), and Echinozoa (class Echinoidea: sea urchins, sand dollars and heart urchins); and class Holothuroidea: sea cucumbers). The fourth subphylum, Homalozoa, has no living representatives. Following is the outline of classification for the phylum.

- Phylum Echinodermata
  - Subphylum: Homalozoa
    - Class: Ctenocystoidea
      - Stylophora
      - Homostelea
      - Homoiostelela
  - Subphylum: Crinozoa
    - Class: Eocrinoidea
      - Crinoidea
        - Subclass: Inadunata
          - Camerata
          - Flexibilia
          - Articulata
    - Class: Rhombifera
      - Diploporita
      - Parablastoidea
      - Edrioblastoidea
      - Paracrinoidea
      - Coronoidea
      - Blastoidea
  - Subphylum: Echinozoa
    - Class: Helicoplacoidea
      - Camptostromatoidea
      - Edriasteroidea
      - Echinoidea

- Subclass: Perischoechinoidea
  - Order: Bothriocidaroida
  - Echinocystoidea
- Subclass: Cidaroida
  - Order: Cidaroida
- Subclass: Euechinoidea
  - Superorder: Echinothuriacea
    - Order: Echinothurioida
  - Superorder: Diadematacea
    - Order: Diadematoidea
    - Micropygoidea
    - Pedinoidea
  - Superorder: Echinacea
    - Order: Hemicidaroida
    - Salenioidea
    - Phymosomatoidea
    - Temnopleuroidea
    - Echinoidea
  - Superorder: Eognathostomata
    - Order: Pygasteroidea
    - Holactypoida
  - Superorder: Neognathostomata
    - Order: Cassiduloida
    - Oligopygoidea
    - Clypeasteroidea
    - Neolampadoidea
  - Superorder: Atelostomata
    - Order: Disasteroidea
    - Holasteroidea
    - Spatangoida
- Class: Ophiocystioidea
  - Holothuroidea
- Subphylum: Asterozoa
  - Class: Asteroidea
    - Order: Platyasterida
      - Trichasteropsida
      - Paxillosida
      - Notomyotida
      - Valvatida
      - Forcipulatida
  - Class: Ophiuroidea
    - Order: Stenurida
      - Oegophiurida
      - Phrynophiurida
      - Ophiurida

Echinoderms evolved very rapidly near the beginning of the Paleozoic Era, and Lower Cambrian deposits contain such divergent branches of the phylum as Homalozoa, Helicoplacoidea, Edriasteroidea, and Eocrinoidea. These are primitive sorts of echinoderms. Cystoids, crinoids, and blastoids, as well as all recognized main groups of asterozoans and echinozoans (except holothurians), appear in Ordovician strata. During the Paleozoic, numerous well-marked evolutionary trends are discernible in nearly all echinoderm groups, including free-moving forms (especially echinoids) as well as crinozoans. Many small classes of echinoderms became extinct during the Paleozoic, and the surviving groups, especially the crinoids, lost many members at the great Late Permian mass extinction. All groups of modern echinoderms have their origin in early Paleozoic stocks, and the lines of their phylogeny are mostly indicated by the fossil record. Echinoids predominate in Mesozoic and Cenozoic echinoderms. [R.C.Mo.; J.J.Se.]

**Echinoidea** An order of Echinacea with a camarodont lantern, smooth test, imperforate nonrenulate tubercles, ambulacral plates of echinoid type, and shallow branchial slits. There are numerous tropical and temperate species, some of them remarkably adapted to living on coral reefs. The four included



families (Paraseleniidae, Echinidae, Strongylocentrotidae, and Echinometridae) are principally distinguished by characters of the pedicellariae. See ECHINACEA; ECHINODERMATA; ECHINOIDEA.

[H.B.F.]

**Echinoidea** A class of Echinozoa known as the sea urchins. These animals have a compact body enclosed in a hard shell, or test, formed from regularly arranged plates which bear movable spines, or radioles (see illustration). There are no arms, but radii are represented by five double rows of tube feet arranged as meridians between the upper and lower poles of the body.

There are about 850 living species, and some 5000 fossil species have been recorded, included in 225 genera. They are classified in 18 orders, which are grouped in 3 subclasses. Sea urchins range in size from approximately 5 mm across the test to 20 cm (8 in.). They differ from other echinoderms in possessing echinochromes in the pigmentation complex. Although many species are dull or dark in color, some are brilliant shades of purple, red, green, or orange. Others species have particolored striped spines, and deep-sea forms may be white.

Sea urchins occur in all seas from low-tide level downward. The rounded (or regular) urchins feed mainly on algae, often hiding by day under stones held over the test by tube feet, and emerging at night or at high tide. The heart urchins and other exocyclic forms live buried in mud or sand, feeding on organic matter in the mud or on selected detritus.

Sea urchins move slowly, using muscles at the bases of the spines to swing the spines like stilts. The suctional tube feet are used to ascend steep surfaces and as anchors.

The test is globular, or nearly so, in those forms in which the anus lies within the apical system. These are often called Regularia. In exocyclic forms the test tends to assume a secondary bilateral symmetry. The radial symmetry is always evident, however, and is five-part (pentamerous). See IRREGULARIA; REGULARIA.

The test is built up of regularly arranged plates which collectively form a rigid or sometimes flexible investing shell. In all echinoids since the Triassic the test is composed of 10 meridional areas. The meridians converge above and below at the upper and lower poles. The equatorial zone is termed the ambitus. Of the 10 meridional areas, 5 correspond to ambulacra, because each of them carries a double row of tube feet. The alternating 5 meridional areas are termed interambulacra, or interamb.

They are usually wider than the ambulacra, or ambis (see illustration).

The mouth lies on the lower (oral) side of the test, surrounded by soft skin, the peristome. In endocyclic forms the mouth is central, but in exocyclic forms it may suffer displacement into the radius and lie opposite the interamb which contains the anus. The radius is then termed anterior. In endocyclic forms and in some of the exocyclic forms the mouth is furnished with a ring of five powerful jaws, each with one large tooth. The jaws and teeth collectively compose the so-called lantern.

Small grasping organs, pedicellariae, are well developed in echinoids, in which they take the form of a beak carried on a stalk. The beak is made up of three (sometimes only two) movable jaws, operated by muscles and sometimes provided with venom glands. They respond to tactile stimuli and seize any small organisms or particles which may touch the skin.

The tube feet evidently serve as tactile and taste organs. A few sea urchins have photosensitive eyespots on the upper surface of the test, scattered in the ectoderm. The ocular pores are not sensitive to light. Minute spherical stalked bodies attached to the skin in some echinoids are believed to be organs of balance.

The alimentary canal is tubular. It lies in the coelom, attached to the wall of the test by mesenteries. The stomach runs from the esophagus in a counterclockwise coil (as viewed from above), and the intestine retraces the route in reverse. The rectum passes upward to the anus.

Like starfishes, sea urchins seem to be sexually mature after 1 year, but continue to grow for several years. The life span is unknown, but may average 5–6 years in medium-sized species. The sexes are normally separate, although fertile hermaphrodites are known. Spines and some other organs are regenerated after injury. See ECHINODERMATA; EUECHINOIDEA; PERISCHOECHINOIDEA.

[H.B.F.]

**Echinozoa** A subphylum of free-living echinoderms in which the body is essentially globoid with meridional symmetry. They lack arms, brachioles, or other appendages, and do not at any time exhibit pinnate structure. The Echinozoa range from the Early Cambrian to the present day. There are four classes that can definitely be placed here: (1) Edrioasteroidea, Lower Cambrian to lower Carboniferous echinozoans in which the mouth and anus were both directed upward and ambulacra (three to five in number) served as food-collecting

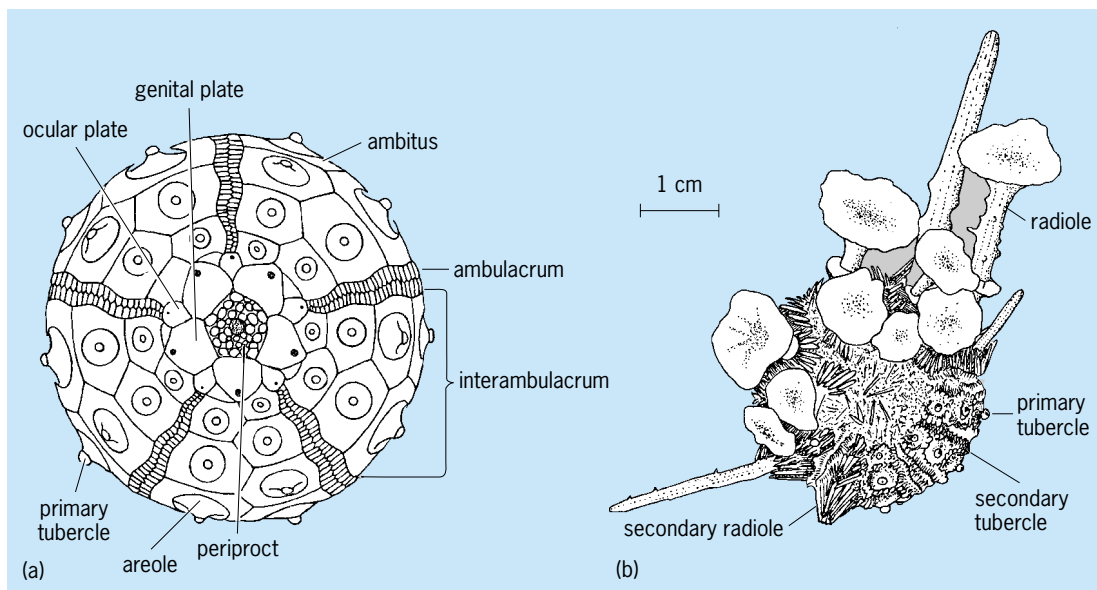

Structure of the naked echinoid test of *Goniocidaris parasol*. (a) Naked test. (b) Test with radioles.

areas; (2) Echinoidea, originating in the Middle Ordovician; (3) Ophiocystioidea of the Lower Ordovician through Middle Devonian; and (4) Holothuroidea, which apparently first appeared in the Devonian. Two other extinct echinoderm classes can be placed here for convenience: (5) Lower Cambrian *Camptostromatoidea* and (6) Lower Cambrian *Helicoplacoidea*. The latter class may be the sister group of both echinozoans and crinozoans.

The oldest definite echinozoans are stromatocystitids of the Lower and Middle Cambrian. This group, which may have *camptostromatids* as its sister group, may have been ancestral to other *edriasteroids* and, perhaps, other echinozoans. The *asterozoans* (*asteroids* and *ophiuroids*) may have been derived from the echinozoans, making the subphylum paraphyletic. See *CAMPTOSTROMATOIDEA*; *ECHINODERMATA*; *ECHINOIDEA*; *EDRIOASTEROIDEA*; *HELICOPLAOIDEA*; *HOLOTHUROIDEA*. [H.P.F.; J.J.Se.]

**Echiurida** A small group of wormlike animals, once linked with the *Sipuncula* and *Priapulida* under the term *Gephyrea*, but now regarded as a separate phylum, with affinities to the annelid worms. They range from the topical to the polar seas, living buried in the sea floor from the intertidal area to depths of 30,000 ft (9000 m).

Their classification has always presented difficulties. In the classification of W. Fisher three orders—*Echiuroinea*, *Xenopneusta* (4 species), and *Heteromyota* (1 species)—are recognized, with one problematic species attached. By far the largest number of species are included in the *Echiuroinea*, which is divided into the families *Bonellidae* and *Echiuridae*. The classification of the *Bonellidae* is the most uncertain and now includes 21 genera with about 35 species. The *Echiuridae* are more stable with only 8 genera but more than 70 species.

The body is saclike or sausage-shaped and often highly colored. Anteriorly there is a prostomium which is readily detached. This may be very long and cleft at the tip (*Bonellidae*), or short and flaplike (*Echiuridae*; see illustration). The mouth, located at the base of the prostomium, leads into the gut, which is divided into several distinct regions. At the posterior end of the body are two very characteristic structures, the anal vesicles, for which an excretory function has been proposed.

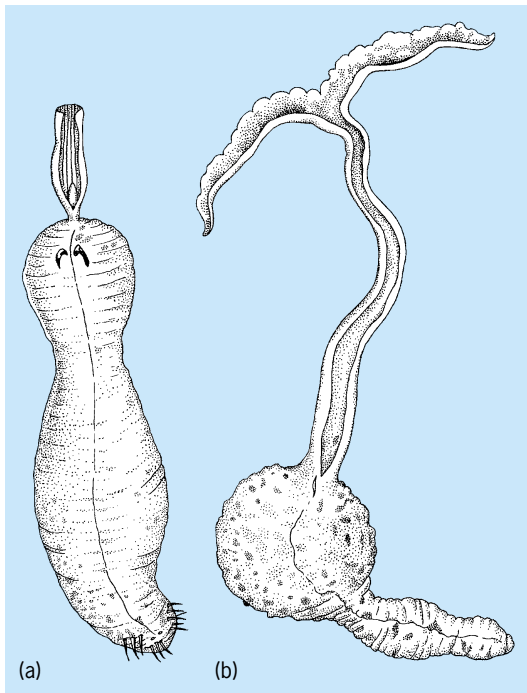

Echiurida. (a) *Echiuris* and (b) *Bonellia*, half size.

The sexes are separate and similar in the *Echiuridae*. In the *Bonellidae* they are separate and very dissimilar, the male being minute and parasitic within or on the female. [M.E.Ri.]

**Echo** A sound wave which has been reflected or otherwise returned with sufficient magnitude and time delay to be perceived in some manner as a sound wave distinct from that directly transmitted. Multiple echo describes a succession of separately indistinguishable echos arising from a single source. When the reflected waves occur in rapid succession, the phenomenon is often termed a flutter echo. Echoes and flutter echoes are generally detrimental to the quality of the acoustics of rooms. They may be minimized through the proper selection of room dimensions, room shape, and distribution of sound-absorbing materials.

Echoes have been put to a variety of uses in measurement problems. For example, the distance between two points can be measured by timing the duration required for a direct sound originating at one location to strike an object at the other point and to return an echo to the location of the initial source. Ultrasonic echo techniques have achieved considerable success in non-destructive testing of materials. See *ECHO SOUNDER*; *ECHOCARDIOGRAPHY*; *REFLECTION OF SOUND*; *SONAR*; *SOUND*; *ULTRASONICS*. [W.J.G.]

**Echo box** A device used to check the output power and spectrum of a radar transmitter. It consists of a low-loss, tunable, resonant cavity connected to the antenna feed line through a fixed coupling circuit so that the fraction of output power supplied to the cavity is always constant. The signal level within the cavity depends on the strength of the portion of the transmitter output spectrum lying within the cavity's narrow passband, which can be tuned to traverse the entire frequency range of interest. A microammeter connected through a crystal rectifier to a loop within the cavity permits reading the signal level. The spectrum can be measured as the cavity is tuned to different frequencies. See *RADAR*. [R.I.B.]

**Echo sounder** A marine instrument used primarily for determining the depth of water by means of an acoustic echo. A pulse of sound sent from the ship is reflected from the sea bottom back to the ship, the interval of time between transmission and reception being proportional to the depth of the water. An echo sounder is really a type of active sonar. It consists of a transducer located near the keel of the ship which serves (in most models) as both the transmitter and receiver of the acoustic signal; the necessary oscillator, receiver, and amplifier which generate and receive the electrical impulses to and from the transducer; and a recorder or other indicator which is calibrated in terms of the depth of water.

Echo sounders, sometimes called fathometers, are used by vessels for navigational purposes, not only to avoid shoal water but as an aid in fixing position when a good bathymetric chart of the area is available. Some sensitive instruments are used by commercial fishers or marine biologists to detect schools of fish or scattering layers of minute marine life. Oceanographic survey ships use echo sounders for charting the ocean bottom. See *SCATTERING LAYER*; *SONAR*; *UNDERWATER SOUND*. [R.W.Mo.]

**Echocardiography** A diagnostic procedure that uses ultrasound at a frequency of 2.5–10 mHz to provide an image of the heart. The principle is that the interface between tissues of different acoustical impedance causes the ultrasound to be reflected to the transducer which spends a fraction of each second receiving these echoes. There are many interfaces between blood and the various structures in the heart that contact blood, such as the heart walls, valves, and great vessels. Also, the surface of the heart reflects ultrasound because it is surrounded by the lungs, which are filled with air. See *ULTRASONICS*.

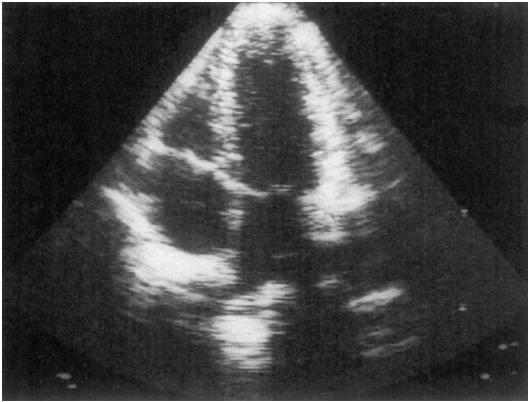

**Two-dimensional echocardiogram from a position near the apex of the ventricles. The left ventricle is on the right, separated from the left atrium below by the mitral valve. The right ventricle is on the left, and the right atrium is below it with the tricuspid valve in between.**

An ultrasound image of the heart is generated on a video monitor (see illustration). The image is generated by moving the ultrasound beam mechanically or electronically repeatedly through an arc. The transducer is usually applied to the anterior chest by using a coupling gel devoid of air. This procedure is referred to as transthoracic echocardiography. Small transducers can also be attached to probes placed in the esophagus behind the heart—a procedure known as transesophageal echocardiography; and during heart surgery the transducer can be placed directly on the heart—a procedure known as epicardial echocardiography. The closer the transducer is to the heart, the higher the resolution of the resulting images.

Two-dimensional echocardiography is completely harmless and provides such excellent images of the heart that it has largely replaced other more risky imaging techniques and those that require radiation exposure. It is unequaled for determining the anatomy and function of heart valves, detecting abnormal amounts of pericardial fluid, and defining the complex anatomy of congenital heart defects. Thus, two-dimensional echocardiography is frequently employed to evaluate suspected or overt heart disease.

Echocardiography can also be used to assess blood flow in the heart by employing the Doppler principle. Three basic types of Doppler echocardiographic systems are available on most ultrasound machines: continuous wave, pulsed, and color flow. In a continuous-wave (CW) Doppler system, sound is continuously transmitted and received. The advantage of continuous-wave Doppler is that the very high velocities of severe structural heart defects are accurately quantitated. Pulsed Doppler avoids the range ambiguity of the continuous-wave Doppler by being able to range-gate the returning echoes so that only certain areas in the sound beam are sampled. However, pulsed Doppler cannot resolve very high velocities. Pulsed and continuous-wave Doppler are useful for detecting and localizing increased velocities associated with obstructions to flow. In the third system, color-flow Doppler, small sample volumes (0.04–0.08 in. or 1–2 mm) throughout the two-dimensional echocardiographic image are sampled for velocity, and only velocities fast enough to result from blood movement are displayed, superimposed on the two-dimensional echocardiographic image and color-encoded. Color Doppler is excellent for displaying abnormal flow due to valve leakage or other structural defects. See DOPPLER EFFECT.

The complete echocardiographic examination also includes selective sampling along certain radians in the arced two-dimensional image, and displaying of the movement of the structures crossed by the radian over time in an analog fashion. This format is called time-motion echocardiography or M-mode echocardiography. It is adjunctive to two-dimensional and

color-flow Doppler echocardiography for answering specific questions about heart structural dimensions and function. See HEART DISORDERS. [M.H.Cr.]

**Echolocation** The biological sonar that bats, porpoises, and certain other animals use to navigate without the visual system. Such animals have evolved the ability to perceive objects by emitting sounds and hearing the echoes that the objects reflect to their ears. The locations and characteristics of the objects are represented by acoustic properties of the echoes, and the ears and auditory systems of these animals act as the sonar receiver. The sense of hearing is specialized for converting echo information into displays of objects, which are perceived as acoustic images that guide the animal's behavior. The best-known examples of echolocating animals are bats (*Microchiroptera*) and porpoises and toothed whales (*Cetacea*). However, several other kinds of mammals also can echolocate. See SONAR.

Bats produce their ultrasonic sonar sounds from the larynx and broadcast them through the open mouth or through a specialized transmitting antenna formed around the nostrils. Porpoises produce their sonar sounds from structures located beneath the blowhole on the top of the head (through which they breathe) and project them into the water through the rounded, protuberant forehead, which contains acoustically specialized tissue. The sonar sounds of porpoises and whales are very brief impulses, or clicks, which contain a wide range of ultrasonic frequencies, all occurring at the same instant. The rate of emission of these sonar clicks depends in part upon the distance to objects that interest the animal, and can vary from several sounds per second to several hundred. Porpoises use their sonar to find fish and presumably to perceive objects beyond the relatively restricted range of vision under water. See CHIROPTERA; PHONORECEPTION; ULTRASONICS. [J.A.Sim.]

**Echovirus** One of the divisions of the enterovirus subgroup, within the picornavirus group of viruses. The name is derived from the term enteric cytopathogenic human orphan virus. More than 34 antigenic types exist. Only certain types have been associated with human illnesses, particularly with aseptic meningitis and febrile disease. Their epidemiology is similar to that of other enteroviruses. Echoviruses resemble polioviruses and coxsackieviruses in size (about 28 nanometers) and in many other properties. Diagnosis is made by isolation and typing of the viruses in tissue culture. Antibodies form during convalescence. See ANIMAL VIRUS; ENTEROVIRUS; PICORNAVIRIDAE. [J.L.Me.]

**Eclipse** The occultation (obscuring) of one celestial body by another. Solar and lunar eclipses take place at syzygies of the Sun, Earth, and Moon, when the three bodies are in a line. At a solar eclipse, the Moon blocks the view of the Sun as seen from the Earth. At a lunar eclipse, the Earth's shadow falls on the Moon, darkening it, and can be seen from wherever on Earth the Moon is above the horizon.

**Solar eclipses.** A solar eclipse can be understood as an occultation of the Sun by the Moon or, equivalently, the Moon's shadow crossing the Earth's surface. The darkest part of the shadow, from which the Sun is entirely hidden, is the umbra (Fig. 1). The outer part of the shadow, from which part of the Sun can be seen, is the penumbra.

Solar eclipses can be central, in which the Moon passes entirely onto the solar disk as seen from Earth, or partial, in which one side of the Sun always remains visible. Central eclipses can be total, in which case the Moon entirely covers the solar photosphere, making the corona visible for the period of totality, or annular, in which case the Moon's angular diameter is smaller than that of the Sun because of the positions of the Earth and Moon in their elliptical orbits. At an annular eclipse, a bright annulus of photospheric sunlight remains visible; it is normally thousands of times brighter than the corona, leaving the sky too blue for the corona to be seen.

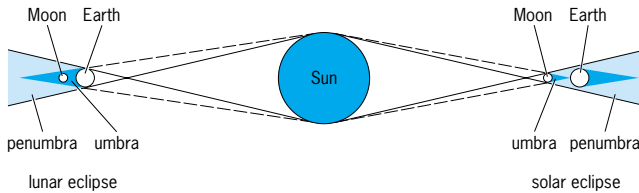

Fig. 1. Circumstances of solar and lunar eclipses (not to scale).

The plane of the Moon's orbit is inclined by  $5^\circ$  to the plane of the Earth's orbit (the ecliptic), so the Moon's shadow commonly passes above or below the Earth each month at new moon. But two to five times each year, the Moon's shadow reaches the Earth, and a partial, annular, or total eclipse occurs. The Moon is approximately 400 times smaller than the Sun but is also approximately 400 times closer, so its angular diameter in the sky is about the same as the Sun's. Thus the Moon fits approximately exactly over the photosphere, making the phenomenon of a total eclipse especially beautiful.

The partial phases of a total eclipse visible from the path of totality last over an hour. In the minute or two before totality, shadow bands—low-contrast bands of light and dark caused by irregularities in the Earth's upper atmosphere—may be seen to race across the landscape. As the Moon barely covers the Sun, photospheric light shines through valleys on the edge of the Moon, making dots of light—Baily's beads—that are very bright in contrast to the background. The last Baily's bead gleams so brightly that it appears as a jewel on a ring, with the band made of the corona; this appearance is known as the diamond ring effect. It usually lasts for 5–10 s, and in the clearest skies for as long as 40 s.

During the diamond ring effect, the solar chromosphere becomes visible around the limb of the Moon, glowing pinkish because most of its radiation is in the form of emission lines of hydrogen, mostly the red hydrogen-alpha line. Its emission-line spectrum apparently flashes into view for a few seconds, and is called the flash spectrum. As the advancing limb of the Moon covers the chromosphere, the corona becomes fully visible (Fig. 2). Its shape is governed by the solar magnetic field; common are equatorial streamers and polar tufts. At the maximum of the solar activity cycle, so many streamers exist that the corona appears round when it is seen in projection, as viewed from Earth. At the minimum of the solar activity cycle, only a few streamers exist so that the corona appears more elongated in projection. See SUN.



Fig. 2. Total solar eclipse of February 26, 1998, observed from Aruba, Netherlands Antilles. Image is composited from several exposures in order to show the wide dynamic range of intensity of the corona and to bring out the structures of the streamers. (Jay M. Pasachoff and Wendy Carlos)

Totality lasts from an instant up through somewhat over 7 min. At its end, the phenomena repeat, including chromosphere, diamond ring, Baily's beads, shadow bands, and the partial phases.

The paths of the Sun and Moon in the sky intersect at two points, the ascending node and the descending node. Only when both the Sun and the Moon are near a node can an eclipse occur. Thus eclipse seasons take place each year, whenever the Sun is near enough to the node so that an eclipse is possible. Each eclipse season is 38 days long. Because the Sun's gravity causes the orientation of the Moon's elliptical orbit to change with an 18.6-year cycle, the nodes slide along the ecliptic and a cycle of two eclipse seasons—an eclipse year—has a period of 346.6 days, shorter than a solar year. See MOON.

There must be at least one solar eclipse each eclipse season, so there are at least two each year. There may be as many as five solar eclipses in a calendar year, though most of these will be partial. Adding lunar eclipses (including penumbral lunar eclipses, which may not be noticeable), there may be seven eclipses in a year.

An important coincidence relates lunar months and eclipse years. A total of 223 lunar months (technically, synodic months, the period of the phases) takes 6585.32 days. A total of 19 eclipse years (passages of the Sun through the same node of the Moon's orbit) takes 6585.78 days, and 242 nodical months (passages of the Moon through the node) take 6585.36 days. Thus eclipses appear with this period of 18 years  $11\frac{1}{3}$  days (plus or minus a day, depending on leap years), a period known as the saros. Further, 239 periods of the variation of distance of the Moon from the Earth, the anomalistic month, is 6585.54 days, so the relative angular sizes of the Sun and Moon are about the same at this interval. As a result of the saros, almost identical eclipses recur every 18 years  $11\frac{1}{3}$  days. The significance of the  $\frac{1}{3}$  day is that the Earth rotates one-third of the way around, and the eclipse path is shifted on the Earth's surface.

Even with advances in space technology, total solar eclipses are the best way of seeing the lower corona. Related eclipse studies include use of the advancing edge of the Moon to provide high spatial resolution for radio observations of the Sun and, historically, of celestial radio sources. See SOLAR CORONA.

The total phase of an eclipse is completely safe to watch with the naked eye. The total brightness of the corona is only that of the full moon, so is equally safe to watch. For direct observation of the partial phases, a special solar filter must be used. Fogged and exposed black-and-white (not color) film that contains silver and is developed to full density provides suitable diminution of the solar intensity across the entire spectrum. Inexpensive commercial solar filters made of aluminized Mylar can also be used. Gelatin "neutral-density" filters are actually not neutral in the infrared, and so should not be used. Neutral-density filters made by depositing chromium or other metals on glass are safe if they are ND4 or ND5, and are commercially available, as is #14 welder's glass. [J.M.P.]

**Lunar eclipses.** A lunar eclipse can occur only when the Moon is full and is near one of the nodes of its orbit. If the Moon enters only the penumbral cone of the Earth (Fig. 1), the eclipse is a penumbral one. If the Moon enters the umbra without being entirely immersed in it, a partial (umbral) eclipse occurs. The eclipse is total if the entire Moon enters the umbra.

The magnitude of an eclipse is the fraction of the diameter of the lunar disk which is eclipsed (in the umbra or in the penumbra) at maximum phase. If the magnitude is larger than 1, the eclipse is total. Penumbral eclipses are not observable unless their magnitude (in the penumbra) is greater than about 0.7.

If penumbral eclipses as well as umbral ones are taken into consideration, the least number of lunar eclipses during a calendar year is two, and the maximum number is five. If only umbral eclipses are considered, the least number of lunar eclipses in one calendar year is zero, and the maximum number is three.

When the Moon passes through the center of the Earth's shadow, the entire eclipse takes  $5\frac{1}{3}$  to  $6\frac{1}{4}$  h, depending on the

Moon's position in its orbit at the time of the eclipse. The first hour is spent in the penumbra (Fig. 1). No darkening is noticeable until about a quarter hour before the first contact with the umbra, because in the penumbra all of the Moon's side facing Earth is still receiving some direct sunlight. Then as the Moon enters the umbra, the eclipsed part of the Moon appears nearly black by contrast with the bright side of the disk. Approximately the second hour is required for all of the Moon to get into the umbra.

The diameter of the umbra where the Moon crosses it is about  $2\frac{2}{3}$  times the Moon's diameter. The total phase of a lunar eclipse can last up to 107 min.

If the Earth had no atmosphere, the Moon would disappear from view while in the umbra. However, the Earth's atmosphere acts like a lens and bends the sunlight into the umbra. The longer waves of red light penetrate the atmosphere better than the short-wave blue light, which is scattered to form the blue of the sky. An observer on the Moon would see the Earth surrounded by a thin ring of bright sunset colors. This explains the usual reddish color of the totally eclipsed Moon. Extremely dark eclipses are due to major volcanic eruptions, whose dust temporarily increases the atmosphere's opacity. See REFRACTION OF WAVES. [J.Mee.]

**Eclipsing variable stars** Double star systems in which the two components are too close to be seen separately but which reveal their duplicity by periodic changes in brightness as each star successively passes between the other and the Earth, that is, eclipses the other. Studies of the light changes and the radial velocity changes of each component permit the computation of the radii, masses, and densities of the components—important quantities that cannot be measured directly in single stars. In addition, these close double stars are useful in studies of mass loss and of stellar evolution. Since eclipsing stars are variable in light, they are included in general variable star catalogs under the same system of nomenclature. See BINARY STAR.

It is now believed that all explosive variables (novae, recurrent novae, and so forth), with the exception of supernovae, are members of close binary systems. At least some of the x-ray sources are close binaries in this state. In a few of the eruptive variables, particularly those known as dwarf novae, rapid scintillation is found, presumably in each system from a hot spot where the transferring mass collides violently with a circumstellar disk of relatively low-density material revolving around the collapsed star; the scintillation stops periodically when the spot is eclipsed by the other component. See NOVA; STELLAR EVOLUTION. [F.B.W.]

**Ecliptic** The apparent path of the Sun across the sky over the course of a year. The Earth's mean orbit defines the ecliptic plane, and an observer on Earth sees the Sun, traveling in this plane over the course of a year, follow the ecliptic. The orbits of the Moon and planets are at slight angles to the ecliptic, but these objects never appear too far in the sky from the ecliptic, which is often drawn on star maps.

The ecliptic intersects the celestial equator at an angle of approximately  $23\frac{1}{2}^\circ$ , an angle known as the obliquity of the ecliptic. See ASTRONOMICAL COORDINATE SYSTEMS; EARTH ROTATION AND ORBITAL MOTION. [J.M.P.]

**Eclogite** A very dense rock composed of red-brown garnet and the grape-green pyroxene omphacite. Eclogites possess basaltic bulk chemistry, and their garnets are rich in the components pyrope, almandine, and grossular, while the pyroxenes are rich in jadeite and diopside.

Eclogite occurrences may be subdivided into three broad categories: Group a eclogites are found as layers, lenses, or boudins in schists and gneisses seemingly of the amphibolite facies. Quartz, together with zoisite or kyanite, commonly occurs in these rocks. Amphibole of barroisitic composition may also be present. Group b eclogites are found as inclusions in kimberlites and basalts. They are frequently accompanied by xenoliths

of garnet peridotite. Group c eclogites are found as blocks and lenses in schists of the glaucophane-schist facies. Such eclogites do not contain kyanite, rarely contain quartz, but bear amphibole, epidote, rutile, or sphene.

Eclogite is the name given to the highest-pressure facies of metamorphism; the critical mineral assemblage defining this facies is garnet + omphacite, together with kyanite or quartz in rocks of basaltic composition. Where sedimentary and granitic rocks have been metamorphosed under eclogite facies conditions, they result in spectacular omphacite + garnet + quartz-bearing mica schists and metagranitic gneisses such as are found in the Sezia-Lanzo zone of the western Alps. See METAMORPHIC ROCKS.

The high density of eclogite, together with its elastic properties, makes it a candidate for upper mantle material. Large quantities of basaltic oceanic crust are returned to the mantle through the process of subduction, where prevailing high pressures convert it to eclogite. The quantity and distribution of eclogite within the mantle is not known; that it occurs is known from the nodules brought up in kimberlite pipes and in basalts. [T.J.B.H.]

**Ecological communities** Assemblages of living organisms that occur together in an area. The nature of the forces that knit these assemblages into organized systems and those properties of assemblages that manifest this organization have been topics of intense debate among ecologists since the beginning of the twentieth century. On the one hand, there are those who view a community as simply consisting of species with similar physical requirements, such as temperature, soil type, or light regime. The similarity of requirements dictates that these species be found together, but interactions between the species are of secondary importance and the level of organization is low. On the other hand, there are those who conceive of the community as a highly organized, holistic entity, with species inextricably and complexly linked to one another and to the physical environment, so that characteristic patterns recur, and properties arise that one can neither understand nor predict from a knowledge of the component species. In this view, the ecosystem (physical environment plus its community) is as well organized as a living organism, and constitutes a superorganism. Between these extremes are those who perceive some community organization but not nearly enough to invoke images of holistic superorganisms. See ECOSYSTEM.

Every community comprises a given group of species, and their number and identities are distinguishing traits. Most communities are so large that it is not possible to enumerate all species; microorganisms and small invertebrates are especially difficult to census. However, particularly in small, well-bounded sites such as lakes or islands, one can find all the most common species and estimate their relative abundances. The number of species is known as species richness, while species diversity refers to various statistics based on the relative numbers of individuals of each species in addition to the number of species. The rationale for such a diversity measure is that some communities have many species, but most species are rare and almost all the individuals (or biomass) in such a community can be attributed to just a few species. Such a community is not diverse in the usual sense of the word. Patterns of species diversity abound in the ecological literature; for example, pollution often effects a decrease in species diversity.

The main patterns of species richness that have been detected are area and isolation effects, successional gradients, and latitudinal gradients. Larger sites tend to have more species than do small ones, and isolated communities (such as those on oceanic islands) tend to have fewer species than do less isolated ones of equal size. Later communities in a temporal succession tend to have more species than do earlier ones, except that the last (climax) community often has fewer species than the immediately preceding one. Tropical communities tend to be very species-rich, while those in arctic climates tend to be species-poor. This

observation conforms to a larger but less precise rule that communities in particularly stressful environments tend to have few species.

Communities are usually denoted by the presence of species, known as dominants, that contain a large fraction of the community's biomass, or account for a large fraction of a community's productivity. Dominants are usually plants. Determining whether communities at two sites are truly representatives of the "same" community requires knowledge of more than just the dominants, however. "Characteristic" species, which are always found in combination with certain other species, are useful in deciding whether two communities are of the same type, though the designation of "same" is arbitrary, just as is the designation of "dominant" or "characteristic."

Communities often do not have clear spatial boundaries. Occasionally, very sharp limits to a physical environmental condition impose similarly sharp limits on a community. For example, serpentine soils are found sharply delimited from adjacent soils in many areas, and have mineral concentrations strikingly different from those of the neighboring soils. Thus they support plant species that are very different from those found in nearby nonserpentine areas, and these different plant species support animal species partially different from those of adjacent areas.

Here two different communities are sharply bounded from each other. Usually, however, communities grade into one another more gradually, through a broad intermediate region (an ecotone) that includes elements of both of the adjacent communities, and sometimes other species as well that are not found in either adjacent community. See ECOTONE.

The environment created by the dominant species, by their effects on temperature, light, humidity, and other physical factors, and by their biotic effects, such as allelopathy and competition, may entrain some other species so that these other species' spatial boundaries coincide with those of the dominants. See PHYSIOLOGICAL ECOLOGY (PLANT); POPULATION ECOLOGY.

More or less distinct communities tend to follow one another in rather stylized order. As with recognition of spatial boundaries, recognition of temporal boundaries of adjacent communities within a sere (a temporary community during a successional sequence at a site) is partly a function of the expectations that an observer brings to the endeavor. Those who view communities as superorganisms are inclined to see sharp temporal and spatial boundaries, and the perception that one community does not gradually become another community over an extended period of time confirms the impression that communities are highly organized entities, not random collections of species that happen to share physical requirements. However, this superorganismic conception of succession has been replaced by an individualistic succession. Data on which species are present at different times during a succession show that there is not abrupt wholesale extinction of most members of a community and concurrent simultaneous colonization by most species of the next community. Rather, most species within a community colonize at different times, and as the community is replaced most species drop out at different times. That succession is primarily an individualistic process does not mean that there are not characteristic changes in community properties as most successions proceed. Species richness usually increases through most of the succession, for example, and stratification becomes more highly organized and well defined. A number of patterns are manifest in aspects of energy flow and nutrient cycling. See ECOLOGICAL SUCCESSION.

Living organisms are characterized not only by spatial and temporal structure but by an apparent purpose or activity termed teleonomy. In the first place, the various species within a community have different trophic relationships with one another. One species may eat another, or be eaten by another. A species may be a decomposer, living on dead tissue of one or more other species. Some species are omnivores, eating many kinds of food; others are more specialized, eating only plants or only animals, or even just one other species. These trophic relationships unite

the species in a community into a common endeavor, the transmission of energy through the community. This energy flow is analogous to an organism's mobilization and transmission of energy from the food it eats.

By virtue of differing rates of photosynthesis by the dominant plants, different communities have different primary productivities. Tropical forests are generally most productive, while extreme environments such as desert or alpine conditions harbor rather unproductive communities. Agricultural communities are intermediate. Algal communities in estuaries are the most productive marine communities, while open ocean communities are usually far less productive. The efficiency with which various animals ingest and assimilate the plants and the structure of the trophic web determine the secondary productivity (production of organic matter by animals) of a community. Marine secondary productivity generally exceeds that of terrestrial communities. See AGROECOSYSTEM; BIOLOGICAL PRODUCTIVITY.

A final property that any organism must have is the ability to reproduce itself. Communities may be seen as possessing this property, though the sense in which they do so does not support the superorganism metaphor. A climax community reproduces itself through time simply by virtue of the reproduction of its constituent species, and may also be seen as reproducing itself in space by virtue of the propagules that its species transmit to less mature communities. For example, when a climax forest abuts a cutover field, if no disturbance ensues, the field undergoes succession and eventually becomes a replica of the adjacent forest. Both temporally and spatially, then, community reproduction is a collective rather than an emergent property, deriving directly from the reproductive activities of the component species. See ALTITUDINAL VEGETATION ZONES; BOG; CHAPARRAL; DESERT; ECOLOGY; GRASSLAND ECOSYSTEM; MANGROVE; MUSKEG; PARAMO; PUNA.

[D.Sim.]

**Ecological competition** The interaction of two (or more) organisms (or species) such that, for each, the birth or growth rate is depressed and the death rate increased by the presence of the other organisms (or species). Competition is recognized as one of the more important forces structuring ecological communities, and interest in competition led to one of the first axioms of modern ecology, the competitive exclusion principle. The principle suggests that in situations where the growth and reproduction of two species are resource-limited, only one species can survive per resource.

The competitive exclusion principle was originally derived by mathematicians using the Lotka-Volterra competition equations. This model of competition predicts that if species differ substantially in competitive ability, the weaker competitor will be eliminated by the stronger competitor. However, a competitive equilibrium can occur if the negative effect of each species on itself (intraspecific competition) is greater than the negative effect of each species on the other species (interspecific competition). Because the competitive exclusion principle implies that competing species cannot coexist, it follows that high species diversity depends upon mechanisms through which species avoid competition. See MATHEMATICAL ECOLOGY.

In general, competitive exclusion can be prevented if the relative competitive abilities of species vary through time and space. Such variation occurs in two ways. First, dispersal rates into particular patches may fluctuate, causing fluctuations in the numerical advantage of a species in a particular patch. Second, competitive abilities of species may be environmentally dependent and, therefore, fluctuate with local environmental changes. Competitive exclusion can also be avoided if fluctuations in environmental factors reduce the densities of potentially competing species to levels where competition is weak and population growth is for a time insensitive to density.

Coexistence is not merely a result of environmental harshness or fluctuations but also involves the critical element of niche differentiation (that is, species must differ from one another if

they are to coexist). However, the focus is not how species coexist by partitioning resources, but how species can coexist on the same resources by differing sufficiently in their responses to environmental conditions and fluctuations. See ECOLOGICAL COMMUNITIES; ECOLOGICAL SUCCESSION.

Competition theory has been applied to human-manipulated ecosystems used to produce food, fiber, and forage crops as well as in forestry and rangeland management. Although many characteristics of agricultural systems are similar to those of natural ecosystems, agricultural communities are unique because they are often managed for single-species (sometimes multi-species) production and they are usually characterized by frequent and intense disturbance. Studies of competition in agriculture have primarily examined crop loss from weed abundance under current cropping practices, and have evaluated various weed control tactics and intercropping systems. Factors that influence competition in agroecosystems include the timing of plant emergence, growth rates, spatial arrangements among neighbors, plant-plant-environment interactions, and herbivory. See ECOLOGY; ECOLOGY, APPLIED. [P.C.M.]

**Ecological energetics** The study of the flow of energy within an ecological system from the time the energy enters the living system until it is ultimately degraded to heat and irretrievably lost from the system. It is also referred to as production ecology, because ecologists use the word production to describe the process of energy input and storage in ecosystems.

Ecological energetics provides information on the energetic interdependence of organisms within ecological systems and the efficiency of energy transfer within and between organisms and trophic levels. Nearly all energy enters the biota by green plants' transformation of light energy into chemical energy through photosynthesis; this is referred to as primary production. This accumulation of potential energy is used by plants, and by the animals which eat them, for growth, reproduction, and the work necessary to sustain life. The energy put into growth and reproduction is termed secondary production. As energy passes along the food chain to higher trophic levels (from plants to herbivores to carnivores), the potential energy is used to do work and in the process is degraded to heat. The laws of thermodynamics require the light energy fixed by plants to equal the energy degraded to heat, assuming the system is closed with respect to matter. An energy budget quantifies the energy pools, the directions of energy flow, and the rates of energy transformations within ecological systems. See BIOLOGICAL PRODUCTIVITY; FOOD WEB; PHOTOSYNTHESIS.

The essentials of ecological energetics can be most readily appreciated by considering energy flowing through an individual; it is equally applicable to populations, communities, and ecosystems. Of the food energy available, only part is harvested in the process of foraging. Some is wasted, for example, by messy eaters, and the rest consumed. Part of the consumed food is transformed but is not utilized by the body, leaving as fecal material or as nitrogenous waste, the by-product of protein metabolism. The remaining energy is assimilated into the body, part of which is used to sustain the life functions and to do work—this is manifest as oxygen consumption. The remainder of the assimilated energy is used to produce new tissue, either as growth of the individual or as development of offspring. Hence production is also the potential energy (proteins, fats, and carbohydrates) on which other organisms feed. Production leads to an increase in biomass or is eliminated through death, migration, predation, or the shedding of, for example, hair, skin, and antlers.

Energy flows through the consumer food chain (from plants to herbivores to carnivores) or through the detritus food chain. The latter is fueled by the waste products of the consumer food chain, such as feces, shed skin, cadavers, and nitrogenous waste. Most detritus is consumed by microorganisms, although this food chain includes conspicuous carrion feeders like beetles and vul-

tures. In terrestrial systems, more than 90% of all primary production may be consumed by detritus feeders. In aquatic systems, where the plants do not require tough supporting tissues, harvesting by herbivores may be efficient with little of the primary production passing to the detritivores.

Traditionally the calorie, a unit of heat energy, has been used in ecological energetics, but this has been largely replaced by the joule. Production is measured from individual growth rates and the reproductive rate of the population to determine the turnover time. The energy equivalent of food consumed, feces, and production can be determined by measuring the heat evolved on burning a sample in an oxygen bomb calorimeter, or by chemical analysis—determining the amount of carbon or of protein, carbohydrate, and lipid and applying empirically determined caloric equivalents to the values. The latter three contain, respectively, 16.3, 23.7, and 39.2 kilojoules per gram of dry weight. Maintenance costs are usually measured indirectly as respiration (normally the oxygen consumed) in the laboratory and extrapolated to the field conditions. Error is introduced by the fact that animals have different levels of activity in the field and are subject to different temperatures, and so uncertainty has surrounded these extrapolations. Oxygen consumption has been measured in animals living in the wild by using the turnover rates of doubly labeled water ( $D_2O$ ).

Due to the loss of usable energy with each transformation, in an area more energy can be diverted into production by plants than by consumer populations. For humans this means that utilizing plants for food directly is energetically much more efficient than converting them to eggs or meat. See BIOMASS; ECOLOGICAL COMMUNITIES; ECOSYSTEM. [W.F.H.]

**Ecological modeling** The use of computer simulations or mathematical equations to address questions that cannot be answered solely by experiments or observations. Ecological models have two major aims: to provide general insight into how ecological systems or ecological interactions work; and to provide specific predictions about the likely futures of particular populations, communities, or ecosystems.

Models can be used to indicate general possibilities or to forecast the most likely outcomes of particular populations or ecosystems. Models differ in whether they are "basic" or are intended to address management decisions. As ecology has grown in its sophistication, models are increasingly used as decision support tools for policy-makers. Models of virtually every possible type of ecological interaction have been developed (competition, parasitism, disease, mutualism, plant-herbivore interactions, and so forth). The models vary in their level of detail. Some models simply keep track of the density of organisms, treating all organisms of any species as identical (mass action models). At the other extreme, the movement and fate of each individual organism may be tracked in an elaborate computer simulation (individual behavior models). See POPULATION ECOLOGY.

Simple algebraic models are very useful for indicating general principles and possibilities. In order to be a management tool, the model must be more complicated and detailed to reflect the specific situation under examination. For example, instead of a few equations, ecologists have modeled spotted owl populations and old growth forests in Washington using a detailed computer simulation that keeps track of habitat in real maps at the scale of hectares. In these simulation models, owls are moved as individuals from one hectare to another, and their fate (survival, death, or reproduction) is recorded in the computer's memory. By tracking hundreds or even thousands of owls moving around in this computer world, different forestry practices corresponding to different logging scenarios can be examined. See ECOLOGY, APPLIED; MATHEMATICAL ECOLOGY; SYSTEMS ECOLOGY.

A model is a formal way of examining the consequences of a series of assumptions about how nature works. Such models refine thinking and clarify what results are implied by any

set of assumptions. As models become more complicated and specific, they can also be used to conduct experiments that are too expensive or impractical in the field.

One danger of ecological modeling is the uncertainty of the models and the shortage of supporting data. Properly used, models allow exploration of a wide range of uncertainty, pointing out the limits of current knowledge and identifying critical information required prior to management decision making. However, it would not be prudent to rely solely on the output of any model. See ECOLOGY. [PKa.]

**Ecological succession** A directional change in an ecological community. Populations of animals and plants are in a dynamic state. Through the continual turnover of individuals, a population may expand or decline depending on the success of its members in survival and reproduction. As a consequence, the species composition of communities typically does not remain static with time. Apart from the regular fluctuations in species abundance related to seasonal changes, a community may develop progressively with time through a recognizable sequence known as the sere. Pioneer populations are replaced by successive colonists along a more or less predictable path toward a relatively stable community. This process of succession results from interactions between different species, and between species and their environment, which govern the sequence and the rate with which species replace each other. The rate at which succession proceeds depends on the time scale of species' life histories as well as on the effects species may have on each other and on the environment which supports them. In some cases, seres may take hundreds of years to complete, and direct observation at a given site is not possible. Adjacent sites may be identified as successively older stages of the same sere, if it is assumed that conditions were similar when each seral stage was initiated. See ECOLOGICAL COMMUNITIES; POPULATION ECOLOGY.

The course of ecological succession depends on initial environmental conditions. Primary succession occurs on novel areas such as volcanic ash, glacial deposits, or bare rock, areas which have not previously supported a community. In such harsh, unstable environments, pioneer colonizing organisms must have wide ranges of ecological tolerance to survive. In contrast, secondary succession is initiated by disturbance such as fire, which removes a previous community from an area. Pioneer species are here constrained not by the physical environment but by their ability to enter and exploit the vacant area rapidly.

As succession proceeds, many environmental factors may change through the influence of the community. Especially in primary succession, this leads to more stable, less severe environments. At the same time interactions between species of plant tend to intensify competition for basic resources such as water, light, space, and nutrients. Successional change results from the normal complex interactions between organism and environment which lead to changes in overall species composition. Whether succession is promoted by changing environmental factors or competitive interactions, species composition alters in response to availability of niches. Populations occurring in the community at a point in succession are those able to provide propagules (such as seeds) to invade the area, being sufficiently tolerant of current environmental conditions, and able to withstand competition from members of other populations present at the same stage. Species lacking these qualities either become locally extinct or are unable to enter and survive in the community.

Early stages of succession tend to be relatively rapid, whereas the rates of species turnover and soil changes become slower as the community matures. Eventually an approximation to the steady state is established with a relatively stable community, the nature of which has aroused considerable debate. Earlier, the so-called climax vegetation was believed to be determined ultimately by regional climate and, given sufficient time, any community in a region would attain this universal condition.

This unified concept of succession, the monoclimate hypothesis, implies the ability of organisms progressively to modify their environment until it can support the climatic climax community. Although plants and animals do sometimes ameliorate environmental conditions, evidence suggests overwhelmingly that succession has a variety of stable end points. This hypothesis, known as the polyclimax hypothesis, suggests that the end point of a succession depends on a complex of environmental factors that characterize the site, such as parent material, topography, local climate, and human influences.

Actions of the community on the environment, termed autogenic, provide an important driving force promoting successional change, and are typical of primary succession where initial environments are inhospitable. Alternatively, changes in species composition of a community may result from influences external to the community called allogenic.

Whereas intrinsic factors often result in progressive successional changes, that is, changes leading from simple to more complex communities, external (allogenic) forces may induce retrogressive succession, that is, toward a less mature community. For example, if a grassland is severely overgrazed by cattle, the most palatable species will disappear. As grazing continues, the grass cover is reduced, and in the open areas weeds characteristic of initial stages of succession may become established.

In some instances of succession, the food web is based on photosynthetic organisms, and there is a slow accumulation of organic matter, both living and dead. This is termed autotrophic succession. In other instances, however, addition of organic matter to an ecosystem initiates a succession of decomposer organisms which invade and degrade it. Such a succession is called heterotrophic. See BIOLOGICALS; EUTROPHICATION; FOOD WEB; PRODUCTIVITY.

Observed changes in the structure and function of seral communities result from natural selection of individuals within their current environment. Three mechanisms by which species may replace each other have been proposed; the relative importance of each apparently depends on the nature of the sere and stage of development.

1. The facilitation hypothesis states that invasion of later species depends on conditions created by earlier colonists. Earlier species modify the environment so as to increase the competitive ability of species which are then able to displace them. Succession thus proceeds because of the effects of species on their environment.

2. The tolerance hypothesis suggests that later successional species tolerate lower levels of resources than earlier occupants and can invade and replace them by reducing resource levels below those tolerated by earlier occupants. Succession proceeds despite the resistance of earlier colonists.

3. The inhibition hypothesis is that all species resist invasion of competitors and are displaced only by death or by damage from factors other than competition. Succession proceeds toward dominance by longer-lived species.

None of these models of succession is solely applicable in all instances; indeed most examples of succession appear to show elements of all three replacement mechanisms.

Succession has traditionally been regarded as following an orderly progression of changes toward a predictable end point, the climax community, in equilibrium with the prevailing environment. This essentially deterministic view implies that succession will always follow the same course from a given starting point and will pass through a recognizable series of intermediate states. In contrast, a more recent view of succession is based on adaptations of independent species. It is argued that succession is disorderly and unpredictable, resulting from probabilistic processes such as invasion of propagules and survival of individuals which make up the community. Such a stochastic view reflects the inherent variability observed in nature and the uncertainty of environmental conditions. In particular, it allows for



succession to take alternative pathways and end points dependent on the chance outcome of interactions among species and between species and their environment.

Consideration of community properties such as energy flow supports the view of succession as an orderly process. The rate of gross primary productivity typically becomes limited also by the availability of nutrients, now incorporated within the community biomass, and declines to a level sustainable by release from decomposer organisms. Species diversity tends to rise rapidly at first as successive invasions occur, but declines again with the elimination of the pioneer species by the climax community.

Stochastic aspects of succession can be represented in the form of models which allow for transitions between a series of different "states." Such models, termed Markovian models, can apply at various levels: plant-by-plant replacement, changes in tree size categories, or transitions between whole communities. A matrix of replacement probabilities defines the direction, pathway, and likelihood of change, and the model can be used to predict the future composition of the community from its initial state. [P.Ran.]

**Ecology** The subdiscipline of biology that concentrates on the relationships between organisms and their environments; it is also called environmental biology. Ecology is concerned with patterns of distribution (where organisms occur) and with patterns of abundance (how many organisms occur) in space and time. It seeks to explain the factors that determine the range of environments that organisms occupy and that determine how abundant organisms are within those ranges. It also emphasizes functional interactions between co-occurring organisms. In addition to being a unique component of the biological sciences, ecology is both a synthetic and an integrative science since it often draws upon information and concepts in other sciences, ranging from physiology to meteorology, to explain the complex organization of nature.

Environment is all of those factors external to an organism that affect its survival, growth, development, and reproduction. It can be subdivided into physical, or abiotic, factors, and biological, or biotic, factors. The physical components of the environment include all nonbiological constituents, such as temperature, wind, inorganic chemicals, and radiation. The biological components of the environment include the organisms. A somewhat more general term is habitat, which refers in a general way to where an organism occurs and the environmental factors present there. See ENVIRONMENT.

A recognition of the unitary coupling of an organism and its environment is fundamental to ecology; in fact, the definitions of organism and environment are not separate. Environment is organism-centered since the environmental properties of a habitat are determined by the requirements of the organisms that occupy that habitat. For example, the amount of inorganic nitrogen dissolved in lake water is of little immediate significance to zooplankton in the lake because they are incapable of utilizing inorganic nitrogen directly. However, because phytoplankton are capable of utilizing inorganic nitrogen directly, it is a component of their environment. Any effect of inorganic nitrogen upon the zooplankton, then, will occur indirectly through its effect on the abundance of the phytoplankton that the zooplankton feed upon. See PHYTOPLANKTON; ZOOPLANKTON.

Just as the environment affects the organism, so the organism affects its environment. Growth of phytoplankton may be nitrogen-limited if the number of individuals has become so great that there is no more nitrogen available in the environment. Zooplankton, not limited by inorganic nitrogen themselves, can promote the growth of additional phytoplankton by consuming some individuals, digesting them, and returning part of the nitrogen to the environment.

Ecology is concerned with the processes involved in the interactions between organisms and their environments, with the mechanisms responsible for those processes, and with the ori-

gin, through evolution, of those mechanisms. It is distinguished from such closely related biological subdisciplines as physiology and morphology because it is not intrinsically concerned with the operation of a physiological process or the function of a structure, but with how a process or structure interacts with the environment to influence survival, growth, development, and reproduction.

Major subdivisions of ecology by organism include plant ecology, animal ecology, and microbial ecology. Subdivisions by habitat include terrestrial ecology, the study of organisms on land; limnology, the study of fresh-water organisms and habitats; and oceanography, the study of marine organisms and habitats.

The levels of organization studied range from the individual organism to the whole complex of organisms in a large area. Autecology is the study of individuals, population ecology is the study of groups of individuals of a single species or a limited number of species, synecology is the study of communities of several populations, and ecosystem, or simply systems, ecology is the study of communities of organisms and their environments in a specific time and place. See POPULATION ECOLOGY; SYSTEMS ECOLOGY.

Higher levels of organization include biomes and the biosphere. Biomes are collections of ecosystems with similar organisms and environments and, therefore, similar ecological properties. All of Earth's coniferous forests are elements in the coniferous forest biome. Although united by similar dynamic relationships and structural properties, the biome itself is more abstract than a specific ecosystem. The biosphere is the most inclusive category possible, including all regions of Earth inhabited by living things. It extends from the lower reaches of the atmosphere to the depths of the oceans. See BIOME; BIOSPHERE.

The principal methodological approaches to ecology are descriptive, experimental, and theoretical. Descriptive ecology concentrates on the variety of populations, communities, and habitats throughout Earth. Experimental ecology involves manipulating organisms or their environments to discover the underlying mechanisms governing distribution and abundance. Theoretical ecology uses mathematical equations based on assumptions about the properties of organisms and environments to make predictions about patterns of distribution and abundance. See THEORETICAL ECOLOGY. [S.J.McN.]

**Ecology, applied** The application of ecological principles to the solution of human problems and the maintenance of a quality life. It is assumed that humans are an integral part of ecological systems and that they depend upon healthy, well-operating, and productive systems for their continued well-being. For these reasons, applied ecology is based on a knowledge of ecosystems and populations, and the principles and techniques of ecology are used to interpret and solve specific environmental problems and to plan new management systems in the biosphere. Although a variety of management fields, such as forestry, agriculture, wildlife management, environmental engineering, and environmental design, are concerned with specific parts of the environment, applied ecology is unique in taking a view of whole systems, and attempting to account for all inputs to and outputs from the systems—and all impacts. In the past, applied ecology has been considered as being synonymous with the above applied sciences.

The objective of applied ecology management is to maintain the system while altering its inputs or outputs. Often, ecology management is designed to maximize a particular output or the quantity of a specific component. Since outputs and inputs are related, maximization of an output may not be desirable; rather, the management objective may be the optimum level. Optimization of systems can be accomplished through the use of systems ecology methods which consider all parts of the system rather than a specific set of components. In this way, a series of strategies or scenarios can be evaluated, and the strategy producing

the largest gain for the least cost can be chosen for implementation.

A variety of general environmental problems within the scope of applied ecology relate to the major components of the Earth: the atmosphere, water, land, and the biota. Applied ecology also is concerned with the size of the human population, since many of the impacts of human activities on the environment are a function of the number and concentration of people. See ECOLOGY; ECOSYSTEM; HUMAN ECOLOGY; SYSTEMS ECOLOGY. [F.B.Go.]

**Ecosystem** A functional system that includes an ecological community of organisms together with the physical environment, interacting as a unit. Ecosystems are characterized by flow of energy through food webs, production and degradation of organic matter, and transformation and cycling of nutrient elements. This production of organic molecules serves as the energy base for all biological activity within ecosystems. The consumption of plants by herbivores (organisms that consume living plants or algae) and detritivores (organisms that consume dead organic matter) serves to transfer energy stored in photosynthetically produced organic molecules to other organisms. Coupled to the production of organic matter and flow of energy is the cycling of elements. See ECOLOGICAL COMMUNITIES; ENVIRONMENT.

All biological activity within ecosystems is supported by the production of organic matter by autotrophs (organisms that can produce organic molecules such as glucose from inorganic carbon dioxide; see illustration). More than 99% of autotrophic production on Earth is through photosynthesis by plants, algae, and certain types of bacteria. Collectively these organisms are termed photoautotrophs (autotrophs that use energy from light to produce organic molecules). In addition to photosynthesis, some production is conducted by chemoautotrophic bacteria (autotrophs that use energy stored in the chemical bonds of inorganic molecules such as hydrogen sulfide to produce organic molecules). The organic molecules produced by autotrophs are used to support the organism's metabolism and reproduction, and to build new tissue. This new tissue is consumed by herbivores or detritivores, which in turn are ultimately consumed by predators or other detritivores.

Terrestrial ecosystems, which cover 30% of the Earth's surface, contribute a little over one-half of the total global photosynthetic production of organic matter—approximately  $60 \times 10^{15}$  grams of carbon per year. Oceans, which cover 70% of the Earth's surface, produce approximately  $51 \times 10^{15}$  g C  $y^{-1}$  of organic matter. See BIOMASS.

**Food webs.** Organisms are classified based upon the number of energy transfers through a food web (see illustration). Photoautotrophic production of organic matter represents the first energy transfer in ecosystems and is classified as primary production. Consumption of a plant by a herbivore is the second energy transfer, and thus herbivores occupy the second trophic level, also known as secondary production. Consumer organ-

isms that are one, two, or three transfers from photoautotrophs are classified as primary, secondary, and tertiary consumers. Moving through a food web, energy is lost during each transfer as heat, as described by the second law of thermodynamics. Consequently, the total number of energy transfers rarely exceeds four or five; with energy loss during each transfer, little energy is available to support organisms at the highest levels of a food web. See ECOLOGICAL ENERGETICS; FOOD WEB.

**Biogeochemical cycles.** In contrast to energy, which is lost from ecosystems as heat, chemical elements (or nutrients) that compose molecules within organisms are not altered and may repeatedly cycle between organisms and their environment. Approximately 40 elements compose the bodies of organisms, with carbon, oxygen, hydrogen, nitrogen, and phosphorus being the most abundant. If one of these elements is in short supply in the environment, the growth of organisms can be limited, even if sufficient energy is available. In particular, nitrogen and phosphorus are the elements most commonly limiting organism growth. This limitation is illustrated by the widespread use of fertilizers, which are applied to agricultural fields to alleviate nutrient limitation. See BIOGEOCHEMISTRY; NITROGEN CYCLE.

Carbon cycles between the atmosphere and terrestrial and oceanic ecosystems. This cycling results, in part, from primary production and decomposition of organic matter. Rates of primary production and decomposition, in turn, are regulated by the supply of nitrogen, phosphorus, and iron. The combustion of fossil fuels is a recent change in the global cycle that releases carbon that has long been buried within the Earth's crust to the atmosphere. Carbon dioxide in the atmosphere traps heat on the Earth's surface and is a major factor regulating the climate. This alteration of the global carbon cycle along with the resulting impact on the climate is a major issue under investigation by ecosystem ecologists. See AIR POLLUTION; CONSERVATION OF RESOURCES; ECOLOGY, APPLIED; HUMAN ECOLOGY; WATER POLLUTION.

[J.B.Jo.]

**Ecotone** A geographic boundary or transition zone between two different groups of plant or animal distributions. The term has been used to denote transitions at different spatial scales or levels of analysis, and may refer to any one of several attributes of the organisms involved. For example, an ecotone could refer to physiognomy (roughly, the morphology or appearance of the relevant organisms), such as between the boreal forest and grassland biomes; or it could refer to composition, such as between oak-hickory and maple-basswood forest associations; or it could refer to both. Ecotones are generally distinguished from other geographic transitions of biota by their relative sharpness. The ecotone between boreal forest and prairie in central Saskatchewan occurs over a hundred kilometers or so, in contrast to the transition from tropical forest to savanna in South America or Africa that is associated with increasing aridity and is dispersed over hundreds of kilometers. The "tension zone" between broadleaf deciduous forests in south-central Michigan and mixed forests to the north is similarly sharp. Ecotones are thought to reflect concentrated long-term gradients of one or more current environmental (rather than historical or human) factors. Though often climatic, these factors can also be due to substrate materials, such as glacial sediments or soils. Regardless of their specific environmental basis, most ecotones are thought to be relatively stable.

Ecotones are often reflected in the distributions of many biota besides the biota used to define them. The prairie-forest ecotone, for example, is defined not only by the dominant vegetation components but also by many faunal members of the associated ecosystems, such as insects, reptiles and amphibians, mammals, and birds, that reach their geographic limits there. See ALPINE VEGETATION; BIOME; ECOLOGICAL COMMUNITIES; ECOSYSTEM; FOREST ECOSYSTEM; GRASSLAND ECOSYSTEM; LIFE ZONES; SAVANNA; ZOOGEOGRAPHY.

[J.R.Har.]

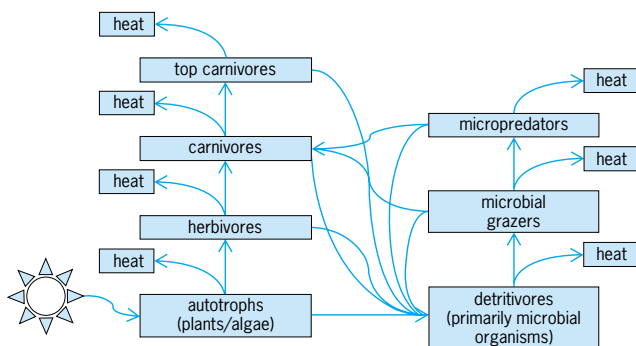

General model of energy flow through ecosystems.

**Eddy current** An electric current induced within the body of a conductor when that conductor either moves through a nonuniform magnetic field or is in a region where there is a change in magnetic flux. It is sometimes called Foucault current. Although eddy currents can be induced in any electrical conductor, the effect is most pronounced in solid metallic conductors. Eddy currents are utilized in induction heating and to damp out oscillations in various devices.

It is possible to reduce the eddy currents by laminating the conductor, that is, by building the conductor of many thin sheets that are insulated from each other rather than making it of a single solid piece. The laminations do not reduce the induced emfs, but if they are properly oriented to cut across the paths of the eddy currents, they confine the currents largely to single laminae, where the paths are long, making higher resistance. See CORE LOSS. [K.V.M.]

**Edema** An abnormal accumulation of fluid in the cells, tissue spaces, or cavities of the body, also known as dropsy. An excess of fluid in the pleural spaces is referred to as hydrothorax, in the pericardial sac as hydropericardium, and in the peritoneal cavity as ascites. Anasarca is a generalized subcutaneous edema.

There are three main factors in the formation of generalized edema and a fourth which plays an important role in the formation of local edema. They are (1) permeability of the capillary wall, (2) colloid osmotic pressure of the plasma proteins, (3) hydrostatic pressure in the capillaries, and (4) lymphatic obstruction.

The management of patients with edema is directed toward the treatment of the underlying medical condition. Diuretics are often used, most successfully in cardiac edema. [R.A.V.; I.N.]

**Edentata** A group of mammals that encompasses several orders of unusual fossil and living animals characterized by reduced or strongly modified teeth. Usually included in this group are the order Pholidota, the pangolins or scaly anteaters of Africa and Southeast Asia; the order Xenarthra, the true anteaters, armadillos, sloths, and their relatives derived mainly from South and Central America; and the extinct Palaeonodonta, an early Cenozoic group of burrowing mammals from North America. The term "edentate" means toothless. Historically a wide range of toothless mammals and mammals with reduced dentition have been incorporated in this taxonomic group, among them aardvarks and echidnas. Modern systematists restrict the term to pholidotans, xenarthrans, and palaeonodonts based on several shared anatomical specializations found exclusively in these three taxa. Only the pangolins and the true anteaters lack teeth entirely, but all edentates are characterized by a reduced dentition. Typically the incisor teeth are lacking, the tooth enamel is strongly reduced or absent (although enamel is retained in a few of the early fossil forms and in the embryos of living armadillos), and tooth replacement is lost. All three groups share digging adaptations, and specializations for feeding on ants and termites. In addition, pangolins and some xenarthrans have a scaly external body covering. Some mammalian systematists have suggested that edentates represent one of the most primitive groups of living placental mammals, although the matter is somewhat controversial. See DENTITION; TOOTH. [T.J.G.]

**Ediacaran biota** A widely distributed group of soft-bodied marine organisms that are preserved as fossils in rocks of latest Proterozoic age (600–543 million years ago; Ma). The biota characterizes a geological period, known as the Ediacarian or the Vendian, which precedes the widespread appearance of animals with mineralized skeletons. The name Ediacara refers to an abandoned mining area about 380 mi (600 km) north of Adelaide, South Australia.

Although Ediacaran fossils were described in the 1930s from southwest Africa (Namibia), it was the discovery in 1946 of abundant fossil "jellyfish" at Ediacara that sparked international in-



Ediacaran trace fossil *Gordia* found on the sole of a sandstone bed in South Australia gives clear evidence for the existence of mobile animals in the late Precambrian.

terest in this biota. Subsequently, similar or identical fossils were found in England; Newfoundland; Russia, the Ukraine, Siberia; North Carolina; Canada; Nevada; and elsewhere. About 30 localities have been described, with the most diverse biotas found at Ediacara, Namibia, and on the coast of the White Sea in northern Russia. As some of these sites could not have been less than about 6000 mi (10,000 km) apart, no matter how the continents were arranged at the time, there is no doubt that the Ediacaran biota was a globally distributed marine biota.

Most known occurrences of Ediacaran organisms precede the earliest great radiation of skeletal fossils (archaeocyaths, trilobites, mollusks, brachiopods), or else they can be placed as latest Proterozoic on other evidence. Radiometric dates have confirmed that there was no significant time gap between the disappearance of the Ediacaran organisms and the Cambrian radiations. In fact, a few Ediacaran fossils have been found in Cambrian strata; the biota did not entirely die out before the Cambrian. See CAMBRIAN.

At almost all sites, the fossils are preserved as impressions in some kind of detrital sedimentary rock. Commonly, they are found on the bases of sandstone beds (South Australia), within sandstone beds (Namibia), or below volcanic ashes swept into deep water by wind and turbidity currents (Newfoundland). The organisms appear to have lived in continental shelf to slope environments and are normally preserved in sediments that were deposited under fairly quiet conditions below normal wave base.

At a conservative estimate there are probably 40–50 distinct genera or probable genera of Ediacaran organisms worldwide. Assigning these genera to higher taxa, however, has been controversial. A real problem is that few of these fossils can unequivocally be referred to living or extinct animal taxa. Because many of the fossils are simply circular structures with or without radial or concentric markings, they impart little information and are difficult to interpret. The recognition of many critical features is hampered by the nature of the preservation. In addition, many Ediacaran fossils, notably most forms from Namibia, are so unusual in shape that they cannot be placed firmly in any modern group. Many workers have placed the more unusual organisms in an extinct higher taxon of phylum grade, commonly named the Petalonamae. Others have used differences in symmetry and body organization to identify and characterize several major taxonomic groups regarded, in general, as extinct higher taxa of phylum or class grade. Some have proposed that all of the Ediacaran organisms were constructed on a single basic plan that was radically different from any other animal. According to this hypothesis, the Ediacarans were "quilted" organisms lacking heads, muscles, or digestive systems, and consisted of parallel sheetlike walls held together by regularly spaced internal partitions, and the whole organism was inflated by body fluids. Proponents of this hypothesis classify the Ediacaran organisms in an extinct kingdom of multicellular life, the Vendobionta. Still others have proposed that the Ediacaran organisms belonged to

extant kingdoms other than the animals; they were lichens, algae, or single-celled or colonial protists. Controversy still reigns, but in all likelihood no hypothesis is entirely incorrect.

The marks left in soft sediments by otherwise unknown animals provide another source of knowledge of late Precambrian animal life. The figure-8-shaped trail in the illustration indicates that animals capable of directed, muscular, gliding motion (like that of a garden snail) coexisted with more typical members of the Ediacaran biota. In a similar fashion, strings of fecal pellets demonstrate the existence of animals with one-way guts, and closely meandering marks imply an ability for systematic grazing. There is little evidence for vertical burrowing in rocks of this age.

Although many Ediacaran fossils are enigmatic, there is sound evidence that sponges, cnidarians, bilaterian worms, and possibly arthropods and other phyla were present. This implies that the Animalia originated even farther back in time. The largest Ediacaran fossils, reaching up to 3 ft (1 m) in length, are flattened "fronds" that had large surfaces compared with their volumes. Proponents of the Vendobionta hypothesis have claimed that such large organisms, lacking guts or muscles, must have been photosynthetic or chemosynthetic and probably contained symbiotic, photosynthetic microorganisms. However, such a lifestyle is also found in modern reef corals and various other marine animals. Alternatively, the high ratio of surface to volume may represent adaptations to an atmosphere and hydrosphere relatively low in oxygen. See PALEONTOLOGY. [B.Ru.; B.Wa.]

**Eel** The name for a number of unrelated fish included in the orders Anguilliformes and Cypriniformes.

The true eels are members of the Anguilliformes, which is also known as the Apodes (see table). There are several hundred species, most of which are marine. They are most common in the shallower waters of tropical and subtropical seas, although a few species do occur in colder waters or at considerable depths. See ANGUILLIFORMES.

Scientific and common names of some species of true eels

Scientific name	Common name
<i>Muraena helena</i>	Moray eel
<i>Phisodonopsis boro</i>	Indian eel
<i>Simenchelys parasiticus</i>	Pug-nosed eel
<i>Anguilla rostrata</i>	American eel
<i>Anguilla vulgaris</i>	European eel
<i>Conger conger</i>	Conger eel

The family Gymnotidae of the order Cypriniformes contains about 32 species which are found in fresh waters of Central and South America. The electric eel (*Electrophorus electricus*), the largest and best-known species of the family, may grow to a length of 8 ft (2.4 m) and weigh 60 lb (27 kg). It can produce an electric shock from its electric organs, which extend almost the length of the body. The bodies of the members of this family are eel-like and may be naked or scaled. See CYPRINIFORMES; ELECTRIC ORGAN (BIOLOGY). [C.B.C.]

**Effective dose 50** A term used chiefly to characterize the potency of a drug by the amount required to produce a response in 50% of the subjects to whom the drug is given; also known as ED<sub>50</sub> or median effective dose.

Median effective dose is most commonly applied in connection with drugs, but it may be used when various other sources of stimuli, for example, x-rays, are under consideration. The response must be of the kind known as quantal, or all-or-nothing, where the investigator is simply able to report that the response either was or was not elicited.

The median effective dose is a well-defined quantity only when the test animal, the end response, and such factors as

the route of injection of a drug and the state of nutrition of the animal are specified. [C.W.]

**Effector systems** Those organ systems of the animal body which mediate overt behavior. Injury to an effector system leads to loss or to subnormal execution of behavior patterns mediated by the system, conditions termed paralysis and paresis, respectively.

Overt behavior consists of either movement or secretion. Movement results from contraction of muscle. Secretion is a function of glands. Neither muscular contraction nor glandular secretion is autonomous but is regulated by an activating mechanism which may be either neural or humoral. In neurally activated systems the effector organ, whether muscle or gland, is supplied by nerve fibers originating from cell bodies situated in the central nervous system or in peripherally located aggregates of nerve cell bodies known as ganglia.

In other effector systems (humoromuscular and humoroglandular) the activating agent is normally a blood-borne chemical substance produced in an organ distant from the effector organ. For example, uterine smooth muscle is uninfluenced by the uterine nerve activity but contracts vigorously when the blood contains pitocin, a chemical substance elaborated by the posterior lobe of the hypophysis.

Finally, some effector systems are hybrid in the sense that both nerves and humors regulate their functions. The smooth muscle of arterioles contracts in response to either nerve stimulation or epinephrine. Secretion of hydrochloric acid by the gastric mucosa is increased by activation of the vagus nerve or by the presence in the blood of histamine. Effector systems with both neural and humoral regulation are never completely paralyzed by denervation but may be deficient in reaction patterns when the quick integrated activation provided by neural regulation is essential. See NERVOUS SYSTEM (VERTEBRATE). [T.C.R.; H.D.P.]

**Efficiency** The ratio, expressed as a percentage, of the output to the input of power (energy or work per unit time). As is common in engineering, this concept is defined precisely and made measurable. Thus, a gear transmission is 97% efficient when the useful energy output is 97% of the input, the other 3% being lost as heat due to friction. A boiler is 75% efficient when its product (steam) contains 75% of the heat theoretically contained in the fuel consumed. All automobile engines have low efficiency (below 30%) because of the total energy content of fuel converted to heat; only a portion provides motive power, while a substantial amount is lost in radiator and car exhaust.

[F.R.E.C.]

**Efflorescence** The spontaneous loss of water (as vapor) from hydrated crystalline solids. The thermodynamic requirement for efflorescence is that the partial pressure of water vapor at the surface of the solid (its dissociation pressure) exceed the partial pressure of water vapor in the air. A typical efflorescent substance is Glauber's salt, Na<sub>2</sub>SO<sub>4</sub> · 10H<sub>2</sub>O. The spontaneous loss of water normally requires that the crystal structure be rearranged, and consequently, efflorescent salts usually go to microcrystalline powders when they lose their water of hydration. See PHASE EQUILIBRIUM; VAPOR PRESSURE. [R.L.S.]

**Egg (fowl)** A single, large, living, female sex cell enclosed in a porous, calcareous shell through which gases may pass. Although they vary in size, shape, and color, the eggs of chickens, ducks, geese, and turkeys are essentially the same in structure and content (see illustration). Inward from the shell are the outer and inner shell membranes which are also permeable to gases. The membranes are constructed to prevent rapid evaporation of moisture from the egg but to allow free entry of oxygen, which is necessary for life. Air begins to penetrate the shell soon after the egg is laid, and it tends to accumulate in a space between the two membranes at the large end of the egg. See CELL (BIOLOGY).

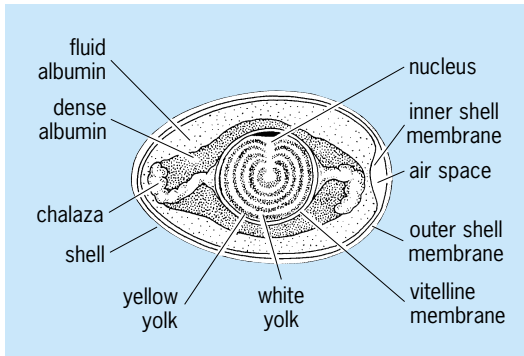

**Egg of a bird.** (After L. P. Sayles, ed., *Biology of the Vertebrates*, 3d ed., Macmillan, 1949)

The inner shell membrane surrounds a mass of fluid albumin which, in turn, encloses a body of dense albumin; these two types of protoplasm constitute the so-called egg white. The central part of the egg is occupied by the yolk, which contains the vital egg nucleus and its associated parts. The yolk consists of alternating layers of yellow and white yolk. The yolk, enclosed by the vitelline membrane, is held in place by the chalaza which is anchored at each end of the egg and prevents undue mechanical disturbance. See CELL NUCLEUS; YOLK SAC. [J.F.F.]

**Eggplant** A warm-season vegetable (*Solanum melongena*) of Asiatic origin belonging to the plant order Polemoniales (formerly Tubiflorales). Eggplant is grown for its usually egg-shaped fleshy fruit and is eaten as a cooked vegetable. Popular purple-fruited varieties (cultivars) are Black Beauty and a number of hybrid varieties; fruits of other colors, including white, brown, yellow, and green, are used chiefly for ornamental purposes. Florida and New Jersey are important eggplant-producing states. See SOLANALES. [H.J.C.]

**Ehrlichiosis** A tick-borne infection that often is asymptomatic but also can produce an illness ranging from a few mild symptoms to an overwhelming multisystem disease. Ehrlichiosis is included with those infections that are said to be emerging, either because they have been recognized only recently or because they were previously well known but now are occurring more frequently.

Human ehrlichiosis is caused by two distinct species: *E. chaffeensis* and an unnamed ehrlichial species. In the United States, *Ehrlichia chaffeensis* infects primarily mononuclear blood cells; the disease produced by this species is referred to as human monocytic ehrlichiosis. The other ehrlichial species invades granulocytic blood cells, causing human granulocytic ehrlichiosis. The latter organism closely resembles *E. equi*, a species that infects horses.

Both of these ehrlichia species are transmitted to humans by the bite of infected ticks. *Ehrlichia chaffeensis* occurs most commonly in the south-central and southeastern states, where it is associated primarily with the Lone Star tick (*Amblyomma americanum*); it is also transmitted by the common dog tick (*Dermacentor variabilis*). The agent of human granulocytic ehrlichiosis is found in the upper midwestern states of Wisconsin and Minnesota, as well as in several northeastern states. This agent seems to be transmitted principally by the deer tick (*Ixodes scapularis*). Although ticks (the vector) are the mode of transmission of ehrlichial infections to humans, the ticks must acquire the ehrlichial organisms from animal sources (the reservoir hosts).

The forms of the disease caused by the two ehrlichial species are indistinguishable. Illness occurs most often during April–September, corresponding to the period when ticks are most active and humans are pursuing outdoor activities. In ehrlichiosis, the incubation period can last from 1 to 3 weeks after exposure to the infected tick. Thereafter, individuals develop fever,

chills, headache, and muscle pains. Gastrointestinal symptoms such as nausea, vomiting, and loss of appetite also are common. Laboratory abnormalities regularly include anemia, low white blood cell and platelet counts, and abnormal liver function. More severely ill individuals also may manifest abnormalities of the central nervous system, lungs, and kidneys. Because the clinical presentation is nonspecific, the diagnosis of ehrlichiosis may not be immediately apparent. Prolonged intervals between the onset of illness and the administration of appropriate therapy can lead to more severe disease symptoms and a greater risk of fatality. See CLINICAL MICROBIOLOGY; HEMORRHAGE; INFECTION.

An important clue to the diagnosis of human granulocytic ehrlichiosis is the recognition of cytoplasmic vacuoles filled with ehrlichiae (morulae) in circulating neutrophils. Careful examination of stained smears of peripheral blood often yields such findings in human granulocytic ehrlichiosis. In disease caused by *E. chaffeensis*, laboratory diagnosis usually is made by detecting an increase in species-specific antibodies in serum specimens obtained during the acute and convalescent phases of the illness. However, such serologic testing is of no use in establishing the diagnosis before treatment is initiated. Therefore, therapy must be initiated on clinical suspicion.

Ehrlichiosis closely resembles another tick-borne illness, Rocky Mountain spotted fever, except that the rash, characteristic of spotted fever, is usually absent or modest. Hence, ehrlichiosis has been referred to as spotless fever. Fortunately, both diseases can be treated with tetracycline antibiotics. Most individuals respond to tetracycline therapy within 48–72 h. See RICKETTSIOSIS.

The avoidance of tick bites is fundamental to preventing ehrlichiosis. [W.Scha.; S.M.St.]

**Eicosanoids** A family of naturally occurring, biologically active substances derived from 20 carbon polyunsaturated fatty acids such as arachidonic acid. Members of the family include prostaglandins, thromboxanes, leukotrienes, and epoxy-eicosatrienoic acids (EETs). Functioning as local hormones, they are synthesized and exert their biological actions in the same tissue. Many have physiological and pathological effects on the cardiovascular, pulmonary, reproductive, and digestive systems.

Physiologically and pathologically, eicosanoids are local hormones. They are synthesized and exert their action in a tissue, and only certain eicosanoids are made by the cells of a tissue. As a result, the action of an eicosanoid is usually discrete and related to the physiological demands of the tissue.

The prostaglandins, leukotrienes, TXA<sub>2</sub>, and anandamide act by binding to and activating membrane receptor proteins. Distinct receptors have been identified for many eicosanoids. The existence of receptor subgroups explains how some eicosanoids such as PGE<sub>2</sub> have multiple actions.

The prostaglandins and TXA<sub>2</sub> have several actions that are necessary for maintaining normal homeostasis and organ integrity. PGE<sub>2</sub> and PGI<sub>2</sub> are potent vasodilators. These prostaglandins are synthesized in the blood vessel in response to vasoconstrictors and antagonize their effects. This action protects the organ from intense vasoconstriction and maintains nutritive blood flow. They also inhibit gastric acid secretion and may exert other cellular protective effects. In their absence, gastric ulcers develop. TXA<sub>2</sub> is made principally by platelets. It causes vasoconstriction and promotes platelet aggregation. These actions prevent excessive blood loss when a blood vessel is damaged or severed. PGI<sub>2</sub> is made by the blood vessel wall and has the opposite effects. It prevents intravascular platelet aggregates from forming and obstructing blood flow. The balance between the proaggregatory or vasoconstrictor action of TXA<sub>2</sub> and the antiaggregatory or vasodilator action of PGI<sub>2</sub> is critical to cardiovascular homeostasis. PGF<sub>2α</sub> contracts uterine smooth muscle. With menstruation and destruction of the uterine lining, arachidonic acid is released and metabolized to PGF<sub>2α</sub>. Contraction of the uterine smooth muscle by PGF<sub>2α</sub> contributes to the pain associated with menstruation. In pregnancy, an increase

in prostaglandin synthesis is a major determinant of the onset of labor.

Increased synthesis of PGE<sub>2</sub> and PGI<sub>2</sub> mediates the vasodilation and pain sensitization associated with inflammation and arthritic conditions. Inhibitors of cyclooxygenase-1 and -2 (important catalysts in the synthesis of prostaglandins) such as aspirin and ibuprofen relieve the signs and symptoms of inflammation. However, they also block the constitutive, homeostatic functions of the prostaglandins by blocking cyclooxygenase-1, which can result in renal failure and gastric ulcers. Selective cyclooxygenase-2 inhibitors such as celecoxib are anti-inflammatory without the deleterious effects on homeostatic functions of the prostaglandins.

The leukotrienes are synthesized by leukocytes, and they also serve as inflammatory mediators. LTB<sub>4</sub> is chemotactic and promotes leukocyte aggregation. Thus, it attracts other inflammatory cells to the site of inflammation and sequesters them. LTC<sub>4</sub>, LTD<sub>4</sub>, and LTB<sub>4</sub> increase capillary permeability, causing the leakage of fluid and protein from the vasculature into the tissue. This contributes to the swelling associated with inflammation. LTC<sub>4</sub> and LTD<sub>4</sub> also cause bronchiolar constriction and increase mucus formation in the airways. These actions are thought to contribute to bronchial asthma. Inhibitors of 5-lipoxygenase and leukotriene receptor antagonists are useful in treating inflammation and bronchial asthma.

The EETs and 20-HETE (hydroxyeicosatetraenoic acid) are involved in the regulation of vascular tone and organ blood flow. In the blood vessel, EETs are synthesized by the endothelial cells in response to vasodilator hormones. The EETs diffuse to the adjacent smooth muscle cells and exert their action. They open potassium channels and hyperpolarize the smooth muscle cell membrane. This results in vasodilation. Thus, EETs serve as mediators of vasodilation. 20-HETE is made by smooth muscle cells in response to increases in intravascular pressure. It is a mediator of myogenic tone in blood vessels. In the blood vessel wall, 20-HETE and the EETs are counterregulatory mechanisms that control blood flow. See ARTERIOSCLEROSIS; ARTHRITIS; ASTHMA; GOUT; PAIN; ULCER. [W.B.C.]

**Eigenfunction** One of the solutions of an eigenvalue equation. A parameter-dependent equation that possesses nonvanishing solutions only for particular values (eigenvalues) of the parameter is an eigenvalue equation, the associated solutions being the eigenfunctions (sometimes eigenvectors). In older usage the terms characteristic equation and characteristic values (functions) are common. Eigenvalue equations appear in many contexts, including the solution of systems of linear algebraic equations (matrix equations), differential or partial differential equations, and integral equations. The importance of eigenfunctions and eigenvalues in applied mathematics results from the widespread applicability of linear equations as exact or approximate descriptions of physical systems. However, the most fundamental application of these concepts is in quantum mechanics where they enter into the definition and physical interpretation of the theory. Only linear eigenvalue equations will be discussed. See EIGENVALUE (QUANTUM MECHANICS); ENERGY LEVEL (QUANTUM MECHANICS); NONRELATIVISTIC QUANTUM THEORY; QUANTUM MECHANICS. [J.M.R.]

**Eigenvalue (quantum mechanics)** If an equation containing a variable parameter possesses nontrivial solutions only for certain special values of the parameter, these solutions are called eigenfunctions and the special values are called eigenvalues.

The eigenfunction-eigenvalue relation is of particular importance in quantum mechanics because of its prominence in the equations which relate the mathematical formalism of the theory with physical results. See QUANTUM MECHANICS. [D.P.]

**Einsteinium** A chemical element, Es, atomic number 99, a member of the actinide series in the periodic table. It is not found

in nature but is produced by artificial nuclear transmutation of lighter elements. All isotopes of einsteinium are radioactive, decaying with half-lives ranging from a few seconds to about 1 year. See ACTINIDE ELEMENTS; PERIODIC TABLE; RADIOACTIVITY.

Einsteinium is the heaviest actinide element to be isolated in weighable form. The metal is chemically reactive, is quite volatile, and melts at 860°C (1580°F); one crystal structure is known. See TRANSURANIUM ELEMENTS. [S.G.T.; G.T.S.]

**El Niño** In general, an invasion of warm water into the central and eastern equatorial Pacific Ocean off the coast of Peru and Ecuador, with a return period of 4–7 years. El Niño events come in various strengths: weak, moderate, strong, very strong, and extraordinary. The size of an El Niño event can be determined using various criteria: the amount of warming of sea surface temperatures in the central and eastern Pacific from their average condition; the areal extent of that warm water anomaly; and the length of time that the warm water lingers before being replaced by colder-than-average sea surface temperatures in this tropical Pacific region.

Under normal conditions the winds blow up the west coast of South America and then near the Equator turn westward to Asia. The surface water is piled up in the western Pacific, and the sea level there is several tens of centimeters above average while the sea level in the eastern Pacific is below average. As the water is pushed toward the west, cold water from the deeper part of the ocean along the Peruvian coast wells up to the surface to replace it. This cold water is rich with nutrients, making the coastal upwelling region along western South America among the most productive fisheries in the world. See UPWELLING.

Every 4–7 years those winds tend to die down and sometimes reverse, allowing the warm surface waters that piled up in the west to move back toward the eastern part of the Pacific Basin. With reduced westward winds the surface water also heats up. Sea level drops in the western Pacific and increases in the eastern part of the basin. El Niño condition can last for 12–18 months, sometimes longer, before the westward flowing winds start to pick up again. Occasionally, the opposite also occurs: the eastern Pacific becomes cooler than normal, rainfall decreases still more, atmospheric surface pressure increases, and the westward winds become stronger. This irregular cyclic swing of warm and cold phases in the tropical Pacific is referred to as ENSO (El Niño Southern Oscillation).

El Niño is considered to be the second biggest climate-related influence on human activities, after the natural flow of the seasons. Although the phenomenon is at least thousands of years old, its impacts on global climate have only recently been recognized. Due to improved scientific understanding and forecasting of El Niño's interannual process, societies can prepare for and reduce its impacts considerably. See CLIMATOLOGY; MARITIME METEOROLOGY; TROPICAL METEOROLOGY. [M.H.G.]

Numerical models that couple the atmosphere to the ocean have been used to successfully predict the sea surface temperature of the tropical Pacific a year or so in advance. The basic reason that the cycle is predictable is that ENSO evolves slowly and regularly. If the initial state of the atmosphere-ocean system can be characterized accurately, the classification of this state in the ENSO sequence is made (even if it is not completely recognizable in each system separately), and the future evolution of the cycle can be predicted. See CLIMATE MODELING. [E.S.S.]

**Elasmobranchii** A subclass of the class Chondrichthyes, the cartilaginous fishes. The elasmobranchs are distinguished by separate gill openings, amphistylic or hyostylic jaw suspension, and sensory ampullae (of Lorenzini) in the head region. Characters shared with members of the other subclass (Holocephali) include a variably calcified cartilaginous endoskeleton, placoid scales, urea-retention mechanism, clasper organs in the male for internal fertilization, and the absence of an air (swim) bladder. See BATOIDEA; CHONDRICHTHYES; CLADOSELACHII; SELACHII. [B.S.]

**Elasticity** The property whereby a solid material changes its shape and size under the action of opposing forces, but recovers its original configuration when the forces are removed. The theory of elasticity deals with the relations between the forces acting on a body and the resulting changes in configuration, and is important in many branches of science and technology, for instance, in the design of structures, in the theory of vibration and sound, and in the study of the forces between atoms in crystal lattices.

The forces acting on a body are expressed as stresses and measured as force per unit area. Thus if a bar *ABCD* of square cross section (illus. *a*) is fixed at one end and subjected to a force *F* uniformly distributed over the other end *DC*, the stress is  $F/(DC)^2$ . This stress causes the bar to become longer and thinner and to assume the shape *A'B'C'D'*. The strain is measured by the ratio (change in length)/(original length), that is, by  $(B'C' - BC)/BC$ . According to Hooke's law, stress is proportional to strain, and the ratio of stress to strain is therefore a constant, in this case the Young's modulus, denoted by *E*, so that  $E = F(BC)/(DC)^2 (B'C' - BC)$ . See HOOKE'S LAW; STRESS AND STRAIN; YOUNG'S MODULUS.

Poisson's ratio  $\sigma$  is the ratio of lateral strain to longitudinal strain so that  $\sigma = BC(DC - D'C')/DC(B'C' - BC)$ . The bar of illustration *a* is in a state of tension, and the stress is tensile; if the force *F* were reversed in direction, the stress would be compressive. Stresses of this type are called direct or normal stresses; a second type of stress, known as tangential or shear stress, is shown in illus. *b*. In this case, the configuration *ABCD* becomes *ABC'D'*, with the shear forces *F* acting in the directions *AB* and *CD*. The shear strain is measured by the angle  $\theta$ , and if the body is originally a cube, the shear stress is  $F/(DC)$ . The ratio of stress to strain,  $F/(DC)^2 \theta$ , is the shear or rigidity modulus *G*, which measures the resistance of the material to change in shape without change in volume.

A further elastic constant, the bulk modulus *k*, measures the resistance to change in volume without changes in shape, and is shown in illus. *c*. The original configuration is represented by the circle *AB*, and under a hydrostatic (uniform) pressure *P*, the circle *AB* becomes the circle *A'B'*. The bulk modulus is then  $k = Pv/\Delta v$ , where  $\Delta v/v$  is the volumetric strain. The reciprocal of the bulk modulus is the compressibility.

The elastic constants may be determined directly in the way suggested by their definitions; for instance, Young's modulus can be determined by measuring the relative extension of a rod or wire subjected to a known tensile stress. Less direct methods are, however, usually more convenient and accurate. Prominent among these are the dynamic methods involving frequency of vibration and velocity of sound propagation. The elastic constants can be expressed in terms of frequency of (or velocity in)

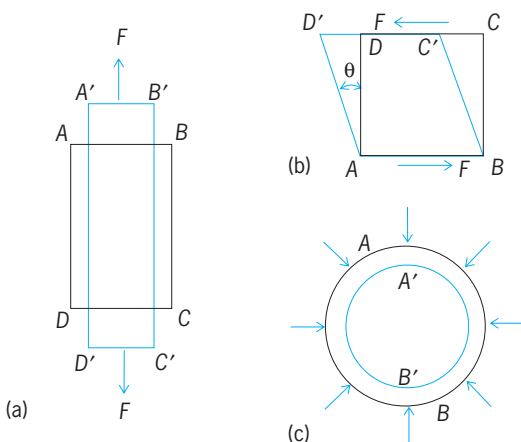

Stresses on a bar. (a) Direct or normal stress. (b) Tangential or shear stress. (c) Change in volume with no change in shape. (All deformations are exaggerated.)

regularly shaped specimens, together with the dimensions and density, and by measuring these quantities, the elastic constants can be found. The elastic constants can also be determined from the flexure and torsion of bars. See ULTRASONICS.

In practice, stress is only proportional to strain, and the strain is only completely recoverable within certain limits called the elastic limits of the material. Above the elastic limits, the material is subject to time-dependent effects, and as the stress is further increased, the ultimate strength of the material is approached. See PLASTICITY; STRENGTH OF MATERIALS. [R.F.S.H.]

**Electret** A solid dielectric with a quasi-permanent electric moment. Electrets may be classified as real-charge electrets and dipolar-charge electrets. Real-charge electrets are dielectrics with charges of one polarity at or near one side of the dielectric and charges of opposite polarity at or near the other side, while dipolar-charge electrets are dielectrics with aligned dipolar charges. Some dielectrics are capable of storing both real and dipolar charges. An example of a charge arrangement of an electret metallized on one surface is shown in the illustration. See POLARIZATION OF DIELECTRICS.

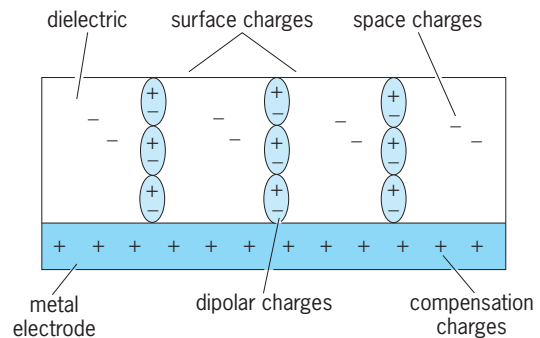

Schematic cross section of an electret disk metallized on one side.

Modern electrets used in research and in applications are often films of 5–50 micrometers thickness (foil electrets) consisting of a suitable material. They are frequently metallized on one or both sides, depending on the intended use.

Important commercial applications of real-charge electrets are in electroacoustic and electromechanical transducers, in air filters, and in electret dosimeters. Also of interest are biological applications based on the blood compatibility of charged polymers or on their favorable influence on wound or fracture healing. Commercial applications of dipolar electrets are in piezoelectric transducers and in pyroelectric detectors. See AIR FILTER; DIELECTRIC MATERIALS; DOSIMETER; ELECTRET TRANSDUCER; ELECTRICAL INSULATION. [G.M.Se.]

**Electret transducer** A device for the conversion of acoustical or mechanical energy into electrical energy, and vice versa, which utilizes a quasi-permanently charged dielectric material (electret). Examples are certain microphones and headphones. Electret devices are therefore self-biased electrostatic or condenser transducers. They thus exhibit all the advantages of this transducer class, such as wide dynamic range and flat response over a frequency range of several decades, without requiring the external bias necessary in conventional transducers of this kind. See ELECTRET; ELECTROSTATICS; TRANSDUCER.

The basic component of all modern electret transducers is a "foil electret" consisting of a thin film of insulating material that has been electrically charged to produce an external electric field. Strongly insulating materials capable of trapping charge carriers, such as the halocarbon polymers, in particular polyfluoroethylenepropylene (Teflon), are best suited for this purpose. Before charging, the material is either metallized on one side or backed up with a metal electrode.

A simple implementation of the most widely used electret transducer is the foil-electret microphone. The diaphragm, typically 0.5- or 1-mil (12- or 25-micrometer) Teflon metallized on one surface, is charged to 100–200 microcoulombs/m<sup>2</sup> (65–130 nanocoulombs/in.<sup>2</sup>) corresponding to an external bias of about 200 V. The nonmetallized surface of this foil electret is placed next to a backplate, leaving a shallow air layer. The stiffness of the air layer can be decreased (and thus the sensitivity of the microphone can be improved) by connecting the air layer to a larger cavity by means of small holes through the backplate. The backplate is either a metal disk or a metal-coated dielectric. The electrical output of the microphone is taken between the backplate, which is insulated from the outer case, and the metal side of the foil. The output is fed into a high-impedance preamplifier. See MICROPHONE.

Compared with conventional electrostatic transducers, electret microphones have the following advantages: they do not require a dc bias; they have three times higher capacitance per unit area, resulting in a better signal-to-noise ratio; and they are not subject to destructive arcing between foil and backplate in humid atmospheres and under conditions of water condensation.

Apart from its use in electroacoustic transducers, such as microphones and earphones, the electret principle has been applied to electromechanical transducers. Examples are touch or key transducers, Korotkov sound pickups, impact-sensitive line transducers, relay switches, and optical display panels.

Because of their favorable properties, simplicity, and low cost, electret transducers have been used often both as research tools and in the commercial market. Among the research applications are microphones for use in acousto-optic spectroscopy, applied to the detection of air pollution and to the study of reaction kinetics of gases and optical absorption of solids. Other applications of electret microphones have been in aeronautics and shock-tube studies. The wide frequency range of electret transducers made possible their application in infrasonic atmospheric studies and in ultrasonic investigations of liquids and solids. In addition, ultrasonic arrays of electret microphones have been used in acoustic holography. Research uses of electromechanical electret transducers have been in such diverse areas as vibration analysis and leak detection in space stations. In these applications, the simplicity and reliability of electret transducers are of importance. See ACOUSTICAL HOLOGRAPHY; INFRASOUND; PHOTOACOUSTIC SPECTROSCOPY; SHOCK TUBE; ULTRASONICS.

Of all commercial applications of electret devices, the high-fidelity electret microphone for amateur, professional, studio, and cassette recorder use is most prominent, accounting for more than one-half of the entire output of high-fidelity microphones. See SOUND RECORDING. [G.M.Se.]

**Electric charge** A basic property of elementary particles of matter. One does not define charge but takes it as a basic experimental quantity and defines other quantities in terms of it.

According to modern atomic theory, the nucleus of an atom has a positive charge because of its protons, and in the normal atom there are enough extranuclear electrons to balance the nuclear charge so that the normal atom as a whole is neutral. Generally, when the word charge is used in electricity, it means the unbalanced charge (excess or deficiency of electrons), so that physically there are enough “nonnormal” atoms to account for the positive charge on a “positively charged body” or enough unneutralized electrons to account for the negative charge on a “negatively charged body.”

In line with this usage, the total charge  $q$  on a body is the total unbalanced charge possessed by the body. For example, if a sphere has a negative charge of  $1 \times 10^{-10}$  coulomb, it has  $6.24 \times 10^8$  electrons more than are needed to neutralize its atoms. The coulomb is the unit of charge in the meter-kilogram-second (mks) system of units. See COULOMB'S LAW; ELECTRICAL UNITS AND STANDARDS; ELECTROSTATICS. [R.P.Wi.]

**Electric contact** A part, in an electrical switching device, made of conducting material, for the purpose of closing, opening, or changing the conductive path of an electrical circuit. To open or close a circuit, an electric contact is made to come in contact with or separate from its mating part. Devices embodying contacts for these purposes are electric switches, relays, contactors, and circuit breakers. Contacts may be actuated directly or through a linkage that is driven either manually, mechanically, electromagnetically, hydraulically, or pneumatically.

An electric contact is also an essential part of a variable resistor. In such an application the contact or wiper provides a moving connection to the resistive element. See RHEOSTAT. [T.H.L.]

**Electric current** The net transfer of electric charge per unit time. It is usually measured in amperes. The passage of electric current involves a transfer of energy. Except in the case of superconductivity, a current always heats the medium through which it passes.

On the other hand, a stream of electrons or ions in a vacuum, which also may be regarded as an electric current, produces no local heating. Measurable currents range in magnitude from the nearly instantaneous  $10^5$  or so amperes in lightning strokes to values of the order of  $10^{-16}$  ampere, which occur in research applications.

All matter may be classified as conducting, semiconducting, or insulating, depending upon the ease with which electric current is transmitted through it. Most metals, electrolytic solutions, and highly ionized gases are conductors. Transition elements, such as silicon and germanium, are semiconductors, while most other substances are insulators. See ALTERNATING CURRENT; CONDUCTION (ELECTRICITY); DIRECT CURRENT; DISPLACEMENT CURRENT; ELECTRIC INSULATOR; SEMICONDUCTOR; SUPERCONDUCTIVITY. [J.W.St.]

**Electric distribution systems** Systems that comprise those parts of an electric power system between the subtransmission system and the consumers' service switches. It includes distribution substations; primary distribution feeders; distribution transformers; secondary circuits, including the services to the consumer; and appropriate protective and control devices. Sometimes, the subtransmission system is also included in the definition.

The subtransmission circuits of a typical distribution system (see illustration) deliver electric power from bulk power sources to the distribution substations. The subtransmission voltage is usually between 34.5 and 138 kV. The distribution substation,

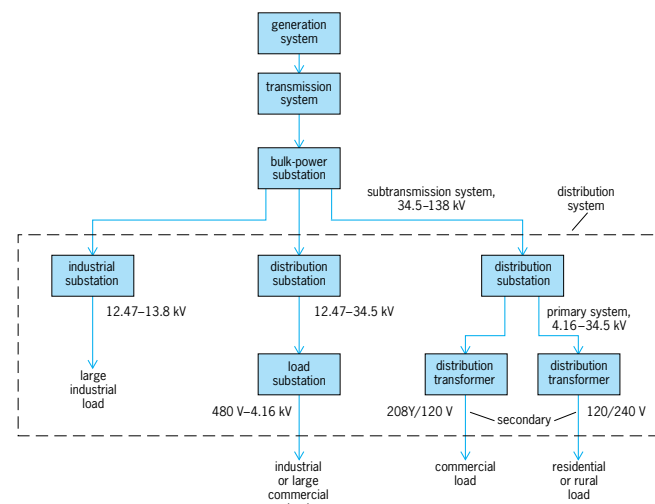

Overview of the power system from generation to consumer's switch.



which is made up of power transformers together with the necessary voltage-regulating apparatus, bus-bars, and switchgear, reduces the subtransmission voltage to a lower primary system voltage for local distribution. The three-phase primary feeder, which usually operates at voltages from 4.16 to 34.5 kV, distributes electric power from the low-voltage bus of the substation to its load center, where it branches into three-phase subfeeders and three-phase and occasionally single-phase laterals. Most of the three-phase distribution system lines consist of three-phase conductors and a common or neutral conductor, making a total of four wires. Single-phase branches (made up of two wires) supplied from the three-phase mains provide power to residences, small stores, and farms. Loads are connected in parallel to common power-supply circuits. See ALTERNATING CURRENT; ELECTRIC POWER TRANSMISSION. [T.Gö.]

**Electric field** A condition in space in the vicinity of an electrically charged body such that the forces due to the charge are detectable. An electric field (or electrostatic field) exists in a region if an electric charge at rest in the region experiences a force of electrical origin. Since an electric charge experiences a force if it is in the vicinity of a charged body, there is an electric field surrounding any charged body.

The electric field intensity (or field strength)  $\mathbf{E}$  at a point in an electric field has a magnitude given by the quotient obtained when the force acting on a test charge  $q'$  placed at that point is divided by the magnitude of the test charge  $q'$ . Thus, it is force per unit charge. A test charge  $q'$  is one whose magnitude is small enough so it does not alter the field in which it is placed. The direction of  $\mathbf{E}$  at the point is the direction of the force  $\mathbf{F}$  on a positive test charge placed at the point. Thus,  $\mathbf{E}$  is a vector point function, since it has a definite magnitude and direction at every point in the field, and its defining equation is Eq. (1).

$$\mathbf{E} = \mathbf{F}/q' \quad (1)$$

Electric flux density or electric displacement  $\mathbf{D}$  in a dielectric (insulating) material is related to  $\mathbf{E}$  by either of the equivalent equations shown as Eqs. (2), where  $\mathbf{P}$  is the polarization of the

$$\mathbf{D} = \epsilon_0 \mathbf{E} + \mathbf{P} \quad \mathbf{D} = \epsilon \mathbf{E} \quad (2)$$

medium, and  $\epsilon$  is the permittivity of the dielectric which is related to  $\epsilon_0$ , by the equation  $\epsilon = k\epsilon_0$ ,  $k$  being the relative dielectric constant of the dielectric. In empty space,  $\mathbf{D} = \epsilon_0 \mathbf{E}$ .

In addition to electrostatic fields produced by separations of electric charges, an electric field is also produced by a changing magnetic field. See ELECTRIC CHARGE; ELECTROMAGNETIC INDUCTION; POTENTIALS. [R.PWi.]

**Electric filter** A transmission network used to selectively modify the components of a signal according to their frequencies. In most cases a filter is used to enhance signals of desired frequencies while suppressing signals of undesired frequencies. An ideal filter would pass only desired frequencies while completely suppressing all unwanted frequencies, without any dispersion in time of the frequencies. Unfortunately, ideal filters are impossible to achieve.

Electric filters are used in most electronic communication systems. Whether communication is over wire, free space, or optical fiber, multiple channels of information can be multiplexed on different frequency bands. Unwanted signals and noise are introduced along the communications path. The main function of electric filters is to separate the desired signal or channel from all others and from any noise or interference. For example, an AM radio receiver may have a low-pass filter after the antenna to separate the AM frequency band from higher frequency bands and, elsewhere in the radio, a band-pass filter to select the desired station out of the AM band. See ELECTRICAL COMMUNICATIONS; MULTIPLEXING AND MULTIPLE ACCESS; RADIO RECEIVER.

Although electronic filters are commonly thought of as devices for conferring selectivity to communication paths, they are

Application ranges of various filter types

Filter type	Frequency range	Bandwidth (% of center frequency)
LC	0–5 GHz	>0.5
Crystal	5 kHz–300 GHz	0.01–5
Ceramic	300 kHz–50 MHz	0.5–20
Mechanical	1 kHz–700 kHz	0.02–10
Surface-acoustic-wave (SAW) resonator	30 kHz–2 GHz	0.01–0.1
SAW transversal	30 kHz–2 GHz	0.2–50
Active	<100 kHz	>0.5
Switched capacitor	<40 kHz	>0.5
Digital	<10 MHz	>0.1
Microwave	0.5 GHz–200 GHz	>0.5
Ceramic dielectric resonator (CDR)	0.7 GHz–5 GHz	>0.1

used in almost every part of electronic equipment, such as the damping element in phase-locked loops, cleanup devices for frequency sources, and pulse expansion and compression devices for radar. One of the simplest and most common filters is the bypass capacitor used to restrict high-frequency electronic noise. See ELECTRICAL NOISE; PHASE-LOCKED LOOPS; RADAR.

Filters are characterized in multiple ways. The expression low-pass, Butterworth, LC describes a filter. The descriptor low-pass indicates the relation of the passed to the rejected frequencies. Butterworth describes the type of polynomials in the transfer function. LC indicates the construction method. This filter is made of inductors ( $L$ 's) and capacitors ( $C$ 's).

Filters are classified by the relationship of the frequencies that are selectively passed, referred to as the passband, to those which are attenuated, referred to as the stopband. An ideal low-pass filter passes all frequencies below a specified cutoff frequency and rejects those above. A high-pass filter does the opposite. An ideal band-pass filter will pass a band of frequencies while rejecting all others; a band-reject filter will reject a band of frequencies and pass all others.

An all-pass filter passes all frequencies but does, however, modify the time delay characteristics. It normally corrects delay distortions caused by other sections of a communication path.

All the above classifications are based on frequency-domain considerations. In addition, there are two terms that apply to the time-response characteristics of a filter. A finite impulse response (FIR) filter, when exposed to a change in input, will settle to a steady state within a finite amount of time. An infinite impulse response (IIR) filter will continue oscillating in a decaying manner forever.

A further consideration in classifying a filter is whether the frequency response is constant in time or varies. If it varies with time, as a function of the input signal, it is known as an adaptive filter. This type of filter finds use in speech and image enhancement and echo cancellation.

Because filters are used over wide frequency and bandwidth ranges and with such varying performance criteria, many methods have been devised for creating a filter function (see table).

Acoustic filters include crystal, ceramic, mechanical, and surface-acoustic-wave (SAW) filters. These devices convert electrical energy to mechanical vibrations, process the signal acoustically, and then convert the energy back to an electrical form. The equations describing a mechanically vibrating resonator, where energy is cycled between kinetic motion and stress, match those of an inductor and capacitor (LC) attached in parallel, where energy is cycled between the electric field of the capacitor and the magnetic field of the inductor. However, the mechanical resonators have much higher  $Q$ 's and better stability than the LC circuit. With the addition of a transducer to convert electrical energy to acoustic, the LC circuits can be replaced with mechanical resonators. See RESONANCE (ACOUSTICS AND MECHANICS); TRANSDUCER.

Many techniques are used to create filters. Inductors are replaced with transistor networks in active filters, discussed below, to reduce size and cost. By using an analog-to-digital converter the transfer function can be created mathematically by a digital processor. At high frequencies, transmission lines and waveguide structures replace lumped elements. See DIGITAL FILTER; INTEGRATED-CIRCUIT FILTER; MICROWAVE FILTER; SWITCHED CAPACITOR. [D.P.H.]

An active filter comprises resistors, capacitors, and active elements such as operational amplifiers. It is also referred to as an active-RC filter.

Active filters can realize the same filter characteristics as passive ones comprising resistor, capacitor, and inductor elements. They have, however, several advantages over their passive counterparts:

1. Active filters can provide gain, and are frequently used to simultaneously match filtering (frequency-determining) and gain specifications.

2. They are readily implemented in integrated-circuit technology, whereas the inductor element of passive filters is not readily realized. As a result, the active filter is inexpensive, and is attractive for its small size and weight. In addition, it is readily included with other signal-processing functions on a single integrated circuit. See INTEGRATED CIRCUITS.

3. The design of active filters is considerably simpler than that of passive ones. In addition, it is easy to provide for variability, which can be used to change filter characteristics by electrical input signals.

The active filter also has some disadvantages:

1. Since the active filter contains electronic components, it requires a power supply, which adds to the complexity of the realization. The electronic components also place restrictions on the level of the signals that can be applied to the filter and on the noise component that the filter may add to the filtered signal. See ELECTRONIC POWER SUPPLY.

2. The mathematical process by which the active filter produces filtering characteristics in general requires the use of internal feedback. When this feedback is positive, the resulting filter may be very sensitive to lack of precision in component values, and the effects of aging and environmental conditions. See FEEDBACK CIRCUIT.

In general, active filters are designed with the assumption that the active elements are ideal (no parasitics). For example, the operational amplifier is assumed to have infinite gain, infinite input impedance, zero output impedance, and an infinite frequency range (gain-bandwidth). All practical filter realizations must be evaluated for the effect that the nonideal parasitics have on actual filter performance. One of the most troublesome of the parasitics is the operational-amplifier gain bandwidth. Typically, for a given application, tuning charts may be developed which can be used to provide compensation for such operational-amplifier limitations. See AMPLIFIER; CIRCUIT (ELECTRONICS); OPERATIONAL AMPLIFIER. [L.P.Hu.]

**Electric furnace** An enclosed space heated by electric power. The furnace may be in such forms as a refractory crucible, a large tiltable refractory basin with a capacity of 100 tons (91 metric tons) and a removable roof, or a long insulated chamber equipped with a continuous conveyor. Heat is provided by an arc to the charge or melt (direct-arc furnace), by an arc between electrodes (indirect-arc furnace), or by an arc confined for concentrated heating by an electromagnetic field (plasma-arc furnace). Heat may also be produced by current flowing in the melt. See ELECTROMETALLURGY; PYROMETALLURGY.

Because the source of heat is nonchemical, electric furnaces are especially desirable in melting alloys of controlled composition. Temperature is also readily controlled. The arc furnace may be used to smelt ores or to refine metals or alloys. Induction furnaces are widely used to melt alloys for castings. Because electric furnaces can be enclosed, they are used for operations that

require controlled or inert atmospheres, such as growing crystals or annealing. When sealed and evacuated, they are used in degassing metals. Furnaces with hearth resistors are used for operations below melting temperatures, such as annealing, and with infrared heat lamps, for drying paints or setting glues. See ARC HEATING; ELECTRIC HEATING; HEAT TREATMENT (METALLURGY); KILN; REFRACTORY. [F.H.R.]

**Electric heating** Methods of converting electric energy to heat energy by resisting the free flow of electric current. Electric heating has several advantages: it can be precisely controlled to allow a uniformity of temperature within very narrow limits; it is cleaner than other methods of heating because it does not involve any combustion; it is considered safe because it is protected from overloading by automatic breakers; it is quick to use and to adjust; and it is relatively quiet. For these reasons, electric heat is widely chosen for industrial, commercial, and residential use.

Resistance heaters produce heat by passing an electric current through a resistance—a coil, wire, or other obstacle which impedes current and causes it to give off heat. Heaters of this kind have an inherent efficiency of 100% in converting electric energy into heat. Devices such as electric ranges, ovens, hot-water heaters, sterilizers, stills, baths, furnaces, and space heaters are part of the long list of resistance heating equipment. See RESISTANCE HEATING.

Dielectric heaters use currents of high frequency which generate heat by dielectric hysteresis (loss) within the body of a nominally nonconducting material. These heaters are used to warm to a moderate temperature certain materials that have low thermal conducting properties; for example, to soften plastics, to dry textiles, and to work with other materials like rubber and wood. See DIELECTRIC HEATING.

Induction heaters produce heat by means of a periodically varying electromagnetic field within the body of a nominally conducting material. This method of heating is sometimes called eddy-current heating and is used to achieve temperatures below the melting point of metal. For instance, induction heating is used to temper steel, to heat metals for forging, to heat the metal elements inside glass bulbs, and to make glass-to-metal joints. See INDUCTION HEATING.

Electric-arc heating is really a form of resistance heating in which a bridge of vapor and gas carries an electric current between electrodes. The arc has the property of resistance. Electric-arc heating is used mainly to melt hard metals, alloys, and some ceramic metals. See ARC HEATING.

Electricity is one choice for heating houses, but with only a 35% efficiency rate, electricity has been a less attractive option than the direct use of gas and oil for heating homes. Common electric heating systems in houses are central heating employing an electric furnace with forced air circulation; central heating employing an electric furnace with forced water circulation; central heating using radiant cables; electrical duct heaters; space (strip) heaters which use radiation and natural convection for heat transfer; and portable space heaters. [M.S.C.]

**Electric insulator** A material that blocks the flow of electric current across it. Insulators are to be distinguished from electrolytes, which are electronic insulators but ionic conductors. Electric insulators are used to insulate electric conductors from one another and to confine electric currents to specified pathways, as in the insulation of wires, electric switchgear, and electronic components. They provide an electrical, mechanical, and heat-dissipation function. The electrical function of an insulator is characterized by its resistivity, its dielectric strength (breakdown voltage), and its dielectric constant (relative permittivity). Insulators can be solid, liquid, or gaseous.

The resistivity of a material is a measure of the electric current density that flows across it in response to an applied electric field. Solid and liquid insulators have direct-current resistivities of

$10^{10}$  ohm-meters at room temperature as compared to  $10^{-8}$   $\Omega\cdot\text{m}$  for a good metal or  $10^{-3}$   $\Omega\cdot\text{m}$  for a fast ionic conductor. See BAND THEORY OF SOLIDS; ELECTRICAL RESISTANCE; ELECTRICAL RESISTIVITY; SEMICONDUCTOR.

A material used in the electrical industry for insulation, capacitors, or encapsulation may be exposed to large voltage gradients that it must withstand for the operating life of the system. Failure occurs if an electric short-circuit develops across the material. Such a failure is called dielectric breakdown. The breakdown voltage gradient, expressed in kilovolts per millimeter, is a measure of the dielectric strength. Dielectric breakdown of a solid is destructive; liquids and gases are self-healing.

An insulator is also known as a dielectric. The dielectric constant  $k$  is defined as the ratio of the capacitance of a flat-plate condenser, or capacitor, with a dielectric between the plates to that with a vacuum between the plates; this ratio is also the relative permittivity of the dielectric. The dielectric constant is a measure of the ability of the insulator to increase the stored charge on the plates of the condenser as a result of the displacement of charged species within the insulator. See CAPACITANCE; CAPACITOR; DIELECTRIC MATERIALS; PERMITTIVITY.

Successful application of solid insulating materials also depends on their mechanical properties. Insulation assemblies commonly must withstand thermal-expansion mismatch, tension, compression, flexing, or abrasion as well as a hostile chemical-thermal environment. The introduction of cracks promotes the penetration of moisture and other contaminants that promote failure, and the presence of pores may cause damaging corona discharge on the surface of a high-voltage conductor. As a result, composite materials and engineered shapes must be tailored to meet the challenges of a particular operational environment. See CORONA DISCHARGE.

For example, glasses and varnishes are used as sealants, and oil is used to impregnate high-voltage, paper-insulated cables to eliminate air pockets. Porcelain is a commonly used material for the suspension of high-voltage overhead lines, but it is brittle. Therefore, a hybrid insulator was developed that consists of a cylindrical porcelain interior covered by a mastic sealant and a silicone elastomer sheath heat-shrunk onto the porcelain core. The circular fins of the outer sheath serve to shed water. However, twisted-pair cables insulated with poly(tetrafluoroethylene) are used for high-speed data transmission where a small dielectric constant of the insulator material is needed to reduce signal attenuation. See CONDUCTOR (ELECTRICITY); ELECTRIC POWER TRANSMISSION; FLUORINE; PORCELAIN; SILICONE RESINS.

Liquid or gas insulation provides no mechanical strength, but it may provide a cheap, flexible insulation not subject to mechanical failure. Biphenyls are used as insulating liquids in capacitors; alkyl benzenes in oil-filled cables; and polybutenes for high-pressure cables operating at alternating-current voltages as high as 525 kV. Sulfur hexafluoride ( $\text{SF}_6$ ) is a nonflammable, nontoxic electron-attracting gas with a breakdown voltage at atmospheric pressure more than twice that of air. Fluorocarbons such as  $\text{C}_2\text{F}_6$  and  $\text{C}_4\text{F}_8$  as well as the Freons are also used, and breakdown voltages have been increased significantly in gas mixtures through a synergistic effect. Used as an insulating medium in high-voltage equipment at pressures up to 10 atm (1 megapascal), sulfur hexafluoride can reduce the size of electrical substations by a factor of 10 over that of air-insulated equipment. Enclosure of metal cable in a metallic conduit filled with sulfur hexafluoride gas has been used to shield nearby workers from exposure to high electric fields. See CIRCUIT BREAKER; FLUOROCARBON; POLYCHLORINATED BIPHENYLS.

Finally, the ability to transfer heat may be an overriding consideration for the choice of an electric insulator. Electrical machines generate heat that must be dissipated. In electronic devices, the thermal conductivity of the solid substrate is a primary consideration. Where mechanical considerations permit, circulating liquid or gaseous insulation is commonly used to carry away heat. Liquids are particularly good transporters of heat, but they are

subject to oxidation. In transformers, for example, the insulators are generally mineral or synthetic oils that are circulated, in some places with gaseous nitrogen to inhibit oxidation, to carry away the heat generated by the windings and magnetic core. See ELECTRICAL INSULATION; TRANSFORMER. [J.B.G.]

**Electric organ (biology)** An effector organ found in six different groups of fishes; output is an electric pulse. Voltages large enough to aid in prey capture or predator deterrence are produced by various strongly electric fishes. These include the electric eel (*Electrophorus electricus*) from South America; the electric catfish (*Malapterurus electricus*) from Africa; the family of electric rays, Torpedinidae, which are widely distributed in the world's oceans; and possibly the stargazer genus, *Astroscoptes*, of the western Atlantic. Weakly electric fishes emit a lower voltage, the energy source for an active electrosensory system that monitors electrical impedance in the environment. These weak signals also serve in intra- and interspecific communication. There are three groups of weakly electric fishes. First, the South American knifefishes, the Gymnotiformes, are a large and diverse group of several families that also include *Electrophorus*. Second, the electrically active African Mormyridae are composed of the numerous species of the family Mormyridae and the single species *Gymnarchus niloticus* in the family Gymnarchidae. Finally, many species of skates and rays of the family Rajidae occur in marine waters around the world.

The strongly electric fishes are remarkable for the high voltage and power of their discharges. For example, the electric eel generates pulses in excess of 500 V. In contrast, a large torpedo generates a smaller voltage, about 50 V in air, but the maximum current is larger, and the peak pulse power can exceed 1 kW (or about 1 hp). The electric organs may constitute a substantial fraction of the body mass. The weakly electric fishes have much smaller organs emitting pulses of a few tenths of a volt to several volts; such amplitudes that are still large compared to those recorded outside ordinary, nonelectric fishes.

Electric organ discharge is explicable in terms of the properties of ordinary excitable cells, that is, those of nerve and muscle. The single generating cells of electric organs are called electrocytes. They are modified striated muscle fibers that have lost the ability to contract, although they retain muscle filaments to varying degrees, and they produce electric signals as muscle fibers do.

A question often asked about the strongly electric fishes is how they keep from electrocuting themselves. When immersed in water, they do not appear to be at all affected by their own discharges, although their electroreceptors are undoubtedly activated. In air, when the organ is not loaded down by the conductivity of the water, they often do twitch when they discharge their organs, but as would be expected, they are much more resistant than other fishes. One factor is that their nerves and central nervous system are well insulated by many layers of connective and fatty tissue. Whether their brains are more resistant to stunning by a given current density has not been determined; certainly the excitability of individual cells is no different from that in animals in general. [M.V.L.B.]

**Electric power generation** The production of bulk electric power for industrial, residential, and rural use. Although limited amounts of electricity can be generated by many means, including chemical reaction (as in batteries) and engine-driven generators (as in automobiles and airplanes), electric power generation generally implies large-scale production of electric power in stationary plants designed for that purpose. The generating units in these plants convert energy from falling water, coal, natural gas, oil, and nuclear fuels to electric energy. Most electric generators are driven either by hydraulic turbines, for conversion of falling water energy; or by steam or gas turbines, for conversion of fuel energy. Limited use is being made of geothermal energy, and developmental work is progressing in the use of

solar energy in its various forms. See ELECTRIC POWER SYSTEMS; GENERATOR; PRIME MOVER.

An electric load (or demand) is the power requirement of any device or equipment that converts electric energy into light, heat, or mechanical energy, or otherwise consumes electric energy as in aluminum reduction, or the power requirement of electronic and control devices. The total load on any power system is seldom constant; rather, it varies widely with hourly, weekly, monthly, or annual changes in the requirements of the area served. The minimum system load for a given period is termed the base load or the unity load-factor component. Maximum loads, resulting usually from temporary conditions, are called peak loads, and the operation of the generating plants must be closely coordinated with fluctuations in the load. The peaks, usually being of only a few hours' duration, are frequently served by gas or oil combustion-turbine or pumped-storage hydro generating units. The pumped-storage type utilizes the most economical off-peak (typically 10 P.M. to 7 A.M.) surplus generating capacity to pump and store water in elevated reservoirs to be released through hydraulic turbine generators during peak periods. This type of operation improves the capacity factors or relative energy outputs of base-load generating units and hence their economy of operation.

The size or capacity of electric utility generating units varies widely, depending upon type of unit; duty required, that is, base-, intermediate-, or peak-load service; and system size and degree of interconnection with neighboring systems. Base-load nuclear or coal-fired units may be as large as 1200 MW each, or more. Intermediate-duty generators, usually coal-, oil-, or gas-fueled steam units, are of 200 to 600 MW capacity each. Peaking units, combustion turbines or hydro, range from several tens of megawatts for the former to hundreds of megawatts for the latter. Hydro units, in both base-load and intermediate service, range in size up to 825 MW.

The total installed generating capacity of a system is typically 20 to 30% greater than the annual predicted peak load in order to provide reserves for maintenance and contingencies.

Voltage regulation is the change in voltage for specific change in load (usually from full load to no load) expressed as percentage of normal rated voltage. The voltage of an electric generator varies with the load and power factor; consequently, some form of regulating equipment is required to maintain a reasonably constant and predetermined potential at the distribution stations or load centers. Since the inherent regulation of most alternating-current (ac) generators is rather poor (that is, high percentage-wise), it is necessary to provide automatic voltage control. The rotating or magnetic amplifiers and voltage-sensitive circuits of the automatic regulators, together with the exciters, are all specially designed to respond quickly to changes in the alternator voltage and to make the necessary changes in the main exciter or excitation system output, thus providing the required adjustments in voltage. A properly designed automatic regulator acts rapidly, so that it is possible to maintain desired voltage with a rapidly fluctuating load without causing more than a momentary change in voltage even when heavy loads are thrown on or off.

In general, most modern synchronous generators have excitation systems that involve rectification of an ac output of the main or auxiliary stator windings, or other appropriate supply, using silicon controlled rectifiers or thyristors. These systems enable very precise control and high rates of response. See SEMICONDUCTOR RECTIFIER; VOLTAGE REGULATOR.

Computer-assisted (or on-line controlled) load and frequency control and economic dispatch systems of generation supervision are being widely adopted, particularly for the larger new plants. Strong system interconnections greatly improve bulk power supply reliability but require special automatic controls to ensure adequate generation and transmission stability. Among the refinements found necessary in large, long-distance interconnections are special feedback controls applied to generator high-speed excitation and voltage regulator systems.

Synchronization of a generator to a power system is the act of matching, over an appreciable period of time, the instantaneous voltage of an alternating-current generator (incoming source) to the instantaneous voltage of a power system of one or more other generators (running source), then connecting them together. In order to accomplish this ideally the following conditions must be met:

1. The effective voltage of the incoming generator must be substantially the same as that of the system.
2. In relation to each other the generator voltage and the system voltage should be essentially 180° out of phase; however, in relation to the bus to which they are connected, their voltages should be in phase.
3. The frequency of the incoming machine must be near that of the running system.
4. The voltage wave shapes should be similar.
5. The phase sequence of the incoming polyphase machine must be the same as that of the system.

Synchronizing of ac generators can be done manually or automatically. In manual synchronizing an operator controls the incoming generator while observing synchronizing lamps or meters and a synchroscope, or both. The operator closes the connecting switch or circuit breaker as the synchroscope needle slowly approaches the in-phase position.

Automatic synchronizing provides for automatically closing the breaker to connect the incoming machine to the system, after the operator has properly adjusted voltage (field current), frequency (speed), and phasing (by lamps or synchroscope). A fully automatic synchronizer will initiate speed changes as required and may also balance voltages as required, then close the breaker at the proper time, all without attention of the operator. Automatic synchronizers can be used in unattended stations or in automatic control systems where units may be started, synchronized, and loaded on a single operator command. See ALTERNATING-CURRENT GENERATOR; GAS TURBINE; GEOTHERMAL POWER; HYDROELECTRIC GENERATOR; NUCLEAR POWER; PHASE-ANGLE MEASUREMENT; STEAM ELECTRIC GENERATOR; SYNCHROSCOPE; WATERPOWER; WIND POWER. [E.C.S.]

**Electric power measurement** The measurement of the time rate at which electrical energy is being transmitted or dissipated in an electrical system. The potential difference in volts between two points is equal to the energy per unit charge (in joules/coulomb) which is required to move electric charge between the points. Since the electric current measures the charge per unit time (in coulombs/second), the electric power  $p$  is given by the product of the current  $i$  and the voltage  $v$  (in joules/second = watts), as in Eq. (1).

$$p = vi \quad (\text{watts}) \quad (1)$$

See ELECTRIC CURRENT; ELECTRICAL UNITS AND STANDARDS; POWER.

Alternate forms of the basic definition can be obtained by using Ohm's law, which states that the voltage across a pure resistance is proportional to the current through the element. This results in Eq. (2), where  $R$  is the resistance of the element and

$$p = i^2 R = \frac{v^2}{R} \quad (\text{watts}) \quad (2)$$

$i$  and  $v$  are the current through and voltage across the resistive element. Other commonly used units for electric power are milliwatts (1 mW = 10<sup>-3</sup> W), kilowatts (1 kW = 10<sup>3</sup> W), megawatts (1 MW = 10<sup>6</sup> W), and, in electromechanical systems, horsepower (1 hp = 746 W). See ELECTRICAL RESISTANCE; OHM'S LAW.

These fundamental expressions yield the instantaneous power as a function of time. In the dc case where  $v$  and  $i$  are each constant, the instantaneous power is also constant. In all other cases where  $v$  or  $i$  or both are time-varying, the instantaneous power is also time-varying. When the voltage and current are periodic with the same fundamental frequency, the instantaneous power is also periodic with twice the fundamental frequency. In this case

a much more significant quantity is the average power, since in most cases the electric power is converted to some other form such as heat or mechanical power and the rapid fluctuations of the power are smoothed by the thermal or mechanical inertia of the output system.

The measurement of power in a dc circuit can be carried out by simultaneous measurements of voltage and current by using standard types of dc voltmeters and ammeters. The product of the readings typically gives a sufficiently accurate measure of dc power. If great accuracy is required, corrections for the power used by the instruments should be made. In ac circuits the phase difference between the voltage and current precludes use of the voltmeter-ammeter method unless the load is known to be purely resistive. When this method is applicable, the instrument readings lead directly to average power since ac voltmeters and ammeters are always calibrated in rms values. See AMMETER; VOLTMETER.

In power-frequency circuits the most common instrument for power measurement is the moving-coil, dynamometer wattmeter. This instrument can measure dc or ac power by carrying out the required multiplication and averaging on a continuous analog basis. The instrument has four terminals, two for current and two for voltage, and reads the average power directly. It can be built with frequency response up to about 1 kHz. See WATTMETER.

Electronic wattmeters are available which give a digital indication of average power. Their primary advantage, in addition to minimizing errors in reading the instrument, is that the frequency range can be greatly extended, up to 100 kHz or more, with good accuracy.

Measurement of the total power in a polyphase system is accomplished by combinations of single-phase wattmeters or by special polyphase wattmeters which are integrated combinations of single-phase wattmeter elements. A general theorem called Blondel's theorem asserts that the total power supplied to a load over  $N$  wires can be measured by using  $N - 1$  wattmeters. The theorem states that the total power in an  $N$ -wire system can be measured by taking the sum of the readings of  $N$  wattmeters so arranged that each wire contains the current coil of one wattmeter. One voltage terminal of each wattmeter is connected to the same wire as its current coil, and the second voltage terminal is connected to a common point in the circuit. If this common point is one of the  $N$  wires, one wattmeter will read zero and can be omitted.

At frequencies significantly above power frequencies, dynamometer wattmeters become inaccurate and cannot be used. The newer digital wattmeters have usable ranges well above audio frequencies and make accurate audio-frequency power measurements quite feasible. Generally, however, power measurements at higher frequencies are based on indirect methods.

For frequencies up to a few hundred megahertz, the voltage across a standard resistance load can be measured and the power calculated from  $V^2/R$ . Instruments which combine the resistive load and voltmeter are called absorption power meters.

A diode may be used as a detector for radio-frequency (rf) power measurement. This type of instrument is simple and easy to use but is less accurate than thermally based systems. See DIODE.

A thermocouple consists of two dissimilar metals joined at one end. When the joined end is heated and the other end is at a lower temperature, an electric current is produced (the thermoelectric or Seebeck effect). The current is proportional to the temperature difference between the two ends. For electric power measurements, the hot end is heated by a resistor supplied from the rf power source to be measured. Modern devices use thin-film techniques to make the thermocouple and resistor to ensure good thermal coupling. The output is a low-level dc signal as in diode detector systems. See THERMOCOUPLE.

A bolometer is basically an electric bridge circuit in which one of the bridge arms contains a temperature-sensitive resis-

tor. In principle, the temperature is detected by the bridge circuit. Bolometric bridges use either barreters or thermistors as the temperature-sensitive resistor. The thermistor, which has largely replaced the barreter since it is more rugged, is a semiconductor device with a negative temperature coefficient. For rf power measurements, the thermistor is fabricated as a small bead with very short lead wires so that essentially all the resistance is in the bead. See BARRETER; BOLOMETER; THERMISTOR.

The most accurate high-frequency power measurement methods involve calorimetric techniques based on direct determination of the heat produced by the input power. The power to be measured is applied to the calorimeter, and the final equilibrium temperature rise is recorded. Then the input signal is removed, and dc power applied until the same equilibrium temperature is attained. The dc power is then the same as the signal power. Calorimeter methods are usually used in standards laboratories rather than in industrial applications. See CALORIMETRY; ELECTRICAL MEASUREMENTS. [D.W.N.]

**Electric power substation** An assembly of equipment in an electric power system through which electrical energy is passed for transmission, distribution, interconnection, transformation, conversion, or switching. See ELECTRIC POWER SYSTEMS.

Specifically, substations are used for some or all of the following purposes: connection of generators, transmission or distribution lines, and loads to each other; transformation of power from one voltage level to another; interconnection of alternate sources of power; switching for alternate connections and isolation of failed or overloaded lines and equipment; controlling system voltage and power flow; reactive power compensation; suppression of overvoltage; and detection of faults, monitoring, recording of information, power measurements, and remote communications. Minor distribution or transmission equipment installation is not referred to as a substation.

Substations are referred to by the main duty they perform. Broadly speaking, they are classified as: transmission substations, which are associated with high voltage levels; and distribution substations, associated with low voltage levels. See ELECTRIC DISTRIBUTION SYSTEMS.

Substations are also referred to in a variety of other ways:

1. Transformer substations are substations whose equipment includes transformers.
2. Switching substations are substations whose equipment is mainly for various connections and interconnections, and does not include transformers.
3. Customer substations are usually distribution substations on the premises of a larger customer, such as a shopping center, large office or commercial building, or industrial plant.
4. Converter stations are complex substations required for high-voltage direct-current (HVDC) transmission or interconnection of two ac systems which, for a variety of reasons, cannot be connected by an ac connection. The main function of converter stations is the conversion of power from ac to dc and vice versa. The main equipment includes converter valves usually located inside a large hall, transformers, filters, reactors, and capacitors.
5. Most substations are installed as air-insulated substations, implying that the bus-bars and equipment terminations are generally open to the air, and utilize insulation properties of ambient air for insulation to ground. Modern substations in urban areas are esthetically designed with low profiles and often within walls, or even indoors.
6. Metal-clad substations are also air-insulated, but for low voltage levels; they are housed in metal cabinets and may be indoors or outdoors.

7. Acquiring a substation site in an urban area is very difficult because land is either unavailable or very expensive. Therefore, there has been a trend toward increasing use of gas-insulated substations, which occupy only 5–20% of the space occupied by the air-insulated substations. In gas-insulated substations, all live equipment and bus-bars are housed in grounded metal

enclosures, which are sealed and filled with sulfur hexafluoride (SF<sub>6</sub>) gas, which has excellent insulation properties.

8. For emergency replacement or maintenance of substation transformers, mobile substations are used by some utilities.

An appropriate switching arrangement for "connections" of generators, transformers, lines, and other major equipment is basic to any substation design. There are seven switching arrangements commonly used: single bus; double bus, single breaker; double bus, double breaker; main and transfer bus; ring bus; breaker-and-a-half; and breaker-and-a-third. Each breaker is usually accompanied by two disconnect switches, one on each side, for maintenance purposes. Selecting the switching arrangement involves considerations of cost, reliability, maintenance, and flexibility for expansion.

A substation includes a variety of equipment. The principal items are transformers, circuit breakers, disconnect switches, bus-bars, shunt reactors, shunt capacitors, current and potential transformers, and control and protection equipment. *See* BUS-BAR; CIRCUIT BREAKER; ELECTRIC PROTECTIVE DEVICES; ELECTRIC SWITCH; RELAY; TRANSFORMER; VOLTAGE REGULATOR.

Good substation grounding is very important for effective relaying and insulation of equipment; but the safety of the personnel is the governing criterion in the design of substation grounding. It usually consists of a bare wire grid, laid in the ground; all equipment grounding points, tanks, support structures, fences, shielding wires and poles, and so forth, are securely connected to it. The grounding resistance is reduced enough that a fault from high voltage to ground does not create such high potential gradients on the ground, and from the structures to ground, to present a safety hazard. Good overhead shielding is also essential for outdoor substations, so as to virtually eliminate the possibility of lightning directly striking the equipment. Shielding is provided by overhead ground wires stretched across the substation or tall grounded poles. *See* GROUNDING; LIGHTNING AND SURGE PROTECTION. [N.G.H.]

**Electric power systems** A complex assemblage of equipment and circuits for generating, transmitting, transforming, and distributing electrical energy.

Electricity in the large quantities required to supply electric power systems is produced in generating stations, commonly called power plants. Such generating stations, however, should be considered as conversion facilities in which the heat energy of fuel (coal, oil, gas, or uranium) or the hydraulic energy of falling water is converted to electricity. *See* ELECTRIC POWER GENERATION; HYDRAULIC TURBINE; NUCLEAR REACTOR; POWER PLANT; STEAM TURBINE.

The transmission system carries electric power efficiently and in large amounts from generating stations to consumption areas. Such transmission is also used to interconnect adjacent power systems for mutual assistance in case of emergency and to gain for the interconnected power systems the economies possible in regional operation.

Another approach to high-voltage long-distance transmission is high-voltage direct current (HVDC), which offers the advantages of less costly lines, lower transmission losses, and insensitivity to many system problems that restrict alternating-current systems. Its greatest disadvantage is the need for costly equipment for converting the sending-end power to direct current, and for converting the receiving-end direct-current power to alternating current for distribution to consumers. *See* TRANSMISSION LINES.

As systems grow and the number and size of generating units increase, and as transmission networks expand, higher levels of bulk-power-system reliability are attained through properly coordinated interconnections among separate systems. Most of the electric utilities in the contiguous United States and a large part of Canada now operate as members of power pools, and these pools in turn are interconnected into one gigantic power grid known as the North American Power Systems Interconnection.

The operation of this interconnection, in turn, is coordinated by the North American Electric Reliability Council (NERC). Each individual utility in such pools operates independently, but has contractual arrangements with other members in respect to generation additions and scheduling of operation. Their participation in a power pool affords a higher level of service reliability and important economic advantages.

Power delivered by transmission circuits must be stepped down in facilities called substations to voltages more suitable for use in industrial and residential areas. *See* ELECTRIC POWER SUBSTATION.

That part of the electric power system that takes power from a bulk-power substation to customers' switches, commonly about 35% of the total plant investment, is called distribution. [W.C.H.]

The operation and control of the generation-transmission-distribution grid is quite complex because this large system has to operate in synchronism and because many different organizations are responsible for different portions of the grid. In North America and Europe, many public and private electric power companies are interconnected, often across national boundaries. Thus, many organizations have to coordinate to operate the grid, and this coordination can take many forms, from a loose agreement of operational principles to a strong pooling arrangement of operating together.

Power-system operations can be divided into three stages: operations planning, real-time control, and after-the-fact accounting. The main goal is to minimize operations cost while maintaining the reliability (security) of power delivery to customers. Operations planning is the optimal scheduling of generation resources to meet anticipated demand in the next few hours, weeks, or months. This includes the scheduling of water, fossil fuels, and equipment maintenance over many weeks, and the commitment (start-up and shutdown) of generating units over many hours. Real-time control of the system is required to respond to the actual demand of electricity and any unforeseen contingencies (equipment outages). Maintaining security of the system so that a possible contingency cannot disrupt power supply is an integral part of real-time control. After-the-fact accounting is the tracking of purchases and sales of energy between organizations so that billing can be generated.

For loosely coordinated operation of the grid, each utility takes responsibility for the operation of its own portion while exchanging all relevant information. For pool-type operations, a hierarchy is set up where the operational decisions may be made centrally and then implemented by each utility. For a large utility, there may be another level in the hierarchy where the decisions are further distributed to different geographical areas of the same utility. All of this requires significant data communication as well as engineering computation within a utility as well as between utilities. The use of modern computers and communications makes this possible, and the heart of system operations in a utility is the energy control center.

The monitoring and control of a power system from a centralized control center became desirable quite early in the development of electric power systems, when generating stations were connected together to supply the same loads. As electrical utilities interconnected and evolved into complex networks of generators, transmission lines, distribution feeders, and loads, the control center became the operations headquarters for each utility. Since the generation and delivery of electrical energy are controlled from this center, it is referred to as the energy control center or energy management system. [A.Bo.]

**Electric power transmission** The transport of generator-produced electric energy to loads. An electric power transmission system interconnects generators and loads and generally provides multiple paths among them. Multiple paths increase system reliability because the failure of one line does not cause a system failure. Most transmission lines operate with three-phase alternating current (ac). The standard frequency in

North America is 60 Hz; in Europe, 50 Hz. The three-phase system has three sets of phase conductors. Long-distance energy transmission occasionally uses high-voltage direct-current (dc) lines. See ALTERNATING CURRENT; DIRECT CURRENT; DIRECT-CURRENT TRANSMISSION.

The electric power system can be divided into the distribution, subtransmission, and transmission systems. With operating voltages less than 34.5 kV, the distribution system carries energy from the local substation to individual households, using both overhead and underground lines. With operating voltages of 69–138 kV, the subtransmission system distributes energy within an entire district and regularly uses overhead lines. With operating voltage exceeding 230 kV, the transmission system interconnects generating stations and large substations located close to load centers by using overhead lines. See TRANSMISSION LINES.

**Overhead alternating-current transmission.** Overhead transmission lines distribute the majority of the electric energy in the system. A typical high-voltage line has three phase conductors to carry the current and transport the energy, and two grounded shield conductors to protect the line from direct lightning strikes. The usually bare conductors are insulated from the supporting towers by insulators attached to grounded towers or poles. Lower-voltage lines use post insulators, while the high-voltage lines are built with insulator chains or long-rod composite insulators. The normal distance between the supporting towers is a few hundred feet.

Transmission lines use ACSR (aluminum cable, steel reinforced) and ACAR (aluminum cable, alloy reinforced) conductors. In an ACSR conductor, a stranded steel core carries the mechanical load, and layers of stranded aluminum surrounding the core carry the current. An ACAR conductor is a stranded cable made of an aluminum alloy with low resistance and high mechanical strength. ACSR conductors are usually used for high-voltage lines, and ACAR conductors for subtransmission and distribution lines. Ultrahigh-voltage (UHV) and extrahigh-voltage (EHV) lines use bundle conductors. Each phase of the line is built with two, three, or four conductors connected in parallel and separated by about 1.5 ft (0.5 m). Bundle conductors reduce corona discharge. See CONDUCTOR (ELECTRICITY).

Transmission lines are subject to environmental adversities, including wide variations of temperature, high winds, and ice and snow deposits. Typically designed to withstand environmental stresses occurring once every 50–100 years, lines are intended to operate safely in adverse conditions.

Variable weather affects line operation. Extreme weather reduces corona inception voltage, leading to an increase in audible noise, radio noise, and telephone interference. Load variation requires regulation of line voltage. A short circuit generates large currents, overheating conductors and producing permanent damage.

The power that a line can transport is limited by the line's electrical parameters. Voltage drop is the most important factor for distribution lines; where the line is supplied from only one end, the permitted voltage drop is about 5%.

Conductor temperature must be lower than the temperature which causes permanent elongation. A typical maximum steady-state value for ACSR is 212°F (100°C), but in an emergency temperatures 10–20% higher are allowed for a short period of time (10 min to 1 h).

Corona discharge is generated when the electric field at the surface of the conductor becomes larger than the breakdown strength of the air. The oscillatory nature of the discharge generates high-frequency, short-duration current pulses, the source of corona-generated radio and television interference. Surface irregularities such as water droplets cause local field concentration, enhancing corona generation. Thus, during bad weather, corona discharge is more intense and losses are much greater. Corona discharge also generates audible noise with two components: a broad-band, high-frequency component, which produces crack-

ling and hissing, and a 120-Hz pure tone. See CORONA DISCHARGE; ELECTRICAL INTERFERENCE.

Transmission-line conductors are surrounded by an electric field which decreases as distance from the line increases, and depends on line voltage and geometry. At ground level, this field induces current and voltage in grounded bodies, causes corona in grounded objects, and can induce fuel ignition. Utilities limit the electric field at the perimeter of right-of-ways to about 1000 V/m. An ac magnetic field around the transmission line also decreases with distance from the line. See ELECTRIC FIELD.

Lightning strikes produce high voltages and traveling waves on transmission lines, causing insulator flashovers and interruption of operation. Steel grounded shield conductors at the tops of the towers significantly reduce, but do not eliminate, the probability of direct lightning strikes to phase conductors. See LIGHTNING AND SURGE PROTECTION.

The operation of circuit breakers causes switching surges that can result in interruption of inductive current, energization of lines with trapped charges, and single-phase ground fault. Modern circuit breakers, operating in two steps, reduce switching surges to 1.5–2 times the 60-Hz voltage. See CIRCUIT BREAKER.

Line current induces a disturbing voltage in telephone lines running parallel to transmission lines. Because the induced voltage depends on the mutual inductance between the two lines, disturbance can be reduced by increasing the distance between the lines and shielding the telephone lines. See ELECTRICAL SHIELDING; INDUCTIVE COORDINATION.

**Underground power transmission.** Most cities use underground cables to distribute electrical energy. These cables virtually eliminate negative environmental effects and reduce electrocution hazards. However, they entail significantly higher construction costs.

Underground cables are divided into two categories: distribution cables (less than 69 kV) and high-voltage power-transmission cables (69–500 kV).

Extruded solid dielectric cables dominate in the 15–33-kV urban distribution system. In a typical arrangement (illus. a), the stranded copper or aluminum conductor is shielded by a semiconductor layer, which reduces the electric stress on the

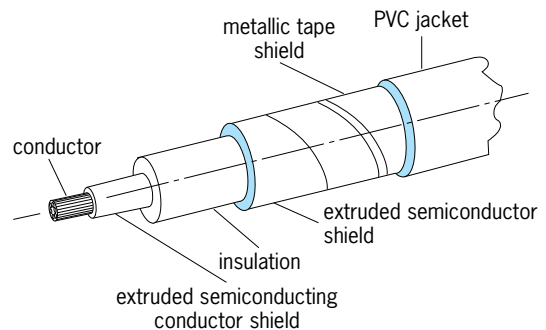

(a)

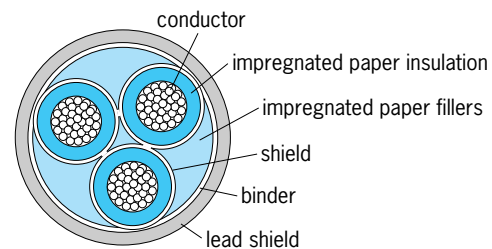

(b)

**Underground distribution cables.** (a) Extruded solid dielectric cable. (b) Three-phase oil-impregnated paper-insulated cable. (After R. Bartnikas Srivastava, *Elements of Cable Engineering*, Sandford Educational Press, 1980)

conductor's surface. Oil-impregnated paper-insulated distribution cables are used for higher voltages and in older installations (illus. *b*).

Cable temperatures vary with load changes, and cyclic thermal expansion and contraction may produce voids in the cable. High voltage initiates corona in the voids, gradually destroying cable insulation. Low-pressure oil-filled cable construction reduces void formation. A single-phase concentric cable has a hollow conductor with a central oil channel. Three-phase cables have three oil channels located in the filler.

**Submarine cables.** High-voltage cables are frequently used for crossing large bodies of water. Water provides natural cooling, and pressure reduces the possibility of void formation. A typical submarine cable has cross-linked polyethylene insulation, and corrosion-resistant aluminum alloy wire armoring that provides tensile strength and permits installation in deep water. See ELECTRIC POWER SYSTEMS. [G.G.K.]

**Electric protective devices** Equipment applied to electric power systems to detect abnormal and intolerable conditions and to initiate appropriate corrective actions. These devices include lightning arresters, surge protectors, fuses, and relays with associated circuit breakers, reclosers, and so forth.

From time to time, disturbances in the normal operation of a power system occur. These may be caused by natural phenomena, such as lightning, wind, or snow; by falling objects such as trees; by animal contacts or chewing; by accidental means traceable to reckless drivers, inadvertent acts by plant maintenance personnel, or other acts of humans; or by conditions produced in the system itself, such as switching surges, load swings, or equipment failures. Protective devices must therefore be installed on power systems to ensure continuity of electrical service, to limit injury to people, and to limit damage to equipment when problem situations develop. Protective devices are applied commensurately with the degree of protection desired or felt necessary for the particular system.

**Protective relays.** These are compact analog or digital networks, connected to various points of an electrical system, to detect abnormal conditions occurring within their assigned areas. They initiate disconnection of the trouble area by circuit breakers. These relays range from the simple overload unit on house circuit breakers to complex systems used to protect extrahigh-voltage power transmission lines. They operate on voltage, current, current direction, power factor, power, impedance, temperature. In all cases there must be a measurable difference between the normal or tolerable operation and the intolerable or unwanted condition. System faults for which the relays respond are generally short circuits between the phase conductors, or between the phases and grounds. Some relays operate on unbalances between the phases, such as an open or reversed phase. A fault in one part of the system affects all other parts. Therefore relays and fuses throughout the power system must be coordinated to ensure the best quality of service to the loads and to avoid operation in the nonfaulted areas unless the trouble is not adequately cleared in a specified time. See FUSE (ELECTRICITY); RELAY.

**Zone protection.** For the purpose of applying protection, the electric power system is divided into five major protection zones: generators; transformers; buses; transmission and distribution lines; and motors (see illustration). Each block represents a set of protective relays and associated equipment selected to initiate correction or isolation of that area for all anticipated intolerable conditions or trouble. The detection is done by protective relays with a circuit breaker used to physically disconnect the equipment. For other areas of protection see GROUNDING; UNINTERRUPTIBLE POWER SYSTEM.

**Fault detection.** Fault detection is accomplished by a number of techniques, including the detection of changes in electric current or voltage levels, power direction, ratio of voltage to current, temperature, and comparison of the electrical quantities

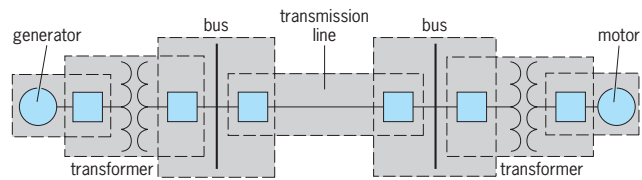

Zones of protection on simple power system.

flowing into a protected area with the quantities flowing out, also known as differential protection.

**Differential protection.** This is the most fundamental and widely used protection technique. The system compares currents to detect faults in a protection zone. Current transformers on either side of the protection zone reduce the primary currents to small secondary values, which are the inputs to the relay. For load through the equipment or for faults outside of the protection zone, the secondary currents from the two transformers are essentially the same, and they are directed so that the current through the relay sums to essentially zero. However, for internal trouble, the secondary currents add up to flow through the relay.

**Overcurrent protection.** This must be provided on all systems to prevent abnormally high currents from overheating and causing mechanical stress on equipment. Overcurrent in a power system usually indicates that current is being diverted from its normal path by a short circuit. In low-voltage, distribution-type circuits, such as those found in homes, adequate overcurrent protection can be provided by fuses that melt when current exceeds a predetermined value.

Small thermal-type circuit breakers also provide overcurrent protection for this class of circuit. As the size of circuits and systems increases, the problems associated with interruption of large fault currents dictate the use of power circuit breakers. Normally these breakers are not equipped with elements to sense fault conditions, and therefore overcurrent relays are applied to measure the current continuously. When the current has reached a predetermined value, the relay contacts close. This actuates the trip circuit of a particular breaker, causing it to open and thus isolate the fault. See CIRCUIT BREAKER.

**Distance protection.** Distance-type relays operate on the combination of reduced voltage and increased current occasioned by faults. They are widely applied for the protection of higher voltage lines. A major advantage is that the operating zone is determined by the line impedance and is almost completely independent of current magnitudes.

**Overvoltage protection.** Lightning in the area near the power lines can cause very short-time overvoltages in the system and possible breakdown of the insulation. Protection for these surges consists of lightning arresters connected between the lines and ground. Normally the insulation through these arresters prevents current flow, but they momentarily pass current during the high-voltage transient to limit overvoltage. Overvoltage protection is seldom applied elsewhere except at the generators, where it is part of the voltage regulator and control system. In the distribution system, overvoltage relays are used to control taps of tap-changing transformers or to switch shunt capacitors on and off the circuits. See LIGHTNING AND SURGE PROTECTION.

**Undervoltage protection.** This must be provided on circuits supplying power to motor loads. Low-voltage conditions cause motors to draw excessive currents, which can damage the motors. If a low-voltage condition develops while the motor is running, the relay senses this condition and removes the motor from service.

**Underfrequency protection.** A loss or deficiency in the generation supply, the transmission lines, or other components of the system, resulting primarily from faults, can leave the system with an excess of load. Solid-state and digital-type underfrequency relays are connected at various points in the system to detect



this resulting decline in the normal system frequency. They operate to disconnect loads or to separate the system into areas so that the available generation equals the load until a balance is reestablished.

**Reverse-current protection.** This is provided when a change in the normal direction of current indicates an abnormal condition in the system. In an ac circuit, reverse current implies a phase shift of the current of nearly  $180^\circ$  from normal. This is actually a change in direction of power flow and can be directed by ac directional relays.

**Phase unbalance protection.** This protection is used on feeders supplying motors where there is a possibility of one phase opening as a result of a fuse failure or a connector failure. One type of relay compares the current in one phase against the currents in the other phases. When the unbalance becomes too great, the relay operates. Another type monitors the three-phase bus voltages for unbalance. Reverse phases will operate this relay.

**Reverse-phase-rotation protection.** Where direction of rotation is important, electric motors must be protected against phase reversal. A reverse-phase-rotation relay is applied to sense the phase rotation. This relay is a miniature three-phase motor with the same desired direction of rotation as the motor it is protecting. If the direction of rotation is correct, the relay will let the motor start. If incorrect, the sensing relay will prevent the motor starter from operating.

**Thermal protection.** Motors and generators are particularly subject to overheating due to overloading and mechanical friction. Excessive temperatures lead to deterioration of insulation and increased losses within the machine. Temperature-sensitive elements, located inside the machine, form part of a bridge circuit used to supply current to a relay. When a predetermined temperature is reached, the relay operates, initiating opening of a circuit breaker or sounding of an alarm. [J.L.BI.]

**Electric rotating machinery** Any form of apparatus, having a rotating member, which generates, converts, transforms, or modifies electric power. Essentially all of the world's electric power is produced by rotating electrical generators, and about 70% of this energy is consumed in driving electric motors. Electric machines are electromechanical energy converters; generators convert mechanical energy into electrical energy and motors convert electrical energy into mechanical energy.

An electric machine can be constructed on the principle that a magnet will attract a piece of permeable magnetic material such as iron or magnetic steel. In illus. *a*, a pole structure is shown along with a magnetic block that is allowed to rotate. The magnetic block will experience a torque tending to rotate it counterclockwise to the vertical direction. This torque called a reluctance or saliency torque, will be in the direction to minimize the reluctance of the magnetic circuit. In illus. *b*, a winding is added to the rotor (the part which is allowed to rotate). In this case there is an additional torque on the rotor in the counterclockwise direction produced by the attraction of opposite poles. This torque will be approximately proportional to the sine of the angle  $\theta$ . While the magnets in the illustration are electromagnets, permanent magnets could be used with the same effect. See MAGNET; WINDINGS IN ELECTRIC MACHINERY.

In these examples, if the rotor were allowed to move under the influence of the magnetic forces, it would eventually come to rest at an equilibrium position,  $\theta = 0$ . Since most applications require continuous motion and constant torque, it is necessary to keep the angle between the rotor magnetic field and the stator magnetic field constant. Thus, in the above examples, the stator magnetic field must rotate ahead of the rotor. See ALTERNATING CURRENT.

Although there are many variations, the three basic machine types are synchronous, induction, and direct-current machines. These machines may be used as motors or as generators, but the basic principles of operation remain the same. The synchronous

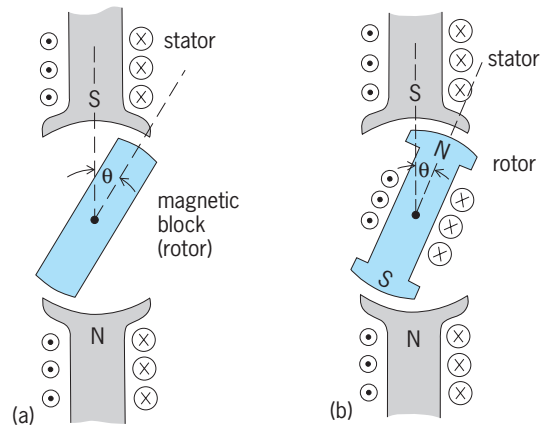

Devices illustrating principles of electric machines. (a) Permeable rotor and stator with magnetic pole structure. (b) Device with magnetic pole structures on both stator and rotor.

machine runs at a constant speed determined by the line frequency. There is an alternating-current winding (normally on the stator) and a direct-current winding (normally on the rotor). See ALTERNATING-CURRENT GENERATOR; ALTERNATING-CURRENT MOTOR; SYNCHRONOUS MOTOR.

The induction machine is another alternating-current machine which runs close to synchronous speed. The alternating-current winding of the stator is similar to that of the synchronous machine. The rotor may have an insulated winding (wound rotor) but more commonly consists of uninsulated bars embedded in a laminated structure and short-circuited at the end (squirrel cage). There is normally no voltage applied to the rotor. The voltages are produced by means of Faraday's law of induction. In an induction motor the stator-produced flux-density wave rotates slightly faster than the rotor during normal operation, and the flux linkages on the rotor therefore vary at low frequency. The rotor currents induced by these time-varying flux linkages produce a magnetic field distribution that rotates at the same speed as the stator-produced flux wave. See INDUCTION MOTOR.

In a direct-current motor, direct current is applied to both the rotor and the stator. The stationary poles on the stator produce a stationary magnetic field distribution. Since the angle between the stator-produced poles and rotor-produced poles must remain constant, the direct-current machine uses a device known as a commutator which switches the current from one rotor circuit to another so that the resulting field is stationary. See DIRECT-CURRENT GENERATOR; DIRECT-CURRENT MOTOR; GENERATOR; MOTOR. [S.Sa.]

**Electric spark** A transient form of gaseous conduction. This type of discharge is difficult to define, and no universally accepted definition exists. It can perhaps best be thought of as the transition between two more or less stable forms of gaseous conduction. For example, the transitional breakdown which occurs in the transition from a glow to an arc discharge may be thought of as a spark. See ELECTRICAL CONDUCTION IN GASES.

Electric sparks play an important part in many physical effects. Usually these are harmful and undesirable effects, ranging from the gradual destruction of contacts in a conventional electrical switch to the large-scale havoc resulting from lightning discharges. Sometimes, however, the spark may be very useful. Examples are its function in the ignition system of an automobile, its use as an intense short-duration illumination source in high-speed photography, and its use as a source of excitation in spectroscopy. In the second case the spark may actually perform the function of the camera shutter, because its extinction renders the camera insensitive. See SPECTROSCOPY; STROBOSCOPIC PHOTOGRAPHY. [G.H.M.]

**Electric susceptibility** A dimensionless parameter measuring the ease of polarization of a dielectric. In a vacuum, the electric flux density  $\mathbf{D}$  (measured in coulombs/m<sup>2</sup>) and electric field strength  $\mathbf{E}$  (volts/m) are related by Eq. (1) where  $\epsilon_0$  is

$$\mathbf{D} = \epsilon_0 \mathbf{E} \quad (1)$$

the permittivity of free space, having the value  $8.854 \times 10^{-12}$  farad/m. In a dielectric material, polarization occurs, and the flux density has the value given by Eq. (2), where  $\epsilon_r$  is the relative

$$\mathbf{D} = \epsilon_0 \epsilon_r \mathbf{E} = \epsilon_0 \mathbf{E} + \mathbf{P} \quad (2)$$

permittivity of the material and  $\mathbf{P}$  is the polarization flux density. This can be written as Eq. (3), where  $\chi_e = \epsilon_r - 1$  is known as the

$$\mathbf{P} = \epsilon_0 (\epsilon_r - 1) \mathbf{E} = \epsilon_0 \chi_e \mathbf{E} \quad (3)$$

electric susceptibility of the dielectric material. It is a measure of that part of the relative permittivity which is due to the material itself.

The electric susceptibility can be related to the polarizability  $\alpha$  by expressing the polarization in terms of molecular parameters. Thus Eqs. (4) hold, where  $N$  is the number of molecules per unit

$$\begin{aligned} \mathbf{P} &= N \langle \boldsymbol{\mu} \rangle_{\text{avg}} = N \alpha \mathbf{E}_L \\ \chi_e &= \frac{N \alpha \mathbf{E}_L}{\epsilon_0 \mathbf{E}} \end{aligned} \quad (4)$$

volume,  $\langle \boldsymbol{\mu} \rangle_{\text{avg}}$  is their average dipole moment, and  $\mathbf{E}_L$  is the local electric field strength at a molecular site. At low concentrations,  $\mathbf{E}_L$  approaches  $\mathbf{E}$ , and the susceptibility is proportional to the concentration  $N$ . For a discussion of the properties and measurement of electric susceptibility see PERMITTIVITY; POLARIZATION OF DIELECTRICS. [R.D.W.; A.E.Ba.]

**Electric switch** A device that makes, breaks, or changes the course of an electric circuit. Basically, an electric switch consists of two or more contacts mounted on an insulating structure and arranged so that they can be moved into and out of contact with each other by a suitable operating mechanism.

The term switch is usually used to denote only those devices intended to function when the circuit is energized or deenergized under normal manual operating conditions; as contrasted with circuit breakers, which have as one of their primary functions the interruption of short-circuit currents. Although there are hundreds of types of electric switches, their application can be broadly classified into two major categories: power and signal.

In power applications, switches function to energize or deenergize an electric load. On the low end of the power scale, wall switches are used in homes and offices for turning lights on and off; dial and push-button switches control power to electric ranges, washing machines, and dishwashers. On the high end of the scale are load-break switches and disconnecting switches in power systems at the highest voltages (several hundred thousand volts).

For power applications, when closed, switches are required to carry a certain amount of continuous current without overheating, and in the open position they must provide enough insulation to isolate the circuit electrically.

Load-break switches are required also to have the capability of interrupting the load current. Although this requirement is easily met in low-voltage and low-current applications, for high-voltage and high-current circuits, arc interrupters, similar to those used in circuit breakers are needed. In medium-voltage applications the most popular interrupter is the air magnetic type, in which the arc is driven into an arc chute by the magnetic field produced by the load current in a blowout coil. See BLOWOUT COIL; CIRCUIT BREAKER.

Some load-break switches may also be required to have the capability of holding the contacts in the closed position during short-circuit conditions so that the contacts will not be blown

open by electromagnetic forces when the circuit breaker in the system interrupts the short-circuit current.

For signal applications, switches are used to detect a specified situation that calls for some predetermined action in the electrical circuit. For example, thermostats detect temperature; when a certain limit is reached, contacts in the thermostat energize or deenergize another electrical switching device to control power flow.

Switches for signaling purposes are often required to have long life, high speed, and high reliability. Contaminants and dust must be prevented from interfering with the operation of the switch. For this purpose, switches are usually enclosed and are sometimes hermetically sealed.

Switches frequently are composed of many single circuit elements, known as poles, all operated simultaneously or in a predetermined sequence by the same mechanism. Switches are often typed by the number of poles and referred to as single-pole or double-pole switches, and so on. It is also common to express the number of possible switch positions per pole, such as a single-throw or double-throw switch. [T.H.L.]

**Electric transient** A temporary component of current and voltage in an electric circuit which has been disturbed. In ordinary circuit problems, a stabilized condition of the circuit is assumed and steady-state values of current and voltage are sufficient. However, it often becomes important to know what occurs during the transition period following a circuit disturbance until the steady-state condition is reached. Transients occur only in circuits containing inductance or capacitance. In general, transients accompany any change in the amount or form of energy stored in the circuit.

The study of transient phenomena is very broad. The mathematical requirements become severe and go far beyond the borders of all known mathematics. Transient analysis often requires the use of calculating machines, models, and tests. Fourier and Laplace transforms have proven indispensable in the modern treatment of transients and these disciplines need be mastered by anyone going far in the study of transients. The analysis of lumped-parameter circuits is comparatively easy. An electric circuit or system under steady-state conditions of constant, or cyclic, applied voltages or currents is in a state of equilibrium. However, the circuit conditions of voltage, current, or frequency may change or be disturbed. Also, circuit elements may be switched in or out of the circuit. Any change of circuit condition or circuit elements causes a transient readjustment of voltages and currents from the initial state of equilibrium to the final state of equilibrium. In a sense the transient may be regarded as superimposed on the final steady state, so that Eq. (1) applies.

$$\left( \begin{array}{c} \text{Instantaneous} \\ \text{condition} \end{array} \right) = \left( \begin{array}{c} \text{final} \\ \text{condition} \end{array} \right) + \left( \begin{array}{c} \text{transient} \\ \text{terms} \end{array} \right) \quad (1)$$

Furthermore, since the instantaneous condition at the first instant of disturbance (time zero) must be the initial condition, it may be described by Eq. (2).

$$\left( \begin{array}{c} \text{Initial} \\ \text{condition} \end{array} \right) = \left( \begin{array}{c} \text{final} \\ \text{condition} \end{array} \right) + \left( \begin{array}{c} \text{transient terms} \\ \text{at time zero} \end{array} \right) \quad (2)$$

In many practical cases transients are one of three types:

1. Single-energy transients, in which only one form of energy storage (either electromagnetic or electrostatic) is present; the transient exhibits simple exponential decay from the initial to the final conditions.

2. Double-energy transients, in which both forms of energy storage are present; the transient is either aperiodic or a damped sinusoid.

3. Combination of 1 and 2.

[L.V.B.]

**Electric vehicle** A ground vehicle propelled by a motor that is powered by electrical energy from rechargeable batteries

or other source onboard the vehicle, or from an external source in, on, or above the roadway. Examples are the golf cart, industrial truck and tractor, automobile, delivery van and other on-highway truck, and trolley bus. In common usage, electric vehicle refers to an automotive vehicle in which the propulsion system converts electrical energy stored chemically in a battery into mechanical energy to move the vehicle. This is classed as a battery-only-powered electric vehicle. The batteries provide the power to propel the vehicle, and to power the lights and all accessories such as air conditioning and radio. The other major class is the hybrid-electric vehicle, which has more than one power source such as battery power with a small internal combustion engine or a fuel cell. See AUTOMOBILE; BATTERY; BUS; FUEL CELL; TRUCK. [D.L.An.]

**Electrical breakdown** A large, usually abrupt rise in electric current in the presence of a small increase in electric voltage. Breakdown may be intentional and controlled or it may be accidental. Lightning is the most familiar example of breakdown.

In a gas, such as the atmosphere, the potential gradient may become high enough to accelerate the naturally present ions to velocities that cause further ionization upon collision with atoms. If the region of ionization does not extend between oppositely charged electrodes, the process is corona discharge. If the region of ionization bridges the gap between electrodes, thereby breaking down the insulation provided by the gas, the process is ionization discharge. When controlled by the ballast of a fluorescent lamp, for example, the process converts electric power to light. In a gas tube the process provides controlled rectification. See GAS TUBE.

In a solid, such as an insulator, when the electric field gradient exceeds  $10^6$  volts/cm, valence bonds between atoms are ruptured and current flows. Such a disruptive current heats the solid abruptly. In a semiconductor if the applied backward or reverse potential across a junction reaches a critical level, current increases rapidly with further rise in voltage. This avalanche characteristic is used for voltage regulation in the Zener diode. In a transistor the breakdown sets limits to the maximum instantaneous voltage that can safely be applied between collector and emitter. See BREAKDOWN POTENTIAL; ELECTRICAL INSULATION; TRANSISTOR; ZENER DIODE. [F.H.R.]

**Electrical codes** Systematic bodies of rules governing the practical application, installation, and interconnection of electrically operated equipment, devices, and electrical wiring systems.

The basic code used throughout the United States is the National Electrical Code, prepared under the direction of the National Fire Protection Association (NFPA). It is approved by the American National Standards Institute. The National Electrical Code is purely advisory as far as the National Fire Protection Association is concerned, but it is very widely used for legal regulatory purposes. The code is administered by various local inspection agencies, whose decisions govern its application to individual installations. The National Electrical Code is incorporated bodily or by reference in many municipal building ordinances, often with additional provisions or restrictions applicable in the particular locality. Some large cities have independent electrical codes; however, the actual provisions in most such codes tend to be basically similar to the National Electrical Code.

Compliance with the provisions of the code can effectively minimize fire and accident hazards in any electrical design. It sets forth requirements that constitute a minimum standard for the framework of electrical design. As stated in its introduction, the code is concerned with the "practical safeguarding of persons and of buildings and their contents from hazards arising from the use of electricity for light, heat, power, radio, signaling and for other purposes." The National Electrical Code is recognized as a legal criterion of safe electrical design and installation. It is used

in court litigation and by insurance companies as a basis for insuring buildings.

In addition to the National Electrical Code itself, other standards and recommended practices are made available by the National Fire Protection Association. These cover such special subjects as hospital operating rooms, municipal fire alarm systems, garages, aircraft hangars, and other equipment with great potential hazards due to improper design.

The National Electrical Safety Code (to be distinguished from the National Electrical Code) is published by the Institute of Electrical and Electronic Engineers, Inc. This code applies to the outdoor circuits of electric utility companies and to similar systems or equipment on commercial and industrial premises.

Standards on the construction and assembly of many types of electrical equipment, materials, and appliances are set forth in literature issued by the Underwriters' Laboratories, Inc. The Underwriters' Laboratories examines, tests, and determines the suitability of materials and equipment to be used according to code regulations. See WIRING. [J.F.McP.]

**Electrical communications** That branch of electrical engineering dealing with the transmission and reception of information. Information can be transmitted over many different types of pathways, such as satellite channels, underwater acoustic channels, telephone cables, and fiber-optic links. Characteristically, any communications link is noisy. The receiver never receives the information-bearing waveform as it was originally transmitted. Rather, what is received is, at best, the sum of what was transmitted and noise. In reality, what is more likely to be received is a distorted version of what was transmitted, with noise and perhaps interference. Consequently, the design and implementation of a communications link are dependent upon statistical signal-processing techniques in order to provide the most efficient extraction of the desired information from the received waveform. See COMMUNICATIONS CABLE; COMMUNICATIONS SATELLITE; DISTORTION (ELECTRONIC CIRCUITS); ELECTRICAL INTERFERENCE; ELECTRICAL NOISE; MICROWAVE; OPTICAL COMMUNICATIONS; RADIO-WAVE PROPAGATION; SIGNAL-TO-NOISE RATIO; TELEPHONE SERVICE; TRANSMISSION LINES; UNDERWATER SOUND; WAVEGUIDE.

Broadly speaking, there are two basic classes of communication waveforms, those involving analog modulation and those involving digital modulation. The former type implies that the modulation process allows the actual information signal to modulate a high-frequency carrier for efficient transmission over a channel; this is achieved by using the continuum of amplitude values of an analog waveform. Examples of analog modulation systems include amplitude-modulation (AM) and frequency-modulation (FM) systems, as well as a variety of others such as single-sideband (SSB), double-sideband (DSB), and vestigial-sideband (VSB) systems. In digital modulation systems, the initial information-bearing waveform, assuming it is in analog form (such as voice or video), is first sampled, then quantized, and finally encoded in a digital format for carrier modulation and transmission over the channel. See AMPLITUDE MODULATION; FREQUENCY MODULATION; MODULATION.

In many communication systems, multiple sources and multiple destinations are present, and the manner in which accessing the channel is achieved becomes important. Perhaps the most common examples of such multiple-access links are those used by commercial radio and television stations. These systems operate by assigning to each transmitted waveform a distinct frequency band which is adjacent to but nominally not overlapping with its neighboring bands. In this way, there is approximately no interference among the various users. This type of operation, known as frequency-division multiple accessing (FDMA), can be used with either analog or digital modulation formats. See MULTIPLEXING AND MULTIPLE ACCESS; RADIO; TELEVISION.

In many cases, the number of potential users is much greater than the number which can be simultaneously accommodated

on the channel. However, if the percentage of time employed by each user is statistically very small, the users can compete for access to the channel. When a given user has a message ready for transmission, most of the time a vacant slot on the channel will be found, allowing data transmission. However, at times, all available slots on the channel are taken, and the user has to delay sending the message.

Systems that operate in this manner are referred to as random-access systems, and are typical of computer communication networks. Depending on the geographical size of such networks, they have come to have their own specialized names. For example, they are known as local-area networks (LANs) if they are concentrated over an area roughly the size of a few blocks or less. If the terminals which are farthest apart are within a few miles of one another, they are referred to as metropolitan-area networks (MANs). Networks that span still larger geographical distances are called wide-area networks (WANs). See DATA COMMUNICATIONS; LOCAL-AREA NETWORKS; WIDE-AREA NETWORKS. [L.B.M.]

**Electrical conduction in gases** The process by means of which a net charge is transported through a gaseous medium. It encompasses a variety of effects and modes of conduction, ranging from the Townsend discharge at one extreme to the arc discharge at the other. The current in these two cases ranges from a fraction of 1 microampere in the first to thousands of amperes in the second. It covers a pressure range from less than  $10^{-4}$  atm (10 pascals) to greater than 1 atm (100 kilopascals). See ARC DISCHARGE; TOWNSEND DISCHARGE.

In general, the feature which distinguishes gaseous conduction from conduction in a solid or liquid is the active part which the medium plays in the process. Not only does the gas permit the drift of free charges from one electrode to the other, but the gas itself may be ionized to produce other charges which can interact with the electrodes to liberate additional charges. Quite apparently, the current voltage characteristic may be nonlinear and multivalued. See ELECTROLYTIC CONDUCTANCE; SEMICONDUCTOR.

The applications of the effects encountered in this area are of significant commercial and scientific value. A few commercial applications are thyratrons, gaseous rectifiers, ignitrons, glow tubes, and gas-filled phototubes. These tubes are used in power supplies, control circuits, pulse production, voltage regulators, and heavy-duty applications such as welders. In addition, there are gaseous conduction devices widely used in research problems. Some of these are ion sources for mass spectrometers and nuclear accelerators, ionization vacuum gages, radiation detection and measurement instruments, and thermonuclear devices for the production of power. [G.H.M.]

**Electrical connector** A device that joins electric conductors mechanically and electrically to other conductors and to the terminals of apparatus and equipment. The term covers a wide range of devices designed, for example, to connect small conductors employed in communication circuits, or at the other extreme, large cables and bus-bars.

Electrical connectors are applied to conductors in a variety of ways. Soldered connectors have a tube or hole of approximately the same diameter as the conductor. The conductor and connector are heated, the conductor inserted, and solder flowed into the joint until it is filled. Solderless connectors are applied by clamping the conductor or conductors in a bolted assembly or by staking or crimping under great mechanical force.

Typical connector types are in-line splice couplers, T-tap connectors, terminal lugs, and stud connectors. Couplers join conductors end to end. T-tap connectors join a through conductor to another conductor at right angles to it (illus. a). Terminal lugs join the conductor to a drilled tongue for bolting to the terminals of equipment (illus. b). Stud connectors join the conductor to equipment studs; the stud clamp is threaded or smooth to match the stud.

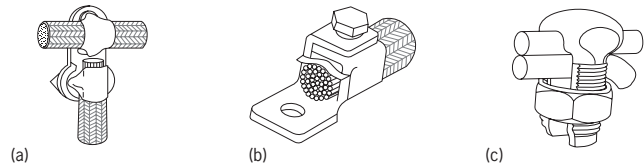

Types of connectors. (a) T-tap connector. (b) Terminal lug. (c) Split-bolt connector.

Split-bolt connectors are a compact construction widely used for splices and taps in building wiring. The bolt-shape casting has a wide and deep slot lengthwise. The conductors are inserted in the slot and the nut is drawn up, clamping the conductors together inside the bolt (illus. c).

Expansion connectors or flexible connectors allow some limited motion between the connected conductors. The clamp portions of the connector are joined by short lengths of flexible copper braid and may also be held in alignment by a telescoping guide.

Separable types consist of matched plugs and receptacles, which may be readily separated to disconnect a conductor or group of conductors from the circuit or system. Separable connectors are commonly used for the connection of portable appliances and equipment to an electric wiring system.

Locking types are designed so that, when coupled, they may not be separated by a strain or pull on the cord or cable. In a typical construction the plug is inserted and twisted through a small arc, locking it securely in place.

Plug receptacles, sometimes called convenience outlets, are a type of wiring device distributed throughout buildings for the attachment of cord plug caps from portable lamps and appliances. In residences at least one such outlet must be provided for every 12 linear feet (3.66 m) or major fraction of wall perimeter. Grounding receptacles have an additional contact that accepts the third round or U-shaped prong of a grounding attachment plug. See WIRING. [J.F.McP]

**Electrical degree** A time interval equal to  $1/360$  of the time required for one complete cycle of alternating current. Mechanical rotation is often measured in degrees,  $360^\circ$  constituting one complete revolution. In describing alternating voltages and currents, the time for one complete cycle is considered to be equivalent to 360 electrical degrees ( $360^\circ$ ) or  $2\pi$  electrical radians. For example, if the frequency  $f$  is 60 cycles per second (60 Hz),  $360^\circ$  corresponds to  $1/60$  second and 1 electrical degree to  $1/21,600$  second.

There is a definite relationship between electrical and mechanical degrees in rotating electric generators and motors. The illustration shows typical coil and angular relationships in a two-pole alternator. As the magnetic field in the machine moves relative to the coils in the armature winding, the coils are linked sequentially by the fluxes of north and south magnetic poles; two flux reversals induce one cycle of voltage in a given coil. Thus, in a two-pole machine  $360^\circ$  of electrical cycle corresponds to  $360^\circ$  of mechanical rotation, and an angle measured in mechanical degrees has the same value in electrical degrees. However, in a machine with more than two poles, one electrical cycle is generated per pair of poles per revolution. For example, a six-pole machine generates three cycles of voltage in each armature coil per revolution. In this case, each mechanical degree is equivalent to 3 electrical degrees. In general, the relationship below is valid,

$$\text{Number of electrical degrees in a given angle} = \frac{p}{2} \cdot \left( \text{number of mechanical degrees in that angle} \right)$$

where  $p$  is the number of magnetic poles of either the rotor or the stator. It follows that the electrical angle between the centers of succeeding poles of opposite polarity is always 180 electrical degrees.

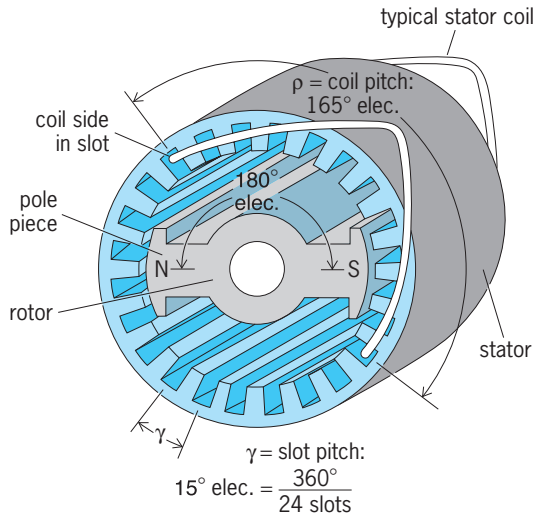

Coil and angular relationships in a two-pole alternator.

The concept of electrical degrees simplifies the analysis of multipolar machines by allowing them to be analyzed on a two-pole basis. Furthermore, it permits trigonometry to be used in solving alternating-current problems. See ALTERNATING CURRENT; ELECTRIC ROTATING MACHINERY; GENERATOR; MOTOR; WINDINGS IN ELECTRIC MACHINERY. [G.McP.]

**Electrical energy measurement** The measurement of the integral, with respect to time, of the power in an electric circuit. The absolute unit of measurement of electrical energy is the joule, or the charge in coulombs times the potential difference in volts. The joule, however, is too small (1 watt-second) for use in commercial practice, and the more commonly used unit is the watt-hour ( $3.6 \times 10^3$  joules). The most common measurement application is in the utility field.

Electrical energy is one of the most accurately measured commodities sold to the general public. Many methods of measurement, with different degrees of accuracy, are possible. Basically, measurements of electric energy may be classified into two categories, direct-current power and alternating-current power. The fundamental concepts of measurement are, however, the same for both.

There are two types of methods of measuring electrical energy: electric instruments and timing means, and electricity meters.

Electric instruments and timing means make use of conventional procedures for measuring electric power and time. Typical methods are listed below. See ELECTRIC POWER MEASUREMENT.

1. Measurement of energy on a direct-current circuit by reading the line voltage and load current at regular intervals over a measured period of time. See CURRENT MEASUREMENT; VOLTAGE MEASUREMENT.

2. Measurement of energy on a direct-current circuit by controlling the voltage and current at constant predetermined values for a predetermined time interval.

3. Measurement of energy on an alternating-current circuit by reading the watts input to the load at regular intervals over a measured period of time.

4. Measurement of energy on an alternating-current circuit by controlling the voltage, current, and watts input to the load at constant predetermined values.

5. Measurement of energy by recording the watts input to the load on a linear chart progressed uniformly with time.

Electricity meters are the most common devices for measuring the vast quantities of electrical energy used by industry and the general public. The same fundamentals of measurement apply as for electric power measurement, but in addition the electricity meter provides the time-integrating means necessary for elec-

tric energy measurement. A single meter is sometimes used to measure the energy consumed in two or more circuits. However, multistator meters are generally required for this purpose.

Watt-hour meters are generally connected to measure the losses of their respective current circuits. These losses are extremely small compared to the total energy being measured and are present only under load conditions. Watt-hour meters used for the billing of residential, commercial, and industrial loads are highly developed devices. See ELECTRICAL MEASUREMENTS. [W.H.Ha.]

**Electrical engineering** The branch of engineering that deals with electric and magnetic forces and their effects. See ELECTRICITY; ENGINEERING; MAGNETISM.

Electrical engineers design computers and incorporate them into devices and systems. They design two-way communications systems such as telephones and fiber-optic systems, and one-way communications systems such as radio and television, including satellite systems. They design control systems, such as aircraft collision-avoidance systems, and a variety of systems used in medical electronics. Electrical engineers are involved with generation, control, and delivery of electric power to homes, offices, and industry. Electric power lights, heats, and cools working and living space and operates the many devices used in homes and offices. Electrical engineers analyze and interpret computer-aided tomography data (CAT scans), seismic data from earthquakes and well drilling, and data from space probes, voice synthesizers, and handwriting recognition. They design systems that educate and entertain, such as computers and computer networks, compact-disk players, and multimedia systems. See CHARACTER RECOGNITION; COMMUNICATIONS SATELLITE; COMPACT DISK; COMPUTER; COMPUTERIZED TOMOGRAPHY; CONTROL SYSTEMS; DIGITAL COMPUTER; ELECTRIC HEATING; ELECTRIC POWER GENERATION; ELECTRIC POWER SYSTEMS.

The integration of communications equipment, control systems, computers, and other devices and processes into reliable, easily understood, and practical systems is a major challenge, which has given rise to the discipline of systems engineering. Electrical engineering must respond to numerous demands, including those for more efficient and effective lights and motors; better communications; faster and more reliable transfer of funds, orders, and inventory information in the business world; and the need of medical professionals for access to medical data and advice from all parts of the world. See INFORMATION SYSTEMS ENGINEERING; MEDICAL INFORMATION SYSTEMS; SYSTEMS ENGINEERING. [E.C.Jo.]

**Electrical impedance** The measure of the opposition that an electrical circuit presents to the passage of a current when a voltage is applied. In quantitative terms, it is the complex ratio of the voltage to the current in an alternating current (ac) circuit.

A generalized ac circuit may be composed of the interconnection of various types of circuit elements. The impedance of the circuit is given by  $Z = V/I$ , where  $Z$  is a complex number given by  $Z = R + jX$ .  $R$ , the real part of the impedance, is the resistance of the circuit, and  $X$ , the imaginary part of the impedance, is the reactance of the circuit. The units of impedance are ohms. See ELECTRICAL RESISTANCE; REACTANCE. [J.O.S.]

**Electrical instability** A condition that is generic to all physical systems that use the amplification of signals, power, or energy in various forms. Electrical circuits are perhaps the best-known example because the use of amplification is very common there. In order for instability to occur, a closed (circular) path must exist, and the net amplification around it must be sufficiently large that any random signal (for example, noise) that travels around the closed path grows uncontrollably. The condition is eventually limited by some physical aspect of the system such as nonlinearity, saturation, or power available. The energy to create the uncontrollable signal growth is obtained by conversion

from some other form of energy. For example, a high-frequency electrical oscillation can draw its energy from a direct-current (dc) power supply. See ENERGY; LINEARITY; SATURATION.

There can be various degrees of stability and instability in an electrical circuit or system, and instability may be desirable or undesirable depending on the context. Desirable instability is displayed by a cross-coupled positive-feedback latch in a computer memory cell, or an oscillator that is used to create the high-frequency carrier wave of a radio transmitter. An undesirable instability might arise in the loss of control over a power transmission system due to surges on the generators, leading to a necessary decoupling of the system. Another example is the high-pitched whine heard when a radio-station telephone caller leaves the home radio receiver on and thus allows feedback from the radio receiver to the telephone, that is, a closed-loop signal path. See FEEDBACK CIRCUIT; OSCILLATOR.

Electrical instability can occur at zero frequency (dc), for example, in the cross-coupled memory latch, but its accidental occurrences are generally at high frequencies. A configuration may be designed to be stable at low frequencies, but inadvertent phase shifts or time delays at higher frequencies may create a positive-feedback situation. For this reason, the design of amplifiers, feedback control systems, and so forth necessarily involves much attention to the higher-frequency aspects even though the desired use may be primarily at lower frequencies. See AMPLIFIER; CONTROL SYSTEM STABILITY; CONTROL SYSTEMS. [M.A.Co.]

**Electrical insulation** A nonconducting material that provides electric isolation of two parts at different voltages. To accomplish this, an insulator must meet two primary requirements: it must have an electrical resistivity and a dielectric strength sufficiently high for the given application. The secondary requirements relate to thermal and mechanical properties. Occasionally, tertiary requirements relating to dielectric loss and dielectric constant must also be observed. A complementary requirement is that the required properties not deteriorate in a given environment and desired lifetime. See CONDUCTOR (ELECTRICITY).

Electric insulation is generally a vital factor in both the technical and economic feasibility of complex power and electronic systems. The generation and transmission of electric power depend critically upon the performance of electric insulation, and now plays an even more crucial role because of the energy shortage.

**Requirements.** The important requirements for good insulation are as follows.

The basic difference between a conductor and a dielectric is that free charge has high mobility on and in a conductor, whereas free charge has little or no mobility on or in a dielectric. Dielectric strength is a measure of the electric stress required to abruptly move substantial charge on or through a dielectric. It deteriorates with the ingress of water and with elevated temperature. For high-voltage (on the order of kilovolts) applications, dielectric strength is the most important single property of the insulation. See DIELECTRIC MATERIALS.

Resistivity is a measure of how much current will be drained away from the conductor through the bulk or along the surface of the dielectric. An insulator with resistivity equal to or greater than  $10^{13}$  ohm-cm may be considered good. See ELECTRICAL RESISTIVITY.

When a dielectric is subjected to an alternating field, a time-varying polarization of the atoms and molecules in the dielectric is produced. The alternation of both the permanent and induced polarization in the dielectric results in power dissipation within the dielectric of which the power factor is a measure. This dielectric power loss is proportional to the product of the dielectric constant and the square of the electric field in the dielectric. Although it may be a loss that is small relative to other losses in most ambient-temperature applications, and even though it generally decreases at low temperatures, it is a relatively important loss for dielectrics to be used at cryogenic temperatures.

The dielectric constant, also known as the relative permittivity or specific inductive capacity, is a measure of the ability of the dielectric to become polarized, taken as the ratio of the charge required to bring the system to the same voltage level relative to the charge required if the dielectric were vacuum. It is thus a pure number, but is in fact not a constant, and may vary with temperature, frequency, and electric-field intensity.

In addition to the problem of intensification of the electric field in regions of relatively lower dielectric constant, a low-dielectric-constant insulation is desirable for two more compelling reasons. In ac transmission cables, the lower the dielectric constant, the more the current and the voltage will be in phase. This means that more usable power will be delivered, without the need for reactive compensation. Furthermore, in reducing the charging current (which is proportional to the dielectric constant), concomitant power losses (related to the square of the charging current) are also reduced. A high dielectric constant is desirable in capacitors, since the capacitance is proportional to it. See CAPACITANCE.

**Properties.** All insulators may be classified as either solid or fluid. Solid insulation is further divided into flexible and rigid types.

**Solid insulation.** Flexible hydrocarbon insulation is generally either thermoplastic or thermosetting. Thermosets are initially soft, and can be extruded by using only pressure. Following heat treatment, when they return to ambient temperature, they are tougher and harder. After thermosetting, nonrubber thermosets are harder, stronger, and have more dimensional stability than the thermoplastics. Thermoplastics are softened by heating, and when cool become hard again. They are heat-extruded.

Cellulose paper insulation is neither thermoplastic nor thermosetting. It is widely used in cables and rotating machinery in multilayers and impregnated with oil. It has a relatively high dielectric loss that hardly decreases with decreasing temperature, which rules it out for cryogenic applications. Because of its high dielectric strength, the high loss has not been a deterrent to its use in conventional ambient-temperature applications. However, the high dielectric strength deteriorates quickly if moisture permeates the paper.

Rigid insulation includes glass, mica, epoxies, ceramoplastics, porcelain, alumina, and other ceramics. Rather than being used to insulate wires and cables, except for mica, these materials are used in equipment terminations (potheads) and as support insulators (in tension or compression) for overhead lines whose primary dielectric is air. These rigid structures must be shock-resistant, be relatively water-impervious, and be able to endure corona discharges over their surfaces.

**Fluid insulation.** Liquids, gases, and vacuum fall in the category of fluid insulation. For all of these, the electrical structure must be such as to contain the fluid in the regions of high electric stress.

The main types of insulating liquids are the mineral oils, silicones, chlorinated hydrocarbons, and the fluorocarbons with dielectric strengths on the order of megavolts per centimeter. Many other liquids also have good dielectric strength, such as carbon tetrachloride, toluene, hexane, benzene, chlorobenzene, alcohol, and even deionized water.

Most gases have a dielectric constant of about 1, and low dielectric loss. Air is used as a dielectric in a wide variety of applications, ranging from electronics to high-voltage (765-kV) and high-power (2000-MW) electric transmission lines. Dry air is a reasonably good insulator. However, its dielectric strength decreases with increasing gap.

Vacuum (that is, pressures of less than  $10^{-5}$  torr or  $10^{-3}$  pascal) has one of the highest dielectric strengths in the gap ranging 0.1 to 1 mm. However, as the gap increases, its dielectric strength decreases rapidly. A perfect vacuum might be expected to be a perfect insulator, since there would be no charge carriers present to contribute to electrical conductance. That this is not so in practice arises because of the effects of a high electric field

or high voltage at the surface of electrodes in vacuum, rather than because a perfect vacuum is far from being realized in the laboratory. The dielectric properties of vacuum can degenerate rapidly because vacuum offers no resistance to the motion of charge carriers, once they are introduced into the vacuum region. [M.R.]

**Electrical interference** Disturbance to the normal or expected operation of electrical or electronic devices, equipment, and systems. Electrical interference is sometimes called radio-frequency interference (RFI) or electromagnetic interference (EMI). Electrical noise is a broader term that includes those phenomena that are generally termed electrical interference, but also includes naturally occurring currents or voltages that are more or less continuous and cannot be completely eliminated.

Electrical interference originates from one or more of the following: transmitters such as those used for broadcast, communication, radar, and navigation; artificial incidental emission sources such as from sparking of motor brushes, automotive ignition, and fluorescent lamps; and natural phenomena such as lightning and electrostatic discharges. The interference emissions may be radiated through space or conducted along the paths of electrical wires in power lines and signal cables. See COMMUNICATIONS CABLE; ELECTROMAGNETIC RADIATION; TRANSMISSION LINES.

There are several means of mitigating electrical interference, including grounding, bonding, shielding, filtering, and transient control. There are two major approaches. One is to reduce radiation from boxes, cabinets, racks, and consoles by the design of multilayer printed circuit boards and backplanes, or to use metal or metallized plastic cases with EMI-protected apertures. The other involves reduction of radiation to or from the interconnecting cable by using filter pin connectors or foil-wrap shields terminated with complete coverage by the connector backshell at the respective box bulkhead. See BONDING; ELECTRIC FILTER; ELECTRIC TRANSIENT; ELECTRICAL NOISE; ELECTRICAL SHIELDING; ELECTROMAGNETIC COMPATIBILITY. [D.R.J.W.]

**Electrical loading** The connection of a specific circuit (called the load) to another circuit. Illustration *a* shows a source of electrical energy (*S*), a coupling circuit (*C*), and a load (*L*). In power transmission, *S* is the generator of the power plant, *C* represents the connecting transmission lines and transformers, and *L* is, for instance, a household with its electrical appliances. The entire system operates to supply the load demand of *L*, that is, the electrical energy required by the load. In a high-fidelity sound system, *S* is the output of the phonograph cartridge or the tape playback head, *C* is the amplifier, and *L* is the coil of the loudspeaker. See ELECTRIC POWER SYSTEMS; SOUND-REPRODUCING SYSTEMS.

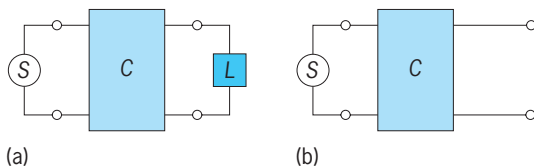

Systems (a) under load and (b) under no load.

When the load is disconnected, the system operates under no-load conditions (illus. *b*).

Loading is used in certain wire-line transmissions in order to improve their characteristics. This is often done by connecting loading inductors along telephone lines, or along certain data transmission circuits. These inductors reduce the attenuation of the line, thus improving the transmission of signals. Waveguides, special antennas, and coaxial cables are often loaded with specific circuits to achieve specific purposes. See ANTENNA (ELECTROMAGNETISM); COAXIAL CABLE; INDUCTOR; TRANSMISSION LINES; WAVEGUIDE. [S.Kar.]

**Electrical measurements** Measurements of the many quantities by which the behavior of electricity is characterized. Measurements of electrical quantities extend over a wide dynamic range and frequencies ranging from 0 to  $10^{12}$  Hz. The International System of Units (SI) is in universal use for all electrical measurements. Electrical measurements are ultimately based on comparisons with realizations, that is, reference standards, of the various SI units. These reference standards are maintained by the National Institute of Standards and Technology in the United States, and by the national standards laboratories of many other countries. See ELECTRICAL UNITS AND STANDARDS.

Direct-current (dc) measurements include measurements of resistance, voltage, and current in circuits in which a steady current is maintained. Resistance is defined as the ratio of voltage to current. For many conductors this ratio is nearly constant, but depends to a varying extent on temperature, voltage, and other environmental conditions. The best standard resistors are made from wires of special alloys chosen for low dependence on temperature and for stability.

The SI unit of resistance, the ohm, is realized by means of a quantized Hall resistance standard. This is based upon the value of the ratio of fundamental constants  $h/e^2$ , where  $h$  is Planck's constant and  $e$  is the charge of the electron, and does not vary with time. See HALL EFFECT.

The principal instruments for accurate resistance measurement are bridges derived from the basic four-arm Wheatstone bridge, and resistance boxes. Many multirange digital electronic instruments measure resistance potentiometrically, that is, by measuring the voltage drop across the terminals to which the resistor is connected when a known current is passed through them. The current is then defined by the voltage drop across an internal reference resistor. For high values of resistance, above a megohm, an alternative technique is to measure the integrated current into a capacitor (over a suitably defined time interval) by measuring the final capacitor voltage. Both methods are capable of considerable refinement and extension. See ELECTRICAL RESISTANCE; HALL EFFECT; OHMMETER; RESISTANCE MEASUREMENT; WHEATSTONE BRIDGE.

The SI unit of voltage, the volt, is realized by using arrays of Josephson junctions. This standard is based on frequency and the ratio of fundamental constants  $e/h$ , so the accuracy is limited by the measurement of frequency. Josephson arrays can produce voltages between  $200 \mu\text{V}$  and 10 V. At the highest levels of accuracy, higher voltages are measured potentiometrically, by using a null detector to compare the measured voltage against the voltage drop across a tapping of a resistive divider, which is standardized (in principle) against a standard cell. See JOSEPHSON EFFECT.

The Zener diode reference standard is the basis for most commercial voltage measuring instruments, voltage standards, and voltage calibrators. The relative insensitivity to vibration and other environmental and transportation effects makes the diodes particularly useful as transfer standards. Under favorable conditions these devices are stable to a few parts per million per year.

Most dc digital voltmeters, which are the instruments in widest use for voltage measurement, are essentially analog-to-digital converters which are standardized by reference to their built-in reference diodes. The basic range in most digital voltmeters is between 1 and 10 V, near the reference voltage. Other ranges are provided by means of resistive dividers, or amplifiers in which gain is stabilized by feedback resistance ratios. In this way these instruments provide measurements over the approximate range from 10 nanovolts to 10 kV. See DIGITAL-TO-ANALOG CONVERTER; MICROPROCESSOR; VOLTAGE MEASUREMENT; VOLTMETER; ZENER DIODE.

The most accurate measurements of direct currents less than about 1 A are made by measuring the voltage across the potential terminals of a resistor when the current is passed through it. Higher currents, up to about 50 kA, are best measured by means of a dc current comparator, which accurately provides the ratio

of the high current to a much lower one which is measured as above. At lower accuracies, resistive shunts may be used up to about 5000 A, but the effective calibration of such shunts is a difficult process. See CURRENT COMPARATOR; CURRENT MEASUREMENT.

Alternating-current (ac) voltages are established with reference to the dc voltage standards by the use of thermal converters. These are small devices, usually in an evacuated glass envelope, in which the temperature rise of a small heater is compared by means of a thermocouple when the heater is operated sequentially by an alternating voltage and by a reference (dc) voltage. Resistors, which have been independently established to be free from variation with frequency, permit direct measurement of power frequency voltages up to about 1 kV. Greater accuracy is provided by multijunction (thermocouple) thermal converters, although these are much more difficult and expensive to make. Improvements in digital electronics have led to alternative approaches to ac measurement. For example, a line frequency waveform may be analyzed by using fast sample-and-hold circuits and, in principle, be calibrated relative to a dc reference standard. Also, electronic root-mean-square detectors may now be used instead of thermal converters as the basis of measuring instruments. See NONSINUSOIDAL WAVEFORM; THERMAL CONVERTERS.

Voltages above a few hundred volts are usually measured by means of a voltage transformer, which is an accurately wound transformer operating under lightly loaded conditions.

The principal instrument for the comparison and generation of variable alternating voltages below about 1 kV is the inductive voltage divider, a very accurate and stable device. They are widely used as the variable elements in bridges or measurement systems. See INDUCTIVE VOLTAGE DIVIDER.

Alternating currents of less than a few amperes are measured by the voltage drop across a resistor, whose phase angle has been established as adequately small by bridge methods. Higher currents are usually measured through the use of current transformers, which are carefully constructed (often toroidal) transformers operating under near-short-circuited conditions. The performance of a current transformer is established by calibration against an ac current comparator, which establishes precise current ratios by the injection of compensating currents to give an exact flux balance. See INSTRUMENT TRANSFORMER.

Commercial instruments for measurement of ac quantities are usually dc measuring instruments, giving a reading of the voltage obtained from some form of ac-dc transducer. This may be a thermal converter, or a series of diodes arranged to have a square-law response, in which case the indication is substantially the root-mean-square value. Some lower-grade instruments measure the value of the rectified signal, which is usually more nearly related to the peak value.

There has been a noticeable trend toward the use of automated measurement systems for electrical measurements, facilitated by the readiness with which modern digital electronic instruments may be interfaced with computers. Many of these instruments have built-in microprocessors, which improve their convenience in use, accuracy, and reliability. For power measurements, see ELECTRIC POWER MEASUREMENT; ELECTRICAL ENERGY MEASUREMENT; WATT-HOUR METER; WATTMETER. For measurements at frequencies above about 300 MHz, see MICROWAVE MEASUREMENTS.

[R.G.Jon.; O.C.J.]

**Electrical model** A mathematical description or electrical equivalent circuit that represents the behavior of a device or system. Models for complex systems are often represented by networks of models for simpler electrical devices such as resistors, capacitors, transistors, and transformers. By using analogies between current or voltage and other physical parameters, equivalent circuits can also be used to analyze thermal, mechanical, magnetic, and acoustic systems. A recurring

issue in development and in application of models is the use of simplifying assumptions to allow a compromise between accuracy and complexity. A hierarchy of models often exists, ranging from highly accurate but complex physics-based nonlinear time-domain computer models to linear equivalent-circuit models suitable for hand calculation. The best model for a particular application is the simplest one that predicts the relevant behavior with acceptable accuracy. See EQUIVALENT CIRCUIT.

Electrical models can be divided into two categories: nonlinear, large-signal and linear, small-signal models. Each of these can be further divided into time-invariant and time- or frequency-dependent categories.

**Large-signal models.** These are usually derived by applying physical laws to generalized devices. This leads to a system of differential equations whose solution comprises the model. Such physically derived models are often highly complex, requiring lengthy computer solutions. An alternative approach is empirical modeling, in which a simple mathematical form is assumed for the model, with key physical parameters being determined by measurements on representative devices. See DIFFERENTIAL EQUATION.

There are two main application areas for large-signal models. One is to find the response of a system to time-varying inputs. The other is to determine the voltages and currents of a circuit with zero input variations, as a preliminary to small-signal analysis.

**Small-signal modeling.** In many applications, current and voltage variations are small enough that the device's characteristics are approximately independent of signal size. This allows the device to be represented by a simplified linear equivalent circuit. To find the values of the equivalent circuit's elements, the input signal is replaced with its average value, and all currents and voltages are found by using the large-signal model. The results represent the quiescent operating point or Q point for the circuit. All currents and voltages can be approximated by series expansions around the Q point.

Linearity has several benefits. One is the applicability of systematic solution methods for linear circuits that simplify both manual and computer solutions. Linearity also allows superposition: a linear system's response to the sum of two inputs equals the sum of its responses to the inputs applied separately. An important consequence of superposition is that the system is completely specified by its response to sinusoids of arbitrary frequency. This frequency response determines the output spectrum for arbitrary inputs. Linear circuits can be analyzed entirely in the frequency domain. See CIRCUIT (ELECTRONICS); GAIN; LINEARITY; RESPONSE; SUPERPOSITION THEOREM (ELECTRIC NETWORKS).

[R.M.Fo.]

**Electrical noise** Interfering and unwanted currents or voltages in an electrical device or system. Electrical noise, or simply noise, has a significant effect on the design and operation of almost all electrical and optical systems which are used to communicate or process information. Noise is responsible for the familiar static observed on home radio receivers, the clicking sounds on frequency-modulation (FM) radios operating in fringe (near-threshold) areas, and the "snow"-type granularity on the viewing screen of a television receiver displaying a weak signal. In general, noise provides the fundamental limitation to the range over which radio or optical signals can be transmitted and received with integrity. Noise is, therefore, of great importance to the engineers who design and operate such systems.

It is convenient to differentiate between noise which results from human activity and that which is naturally occurring. Noise which results from human activity, such as that generated by an electrical appliance or an automotive ignition, can usually be eliminated or minimized by good design practice (shielding, filtering, equipment location, and so forth). Naturally occurring noise can be further subdivided into that which is irregular or erratic in nature and that which is more or less continuous.



An example of noise which is irregular or erratic is that associated with an electrical storm. This type of noise is sometimes dealt with in the system design, but since it is only occasionally present, it does not ordinarily constitute a design limitation. On the other hand, naturally occurring noise which is essentially continuous in time is responsible for the fundamental limitation cited above. The remainder of the article therefore concentrates on this type of noise. See ATMOSPHERIC ELECTRICITY; CROSSTALK; ELECTRIC FILTER; ELECTRICAL INTERFERENCE; ELECTRICAL SHIELDING; ELECTROMAGNETIC COMPATIBILITY; ELECTRONIC EQUIPMENT GROUNDING; GROUNDING; STATIC.

Most noise generation is a consequence of the spontaneous fluctuations which occur within matter at the microscopic level. In electrical circuits these fluctuations give rise to what are commonly referred to as thermal noise and shot noise. Thermal noise is generated by the random motion of free electrons in a resistor or any conductor with resistance. The random motion, and thus the noise generated, is proportional to the temperature of the medium. At absolute zero temperature on the Kelvin scale ( $-459.67^{\circ}\text{F}$ ), all motion ceases and no noise is generated. Shot noise is most commonly identified with the fluctuations in the current of a vacuum tube caused by the random emission of electrons from its heated cathode. Shot noise is also observed in semiconductor devices as random fluctuations in carrier density when an electric field is applied. There are other types of noise associated with electrical circuits, but shot noise and thermal noise are by far the most important. See FREE-ELECTRON THEORY OF METALS; KINETIC THEORY OF MATTER; SEMICONDUCTOR; VACUUM TUBE.

In a system in which signals are transmitted through the atmosphere [for example, amplitude-modulation (AM) or FM radio broadcast, or satellite communications], the receiving system will always receive noise as well as the desired signals. This noise is a result of thermal radiation from the Earth, planets, Sun, Moon, the galaxy (galactic noise), radio-emitting stars, and atmospheric gases. In addition, there is a small background level of thermal radiation, uniformly distributed, which is believed associated with the big bang origin of the universe. All of these noise sources, weighted by the directional characteristics of the receiving antenna, will contribute to the overall system noise. See COSMIC BACKGROUND RADIATION; HEAT RADIATION; TERRESTRIAL RADIATION.

In an optical communications system, a signal level is represented by a number of energy packets called photons. The mean arrival rate of the photons at the detector is proportional to the optical intensity or signal strength. At the detector (a photodiode), the photons are absorbed, each creating a hole-electron pair and thus a current in which the electrons are randomly positioned in time and in which the mean number of electrons is proportional to the optical intensity. The statistical nature of this process gives rise to fluctuations in the number of photons representative of a given level and, subsequently, the number of electrons generated to represent that level. If the detector has internal gain as in an avalanche photodiode, each hole-electron pair can create additional hole-electron pairs. This process, however, is statistical in nature, resulting in a mean value of gain but giving rise to additional fluctuations in the generated current. See MICROWAVE SOLID-STATE DEVICES; OPTICAL COMMUNICATIONS; OPTICAL DETECTORS; PHOTODIODE; PHOTON. [R.W.K.]

**Electrical noise generator** A device that produces electrical noise for use in electrical measurements. Electrical noise generators are commonly employed to measure the noise figure or noise temperature of radio receivers. They are also used in various other tests in radar and communications systems. Celestial noise sources are used to calibrate large antennas.

Some standard types of noise generators are hot-wire, diode, gas-discharge tube, hot and cold loads (terminations), and radio-star. A hot-wire noise source consists of the filament of a lamp heated by direct current. Thermal noise having spectral density  $4 kTR$ , where  $k$  is Boltzmann's constant and  $T$  and  $R$  are the

temperature and resistance of the filament respectively, is generated across the terminals of the filament. A diode noise generator utilizes the temperature-limited shot effect to generate noise. At frequencies less than the reciprocal transit time of the diode, the noise spectral density is  $2e\bar{I}$ , where  $e$  is the charge on the electron and  $\bar{I}$  is the average anode current. A gas-discharge noise generator, commonly referred to as a noise tube, consists of a fluorescent light tube enclosed in a waveguide. Noise generation is essentially thermal. The noise tube is commonly employed at microwave frequencies. Hot and cold loads consist of well-matched terminations, either transmission line or waveguide, held at a given temperature by using an oven or by applying cryogenic refrigeration. Noise generation is thermal. Common temperatures for noise-generating terminations are nominally 80 and 300 K (minus 316 and plus  $80^{\circ}\text{F}$ ).

Celestial radio sources (radio stars) are commonly employed as reference noise sources for evaluating the characteristics of very low-noise, high-gain space communications receiving antennas. There are a number of accurately calibrated sources available—the choice depending on system parameters (frequency, antenna gain, system noise temperature, elevation angle, and so forth) and physical location. The most common radio sources employed are Cassiopeia A, Taurus A, Cygnus A, and Orion A. The first three are classified as nonthermal sources in which radiation results from relativistic electrons interacting with an interstellar magnetic field. The electrons are rotated in a plane perpendicular to the magnetic field direction, and radiation is characterized by a component polarized parallel to that plane. The polarized component is small, however, and the major portion of the radiation is unpolarized. The nonthermal sources have flux densities which decrease with increasing frequency and, consequently, tend to have a cutoff frequency above which they are not usable. Orion A is a thermal source in which radiation occurs from a hot, ionized cloud. Orion A has a constant flux density at frequencies above 2 GHz. As a point of reference, a typical value of thermal noise received from Cassiopeia A by a 10-m-diameter (33-ft) antenna operating in the C band (4–6 GHz) would be about 150 K (minus  $190^{\circ}\text{F}$ ). See ELECTRICAL NOISE; POLARIZED LIGHT; RADIO ASTRONOMY. [R.W.K.]

**Electrical resistance** Opposition of a circuit to the flow of electric current. Ohm's law states that the current  $I$  flowing in a circuit is proportional to the applied potential difference  $V$ . The constant of proportionality is defined as the resistance  $R$ . Hence, Eq. (1) holds. If  $V$  and  $I$  are measured in volts and

$$V = IR \quad (1)$$

amperes, respectively,  $R$  is measured in ohms. Microscopically, resistance is associated with the impedance to flow of charge carriers offered by the material. For example, in a metallic conductor the charge carriers are electrons moving in a polycrystalline material in which their journey is impeded by collisions with imperfections in the local crystal lattice, such as impurity atoms, vacancies, and dislocations. In these collisions the carriers lose energy to the crystal lattice, and thus Joule heat is liberated in the conductor, which rises in temperature. The Joule heat  $P$  is given by Eq. (2).

$$P = I^2R = IV = \frac{V^2}{R} \quad (2)$$

See CRYSTAL DEFECTS; ELECTRICAL CONDUCTIVITY OF METALS; ELECTRICAL RESISTIVITY; JOULE'S LAW; OHM'S LAW. [P.A.S.]

**Electrical resistivity** The electrical resistance offered by a homogeneous unit cube of material to the flow of a direct current of uniform density between opposite faces of the cube. Also called specific resistance, it is an intrinsic, bulk (not thin-film) property of a material. Resistivity is usually determined by calculation from the measurement of electrical resistance of samples

having a known length and uniform cross section according to the following equation, where  $\rho$  is the resistivity,  $R$  the measured resistance,  $A$  the cross-sectional area, and  $l$  the length. In the mks system (SI), the unit of resistivity is the ohm-meter. Therefore, in the equation below, resistance is expressed in ohms, and the sample dimensions in meters.

$$\rho = RA/l$$

The room-temperature resistivity of pure metals extends from approximately  $1.5 \times 10^{-8}$  ohm-meter for silver, the best conductor, to  $135 \times 10^{-8}$  ohm-meter for manganese, the poorest pure metallic conductor. Most metallic alloys also fall within the same range. Insulators have resistivities within the approximate range of  $10^8$  to  $10^{16}$  ohm-meters. The resistivity of semiconductor materials, such as silicon and germanium, depends not only on the basic material but to a considerable extent on the type and amount of impurities in the base material. Large variations result from small changes in composition, particularly at very low concentrations of impurities. Values typically range from  $10^{-4}$  to  $10^5$  ohm-meters. See ELECTRICAL INSULATION; ELECTRICAL RESISTANCE; SEMICONDUCTOR.

The temperature coefficients (changes with temperature) of resistivity of pure metallic conductors are positive. Resistivity increases by about 0.4%/K at room temperature and is nearly proportional to the absolute temperature over wide temperature ranges. As the temperature is decreased toward absolute zero, resistivity decreases to a very low residual value for some metals. The resistivity of other metals abruptly changes to zero at some temperature above absolute zero, and they become superconductors.

Metals, and some semiconductors in particular, exhibit a change in resistivity when placed in a magnetic field. Theoretical relations to explain the observed phenomena have not been well developed. [C.E.A.]

**Electrical shielding** The imposition of a metal or composite barrier between one or more sources of electrical noise and their victims with the objective of reducing or eliminating electrical interference. Examples of the barrier are the case or housing of equipment; shields covering interconnecting cables between equipment; large cabinets, racks, or consoles; shielded (screen) rooms; and entire shielded buildings or vehicles.

The principal measure of a shield's performance is the shielding effectiveness. It is defined by the equation below, where  $SE_{dB}$

$$SE_{dB} = 20 \log_{10} \frac{F_b}{F_a}$$

is the shielding effectiveness in decibels,  $F_b$  is the electric (or magnetic) field strength before imposition of the barrier, and  $F_a$  is the electric (or magnetic) field strength after imposition of the barrier. See DECIBEL.

Shielding is obtained by the combination of reflection loss and absorption loss. The former is due to the impedance mismatch between the wave impedance of an oncoming wave and the surface impedance of the interposed barrier. Absorption loss corresponds to the attenuation due to skin effect at higher frequencies, and is dependent upon the frequency, conductivity, permeability, and thickness of the barrier. Shielding effectiveness is the sum of both losses. See ABSORPTION OF ELECTROMAGNETIC RADIATION; ATTENUATION (ELECTRICITY); RADAR-ABSORBING MATERIALS; REFLECTION AND TRANSMISSION COEFFICIENTS; REFLECTION OF ELECTROMAGNETIC RADIATION; SKIN EFFECT (ELECTRICITY).

Most intentional shields are made of metal to ensure high reflection losses. Even thin metals, such as household aluminum foils (with a thickness of about 1.5 mils or 0.038 mm), offer shielding effectiveness in excess of 100 dB. At low frequencies, these foils become electromagnetically transparent (that is, they do not attenuate magnetic fields). Thus, if there is a shielding problem due to the selection and makeup of the metal barrier, it is likely to occur only for low-frequency magnetic fields.

To obtain significant shielding to magnetic fields at low frequencies, the metal barrier must be very thick or composed of a highly permeable material such as Mumetal, Supermalloy, or Hypernom. Often such shields are fabricated in two or more layers, frequently laminated, to obtain good shielding properties per unit size or weight. See ELECTRICAL INTERFERENCE; ELECTRICAL NOISE. [D.R.J.W.]

**Electrical units and standards** The process of measurement consists in finding out how many times the quantity to be measured contains a fixed quantity of the same kind, called a unit. The definitions of the units often involve complex physical theory and do not lend themselves readily to practical realization. The concrete representations of units are known as measurement standards. In practice, measurements are made by using an instrument calibrated against a local reference standard, which itself has been calibrated either directly or by several links in a traceability chain against the national standard held by the national standards laboratory.

**Electrical and magnetic units.** A proposal by W. E. Weber in 1851 led to the absolute cgs system in which all units of quantities to be measured could be derived from the base units of length, mass, and time—the centimeter, gram, and second. This system was widely adopted although it had three weaknesses: the size of the units was inconvenient for practical use; it was difficult to realize the units from their definitions; and there were separate sets of units for electrostatic and electromagnetic quantities, based respectively on the inverse-square laws of force between electric charges and between magnetic poles.

**International units.** The first weakness was resolved by international agreement in 1881 to fix the practical units—the volt, the ohm, and the ampere—at  $10^8$ ,  $10^9$ , and 0.1 times the respective cgs electromagnetic units. The other weaknesses were avoided by the decisions of the 1908 International Congress in London, where realizations of these units in terms of easily reproducible standards were defined.

**The mksa units.** A more fundamental change resulted from a proposal by G. Giorgi in 1902. This led to the adoption of the mksa system of units, in which there are four base units: the meter, the kilogram, the second, and the ampere. Use of the meter and the kilogram instead of the centimeter and the gram gave units of a size more convenient for practical use, and use of the ampere as a base unit resolved the conflict between electrostatic and electromagnetic units while maintaining the magnitudes of the widely used practical units. This was a truly coherent system, in the sense that other units were derived from the base units without the need for factors of proportionality other than unity.

**SI units.** From the mksa system the present-day SI (Système International), formally adopted in 1954, has developed, by the addition of further base units to include other fields of measurement. The seven base units of SI are the kilogram (kg; mass); second (s; time); meter (m; length); ampere (A; electric current); kelvin (K; thermodynamic temperature); candela (cd; luminous intensity); and mole (m; amount of substance). The units of other physical quantities (derived units) are derived from the base units by simple numerical relations.

The SI base unit for electrical measurements is the ampere (A), the unit of electric current. It is defined in terms of a hypothetical experiment as that constant current which, if maintained in two straight parallel conductors of infinite length, of negligible circular cross section, and placed 1 meter apart in vacuum, would produce between these conductors a force equal to  $2 \times 10^{-7}$  newton per meter of length.

The volt (V) is the unit of potential difference and of electromotive force. It is defined as the potential difference between two points of a conducting wire carrying a constant current of 1 ampere when the power dissipated between these points is equal to 1 watt. From the ampere and the volt, the ohm is derived by Ohm's law, and the other derived quantities follow in a similar

manner by the application of known physical laws. See OHM'S LAW.

The remaining units of electrical and magnetic quantities are:

**Coulomb (C):** The unit of electric charge, equal to 1 ampere-second. The coulomb is the quantity of electricity carried in 1 second by a current of 1 ampere.

**Farad (F):** The unit of capacitance, equal to 1 coulomb per volt. The farad is the capacitance of a capacitor between the plates of which there appears a potential difference of 1 volt when it is charged by a quantity of electricity of 1 coulomb.

**Henry (H):** The unit of inductance, equal to 1 weber per ampere. The henry is the inductance of a closed circuit in which an electromotive force of 1 volt is produced when the electric current in the circuit varies uniformly at the rate of 1 ampere per second.

**Ohm ( $\Omega$ ):** The unit of electrical resistance, equal to 1 volt per ampere. The ohm is defined as the resistance between two points of a conductor when a constant potential difference of 1 volt, applied to these points, produces in the conductor a current of 1 ampere, the conductor not being the seat of any electromotive force.

**Siemens (S):** The unit of electrical conductance (the reciprocal of resistance), equal to 1 ampere per volt. It was formerly known as the mho.

**Tesla (T):** The unit of magnetic flux density, equal to 1 weber per square meter.

**Weber (Wb):** The unit of magnetic flux, equal to 1 volt-second. The weber is the magnetic flux which, linking a circuit of one turn, would produce in it an electromotive force of 1 volt if it were reduced to zero at a uniform rate in 1 second.

The mechanical units of frequency (hertz), energy or work (joule), and power (watt) are frequently involved in expressing electrical and magnetic quantities. The cgs units, such as the gauss, gilbert, maxwell, and oersted, formerly used, are not part of the SI and are now obsolete. See UNITS OF MEASUREMENT.

**Electrical standards.** Realization of the values of the electrical and other units from their SI definitions involves great experimental difficulties. For this reason, it is customary for national standards laboratories to maintain stable primary standards of the units against which other reference standards can be compared. From time to time, absolute determinations of the values of these primary standards are made in terms of their definitions. By the late 1980s, the Josephson effect and the quantum Hall effect had made possible the standardization of the volt and the ohm by relation to fundamental physical constants. The recommendation by the CCE of the values to be adopted for these constants in 1990 led to a complete change in primary electrical standards and the method of handling them; and all the major national laboratories, and the BIPM, now use this method. See FUNDAMENTAL CONSTANTS; HALL EFFECT; JOSEPHSON EFFECT.

For many years the primary standards maintained by most laboratories were the volt, in terms of the mean electromotive force of a group of Weston cells, and the ohm, using a group of standard resistors. A range of reference standards of other quantities are derived from these, including direct-current (dc) voltage and resistance at a variety of levels; alternating-current (ac) voltage, resistance, and power; capacitance and inductance; radio-frequency (rf) and microwave quantities; magnetic quantities and properties of materials; dielectric properties; and other quantities. These secondary standards are used for day-to-day measurements and for the calibration of local reference standards of other users in the national measurement system. See CAPACITANCE MEASUREMENT; ELECTRIC POWER MEASUREMENT; INDUCTANCE MEASUREMENT; MAGNETIC MATERIALS; MICROWAVE MEASUREMENTS; PERMITTIVITY; RESISTANCE MEASUREMENT; VOLTAGE MEASUREMENT.

[A.E.Ba.]

**Electricity** Physical phenomena involving electric charges, their motions, and their effects. The motion of a charge is affected by its interaction with the electric field and, for a

moving charge, the magnetic field. The electric field acting on a charge arises from the presence of other charges and from a time-varying magnetic field. The magnetic field acting on a moving charge arises from the motion of other charges and from a time-varying electric field. Thus electricity and magnetism are ultimately inextricably linked. In many cases, however, one aspect may dominate, and the separation is meaningful. See ELECTRIC CHARGE; ELECTRIC FIELD; MAGNETISM.

The quantitative development of electricity began late in the eighteenth century. J. B. Priestley in 1767 and C. A. Coulomb in 1785 discovered independently the inverse-square law for stationary charges. This law serves as a foundation for electrostatics. See COULOMB'S LAW; ELECTROSTATICS.

In 1800 A. Volta constructed and experimented with the voltaic pile, the predecessor of modern batteries. It provided the first continuous source of electricity. In 1820 H. C. Oersted demonstrated magnetic effects arising from electric currents. The production of induced electric currents by changing magnetic fields was demonstrated by M. Faraday in 1831. In 1851 he also proposed giving physical reality to the concept of lines of force. This was the first step in the direction of shifting the emphasis away from the charges and onto the associated fields. See ELECTROMAGNETIC INDUCTION; ELECTROMAGNETISM; LINES OF FORCE.

In 1865 J. C. Maxwell presented his mathematical theory of the electromagnetic field. This theory, which proposed a continuous electric fluid, not only synthesized a unified theory of electricity and magnetism, but also showed optics to be a branch of electromagnetism. See ELECTROMAGNETIC RADIATION; MAXWELL'S EQUATIONS.

The developments of theories about electricity subsequent to Maxwell have all been concerned with the microscopic realm. Faraday's experiments on electrolysis in 1833 had indicated a natural unit of electric charge, thus pointing toward a discrete rather than continuous charge. The existence of electrons, negatively charged particles, was postulated by A. Lorenz in 1895 and demonstrated by J. J. Thomson in 1897. The existence of positively charged particles (protons) was shown shortly afterward (1898) by W. Wien. Since that time, many particles have been found having charges numerically equal to that of the electron. The question of the fundamental nature of these particles remains unsolved, but the concept of a single elementary charge unit is apparently still valid. See BARYON; ELECTROLYSIS; ELECTRON; ELEMENTARY PARTICLE; HYPERON; MESON; PROTON; QUARKS.

The sources of electricity in modern technology depend strongly on the application for which they are intended.

The principal use of static electricity today is in the production of high electric fields. Such fields are used in industry for testing the ability of components such as insulators and condensers to withstand high voltages, and as accelerating fields for charged-particle accelerators. The principal source of such fields today is the Van de Graaff generator. See PARTICLE ACCELERATOR.

The major use of electricity arises in devices using direct current and low-frequency alternating current. The use of alternating current, introduced by S. Z. de Ferranti in 1885–1890, allows power transmission over long distances at very high voltages with a resulting low-percentage power loss followed by highly efficient conversion to lower voltages for the consumer through the use of transformers. See ALTERNATING CURRENT; ELECTRIC CURRENT.

Large amounts of direct current are used in the electrodeposition of metals, both in plating and in metal production, for example, in the reduction of aluminum ore. See DIRECT CURRENT; ELECTROCHEMISTRY; ELECTROMETALLURGY; ELECTROPLATING OF METALS.

The principal sources of low-frequency electricity are generators based on the motion of a conducting medium through a magnetic field. The moving charges interact with the magnetic field to give a charge motion that is normal to both the direction of motion and the magnetic field. In the most common form, conducting wire coils rotate in an applied magnetic field. The rotational power is derived from a water-driven turbine in the

case of hydroelectric generation, or from a gas-driven turbine or reciprocating engine in other cases. See ALTERNATING-CURRENT GENERATOR; DIRECT-CURRENT GENERATOR; ELECTRIC POWER GENERATION; GENERATOR.

Many high-frequency devices, such as communications equipment, television, and radar, involve the consumption of only moderate amounts of power, generally derived from low-frequency sources. If the power requirements are moderate and portability is needed, the use of ordinary chemical batteries is possible. Ion-permeable membrane batteries are a later development in this line. Fuel cells, particularly hydrogen-oxygen systems, are being developed. They have already found extensive application in earth satellite and other space systems. The successful use of thermoelectric generators based on the Seebeck effect in semiconductors has been reported. See BATTERY; FUEL CELL; ION-SELECTIVE MEMBRANES AND ELECTRODES; THERMOELECTRIC POWER GENERATOR; THERMOELECTRICITY.

The solar battery, also a semiconductor device, has been used to provide charging current for storage batteries in telephone service and in communications equipment in artificial satellites. See SOLAR CELL.

Direct conversion of mechanical energy into electrical energy is possible by utilizing the phenomena of piezoelectricity and magnetostriction. These have some application in acoustics and stress measurements. Pyroelectricity is a thermodynamic corollary of piezoelectricity. See MAGNETOSTRICTION; PIEZOELECTRICITY; PYROELECTRICITY. [W.Ar.]

**Electrochemical equivalent** The mass of a substance, according to Faraday's law, produced or consumed by electrolysis with 100% current efficiency during the flow of a quantity of electricity equal to 1 faraday or 96,487 coulombs (1 coulomb corresponds to a current of 1 ampere during 1 second). Electrochemical equivalents are essential in the calculation of the current efficiency of an electrode process.

The electrochemical equivalent of a substance is equal to the gram-atomic or gram-molecular mass of this substance divided by the number of electrons involved in the electrode reaction. For example, the electrochemical equivalent of zinc, for which two electrons are required in order to deposit one atom, is  $Zn/2$  or 65.37/2 g. Thus, the faraday is equal to the product of the charge of the electron times the number of electrons (the Avogadro number) required to react with 1 atom- or molecule-equivalent of substance. See COULOMETER; ELECTROLYSIS. [P.De.]

**Electrochemical process** The principles of electrochemistry may be adapted for use in the preparation of commercially important quantities of certain substances, both inorganic and organic in nature. See ELECTROCHEMISTRY.

**Inorganic processes.** Inorganic chemical processes can be classified as electrolytic, electrothermic, and miscellaneous processes including electric discharge through gases and separation by electrical means. In electrolytic processes, chemical and electrical energy are interchanged. Current passed through an electrolytic cell causes chemical reactions at the electrodes. Voltaic cells convert chemicals into electricity. Electrothermic processes use electricity to attain the necessary temperature for reaction. For related information see ELECTROCHEMISTRY; ELECTROLYSIS; ELECTROLYTIC CONDUCTANCE; ELECTROMOTIVE FORCE (CELLS).

**Electrolysis in aqueous solutions.** The electrolysis of water to form hydrogen and oxygen, according to the reaction  $2H_2O \rightarrow 2H_2 + O_2$ , may be considered as the simplest process for aqueous electrolytes. It does not compete with hydrogen from propane or from natural gas and with oxygen from liquid air, except in small installations. While simplicity, high hydrogen purity requirement, and lower capital cost (in small plants) have justified electrolytic plants, severely rising energy costs have limited such applications. Heavy water, or deuterium oxide, used in moderating nuclear reactors is also a by-product of the electrolysis of water. See DEUTERIUM; HEAVY WATER; HYDROGEN; OXYGEN.

**Metallurgical applications.** Protective or decorative coatings on a base metal such as steel are obtained by electroplating. Plating may also be used to replace worn metal or to provide a wear-resistant surface. Electrogalvanizing is preferred over hot dipping for applying zinc to steel. Tin plate for containers is electrolytic. See ELECTROPLATING OF METALS; METAL COATINGS.

Electroforming is a method of forming or reproducing articles by electrodeposition. In contrast to electroplating, the product is removed from the base surface or mold. Electrodeposition of metal powders is used to produce particles in the 1- to 1000-micrometer range for use in powder metallurgy and metallic pigments. Electrolytic polishing of metals is accomplished by making the article anodic in an electrolyte of mixed acids. Electrolytic machining of metals is accomplished by making the metal part anodic in a suitable electrolyte. Electrorefining is a process for purifying metals and recovering their impurities, which at times are more valuable than the original metal. Electrowinning, sometimes termed aqueous electrometallurgy, involves processing of metallic ores by leaching solutions to obtain metal-containing electrolytes which can be processed with insoluble anodes and metal cathodes. See ELECTROMETALLURGY; ELECTROPOLISHING.

**Alkali-chlorine processes.** Electrolysis of alkali halides is the basis of the alkali-chlorine and chlorate industries. Chlorine,  $Cl_2$ , and caustic soda, NaOH (or caustic potash, KOH), are made by electrolysis of brine, a solution of sodium chloride, NaCl, in water. Hydrochloric acid electrolysis is of interest for recovery of chlorine from HCl resulting as a by-product from organic chlorinations. See CHLORINE.

**Oxidations and reductions.** These reactions occur in all cells, but in a narrower sense oxidation reactions are those in which oxygen or chlorine at the anode oxidizes some material to form a new compound; reduction reactions are those in which hydrogen, liberated at the cathode, reduces a material to a new product. There are no commercial applications of inorganic electrochemical reductions by this narrow definition.

**Ion-permeable membrane cells.** These utilize diaphragms made of ion-exchange resins. Cation-permeable membranes permit cations to pass through but not anions, whereas the reverse holds for anion-permeable membranes. Purification of sea water is the most important application. Salt has been recovered from sea water which has been concentrated in this way. See ION-SELECTIVE MEMBRANES AND ELECTRODES.

**Fused-salt electrolysis.** Aluminum, barium, beryllium, cerium and misch metal, fluorine, lithium, magnesium, sodium, molybdenum, thorium, titanium, uranium, and zirconium are obtained by electrolysis of fused salts, because water interferes with the desired reaction. Raw materials must all be purified before addition to fused-salt cells, because purification of the electrolyte is not economical as in aqueous electrolytes. Metalizing is a process of depositing a metal as an alloy on a substrate from a fused complex metal salt.

**Electrothermics.** The manufacture of many products requires temperatures higher than can be obtained by combustion methods. Electric heat can usually be developed at, or close to, the point where it is required, so that it is relatively quick. It permits easy control of the atmosphere for oxidizing, reducing, or neutral conditions.

Products of the electric furnace include iron and steel; ferroalloys; nonferrous metals and alloys; the exotic metals titanium, zirconium, hafnium, thorium, and uranium; and nonmetallic products such as calcium carbide, calcium cyanamide, sodium cyanide, silicon carbide, boron carbide, and graphite. See ELECTRIC FURNACE; PYROMETALLURGY.

Zone refining of metals for the electronics industry, such as silicon for diodes and transistors, is accomplished by induction melting of the metal in a narrow zone and slow movement of the molten zone in the metal ingot from one end to the other in an evacuated or inert gas-filled enclosure. Impurities move toward the end of the ingot. The operation is repeated until the desired purity is obtained. See ZONE REFINING.

**Electrodialysis.** This is the separation of low-molecular-weight electrolytes from aqueous solutions by migration of the electrolyte through semipermeable membranes in an electric field. It is used on an industrial scale for deashing starch hydrolyzates and whey, and in many municipalities for producing potable water from saline water. Its uses also include the concentration of liquid foods such as dairy products and citrus juices, the recovery of sulfite pulp waste and pickling acid, and the isolation of proteins. See COLLOID; DIALYSIS.

**Electrophoretic deposition.** This is the deposition of a non-conductive material in a finely divided state from a suspension in an inert medium. Electrophoresis is the migration of colloidal particles, which acquire positive or negative charges in an electric field. The process is useful in electropainting; for instance, electropainting of automobile bodies and other objects has now been adopted on a large scale. Rubber latex is an example of a negatively charged colloid which can be plated on an anode. Electronic components can be coated with inorganic salts, oxides, and ceramics suspended in organic media. See ELECTROPHORESIS.

**Electroendosmosis.** This is the movement of a liquid with respect to an immobilized colloid in an electric field. The process is used in the dehydration of peat, dye pastes, and clay. It is also used commercially for dewatering soils in mining, road building construction, and other civil engineering works.

**Electrostatic technique.** The deposition of charged particles from suspension in gases has many useful applications. The Cottrell electrostatic precipitator removes dusts and mists from gases. See DUST AND MIST COLLECTION; ELECTROSTATIC PRECIPITATOR.

Spray painting with a high voltage between the spray gun and the work is particularly effective in providing an even coating with an economical use of paint on irregular and open surfaces, such as a screen.

In xerography a sheet of plain paper is electrically sensitized in those areas corresponding to an original so that colored resin particles carrying an opposite charge are attracted and retained only on the sensitized areas, thus producing a visible image corresponding to the original.

Abrasive paper and cloth are coated with an adhesive and abrasive powders attracted to the base material in an electrostatic field. Pile fabrics can be produced in a similar manner, with the short fibers oriented by the electric field.

**Organic processes.** Organic electrochemistry was once regarded as a tantalizing area with many important laboratory achievements but few successes in commercial practice. This situation is changing, however, in that electroorganic processes are likely to prove commercially advantageous if they can fulfill either of two conditions: (1) performance under conditions of voltage corresponding thermodynamically to the conversion of an organic group to a reduced or oxidized group, with the cell products relatively easy to isolate and purify; (2) performance of a highly selective, specific technique to make an addition at a double bond, or to split a particular bond (for example, between carbon atoms 17 and 18 of a complex molecule having 25 carbon atoms).

Selectivity and specificity are highly important in electroorganic processes for the manufacture of complicated molecules of vitamins and hormones—as well as for the medicinal products whose action on pathogenic organisms is a function of their spatial arrangement, steric forms, and resonance.

The electrolytic approach can also be competitive for some low-cost, tonnage products. Here continuous processing is important, and only a single phase should be present, that is, a solution rather than an emulsion, dispersion, or mechanical mixture. Only for fairly valuable products is it practical to find a conducting solvent and then to engineer around it.

The electrolytic oxidation and reduction of organic compounds differ from the corresponding and more familiar inorganic reactions only in that organic reactions tend to be more complex and have low yields. The electrochemical principles are

precisely those of inorganic reactions, while the procedures for handling the chemicals are precisely those of organic chemistry.

[C.L.M.]

**Electrochemical series** A series in which the metals are listed in the order of their chemical reactivity, the most active at the top and the less reactive or more “noble” metals at the bottom. In a broader sense such an activity series need not be limited to the metals but may be carried on through the electronegative (nonmetallic) elements as well. See the table for a list of common elements.

Electrochemical series of the elements\*

Lithium	Li	Aluminum	Al	Molybdenum	Mo
Potassium	K	Titanium	Ti	Tin	Sn
Rubidium	Rb	Zirconium	Zr	Lead	Pb
Cesium	Cs	Manganese	Mn	Germanium	Ge
Radium	Ra	Vanadium	V	Tungsten	W
Barium	Ba	Niobium	Nb	<b>Hydrogen</b>	<b>H</b>
Strontium	Sr	Boron	B	Copper	Cu
Calcium	Ca	Silicon	Si	Mercury	Hg
Sodium	Na	Tantalum	Ta	Silver	Ag
Lanthanum	La	Zinc	Zn	Gold	Au
Cerium	Ce	Chromium	Cr	Rhodium	Rh
Magnesium	Mg	Gallium	Ga	Platinum	Pt
Scandium	Sc	Iron	Fe	Palladium	Pd
Plutonium	Pu	Cadmium	Cd	Bromine	Br
Thorium	Th	Indium	In	Chlorine	Cl
Beryllium	Be	Thallium	Tl	Oxygen	O
Uranium	U	Cobalt	Co	Fluorine	F
Hafnium	Hf	Nickel	Ni		

\*According to standard oxidation potentials  $E^\circ$  at 25°C (77°F).

The electrochemical series as it applies to metals was first established by laboratory experiments in which the purpose was to determine which metals would displace others from solutions of their salts. By exhaustive experiments it becomes possible to draw up a complete list in the order of chemical activity, in which the metals at the top of the list are those which are found to give up their electrons most readily (that is, are the most electropositive elements). Such a list is shown in the table, where lithium exhibits the most reactivity as a metal.

To obtain an accurate and reproducible activity series, it is best to use the electrode potential, or oxidation-reduction potential, which is defined as the voltage developed by a sample of pure metal immersed in a solution of one of its salts (at unit activity and at 25°C or 77°F) versus a hydrogen electrode immersed in hydrochloric or sulfuric acid of equivalent concentration. See ELECTROCHEMISTRY; ELECTRODE POTENTIAL; ELECTRONEGATIVITY; OXIDATION-REDUCTION. [E.G.Ro.]

**Electrochemical techniques** Experimental methods developed to study the physical and chemical phenomena associated with electron transfer at the interface of an electrode and solution. The objective is to obtain either analytical or fundamental information regarding electroactive species in solution. Fundamental electrode characteristics may be investigated also.

The physical and chemical phenomena important in electrode processes generally occur very close to the electrode surface (usually within a few micrometers). Mass transfer of species involved in an electrode process to and from the bulk of solution is one important aspect. Inclusion of a large excess of inert electrolyte in most electrochemical systems eliminates electrical migration as an important means of mass transfer for electroactive species, and only convection and diffusion are considered.

Important chemical aspects of electrode processes include the oxidation or reduction occurring as a result of electron transfer, and coupled chemical reactions. Coupled reactions are initiated by production or depletion of the primary products or reactants at the electrode surface. Identification of the nature and

mechanism of such coupled reactions is of particular importance in studies of electrode reactions of organic compounds, where multireaction cascades are often found to be initiated by electron transfer to or from an electrode.

The primary experimental variables involved in electrochemical techniques are the potential  $E$ , the current  $I$ , and the time  $t$ . Either the potential or current at the working electrode is controlled and the other observed as a function of time. The many ways in which either may be controlled give rise to a wide variety of controlled-potential or controlled-current techniques. In all such techniques it is necessary to specify whether mass transport of the electroactive species to the electrode is by convection or diffusion, since mathematical treatments of these two processes are quite different. Mass transport by convection is more efficient than diffusion by several orders of magnitude but is much more difficult to model mathematically.

The general scheme for electron transfer at an electrode in solution is shown in reaction (1), where  $O$  and  $R$  are the oxidized



and reduced forms of the electroactive species and  $n$  is the number of electrons transferred. When  $k_f$  and  $k_b$ , the rate constants for the forward and back reaction, respectively, are very fast and  $O$  and  $R$  are not involved in preceding or following chemical reactions, the system is called reversible and the Nernst equation (2) holds. In this relation  $E$  is the electrode potential,  $E^{\circ'}$  is the

$$E = E^{\circ'} + \frac{0.059}{n} \log \frac{C_O}{C_R} \quad (2)$$

formal standard potential for the redox couple, and  $C_O$  and  $C_R$  are concentrations at the electrode surface. In the following discussions, only reversible reduction processes will be considered, although oxidations are equally applicable. See ELECTROCHEMICAL PROCESS; ELECTRODE; ELECTRODE POTENTIAL; ELECTROLYSIS.

**Controlled potential.** A variety of methods of this type have been developed, depending on whether the electrode potential is held constant or varied during the experiment and on whether mass transport is by convection (stirring) or diffusion.

In constant potential with convection, known as controlled potential electrolysis, the electrode potential is held constant as the solution is stirred or the electrode is rotated at a constant rate. The current is controlled by the concentration of electroactive substance and the stirring rate. Complete conversion of the electroactive substance takes place at a first-order rate whose constant is determined by cell geometry and stirring efficiency. Under ideal circumstances, electrolysis is complete in a manner of minutes.

In constant potential with diffusion (chronoamperometry), when a reducing potential is imposed instantaneously on a stationary working electrode in quiescent solution, current will rise sharply and then decay as the electroactive species in the electrode vicinity is depleted by electrolysis. The magnitude of the current is proportional to the bulk concentration of electroactive species, and if the imposed potential is sufficiently negative of  $E^{\circ'}$ , the Nernst equation demands complete conversion to the reduced form. Under these conditions the current for this so-called potential-step experiment is diffusion-controlled and decays with  $1/t^{1/2}$ .

An important variant on this experiment is double-potential-step chronoamperometry, in which a second potential step is applied. During the initial step, electrolysis occurs, depleting the oxidized form  $O$ , but producing the reduced form  $R$  in the immediate vicinity of the electrode. If the potential is instantaneously switched back to the initial value after a time  $\tau$ , species  $R$  will be reoxidized. A wide dynamic range of rate constants can be measured by varying  $\tau$ .

**Variable potential.** Several procedures have been developed in this area. In linear sweep voltammetry (LSV), the po-

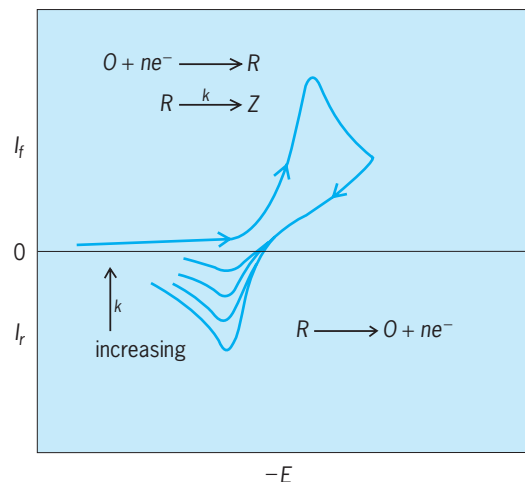

Current-voltage curves in cyclic voltammetry.

tential of a stationary electrode in quiescent solution is varied by applying a linear voltage ramp to the electrode. The resulting signal is recorded as a plot of current versus potential.

The most widely used electrochemical technique is cyclic voltammetry, which bears the same relation to linear sweep voltammetry as double-potential-step chronoamperometry does to the single-step experiment. That is, at the end of the first linear ramp, the potential is swept linearly back to the initial potential. Typical cyclic voltammograms are shown in illustration for the case of reduction of  $O$  to  $R$  and subsequent decomposition of  $R$  to  $Z$ . The illustration shows a series of cyclic voltammograms corresponding to different values of the rate constant  $k$ . As in the double-step experiment, the appearance of the forward sweep is unaffected by the coupled chemical process. However, as  $k$  increases, the height of the peak on the reverse sweep due to reoxidation of  $R$  decreases. Sweep rates may be varied over a range of roughly  $10^{-2}$  to  $10^2$  V/s in conventional cyclic voltammetry. With proper experimental design this may be extended considerably, as high as  $10^5$  V/s or greater by using microelectrodes (electrodes with diameters in the micrometer range).

**Controlled current.** Controlled current techniques, although easier to implement than those in which the potential is controlled, are not as selective and therefore have fallen out of favor in recent years. In chronopotentiometry, a constant current is imposed at the working electrode, and its potential is monitored with time. Coulostatic analysis involves application of a very large, short pulse of current to the electrode, after which the cell circuit is opened. The current pulse charges up the electrode-solution interface to a new potential, and the electrode discharges, and returns to its original potential, by reducing the electroactive species in solution. [A.J.Fr.]

**Electrochemistry** The science dealing with the chemical changes accompanying the passage of an electric current, or the reverse process in which a chemical reaction is used as the source of energy to produce an electric current, as in a battery. Ionic conduction in electrolytes (liquid solutions, molten salts, and certain ionically conductive solids) is a phase of electrochemistry. Conduction in metals, semiconductors, and gases is generally considered a portion of physics. Other aspects of electrochemistry are described below. See ELECTROLYTIC CONDUCTANCE.

**Galvanic cells.** These are better known as electric batteries. Many chemical reactions can be arranged to produce electrical energy by physically separating the reaction into two half-reactions, one supplying electrons to an electrode forming the negative terminal of the cell, and the other removing the electrons from the positive terminal. See BATTERY; FUEL CELL.

**Electrodeposition.** The most important type of chemical reaction brought about by the passage of electric current is the deposition of a metal at a cathode from a solution of its ions. Electroforming is a variety of electrodeposition in which an article to be reproduced is rendered conductive by spraying a thin metallic coating, then electroplated with a metallic deposit that is stripped from its substrate and filled with backing to reproduce the original article. Electrowinning is used for the commercial production of active metals, such as aluminum, magnesium, and sodium, from molten salts and others, such as copper, manganese, and antimony, from aqueous solution. Electrorefining is commonly used to purify metals such as silver, lead, and copper. The impure metal is used as the anode, and purified metal is deposited at the cathode. See ELECTROPLATING OF METALS.

**Electrolytic processes.** Many electrode reactions other than metal deposition are of commercial or scientific use. Electrolysis of brine to yield chlorine at the anode, hydrogen at the cathode, and sodium hydroxide in the electrolyte is an important industrial process. Many organic compounds can be prepared electrolytically. See ELECTROLYSIS.

**Electroanalytical chemistry.** Many electrochemical measurements are useful for analytical purposes. Electrodes that are commonly used for analytical purposes through measurement of their potentials include the glass electrode for pH measurements, and ion-selective electrodes for certain ions, such as sodium or potassium ion (special glass compositions), calcium ion (liquid membrane), and fluoride ion (doped lanthanum fluoride single crystals). Polarography involves the use of a dropping mercury electrode as one electrode of an electrolytic cell. Qualitative analysis is carried out by measurement of characteristic potentials (half-wave potentials) for electrode processes, and quantitative analysis by measurement of diffusion-controlled currents. Coulometry involves the application of Faraday's law for analytical purposes.

Other analytical applications of electrochemistry include chronopotentiometry (measurement of potential-time transients under constant current conditions), and linear sweep and cyclic voltammetry (measurement of currents with linear voltage scan). Several titration methods involve electrochemical measurements, for example, conductometric, potentiometric, and amperometric titrations. See POLAROGRAPHIC ANALYSIS; TITRATION.

**Miscellaneous phenomena.** Electrochemical transport of ions through synthetic or natural membranes is important for processes, such as desalination of water and electro dialysis. In biological systems, the transmittal of nerve impulses and the generation of electrical signals, such as brain waves, are basically of electrochemical origin. A set of related phenomena can be grouped together under electrokinetic behavior, including the motion of colloidal particles in an electric field (electrophoresis), the motion of the liquid phase relative to a stationary solid under the influence of a potential gradient (electroosmosis), and the inverse generation of a potential gradient caused by a flowing liquid (streaming potential). Alternating-current phenomena, such as dielectric behavior, double-layer charging, and faradaic rectification, may also be included in a general definition of electrochemistry. Corrosion and passivation of metals are electrochemical in nature. [H.A.L.]

**Organic electrochemistry.** Organic electrochemistry involves the study of the chemical reactions that take place when an electric current is passed through a solution containing one or more organic compounds. It is a highly interdisciplinary science. Understanding and fully developing a given organic electrochemical reaction may involve techniques of synthesis, purification, and identification of organic compounds, as well as theory and practice of a variety of sophisticated electroanalytical techniques, surface science, cell design, electronics, engineering scaleup, and materials modification. Organic electrochemistry has been of increasing interest for industrial applications in recent years because the costs of electrochemistry have been rising more slowly than the costs of conventional chemical reagents,

and because electrochemical procedures can be environmentally less intrusive than other chemical processes. A number of so-called fine chemicals are made electrochemically on a scale ranging from several kilograms to several tons per day. A few chemicals are made on much larger scale; the best known is adiponitrile  $[\text{NC}(\text{CH}_2)_4\text{CN}]$ , a key intermediate in the synthesis of nylon. See ORGANIC CONDUCTOR.

Cathodic organic reactions fall into several categories: cleavage of single bonds, reduction of functional groups, and reduction of large conjugated systems such as activated alkenes and aromatic compounds. Anodic reactions are equally diverse. The oldest and best-known anodic reaction is the Kolbe reaction, in which electrochemical oxidation of carboxylate ions yields dimeric products with evolution of carbon dioxide. A wide range of functional groups can be accommodated in this versatile reaction.

The powerful yet precisely controllable oxidizing and reducing conditions that can be achieved electrochemically are useful for generating novel organic intermediates, including carbocations, carbanions, radicals, radical ions, carbenes, nitrenes, and arynes. These reactive intermediates are frequently trapped by other organic substances added to the medium to extend the synthetic utility of an electrode reaction.

Voltammetric methods are commonly used to provide detailed mechanistic information. In these, the electrode potential is varied in a controlled fashion in the vicinity of the redox potential of the substrate, and the current response is measured as a function of experimental variables such as scan rate, concentration, and added reagents. Other methods include identification of the products from a preparative electrolysis (generally carried out at controlled potential in mechanistic experiments); coulometry, or measurement of the actual amount of current passed in the electrolysis; comparison of experimental responses with computer simulations of the theoretical behavior for various mechanisms; studies of changes in the structure of the electrode surface during electrolysis; and spectroscopic identification of intermediates. Microelectrodes, which have micrometer diameters, extend the speeds with which electrochemical measurements can be made, and thus permit measurement of even very fast rates of chemical reactions associated with electron transfers at electrodes. See REACTIVE INTERMEDIATES. [A.J.Fr.]

**Electrochromic devices** Self-contained, hermetically sealed, two-electrode electrolytic cells that change their ability to transmit (or reflect) light in response to a small bias (typically 1–2 V) applied across the two electrodes. The operation of electrochromic devices relies upon their electrochromic material content. These materials are organic or inorganic substances that are able to interconvert between two or more color states upon oxidation or reduction, that is, upon electrolytic loss or gain of electrons. The electrochromic materials that are appropriate for most practical applications are strong light absorbers in one redox state but colorless in another.

A typical electrochromic device is a sandwichlike structure with two glass plates and an electrolyte (see illustration). Each glass plate is coated on the inside with a transparent electrically conducting layer of indium-tin oxide, which operates as an electrode. Electrochromic mirrors include an additional reflective coating (for example, aluminum) on the outside of one of the glass plates. The electrolyte carries the ionic current inside the cell between the two electrodes, and it can be as simple as a salt (for example, sodium chloride, NaCl) dissolved in a dissociating solvent such as water. However, development has focused on gel and solid electrolytes, because they offer several advantages: they are easier to confine in the space between the electrodes; they function as laminators holding the two glass plates together; and their use minimizes the hydrostatic pressure that can cause substrate deformation and leakage problems, particularly in large-area devices such as smart windows.

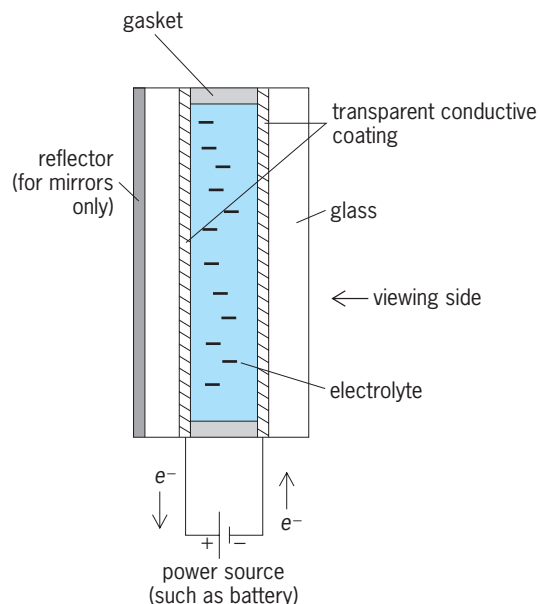

**Electrochromic device.** The electrochromic materials can be either dissolved in the electrolyte or coated on the transparent electrodes.

State-of-the-technology electrochromic devices utilize two electrochromic materials with complementary properties: the first electrochromic material is normally reduced ( $ECM_1^{\text{red}}$ ) and undergoes a colorless-to-colored transition upon oxidation (loss of electrons), while the second electrochromic material is normally oxidized ( $ECM_2^{\text{ox}}$ ) and undergoes a similar transition upon reduction (gain of electrons). The electrochromic materials  $ECM_1^{\text{red}}$  and  $ECM_2^{\text{ox}}$  are selected so that they do not react with each other. The oxidation of  $ECM_1^{\text{red}}$  and the reduction of  $ECM_2^{\text{ox}}$  then are forced by the external power source (see illustration), which operates as an electron pump consuming energy in order to transfer electrons from one electrode to the other. Oxidation of  $ECM_1^{\text{red}}$  occurs at the positive electrode (anode) and is a source of electrons, while reduction of  $ECM_2^{\text{ox}}$  occurs at the negative electrode (cathode) and is a sink of electrons. This approach, known as complementary counterelectrode technology, has two distinct advantages. First, the long-term operating stability of the electrochromic cell is greatly enhanced, because providing both a source and a complementary sink of electrons within the same cell prevents any electrolytic decomposition of the electrolyte. Second, the reinforcing effect of two electrochromic materials changing color simultaneously enhances the contrast difference between the color states per unit charge consumed. Depending on the location of the two electrochromic materials within the electrochromic devices, three main types of such devices exist: solution, precipitation, and thin-film. See ELECTRODE; ELECTROLYTE; OXIDATION-REDUCTION.

Electrochromic devices are analogous to liquid-crystal devices in that they do not generate their own light but modulate the ambient light. Liquid-crystal devices require use of polarizers; consequently, their viewing angle is limited, and lateral size limitations are imposed because the spacing between the electrodes (thickness) must be controlled within a few micrometers over the entire device area. Electrochromic devices do not require polarizers, thereby allowing a viewing angle approaching  $180^\circ$ , and contrast ratios similar to black ink on white paper (20:1 or better); moreover, control of the thickness is not important. Other desirable features of electrochromic devices include inherent color, continuous gray scale, and low average power consumption for the thin-film-type devices. Furthermore, it has been shown that electrochromic thin films can be patterned with a 2–5- $\mu\text{m}$  resolution to form a large number of display elements that can

be matrix-addressed. Nevertheless, even though there is no apparent intrinsic limitation, the best cycling lifetimes claimed for electrochromic materials are of the order of 10–20 million cycles, while the lifetime of liquid-crystal devices is of the order of several hundred million cycles. This long lifetime has made liquid-crystal devices a very successful technology in matrix-addressed, flat-panel displays.

The larger tolerance in thickness variation for electrochromic devices renders them better suited than liquid-crystal devices for large-area light modulation applications, such as smart windows, space dividers, and smart mirrors. Another possible application is in large-area displays that do not need frequent refreshing, such as signs and announcement boards. Reconfigurable optical recording devices (for example, disks) have been proposed as a high-resolution application that is within the presently available lifetimes of electrochromic materials. See ELECTROCHEMICAL PROCESS; ELECTROCHEMISTRY; ELECTRONIC DISPLAY; ELECTROOPTICS; LIQUID CRYSTALS. [N.Le.]

**Electroconvulsive therapy** The technique of eliciting convulsions by applying an electric current through the brain of a human or an experimental animal for a brief period. Low current produces clonic (rapidly alternating muscle contraction and relaxation) convulsions, while high current produces tonic (steady muscle contraction) convulsions followed by clonic convulsions. Tonic convulsions cause loss of consciousness for a brief period. In the early 1930s drug-induced convulsions were used as treatment for mental disorders. In 1938 M. Cerletti and L. Bini introduced electroconvulsive therapy (ECT) treatments as a more convenient and reliable procedure. ECT subsequently replaced convulsive drugs and is still used in some circumstances as a treatment for severe mental depression. The bases of the effectiveness of ECT as a clinical treatment are not known. [J.L.McG.]

**Electrode** An electrical conductor through which an electric current enters or leaves a conducting medium, whether it be an electrolytic solution, solid, molten mass, gas, or vacuum. For electrolytic solutions, many solids, and molten masses, an electrode is an electric conductor at the surface of which a change occurs from conduction by electrons to conduction by ions. For gases and vacuum, the electrodes merely serve to conduct electricity to and from the medium. See ELECTRODE POTENTIAL; ELECTROLYSIS; ELECTROMOTIVE FORCE (CELLS). [W.J.H.]

**Electrode potential** The equilibrium potential difference between two conducting phases in contact, most often an electronic conductor such as a metal or semiconductor on the one hand, and an ionic conductor such as an electrolyte solution (a solution containing ions) on the other. Electrode potentials are not experimentally accessible, but the differences in potential between two electronic conductors making contact with the same ionic conductor (that is, the difference between two electrode potentials) can be measured. A useful scale of electrode potentials can therefore be obtained when a particular electrode potential is set equal to zero by definition. There are several conventions, based on different definitions of the zero point on the scale of electrode potential, but all tables use the so-called standard hydrogen convention. See ELECTRODE; REFERENCE ELECTRODE.

The interfacial potential difference is usually the consequence of the transfer of some charge carriers from one conducting phase to the other. For example, when a piece of silver, which contains silver ions and free, so-called conduction electrons, is in contact with an aqueous solution of silver nitrate, the only species common to the two phases are the silver ions. Their concentration (volume density) is constant in the metal but variable (from zero to the solubility limit of the silver salt used) in the solution. When more silver ions transfer from the solution to the metal than in the opposite direction, an excess of negatively charged nitrate ions remains in the solution, which therefore acquires a



negative charge. However, the metal gains more silver ions than it loses, and therefore acquires a positive charge. Such a charge separation leads to a potential difference across the boundary between the two phases. The continued buildup of such charges makes the potential of the metal more and more positive with respect to that of the solution. This effect in turn leads to electrostatic repulsion of the silver ions in the solution phase immediately adjacent to the metal; these are the very metal ions that are candidates for transfer across the boundary. Consequently, the electrostatic repulsion decreases the tendency of silver ions to move from the solution to the metal, and eventually the process reaches equilibrium, at which point the tendency of ions to transfer is precisely counterbalanced by the repulsion of the candidate ions by the existing potential difference. At that potential, there is no further net transfer of charges between the contacting phases, although individual charges can still exchange across the phase boundary, a process which gives rise to the exchange current.

For a metal in contact with its metal ions of valence  $z$ , the potential difference  $E$  can be expressed in terms of a standard potential  $E^\circ$  (describing the affinity of the metal for its ions) and the concentration  $c$  of these ions in solution through the Nernst equation (1), where  $R$  is the gas constant,  $T$  is the absolute temperature, and  $F$  is the Faraday.

$$E = E^\circ + (RT/zF) \ln c \quad (1)$$

When the metal ions in solution form a sparingly soluble salt, the solubility equilibrium can be used to convert a metal electrode responding to its own metal cations (positive ions) into an electrode responding to the concentration of anions (negative ions). Typical examples are the silver/silver chloride electrode, based on the low solubility of silver chloride (AgCl), and the calomel electrode, based on the poor solubility of calomel ( $\text{Hg}_2\text{Cl}_2$ ).

An equilibrium potential difference between a metal and an electrolyte solution can also be established when the latter contains a redox couple, that is, a pair of chemical components that can be converted into each other by the addition or withdrawal of electrons, by reduction or oxidation respectively. In that case the metal often merely acts as the supplier or acceptor of electrons. When metal electrons are donated to the solution, the oxidized form of the redox couple is reduced; when the metal withdraws electrons from the redox couple, its reduced component is oxidized. Again, the buildup of a charge separation generates a potential difference, which counteracts the electrochemical charge transfer and eventually brings the process to equilibrium, a state in which the rate of oxidation is exactly equal to the rate of reduction. The dependence of the equilibrium electrode potential on the concentrations of  $c_{\text{ox}}$  and  $c_{\text{red}}$  of the oxidized and reduced forms respectively is described by a Nernst equation of the form (2), where  $n$  denotes the number of electrons

$$E = E^\circ + (RT/nF) \ln(c_{\text{ox}}/c_{\text{red}}) \quad (2)$$

( $e^-$ ) transferred between the oxidized species (Ox) and the reduced species (Red) in the reactions  $\text{Ox} + ne^- \rightleftharpoons \text{Red}$ . A typical example is the reduction of hydrogen ions  $\text{H}^+$  to dissolved hydrogen molecules  $\text{H}_2$ , and vice versa, in which case the reactions are  $2\text{H}^+ + 2e^- \rightleftharpoons \text{H}_2$ , and for which the Nernst equation is of the form (3).

$$E = E^\circ + (RT/2F) \ln(c_{\text{H}^+}^2/c_{\text{H}_2}) \quad (3)$$

Redox potentials involving a gas are often established slowly, if at all. For determinations of such a redox potential, platinum is often used as the metal, because it is chemically and electrochemically stable. See OXIDATION-REDUCTION.

Electrode potentials can also be established at double phase boundaries, such as that between two aqueous solutions separated by a glass membrane. This glass electrode is commonly used for measurements of the pH, a measure of the acidity or

basicity of solutions. The mechanism by which the glass electrode operates involves ion exchange of hydrogen ions at the two glass-solution interfaces. See ION EXCHANGE.

In all the above examples, the two contacting phases can have only one type of charge carrier in common. Usually, no equilibrium potential difference is established when more than one type of charge carrier can cross the interface, but often (depending on the nature of the metal and of the chemical components of the solution, and sometimes also depending on the geometry of the contact region) an apparently stable potential can still be obtained, which corresponds to zero net charge transfer. This can be a so-called mixed potential, important in metal corrosion, or a junction potential, which figures in most measurements of electrochemical potentials and usually limits the accuracy and precision of such measurements, including that of the pH. See CORROSION.

In determining electrode potentials, there are several complications. In the first place, it follows from thermodynamics that the Nernst equation should be written in terms of activities rather than concentrations. The difference between these two parameters is often small but seldom completely negligible.

Second, measurements of potential differences always involve the potential difference between two metals rather than that between a metal and a solution. Therefore, electrode potentials as defined above cannot be measured either. Because these measurements involve a potential difference, there has been considerable confusion about the definition of that difference; that is, whether it is defined as the potential of the metal minus that of the solution, or the other way around. This is a matter of a sign convention. The problem is usually framed in terms of oxidation potentials versus reduction potentials.

There are four main applications for measurements of electrode potentials: (1) in the establishment of the oxidative and reductive power of redox systems, the so-called electromotive series; (2) as concentration probes, such as in pH measurements; (3) as sources of chemical equilibrium data; and (4) as the primary (or independent) variable in studies of electrode reactions.

[R.DeD.]

**Electrodermal response** A transient change in certain electrical properties of the skin, associated with the sweat gland activity and elicited by any stimulus that evokes an arousal or orienting response. Originally termed the psychogalvanic reflex, this phenomenon became known as the galvanic skin response. Electrodermal response (EDR) has replaced galvanic skin response as the collective term.

The skin of a relaxed person has a low electrical conductance (high resistance), and the skin surface is some 40 mV negative with respect to interior tissues. Sweat gland activity changes these electrical properties by increasing skin conductance and by changing the balance of positive and negative ions in the secreted fluid.

Tonic skin conductance varies with psychological arousal, rising sharply when the subject awakens and rising further with activity, mental effort, or especially stress. Phasic skin conductance responses are wavelike increases in skin conductance that begin 1–2 s after stimulus onset and peak within about 5 s. The amplitude of the skin conductance response varies with the subjective impact of the eliciting stimulus, which in turn varies with the intensity of the stimulus, its novelty or unexpectedness for the subject, and its meaning or signal value. Aroused subjects display spontaneous skin conductance responses, generated apparently by mental events or other internal stimuli; their frequency, like the tonic skin conductance level, increases with the level of arousal.

Electrodermal responses are measured in studies of emotion and stress, conditioning, habituation, and cognitive processing, that is, when it is desired to assess the differential or changing impact of a series of stimuli. See ELECTROENCEPHALOGRAPHY; LIE DETECTOR; SYMPATHETIC NERVOUS SYSTEM.

[D.T.L.]

**Electrodiagnosis** Diagnosis employing equipment that can be used clinically to measure the intrinsic electrical activity of the heart (electrocardiography), the brain (electroencephalography), and skeletal muscles (electromyography). Electrodiagnostic procedures depend upon the difference in electrical potential between the interior and external surfaces of living cells. This potential is created by using cellular metabolic energy to maintain the concentration gradient of ions across the cell membrane. A discharge of the electrical potential (depolarization) by stimulation or injury occurs in a wave proceeding from cell to cell. These electrical forces are conducted through the tissues to the surface of the body where electrodiagnostic equipment amplifies and records the changes in potential. See ELECTROENCEPHALOGRAPHY; ELECTROMYOGRAPHY.

In a second type of electrodiagnostic procedure, signals elicited by electrical stimulation of a nerve are measured either over a muscle supplied by the nerve or along the nerve itself. A set of diagnostic tests called evoked potentials records the electrical responses of the brain that follow visual or auditory stimuli. [S.Marg.]

**Electrodynamics** The study of the relations between electrical, magnetic, and mechanical phenomena. This includes considerations of the magnetic fields produced by currents, the electromotive forces induced by changing magnetic fields, the forces on currents in magnetic fields, the propagation of electromagnetic waves, and the behavior of charged particles in electric and magnetic fields. Classical electrodynamics deals with fields and charged particles in the manner first systematically described by J. C. Maxwell, whereas quantum electrodynamics applies the principles of quantum mechanics to electrical and magnetic phenomena. Relativistic electrodynamics is concerned with the behavior of charged particles and fields when the velocities of the particles approach that of light. Cosmic electrodynamics is concerned with electromagnetic phenomena occurring on celestial bodies and in space. See ELECTROMAGNETISM; QUANTUM ELECTRODYNAMICS; RELATIVISTIC ELECTRODYNAMICS. [J.W.St.]

**Electroencephalography** The biomedical technology and science of recording the minute electric currents produced by the brains of human beings and other animals. Electroencephalography (EEG) has important clinical significance for the diagnosis of brain disease. The interpretation of EEG records has become a clinical specialty for neurological diagnosis.

The recording machine, the electroencephalograph, usually produces a 16-channel ink-written record of brain waves, the electroencephalogram. It is interpreted by an electroencephalographer. The placement of about 20 equally spaced electrodes pasted to the surface of the scalp is in accordance with the standard positions adopted by the International Federation of EEG, and is called the 10/20 system. Electrode positions are carefully measured so that subsequent EEGs from the same person can be compared. About 10 patterns or montages of combinations of electrode pairs are selected for transforming the spatial location from the scalp to the channels which are traced on the EEG pen writer.

The aggregate of synchronized neuronal activity from hundreds of thousands or millions of neurons acting together form the electrical patterns on the surface of the brain (brain waves). The cellular basis of the EEG depends on the spontaneous fluctuations of postsynaptic membrane potentials between the inside and the outside of the dendritic processes of postsynaptic cells. See SYNAPTIC TRANSMISSION.

Electrical voltage is transduced from the scalp by differential input amplifiers and amplified about a million times in order to drive the pens for the paper record. The recording usually takes 30–60 min during a relaxed waking state, and also during sleep when possible. Often, activating procedures are used, such as a flickering light stimulator and hyperventilation or overbreathing for about 3 min.

EEG waves are defined by form and frequency. Various frequencies are given Greek letter designations. Alpha rhythm is defined as 8–12-Hz sinusoidal rhythmical waves. Alpha waves are normally present during the waking and relaxed state and enhanced by closing the eyes. They are suppressed or desynchronized when the eyes are open, or when the individual is emotionally aroused or doing mental work. They may be synchronized by bright light flashes and driven over a wide range of frequencies by repetitive visual stimulation (alpha driving). They are of highest amplitude in the posterior regions of the brain. The alpha rhythm develops with age, reaching maturity by about 12 years, stabilizes, and then declines in frequency and amplitude in old age (over 65).

Beta rhythms are faster, low-voltage sinusoidal waves, usually about 14–30 Hz. They are more prominent in the frontal areas. They are often synchronized and prevalent during sedation with phenobarbital or with the use of tranquilizers and some sedative drugs.

Slower rhythms are theta and delta waves. Theta waves of 4–7 Hz usually replace the alpha rhythm during drowsiness and light sleep. Delta waves of 0.5–4 Hz are present during deep sleep in normal people of all ages and they are the primary waves present in the records of normal infants. Delta waves are almost always pathological in the waking records of adults.

The EEG reveals functional abnormalities of the brain, whether caused by localized structural lesions, essential paroxysmal states such as epilepsy, or toxic and abnormal metabolic conditions. The three major classes of abnormalities are asymmetries between the hemispheres, slow rhythms, and very sharp waves or spikes. Slow waves represent a depression of cerebral cortical activity or injury in the projection pathways beneath the recording electrodes. Sharp waves or spikes often indicate a hyperexcitable or irritable state of the cortex. During a full epileptic seizure attack, spikes become repetitive and synchronized over the whole surface of the brain. See SEIZURE DISORDERS.

The EEG is frequently used for the evaluation of comatose states. The record is slowed in all areas in coma, with delta waves predominating. If the EEG becomes isoelectric or flat for several hours, brain function is not recoverable and the coma may be considered terminal. "Brain death" is indicated by a flat EEG, recorded at the highest gain with widely spaced electrode positions and the absence of cerebral reflexes and spontaneous respiration. See DEATH.

Computer advances in the analysis of EEG signals that are emitted by the brain during sensory stimulation and motor responses have led to the discovery and measurement of electrical waves known as event-related potentials or evoked potentials. These responses are averaged by a computer to enhance the small signals and increase the signal-to-noise ratio, so that they may be graphed and seen.

The complexity of evoked potential and EEG analysis makes interpretation difficult in relation to where various components originate and their pattern of spread through time along the neural transmission pathways. In the 1980s, with the development of minicomputers and color graphics screens, the presentation of topographic information could be analyzed in sophisticated statistical ways for research and clinical purposes by electroencephalographers and neurophysiologists. This method is best known as brain electrical activity mapping (BEAM) and is used in many research investigations of brain activity patterns in learning and language dysfunctions, psychiatric disorders, aging changes and dementia, and studies of normal and impaired child development. Difficult neurological diagnostic problems that do not show anatomical deformities by brain scan methods may often be clarified by these new electrographic procedures. See BRAIN; NEUROBIOLOGY. [J.Co.]

**Electrokinetic phenomena** Phenomena associated with the movement of charged particles through a continuous medium or with the movement of a continuous medium over

a charged surface. The four principal electrokinetic phenomena are electrophoresis, electroosmosis, streaming potential, and sedimentation potential, or Dorn effect. These phenomena are related to one another through the zeta potential  $\zeta$  of the electrical double layer which exists in the neighborhood of the charged surface. See ELECTROPHORESIS; STREAMING POTENTIAL. [Q.V.W.]

**Electroless plating** A chemical reduction process which, once initiated, is autocatalytic. The process is similar to electroplating except that no outside current is needed. The metal ions are reduced by chemical agents in the plating solutions, and deposit on the substrate. An advantage of electroless plating with current is the more uniform thickness of the surface coating.

Electroless plating is used for coating nonmetallic parts. Decorative electroless plates are usually further coated with electrodeposited nickel and chromium. There are also applications for electroless deposits on metallic substrates, especially when irregularly shaped objects require a uniform coating. Electroless copper is used extensively for printed circuits, which are produced either by coating the nonmetallic substrate with a very thin layer of electroless copper and electroplating to the desired thickness or by using the electroless process only. Electroless iron and cobalt have limited uses. Electroless gold is used for microcircuits and connections to solid-state components. Deeply recessed areas which are difficult to plate can be coated by the electroless process. See ELECTROPLATING OF METALS. [R.W.]

**Electroluminescence** A general term for the luminescence excited by the application of an electric field to a system, usually in the solid state. Solid-state electroluminescent systems can be made quite thin, leading to applications in thin-panel area light sources and flat screens to replace cathode-ray tubes for electronic display and image formation. See LUMINESCENCE.

Modern interest in electroluminescence dates from the discovery by G. Destriau in France in 1936 that when a zinc sulfide (ZnS) phosphor powder is suspended in an insulator (oil, plastic, or glass ceramic) and an intense alternating electric field is applied with capacitorlike electrodes, visible light is emitted. The phosphor, prepared from zinc sulfide by addition of a small amount of copper impurity, was later shown to contain particles of a copper sulfide ( $\text{Cu}_2\text{S}$ ) phase in addition to copper in its normal role as a luminescence activator in the zinc sulfide lattice. The intensification of the applied electric field by the sharp conductive or semiconductive copper sulfide inhomogeneities is believed to underlie the mechanism of Destriau-type electroluminescence. Minority carriers are ejected from these high-field spots into the low- or moderate-field regions of the phosphor, where they recombine to excite the activator centers. The structure of a Destriau-type electroluminescent cell is shown in the illustration; the light is observed through the transparent indium-tin oxide electrode. See LIGHT PANEL.

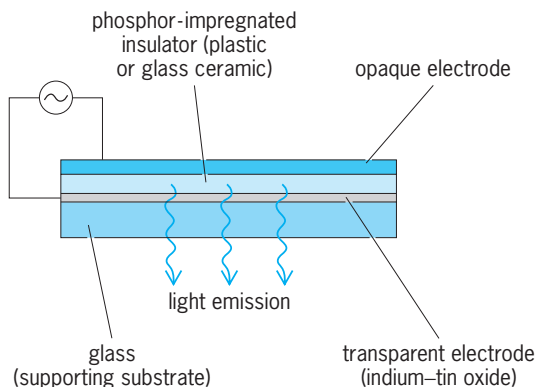

Structure of powdered-phosphor (Destriau) electroluminescent cell, edge view (not to scale).

The application of electroluminescence to display and image formation received great impetus from work in the late 1960s and mid-1970s on thin-film electroluminescence (TFEL), giving rise to devices that are different in structure and mechanism from the Destriau conditions. The phosphor in these devices is not a powder but a thin (about 500 nanometers) continuous film prepared by sputtering or vacuum evaporation. The luminescence activators are manganese or rare-earth ions, atomic species with internal electronic transitions that lead to characteristic luminescence. The phosphor film does not contain copper sulfide or any other separate phase, and is sandwiched between two thin (about 200 nm) transparent insulating films also prepared by evaporative means. Conducting electrodes are applied to the outside of each insulating film; one of the electrodes is again a transparent coating of indium-tin oxide on glass, which serves as supporting substrate. If an imaging matrix is desired, both electrodes consist of grids of parallel lines, with the direction of the grid on one insulator (row) orthogonal to the other grid (column). By approximate circuitry the entire matrix can be scanned, applying voltage where desired to a phosphor element that is located between the intersection of a row and column electrode. A thin-film electroluminescent device acts like a pure capacitor at low applied voltage; no light is emitted until the voltage reaches a threshold value determined by the dielectric properties of the insulator and phosphor films. Above this threshold a dissipative current flows, and light emission occurs. The brightness increases very steeply with the applied voltage but is finally saturated. The light output, or average brightness, is roughly proportional to the frequency up to at least 5 kHz, and also depends on the waveform of the applied voltage.

The best thin-film electroluminescent phosphor is manganese-activated zinc sulfide, which emits yellow light peaking at 585 nm. Activation of zinc sulfide and certain alkaline earth sulfides with different rare earths has yielded many other promising electroluminescent phosphors emitting blue, green, red, and white, and making full-color matrix-addressed thin-film electroluminescent displays possible. The light output of thin-film electroluminescent displays has been very reliable, with typically only 10% loss after tens of thousands of hours of operation.

Injection electroluminescence results when a semiconductor *pn* junction or a point contact is biased in the forward direction. This type of emission, first observed from silicon carbide (SiC) in 1907, is the result of radiative recombination of injected minority carriers, with majority carriers being a material. Such emission has been observed in a large number of semiconductors. The wavelength of the emission corresponds to an energy equal, at most, to the forbidden band gap of the material, and hence in most of these materials the wavelength is in the infrared region of the spectrum. If a *pn* junction is biased in the reverse direction, so as to produce high internal electric fields, other types of emission can occur, but with very low efficiency. See JUNCTION DIODE; SEMICONDUCTOR; SEMICONDUCTOR DIODE.

Light emission may also occur when electrodes of certain metals, such as Al or Ta, are immersed in suitable electrolytes and current is passed between them. In many cases this galvanoluminescence is electroluminescence generated in a thin oxide layer formed on the electrode by electrolytic action. In addition to electroluminescence proper, other interesting effects (usually termed electrophotoluminescence) occur when electric fields are applied to a phosphor which is concurrently, or has been previously, excited by other means. These effects include a decrease or increase in steady-state photoluminescence brightness when the field is applied, or a burst of afterglow emission if the field is applied after the primary photoexcitation is removed. See PHOTOLUMINESCENCE. [J.H.S.; C.C.K.]

**Electrolysis** A means of producing chemical changes through reactions at electrodes in contact with an electrolyte by the passage of an electric current. Electrolysis cells, also known

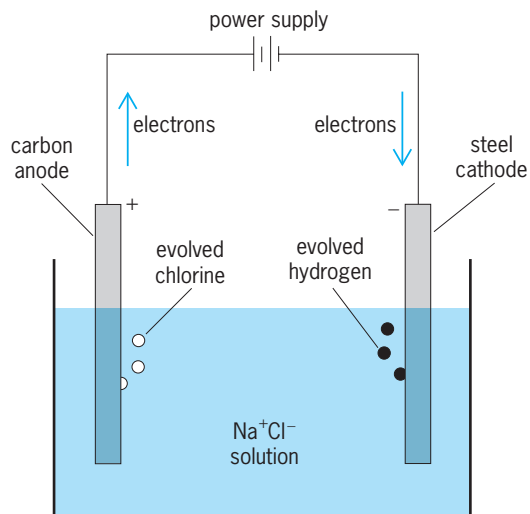

Schematic diagram of an electrolysis cell in which the electrolyte is a solution of sodium chloride.

as electrochemical cells, generally consist of two electrodes connected to an external source of electricity (a power supply or battery) and immersed in a liquid that can conduct electricity through the movement of ions. Reactions occur at both electrode-solution interfaces because of the flow of electrons. Reduction reactions, where substances add electrons, occur at the electrode called the cathode; oxidation reactions, where species lose electrons, occur at the other electrode, the anode. In the cell shown in the illustration, water is reduced at the cathode to produce hydrogen gas and hydroxide ion; chloride ion is oxidized at the anode to generate chlorine gas. Electrodes are typically constructed of metals (such as platinum or steel) or carbon. Electrolytes usually consist of salts dissolved in either water or a nonaqueous solvent, or they are molten salts. See ELECTROCHEMISTRY; ELECTRODE; ELECTROLYTE; OXIDATION-REDUCTION.

There are many industrial applications for the production of important inorganic chemicals. Chlorine and alkali are produced by the large-scale electrolysis of brine (the chloralkali process) in cells carrying out the same reactions as those shown in the illustration. Other chemicals produced include hydrogen and oxygen (via water electrolysis), chlorates, peroxysulfate, and permanganate.

The major electrolytic processes involving organic compounds are the hydromerization of acrylonitrile to produce adiponitrile and the production of tetraethyllead. Many other organic compounds have been studied on the laboratory scale.

Electroplating involves the electrochemical deposition of a thin layer of metal on a conductive substrate, for example, to produce a more attractive or corrosion-resistant surface. Chromium, nickel, tin, copper, zinc, cadmium, lead, silver, gold, and platinum are the most frequently electroplated metals. Metal surfaces can also be electrolytically oxidized (anodized) to form protective oxide layers. This surface-finishing technique is most widely used for aluminum but is also used for titanium, copper, and steel. See ELECTROPLATING OF METALS.

Metals can be purified by electrorefining. Here, the impure metal is used as the anode, which dissolves during the electrolysis. The metal is plated, in purer form, on the cathode. Copper, nickel, cobalt, lead, and tin are all purified by this technique. See ELECTROMETALLURGY.

Electroanalysis involves the use of electrolytic processes to identify and quantitate a species. Coulometric methods are based on measuring the quantity of electricity used for a desired process. Voltammetric methods allow characterization of

species through an analysis of the effect of potential and electrolysis conditions on the observed currents. [A.J.Ba.]

**Electrolyte** A material that conducts an electric current when it is fused or dissolved in a solvent, usually water. Electrolytes are composed of positively charged species, called cations, and negatively charged species, called anions. For example, sodium chloride (NaCl) is an electrolyte composed of sodium cations ( $\text{Na}^+$ ) and chlorine anions ( $\text{Cl}^-$ ). The ratio of cations to anions is always such that the substance is electrically neutral. If two wires connected to a light bulb and to a power source are placed in a beaker of water, the light bulb will not glow. If an electrolyte, such as sodium chloride, is dissolved in the water, the light bulb will glow because the solution can now conduct electricity. The amount of electric current that can be carried by an electrolyte solution is proportional to the number of ions dissolved. Thus, the bulb will glow more brightly if the amount of sodium chloride in the solution is increased. See ELECTRIC CURRENT; ION.

Any substance that produces ions when dissolved is an electrolyte. These substances include ionic materials composed of simple monatomic ions, such as sodium chloride, or substances composed of polyatomic ions, such as ammonium nitrate ( $\text{NH}_4\text{NO}_3$ ). When these substances are dissolved, hydrated ions are generated, as in reactions (1) and (2).

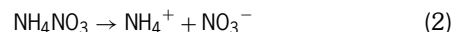

A special type of electrolyte is an acid, in which the cation is  $\text{H}^+$ . When acids are dissolved in water,  $\text{H}^+$  ions are produced along with an anion, which can be either a monatomic ion, as in hydrochloric acid (HCl), or a polyatomic ion, as in nitric acid ( $\text{HNO}_3$ ) or acetic acid ( $\text{HC}_2\text{H}_3\text{O}_2$ ), as in reactions (3)–(5).

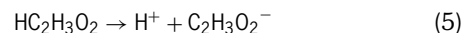

Electrolytes such as sodium hydroxide (NaOH) that yield the hydroxyl ( $\text{OH}^-$ ) anion when dissolved in water are called bases [reaction (6)]. Some molecules that do not contain ions, such as



ammonia ( $\text{NH}_3$ ), generate  $\text{OH}^-$  ions when dissolved in water as in reaction (7); these bases are also electrolytes. Polar covalent

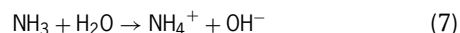

molecules, such as ethanol, dissolve in water but do not generate any ions and are called nonelectrolytes.

Many electrolytic substances completely dissociate into ions when they are dissolved in water. In these cases, the reactions shown above would proceed completely to the right, leaving only dissolved ions and no associated, electrically neutral molecules. For example, when sodium chloride is dissolved in water, all of the dissolved material is present as  $\text{Na}^+$  and  $\text{Cl}^-$  ions, with no dissolved NaCl molecules. Substances that completely dissociate are called strong electrolytes, because every molecule dissolved generates ions that contribute to the electrical conductivity. Ionic substances, such as NaCl and  $\text{NH}_4\text{NO}_3$ , are strong electrolytes. Acids and bases that completely dissociate are called strong acids and strong bases, and these substances are also strong electrolytes. Hydrochloric acid (HCl) and  $\text{HNO}_3$  are strong acids, so every molecule of HCl or  $\text{HNO}_3$  that dissolves generates a  $\text{H}^+$  cation and a  $\text{Cl}^-$  or  $\text{NO}_3^-$  anion, respectively.

Some substances dissolve in water but do not dissociate completely. For example, when acetic acid is dissolved in water, some

molecules dissociate to form  $H^+$  and  $C_2H_3O_2^-$  ions, while others remain associated as  $C_2H_3O_2H$  units, which contain polar O-H bonds and are therefore readily soluble in water. Acids such as acetic acid that do not dissociate completely are called weak acids. Similarly, the reaction of ammonia with water in reaction (7) proceeds to only a small extent. Thus, some molecules of ammonia react with water to generate  $OH^-$  and  $NH_4^+$  ions, but many simply remain as  $NH_3$ . Since each dissolved molecule of ammonia does not generate an  $OH^-$  anion, ammonia is said to be a weak base. See IONIC EQUILIBRIUM.

In biological systems, electrolytes play important roles in regulating kidney function and the retention of water. Electrolytes are also vital for providing the electric current needed for nerve impulses in neurons. See OSMOREGULATORY MECHANISMS. [H.H.T.]

**Electrolytic conductance** The transport of electric charges, under electric potential differences, by particles of atomic or larger size. This phenomenon is distinguished from metallic conductance, which is due to the movement of electrons. The charged particles that carry the electricity are called ions.

Positively charged ions are termed cations; the sodium ion,  $Na^+$ , is an example. The negatively charged chloride ion,  $Cl^-$ , is typical of anions. The negative charges are identical with those of electrons or integral multiples thereof. The unit positive charges have the same magnitude as those of electrons but are of opposite sign. Colloidal particles, which may have relatively large weights, may be ions, and may carry many positive or negative charges. Electrolytic conductors may be solids, liquids, or gases. Semiconductors have properties that are intermediate between the metallic and electrolytic types. See ELECTROCHEMISTRY; ELECTROMOTIVE FORCE (CELLS).

Conductances are usually reported as specific conductances  $\kappa$ , which are the reciprocals of the resistances of cubes of the materials, 1 cm (0.39 in.) in each dimension, placed between electrodes 1 cm square, on opposite sides. These units are sometimes called mhos, that is, ohm spelled backward. Conductances of solutions are usually measured by a method in which a Wheatstone bridge is employed. See WHEATSTONE BRIDGE. [H.A.L.]

**Electromagnet** A soft-iron core that is magnetized by passing a current through a coil of wire wound on the core. Electromagnets are used to lift heavy masses of magnetic material and to attract movable magnetic parts of electric devices, such as solenoids, relays, and clutches.

The difference between cores of an electromagnet and a permanent magnet is in the retentivity of the material used. Permanent magnets, initially magnetized by placing them in a coil through which current is passed, are made of retentive (magnetically "hard") materials which maintain the magnetic properties for a long period of time after being removed from the coil. Electromagnets are meant to be devices in which the magnetism in the cores can be turned on or off. Therefore, the core material is nonretentive (magnetically "soft") material which maintains the magnetic properties only while current flows in the coil. All magnetic materials have some retentivity, called residual magnetism; the difference is one of degree. See MAGNETIZATION.

In an engineering sense the word electromagnet does not refer to the electromagnetic forces incidentally set up in all devices in which an electric current exists, but only to those devices in which the current is primarily designed to produce this force, as in solenoids, relay coils, electromagnetic brakes and clutches, and in tractive and lifting or holding magnets and magnetic chucks.

Electromagnets may be divided into two classes: traction magnets, in which the pull is to be exerted over a distance and work

is done by reducing the air gap; and lifting or holding magnets, in which the material is initially placed in contact with the magnet. Examples of the latter type are magnetic chucks and circular lifting magnets. For examples of the first type. See BRAKE; CLUTCH; RELAY; SOLENOID (ELECTRICITY). [J.Me.]

**Electromagnetic compatibility** The situation in which electrical and electronic devices and systems work as intended, both within themselves and in their electromagnetic environment.

Electromagnetic interference (EMI) is said to exist when unwanted voltages or currents are present so that they adversely affect the performance of a device or system. Such voltages or currents may reach the victim circuit or device by conduction or by nonionizing radiation. In all cases, electromagnetic interference arises because of a combination of three factors: a source, a transmission path, and a response, at least one of which is unplanned. Electromagnetic interference control refers to the process of making design changes or adjustments of signal or noise levels in order to achieve electromagnetic compatibility (EMC).

The purpose of shielding is to confine radiated energy to a specific region, or to prevent radiated energy from entering a specific region. The most effective shield is a solid metallic enclosure, made of a permeable metal (for example, iron or steel) if frequencies below 100 kHz are to be shielded, or of any metal if higher frequencies are to be shielded. However, the solid shield does not permit light, air, water, or other substances to be passed through it, so shields with holes, including screens, braids, and honeycomb arrangements, as well as conductive glass may be needed. The widespread use of plastic enclosures has made thin film shields vital in achieving the needed shielding effectiveness in the use of such enclosures. See ELECTRICAL SHIELDING; MAGNETIC MATERIALS.

An electrical filter offers relatively little opposition to the passage of certain frequencies or direct current (dc) while blocking the passage of other frequencies. Accordingly, filters play a significant role in reducing conducted interference to the extent that such interference has a spectral content different from that of the desired signals.

A filter may be either reflective or lossy. Reflective filters present an impedance mismatch to unwanted frequencies, thereby returning them to the input, whereas lossy filters absorb unwanted frequencies. A filter may be designed on a time-domain basis as well as on a frequency-domain basis. See ELECTRIC FILTER; IMPEDANCE MATCHING.

Digital systems, such as computers, tend to interfere with analog systems, such as voice and video communications, more readily than analog systems interfere with digital systems. Therefore, data streams to be transmitted over analog voice circuits are converted to a quasianalog tone form first. Computer clocks also may have to be shielded and their output circuits may have to be filtered to prevent interference to communication equipment. In addition, personal computers must be connected to television receivers so that the video output of the personal computer does not reach the television receiving antenna, which then would radiate such signals. See ELECTRICAL NOISE. [B.E.K.]

**Electromagnetic field** A changing magnetic field always produces an electric field, and conversely, a changing electric field always produces a magnetic field. This interaction of electric and magnetic forces gives rise to a condition in space known as an electromagnetic field. The characteristics of an electromagnetic field are expressed mathematically by Maxwell's equation. See ELECTRIC FIELD; ELECTROMAGNETIC RADIATION; ELECTROMAGNETIC WAVE. [J.Be.]

**Electromagnetic induction** The production of an electromotive force either by motion of a conductor through a

magnetic field in such a manner as to cut across the magnetic flux or by a change in the magnetic flux that threads a conductor. See ELECTROMOTIVE FORCE (EMF).

If the flux threading a coil is produced by a current in the coil, any change in that current will cause a change in flux, and thus there will be an induced emf while the current is changing. This process is called self-induction. The emf of self-induction is proportional to the rate of change of current.

The process by which an emf is induced in one circuit by a change of current in a neighboring circuit is called mutual induction. Flux produced by a current in a circuit *A* threads or links circuit *B*. When there is a change of current in circuit *A*, there is a change in the flux linking coil *B*, and an emf is induced in circuit *B* while the change is taking place. Transformers operate on the principle of mutual induction. See TRANSFORMER.

The phenomenon of electromagnetic induction has a great many important applications in modern technology. See COUPLED CIRCUITS; GENERATOR; INDUCTION HEATING; MICROPHONE; MOTOR; SERVOMECHANISM. [K.V.M.]

**Electromagnetic pulse (EMP)** A transient electromagnetic signal produced by a nuclear explosion in or above the Earth's atmosphere. Though not considered dangerous to people, the electromagnetic pulse (EMP) is a potential threat to many electronic systems.

In a typical nuclear detonation, parts of the shell casing and other materials are rapidly reduced to a very hot, compressed gas, which upon expansion gives rise to enormous amounts of mechanical and thermal energy. At the same time the nuclear reactions release tremendous amounts of energy as initial nuclear radiation (INR). This INR is in the form of rapidly moving neutrons and high-energy electromagnetic radiation, called x-rays and prompt gamma rays. About a minute after detonation, the radioactive decay of the fission products gives rise to additional gamma rays and electrons (or beta particles), known as residual nuclear radiation (RNR). The distribution of the total explosive energy of a hypothetical fission detonation in the atmosphere below an altitude of 6 mi (10 km) is 50% blast, 35% thermal, 10% RNR, 5% INR. At higher altitudes where the air is less dense, the thermal energy increases and the blast energy decreases proportionately. See BETA PARTICLES; GAMMA RAYS; NUCLEAR FISSION; NUCLEAR REACTION; RADIOACTIVITY.

EMP is associated with the INR output, which is a small percentage of the total explosive energy. Nevertheless, EMP is still capable of transferring something of the order of 0.1–0.9 joule/m<sup>2</sup> (0.007–0.06 ft-lbf/ft<sup>2</sup>) onto a collector, more than enough to cause upset or damage to normal semiconductor devices.

As the prompt gammas move away from a high-altitude nuclear detonation, those gamma rays moving toward the Earth penetrate a more dense region of the atmosphere called the source or deposition region. In this 6-mi thick (10-km) region, approximately 15–21 mi (25–35 km) above the Earth, the highly energetic gamma rays interact with the air molecules to form Compton electrons (with energies starting at 1 MeV) and less energetic gamma rays, which then proceed in the same general direction as the original gamma rays. The fast Compton electrons eventually slow down by stripping other electrons from air molecules to form secondary electron-ion pairs. (Though these secondary electrons and ions do not contribute to the generation of the EMP, they do cause the region to become highly conductive, and therefore play an important role in determining the EMP wave shape and amplitude.) While slowing down, the very intense, short-duration flux of Compton electrons is also deflected by the Earth's geomagnetic field. The Compton electrons then spiral about the geomagnetic lines, radiating electromagnetic energy in the form of EMP until they eventually recombine with local, positively charged ions. See COMPTON EFFECT; SYNCHROTRON RADIATION.

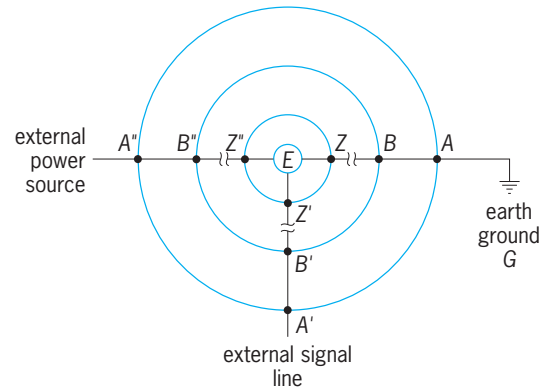

Typical system protection scheme.

It is also possible for INR (both x-rays and gamma rays) to directly interact with systems, causing EMP signals internal to structures. This phenomenon has been called internal or system-generated EMP and is potentially a serious problem for satellites in orbit and for electronics in metallic enclosures on or near the ground. These forms of EMP are generated by x-rays interacting with satellites and gamma rays impinging on ground-based enclosures, producing currents of Compton electrons internally that then produce internal electromagnetic waves. They are very dependent upon the nuclear detonation, the system topology, and the relative position of one to the other.

An estimate of about 1 joule (0.7 ft-lbf) of EMP-coupled energy is considered reasonable for many systems. Even if the coupling onto circuits is inefficient, as little as 10<sup>-13</sup> J can upset some semiconductor devices and 10<sup>-6</sup> J can cause damage. The potential for such upset and damage in critical electronic circuits has led to the incorporation of EMP protection in many system designs. This protection is most prevalent in communications systems whose disruption by EMP is considered an important civil and military vulnerability.

The most common form of protection incorporated in system designs is a combination of shielding and penetration control. The illustration shows a protection scheme in which a system's electronics *E* is isolated from the external environment by one or more nested, shielded enclosures (often called Faraday cages). Penetration control is then maintained by minimizing the number of shield penetrations (in this case, a power line, a signal line, and a ground wire connecting *E* to earth ground *G*) and by applying terminal protection devices, such as spark gaps, high-power Zener diodes, or metal oxide varistors, at selected shield penetration points (*A*, *A'*, *A''*, *B*, *B'*, and *B''*; or *Z*, *Z'*, and *Z''*; or both). In this way, system protection can be designed not only for EMP but also for other electromagnetic transients (such as near-strike lightning and electromagnetic interference). Furthermore, cost-effective, field maintainable protection can be achieved by properly selecting off-the-shelf shielding techniques and terminal protection devices and applying them to systems. See ELECTRIC PROTECTIVE DEVICES; ELECTRICAL INTERFERENCE; ELECTRICAL SHIELDING; ELECTROMAGNETIC RADIATION; LIGHTNING AND SURGE PROTECTION; NUCLEAR EXPLOSION. [R.A.Pf.]

**Electromagnetic pump** A pump that operates on the principle that a force is exerted on a current-carrying conductor in a magnetic field. The high electrical conductivity of the liquid metals pumped (liquid metals are used as the heat-transfer media in some nuclear reactors and magnetohydrodynamic systems) allows a pumping force to be developed within the metals when they are confined in a duct or channel and subjected to a magnetic field and to an electric current. These pumps are designed principally for use in liquid-metal-cooled reactor plants where liquid lithium, sodium, potassium, or sodium-potassium

alloys are pumped. Other metallic and nonmetallic liquids of sufficiently high electrical conductivity, such as mercury or molten aluminum, lead, and bismuth, may also be pumped in nonnuclear applications. The absence of moving parts within the pumped liquid eliminates the need for seals and bearings that are found in conventional mechanical pumps, thus minimizing leaks, maintenance, and repairs, and improving reliability. In liquid-metal-cooled nuclear reactor plants, electromagnetic pumps with a capacity of up to several thousand gallons per minute have operated without maintenance for decades. See MAGNETOHYDRODYNAMICS; NUCLEAR POWER; NUCLEAR REACTOR. [L.R.D.]

**Electromagnetic radiation** Energy transmitted through space or through a material medium in the form of electromagnetic waves. The term can also refer to the emission and propagation of such energy. Whenever an electric charge oscillates or is accelerated, a disturbance characterized by the existence of electric and magnetic fields propagates outward from it. This disturbance is called an electromagnetic wave. The frequency range of such waves is tremendous, as is shown by the electromagnetic spectrum in the table. The sources given are typical, but not mutually exclusive.

Electromagnetic spectrum			
Frequency, Hz	Wavelength, m	Nomenclature	Typical source
$10^{23}$	$3 \times 10^{-15}$	Cosmic photons	Astronomical
$10^{22}$	$3 \times 10^{-14}$	$\gamma$ -rays	Radioactive nuclei
$10^{21}$	$3 \times 10^{-13}$	$\gamma$ -rays, x-rays	
$10^{20}$	$3 \times 10^{-12}$	x-rays	Atomic inner shell
		Positron-electron annihilation	
$10^{19}$	$3 \times 10^{-11}$	Soft x-rays	Electron impact on a solid
$10^{18}$	$3 \times 10^{-10}$	Ultraviolet, x-rays	Atoms in sparks
$10^{17}$	$3 \times 10^{-9}$	Ultraviolet	Atoms in sparks and arcs
$10^{16}$	$3 \times 10^{-8}$	Ultraviolet	Atoms in sparks and arcs
$10^{15}$	$3 \times 10^{-7}$	Visible spectrum	Atoms, hot bodies, molecules
$10^{14}$	$3 \times 10^{-6}$	Infrared	Hot bodies, molecules
$10^{13}$	$3 \times 10^{-5}$	Infrared	Hot bodies, molecules
$10^{12}$	$3 \times 10^{-4}$	Far-infrared	Hot bodies, molecules
$10^{11}$	$3 \times 10^{-3}$	Microwaves	Electronic devices
$10^{10}$	$3 \times 10^{-2}$	Microwaves, radar	Electronic devices
$10^9$	$3 \times 10^{-1}$	Radar	Electronic devices
		Interstellar hydrogen	
$10^8$	3	Television, FM radio	Electronic devices
$10^7$	30	Short-wave radio	Electronic devices
$10^6$	300	AM radio	Electronic devices
$10^5$	3000	Long-wave radio	Electronic devices
$10^4$	$3 \times 10^4$	Induction heating	Electronic devices
$10^3$	$3 \times 10^5$		Electronic devices
100	$3 \times 10^6$	Power	Rotating machinery
10	$3 \times 10^7$	Power	Rotating machinery
1	$3 \times 10^8$		Commutated direct current
0	Infinity	Direct current	Batteries

In theory, any electromagnetic radiation can be detected by its heating effect. This method has actually been used over the range from x-rays to radio. Ionization effects measured by cloud chambers, photographic emulsions, ionization chambers, and Geiger counters have been used in the  $\gamma$ - and x-ray regions. Direct photography can be used from the  $\gamma$ -ray to the infrared region.

Fluorescence is effective in the x-ray and ultraviolet ranges. Bolometers, thermocouples, and other heat-measuring devices are used chiefly in the infrared and microwave regions. Crystal detectors, vacuum tubes, and transistors cover the microwave and radio frequency ranges. See ANTENNA (ELECTROMAGNETISM); DIFFRACTION; ELECTROMAGNETIC WAVE; GAMMA RAYS; HEAT RADIATION; INFRARED RADIATION; INTERFERENCE OF WAVES; LIGHT; MAXWELL'S EQUATIONS; MICROWAVE; POLARIZATION OF WAVES;

RADIATION; RADIO-WAVE PROPAGATION; REFLECTION OF ELECTROMAGNETIC RADIATION; REFRACTION OF WAVES; SCATTERING OF ELECTROMAGNETIC RADIATION; TRANSMISSION LINES; ULTRAVIOLET RADIATION; WAVE MOTION; X-RAYS. [W.R.Sm.]

**Electromagnetic wave** A disturbance, produced by the acceleration or oscillation of an electric charge, which has the characteristic time and spatial relations associated with progressive wave motion. A system of electric and magnetic fields moves outward from a region where electric charges are accelerated, such as an oscillating circuit or the target of an x-ray tube. The wide wavelength range over which such waves are observed is shown by the electromagnetic spectrum. The term electric wave, or hertzian wave, is often applied to electromagnetic waves in the radar and radio range. Electromagnetic waves may be confined in tubes, such as wave guides, or guided by transmission lines. They were predicted by J. C. Maxwell in 1864 and verified experimentally by H. Hertz in 1887. See ELECTROMAGNETIC RADIATION. [W.R.Sm.]

**Electromagnetic wave transmission** The transmission of electrical energy by wires, the broadcasting of radio signals, and the phenomenon of visible light are all examples of the propagation of electromagnetic energy. Electromagnetic energy travels in the form of a wave. Its speed of travel is approximately  $3 \times 10^8$  m/s (186,000 mi/s) in a vacuum and is somewhat slower than this in liquid and solid insulators. An electromagnetic wave does not penetrate far into an electrical conductor, and a wave that is incident on the surface of a good conductor is largely reflected. See ELECTROMAGNETIC WAVE.

Electromagnetic waves originate from accelerated electric charges. For example, a radio wave originates from the oscillatory acceleration of electrons in the transmitting antenna. The light that is produced within a laser originates when electrons fall from a higher energy level to a lower one.

The waves emitted from a source are oscillatory and are described in terms of frequency of oscillation. The method of generating an electromagnetic wave depends on the frequency used, as do the techniques of transmitting the energy to another location and utilizing it when it has been received. Communication of information to a distant point is generally accomplished through the use of electromagnetic energy as a carrier.

The illustration shows the configuration of the electric and magnetic fields about a short vertical antenna in which flows a sinusoidal current. The picture applies either to an antenna in free space (in which case the illustration shows only the upper half of the fields), or to an antenna projecting above the surface of a highly conducting plane surface. In the latter case the conducting plane represents to a first approximation the surface of the Earth. The fields have symmetry about the axis through the antenna. For pictorial simplicity only selected portions of the fields are shown in this illustration. The magnetic field is circular about the antenna, is perpendicular at every point to the direction of the electric field, and is proportional in intensity to the magnitude of the electric field, as in a plane wave. All parts of the wave travel radially outward from the antenna with the velocity equal to that of a plane wave in the same medium.

Often it is desired to concentrate the radiated energy into a narrow beam. This can be done either by the addition of more antenna elements or by placing a large reflector, generally parabolic in shape, behind the antenna. The production of a narrow beam requires an antenna array, or alternatively a reflector, that is large in width and height compared with a wavelength. The very narrow and concentrated beam that can be achieved by a laser is made possible by the extremely short wavelength of the radiation as compared with the cross-sectional dimensions of the radiating system.

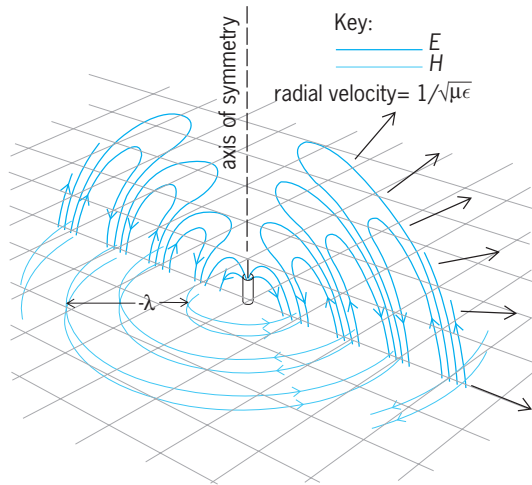

**Configuration of electric and magnetic fields about a short vertical antenna.**  $E$  = electric field intensity;  $H$  = magnetic field intensity;  $\mu$  = absolute permeability of the medium;  $\epsilon$  = permittivity of the medium;  $\gamma$  = wavelength.

The ground is a reasonably good, but not perfect, conductor; hence, the actual propagation over the surface of the Earth will show a more rapid decrease of field strength than that for a perfect conductor. Irregularities and obstructions may interfere. In long-range transmission the spherical shape of the Earth is important. Inhomogeneities in the atmosphere refract the wave somewhat. For long-range transmission, the ionized region high in the atmosphere known as the Kennelly-Heaviside layer, or ionosphere, can act as a reflector. See RADIO-WAVE PROPAGATION.

When an electromagnetic wave is introduced into the interior of a hollow metallic pipe of suitably large cross-sectional dimensions, the energy is guided along the interior of the pipe with comparatively little loss. The most common cross-sectional shapes are the rectangle and the circle. The cross-sectional dimensions of the tube must be greater than a certain fraction of the wavelength; otherwise the wave will not propagate in the tube. For this reason hollow waveguides are commonly used only at wavelengths of 10 cm or less (frequencies of 3000 MHz or higher). A dielectric rod can also be used as a waveguide. Such a rod, if of insufficient cross-sectional dimensions, can contain the electromagnetic wave by the phenomenon of total reflection at the surface. See WAVEGUIDE.

Electromagnetic energy can be propagated in a simple mode along two parallel conductors. Such a waveguiding system is termed a transmission line. Three common forms are the coaxial cable, two-wire line, and parallel strip line. As the wave propagates along the line, it is accompanied by currents which flow longitudinally in the conductors. These currents can be regarded as satisfying the boundary condition for the tangential field at the surface of the conductor. The conductors have a finite conductivity, and so these currents cause a transformation of electrical energy into heat. The energy lost comes from the stored energy of the wave, and so the wave, as it progresses, diminishes in amplitude. The conductors are necessarily supported by insulators which are imperfect and cause additional attenuation of the wave. See COAXIAL CABLE; TRANSMISSION LINES.

[W.C.Jo.]

**Electromagnetism** The branch of science dealing with the observations and laws relating electricity to magnetism. Electromagnetism is based upon the fundamental observations that a moving electric charge produces a magnetic field and that a charge moving in a magnetic field will experience a force. The magnetic field produced by a current is related to the current,

the shape of the conductor, and the magnetic properties of the medium around it by Ampère's law. The magnetic field at any point is described in terms of the force that it exerts upon a moving charge at that point. The electrical and magnetic units are defined in terms of the ampere, which in turn is defined from the force of one current upon another. The association of electricity and magnetism is also shown by electromagnetic induction, in which a changing magnetic field sets up an electric field within a conductor and causes the charges to move in the conductor. See AMPÈRE'S LAW; EDDY CURRENT; ELECTRICITY; ELECTROMAGNET; ELECTROMAGNETIC INDUCTION; FARADAY'S LAW OF INDUCTION; HALL EFFECT; INDUCTANCE; LENZ'S LAW; MAGNETIC CIRCUITS; MAGNETISM; RELUCTANCE.

[K.V.M.]

**Electrometallurgy** The branch of process metallurgy dealing with the use of electricity for smelting or refining of metals. The electrochemical effect of an electric current brings about the reduction of metallic compounds, and thereby the extraction of metals from their ores (electrowinning) or the purification of the metals (electrorefining).

In other metallurgical processes, electrically produced heat is utilized in smelting, refining, or alloy manufacturing. For a discussion of electrothermics, that is, the theory and applications of electric heating to metallurgy, See ELECTRIC FURNACE; ELECTRIC HEATING; ELECTROCHEMICAL PROCESS; STEEL MANUFACTURE.

[PDu.]

**Electrometer** A highly sensitive instrument which measures all or some of the following variables: current, charge, voltage, and resistance. There are two classes of electrometers, mechanical and electronic. The mechanical instruments have been largely replaced by electronic types. See CURRENT MEASUREMENT; ELECTRICAL MEASUREMENTS; VOLTAGE MEASUREMENT.

Mechanical electrometers rely for their operation on the mechanical forces associated with electrostatic fields. Attracted-disk instruments, in which the attractive force between two plates, with a potential difference between them, is measured in terms of the fundamental units of mass and length, are sometimes termed absolute electrometers. They are widely used as electrostatic voltmeters for measuring potentials greater than 1 kilovolt. See ELECTRICAL UNITS AND STANDARDS.

The quadrant electrometer consists of a cylindrical metal box divided into quadrants which stand on insulating pillars. Opposite quadrants are connected electrically, and a light, thin metal vane of large area is suspended by a conducting torsion fiber inside the quadrants. An unknown potential is applied across the two quadrant pairs, and electrostatic forces on the vane cause a deflection proportional to the potential. Potentials as low as 10 millivolts can be measured. Small charges and currents can also be measured if the capacitance between vane and quadrants is known. See ELECTROSCOPE; ELECTROSTATICS; VOLTMETER.

Electronic electrometers utilize some form of electronic amplifier, typically an operational amplifier with a field-effect-transistor input stage to minimize the input current. In the most sensitive applications, problems arise due to drift in the amplifier characteristics and electrical noise present in the circuit components. To obviate these effects, electrometers employing a vibrating capacitor or varactor diodes are used. The signal to be measured is converted to an alternating-current (ac) signal and subsequently amplified by an ac amplifier which is less susceptible to drift and noise. The amplified signal is finally reconverted to direct current (dc). See AMPLIFIER; ELECTRICAL NOISE; TRANSISTOR; VARACTOR.

[R.W.J.B.]

**Electromotive force (cells)** The voltage or electric potential difference across the terminals of a cell when no current



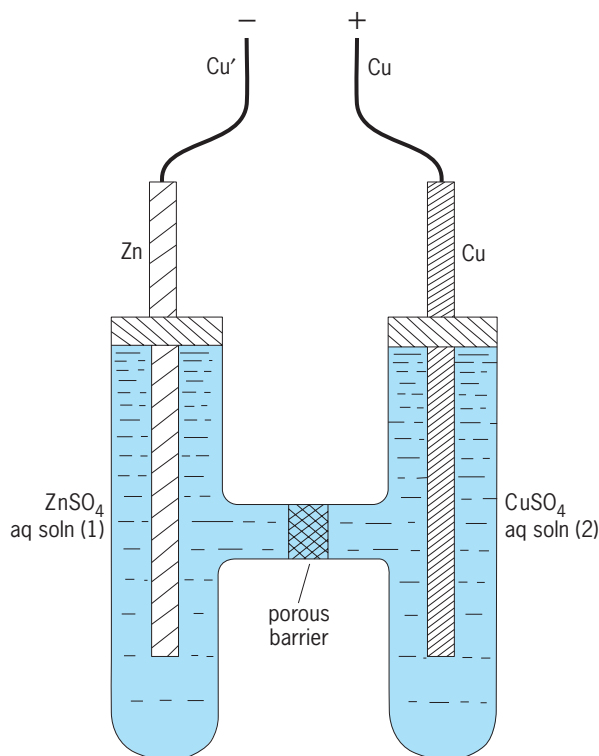

Cross-section diagram of Daniell cell. (After W. J. Moore, *Physical Chemistry, 5th ed., Longman, 1974*)

is drawn from it. The electromotive force (emf) is the sum of the electric potential differences produced by a separation of charges (electrons or ions) that can occur at each phase boundary (or interface) in the cell. The magnitude of each potential difference depends on the chemical nature of the two contacting phases. Thus, at the interface between two different metals, some electrons will have moved from the metal with a higher free energy of electrons to the metal with a lower free energy of electrons. The resultant charge separation will produce a potential difference, just as charge separation produces a voltage across a capacitor; at equilibrium this exactly opposes further electron flow. Similarly, potential differences can be produced when electrons partition across a metal|solution interface or metal|solid interface, and when ions partition across a solution|membrane|solution interface. See CHEMICAL THERMODYNAMICS; ELECTROMOTIVE FORCE (EMF).

How a cell emf is composed of the sum of interfacial potential differences is shown by the Daniell cell (see illustration), where aq soln denotes an aqueous solution, a solid line indicates a phase boundary, and the broken line a porous barrier permeable to all the ions in the adjacent solutions. The copper connector to the zinc electrode is denoted Cu'. The barrier prevents physical mixing of the zinc sulfate (ZnSO<sub>4</sub>) and copper sulfate (CuSO<sub>4</sub>) solutions.

The cell emf is the open-circuit (that is, zero current) potential difference measured between the two Cu leads (any potential-measuring device must ultimately measure the potential difference between two chemically identical phases, in this example the Cu and Cu' phases).

It is convenient to describe any electrochemical cell in terms of half cells. A half cell consists of an oxidant (Ox) and reductant (Red) such that  $\text{Ox} + ne^- \rightleftharpoons \text{Red}$ ; species Ox and Red are commonly referred to as a redox couple. The Daniell cell, for example, comprises the two half cells  $\text{Cu}^{2+} + 2e^- \rightleftharpoons \text{Cu}$  (redox couple is  $\text{Cu}^{2+} | \text{Cu}$ ) and  $\text{Zn}^{2+} + 2e^- \rightleftharpoons \text{Zn}$  (redox couple is  $\text{Zn}^{2+} | \text{Zn}$ ) with the half-cell potentials  $E_{\text{Cu}^{2+}|\text{Cu}}$  and  $E_{\text{Zn}^{2+}|\text{Zn}}$  given by Eqs. (1)

and (2), where  $F$  is the Faraday constant (96485.3 coulombs

$$E_{\text{Cu}^{2+}|\text{Cu}} = E_{\text{Cu}^{2+}|\text{Cu}}^\circ + \frac{RT}{2F} \ln a_{\text{Cu}^{2+}} \quad (1)$$

$$E_{\text{Zn}^{2+}|\text{Zn}} = E_{\text{Zn}^{2+}|\text{Zn}}^\circ + \frac{RT}{2F} \ln a_{\text{Zn}^{2+}} \quad (2)$$

for the Avogadro number of electrons),  $R$  is the gas constant (8.3144 joules/mole/degree Kelvin),  $T$  is the temperature in Kelvin, and  $a$  is the activity of the species shown. Such expressions are useful only if the standard electrode potential  $E^\circ$  value for each half cell is known. Values of  $E^\circ$  can be assigned to any given half cell by arbitrarily specifying that  $E_{\text{H}^+|\text{H}_2}^\circ$  [the  $E^\circ$  for the standard hydrogen electrode (SHE) half cell,  $\text{H}^+(\text{aq}, a = 1) + e^- \rightleftharpoons \frac{1}{2}\text{H}_2(\text{g}, 1 \text{ atm})$ ] is zero. The temperature dependence  $dE_{\text{H}^+|\text{H}_2}^\circ/dT$  is also specified as zero.  $E^\circ$  values versus the SHE for selected half cells are given in the table. In principle, any  $E^\circ$  (and its temperature dependence) can be measured directly versus the SHE, or another half cell whose electrode potential and temperature dependence have been determined. Such an electrode is termed a reference electrode. The reference electrode is a half cell designed so that its potential is stable, and reproducible, and it neither contaminates nor is contaminated by the medium in which it is immersed. Two convenient reference electrodes commonly used in aqueous systems are the saturated calomel and the silver|silver chloride electrodes (see table). See ELECTROCHEMISTRY; OXIDATION-REDUCTION; REFERENCE ELECTRODE.

The emf produced by a single cell or a set of cells in series (a battery) is used as a dc power source for a wide array of applications, ranging from powering wristwatches to emergency power supplies. The emf of the saturated Weston cell (scheme 3;



sat aq = saturated aqueous solution) still serves as a high-level voltage reference for the National Institute of Standards and Technology. However, Josephson arrays are now considered the most precise voltage references, and Zener diodes are used to produce reference voltages for many laboratory and field voltage measurement devices.

There are also a few photoelectrochemical cells with possible application in solar energy conversion, such as the Grätzel cell (scheme 4; nonaq = nonaqueous solution), where the cell emf

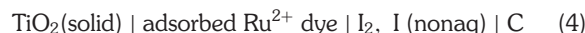

is produced by absorption of visible light.

Selected standard electrode potentials at 25°C

Electrode reaction	$E^\circ/V$
$\text{Li}^+(\text{aq}) + e^- \rightleftharpoons \text{Li}(\text{s})$	-3.045
$\text{Zn}^{2+}(\text{aq}) + 2e^- \rightleftharpoons \text{Zn}(\text{s})$	-0.763
$2\text{H}^+(\text{aq}) + 2e^- \rightleftharpoons \text{H}_2(\text{g})$	0
$\text{Hg}_2\text{Cl}_2(\text{s}) + 2e^- \rightleftharpoons 2\text{Hg}(\text{l}) + 2\text{Cl}^-(\text{sat aq KCl})$	0.246
$\text{AgCl}(\text{s}) + e^- \rightleftharpoons \text{Ag}(\text{s}) + \text{Cl}^-(\text{aq})$	0.222
$\text{Cu}^{2+}(\text{aq}) + 2e^- \rightleftharpoons \text{Cu}(\text{s})$	0.337
$\text{Fe}(\text{CN})_6^{3-}(\text{aq}) + e^- \rightleftharpoons \text{Fe}(\text{CN})_6^{4-}(\text{aq})$	0.69
$\text{O}_2(\text{g}) + 4\text{H}^+(\text{aq}) + 4e^- \rightleftharpoons 2\text{H}_2\text{O}$	1.223
$\text{F}_2(\text{g}) + 2\text{H}^+ + 2e^- \rightleftharpoons 2\text{HF}(\text{aq})$	3.06

The emf of a cell can also be used as an indicator of chemical composition. Devices that depend on the measurement of an open circuit-cell potential work well when the device is sensitive to a single analyte, but they are notoriously sensitive to interferences. An example is the so-called alkaline error that occurs when glass electrodes are used to measure very high pH values. For complex systems containing several species that can undergo electrochemical reaction, individual  $E^\circ$  values can be determined using electroanalytical techniques that involve controlling the potential applied to a cell with measurement of the resultant current. Techniques such as polarography and cyclic voltammetry, for example, involve changing the potential of an indicator electrode and observing a wave or peak in the current at the redox potential of the species in solution; the height of the wave or peak indicates the concentration of that species. See BATTERY; ELECTROCHEMICAL TECHNIQUES; FUEL CELL; POLAROGRAPHIC ANALYSIS. [M.D.Ar.; S.W.F.]

**Electromotive force (emf)** A measure of the strength of a source of electrical energy. The term is often shortened to emf. It is not a force in the usual mechanical sense (and for this reason has sometimes been called electromotance), but it is a conveniently descriptive term for the agency which drives current through an electric circuit. In the simple case of a direct current  $I$  (measured in amperes) flowing through a resistor  $R$  (in ohms), Ohm's law states that there will be a voltage drop (or potential difference) of  $V = IR$  (in volts) across the resistor. To cause this current to flow requires a source with emf (also measured in volts)  $E = V$ . More generally, Kirchhoff's voltage law states that the sum of the source emf's taken around any closed path in an electric circuit is equal to the sum of the voltage drops. This is equivalent to the statement that the total emf in a closed circuit is equal to the line integral of the electric field strength around the circuit. See ELECTRIC CURRENT; ELECTRIC FIELD; ELECTRICAL RESISTANCE; OHM'S LAW.

An emf may be steady (direct), as for a battery, or time-varying, as for a charged capacitor discharging through a resistor. Emf's may be generated by a variety of physical, chemical, and biological processes. Some of the more important are:

1. Electrochemical reactions, as used in direct-current (dc) batteries, in which the emf results from the reactions between electrolyte and electrodes. See BATTERY; ELECTROCHEMISTRY; ELECTROMOTIVE FORCE (CELLS).

2. Electromagnetic induction, in which the emf results from a change in the magnetic flux linking the circuit. This finds application in alternating-current rotary generators and transformers, providing the basis for the electricity supply industry. See ALTERNATING-CURRENT GENERATOR; ELECTROMAGNETIC INDUCTION; FARADAY'S LAW OF INDUCTION; TRANSFORMER.

3. Thermoelectric effects, in which a temperature difference between different parts of a circuit produces an emf. The main use is for the measurement of temperature by means of thermocouples; there are some applications to electric power generation. See THERMOCOUPLE; THERMOELECTRIC POWER GENERATOR; THERMOELECTRICITY.

4. The photovoltaic effect, in which the absorption of light (or, more generally, electromagnetic radiation) in a semiconductor produces an emf. This is widely used for scientific purposes in radiation detectors and also, increasingly, for the generation of electric power from the Sun's radiation. See PHOTOVOLTAIC EFFECT; RADIOMETRY; SOLAR CELL.

5. The piezoelectric effect, in which the application of mechanical stress to certain types of crystal generates an emf. There are applications in sound recording, in ultrasonics, and in various types of measurement transducer. See ALTERNATING-CURRENT CIRCUIT THEORY; DIRECT-CURRENT CIRCUIT THEORY; DIRECT-CURRENT MOTOR; KIRCHHOFF'S LAWS OF ELECTRIC CIRCUITS; MICROPHONE; PIEZOELECTRICITY; TRANSDUCER; ULTRASONICS. [A.E.Ba.]

**Electromyography** The detection and recording of electrical activity generated by muscle fibers. The basic elements of motor control in the body are the motor units which comprise motor neurons in the brainstem or spinal cord, their axons, and from ten to several hundred muscle fibers supplied by each motor neuron. Motor units vary in the size and properties of their motoneurons, the sizes and conduction velocities of their axons, the morphology of their nerve muscle junctions, and the structure and physiological properties of the muscle fibers supplied by each motor neuron.

Impulses originating in single motoneurons in response to various command signals from the central nervous system conduct to the periphery of the unit, normally causing all the muscle fibers in the unit to discharge. The electrical activity generated by the more or less synchronous discharges of all the muscle fibers in the unit may be detected by recording electrodes on the skin surface or by needles inserted into the muscle. Such potentials reflect the electrical activity generated by the whole motor unit.

Diseases affecting motor neurons are sometimes accompanied by spontaneous discharges of the axons. Additionally, degeneration of motor axons may leave some muscle fibers deprived of their normal innervation, some of which spontaneously fire. Such single muscle-fiber discharges are called fibrillations and are readily detected for diagnostic purposes by needle electrodes inserted into the muscle.

Electromyography may also be used to study primary muscle diseases such as the muscular dystrophies, and a wide variety of other metabolic inflammatory and congenital myopathies affecting the muscle fibers rather than motor neurons or their axons. See BIOPOTENTIALS AND IONIC CURRENTS; ELECTRODIAGNOSIS. [W.F.Br.]

**Electron** An elementary particle which is the negatively charged constituent of ordinary matter. The electron is the lightest known particle which possesses an electric charge. Its rest mass is  $m_e \cong 9.1 \times 10^{-28}$  g, about  $1/1836$  of the mass of the proton or neutron, which are, respectively, the positively charged and neutral constituents of ordinary matter. Discovered in 1895 by J. J. Thomson in the form of cathode rays, the electron was the first elementary particle to be identified. See ELECTRIC CHARGE; ELEMENTARY PARTICLE; NUCLEAR STRUCTURE.

The charge of the electron is  $-e \cong -4.8 \times 10^{-10}$  esu =  $-1.6 \times 10^{-19}$  coulomb. The sign of the electron's charge is negative by convention, and that of the equally charged proton is positive. This is a somewhat unfortunate convention, because the flow of electrons in a conductor is thus opposite to the conventional direction of the current.

Electrons are emitted in radioactivity (as beta rays) and in many other decay processes; for instance, the ultimate decay products of all mesons are electrons, neutrinos, and photons, the meson's charge being carried away by the electrons. The electron itself is completely stable. Electrons contribute the bulk to ordinary matter; the volume of an atom is nearly all occupied by the cloud of electrons surrounding the nucleus, which occupies only about  $10^{-13}$  of the atom's volume. The chemical properties of ordinary matter are determined by the electron cloud. See BETA; MESON; RADIOACTIVITY.

The electron obeys the Fermi-Dirac statistics, and for this reason is often called a fermion. One of the primary attributes of matter, impenetrability, results from the fact that the electron, being a fermion, obeys the Pauli exclusion principle; the world would be completely different if the lightest charged particle were a boson, that is, a particle that obeys Bose-Einstein statistics. See BOSE-EINSTEIN STATISTICS; EXCLUSION PRINCIPLE; FERMI-DIRAC STATISTICS; POSITRON. [C.J.G.]

**Magnetic moment.** The electron has magnetic properties by virtue of (1) its orbital motion about the nucleus of its parent atom and (2) its rotation about its own axis. The magnetic

properties are best described through the magnetic dipole moment associated with 1 and 2. The classical analog of the orbital magnetic dipole moment is the dipole moment of a small current-carrying circuit. The electron spin magnetic dipole moment may be thought of as arising from the circulation of charge, that is, a current, about the electron axis; but a classical analog to this moment has much less meaning than that to the orbital magnetic dipole moment. The magnetic moments of the electrons in the atoms that make up a solid give rise to the bulk magnetism of the solid.

**Spin.** That property of an electron which gives rise to its angular momentum about an axis within the electron. Spin is one of the permanent and basic properties of the electron. Both the spin and the associated magnetic dipole moment of the electron were postulated by G. E. Uhlenbeck and S. Goudsmit in 1925 as necessary to allow the interpretation of many observed effects, among them the so-called anomalous Zeeman effect, the existence of doublets (pairs of closely spaced lines) in the spectra of the alkali atoms, and certain features of x-ray spectra. See SPIN (QUANTUM MECHANICS).

The spin quantum number is  $s$ , where  $s$  is always  $1/2$ . This means that the component of spin angular momentum along a preferred direction, such as the direction of a magnetic field, is  $\pm 1/2\hbar$ , where  $\hbar$  is Planck's constant  $h$  divided by  $2\pi$ . The spin angular momentum of the electron is not to be confused with the orbital angular momentum of the electron associated with its motion about the nucleus. In the latter case the maximum component of angular momentum along a preferred direction is  $l\hbar$ , where  $l$  is the angular momentum quantum number and may be any positive integer or zero. See QUANTUM NUMBERS.

The electron has a magnetic dipole moment by virtue of its spin. The approximate value of the dipole moment is the Bohr magneton  $\mu_0$  which is equal to  $eh/4\pi mc = 9.27 \times 10^{-21}$  erg/oersted, where  $e$  is the electron charge measured in electrostatic units,  $m$  is the mass of the electron, and  $c$  is the velocity of light. (In SI units,  $\mu_0 = 9.27 \times 10^{-24}$  joule/tesla.) The orbital motion of the electron also gives rise to a magnetic dipole moment  $\mu_l$ , that is equal to  $\mu_0$  when  $l = 1$ . [Ar.R.]

**Electron affinity** The amount of energy released when an electron at rest is captured by a species M, producing the negative ion  $M^-$ . The electron affinity of a species M can also be thought of as the ionization potential of the negative ion  $M^-$ . Stated in terms of a chemical equation, the electron affinity of a species M is equal to the exothermicity of the reaction  $e + M \rightarrow M^-$ , where the negative ion  $M^-$  is left in its lowest electronic, vibrational, and rotational state. See IONIZATION POTENTIAL.

If the electron affinity of M is negative, the  $M^-$  ion is unstable with respect to decomposition into  $M + e$ . Most atoms have positive electron affinities, even though there is no net Coulomb attraction between the electron and the atom until the electron is close enough to be "a part of the atom." The simple rules of chemical valency provide a qualitative guide to the magnitude of electron affinities. Thus the noble gases, which have a filled outer electronic shell and are chemically inert, are not capable of binding an additional electron to form a negative ion. The largest electron affinities are possessed by the halogens, atoms which require only one additional electron to fill the valence shell. See VALENCE.

The major exception to this concept is that multiply charged negative ions—for example,  $O^{2-}$ , one of many multiply charged negative ions which are stable in solution—are not stable in the gas phase. The ability to place more than one additional electron in the valence shell of a neutral atom or molecule appears to come from the medium: the solvent shell surrounding the ion in liquid solutions and the amorphous or crystalline region surrounding the ion in solids. [W.C.L.]

**Electron capture** The process in which an atom or ion passing through a material medium either loses or gains one or more orbital electrons. In the passage of charged particles (defined here as nuclei having more or less than  $Z$  atomic electrons, where  $Z$  is the atomic number) through matter, the capture (and loss) of electrons is an important process in the slowing down of the particles and therefore has a strong influence on their range. Thus a neutral hydrogen atom loses only about half as much energy per centimeter as the positively charged proton in passing through matter consisting of light elements.

For the ordinary charged particles (alpha particles and protons) the capture process is important only at low energies, when the particle velocity is of the order of electron velocities in the stopping material, and thus is important at the end of the range. For fission fragments, however, which initially have a large excess of positive charges, electron capture occurs immediately and continues throughout the slowing-down process. This fact causes the energy-loss mechanisms at the latter part of the range to be different for fission fragments and protons or  $\alpha$ -particles. See NUCLEAR FISSION.

The nuclear capture of electrons ( $K$  capture) occurs by a process quite different from atomic capture and is in fact a consequence of the general beta interaction. This general interaction includes  $\beta^-$  decay (the oldest known beta transformation and hence the name),  $\beta^+$  decay (or positron decay), and  $K$  capture, the latter so called because the electron captured by the nucleus is taken from the  $K$  shell (the shell nearest the nucleus) of atomic electrons. A second-order process, called  $L$  capture, can also occur, in which (to speak pictorially and thus somewhat imprecisely) an  $s$  electron (from the  $K$  shell) is captured with the simultaneous transition of a  $p$  electron (from the  $L$  shell) to the  $K$  shell with the emission of gamma radiation. See RADIOACTIVITY. [McA.H.H.]

**Electron configuration** The orbital arrangement of an atom's electrons. Negatively charged electrons are attracted to a positively charged nucleus to form an atom or ion. Although such bound electrons exhibit a high degree of quantum-mechanical wavelike behavior, there still remain particle aspects to their motion. Bound electrons occupy orbitals that are somewhat concentrated in spatial shells lying at different distances from the nucleus. As the set of electron energies allowed by quantum mechanics is discrete, so is the set of mean shell radii. Both these quantized physical quantities are primarily specified by integral values of the principal, or total, quantum number  $n$ . The full electron configuration of an atom is correlated with a set of values for all the quantum numbers of each and every electron. In addition to  $n$ , another important quantum number is  $l$ , an integer representing the orbital angular momentum of an electron in units of  $h/2\pi$ , where  $h$  is Planck's constant. The values 1, 2, 3, 4, 5, 6, 7 for  $n$  and 0, 1, 2, 3 for  $l$  together suffice to describe the electron configurations of all known normal atoms and ions, that is, those that have their lowest possible values of total electronic energy. The first seven shells are also given the letter designations  $K, L, M, N, O, P,$  and  $Q$  respectively. Electrons with  $l$  equal to 0, 1, 2, and 3 are designated  $s, p, d,$  and  $f$ , respectively. See QUANTUM MECHANICS; QUANTUM NUMBERS.

In any configuration the number of equivalent electrons (same  $n$  and  $l$ ) is indicated by an integral exponent (not a quantum number) attached to the letters  $s, p, d,$  and  $f$ . According to the Pauli exclusion principle, the maximum is  $s^2, p^6, d^{10},$  and  $f^{14}$ . See EXCLUSION PRINCIPLE.

An electron configuration is categorized as having even or odd parity, according to whether the sum of  $p$  and  $f$  electrons is even or odd. Strong spectral lines result only from transitions between configurations of unlike parity. See PARITY (QUANTUM MECHANICS).

Distribution of electrons in the atoms																								
Element and atomic number	K			L			M			N				O				Ground term	Ionization potential, eV					
	1,0 1s	2,0 2s	2,1 2p	3,0 3s	3,1 3p	3,2 3d	4,0 4s	4,1 4p	4,2 4d	4,3 4f	5,0 5s	5,1 5p	5,2 5d	5,3 5f										
H 1	1	—	—	—	—	—	—	—	—	—	—	—	—	—	$^2S_{1/2}$	13.5981								
He 2	2	—	—	—	—	—	—	—	—	—	—	—	—	—	$^1S_0$	24.5868								
Li 3	2	1	—	—	—	—	—	—	—	—	—	—	—	—	$^2S_{1/2}$	5.3916								
Be 4	2	2	—	—	—	—	—	—	—	—	—	—	—	—	$^1S_0$	9.322								
B 5	2	2	1	—	—	—	—	—	—	—	—	—	—	—	$^2P_{1/2}^\circ$	8.298								
C 6	2	2	2	—	—	—	—	—	—	—	—	—	—	—	$^3P_0$	11.260								
N 7	2	2	3	—	—	—	—	—	—	—	—	—	—	—	$^4S_{3/2}$	14.534								
O 8	2	2	4	—	—	—	—	—	—	—	—	—	—	—	$^3P_2$	13.618								
F 9	2	2	5	—	—	—	—	—	—	—	—	—	—	—	$^2P_{3/2}^\circ$	17.422								
Ne 10	2	2	6	—	—	—	—	—	—	—	—	—	—	—	$^1S_0$	21.564								
Na 11	Neon configuration			1	—	—	—	—	—	—	—	—	—	—	$^2S_{1/2}$	5.139								
Mg 12				2	—	—	—	—	—	—	—	—	—	—	—	—	$^1S_0$	7.646						
Al 13				2	1	—	—	—	—	—	—	—	—	—	—	—	$^2P_{1/2}^\circ$	5.986						
Si 14				2	2	—	—	—	—	—	—	—	—	—	—	—	$^3P_0$	8.151						
P 15				2	3	—	—	—	—	—	—	—	—	—	—	—	$^4S_{3/2}$	10.486						
S 16				2	4	—	—	—	—	—	—	—	—	—	—	—	$^3P_2$	10.360						
Cl 17				2	5	—	—	—	—	—	—	—	—	—	—	—	$^2P_{3/2}^\circ$	12.967						
Ar 18				2	6	—	—	—	—	—	—	—	—	—	—	—	$^1S_0$	15.759						
K 19	Argon configuration					—	1	—	—	—	—	—	—	—	$^2S_{1/2}$	4.341								
Ca 20						—	2	—	—	—	—	—	—	—	—	—	—	—	$^1S_0$	6.113				
Sc 21						1	2	—	—	—	—	—	—	—	—	—	—	—	$^2D_{3/2}$	6.54				
Ti 22						2	2	—	—	—	—	—	—	—	—	—	—	—	$^3F_2$	6.82				
V 23						3	2	—	—	—	—	—	—	—	—	—	—	—	$^4F_{3/2}$	6.74				
Cr 24						5	1	—	—	—	—	—	—	—	—	—	—	—	$^7S_3$	6.765				
Mn 25						5	2	—	—	—	—	—	—	—	—	—	—	—	$^6S_{5/2}$	7.432				
Fe 26						6	2	—	—	—	—	—	—	—	—	—	—	—	$^5D_4$	7.870				
Co 27						7	2	—	—	—	—	—	—	—	—	—	—	—	$^4F_{9/2}$	7.86				
Ni 28						8	2	—	—	—	—	—	—	—	—	—	—	—	$^3F_4$	7.635				
Cu 29						10	1	—	—	—	—	—	—	—	—	—	—	—	$^2S_{1/2}$	7.726				
Zn 30						10	2	—	—	—	—	—	—	—	—	—	—	—	$^1S_0$	9.394				
Ga 31						10	2	1	—	—	—	—	—	—	—	—	—	—	$^2P_{1/2}^\circ$	5.999				
Ge 32						10	2	2	—	—	—	—	—	—	—	—	—	—	$^3P_0$	7.899				
As 33						10	2	3	—	—	—	—	—	—	—	—	—	—	$^4S_{3/2}$	9.81				
Se 34						10	2	4	—	—	—	—	—	—	—	—	—	—	$^3P_2$	9.752				
Br 35						10	2	5	—	—	—	—	—	—	—	—	—	—	$^2P_{3/2}^\circ$	11.814				
Kr 36						10	2	6	—	—	—	—	—	—	—	—	—	—	$^1S_0$	13.999				
Rb 37	Krypton configuration									—	—	1	—	—	—	$^2S_{1/2}$	4.177							
Sr 38										—	—	2	—	—	—	—	—	—	—	—	—	$^1S_0$	5.693	
Y 39										1	—	2	—	—	—	—	—	—	—	—	—	—	$^2D_{3/2}$	6.38
Zr 40										2	—	2	—	—	—	—	—	—	—	—	—	—	$^3F_2$	6.84
Nb 41										4	—	1	—	—	—	—	—	—	—	—	—	—	$^6D_{1/2}$	6.88
Mo 42										5	—	1	—	—	—	—	—	—	—	—	—	—	$^7S_3$	7.10
Tc 43										5	—	2	—	—	—	—	—	—	—	—	—	—	$^6S_{5/2}$	7.28
Ru 44										7	—	1	—	—	—	—	—	—	—	—	—	—	$^5F_5$	7.366
Rh 45										8	—	1	—	—	—	—	—	—	—	—	—	—	$^4F_{9/2}$	7.46
Pd 46										10	—	—	—	—	—	—	—	—	—	—	—	—	$^1S_0$	8.33
Ag 47	Palladium configuration			—	1	—	—	—	—	—	—	—	—	—	$^2S_{1/2}$	7.576								
Cd 48				—	2	—	—	—	—	—	—	—	—	—	—	—	$^1S_0$	8.993						
In 49				—	2	—	—	—	—	—	—	—	—	—	—	—	$^2P_{1/2}^\circ$	5.786						
Sn 50				—	2	—	—	—	—	—	—	—	—	—	—	—	$^3P_0$	7.344						
Sb 51				—	2	3	—	—	—	—	—	—	—	—	—	—	$^4S_{3/2}$	8.641						
Te 52				—	2	4	—	—	—	—	—	—	—	—	—	—	$^3P_2$	9.01						
I 53				—	2	5	—	—	—	—	—	—	—	—	—	—	$^2P_{3/2}^\circ$	10.457						
Xe 54				—	2	6	—	—	—	—	—	—	—	—	—	—	$^1S_0$	12.130						

(continued)

Insofar as they are known from spectroscopic investigations, the electron configurations characteristic of the normal or ground states of the first 103 chemical elements are shown in the table.

In the next-to-last column of the table, the spectral term of the energy level with lowest total electronic energy is shown. The main part of the term symbol is a capital letter, *S*, *P*, *D*, *F*, and so on, that represents the total electronic orbital angular

momentum. Attached to this is a superior prefix, 1, 2, 3, 4, and so on, that indicates the multiplicity, and an anterior suffix, 0,  $1/2$ , 1,  $3/2$ , 2,  $5/2$ , and so on, that shows the total angular momentum, or *J* value, of the atom in the given state. A sign ° above the *J* value signifies that the spectral term and electron configuration have odd parity.

The last column of the table presents the first ionization potential of the atom, the energy required to remove from an

Distribution of electrons in the atoms (cont.)

Element and atomic number	Configuration of inner shells	N	O					P			Q	Ground term	Ionization potential, eV
		4,3 4f	5,0 5s	5,1 5p	5,2 5d	5,3 5f	6,0 6s	6,1 6p	6,2 6d	7,0 7s			
Cs 55		—			—	—	1	—	—	—	$2S_{1/2}$	3.894	
Ba 56		—			—	—	2	—	—	—	$1S_0$	5.211	
La 57		—			1	—	2	—	—	—	$2D_{3/2}$	5.5770	
Ce 58		1			1	—	2	—	—	—	$1G_4$	5.466	
Pr 59		3			—	—	2	—	—	—	$4I_{9/2}$	5.422	
Nd 60		4			—	—	2	—	—	—	$5I_4$	5.489	
Pm 61		5			—	—	2	—	—	—	$6H_{5/2}$	5.554	
Sm 62	The shells 1s to 4d contain 46 electrons	6	The shells 5s to 5p contain 8 electrons		—	—	2	—	—	—	$7F_0$	5.631	
Eu 63		7		—	—	—	2	—	—	—	—	$8S_{7/2}$	5.666
Gd 64		7		1	—	—	2	—	—	—	—	$9D_{5/2}$	6.141
Tb 65		9		—	—	—	2	—	—	—	—	$6H_{15/2}$	5.852
Dy 66		10		—	—	—	2	—	—	—	—	$5I_8$	5.927
Ho 67		11		—	—	—	2	—	—	—	—	$4I_{15/2}$	6.018
Er 68		12		—	—	—	2	—	—	—	—	$3H_6$	6.101
Tm 69		13		—	—	—	2	—	—	—	—	$2F_{7/2}$	6.184
Yb 70		14		—	—	—	2	—	—	—	—	$1S_0$	6.254
Lu 71		14		1	—	—	2	—	—	—	—	$2D_{3/2}$	5.426
Hf 72					2	—	2	—	—	—	$3F_2$	6.865	
Ta 73					3	—	2	—	—	—	$4F_{3/2}$	7.88	
W 74	The shells 1s to 5p contain 68 electrons	4			—	—	2	—	—	—	$5D_0$	7.98	
Re 75		5			—	—	2	—	—	—	$6S_{5/2}$	7.87	
Os 76		6			—	—	2	—	—	—	$5D_4$	8.5	
Ir 77		7			—	—	2	—	—	—	$4F_{9/2}$	9.1	
Pt 78		9			—	—	1	—	—	—	$3D_3$	9.0	
Au 79						—	—	1	—	—	—	$2S_{1/2}$	9.22
Hg 80					—	—	2	—	—	—	$1S_0$	10.43	
Tl 81					—	—	2	1	—	—	$2P_{1/2}^1$	6.108	
Pb 82					—	—	2	2	—	—	$3P_0$	7.417	
Bi 83					—	—	2	3	—	—	$4S_{3/2}$	7.289	
Po 84					—	—	2	4	—	—	$3P_2$	8.43	
At 85					—	—	2	5	—	—	$2P_{3/2}^2$		
Rn 86					—	—	2	6	—	—	$1S_0$	10.749	
Fr 87					—	—	2	6	—	1	$2S_{1/2}$		
Ra 88					—	—	2	6	—	2	$1S_0$	5.278	
Ac 89					—	—	2	6	1	2	$2D_{3/2}$	5.17	
Th 90					—	—	2	6	2	2	$3F_2$	6.08	
Pa 91	The shells 1s to 5d contain 78 electrons				2	—	2	6	1	2	$4K_{11/2}$	5.89	
U 92					3	—	2	6	1	2	$5L_6$	6.05	
Np 93					4	—	2	6	1	2	$6L_{11/2}$	6.19	
Pu 94					6	—	2	6	—	2	$7F_0$	6.06	
Am 95					7	—	2	6	—	2	$8S_{7/2}$	5.993	
Cm 96					7	—	2	6	1	2	$9D_2$	6.02	
Bk 97					9	—	2	6	0	2	$6He_{5/2}$	6.23	
Cf 98					10	—	2	6	0	2	$5I_8$	6.30	
Es 99					11	—	2	6	0	2	$4I_{15/2}$	6.42	
Fm 100					12	—	2	6	0	2	$3H_6$	6.50	
Md 101					13	—	2	6	0	2	$2F_{7/2}^2$	6.58	
No 102					14	—	2	6	0	2	$1S_0$	6.65	
Lw 103					(14)	—	2	6	(1)	(2)			

atom its least firmly bound electron and transform a neutral atom into a singly charged ion. See ATOMIC STRUCTURE AND SPECTRA; IONIZATION POTENTIAL. (J.E.B.)

**Electron diffraction** The phenomenon associated with interference processes that occur when electrons are scattered by atoms to form diffraction patterns. The wave character of electrons is shown most strikingly, and doubtless most conclusively, by the phenomena of interference. For this reason, the diffraction of electrons presents the most obvious confirmation of quantum mechanics. Because of the dependence of the diffraction pattern on the distances between the atoms, electron diffraction is also an important tool for the study of the structure of crystals and of free molecules, analogous to the use of x-rays for these purposes. See X-RAY CRYSTALLOGRAPHY; X-RAY DIFFRACTION.

According to energy  $E = eV$  (where  $e$  is electron charge and  $V$  is potential difference), two major techniques of structure analysis with electron beams are distinguished: low-energy electron

diffraction (LEED) [ $E \simeq 5\text{--}500$  eV] and high-energy electron diffraction (HEED) [ $E \simeq 5\text{--}500$  keV]. In addition, electrons generated in condensed matter by incident electrons or x-ray photons are diffracted (in Auger electron diffraction and photoelectron diffraction). Unlike neutrons and x-rays, electrons penetrate matter only for a very short distance before they lose energy (by inelastic scattering) or are scattered elastically (diffracted). See COHERENCE; DIFFRACTION; INTERFERENCE OF WAVES; MEAN FREE PATH; QUANTUM MECHANICS.

**Low-energy electron diffraction.** LEED is used mainly for the study of the structure of single-crystal surfaces and of processes on such surfaces that are associated with changes in the lateral periodicity of the surface. A monochromatic, nearly parallel electron beam, of  $10^{-4}$  to  $10^{-3}$  m ( $4 \times 10^{-3}$  to  $4 \times 10^{-2}$  in.) in diameter, strikes the surface, usually at normal incidence. The elastically backscattered electrons are separated from all other electrons by a retarding field and detected with a suitable movable collector or, more frequently on a hemispherical fluorescent

screen with the crystal in its center. The intensity of the diffraction spots can be measured as a function of the energy of the incident electrons to obtain so-called  $I(V)$  curves.

The most important contribution of LEED is to the understanding of chemisorption, which precedes corrosion and, in many cases, epitaxy. Here, not only the structure of many adsorption systems, mainly of gases on metals, or metals on other metals and semiconductors, has been studied, but also the kinetics of the adsorption and desorption process as well as changes in the adsorption layer upon heating. The combination of LEED with Auger electron spectroscopy (AES) and with work-function measurements has proven particularly powerful in these studies, because such methods give the coverage and information on the location of the adsorbed atoms normal to the surface. Combining LEED with other complementary techniques such as ion scattering spectroscopy, electron energy loss spectroscopy, or photoelectron spectroscopy has become increasingly popular and can enable the elimination of ambiguities in the interpretation of many LEED results. See ADSORPTION; AUGER EFFECT; CORROSION; ELECTRON SPECTROSCOPY; SURFACE AND INTERFACIAL CHEMISTRY; SURFACE PHYSICS.

**High-energy electron diffraction.** HEED is used mainly for the study of the structure of thin foils, films, and small particles (thickness or diameter of  $10^{-9}$  to  $10^{-6}$  m or  $4 \times 10^{-8}$  to  $4 \times 10^{-5}$  in.), of molecules, and also of the surfaces of crystalline materials. A monochromatic, usually nearly parallel, electron beam with a diameter of  $10^{-3}$  to  $10^{-8}$  m ( $4 \times 10^{-2}$  to  $4 \times 10^{-7}$  in.) is incident on the target. The forward-scattered electrons (backscattering is negligible) are detected by means of a fluorescent screen, a photoplate, or some other current-sensitive detector, usually without the inelastically scattered electrons being eliminated.

Similar to LEED, reflection HEED (RHEED) can be used for the determination of the lateral arrangement of the atoms in the topmost layers of the surface, including the structure of adsorbed layers. Although it is more convenient to deduce the periodicity of the atomic arrangement parallel to the surface from LEED patterns than from RHEED patterns, LEED frequently becomes inapplicable when the surface is rough. This usually occurs in the later stages of corrosion or in precipitation. In such investigations RHEED is far superior to LEED because the fast electrons can penetrate the asperities and produce a transmission HEED (THEED) pattern. RHEED has become particularly important for thin-film growth monitoring via the specular beam intensity oscillations caused by monolayer-by-monolayer growth. See CRYSTAL GROWTH.

In scanning HEED (SHEED) the diffracted electrons are not recorded on photographic film but are directly measured electronically with sensitive detectors. By moving the detector across the diffraction pattern or by deflecting the diffracted electrons across a stationary detector (scanning), the intensity distribution in the diffraction pattern can be displayed quantitatively on an XY recorder. The main application of SHEED is in the study of processes which are accompanied by changes of the intensity distribution, such as the growth of thin films and annealing and corrosion processes.

The technological importance of thin film and interface devices has led to an upsurge of thin film growth studies by conventional transmission HEED (THEED), usually combined with transmission electron microscopy. Information obtained this way has been mainly on the orientation of the crystallites composing the film. [E.B.]

**Diffraction in gases and liquids.** Electron diffraction in gases and liquids is similar in principle to that in solids; the differences arise from the lack in gases and liquids of any highly regular arrangement of the component atoms. In gases the low density makes it possible to study diffraction by individual atoms and molecules. The results obtained from monatomic gases represent the density of electronic charge in the atom as a function of the distance from the nucleus. The results from gaseous poly-

atomic molecules represent the equilibrium distances between the atomic nuclei and the average amplitudes of vibration associated with these distances. Liquids have been studied much less thoroughly than have gases. See NEUTRON DIFFRACTION; SCATTERING EXPERIMENTS (ATOMS AND MOLECULES); SCATTERING EXPERIMENTS (NUCLEI). [L.O.B.]

**Electron emission** The liberation of electrons from a substance into vacuum. Since all substances are built up of atoms and since all atoms contain electrons, any substance may emit electrons; usually, however, the term refers to emission of electrons from the surface of a solid.

The process of electron emission is analogous to that of ionization of a free atom, in which the latter parts with one or more electrons. The energy of the electrons in an atom is lower than that of an electron at rest in vacuum; consequently, in order to ionize an atom, energy must be supplied to the electrons in some way or other. By the same token, a substance does not emit electrons spontaneously, but only if some of the electrons have energies equal to, or larger than, that of an electron at rest in vacuum. This may be achieved by various means, such as by heating, irradiation with light (photoemission), bombardment with charged particles (secondary emission), or use of a strong electric field (field, or cold, emission). See FIELD EMISSION; PHOTOEMISSION; SECONDARY EMISSION; THERMIONIC EMISSION. [A.J.D.]

**Electron-hole recombination** The process in which an electron, which has been excited from the valence band to the conduction band of a semiconductor, falls back into an empty state in the valence band, which is known as a hole. See BAND THEORY OF SOLIDS.

Light with photon energies greater than the band gap can be absorbed by the crystal, exciting electrons from the filled valence band to the empty conduction band (illus. a). The state in which an electron is removed from the filled valence band is known as a hole. It is analogous to a bubble in a liquid. The hole can be thought of as being mobile and having positive charge. The excited electrons and holes rapidly lose energy (in about  $10^{-12}$  s) by the excitation of lattice phonons (vibrational quanta). The excited electrons fall to near the bottom of the conduction band, and the holes rise to near the top of the valence band, and then on a much longer time scale (of  $10^{-9}$  to  $10^{-6}$  s) the electron drops across the energy gap into the empty state represented by the hole. This is known as electron-hole recombination. An energy approximately equal to the band gap is released in the process. Electron-hole recombination is radiative if the released energy is light and nonradiative if it is heat. See PHONON.

Electron-hole recombination requires an excited semiconductor in which both electrons and holes occupy the same volume of the crystal. This state can be produced by purely electrical

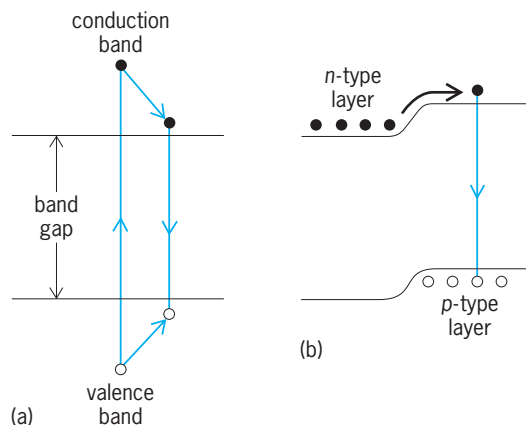

Recombination of electrons and holes generated by (a) optical absorption and (b) a forward-biased  $pn$  junction.

means by forward-biasing a *pn* junction. The current passing through a *pn* diode in electrons per second equals the rate of electron-hole recombination (illus. *b*). A major application of this phenomenon is the light-emitting diode. See LIGHT-EMITTING DIODE; LUMINESCENCE; SEMICONDUCTOR DIODE.

Efficient radiative recombination between free electrons and holes takes place only in direct-bandgap semiconductors. During an optical transition, momentum is conserved, and since the photon carries away negligible momentum, transitions take place only between conduction-band and valence-band states having the same momentum. This is easily satisfied in direct-bandgap semiconductors, because electrons and holes collect at the conduction band at minimum and the valence band at maximum, and both extrema have the same momentum. However, for indirect-bandgap semiconductors, the conduction-band minimum and valence-band maximum have very different momenta, and consequently optical transitions between free electrons and holes are forbidden. Radiative electron-hole recombination is possible in indirect-band-gap semiconductors when the transition is assisted by lattice phonons and impurities. See CRYSTAL.

Apart from its application in light-emitting diodes and laser operation, radiative recombination, especially at low temperatures (approximately 2 K or  $-456^{\circ}\text{F}$ ), has been a very important tool for studying the interaction of electrons and holes in semiconductor crystals. See EXCITON.

Competing with radiative recombination are the nonradiative recombination processes of multiphonon emission and Auger recombination. It is suspected that nonradiative recombination by multiphonon emission drives the movement of atoms at room temperature that are responsible for device degradation phenomena such as the climb of dislocations found in GaAs light-emitting diodes and lasers. Auger recombination has been shown to limit the performance of long-wavelength (1.3–1.6 micrometer) lasers and light-emitting diodes used in optical communication systems. See AUGER EFFECT; LASER; OPTICAL COMMUNICATIONS; SEMICONDUCTOR. [C.H.He.]

**Electron lens** An electric or magnetic field, or a combination thereof, which acts upon an electron beam in a manner analogous to that in which an optical lens acts upon a light beam. Electron lenses find application for the formation of sharply focused electron beams, as in cathode-ray tubes, and for the formation of electron images, as in infrared converter tubes, various types of television camera tubes, and electron microscopes.

Any electric or magnetic field which is symmetrical about an axis is capable of forming either a real or a virtual electron image of an object on the axis which either emits electrons or transmits electrons from another electron source. Hence, an axially symmetric electric or magnetic field is analogous to a spherical optical lens.

The lens action of an electric and magnetic field of appropriate symmetry can be derived from the fact that it is possible to define an index of refraction for electron paths in such fields. This index depends on the field distribution and the velocity and direction of the electrons.

Electron lenses differ from optical lenses both in that the index of refraction is continuously variable within them and in that it covers an enormous range. Furthermore, in the presence of a magnetic field, the index of refraction depends both on the position of the electron in space and on its direction of motion. It is not possible to shape electron lenses arbitrarily. See ELECTROSTATIC LENS; MAGNETIC LENS. [E.G.R.]

**Electron microscope** A device for forming greatly magnified images of objects by means of electrons. Electron microscopes serve primarily two purposes: the visual examination of structures too fine to be resolved with ordinary, or light, microscopes, and the study of surfaces that emit electrons. The first function made transmission electron microscopes essential

research tools in biology, chemistry, and metallurgy. Beginning in the 1960s the scanning electron microscope came to play an increasingly important role in the study of the surfaces of solid objects at more moderate magnifications. Various emission electron microscopes serve more specialized research purposes. See FIELD-EMISSION MICROSCOPY; SCANNING ELECTRON MICROSCOPE; THERMIONIC EMISSION.

A transmission electron microscope consists in its simplest form of a source supplying a beam of electrons of uniform velocity, a condenser lens for concentrating the electrons on the specimen, a specimen stage for displacing the specimen which transmits the electron beam, an objective lens, a projector lens, and a fluorescent screen on which the final image is observed. For permanent record of the image, the fluorescent screen is replaced by a photographic plate or film.

Electrons are strongly scattered by all forms of matter, including air. Hence the entire instrument must be evacuated to about  $10^{-4}$  mmHg ( $10^{-7}$  atm or  $10^{-2}$  pascal). Furthermore, the lenses cannot be material in nature. Instead, they are electric or magnetic fields, symmetrical about the axis of the instrument, that have the property of bending the electron paths toward the axis, just as converging glass lenses bend light rays toward their axis. Lens strength is varied by varying the current. Most electron microscopes employ magnetic lenses of this type. These have yielded the highest resolution and magnification attained.

However, good results have also been obtained with electron microscopes employing unipotential electrostatic lenses and magnetic lenses excited by permanent magnets. See ELECTRON LENS; ELECTROSTATIC LENS; MAGNETIC LENS.

A microscope can, at best, permit the discrimination of two point objects greater than  $0.7\lambda/\sin\theta$  apart. Here  $\lambda$  is the wavelength of the illuminating radiation, and  $\theta$  is the aperture angle of the cone of radiation that participates in forming the image. For green light,  $\lambda = 500$  nanometers. Even for ultraviolet radiation in an immersion medium of refractive index 1.5,  $\lambda$  is no less than 170 nm. Since light and ultraviolet microscope objectives can be designed to utilize practically all the radiation passing through the specimen,  $\sin\theta \cong 1$ , and the least resolvable distance for the ultraviolet microscope is about 100 nm. For 50- to 100-kV electrons, such as are commonly employed in electron microscopes, the wavelength range is 0.0053–0.0037 nm. Hence, even though a cone of radiation with an aperture angle less than 0.01 radian contributes to an image of optimum sharpness, object separations smaller than 0.3 nm have been resolved with the electron microscope. Thus the electron microscope has several hundred times the resolving power of the light microscope. Similarly, whereas the maximum useful magnification of the light microscope is about 2000, that of the electron microscope may approach 1,000,000. The maximum useful magnification is the least magnification of the image that reveals to the observer all the specimen detail that the microscope is capable of conveying.

Electrons are commonly emitted from the tip of a fine tungsten-wire hairpin filament or, to further reduce the size of the effective electron source, from a sharply pointed segment of wire welded to the filament tip. The filament is maintained at a carefully stabilized negative potential of 50–100 kV with respect to the remainder of the instrument. Electrons enter the instrument through an anode aperture. The intensity and convergence of the electron beam that is falling on the specimen are adjusted by varying the coil current of the condenser lens. Image contrasts are formed by the scattering of electrons out of the narrow cone that contributes to the formation of the image; denser or thicker portions of the specimen scatter more electrons and hence appear darker in the image. The sharpness of the image observed on the screen is adjusted by varying the objective coil current, and its magnification by varying the projector coil current. Both currents must be carefully stabilized to yield high resolution.

In addition to the standard transmission microscopes operating at 50–100 kV, a number of very high-voltage instruments

have been constructed (for operation up to 1500 kV). The advantage of high-voltage electron microscopy does not lie in greater resolving power but in increased penetration, which is particularly valuable in the direct study of metal sections prepared with a microtome. [E.G.R.]

The application of the electron microscope to examination and investigation of the ultrastructure of materials has become so extensive that there is hardly an area in biological and nonbiological research where electron microscopy does not play a role. In biological and medical research the development of sectioning techniques has extended electron microscopy down to observations at the macromolecular level for delineation of the complex organization of cell components such as membranes, mitochondria, endoplasmic reticulum, and ribosomes. Other techniques have been developed for studies on the structure of virus and even individual proteins and nucleic acids. Nonbiological solid materials have also become objects of extensive and fruitful investigation. Diffraction microscopy, together with the development of adequate techniques of sectioning and thinning crystalline materials such as metals, now makes the observation of defect structure in solids an important aspect of electron microscopy. See ELECTRON DIFFRACTION. [B.M.Si.]

### Electron paramagnetic resonance (EPR) spectroscopy

The study of the resonant response to microwave- or radio-frequency radiation of paramagnetic materials placed in a magnetic field. It is sometimes referred to as electron spin resonance (ESR). Paramagnetic substances normally have an odd number of electrons or unpaired electrons, but sometimes electron paramagnetic resonance (EPR) is observed for ions or biradicals with an even number of electrons. EPR spectra are normally presented as plots of the first derivative of the energy absorbed from an oscillating magnetic field at a fixed microwave frequency versus the magnetic field strength. The dispersion may also be detected.

To overcome the intrinsic low sensitivity of the magnetic dipole transitions responsible for EPR, samples are placed in resonant cavities. Routine experiments are carried out in the steady state at a fixed microwave frequency of approximately 9 gigahertz by slowly sweeping the magnetic field through resonance. Free electrons resonate in a magnetic field of 3250 gauss (325 millitesla) at the microwave frequency of 9.1081 GHz, whereas organic free radicals resonate at slightly different magnetic fields characteristic of each particular molecule. See ELECTRON SPIN; MAGNETIC RESONANCE; PARAMAGNETISM.

The observation of EPR spectra depends on spin-lattice relaxation, which is the exchange of magnetic energy with the thermal motion of the crystal or molecule. For transition-metal ions and rare-earth ions, experiments often require operation at or near liquid helium temperature (4 K;  $-269^{\circ}\text{C}$ ;  $-452^{\circ}\text{F}$ ). Organic free radicals can usually be studied successfully at room temperature. See MAGNETIC RELAXATION.

**Applications.** EPR spectroscopy is used to determine the electronic structure of free radicals as well as transition-metal and rare-earth ions in a variety of substances, to study interactions between molecules, and to measure nuclear spins and magnetic moments. It is applied in the fields of physics, chemistry, biology, archeology, geology, and mineralogy. It is also used in the investigation of radiation-damaged materials and in radiation dosimetry.

The basic physics of transition-metal ions and rare-earth ions present in low concentrations in diamagnetic host crystals has provided a theoretical basis for how electronic structure is modified by the surrounding atoms. Particular applications include probing phase transitions in solids and studies of pairs and triads of magnetically interacting ions.

Applications of EPR in chemistry include characterization of free radicals, studies of organic reactions, and investigations of the electronic properties of paramagnetic inorganic molecules. Information obtained is used in the investigation of molecular

structure. EPR is used widely in biology in the study of metal proteins, for nitroxide spin labeling, and in the investigation of radicals produced during reaction processes in proteins and other biomacromolecules. EPR has proved to be an important technique for interdisciplinary investigations of photosynthetic systems. By means of EPR, more than 20 proteins that function in the mitochondrial respiratory chains of mammals have been identified, and details regarding their electron transfer processes have been elucidated.

**Solids.** EPR spectra from single crystals clearly provide the greatest amount of information. These include crystals containing small concentrations of paramagnetic ions substituting for the regular ions in the crystal or, for organic molecules, small fractions of free radicals produced by ionizing radiation. Spectra which may contain up to several hundred lines are often highly anisotropic; that is, they change with the orientation of the magnetic field direction in the crystal. Transition-metal-ion and rare-earth-ion EPR spectra in crystals are generally much more anisotropic than free radicals due to the intrinsic anisotropy of the electron magnetic moments, and of other effects that are important when there is more than one unpaired electron.

The occurrence of many lines is due to interactions of the orbital motions of electrons with the electric potential of the local surrounding atoms, and to hyperfine interactions between the paramagnetic electrons and nuclear magnetic moments of the paramagnetic ion and surrounding atoms. In the case of free radicals, symmetric or nearly symmetric characteristic hyperfine patterns are observed. From knowledge of hyperfine interactions with nuclei whose spins and magnetic moments are known, the electron distribution throughout a molecule may be determined. Since hyperfine interactions vary as the reciprocal of the cube of the distance between the center of the free radical and the nucleus, structural information may be obtained in addition to electron densities.

**Liquids and motional averaging.** Spectra in solution due to free radicals are often quite simple as a result of motional averaging, and this clearly gives less information than would be obtained from a single-crystal investigation. Linewidths are very narrow (approximately 0.1 gauss or smaller). By varying the temperature above and below room temperature, EPR spectra range from the frozen solution at low temperatures, with a powderlike spectrum, to rapid motional averaging at room temperature where anisotropies are averaged out. The intermediate region can provide information about slow molecular motions, which is especially important for nitroxide spin labels selectively attached to different parts of macromolecules such as the components of natural and synthetic phospholipid membranes, liquid crystals, and proteins. Such measurements have revealed important structural and functional information. [J.R.P.]

**Electron-positron pair production** A process in which an electron and a positron are simultaneously created in the vicinity of a nucleus or subatomic particle. Electron-positron pair production is an example of the materialization of energy predicted by special relativity and is accurately described by quantum electrodynamics. Pair production usually refers to external pair production, in which the positron (positively charged antielectron) and electron are created from a high-energy gamma ray as it passes through matter. Electron-positron pairs are also produced from internal pair conversions in nuclei, decays of unstable subatomic particles, and collisions between charged particles. See QUANTUM ELECTRODYNAMICS.

In external conversion, the energy of an incoming gamma ray (a high-energy electromagnetic photon) is directly converted into the mass of the electron-positron pair. The photon energy  $h\nu$  (where  $h$  is Planck's constant and  $\nu$  is the photon frequency) must therefore exceed twice the rest mass of the electron  $2m_0c^2$ , equal to 1.022 MeV ( $m_0$  is the electron mass,  $c$  the velocity of light). In order to conserve both energy and momentum in this process, the pair must be created near a nucleus, which recoils



to balance the momentum of the incoming photon with the momenta of the created electron and positron. Because the nucleus is so much heavier than the electron, it carries away almost no energy from the pair, and the energy of the photon in excess of  $2m_0c^2$  is shared unequally as kinetic energy by the positron and electron. Individually, the electron and positron each exhibit a distribution of kinetic energies ranging from zero to the maximum available energy,  $E_{\max} = h\nu - 2m_0c^2$ , correlated with one another so that their sum is equal to  $E_{\max}$ . Similarly, the positron and electron are emitted over a broad range of angles, although they exhibit a tendency to move in the same direction, which reflects the momentum of the incoming photon. For incident photon energies above 5 MeV, external pair production is the dominant mechanism by which gamma rays are absorbed in matter. See GAMMA-RAY DETECTORS; GAMMA RAYS; PHOTON.

Internal pair creation differs from external conversion in that the positron and electron are created directly from energy liberated by the deexcitation of an excited nucleus (produced, for example, in radioactive decay or nuclear collisions) to a state of lower energy, if the transition energy exceeds the pair mass threshold of  $2m_0c^2$ . Internal pair creation usually occurs only  $10^{-3}$  times as often as deexcitation by gamma-ray emission, although the exact pair creation probability, as well as the angular correlation between the emitted positron and electron, depends on the nuclear charge and upon the energy and multipolarity of the nuclear transition. See RADIOACTIVITY.

Many unstable subatomic particles, such as the neutral Z boson and J/psi meson, decay into a positron-electron pair alone or with other particles. Since the decaying parent particle is massive, momentum is conserved without the presence of an additional nucleus as is required in external conversion. Decay into a single pair alone creates a positron and electron with equal and opposite momenta. [T.E.C.]

**Electron-probe microanalysis** A method used for determining the elemental composition of materials, based on the x-rays emitted by different elements when bombarded with high-energy electrons. It is a micro method that can detect x-ray photons emitted by the atoms within a small volume excited by an electron beam focused to 10 nanometers diameter or less. In biology electron-probe microanalysis can be used to determine the composition of cell organelles without isolating them and therefore altering the distribution of diffusible elements.

High-energy electrons can ionize atoms, ejecting an inner-shell electron. To fill the resultant vacancy, an outer-shell electron falls into the ionized shell; the atom remains in the higher-energy excited state. The emission of a characteristic x-ray by the ionized atom is one of the mechanisms for releasing its excess energy. Another mechanism is the emission of Auger electrons; the probability of ejecting an x-ray instead of an Auger electron is the fluorescence yield. In the case of electron-probe microanalysis the source of the exciting electrons is the electron gun, which, in modern electron microscopes equipped with field-emission guns, can produce a focused beam narrower than 1 nm. The x-rays emitted as the result of atomic ionization are called characteristic x-rays, because their energy is characteristic of the core shell of the ionized element and of the shell from which the electron relaxed into the vacancy. See AUGER EFFECT; SURFACE PHYSICS; X-RAY FLUORESCENCE ANALYSIS. [A.P.S.]

**Electron spectroscopy** A form of spectroscopy which deals with the emission and recording of the electrons which constitute matter—solids, liquids, or gases. The usual form of spectroscopy concerns the emission or absorption of photons (x-rays, ultraviolet rays, visible or microwave wavelengths, and so on). Electron spectra can be excited by x-rays, which is the basis for electron spectroscopy for chemical analysis (ESCA), or by ultraviolet photons, or by ions (electrons). By means of ESCA, complete sets of photoelectron lines can be excited from the internal (core) levels as well as from the external (valence

region. Also, complete sequences of the Auger electron lines are automatically obtained in this mode. See AUGER EFFECT.

The electron lines in an ESCA spectrum are extremely sharp and well suited for precision measurements. With a high-resolving ESCA spectrometer which has a magnetic or electrostatic focusing dispersive system, the electron lines have widths which are set by the limit caused by the uncertainty principle (the “inherent” widths of atomic levels). With a suitable choice of radiation, electron spectroscopy reproduces directly the electronic level structure from the innermost shells (core electrons) to the atomic surface (valence or conduction band). Furthermore, all elements from hydrogen to the heaviest ones can be studied even if the element occurs together with several other elements and even if the element represents only a small part of the chemical compound. See LINE SPECTRUM.

When applied to solid materials, ESCA is a typical surface spectroscopy with applications to problems such as chemical surface reactions, for example, corrosion or heterogeneous catalysis. ESCA also reproduces bulk matter properties such as valence electron band structures. Electron spectroscopy can supply a detailed knowledge of the valence orbital structure for all molecules which can be brought into gaseous form with pressures of  $10^{-5}$  torr ( $10^{-3}$  pascal) or more. Under certain conditions, liquids and solutions of various compositions can be studied by ESCA techniques.

A unique feature of ESCA is that, if the exact position of the electron lines characteristic of the various elements in the molecule is measured, the area of inspection can be moved from one atomic species to another in the molecular structure. If the structure of the molecule is known, the charge distribution can be estimated in a simple way by using, for example, the electronegativity concept and assuming certain resonance structures. More sophisticated quantum-chemical treatments can also be applied. Conversely, if, by means of ESCA, the approximate charge distribution is known, conclusions concerning the structure of the molecule can be drawn. See ATOMIC STRUCTURE AND SPECTRA; ELECTRON CONFIGURATION; ELECTRONEGATIVITY; MOLECULAR ORBITAL THEORY; SPECTROSCOPY. [K.S.]

**Electron spin** That property of an electron which gives rise to its angular momentum about an axis within the electron. Spin is one of the permanent and basic properties of the electron. Both the spin and the associated magnetic dipole moment of the electron were postulated by G. E. Uhlenbeck and S. Goudsmit in 1925 as necessary to allow the interpretation of many observed effects, among them the so-called anomalous Zeeman effect, the existence of doublets (pairs of closely spaced lines) in the spectra of the alkali atoms, and certain features of x-ray spectra. See SPIN (QUANTUM MECHANICS).

The spin quantum number is  $s$ , which is always  $1/2$ . This means that the component of spin angular momentum along a preferred direction, such as the direction of a magnetic field, is  $\pm 1/2\hbar$ , where  $\hbar = h/2\pi$  and  $h$  is Planck's constant. The spin angular momentum of the electron is not to be confused with the orbital angular momentum of the electron associated with its motion about the nucleus. In the latter case the maximum component of angular momentum along a preferred direction is  $l\hbar$ , where  $l$  is the angular momentum quantum number and may be any positive integer or zero. See ANGULAR MOMENTUM; QUANTUM NUMBERS.

**Electron magnetic moment.** The electron has a magnetic dipole moment by virtue of its spin. The approximate value of the dipole moment is the Bohr magneton  $\mu_0$  which is equal, in SI units, to  $eh/4\pi m = 9.27 \times 10^{-24}$  joule/tesla, where  $e$  is the electron charge measured in coulombs, and  $m$  is the mass of the electron. The orbital motion of the electron also gives rise to a magnetic dipole moment  $\mu_l$  that is equal to  $\mu_0$  when  $l = 1$ . See MAGNETON.

The orbital magnetic moment of an electron can readily be deduced with the use of the classical statements of electromagnetic theory in quantum-mechanical theory; the simple classical

analog of a current flowing in a loop of wire describes the magnetic effects of an electron moving in an orbit. The spin of an electron and the magnetic properties associated with it are, however, not possible to understand from a classical point of view.

In the Landé  $g$  factor,  $g$  is defined as the negative ratio of the magnetic moment, in units of  $\mu_0$ , to the angular momentum, in units of  $\hbar$ . For the orbital motion of an electron,  $g_l = 1$ . For the spin of the electron the appropriate  $g$  value is  $g_s \approx 2$ ; that is, unit spin angular momentum produces twice the magnetic moment that unit orbital angular momentum produces. The total electronic magnetic moment of an atom depends on the state of coupling between the orbital and spin angular momenta of the electron.

**Atomic beam measurements.** With the development of spectroscopy by the atomic beam method, a new order of precision in the measurement of the frequencies of spectral lines became possible. By using the atomic-beam techniques, it became possible to measure  $g_s/g_l$  directly, with the result  $g_s/g_l = 2(1.001168 \pm 0.000005)$ . The magnetic moment of the electron therefore is not  $\mu_0$  but  $1.001168\mu_0$ , or equivalently the  $g$  factor of the electron departs from 2 by the so-called  $g$  factor anomaly defined as  $a = (g_2 - 2)/2$  so that  $\mu = (1 + a)\mu_0$ . Thus the first molecular beam work gave  $a = 0.001168$ . See MOLECULAR BEAMS.

**Calculation of  $g$ -factor anomaly.** It is not possible to give a qualitative description of the effects which give rise to the  $g$ -factor anomaly of the electron. The detailed theoretical calculation of the quantity is in the domain of quantum electrodynamics, and involves the interaction of the zero-point oscillation of the electromagnetic field with the electron. Comparison of theoretical determination of  $a$  with its experimental measurement constitutes the most accurate and direct existing test of the theory of quantum electrodynamics. See ATOMIC STRUCTURE AND SPECTRA; GYROMAGNETIC RATIO; QUANTUM ELECTRODYNAMICS; QUANTUM MECHANICS. [A.Ri.; T.Ki.]

**Electron-transfer reaction** A reaction in which one electron is transferred from one molecule or ion to another molecule or ion. Electron-transfer reactions are ubiquitous in nature. Some are deceptively simple [for example, reaction (1),



where the asterisk is used to identify a specific isotope]; others look very complicated (for example, the long-range electron transfers found in biology). The widespread occurrence of electron-transfer reactions has stimulated much theoretical and experimental work. See CHEMIOSMOSIS; PHOTOSYNTHESIS.

The simplest reactions in solution chemistry are electron self-exchange reactions (2), in which the reactants and products are



the same (the asterisk is used to identify a specific isotope). The only way to determine chemically that a reaction has taken place is to introduce an isotopic label. There is no change in the free energy ( $\Delta G^\circ = 0$ ) for this type of reaction.

Much more common are cross reactions (3), where  $A_{ox}$  is the



oxidized reactant,  $B_{red}$  is the reduced reactant,  $A_{red}$  is the reduced product, and  $B_{ox}$  is the oxidized product. For these reactions,  $\Delta G^\circ \neq 0$ .

Both types of electron-transfer reactions (self-exchange and cross reactions) can be classified broadly as inner sphere or outer sphere. In an inner-sphere reaction, a ligand is shared between the oxidant and reductant in the transition state. An outer-sphere reaction, on the other hand, is one in which the inner coordination shells of both the oxidant and reductant remain intact in the transition state. There is no bond breaking or bond making, and no shared ligands between redox centers. Long-range

electron transfers in biology are all of the outer-sphere type. See OXIDATION-REDUCTION.

**Electron-transfer theory.** The simplest electron transfer occurs in an outer-sphere reaction. The changes in oxidation states of the donor and acceptor centers result in a change in their equilibrium nuclear configurations. This process involves geometrical changes, the magnitudes of which vary from system to system. In addition, changes in the interactions of the donor and acceptor with the surrounding solvent molecules will occur. The Franck-Condon principle governs the coupling of the electron transfer to these changes in nuclear geometry: during an electronic transition, the electronic motion is so rapid that the nuclei (including metal ligands and solvent molecules) do not have time to move. Hence, electron transfer occurs at a fixed nuclear configuration. In a self-exchange reaction, the energies of the donor and acceptor orbitals (hence, the bond lengths and bond angles of the donor and acceptor) must be the same before efficient electron transfer can take place. See FRANCK-CONDON PRINCIPLE.

**Long-range electron transfer.** The rate of long-range electron transfer between an electron donor ( $B_{red}$ ) and an electron acceptor ( $A_{ox}$ ) depends on both the electronic coupling between  $A_{ox}$  and  $B_{red}$  (which is a function of the intersite  $A_{ox}/B_{red}$  distance  $d$ , the nature of the intervening medium, and the relative  $A_{ox}/B_{red}$  orientation, where // represents the protein medium that separates the donor and the acceptor) and an activation energy term. A standard theoretical rate equation (4) expresses  $k_{et}$

$$k_{et} = \nu[\{\exp(-\beta d)\}\exp[(\lambda + \Delta G^\circ)^2/4\lambda RT]] \quad (4)$$

in terms of these factors; here,  $\nu$  is a frequency factor,  $\beta$  is a medium- and orientation-dependent quantity,  $d$  is the intersite distance,  $\lambda$  is the reorganization energy,  $\Delta G^\circ$  is the reaction free energy of the electron-transfer process,  $R$  is the universal gas constant, and  $T$  is the absolute temperature of the system. Experiments in several laboratories have been designed to estimate the values of  $\lambda$  and  $\beta$  in modified metalloproteins, rigid organic molecules, and protein-protein complexes.

[B.E.Bo.; W.R.El.; H.B.Gr.; T.J.Me.]

**Electron tube** A device in which electrons can travel through a sealed chamber containing at least two electrodes and gas at a very low pressure. The gas pressure usually ranges from about  $10^{-6}$  to  $10^{-9}$  atm ( $10^{-1}$  to  $10^{-4}$  pascal). At the low extreme of this pressure range, electron tubes are sometimes referred to as vacuum tubes, and at the high extreme as gas tubes. See GAS TUBE; VACUUM TUBE.

At least one of the electrodes must emit electrons, and at least one must collect electrons. The emitting electrode, the cathode, may emit electrons through one or more of four mechanisms: thermionic or primary emission, secondary emission photoelectric emission, or field emission. Electrons must acquire more energy than they have in the conduction band of a metal in order to escape from the surface of a metal. They acquire this energy, respectively, in the four mechanisms listed above, from heat, electron or ion impact, a photon impact, or an external electric field. Photoelectric emission is used in light-sensing devices, often in combination with secondary electron multiplication to amplify the current. Secondary emission, sometimes in combination with thermionic emission, plays an important role in magnetrons and in crossed-field amplifiers. Field emission is used in some experimental amplifiers, flat-panel display devices, and x-ray tubes, but by far the most common type of emitting electrode used in electron tubes is the thermionic cathode. See CATHODE-RAY TUBE; FIELD EMISSION; FLAT-PANEL DISPLAY DEVICE; MAGNETRON; PHOTOEMISSION; PHOTOMULTIPLIER; PHOTOTUBE; SECONDARY EMISSION; THERMIONIC EMISSION; X-RAY TUBE.

A diode is a two-electrode tube, with a cathode and a collecting electrode. A. Fleming (1904) developed the first thermionic diode using an oxide cathode. Because the collecting electrode is usually operated at a positive potential with respect to the

cathode in order to collect much of the available electron current from the cathode, it is called an anode. Even so, because of the thermal energy of thermionic electrons, the anode can collect some electrons when it has a slightly negative potential. See DIODE.

L. DeForest (1906) added a third electrode to a diode in order to control the current flow from cathode to anode. This third electrode, the grid, took the form of a fairly open array or mesh made of wires with a diameter small compared to their spacing. In this geometry, much of the electric field from the anode terminates on the grid, and the field from the grid that terminates on the cathode exerts a primary influence on the space-charge current that flows to or through the grid. When the grid is at a negative potential with respect to the cathode, current flows due to the anode field that leaks through the grid, but the grid can collect no current. When the grid and anode are both positive, much more current flows and divides between the grid and anode.

Unfortunately, in triode amplifiers at high frequencies, the capacitance between the anode and grid electrodes, in combination with typical grid circuit reactances, can cause positive feedback, regeneration, or oscillation unless circuits that provide compensating negative feedback are used. For this reason W. Schottky (1919) invented the tetrode, which has a second or screen grid between the first or control grid and the anode. This grid was operated at a constant positive potential and effectively shielded the control grid from the anode. At large signal levels, it also created a problem by collecting secondary electrons emitted from the anode as a result of primary electron impacts when the instantaneous voltage on the anode was less than the screen grid voltage. This problem was dealt with in two ways. G. Jobst and D. H. Tellegen (1926) introduced the pentode, which has a third very open suppressor grid between the screen grid and the anode. It was connected to the cathode. This created an electric field which returned secondary electrons to the anode. A more elegant solution to the secondary electron problem was provided in the beam-power tetrode. In these tetrodes the anode was placed far enough from the screen grid that the charge of the electrons traveling between the screen grid and anode actually depressed the potential in the space between the screen and anode enough to return secondary electrons to the anode.

The tubes discussed so far act as valves that control the flow of a current to a load. The potential energy of the current is derived from a direct-current power source. There is another class of electron tubes, most of which are referred to as microwave tubes, in which electrons are accelerated to a velocity at which they have a kinetic energy that is equivalent to the full voltage of the power supply that was used to accelerate them. If these electrons are bunched periodically in time, they can be made to give up their energy to the electric field in a gap or gaps in a very high frequency or microwave circuit. Microwave tubes include the inductive output tube, the klystron, traveling-wave tubes, crossed-field devices, and cyclotron-resonance devices.

In the inductive output tube, invented by A. V. Haeff (1939), an electron beam is amplitude-modulated with a grid and then accelerated through a hole in the first accelerating electrode to form the high-velocity beam of electrons that passes through a gap in the center conductor of the coaxial external cavity resonator and into the collector. Inductive output tubes are used in many television transmitters operating between 470 and 900 MHz.

The klystron, invented by R. Varian and S. Varian (1939), has a similar output cavity and collector, but has a beam which is first accelerated in a diode electron gun and then velocity-modulated in another reentrant cavity gap. Fast electrons overtake slowed electrons and yield an intensity-modulated beam by the time the electrons reach the output cavity. Additional cavities may be interposed between the input and output cavities to provide very high gain (often as high as 60 dB). See KLYSTRON.

In traveling-wave tubes (see illustration) invented by R. Kompfner (1946), a high-velocity electron beam is velocity-

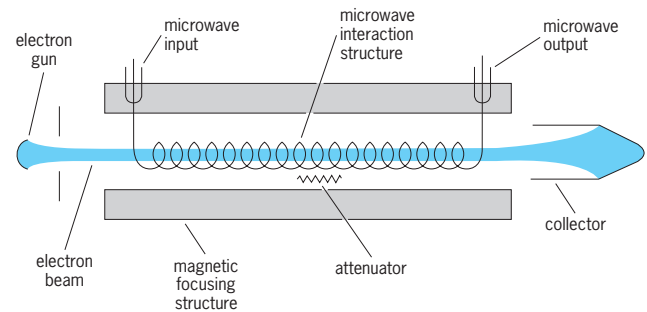

Basic elements of a typical traveling-wave tube. (After D. Christiansen, ed., *Electronic Engineers' Handbook*, 4th ed., McGraw-Hill, 1996)

modulated by, and gives up its energy to, periodically loaded or helical waveguides which slow the electromagnetic wave to a velocity nearly equal to that of the electron beam. Again very high gain is possible. See TRAVELING-WAVE TUBE.

Input-output tubes, klystrons, and traveling-wave tubes are used in television broadcasting, satellite communications systems, radar, scientific accelerators, medical accelerators used for cancer therapy, and military countermeasures equipment.

In magnetrons and crossed-field amplifiers, electrons circulate about a cylindrical cathode in a radial direct-current electric field and an axial magnetic field. Concentric with, and outside, the cathode is a periodically loaded transmission line that propagates a wave having components that travel in synchronism with the rotating electron cloud. The electrons follow orbits that allow them to take energy from the radial direct-current electric field and transfer it to the circumferential radio-frequency electric field of the wave on the circuit. Magnetrons are used in huge quantities in household microwave ovens. They and crossed-field amplifiers are also used in ground-based, shipboard, and airborne radars.

Cyclotron-resonance devices including gyrotrons, gyroklystrons, and gyro-traveling-wave tubes again employ electrons that have been accelerated to the full energy provided by the electrical power supply. The beam is formed in a magnetic field so that it has a great deal of momentum perpendicular to the magnetic field, and the electrons follow helical paths. A radio-frequency electric field perpendicular to the axis of the electron trajectories will modulate the energy of the electrons and hence the relativistic mass and the cyclotron frequency. This azimuthal velocity modulation causes the electrons to draw into rodlike bunches that can give up their energy to a circuit supporting either the same alternating electric field that bunched them (in a gyrotron), or to an alternating electric field in another circuit (in a gyroklystron). Cyclotron-resonance devices can be built using very long circuits producing very weak electric fields, and as a result, having very low losses at very high frequencies. Efficient gyrotrons have been built at frequencies as high as several hundred gigahertz and have produced continuous power of hundreds of kilowatts. See GYROTRON; MICROWAVE TUBE. [R.S.Sy.]

**Electron wake** The pattern of electron density fluctuation and electromagnetic disturbance set up by the passage of a swift ion through condensed matter. In dense media that can sustain well-defined resonance oscillations at a frequency  $\omega_0$ , wakes of periodic character will form behind swift charged particles having speed  $v$ . The periodicity in space,  $\lambda$ , the distance between troughs of the wake, is given by Eq (1). The oscillations

$$\lambda = \frac{2\pi v}{\omega_0} \quad (1)$$

trail behind the ion, move with the ion velocity, and have the frequency  $\omega_0$ . In addition, close collisions between the ion and electrons of the medium cause electrons to recoil to form

the analog of a bow wave ahead of the ion. See RESONANCE (QUANTUM MECHANICS).

The wake at the position of the guiding ion is of special significance. The electric field there times the ion charge represents the reaction of the medium to the ion and yields the stopping power of the medium for the ion, that is, the energy loss per unit path length.

When molecular ions are injected into a solid with speeds greater than  $v_0 = 2.2 \times 10^6$  m/s, the so called Bohr speed (the speed of an electron in the ground state of hydrogen according to the Bohr model), the valence electrons are stripped, leaving atomic ions to propagate as clusters of correlated charged particles through the medium. A dicluster is composed of two atomic ions travelling close together at nearly the same velocity. A wake is formed given by a (generally nonlinear) superposition of wakes due to the individual ions of the cluster. The dynamically modified Coulomb repulsion between its constituents causes the cluster, in effect, to explode. A pair of ions traveling with the same initial velocity, and created exactly abreast of one another, will recede rapidly from one another because of the Coulomb force acting on them. In typical experiments, the cluster-particle interaction probes the slope of the cluster wake potential near the origin, because the foils used in most experiments are so thin that the separation of the ions after traveling through the foil does not greatly exceed their initial separation. An important effect of the wake interaction is to cause the cluster to lose energy at a faster rate than would its isolated constituents traveling at the same speed, because the wake field of a given ion in a cluster acts, in most experiments, to retard the other ions of the cluster.

Measurements of the angular deflections and energy losses of protons resulting from diclusters formed from swift  $(\text{HeH})^+$  or  $(\text{OH})^+$  ions bombarding thin foils yield angular distributions that have a circular character due to the action of a Coulomb explosion. Such distributions generally have a large peaked region on the perimeter due to the trailing protons that are focused by the wake of the other ion in the Coulomb explosion. There is also a much smaller peak due to protons that lead the ion. Such experiments have been important in establishing the structure of molecular ions that were formerly not well known.

In other work with diclusters, the oscillatory character of the wake is vividly displayed in a two-foil experiment. A cluster enters the first foil and, after passing through a vacuum separating the carbon foils, enters the second one. The trailing ion experiences the wake force of the leading one. The dependence of the yield of secondary electrons from a final target on the distance between carbon foils shows the characteristic oscillatory behavior. See CHARGED PARTICLE BEAMS; COULOMB EXPLOSION. [R.H.R.]

**Electronegativity** According to L. Pauling, "the power of an atom in a molecule to attract electrons to itself." Quantitative definitions and scales of electronegativity have been based not on electron distribution itself but on properties which were assumed to reflect electronegativity.

The electronegativity of an element depends upon its valence state and thus is not an invariant atomic property. As an example, the electron-withdrawing ability of an  $sp^n$  hybrid orbital centered on carbon and directed toward hydrogen increases as the percentage of  $s$  character in the orbital increases in the series ethane < ethylene < acetylene. Thus, according to this concept of orbital electronegativity, each element exhibits a range of electronegativity values.

The original scale, proposed by Pauling in 1932, is based upon the difference between the energy of the A-B bond in the compound  $\text{AB}_n$  and the mean of the energies of the homopolar bonds A-A and B-B (see table). R. S. Mulliken proposed that the electronegativity of an element is given by the average of the valence-state ionization potential and electron affinity. The Mulliken approach is consistent with Pauling's original definition and gives orbital electronegativities, not invariant atomic electronegativities. Electronegativity was defined by

Average electronegativities from thermochemical data

Element	Value	Element	Value
H	2.20	Al	1.61
Li	0.98	Ga	1.81
Na	0.93	In	1.78
K	0.82	Tl	2.04
Rb	0.82	C	2.55
Cs	0.79	Si	1.90
Be	1.57	Ge	2.01
Mg	1.31	Sn	1.96
Ca	1.00	Pb	2.33
Sr	0.95	N	3.04
Ba	0.89	P	2.19
Sc	1.36	As	2.18
Ti	1.54	Sb	2.05
V	1.63	Bi	2.02
Cr	1.66	O	3.44
Mn	1.55	S	2.58
Fe	1.83	Se	2.55
Co	1.88	F	3.98
Ni	1.91	Cl	3.16
Cu	1.90	Br	2.96
Zn	1.65	I	2.66
B	2.04		

A. L. Allred and E. G. Rochow as the force of attraction between a nucleus and an electron from a bonded atom. A quantum-defect electronegativity scale has been developed from potentials based on atomic spectral data, and a nonempirical scale has been calculated by an ab initio method using floating gaussian orbitals.

Other methods for calculating electronegativities utilize such observables as bond-stretching force constants, electrostatic potentials, spectra, and covalent radii. The measurement of electronegativities involves observations of properties dependent upon electron distribution. Close agreement of electronegativity values obtained from measurements of several diverse properties lends confidence and utility to the concept. [A.L.A.]

**Electronic display** An electronic component used to convert electrical signals into visual imagery in real time suitable for direct interpretation by a human operator. It serves as the visual interface between human and machine. The visual imagery is processed, composed, and optimized for easy interpretation and minimum reading error. The electronic display is dynamic in that it presents information within a fraction of a second from the time received and continuously holds that information, using refresh or memory techniques, until new information is received. The image is created by electronically making a pattern from a visual contrast in luminance between (1) individual electrically alterable picture elements (pixels) in a matrix array of pixels in flat-panel displays (FPDs) or (2) electrically excited and nonexcited areas in a phosphor film in cathode-ray tubes (CRTs). High-information-content (HIC) displays are those displays that have a sufficient number of pixels (75,000 to 2,000,000) to show standard or high-definition television images, or comparable computer images.

The use of electronic displays for presentation of graphs, symbols, alphanumerics, and still and video pictures has doubled every several years, in parallel with the rapid expansion of microelectronics. Electronic displays have largely replaced traditional mechanical devices, counters, galvanometers, and, to a degree, hardcopy (paper) means for presenting information. This change is due to the increased use of computers, microprocessors, inexpensive large-scale integration (LSI) electronics, and digital mass memories. The success of the digital watch, hand-held calculator, and personal computer is directly attributable to the availability of inexpensive LSI electronics and electronic displays. See CALCULATORS; COMPUTER; COMPUTER GRAPHICS; COMPUTER STORAGE TECHNOLOGY; INTEGRATED CIRCUITS; MICROCOMPUTER; MICROPROCESSOR; WATCH.

Electronic display spectrum of applications

Classification	Characteristics	Applications	Electronic technologies
Pseudoanalog	Dedicated arrangement of discrete pixels used to present analog or qualitative information	Meterlike presentations, go/no-go messages, legends and alerts, analog-like (watch) dial	Gas discharge, light-emitting diodes, liquid crystal, incandescent lamps
Alphanumeric	Dedicated alphanumeric pixel font of normally less than 480 characters; most common is 4- and 8-character numeric displays	Digital watches, calculators, digital multimeters, message terminals, games	Liquid crystal, light-emitting diodes, vacuum fluorescent, gas discharge, incandescent lamps
Vectorgraphic	Large orthogonal uniform array of pixels which are addressable at medium to high speeds; normally, monochromatic with no gray scale; may have memory; normally, over 480 characters and simple graphics	Computer terminals, TWX terminals, arrivals and departures, scheduling terminals, weather radar, air-traffic control, games	Cathode-ray tube, plasma panels, gas discharge, vacuum fluorescent, electroluminescence, PMLCD, LED
Video	Large orthogonal array of pixels which are addressed at video rates (30 frames per second); monochromatic with gray scale or full color; standardized raster scan addressing interface, arrays of pixels approximately 240 rows by 320 columns and larger	Entertainment television, graphic arts, earth resources, video repeater, medical electronics, aircraft flight instruments, computer terminals, command and control, games	Cathode-ray tube, plasma panels, electroluminescence, AMLCD, LED

The major electronic display application is in home color television. The computer terminal using a CRT or FPD is the most important industrial application of electronic displays. With advances in high-information-content FPD technology, the electronic display industry went through a dramatic change in the early 1990s. This was primarily due to breakthroughs and manufacturing advances in liquid-crystal displays (LCDs). Color active-matrix LCDs (AMLCDs) have better performance than color CRTs for video and computer graphics and are thin and portable. However, the AMLCDs are several times more expensive than CRTs, so their use remains restricted to applications such as personal computers and television receivers where the CRT will not fit. See LIQUID CRYSTALS.

The primary applications of the CRT are in home entertainment television, computer monitors, scientific and electrical engineering oscilloscopes, radar display, and alphanumeric and graphic electronic displays. See OSCILLOSCOPE; RADAR; TELEVISION.

Because of the depth dimension of the CRT, there has been a concentrated effort to develop FPDs. A primary motivating factor has been to achieve a flat high-information-content display which could be hung on a wall or carried in a briefcase. Over the years, the electrical phenomena most extensively developed for FPDs have been gas discharge (plasma), electroluminescence, light-emitting diode, cathodoluminescence, and liquid crystallinity. The cost of FPDs is higher than CRTs on a character-per basis for HIC displays. See CATHODOLUMINESCENCE; ELECTROLUMINESCENCE; LIGHT-EMITTING DIODE.

Before the 1990s, cost and performance limitations restricted the use of FPDs to specialized applications. With the advent of two major breakthroughs in the 1980s, LCDs emerged as the leading FPD. These two breakthroughs were the invention of the supertwisted nematic (STN) LCD, often referred to as passive-matrix LCD (PMLCD), and the evolution of a manufacturable AMLCD. The STN inventions improve LCDs so that they can be made as a HIC FPD because of improvements in the matrix addressing capability. Both of these types are made in monochrome and full color. The AMLCD is fast enough for video and for multimedia displays, comparable to a CRT. The PMLCD is fast enough for computer use but not video; however, PMLCDs are about half the cost of AMLCDs.

Applications of LCDs include portable computing devices and memory aids; electronic games; moving map devices in conjunction with global positioning satellites (GPS) for navigation of boats, aircraft, and motored vehicles; educational devices and video for portable handheld devices; and displays for television, entertainment, education, and information dissemination. LCDs are also used in helmet displays and virtual-reality displays. See SATELLITE NAVIGATION SYSTEMS; VIDEO GAMES.

The smaller AMLCDs are used in camcorder viewfinders, helmet displays, and projectors. The medium-size displays are used

in all the applications that are viewed directly, such as portable computers or television receivers.

PMLCDs are used with the STN configuration of LCD in devices where some reduction in performance is acceptable, such as portable computer displays that do not require video imagery. PMLCDs in the basic twisted nematic (TN) mode are used in inexpensive toys, automotive panels, meter displays, and watches.

Electronic displays can be categorized into four classifications; as shown in the table. Each classification is defined by natural technical boundaries and cost considerations. The categorization is useful in visualizing the extent to which electronic displays are used.

Color can be created on a CRT equipped with a shadow mask duplicating quite closely all colors that occur in nature. This is done in the CRT by using three different electron guns and three phosphors in a triad of red, green, and blue on the screen at each pixel. The shadow mask is a metal screen with one hole for each triad of phosphor dots (pixel). It is precisely located and aligned with the phosphor screen. Electron beams from each of three guns are constrained by each shadow mask hole to hit each respective phosphor dot.

Penetration phosphors are also used to create color on CRT displays to eliminate the need for the shadow mask and extra guns. However, the color is limited and the brightness is low. Normally, two phosphors are placed on the screen in two layers or in microspheres of two layers. The gun and CRT anode are operated in two energy states to produce either a high-energy or a low-energy electron beam switchable in time.

Monochromatic as well as full color is readily produced by FPD technologies. Full color is produced by using a triad of red, green, and blue for each pixel, or sequential flashing at 180 Hz of red, green, or blue at each pixel area. Full color is very important for entertainment television displays. Most industrial electronic displays do not necessarily need full color, but full color has been used more frequently as color display costs have decreased. In these applications, the color display instrument is usually a CRT using the shadow-mask color technique.

The essence of electronic displays is based upon the ability to turn on and off individual pixels (Fig. 1). A typical HIC display will have a quarter million pixels in an orthogonal array, each under individual control by the electronics. The pixel resolution is normally just at or below the resolving power of the eye at one minute of arc. Thus, a good-quality picture can be created from a pattern of activated pixels. The pixel concept for electronic displays has evolved from the modern FPD technologies and digital electronics.

With flat-panel and CRT digital display techniques, alphanumeric character fonts are created by turning on the appropriate pixels in an array. One standard size is a  $5 \times 7$  array with two pixels between characters and two pixels between rows (Fig. 1). All the letters and numbers can be created on this common

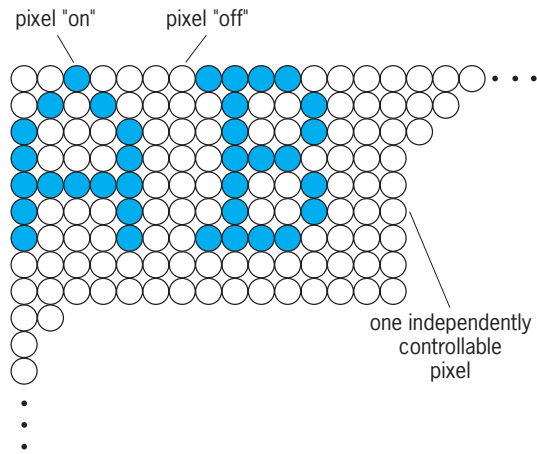

Fig. 1. Pixel array used for creating electronic display images.

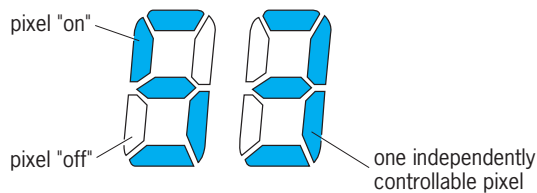

Fig. 2. Seven-bar numeric font.

array format. A very efficient and elegant array has evolved for portraying numeric characters and many letters of the alphabet, called the seven-bar font (Fig. 2). Each bar is a pixel by definition. This font was initially considered crude when compared to the Leroy font and other more esthetic printer fonts. It is now universally accepted. A similar 14 bar font is sometimes used for alphanumeric characters. [L.E.T.]

**Electronic listening devices** Devices which are used to capture the sound waves of conversation originating in an ostensibly private setting in a form, usually as a magnetic tape recording, which can be used against the target by adverse interests.

There are two kinds of electronic listening devices. One takes advantage of equipment already present on the target's premises, such as a telephone, radio, phonograph, television set, public-address loudspeaker, or tape recorder, to act as a microphone, transmitter, or power supply. The other does not. In the former case, the target's equipment is said to have been compromised.

Compromise of the target's own equipment takes advantage of the fact that any loudspeaker is capable of functioning just as well as a microphone, that convenient sources of dc power are available within the equipment, or that the equipment is connected to power or signal lines that can transmit the intercepted conversation to some place where recording can conveniently be accomplished. The equipment most frequently compromised is the telephone handset.

Eavesdropping devices that can stand alone are known commonly as "bugs." They take advantage of many developments of modern technology, such as microcircuits, miniature ceramic microphones, and miniature batteries. Electronically a bug is often just a two-stage frequency-modulated transmitter: an audio amplifier and a variable-frequency radio-frequency (rf) oscillator. Bugs may operate on any frequency from 20 to 1000 MHz, but usually they snuggle up beside a powerful local FM or vhf television station. See AMPLIFIER; OSCILLATOR; RADIO TRANSMITTER.

A popular hybrid between a compromise device and a bug is the telephone drop-in. In this design, an FM transmitter is

made in the form of a telephone microphone. The eavesdropper can casually unscrew the mouthpiece of his target's telephone handset and substitute the drop-in for the original microphone. The range of this device is about 240 ft (75 m). It has the added advantage of drawing its dc power from the telephone company central battery. [J.M.C.]

**Electronic mail** The asynchronous transmission of messages by using computers and data-communication networks. Historically, electronic mail (or e-mail) referred to any of a number of technologies that allowed people to send documents to one another through electronic means. It was frequently used to describe both wirephoto [the precursor of the facsimile (fax) machine] and telegraphy. Subsequently, usage of the term focused upon the narrower sense given above. See FACSIMILE; TELEGRAPHY.

The use of electronic mail grew continuously until the late 1980s but never achieved widespread use outside of work groups or corporations. The limiting factor was the complicated addressing that had to be worked out before a message could be successfully transmitted.

There were two proposed methods to solve the problem of mail-system identification and routing. The Organization for International Standardization (ISO) formulated the X.400 standard, and the Internet community developed an extended use of the domain name system (DNS). Many impediments to the spread of X.400, such as high software costs and delays in standardization, caused the freely available DNS solution to become the de facto standard.

The DNS describes a worldwide distributed database in which each site maintains its own information about how to route messages to a computer within its administrative domain. A computer wishing to send a message to another asks the DNS for the routing information and uses the information returned to make the connection. This allows a person on virtually any online networking service to send mail to another person by giving only the personal identification and the e-mail system name of the recipient. See DISTRIBUTED SYSTEMS (COMPUTERS).

From the time the usage of the term narrowed to exclude facsimile until the early 1990s, generally only coded textual information could be transferred via e-mail. The transmission of nontextual data required special preprocessing, postprocessing, and prior arrangements between the sending and receiving parties. It was very difficult to make these kinds of transfers if the sending and receiving computers were different types.

This restriction was lifted with the adoption of the MIME (Multimedia Internet Mail Enhancements) standard. It described a way of encoding an arbitrary list of media types within a normal textual message in an operating-system-independent manner. Finally, different types of systems could send executable, sound, picture, movie, and other kinds of files to each other via e-mail. See MULTIMEDIA TECHNOLOGY.

The spread of electronic mail was also hampered by its lack of security. As mail was passed from one site to another closer to its destination, system administrators at each intermediate site could read messages. Also, the source of an e-mail message may be fairly easily forged to make it either untraceable or appear to come from another person. This limited the use of e-mail to so-called friendly applications. Public-key cryptography has been applied to e-mail messaging, notably in PEM (Privacy Enhanced Mail), in response to these security concerns. See COMPUTER SECURITY; CRYPTOGRAPHY.

Since the communications speeds required for e-mail are quite modest, messages are sometimes transmitted by wireless means. Cell phones and personal digital assistants can send and receive e-mail through Earth-satellite relay. See INTERNET; WORLD WIDE WEB. [E.Kro.]

**Electronic navigation systems** Systems that provide a variety of navigational parameters through the

application of the electronic sciences. Typical parameters are distance and bearing from a vehicle to a known point, and the present position of the vehicle in a particular coordinate system. From the knowledge of present position, the course and distance to a destination can be calculated. Most systems are based on the use of electromagnetic (radio) waves, and those described here are used by aircraft, ships, land vehicles, and space vehicles.

The use of radio waves has been found to be attractive because of their known, and nearly constant, velocity of propagation, namely, the speed of light ( $c$ ), which is about  $1.86 \times 10^5$  mi/s ( $3 \times 10^8$  m/s). Thus, if the time ( $t$ ) of travel of the radio signal between two points is accurately measured, the distance or range ( $d$ ) between the points can be accurately determined from the equation  $d = ct$ . Ships also use systems based on underwater sound waves, with due allowance for the much slower speed of sound in water. Also, electromagnetic waves in the visible (optical) or near-visible spectrum can be used in a similar manner for distance measurement. See ELECTROMAGNETIC RADIATION; LIGHT; SONAR; UNDERWATER NAVIGATION; UNDERWATER SOUND.

From an electronic viewpoint, all systems can be classified as either cooperative or self-contained. From a navigational viewpoint, systems are frequently classified as positioning or dead-reckoning systems. Most positioning systems are cooperative systems, while most dead-reckoning systems are self contained. Many modern systems combine the data from cooperative and self-contained sensors to obtain a more accurate solution. Such systems have been called multisensor, integrated, or hybrid systems. See DEAD RECKONING.

**Cooperative systems.** The two general categories of cooperative radio systems are point-source systems and multiple-source systems. Point-source systems typically determine position in a relative coordinate system by measuring the distance and bearing to a transmitting source at a known location. See RHO-THETA SYSTEM.

Perhaps the earliest form of a point-source radio system is the direction finder, in which the signal from a single transmitter source is received at two known points or elements. The direction from the vehicle to the source is determined by measuring the differential distance (or phase) of the signals received at the two points or elements. For operational convenience (size), it is desirable to have the two receiving points close together and to use common circuitry at both measuring points. A loop antenna fulfills both of these requirements. The loop is rotated until the currents in the two vertical arms of the loop are equal in amplitude and phase so that the output of the receiver is zero. The transmitter source is then located  $90^\circ$  from the plane of the loop. In simple loops, there is a  $180^\circ$  ambiguity, but this is typically resolved by temporarily connecting an omnidirectional antenna to the receiver input. See DIRECTION-FINDING EQUIPMENT.

The angular measurement errors, particularly on aircraft and ships, can be quite large ( $3^\circ$  or more). However, direction finders are still used, particularly for backup navigation and emergency homing.

Another class of point-source angle-measuring systems is based on the use of rotating or scanning antenna beams at the transmitter source and reception (or reflection) of the transmitted signal by the user vehicle receiver. For example, if a ground transmitter generates a rotating cardioid amplitude pattern at a fixed rate plus an omnidirectional reference signal, the user receiver can measure the relative phase difference between these two signals and thereby determine the bearing to the transmitter source. The very high frequency (VHF) omnidirectional range (VOR), used worldwide for short-distance aircraft navigation, is based on this principle. See VOR (VHF OMNIDIRECTIONAL RANGE).

Another point-source technique for bearing measurement is based on using a radiated dual-lobe structure, with the carrier in each lobe being modulated at different frequency tones and phases. The user receiver can then detect when the vehicle is operating at the intersection of the two beams. The instrument landing system (ILS), which is used worldwide for aircraft ap-

proach and landing, is based on that principle. See INSTRUMENT LANDING SYSTEM (ILS).

Theoretically, there are two possible types of point-source systems for distance determination. One is based on the two-way (round-trip) ranging principle. The interrogator, which may be located on the navigating vehicle, transmits a signal, typically a pulse or pair of pulses, at a known time, which is stored in the equipment. The signal is received at a transponder and, after a fixed, known delay, is retransmitted toward the interrogator. When received by the interrogator's receiver, it becomes an input to the ranging circuit. This circuit measures the time difference between the original transmission time and the time of reception (less the known fixed delay), which (when multiplied by the speed of light) is a direct measure of the two-way distance. Such a system is the basis of the distance-measuring equipment (DME), used for short-range navigation worldwide, and also of the Air-Traffic Control Radar Beacon System (ATCRBS), used for air-traffic control surveillance on a global basis. See AIR-TRAFFIC CONTROL; DISTANCE-MEASURING EQUIPMENT.

A second possible technique for point-source distance determination is one-way signal-delay (time-of-arrival) measurement between a transmitter source at a known location and a user receiver. In this case, a successful measurement is possible only if the transmitter oscillator (clock) and the user receiver oscillator (clock) are precisely time synchronized. Since this synchronization is frequently impossible at reasonable equipment cost, no practical point-source distance measurement system based on such synchronization has been developed, but several modern multisensor systems (discussed below) have modes that employ this principle.

Multiple-source radio systems employ multiple transmitter sources, and user vehicle equipment typically consisting of a receiver or a receiver-transmitter. The four major categories of such systems (with some implementations using combinations of these) are hyperbolic systems, pseudorange systems, one-way synchronous ranging (direct-ranging) systems, and two-way (round-trip) ranging systems.

Hyperbolic systems were the first to be developed, but they are still in widespread use. Three or more transmitter sources transmit time-synchronized continuous-wave or pulsed signals. The user receiver measures time differences of signals from pairs of stations. Loci of constant time differences, or (equivalently) constant differences in distance, from two stations form hyperbolic lines of position (LOPs). The point where two lines of position cross is the position of the user vehicle. The Loran C system is based on this hyperbolic principle. See DECCA; HYPERBOLIC NAVIGATION SYSTEM; LORAN.

Pseudorange has some similarity in configuration to hyperbolic systems, but does not use time differences. Several transmitter sources (for example, space vehicles or terrestrial stations), whose positions are made known to the user, transmit highly time-synchronized signals based on an established system time. With the periodic times of transmission epochs of the signals from the sources provided or known to the user, the user measures the time of arrival (TOA) of each signal with respect to the user's own clock time, which normally has some offset from system time. This range measurement is called pseudorange, since it differs from the true range as a result of the offset of the user's clock relative to the system (transmitter) time. From successive or simultaneous time-of-arrival (pseudorange) measurements from four (or more) sources, the user receiver then calculates the three-dimensional position coordinates and its own clock offset (from system time). This is accomplished by solving four simultaneous quadratic equations (usually the computations are linearized), involving the three known position coordinates of the sources and the four unknowns, namely, the three user position coordinates and the user's clock offset. Thus, such a system accurately determines not only the user's three-dimensional position but also system time, which is easily related to Universal Time Coordinated (UTC). The pseudorange concept is the basis of

operation of two major satellite navigation systems for worldwide use, the U.S. Global Positioning System (GPS) and the Russian Global Navigation Satellite System. See SATELLITE NAVIGATION SYSTEMS.

The implementation of one-way synchronous ranging between one of the transmitter sources and the user receiver was discussed above. In order for a true one-way range measurement to be made, the clock of the user receiver must first be synchronized to that of the transmitter source. In some systems, this is accomplished by an independent means, for example, in the JTIDS-RelNav system and in the Position Location Reporting System (PLRS). The concept is also used in one mode of certain hyperbolic systems, notably Loran C. Two implementations are possible, the rho-rho method or the multiple-rho method. The rho-rho method requires only two source transmitters, but also requires a highly stable user receiver oscillator (clock) and precise knowledge of the time of transmission from the source stations. The multiple-rho method requires at least three stations. Using three lines of position permits clock oscillator self-calibration, much as the previously discussed pseudorange concept, and therefore leads to a much less stringent clock oscillator requirement.

Two-way (round-trip) ranging involves multiple two-way distance measurements of the type discussed above. To obtain a completely unambiguous horizontal position fix, three such two-way ranges are required; however, two are usually sufficient. The major disadvantage of this concept is that the user requires a transmitter as well as a receiver. A typical application of this concept is DME-DME or multiple-DME operation for civil aviation navigation.

**Self-contained systems.** These systems can be classified as radiating or nonradiating. Radiating systems may be subject to jamming and to homing by radiation-seeking missiles, although the effects of jamming are typically small. Radiating systems include the radar altimeter, airborne mapping radar, map matching, and Doppler radar. See AIRBORNE RADAR; ALTIMETER; DOPPLER RADAR; ELECTRONIC WARFARE; HOMING; JAMMING.

Nonradiating systems, such as inertial, offer essentially complete protection against jamming. Inertial navigation systems, consisting of accelerometers, gyroscopes, and computers, continuously determine position, velocity, acceleration, direction, and vehicle attitude (pitch and roll), based on Newton's second law. See ACCELEROMETER; GYROSCOPE; INERTIAL GUIDANCE SYSTEM.

[W.R.Fr.; R.Gr.]

**Electronic packaging** The technology relating to the establishment of electrical interconnections and appropriate housing for electrical circuitry. Electronic packages provide four major functions: interconnection of electrical signals, mechanical protection of circuits, distribution of electrical energy (that is, power) for circuit function, and dissipation of heat generated by circuit function.

**Printed circuitry.** As solid-state transistors started to replace vacuum-tube technology, it became possible for electronic components, such as resistors, capacitors, and diodes, to be mounted directly by their leads into printed circuit boards or cards, thus establishing a fundamental building block or level of packaging that is still in use. See PRINTED CIRCUIT.

**Packaging hierarchy.** Complex electronic functions often require more individual components than can be interconnected on a single printed circuit card. Multilayer card capability was accompanied by development of three-dimensional packaging of daughter cards onto multilayer mother boards.

Integrated circuitry allows many of the discrete circuit elements such as resistors and diodes to be embedded into individual, relatively small components known as integrated circuit chips or dies. In spite of incredible circuit integration, however, more than one packaging level is typically required, in part because of the technology of integrated circuits itself.

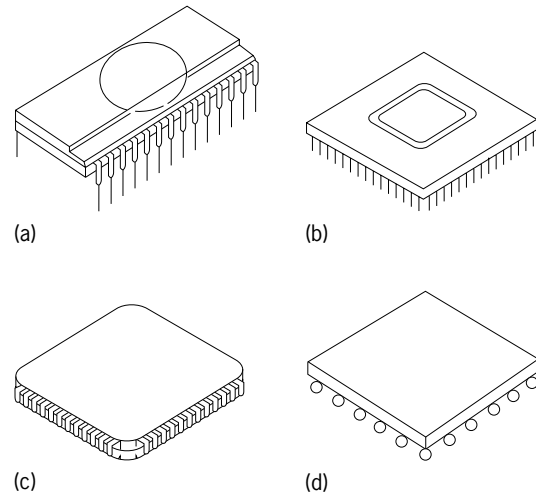

Typical first-level packages. (a) Dual in-line package. (b) Pin grid array. (c) Leadless chip carrier. (d) Ball grid array.

Integrated circuit chips are quite fragile, with extremely small terminals. First-level packaging achieves the major functions of mechanically protecting, cooling, and providing capability for electrical connections to the delicate integrated circuit. At least one additional packaging level, such as a printed circuit card, is utilized, as some components (high-power resistors, mechanical switches, capacitors) are not readily integrated onto a chip. For very complex applications, such as mainframe computers, a hierarchy of multiple packaging levels is required. See INTEGRATED CIRCUITS.

**First-level packaging.** Chip-to-package interconnection is typically achieved by one of three techniques: wire bond, tape-automated bond, and solder-ball flip chip. The wire bond is the most widely used first-level interconnection; it employs ultrasonic energy to weld very fine wires mechanically from metallized terminal pads along the periphery of the integrated circuit chip to corresponding bonding pads on the surface of the substrate. In the tape-automated bond, photolithographically defined gold-plated copper leads are formed on a polyimide carrier that is usually handled like 35mm photographic roll film, with perforated edges to reel the film or tape. Solder-ball flip-chip technique involves the formation of solder bump contacts on the terminals of the integrated chips and reflowing the solder with the chip flipped in such a way that the bump contacts touch and wet to matching pads on the substrate.

Substrates for first-level packages are quite varied. A major classification is whether the package supports a single integrated circuit chip (single-chip module) or more than one chip (multi-chip module). The former is by far the most common. Substrate insulator materials for multichip and single-chip modules are selected from one of two broad groups of materials, organics and ceramics.

Means for interconnecting to the second-level package often dictate the general form of the first-level package (see illustration). See ELECTRONICS.

[P.J.Br.]

**Electronic power supply** A source of electric power (voltage and current) to operate electronic circuits. Active electronic circuits contain such devices as transistors or vacuum tubes and require external power to amplify, filter, modify, or create electrical signals. The most common source of energy for electronic circuits is obtained by converting the electrical energy available in the conventional alternating-current (ac) electric power mains to an appropriate voltage or current. These converters, or electronic power supplies, can be implemented with a wide variety of circuits. Other power sources include batteries,



mechanically driven generators, photovoltaic (solar) cells, and fuel cells. See ALTERNATING CURRENT; CONVERTER.

Most electronic circuits require a direct-current (dc) or constant voltage. If ac power is required, an oscillator or a simple transformer is used. Although some dc-to-dc converters are used, most dc power supplies convert the alternating power from the ac main to dc power. These ac-to-dc power supplies are classified according to the type of circuits used to realize the conversion: rectification, filtering, and regulation. Simple battery chargers are examples of power supplies that do not require filtering or regulation.

**Rectification.** An essential step in the conversion of ac to dc is a process called rectification. Rectification converts ac voltage to a waveform with average or dc value by passing only one polarity (half-wave) or by generating the magnitude or absolute value (full-wave). Three types of rectifier (diode) circuits are commonly used. Only one diode is required to obtain half-wave rectification. Full-wave rectification can be obtained with four diodes connected in a bridge configuration or with two diodes and a center-tapped transformer. Transformers are normally used at the input of the rectifiers to increase or decrease the voltage and isolate the dc output from the ac input for safety purposes. See DIODE; RECTIFIER; TRANSFORMER.

**Filtering.** For most applications the ac or alternating portion of the rectified output is unwanted and may cause undesirable results, such as an annoying hum in audio systems. A capacitor can be used to reduce or filter the ac portion of the rectified waveform. The capacitor is charged through the diodes to the peak ac voltage minus the diode forward voltage. Some of the charge stored on the capacitor is delivered to the load each cycle, but the next voltage peak recharges the capacitor. See CAPACITOR; ELECTRIC FILTER.

**Regulation.** Regulators are often used to make the power supply output insensitive to input voltage amplitude variations and further reduce the ripple voltage. The regulator may also be used to adjust or change the dc output voltage and limit the amount of current delivered by the power supply. Regulators are a form of dc-to-dc converter.

The oldest and simplest type of regulator is the linear regulator. A simple linear regulator is the shunt type. It consists of a Zener diode and a current-limiting resistor. The Zener diode establishes a fixed, or reference, voltage if it is properly reverse biased. Another common type of linear regulator is the series-pass regulator. See TRANSISTOR; ZENER DIODE.

More modern power supplies have switching regulators, and are informally called switchers. There are more than a dozen different topologies (basic block diagrams) for switching regulators, but they all use one or more transistors acting as switches; either ON or OFF. In addition to the solid-state (transistor) switches, a typical switching regulator uses capacitors and inductors to store energy and diodes to direct the current.

Other common types of switching regulators are called buck-boost (or flyback) and push-pull or (buck-derived). Switching regulators can be used to generate multiple outputs at different voltage levels. The improved efficiency of switching regulators is due to the fact that energy is stored very efficiently in inductors and capacitors. The remaining losses in the control circuitry, switches, and the diodes are small compared to linear regulators. See INDUCTOR; VOLTAGE REGULATOR.

**Ferroresonant transformer-based power supplies.** These have some advantages for high-current applications such as battery chargers. Ferroresonant power supplies use nonlinear magnetic properties and a resonant circuit to regulate the output voltage, and they have efficiencies similar to switching power supplies. Power supplies driven by three-, six-, or twelve-phase ac are easier to filter, and they generate much lower harmonic distortion of the current in the ac power system. [N.G.Di.]

**Electronic switch** An electronic device in which one or more input signals can be routed to one or more outputs by

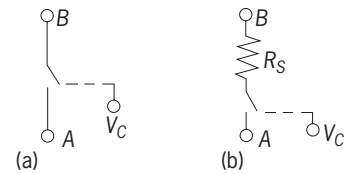

Switching devices. (a) Symbol for electronic switch. (b) Simple model of electronic switch.

the application of the appropriate electrical control signals. The term is most often applied when analog signals are involved, but the terminology is occasionally used when digital signals are involved.

Conceptually, an electronic switch can be visualized as a group of one or more mechanical electrical switches (such as light switches used in commercial wiring or toggle switches used in many electronic control panels) in which, instead of mechanically opening or closing the contacts, the physical opening and closing is achieved by applying appropriate electrical control signals to separate terminals on the switch in much the same way that a relay performs. The electronic switch does not contain mechanical contacts but semiconductor devices such as bipolar junction transistors or field-effect transistors. The basic electronic switch is depicted in illus. a. A and B are the terminals of the switch. When a control signal is applied to  $V_C$ , the switch closes. When the electronic switch is closed, a small residual resistance  $R_s$  remains between the terminals as depicted in the simple model of illus. b. The value of this resistance is termed the on resistance. In most applications the nonzero on resistance does not prove problematic, but the user needs to be aware of this limitation. The electronic switch is typically bidirectional in the sense that the terminals A and B are interchangeable. See ELECTRIC SWITCH; RELAY; TRANSISTOR.

Electronic switches can be very small, allowing a large number of these devices to be placed in a small area they can be very fast, with on and off response times which are orders of magnitude faster than can be achieved with mechanical counterparts; and they are considerably more reliable over a large number of cycles than their mechanical counterparts. [R.L.Ge.]

**Electronic test equipment** Apparatus used for the evaluation of electronic components, subassemblies, and systems.

The galvanometer was an early electromechanical instrument that converted current into angular rotation of a needle pointer across the face of a scale. The instrument consisted of a fine wire coil mechanically connected to a pivoting element. The coil was located in the field of a permanent magnet so that when current flowed through the coil the induced magnetic field rotated the element, causing the needle to move across the scale. This instrument could be used as a voltmeter, since a higher voltage induces a larger current flow through the coil. The advent of the cathode-ray tube (CRT) enabled the development of another widely used instrument, the oscilloscope. The CRT translates voltage into the deflection of an electron beam, which visibly activates a luminescent phosphor inside the face of the tube. When a voltage is connected to the vertical plates, the visual representation on the CRT face has the amplitude and polarity of the voltage displayed as a function of time. See AMMETER; CATHODE-RAY TUBE; GALVANOMETER; OSCILLOSCOPE; VOLTMETER.

An important advance in electronic test equipment was the incorporation of circuits that directly converted the analog signal to be measured into a digital reading. The most significant impact of these converters was to enable a computer interface to the equipment to be set up allowing direct computer monitoring and control of the instrument. Other equipments were designed with embedded computers, which provided very sophisticated analysis of the data within the instrument itself.

See ANALOG-TO-DIGITAL CONVERTER; DIGITAL-TO-ANALOG CONVERTER; EMBEDDED SYSTEMS.

The best example of this enhancement is with spectrum analyzers. Digital signal processing (DSP) electronics have been included in these instruments which provide a frequency spectral analysis of the input signal. These instruments are widely used in the evaluation of radio communication signals, acoustic signal processing, and the analysis of mechanical forces and vibration. See SPECTRUM ANALYZER.

The complexity and sophistication of electronic components and subassemblies became more complicated. Multiple test instruments were integrated to form rack-and-stack automatic test equipment, where the individual instruments were connected to a control computer by a common bus. These computer-controlled testers were very efficient at providing the input stimulus to the unit under test and monitoring the output response. See ELECTRONICS; INTEGRATED CIRCUITS; LOGIC CIRCUITS; MICROPROCESSOR; SIGNAL GENERATOR.

The ability of automatic test equipment to sort out good from bad units is only the first requirement of modern production test equipment. Since the repair of defective units can be costly, the design and program development of test equipment frequently must include special provisions to provide failure-mode analysis. Information such as the probable defective component on a printed circuit board or the probable defective board in a system is of great value in efficient repair. Some test systems include fault dictionaries, supplemental tests after first failure, or even artificial-intelligence features to assist in repair. [W.R.Ma.]

**Electronic warfare** Use of techniques, devices, and equipment by an adversary to deny or counteract the enemy's use of radar, communications, guidance, or other radio-wave devices. Because of the use of optical and infrared techniques for communications, guidance, detection, and control, electronic warfare techniques are sometimes called electromagnetic, rather than electronic, to convey more adequately the idea that countermeasures are not confined to the portion of the spectrum where electronic techniques alone are applicable but may be used throughout the electromagnetic spectrum.

Traditionally, electronic warfare equipment and techniques are categorized as active and passive, depending on whether or not they radiate their own energy. The passive category includes reconnaissance or surveillance equipment that detects and analyzes electromagnetic radiation from radar and communications transmitters in a potential enemy's aircraft, missiles, ships, satellites, and ground installations. The reconnaissance devices may be used to identify and map the location of emitters without in any way altering the nature of the signals they receive. Other types of passive electronic warfare equipment do seek to enhance or change the nature of the energy reflected back to enemy radars, but they do not generate their own energy.

Active electronic warfare equipment generates energy, either in the form of noise to confuse an enemy's electromagnetic sensors or by generating false or time-delayed signals to deceive radio or radar equipment and their operators. See ELECTRICAL NOISE.

**Passive systems.** Reconnaissance or surveillance electronic warfare systems are carried by Earth-orbiting satellites, aircraft, ships, uncrewed (drone) aircraft, and automotive vehicles. Some are located on the ground. A few systems are small enough to be carried by a person. Reconnaissance systems are interchangeably called ferret or electronic intelligence (elint) systems. They consist of sensitive receivers electromechanically or electronically tuned over desired portions of the spectrum in search of transmissions of interest. Bearing to an intercepted signal can be determined by direction-finding techniques. Once secured, the signals can be displayed for analysis by an operator or stored on tape or other storage media for subsequent analysis.

Warning-receiver systems, which came into widespread use on United States tactical and transport aircraft during the Viet-

namese war, are a more limited form of the elint system. Unlike the latter, which is intended to search for signals over a broad range of the spectrum, the warning receiver is programmed to alert a pilot when the aircraft is being illuminated by a specific radar signal above predetermined power thresholds anticipated by elint systems. When the pilot has been alerted, the aircraft can be maneuvered to evade the threat or initiate counteraction with onboard electronic warfare capability.

One of the oldest passive electronic warfare techniques, made famous by a Royal Air force raid on Hamburg in 1943, is the use of chaff. These are metallic strips cut to lengths resonant at the defense radar frequency so that they return spurious radar echoes to enemy radar. Chaff can confuse an enemy by generating false targets, or noise, forcing the enemy to take time to analyze the returns and sort real from false targets. Chaff can screen or mask aircraft or higher-speed ships so that the enemy is unable to determine their presence, or chaff can help an aircraft break track once it is alerted by its warning receiver that it is being tracked by radar.

Other passive electronic warfare techniques include the use of special radar-absorbing materials, such as ceramics or ferrites, which reduce reflection coefficients so that the amount of radar energy returned to the illuminating radar is reduced; the special shaping of bodies, specifically in missile reentry systems, that reduces the vehicle's radar cross section; the use of corner reflectors, or Luneberg lenses, which concentrate the energy they reflect back to the radar.

**Active systems.** The many active electronic warfare techniques can be classified broadly either as noise or deception jamming. The former is the oldest, simplest, and most straightforward, but requires higher average power levels and is more expensive. Deception jamming is the more artful and sophisticated technique, operating on the characteristics of the pulse train generated by threat radars.

Deception-jamming techniques are predicated on the idea of operating on pulses received from the enemy so that the signal reradiated from the target deceives the enemy radar or its operators. For instance, the deception set may receive an enemy radar pulse, circulate it through a delay line, amplify it, and reradiate it back toward the enemy. Because the enemy determines the position of the target by the round-trip transit time of the radar energy, the radar decision circuitry will conclude that the target is at a greater distance than it actually is because of the deceptive pulse delay inserted in that round-trip period by the active set. Similarly, the deception set may operate on the radar pulse train, returning many pulses instead of one, in an effort to deceive the enemy into believing there are many targets spaced at different positions. [B.Mi.]

**Electronics** Technology involving the manipulation of voltages and electric currents through the use of various devices for the purpose of performing some useful action. This large field is generally divided into two primary areas, analog electronics and digital electronics.

**Analog electronics.** Historically, analog electronics was used in large part because of the ease with which circuits could be implemented with analog devices. However, as signals have become more complex, and the ability to fabricate extremely complex digital circuits has increased, the disadvantages of analog electronics have increased in importance, while the importance of simplicity has declined.

In analog electronics, the signals to be manipulated take the form of continuous currents or voltages. The information in the signal is carried by the value of the current or voltage at a particular time  $t$ . Some examples of analog electronic signals are amplitude-modulated (AM) and frequency-modulated (FM) radio broadcast signals, thermocouple temperature data signals, and standard audio cassette recording signals. In each of these cases, analog electronic devices and circuits can be used to render the signals intelligible.

Commonly required manipulations include amplification, rectification, and conversion to a nonelectronic signal. Amplification is required when the strength of a signal of interest is not sufficient to perform the task that the signal is required to do. However, the amplification process suffers from the two primary disadvantages of analog electronics: (1) susceptibility to replication errors due to nonlinearities in the amplification process and (2) susceptibility to signal degradation due to the addition, during the amplification process, of noise originating from the analog devices composing the amplifier. These two disadvantages compete with the primary advantage of analog electronics, the ease of implementing any desired electronic signal manipulation. See AMPLIFIER; DISTORTION (ELECTRONIC CIRCUITS); ELECTRICAL NOISE.

**Digital electronics.** The advent of the transistor in the 1940s made it possible to design simple, inexpensive digital electronic circuits and initiated the explosive growth of digital electronics. Digital signals are represented by a finite set of states rather than a continuum, as is the case for the analog signal. Typically, a digital signal takes on the value 0 or 1; such a signal is called a binary signal. Because digital signals have only a finite set of states, they are amenable to error-correction techniques; this feature gives digital electronics its principal advantage over analog electronics. See ELECTRON TUBE; TRANSISTOR.

In common two-level digital electronics, signals are manipulated mathematically. These mathematical operations are known as boolean algebra. The operations permissible in boolean algebra are NOT, AND, OR, and XOR, plus various combinations of these elemental operations. See BOOLEAN ALGEBRA.

Electronic circuits are composed of various electronic devices, such as transistors, resistors, and capacitors. In circuits built from discrete components, the components are typically soldered together on a fiberglass board known as a printed circuit board. On one or more surfaces of the printed circuit board are layers of conductive material which has been patterned to form the interconnections between the different components in the circuit. In some cases, the circuits necessary for a particular application are far too complex to build from individual discrete components, and integrated-circuit technology must be employed. Integrated circuits are fabricated entirely from a single piece of semiconductor substrate. It is possible in some cases to put several million electronic devices inside the same integrated circuit. Many integrated circuits can be fabricated on a single wafer of silicon at one time, and at the end of the fabrication process the wafer is sawed into individual integrated circuits. These small pieces, or chips as they are popularly known, are then packaged appropriately for their intended application. See CAPACITOR; INTEGRATED CIRCUITS; PRINTED CIRCUIT; RESISTOR.

The microprocessor is the most important integrated circuit to arise from the field of electronics. This circuit consists of a set of subcircuits that can perform the tasks necessary for computation and are the heart of modern computers. Microprocessors that understand large numbers of instructions are called complete instruction set computers (CISCs), and microprocessors that have only a very limited instruction set are called reduced instruction set computers (RISCs). See DIGITAL COMPUTER; MICROPROCESSOR.

Other circuit designs have been standardized and reduced to integrated-circuit form as well. An example of this process is seen in the telephone modem. Modulation techniques have been standardized to permit the largest possible data-transfer rates in a given amount of bandwidth, and standardized modem chips are available for use in circuit design. See MODEM.

The memory chip is another important integrated electronic circuit. This circuit consists of a large array of memory cells composed of a transistor and some other circuitry. As the storage capacity of the memory chip has increased, significant miniaturization has taken place. See CIRCUIT (ELECTRONICS); SEMICONDUCTOR MEMORIES. [D.R.A.]

**Electronvolt** A unit of energy used for convenience in atomic systems. Specifically, it is the change in energy of an

electron, or of any particle having a charge numerically equal to that of an electron, when it is moved through a difference of potential of 1 mks volt. Its value (in mks units) is obtained from the equation  $W = qV$ , where  $W$  is energy in joules,  $q$  the charge in coulombs, and  $V$  the potential difference in volts. For a potential difference of 1 volt and the electronic charge of  $1.602 \times 10^{-19}$  coulomb, the electronvolt is  $1.602 \times 10^{-19}$  joule. See ELECTRON; IONIZATION POTENTIAL. [G.H.M.]

**Electrooptics** The branch of physics which deals with the influence of an electric field on the optical properties of matter, especially in its crystalline form. These properties include transmission, emission, and absorption of light.

An electric field applied to a transparent crystal can change its refractive indexes and, therefore, alter the state of polarization of light propagating through it. When the refractive-index changes are directly proportional to the applied field, the phenomenon is termed the Pockels effect. When they are proportional to the square of the applied field, it is called the Kerr effect. See KERR EFFECT; POLARIZED LIGHT; REFRACTION OF WAVES.

The Pockels effect is used in a light modulator called the Pockels cell. This device (see illustration) consists of a crystal  $C$  (usually potassium dihydrogen phosphate, or KDP) placed between two polarizers  $P_1$  and  $P_2$  whose axes are crossed. Ring electrodes bonded to two crystal faces allow an electronic driver  $V$  to apply an electric field parallel to the axis  $OZ$  along which a light beam (for example, a laser beam) is made to propagate. Pockels cells can be switched on and off in well under 1 nanosecond. See LASER; OPTICAL MODULATORS.

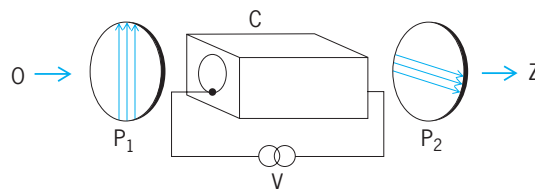

**Pockels cell light modulator.** The bold arrows represent a light beam.

The linearity and high-speed response of the Pockels effect within an electrooptic crystal make possible a unique optical technique for measuring the amplitude of repetitive high-frequency (greater than 1 GHz) electric signals that cannot be measured by conventional means. The technique, known as electrooptic sampling, employs a special traveling-wave Pockels cell between crossed polarizers. It is used to analyze ultrafast electric signals such as those generated by high-speed transistors and optical detectors. [M.A.D.; J.A.V.]

A self-electrooptic-effect device (SEED) is a combination of a quantum-well electrooptic modulator with a photodetector which, when light shines on it, changes the voltage on the modulator. Although the device relies internally on an electrooptic effect, the output from the modulator is controlled by the light shining on the photodetector, giving an optically controlled device with an optical output. Most of these devices rely on the quantum-confined Stark effect in semiconductor quantum-well heterostructures as the electrooptic mechanism and utilize the changes in optical absorption resulting from this mechanism. See SEMICONDUCTOR HETEROSTRUCTURES; STARK EFFECT. [D.A.B.M.]

**Electrophilic and nucleophilic reagents** Electrophilic reagents are chemical species which, in the course of chemical reactions, acquire electrons, or a share in electrons, from other molecules or ions. Although this definition embraces all oxidizing agents and all Lewis acids, electrophilic reagents are ordinarily thought of as cationic species, such as  $H^+$ ,  $NO_2^+$ ,  $Br^+$ , or  $SO_3$  (or carriers of these species such as  $HCl$ ,  $CH_3COONO_2$ , or  $Br_2$ ), which can form stable covalent bonds with carbon

atoms. Electrophilic reagents frequently are positively charged ions (cations). See ACID AND BASE.

Nucleophilic reagents are the opposite of electrophilic reagents. Nucleophilic reagents give up electrons, or a share in electrons, to other molecules or ions in the course of chemical reactions. Nucleophilic reagents frequently are negatively charged ions (anions). Typical nucleophilic reagents are hydroxide ion ( $\text{OH}^-$ ), halide ions ( $\text{F}^-$ ,  $\text{Cl}^-$ ,  $\text{Br}^-$ , and  $\text{I}^-$ ), cyanide ion ( $\text{CN}^-$ ), ammonia ( $\text{NH}_3$ ), amines, alkoxide ions (such as  $\text{CH}_3\text{O}^-$ ), and mercaptide ions (such as  $\text{C}_6\text{H}_5\text{S}^-$ ). See SUBSTITUTION REACTION. [J.F.B.]

**Electrophoresis** The migration of electrically charged particles in solution or suspension in the presence of an applied electric field. Each particle moves toward the electrode of opposite electrical polarity. For a given set of solution conditions, the velocity with which a particle moves divided by the magnitude of the electric field is a characteristic number called the electrophoretic mobility. The electrophoretic mobility is directly proportional to the magnitude of the charge on the particle, and is inversely proportional to the size of the particle. An electrophoresis experiment may be either analytical, in which case the objective is to measure the magnitude of the electrophoretic mobility, or preparative, in which case the objective is to separate various species which differ in their electrophoretic mobilities under the experimental solution conditions.

**Gel techniques.** Electrophoresis was first employed as an experimental technique by Arne Tiselius in 1937. The apparatus of Tiselius detected electrophoretic motion by the moving-boundary method, in which a boundary is created between the solution of particles to be examined and a sample of pure solvent. As the particles migrate in an electric field, the boundary between solution and solvent can be observed to move, and if there are a number of species in the solution with different electrophoretic mobilities, a series of boundaries of various shapes and magnitudes can be detected. The moving-boundary method was used for three decades to separate complex mixtures of charged macromolecules in solution and to study the physical characteristics of solutions of proteins and other macromolecules of biological and industrial importance.

The resolving power of electrophoresis was greatly improved by the introduction of the use of gel supporting media. The gel matrix prevents thermal convection caused by the heat which results from the passage of electric current through the sample. The absence of convection reduces greatly the mixing of the various parts of the sample, and therefore allows for more stable separation. The dimensions of the cross-links of the gel may also provide a molecular sieving effect, which increases the resolving power of the electrophoretic separation of molecules of different size. In addition, the gel media may support a gradient of a separate reagent, which assists in the separation of macromolecules. Gradients of pH and of reagents of various types may be combined in two-dimensional arrays for even greater resolving power. A very successful derivative of the gel technique is the determination of the molecular weights of protein molecules by electrophoresis of the molecules in a gel medium which contains substantial amounts of detergent. The detergent denatures the protein molecules, changing them from globular, compact structures to long, flexible polymers which are coated with detergent molecules. These polymers move in the electric field through the gel medium with a velocity which is determined by the length of the polymer, and therefore by the molecular weight of the protein unit. This method is the most common technique for the determination of molecular weights of proteins in biochemical studies. See GEL; pH; PROTEIN.

**Isoelectric focusing.** An important variation of the electrophoresis technique is isoelectric focusing. In this technique the medium supports a pH gradient which includes the isoelectric pH of the species being studied. Many charged macromolecules have both positive and negative charges on their surfaces, and

the electrophoretic mobility is related to the net excess of charge of one type or the other. As the pH becomes more acidic, the number of positive charges increases, and as the pH becomes more basic, the number of negative charges increases. For each molecule of this type, there is one pH at which the net charge on the surface is zero, so that the molecule does not move when an electric field is applied and thus has an electrophoretic mobility of zero. This pH is called the isoelectric pH. If the molecule is introduced into a pH gradient which includes its isoelectric pH, it will migrate to the position of the isoelectric pH and then become stationary. In this way, all molecules of a given isoelectric pH will migrate to the same region—hence the term isoelectric focusing. The method of isoelectric focusing is particularly good for the analysis of microheterogeneity of protein species and other species which may differ slightly in their chemical content. See ISOELECTRIC POINT.

**Laser applications.** Application of the optical laser to electrophoretic detection resulted in the development of a technique which can be used for analytical electrophoresis experiments on particles of all sizes. The basic principle is that the highly monochromatic (single-frequency) laser light impinges upon the particles and is scattered from the particles in all directions. When observing the laser light which has been scattered from a moving particle, one can detect that there is a slight shift in the frequency of the light as a result of the motion of the particle. The application of the laser Doppler principle to electrophoresis experiments, often called electrophoretic light scattering (ELS), is an important method for the rapid determination of electrophoretic velocities. Electrophoretic light scattering has been used for the study of many types of living cells, cell organelles, viruses, proteins, nucleic acids, and synthetic polymers. See DOPPLER EFFECT; ELECTROLYTIC CONDUCTANCE; LASER; SCATTERING OF ELECTROMAGNETIC RADIATION. [B.R.W.]

**Capillary electrophoresis.** Electrophoresis can be performed in a capillary format. A typical system consists of two reservoirs and a capillary filled with a buffer solution. A high voltage is applied across the capillary by using a high-voltage power supply. The very small diameter capillaries (typically 5–100 micrometers) employed in this technique allow for efficient heat dissipation. Therefore, much higher voltages can be employed than those used in slab gel electrophoresis, leading to faster, more efficient separations. Compounds are separated on the basis of their net electrophoretic mobilities.

Most often, the detector is placed on line and analytes are detected as they flow past the detector. Spectroscopic detection (ultraviolet and laser-based fluorescence) is usually performed in this manner by using the capillary itself as the optical cell. Alternatively, detectors can be placed off line (after the column). In this case, the detector is isolated from the applied electric field through the use of a grounding joint. Electrochemical detection and mass spectroscopic detection are generally accomplished in this manner, since the electric field can interfere with the performance of these detectors.

Capillary zone electrophoresis is the simplest and most widely used form of capillary electrophoresis. The capillary is filled with a homogeneous buffer, and compounds are separated on the basis of their relative charge and size. Most often, fused silica capillaries are employed. In this case, an electrical double layer is produced at the capillary surface due to the attraction of positively charged cations in the buffer to the ionized silanol groups on the capillary wall. In the presence of an electric field, the cations in the diffuse portion of this double layer move toward the cathode and drag the solvent with them, producing an electroosmotic flow. The resulting flow profile is flat rather than the parabolic shape characteristic of liquid chromatography. This flat flow profile causes analytes to migrate in very narrow bands and leads to highly efficient separations. The electroosmotic flow is also pH dependent, and it is highest at alkaline pH values.

In most cases, the electroosmotic flow is the strongest driving force in the separation, and all analytes, regardless of charge,

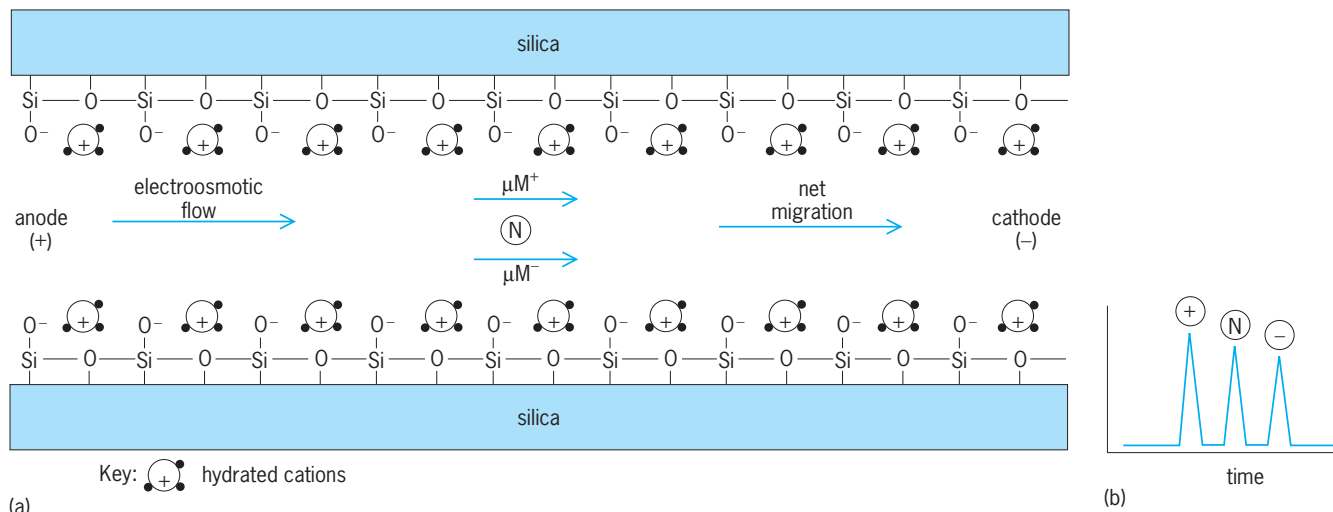

**Capillary zone electrophoresis.** (a) Separation mechanism showing electrophoretic mobility of the positive ion ( $\mu M^+$ ) and negative ion ( $\mu M^-$ ); N is a neutral molecule. (b) Migration order of the ions.

migrate toward the cathode. Therefore, it is possible to separate and detect positive, negative, and neutral molecules in the same electrophoretic run, if the detector is placed at the cathodic end. Negatively charged compounds are attracted to the anode but are swept up by the electroosmotic flow and elute last. Neutral molecules, which are not separated from each other in capillary zone electrophoresis, elute as a single band with the same velocity as the electroosmotic flow. Positive compounds have positive electrophoretic mobilities in the same direction as the electroosmotic flow, and they elute first (see illustration). Capillary zone electrophoresis is generally employed for the separation of small molecules, including amino acids, peptides, and small ions, and for the separation of drugs, their metabolites, and degradation products.

All capillary electrophoresis methods have the advantage of the ability to analyze small volumes (typical injection volumes are 1–50 nanoliters). This makes it possible to analyze very small samples or to use the same sample for several different analyses. One unique application of this technique is the determination of amino acids and neurotransmitters in single cells. [S.Lu.]

**Alternating-field electrophoresis.** Alternating-field agarose gel electrophoresis is a technique for separating very large molecules of deoxyribonucleic acid (DNA); fragments of DNA ranging in size from 30 to 10,000 kilobasepairs (kb) can be resolved. For the molecular biologist, this is a considerable advance over conventional agarose gel electrophoresis, which is limited to the resolution of less than 50 kb.

Conventional gel electrophoresis employs a single pair of electrodes to generate an electric field that is constant in both time and direction and that is uniform across the gel. DNA molecules are negatively charged with a uniform charge-to-mass ratio and thus migrate steadily toward the positive electrode. Although DNA is a linear molecule, in solution it tends to collapse into a random coil configuration. Agarose is a porous material that acts like a sieve, retarding the movement of the DNA; the larger the molecule, the more the retardation, and thus the molecules separate on the basis of size. However, above approximately 50 kb, the dimensions of the random coil are larger than the pore size of the agarose. The DNA can no longer be sieved through the gel, and resolution is lost.

Contrary to conventional electrophoresis, alternating-field electrophoresis does not use a constant electric field but one which regularly alternates in direction. With each change in field direction, the DNA molecules attempt to reorient themselves. When this happens, an end or a small loop of the molecule,

which has dimensions much smaller than those of the random coil of the entire molecule, may find itself positioned by a pore in the agarose. The electric field can then pull the DNA by the end through the hole. When the field regularly alternates from one direction to another, the DNA regularly reorients and is pulled through an adjacent hole.

Not all molecules in the system will make equal progress under these conditions, because not all molecules can reorient themselves with equal speed. The larger the molecule, the more time it requires in a given field strength (determined by the applied voltage) to change directions and the less time it has left to move. [K.Ga.]

**Electroplating of metals** The process of electrodepositing metallic coatings to alter the existing surface properties or the dimensions of an object. Electroplated coatings are applied for decorative purposes, to improve resistance to corrosion or abrasion, or to impart desirable electrical or magnetic properties. Plating is also used to increase the dimensions of worn or undersized parts. An example of a decorative coating is that of nickel and chromium on automobile bumpers. However, in this application, corrosion and abrasion resistance are also important. An example of electrodeposition used primarily for corrosion protection is zinc plating on such steel articles as nuts, bolts, and fasteners. Since zinc is more readily attacked by most atmospheric corrosive agents, it provides galvanic or sacrificial protection for steel. An electrolytic cell is formed in which zinc, the less noble metal, is the anode, and steel, the more noble one, the cathode. The anode corrodes, and the cathode is protected. See ELECTROCHEMISTRY.

The electroplating process consists essentially of connecting the parts to be plated to the negative terminal of a direct-current source and another piece of metal to the positive pole, and immersing both in a solution containing ions of the metal to be deposited. The part connected to the negative terminal becomes the cathode, and the other piece the anode. In general, the anode is a piece of the same metal that is to be plated. Metal dissolves at the anode and is plated at the cathode. See ELECTROLYSIS.

Most plating solutions are of the aqueous type. There is a limited use of fused salts or organic liquids as solvents. Nonaqueous solutions are employed for the deposition of metal with lower hydrogen overvoltages; that is, hydrogen rather than the metal is reduced at the cathode in the presence of water.

In order for adherent coatings to be deposited, the surface to be plated must be clean, that is, free from all foreign substances

such as oils and greases, as well as oxides or sulfides. The two essential steps are cleaning and pickling.

Three principal cleaning methods are employed to remove grease and attached solids. (1) In solvent cleaning, the articles undergo vapor degreasing, in which a solvent such as tri- or tetrachloroethylene is boiled in a closed system, and its vapors are condensed on the metal surfaces. (2) In emulsion cleaning, the metal parts are immersed in a warm mixture of kerosene, a wetting agent, and an alkaline solution. (3) In electrolytic cleaning, the articles are immersed in an alkaline solution, and a direct current is passed between them and the other electrode, which is usually steel. Ultrasonic cleaning is also used extensively, especially for blind holes or gears packed with soils. Ultrasonic waves introduced into a cleaning solution facilitate and accelerate the detachment of solid particles embedded in crevices and small holes.

In the pickling process, oxides are removed from the surface of the basis metal. For steel, warm, dilute sulfuric acid is used in large-scale operations because it is inexpensive; but room-temperature, dilute hydrochloric acid is also used for pickling because it is fast-acting. Hydrogen embrittlement may be caused by the diffusion of hydrogen in steel (especially high-carbon steel) during pickling and also in certain plating operations. See **EMBRITTLMENT**.

Electropolishing is used when a thin, bright deposit is to be produced. In this case, the substrate surface contours are essentially copied by the deposit. The substrate surface therefore must have a bright finish which can be attained by electropolishing. See **ELECTROPOLISHING**.

Special processes, such as electroforming and anodizing, are required for certain applications. Electroforming is a special type of plating in which thick deposits are subsequently removed from the substrate, which acts as a mold. The process is particularly suitable for forming parts which require intricate designs on inside surfaces. Important applications of electroforming are in the production of phonograph record masters, printing plates, and some musical instruments and fountain pen caps as well in waveguides. In anodizing, a process related to plating, an oxide is deposited on a metal which is the anode in a suitable solution. The process is primarily used with aluminum, but it can be applied to beryllium, magnesium, tantalum, and titanium. Colored coatings can be produced by the incorporation of dyes. See **METAL COATINGS**. [R.W.]

**Electropolishing** A method of polishing metal surfaces by applying an electric current through an electrolytic bath in a process that is the reverse of plating. The metal to be polished is made the anode in an electric circuit. Anodic dissolution of protuberant burrs and sharp edges occurs at a faster rate than over the flat surfaces and crevices, possibly because of locally higher current densities. The result produces an exceedingly flat, smooth, brilliant surface.

Electropolishing is used for many purposes. The brilliance of the polished surface makes an attractive finish. Because the polished surface has the same structural properties as the base metal, it serves as an excellent surface for plating. Electropolishing avoids causing differential surface stresses, one of the requirements for the formation of galvanic cells which cause corrosion. Because no mechanical rubbing is involved, work hardening is avoided. Contaminants, which often are associated with the use of abrasives and polishing compounds, are also avoided. The surface is left clean and may require little or no preparation for subsequent treatment or use. Electropolishing also minimizes loss of high-temperature creep-rupture strength. See **ELECTROPLATING OF METALS**. [W.W.Sn.]

**Electroscope** An instrument for detecting the presence and sign of an electric charge. It is the simplest type of ionization chamber. See **IONIZATION CHAMBER**.

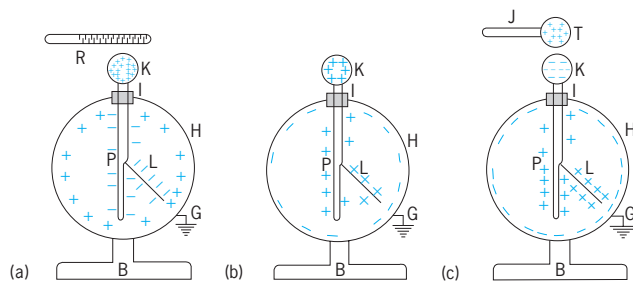

**Electroscope.** (P is a metal support terminating in knob K; B is the base; I is an insulator; and H is a cylindrical metal housing with flat ends and windows.) (a) Being charged by induction by negative charge on hard-rubber rod R. (b) Positive charge left on its leaf after induction process is complete. (c) Testing the sign of an unknown charge on test ball T.

The illustration shows a common type of simple gold-leaf electroscope. Gold leaf (L) is used because it is an extremely thin conducting foil which has low mass per unit area and is very flexible. Hence, it responds quickly and vigorously to small electrostatic forces. In the illustration H serves as a grounded electrostatic shield, as well as a shield against air currents. The hard-rubber rod R (illus. a) with its negative charge has set up the charge distribution by the process of electrostatic induction. The response shown is a test for the fact that R has a charge. See **ELECTROSTATICS**.

To leave the electroscope with a net charge, a grounded conductor is touched to K so that the surplus electrons on P and L go off to ground, leaving the bound positive charge on K. The ground connection is then broken and R is removed. At this stage (illus. b) the electroscope is said to have a positive charge because there is a positive charge on its leaf system.

If an electroscope has a charge of known sign, as in illus. b, it can be used to test the sign of an unknown charge, as in illus. c, where the metal test ball (T), with its insulating handle (J), has the unknown charge. In the situation pictured, L moves farther away from P as T is brought slowly up toward K, showing that T has a positive charge. If T had a negative charge, L would move toward P, as T slowly approaches K. The converse situation, if the leaf system in illustration c had a negative charge initially, can be readily visualized.

Although electroscopes have been built with a wide variety of geometries, the principle of operation is essentially the same for all. If an electroscope has a scale, permitting quantitative measurements, it is called an electrometer or electrostatic voltmeter. For information on electrometers see **VOLTMETER**. [R.P.Wi.]

**Electrostatic lens** An electrostatic field with axial or plane symmetry which acts upon beams of charged particles of uniform velocity as glass lenses act on light beams. The action of electrostatic fields with axial symmetry is analogous to that of spherical glass lenses, whereas the action of electrostatic fields with plane symmetry is analogous to that of cylindrical glass lenses. Plane symmetry as used here signifies that the electrostatic potential is constant along any normal to a family of parallel planes.

The action of an electrostatic lens on the paths of charged particles passing through it is most readily visualized with the aid of an equipotential plot of the fields in a plane of symmetry of the lens. The equipotential lines in the plot indicate the intersection with the plane of the drawing of surfaces on which the electrostatic potential is a constant. The paths of charged particles in the electrostatic field are bent toward the normals of the equipotentials as the particles are accelerated, and away from the normals as the particles are decelerated.

Axially symmetric lenses are generally formed at or between circular apertures and cylinders maintained at suitable potentials. For any of these it is possible to define focal points, principal

planes, and focal lengths in the same manner as for light lenses and to determine with their aid image magnification for any object position.

Lenses of plane symmetry, analogous to cylindrical glass lenses, are formed between parallel planes and at slits, replacing the circular cylinders and apertures of lenses with axial symmetry. [E.G.R.]

**Electrostatic precipitator** A device used to remove liquid droplets or solid particles from a gas in which they are suspended. The process depends on two steps. In the first step the suspension passes through an electric discharge (corona discharge) area where ionization of the gas occurs. The ions produced collide with the suspended particles and confer on them an electric charge. The charged particles drift toward an electrode of opposite sign and are deposited on the electrode where their electric charge is neutralized. The phenomenon would be more correctly designated as electrodeposition from the gas phase.

The use of electrostatic precipitators has become common in numerous industrial applications. Among the advantages of the electrostatic precipitator are its ability to handle large volumes of gas, at elevated temperatures if necessary, with a reasonably small pressure drop, and the removal of particles in the micrometer range. Some of the usual applications are: (1) removal of dirt from flue gases in steam plants; (2) cleaning of air to remove fungi and bacteria in establishments producing antibiotics and other drugs, and in operating rooms; (3) cleaning of air in ventilation and air conditioning systems; (4) removal of oil mists in machine shops and acid mists in chemical process plants; (5) cleaning of blast furnace gases; (6) recovery of valuable materials such as oxides of copper, lead, and tin; and (7) separation of rutile from zirconium sand. [G.S.M.; W.O.M.]

**Electrostatics** The class of phenomena recognized by the presence of electrical charges, either stationary or moving, and the interaction of these charges, this interaction being solely by reason of the charges and their positions and not by reason of their motion. See ELECTRIC CHARGE.

At least 90% of the topics that are normally classified as electrostatics are concerned with the manipulation of charged particles by electric fields. When a particle becomes charged by rubbing or other means, it has either a surplus or a deficit of electrons. A body with a surplus of electrons is said to be negatively charged; a body with a deficiency, positively charged. The amount or quantity of charge on a body is expressed in coulombs (positive or negative). A coulomb is an enormous amount of charge, and in most electrostatic situations charge levels of a small fraction of a coulomb give rise to significant effects. Electrostatic forces always exist between charged bodies. Bodies with like charge experience repulsive forces, while oppositely charged bodies experience attraction.

**Principles.** If two bodies are charged to  $Q_1$  and  $Q_2$  coulombs and are separated in vacuum by a distance of  $r$  meters, the force  $F$  in newtons between them is given by Coulomb's law, Eq. (1).

$$F = \frac{Q_1 Q_2}{4\pi \epsilon_0 r^2} \quad (1)$$

In electrical science,  $\epsilon_0$  is an important constant known as the permittivity or dielectric constant of free space, and is also sometimes called the primary electric constant. It has the value  $\epsilon_0 = 8.85416 \times 10^{-12}$  farad per meter. See COULOMB'S LAW; PERMITTIVITY.

Coulomb's law shows that a body charged to  $Q_1$  experiences a force due to the presence of another body charged to  $Q_2$ .  $Q_2$  may be considered to influence the whole of space surrounding it, because if  $Q_1$  were to be positioned anywhere it would experience a force due to the presence of  $Q_2$ . The property of a charge to influence the whole of space can be modeled by a three-dimensional force field permeating the whole of the space surrounding the charge  $Q_2$ . This field is called the electric field.

When there are many charged bodies present in an environment, the force that would be exerted on a charged particle at any location can be found by calculating the field at the location due to the presence of each charged body separately, and the net field is obtained by adding up the individual components. See ELECTRIC FIELD.

A system of charged particles or bodies is unstable unless the particles are prevented from moving, since the like-charged particles will repel each other until they are infinitely far apart, and oppositely charged bodies will attract one another and come together. The system has potential energy. The potential energy of two charged particles separated by a distance  $r$  can be shown to be given by Eq. (2). See ENERGY; POTENTIALS.

$$\text{Potential energy} = \frac{Q_1 Q_2}{4\pi \epsilon_0 r} \quad \text{joules} \quad (2)$$

**Charging methods.** The three principal methods of applying electric charge to objects are corona charging, induction charging, and tribocharging. See ENERGY.

The corona-charging method relies upon the impact of charged atoms or molecules (ions) on charged bodies. Copious quantities of ions may be generated by a corona discharge, which is a region in which an intense electric field acts upon air molecules and ionizes them so that free ions are produced. A sharply pointed electrode maintained at a high positive or negative potential induces a stream of positive or negative ions which may be used for charging surfaces. The stream of ions from a corona point is usually so intense that neutral air molecules become entrained in the flow to produce a corona wind which can deflect a candle flame. Ions from a corona discharge may be used to charge isolated bodies, insulating surfaces or particles by simply directing a corona wind onto the surface to be charged. In the case of particles, it is normally sufficient for them to pass through a corona discharge region to receive a significant charge from ion-particle collisions. See CORONA DISCHARGE.

Surfaces may be charged by exposure to an electrostatic field. If the surface is a liquid and it is disrupted into droplets, they will be electrically charged. Induction charging of equipment and personnel may occur when they are exposed to an electric field. Personnel charged in this way may generate electrostatic discharges when approaching grounded surfaces. Sensitive micro-electronic devices can be damaged and computer data can be corrupted by such discharges.

**Applications.** Electrostatics is put to good use in a wide variety of applications. For examples, the electrostatic precipitator enables smoke emissions from power-station chimneys, smelting plants, and other industrial plants to be reduced to relatively low, acceptable levels. On a smaller scale, efficient filters exist for removing dust from the air in offices, public places, and the home. In some filters, dust particles undergo corona charging as they are sucked by a fan through a duct, and are then collected on grounded electrodes; in others, permanently electrified filter material is used, made from thin plastic sheets which have been treated by surface bombardment from a corona ion source. See AIR FILTER; ELECTROSTATIC PRECIPITATOR.

In several applications which utilize electrostatics, solid or liquid particles are charged and sprayed onto grounded objects. Dry powder coating is used in many industries in preference to the wet-paint-spraying process. Crop spraying is another important application in which electrostatic forces help to efficiently apply herbicides or insecticides. Research into electrostatics, sometimes called electrohydrodynamic atomization, is leading to new applications for the deposition of ceramic, glass, and polymer films and for powder particle production of special materials. The electrostatics of materials is also used for analysis by means of mass spectrometry, as the electrostatic process is gentle and does not disrupt delicate complex molecules.

In electrophotography an optical system is used to project the image to be copied onto a light-sensitive semiconducting surface precharged by a corona source. Exposure of the surface to

light reduces the electrical conductivity of the material and allows surface charge to leak away to a back plate in proportion to the intensity of the light, so that bright parts of the image are regions that have lost most of the original charge while dark zones remain fully charged. A mixture of very fine black toner particles and coarser carrier particles is then brought into contact with the charged surface. Transfer of only charged toner particles onto the latent charged surface occurs. A sheet of paper is then laid over the toner-covered surface, and transfer of toner to paper occurs so that an image remains on the paper when it is peeled off the surface. Some ink-jet printers also utilize electrostatic principles; by ensuring that ink drops are formed in the presence of an electrostatic field, they become charged and may be deflected electrostatically to a printing surface. See PHOTOCOPYING PROCESSES; PRINTING.

Another development being commercially exploited is the production of metallic ion or droplet beams using electrostatic forces acting upon a liquid-metal surface. Considerable success has been achieved with many molten metals including gold and silver. Either ion or charged droplet beams may be formed depending on the operating conditions of the source. The beams so formed may be very well defined and directed with great accuracy onto targets where they can be used for ion implantation or for the formation of conducting tracks in the fabrication of microelectronic circuits. See INTEGRATED CIRCUITS; ION IMPLANTATION.

Electrostatic treaters using electric fields have been used to separate water droplets from crude oil as well as move and deposit inorganic particles of sand, mud, and clay and organic particles.

Ion engines which produce thrust by electrostatically accelerating mercury or cesium ions have been successfully operated in space. Colloid thrusters, operating on exactly the same principles as electrostatic paint or crop sprayers, have also been developed. In these a propellant such as glycerol is atomized and accelerated from a nozzle by an electrostatic field. See ION PROPULSION.

[A.G.B.]

**Electrostriction** A form of elastic deformation of a dielectric induced by an electric field; specifically, the term applies to those components of strain which are independent of reversal of the field direction. Electrostriction is a property of all dielectrics and is thus distinguished from the converse piezoelectric effect, a field-induced strain which changes sign upon field reversal and which occurs only in piezoelectric materials. See DIELECTRIC MATERIALS; PIEZOELECTRICITY.

The electrostrictive effect in certain ceramics is employed for commercial purposes in electromechanical transducers for sonic and ultrasonic applications. See MICROPHONE.

[R.D.W.]

**Electrotherapy** The use of electric current to treat disease. Electrotherapy is based on principles developed during the nineteenth and twentieth centuries following the first demonstration of "animal electricity" by Luigi Galvani in the eighteenth century. See ELECTROCONVULSIVE THERAPY.

**Low-frequency electrotherapy.** Low-frequency electrotherapy uses relatively weak alternating electric currents. They are delivered by electrodes that are placed under or on the surface of the body and are connected to pulse-shaping circuits that are located inside or outside the body.

Electrodes that stimulate electrically excitable cells, such as those in muscle and nerve tissues, are usually placed directly in or on the tissue by surgery or are inserted through a vein by catheterization. There are many applications for electrode stimulation: irregular heart rhythms can be controlled by pacemakers; muscles, such as those of the diaphragm and urinary bladder, that become paralyzed can be made to contract electrically; and long-term pain can be relieved by implanting electrodes in the spinal canal. Surface electrodes are widely used for temporary relief of pain; for preventing muscle atrophy after injury or immo-

bilization; and for treatment of curvature of the spine, or scoliosis. See CARDIAC ELECTROPHYSIOLOGY; MUSCLE; PAIN.

A wide variety—if not all—of the body's nonexcitable cells alter their function in specific ways and at specific times in response to appropriate, very weak electrical stimuli. Much of the progress in electrotherapy has evolved from the observation that both hard and soft tissues, such as bone and arteries, become electrically charged when they are cyclically deformed by mechanical or hydrodynamic forces. By establishing the patterns and values of those stress-generated voltages in bone, researchers have been able to develop three methods of influencing the behavior of nonexcitable cells that are involved in the repair of nonunited fractures. The first clinical method for treating nonunited fractures employed surgically implanted electrodes. Unfortunately, surgical methods carry a risk of infection, and direct currents can result in adverse electrochemical reactions around the electrodes. Two noninvasive electrical methods have proved effective in altering cellular behavior. The first involves the placement of dynamically charged, insulated plates outside tissue-culture vessels or the fractured limbs of animals. The second method uses one or more coils of wire coupled to a pulse generator to create a weak time-varying magnetic field that penetrates the body, much as radio waves enter a closed building. As the understanding of their mechanisms of action at the cellular and subcellular levels has increased, pulsed electromagnetic fields have been used successfully to treat other problems of bone and its surrounding soft tissue.

[C.A.L.B.]

**Diathermy.** Therapy for afflicted deep tissues that do not respond to conventional methods, such as infrared heating or heating pads, can often be achieved with diathermy. Heating results from the electrical resistance of tissue to high-frequency or microwave currents. Increasing the tissue temperature to a range of 106–113°F (41–45°C) increases the physiologic response and therapeutic benefit, which includes increased extensibility of collagen tissues in joint contractures, decreased joint stiffness in rheumatoid arthritis, and pain relief and reduction of muscle spasms through the local action of heat on nerve endings and receptors. Warming can also resolve inflammatory infiltrates, edema, and exudates and increase blood flow in diseased or damaged tissue. Heating has been used in cancer therapy under proper temperature control.

**Hyperthermia.** Hyperthermia is an experimental method of treating malignant tumors that uses heat alone, heat in combination with ionizing (x-ray) radiation, or heat with chemotherapy. One form of heating involves the application of radio-frequency energy by using methods similar to—but more sophisticated and more carefully controlled than—those in diathermy treatment. The effective temperature range of hyperthermia is very narrow, 108–111°F (42.5–44°C); the benefits are minimal at lower temperatures, and damage to normal cells is probable at higher temperatures. Several mechanisms are thought to account for the selective destruction of tumor cells: (1) selective heating caused by the lower rate of blood flow in tumor tissues; (2) greater sensitivity of tumor cells to heat due to their hypoxic, acidic, and poor nutritional state; (3) synergism of ionizing radiation and hyperthermia due to thermal killing of cells that are hypoxic and are at those critical stages of growth when they are most resistant to radiation; and (4) increase in cell membrane permeability and sensitivity to chemotherapeutic drugs. See THERMOTHERAPY.

[A.W.G.]

**Electrothermal propulsion** Vehicular propulsion that involves electrical heating to raise the energy level of the propellant. In contrast, chemical rockets use the chemical energy of one or more propellants to heat and accelerate the decomposition products (monopropellants) or combustion products (bipropellants) for thrusting purposes. In both instances, the high-energy propellant gases are exhausted through a nozzle where they are accelerated to a high velocity, and thrust is produced by reaction. By decoupling the heating or energy addition



process from the restraints of propellant chemistry considerations, electrothermal devices can be operated on a wide variety of materials, many of which would not otherwise be considered to be propellants. Water and space station liquid-waste streams are two examples of such propellants being considered for electrothermal propulsion purposes. See ROCKET PROPULSION.

Practical electrothermal thrusters come in two forms, resistojets and arcjets. In resistojets, which are now flying in a station keeping role on many communications satellites, the electrical energy is first deposited in a heater or resistive element and then transferred to the propellant. The need to first heat a material limits the maximum operating temperature and the maximum enthalpy of the propellant. As a consequence, the essential simplicity of the device is balanced by well-defined limitations on exhaust velocity or specific impulse. Arcjets circumvent this limitation by using the propellant as the heater element. An electric arc discharge passes directly through the propellant. High temperatures and specific-impulse values can be achieved but only at the price of design complexity. See ARC DISCHARGE; SPECIFIC IMPULSE.

One further and fundamental distinction is that electrical thrusters are power-limited whereas chemical thrusters are energy-limited. By definition, electrical propulsion systems must have an associated power supply for operation. Solar panels or nuclear power supplies can supply well-defined power to the thruster for essentially unlimited time. Consequently, although the power level is well constrained, the total energy available is virtually boundless. Chemical systems are exactly opposite. In this case, the total energy available for propulsion is well defined by the propellant volume. However, the rate at which this propellant is used, the rate of energy usage per unit time, or the power can be exceedingly high. Chemical thrusters are ideal for escaping the Earth's gravity well; electrical thrusters are ideal for moving payloads in low-acceleration conditions removed from gravity wells, that is, for the more ambitious missions far removed from low Earth orbit. See SPACECRAFT PROPULSION. [G.W.Bu.]

**Electroweak interaction** One of the three basic forces of nature, along with the strong nuclear interaction and the gravitational interaction. The terms "force" and "interaction between particles" are used interchangeably in this context. All of the known forces, such as atomic, nuclear, chemical, or mechanical forces, are manifestations of one of the three basic interactions.

Until the early 1970s, it was believed that there were four fundamental forces: strong nuclear, electromagnetic, weak nuclear, and gravity. It was by the work of S. Glashow, S. Weinberg, and A. Salam that the electromagnetic and the weak nuclear forces were unified and understood as a single interaction, called the electroweak interaction. This unification was a major step in understanding nature, similar to the achievement of J. C. Maxwell and others a century earlier in unifying the electric forces and magnetic forces into the electromagnetic interactions. A goal of theoretical physics is to achieve a further simplification in understanding nature and describe the presently known three basic interactions in a unified way, usually referred to as the grand unified theory (GUT). Whether this is possible remains to be seen. See ELECTROMAGNETISM; FUNDAMENTAL INTERACTIONS; GRAVITATION; MAXWELL'S EQUATIONS; STRONG NUCLEAR INTERACTIONS; WEAK NUCLEAR INTERACTIONS.

Some of the properties of the basic interactions are summarized in the table. The strong nuclear forces are the strongest, electroweak is intermediate, and gravity the most feeble by a huge factor. The ranges, that is, the distances over which the forces act, also differ greatly. The strong nuclear and the weak interactions have a very short range, while electromagnetism and gravity act over very large distances. Thus, at very short subatomic distances the strong nuclear force, which holds the atomic nucleus together and governs many interactions of the subnuclear particles, dominates. At larger distances the electro-

magnetic forces dominate, and hold the atom together and govern chemical and most mechanical forces in everyday life. At even larger scales, objects such as planets, stars, and galaxies are electrically neutral (have an exact balance of positive and negative electric charges) so that the electromagnetic forces between them are negligible, and thus the gravitational forces dominate in astronomical and cosmological situations.

Each of the basic forces acts on, or depends on, different properties of matter. Gravity acts on mass, and electromagnetic forces act on electric charges that come in two kinds, positive and negative. The strong nuclear forces act on a much less well-known property, called color charge, which come in three kinds,  $r$ ,  $b$ , and  $g$  (often called red, blue, and green). The weak nuclear forces act on equally esoteric properties called weak isospin  $t$  and hypercharge  $y$ . While the mass and the electric charge are properties that are recognized in everyday situations, the color charge and the weak isospin and hypercharge have no correspondence in the large-scale everyday world. See COLOR (QUANTUM MECHANICS); ELECTRIC CHARGE; HYPERCHARGE; I-SPIN; MASS.

All known forms of matter are made of molecules and atoms, which are made up of the nucleus (protons and neutrons) and orbital electrons. These in turn can be understood to be made up of the fundamental constituents, the quarks and the leptons. Each of these comes in six kinds. All of the quarks and leptons have gravitational and weak interactions since they have nonzero values of mass and weak isospin and hypercharge. The particles with zero electric charge have no electromagnetic interactions, and the leptons have no strong nuclear interactions since they carry no color charge. See LEPTON; QUARKS.

The present understanding is that the basic forces are not contact forces but act over distances larger than the sizes of the particles (action at a distance). In this picture, based on field theory, the forces are carried or mediated by intermediate particles that are called gauge bosons. For example, the electromagnetic force between an electron and a proton is carried by the quantum of the electromagnetic field called the photon ( $\gamma$ ). The strong nuclear force is carried by the gluon ( $g$ ), and the gravitational force is carried by the graviton ( $G$ ). The weak nuclear force comes in two categories: the charge-changing (charged-current, for short) mediated by the  $W^\pm$  bosons, and the neutral-current weak interactions mediated by the  $Z^0$  boson. See GLUONS; GRAVITON; INTERMEDIATE VECTOR BOSON; PHOTON.

All of the fundamental constituents, the quarks and the leptons, carry one-half unit of angular momentum (spin =  $1/2$ ) as if they were spinning around their own axis. (Such particles are called fermions.) By the rules of quantum mechanics, the direction of this spin is quantized to be either parallel or antiparallel to the direction of motion of the particle. Particles with spin direction parallel to their direction of motion have helicity  $+1$  and are called right-handed, and particles with antiparallel spin have helicity  $-1$  and are called left-handed. One of the symmetries of nature is called parity, which is a symmetry between right-handed and left-handed coordinate systems. If parity symmetry holds, left-handed and right-handed particles must have the same interactions. In 1956 T. D. Lee and C. N. Yang proposed that parity symmetry is violated in the weak interactions, and this proposal was soon verified experimentally. It was found that the left-handed and the right-handed particles have different weak interactions. In particular, the right-handed particles have no weak isospin, and thus only the left-handed particles participate in the charged-current weak interactions. See ANGULAR MOMENTUM; HELICITY (QUANTUM MECHANICS); PARITY (QUANTUM MECHANICS); SPIN (QUANTUM MECHANICS).

Until the early 1970s, the electromagnetic and the weak interactions were believed to be separate basic interactions. At that time the Weinberg-Salam-Glashow model was proposed to understand these two interactions in a unified way. In its original form, this model, based on an unbroken gauge symmetry, led to some physically unacceptable features such as zero masses for all the constituent particles and predictions of infinities for

Basic forces in nature				
Interaction	Relative strength	Property acted on	Force carrier	Range
Strong nuclear	1	Color charge ( $r, g, b$ )	Gluon ( $g$ )	$10^{-13}$ cm
Electroweak	Electromagnetic	Electric charge ( $q$ )	Photon ( $\gamma$ )	$\infty$
	Weak nuclear	Weak charges ( $t_3, y$ )	Bosons ( $W^\pm, Z^0$ )	$10^{-16}$ cm
Gravity	$10^{-40}$	Mass ( $m$ )	Graviton ( $G$ )	$\infty$

some measurable quantities. Through the pioneering work of G. 'tHooft, M. Veltman, and others, it was shown that the theory can be made renormalizable, removing the infinities and providing masses to the particles, by spontaneous breaking of the gauge symmetry and the introduction of one new particle, the Higgs boson. See GAUGE THEORY; HIGGS BOSON; RENORMALIZATION; SYMMETRY BREAKING.

The neutral gauge bosons, the  $W^0$  and  $B^0$ , form a quantum-mechanical mixture, which produces the two physically observable gauge bosons, the  $\gamma$  and the  $Z^0$ , as given by Eqs. (1). The  $\gamma$  is

$$\begin{aligned} \gamma &= \sin \theta W^0 + \cos \theta B^0 \\ Z^0 &= \cos \theta W^0 - \sin \theta B^0 \end{aligned} \quad (1)$$

the well-known photon that mediates the electromagnetic interactions. The  $Z^0$  mediates the neutral-current weak interactions, and the  $W^\pm$  mediate the charged-current weak interactions. In this way, all of these interactions are described by a common unified theory. The mixing angle  $\theta$  in Eqs. (1), forming the  $\gamma$  and the  $Z^0$ , is called the weak mixing angle and is the fundamental parameter of the theory. The strength and nature of the interactions of the particles are determined by the vector and axial vector coupling constants  $g_v$  and  $g_A$ . In the electroweak model all of these couplings are given in terms of the single parameter of the theory, the weak mixing angle, and the properties of the leptons and quarks. The model also gives a relationship between the electric charge  $q$  and the weak charges  $t_3$  and  $y$ , Eq. (2).

$$q = t_3 + 1/2y \quad (2)$$

See NONRELATIVISTIC QUANTUM THEORY; QUANTUM MECHANICS.

The coupling constants that govern the electroweak interactions of all of the particles can be summarized as:

1. Electromagnetic interactions:  $g_v = q$ ,  $g_A = 0$
2. Charged current weak interactions:  $g_v = -g_A = t$
3. Neutral current weak interactions:  $g_v = t_3 - 2q \sin^2 \theta$ ,  
 $g_A = -t_3$

In the above expressions,  $t$  stands for the magnitude of the weak isospin, and  $t_3$  is its projection along an axis of quantization.

The electroweak theory has great predictive power. Its first and most striking prediction was the existence of neutral-current weak interactions mediated by the  $Z^0$  boson. Until the time of this prediction, the weak interactions were believed to be of charged-current nature only, with no neutral-current component.

A second major triumph for the electroweak theory was the discovery of the  $W$  and  $Z$  bosons in 1983 at the proton-antiproton collider at the CERN Laboratory in Geneva, Switzerland, with masses very close to the values predicted by the theory. At this time the validity of the theory was considered to be firmly established. See PARTICLE ACCELERATOR.

The successful electroweak theory, combined with quantum chromodynamics (QCD), the theory describing the strong nuclear interactions, forms the so-called standard model of particle physics. This standard model has been brilliantly successful in accurately predicting and describing all experimental results over a huge energy range, varying from the electronvolt energies of atomic physics to the 100-GeV energy range of the largest

existing particle colliders. As such, it represents a landmark achievement of both experimental and theoretical physics. See QUANTUM CHROMODYNAMICS; STANDARD MODEL.

In spite of these great successes, two major problems remain to be solved in this field. The first one is that the standard model in its present form cannot explain the masses of the fundamental constituents, the quarks and leptons. These masses vary over a large range, from a few electronvolts to 174 GeV. The basic gauge symmetry on which the standard model is based would indicate that these masses should all be the same. There must therefore be an additional piece of the puzzle, usually referred to as the source of the electroweak symmetry breaking, that remains to be found. Hypothetical ideas about this missing element of the model range from the prediction of a single additional particle, the Higgs boson, to complicated models such as supersymmetry that predict dozens of new elementary particles. See HIGGS BOSON; SUPERSYMMETRY; SYMMETRY BREAKING.

The second outstanding problem is the search for a theory that not only describes the strong nuclear and the electroweak interactions but includes gravity as well. The standard model is based on the principles of quantum mechanics, while the current understanding of the gravitational forces is based on Einstein's theory of general relativity. No one so far has been able to combine these two theories; that is, a quantum theory of gravity does not, as yet, exist. The search for such a grand unified theory is a major focus of activity in theoretical physics. See ELEMENTARY PARTICLE; QUANTUM GRAVITATION; RELATIVITY. [C.B.]

**Element (chemistry)** An element is a substance made up of atoms with the same atomic number. Some common elements are oxygen, hydrogen, iron, copper, gold, silver, nitrogen, chlorine, and uranium. Approximately 75% of the elements are metals and the others are nonmetals. Most of the elements are solids at room temperature, two of them (mercury and bromine) are liquids, and the rest are gases.

A few of the elements are found in nature in the free (uncombined) state. Some of these are oxygen, nitrogen, the noble gases (helium, neon, argon, krypton, xenon, and radon), sulfur, copper, silver, and gold. Most of the elements in nature are combined with other elements in the form of compounds. The most abundant element on the Earth is oxygen; the next most abundant is silicon. The most abundant element in the universe is hydrogen and the next most abundant is helium. See ELEMENTS, GEOCHEMICAL DISTRIBUTION OF.

The elements are classified in families or groups in the periodic table. Elements are also frequently classified as metals and nonmetals. A metallic element is one whose atoms form positive ions in solution, and a nonmetallic element is one whose atoms form negative ions in solution. See PERIODIC TABLE.

Atoms of a given element have the same atomic number, but may not all have the same atomic weight. Atoms with identical atomic numbers but different atomic weights are called isotopes. Oxygen, for example, is made up of atoms whose atomic weights are 16, 17, and 18. Hydrogen is made up of isotopes 1, 2, and 3; the isotopes of masses 2 and 3 are called deuterium and tritium, respectively. Carbon is made up of isotopes 11, 12, 13, and 14. Carbon-14 is radioactive and is used as a tracer in many chemical experiments.

All the elements have isotopes, although in certain cases only synthetic isotopes are known. Thus, fluorine exists in nature as  $^{19}\text{F}$ , but the artificial radioactive isotope  $^{18}\text{F}$  can be prepared. Many of the isotopes of the different elements are unstable, or radioactive, and hence they disintegrate to form stable atoms either of that element or of some other element. See ATOMIC MASS; RADIOACTIVITY.

The origin of the chemical elements is believed to be the result of the synthesis by fusion processes at very high temperatures (in the order of  $100,000,000^\circ\text{C}$  or  $180,000,000^\circ\text{F}$  and higher) of the simple nuclear particles (protons and neutrons) first to heavier atomic nuclei such as those of helium and then on to the heavier and more complex nuclei of the light elements (lithium, boron, and so on). The helium atoms bombard the atoms of the light elements and produce neutrons. The neutrons are captured by the nuclei of elements and produce heavier elements. See NUCLEOSYNTHESIS.

A number of elements that are found in only very slight traces or not at all in nature, such as technetium, promethium, astatine, francium, and all the elements with atomic numbers above 92, have been synthesized by a variety of nuclear reactions that involve transmuting atoms of one element into atoms of another by bombarding that element with neutrons or fast-moving particles (protons, deuterons, and alpha particles) which will change the atomic number to that of the new element. See ATOMIC STRUCTURE AND SPECTRA; TRANSURANIUM ELEMENTS. [A.B.G.]

**Element 111** Element 111 was discovered in late 1994. It should be a homolog of the elements gold, silver, and copper. It is expected to be the ninth element in the 6d shell, but the half-life of 1.5 ms of the only isotope known today is too short to allow chemical studies. See COPPER; GOLD; HALF-LIFE; RADIOISOTOPE; SILVER.

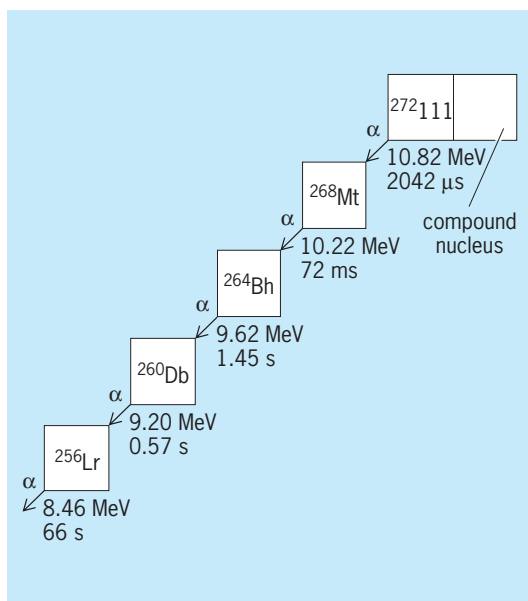

Sequence of decay chains that document the discovery of element 111. Numbers below boxes are alpha energies and correlation times. Element 111 is produced in the reaction  $^{64}\text{Ni} + ^{209}\text{Bi} \rightarrow ^{272}_{111} + 1n$ .

The element was discovered on December 17, 1994, at GSI (Gesellschaft für Schwerionenforschung), Darmstadt, Germany, by detection of the isotope  $^{272}_{111}$  (the isotope of element 111 with mass number 272), which was produced by fusion of a nickel-64 projectile and a bismuth-209 target nucleus after the fused system was cooled by emission of one neutron. Sequential alpha decays to meitnerium-268, bohrium-264, dubnium-260, and lawrencium-256 allowed identification from the known decay properties of  $^{260}\text{Db}$  and  $^{256}\text{Lr}$ . In the decay chain (see illus-

tration), the first three members are new isotopes. The isotope  $^{272}_{111}$  has a half-life of 1.5 ms, and is produced with a cross section of  $3.5 \times 10^{-36} \text{ cm}^2$ . Altogether, three chains were observed. The new isotopes meitnerium-268 and bohrium-264 are the heaviest isotopes of these elements currently known. Their half-lives of 70 ms and 0.4 s, respectively, are longer than those of the previously known isotopes of these elements. See ALPHA PARTICLES; NEUTRON; NUCLEAR REACTION. [P.Ar.]

**Element 112** Element 112 was discovered in 1996. It should be a heavy homolog of the elements mercury, cadmium, and zinc. It is expected to be the last element in the 6d shell. No chemistry is possible in the near future as all cross sections are in the range of  $10^{-36} \text{ cm}^2$  and the half-lives are short. See CADMIUM; HALF-LIFE; MERCURY (ELEMENT); ZINC.

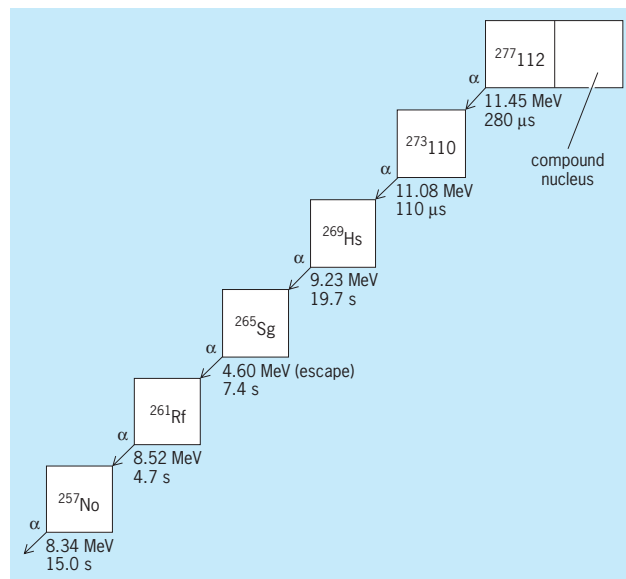

Sequence of decay chains that document the discovery of element 112. Numbers below boxes are alpha energies and correlation times. Element 112 is produced in the reaction  $^{70}\text{Zn} + ^{208}\text{Pb} \rightarrow ^{277}_{112} + 1n$ .

Element 112 was discovered on February 9, 1996, at GSI (Gesellschaft für Schwerionenforschung), Darmstadt, Germany, by detection of the isotope  $^{277}_{112}$ , which was produced by fusion of a zinc-70 projectile and a lead-208 target nucleus following the cooling down of the fused system by emission of a single neutron. Sequential alpha decays to  $^{273}_{110}$ , hassium-269, seaborgium-265, rutherfordium-261, and nobelium-257 allowed unambiguous identification by using the known decay properties of the last three members of the chain. In the decay chain (see illustration), the first three members are new isotopes. Isotope  $^{277}_{112}$  has a half-life of 0.24 ms, and it is produced with a cross section of  $1.0 \times 10^{-36} \text{ cm}^2$  (the smallest observed in the production of heavy elements). The new isotopes of darmstadtium and hassium are of special interest. Their half-lives and alpha energies are very different, as is characteristic of a closed-shell crossing. At the neutron number  $N = 162$ , a closed shell was theoretically predicted, and this closed shell is verified in the decay chain observed. Isotope  $^{269}\text{Hs}$  has a half-life of 9 s, which is long enough to allow studies on the chemistry of this element. The crossing of the neutron shell at  $N = 162$  is an important achievement in the field of research on superheavy elements. The stabilization of superheavy elements is based on high fission barriers, which are due to corrections in the binding energies found near closed shells. The shell at  $N = 162$  is the first such shell predicted, and is now verified. See ALPHA PARTICLES; ELEMENT 111; HASSIUM; LEAD; NEUTRON; NOBELIUM; NUCLEAR STRUCTURE; RADIOISOTOPE; RUTHERFORDIUM; SEABORGIUM. [P.Ar.]

**Elementary particle** A particle that is not a compound of other particles. At one time the elementary particles of matter were the atoms of the chemical elements, but the atoms are now known to be compounds of the electron, proton, and neutron. In turn, the proton and neutron, and likewise all the other hadrons (strongly interacting particles), are now known to be compounds of quarks. It is convenient, however, to continue to call hadrons elementary particles to distinguish them from their compounds (atomic nuclei, for instance); this usage is also justified by the fact that quarks are not strictly particles, because, as far as is known, they cannot be isolated. The term fundamental particle can be used to denote particles that are truly fundamental constituents of matter and are not compounds in any sense. See ELECTRON; HADRON; NEUTRON; PROTON; QUARKS.

The known fundamental particles (see table) fall into two categories: the gauge bosons, comprising the photon, gluon, and weak bosons; and the fermions, comprising the quarks and leptons. The graviton, the quantum of the gravitational field, has been omitted from table since it plays no role in high-energy particle physics: it is firmly predicted by theory, but the prospect of direct observation is exceedingly remote. Of the gauge bosons, the photon has been known since the beginning of quantum mechanics. The heavy gauge bosons  $W^\pm$  and  $Z^0$  were observed in 1983; their properties had been deduced from the weak interactions, for which they are responsible. The lightest (and stable) lepton, the electron ( $e$ ), is the first known fundamental particle. The next found was the muon ( $\mu$ , originally called the mu meson). The fundamental fermions are grouped into three families. Gluons and quarks are never seen as free particles; this phenomenon is known as confinement. Particles that are composed of quarks and gluons are called hadrons; essentially, mesons are composed of a quark-antiquark pair  $q\bar{q}$ , and baryons are three quarks  $qqq$ , bound together by the exchange of gluons. See BARYON; GLUONS; GRAVITON; INTERMEDIATE VECTOR BOSON; LEPTON; MESON; PHOTON.

Particles with the properties of the quarks of the quark model (charges  $\pm\frac{2}{3}e$  or  $\pm\frac{1}{3}e$  and masses less than 300 MeV) have never been observed. Direct evidence both for quarks and for their confinement is given by the phenomenon of hadronic jets. For example, in high-energy deep-inelastic electron-proton scattering, in which the electron loses a sizable fraction of its energy, the observed cross section shows that the charge of the proton is carried by pointlike (radius less than  $10^{-1}$  femtometer) particles of small mass. However, no such particles are seen in the final state of this process, or indeed of any other high-energy collision. What is seen is a narrow shower of hadrons. The interpretation is that the electron scatters off one of the quarks in the proton and gives it a large energy and momentum, the quark responding as though it were a free particle of mass much less than 100 MeV, consistent with the masses of the  $u$  and  $d$  quarks (see table). Later, through the production of quark-antiquark pairs, the energy and momentum of the struck quark is divided among a number of hadrons, mostly pions, a process called hadronization or fragmentation of the quark, which is to be distinguished from the decay of a free particle. The resulting shower of hadrons, whose total momentum vector is roughly that of the original quark, is called a hadronic jet (like a jet of water which breaks up into a spray of droplets). Such jets are also seen in other high-energy reactions, such as  $e^+e^-$  annihilation into hadrons, and also in  $pp$  collisions; they are the closest available phenomenon to the actual observation of a quark as a free particle.

To each kind of particle there corresponds an antiparticle, or conjugate particle, which has the same mass and spin, belongs to the conjugate representation (multiplet) of internal symmetry, and has opposite values of charge,  $I_3$ , strangeness, and so forth (quantum numbers which are conserved additively). The product of the space parities of a particle and its antiparticle is  $+1$  if the particle is a boson,  $-1$  if a fermion. For instance, the electron  $e$  and its antiparticle, the positron  $e^+$ , have the same masses and spins, and opposite charges and lepton number, and an  $S$ -wave

state of  $e$  and  $e^+$  has parity  $-1$ . Particles for which the antiparticle is the same as the particle are called self-conjugate; examples are the photon  $\gamma$  and the neutral pion  $\pi^0$ . The equality of masses implies the equality of lifetimes of particle and antiparticle. Thus the positron is stable; however, in the presence of ordinary matter it soon annihilates with an electron, and thus is not a component of ordinary matter. See ANTIMATTER; POSITRON.

The interactions of particles are responsible for their scattering and transformations (decays and reactions). Because of interactions, an isolated particle may decay into other particles. Two particles passing near each other may transform, perhaps into the same particles but with changed momenta (elastic scattering) or into other particles (inelastic scattering). The rates or cross sections of these transformations, and so also the interactions responsible for them, fall into three groups: strong (typical decay rates of  $10^{21}$ – $10^{23}$   $s^{-1}$ ), electromagnetic ( $10^{16}$ – $10^{19}$   $s^{-1}$ ), and weak ( $<10^{15}$   $s^{-1}$ ). Strong interactions occur only between hadrons. Electromagnetic interactions result from the coupling of charge to the electromagnetic field. Weak interactions are usually unobservable in competition with strong or electromagnetic interactions. They are observable only when they do something which those much stronger interactions cannot do (forbidden by the selection rules); for instance, by changing flavors they can make a particle decay which would otherwise be stable, and by making parity-violating transition amplitudes they can produce an otherwise absent asymmetry in the angular distribution of a reaction. See SELECTION RULES (PHYSICS).

Most particles are unstable and decay into smaller-mass particles. The only particles which appear to be stable are the massless particles (graviton, photon), the neutrinos (possibly massless), the electron, the proton, and the ground states of stable nuclei, atoms, and molecules. It is speculated that some or all of the neutrinos may be massive and unstable and that the proton (and therefore all nuclei) may be unstable. The present view is that the only massive particles which are strictly stable are the electron and the lightest neutrino(s). The electron is the lightest charged particle; its decay would be into neutral particles and could not conserve charge. Likewise, the lightest neutrino is the lightest fermion; its decay would be into bosons and could not conserve angular momentum. See NEUTRINO.

The unstable elementary particles must be studied within a short time of their creation, which occurs in the collision of a fast (high-energy) particle with another particle. Such fast particles exist in nature, namely the cosmic rays, but their flux is small; thus most elementary particle research is based on high-energy particle accelerators. See COSMIC RAYS; NUCLEAR REACTION; PARTICLE ACCELERATOR; PARTICLE DETECTOR.

Hadrons can be divided into the quasistable (or hadronically stable) and the unstable. The quasistable hadrons are simply those that are too light to decay into other hadrons by way of the strong interactions, such decays being restricted by the requirement that isobaric spin  $I$  and flavors be conserved.

The unstable hadrons are also called particle resonances. Their lifetimes, of the order of  $10^{-23}$  s, are much too short to be observed directly. Instead they appear, through the uncertainty principle, as spreads in the masses of the particles—that is, in their widths—just as in the case of nuclear resonances. See UNCERTAINTY PRINCIPLE.

A characteristic of the hadrons is that they are grouped into  $i$ -spin multiplets (for example,  $n, p; \pi^-, \pi^0, \pi^+$ ); the masses of the particles in each multiplet differ by only a few megaelectronvolts (MeV). The  $i$ -spin multiplets of hadrons themselves form groups (called supermultiplets) which were recognized in 1961 as multiplets (representations) of the group  $SU_3$  (now referred to as  $SU_3^{\text{flavor}}$  to distinguish this physical symmetry from  $SU_3^{\text{color}}$ ). For instance, the lightest mesons ( $\eta, K, \bar{K}, \pi$ ) and baryons ( $\Lambda, N, \Xi, \Sigma$ ) are each a set of eight particles having  $i$ -spins  $I = (0, \frac{1}{2}, \frac{1}{2}, 1)$  and hypercharges  $Y = (0, 1, -1, 0)$  respectively; this pattern is that of the octet,  $\{8\}$ , representation of the group  $SU_3$ . Again, the lowest-mass  $J^P = \frac{3}{2}^+$  baryons ( $\Delta, \Sigma^*, \Xi^*, \Omega$ ), ten particles with

The fundamental particles <sup>a</sup>					
<b>Gauge bosons</b>		$J_C^P = 1^-$	Self-conjugate except $\bar{W}^+ = W^-$ .		
Name	Symbol	Charge <sup>b</sup>	Mass and width, GeV	Couplings	
Photon	$\gamma$	0	0	$A \Rightarrow \gamma A$	
Gluon <sup>c</sup>	$g$	0	0	$A \Rightarrow gA'$	
Weak bosons					
Charged	$W^\pm$	$\pm 1$	80.4, 2.1	$U \Rightarrow W^+ D$	
Neutral	$Z^0$	0	91.2, 2.5	$A \Rightarrow Z^0 A$	
<b>Fermions</b> $J = 1/2$ All have distinct antiparticles, except perhaps the neutrinos.					
Name	Charge <sup>b</sup>	Symbol and mass, GeV	Symbol and mass, GeV	Symbol and mass, GeV	
Leptons					
Neutrinos	0	$\nu_e$ $< 3 \times 10^{-9}$	$\nu_\mu$ $< .0002$	$\nu_\tau$ $< .02$	
Charged leptons	-1	$e$ .00051	$\mu$ .106 <sup>f</sup>	$\tau$ 1.78 <sup>f</sup>	
Quarks <sup>c</sup>					
Up type	$2/3$	$u$ .005	$c$ 1.4	$t$ 178 <sup>g</sup>	
Down type	$-1/3$	$d$ .01	$s$ .15	$b$ 4.8	
<sup>a</sup> The graviton, with $J_C^P = 2^+$ , has been omitted, since it plays no role in high-energy particle physics.					
<sup>b</sup> In units of the proton charge.					
<sup>c</sup> The gluon is a color SU <sub>3</sub> octet (8); each quark is a color triplet (3). These colored particles are confined constituents of hadrons; they do not appear as free particles.					
<sup>e</sup> The three known families (generations) of fermions are displayed in three columns.					
<sup>f</sup> The $\mu$ and $\tau$ leptons are unstable, with mean lives of $2.2 \times 10^{-6}$ s and $2.9 \times 10^{-13}$ s respectively.					
<sup>g</sup> The $t$ quark has a width $\approx 2$ GeV, with dominant decay to $Wb$ .					

$I = (3/2, 1, 1/2, 0)$  and  $Y = (1, 0, -1, -2)$ , form a decuplet,  $\{10\}$ , representation of SU<sub>3</sub>. The spread of the masses in these groups is about a hundred times greater than in the  $i$ -spin multiplets, a few hundred MeV compared to a few MeV. According to the quark model, this SU<sub>3</sub> symmetry and the pattern of charges in the SU<sub>3</sub> multiplets result simply from the existence of a third kind (flavor) of quark, the  $s$  (strange) quark, with charge the same as the  $d$  quark, namely  $1/3$ , together with the flavor independence of the glue force; that is, all three quarks  $u$ ,  $d$ , and  $s$  have the same interaction with the glue field. The resulting flavor SU<sub>3</sub> symmetry is broken by the relatively large mass of the  $s$ , approximately 150 MeV. The three quarks make up the fundamental triplet,  $\{3\}$ , representation of SU<sub>3</sub>.

Hadrons are known which contain yet more massive quarks, the  $c$  and the  $b$  (see the table). The resulting symmetry is badly broken, and the supermultiplets hardly recognizable.

It appears that the "glue" field which binds quarks together to make hadrons is a Yang-Mills (that is, a non-abelian) gauge field of an SU<sub>3</sub> symmetry group, SU<sub>3</sub><sup>color</sup>. This is an exact symmetry of nature. The quanta of the field are called gluons, and its quantum theory is called quantum chromodynamics (QCD). The gluon field resembles the electromagnetic field, but has an internal symmetry index (octet index) which runs over eight values; that is, there are really eight fields, corresponding to the eight parameters needed to specify an SU<sub>3</sub> transformation. Just as the electromagnetic field is coupled to (that is, photons are emitted and absorbed by) the density and current of a conserved quantity, charge, the gluon field is coupled to color. The coupling of the gluon to a particle is fixed by the color of the particle (that is, what member of what color multiplet) and just one universal coupling constant  $g$ , analogous to the electronic unit of charge  $e$ . (The analogy breaks down in quantum theory, as discussed below; the quantity  $g$  is no longer constant but it is still universal.) See GAUGE THEORY.

Since the long-range forces observed between hadrons are no different than those between other particles, hadrons must be colorless, that is, color singlet combinations of quarks, their colored constituents. The two simplest combinations of quarks which can be colorless are  $\bar{q}_1 q_2$  and  $q_1 q_2 q_3$ ; these are found in nature as the basic structure of mesons and baryons, respectively.

The exchange of gluons between any of the quarks in these colorless combinations gives rise to an attractive force, which binds them together.

Gluons are not colorless, and therefore they are coupled to themselves. This situation is very different from electromagnetism, where the photon does not carry charge. The consequence of this self-coupling of massless particles is a severe infrared (small momentum transfer or large distance) divergence of perturbation theory. In particular, the interaction between two colored particles through the gluon field, which in lowest order is an inverse-square Coulomb force, proportional to  $g^2/r^2$  (where  $r$  is the distance between the particles), becomes stronger than this inverse-square force at larger  $r$ . A way of describing this is to say that the coupling constant  $g$  is effectively larger at larger  $r$ ; this defines the so-called running coupling constant  $g(r)$ . According to the first-order radiative correction,  $g(r)$  becomes infinite at a certain distance, the so-called scale parameter  $r_c$ .

A specific form for the gluonic force between two colored particles, at large  $r$ , namely that it falls to a nonzero constant value  $\lambda$ , of the order of  $\hbar c r_c^{-2}$  (where  $\hbar$  is Planck's constant divided by  $2\pi$ , and  $c$  is the speed of light), is suggested by a model, the superconductor analogy. This force is confining.

The conjecture is that the vacuum is like a superconductor with respect to color, with the interchange, however, of electric and magnetic quantities. That is, the vacuum acts like a color magnetic superconductor which confines color flux into bundles which have a diameter of order  $r_c$  and an energy per unit length equal to  $\lambda$  of order  $\hbar c r_c^{-2}$ . The color flux bundles run between colored particles; they can also form closed loops. These flux bundles are often idealized as having vanishing diameter and are then called strings. This idealization is obviously good only if the flux bundles are long compared to  $r_c$ , and if their local radius of curvature is always much larger than  $r_c$ .

According to the so-called naive quark model, hadrons are bound states of nonrelativistic (slowly moving) quarks, analogous to nuclei as bound states of nucleons. The interactions between the quarks are taken qualitatively from QCD, namely a confining central potential and (exactly analogous to electrodynamic interactions) spin-spin (hyperfine) and spin-orbit potentials; quantitatively, these potentials are adjusted to make the

energy levels of the model system fit the observed hadron masses. This model should be valid for hadrons composed of heavy quarks but not for hadrons containing light quarks ( $u, d, s$ ), but in fact it succeeds in giving a good description of many properties of all hadrons. One reason is that many of these properties follow from so-called angular physics, that is, symmetry-based physical principles that transcend the specific model. A meson is a bound state of a quark and an antiquark,  $q_1\bar{q}_2$ . A baryon is a bound state of three quarks,  $q_1q_2q_3$ .

The known heavy quarks are the  $c$  (charm),  $b$  (bottom), and  $t$  (top) quarks, whose masses are larger than the natural energy scale of QCD,  $\approx 1$  GeV. But because the width of the  $t$  is also larger than 1 GeV, the  $t$  quark decays before the QCD force acts on it, and thus before any well-defined hadron forms. So in the present context "heavy quarks" mean only  $c$  and  $b$ . A hadron which contains a single heavy quark resembles an atom; the heavy quark sits nearly at rest at the center, and is a static source of the color field, just as the atomic nucleus is a static source of the electric field. Just as an atom is changed very little (except in mass) if its nucleus is replaced by another of the same charge (an isotope), a heavy-quark hadron is changed very little (except in mass) if its heavy quark is replaced by another of the same color. This is called heavy-quark symmetry. So, for example, the  $D, D^*, B, \text{ and } B^*$  mesons are similar, except in mass. This plays an important role in the quantitative analysis of their weak decays.

If a hadron contains two heavy quarks, then in a not too highly excited state the heavy quarks move slowly, compared to the speed of light  $c$ , and so the effect of the exchange of gluons between the quarks can be approximated (up to radiative corrections) by a potential energy which depends only on the positions of the quarks (local static potential); further, the wave function of the system satisfies the ordinary nonrelativistic Schrödinger equation. Consequently, the properties of hadrons composed of heavy quarks are rather easily calculated.

Mesons with the composition  $c\bar{c}$  and  $b\bar{b}$  are called charmonium and bottomonium, respectively. These names are based on the model of positronium,  $e\bar{e}^-$ ; the generic name for flavorless mesons,  $q\bar{q}$ , is quarkonium. Since both heavy quarkonium and positronium are systems of a fermion bound to its antifermion by a central force, they are qualitatively very similar.

The electroweak theory, starting from the observation that both the electromagnetic and weak interactions result from the exchange of vector (spin-1) bosons, has unified these interactions into a spontaneously broken gauge theory. Similarly, the observation that the strong (hadronic) interactions are also due to the exchange of vector bosons (gluons) suggests that all these vector bosons (the photon, the three weak bosons, and the eight gluons) are quanta of the components of the gauge field of a large symmetry group,  $SU_5$  or larger. Such theories are called grand unification theories (GUTs). The large symmetry group of the grand unification theory must be spontaneously broken, making all the gauge bosons massive except the gluon octet and the photon, leaving  $SU_3 \times U_1$  (color  $\times$  electromagnetism) as the apparent gauge symmetry of the world. See GRAND UNIFICATION THEORIES.

In these theories, the leptons and quarks occur together in multiplets of the large symmetry group. These multiplets are called families (or generations). The known fundamental fermions do seem to fall into three families (see table). Each family consists of a weak  $i$ -spin doublet of leptons (neutrino [charge 0] and charged lepton [charge  $+e$ ]), and a color triplet of weak  $i$ -spin doublets of quarks (up-type [charge  $\frac{2}{3}e$ ] and down-type [charge  $-\frac{1}{3}e$ ]). [C.J.G.]

**Elements, cosmic abundance of** The average chemical and isotopic composition of the solar system is appropriately referred to as cosmic, since this elemental abundance distribution is found to be nearly the same for interstellar gas and for young stars associated with gas and dust

in the spiral arms of galaxies. The Sun makes up more than 99.9% of the mass of the solar system, so the bulk chemical composition of the solar system is essentially the same as that of the Sun. The cosmic abundances of the nonvolatile elements are determined from chemical analyses of a type of meteorite known as CI chondrites, whereas the relative abundances of the volatile elements are determined from quantitative measurements of the intensities of elemental emission lines from the Sun's photosphere. In most silicate-rich meteorites and the Earth, Moon, Venus, and Mars, the most abundant elements are oxygen, magnesium, silicon, iron, aluminum, and calcium. Average solar-system composition consists of 70.7 wt % hydrogen, 27.4 wt % helium, and only 1.9 wt % of all remaining elements, lithium to uranium. Cosmic abundances are now widely referred to as standard abundances in the astrophysical literature. See ASTRONOMICAL SPECTROSCOPY; ELEMENT (CHEMISTRY); ELEMENTS, GEOCHEMICAL DISTRIBUTION OF.

Cosmic abundances of elements have several important uses. First, by comparing cosmic abundances to chemical analyses of various types of meteorites, inferences can be made about chemical fractionation processes that occurred in the primitive solar nebula, such as condensation and vaporization. Also, by comparing them to rock compositions, inferences can be made about processes that occurred early in the history of rocky planets, such as separation of a metallic core and differentiation of silicates into mantle and crust. Second, cosmic abundances serve as a standard of comparison for spectroscopic measurements of elemental abundances of the photospheres of other stars and for measurements of elemental and isotopic abundances in cosmic rays. Finally, nucleosynthesis occurs in many different stellar environments. Explanations of nucleosynthesis must account for how elements and isotopes from various astrophysical sources are made and then mixed to form the solar system's average chemical and isotopic composition. See NUCLEOSYNTHESIS; SOLAR SYSTEM. [A.M.D.]

**Elements, geochemical distribution of** The distribution of the chemical elements within the Earth in space and time. Knowledge of the geochemical distribution of the elements in the Earth, particularly in the Earth's crust, and of the processes that lead to the observed distributions make it possible to locate and use efficiently essential elements and minerals and to predict their dispersal patterns when they reenter the natural environment after use.

To understand the present-day distribution of the elements in the Earth, it is necessary to go back to the time of Earth formation approximately 4.5 billion years ago. It is generally believed that the Earth and the other planets in the solar system formed by agglomeration of smaller fragments of solid material orbiting around the Sun. This material had precipitated from a cooling hot gas cloud (the solar nebula), with the most refractory materials condensing out first, the most volatile last. The distribution of elements in the solar system in this early phase thus had much to do with volatility, and the solid material that aggregated to form the planets was a mix of volatile and nonvolatile materials. See COSMOCHEMISTRY; ELEMENTS, COSMIC ABUNDANCE OF; SOLAR SYSTEM.

Although the Earth may have been an approximately homogeneous mixture of accreted materials at the time of its formation, it is now made of many chemically distinct parts. At the fundamental level, these are the core, the mantle, and the crust. While chemical fractionation in the solar nebula depended upon volatility, chemical differentiation within the Earth took place by the separation of molten material from unmelted residue under the influence of gravity. Because large amounts of energy were released from accreting fragments, the early Earth was very hot, and during the accretion stage itself, temperatures in some parts exceeded the melting point of iron metal. Pools of dense molten iron, with dissolved nickel and other elements, aggregated and sank through the Earth under gravity to form the core, leav-

**Element distribution among some of the major subdivisions of the Earth\***

Element	Continental crust	Oceanic crust	Upper mantle	Core <sup>†</sup>
Oxygen	45.3	43.6	44.2	—
Silicon	26.7	23.1	21.0	—
Aluminium	8.39	8.47	1.75	—
Iron	7.04	8.16	6.22	85.5
Calcium	5.27	8.08	1.86	—
Magnesium	3.19	4.64	24.0	—
Sodium	2.29	2.08	0.25	—
Potassium	0.91	0.13	0.02	—
Titanium	0.68	1.12	0.11	—
Nickel	0.011	0.014	0.20	5.5
Sulfur	NA	NA	NA	9.0

\*Estimates of element abundances are in percent by weight and are arranged in order of decreasing abundance in the continental crust. Sulfur contents are not well known and are designated "not applicable."

<sup>†</sup>The estimate for the core is just one of several models. Others substitute light elements such as oxygen, carbon, or silicon for some or most of the sulfur shown here.

ing behind a mantle of silicate and oxide minerals. The present core constitutes about 32.4% of the Earth's mass. The distinct parts of the Earth possess unique overall compositions (see table).

The large-scale distribution of the elements in the Earth depends on the affinity of each element for specific compounds or phases. Those elements that alloy easily with iron, for example, are mostly sequestered in the Earth's core; those which form oxides and silicate minerals tend to be concentrated in the Earth's crust and mantle. Although many elements display multiple characteristics depending on the chemical environment, a classification according to geochemical affinity is nevertheless useful. The categories in this classification include atmophile (elements that are gases and concentrate in the atmosphere), lithophile (elements that form silicates or oxides and are concentrated in the minerals of the Earth's crust), siderophile (elements that alloy easily with iron and are concentrated in the core), and chalcophile (elements such as copper which commonly form sulfide minerals if sufficient sulfur is available).

Although geochemists have a good general knowledge of the overall distribution of elements in the core and mantle, much more detailed information is available about the chemical composition of the crust, which is accessible. The crust is actually composed of two major parts with quite different compositions, thickness, and average age: the continental crust and the oceanic crust.

Although all elements are present, the crust is made almost entirely of just nine chemical elements: oxygen, silicon, aluminum, iron, magnesium, calcium, sodium, potassium, and titanium. Oxygen and silicon are by far the most abundant. The most common minerals in the crust are those of the silicate family, in which the basic building block is a silicon atom surrounded by four oxygen atoms in the form of a tetrahedron. The crust is essentially a framework of oxygen atoms bound together by the common cations. See CHEMICAL BONDING; SILICATE MINERALS.

A variety of processes act to make the crust chemically heterogeneous on many scales. Many of these processes involve liquid water. Running water physically sorts particles depending on size and density, which are ultimately related to chemical composition. It is also a superb solvent, carrying many elements in solution under different conditions of temperature and pressure, and depositing them when these conditions change. Processes involving water account for many ore deposits, in which extreme concentrations of some elements occur relative to their average abundance in the crust. One example is the circulating hydrothermal solutions in volcanically active parts of the crust, which can leach metals from their normally dispersed state in large volumes of volcanic rocks and deposit them in concentrated zones as the

solutions cool and encounter different rock types. Another example is the action of weathering in tropical regions with high rainfall, which can leach away all but the least soluble components from large volumes of rock, leaving behind mineral deposits rich in aluminum or, depending on the original composition of the rocks being weathered, metals such as iron and nickel. See ELEMENT (CHEMISTRY); GEOCHEMISTRY; ORE AND MINERAL DEPOSITS; WATER; WEATHERING PROCESSES. [G.Fau.; J.D.MacD.]

**Elephant** The common name for two living species of mammals in the family Elephantidae, one of several families included in the order Proboscidea. The remaining families contain extinct animals, such as the mammoth. One of the living species (*Loxodonta africana*) is indigenous to Africa, and the other (*Elephas maximum*) ranges throughout Southeast Asia.

These animals are terrestrial and entirely herbivorous. The nostrils and upper lip are elongated into a proboscis, the trunk, which is a powerful and sensitive organ specialized to form a prehensile, food-gathering structure. The upper incisors protrude from the mouth on either side of the trunk as tusks, which continually grow throughout the life of the animal. The hard, thick skin of the elephant is sparsely covered with hair, and serves as an insulator. The eyes are tiny but vision is keen. The tail is short; large columnar legs support the massive body.

Elephants live and travel in herds which were originally composed of several hundred individuals, but the usual number is now around 20 animals, with a mature bull, a number of cows and calves, and some younger bulls. Elephants are at ease in water, and they bathe and roll in the mud as a protective measure since, despite the thickness of the skin, they are sensitive to intense sun and insects.

Bulls reach sexual maturity at the age of 15, while cows mature earlier. The gestation period averages 20–22 months with a single calf being born. Twins are rare. The newborn, which may be 3 ft (0.9 m) tall and weigh 200 lb (90 kg), grows rapidly. See MAMMALIA; PROBOSCIDEA. [C.B.C.]

**Eleutherozoa** One of the two subphyla into which the phylum Echinodermata had been customarily divided. The Eleutherozoa are now best considered as comprising at least two distinct subphyla: (1) the Echinozoa, spherical-bodied forms with meridional symmetry; and (2) the Asterozoa, starshaped forms with radially divergent axes of symmetry. See ECHINODERMATA; ECHINOZOA. [H.B.F.]

**Elevating machines** Materials-handling machines that lift and lower a load along a fixed vertical path of travel with intermittent motion. In contrast to hoisting machines, elevating machines support their loads instead of carrying them suspended, and the path they travel is both fixed and vertical. They differ from vertical conveyors in operating with intermittent rather than continuous motion. Industrial lifts, stackers, and freight elevators are the principal classes of elevating machines.

A wide range of mechanically, hydraulically, and electrically powered machines are classified as industrial lifts (Fig. 1). They are adapted to such diverse operations as die handling and feeding sheets, bar stock, or lumber. In some locations with differences in floor level between adjacent buildings, lifts take the form of broad platforms to serve as floor levelers to obviate the need for ramps. They are also used to raise and lower loads between the ground and the beds of carriers when no loading platform exists. Lifting tail gates attached to the rear of trucks are similarly used for loading or unloading merchandise on sidewalks or roads and at points where the lack of a raised dock would make loading or unloading difficult.

Stackers are tiering machines and portable elevators used for stacking merchandise with basically portable vertical frames that support and guide the carriage, to which is attached a platform, pair of forks, or other suitable lifting device (Fig. 2). Horizontal movement is effected by casters on the bottom of the vertical

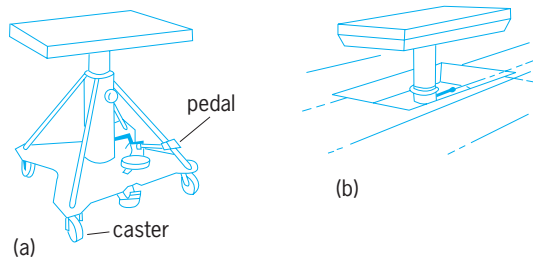

Fig. 1. Examples of industrial lifts, (a) Hydraulic elevating work table. (b) Hydraulic lift floor leveler.

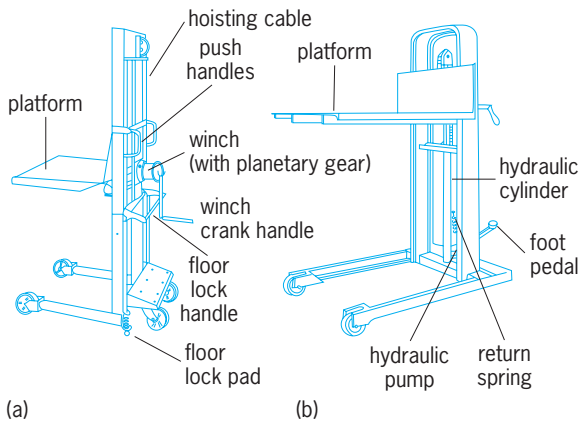

Fig. 2. Two types of electric and hydraulic stackers, (a) Hand type, (b) Hydraulic foot type.

frame, and can be accomplished manually, or mechanically, by using the same power source as the lifting mechanism. These casters are usually provided with floor locks bolted in position during the elevating or lowering operation. Used in conjunction with cranes, stackers are widely applied to the handling of materials on storage racks and die racks.

Examples of industrial elevators range from those set up temporarily on construction jobs for moving materials and personnel between floors to permanent installations for mechanized handling in factories and warehouses. Dumbwaiters are a type of industrial elevator; they carry parts, small tools, samples, and similar small objects between buildings, but are not permitted to carry people. The most common and economical elevator employs electric motors, cables, pulleys, and counterweights. See MATERIALS-HANDLING EQUIPMENT. [A.M.P.]

**Elevator** A platform or enclosure that is raised and lowered in a vertical hoistway to transport freight or people. The term elevator can also encompass all of the hoisting equipment, motor, cables, and accessories. See ELEVATING MACHINES.

The closed passenger car of a modern elevator rests inside a steel frame. The car and the car frame ride up and down on steel rails in an elevator shaft or hoistway. Guide shoes or rollers on the frame keep the car in place on the rails. Most elevators also have a heavy weight, called a counterweight, attached to the other end of the steel hoisting ropes that pass over the driving machine pulley. The counterweight offsets much of the weight of the car and passengers, thereby reducing power requirements.

The typical elevator control system is made up of a speed-sensing device known as a governor, a clamping device (safety) mounted under each end of the car frame that grips the guide rail when tripped, a tension sheave (pulley) in the pit, and a steel rope. See GOVERNOR.

Control devices are also built into the door and its control circuit. When the doors open, control circuits prevent the car

from moving away from the landing, but permit releveling if the car moves as passengers enter or leave the elevator (load changes).

In modern elevators, microprocessor computer systems control elevator position, direction of travel, speed, door operation, passenger waiting time, flight time, energy consumption, and system diagnostics. Modern elevators include Braille buttons and voice announcements of the floors to help the sight-impaired. [C.DiT.]

**Elevator (aircraft)** The hinged rear portion of the longitudinal stabilizing surface or tail plane of an aircraft used to obtain longitudinal- or pitch-control moments. The angular setting of the elevator is controlled by the human or automatic pilot through the flight-control system. A typical elevator control surface is shown in the illustration. See FLIGHT CONTROLS.

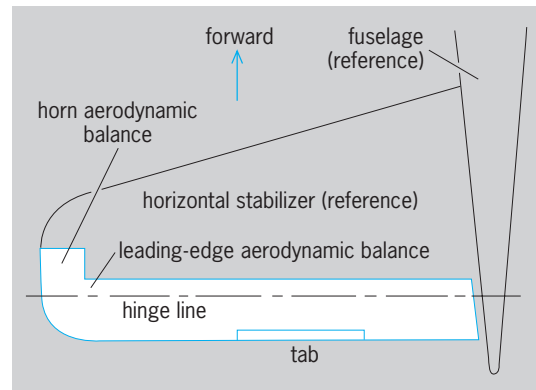

Elevator control surface (left-hand side).

The elevator is used to perform pitching maneuvers, or maneuvers in which the aircraft's plane of symmetry is not disturbed. These maneuvers include airspeed adjustments and acceleration normal to the flight path (pull-ups or push-downs). The elevator also serves to adjust the aircraft's attitude with respect to the ground for takeoff and landing. [M.J.A.]

**Elevon** A movable surface at the trailing edge of a tailless airplane that provides pitch and roll control. Elevons hinged on each side of the rear wing surface (see illustration) nose the airplane up or down, and roll one wing up and the other down. The term elevon is derived from elevator and aileron, and, in effect, elevons provide the same control as conventional elevators and ailerons. An example of an airplane employing elevons is the orbiter vehicle for the space shuttle. See AILERON; ELEVATOR (AIRCRAFT); SPACE SHUTTLE; TAIL ASSEMBLY.

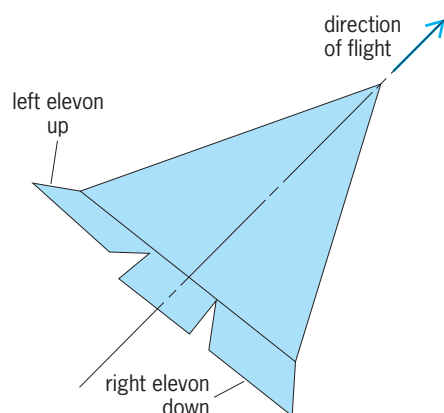

Elevons on the trailing edge of a delta wing.



When the elevons on both sides of the wing are deflected upward, they combine to produce a nose-up pitching moment on the wing and, hence, on the tailless airplane. If the elevon on the right wing is deflected upward and the one on the left wing downward, the differential movement does not result in any pitching moment, since the nose-up and nose-down pitching moments produced by the two elevons cancel each other. However, the lift on the right wing decreases, and that on the left wing increases; the combined effect produces a moment on the airplane tending to roll it to the right. Deflecting the elevons in the opposite directions causes the wing to roll to the left, and deflecting both elevons downward produces a nose-down moment. See AIRPLANE; WING. [B.W.McC.]

**Ellipse** A member of the class of curves that are intersections of a plane with a cone of revolution. The ellipse is obtained when the plane cuts all the elements of one nappe, and does not go through the apex. In the illustration, denote the distance between two points  $F, F'$  of a plane by  $2c, c > 0$ , and let  $2a$  be a constant, with  $a > c$ . The ellipse with foci  $F$  and  $F'$  and major axis  $2a$  is the locus of points  $P$  of the plane such that  $PF + PF' = 2a$ , where  $PF$  denotes the distance of  $P$  and  $F$ . This suggests the following construction of an ellipse. Put pins at  $F$  and  $F'$ , and slip over them a loop of thread of length  $2a + 2c$ , pulling the thread taut with a pencil. If the pencil is moved, keeping the thread taut, its point traces an ellipse. See CONIC SECTION.

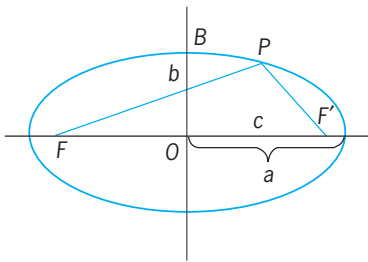

An ellipse, as described in the text.

The midpoint of  $F, F'$  is the center  $O$  of the ellipse, and the chord through  $O$  perpendicular to the major axis is the minor axis, whose length is denoted by  $2b$ . If  $B$  is a point in which the minor axis intersects the ellipse, then  $BF = BF' = a$ , and so  $c^2 = a^2 - b^2$ . The ratio  $c/a = \epsilon < 1$  is the eccentricity of the ellipse. See ANALYTIC GEOMETRY. [L.M.BI.]

**Ellipsometry** A technique for determining the properties of a material from the characteristics of light reflected from its surface. The materials studied include thin films, semiconductors, metals, and liquids.

When an electromagnetic wave passes through a medium, it causes the electrons associated with the atoms of the medium to oscillate at the frequency of the wave. As a result, the wave is slowed so that its velocity in the medium is less than its velocity in empty space. Another result may be a transfer of energy from the wave to the electrons, thereby causing the amplitude of the wave to decrease as it penetrates into the material. These two processes are described phenomenologically by the complex refractive index. See ABSORPTION OF ELECTROMAGNETIC RADIATION; REFRACTION OF WAVES.

When an electromagnetic wave is incident on a medium, only part of it is transmitted into the medium. The fraction reflected depends on the complex refractive index, the angle of incidence, and the polarization state of the wave. For multilayers with different complex refractive indices, the fraction also depends on the layer thicknesses. The two basic types of polarization are parallel, designated  $p$ , and perpendicular, designated  $s$ . These terms refer to the orientation of the electric vector with respect to the plane of incidence, which is defined by the directions

of the incident and reflected waves. The (intensity-independent) ratios of the amplitudes and phases of the reflected and incident  $p$ - and  $s$ -polarized electric fields are described by the complex reflectances  $r_p$  and  $r_s$ . See POLARIZATION OF WAVES; POLARIZED LIGHT; REFLECTION OF ELECTROMAGNETIC RADIATION.

The (also intensity-independent) ratio of the  $p$ - to the  $s$ -polarized component of such a wave is termed the polarization state. Simple examples include linear polarization, where the  $p$ - and  $s$ -polarized components are in phase, and circular polarization, where the  $p$ - and  $s$ -polarized amplitudes are equal but the phases differ by  $90^\circ$ . The geometric terms refer to the locus of the  $p$  and  $s$  (or  $y$  and  $x$ ) components of the electric field when plotted in the complex plane. The general polarization state is elliptical.

Since the complex reflectances  $r_p$  and  $r_s$  depend on the properties of the medium, the medium can be investigated by determining its reflectance for either  $p$ - or  $s$ -polarized light, that is, by determining the ratio of reflected and incident intensities  $I_{\text{refl}}/I_{\text{inc}} = R = |r|^2$ . This is the objective of reflectometry. Alternatively, because  $r_p$  and  $r_s$  are different, the complex reflectance ratio  $\rho = r_p/r_s$ , which is equal to the ratio of reflected and incident polarization states, can also be determined. This is the objective of ellipsometry. The ratio  $\rho$  is traditionally expressed in terms of angles  $\psi$  and  $\Delta$  as in the equation below.

$$\rho = \frac{r_p}{r_s} = \tan \psi e^{i\Delta}$$

Because it deals with complex, intensity-independent quantities, an ellipsometric measurement is analogous to an impedance measurement. This gives ellipsometry certain advantages relative to reflectometry, such as higher accuracy and higher information content in a single measurement. A standard experimental approach, now used almost exclusively in spectroscopic applications, is to determine  $\rho$  by establishing a known state of polarization for the incident beam, for example, by passing it through a fixed linear polarizer, then determining the polarization state of the beam after reflection by passing it through a rotating linear polarizer, called an analyzer. The rotating analyzer essentially unrolls the polarization ellipse, allowing the azimuth angle of its major axis and its minor-major axis ratio to be determined by the phase and amplitude of the alternating-current component of the detected intensity. See ALTERNATING-CURRENT CIRCUIT THEORY; ELECTRICAL IMPEDANCE.

The primary application of ellipsometry is materials analysis, particularly the nondestructive analysis of thin films in semiconductor technology. Developing applications include the real-time monitoring and control of dynamic processes such as material deposition and etching. Spectroellipsometry, where the complex refractive index is measured and analyzed as a function of wavelength, has almost exclusively replaced reflectometry in materials analysis. Deposition and etching involve kinetic ellipsometry, where single-wavelength data are monitored as a function of time. See FILM (CHEMISTRY); INTEGRATED CIRCUITS; NONDESTRUCTIVE EVALUATION; SEMICONDUCTOR HETEROSTRUCTURES; VAPOR DEPOSITION. [D.E.As.]

**Elliptic function and integral** In a certain sense, elliptic integrals are the simplest integrals not expressible in terms of elementary functions; elliptic functions arise as the inverse functions of certain elliptic integrals.

Let  $R$  be a rational function of  $x$  and  $y$ , and set  $I = \int R(x,y)dx$ .  $I$  can be expressed in terms of elementary functions if  $y^2$  is a polynomial of degree 2 or less in  $x$ . If  $y^2$  is a polynomial of degree 3 or 4 in  $x$ ,  $I$  cannot in general be expressed in terms of elementary functions and is called an elliptic integral. The standard elliptic functions are analogous to trigonometric functions. Trigonometric functions may be defined as the inverse functions of certain integrals of the form  $I$ ; they satisfy differential equations, are periodic functions, and may alternatively be obtained

as the "simplest" periodic functions. The standard elliptic functions are the inverse functions of certain elliptic integrals; they satisfy differential equations of order 1 and degree 2, are doubly periodic functions, and may alternatively be obtained as the "simplest" doubly periodic functions.

In geometry elliptic functions or integrals arise in determining the length of an arc of an ellipse, hyperbola, or lemniscate, the surface of an ellipsoid, geodesics on quadrics of revolution, parametric representations of plane cubic curves or, more generally, curves of genus 1, conformal representation problems, and other problems. There are applications to differential equations (Lamé's equation, diffusion equation, and others) in analysis, and there are applications in a great variety of problems in number theory. In the physical sciences elliptic functions or integrals appear in potential theory both through conformal representations and in the potential of an ellipsoid, in the theory of elastica, the pendulum, in rigid body motion, in Green's functions in heat conduction and diffusion theory, and many other problems. [A.Er.]

**Elm** Any species of *Ulmus*, a genus of hardwood trees in the Northern Hemisphere, with simple, serrate, deciduous leaves. The American or white elm (*U. americana*) is the most important species. It ranges from the eastern half of the United States westward as far as the base of the northern Rockies and southward through central Texas to the Gulf of Mexico. The tree is also found in southern Canada.

The tree was very popular as a shade tree, perhaps better adapted as a street tree than any other species because the upper branches spread, joining with elms across the street to form an arch. Once abundant, the elm has been severely attacked by the lethal Dutch elm disease imported from Europe. The future of the species is uncertain. [A.H.G./K.P.D.]

**Elopiiformes** A primitive order of soft-rayed, teleost fishes, including the tarpons, bonefishes, and their relatives, that was formerly included in the Clupeiformes. The elopiforms have a single dorsal fin composed of soft rays only (see illustration).

The most important characteristic of the order involves the occurrence in early development of a leptoccephalous larval stage. This larva is translucent, ribbonlike, and strongly toothed; eventually it passes through a marked transformation to adult form. This developmental pattern characterizes only two other orders of teleosts, the Notacanthiformes (spiny eels and halosaurs) and the Anguilliformes (true eels), groups which are therefore believed to be descendants of elopiforms. See ANGUILLIFORMES; CLUPEIFORMES; NOTACANTHIFORMES.

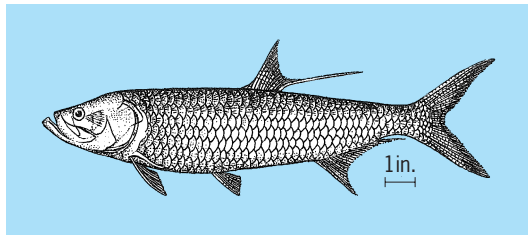

Tarpon (*Megalops atlantica*). 1 in. = 2.54 cm. (After G. B. Goode, *Fishery Industries of the United States*, Sect. 1, 1884)

The elopiforms have a well-represented paleontological history since the Jurassic, on all continents. They were especially abundant in the Cretaceous. Extant forms are classified in 2 families, 4 genera, and 12 species. Most inhabit tropical to temperate shore waters of all oceans, but tarpons invade rivers, sometimes for long distances. See ACTINOPTERYGII; TARPON; TELEOSTEI. [R.M.B.]

**Embedded systems** Computer systems that cannot be programmed by the user because they are preprogrammed for a specific task and are buried within the equipment they serve. The term derives from the military, where computer systems are generally activated by the flip of a switch or the push of a button. The continual increase in the densities of ever-smaller microprocessors, on silicon chips that fit on a thumbnail, and the attendant decreases in their costs, has pushed the concept of embedded systems well beyond the original military applications. Embedded systems are also used in industrial, automotive, consumer, and medical applications.

Most embedded microprocessors are of the CISC (complex-instruction-set computer) type, and most of these are used in applications where low cost is paramount and performance is secondary, such as consumer products. The later-generation microprocessors have wider bus widths, up to 64 bits, and thus can do more computations. See MICROPROCESSOR.

Since about 1990, microprocessors of the RISC (reduced-instruction-set computer) type have appeared, with much greater computational capability and at greater cost. RISC processors are used mostly in those embedded applications where performance is primary and low cost is secondary. They are used in engineering workstations, where the computational burdens of high-resolution graphics require such processors. See COMPUTER-AIDED ENGINEERING; COMPUTER GRAPHICS; COMPUTER SYSTEMS ARCHITECTURE. [R.AL.]

**Embioptera** A peculiar order of silk-spinning, orthopteroid insects related to termites, commonly called the embiids or web spinners. This order comprises about 1000 species which are chiefly tropical in distribution. The body is linear and supple (see illustration). The legs are short with three-segmented tarsi. The forelegs are adapted for spinning silk, and the hindlegs for reverse locomotion. Metamorphosis is incomplete. The females are neoteinic and wingless (apterous). Males are usually winged (alate), but in certain genera and species they are apterous. The wings are subequal and elongate. The wings are flexible when in repose and folded over the back, but are stiffened when extended for flight by the blood pressure in the saclike veins. Flight is a poorly directed, whirling flutter.

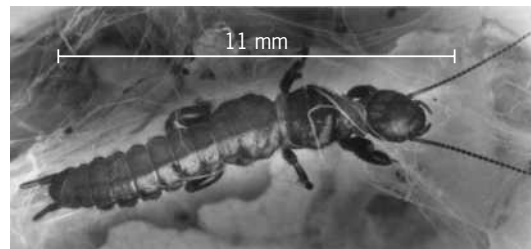

Body form of a typical embiid (*Parahagadochir trachelia*). (From E. S. Ross, *Insects Close Up*, University of California Press, 1953)

The silk galleries, which constitute a safe shelter for all embiid activities except adult dispersal, radiate on or in the food supply which also constitutes the habitat and consists of bark, lichens, moss, dead leaves, or grass. Many individuals, usually the brood of one female, may occupy one gallery system. See INSECTA; ORTHOPTERA. [E.S.R.]

**Embolism** The sudden blocking of an artery or vein by a clot or other substance which has been brought to its place by the blood current. The material carried in the circulation in this process is an embolus. Emboli may be composed of thrombi, fat, air, tumor cells, masses of bacteria or parasites, bone marrow, amniotic fluid, or atheromatous material from the vessel wall. With complete obstruction of a vessel by an embolus an infarct may result. See INFARCTION. [R.A.V.]

**Embrithopoda** An order established for the unique mammal *Arsinoitherium*, which has been found only in early Oligocene deposits in northern Egypt. This animal was of rhinoceros size with a large body and short pillarlike legs (see illustration). There were two huge, scimitarlike horns over the

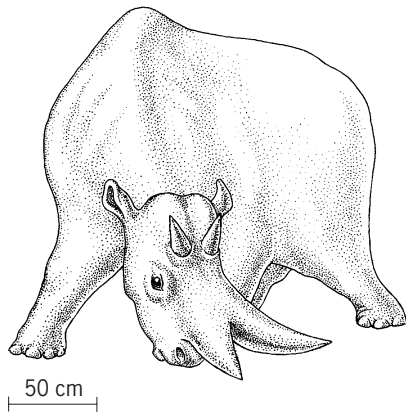

*Arsinoitherium*, the early Oligocene embrithopod from Egypt. (After C. R. Knight)

nose and two much smaller, peglike horns over the eyes. The exact relationship of this exotic order to other orders is not clear, but similarities to both the uinatheres, or Dinocerata, and Hyracoidea have been interpreted by some authorities as evidence of kinship. See DINOCERATA; MAMMALIA. [M.C.McK.]

**Embrittlement** A general set of phenomena whereby materials suffer a marked decrease in their ability to deform (loss of ductility) or in their ability to absorb energy during fracture (loss of toughness), with little change in other mechanical properties, such as strength and hardness. Embrittlement can be induced by a variety of external or internal factors, for example, (1) a decreasing or an increasing temperature; (2) changes in the internal structure of the material, namely, changes in crystallite (grain) size, or in the presence and distribution of alloying elements and second-phase particles; (3) the introduction of an environment which is often, but not necessarily, corrosive in nature; (4) an increasing rate of application of load or extension; and (5) the presence of surface notches.

Low-temperature embrittlement results from a competition between deformation and brittle fracture, with the latter becoming preferred at a critical temperature. For a material to be useful structurally, it is desirable that this critical temperature be below the minimum anticipated service temperature; in most cases, this is room temperature. At high temperatures, internal structural changes that lead to intergranular embrittlement can occur. Embrittlement usually occurs in the creep temperature range, a temperature at which deformation can occur under very low stresses; and the two processes are believed to be connected.

In many metals, particularly structural steels, annealing or heat treating in certain temperature ranges sensitizes the grain boundaries in such a way that intergranular embrittlement subsequently occurs during service. To reduce the brittleness, the steel undergoes an annealing treatment called tempering, which, while decreasing the strength, usually increases the toughness. The exception to this trade-off occurs when the steel is tempered at 1000°F (538°C). This can lead to a mode of intergranular fracture called temper embrittlement; such a process has led to catastrophic failures in turbines, rotors, and other high-strength steel parts. In other metals, there are less specific but similar types of embrittlement resulting from critical heat treatments. See HEAT TREATMENT (METALLURGY); TEMPERING.

Metals can fracture catastrophically when exposed to a variety of environments. These environments can range from liquid metals to aqueous and nonaqueous solutions to gases such as hydrogen.

If a thin film of a liquid metal is placed on the oxide-free surface of a solid metal, the tensile properties of the solid metal will not be affected, but the fracture behavior can be markedly different from that observed in air. Although many different liquid metals are capable of inducing embrittlement in a variety of solid metals, some of the more common couples, many of which have important engineering and design consequences, are mercury embrittlement of brass, lead embrittlement of steel, and gallium embrittlement of aluminum.

Stress corrosion cracking can occur when a metal is stressed and simultaneously exposed to an environment which may be, but is not necessarily, corrosive in nature. Both stress and environment are required; if only one of these elements is present, the metal usually displays no embrittlement. See CORROSION.

Hydrogen embrittlement is a form of embrittlement often considered to be a type of stress corrosion cracking. Hydrogen atoms can enter a metal, causing severe embrittlement, again with little effect on other mechanical properties. This phenomenon was originally observed, and is most critical in, steels, but it is not documented to occur in titanium and nickel alloys, and may lead to cracking in other alloy systems as well.

Factors such as notches and the rate of application of stress can modify the response of a material to a specific type of embrittlement. In general, notches or surface flaws always enhance embrittlement, both by acting as a stress raiser and by providing a preexisting crack. [I.M.B.]

**Embryobionta** One of the two plant subkingdoms, the other being the Thallobionta. The Embryobionta are here considered to include eight divisions, the Rhyniophyta, Bryophyta, Psilotophyta, Lycopodiophyta, Equisetophyta, Polypodiophyta, Pinophyta, and Magnoliophyta. The Rhyniophyta are represented only by Paleozoic fossils, but the other seven divisions have both modern and fossil representatives. See the separate articles on each division.

The Embryobionta differ from the green algae (Chlorophyta) and from most Thallobionta in that the normal life cycle of the Embryobionta shows a well-marked alternation of generations in which the sporophyte (spore-producing, typically diploid) generation always begins its development as a parasite on the gametophyte (gamete-producing, typically haploid) generation. The young sporophyte is called an embryo.

The more primitive divisions of Embryobionta have the gametes produced in multicellular sex organs (archegonia and antheridia), in contrast to the unicellular oogonia and antheridia of the Thallobionta in general. In the more advanced divisions (Pinophyta and Magnoliophyta) of Embryobionta, the antheridia and archegonia are highly modified or entirely suppressed, in conformity with the general reduction of the gametophyte generation.

All divisions of Embryobionta except the Bryophyta have specialized conducting tissues (xylem and phloem) in the sporophyte. With the exception of most bryophytes, they also commonly have a characteristic stomatal apparatus which controls the opening and closing of numerous tiny pores (stomates) in the leaves and stems in response to environmental conditions. These specializations, together with the progressive reduction of the gametophyte in the more advanced divisions, reflect the progressive evolutionary adaptation of the Embryobionta to life on dry land instead of in the ancestral water. The Embryobionta are therefore often called the land plants, in spite of the fact that many of them, such as the water lilies, have returned to an aquatic habitat. The seven divisions of Embryobionta which characteristically have xylem and phloem have sometimes been treated as a single comprehensive division under the name Tracheophyta. See PLANT KINGDOM; THALLOBIONTA. [A.Cr.]

**Embryogenesis** The formation of an embryo from a fertilized ovum, or zygote. Development begins when the zygote, originating from the fusion of male and female gametes, enters a period of cellular proliferation, or cleavage. Cells of the embryo subsequently give rise to the tissues and organs of the body in a temporal and spatial pattern that creates a functional, multicellular organism.

Following cleavage, the cells of the animal embryo rearrange into three germ layers: an outer ectoderm, a middle mesoderm, and an inner endoderm. Cells, responding to intrinsic and extrinsic factors, eventually segregate from the germ layers and organize into the rudiments of the tissues and organs of the body. These rudiments alter the size and the shape of the embryo, endowing the body with its axial symmetry. Cellular growth and differentiation are the principal processes that transform the rudiments into functional tissues and organs. Once the organs and organ systems are formed, further development consists primarily of growth. *See* GERM LAYERS. [M.J.Ca.]

Major features of embryogenesis in flowering plants include the formation of root and shoot apical meristems; differentiation of primary vascular tissue; the transition from a heterotrophic zygote to an embryo capable of independent growth and development; and preparations for desiccation, dormancy, and germination. *See* APICAL MERISTEM; CELL DIFFERENTIATION; DEVELOPMENTAL BIOLOGY; EMBRYOLOGY; EMBRYONIC DIFFERENTIATION; EMBRYONIC INDUCTION. [D.W.Me.]

**Embryology** The study of the development of an organism, commencing with the union of male and female gametes. Embryology literally means the study of embryos, but this definition is restrictive. An embryo is an immature organism contained within the coverings of an egg or within the body of the mother. Strictly speaking, the embryonic period ends at metamorphosis, hatching, or birth. Since developmental processes continue beyond these events, the scope of embryology is customarily broadened to encompass the entire life history of an organism. Embryology may, in this wider context, consider the mechanisms of both asexual reproduction and regeneration.

**Animals.** The production of male and female gametes is commonly considered to be the first phase in animal development. The differentiating gametes arise from diploid stem cells in the gonads. Cell division by meiosis reduces the number of chromosomes carried by a mature gamete to one-half that present in the stem cell. *See* GAMETOGENESIS.

The union of gametes (spermatozoon and ovum), representing the second phase of development, creates a diploid zygote with the potential to form an entire organism. Two events must occur for successful fertilization: the ovum must respond to contact with the spermatozoon by making preparations for further development, an event called activation, and the haploid nucleus of the spermatozoon must combine with the haploid nucleus of the ovum, an event called amphimixis.

Fertilization is the typical method to initiate development, but it is not the only method. In a few animals, the ovum develops independently by parthenogenesis, that is, without the participation of a spermatozoon.

A period of cell proliferation, converting the unicellular zygote into a multicellular embryo, represents the third phase of development. Cleavage is a modified form of cell division by mitosis, distinguished by little or no growth between the divisions. The cells of the embryo, or blastomeres, become progressively smaller at the end of each division, so the embryo maintains the relative size and shape of the zygote. Small, fluid-filled spaces form between the cleaving blastomeres, and these spaces eventually coalesce to create an internal cavity, or blastocoel. Upon the appearance of a blastocoel, the cells of an embryo are referred to collectively as the blastoderm. *See* BLASTULATION.

The fourth phase of development is poorly delineated from cleavage, because the cells of the embryo continue to divide.

Gastrulation is distinguished from cleavage by extensive cell rearrangements that lead, in most animals, to the establishment of three germ layers: an outer ectoderm, a middle mesoderm, and an inner endoderm. Endodermal and mesodermal cells of the blastoderm migrate to the inside of the embryo, while ectodermal cells remain on the surface, where they spread to completely cover the body.

Control of development passes from the cytoplasm to the nucleus immediately prior to gastrulation. Responding to cytoplasmic cues, the nuclei begin to specify the production of proteins that make the cells qualitatively different from one another. In a few invertebrates, the transfer of control from cytoplasm to nucleus actually fixes the developmental fate of a cell. In most other organisms, and particularly in vertebrates, the determination of cell fate is not finalized until the blastoderm has rearranged into the three germ layers. *See* CELL LINEAGE; GASTRULATION; GERM LAYERS.

The organization of cells into the tissues and organs of the body, constituting the fifth phase of development, is closely allied with gastrulation. Blastodermal rearrangements during creation of the germ layers shift cells into new positions and bring about new intercellular relationships. The developmental fate of a cell can, to a considerable degree, be the consequence of its new position. The influence exerted by one group of cells over the developmental fate of a neighboring group is called induction. Induction occurs by the transmission of chemical substances, called inducing agents.

Differentiation, or the process by which a cell becomes specialized, correlates to a reduction in the amount of genetic information that is expressed. Determination, or the fixation of a developmental fate, occurs when a cell has such a limited amount of usable genetic information that it must commit to a terminal pathway of differentiation. *See* CELL DIFFERENTIATION.

Cellular differentiation is just one aspect of morphogenesis, or the development of form. Morphogenesis must be considered at all levels of organization, ranging from the individual cell to the whole organism. Such a broad perspective complicates the formulation of general theories of development. Presently, no comprehensive theory exists, but there are some embryologists who anticipate that a theory is possible once activities of the DNA molecule have been fully integrated into the topic of development. *See* ANIMAL MORPHOGENESIS; REPRODUCTION (ANIMAL). [M.J.Ca.]

**Plants.** Reproductive development in multicellular plants is generally divided into three phases: gametogenesis, fertilization, and embryogenesis. The zygote produced by the fusion of male and female gametes divides to form a multicellular embryo with meristematic regions that ultimately produce the adult plant.

Development of the cell in flowering plants begins with a diploid megasporocyte located within the nucellar tissue of an immature ovule. This megasporocyte undergoes meiosis to form a tetrad of four haploid megaspores. In the most common pattern of development, three of these megaspores degenerate, leaving a single functional megaspore that undergoes several postmeiotic mitoses to form a mature megagametophyte (embryo sac) composed of seven cells and eight haploid nuclei. One of these haploid cells is the egg cell.

Development of the male gametes begins with numerous diploid cells (microsporocytes) located within the anthers of an immature flower. Each microsporocyte undergoes meiosis to form a tetrad of four haploid microspores, which then separate and enlarge to form mature pollen grains. Each microspore divides unequally to form a large vegetative cell, and a small generative cell located within the cytoplasm of the vegetative cell. The generative cell divides again, in either the maturing pollen grain or the elongating pollen tube, to form two genetically identical male gametes, the sperm cells.

The zygote is produced as part of a unique process known as double fertilization. One of the male gametes fuses with the egg

cell to form the diploid zygote, while the other male gamete fuses with two polar nuclei, located near the center of the embryo sac, to form a triploid endosperm nucleus. Following double fertilization, the zygote develops into an embryo composed of two parts, the embryo proper and the suspensor. The embryo proper ultimately differentiates into the mature embryo, whereas the suspensor degenerates during later stages of development and is not usually present at maturity.

Flowering plants can be divided into two groups, monocots and dicots. In most dicots, the endosperm tissue is gradually absorbed by the developing embryo and is not present in the mature seed. Nutrients required for the germination of dicot seeds are generally stored in the embryonic leaves known as cotyledons. In contrast, most mature monocot seeds contain a significant amount of starchy endosperm tissue that serves as a source of nutrients for the germinating seedling.

Two important regions of the mature embryo are the root and the shoot apical meristems. The entire shoot system (stems, leaves, and flowers) of the adult plant forms from cells that are located in the shoot apical meristem of the mature embryo. The root apical meristem that is formed during embryogenesis becomes active during the early stages of germination and ultimately produces the entire root system of the adult plant. See APICAL MERISTEM; ROOT (BOTANY).

The final stages of embryogenesis in angiosperms include maturation, desiccation, and preparation for seed dormancy.

Different patterns of embryo development are found in gymnosperms and in the more primitive vascular and nonvascular plants. Double fertilization and the development of a nutritive endosperm tissue are features unique to the angiosperms. The haploid microgametophyte (germinating pollen grain) in most gymnosperms contains two male gametes, but only one of these participates in fertilization. The nutritive function served by the endosperm tissue in angiosperms is served in gymnosperms by the large haploid megagametophyte. Early divisions of the zygote are also different in gymnosperms; the zygote typically undergoes a series of free nuclear divisions during the earliest stages of embryogenesis, and multiple embryos often arise from a single zygote through a process known as polyembryony. Even more striking differences in embryogenesis are found in ferns and mosses, where the haploid or gametophytic phase of the life cycle is much more extensive.

Several major differences also exist between embryogenesis in plants and animals. Plant cells are surrounded by a cell wall that limits the contact and movement between adjacent cells. Embryogenesis in plants therefore proceeds without the morphogenetic movements that are characteristic of animal development. Morphogenesis in plants is also not limited to embryo development, but occurs throughout the life cycle. The mature plant embryo is therefore not simply a miniature version of the adult plant. See PLANT MORPHOGENESIS. [D.W.Me.]

**Embryonated egg culture** Embryonated eggs are among the most useful and available forms of living animal tissue for the isolation and identification of animal viruses, for titrating viruses, and for quantity cultivation in the production of viral vaccines. The embryo proper, chorioallantoic membrane, yolk sac, allantoic sac, or amniotic sac may be inoculated in hen eggs of various ages, so that a wide choice of types of tissue is available to fit the characteristics of the virus under study or for special studies. The chorioallantoic membrane is frequently used; in some infections, such as smallpox, vaccinia, and herpes simplex, characteristic lesions are produced which in some cases may resemble those in the natural host. See ANIMAL VIRUS. [J.L.Me.]

**Embryonic differentiation** The process by which specialized and diversified structures arise during development of the embryo. The process involves (1) an increase in the number

of cell types, and (2) an increase in morphological heterogeneity through the arrangement of cells into increasingly complex structural patterns in the form of tissues and organs. See HISTOGENESIS.

Differentiation begins in most organisms with fertilization of an egg with a sperm, after which the relatively large egg divides into many smaller cells called blastomeres. The blastomeres receive unequal portions of the cytoplasmic materials of the egg and are therefore initially somewhat different from each other. At the end of cleavage, the blastomeres are organized into a blastula, commonly either a hollow ball of cells or a flattened two-layered disk of cells. The cells of the blastula lie in different relative positions from those that will be occupied by their descendants in the adult organism. By a process known as gastrulation, they move to their approximate final positions and are arranged into three basic layers, called germ layers. However, only two layers form in the simpler multicellular organisms. The outer layer is the ectoderm, from which arise the nervous system and the epidermal layer of the skin. The innermost germ layer, the entoderm, forms the epithelial lining of the digestive tract and contributes the essential tissue of associated organs. In all but the most primitive animals a third germ layer, the mesoderm, is formed by cells which come to lie in the area between the other two layers. In higher animals the mesoderm gives rise to most of the cells of the organism, such as those found in the muscles, skeleton, blood, connective tissue, kidneys, gonads, and certain other organs. The molding of groups of embryonic cells into such diverse tissues and organs proceeds through a variety of morphogenetic processes, such as migration, aggregation, dispersion, delamination, folding, and differential local growth of cells. See BLASTULATION; GASTRULATION; GERM LAYERS.

Underlying the visible structural diversification of the embryo is the more fundamental and concomitant process of cellular differentiation (chemodifferentiation), by which embryonic cells are transformed into the highly specialized cells of the adult.

The mechanisms by which the course of cellular differentiation is realized are not precisely known. The factors involved may, however, be divided into two classes: (1) intrinsic, those operating within the cell, and (2) extrinsic, those brought to bear upon the cell from outside. Both classes of factors play a role in the differentiation of every cell. However, the relative importance of these factors varies considerably from one cell strain to another and also within the same cell at different stages in its development.

The fertilized egg begins development with a rich endowment, consisting of a nucleus with a set of paternal and maternal chromosomes together with a complexly organized cytoplasm. The activation of the egg by the sperm sets off a chain of actions and reactions that progressively transform the physical and chemical constitution of each descendant cell. The emergence of new cell characteristics may be attributed to an oscillating interaction between the intrinsic gene makeup of the cell and the surrounding cytoplasm. The dynamic imbalance existing between these interacting components drives the cell along its path of differentiation. In certain kinds of invertebrate embryos, interactions within each separate cell seem sufficient for guiding differentiation to its terminal state. Such embryos exhibit mosaic development. By contrast, in the embryos of vertebrates and certain invertebrates such as echinoderms, influences from adjacent cells are an essential part of the differentiation process. These embryos show regulative development. See CELL LINEAGE; DEVELOPMENTAL BIOLOGY; EMBRYONIC INDUCTION. [C.L.Ma.]

**Embryonic induction** In the early development of many tissues and organs of complex, multicellular organisms, the action of one group of cells on another that leads to the establishment of the developmental pathway in the responding tissue. The groups of cells which influence the responding cells

are termed the inducing tissue. Since specific inducing tissues cannot act on all types of cells, those cells which can respond are referred to as competent to react to the action of a specific inducer stimulus.

Embryonic induction is considered to play an important role in the development of tissues and organs in most animal embryos, from the lower chordates to the higher vertebrates.

Perhaps the first major induction phenomenon occurs during the final stages of gastrulation of most animal embryos. Following fertilization, the egg divides to form a multicellular blastula-stage embryo. The cells of the blastula then undergo a series of movements which generate a more complex embryo, the gastrula, which contains three major groups of cells: ectoderm, mesoderm, and endoderm. The mesoderm actually arises as cells move from the surface of the embryo to the inside. Once inside, they induce the cells which reside over them, the surface ectoderm cells, to develop into the neural tube. The neural tube eventually forms the central nervous system. The first induction event of early embryogenesis is called primary embryonic induction. The migratory cells which invaginate from the surface and induce the development of the neural tube are termed the embryonic organizer. The first step in the sequence of events termed primary embryonic induction is the acquisition by the mesoderm of neural inducing activity. Proteins such as fibroblast growth factor and activin, which belong to a category of so-called peptide growth factors, play key roles in programming the mesoderm cells to induce overlying ectoderm to differentiate into neural structures. See GASTRULATION.

The development of a large number of tissues and organs is influenced by embryonic inductions. Various eye structures (lens, optic cup, and so on), internal ear structures, as well as several tissues (for example, vertebral cartilage) emerge from cells which were acted upon by inducer tissues. See NERVOUS SYSTEM (VERTEBRATES).

Limbs, kidney, nasal structures, salivary glands, pancreas, teeth, feathers, and hair are organs which require inductive stimuli. It is not known whether a single common mechanism underlies each of those inductions. Many scientists believe that inductive interactions are mediated by cell-cell contacts; that is, the developmental information which is transferred from the inducing tissue is thought to reside at the cell surface of that tissue. Perhaps the surface of the responding tissue recognizes the signal molecules present on the surface of the inducing tissue. In other instances, a secreted protein might move among various cells or tissues and exert its effects on competent cells.

The principles of animal development also apply to plants. A greater role is, however, usually played by the diffusion of small-molecular-weight signal molecules rather than cell-cell contacts or protein growth factors. The earliest stages of plant embryo development involve groups of cells acquiring the competence to respond to inductive signals. Later in development, inductive signaling also becomes important. For example, in flowering plants the distance between nodes along the stem elongates, and lateral buds form below the shoot apex. The buds are believed to develop in response to a concentration gradient of signal molecules which exists along the stem. Thus, a process which is analogous to embryonic limb bud formation in animals is played out, and both plant and animal inductions can be conceptualized in similar terms. See CELL DIFFERENTIATION; DEVELOPMENTAL BIOLOGY; EMBRYOLOGY; PLANT MORPHOGENESIS.

[G.M.M.]

**Emerald** The medium- to dark-green gem variety of the mineral beryl, crystallizing in the hexagonal system. A flawless emerald with good color is one of the most sought after and highly prized of all precious gems. Emerald is restricted in its occurrence, and only infrequently are exceptional stones found; most emeralds are flawed and cloudy, and few stones command high prices.

In contradistinction to beryl and its other gem varieties, emeralds have only been found in mica schists or metasomalized limestones. The most outstanding occurrences include the Muzo and El Chivor mines in Colombia. Noteworthy occurrences in mica schists include Tokovoja in the Ural Mountains, where emerald occurs with the beryllium minerals chrysoberyl (and its gem variety alexandrite) and phenakite; Habachtal, Austria; Transvaal, South Africa; and Kaliguman, India. The ultimate source of an emerald can often be assessed by a study of its inclusions. See BERYL; GEM. [P.B.M.]

**Emergency medicine** The medical specialty that comprises the immediate decision making and action necessary to prevent death or further disability under emergency conditions. It is based primarily in hospital emergency departments, but with extensive responsibilities for supervising emergency medical systems outside the hospital (paramedics).

Prehospital care is professional emergency care delivered before the patient reaches the hospital. Care is provided by paramedics and emergency medical technicians. Paramedics are technicians trained in techniques such as electric shock for defibrillation of the heart, insertion of a tube into the trachea to assist respiration, and the use of intravenous drugs normally administered by physicians. They operate under the supervision of an emergency physician, usually by radio communication. Emergency medical technicians (EMTs) are trained in first aid, give no medication, seldom communicate with a doctor, and often receive very little medical supervision.

Trauma is physical injury, whether minor or major; it does not include medical emergencies due to other causes. In major trauma (usually caused by vehicular or industrial accidents, stabbing or gunshot wounds, or falls) the best care requires rapid transport to the hospital. Proper treatment of trauma requires prompt assessment by qualified paramedics, who may have to immobilize the neck to prevent spinal cord injury, protect the breathing passages, or administer intravenous fluid to replace blood lost by hemorrhage. Further evaluation and treatment by a qualified emergency physician must take place immediately upon arrival at the emergency department or trauma center. Trauma care has also been revolutionized by the advent of computerized tomographic x-ray. See COMPUTERIZED TOMOGRAPHY.

Burns are a very serious injury because the protective barrier of the skin is destroyed, leading to massive loss of body fluids, development of shock, and invasion by bacteria. Patients with major burns are best treated in specialized burn centers and should be taken there promptly. Burn mortality has dropped significantly because of prompt intravenous administration of very large volumes of fluid to replace body fluid losses, and the use of antibiotics. See BURN.

Cardiac arrest occurs when the heart suddenly goes into an abnormal rhythm so that it does not pump blood; it is the chief cause of death in heart attack. Cardiac arrest tends to occur in the first few hours of heart attack, often before the patient has even decided to go to the hospital, and sometimes is not preceded by any symptoms. If treated by defibrillation (electric shock to the heart) within the first 6 min, it is reversible. Otherwise, death is certain. Therefore, to save lives, emergency medical service programs must deliver paramedics to the patient's side within 6 min of the arrest.

Innumerable poisonings occur every year in the United States, involving thousands of products. Poison centers have been established in every state, where trained physicians and pharmacologists equipped with electronic and on-line references provide emergency telephone consultation. Poison centers have greatly improved the quality of care in poisoning cases. [M.Ca.]

**Emery** A natural mixture of corundum with magnetite or with hematite and spinel. Because the mixture is very intimate

and appears to be quite homogeneous, it was considered to be a single mineral species until the middle of the 19th century. The aggregate has a gray-to-black color and is extremely tough and difficult to break. The specific gravity varies from 3.7 to 4.3, depending upon the relative amounts of the constituent minerals. The hardness is about 8 (Mohs scale), less than that of pure corundum which is 9, and is more dependent upon the physical state of aggregation than on the percentage of corundum. See CORUNDUM.

Although synthetic abrasives have replaced emery in many of its earlier uses, it is still used as an abrasive and polishing material by lapidaries and in the manufacture of lenses, prisms, and other optical equipment. Emery wheels, emery paper, and emery cloth are used not only by lapidaries but also by machinists in the grinding and polishing of steel. See ABRASIVE; GRINDING; MAGNETITE. [C.S.Hu.]

**Emission spectrochemical analysis** A technique conducted by monitoring and measuring the spectrum of light caused to be emitted by the material to be analyzed. In general, there are many ways in which to conduct an emission spectrometric measurement; the differences among approaches result mainly from the choice of location within the electromagnetic spectrum at which to observe emitted radiation. However, emission spectrochemical analysis traditionally refers to those analytical determinations based on radiation in the visible through vacuum ultraviolet region of the electromagnetic spectrum (wavelengths about 800 to 100 nanometers). The technique is used principally to detect (qualitative analysis) and determine (quantitative analysis) metals and some nonmetals. Under optimum conditions, as little as  $10^{-10}$  gram of an element per gram of sample can be determined.

The steps in emission spectrochemical analysis are: vaporization and atomization of sample; excitation of atomic vapor; resolution of emitted radiation; and observation and measurement of resolved radiation. See SPECTROSCOPY. [A.T.Z.]

**Emissivity** The ratio of the radiation intensity of a non-black body to the radiation intensity of a blackbody. This ratio, which is usually designated by the Greek letter  $\epsilon$ , is always less than or just equal to one. The emissivity characterizes the radiation or absorption quality of nonblack bodies. Published values are readily available for most substances. Emissivities vary with temperature and also vary throughout the spectrum. For an extended discussion of blackbody radiation and related information see HEAT RADIATION.

A spectral emissivity of zero means that the heat radiator emits no radiation at this wavelength. Strongly selective radiators, such as insulators or ceramics, have spectral emissivities close to 1 in some parts of the spectrum, and close to zero in other parts. Carbon has a high spectral emissivity throughout the visible and infrared spectrum, exceeding 0.90 in certain portions; thus carbon is a good blackbody radiator. Tantalum is the only metal with a spectral emissivity greater than 0.5 in the visible spectrum. All other metals have a lower spectral emissivity. Tungsten is a relatively good emitter, with a spectral emissivity of 0.43–0.47 within the visible region of the spectrum. See BLACKBODY. [H.G.S.; P.J.W.]

**Emitter follower** A circuit that uses a common-collector transistor amplifier stage with unity voltage gain, large input resistance  $R_i$ , and small output resistance  $R_o$  (see illustration). In its behavior, the emitter follower is analogous and very similar to the source follower in metal-oxide-semiconductor (MOS) circuits. Many electronic circuits have a relatively high output resistances and cannot deliver adequate power to a low-resistance load, or do suffer unacceptable voltage attenuation. In these cases, an emitter follower acts as a very simple buffer. Widely

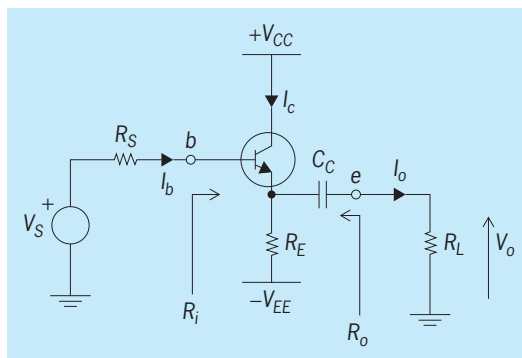

Schematic diagram of an emitter follower circuit.

used, it is often found as the last stage of a multistage amplifier so that the circuit is better able to drive a low-resistance load. See AMPLIFIER. [R.Sc.]

**Emotion** An umbrella concept in the common language, typically defined by instantiation by reference to a variety of mental and behavioral states. These range from lust to a sense of liking, from joy to hostile aggression, and from esthetic appreciation to disgust. Emotions are usually considered to be accompanied by some degree of internal, frequently visceral, excitement, as well as strong evaluative components. Emotions are also often described as irrational, that is, not subject to deliberative cogitation, and as interfering with normal thought processes.

These latter qualities are often exacerbated in the emotional behavior and expression seen in clinical cases. The expression of strong emotions is typically considered to be symptomatic of some underlying conflict, and even the positive emotions are used as indices of unusually strong attachments and atypical earlier experiences. Sigmund Freud introduced the concept of repression to describe a defense mechanism against the occurrence of strong emotional experiences. From the psychoanalytic point of view, what is repressed is not the emotion itself, since the very concept of emotion implies conscious experience, but rather the memory of an event which, if it became conscious, would lead to strong conflicts and emotional consequences. Many other defense mechanisms, such as rationalization and compulsive or obsessive neurotic symptoms, are also seen as serving the purpose of avoiding conscious conflict and emotional sequelae. See PSYCHOANALYSIS. [G.M.]

**Emphysema** A disorder of pulmonary inflation characterized by enlargement and destruction of the air spaces. The key element in this definition is the word destruction for it implies the irreversible loss of a given area of the pulmonary parenchyma. Certain variants of this condition do not necessarily imply irreparable destruction of pulmonary tissue but rather overdistention of air spaces, and consequently are not properly classified as emphysema.

Generalized emphysema probably has many causes; most share chronic bronchiolitis as a factor. Narrowing at this level would cause retention of air, leading to dilatation and rupture of alveolar septa. Increasing attention is being given to heavy cigarette smoking and air pollution as contributing factors. Given the dilatation of the air spaces, the total air space in the lungs is increased. However, the lungs cannot be properly emptied and are functionally impaired.

Emphysema, if widespread, will cause very serious limitation in physical activity. Many cases, however, are compatible with long survival. Complications of severe emphysema include right heart failure (cor pulmonale), respiratory acidosis, and rupture of bullae with development of pneumothorax.

The important variants of emphysema are as follows. Centrilobular emphysema affects predominantly respiratory

bronchioles without involvement of the more peripheral elements. In diffuse vesicular emphysema, the most common form, all elements of the respiratory unit (respiratory bronchiole, alveolar ducts, alveolar sacs, and alveoli) are dilated. Senile emphysema was formerly applied to barrel-chested elderly people; however, functional impairment is, in most cases, inconspicuous. This condition is also known as aging lung. See BRONCHIAL DISORDERS. [V.E.G.]

**Empirical method** The empirical method is generally characterized by the collection of a large amount of data before much speculation as to their significance, or without much idea of what to expect, and is to be contrasted with more theoretical methods in which the collection of empirical data is guided largely by preliminary theoretical exploration of what to expect. The empirical method is necessary in entering hitherto completely unexplored fields and becomes increasingly less purely empirical as the acquired mastery of the field increases. Successful use of an exclusively empirical method demands a high degree of intuitive ability in the practitioner. [P.W.Br./G.Ho.]

**Emulsion** A dispersion of one liquid in a second immiscible liquid. Since the majority of emulsions contain water as one of the phases, it is customary to classify emulsions into two types: the oil-in-water (O/W) type consisting of droplets of oil dispersed in water, and the water-in-oil (W/O) type in which the phases are reversed. The continuous liquid is referred to as the dispersion medium, and the liquid which is in the form of droplets is called the disperse phase.

A stable emulsion consisting of two pure liquids cannot be prepared; to achieve stability, a third component, an emulsifying agent, must be present. Generally, the introduction of an emulsifying agent will lower the interfacial tension of the two phases. A large number of emulsifying agents are known; they can be classified broadly into several groups. The largest group is that of the soaps, detergents, and other compounds whose basic structure is a paraffin chain terminating in a polar group. Some solid powders can act as emulsifiers by being wetted more by one phase than by the other. Whichever phase shows the greater wetting power will become the dispersion medium. Many naturally occurring emulsions, such as milk or rubber latex, are stabilized by proteins. Egg yolk proteins stabilize mayonnaise and salad dressing. Certain hydrophilic colloids such as gum arabic or gelatin also stabilize water-in-oil emulsions by a similar mode of action.

Emulsions may be prepared readily by shaking together the two liquids or by adding one phase drop by drop to the other phase with some form of agitation, such as irradiation by ultrasonic waves of high intensity. In industry, emulsification is accomplished by means of emulsifying machines.

The breaking of emulsions is necessary in many industrial operations, for example, in the separation of water-in-oil emulsions in the petroleum industry and in product recovery from emulsions produced by the steam distillation of organic liquids. Emulsions may be broken by (1) addition of multivalent ions of charge opposite to the emulsion droplet, (2) chemical action (addition of acids to emulsions stabilized by soaps), (3) freezing, (4) heating, (5) aging, (6) centrifuging, (7) application of high-potential alternating electric fields, and (8) treatment with ultrasonic waves of low intensity. See COLLOID; DETERGENT; SOAP. [G.S.M.; W.O.M.]

**Enargite** A mineral having composition  $\text{Cu}_3\text{AsS}_4$ . In some places enargite is a valuable ore of copper. The mineral has perfect prismatic cleavage, metallic luster, and grayish-black color. The hardness is 3 on Mohs scale, and the specific gravity is 4.44. Enargite is one of the rarer copper ore minerals and it has been mined in Yugoslavia, Peru, the Philippines, and the United States at Butte, Montana, and Bingham Canyon, Utah. Probably the largest deposit is at Chuquibambilla, Chile. [C.S.Hu.]

**Encalyptales** An order of the true mosses (subclass Bryidae) that grow in dull, dark tufts on soil or soil-covered rock, generally in calcareous areas. The Encalyptales consist of a single family and two genera, the better known being *Encalypta*, the extinguisher moss, so called because of its long calyptra of candlesnuffer form.

Encalyptales are characterized by broad, papillose leaves and erect capsules covered by very long calyptrae. The stems are erect and simple or forked with folded, incurved leaves. Leaves are broadly acute to rounded and often abruptly short-pointed to hair-pointed with a strong midrib ending at or beyond the leaf tip. The sporophytes are terminal, with elongate setae, and erect, cylindrical, and ribbed capsules. The operculum is long-rostrate, and the peristome variable in structure. The spores are often large and quite various in sculpturing. See BRYIDAE; BRYOPHYTA; BRYOPSIDA; POTTIALES. [H.Cr.]

**Endangered species** A species that is in danger of extinction throughout all or a significant portion of its range. "Threatened species" is a related term, referring to a species likely to become endangered within the foreseeable future. The main factors that cause species to become endangered are habitat destruction, invasive species, pollution, and overexploitation.

Habitat destruction is the single greatest threat to species around the globe. Natural habitat includes the breeding sites, nutrients, physical features, and processes such as periodic flooding or periodic fires that species need to survive. Humans have altered, degraded, and destroyed habitat in many different ways. Logging around the world has destroyed forests that are habitat to many species. This has a great impact in tropical areas, where species diversity is highest. Although cut forests often regrow, many species depend upon old-growth forests that are over 200 years old; these forests are destroyed much faster than they can regenerate. Agriculture has also resulted in habitat destruction. In the United States, tallgrass prairies that once were home to a variety of unique species have been almost entirely converted to agriculture. Housing development and human settlement have cleared large areas of natural habitat. Mining has destroyed habitat because the landscape often must be altered in order to access the minerals. Finally, water development, especially in arid regions, has fundamentally altered habitat for many species. Dams change the flow and temperature of rivers and block the movements of species up and down the river. Also, the depletion of water for human use (usually agriculture) has dried up vegetation along rivers and left many aquatic species with insufficient water.

The invasion of nonnative species is another major threat to species worldwide. Invasive species establish themselves and take over space and nutrients from native species; they are especially problematic for island species, which often do not have defensive mechanisms for the new predators or competitors. Habitat destruction and invasion of nonnative species can be connected in a positive feedback loop: when habitat is degraded or changed, the altered conditions which are no longer suitable for native species can be advantageous for invasive species. In the United States, approximately half of all endangered species are adversely affected by invasive species.

Pollution directly and indirectly causes species to become endangered. In some cases, pesticides and other harmful chemicals are ingested by animals low on the food chain. When these animals are eaten by others, the pollutants become more and more concentrated, until the concentration reaches dangerous levels in predators and omnivores. These high levels cause reproductive problems and sometimes death. In addition, direct harm often occurs when pollutants make water uninhabitable. Agriculture and industrial production cause chemicals such as fertilizers and pesticides to reach waterways. Lakes have become too acidic from acid rain. Other human activities such as logging,



grazing, agriculture, and housing development cause siltation in waterways. Largely because of this water pollution, two out of three fresh-water mussel species in the United States are at risk of extinction. See ACID RAIN; WATER POLLUTION.

Many species have become endangered or extinct from killing by humans throughout their ranges. For example, the passenger pigeon, formerly one of the most abundant birds in the United States, became extinct largely because of overexploitation. This overexploitation is especially a threat for species that reproduce slowly, such as large mammals and some bird species. Overfishing by large commercial fisheries is a threat to numerous marine and fresh-water species. See FISHERIES CONSERVATION.

Efforts to save species focus on ending exploitation, halting habitat destruction, restoring habitats, and breeding populations in captivity. In the United States, the Endangered Species Act of 1973 protects endangered species and the ecosystems upon which they depend. Internationally, endangered species are protected from trade which depletes populations in the wild, through the Convention on International Trade in Endangered Species (CITES). Over 140 member countries act by banning commercial international trade of endangered species and by regulating and monitoring trade of other species that might become endangered. For example, the international ivory trade was halted in order to protect elephant populations from further depletion.

Typically, the first step is identifying which species are in danger of extinction throughout all or part of their range and adding them to an endangered species list. In the United States, species are placed on the endangered species list if one or more factors puts it at risk, including habitat destruction or degradation, overutilization, disease, and predation. Florida and California contain the most endangered species of all the contiguous 48 states. Hawaii has more endangered species than any other state. Hawaii, like other islands, has a diversity of unique species that occur nowhere else in the world. These species are also highly susceptible to endangerment because they tend to have small population sizes, and because they are particularly vulnerable to introduced competitors, predators, and disease.

For many endangered species, a significant captive population exists in zoos and other facilities around the world. By breeding individuals in captivity, genetic variation of a species can be more easily sustained, even when the species' natural habitat is being destroyed. Some species exist only in captivity because the wild population became extinct. For a few species, captive individuals have been reintroduced into natural habitat in order to establish a population where it is missing or to augment a small population. Depending on the species, reintroduction can be very difficult and costly, because individual animals may not forage well or protect themselves from predators. See ECOLOGY; EXTINCTION (BIOLOGY). [L.H.W.]

**Endocrine system (invertebrate)** The chemical integrating system in animals that lack a vertebral (spinal) column. An endocrine system consists of those glandular cells, tissues, and organs whose products (hormones) supplement the rapid, short-term coordinating functions of the nervous system. Almost all of the information about invertebrates pertains to the more highly evolved groups that will be discussed below, the annelids, echinoderms, mollusks, and most particularly two classes of arthropods, the insects and crustaceans. Several of the hormones in invertebrates are neurohormones, that is, they are produced by nerve cells. See NEUROSECRETION.

**Insects.** Increase in linear dimensions of an insect can only occur at periodic intervals when the restricting exoskeleton is shed during a process known as molting. Once an insect becomes an adult, it ceases to molt. The orderly sequence of molts that leads from the newly hatched insect to the adult is controlled by three hormones. The brain produces a neurohormone which stimulates a pair of glands in the prothorax, the prothoracic glands, causing release of the molting hormone, ecdysone.

A third hormone, the juvenile hormone, produced by a pair of glands near the brain, functions during the juvenile molts to suppress the differentiation of adult tissues. Juvenile hormone permits growth but prevents maturation. See ECDYSONE.

Two neurohormones with antagonistic actions are involved in regulating the water content of insects. One, the diuretic hormone, promotes water loss by increasing the volume of fluid secreted into the Malpighian tubules, the excretory organs. The second, the antidiuretic hormone, acts to conserve water by causing the wall of the rectum to increase the volume of water resorbed from its lumen while lowering the excretion rate from the Malpighian tubules.

Bursicon, a protein neurohormone, is responsible for the tanning and hardening of the newly formed cuticle. During the development of some insects, a period of arrested development occurs, termed the diapause. The mechanisms controlling the onset and the termination of diapause are largely unknown. However, in some insects there is evidence for a hormone, proctodone, that reinitiates development. A very few species of insects, most notably the stick insect (*Carausius morosus*), have the ability to change color. This insect becomes darker at night and lighter by day as a result of the rearrangement of pigment granules within the epidermal cells. Darkening is due to a hormone produced in the brain.

**Crustaceans.** Higher crustaceans have a structure, the sinus gland, which in most stalk-eyed species lies in the eyestalk and is the storage and release site of a molt-inhibiting hormone. The Y-organs, a pair of structures found in the anterior portion of the body near the excretory organs, are the source of the crustacean molting hormone, crustecdysone. Chemically, crustecdysone is very similar to the ecdysone from insects; both substances can cause molting in crustaceans and insects. The sinus gland is a neuroendocrine structure, but the Y-organs are nonneural.

Crustacean pigment cells (chromatophores) are under hormonal control, as in insects. The active substances are released from the sinus glands and the postcommissural organs, which lie near the esophagus. Substances have been found that cause dispersion of the pigment within the chromatophore, as well as substances with the opposite action. See CHROMATOPHORE.

The compound eye of crustaceans has three retinal pigments. The movements of these pigments with illumination level control the amount of light impinging on the photosensitive cells. A substance has been found that causes the migration of these pigments toward the light-adapted positions and another substance that causes migration toward dark-adapted positions.

The pericardial organs, which are found near the heart, are neuroendocrine organs that cause an increase in the amplitude of the heart beat. The sinus gland contains the hyperglycemic hormone, which causes a rise in blood glucose.

**Annelids.** Strong evidence for hormones in annelids has been obtained from studies of the reproductive system. One substance that has been found in some marine annelids inhibits maturation of the gametes. This substance was thought to have been produced by the brain, but studies show that another structure, the infracerebral gland, which lies ventral to the brain, may be involved.

**Echinoderms.** The radial nerves of starfishes contain two substances that are required for the maintenance of a normal reproductive cycle. One, the shedding substance, induces spawning. The second, shedhibin, inhibits the former.

**Mollusks.** The best-established endocrine organs in mollusks, the optic glands, occur in the octopus and squid. They are a pair of small structures, found near the brain, that produce a substance which causes gonadal maturation. The optic glands in turn are regulated by inhibitory nerves from the brain. There is also some evidence that a portion of the nervous system (the pleural ganglia) may secrete a hormone that affects water balance. Removal of the pleural ganglia from a fresh-water snail results in swelling of the animal due to the influx of water. [M.F.]

**Endocrine system (vertebrate)** A system of chemical communication among cells. The classical vertebrate endocrine system consists of a group of discrete glands that secrete unique products (hormones) into the bloodstream. These products travel in the blood to distant sites or targets where they cause specific physiological responses. Thus endocrine glands differ from exocrine glands, in that they lack ducts and deliver their secretions in the bloodstream. The classical definition of an endocrine system has become harder to apply with the discovery of scattered cells rather than discrete glands that act as endocrine organs, of endocrine cells that affect themselves (autocrine effect) or nearby targets (paracrine effect) by diffusion through extracellular fluids rather than the bloodstream, and of neurons that secrete hormones (neurosecretion). All of these mechanisms, however, allow for chemical intercellular communication and can be considered part of the endocrine system. See NEUROSECRETION.

One important function of the endocrine system, along with the nervous system, is to maintain homeostasis, that is, a constancy of the internal environment of an organism. Thus an organism reacts and adjusts physiologically to changes in its external environment. The roles of the endocrine and nervous systems in maintaining homeostasis are many, complementary, and overlapping. See HOMEOSTASIS; NERVOUS SYSTEM (VERTEBRATE).

**Nature of hormones.** Hormones are the products of endocrine cells. They are either proteinlike or steroidal. Peptide hormones are produced by protein synthetic mechanisms directed by the genes of the endocrine cells. They are stored in endocrine cells in secretory granules that bud off the endoplasmic reticulum and Golgi membranes, where protein synthesis occurs. The granules leave the cell by endocytosis and enter the bloodstream. Steroid hormones, on the other hand, are produced from cholesterol by a number of well-characterized, enzyme-catalyzed steps. Cholesterol is thus converted stepwise to various steroid families: the hormones of the adrenal cortex (cortisol and aldosterone), the estrogens (estradiol) from the ovary, and the androgens (testosterone) from the testis. Steroid hormones diffuse across the endocrine cell plasma membrane to enter the circulation. See HORMONE; PROTEIN; STEROID.

Since in most cases the blood carries hormones throughout the body, there must be a system by which only certain tissues respond to each hormone. This is accomplished by receptors, which are binding sites either on the surface of the target cell or within its nucleus. Receptors are high-molecular-weight proteins; the structure of some, such as the insulin receptor, is known. In general, peptide hormones cannot cross the plasma membrane, so their receptors are located there, whereas steroid hormones do pass through the plasma membrane of their targets and bind to nuclear receptors, probably located in the deoxyribonucleic acid (DNA).

In order for peptide hormones to stimulate physiological changes within the target cell, the "message" must be passed from the hormone-receptor complex of the plasma membrane to the interior of the cell. This process of signaling across the plasma membrane is accomplished by so-called second messengers of which the best known is adenosine 3',5'-cyclic monophosphate (cyclic AMP). Steroid hormones, of course, have no need for second messengers since they are lipid-soluble and pass readily through the plasma membrane and into the cell. See CELL MEMBRANES; SECOND MESSENGERS.

Once hormones are bound with their receptors and have stimulated their target cells, physiological responses occur. This may involve such biochemical processes as conversion of an inactive form of an enzyme into an active one, stimulation of critical enzymatic pathways, increase in transport of glucose or amino acids into cells, or synthesis of new proteins. These events may result in overall changes in cell or organ function, metabolism, growth, or even the behavior of the organism.

The endocrine system is regulated by control mechanisms, the means by which homeostasis is achieved. The most common relationship between the hormone and its target is one of negative feedback, whereby the response to the hormonal stimulus turns off the original stimulus. For example, the endocrine pancreatic beta cells produce insulin in response to high blood sugar levels. Insulin is released into the blood, where it causes its target cells to take up glucose, thus reducing blood sugar. When blood glucose concentration falls, the secretion of insulin is turned off. The system is turned back on when the blood glucose content gradually increases again. See CARBOHYDRATE METABOLISM; INSULIN.

**Pituitary gland and hypothalamus.** The pituitary gland, or hypophysis, is located near the base of the brain. It secretes many hormones and controls the function of other endocrine glands. The production and release of the various pituitary hormones are regulated in turn by small peptide-releasing hormones from the hypothalamus of the brain. These factors are produced by neurosecretory neurons and travel to the adenohypophysis (anterior lobe of the pituitary) by way of a portal blood system. The releasing hormones stimulate specific cells of the adenohypophysis to produce and release their hormones. Generally speaking, each of the adenohypophysial hormones is affected by a separate releasing hormone. Thus, the hypothalamic thyrotropin-releasing hormone stimulates the synthesis and release of thyroid-stimulating hormone (thyrotropin) by the adenohypophysis. Other adenohypophysial hormones include adrenocorticotrophic hormone, which stimulates the production of steroid hormones by the adrenal cortex; growth hormone, which stimulates protein synthesis and growth in many cells; prolactin, which stimulates the production of milk by the mammary glands and is important in many other functions; follicle-stimulating hormone, which induces growth of the follicles of the ovary prior to ovulation; and luteinizing hormone, which induces ovulation. The release of both follicle-stimulating and luteinizing hormones is governed by gonadotropin-releasing hormone.

Other hypothalamic hormones do not reach the pituitary by way of the bloodstream; instead they travel down the long axons of the neurosecretory cells into the neurohypophysis (posterior lobe of the pituitary). Oxytocin acts upon the mammary glands of female mammals to cause milk release in response to suckling by the young, and stimulates the uterus to contract at the end of pregnancy to aid in expulsion of the offspring. Vasopressin (or antidiuretic hormone) is important in water conservation by the kidney tubules and also produces an increase in blood pressure. See PITUITARY GLAND.

**Thyroid gland.** The thyroid gland lies in the neck region of mammals. It produces two closely related hormones, triiodothyronine and thyroxine. These both increase the metabolic rate of an organism, and increase enzyme activity and protein synthesis. The thyroid hormones act along with growth hormone to promote cell growth and development. Thyroid hormones are peptides but their three-dimensional structures may be similar to those of steroid hormones. Thus they are unusual in their ability to pass through the plasma membrane of their target cells and bind to nuclear receptors.

The control of hormone secretion by the thyroid (as well as by the adrenal cortex and gonads) involves more complex feedback relationships. These endocrine glands are affected by the levels of hormones from the adenohypophysis. In the case of the thyroid gland, thyrotropin-releasing factor from the hypothalamus stimulates the release of thyroid-stimulating hormone by the adenohypophysis. In response, the thyroid secretes thyroxine and triiodothyronine. High blood levels of the thyroid hormones inhibit the secretion of both thyrotropin-releasing factor (long-loop feedback) and thyroid-stimulating hormone (short-loop feedback). See THYROID GLAND.

**Calcium regulation.** The parathyroid glands derive their name from the fact that in mammals they are embedded within

the thyroids. These small glands are essential for life, as they regulate the concentration of calcium ion in blood and other extracellular fluids. If calcium is too low, the animal goes into tetanic convulsions and dies, whereas if calcium is too high, abnormal calcification and stone formation can occur. Parathyroid hormone is a protein hormone that raises the blood calcium levels (hypercalcemia). The hormone acts upon bone to cause the release of calcium and phosphate, and upon the kidney to increase the reabsorption (conservation) of calcium and excretion of phosphate.

Vitamin D is now recognized as a steroidlike hormone, although it does not originate from an endocrine gland. It is synthesized from precursors present in the diet or produced after exposure of skin lipids to ultraviolet light. Vitamin D plays roles in calcium conservation by the kidney and in bone mineralization, but its most important function is to enhance calcium transport across intestinal cells and thus conserve dietary calcium. See VITAMIN D.

Calcitonin is a newly recognized peptide hormone produced by thyroid cells in mammals (different cells from those that produce thyroid hormones) and from the ultimobranchial glands of nonmammalian vertebrates. Calcitonin is hypocalcemic and acts by inhibiting calcium loss from bone. Of the three calcium-regulating hormones, it appears to be the least important. See PARATHYROID GLAND.

**Carbohydrate regulation.** Insulin and glucagon are peptide hormones produced by endocrine cells of the pancreatic islets. Insulin is produced by the pancreatic beta cells and is the only hormone that decreases blood sugar (glucose) levels. It acts on its target cells (skeletal muscle, fat cells) to increase the uptake of glucose, amino acids, and fatty acids. Once taken into cells, glucose is used in metabolic reactions or stored as glycogen, a large carbohydrate. Insulin also causes the conversion of amino acids to proteins and fatty acids to fats in the target cells. In the absence of insulin, as in diabetes mellitus, the target cells cannot take up glucose, and thus the body must utilize amino acids and fats as energy sources. These processes result in the accumulation of toxic metabolic products which eventually disrupt the acid-base balance, leading to coma and death. See DIABETES.

Glucagon, in contrast, is a hyperglycemic hormone. It is a small peptide from the pancreatic islet alpha cells that acts upon liver cells to cause the conversion of glycogen to glucose by activation of key enzymes in a complex metabolic pathway.

Many other hormones elevate blood sugar levels. For example, epinephrine (adrenalin), an amino acid derivative from the adrenal medulla, acts by the same pathway as glucagon to convert glycogen to glucose, except that the targets of epinephrine are skeletal and heart muscle. Epinephrine is secreted in times of stress and serves to prepare the body for an emergency by increasing the availability of energy in the form of glucose and by increasing the heart rate and blood pressure.

Growth hormone, a large protein hormone from the adenohypophysis, is secreted in response to low blood sugar levels. This hormone elevates blood sugar by blocking the uptake of glucose by cells and by favoring the utilization of fats rather than glucose as an energy source.

Many of the adrenal cortical hormones, such as cortisol, are known collectively as glucocorticoids, because they also elevate blood glucose levels. These steroid hormones favor the production of glucose from proteins and fats rather than glycogen (gluconeogenesis). Glucocorticoids also exert an anti-inflammatory action, which makes them useful for treatment of arthritis and other diseases. See ADRENAL GLAND.

**Salt and water regulation.** Several hormones affect the ability of the kidney to conserve or excrete salts and water. The antidiuretic hormone (vasopressin) promotes water reabsorption by the kidney tubules, so that the organism excretes less water.

The secretion of vasopressin is regulated by hypothalamic neurosecretory neurons that are sensitive to the concentration of salts in the extracellular fluids. In the absence of vasopressin, an individual excretes great volumes of dilute urine, leading to severe dehydration (diabetes insipidus).

Salt excretion is regulated mainly by two hormones that act in opposition. Aldosterone is an adrenal cortical steroid that promotes the reabsorption of sodium by the kidney tubules and thus decreases its excretion in the urine. In contrast, atriopeptin (atrial natriuretic factor), a peptide that originates in heart muscle, acts upon the kidney to increase the excretion of sodium in the urine. See OSMOREGULATORY MECHANISMS.

**Reproductive hormones.** Probably the best-studied endocrine glands are the gonads, the testes of the male and the ovaries of the female. The gonads are regulated by the follicle-stimulating hormone and luteinizing hormone from the adenohypophysis. In the male, follicle-stimulating hormone stimulates the initiation of sperm formation by the testis tubules, and luteinizing hormone acts on the nearby Leydig cells of the testis to produce testosterone, the principal male sex hormone. Testosterone acts by a paracrine mechanism to cause the final maturation of sperm, and by way of the blood to stimulate development of the male reproductive system and secondary sex characteristics. See TESTIS.

In the female, follicle-stimulating hormone stimulates the growth of the ovarian follicles at the beginning of each reproductive cycle. As the follicles grow, they produce estradiol. Increasing levels of estradiol cause feedback inhibition of gonadotropin-releasing hormone. High levels of estradiol also have an unusual positive feedback effect upon the hypothalamus and adenohypophysis to cause a surge in the secretion of luteinizing hormone, which results in ovulation. The corpus luteum, a remnant of the ovulated follicle, produces both estradiol and the second major female sex hormone, progesterone. Progesterone is necessary for the maintenance of a quiescent uterus during pregnancy, and both estrogen and progesterone are important in the regulation of the female reproductive cycle. Estradiol is also essential for the growth and maturation of the female reproductive system and secondary sex characteristics. In both males and females, the sex hormones affect reproductive behavior. See OVARY; REPRODUCTIVE BEHAVIOR.

**Other hormones.** There are many other factors that act in various ways to achieve homeostasis or intercellular communication, such as a large number of peptides found in both gastrointestinal cells and the brain. These were recognized for many years as gastrointestinal hormones which aid in secretion of digestive juices and motility of the gastrointestinal tract. Their function in the brain appears to be different, and there is evidence that they act in pain reception or analgesia, as factors that stimulate or curb appetite, or in memory or other functions. This field of neuropeptide hormones is in its infancy and serves to emphasize the close relationship between the endocrine and nervous systems in intercellular communication. [N.B.C.]

**Endocrinology** The study of the glands of internal secretion, the endocrine glands, and the hormones which they synthesize and secrete. These glands are ductless; the hormones are secreted directly into the blood to be carried to the target tissue or organ. The hormones, or chemical messengers, are highly specific and their action may be selective or generalized. See ENDOCRINE SYSTEM (VERTEBRATE); HORMONE. [S.P.P.]

**Endocytosis** The process by which animal cells internalize particulate material (such as cellular debris and microorganisms), macromolecules (such as proteins and complex sugars), and low-molecular-weight molecules (such as vitamins and simple sugars). Cells engage in at least three different types of endocytosis: phagocytosis where cells engulf particulate material,

receptor-mediated-endocytosis of macromolecules, and potocytosis of small molecules.

Some of the essential nutrients that a cell needs are scarce in the environment. The cells overcome this problem by expressing high-affinity receptors, or binding sites, on the membrane surface. Each type of receptor is specific for either macromolecules or molecules. These endocytic receptors are capable of concentrating their ligand at the cell surface before carrying it into the cell, thus increasing the efficiency of uptake.

In all three endocytic pathways the internalization step begins with the invagination of plasma membrane and the conversion of this membrane into a closed vesicle called an endosome. Each of the pathways has its own set of molecules that control internalization. These molecules assemble at the cell surface and physically deform the membrane into the shape of a vesicle. The vesicle, the endosome, then detaches and migrates to other locations within the cell. The same cell-surface assemblage of molecules also attracts endocytic receptors that are moving around on the cell surface, causing them to cluster over the site of internalization. Receptor clustering, which is essential for efficient uptake, is sometimes stimulated by ligand binding.

Endosomes that are generated by the phagocytic and receptor-mediated endocytic pathways often fuse with lysosomes that contain many different hydrolytic enzymes. Small molecules, by contrast, do not need further processing, so during potocytosis they are delivered directly to the cytoplasm. See CELL MEMBRANES; LYSOSOME.

**Phagocytosis.** Phagocytosis is a receptor-mediated process where the receptors function as adhesive elements that bond the plasma membrane to the particle. The adhesive interaction of the phagocytic receptors with the membrane stimulates invagination. A critical molecule in this activity is actin, the same protein that provides power for muscle contraction. Surface membranes contain actin-binding proteins that link the phagocytic receptor to the actin cytoskeleton of the cell. Thus, when a particle binds to its endocytic receptor, a signal cascade is initiated that stimulates the recruitment of actin filaments to the site of phagocytosis. See CYTOSKELETON; PHAGOCYTOSIS; SIGNAL TRANSDUCTION.

**Receptor-mediated endocytosis.** The clathrin-coated pit is a segment of cell membrane that is specialized for receptor-mediated endocytosis. Each pit can be recognized by the presence of a polygonal lattice on the cytoplasmic surface of the membrane. This lattice shapes the plasma membrane into a coated vesicle that immediately uncoats and fuses with endosomes. The endosome functions as a switching area that directs membrane and content molecules to specific locations within the cell.

**Potocytosis.** Potocytosis uses membrane proteins that are anchored by lipid rather than protein as endocytic receptors. The lipid anchor causes the attached proteins to migrate in the plane of the membrane and cluster in a membrane specialization called a caveola. Clustering ensures that any ligand bound to these receptors will be concentrated in this location. When caveolae close, they create a tiny compartment of uniform size that is sealed off from the extracellular space. When the ligand dissociates from its receptor, it reaches such a high concentration that it naturally flows through water-filled membrane channels into the cell.

The closed caveolar compartment appears to be a unique space for the cell. It is transient, does not merge with other organelles, and can selectively concentrate extracellular molecules or ions and deliver them to the cytoplasm. In addition to importing molecules, cells can also use this space to store and process incoming or outgoing messengers that affect cell behavior. See CELL (BIOLOGY); CELL PERMEABILITY. [R.G.W.A.]

**Endodermis** The single layer of plant cells that is located between the cortex and the vascular (xylem and phloem) tis-

ues. It has its most obvious development in roots and subaerial stems. The endodermis has many apparent functions: absorption of water, selection of solutes and ions, and production of oils, antibiotic phenols, and acetylenic acids.

The endodermis has been found to have extra sets of chromosomes as compared with cortical and other cells in the plant. In some plants the chromosome numbers may be so high in the endodermis that four sets of chromosomes may occur in each endodermal cell. The larger amount of nuclear material and nucleic acid in the cells of the endodermis may in part account for the great capacity of endodermal cells to produce large amounts of chemical substances, such as acetylenic oils, high in caloric energy. See CORTEX (PLANT); HYPODERMIS. [D.S.V.F.]

**Endoplasmic reticulum** An intracellular membrane system that is present in all eukaryotic cells. In most cells the endoplasmic reticulum is thought to consist of only one continuous membrane enclosing only a single space. However, in protozoa, some unicellular algae, and possibly some fungi, the endoplasmic reticulum occurs as separate, multiple vesicles. See CELL MEMBRANES.

Several morphologically and functionally distinct domains of this continuous membrane system can be distinguished. At the level of the nuclear pores, the inner nuclear membrane is continuous with the outer nuclear membrane; both membranes together are referred to as the nuclear envelope. The outer nuclear membrane in turn is continuous with the rough endoplasmic reticulum, which contains specialized regions, termed transitional elements, and is continuous with the smooth endoplasmic reticulum. The two membranes of the nuclear envelope enclose the perinuclear space. The rough and smooth endoplasmic reticula and the transitional element enclose a space called the intracisternal space, or lumen. Both intracisternal and perinuclear spaces form a single compartment. All nucleated cells contain at least a nuclear envelope, but the amount of smooth and rough endoplasmic reticula varies greatly among different cell types. See CELL NUCLEUS.

The term rough endoplasmic reticulum is based on the morphologic appearance of attached ribosomes, which are absent from smooth endoplasmic reticulum. (Ribosomes are also associated with the outer nuclear membrane; in fact, the outer nuclear membrane and the rough endoplasmic reticulum appear to be functionally equivalent.) Another morphologic distinction is the organization of the rough endoplasmic reticulum in interconnected flattened sacs (called cisternae), whereas the smooth

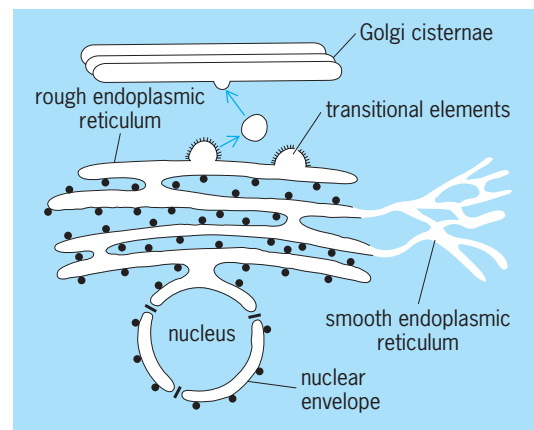

**Nuclear envelope, connected to the rough and smooth endoplasmic reticulum. The rough endoplasmic reticulum is linked to the cis cisternae of the Golgi complex by vesicles that shuttle between the two compartments.**

endoplasmic reticulum forms a tubular network (see illustration). See RIBOSOMES.

The rough endoplasmic reticulum is the site of translocation of secretory and lysosomal proteins from the cytosol to the intracisternal space, and of integration into the membrane of integral membrane proteins. Except for integral membrane proteins of chloroplast, mitochondria, and peroxisomes, essentially all other integral membrane proteins are integrated into the endoplasmic reticulum and either remain there (resident endoplasmic reticulum membrane proteins) or are subsequently distributed to other cellular membranes.

The signal hypothesis was formulated to explain how these proteins are targeted to and then translocated across or integrated into the endoplasmic reticulum membrane. Its tenets are that all polypeptides targeted to this membrane contain a discrete sequence (termed the signal sequence), that a complex machinery recognizes this sequence, and that recognition triggers the opening of a proteinaceous channel through which the polypeptide passes across the membrane. In the case of membrane proteins, the existence of an additional topogenic sequence, the so-called stop-transfer sequence, was postulated. This sequence is thought to trigger opening of the channel to the lipid bilayer to abort translocation and thus integrate the protein into the lipid bilayer.

The rough endoplasmic reticulum also contains numerous enzymes, most of which are involved in the modification of the nascent protein chain on the cisternal side. Thus the main function of the rough endoplasmic reticulum and the outer nuclear membrane is to serve as a port of entry of secretory, lysosomal, and integral membrane proteins and as the site of their initial modification. See CYTOCHEMISTRY.

Secretory and lysosomal proteins as well as those integral membrane proteins that are not residents of the endoplasmic reticulum are next transported to the cis Golgi cisternae. The transitional elements represent sites of transport from the rough endoplasmic reticulum. Coated vesicles carrying proteins to be transported form at these sites and, after uncoating, eventually fuse with the cis Golgi cisternae. See GOLGI APPARATUS.

Smooth endoplasmic reticulum contains enzymes for phospholipid biosynthesis, steroid biosynthesis, and drug detoxification. See CELL (BIOLOGY); CELL ORGANIZATION; ENZYME.

[G.B.B.]

**Endopterygota** A division (also known as Holometabola) of the subclass Pterygota, including those insects that undergo complete metamorphosis during their life cycle. That is, individual development goes through four distinct stages: egg, larva (trophic), pupa (reconstructive), and adult (reproductive). The larval and adult stages often live in very different adaptive zones and have very different life forms, necessitating a quiescent pupal stage in which extensive restructuring takes place. Internalization of the developing wings and the advent of the pupa combine to form a key general adaptation that breaks the constraining linkage between trophic and reproductive life forms, allowing each to evolve for its own special function. This adaptation probably accounts for the rapid rise of the Endopterygota to a dominant position among the insects from the Permian to the present.

The division Endopterygota comprises a large majority of all insects, distributed in the orders Coleoptera, Neuroptera, Strepsiptera, Mecoptera, Siphonaptera, Trichoptera, Lepidoptera, Diptera, and Hymenoptera. It is thought to be monophyletic. See EXOPTERYGOTA; INSECTA; PTERYGOTA.

[W.L.Brø.]

**Endorphins** A family of endogenous morphinelike peptides present within the central nervous system. The term endorphin is generic, referring to all the opioid peptides, while specific

peptides are given individual names, such as the enkephalins and  $\beta$ -endorphin. Their discovery has greatly enhanced the understanding of the mechanism of action of opiate drugs and how the perception of pain is modulated within the central nervous system. See OPIATES; PAIN.

Morphine, codeine, and their many synthetic and semisynthetic analogs are effective pain killers that act through specific recognition sites, or receptors, localized on the surface of neurons within selected brain regions. These receptors have been extensively characterized, and a number of different subtypes have been identified which vary in their specificity for various opiates and opioid peptides and in the actions they mediate. The existence of these highly specific receptors implied that morphine was mimicking endogenous compounds within the brain with morphinelike actions, which have since been termed endorphins. See MORPHINE ALKALOIDS.

The first endorphins to be isolated were the enkephalins, two pentapeptides differing only in their fifth amino acid, which is either methionine or leucine. Since the initial description of the enkephalins, a number of opioid peptides have been reported that all share either the structure of methionine (Met) enkephalin or leucine (Leu) enkephalin as their first five amino acids. The major genes for these peptides have been identified.  $\beta$ -Endorphin is perhaps the most interesting peptide; it is cogenerated with important, nonopioid hormones.

The enkephalins are distributed unevenly throughout the brain, with very high levels in the basal ganglia, the thalamus, and the periaqueductal gray. In addition, there are high concentrations of enkephalins in the adrenal medulla, where they are co-released with norepinephrine in response to stress, among other stimuli. The dynorphins and  $\alpha$ -endorphin are located within the central nervous system with a distribution similar to that of the enkephalins. See STRESS (PSYCHOLOGY).

$\beta$ -Endorphin has been identified in only a single group of cells within the hypothalamus. Its highest levels are in the pituitary gland. Within the pituitary, both ACTH and  $\beta$ -endorphin are derived from the same precursor protein and are located within the same cells. Stimuli that release ACTH, a stress hormone which in turn induces the adrenal gland to release steroids, also co-release  $\beta$ -endorphin at the same time. Thus, stressful stimuli that release ACTH and norepinephrine also release both  $\beta$ -endorphin from the pituitary and enkephalins from the adrenal into the blood. This is particularly intriguing in view of the decreased perception of pain reported under periods of stress, such as combat. See ENDOCRINE SYSTEM (VERTEBRATE).

All the endorphins can modulate the intensity of pain despite the fact that they act through different classes of opiate receptors. However, the presence of high concentrations of endorphins in brain regions unrelated to pain perception clearly demonstrates that the full range of actions of these compounds within the brain is not yet fully understood. Furthermore, their systemic hormonal role remains uncertain. See NERVOUS SYSTEM (VERTEBRATE).

[G.Pas.]

**Endotoxin** A biologically active substance produced by bacteria and consisting of lipopolysaccharide, a complex macromolecule containing a polysaccharide covalently linked to a unique lipid structure, termed lipid A. All gram-negative bacteria synthesize lipopolysaccharide, which is a major constituent of their outer cell membrane. One major function of lipopolysaccharide is to serve as a selectively permeable barrier for organic molecules in the external environment. Different types of gram-negative bacteria synthesize lipopolysaccharide with very different polysaccharide structures. The biological activity of endotoxic lipopolysaccharide resides almost entirely in the lipid A component. See CELL MEMBRANES; LIPID; POLYSACCHARIDE.

When lipopolysaccharides are released from the outer membrane of the microorganism, significant host responses are

initiated in humans and other mammals. It is generally accepted that lipopolysaccharides are among the most potent microbial products, known for their ability to induce pathophysiological changes, in particular fever and changes in circulating white blood cells. In humans as little as 4 nanograms of purified lipopolysaccharide per kilogram of body weight is sufficient to produce a rise in temperature of about 3.6°F (2°C) in several hours. This profound ability of the host to recognize endotoxin is thought to serve as an early warning system to signal the presence of gram-negative bacteria.

Unlike most microbial protein toxins (which have been termed bacterial exotoxins), endotoxin is unique in that its recognized mode of action does not result from direct damage to host cells and tissues. Rather, endotoxin stimulates cells of the immune system, particularly macrophages, and of the vascular system, primarily endothelial cells, to become activated and to synthesize and secrete a variety of effector molecules that cause an inflammatory response at the site of bacterial invasion. These mediator molecules promote the host response which results in elimination of the invading microbe. Thus, under these circumstances lipopolysaccharide is not a toxin at all, but serves an important function by helping to mobilize the host immune system to fight infection. See CYTOKINE; IMMUNOLOGY.

Even though endotoxin stimulation of host cells is important to host defense against infection, overstimulation due to excess production of endotoxin can lead to serious consequences. Endotoxin-induced multiple-organ failure continues to be a major health problem, particularly in intensive care; it has been estimated that as many as 50,000 deaths annually occur in the United States as the result of endotoxin-induced shock.

Immunization of humans with endotoxin vaccines to protect against endotoxin shock has not been considered practical. Efforts to provide immunologic protection against endotoxin-related diseases have focused upon development of antibodies that recognize the conserved lipid A structure of endotoxin as a means of passive protection against the lethal effects of this microbial product. See BACTERIA; MEDICAL BACTERIOLOGY; VACCINATION. [D.C.M.]

**Energy** The ability of one system to do work on another system. There are many kinds of energy: chemical energy from fossil fuels, electrical energy distributed by a utility company, radiant energy from the Sun, and nuclear energy from a reactor. The units of energy include ergs, joules, foot-pounds, and foot-poundals. Work and heat have the same units as energy, but are entirely different physical concepts. See HEAT; WORK.

Any particle or system of particles subject to conservative forces has two kinds of energy, potential energy and kinetic energy. Potential energy is the energy due to position or configuration, and kinetic energy is the energy due to motion.

Energy is conserved for all isolated mechanical systems. This is because if a system A is isolated, there is no other system B that it can give any energy to, and its total energy must remain constant. This system A can convert kinetic energy to potential energy, and it can convert one form of potential energy to another, but the total energy must remain the same. The meaning of conserved total energy is that the system has the same value of total energy at all times. See CONSERVATION OF ENERGY.

In 1905 A. Einstein showed that at high velocities near the speed of light important modifications must be made in physical concepts. One particularly radical idea which he advanced was that space and time are not independent, but rather are two aspects of the same object, a space-time manifold. This necessitated a reexamination of the concept of energy and led to the conclusion that the inertia, or mass  $m$ , depends upon its energy through the mass-energy relation shown below, where  $c$  is the

$$E = mc^2$$

speed of light in vacuum. Furthermore, energy and momentum conservation become joined in a single four-momentum conservation law in special relativity. See INTERNAL ENERGY; RELATIVITY.

[B.DeF]

**Energy conversion** The process of changing energy from one form to another. There are many conversion processes that appear as routine phenomena in nature, such as the evaporation of water by solar energy or the storage of solar energy in fossil fuels. In the world of technology the term is more generally applied to operations of human origin in which the energy is made more usable; for instance, the burning of coal in power plants to convert chemical energy into electricity, the burning of gasoline in automobile engines to convert chemical energy into propulsive energy of a moving vehicle, or the burning of a propellant for ion rockets and plasma jets to provide thrust.

There are well-established principles in science which define the conditions and limits under which energy conversions can be effected, for example, the law of the conservation of energy, the second law of thermodynamics, the Bernoulli principle, and the Gibbs free-energy relation. Recognizable forms of energy which allow varying degrees of conversion include chemical, atomic, electrical, mechanical, light, potential, pressure, kinetic, and heat energy. In some conversion operations the transformation of energy from one form to another, more desirable form may approach 100% efficiency, whereas with others even a "perfect" device or system may have a theoretical limiting efficiency far below 100%. See ENERGY SOURCES. [T.Ba.]

**Energy level (quantum mechanics)** One of the allowed values of the internal energy of an isolated physical system. This energy is not free to vary continuously above its minimum value, as predicted by classical mechanics, but is constrained to lie among a set or spectrum of particular values. This spectrum may consist of both an isolated discrete portion and a continuous component of restricted range. The term energy level usually refers to one of the allowed values in the discrete set.

The primary indication for the existence of discrete energy levels came from the study of the spectrum of emissions of energetically excited atomic systems. Historically, the most important such spectrum is that of the simplest atom, hydrogen, a system of one proton and one electron bound together by their electromagnetic attraction. Within the framework of classical physics, the structure of the hydrogen atom poses fundamental problems. The first is the existence of a stable ground state: An electron in orbit around a proton is in constant acceleration, and therefore, according to Maxwell's classical electromagnetic theory, should continuously radiate away energy. Furthermore, the radiation emitted as the atom decays to a lower energy state should form a continuous spectrum of frequencies. However, the hydrogen atom both possesses a stable ground state and emits radiation at only a discrete set of frequencies.

In 1913 N. Bohr made a fundamental advance by postulating that the angular momentum of the electron-proton system could take on only a discrete set of values. The angular momentum is said to be quantized. A consequence is that the excitation energies of the hydrogen atom also have a discrete spectrum. Bohr made the further postulate that the atom decays from an excited level,  $E_k$ , only by making a transition to a lower energy level,  $E_j$ , emitting a single light quantum (photon) in the process. The energy,  $E_\gamma$ , of this photon is given by the conservation of energy,  $E_\gamma = E_k - E_j$ . Although Bohr's postulates are in many ways without real foundation, they were later justified and extended by the development of quantum mechanics. See ATOMIC STRUCTURE AND SPECTRA.

The quantization of the allowed energy values that occurs in quantum mechanics has analogs for other physical quantities as well, such as angular momentum. The basic reason why such quantization occurs for bound systems of particles in quantum mechanics but not in classical mechanics is that in quantum mechanics particles have associated wavelike attributes, specifically a wave function which encodes the dynamical state of the particle. (This is the content of wave-particle duality.) The wave function of a bound state satisfies an equation similar in many ways to the equation describing waves on a guitar string or drumhead of finite extent. Such musical instruments produce only certain specific notes, or frequencies, for a given length of string or size of drumhead. In other words, the frequencies are quantized. Similarly, the modes of oscillation of the wave function for a quantum system of finite extent are also quantized, leading to discrete energy levels, and so forth. An unbound quantum system, however, is analogous to a string of infinite length, which can play a continuous range of notes.

Energy levels are of great importance for many systems other than simple atoms such as hydrogen. For instance, they determine the interactions and binding of molecules in chemistry and biochemistry, the stability or decay of nuclei, and the macroscopic properties of solids, such as the optical properties of dyes or semiconductors. The observed spectroscopy of the energy levels of a system can also elucidate the properties of a new force, just as the study of hydrogen led to the development of quantum mechanics and quantum field theory. [J.M.R.]

**Energy metabolism** Energy metabolism, or bioenergetics, is the study of energy changes that accompany biochemical reactions. Energy sustains the work of biosynthesis of cellular and extracellular components, the transport of ions and organic chemicals against concentration gradients (osmotic work), the conduction of electrical impulses in the nervous system, and the movement of cells and the whole organism. Sunlight is the ultimate source of energy for life. Photosynthetic cells use light energy to produce chemical energy and reducing compounds, used to convert carbon dioxide into organic chemicals such as glucose. The energy from the oxidation of carbohydrates, fats, and proteins sustains the biochemical reactions required for life.

The main sources of chemical energy for most organisms are carbohydrates, fats, and protein. Energy content is expressed in calories or joules. The nutritional calorie, or kilocalorie (kcal), in foodstuffs is equivalent to 1000 calories. The energy content per gram of carbohydrate is 4 kcal (16 J); protein, 4 kcal (16 J); and fat, 9 kcal (36 J). The metabolism of foodstuffs yields chemical energy and heat.

Energy is defined as the ability to do work, and metabolism represents the biochemical reactions that a cell can perform to produce energy. The most important thermodynamic parameter in bioenergetics is the free energy change,  $\Delta G$ , occurring at constant temperature and pressure (the usual conditions for chemical reactions inside the cell). The Gibbs free energy change is defined as the free energy content of the final state minus the free energy content of the initial state.

All feasible reactions occur with a negative free energy change; the final state has less free energy than the initial state; that is,  $\Delta G < 0$  (process is exergonic). If the free energy of the final state is more than that of the initial state,  $\Delta G$  is positive and the reaction is not feasible without the input of energy;  $\Delta G > 0$  (process is endergonic). When the free energy change is zero, the reaction or process is at equilibrium;  $\Delta G = 0$  (process is isoergonic). See FREE ENERGY.

The complete oxidation of one mole of glucose to carbon dioxide and water is associated with the liberation of free energy. Energy is released in a stepwise fashion and is coupled to

the biosynthesis of adenosine triphosphate (ATP) from adenosine diphosphate (ADP) and inorganic phosphate ( $P_i$ ). The reaction of ATP with water to produce ADP and  $P_i$  results in the liberation of a large amount of energy (30 kJ, or 7 kcal per mole). Such compounds are said to be energy-rich and to possess a high-energy bond. Lipmann's law is the cornerstone of energy metabolism: ATP serves as the common currency of energy exchange in living systems (animals, plants, and bacteria). The ATP-ADP couple receives and distributes chemical energy in all living systems. Creatine phosphate is an energy-rich compound found in vertebrate muscle and brain; it is a storage form of chemical energy and can energize the regeneration of ATP from ADP. Such a reaction occurs in vigorously exercising skeletal muscle when ATP is expended to produce contraction. See ADENOSINE DIPHOSPHATE (ADP); ADENOSINE TRIPHOSPHATE (ATP).

[R.Ros.]

**Energy sources** Sources from which energy can be obtained to provide heat, light, and power. Sources of energy have evolved from human and animal power to fossil fuels, uranium, water power, wind, and the Sun.

The principal fossil fuels are coal, lignite, peat, petroleum, and natural gas; other potential sources of fossil fuels include oil shale and tar sands. As fossil fuels become depleted, nonfuel sources and fission and fusion sources will become of greater importance since they are renewable. Nuclear power is based on the fission of uranium, thorium, and plutonium, and the fusion power is based on the forcing together of the nuclei of two light atoms such as deuterium, tritium, or helium-3. See COAL; NATURAL GAS; NUCLEAR POWER; OIL SAND; OIL SHALE; PETROLEUM.

Nonfuel sources of energy include wastes, water, wind, geothermal deposits, biomass, and solar heat. See BIOMASS; GEOTHERMAL POWER; SOLAR ENERGY; WATERPOWER; WIND POWER.

Fuels which do not exist in nature are known as synthetic fuels. They are synthesized or manufactured from varieties of fossil fuels which cannot be used conveniently in their original forms. Substitute natural gas is manufactured from coal, peat, or oil shale. Synthetic liquid fuels can be produced from coal, oil shale, or tar sands. Both gaseous and liquid fuels can be synthesized from renewable resources, collectively called biomass. These carbon sources are trees, grasses, algae, plants, and organic waste. Production of synthetic fuels, particularly from renewable resources, increases the scope of available energy sources.

Energy management includes not only the procurement of fuels on the most economical basis, but the conservation of energy by every conceivable means. Whether this is done by squeezing out every Btu through heat exchangers, or by room-temperature processes instead of high-temperature processes, or by greater insulation to retain heat which has been generated, each has a role to play in requiring less energy to produce the same amount of goods and materials. [G.C.G.]

**Energy storage** The general method and specific techniques for storing energy derived from some primary source in a form convenient for use at a later time when a specific energy demand is to be met, often in a different location.

In the past, energy storage on a large scale had been limited to storage of fuels. For example, large amounts of natural gas and petroleum are routinely stored. On a smaller scale, electric energy is stored in batteries that power automobile starters and a great variety of portable appliances. In the future, energy storage in many forms is expected to play an increasingly important role in shifting patterns of energy consumption away from scarce to more abundant and renewable primary resources.

An example of growing importance is the storage of electric energy generated at night by coal or nuclear power plants to meet

peak electric loads during daytime periods. This is achieved by pumped hydroelectric storage, that is, pumping water from a lower to a higher reservoir at night and reversing this process during the day, with the pump then being used as a turbine and the motor as a generator.

Off-peak electric energy can also be converted into mechanical energy by pumping air into a suitable cavern where it is stored at pressures up to 80 atm (8 megapascals). Turbines and generators can then be driven by the air when it is heated and expanded.

The development of advanced batteries (such as nickel-zinc, nickel-iron, zinc-chloride, and sodium-sulfur) with characteristics superior to those of the familiar lead-acid battery could result in use of battery energy storage on a large scale. For example, batteries lasting 2000 or more cycles could be used in installations of several-hundred-thousand-kilowatt-hour capacity in various locations on the electric power grid, as an almost universally applicable method of utility energy storage. Batteries combining these characteristics with energy densities (storage capacity per unit weight and volume) well above those of lead-acid batteries could provide electric vehicles with greater range. *See BATTERY.*

Ceramic brick "storage heaters" that store off-peak electricity in the form of heat have gained wide acceptance for heating buildings in Europe, and the barriers to their increased use in the United States are more institutional and economic than technological.

Solar hot-water storage is technically simple and commercially available. However, the use of solar energy for space heating requires relatively large storage systems, with water or rock beds as storage media, and difficulties can arise in integrating this storage with existing buildings while keeping costs within acceptable limits. *See SOLAR ENERGY; SOLAR HEATING AND COOLING.*

Heat or electricity may be stored by using these energy forms to force certain chemical reactions to occur. Such reactions are chosen so that they can be reversed readily with release of energy; in some cases the products can be transported from the point of generation to that of consumption. For example, reactions which produce hydrogen could become attractive since hydrogen could be stored for extensive periods of time and then conveniently used in either combustion devices or in fuel cells. *See FUEL CELL.*

Electrical energy can be stored directly in the form of large direct currents used to create fields surrounding the superconducting windings of electromagnets. In principle such devices appear attractive because their storage efficiency is high. However, the need for maintaining the system at temperatures approaching absolute zero and, particularly, the need to physically restrain the coils of the magnet when energized require expensive auxiliary equipment (insulation, vacuum vessels, and structural supports). *See SUPERCONDUCTING DEVICES.*

Storage of kinetic energy in rotating mechanical systems such as flywheels is attractive where very rapid absorption and release of the stored energy is critical. However, research indicates that even advanced designs and materials are likely to be too expensive for utility energy storage on a significant scale, and applications will probably remain limited to systems where high power capacity and short charging cycles are the prime consideration. [F.K.; T.R.S.]

**Engine** A machine designed for the conversion of energy into useful mechanical motion. The principal characteristic of an engine is its capacity to deliver appreciable mechanical power, as contrasted to a mechanism such as a clock, whose significant output is motion. By usage an engine is usually a machine that burns or otherwise consumes a fuel, as differentiated from an electric machine that produces mechanical power without alter-

ing the composition of matter. Similarly, a spring-driven mechanism is said to be powered by a spring motor; a flywheel acts as an inertia motor. By definition a hydraulic turbine is not an engine, although it competes with the engine as a prime source of mechanical power. *See ENERGY CONVERSION; HYDRAULIC TURBINE; MOTOR; PRIME MOVER; WATERPOWER.*

Traditionally, engines are classed as external or internal combustion. External combustion engines consume their fuel or other energy source in a separate furnace or reactor. A further basis of classification concerns the working fluid. If the working fluid is recirculated, the engine operates on a closed cycle. If the working fluid is discharged after one pass through boiler and engine, the engine operates on an open cycle. The commonest types of engine use atmospheric air in open cycles both as the principal constituent of their working fluids and as oxidizer for their fuels. *See DIESEL ENGINE; GAS TURBINE; INTERNAL COMBUSTION ENGINE; NUCLEAR REACTOR; ROTARY ENGINE; STEAM-GENERATING FURNACE; STIRLING ENGINE; TURBINE PROPULSION.* [D.L.An.; F.H.R.]

**Engine cooling** A cooling system in an internal combustion engine that is used to maintain the various engine components at temperatures conducive to long life and proper functioning. Gas temperatures in the cylinders may reach 4500°F (2500°C). This is well above the melting point of the engine parts in contact with the gases; therefore it is necessary to control the temperature of the parts, or they will become too weak to carry the stresses resulting from gas pressure. The lubricating oil film on the cylinder wall can fail because of chemical changes at wall temperatures above about 400°F (200°C). Complete loss of power may take place if some spot in the combustion space becomes sufficiently heated to ignite the charge prematurely on the compression stroke. *See INTERNAL COMBUSTION ENGINE.*

A thin protective boundary of relatively stagnant gas of poor heat conductivity exists on the inner surfaces of the combustion space. If the outer cylinder surface is placed in contact with a cool fluid such as air or water and there is sufficient contact area to cause a rapid heat flow, the resulting drop in temperature produced by the heat flow in the inside boundary layer keeps the temperature of the cylinder wall much closer to the temperature of the coolant than to the temperature of the combustion gas.

If the coolant is water, it is usually circulated by a pump through jackets surrounding the cylinders and cylinder heads. The water is circulated fast enough to remove steam bubbles that may form over local hot spots and to limit the water's temperature rise through the engine to about 15°F (8°C). In most engines in automotive and industrial service, the warmed coolant is piped to an air-cooled heat exchanger called a radiator (see illustration). The airflow required to remove the heat from the radiator is supplied by an electric or engine-driven fan; in automotive applications the airflow is also supplied by the forward motion of the vehicle. The engine and radiator may be separated and each placed in the optimum location, being connected through piping. To prevent freezing, the water coolant is usually mixed with ethylene glycol. *See ANTIFREEZE MIXTURE; ETHYLENE GLYCOL; HEAT EXCHANGER.*

Engines are often cooled directly by a stream of air without the interposition of a liquid medium. The heat-transfer coefficient between the cylinder and airstream is much less than with a liquid coolant, so that the cylinder temperatures must be much greater than the air temperature to transfer to the cooling air the heat flowing from the cylinder gases. To remedy this situation and to reduce the cylinder wall temperature, the outside area of the cylinder, which is in contact with the cooling air, is increased by finning. The heat flows easily from the cylinder metal into



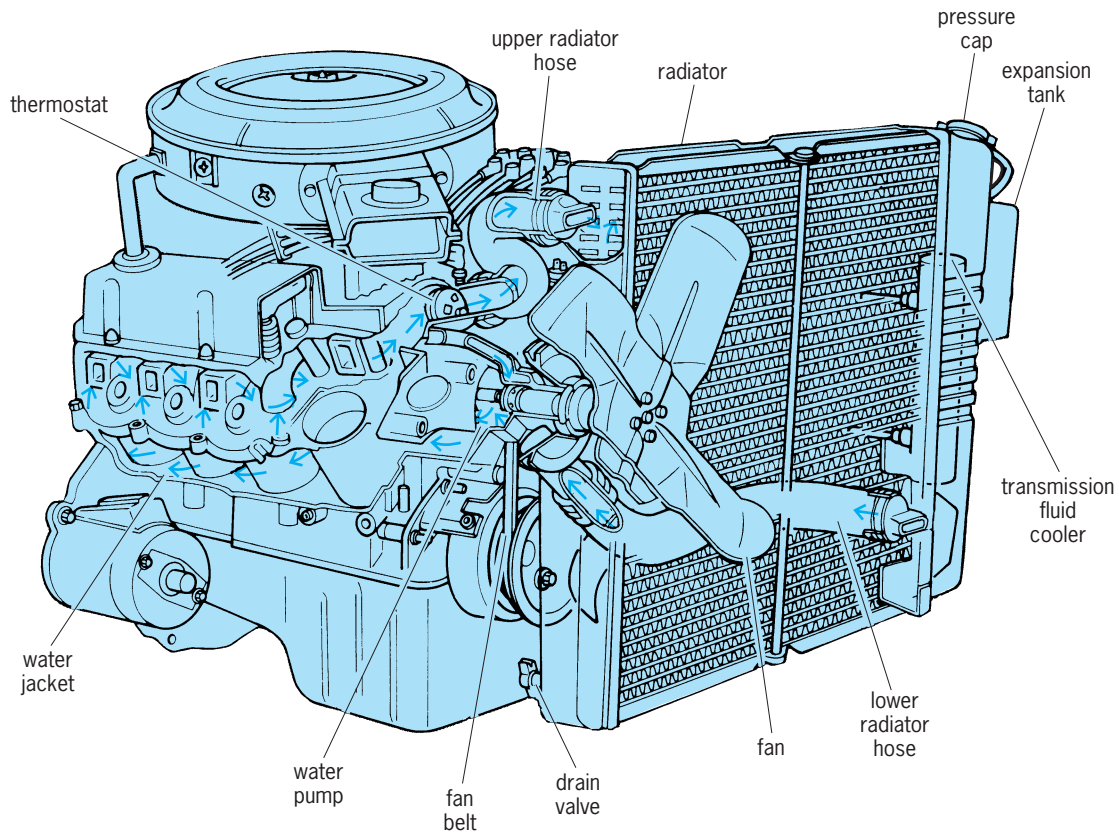

Cooling system of a V-8 automotive spark-ignition engine. The arrows show the direction of coolant flow through the engine water jackets and cooling system. (Ford Motor Co.)

the base of the fins, and the great area of finned surface permits heat to be transferred to the cooling air. See HEAT TRANSFER. [A.R.R.; D.L.An.]

**Engine lubrication** In an internal combustion engine, the system for providing a continuous supply of oil between moving surfaces during engine operation. This viscous film, known as the lubricant, lubricates and cools the power transmission components while removing impurities, neutralizing chemically active products of combustion, transmitting forces, and damping vibrations. See INTERNAL COMBUSTION ENGINE; LUBRICANT.

Automotive engines are generally lubricated with petroleum-base oils that contain chemical additives to improve their natural properties. Synthetic oils are used in gas turbines and may be used in other engines. Probably the most important property of oil is the absolute viscosity, which is a measure of the force required to move one layer of the oil film over the other. If the viscosity is too low, a protecting oil film is not formed between the parts. With high viscosity too much power is required to shear the oil film, and the flow of oil through the engine is retarded. Viscosity tends to decrease as temperature increases. Viscosity index (VI) is a number that indicates the resistance of an oil to changes in viscosity with temperature. The smaller the change in viscosity with temperature, the higher the viscosity index of the oil. See VISCOSITY.

Small two-stroke cycle engines may require a premix of the lubricating oil with the fuel going into the engine, or the oil may be injected into the ingoing air-fuel mixture. This is known as a total-loss lubricating system because the oil is consumed during engine operation.

Most automotive engines have a pressurized or force-feed lubricating system in combination with splash and oil mist lubrication. The lubricating system supplies clean oil cooled to the proper viscosity to the critical points in the engine, where the motion of the parts produces hydrodynamic oil films to separate and support the various rubbing surfaces. The oil is pumped under pressure to the bearing points, while sliding parts are lubricated by splash and oil mist. After flowing through the engine, the oil collects in the oil pan or sump, which cools the oil and acts as a reservoir while the foam settles out. Some engines have an oil cooler to remove additional heat from the oil. See WEAR.

[D.L.An.]

**Engine manifold** An arrangement or collection of pipes or tubing with several inlet or outlet passages through which a gas or liquid is gathered or distributed. The manifold may be a casting or fabricated of relatively light material. Manifolds are usually identified by the service provided, such as the intake manifold and exhaust manifold on the internal combustion engine. Some types of manifolds for handling oil, water, and other fluids such as engine exhaust gas are often called headers. In the internal combustion engine, the intake and exhaust manifolds are an integral part of multicylinder engine construction and essential to its operation. See INTERNAL COMBUSTION ENGINE.

The engine intake manifold is a casting or assembly of passages through which air or an air-fuel mixture flows from the air-intake or throttle valves to the intake valve ports in the cylinder head or cylinder block. In a spark-ignition engine with a carburetor or throttle-body fuel injection, the intake manifold carries an air-fuel mixture. In an engine with port fuel injection or in a diesel engine, the intake manifold carries only air. For the diesel engine, the air should be inducted with a minimum of pressure drop. The purpose of the intake manifold is to distribute the air

or air-fuel mixture uniformly to each of the cylinders and to assist in the vaporization of the fuel.

The engine exhaust manifold is a casting or assembly of passages through which the products of combustion leave the exhaust-valve ports in the cylinder head or cylinder block and enter the exhaust piping system. The purpose of the exhaust manifold is to collect and carry these exhaust gases away from the cylinders with a minimum of back pressure.

Some automotive spark-ignition engines have an air-distribution manifold as part of the exhaust-emission control system. This manifold distributes and proportions air to the individual exhaust ports through external tubing or integral passageways. [D.L.An.]

**Engineering** Most simply, the art of directing the great sources of power in nature for the use and the convenience of people. In its modern form engineering involves people, money, materials, machines, and energy. It is differentiated from science because it is primarily concerned with how to direct to useful and economical ends the natural phenomena which scientists discover and formulate into acceptable theories. Engineering therefore requires above all the creative imagination to innovate useful applications of natural phenomena. It seeks newer, cheaper, better means of using natural sources of energy and materials.

The typical modern engineer goes through several phases of career activity. Formal education must be broad and deep in the sciences and humanities. Then comes an increasing degree of specialization in the intricacies of a particular discipline, also involving continued postscholastic education. Normal promotion thus brings interdisciplinary activity as the engineer supervises a variety of specialists. Finally, the engineer enters into the management function, weaving people, money, materials, machines, and energy sources into completed processes for the use of society.

For articles on various engineering disciplines see CHEMICAL ENGINEERING; CIVIL ENGINEERING; ELECTRICAL ENGINEERING; INDUSTRIAL ENGINEERING; MANUFACTURING ENGINEERING; MARINE ENGINEERING; MECHANICAL ENGINEERING; METHODS ENGINEERING; MINING; NUCLEAR ENGINEERING. [J.W.B.]

**Engineering design** Engineering is concerned with the creation of systems, devices, and processes useful to, and sought by, society. The process by which these goals are achieved is engineering design.

The process can be characterized as a sequence of events as suggested in Fig. 1. The process may be said to commence upon the recognition of, or the expression of, the need to satisfy some human want or desire, the "goal," which might range from the detection and destruction of incoming ballistic missiles to a minor kitchen appliance or fastener.

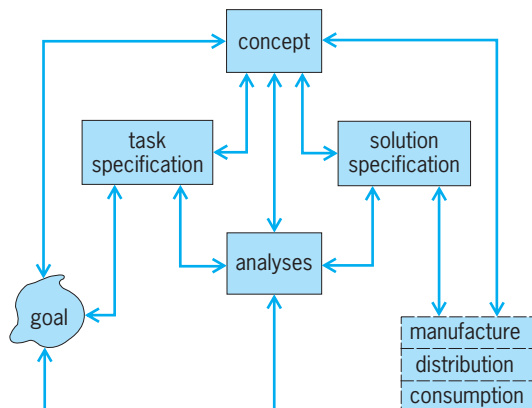

Fig. 1. Engineering design process.

**Concept formulation.** The first obligation of the engineer is to develop more detailed quantitative information which defines the task to be accomplished in order to satisfy the goal, labeled on Fig. 1 as task specification. At this juncture the scope of the problem is defined, and the need for pertinent information is established. Generation of ideas for possible solutions to the problem is the creative stage, called the concept formulation. When great strides in engineering are made, this represents ingenious, innovative, inventive activity; but even in more pedestrian situations where rational and orderly approaches are possible, the conceptual stage is always present. The concept does not represent a solution, but only an idea for a solution. It can only be described in broad, qualitative, frequently graphical terms. Concepts for possible solutions to engineering challenges arise initially as mental images which are recorded first as sketches or notes and then successively tested, refined, organized, and ultimately documented by using standardized formats.

Concepts are accompanied and followed by, sometimes preceded by, acts of evaluation, judgment, and decision. It is in fact this testing of ideas against physical, economic, and functional reality that epitomizes engineering's bridge between the art of innovation and science. The process of analysis is sometimes intuitive and qualitative, but it is often mathematical, quantitative, careful, and precise.

Production considerations can have a profound influence on the design process, especially when high-volume manufacture is anticipated. Evolutionary products manufactured in large numbers, such as the automobile, are tailored to conform with existing production equipment and techniques such as assembly procedures, interchangeability, scheduling, and quality control. New techniques such as those associated with space exploration, where volume production is not a central concern, factor into the engineering design process in a very different fashion.

Similarly, the design process must anticipate and integrate provisions for distribution, maintenance, and ultimate replacement of products. Well-conceived and executed engineering design will encompass the entire product cycle from definition and conception through realization and demise and will give due consideration to all aspects.

**Hierarchy of design.** An adequate description of the engineering design process must have both general validity and applicability to a wide variety of engineering situations: tasks simple or complex, small- or large-scale, short-range or far-reaching. That is to say, there is a hierarchy of engineering design situations.

Systems engineering occupies one end of the spectrum. The typical goal is very broad, general, and ambitious, and the concepts are concerned with the interrelationships of a variety of subsystems or components which, taken together, make up the system to accomplish the desired goal. See SYSTEMS ENGINEERING.

**Time-worker-power resource dynamics.** Another dimension of the dynamics of the engineering design process is the elapse of time and expenditure of worker-hours in the evolution of an engineering design project. Figure 2 plots time as the abscissa and resources (worker-power or dollars) as the ordinate. The various stages of the engineering design process are set out in time sequence from left to right.

Goal refinement, task specification, and first-order concept and analyses iterations are conducted by one to a few engineers in the early stages to establish the feasibility of the idea and to block out possible approaches. This is usually called the advanced design stage.

As the design concept becomes more specific and substantive, more and more engineers, technicians, and draftsmen become involved in the project. In projects of significant size, the problem of coordinating and integrating the efforts of the many participants of different talents and skills becomes itself a major consideration. See PERT.

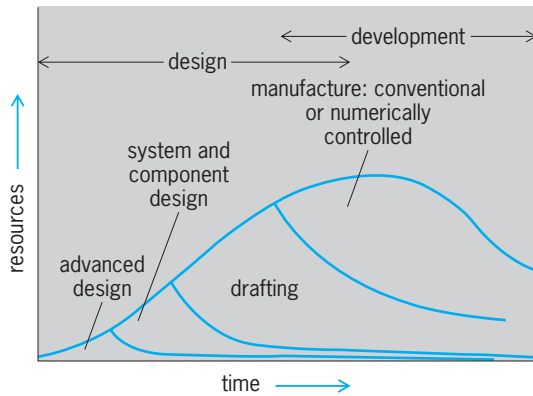

Fig. 2. Elapse of time and resources in an engineering design project, showing various stages in sequence.

**Use of the computer in design.** The use of the computer, both analog and digital, in the engineering design process has increased. Where economically justified, the overall engineering design process for a product is mechanized via computer programming. See COMPUTER; COMPUTER-AIDED DESIGN AND MANUFACTURING; COMPUTER STORAGE TECHNOLOGY; MULTIACCESS COMPUTER.

The speed, memory, and accuracy of the computer to iteratively calculate, store, sort, collate, and tabulate have greatly enhanced its use in design and encouraged the study, on their own merits, of the processes and subprocesses exercised in the design process. These include optimization or sensitivity analysis, reliability analysis, and simulation as well as design theory. See DIGITAL COMPUTER.

Optimization analyses, given a model of the design and using linear and nonlinear programming, determines the best values of the parameters consistent with stated criteria and further studies the effects of variations in the values of the parameters.

Reliability is a special case of optimization where the emphasis is to choose or evaluate a system so as to maximize its probability of successful operation, for example, the reliability of electronics. See CIRCUIT (ELECTRONICS).

Simulation, as of dynamic systems, is mathematical modeling to study the response of a design to various inputs and disturbances. The analog computer has been widely used for simulation through its physical modeling of the mathematic analytical relationships of the proposed design. See ANALOG COMPUTER; SIMULATION.

Decision theory deals with the general question of how to choose between a great number of alternatives according to established criteria. It proposes models of the decision process as well as defining techniques, that is, programs or algorithms, of calculation by which to make choices. See DECISION THEORY.

**Graphical input/output.** In many fields of design—notably architecture; design of airplanes, automobiles, and ships; and almost all mechanical design—the designer works largely in visual terms. A way has been found to set up the computer to interpret drawings. Moreover, the computer has become an active partner in the act of drawing, so that it can provide a certain superskill in preparing the drawing once the human operator has made intentions clear. See COMPUTER GRAPHICS. [R.W.M.]

**Engineering drawing** A graphical language used by engineers and other technical personnel associated with the engineering profession. The purpose of engineering drawing is to convey graphically the ideas and information necessary for the construction or analysis of machines, structures, or systems. See COMPUTER GRAPHICS; DRAFTING; GRAPHIC METHODS; SCHEMATIC DRAWING.

The basis for much engineering drawing is orthographic representation (projection). Objects are depicted by front, top, side,

auxiliary, or oblique views, or combinations of these. The complexity of an object determines the number of views shown. At times, pictorial views are shown. See DESCRIPTIVE GEOMETRY; PICTORIAL DRAWING.

Engineering drawings often include such features as various types of lines, dimensions, lettered notes, sectional views, and symbols. They may be in the form of carefully planned and checked mechanical drawings, or they may be freehand sketches. Usually a sketch precedes the mechanical drawing.

Many objects have complicated interior details which cannot be clearly shown by means of front, top, side, or pictorial views. Section views enable the engineer or detailer to show the interior detail in such cases. Features of section drawings are cutting-plane symbols, which show where imaginary cutting planes are passed to produce the sections, and section-lining (sometimes called cross-hatching), which appears in the section view on all portions that have been in contact with the cutting plane.

In addition to describing the shape of objects, many drawings must show dimensions, so that workers can build the structure or fabricate parts that will fit together. This is accomplished by placing the required values (measurements) along dimension lines (usually outside the outlines of the object) and by giving additional information in the form of notes which are referenced to the parts in question by angled lines called leaders.

Layout drawings of different types are used in different manufacturing fields for various purposes. One is the plant layout drawing, in which the outline of the building, work areas, aisles, and individual items of equipment are all drawn to scale. Another type of layout, or preliminary assembly, drawing is the design layout, which establishes the position and clearance of parts of an assembly.

A set of working drawings usually includes detail drawings of all parts and an assembly drawing of the complete unit. Assembly drawings vary somewhat in character according to their use, as design assemblies or layouts; working drawing assemblies; general assemblies; installation assemblies; and check assemblies.

Schematic or diagrammatic drawings make use of standard symbols which indicate the direction of flow. In piping and electrical schematic diagrams, symbols are used. The fixtures or components are not labeled in most schematics because the readers usually know what the symbols represent. See SCHEMATIC DRAWING; WIRING DIAGRAM.

Structural drawings include design and working drawings for structures such as building, bridges, dams, tanks, and highways. Such drawings form the basis of legal contracts. Structural drawings embody the same principles as do other engineering drawings, but use terminology and dimensioning techniques different from those shown in previous illustrations. See NOMOGRAPH. [C.J.B.]

**Engineering geology** The application of education and experience in geology and other geosciences to solve geological problems posed by civil engineering works. The branches of the geosciences most applicable are surficial geology, petrofabrics, rock and soil mechanics, geohydrology, and geophysics, particularly exploration geophysics and earthquake seismology.

The terms engineering geology and environmental geology often seem to be used interchangeably. Specifically, environmental geology is the application of engineering geology in the solution of urban problems; in the prediction and mitigation of natural hazards such as earthquakes, landslides, and subsidence; and in solving problems inherent in disposal of dangerous wastes and in reclaiming mined lands.

Another relevant term is geotechnics, the combination of pertinent geoscience elements with civil engineering elements to formulate the civil engineering system that has the optimal interaction with the natural environment. [W.R.J.]

**Enopla** A class of the phylum Rhynchocoela which is divided into the orders Hoplonemertini (free-living) and

Bdellonemertini or Bdellomorpha (symbiotic). In both orders the mouth is anterior to the brain, the nervous system is inside the body wall musculature, and the vascular system is well developed. See ANOPLA; BDELLONEMERTINI; HOPLONEMERTINI; RHYNCHOCOELA. [J.B.J.]

**Enoplida** An order of nematodes having the cuticle of the cephalic region doubled or formed into a cap or helmet. The helmet results from the infolding of the cuticle over the extreme anterior end of the esophagus. The stoma may possess armature in the form of teeth or movable jaws. Even though the stoma is surrounded by esophageal tissue, the anterior portion of the movable jaws is of cheilostomal origin. The well-developed esophagus is nearly cylindrical, and the esophagointestinal valve is prominent. The five esophageal glands are located in the posterior region of the esophagus; however, the orifices for these glands are located anterior to the nerve ring. The dorsal and two anterior subventral glands open at the base of the stoma or through the stomatal teeth. The amphid apertures may be transverse slits or elongate ovals. The cephalic sensilla are most often in two whorls: an anterior circumoral whorl of 6 and a posterior whorl of 10 (6 + 4); in some taxa this whorl is clearly separated into the ancestral state of a circlet of 6 and one of 4. A single medioventral excretory cell is usually present; the orifice is generally at the level of or anterior to the nerve ring. Medioventral supplementary organs may be present on males. The male spicules are paired and accompanied by a gubernaculum. Caudal glands and a cuticular spinneret are found in males and females.

There are two enoplid superfamilies, Enoploidea and Oxystominoidea. The Enoploidea are free-living marine nematodes comprising small to very large species in five well-defined families: Leptosomatidae, Lauratonematidae, Phanodermatidae, Thoracostomopsidae, and Enoplidae. While the feeding habits are largely unknown, it has been postulated that the group is predaceous or omnivorous. The group is almost exclusively marine in habitat, but a few species have been reported from brackish water or soils. Oxystominoidea contain species that maintain the most ancestral of characters known in the phylum. They are separated from other Enoplida by not having the lip region (=cephalic region) set off by a groove. See NEMATA. [A.R.M.]

**Enstatite** The name given to the magnesian end member ( $MgSiO_3$ ) of the orthorhombic pyroxene solid-solution series. The mineral is usually yellowish-gray, becoming greenish with a little iron present, and transparent in thin sections.

Enstatite is an important mineral in the upper mantle of the Earth, and coexists with clinopyroxene, garnet, olivine, and plagioclase. Enstatite, clinopyroxene, and garnet rocks called eherzolites are common in certain alpine mountain terrains and as nodules in some diamond-bearing rocks called kimberlites. See PYROXENE. [G.W.DeV.]

**Enteropneusta** A class of Hemichordata with approximately 70 species commonly known as acorn worms. They are free-living, solitary animals with a very soft cylindrical body lacking external appendages. The size is highly variable, from 1 in. to 8 ft (2.5 cm to 2.5 m), and the color ranges from white to shades of violet. The body is covered with cilia and mucus and is always divided into proboscis, collar, and trunk. Sometimes the animal smells like iodoform, and sometimes it shows luminescence.

The acorn worms usually live in shallow waters, buried in the sandy or muddy bottoms, but some species occur at depths of more than 9900 ft (3000 m). The proboscis and collar (the acorn) are used in excavating burrows. During this activity, water, slime, sediment, and organic particles enter the mouth and pass into the gut. Seawater is filtered and expelled through the gill slits, while the organic matter and sediment are retained to be digested.

The trunk is differentiated into four regions: the branchial region, externally recognized by two longitudinal rows of dorsal gill pores; the genital region, characterized by the gonads, which occur dorsolaterally; the hepatic region, distinguishable by a darker color and sometimes by the presence of external sacculations. The final region, the abdominal, is simply tubular with a terminal anus.

The sexes are distinct. Each gonad opens externally in a pore through which the gametes are shed. Either the eggs are relatively yolky and develop directly, with a free-swimming larval stage that hatches into a miniature acorn worm, or they lack yolk and develop through a planktonic tornaria larval stage. Only one species (*Xenopleura vivipara*) is viviparous, and only one (*Balanoglossus capensis*) reproduces asexually, but all enteropneusts have strong regeneration power. See HEMICHORDATA. [J.B.]

**Enterovirus** One of the two subgroups of human picornaviruses. Enteroviruses include the polioviruses, the coxsackieviruses, and the echoviruses. They are small (17–28 nanometers in diameter), contain ribonucleic acid (RNA), and are resistant to ether. The enteroviruses multiply chiefly in the alimentary tract. The polioviruses, most echoviruses, and a number of the coxsackieviruses can be grown in cell cultures of monkey origin, as well as in human cells.

Enteroviruses are widespread during summer and fall in temperate climates, but may circulate throughout the year in tropical areas. The majority of enterovirus infections are benign and inapparent. However, when these viruses invade tissues other than the enteric tract, serious diseases may result, as when poliovirus invades the spinal cord or when some of the coxsackievirus types invade the heart muscle. See ANIMAL VIRUS; COXSACKIEVIRUS; ECHOVIRUS; PICORNAVIRIDAE; POLIOMYELITIS; RHINOVIRUS. [J.L.Me.]

**Enthalpy** For any system, that is, the volume of substance under discussion, enthalpy is the sum of the internal energy of the system plus the system's volume multiplied by the pressure exerted by the system on its surroundings. The sum is given the special symbol  $H$  primarily as a matter of convenience because this sum appears repeatedly in thermodynamic discussion. Previously, enthalpy was referred to as total heat or heat content, but these terms are misleading and should be avoided. Enthalpy is, from the viewpoint of mathematics, a point function, as contrasted with heat and work, which are path functions. Point functions depend only on the initial and final states of the system undergoing a change; they are independent of the paths or character of the change. For change in enthalpy with pressure or temperature see THERMODYNAMIC PRINCIPLES; ENTROPY; THERMODYNAMIC PROCESSES. [H.C.W.; W.A.S.]

**Entodiniomorphida** An order of the Spirotrichia. These are strikingly different-looking ciliates, covered with a smooth, firm pellicle. They are devoid of external ciliature except for the adoral zone of membranelles and, occasionally, one or two other tufts or zones of other specialized cilia (see illustration). Internal organization of the body is very specialized and complex. These organisms are considered to be highly evolved.

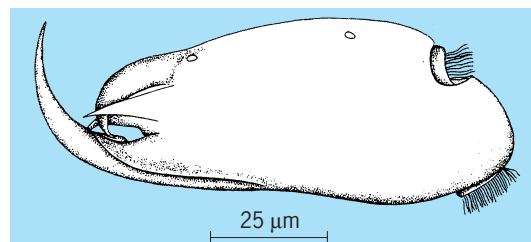

*Ophryoscolex*, an entodiniomorphid.

Entodiniomorphids occur exclusively as endocommensals of herbivorous mammals, either in the rumen and reticulum of ruminants or in the colon of certain higher mammals. See CILIOPHORA; PROTOZOA; SPIROTRICHIA. [J.O.C.]

**Entomology, economic** The study of insects that have a direct influence on humanity. Though this includes beneficial as well as harmful species, most attention is devoted to the latter and how they become pests and are controlled. The emphasis on managing harmful insects reflects the immediacy and seriousness of pest problems, particularly the destruction of food and the transmission of disease. These are highly visible problems, whereas the benefits gained from useful insects are not so clearly understood, nor so well documented economically.

Central to the definition of a pest is determination of the economic threshold. Any insect population, when introduced into a favorable environment, increases numbers until reaching an environmental carrying capacity. In pest insects, there exists a density above which the insect population interferes with human health, comfort, convenience, or profits. When this economic threshold is reached, a decision must be made to utilize some control measure to prevent further increase in numbers. Often, the presence of even a single insect is sufficient to warrant control measures, for instance, when that insect is a flea harboring the plague bacillus, or a mosquito capable of transmitting malaria. Also, consumer expectations in most markets are for insect-free produce, so that the economic threshold can be very low on items that people eat. However, economic thresholds may be higher for insects that damage only the inedible portions of crop plants such as the leaves of beans, tomatoes, and apple trees. In any case, knowledge of the amount of injury which is due to different densities of insects is an important prerequisite for efficient management.

**Pest management.** Management of insect pests begins with prevention. Many of the United States' most noxious insects have been imported from overseas: most domestic cockroaches, the gypsy moth, Japanese beetle, corn borer, housefly, cabbage-worm, and codling moth are just a few. Some North American insects have spread elsewhere too—the Colorado potato beetle to Europe and the fall webworm to Japan. To stem the flow of insect invasions, the federal government's Animal and Plant Health Inspection Service maintains inspection facilities for the examination of all incoming shipments of plant or other material that may harbor pests.

Once a pest is established, its spread can sometimes be slowed by an efficient system of local quarantines, early detection, and local eradication. A widely used eradication method is the application of synthetic chemical insecticides. Insecticides were once regarded as a panacea for pest problems, but the development of resistant strains of major insect pests, together with the rising cost of materials and application, has led to recognition that insecticides are more efficiently utilized in a program integrating them with other techniques in a framework of total crop management. See INSECTICIDE.

Another method is biological control, in which insects have had their numbers checked by natural enemies. Economic entomologists have effectively reduced densities of several pests by releasing parasites or predators. Natural enemies that are mobile and relatively restricted in diet do the best job of biological control. See INSECT CONTROL, BIOLOGICAL.

Crop rotation is a standard agronomic practice that often reduces damage due to insects. Rotation of alfalfa or soybeans with corn reduces populations of corn rootworms, wireworms, and white grubs. The physical disruption of autumnal plowing and disking destroys many insects that could overwinter in stubble or on the soil surface.

The cleanup of breeding and gathering sites is useful, especially in management of medically important insects, many of which have evolved resistance to the commoner insecticides. In general, the most successful programs of insect pest manage-

ment rely on integrated control or the use of several methods in concert to control a complex of pests.

**Beneficial insects.** It has been estimated that the dollar value gained from a single insect, the honeybee, equals the loss from damage plus cost of control for all pests combined. Honeybees are managed for their honey and beeswax, but their most valued service is pollination of crop plants. Bees of many species are the chief pollinators, though wasps, flies, moths, butterflies, and beetles pollinate as well. See POLLINATION.

Silk is produced by larvae of the silkworm, an insect so thoroughly domesticated that it cannot climb its food plant, mulberry, with its degenerated legs. The silkworm apparently no longer survives in the wild. Many uses of silk have been taken over by less expensive synthetic materials.

Other insects may be equally beneficial, but their value is not so easily calculated. Foremost among these are predatory insects of several orders. These predators may prevent other insects from ever reaching an economic threshold and thus becoming pests. Innumerable insect species are scavengers, quietly but efficiently breaking down the remains of dead plants and animals. A lack of scavenging insects would, however, result in a great increase of decomposing organic material lying about. Plant-eating insects have been set to beneficial use when their diets consist mainly of unwanted weeds.

Certain rare and showy butterflies and beetles are sought after so that they have considerable economic worth. Conservation of rare and endangered insects incurs some expense as well. Habitat management to conserve rare insects is a valid and growing concern of economic entomologists.

Finally, insects have rendered invaluable service to science, and thus to humanity, as easily reared experimental animals for investigation of basic principles of genetics, biochemistry, development, and behavior. See INSECTA. [D.J.Hor.]

**Entoprocta** A phylum of sessile, aquatic, often colonial invertebrates having a looped gut with both mouth and anus situated inside a cirlet of tentacles, a pseudocoelomate body cavity, and no hardened skeleton. The phylum is divided into two orders, Loxosomatida (or Solitaria), with about 100 species, and Pedicellinida (or Coloniales), with about 30. No fossils are known.

Entoprocts are mainly marine, and may be encountered as small colonies on seaweeds and bryozoans near low tidemark. The colonies consist of threadlike, creeping stolons and erect zooids arising at intervals from them (see illustration). Noncolonial forms have similar zooids but lack the stolons. Each zooid is goblet-shaped, consisting of a basal stalk supporting a rounded or pyriform viscera-containing dilatation, the calyx.

The entoprocts feed on particles filtered from the surrounding water. Long lateral cilia drive water inward between the tentacles, while shorter cilia on the inner face convey particles trapped in mucus down the tentacles. These frontal tracts join an annular ciliated groove, which dips into the mouth.

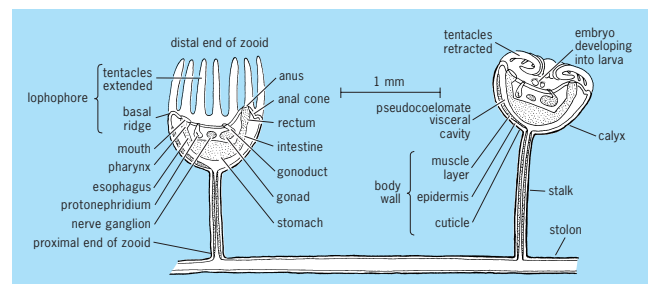

**Morphological features of an entoproct zooid, in vertical cross section.**

Entoprocts reproduce asexually and sexually. Dispersal is by means of sexually produced larvae. Zooids may be unisexual or hermaphroditic. Gonads are paired, with the ducts uniting before opening into the coelom. Fertilization is internal. [J.S.R.]

**Entropy** A function first introduced in classical thermodynamics to provide a quantitative basis for the common observation that naturally occurring processes have a particular direction. Subsequently, in statistical thermodynamics, entropy was shown to be a measure of the number of microstates a system could assume. Finally, in communication theory, entropy is a measure of information. Each of these aspects will be considered in turn. Before the entropy function is introduced, it is necessary to discuss reversible processes.

**Reversible processes.** Any system under constant external conditions is observed to change in such a way as to approach a particularly simple final state called an equilibrium state. For example, two bodies initially at different temperatures are connected by a metal wire. Heat flows from the hot to the cold body until the temperatures of both bodies are the same. It is common experience that the reverse processes never occur if the systems are left to themselves; that is, heat is never observed to flow from the cold to the hot body. Max Planck classified all elementary processes into three categories: natural, unnatural, and reversible. Natural processes do occur, and proceed in a direction toward equilibrium. Unnatural processes move away from equilibrium and never occur. A reversible process is an idealized natural process that passes through a continuous sequence of equilibrium states.

**Entropy function.** The state function entropy  $S$  puts the foregoing discussion on a quantitative basis. Entropy is related to  $q$ , the heat flowing into the system from its surroundings, and to  $T$ , the absolute temperature of the system. The important properties for this discussion are:

1.  $dS > q/T$  for a natural change.

$dS = q/T$  for a reversible change.

2. The entropy of the system  $S$  is made up of the sum of all the parts of the system so that  $S = S_1 + S_2 + S_3 \dots$ . See HEAT; TEMPERATURE; THERMODYNAMIC PRINCIPLES.

**Nonconservation.** In his study of the first law of thermodynamics, J. P. Joule caused work to be expended by rubbing metal blocks together in a large mass of water. By this and similar experiments, he established numerical relationships between heat and work. When the experiment was completed, the apparatus remained unchanged except for a slight increase in the water temperature. Work ( $W$ ) had been converted into heat ( $Q$ ) with 100% efficiency. Provided the process was carried out slowly, the temperature difference between the blocks and the water would be small, and heat transfer could be considered a reversible process. The entropy increase of the water at its temperature  $T$  is  $\Delta S = Q/T = W/T$ . Since everything but the water is unchanged, this equation also represents the total entropy increase. The entropy has been created from the work input, and this process could be continued indefinitely, creating more and more entropy. Unlike energy, entropy is not conserved. See CONSERVATION OF ENERGY; THERMODYNAMIC CYCLE; THERMODYNAMIC PROCESSES.

**Degradation of energy.** Energy is never destroyed. But in the Joule friction experiment and in heat transfer between bodies, as in any natural process, something is lost. In the Joule experiment, the energy expended in work now resides in the water bath. But if this energy is reused, less useful work is obtained than was originally put in. The original energy input has been degraded to a less useful form. The energy transferred from a high-temperature body to a lower-temperature body is also in a less useful form. If another system is used to restore this degraded energy to its original form, it is found that the restoring system has degraded the energy even more than the original system had. Thus, every process occurring in the world results in an overall increase in entropy and a corresponding degradation in energy. [W.F.J.]

**Measure of information.** The probability characteristic of entropy leads to its use in communication theory as a measure of information. The absence of information about a situation is equivalent to an uncertainty associated with the nature of the situation. This uncertainty is the entropy of the information about the particular situation. See INFORMATION THEORY. [F.H.R.]

**Environment** The sum of all external factors, both biotic (living) and abiotic (nonliving), to which an organism is exposed. Biotic factors include influences by members of the same and other species on the development and survival of the individual. Primary abiotic factors are light, temperature, water, atmospheric gases, and ionizing radiation, influencing the form and function of the individual.

For each environmental factor, an organism has a tolerance range, in which it is able to survive. The intercept of these ranges constitutes the ecological niche of the organism. Different individuals or species have different tolerance ranges for particular environmental factors—this variation represents the adaptation of the organism to its environment. The ability of an organism to modify its tolerance of certain environmental factors in response to a change in them represents the plasticity of that organism. Alterations in environmental tolerance are termed acclimation. Exposure to environmental conditions at the limit of an individual's tolerance range represents environmental stress. See ADAPTATION (BIOLOGY); ECOLOGY; PHYSIOLOGICAL ECOLOGY (ANIMAL); PHYSIOLOGICAL ECOLOGY (PLANT).

**Abiotic factors.** The spectrum of electromagnetic radiation reaching the Earth's surface is determined by the absorptive properties of the atmosphere. Biologically, the most important spectral range is 300–800 nanometers, incorporating ultraviolet, visible, and infrared radiation. Visible light provides the energy source for most forms of life. Light absorbed by pigment molecules (chlorophylls, carotenoids, and phycobilins) is converted into chemical energy through photosynthesis. Light availability is especially important in determining the distribution of plants. Photosynthetic organisms can exist within a wide range of light intensities. Full sunlight in the tropics is around  $2000 \mu\text{mol photons} \cdot \text{m}^{-2} \cdot \text{s}^{-1}$ . Photosynthetic organisms have survived in locations where the mean light is as low as 0.005% of this value. See INSOLATION; PHOTOSYNTHESIS; SOLAR RADIATION.

In addition to providing energy, light is important in providing an organism with information about its surroundings. The human eye, for example, is able to respond to wavelengths of light between 400 and 700 nm—the visible range. Within this range, sensitivity is greatest in the green part of the spectrum. This is the portion of the spectrum that plants absorb least, and so is the principal part of the spectrum to be reflected.

Temporal variation in light also provides an important stimulus. Life forms from bacteria upward are able to detect and respond to daily light fluctuations. Such a response may be directly controlled by the presence or absence of light (diurnal rhythms) or may persist when the variation in light is removed (circadian rhythms). In the latter case, regulation is through an internal molecular clock, which is able to predict the daily cycle. Such circadian clocks are normally reset by light on a daily basis. Processes controlled by circadian clocks range from the molecular (gene expression) to the behavioral (for example, sleep patterns in animals or leaf movements in plants). See PHOTOPERIODISM.

Ultraviolet radiation has the ability to break chemical bonds and so may lead to damage to proteins, lipids, and nucleic acids. Damage to DNA may result in genetic mutations. The ozone layer in the stratosphere is responsible for absorbing a large proportion of ultraviolet radiation reaching the outer atmosphere. As ozone is destroyed by the action of pollutants such as chlorofluorocarbons, the proportion of ultraviolet radiation reaching the surface of the Earth rises.

Water is ubiquitous in living systems, as the universal solvent for life, and is essential for biological activity. Many organisms have evolved the ability to survive prolonged periods in the total

absence of water, but this is achieved only through the maintenance of an inactive state. Water availability remains a primary environmental factor limiting survival on land. Primitive land organisms possess little or no ability to conserve water within their cells and are termed poikilohydric. Examples include amphibians and primitive plants such as most mosses and liverworts. These are confined to places where water is in plentiful supply or they must be able to tolerate periods of desiccation. Lichens can survive total water loss and rapidly regain activity upon rewetting. Such organisms must be able to minimize the damage caused to cellular structures when water is lost. Dehydration causes irreversible damage to membranes and proteins. This damage can be prevented by the accumulation of protective molecules termed compatible solutes.

Homeohydric organisms possess a waterproof layer that restricts the loss of water from the cells. Such waterproofing is never absolute, as there is still a requirement to exchange gas molecules and to absorb organic or mineral nutrients through a water phase. Water conservation allows organisms to live in environments in which the water supply is extremely low. In extremely arid environments, behavioral adaptations may allow the water loss to be minimized. Animals may be nocturnal, emerging when temperatures are lower and hence evaporation minimized. Cacti possess a form of photosynthesis, crassulacean acid metabolism (CAM), that allows them to separate gas exchange and light capture. See GROUND-WATER HYDROLOGY; OSMOREGULATORY MECHANISMS; PLANT-WATER RELATIONS.

Temperature is a determinant of survival in two ways: (1) as temperatures decrease, the movement of molecules slows and the rate of chemical reactions declines; (2) temperature determines the physical state of water.

The slowing of metabolic activity at low temperatures is illustrated in reptiles. Such poikilothermic animals, unable to maintain their internal temperature, are typically inactive in the cold of morning. They bask in the sun to increase their body temperature and so become active. High temperatures will cause the three-dimensional structure of proteins to break down, preventing the organisms from functioning. Organisms adapted to extremely high temperatures need more rigid proteins that maintain their structure. Temperature also affects the behavior of cell membranes, made up of lipids and proteins in a liquid crystalline state. At low temperatures, the membrane structure becomes rigid and liable to break. At high temperatures, it becomes too fluid and again liable to disintegrate. In adapting to different temperatures, organisms alter the composition of the lipids in their membranes, whose melting temperature is thereby changed. This outcome also applies to storage lipids. Hence, cold-water fish are a useful source of oils, whereas mammals, with their higher body temperature, contain fats. The effect of temperature on membranes is thought to be a key factor determining the temperature range that an organism is able to survive.

The effect of temperature on the physical state of water is essential to determining the availability of that water to organisms. Poikilothermic organisms may find that the water in their cells begins to freeze at low temperatures. Certain species can survive total freezing through the prevention of ice crystal formation altogether which would otherwise damage cellular structures. To survive low temperatures, cells must be able to survive desiccation, and so low-temperature tolerance involves the formation of compatible solutes. High temperatures increase the rate of evaporation of water. Hence, where water supply is limiting, an organism's ability to survive high temperatures is impaired.

Mammals and birds, homeothermic organisms, are able to regulate their internal temperature, limiting the effects of external temperature variations. Temperature still acts as an environmental constraint in such organisms, however. Cooling is achieved through sweating and hence loss of water. Heat is produced through the metabolism of food, and hence survival in cold climates requires a high metabolic rate. See CRYPTOBIOSIS; HIBERNATION AND ESTIVATION; THERMOREGULATION.

The atmosphere on Earth is thought to be determined to a large extent by the presence of life. At the same time, organisms have evolved to survive in the atmosphere as it is. The atmospheric constituents with the most direct biological importance are oxygen ( $O_2$ ) and carbon dioxide ( $CO_2$ ). Oxygen makes up approximately 20% of the atmosphere and is due to the occurrence of oxygenic photosynthesis. This process involves the simultaneous uptake of  $CO_2$  to make sugars. Aerobic respiration involves the reverse of this process, the release of  $CO_2$  and the uptake of  $O_2$  to form water. Hence, the current atmosphere represents the balance of previous biological activity. For most terrestrial organisms, neither  $CO_2$  nor  $O_2$  is limiting in the atmosphere; however, the need to get either or both of these gases to cells may represent a limitation on size or on the ability to tolerate water stress. Limitation of either gas may be important in aquatic environments, where the concentration of each is significantly lower.

Nitrogen is also required by all organisms but cannot be used by most in the gaseous form. Nitrogen fixation, the conversion of  $N_2$  gas into a biologically useful form, occurs in some species of bacteria and cyanobacteria or may be caused by lightning.

Atmospheric gases are important in determining the climate and the light environment. Absorption of electromagnetic radiation by the atmosphere determines the spectrum of light reaching the Earth's surface. Absorption and reflectance of infrared radiation by greenhouse gases such as  $CO_2$  and water vapor regulate temperature. See PHOTORESPIRATION; RESPIRATION.

Among other environmental factors determining the range and distribution and form of organisms are mechanical stimuli such as wind or water movement, and the presence of metals, inorganic nutrients, and toxins in the air, soil, or food.

**Biotic factors.** The biotic environment of an individual is made up of members of the same or other species. Intraspecific interactions involve the need to breed with other individuals, to gain protection through living in a group, and to compete for resources such as food, light, nutrients, and space. The optimal population density depends on the availability of resources and on the behavior, size, and structure of the organism. Interspecific interactions may also be positive or negative. For example, symbiotic relationships involve the mutual benefit of the individuals involved, whereas competition for resources is deleterious to both. Although predation exerts a negative influence on the population as a whole, the success of an individual may be enhanced if a predator removes one of its conspecific competitors.

Humans alter their environment in ways that exceed the impact of all other organisms. For example, the release of greenhouse gases into the atmosphere contributes to climate alterations over the entire planet. This in turn has impacts on the distribution of all other species. The release of pollutants into the environment brings organisms into contact with stresses to which they were not previously exposed. This causes the evolution of new varieties, eventually perhaps new species, adapted to the polluted environments. See AIR POLLUTION; BIOSPHERE; HUMAN ECOLOGY; WATER POLLUTION.

For any given organism, it is often possible to identify a factor in the environment that limits survival and growth. The limiting factor may change through time. Such a change may cause the organism to be at the limit of or outside its tolerance range for that or another environmental factor. In such cases, the organism is said to suffer stress. If the stress to which an individual is exposed is extreme, it may result in irreversible damage and death. Exposure to moderate stress, however, results in a period of acclimation within the organism that allows it to adjust to the new conditions. Organisms exposed gradually to new conditions usually have a higher chance of survival than those exposed suddenly. See POPULATION ECOLOGY.

Where a particular environmental factor (or combination of factors) dominates the growth and development of organisms, it is often found that the adaptations and gross features of the

landscape will be the same, even when the actual species are different. Thus, mediterranean vegetation is found not only around the Mediterranean Sea but also in California and South Africa, where the conditions of hot dry summers and warm wet winters occur. Regions with similar environmental conditions are classed as biomes. The occurrence of such global vegetation types clearly illustrates the role played by the environment in determining the form and function of individual species. [G.J.]

**Environmental engineering** The division of engineering concerned with the environment and management of natural resources. The environmental engineer places special attention on the biological, chemical, and physical reactions in the air, land, and water environments and on improved technology for integrated management systems, including reuse, recycling, and recovery measures.

Environmental engineering began with consideration of the need for acceptable drinking water and for management of liquid and solid wastes. Abatement of air and land contamination became new challenges for the environmental engineer, followed by toxic-waste and hazardous-waste concerns. The environmental engineer is also instrumental in the mitigation and protection of wildlife habitat, preservation of species, and the overall well-being of ecosystems.

The principal environmental engineering specialties are air-quality control, water supply, wastewater disposal, stormwater management, solid-waste management, and hazardous-waste management. Other specialties include industrial hygiene, noise control, oceanography, and radiology. See AIR POLLUTION; AIR POLLUTION, INDOOR; HAZARDOUS WASTE; WATER POLLUTION; WATER SUPPLY ENGINEERING. [R.A.Cor.]

**Environmental fluid mechanics** The study of the flows of air and water, of the species carried by them, and of their interactions with geological, biological, social, and engineering systems in the vicinity of a planet's surface. The environment on the Earth is intimately tied to the fluid motion of air (atmosphere), water (oceans), and species concentrations (air quality). In fact, the very existence of the human race depends upon its abilities to cope within the Earth's environmental fluid systems.

Meteorologists, oceanologists, geologists, and engineers study environmental fluid motion. Weather and ocean-current forecasts are of major concern, and fluid motion within the environment is the main carrier of pollutants. Biologists and engineers examine the effects of pollutants on humans and the environment, and the means for environmental restoration. Air quality in cities is directly related to the airborne spread of dust particles and of exhaust gases from automobiles. The impact of pollutants on drinking-water quality is especially important in the study of ground-water flow. Likewise, flows in porous media are important in oil recovery and cleanup. Lake levels are significantly influenced by climatic change, a relationship that has become of some concern in view of the global climatic changes that may result from the greenhouse effect (whereby the Earth's average temperature increases because of increasing concentrations of carbon dioxide in the atmosphere). See AIR POLLUTION; GREENHOUSE EFFECT; WEATHER FORECASTING AND PREDICTION.

**Scales of motion.** Environmental fluid mechanics deals with the study of the atmosphere, the oceans, lakes, streams, surface and subsurface water flows (hydrology), building exterior and interior airflows, and pollution transport within all these categories. Such motions occur over a wide range of scales, from eddies on the order of centimeters to large recirculation zones the size of continents. This range accounts in large part for the difficulties associated with understanding fluid motion within the environment. In order to impart motion (or inertia) to the atmosphere and oceans, internal and external forces must develop. Global external forces consist of gravity, Coriolis, and centrifugal forces, and electric and magnetic fields (to a lesser extent). The internal forces of pressure and friction are created at the

local level, that is, on a much smaller spatial scale; likewise, these influences have different time scales. The winds and currents arise as a result of the sum of all these external and internal forces.

**Governing equations.** The foundations of environmental fluid mechanics lie in the same conservation principles as those for fluid mechanics, that is, the conservation of mass, momentum (velocity), energy (heat), and species concentration (for example, water, humidity, other gases, and aerosols). The differences lie principally in the formulations of the source and sink terms within the governing equations, and the scales of motion. These conservation principles form a coupled set of relations, or governing equations, which must be satisfied simultaneously. The governing equations consist of nonlinear, independent partial differential equations that describe the advection and diffusion of velocity, temperature, and species concentration, plus one scalar equation for the conservation of mass. In general, environmental fluids are approximately newtonian, and the momentum equation takes the form of the Navier-Stokes equation. An important added term, neglected in small-scale flow analysis, is the Coriolis acceleration,  $2\Omega \times V$ , where  $\Omega$  is the angular velocity of the Earth and  $V$  is the flow velocity. See CONSERVATION LAWS (PHYSICS); CONSERVATION OF ENERGY; CONSERVATION OF MASS; CONSERVATION OF MOMENTUM; CORIOLIS ACCELERATION; DIFFERENTIAL EQUATION; DIFFUSION; FLUID-FLOW PRINCIPLES; NAVIER-STOKES EQUATION; NEWTONIAN FLUID.

Fortunately, not every term in the Navier-Stokes equation is important in all layers of the environment. The key to being able to obtain solutions to the Navier-Stokes equation lies in determining which terms can be neglected in specific applications. For convenience, problems can be classified on the basis of the order of importance of the terms in the equations utilizing nondimensional numbers based on various ratios of values. See DIMENSIONLESS GROUPS.

**Measurements.** Because of the scales of motion and time associated with the environment, and the somewhat random nature of the fluid motion, it is difficult to conduct full-scale, extensive experimentation. Likewise, some quantities (such as vorticity or vertical velocity) resist direct observations. It is necessary to rely on the availability of past measurements and reports (as sparse as they may be) to establish patterns, especially for climate studies. However, some properties can be measured with confidence.

**Modeling.** There are two types of modeling strategies: physical and mathematical. Physical models are small-scale (laboratory) mockups that can be measured under variable conditions with precise instrumentation. Such modeling techniques are effective in examining wind effects on buildings and species concentrations within city canyons (flow over buildings). Generally, a large wind tunnel is needed to produce correct atmospheric parameters (such as Reynolds number) and velocity profiles. Mathematical models (algebra- and calculus-based) can be broken down further into either analytical models, in which an exact solution exists, or numerical models, whereby approximate numerical solutions are obtained using computers. See WIND TUNNEL. [D.W.P.]

**Environmental geology** The branch of geology that deals with the ways in which geology affects people. Examples of the effect of geology on human civilizations include (1) the ways that fertile soils develop from rocks and how these soils can become polluted by human activities; (2) how rocks and soils move down-slope to destroy roads, houses, and other human constructions; (3) sources of surface and subsurface water supplies and how they become polluted; (4) why floods occur where they do and how human activities affect floods; (5) locations of earthquakes and volcanic eruptions and the dangers they pose; (6) location of mineral resources such as copper, oil and gas, and uranium, and how mining these resources can pollute the environment; (7) how human activities can pollute the



atmosphere and cause global warming, sea-level rise, and ozone depletion. See AIR POLLUTION; EARTHQUAKE; SOIL CONSERVATION; VOLCANO; WATER POLLUTION. [H.B.]

**Environmental management** The development of strategies to allocate and conserve resources, with the ultimate goal of regulating the impact of human activities on the surrounding environment. "Environment" here usually means the natural surroundings, both living and inanimate, of human lives and activities. However, it can also mean the artificial landscape of cities, or occasionally even the conceptual field of the noosphere, the realm of communicating human minds.

Environmental management is a mixture of science, policy, and socioeconomic applications. It focuses on the solution of the practical problems that humans encounter in cohabitation with nature, exploitation of resources, and production of waste. In a purely anthropocentric sense, the central problem is how to permit technology to evolve continuously while limiting the degree to which this process alters natural ecosystems. Environmental management is thus intimately intertwined with questions regarding economic growth, equitable distribution of consumable goods, and conserving resources for future generations. Environmental managers fall within a broad spectrum, from those who would limit human interference in nature to those who would increase it in order to guide natural processes along benign paths. Participants in the process of environmental management fall into seven main groups: (1) governmental organizations at the local, regional, national, and international levels, including world bodies such as the United Nations Environment Programme and the U.N. Conference on Environment and Development; (2) research institutions, such as universities, academies, and national laboratories; (3) bodies charged with the enforcement of regulations, such as the U.S. Environmental Protection Agency; (4) businesses of all sizes and multinational corporations; (5) international financial institutions, such as the World Bank and International Monetary Fund; (6) environmental nongovernmental organizations, such as the World Wildlife Fund for Nature; and (7) representatives of the users of the environment, including tribes, fishermen, and hunters. The agents of environmental management include foresters, soil conservationists, policy-makers, engineers, and resource planners.

Some common themes of environmental management are bilateral and multilateral environmental treaties; design and use of decision-support systems; environmental policy formulation, enactment, and policing of compliance; estimation, analysis, and management of environmental risk; management of recreation and tourism; natural resource evaluation and conservation; positive environmental economics; promotion of positive environmental values by education, debate, and information dissemination; and strategies for the rehabilitation of damaged environments.

The need to improve management of the environment has given rise to several new techniques. There is environmental impact analysis, which was first formulated in California and is codified in the U.S. National Environmental Policy Act (NEPA). Through the environmental impact statement, it prescribes the investigatory and remedial measures that must be taken in order to mitigate the adverse effects of new development. It is intended to act in favor of both prudent conservation and participatory democracy. Another technique is environmental auditing, which uses the model of the financial audit to examine the processes and outcomes of environmental impacts. It requires value judgments, which are usually set by public preference, ideology, and policy, to define what are regarded as acceptable outcomes. Audits use techniques such as life-cycle analysis and environmental burden analysis to assess the impact of, for example, manufacturing processes that consume resources and create waste. [D.Ale.]

**Environmental radioactivity** Radioactivity that originates from natural and anthropogenic sources, including

radioactive materials in food, housing, and air, radioactive materials used in medicine, nuclear weapon tests in the open atmosphere, and radioactive materials used in industry and power generation.

Natural radioactivity, which is by far the largest component to which humans are exposed, is of both terrestrial and extraterrestrial (cosmic) origin. About 340 nuclides are known in nature, of which 70 are radioactive and are found mainly among the heavy elements. Three nuclides which are responsible for most of the terrestrial component are potassium-40, uranium-238, and thorium-232.

The average person in the United States receives 80–180 mrem/year (0.8–1.8 millisieverts/year) from natural sources of ionizing radiation, depending on the organ considered. Most of this dose originates from radioactive materials in the Earth's crust. The external dose due to cosmic rays is an average of about 28 mrem/year (0.28 mSv/year), a value that increases with altitude due to reduced shielding of cosmic radiation by the atmosphere. The human body is also exposed to radionuclides in food and water. Potassium-40 is the most important of these, with radium-226 and radium-228 of perhaps less importance from the point of view of the dose delivered.

There are wide deviations from the average doses. Thus, at one extreme, miners working underground in the presence of radioactive ore can be exposed to such high levels of atmospheric radon that they develop lung cancer. There are also geographical areas where the levels of natural radioactivity are unusually high. Six types of anomalies that can be important from the point of view of population exposure are: monazite sands and other placers, alkaline intrusives and granites of the Conway type in New Hampshire, bauxites and intensely weathered soils, uraniumiferous phosphate rock (and soils), ground waters enriched in radium and radon, and black shales and related organic accumulations. The natural radioactive environment can also be altered by human activities, such as building construction, combustion of fossil fuels, aircraft travel, medical procedures, nuclear weapons testing, and nuclear power plants.

Although various national and international regulatory organizations have proposed guidelines that limit the per capita dose received by individuals in the general population to 170 mrem/year (1.7 mSv/year), it has become evident that nuclear power plants can be routinely operated so that the general population will not be exposed to more than 1% of this limit. See NUCLEAR POWER; NUCLEAR REACTOR; RADIOACTIVE WASTE MANAGEMENT; RADIOACTIVITY. [M.E.]

**Environmental test** The evaluation of a physical system (engineering product) in conditions which simulate one or more of the environments that may harm the system or adversely affect its performance. In addition to the evaluation of a finished product, environmental testing can play an important role throughout a product's design/development cycle to ensure that the materials and manufacturing processes employed can meet the stresses imposed by the environment in which the product is likely to operate. By not waiting until a finished product is evaluated, manufacturers can use environmental testing to eliminate costly redesigns late in the design/development cycle.

Because it is necessary to precisely control the environmental factors which define the test (for example, temperature, vibration level, or altitude), environmental testing is typically conducted in specially designed facilities, or environmental chambers. Some environmental chambers can generate extremely high and low temperatures and humidity levels. Others can simulate corrosive environments such as salt sprays. Products and equipment intended for military use are often subjected to the harshest and most variable of environmental conditions. The military has pioneered the creation of well-documented standards and specifications for the evaluation and testing of any products or equipment which it will purchase.

Civilian organizations, such as the Society of Automotive Engineers, publish standards for automotive and aerospace equipment. In addition, nearly 100 countries have adopted the International Organization for Standardization (ISO) 9000 series of standards for quality management and quality assurance. These standards are implemented by thousands of manufacturing and service organizations, both public and private. Of the ISO 9000 family standards, ISO 9003 covers quality assurance obligations of the manufacturer in the areas of final inspection and testing. Among the guidelines provided by ISO 9003 are those dedicated to (1) developing procedures to inspect, test, and verify that final products meet all specified requirements before they are sold; (2) developing procedures to control and calibrate the testing equipment; (3) ensuring that every product is identified as having passed or failed the required tests. ISO 9003 will have a significant impact upon the standardization of environmental testing in both civilian and military endeavors.

An incomplete but representative list of environmental tests requiring dedicated test chambers includes tests for altitude, dust, explosiveness, flammability, fungus, humidity, icing, acoustic vibration, overpressure, rain, salt fog, sand, temperature, and wind. Tests typically not requiring chambers but still utilizing dedicated mechanical testing equipment include acceleration, fatigue cycling, transportation simulation, shock, and vibration.

[R.A.He.]

**Environmental toxicology** A broad field of study encompassing the production, fate, and effects of natural and synthetic pollutants in the environment. The breadth of this field depends on the definition of environment. It can be defined as narrowly as the home and workplace or as broadly as the entire Earth and its biosphere. Environmental toxicology is truly an interdisciplinary science. The effects of a pollutant on the environment depend on the amount released (the dose) and its chemical and physical properties. Pollutants can be grouped according to their origin and effects.

Pollution from nutrients is generally a problem of aquatic systems. Carbon, nitrogen, and phosphorus are essential nutrients and, when present in excess, can result in an overstimulation of microbial and plant growth. Nutrients enter the environment in runoff from fertilized agricultural areas, and in effluents from municipal and industrial waste and decaying plant material. See EUTROPHICATION.

Pathogenic bacteria and protozoa can be a major source of pollution in areas that receive untreated sewage, items from ocean dumping, and improperly discarded hospital waste. Toxic metabolites of fungal origin (mycotoxins) are also potential pollutants. See AFLATOXIN.

Forest fires, volcanic eruptions, and dust storms can be major sources of suspended materials. These materials can also originate in runoff from agricultural areas, construction and mining sites, and roads and other paved areas. Truck and automobile exhaust and industrial discharge to the atmosphere are also sources of suspended solids.

Metabolic processes and natural combustion and thermal activity (such as forest fires and volcanoes) can release large amounts of gaseous by-products to the atmosphere. However, natural inputs are minor compared to atmospheric pollutants due to human activity. Although most anthropogenic air pollution is produced by the various forms of transportation, emission from stationary sources of fuel combustion (for example, factories and power plants) are responsible for the greatest amount of hazardous materials released. See AIR POLLUTION; GREENHOUSE EFFECT.

All living organisms require certain metals for physiological processes. These elements, when present at concentrations above the level of homeostatic regulation, can be toxic. In addition, there are metals that are chemically similar to, but higher in molecular weight than, the essential metals (heavy metals).

Organic solvents are used widely and in large amounts in industries, laboratories, and homes. They are released to the atmosphere as vapor and can pose a significant inhalation hazard. Improper storage, use, and disposal have resulted in the contamination of surface and ground waters and drinking water. See WATER POLLUTION.

The pesticides represent an important group of materials that can enter the environment as pollutants. They are highly toxic, and many nontarget organisms can suffer harmful effects if misuse or unintended release occurs. See PESTICIDE.

Coal and petroleum-derived materials and by-products are major environmental pollutants. Widespread use has led to enormous releases to the environment of distillate fuels, crude oils, runoff from coal piles, exhaust from internal combustion-fired power plants, industrial emissions, and emissions from municipal incinerators. The toxicity of polycyclic aromatic hydrocarbons is perhaps one of the most serious long-term problems associated with the use of petroleum. They accumulate in soil, sediment, and biota, and at high concentrations can be acutely toxic. See FOSSIL FUEL.

Polychlorinated biphenyls (PCBs) are produced by the chlorination of biphenyl, giving rise to mixtures of up to 210 possible products. They have been used worldwide in electrical equipment, vacuum pumps, hydraulic fluids, heat-transfer systems, lubricants, and inks. The related polybrominated biphenyls (PBBs) have been used as fire retardants. Major sources of polychlorinated biphenyls have included leaks from waste disposal facilities, vaporization during combustion, and disposal of industrial fluids. Their use has been largely restricted or eliminated. Environmental concentrations are decreasing, but with their persistence they remain significant pollutants. Chlorinated dibenzop-dioxins and dibenzofurans are formed during the heating of chlorophenols, and have been identified as potential contaminants in the herbicide 2,4,5-T. They can be formed during the incineration of municipal wastes, polychlorinated biphenyls, or plant materials treated with chlorophenols. See ENVIRONMENTAL ENGINEERING; POLYCHLORINATED BIPHENYLS; TOXICOLOGY. [J.T.O.]

**Enzyme** A catalytic protein produced by living cells. The chemical reactions involved in the digestion of foods, the biosynthesis of macromolecules, the controlled release and utilization of chemical energy, and other processes characteristic of life are all catalyzed by enzymes. In the absence of enzymes, these reactions would not take place at a significant rate. Several hundred different reactions can proceed simultaneously within a living cell, and the cell contains a comparable number of individual enzymes, each of which controls the rate of one or more of these reactions. The potentiality of a cell for growing, dividing, and performing specialized functions, such as contraction or transmission of nerve impulses, is determined by the complement of enzymes it possesses. Some representative enzymes, their sources, and reaction specificities are shown in the table.

**Characteristics.** Enzymes can be isolated and are active outside the living cell. They are such efficient catalysts that they accelerate chemical reactions measurably, even at concentrations so low that they cannot be detected by most chemical tests for protein. Like other chemical reactions, enzyme-catalyzed reactions proceed only when accompanied by a decrease in free energy; at equilibrium the concentrations of reactants and products are the same in the presence of an enzyme as in its absence. An enzyme can catalyze an indefinite amount of chemical change without itself being diminished or altered by the reaction. However, because most isolated enzymes are relatively unstable, they often gradually lose activity under the conditions employed for their study.

**Chemical nature.** All enzymes are proteins. Their molecular weights range from about 10,000 to more than 1,000,000. Like other proteins, enzymes consist of chains of amino acids linked together by peptide bonds. An enzyme molecule may contain one or more of these polypeptide chains. The sequence

**Some representative enzymes, their sources, and reaction specificities**

Enzyme	Some sources	Reaction catalyzed
Pepsin	Gastric juice	Hydrolysis of proteins to peptides and amino acids
Urease	Jackbean, bacteria	Hydrolysis of urea to ammonia and carbon dioxide
Amylase	Saliva, pancreatic juice	Hydrolysis of starch to maltose
Phosphorylase	Muscle, liver, plants	Reversible phosphorylation of starch or glycogen to glucose-1-phosphate
Transaminases	Many animal and plant tissues	Transfer of an amino group from an amino acid to a keto acid
Phosphohexose isomerase	Muscle, yeast	Interconversion of glucose-6-phosphate and fructose-6-phosphate
Pyruvic carboxylase	Yeast, bacteria, plants	Decarboxylation of pyruvate to acetaldehyde and carbon dioxide
Catalase	Erythrocytes, liver	Decomposition of hydrogen peroxide to oxygen and water
Alcohol dehydrogenase	Liver	Oxidation of ethanol to acetaldehyde
Xanthine oxidase	Milk, liver	Oxidation of xanthine and hypoxanthine to uric acid

of amino acids within the polypeptide chains is characteristic for each enzyme and is believed to determine the unique three-dimensional conformation in which the chains are folded. This conformation, which is necessary for the activity of the enzyme, is stabilized by interactions of amino acids in different parts of the peptide chains with each other and with the surrounding medium. These interactions are relatively weak and may be disrupted readily by high temperatures, acid or alkaline conditions, or changes in the polarity of the medium. Such changes lead to an unfolding of the peptide chains (denaturation) and a concomitant loss of enzymatic activity, solubility, and other properties characteristic of the native enzyme. Enzyme denaturation is sometimes reversible. See AMINO ACIDS; PROTEIN.

Many enzymes contain an additional, nonprotein component, termed a coenzyme or prosthetic group. This may be an organic molecule, often a vitamin derivative, or a metal ion. The coenzyme, in most instances, participates directly in the catalytic reaction. For example, it may serve as an intermediate carrier of a group being transferred from one substrate to another. Some enzymes have coenzymes that are tightly bound to the protein and difficult to remove, while others have coenzymes that dissociate readily. When the protein moiety (the apoenzyme) and the coenzyme are separated from each other, neither possesses the catalytic properties of the original conjugated protein (the holoenzyme). By simply mixing the apoenzyme and the coenzyme together, the fully active holoenzyme can often be reconstituted. The same coenzyme may be associated with many enzymes which catalyze different reactions. It is thus primarily the nature of the apoenzyme rather than that of the coenzyme which determines the specificity of the reaction. See BIOLOGICAL OXIDATION; COENZYME.

The complete amino acid sequence of several enzymes has been determined by chemical methods. By x-ray crystallographic methods even the exact three-dimensional molecular structure of a few enzymes has been deduced. See X-RAY CRYSTALLOGRAPHY.

**Classification and nomenclature.** Enzymes are usually classified and named according to the reaction they catalyze. The principal classes are as follows.

Oxidoreductases catalyze reactions involving electron transfer, and play an important role in cellular respiration and energy production. Some of them participate in the process of oxidative phosphorylation, whereby the energy released by the oxidation of carbohydrates and fats is utilized for the synthesis of adenosine

triphosphate (ATP) and thus made directly available for energy-requiring reactions.

Transferases catalyze the transfer of a particular chemical group from one substance to another. Thus, transaminases transfer amino groups, transmethylases transfer methyl groups, and so on. An important subclass of this group are the kinases, which catalyze the phosphorylation of their substrates by transferring a phosphate group, usually from ATP, thereby activating an otherwise metabolically inert compound for further transformations.

Hydrolases catalyze the hydrolysis of proteins (proteinases and peptidases), nucleic acids (nucleases), starch (amylases), fats (lipases), phosphate esters (phosphatases), and other substances. Many hydrolases are secreted by the stomach, pancreas, and intestine and are responsible for the digestion of foods. Others participate in more specialized cellular functions. For example, cholinesterase, which catalyzes the hydrolysis of acetylcholine, plays an important role in the transmission of nervous impulses. See ACETYLCHOLINE.

Lyases catalyze the nonhydrolytic cleavage of their substrate with the formation of a double bond. Examples are decarboxylases, which remove carboxyl groups as carbon dioxide, and dehydrases, which remove a molecule of water. The reverse reactions are catalyzed by the same enzymes.

Isomerases catalyze the interconversion of isomeric compounds.

Ligases, or synthetases, catalyze endergonic syntheses coupled with the exergonic hydrolysis of ATP. They allow the chemical energy stored in ATP to be utilized for driving reactions uphill.

**Specificity.** The majority of enzymes catalyze only one type of reaction and act on only one compound or on a group of closely related compounds. There must exist between an enzyme and its substrate a close fit, or complementarity. In many cases, a small structural change, even in a part of the molecule remote from that altered by the enzymatic reaction, abolishes the ability of a compound to serve as a substrate. An example of an enzyme highly specific for a single substrate is urease, which catalyzes the hydrolysis of urea to carbon dioxide and ammonia. On the other hand, some enzymes exhibit a less restricted specificity and act on a number of different compounds that possess a particular chemical group. This is termed group specificity.

A remarkable property of many enzymes is their high degree of stereospecificity, that is, their ability to discriminate between asymmetric molecules of the right-handed and left-handed configurations. An example of a stereospecific enzyme is L-amino acid oxidase. This enzyme catalyzes the oxidation of a variety of amino acids of the type  $R-CH(NH_2)COOH$ . The rate of oxidation varies greatly, depending on the nature of the R group, but only amino acids of the L configuration react. See STEREOCHEMISTRY. [D.W.]

**Enzyme inhibition** The prevention of an enzymic process as a result of the interaction of some substance with an enzyme so as to decrease the rate of the enzymic reaction. The substance causing such an effect is termed an inhibitor. Enzyme inhibitors are important as chemotherapeutic agents, as regulators in normal control of enzymic processes in living organisms, and as useful agents in the study of biochemistry. See ANTIBIOTIC; CHEMOTHERAPY; ENZYME.

Inhibitors have been classified as competitive, noncompetitive, and uncompetitive. The effect of a competitive inhibitor is to bind only free enzyme. This can be reversed by sufficiently increased substrate concentrations, so that essentially all of the enzyme is bound into an enzyme-substrate complex. Since both noncompetitive and uncompetitive inhibitors interact with the enzyme-substrate complex, their effects are not nullified by increased concentrations of substrate. An uncompetitive inhibitor exerts less effect (as percent of control) at low than at high substrate concentrations, since less of the enzyme is in the form of the enzyme-substrate complex, with which it interacts. A

noncompetitive inhibitor, which reacts with both free enzyme and the enzyme-substrate complex, exerts comparable effects at all substrate concentrations. [W.Sh.]

**Eocanthocephala** An order of the Acanthocephala characterized by the presence of a small number of giant subcuticular nuclei which are similar to the embryonic nuclei. Body spines may or may not be present and the chief lacunar vessels are dorsal and lateral. Proboscis hooks are few in number and arranged in circles. Eggs are ellipsoidal and thin shelled. These worms are parasitic in cold-blooded vertebrates (turtles, fish). The cystacanth occurs in crustaceans. See ACANTHOCEPHALA.

[D.V.Mo.]

**Eocene** The second oldest of the five major worldwide divisions (epochs) of the Tertiary Period (Cenozoic Era), the interval of time (epoch) extending from the end of the Paleocene Epoch to the beginning of the Oligocene Epoch; the middle epoch of the older Tertiary (Paleogene of some authors, Nummulitic of earlier French authors). See CENOZOIC; OLIGOCENE; PALEOCENE; TERTIARY.

The Paleocene/Eocene boundary has been formally defined at the 5.2-ft (1.6-m) level in the Dababiya Quarry section approximately 22 mi (35 km) south of Luxor in the Upper Nile Valley, Egypt. This level coincides with a global carbon isotope excursion associated with significant climatic warming and biotic changes and is about 1 million years older than the base of the classic Ypresian Stage, normally considered the oldest stage of the Eocene. There are varying opinions regarding what to do with the associated stage boundaries. The most prevalent proposes retaining the Ypresian Stage in its present position, with an estimated age for its base of about 54 Ma, and insert the Sparnacian Stage as the lowest stage of the newly redefined Eocene.

Eocene strata are widespread throughout the world and on the deep ocean floor. They include the common sedimentary types and vary from terrestrial, to marginal (estuarine), to normal marine pelagic origin. Igneous activity, while not as extensive as in the later part of the Cenozoic, was notable in some areas such as East Greenland, Oregon, Washington, and British Columbia.

Early Paleogene temperatures, including those of high latitudes, were the warmest of the Cenozoic; peak warming occurred in the early Eocene. The Earth was in a greenhouse state, with partial pressure of carbon dioxide (pCO<sub>2</sub>) levels in the early Eocene estimated to have been six times higher than present-day values. During the late Paleocene to the early Eocene, deep-sea temperatures at high southern latitudes warmed by some 7–9°F (4–5°C), from about 50–52°F (10–11°C) to about 57–61°F (14–16°C), while surface temperatures increased by some 9–11°F (5–6°C), with maximum temperatures in excess of 68°F (20°C). At low latitudes, surface water temperatures remained relatively constant and comparable to values of the present-day ocean. Superimposed on this long-term trend was a relatively abrupt (<10,000 years) 2.5–3% drop in δ<sup>13</sup>C (the difference in isotopic ratios <sup>12</sup>C/<sup>13</sup>C between a sample and a standard) and concomitant marine productivity that has been associated, in turn, with a major turnover (extinction of almost 50%) of the deep-sea benthic (bottom-dwelling) foraminiferal fauna. This drop in δ<sup>13</sup>C has been identified both in marine organisms and in mammalian bone enamel and paleosol carbonates in terrestrial sections in the Big Horn Basin of the western interior of North America and in the type Sparnacian (that is earliest Eocene) in the Paris Basin. See EXTINCTION (BIOLOGY); GEOLOGIC THERMOMETRY; PALEOSOL.

The diversification of life seen in the Paleocene continued in the Eocene, a reflection of the poleward expansion of the tropics, particularly during early Eocene time. In the oceanic realm, microplanktonic animals (foraminiferans) and plants (calcareous nannoplankton) flourished and diversified, as did true bony fishes and siphonate gastropods. In shallow, tropical waters the so-called larger foraminiferans extended their geographic range to latitude 50° north, but the latter group disappeared

at the end of the Eocene owing to cooling temperatures. Indeed, microplanktonic animals and plants experienced a gradual but inexorable decline in diversity starting in the late middle Eocene. Succeeding Oligocene faunas and floras were much reduced in diversity and much more uniformly distributed. See FORAMINIFERIDA.

On land, subtropical floras extended as far north as southern England and the North American Pacific coast of Puget Sound and southern Alaska. Indeed, the floras of southern England resembled those of modern-day China, Malaysia, and Australia. In the humid interior, thick and extensive mud deposits (the Green River Shale) in Colorado contain a beautifully preserved freshwater fish fauna eagerly sought after by fossil collectors.

Europe was separated from the Eurasian land mass east of the Urals by a north-south seaway extending from the Arctic to the Tethys Sea—the Turgai Straits. Following the elimination of the elevated corridor that allowed transatlantic poleward migration between Europe and North America in late early Eocene time, middle and late Eocene time witnessed the development of extensive endemic animal evolution. Bats, flying lemurs, creodont carnivores, artiodactyls (cloven-hoof mammals, such as cattle, deer, and camels) and perissodactyls (odd-toed, hoofed mammals, such as rhinoceroses and horses), notoungulates (predominantly South American), and edentates reflect the diversification of primitive placental forms. The massive, rhinoceroslike herbivores called titanotheres and uintatheres appeared alongside the small early progenitors of the modern horse, *Hyracotherium* (known popularly as *Eohippus*). See MAMMALIA; PERISSODACTYLA.

In the Eocene, some mammals turned toward life in the sea; sea cows appeared in the middle Eocene, while the earliest whales (zeuglodonts) appeared in the North Atlantic–Gulf of Mexico region and the aquatic ancestors of the proboscideans appeared in the late Eocene. [W.A.Ber.]

**Eocrinoidea** A medium-sized class of primitive, brachiole-bearing, blastozoan echinoderms of the class Crinozoa that ranged from the Early Cambrian to the Middle Silurian, although few eocrinoids survived past the Middle Ordovician. About 32 eocrinoid genera have been described from North America, Europe, North Africa, and Australia. Eocrinoids are the most diverse class of echinoderms known from the Cambrian with about 15 genera, and different members appear to have been ancestral to nearly all of the more advanced brachiole-bearing echinoderm classes that appeared in the Early or Middle Ordovician.

Eocrinoids have a globular, conical, or flattened theca or body, with many irregularly arranged to partly organized, imbricate or adjacent plates. Most Cambrian genera have sutural pores on the plate margins, apparently for respiration. Many early eocrinoids have a multiplated, cylindrical to slightly inflated holdfast for attaching the theca to objects lying on the sea floor. Holdfasts apparently evolved into a true columnal-bearing stem in late Middle Cambrian eocrinoids. Eocrinoids typically have two to five short ambulacral grooves radiating from the mouth on the summit to many long, erect, biserial brachioles that were used for feeding. Most eocrinoids were attached, low- to medium-level suspension feeders that used the brachioles to collect small food particles drifting by the theca. See CRINOZOA; ECHINODERMATA.

[J.Sp.]

**Eolian landforms** Topographic features generated by the wind. The most commonly seen eolian landforms are sand dunes created by transportation and accumulation of wind-blown sand. Blankets of wind-deposited loess, consisting of fine-grained silt, are less obvious than dunes, but cover extensive areas in some part of the world.

Where abundant loose sand is available for the wind to carry, sand dunes develop. As soon as enough sand accumulates in one place, it interferes with the movement of air and a wind shadow is produced which contributes to the shaping of the pile of sand.

Dunes advance downwind by erosion of sand on the windward side and redeposition on the slip face. Dunes may have a variety of shapes, depending on wind conditions, vegetation, and sand supply. The fine silt and clay winnowed out from coarser sand is often blown longer distances before coming to rest as a blanket of loess mantling the preexisting topography. Thick deposits of loess are most often found in regions downwind from glacial outwash plains or alluvial valleys. See DUNE; LOESS; SAND. [D.J.E.]

**Eosuchia** The oldest, most primitive, and only extinct order of lepidosaurian reptiles; they are clearly ancestral of the other two orders (Rhynchocephalia and Squamata). They have a typical diapsid skull, with at most a partial reduction of the lower arcade. Tooth implantation is subthecodont.

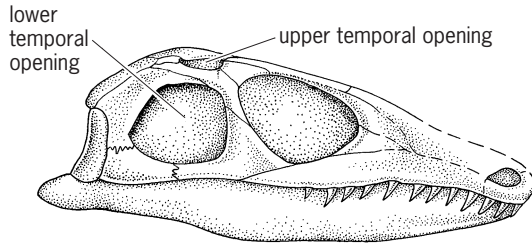

Lateral view of *Youngina* skull, Upper Permian to Lower Triassic. (After A. S. Romer, *Vertebrate Paleontology*, 3d ed., University of Chicago Press, 1966)

Of the four suborders, the oldest is the Younginiformes, including forms such as *Youngina* (see illustration). These, ranging from the Middle Permian to the Lower Triassic and found mainly in South Africa, were small unspecialized lizard-like reptiles. The Prolacertiformes, also terrestrial, range throughout the Triassic. They include forms in which a reduction of the lower temporal arcade and other features indicate a transition toward the Squamata (lizards). The Thalattosauria include a few marine reptiles from the Middle Triassic. The Choristodera include only one genus, *Champsosaurus*, a much later reptile (Upper Cretaceous to Lower Eocene), which had amphibious habits and seems to have been an eosuchian offshoot. See LEPIDOSAURIA; REPTILIA; SQUAMATA. [A.J.C.]

**Ephedrales** An order of the class Ginkgoopsida having about 35 species in the genus *Ephedra*. These plants are mostly of arid regions. They include freely branched, low shrubs with reduced, scalelike leaves and green photosynthetic twigs. The species are dioecious (seldom gynodioecious). The genus is known from Asia to Europe, in northern Africa, in the United States and Mexico, and from Bolivia to Patagonia. It is not known in the fossil record. See GINKGOOPSIDA; PINOPHYTA; PLANT KINGDOM. [T.A.Z.]

**Ephemeris** A table of data, especially astronomical data, that depend on the time, usually arranged with values of the time in the left-hand column. A lunar ephemeris, for example, may give the right ascension and declination of the Moon for every hour of a particular year. *The American Ephemeris and Nautical Almanac* is an annual volume published by the Nautical Almanac Office, U.S. Naval Observatory, with ephemerides of the Sun, Moon, planets, and satellites, and other astronomical data. [G.M.C.]

**Ephemeroptera** An order of insects commonly known as mayflies. They are aquatic and live in clean, fresh waters during their immature, or nymphal, lives. Nymphs are adapted to aquatic environments ranging from ponds to mountain streams. Most mayfly nymphs are vegetarians, and most species are present throughout the year as nymphs. As immature insects,

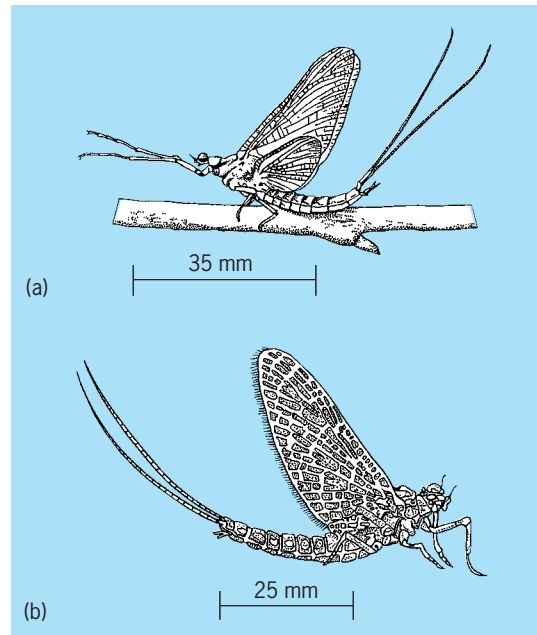

Ephemeroptera. (a) Mayfly, adult male, *Hexagenia* sp., in usual resting position. (b) Mayfly nymph, *Isonychia* sp. (After A. H. Morgan, *Field Book of Ponds and Streams*, copyright 1930 by G. Putnam's Sons)

they constitute a year-round basic food supply for carnivores of their communities, especially for fishes, and trout in particular. Nymphs and adults are models for artificial bait flies (see illustration).

Mayfly nymphs are distinguished from all other aquatic insects by the paired tracheal gills on the back of each of the first seven abdominal segments. The body ends in two or three finely segmented tailpieces. The mouthparts are highly interesting examples of adaptations for scraping, cutting, and crushing the various plant cells, which are the chief food.

As subadults, mayflies have the general adult form and useless mouthparts. They are clothed by a thin, furry, grayish skin which accounts for the common name, duns. The adult has transparent wings, shining body, and useless mouthparts; the males generally have extremely large eyes, which may be divided, and long front legs. This stage is brief, lasting from a few hours to several days. In a few mayflies, the legs of the female, and those of the male, except for the front ones, are nonfunctional and the brief adult life is spent entirely in flight. The quivering of the tailpieces during the mating flight gave them the name spinners. Thousands join in the twilight mating swarms, rhythmic dancing flights unequalled by other insects. See INSECTA. [A.H.M./L.Ber.]

**Epicaridea** A suborder of the Isopoda which are parasitic on various crustaceans, mainly marine forms. The females are sometimes modified so strongly as to leave almost no indication of their isopod nature. The female pierces the host's skin with the aid of styliform mandibles to suck blood. The dwarf male attaches to the female, from which it takes nourishment, and retains its isopod structure.

The suborder is divided into two tribes, the Cryptoniscina and Bopyrina. The Cryptoniscina live on Entomostraca and are protandrous hermaphrodites. The cryptoniscium larva attaches to a suitable female, develops testes without any change in its external appearance, and acts as a male. After the death of the host, it metamorphoses into a female, ultimately undergoing anatomical degradation that leaves it a mere bulky sac distended with developing embryos.

The Bopyrina are dioecious, but it has been shown experimentally in some forms that the cryptoniscium is ambipotent,

and a presumptive young male removed from the female develops into either a female or intersex. The tribe includes three families: Bopyridae, Entoniscidae, and Dajidae. See ISOPODA.

[S.M.S.]

**Epicycloid** A curve traced by a point  $P$  on a circle with radius  $r$  and center  $O'$  that rolls on the convex side of a fixed circle with radius  $R$  and center  $O$  (see illustration). The term is

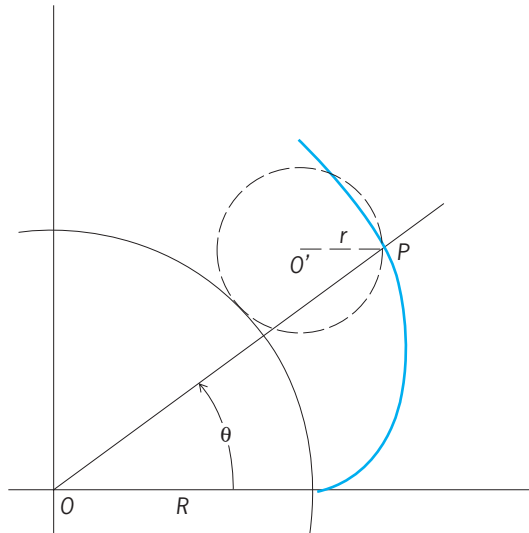

Diagram of an epicycloid.

also occasionally applied to the curve generated by a point on the prolongation of the radius of a circle as the circle rolls on a straight line. It is a cardioid when the rolling circle has the same radius as the fixed circle. See CARDIOID.

[L.M.B.]

**Epidemic** The occurrence of cases of disease in excess of what is usually expected for a given period of time. Epidemics are commonly thought to involve outbreaks of acute infectious disease, such as measles, polio, or streptococcal sore throat. More recently, other types of health-related events such as homicide, drownings, and even hysteria have been considered to occur as "epidemics."

Confusion sometimes arises because of overlap between the terms epidemic, outbreak, and cluster. Although they are closely related, epidemic may be used to suggest problems that are geographically widespread, while outbreak and cluster are reserved for problems that involve smaller numbers of people or are more sharply defined in terms of the area of occurrence. For example, an epidemic of influenza could involve an entire state or region, whereas an outbreak of gastroenteritis might be restricted to a nursing home, school, or day-care center. The term cluster may be used to refer to noncommunicable disease states.

In contrast to epidemics, endemic problems are distinguished by their consistently high levels over a long period of time. Lung cancer in males has been endemic in the United States, whereas the surge of lung cancer cases in women in the United States represents an epidemic problem that has resulted from increase in cigarette smoking among women in general. A pandemic is closely related to an epidemic, but it is a problem that has spread over a considerably larger geographic area; influenza pandemics are often global.

Disease and epidemics occur as a result of the interaction of three factors, agent, host, and environment. Agents cause the disease, hosts are susceptible to it, and environmental conditions permit host exposure to the agent. An understanding of

the interaction between agent, host, and environment is crucial for the selection of the best approach to prevent or control the continuing spread of an epidemic.

For infectious diseases, epidemics can occur when large numbers of susceptible persons are exposed to infectious agents in settings or under circumstances that permit the spread of the agent. Spread of an infectious disease depends primarily on the chain of transmission of an agent: a source of the agent, a route of exit from the host, a suitable mode of transmission between the susceptible host and the source, and a route of entry into another susceptible host. Modes of spread may involve direct physical contact between the infected host and the new host, or airborne spread, such as coughing or sneezing. Indirect transmission takes place through vehicles such as contaminated water, food, or intravenous fluids; inanimate objects such as bedding, clothes, or surgical instruments; or a biological vector such as a mosquito or flea. See EPIDEMIOLOGY; INFECTIOUS DISEASE; PUBLIC HEALTH.

[R.A.Go.]

**Epidemic viral gastroenteritis** A clinical syndrome characterized by acute infectious gastroenteritis with watery diarrhea, vomiting, malaise, and abdominal cramps with a relatively short incubation period (12–36 h) and duration (24–48 h). A viral etiology is suspected when bacterial and parasitic agents are not found. In the United States, no etiologic agent can be found in 70% of the outbreaks of gastroenteritis. Most of these may be due to viral agents, such as the Norwalk, Snow Mountain, and Hawaii agents, astroviruses, caliciviruses, adenoviruses, nongroup A rotaviruses, and paroviruses. Epidemics are common worldwide and have occurred following the consumption of fecally contaminated raw shellfish, food, or water, although the virus may be spread by airborne droplets as well. Epidemics are most frequent in residential homes, camps, institutions, and cruise ships. Many individual cases of mild diarrhea may in fact occur in epidemics for which the source of the infection cannot be found. Epidemic viral gastroenteritis is distinct from rotavirus diarrhea, a seasonal disease in winter that is the most common cause of diarrhea in young children, and affects virtually all children in the first 4 years of life. Since the diarrhea is often mild and of short duration, attention should be given to rehydration therapy and prevention by identification of the source. Fatalities have been associated with severe dehydration and loss of fluids and electrolytes in the stool. See ANIMAL VIRUS; DIARRHEA; INFANT DIARRHEA.

[R.G.]

**Epidemiology** The study of the distribution of diseases in populations and of factors that influence the occurrence of disease. Epidemiology examines epidemic (excess) and endemic (always present) diseases; it is based on the observation that most diseases do not occur randomly, but are related to environmental and personal characteristics that vary by place, time, and subgroup of the population. The epidemiologist attempts to determine who is prone to a particular disease; where risk of the disease is highest; when the disease is most likely to occur and its trends over time; what exposure its victims have in common; how much the risk is increased through exposure; and how many cases of the disease could be avoided by eliminating the exposure.

In the course of history, the epidemiologic approach has helped to explain the transmission of communicable diseases, such as cholera and measles, by discovering what exposures or host factors were shared by individuals who became sick. Modern epidemiologists have contributed to an understanding of factors that influence the risk of chronic diseases, particularly cardiovascular diseases and cancer, which account for most deaths in developed countries today. Epidemiology has established the causal association of cigarette smoking with heart disease; shown that acquired immune deficiency syndrome (AIDS) is associated with certain sexual practices; linked menopausal estrogen

use to increased risk of endometrial cancer but to decreased risk of osteoporosis; and demonstrated the value of mammography in reducing breast cancer mortality. By identifying personal characteristics and environmental exposures that increase the risk of disease, epidemiologists provide crucial input to risk assessments and contribute to the formulation of public health policy.

Epidemiologic studies, based mainly on human subjects, have the advantage of producing results relevant to people, but the disadvantage of not always allowing perfect control of study conditions. For ethical and practical reasons, many questions cannot be addressed by experimental studies in humans and for which observational studies (or experimental studies using laboratory animals or biomedical models) must suffice. Still, there are circumstances in which experimental studies on human subjects are appropriate, for example, when a new drug or surgical procedure appears promising and the potential benefits outweigh known or suspected risks. See DISEASE; EPIDEMIC.

Descriptive epidemiologic studies provide information about the occurrence of disease in a population or its subgroups and trends in the frequency of disease over time. Data sources include death certificates, special disease registries, surveys, and population censuses; the most common measures of disease occurrence are (1) mortality (number of deaths yearly per 1000 of population at risk); (2) incidence (number of new cases yearly per 100,000 of population at risk); and (3) prevalence (number of existing cases at a given time per 100 of population at risk). Descriptive measures are useful for identifying populations and subgroups at high and low risk of disease and for monitoring time trends for specific diseases. They provide the leads for analytic studies designed to investigate factors responsible for such disease profiles.

Analytic epidemiologic studies seek to identify specific factors that increase or decrease the risk of disease and to quantify the associated risk. In observational studies, the researcher does not alter the behavior or exposure of the study subjects, but observes them to learn whether those exposed to different factors differ in disease rates. Alternatively, the researcher attempts to learn what factors distinguish people who have developed a particular disease from those who have not. In experimental studies, the investigator alters the behavior, exposure, or treatment of people to determine the impact of the intervention on the disease. Usually two groups are studied, one that experiences the intervention (the experimental group) and one that does not (the control group). Outcome measures include incidence, mortality, and survival rates in both the intervention and control groups.

[V.L.E.]

**Epidermal ridges** Minute corrugations of the skin. They compose a sculpturing, termed dermatoglyphics, which characterizes the palmar and plantar surfaces of all primates. These areas lack hair and sebaceous (oil) glands, but sweat glands are numerous. In certain kinds of monkeys, a portion of the under-surface of the tail bears similarly specialized skin.

The ridges over the human hand as a whole, in young adult males, average 0.48 mm in breadth. They are slightly narrower in females, 0.43 mm. Ridges serve two functions: (1) They increase security of contact with objects, in the manner of the milling of a tool handle. Ducts of sweat glands open on the summits of ridges, and moistening of the skin augments the security of contact. (2) They enhance the sense of touch. In passing the fingers or palm over an object for judging its texture, the slight displacement of ridges heightens stimulation of the underlying nerve endings.

The characteristics of individual ridges and their collective configurations are not ordinarily studied by direct inspection of the skin. Instead, they are examined in prints, usually impressions of the inked surface, made for the purpose of record, or natural imprints made by chance contact. See FINGERPRINT. [H.Cu.]

**Epidermis (plant)** The outermost layer (occasionally several layers) of cells on the primary plant body. Its structure is variable; this article singles out five structural components of the tissue: (1) cuticle; (2) stomatal apparatus (including guard cells and subsidiary cells); (3) bulliform (motor) cells; (4) trichomes; and (5) root hairs.

Leaves, herbaceous stems, and floral organs usually retain the epidermis through life. Most woody stems retain it for one to many years, after which it is replaced. In roots it is usually short-lived. See LEAF; PERIDERM.

Cutin is a mixture of fatty substances characteristically found in epidermal cells. It impregnates the outer cell walls and occurs as a continuous layer (cuticle) on the outer surface. The cuticle covers the surfaces of young stems, leaves, floral organs, and even apical meristems. Waxes appear as a deposit on the outside of the cuticle in many plants; the bloom on purple grapes and plums is an example. Most often the waxes are present in small quantity, but the leaves of some plants may be almost white with wax (*Echeveria subrigida*). The waxes of a few species are of great commercial value in the manufacture of polishes for floors, furniture, automobiles, and shoes. Other substances, such as gums, resins, and salts, usually in crystalline form, may be deposited on the outside of the cuticle.

The apertures in the epidermis which are surrounded by two specialized cells, the guard cells, are known as stomata. The singular form, stoma, is derived from the Greek word for mouth. However, some authorities prefer to include both aperture and guard cells within the concept of stoma. The apertures of stomata are contiguous with the intercellular space system of underlying tissues and thus permit gas exchange between

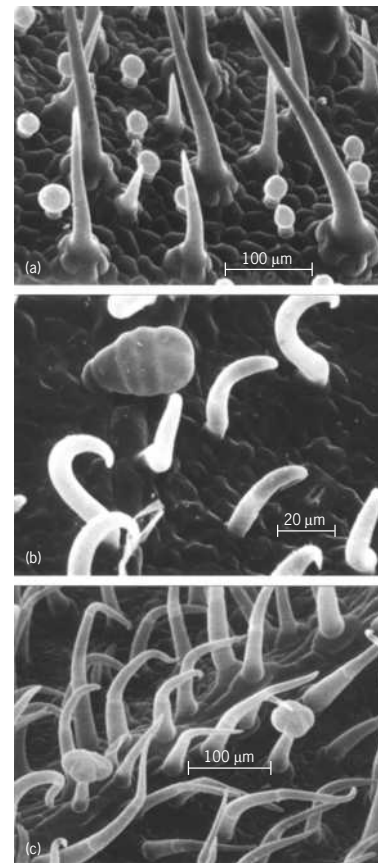

**Trichomes.** (a) Unicellular and glandular (colleters) hairs of the geranium (*Pelargonium*), (b) Unicellular-hooked and uniseriate, club-shaped hairs of the bean (*Phaseolus*). (c) Uniseriate and glandular hairs of the tomato (*Lycopersicon*).

internal cells and the external environment. The opening and closing of the stomatal aperture is caused by relative changes in turgor between the guard cells and surrounding epidermal cells.

Bulliform (motor) cells are large, highly vacuolated cells that occur on the leaves of many monocotyledons but are probably best known in grasses. They are thought to play a role in the unfolding of developing leaves and in the rolling and unrolling of mature leaves in response to alternating wet and dry periods.

Appendages derived from the protoderm are known as trichomes; the simplest are protrusions from single epidermal cells. Included in the concept, however, are such diverse structures as uniseriate hairs, multiseriate hairs (*Begonia*, *Saxifraga*), anchor hairs, stellate hairs, branched (candelabra) hairs, peltate scales, stinging hairs, and glandular hairs (see illustration). Cotton and kapok fibers are unicellular epidermal hairs.

Root hairs are thin-walled extensions of certain root epidermal cells. They develop only on growing root tips and may arise from any epidermal cell, or from specialized cells known as trichoblasts. The life of a given root hair is usually numbered in days. See ROOT (BOTANY); SECRETORY STRUCTURES (PLANT).

[N.H.B.]

**Epidote** The group name for a family of minerals of general composition  $\text{Ca}_2(\text{Fe}^{3+}, \text{Al}, \text{Mn}^{3+})\text{Al}_2\text{O}[\text{SiO}_4][\text{Si}_2\text{O}](\text{OH})$  that occur widely in metamorphic and igneous rocks. Epidote [octahedral ferric iron ( $\text{Fe}^{3+}$ ) dominant] and clinozoisite [aluminum (Al) dominant] represent the most common compositions among the epidote group; a third composition, piemontite [manganese ( $\text{Mn}^{3+}$ ) dominant], is less abundant. Allanite refers to compositions displaying significant rare-earth (such as lanthanum or cerium) substitution for calcium ( $\text{Ca}^{2+}$ ), with corresponding replacement of  $\text{Fe}^{3+}$  by ferrous iron ( $\text{Fe}^{2+}$ ). A fifth member, zoisite, is equivalent to clinozoisite, but it has a different crystalline system. Rare epidote-clinozoisites abundant in chromium (Cr), vanadium (V), and lead (Pb) and allanites rich in fluorine (F), beryllium (Be), and phosphorus (P) also exist. See CRYSTAL STRUCTURE; SOLID SOLUTION.

Epidote group minerals, particularly epidote and clinozoisite, are common and widespread in regional- and contact-metamorphic rocks, both as primary and secondary (that is, alteration) minerals. They occur together as individual grains, as intergrowths, or as zoned crystals. Epidote and (clino)zoisite are found in aluminous limestones with grossularite, anorthite, microcline, quartz, and calcite; in mafic schists and gneisses with hornblende, albite, and chloritoid; in actinolite greenschists with chlorite, sphene, albite, quartz, calcite, and magnetite; in hornfels with diopside, actinolite, grossularite, and albite; in glaucophane schists; in quartzites; and in slates. Approximate depth-temperature conditions of their formation range from 5–25 km (3–15 mi) and 300–500°C (570–1020°F; low-grade) to 5–25 km (3–15 mi) and 450–650°C (840–1200°F; medium-grade). However, their stabilities are also sensitive to the pressure of oxygen in the rock during metamorphism. See METAMORPHIC ROCKS.

[P.S.D.]

**Epinephrine** A hormone which is the predominant secretion from the adrenal medulla; also known as adrenalin, it has the structure shown. Epinephrine is a sympathomimetic substance;

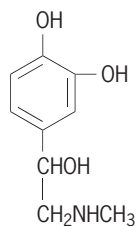

that is, it acts on tissue supplied by sympathetic nerves, and generally the effects of its action are the same as those of other nerve stimuli. Conversely, the stimulation of the splanchnic or visceral nerves will cause the rapid release of the hormone from the medullary cells of the adrenal gland. Thus, epinephrine plays an important role in preparing the organism to meet conditions of physiologic emergency.

When injected intravenously, epinephrine causes an immediate and pronounced elevation in blood pressure, which is due to the coincident stimulation of the action of the heart and the constriction of peripheral blood vessels. The chief metabolic changes following the injection of epinephrine are a rise in the basal metabolic rate and an increase of blood sugar. These effects of epinephrine are transitory. See ADRENAL GLAND; CARBOHYDRATE METABOLISM. [C.H.L.]

**Epitaxial structures** Epitaxial interfaces in solids are a special class of crystalline interfaces where the molecular arrangement of one crystal on top of another is defined by the crystallographic and chemical features of the underlying crystal. The term “epitaxy” was introduced to describe the importance of having parallelism between two lattice planes with similar networks of closely similar spacing. Epitaxial phenomena are important to study and understand, as they occur widely in nature (such as oxidation) and are the foundation by which modern semiconductor devices are grown and fabricated. See CRYSTAL GROWTH.

Epitaxial interfaces are a subset of a class of interfaces where lattice planes achieve a correspondence across an interface. If the matching is not perfect, such a correspondence can be achieved by a number of ways, including dilation and contraction of lattice planes; rotation of overgrowth (epilayer relative to the orientation of the substrate) until a set of closely matched lattice spacing can be found; and tilting of the epilayer with respect to the substrate (see illustration).

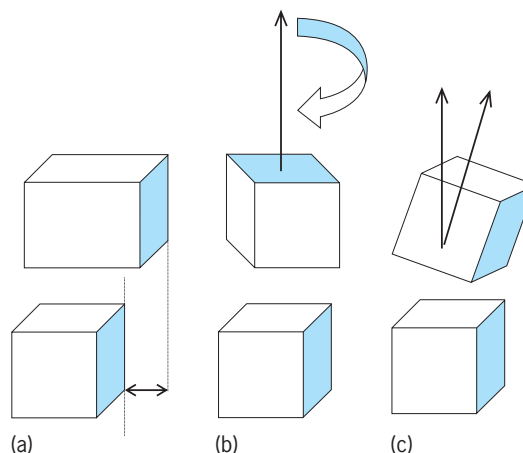

Matching of lattice planes between the substrate and the epitaxial layer by (a) expansion or contraction of lattice plane, (b) in-plane rotation, and (c) tilting (out-of-plane rotation).

The extent to which epitaxial films are mechanically stable due to coherency stresses is governed not only by the extent of lattice misfit but also by the strength of the chemical bond between the epilayer and the substrate. This property of adhesion is manifested by the extent to which the overlayer wets the substrate. Extremely thin layers that are only a few atoms thick can be produced. Such thin layers form the microstructural foundation for the fabrication of quantum wells, which are extremely important in semiconductor device applications. See QUANTIZED ELECTRONIC STRUCTURE (QUEST). [K.Ra.]



**Epithelium** One of the four primary tissues of the body, which constitutes the epidermis and the lining of respiratory, digestive, and genitourinary passages. The major characteristic of epithelium is that the cells are close together, separated by a very small amount of intercellular substance. Epithelium may be derived from any of the three primary germ layers of the very early embryo—ectoderm, endoderm, or mesoderm. With very few exceptions, epithelium is free of blood vessels.

The functions of epithelium are varied and include (1) protective function, by completely covering the external surface (including the gastrointestinal surface—and the surface of the whole pulmonary tree including the alveoli); (2) secretory function, by secreting fluids and chemical substances necessary for digestion, lubrication, protection, excretion of waste products, reproduction, and the regulation of metabolic processes of the body; (3) absorptive function, by absorbing nutritive substances and preserving water and salts of the body; (4) sensory function, by constituting important parts of sense organs, especially of smell and taste; and (5) lubricating function, by lining all the internal cavities of the body, including the peritoneum, pleura, pericardium, and the tunica vaginalis of the testis.

The forces which hold the epithelial cells together are not satisfactorily understood. The intercellular substance between the cells, also called cement substance, is undoubtedly important. The interdigitation of adjacent cell surfaces and the occurrence of intercellular bridges in certain cells may also be important in holding the cells together. Finally, in certain cells local modifications of contiguous surfaces and the intervening intercellular substances, which together form the terminal bars, may be effective in the same way.

The outstanding property of the arrangement of most of the epithelium of the body is the economy of space achieved in the face of a broad exposure of the cell surfaces. The efficiency is achieved by the presence of numerous folds, which may be gross or microscopic and temporary or permanent. A part must also be attributed to the surface specialization of the epithelial cells themselves, such as their minute, fingerlike processes. Another specialization of the surface or epithelial cell is the occurrence of motile cilia. See CILIA AND FLAGELLA.

Classification of epithelia is based on morphology, that is, on the shape of the cells and their arrangement (see illustration):

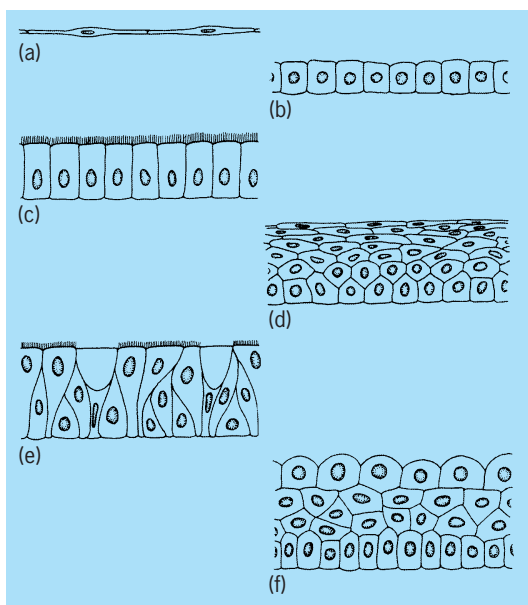

Cellular arrangements in epithelial tissues. (a) Squamous. (b) Cuboidal. (c) Columnar. (d) Stratified squamous. (e) Pseudostratified. (f) Transitional.

- I. Single-layered.
  - A. Squamous (mesothelium, descending loop of Henle in the kidney)—thin, flat.
  - B. Cuboidal (duct, thyroid, choroid plexus)—cubelike.
  - C. Columnar (intestine), sometimes ciliated (Fallopian tube, or oviduct)—tall.
- II. Multiple-layered or stratified.
  - A. Squamous (skin, esophagus, vagina)—superficial cells thin and flat, deeper cells cuboidal and columnar.
  - B. Columnar (pharynx, large ducts of salivary glands), sometimes ciliated (larynx)—two or more layers of tall cells.
- III. Pseudostratified (male urethra), sometimes ciliated (respiratory passages)—all cells reach to basement membrane but some extend toward the surface only part of the way, while others reach the surface.
- IV. Transitional (urinary bladder)—like stratified squamous in the fully distended bladder; in the empty bladder, superficial cells rounded, almost spherical.

An important property of epithelium is the ability of its cells to glide over surfaces. This allows replacement of dead cells to take place in the normal state, while presenting a closed surface to the external environment; replacement is especially important in wound repair. Gliding ability is also manifested normally in the movement of cells which slide over each other in transitional epithelium, for example, when the urinary bladder is being distended or contracted. See GLAND. [I.G.]

**Epoxide** A member of a class of three-membered ring cyclic ethers that are also known as oxiranes or alkylene oxides. The basic structure of an epoxide is analogous to that of the first member, ethylene oxide, shown below.

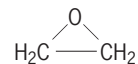

See ETHYLENE OXIDE.

Epoxides are made primarily by select oxidation reactions of alkenes; however, another classical preparation results from the ring closure of halohydrins by way of intramolecular nucleophilic displacement; that is, the reaction occurs within the same molecule, the alkoxide ion displacing the halogen to form a ring. The interest in epoxides results from their ease in preparation, and their usefulness as a reactive functional group that can give a variety of products after treatment with either electrophilic or nucleophilic reagents, or on occasion after treatment with oxidizing (for example, periodic acid) and reducing (for example, titanocene dichloride) agents. The ease of opening of the strained three-membered ring epoxides with attack of reagents in a stereospecific manner gives one or two stereochemical products (when applicable), usually in good yield. Epoxides are also used to prepare monomers, prepolymers, polymers, and copolymers. See ALKENE; ELECTROPHILIC AND NUCLEOPHILIC REAGENTS; HETEROCYCLIC COMPOUNDS.

Poly(ethylene oxide),  $(\text{CH}_2\text{CH}_2\text{O})_n$ , was one of the first polymers to be prepared in the laboratory. The use of numerous epoxides (as monomers, or for the synthesis of other epoxide monomers or prepolymers) in polymer synthesis has been quite extensive, and these polyethers have been prepared by both cationic and anionic polymerization techniques. The molecular weights of resulting polyethers generally range from 500 to 10,000, usually because of interfering chain-transfer reactions. An especially interesting synthesis is the opening of propylene oxide to give optically active poly(propylene oxides). Epoxides are used in the preparation of copolymers. See COPOLYMER; FURAN; POLYETHER RESINS; POLYMERIZATION.

Epoxides are promoters; that is, they are easy to polymerize, and their polymerization causes more difficult cyclic ethers such as tetrahydrofuran to polymerize. Epichlorohydrin has also been used for the preparation of prepolymers by condensations with

the sodium salt of bisphenols. The epichlorohydrin/bisphenol A and other epoxide prepolymers have been used for the preparation of epoxy resins (thermosets), which are cross-linked (3D) polymers, linear polymers that are connected by cross-linked molecular units. They are insoluble, infusible, and intractable, and sometimes are called epoxy resins. For example, a low-molecular-weight epoxy prepolymer can be treated and cross-linked with a polyamine or smaller molecules such as diethylenetriamine, or cross-linked by the addition of carboxylic acid anhydrides, such as maleic anhydride. Other polymers can also be incorporated or can participate in the cross-linking process, and include phenolics, ureas, and melamines. The products resulting from these prepolymer techniques are used for surface coating materials, molding, pipes, laminating, repair of damaged automobile bodies, manufacture of articles reinforced with glass fibers, durable and tough epoxy resin adhesives (glues), and many other applications. [C.F.B.]

**Epsomite** A mineral with the chemical composition  $MgSO \cdot 7H_2O$ . Epsomite, or epsom salt, occurs in clear, needle-like, orthorhombic crystals. More commonly it is massive or fibrous, although crystals from salt lakes on Kruger Mountain near Orville, Washington, are reported to be several feet long. Fracture is conchoidal. Luster varies from vitreous to silky. Hardness is 2–2.5 on Mohs scale and specific gravity is 1.68. The mineral has a salty bitter taste and is soluble in water. Epsomite is found as a capillary coating in limestone caves and in coal or metal mine galleries. It is also found associated with gypsum and in thin layers in salt deposits of oceanic origin or from salt lakes. [E.C.T.C.]

**Epstein-Barr virus** An antigenically distinct member of the herpesvirus group of viruses, whose genome is DNA. EB virus is the cause of one benign disease (infectious mononucleosis), and is associated with certain types of cancer; however, the great majority of EB virus infections are clinically inapparent. The virus was detected initially by electron microscopy in a small proportion of cells in continuous lymphoblastoid cell lines derived from Burkitt's lymphoma (but particles have not been seen in cells of the tumor itself). The virus also has been detected in cell lines derived from nasopharyngeal carcinomas, a type of cancer found with high frequency in persons from southern China. The virus is found in peripheral blood leukocytes from normal individuals and from patients with infectious mononucleosis. See INFECTIOUS MONONUCLEOSIS; LYMPHOMA.

If EB virus is indeed confirmed as having a role in the development of human malignancies, then one major question to be resolved is how a virus so ubiquitous can be involved in so wide a variety of responses. However, it should be recalled that many virus infections (for example, polio virus, hepatitis viruses, certain of the arboviral encephalitides) have a wide spectrum of outcomes, ranging from inapparent infection to severe syndromes. See ANIMAL VIRUS; ONCOLOGY. [J.L.Me.]

**Equalizer** An electronic filter that modifies the frequency response (amplitude and phase versus frequency) of a system for a specific purpose. Equalizers typically realize a more complicated frequency response in which the amplitude response varies continuously with frequency, amplifying some frequencies and attenuating others. An equalizer may have a response fixed in time or may be automatically and continuously adjusted. However, its frequency response is usually matched to some external physical medium, such as an acoustic path or communication channel, and thus inherently needs to be adjustable.

Equalizers can be used in many applications. In music and sound reproduction, equalizers can compensate for artifacts of the electrical-to-sound conversion or for unwanted characteristics of the acoustic environment such as sound reflections or absorption. Sound-recording and sonar systems can use equalizers to reduce unwanted interference. Most analog recording and

playback devices, such as audio and video tape recorders, incorporate equalizers to compensate for the undesirable aspects of the recording medium, such as high-frequency roll-off, as well as to reduce noise and maximize dynamic range. See ELECTRICAL INTERFERENCE; ELECTRICAL NOISE; SONAR; SOUND RECORDING.

Equalization is also used to enhance the performance of systems that communicate or record digital signals (streams of bits). All communications and recording systems utilize a physical medium, such as wires; coaxial cables; radio, acoustic, or optical-fiber waveguides; or magnetic and optical recording media. These media cause distortion; that is, the output signal is different from the input signal. For example, on radio or acoustic channels there are often multiple paths from transmitter to receiver, each having a slightly different delay and superimposed at the receiver. An equalizer is an electrical device that compensates for this distortion, reversing the effect of the channel and returning a waveform approximating the input signal. The channel output signal in response to a particular input signal (. . . , 0, 0, 1, 0, 0. . .) may differ from the input, but the equalizer output reproduces the channel input, at least to close approximation (see illustration). See DISTORTION (ELECTRONIC CIRCUITS).

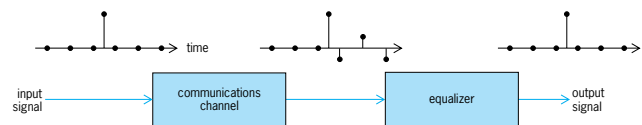

**Communications channel with an equalizer placed at the output. The equalizer recovers an accurate replica of the channel input signal.**

If the characteristics of the channel are well known, the equalizer can be fixed, or nonadaptive. More commonly, the detailed characteristics of a channel are not known in advance. For example, an equalizer may be required to compensate for any length of wire, from very short up to a maximum. In other cases, the channel may be varying with time, as is characteristic of the radio channel from a fixed transmitter to a moving vehicle. An adaptive equalizer is able to adjust itself to compensate. Adaptive equalizers are important for achieving high bit rates in telephone computer modems, and also for digital communications over radio channels. See DATA COMMUNICATIONS; MODEM. [D.G.M.]

**Equation of time** The annual, cyclic variation between mean solar time shown on uniformly running clocks and apparent solar time displayed on sundials.

In the course of the Sun's daily east-to-west transit of the sky, the Sun crosses the meridian, an imaginary line running from north to south that passes overhead and divides the sky into equal halves. An observer in the middle of a time zone generally thinks of noon as being the moment that the Sun reaches the meridian. This event, however, corresponds to noon recorded by mechanical or electronic clocks on only four dates each year (approximately April 16, June 14, September 1, and December 25). On all other dates the Sun reaches the meridian either early or late, with the extremes being 16.3 min early around November 3 and 14.3 min late around February 12. This difference is the equation of time, and results from the combined effects of Earth's axis of rotation being tipped  $23^\circ$  relative to Earth's orbital plane and the elliptical rather than circular shape of the orbit. See MERIDIAN.

The elliptical orbit brings the Earth closest to the Sun in January. This proximity, as J. Kepler discovered in the sixteenth century, causes the Earth to move more rapidly in its orbit than in July, when the Earth is farthest from the Sun. The changing orbital speed varies the Sun's apparent rate of motion along the ecliptic and is in part responsible for the equation of time. See CELESTIAL MECHANICS; KEPLER'S LAWS.

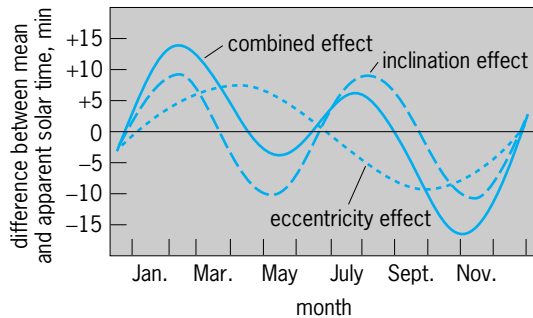

Graph of the equation of time, showing how the equation results from combining the effects of the inclination of the Earth's axis and the eccentricity of its orbit. (After B. M. Oliver, *The shape of the analemma*, *Sky Telesc.*, 44:20-22, July 1972)

Slightly more influential is Earth's tipped axis, which varies the Sun's position north and south of the celestial equator according to the season. Around the time of the spring and autumn equinoxes the Sun moves at a steep angle relative to the celestial equator. Its daily motion projected onto the equator is less than at the solstices, when the Sun travels parallel to the equator. This situation also creates a departure between the Sun's actual position and that of a mean Sun moving uniformly along the celestial equator. The effects of the inclination of the Earth's axis and the eccentricity of its orbit are combined (see illustration).

[D.D.C.]

**Equations, theory of** The branch of mathematics concerned with finding facts concerning the roots of algebraic equations and finding methods for obtaining them. The most important type of algebraic equation is the polynomial equation in one unknown which is an expression of the form  $f(x) = a_n x^n + a_{n-1} x^{n-1} + \dots + a_1 x + a_0 = 0$ , where  $x$  is called the unknown, or variable;  $n$  is a positive whole number; and the  $a_i$ , with  $i = 0, 1, \dots, n$ , are constants, or fixed numbers, called coefficients of the equation. The left member of the equation is called a polynomial in one variable of degree  $n$ . A root of such an equation is a number which, when substituted for the variable  $x$ , makes the left member zero. For example, 3 is a root of the equation  $x^3 + 2x^2 - 13x - 6 = 0$ . In addition, systems of equations in one or more variables are considered, and here the problem is to find values for the variables which simultaneously satisfy each equation of the system. See LINEAR SYSTEMS OF EQUATIONS; POLYNOMIAL SYSTEMS OF EQUATIONS.

The topics covered in a systematic study of the theory of equations can be placed in the following principal subdivisions: properties of a polynomial which do not depend on the particular number system containing the coefficients of the polynomial; factorization of polynomials; equations with coefficients which are rational, real, or complex numbers; determination of bounds for real roots, and systematic methods for approximating real roots of equations; the solution of quadratic, cubic, and quartic equations by radicals.

The factorization of a polynomial  $f(x)$  depends on the particular number field  $F$  under consideration. For example, the polynomial  $x^5 - \frac{1}{2}x^4 - x^3 + \frac{1}{2}x^2 - 2x + 1$ , having coefficients which are rational numbers, factors as

$$(x^2 + 1)(x^2 - 2)(x - \frac{1}{2})$$

over the rational numbers, as

$$(x^2 + 1)(x - \sqrt{2})(x + \sqrt{2})(x - \frac{1}{2})$$

over the real numbers, and as

$$(x + i)(x - i)(x - \sqrt{2})(x + \sqrt{2})(x - \frac{1}{2})$$

over the complex numbers. A polynomial  $f(x)$  with coefficients in  $F$  is irreducible over  $F$  if it cannot be expressed as a

product of polynomials of lower degree. Every polynomial can be expressed in essentially one way as a product of irreducible factors, although there is no general algorithm which enables one to obtain this expression.

The fundamental theorem of algebra states that a polynomial equation with complex coefficients has a complex root. From this it follows immediately that a polynomial of degree  $n$  with complex coefficients factors into  $n$  linear factors over the complex numbers.

Polynomial equations of degree 2, 3, and 4 are solvable by radicals. This means that there are formulas which give the roots in terms of the coefficients of the equation and that these formulas involve only the rational operations and the operation of extraction of roots. By use of the Galois theory of equations, it can be proved that for  $n > 4$  there cannot exist a formula involving only rational operations and root extractions for expressing the roots of every polynomial equation of degree  $n$  in terms of the coefficients. See DETERMINANT; MATRIX THEORY. [R.A.Be.]

**Equator** The great circle around the Earth, equally distant from the North and South poles, which divides the Earth into Northern and Southern hemispheres. It is the greatest circumference of the Earth because of centrifugal force from rotation, and resultant flattening of the polar areas.

The Earth's rotational axis is vertical to the plane of the Equator, and because the inclination of the axis is  $66\frac{1}{2}^\circ$  from the plane of the ecliptic, the plane of the Equator is always inclined  $23\frac{1}{2}^\circ$  from the ecliptic.

The celestial equator in astronomy is equally distant from the celestial poles and is the great circle in which the plane of the terrestrial Equator intersects the celestial sphere. See ASTRONOMY; MATHEMATICAL GEOGRAPHY. [V.H.E.]

**Equatorial currents** Ocean currents near the Equator. The westward trade winds that prevail over the tropical Atlantic and Pacific oceans drive complex oceanic circulations characterized by alternating bands of eastward and westward currents. The intense currents are confined to the surface layers of the ocean; below a depth of approximately 100 m (330 ft) the temperature is much lower, and the speed of ocean currents is much slower. The westward surface currents tend to be divergent—they are associated with a parting of the surface waters—and therefore entrain cold water from below. The water temperature rises as the currents flow westward, so that temperatures are low in the east and high in the west, except between  $3$  and  $10^\circ\text{N}$  where eastward surface currents create a band of warm water across the Pacific and Atlantic oceans. The distinctive sea surface temperature pattern in which surface waters are warm in the west and cold in the east, except for the warm band just north of the Equator, reflects the oceanic circulation. A dramatic change in this pattern every few years during El Niño episodes, when the temperature of the eastern tropical Pacific Ocean rises, is associated with an intensification of the eastward currents and a weakening (sometimes reversal) of the westward currents. See EL NIÑO.

The South Equatorial Current flows westward in the upper ocean, has its northern boundary at approximately  $3^\circ\text{N}$ , and attains speeds in excess of 1 m/s (3.3 ft/s) near the Equator. It is directly driven by the westward trade winds and has its origins in the cold, northwestward-flowing Peruvian coastal current. Because the Coriolis force deflects water parcels to their right in the Northern Hemisphere and to their left in the Southern Hemisphere, this current is divergent at the Equator. As a consequence, cold water from below wells up along the Equator. See CORIOLIS ACCELERATION; UPWELLING.

The North Equatorial Countercurrent flows eastward immediately to the north of the South Equatorial Current. The boundary between these two currents is a sharp thermal front that is clearly evident in satellite photographs. The front can literally be

a green line, hundreds of yards wide, because of the abundance of phytoplankton. This current, which is counter to the wind, is driven by the torque (curl) that the wind exerts on the ocean. To its north is a colder westward current known as the North Equatorial Current. See OCEAN WAVES; PHYTOPLANKTON.

The Equatorial Undercurrent, which in the Pacific Ocean was originally known as the Cromwell Current, is an intense, narrow, eastward, subsurface jet that flows precisely along the Equator across the width of the Pacific. Its core, where speeds can be in excess of 1.5 m/s (5 ft/s), is at an approximate depth of 100 m (330 ft); its width is approximately 200 km (120 mi). A similar current exists in the Atlantic Ocean. In the Indian Ocean it is often present along the Equator, in the western part of the basin during March and April when westward winds prevail over that region. Such winds (including the trade winds over the Pacific and Atlantic oceans) pile up warm surface waters in the west while exposing cold waters to the surface in the east. See ATLANTIC OCEAN; INDIAN OCEAN; PACIFIC OCEAN. [S.G.P.]

**Equilibrium of forces** In a mechanical system the condition under which no acceleration takes place. Newtonian mechanics today is based upon two definitions which modify, but are essentially equivalent to, Newton's three fundamental laws. These definitions postulate the action of forces on particles. A particle is defined as a conceptual volume element that has mass and is sufficiently small to have point location. A body is defined as a system of particles. To develop the mechanics of a body, these definitions are applied to each of its particles and their influences summed. See ACCELERATION.

The law of motion is that, in a newtonian frame of reference (with few exceptions, a frame of reference fixed with respect to Earth is considered to be newtonian), a particle of mass  $m$  acted on by resultant force  $\mathbf{F}$  has acceleration  $\mathbf{a}$  in accordance with the equation  $\mathbf{F} = k\mathbf{ma}$ . Therein,  $k$  is a positive constant whose value depends upon the units in which  $\mathbf{F}$ ,  $m$ , and  $\mathbf{a}$  are measured. The action-reaction law states that when one particle exerts force on another, the other particle exerts on the one a collinear force equal in magnitude but oppositely directed.

A body acted upon by force is in equilibrium when its constituent particles are in equilibrium. The forces exerted on its particles (and therefore on the body) are either internal or external to the body. An internal force is one exerted by one particle on another in the same body. An external force is one exerted on a particle or the body by a particle not of the body. See DYNAMICS; KINETICS (CLASSICAL MECHANICS); STATICS. [N.S.F.]

**Equine infectious anemia** A lentivirus-induced disease of the horse family with an almost worldwide distribution. It is characterized by recurring fever, platelet reduction, weight loss, edema, and anemia. Although death can occur, there is usually an eventual cessation of clinical signs. However, host defenses are unable to completely eliminate the virus, and the animal remains a persistently infected inapparent carrier.

The equine infectious anemia virus is in the *Lentivirus* genus of the family Retroviridae. Although it is closely related to the human immunodeficiency viruses (HIV-1, HIV-2), its genetic organization is the least complex of this group of viruses.

Equine infectious anemia virus infects only members of the horse family. The mechanical transfer of blood between animals by large blood-feeding insects (mainly horse flies and deer flies) is probably the most important mechanism of natural transmission. However, the virus can be efficiently transmitted by humans if sterile techniques are not observed during veterinary procedures.

Clinical responses to equine infectious anemia virus infection can range from an extremely severe disease resulting in death to an absence of obvious signs. However, when disease occurs it is usually observed shortly after exposure to the virus (incubation periods of 10–45 days are common) and consists of fever, platelet reduction (thrombocytopenia), lethargy, loss of

appetite, and petechial hemorrhages. Most horses survive this acute episode but in many cases progress to the chronic form of the disease, characterized by recurring fever, thrombocytopenia, anemia, weight loss, edema, and hemorrhage. Each fever episode is associated with massive amounts of viral replication that occurs predominantly in the mature tissue macrophages of the liver and spleen and results in the release of millions of viral particles into the bloodstream. This extensive replication triggers the release of powerful molecules called cytokines, such as tumor necrosis factor alpha (TNF $\alpha$ ), that are normally associated with inflammatory reactions.

Equine infectious anemia virus employs numerous mechanisms to avoid removal by host defenses. These mechanisms range from infecting and possibly compromising the efficiency of a key cell type in the immune system to possessing a surface unit protein with a fundamental structure that confers partial resistance to neutralizing antibodies. Another property of this protein is its ability to withstand considerable alterations in amino acid content without loss of function. This, in combination with a high mutation rate, facilitates the emergence of variants that are completely resistant to the strain-specific neutralizing antibodies produced within the first months of infection. Although additional strain-specific neutralizing antibodies may be generated against these variants, the mutational capabilities of this virus permit still more resistant types to arise. See IMMUNITY.

A safe and effective vaccine that rapidly induces protection against all strains of the equine infectious anemia virus is not yet available; this virus is controlled in most areas of the world by serological testing that detects the presence of antibodies against the major core protein of the virus. If a horse tests positive, further transmission of the equine infectious anemia virus can usually be prevented by segregation or quarantine. See RETROVIRUS; VIRUS INFECTION, LATENT, PERSISTENT, SLOW. [R.F.Co.; C.J.I.]

**Equinox** One of the two places in the sky where the ecliptic crosses the celestial equator; or one of the two times of the year when the Sun crosses these points. The ecliptic is the great circle across the sky that marks the mean path of the Sun; the celestial equator is the great circle that is an extension into the sky of the Earth's mean Equator. These two great circles meet at two points, one of which is the vernal equinox and the other the autumnal equinox. The Sun passes the vernal equinox each year about March 20, and the autumnal equinox about September 22. The dates and times drift with the difference between the actual solar years and 365 days, and are corrected by leap years. See ASTRONOMICAL COORDINATE SYSTEMS; CALENDAR; TIME.

The term equinox is derived from the Latin for equal nights, indicating that the day and night are of equal duration. However, the actual duration of daylight is several minutes longer on the days of the equinoxes. The equinoctial dates are geometrical constructions in which the Sun is treated as a point; in actuality the top of its disk rises a few minutes ahead of its center. Furthermore, refraction in the Earth's atmosphere makes the Sun appear higher in the sky than it actually is, an effect that also lengthens daylight by several minutes. See METEOROLOGICAL OPTICS; REFRACTION OF WAVES. [J.M.P.]

**Equisetales** An order of the division Sphenophyta, subkingdom Embryobionta. The Equisetales, commonly known as horsetails, is represented by a single living genus, *Equisetum*, with about 25 species found both in moist and dry habitats. These plants grow throughout the world, except in Australia and New Zealand. The plants range from herbaceous to shrubby and rarely exceed 3 or 4 ft (0.9 or 1.2 ft) in height, although some tropical species grow much taller.

The plant body is commonly composed of perennial underground stems (rhizomes) with various types of aerial stems (see illustration) in different species. Some of these are perennial, others annual; some are unbranched and reproductive, others

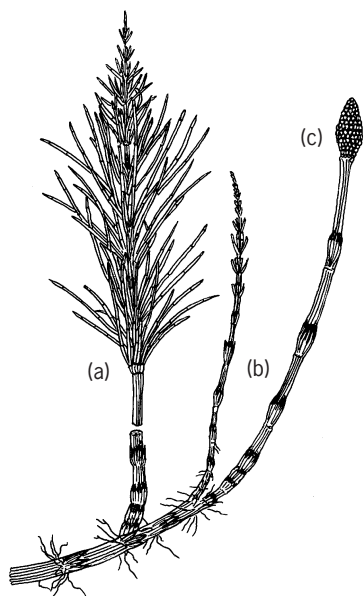

*Equisetum arvense*. (a) Sterile shoot. (b) Fertile shoot growing from an underground rootstock. (c) Cone. (After E. W. Sinnott and K. S. Wilson, *Botany: Principles and Problems*, 6th ed., McGraw-Hill, 1963)

much branched and vegetative. The bushy structure of the latter is suggestive of the common name, horsetail. [P.A.V.]

**Equivalent circuit** A representation of an actual electric circuit or electronic device by a simple circuit whose behavior is very near to that of the actual circuit over a specified range of conditions. When these conditions are satisfied, the equivalent circuit may be said to constitute a macromodel of the actual circuit. The use of equivalent circuits is important in many of the analysis and design operations associated with electronic circuits. Many electric circuits, for example, active-RC (resistance-capacitance) filters, require the use of large numbers of operational amplifiers. In such applications, the use of equivalent circuits greatly simplifies analysis and design operations. See CIRCUIT (ELECTRICITY); CIRCUIT (ELECTRONICS); ELECTRIC FILTER; INTEGRATED CIRCUITS; OPERATIONAL AMPLIFIER; TRANSISTOR.

Two of the best-known equivalent circuits are the Thévenin equivalent circuit and the Norton equivalent circuit. The Thévenin equivalent circuit consists of the series connection of a voltage source and a two-terminal circuit; the Norton equivalent circuit consists of the parallel connection of a current source and a two-terminal circuit. In both circuits, the output of the voltage or current source is usually dependent on the electric signals applied to the input terminals. See NETWORK THEORY; THÉVENIN'S THEOREM (ELECTRIC NETWORKS). [L.P.Hu.]

**Equivalent weight** The number of parts by weight of an element or compound which will combine with or replace, directly or indirectly, 1.008 parts by weight of hydrogen, 8.00 parts of oxygen, or the equivalent weight of any other element or compound. For all elements, the atomic weight is equal to the equivalent weight times a small whole number, called the valence of the element. An element can have more than one valence and therefore more than one equivalent weight. See ELEMENTS; VALENCE.

The concept of equivalent weight, together with that of gram-equivalent weight, tends to have been abandoned, and relations are expressed in terms of balanced stoichiometric chemical equations and relative numbers of moles reacting. See ELECTROCHEMICAL EQUIVALENT; MOLE (CHEMISTRY); STOICHIOMETRY. [T.C.W.]

**Erbium** A chemical element, Er, atomic number 68, atomic weight 167.26, belonging to the rare-earth group. The naturally occurring element is made up of the six stable isotopes. The rose-pink oxide,  $\text{Er}_2\text{O}_3$ , dissolves in mineral acids to give rose-colored solutions. The salts are paramagnetic and the ions are trivalent. At low temperatures the metal is antiferromagnetic and at still lower temperatures becomes strongly ferromagnetic. For properties of the metal see RARE-EARTH ELEMENTS. [F.H.Sp.]

**Ergosterol** A steroid that belongs to the class of unsaponifiable lipids. It was first isolated from ergot bodies. Ergosterol is a white crystalline compound, insoluble in water and soluble in organic solvents, with the structural formula shown here.

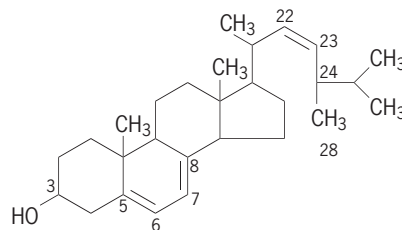

Ergosterol differs from cholesterol by having three positions of unsaturation, at carbon atoms 5-6, 7-8, and 22-23, and containing a methyl group (carbon atom 28) substituted for a hydrogen atom at carbon atom 24. See CHOLESTEROL.

Ultraviolet irradiation of ergosterol leads to the formation of calciferol (vitamin  $\text{D}_2$ ). Under controlled conditions, a more than 50% yield of vitamin  $\text{D}_2$  can be obtained. The process is used commercially. see STEROID; VITAMIN D. [W.J.V.W.]

**Ergot and ergotism** Ergot is the seedlike body of fungi (molds) of the genus *Claviceps*; ergotism is a complex disease of humans and certain domestic animals caused by ingestion of grains and cereals infested with ergot. Ingestion of these long, hard, purplish-black structures called sclerotia may lead to convulsions, abortion, hallucinations, or death. During the Middle Ages, hundreds of thousands of people are believed to have died from this disease, often referred to as holy fire, St. Anthony's fire, or St. Vitus' dance. Epidemics in humans, although less prevalent in modern times, last occurred in 1951, and the potential danger is always present, as shown by annual livestock losses due to ergot poisoning. There are 32 recognized species of *Claviceps*, most of which infect members of the grass family. Only three species are parasitic on the rushes and sedges. See PLANT PATHOLOGY; POISON.

Sclerotia have an unusual chemical makeup. They carry only 10% water by weight, and 50% of the dry weight is composed of fatty acids, sugars, and sugar alcohols, which make the ergot a storehouse of energy. Unfortunately, they also contain the poisonous alkaloids, ranging from 0 to 1.2% of the dry weight.

There are three types of ergotism (gangrenous, convulsive, and hallucinogenic). Their symptoms often overlap; the hallucinogenic form is usually observed in combination with one of the other two. The unusual combination of gangrenous and convulsive symptoms is sometimes observed in the Balkans and areas near the Rhine River.

The hallucinogenic form often includes symptoms of one of the other types. In its more pure form, it is referred to as choreomania, St. Vitus' dance, or St. John's dance. Vivid hallucinations are accompanied by psychic intoxication reminiscent of the effects of many of the modern psychedelic drugs. Early reports state that the disease usually manifested itself in the form of strange public dances that might last for days or weeks on end. Dancers made stiff jerky movements accompanied by wild hopping, leaping, screaming, and shouting. They were often heard

conversing with devils or gods, and danced compulsively, as if possessed, until exhaustion caused them to fall unconscious or to lie twitching on the ground. High mortality rates were associated with severe epidemics involving any of the three forms of ergotism. The success with which the disease is controlled in humans has been brought about by (1) agricultural inspection, (2) use of wheat, potatoes, and maize instead of rye, (3) limited control of ergot, (4) reserves of sound grain, and (5) forecasting severe ergot years. The most recent and best-recorded epidemic was in southern France in 1951 when an unscrupulous miller used moldy grain to make flour.

In the early twentieth century two ergot alkaloids (ergotoxine and ergotamine) were isolated. Unfortunately, they caused significant side effects and were not as specific or active as some of the crude aqueous preparations. Shortly after its discovery, ergotamine was found to be effective in the treatment of migraines. Both ergotoxine and ergotamine cause vasoconstriction that can lead to gangrene with chronic use. See HEADACHE.

In 1935 a new water-soluble ergot alkaloid, ergonovine, was synthesized. Ergonovine is used to facilitate childbirth by stimulating uterine contractions. Many other important lysergic acid derivatives have been produced by means of semisynthesis. Of these derivatives, LSD-25 (*d*-lysergic acid diethylamide) is the most famous. LSD has been used experimentally, mainly in psychiatry and neurophysiology. See PSYCHOTOMIMETIC DRUG.

Through extensive research, many other uses for ergot alkaloids has been found. Ergotamine and dihydroergotamine are used to treat migraines, and methysergine is used in migraine prophylaxis. Dihydroergotoxine is prescribed for hypertension, cerebral diffuse sclerosis, and peripheral vascular disorders. Ergocorine and the less toxic agroclavine have been reported as unusual experimental birth-control agents. The drugs appear to inhibit implantation of the ovum. Several semisynthetic alkaloids are also active implantation inhibitors. [R.L.M.]

**Ericales** An order of flowering plants, division Magnoliophyta (angiosperms), in the large asterid assemblage (often Asteroideae in previous systems of classification). Nearly all of the 24 families assigned to the order have previously been considered members of several orders in the subclass Dilleniidae. Ericales are a diverse group that have general asterid characters: tenuinucellate ovules; flowers with fused sepals, and often, fused petals with the anthers fused at least basally to the petals, even when the petals are apparently free; cellular endosperm formation; and tegumentary tapeta.

The largest families are Ericaceae (1350 species), Primulaceae (1000 species), Myrsinaceae (1000 species), Sapotaceae (800 species), and Balsaminaceae (600 species). The two biggest families are largely temperate herbs (Primulaceae), and the next three are largely tropical trees or herbs (Balsaminaceae). A relationship between the first four families has been known for many years, but the last has nearly always been considered related to the rosoid family Geraniaceae.

Familiar plants belonging to Ericales include rhododendrons (*Rhododendron*, Ericaceae), camellias (*Camellia*, also the genus of tea, Theaceae), primroses (*Primula*, Primulaceae), phlox (*Phlox*, Polemoniaceae), and impatiens (*Impatiens*, Balsaminaceae). See BLUEBERRY; DILLENIIDAE; MAGNOLIOPSIDA; PLANT KINGDOM. [M.W.C.]

**Eriocaulales** An order of flowering plants, division Magnoliophyta (Angiospermae), subclass Commelinidae of the class Liliopsida (monocotyledons). The order consists of the single family Eriocaulaceae, with about 1200 species. The Eriocaulales are Commelinidae with a reduced (or no) perianth and with unisexual flowers aggregated into a dense, involucre head that is elevated above the clustered, basal leaves on a long peduncle. Although the individual flowers are small and inconspicuous, the heads are more or less showy and pollination is usually by insects, in spite of the absence of nectar and nectaries. The order

is of negligible economic importance. See COMMELINIDAE; LILIOPSIDA. [A.Cr.]

**Erosion** The result of processes that entrain and transport earth materials along coastlines, in streams, and on hillslopes. Wind and water are common agents through which forces are applied to resistant rocks, soils, or other unconsolidated materials. Erosion types often are designated on the basis of the agent: wind erosion, fluvial (water) erosion, and glacial erosion. Fluvial erosion usually has been regarded as the most effective type in shaping the land surface during recent geologic time. Under certain environmental conditions, however, wind erosion moves considerable quantities of earth materials, as demonstrated during the "dust bowl" years in the United States. Glacial erosion shaped much of the land surface during the Quaternary Period of geologic time. Each type of erosion produces distinctive landforms, contributing to the diversity of terrestrial landscapes. See DESERT EROSION FEATURES; EOLIAN LANDFORMS; FLUVIAL EROSION LANDFORMS; GEOMORPHOLOGY; GLACIOLOGY; MASS WASTING; QUATERNARY; STREAM TRANSPORT AND DEPOSITION.

Forces exerted by erosion processes must exceed resistances of earth materials for entrainment and transportation to occur. Environmental conditions determine the magnitude of the forces, the resistances, and the relations among them. Erosion rates are highly variable in time and space due to changing relations between forces and resistances. The major factors governing wind-erosion rates are wind velocity, topography, surface roughness, soil properties and soil moisture, vegetation cover, and land use. The major factors governing fluvial-erosion rates on hillslopes are rainfall energy, topography, soil properties, vegetation cover, and land use. The major factors governing fluvial-erosion rates in stream channels are depth and velocity of water flow, together with the size and cohesiveness of the bed and bank materials. The major factors governing glacial-erosion rates are the depth and velocity of ice flow, together with the hardness of the bed and side-wall materials.

Accelerated erosion by fluvial processes may be the most important environmental problem worldwide because of its spatial and temporal ubiquity. Erosion rates commonly exceed soil-formation rates, causing depletion of soil resources. The effects of erosion are insidious due to the removal of the fertile topsoil horizon, compromising food production. Sediment frequently is transported well beyond the source area to degrade water quality in streams and lakes, harm aquatic life, reduce the water-storage capacity of reservoirs, and increase channel-maintenance costs. See SOIL; SOIL CONSERVATION. [T.J.T.]

**Errantia** A group of 34 families of Polychaeta in which the anterior, or cephalic, region is more or less fully exposed and the body is often long, linear to short, and depressed. The segments of these worms are similar or change gradually. The pharynx is often heavily muscularized and eversible, and its inner walls are fortified with calcified or chitinized plates or jaws. Some families are benthic throughout their life, others are entirely pelagic, and some have pelagic larval and reproductive stages and benthic trophic development. Errantia occur in all seas, at all depths, and in inland seas or lakes. They range in length from a few tenths of an inch (few millimeters) to 6 ft (1.8 m). See POLYCHAETA.

There are 6 families of scale bearers and allies: Aphroditidae (9 genera and about 85 species) include the sea mouse (*Aphrodita*) and the giant cold-water *Laetmonice*. Polynoidae (75 genera, 600 species) are in all seas and at all depths. Most are benthic, some are pelagic (*Drieschia*, *Nectochaeta*), and others are commensal (*Arctonoe*, *Hesperonoe*, *Polynoe*); some are known only from abyssal depths (*Macellicephalo*). Common genera are *Harmothoe*, *Lepidonotus*, and *Halosydna*. Polyodontidae (8 or 9 genera and about 35 species) are tubicolous and often large-bodied. Some secrete fibers to construct tubes. They are worldwide, occurring chiefly in tropical latitudes. Typical genera are *Eupanthalis*, *Panthalis*, and *Polyodontes*. Sigalionidae

(10 genera and about 130 species) are worldwide and occur in all latitudes, from littoral to abyssal depths. The best-known genera are *Leanira*, *Psammolyce*, *Sigalion*, *Sthenelais*, and *Thalenessa*. The other 5 families are small: Peisidicidae (1 genus, 3 species); Pareulepidae (1 genus, 8 species); Pisionidae (5 genera, 12 species); Chrysopetalidae (4 genera, 18 species); and Palmyridae (1 genus, 2 species).

There are 3 Amphinomorpha families: Amphinomidae (18 genera and about 120 species) comprise the stinging or fire worms; a burning sensation results from handling them. Common genera are the large, brilliantly colored *Amphinome* and *Hermodice*—the “scorpions of the sea.” Euphosinidae (Fig. 1; 2 genera, 45 species) and Spintheridae (1 genus, 8 species) are short and depressed and are associated with sponges and other colonial animals.

The leaf-bearing and pelagic groups are composed of 8 families. The Phyllodocidae (30 genera, more than 240 species) are often brilliantly iridescent and are highly motile, with arresting colors and ornamentation. They occur in all seas and at all depths. Common genera are *Anaitides*, *Eulalia*, *Eteone*, and *Phyllococe*. The pelagic families allied to the Phyllodocidae are Alciopidae (10 genera, 41 species); Lopadorrhynchidae (2 genera, 5 species); Iospilidae (4 genera, 7 species); Pontodoridae (single genus and species); and Typhloscolecidae (3 genera, 14 species). The benthic families are Lacydonidae (3 genera, 6 species), and Tomopteridae, or glass worms (2 genera and about 40 species).

The Hesionidae (22 genera, more than 82 species), and the Pilargidae (6 genera and about 25 species) differ from other depressed; a few are long and linear. Some are free-living; others commensal. The best-known genera are *Hesionie*, *Leocrates*, *Oxydromus*, and *Podarke* in the Hesionidae and *Ancistrosyllis* and *Pilargis* in the Pilargidae.

Syllidae comprise the second largest of polychaete families; they have 55–60 genera and more than 400 species. Most occur along intertidal rocky shores among epiphytic plants or animals or in encrusting sponges. They are chiefly foraging predators or scavengers, identified by their long, linear, translucent bodies with articulated cirri (Fig. 2).

Nereidae is known for about 27 genera and more than 360 species. Most are marine, occurring in worldwide seas and at all depths; a few are euryhaline, entering tidal streams or inland seas, or occur in thermal springs and high mountain lakes. Common genera are *Nereis*, *Neanthes*, *Ceratocephale*, *Platynereis*, and *Perinereis*.

Nephtyidae (4 genera and about 85 species) are sometimes called sandworms for their occurrence in intertidal sands, where their highly opalescent colors and rapid movements render them almost invisible. They occur in worldwide seas at all depths. Common genera are *Nephtys* and *Aglaophamus*.

Sphaerodoridae (2 genera and about 18 species) are small, short- to long-bodied, and usually papillated; usually their occurrence is rare.

Glyceridae (3 genera and about 66 species) are characterized by the enormous eversible proboscis used in food capture

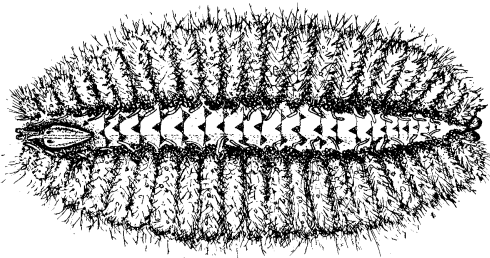

Fig. 1. *Euphosine*, of the Euphosinidae, dorsal view. (After McIntosh)

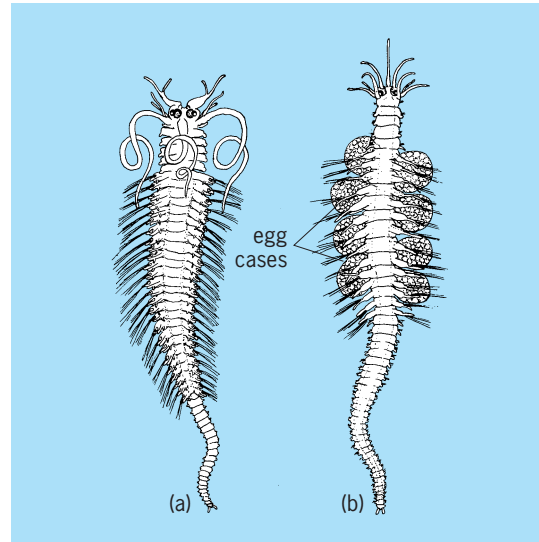

Fig. 2. *Procerastea* of the Syllidae (Autolytinae). (a) Epitokous male, dorsal view. (b) Epitokous female with attached egg cases, dorsal view.

and forward progression. Closely allied, the family Goniadidae (7 genera and more than 60 species) occurs in all seas and at all depths. *Glycinde*, *Goniada*, *Goniadides*, and *Ophioglycera* are worldwide in occurrence.

The superfamily Eunicea comprises 6 families. Onuphidae (10 genera and about 100 species) are tubicolous, grazing, herbivorous, scavenging, are worldwide in occurrence, and exist in intertidal to abyssal depths. Eunicidae (7 genera and about 225 species) are mainly from tropical seas; included are the coral-eating *Lysidice*, and a bait worm, *Marphysa*. Lumbrineridae (3 genera and about 130 species) are known in all seas. Arabelleidae (9 genera and about 66 species) chiefly include free-living and parasitic species. Lysaretidae (3 genera, 8 species) include large fish-bait worms (*Lysarete* and *Halla*) in tropical regions where they occur. *Iphitime* is an ectoparasite on large crabs. Dorvilleidae (3 genera and about 40 species) are small to minute and are chiefly intertidal in epiphytic growth.

Two parasitic families allied to the Eunicea are the Histriobdellidae, ectoparasites of crayfishes (2 genera, 5 species), and the Ichthyotomidae, parasites of fishes (single genus and species). See ANNELIDA.

[O.H.]

**Erysipelothrix** A genus of gram-positive bacteria comprising at least two species, *E. rhusiopathiae* and *E. tonsillarum*. *Erysipelothrix rhusiopathiae* is the more pathogenic and causes disease in a variety of animal species, including humans. It is a rod-shaped organism,  $0.3 \times 1\text{--}2$  micrometers, that may form filaments in old cultures and in chronically infected tissues. It occurs in the tonsils of healthy swine and on the surfaces of fish and other aquatic species; it is shed in the urine, oral secretions, and feces of infected animals. Organisms deposited in the soil may survive for years and may be a source of infection for susceptible domestic and wild animals and birds.

*Erysipelothrix rhusiopathiae* causes disease in swine (erysipelas), turkeys, lambs, and a variety of other domestic and wild mammals and birds. Infections are acquired via skin abrasions, or occur when organisms in the tonsil invade the bloodstream of swine stressed by excessive heat. The organism spreads via contaminated excretions and saliva. Infections in humans are associated with occupational exposure to the organism (veterinarians, butchers, pathologists, fish-handlers). They are usually acquired via minor cuts and abrasions on the hands or arms, leading to a painful local purplish erythema

termed erysipeloid. This infection may occasionally lead to invasion of the bloodstream or joints.

*Erysipelothrix rhusiopathiae* is easily demonstrated microscopically and by culture of blood and tissues of affected animals. Penicillin is the antibiotic of choice for treatment of infected animals or humans. Protective immunity is stimulated by live attenuated strains or by inactivated virulent *E. rhusiopathiae*. See MEDICAL BACTERIOLOGY. [J.F.T.]

**Escalator** A continuously moving stairway and handrail. The escalator (see illustration) transports a continuous stream



Cutaway view of escalator. (Otis Elevator Co.)

of passengers from floor to floor. Usually speed is 100 ft/min (0.5 m/s); slope is standardized at 30°. Steps ride on resilient rollers running on tracks; endless roller chains propel the steps, the chains being driven by sprockets and a worm drive. An electric motor at the top of the escalator provides the motive force. The direction of travel can be reversed in accordance with the flow of traffic. [F.H.R.]

**Escape velocity** Minimum speed away from a parent body that a particle must acquire to escape permanently from the gravitational attraction of the parent. Escape velocity is also termed parabolic velocity. See ORBITAL MOTION.

Earth retains an atmosphere because the escape velocity is considerably higher than the mean velocity of the gas molecules in its atmosphere. For a space ship to escape from Earth and travel to another planet or orbit about the Sun, it must reach escape velocity. This velocity can be calculated by equating the kinetic energy of the moving body to the work necessary to overcome the gravity at the surface of the parent. For Earth,  $v_{\text{escape}} = 11.2 \times 10^3$  m/s. See SATELLITE (SPACECRAFT). [R.L.Du.]

**Escapement** A mechanism in which a toothed wheel engages alternate pallets attached to an oscillating member. The escapement is found principally in timepieces but may be employed wherever oscillating motion is required.

In a mechanical clock or watch, the escapement intervenes between the energy source (spring or elevated weight) and the regulating device (pendulum or balance wheel). It is acted upon by both. The escape wheel is mounted on the same shaft as the last wheel of the gear train, and impulses are delivered from the escape wheel to operate the regulating device. The regulating device, which has a natural period of oscillation, determines the rate at which it will receive these impulses, and thus regulates the rate of going of the timepiece.

The anchor recoil escapement (Fig. 1) is used with a pendulum and takes its name from the shape of its oscillating member and its action. In the position shown, pallet *B* has just received an impulse from the escape wheel, the impulse swinging the pendulum to the left. When pallet *B* has cleared the tooth, allowing

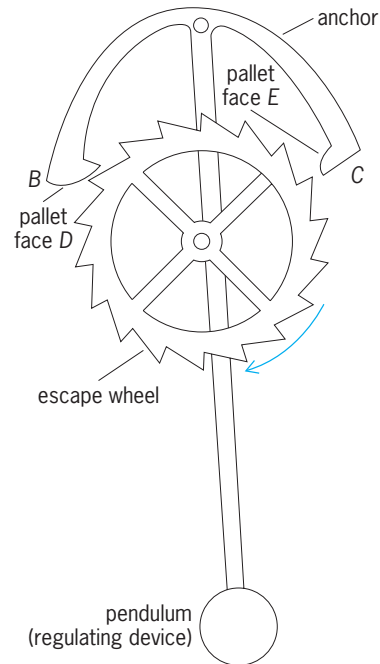

Fig. 1. Anchor recoil escapement.

the wheel to escape, pallet *C* will be in position to arrest the wheel. Recoil, or momentary reversal of the escape wheel, occurs just after it is arrested because the pendulum has not quite completed its swing. The wheel tooth in contact with pallet *C* will then give the oscillating parts an impulse in the opposite direction.

Modern watches generally employ a detached-lever escapement (Fig. 2), which has banking pins *B* to limit the oscillation

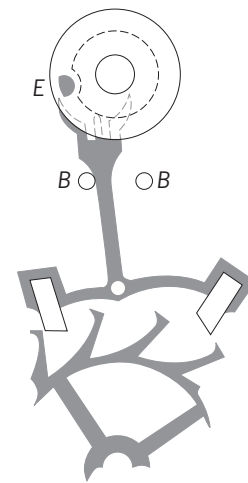

Fig. 2. Detached-lever escapement, often used in modern watches. (After F. J. Britten, *Britten's Old Clocks and Watches and Their Makers*, 7th ed., Dutton, 1956)

of the anchor and its lever. An escapement is termed detached when the regulating device, in this case the balance wheel, is given an impulse during only a small part of its operating cycle. When the fork reaches the end of its swing, it is lightly locked by a wheel tooth and remains stationary until the returning impulse pin *E* causes sufficient recoil of the escape wheel to release the pallet. See CHRONOMETER; CLOCK.

Some modern watches employ a light ratchet powered by a vibrating reed at 360 Hz. See WATCH. [D.PAD.]



**Escarpment** A long line of cliffs or steep slopes that break the general continuity of the land by separating it into two level or sloping surfaces. Some very high escarpments, or scarps, may form by vertical movement along faults. Often a whole block of land may be forced upward while the adjacent block is down-faulted. See FAULT AND FAULT STRUCTURES.

Other types of escarpments form by differential weathering and erosion of contrasted rock types. Less resistant rocks, such as clay or shale, are often eroded from beneath resistant cap rocks, such as sandstone and limestone. With support removed from below, the cap rock fails and the escarpment retreats. Escarpments are often very prominent in arid regions, where hardened weathering products may form extensive cap rocks known as duricrusts.

Some of the largest known escarpments occur on the planet Mars, where erosion has presumably been much slower than on the Earth in reducing primary structural relief. See MARS. [V.R.B.]

**Escherichia** A genus of bacteria named for Theodor Escherich, an Austrian pediatrician and bacteriologist, who first published on these bacteria in 1885. *Escherichia coli* is the most important of the six species which presently make up this genus, and it is among the most extensively scientifically characterized living organisms. *Escherichia coli* are gram-negative rod-shaped bacteria approximately  $0.5 \times 1\text{--}3$  micrometers in size. Molecular taxonomic analysis based on the nucleotide sequences of ribosomal ribonucleic acid (RNA) has revealed that *Shigella*, a bacterial genus of medical importance previously thought to be distinct from *E. coli*, is actually the same species.

The natural habitat of *E. coli* is the colon of mammals, reptiles, and birds. In humans, *E. coli* is the predominant bacterial species inhabiting the colon that is capable of growing in the presence of oxygen. The presence of *E. coli* in the environment is taken to be an indication of fecal contamination.

Most strains of *E. coli* are harmless to the humans and other animals they colonize, but some strains can cause disease when given access to extraintestinal sites or the intestines of noncommensal hosts. *Escherichia coli* is the most important cause of urinary tract infections. Women are more susceptible than men; four out of ten women experience at least one urinary tract infection in their lifetime. Urinary tract infections may extend into the bloodstream, especially in hospitalized patients whose defenses are compromised by the underlying illness. This may lead to a type of whole-body inflammatory response known as sepsis, which is frequently fatal. Certain *E. coli* strains can invade the intestine of the newborn and cause sepsis and meningitis. These strains are acquired at birth from *E. coli* which have colonized the vagina of the mother.

Several different strains of *E. coli* cause intestinal infections. In the developing world, the most important of these are the enterotoxigenic *E. coli*, which produce enterotoxins that act on the epithelial cells lining the small intestine, causing the small intestine to reverse its normal absorptive function and secrete fluid. This leads to a dehydrating diarrhea which can be fatal, especially in poorly nourished infants. Therapy consists of oral or, in serious cases, intravenous rehydration. Enterotoxigenic *E. coli* are transmitted by ingestion of fecally contaminated water and food, and are a common cause of diarrheal disease in travelers in developing countries.

An important group of pathogenic *E. coli* in developed countries are the enterohemorrhagic strains, especially the serotype known as *E. coli* O157:H7. These strains are normal in cattle but cause bloody diarrhea in humans. A complication of approximately 10% of cases is a potentially fatal disease known as hemolytic uremic syndrome. The virulence of these strains involves the close attachment of bacteria to epithelial cells lining the colon, resulting in alteration of the epithelial cell structure, and the production of Shiga toxin. The toxin enters the bloodstream after being absorbed in the colon and damages the endothelial cells lining the blood vessels of the colon, resulting in bloody

diarrhea. In cases of hemolytic uremic syndrome, the toxin circulating in the blood damages blood vessels in the kidney, resulting in kidney failure and anemia. Enterohemorrhagic *E. coli* are acquired by the ingestion of undercooked beef, uncooked vegetables, or unpasteurized juices from fruits which have been contaminated with the feces of infected cattle. An infection can also be acquired from contact with a human infected with the organism and from contaminated water. Children and the elderly are at greatest risk of developing hemolytic uremic syndrome.

Other strains which are pathogenic in the human colon include the enteroinvasive *E. coli* (including *Shigella*) and the enteropathogenic *E. coli*. Enteroinvasive *E. coli* cause a disease called bacillary dysentery characterized by bloody diarrhea. Enteropathogenic *E. coli* have been associated with protracted diarrhea in infants and can occasionally cause severe wasting. See DIARRHEA; TOXIN. [S.L.M.]

**Esker** A sinuous ridge composed predominantly of sand and gravel deposited by glacial meltwater. Eskers vary in degree of continuity, and range in size from a few meters (1 m = 3.3 ft) to tens of meters high and from a few meters to a hundred or more kilometers long. They have steep ice-contact slopes and were deposited in channels confined by ice. Most eskers generally parallel the direction of ice flow, and while most follow valleys and have a normal down-drainage slope, some trend up a regional or local slope. [W.H.J.]

**Esophagus** A section of the alimentary canal that is interposed between the pharynx and the stomach. Because of divergent specializations in the various vertebrates, the esophagus cannot be described in general terms and is not always distinguishable.

In humans it is a tube running the full length of the neck and the thorax, held in its position ventral to the vertebral centra by a tunica adventitia of loose connective tissue. It has an inner lining of folded mucous membrane with an exceptionally thick lamina propria, a submucosa of elastic and collagenous connective tissue, and two layers of muscle. The musculature is striated in the anterior third of its length, unstriated in the posterior third, and variably intermixed in the middle. It is supplied with autonomic nerve fibers.

Although normally collapsed, the human esophagus is capable of considerable distension during the rapid passage of swallowed material, under which condition the folds of mucous membrane and lamina propria are temporarily smoothed out. Numerous microscopic esophageal glands open into the lumen, extending their compound tubules out into the submucosa.

In humans the transition from the esophagus to the stomach occurs quite abruptly at the diaphragm. The pharynx narrows posteriorly like a funnel and the foregut may thereupon enlarge, but much of what appears to be stomach may have an esophageal character histologically. See DIGESTIVE SYSTEM. [W.W.B.]

**Essential oils** Volatile, fragrant oils obtained from plants. Essential oils are distinguished from those known as fixed oils, which are mainly triglycerides of fatty acids. Essential oils have been obtained from over 3000 plants and are designated and defined by the plant species and sometimes the geographical location. The sources of these oils are diverse, including flower petals (for example, rose and jasmine), spices (cinnamon and ginger), pine oil and turpentine, and citrus fruit peels. Compounds present in the juice that may contribute to the distinctive flavor of a fruit or berry are not, strictly speaking, components of the essential oil. Chemically, essential oils are extremely complex mixtures containing compounds of every major functional-group class. The oils are isolated by steam distillation, extraction, or mechanical expression of the plant material; often only certain parts, such as roots, buds, leaves, or flower petals, are used.

Essential oils have been produced and used for flavoring, incense, and medicinal purposes for many centuries. [J.Mo.]

**Ester** The product of a condensation reaction (esterification) in which a molecule of an acid unites with a molecule of alcohol with elimination of a molecule of water as shown in the following reaction.

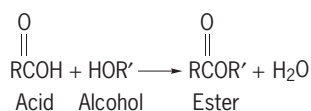

At one time it was thought that esterification was analogous to neutralization, and esters are still named as though they are "alkyl salts" of carboxylic acids.

Esters are generally insoluble in water and have boiling points slightly higher than hydrocarbons of similar molecular weight.

Ethyl and butyl acetates are volatile industrial solvents, used particularly in the formulation of lacquers. Higher-boiling esters such as butyl phthalate are used as softening agents (plasticizers) in the compounding of plastics. The natural waxes of biological origin are largely simple esters. For example, a principal component of beeswax is myricyl palmitate. See SOLVENT; WAX, ANIMAL AND VEGETABLE.

Esters of cellulose (cellulose triacetate) are used in photographic film, as a textile fiber (acetate rayon), and several have become important as thermoplastic materials. Cellulose nitrate, called celluloid pyroxylin, forms celluloid, dynamite cotton, and gun cotton. Cordite and ballistite are made from gun cotton. Dimethyl and diethyl sulfates (esters of sulfuric acid) are excellent agents for alkylating organic molecules that contain labile hydrogen atoms, for example, starch and cellulose.

Esters of unsaturated acids, for example, acrylic or methacrylic acid, are reactive and polymerize rapidly, yielding resins; thus, methyl methacrylate yields a polymethyl methacrylate resin (Lucite). Analogously, esters of unsaturated alcohols are reactive and readily react with themselves; thus, vinyl acetate polymerizes to polyvinyl acetate.

Many low-molecular-weight esters have characteristic, fruit-like odors: banana (isoamyl acetate), rum (isobutyl propionate), and pineapple (butyl butyrate). These esters are used to some extent in compounding synthetic flavors and perfumes. See ALCOHOL; CARBOXYLIC ACID; DRYING OIL; FAT AND OIL; POLYESTER RESINS.

[P.E.F.]

**Estimation theory** A branch of probability and statistics concerned with deriving information about properties of random variables, stochastic processes, and systems based on observed samples. Some of the important applications of estimation theory are found in control and communication systems, where it is used to estimate the unknown states and parameters of the system.

The estimation problem for dynamic systems may be divided into two parts: parameter estimation and state estimation. The basic difference between a parameter and the state is that the former either does not change at all or changes slowly in time, whereas the latter continuously evolves in time. For example, the state of a satellite is a six-dimensional vector consisting of three position variables and three velocity variables along the axes of an orthogonal coordinate system. The parameters of the satellite are its mass, inertia, and so on. In many control and communication problems, some of the system parameters are not known with desired accuracy. The problem of estimating these parameters from observed data is called parameter identification, though it is basically a problem of estimation. The more general problem of developing a mathematical model of the system from observed data is called system identification. On the other hand, the problem of state estimation is described by names such as signal processing, filtering, and smoothing.

The problem belongs to the theory of stochastic processes and is also commonly known as time series analysis. See STOCHASTIC PROCESS.

Three basic approaches used for estimation are least-squares, maximum-likelihood, and Bayesian. An estimator is defined as a function of the observations possessing certain desirable properties such as unbiasedness, consistency, and minimum variance. A Kalman filter provides estimates that are optimal in the least-squares, maximum-likelihood and Bayesian sense for a Gauss-Markov model. (A stochastic process is Markov if, given its present state, its future is independent of its past.)

Since their introduction in 1960, Kalman filters and their extensions have found numerous applications. Initially, these filters were developed for space applications such as satellite orbit determination, inertial navigation, Apollo lunar landing module guidance, and so on. The applications to power systems and industrial processes were developed shortly thereafter. Kalman filters have been used for forecasting, water quality prediction, hurricane tracking, aircraft landing systems, and stochastic control. See CONTROL SYSTEMS; FLIGHT CONTROLS; GUIDANCE SYSTEMS; PROCESS CONTROL; STATISTICS; SYSTEMS ENGINEERING. [R.K.M.]

**Estrogen** A substance that maintains the secondary sex characters and organs, such as mammary glands, uterus, vagina, and fallopian tubes, of mammalian females. Naturally occurring substances with this activity are steroid hormones. The principal estrogenic hormone substances are 17( $\beta$ )-estradiol (with the structure shown), estrone, and estriol. They are produced and

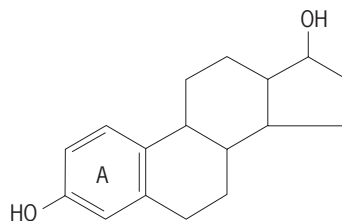

secreted directly into the bloodstream by the ovary, testis, adrenal, and placenta of pregnancy. Two other naturally occurring estrogenic hormones, equilin and equilenin, have been obtained only from the urine of pregnant mares and are apparently peculiar to that species. Stilbestrol, a synthetic compound with considerable estrogenic activity, has been used extensively in medical practice. See HORMONE; STEROID. [R.I.D.]

**Estrus** The period in mammals during which the female ovulates and is receptive to mating. It is commonly referred to as rut or heat. From one estrus period to the next there occurs a series of changes, particularly in the ovary, uterus, and vagina, termed the estrous cycle. With reference to the ovary, the cycle can be divided into a follicular phase, during which the Graafian follicles are ripening, and a luteal phase, during which the corpora lutea develop in the ovulated follicles. During these two phases, mainly estrogen and progesterone, respectively, are secreted, and these hormones control the uterine and vaginal changes. The beginning of the follicular phase is termed proestrus, and the luteal phase metestrus. Following the latter, there is a period of relatively little change, termed diestrus. In species in which the latter is prolonged, it is termed anestrus. See ESTROGEN; OVUM; REPRODUCTION (ANIMAL). [A.T.; H.L.H.]

**Estuarine oceanography** The study of the physical, chemical, biological, and geological characteristics of estuaries. An estuary is a semienclosed coastal body of water which has a free connection with the sea and within which the sea water is measurably diluted by fresh water derived from land drainage. Many characteristic features of estuaries extend into the coastal areas beyond their mouths, and because the techniques of measurement and analysis are similar, the field of estuarine

oceanography is often considered to include the study of some coastal waters which are not strictly, by the above definition, estuaries. Also, semienclosed bays and lagoons exist in which evaporation is equal to or exceeds freshwater inflow, so that the salt content is either equal to that of the sea or exceeds it. Hypersaline lagoons have been termed negative estuaries, whereas those with precipitation and river inflow equaling evaporation have been called neutral estuaries. Positive estuaries, in which river inflow and precipitation exceed evaporation, form the majority, however.

Within estuaries, the river discharge interacts with the sea water, and river water and sea water are mixed by the action of tidal motion, by wind stress on the surface, and by the river discharge forcing its way toward the sea. There is a small difference in salinity between river water and sea water, but it is sufficient to cause horizontal pressure gradients within the water which affect the way it flows. Salinity is consequently a good indicator of estuarine mixing and the patterns of water circulation.

Estuarine ecological environments are complex and highly variable when compared with other marine environments. They are richly productive, however. Because of the variability, fewer species can exist as permanent residents in this environment than in some other marine environments, and many of these species are shellfish that can easily tolerate short periods of extreme conditions. Motile species can escape the extremes. A number of commercially important marine forms are indigenous to the estuary, and the environment serves as a spawning or nursery ground for many other species. See MARINE ECOLOGY.

The patterns of sediment distribution and movement depend on the type of estuary and on the estuarine topography. The type of sediment brought into the estuary by the rivers, by erosion of the banks, and from the sea is also important; and the relative importance of each of these sources may change along the estuary. Fine-grained material will move in suspension and will follow the residual water flow, although there may be deposition and re-erosion during times of locally low velocities. The coarser-grained material will travel along the bed and will be affected most by high velocities and, consequently, in estuarine areas, will normally tend to move in the direction of the maximum current. [K.R.D.]

**Ether** One of a class of organic compounds characterized by the structural feature of an oxygen atom linking two hydrocarbon groups, R—O—R'. Ethers are used widely as solvents, both in chemical manufacture and in the research laboratory.

The hydrocarbon radicals R and R' may be identical (simple ether) or different (mixed ether). They may be aromatic or aliphatic, and the names of the ethers correspond to the hydrocarbon groups present. Thus, CH<sub>3</sub>—O—CH<sub>3</sub> is methyl ether, rarely dimethyl ether, and C<sub>6</sub>H<sub>5</sub>—O—CH<sub>3</sub> is phenyl methyl ether.

Simple ethers may be considered to be the anhydrides of alcohols and are manufactured from alcohols by catalytic dehydration, as in reaction (1), or from olefins by controlled catalytic hydration, as in reaction (2).

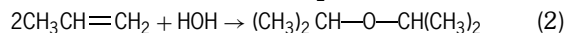

Ethers are less soluble in water than are the corresponding alcohols, but are miscible with most organic solvents. Low-molecular-weight ethers have a lower boiling point than the corresponding alcohols, but for those ethers containing radicals larger than butyl, the reverse is true. Inertness at moderate temperatures, an outstanding chemical characteristic of the saturated alkyl ethers, leads to their wide use as reaction media.

The best known of the ethers is ethyl ether, sometimes called diethyl ether or simply ether, CH<sub>3</sub>CH<sub>2</sub>OCH<sub>2</sub>CH<sub>3</sub>. It is used in industry as a solvent and in medicine as an anesthetic. When ethyl ether is used as a solvent, its high volatility can cause loss. However this volatility is advantageous in that the ether can be

readily removed from the concentrated or crystallized product. The toxicity to humans is low, and recovery from overexposure is rapid and complete. It readily forms explosive mixtures with air, and on standing in containers which have been opened, it forms dangerous peroxides.

Several cyclic ethers (epoxides) are of special importance and interest. The simplest of these is ethylene oxide or oxirane (1), made industrially by the oxidation of ethylene with air over a silver catalyst. Dioxane or 1,4-dioxane (2) is prepared by the catalytic dimerization of ethylene oxide. It is used extensively as an industrial solvent. Furan (3), made by the decarbonylation of furfural, is the most important ether obtained from an agricultural source. Most of it is hydrogenated to form the useful solvent tetrahydrofuran (4). See ETHYLENE OXIDE; FURAN.

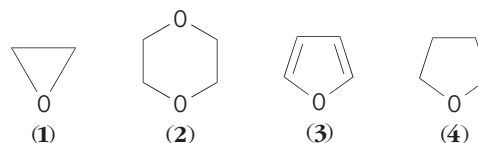

Certain large-ring polyethers, the crown ethers, are able to increase the solubility of alkali metal salts in nonpolar organic solvents. Specific metal complexes are formed by these crown ethers with alkali metal cations, the specificity for a given cation depending upon the hole in the middle of the crown ether structure. See HETEROCYCLIC COMPOUNDS. [P.E.F.]

**Ethology** The study of animal behavior. Modern ethology includes many different approaches, but the original emphasis, as expounded by Konrad Lorenz and Niko Tinbergen, was placed on the natural behavior of animals. This contrasted with the focus of comparative psychologists on behavior in artificial laboratory situations such as mazes and puzzle boxes. Ethologists view the naturalistic approach as crucial because it reveals the environmental and social circumstances in which the behavior originally evolved, and prepares the way for more realistically designed laboratory experiments. The approach goes back to the stress that Charles Darwin placed on hereditary contributions to behavior in all species, including humans. Viewing behavior as a product of evolutionary history has helped to elucidate many otherwise puzzling aspects of its biology and has paved the way for the new science of neuroethology, concerned with how the structure and functioning of the brain controls behavior and makes learning possible.

A central concept in classical ethology is that of the innate release mechanism. If a species has had a long history of experience with certain stimuli, especially those involving survival and reproduction, then to the extent that genes affect the ability to attend closely to such stimuli, natural selection leads to adaptations enhancing responsiveness to them. A common first step in the study of these adaptations was investigation of the development of responsiveness to such stimuli in infancy, focusing on situations that the ethologist knew to be especially relevant to survival. The term innate releasing mechanism, set forth by Tinbergen and Lorenz, eschews notions of innate mental imagery and has proved fertile in understanding how genes influence behavioral development, and in focusing attention of neuroethologists on inborn physiological mechanisms that permit learning while encouraging the infant to attend closely to very specific stimuli, the nature of which varies from species to species according to differences in ecology and social organization.

In birds, such as the herring gull, innate release mechanisms are also better thought of as having evolved to guide processes of perceptual learning, rather than to design animals as though they were automata. Learning is as important in the development of the behavior of many animals as in the human species. Yet as the young organism interacts with social and physical environments with which it has evolved adaptive relationships, the course that learning takes in nature is guided and profoundly influenced by

the innate predispositions that the organism brings to bear on dealing with the situation.

Perceptions of the external world provide a basis for both thought and action. It is a fundamental axiom of ethology that each organism's brain is armed with genetically determined programs of action which, in their own way, are as predictable and controlled as the genetic programs for developing anatomical structures such as a brain or a face. Ethologists have shown that it is possible to reconcile the need to modify patterns of action on the basis of experience with the possession of basic patterns of action that are coordinated by the brain, innately controlled, and often distinct from species to species. The concept of the fixed action pattern remains fundamental to understanding the development of the ability to act. Innate "motor programs," generated by the brain, are the natural units out of which behavior emerges during development. Each of these programs designates not a single completely stereotyped action, but a range of options which are limited but sufficient that selection among them allows for adjustments through experience. Close study reveals that sometimes the modifiability of actions lies in the potential flexibility of orientation, timing, and sequencing of actions rather than in the basic patterns or coordinations from which complex actions are built up. Thus nervous systems make some behavioral adjustments promptly and easily and others only with much greater difficulty, in harmony with species differences in the requirements for patterns of action as dictated by the species' structure and mode of life. Ethologists have found repeatedly that while social experience is vital in many animals for normal development of actions and responses, animals reared in restricted environments may still develop many units of action that are normal. The animal has to learn, however, how to put them together in an adaptive sequence.

Modern research on the ethology of learning began when Lorenz discovered imprinting in geese. He found that if he led a flock of newly hatched goslings himself they became imprinted on him. When mature, they would court people as though confused about their own species identity. Learning occurred very rapidly and tended to be restricted to a short sensitive phase early in life. The learning is highly focused by genetically determined preferences both to follow a parent-object with particular appearance and emitting species-specific calls, and also to learn most quickly and accurately at a particular stage of development. The interplay between nature (genetic predisposition) and nurture (environmental influence) in learning is displayed especially clearly in imprinting, hence its special interest to biologists and psychiatrists. Indications are that it is not concerned so much with learning about species as with learning to recognize individual parents and kin, both to ensure mating with one's own kind and to avoid incestuous inbreeding.

There are many forms of imprinting. So-called filial imprinting, ensuring that ducklings and goslings follow only their parent, is distinct from sexual imprinting, affecting mate choice in adulthood; the sensitive phases for learning are different in each case. Imprinting-like processes also shape the development of food preferences and abilities to use the Sun and stars in navigation.

Unlike psychological studies of animal learning in the laboratory, which have tended to favor the "blank-slate" view of the brain's contribution to learning, ethology emphasizes the need to understand all aspects of the biology of a species under study before one can hope to understand how the animal learns to cope with the many complexities of individual existence and social living. Thus ethology may lead not only to an understanding of how natural behavior evolves, but also to new insights into how brains help organisms learn to cope with social and environmental problems confronting them as individuals. See ANIMAL COMMUNICATION; BEHAVIOR GENETICS; INSTINCTIVE BEHAVIOR.

[P.R.M.]

**Ethyl alcohol** Probably the best known of the alcohols, ethyl alcohol, formula  $\text{CH}_3\text{CH}_2\text{OH}$ , is also called alcohol,

ethanol, grain alcohol, industrial alcohol, fermentation alcohol, cologne spirits, ethyl hydroxide, and methylcarbinol. Pure ethyl alcohol is a colorless, limpid, volatile liquid which is flammable and toxic and has a pungent taste. It boils at  $78.4^\circ\text{C}$  ( $173^\circ\text{F}$ ) and melts at  $-112.3^\circ\text{C}$  ( $-170.1^\circ\text{F}$ ), has a specific gravity of 0.7851 at  $20^\circ\text{C}$  ( $68^\circ\text{F}$ ), and is soluble in water and most organic liquids. It is one of the most important industrial organic chemicals. Ethyl alcohol is produced by chemical synthesis and by fermentation or biosynthetic processes. See BIOSYNTHESIS; ORGANIC SYNTHESIS.

Ethyl alcohol is used as a solvent, extractant, antifreeze, and intermediate in the synthesis of innumerable organic chemicals. It is also an essential ingredient of alcoholic beverages.

Various grades of ethyl alcohol are produced, depending on their intended use. U.S. Pharmaceutical (USP XV) grade is the water azeotrope of ethyl alcohol and is 95% ethyl alcohol by volume. National Formulary (NFX) grade is 99+% ethyl alcohol by weight; it is also called absolute, or anhydrous, alcohol. This grade is generally prepared by azeotropic dehydration with benzene and therefore usually contains about 0.5% benzene. Denatured alcohol contains a small amount of a malodorous or obnoxious material to prevent the use of this grade of ethyl alcohol for beverage purposes. See AZEOTROPIC MIXTURE.

The major use of ethyl alcohol is as a starting material for various organic syntheses. Bimolecular dehydration of ethyl alcohol gives diethyl ether, which is employed as a solvent, extractant, and anesthetic. Dehydrogenation of ethyl alcohol yields acetaldehyde, which is the precursor of a vast number of organic chemicals, such as acetic acid, acetic anhydride, chloral, butanol, crotonaldehyde, and ethylhexanol. Reaction with carboxylic acids or anhydrides yields esters which are useful in many applications. The hydroxyl group of ethyl alcohol may be replaced by halogen to give the ethyl halides. Treatment with sulfuric acid gives ethyl hydrogen sulfate and diethyl sulfate, a useful ethylating agent. Reaction of ethyl alcohol with aldehydes gives the respective diethyl acetals, and reaction with acetylene produces the acetals, as well as ethyl vinyl ether. Treatment of ethyl alcohol with ammonia produces acetonitrile, which may be reduced to ethylamine. These and other ethyl alcohol-derived chemicals are used in dyes, drugs, synthetic rubber, solvents, extractants, detergents, plasticizers, lubricants, surface coatings, adhesives, moldings, cosmetics, explosives, pesticides, and synthetic fiber resins.

[H.J.P.; E.M.M.]

**Ethylene** A colorless gas, formula  $\text{CH}_2=\text{CH}_2$ , with a boiling point of  $-103.8^\circ\text{C}$  ( $-155^\circ\text{F}$ ) and a melting point of  $-169.4^\circ\text{C}$  ( $-273^\circ\text{F}$ ). Ethylene is the most important synthetic organic chemical in terms of volume, sales value, and number of derivatives. About half of the ethylene produced is used in the manufacture of polyethylene; ethylene dichloride and vinyl chloride production uses about 20%, synthesis of ethylene oxide and derivatives account for about 12%, and styrene production consumes about 8% of the ethylene. Other important derivatives are ethanol, vinyl acetate, and acetaldehyde. Thermal cracking of hydrocarbons in the presence of steam is the most widely used process for producing ethylene.

Polyethylene, the most important derivative of ethylene, is produced by both high- and low-pressure processes to make high- and low-density, high-molecular-weight thermoplastic polymers. Aluminum alkyl catalysts (Ziegler polymerization) are used to polymerize ethylene to relatively low-molecular-weight, straight-chain hydrocarbon derivatives which are convertible to even-numbered-carbon linear olefins, alcohols, and acids. Commercial processes use palladium-catalyzed oxidation of ethylene to produce acetaldehyde, or if acetic acid is used as the solvent, vinyl acetate. Chlorination and oxychlorination processes are used to make vinyl chloride. Ethylene oxide is produced by silver-catalyzed oxidation of ethylene. Acid-catalyzed hydration of ethylene produces ethanol competitively

with fermentation processes. See ACETYLENE; ALKENE; ETHYL ALCOHOL; ETHYLENE OXIDE; POLYMER. [R.K.Ba.]

**Ethylene glycol** A colorless, nearly odorless, sweet-tasting, hygroscopic liquid, formula  $\text{HOCH}_2\text{CH}_2\text{OH}$ . It is relatively nonvolatile and viscous and is the simplest member of the glycol family. Ethylene glycol freezes at  $-13^\circ\text{C}$  ( $8.6^\circ\text{F}$ ), boils at  $197.6^\circ\text{C}$  ( $387.7^\circ\text{F}$ ), and is completely soluble in water, common alcohols, and phenol. Low molecular weight, low volatility, water solubility, and low solvent action on automobile finishes make ethylene glycol ideal as a radiator antifreeze and coolant. Other uses for this commodity chemical are in polyester resins, explosives, brake and shock-absorber fluids, and alkyl-type resins. See ANTIFREEZE MIXTURE; GLYCOL; POLYESTER RESIN.

Dibasic acids or anhydrides react with ethylene glycol to form polyester condensation polymers. Reaction with terephthalic acid or its esters produces polyester resins which can be spun to fibers that find wide use in clothing and general fabrics applications. The polymer also has important film applications. See ETHYLENE OXIDE; POLYETHYLENE GLYCOL. [R.K.Ba.]

**Ethylene oxide** The simplest cyclic ether or epoxide, with the formula  $\text{C}_2\text{H}_4\text{O}$ , and the structure shown. It is also called

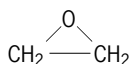

epoxyethane and oxirane. Commercial processes use either air or oxygen to oxidize ethylene to ethylene oxide. See ETHER; ETHYLENE; HETEROCYCLIC COMPOUNDS.

Ethylene oxide is a colorless gas boiling at  $10.4^\circ\text{C}$  ( $50.7^\circ\text{F}$ ) and melting at  $-112^\circ\text{C}$  ( $-169.6^\circ\text{F}$ ). Its vapors are flammable and explosive, and it is considered a relatively toxic liquid and gas. It is miscible in all proportions with water, alcohols, ethers, and other organic solvents.

About 50% of the ethylene oxide produced is converted to ethylene glycol; about 30% is used in the manufacture of non-ionic surfactants, glycol ethers, and ethanolamines. Gaseous ethylene oxide in  $\text{CO}_2$  or difluoromethane is used as a fumigant and a sterilizing agent for medical equipment. See ETHYLENE GLYCOL. [R.K.Ba.]

**Ethylenediaminetetraacetic acid** A chelating agent for metallic ions, abbreviated EDTA. The structural formula is shown below. Tetrasodium EDTA is the most common form in

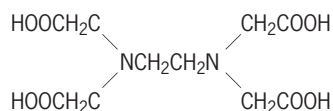

commerce, but other metallic chelates are marketed, for example, iron, zinc, and calcium. Tetrasodium EDTA is a white solid, very soluble in water and forming a basic solution. Prepared from ethylenediamine, formaldehyde, and sodium cyanide in basic solution, or from ethylenediamine and sodium chloroacetate, EDTA is a strong complexing and chelating agent. It reacts with many metallic ions to form soluble chelates. As such, it is widely used in analysis to retain alkaline earths and heavy metals in solution. The iron chelate is useful in lawn management and gardening as a replacement for ferrous sulfate (copperas). Calcium EDTA is used to control the deterioration of natural seawater in aquariums. Calcium disodium salt of EDTA is used in pharmaceuticals to prevent calcium depletion of the body during therapy. See CHELATION; COORDINATION COMPLEXES. [F.W.]

**Eucalyptus** A large and important genus of Australian forest trees; includes about 500 species in the family Myrtaceae. Only two species occur naturally outside Australia in the adjacent islands. Eucalypts occur throughout Australia except in coastal tropical and subtropical rainforests in Queensland and

New South Wales and in temperate rainforests in Victoria and Tasmania. They are confined to water courses in the extensive arid zones of central and northwest Australia. Eucalypts grow from sea level to tree line (6600 ft or 2000 m). Because of its large geographic range the genus exhibits many habits, from tall trees to multistemmed, shrubby species called mallees.

*Eucalyptus* is an evergreen genus with four different leaf types—seedling, juvenile, intermediate, and adult—depending on plant maturity. Juvenile leaves of some species, particularly those that are silvery blue and oval, are extensively used for floral decorations. Most species have white or cream flowers. Some species, particularly those from Western Australia, are planted widely as ornamentals.

Eucalypts have been planted widely for commercial use in Brazil and other South American countries, Africa, the Indian subcontinent, and the Middle East. They are used extensively for fuel and construction and are an important component of third world economies. Foliage of some species yields essential oils for medicines and perfumes. Tannins are extracted from the bark of certain species. See ESSENTIAL OILS; MYRTALES; TREE. [R.L.E.]

**Eucarida** The largest and most highly evolved superorder of the crustacean class Malacostraca. It contains the orders Euphausiacea, Amphionidacea, and Decapoda; alternatively, the orders Pygocephalomorpha (fossil), Lophogastrida, Mysida, Euphausiacea, Amphionidacea, and Decapoda are recognized. Despite the great morphological and ecological diversity of eucaridans given either classification, all share (1) a well-developed carapace that is fused to all the thoracic somites; (2) stalked and movable eyes, although in a few these have been secondarily reduced; (3) mandibles that lack a mobile element between the incisor and molar processes (except Mysidacea); (4) a telson without a caudal furca; (5) heart and gills that are thoracic in position; and (6) typically metamorphic larval development. See AMPHIONIDACEA; CRUSTACEA; DECAPODA (CRUSTACEA); EUPHAUSIACEA; MALACOSTRACA; MYSIDACEA. [PA.McL.]

**Euclidean geometry** The chief subject matter of the monumental 13-volume work called *The Elements*, written about 300 B.C. by the Greek mathematician Euclid, who taught and founded a school of geometry at Alexandria. One of the milestones in the history of scientific thought, these books of Euclid still occupy an important position in mathematical instruction today.

Geometry, as developed in Euclid, was a systematic body of mathematical knowledge, built by deductive reasoning upon a foundation of three main pillars: (1) definitions of such things as points, lines, planes, angles, circles, and triangles; (2) the assumption of certain geometrical postulates regarded as true but perhaps not self-evident; and (3) the assumption of certain axioms or common notions which were taken to be self-evident truths. The body of Euclid's great work consists of a set of propositions or theorems, each derived systematically and logically from the definitions, axioms, and postulates of his foundation and from theorems already proved.

Five postulates may be paraphrased as:

1. A unique straight line can be drawn from any point to any other point.
2. A finite straight line can be extended continuously in either direction in a straight line.
3. A circle can be described with any given center and radius.
4. All right angles are equal.
5. If a straight line falling on two straight lines makes interior angles on the same side with a sum less than two right angles, the two straight lines, if produced indefinitely, meet on that side on which the angle sum is less than two right angles.

This fifth postulate is known as the parallel postulate and is essentially equivalent to the statement that "a unique line

parallel to a given line can be constructed through any point not on the line." For 2000 years many unsuccessful attempts were made to prove that this postulate was a consequence of Euclid's other postulates, definitions, and axioms. Only as recently as the nineteenth century did N. I. Lobachevski (1793–1856), J. Bolyai (1802–1860), and G. F. B. Riemann (1826–1866) show that the parallel postulate was independent of the others, by constructing so-called noneuclidean geometries in which the fifth postulate is not valid.

Certain axioms were stated by Euclid and treated as self-evident truths.

1. Things which are equal to the same thing are equal to each other.
2. If equals be added to equals, the wholes are equal.
3. If equals be subtracted from equals, the remainders are equal.
4. Things which coincide with one another are equal to one another.

A fifth axiom, ascribed by Proclus to Euclid, is believed to have been added by later writers.

5. The whole is greater than the part.

The last has also been replaced by the statement: The whole is equal to the sum of its parts.

The first six books of Euclid include most of the subject matter commonly taught in high school geometry. Book 1, after listing a large number of definitions and the postulates and axioms described above, contains 48 propositions, including many properties relating to perpendicular and parallel lines, angles, and congruent triangles, and the book culminates with the important Pythagorean theorem.

Book 2 contains 14 propositions on geometrical algebra, establishing relationships between the areas of certain related squares and rectangles. Book 3 deals with circles, chords, inscribed angles, and other figures related to the circle; book 4 with inscribed and circumscribed circles and polygons; book 5 with ratios; and book 6 with areas and similar triangles. Books 7, 8, 9, and 10 are concerned with number theory, square and cube roots, and incommensurable magnitudes; books 11 and 12 are concerned with solid geometry and mensuration; and book 13 is concerned with extreme and mean ratio and the five regular solids. See DIFFERENTIAL GEOMETRY; POLYHEDRON; PROJECTIVE GEOMETRY; SOLID (GEOMETRY). [J.S.F.]

**Eucoccida** The most important order of the protozoan subclass Coccidia. In this group there is alternation of asexual and sexual phases of the life cycle, and the parasitic stages occur within the cells of vertebrates or invertebrates. There are three suborders.

In the suborder Adeleina, the macrogamete and microgametocyte are joined during development (syzygy) and the microgametocytes produce only a few microgametes. Members of this suborder are parasites of invertebrates and lower vertebrates; a few even occur in higher vertebrates.

In the suborder Eimeriina, there is no syzygy and the microgametocytes produce a large number of microgametes. This group contains several hundred species of coccidia, most of which occur in the intestinal cells of vertebrates.

In the suborder Haemosporina, there is no syzygy and the microgametocytes produce a moderate number of microgametes. Asexual development takes place in the blood cells of vertebrates, and sexual development in blood-sucking insects or mites. This suborder contains *Plasmodium*, species of which cause malaria in humans, lower primates, birds, and other vertebrates. See COCCIDIA; MALARIA; PROTOZOA. [N.D.L.]

**Eucommiales** An order of flowering plants, division Magnoliophyta (Angiospermae), in the subclass Hamamelidae of the

class Magnoliopsida (dicotyledons). The order consists of a single family, genus, and species, *Eucommia ulmoides*, of China. It is a simpleleaved tree with reduced, solitary flowers that lack a perianth, and leaves without stipules, the paired basal appendages found on many leaves. See HAMAMELIDAE; MAGNOLIOPSIDA. [A.Cr.]

**Eudicotyledons** One of the two major types of flowering plants (angiosperms), characterized by possession of three apertures in their pollen; the other major type is magnoliids. Although this difference in pollen development and form has been known for a long time, it has become clear, as a result of several studies of deoxyribonucleic acid (DNA) sequences, that this difference is very significant. The high degree of coincidence of the genetic data with this pollen distinction means that it is more important to recognize this distinction than the number of seed leaves, as previously thought. See DICOTYLEDONS; FLOWER; MAGNOLIALES; MONOCOTYLEDONS. [M.W.C.; M.F.F.]

**Euechinoidea** A subclass of Echinoidea (sea urchins, sand dollars, and heart urchins) in which the test plates are consistently arranged in double rows or columns. Five double rows bear the tube-feet (the ambulacral rows), and these alternate with five which do not (the interambulacral rows). See ATELOSTOMATA; DIADEMATA; ECHINACEA; ECHINODERMATA; ECHINOIDEA. [A.C.C.]

**Eugenics** The study of factors that influence the hereditary qualities of future generations. It may be thought of as both a science and a social movement. Eugenics proposes to improve humanity's future by increasing the number of children produced by persons who are, by some definition, superior and by reducing the number produced by persons who are physically or mentally deficient. Attempts to encourage larger families from superior parents are called positive eugenics, attempts to reduce the number of children from defective parents negative eugenics.

There have been a number of proposals regarding negative eugenics in the United States. Several of the states have laws providing for sterilization of persons with severe mental or physical defects. Segregation of persons in public institutions also has the effect of reducing the number of births. Finally there is the advocacy of greater use of contraceptives by persons likely to transmit hereditary weaknesses. Positive eugenics has consisted largely of exhortations for the well endowed to have more children.

Such eugenic proposals have not had complete acceptance. There are objections on religious grounds. There are those who think that eugenic laws, particularly if they involve compulsory sterilization, are an unwarranted infringement on basic human rights. A different reservation comes from those who point out that knowledge of human heredity is not very complete and that prediction of the attributes of children from their parents is not very exact.

The spectacular success of cellular and molecular genetics and the possibility of directly changing, replacing, or otherwise influencing the deoxyribonucleic acid (DNA) in bacteria and viruses have led to considerable speculation about what humans can do to their heredity if and when the techniques known for microbes become available. However, such possibilities are still very much in the future, nobody knows how far away. See HUMAN GENETICS. [J.F.Cr.]

**Euglenida** An order of the class Phytamastigophorea. This order of protozoans, also known as Euglenoidina, includes the largest green noncolonial flagellates, *Euglena ehrenbergii*, which are 400 micrometers long. Many of the colorless members are also large. They have one or two equal or subequal flagella. There are relatively few genera of Euglenida. See PHYTAMASTIGOPHOREA.

Euglenids generally show an anteroposterior elongation; however, *Trachelomonas volvocina* is practically spherical, and

*Euglena acus* is extremely needlelike. Many are enclosed in a thick pellicle which is sculptured into keels. The pellicle is sometimes ornamented with striae or small wartlike protuberances. Colony formation is restricted to *Colacium*, in which a flagellated euglenoid cell usually attaches to a copepod by its anterior end and develops into an arboroid structure of several nonflagellated cells. Tests or shells are common.

Euglenids have two distinguishing features. They synthesize a starchlike polysaccharide, paramylum; and they have a gullet-reservoir system.

In habitat the Euglenida are widespread. Green members occur mostly in fresh water and frequently in such numbers as to form blooms. Unlike the Phytomonadida, the Euglenida appear in warmer waters but do not seem to occur in hot springs. They abound in citrus-waste lagoons and in later stages of sewage-treatment waters, an indication of their partially saprozoic nutrition. See MASTIGOPHORA; PROTOZOA. [J.B.L.]

**Euglenophyceae** A class coextensive with the division Euglenophycota, comprising unicellular colorless or photosynthetic flagellates with very distinctive cytological characters. In protozoological classification, these organisms constitute an order, Euglenida, of the class Phytomastigophora. Although photosynthetic euglenoids are like Chlorophycota in containing chlorophyll *a* and *b*, in most other respects they are so different from those algae as to suggest an independent phylogenetic origin of their pigments. About 1000 species have been described and classified into about 40 genera and 6 orders. See EUGLENIDA.

Most euglenoids are free-swimming and have two flagella, one of which may be nonemergent, arising from an anterior invagination known as a reservoir. Photosynthetic euglenoids contain one to many grass-green chloroplasts, which vary from minute disks to expanded plates or ribbons. Colorless euglenoids depend on osmotrophy or phagotrophy for nutrient assimilation.

Euglenoids are found most commonly in fresh water rich in organic matter, but they also occur in marine or brackish habitats, on mud or sand, and in ice or snow. A few species prefer very acidic water. [P.C.Si.; R.L.Moe]

**Eugregarinida** An order of the subclass Gregarina. These protozoans are common parasites of invertebrates such as the arthropods and annelids. Only sexual reproduction occurs in the life history of these animals; schizogony is lacking. This order is divided into the suborders Cephalina and Acephalina. In North America grasshoppers of the genus *Melanoplus* are commonly the host for the cephaline *Gregatina rigida*, inhabiting the lumen of the gut. See GREGARINIA; INVERTEBRATE PATHOLOGY; PROTOZOA. [E.R.B./N.D.L.]

**Eukaryotae** The vast array of living and fossil organisms comprising all taxonomic groups above the primitive unicellular prokaryotic level typified by the bacteria. The Eukaryotae thus include all plants and animals, the unicellular protists, and the fungi.

All organisms in this group possess an organized nucleus (or nuclei) in their cells, with a surrounding nuclear envelope and paired deoxyribonucleic acid-containing chromosomes; and elaborate cytoplasmic organelles, such as mitochondria, Golgi bodies, lysosomes, peroxisomes, endoplasmic reticulum, microfilaments and microtubules in various arrays, and, in photosynthetic forms, plastids or chloroplasts. Characteristically, centrioles, cilia, or flagelia are also present, the latter locomotory organelles composed mainly of tubulin with microtubules exhibiting a universal 9 + 2 pattern. See CILIA AND FLAGELLA; PROKARYOTAE.

Organization at the organismal level ranges from solitary unicellular to colonial unicellular, mycelial, syncytial (coenocytic), and truly multicellular with extensive tissue differentiation. Modes of nutrition run the gamut: absorptive, ingestive, photoautotrophic, plus combinations of these three major kinds.

Life cycles vary tremendously, with haploidy more characteristic of "lower" groups and diploidy of the "higher" taxa. Reproduction, similarly, includes both asexual and sexual methods. In the "higher" multicellular forms, true embryos develop from the diploid zygote stage, which has resulted from fusion of sperm and egg cells.

Aerobic metabolism is commonly exhibited, especially by aquatic and terrestrial forms; anaerobic mechanisms exist, however, for numerous species found in poorly oxygenated habitats, including various sites within bodies of host organisms.

Size of species range from 1 micrometer (certain protozoa and algae) to many meters (whales, trees). Habitats cover all possible ecological niches: aquatic, terrestrial, and aerial, for free-living forms (many of which are motile, with the major exception of the trophic stage of various plants); and in or on all kinds of hosts, for symbiotic or parasitic forms (internal habitats, including cells, tissues, organs, or various body cavities). Dormant stages include cysts, spores, and seeds; these are often involved in dispersion or propagation of the species. See ANIMAL KINGDOM; FUNGI; PLANT KINGDOM; PROTOZOA. [J.O.C.]

**Euler angles** Three angular parameters that specify the orientation of a body with respect to reference axes. They are used for describing rotating systems such as gyroscopes, tops, molecules, and nonspherical nuclei. They are not symmetrical in the three angles but are simpler to use than other rotational parameters.

Unfortunately, different definitions of Euler's angles are used, and therefore it is confusing to compare equations in different references. The definition given here is the majority convention according to H. Margenau and G. Murphy.

Let *OXYZ* be a right-handed cartesian (right-angled) set of fixed coordinate axes and *Oxyz* a set attached to the rotating body (see illustration).

The orientation of *Oxyz* can be produced by three successive rotations about the fixed axes starting with *Oxyz* parallel to *OXYZ*. Rotate through (1) the angle  $\psi$  counterclockwise about *OZ*, (2) the angle  $\theta$  counterclockwise about *OX*, and (3) the angle  $\phi$  counterclockwise about *OZ* again. The line of intersection *OK* of the *xy* and *XY* planes is called the line of nodes.

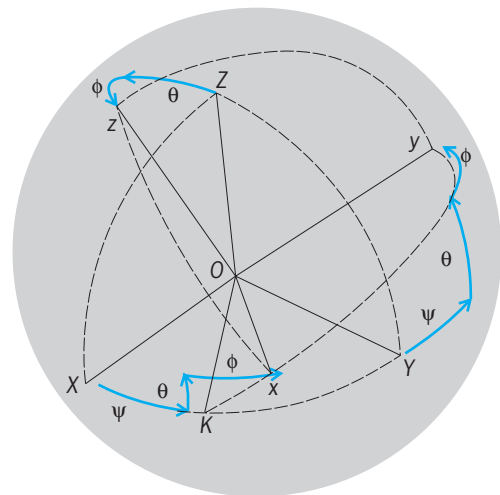

**Euler angles.** The successive movements of the axes on a unit sphere described in the text are shown by arrows. The complete rotation may also be obtained by a different sequence of rotations, namely, first through  $\phi$  about *OZ*, then through  $\theta$  about the displaced *x* axis (which is *OK*), then through  $\psi$  about *OZ*.

Denote a rotation about *OZ*, for example, by *Z* (angle). Then the complete rotation is, symbolically, given by the equation below where the rightmost operation is done first.

$$R(\psi, \theta, \phi) = Z(\phi)X(\theta)Z(\psi) \quad [\text{B.G.}]$$

**Euler's equations of motion** A set of three differential equations expressing relations between the force moments, angular velocities, and angular accelerations of a rotating rigid body. They are equations of motion in the usual dynamical sense, of forms (1)–(3).

$$I_1(d\omega_1/dt) + (I_3 - I_2)\omega_2\omega_3 = M_1 \quad (1)$$

$$I_2(d\omega_2/dt) + (I_1 - I_3)\omega_3\omega_1 = M_2 \quad (2)$$

$$I_3(d\omega_3/dt) + (I_2 - I_1)\omega_1\omega_2 = M_3 \quad (3)$$

The formulation employs as coordinate axes the three principal axes of rotational inertia of the body that can rotate about a body-fixed point, which is the center of mass if constraints are absent. These reference axes, which form a righthand set, are indicated by subscripts 1, 2, and 3 in the equations, where  $I_1$ ,  $I_2$ , and  $I_3$  represent the principal moments of inertia;  $\omega_1$ ,  $\omega_2$ , and  $\omega_3$  the angular velocities about the axes;  $M_1$ ,  $M_2$ , and  $M_3$  the corresponding force moments; and  $t$  the time. See RIGID-BODY DYNAMICS. [R.A.Fi.]

**Eumagnoliids** An informal set of flowering plant orders that contains Laurales, Magnoliales, Piperales, and Winterales, plus the monocotyledons, and in total contains roughly one-third of angiosperm species. Formerly, many have equated this group (minus the monocotyledons) to the subclass Magnoliidae, but studies of sequences of deoxyribonucleic acid (DNA) have demonstrated that orders such as Nymphaeales and Ranunculales are distantly related to the others and that the monocotyledons are much closer. A formal taxonomy for this group is not yet feasible because until more data are collected the exact relationships of the eumagnoliids to the eudicots are not clear. The eumagnoliids, including the monocotyledons, exhibit a set of characteristics that reflect their relatively close relationships; these include a tendency to trimerous flowers and a suite of chemical compounds restricted to the group. They also have a set of traits that are "primitive" by most estimations; these include vesselless wood, laminar stamens, and laminar placentation. It now seems quite clear that although the eumagnoliids exhibit some primitive traits they are neither the most archaic nor the earliest of angiosperms, and they contain some of the most advanced taxa, such as many of the monocotyledons (grasses, palms, and orchids). See LAURALES; LILIOPSIDA; MAGNOLIALES; PIPERALES; PLANT TAXONOMY. [M.W.C.]

**Eumalacostraca** The major subdivision (subclass) of the crustacean class Malacostraca. It comprises three, four, or five Recent superorders: Syncarida, Peracarida, and Eucarida are most commonly included and are all that are recognized here. However, some carcinologists still insist on ranking the Hoplocarida among eumalacostracans. Acceptance of a separate superorder, Pancarida for the Thermobaenacea, has not received general support, and thermobaenaceans are commonly now included with peracaridan taxa.

Formerly, the concept of the Eumalacostraca as a homogeneous evolutionary unit generated virtually no controversy. The subclass was defined by a series of characters referred to as the caridoid facies: carapace enclosing the thorax; stalked, movable eyes; biramous antennules; scalelike antennal exopod; thoracopods with natatory exopods; abdomen with well-developed, complex musculature designed for flexing it; telson and uropods forming a tailfan; biramous pleopods 1–5; and internal organs primarily excluded from the abdomen. Opponents of the caridoid theory point to the fact that several of these attributes are not restricted to eumalacostracans, and conversely, not all eumalacostracans possess all of them. The carapace, its origin and evolution, has provided the greatest controversy.

The basic body plan common to all eumalacostracans includes a head of five somites, a thorax of eight somites, and an abdomen of six somites, plus a terminal telson. Zero to three pairs of thoracic somites may be fused to the head and their thoracopods and modified to form feeding appendages (maxillipeds). The thorax usually has five to eight pairs of ambulatory or specialized appendages (pereopods); the abdomen may or may not have paired appendages (pleopods) on the first five somites; and the sixth somite usually has a pair of well-developed appendages (uropods). Female gonopores (coxal or sternal) are present at the level of the sixth thoracic somite, while male gonopores are at the level of the eighth.

Two caridoid attributes shared by the majority of eumalacostracans are the strong abdominal musculature and well-developed tailfan. Together with accompanying neural elements, these appear to be designed as a highly efficient propulsion mechanism, that is, an escape reaction.

Most eumalacostracans are dioecious; however, some isopods, tanaids, and a few decapods are hermaphroditic. Fertilization is by means of spermatophores and may be external or internal. See CRUSTACEA; EUCARIDA; MALACOSTRACA; PERACARIDA; SYNCARIDA. [P.A.McL.]

**Eumycetozoida** An order of Mycetozoa. These are slime molds which form a plasmodium, a multinucleate stage that may in some species measure a foot (30 cm) or more across. The plasmodium, typically found on decaying plant material, is a migratory phagotroph preying on microorganisms. A mature plasmodium is a sheet of protoplasm containing a network of channels through which rapid endoplasmic streaming occurs.

Resistant cysts (spores), possibly haploid, are produced in sporangia. Liberated spores hatch into myxoflagellates or myxamebae (which may change into flagellates). Either type may represent gametes, and mating types have been reported in certain species. [R.PH.]

**Eumycota** True fungi, a group of heterotrophic organisms with absorptive nutrition, capable of utilizing insoluble food from outside the cell by secretion of digestive enzymes and absorption. Glycogen is the primary storage product of fungi. Most fungi have a well-defined cell wall that is composed of chitin and glucans. Spindle pole bodies, rather than centrioles, are associated with the nuclear envelope during cell division in most species. Typically, the fungal body (thallus) is haploid and consists of microscopic, branched, threadlike hyphae (collectively called the mycelium), which develop into radiating, macroscopic colonies within a substrate or host. The filamentous hypha may be divided by cross walls (septa) into compartments. Hyphal growth is apical. Some species are coenocytic (without cross walls); others, including yeasts, are unicellular. Reproductive bodies are highly variable in morphology and size, and may be asexual or sexual.

Great changes in understanding the phylogenetic relationships of fungi have been brought about by the use of characters derived from deoxyribonucleic acid (DNA) sequences and the use of computer-assisted phylogenetic analysis; these changes are reflected in current classification schemes. A modern classification follows:

- Eumycota
  - Phylum: Chytridiomycota
  - Phylum: Zygomycota
    - Class: Zygomycetes
      - Trichomycetes
  - Phylum: Ascomycota
    - Class: Archiascomycetes
      - Hemiascomycetes
      - Euascomycetes
  - Phylum: Basidiomycota



Class: Hymenomycetes  
 Urediniomycetes  
 Ustilaginomycetes

Fungi are found in practically every type of habitat. Most are strictly aerobic, although a few are anaerobes that live in the gut of herbivores. Some species are thermophilic. Many fungi form saprobic (including parasitic) relationships with animals and plants; the majority are saprobes. As now recognized, the Eumycota are a monophyletic group of the crown eukaryotes, presumed to have been present in the fossil record 900–570 million years ago. See FUNGI; MYXOMYCOTA; OOMYCETES. [M.B.I.]

**Euphausiacea** A well-defined marine order of the class crustacea. All are shrimplike in appearance. The order contains two families, one with a single species, the other with 84 species divided among 10 genera. Euphausiids are predominantly pelagic organisms, but a few species are neritic. Euphausiids form a significant proportion of the total planktonic biomass.

Euphausiids, with the exception of *Bentheuphausia amblyops*, possess photophores that emit a brilliant blue-green light. The eyes are compound and contain three pigments: a carotenoid (astaxanthin), a melanoid, and a photolabile substance that is probably a visual pigment. Respiration is by means of foliose, digitiform gills located at the bases of the second to eighth thoracic appendages.

The blood is a pale, leukocyte-bearing fluid with hemocyanin as the respiratory pigment. The heart is compact and has two pairs of ostia.

All species are strictly marine and do not occur in freshwater or brackish environments. Species are found in all oceans and seas, with the exception of the brackish Baltic and Black seas. Known as krill to whalers, they constitute the diet of many whales, particularly the whalebone whales. The euphausiids can be processed to yield large quantities of protein. Krill pastes and meal can be manufactured to feed domestic animals or used in therapeutic diets. Krill sausages, krill-stuffed eggs, and shrimp butter are already marketable products in Japan, Russia, and Germany. See CRUSTACEA; DECAPODA (CRUSTACEA); MALACOSTRACA. [J.Mau.]

**Euphorbiales** An order of flowering plants, division Magnoliophyta (Angiospermae), in the subclass Rosidae of the class Magnoliopsida (dicotyledons). The order consists of the large family Euphorbiaceae (about 7500 species) and 3 small satellite families which have fewer than 100 species among them. The Euphorbiales are a group of few-ovulate, mostly simple-leaved Rosidae in which the flowers have become unisexual and then undergone further reduction accompanied by aggregation.

The Christmas poinsettia (*E. pulcherrima*) and the para rubber tree (*Hevea brasiliensis*) are well-known members of the Euphorbiaceae. Many African euphorbiads are spiny stem-succulents which resemble cacti in habit. Aside from the pronounced floral differences, the euphorbiads have a milky juice, which the cacti do not. See MAGNOLIOPSIDA; PLANT KINGDOM; ROSIDAE. [A.Cr.; T.M.Ba.]

**Europe** Although long called a continent, in many physical ways Europe is but a great western peninsula of the Eurasian landmass. Its eastern limits are arbitrary and are conventionally drawn along the water divide of the Ural Mountains, the Ural River, the Caspian Sea, and the Caucasus watershed to the Black Sea. On all other sides Europe is surrounded by salt water. Of the oceanic islands of Franz Josef Land, Spitsbergen (Svalbard), Iceland, and the Azores, only Iceland is regarded as an integral part of Europe; thus the northwestern boundary is drawn along the Danish Strait.

Europe is not only peninsular but has a large ratio of shoreline to land area reflecting a notable interfingering of land and sea. Excluding Iceland, the maximum north-south distance is (3529 mi) (5680 km); and the greatest east-west extent is 2398 mi

(3860 km). Of Europe's area of 3,881,000 mi<sup>2</sup> (10,050,000 km<sup>2</sup>) 73% is mainland, 19% peninsulas, and 8% islands. Also, 51% of the land is less than 155 mi (250 km) from shores and another 23% lies closer than 310 mi (500 km). This situation is caused by the inland seas that enter, like arms of the ocean, deep into the northern and southern regions of Europe, which thus becomes a peninsula of peninsulas. The most notable of these branching arms of salt water are the White Sea, the North Sea, the Baltic Sea with the Gulf of Bothnia, the English Channel (La Manche), the Mediterranean Sea with its secondary branches, and finally, the Black Sea. Even the Caspian Sea, presently the largest salt-water lake of the world, formed part of the southern seas before the folding of the Caucasus. The penetration of the landmass by these seas brings marine influences deep into the continent and provides Europe with a balanced climate favorable for human evolution and settlement.

Europe has a unique diversity of land forms and natural resources. The relief, as varied as that of other continents, has an average elevation of 980 ft (300 m) as compared with North America's 1440 ft (440 m). The shape and the overall physiographic aspect of the great peninsula are controlled by geologic structure which delimits the major regional units.

Climate is determined by a number of factors. Probably the most important are a favorable location between 35° and 71°N latitudes on the western or more maritime side of the world's largest continental mass; the west-to-east trend (rather than north-south) of the lofty southern ranges and the Central Lowlands, as well as of the inland seas, which permit the prevailing westerly winds of these latitudes to carry marine influences deep into the continent; the beneficial influence of the North Atlantic Drift, which makes possible ice-free coasts far within the Arctic Circle; and the low elevation of the northwestern mountain ranges and the Urals, which allows the free shifting of air masses over their crests.

The intricate relief and the climates of Europe are well reflected in the drainage system. Extensive drainage basins with large slow-flowing rivers are developed only in the Central Lowlands, especially in the eastern part. Streams with the greatest discharge empty into the Black Sea and the North Sea, although Europe's longest river, the Volga, feeds the Caspian Sea. Second in dimension is the Danube, which crosses the Carpathian Basin and cuts its way twice through mountain ranges at the Gate of Bratislava and at the Iron Gate. The Rhine and Rhone are the two major Alpine rivers with headwater sources close to each other but feeding the North Sea and the Western Mediterranean Basin, respectively. Abundant precipitation throughout the year, as well as the permeable soils and the dense vegetation which temporarily store the water, provides the streams of Europe north of the Southern Highlands with ample water throughout the seasons. The combined effects of poor vegetation, rocky and desolate limestone karstlands, and slight annual precipitation result in intermittent flow of the rivers along the Mediterranean coast, especially on the eastern side of peninsulas. Only the Alpine rivers carry enough water, and if it were not for the Danube and Rhone, both originating in regions north of the Alps, the only major river of the Mediterranean basin would be the Po. See ATLANTIC OCEAN; BALTIC SEA; BLACK SEA; CONTINENT; MEDITERRANEAN SEA. [G.T.]

**Europium** A chemical element, Eu, atomic number 63, atomic weight 151.96, a member of the rare-earth group. The stable isotopes, <sup>151</sup>Eu and <sup>153</sup>Eu, make up the naturally occurring element. The metal is the second most volatile of the rare earths and has a considerable vapor pressure at its melting point. It is very soft, is rapidly attacked by air, and really belongs more to the calcium-strontium-barium series than to the rare-earth series. See PERIODIC TABLE.

The element is attractive to the atomic industry, since the elements can be used in control rods and as nuclear poisons. These poisons are materials added to a nuclear reactor to

balance the excess reactivity at start-up, and are so chosen that the poisons burn out at the same rate as the excess activity decreases. The television industry uses considerable quantities of phosphors, such as europium-activated yttrium orthovanadates, and other europium-activated yttrium phosphors have been patented. These phosphors give a brilliant red color and are used in the manufacture of television screens. See RARE-EARTH ELEMENTS. [F.H.Sp.]

**Eurypterida** An extinct Paleozoic group of aquatic arthropods, belonging to the subphylum Chelicerata and class Merostomata and thus related to the living marine xiphosurans (horseshoe crabs) and terrestrial arachnids (spiders, scorpions). Although most eurypterids were less than 10 in. (25 cm) in length, some members of the group were the largest arthropods of all time, reaching sizes up to 6 ft (2 m).

The anterior portion of the eurypterid body is the prosoma. The prosoma is covered dorsally by the carapace, which bears a large pair of lateral compound eyes and a small pair of median simple eyes or ocelli. Visible on the ventral surface of the prosoma are six pairs of appendages. The posterior opisthosoma consists of 12 unfused segments and the terminal telson or tail spine.

Eurypterid fossils are found worldwide. The chitinous body of eurypterids is not mineralized, and so fossil remains are rare and generally restricted to a limited number of ancient aquatic environments. Almost all of the approximately 300 described species, belonging to about 65 genera, are from single localities or regions.

Eurypterids were almost exclusively aquatic, although some forms may have been amphibious. A number of forms were dominantly benthonic, but most were active and agile swimmers. Most eurypterids were probably carnivores, although they lacked the ability to crush heavily armored prey. See ARTHROPODA. [R.Pl.]

**Eustigmatophyceae** A small class of nonmotile, photo-synthetic, unicellular algae, segregated from the class Xanthophyceae (Tribophyceae) on the basis of cytological, ultrastructural, and biochemical features of the vegetative cell and zoospore. Because of their lack of chlorophyll *b*, these organisms may be placed in the division Chromophycota, but their lack of chlorophyll *c*, in contrast to other chromophytes, supports recognition at a higher level (such as the division Eustigmatophyta). Only a dozen species in three genera are known. These live chiefly in fresh water, but also in marine habitats and in soil. See ALGAE; XANTHOPHYCEAE. [P.C.Si.; R.L.Moe]

**Eutardigrada** An order of tardigrades, lacking a cirrus lateralis, a sensory cephalic appendage, and a clava, or club-shaped appendage. Pharyngeal pockets are strengthened by separated rods or macroplocoids or are without thickenings. Claws are of different size, arranged in two pairs in which a larger and smaller claw are united. In *Milnesium* the claws are separated. *Haplomacrobotus* has two simple claws. See HETERO-TARDIGRADA; TARDIGRADA. [E.M./Ev.M.]

**Eutectics** The microstructures that result when a solution of metal of eutectic composition solidifies. The eutectic reaction must be distinguished from eutectic microstructures. The eutectic reaction is a reversible transformation of a liquid solution to two or more solids, under constant pressure conditions, at a constant temperature denoted as the eutectic temperature. Microstructures which are wholly eutectic in nature can occur only for a single, fixed composition in each alloy system demonstrating the reaction.

Although technologically important alloy systems, particularly the Fe-C system (all cast irons used commercially pass through a eutectic reaction during solidification), exhibit at least one eutectic reaction, there has been little exploitation of wholly eutectic

microstructures for structural purposes. Some eutectic fusible alloys are used as solders, as heat-transfer media, for punch and die mold and pattern applications, and as safety plugs. A silver-copper eutectic alloy is also used for high-temperature soldering applications. See SOLDERING.

Directional solidification of eutectic alloys so as to create a microstructure well aligned parallel to the growth direction produces high-strength, multiphase composite materials with excellent mechanical properties. Among the major advantages of these alloys are extraordinary thermal stability of unstressed microstructures, retention of high strength to very close to the eutectic temperature of the respective alloys, and the ability to optimize strength by appropriate alloying additions to induce either solid-solution strengthening or intraphase precipitation of additional phases.

The most likely future applications for aligned eutectics are as gas turbine engine materials (turbine blades or stator vanes) or in nonstructural applications such as superconducting devices in which directionality of physical properties is important. See ALLOY; METAL; SOLID SOLUTION. [N.S.S.]

**Eutheria** A higher-level taxon that includes all mammals except monotremes and marsupials. Eutheria (Placentalia) is variously ranked as an infraclass or cohort within Mammalia. Eutheria includes over 4000 living species arranged in 18 orders; another 12 orders are known only from fossils. An ecologically diverse group, Eutheria includes primates, insectivores, bats, rodents, carnivores, elephants, ungulates, and whales. Like other mammals, eutherians are generally fur-covered and produce milk to nourish their young. In part because they can make their own body heat and regulate their body temperature, eutherians are widely distributed over most continents and occur in all oceans.

Eutherians, often called placental mammals, have a unique reproductive system in which unborn young are nourished for an extended period via a placenta. This system permits retention of the young in the protective environment of the uterus during most of early development. Fetal survival rates are high under most conditions. Young are born in a relatively advanced state of development and are never sheltered in a pouch after birth. Gestation time ranges from 20 days (for example, shrews and hamsters) to 22 months (elephants). Many eutherians have only one or two young per pregnancy, but as many as 20 offspring may be produced at a single birth in some species.

Eutherians range in size from insectivores and bats that weigh only a few grams to blue whales that can weigh over 190,000 kg (420,000 lb). All have a relatively large brain and exhibit complex behavior, with many living in social groups. Eutherians exhibit more variation in ecology than any other group of vertebrates, and these differences are reflected in their morphological specializations.

The fossil record of Eutheria extends back at least into the Cretaceous Period. Several differences in the skull and dentition distinguish fossil eutherians from early members of other mammal lineages (for example, marsupials). The earliest eutherians were apparently small, nocturnal mammals that may have resembled some modern insectivores. Although Cretaceous eutherians are known from most continents, diversification of the modern orders apparently did not occur until the Paleocene and Eocene. See ARTIODACTYLA; CETACEA; CHIROPTERA; DENTITION; MAMMALIA; METATHERIA; RAT; THERIA. [N.B.S.]

**Eutrophication** The deterioration of the esthetic and life-supporting qualities of lakes and estuaries, caused by excessive fertilization from effluents high in phosphorus, nitrogen, and organic growth substances. Algae and aquatic plants become excessive, and, when they decompose, a sequence of objectionable features arise. Water supplies drawn from such lakes must be filtered and treated. Diversion of sewage, better utilization of manure, erosion control, improved sewage treatment and

harvesting of the surplus aquatic crops alleviate the symptoms. Prompt public action is essential. See WATER CONSERVATION; WATER POLLUTION. [A.D.H.]

**Evaporation** The process by which a liquid is converted into a vapor. In the liquid phase, the substance is held together by intermolecular forces. As the temperature is raised, the molecules move more vigorously, and in increasingly high proportion have sufficient energy to escape from their neighbors. Evaporation is therefore slow at low temperatures but faster at higher temperatures. In an open vessel, the molecules escape from the vicinity of the liquid, and there is a net migration from the liquid to the atmosphere. In a closed vessel, net evaporation continues until the number of molecules in the vapor has risen to the stage at which the rate of return from the vapor to the liquid is equal to the rate of evaporation. At this stage there is a dynamic equilibrium between the liquid and its vapor, with evaporation and its reverse, condensation, occurring at the same rate. The pressure of the vapor in the closed vessel is called the vapor pressure of the substance; its value depends on the temperature. Boiling occurs in an open vessel (but not in a closed vessel) when the vapor pressure is equal to the ambient pressure. See BOILING POINT; KINETIC THEORY OF MATTER; VAPOR PRESSURE.

Evaporation is an endothermic (heat-absorbing) process because molecules must be supplied with energy to overcome the intermolecular forces. The enthalpy of vaporization,  $\Delta_{\text{vap}}H$  (formerly, the latent heat of vaporization) is the heat required at constant pressure per mole of substance for vaporization. The entropy of vaporization,  $\Delta_{\text{vap}}S$ , at the boiling point,  $T_b$ , is equal to  $\Delta_{\text{vap}}H/T_b$ . According to Trouton's rule, for many liquids the entropy of vaporization is close to  $85 \text{ J/K} \cdot \text{mol}$ . This value reflects the similar change in disorder that occurs when a liquid is converted into a gas. However, certain liquids (water and mercury among them) are more structured than others, and have a bigger entropy of vaporization than Trouton's rule suggests. See ENTHALPY; ENTROPY; THERMODYNAMIC PRINCIPLES.

Volatile liquids evaporate more rapidly than others at the same temperature. Such liquids have relatively weak intermolecular forces. In general, the rate of evaporation depends on the strengths of the intermolecular forces and the rate at which heat is supplied to the liquid. See INTERMOLECULAR FORCES; LIQUID. [P.W.A.]

**Evaporator** A device used to vaporize part or all of the solvent from a solution. The valuable product is usually either a solid or a concentrated solution of the solute. If a solid, the heat required for evaporation of the solvent must have been supplied to a suspension of the solid in the solution, otherwise the device would be classed as a drier. The vaporized solvent may be made up of several volatile components, but if any separation of these components is effected, the device is properly classed as a still or distillation column. When the valuable product is the vaporized solvent, an evaporator is sometimes mislabeled a still, such as water still, and sometimes is properly labeled, such as boiler-feedwater evaporator. In the great majority of evaporator installations, water is the solvent that is removed. See DISTILLATION.

Evaporators are used primarily in the chemical industry. For example, common salt is made by boiling a saturated brine in an evaporator. The salt precipitates as a solid in suspension in the brine. This slurry is pumped continuously to a filter, from which the solids are recovered and the liquid portion returned for further evaporation. Evaporators are widely used in the food industry, usually as a means of reducing volume to permit easier storage and shipment. Evaporators are also the most commonly used means of producing potable water from sea water or other contaminated sources.

The vaporization of solvent requires large amounts of heat. Provisions for transferring this heat to the solution constitute the largest element of evaporator cost and the principal means of

distinguishing between types of evaporators. Practically all evaporators fall into one of the following categories:

1. Submerged-combustion evaporators: those heated by a flame that burns below the liquid surface, and in which the hot combustion gases are bubbled through the liquid.
2. Direct-fired evaporators: those in which the flame and combustion gases are separated from the boiling liquid by a metal wall, or heating surface.
3. Stem-heated evaporators: those in which steam or other condensable vapor is the source of heat, and in which the steam condenses on one side of the heating surface and the heat is transmitted through the wall to the boiling liquid. See EVAPORATION. [F.C.S.]

**Evergreen plants** Plants that retain their green foliage throughout the year. Popularly, needle-leaved trees (pine, fir, juniper, spruce) and certain broad-leaved shrubs (rhododendron, laurel) are called evergreens. In warm regions many broad-leaved trees (magnolia, live oak) are evergreen, and in the tropics most trees are evergreen and nearly all have broad leaves. Many herbaceous biennials and perennials have basal rosettes with leaves close to the ground that remain green throughout the winter. See FOREST AND FORESTRY; LEAF; PLANT TAXONOMY. [N.A.]

**Evolutionary computation** A rapidly growing interdisciplinary science area that is concerned with modeling aspects of natural evolution in order to solve real-world problems. Living organisms, as well as those long extinct, demonstrate optimized complex behavior at all levels: cells, organs, individuals, and populations. Charles Darwin wrote of "organs of extreme perfection" when describing the ability of evolution to craft ingenious solutions to complex problems such as vision. Evolution is the great unifying principle of biology, but it extends beyond biology and can be used as an engineering principle where individuals in a population of candidate solutions to some particular problem undergo random variation (mutation and recombination) and

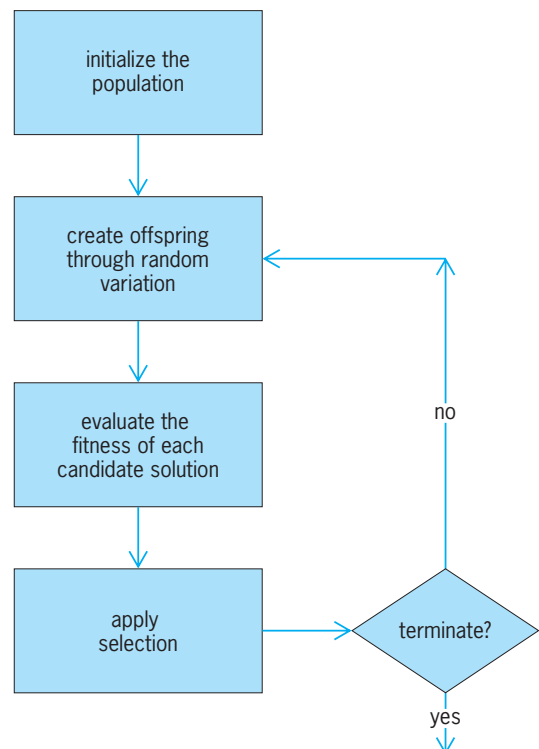

Typical flowchart for an evolutionary algorithm.

face competition and selection based on their appropriateness for the task at hand.

The common use of an evolutionary algorithm requires four elements: (1) an evaluation (fitness) function that describes the quality of any candidate solution in quantitative terms, (2) a representation or data structure that the computer uses to store solutions, (3) a random variation operator (or operators) that transform "parents" into "offspring," and (4) a means for selecting which solutions will survive to the next generation and which will be eliminated. In addition, the process must be initialized with a population of candidate solutions to the task at hand. This is often accomplished by seeding the first population with completely random solutions; however, if domain-specific knowledge is available regarding which solutions may be better than others, these hints can be used to bias the initial population and may accelerate the evolutionary optimization procedure.

An evolutionary algorithm (see illustration) is executed over a series of generations of random variation and selection. The variation to the existing solutions can come in the form of single-parent or multiparent operators. Alternative choices offer different sampling distributions from the space of all possible solutions. Each of the individuals in the population is scored with respect to how well the individual accomplishes the task at hand (fitness), and selection is used to eliminate some subset of the population or to amplify the percentage of above-average solutions. The algorithm terminates when some extrinsic criterion has been satisfied, such as prescribed maximum number of generations, or a suitable error tolerance. Over time, by eliminating poor solutions and extending the evolutionary search around those that appear better, the population can discover superior solutions to complex problems.

In comparison to traditional problem-solving techniques, evolutionary algorithms are often much faster and more adaptable to changes in the environment because whatever knowledge has been learned about how to solve a problem is contained in the collection of individual solutions that has survived up to that point. In contrast with, say, dynamic programming, an evolutionary algorithm need not be restarted when facing new data. This feature promises to have a significant potential in future problem solving. As the spread of data and processing speeds continue to increase, it will be necessary to make decisions ever more quickly. The evolutionary approach of bootstrapping off the current basis set of knowledge may eventually become the standard approach to real-world, real-time problem solving. See ALGORITHM; CONCURRENT PROCESSING; DISTRIBUTED SYSTEMS (COMPUTERS); GENETIC ALGORITHMS; MULTIPROCESSING; OPTIMIZATION; ORGANIC EVOLUTION; SUPERCOMPUTER. [D.B.F.]

**Exchange interaction** A quantum-mechanical phenomenon that gives the energy of two elementary particles. Exchange effects arise for all kinds of elementary particles, but these effects were first introduced into physics in consideration of atomic structure and the energy of the electrons in an atom. In this context, they arise as a consequence of two facts: electrons are indistinguishable, and they obey the Pauli exclusion principle. See ELEMENTARY PARTICLE.

Indistinguishability demands that the wave function describing two electrons either is unchanged or changes sign when the labels of the two electrons are exchanged (that is, it is either symmetric or antisymmetric to this exchange). In the case of electrons, the wave function is antisymmetric; this is a more precise statement of the Pauli exclusion principle. See ELECTRON; EXCLUSION PRINCIPLE.

When the spins of the two electrons are parallel the spatial part of the wave function is antisymmetric under exchange, and when they are opposed it is symmetric. The distribution in space of the two electrons is different in these two states, and so their mutual electrostatic energy is different. This difference in the electrostatic energy, called the exchange energy, appears as an

interaction between the two electrons which depends on their relative orientation (although this dependence is incidental).

Exchange is the mechanism by which the electron spins in many magnetic materials are lined up parallel or opposed (for example, in  $\alpha$ -iron and the ferrites). It is also the mechanism whereby the electron spins are parallel in the first excited state of the helium atom, and the spins of the two electrons are opposed in the carbon-carbon covalent bond. See ATOMIC STRUCTURE AND SPECTRA; CHEMICAL BONDING; ELECTRON CONFIGURATION; FERROMAGNETISM; QUANTUM MECHANICS; SPIN (QUANTUM MECHANICS). [J.M.D.]

**Excitation** Any of a number of different phenomena which alter a system in some way or result in some type of response. In electrical network theory, an excitation initiates a response or a response sequence. In other areas of technology, an excitation establishes an altered condition which causes an apparatus or system to exhibit useful response capabilities.

In electrical network theory, the term excitation designates a time-varying independent voltage or current in an  $n$ -port system or network. The independent voltage or current—which is also referred to as the excitation or the excitation signal—causes a network response which affects the voltage or current at the dependent port. The nature of the network response, and therefore of the dependent voltage or current, derives from the characteristics of the network. See MULTIVIBRATOR; NETWORK THEORY.

In atomic physics, excitation means the addition of energy to an atom at ground state to produce an excited state. See ATOMIC STRUCTURE AND SPECTRA; EXCITATION POTENTIAL.

In other contexts, excitation means the application of energy to one portion of a system or apparatus in a manner that enables another portion to perform a specialized function. Excitation energy may differ from the output energy in source, form, level, or location. That is, an excitation produces a primary effect that is linked, through an intermediate physical phenomenon, to a dependent secondary effect. For example, a dynamic loudspeaker uses an excitation current in a field coil to generate a magnetic field; only then can a second magnetic field, generated by an audio signal, actuate the voice cone and produce sound waves. See LOUDSPEAKER. [W.W.Sn.]

**Excitation potential** The difference in potential between an excited atomic or molecular state and the ground state. The term is most generally used in connection with electron excitation, but it can be applied to excited molecular vibrational and rotational states.

A closely related term is excitation energy. If the unit of potential is taken as the volt and the unit of energy as the electron volt, then the two are numerically equal. According to the Bohr theory, there is a relationship between the wavelength of the photon associated with the transition and the excitation energies of the two states. Thus the basic equation for the emission or absorption of energy is as shown below, where  $h$  is Planck's constant,

$$\frac{hc}{\lambda} = E_i - E_f$$

$c$  the velocity of light,  $\lambda$  the wavelength of the photon, and  $E_f$  and  $E_i$  the energies of the final and initial states, respectively. See EXCITED STATE; GROUND STATE; IONIZATION POTENTIAL. [G.H.M.]

**Excited state** In quantum mechanics, a stationary state of higher energy than the lowest stationary state or ground state of a particle or a system of particles. Customarily, only bound stationary states, which generally are at most denumerably infinite in number, are spoken of as excited, although the formal quantum theory often treats the noncountable unbound stationary states on an equal footing with the bound states. See GROUND STATE; METASTABLE STATE. [E.G.]

**Exciton** A fundamental quantum of electronic excitation in condensed matter, consisting of a negatively charged electron and a positively charged hole bound to each other by electrostatic attraction. Excitons exist in all kinds of condensed matter, whenever it is possible for an electron to be excited from a filled energy level to an empty one, leaving behind a hole. Unlike an excitation in a single atom or molecule, an exciton can in general move through the solid like a particle. Excitons transport energy, not charge or mass. Typically, an exciton is created when a photon is absorbed in a solid; the exciton then moves through the crystal; and finally the electron and hole recombine, resulting in the emission of another photon, often at a wavelength different from that of the original photon. Excitons can also be created by injection of free electrons into excited states via an electric current. See CRYSTAL ABSORPTION SPECTRA; ELECTRON-HOLE RECOMBINATION; HOLE STATES IN SOLIDS; LUMINESCENCE.

Excitons fall into two broad classes, Wannier (or Wannier-Mott) excitons and Frenkel excitons, based on their size relative to the interatomic or intermolecular distances in the material. In Wannier excitons, typically observed in covalent semiconductors and insulators, the electron and hole are separated by a distance much larger than the atomic spacing, so that the effect of the crystal lattice on the exciton can be taken into account primarily via an average permittivity. In Frenkel excitons, typically seen in molecular or rare-gas crystals, the electron and hole are separated by a distance comparable to the atomic spacing, so that the exciton is localized to a single site at any given time. Wannier excitons move essentially like free particles, while motion of Frenkel excitons is envisioned as hopping from one site to another. See ELECTRIC INSULATOR; SEMICONDUCTOR. [D.Sn.]

**Exclusion principle** No two electrons may simultaneously occupy the same quantum state. This principle, often called the Pauli principle, was first formulated by Wolfgang Pauli in 1925 and, for time-independent quantum states, it means that no two electrons may be described by state functions which are characterized by exactly the same quantum numbers. In addition to electrons, all known particles having half-integer intrinsic angular momentum, or spin, obey the exclusion principle. It plays a central role in the understanding of many diverse phenomena, including the periodic table of the elements and their chemical activities, the electron contribution to the specific heat of metals, the shell structure in the atomic nucleus analogous to that of electrons in atoms, and certain symmetries in the scattering of identical particles. See ANGULAR MOMENTUM; QUANTUM NUMBERS; SPIN (QUANTUM MECHANICS).

Using the fact that a system will try to occupy the state of lowest possible energy, the electron configuration of atoms may be understood by simply filling the single-particle energy levels according to the Pauli principle. This is the basis of Niels Bohr's explanation of the periodic table. See ATOMIC STRUCTURE AND SPECTRA; ELECTRON CONFIGURATION. [S.A.Wi.]

**Exon** In split genes, a portion that is included in the ribonucleic acid (RNA) transcript of a gene and survives processing of the RNA in the cell nucleus to become part of a spliced messenger RNA (mRNA) or structural RNA in the cell cytoplasm. Split genes are those in which regions that are represented in mature mRNAs or structural RNAs (exons) are separated by regions that are transcribed along with exons in the primary RNA products of genes, but are removed from within the primary RNA molecule during RNA processing steps (introns). See INTRON; RIBONUCLEIC ACID (RNA).

Exons comprise three distinct regions of a protein-coding gene. The first is a portion that is not translated into protein, but contains the signal for the beginning of RNA synthesis, and sequences that direct the mRNA to ribosomes for protein synthesis. The second is a set of exons containing information that is translated into the amino acid sequence of a protein. The third region of a gene that becomes part of an mRNA is an untranslated end

portion that contains signals for transcription termination and for the addition of a polyadenylate tract at the end of a transcript.

The mechanism by which the exons are joined in RNA copies of genes is called RNA splicing, and it is part of the maturation of mRNAs and some transfer and ribosomal RNAs (tRNAs and rRNAs) from primary transcripts of genes. Three different RNA splicing processes have been identified. One involves mRNA precursors in nuclei, and specific sequences at exon-intron junctions that are recognized by certain nuclear ribonucleoprotein particles that facilitate the cleavage and ligation of RNA. Another applies to nuclear precursors of tRNA, where splice sites are determined by structural features of the folded RNA molecules. The third form of splicing was discovered in studies of protozoan rRNA synthesis, and has also been shown to be a part of the maturation of both rRNA and mRNA in yeast mitochondria; it is an autocatalytic process that requires neither an enzyme nor added energy such as from adenosine triphosphate. See GENE; GENETIC CODE; PROTEIN; RIBOSOMES. [P.M.R.]

**Exopterygota** A division (also known as Hemimetabola) of the subclass Pterygota, including those insects that show relatively slight change in body form with growth. They develop through a series of immature forms (nymphs) from hatchling to adult, so that wings grow as external pads and enlarge with each molt. The nymphs are often scaled-down copies of the adults, but in some cases, a considerable difference in body form exists between adults and their immature forms.

Exopterygota are a very diverse group, encompassing plant feeders, predators, and animal parasites, and living in nearly all habitats and areas where insects are found. Common examples of Exopterygota are mayflies, dragonflies, grasshoppers, termites, cockroaches, aphids, plant bugs, biting and sucking lice, and thrips. See ENDOPTERYGOTA; INSECTA; PTERYGOTA. [W.L.Br.]

**Exotic nuclei** Nuclei with ratios of neutron number  $N$  to proton number  $Z$  much larger or much smaller than those of nuclei found in nature. Studies of nuclear matter under extreme conditions, in which the nuclei are quite different in some way from those found in nature, are at the forefront of nuclear research. Such extreme conditions include nuclei at high temperature and at high density (several times normal nuclear density), as well as those with larger or smaller  $N/Z$  ratios. The  $N/Z$  ratio depends on the nature of the attractive nuclear force that binds the protons and neutrons in the nucleus and its competition and complex interplay with the disruptive Coulomb or electrical force that pushes the positively charged protons apart.

A chart of the nuclides is shown in the illustration. The squares are the stable nuclei ( $Z \leq 83$ ) and the very long-lived nuclei (with half-lives of the order of  $10^9$  years or more) found in nature. The first jagged lines to either side are the limits of the presently observed nuclei; very little is known about those at the edges. The light, stable nuclei (such as  $^4\text{He}$ ) have  $Z = N$ , reflecting the preference of the nuclear forces for  $N = Z$  symmetry, but as  $Z$  increases, the strength of the Coulomb force demands more neutrons than protons to make a particular element stable, and  $N \approx 1.6 Z$  for the heaviest long-lived nuclei (such as  $^{238}\text{U}$ ). For  $Z > 92$ , the Coulomb force causes most nuclei to spontaneously fission. See NUCLEAR FISSION.

Stable nuclei lie in the so-called valley of beta stability. As the  $N/Z$  ratio decreases (proton-rich nuclei) or increases (neutron-rich nuclei) compared to that of the stable isotopes, there is, respectively, energy for a proton or neutron in the nucleus to undergo beta ( $\beta^+$ ,  $\beta^-$ ) decay to move the nucleus back toward stability. Most knowledge of nuclear structure and decay has been gained from nuclei in or near the valley of beta stability. See RADIOACTIVITY.

The spherical shell model was developed to explain the so-called spherical magic numbers for protons and neutrons, which give nuclei with these numbers a very stable structure and spherical shape. Spherical magic  $Z$  and  $N$  of 2, 8, 20, 28, 50, 82, and

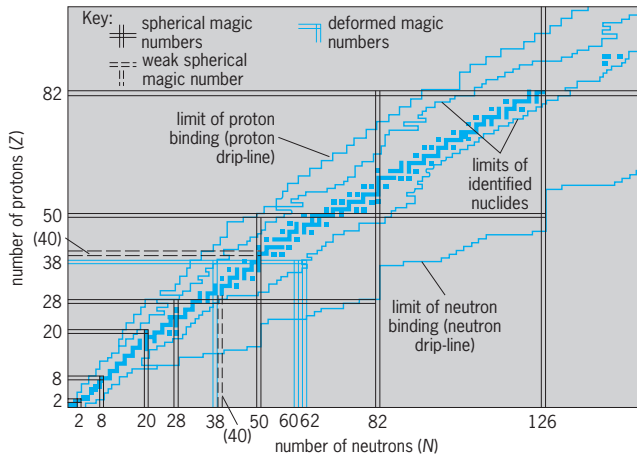

**Chart of the nuclides. The squares are the stable and very long-lived nuclei found in nature.**

126, and the weaker magic  $Z$  and  $N$  at 40, are shown in the illustration as horizontal and vertical lines. The nuclear shell model resembles the atomic shell model, where the noble gases (helium, neon, argon, and so forth) have filled shells and then there is a gap in the binding energy to the next electron shell (or orbit). A major question concerns what happens to these spherical magic proton and neutron gaps (orbits) in exotic nuclei. See NUCLEAR STRUCTURE.

Another major question concerns the decay modes whereby a nucleus rids itself of excess energy and returns to the stable forms of nuclear matter. As  $N/Z$  decreases or increases from the stable values, a point is reached for a given  $Z$  where, if one more neutron is pulled out, one proton becomes unbound (an isotope of that element cannot exist with that number of neutrons), or, if one more neutron is added, that neutron is not bound to that nucleus. These limits define, respectively, the proton and neutron drip-lines (the jagged lines furthest from the valley of stability in the illustration).

Answers to the above questions give significant insights into the structure and decay modes of nuclear matter that make it possible to test and extend theoretical models of the nucleus and the understanding of the nature of both the strong and weak nuclear forces. These insights could not be gained by studies of nuclei in and near the valley of stability.

These insights include the discovery of nuclear shape coexistence. Competing bands of levels occur in one nucleus, which overlap in energy but are quite separate in their decays because they are built on quite different coexisting nuclear shapes. Shape coexistence is now known to be important in many nuclei throughout the periodic table.

A significant advance was made in the nuclear shell model with the discovery of new magic numbers associated with shell gaps in the energies of the proton and neutron orbitals. These new numbers may be called deformed magic numbers because they stabilize a nucleus in a deformed shape, just as the spherical magic numbers give stability to a spherical shape. The deformed magic numbers (shell gaps) identified so far include  $N$  and  $Z$  of 38 and  $N$  of 60 and 62.

Exotic nuclei exhibit decay modes not seen near stability, such as proton radioactivity and beta-delayed particle emission. (After beta decay, the highly excited nucleus can emit one or more particles, such as one or two protons, an alpha particle, or one or two neutrons.) [J.H.H.]

**Exotic viral diseases** Viral diseases that occur only rarely in human populations of developed countries. However, many of these diseases cause significant human morbidity and mortality in underdeveloped areas, and have the proven capac-

ity to be transported to population centers in developed countries and to cause explosive outbreaks or epidemics. Most of the exotic viruses are zoonotic, that is, they are transmitted to humans from an ongoing life cycle in animals or arthropods; the exception is smallpox.

Important diseases caused by exotic viruses include yellow fever, Venezuelan equine encephalitis, Rift Valley fever, tick-borne encephalitis, Crimean hemorrhagic fever, rabies, Lassa fever, hemorrhagic fever, and Marburg and Ebola hemorrhagic fevers. Control of these diseases is often very difficult because of the lack of detailed knowledge about the natural history of the viruses in their natural animal hosts, and because of the difficulty of controlling natural populations of alternative hosts such as insects or rodents. [F.A.M.]

**Expert control system** A type of intelligent control system which can emulate the reasoning procedures of a human expert in order to generate the necessary control action. Expert control systems seek to incorporate knowledge about control system design, practical operations, and abnormal system recovery plans to automate tasks normally performed by experienced control engineers (the experts). Techniques relating to the field of artificial intelligence are usually used for the purpose of acquiring and representing knowledge and for generating control decisions through an appropriate reasoning mechanism. As it operates essentially on a knowledge base, an expert control system is often referred to as a knowledge-based control system. One of the most important benefits associated with the use of an expert control system is the inherent capability of the system to deal with uncertainty in information. Information provided to these systems can be general, qualitative, or vague because, like humans, expert control systems possess functionalities to perceive, reason, infer, and deduce new information. They can learn, gain new knowledge, and improve their performance through experience.

The principal components almost certain to be present in all expert control systems are the knowledge source, the database, the inference engine, the control algorithms, and the interface between the expert control system and humans (see illustration).

Central to an expert system is the knowledge source (or knowledge base), which contains knowledge in a specific domain (control in this context). This knowledge consists of domain-specific facts and heuristics, usually in the form of rules or frames, useful for solving problems in the domain.

The database is a short-term memory component which contains the current problem status, inference states, and the history of solutions to date for reference purposes.

The inference engine operates on the information from the knowledge source, from the associated database, or from the

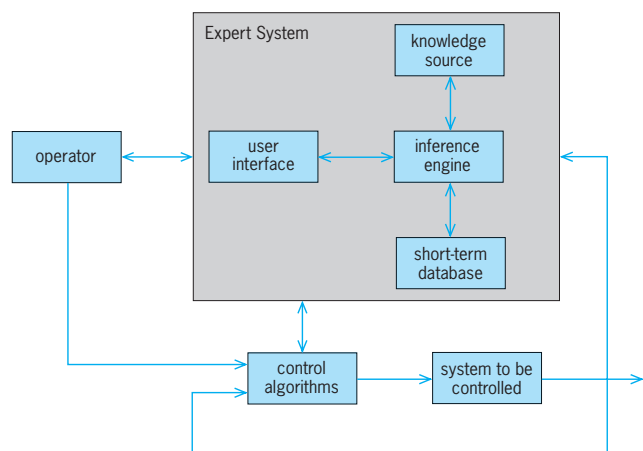

**Basic architecture of an expert control system.**

user; guides the search process according to the programmed strategy and search algorithms; and uses the inferring mechanisms, usually in the forms of rules of logic, to solve problems, arrive at conclusions, and activate the final control actions.

The control algorithms are the tools for the expert systems to perform the final control action. A rich library of control algorithms, with advanced features, is usually made available.

The user interface allows the user to interact with the overall system, browse through the knowledge source, edit rules, and perform many other interactive tasks. See ARTIFICIAL INTELLIGENCE; CONTROL SYSTEMS; EXPERT SYSTEMS; PROCESS CONTROL.

[T.H.Le.; K.K.T.; C.C.Ha.; K.C.Ta.]

**Expert systems** Methods and techniques for constructing human-machine systems with specialized problem-solving expertise. The pursuit of this area of artificial intelligence research has emphasized the knowledge that underlies human expertise and has simultaneously decreased the apparent significance of domain-independent problem-solving theory. In fact, new principles, tools, and techniques have emerged that form the basis of knowledge engineering.

Expertise consists of knowledge about a particular domain, understanding of domain problems, and skill at solving some of these problems. Knowledge in any specialty is of two types, public and private. Public knowledge includes the published definitions, facts, and theories which are contained in textbooks and references in the domain of study. But expertise usually requires more than just public knowledge. Human experts generally possess private knowledge which has not found its way into the published literature. This private knowledge consists largely of rules of thumb or heuristics. Heuristics enable the human expert to make educated guesses when necessary, to recognize promising approaches to problems, and to deal effectively with erroneous or incomplete data. The elucidation and reproduction of such knowledge are the central problems of expert systems.

Researchers in this field suggest several reasons for their emphasis on knowledge-based methods rather than formal representations and associated analytic methods. First, most of the difficult and interesting problems do not have tractable algorithmic solutions. This is reflected in the fact that many important tasks, such as planning, legal reasoning, medical diagnosis, geological exploration, and military situation analysis, originate in complex social or physical contexts, and generally resist precise description and rigorous analysis.

The second reason for emphasizing knowledge is pragmatic: human experts achieve outstanding performance because they are knowledgeable. If computer programs embody and use this knowledge, they too attain high levels of performance. This has been proved repeatedly in the short history of expert systems. Systems have attained expert levels in several tasks: mineral prospecting, computer configuration, chemical structure elucidation, symbolic mathematics, chess, medical diagnosis and therapy, and electronics analysis.

The third motivation for focusing on knowledge is the recognition of its intrinsic value. Traditionally, the transmission of knowledge from human expert to trainee has required education and internship periods ranging from 3 to 20 years. By extracting knowledge from humans and transferring it to computable forms, the costs of knowledge reproduction and exploitation can be greatly reduced. At the same time, the process of knowledge refinement can be accelerated by making the previously private knowledge available for public test and evaluation.

Most of the knowledge-engineering applications fall into a few distinct types, summarized in the table.

The ideal expert system contains: a language processor for problem-oriented communications between the user and the expert system; a blackboard for recording intermediate results; a knowledge base comprising facts plus heuristic planning and problem-solving rules; an interpreter that applies these rules; a scheduler to control the order of rule processing; a consistency

**Generic categories of knowledge engineering applications**

Category	Problem addressed
Interpretations	Inferring situation descriptions from sensor data
Prediction	Inferring likely consequences of given situations
Diagnosis	Inferring system malfunctions from observables
Design	Configuring objects under constraints
Planning	Designing actions
Monitoring	Comparing observations to plan vulnerabilities
Debugging	Prescribing remedies for malfunctions
Repair	Executing a plan to administer a prescribed remedy
Instruction	Diagnosing, debugging, and repairing students' knowledge weaknesses
Control	Interpreting, predicting, repairing, and monitoring system behaviors

enforcer that adjusts previous conclusions when new data or knowledge alter their bases of support; and a justifier that rationalizes and explains the system's behavior. See ARTIFICIAL INTELLIGENCE.

Agents are autonomous programs; programs that communicate with an agent communication language (for example, KQML); mobile programs that can travel from one computer to another; or programs that collaborate with humans in solving tasks, offloading tedious tasks, and acting as monitors and liaisons with other agents. Agents can also be viewed as higher-level architectural components, providing distributed open architectures in which the agents can be registered, requests can be brokered, and different organizational structures can be used to solve higher-level tasks. In this architectural view, they are distinguished from objects by their persistence, autonomy, communications capabilities, and behavior. Another key aspect of most agent definitions is the agent's dynamic and uncertain environment. Agents also may or may not have graphical representations, commonly called avatars or personas.

Agents can vary from simple programs, lacking knowledge, to sophisticated autonomous real-time control systems that provide both deliberative reasoning (for example, including sophisticated planning and scheduling) and fast real-time response. The vast majority of simple utilitarian agents, such as off-line browsers that automatically download Web sites, or agents that monitor Web pages for changes, are not knowledge-based. Most knowledge-based agents are still experimental. See INTERNET; WORLD WIDE WEB.

[F.H.Ro.; W.Mu.]

**Explosive** A substance containing a large amount of stored energy that can be released suddenly, thereby converting the substance into compressed gases or numerous fragments that expand with great force or velocity. An explosion is a sudden expansion of matter into a much larger volume than it formerly occupied, or a sudden increase in the pressure exerted by confined matter.

Uses of industrial explosives include blasting ore, coal, and rock in mining and construction, generating vibrations in seismic prospecting for oil and gas, stimulating and perforating gas and oil wells, bonding sheets of dissimilar metals to each other, and synthesizing industrial diamonds. In contrast to military explosives, industrial explosives tend to have larger critical diameters, lower densities, lower detonation velocities, and lower explosion pressures; and to have more complex compositions and lower cost. Most military explosives are rigid solids, whereas most industrial explosives are formulated to be plastic, pumpable, or free-flowing to permit filling the cross section of deep, rough, and irregular holes in rock.

Industrial explosives usually contain separate fuel and oxidizer ingredients in intimate combination. Usually, they also contain a sensitizer to aid in the initiation and propagation of detonation. Other ingredients may be used to increase or decrease density, to increase explosion energy, to prevent the detonation from igniting methane in coal mines, to provide plasticity, pumpability, or flowability, to prevent setting or stiffening during storage or

at low temperature, to prevent separation of ingredients and chemical instability during storage, and to provide resistance to desensitization by water, low temperature, hydrostatic pressure, or transient pressure from explosions in nearby holes. Industrial explosives are usually packaged in bags or cartridges of polymer film or paper, or are carried in bulk form to the blasting site, where they are blown or pumped into the holes through hoses. Sometimes they are mixed at the blasting site.

Most military explosives are simple compositions formulated for high energy density, loading in munitions plant, and long storage life. Most of them are based on explosive chemical compounds that incorporate both oxidizer and fuel components in the same molecule. Many of these compounds are used for special purposes in industrial explosives also. [D.L.C.]

**Explosive forming** The shaping or modifying of metals by means of explosions. The explosives may be of either the detonating or deflagrating type. Explosive gas mixtures or stored gas at high pressure may also provide the motive power.

Cold welds can be made between dissimilar metals by driving the two parts together under explosive impact. In other applications of explosive-forming methods, powders are pressed into solid billets. In a different application, high explosives are used to cut large blocks of metal and even to split thin sheets into two layers of exactly one-half the original thickness. Explosives can also be employed to extrude metal shapes and to punch hard metals with the aid of dies. Shapes produced explosively are very exact and free from the fine cracks that sometimes result when pressure is applied slowly. See METAL FORMING. [W.E.Go.]

**Exponent** In mathematics a symbol or number written to the right of and above another symbol or number to denote how many times the latter is to be multiplied by itself. For example,  $7^3 = 7 \cdot 7 \cdot 7$ , and  $a^3 = a \cdot a \cdot a$ . By use of this convenient mathematical device, the number 420,000,000,000,000 can be expressed unmistakably and more compactly as  $4.2 \times 10^{14}$ , which is read as, "four and two-tenths times ten multiplied by itself fourteen times" or, more properly, "four and two-tenths times ten to the fourteenth power." This abbreviated notation is particularly valuable in expressing the extremely large or extremely small numbers encountered in modern scientific work. For example, 0.000000143 may be expressed as

$$\frac{143}{1,000,000,000} \text{ or } \frac{143}{10^9} \text{ or } 1.43 \times 10^{-7}$$

Operations with exponents are governed by the following rules:

- $x^a x^b = x^{a+b}$ . Example,  $x^2 x^3 = xx \cdot xxx = x^5$ .
- $(x^a)^b = x^{ab}$ . Example,  $(x^2)^3 = (x^2)(x^2)(x^2) = x^6$ .
- $(xy)^a = x^a y^a$ . Example,  $(xy)^3 xyxyxy = xxxxyyy = x^3 y^3$ .
- If  $y \neq 0$ ,  $\left(\frac{x}{y}\right)^a = \frac{x^a}{y^a}$ . Example,  $\left(\frac{x}{y}\right)^3 = \frac{x}{y} \cdot \frac{x}{y} \cdot \frac{x}{y} = \frac{x^3}{y^3}$ .
- If  $x \neq 0$ ,  $\frac{x^a}{x^b} = x^{a-b}$ . Example,  $\frac{x^5}{x^2} = \frac{xxxxx}{xx} = xxx = x^3$ .

See ALGEBRA.

[A.N.L.; S.Bo.]

**Exposure meter** An indicating instrument used in photography to determine lens aperture and shutter speed. An exposure meter may be used either in the darkroom to determine approximate printing time for a contact print or an enlargement or, more usually, with a camera to determine exposure of film.

Exposure meters are of two basic types, photovoltaic and photoconductive. In photovoltaic meters, a selenium cell converts

photons to electrons, producing a current directly proportional to received light. A sensitive microammeter indicates this current to the user.

In the photoconductive meter, a cadmium sulfide cell changes conductivity in proportion to the received light. A battery (usually a mercury cell) supplies power through the cadmium sulfide cell to the meter movement. Because the received light serves to control the power from the battery, this type of instrument is about three orders of magnitude more power-sensitive than the photovoltaic type.

Used at the camera, either type of meter serves as a brightness meter to measure reflected light from the subject. Used at the subject, with a diffuser head over the exposure meter lens, the instrument serves as an illumination meter to indicate incident light. See PHOTOGRAPHY; PHOTOMETRY. [F.H.R.]

### Extended x-ray absorption fine structure (EXAFS)

The structured absorption on the high-energy side of an x-ray absorption edge. The absorption edges for an element are abrupt increases in x-ray absorption that occur when the energy of the incident x-ray matches the binding energy of a core electron (typically a 1s or a 2p electron). For x-ray energies above the edge energy, a core electron is ejected from the atom. The ejected core electron can be thought of as a spherical wave propagating outward from the absorbing atom. The photoelectron wavelength is determined by its kinetic energy, which is in turn determined by the difference between the incident x-ray energy and the core-electron binding energy. As the x-ray energy increases, the kinetic energy of the photoelectron increases, and thus its wavelength decreases. See ABSORPTION OF ELECTROMAGNETIC RADIATION; LIGHT; PHOTOEMISSION; QUANTUM MECHANICS.

The x-ray-excited photoelectron will be scattered by the neighboring atoms surrounding the absorbing atom. The portion of the photoelectron wave that is scattered back in the direction of the absorbing atom is responsible for the EXAFS oscillations. If the outgoing and backscattered photoelectron waves are out of phase and thus interfere destructively, there is a local minimum in the x-ray absorption cross section. At a higher x-ray energy (shorter photoelectron wavelength), constructive interference leads to a local maximum in x-ray absorption (see illustration). EXAFS thus arises from photoelectron scattering, making it a spectroscopically detected scattering method. See INTERFERENCE OF WAVES; SCATTERING OF ELECTROMAGNETIC RADIATION.

EXAFS typically refers to structured absorption from approximately 50 to 1000 eV or more above the absorption edge. X-ray absorption near edge structure (XANES) is often used to refer to the structure in the near (around 50 eV) region of the edge. X-ray absorption fine structure (XAFS) has gained some

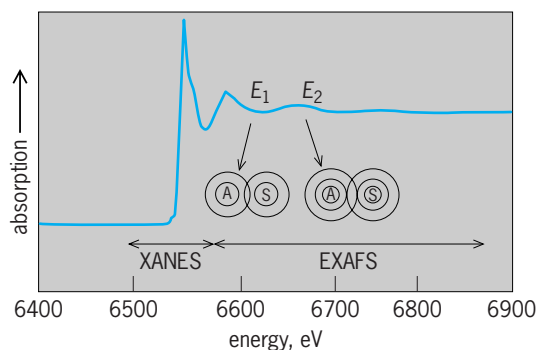

X-ray absorption spectrum for manganese, showing XANES and EXAFS regions. As the x-ray energy increases from  $E_1$  to  $E_2$ , the interference of the outgoing and backscattered photoelectron wave (shown schematically by concentric circles around the absorbing, A, and scattering, S, atoms) changes from destructive to constructive.



currency as a reference to the entire structured absorption region (XANES+EXAFS).

EXAFS spectra contain structural information comparable to that obtained from single-crystal x-ray diffraction. The principal advantage of EXAFS in comparison with crystallography is that EXAFS is a local structure probe and does not require the presence of long-range order. This means that EXAFS can be used to determine the local structure in noncrystalline samples. See X-RAY CRYSTALLOGRAPHY. [J.P.Ha.]

**Extinction (biology)** The death and disappearance of a species. The fossil record shows that extinctions have been frequent in the history of life. Mass extinctions refer to the loss of a large number of species in a relatively short period of time. Episodes of mass extinction occur at times of rapid global environmental change; five such events are known from the fossil record of the past 600 million years. Human activity is causing extinctions on a scale comparable to the mass extinctions in the fossil record.

**Record.** An extinction may be of two types; phyletic or terminal. Phyletic extinction occurs when one species evolves into another with time; in this case, the ancestral species can be called extinct. However, because the evolutionary lineage has continued, such extinctions are really pseudoextinctions. In contrast, terminal extinction marks the end of an evolutionary lineage, termination of a species without any descendants. Most extinctions recorded in the fossil record and those occurring today are terminal. It has been estimated that 99% of all species that have ever lived are now extinct. See ORGANIC EVOLUTION.

The fossil record is best known for marine organisms. The mass extinctions of the marine fossil record occurred during the Late Ordovician, Late Devonian, Late Permian, Late Triassic, and Late Cretaceous. These mass extinctions affected a variety of organisms in many different ecological settings. Terrestrial and marine mass extinctions seem to occur at about the same time. The Late Permian, Late Triassic, and Late Cretaceous are also times of extinction for terrestrial vertebrates; the most dramatic extinction of terrestrial vertebrates took place at the end of the Cretaceous, when the last dinosaurs died off. See DINOSAUR.

The best record of terrestrial vertebrate extinction is that of the Pleistocene. Late Pleistocene extinctions in North America are especially well known—33 genera of mammals vanished during the last 100,000 years. These extinctions were concentrated among the large mammals—those over 100 lb (44 kg) in weight—and most occurred during a short time interval approximately 11,000 years ago.

**Causes.** Ever since the work of Georges Cuvier, the French naturalist who demonstrated the reality of extinction, explanations have fascinated both scientists and the general public. Cuvier invoked sudden catastrophic events, whereas his contemporaries favored more gradual processes. These two themes, catastrophism and gradualism, are still debated.

In 1980 high concentrations of iridium were reported precisely at the Cretaceous-Tertiary boundary. Iridium is rare in most rocks but more abundant in meteorites. It was proposed, therefore, that an asteroid struck the Earth 65 million years ago. The impact darkened the atmosphere with dust, caused a catastrophic short-term cooling of the climate, and thus led to the extinction of dinosaurs and many other Cretaceous species. The iridium-rich layer at the boundary marks this terminal Cretaceous event.

Astronomical theories have been put forward to explain the Late Cretaceous extinctions as well as the 26-million-year periodicity. In one theory, the Sun has a distant companion star that would pass in orbit near the solar system's cloud of comets every 26 million years. This might perturb many comets, sending a few into the Earth. A comet would produce the same effects as an asteroid.

Other explanations for mass extinctions include lowered sea level, climatic cooling, and changes in oceanic circulation. Biotic processes such as disease, predation, and competition may also

cause the extinction of species but are difficult to prove from the fossil record because they leave little evidence. Biotic factors usually affect only one or a few interdependent species. Predation and competition are important causes of more recent extinctions, which continue today. Human activities such as hunting and fishing (predation), habitat alteration (competition for space), and pollution have probably destroyed thousands of species. These activities, together with continued tropical deforestation and resulting changes in climate, are likely to cause extinctions that will be comparable to the mass extinctions seen in the fossil record. See FOSSIL. [K.W.F.]

**Extraction** A method of separating the constituents of a mixture utilizing preferential solubility of one or more components in a second phase. Commonly, this added second phase is a liquid, while the mixture to be separated may be either solid or liquid. If the starting mixture is a liquid, then the added solvent must be immiscible or only partially miscible with the original and of such a nature that the components to be separated have different relative solubilities in the two liquid phases.

Solvent extraction processes can be divided into two broad categories according to the origins of the differential solubility. On the one hand, it arises from purely physical differences between the two solutes, such as polarity, while in other cases it can be traced to definite chemical interaction between solute and solvent. Categories of major importance for the latter cases are ion-association systems and chelate compounds.

Liquid/solid extraction may be considered as the dissolving of one or more components in a solid matrix by simple solution, or by the formation of a soluble form by chemical reaction. The largest use of liquid/solid extraction is in the extractive metallurgical, vegetable oil, and sugar industries. The field may be subdivided into the following categories: leaching, washing extraction, and diffusional extraction. Leaching involves the contacting of a liquid and a solid (usually an ore) and the imposing of a chemical reaction upon one or more substances in the solid matrix so as to render them soluble. In washing extraction the solid is crushed to break the cell walls, permitting the valuable soluble product to be washed from the matrix. In diffusional extraction the soluble product diffuses across the denatured cell walls (no crushing involved) and is washed out of the solid.

Liquid/liquid extraction separates the components of a homogeneous liquid mixture on the basis of differing solubility in another liquid phase. Because it depends on differences in chemical potential, liquid/liquid extraction is more sensitive to chemical type than to molecular size. This makes it complementary to distillation as a separation technique. One of the first large-scale uses was in the petroleum industry for the separation of aromatic from aliphatic compounds. Liquid/liquid extraction also has found application for many years in the coal tar industry. On a smaller scale, extraction is a key process in the pharmaceutical industry for recovery of antibiotics from fermentation broths, in the recovery and separation of vitamins, and for the production of alkaloids from natural products. See CHEMICAL SEPARATION TECHNIQUES. [B.M.S.]

**Extrapolation** A process in mathematics used to find the value of a function outside its tabulated values. This is done as in interpolation by assuming that over a small range of  $x$  the function may be closely approximated by a polynomial or some other readily computed function. Any of the interpolation formulas can be used, therefore, and the desired value of  $x$  substituted in them. See INTERPOLATION. [K.S.K.]

**Extraterrestrial intelligence** The potential existence beyond the Earth of other advanced civilizations with a technology at least as developed as that on Earth. The idea that life, especially life with intelligence, might exist in other parts of the universe is a very old one. Early ideas were based on an intuitive belief in the enormity of the universe and in what is

now called the mediocrity principle, namely that there is nothing special about the Sun, the Earth, and the human race.

Present ideas are also based on the mediocrity principle supported by the universality of the laws of physics and chemistry, and by the enormity of the universe. The Sun is one of  $2 \times 10^{11}$  stars of the Galaxy (the Milky Way), and there are about  $10^{11}$  galaxies in the visible universe. The chemical evolution, that is, the natural formation of complex organic compounds, that led to the origin of life on Earth is quite common in the universe. Life on Earth started at least  $3.5 \times 10^9$  years ago, that is, soon after the formation of the oceans, indicating a rather straightforward natural process. Through mutations and Darwinian selection, evolution advanced slowly from primitive unicellular microorganisms to advanced multicellular organisms with intelligence. Intelligence, which is favored by evolution because it has a high survival value, evolved into a technological society.

The search for extraterrestrial intelligence was initiated only after the development of radio astronomy and large radio telescopes, because radio waves seem to be the most efficient means of communication over interstellar distances. At least 60 radio searches have been carried out, and three radio observatories search continuously for radio signals. The results continue to be negative, but selecting the proper frequency, bandwidth, polarization, target, and so forth, is an extremely complex problem. See RADIO ASTRONOMY; RADIO TELESCOPE.

In the early 1960s, F. Drake developed an equation to estimate the number  $N$  of advanced technological civilizations currently active in the Galaxy. The Drake equation,  $N = R \times P \times L$ , gives  $N$  in terms of the rate  $R$  at which new stars are born in the Galaxy, the probability  $P$  (actually a product of probability factors) that any one of these stars will possess the necessary conditions (luminosity, planets at the appropriate distances, and so forth) for life to originate and to slowly evolve to a technological civilization, and the average longevity  $L$  of such civilizations. The values advocated by the proponents of the Drake equation yield a value of  $N$  of approximately 200,000 stellar civilizations. However, the uncertainties in  $P$  and  $L$  are very large and some scientists think that the human race is probably the only advanced civilization in the Galaxy; that is,  $N$  equals 1.

In the mid-1970s, the possibility of large human colonies in space began to be seriously considered, and the idea that such self-sustained habitats could undertake multigeneration trips of several centuries to other stars began to gain acceptance. Many scientists think that galactic colonization is not only possible but an almost inevitable consequence of the evolution of intelligence and technology. This concept, however, leads to two extreme alternatives: either the Galaxy has already been colonized, in which case  $N$  must be very large; or it has not been colonized, because no one was there to do so, in which case  $N$  must be very small. Both alternatives are contrary to the results of the Drake equation, which negates galactic colonization and predicts an intermediate value of  $N$ . All three alternatives, however, contain serious contradictions which are not easy to reconcile. [M.D.Pa.]

**Extrusion** The forcing of solid metal through a suitably shaped orifice under compressive forces. Extrusion is somewhat analogous to squeezing toothpaste through a tube, although some cold extrusion processes more nearly resemble forging, which also deforms metals by application of compressive forces. Most metals can be extruded, although the process may not be economically feasible for high-strength alloys.

The most widely used method for producing extruded shapes is the direct, hot extrusion process. In this process, a heated billet of metal is placed in a cylindrical chamber and then compressed by a hydraulically operated ram (see illustration). The opposite end of the cylinder contains a die having an orifice of the desired shape; as this die opening is the path of least resistance for the billet under pressure, the metal, in effect, squirts out of the open-

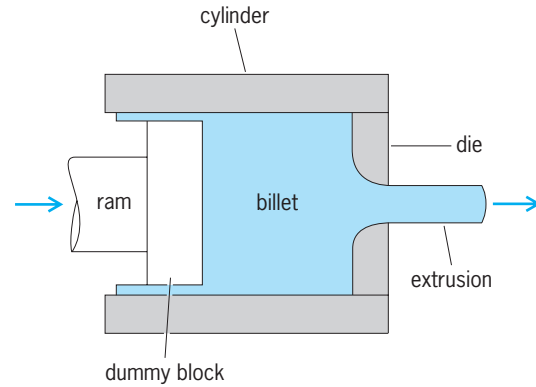

Schematic of the direct, hot extrusion process.

ing as a continuous bar having the same cross-sectional shape as the die opening. By using two sets of dies, stepped extrusions can be made.

The extrusion of cold metal is variously termed cold pressing, cold forging, cold extrusion forging, extrusion pressing, and impact extrusion. The term cold extrusion has become popular in the steel fabrication industry, while impact extrusion is more widely used in the nonferrous field.

The original process (identified as impact extrusion) consists of a punch (generally moving at high velocity) striking a blank (or slug) of the metal to be extruded, which has been placed in the cavity of a die. Clearance is left between the punch and die walls; as the punch comes in contact with the blank, the metal has nowhere to go except through the annular opening between punch and die. The punch moves a distance that is controlled by a press setting. This distance determines the base thickness of the finished part. The process is particularly adaptable to the production of thin-walled, tubular-shaped parts having thick bottoms, such as toothpaste tubes.

Advantages of cold extrusion are higher strength because of severe strain-hardening, good finish and dimensional accuracy, and economy due to fewer operations and minimum of machining required. See METAL FORMING. [R.L.Fr.]

**Eye (invertebrate)** An aggregation of photoreceptor cells together with any associated optical structures. Eyes occur almost universally among animals, and are possessed by some species of virtually every major animal phylum. However, the complexity of eyes varies greatly, and this sense organ undoubtedly evolved independently a number of times within the animal kingdom.

The simplest invertebrate organs that might be considered to be eyes are clusters of photoreceptor cells located on the surface of the body. Pigment cells are usually interspersed among the photoreceptors, giving the eye a red or black color. Accessory structures, such as the lens and cornea, are usually absent. Simple eyes of this type, called pigment spot ocelli, are found in such invertebrates as jellyfish, flatworms, and sea stars.

The most basic image-forming type of invertebrate eye probably arose from such patches of photoreceptor cells by an in-sinking of the sensory epithelium to form a cup, which may have become closed in conjunction with the evolution of a cornea and lens. Such an evolutionary history is clearly suggested by the embryology and comparative anatomy of many invertebrates.

In bilateral cephalic invertebrates, the eyes are typically paired and located at the anterior end of the body. Although one pair is usual, as in mollusks and many arthropods, multiple pairs are not uncommon. Some polychaete annelids have 4 eyes, and scorpions may have as many as 12. The greatest number of eyes is found in marine flatworms, where there may be over 100 ocelli scattered over the dorsal anterior surface and along the

sides of the body. The occurrence of eyes on parts of the body other than the head is usually correlated with radial symmetry or unusual modes of existence.

The primitive function of animal eyes was merely to provide information regarding the intensity, direction, and duration of environmental light. The perception of objects is dependent upon several factors, namely, the number of photoreceptors in the retina, the quality of the optics, and central processing of visual information.

Image formation has evolved as an additional capacity of the eyes of some invertebrates. The number of photoreceptor cells composing the retinal surface is of primary importance, since each photoreceptor cell or group of cells acts as the detector for one point of light. An image is formed by the retina through the association of points of light of varying intensity, much as an image is produced by an array of pixels on a computer monitor. The ability of an eye to form an image and the coarseness or fineness of the image are, therefore, dependent upon the number of points of light that are distinguished which, in turn, is dependent upon the number of photoreceptor cells composing the retina. A large number of photoreceptor cells must be present to produce even a coarse image. The great majority of invertebrate eyes cannot form a detailed image because they do not possess a sufficient number of photoreceptor cells. The number of photoreceptor cells might be sufficient to detect movement of an object, but is inadequate to provide much information about the object's form. See PHOTORECEPTION.

The focusing mechanisms of invertebrate eyes vary considerably. The focus of arthropod eyes tends to be fixed, that is, the distance between the optical apparatus and the retina cannot be changed. Thus objects are in focus only at a certain distance from the eye, determined by the distance between the lens and the retina.

The oceanic family of swimming polychaete worms, Alciopidae, have eyes of that are focused hydrostatically. A bulb to one side of the eye injects fluid into the space between the retina and the lens, forcing the lens outward. Another mechanism is employed in octopods whereby lens movement is brought about by a ciliary muscle attached to the lens (as in aquatic vertebrates, like fish).

The compound eye of crustaceans, insects, centipedes, and horseshoe crabs has a sufficiently different construction from that of other invertebrates to warrant separate discussion. The structural unit of the compound eye is called an ommatidium (see illustration). The outer end of the ommatidium is composed of a cornea, which appears on the surface of the eye as a facet. Beneath the cornea is an elongated, tapered crystalline cone; in many compound eyes the cornea and cone together function as a lens. The receptor element at the inner end of the ommatidium is composed of one or more central translucent cylinders (rhabdome), around which are located several photoreceptor cells (typically 7 or 8).

The rhabdome is the initial photoreceptive element, and it in turn stimulates the adjacent photoreceptor cells to depolarize. The photoreceptor element of each ommatidium functions as a unit and can respond only to one point of light. Thus image formation is dependent upon the number of photoreceptor units present. The number of ommatidia composing a compound eye varies greatly.

Pigment granules surround the ommatidium proximally and distally, forming a light screen that separates one ommatidium from another. The pigment granules migrate, depending upon the amount of light. In bright light the ommatidium is adapted by funneling light directly down to the rhabdome, by extending the pigment screen, so that light received by one ommatidium is prevented from stimulating the rhabdome of another. Under these conditions the image produced is said to be appositional, or mosaic. The term mosaic has been misinterpreted to mean that a given ommatidium forms a separate image, even if only a part of the image. In general, however, the compound eyes function like

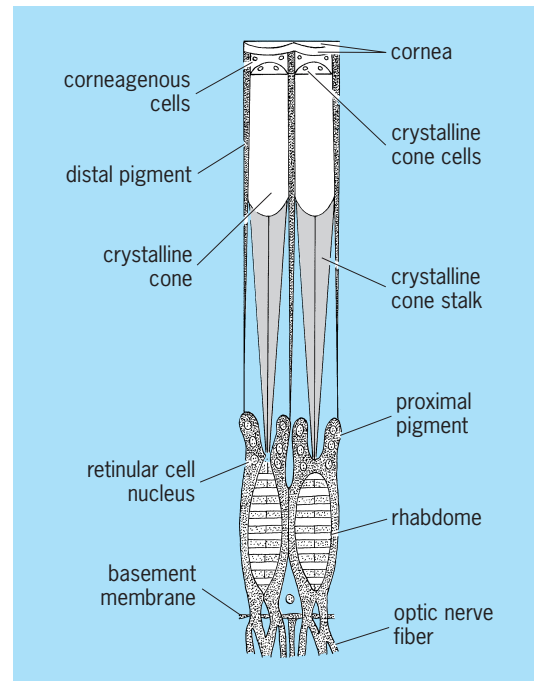

Two ommatidia from compound eye of crayfish *Astacus*. (After R. D. Barnes, *Invertebrate Zoology*, 2d ed., W. B. Saunders, 1968)

any other eye—each photoreceptor unit represents one point in visual space. It is not obvious whether or not compound eyes have any special advantages over other eye designs, despite their universal occurrence in crustaceans and insects. However, in many arthropods the total corneal surface is greatly convex, resulting in a wide visual field.

Many invertebrate eyes are capable of seeing and analyzing patterns of polarized light in nature. This capacity reaches its apex in compound eyes, as well as in the simple eyes of cephalopods. Cuttlefish are known to communicate with each other with displays produced on their body surfaces that are visible only to animals that have polarization vision. Most invertebrates with polarization vision, however, use this ability to navigate with the assistance of patterns of polarization in the sky that occur naturally due to scattering of sunlight by the atmosphere. Bees and ants can find their way back to their nests or hives using only these celestial polarization cues. See EYE (VERTEBRATE). [T.W.C.; R.D.B.]

**Eye (vertebrate)** A sense organ that acts as a photoreceptor capable of image formation. The eye of vertebrates is constructed along a basic anatomical pattern which, in the diversification of animals, has undergone a variety of structural and functional modifications associated with different ecologies and modes of living. Often compared with a camera, the vertebrate eye is conveniently described in terms of its wall, cavities, and lens (see illustration).

**Wall.** The wall of the eye consists of three distinct layers or tunics which, from outward to inward, are termed the fibrous, vascular, and sensory tunics.

**Fibrous tunic.** This continuous, outermost fibrous tunic comprises a transparent anterior portion, the cornea, and a tough posterior portion, the sclera. In the human, the cornea represents about one-sixth of the fibrous tunic, the sclera five-sixths.

The vertebrate cornea exhibits very few modifications in structure regardless of environmental influences. Its major constituent is connective tissue (both cells and fibers), regularly arranged and bordered on both anterior and posterior surfaces by an epithelium. The anterior epithelium is stratified, ectodermal in origin, and continuous with the (conjunctival) epithelium lining the

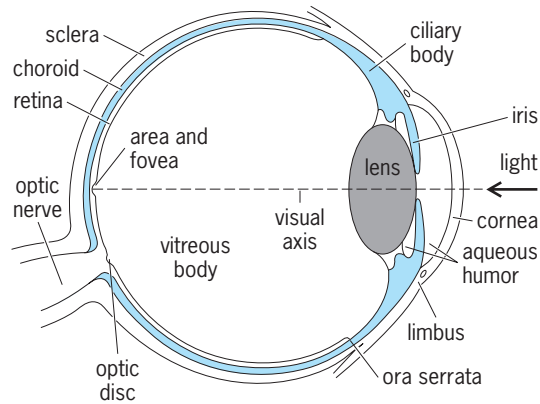

Horizontal section through human eye.

eyelids. The transparency of the cornea is attributed to the geometric organization of its connective tissue elements, its constant state of deturgescence, and its chemical composition. It is the first ocular component traversed by the incoming light.

The sclera, a tough connective tissue tunic, provides support for the eye and serves for the attachment (insertions) of the muscles that move it.

The limbus is located at the angle of the anterior chamber. This small, circular transitional zone between the cornea and the sclera houses the major route for the discharge of aqueous humor from the anterior chamber.

**Vascular tunic.** The vascular tunic or uvea makes up the middle layer of the wall of the eye. It does not form a continuous layer around the eye but is deficient anteriorly, where the opening is termed the pupil. Beginning at the pupil, three continuous components of the uvea can easily be recognized: the iris, ciliary body, and choroid.

The iris is a spongy, circular diaphragm of loose, pigmented connective tissue separating the anterior and posterior chambers and housing a hole, the pupil, in its center. When heavily pigmented, the human iris appears brown; when lightly pigmented, blue.

The ciliary body is continuous with the root of the iris. The posterior epithelium of the iris continues along the internal surface of the ciliary body as a double layer of cells (ciliary part of the retina) which assumes many folds for the attachment of the suspensory ligament of the lens. This ligament holds the lens in position and shape, and marks the posterior boundary of the posterior chamber. The inner layer of the ciliary epithelium contains no pigment. It produces aqueous humor which flows into the posterior chamber and thence into the anterior chamber (via the pupil). The continual production and removal of this fluid maintain the intraocular pressure of the eye (which is increased in glaucoma).

The choroid is the most posterior portion of the uvea. It is directly continuous with the subepithelial portion of the ciliary body and consists primarily of blood vessels embedded within deeply pigmented connective tissue.

**Sensory tunic.** The retina is the sensory tunic of the eye. It has the form of a cup closely applied to the inner portion of the choroid, and, internally, it is slightly adherent to the semisolid vitreous body. The vertebrate retina contains the light-sensitive receptors (visual cells) and a complex of well-organized impulse-carrying nerve cells (neurons), all arranged into discrete layers.

The pigment epithelium forms an important barrier between the light-sensitive receptors (visual cells) and their blood supply, the choroid. As in the choroid, the pigmentation serves to absorb light and prevent its reflection.

The rods and cones of vertebrates generally occur as single units, but combinations of each type are frequently encountered in several vertebrate classes. Cones appear to be adapted for

photopic, or daylight, vision, based on correlations with the visual habits of the animals involved. Rods, which predominate in nocturnal vertebrates, are adapted for scotopic, or night, vision. Except for their external process, the structure of these cells does not reflect these differences. See PHOTORECEPTION; VISION.

An important adaptation for improving visual detail in vertebrates is the formation of circumscribed thickenings of the retina resulting from localized increases in the number of visual cells and the other retinal neurons associated synaptically with them. Such thickenings, termed areas of acute vision, appear in some members of all vertebrate classes and reach their greatest development in birds, in which one to three distinct areas may be found in the same retina. Only a single area occurs in humans; it is colored yellow and is called the macula. The macula is situated in the center of the fundus and contains only cones.

**Cavities.** Three cavities or chambers are present within the vertebrate eye: anterior, posterior, and vitreous. The anterior and posterior chambers are continuous with one another at the pupil and are filled with the aqueous humor. The eye is normally maintained in a distended state by the (intraocular) pressure created by this fluid. The vitreous cavity, on the other hand, is filled with a semisolid material, the vitreous body, which is fixed in amount and relatively permanent. Its consistency is not uniform in all vertebrates, however.

**Lens.** The lens is a transparent body, supported by thin suspensory fibers and by the vitreous body behind and by the iris in front. It is completely cellular, the anterior cells forming a thin epithelium, and the posterior cells, much elongated, forming the so-called lens fibers. The entire lens is surrounded by an elastic capsule which serves for the attachment of the ciliary zonule. In all vertebrates the lens functions in accommodation, either by moving backward and forward or by changing its shape. An opacity of the lens is termed a cataract.

[D.B.M.; R.O'Ra.]

**Electrophysiology of rods and cones.** Visual information perceived by the vertebrate eye is fed to the brain in the form of coded electrical impulses that are initiated by the light-sensitive, visual-pigment-containing outer segments of the rods and cones. Light striking the outer segments is absorbed by these pigments, resulting—in the case of rhodopsin, for example—in the isomerization of the 11-*cis*-retinal chromophore to all *trans*-retinal. The outcome of this photolytic process is a change in electrical activity at the plasma membrane enclosing the outer segments, and a sudden and drastic decrease in its permeability (particularly to  $\text{Na}^+$ ). The net result is a hyperpolarization response, or increased negativity of membrane potential. Hyperpolarization generates a membrane current that spreads to the inner segment and finally to the synaptic terminal, where it regulates the release of neurotransmitter and thus controls the flow of information from the visual cells to other retinal cells (bipolars, horizontals, other photoreceptors).

Cyclic GMP is directly responsible for regulating the permeability of the plasma membrane by opening ionic channels (in the light). Its concentration is controlled by a peripheral membrane enzyme, phosphodiesterase, which in turn is activated by transducin, an intracellular messenger protein generated by a photolytic intermediate of rhodopsin. Since one molecule of photoactivated rhodopsin can react with many molecules of transducin, an amplification of the visual cells' response is produced, the final amplitude being enhanced by breakdown of cyclic GMP by phosphodiesterase and subsequent closure of outer segment ionic channels and hyperpolarization.

Since photoreceptors are depolarized in the dark, their axon terminals continually release a transmitter that hyperpolarizes (inhibits) the bipolar cell, and since this cell is hyperpolarized in the dark, it is prevented from releasing its excitatory transmitter at the ganglion cell synapse so that the synapse is not excited. In the light, hyperpolarization of the visual cells causes a decrease in the amount of inhibitory transmitter released at the bipolar

synapse, leading to a depolarization of the latter, which in turn increases the amount of excitatory transmitter released at the bipolar-ganglion synapses and affecting the ganglion cells.

A change in the light energy taking place across the retina also initiates a transient complex of electrical waveforms, the electroretinogram, which is recorded as a difference in potential between the cornea and the back of the eye. [D.B.M.]

**Eye disorders** Disorders of form and function that affect the eye. Disorders of form affect the way the eye looks or feels; disorders of function affect vision. Normal vision requires proper performance from the entire visual system, from the precorneal tear film to the occipital cortex. See EYE (VERTEBRATE); VISION.

The eyelids contain many glands that are susceptible to acute or chronic infection. Acute infection produces a hordeolum, or sty, which is a localized nodule up to several millimeters in diameter swelling may develop rapidly. Chronic infection results in a granulomatous nodule, or chalazion. In many cases, surgical removal is indicated.

Conjunctivitis is an inflammation of the conjunctiva, regardless of cause, which may include viral, bacterial, or chlamydial infection; mechanical or chemical trauma; allergy; and so on. The symptoms of conjunctivitis depend on the cause and generally include conjunctival redness (hyperemia), swelling (chemosis), mild to moderate discomfort, and tearing. If the conjunctiva is the only structure involved, vision is usually affected minimally or not at all. Infectious conjunctivitis is often termed pink eye because of the bright red appearance of the conjunctiva. Bacterial infections are usually responsible for pink eye in children. Infectious conjunctivitis in adults is commonly caused by viral agents. Chlamydial infections are responsible for inclusion conjunctivitis and ophthalmia neonatorum in the United States and trachoma in many arid regions of the third world. The initial infection involves the conjunctiva, but ultimately trachoma results in blindness due to a scarred, vascularized, opaque cornea. See VISUAL IMPAIRMENT.

If the cornea and conjunctiva are both involved, the condition is referred to as keratoconjunctivitis. Adenovirus infection causes keratoconjunctivitis. If lubrication by the lacrimal glands or accessory lacrimal glands is interrupted by infection, trauma, or autoimmune disease, one of the dry-eye syndromes may ensue. The symptoms include a mild foreign-body sensation, light sensitivity (photophobia), and gritty feeling in the eyes that progresses throughout the day. Paradoxically, increased tearing (epiphora) can be a symptom of dry eyes.

Glaucoma is a serious eye disorder with many subclassifications. It is characterized by intraocular pressure sufficiently high to cause characteristic damage to the optic nerve. See GLAUCOMA.

The leading cause of blindness in the world is cataract, an opacity within the crystalline lens. The overwhelming majority of cataracts have no specific cause and are associated with aging. Effective therapy almost always involves surgical removal of the lens. See CATARACT.

Degeneration of the retina produces a painless distortion or loss of vision. The function may be disrupted in many ways. The retina itself may be affected by infectious processes. Cytomegalovirus retinitis, for instance, is a frequent cause of visual loss in individuals with acquired immune deficiency syndrome (AIDS). Primary retinal degeneration may occur in many forms. Retinitis pigmentosa tends to manifest itself early in life and progresses from peripheral to central visual loss; prognosis depends in part on the hereditary pattern of the disease. Involuntary macular degeneration is fairly common in the elderly. It affects the central vision first and rarely spreads to the peripheral vision. Between these two extremes is a very large number of progressive retinal dystrophies and degenerations, involving central or peripheral vision or both. Although the ultimate visual loss is variable, it is often severe.

Retinal detachment occurs when the sensory layers of the retina are separated from their supporting foundations. It is classified as rhegmatogenous (caused by a retinal hole) or nonrhegmatogenous. Rhegmatogenous retinal detachment occurs spontaneously or following trauma. Nonrhegmatogenous retinal detachment occurs as a final stage of such pathologic conditions as retinopathy of prematurity or diabetic retinopathy. The symptoms of retinal detachment are a painless and sudden segmental or total visual loss in one eye. Treatment is aimed at reestablishing the connection between the sensory-neural retina and its supporting structures.

Diabetic retinopathy is a common cause of severe retinal disease. Research has developed many methods of interrupting the progression of diabetic retinopathy. The most effective include laser therapy for localized retinal edema, hemorrhage, and neovascularization, and vitrectomy for late-stage diabetic retinopathy with vitreous hemorrhage and retinal traction. [M.Dr.]

**Eyeglasses and contact lenses** Lenses worn to improve vision. The primary function of the eye is to focus light energy on the retina. In the optics of a normal eye, parallel rays of light are refracted into sharply focused points of light on the retina. Refraction is necessary because all natural light rays are divergent. The degree of divergence (or minus power) varies with distance: the closer the observer to the light source, the greater the divergence. The unit of measure of divergence is the diopter; the divergence of light rays in diopters is the reciprocal of the distance of the observer from the light source. The human eye is approximately 1/60 m (1.67 cm or 0.65 in.) and therefore requires about 60 diopters of converging (plus) power to bring light rays parallel at the cornea into focus on the retina.

If the eye is too long or possesses too much converging power, as in nearsightedness (or myopia), the image on the retina is made up of blurred circles rather than focused points of light. This may be remedied in two ways. First, the observer may move closer to the object. A second method of correcting nearsightedness is to introduce a minus lens (or divergence) into the path of light striking the eye. This can be done with concave lenses.

The converse is true for farsightedness. The farsighted (or hyperopic) eye is too short or too weak in refracting power. The convergence applied to incoming light is insufficient to focus it at the retina, and blurred circles form rather than focused points of light. To correct this, plus lenses that add convergence to incoming light are used.

Accommodation, the ability of the eye to change its refractive power for sharp viewing across different distances, decreases with age, and by the mid-forties or early fifties it is often difficult to read print at a normal distance. This condition is known as presbyopia and is corrected with reading glasses, or bifocals in which the distance prescription is in the upper segment and plus power in a lower segment.

In addition to eyeglasses worn in frames, contact lenses can be used to assist the eye in forming a sharp image. The contact lens rests directly on the precorneal tear film; its front surface becomes the initial refracting surface of the eye. Contact lenses can be either divergent or convergent and are classified as hard, soft, or gas-permeable hard according to the materials that they are made of, their rigidity or flexibility, and their permeability to oxygen and other gases. Traditional hard contact lenses are the most rigid and tend to be smaller in diameter than the cornea. Soft lenses are usually larger in diameter than hard contact lenses, very thin and flexible, permeable to oxygen and other gases, and tend to take the shape of the cornea. A gas-permeable contact lens is an improvement of the hard contact lens. It is more rigid than a soft lens but more permeable to gases than the older hard contact lenses. See EYE (VERTEBRATE); GEOMETRICAL OPTICS; VISION. [M.Dr.]

**Eyepiece** A lens or optical system which offers to the eye the image originating from another system (the objective), at a suitable viewing distance. The image can be virtual. See OPTICAL IMAGE.

In modern instruments, most eyepieces (also called oculars) are not independently corrected for all errors. They are designed to balance out certain residual aberrations of the objective or (as in the microscope) of a group of objectives, for instance, chromatic difference of magnification. See ABERRATION (OPTICS).

The Ramsden eyepiece consists of two planoconvex lenses, the field lens and the eye lens, with their plane sides out. Both of these lenses have the same power and focal length; their separation is equal to their common focal length. See GEOMETRICAL OPTICS; LENS (OPTICS).

The Huygens eyepiece also consists of two planoconvex lenses, but the plane sides of both lenses face the eye. The focal length of the field lens is in general three times that of the eye lens, and the separation is twice the focal length of the eye lens.

[M.J.H.]

# F

**Fabales** An order of flowering plants, division Magnoliophyta (Angiospermae), in the subclass Rosidae of the class Magnoliopsida (dicotyledons). The order consists of three closely related families (Mimosaceae, Caesalpiniaceae, Fabaceae) collectively called the legumes. Members of the order typically have stipulate, compound leaves, 10–many stamens which are often united by the filaments, and a single capel which gives rise to a dry fruit (legume) that opens at maturity by splitting along two sutures, releasing the nonendospermous seeds. Many, or perhaps most, members of the order harbor symbiotic nitrogen-fixing bacteria in the roots. *See* ALFALFA; BEAN; CLOVER; COWPEA; LESPEDEZA; LOCUST (FORESTRY); MAGNOLIOPSIDA; PEA; PEANUT; SOYBEAN; VETCH. [T.M.Ba.]

**Facies (geology)** Any observable attribute of rocks, such as overall appearance, composition, or conditions of formation, and changes that may occur in these attributes over a geographic area. The term facies is widely used in connection with sedimentary rock bodies, but is not restricted to them. In general, facies are not defined for sedimentary rocks by features produced during weathering, metamorphism, or structural disturbance. In metamorphic rocks specifically, however, facies may be identified by the presence of minerals that denote degrees of metamorphic change.

**Sedimentary facies.** The term sedimentary facies is applied to bodies of sedimentary rock on the basis of descriptive or interpretive characteristics. Descriptive facies are based on lithologic features such as composition, grain size, bedding characteristics, and sedimentary structures (lithofacies) or on biological (fossil) components (biofacies), or on both. Individual lithofacies or biofacies may be single beds a few millimeters thick or a succession of beds tens to hundreds of meters thick. For example, a river deposit may consist of decimeters-thick beds of a conglomerate lithofacies interbedded with a cross-bedded sandstone lithofacies. The fill of certain major Paleozoic basins may be divided into units hundreds of meters thick comprising a shelly facies, containing such fossils as brachiopods and trilobites, and graptolitic facies.

The term facies can be used also in an interpretive sense for groups of rocks that are thought to have been formed under similar conditions. This usage may emphasize specific depositional processes, such as a turbidite facies, or a particular depositional environment such as a shelf carbonate facies, encompassing a range of depositional processes.

Groups of facies (usually lithofacies) that are commonly found together in the sedimentary record are known as facies assemblages or facies associations. These groupings provide the basis for defining broader, interpretive facies for the purpose of paleogeographic reconstruction. *See* PALEOGEOGRAPHY.

[A.D.M.]

A metamorphic facies is a collection of rocks containing characteristic mineral assemblages developed in response to burial and heating to similar depths and temperatures. It can represent either the diagnostic mineral assemblages that indicate the physical conditions of metamorphism or the pressure-temperature conditions that produce a particular assemblage in a rock of a specific composition.

The metamorphic facies to which a rock belongs can be identified from the mineral assemblage present in the rock; the pressure and temperature conditions represented by each facies are broadly known from experimental laboratory work on mineral stabilities. These facies names are based on the mineral assemblages that develop during metamorphism of a rock with the composition of a basalt, which is a volcanic rock rich in iron and magnesium and with relatively little silica. For example, the dominant mineral of the blueschist facies (in a rock of basaltic composition) is a sodium- and magnesium-bearing silicate called glaucophane, which is dark blue in outcrop and blue or violet when viewed under the microscope. Characteristic minerals of the greenschist facies include chlorite and actinolite, both of which are green in outcrop and under the microscope. Basaltic rocks metamorphosed in the amphibolite facies are largely composed of an amphibole called hornblende. The granulite facies takes its name from a texture rather than a specific mineral: the pyroxenes and plagioclase that are common minerals in granulite facies rocks typically form rounded crystals of similar size that give the rock a granular fabric. *See* AMPHIBOLITE; BASALT; BLUESCHIST; GLAUCOPHANE; GRANULITE; METAMORPHIC ROCKS; METAMORPHISM; PYROXENE.

[J.Se.]

**Facsimile** The process by which a document is scanned and converted into electrical signals which are transmitted over a communications channel and recorded on a printed page or displayed on a computer screen. The scanner may be compared with a camcorder, and the recorder is similar to an office copier or a computer printer. As an alternative to scanning, a document stored in computer memory can be transmitted. As an alternative to recording, a text facsimile (fax) image can be captured in computer memory and converted into computer-processable text by optical character recognition (OCR) software. Telephone lines or satellites provide the communication channel.

Most facsimile units communicate over the Public Switched Telephone Network, alternatively called the General Switched Telephone Network. A built-in high-speed digital modem automatically selects the highest modem speed (28,800–2400 bits/s) common to both facsimile units. If the telephone-line quality is not good enough for this transmission speed, a lower speed is negotiated during initialization. *See* MODEM; TELEPHONE SERVICE.

In the scanning process, an image of the original page is formed by a lens in a way similar to that of an ordinary camera. A charge-coupled-device linear array of small photodiodes is substituted in the facsimile scanner for the camera film. The portion of the image falling on the linear diode array is a thin line, 0.005 in. (0.13 mm) high, across the top of the page being transmitted. Typically, 1728 diodes are used to view this line for a page 8½ in. (216 mm) wide. The photodiode corresponding to the left edge of the page is first checked to determine whether the very small portion of the image it detects is white (the paper background) or black (a mark). The spot detected by a single photodiode is called a picture element (a pel for short if it is recorded as either black or white, or a pixel if a gray

scale is used). Each of the 1728 diodes is checked in sequence, to read across the page. Then the original page is stepped the height of this thin line, and the next line is read. The step-and-read process repeats until the whole page has been scanned. See CAMERA; CHARGE-COUPLED DEVICES; PHOTODIODE; TELEVISION CAMERA.

Another class of flatbed scanner uses a contact image sensor linear array of photodiodes whose width is the same as the scanned width. One version has a linear array of fiber-optics rod lenses between the page being scanned and the sensor array. Light from a fluorescent lamp or a linear light-emitting-diode array illuminates the document beneath the rod lenses. The reflected light picked up by the sensor generates a signal that is proportional to the brightness of the spot being scanned. A second version has a hole in the center of each square pixel sensor element. Light from a light-emitting diode passes through this hole to illuminate the area of the document page at this pixel. No lenses or other optical parts are used. See FIBER-OPTICS IMAGING; LIGHT CURVES.

In drum-type scanning, the original sheet of paper is mounted on a drum that rotates while the scan head with a photosensor moves sideways the width of one scanning line for each turn of the drum. Drum-type scanners are used mainly for remote publishing facsimiles and for color scanning in graphic arts systems.

In the recording process, facsimile signals are converted into a copy of the original. Facsimile receivers commonly print pages as they are received, but in an alternative arrangement pages may be stored and viewed on a computer screen.

[K.R.McC.]

**Factor analysis** A method of quantitative multivariate analysis with the goal of representing the interrelationships among a set of continuously measured variables (usually represented by their intercorrelations) by a number of underlying, linearly independent reference variables called factors. Although the term factor analysis has come to represent a family of analysis methods, the two most commonly used approaches are the full component model, in which the entire variance of the variables (represented by unities inserted in the principal diagonal of the correlation matrix) is analyzed, and the common factor model, in which the proportion of the variance that is accounted for by the common factors (represented by communality estimates inserted in the principal diagonal) is analyzed.

The method was developed in England around the turn of the century and was first applied to the study of the structure of intellectual abilities. Since then it has been used in many disciplines, from agriculture to zoology, in which the underlying structure of multiple variables and their representation in that structure are of interest. Another application of factor analysis is to represent parsimoniously the variables in the set on which the observations are made by a smaller number of underlying reference variables or factors. See STATISTICS. [B.Fr.]

**Fagales** An order of flowering plants, division Magnoliophyta (Angiospermae), in the superorder Rosidae of Eudicotyledon. The order consists of 8 families (Betulaceae, Casuarinaceae, Fagaceae, Juglandaceae, Myricaceae, Nothofagaceae, Rhoipteleaceae, Ticodendraceae) and approximately 30 genera and nearly 1000 species. The Fagales are either simple or compound-leaved, woody plants. Flowers are mostly unisexual and much reduced for wind pollination. The female flowers produce one- or two-seeded nut fruits (for example, acorn, chestnut, walnut); the male flowers are grouped into pendant catkins (see illustration). Birch (*Betula*), beech (*Fagus*), walnut



Butternut or white walnut (*Juglans cinerea*), a North American species showing compound leaves and slender drooping male catkins. (Ken Sytsma, University of Wisconsin)

(*Juglans*), and oak (*Quercus*) are members of the Fagales. See BEECH; BIRCH; MAGNOLIOPHYTA; OAK; PLANT KINGDOM; ROSIDAE. [K.J.Sy.]

**Falconiformes** A worldwide order of diurnal predacious birds without obvious affinities to other orders of birds. The New World vultures, which had been included in the Falconiformes, are now placed with the Ciconiiformes. See CICONIIFORMES; STRIGIFORMES.

The Falconiformes are divided into two suborders. The first, Accipitres, has three families: Pandionidae (osprey; one species); Accipitridae (hawks, eagles, kites, harriers, and Old World vultures; 217 species); and Sagittariidae (secretary bird; one species). The second suborder, Falcone, contains a single family, Falconidae (falcons, caracaras; 62 species).

The diurnal raptors have strong feet, usually with three toes pointing forward and one pointing backward, and ending with sharp claws. Their beaks are hooked and powerful. Their well-developed wings vary in shape according to the type of flight: long and pointed in falcons, short and broad in accipitrine hawks, and long and broad in vultures, eagles, and buzzards. Hawks are flying specialists, although most species can walk well. They hunt from the air, and they feed on animal prey from insects to sizable vertebrates, including fish, and on carrion.

The osprey is specialized for catching fish with a reversible fourth toe, well-developed claws, and spiny scales along its toes. The one species is found almost worldwide. The secretary bird of Africa is long-legged and specialized for a terrestrial way of life. It runs rapidly, flies only infrequently, and catches poisonous snakes as well as many other vertebrates. See AVES. [W.J.B.]

**Fallopian tube** The upper part of the female oviduct present in humans and other higher vertebrates. The Fallopian tube extends from the ovary to the uterus and transports ova from the ovary to the cavity of the uterus. Each tube is about 5 in. (12.5 cm) long; one lies on either side of the uterus and is attached at the upper portion. Each curves outward to end in a



hoodlike opening, the infundibulum, with many fingerlike projections; the cavity of the Fallopian tube is continuous with the cavity of the coelom. The ovaries lie below and inside the tubal curve.

The ovum remains viable in the oviduct for about 1–3 days only. If fertilization occurs, the ovum moves into the cavity of the uterus and then implants on its wall. If fertilization fails to occur, the ovum degenerates in the uterus. Occasionally, a fertilized ovum fails to enter the uterus, or may be freed into the abdominal cavity, so that an ectopic pregnancy results if the ovum finds a site for implantation. See PREGNANCY DISORDERS; REPRODUCTIVE SYSTEM. [W.B.]

**Fan** A fan moves gases by producing a low compression ratio, as in ventilation and pneumatic conveying of materials. The increase in density of the gas in passing through a fan is generally negligible; the pressure increase or head is usually measured in inches of water.

Blowers are fans that operate where the resistance to gas flow is predominantly downstream of the fan. Exhausters are fans that operate where the flow resistance is mainly upstream of the fan.

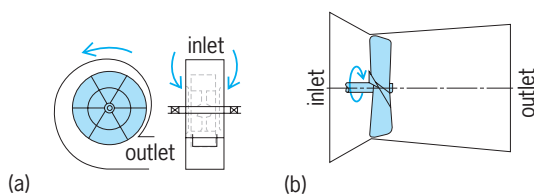

Fan types. (a) Centrifugal. (b) Axial.

Fans are further classified as centrifugal or axial (see illustration). The housing provides an inlet and an outlet and confines the flow to the region swept out by the rotating impeller. The impeller imparts velocity to the gas, and this velocity changes to a pressure differential under the influence of the housing and ducts connected to inlet and outlet. [T.Ba.]

**Faraday effect** Rotation of the plane of polarization of a beam of linearly polarized light when the light passes through matter in the direction of the lines of force of an applied magnetic field. Discovered by M. Faraday in 1846, the effect is often called magnetic rotation. See MAGNETOOPTICS.

The Faraday effect is particularly simple in substances having sharp absorption lines, that is, in gases and in certain crystals, particularly at low temperatures. Here the effect can be fully explained from the fundamental properties of the atoms and molecules involved. In other substances the situation may be more complex, but the same principles furnish the explanation.

Rotation of the plane of polarization occurs when there is a difference between the indices of refraction  $n^+$  for right-handed polarized light and  $n^-$  for left-handed polarized light. Most substances do not show such a difference without a magnetic field, except optically active substances such as crystalline quartz or a sugar solution. It should be noted that the index of refraction in the vicinity of an absorption line changes with the frequency. See ABSORPTION; POLARIZED LIGHT. [G.H.Di.; W.W.W.]

**Faraday's law of induction** A statement relating an induced electromotive force (emf) to the change in magnetic flux that produces it. For any flux change that takes place in a circuit, Faraday's law states that the magnitude of the emf  $\xi$  induced in the circuit is proportional to the rate of change of flux as in the expression below.

$$\xi \propto \frac{d\Phi}{dt}$$

The time rate of change of flux in this expression may refer to any kind of flux change that takes place. If the change is motion of a conductor through a field,  $d\Phi/dt$  refers to the rate of cutting flux. If the change is an increase or decrease in flux linking a coil,  $d\Phi/dt$  refers to the rate of such change. It may refer to a motion or to a change that involves no motion. See ELECTROMAGNETIC INDUCTION. [K.V.M.]

**Farm crops** Farm crops may be roughly classed as follows: (1) food crops—the bread grains (wheat and rye), rice, sugar crops (sugarbeets and sugarcane), potatoes, and dry legume seeds (peanuts, beans, and peas); (2) feed crops—corn, sorghum grain, oats, barley, and all hay and silage; and (3) industrial crops—cotton (lint and seed), soybeans, flax, and tobacco. See separate articles on these topics.

Crop production is regionalized in the United States in response to the combination of soil and climatic conditions and to the land topography, which favors certain kinds of crop management. In general, commercial farm crops are confined to land in humid and subhumid climates that can be managed to minimize soil and water erosion damage, where soil productivity can be kept at a relatively high level, and where lands are smooth enough to permit large-scale mechanized farm operations. In less well-watered regions, cropping is practiced efficiently on fairly level, permeable soils, where irrigation water can be supplied. The tilled crops, such as corn, sorghums, cotton, potatoes, and sugar crops, are more exacting in soil requirements than the close-seeded crops, such as wheat, oats, barley, rye, and flax. The crops planted in soil stands, mostly hay crops (as well as pastures), are efficient crops for lands that are susceptible to soil and water erosion.

The major farming regions of the United States are named from the predominant kinds of crops grown, even though there is tremendous diversity within each region. The Corn Belt includes a great central area extending from Nebraska and South Dakota east across much of Iowa, Missouri, Illinois, and Indiana to central Ohio. To the north and east of this region is the Hay and Dairy Region, which actually grows large quantities of feed grains. To the south of the Corn Belt is the Corn and Winter-Wheat Belt. The southern states, once the Cotton Belt, now concentrate on hay, pasture, and livestock, with considerable acreages of soybeans and peanuts. The cultivated portions of the Great Plains, extending from Canada to Mexico, are divided into a spring-wheat region in the Dakotas and a winter-wheat region from Texas to Nebraska. The Intermountain Region, between the Rocky Mountains and the Cascade-Sierra Nevada mountain ranges, is cropped only where irrigation is feasible, and a wide range of farm crops is grown. In the three states of the Pacific Region, a great diversity of crops is grown. Cotton is now concentrated in the irrigated regions from Texas to California.

The United States is known most widely for its capacity to produce and export wheat. However, this nation has become a major producer of soybeans for export, and rice exports have become important. Most of the other farm crops are consumed within the United States. Tobacco and sugar crops are high acre-value crops, as are potatoes, peanuts, and dry beans. The production of these high acre-value crops is concentrated in localized areas where soils and climate are particularly favorable, rather than in broad acreages. See AGRICULTURAL SCIENCE (PLANT); AGRICULTURAL SOIL AND CROP PRACTICES. [H.B.S.]

**Fat and oil** Naturally occurring esters of glycerol and fatty acids that have commercial uses. Since fats and oils are triesters, they are commonly called triglycerides or simply glycerides. A glyceride may be designated a fat or oil, depending on its melting point. A fat is solid and an oil is liquid at room temperature. Some liquid waxes are incorrectly referred to as oils. See ESTER; TRIGLYCERIDE; WAX, ANIMAL AND VEGETABLE.

The structure of triglycerides is shown below, where  $R_1$ ,  $R_2$ , and  $R_3$  represent the alkyl chain of the fatty acid.

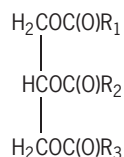

The physical and chemical properties of fats and oils are determined to a large extent by the types of fatty acids in the glyceride. It is possible for all the acids to be identical, but this is rare. Usually there are two or even three different acids esterified to each glycerol molecule.

In all commercially important glycerides, the fatty acids are straight-chain, and nearly all contain an even number of carbon atoms. Most fats and oils are based on  $C_{16}$  and  $C_{18}$  acids with zero to three ethylenic bonds. There are exceptions, such as coconut oil, which is rich in shorter-chain acids, and some marine oils, which contain acids with as many as 22 or more carbons and six or more ethylenic linkages.

The majority of fats and oils come from only a few sources. Plant sources are nuts or seeds, and nearly all terrestrial animal fats are from adipose tissue. Marine oils come principally from the whole body, although a small amount comes from trimmings. Plant fats and oils are obtained by crushing and solvent extraction. Animal and marine oils are nearly all recovered by rendering. This is a process of heating fatty tissue with steam or hot water to melt and free the glyceride, followed by separating the oil or fat from the aqueous layer. See SOLVENT EXTRACTION.

There are some uses for fats and oils in their native state, but ordinarily they are converted to more valuable products. The most important changes are hydrolysis and hydrogenation. Hydrolysis is commonly called splitting. The purpose is to hydrolyze the ester into its constituent glycerol and fatty acids, which are valuable intermediates for many compounds. Hydrogenation is the catalytic addition of hydrogen to ethylenic bonds, and is applicable to both acids and glycerides. The purpose of hydrogenation is usually to raise the melting point or to increase the resistance to oxidation. See HYDROGENATION; HYDROLYTIC PROCESSES. [H.M.H.]

**Fat and oil (food)** One of the three major classes of basic food substances, the others being protein and carbohydrate. Fats and oils are a source of energy. They also aid in making both natural and prepared foods more palatable by improving the texture and providing a more desirable flavor. See FOOD.

Fats are grouped according to source. Animal fats are rendered from the fatty tissues of hogs, cattle, sheep, and poultry. Butter is obtained from milk. Vegetable oils are pressed or extracted from various plant seeds, primarily from soybean, cottonseed, corn (germ), peanut, sunflower, safflower, olive, rapeseed, sesame, coconut, oil palm (pulp and kernel separately), and cocoa beans. Marine oils, which are not consumed in the United States, are obtained mostly from herring, sardine, and pilchard.

Fats and oils are important in the diet. They are the most concentrated form of food energy, contributing about 9 cal/g (38 joules/g), as compared to about 4 cal/g (17 joules/g) for carbohydrates and proteins. Fats make a meal more satisfying by creating a feeling of fullness, and also delay the onset of hunger. Contrary to popular belief, fats are highly digestible, with 94–98% of the ingested fat being absorbed from the intestinal tract.

The polyunsaturated fatty acids, primarily linoleic and arachidonic, are essential nutrients; that is, they are not synthesized by the body but are required for tissue development. Absence of these fatty acids from the diet results in an essential fatty acid syndrome and in a specific form of eczema in infants. Vegetable oils are an excellent source of linoleic acid, while meat fats pro-

vide arachidonic acid in small but significant amounts. Fats and oils are carriers of the oil-soluble vitamins A and D, and are the main source of vitamin E. They also have a sparing action on some of the B complex vitamins. See NUTRITION.

Several forms of deterioration may occur in fats and oils. Flavor and odor may develop after deodorization of a product to complete blandness. The flavor is generally characteristic of the oil source and is therefore usually acceptable. However, soybean oil can develop disagreeable flavors described as beany, grassy, painty, fishy, or like watermelon rind. Beef fat can become tallow, which is also objectionable. Reversion is apparently caused by changes in substances which have been oxidized prior to, but not removed by, deodorization.

Oxidative rancidity is a serious flavor defect and highly objectionable. It starts with the formation of hydroperoxides which then decompose to form aldehydes which have a pungent, disagreeable flavor and odor. Retardation of oxidation is brought about by using opaque, airtight containers, or nitrogen blanketing if clear glass bottles are used. Antioxidants are required in meat fats, since lard, tallow, and so on contain no natural antioxidant material. Vegetable oils contain tocopherols. Additional antioxidant, with the exception of tertiary butyl hydroquinone (TBHQ), has little benefit for these oils.

Hydrolytic rancidity results from the liberation of free fatty acids by the reaction of fats and oils with water. While most fats show no detectable off flavors, coconut and other lauric acid oils develop a soapy flavor, and butter develops the strong characteristic odor of butyric acid. Packaged coconut-oil products and lauric-type hard butters sometimes contain added lecithin, which acts as a moisture scavenger, thereby retarding hydrolytic rancidity development.

Fats and oils used in deep fat frying can break down under adverse conditions, especially where frying is intermittent or the fryer capacity is not fully used. Deterioration ultimately results in the oil becoming very dark in color, viscous, foul-odored, and foaming badly during frying. The oil becomes oxidized and then polymerized, requiring that it be discarded, since it imparts strong off flavors to the fried food.

Crystal structure transformation of packaged shortening results in formation of a grainy, soft product, which may also lose incorporated gas and take on the appearance of petroleum jelly. Similar changes in crystal structure can cause bloom in chocolate coatings, a defect which gives a white haze or even open grain on an originally smooth, glossy surface. Chocolate bloom can be inhibited by the addition of lecithin or polysorbates or both. See LIPID. [T.J.W.]

**Fate maps (embryology)** Diagrams of embryos showing the structures that the parts will become in the course of normal development. A series of fate maps for different developmental stages depicts the normal morphogenetic movements that the cells and tissues of an embryo undergo. However, a fate map for a given stage does not in itself include information about the developmental pathway to which different parts of the embryo are committed. States of commitment must be deduced by comparing the structures predicted by the fate map with those formed by tissue regions in isolation, or after grafting to unusual positions. An accurate fate map is thus a necessary tool for further studies in experimental embryology. See EMBRYOGENESIS; TRANSPLANTATION BIOLOGY.

For embryos in which there is no increase in size during development, and no random mixing of cells, it is possible in principle to project the fate map back into the fertilized egg. For example, in the nematode *Caenorhabditis elegans* the exact lineage of every cell has been determined. Where there is some local cell mixing, as in amphibian embryos, the fate map cannot be so precise, and represents the average behavior of a population of embryos. See CELL LINEAGE.

Clonal analysis, a special form of fate mapping in which a single cell is labeled, can give two pieces of information that a

fate map of extended multicellular regions cannot. It allows for the detection of stem cells, which produce an entire structure by a sequence of unequal cell divisions. It also can set a lower bound to the time of developmental commitment. If a single cell can populate two structures, then clearly it cannot have been irreversibly committed to become either structure at the time of labeling.

In clonal analysis of plants, cells are labeled by exposing the seed or developing plant to ionizing irradiation or a chemical mutagen to produce chromosome mutations that result in distinct phenotypic alterations, usually deficiencies in the pigments chlorophyll or anthocyanin. The low frequency of mutations produced indicates that these are single-cell events. Because all of the progeny of a labeled cell will carry the same chromosome mutation, a shoot meristem cell labeled with a chlorophyll deficiency mutation, for example, will produce a sector, or clone, of white tissue in the developing plant. It is possible to deduce the number and fate of meristem cells labeled at one stage of development by examining the size and position of sectors present in the plant at a later stage of development. For example, a sector extending the entire length of the shoot would be generated by a permanent initial cell at the center of the meristem; if the width of that sector occupied one-third of the circumference of the shoot, then the shoot must have been formed by three such initial cells. See MUTATION; PLANT GROWTH. [D.E.J.]

**Fault analysis** The detection and diagnosis of malfunctions in technical systems. Such systems include production equipment, transportation vehicles, and household appliances. While the need to detect and diagnose malfunctions is as old as the construction of such systems, advanced fault detection has been made possible only by the proliferation of the computer. Fault detection and diagnosis actually means a scheme in which a computer monitors the technical equipment to signal any malfunction and determine the components responsible for it. The detection and diagnosis of the fault may be followed by automatic actions enabling the fault to be corrected, such that the system may operate successfully even under the particular faulty condition.

Fault detection and diagnosis applies to both the basic technical equipment and the actuators and sensors attached to it. Actuator and sensor fault detection is very important because these devices are quite prone to faults.

The on-line or real-time detection and diagnosis of faults means that the equipment is constantly monitored during its regular operation by a permanently connected computer, and any discrepancy is signaled almost immediately. On-line monitoring is very important for early detection of any component malfunction, before it can lead to more substantial equipment failure. In contrast, off-line diagnosis involves the monitoring of the system by a special, temporarily attached device, under special conditions (for example, car diagnostics at a service station).

The diagnostic activity may be broken down into several logical stages. Fault detection is the indication of something going wrong in the system. Fault isolation is the determination of the fault location (the component which malfunctions), while fault identification is the estimation of its size.

Fault detection and isolation can never be performed with absolute certainty, because of circumstances such as noise, disturbances, and model errors. There is always a trade-off between false alarms and missed detections, the proper balance depending on the particular application. [J.J.G.]

**Fault and fault structures** Products of fracturing and differential movements along fractures in continental and oceanic crustal rocks. Faults range in length and magnitude of displacement from small structures visible in hand specimens, displaying offsets of a centimeter or less, to long, continuous crustal breaks, extending hundreds of kilometers in length and accommodating displacements of tens or hundreds of kilome-

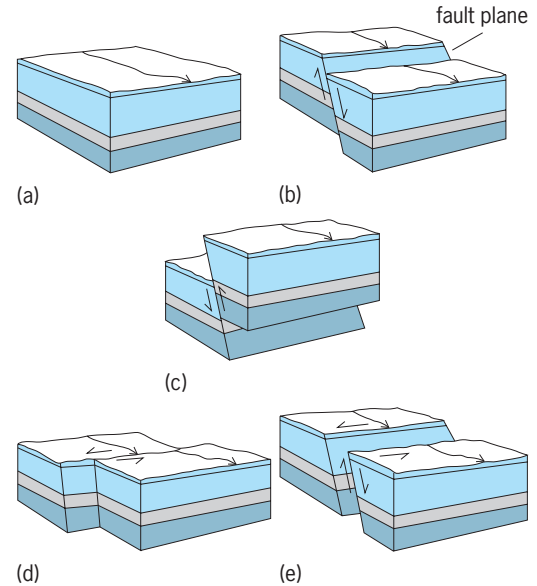

**Slip on faults.** (a) Block before faulting; (b) normal-slip; (c) reverse-slip; (d) strike-slip; (e) oblique-slip. (After F. Press and R. Siever, *Earth*, 2d ed., 1978)

ters. Faults exist in deformed rocks at the microscopic scale, but these are generally ignored or go unrecognized in most geological studies. Alternatively, where microfaults systematically pervade rock bodies as sets of very closely spaced subparallel, planar fractures, they are recognized and interpreted as a type of cleavage which permitted flow of the rock body. Fractures along which there is no visible displacement are known as joints. Large fractures which have accommodated major dilational opening (a meter or more) perpendicular to the fracture surfaces are known as fissures. Formation of fissures is restricted to near-surface conditions, for example, in areas of crustal stretching of subsidence.

In addition to describing the physical and geometric nature of faults and interpreting time of formation, it has been found to be especially important to determine the orientations of minor fault structures (such as striae and drag folds) which record the sense of relative movement. Evaluating the movement of faulting can be difficult, for the apparent relative movement (separation) of fault blocks as seen in map or outcrop may bear little or no relation to the actual relative movement (slip). The slip of the fault is the actual relative movement between two points or two markers in the rock that were coincident before faulting (see illustration). Strike-slip faults have resulted in horizontal movements between adjacent blocks; dip-slip faults are marked by translations directly up or down the dip of the fault surface; in oblique-slip faults the path of actual relative movement is inclined somewhere between horizontal and dip slip.

Recognizing even the simplest translational fault movements in nature is often enormously difficult because of complicated and deceptive patterns created by the interference of structure and topography, and by the absence of specific fault structures which define the slip path. While mapping, the geologist mainly documents apparent relative movement (separation) along a fault, based on what is observed in plan-view or cross-sectional exposures. See TRANSFORM FAULT. [G.H.D.]

**Fault-tolerant systems** Systems, predominantly computing and computer-based systems, which tolerate undesired changes in their internal structure or external environment. Such changes, generally referred to as faults, may occur at various times during the evolution of a system, beginning with its specification and proceeding through its utilization. Faults that occur during specification, design, implementation, or

modification are called design faults; those occurring during utilization are referred to as operational faults. The use of fault tolerance techniques is based on the premise that a complex system, no matter how carefully designed and validated, is likely to contain residual design faults and to encounter unpreventable operational faults.

Generally, fault tolerance techniques attempt to prevent lower-level errors (caused by faults) from propagating into system failures. By using various types of structural and informational redundancy, such techniques either mask a fault (no errors are propagated to the faulty subsystem's output) or detect a fault (via an error) and then effect a recovery process which, if successful, prevents a system failure. In the case of a permanent internal fault, the recovery process usually includes some form of structural reconfiguration (for example, replacement of a faulty subsystem with a spare or use of an alternate program) which prevents the fault from causing further errors. Typically, a fault-tolerant system design will incorporate a mix of fault tolerance techniques which complement the techniques used for fault prevention. See SOFTWARE ENGINEERING. [J.F.Me.]

**Feather** A specialized keratinous outgrowth of the skin, which is a unique characteristic of birds. Feathers are highly complex structures that provide insulation, protection against mechanical damage, and protective coloration, and also function significantly in behavior. One special functional role is in flight, where feathers provide propulsive surfaces and a body surface aerodynamically suitable for flight. Feathers are used in maintenance of balance and occasionally in the capture of prey and various specialized displays.

A representative definitive feather contains a single long central axis which supports a row of small branchlike structures along each side (barbs). Barbs form the vane, or web, of the feather. Individual barbs branch off at variable angles and point toward the outer tip of the feather. The barbules are small branches from the barbs. They lie in the same plane as the barbs and arise in rows from their anterior and posterior surfaces. The anterior barbules have a flattened base and a series of small hooklike projections which attach to the proximal ridge of the posterior barbules of the next barb, forming an interlocking structure characterized by its great strength and light weight. All feather types consist basically of these structural elements.

Most of the superficial feathers are contour feathers (pennae). These include the large flight feathers (remiges) of the wing and the long tail feathers (rectrices). Other common feather types include the down feathers (plumulae), intermediate types (semiplumes), and filoplumes (see illustration).

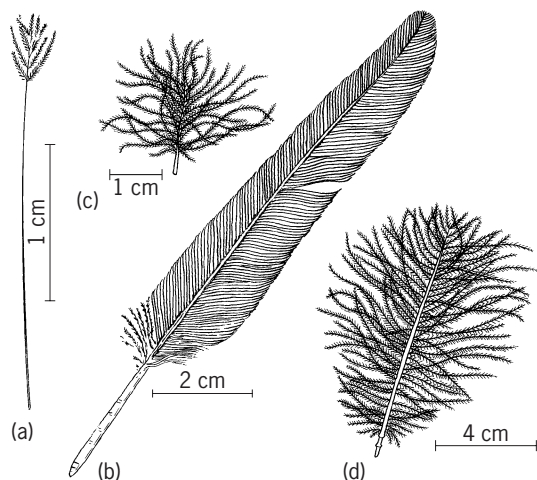

Types of feathers. (a) Filoplume. (b) Vane or contour. (c) Down. (d) Semiplume. (After J. C. Welty, *The Life of Birds*, Saunders, 1962)

Feathers normally undergo attrition because of the physical abuse attendant to the normal activity of birds. In most species, feathers are replaced completely at least annually, and many of the feathers are replaced more frequently. The sequence of feather molt is surprisingly orderly. Penguins, which shed large patches of feathers in an irregular pattern, are an exception. In most species the power of flight is retained during molt. The molt, that is, the normal shedding of feathers and their replacement by a new generation of feathers, is a single growth process which is actively concerned only with the production of the new generation of feathers. The old feathers are pushed out of the follicles passively.

A major physiological role of feathers is to provide insulation. This is accomplished by regulating the configuration of feather and skin in such a way that differing amounts of air are trapped in the dead space so formed. A second mechanism for control of heat dissipation is the balance of the exposure of feathered and unfeathered body parts.

Feathers act as a protective boundary in their role of providing waterproofing. Water repellency is a structural feature of feathers and is the result of precise geometric relationships between the diameter and spacing of barbs and barbules. Preening appears to be more important in the maintenance of this structure than it is for the application of oils or any other natural product, as was once thought.

A third function of the surface configuration and overall pattern of feathers is in the area of behavioral adaptations. These may be of two types. First is concealment, when the bird is cryptically marked to match its background and escape detection. The second type consists of various types of advertisement. See PROTECTIVE COLORATION. [A.H.B.]

**Federal Telecommunications System** A private telecommunications network that provides switched voice and data services for government employees in the 50 states of the United States, Guam, Puerto Rico, and the U.S. Virgin Islands.

The Federal Telecommunications System (FTS) intercity services are divided into two nationwide networks, each provided by one of the two vendors. Both vendors provide all-digital, fiber-optic backbone networks that support the integration of voice and nonvoice services on switching and transmission components at lower cost than in the previous system. See OPTICAL COMMUNICATIONS; SWITCHING SYSTEMS (COMMUNICATIONS).

The FTS2000 network includes six services and a wide range of capabilities. The enhanced systems have grown significantly in terms of voice usage and provide a full range of data services to meet the growing needs of the federal government. [W.PCu.]

**Feedback circuit** A circuit that returns a portion of the output signal of an electronic circuit or control system to the input of the circuit or system. When the signal returned (the feedback signal) is at the same phase as the input signal, the feedback is called positive or regenerative. When the feedback signal is of opposite phase to that of the input signal, the feedback is negative or degenerative.

The use of negative feedback in electronic circuits and automatic control systems produces changes in the characteristics of the system which improve the performance of the system. In electronic circuits, feedback is employed either to alter the shape of the frequency-response characteristics of an amplifier circuit and thereby produce more uniform amplification over a range of frequencies, or to produce conditions for oscillation in an oscillator circuit. It is also used because it stabilizes the gain of the system against changes in temperature, component replacement, and so on. Negative feedback also reduces nonlinear distortion. In automatic control systems, feedback is used to compare the actual output of a system with a desired output, the difference being used as the input signal to a controller. See AMPLIFIER; NEGATIVE-RESISTANCE CIRCUITS; SERVOMECHANISM. [H.F.K.]

**Feldspar** Any of a group of aluminosilicate minerals whose crystal structures are composed of corner-sharing  $[\text{AlO}_4]$  and  $[\text{SiO}_4]$  tetrahedra linked in an infinite three-dimensional array, with charge-balancing cations primarily sodium (Na), potassium (K), and calcium (Ca) occupying large, irregular cavities in the framework of the tetrahedra. Collectively, the feldspars constitute about 60% of the outer 8–10 mi (13–17 km) of the Earth's crust. They are nearly ubiquitous igneous and metamorphic rocks, and are a primary constituent of arkosic sediments derived from them. The importance of the many feldspars that occur so widely in igneous, metamorphic, and some sedimentary rocks cannot be underestimated, especially from the viewpoint of a petrologist attempting to unravel earth history. See ARKOSE; MINERALOGY; PETROLOGY; SILICATE MINERALS.

With weathering, feldspars form commercially important clay materials. Economically, feldspars are valued as raw material for the ceramic and glass industries, as fluxes in iron smelting, and as constituents of scouring powders. Occasionally their luster or colors qualify them as semiprecious gemstones. Some decorative building and monument stones are predominantly composed of weather-resistant feldspars. See CLAY MINERALS; IGNEOUS ROCKS; METAMORPHIC ROCKS.

The general formula  $\text{AT}_4\text{O}_8$  characterizes the chemistry of feldspars, where T (for tetrahedrally coordinated atom) represents aluminum (Al) or silicon (Si). The A atom is  $\text{Ca}^{2+}$  or barium ( $\text{Ba}^{2+}$ ) for the  $[\text{Al}_2\text{Si}_2\text{O}_8]^{2-}$  alkaline-earth feldspars and  $\text{Na}^+$  or  $\text{K}^+$  for the  $[\text{AlSi}_3\text{O}_8]^-$  alkali feldspar series of solid solutions and mixed crystals.

Knowledge of a feldspar's composition and its crystal structure is indispensable to an understanding of its properties. However, it is the distribution of the Al and Si atoms among the available tetrahedral sites in each chemical species that is essential to a complete classification scheme, and is of great importance in unraveling clues to the crystallization and thermal history of many igneous and metamorphic rocks.

Alkali feldspars are assigned to the polymorphs of  $\text{KAlSi}_3\text{O}_8$  and  $\text{NaAlSi}_3\text{O}_8$  in accordance with their symmetry and the Al content of their tetrahedral sites. See ALBITE; MICROCLINE; ORTHOCLASE.

Anorthoclase is a triclinic solid solution of composition  $\text{Or}_{37}\text{Ab}_{63}\text{-Or}_0\text{Ab}_{100}$  containing up to 10 mol % anorthite, or more. See ANORTHOCLASE.

Plagioclase feldspars containing significant amounts of exsolved K-rich feldspar are called antiperthites. It is only in once-molten rocks quenched at very high temperatures that the full range of so-called high plagioclases exist as simple solid solutions. With very slow cooling over millions of years, complex textures develop in most feldspar crystals as a coupled NaSi, CaAl ordering. See ANDESINE; BYTOWNITE; LABRADORITE; OLIGOCLASE; SOLID SOLUTION.

The variable properties of feldspars are determined by their structure, symmetry, chemical composition, and crystallization and subsequent history of phase transformation, exsolution, and alternation or deformation. Very few feldspars are transparent and colorless; many are white or milky due to internal reflections of light from inclusions, exsolution interfaces, and fracture or cleavage surfaces. Plagioclases are slightly harder (6–6.5) on Mohs scale than K-rich feldspars (6). Feldspars are brittle and, when broken, cleave along the (001) and (010) crystallographic planes. [P.H.R.]

**Feldspathoid** A member of the feldspathoid group of minerals. Members of this group are characterized by the following related features: (1) All are aluminosilicates with one or more of the large alkali ions (for example, sodium, potassium) or alkaline-earth ions (for example, calcium, barium). (2) The proportion of aluminum relative to silicon, both of which are tetrahedrally coordinated by oxygen, is high. (3) Although the crystal structures of many members are different, they are all classed as tektosilicates. (4) They occur principally in igneous rocks, but

only in silica-poor rocks, and do not coexist with quartz ( $\text{SiO}_2$ ). Feldspathoids react with silica to yield feldspars, which also are alkali-alkaline-earth aluminosilicates. Feldspathoids commonly occur with feldspars. See FELDSPAR; SILICATE MINERALS.

The principal species of this group are the following:

Nepheline	$\text{KNa}_3[\text{AlSiO}_4]_4$
Leucite	$\text{K}[\text{AlSi}_2\text{O}_6]$
Cancrinite	$\text{Na}_6\text{Ca}[\text{CO}_3   (\text{AlSiO}_4)_6] \cdot 2\text{H}_2\text{O}$
Sodalite	$\text{Na}_8[\text{Cl}_2   (\text{AlSiO}_4)_6]$
Nosean	$\text{Na}_8[\text{SO}_4   (\text{AlSiO}_4)_6]$
Hautyne	$(\text{Na,Ca})_{8-4}(\text{SO}_4)_{2-1}(\text{AlSiO}_4)_6]$
Lazurite	$(\text{Na,Ca})_8[(\text{SO}_4,\text{S,Cl})_2   (\text{AlSiO}_4)_6]$

The last four species (sodalite group) are isostructural, and extensive solid solution occurs between end members; but members of the sodalite group, cancrinite, leucite, and nepheline have different crystal structures. See CANCRINITE; LAZURITE; LEUCITE; LEUCITE ROCK; SODALITE. [D.R.P.]

**Feline infectious peritonitis** A fatal disease of both domestic and exotic cats (particularly cheetahs) caused by feline infectious peritonitis virus, a member of the Coronaviridae family. There are multiple strains of the virus which vary in virulence. Feline infectious peritonitis virus is closely related morphologically, genetically, and antigenically to other members of the Coronaviridae and arises as mutants from feline enteric coronaviruses, which infect cats but generally induce very mild or inapparent gastroenteritis. All coronaviruses are single-stranded ribonucleic acid (RNA) viruses with poor or no error correction during replication, resulting in relatively high mutation rates.

Feline coronaviruses are contracted primarily during exposure to infectious cat feces in the environment, but also via ingestion or inhalation during cat-to-cat contact. Feline infectious peritonitis virus is relatively labile once outside the cat's body but may be able to survive for as long as 7 weeks if protected from heat, light, and desiccation. It is readily inactivated by most disinfectants.

Signs of infection with feline infectious peritonitis virus depend upon the severity of infection, the relative ability of the immune system to minimize some of the characteristic inflammatory lesions, and the organ systems affected. There are two clinical forms of the disease. Wet feline infectious peritonitis, which is characterized by protein and fluid leakage into the abdominal cavity (or less frequently thoracic and scrotal spaces), occurs in cats with overwhelming infection, with poor immunity, or during late stages of other forms of the virus. In contrast, if a cat has a moderately competent (but ultimately ineffectual) immune response to the virus infection, granulomas may arise in infected tissues. This form of the disease, known as dry feline infectious peritonitis, commonly affects kidneys, liver, lymph nodes, mesentery, diaphragm, the outer surface of the intestine, and the neurological system. Wet or effusive feline infectious peritonitis is characterized by abdominal swelling, jaundice, and typically difficulty in breathing.

As with most viral infections, there is no specific antiviral drug of proven efficacy in the treatment of feline infectious peritonitis. Clinical management rests upon palliative treatment of the specific signs exhibited by each cat, and upon antibiotics, when indicated, to reduce secondary bacterial infections. The most important therapeutic approach involves the administration of immunosuppressive doses of corticosteroids to reduce the cat's immune response to the virus. See ANIMAL VIRUS; VIRUS. [J.E.F.]

**Feline leukemia** A type of cancer caused by the feline leukemia virus, a retrovirus which affects only a small percentage of freely roaming or domestic cats. The feline leukemia virus is genetically and morphologically similar to murine leukemia

virus, from which it presumably evolved several million years ago.

About 1–5% of healthy-appearing wild or freely roaming domestic cats have lifelong (persistent) infections. These carrier cats shed the virus in urine, feces, and saliva. The principal route of infection is oral. Infections occurring in nature are usually inapparent or mild, and 95% of such cats recover without any signs of illness. Mortality due to a feline leukemia virus infection occurs mainly among persistently infected cats and at a rate of around 50% per year.

There is no treatment that eliminates the virus. Supportive or symptomatic treatment may prolong life for weeks or months, depending on the particular disease manifestation. All cats should be tested for the presence of the virus prior to putting them in contact with feline leukemia virus-free animals. Healthy-appearing or ill infected cats should not be in intimate contact with non-infected cats, even if the latter have been vaccinated. Feline leukemia virus vaccines are available and should be administered annually, although they should not be considered a substitute for testing, elimination, and quarantine procedures. See LEUKEMIA; RETROVIRUS. [N.C.P.]

**Feline panleukopenia** An acute viral infection of cats, also called feline viral enteritis and (erroneously) feline distemper. The virus infects all members of the cat family (Felidae) as well as some mink, ferrets, and skunks (Mustelidae); raccoons and coati mundi (Procyonidae); and the binturong (Viverridae). Panleukopenia is the most important infectious disease of cats. This disease occurs worldwide, and nearly all cats are exposed by their first year because the virus is stable and ubiquitous; the disease is rarely seen in older cats. Without treatment, this disease is often fatal.

Feline panleukopenia virus is classified as a parvovirus, and is one of the smallest known viruses. It is antigenically identical to the mink enteritis virus, and only minor antigenic differences exist between feline panleukopenia virus and canine parvovirus. It is believed that canine parvovirus originated as a mutation from feline panleukopenia virus.

The disease is severe and life threatening in 20–50% of cases. The cat is depressed and may refuse food or water; vomiting and diarrhea are common, resulting in severe dehydration. The cat may have a fever or a subnormal temperature. A low white blood cell count confirms the diagnosis as panleukopenia. Diagnosis can be made by autopsy and evidence of the destruction of the intestinal crypts and villus shortening.

Highly effective and safe vaccines are available for the prevention of panleukopenia. Premises contaminated by feline panleukopenia virus are extremely difficult to disinfect; chlorine bleach, formaldehyde, or a certain quaternary ammonium disinfectant will destroy the virus. A cat should be successfully immunized before being introduced to premises where a pan-leukopenia-infected cat previously lived. See ANIMAL VIRUS. [J.H.Car.]

**Fennel** *Foeniculum vulgare*, a culinary herb of the parsley family (Apiaceae). It is grown for the dried, ripe fruits or seeds which are used in bread, pickles, liqueurs, and meat sauces and dishes. Although similar in odor to anise, fennel seed can be distinguished by its warm, sweet character. See APIALES.

The three fennel varieties of commercial importance are *vulgare*, *dulce*, and *piperitum*. The variety *vulgare* is grown for its seed and the essential oil, obtained by steam distillation and known as bitter fennel oil. The variety *dulce* (finocchio or Florence fennel) is grown for four products; seed and leaf for culinary use, the enlarged leaf base for a vegetable, and for the essential oil from the seeds (sweet fennel oil). The young stems of Italian fennel, variety *piperitum*, are used for flavoring in salads.

Fennel is native to southern Europe and the Mediterranean region and is presently cultivated as an annual or biennial plant

in southern and eastern Europe, India, Argentina, China, and Pakistan. See SPICE AND FLAVORING. [S.Kir.]

**Fermentation** Decomposition of foodstuffs generally accompanied by the evolution of gas. The best-known example is alcoholic fermentation, in which sugar is converted into alcohol and carbon dioxide. During fermentation organic matter is decomposed in the absence of air (oxygen); hence, there is always an accumulation of reduction products, or incomplete oxidation products. Some of these products (for example, alcohol and lactic acid) are of importance to humans, and fermentation has therefore been used for their manufacture on an industrial scale. There are also many microbiological processes that go on in the presence of air while yielding incomplete oxidation products. Good examples are the formation of acetic acid (vinegar) from alcohol by vinegar bacteria, and of citric acid from sugar by certain molds (for example, *Aspergillus niger*). These microbial processes, too, have gained industrial importance, and are often referred to as fermentations, even though they do not conform to L. Pasteur's concept of fermentation as a decomposition in the absence of air. See INDUSTRIAL MICROBIOLOGY. [C.B.V.N.]

**Fermi-Dirac statistics** The statistical description of particles or systems of particles that satisfy the Pauli exclusion principle. This description was first given by E. Fermi, who applied the Pauli exclusion principle to the translational energy levels of a system of electrons. It was later shown by P. A. M. Dirac that this form of statistics is also obtained when the total wave function of the system is antisymmetrical. See EXCLUSION PRINCIPLE.

Such a system is described by a set of occupation numbers  $\{n_i\}$  which specify the number of particles in energy levels  $\epsilon_i$ . It is important to keep in mind that  $\epsilon_i$  represents a finite range of energies, which in general contains a number, say  $g_i$ , of non-degenerate quantum states. In the Fermi statistics, at most one particle is allowed in a nondegenerate state. (If spin is taken into account, two particles may be contained in such a state.) This is simply a restatement of the Pauli exclusion principle, and means that  $n_i \leq g_i$ . The probability of having a set  $\{n_i\}$  distributed over the levels  $\epsilon_i$ , which contain  $g_i$  nondegenerate levels, is described by Eq. (1), which gives just the number of ways that  $n_i$  can be

$$W = \prod_i \frac{g_i!}{(g_i - n_i)! n_i!} \quad (1)$$

picked out of  $g_i$ , which is intuitively what one expects for such a probability. The equilibrium state which actually exists is the set of  $n_i$ 's that makes  $W$  a maximum, under the auxiliary conditions given in Eqs. (2a) and (2b). These conditions express the fact that

$$\sum_i n_i = N \quad (2a)$$

$$\sum_i n_i \epsilon_i = E \quad (2b)$$

the total energy  $E$  and the total number of particles  $N$  are given. Equation (3) holds for this most probable distribution. Here  $A$

$$n_i = \frac{g_i}{\frac{1}{A} e^{\beta \epsilon_i} + 1} \quad (3)$$

and  $\beta$  are parameters, to be determined from Eq. (3); in fact,  $\beta = 1/kT$ , where  $k$  is Boltzmann's constant and  $T$  is the absolute temperature. When the 1 in the denominator may be neglected, Eq. (3) goes over into the Boltzmann distribution.

Classical conditions pertain when the volume per particle is much larger than the volume associated with the de Broglie wavelength  $\lambda$  of a particle. For electrons in a metal at 300 K, the ratio of the volume per particle to  $\lambda^3$  has the value  $10^{-4}$ , showing that classical statistics fail altogether. When the classical distribution fails, a degenerate Fermi distribution results. A somewhat

lengthy calculation yields the result that in this case the contribution of the electrons to the specific heat is negligible. This resolves an old paradox, for, according to the classical equipartition law, the electronic specific heat  $C$  should be  $(3/2)Nk$ , whereas in reality it is very small. See BOSE-EINSTEIN STATISTICS; KINETIC THEORY OF MATTER; QUANTUM STATISTICS; STATISTICAL MECHANICS. [M.Dr.]

**Fermi surface** The surface in the electronic wavenumber space of a metal that separates occupied from empty states. Every possible state of an electron in a metal can be specified by the three components of its momentum, or wavenumber. The name derives from the fact that half-integral spin particles, such as electrons, obey Fermi-Dirac statistics and at zero temperature fill all levels up to a maximum energy called the Fermi energy, with the remaining states empty. See FERMI-DIRAC STATISTICS.

The fact that such a surface exists for any metal, and the first direct experimental determination of a Fermi surface (for copper) in 1957, were central to the development of the theory of metals. A surprise arising from the earliest determined Fermi surfaces was that many of the shapes were close to what would be expected if the electrons interacted only weakly with the crystalline lattice. The long-standing free-electron theory of metals was based upon this assumption, but most physicists regarded it as a serious oversimplification. See FREE-ELECTRON THEORY OF METALS.

The momentum  $p$  of a free electron is related to the wavelength  $\lambda$  of the electronic wave by the equation below, where  $\hbar$

$$p = \frac{2\pi\hbar}{\lambda}$$

is Planck's constant divided by  $2\pi$ . The ratio  $2\pi/\lambda$ , taken as a vector in the direction of the momentum, is called the wavenumber  $k$ . If the electron did not interact with the metallic lattice, the energy would not depend upon the direction of  $k$ , and all constant-energy surfaces, including the Fermi surface, would be spherical.

The Fermi surface of copper was found to be distorted (see illustration) but was still a recognizable deformation of a sphere. The polyhedron surrounding the Fermi surface in the illustration is called the Brillouin zone. It consists of Bragg-reflection planes, the planes made up of the wavenumbers for which an electron can be diffracted by the periodic crystalline lattice. The square faces, for example, correspond to components of the wavenumber along one coordinate axis equal to  $2\pi/a$ , where  $a$  is the cube

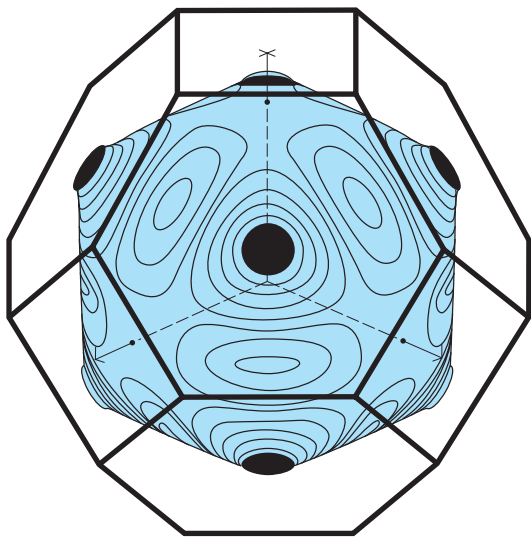

Fermi surface of copper, as determined in 1957; two shapes were found to be consistent with the original data, and the other, slightly more deformed version turned out to be correct.

edge for the copper lattice. For copper the electrons interact with the lattice so strongly that when the electron has a wavenumber near to the diffraction condition, its motion and energy are affected and the Fermi surface is correspondingly distorted. The Fermi surfaces of sodium and potassium, which also have one conducting electron per atom, are very close to a sphere. These alkali metals are therefore more nearly free-electron-like. See BRILLOUIN ZONE.

In transition metals there are electrons arising from atomic  $d$  levels, in addition to the free electrons, and the corresponding Fermi surfaces are more complex than those of the nearly free-electron metals. However, the Fermi surfaces exist and have been determined experimentally for essentially all elemental metals.

The motion of the electrons in a magnetic field provides the key to experimentally determining the Fermi surface shapes. The simplest method conceptually derives from ultrasonic attenuation. Sound waves of known wavelength pass through the metal and a magnetic field is adjusted, yielding fluctuations in the attenuation as the orbit sizes match the sound wavelength. This measures the diameter of the orbit and Fermi surface. The most precise method uses the de Haas-van Alphen effect, based upon the quantization of the electronic orbits in a magnetic field. Fluctuations in the magnetic susceptibility give a direct measure of the cross-sectional areas of the Fermi surface. See DE HAAS-VAN ALPHEN EFFECT; SKIN EFFECT (ELECTRICITY); ULTRASONICS. [W.A.H.]

**Fermium** A chemical element, Fm, atomic number 100, the eleventh element in the actinide series. Fermium does not occur in nature; its discovery and production have been accomplished by artificial nuclear transmutation of lighter elements. Radioactive isotopes of mass number 244–259 have been discovered. The total weight of fermium which has been synthesized is much less than one-millionth of a gram. See ACTINIDE ELEMENTS; PERIODIC TABLE; RADIOACTIVITY.

Spontaneous fission is the major mode of decay for  $^{244}\text{Fm}$ ,  $^{256}\text{Fm}$ , and  $^{258}\text{Fm}$ . The longest-lived isotope is  $^{257}\text{Fm}$ , which has a half-life of about 100 days. Fermium-258 decays by spontaneous fission with a half-life of 0.38 millisecond. This suggests the existence of an abnormality at this point in the nuclear periodic table. See NUCLEAR CHEMISTRY; NUCLEAR REACTION; TRANSURANIUM ELEMENTS. [G.T.S.]

**Ferret** The name for the largest member of the weasel family, Mustelidae. This carnivorous animal, also known as the black-footed ferret (*Mustela nigripes*), is an inhabitant of the western states in the Rocky Mountain area, where it is referred to as the prairie dog ferret or prairie dog hunter. Though once abundant, ferrets are now very rare; they suffered from the poisoning campaigns against prairie dogs and larger carnivores.

Two litters are born each year after a gestation period of about 60 days, with 5–10 young in each litter. The maximum life is 13 years. See CARNIVORA; WEASEL. [C.B.C.]

**Ferricyanide** The common name for hexacyanoferrate(III), a compound containing the complex ion  $[\text{Fe}(\text{CN})_6]^{3-}$ .

The  $[\text{Fe}(\text{CN})_6]^{3-}$  ion is kinetically unstable, and it dissociates to give the free cyanide anion,  $\text{CN}^-$ . It is therefore quite toxic. In contrast, the ferrocyanide ion,  $[\text{Fe}(\text{CN})_6]^{4-}$ , is stable.

The sodium  $[\text{Na}_3\text{Fe}(\text{CN})_6]$  and potassium  $[\text{K}_3\text{Fe}(\text{CN})_6]$  salts have been isolated as ruby-red crystals and are photosensitive. The potassium salt reacts with metallic silver to produce silver ferrocyanide, and it is used in photographic processes. In addition, the  $[\text{Fe}(\text{CN})_6]^{3-}$  ion is used in blueprint materials, wood stains, and electroplating process, and as a mild oxidizing agent in organic synthesis. See FERROCYANIDE.

The addition of Fe II to ferricyanide produces Prussian blue ( $\text{Fe}_4\text{III}[\text{Fe}(\text{CN})_6]_3 \cdot x\text{H}_2\text{O}$ , where  $x = \sim 14-16$ ), a pigment discovered nearly 300 years ago. The structure of this mixed-valence complex has been determined by x-ray analysis and

powder neutron diffraction studies. See COORDINATION CHEMISTRY; COORDINATION COMPLEXES; CYANIDE; IRON. [T.J.Me.]

**Ferrimagnetic garnets** A class of ferrimagnetic oxide materials that have the garnet crystal structure. The typical formula of a ferrimagnetic garnet is  $X_3Fe_5O_{12}$ , where the trivalent X ion is yttrium, or any of the rare-earth ions with an atomic number greater than 61. (The rare-earth ions below samarium apparently have radii too large to fit into the garnet structure.) However, the larger rare earths and lanthanum can substitute partially for some of the yttrium or smaller rare earths. See FERRIMAGNETISM; FERRITE; RARE-EARTH ELEMENTS.

Ferrimagnetic garnets are of great theoretical interest because they have a highly ordered structure and because they accommodate rare-earth ions, some of which have a small contribution to their magnetism due to the orbital motion of electrons, in addition to the magnetism due to electron spin. The first practical engineering interest in the ferrimagnetic garnets was due to the yttrium iron garnet, which is used in certain microwave ferrite devices because of its very narrow ferromagnetic resonance absorption line. Development of magnetic bubbles for use in solid-state nonvolatile memory devices resulted in a large research effort on complex rare-earth iron garnets. In these garnets several different rare-earth ions are simultaneously incorporated in the structure in concentrations designed to optimize a number of physical and magnetic properties which influence the memory parameters. See COMPUTER STORAGE TECHNOLOGY; FERRITE DEVICES; GYRATOR. [M.E.Jo.]

**Ferrimagnetism** A specific type of ordering in a system of magnetic moments or the magnetic behavior resulting from such order. In some magnetic materials the magnetic ions in a crystal unit cell may differ in their magnetic properties. This is clearly so when some of the ions are of different species. It is also true for similar ions occupying crystallographically inequivalent sites. Such ions differ in their interactions with other ions, because the dominant exchange interaction is mediated by the neighboring nonmagnetic ions. They also experience different crystal electric fields, and these affect the magnetic anisotropy of the ion. A collection of all the magnetic sites in a crystal with identical behavior is referred to as a magnetic sublattice. A material is said to exhibit ferrimagnetic order when, first, all moments on a given sublattice point in a single direction and, second, the resultant moments of the sublattices lie parallel or antiparallel to one another. The notion of such an order is due to L. Néel, who showed in 1948 that its existence would explain many of the properties of the magnetic ferrites. See FERRITE; FERROMAGNETISM.

In general, there is a net moment, the algebraic sum of the sublattice moments, just as for a normal ferromagnet. However, its variation with temperature rarely exhibits the very simple behavior of the normal ferromagnet. For example, in some materials, as the temperature is raised over a certain range, the magnetization may first decrease to zero and then increase again. Ferrimagnets can be expected, in their bulk properties, measured statically or at low frequencies, to resemble ferromagnets with unusual temperature characteristics. See CURIE TEMPERATURE. [L.R.W.]

**Ferrite** Any of the class of magnetic oxides. Typically the ferrites have a crystal structure which has more than one type of site for the cations. Usually the magnetic moments of the metal ions on sites of one type are parallel to each other, and antiparallel to the moments on at least one site of another type. Thus ferrites exhibit ferrimagnetism. See FERRIMAGNETISM; MAGNETIC MATERIALS.

There are three important classes of commercial ferrites. One class has the spinel structure, with the general formula  $M^{2+}Fe_2^{3+}O_4$ , where  $M^{2+}$  is a divalent metal ion. So-called linear ferrites used in inductors and transformers are made of Mn and Zn (for frequencies up to 1 MHz) and Ni and Zn (for frequen-

cies greater than 1 MHz). MgMn ferrites are used in microwave devices such as isolators and circulators. Until the late 1970s, ferrites with square loop shapes held a dominant position as computer memory-core elements, but these gave way to semiconductors. See COMPUTER STORAGE TECHNOLOGY.

The second class of commercially important ferrites have the garnet structure, with the formula  $M_3^{3+}Fe_5^{3+}O_{12}$ , where  $M^{3+}$  is a rare-earth or yttrium ion. Yttrium-based garnets are used in microwave devices. Thin monocrystalline films of complex garnets have been developed for bubble domain memory devices.

The third class of ferrites has a hexagonal structure, of the  $M^{2+}Fe_{12}^{3+}O_{19}$  magnetoplumbite type, where  $M^{2+}$  is usually Ba, Sr, or Pb. Because of their large magnetocrystalline anisotropy, the hexagonal ferrites develop high coercivity and are an important member of the permanent magnet family.

Another magnetic oxide,  $\gamma$ - $Fe_2O_3$ , also has the spinel structure, but has no divalent cations. It is the most commonly used material in the preparation of magnetic recording tapes. See FERRITE DEVICES. [G.Y.C.]

**Ferrite devices** Electrical devices whose principle of operation is based upon the use and properties of ferrites, which are magnetic oxides. Ferrite devices are divided into two categories, depending on whether the ferrite is magnetically soft (low coercivity) or hard (high coercivity). Soft ferrites are used primarily as transformers, inductors, and recording heads, and in microwave devices. Since the electrical resistivity of soft ferrites is typically  $10^6$ – $10^{11}$  times that of metals, ferrite components have much lower eddy current losses and hence are used at frequencies generally above about 10 kHz. Hard ferrites are used in permanent-magnet motors, loudspeakers, and holding devices, and as storage media in magnetic recording devices. One type of soft ferrite, referred to as square-loop ferrites, was once deployed in huge quantities as cores for digital computer memories but has now been replaced by semiconductor integrated circuits. See FERRIMAGNETISM; FERRITE. [G.Y.C.]

**Ferroalloy** A member of an important group of metallic raw materials required for the steel industry. Ferroalloys are the principal source of such additions as silicon and manganese which are required for even the simplest plain-carbon steels; and chromium, vanadium, tungsten, titanium, and molybdenum, which are used in both low- and high-alloy steels. Ferroalloys are unique in that they are brittle and otherwise unsuited for any service application, but they are important as the most economical source of these elements for use in the manufacture of the engineering alloys. These same elements can also be obtained, at much greater cost in most cases, as essentially pure metals. The ferroalloys contain significant amounts of iron and usually have a lower melting range than the pure metals and are therefore dissolved by the molten steel more readily than the pure metal. In other cases, the other elements in the ferroalloy serve to protect the critical element against oxidation during solution and thereby give higher recoveries. Ferroalloys are used both as deoxidizers and as a specified addition to give particular properties to the steel. See STEEL. [G.D.]

**Ferrocyanide** The common name for hexacyanoferrate(II), a compound containing the complex ion  $[Fe(CN)_6]^{4-}$ . The oxidation state of iron is 2+ ( $Fe^{2+}$  or  $Fe^{II}$ ) and is low spin (spin paired), consistent with the strong field nature of the cyanide ( $CN^-$ ) ligand.

The  $[Fe(CN)_6]^{4-}$  ion is very stable, with the  $CN^-$  ligands adopting the octahedral geometry typical of  $Fe^{II}$  complexes. The free acid hydrogen hexacyanoferrate(II),  $H_4[Fe(CN)_6]$ , is soluble in water and is isolated as a white powder by ether precipitation of the ion in strongly acidic solutions. The salts of sodium,  $Na_4Fe(CN)_6$ , and potassium,  $K_4Fe(CN)_6$ , are prepared by heating an aqueous mixture of sodium cyanide ( $NaCN$ ), iron(II)



sulfate ( $\text{FeSO}_4$ ), and other salts. The complexes are substitutionally inert (in contrast to ferricyanide,  $[\text{Fe}(\text{CN})_6]^{3-}$ , which dissociates rapidly) and are isolated as yellow crystalline decahydrate solids that are insoluble in most organic solvents. Hexacyanoferrate(II) may be converted to hexacyanoferrate(III) (ferricyanide) by strong oxidizing agents such as peroxides and permanganate ion. See FERRICYANIDE.

Ferrocyanide is a commonly used as a reducing agent; and principal applications include the preparation of dyes, preparation of fixatives used in photography, and stabilization of synthetic and natural latex foams, and as an emulsion polymerization catalyst.

Nearly 300 years ago the mixed-valence compound Prussian blue ( $\text{Fe}_4^{\text{III}}[\text{Fe}^{\text{II}}(\text{CN})_6]_3 \cdot x\text{H}_2\text{O}$ , where  $x = 14-16$ ) was discovered to be a pigment. Prussian blue is prepared by the addition of  $\text{Fe}^{\text{III}}$  to  $[\text{Fe}(\text{CN})_6]^{4-}$  or of  $\text{Fe}^{\text{II}}$  to  $[\text{Fe}(\text{CN})_6]^{3-}$ , and the structure has been determined by x-ray analysis and powder neutron diffraction studies. Uses of this complex, also known as Turnbull's blue, include artists' colors, carbon paper, typewriter ribbons, and printing inks. The reduction of Prussian blue results in the formation of Everitt's salt,  $\text{K}_2[\text{Fe}^{\text{II}}\text{Fe}^{\text{II}}(\text{CN})_6]$ . See COORDINATION CHEMISTRY; COORDINATION COMPLEXES; CYANIDE; IRON. [T.J.M.]

**Ferroelectrics** Crystalline substances which have a permanent spontaneous electric polarization (electric dipole moment per cubic centimeter) that can be reversed by an electric field. In a sense, ferroelectrics are the electrical analog of the ferromagnets, hence the name. The spontaneous polarization is the so-called order parameter of the ferroelectric state. The names Seignette-electrics or Rochelle-electrics, which are also widely used, are derived from the name of the first substance found to have this property, Seignette salt or Rochelle salt. See FERROMAGNETISM.

From a practical standpoint ferroelectrics can be divided into two classes. In ferroelectrics of the first class, spontaneous polarization can occur only along one crystal axis; that is, the ferroelectric axis is already a unique axis when the material is in the paraelectric phase. Typical representatives of this class are Rochelle salt, monobasic potassium phosphate, ammonium sulfate, guanidine aluminum sulfate hexahydrate, glycine sulfate, colemanite, and thiourea.

In ferroelectrics of the second class, spontaneous polarization can occur along several axes that are equivalent in the paraelectric phase. The following substances belong to this class: barium(IV) titanate-type (or perovskite-type) ferroelectrics; cadmium niobate; lead niobate; certain alums, such as methyl ammonium alum; and ammonium cadmium sulfate.

From a scientific standpoint, one can distinguish proper ferroelectrics and improper ferroelectrics. In proper ferroelectrics, the structure change at the Curie temperature can be considered a consequence of the spontaneous polarization. In improper ferroelectrics, the spontaneous polarization can be considered a by-product of another structural phase transition. Examples of such systems are gadolinium molybdate and boracites.

The spontaneous polarization can occur in at least two equivalent crystal directions; thus, a ferroelectric crystal consists in general of regions of homogeneous polarization that differ only in the direction of polarization. These regions are called ferroelectric domains. Ferroelectrics of the first class consist of domains with parallel and antiparallel polarization, whereas ferroelectrics of the second class can assume much more complicated domain configurations. The region between two adjacent domains is called a domain wall. Within this wall, the spontaneous polarization changes its direction.

As a rule, the dielectric constant  $\epsilon$  measured along a ferroelectric axis increases in the paraelectric phase when the Curie temperature is approached. In many ferroelectrics, this increase can be approximated by the Curie-Weiss law. See CURIE-WEISS LAW.

Ferroelectrics can be divided into two groups according to their piezoelectric behavior. The ferroelectrics in the first group are already piezoelectric in the unpolarized phase. Those piezoelectric moduli which relate stresses to polarization along the ferroelectric axis have essentially the same temperature dependence as the dielectric constant along this axis, and hence become very large near the Curie point. The spontaneous polarization gives rise to a large spontaneous piezoelectric strain which is proportional to the spontaneous polarization.

The ferroelectrics in the second group are not piezoelectric when they are in the paraelectric phase. However, the spontaneous polarization lowers the symmetry so that they become piezoelectric in the polarized phase. This piezoelectric activity is often hidden because the piezoelectric effects of the various domains can cancel. However, strong piezoelectric activity of a macroscopic crystal or even of a polycrystalline sample occurs when the domains have been aligned by an electric field. The spontaneous strain is proportional to the square of the spontaneous polarization. See PIEZOELECTRICITY.

Antiferroelectric crystals are characterized by a phase transition from a state of lower symmetry (generally low-temperature phase) to a state of higher symmetry (generally high-temperature phase). The low-symmetry state can be regarded as a slightly distorted high-symmetry state. It has no permanent electric polarization, in contrast to ferroelectric crystals. The crystal lattice can be regarded as consisting of two interpenetrating sublattices with equal but opposite electric polarization. This state is referred to as the antipolarized state. In a certain sense, an antiferroelectric crystal is the electrical analog of an antiferromagnetic crystal.

The piezoelectric effect of ferroelectrics (and certain antiferroelectrics) finds numerous applications in electromechanical transducers. The large electrooptical effect (birefringence induced by an electric field) is used in light modulators. In certain ferroelectrics, light can induce changes of the refractive indices. These substances can be used for optical information storage and in real-time optical processors. The temperature dependence of the spontaneous polarization corresponds to a strong pyroelectric effect which can be exploited in thermal and infrared sensors.

[W.K.]

**Ferromagnetism** A property exhibited by certain metals, alloys, and compounds of the transition (iron group), rare-earth, and actinide elements in which, below a certain temperature called the Curie temperature, the atomic magnetic moments tend to line up in a common direction. Ferromagnetism is characterized by the strong attraction of one magnetized body for another.

Atomic magnetic moments arise when the electrons of an atom possess a net magnetic moment as a result of their angular momentum. The combined effect of the atomic magnetic moments can give rise to a relatively large magnetization, or magnetic moment per unit volume, for a given applied field. Above the Curie temperature, a ferromagnetic substance behaves as if it were paramagnetic: Its susceptibility approaches the Curie-Weiss law. The Curie temperature marks a transition between order and disorder of the alignment of the atomic magnetic moments. Some materials having atoms with unequal moments exhibit a special form of ferromagnetism below the Curie temperature called ferrimagnetism. See CURIE TEMPERATURE; CURIE-WEISS LAW; ELECTRON SPIN; FERRIMAGNETISM; MAGNETIC SUSCEPTIBILITY; PARAMAGNETISM.

The characteristic property of a ferromagnet is that, below the Curie temperature, it can possess a spontaneous magnetization in the absence of an applied magnetic field. Upon application of a weak magnetic field, the magnetization increases rapidly to a high value called the saturation magnetization, which is in general a function of temperature. For typical ferromagnetic materials, their saturation magnetizations, and Curie temperatures, see MAGNETIZATION.

Small regions of spontaneous magnetization, formed at temperatures below the Curie point, are known as domains. As

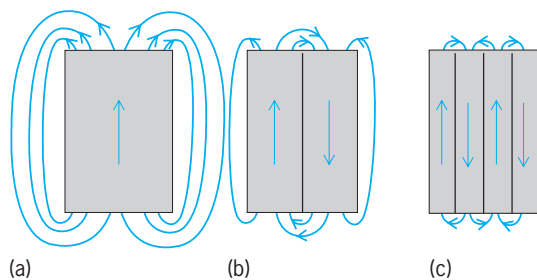

**Lowering of magnetic field energy by domains. (a) Lines of force for a single domain. (b) Shortening of lines of force by division into two domains. (c) Reduction of field energy by further subdivision.**

shown in the illustration, domains originate in order to lower the magnetic energy. In illus. *b* it is shown that two domains will reduce the extent of the external magnetic field, since the magnetic lines of force are shortened. On further subdivision, as in, this field is still further reduced.

Another way to describe the energy reduction is to note that the interior demagnetizing fields, coming from surface poles, are much smaller in the long, thin domains of illus. *c* than in the “fat” domain of illus. *a*.

The question arises as to how long this subdivision process continues. With each subdivision there is a decrease in field energy, but there is also an increase in Heisenberg exchange energy, since more and more magnetic moments are aligning antiparallel. Finally a state is reached in which further subdivision would cause a greater increase in exchange energy than decrease in field energy, and the ferromagnet will assume this state of minimum total energy.

Materials easily magnetized and demagnetized are called soft; these are used in alternating-current machinery. The problem of making cheap soft materials is complicated by the fact that readily fabricated metals usually have many crystalline boundaries and crystal grains oriented in many directions. The ideal cheap soft material would be an iron alloy fabricated by some inexpensive technique which results in all crystal grains being oriented in the same or nearly the same direction. Various complicated rolling and annealing methods have been discovered in the continued search for better grain-oriented or “cube-textured” steels.

Materials which neither magnetize nor demagnetize easily are called hard; these are used in permanent magnets. A number of permanent-magnet materials have enjoyed technological importance. The magnet steels contain carbon, chromium, tungsten, or cobalt additives, serving to impede domain wall motion and thus to generate coercivity. Alnicos are aluminum-nickel-iron alloys containing finely dispersed, oriented, elongated particles precipitated by thermal treatment in a field. Hard ferrite magnets are based on the oxides  $\text{BaFe}_{12}\text{O}_{19}$  and  $\text{SrFe}_{12}\text{O}_{19}$ . Hard ferrite magnets are relatively inexpensive and are used in a great variety of commercial applications. Rare earth-transition metal materials whose rare-earth component provides huge magnetocrystalline anisotropy can be translated into large coercivity in a practical magnet, while the magnetization arises chiefly from the transition-metal component. Examples include samarium-cobalt magnets based on the  $\text{SmCo}_5$  or  $\text{Sm}_2\text{Co}_{17}$  intermetallic compounds.

[E.A.; F.Ke.; J.F.He.]

**Ferry** A ship specifically configured for carrying passengers between two points. It permits persons to make their way from one place to another across a body of water, and it may carry vehicles, including commercial vehicles. A ferry is distinct from a cruise ship or a cargo ship. For a cruise ship the voyage itself is the destination, whereas with a ferry the journey's end point is the destination. While a ferry may carry cargo, in contrast to

a cargo ship, this cargo is contained in a commercial vehicle accompanied by a driver.

Ferries may range in speed from slow vessels of 10 knots (18.5 km/h) or less to ultrafast ferries with speeds exceeding 60 knots (110 km/h). They may carry passengers only, or they may carry a mixture of passengers and private automobiles, or passengers, cars, and trucks. Ferries may be characterized by their hull form and their propulsion plant.

The most common hull design for ferries is the displacement monohull ship form, which has one hull. Monohull ferries have been built in all sizes and speeds. Among monohulls a unique form is the double-ended ferry. On short runs, it makes operational sense to build a ship which is identical fore and aft. For example, in use for river crossing, this ship simply shuttles from one dock to the other, putting one “bow” into the slip at one port, the other “bow” at the other port.

The catamaran hull is a very popular form, particularly for high-speed ferries. A catamaran is a twin-hulled ship, having two hulls side by side. The two hulls are generally separated by a distance about equal to the beam of one hull. This results in a broad main deck area, which is more nearly square than the slender deck found on a monohull ship. Because of the broad expanse of the deck area, and because its low-aspect-ratio shape is easier to load with vehicles, the catamaran hull form has been very successfully incorporated into ferry service.

Ferry propulsion systems depend upon the speed and hull form of the ship. The most common propulsion system is the conventional screw propeller. This is a submerged helical screw at the stern of the ship, driven by the ship's engines. Double-ended ferries require some form of reversible or double-ended propulsion system. See PROPELLER (MARINE CRAFT).

High speed ferries demand much higher power. The higher weight sensitivity of a fast ferry frequently leads to use of gas turbine engines because of their light weight. See MARINE ENGINE.

Virtually all low-speed ferries and many high-speed ferries are propeller-driven. However, at speeds above about 40 knots (75 km/h) the hydrodynamic efficiency of the waterjet propulsor becomes superior to that of a propeller. As a consequence, almost all the fastest high-speed ferries use waterjet propulsion.

[C.B.McK.]

**Fertilizer** Materials added to the soil, or applied directly to crop foliage, to supply elements needed for plant nutrition. These materials may be in the form of solids, semisolids, slurry suspensions, pure liquids, aqueous solutions, or gases.

The chemical elements nitrogen, phosphorus, and potassium are the macronutrients, or primary fertilizer elements, which are required in greatest quantity. Sulfur, calcium, and magnesium, called secondary elements, are also necessary to the health and growth of vegetation, but they are required in lesser amounts compared to the macronutrients. The other elements of agronomic importance, called micronutrients and provided for plant ingestion in small (or trace) amounts, include boron, cobalt, copper, iron, manganese, molybdenum, and zinc. All these fertilizer elements, along with other chemical elements, occur naturally in agricultural soils in varying concentrations and mineral compositions which may or may not be in forms readily accessible to root systems of plants. The addition of fertilizer to soils used for the production of commercial crops is necessary to correct natural deficiencies and to replace the components absorbed by the crops in their growth.

Crop requirements of fertilizer components could be satisfied by the spreading of individual materials for each element deficient in the soil. However, economy favors the single application of a balanced mixture that satisfies all nutritional needs of a crop. Many commercial fertilizers therefore contain more than one of the primary fertilizer elements.

The compositions of fertilizer mixtures, in terms of the primary fertilizer elements, are identified by an N-P-K code: N denotes elemental nitrogen; P denotes the anhydride of phosphoric acid

( $P_2O_5$ ); K denotes the oxide of potassium ( $K_2O$ ). All are expressed numerically in percentage composition, or units of 20 lb each per short ton (10 kg per metric ton) of finished fertilizer as packaged. Formula 8-32-16 thus contains a mixture aggregating 8 wt % N in some form of nitrogen compounds, 32 wt %  $P_2O_5$  in some form of phosphates, and 16 wt %  $K_2O$  in some form of potassium compounds, to give a product with a total of 56 fertilizer units. The commercial N-P-K formulas are generally in whole numbers. None of the N-P-K formulas totals 100% plant nutrients because the formulas indicate only the nutrient portions of the primary-element compounds and do not account for any other materials present.

Aqueous solutions of urea, ammonia, and ammonium nitrate (UAN solutions) are used directly by the farmers as well as in the preparation of granular N-P-K products by mixing with other materials. UAN solutions are also spread directly by field application or used to prepare complete N-P-K fertilizer solutions or suspensions. Suspension fertilizers consist of aqueous slurries of fine crystals in saturated solutions that are stabilized by small amounts of gelling materials, such as attapulgite clay. Suspensions can be maintained in uniform composition during spreading on the fields, and give better dispersion than granular material. See FERTILIZING. [A.Lo.]

Organic fertilizers are organic materials of vegetable and animal origin which contain certain macro, secondary, or micro nutrients that can be utilized by plants after application to agricultural soils. The primary nutrient sources of vegetable origin are crop residues, green manures, oilseed cakes, seaweeds, and miscellaneous food processing and distillery wastes. Also included in this category is biologically fixed nitrogen from legumes in association with root-nodulating bacteria of the genus *Rhizobium*. Animal sources include animal manures and urine, sewage sludge, septage, latrine wastes, and to a lesser extent materials such as blood meal, bone meal, and fish scraps. Often organic fertilizers are of mixed animal and vegetable origin, such as most farmyard manures, rural and urban composts, and sewage effluents and sludges. See NITROGEN FIXATION; SOIL MICROBIOLOGY. [R.I.P.; J.F.P.]

**Fertilizing** Addition of elements or other materials to the soil to increase or maintain plant yields. Fertilizers may be organic or inorganic. Organic fertilizers are usually manures and waste materials which in addition to providing small amounts of growth elements also serve as conditioners for the soil. Commercial fertilizers are most often inorganic. See FERTILIZER.

Methods of applying fertilizers vary widely and depend on such factors as kind of crop and stage of growth, application rates, physical and chemical properties of the fertilizer, and soil type. Two basic application methods are used, bulk spreading and precision placement. Time and labor are saved by the practice of bulk spreading, in which the fertilizer is broadcast over the entire area by using large machines which cover many acres in a short time. Precision placement, in which the fertilizer is applied in one or more bands in a definite relationship to the seed or plants, requires more equipment and time, but usually smaller amounts of fertilizer are needed to produce a given yield increase.

For some deep-rooted plants, subsoil fertilization to depths of 12–20 in. (30–50 cm) is advantageous. This is usually a separate operation from planting, and uses a modified subsoil plow followed by equipment to bed soil over the plow furrow, thereby eliminating rough soil conditions unfavorable for good seed germination. Top-dressings are usually applied by broadcasting over the soil surface for closely spaced crops such as small grains.

Since solid fertilizers range from dense heavy materials to light powders and liquid fertilizers range from high pressure to zero pressure, a variety of equipment is required for accurate metering and placement. In addition, application rates may be as low as 50 lb/acre (56 kg/hectare) or as high as 6 tons/acre (13.3 metric tons/hectare). Large bulk spreaders usually use drag chains or augers to force the material through a gate or opening whose

size is varied to regulate the amount passing through and falling on the spreader.

Liquid fertilizer of the high-pressure type (for example, anhydrous ammonia) is usually regulated by valves or positive displacement pumps. The size of the orifice may be controlled manually or automatically by pressure-regulating valves. Low-pressure solutions may be metered by gravity flow through orifices, but greater accuracy is obtained by using compressed air or other gases to maintain a constant pressure in the tank. This method eliminates the effect of temperature and volume changes. Nonpressure solutions may be metered by gravity or by gear, roller, piston, centrifugal, or hose pumps. The accuracy of the gravity type can be improved by the use of a constant head device by which all air is introduced into the tank at the bottom.

Nonvolatile fertilizer solutions are often pumped into the supply lines of irrigation systems to allow simultaneous fertilization and irrigation. With the exception of bulk spreaders and other broadcasters, most fertilizer application devices are built as attachments which can be mounted in conjunction with planters, cultivators, and herbicide applicators. Often the tanks, pumps, and controls used for liquid fertilizers are also used for applying other chemicals such as insecticides. [J.G.F.]

**Fescue** A group of approximately 100 species of grass; more than 30 are represented in the United States. Tall fescue (*Festuca arundinacea*), a perennial cool-season plant introduced from Europe, occupies about  $35 \times 10^6$  acres ( $15 \times 10^6$  hectares), primarily in the humid south-central region of the United States. It is popular because of its ease of establishment, vigor, wide range of adaptation, long grazing season, tolerance to abuse, sufferance of drought and poor soils, pest resistance, good seed production, and esthetic value when used for turf, ground cover, and conservation purposes. It is used primarily as pasture and hay for beef cattle, with lesser use for dairy cows or replacement heifers, sheep, and horses. The leafy and vigorous plants can grow to 3–4 ft (0.9–1.2 m) if undisturbed; under grazing or clipping, they can form a dense sod when sufficient water and fertility are available.

Other important fescues include meadow fescue (*F. elatior*), red fescue (*F. rubra*), Chewings fescue (*F. rubra* var. *commutata*), Idaho fescue (*F. idahoensis*), and sheep fescue (*F. ovina*). See CYPERALES; GRASS CROPS. [H.A.Fr.]

**Fetal alcohol syndrome** A spectrum of changes in the offspring of women who consume alcoholic beverages during pregnancy, ranging from severe growth deficiency, mental retardation, and abnormal facial features to mild mental changes. Physical abnormalities include limitation of joint motion, increased congenital heart malformation rate, short palpebral fissures, and maxillary hypoplasia with relative prognathism.

The frequency of adverse outcome of pregnancies of chronic alcoholic women is very high. There is an eightfold increase in perinatal mortality, and the frequency of the fetal alcohol syndrome in the surviving children is high. Almost half of the offspring have IQs below 80, and a smaller percentage have the dysmorphic features noted above.

Medical advice regarding the consumption of alcoholic beverages during pregnancy involves three principles: heavy drinking is clearly deleterious to the fetus; abstinence from alcoholic beverages immediately preceding and during pregnancy is the only assured safe course of action presently known; and therapeutic attention should also be directed to the problems leading to the alcoholism so that the psychological environment of the offspring may be improved. See ALCOHOLISM; BEHAVIORAL TOXICOLOGY. [N.K.M.]

**Fetal membrane** One of the membranous structures which surround the embryo during its developmental period. Since such membranes are external to the embryo proper, they

are called extraembryonic membranes. They function in the embryo's protection, nutrition, respiration, and excretion.

There are four fetal membranes—the amnion, chorion, yolk sac, and allantois. In the course of development, the chorion becomes the outermost, and the amnion the innermost, membrane surrounding the developing embryo. As the allantois increases in size, it expands and becomes closely associated, if not fused, with the chorion. The two membranes together are known as the chorioallantoic membrane.

The amniotic cavity within which the embryo is enclosed becomes filled with an aqueous fluid which gives osmotic and physical protection to the embryo during the remainder of its fetal existence. Smooth muscle fibers in the amnion spontaneously contract and gently rock the embryo before it develops the capacity for spontaneous movement.

As the stored nutrients of the yolk are depleted during development, the yolk sac gradually decreases in size and is eventually incorporated into the midgut of the embryo. The yolk sac in the nonyolky eggs of placental mammals is vestigial. It has evolutionary but essentially no functional significance.

At the time of birth or hatching, the embryo becomes completely separated from the amnion and chorion and from the major portion of the allantois. The proximal portion of the latter remains within the embryo, however, as the urinary bladder. See ALLANTOIS; AMNION; CHORION; YOLK SAC. [A.R.B.]

**Fever** An elevation in the central body temperature of warm-blooded animals caused by abnormal functioning of the thermoregulatory mechanisms. Fever accompanies a wide variety of disease states, both infectious and noninfectious, and in the great majority of instances is due to an abnormality in the regulation of body temperature by the central nervous system. See THERMOREGULATION.

Experimental studies on the cause of fever suggest that leukocytes, as well as the fixed macrophages can be activated by various stimuli to produce a fever-inducing substance—endogenous pyrogen (EP). Endogenous pyrogen has been characterized as a protein of relatively low molecular weight (13,000) with an essential lipid moiety.

The mechanisms responsible for elevating body temperature include: reduction in heat loss by constriction of peripheral vessels whose tone is under control of the sympathetic nervous system; inhibition of panting and sweating, the latter by way of the cholinergic nerves; and increased heat production by means of shivering in voluntary muscles innervated by somatic motor nerves.

There is no clear evidence that elevated body temperature evoked by most infections is directly injurious to microbial invaders. As fever regularly accompanies inflammation, however, increased body temperature may well accelerate certain biochemical reactions of use to the host in combating infection. See HOMEOSTASIS; INFLAMMATION. [E.At.]

**Feynman diagram** A pictorial representation of elementary particles and their interactions. Feynman diagrams show paths of particles in space and time as lines, and interactions between particles as points where the lines meet.

The illustration shows Feynman diagrams for electron-electron scattering. In each diagram, the straight lines represent space-time trajectories of noninteracting electrons, and the wavy lines represent photons, particles that transmit the electromagnetic interaction. External lines at the bottom of each diagram represent incoming particles (before the interactions), and lines at the top, outgoing particles (after the interactions). Interactions between photons and electrons occur at the vertices where photon lines meet electron lines. See ELECTRON; PHOTON.

Each Feynman diagram corresponds to the probability amplitude for the process depicted in the diagram. The set of all distinct Feynman diagrams with the same incoming and outgoing lines corresponds to the perturbation expansion of a matrix element of

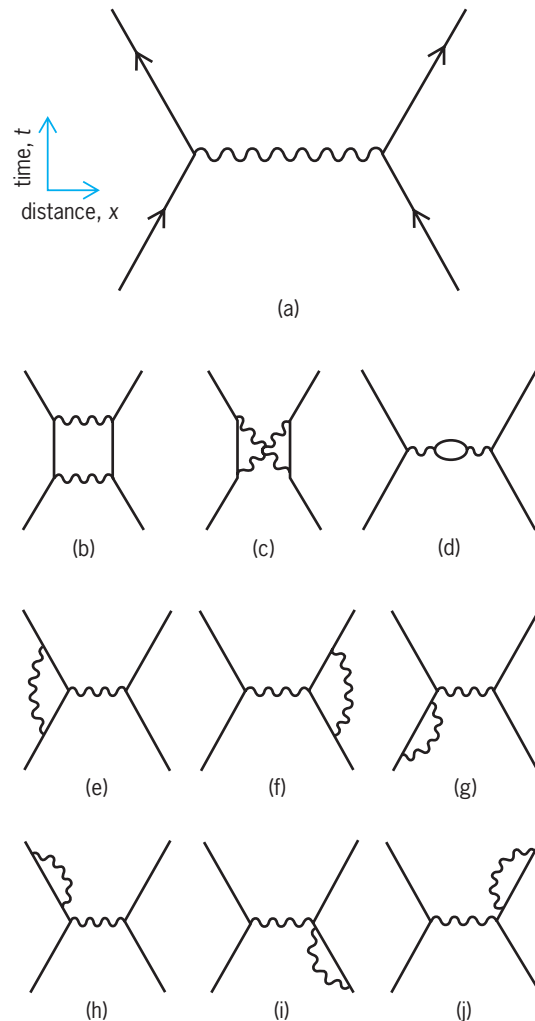

Feynman diagrams for electron-electron (Møller) scattering: (a) second-order diagram (two-vertices); (b–j) fourth-order diagrams.

the scattering matrix in field theory. This correspondence can be used to formulate the rules for writing the amplitude associated with a particular diagram. The perturbation expansion and the associated Feynman diagrams are useful to the extent that the strength of the interaction is small, so that the lowest-order terms, or diagrams with the fewest vertices, give the main contribution to the matrix element. See PERTURBATION (QUANTUM MECHANICS); SCATTERING MATRIX.

Since their introduction in quantum electrodynamics, Feynman diagrams have been widely applied in other field theories. They are employed in studies of electroweak interactions, certain situations in quantum chromodynamics, in acousto-optics, and in many-body theory in atomic, nuclear, plasma, and condensed matter physics. See ACOUSTOOPTICS; ELEMENTARY PARTICLE; FUNDAMENTAL INTERACTIONS; QUANTUM CHROMODYNAMICS; QUANTUM ELECTRODYNAMICS; QUANTUM FIELD THEORY; WEAK NUCLEAR INTERACTIONS. [P.M.]

**Feynman integral** A technique, also called the sum over histories, which is basic to understanding and analyzing the dynamics of quantum systems. It is named after fundamental work of Richard Feynman. The crucial formula gives the quantum probability density for transition from a point  $q_0$  to a point  $q_1$  in time  $t$  as the expression below, where  $S(\text{path})$  is the classical

$$\int \exp[iS(\text{path})/\hbar]d(\text{path})$$

mechanical action of a trial path, and  $\hbar$  is the rationalized Planck's constant. The integral is a formal one over the infinite-dimensional space of all paths which go from  $q_0$  to  $q_1$  in time  $t$ . Feynman defines it by a limiting procedure using approximation by piecewise linear paths.

Feynman integral ideas are especially important in quantum field theory, where they not only are a useful device in analyzing perturbation series but are also one of the few nonperturbative tools available. See QUANTUM FIELD THEORY.

An especially attractive element of the Feynman integral formulation of quantum dynamics is the classical limit,  $\hbar \rightarrow 0$ . Formal application of the method of stationary phase to the above expression says that the significant paths for small  $\hbar$  will be the paths of stationary action. One thereby recovers classical mechanics in the hamiltonian stationary action formulation. See LEAST-ACTION PRINCIPLE. [B.Si.]

**Fiber bundle** A decomposition of a space  $E$  into a family of identical subspaces (fibers). The space of subspaces is called the base space. Fiber bundles arise naturally in many physical situations. The theory of fiber bundles has been applied to gauge theory in physics, and there is a lively interaction centered on ideas related to fiber bundles and gauge theories in which significant results have been contributed in both areas. The development of the mathematical theory of fiber bundles was begun in the 1930s and has numerous applications within mathematics.

A fiber bundle consists of three topological spaces, a fiber  $F$ , a total space  $E$ , and a base  $B$ , together with a continuous map  $\pi: E \rightarrow B$  from the total space to the base. The set of points in  $E$  that map to a given point  $b$  in  $B$  is called the fiber over  $b$ . It is required that each fiber be topologically equivalent (that is, homeomorphic) to  $F$ . Moreover, the total space  $E$  has a local product structure: For a set  $U$  of points in  $B$  that are sufficiently close together, the points  $\pi^{-1}(U)$  in  $E$  that map to  $U$  can be identified with the set of pairs  $(b, x)$  with  $b$  an element of  $U$  and  $x$  an element of  $F$ ; that is,  $\pi^{-1}(U)$  is homeomorphic to  $U \times F$ . See TOPOLOGY.

The simplest nontrivial example of a fiber bundle is the Möbius strip (see illustration). It is constructed by twisting one end of a piece of paper and then gluing the two ends together. The fibers are line segments, and the space of line segments is a circle. The map  $\pi$  takes all the points in a fiber into the same point on the circle.

Tangent bundles are among the earliest examples of fiber bundles. For spaces  $M$  (called manifolds) which are locally like a euclidean space, the space  $T(M)$  consisting of pairs  $(x, v)$  with  $x$  a point in  $M$  and  $v$  a vector tangent at  $x$  to a path in  $M$  is called the tangent bundle to  $M$ ; the fibers form a vector space, and

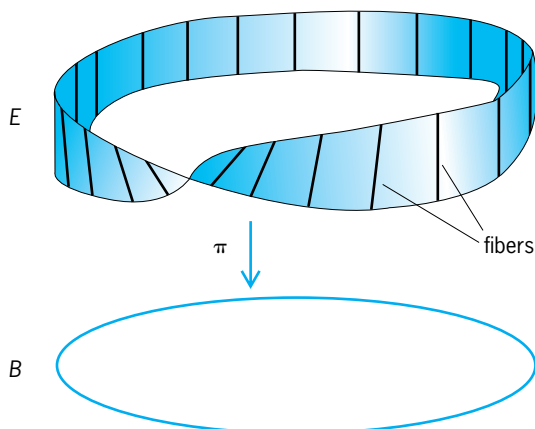

Möbius strip, the simplest nontrivial example of a fiber bundle.

the base space is  $M$ . Fiber bundles in which the fibers are vector spaces are called vector bundles. See MANIFOLD (MATHEMATICS).

Laws of physics are often invariant under the action of an appropriate group. Fiber bundles arise in physics in situations where such a group appears as an internal or local symmetry group; the local symmetry group is the fiber. See GROUP THEORY; SYMMETRY LAWS (PHYSICS).

There are numerous, fundamental applications of fiber bundles within mathematics. Many of these applications are obtained through associating numerical invariants to vector bundles. The geometry of manifolds is then studied in terms of invariants of the tangent bundle of the manifold. [R.Po.]

**Fiber crops** Crops that are grown because of their content or yield of fibrous material which is used for many commercial purposes and for home industry. Fibers may be extracted from various parts of different plants.

Long, multiple-celled fibers can be subdivided into hard, or leaf, fibers that traditionally are used for cordage, such as sisal for binder and baler twine and abaca or manila hemp for ropes; soft, or bast (stem), fibers that are used for textiles, for example, flax for linen, hemp for small twines and canvases, and jute and kenaf for industrial textiles such as burlap; and miscellaneous fibers that may come from the roots, such as "broom" root for brushes, or stems, as Spanish moss for upholstery, or fruits, as coir from coconut husks for cordage and floor coverings. See separate articles on these topics.

Short, one-celled fibers come from the seeds or seed pods of plants such as cotton and kapok. Cotton is the world's most widely grown and used textile fiber. See COTTON; KAPOK TREE; NATURAL FIBER. [E.G.N.]

**Fiber-optic circuit** The path of information travel, usually from one electrical system to another, in which light acts as the information carrier and is propagated by total internal reflection through a transparent optical waveguide. An electrooptic modulator and an optoelectric demodulator are required to convert the electrical signals into light and back again at the transmit and receive ends of the link, respectively.

A fiber-optic circuit, or link, is used for data transmission when a shielded twisted pair or a coaxial cable fails to meet one or more required performance criteria of the system designer. Depending upon fiber type, the distance-bandwidth product of a fiber is tens to thousands of times larger than that of electrical transmission. An optical communication fiber is a nearly perfect waveguide for light, meaning that little or no energy escapes through radiation. Thus, the data traveling in the fiber are secure from eavesdropping, as well as being harmless in or around equipment sensitive to electromagnetic interference. Telecommunication fiber also has a very small diameter, 5–10 micrometers (0.0002–0.0005 in.), which allows telecommunication cables to be fabricated with a much higher packing density. Also, the most common materials used to make the fibers, silica and plastic, are less dense than copper, making the cable lighter. Lastly, since the fiber is a dielectric it can be used in volatile or sensitive environments that require electrical isolation. See ELECTRICAL INTERFERENCE; OPTICAL COMMUNICATIONS; OPTICAL FIBERS.

The transmitter generally consists of a silicon integrated circuit that converts input voltage levels from a personal computer or a mainframe into current pulses. These, in turn, drive a light-emitting diode (LED). See INTEGRATED CIRCUITS; LIGHT-EMITTING DIODE.

Light from the fiber is focused onto a reverse-biased  $pn$ -junction photodiode that generates an electron-hole pair for each photon impinging on or near its active area. Another circuit, usually a silicon integrated circuit, amplifies this electron-hole current and converts it into voltage levels suitable for interfacing with the computer at the receiving end. See PHOTODIODE; PHOTOVOLTAIC EFFECT. [K.W.Li.]

**Fiber-optic sensor** A sensor that uses thin optical fibers to carry light to and from a location to be probed. In performing the sensing, light can be lost from the fibers or modified in velocity by the action of the phenomena on the fiber. Fiber-optic sensors are ideal for probing in remote or hostile locations, where miniature sensors are required such as in the body, or where extreme sensitivity is required. Two classes of fiber sensors have evolved: intensity sensors, in which the amplitude of light in the fiber is changed during sensing, and interferometric sensors, in which the velocity of light or its phase is modified during sensing. The latter class has proved to be extremely sensitive; intensity sensors are used where moderate performance is acceptable and lower cost is important. Depending on their design, intensity sensors can respond to pressure, temperature, liquid level, position, flow, smoke, displacement, electric and magnetic fields, chemical composition, and numerous other conditions.

Optical interferometry is one of the most sensitive means of detecting displacements as small as  $10^{-13}$  m. Interferometric fiber sensors apply this technology to sense many physical phenomena. A fiber gyro based on the Sagnac effect is formed by making a fiber loop which, when rotated, causes the light traveling in both directions in the loop to experience different velocities with or against the rotation. A second type of interferometric sensor is constructed by using the Mach-Zehnder interferometer. Sensitivities equal to or surpassing the best conventional technologies have been achieved in these sensors. See GYROSCOPE; INTERFEROMETRY. [T.G.G.]

**Fiber-optics imaging** The use of fiber optics in image transmission, based on the ability of a precisely aligned bundle of optical fibers to transmit an image from one end of the bundle to the other. Each fiber transmits one element of the image so that the complete image is made up of a matrix of dots (pixels) which blend into a recognizable image like a halftone picture on a printed page.

Light is transmitted through individual fibers by means of total internal reflection from the fiber walls. For efficient transmission, each fiber has a highly transparent core (usually glass) coated with a layer (cladding) of lower refractive index (also usually glass). This cladding prevents light from leaking into neighboring fibers (crosstalk) and protects the core from contamination and wear. Fiber bundles may be either flexible or rigid. See CROSSTALK; OPTICAL MATERIALS; REFRACTION OF WAVES.

Flexible image bundles are used in a wide variety of industrial and medical fiberscopes or endoscopes to transmit the image from an objective lens at the distal end to an eyepiece in the control handle. Industrial fiberscopes ranging in length from 3 to 8 ft (1 to 2.5 m) are used in aircraft engine inspection, for example, examination of turbine blades. Longer industrial fiberscopes are used for pipe and weld inspection, including those in nuclear power plants.

Medical endoscopes range in size from less than 0.08 in. (2 mm) for viewing inside the arteries (cardioscope) to 0.6 in. (15 mm) for examining the colon (colonoscope). The latter has an operating channel large enough to perform surgery via remotely controlled forceps or electro-surgical snares. Intermediate-sized endoscopes are used to view the bronchi (bronchoscope), the kidneys (nephroscope), the bladder (cystoscope), the throat (laryngoscope), and the stomach (gastroscope).

Fused-fiber boules are the starting point for various image-transmitting components, including faceplates (windows) for image-intensifier tubes and cathode-ray tubes, image inverters (twisters), magnifiers, and rigid conduits. Image intensifier tubes are used in military night-vision devices, low-light television cameras, and astronomical telescopes. In a cathode-ray tube the fiber-optic faceplate is used to transmit the image on the phosphor screen to the exit face for printing directly onto photographic material. See CATHODE-RAY TUBE; LIGHT AMPLIFIER; OPTICAL FIBERS. [W.P.S.]

**Fibrinogen** The major clot-forming substrate in the blood plasma of vertebrates. Though fibrinogen represents a small fraction of plasma proteins (normal human plasma has a fibrinogen content of 2–4 mg/ml of a total of 70 mg protein/ml), its conversion to fibrin causes a gelation which blocks the flow of blood. Upon injury, sufficient amounts of the clotting enzyme, thrombin, are generated in about 5 min clotting time to produce a gel. Although clotting in the circulation (thrombosis) can be extremely dangerous, clotting is an essential and normal response for preventing the loss of blood. Individuals born with the hereditary absence of fibrinogen (afibrinogenemia) suffer from severe bleeding, which can be counteracted by transfusing normal plasma or purified fibrinogen. See HEMORRHAGE; THROMBOSIS.

Fibrinogen is synthesized by the hepatocytes in the liver, and the synthetic rate can be stimulated by hormones. Significant amounts of carbohydrates become attached to the protein before it is secreted into the circulation; alterations in its carbohydrate composition as found in some liver diseases can give rise to abnormal fibrinogens with defective clotting properties.

Clotting is regulated by two enzymes, thrombin and factor XIII<sub>a</sub> (fibrinolygase, activated fibrin-stabilizing factor, transglutaminase). Thrombin exerts a dual control by regulating the rate of fibrin formation as well as producing factor XIII<sub>a</sub>. In the plasma milieu, the fibrin molecules readily aggregate into a clot. In order to obtain a clot structure of a strength sufficient to stem bleeding, however, it is necessary for the thrombin-modified factor XIII to be activated to XIII<sub>a</sub>. Factor XIII<sub>a</sub> acts as a transamidating enzyme which strengthens the fibrin clot by creating cross-links between the molecules. Without such cross-links, a clot structure would be like a brick wall without mortar. Individuals with the hereditary absence of factor XIII often suffer from severe bleeding, even though their clotting times are in the normal range. See BLOOD; HEMOPHILIA; IMMUNOGLOBULIN. [L.Lo.]

**Fibromyalgia syndrome** A common disorder characterized by acute and debilitating widespread musculoskeletal pain. It occurs predominantly in adult women and is not limited to any particular geographic region, ethnic group, or climate. The diagnostic feature is the elicitation of acute tenderness or pain by pressure on specific trigger points that can be mapped on the body. Of unknown cause, the disease may be prompted by an injury, physical or emotional stress, or sleep disturbance.

Fibromyalgia syndrome is accompanied by a series of symptoms including massive fatigue, headaches, insomnia, memory loss, diminished capacity to concentrate, low-grade fever, and pains in joints. Since these symptoms are similar to those seen in chronic fatigue immune dysfunction syndrome, it is thought that there may be a direct relationship between the two conditions. If this is so, fibromyalgia syndrome either may be caused by a dysfunction of the immune system or may be related to a previous viral or other infectious episode. See CHRONIC FATIGUE IMMUNE DYSFUNCTION SYNDROME.

If not treated, the disease can persist for a long period, frequently several years. Treatment is symptomatic and includes pain relievers and antispasmodics. The immune dysfunction and mental incapacity are also treated. [D.En.]

**Fibrous protein** One of two major classes of protein molecules, the other being termed globular protein. Fibrous proteins function either in a filamentous aggregate or as long, thin molecules.

One major category of fibrous proteins is the  $\alpha$ -fibrous group. It includes intermediate filaments (occurring in skin, wool, and neurons), muscle proteins (myosin, paramyosin, and tropomyosin), and fibrinogen (a plasma protein that forms clots). The protein chain forms a right-handed  $\alpha$ -helical structure that is stabilized by hydrogen bonds that lie parallel to the axis of the helix (see illustration). Non-filament-forming  $\alpha$ -fibrous proteins include laminin, a triple-stranded molecule found in the basement membrane of certain cells.

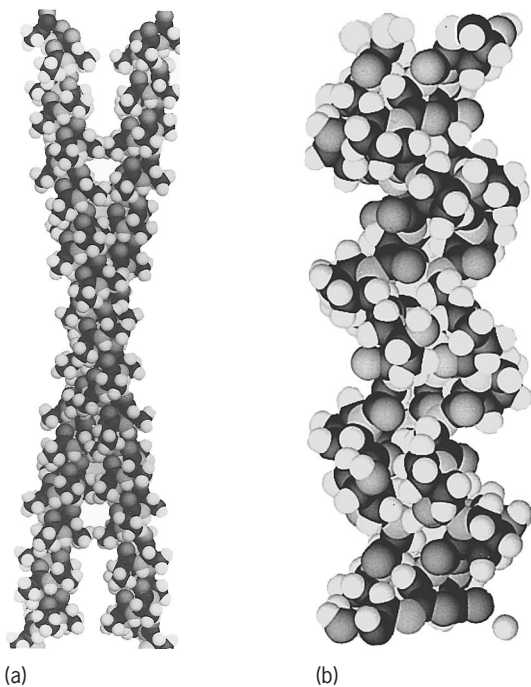

Fibrous proteins. (a)  $\alpha$ -Fibrin protein. (b) Collagen.

The second major category is based on the  $\beta$  structure. Feather and scale keratin have a twisted  $\beta$ -sheet structure, that is, an extended array of chains which are held together by hydrogen bonds positioned perpendicular to the chain axis. The sheet aggregates laterally and helically to generate a filamentous structure.

The third major category is exemplified by collagen, a major component of skin, tendon, bone, cornea and cartilage (see illustration). The molecules contain three chains, each of which coils up into a threefold helix. The chains then coil around one another in a right-handed manner to generate the collagen molecule. In turn, molecules generally aggregate to form fibrils.

Fibrous proteins also include the thin filaments of muscle in which globular subunits aggregate helically, and individual molecules that contain long strings of globular domains. See COLLAGEN; FIBRINOGEN; MUSCLE PROTEINS; PROTEIN. [D.A.D.P.]

**Fidelity** The degree to which the output of a system accurately reproduces the essential characteristics of its input signal. Thus, high fidelity in a sound system means that the reproduced sound is virtually indistinguishable from that picked up by the microphones in the recording or broadcasting studio. Similarly, a television system has a high fidelity when the picture seen on the screen of a receiver corresponds in essential respects to that picked up by the television camera. Fidelity is achieved by designing each part of a system to have minimum distortion, so that the waveform of the signal is unchanged as it travels through the system. See DISTORTION (ELECTRONIC CIRCUITS); SOUND-REPRODUCING SYSTEMS. [J.Mar.]

**Field emission** The emission of electrons from a metal or semiconductor into vacuum (or a dielectric) under the influence of a strong electric field. In field emission, electrons tunnel through a potential barrier, rather than escaping over it as in thermionic or photoemission. The effect is purely quantum-mechanical, with no classical analog. It occurs because the wave function of an electron does not vanish at the classical turning point, but decays exponentially into the barrier (where the electron's total energy is less than the potential energy). Thus there is a finite probability that the electron will be found on the

outside of the barrier. See PHOTOEMISSION; QUANTUM MECHANICS; THERMIONIC EMISSION.

For a metal at low temperature, the process can be understood in terms of the illustration. The metal can be considered a potential box, filled with electrons to the Fermi level, which lies below the vacuum level by several electronvolts. The distance from Fermi to vacuum level is called the work function,  $\phi$ . The vacuum level represents the potential energy of an electron at rest outside the metal, in the absence of an external field. In the presence of

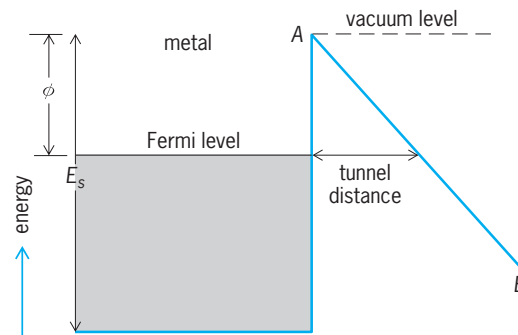

Diagram of the energy-level scheme for field emission from a metal at absolute zero temperature.

a strong field, the potential outside the metal will be deformed along the line  $AB$ , so that a triangular barrier is formed, through which electrons can tunnel. Most of the emission will occur from the vicinity of the Fermi level where the barrier is thinnest. See ELECTRON EMISSION; FIELD-EMISSION MICROSCOPY. [R.Gom.]

**Field-emission microscopy** A technique that uses field emission of electrons or positive ions from a needle-shaped emitter to produce a magnified image of the emitter surface on a fluorescent screen.

In the field electron microscope, the image reveals the variation in work function of the emitter surface. Due to the large lateral velocity of the emitted electrons, which arises from a diffraction effect of the de Broglie wave and the large kinetic energy of electrons inside the metal, a resolution of only about 2.5 nanometers can be achieved. The field electron microscope has been used to study adsorption and desorption of gases and vapor-deposited materials, surface migration of adsorption layers and absorbed atoms on single crystal faces, and surface reactions in catalysis. Medium-sized individual molecules such as phthalocyanin have been made visible also. See DE BROGLIE WAVELENGTH; ELECTRON MICROSCOPE; FIELD EMISSION; WORK FUNCTION (ELECTRONICS).

In the field ion microscope, the emitter is kept at a high positive potential while the microscope chamber is filled with helium, neon, or argon at a pressure of  $10^{-5}$  to  $10^{-4}$  torr ( $10^{-3}$  to  $10^{-2}$  pascal) [see illustration]. Under a field of several tens of volts per nanometer, an image gas molecule can be ionized above a protruding surface atom when an atomic electron tunnels into the metal. The ion is then accelerated to the screen by the applied field. Every second about 1000 ions are formed above the same surface atom; thus the atom is continuously imaged. When the tip is cooled down to the temperature of liquid hydrogen or nitrogen, the thermal energy of the image gas molecules is greatly reduced. In combination with their very short de Broglie wavelength, a resolution of about 0.25 nm can be achieved. This is sufficient to resolve the atomic structure of most surfaces. In addition, surface atoms can be evaporated by the applied field if it is gradually increased. Therefore the atomic structure of lattice defects inside the bulk can be revealed also. By using a channel plate for image intensification and image gases of high or low ionization energy, a wide range of metals from beryllium to uranium, semiconductors, and some compounds such

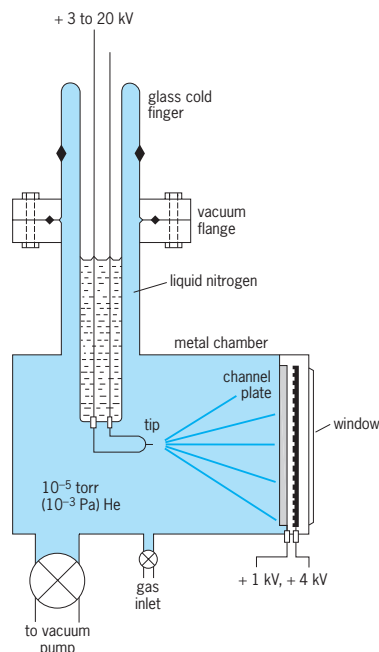

Field ion microscope.

as high-temperature oxide superconductors can be imaged. See CHANNEL ELECTRON MULTIPLIER; TUNNELING IN SOLIDS.

The field ion microscope has been used as a research tool for studying lattice defects such as vacancies, interstitials, dislocations, grain boundaries, and radiation damages in metals and alloys. It has also been used to observe directly the behavior of single adsorbed atoms on metal surfaces. See CRYSTAL DEFECTS.

The atom-probe field ion microscope combines the field ion microscope with a single ion detection sensitivity mass spectrometer, usually a time-of-flight spectrometer. The tip is mounted on a gimbal system, and a channel plate screen assembly with a small probe hole is used. Behind the probe hole is a flight tube 3–24 ft (1–8 m) long. The probe hole usually covers several atomic image diameters. The chemical identity of atoms chosen by the investigator from the field ion image can be analyzed one by one by adjusting the gimbal until the image of the atoms falls into the probe hole. Nanosecond high-voltage pulses or subnanosecond laser pulses are then applied to field-evaporate surface atoms one by one. Because of the ion optics, only those atoms that have their image covered by the probe hole can go through the probe hole and be detected. From the flight times of these ions, their mass-to-charge ratios are calculated and chemical species identified. See TIME-OF-FLIGHT SPECTROMETERS.

The atom-probe field ion microscope represents the ultimate in chemical analysis, that is, an atom selected by an investigator can be analyzed. As field evaporation starts from the edges of a surface layer, composition of a solid surface can also be analyzed atomic layer by atomic layer. The spatial resolution in atom-probe chemical analysis is approximately 5 to 10 angstroms in the lateral direction and much better than 1 angstrom in the vertical direction. [T.T.T.]

**Field theory (mathematics)** In algebra, the term field is used to designate an algebraic system or structure containing at least two elements and having two binary rules of composition: addition and multiplication (that is, if  $a$  and  $b$  are any two elements of the field, then  $a + b$  and  $ab$  are defined and are elements of the field). The structure rules are as follows: The elements form an abelian (commutative) group under addition with the additive identity denoted by 0; that is,  $a + 0 = a$  for all elements  $a$ . The set of nonzero elements (and there are some since the field has at least two elements) form an abelian group

under multiplication with the multiplicative identity denoted by 1. It follows that all nonzero elements have a multiplicative inverse or reciprocal. The two rules of composition are related by the distributive law:  $(a + b)c = ac + bc$  for all elements  $a, b, c$ . It follows from the distributive law that  $a \cdot 0 = 0$  for all elements  $a$ , since  $1 \cdot a = (1 + 0)a = 1 \cdot a + 0 \cdot a$ , and consequently  $0 = 0 \cdot a$ . See GROUP THEORY.

The most familiar example of a field is the set  $\mathbf{Q}$  of all rational numbers  $(0, 1, 2, \frac{1}{2}, -1, -2, -\frac{1}{2}, 3, \frac{1}{3}, \frac{2}{3}, \dots)$  with the usual rules for equality, addition, and multiplication. Other examples are the set  $\mathbf{R}$  of all real numbers and the set  $\mathbf{C}$  of all complex numbers (both with the usual rules of addition and multiplication). The set of rational functions (formal quotients of two polynomials with rational coefficients) also constitute a field under the usual rules for equality, addition, and multiplication. See ALGEBRA; COMPLEX NUMBERS; REAL VARIABLE.

There are fields which contain only finitely many elements. The simplest example is obtained by considering the residue class ring of the integers modulo a prime  $p$ . This field, which may be denoted by  $\mathbf{F}_p$ , has as its elements the  $p$  distinct arithmetic progressions or residue classes modulo the prime  $p$ , namely  $I_0, I_1, \dots, I_{p-1}$  where  $I_j$  consists of the integers  $j, j \pm p, j \pm 2p, \dots$ . The rules of composition are given by Eqs. (1) and (2).

$$I_j + I_k = I_s \quad \text{if } j + k \text{ lies in } I_s \quad (1)$$

$$I_j I_k = I_t \quad \text{if } jk \text{ lies in } I_t \quad (2)$$

If  $F$  is a field, and a subset  $A$  of  $F$  is a field under the rules of composition of  $F$ , then  $A$  is said to be a subfield of  $F$ , and  $F$  is said to be an extension of  $A$ . Thus the field of rational numbers  $\mathbf{Q}$  is a subfield of the field of real numbers  $\mathbf{R}$ , and  $\mathbf{R}$  is an extension of  $\mathbf{Q}$ . If a field  $F$  is an extension of the field  $A$ , then  $F$  is a vector space over  $A$ . If, as a vector space,  $F$  is of finite dimension  $n$  over  $A$ , then  $F$  is said to be an extension of  $A$  of degree  $n$ . See LINEAR ALGEBRA.

If a field  $F$  is such that every polynomial equation over  $F$  of positive degree has a solution in  $F$ , then  $F$  is said to be algebraically closed. The field of all complex numbers is algebraically closed; but this is a theorem in analysis. The field of rational numbers, the fields of residue classes modulo a prime  $p$ , and the field of real numbers are not algebraically closed. Given any field  $\bar{F}$ , there exists a unique (to within isomorphism) minimal extension  $\hat{F}$  of  $F$  such that  $\hat{F}$  is algebraically closed. [D.J.L.]

**Fig** A species of deciduous tree, *Ficus caria*, of the mulberry family (Moraceae). Leaves are characteristically palmate, with 3 to 7 lobes. A milky latex containing the protein-digesting enzyme ficin is produced. It is of southwest Asian origin and is now cultivated in the subtropical regions of the world for its edible fruit, especially in Asia, Africa, Europe, and the United States.

The fig is a multiple or collective fruit that develops from a fleshy compound inflorescence in the form of a hollow structure (syconium) with an apical canal or pore (ostiole) and numerous tiny unisexual flowers lining the inner wall. The flowers are long-style pistillate (female); short-style pistillate (female); and staminate (male). Two forms of trees characterize *F. caria*: fig and caprifig. The fig bears long-style pistillate flowers exclusively and produces the edible figs of commerce. The caprifig bears short-style pistillate flowers and staminate flowers which are clustered around the inner opening of the ostiole. Caprifigs are the source of pollen for certain cultivars of figs whose flowers must be pollinated to set a crop of fruit. See FLOWER; FRUIT.

Figs that are to be eaten or marketed fresh, canned, candied, pickled, or made into jam or preserve usually are picked from the trees by hand. The bulk of the world's fig crop either is eaten dry or is marketed as dried figs or as fig paste, which is used for making fig bars and other bakery products. Figs to be used in these ways usually are allowed to dry on the trees and drop to the ground for harvesting either by hand or by machinery. See FRUIT, TREE. [W.B.S.]



**Filbert** A nut from any plant in the genus *Corylus* (Betulaceae); also called hazelnut. About 15 species are recognized, distributed widely over the north temperate zone and ranging in size from shrubs to tall trees. Filberts in commerce are derived mostly from the European species *C. avellana* and *C. maxima*. Hybrids of these with the American species, *C. americana*, are grown sparingly in the eastern United States.

Filberts are grown widely in Europe and the Mediterranean basin, where much of the crop is consumed locally. Imports to the United States come mostly from Turkey. In the United States filberts are grown in Oregon and Washington. Filberts are sold in shell, or the kernels are roasted and used in confectionery and baked goods. [L.H.MacD.]

**Film (chemistry)** A material in which one spatial dimension, thickness, is much smaller than the other two. Films can be conveniently classified as those that support themselves and those that exist only as layers on top of a supporting substrate. The latter are known as thin films and have their own specialized science and technology.

Thin films, from one to several hundred molecular layers, are generally defined as those that lie on a substrate, either liquid or solid. Monomolecular films on the surface of water can be made by adding appropriate materials in extremely small quantity to the surface. These materials are inappreciably soluble in water, rendered so by a large hydrocarbon or fluorocarbon functional group on the molecule or by other means; they are, however, able to dissolve in the surface of water by virtue of a hydrogen-bonding group or groups on the molecule.

Thin films can also be deposited directly onto solid substrates by evaporation of material in a vacuum, by sputtering, by chemical reaction (chemical vapor deposition), by ion plating, or by electroplating. See DIAMOND; ELECTROPLATING OF METALS; MONOMOLECULAR FILM; SPUTTERING; VACUUM METALLURGY; VAPOR DEPOSITION.

Thin films play an extensive role in both traditional and emerging technologies. Examples are foams and emulsions, the active layers in semiconductors, the luminescent and protective layers in electroluminescent thin-film displays, and imaging and photoelectric devices. See ELECTROLUMINESCENCE; ELECTRONIC DISPLAY; EMULSION; FOAM; SOLAR CELL.

Self-supported films have a nominal thickness not larger than 250 micrometers. Films of greater thickness are classified as sheets or foils. Self-supported films are commonly composed of organic polymers, either thermoplastic resins or cellulose-based materials. See POLYMER. [S.Ro.]

**Filosia** A subclass of Rhizopodea characterized by slender filopodia which rarely anastomose. The two orders are Aconchulinida and Gromiida. See ACONCHULINIDA; GROMIIDA; PROTOZOA; RHIZOPODEA. [R.PH.]

**Filtration** The separation of solid particles from a fluid-solids suspension of which they are a part by passage of most of the fluid through a septum or membrane that retains most of the solids on or within itself. The septum is called a filter medium, and the equipment assembly that holds the medium and provides space for the accumulated solids is called a filter. The fluid may be a gas or a liquid. The solid particles may be coarse or very fine, and their concentration in the suspension may be extremely low (a few parts per million) or quite high (>50%).

The object of filtration may be to purify the fluid by clarification or to recover clean, fluid-free particles, or both. In most filtrations the solids-fluid separation is not perfect. In general, the closer the approach to perfection, the more costly the filtration; thus the operator of the process cannot justify a more thorough separation than is required.

Gas filtration involves removal of solids (called dust) from a gas-solids mixture because: (1) the dust is a contaminant rendering the gas unsafe or unfit for its intended use; (2) the dust

particles will ultimately separate themselves from the suspension and create a nuisance; or (3) the solids are themselves a valuable product that in the course of its manufacture has been mixed with the gas.

Three kinds of gas filters are in common use. Granular-bed separators consist of beds of sand, carbon, or other particles which will trap the solids in a gas suspension that is passed through the bed. Bag filters are bags of woven fabric, felt, or paper through which the gas is forced; the solids are deposited on the wall of the bag. Air filters are light webs of fibers, often coated with a viscous liquid, through which air containing a low concentration of dust can be passed to cause entrapment of the dust particles. See AIR FILTER; DUST AND MIST COLLECTION.

Liquid filtration is used for liquid-solids separations in the manufacture of chemicals, polymer products, medicinals, beverages, and foods; in mineral processing; in water purification; in sewage disposal; in the chemistry laboratory; and in the operation of machines such as internal combustion engines.

Liquid filters are of two major classes, cake filters and clarifying filters. The former are so called because they separate slurries carrying relatively large amounts of solids. They build up on the filter medium as a visible, removable cake which normally is discharged "dry" (that is, as a moist mass), frequently after being washed in the filter. It is on the surface of this cake that filtration takes place after the first layer is formed on the medium. The feed to cake filters normally contains at least 1% solids. Clarifying filters, on the other hand, normally receive suspensions containing less than 0.1% solids, which they remove by entrapment on or within the filter medium without any visible formation of cake. The solids are normally discharged by backwash or by being discarded with the medium when it is replaced. See CLARIFICATION. [S.A.M.]

**Fine structure (spectral lines)** The closely spaced groups of lines observed in the spectra of the lightest elements, notably hydrogen and helium. The components of any one such group are characterized by identical values of the principal quantum number  $n$ , but different values of the azimuthal quantum number  $l$  and the angular momentum quantum number  $j$ .

In atoms having several electrons, this fine structure becomes the multiplet structure resulting from spin-orbit coupling. This gives splittings of the terms and the spectral lines that are "fine" for the lightest elements but that are very large, of the order of an electronvolt, for the heavy elements. [F.A.J./W.W.W.]

**Fingerprint** Distinctive ridges that appear on the bulbs of the inside of the end joints of the fingers and thumbs. Fingerprints are an infallible means of identification. In addition to their value in criminal matters, fingerprints can ensure personal identification for humanitarian reasons, such as in cases of amnesia, missing persons, or unknown deceased. Fingerprints are invaluable in effecting identifications in tragedies such as fire, flood, and vehicle crashes. The vast majority of fingerprints maintained in the Identification Division of the Federal Bureau of Investigation of the United States, the largest repository of fingerprints in the world, are civil records.

Fingerprints fall into three general types of patterns (see illustration). Each group bears the same general characteristics or family resemblance. The three general pattern types may be further divided into subgroups by means of smaller differences existing between the patterns in the same general group. The arch group includes the plain arch and the tented arch. The loop group includes the radial and ulnar loops. The whorl group includes four types of whorls, the plain whorl, central pocket loop, double loop, and accidental whorl.

The pattern area is that part of a fingerprint in which appear the cores, deltas, and ridges that are used for classification. The pattern areas of loops and whorls are enclosed by type lines, which may be defined as the two innermost ridges which start

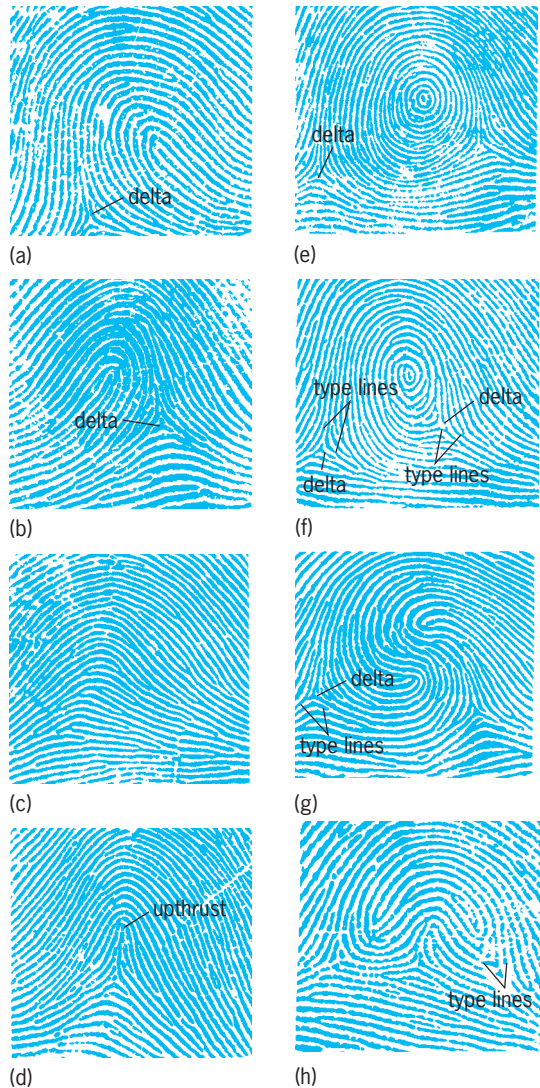

**Types of fingerprint patterns.** (a–b) Loop patterns: (a) ulnar loop; (b) radial loop. (c–d) Arch patterns: (c) plain arch; (d) tented arch. (e–h) Whorl patterns: (e) plain whorl; (f) central pocket loop; (g) double loop; (h) accidental whorl. (Federal Bureau of Investigation)

parallel, diverge, and surround or tend to surround the pattern area.

Within the pattern areas of loops and whorls are the focal points which are used in the detailed classification. These points are called the delta and the core. The delta is that point on a ridge at or in front of and nearest the center of the divergence of the type lines. A core may be defined as that point on a ridge which is located in the approximate center of the finger impression.

The distinctive ridges of the palms of the hands and the soles of the feet closely resemble those of the fingerprint and can be identified in the same way. Footprints of persons having no fingers are taken for record purposes. Fingerprint, palm print, and sole print identifications have all been accepted as evidence by the courts. See EPIDERMAL RIDGES. [J.E.Ho.]

**Finite element method** A numerical analysis technique for obtaining approximate solutions to many types of engineering problems. The need for numerical methods arises from the fact that for most practical engineering problems analytical solutions do not exist. While the governing equations and boundary conditions can usually be written for these problems, difficulties introduced by either irregular geometry or other dis-

continuities render the problems intractable analytically. To obtain a solution, the engineer must make simplifying assumptions, reducing the problem to one that can be solved, or a numerical procedure must be used. In an analytic solution, the unknown quantity is given by a mathematical function valid at an infinite number of locations in the region under study, while numerical methods provide approximate values of the unknown quantity only at discrete points in the region. In the finite element method, the region of interest is divided up into numerous connected subregions or elements within which approximate functions (usually polynomials) are used to represent the unknown quantity.

The physical concept on which the finite element method is based has its origins in the theory of structures. The idea of building up a structure by fitting together a number of structural elements (see illustration) was used in the early truss and framework analysis approaches employed in the design of bridges and buildings in the early 1900s. By knowing the characteristics of individual structural elements and combining them, the governing equations for the entire structure could be obtained. This process produces a set of simultaneous algebraic equations. The limitation on the number of equations that could be solved posed a severe restriction on the analysis. The introduction of the digital computer has made possible the solution of the large-order systems of equations.

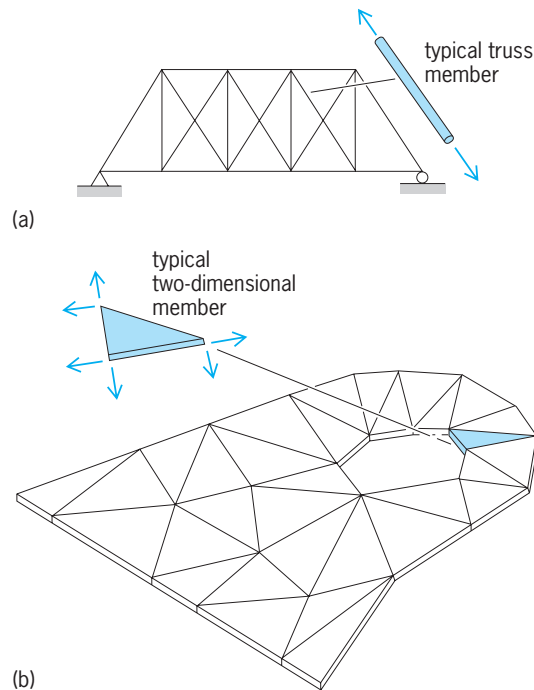

**Structures modeled by fitting together structural elements:** (a) truss structure; (b) two-dimensional planar structure.

The finite element method is one of the most powerful approaches for approximate solutions to a wide range of problems in mathematical physics. The method has achieved acceptance in nearly every branch of engineering and is the preferred approach in structural mechanics and heat transfer. Its application has extended to soil mechanics, heat transfer, fluid flow, magnetic field calculations, and other areas. [T.B.]

**Finite mathematics** Those parts of mathematics which deal with finite sets. More generally, finite mathematics is taken to include those fields which make no use of the concept of limit; thus linear programming, which finds maxima and minima through the four arithmetic operations, is included, whereas classical optimization, which uses differential calculus, is excluded. Other subjects generally considered in the finite mathematics include finite set theory; logic; the study of finite groups, rings, and

fields; combinatorial theory; linear algebra; probability; game theory; dynamic programming; and networks. See FIELD THEORY (MATHEMATICS); GAME THEORY; GROUP THEORY; LINEAR ALGEBRA; LINEAR PROGRAMMING; LOGIC; OPTIMIZATION; PROBABILITY; RING THEORY; SET THEORY. [G.Ow.]

**Fiord** A segment of a troughlike glaciated valley partly filled by an arm of the sea. It differs from other glaciated valleys only in the fact of submergence. The floors of many fiords are elongate basins excavated in bedrock, and in consequence are shallower at the fiord mouths than in the inland direction. The seaward rims of such basins represent lessening of glacial erosion at the coastline, where the former glacier ceased to be confined by valley walls and could spread laterally. Some rims are heightened by glacial drift deposited upon them in the form of an end moraine.

Fiords occur conspicuously in British Columbia and southern Alaska, Greenland, Arctic islands, Norway, Chile, New Zealand, and Antarctica—all of which are areas of rock resistant to erosion, with deep valleys, and with strong former glaciation. [R.F.FI.]

**Fir** Any tree of the genus *Abies*, of the pine family, characterized by erect cones, by the absence of resin canals in the wood but with many in the bark, and by flattened needlelike leaves which lack definite stalks. The leaves usually have two white lines on the underside and leave a circular scar when they fall.

The native fir of the northeastern United States and adjacent Canada is *A. balsamea*. Its principal uses are for paper pulp, lumber, boxes and crates, and as a source of the liquid resin called Canada balsam. In the eastern United States the fir is commonly used as a Christmas tree.

The Fraser fir (*A. fraseri*) is a similar species found in the southern Appalachians.

Several species of *Abies* grow in the Rocky Mountains region and westward to the Pacific Coast. The most important commercially is the white fir (*A. concolor*), also known as silver fir. Other western species of commercial importance are the subalpine fir (*A. lasiocarpa*), grand fir (*A. grandis*), Pacific silver fir (*A. amabilis*), California red fir (*A. magnifica*), and noble fir (*A. procera*). See PINALES. [A.H.G./K.PD.]

**Fire** A rapid but persistent chemical reaction accompanied by the emission of light and heat. The reaction is self-sustaining, unless extinguished, to the extent that it continues until the fuel concentration falls below a minimum value. Most commonly, it results from a rapid exothermic combination with oxygen by some combustible material. Flame, the visible manifestation of fire, results from a heating to incandescence of minute particulate matter composed principally of incompletely burned fuel. See COMBUSTION; FLAME. [E.J.J.]

**Fire detector** A device designed to initiate a desired action in response to a change in its surroundings caused by an unwanted fire. Heat detectors respond when the surrounding temperature exceeds a specific minimum value or when the rate of rise exceeds a specified rate. Heat-detector sensing elements are normally mechanical, employing components which melt or expand when heated, but can also be electronic, using elements which produce thermoelectric voltages or change in conductivity.

Smoke detectors are also commonly used fire detectors. They respond when the concentration of solid or liquid particles in the air exceeds a selected value. In ionization-type smoke detectors, a small radioactive source is employed to make the air within the sensing chamber slightly electrically conductive. The presence of particles reduces this conductivity in proportion to the number of particles present. In photoelectric-type smoke detectors, a light source and light-sensitive receiver are arranged so that light from the source does not normally strike the receiver. Smoke particles reflect light from the source onto the receiver in proportion to the number of particles present.

Flame detectors contain receiving elements sensitive to light in certain specific infrared or ultraviolet wavelengths characteristic of flames. Flame detectors can detect a fire within a few milliseconds and are therefore most often used to activate explosion-suppression systems.

The actions initiated by fire detectors include sounding of audible and visual alarms, signal transmission to remote monitoring stations, activation of extinguishing systems, and emergency shutdown of equipment or processes which might increase the severity of the fire hazard. See AUTOMATIC SPRINKLER SYSTEM; FIRE EXTINGUISHER. [R.W.Buk.]

**Fire extinguisher** Fire may be extinguished by the following methods: (1) cooling the burning materials; (2) blanketing the fire with inert gas that chokes it for lack of oxygen; (3) introducing materials that inhibit combustion; and (4) covering the burning matter with a blanket or a layer of solid particles that prevent access of air. Fire extinguishers operate on one or a combination of these principles.

Water is the most effective cooling agent used in fire extinguishing. The generation of steam also drives away the air and forms a blanket, but being less dense than air, it is rapidly displaced. Wetting agents and foaming agents increase the effectiveness of water. In the small, first-aid, water fire extinguishers, a propellant must be provided. Usually this is carbon dioxide, which is either generated when needed or stored in a cartridge. Water should not be used on oil fires or on electrical fires.

Automatic water sprinkler systems are a common form of fire protection in industrial plants and large buildings. The installation of these systems is the greatest single factor to be credited for the sharply reduced incidence of disastrous fires in recent years. See AUTOMATIC SPRINKLER SYSTEM.

Carbon dioxide is a safe and effective extinguisher for all confined fires. It acts as an inert blanket, and because it is heavier than air, it will exclude oxygen very efficiently from a fire on the floor of a building or in a vat or similar vessel. It is not effective in an elevated location or outdoors where the wind can blow the gas away.

A dry powder, consisting principally of sodium bicarbonate, may also be used as a fire extinguisher. The powder must have the correct particle size and contain materials that prevent it from caking. The action of the powder is threefold: to generate carbon dioxide; to cool the burning material; and to provide a shielding to prevent access of air. Dry chemical is useful for small fires, and especially electrical fires.

Carbon tetrachloride,  $\text{CCl}_4$ , has had a long history as a fire-extinguishing agent. As it is customarily used, in small quantities, the principal action is to supply a heavy blanket of vapor over the fire. In addition, carbon tetrachloride, in common with all the halogenated compounds, has a definite chemical inhibiting effect on combustion. Other halogenated hydrocarbons that have been used are chlorobromomethane, and several of the fluorinated hydrocarbons known as freons. The principal difficulty, however, with all the halogenated hydrocarbons, and with  $\text{CCl}_4$ , in particular, is toxicity.

Other extinguishing methods should be mentioned that require no special equipment. For a household fire, especially involving clothing on a person, a blanket or a rug provides an effective means to smother the fire. Small fires around a kitchen stove may be snuffed out with salt or, better still, with bicarbonate of soda. A bucket of sand, strategically located, is also useful against domestic fire hazards. [W.E.Go.]

**Fire technology** The application of results of basic research and of engineering principles to the solution of practical fire protection problems, but entailing, in its own right, research into fire phenomena and fire experience.

The contribution of the practices of fire prevention is potentially much greater than that of the actual fire-fighting activities. Fire-prevention and loss-reduction measures take many

forms, including fire-safe building codes, periodic inspection of premises, fire-detection and automatic fire-suppression systems in industrial and public buildings, the substitution of flame-retardant materials for their more flammable counterparts, and the investigation of fires of suspicious origin, serving to deter the fraudulent and illegal use of fire. See AUTOMATIC SPRINKLER SYSTEM; FIRE DETECTOR.

The fundamental techniques used by fire fighters consist primarily of putting water on a fire. Water serves to cool a burning material down to a point where it does not produce gases that burn. While water is the most practical and inexpensive extinguishing agent, modern technology has provided not only additives to water to render desirable properties such as easy flow or enhanced sticking, but also chemical and physical extinguishants such as fluorocarbons, surfactant film-forming proteins, and foams. See FIRE EXTINGUISHER.

A general approach to fire control has been developed involving use of flame inhibitors. Unlike older fire-extinguishing materials such as water and carbon dioxide, these agents operate indirectly in that they interfere with those reactions within a flame that lead to sustained release of heat. As a result, temperature of the system falls below ignition temperature. The most effective liquids are the halogenated hydrocarbons such as chlorobromomethane (CB) and bromotrifluoromethane (better known as Halon 1301) which are colorless, odorless, and electrically nonconductive. See HALOGENATED HYDROCARBON.

In dry-powder chemical extinguishers, ammonium dihydrogen phosphate is the most useful fire inhibitor. Other dry-powder inhibitors are salts of alkali metals (which include lithium, sodium, potassium, rubidium, and cesium).

Foams are also widely used. Protein-type, low-expansion foams, particularly useful in quenching burning volatile petroleum products, are used in crash-rescue operations. High-expansion foams are available for fire suppression in enclosed areas. Some foams of this type are generated at a rate of 15,000 ft<sup>3</sup>/min (424.8 m<sup>3</sup>/min). They can contain sufficient air to allow a human to breathe inside them.

A film-forming solution of a specific fluorocarbon surfactant in water, known as light water, was developed by the U.S. Navy for use with dry chemicals to fight aircraft crash fires. It may be used either as a liquid or as a low-expansion foam to interfere with the release of flammable vapors from the burning fuel. Light water is also useful in extinguishing petroleum storage tank fires and may find application to urban fires once the cost is no longer prohibitive. [S.B.M.; A.M.K.]

**Fire-tube boiler** A steam boiler in which hot gaseous products of combustion pass through tubes surrounded by boiler water. The water and steam in fire-tube boilers are contained within a large-diameter drum or shell, and such units often are referred to as shell-type boilers. Heat from the products of combustion is transferred to the boiler water by tubes or flues of relatively small diameter (approximately 3–4 in. or 7.5–10 cm) through which the hot gases flow. The tubes are connected to

tube sheets at each end of the cylindrical shell and serve as structural reinforcements to support the flat tube sheets against the force of the internal water and steam pressure. Braces or tension rods also are used in those areas of the tube sheets not penetrated by the tubes.

Fire-tube boilers may be designed for vertical, inclined, or horizontal positions. One of the most generally used types is the horizontal-return-tube (HRT) boiler (see illustration). In the HRT boiler, part of the heat from the combustion gases is transferred directly to the lower portion of the shell. The gases then make a return pass through the horizontal tubes or flues before being passed into the stack. See STEAM-GENERATING UNIT. [G.W.K.]

**Fischer-Tropsch process** The synthesis of hydrocarbons and, to a lesser extent, of aliphatic oxygenated compounds by the catalytic hydrogenation of carbon monoxide. The synthesis was discovered in 1923 by F. Fischer and H. Tropsch at the Kaiser Wilhelm Institute for Coal Research in Mulheim, Germany. The reaction is highly exothermic, and the reactor must be designed for adequate heat removal to control the temperature and avoid catalyst deterioration and carbon formation. The sulfur content of the synthesis gas must be extremely low to avoid poisoning the catalyst. See COAL GASIFICATION. [J.H.F.]

**Fisher** A carnivorous mammal that is a member of the family Mustelidae, which also includes the minks, ferrets, martens, weasels, badgers, otters, skunks, and wolverine. The American fisher (*Martes pennanti*) occurs in forested areas of North America. The fur, which is valuable, is variable in color, but always dark, and does not change color seasonally. The fisher has a long, lithe powerful body with short legs and a long muzzle. These animals breed once a year, and the two to four young are born in the nest high above the ground. This species is now nearly extinct in the eastern United States. See BADGER; CARNIVORA; MARTEN; OTTER; SKUNK; WEASEL; WOLVERINE. [C.B.C.]

**Fisheries ecology** The study of ecological processes that affect exploited aquatic organisms, in both marine and freshwater environments. Because this field is primarily motivated by an attempt to harvest populations, special attention has been given to understanding the regulation of aquatic populations by nature and humans. The foundations of fisheries ecology lie in population and community ecology, with ideas and methods from physiology, genetics, molecular biology, and epidemiology being increasingly relevant. Because of issues associated with harvesting biological resources, fisheries ecology must also go beyond biology and ecology into sociology and economics. See ECOLOGY.

The problem of regulating the exploitation of aquatic organisms in order to ensure sustained harvest lies at the core of fisheries ecology. Most experts agree that the harvest of marine resources has peaked and increased yields are likely to come only from fine-tuning of regulations on stocks that are fully exploited.

The typical unit at which management efforts are directed is the exploited population, customarily termed a stock. A central aspect of assessing fisheries resources is to identify these stocks and determine how isolated they are from other stocks of the same species. For example, there are 20 major recognized stocks of cod in the North Atlantic Ocean, each on the whole isolated from every other and distinct with regard to several biological characteristics that determine the potential for harvest. The three main population processes that govern the size and productivity of given stock are somatic growth, mortality, and recruitment (the incorporation of new individuals into the population through birth). A typical assessment of an exploited stock includes the study of these three processes, as well as some protocol to estimate abundance. From this information, and aided by mathematical models and statistical tools, fisheries biologists produce recommendations on how many individuals to harvest, of what size or age, when, and where.

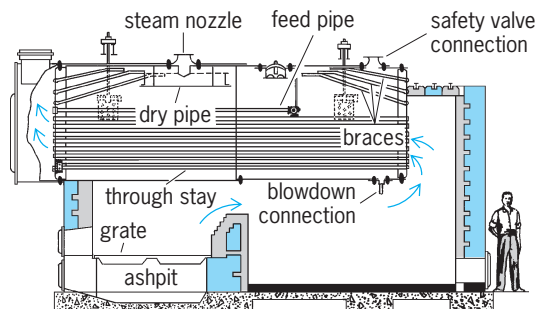

Horizontal-return-tube boiler.

The early history of modern fishing was characterized by attempts to ensure an increasing supply of aquatic organisms at all costs. In the last two decades, that view has yielded to a more realistic perspective, increasingly heedful to the natural limits of aquatic resources and to many environmental aspects of harvested systems. These include habitat degradation, overfishing, incidental mortality of nontarget species, and the indirect effects of species removal at the ecosystem level. See MARINE CONSERVATION; MARINE FISHERIES. [M.Pa.; P.D.]

**Fissidentales** An order of the true mosses (subclass Bryidae) consisting of a single family, the Fissidentaceae, and about 800 species in the genus *Fissidens* plus a few others distributed in four or five segregate genera. *Fissidens* is the largest genus of mosses. The Fissidentales are unique in leaf form and arrangement. The plants, erect and simple or forked, grow (except at the earliest stages) from a two-sided apical cell. The leaves, arranged edgewise to the stem in two rows, have two sheathing blades which clasp the stem and the base of the next leaf above. See BRYIDAE; BRYOPHYTA; BRYOPSIDA. [H.Cr.]

**Fission track dating** A method of dating geological and archeological specimens by counting the radiation-damage tracks produced by spontaneous fission of uranium impurities in minerals and glasses. During fission two fragments of the uranium nucleus fly apart with high energy, traveling a total distance of about 25 micrometers (0.001 in.) and creating a single, narrow but continuous, submicroscopic trail of altered material, where atoms have been ejected from their normal positions. Such a trail, or track, can be revealed by using a chemical reagent to dissolve the altered material, and the trail can then be seen in an ordinary microscope. The holes produced in this way can be enlarged by continued chemical attack until they are visible to the unaided eye.

Track dating is possible because most natural materials contain some uranium in trace amounts and because the most abundant isotope of uranium,  $^{238}\text{U}$ , fissions spontaneously. Over the lifetime of a rock substantial numbers of fissions occur; their tracks are stored and thus leave a record of the time elapsed since track preservation began. The number of tracks produced in a given volume of material depends on the uranium content as well as the age, so that it is necessary to measure the uranium content before an age can be determined.

One feature unique to this dating technique is the time span to which it is applicable. It ranges from less than 100 years for certain synthetic, decorative glasses to approximately 4,500,000,000 years, the age of the solar system. A second useful feature is that measurements can sometimes be made on extremely minute specimens, such as chips of meteoritic minerals or fragments of glass from the ocean bottom. A third useful feature is that each mineral dates the last cooling through the temperature below which tracks are retained permanently. Since this temperature is different for each mineral, it is possible to measure the cooling rate of a rock by dating several minerals—each with a different track-retention temperature. See AMINO ACID DATING; ROCK AGE DETERMINATION. [R.L.F.; P.B.P.; R.M.W.]

**FitzGerald-Lorentz contraction** The contraction of a moving body in the direction of its motion. In 1892 G. F. FitzGerald and H. A. Lorentz proposed independently that the failure of the Michelson-Morley experiment to detect an absolute motion of the Earth in space arose from a physical contraction of the interferometer in the direction of the Earth's motion. According to this hypothesis, as formulated more exactly by Albert Einstein in the special theory of relativity, a body in motion with speed  $v$  is contracted by a factor  $\sqrt{1 - v^2/c^2}$  in the direction of motion, where  $c$  is the speed of light. See LIGHT; RELATIVITY. [E.L.Hi.]

**Flabellifera** The largest and morphologically most generalized suborder of isopod crustaceans. The biramous uropods are attached to the sides of the abdomen and may with the last abdominal segment form a caudal fan (see illustration). More than 1400 species and over 10 families are known.

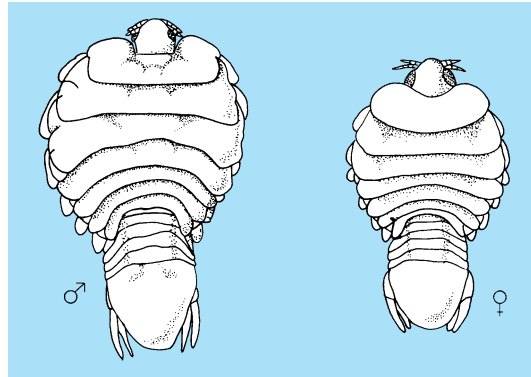

*Ichthyoxenus jellinghausii* Herklots, male and female. (Proceedings of U.S. National Museum)

Members of the family Cirolanidae are actively swimming predators and scavengers with biting mouthparts. They feed on dead and living animals and are notorious for their attacks on the bait of line fishermen and on fishes caught in nets. The legs of bathers are also sometimes bitten.

Members of the families Corallanidae and Excorallanidae are sometimes found parasitizing fishes, but are often free-living. The families Aegidae and Cymothoidae include fish parasites; the Aegidae feed by sucking blood. The Cymothoidae are more highly adapted for a parasitic life than other Flabellifera.

The gribbles, Limnoriidae, are well known for the damage they cause to marine structures of wood. In the family Sphaeromatidae, some species of *Sphaeroma* are economically important in tropical seas because of their habits of boring into wood, clay, and rock. Isopods of the family Serolidae are greatly flattened forms which live partially buried on sandy bottoms. See ISOPODA. [T.E.B.]

**Flame** An exothermic reaction front or wave in a gaseous medium. Consider a uniform body of gas in which an exothermic chemical reaction (that liberates heat) is initiated by raising the temperature to a sufficiently high level; the reaction is started by a localized release of heat, as by a sufficiently energetic spark, and then spreads from the point of initiation. If the reaction is relatively slow, the whole gas will be involved before the initial region has finished reacting. If the reaction is relatively fast, the reaction zone will develop as a thin front or wave propagating into the unreacted gas, leaving fully reacted gas behind. If the front, in addition, shows luminosity (emission of light), the flame may be considered a classical example. However, perceptible emission of visible radiation is not essential to the definition.

Sufficient reaction rates may also be attained under special conditions (when the gas is very slowly heated inside a closed vessel) without very high temperatures if free radicals are generated in good concentration; this gives so-called cool flames.

The most common flame-producing reaction is combustion, which is broadly defined as a reaction between fuel and an oxidizer. The oxidizer is typically oxygen (usually in air), but a variety of other substances (for example, bromine with hydrogen) can play the same role in combination with the right fuel. While the overall theoretical reaction in a combustion flame—namely, fuel and oxidizer making fully oxidized products such as carbon dioxide and water vapor—is invariably simple, the actual reaction mechanism is typically very complex, involving many intermediate steps and compounds. Free radicals are generally

present and figure prominently in the mechanism. See FREE RADICAL.

An overall reaction involving just one reactant is chemical decomposition, for example, ozone decomposing into oxygen. Decomposition flames are usually simpler chemically than combustion flames.

Combustion flames are broadly divided into premixed flames and diffusion flames. Premixed flames occur when fuel and oxidizer are mixed before they burn. Diffusion flames occur when fuel and oxidizer mix and burn simultaneously. The intermediate case, with partial premixing, has been of relatively low theoretical and practical interest. Flames are further categorized on the basis of shape, time behavior (stationary or moving), flow regime (laminar or turbulent), buoyancy regime (forced convection or natural convection), presence or absence of confinement (as by combustion chamber walls), and flow complications (such as swirling flow and crosswind). [H.A.Bec.]

**Flameproofing** The process of treating materials so that they will not support combustion. Although cellulosic materials such as paper, fiberboard, textiles, and wood products cannot be treated so that they will not be destroyed by long exposure to fire, they can be treated to retard the spreading of fire and to be self-extinguishing after the ligniting condition has been removed.

Numerous methods have been proposed for flameproofing cellulosic products. One of the simplest and most commonly used for paper and wood products is impregnation with various soluble salts, such as ammonium sulfate, ammonium phosphate, ammonium sulfamate, borax, and boric acid. Special formulations are often used to minimize the effects of these treatments on the color, softness, strength, permanence, or other qualities of the paper. For some applications, these treatments are not suitable because the salts remain soluble and leach out easily on exposure to water. A limited degree of resistance to leaching can be achieved by the addition of latex, lacquers, or waterproofing agents. In some cases the flameproofing agent can be given some resistance to leaching by causing it to react with the cellulose fiber (for example, urea and ammonium phosphate).

Leach-resistant flameproofing may also be obtained by incorporating insoluble retardants in the paper during manufacture, by application of insoluble materials in the form of emulsions, dispersions, or organic solutions, or by precipitation on, or reaction with, the fibers in multiple-bath treatments. The materials involved are of the same general types as those used for flameproofing textiles and include metallic oxides or sulfides and halogenated organic compounds. See COMBUSTION; TEXTILE CHEMISTRY. [T.A.H.]

**Flash welding** A form of resistance welding that is used for mass production. The welding circuit consists of a low-voltage, high-current energy source (usually a welding transformer) and two clamping electrodes, one stationary and one movable.

The two pieces of metal to be welded are clamped tightly in the electrodes, and one is moved toward the other until they meet, making light contact. Energizing the transformer causes a high-density current to flow through small areas that are in contact with each other. Flashing starts, and the movable workpiece must accelerate at the proper rate to maintain an increasing flashing action. After a proper heat gradient has been established on the two edges to be welded, an upset force is suddenly applied to complete the weld. This upset force extrudes slag, oxides, molten metal, and some of the softer plastic metal, making a weld in the colder zone of the heated metal. See RESISTANCE WELDING. [E.J.L.]

**Flat-panel display device** An electronic display in which a large orthogonal array of display elements, such as liquid-crystal or electroluminescent elements, form a flat screen.

The term "flat-panel display" is actually a misnomer, since thinness is the distinguishing characteristic. Most television sets and computer monitors currently employ cathode-ray tubes. Cathode-ray tubes cannot be thin because the light is generated by the process of cathodoluminescence whereby a high-energy electron beam is scanned across a screen covered with an inorganic phosphor. The cathode-ray tube must have moderate depth to allow the electron beam to be magnetically or electrostatically scanned across the entire screen. See CATHODE-RAY TUBE; CATHODOLUMINESCENCE; ELECTRONIC DISPLAY.

For a flat-panel display technology to be successful, it must at least match the basic performance of a cathode-ray tube by having (1) full color, (2) full gray scale, (3) high efficiency and brightness, (4) the ability to display full-motion video, (5) wide viewing angle, and (6) wide range of operating conditions. Flat-panel displays should also provide the following benefits: (1) thinness and light weight, (2) good linearity, (3) insensitivity to magnetic fields, and (4) no x-ray generation. These four attributes are not possible in a cathode-ray tube.

Flat-panel displays can be divided into three types: transmissive, emissive, and reflective. A transmissive display has a backlight, with the image being formed by a spatial light modulator. A transmissive display is typically low in power efficiency; the user sees only a small fraction of the light from the backlight. An emissive display generates light only at pixels that are turned on. Emissive displays should be more efficient than transmissive displays, but due to low efficiency in the light generation process most emissive and transmissive flat panel displays have comparable efficiency. Reflective displays, which reflect ambient light, are most efficient. They are particularly good where ambient light is very bright, such as direct sunlight. They do not work well in low-light environments.

Most flat-panel displays are addressed as an X-Y matrix, the intersection of the row and column defining an individual pixel (see illustration). Matrix addressing provides the potential for an all-digital display. Currently available flat-panel display devices range from 1.25-cm (0.5-in.) diagonal displays used in head-mounted systems to 125-cm (50-in.) diagonal plasma displays.

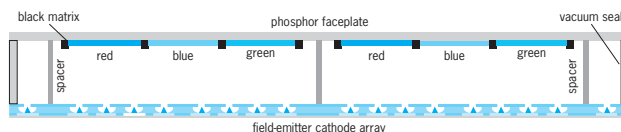

**Field-emission display, an example of a matrix-addressed display. Each pixel is addressed in an X-Y matrix. In the case of a color display, each pixel is subdivided into a red, a blue, and a green subpixel.**

Currently, most commercially manufactured flat-panel display devices are liquid-crystal displays (LCDs). The benchmark for flat-panel display performance is the active matrix liquid-crystal display (AMLCD). Most portable computers use AMLCDs. Competing flat-panel display technologies include electroluminescent displays, plasma display panels, vacuum fluorescent displays, and field-emission displays. Electroluminescent displays are often used in industrial and medical applications because of their ruggedness and wide range of operating temperatures. Plasma display panels are most often seen as large flat televisions, while vacuum fluorescent displays are used in applications where the information content is fairly low, such as the displays on appliances or in automobiles. Field-emission displays are the most recent of these flat-panel technologies. [B.E.G.]

**Flavonoid** A large category of natural plant products that derive from  $\gamma$ -pyrone. All flavonoid compounds, which are derived from either 2-phenylbenzopyrone (structure **1**) or 3-phenylbenzopyrone (**2**), can be classified into 10 groups:

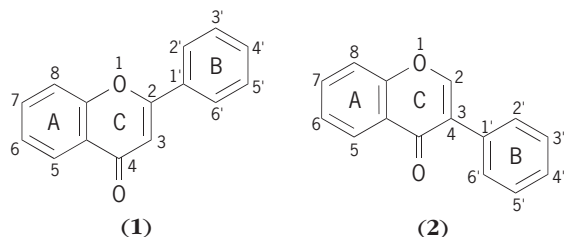

chalcones, flavanones, flavones, flavonols, anthocyanidins (flavylium cations), flavan 3-ols (catechins), flavan 3,4-diols (proanthocyanidins), biflavonoids and oligomeric flavonoids, isoflavonoids, and the aurones. They differ in the oxidation level or substitution pattern of their heterocyclic ring (ring C).

More than 1300 different flavonoid compounds have been isolated from plants. Individual flavonoids in a group differ from each other by the number and position of the hydroxy, methoxy, and sugar substituents. As a rule, flavonoid compounds occur in plants as glycosides, with hexoses such as glucose, galactose, and rhamnose, and pentoses such as arabinose and xylose as the most commonly found sugars. The sugars can be attached singly or in combination with each other. Glycosylation renders these compounds water-soluble and permits their accumulation in the vacuoles of cells. See GLYCOSIDE.

The few reports available indicate that flavonoids accumulate in epidermal tissues, with approximately 70% in the upper and 30% in the lower epidermis. Vacuoles are probably the only site of flavonoid accumulation in the cells, but synthesis of flavonoids takes place in the cytoplasm.

Flavonoid compounds were once regarded as stray end products of metabolism, but some are now known to be physiologically active. For example, a number of flavonoid compounds were discovered to be the host-specific signal molecules in the formation of nitrogen-fixing root modules. In addition, flavonoids have been linked to protection from ultraviolet radiation. The enzymatic machinery for flavonoid production is induced by ultraviolet irradiation. Flavonoids accumulate in the vacuoles of epidermal cells and absorb light strongly in the critical range of 280–380 nm, where damage caused by ultraviolet radiation occurs. Finally, many plant species synthesize phytoalexins upon invasion by microorganisms. The majority of phytoalexins produced by legumes are isoflavonoids, and each plant species seems to produce a specific compound.

Because of their strikingly vivid color, ranging from deep red through purple to deep blue, anthocyanins represent the most visible class of flavonoid compounds. Anthocyanins are most obvious in flowers and fruits, but they are also present in roots, stems, leaves, seeds, and other parts of the plant. The accumulated anthocyanins, together with carotenes, provide the varied colors characteristic of autumn. Anthocyanins are also produced when plants are subjected to other stress, such as ultraviolet radiation, injury by insects, malnutrition, or unusual concentrations of metal. See PLANT METABOLISM. [G.Hr.]

**Flavor** Any of the six different varieties of quarks. All hadronic matter is composed of quarks, the most elementary constituents of matter. The six different flavors are labeled *u*, *d*, *s*, *c*, *b*, and *t*, corresponding to up, down, strange, charmed, bottom, and top. Quarks are all spin- $1/2$  fermions. The *u*, *c*, and *t* flavors carry a positive electric charge equal in magnitude to two-thirds that of the electron; the *d*, *s*, and *b* flavors have a negative charge one-third that of the electron. Different flavored quarks have vastly different masses ranging from the lightest, the *u* quark, with a mass around  $5 \text{ MeV}/c^2$  (where *c* is the speed of light), equal to the mass of about 10 electrons, to the top quark, with a mass 35,000 times greater, or  $175 \text{ GeV}/c^2$ , about the mass of a gold atom. Quarks of any flavor are further characterized by three additional quantum numbers called color: red, green,

and blue. Each quark has an antiquark counterpart carrying the corresponding anticolor. See ANTIMATTER; COLOR (QUANTUM MECHANICS); ELEMENTARY PARTICLE; QUARKS. [V.F.]

**Flax** The flax plant (*Linum usitatissimum*) is the source of two products: flaxseed for linseed oil and fiber for linen products. Plants with two distinct types of growth are used for seed and fiber production.

Flax for fiber requires fertile, well-drained, and well-prepared soil and a cool, humid climate. The best-known use for flax fiber is in the manufacture of fine linen fabrics; other uses are linen thread, linen twine, toweling, and canvas. Seed from fiber flax is used for replanting and for oil. The major producer of flax fiber is Russia, but the world's best fiber comes from Belgium and adjoining countries. Most Irish linen is manufactured from fiber produced in Belgium. See NATURAL FIBER; TEXTILE.

Seedflax is the source of linseed oil. The principal uses of linseed oil are in the manufacture of protective coatings—paint, varnish, and lacquer. It is also used in linoleum, printer's ink, and patent and imitation leathers, and as core oil for making sand forms in metal casting. The linseed cake remaining after the oil is extracted is used as a high-protein livestock feed. Large quantities of clean (weed-free) straw from seedflax are used in the production of a high-grade paper. This product is used to make cigarette and other fine papers. The world's major producers of flaxseed are Argentina, Canada, India, Russia, and the United States. [E.G.N.; J.O.Cu.]

**Flexibilia** An extinct subclass of stalked or creeping Crinoidea which includes some 50 Paleozoic genera, ranging from Ordovician to Permian times. A flexible tegmen was present with open ambulacral grooves. One of the five oral plates served as a madreporite. The anus was at the tip of a short siphon. The uniserial arms branched freely, arching inward to form

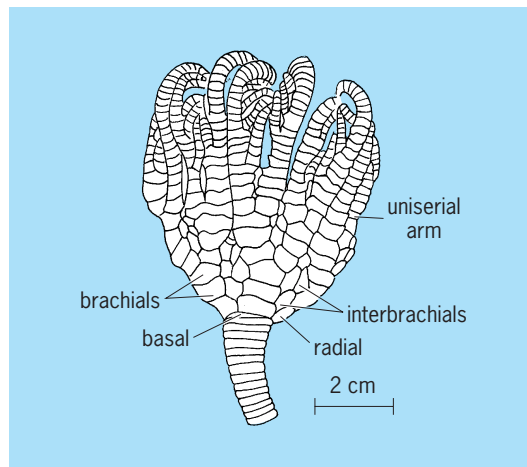

*Talanterocrinus* sp.

a globular crown (see illustration). The cylindrical stem lacked cirri and was sometimes discarded to produce a creeping adult. See CRINOIDEA; ECHINODERMATA. [H.B.F.]

**Flexible manufacturing system** A factory or part of a factory made up of programmable machines and devices that can communicate with one another. Materials such as parts, pallets, and tools are transported automatically within the flexible manufacturing system and sometimes to and from it. Some form of computer-based, unified control allows complete or partial automatic operation. Flexible manufacturing systems are part of a larger computer-based technology, termed computer-integrated

manufacturing (CIM), which encompasses more than the movement and processing of parts on the factory floor. See AUTOMATION; COMPUTER-AIDED DESIGN AND MANUFACTURING; COMPUTER-INTEGRATED MANUFACTURING.

The programmable machines and devices are numerically controlled machine tools, robots, measuring machines, and materials-handling equipment. Each programmable machine or device typically has its own controller which is, in effect, a dedicated digital computer; programs must be written for these controllers, usually in special-purpose languages designed to handle the geometry and machining. Increasingly, numerically controlled machines are being programmed by graphical presentations on computer screens, that is, graphical computer interfaces. This allows the programmer to follow the machining operation and specify desired operations without the need for statements in a programming language. Robots have usually been programmed by so-called teaching, where the robot is physically led through a sequence of movements and operations; the robot remembers them and carries them out when requested. See COMPUTER GRAPHICS; DIGITAL COMPUTER; INTELLIGENT MACHINE; MATERIALS-HANDLING EQUIPMENT; PROGRAMMING LANGUAGES; ROBOTICS.

The programmable machines and devices communicate with one another via an electronic connection between their controllers. Increasingly, this connection is by means of local-area networks, that is, communication networks that facilitate high-speed, reliable communication throughout the entire factory. See LOCAL-AREA NETWORK.

The automatic material transport system is usually a guided, computer-controlled vehicle system. The vehicles are usually confined to a fixed network of paths, but typically any vehicle can be made to go from any point in the network to any other point. The network is different from a classical assembly line in that it is more complex and the flow through it is not in one direction.

Commands and orders to the flexible manufacturing system are sent to its computer-based, unified control. The control, in turn, issues orders for the transport of various kinds of material, the transfer of needed programs, the starting and stopping of programs, the scheduling of these activities, and other activities.

Flexible manufacturing systems are flexible in the sense that their device controllers and central control computer can be reprogrammed to make new parts or old parts in new ways. They can also often make a number of different types of parts at the same time. However, this flexibility is limited to a certain family of parts, for example, axles. A general goal for designers is to increase flexibility, and advanced flexible manufacturing systems are more flexible than the earlier ones. [A.W.N.]

**Flight** Movement through the atmosphere or space, sustained by aerodynamic reaction or other forces. Animal flight includes gliding and flapping flight. Flapping flight in vertebrates was probably preceded by gliding; in insects it may have originated by leaping and gliding, by surface skimming on water, or (if small enough) by passive floating in the air. Flying insects show greater variation than flying vertebrates, and their flight spans a wider range of Reynolds numbers, which is the ratio of inertial forces to viscous forces in the flow. Flight of tiny insects is in the lower range of Reynolds numbers, where viscous forces are dominant, whereas large insects and vertebrates operate in the higher range, where inertial forces are important.

Flight is very expensive in terms of energy cost per unit time. However, flying animals can travel several times faster than non-flying ones, and the cost of carrying a unit of weight of an animal through a unit distance (cost of transport) is lower for flight than for running, but higher than for swimming.

The flight characteristics of large insects and vertebrates can be understood by aircraft aerodynamics. In steady level flight, an

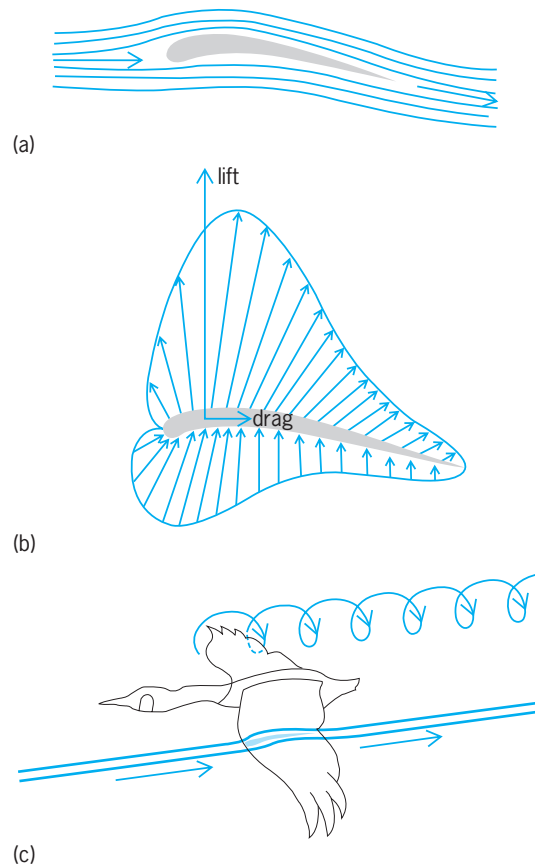

**Aerodynamics of flight. (a) Airflow around a typical wing profile. (b) Pressure distribution around a typical wing profile. (c) The difference in pressure disappears toward the wingtips as trailing vortices in the wake. (After M. Brooke and T. Birkhead, eds., *Cambridge Encyclopedia of Ornithology*, Cambridge University Press, 1991)**

animal and an aircraft must generate forces that support weight against gravity and provide propulsive thrust against drag forces. The forces acting on an airfoil (the shape of the cross section of the wings) moving through the air depend upon the flow pattern around it. Because of the asymmetric profile on an airfoil, the air flowing over the upper surface travels farther and flows faster than air passing underneath. According to Bernoulli's principle, pressure falls when speed rises in a moving fluid, resulting in a pressure difference between the upper and lower sides of the airfoil (illus. a). This pressure difference has to disappear gradually toward the wingtips, and some air will flow upward around the wingtips. The air moves downward behind the wing as trailing vortices (illus. b), and the reaction of this momentum flow is experienced by the wing as lift. The stronger the vortex, the greater the lift generated, but with some energy loss to drag. The lift force is responsible for weight support (its vertical component) and thrust or drag (its horizontal component). See AERODYNAMIC FORCE; AIRFOIL; BERNOULLI'S THEOREM.

Energy must be expended to generate the trailing vortices in the wake and to overcome friction on the wing and body surfaces. These energy losses are experienced as drag forces, which act parallel to the direction of movement of the airfoil. Since drag is a retarding force, the animal must either descend (glide) through the air at such an angle that a component of its weight balances the drag, or do mechanical work with its flight muscles (flap its wings) to overcome it. The rate at which this work is done is the mechanical power required to fly, and it equals speed times drag (measured in watts). The flight muscles also produce heat when they contract, so the total metabolic power expenditure is the sum of this heat loss and the mechanical power.



The metabolic power is estimated to be four to five times the mechanical power, and is dependent on the size of the animal. See WORK.

Compared with active flight, gliding flight is very inexpensive, and is found in a wide range of animals, such as squirrels, marsupials, lizards, frogs, fishes, and even one snake. It is the main component in soaring flight used by many birds and some bats, when the animals use thermals or updrafts. Gliding in birds costs only two to three times the basal metabolic rate, because the flight muscles do not perform any mechanical work other than for stability and control of movements, and produce mostly static forces to keep the wings down on the horizontal plane, opposing the aerodynamic force.

When gliding, the wings of the animal leave behind a continuous vortex sheet that rolls up into a pair of vortex tubes (wingtip vortices), as in fixed-wing airplanes (illus. *b*). The lift produced balances the animal's weight, but potential energy must be used to overcome the drag and the animal loses height. An animal gliding at steady speed descends at an angle to the horizontal (glide angle), established by the ratio of lift to drag (glide ratio). The best glide ratios in birds range from 10:1 to 15:1 for vultures and birds of prey and reach 23:1 in the wandering albatross, whereas modern gliders can achieve 45:1. An animal cannot glide more slowly than its stalling speed, which in birds can be reduced by splaying the wingtip primaries, or by spreading the alula (a digit of the wing) at the wrist, or both. An animal can increase its gliding speed by flexing the wings and reducing the wing area.

Hovering flight represents the most expensive form of animal flapping flight. The essence of hovering is to produce a vertical force to balance body weight. The wake consists of a chain of vortex rings continuously shed during the wing strokes. In hummingbirds and insects, lift is produced during both the downstroke and upstroke of the wings (symmetrical hovering), and two vortex rings are produced during each wing stroke. In other hovering animals the wings are flexed during the upstroke (asymmetrical hovering), and the rings are produced during the downstrokes only. See AERODYNAMICS; AVES. [U.M.N.]

**Flight controls** The devices and systems which govern the attitude of an aircraft and, as a result, the flight path followed by the aircraft. Flight controls are classified as primary flight controls, auxiliary flight controls, and automatic controls. In the case of many conventional airplanes, the primary flight controls utilize hinged, trailing-edge surfaces called elevators for pitch, ailerons for roll, and the rudder for yaw. These surfaces are operated by the human pilot in the cockpit or by an automatic pilot. In the case of vertically rising aircraft, a lift control is provided. See AILERON; AIRCRAFT RUDDER; ELEVATOR (AIRCRAFT); ELEVON.

Controls to govern the engine power and speed, while not usually classified as flight controls, are equally important in the overall control of the aircraft. This is especially true if the engine exhaust can be directed to produce pitch or yaw motions.

Auxiliary flight controls may include trimming devices for the primary flight controls, as well as landing flaps, leading-edge flaps or slats, an adjustable stabilizer, a wing with adjustable sweep, dive brakes or speed brakes, and a steerable nose wheel.

Automatic controls include systems which supplement or replace the human pilot as a means of controlling the attitude or path of the aircraft. Such systems include automatic pilots, stability augmentation systems, automatic landing systems, and active controls. Active controls encompass automatic systems which result in performance improvement of the aircraft by allowing reductions in structural weight or aerodynamic drag, while maintaining the desired integrity of the structure and stability of flight.

The control system incorporates a set of cockpit controls which enable the pilot to operate the control surfaces. Because of the approximately fixed size and strength of the human pilot and the

need to standardize the control procedures for airplanes, the primary controls are similar in most types of airplanes. The cockpit controls incorporate a control stick which operates the elevators and ailerons, and pedals which operate the rudder. Sometimes a column/wheel arrangement is used to operate the elevators and ailerons, respectively. The cockpit controls for auxiliary control devices are not as completely standardized as those for the primary controls.

Control systems with varying degrees of complexity are required, depending on the size, speed, and mission of an airplane. In relatively small or low-speed airplanes, the cockpit controls may be connected directly to the control surfaces by cables or pushrods, so that the forces exerted by the pilot are transmitted directly to the control surfaces. In large or high-speed airplanes, the forces exerted by the pilot may be inadequate to move the controls. In these cases, either an aerodynamic activator called a servotab or spring tab may be employed, or a hydraulic activator may be used. In some airplanes, particularly those with swept wings and those which fly at high altitudes, the provision of adequate static stability and damping of oscillations by means of the inherent aerodynamic design of the airplane becomes difficult. In these cases, stability augmentation systems are used. These systems utilize sensors such as accelerometers and gyroscopes to sense the motion of the airplane. These sensors generate electrical signals which are amplified and used to operate the hydraulic actuators of the primary control surfaces to provide the desired stability or damping. See STABILITY AUGMENTATION.

The weight and complication of mechanical control linkages and the extensive reliance on electrical signals in automatic controls led to the development of control systems in which the control inputs from the pilot, as well as those from the stability augmentation sensors, are transmitted to the primary control actuators by electrical signals. Systems of this type are called fly-by-wire systems. The electrical signals are readily compatible with computers, typically digital, which can perform the functions of combining the signals from the pilot and the sensors. See DIGITAL COMPUTER.

Fly-by-wire systems can malfunction when exposed to high-intensity electromagnetic fields. The solution to this problem has been to shield the transmission media and extensively test the system before certifying it, adding cost and weight to the system. These difficulties, the intrinsic immunity of optical technology to electromagnetic interference, and the availability of optical-fiber-based transmission media from the communications industry led to the development of fly-by-light systems. These systems use optical fibers to transmit signals instead of wires; the interface units are replaced with optical-electrical converters. See OPTICAL COMMUNICATIONS; OPTICAL FIBERS.

There are three major reasons why digital flight control computers are used in modern airplanes. First, digital flight control computers can enhance the pilot's control of the airplane by optimizing the movement of the control surfaces in response to pilot commands, over the operating flight conditions of the airplane. Second, as a result of their ability to rapidly monitor and interpret multiple sensor inputs, digital flight control computers can often exceed the performance of an unassisted pilot in compensating for critical situations which might otherwise result in loss of airplane control. Third, digital flight control computers permit input directly from remote control and navigation devices such as digital automatic landing systems, assisting the pilot in zero-visibility conditions or freeing the pilot for other airplane management tasks.

A digital flight control computer evaluates its inputs based on precomputed models of the airplane's expected behavior under various conditions of flight in order to produce command signals for the control surface actuators. Typically, wind-tunnel data are used to derive and verify the precomputed models used in the computer. Test flights and computer simulations are also used extensively to verify computer operation. See AIRCRAFT TESTING; WIND TUNNEL.

The flight of an aircraft may be controlled automatically by providing the necessary signals for navigation as inputs to the control system. In practice, automatic pilots are used to relieve the human pilot of routine flying for long periods, and automatic control systems are used to make precision landings and takeoffs under conditions of reduced visibility. *See* AUTOPILOT.

[W.H.P.; P.D.A.]

**Flight dynamics** The study of the motion of an aircraft or missile. Flight dynamics is generally concerned with transient or short-term effects, which have to do with the stability and control of the vehicle, rather than with calculating such performance as ultimate range, attitude, or velocity of the vehicle. Sometimes, however, the two are treated together, particularly in the case of aircraft. *See* AEROELASTICITY; FLIGHT CONTROLS.

[J.R.Se.]

**Flight science** The sum total of all knowledge that enables humans to accomplish flight. Flight science is compounded of both science and engineering. It is concerned with airplanes, missiles, and crewed and uncrewed space vehicles.

The scope of flight science is illustrated by some of the diverse fields which are included within it, such as electronics, aerodynamics, propulsion engineering, structural engineering, nuclear engineering, metallurgy, chemistry, space medicine, certain parts of astronomy, mathematics, classical and modern physics, and other branches of engineering, such as civil engineering for the planning and construction of airports. These constitute the major branches of science and technology needed to solve modern flight problems.

[J.R.Se.]

**Floodplain** The relatively broad and smooth valley floor that is constructed by an active river and periodically covered with floodwater from that river during intervals of overbank flow. Engineers consider the floodplain to be any part of the valley floor subject to occasional floods that threaten life and property. Various channel improvements or impoundments may be used to restrict the natural process of overbank flow. Geomorphologists consider the floodplain to be a surface that develops by the active erosional and depositional processes of a river. Floodplains are underlain by a variety of sediments, reflecting the fluvial history of the valley.

Most floodplains consist of the following types of deposits: colluvium—slope wash and mass-wasting products from the valley sides, as is common in small, narrow floodplains; channel lag—coarse debris marking the bottoms of former channels; lateral accretion deposits—sand and gravel deposited as the meandering river migrates laterally; vertical accretion deposits—clay and silt deposited by overbank flooding of the river; crevasses-play deposits—relatively coarse sediment carried through breaks in the natural river levees and deposited in areas that usually receive overbank deposition; and channel-fill deposits—fills of former river channels. Channel fills may be coarse for sandy rivers. The noncohesive character of coarse sediments allows these rivers to easily erode laterally. *See* STREAM TRANSPORT AND DEPOSITION.

[V.R.B.]

**Floor construction** A floor of a building generally provides a wearing surface on top of a flat support structure. Its form and materials are chosen for architectural, structural, and cost reasons. A ground-supported floor may be of almost any firm material, ranging from compacted soil to reinforced concrete. It is supported directly by the subsoil below.

An elevated floor spans between, and is supported by, beams, columns, or bearing walls. It is designed to be strong and stiff enough to support its design loading without excessive deflection; to provide for an appropriate degree of fire resistance; and to supply diaphragm strength to maintain the shape of the building as a whole, if necessary. A ceiling may be hung from the underside of the floor assembly as a finish surface for the room

below. The optimum floor design meets these criteria while being as thin as possible and economical to construct. *See* BEAM; COLUMN; LOADS, TRANSVERSE.

Wooden floors are generally used in light residential construction. Such flooring generally consists of a finish floor installed on a subfloor of tongue-and-groove planking or plywood, spanning between wooden beams that are commonly called joists. Slabs fabricated of reinforced concrete are a common type of floor for heavier loading. The concrete is cast on forms, and reinforced with properly placed and shaped steel bars (rebars), so as to span between steel or reinforced concrete beams or between bearing walls. Composite floors are commonly used in modern office building construction. Concrete is cast on, and made structurally integral with, corrugated metal deck, which spans between steel joists of either solid-beam or open-web types, generally spaced between about 16–48 in. (40–120 cm) on center. Prestressed concrete is used for long span slabs. Highly prestressed high-tension steel wires within the high-strength concrete slab produce a thin, stiff, and strong floor deck. A lift slab is used for economy and efficiency. A concrete slab is first formed at ground level, reinforced and cured to adequate strength, and then carefully jacked up into its final position on supporting columns. *See* COMPOSITE BEAM; CONCRETE SLAB; PRESTRESSED CONCRETE; STRUCTURAL DESIGN.

[M.A.]

**Floriculture** The segment of horticulture concerned with commercial production, marketing, and sale of bedding plants, cut flowers, potted flowering plants, foliage plants, flower arrangements, and noncommercial home gardening.

Commercial crops are grown either in the field or under protected cultivation, such as in glass or plastic structures. Field production is confined to warm climates or to summer months in colder areas. Typical field crops are gladiolus, peonies, stock, gypsophila, asters, and chrysanthemums. Greenhouse production is not as confined by climate or season, but most greenhouses are located in areas that have advantages such as high light intensity, cool night temperatures, or ready access to market. Jet air transportation resulted in major changes in international crop production.

Pronounced improvements in cultivars have been realized because of excellent breeding programs conducted by commercial propagators and by some horticulture departments. Modern cultivars have traits such as more attractive flower colors and forms, longer-lasting flowers, better growth habit, increased resistance to insects and disease organisms, or ability to grow and flower at cooler night temperatures. *See* BREEDING (PLANT).

[R.A.L.]

**Flotation** A process used to separate particulate solids, which have been suspended in a fluid, by selectively attaching the particles to be removed to a light fluid and allowing this mineralized fluid aggregation to rise to where it can be removed. The principal use of the process is to separate valuable minerals from waste rock, or gangue, in which case the ground ore is suspended in water and, after chemical treatment, subjected to bubbles of air. The minerals which are to be floated attach to the air bubbles, rise through the suspension, and are removed with the froth which forms on top of the pulp. Although most materials subjected to flotation are minerals, applications to chemical and biological materials have been reported.

[R.L.At.]

**Flow-induced vibration** The dynamic response of structures immersed in or conveying fluid flow. Fluid flow is a source of energy that can induce structural and mechanical oscillations. Flow-induced vibrations best describe the interaction that occurs between the fluid's dynamic forces and a structure's inertial, damping, and elastic forces. *See* FLUID MECHANICS; MECHANICAL VIBRATION; STRUCTURAL ANALYSIS; VIBRATION.

The study of flow-induced vibrations has rapidly developed in aeronautical and nonaeronautical engineering. In aeronautics,

flow-induced vibration is often referred to as flutter, a topic of aeroelasticity concerning the mutual interactions of aerodynamic, elastic, and inertial forces in a flying object, its components, or its propulsion systems. Flow-induced vibration also covers classical flutter of an airfoil in a low-speed flow, stall flutter associated with a separated flow, and buffeting flutter related to turbulent wakes. Nonaeronautical flow-induced vibrations are often found in blood vessels, smokestacks, suspension bridges, oil pipe lines, power transmission lines, telephone wires, television antennas, heat exchanger tubes, nuclear fuel assemblies, and submarine periscopes and hulls. All nonaeronautical structures are unstreamlined and susceptible to both stall flutter and buffeting flutter caused by flow separation. The interaction of these structures with a fluid stream usually is more complicated than that of aeronautical structures and offers more possibilities for the flow to trigger unstable oscillations in the structures. See AEROELASTICITY; FLUTTER (AERONAUTICS).

**Aircraft wing flutter.** The fluid-elastic instability of an airplane wing or its control surfaces in a smooth flow without shock waves is called classical flutter. Flight tests show that the lift on an airfoil increases with increasing Mach number for a fixed angle of attack. This lifting force reaches a maximum at a critical Mach number, then drops sharply, and never increases no matter how high the flight speed is. This drop is due to flow separation or shock wave formation. Either of these two flow mechanisms can cause the airfoil to stall or can damage it. In these cases, the airfoil is said to be stall-fluttered or shock-stalled, depending on the flow process. See SHOCK WAVE.

When a flow separates from an airplane wing, the flow behind the wing is turbulent and random in nature. The airplane's tail is therefore subject to random excitations from the wing's turbulent wake. The wings and tails that oscillate randomly can lose stability. This type of dynamic aeroelastic instability is called buffeting flutter because the oscillations are random. See BOUNDARY-LAYER FLOW; TURBULENT FLOW; WAKE FLOW.

**Vibrations of cylinder arrays.** Among the topics of flow-induced vibration, cylindrical structures play very important and vital roles. For instance, the slender bodies of aircraft fuselages, missiles, and rockets, and the main bodies of industrial smokestacks, power transmission cables, telephone wires, oil pipelines, reactor fuel rods, heat-exchanger tubes, and offshore structures, as well as the blood vessels are primarily made up of cylindrical structures. These structures, when in operation, are subject to unsteady fluid-dynamic forces and prone to vibrations. Such vibrations can be classified as axial-flow-induced or cross-flow-induced vibrations, depending on the incident angle of the incoming flow with respect to the cylinders' axes. Stall and buffeting flutter, also called fluid-elastic instabilities, including fluid-damping- and fluid-stiffness-controlled instabilities, as well as vortex shedding are all possible during flow-induced vibration. [S.S.C.; W.W.Li.]

**Flow measurement** The determination of the quantity of a fluid, either a liquid, vapor, or gas, that passes through a pipe, duct, or open channel. Flow may be expressed as a rate of volumetric flow (such as liters per second, gallons per minute, cubic meters per second, cubic feet per minute), mass rate of flow (such as kilograms per second, pounds per hour), or in terms of a total volume or mass flow (integrated rate of flow for a given period of time).

Flow measurement, though centuries old, has become a science in the industrial age. This is because of the need for controlled process flows, stricter accounting methods, and more efficient operations, and because of the realization that most heating, cooling, and materials transport in the process industries is in the form of fluids, the flow rates of which are simple and convenient to control with valve or variable speed pumps. See PROCESS CONTROL.

Measurement is accomplished by a variety of means, depending upon the quantities, flow rates, and types of fluids involved.

Many industrial process flow measurements consist of a combination of two devices: a primary device that is placed in intimate contact with the fluid and generates a signal, and a secondary device that translates this signal into a motion or a secondary signal for indicating, recording, controlling, or totalizing the flow. Other devices indicate or totalize the flow directly through the interaction of the flowing fluid and the measuring device that is placed directly or indirectly in contact with the fluid stream. See METERING ORIFICE; PITOT TUBE; VENTURI TUBE. [M.Br.; L.P.E.]

**Flow of solids** The gravity flow of particulate solids such as ceramic powders, plastic pellets, and ores in the form of separate particles, with the particles in contact and the voids between them filled with gas, usually air.

Particulate solids are a two-phase, solid-gas system. They are compressible; their bulk density changes during flow. Since the volume of the particles changes little during this process, it is the size of the voids that is mostly affected. Changes in the size of the voids can cause changes in gas pressure and result in gas-pressure gradients across a flowing solid which tend to reduce the rate of gravity discharge. When the solid is made up of large particles, that is, its permeability is high, when the required flow rates are low, the gas-pressure gradients are not significant; the gaseous phase can be ignored and the solid treated as a one-phase, solid-only system.

A bin (silo, bunker) generally consists of a vertical cylinder and a converging hopper. From the standpoint of flow, there are three types of bins: mass-flow, funnel-flow, and expanded-flow.

Mass flow occurs when the hopper walls are sufficiently steep and smooth to cause flow of all the solid, without stagnant regions, whenever any solid is withdrawn. The range of hopper slope and friction angles leading to mass flow is shown in the illustration. Funnel flow will occur unless both the conditions for mass flow shown there are satisfied.

Mass-flow bins have advantages. Flow is uniform, and feed density is practically independent of the head of solid in the bin. Segregation is minimized because, while a solid may segregate at the point of charge into the bin, continuity of flow enforces remixing of the fractions within the hopper. Mass-flow bins have

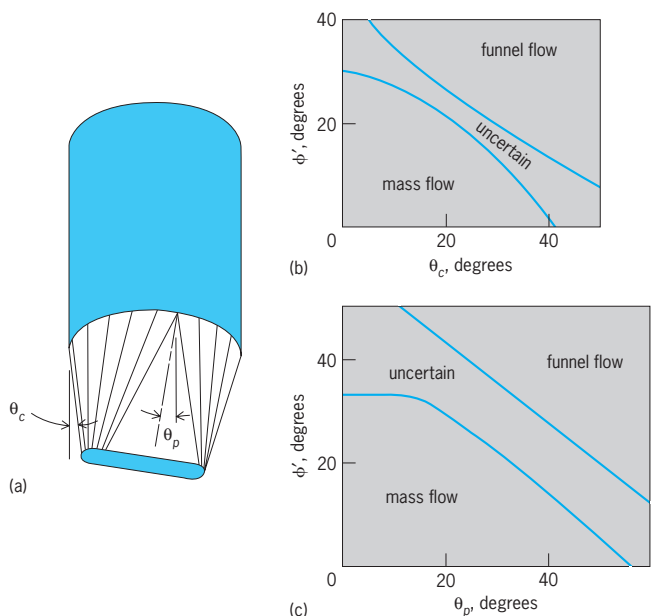

**Bounds on mass flow and funnel flow.** (a) Geometry of a transition hopper, showing slope angles  $\theta_c$  and  $\theta_p$ . (b) Range of kinematic angle of friction ( $\phi'$ ) and  $\theta_c$  leading to mass flow and funnel flow. (c) Range of  $\phi'$  and  $\theta_p$  leading to mass flow and funnel flow.

a first-in-first-out flow sequence, thus ensuring uniform residence time and deaeration of the stored solid.

Funnel flow occurs when the hopper walls are not sufficiently steep and smooth to force material to slide along the walls or when the outlet of a mass-flow bin is not fully effective.

In a funnel-flow bin, solid flows toward the outlet through a channel that forms within stagnant material. The diameter of that channel approximates the largest dimension of the effective outlet. As the level of solid within the channel drops, layers slough off the top of the stagnant mass and fall into the channel. This erratic behavior is detrimental with cohesive solids since the falling material packs on impact, thereby increasing the chance of material developing a stable arch across the hopper so that a complete stoppage of flow results. A channel, especially a narrow, high-velocity channel, may empty out completely, forming what is known as a rathole, and powder charged into the bin then flushes through. Powders flowing at a high rate in a funnel-flow bin may remain fluidized because of the short residence time in the bin, and flush on exiting the bin. A rotary valve is often used under these conditions to contain the material, but a uniform flow rate cannot be ensured because of the erratic flow to the valve.

Funnel-flow bins are more prone to cause arching of cohesive solids than mass-flow bins, and they therefore require larger outlets for dependable flow. These bins also cause segregation of solids and are unsuitable for solids which degrade with time in the stagnant regions. Cleanout of a funnel-flow bin is often uncertain because solids in the stagnant regions may pack and cake.

Expanded-flow bins are formed by attaching a mass-flow hopper to the bottom of a funnel-flow bin. The outlet usually requires a smaller feeder than would be the case for a funnel-flow bin. The mass-flow hopper should expand the flow channel to a dimension sufficient to prevent ratholing. [A.W.Je.; J.W.Ca.]

**Flower** A higher plant's sexual apparatus in the aggregate, including the parts that produce sex cells and closely associated attractive and protective parts (Fig. 1). "Flower" as used in this article will be limited, as is usual, to the angiosperms, plants with enclosed seeds and the unique reproductive process called double fertilization. In its most familiar form a flower is made up of four kinds of units arranged concentrically. The green sepals (collectively termed the calyx) are outermost, showy petals (the corolla) next, then the pollen-bearing units (stamens, androecium), and

finally the centrally placed seed-bearing units (carpels, gynoecium). This is the "complete" flower of early botanists, but it is only one of an almost overwhelming array of floral forms. One or more kinds of units may be lacking or hard to recognize depending on the species, and evolutionary modification has been so great in some groups of angiosperms that a flower cluster (inflorescence) can look like a single flower.

**Flora diversity.** Most botanical terms are descriptive, and a botanist must have a large store of them to impart the multifariousness of flowers. The examples that follow are only a smattering. An extra series of appendages alternating with the sepals, as in purple loosestrife, is an epicalyx. A petal with a broad distal region and a narrow proximal region is said to have a blade and claw; the crape myrtle has such petals. The term perianth, which embraces calyx and corolla and avoids the need to distinguish between them, is especially useful for a flower like the tulip, where the perianth parts are in two series but are alike in size, shape, and color. The members of such an undifferentiated perianth are tepals. When the perianth has only one series of parts, however, they are customarily called sepals even if they are petal-like, as in the windflower.

A stamen commonly consists of a slender filament topped by a four-lobed anther, each lobe housing a pollen sac. In some plants one or more of the androecial parts are sterile rudiments called staminodes: a foxglove flower has four fertile stamens and a staminode. Carpellode is the corresponding term for an imperfectly formed gynoecial unit.

A gynoecium is apocarpous if the carpels are separate (magnolia, blackberry) and syncarpous if they are connate (tulip, poppy). Or the gynoecium may regularly consist of only one carpel (bean, cherry). A solitary carpel or a syncarpous gynoecium can often be divided into three regions: a terminal, pollen-receptive stigma; a swollen basal ovary enclosing the undeveloped seeds (ovules); and a constricted, elongate style between the two. The gynoecium can be apocarpous above and syncarpous below; that is, there can be separate styles and stigmas on one ovary (wood sorrel).

Every flower cited so far has a superior ovary: perianth and androecium diverge beneath it (hypogyny). If perianth and androecium diverge from the ovary's summit, the ovary is inferior and the flower is epigynous (apple, banana, pumpkin). A flower is perigynous if the ovary is superior within a cup and the other floral parts diverge from the cup's rim (cherry). A syncarpous ovary is unilocular if it has only one seed chamber, plurilocular if septa divide it into more than one. The ovules of a plurilocular ovary are usually attached to the angles where the septa meet; this is axile placentation, a placenta being a region of ovular attachment. There are other ways in which the ovules can be attached—apically, basally, parietally, or on a free-standing central placenta—each characteristic of certain plant groups (Fig. 2).

The term bract can be applied to any leaflike part associated with one or more flowers but not part of a flower. Floral bracts are frequently small, even scalelike, but the flowering dogwood has four big petal-like bracts below each flower cluster. The broad end of a flower stalk where the floral parts are attached is the receptacle. The same term is used, rather inconsistently, for the broad base bearing the many individual flowers (florets) that make up a composite flower like a dandelion or a sunflower.

**Sexuality.** A plant species is dioecious if its stamens and carpels are in separate flowers. A dioecious species is monoecious if each plant bears staminate and carpellate (pistillate) flowers, dioecious if the staminate and carpellate flowers are on different plants. The corn plant, with staminate inflorescences (tassels) on top and carpellate inflorescences (ears) along the stalk, is monoecious. Hemp is a well-known dioecious plant.

**Nectaries.** Flowers pollinated by insects or other animals commonly have one or more nectaries, regions that secrete a sugar solution. A nectary can be nothing more than a layer of tissue lining part of a floral tube or cup (cherry), or it can be as conspicuous as the secretory spur of a nasturtium or a

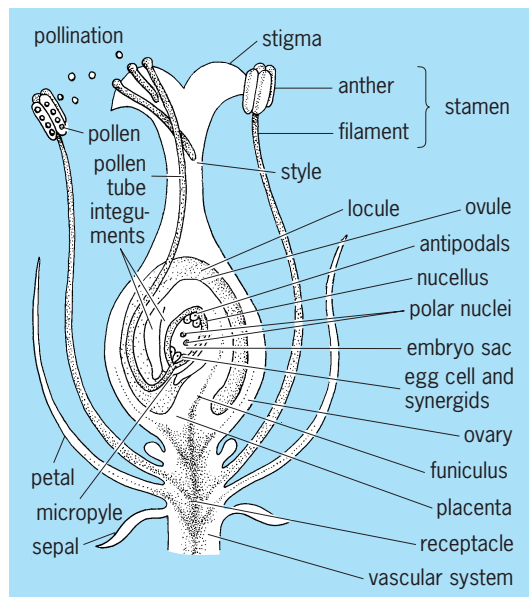

Fig. 1. Flower structure, median longitudinal section.

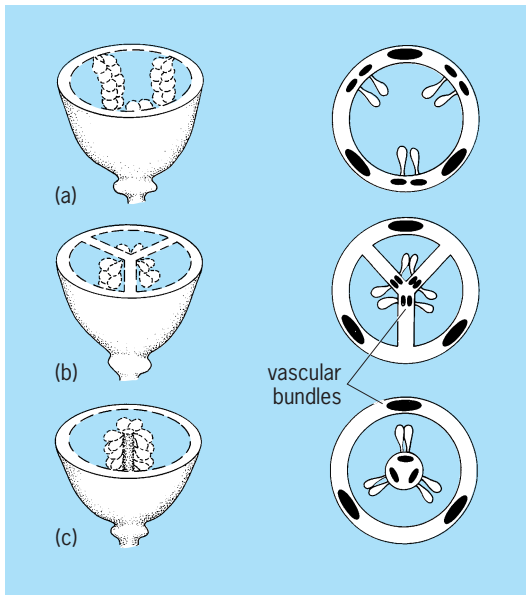

Fig. 2. Placentation: (a) parietal, (b) axile, and (c) free central. (After P. H. Raven, R. F. Evert, and H. Curtis, *Biology of Plants*, Worth Publishers, 1976)

larkspur. It can be a cushionlike outgrowth at the base of a superior ovary (orange blossom) or atop an inferior ovary (parsley family). Gladiolus and a number of other monocotyledons have septal nectaries, deep secretory crevices where the carpels come together. Substances that give off floral odors—essential oils for the most part—ordinarily originate close to the nectar-producing region but are not coincident with it. Production by the epidermis of perianth parts is most common, but in some species the odor emanates from a more restricted region and may even come from a special flap or brush. Most insect-pollinated plants have visual cues, some of them outside the human spectral range, as well as odor to bring the pollinators to the flowers and guide them to the nectar. See SECRETORY STRUCTURES (PLANT).

**Inflorescence.** Inflorescence structure, the way the flowers are clustered or arranged on a flowering branch, is almost as diverse as floral structure. To appreciate this, one need only contrast the drooping inflorescences (catkins) of a birch tree with the coiled flowers of a forget-me-not or with the solitary flower of a tulip. In some cases one kind of inflorescence characterizes a whole plant family. Queen Anne's lace and other members of the parsley family (Umbelliferae) have umbrellalike inflorescences with the flower stalks radiating from almost the same point in a cluster. The stalkless flowers (florets) of the grass family are grouped into clusters called spikelets, and these in turn are variously arranged in different grasses.

Flowers of the arum family (calla lily, jack-in-the-pulpit), also stalkless, are crowded on a thick, fleshy, elongate axis. In the composite family, florets are joined in a tight head at the end of the axis; the heads of some composites contain two kinds, centrally placed florets with small tubular corollas and peripheral ray florets with showy, strap-shaped corollas (the "petals" one plucks from a daisy). See INFLORESCENCE.

**Anatomy.** Some of the general anatomical features of leaves can be found in the floral appendages. A cuticle-covered epidermis overlies a core of parenchyma cells in which there are branching vascular bundles (solitary bundles in most stamens). Sepal parenchyma and petal parenchyma are often spongy, but palisade parenchyma occurs only rarely in flowers and then only in sepals. As in other parts of the plant, color comes mostly from plastids in the cytoplasm and from flavonoids in the cell sap. Cells of the petal epidermis may have folded side walls that interlock so as to strengthen the tissue. In some species the outer walls of the epidermis are raised as papillae; apparently, this is

part of the means of attracting pollinators, for the papillae are light reflectors.

**Stamen.** As a stamen develops, periclinal divisions in the second cell layer of each of its four lobes start a sequence that will end with the shedding of pollen. The first division makes two cell layers. The outer daughter cells give rise to the wall of the pollen sac, and the inner ones are destined to become pollen after further divisions. When mature, a pollen sac typically has a prominent cell layer just below a less distinctive epidermis. The inner wall and the side walls of an endothecium cell carry marked thickenings, but the outer wall does not. Splitting of the ripe anther is due partly to the way in which these differentially thickened walls react to drying and shrinking and partly to the smaller size of the cells along the line of splitting. See POLLEN.

**Carpel.** Like other floral parts, a carpel is made up of epidermis, parenchyma, and vascular tissue. In addition, a carpel commonly has a special tissue system on which pollen germinates and through which, or along which, pollen tubes are transmitted to the ovules. Most angiosperms have solid styles, and the transmitting tissue is a column of elongate cells whose softened walls are the medium for tubal growth. The epidermis at the stigmatic end of a carpel usually changes to a dense covering of papillae or hairs; the hairs can be unicellular or pluricellular, branched or unbranched. In taxa with hollow styles, the transmitting tissue is a modified epidermis running down the styler canal. There are two kinds of receptive surfaces, and they are distributed among the monocotyledons and the dicotyledons with taxonomic regularity. One kind has a fluid medium for germinating the pollen, and the other has a dry proteinaceous layer over the cuticle. The proteins of the dry stigmas have a role in the incompatibility reactions that encourage outbreeding.

**Ovule.** Ovule development usually takes place as the gynoecium forms, but it may be retarded when there is a long interval between pollination and fertilization (oaks, orchids). A typical ovule has a stalk (funiculus), a central bulbous body (nucellus), and one or two integuments (precursors of seed coats), which cover the nucellus except for a terminal pore (micropyle). Orientation of the ovule varies from group to group. It can be erect on its stalk or bent one way or another to differing degrees. There are also taxonomic differences in the extent to which the ovule is vascularized by branches from the gynoecial vascular system. See FRUIT; REPRODUCTION (PLANT). [R.H.E.]

**Fluid coupling** A device for transmitting rotation between shafts by means of the acceleration and deceleration of a

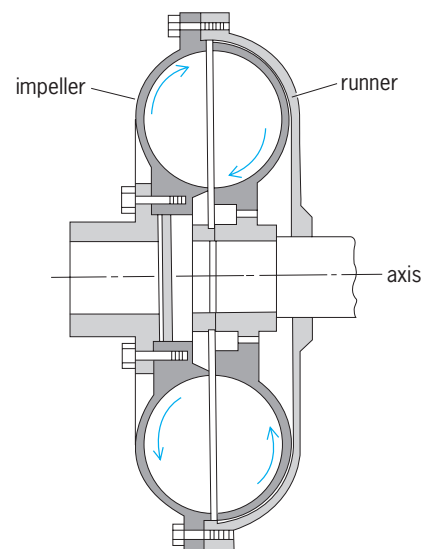

Basic fluid coupling.

hydraulic fluid. Structurally, a fluid coupling consists of an impeller on the input or driving shaft and a runner on the output or driven shaft. The two contain the fluid (see illustration). Impeller and runner are bladed rotors, the impeller acting as a pump and the runner reacting as a turbine. Basically, the impeller accelerates the fluid from near its axis, at which the tangential component of absolute velocity is low, to near its periphery, at which the tangential component of absolute velocity is high. This increase in velocity represents an increase in kinetic energy. The fluid mass emerges at high velocity from the impeller, impinges on the runner blades, gives up its energy, and leaves the runner at low velocity. See HYDRAULICS. [H.J.Wir.]

**Fluid flow** Motion of a fluid subjected to unbalanced forces or stresses. The motion continues as long as unbalanced forces are applied. For example, in the pouring of water from a pitcher the water velocity is very high over the lip, moderately high approaching the lip, and very low near the bottom of the pitcher. The unbalanced force is gravity, that is, the weight of the tilted water particles near the surface. The flow continues as long as water is available and the pitcher remains tilted. See FLUIDS.

A fluid may be a liquid, vapor, or gas. The term vapor denotes a gaseous substance interacting with its own liquid phase, for example, steam above water. If this phase interaction is not important, the vapor is simply termed a gas.

Gases have weak intermolecular forces and expand to fill any container. Left free, gases expand and form the atmosphere of the Earth. Gases are highly compressible; doubling the pressure at constant temperature doubles the density. See GAS.

Liquids, in contrast, have strong intermolecular forces and tend to retain constant volume. Placed in a container, a liquid occupies only its own volume and forms a free surface which is at the same pressure as any gas touching it. Liquids are nearly incompressible; doubling the pressure of water at room temperature, for example, increases its density by only 0.005%.

Liquids and vapors can flow together as a mixture, such as steam condensing in a pipe flow with cold walls. This constitutes a special branch of fluid mechanics, covering two-phase-flow.

The physical properties of a fluid are essential to formulating theories and developing designs for fluid flow. Especially important are pressure, density, and temperature.

Since shear stresses cause motion in a fluid and result in differences in normal stresses at a point, it follows that a fluid at rest must have zero shear and uniform pressure at a point. This is the hydrostatic condition. The fluid pressure increases deeper in the fluid to balance the increased weight of fluid above. For liquids, and for gases over short vertical distances, the fluid density can be assumed to be constant. See HYDROSTATICS.

When a fluid is subjected to shear stress, it flows and resists the shear through molecular momentum transfer. The macroscopic effect of this molecular action, for most common fluids, is the physical property called viscosity. Shear stress results in a gradient in fluid velocity; the converse is also true.

The common fluids for which the linear relationship of flow velocity and shear stress holds are called newtonian viscous fluids. More complex fluids, such as paints, pastes, greases, and slurries, exhibit nonlinear or non-newtonian behavior and require more complex theories to account for their behavior. See NEWTONIAN FLUID; NON-NEWTONIAN FLUID; VISCOSITY.

A common characteristic of all fluids, whether newtonian or not, is that they do not slip at a solid boundary. No matter how fast they flow away from the boundary, fluid particles at a solid surface become entrapped by the surface structure. The macroscopic effect is that the fluid velocity equals the solid velocity at a boundary. This is called the no-slip condition where the solid is fixed, so that the fluid velocity drops to zero there. No-slip sets up a slow-moving shear layer or boundary layer when fluid flows near a solid surface. The theory of boundary-layer flow is well developed and explains many effects involving viscous flow

past immersed bodies or within passages. See BOUNDARY-LAYER FLOW.

All fluids are at least slightly compressible, that is, their density increases as pressure is applied. In many flows, however, compressibility effects may be neglected. A very important parameter in determining compressibility effects is the Mach number  $Ma$ , or ratio of flow velocity  $V$  to fluid speed of sound. For subsonic flow,  $Ma < 1$ , whereas for supersonic flow,  $Ma > 1$ . The flow is essentially incompressible if  $Ma < 0.3$ ; hence for air the flow velocity is less than about 100 m/s (330 ft/s). Almost all liquid flows and many gas flows are thus treated as incompressible. Even a supersonic airplane lands and takes off in the incompressible regime. See COMPRESSIBLE FLOW; MACH NUMBER.

For various types of fluid flow see FLUID MECHANICS; HYDRODYNAMICS; ISENTROPIC FLOW; LAMINAR FLOW; PIPE FLOW; RAREFIED GAS FLOW; TURBULENT FLOW; WAKE FLOW. [F.M.Wh.]

**Fluid mechanics** The engineering science concerned with the relation between the forces acting on fluids (liquids and gases) and their motions, and with the forces caused by fluids on their surroundings. It is distinct from solid mechanics by virtue of the different responses of fluids and solids to applied forces. In an ideal elastic solid, the deflection or deformation is proportional to the applied stress, whereas a fluid cannot support an applied shear stress unless it is in motion. In most fluids, called simple or newtonian fluids, it is the rate of deformation of the fluid, as opposed to the amount of deformation in a solid, that is proportional to the applied stress. See FLUID FLOW; NEWTONIAN FLUID.

Many substances of everyday experience and of engineering importance are found naturally in the fluid state. These include water (liquid and vapor), air (gaseous and liquid), as well as other liquids and gases of natural and industrial importance. The most common fluids are newtonian under most flow conditions.

Fluid mechanics treats the fluid as a continuum, ignoring the fact that it actually consists of individual molecules that may be, in the case of gases, widely spaced compared to molecular dimensions. Nevertheless, the continuum assumption is valid for almost all applications down to the size of bacteria. An exception occurs with gases at very low densities, such as exist in the uppermost regions of the atmosphere. At extremely high altitudes the mean free paths of air molecules—that is, the distances they travel between collisions in random thermal motion—can become as large, or even larger than, the dimensions of a space vehicle, making the assumption of a continuum invalid. See RAREFIED GAS FLOW.

Fluid mechanics is of fundamental importance to a number of disciplines, including aerospace, chemical, civil, environmental, mechanical, and ocean engineering, as well as to climatology, geology, meteorology, and oceanography. Applications in these fields include, but are not limited to, the study of fluid forces acting on vehicles; flows in natural rivers and artificial channels and the flow of ground water; the dispersion of pollutants in the atmosphere, lakes, rivers, and oceans; the flows in the circulatory and pulmonary systems of humans and animals; the flows in pipelines that carry crude oil and natural gas over many hundreds, or even thousands, of miles from the petroleum fields of their origin to deep-water ports or refineries; the flow of molten plastics or metals filling molds in the manufacture of numerous solid parts; the flow in pumps for water distribution systems; and both hydraulic and gas turbines for power generation and propulsion. Fluid mechanics forms the basis for much of chemistry and physics, and is sometimes applied to such apparently remote fields as cosmology. The fluid mechanical behavior of gases and liquids plays an important role in the dispersion of dissolved or entrained substances. See AERODYNAMIC FORCE; AERODYNAMICS; BIOMEDICAL ENGINEERING; HYDRAULICS; HYDRODYNAMICS. [D.A.Ca.; J.A.Li.]

**Fluidization** The processing technique employing a suspension or fluidization of small solid particles in a vertically rising stream of fluid—usually gas—so that fluid and solid come into intimate contact. This is a tool with many applications in the petroleum and chemical process industries. Suspensions of solid particles by vertically rising liquid streams are of lesser interest in modern processing, but have been shown to be of use, particularly in liquid contacting of ion-exchange resins. However, they come in this same classification and their use involves techniques of liquid settling, both free and hindered (sedimentation), classification, and density flotation. See ION EXCHANGE; MECHANICAL CLASSIFICATION.

The interrelations of hydromechanics, heat transfer, and mass transfer in the gas-fluidized bed involve a very large number of factors. Because of the excellent contacting under these conditions, numerous chemical reactions are also possible—either between solid and gas, two fluidized solids with each other or with the gas, or most important, one or more gases in a mixture with the solid as a catalyst. In the usual case, the practical applications in plants have far outrun the exact understanding of the physical, and often chemical, interplay of variables within the minute ranges of each of the small particles and the surrounding gas phase.

With such excellent opportunities for heat and mass transfer to or from solids and fluids, fluidization has become a major tool in such fields as drying, roasting, and other processes involving chemical decomposition of solid particles by heat. An important application has been in the catalysis of gas reactions, wherein the excellent opportunity of heat transfer and mass transfer between the catalytic surface and the gas stream gives performance unequaled by any other system. See CATALYSIS; CRACKING; FLUIDIZED-BED COMBUSTION; GAS ABSORPTION OPERATIONS; HEAT TRANSFER; UNIT OPERATIONS. [D.F.O.]

**Fluidized-bed combustion** A method of burning fuel in which the fuel is continually fed into a bed of reactive or inert material while a flow of air passes up through the bed, causing it to act like a turbulent fluid. Fluidized beds have long been used for the combustion of low-quality, difficult fuels and have become a rapidly developing technology for the clean burning of coal. See FLUIDIZATION.

A fluidized-bed combustor is a furnace chamber whose floor is slotted, perforated, or fitted with nozzles. Air is forced through the floor and upward through the chamber. The chamber is partially filled with particles of either reactive or inert material, which will fluidize at an appropriate air flow rate. When fluidization takes place, the bed of material expands (bulk density decreases) and exhibits the properties of a liquid. As air velocity increases, the particles mix more violently, and the surface of the bed takes on the appearance of a boiling liquid. If air velocity were increased further, the bed material would be blown away.

Once the bed is fluidized, its temperature can be increased with ignitors until a combustible material can be injected to burn within the bed. Proper selection of air velocity, operating temperature, and bed material will cause the bed to act as a chemical reactor. The three broad areas of application of fluidized-bed combustion are incineration, gasification, and steam generation. See COAL GASIFICATION; COMBUSTION; GAS TURBINE; STEAM-GENERATING UNIT. [M.Po.]

**Fluids** Substances that flow under shear stress and have a density range from essentially zero (gases) to solidlike values (liquids). Fluids are one of the two major forms of matter. Solids, the other form, generally deform very little when shear forces are applied, and their densities do not change significantly with pressure or temperature.

The distinction between solids and fluids is easily seen in substances and mixtures which show a well-defined melting process. For substances with large molecules, such as polymers, ceramics, and biologicals, this distinction is less clear. Instead, there is

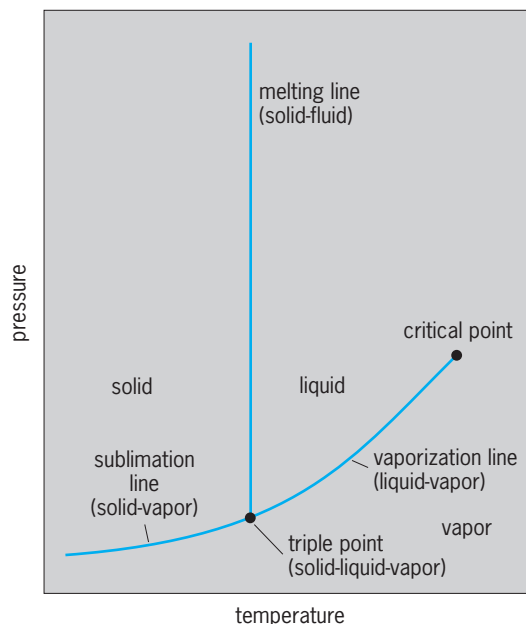

Conditions of pure-component phase behavior.

a slow evolution of structure and of resistance to flow as temperature or some other variable is changed. See GLASS TRANSITION; MELTING POINT; POLYMER.

Molecular density varies greatly in fluids and is their most important characteristic. The distinction between vapors (or gases) and liquids is most clear for substances and mixtures that show well-defined vaporizing (boiling) and condensing processes. The high-density liquid boils to make a low-density gaseous vapor. The illustration shows the pressures and temperatures for which pure substances are single phases. At the conditions of the lines between the single-phase regions, two phases can be observed to coexist. At the state of intersection of the lines (the triple point), three phases can coexist. For most substances, the triple-point pressure is well below atmospheric. However, for carbon dioxide, it is very high, so that dry ice sublimates rather than melts, as water ice does. Beyond the end of the liquid-vapor (saturation or vapor-pressure) line, vaporization and condensation cannot be observed. The state at the end of this line is called the critical point, where all the properties of the vapor and liquid become the same. There is no such end to the solid-liquid (or melting) line, because the solid and fluid structures cannot become the same. See CRITICAL PHENOMENA; PHASE TRANSITIONS; TRIPLE POINT.

Mixtures of fluids show the same general density and multiphase behavior as pure fluids, but the composition is an extra variable to be considered. For example, the density differences between the vapor and the liquid phases cause them to have different relative amounts of the components. This difference in composition is the basis of the separation process of distillation, where the vapor will be richer in some components while the liquid will be richer in others. It is also possible for mixtures of liquids to be partially or nearly wholly immiscible, as are water and oil. The separation process of liquid extraction, used in some metal-purification systems and chemical-pollution-abatement processes, depends on different preferences of chemical solutes for one liquid phase or the other. See DISTILLATION; EXTRACTION; PHASE RULE.

The usual observation of the presence of more than one fluid phase is the appearance of the boundary or interface between them. This is seen because the density or composition (or both) changes over a distance of a few molecular diameters, and this variation bends or scatters light in a detectable way. At the interface, the molecules feel different forces than in the bulk phases and thus have special properties. Energy is always required to create interface from bulk, the amount per unit area being called

the interfacial tension. Water is a fluid with an extremely high vapor-liquid (or surface) tension; this surface tension allows insects to crawl on ponds and causes sprinkler streams to break up into sprays of droplets. See INTERFACE OF PHASES; SURFACE TENSION.

In mixtures, the molecules respond differently to the interfacial forces, so the interfacial composition is generally different from that of the bulk. This has also been the basis of a separation process. If the difference of composition is great enough and it varies with time and position because of evaporation of one or more of the components, the interfacial forces can push the fluid into motion, as can be observed on the walls of a glass of brandy (the Marangoni effect). Some substances strongly adsorb at the interface because their chemical structure has one part that prefers to be in one phase, such as water, and another part that prefers the other phase, such as oil or air. Such surfactants or detergents help solubilize dirt into wash water, keep cosmetics and other immiscible mixtures together, and form foams when air and soapy water are whipped together. See ADSORPTION; DETERGENT; FOAM; SURFACTANT.

Besides the relations among pressure, density, temperature, and composition of static or equilibrium fluids, there are also characteristics associated with fluid flow, heat transfer, and material transport. For example, when a liquid or gas flows through a tube, energy must be supplied by a pump, and there is a drop in pressure from the beginning to the end of the tube that matches the rise in pressure in the pump. The pump work and pressure drop depend on the flow rate, the tube size and shape, the density, and a property of the molecules called the viscosity. The effect arises because the fluid molecules at the solid tube wall do not move and there are velocity gradients and shear in the flow. The molecules that collide with one another transfer momentum to the wall and work against one another, in a sort of friction which dissipates mechanical energy into internal energy or heat. The greater the viscosity, the greater the amount of energy dissipated by the collisions and the greater the pressure drop. If only chemical constitution and physical state are needed to characterize the viscosity, and if shear stress is directly proportional to velocity gradient, the fluid is called newtonian and the relation for pressure drop is relatively simple. If the molecules are large or the attractive forces are very strong over long ranges, as in polymers, gels, and foods such as bread dough and cornstarch, the resistance to flow can also depend on the rate of flow and even the recent deformations of the substance. These fluids are called non-newtonian, and the relationship of flow resistance to the applied forces can be very complex. See FLUID FLOW; NEWTONIAN FLUID; NON-NEWTONIAN FLUID; VISCOSITY.

Another fluid-transport property, thermal conductivity, indicates the ability of a static fluid to pass heat from higher to lower temperature. This characteristic is a function of chemical constitution and physical state, as is the viscosity. In mixtures, these properties may involve simple or complex dependence on composition, the variation becoming extreme if the unlike species strongly attract each other. The values of both properties increase rapidly near a critical point. See CONDUCTION (HEAT); HEAT TRANSFER.

Finally, the ability of molecules to change their relative position in a static fluid is called the diffusivity. This is a particularly important characteristic for separation processes whose efficiency depends on molecular motion from one phase to another through a relatively static interface, or on the ability of some molecules to move faster than others in a static fluid under an applied force. See DIFFUSION; GAS; LIQUID. [J.P.O'C.]

**Fluorescence** Fluorescence is generally defined as a luminescence emission that is caused by the flow of some form of energy into the emitting body, this emission ceasing abruptly when the exciting energy is shut off. In attempts to make this definition more meaningful it is often stated, somewhat arbitrarily, that the decay time, or afterglow, of the emission must be of

the order of the natural lifetime for allowed radiative transitions in an atom or a molecule, which is about  $10^{-8}$  s for transitions involving visible light. Perhaps a better distinction between fluorescence and its counterpart, phosphorescence, rests not on the magnitude of the decay time per se, but on the criterion that the fluorescence decay is temperature-independent.

In the literature of organic luminescence, the term fluorescence is used exclusively to denote a luminescence which occurs when a molecule makes an allowed optical transition. Luminescence with a longer exponential decay time, corresponding to an optically forbidden transition, is called phosphorescence, and it has a different special distribution from the fluorescence. See PHOSPHORESCENCE.

The decay time of fluorescent materials varies widely, from the order of  $5 \times 10^{-9}$  s for many organic crystalline materials up to 2 s for the europium-activated strontium silicate phosphor. Fluorescent materials with decay times between  $10^{-9}$  and  $10^{-7}$  s are used to detect and measure high-energy radiations, such as x-rays and gamma rays, and high-energy particles such as alpha particles, beta particles, and neutrons. These agents produce light flashes (scintillations) in certain crystalline solids, in solutions of many polynuclear aromatic hydrocarbons, or in plastics impregnated with these hydrocarbons. The so-called fluorescent lamps employ the luminescence of gases and solids in combination to produce visible light. See ABSORPTION; FLUORESCENT LAMP; LUMINESCENCE. [J.H.S.; C.C.K.]

**Fluorescence microscope** An instrument for the observation and study of microscopic specimens that absorb light and emit fluorescence. In most cases, in order to obtain specific and meaningful fluorescence, staining with fluorescing dyes called fluorophores or fluorochromes is necessary. Fluorescence microscopy is a highly sensitive method, since often minute quantities of a fluorophore can be visualized with good microscopic contrast. In appropriate applications, brightly fluorescing images can be observed against a dark background. Individual fluorophores have different absorption and emission spectra and a different quantum efficiency (the ratio between the energy absorbed and the energy emitted), factors that must be considered for optimum fluorescence. See BIOLUMINESCENCE; FLUORESCENCE.

The basics for fluorescence microscopy are the light source necessary to illuminate the specimen and the optics needed to observe the fluorescence. In addition, filters must be used to single out appropriate excitation and emission wavelengths. Excitation filters select out a limited range of excitation wavelengths from the light source that corresponds to the absorption spectrum of the fluorochrome. Barrier filters separate emitted light from unabsorbed exciting light. Fluorescence can then be observed by eye, photographed, measured by a photomultiplier, or recorded by a television camera. Two types of illumination are used in fluorescence microscopy: transmitted and incident. The earliest fluorescence microscopes relied on transmitted illumination, which generally used a dark-ground condenser to facilitate the separation of fluorescent and exciting light. With the development of epi-illumination, the exciting light reaches the preparation from above by way of a dichroic mirror and the objective, which at the same time acts as a condenser. Epi-illumination by means of a vertical illuminator, which permits the excitation with more wavelengths, is known as a fluorescence illuminator, and has become the routine instrument for fluorescence microscopy.

In laser-scanning fluorescence microscopy, the object is not illuminated as a whole but is scanned step by step with a laser-illuminated spot. From each point the fluorescence is measured and, after analog-to-digital conversion, stored as a matrix in computer memory. The main advantage of laser-scanning microscopy over conventional methods in fluorescence microscopy is the point-by-point illumination. Most stray light is avoided. In the confocal mode, the fluorescence from above and below the selected focal plane is almost completely eliminated from the



image, removing most of the glare experienced in conventional fluorescence microscopy of thicker specimens. Confocal fluorescence microscopy allows optical image sectioning of the specimen and, after combining the multiple images at different focal levels of a specimen, a computerized reconstruction of three-dimensional images of a section. See CONFOCAL MICROSCOPY; LASER.

The primary application of fluorescence microscopy is in the field of medicine, where diagnostic tests have been developed that use monoclonal antibodies to which a red, green, or blue fluorescent dye has been attached. The dyes thus reveal various components in the specimen, such as bacteria, viruses, or macromolecules like deoxyribonucleic acid (DNA) and ribonucleic acid (RNA). See IMMUNOFLUORESCENCE. [J.S.P.]

**Fluorescent lamp** A lamp that produces light largely by conversion of ultraviolet energy from a low-pressure mercury arc to visible light. Phosphors, chemicals that absorb radiant energy of a given wavelength and reradiate at longer wavelengths, produce most of the light provided by fluorescent lamps. See PHOSPHORESCENCE.

The lamp consists of a glass tube containing two electrodes, a coating of activated powdered phosphor, and small amounts of mercury. The glass tube seals the inner parts from the atmosphere. The electrodes provide a source of free electrons to initiate the arc, and are connected to the external circuit through the ends of the lamp. The phosphor converts short-wave ultraviolet energy into visible light. The mercury, when vaporized in the arc, produces the ultraviolet radiation that causes fluorescence. An inert gas, such as argon, krypton, or neon, introduced in small quantities provides the ions that facilitate starting of the lamp (see illustration). See FLUORESCENCE.

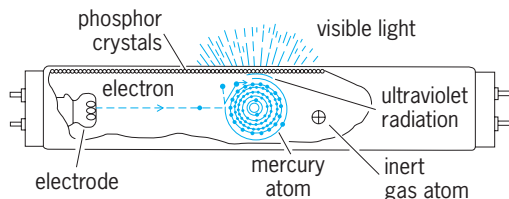

Parts of a typical fluorescent lamp.

Fluorescent lamps are usually operated on ac circuits with a frequency of 60 Hz. However, higher frequencies permit higher-efficacy lamp operation along with ballasts of lower power dissipation per watt. Consequently, systems have been developed for the operation of fluorescent lamps at frequencies from 360 to 50,000 Hz. The most important high-frequency ballasts operate the lamps in the 25-kHz range, are lighter in weight, can have flicker-free light output, and will continue to be more cost-effective as the cost of electricity increases. Electronic technology permits these ballasts to be made with more features, such as dimming and low-cost remote controls, enhancing their overall performance value.

Fluorescent lamps provide light at several times the efficacy of incandescent lamps, the exact ratio depending on the fluorescent lamp color. Lamp color is determined by the selection of chemicals used in the phosphors; various chemicals respond to the ultraviolet energy in the arc by producing different colors of light. Several types of essentially white fluorescent lamps are available commercially, as well as a range of tinted and saturated colors. [E.E.H.]

**Fluorine** A chemical element, F, atomic number 9, the member of the halogen family that has the lowest atomic number and atomic weight. Although only the isotope with atomic weight 19 is stable, the other, radioactive isotopes between atomic weight 17 and 22 have been artificially prepared. Fluorine is

the most electronegative element, and by a substantial margin the most chemically energetic of the nonmetallic elements. See PERIODIC TABLE.

**Properties.** The element fluorine is a pale yellow gas at ordinary temperatures. The odor of the element is somewhat in doubt. Some physical properties are listed in the table. The reactivity of the element is so great that it will react readily at ordinary temperatures with many other elementary substances, such as sulfur, iodine, phosphorus, bromine, and most metals. Since the products of the reactions with the nonmetals are in the liquid or gaseous state, the reactions continue to the complete consumption of the fluorine, frequently with the evolution of considerable heat and light. Reactions with the metals usually form a protective metallic fluoride which blocks further reaction, unless the temperature is raised. Aluminum, nickel, magnesium, and copper form such protective fluoride coatings.

Fluorine reacts with considerable violence with most hydrogen-containing compounds, such as water, ammonia, and all organic chemical substances whether liquids, solids, or gases. The reaction of fluorine with water is very complex, yielding mainly hydrogen fluoride and oxygen with less amounts of hydrogen peroxide, oxygen difluoride, and ozone. Fluorine displaces other nonmetallic elements from their compounds, even those nearest fluorine in chemical activity. It displaces chlorine from sodium chloride, and oxygen from silica, glass, and some ceramic materials. In the absence of hydrofluoric acid, however, fluorine does not significantly etch quartz or glass even after several hours at temperatures as high as 390°F (200°C).

Fluorine is a very toxic and reactive element. Many of its compounds, especially inorganic, are also toxic and can cause severe and deep burns. Care must be taken to prevent liquids or vapors from coming in contact with the skin or eyes.

**Natural occurrence.** At an estimated 0.065% of the Earth's crust, fluorine is roughly as plentiful as carbon, nitrogen, or chlorine, and much more plentiful than copper or lead, though much less abundant than iron, aluminum, or magnesium. Compounds whose molecules contain atoms of fluorine are widely distributed in nature. Many minerals contain small amounts of the element, and it is found in both sedimentary and igneous rocks.

**Uses.** Fluorine-containing compounds are used to increase the fluidity of melts and slags in the glass and ceramic industries. Fluorspar (calcium fluoride) is introduced into the blast furnace to reduce the viscosity of the slag in the metallurgy of iron. Cryolite,  $\text{Na}_2\text{AlF}_6$ , is used to form the electrolyte in the metallurgy of aluminum. Aluminum oxide is dissolved in this electrolyte, and the metal is reduced electrically from the melt. The use of halocarbons containing fluorine as refrigerants was patented in 1930, and these volatile and stable compounds found a market in aerosol propellants as well as in refrigeration and air-conditioning systems. However, use of fluorocarbons as propellants has declined sharply because of concern over their possible damage to the ozone layer of the atmosphere. A use for fluorine that became prominent during World War II is in the enrichment of the fissionable isotope  $^{235}\text{U}$ ; the most important process employed

#### Physical properties of fluorine

Property	Value
Atomic weight	18.998403
Boiling point, °C	-188.13
Freezing point, °C	-219.61
Critical temperature, °C	-129.2
Critical pressure, atm*	55
Density of liquid at b.p., g/ml	1.505
Density of gas at 0°C + 1 atm*, g/liter	1.696
Dissociation energy, kcal/mol	36.8
Heat of vaporization, cal/mol	1510
Heat of fusion, cal/mol	121.98
Transition temperature (solid), °C	-227.61

\*1 atm = 101.325 kilopascals.

uranium hexafluoride. This stable, volatile compound was by far the most suitable material for isotope separation by gaseous diffusion.

While consumers are mostly unaware of the fluorine compounds used in industry, some compounds have become familiar to the general public through minor but important uses, such as additives to toothpaste and nonsticking fluoropolymer surfaces on frying pans and razor blades (for example Teflon).

**Compounds.** In all fluorine compounds the high electronegativity of this element suggests that the fluorine atom has an excess of negative charge. It is convenient, however, to divide the inorganic binary fluorides into saltlike (ionic lattice) nonvolatile metallic fluorides and volatile fluorides, mostly of the nonmetals. Some metal hexafluorides and the noble-gas fluorides show volatility that is frequently associated with a molecular compound. Volatility is often associated with a high oxidation number for the positive element.

The metals characteristically form nonvolatile ionic fluorides where electron transfer is substantial and the crystal lattice is determined by ionic size and the predictable electrostatic interactions. When the coordination number and valence are the same, for example,  $\text{BF}_3$ ,  $\text{SiF}_4$ , and  $\text{WF}_6$ , the binding between metal and fluoride is not unusual, but the resulting compounds are very volatile, and the solids show molecular lattices rather than ionic lattice structures. For higher oxidation numbers, simple ionic lattices are less common and, while the bond between the central atom and fluorine usually still involves transfer of some charge to the fluorine, molecular structures are identifiable in the condensed phases.

In addition to the binary fluorides, a very large number of complex fluorides have been isolated, often with a fluoroanion containing a central atom of high oxidation number. The binary saltlike fluorides show a great tendency to combine with other binary fluorides to form a large number of complex or double salts.

The fluorine-containing compounds of carbon can be divided into fluorine-containing hydrocarbons and hydrocarbon derivatives (organic fluorine compounds) and the fluorocarbons and their derivatives. The fluorine atom attached to the aromatic ring, as in fluorobenzene, is quite unreactive. In addition, it reduces the reactivity of the molecule as a whole. Dyes, for example, that contain fluorine attached to the aromatic ring are more resistant to oxidation and are more light-fast than dyes that do not contain fluorine. Most aliphatic compounds, such as the alkyl fluorides, are unstable and lose hydrogen fluoride readily. These compounds are difficult to make and to keep and are not likely to become very important. See FLUOROCARBON; HALOGEN ELEMENTS. [I.S.]

**Organic compounds.** The carbon compounds containing fluorine belong to several classes, depending on what other substituents besides fluorine are present. The physical properties and chemical reactivity of organic molecules containing fluorine are quite different when compared to the same molecules containing other halogen atoms, such as chlorine. This is due, in part, to a unique combination of the properties of fluorine, which include its small atomic size and high electronegativity. Stepwise replacement of several or all of the hydrogen atoms or other substituents attached to carbon is possible.

Many methods are available for creating a carbon-to-fluorine bond. A widely used method is to exchange a chlorine attached to carbon by reacting the compound with hydrofluoric acid. Elemental fluorine, which is very highly reactive, has also been used to prepare fluorine-containing compounds from a wide variety of organic compounds. The unusual property imparted to an organic molecule by fluorine substitution has led to the development of compounds that fulfill specific needs in refrigeration, medicine, agriculture, plastics, textiles, and other areas.

**Fluoroolefins.** These are a class of unsaturated carbon compounds containing fluorine; that is, they have a  $\text{C}=\text{C}$  in addition to other substituents. A typical fluoroolefin is tetrafluoroethy-

lene ( $\text{F}_2\text{C}=\text{CF}_2$ ). It is prepared from chlorodifluoromethane ( $\text{CHClF}_2$ ), which loses  $\text{HCl}$  upon heating to produce  $\text{F}_2\text{C}=\text{CF}_2$ .

Many fluoroolefins combine with themselves or other olefins by the process of polymerization. Thus, polymerization of  $\text{F}_2\text{C}=\text{CF}_2$  yields the polymer polytetrafluoroethylene (PTFE). This remarkable solid substance has outstanding physical and chemical properties. Nonstick polytetrafluoroethylene surfaces are used in kitchen utensils, bearings, skis, and many other applications. Since polytetrafluoroethylene is very viscous above its melting point, special methods have to be used for fabrication. For this reason, copolymers of tetrafluoroethylene with such olefins as ethylene have been developed. The chemical resistance of these copolymers is less than that of perfluorinated polymers. To obtain polymers with desired properties, the chemical processes to make them are carried out under rigorously controlled conditions. See COPOLYMER; POLYFLUOROOLEFIN RESINS; POLYMER; POLYMERIZATION.

There are many oxygen-containing fluorocarbons such as ethers, acids, ketones, and alcohols. Simple, fluorinated ethers are compounds of the type  $\text{R-O-R}$ , where R is a fluorinated alkyl group. The simple compound perfluoro ether ( $\text{F}_3\text{COCF}_3$ ) is an analog of dimethyl ether. See ETHER.

Organofluorine chemicals offer some unique properties and solutions. In addition to the applications mentioned above, they are used in dyes, surfactants, pesticides, blood substitutes, textile chemicals, and biologically active compounds. See FLUOROCARBON; HALOGENATED HYDROCARBON. [V.N.M.R.]

**Fluorite** A mineral of composition  $\text{CaF}_2$ . It is the most abundant fluorine-bearing mineral, and occurs as cubes or compact masses and more rarely as octahedra with complex modifications. Fluorite has a perfect octahedral cleavage, hardness 4 (Mohs scale), and specific gravity 3.18. The color is extremely variable, the most common being green and purple; but fluorite may also be colorless, white, yellow, blue, or brown. Colors may result from the presence of impurity ions. Fluorite frequently emits a blue-to-green fluorescence under ultraviolet radiation, especially if rare-earth or hydrocarbon material is present. Some fluorites are thermoluminescent; that is, they emit light when heated.

Fluorite occurs as a typical hydrothermal vein mineral with quartz, barite, calcite, sphalerite, and galena. Crystals of great beauty from Cumberland, England, and Rosiclare, Illinois, are highly prized by mineral fanciers. It also occurs as a metasomatic replacement mineral in limestones and marbles. [P.B.M.]

**Fluorocarbon** Any of the organic compounds in which all of the hydrogen atoms attached to a carbon atom have been replaced by fluorine; also referred to as a perfluorocarbon. Fluorocarbons are usually gases or liquids at room temperature, depending on the number of carbon atoms in the molecule. A major use of gaseous fluorocarbons is in radiation-induced etching processes for the microelectronics industry; the most common one is tetrafluoromethane. Liquid fluorocarbons possess a unique combination of properties that has led to their use as inert fluids for cooling of electronic devices and soldering. Solubility of gases in fluorocarbons has also been used to advantage. For example, they have been used in biological cultures requiring oxygen, and as liquid barrier filters for purifying air. See FLUORINE; HALOGENATED HYDROCARBON. [V.N.M.R.]

**Flutter (aeronautics)** An aeroelastic self-excited vibration with a sustained or divergent amplitude, which occurs when a structure is placed in a flow of sufficiently high velocity. Flutter is an instability that can be extremely violent. At low speeds, in the presence of an airstream, the vibration modes of an aircraft are stable; that is, if the aircraft is disturbed, the ensuing motion will be damped. At higher speeds, the effect of the airstream is to couple two or more vibration modes such that the vibrating structure will extract energy from the airstream.

The coupled vibration modes will remain stable as long as the extracted energy is dissipated by the internal damping or friction of the structure. However, a critical speed is reached when the extracted energy equals the amount of energy that the structure is capable of dissipating, and a neutrally stable vibration will persist. This is called the flutter speed. At a higher speed, the vibration amplitude will diverge, and a structural failure will result. See AEROELASTICITY.

Aircraft manufacturers now have engineering departments whose primary responsibility is fluffer safety. Modern flutter analyses involve extensive computations, requiring the use of large-capacity, high-speed digital computers. Flutter engineers contribute to the design by recommending stiffness levels for the structural components and control surface actuation systems and weight distributions on the lifting surfaces, so that the aircraft vibration characteristics will not lead to flutter within the design speeds and altitudes. See AIRFRAME; WING. [W.P.R.]

**Fluvial erosion landforms** Landforms that result from erosion by water flowing on land surfaces. This water may concentrate in channels as streams and rivers or flow in thin sheets and rills down slopes. Essentially all land surfaces are subjected to modification by running water, and it is among the most important surface processes. Valleys are cut, areas become dissected, and sediment is moved from land areas to ocean basins. With increasing dissection and lowering of the landscape, the land area may pass through a series of stages known as the fluvial erosion cycle.

The most distinctive fluvial landform is the stream valley. Valleys range greatly in size and shape, as do the streams that flow in them. They enlarge both through down and lateral cutting by the stream and mass wasting processes acting on the valley sides.

Waterfalls occur where there is a sudden drop in the stream bed. This is often the case where a resistant rock unit crosses the channel and the stream is not able to erode through it at the same rate as the adjacent less resistant rock. Waterfalls also occur where a main valley has eroded down at a faster rate than its tributary valleys which are left hanging above the main stream. With time, waterfalls migrate upstream and are reduced to rapids.

Many streams flow in a sinuous or meandering channel, and stream velocity is greatest around the outside of meander bends. Erosion is concentrated in this area, and a steep, cut bank forms. If the river meander impinges against a valley wall, the valley will be widened actively.

A stream terrace represents a former floodplain which has been abandoned as a result of rejuvenation or downcutting by the stream. It is a relatively flat surface with a scarp slope that separates it from the current floodplain or from a lower terrace. Terraces are common features in valleys and are the result of significant changes in the stream system through time. See FLOODPLAIN.

Fluvial erosion also has regional effects. Streams and their valleys form a drainage network which reflects the original topography and geologic conditions in the drainage basin. A dendritic drainage pattern, like that of a branching tree, is the most common and reflects little or no control by underlying earth materials. Where the underlying earth materials are not uniform in resistance, streams develop in the least resistant areas, and the drainage pattern reflects the geology. If the rocks contain a rectangular joint pattern, a rectangular drainage pattern develops; if the rock units are tilted or folded, a trellis pattern of drainage is common. Topography also controls drainage development; parallel and subparallel patterns are common on steep slopes, and a radial pattern develops when streams radiate from a central high area. See EROSION; RIVER; STREAM TRANSPORT AND DEPOSITION. [W.H.J.]

**Fluvial sediments** Deposits formed by rivers. A river accumulates deposits because its capacity to carry sediment has

been exceeded, and some of the sediment load is deposited. Such accumulations range from temporary bars deposited on the insides of meander bends as a result of a loss of transport energy within a local eddy, to deposits tens to hundreds of meters thick formed within major valleys or on coastal plains as a result of the response of rivers to a long-term rise in base level or to the uplift of sediment source areas relative to the alluvial plain. The same processes control the style of rivers and the range of deposits that are formed, so that a study of the deposits may enable the geologist to reconstruct the changes in controlling factors during the accumulation of the deposits. See DEPOSITIONAL SYSTEMS AND ENVIRONMENTS; RIVER; STREAM TRANSPORT AND DEPOSITION.

Coarse debris generated by mechanical weathering, including boulders, pebbles, and sand, is rolled or bounced along the river bed and is called bedload. The larger particles may be moved only infrequently during major floods. Finer material, of silt and clay grade, is transported as a suspended load, and there may also be a dissolved load generated by chemical weathering. Whereas the volume of sediment tends to increase downstream within a drainage system, as tributaries run together, the grain size generally decreases as a result of abrasion and selective transport. This downstream grain-size decrease may assist in the reconstruction of transport directions in ancient deposits where other evidence of paleogeography has been obscured by erosion or tectonic change. See MASS WASTING.

River deposits of sediment occur as four main types. (1) Channel-floor sediments consist of the coarsest bedload, such as gravel, waterlogged vegetation, or fragments of caved bank material. (2) Bar sediments are accumulations of gravel, sand, or silt which occur along river banks and are deposited within channels, forming bars that may be of temporary duration, or may last for many years, eventually becoming vegetated and semipermanent. (3) Channel-top and bar-top sediments are typically composed of fine-grained sand and silt, and are formed in the shallow-water regions on top of bars, in the shallows at the edges of channels, and in abandoned channels. (4) Floodplain deposits are formed when the water level rises above the confines of the channel and overflows the banks. Much of the coarser floodplain sediment is deposited close to the channel, in the form of levees; silt and mud may be carried considerable distances from the channel, forming blanketlike deposits. See FLOODPLAIN.

The thickest (up to 6 mi or 10 km) and most extensive fluvial deposits occur in convergent plate-tectonic settings, including regions of plate collision, because this is where the highest surface relief and consequently the most energetic rivers and most abundant debris are present. Some of the most important accumulations occur in foreland basins, which are formed where the continental margin is depressed by the mass of thickened crust formed by convergent tectonism. See BASIN.

Thick fluvial deposits also occur in rift basins, where continents are undergoing stretching and separation. The famous hominid-bearing sediments of Olduvai Gorge and Lake Rudolf are fluvial and lacustrine deposits formed in the East Africa Rift System. Fluvial deposits are also common in wrench-fault basins, such as those in California.

Significant volumes of oil and gas are trapped in fluvial sandstones. Placer gold, uranium, and diamond deposits of considerable economic importance occur in the ancient rock record in South Africa and Ontario, Canada, and in Quaternary deposits in California and Yukon Territory. Fluvial deposits are also essential aquifers, especially the postglacial valley-fill complexes of urban Europe and North America. [A.D.M.]

**Fluxional compounds** Molecules that undergo rapid intramolecular rearrangements among equivalent structures in which the component atoms are interchanged. The rearrangement process is usually detected by nuclear magnetic resonance (NMR) spectroscopy. With sufficiently rapid rates, a single resonance is observed in the NMR spectrum for a molecule that

might be expected to have several nonequivalent nuclei on the basis of its instantaneous structure.

Within organic chemistry, degenerate Cope rearrangements represented some of the first examples of interconversions between equivalent structures, but these were relatively slow. The rate of this rearrangement is rapid in more complex molecules. The epitome of degeneracy is reached in bullvalene, which has more than 1,200,000 equivalent structures and rapidly interconverts among them.

Fluxional molecules are frequently encountered in organometallic chemistry, and rapid rearrangements which involve migrations about unsaturated organic rings are commonly observed. The best known (called ring-whizzers) are cyclopentadienyl and cyclooctatetraene complexes of iron.

Inorganic structures also exhibit fluxional phenomena, and five-coordinate complexes provide the greatest number of well-known examples, one being phosphorus pentafluoride (PF<sub>5</sub>).

The rearrangement of PF<sub>5</sub> involves interconversion of the trigonal bipyramidal molecule to a square pyramidal configuration and back. If two such nonequivalent structures are present in observable concentrations but interconvert rapidly to cause averaging in the NMR experiments, they are said to be stereochemically nonrigid. This term is generally taken to embrace all compounds that undergo rapid reversible intramolecular rearrangements. Thus, fluxional compounds are a subset of nonrigid compounds with equivalent structures. Nonequivalent structures, that is, tautomers, might be stereochemically nonrigid if they rearranged rapidly, but would not be considered fluxional.

Some workers prefer to reserve the term fluxional for molecules in which bonds are broken and reformed in the rearrangement process. Hence, of the examples above, only bullvalene and the iron complexes would be termed fluxional, whereas all would be considered stereochemically nonrigid. See NUCLEAR MAGNETIC RESONANCE (NMR); RESONANCE (MOLECULAR STRUCTURE); TAUTOMERISM. [J.W.F.]

**Fly** A member of the insect order Diptera. Insects of other orders are popularly called flies; mayflies, stoneflies, dragonflies, dobsonflies, and caddis flies all have four wings and therefore are not true flies. Mosquitoes, gnats, and midges all have two wings and are therefore also true flies, order Diptera. Hindwings of all Diptera are greatly reduced balancing organs called halteres.

Flies are a numerous and diverse lot, with over 85,000 described species worldwide. North America has 16,000 species belonging to 107 families. Flies are old, their fossils dating from the Triassic, over 200,000,000 years ago.

The flies of greatest importance to humanity are those that suck blood from people or domestic animals. Females of many mosquitoes, deerflies, horseflies, blackflies, and gnats require a meal of blood before producing eggs. When biting, they may introduce pathogenic microorganisms. Mosquitoes may transmit malaria, yellow fever, viral encephalitis, or parasitic roundworms. Tropical blackflies transmit onchocerciasis (river blindness), and sandflies transmit leishmaniasis, a debilitating protozoan infection. Tsetse flies, in which both sexes bite, transmit African sleeping sickness.

Some flies that do not bite may become a nuisance because of their sheer numbers and association with human habitations. The ubiquitous housefly is bothersome and, in unsanitary situations, may contaminate food with the pathogens of hepatitis, polio, cholera, typhoid, or tuberculosis.

Many thousands of flies are predatory, and they doubtless help to suppress populations of insect pests. Especially important are larvae of the family Syrphidae that eat up to 50 aphids per day. Scavenging Diptera are quite important in aiding the quick breakdown of dead animals and plants. See DIPTERA; ENTOMOLOGY, ECONOMIC. [D.J.Hor.]

**Flywheel** A rotating mass used to maintain the speed of a machine between given limits while the machine releases or

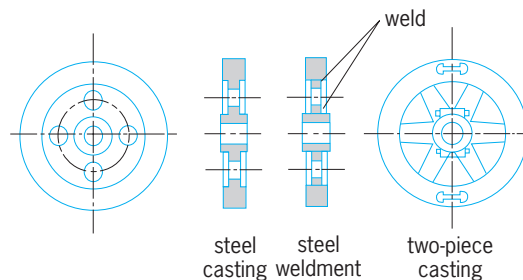

Typical flywheel structures.

receives energy at a varying rate. A flywheel is an energy storage device. It stores energy as its speed increases, and gives up energy as the speed decreases. The specifications of the machine usually determine the allowable range of speed and the required energy interchange.

The difficulty of casting stress-free spoked flywheels leads the modern designer to use solid web castings or welded structural steel assemblies. For large, slow-turning flywheels on heavy-duty diesel engines or large mechanical presses, cast-spoked flywheels of two-piece design are standard (see illustration). See ENERGY STORAGE. [L.S.L.]

**Foam** A material made up of gas bubbles separated from one another by films of liquid. The bubbles are spherical when the liquid films separating them are thick (approximately 0.01 mm). Pure liquids do not foam; that is to say, they cannot produce liquid films of any permanence. Relatively permanent films are created only when a substance is present that is adsorbed at the surface of the liquid. Substances capable of being so adsorbed may be in true solution in the liquid or may be particles of a finely divided solid, which, because of poor wetting by the liquid, remain at the surface. In both cases, surface layers of the added substance are produced. The reluctance of the adsorbed substance to enter the bulk of the liquid preserves the surface and, hence, the thermodynamic stability of the foam. See SURFACTANT.

Although thermodynamically stable, a foam is mechanically fragile. Offsetting this fragility to some extent are mechanisms that provide the liquid films with resiliency and plasticity.

Although foams of exceptional stability are desired in some commercial applications, foam is a nuisance in many situations. A common recourse is the addition of chemical antifoams, which are usually insoluble liquids of very low surface tension. When a droplet of such a liquid is sprayed onto the foam or is carried into it by mechanical agitation, it spreads spontaneously and rapidly at the surface of the film, virtually sweeping the film away as it does so. See ADSORPTION; INTERFACE OF PHASES; SURFACE TENSION. [S.Ro.]

**Focal length** A measure of the collecting or diverging power of a lens or an optical system. Focal length, usually designated  $f'$  in formulas, is measured by the distance of the focal point (the point where the image of a parallel entering bundle of light rays is formed) from the lens, or more exactly by the distance from the principal point to the focal point. See GEOMETRICAL OPTICS.

The power of a lens system is equal to  $n'/f'$ , where  $n'$  is the refractive index in the image space ( $n'$  is usually equal to unity). A lens of zero power is said to be afocal. Telescopes are afocal lens systems. See DIOPTRIC; LENS (OPTICS); TELESCOPE. [M.J.H.]

**Fog** A cloud comprising water droplets or (less commonly) ice crystals formed near the ground and resulting in a reduction in visibility to below 0.6 mi (1 km). This is lower than that occurring in mist, comprising lower concentration of water droplets, and haze, comprising smaller-diameter aerosol particles.

Fog results from the cooling of moist air below its saturation (dew) point. Droplets form on hygroscopic nuclei originating from ocean spray, combustion, or reactions involving trace chemicals in the atmosphere. Visibility is reduced even more when such nuclei are present in high concentrations and faster cooling rates activate a larger fraction of such nuclei. Thus, polluted fog, with more numerous smaller droplets, results in lower visibility for a given water content. See DEW POINT.

Haze, the precursor to fog and mist, forms at relative humidity below 100% to about 80%. It is composed of hygroscopic aerosol particles grown by absorption of water vapor to a diameter of about 0.5 micrometer, concentration 1000 to 10,000 per cubic centimeter. Fog and mist form as the relative humidity increases just beyond saturation (100%), so that larger haze particles grow into cloud droplets with a diameter of 10  $\mu\text{m}$  and a concentration of several hundred per cubic centimeter. Fog and mist are a mix of lower-concentration cloud droplets and higher-concentration haze particles. By contrast, smog is formed of particles of 0.5–1- $\mu\text{m}$  diameter, produced by photochemical reactions with organic vapors from automobile exhaust. See ATMOSPHERIC CHEMISTRY; HUMIDITY; SMOG. [J.Hal.]

**Fold and fold systems** Layered rocks that have been distorted into wavelike forms. Some folds are fractions of an inch across and have lengths measured in inches, whereas others are a few miles wide and tens of miles long.

Some terms used to describe folds are shown in the illustration. The axial surface divides a fold into two symmetrical parts, and the intersection of the axial surface with any bed is an axis. In general, an axis is undulatory, its height changing along the trend of the fold. Relatively high points on an axis are culminations; low points are depressions. The plunge of a fold is the angle between an axis and its horizontal projection. The limbs or flanks are the sides. A limb extends from the axial surface of one fold to the axial surface of the adjacent fold. Generally, the radius of curvature of a fold is small compared to its wavelength and amplitude, so that much of the limb is planar. The region of curvature is the hinge. See ANTICLINE; SYNCLINE.

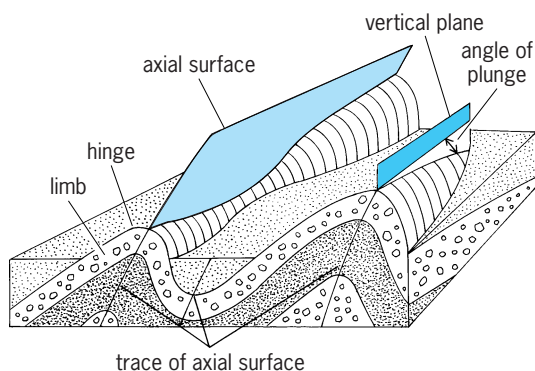

Elements of folds.

The geometry of folds is described by the inclination of their axial surfaces and their plunges. Upright folds have axial surfaces that dip from  $81^\circ$  to  $90^\circ$ ; inclined folds have axial surfaces that dip from  $10^\circ$  to  $80^\circ$ ; and recumbent folds have axial surfaces that dip less than  $10^\circ$ . Vertical folds plunge from  $81^\circ$  to  $90^\circ$ ; plunging folds plunge from  $10^\circ$  to  $80^\circ$ ; and horizontal folds plunge less than  $10^\circ$ . Auxiliary descriptive terms depend on the attitude or the relative lengths of the limbs. Overturned folds are inclined folds in which both limbs dip in the same direction; isoclinal folds are those in which both limbs are parallel; symmetrical folds have limbs of equal length; and asymmetrical folds have limbs of unequal length. The descriptions of folds consist of combinations of the above terms, for example, isoclinal upright horizontal fold, overturned plunging fold, asymmetrical inclined horizontal fold.

In a section of folded rocks the layers possess different rheological properties; some have apparent stiffness (competency), whereas others behave less stiffly (incompetency). The most competent layers or group of layers control the folding, and the less competent units tend to conform to the fold-form of the most competent units.

Folds generally do not occur singly but are arranged in festoons in mobile belts with lengths of thousands of miles and widths of hundreds of miles. The folds of these belts, or fold systems, commonly consist of great complex structures composed of many smaller folds. The development of fold systems is closely tied to concepts of global tectonics. The favored hypothesis is that of plate tectonics, in which fold systems are formed at converging margins where continents are overridden by oceanic crust, or where collision occurs between a continent and an island arc or between two continents. [P.H.O.]

**Folic acid** A yellow vitamin, slightly soluble in water, which is usually found in conjugates containing varying numbers of glutamic acid residues. It is also known as pteroylglutamic acid (PGA), and has the structural formula shown.

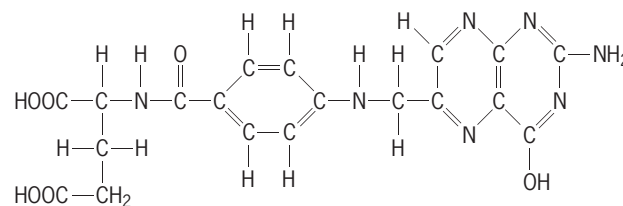

Folic acid is so widespread in nature and intestinal synthesis is so great that a folic acid deficiency in humans because of low dietary intake is probably not very common. Deficiencies of other nutrients (particularly iron, ascorbic acid, or vitamin B<sub>12</sub>) may lead to a number of clinical conditions in which folic acid deficiency is involved. These include various nutritional macrocytic anemias, sprue, idiopathic steatorrhea, and pernicious anemia. See VITAMIN. [S.N.G.]

**Food** Any substance taken into the body for the purpose of providing nourishment. However, factors such as satisfying social needs, achieving psychological ends, and satisfying hunger, more than nutritional needs, govern the selection and consumption of foods. When foods are selected carefully, they can provide all of the essential nutrients needed for normal functioning of the human body. In this context, food is necessary to provide energy, to provide structural components for building and repairing body tissues, and to regulate body processes. See METABOLISM; NUTRITION.

There are essential nutrients (carbohydrates, fats, proteins, minerals, vitamins, and water) that have specific functions in the human body. When the energy-yielding nutrients, that is, carbohydrates, fats, and proteins, are oxidized in the body, energy is captured in a chemical compound known as adenosine triphosphate (ATP), which will then release the energy slowly so that it can be used for physical activity (work), heat production, and metabolic processes. Enzymes, vitamins, and minerals, as well as water, are needed in order for these oxidation reactions to take place. Energy requirements are expressed in terms of kilocalories (kcal), calories (cal), or kilojoules (kJ). Fats and carbohydrates contain only the elements carbon, oxygen, and hydrogen. Since fats contain less oxygen than carbohydrates, they have greater potential for oxidation and thus provide more energy per gram than carbohydrates. Proteins also contain nitrogen, but this does not contribute substantially to the energy value. The physiological fuel value, or the amount of energy generated in the body, of 1 gram of protein is 4 kcal (17 kJ); carbohydrate, 4 kcal (17 kJ); fat, 9 kcal (38 kJ). See ENZYME; VITAMIN.

Although it is unlikely that any individual food or combination of foods can provide complete disease protection, risk of chronic disease can be reduced by increased consumption of plant-based foods and decreased consumption of fats. See FOOD ENGINEERING; FOOD MANUFACTURING; FOOD MICROBIOLOGY; FOOD SCIENCE. [B.P.KI.]

**Food engineering** The application of engineering concepts and principles to the conversion of raw foods into safe consumer products of the highest possible quality. The entire spectrum of food engineering is associated with operation and maintenance of food processing plants as well as sophisticated research involving process design.

The applications of engineering in food handling, processing, packaging, and distribution can be described in terms of unit operations. There are many different unit operations associated with the conversion of raw food materials to consumer products. The movement of foods and other materials within the processing plant requires the use of unique equipment and processes. For example, special sanitary pumps are used to transport liquid foods, and the material-handling equipment for solid foods requires careful design for product-contact surfaces.

The importance of thermal treatments for food preservation requires that a broad range of heat-exchange equipment be used. Heat exchangers for liquids are unique in terms of sanitary design and cleanability of surfaces following thermal processing. A special component of thermal preservation is the design of thermal processes.

Several unit operations involve heat transfer in order to achieve the desired preservation even though storage stability is not the direct result of thermal treatment. An excellent example is the freezing process, where removal of thermal energy reduces product temperatures to levels where deterioration reactions are significantly inhibited. Concentration processes achieve a degree of preservation by reducing the availability of water for deterioration reactions, although the primary aim is reduction of liquid-product mass and volume. Although traditional concentration processes have used thermal energy to evaporate water, membranes of various types are now used to achieve the same results. The preservation of food products is achieved by reduction of the water content to low levels by means of dehydration processes which use thermal energy. These processes are applied to liquid foods and to products that are naturally solid.

Another series of unit operations is used to alter the product composition or structure in some manner. These include separation, mixing, and extrusion. Separation processes are designed to divide food products into two or more components. While a variety of physical or chemical properties of the product components are used in the various separation processes, two of the most important processes are filtration and extraction. Filtration, a physical process, has several applications in addition to its use for separating product components. Extraction is most often designed to remove a specific or unique product component for use in a separate operation or product formulation. After separation, the final product is obtained through the use of a mixing process which includes a variety of equipment types. Finally, the extrusion process involves the use of both thermal and flow properties to achieve product preservation as well as some specified set of structural and textural characteristics.

The importance of cleaning and sanitation must be emphasized due to direct relationships to final product quality. The required operations vary considerably depending on the type of product handled and the type of equipment used. The processes required to manage the wastes generated during food handling, processing, packaging, and distribution are all similar, and many of the waste-handling and treatment operations are the same as those used directly with the food products.

The final operation to which the product is subjected before distribution is packaging. The package barrier is important for maintaining food products at desirable quality levels. Food pack-

aging involves the selection of equipment needed for placing the product in the package as well as the selection of packaging material needed to protect the product in an optimum manner.

An engineering input to food handling, processing, packaging, and distribution that is applied to almost all unit operations is process control. The use of instrumentation and associated electronic controls has a significant impact on the efficiency of all components of the food delivery system. See FOOD; FOOD MANUFACTURING; FOOD MICROBIOLOGY; FOOD PRESERVATION; FOOD SCIENCE; UNIT OPERATIONS. [D.R.H.]

**Food fermentation** Production of food with the aid of microorganisms, which may be yeasts, molds, or bacteria. Fermented commodities include cereals such as wheat, rice, sorghum, corn; legumes, peanuts, soybeans, pulses; red meat, sausages, pork; milk; fish, shellfish; and plant juices. There are countless varieties of food fermentations in the world, sometimes known under different names in different countries and varying greatly in complexity. See FERMENTATION.

Among the molds used in food fermentations are *Aspergillus*, *Rhizopus*, *Penicillium*, *Neurospora*, *Actinomucor*, *Mucor*, *Amylomyces*, and *Monascus*. The yeasts include species of *Saccharomyces*, *Zygosaccharomyces*, and *Candida*. The bacteria are *Bacillus* and lactic acid bacteria, including *Lactobacillus*, *Streptococcus*, *Pediococcus*, and *Leuconostoc*.

The inoculum or fermentation starter may be of four types. The substrate may be moistened, heat-sterilized, and inoculated with a single organism. In a second type, more than one strain of a single species is used. A third type of inoculum contains more than one species of microorganism. Finally, some substrates contain a complex inoculum in which many different microorganisms of unknown identity are present. [C.W.H.]

**Food manufacturing** A total sequence of food operations, including the growth and selection of raw materials, harvesting, processing, preservation, and distribution. In general, the aim of all food manufacturing operations is to extend the availability of seasonal crops to year-round use.

The products of food manufacturing differ from traditional foods of plant or animal origin which have undergone minimal treatment. For example, the quality of apples sold in the winter can be maintained, through the use of controlled-atmosphere storage, which retards the ripening process by controlling the levels of oxygen, nitrogen, and carbon dioxide in the atmosphere of the storage facility. Atmosphere control is also used to hasten ripening so that fruits may be harvested in the unripe stage for ease of handling and then ripened rapidly in storage. In other cases the package itself allows the diffusion of only certain atmospheric gases and thus maintains quality. There are certain foods that cannot be maintained in a state close to the raw product. Tomatoes, for example, are not amenable to freezing or long periods of storage. Therefore, such products as heat-processed sauces, pastes, and stewed tomatoes have been developed. Other food products are even further removed from the raw product: oil is produced from seed; and plant proteins are used as extenders or substitutes for meat, as additives for nutritious beverages, and as bases for many formulated foods.

There are many other forms of food preservation representing both ancient and modern technologies. The ancient operation of sun-drying was first employed when it was realized that dried fruits remained wholesome and edible for long periods of time. Today, with the additional knowledge that drying, evaporation, and concentration all reduce the water activity or increase the osmotic pressure of a food to the point where bacteria will not grow, this technology is used for sophisticated products such as powdered milk and freeze-dried mushrooms. Food additives, such as salt, sugar, and other solutes, which reduce the water activity or increase the osmotic pressure, and acids, which inhibit bacterial growth, also achieve the preservation effect. Many food additives are natural in origin, and their preservative effect was

noted in nature prior to their use as food additives. Freezing, heat sterilization (canning), pasteurization, fermentation, baking, and meat curing are other well-known forms of preservation. Irradiation processes for food have also been developed, and low-level irradiation has been approved in the United States by the Food and Drug Administration (FDA).

Food manufacturing is not solely involved with the preservation of food but is also concerned with the production of high-quality, appealing, wholesome food. To fulfill these goals, five broad categories of food additives are often used: flavors, coloring agents, preservatives, texturizing agents, and miscellaneous. The last category includes a variety of substances that may retain moisture, control acidity, act as leavening agents, or provide nutrients such as vitamins and minerals.

The final operation in the manufacturing process is that of packaging, which is governed by the physicochemical attributes of the food, the preservation process involved, the gaseous permeability desired, the conditions under which the product is to be stored, the desirability of viewing the product through a clear film or glass, and the expense.

Historically, metal and glass have been used to package heat-processed foods; more flexible films are used for foods which undergo less vigorous treatment. Adoption of the regulation allowing the use of hydrogen peroxide as a package sterilant has permitted the use of nonrigid flexible packages for heat-sterilized foods (aseptic packaging). This type of packaging is very cost-effective. See FOOD ENGINEERING; FOOD PRESERVATION. [F.M.C.]

**Food microbiology** A subdiscipline in the field of microbiology concerned with the study of bacteria, fungi, and viruses that grow in or are transmitted by foods. While bacteria are frequently associated with food spoilage and food poisoning, some species preserve foods through fermentation or produce food ingredients. Food microbiology is a broad field that can include not only microbiology but also sanitation, epidemiology, biochemistry, engineering, statistics, and mathematical modeling.

Most food-related illnesses have historically been attributed to one of five major groups of pathogenic bacteria. These five groups are *Salmonella* and *Shigella*; *Clostridium botulinum*; *Clostridium perfringens* and *Bacillus cereus*; and *Staphylococcus aureus*. These have been joined by the emerging pathogens *Yersinia enterocolitica*, *Escherichia coli*, *Listeria monocytogenes*, and *Campylobacter jejuni*. See BACTERIA; FOOD POISONING.

When certain bacteria grow in foods, they produce desirable flavors and textures, and may also inhibit pathogenic organisms. Most of these bacteria belong to the genera *Streptococcus*, *Lactobacillus*, *Leuconostoc*, *Pediococcus*, or *Micrococcus*. They are used to make fermented dairy products, meats, and vegetables, and to preserve food by converting the sugars needed by competing microbes to lactic acid, which inhibits their growth. *Acetobacter* and *Gluconobacter* are used in the production of vinegar. Yeasts, usually *Saccharomyces*, which produce ethanol and carbon dioxide, are used in the processes of brewing and baking.

Modern food microbiology views foods as habitats where different organisms compete for survival. The fact that there are 250 genera of bacteria and that only 25 of these (8 pathogenic) are found in foods suggests that foods provide unique ecological niches. Viruses do not reproduce in foods and are not competitors in this sense (the food acts only as a carrier). Yeasts and molds usually grow more slowly than bacteria and are rarely a problem in foods that support bacterial growth. See FUNGI; YEAST.

Bacteria reproduce by binary fission; it takes only 20 doublings for one cell to yield more than 1 million cells. In environments where the doubling time is short, this occurs quite rapidly. Many preservation methods alter foods' environmental conditions, such as temperature, acidity, and water and oxygen availability, in order to slow microbial growth. See BACTERIAL GROWTH.

Microbial analysis of foods frequently requires "zero defects" in the absence of 100% testing. Legally, ready-to-eat foods must be free of *Salmonella*. This demands that the food microbiologist be able to detect one *Salmonella* among millions of innocuous bacteria in a pound of food. Moreover, all of the food cannot be tested because microbial analysis is destructive. Therefore, statistical sampling plans determine how many samples must be tested to have confidence that the whole lot is free of *Salmonella*.

In the classical methods for counting microorganisms, a food or its homogenate is highly diluted so that only 30–300 cells are transferred to growth media. After 2–10 days, each cell grows into a colony, and these are counted and multiplied by the dilution factor to estimate the number of cells in the food. Automated methods have been developed that measure growth products, bacterial deoxyribonucleic acid (DNA), or specific toxins; these methods dramatically reduce the analysis time and are rapidly replacing the petri-dish method.

A procedure known as hazard analysis critical control points (HACCP) can replace much postproduction testing. This technique examines a food, its ingredients, and its processing to identify points critical to safety. These points are then heavily monitored during production; if they are maintained, a safe product results.

Advances in molecular biology have generated interest in applications to food processing. The most important contribution of biotechnology to food microbiology is the production of probes that detect pathogenic organisms much faster than conventional methods. For example, conventional methods require 5 days to confirm the presence of *Salmonella* in foods; probes that detect *Salmonella*-specific DNA or antigens can give similar results in 2 days.

The dairy industry has benefitted from advances in biotechnology by acquiring the ability to determine the genetic basis for the bacterial metabolism of lactose in milk and to stabilize it. In addition, enzymes that accelerate the aging of cheese have become commercially available, making it possible to produce a cheese with the taste of 9-month-old cheddar in just 3 months. See BACTERIA; BIOTECHNOLOGY; ENZYME; FOOD ENGINEERING; FOOD MANUFACTURING; FOOD PRESERVATION; GENETIC ENGINEERING; VIRUS. [T.J.Mo.]

**Food poisoning** An acute gastrointestinal or neurologic disorder caused by bacteria or their toxic products, by viruses, or by harmful chemicals in foods.

Bacteria may produce food poisoning by three means: (1) they infect the individual following consumption of the contaminated food; (2) they produce a toxin in food before it is consumed; or (3) they produce toxin in the gastrointestinal tract after the individual consumes the contaminated food.

Infectious bacteria associated with food poisoning include *Brucella*, *Campylobacter jejuni*, enteroinvasive *Escherichia coli*, enterohemorrhagic *E. coli*, *Listeria monocytogenes*, *Salmonella*, *Shigella*, *Vibrio parahaemolyticus*, *V. vulnificus*, and *Yersinia enterocolitica*. These organisms must be ingested for poisoning to occur, and in many instances only a few cells need be consumed to initiate a gastrointestinal infection. *Salmonella* and *C. jejuni* are the most prevalent causes of food-borne bacterial infections. See YERSINIA.

*Staphylococcus aureus* and *Clostridium botulinum* are bacteria responsible for food poisonings resulting from ingestion of preformed toxin. *Staphylococcus aureus* produces heat-stable toxins that remain active in foods after cooking. *Clostridium botulinum* produces one of the most potent toxins known. Botulinum toxin causes neuromuscular paralysis, often resulting in respiratory failure and death. See BOTULISM; STAPHYLOCOCCUS; TOXIN.

Food-poisoning bacteria that produce toxin in the gastrointestinal tract following their ingestion include *Bacillus cereus*, *Clostridium perfringens*, enterotoxigenic *E. coli*, and *V. cholerae*. *Bacillus cereus* and *C. perfringens* are spore-forming

bacteria that often survive cooking and grow to large numbers in improperly refrigerated foods. Following ingestion, their cells release enterotoxins in the intestinal tract. Enterotoxigenic *E. coli* is a leading cause of travelers' diarrhea. See DIARRHEA; ESCHERICHIA.

Viruses that cause food-borne disease generally emanate from the human intestine and contaminate food through mishandling by an infected individual, or by way of water or sewage contaminated with human feces. Hepatitis A virus and Norwalk-like virus are the preeminent viruses associated with food-borne illness. See HEPATITIS.

Chemical-induced food poisoning is generally characterized by a rapid onset of symptoms which include nausea and vomiting. Foods contaminated with high levels of heavy metals, insecticides, or pesticides have caused illness following ingestion. See FOOD MICROBIOLOGY; MEDICAL BACTERIOLOGY; TOXICOLOGY.

[M.Do.]

**Food preservation** The branch of food science and technology that deals with the practical control of factors capable of adversely affecting the safety, nutritive value, appearance, texture, flavor, and keeping qualities of raw and processed foods. Since thousands of food products differing in physical, chemical, and biological properties can undergo deterioration from such diverse causes as microorganisms, natural food enzymes, insects and rodents, industrial contaminants, heat, cold, light, oxygen, moisture, dryness, and storage time, food preservation methods differ widely and are optimized for specific products. See FOOD SCIENCE.

Food preservation methods involve the use of heat, refrigeration, freezing, concentration, dehydration, irradiation, pH control, chemical preservatives, and packaging applied to produce various degrees of preservation in accordance with the differing use patterns and shelf-life needs of unique products.

Thermal processes to preserve foods vary in intensity. True sterility to ensure total destruction of the most heat-resistant bacterial spores in nonacidic foods may require a treatment of at least 250°F (121°C) of wet heat for at least 15 min to be delivered throughout the entire food mass. The term commercial sterility refers to a less severe condition that still assures destruction of all pathogenic organisms, as well as organisms that, if present, could grow in the product and produce spoilage under normal conditions of handling and storage. See STERILIZATION.

Many foods are subjected to still less severe heating by methods that produce pasteurization to assure destruction of pathogens and extend product shelf life. See PASTEURIZATION.

The slowing of biological and chemical activity with decreasing temperature is the principle behind cooling (refrigeration) and freezing preservation. In addition, when water is converted to ice, free water required for its solvent properties by all living systems is removed. Commercial freezing methods utilize refrigerated still air; high-velocity air, which is faster and more efficient; and high-velocity air made to suspend particulate foods, such as peas, as in a fluidized-bed fast freezer. Indirectcontact freezing utilizes hollow flat plates chilled with an internally circulated refrigerant to freeze solid foods, or with refrigerated tubular heat exchangers that rapidly slush-freeze liquids. Immersion freezing involves direct contact of the food or its container with refrigerants approved for food or a fast-freezing cryogenic liquid. See COLD STORAGE.

When sufficient water is removed from foods, microorganisms will not grow, and many enzymatic and nonenzymatic reactions will cease or be markedly slowed. Concentration preservation can be achieved by physically removing water, as by boiling or with lower-temperature vacuum evaporation, or by binding water through the addition of sugar, salt, or other solutes.

Foods preserved by dehydration contain considerably lower water activity and less total water than concentrated foods. Most dehydration methods utilize heat to vaporize and remove water. The heat and oxygen sensitivity of many foods necessitates vacuum dehydration for high quality. Under vacuum, water can be removed at reduced temperature, and oxidative changes

are minimized. In freeze-drying, foods are frozen quickly and placed in a chamber under high vacuum. A food's structure remains rigid as it goes directly from the frozen state to dryness. See SUBLIMATION.

Food irradiation remains highly controversial, partly because of fears that the safety of products and processes cannot be adequately regulated. The natural acids of certain fruits and vegetables, acid added as a chemical, and acid produced by fermentation can inhibit or partially inhibit several pathogenic and spoilage organisms. The pH of acidic foods, however, is rarely sufficiently low to assure long-term preservation from acid alone. Many acidic and fermented foods further depend upon prior pasteurization of their ingredients, the addition of salt and other chemicals, and refrigeration. See pH.

The U.S. Food and Drug Administration and comparable agencies in various countries vigorously regulate the chemicals that may be added to foods as well as the conditions of their use. Chemical preservatives and similar substances include antimicrobials, enzyme inhibitors, and antioxidants. There is much pressure to remove chemicals from the food supply, especially where their effects can be achieved by other means.

Packaging protects foods from contamination, moisture gain or loss, flavor loss and odor pickup, the adverse effects of light, physical damage, and intentional tampering. Ultimately, a food product's quality and storage life are determined largely by its package. See FOOD ENGINEERING; FOOD MANUFACTURING; FOOD MICROBIOLOGY.

[N.N.P.]

**Food science** The study of the physical, chemical, and biological properties of foods, in addition to the factors affecting them and their ultimate effects upon the sensory, nutritional, and storage properties and the safety of foods. Food properties are influenced by growing, harvesting, and slaughtering practices, preservation and preparation methods, processing and storage conditions, and packaging. Food science and its applications must be further concerned with economics and marketing; food preferences of various populations; quality assurance and control; regulatory aspects dealing with safety, wholesomeness, and honest representation; and the production of affordable, quality food on a worldwide basis. Therefore, food science interfaces with and draws upon many disciplines, including chemistry, physics, mathematics, the plant and animal sciences, biochemistry, enzymology, microbiology, genetics, engineering, statistics, computer science, nutrition, toxicology, psychology, and law.

Food science deals with many food commodities and thousands of derived products. These commodities are processed for many reasons, including preservation, creation of new product forms, improvement of sensory and nutritional qualities, convenience, and removal of natural toxicants. Common processes are heating, cooling, freezing, concentration, dehydration, fermentation, sometimes irradiation, and packaging. Each process can be further classified by method. Each process utilizes unique equipment that requires optimization of variables to maximize product quality and minimize costs, and is capable of yielding product with distinct characteristics. Further, commodities are increasingly utilized for their constituents which are separated, extracted, chemically and physically modified, and then recombined into an endless variety of formulated and engineered foods that are indistinguishable from their source materials. This often requires the use of highly specific food additives to improve processing properties and acceptance factors, including nutritional quality. Nutrient levels and nutrient availability from foods may be decreased or increased by handling and processing practices.

Food science is also concerned with all aspects of food safety, including natural food toxicants, industrial contaminants, misuse of food additives, and microbiological contamination, as well as methods for the detection, exclusion, inactivation, removal, and regulation of harmful substances. See FOOD ENGINEERING; FOOD MANUFACTURING.

[N.N.P.]



**Food web** A diagram depicting those organisms that eat other organisms in the same ecosystem. In some cases, the organisms may already be dead. Thus, a food web is a network of energy flows in and out of the ecosystem of interest. Such flows can be very large, and some ecosystems depend almost entirely on energy that is imported. A food chain is one particular route through a food web.

A food web helps depict how an ecosystem is structured and functions. Most published food webs omit predation on minor species, the quantities of food consumed, the temporal variation of the flows, and many other details.

Along a simple food chain, A eats B, B eats C, and so on. For example, the energy that plants capture from the sun during photosynthesis may end up in the tissues of a hawk. It gets there via a bird that the hawk has eaten, the insects that were eaten by the bird, and the plants on which the insects fed. Each stage of the food chain is called a trophic level. More generally, the trophic levels are separated into producers (the plants), herbivores or primary consumers (the insects), carnivores or secondary consumers (the bird), and top carnivores or tertiary consumers (the hawk).

Food chains may involve parasites as well as predators. The lice feeding in the feathers of the hawk are yet another trophic level. When decaying vegetation, dead animals, or both are the energy sources, the food chains are described as detrital. Food chains are usually short; the shortest have two levels. One way to describe and simplify various food chains is to count the most common number of levels from the top to the bottom of the web. Most food chains are three or four trophic levels long (if parasites are excluded), though there are longer ones.

There are several possible explanations for why food chains are generally short. Between each trophic level, much of the energy is lost as heat. As the energy passes up the food chain, there is less and less to go around. There may not be enough energy to support a viable population of a species at trophic level five or higher.

This energy flow hypothesis is widely supported, but it is also criticized because it predicts that food chains should be shorter in energetically poor ecosystems such as a bleak arctic tundra or extreme deserts. These systems often have food chains similar in length to energetically more productive systems. See ECOLOGICAL ENERGETICS.

Another hypothesis about the shortness of food chains has to do with how quickly particular species recover from environmental disasters. For example, in a lake with phytoplankton, zooplankton, and fish, when the phytoplankton decline the zooplankton will also decline, followed by the fish. The phytoplankton may recover but will remain at low levels, kept there by the zooplankton. At least transiently, the zooplankton may reach higher than normal levels because the fish, their predators, are still scarce. The phytoplankton will not completely recover until all the species in the food chain have recovered. Mathematical models can show that the longer the food chain, the longer it will take its constituent species to recover from perturbations. Species atop very long food chains may not recover before the next disaster. Such arguments predict that food chains will be longer when environmental disasters are rare, short when they are common, and will not necessarily be related to the amount of energy entering the system.

The number of trophic levels a food web contains will determine what happens when an ecosystem is subjected to a short, sharp shock—for example, when a large number of individuals of one species are killed by a natural disaster or an incident of human-made pollution and how quickly the system will recover. The food web will also influence what happens if the abundance of a species is permanently reduced (perhaps because of harvesting) or increased (perhaps by increasing an essential nutrient for a plant).

Some species have redundant roles in an ecosystem so that their loss will not seriously impair the system's dynamics. Therefore, the loss of such species from an ecosystem will not have a

substantial effect on ecosystem function. The alternative hypothesis is that more diverse ecosystems could have a greater chance of containing species that survive or that can even thrive during a disturbance that kills off other species. Highly connected and simple food webs differ in their responses to disturbances, so once again the structure of food webs makes a difference. See ECOLOGICAL COMMUNITIES; ECOSYSTEM; POPULATION ECOLOGY.

[S.Pi.]

**Foot-and-mouth disease** A highly contagious viral disease of domesticated and wild cloven-hoofed animals with the potential to cause enormous economic losses. It is characterized by the formation of vesicles on the feet, in and around the mouth, and on the mammary gland. At the acute stage there is high fever, depression, lameness, and reduced appetite. Milking animals show a sudden reduction in production. The mortality in adult animals is usually less than 3%, but in young animals it can exceed 90%.

The causative virus is a member of the *Aphthovirus* genus of the family Picornaviridae. The virus can infect by different routes and mechanisms. During the acute phase of disease, large amounts of virus occur throughout the tissues and organs of the infected animal and in its excretions and secretions. The movement of infected animals and the transmission of virus by contact to susceptible animals in a new herd or flock is by far the most common mechanism of spread. Next in frequency is the movement of contaminated animal products, such as meat and milk—most likely to infect pigs through ingestion.

Immunity to the disease is primarily mediated through neutralizing antibodies directed against the structural proteins of the virus. Specific antibodies are detectable by bioassay 4–5 days after infection, at which time viremia ceases and there is a progressive reduction in virus excretion as the lesions heal. The detection of the viral antigen is sufficient for a positive diagnosis. Normally, viral antigen is detected and serotyped by enzyme-linked immunosorbent assay (ELISA).

Control in countries where the disease is endemic or sporadic is mainly by vaccination. The vaccines contain inactivated viral antigens of one or more serotypes, depending on the prevailing disease situation. Immunity following primary and booster doses of vaccine lasts for around 6 months. See ANIMAL VIRUS; EPIDEMIOLOGY; SEROLOGY.

[A.I.D.]

**Foot disorders** Musculoskeletal, neurological, or dermatologic abnormalities of the foot. They may be of developmental or acquired origin.

Clubfoot, also known as talipes, is a congenital deformity of the foot characterized by a club-shaped appearance, and occurs in approximately 1 in 1000 live births. Clubfoot takes a number of forms, the most common being talipes equinovarus, an extreme turning down and under of the foot.

During normal intrauterine development, and normally continuing after birth, the position of the foot changes gradually from one of inversion such that the soles of both feet face each other to one of alignment with the leg. In the flatfoot that positional change is not always complete, so that the foot undergoes a series of complex compensations to reach the ground that is called pronation. Twisting of the ankle and obliteration of the normal arch of the foot result. In addition, the joints of the foot tend to lose their functional articular contacts, and the resulting hypermobility at the joint interfaces predisposes the foot to arthritis. Bunions and hammertoe deformities, with painful stretching of the soft tissues of the sole, are additional complications that result from hypermobility.

Heel spurs, or calcaneal exostoses, are bony growths produced by excessive musculoskeletal tension at the heel. When the pull by ligaments and connective tissue becomes excessive, as is seen with flatfoot deformities and tight or shortened heel cords, the

outer covering of the heel bone known as the periosteum enlarges. The bone growth is known as an exostosis or spur.

The nerves of the foot are subject to irritation from pressure originating from the structures of the foot and from external forces. In cases of Morton's neuroma, the third intermetatarsal nerve thickens over a period of years, and a small benign fusiform tumor eventually forms in the space between the third and fourth toes. The posterior tibial nerve is located at the inside of the ankle behind the ankle bone, and it travels to the bottom of the foot through a channel known as the tarsal canal. In tarsal tunnel syndrome, the nerve becomes compressed and damaged within the tarsal canal.

The skin of the foot undergoes stress from pressure and friction. As a response, it protects itself with defensive modifications such as corns and calluses that themselves cause pain.

Warts are tumors of the skin induced by the human papilloma virus. Second only to corns and calluses in prevalence, warts are benign skin lesions. Transmission of warts from person to person may occur, but individual immunity plays an important role in susceptibility to these infectious lesions.

Ingrown toenail, also called onychocryptosis, is caused by the penetration of the free portion, or edge, of the nail into the surrounding soft tissue. The cause may be related to congenital variations in the shape of the nail itself or the nail fold (the skin adjacent to the edges of the nail), biomechanical abnormalities in foot structure or function, nail disease, or ill-fitting footwear.

[H.Lem.]

**Forage crops** Grasses and legumes that make up grasslands and are used as forages for livestock. The grasslands represent an ancient renewable natural resource. They form 25% of the world's vegetation and occupy the largest area of any single plant type. They benefit humanity indirectly by providing food for both wild animals and domesticated livestock, some of which are ruminants that, because their digestive systems contain microorganisms, are able to digest fibrous forage material. Thus, the prime value of grassland areas lies in the meat, milk, or work produced by the livestock that graze on them. See GRASSLAND ECOSYSTEM; LEGUME.

Grasslands have other attributes as well. In order to withstand the tug and pull of the grazing animal, a forage plant must have an extensive root system, and this makes a contribution to soil fertility. When the plant is grazed or cut, the photosynthetic area that remains is not large enough to provide sugars to maintain root respiration, and so part of the root system dies and adds to the organic material in the soil and to soil structure. Such is the basis of many highly productive crop rotations that maintain soil fertility without expensive fertilizer applications. Most forage plants are long-lived perennials that can be defoliated repeatedly during a growing season.

Forages also protect the soil from erosion by both wind and water. In fact, where row crop farming has led to soil deterioration, as it did when dust bowl conditions prevailed in North America, forages are used to restore and stabilize the land. See EROSION.

[P.D.W.]

**Foraminiferida** An order of Granuloreticulosa in the class Rhizopodea. Foraminiferans are dominantly marine protozoans, with a secreted or agglutinated shell, or test, enclosing the continually changing ameboid body (see illustration) that characterizes this and other orders of the superclass Sarcodina. Their unique combination of long geologic history, ubiquitous geographic distribution, and exceptional diversity of test composition, form, and structure make the foraminiferans the most useful of all marine fossils for stratigraphic correlation, geologic age dating of sediments, and paleoecologic interpretation. Their tests accumulated in great numbers and are recoverable from small quantities of sediment, rock outcroppings, well cores or cuttings, or ocean dredging and submarine coring.

Pseudopodia from the ameboid body form a delicate anastomosing network of 2–10 times the test diameter. The pseudopodial net may arise from the apertural region of the test alone in those with tectinous, porcelaneous, and agglutinated walls, or may radiate in all directions through many tiny perforations of the hyaline test wall. The pseudopodia variously serve in capture, ingestion, and digestion of food, in test and temporary cyst construction, for anchorage, and for locomotion. The characteristic granular streaming of the continuously moving cytoplasm differentiates the Foraminiferida from the other Sarcodina orders.

The foraminiferan constructs its own test. Growth of the individual may cease after test construction, or the test may enlarge by continued growth in one or more directions (tubular or branching tests) or by periodic formation of separate but always interconnected chambers. Growth may be either continuous or periodic and may be in a straight line, a planispiral or trochospiral coil, a cycle, or a zigzag. The latter (zigzag) is expressed by chambered forms in biseriality. Variations and combinations of these growth patterns occur repeatedly in different lineages (isomorphism).

As is true of most protists with skeletons or tests, systematic differentiation and classification of foraminiferans is based on test composition, microstructure, and gross morphology. Information currently available concerning cytoplasmic characters, life cycles, and so on has shown good agreement with this classification, although the function and origin of many shell characters believed to be of systematic importance (canal systems, pores, septal doubling, and apertural tooth plates) are yet undetermined. There are 11 suborders.

Foraminiferans have shown a remarkable diversification and rapid evolutionary development over their 500,000,000-year known history. Some with uncomplicated tests have been reported to have a long geologic range, but most with diagnostic

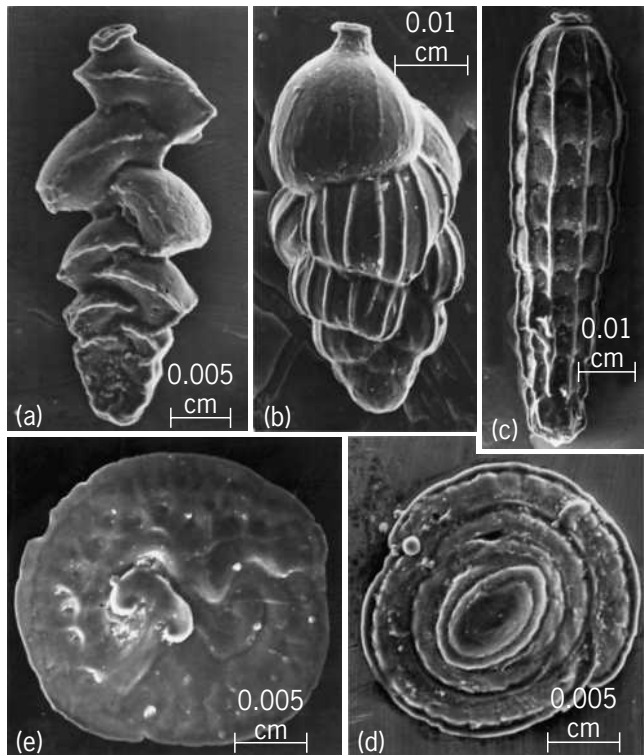

Scanning electron micrographs of foraminiferans of suborder Rotaliina. Superfamily Buliminacea: (a) *Eouvigerina*, elongate test. (b) *Uvigerina*, elongate triserial test. (c) *Siphogenerinoides*, reduced early biserial stage. Superfamily Spirillinacea: (d) *Patellina*: (d) spiral view of low conical test; (e) umbilical view. (R. B. MacAdam, Chevron Oil Field Research Co.)

shell structure and morphology had relatively short histories, each successively replaced by others. The oldest-known and presumably primitive tests are the morphologically simple tectinous and agglutinated one of the Cambrian and Ordovician, globular, tubular, branching, or irregular form.

Most foraminiferans are benthic, living upon the sea floor, within the upper few centimeters of ooze, or upon benthic algae or other organisms. They occur from the intertidal zone to oceanic depths, in brackish, normal marine, or hypersaline waters, and from the tropics to the poles. Some modern Lagynacea live in fresh water, but none are known as fossils. Assemblages vary widely in response to local conditions, with the greatest diversity occurring in warm, shallow water. A smaller number, the Globigerinina, are planktonic, living at various depths in the water column from the surface to the bottom, being most numerous between 18 and 90 ft (6 and 30 m). Vertical migration may be diurnal and may occur during ontogenetic development. The preferred depth range of a species may vary geographically in response to temperature differences or to changes in water density. See GRANULORETICULOSIA; RHIZOPODEA; SARCODINA. [H.T.L.]

**Force** Force may be briefly described as that influence on a body which causes it to accelerate. In this way, force is defined through Newton's second law of motion.

This law states in part that the acceleration of a body is proportional to the resultant force exerted on the body and is inversely proportional to the mass of the body. An alternative procedure is to try to formulate a definition in terms of a standard force, for example, that necessary to stretch a particular spring a certain amount, or the gravitational attraction which the Earth exerts on a standard object. Even so, Newton's second law inextricably links mass and force. See ACCELERATION; MASS.

One may choose either the absolute or the gravitational approach in selecting a standard particle or object. In the so-called absolute systems of units, it is said that the standard object has a mass of one unit. Then the second law of Newton defines unit force as that force which gives unit acceleration to the unit mass. Any other mass may in principle be compared with the standard mass ( $m$ ) by subjecting it to unit force and measuring the acceleration ( $a$ ), with which it varies inversely. By suitable appeal to experiment, it is possible to conclude that masses are scalar quantities and that forces are vector quantities which may be superimposed or resolved by the rules of vector addition and resolution.

In the absolute scheme, then, the equation  $\mathbf{F} = m\mathbf{a}$  is written for nonrelativistic mechanics; boldface type denotes vector quantities. This statement of the second law of Newton is in fact the definition of force. In the absolute system, mass is taken as a fundamental quantity and force is a derived unit of dimensions  $MLT^{-2}$  ( $M$  = mass,  $L$  = length,  $T$  = time).

The gravitational system of units uses the attraction of the Earth for the standard object as the standard force. Newton's second law still couples force and mass, but since force is here taken as the fundamental quantity, mass becomes the derived factor of proportionality between force and the acceleration it produces. In particular, the standard force (the Earth's attraction for the standard object) produces in free fall what one measures as the gravitational acceleration, a vector quantity proportional to the standard force (weight) for any object. It follows from the use of Newton's second law as a defining relation that the mass of that object is  $m = w/g$ , with  $g$  the magnitude of the gravitational acceleration and  $w$  the magnitude of the weight. The derived quantity mass has dimensions  $FT^2L^{-1}$ . See FREE FALL. [G.E.P.]

**Force fit** A means for holding mating mechanical parts in fixed position relative to each other. In a force fit of cylindrical parts, the inner member has a greater diameter than the hole of the outer member; that is, the metals of the two parts interfere. In a true force fit, the parts are highly stressed, the interference

amounting to 0.002 or 0.003 in. (0.05 or 0.07 mm) for parts with a basic diameter of 1 in. See ALLOWANCE; SHRINK FIT. [P.H.B.]

**Forced oscillation** A response of a mechanical or electrical system in reaction to an external signal.

A simple electrical  $RLC$  circuit (illus. a) consists of a resistor with resistance  $R$  (measured in ohms), an inductor with inductance  $L$  (measured in henrys), and a capacitor with capacitance  $C$  (measured in farads). The dynamics relating the input voltage,  $u(t)$ , to the current,  $y(t)$ , passing through the resistor are described by Eq. (1). Equation (1) states that the input voltage is equal to

$$L \frac{dy}{dt} + Ry + \frac{1}{C} \int y dt = u(t) \quad (1)$$

the sum of the voltage across the inductor, the voltage across the resistor, and the voltage across the capacitor, where the voltage across the inductor is the product of its inductance ( $L$ ) and the rate of change of the current through the inductor; the voltage across the resistor is the product of its resistance ( $R$ ) and the current passing through it; and the voltage across the capacitor is the integral over time of the current through the capacitor (that is, the charge on the capacitor plates) divided by the capacitance ( $C$ ).

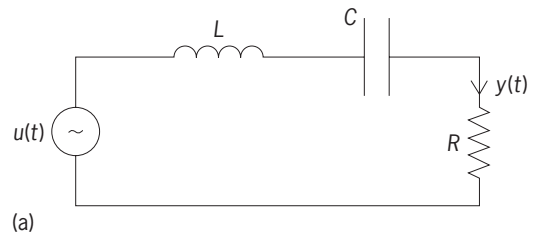

(a)

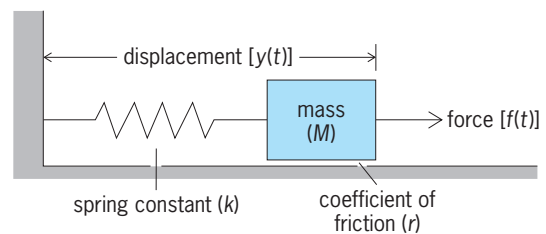

(b)

**Examples of forced oscillation. (a) Electrical system, an  $RLC$  circuit. (b) Analogous mechanical system, a spring-mass-damper system.**

A fundamental property of differential equations states that the response of a differential equation to a periodic input can be decomposed as a sum of two responses. The first one, called the zero-input response or free oscillation, is due to initial energy stored in the circuit and decays eventually to zero. The second one, due to the voltage input  $u(t)$ , converges to a periodic signal with the same frequency as  $u(t)$ . The latter is referred to as the forced oscillation or the steady-state response. The decaying rate of the free oscillation depends on the time constant of the circuit which is determined by the values of  $R$ ,  $L$ , and  $C$  and the structure of the circuit. See TIME CONSTANT.

Similarly, an analogous mechanical system, a simple spring-mass-damper system (illus. b), consists of a body with mass  $M$ , which is attached to a wall by a spring with spring constant  $k$ , and rests on a horizontal surface over which it moves with friction coefficient  $r$ . The dynamic equation that relates the force applied to the body,  $f(t)$ , to the body's displacement,  $y(t)$ , is given by Eq. (2). Equation (2) states that the force applied to the body

$$M \frac{d^2 y(t)}{dt^2} + r \frac{dy(t)}{dt} + ky(t) = f(t) \quad (2)$$

equals the sum of the three quantities: the product of the body's

mass and its acceleration, the negative of the frictional force, and the negative of the force exerted by the spring. Here, the negative of the frictional force is the product of the coefficient of friction and the body's velocity, and the negative of the force exerted by the spring is the product of the spring constant and the body's displacement. Moreover, the body's velocity is the first derivative of its displacement with respect to time, and its acceleration is the second derivative of its displacement with respect to time.

Analogous to the *RLC* circuit case, application of a sinusoidal force  $f(t)$  results eventually in a forced oscillation of the displacement  $y(t)$  that is also a sinusoidal function. The magnitude and the phase of the displacement  $y(t)$  depends on the complex mechanical impedance that is a function of the mass ( $M$ ), the spring constant ( $k$ ), and the friction coefficient ( $r$ ). The exact evaluation is similar to the *RLC* circuit case. See MECHANICAL IMPEDANCE; MECHANICAL VIBRATION; OSCILLATION; VIBRATION. [E.W.Ba.]

**Forcipulatida** An order of Asteroidea characterized by straight or crossed pedicellariae or both. These may be carried on stalks, and in some cases are arranged in rosettes around the bases of the spines. The spines usually occur singly, and are ungrouped. The body is stellate in outline, but is not necessarily restricted to five arms or radial axes.

The order contains four families, whose genera are numerous and widely distributed. The *Brisingidae* and *Zoroasteridae* are characteristically deep-water families, and the former includes species with as many as 44 arms. The *Asteridae* is the largest family, and includes many well-known predatory starfishes, some of which are economically significant because of the damage they inflict upon oyster and clam beds. The fourth family is the *Heliasteridae*. See ASTEROIDEA; ECHINODERMATA. [A.C.C.]

**Forensic anthropology** The application of physical anthropology theory and techniques to answering questions for the law. Medical evidence and biological techniques used on the living can be applied to intact remains, as can extensive internal examinations and histological preparations. However, burned, decomposed, mutilated, or fragmented bodies contain less soft tissue evidence and are therefore more difficult for the medical examiner or forensic pathologist to analyze. In these cases, the information provided by the skeleton becomes more important, and may yield the only information available about the identity of the individual and the circumstances surrounding death. Age, sex, ancestry, stature, muscularity, handedness, habits, occupational activities, disease, and injuries can be ascertained from elements of the skeleton, and in such cases the services of a forensic anthropologist may be a valuable adjunct to the work of the forensic pathologist or coroner.

Training is required in such areas as skeletal variation in current populations or injuries from modern weapons. Many physical anthropologists, however, are increasingly involved in the forensic applications of their expertise, a few on a full-time basis. Recently, archeologists have been asked to aid in the excavation of human remains from clandestine graves, and so the field of forensic archeology has arisen, but the term "forensic anthropology" usually refers to the biological aspects. See ANTHROPOLOGY; ARCHEOLOGY; PHYSICAL ANTHROPOLOGY. [D.L.F.]

**Forensic biology** The study of biological evidence such as DNA (deoxyribonucleic acid) which may link a suspect or victim to a crime, disprove an alibi, or develop leads in a criminal investigation. Biological evidence may also exonerate the innocent. See DEOXYRIBONUCLEIC ACID (DNA).

Biological evidence has been associated with many types of crime but is typically seen with violent crimes such as homicide, assault, sexual assault, child abuse, and hit-and-run accidents. Common sources submitted to forensic laboratories are blood and bloodstains; semen and seminal stains; tissues and organs; bones and teeth; hairs and nails; and saliva, urine, and other biological fluids.

**Evidence transfer and collection.** Biological specimens can be used to make linkages (for example, person-person, person-other physical evidence, and person-crime scene). In general, biological evidence can be transferred by direct deposit or by secondary transfer.

Blood, semen, body tissue, bone, hair, urine, and saliva can be transferred to an individual's body or clothing, to an object, or to a crime scene by direct deposit. Once liquid biological materials are deposited, they adhere to the surface or the substratum and become stains. Nonfluid biological evidence, such as tissue or hair, can also be transferred by direct contact.

Blood, semen, tissue, hair, saliva, or urine also can be transferred to a person, object, or location through an intermediary (a person or an object). With secondary transfer, there is no direct contact between the original source (donor of the biological evidence) and the target surface. Secondary transfer may, but does not necessarily, establish a direct link between an individual and a crime.

The ability to analyze biological evidence is impacted by many factors regarding its collection. Unless the evidence is properly recognized, documented, collected, packaged, and preserved, it will not meet the legal or scientific requirements for admissibility into a court of law.

**Laboratory analysis.** The identification of individuals by analyzing their biological material such as blood, semen, hair, and bone has been used since 1904. Historically, testing has been based on serological markers, including red blood cell antigen systems, isoenzymes, red cell and serum protein variants, and human leukocyte antigens (HLAs). Since the mid-1980s, DNA analysis has been increasingly important in forensic science, forensic medicine, and paternity testing. Genetic variation can be detected by many DNA tests, including restriction fragment length polymorphism (RFLP) analysis, polymerase chain reaction (PCR), and DNA sequencing. Developments in the 1990s, such as more sensitive and discriminating PCR typing methods, the felon DNA databank, and increased governmental funding, have greatly enhanced the use of DNA in criminal investigations. See FORENSIC CHEMISTRY; FORENSIC MEDICINE.

**Serological methods.** Prior to the advent of DNA typing, serological tests were employed to identify the source of the biological evidence, to determine if the sample was of human origin, and to individualize the specimen. Today, serological analysis is generally limited to identifying the type of biological evidence collected. Subsequently, the evidence is individualized by DNA analysis. The process of examining items for the presence of biological material begins with recognizing and identifying likely candidates for further testing. First, various screening tests determine if a stain could be blood, saliva, or semen. Second, confirmatory tests identify the source of the body fluid (for example, human blood). Third, the body fluid is individualized.

**DNA testing.** The ability to differentiate between individuals using genetic markers can be pivotal to the successful investigation of many crimes. Evidence that is suitable for DNA typing (with the exception of mitochondrial DNA) is limited to samples containing nucleated cells. Conventional DNA typing is possible only on hairs with roots. The hair shaft does not contain nuclei and can be typed only by mitochondrial DNA analysis. Other types of biological material such as tears, perspiration, serum, and other body fluids without nucleated cells are not amenable to standard DNA analysis.

Several factors affect the ability to obtain DNA typing results. The first issue is sample quantity. The second factor is sample degradation. The third consideration is sample purity.

Two general types of genetic variation are exploited by forensic DNA typing methods: length differences produced by variable number of tandem repeats (VNTRs) and sequence variation (single base changes). Most forensic DNA tests detect length variation. Numerous loci have been identified which contain multiple copies of a core element arranged head to tail. The number of these repeated units can differ from person to person. Following

restriction endonuclease digestion which cuts the double helix at specific sites flanking the variable region, DNA fragments ranging in size from 500 to 22,000 base pairs are resolved by agarose gel electrophoresis. This process is RFLP analysis, and it is the oldest DNA typing method for both criminal and paternity cases. See ELECTROPHORESIS.

Polymerase chain reaction (PCR) amplifies (duplicates) small segments of DNA. At the end of the process, the target DNA molecule has been amplified 1 million to 10 million times. As a forensic tool, PCR-based strategies have several advantages over RFLP analysis. First, PCR requires only trace quantities of DNA, approximately 10 to 100 times less than RFLP typing. Second, PCR generates a large quantity of product in a very short period of time, considerably less time than that required for typing by RFLP analysis. Third, degradation of the DNA sample is less of a concern when using PCR because it amplifies small segments of DNA. See GENE AMPLIFICATION.

Mitochondrial DNA (mtDNA) analysis is an important forensic tool. The mitochondrial genome contains 16,569 base pairs of circular DNA. Mitochondrial DNA exists outside the nucleus and is present in multiple copies per cell. In addition, mtDNA is maternally inherited. Typically, mtDNA typing involves PCR amplification followed by direct sequencing of the DNA. Mitochondrial DNA testing is extremely sensitive and is particularly useful with minute samples (for example, old or degraded skeletal remains) and tissues (for example, hair shafts) lacking nuclear DNA. Given its inheritance, an mtDNA profile can be compared to anyone with the same maternal lineage. See MITOCHONDRIA.

**Felon DNA databanks.** A significant development in forensic science is felon DNA databanks. Given the high rate of recidivism associated with sexual assault, felon DNA databanks are particularly useful for solving these crimes; they will also assist in the investigation of many other violent crimes. The national DNA databank system, CODIS (Combined DNA Index System), became operational in fall 1998. This allows states to compare their no-suspect profiles to a national DNA repository and solve additional crimes. [H.C.L.; C.La.; H.M.C.]

**Forensic chemistry** The application of chemistry to the study of physical materials or theoretical problems, the results of which may be entered into court as technical evidence. Boundaries are not sharply defined for forensic chemistry, and it includes topics that are not entirely chemical in nature.

Some of the items most often encountered in crime laboratories, and the information sought in regard to them, are: (1) body fluids and viscera to be analyzed for poisons, drugs, or alcohol, quantitation of which may assist in determining the dosage taken or the person's behavior prior to death; (2) licit and illicit pills, vegetable matter, and pipe residues for the presence of controlled substances; (3) blood, saliva, and seminal stains, usually in dried form, to be checked for species, type, and genetic data; (4) hairs, to determine if animal or human; if human, the race, body area of origin, and general characteristics; (5) fibers, to determine type (animal, vegetable, mineral, or synthetic), composition, dyes used, and processing marks; (6) liquor, for alcoholic proof, trace alcohols, sugars, colorants, and other signs of adulteration; (7) paint, glass, plastics, and metals, usually in millimeter-sized chips, to classify and compare to known materials; (8) inks on documents, to determine type, dye content, or possible age; also chemical obliterations and restoration of chaffed papers; (9) swabs from the hands of suspects, to be checked for the presence of gunshot residue; (10) debris from a fire or explosion scene, for the remains of the accelerant or explosive used. See ANALYTICAL CHEMISTRY; FORENSIC MEDICINE; FORENSIC TOXICOLOGY. [M.J.C.]

**Forensic medicine** The branch of medicine concerned with the resolution of legal issues by the application of scientific medical knowledge. The issues may be of criminal or civil nature. The specialty of forensic medicine is often referred to as le-

gal medicine in Europe and in Spanish-speaking countries. The development of forensic medicine began in Europe in the early nineteenth century. Although forensic medicine has its basis in the specialty of pathology, physicians in other specialties, such as psychiatry, orthopedics, cardiology, and neurology as well as specialists in other disciplines, may be called on to resolve legal questions posed by judges, attorneys, investigators, and hearing boards.

In death investigations, a number of forensic specialists may work together. A forensic odontologist may be called in to identify the deceased person through dental examination, or the perpetrator of bite marks left on the deceased's body. A forensic anthropologist may be needed to identify skeletal remains; a forensic toxicologist for the identification of poisons or drugs; and a criminalist for investigation at the scene and collection of evidence, or for study of trace evidence such as blood stains, hair, paints, and seminal fluid. In cases of equivocal suicides, forensic psychiatrists and psychologists may be called in. Recently the biomechanical engineer has been added to the roster of forensic specialists, to test and study injury patterns to determine how the injury came about. The forensic medical specialist may express an opinion in writing or may be required to testify in person in the courtroom. As with all legal proceedings, the physician witness must be cognizant of issues such as the degree of proof, the chain of custody of specimens or evidence, competency of the witness, and court procedures.

An important development in forensic medicine is genetic analysis. Every individual has a unique genetic content determined by deoxyribonucleic acid (DNA) sequences. The DNA present in forensic samples such as hair, bloodstains, and seminal fluid can identify a suspect. One analysis technique is called DNA fingerprinting; it can be used to compare the DNA sequence of a suspect or a defendant with material evidence at the crime scene. The DNA is broken into unique fragments by restriction endonucleases and then separated by electrophoresis. The pattern seen after hybridization with specific probes is called the DNA fingerprint, and like an ordinary fingerprint is characteristic of the individual. DNA analysis is also used in identification of an unknown person or of parts of a human body. Paternity exclusion by ABO blood typing has been replaced by DNA fingerprinting. See DEOXYRIBONUCLEIC ACID (DNA); FORENSIC ANTHROPOLOGY; FORENSIC TOXICOLOGY. [T.T.N.]

**Forensic toxicology** An interdisciplinary science dealing with the adverse effects of drugs and chemicals on various biological systems in a medical-legal context. The forensic toxicologist may work with a medical examiner or coroner in order to determine the role that a particular chemical compound may have played in a death. The forensic toxicologist's activities may also involve assessing emergency room patients, helping to determine suitability of an individual for employment or promotion, screening for performance-altering drugs in athletes, and working with law enforcement agencies, for example, performing tests to determine if a driver operated a motor vehicle under the influence of drugs. The forensic toxicologist is involved not only in the analysis of body fluids and tissue for drugs and poisons but also in the interpretation of the resulting information in a judicial context.

Toxicological data can be obtained from pharmaceutical manufacturers, published literature, or various registries. The greatest challenge facing the forensic toxicologist is the interpretation of cases involving combinations of drugs and chemicals and their complex interactions. See FORENSIC CHEMISTRY; FORENSIC MEDICINE; TOXICOLOGY. [J.H.Bi.]

**Forest and forestry** A plant community consisting predominantly of trees and other woody vegetation, growing closely together, is a forest. Forests cover about one-fourth of the land area on Earth. The trees can be large and densely packed, as they are in the coastal forests of the Pacific Northwest, or they

can be relatively small and sparsely scattered, as they are in the dry tropical forests of sub-Saharan Africa.

Forests are complex ecosystems that also include soils and decaying organic matter, fungi and bacteria, herbs and shrubs, vines and lichens, ferns and mosses, insects and spiders, reptiles and amphibians, birds and mammals, and many other organisms. All of these components constitute an intricate web with many interconnections. *See* FOREST ECOSYSTEM.

Forests have important functions, such as cleansing the air, moderating the climate, filtering water, cycling nutrients, providing habitat, and performing a number of other vital environmental services. They also supply a variety of valuable products ranging from pharmaceuticals and greenery to lumber and paper products. *See* FOREST TIMBER RESOURCES; LUMBER.

**Forest types.** There are many ways to classify forests, as by (1) location (for example, temperate zone forests, tropical zone forests); (2) ownership (for example, public forests, private forests); (3) age or origin (for example, old-growth forests, second-growth forests, plantation forests); (4) important species (such as Douglas-fir forests, redwood forests); (5) economic and social importance (for example, commercial forests, noncommercial forests, urban forests, wilderness); (6) wood properties (for example, hardwood forests, softwood forests); (7) botanical makeup (for example, broadleaf forests, evergreen forests); or (8) a combination of features (such as moist temperate coniferous forests, dry tropical deciduous forests). The last approach tends to be the most descriptive because it often integrates several dominant characteristics related to climate, geography, and botanical features.

Some examples of the major forest types are: Northern coniferous forests which span the cold, northern latitudes of Canada and Europe; Temperate mixed forests which occupy the eastern United States, southeastern Canada, central Europe, Japan, and East Asia, and parts of the Southern Hemisphere in Chile, Argentina, Australia, and New Zealand; Temperate rainforests which are situated along moist, coastal regions of the Pacific Northwest, southern Chile, southeastern Australia, and Tasmania; Tropical rainforests which are found in the equatorial regions of Central and South America (for example, Costa Rica, Brazil, and Ecuador); on the west coast of Africa (for example, Congo, Ivory Coast, and Nigeria); and Southeast Asia (for example, Thailand, Malaysia, and Indonesia); Dry forests which occur in the southwestern United States, the Mediterranean region, sub-Saharan Africa, and semiarid regions of Mexico, India, and Central and South America; and mountain forests which are characteristic of mountainous regions throughout the world.

**Characteristics.** Although forests take a variety of forms, they have several features in common that allow them to develop in their respective environments. Forests generally contain a broad array of species, each of which is well adapted to the environmental conditions of the region. This biodiversity and adaptability help the forests cope with natural (and in some cases human-caused) forces of destruction, including wildfire, windstorms, floods, and pests. This built-in resiliency also allows the periodic extraction of wood and other products without jeopardizing the long-term health and productivity of the ecosystems—provided such harvesting operations are performed with care. Forests are dynamic—they are constantly changing at both landscape and smaller scales of resolution. This natural propensity to change and develop over time is called forest succession. Forests have a mitigating influence on the environment. This characteristic not only facilitates their own survival and development but also moderates the surrounding climate.

**Ecological processes and hydrologic cycle.** Forests play a vital role in ecological processes. From a global perspective, they help convert carbon dioxide in the atmosphere to oxygen, thereby facilitating life for aerobic organisms. Forests can also capture, store, convert, and recycle a variety of nutrients such as nitrogen, phosphorus, and sulfur. Forests also play a critical role in the hydrologic cycle. Finally, forests play a crucial ecological

role in the habitat that they provide for countless organisms. *See* AIR POLLUTION; ECOLOGICAL SUCCESSION; FOREST SOIL; FORESTRY, URBAN.

**Forestry and forest management.** The Society of American Foresters defines forestry as the science, the art, and the practice of managing and using for human benefit the natural resources that occur on and in association with forest lands. Natural resources have traditionally entailed major commodities such as wood, forage, water, wildlife, and recreation. However, the concept of forestry has expanded to encompass consideration of the entire forest ecosystem, ranging from mushrooms to landscapes. The practice of forestry requires in-depth knowledge of the complex biological nature of the forest. It also requires an understanding of geology and soils, climate and weather, fish and wildlife, forest growth and development, and social and economic factors. Foresters, wildlife managers, park rangers, and other natural resource specialists are trained in biology, physics, chemistry, mathematics, statistics, computer science, communications, economics, and sociology. *See* FOREST MANAGEMENT.

Silviculture is the art, science, and practice of controlling the establishment, composition, and growth of a forest. It entails the use of both natural and induced processes to foster forest development. For example, reforestation of a harvested or burned-over area can be accomplished by natural seeding from nearby trees or by planting seedlings. *See* REFORESTATION; SILVICULTURE.

**Laws and policies.** The management of forest land in the United States is regulated by numerous laws and policies. Federal agencies must comply with laws such as the National Forest Management Act (1976), the Forest and Rangeland Renewable Resources Planning Act (1974), and the National Environmental Policy Act (1969). Other public and private forest landowners generally must comply with state regulations or guidelines designed to promote sound forest stewardship in their respective regions. Policy makers in government, industry, environmental organizations, and the private sector strive to balance the multitude of interests surrounding forest resources. Input from the public as well as resource managers and specialists is a crucial ingredient in the process.

**Utilization of forest resources.** Forests are often focused on particular uses. For example, plantation forests are generally designed to produce wood and fiber products. Conversely, public forests are increasingly devoted to nonconsumptive purposes such as the preservation of biodiversity, natural conditions, and scenic vistas. However, all forests can provide multiple benefits, including harvestable products, watershed protection, recreation opportunities, wildlife habitat, and ecological services. *See* FOREST GENETICS; FOREST HARVEST AND ENGINEERING; FOREST MANAGEMENT; WOOD PRODUCTS. [M.J.Cou.]

**Forest ecosystem** The entire assemblage of organisms (trees, shrubs, herbs, bacteria, fungi, and animals, including people) together with their environmental substrate (the surrounding air, soil, water, organic debris, and rocks), interacting inside a defined boundary. Forests and woodlands occupy about 38% of the Earth's surface, and they are more productive and have greater biodiversity than other types of terrestrial vegetation. Forests grow in a wide variety of climates, from steamy tropical rainforests to frigid arctic mountain slopes, and from arid interior mountains to windy rain-drenched coastlines. The type of forest in a given place results from a complex of factors, including frequency and type of disturbances, seed sources, soils, slope and aspect, climate, seasonal patterns of rainfall, insects and pathogens, and history of human influence.

**Ecosystem concept.** Often forest ecosystems are studied in watersheds draining to a monitored stream: the structure is then defined in vertical and horizontal dimensions. Usually the canopy of the tallest trees forms the upper ecosystem boundary, and plants with the deepest roots form the lower boundary. The horizontal structure is usually described by how individual trees, shrubs, herbs, and openings or gaps are distributed.

Wildlife ecologists study the relation of stand and landscape patterns to habitat conditions for animals.

Woody trees and shrubs are unique in their ability to extend their branches and foliage skyward and to capture carbon dioxide and most of the incoming photosynthetically active solar radiation. Some light is reflected back to the atmosphere and some passes through leaves to the ground (infrared light). High rates of photosynthesis require lots of water, and many woody plants have deep and extensive root systems that tap stored ground water between rain storms. Root systems of most plants are greatly extended through a relation between plants and fungi, called mycorrhizal symbiosis. See PHOTOSYNTHESIS; ROOT (BOTANY).

The biomass of a forest is defined here as the mass of living plants, normally expressed as dry weight per unit area. Biomass production is the rate at which biomass is accrued per unit area over a fixed interval, usually one year. If the forest is used to grow timber crops, production measures focus on the biomass or volume of commercial trees. Likewise, if wildlife populations are the focus of management, managers may choose to measure biomass or numbers of individual animals. Ecologists interested in the general responses of forest ecosystems, however, try to measure net primary production (Npp), usually expressed as gross primary production (Gpp) minus the respiration of autotrophs (Ra).

Another response commonly of interest is net ecosystem production (NEP),

$$NEP = Gpp - (Ra + Rh) = Npp - Rh$$

usually expressed as where Rh is respiration of heterotrophs. See BIOMASS.

Productivity is the change in production over multiple years. Monitoring productivity is especially important in managed forests. Changes in forest productivity can be detected only over very long periods. See BIOLOGICAL PRODUCTIVITY.

Forested ecosystems have great effect on the cycling of carbon, water, and nutrients, and these effects are important in understanding long-term productivity. Cycling of carbon, oxygen, and hydrogen are dominated by photosynthesis, respiration, and decomposition, but they are also affected by other processes. Forests control the hydrologic cycle in important ways. Photosynthesis requires much more water than is required in its products. Water is lost back to the atmosphere (transpiration), and water on leaf and branch surfaces also evaporates under warm and windy conditions. Water not taken up or evaporated flows into the soil and eventually appears in streams, rivers, and oceans where it can be reevaporated and moved back over land, completing the cycle.

Forest plants and animals alter soil characteristics, for example, by adding organic matter, which generally increases the rate at which water infiltrates and is retained. Nutrient elements cycle differently from water and from each other.

Elements such as phosphorus, calcium, and magnesium are released from primary minerals in rocks through chemical weathering. Elements incorporated into biomass are returned to the soil with litterfall and root death; these elements become part of soil organic matter and are mineralized by decomposers or become a component of secondary minerals. All elements can leave ecosystems through erosion of particles and then be transported to the oceans and deposited as sediment. Deeply buried sediments undergo intense pressure and heat that reforms primary minerals. Volcanoes and plate tectonic movements eventually distribute these new minerals back to land.

Nitrogen is the most common gas in the atmosphere. Only certain bacteria can form a special enzyme (nitrogenase) which breaks apart  $N_2$  and combines with photosynthates to form amino acids and proteins. In nature, free-living  $N_2$ -fixing microbes and a few plants that can harbor  $N_2$ -fixing bacteria in root nodules play important roles controlling the long-term productivity of forests limited by nitrogen supply. Bacteria that con-

vert ammonium ion ( $NH_4^+$ ) to  $NO_3^-$  (nitrifiers) and bacteria that convert  $NO_3^-$  back to  $N_2$  (denitrifiers) are important in nitrogen cycling as well. See FOREST SOIL; HYDROLOGY; NITROGEN CYCLE.

Changes in the plant species of a forest over 10 to 100 years or more are referred to as succession. Changes in forest structure are called stand development; changes in composition, structure, and function are called ecosystem development. Simplified models of succession and development have been created and largely abandoned because the inherent complexity of the interacting forces makes model predictions inaccurate. See ECOLOGICAL SUCCESSION; FOREST FIRE. [B.T.B.]

**Streams.** One of the products of an undisturbed forest is water of high quality flowing in streams. The ecological integrity of the stream is a reflection of the forested watershed that it drains. When the forest is disturbed (for example, by cutting or fire), the stream ecosystem will also be altered. Forest streams are altered by any practices or chemical input that alter forest vegetation, by the introduction of exotic species, and by the construction of roads that increase sediment delivery to streams. See ACID RAIN; STREAM POLLUTION; STREAM TRANSPORT AND DEPOSITION. [J.L.Mey.]

**Vertebrates.** Forest animals are the consumers in forest ecosystems. They influence the flow of energy and cycling of nutrients through systems, as well as the structure and composition of forests, through their feeding behavior and the disturbances that they create. In turn, their abundance and diversity is influenced by the structure and composition of the forest and the intensity, frequency, size, and pattern of disturbances that occur in forests. Forest vertebrates make up less than 1% of the biomass in most forests, yet they can play important functional roles in forest systems.

**Invertebrates.** Invertebrates are major components of forest ecosystems, affecting virtually all forest processes and uses. Many species are recognized as important pollinators and seed dispersers that ensure plant reproduction. Even so-called pests may be instrumental in maintaining ecosystem processes critical to soil fertility, plant productivity, and forest health.

Invertebrates affect forests primarily through the processes of herbivory and decomposition. They are also involved in the regulation of plant growth, survival, and reproduction; forest diversity; and nutrient cycling. Typically, invertebrate effects on ecosystem structure and function are modest compared to the more conspicuous effects of plants and fungi. However, invertebrates can have effects disproportionate to their numbers or biomass.

Changes in population size also affect the ecological roles of invertebrates. For example, small populations of invertebrates that feed on plants may maintain low rates of foliage turnover and nutrient cycling, with little effect on plant growth or survival, whereas large populations can defoliate entire trees, alter forest structure, and contribute a large amount of plant material and nutrients to the forest floor. Different life stages also may represent different roles. Immature butterflies and moths are defoliators, whereas the adults often are important pollinators. [T.Sc.]

**Microorganisms.** Microorganisms, including bacteria, fungi, and protists, are the most numerous and the most diverse of the life forms that make up any forest ecosystem. The structure and functioning of forests are dependent on microbial interactions. Four processes are particularly important: nitrogen fixation, decomposition and nutrient cycling, pathogenesis, and mutualistic symbiosis.

Nitrogen fixation is crucial to forest function. While atmospheric nitrogen is abundant, it is unavailable to trees or other plants unless fixed, that is, converted to ammonia ( $NH_4$ ), by either symbiotic or free-living soil bacteria. See AIR POLLUTION; NITROGEN FIXATION.

Most microorganisms are saprophytic decomposers, gaining carbon from the dead remains of other plants or animals. In the

process of their growth and death, they release nutrients from the forest litter, making them available once again for the growth of plants. Their roles in carbon, nitrogen, and phosphorus cycling are particularly important. Fungi are generally most important in acid soils beneath conifer forests, while bacteria are more important in soils with a higher pH. Bacteria often are the last scavengers in the food web and in turn serve as food to a host of microarthropods.

Microorganisms reduce the mass of forest litter and, in the process, contribute significantly to the structure and fertility of soils as the organic residue is incorporated.

Some bacteria and many fungi are plant pathogens, obtaining their nutrients from living plants. Some are opportunists, successful as saprophytes, but capable of killing weakened or wounded plant tissues. Others require a living host, often preferring the most vigorous trees in the forest. Pathogenic fungi usually specialize on roots or stems or leaves, on one species or genus of trees.

Pathogenic fungi are important parts of all natural forest ecosystems. The forest trees evolved with the fungi, and have effective means of defense and escape, reducing the frequency of infection and slowing the rates of tissue death and tree mortality. However, trees are killed, and the composition and structure of the forest is shaped in large part by pathogens.

Pathogens remove weak or poorly adapted organisms from the forest, thus maintaining the fitness of the population. Decay fungi that kill parts of trees or rot the heartwood of living trees create an essential habitat for cavity-nesting birds and the other animals dependent on hollow trees.

By killing trees, pathogens create light gaps in the forest canopy. The size and rate of light gap formation and the relative susceptibility of the tree species present on the site determine the ecological consequences of mortality. Forest succession is often advanced as shade-tolerant trees are released in small gaps. Gaps allow the growth of herbaceous plants in the island of light, creating habitat and food diversity for animals within the forest. In many forests, pathogens are the most important gap formers and the principal determinants of structure and succession in the long intervals between stand-replacing disturbances such as wildfires or hurricanes. See ECOLOGICAL SUCCESSION; PLANT PATHOLOGY.

The fungus roots of trees, and indeed most plants, represent an intimate physical and physiological association of particular fungi and their hosts. Mycorrhizae are the products of long coevolution between fungus and plant, resulting in mutual dependency. Mycorrhizae are particularly important to trees because they enhance the uptake of phosphorus from soils. Mycorrhizal fungi greatly extend the absorptive surface of roots through the network of external hyphae. See ECOSYSTEM; FOREST AND FORESTRY; MYCORRHIZAE. [E.Ha.]

**Forest fire** The term wildfire refers to all uncontrolled fires that burn surface vegetation (grass, weeds, grainfields, brush, chaparral, tundra, and forest and woodland); often these fires also involve structures. In addition to the wildfires, several million acres of forest land are intentionally burned each year under controlled conditions to accomplish some silvicultural or other land-use objective or for hazard reduction.

Most wildfires are caused by human beings, directly or indirectly. In the United States less than 10% of all such fires are caused by lightning, the only truly natural cause. In the West (the 17 Pacific and Rocky Mountain states) lightning is the primary cause, with smoking (cigarettes, matches, and such) the second most frequent. Combined they account for 50 to 75% of all wildfires. In the 13 southern states (Virginia to Texas) the primary cause is incendiary. This combined with smoking and debris burning make up 75% of the causes. The 20 eastern states have smoking and debris burning as causing close to 50% of all wildfires. Miscellaneous causes of wildfires are next in importance in most regions. The other causes of wildfires are machine use

and campfires. Machine use includes railroads, logging, sawmills, and other operations using equipment.

The manner in which fuel ignites, flame develops, and fire spreads and exhibits other phenomena constitutes the field of fire behavior. Factors determining forest fire behavior may be considered under four headings: attributes of the fuel, the atmosphere, topography, and ignition. A forest fire may burn primarily in the crowns of trees and shrubs (a crown fire); primarily in the surface litter and loose debris of the forest floor and small vegetation (a surface fire); or in the organic material beneath the surface litter (a ground fire). The most common type is a surface fire.

The U.S. Forest Service has developed a National Fire Danger Rating System (NFDRS) to provide fire-control personnel with numerical ratings to help them with the tasks of fire-control planning and the suppression of specific fires. The system includes three basic indexes: an occurrence index, a burning index, and a fire load index. Each of these is related to a specific part of the fire-control job. These indexes are used by dispatchers in making decisions on setting up firefighting forces, lookout systems, and so forth. [W.S.Br.]

**Forest genetics** The subdiscipline of genetics concerned with genetic variation and inheritance in forest trees. The study of forest genetics is important because of the unique biological nature of forest trees (large, long-lived plants covering 30% of the Earth's surface) and because of the trees' social and economic importance. Forest genetics is the basis for conservation, maintenance, and management of healthy forest ecosystems; and development of programs which breed high-yielding varieties of commercially important tree species.

**Variation in natural forests.** The outward appearance of a tree is called its phenotype. The phenotype is any characteristic of the tree that can be measured or observed such as its height or leaf color. The phenotype is influenced by (1) the tree's genetic potential (its genotype); and (2) the environment in which the tree grows as determined by climate, soil, diseases, pests, and competition with other plants.

No two trees of the same species have exactly the same phenotype, and in most forests there is tremendous phenotypic variation among trees of the same species. Forest geneticists often question whether the observed phenotypic variation among trees in forests is caused mostly by genetic differences or by differences in environmental effects. Common garden tests are often used to hold the environment constant and therefore isolate the genetic and environmental effects on phenotypic variability.

**Geographic variation.** The term "provenance" refers to a specific geographical location within the natural range of a tree species. Natural selection during the course of evolution has adapted each provenance to its particular local environment. This means that there are large genetic differences among provenances growing in different environments. Provenances originating from colder regions, for example, tend to have narrower crowns with flatter branches better adapted to the dry snow and types of frosts in colder climates. To demonstrate that these differences are genetic in origin, common garden tests called provenance tests have been planted. That is, seed has been collected from several provenances and planted for comparison in randomized, replicated studies in various forest locations. The study of geographic variation through provenance tests should be a first step in the genetic research of any tree species.

**Genetic variation.** In addition to genetic differences among provenances, there is usually substantial genetic variation among trees within the same provenance and even within the same forest stand. There are two reasons for this genetic diversity: (1) Different trees have different genotypes in most natural stands. (2) Each tree is heterozygous for many genes, meaning that a given tree has multiple forms (different alleles) of many genes. Population genetics studies patterns of genetic diversity in populations (such as forest stands). Results of many studies have



shown that most forest tree species maintain very high levels of genetic diversity within populations. See POPULATION GENETICS.

**Forest tree breeding.** Beginning with the natural genetic variation that exists in an undomesticated tree species, tree breeding programs use selection, breeding, and other techniques to change gene frequencies for a few key traits of the chosen species. As with agricultural crops, tree breeders produce genetically improved, commercial varieties that are healthier, grow faster, and yield better wood products. After an existing forest stand is harvested, a new stand of trees is planted to replace the previous stand in the process called reforestation. Use of a genetically improved variety for this reforestation means that the new plantation will grow faster and produce wood products sooner than did the previous stand.

Several laboratory techniques promise to make major contributions to forest genetics and tree breeding: (1) Somatic embryogenesis is a technique to duplicate (or propagate) selected trees asexually from their vegetative (somatic) cells, and this allows the best trees to be immediately propagated commercially as clones without sexual reproduction (that is, no seed is involved). (2) Genetic mapping of some important tree species is well under way, and these maps will be useful in many ways to understand the genetic control of important traits, such as disease resistance. (3) Marker-assisted selection is the use of some kinds of genetic maps to help select excellent trees at very early ages based on their deoxyribonucleic acid (DNA) genotype as assessed in a laboratory (instead of growing trees in the field and selecting based on performance in the forest). (4) Functional genomic analysis is an exciting new field of genetics that aims to understand the function, controlled expression, and interaction of genes in complex traits such as tree growth. (5) Genetic engineering or genetic modification is the insertion of new genes into trees from other species.

**Conservation of genetic resources.** For commercially important species of forest trees, gene conservation is practiced by tree breeding programs to sustain the genetic diversity needed by the program. However, conservation of genetic diversity is a major global concern and is important for all forest species to maintain the health and function of forest ecosystems, and to sustain the genetic diversity of noncommercial species that may eventually have economic value. There are two broad categories of gene conservation programs. In-situ programs conserve entire forest ecosystems in forest reserves, national parks, wilderness areas, or other areas set aside for conservation purposes. Ex-situ programs obtain a sample of the genotypes from different provenances of a single tree species and collect seed or vegetative plant material from each genotype to store in a separate location (such as a seed bank in a refrigerated room). Both types of programs are important for conserving the world's forest resources. See BREEDING (PLANT); FOREST AND FORESTRY; FOREST ECOSYSTEM; GENETIC ENGINEERING; PLANT PROPAGATION. [T.L.W.]

**Forest harvest and engineering** Application of engineering principles to the solution of forestry problems, such as those dealing with harvesting, forest transportation, materials handling, and mechanical silviculture, with regard to long-range environmental and economic effects.

The work that forest engineers perform varies widely throughout the United States. In the Northeast and Southeast, tasks include mechanization of harvesting, site preparation, planting, and product handling. Development and modification of machinery is an important part of this job, as is the improvement of the ability of workers to use machines in the woods, an activity known as work science. In the West, the terrain changes the job, as does the size of the trees usually harvested. Planning, design, and construction of road systems are major operational and environmental challenges in the West. Harvesting with mechanical fellers or yarding with ground skidders is often limited by tree size and terrain. Cable systems are commonly used to overcome these constraints, and the design and layout of these

cable logging units require a great deal of engineering skill if logging is to be done in an economic and environmentally acceptable manner. In short, the skills possessed by forest engineers in the eastern United States parallel most closely those of the mechanical or agricultural engineer. In the West, the skills are more closely aligned with civil engineering. See AGRICULTURAL ENGINEERING; CIVIL ENGINEERING; FOREST AND FORESTRY; MECHANICAL ENGINEERING; SILVICULTURE. [J.E.O'L.]

**Forest management** The planning and implementation of sustainable production of forest crops and other forest resources and uses. Key decisions include land allocation to different uses or combination of uses, silvicultural method and practices, intensity of management, timber harvest scheduling, and environmental protection.

Nearly three-fourths (360 million acres or 140 million hectares) of all commercial forest land in the United States is privately owned by farmers, forest investment groups, other types of nonindustrial owners, or industrial firms engaged in the business of growing and harvesting timber for conversion to wood products. The objectives and practices of private owners are extremely diverse. Many states and local governments have enacted laws that regulate the practice of private forestry. Therefore, management planning for a specific property requires a detailed review of the owner's objectives, resources, and any legal constraints regarding land uses or choice of management practices in the local area.

One-fourth (about 120 million acres or 49 million hectares) of the commercial forest in the United States is administered by federal and state agencies. The National Forest System, managed by the U.S. Forest Service, is particularly important in the western United States, where it includes nearly one-half of the commercial forest. Each national forest is required by federal law to develop a long-term land management plan, involve the public in evaluating alternatives, project future practices and outputs, and identify methods to mitigate adverse environmental impacts. These plans provide for timber harvesting, wilderness management, watershed protection, wildlife habitat, and other services in combinations that vary from forest to forest. The recovery plans of many endangered species occur primarily on public forest lands.

Forest land-use planning and project implementation requires information about the physical, vegetative, and developmental characteristics of forest resources within the management unit. Aerial photography, satellite imagery, and statistically designed ground surveys are commonly used to obtain the necessary information. The resource assessment should normally include estimates of timber volume classified according to species, age or size class, quality, location, and other attributes that affect value in the local market or have relevance to decision-making. Typically, statistically designed sampling procedures using plots or strips are employed by specially trained technicians to estimate volume. Information about nontimber resources such as wildlife, streams and lakes, fisheries, and historical and archeological sites may also be required, depending upon the owner's objectives and local forest practice regulations. Assessment methods normally utilize both ground and aerial surveys, and professional specialists employed by the owner or by outside consultants. See FOREST MEASUREMENT; GEOGRAPHIC INFORMATION SYSTEMS; LAND-USE PLANNING; REMOTE SENSING.

A forest typically will have complex structure. There may be a range of soil types, slopes, and aspects that differ in potential productivity. To facilitate planning for such complex situations, optimization methods may be used to schedule management activities over time, determine the timber harvest level, allocate the land base among alternative uses, and calculate benefits and costs. A common method, linear programming, requires that the manager specify both a linear objective function to be maximized and a set of linear equations that describe management

constraints. See LINEAR PROGRAMMING; FOREST TIMBER RESOURCES; SILVICULTURE.

Modern forest management usually involves the production of multiple services of value to the owner or to society. Determining the best mix of services requires technical information on trade-offs between the different outputs, costs and values, and pertinent legal constraints. Subjective evaluations may be required in the case of unpriced services such as wildlife, water, and scenery. Forest structure has a major impact on the mix of outputs. Forest outputs or services can generally be classified as complementary or competitive. Services are complementary if an increase in the output of one is accompanied by an increase in the output of the other. They are competitive if effort to increase the output of one results in a reduction in the output of the other. In response to concerns about landscapes, such as maximum opening sizes, spatial diversity, and wildlife habitat, new scheduling methods are being developed and used (for example, tabu search, simulated annealing, and heuristics). Unlike linear programming, these methods do not guarantee optimal solutions. However, they do provide quality solutions that consider the complexity of modern forest management and can be implemented on the ground. See FOREST AND FORESTRY. [D.E.Te.]

**Forest measurement** The science and practice of measuring the volume, growth, and development of trees individually and collectively and estimating the products obtainable from them. Foresters use quantitative sciences such as mathematics and statistics for these measurements.

Regardless of the land management objectives—timber, wildlife, recreation, watershed, or a combination of these resources—the tree overstory (the forest canopy) must be quantified for informed decision making. Forest cover is an important part of wildlife habitat, and the understory component is related to the overstory characteristics. The recreation potential of wildland is a function of many variables, including the size and number of trees present. Water yields are related to the composition and density of the tree canopy. The measurement principles discussed here are applicable to all forest resource management situations that require quantitative information about the tree component of the land base.

Standing trees are commonly measured for diameter, height, and age. The diameter and height measurements are used to estimate the volume (or weight) and value of individual trees; ages are used in assessing site quality and predicting growth. See DENDROLOGY; TREE GROWTH; WOOD ANATOMY.

In addition to inventories aimed at determining current conditions, land managers need trend data. Monitoring consists of collecting information over time, generally on a sample basis by measuring change in key indicator variables, in order to determine the effects of management treatments in the long term. These data, along with research results, can be used to modify management on a continuing basis to ensure that objectives are being met. The sampling design for monitoring generally involves repeated measurements on the same sample plots or individuals.

Forest inventory information is commonly stored, updated, and retrieved through geographic information systems (GISs). A GIS is a computerized database for storing, manipulating, and displaying map (spatial) data and tabular (attribute) information. In a GIS, forest inventory information can be stored in a computer and directly linked to associated forest maps, making it easier and faster to analyze and graphically display the results of forest inventories. GISs can make forest inventory information more powerful by allowing forest resource managers to integrate it with other data commonly needed to make management decisions.

Foresters estimate site quality to assess present and future forest productivity and to provide a frame of reference for land management. Many parameters that affect productivity are difficult or impossible to measure directly, and as a consequence

site quality is determined indirectly. Most commonly, site quality is evaluated from tree height in relation to age. Theoretically, height growth is sensitive to differences in site quality, is little affected by varying stand-density levels, is relatively stable under varying thinning intensities, and is strongly correlated with volume. Thus height has been found to be a practical, consistent, and useful indication of site quality.

Quantitative measures of stand density are used when deriving silvicultural prescriptions and predicting growth and yield. The two most commonly used measures of stand density are tree basal area per unit area and number of trees per unit area. Stand basal area is the cross-sectional area at diameter at breast height of all stems, or some specified portion of the stand, expressed on a per-acre (or per-hectare) basis. Similarly, trees per acre may be determined for all stems or for some specified portion of the stand. See SILVICULTURE.

Growth is the increase (increment) over a given period of time. Yield is the total amount available for harvest at a given time, that is, the summation of the annual increments. The factors most closely related to growth and yield of forest stands of a given species composition are the point in time in stand development, the site quality, and the degree to which the site is occupied. See FOREST AND FORESTRY; FOREST MANAGEMENT. [H.E.B.]

**Forest pest control** Forest pest control or forest protection refers to the approaches and tactics for protecting forests from insects and pathogens. The traditional view is that plant-feeding insects and pathogens are destructive agents that must be controlled to protect forest resources. Pest activity generally is triggered by specific changes in host-tree condition and density that often result from forest management practices. Integrated forest pest management represents the current approach to optimize accomplishment of forest management goals by evaluating the costs and benefits of various forest species for production of multiple resources. A number of pest management tools are available, including computerized models that facilitate evaluation and decision-making, and a variety of chemical, biological, and silvicultural techniques for manipulating pest abundances. See PLANT PATHOLOGY.

A variety of organisms can interfere with forest management objectives. Most of these are insects, fungal pathogens, and nematodes. Insects are responsible for vectoring some microbial pathogens, and pathogens frequently increase the vulnerability of infected trees to insects.

A critical first step in integrated forest pest management is identification of the forest management goals. If not justified by contribution to forest management goals, that is, optimized production of forest resources, suppression represents unnecessary costs in terms of time, money, and environmental quality.

Forest managers must be aware of potential impediments, including effects of insect and pathogens, in the accomplishment of their goals. Effective management requires information on which species can affect forest resources and at what densities. The relative threats of potential pests to particular management goals must be weighed carefully to determine tolerable or optimal abundances. Substantial data are needed to evaluate pest status. Examples of information needed for assessment include current and projected abundances of potential pests, action thresholds (abundance at which loss of resources exceeds costs of control efforts), environmental conditions favorable to various pests, and factors that influence the effectiveness of control tactics. This information can be used to project losses or gains for various forest resources as a result of specific insect or pathogen species. Such projections can be improved greatly by use of computerized models that synthesize available data and permit simulation and prediction of resource production under various environmental conditions or pest management scenarios.

The objective of pest suppression should be maintenance of pest populations below their action thresholds. Elimination of native species is impractical and would interfere with their

natural ecological functions. Reducing abundances to levels that no longer interfere with management goals is sufficient. However, preventing the establishment of exotic species may be critical to sustainability of forest resources.

A variety of control options are available, but many have limited utility against particular pest species. Pesticides can be applied as aerial or ground aerosols or as fumigants. Fungicides are relatively ineffective against fungal pathogens that generally are protected from exposure. Microbial pathogens and antibiotics can be delivered as aerosols or applied to surfaces exposed to infectious agents. Other biological control options include augmentation of natural enemy populations. Biological control is most effective when the predator, parasite, or pathogen selectively and efficiently preys on the pest species. Pheromones are chemicals produced by animals, most commonly to attract potential mates. In some species, especially of bark beetles, a combination of attractive and repellent pheromones limits population density and reduces competition for resources. Silvicultural options include thinning, prescribed understory burning, and fertilization to reduce competition among trees for light, water, and nutrient resources. Thinning also slows spread of insects and pathogens between trees.

A goal of integrated forest pest management is variation in control tactics over time and across landscapes to minimize development of resistance to particular control options. See FUNGISTAT AND FUNGICIDE; INSECT CONTROL, BIOLOGICAL; PESTICIDE; PHEROMONE; SILVICULTURE. [T.Sc.]

**Forest recreation** Recreation involving direct contact with forests in various activities ranging from walking in the woods to wilderness backpacking. The primary suppliers of forest recreation opportunities in the United States are federal land management agencies such as the U.S. Department of Agriculture (USDA) Forest Service, the National Park Service, and the Bureau of Land Management; state recreation, park, wildlife, and forest departments; and private landowners and corporations (ski areas, industrial forests, resorts).

In the early decades of the twentieth century, recreation management was mostly custodial management, keeping areas free from litter and pollutants and providing fire protection. As recreation use increased dramatically in the 1950s, a concept of activity-based management emerged with a focus on the numbers of users, the activities in which they participated, and the sites necessary for participation. In 1958 the U.S. Congress empaneled the Outdoor Recreation Resources Review Commission to assess the situation and make recommendations for the future of outdoor recreation. See FOREST MANAGEMENT.

As outdoor recreation use of forests grew and as research began to focus on behavior of participants, the activity-based management concept evolved into a more sophisticated concept of experience-based management that focused on the achievement of satisfying experiences from recreation engagement. Three important concepts that have come from experience-based management are a definition of recreation that is behaviorally based, the Recreation Opportunity Spectrum (ROS) approach to recreation classification and management, and the Limits of Acceptable Change (LAC) planning system.

Using specific criteria to define different types of outdoor recreation, the Recreation Opportunity Spectrum allows managers to characterize the kind of recreation to be offered and to guide management decisions. It also is used to assess the impacts of recreation and proposed recreation on other uses such as timber management.

The Limits of Acceptable Change incorporates the Recreation Opportunity Spectrum and explicitly makes monitoring and evaluation of use and impacts a part of planning and management. The Limits of Acceptable Change is important in integrating forest recreation issues and concerns into multiple-use land management.

Recreation management has evolved to focus on the potential benefits that recreationists, society, and communities might realize from recreation opportunities and participation. This has become known as benefits-based management, and expected benefits are used to guide design of recreation sites and their access systems, to develop recreation information programs, and to integrate recreation with other forest uses.

The educational, physical, and mental health effects on individuals engaged in recreation on forest lands can have positive effects on sustainability of environmental and natural resources. Likewise, recreation can be detrimental. For example, wildlife can be adversely affected by off-road vehicle users or traffic on recreational roads. A major challenge for forestland managers is to help people achieve their recreational goals, but in ways that minimize negative impacts on ecosystems. See FOREST AND FORESTRY; FOREST ECOSYSTEM. [P.J.Bro.]

**Forestry, urban** The planning and implementation of actions to establish, protect, restore, and maintain trees and forests in cities and smaller communities. When it began in the 1960s, the field of urban forestry focused on individual trees along streets and adjacent to homes and buildings, and on groups of trees in specific spatial areas such as parks. Since then, it has evolved toward more holistic consideration of the structure, processes, and functions of urban ecosystems at a larger scale. Scientists have come to realize that trees and forests play a critical role in maintaining healthy urban ecosystems, providing ecological services such as filtering water and air pollution, reducing stormwater flows, sequestering carbon emissions, conserving energy, and reducing soil erosion, as well as providing human health benefits, recreation, esthetics, and fish and wildlife habitat. These ecological services can be translated into economic values worth billions of dollars by comparing them to the costs of achieving the same benefits with technology and human-made infrastructure. Urban trees, forests, and related vegetation are often referred to as green infrastructure in order to compare and contrast them with human-made or hard infrastructure, such as buildings and roads. See ECOLOGICAL COMMUNITIES; ECOLOGICAL SUCCESSION.

New satellite remote sensing and geographic information system tools are enabling communities to assess changes in their green infrastructure and to develop plans for restoring and maintaining urban trees and forests. City planners and policymakers use the same tools to address other urban infrastructure needs, such as transportation and housing, which allows them to integrate green infrastructure information into plans for other infrastructure development.

As urban forestry has expanded to include larger ecosystems, spatial boundaries between urban and rural areas have begun to blur. Their ecological, social, and economic links have come into view. Watershed connections have become a key consideration, while other social and economic links related to movements of people, businesses, goods, and services have also become clearer. Rural lands, both public and private, provide an array of ecological services to nearby cities, including drinking water, recreational opportunities, fish and wildlife habitat, and agricultural and forest products.

Urban forests are owned by a diverse array of public and private entities, including individual homeowners, private businesses, and federal, state, and local governments. Their management and use are closely tied to the homes, buildings, transportation systems, utilities, and other infrastructure in an urban area. A key challenge is coordinating the efforts of the large number of individuals, groups, and organizations involved in urban forestry, each with its own information, resources, and objectives. See LAND-USE PLANNING. [G.J.Ga.; G.A.Mo.]

**Forging** The plastic deformation of metals, usually at elevated temperatures, into desired shapes by compressive forces exerted through a die. Forging processes are usually classified either by the type of equipment used or by the geometry of the

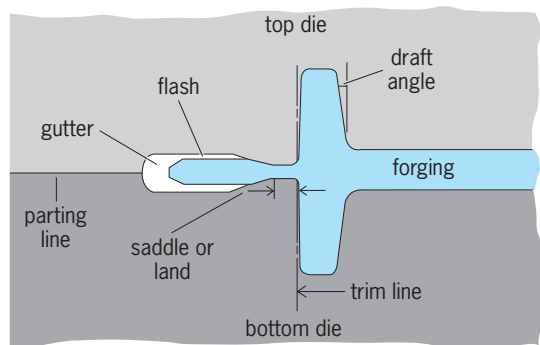

Closed-die forging terminology.

end product. The simplest forging operation is upsetting, which is carried out by compressing the metal between two flat parallel platens. From this simple operation, the process can be developed into more complicated geometries with the use of dies. A number of variables are involved in forging; among major ones are properties of the workpiece and die materials, temperature, friction, speed of deformation, die geometry, and dimensions of the workpiece.

In practice, forgeability is related to the material's strength, ductility, and friction. In terms of factors such as ductility, strength, temperature, friction, and quality of forging, various engineering materials can be listed as follows in order of decreasing forgeability: aluminum alloys, magnesium alloys, copper alloys, carbon and low-alloy steels, stainless steels, titanium alloys, iron-base superalloys, cobalt-base superalloys, columbium alloys, tantalum alloys, molybdenum alloys, nickel-base superalloys, tungsten alloys, and beryllium. See METAL.

Some of the terminology in forging is shown in the illustration. Draft angles facilitate the removal of the forging from the die cavity. The purpose of the saddle or land in the flash gap is to offer resistance to the lateral flow of the material so that die filling is encouraged. Die filling increases as the ratio of land width to thickness increases up to about 5; larger ratios do not increase filling substantially and are undesirable due to increased forging loads and excessive die wear. The purpose of the gutter is to store excess metal. The flash is removed either by cold or hot trimming or by machining.

A number of methods produce the necessary force and die movement for forging. Two basic categories are open-die and closed-die forging. Drop hammers supply the energy through the impact of a falling weight to which the upper die is attached. Another type of forging equipment is the mechanical press. For large forgings the hydraulic press is the only equipment with sufficient force. However, the speed for such presses is about one-hundredth that of hammers. See METAL FORMING. [S.Ka.]

**Formaldehyde** The simplest aldehyde, formula  $\text{HCH}=\text{O}$ . Because of its extreme reactivity, even with itself, it cannot be readily isolated or handled in the pure state. Therefore, it is produced and marketed as an aqueous solution (usually 37–50% formaldehyde by weight), sometimes known as Formalin. It is also sold as the solid hydrated polymer known as paraformaldehyde or paraform.

Formaldehyde is used principally to produce synthetic resins and adhesives by reaction with phenols, urea, and melamine. Other uses are in the manufacture of textiles, dyes, drugs, paper, leather, photographic materials, embalming agents, disinfectants, and insecticides. See ALDEHYDE; PHENOLIC RESIN. [L.M.]

**Formation** A fundamental geological unit used in the description and interpretation of layered sediments, sedimentary rocks, and extrusive igneous rocks. A formation is defined on the basis of lithic characteristics and position within a stratigraphic

succession. It is usually tabular or sheetlike, and is mappable at the Earth's surface or traceable in the subsurface (for example, between boreholes or in mines). Examples are readily recognized in the walls of the Grand Canyon of northern Arizona. Each formation is referred to a section or locality where it is well developed (a type section), and assigned an appropriate geographic name combined with the word formation or a descriptive lithic term such as limestone, sandstone, or shale (for example, Temple Butte Formation, Hermit Shale). This usage of "formation" by geologists differs from its informal lay usage for stalactites, stalagmites, and other mineral buildups in caves. See STRATIGRAPHY.

Distinctive lithic characteristics used to designate formations include chemical and mineralogical composition, particle size and other textural features, primary sedimentary or volcanic structures related to processes of accumulation, fossils or other organic content, and color. Contacts or boundaries between formations are chosen at surfaces of abrupt lithic change or within zones of gradational lithic character. Commonly, these contacts correspond with recognizable changes in topographic expression, related to variations in resistance to weathering. See SEDIMENTARY ROCKS; SEDIMENTOLOGY.

Mappability is an essential characteristic of a formation because such units are used to delineate geological structure (faults and folds), and it is useful to be able to recognize individual formations in isolated outcrops or areas of poor exposure. Well-established formations are commonly divisible into two or more smaller-scale units termed members and beds (for example, subdivisions of the Redwall Limestone). In other cases, formations of similar lithic character or related genesis are combined into composite units termed groups and supergroups (for example, Supai Group). The rank of a named unit may vary from one area to another (for example, from group to formation) according to whether or not subunits are readily mappable. Changes in rank are also justified in the light of new geological knowledge.

Although commonly used as a framework for interpreting geological history, formations and related units are conceptually independent of geological time. They may represent either comparatively short or comparatively long intervals of time. Accumulation of a particular unit may have begun earlier in some places than in others, and the time span represented by a unit may be influenced by later erosion. In some cases, a formation cropping out at one locality may be entirely older or younger than the same lithic unit at another locality. Although the concept of time plays no role in the definition of a formation, evidence of age is useful in the recognition of lithologically similar units far from their type localities. [N.C.B.]

**Fossil** A record of earlier life buried in rock. Originally meaning any distinctive object that has been dug up (from Latin *fodio*, dig), the term "fossil" soon came to refer particularly to things resembling animals and plants.

**Fossilization.** A widespread conception is that a fossil is a shell or skeleton turned into stone. This picture represents only a few of the ways in which life can leave its trace in Earth's accreting skin of sedimentary rocks. Any part of an organism can get preserved, not only hard parts but also soft tissues, cells, and organelles. Even when nothing of the original organisms is preserved, impressions and traces in the sediment give important information about their former presence, activities, and ecological roles. Also, fossilization can imply everything from preservation of the almost unaltered original tissues to their complete replacement with sediment or minerals growing in place. Organic molecules can be preserved, though in a more or less degraded state.

The biosphere normally recycles all organic and inorganic matter produced by organisms; fossils represent dead individuals that to some degree escaped that process. Most decomposition is by aerobic scavengers, fungi, and bacteria, and so a prerequisite for fossilization is that the dead body is quickly and permanently

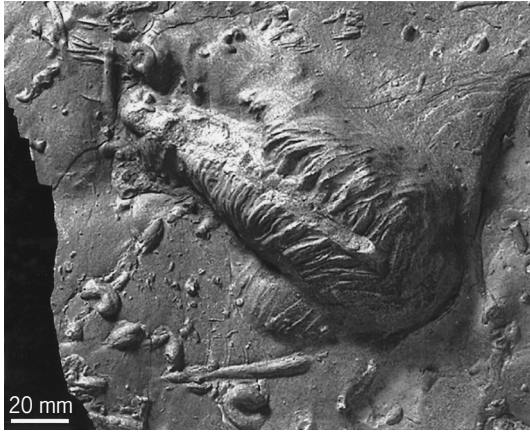

**Trace fossil, *Cruziana***, formed by an arthropod (probably a trilobite) digging for a wormlike animal in soft mud during the Cambrian Period. The picture shows the lower side of a sandstone bed casting of the original markings in the mud (now vanished). (Swedish Geological Survey; from S. Jensen, *Trace fossils from the Lower Cambrian Mickwitzia sandstone, south-central Sweden, Fossils and Strata*, 42, 1997)

subjected to an environment in which decomposers cannot be active. A combination of anoxic water and rapid sedimentation is a typical condition favorable to fossilization, though other conditions, such as extreme temperatures, salinity, poisonous environment, desiccation, or rapid mineralization, are also known to promote fossilization. Some kind of microbial activity, however, seems to be a prerequisite for many types of fossilization, particularly of soft tissue. See EDIACARAN BIOTA.

**Shells and skeletons.** Mineralized hard parts, such as shells, spicules, and bones, are by far the most common type of fossil. Although they typically contain a substantial proportion of organic material, their mineral phase usually ensures that they are more resistant than soft tissues to biological decomposers. The most common skeletal minerals are opal (hydrated silica), apatite (calcium phosphates), and calcite and aragonite (calcium carbonates). Even when none of the original hard tissue is preserved, its former presence may promote fossilization through its initial resistance to degradation. Shells are frequently preserved as molds or casts; for example, lithified infillings (internal molds) of mollusk shells are common fossils. Some hard or protective tissues may not contain any appreciable mineral phase but are nevertheless resistant to degradation and may commonly be fossilized. Arthropod cuticle, cnidarian perisarc, hemichordate periderm, leaf cuticle, and spore exine are examples of such outer protective tissues. What gives them their resistance is usually tanned proteins, polysaccharides, or waxes.

**Exceptional preservation.** Paleontology is increasingly dependent on sites with unusual conditions of preservation, allowing for the fossilization of soft as well as hard parts and of more complete samples of the total biota. Early silicification of sediments may trap and preserve biota; this is the main process responsible for knowledge of the microbially dominated biosphere of the Archean and Proterozoic eons, up to about 550 million years ago. Another process known to promote exquisite preservation is impregnation with calcium phosphate during early diagenesis (physical and chemical changes occurring in sediments between deposition and solidification); this has been known to preserve soft tissues, even to cellular detail. Seemingly destructive forest fires may result in excellently preserved plant tissues through coalification. Amber, fossilized tree resin, is well known for its capacity to trap and fossilize insects and other small animals and plant parts. Freezing has yielded spectacular finds of soft-tissue preservation of, for example, mammoths. The dependence on permanent low temperatures for maintaining the fos-

sils, however, limits this kind of preservation to the most recent fossil biotas.

Various types of fine-grained shales and mudstones are more or less compressed by the weight of overlying sediment, and so the fossils are not preserved in as full relief as in the other types of extraordinary preservation mentioned earlier. However, the shaley deposits are capable of preserving much larger fossils than most of the other processes. See BURGESS SHALE.

Other types of exceptional fossil preservation are known, though they are more incidental and may be restricted to a short stratigraphic interval.

Trace fossils (marks of animal activities in sediment) and coprolites (fossilized feces) generally give less information than body fossils about the anatomy of the ancient organisms, but they are important sources of ecological and behavioral information (see illustration). See TRACE FOSSILS. [J.J.Se.]

**Fossil apes** Apes and humans are closely related primates in the superfamily Hominoidea. The living hominoids are subdivided into the families Hylobatidae and Hominidae. The hylobatids or lesser apes (genus *Hylobates*) are represented by approximately nine species found throughout Southeast Asia. Humans and the great apes—the orangutan (*Pongo pygmaeus*), the gorilla (*Gorilla gorilla*), the common chimpanzee (*Pan troglodytes*), and the pygmy chimpanzee or bonobo (*Pan paniscus*)—are grouped in the Hominidae. In the past, the great apes were included in a separate family, the Pongidae, but subsequent anatomical and molecular studies showed that the African apes (*Gorilla* and *Pan*) are more closely related to humans than they are to the Asian orangutan.

The evolutionary history of the extant hominoids is poorly known, with the notable exception of humans, which have a relatively complete fossil record extending back more than 4 million years. The earliest fossil apes that can be definitively linked to the modern hylobatids are known from sites in China dated to less than 1.5 million years ago (Ma), while the fossil record for the African apes is entirely unknown. The evolution of the orangutan is, by comparison, much better documented. In contrast to the paucity of fossils available to trace the evolutionary history of hominoids over the past 5 million years, there is a wealth of evidence from the Miocene Period (23–5 Ma). This evidence shows that apes were once much more common and more diverse than they are today.

**Proconsulids.** The remains of apelike fossil primates, commonly known as proconsulids, have been recovered from sites in Kenya, Uganda, and Saudi Arabia dating to the early Miocene (23–16 Ma). Studies have shown that proconsulids represent either the earliest known hominoids or primitive stem catarrhines (the group which gave rise to both Old World monkeys and apes). They are certainly more primitive than any of the living apes, retaining generalized skulls and teeth, and monkeylike postcranial skeletons. However, during the early Miocene there was at least one species of hominoid living in East Africa, *Morotopithecus bishopi*, which had already acquired some of the unique features of modern apes.

During the middle Miocene (16–10 Ma), conditions in East Africa became somewhat drier, cooler, and more seasonal, and open woodland habitats replaced the humid tropical forests that were typical of the early Miocene. These ecological changes coincided with the appearance in East Africa of a more advanced type of hominoid, *Kenyapithecus*. The limb bones indicate that *Kenyapithecus* was more terrestrially adapted than proconsulids and exhibited a number of specialized features that link it more closely to extant hominoids.

**Eurasian hominoids.** Until the middle Miocene, hominoids were restricted to Africa, but during this period they migrated into Eurasia. Once in Eurasia, hominoids became established over a wide geographical region, extending from Spain in western Europe to eastern China, and they became increasingly diversified during the middle and late Miocene (16–5 Ma). The

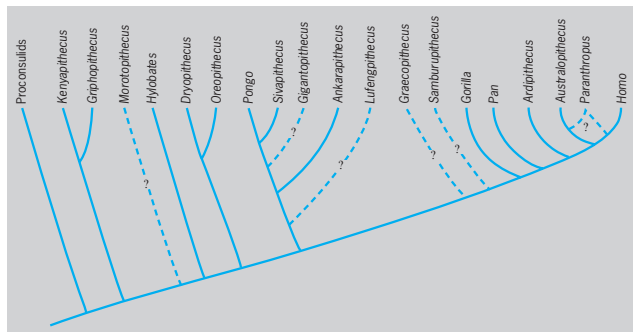

Cladogram of the evolutionary relationships of fossil and living apes. Broken lines indicate uncertain relationships.

best-known fossil Eurasian hominoids are *Dryopithecus* (western and central Europe), *Oreopithecus* (Italy), *Graecopithecus* or *Ouranopithecus* (Greece), *Ankarapithecus* (Turkey), *Sivapithecus* (Indo-Pakistan), and *Lufengpithecus* (China). Of these forms, *Sivapithecus* is evidently closely related to the living orangutan, but the relationships of the other Eurasian Miocene hominoids remain contentious (see illustration).

An ecological shift from moist temperate woodlands to drier, more seasonal habitats during the later Miocene coincided with a sharp decline in the diversity of hominoids in Eurasia. The only survivor in Europe toward the end of the Miocene was *Oreopithecus*, a highly specialized relative of *Dryopithecus*. *Lufengpithecus* and *Sivapithecus*, along with *Gigantopithecus*, are found in the late Miocene of Asia. All of these Eurasian hominoids became extinct by the close of the Miocene, except for *Gigantopithecus*, whose remains have been recovered from Pleistocene cave sites in China dated to less than 1 Ma.

Hominoids also became extremely rare in Africa during the late Miocene. A large hominoid, *Samburupithecus*, known only by a single maxilla from Kenya (dated to 10–8 Ma), may represent a close relative of the African apes and humans. The earliest definitive record of fossil hominoids that are more closely related to humans than they are to the African great apes is known from the Pliocene (5.2–1.6 Ma) with the appearance of *Ardipithecus ramidus* from Ethiopia (4.4 Ma), *Australopithecus anamensis* from Kenya (4.2–3.9 Ma), and *Australopithecus afarensis* from Ethiopia and Tanzania (4–3 Ma). See APES; FOSSIL HUMANS; MAMMALIA; MONKEY. [T.Har.]

**Fossil fuel** Any naturally occurring carbon-containing material which when burned with air (or oxygen) produces (directly) heat or (indirectly) energy. Fossil fuels can be classified according to their respective forms at ambient conditions. Thus, there are solid fuels (coals); liquid fuels (petroleum, heavy oils, bitumens); and gaseous fuels (natural gas, which is usually a mixture of methane, CH<sub>4</sub>, with lesser amounts of ethane, C<sub>2</sub>H<sub>6</sub>, hydrogen sulfide, H<sub>2</sub>S, and numerous other constituents in small proportions).

#### Heating values of representative fuels

Fossil fuel	Btu/lb	Btu/ft <sup>3</sup>	MJ/k	MJ/m <sup>3</sup>
Natural gas		900		33.5
Petroleum	19,000		44.1	
Heavy oil	18,000		41.8	
Tar-sand bitumen	17,800		41.3	
Coal				
Lignite	8,000*		18.6	
Subbituminous	10,500*		24.4	
Bituminous	15,500*		36.0	
Anthracite	15,000*		34.8	

\*Representative values are given because of the spread of subgroups with various heating values.

One important aspect of the fossil fuels is the heating value of the fuel, which is measured as the amount of heat energy produced by the complete combustion of a unit quantity of the fuel. For solid fuels and usually for liquid fuels the heating value is quoted for mass, whereas for gaseous fuels the heating value is quoted for volume. The heating values are commonly expressed as British thermal units per pound (Btu/lb). In SI units the heating values are quoted in megajoules per kilogram (MJ/kg). For gases, the heating values are expressed as Btu per cubic foot (Btu/ft<sup>3</sup>) or as megajoules per cubic meter (MJ/m<sup>3</sup>). The table gives heating values of representative fuels. See ASPHALT AND ASPHALTITE; COAL; ENERGY SOURCES; HEAT; NATURAL GAS; PETROLEUM. [J.G.S.]

**Fossil humans** All prehistoric skeletal remains of humans which are archeologically earlier than Neolithic (necessarily an imprecise limit), regardless of degree of mineralization or fossilization of bone, and regardless of whether the remains may be classed as *Homo sapiens sapiens*, anatomically modern humans. In this sense, the term “humans” is used broadly to mean all primates related to living people since the last common ancestor of people and African apes, thus all species currently included in the genera *Homo*, *Australopithecus*, *Ardipithecus*, and *Paranthropus*.

**Prehuman ancestry.** Humans are catarrhine primates, part of a group including Old World monkeys, apes, and various extinct forms. Most evidence from both comparative morphology and molecular studies of proteins shows that humans’ closest living relatives are the African apes: the chimpanzee and the gorilla. Less close is the Asian orangutan, and most distinctive of all apes are the gibbons.

The oldest certain representatives of the Catarrhini are fossils from the Fayum beds of northern Egypt dated around 34 million years ago (Ma). The best known is *Propliopithecus* (= *Aegyptopithecus*) *zeuxis*, a species near the common ancestor of apes, humans, and Old World monkeys (see illustration). Hominoid evolution took place only in Africa in the late Oligocene and early Miocene (26–17 Ma). See FOSSIL APES; FOSSIL PRIMATES; MOLECULAR ANTHROPOLOGY; MONKEY; PRIMATES.

**Pliocene Homininae.** *Australopithecus*, the first truly humanlike beings, appear in the fossil record in quantity some 4.5 Ma, during the early Pliocene. Pliocene humans have been grouped in various ways, but it now seems that four main types can be distinguished. Three of these, dating from 4.5–1 Ma, have often been assigned to the genus *Australopithecus* and can informally be termed australopiths; the fourth group includes early species of *Homo*, beginning about 2.5 Ma. All australopith species appear to share a number of basic characteristics distinguishing them from living and fossil apes and also from later humans, although clearly linking them to the latter. Many researchers are coming to accept a division into at least the two genera *Australopithecus* and *Paranthropus*, and one species has been placed in its own genus, *Ardipithecus*, but others continue to recognize only a single genus, *Australopithecus*. See AUSTRALOPITHECINE.

The oldest known probable human species, *Ardipithecus ramidus*, is based upon a small group of fossils found at the Aramis locality in the Middle Awash Valley, Ethiopia. The remains of *Ard. ramidus* described so far document a mosaic pattern combining features similar to those of younger humans with others reflecting retention of apelike conditions. The remaining components of the *Ard. ramidus* mosaic are all reasonably interpreted as ancestral conditions, to be expected in an ancient human ancestor. Slightly younger hominin fossils named *Aus. anamensis* have been found since 1994 at sites in the southern Lake Turkana region of Kenya.

Fossils from sites in Ethiopia and Tanzania reveal far more details about a still younger species, *Aus. afarensis*. In 1974 a partial skeleton was found and identified as a female by its pelvic bones (and small size compared to other fossils) and nicknamed Lucy. Lucy’s pelvis and leg bones, as well as remarkably preserved

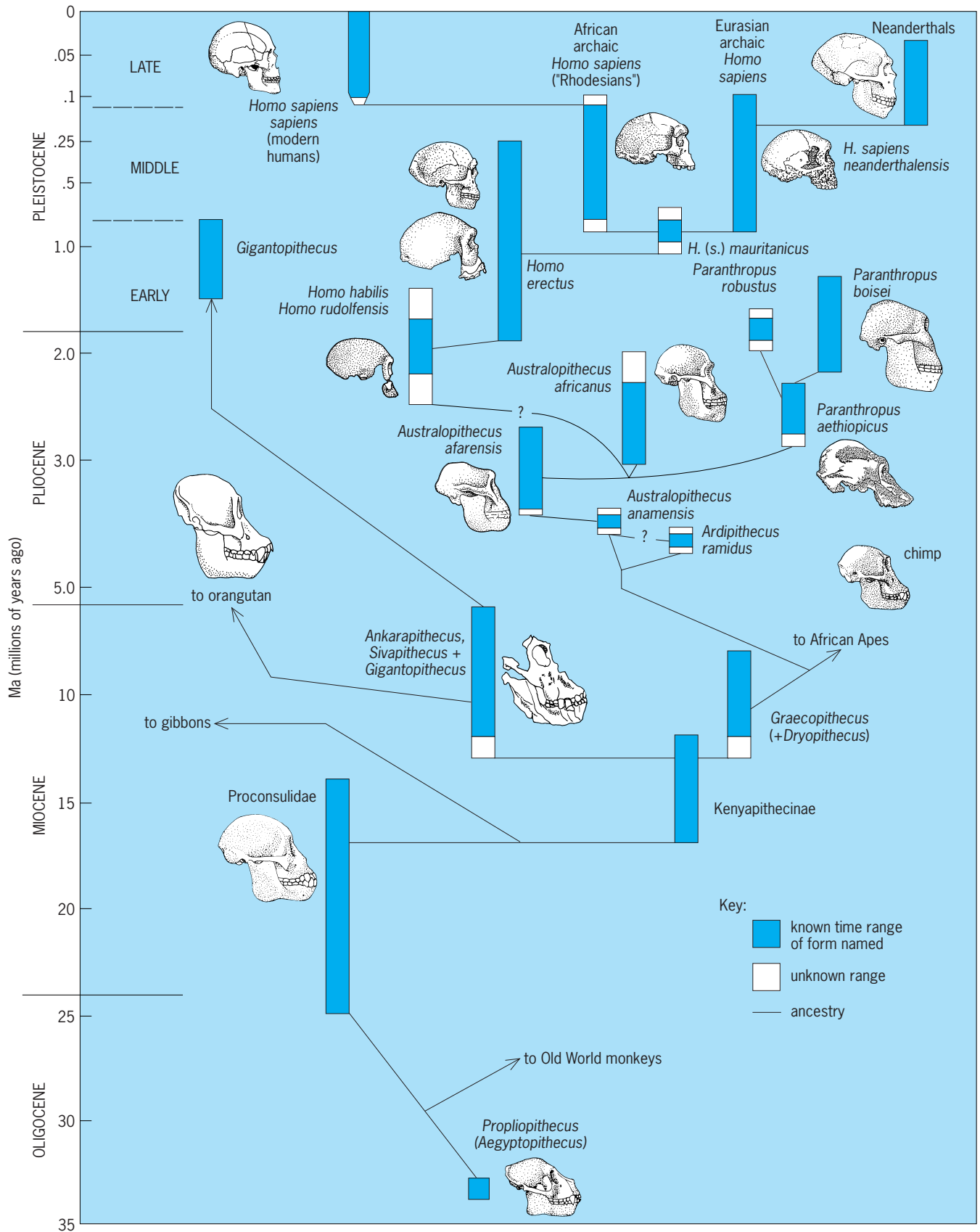

Human phylogeny from the Oligocene to the present time, showing the skulls of the major known fossil relatives and possible ancestors of modern humans.

footprints from Laetoli, clearly demonstrate that upright bipedal walking was well developed by 3.6 Ma, along with a brain somewhat larger than in modern apes of similar body size. Arguments as to the priority of brain expansion or walking ability in human evolution thus have yet to be resolved. *Australopithecus afarensis* combines both of these advanced, human characteristics with numerous other features reminiscent of later Miocene hominids and modern apes.

**Early Homo.** The only other genus of the Hominini is *Homo*, true humans, into which all later forms are placed. The identification of the earliest specimens of *Homo* is a subject of debate among paleoanthropologists. In the late 1970s the scientific pendulum had swung back to an idea proposed on less secure grounds by L. S. B. Leakey and colleagues in 1964. They named the species *H. habilis*, based on several finds from Olduvai. It was made clear from additional finds at Olduvai, Lake Turkana, and probably an upper level at Sterkfontein that a relatively small-brained (510–700 ml) and small-toothed *Homo* was present in the 2.0–1.5 Ma time period.

Several fossils, especially from the Lake Turkana region, appeared to represent a different “morph” or structural pattern. These were typified by skull KNM-ER-1470 (its catalog number in the Kenya National Museum) which has a brain size of about 750 ml, a high rounded vault and probably large teeth but a relatively protruding face. It has been suggested that the known variation in brain size and other aspects of craniofacial morphology is too great to represent merely the sexes of even a strongly dimorphic species. All of the Olduvai fossils, the smaller Turkana region specimens and some from South Africa, are recognized as *H. habilis*, while the 1470 specimen and other larger (non-*Paranthropus*) individuals from Turkana are considered as *H. rudolfensis*. This two-species view is gaining adherents and is accepted here.

**Homo erectus.** While *H. habilis* and *H. rudolfensis* apparently were short-lived and relatively rare African species, their likely successor, *H. erectus*, was common, widespread, and long-surviving. The first fossils were found in Java in 1893 and termed *Pithecanthropus erectus*. Each of the later finds in China and across Africa were given distinctive generic and specific names, but all are now usually considered local variants or subspecies of the single species *H. erectus*.

The earliest specimens are probably from East Africa, dating to as much as 1.9 Ma. *Homo erectus* (presumably as a result of increasing population size) spread into Eurasia through the Middle East, perhaps earlier than has previously been thought. Nonetheless, *H. erectus* must have been the first human species to leave Africa in large numbers. Fossils of this species may extend in Asia to nearly 200,000 years ago, mostly associated with fauna from the warmer intervals in this time of alternating glacial climate. The first Chinese *H. erectus*, called Beijing (Peking) man, was found at Zhoukoudian, near Beijing, where they occupied a large cave during most of the period between 500 and 250 Ka. Although there have been claims, no definite *H. erectus* fossils are yet known from Europe, nor are archeological remains or more modern humans unambiguously documented there as older than about 800,000 years.

**Premodern Homo sapiens.** It has been suggested that the increased rigor of the glacial climate in Europe at this time was the impetus leading to the evolution of humans who seem to be physically more “modern” in several ways than Afro-Asian *H. erectus*. These people are often termed early or archaic *H. sapiens*, or sometimes placed in their own species, *H. heidelbergensis*. There are competing interpretations of the number of species of *Homo* known in the past million years. Some workers continue to place all post-*erectus* fossils in archaic *Homo sapiens*, sometimes recognizing a variety of temporal and geographic subspecies (such as the Neanderthals and anatomically modern humans). However, some researchers accept between three and six species in the same time period: *H. antecessor*, *H. heidelbergensis* (either restricted to Europe or extended to Africa and

even East Asia), *H. rhodesiensis* (for early African “archaics”), *H. neanderthalensis*, *H. sapiens* (restricted to anatomically modern humans), and perhaps others.

Early representatives of *H. s. neanderthalensis* and *H. s. rhodesiensis* occur in Europe and Africa between 500 (or even 600) and 250 Ka, thus contemporaneous with *H. erectus* populations in eastern Asia. It is likely that these archaic *H. sapiens* spread gradually eastward across the Old World, replacing late-surviving populations of the broadly ancestral *H. erectus* everywhere by 200 Ka, when a poorly known (and here unnamed) variant occurs in northern China. These three geographic variants were not only distinct from *H. erectus* but also from each other to a greater degree than is true among living varieties or “races” of anatomically modern humans.

The best known of the archaic varieties are the Neanderthals, from Europe and western Asia. It now seems likely that this group evolved locally in Europe from earliest *H. sapiens* via intermediate forms (“pre-Neanderthals” or “ante-Neanderthals”). They were essentially stocky humans, but had long, low skulls with a projecting occipital region, large faces, teeth, and brow ridges; and brains averaging 1500 ml in volume. There is intense argument among paleoanthropologists as to how “modern” the Neanderthals were behaviorally, in terms of their stoneworking and hunting techniques and modes of foraging. Such controversies feed back into the question of whether the Neanderthals are a distinct species or, as accepted here, a distinctive subspecies of *H. sapiens*. A related question is whether the Neanderthals were in any way ancestral to anatomically modern humans, especially of Europe.

**Spread of modern humans.** One of the major foci of recent paleoanthropological research is the clarification of the area of origin and early history of anatomically modern humans, *H. s. sapiens*. The skull of this form is characterized by a small, upright face; small teeth and brow ridges; chin; and high, rounded braincase. There are no specimens of this type known (or even hinted at) anywhere in the world earlier than about 150 thousand years ago (Ka). But from about 150–100 Ka, in eastern and southern Africa, some fossils suggest the persistence of a “Rhodesian-like” morphology, while others are often considered to be nearly modern. Two somewhat younger sites in South Africa have produced the most important evidence. In combination, these remains and other, less complete fossils indicate that early moderns were living in sub-Saharan Africa by about 100 Ka. From such a possible sub-Saharan origin, anatomically modern *H. s. sapiens* may have spread across the Old World, differentiating into local races by 80–50 Ka. This view of human dispersal has received support from studies of the distribution pattern of human mitochondrial deoxyribonucleic acid (DNA) haplotypes (variants) and other genetic evidence. The majority of these studies suggest that the major dichotomy in modern human population genetics is between Eurasians and Africans. Such results fit well with the fossil evidence for African versus Eurasian divergence about 100 Ka.

In contrast to the “Out of Africa” view of human dispersal (based on the idea that modern humans evolved in sub-Saharan Africa more than 100,000 years ago from Neanderthal populations), a minority view (the “Multiregional” hypothesis) interprets the fossil record to document the nearly parallel origin of modern humans in different regions of the Old World from a *H. erectus* ancestry. Each regional variety is said to present morphological characteristics linking archaic to modern populations, while gene flow between regions kept the geographical varieties united in a single species at any one time. Most scholars reject the implication that Neanderthals, for example, were ancestral to modern Europeans, or Chinese *H. erectus* to modern north Asians. See EARLY MODERN HUMANS. [E.D.]

**Fossil primates** Extinct members of the order of mammals to which humans belong. All current classifications divide the living primates into two major groups (suborders), but zoologists differ as to whether the tarsier (*Tarsius*) should be classified



with the lower primates (lemurs, lorises, and bushbabies) or the higher primates (New and Old World monkeys, greater and lesser apes, and humans).

All primates have a common origin which, however, is not reflected in the universal possession of a suite of diagnostic features. The order as a whole has been characterized in terms of showing a group of progressive evolutionary trends, notably toward the predominance of the visual sense, the reduction of the sense of smell and associated structures, improved grasping and manipulative capacities, and enlargement of the higher centers of the brain. Among the extant primates, the lower primates more closely resemble forms that evolved relatively early in the history of the order, while the higher primates represent a group more recently evolved (see illustration).

**Early primates.** The earliest primates are placed in their own suborder, Plesiadapiformes, because they have no direct evolutionary links with, and bear no adaptive resemblances to, any group of living primates. However, the chewing teeth and the locomotor anatomy of these fossil forms sufficiently resemble those of later primates to demonstrate the common origin of the two groups. Best known from the Paleocene Epoch, around 66–54 million years ago (Ma), and found in both the Old World and the New World, the plesiadapiforms retained clawed hands and feet, had rather small brains compared to their body size, possessed large specialized front teeth, and were probably arboreal in habit.

**Eocene primates.** Often termed euprimates, they are divided broadly into lemurlike forms, usually grouped into the superfamily Adapoidea, and tarsierlike forms (Omomyoidea). Eocene primates of both the Old and New Worlds already display the trends that mark modern primates as a whole: These arboreal animals possessed grasping hands and feet in which sharp claws were replaced by flat nails backing sensitive pads; the snout was reduced, suggesting a deemphasis of smell, while the bone-ringed eyes faced more forward, producing stereoscopic vision and suggesting primary reliance on the sense of sight; and the brain was somewhat enlarged relative to body size when compared to those of other mammals of the period.

**Modern lower primates.** The extant lower primates are allocated to the suborder Prosimii if *Tarsius* is included, and to the suborder Strepsirhini if this strange primate is excluded, as is provisionally done here (see illustration). There is no ancient primate fossil record in Madagascar, home of the most diverse

group of modern lower primates, but extinct species little more than a thousand years old document a much wider adaptive radiation before the arrival of humans on the island.

**Tarsiers.** The tiny *Tarsius*, which lives today in Southeast Asia, represents a link between the strepsirhines and the anthropoids (monkeys, apes, and humans). In many respects it is related to the anthropoids, but dentally it is usually thought primitive, although some authors have found similarities to some strepsirhines. The extinct Eocene omomyoids are close to tarsiers skeletally; they are often considered broadly ancestral to the anthropoids for that reason and also because some have monkeylike front teeth.

**Higher primates.** The anthropoids include three main groups (infraorders) of living animals and their extinct relatives paracatarrhini (archaic anthropoids), platyrrhini (New World anthropoids), and catarrhini (old world anthropoids). Their divergence from a possibly omomyoid stock probably took place some 50 Ma. The monkeys of the New World and those of the Old are of similar evolutionary grade, but the latter share a much more recent common ancestry with apes and humans, with which they are grouped in the infraorder Catarrhini.

Three main groups of early higher primates are the oligopithecids, the parapithecids, and the propliopithecids. The former two appear to be only distantly related to any of the living monkeys or apes. The propliopithecids may be close to the common ancestry of later catarrhines (Old World anthropoids). These arboreal animals were the size of small cats, with apelike teeth, small brain, and limbs similar to those of the acrobatic South American atelines. Representatives of modern lineages begin to occur in the fossil record by about 28–20 Ma in both hemispheres.

**New World primates.** The platyrrhine or ateloid monkeys of South and Central America are divided into two families. All living (and well-known extinct) forms are arboreal and occupy forested areas between Argentina and southern Mexico. A distinctive evolutionary pattern observed in this group is the antiquity of the extant lineages as reflected by the close relationships of most of the few known fossils to modern genera. The small marmosets and the common squirrel and capuchin monkeys are grouped into the family Cebidae, while the generally large-bodied spider-howler and saki-uakari groups are linked to the smaller titis and (probably) owl monkeys in the Atelidae. These two families differ in the relative robustness of their jaws and reduction of last molars. See MONKEY.

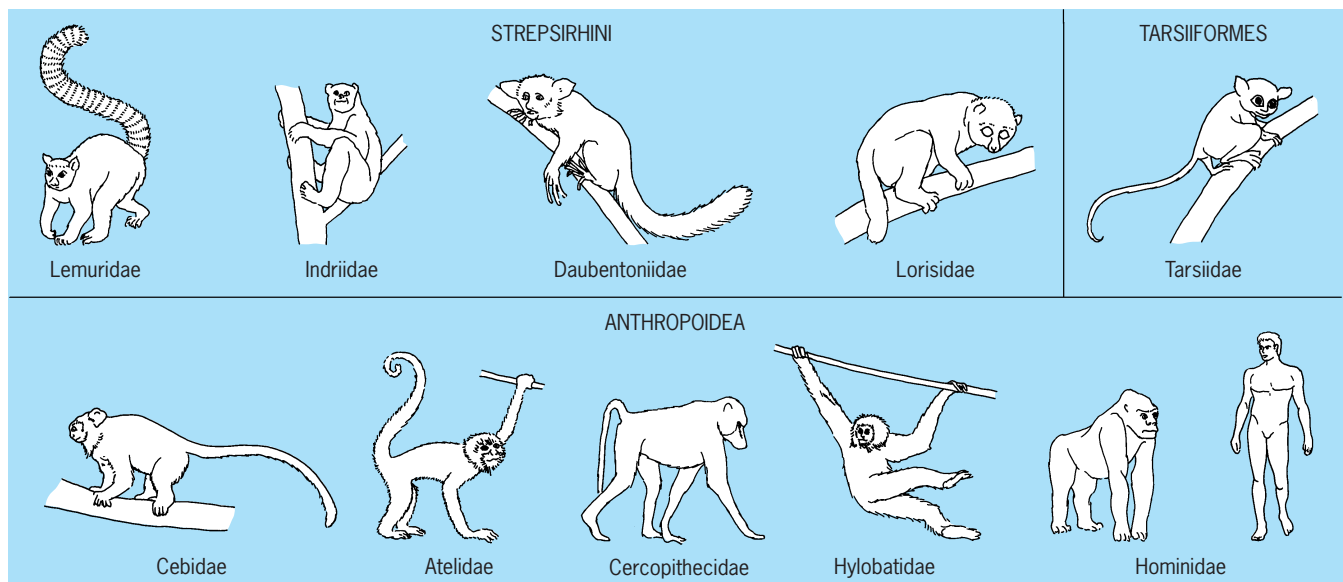

Representatives of living primate families.

The earliest fossil platyrrhine, 26-million-year-old *Branisella* from Bolivia, is as yet known only by teeth and jaw fragments. The largest number of fossil platyrrhines comes from the La Venta beds of Colombia, dated about 13 Ma. The last 100,000 years saw another flowering of extinct platyrrhine lineages. A cave site in eastern Brazil has yielded partial skeletons of "giant" relatives of the howler and spider monkeys, while several localities in the Caribbean produced controversial fossils perhaps related to howlers, saki-uakaris, and squirrel monkeys (or possibly representing a distinct lineage whose members came to resemble those other groups).

**Old World monkeys.** The living Cercopithecoidea (see illustration) are divided into two subfamilies, Colobinae and Cercopithecoidea. The oldest cercopithecoidea are found in Africa, with a few fossil forms such as *Victoriapithecus* of 20–15 Ma probably predating the divergence of the modern subfamilies. The cercopithecoidea include a wide variety of forms, all of which share cheek pouches for temporary food storage and usually large incisors reflecting a fruit diet; colobines, by contrast, are more restricted in morphology, range, and behavior pattern, and all are leaf eaters with a complicated digestive tract to facilitate the low-nutrition diet.

The earliest members of the two living subfamilies also are mainly African. One colobine jaw is known by 9 Ma, and from 7 to 5 Ma species of both cercopithecoidea and colobines become more abundant. Large collections of Old World monkey fossils have been recovered from East and South African sites (often in association with early human remains) in the 4–1.5 Ma interval.

Cercopithecoidea entered Eurasia from Africa. *Mesopithecus pentelicus*, an 11 to 8-million-year-old colobine known in a geographical range from Germany through Afghanistan, is the best-represented Eurasian fossil monkey, with dozens of individuals recovered from sites in Greece. The living macaques (*Macaca*) are widespread across eastern Asia and in North Africa, and their fossil record adds to that large range. Scattered specimens are known from North Africa after 7 Ma, and populations have been recovered across Europe from 5.5 Ma to about 100,000 years ago.

**Hominoids.** The most humanlike of all primates are the apes, which form a group distinguished by generally large body size, relatively large brain, lack of an external tail, and advanced placentation pattern. Living forms include the lesser apes, or gibbons (*Hylobates*), placed in their own family Hylobatidae, and the several great apes: orangutan (*Pongo*), chimpanzee (*Pan*), and gorilla (*Gorilla*). The great apes and humans, along with some extinct relatives, are grouped as the Hominidae by some authors, while others place only humans in the Hominidae and class all great apes in the Pongidae.

One of the earliest probable members of Hominoidea is *Proconsul*, of the East African Miocene, 23–14 million years old; a few teeth of a similar form date to 26 Ma. *Proconsul* is well known by most of its skeleton. Several species ranged in size from small chimpanzee to small gorilla, with a somewhat chimp-like skull, large projecting canine teeth, and limb bones seemingly adapted to quadrupedal running. However, *Proconsul* has few of the defining features of the ape group. For the present, *Proconsul* is retained as a hominoid belonging to a distinct archaic family of its own. Two other groups of roughly contemporaneous species (the Eurasian Pliopithecoidea and the African "*Dendropithecus-group*") are clearly more "primitive" than *Proconsul*, although they have at times wrongly been included in Hominoidea, usually as purported relatives of the gibbons. The oldest fossil gibbons date only to about 1 Ma.

Although interpretations vary, there appear to be three groups of Eurasian hominoids between 13 and 7 Ma. *Dryopithecus* is characteristic of the Dryopithecoidea, which may include the common ancestors of all later great apes (and humans).

**Spread of modern ape ancestors.** Most scientists today agree that, of the great apes, the orangutan is evolutionarily farthest from humans. As a result, orangutans and their extinct

relatives are here placed in the subfamily Ponginae, while African apes, humans, and their relatives are included in Homininae. The orangutan lineage is, however, the oldest well-documented one among all catarrhines. See APES.

Two species which probably belong to the Ponginae are placed in the genus *Gigantopithecus*: One dates to about 9–6 Ma from India and Pakistan; the other lived about 1.5–0.5 Ma in China and perhaps Vietnam. Hundreds of specimens, mostly isolated teeth, are known from China, and these document a species which was probably the largest primate that ever lived (perhaps weighing 200–400 kg or 440–880 lb).

The pongines probably evolved in Asia from an arboreal dryopithecoidea (or even kenyapithecoidea) ancestry which expanded into less forested environments. Such a habitat would have provided an abundance of gritty and tough food objects, to which this group's dentition appears adapted. They share with orangutans and some early humans a complex of dental-related features.

The origin of the Homininae is more problematic. The fossil ape *Graecopithecus* (also termed *Ouranopithecus*) is known from several Greek localities estimated to date between 10 and 8 Ma. Well-preserved facial material of this animal and of *Dryopithecus* recovered or reanalyzed in the 1990s has led different workers to suggest that one or both forms may lie near the split between Ponginae and Homininae or already on the hominine lineage, effectively close to the common ancestor of African apes and humans. At present *Graecopithecus* appears more derived in the direction of later hominines. At about the same time in Africa, the only known ape fossil is a single upper jaw which was named *Samburupithecus* in 1997 and which may also represent an early, gorillalike member of Homininae. These fossils imply that the hominines may have evolved in Eurasia and then returned to Africa after about 10 Ma. Previous workers often thought that the hominine lineage could be traced purely within Africa, but that hypothesis now appears less likely.

The ancestry of the African apes is still a mystery, as no fossils have yet been found which clearly represent their lineage before or after separation from humans. See FOSSIL HUMANS; MAMMALIA.

[E.D.; I.Ta.]

**Fossil seeds and fruits** Seeds, ovules containing a fertilized egg and ready to be shed from the plant, are reproductive organs characteristic of both gymnospermous and angiospermous plants. In angiosperms (Magnoliophyta) an additional structure, the matured ovary, encloses one or more seeds to form a fruit. Seeds and fruits are less commonly found as fossils than are vegetative remains. They may be preserved structurally as casts, or as compressions which are sometimes found with leaf compressions. Seeds and fruits often occur in lignites. See LIGNITE; MAGNOLIOPHYTA.

The oldest known seed plants are of Mississippian age. Carboniferous seed plants include the extinct Cordaitales, probable conifer ancestors, and Pteridospermae, seed plants with fernlike foliage. During the Mesozoic Era, all major modern groups of seed plants were represented, along with members of the declining cordaitalean and pteridospermous stocks. Among the most completely known Mesozoic seeds are those of the cycadeoids, extinct cycad relatives. See CORDAITALES; CYCADEOIDALES; PTERIDOSPERMS.

Upper Cretaceous fruits are known from northern Africa, Long Island, New York, and elsewhere. Tertiary fruits and seeds have been found in numbers in the United States in the Brandon lignite of Vermont and in the Clarno Formation of central Oregon. The best-known European Tertiary fruits and seeds are from the brown coals of Germany and the Eocene London Clay Formation of England.

Important paleobotanical findings resulting from the study of fossil seeds and fruits include the knowledge obtained of the independent evolution of the seed habit in unrelated groups; the discovery that much Carboniferous fernlike foliage was borne

on seed plants rather than on ferns; and the discovery that *Glossopteris*, an important plant in widespread Permian floras of the Southern Hemisphere, was a seed plant. Pyritized fruits from the London Clay Formation reveal the presence of many extinct genera along with modern genera in early Tertiary time. Morphological changes in herbaceous angiosperm seeds from sequences of Tertiary beds furnish data on rates of evolution in plants. Because plant classification is based primarily upon reproductive structures, fossil seeds and fruits provide highly reliable evidence for identification and interpretation of fossil plants. See PALEOBOTANY. [R.A.Sc.]

**Foucault pendulum** A pendulum or swinging weight, supported by a long wire, by which J. B. L. Foucault demonstrated in 1851 the rotation of Earth on its axis. Foucault used a 62-lb (28-kg) iron ball suspended on about a 200-ft (60-m) wire in the Pantheon in Paris. The upper support of the wire restrains the wire only in the vertical direction. The bob is set swinging along a meridian in pure translation (no lateral or circular motion). In the Northern Hemisphere the plane of swing appears to turn clockwise; in the Southern Hemisphere it appears to turn counterclockwise, the rate being 15 degrees times the sine of the local latitude per sidereal hour. Thus, at the Equator the plane of swing is carried around by Earth and the pendulum shows no apparent rotation; at either pole the plane of swing remains fixed in space while Earth completes one rotation each sidereal day. See DAY; INERTIAL GUIDANCE SYSTEM; PENDULUM; SCHULER PENDULUM. [F.H.R.]

**Foundations** Structures or other constructed works are supported on the earth by foundations. The word "foundation" may mean the earth itself, something placed in or on the earth to provide support, or a combination of the earth and the elements placed on it. The foundation for a multistory office building could be a combination of concrete footings and the soil or rock on which the footings are supported. The foundation for an earth-fill dam would be the natural soil or rock on which the dam is placed. Concrete footings or piles and pile caps are often referred to as foundations without including the soil or rock on which or in which they are placed. The installed elements and the natural soil or rock of the earth form a foundation system; the soil and rock provide the ultimate support of the system. Foundations that are installed may be either soil-bearing or rock-bearing. The reactions of the soil or rock to the imposed loads generally determine how well the foundation system functions. In designing the installed portions, the designer must determine the safe pressure which can be used on the soil or rock and the amount of total settlement and differential settlement which the structure can withstand.

The installed parts of the foundation system may be footings, mat foundations, slab foundations, and caissons or piles, all of which are used to transfer load from a superstructure into the earth. These parts, which transmit load from the superstructure to the earth, are called the substructure (see illustration).

Footings or spread foundations are used to spread the loads from columns or walls to the underlying soil or rock. Normally, footings are constructed of reinforced concrete; however, under some circumstances they may be constructed of plain concrete or masonry. When each footing supports only one column, it is square. Footings supporting two columns are called combined footings and may be either rectangular or trapezoidal. Cantilever footings are used to carry loads from two columns, with one column and one end of the footing placed against a building line or exterior wall. Footings supporting walls are continuous footings.

Mat or raft foundations are large, thick, and usually heavily reinforced concrete mats which transfer loads from a number of columns or columns and walls to the underlying soil or rock. Mats are also combined footings, but are much larger than a footing supporting two columns. They are continuous footings

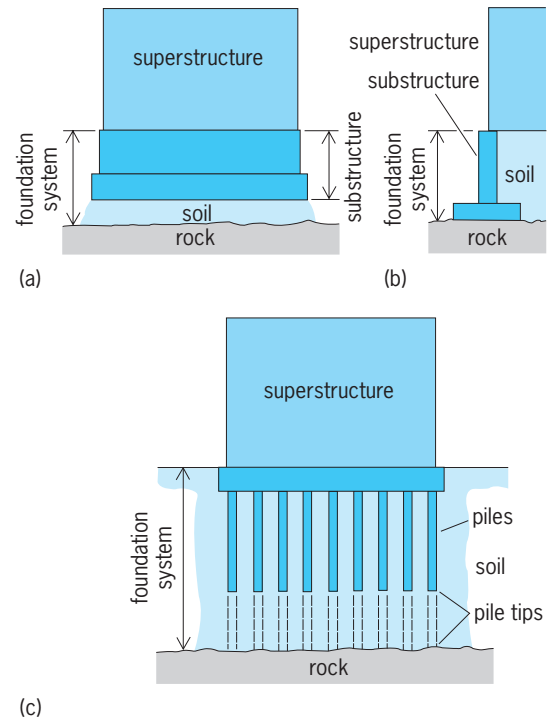

Examples of foundation systems. (a) Structure supported on a foundation bearing on soil. (b) Structure supported on a foundation bearing on rock. (c) Structure supported by a pile foundation.

and are designed to transfer a relatively uniform pressure to the underlying soil or rock.

Slab foundations are used for light structures wherein the columns and walls are supported directly on the floor slab. The floor slab is thickened and more heavily reinforced at the places where the column and wall loads are imposed. See CAISSON FOUNDATION; PILE FOUNDATION; RETAINING WALL. [G.M.R.]

**Four-bar linkage** A basic linkage mechanism used in machinery and mechanical equipment. The term has been applied to three types of linkages: plane, spherical, and skew.

The plane four-bar linkage (Fig. 1) consists of four pin-connected links forming a closed loop, in which all pin axes are parallel. The spherical four-bar linkage consists of four pin-connected links forming a closed loop, in which all pin axes intersect at one point. The skew four-bar linkage (Fig. 2) consists of four jointed links forming a closed loop, in which crank 2 and link 4 are pin-connected to ground 1 and the axes of the pins are generally nonparallel and nonintersecting; coupler 3 is connected to crank 2 and link 4 by ball joints.

Four-bar linkages are most frequently used to convert a uniform continuous rotation (the motion of crank 2) into a nonuniform rotation or oscillation (the motion of link 4). In instrument

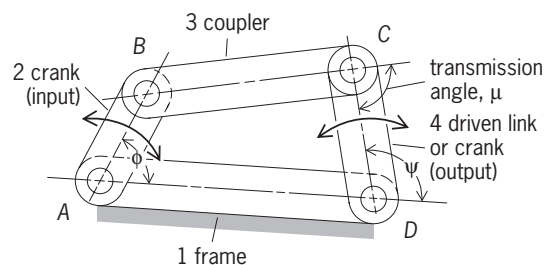

Fig. 1. Plane four-bar linkage with joints at A, B, C, and D.  $\phi$ ,  $\psi$ , and  $\mu$  are angles defining orientations of joints.

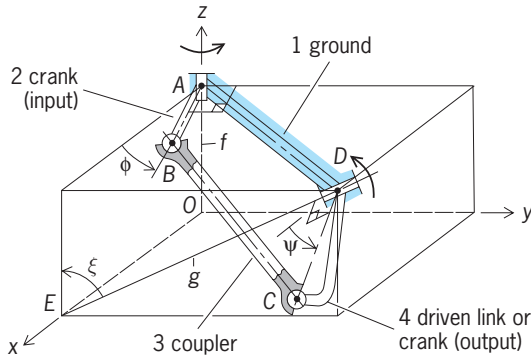

Fig. 2. Skew four-bar linkage with joints at A, B, C, and D. OA = f; ED = g; OE = common perpendicular between axes of pin joints at A and D;  $\phi$ ,  $\psi$ , and  $\xi$  are angles defining orientations of joints.

applications the primary function of the linkage is the conversion of motion, while in power applications both motion conversion and power transmission are fundamental.

Each of the above linkages can be proportioned for three types of motion, or linkage types: crank-and-rocker, drag, and double-rocker.

Crank-and-rocker linkages have a motion in which the crank (link 2) is capable of unlimited rotation, while the output link (link 4) oscillates or rocks through a fraction of one turn (usually less than  $90^\circ$ ). This is the most common form of the plane and the skew four-bar linkage, and is used in machinery and appliances of all types.

In drag linkages the motions of cranks 2 and 4 are both capable of unlimited rotations. The plane drag linkage has been used for quick-return motions. The most common drag linkage is the spherical drag linkage. One such linkage is the Hooke-type universal joint, or hooke joint. See UNIVERSAL JOINT.

In double-rocker linkages, neither crank 2 nor 4 is capable of complete rotations. Such motions occur in hand tools and mechanical equipment in which only limited rotations are required. See LINKAGE (MECHANISM); STRAIGHT-LINE MECHANISM. [FF]

**Fourier series and transforms** Mathematical tools for the analysis of functions through decomposition into sinusoids. In 1822, J. Fourier proposed that ordinary mathematical functions could be represented by a sum of sinusoids, even though at first sight it might seem that the blandness and repetitive nature of the sinusoid ill suited it to accommodate the variety of functions in general. The advantage of such a representation is this: A differential equation that is difficult to solve under the untidy given external conditions that often arise in technology may very well be soluble under an external condition that is simply sinusoidal. If solutions can be obtained for each of the constituent sinusoids that make up the given external function, then perhaps the required solution will be the sum of the separate simple solutions. This was indeed so in the case studied by Fourier, who was interested in the differential equation governing the diffusion of heat in homogeneous solids; in fact, it is often the case that solving for sinusoids permits synthesis of the required solution. When this does happen, the solution is itself composed of sinusoids and there is said to be a sinusoidal response to sinusoidal input; the differential equation will also exhibit linearity combined with shift invariance. See DIFFERENTIAL EQUATION; HARMONIC ANALYZER; LINEARITY; TRIGONOMETRY.

A Fourier series is a sum of a constant and any number of sinusoidal functions, say of  $t$ , with the property that the frequencies of the component functions belong to an arithmetic sequence. An example is expression (1), where  $\omega_0$  is the fundamental frequency. 
$$2 + \cos(\omega_0 t + 0.4) + \frac{1}{2} \cos(2\omega_0 t + 0.5) + \frac{1}{4} \cos(3\omega_0 t - 0.2) \quad (1)$$

quency. The phase of each term is arbitrary, as is the amplitude, and in particular the amplitude associated with the fundamental term may be zero. Allowing an amplitude  $c_n$  for the  $n$ th term, and a phase  $\alpha_n$ , the most general time-dependent Fourier series is given by expression (2). An equivalent expression, which uses

$$\sum_{n=0}^{\infty} c_n \cos(n\omega_0 t + \alpha_n) \quad (2)$$

two amplitudes  $a_n$  and  $b_n$  instead of one amplitude and a phase, is (3), where the coefficients in the two expressions are related by Eqs. (4). If the fundamental frequency is unity, the Fourier series in its simplest form results in expression (5). Fourier series have

$$\sum_{n=0}^{\infty} (a_n \cos n\omega_0 t + b_n \sin n\omega_0 t) \quad (3)$$

$$\begin{aligned} a_n &= c_n \cos \alpha_n \\ b_n &= -c_n \sin \alpha_n \end{aligned} \quad (4)$$

$$a_0 + (a_1 \cos t + b_1 \sin t) + (a_2 \cos 2t + b_2 \sin 2t) + \dots \quad (5)$$

wide application in physics because systems that vibrate in response to a stimulus often do so periodically; a violin string offers an example. The reason that the vibrations of a clamped uniform string are closely periodic is that the velocity of low-amplitude transverse waves on a stretched uniform string is dependent, to a good approximation, on only the string tension and the string mass per unit length. See VIBRATION.

Not all natural vibrations are periodic; examples are furnished by drums, bells, bars, and horns, where the more general trigonometric series applies, namely expression (6). The frequencies  $\omega_n$  in such cases are not necessarily in arithmetic sequence.

$$\sum_{n=0}^{\infty} c_n \cos(\omega_n t + \alpha_n) \quad (6)$$

No term in the series (5) is altered in value if  $t$  is replaced by  $t + 2\pi$ ; consequently if the series has a finite sum, that sum will be a function of  $t$  that is periodic in  $t$  with period  $2\pi$ . In the discussion of Fourier series, attention may therefore be restricted to periodic functions. A real function  $f(t)$  defined on the closed interval  $[-\pi, \pi]$  and periodic with period  $2\pi$  is said to have a Fourier series (5), where the coefficients are given by Eq. (7), and for  $n > 0$ , by Eqs. (8) and (9).

$$a_0 = \frac{1}{2\pi} \int_{-\pi}^{\pi} f(t) dt \quad (7)$$

$$a_n = \frac{1}{\pi} \int_{-\pi}^{\pi} f(t) \cos nt dt \quad (8)$$

$$b_n = \frac{1}{\pi} \int_{-\pi}^{\pi} f(t) \sin nt dt \quad (9)$$

The integrals in Eqs. (8) and (9), which are Fourier integrals, have been of great historical importance. In modern times they have gained additional importance for Fourier analysis of aperiodic functions and the corresponding spectral analysis or diffraction of electromagnetic radiation (especially for chemical analysis by ultraviolet, visible, and infrared light, and by x-rays), microwaves, seismic waves, sound waves, ocean waves and tides, and vibrations. The advent of fast computing has also given importance to algorithms such as the fast Fourier and fast Hartley transforms, which have facilitated progress in plasma physics and fluid dynamics, where numerical multidimensional analysis was previously infeasible. See DIFFRACTION; HOLOGRAPHY; INFRARED SPECTROSCOPY; INTERFEROMETRY; OCEAN WAVES; SEISMOLOGY; X-RAY CRYSTALLOGRAPHY.

A function  $f(x)$  that is not periodic does not analyze into a discrete set of terms, each of which has finite energy carried by a single frequency, but rather into a spectral continuum. This continuum is analogous to the spectrum of sunlight, whose energy

spectrum is describable in terms of the energy per hertz or other unit of frequency. A function  $f(x)$  and its amplitude spectrum or Fourier transform  $F(s)$  are related by Eqs. (10). If  $x$  represents

$$\begin{aligned} F(s) &= \int_{-\infty}^{\infty} f(x)e^{-i2\pi sx} dx \\ f(x) &= \int_{-\infty}^{\infty} F(s)e^{i2\pi sx} ds \end{aligned} \quad (10)$$

time in seconds, then  $s$  is frequency in cycles per second, or hertz; while if  $x$  represents distance, then  $s$  is spatial frequency in cycles per unit of  $x$ . [R.N.Br.]

**Fractals** Geometrical objects that are self-similar under a change of scale, for example, magnification. The concept is helpful in many disciplines to allow order to be perceived in apparent disorder. For instance, in the case of a river and its tributaries, every tributary has its own tributaries so that it has the same structure organization as the entire river except that it covers a smaller area. The branching of trees and their roots as well as that of blood vessels, nerves, and bronchioles in the human body follows the same pattern. Other examples include a landscape with peaks and valleys of all sizes, a coastline with its multitude of inlets and peninsulas, the mass distribution within a galaxy, the distribution of galaxies in the universe, and the structure of vortices in a turbulent flow. The rise and fall of economic indices has a self-similar structure when plotted as a function of time. See GALAXY, EXTERNAL; TURBULENT FLOW; UNIVERSE.

The triadic Koch curve, shown in the illustration, is a good example of how a fractal may be constructed. The procedure begins with a straight segment. This segment is divided into three equal parts, and the (single) central piece is replaced by two similar pieces (illus. a). The same procedure is now applied to each of the four new segments (illus. b), and this is repeated an infinite number of times. The curve is self-similar, because a magnification by 3 of any portion will look the same as the original curve.

Fractals came into natural sciences when it was recognized that natural objects are random versions of mathematical fractals. They are self-similar in a statistical sense; that is, given a sufficiently large number of samples, a suitable magnification of a part of one sample can be matched closely with some member of the ensemble. Unlike the Koch curve which must be magnified by an integral power of 3 to achieve self-similarity, natural fractal objects are usually self-similar under arbitrary magnification.

Physicists have used the concept of fractals to study the properties of amorphous solids and rough interfaces and the dynamics

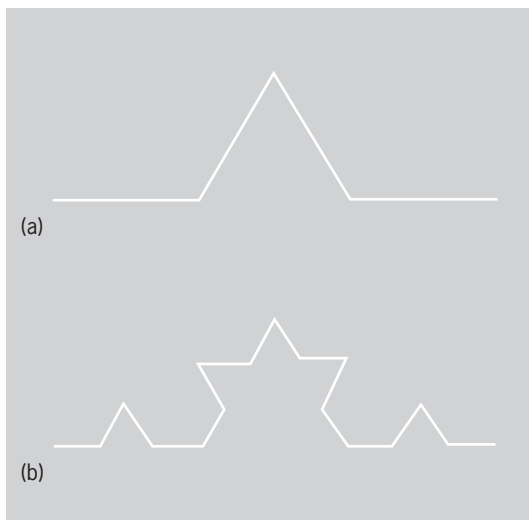

Koch curve, (a) first and (b) second stages.

of turbulence. It has also been found useful in physiology to analyze the heart rhythm and to model blood circulation, and in ecology to understand population dynamics. In computer graphics it has been shown that the vast amount of information contained in a natural scene can be compressed very effectively by identifying the basic set of fractals therein together with their rules of construction. When the fractals are reconstructed, a close approximation of the original scene is reproduced. See AMORPHOUS SOLID; CARDIOVASCULAR SYSTEM; COMPUTER GRAPHICS. [S.H.L.]

**Frame of reference** A base to which to refer physical events. A physical event occurs at a point in space and at an instant of time. Each reference frame must have an observer to record events, as well as a coordinate system for the purpose of assigning locations to each event. The latter is usually a three-dimensional space coordinate system and a set of standardized clocks to give the local time of each event. For a discussion of the geometrical properties of space-time coordinate systems see SPACE-TIME. See also RELATIVITY.

In the ordinary range of experience, where light signals, for all practical purposes, propagate instantaneously, the time of an event is quite distinct from its space coordinates, since a single clock suffices for all observers, regardless of their state of relative motion. The set of reference frames which have a common clock or time is called newtonian, since Isaac Newton regarded time as having invariable significance for all observers.

For discussion of other types of reference frames see ACCELERATED REFERENCE FRAME; ASTRONOMICAL REFERENCE FRAME. [B.G.]

**Francisella** A genus of very small, coccoid to ellipsoidal, pleomorphic, nonmotile and nonsporulating, gram-negative, rod-shaped bacteria. Fastidious and strictly aerobic, it grows at 98.6°F (37°C) within several days, but only in enriched media such as coagulated egg yolk or glucose-cysteine-blood-agar. The organisms occur in natural waters of the Northern Hemisphere, and can be parasitic and pathogenic in birds, arthropods, and mammals, including humans. *Francisella tularensis* has been found in many wild animals throughout North America, continental Europe, and Asia. Tularemia in humans is acquired via transmission by blood-sucking arthropods or by contact with infected animals, most frequently by hunters and butchers. See ANTIBIOTIC; MEDICAL BACTERIOLOGY; TULAREMIA. [W.Ma.]

**Francium** A chemical element, Fr, atomic number 87, an alkali metal element falling below cesium in group I of the periodic table. Distinguished by nuclear instability, francium exists only in short-lived radioactive forms, the most durable of which has a half-life of 21 min. The chief isotope of francium is actinium-K, an isotope of mass 223, which arises from the radioactive decay of the element actinium. From the properties of the known isotopes, it is reasonably certain that no long-lived form of element 87 will ever be found in nature or synthesized artificially. See PERIODIC TABLE.

The chemical properties of francium can be studied only on the tracer scale. The element has all the properties expected of the heaviest alkali element. With few exceptions, all the salts of francium are water-soluble. See ACTINIUM; ALKALI METALS. [E.K.H.]

**Franck-Condon principle** The generalization that the transition from one energy state of a molecular system to another occurs so nearly instantaneously that the nuclei of the atoms involved can be considered as stationary during the process. The Franck-Condon principle is closely related to the Born-Oppenheimer approximation, in which the various motions (electronic, nuclear vibrations and rotations) are considered to be separable, and in which the electrons respond to the instantaneous vibrations of the system whereas the system responds only to the average position of the electrons. The principle, proposed by J. Franck in 1925 and developed

quantum-mechanically by E. U. Condon in 1928, is important in discussing systems of more than one atom. It is therefore valuable in molecular spectroscopy and in the interpretation of the optical properties of liquids and solids. See MOLECULAR STRUCTURE AND SPECTRA. [J.H.S.; C.C.K.]

**Franklinite** A natural member of the spinel structure type, with composition  $Zn^{2+}Fe_2^{3+}O_4$ . The habit is octahedral, often modified by the cube and dodecahedron, but the mineral usually occurs as bands of isolated rounded grains, blebs, or compact masses. It is black with a metallic luster and red internal reflections; its hardness is 6 (Mohs scale); specific gravity is 5.3; and it is weakly magnetic.

Franklinite is confined in its occurrence to the unique ore bodies at Franklin and Sterling Hill (Ogdensburg), Sussex County, New Jersey. Franklinite is a major ore mineral and is still mined at Sterling Hill for spiegeleisen and zinc. See WILLEMITE; ZINC; ZINCITE. [P.B.M.]

**Fraunhofer lines** Dark absorption features in the solar spectrum. J. von Fraunhofer first studied them in 1814. They occur from the ultraviolet at about 180 nanometers to the infrared at 20 micrometers. Each line represents the net absorption of light by a particular atom or molecule. Most lines form in the Sun's atmosphere, although the Earth's telluric spectrum contributes lines of molecular oxygen ( $O_2$ ), carbon monoxide (CO), and other molecules. Some lines, such as Fraunhofer's C line in the red (hydrogen-alpha), can be seen with a pocket spectroscope. Powerful research instruments reveal millions of lines, most of which are weak and blended together in an almost inextricable tangle.

A spectrum line is caused by the absorption of photons of light that excite the atom from a lower to a higher energy level. Spontaneous decay back to the atom's lower level then follows, accompanied by the isotropic emission of light at the wavelength of the line. The result is a loss of light in the Sun-Earth direction.

The study of the Fraunhofer spectrum is the principal means of learning about physical conditions in the solar atmosphere. On the resolved solar disk, variations in line strength from point to point convey information about temperature, Doppler shifts of the lines reveal gas motions, and line splitting from the Zeeman effect maps magnetic fields. Because each line represents a chemical element, the composition of the solar atmosphere can be deduced. See ASTRONOMICAL SPECTROSCOPY; DOPPLER EFFECT; SOLAR MAGNETIC FIELD; SUN; SUPERGRANULATION; ZEEMAN EFFECT. [W.C.Li.]

**Free-electron theory of metals** The treatment of a metal as containing a gas of electrons completely free to move within it. The theory was originally proposed in 1900 to describe and correlate the electrical and thermal properties of metals. Later, quantum mechanics became the basis for the theory of most of the general properties of simple metals such as sodium, with one free electron per atom, magnesium with two, and aluminum with three. Transition metals, such as iron, have partially filled electronic *d* states and are not treated by the free-electron model.

Three years after J. J. Thomson's 1897 discovery of the electron, P. Drude suggested that the transport properties of metals might be understood by assuming that their electrons are free and in thermal equilibrium with their atoms. This theory was made more quantitative by H. A. Lorentz. Assuming that the mean free path of electrons was limited by collisions, he was able to derive Ohm's law for the electrical conductivity and obtain the ratio of thermal to electrical conductivity in excellent agreement with experiment. This ratio, divided by the absolute temperature, is called the Wiedemann-Franz ratio and had been observed to be universal 50 years earlier. See CONDUCTION (ELECTRICITY); CONDUCTION (HEAT); ELECTRICAL CONDUCTIVITY OF METALS; KINETIC

THEORY OF MATTER; MEAN FREE PATH; OHM'S LAW; THERMAL CONDUCTION IN SOLIDS; WIEDEMANN-FRANZ LAW.

The theory, however, had two major shortcomings. First, it predicted a large component of the specific heat of a metal, not present in insulators, which was not observed. Second, comparison of the theory with experiment indicated that the mean free path of the electrons became extremely large at low temperatures; the model offered no justification.

In 1928 A. Sommerfeld revised Lorentz's treatment by using quantum statistics, which removed the difficulty of the specific heat without losing the successful description of transport properties. The resulting theory remains the basis for the understanding of most transport properties of metals and semiconductors. At about the same time, W. V. Houston and F. Bloch solved the quantum-mechanical wave equation for electrons in a regular periodic structure, finding that they could indeed have arbitrarily large mean free paths if there were no defects in the periodicity, thereby putting the free-electron theory on a firm basis. See BAND THEORY OF SOLIDS; BLOCH THEOREM; FERMI-DIRAC STATISTICS; SPECIFIC HEAT OF SOLIDS; STATISTICAL MECHANICS.

Even in the context of a free-electron gas, there are strong Coulomb interactions between electrons which are frequently neglected in the free-electron theory of metals. This neglect was justified in the late 1950s by L. D. Landau, who asserted that, even with strong electron-electron interactions, there is a one-to-one correspondence between the excited states, called quasi-particle states, of the real system and the one-electron excitations from the ground state of the noninteracting electron gas. Thus, the formulations for free-electron theory still follow, but perhaps with modifications of parameters such as mass. Subsequent theory indicates that indeed these modification due to the electron-electron interaction are extremely small for the low-energy excitations present in thermal equilibrium, and so again the simplest theory succeeds for many properties, although substantial modifications are required for the higher-energy excitations caused by light. There are additional corrections, which are much larger than those from the electron-electron interaction, arising from the interaction between electrons and phonons, the quantum-mechanical term for lattice vibrations. In many metals these vibrations reduce the electron velocities by factors of as much as 2, increasing the electronic specific heat although they turn out not to modify the conductivity itself. See PHONON.

Another feature of the electron-phonon interaction is a resulting interaction among electrons, which is attractive and tends to cancel or exceed the repulsive electron-electron interaction. At low temperatures the net attraction binds electrons in pairs in a superconducting state. The theory of J. Bardeen, J. R. Schrieffer, and L. N. Cooper (the BCS theory of superconductivity), which first explained this phenomenon, is also a free-electron theory, but assumes that the free electrons have such a net attractive interaction. In contrast, it is generally believed that the high-temperature superconductors discovered in 1986 are very far from free-electron in character, and most workers do not believe that phonons are primarily responsible for the attractive interaction. See SOLID-STATE PHYSICS; SUPERCONDUCTIVITY. [W.A.H.]

**Free energy** A term in thermodynamics which in different treatments may designate either of two functions defined in terms of the internal energy *E* or enthalpy *H*, and the temperature-entropy product *TS*.

The function (*E* - *TS*) is the Helmholtz free energy and is the function ordinarily meant by free energy in European references. The Gibbs free energy is the function (*H* - *TS*). For the Lewis and Randall school of American chemical thermodynamics, this is the function meant by the free energy *F*. To avoid confusion with the symbol *F* as applied elsewhere to the Helmholtz free energy, the symbol *G* has also been used. Another development was the introduction of the name free enthalpy, with symbol *G*, for the Gibbs function. See WORK FUNCTION (THERMODYNAMICS).

For a closed system (no transfer of matter across its boundaries), the work which can be done in a reversible isothermal process is given by the series shown in Eq. (1). For these conditions,

$$W_{rev} = -\Delta A = -\Delta(E - TS) = -(\Delta E - T\Delta S) \quad (1)$$

$T\Delta S$  represents the heat given up to the surroundings. Should the process be exothermal,  $T\Delta S < 0$ , then actual work done on the surroundings is less than the decrease in the internal energy of the system. The quantity  $(\Delta E - T\Delta S)$  can then be thought of as a change in free energy, that is, as that part of the internal energy change which can be converted into work under the specified conditions. This then is the origin of the name free energy. Such an interpretation of thermodynamic quantities can be misleading, however; for the case in which  $T\Delta S$  is positive, Eq. (1) shows that the decrease in "free" energy is greater than the decrease in internal energy. See CHEMICAL THERMODYNAMICS.

For constant temperature and pressure in a reversible process the decrease in the Gibbs function  $G$  for the system again corresponds to a free-energy change in the above sense, since it is equal to the work which can be done by the closed system other than that associated with its change in volume  $\Delta V$  under the given constant pressure  $P$ . The relations shown in Eq. (2) can be formed since  $\Delta H = \Delta E + P\Delta V$ .

$$\Delta G = -(\Delta H - T\Delta S) = W_{net} = W_{rev} - P\Delta V \quad (2)$$

Each of these free-energy functions is an extensive property of the state of the thermodynamic system. For a specified change in state, both  $\Delta A$  and  $\Delta G$  are independent of the path by which the change is accomplished. Only changes in these functions can be measured, not values for a single state.

The thermodynamic criteria for reversibility, irreversibility, and equilibrium for processes in closed systems at constant temperature and pressure are expressed naturally in terms of the function  $G$ . For any infinitesimal process at constant temperature and pressure,  $-dG \geq \delta w_{net}$ . If  $\delta w_{net}$  is never negative, that is, if the surroundings do no net work on the system, then the change  $dG$  must be negative or zero. For a reversible differential process,  $-dG > \delta w_{net}$ ; for an irreversible process,  $-dG > \delta w_{net}$ . The free energy  $G$  thus decreases to a minimum value characteristic of the equilibrium state at the given temperature and pressure. At equilibrium,  $dG = 0$  for any differential process taking place, for example, an infinitesimal change in the degree of completion of a chemical reaction. A parallel role is played by the work function  $A$  for conditions of constant temperature and volume. Because temperature and pressure constitute more convenient working variables than temperature and volume, it is the Gibbs free energy which is the more commonly used in thermodynamics. See ENTROPY; THERMODYNAMIC PRINCIPLES. [P.J.B.]

**Free fall** The accelerated motion toward the center of the Earth of a body acted on by the Earth's gravitational attraction and by no other force. If a body falls freely from rest near the surface of the Earth, it gains a velocity of approximately 9.8 m/s every second. Thus, the acceleration of gravity  $g$  equals 9.8 m/s<sup>2</sup> or 32.16 ft/s<sup>2</sup>. This acceleration is independent of the mass or nature of the falling body. For short distances of free fall, the value of  $g$  may be considered constant. After  $t$  seconds the velocity  $v_t$  of a body falling from rest near the Earth is given by Eq. (1).

$$v_t = gt \quad (1)$$

If a falling body has an initial constant velocity in any direction, it retains that velocity if no other forces are present. If other forces are present, they may change the observed direction and rate of fall of the body, but they do not change the Earth's gravitational pull; therefore a body may still be thought of as freely "falling" even though the resultant observed motion is upward.

For a body falling a very large distance from the Earth, the acceleration of gravity can no longer be considered constant. According to Newton's law of gravitation, the force between any two bodies varies inversely with the square of the distance

between them; therefore with increasing distance between any body and the Earth, the acceleration of the body toward the Earth decreases rapidly. The final velocity  $v_f$ , attained when a body falls freely from an infinite distance to the surface of the Earth, is given by Eq. (2), where  $R$  is the radius of the Earth,

$$v_f = \sqrt{2gR} \quad (2)$$

which gives a numerical value of 11.3 km/s or 7 mi/s. This is consequently the "escape velocity," the initial upward velocity for a rising body to completely overcome the Earth's attraction.

Because of the independent action of the forces involved, a ball thrown horizontally or a projectile fired horizontally with velocity  $v$  will be accelerated downward at the same rate as a body falling from rest, regardless of the horizontal motion.

At a sufficiently large horizontal velocity, a projectile would fall from the horizontal only at the same rate that the surface of the Earth curves away beneath it. The projectile would thus remain at the same elevation above the Earth and in effect become an earth satellite. See BALLISTICS; GRAVITATION. [R.D.Ru.]

**Free radical** Any molecule or atom which possesses one unpaired electron. There are some molecules which contain more than one unpaired electron (for example, oxygen); they normally are not considered as free radicals. Free radicals can be chemically very reactive (for example, the methyl radical) or they can be very stable entities (for example, nitric oxide).

Free radicals can be grouped into three major classes: atoms (for example, H, F, and Cl), inorganic radicals (for example, OH, CN, NO<sub>2</sub>, and ClO<sub>3</sub>), and organic radicals (for example, CH<sub>3</sub>, CH<sub>3</sub>CH<sub>2</sub>, and C<sub>6</sub>H<sub>6</sub><sup>-</sup>). Such radicals are of great importance since they often appear as intermediates in thermal and photochemical reactions. Radicals are also known to initiate and propagate polymerization and combustion reactions.

In general, free radicals are formed by the rupture of a bond in a stable molecule with the production of two fragments, each with an unpaired electron. The resulting free radicals may participate in further reactions or may combine to reform the original compound.

There are many ways in which radicals can be generated—among these are thermal decomposition, electric discharge photochemical reactions, electrolysis at an electrode such as mercury or platinum, rapid mixing of two reactants, and gamma- or x-ray irradiation. [J.R.Bo.]

**Frequency (wave motion)** The number of times which sound pressure, electrical intensity, or other quantities specifying a wave vary from their equilibrium value through a complete cycle in unit time. The most common unit of frequency is the hertz (Hz), which is equal to 1 cycle per second. In one cycle there is a positive variation from equilibrium, a return to equilibrium, then a negative variation, and return to equilibrium. This relationship is often described in terms of the sine wave, and the frequency referred to is that of an equivalent sine-wave variation in the parameter under discussion. See FREQUENCY MEASUREMENT; SINE WAVE; WAVE MOTION. [W.J.G.]

**Frequency counter** An electronic instrument used to precisely measure the frequency of an input signal. Frequency counters are commonly used in laboratories, factories, and field environments to provide direct frequency measurements of various devices. The most common applications for frequency counters are measurement and characterization of oscillator and transmitter frequencies. See OSCILLATOR; RADIO TRANSMITTER.

There are several classes of frequency counters. Basic frequency counters provide measurement of frequency only. Universal counter-timers are two-channel instruments that provide measurement of frequency, period, phase, totalize (the total number of pulses generated by some type of event over the duration of an experiment), ratio (of frequencies on two channels), and time intervals such as pulse width or rise time. Microwave

counters are an extension of basic frequency counters offering coverage of microwave frequency ranges to 40 GHz and beyond. See MICROWAVE.

The three main architectures are conventional counting, reciprocal counting, and continuous counting. Conventional counting is the oldest and simplest but has the lowest performance and the least measurement flexibility. A conventional counter uses a simple register to count each cycle of the input signal during a 1-s measurement gate time.

Reciprocal counting is the most common architecture. It provides improved performance and flexibility over conventional counting. The main gate is set by the user and determines the nominal time over which the measurement is to be made (measurement gate time).

Continuous counting is based on the reciprocal technique, but employs high-speed digital circuits to continuously sample the contents of the count registers. These continuous samples can be digitally processed to provide improved resolution to as many as 12 digits in 1 s of measurement time. [B.Dr.]

**Frequency divider** An electronic circuit that produces an output signal at a frequency that is an integral submultiple of the frequency of the input signal.

Several information-processing and transmitting techniques require frequency division. In television, for example, it is essential to maintain a precise relationship between the horizontal-scanning frequency and the vertical-scanning frequency. Frequency division can be conveniently accomplished in two ways, digital division and division by triggering a subharmonic.

Many circuits are available to count pulses. A bistable or flip-flop circuit produces one output pulse for every two input pulses. By cascading successive flip-flops, any desired degree of division can be obtained. This is the method of digital division.

Any circuit which has a characteristic resonance responds to certain types of input energy by ringing, that is, by going through one or more cycles of electrical activity caused by the nature of the circuit rather than by the nature of the input. This characteristic can be used to accomplish frequency division, provided the input frequency does not vary over any extensive frequency range. This is the method for triggering a subharmonic. [W.W.Sn.]

**Frequency measurement** The determination of the number of cycles of a periodically varying quantity occurring in unit time. Many physical systems demonstrate cyclic behavior; that is, one or more of their properties vary in a characteristic fashion before returning to the initial value and then repeating the cycle. Examples are the angular positions of the planets and satellites in the solar system, the pressure in a cylinder in a reciprocating engine, and the heights and fields associated with surface, acoustic, and electromagnetic waves. The duration of a single cycle, the period, may vary widely, from  $10^{-27}$  s for the electromagnetic field associated with a cosmic gamma ray to  $10^8$  years for the rotation of a galaxy in space. The frequency, which is the inverse of the period, is the number of cycles, including fractions, occurring in unit time. The unit of frequency is the hertz (Hz), named after Heinrich Hertz, who investigated the nature of electromagnetic radiation. Measurement of the characteristic frequencies of a system, and their variation with time or under changing conditions, yields valuable information on its properties and behavior. Together with temperature and voltage, frequency ranks as one of the quantities most often measured in modern science and technology. See CELESTIAL MECHANICS; CERENKOV RADIATION; ELECTROMAGNETIC RADIATION; GAMMA-RAY ASTRONOMY; MILKY WAY GALAXY; WAVE MOTION.

The measurement of an unknown frequency requires a standard producing a fixed, stable, and known frequency, and a system or technique for the comparison of the unknown frequency with the standard. In the past, a wide variety of analog techniques and material standards have been employed. An example is the use of a tuning fork to adjust a musical instrument, usually a

piano. Analog frequency measurement techniques possessed two major disadvantages: The frequency of the standards depended upon the material properties and dimensions of critical components, which meant that they were prone to drift and affected by variations in the ambient temperature. In addition, optimum accuracy was achieved only when the unknown and standard frequencies were close or harmonically related.

Developments in electron-tube and, later, solid-state electronics improved matters. These included the quartz crystal oscillator, in which a thin slice of crystalline quartz acts as the resonant element in an electronic feedback circuit. As a result of the sharpness of the resonance and the stability of the properties of the quartz, this device provides a stable frequency in the range from 10 kHz to 100 MHz and remains the most common secondary frequency standard in use. In addition, a range of circuits were developed to generate more complex harmonic and subharmonic frequencies from a standard source. This led ultimately to the frequency synthesizer which, with an array of phase-locked loops, could be set to produce one of a very wide range of output frequencies. In use, however, it was still necessary to measure the beat or heterodyne frequency from the unknown frequency. See FEEDBACK CIRCUIT; FREQUENCY DIVIDER; FREQUENCY MULTIPLIER; OSCILLATOR; PHASE-LOCKED LOOPS; PIEZOELECTRICITY; QUARTZ CLOCK.

Fast, inexpensive solid-state digital circuits have replaced analog frequency measurement techniques and many of their associated standards. The underlying principle of the digital technique is simple: the electrical signal from the sensor or transducer observing the physical system under test generally contains, from Fourier analysis, the fundamental frequency and components at integral harmonics of this frequency. It is filtered to select the fundamental and converted into a rectangular waveform, representing transitions between the binary logic levels 0 and 1. A frequency measurement then consists of counting the number of positive- or negative-going transitions between the two levels in a known time. See FOURIER SERIES AND TRANSFORMS.

In parallel with the production of counters capable of operating at frequencies up to around 1 GHz, frequency standards based upon selected atomic transitions rather than the properties of bulk materials have been developed. These have the advantage that the frequency produced from a particular transition is in principle universal; that is, it is largely independent of the design of the standard and the materials used in its construction, and of changes in the ambient conditions. The combination of high-speed digital counters and of very stable atomic reference sources allows a wide range of frequencies to be determined simply, inexpensively, and very accurately.

As a result, much work has been carried out on the definition and measurement of other physical quantities in terms of frequency. Clearly, time and frequency are closely related; not only are the measurement, calibration, and dissemination techniques largely interchangeable, but any frequency standard may be converted into a standard of time, that is, a clock, by adding an appropriately designed counter. The unit of time, the second, is itself defined as the duration of 9 192 631 770 cycles of the electromagnetic radiation corresponding to the transition between the two hyperfine levels of the ground state of the cesium-133 atom. The primary standards of voltage and resistance are now also realized in terms of frequency using, respectively, the superconducting Josephson effect and the von Klitzing (quantum Hall) effect. See ATOMIC TIME; ELECTRICAL UNITS AND STANDARDS; RESISTANCE MEASUREMENT; TIME; VOLTAGE MEASUREMENT.

To calibrate the internal quartz oscillators in frequency counters, and to enable frequency measurements to be made at the highest accuracies, up to and occasionally beyond  $10^{-12}$ , standards laboratories require a selection of very stable frequency standards. The four types in common use are the temperature-stabilized or ovened quartz crystal oscillator, the rubidium gas cell, the cesium atomic beam standard, and the hydrogen maser. Their performance depends essentially upon the quality factor  $Q$ —the ratio of the resonant or transition frequency  $f_T$  to its



half-bandwidth—and the sensitivity of  $f_T$  to changes in the properties of materials or in the ambient and operating conditions.

Quartz oscillators are employed in most of the atomic standards to reduce the short-term noise and to provide a convenient output frequency (usually 10 MHz). In these,  $f_T$  is set by atomic transitions whose properties are in principle fixed and universal. In practice, small interactions with the containment system and the operating conditions mean that this ideal is not completely realized. In the rubidium gas cell, the transition is perturbed by collisions with other buffer gas atoms whose temperature and composition may change in time; in the hydrogen maser, collisions of the hydrogen atoms with the inert coating inside the containing bulb produce the so-called wall shift, which depends upon the condition of the coating. Atoms in the cesium beam standard are very well isolated from each other and the container, and this is reflected in the low drift rates and temperature coefficients observed. See ATOMIC CLOCK. [P.B.Co.]

**Frequency modulation** A special kind of angle modulation in which the instantaneous frequency of a sine-wave carrier is varied by an amount proportional to the magnitude of the modulating wave. See ANGLE MODULATION; PHASE MODULATION.

Either amplitude modulation (AM) or frequency modulation (FM) offers a solution to the important problem of how to impress the message wave to be communicated upon a high-frequency oscillation. However, FM offers important advantages in exchange for extra bandwidth occupancy. Also, FM with negative feedback minimizes noise problems and receiver distortion. See MODULATION.

Frequency modulation is defined in terms of a generalized concept known as instantaneous frequency which is directly proportional to the time rate of change of the angle of a sine function, the argument of which is a function of time. When the argument is expressed in radians and the time in seconds, the instantaneous frequency in hertz is the time rate of change of the angle divided by  $2\pi$ .

In frequency modulation the instantaneous frequency is linearly proportional to the magnitude of the modulating wave. Louder tones with AM mean greater changes in amplitude. Louder tones with FM mean greater changes in frequency.

In radio broadcasting, provided the frequency deviation (peak difference between instantaneous and carrier frequencies) is large and provided multipath transmission effects are small, FM is capable of high-fidelity reception combined with the advantages of reduced noise, less interference between stations, and less transmitter power to cover a given area. Constant average power and constant peak power that is only twice the average power are two factors that permit a ready realization of a simple high-efficiency transmitter, simplify problems of automatic volume control, and allow amplifiers and other devices to operate closer to their maximum power capability without the penalties normally associated with nonlinearities.

Practically, when estimating approximate bandwidth occupancy, a rule of thumb states that angle modulation requires the band traversed by the instantaneous frequency plus the bandwidth of the modulating wave added at both top and bottom. For some purposes an even wider band may be required.

Moreover, unambiguous representation and recovery of the wanted message by angle-modulation techniques also require that the unmodulated carrier frequency comfortably exceed the sum of the frequency deviation in the down direction plus the bandwidth of the modulating wave. In other words, in FM the carrier frequency must be high compared to the maximum frequency deviation.

For certain types of noise disturbance characterized by a noise spectrum that is uncorrelated and independent of frequency, the ratio of average signal power to average noise power in the output of the FM receiver will be proportional to the square of the peak-frequency deviation. Therefore under certain important conditions, the signal-to-noise ratio of an angle-modulation

system improves 6 decibels for each 2:1 increase in bandwidth occupancy.

However, the noise advantage of FM cannot be increased indefinitely. As the bandwidth occupancy is continually increased to accommodate an increased frequency deviation, more noise reaches the FM detector. Presently, the assumption that the noise is less than the so-called improvement threshold is violated, whereupon the noise advantage of FM is quickly lost. FM with negative feedback acts differently in that the improvement threshold is minimized and held constant, independent of the bandwidth occupied by the incoming FM signal. FM with negative feedback is accompanied by a decrease in distortion originating within the FM receiver and by an increased tolerance to noise failing within the frequency band occupied by the incoming FM signal. These two important advantages are not possessed by nonfeedback receivers. Substantial benefits are realized only when the amount of negative feedback is large. In common with nonfeedback FM systems, any large reduction in noise must be paid for by a corresponding increase in the bandwidth occupied by the transmitted FM signal.

Many schemes for production and detection are possible and nearly all use spectrum translation. For the production of FM most schemes resort to spectrum multiplication. Spectrum translation of an angle-modulated wave is accomplished by single-sideband modulation. The translated spectrum, with or without inversion, is centered about a new carrier. Otherwise its significant properties are unchanged. Spectrum multiplication implies angle multiplication. By generating the  $x$ th harmonic of an angle-modulated wave, the angle is multiplied by  $x$ . If the required multiplication is too great, then after a convenient number of multiplications the resulting spectrum may be translated downward and multiplication resumed. See FREQUENCY-MODULATION DETECTOR; FREQUENCY-MODULATION RADIO. [H.S.B.]

**Frequency-modulation detector** A device for the detection or demodulation of a frequency-modulated (FM) wave. FM detectors operate in several ways. In one class of detector, known as a discriminator, the frequency modulation is first converted to amplitude modulation, which is then detected by an amplitude-modulation detector. Another type of FM detector employs a phased-locked oscillator to recover the modulation. A still different type converts the frequency modulation to plus-rate modulation, which can be converted to the desired signal by use of an integrating circuit. See AMPLITUDE-MODULATION DETECTOR. [C.L.A.]

**Frequency-modulation radio** Radio transmission accomplished by symmetrical variation of the carrier frequency by an analog input signal. The amount of swing from center frequency is dependent upon the peak value of the modulating voltage, as well as upon its frequency. The frequency of the modulation signal governs the rate at which the changes in carrier frequency occur. Frequency-modulation (FM) sidebands are formed during the modulation process and are separated from one another by an amount equal to the audio frequency. The amplitude of the sidebands diminishes progressively as the sidebands occur farther and farther from the center frequency, and the number of significant sidebands depends on the amplitude of the modulating signal. The deviation ratio of the carrier-frequency variation to the highest signal frequency transmitted may be any selected value, from fractional to large values.

Because there is no amplitude change in the output of an FM transmitter, whatever the deviation ratio, this mode is an almost perfect cure for amplitude-related interference problems that plague radio-frequency reception. Another property of FM receivers is the relative freedom from interference between distant and local stations using the same channel; only the strongest signal is received, even if the wanted signal is only 3–6 dB stronger than the interfering one. This characteristic is known

as the capture effect. In contrast, AM radio signals differing in strength by 35 dB result in noticeable interference.

Since most FM receivers are equipped with a muting circuit (squelch) that silences the audio channel when no signal is present, an irritating hiss noise is not emitted from the loudspeaker when the frequency (or channel) being monitored is not in use.

Frequency modulation is used mainly for transmissions above 25 megahertz (MHz). Typical uses are in broadcasting, television sound, mobile radio telephony, radio paging systems, space telemetry, intercity microwave relaying of all classes of public traffic including voice channels, teleprinting, facsimile, broadcast network programs, and television and computer data, and intercontinental telecommunications via satellite. Frequency modulation is used for both analog and digital communications, and phase modulation as well as frequency modulation is employed.

**FM broadcasting.** The frequency band 88–108 MHz is allocated to FM broadcasting in a large part of the world by international agreement. For a channel spacing of 200 kHz, there are 100 allocatable channels for transmission of an audio range of 50–15,000 Hz, with a frequency-deviation ratio of 5. This means that there are five significant sidebands above and below the carrier, the carrier is deviated a maximum of  $\pm 75$  kHz, and the emitted spectrum is twice this value. Because of the relatively small signal power in the modulating frequencies above 4 kHz, the received signal-to-noise ratio is improved substantially by preemphasis of the audio signal in transmission, necessitating complementary deemphasis in the receiver to restore natural program balance. In fact, preemphasis produces a sort of hybrid form of modulation, being pure frequency modulation at the lowest audio frequencies, and gradually changing to phase modulation at the highest. See FREQUENCY MODULATION.

**FM mobile transmission.** Millions of land, maritime, and aeronautical mobile FM transceivers are employed by police, firemen, public safety agencies, industrial and commercial enterprises, private citizens, and radio amateurs who desire the benefits of enroute telephony. The intensity of such usage has grown exponentially, mainly because of the availability of reliable, small, low-power-consumption solid-state equipments that are economical, and also because of the public realization of the benefits of having such communications.

**Radio relaying.** Frequency modulation is used for microwave radio relaying over land, over water, and to great distances using satellites, sometimes carrying thousands of simultaneous telephone conversations or several television channels.

The advent of requirements for short-haul services, local distribution networks within cities, television relay, and a wide variety of optical communication services including high-speed computer communications, electronic mail, data transmission, and other services, where it may be cost-effective to avoid the local telephone loop, presents another application for FM radio relaying.

**Telegraphy.** Telegraphy, including teleprinting and binary digital data transmission, is based on shifting the carrier frequency or its phase between two limiting values, one of which represents a mark signal and the other a space signal. This frequency shift (or phase shift) is a form of FM signaling used over a wire, cable, or radio. See TELEGRAPHY.

**Facsimile.** Black-and-white images (line drawings and typed copy) can be transmitted by employing the principles used in FM telegraphy; one limit frequency corresponds to black, and the other to white, on the image to be transmitted. A continuous gray scale can be transmitted and recorded if, instead of just two frequencies, a continuous frequency shift is employed between some low frequency (say, 1500 Hz) and some higher frequency (say, 2700 Hz), the exact frequency at any instant being proportional to the gray level of the image. See FACSIMILE.

**Telemetry.** Frequency modulation is the preferred method for transmission of information or data from a remote or inaccessible location such as a rocket vehicle in flight. Each condition

to be remotely observed actuates one subchannel, which, when multiplexed with other channels reporting other status conditions, modulates the radio carrier by frequency modulation. See TELEMETERING. [J.S.B.]

**Frequency modulator** An electronic circuit or device producing frequency modulation. This device changes the frequency of an oscillator in accordance with the amplitude of a modulating signal. If the modulation is linear, the frequency change is proportional to the amplitude of the modulating voltage.

High-frequency oscillators usually employ either *LC* (inductance-capacitance) tuned circuits or piezoelectric crystals to establish the frequency of oscillation. This frequency can be controlled by changing the effective capacitance or inductance of the tuned circuit in accordance with the modulating signal. Practical circuits usually employ a varactor diode to change the oscillator in accordance with a modulating voltage.

The oscillators in high-frequency electronic systems, such as frequency-modulating (FM) transmitters, usually employ piezoelectric crystals for precise control of the carrier frequency. These crystals are equivalent to a series *LC* tuned circuit with an extremely high *Q*. The crystal holder has a small capacitance which is in parallel with the crystal and therefore causes parallel resonance at a slightly higher frequency than the series resonant frequency of the crystal. The actual oscillator frequency is between these two resonant frequencies and is controllable by the parallel capacitance. See PIEZOELECTRICITY; *Q* (ELECTRICITY).

The junction capacitance of a semiconductor diode varies with the diode voltage, and a reverse-biased diode may be used to control the oscillator frequency to produce frequency modulation. Low-loss diodes designed for this service are known as varactor diodes and have trade names such as Varicaps or Epicaps. A basic varactor modulating scheme is shown in the illustration. In this circuit, the transistor that drives the varactor modulator provides reverse bias as well as the modulating voltage  $v_m$ . The radio-frequency (rf) choke provides very high impedance at the oscillator frequency to isolate the transistor amplifier output impedance from the oscillator circuit but to allow the modulating signal to pass through with negligible attenuation. Only the frequency-determining part of the oscillator is shown. The symbols  $C_c$ ,  $L_c$ , and  $R$  represent the electrical equivalents of the compliance, mass, and loss, respectively, of the crystal;  $C_h$  is the crystal-holder capacitance and  $C_b$  is a dc blocking capacitor. See SEMICONDUCTOR DIODE; VARACTOR.

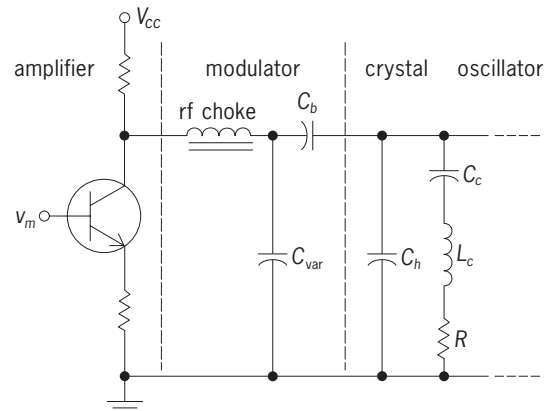

Basic varactor modulator circuit.  $V_{cc}$  = collector supply voltage.

The varactor-diode modulator is also commonly used to control the frequency of local oscillators in radio receiving equipment where programmed, push-button, or remote tuning is desirable. In these applications, conventional *LC* tuned circuits may be used. [C.L.A.]

**Frequency multiplier** An electronic circuit that produces an output frequency which is an integral multiple of the input frequency. There are two basic types of frequency multipliers. The first type is a nonlinear amplifier which generates harmonics in its output current and a tuned load that resonates at one of these harmonics. The second type uses the nonlinear capacitance of a junction (semiconductor) diode to couple energy from the input circuit, which is tuned to the fundamental, to the output circuit, which is tuned to the desired harmonic.

A highly efficient doubler can be devised by using two amplifiers, such as transistors, with their inputs driven with opposite polarity, obtained from opposite ends of a center-tapped coil, and their outputs connected in parallel. See **AMPLIFIER**; **SEMICONDUCTOR**. [C.L.A.]

**Fresh-water ecosystem** Fresh water is best defined, in contrast to the oceans, as water that contains a relatively small amount of dissolved chemical compounds. Some studies of fresh-water ecosystems focus on water bodies themselves, while others include the surrounding land that interacts with a lake or stream. See **ECOLOGY**; **ECOSYSTEM**.

Fresh-water ecosystems are often categorized by two basic criteria: water movement and size. In lotic or flowing-water ecosystems the water moves steadily in a uniform direction, while in lentic or standing-water systems the water tends to remain in the same general area for a longer period of time. Size varies dramatically in each category. Lotic systems range from a tiny rivulet dripping off a rock to large rivers. Lentic systems range from the water borne within a cup formed by small plants or tree holes to very large water bodies such as the Laurentian Great Lakes. Fresh-water studies also consider the interactions of the geological, physical, and chemical features along with the biota, the organisms that occur in an area.

**Physical environment.** The quantity and spectral quality of light have major influences on the distribution of the biota and also play a central role in the thermal structure of lakes. The light that reaches the surface of a lake or stream is controlled by latitude, season, time of day, weather, and the conditions that surround a water body. Light penetration is controlled by the nature of water itself and by dissolved and particulate material in a water column.

Water exhibits a number of unusual thermal properties, including its existence in liquid state at normal earth surface temperatures, a remarkable ability to absorb heat, and a maximum density at 39.09°F (3.94°C), which leads to a complex annual cycle in the temperature structure of fresh-water ecosystems.

As water is warmed at the surface of a lake, a stable condition is reached in which a physically distinct upper layer of water, the epilimnion, is maintained over a deeper, cooler stratum, the hypolimnion. The region of sharp temperature changes between these two layers is called the metalimnion. The characteristic establishment of two layers is of major importance in the chemical cycling within lakes and consequently for the biota.

As the surface waters of a lake cool, the density of epilimnetic waters increases, which decreases their resistance to mixing with the hypolimnion. If cooling continues, the entire water column will mix, an event known as turnover. At temperatures below 39.09°F (3.94°C), water again becomes less dense; ice and very cold water float above slightly warmer water, maintaining liquid water below ice cover even in lakes in the Antarctic. Many lakes in the temperate zones undergo two distinct periods of mixing annually, one in the spring and the other in the fall, that separate periods of stratification in the summer and winter.

Water movement is more extensive in lotic than in standing-water ecosystems, but water motion has important effects in both types. Turbulence occurs ubiquitously and affects the distribution of organisms, particles, dissolved substances, and heat. Turbulence increases with the velocity of flowing water, and the amount of material transported by water increases with turbu-

lence. Flowing-water ecosystems are characterized by large fluctuations in the velocity and amount of water. Aside from surface waves on large lakes, most water movement in lentic systems is not conspicuous. See **LAKE**; **LIMNOLOGY**; **RIVER**.

**Chemical environment.** For an element, three basic parameters are of importance: the forms in which it occurs, its source, and its concentration in water relative to its biological demand or effect. Most elements are derived from dissolved gases in the atmosphere or from minerals in geological materials surrounding a lake. In some cases the presence of elements is strongly mediated by biological activities. See **BIOGEOCHEMISTRY**.

Oxygen occurs as dissolved O<sub>2</sub> and in combination with other elements resulting from chemical or biological reactions. It enters water primarily from the atmosphere through a combination of diffusion and turbulent mixing. When biological demands for oxygen exceed supply rates, it can be depleted from fresh-water ecosystems. Anoxic conditions occur in hypolimnia during summer and under ice cover in winter when lake strata are isolated from the atmosphere. Oxygen depletion may also occur in rivers that receive heavy organic loading. Aside from specialized bacteria, few organisms can occur under anoxic conditions.

Carbon dioxide is derived primarily from the atmosphere, with additional sources from plant and animal respiration and carbonate minerals. Its chemical species exert a major control on the hydrogen ion concentration of water (the acidity or pH). See **pH**.

Phosphorus occurs primarily as a phosphate ion or in a number of complex organic forms. It is the element which is most commonly in the shortest supply relative to biological demand. Phosphorus is thus a limiting nutrient, and its addition to fresh-water ecosystems through human activities can lead to major problems due to increased growth of aquatic plants.

Nitrogen occurs in water as N<sub>2</sub>, NO<sub>2</sub>, NO<sub>3</sub>, NH<sub>4</sub>, and in diverse organic forms. It may be derived from precipitation and soils, but its availability is usually regulated by bacterial processes. Nitrogen occurs in relatively short supply relative to biological demand. It may also limit growth in some fresh-water systems, particularly when phosphorus levels have been increased because of human activity. See **NITROGEN FIXATION**.

A variety of other elements also help determine the occurrence of fresh-water organisms either directly or by the elements' effects on water chemistry.

**Biota.** In addition to taxonomy, fresh-water organisms are classified by the areas in which they occur, the manner in which they move, and the roles that they occupy in trophic webs. Major distinctions are made between organisms that occur in bottom areas and those within the water column, the limnetic zone. Production is the most difficult variable to measure, but it provides the greatest information on the role of organisms in an ecosystem. See **BIOLOGICAL PRODUCTIVITY**; **BIOMASS**.

Plankton organisms occur in open water and move primarily with general water motion. Planktonic communities occur in all lentic ecosystems. In lotic systems they are important only in slow-moving areas.

Phytoplankton (plant plankton) comprise at least eight major taxonomic groups of algae, most of which are microscopic. They exhibit a diversity of forms ranging from one-celled organisms to complex colonies. See **ALGAE**; **BACILLARIOPHYCEAE**; **PHYTOPLANKTON**.

Zooplankton (animal plankton) comprise protozoans and three major groups of eukaryotic organisms: rotifers, cladocerans, and copepods. Most are microscopic but some are clearly visible to the naked eye. See **COPEPODA**; **POPULATION ECOLOGY**; **ROTIFERA**; **ZOOPLANKTON**.

Animals, such as fishes and swimming insects, that occur in the water column and can control their position independently of water movement are termed nekton. In addition to their importance as a human food source, fishes may affect zooplankton, benthic invertebrates, vegetation, and lake sediments.

Benthic organisms are a diverse group associated with the bottoms of lakes and streams. The phytobenthos ranges from

microscopic algae to higher plants. Benthic animals range from microscopic protozoans and crustaceans to large aquatic insects and fishes. See FOOD WEB.

Bacteria occur throughout fresh-water ecosystems in planktonic and benthic areas and play a major role in biogeochemical cycling. Most bacteria are heterotrophic, using reduced carbon as an energy source; others are photosynthetic or derive energy from reduced compounds other than carbon. See BACTERIAL PHYSIOLOGY AND METABOLISM.

**Interactions.** Ultimately the conditions in a fresh-water ecosystem are controlled by numerous interactions among biotic and abiotic components. Primary production in a fresh-water ecosystem is controlled by light and nutrient availability. As light diminishes with depth in a column of water, a point is reached where energy for photosynthesis balances respiratory energy demands. In benthic areas, the region where light is sufficient for plant growth is termed the littoral zone; deeper areas are labeled profundal.

Nutrient availability generally controls the total amount of primary production that occurs in fresh-water ecosystems. One classification scheme for lakes ranks them according to total production, ranging from oligotrophic lakes, where water is clear and production is low, to eutrophic systems, characterized by high nutrient concentrations, high standing algal biomass, high production, low water clarity, and low concentrations of oxygen in the hypolimnion. Eutrophic conditions are more likely to occur as a lake ages. This aging process, termed eutrophication, occurs naturally but can be greatly accelerated by anthropogenic additions of nutrients. A third major lake category, termed dystrophy, occurs when large amounts of organic materials that are resistant to decomposition wash into a lake basin. These organic materials stain the lake water and have a major influence on water chemistry which results in low production. See BOG; EUTROPHICATION.

[T.M.F.]

**Friction** Resistance to sliding, a property of the interface between two solid bodies in contact. Many everyday activities like walking or gripping objects are carried out through friction, and most people have experienced the problems that arise when there is too little friction and conditions are slippery. However, friction is a serious nuisance in devices that move continuously, like electric motors or railroad trains, since it constitutes a dissipation of energy, and a considerable proportion of all the energy generated by humans is wasted in this way. Most of this energy loss appears as heat, while a small proportion induces loss of material from the sliding surfaces, and this eventually leads to further waste, namely, to the wearing out of the whole mechanism. See WEAR; WORK.

In stationary systems, friction manifests itself as a force equal and opposite to the shear force applied to the interface. Thus, as in the illustration, if a small force  $S$  is applied, a friction force  $P$  will be generated, equal and opposite to  $S$ , so that the surfaces remain at rest.  $P$  can take on any magnitude up to a limiting value  $F$ , and can therefore prevent sliding whenever  $S$  is less than  $F$ . If the shear force  $S$  exceeds  $F$ , slipping occurs. During sliding, the friction force remains approximately equal to  $F$  and always acts in a direction opposing the relative motion. The friction force is proportional to the normal force  $L$ , and the constant of proportionality is defined as the friction coefficient  $f$ . This is expressed by the equation  $F = fL$ .

In prehistoric and early historic times, humans' main interest in friction was to reduce the friction coefficient, to reduce the labor involved in dragging heavy objects. This led to the invention of lubricants, the first of which were animal fats and vegetable oils. A great breakthrough was the use of rolling action, first in the form of rolling logs and then in the form of wheels, to take advantage of the lower friction coefficients of rolling systems. See LUBRICANT.

In modern engineering practice available materials and lubricants reduce friction to acceptable values. In special circum-

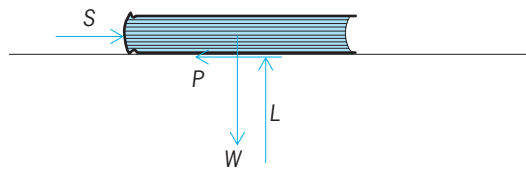

The forces acting on a book resting on a flat surface when a shear force  $S$  is applied. The friction from  $P$  is equal to  $S$  (up to a limiting value  $F$ ), while  $L$ , the normal force, is equal to the weight  $W$  of the book.

stances when energy is critical, determined efforts to minimize friction are undertaken. Friction problems of practical importance are those of getting constant friction in brakes and clutches, so that jerky motion is avoided, and avoiding low friction in special circumstances, such as when driving a car on ice or on a very wet road. Also, there is considerable interest in developing new bearing materials and new lubricants that will produce low friction even at high interfacial temperatures and maintain these properties for long periods of times, thus reducing maintenance expenses. Perhaps the most persistent problem is that of avoiding frictional oscillations, a constant cause of noise pollution of the environment. [E.R.]

**Friedel-Crafts reaction** A substitution reaction, catalyzed by aluminum chloride, in which an alkyl ( $R-$ ) group or an acyl ( $RCO-$ ) group replaces a hydrogen atom of an aromatic nucleus. This general reaction is the most important member of a larger group of aromatic substitution reactions known to be catalyzed by conventional or Lewis acids.

In the classical alkylation reaction, an alkyl halide ( $RX$ ) serves as the alkylating agent. Alkenes may be substituted for alkyl halides. For acylation of aromatic hydrocarbons, acyl halides have proved most valuable although acid anhydrides have also been used. See AROMATIC HYDROCARBON; SUBSTITUTION REACTION.

[C.K.B.]

**Fringe (optics)** One of the light or dark bands produced by interference or diffraction of light. Distances between fringes are usually very small, because of the short wavelength of light. Fringes are clearer and more numerous when produced with light of a single color.

Diffraction fringes are formed when light from a point source, or from a narrow slit, passes by an opaque object of any shape. Interference fringes are obtained by bringing together two or more beams of light that have originated from a common source. This is usually accomplished by means of an apparatus especially designed for the purpose called an interferometer, although interference fringes may also be seen in nature. Examples are the colors in a soap film and in an oil film on water. See DIFFRACTION; INTERFERENCE OF WAVES; INTERFEROMETRY; RESOLVING POWER (OPTICS). [F.A.J./W.W.W.]

**Front** An elongated, sloping zone in the troposphere, within which changes of temperature and wind velocity are large compared to changes outside the zone. Thus the passage of a front at a fixed location is marked by rather sudden changes in temperature and wind and also by rapid variations in other weather elements such as moisture and sky condition.

In its idealized sense, a front can be regarded as a sloping surface of discontinuity separating air masses of different density or temperature. In practice, the temperature change from warm to cold air occurs mainly within a zone of finite width, called a transition or frontal zone. The three-dimensional structure of the frontal zone is shown in the illustration. In typical cases, the zone is about 1 km (0.6 mi) in depth and 100–200 km (60–120 mi) in width, with a slope of approximately 1/100. The cold air lies beneath the warm in the form of a shallow wedge. Temperature

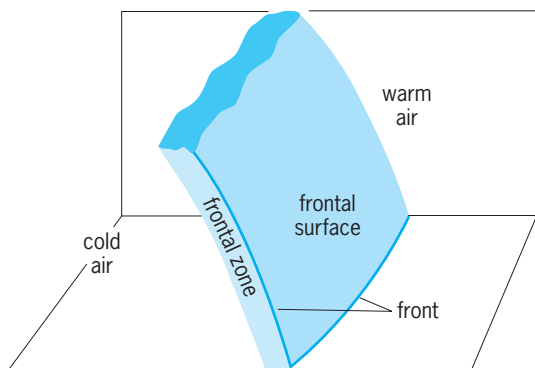

Schematic diagram of the frontal zone, angle with Earth's surface much exaggerated

contrasts generally are strongest at or near the earth's surface, the frontal zone usually being narrowest near the ground and becoming wider and more diffuse with height.

The surface separating the frontal zone from the adjacent warm air mass is referred to as the frontal surface, and it is the line of intersection of this surface with a second surface, usually horizontal or vertical, that strictly speaking constitutes the front. According to this more precise definition, the front represents a discontinuity in temperature gradient rather than in temperature itself. The boundary on the cold air side is often ill-defined, especially near the earth's surface, and for this reason is not represented in routine analysis of weather maps. See WEATHER MAP.

The wind gradient, or shear, like the temperature gradient, is larger within the frontal zone than on either side of it. In well-developed fronts the shift in wind direction often is concentrated along the frontal surface, while a more gradual change in wind speed may occur throughout the frontal zone. An upper-level jet stream normally is situated above the frontal zone. See JET STREAM. [S.E.M.]

**Frost** A covering of ice in one of several forms produced by the freezing of supercooled water droplets on objects colder than 32°F (0°C). The partial or complete killing of vegetation, by freezing or by temperatures somewhat above freezing for certain sensitive plants, also is called frost. Air temperatures below 32°F (0°C) sometimes are reported as "degrees of frost"; thus, 10°F (-12°C) is 22 degrees of frost (this usage is confined to the Fahrenheit scale and is not applied to Celsius temperatures).

Frost forms in exactly the same manner as dew except that the individual droplets that condense in the air a fraction of an inch from a subfreezing object are themselves supercooled, that is, colder than 32°F (0°C). When the droplets touch the cold object, they freeze immediately into individual crystals. When additional droplets freeze as soon as the previous ones are frozen, and hence are still close to the melting point because all the heat of fusion has not been dissipated, amorphous frost or rime results.

At more rapid rates of condensation, the drops form a thin layer of liquid before freezing, and glaze or glazed frost ("window ice" on house windows, "clear ice" on aircraft) generally follows. Glaze formation on plants, buildings and other structures, and especially on wires sometimes is called an ice storm, a silver frost storm, or thaw.

At slower deposition rates, such that each crystal cools well below the melting point before the next joins it, true crystalline or hoar frosts form. These include fernlike assemblages on snow surfaces, called surface hoar; similar feathery plumes in cold buildings, caves, and crevasses, called depth hoar; and the common window frost or ice flowers on house windows.

Killing frosts or freezes damage or kill vegetation depending on their duration and their intensity, that is, how far the plant

temperatures go below 32°F (0°C). Such conditions result from advection of much colder air, which then cools the plants, as in the infamous cold waves of the north-central United States; or from radiational cooling of the plants themselves, by long-wave radiation to clear skies at night. In either case, the extent to which plant fluids freeze determines the severity of the frost. See AIR TEMPERATURE; DEW; DEW POINT. [A.Cou.]

**Froude number** The dimensionless quantity  $U(gL)^{-1/2}$ , where  $U$  is a characteristic velocity of flow,  $g$  is the acceleration of gravity, and  $L$  is a characteristic length. The Froude number can be interpreted as the ratio of the inertial to gravity forces in the flow. This ratio may also be interpreted physically as the ratio between the mean flow velocity and the speed of an elementary gravity (surface or disturbance) wave traveling over the water surface. See WAVE MOTION IN LIQUIDS.

When the Froude number is equal to one, the speed of the surface wave and that of the flow is the same. The flow is in the critical state. When the Froude number is less than one, the flow velocity is smaller than the speed of a disturbance wave traveling on the surface. Flow is considered to be subcritical (tranquil flow). Gravitational forces are dominant. The surface wave will propagate upstream and, therefore, flow profiles are calculated in the upstream direction. When the Froude number is greater than one, the flow is supercritical (rapid flow) and inertial forces are dominant. The surface wave will not propagate upstream, and flow profiles are calculated in the downstream direction.

The Froude number is useful in calculations of hydraulic jump, design of hydraulic structures, and ship design, where forces due to gravity and inertial forces are governing. In these cases, geometric similitude and the same value of the Froude number in model and prototype produce a good approximation to dynamic similitude. See DIMENSIONAL ANALYSIS; DIMENSIONLESS GROUPS; HYDRAULICS; SHIP DESIGN. [R.M.Wr.]

**Fructose** A sugar that is the commonest of ketoses and the sweetest of the sugars. It is also known as D-fructose, D-fructopyranose, and levulose fruit sugar. It is found in free state, usually accompanied by D-glucose and sucrose in fruit juices, honey, and nectar of plant glands. D-Fructose is the principal sugar in seminal fluid. See CARBOHYDRATE.

Fructose is readily utilized by diabetic animals. In persons with diabetes mellitus or parenchymal hepatic disease, the impairment of fructose tolerance is relatively small and not at all comparable to the diminution in their tolerance to glucose. See MONOSACCHARIDE. [W.Z.H.]

**Fruit** A matured carpel or group of carpels (the basic units of the gynoecium or female part of the flower) with or without seeds, and with or without other floral or shoot parts (accessory structures) united to the carpel or carpels. Carpology is the study of the morphology and anatomy of fruits. The ovary develops into a fruit after fertilization and usually contains one or more seeds, which have developed from the fertilized ovules. Parthenocarpic fruits usually lack seeds. Fruitlets are the small fruits or subunits of aggregate or multiple fruits. Flowers, carpels, ovaries, and fruits are, by definition, restricted to the flowering plants (angiosperms), although fruitlike structures may enclose seeds in certain other groups of seed plants. The fruit is of ecological significance because of seed dispersal. See SEED.

**Morphology.** A fruit develops from one or more carpels. Usually only part of the gynoecium, the ovary, develops into a fruit; the style and stigma wither. Accessory (extracarpellary or non-carpellary) structures may be closely associated with the carpel or carpels and display various degrees of adnation (fusion) to them, thus becoming part of the fruit. Such accessory parts include sepals (as in the mulberry), the bases of sepals, petals, and stamens united into a floral tube (apple, banana, pear, and other species with inferior ovaries), the receptacle (strawberry), the pedicel and receptacle (cashew), the peduncle (fleshy part of

the fig), the involucre composed of bracts and bracteoles (walnut and pineapple), and the inflorescence axis (pineapple). See FLOWER.

A fruit derived from only carpellary structures is called a true fruit, or, because it develops from a superior ovary (one inserted above the other floral parts), a superior fruit (corn, date, grape, plum, and tomato). Fruits with accessory structures are called accessory (or inapty, false or spurious) fruits (pseudocarps), or, because of their frequent derivation from inferior ovaries (inserted below the other floral parts), inferior fruits (banana, pear, squash, and walnut).

Fruits can be characterized by the number of ovaries and flowers forming the fruit. A simple fruit is derived from one ovary, an aggregate fruit from several ovaries of one flower (magnolia, rose, and strawberry). A multiple (collective) fruit is derived from the ovaries and accessory structures of several flowers consolidated into one mass (fig, pandan, pineapple, and sweet gum).

The fruit wall at maturity may be fleshy or, more commonly, dry. Fleshy fruits range from soft and juicy to hard and tough. Dry fruits may be dehiscent, opening to release seeds, or indehiscent, remaining closed and containing usually one seed per fruit. Fleshy fruits are rarely dehiscent.

The pericarp is the fruit wall developed from the ovary. In true fruits, the fruit wall and pericarp are synonymous, but in accessory fruits the fruit wall includes the pericarp plus one or more accessory tissues of various derivation. Besides the fruit wall, a fruit contains one or more seed-bearing regions (placentae) and often partitions (septa).

**Anatomy.** Anatomically or histologically, a fruit consists of dermal, ground (fundamental), and vascular systems and, if present, one or more seeds. After fertilization the ovary and sometimes accessory parts develop into the fruit; parthenocarpy is fruit production without fertilization. The fruit generally increases in size and undergoes various anatomical changes that usually relate to its manner of dehiscence, its mode of dispersal, or protection of its seeds. The economically important, mainly fleshy fruits have received the most histological and developmental study.

Size increase of fruits is hormonally controlled and results from cell division and especially from cell enlargement. Cell number, volume, and weight thus control fruit weight. Cell division generally is more pronounced before anthesis (full bloom); cell enlargement is more pronounced after.

**Functional aspects.** Large fruits generally require additional anatomical modifications for nutrition or support or both. The extra phloem in fruit vascular bundles and the often increased amount of vascular tissue in the fruit wall and septa supply nutrients to the developing seeds and, especially in fleshy fruits, to the developing walls. Large, especially fleshy fruits (apple, gourd, and kiwi) usually contain proportionally more vascular tissue than small fruits. Vascular tissue also serves for support and in lightweight fruits may be the chief means of support.

Crystals, tannins, and oils commonly occur in fruits and may protect against pathogens and predators. The astringency of tannins, for example, may be repellent to organisms. With fruit maturation, tannin content ordinarily decreases, so the tannin repellency operative in early stages is superseded in fleshy fruits by features (tenderness, succulence, sweetness through odor and increased sugar content, and so on) attractive to animal dispersal agents. Many fruits are dispersed by hairs, hooks, barbs, spines, and sticky mucilage adhering the fruit to the surface of the dispersal agent. Lightweight fruits with many air spaces or with wings or plumes may be dispersed by wind or water. Gravity is always a factor in dispersal of fruits and seeds. [R.S.]

**Fruit, tree** Tree fruits include temperate, subtropical and tropical zone species. Most temperate zone fruits are grown principally in regions protected from prolonged summer heat and severe winter cold (above  $-10$  to  $-15^{\circ}\text{F}$  or  $-23$  to  $-26^{\circ}\text{C}$ ). The principal deciduous tree fruits grown in the United States are

apple, peach, pear, plum, apricot, sweet cherry, tart cherry, and nectarine. Tree nuts, such as almond, pecan, walnut, and filbert, are sometimes classified as deciduous tree fruit crops.

Most subtropical fruit trees are evergreen. They will withstand temperatures somewhat below freezing during their dormant or semidormant season, but not the extreme temperatures tolerated by the temperate zone crops. Major subtropical fruits in the United States are the citrus group (for example, orange, grapefruit, lemon), olive, avocado, fig, and others of lesser importance. The Japanese persimmon might be considered as a borderline case between the temperate and subtropical zone groups, and avocado is often classed as a tropical fruit.

The tree fruit crops are grown commercially in orchards or groves, usually in single rows which permit necessary cultural operations for each tree. Nearly all tree fruit crops have similar requirements of training, pruning, spraying to control diseases and insects, and cultivation or chemical control of weeds. [R.P.L.]

**Fucales** A large and diverse order of conspicuous brown algae (Phaeophyceae) including such well-known seaweeds as *Fucus* and *Sargassum*. Definitive features include apical growth, production of sex organs in cavities, and a life history with only one somatic phase, which is diploid. The mature thallus consists typically of a holdfast from which arise several axes with dichotomous or radial primary branching. Sexual reproduction is oogamous, with oogonia and antheridia produced in flask-shaped cavities called conceptacles.

In the family Fucaceae (rockweeds), the thallus typically is composed of a discoid or conical holdfast with a cluster of erect fronds that are branched dichotomously in one plane. *Fucus* is common throughout the North Atlantic and North Pacific. *Pelvetia* is also common in the Northern Hemisphere, but is not found on the American side of the Atlantic. *Ascophyllum* occurs abundantly in the North Atlantic, both in exposed sites and in estuaries far from the open sea. In subtropical and tropical regions of all oceans, the family Sargassaceae is common, dominating the biomass of benthic seaweeds. The holdfast is discoid, conical, hapteroid (with root-like outgrowths), or rhizomatous. *Sargassum* is by far the largest and most important genus in the Sargassaceae. Hundreds of species and varieties have been described.

Rockweeds are well known to coastal peoples of the temperate regions of the Northern Hemisphere. Traditionally, the seaweed was either plowed into the soil as a green manure or burned to an ash that was spread on the fields. In modern chemical industry, *Ascophyllum* is an important source of alginate, especially in Norway. See ALGAE; ALGINATE; PHAEOPHYCEAE. [P.C.St.; R.L.Moe.]

**L-Fucose** A methyl pentose (also known as 6-deoxy-L-galactose, L-galactomethyllose, L-rhodoose, and L-fucopyranose) present in some algae (seaweed), especially in *Laminaria digitata*, and in a number of gums; it has been identified in the polysaccharides of blood group-specific substances from animal and human sources. L-Fucose has also been found to be a constituent of certain bacterial polysaccharides. See BLOOD GROUPS; MONOSACCHARIDE. [W.Z.H.]

**Fuel cell** An electrical cell that converts the intrinsic chemical free energy of a fuel directly into direct-current electrical energy in a continuous catalytic process. As in the classical definition of catalysis, the fuel cell should not itself undergo change; that is, unlike the electrodes of a battery, its electrodes ideally remain invariant. For most fuel-oxidant combinations, the available free energy of combustion is somewhat less than the heat of combustion. In a typical thermal power conversion process, the heat of combustion of the fuel is turned into electrical work via a Carnot heat-engine cycle coupled with a rotating electrical generator. Since the Carnot conversion rarely proceeds at an efficiency exceeding 40% because of heat source and sink temperature limitations, the efficiency of conversion in a fuel cell

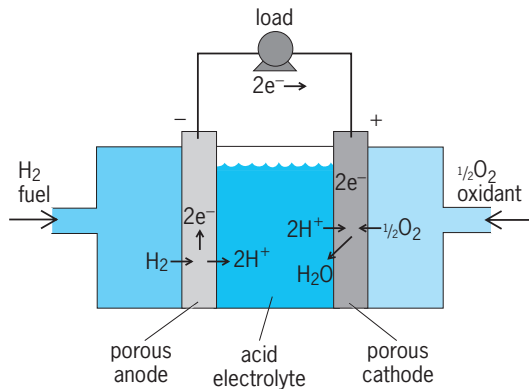
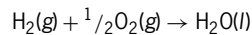

Diagram showing the principle of operation of a fuel cell. (After A. J. Appleby and F. R. Foulkes, *Fuel Cell Handbook*, Van Nostrand Reinhold, 1989)

can be greater than in a heat engine, especially in small devices. See CARNOT CYCLE; CATALYSIS.

The fuel cell reaction usually involves the combination of hydrogen (H) with oxygen (O)



as shown in the illustration. Under standard conditions of temperature and pressure, 25°C (77°F) and 1 atm (100 kilopascals), the reaction takes place with a free-energy change  $\Delta G = -56.69$  kcal (237 kilojoules) per mole of water. Since the formation of water involves two electrons, this value corresponds to  $-1.23$  electronvolts (1 eV = 23.06 kcal/equivalent). Thus, at thermodynamic equilibrium (zero current), the cell voltage should be 1.23 V, yielding a theoretical efficiency based on the heat of combustion [ $\Delta H$  for  $\text{H}_2\text{O}(\text{l}) = -1.48$  eV] of 83.1%. See FREE ENERGY.

At a net (nonzero) current, all cells show losses in cell voltage (V). In low-temperature fuel cells, these are due largely to the kinetic slowness (irreversibility) of the oxygen reduction reaction, which requires the breaking of a double bond with transfer of four electrons per molecule in a complex sequence of reactions. In high-temperature systems, oxygen reduction losses are less significant, since the reaction rate increases with temperature. However, the available free energy then decreases, falling to a value corresponding to about 1.0 V at 1000°C (1832°F). A further thermodynamic loss results from high cell fuel (or oxidant) conversion to avoid waste, so that the effective reversible potential is displaced from the standard state. Thus, at high temperature, the major loss is thermodynamic, which tends to compensate for the irreversible oxygen electrode losses at low temperature. As a result, cell voltages under typical loads vary from about 0.6 V for simple terrestrial cells to 1.0 V for aerospace cells. Cell voltage falls with increasing current per unit area. Since thermal efficiency is given by  $V/1.48$ , cell performance is a compromise between relative cost (that is, kilowatts available per unit area) and fuel efficiency, to give the lowest cost of electricity for a given application. See OXIDATION-REDUCTION.

While any chemically suitable fuel, including metals such as lithium (Li), sodium (Na), aluminum (Al), and zinc (Zn), may be used in a fuel cell, hydrocarbons (for example, natural gas) will not react at a significant rate in low-temperature fuel cells. They will crack thermally before reacting electrochemically if injected directly into high-temperature fuel cells. Simple low-power units operating directly on methanol at ambient temperature do find some use, and liquid-fueled hydrazine cells have also found specialized applications. However, the high manufacturing energy requirement for hydrazine, together with its high cost and hazardous nature, leaves hydrogen the only suitable general high-performance fuel candidate. See HYDRAZINE; HYDROGEN; METHANOL.

For practical fuel cells, hydrogen can be produced from readily available fuels such as clean light distillate (for example, naphtha), usually by steam reforming, or from coal via gasification at high temperature (the direct use of coal or carbon has been abandoned). In the high-temperature cells under certain conditions, internal steam reforming of simple hydrocarbons and alcohols (for example methane and methanol) can take place by the injection of the fuel with steam, which avoids cracking. Since methanol fuel reacts only slowly at low temperature, it is also steam-reformed to hydrogen. Methanol reforming takes place at only about 250°C (480°F), giving mixtures of hydrogen and carbon dioxide ( $\text{CO}_2$ ) with a small amount of carbon monoxide (CO). In contrast, steam reforming of higher-molecular-weight alcohols or clean light distillates requires temperatures in excess of 700°C (1290°F). This favors mixtures of hydrogen and carbon monoxide, as in coal synthesis gas. [A.J.A.]

**Fuel gas** A fuel in the gaseous state whose potential heat energy can be readily transmitted and distributed through pipes from the point of origin directly to the place of consumption. The types of fuel gases are natural gas, LP gas, refinery gas, coke oven gas, and blast-furnace gas. The last two are used in steel mill complexes.

Most fuel gases are composed in whole or in part of the combustibles hydrogen, carbon monoxide, methane, ethane, propane, butane, and oil vapors and, in some instances, of mixtures containing the inert nitrogen, carbon dioxide, and water vapor. See COAL GASIFICATION; LIQUEFIED NATURAL GAS (LNG); LIQUEFIED PETROLEUM GAS (LPG); NATURAL GAS. [J.Hu.]

**Fuel injection** The pressurized delivery of a metered amount of fuel into the intake airflow or combustion chambers of an internal combustion engine. Metering of the fuel charge may be performed mechanically or electronically. In a diesel engine, the fuel is injected directly into the combustion chamber (direct injection) or into a smaller connected auxiliary chamber (indirect injection). In the spark-ignition engine, the fuel is injected into the air before it enters the combustion chamber by spraying the fuel into the airstream passing through the throttle body (throttle-body injection) or into the air flowing through the port to the intake valve (port injection). See COMBUSTION CHAMBER.

The diesel engine must be supplied with fuel from the injection nozzle at a pressure of 1500–5000 lb/in.<sup>2</sup> (10–35 megapascals) for indirect-injection engines, and up to 15,000 lb/in.<sup>2</sup> (100 MPa) or higher for direct-injection engines. The high pressure is necessary to deliver fuel against the highly compressed air in the engine cylinders at the end of the compression stroke, and to break up the fuel oil which has low volatility and is often viscous. Extremely accurate fuel metering is necessary, with the start of injection occurring within a precision of up to 1° of engine crankshaft angle. A timing device in the injection pump automatically advances the start of fuel delivery as engine speed increases to optimize the start of combustion.

The intake air is not throttled in a diesel engine, with load and speed control accomplished solely by controlling the quantity of fuel injected. The mean effective pressure developed by combustion is controlled by the volumetric capacity of the injection pump. To prevent an unloaded diesel engine from increasing in speed until it destroys itself, a governor is required to limit maximum engine speed. See DIESEL CYCLE; DIESEL ENGINE; GOVERNOR; INTERNAL COMBUSTION ENGINE; MEAN EFFECTIVE PRESSURE.

On automotive spark-ignition engines, the carburetor has largely been replaced by a gasoline fuel-injection system with either mechanical or electronic control of fuel metering. Many of the systems are of the speed-density type, in which the mass airflow rate is calculated based on cylinder displacement and the measured intake-manifold absolute pressure (engine load), engine speed, intake-manifold air temperature, and theoretical volumetric efficiency. When the feedback signal from an

exhaust-gas oxygen sensor is included, these systems allow the engine air-fuel ratio to be maintained near the stoichiometric ratio (14.7:1) during normal operating conditions. This minimizes exhaust emissions. See CARBURETOR.

In the typical gasoline fuel-injection system, an electric fuel pump provides a specified fuel flow at the required system pressure to one or more fuel-injection valves, or fuel injectors. The gasoline fuel injector is an electromagnetic (solenoid-operated) or mechanical device used to direct delivery of or to meter pressurized fuel, or both. A fuel-pressure regulator maintains a controlled fuel pressure at each injector, or a controlled differential pressure across the injector. See FUEL PUMP; FUEL SYSTEM. [D.L.An.]

**Fuel oil** Any of the petroleum products which are less volatile than gasoline and are burned in furnaces, boilers, or other types of heaters. The two primary classes of fuel oils are distillate and residual. Distillate fuel oils are composed entirely of material which has been vaporized in a refinery distillation tower. Consequently, they are clean, free of sediment, relatively low in viscosity, and free of inorganic ash. Residual fuel oils contain fractions which cannot be vaporized by heating. These fractions are black and viscous and include any inorganic ash components which are in the crude. In some cases, whole crude is used as a residual fuel.

Distillate fuel oils are used primarily in applications where ease of handling and cleanliness of combustion are more important than fuel price. The most important use is for home heating. They are also used in certain industrial applications where low sulfur or freedom from ash is important. Increasing amounts of distillate fuel oils have been burned in gas turbines used for electricity generation. See GAS TURBINE.

Residual fuel oils are used where fuel cost is an important enough economic factor to justify additional investment to overcome the handling problems they pose. They are particularly attractive where large volumes of fuel are used, as in electric power generation, industrial steam generation, process heating, and steamship operation. See ELECTRIC POWER GENERATION; OIL FURNACE. [C.W.S.]

**Fuel pump** A mechanical or electrical pump for drawing fuel from a storage tank and forcing it to an engine or furnace. The type of pump chosen for a given fuel depends to a great extent on the volatility of the liquid to be pumped. In a gasoline engine the fuel is highly volatile at ambient temperature. Therefore, the fuel line is completely sealed from the tank to the carburetor or fuel-injection system to prevent escape of fuel and to enable the pump to purge the line of vapor in the event of vapor lock—a condition in which the fuel vaporizes owing to abnormally high ambient temperature. See CARBURETOR; FUEL INJECTION; FUEL SYSTEM.

Most carbureted gasoline engines use a spring-loaded diaphragm-type mechanical pump which is normally actuated by a rocker arm or pushrod that rides on an eccentric on the engine camshaft. Electric motor-driven and solenoid-operated diaphragm pumps and plunger pumps are also available that can be mounted near the main fuel tank to minimize vapor lock in the fuel lines. Many gasoline-engine vehicles have a submersible electric fuel pump, which serves as the main supply pump, located in the fuel tank. In some fuel-injection systems, the in-tank pump is used as the supply pump for a high-pressure fuel-injection pump. The in-tank pump may be of the gear, plunger, sliding-vane, or impeller type.

Diesel engines normally use a gear, plunger, or vane-type pump to supply fuel to the injection pump. In the diesel engine, where fuel is injected at high pressure through an injection nozzle into the highly compressed air in the combustion chamber, a plunger or piston serves as its own inlet valve and as the compression member of the injection pump. When the required high pressure is reached in the injection nozzle, a spring-biased

needle valve opens and fuel sprays into the combustion chamber. In an oil-fired furnace, although nozzle pressures need not be so high as in diesel engines, a piston pump is also used to provide positive shutoff of the fuel line when the pump stops. See DIESEL ENGINE. [D.L.An.]

**Fuel system** The system that stores fuel for present use and delivers it as needed to an engine; includes the fuel tank, fuel lines, pump, filter, vapor return lines, carburetor or injection components, and all fuel system vents and evaporative emission control systems or devices that provide fuel supply and fuel metering functions. Some early vehicles and other engines had a gravity-feed fuel system, in which fuel flowed to the engine from a tank located above it. Automotive and most other engines have a pressurized fuel system with a pump that draws or pushes fuel from the tank to the engine. See CARBURETOR; FUEL INJECTION; FUEL PUMP.

**Automobile.** The commonly used components for automobile and stationary gasoline engines are fuel tank, fuel gage, filter, electric or mechanical fuel pump, and carburetor or fuel-injection system. In the past, fuel metering on automotive engines was usually performed by a carburetor. However, this device has been largely replaced by fuel injection into the intake manifold or ports, which increases fuel economy and efficiency while lowering exhaust gas emissions. Various types of fuel management systems are used on automotive engines, including electronically controlled feedback carburetors, mechanical continuous fuel injection, and sequential electronic fuel injection. See AUTOMOBILE. [D.L.An.]

**Aircraft.** The presence of multiple engines and multiple tanks complicates the aircraft fuel system. Also, the reduction of pressure at altitude necessitates the regular use of boost pumps, submerged in the fuel tanks, which are usually of the centrifugal type and electrically driven. These supplement the engine-driven fuel supply pumps, which are usually of the gear or eccentric vane type. Components of a typical aircraft fuel system include one main and two auxiliary tanks with their gages; booster, transfer, and engine-driven pumps; various selector valves; and a fuel jettisoning or defuel valve and connection, which is typical also of what would be needed for either single-point ground or flight refueling (see illustration). The arrangement is usually such that all the fuel supply will pass to the engines by way of the main tank, which is refilled as necessary from the auxiliary tanks. In case of emergency, the system selector valve may connect the auxiliary tanks to the engines directly. Tank vents, not shown, are

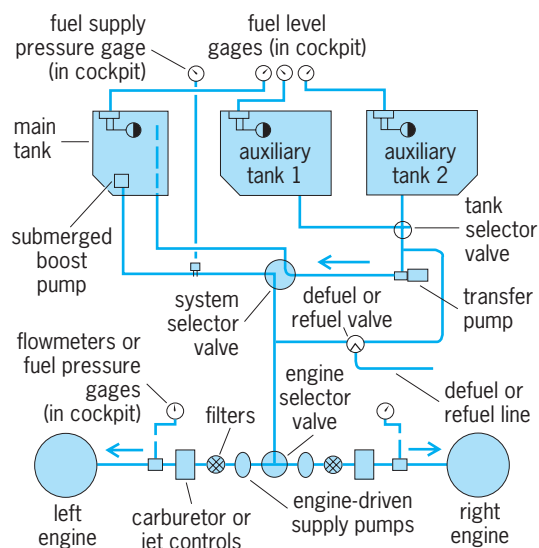

Diagram of a typical aircraft fuel system.



arranged so that overflow will go safely overboard. See AIRCRAFT ENGINE. [J.A.B.]

**Fugacity** A function introduced by G. N. Lewis to facilitate the application of thermodynamics to real systems. Thus, when fugacities are substituted for partial pressures in the mass action equilibrium constant expression, which applies strictly only to the ideal case, a true equilibrium constant results for real systems as well.

The fugacity  $f_i$  of a constituent  $i$  of a thermodynamic system is defined by the following equation (where  $\mu_i$  is the chemical po-

$$\mu_i = \mu_i^* + RT \ln f_i$$

tential and  $\mu_i^*$  is a function of temperature only), in combination with the requirement that the fugacity approach the partial pressure as the total pressure of the gas phase approaches zero. At a given temperature, this is possible only for a particular value for  $\mu_i^*$ , which may be shown to correspond to the chemical potential the constituent would have as the pure gas in the ideal gas state at 1 atm pressure. This definition makes the fugacity identical to the partial pressure in the ideal gas case. For real gases, the ratio of fugacity to partial pressure, called the fugacity coefficient, will be close to unity for moderate temperatures and pressures. At low temperatures and appropriate pressures, it may be as small as 0.2 or less, whereas at high pressures at any temperature it can become very large. See ACTIVITY (THERMODYNAMICS); CHEMICAL EQUILIBRIUM; CHEMICAL THERMODYNAMICS; GAS. [P.J.B.]

**Fullerene** A hollow, pure carbon molecule in which the atoms lie at the vertices of a polyhedron with 12 pentagonal faces and any number (other than one) of hexagonal faces. The molecule was named after R. Buckminster Fuller, the inventor of geodesic domes, which conform to the same underlying structural formula.

Buckminsterfullerene ( $C_{60}$  or fullerene-60; Fig. 1) is the archetypal member of the fullerenes. Other stable members of the fullerene family have similar structures (Fig. 2). The fullerenes can be considered, after graphite and diamond, to be the third well-defined allotrope of carbon. Macroscopic amounts of various fullerenes were first isolated in 1990, and since that time it has been discovered that members of this class of spheroidal organic molecules have numerous novel physical and chemical properties. The fullerenes promise to have synthetic, pharmaceutical, and industrial applications. Derivatives have been found to exhibit fascinating electrical and magnetic behavior, in particular

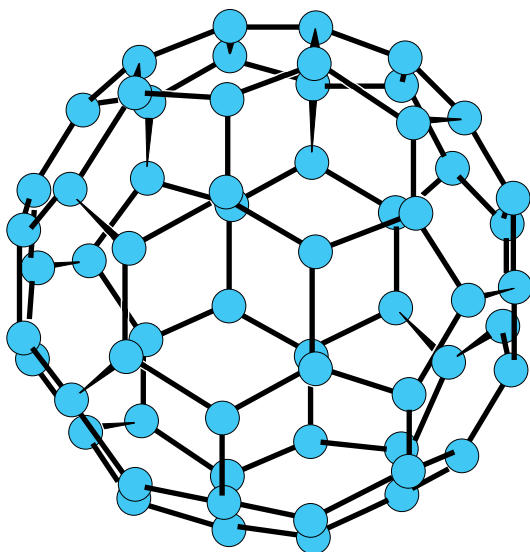

Fig. 1. Structure of fullerene-60 ( $C_{60}$ ).

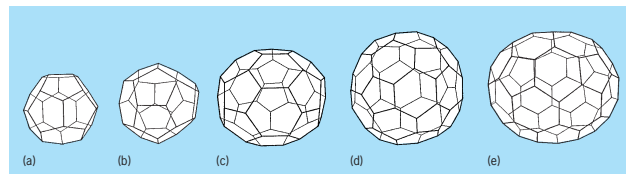

Fig. 2. Some of the more stable members of the fullerene family. (a)  $C_{28}$ . (b)  $C_{32}$ . (c)  $C_{50}$ . (d)  $C_{60}$ . (e)  $C_{70}$ .

superconductivity and ferro-magnetism. See CARBON; DIAMOND; GRAPHITE.

**Structures and properties.** In the fullerene molecule an even number of carbon atoms are arrayed over the surface of a closed hollow cage. Each atom is trigonally linked to its three near neighbors by bonds that delineate a polyhedral network, consisting of 12 pentagons and  $n$  hexagons. (Such structures conform to Euler's theorem for polyhedrons in that  $n$  may be any number other than one including zero.) All 60 atoms in fullerene-60 are equivalent and lie on the surface of a sphere distributed with the symmetry of a truncated icosahedron. The 12 pentagons are isolated and interspersed symmetrically among 20 linked hexagons.

In benzene solution, fullerene-60 is magenta and fullerene-70 red. Fullerene-60 forms translucent magenta face-centered cubic (fcc) crystals that sublime. The ionization energy is 7.61 eV and the electron affinity is 2.6–2.8 eV. The strongest absorption bands lie at 213, 257, and 329 nanometers. Studies with nuclear magnetic resonance spectroscopy yield a chemical shift of 142.7 parts per million; this result is commensurate with an aromatic system.

Solid  $C_{60}$  exhibits interesting dynamic behavior in that at room temperature the individual round molecules in the face-centered cubic crystals are rotating isotropically (that is, freely) at around  $10^8$  Hz. At around 260 K (8.3°F) there is a phase transition to a simple cubic (sc) lattice accompanied by an abrupt lattice contraction. Rotation is no longer free, and the individual molecules make rotational jumps between two favored (relative) orientational configurations—in the lower-energy one a double bond lies over a pentagon, and in the other it lies over a hexagon. At 90 K (–300°F) the individual molecules stop rotating altogether, freezing into an orientationally disordered crystal involving a mix of the two configurations. See CRYSTAL.

**Chemistry and formation.** Fullerene-60 behaves as a soft electrophile, a molecule that readily accepts electrons during a primary reaction step. It can readily accept three electrons and perhaps even more. The molecule can be multiply hydrogenated, methylated, ammonated, and fluorinated. It forms exohedral complexes in which an atom (or group) is attached to the outside of the cage, as well as endohedral complexes in which an atom is trapped inside the cage.

The  $C_{60}$  molecule behaves as though it has only a single resonance form—one in which the 30 double bonds are localized in the bonds that interconnect the pentagons. This is a key factor, as addition to these double bonds is the most important reaction as far as the application of  $C_{60}$  in synthesis is concerned.

On exposure of  $C_{60}$  to certain alkali and alkaline earth metals, exohedrally doped crystalline materials are produced that exhibit superconductivity at relatively high temperatures (10 to 33 K or –440 to –400°F). The  $C_{60}$  molecule has a triply degenerate lowest unoccupied molecular orbital (LUMO), which in the superconducting materials is half filled, containing three electrons. Other ionic phases, such as  $M_nC_{60}$  ( $n = 1, 2, 4, 6$ , where  $M$  is the intercalated metal atom), exist but are not superconducting—they appear to be metallic or semiconductor/insulators. See MOLECULAR ORBITAL THEORY; SUPERCONDUCTIVITY.

Perhaps the most important aspect of the fullerene discovery is that the molecule forms spontaneously. This fact has important implications for understanding the way in which extended

carbon materials form, and in particular the mechanism of graphite growth and the synthesis of large polycyclic aromatic molecules. It has become clear that as far as pure carbon aggregates of around 60–1000 atoms are concerned, the most stable species are closed-cage fullerenes. [J.Hare; H.W.Kr.]

**Fuller's earth** Any natural earthy material that decolorizes mineral and vegetable oils and has high sorbent capacity for water and oil. The term fuller's earth has no genetic or mineralogical significance. However, the most common earthy materials classed as fuller's earth are calcium montmorillonites and palygorskites (attapulgites) and sepiolites. The term originated in England, where in ancient times raw wool was cleaned by kneading it in water with clay materials that adsorbed dirt and lanolin. The process was known as fulling, and the clay or earth became known as fuller's earth. See ADSORPTION; MONTMORILLONITE; SEPIOLITE.

Several clay deposits in the world are mined and processed for their absorbent, adsorbent, and decolorizing or bleaching properties. Some clays have a high natural decolorizing ability; however, in most instances a clay, normally a calcium montmorillonite, is acid-activated to enhance its bleaching or decolorizing properties. Sulfuric acid is commonly used, and in the treatment process sodium, calcium, magnesium, and iron that occupy the cation exchange sites on the clay surface are removed by the acid and replaced by hydrogen. Also, some aluminum, iron, or magnesium is removed from the mineral structure, increasing the negative charge on the clay surface. These highly charged surfaces covered with hydrogen ions selectively absorb the color bodies and other impurities in the oil. See CLAY; CLAY MINERALS.

The largest applications for fuller's earth are as sorbents, and by far the biggest market is pet-litter production. Other large sorbent applications are as carriers for insecticides, pesticides, and fertilizers used in agriculture and as absorbers of oil and water spills on the floors of machine shops, factories, service stations, and other manufacturing plants for safety purposes. [H.H.Mu.]

**Fulminate** A compound containing the —ONC group and derived from fulminic acid, HONC. Fulminates are isomeric with cyanates; that is, cyanates have the same atoms but in different arrangement, —OCN.

The fulminates have been commercially important because of the use of mercury fulminate,  $\text{Hg}(\text{ONC})_2$ , in priming compositions and as an initial detonating agent; lead azide is replacing mercury fulminate as a detonating agent. See CYANATE. [E.E.W.]

**Fumigant** A pesticidal chemical or chemical formulation that functions in a gaseous state. Chemical formulations are designed to increase toxicity, reduce flammability, give off warning odors, and provide for sorption at different rates.

Physical types of fumigants include gases, liquids, and solids. There are several chemical types of fumigants. These include: halogenated hydrocarbons, such as carbon tetrachloride and ethylene dibromide; sulfur-containing compounds, such as carbon disulfide and sulfur dioxide; cyanides, such as hydrogen cyanide and calcium cyanide; and others, such as phosphine and ethylene dioxide.

Fumigants are used in space fumigations to disinfest food-processing plants, warehouses, grain elevators, boxcars, shipholds, stores, and households, and in spot fumigations within those structures. They are used in atmospheric vaults and vacuum chambers and are applied extensively to stacked bags of grain or stored foods under polyethylene sheets, to trees under tents to control scale insects, and to areas of land to destroy weeds, soil-infesting insects, and nematodes. [D.A.W.]

**Funariales** An order of the true mosses (subclass Bryidae). The Funariales, often annuals or biennials and sometimes

ephemeral, are for the most part characterized by a uniformity of gametophytic structure in contrast to a variability of sporophytic characters. Reduction in sporophytic characters is often associated with disturbed habitats and a shortened life cycle.

The plants are generally small or minute, growing scattered or tufted mostly on soil. The stems are erect, and the leaves, inserted in numerous rows, are usually broadly oblong-lingulate and rounded-to-acuminate at the apex, with a single costa. The leaf cells are lax, thin-walled, and smooth, or less commonly papillose because of projecting upper ends. The sporophytes are terminal with variable seta length. The capsules are generally exserted, erect, and symmetric but sometimes inclined and strongly asymmetric, ovoid to pyriform, and often with a noticeably differentiated sterile neck. The spores may be spherical or tetrahedral, while the calyptra may be cucullate or mitrate.

The Funariales include five families (Funariaceae, Gigaspermaceae, Disceliaceae, Pseudoditrichaceae, and Splachnobryaceae), and are heterogeneous in composition. See BRYIDAE; BRYOPHYTA; BRYOPSIDA. [H.Cr.]

**Function generator** An electronic instrument which generates periodic voltage or current waveforms that duplicate various types of well-defined mathematical functions. The simplest function generator usually generates a combination of square waves, triangular waves, and sine waves.

One electronic circuit approach to the design of a simple function generator is to begin with a bistable multivibrator or "flip-flop" controlled in time by a succession of clock pulses which generates the square wave. The triangular waveform is obtained by integrating the square wave through the use of the operational amplifier integrator. The sine wave is obtained by applying the triangular wave to a shaping circuit consisting of a combination of resistors and diodes. See AMPLIFIER; MULTIVIBRATOR; WAVE-SHAPING CIRCUITS.

Alternatively the sine wave may be generated by a sinusoidal oscillator. From this output, the square wave may be obtained by amplification, limiting, and clipping of the sine wave. Then the triangular wave may be obtained using an integrator as before. See LIMITER CIRCUIT.

A combination of counters, programmed read-only memories (PROMS), and a digital-to-analog converter can be used as a function generator, generating almost any function desired to almost any degree of accuracy. See COMPUTER STORAGE TECHNOLOGY; DIGITAL-TO-ANALOG CONVERTER. [G.M.G.]

**Functional analysis and modeling (engineering)** The discipline that addresses the activities that a system, a software, or an organization must perform to achieve its desired outputs; that is, what transformations are necessary to turn the available inputs into the desired outputs. Additional considerations include the flow of data or items between functions, the processing instructions that are available to guide the transformations, and the control logic that dictates the activation and termination of functions. Functional analysis diagrams have been developed to capture some or all of these concepts.

Functional analysis is performed in systems engineering, software systems engineering, and business process reengineering as a portion of the design process. These design processes typically involve the steps of requirements definition and analysis, functional analysis, physical or resource definition, and operational analysis. This last step of operational analysis involves the marriage of functions with resources to determine if the requirements are met. The concept of examining the logical architecture via functional analysis concurrent with the development of the physical architecture has become a well-accepted principle in the related fields of systems engineering, software engineering, and business process reengineering. See REENGINEERING; SOFTWARE ENGINEERING; SYSTEMS ENGINEERING.

**Elements.** There are four elements to be addressed by any specific functional analysis approach. First, the functions are represented as a hierarchical decomposition, in which there is a top-level function for the system or organization. The top-level function is partitioned into a set of subfunctions that use the same inputs and produce the same outputs as the top-level function. Each of these subfunctions can then be partitioned further, with the decomposition process continuing as often as it is useful.

Second, functional analysis diagrams can represent the flow of data or items among the functions within any portion of the functional decomposition. As the first and subsequent functional decompositions are examined, it is common for one function to produce outputs that are not useful outside the boundaries of the system or organizations. These outputs are needed by other functions in order to produce the needed and expected external outputs.

Processing instructions are a third element that appear in some functional analysis diagrams. These instructions contain the needed information for the functions to transform the inputs to the outputs.

The fourth element is the control flow that sequences the termination and activation of the functions so that the process is both efficient and effective.

**Feedback and control.** Feedback plays an important role in functional analysis and modeling. Feedback and control is the comparison of the actual characteristics of an output with desired characteristics of that output for the purpose of adjusting the process of transforming inputs into that output. Open-loop control processes may or may not make this measurement, but in either case make no adjustments to the process once started. Closed-loop control processes use measurements of the output as feedback for the purpose of adjusting or controlling the transformation process. [D.M.B.]

**Fundamental constants** That group of physical constants which play a fundamental role in the basic theories of physics. These constants include the speed of light in vacuum,  $c$ ; the magnitude of the charge on the electron,  $e$ , which is the fundamental unit of electric charge; the mass of the electron,  $m_e$ ; Planck's constant,  $\hbar$ ; and the fine-structure constant,  $\alpha$ .

These five quantities typify the different origins of the fundamental constants:  $c$  and  $\hbar$  are examples of quantities which appear naturally in the mathematical formulation of certain physical theories—Einstein's theories of relativity, and quantum theory, respectively;  $e$  and  $m_e$  are examples of quantities which characterize the elementary particles of which all matter is constituted; and  $\alpha$ , the fundamental constant of quantum electrodynamics (QED), is an example of quantities which are combinations of other fundamental constants, but are actually constants in their own right since the same combination always appears together in the basic equations of physics.

Reliable numerical values for the fundamental physical constants are required for two main reasons. First, they are necessary if quantitative predictions from physical theory are to be obtained. Second, and even more important, the self-consistency of the basic theories of physics can be critically tested by a careful intercomparison of the numerical values of fundamental constants obtained from experiments in the different fields of physics. In general, the accuracy of fundamental constants determinations has continually improved over the years. Whereas in the past, 100 ppm (0.01%) and even 1000 ppm (0.1%) measurements were commonplace, today 0.01 ppm and better determinations are not unusual (ppm = parts per million).

Complex relationships can exist among groups of constants and conversion factors, and a particular constant may be determined either directly by measurement or indirectly by an appropriate combination of other directly measured constants. If the direct and indirect values have comparable accuracy, then both must be taken into account in order to arrive at a best value for that quantity. (By best value is meant that value believed to be closest to the true but unknown value.) Generally, each of the several routes which can be followed to a particular constant, both direct and indirect, will give a slightly different numerical value. Such a situation may be satisfactorily handled by the mathematical method known as least-squares. This technique provides a self-consistent procedure for calculating best "compromise" values of the constants from all of the available data. It automatically takes into account all possible routes and determines a single final value for each constant being calculated. It does this by weighting the different routes according to their relative uncertainties. The appropriate weights follow from

Recommended values (1986) of selected fundamental physical constants

Quality	Symbol	Numerical value*	Units†	Relative uncertainty, ppm
Speed of light in vacuum	$c$	299792458	m/s	(defined)
Constant of gravitation	$G$	6.67259(85)	$10^{-11} \text{ m}^3/(\text{kg} \cdot \text{s}^2)$	128
Planck constant	$h$	6.6260755(40)	$10^{-34} \text{ J} \cdot \text{s}$	0.60
Elementary charge	$e$	1.60217733(49)	$10^{-19} \text{ C}$	0.30
Magnetic flux quantum, $h/(2e)$	$\Phi_0$	2.06783461(61)	$10^{-15} \text{ Wb}$	0.30
Fine-structure constant, $\mu_0 e^2/(2h)$	$\alpha$	7.29735308(33)	$10^{-3}$	0.045
	$\alpha^{-1}$	137.0359895(61)		0.045
Electron mass	$m_e$	9.1093897(54)	$10^{-31} \text{ kg}$	0.59
Proton mass	$m_p$	1.6726231(10)	$10^{-27} \text{ kg}$	0.59
Neutron mass	$m_n$	1.6749286(10)	$10^{-27} \text{ kg}$	0.59
Proton-electron mass ratio	$m_p/m_e$	1836.152701(37)		0.020
Rydberg constant, $m_e c \alpha^2/(2\hbar)$	$R_\infty$	1.0973731534(13)	$\text{m}^{-1}$	0.0012
Bohr radius, $\alpha/(4\pi R_\infty)$	$a_0$	5.29177249(24)	$10^{-11} \text{ m}$	0.045
Compton wavelength of the electron, $h/(m_e c) = \alpha^2/(2R_\infty)$	$\lambda_c$	2.42631058(22)	$10^{-12} \text{ m}$	0.089
Classical electron radius, $\mu_0 e^2/(4\pi m_e) = \alpha^3/(4\pi R_\infty)$	$r_e$	2.81794092(38)	$10^{-15} \text{ m}$	0.13
Bohr magneton, $eh/(4\pi m_e)$	$\mu_B$	9.2740154(31)	$10^{-24} \text{ J/T}$	0.34
Electron magnetic moment in Bohr magnetons	$\mu_e/\mu_B$	1.001159652193(10)		$10^{-5}$
Nuclear magneton, $eh/(4\pi m_p)$	$\mu_N$	5.0507866(17)	$10^{-27} \text{ J/T}$	0.34
Proton magnetic moment in nuclear magnetons	$\mu_p/\mu_N$	2.792847386(63)		0.023
Boltzmann constant	$k$	1.380658(12)	$10^{-23} \text{ J/K}$	8.5
Avogadro constant	$N_A$	6.0221367(36)	$10^{-23}/\text{mol}$	0.59
Fataday constant, $N_A e$	$F$	96485.309(29)	$\text{C/mol}$	0.30
Molar gas constant, $N_A k$	$R$	8.314510(70)	$\text{J}/(\text{mol} \cdot \text{K})$	8.4

\*The digits in parentheses represent the one-standard-deviation uncertainties in the last digits of the quoted value.

†C = coulomb, J = joule, kg = kilogram, m = meter, mol = mole, s = second, T = tesla, Wb = weber.

the uncertainties assigned the individual measurements constituting the original set of data.

The 1986 least-squares adjustment, carried out under the auspices of the CODATA Task Group on Fundamental Constants, succeeded a CODATA adjustment in 1973 by E. R. Cohen and B. N. Taylor; CODATA, the Committee on Data for Science and Technology, is an interdisciplinary committee of the International Council of Scientific Unions. Recommended values are shown in the table. [E.R.Co.]

**Fundamental interactions** Fundamental forces that act between elementary particles, of which all matter is assumed to be composed.

At present, four fundamental interactions are distinguished. Their properties are summarized in the table.

**Properties of the four fundamental interactions**

Interaction	Range	Exchanged quanta
Gravitational	Long-range	Gravitons ( $g$ )
Electromagnetic	Long-range	Photons ( $\gamma$ )
Weak nuclear	Short-range $\approx 10^{-18}$ m	$W^+$ , $Z^0$ , $W^-$
Strong nuclear	Short-range $\approx 10^{-15}$ m	Gluons ( $G$ )

The gravitational interaction manifests itself as a long-range force of attraction between all elementary particles.

The electromagnetic interaction is responsible for the long-range force of repulsion of like, and attraction of unlike, electric charges. At comparable distances, the ratio of gravitational to electromagnetic interactions (as determined by the strength of respective forces between an electron and a proton) is approximately  $4 \times 10^{-37}$ . See COULOMB'S LAW; ELECTROSTATICS; GRAVITATION.

In modern quantum field theory, the electromagnetic interaction and the forces of attraction or repulsion between charged particles are pictured as arising secondarily as a consequence of the primary process of emission of one or more photons (particles or quanta of light) emitted by an accelerating electric charge (in accordance with Maxwell's equations) and the subsequent reabsorption of these quanta by a second charged particle. A similar picture may also be valid for the gravitational interaction.

The third fundamental interaction is the weak nuclear interaction, which is responsible for the decay of a neutron into a proton, an electron, and an antineutrino. Unlike electromagnetism and gravitation, weak interactions are short-range, the range of the force being of the order of  $10^{-18}$  m.

An important question was finally answered in 1983: Is the weak interaction similar to electromagnetism in being mediated primarily by intermediate objects, the  $W^+$  and  $W^-$  particles. The experimental answer, discovered at the CERN laboratory at Geneva, is that  $W^+$  and  $W^-$  do exist, with a mass of  $80.4 \text{ GeV}/c^2$ . Each carries a spin of magnitude  $\hbar$ , where  $\hbar$  is Planck's constant divided by  $2\pi$ , just as does the photon ( $\gamma$ ). The mass of these particles gives the range of the weak interaction. See INTERMEDIATE VECTOR BOSON.

Another crucial discovery in weak interaction physics was the neutral current phenomenon in 1973, that is, the discovery of new types of weak interactions where (as in the case of electromagnetism or gravity) the nature of the interacting particles is not changed during the interaction. The 1983 experiments at CERN also gave evidence for the existence of an intermediate particle  $Z^0$ , with a mass of  $91.2 \text{ GeV}/c^2$ , which is believed to mediate such reactions. See NEUTRAL CURRENTS; WEAK NUCLEAR INTERACTIONS.

The fourth fundamental interaction is the strong nuclear interaction between protons and neutrons, which resembles the weak nuclear interaction in being short-range, although the range is of the order of  $10^{-15}$  m rather than  $10^{-18}$  m. Within this range of

distances the strong force overshadows all other forces between protons and neutrons.

Protons and neutrons are themselves believed to be made up of yet more fundamental entities, the up ( $u$ ) and down ( $d$ ) quarks ( $P = uud, N = udd$ ). Each quark is assumed to be endowed with one of three color quantum numbers [conventionally labeled red ( $r$ ), yellow ( $y$ ), and blue ( $b$ )]. The strong nuclear force can be pictured as ultimately arising through an exchange of zero rest-mass color-carrying quanta of spin  $\hbar$  called gluons ( $G$ ) [analogous to photons in electromagnetism], which are exchanged between quarks (contained inside protons and neutrons). Since neutrinos, electrons, and muons (the so-called leptons) do not contain quarks, their interactions among themselves or with protons and neutrons do not exhibit the strong nuclear force. See COLOR (QUANTUM MECHANICS); GLUONS; LEPTON; QUANTUM CHROMODYNAMICS; QUARKS; STRONG NUCLEAR INTERACTIONS.

Three of the four fundamental interactions (electromagnetic, weak nuclear, and strong nuclear) appear to be mediated by intermediate quanta (photons  $\gamma$ ;  $W^+$ ,  $Z^0$ , and  $W^-$ ; and gluons  $G$ , respectively), each carrying spin of magnitude  $\hbar$ . This is characteristic of the gauge interactions, whose general theory was given by H. Weyl, C. N. Yang, R. Mills, and R. Shaw. This class of interactions is further characterized by the fact that the force between any two particles (produced by the mediation of an intermediate gauge particle) is universal in the sense that its strength is (essentially) proportional to the product of the intrinsic charges (electric, or weak-nuclear, or strong-color) carried by the two interacting particles concerned.

The fourth interaction (the gravitational) can also be considered as a gauge interaction, with the intrinsic charge in this case being the mass; the gravitational force between any two particles is proportional to the product of their masses. The only difference between gravitation and the other three interactions is that the gravitational gauge quantum (the graviton) carries spin  $2\hbar$  rather than  $\hbar$ . It is an open question whether all fundamental interactions are gauge interactions. See GAUGE THEORY.

Ever since the discovery and clear classification of these four interactions, particle physicists have attempted to unify these interactions as aspects of one basic interaction between all matter. A unification of weak and electromagnetic interactions, employing the gauge ideas was suggested by S. Glashow and by A. Salam and J. C. Ward in 1959. Following this initial attempt, Glashow (and independently Salam and Ward) noted that such a unification could be effected only if neutral current weak interactions were postulated to exist.

There were two major problems with this unified electroweak gauge theory considered as a fundamental theory. Yang and Mills had shown that masslessness of gauge quanta is the hallmark of unbroken gauge theories. The origin of the masses of the weak interaction quanta  $W^+$ ,  $W^-$ , and  $Z^0$  (or equivalently the short-range of weak interactions), as contrasted with the masslessness of the photon (or equivalently the long-range character of electromagnetism), therefore required explanation. The second problem concerned the possibility of reliably calculating higher-order quantum effects with the new unified electroweak theory, on the lines of similar calculations for the "renormalized" theory of electromagnetism elaborated by S. Tomonaga, Schwinger, Feynman, and F. J. Dyson around 1949. The first problem was solved by S. Weinberg and Salam and the second by G. 't Hooft and by B. W. Lee and J. Zinn-Justin. See RENORMALIZATION.

Weinberg and Salam considered the possibility of the electroweak interaction being a "spontaneously broken" gauge theory. By introducing an additional self-interacting Higgs-Englert-Brout-Kibble particle into the theory, they were able to show that the  $W^+$ ,  $W^-$ , and  $Z^0$  would acquire well-defined masses through the so-called Higgs mechanism. The predicted theoretical mass values of the  $W$  and  $Z$  particles are in good accord with the experimental values found by the CERN 1983 experiments.

The Weinberg-Salam electroweak theory contains an additional neutral particle (the Higgs) but does not predict its mass.

A search for this particle will be undertaken when the large hadron collider (LHC) at CERN comes into commission. See ELECTROWEAK INTERACTION; HIGGS BOSON; PARTICLE ACCELERATOR; SYMMETRY BREAKING.

The gauge unification of weak and electromagnetic interactions, which started with the observation that the relevant mediating quanta ( $W^+$ ,  $W^-$ ,  $Z^0$ , and  $\gamma$ ) possess intrinsic spin  $\hbar$ , can be carried further to include strong nuclear interactions as well, if these strong interactions are also mediated through quanta (gluons) carrying spin  $\hbar$ . The resulting theory, which appears to explain all known low-energy phenomena, is called the standard model. (It is a model based on three similarly constituted generations of quarks and leptons plus the mediating quanta  $W^+$ ,  $W^-$ ,  $Z^0$ , photons, and gluons plus the Higgs particle.) A complete gauge unification of all three forces (electromagnetic, weak nuclear, and strong nuclear) into a single electronuclear interaction seems plausible. Such a (so-called grand) unification necessarily means that the distinction between quarks on the one hand and neutrinos, electrons, and muons (leptons) on the other, must disappear at sufficiently high energies, with all interactions (weak, electromagnetic, and strong) clearly manifesting themselves then as facets of one universal gauge force. The fact that at low energies presently available, these interactions exhibit vastly different effective strengths is ascribed to differing renormalizations due to successive spontaneous symmetry breakings. A startling consequence of the eventual universality and the disappearance of distinction between quarks and leptons is the possibility of protons transforming into leptons and pions. Contrary to the older view, protons would therefore decay into leptons and pions and not live forever. See GRAND UNIFICATION THEORIES; PROTON; STANDARD MODEL.

Research in unification theories of fundamental interactions is now concerned with uniting the gauge theories of gravity and of the electronuclear interactions. The most promising approach appears to be that of superstring theories. Such theories appear to describe the only possible theory of gravity which is finite and suffers from no ultraviolet infinities. A closed string is a (one-dimensional) loop which may exist in a  $d$ -dimensional space-time (where  $d$  must equal 10 to completely eliminate all ultraviolet infinities). The quantum oscillations of the string correspond to particles of higher spins and higher masses. The theory has a unique built-in gauge symmetry. See SUPERSTRING THEORY.

[A.S.]

**Fungal biotechnology** All aspects of cultivating fungi together with products and processes derived from such cultures. Fungi exhibit a wide range of biosynthetic and biodegradative activities. Since fungi can bring about chemical change in almost any natural or synthetic organic molecule, many species have been selected and propagated in pure culture specifically for applications in biotechnology and industry, for example in food and beverage production.

While the fermentation industry remains the largest and economically most important user of fungal cultures, fungi are also utilized by the pharmaceutical, cosmetic, chemical, agricultural, food, enzyme, wood product, and waste treatment industries. In the United States, two prominent examples of fungal products are citric acid, with an annual production of 350,000 tons (160,000 kg), and beta-lactam antibiotics. Yeasts are the most commercially exploited microorganisms. They have been used extensively in baking, brewing, winemaking, and distilling, and in making various metabolic products. Several million tons of fresh yeast are produced each year, mostly for the baking industry. See FERMENTATION; FOOD FERMENTATION.

Because they are capable of secreting large quantities of certain proteins in liquid culture, fungi have proven to be useful as cloning hosts for the production of recombinant proteins of fungal and human origin. Technologies have been developed to scale up the production of new or novel products. *Aspergillus nidulans* has been designed to produce many human therapeutic

proteins, including growth factors and protein hormones. The yeasts *Sac. cerevisiae* and *P. pastoris* have been utilized for the expression of human interferon and serum albumin. Yeast chromosomes are also being employed in the mapping of the human genome. See GENETIC ENGINEERING.

[S.C.J.]

Manufactured products which contain living fungi and are used to control pests are called mycopensticides. They are utilized to control weeds, harmful insects, nematodes (roundworms), or even other fungi. Although formerly confined to experimental settings, mycopensticides are increasingly available as commercial products, especially for the agricultural market. They may impact pest populations through direct parasitism, secretion of antibiotics, competition for nutrients, or a combination of these effects, and may be used alone or in combination with chemical pesticides.

[F.M.D.]

**Fungal ecology** The subdiscipline in mycology and ecology that examines community composition and structure; responses, activities, and interactions of single species; and the functions of fungi in ecosystems. These organisms display an extraordinary diversity of ecological interactions and life history strategies, but are alike in being efficient heterotrophs. Fungi, along with bacteria, are the primary decomposers, facilitating the flow of energy and the cycling of materials through ecosystems. See ECOLOGICAL ENERGETICS; FUNGI.

Fungi occur in many different habitat types—on plant surfaces; inside plant tissues; in decaying plant foliage, bark and wood; and in soil—generally changing in abundance and species composition through successional stages of decomposition. Fungi are also found in marine and aquatic habitats; in association with other fungi, lichens, bacteria, and algae; and in the digestive tracts and waste of animals. Some fungi grow in extreme environments: rock can harbor free-living endolithic fungi or the fungal mutualists of lichens; thermotolerant and thermophilic fungi can grow at temperatures above 45°C (113°F); psychrophilic fungi can grow at temperatures to below -3°C (27°F). Xerotolerant fungi are able to grow in extremely dry habitats, and osmotolerant fungi grow on substrates with high solute concentrations. Most fungi are strict aerobes, but species of the chytrid *Neocallimastix*, which inhabit the rumen of herbivorous mammals, are obligate anaerobes. Several aquatic fungi are facultative anaerobes. Many fungi occur as free-living saprobes, but fungi are particularly successful as mutualistic, commensal, or antagonistic symbionts with other organisms. See POPULATION ECOLOGY.

Fungi possess unique features that affect their capacity to adapt and to function in ecosystems:

1. Fungi are composed of a vegetative body (hyphae or single cells) capable of rapid growth. Hyphae are linear strands composed of tubular cells that are in direct contact with the substrate. The cells secrete extracellular enzymes that degrade complex polymers, such as cellulose, into low-molecular-weight units that are then absorbed and catabolized. Many fungi also produce secondary metabolites such as mycotoxins and plant growth regulators that affect the outcomes of their interactions with other organisms.

2. Filamentous fungi are able to mechanically penetrate and permeate the substrate.

3. Fungi have an enormous capacity for metabolic variety. Fungal enzymes are able to decompose highly complex organic substances such as lignin, and to synthesize structurally diverse, biologically active secondary metabolites. Saprotrophic fungi are very versatile; some are able to grow on tree resins and even in jet fuel.

4. Structural and physiological features of fungi facilitate absorption and accumulation of mineral nutrients as well as toxic elements. The capacity of fungi to absorb, accumulate, and translocate is especially significant ecologically where hyphal networks permeate soil and function as a link between microhabitats.

5. Fungi have the capacity for indeterminate growth, longevity, resilience, and asexual reproduction. The vegetative cells of Eumycota are often multinucleate, containing dissimilar haploid nuclei. This combination of features gives the fungi an unparalleled capacity for adaptation to varying physiological and ecological circumstances and ensures a high level of genetic diversity.

6. Many species of fungi have a capacity to shift their mode of nutrition. The principal modes are saprotrophy (the utilization of dead organic matter) and biotrophy, which is characteristic of parasitic, predacious, and mutualistic fungi (including mycorrhizae and lichen fungi). See BIODEGRADATION; FUNGAL GENETICS; MYCORRHIZAE.

Fungi interact with all organisms in ecosystems, directly or indirectly, and are key components in ecosystem processes. As decomposers, fungi are crucial in the process of nutrient cycling, including carbon cycling as well as the mineralization or immobilization of other elemental constituents. As parasites, pathogens, predators, mutualists, or food sources, fungi can directly influence the species composition and population dynamics of other organisms with which they coexist. Fungi may act both as agents of successional change or as factors contributing to resilience and stability. Mycorrhizal fungi function as an interface between plant and soil, and are essential to the survival of most plants in natural habitats.

There are several economically important areas that benefit from application of the principles of fungal ecology: biotechnology, biological control, bioremediation, agriculture, forestry, and land reclamation. With only a small fraction of the total species known, the fungi offer a rich potential for bioprospecting, the search for novel genetic resources with unique, useful biochemical properties. See ECOLOGY; ECOSYSTEM; FUNGI; FUNGAL BIOTECHNOLOGY. [M.Ch.; J.K.St.]

**Fungal genetics** The study of gene structure and function in fungi. Genetic research has provided important knowledge about genes, heredity, genetic mechanisms, metabolism, physiology, and development in fungi, and in higher organisms in general, because in certain respects the fungal life cycle and cellular attributes are ideally suited to both mendelian and molecular genetic analysis.

Fungal nuclei are predominantly haploid; that is, they contain only one set of chromosomes. This characteristic is useful in the study of mutations, which are usually recessive and therefore masked in diploid organisms. Mutational dissection is an important technique for the study of biological processes, and the use of haploid organisms conveniently allows for the immediate expression of mutant genes. See MUTATION.

Reproduction in fungi can be asexual, sexual, or parasexual (see illustration). Asexual reproduction involves mitotic nuclear division during the growth of hyphae, cell division, or the production of asexual spores. Sexual reproduction is based on meiotic nuclear divisions fairly typical of eukaryotes in general. In ascomycetes and basidiomycetes, the spores, containing nuclei that are the four products of a single meiosis, remain together in a group called a tetrad. The isolation and testing of the phenotypes of cultures arising from the members of a tetrad (tetrad analysis) permit the study of the genetic events occurring in individual meioses; this possibility is offered by virtually no other eukaryotic group. In other groups, genetic analysis is limited to products recovered randomly from different meioses. Since a great deal of genetic analysis is based on meiosis, fungal tetrads have proved to be pivotal in shaping current ideas on this key process of eukaryotic biology. See EUKARYOTAE; MEIOSIS.

Because their preparation in large numbers is simple, fungal cells are useful in the study of rare events (such as mutations and recombinations) with frequencies as little as one in a million or less. In such cases, selective procedures must be used to identify cells derived from the rare events. The concepts and techniques of fungal asexual and parasexual genetics have been applied

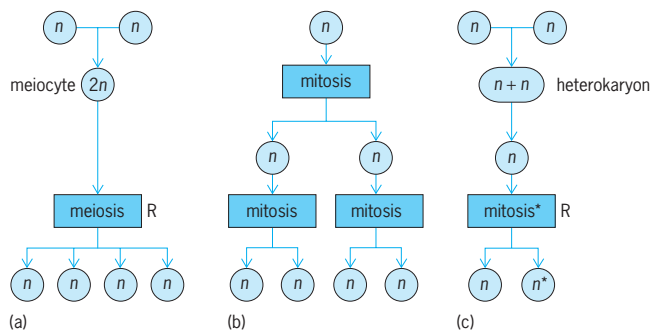

**Three different kinds of reproduction occurring in fungi, each of which provides opportunities for genetic analysis. (a) Sexual reproduction leads to recombination (R) of genes at meiosis. (b) Asexual reproduction (shown here in a typical haploid fungal cell) usually reproduces the gene set faithfully. (c) Parasexual reproduction derives from an atypical mitotic division of an unstable cell that produces haploid cells and other aneuploid (deviating from normal chromosome complement) unstable intermediates.**

to the genetic manipulation of cultured cells of higher eukaryotes such as humans and green plants. However, the techniques remain much easier to perform with fungi.

The fact that each enzyme is coded by its own specific gene was first recognized in fungi and was of paramount importance because it showed how the many chemical reactions that take place in a living cell could be controlled by the genetic apparatus. The discovery arose from a biochemical study of nutritional mutants in *Neurospora*. See ENZYME.

In genetically transformed organisms, the genome has been modified by the addition of DNA, a key technique in genetic engineering. The cell wall is temporarily removed; exogenous DNA is then taken up by cells and the cell wall is restored. The incorporation of DNA must be detected by a suitable novel genetic marker included on the assimilated molecule in order to distinguish transformed from nontransformed cells. The fate of the DNA inside the cell depends largely on the nature of the vector or carrier. Some vectors can insert randomly throughout the genome. Others can be directed to specific sites, either inactivating a gene for some purpose or replacing a resident gene with an engineered version present on the vector. A third kind of vector remains uninserted as an autonomously replicating plasmid. The ability to transform fungal cells has permitted the engineering of fungi with modified metabolic properties for making products of utility in industry. See GENETIC ENGINEERING.

A surprising development in the molecular biology of eukaryotes was the discovery of transposons, pieces of DNA that can move to new locations in the chromosomes. Although transposons were once known only in bacteria, they are now recognized in many eukaryotes. The transposons found in fungi mobilize by either of two processes: one type via a ribonucleic acid (RNA) intermediate that is subsequently reverse-transcribed to DNA, and the other type via DNA directly. In either case, a DNA copy of the transposed segment is inserted into the new site and may contain, in addition to the transposon itself, segments of contagious DNA mobilized from the original chromosomal site. Because of the rearrangements which transposons may produce, they have been important in the evolution of the eukaryotic genome. See FUNGI; GENETICS; TRANSPOSONS. [A.J.F.G.; R.U.]

**Fungal infections** Several thousand species of fungi have been described, but fewer than 100 are routinely associated with invasive diseases of humans. In general, healthy humans have a very high level of natural immunity to fungi, and most fungal infections are mild and self-limiting. Intact skin and mucosal surfaces and a functional immune system serve as the

primary barriers to colonization by these ubiquitous organisms, but these barriers are sometimes breached.

Unlike viruses, protozoan parasites, and some bacterial species, fungi do not require human or animal tissues to perpetuate or preserve the species. Virtually all fungi that have been implicated in human disease are free-living in nature. However, there are exceptions, including various *Candida* spp., which are frequently found on mucosal surfaces of the body such as the mouth and vagina, and *Malassezia furfur*, which is usually found on skin surfaces that are rich in sebaceous glands. These organisms are often cultured from healthy tissues, but under certain conditions they cause disease. Only a handful of fungi cause significant disease in healthy individuals. Once established, these diseases can be classified according to the tissues that are initially colonized.

**Superficial mycoses.** Four infections are classified in the superficial mycoses. Black piedra, caused by *Piedraia hortai*, and white piedra, caused by *Trichosporon beigelii*, are infections of the hair. The skin infections include tinea nigra, caused by *Exophiala werneckii*, and tinea versicolor, caused by *M. furfur*. Where the skin is involved, the infections are limited to the outermost layers of the stratum corneum; in the case of hairs, the infection is limited to the cuticle. In general, these infections cause no physical discomfort to the patient, and the disease is brought to the attention of the physician for cosmetic reasons.

**Cutaneous mycoses.** The cutaneous mycoses are caused by a homogeneous group of keratinophilic fungi termed the dermatophytes. Species within this group are capable of colonizing the integument and its appendages (the hair and the nails). In general, the infections are limited to the nonliving keratinized layers of skin, hair, and nails, but a variety of pathologic changes can occur depending on the etiologic agent, site of infection, and immune status of the host. The diseases are collectively called the dermatophytoses, ringworms, or tinea. They account for most of the fungal infections of humans.

**Subcutaneous mycoses.** The subcutaneous mycoses include a wide spectrum of infections caused by a heterogeneous group of fungi. The infections are characterized by the development of lesions at sites of inoculation, commonly as a result of traumatic implantation of the etiologic agent. The infections initially involve the deeper layers of the dermis and subcutaneous tissues, but they eventually extend into the epidermis. The lesions usually remain localized or spread slowly by direct extension via the lymphatics, for example, subcutaneous sporotrichosis.

**Systemic mycoses.** The initial focus of the systemic mycoses is the lung. The vast majority of cases in healthy, immunologically competent individuals are asymptomatic or of short duration and resolve rapidly, accompanied in the host by a high degree of specific resistance. However, in immunosuppressed patients the infection can lead to life-threatening disease. See FUNGI; MEDICAL MYCOLOGY. [G.S.K.]

**Fungal virus** Any of the viruses that infect fungi (mycoviruses). In general these viruses are spheres of 30–45-nanometer diameter composed of multiple units of a single protein arranged in an icosahedral structure enclosing a genome of segmented double-stranded ribonucleic acid (dsRNA). Viruses are found in most species of fungi, where they usually multiply without apparent harm to the host. Most fungal viruses are confined to closely related species in which they are transmitted only through sexual or asexual spores to progeny or by fusion of fungal hyphae (filamentous cells). Some fungal strains are infected with multiple virus species. Although hundreds of virus-containing fungi have been reported, very few have been studied in significant detail. Three families of mycoviruses are recognized by the International Committee on Taxonomy of Viruses. The most thoroughly studied mycoviruses are in the family Totiviridae. See FUNGI; MYCOLOGY; PLANT PATHOLOGY; VIRUS; VIRUS CLASSIFICATION. [R.FBo.]

**Fungi** Nucleated, usually filamentous, sporebearing organisms devoid of chlorophyll; typically reproducing both sexually and asexually; living as parasites in plants, animals, or other fungi, or as saprobes on plant or animal remains, in aquatic, marine, terrestrial, or subaerial habitats. Yeasts, mildews, rusts, mushrooms, and truffles are examples of fungi.

Some fungal classifications were constructed to facilitate identification, whereas others emphasize phylogeny. The more widely used classifications reflect a series of compromises between identification and phylogeny, and tend to conserve the vocabulary and nomenclature familiar to broad groups of users. The following is a conventional classification, in which all organisms are treated as members of the kingdom Fungi:

Division: Eumycota  
 Subdivision: Mastigomycotina  
 Class: Chytridiomycetes  
   Hyphochytriomycetes  
   Oomycetes  
 Subdivision: Zygomycotina  
 Class: Zygomycetes  
   Trichomycetes  
 Subdivision: Ascomycotina  
 Class: Hemiascomycetes  
   Plectomycetes  
   Pyrenomycetes  
   Discomycetes  
   Loculoascomycetes  
 Subdivision: Basidiomycotina  
 Class: Hymenomycetes  
   Gasteromycetes  
   Urediniomycetes  
   Ustilaginomycetes  
 Subdivision: Deuteromycotina  
 Class: Blastomycetes  
   Hyphomycetes  
   Coelomycetes  
   Agonomycetes  
 Division: Myxomycota [F.M.D.]

Organisms in the kingdom Fungi are mostly haploid, use chitin as a structural cell-wall polysaccharide, and synthesize lysine by the alpha amino adipic acid pathway; and their body is made of branching filaments (hyphae). The fungi arose about 1 billion years ago along with plants (including green algae), animals plus choanoflagellates, red algae, and stramenopiles. Ribosomal comparison indicates that the closest relatives to the fungi are the animals plus choanoflagellates. See CHOANOFAGELLIDA.

Ascomycetes are the most numerous fungi (75% of all described species), and include lichen-forming symbionts. The group has traditionally been divided into unicellular yeasts and allies with naked asci, and hyphal forms with protected asci. However, ribosomal gene sequences indicate that some traditional yeasts and allied forms diverged early (early ascomycetes), at about the time ascomycetes were diverging from basidiomycetes. Hyphal ascomycetes protect their asci with a variety of fruiting bodies; the earliest fruiting bodies may have been open cups (Discomycetes), while in more recent groups they are flask shaped (Pyrenomycetes and Loculoascomycetes) or are completely closed (Plectomycetes). Ascomycetes lacking sexual structures have been classified in the Fungi Imperfecti, but molecular comparisons now allow their integration with the ascomycetes. See ASCOMYCOTA; DEUTEROMYCOTINA; DISCOMYCETES; LOCULOASCOMYCETES; PLECTOMYCETES; PLECTOMYCETES. [J.W.T.]

The mycelium, generally the vegetative body of fungi, is extremely variable. Unicellular forms, thought to be primitive or derived, grade into restricted mycelial forms; in most species, however, the mycelium is extensive and capable of indefinite growth. Some are typically perennial though most are ephemeral. The

mycelium may be nonseptate, that is, coenocytic, with myriad scattered nuclei lying in a common cytoplasm, or septate, with each cell containing one to a very few nuclei or an indefinite number of nuclei. Septa may be either perforate or solid. Cell walls are composed largely of chitinlike materials except in one group of aquatic forms that have cellulose walls. Most mycelia are white, but a wide variety of pigments can be synthesized by specific forms and may be secreted into the medium or deposited in cell walls and protoplasm. Mycelial consistency varies from loose, soft wefts of hyphae to compact, hardened masses that resemble leather. Each cell is usually able to regenerate the entire mycelium, and vegetative propagation commonly results from mechanical fragmentation of the mycelium.

Asexual reproduction, propagation by specialized elements that originate without sexual fusion, occurs in most species and is extremely diverse. The most common and important means of asexual reproduction are unicellular or multicellular spores of various types that swim, fall, blow, or are forcibly discharged from the parent mycelium.

Sexual reproduction occurs in a majority of species of all classes. Juxtaposition and fusion of compatible sexual cells are achieved by four distinct sexual mechanisms, involving various combinations of differentiated sexual cells (gametes), undifferentiated sexual cells (gametangia), and undifferentiated vegetative cells. [J.R.Ra.]

Fungi obtain organic substances (food) from their environment which have been produced through the (photosynthetic) activities of green plants, since fungi do not contain chlorophyll and are unable to manufacture their own food. Fungi are able to digest food externally by releasing enzymes into their environment. These smaller molecules can be absorbed into the fungal body and transported to various locations where they can be used for energy or converted into different chemicals to make new cells or to serve other purposes. Some of the by-products of fungal metabolism may be useful to humans. Most fungi use nonliving plant material for food, but a few use nonliving animal material and therefore are called saprophytic organisms. In nature the decomposition of dead plant material is an important function of fungi, as the process releases nutrients back into the surrounding ecosystem where they can be reused by other organisms, including humans. See BIODEGRADATION; FUNGAL ECOLOGY.

A few fungi have the physiological capability to grow on living plants and may cause diseases such as wheat rust or corn smut on these economically important plants. Some fungi can grow on grains and may produce substances known as aflatoxins which can be detrimental to animals or humans. A few species of fungi have the ability to grow and acquire their food from skin or hair on living animals such as cats, horses, and humans. The disease known as ringworm may result. It is not caused by a worm but by an expanding circular growth of a fungus which has the physiological capability to use the components of skin or hair as the food source. The most frequently encountered fungal disease in humans is candidiasis, which is caused by one of the few fungi that is normally found associated with humans (*Candida albicans*). See AFLATOXIN; MEDICAL MYCOLOGY; PLANT PATHOLOGY; YEAST INFECTION.

A number of fungal species are able to enter plant roots and develop an association that may be beneficial to the plant under natural field conditions. This association of a higher plant root and a fungus that does not produce a disease is called a mycorrhiza. This fungal association with the plant root may permit the plant to live under soil conditions where it may not otherwise survive because of an excess of acid in the soil or a lack or excess of certain nutrients. See MYCORRHIZAE.

Certain species of fungi have been used by humans since early times in the preparation of foods such as leavened bread, cheeses, and beverages. Additional by-products of fungal physiology are used in industrial applications such as antibiotics, solvents, and pharmaceuticals. See FUNGAL BIOTECHNOLOGY; INDUSTRIAL MICROBIOLOGY; YEAST. [M.C.W.]

**Fungistat and fungicide** Synthetic or biosynthetic compounds used to control fungal diseases in animals and plants. A fungistat prevents the spread of a fungus, whereas a fungicide kills the fungus.

Seeds and seedlings are protected against fungi in the soil by treating the seeds and the soil with fungicides. Seed-treating materials must be safe for seeds and must resist degradation by soil and soil microorganisms. Some soil fungicides are safe to use on living plants. Others are injurious to seeds and living plants. These compounds are useful because they are volatile. Used before planting, they have a chance to kill soil fungi and then escape from the soil.

Formic acid, acetic acid, and propionic acid up through pelargonic acid and capric acid (the C<sub>1</sub>-C<sub>10</sub> volatile fatty acids) possess significant fungicidal activity. Many of them are present in natural foodstuffs that are resistant to fungal attack. Use of the volatile fatty acids and their salts in bread to prevent rye mold is widespread. A. I. Virtanen was awarded the Nobel prize in 1945 for his discovery and development of these lower volatile fatty acids to prevent fungal growth and so preserve the nutritious quality of cattle fodders. Since these volatile fatty acids stop fungal growth, they prevent mycotoxin generation and lessen the risk of cancer from exposure to mycotoxins. See ANIMAL FEEDS.

[J.G.H.; S.Ri.]

Two types of fungicides are used to control plant diseases: (1) Surface protectants remain on the plant surface and exert their toxic action on fungi before they have penetrated into plant tissue. (2) Systemic fungicides move into plant tissue and exert their toxic action on fungi which have already penetrated internally. These fungicides can also provide surface protection by acting on fungi before they have penetrated the plant.

Most agricultural fungicides are systemic compounds that act at a single target site in fungal cells, such as cell membranes, microtubules, or ribosomes.

There have been very few instances of fungal resistance to surface protectant fungicides which is attributed to their action at multiple sites within fungal cells. However, most systemic fungicides that act at a single site have generated serious problems with fungal resistance. A single gene mutation in a fungus can lead to loss of effectiveness of all fungicides in a particular mode-of-action group. Experience has shown that frequent, uninterrupted use of a fungicide increases the risk for development of a resistant strain of the target organism. That risk can be reduced by alternating use of fungicides with different modes of action or by using them in mixtures. See FUNGI. [H.D.S.]

**Furan** One of a group of organic heterocyclic compounds containing a diunsaturated ring of four carbon atoms and one oxygen atom. Furan (I) is a typical member of the group. Furfural (II) and some of its close relatives, such as furfuryl alcohol, tetrahydrofurfuryl alcohol, and tetrahydrofuran, are important chemicals of commerce. See HETEROCYCLIC COMPOUNDS.

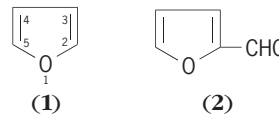

Furan (I) is a colorless, volatile liquid, bp 31.4°C (88.5°F), which is stable to alkali but not to mineral acid. Its water solubility is approximately 1% at room temperature. On exposure to air, furan decomposes very slowly by autoxidation. Substituted furans, particularly negatively substituted furans, are much less sensitive. The furan system is aromatic. Nitration, halogenation, acylation, mercuration, and sulfonation reactions occur with relative ease. [W.J.Ge.]

**Fuse (electricity)** An expendable protective device that eliminates overload on an electric circuit. The fuse is connected



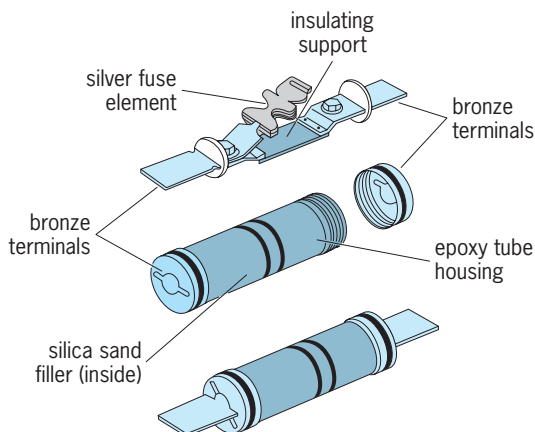

Power fuse assembly. (After A. J. Pansini, *Electric Power Equipment*, Prentice-Hall, 1988)

in series with the circuit being protected. The components of a typical low-voltage high-power fuse are a fuse element or wire, an insulating material support and housing, two metal end fittings, and a filler (see illustration).

The fuse element is a silver strip or wire that melts when the current is higher than the rated value. The melting of the wire generates an electric arc. The extinction of this arc interrupts the current and protects the circuit. The fuse element is connected to the metal end fittings which serve as terminals. See ARC DISCHARGE.

The filler facilitates the arc extinction. The most commonly used filler is sand, which surrounds the fuse element. When the fuse element melts, the heat of the arc melts the sand near the element. This removes energy from the arc, creating a channel filled with the mixture of melted sand and metal. The metal particles from the melting fuse wire are absorbed by the melted sand. This increases the channel resistance, which leads to the gradual reduction of the current and the extinction of the arc. The insulating support and the tubular housing holds the fuse elements and the filler, which also serves as insulator after the fuse has interrupted the current.

The interruption time is the sum of the melting and the arcing time. It is inversely proportional to the current, that is, a higher current melts the wire faster. The fuse operates in a time-current band between maximum interruption time and minimum meeting time. It protects the electric circuit if the fault current is interrupted before the circuit elements are overheated. The arc extinction often generates overvoltages, which produce flashovers and damage. A properly designed fuse operates without overvoltage, which is controlled by the shape of the fuse element and by the filler. [G.G.K.]

**Fused-salt phase equilibria** Conditions in which two or more phases of fused-salt mixtures can coexist in thermodynamic equilibrium. Phase diagrams of these equilibrium conditions summarize basic knowledge about fused salts. Numerous advances in the technologies which are based on high-temperature chemistry have become possible through the increase in knowledge about fused salts. The increasingly significant role of fused salts in industrial processes is evident in the widening application of these materials as heat-transfer media, in extractive metallurgy, in nonaqueous reprocessing of nuclear reactor fuels, and in the development of nuclear reactors which create more fuel than they consume (breeder reactors). See NUCLEAR REACTOR; PHASE EQUILIBRIUM.

Fused-salt mixtures find application in technology when the need arises for liquids which are stable at high temperatures. For most applications, suitably low melting temperatures and low vapor pressures are primary considerations. To some extent these

requirements are conflicting, because salts which are useful in obtaining low freezing temperatures often tend to have appreciable covalent character and therefore to exhibit unfavorably high vapor pressures.

As a special class of liquids, one which is composed entirely of positively and negatively charged ions undiluted by weak-electrolyte supporting media, fused salts are used in many different types of research. For example, advances in solution theory, thermodynamics, and crystal chemistry have come about through studies of fused-salt systems. See FUSED-SALT SOLUTION.

A close connection between fused-salt phase diagrams and geochemistry stems from the model principle developed by V. M. Goldschmidt, who noted that isomorphous structures are assumed by ions of the same proportionate size and stoichiometric relations but of different charge. Thus the fluorides of beryllium, calcium, and magnesium, for example, are structural models for silicon dioxide ( $\text{SiO}_2$ ), titanium dioxide ( $\text{TiO}_2$ ), and zirconium dioxide ( $\text{ZrO}_2$ ). The fluoride structures are referred to as weakened models because of the smaller electrostatic forces resulting from smaller ionic charges; they have been useful for comparisons with oxide and silicate systems. According to Goldschmidt's interpretation, saltlike materials were derived from components such as water ( $\text{H}_2\text{O}$ ), carbon dioxide ( $\text{CO}_2$ ), sulfur trioxide ( $\text{SO}_3$ ), chlorine ( $\text{Cl}_2$ ), and fluorine ( $\text{F}_2$ ), which were volatilized from molten magmas as they crystallized. Crystallization equilibria in fused-salt systems therefore provide a convenient way to study the mechanisms occurring in the formation of igneous rocks. See IGNEOUS ROCKS. [R.E.Th.]

**Fused-salt solution** A nonaqueous solvent system particularly useful in coordination chemistry. Fused salts are a large class of liquids which are composed largely of ions. Many simple inorganic salts melt at rather high temperatures (greater than  $600^\circ\text{C}$  or  $1000^\circ\text{F}$ ), forming liquids which have high specific conductivities,  $1\text{--}6\text{ ohm}^{-1}\cdot\text{cm}^{-1}$ . There are, however, a number of exceptions to this generalization; for example, the electrical conductivity of  $\text{AlCl}_3$  decreases sharply upon melting due to the formation of molecular liquid ( $\text{Al}_2\text{Cl}_6$ ). See HIGH-TEMPERATURE CHEMISTRY; SOLVENT.

The use of binary or ternary melt compositions results in liquids which typically have much lower melting temperatures and somewhat lower specific conductivities than do pure salts. The choice of melts for use as solvents is frequently based on such considerations as the availability and cost, the lowest melting temperature attainable, and the ease of purification of the solvent, as well as the width of the electrochemical span and the spectroscopic transparency of the melt. Several molten-salt solvents, such as the  $\text{LiCl-KCl}$  eutectic and the equimolar  $\text{NaNO}_3\text{--KNO}_3$  melt, have been extensively studied, and many of their physical and chemical properties are well known. Many melt systems, particularly ternary and more complex compositions, have been only partially characterized; their physical properties are estimated by using the data available for less complex systems, such as the binary component melts.

One use of fused salts is as media for organic reactions. Not only does the fused-salt environment provide for a better thermal control of the reaction (heat dissipation is readily possible), but the fused salt may serve as a catalyst. For example, molten  $\text{SbCl}_3$  and  $\text{ZnCl}_2$  have been found to be effective hydrocracking catalysts for coal. It has been found that polycyclic hydrocarbons, such as anthracene, undergo several types of reactions in  $\text{SbCl}_3$  melts, including formation of radical cations and protonated species which react further to form condensed systems, such as anthra[2.1-a]aceanthrylene. See CATALYSIS.

Another technological area of great interest in which molten salts play a key role is that of advanced batteries and fuel cells. Thus,  $\text{LiCl-KCl}$  eutectic is the solvent in the rechargeable  $\text{Li(Al)-FeS}$  (or  $\text{FeS}_2$ ) battery, and sodium polysulfide melts are employed in the sodium/sulfur battery which operates at about  $350^\circ\text{C}$  ( $660^\circ\text{F}$ ). The rechargeable cell  $\text{Na/Na}^+$  conductor/ $\text{S(IV)}$

in  $\text{AlCl}_3\text{-NaCl}$  has an open circuit voltage of 4.2 V at 200–250°C (390–480°F) as well as high energy densities.

Molten carbonates, such as the ternary  $\text{Li}_2\text{CO}_3\text{-Na}_2\text{CO}_3\text{-K}_2\text{CO}_3$  melt, are used in fuel cells which employ  $\text{H}_2/\text{CO}$  mixtures and oxygen as electrochemical fuels. See BATTERY; FUEL CELL. [G.Ma.]

**Fuselage** The component of an aircraft that provides the payload containment and the structural connection for the wing and the empennage (tail assembly). The fuselage and the wing are major structural components of an aircraft. The fuselage is the mounting structure for the horizontal and tail surfaces that provides stability as well as the means of introducing pitch and yaw control to the aircraft. For some aircraft like fighter and private aircraft, the fuselage houses the engine or engines. The nose or tail gear and the main landing gear are often attached to the fuselage structure.

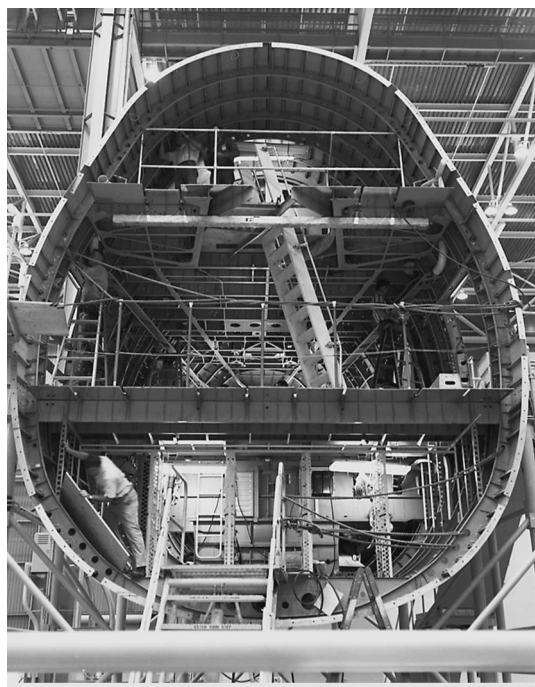

Boeing 747 fuselage with stringer-stiffened skin supported by frames. (Boeing Co.)

The history of the construction of aircraft fuselages has evolved through the early wood truss structural arrangements to the current metal semi-monocoque shell structures. A majority of aircraft fuselages are fabricated from aluminum alloys and are produced by a process of automatic machining of the skins and stringers (see illustration), with much of the assembly being done by automatic drilling, countersinking, and fastener installation. In some areas, adhesive bonding is used as a means of attaching doublers to reinforce skin panels. In many of the high-performance aircraft, such as fighters and bombers, extensive use is made of titanium and high-strength steel. See AIRFRAME. [J.E.Mc.]

**Fusulinacea** An extinct superfamily of marine organisms in the phylum Protozoa, order Foraminiferida. Fusulinaceans first appeared late in the Mississippian Period, and in the succeeding 100,000,000 years evolved into more than 125 genera and 6000 species before becoming extinct near the close of the Permian Period. Among protozoans fusulinaceans became giants, many reaching 0.4 in. (1 cm) in length and some even attaining 4 in. (10 cm) in length. The group is characterized by rapid evolution of distinctive morphological features, which have enabled pale-

ontologists to establish a detailed fusulinacean phylogeny and biostratigraphic zonation.

In general, the calcareous shell of fusulinaceans is constructed on a simple plan. The initial chamber, the proloculus, is a small calcareous sphere with an opening on one side. As the individual grew and the volume of protoplasm increased, chambers were added successively in a planispiral coil around the proloculus. In most genera these chambers overlap the ends of the previous chambers and become elongate, parallel to the axis of coiling. The spiral wall (spirotheca) is composed of several layers. The initial wall is formed of a thin, dark organic-rich layer (tectum), beneath which is a thicker translucent layer (diaphanotheca) formed of calcium carbonate. See FORAMINIFERIDA. [C.A.R.]

**Fuzzy sets and systems** A fuzzy set is a generalized set to which objects can belong with various degrees (grades) of memberships over the interval [0,1]. Fuzzy systems are processes that are too complex to be modeled by using conventional mathematical methods. In general, fuzziness describes objects or processes that are not amenable to precise definition or precise measurement. Thus, fuzzy processes can be defined as processes that are vaguely defined and have some uncertainty in their description. The data arising from fuzzy systems are, in general, soft, with no precise boundaries. Examples of such systems are large-scale engineering complex systems, social systems, economic systems, management systems, medical diagnostic processes, and human perception. See SET THEORY.

The mathematics of fuzzy set theory was originated by L. A. Zadeh in 1965. It deals with the uncertainty and fuzziness arising from interrelated humanistic types of phenomena such as subjectivity, thinking, reasoning, cognition, and perception. This type of uncertainty is characterized by structures that lack sharp (well-defined) boundaries. This approach provides a way to translate a linguistic model of the human thinking process into a mathematical framework for developing the computer algorithms for computerized decision-making processes. The theory has grown very rapidly. Many fuzzy algorithms have been developed for application to process control, medical diagnosis, management sciences, engineering design, and many other decision-making processes where soft data are generated. Thus, fuzzy mathematics provides a modeling link between the human reasoning process, which is vague, and computers, which accept only precise data.

For example, in the design of many engineering systems, process information is not available both because it is difficult to understand precisely the complexity of the phenomena and because human reasoning is inexact and is based upon subjective perception. However, by virtue of knowledge and experience, which is inexact, it is possible to build increasingly good systems. In fact, fuzziness in thinking and reasoning processes is an asset since it makes it possible to convey a large amount of information with a very few words. However, in order to emulate this experience and these reasoning processes on a computer, for example, for intelligent robotics applications and medical diagnosis, a mathematical precision must be given to the vagueness of the information so that a computer can accept it. This is done by using the theory of fuzzy sets. Probability theory deals with the uncertainty or randomness that arises in mechanistic systems, whereas fuzzy set theory has been created to deal with the uncertainty that arises in human cognitive processes. See PROBABILITY.

The premise of fuzzy set theory is that the key elements in human reasoning processes are not numbers but labels of fuzzy sets. The degree of membership is specified by a number between 1 (full membership) and 0 (full nonmembership). An ordinary set is a special case of a fuzzy set, where the degree of membership is either 0 or 1. By virtue of fuzzy sets, human concepts like small, big, rich, old, very old, and beautiful can be translated into a form usable by computers. [M.M.G.]

**Fuzzy-structure acoustics** Large structures such as ships and airplanes can undergo a variety of complicated vibrations. Such structures typically consist of an outer body made of metal plating (for example, the hull of a ship) or perhaps a massive metallic frame (for example, the chassis of a truck), and a large variety of internal objects that are connected to either the plating or the frame. In designing such structures, it is highly desirable to have some method for predicting how they will vibrate under various conditions. The radiation of sound caused by these vibrations, either into the environment or into the empty portions of the structure, is also of interest because this sound is often either unwanted noise or a means of inferring information about the details of the structure or the excitation. Fuzzy-structure acoustics refers to a class of conceptual viewpoints in which precise, computationally intensive models of the overall structure are replaced by nonprecise analytical models, for which the initial information is said to be fuzzy. *See* FUZZY SETS AND SYSTEMS.

Fuzzy-structure theories divide the overall structure into a master structure and one or more attached structures, the latter being referred to as the fuzzy substructures, the internal structures, or the internals. (An example of a master structure is the hull and major framework of a ship.) The master structure is presumed to be sufficiently well known at the outset that its vibrations or dynamical response could be predicted if the forces that were exerted on it were known. Some of the forces are exerted on it by the substructures at the points at which they are attached. Such forces can be very complicated; nevertheless, there is some hope

that a satisfactory approximate prediction of the vibrations of the master structure itself can be achieved with a highly simplified model.

The fuzzy substructures can be regarded as structures that are not known precisely. Recently developed theories of fuzzy structures lead, after various plausible idealizations, to a formulation that requires only a single function, this being the modal mass per unit frequency bandwidth. The influence of fuzzy substructures attached to the master structure tends to resemble that of an added frequency-dependent mass attached to the master structure in parallel with a frequency-dependent dashpot connecting the master structure to a hypothetical rigid wall. The added mass is a frequency-weighted integral over the modal mass per unit natural frequency, the weighting being such that the natural modes whose natural frequencies are less than the driving frequency have a positive contribution, while those for which the natural frequencies are greater than the driving frequency have a negative contribution. The master structure can seem to be less massive than it actually is when the bulk of the substructure mass is associated with resonant frequencies less than the excitation frequency.

One implication of the newly emerging fuzzy-structure theories is that, insofar as there is concern with the vibrations of only the master structure, it is possible to drastically curtail the estimation or measurement of any parameters within the substructures that are associated with internal damping. *See* MECHANICAL VIBRATION; VIBRATION. [A.D.P.]



# G

**Gabbro** The plutonic equivalent of its more abundant extrusive equivalent, basalt. Because it crystallized from a magma intruded deep within the crust, gabbro has a grain size visible to the naked eye with approximately equal amounts of calcic plagioclase (with 50% or more anorthite, the calcium aluminium feldspar) and pyroxene. Olivine is common as an early crystallized mineral, but either nepheline or quartz could be a late-stage crystallization product found in the matrix. Hornblende or biotite is commonly formed as an alteration product of pyroxene during the late stages of the magmatic crystallization, when water becomes enriched in the residual magma. See BIOTITE; HORN-  
BLLENDE.

Gabbro is found in diverse tectonic environments, ranging through oceanic ridges, convergent plate boundaries, stable continents, and rifts. The forms of the intrusive gabbro bodies include dikes, sills, pipes, laccoliths, stocks, batholiths, and large layered intrusive complexes.

The grain size of gabbroic rocks ranges from a millimeter to centimeters. The finer-grained gabbro is commonly referred to as a diabase (or dolerite in the United Kingdom) that usually has small granular pyroxene interstitially enclosed by randomly oriented laths of calcic plagioclase. This diabasic texture results from the faster cooling of the magma due to its injection as small dikes and sills in shallow crust. In coarser-grained gabbro found in large plutons injected in deeper crust, the pyroxenes are larger and enclose partially (a texture called subophitic) or fully (a texture called ophitic) randomly oriented labradorite. Gabbros with mineral grains larger than 2 cm (0.8 in.) are rare, but such rocks are referred to as gabbro pegmatites. At contacts with country rock, the gabbro is commonly very fine grained or glassy because of the fast chilling of the magma. In some plutons, especially near their margins, gabbroic minerals are aligned perpendicular to the walls, yielding comb layering. See DOLERITE; MAGMA; PLUTON.

Unlike basalts, which are found in surface or near-surface environments, gabbros are found as shallow-to-deep intrusive bodies. Large blocks measuring more than 10 km (6 mi) thick, with a suite of rocks including serpentinite, pillow lavas, and chert, contain gabbro. This suite, called ophiolites, is commonly found on continents along convergent plate boundaries; it is thought to have been tectonically emplaced by thrusting onto the continental margins. It consists of a suite of rocks that are believed to represent the oceanic crust and upper mantle. See CHERT; OPHIOLITE; SERPENTINITE; STRATIGRAPHY. [A.M.K.]

**Gadiformes** A well-defined order of actinopterygian fishes, also known as the Anacanthini, which includes the codfishes and grenadiers, or rattails. Structurally the group is more or less intermediate between typical soft-rayed and spiny-rayed fishes. As in the former, there are no fin spines, the scales are cycloid, and the pelvic fin often has many rays. As in typical perciforms, however, the swim bladder has no duct, the orbitosphenoid and mesocoracoid are absent, and the upper jaw is bordered only by the protractile premaxillae. The pelvic fins, if present, are jugular in position but are attached to the cleithra only by ligaments. See CODFISH; PERCIFORMES.

Gadiform fishes are known from the Paleocene. Recent forms are classified into 8 families, about 185 genera, and nearly 730 species. The best-known family, the Gadidae, comprises

60 species that live in northern seas, where cod, haddock, pollock, and hake form the basis for extensive commercial fisheries. See ACTINOPTERYGII. [R.M.B.]

**Gadolinium** A metallic chemical element, Gd, atomic number 64 and atomic weight 157.25, belonging to the rare-earth group. The naturally occurring element is composed of eight isotopes. It is named in honor of the Swedish scientist J. Gadolin. The oxide, Gd<sub>2</sub>O<sub>3</sub>, in powdered form is white, and solutions of the salt are colorless. Gadolinium metal is paramagnetic and becomes strongly ferromagnetic below room temperatures. The Curie point, where this transition occurs, is about 16 K. See PERIODIC TABLE; RARE-EARTH ELEMENTS. [F.H.S.]

**Gages** Devices for determining the relative size or shape of objects. The function of gages is to determine whether parts are within or outside of the specified tolerances, which are expressed in a linear unit of measurement. Gages are the most widely used production tools for controlling linear dimensions during manufacture and for assuring interchangeability of finished parts. A gage may be an indicating type that measures the amount of deviation from a mean or basic dimension, or it may be a fixed type that simply accepts parts within tolerance and rejects parts outside tolerance. See TOLERANCE. [R.A.Bo.]

**Gain** An increase in signal power or voltage produced by an amplifier in transmitting a signal from one point to another. The amount of gain is usually expressed in decibels above a reference level. See AMPLIFIER.

Antenna gain is a measure of the effectiveness of a directional antenna as compared to a nondirectional antenna. See ANTENNA (ELECTROMAGNETISM). [J.Mar.]

**Galactose** A monosaccharide and a constituent of oligosaccharides, notably lactose, melibiose, raffinose, and stachyose. It is also known as D-galactose and cerebrose (see illustration). Agar, gum arabic, mesquite gum, larch arabo galactan, and a variety of other gums and mucilages contain D-galactose. See AGAR; GUM; MONOSACCHARIDE.

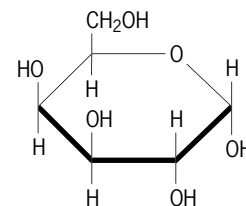

Structural formula for  $\alpha$ -D-galactose.

L-Galactose (enantiomorph of D-galactose) occurs in several polysaccharides, including agar, flaxseed mucilage, snail galactogen, and chagal gum. Since D-galactose is usually also present, hydrolysis of these polysaccharides produces DL-galactose. See CARBOHYDRATE; POLYSACCHARIDE. [W.Z.H.]

**Galaxy, external** One of the large self-gravitating aggregates of stars, gas, and dust that contain nearly all of the observed matter in the universe. Typical large galaxies have symmetric and regular forms, are about 50,000 light-years ( $3 \times 10^{17}$  mi or  $5 \times 10^{17}$  km) in diameter, and are roughly  $3 \times 10^{10}$  times more luminous than the Sun. The stars and other material within a galaxy move through it, often in regular rotation, with periods of a few hundred million years. The nearest galaxies to the Milky Way Galaxy, the Magellanic Clouds, are about 150,000 light-years ( $9 \times 10^{17}$  mi or  $1.5 \times 10^{18}$  km) away; the farthest, almost  $1 \times 10^{10}$  light-years ( $6 \times 10^{22}$  mi or  $1 \times 10^{23}$  km). See MAGELLANIC CLOUDS.

The hundreds of billions of stars making up a galaxy are not generally individually observable with current telescope technology because they are too faint and distant. Only the brightest stars in the nearest galaxies can be observed directly with large telescopes. Two general types of stellar populations are distinguished: One type (population I) is characterized by the presence of young stars and by ongoing star formation. It is usually associated with the presence of gas. The second type (population II) shows an absence of gas and young stars as well as other indications that star formation ceased long ago. The Sun is a population I star. See STAR; STELLAR POPULATION.

Galaxies contain gas (mostly un-ionized hydrogen) in amounts varying from essentially zero up to a considerable fraction of their total mass. Dust in galaxies, although small in mass (typically 1% of the gas mass), is often dramatic in appearance because it obscures the starlight. See INTERSTELLAR MATTER.

Galaxies generally display strikingly regular forms. The most common form is a disk with a central bulge. The disk is typically 100,000 light-years ( $6 \times 10^{17}$  mi or  $1 \times 10^{18}$  km) in diameter and only about 1000 light-years ( $6 \times 10^{15}$  mi or  $1 \times 10^{16}$  km) thick. Its appearance is characterized by radially decreasing brightness with a superposed spiral or bar pattern, or both (see illustration). The central bulge may vary in size from hundreds to many thousands of light-years. Such galaxies are classified as spirals (S) and subclassified a, b, or c (for example, Sa) to distinguish increasingly open spiral structure and small bulge size. The letter



"Whirlpool" galaxy (NGC 5194), type Sc, and a companion irregular satellite (NGC 5195)

B is added after the S in the classification of spiral galaxies that contain conspicuous barlike features. The Milky Way Galaxy is an Sb type. See MILKY WAY GALAXY.

Another common type of galaxy is a featureless ellipsoid with radially decreasing brightness. These galaxies are classified as ellipticals (E) and subclassified according to their axial ratios by a number from 0 (E0 = round) to 7 (E7 = 3-to-1 axial ratio). They may vary in size from thousands to several hundred thousand light-years. They are most commonly found in clusters of galaxies and rarely contain much gas or dust. The brightest galaxies are usually ellipticals. [E.L.T.; J.B.T.]

Some galaxies lie outside the normal range of morphologies. One of the more spectacular examples of such exotic galaxies is the starbursters, galaxies that are presently manufacturing stars at an unusually vigorous rate. It is now known that some gravitational impulse has triggered the unusual star formation activity in at least most cases. Another type of exotic galaxy is the low-surface-brightness galaxies, star systems that have such a low spatial density of stars that they are almost invisible. A significant fraction of the mass of the universe may be in the form of these nearly invisible galaxies. [PHod.]

Although galaxies are scattered through space in all directions for as far as they can be observed, their distribution is not uniform or random. Most galaxies are found in associations containing from two to hundreds of individual bright galaxies and at least 10 times as many fainter dwarf galaxies. The Milky Way Galaxy and the Andromeda Nebula are members of a cluster called the Local Group. See ANDROMEDA GALAXY; LOCAL GROUP.

On scales larger than individual small groups and rich clusters, the distribution of galaxies through space is still not random. This very large scale structure in the galaxy distribution is usually referred to as superclustering to indicate that it involves the higher-order clustering of the individual first-order associations of galaxies. Neither empirical nor theoretical understanding of this very large scale structure is well established or generally agreed upon. See UNIVERSE.

In the very central regions (sizes at least as small as a light-year,  $6 \times 10^{12}$  mi or  $1 \times 10^{13}$  km) of galaxies, violent and apparently explosive behavior is often observed. This activity is manifested in many ways, including the high-velocity outflow of gas, strong nonthermal radio emission (implying relativistic particles and magnetic fields), intense and often polarized and highly variable radiation at infrared, optical, ultraviolet, and x-ray wavelengths, and ejection of jets of relativistic material. In the most extreme cases the energy in the nuclear activity surpasses that in the rest of the galaxy combined. These phenomena are generically referred to as nuclear activity, and the objects that exhibit them are called active galactic nuclei.

There are a variety of classes of active galactic nuclei. The Seyfert galaxies display the broad emission lines produced by the rapid outflow of hot gas but frequently do not exhibit much radio-wavelength emission. Another complementary class shows strong radio emission but weak or absent emission lines. Yet another class (BL Lac objects, often referred to as blazars) also shows only weak emission lines but is often extremely variable. When active galactic nuclei achieve such great luminosities that they dominate that of the rest of the galaxy, they are sometimes referred to as AGNs. Quasars are widely believed to be the most extreme sort of active galactic nuclei, having emission so intense that the ordinary galaxy in which they exist is entirely lost in the glare of the nuclear emission. See QUASAR.

Perhaps the most intriguing question concerning active galactic nuclei is that of the nature of the energy source that drives all of their diverse phenomena. According to a widely accepted best guess or consensus model, active galactic nuclei are powered by the energy released when matter falls into a massive black hole occupying the center of a galaxy. These black holes are imagined to have masses in the rough range of  $10^6$ – $10^9$  solar masses and to have formed because of the high density of material expected to accumulate at the center of a galaxy due to

its gravitational field. Such a black hole will continue to accrete any gas that finds its way into the vicinity. As such gas falls toward the black hole, its angular momentum will cause it to take up a nearly circular orbit in a disk of material surrounding the black hole. This disk (called an accretion disk) will slowly inject gas into the black hole. As the gas approaches the black hole, the latter's enormous gravitational field will compress and heat the gas to very high temperatures, causing it to radiate. A given mass of gas can release 10 or more times as much energy in this way as it could if it were used as nuclear fuel in a star or a reactor. See ASTROPHYSICS, HIGH-ENERGY; BLACK HOLE. [E.L.T.; J.B.T.]

**Galena** A mineral with composition PbS (lead sulfide) and belonging to the rock salt (NaCl) structure type. Galena usually occurs as cubes, sometimes modified by the octahedral form, with perfect cubic cleavage, brilliant metallic luster, color lead gray, specific gravity 7.5, and hardness  $2\frac{1}{2}$  on Mohs scale.

Galena is widely distributed and constitutes by far the most important ore for lead. Silver, antimony, arsenic, copper, and zinc minerals often occur in intimate association with galena; consequently, galena ores mined for lead also include many valuable by-products. Important localities include Broken Hill, Australia; the tristate district of Missouri, Kansas, and Oklahoma; and numerous occurrences in Colorado, Montana, and Idaho. [P.B.M.]

**Galilean transformations** The family of mathematical transformations used in newtonian mechanics to relate the space and time variables of uniformly moving (inertial) reference systems. In the simple case of two similarly oriented cartesian reference frames, moving along their common ( $x, x'$ ) axis, the transformation equations can be put in the form

$$x' = x - vt \quad y' = y \quad z' = z \quad t' = t$$

where  $x, y, z$  and  $x', y', z'$  are the space coordinates of a given particle, and  $v$  is the speed of one system relative to the other. See FRAME OF REFERENCE. [E.L.Hi.]

**Gallbladder** A hollow muscular organ, present in humans and most vertebrates, which receives dilute bile from the liver, concentrates it, and discharges it into the duodenum. It also participates in the entero-hepatic (re)circulation of bile, and in secretion and removal of conjugated xenobiotics, including radiopaque substances taken orally or intravenously for diagnostic purposes. Although not a vital organ, it stores bile, regulates biliary tract pressures, and, when diseased, enhances precipitation of various constituents of the bile as gallstones.

The system of bile ducts lying outside the liver is known as the extrahepatic biliary tract. In humans (Illus.) right and left hepatic ducts empty into the common hepatic duct, which continues to the duodenum as the common bile duct, or ductus choledochus. The gallbladder and cystic duct thus appear to be accessory organs and therefore are removable. However, they are converted into main-line structures by the presence of a sphincter (sphincter of Oddi) at the choledochoduodenal junction. Tonic contraction of this sphincter between meals forces the bile to back up into the gallbladder.

In most other vertebrates essentially similar relations exist except when the gallbladder is absent, but there is considerable variation in proportion and arrangement of ducts, including the pancreatic ducts. See LIVER; PANCREAS.

In humans, evacuation of the gallbladder is accomplished by a trigger mechanism which is set off by the presence of fatty foods, meat, and hydragogue cathartics in the duodenum and upper jejunum. Absorption of these substances by the mucous membrane results in the release of cholecystokinin (CCK), a hormone which rapidly circulates in the bloodstream and simultaneously produces contraction of the gallbladder and relaxation of the sphincter of Oddi. The most effective food is egg yolk, which

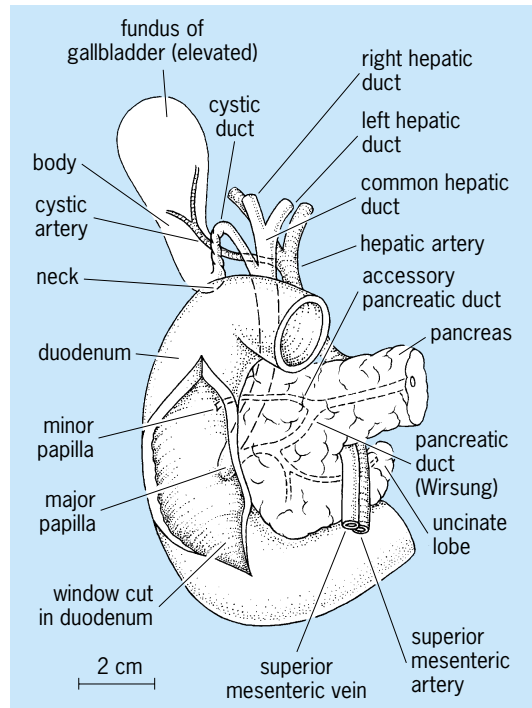

Extrahepatic biliary tract in humans.

contains certain *l*-amino acids. Resorption of bile salts by the intestine stimulates secretion of bile for hours after a meal. See DIGESTIVE SYSTEM. [E.A.B.; J.Gi.]

**Gallbladder disorders** Although not essential to life or health, the gallbladder is the site and source of appreciable suffering and disease in humans. With its cystic duct, the gallbladder constitutes a blind-ended, lateral extension of the common bile duct. Besides acting as a reservoir for bile, the gallbladder concentrates and otherwise alters the composition of bile. See GALLBLADDER.

Gallstones are round, oval, or faceted concretions formed within the gallbladder from the salts and pigment of bile. Although the mechanism and reason for their formation are not clearly understood, the major predisposing factors are stasis (prolonged retention of bile in the gallbladder), abnormal composition of the bile (excessive amounts of cholesterol, bilirubin, or calcium), and infection. Passage of a gallstone through the ducts into the duodenum usually produces severe pain, called biliary colic. If a stone causes obstruction of the ducts, the result may be damage to the liver, pancreas, biliary system, and related structures either directly or through concomitant inflammation. Gallstones are rare in animals, although they have been found in nearly all species, especially in cattle. See BILIRUBIN; CHOLESTEROL; CIRRHOSIS.

Cholecystitis, or inflammation of the gallbladder, is a common disease in humans. It is nearly always associated with gallstones and is particularly common in obese middle-aged women. It is rare in animals. Most cases are thought to be the result of chemical irritation caused by excessively concentrated bile, which is in turn the result of partial or complete obstruction to the outflow of bile. Prolonged or recurrent episodes of inflammation result in chronic cholecystitis, characterized by thickening and scarring of the wall, contraction, and impairment of normal function.

Malignant tumors in the gallbladder are almost invariably associated with the presence of gallstones. Because they produce little in the way of symptoms, and because they very soon invade the liver, these tumors are rarely curable by surgical therapy at the time they are discovered. Benign tumors of the gallbladder and ducts are rare in humans, and in animals both benign and

malignant tumors of these sites are extremely uncommon. See LIVER DISORDERS. [M.R.H.]

**Galliformes** A large order of birds containing the gallinaeous or chickenlike birds. They are found worldwide, although the several subgroups have a more limited distribution. Part of the superorder Neognathae, the galliforms are closely related to the anseriforms and include the most important domesticated birds, the chicken (*Gallus gallus*) and the turkey (*Meleagris gallopavo*). See ANSERIFORMES.

The order Galliformes is divided into two suborders with two families, as follows.

#### Order Galliformes

##### Suborder Cracoidea

Family: Megapodiidae (megapodes or brush turkeys; 7 species)

Cracidae (curassows, guans, chachalacas; 49 species)

##### Suborder Phasianoidea

Family: Phasianidae (grouse, pheasant, quail, guinea fowl, turkey; 212 species)

Subfamily: Tetraonidae (grouse)

Phasianinae (pheasant, peafowl, chicken)

Odontophorinae (New World quail)

Numidinae (guinea fowl)

Meleagrinae (turkey)

The galliforms have been one of the most economically important group of birds to humans. Almost all species have been or are still being hunted for food. Many species of galliforms have become reduced in numbers because of overhunting and habitat destruction. Some species, especially the forest pheasants of Asia, are seriously endangered. See AVES. [W.J.B.]

**Gallium** A chemical element, Ga, atomic number 31, atomic weight 69.72. Gallium is a member of group 13 and the fourth period of the periodic table (IUPAC). See PERIODIC TABLE.

The major commercial sources of gallium are bauxite, containing gallite ( $\text{CuGaS}_2$ ), and zinc and germanium sulfides. Normal ore-grade deposits usually contain substantially less than 0.1% gallium. In the United States the bauxite deposits in Arkansas and the zinc deposits in Oklahoma are the main sources of domestic production. Much of the gallium used in the United States is imported from Switzerland and Germany, with lesser amounts from Canada and France. See BAUXITE.

Gallium is a unique element in that it possesses the largest liquid range of any element. Its normal freezing point of  $29.78^\circ\text{C}$  ( $85.60^\circ\text{F}$ ) is lower than any metal except mercury and cesium. Its boiling point is in the vicinity of  $2420^\circ\text{C}$  ( $4388^\circ\text{F}$ ), although there is some uncertainty owing to the reactivity of gallium with the container material at this temperature.

The valence-electron notation of gallium corresponding to its ground-state term is  $[\text{Ar}, 3d^{10}4s^24p^1]$ , which accounts for the maximum oxidation state of III in its chemistry. Compounds of formal oxidation state II and I are also known.

Approximately 95% of the gallium consumed in the United States and presumably in the world is used in the electronics industry. Minor quantities have been used or studied for use in thermometers, low-melting solders, as a heat-transfer fluid, in arc lamps, batteries, vanadium-gallium superconductors, and in catalytic mixtures.

The most important gallium semiconductors are gallium arsenide (GaAs) and gallium phosphide (GaP). The magnitude of the energy gap in GaAs favors its use in transistors. The electron mobility in GaAs is very much higher than the hole mobility; in contrast, the electron and hole mobility in GaP are of similar magnitude and very much lower than in GaAs. By doping

with the appropriate elements, these properties can be altered. Electron transport (*n*-type) GaP semiconductors are used in rectifiers, hole transport (*p*-type) in light sources and photocells. *n*-Type GaAs semiconductors are used in injection lasers and *p*-type GaAs in electroluminescent transistors. See HOLE STATES IN SOLIDS; SEMICONDUCTOR.

GaN is prepared by the reaction of metallic gallium or  $\text{Ga}_2\text{O}_3$  at elevated temperature with ammonia, and the other semiconductors by direct reaction with the elements or  $\text{Ga}_2\text{O}$  at high temperature. See ALUMINUM; INDIUM; THALLIUM. [E.M.L.]

**Galvanizing** The generic term for any of several techniques for applying thin coatings of zinc to iron or steel stock or finished products to protect the ferrous base metal from corrosion; more specifically, the hot dipping that is widely practiced with mild steel sheet and corrugated sheets. During dipping, molten zinc reacts with the steel to form a brittle zinc-iron alloy. For marine use, magnesium is added.

An electrolytic process (also called cold galvanizing or electrogalvanizing) is also used for wire, as well as for applications requiring deep drawing. An alloy layer does not form, hence the smooth electroplated coating does not flake in the drawing die. See METAL COATINGS. [F.H.R.]

**Galvanomagnetic effects** Electrical and thermal phenomena occurring when a current-carrying conductor or semiconductor is placed in a magnetic field. The galvanomagnetic effects are closely related to the thermomagnetic effects. See THERMOMAGNETIC EFFECTS.

Let the electric current density  $j$  be transverse to the magnetic field  $H_z$ , for example, along  $x$ . Then the following transverse-transverse effects are observed: (1) Hall effect, an electric field along  $y$ . (2) Ettingshausen effect, a temperature gradient along  $y$ . Also the following transverse-longitudinal effects are observed: (3) Transverse magnetoresistance, an electrical potential change along  $x$ . (4) Nernst effect, a temperature gradient along  $x$ . See HALL EFFECT; MAGNETORESISTANCE.

Let the electric current density  $j$  be along  $H$ . Then, the most important effect is longitudinal magnetoresistance, or an electrical potential change along  $H$ . [E.A.; F.Ke.]

**Galvanometer** A device for indicating very small electric currents. Although the deflection of a galvanometer results from current in the moving coil, the voltage in a closed circuit producing this current is frequently the quantity of interest to the user. In this mode, galvanometers are used to detect a null or an unbalanced condition in a bridge or potentiometer circuit. Electronic instruments that employ amplifying circuits to achieve sensitivities approaching the nanovolt level are also used as balance detectors in bridge circuits. However, in applications where extreme sensitivity and high rejection of ac signals are required, a galvanometer in combination with a photocell amplifier is to be preferred.

Galvanometers may also be used ballistically to integrate a transient current, as from the discharge of a capacitor, or a transient voltage, as produced when a coil moves relative to a magnetic field. See CURRENT MEASUREMENT; VOLTAGE MEASUREMENT.

The d'Arsonval galvanometer is the most common type and is widely used. Its indicating system consists of a light coil of wire suspended from a copper or gold ribbon a few thousandths of an inch wide and less than 0.001 in. (0.025 mm) thick. This coil, free to rotate in the radial field between the shaped pole pieces of a permanent magnet, carries a small mirror which serves as an optical pointer and indicates the coil position by reflecting a light beam onto a fixed scale. Current is conducted to and from the coil by the suspension ribbons. The torque which deflects the indicating element is produced by the reaction of the coil current with the magnetic field in which it is suspended.

Voltage sensitivity is of importance in applications where the galvanometer serves as the detector of unbalance in a bridge



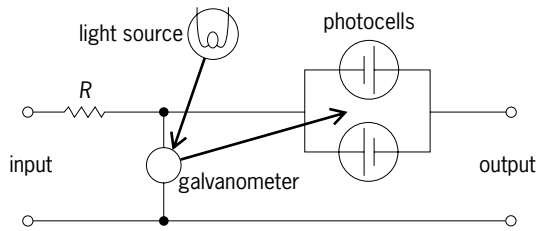

Simplified schematic of photodiode galvanometer amplifier.

or potentiometer network. The energy of motion in the indicating system must be dissipated and the system brought to rest in order for the deflection to be evaluated. This process, common to all indicating systems in which equilibrium must be achieved between a driving torque and a restoring torque, is called damping. See DAMPING.

The sensitivity of modern galvanometers ranges up to 0.04 in. (1 mm) of deflection, on a scale 40 in. (1 m) distant from the mirror, for a current of 0.00001 microampere. Such a galvanometer may have a coil resistance of 800 ohms and a critical damping resistance of 100,000  $\Omega$ . The voltage response of this instrument amounts to 0.04 in./microvolt (1 mm/ $\mu$ V) at critical damping. A galvanometer designed for voltage sensitivity, has a coil resistance of 20  $\Omega$ , a critical damping resistance of 30  $\Omega$ , and a response of 0.04 in. (1 mm) for 0.05  $\mu$ V in the critically damped circuit. It will be seen from these examples that a large response to current is associated with large coil resistance and high critical damping resistance, whereas voltage response is associated with low coil resistance and low critical damping resistance.

The limitations reached in improving a galvanometer's resolution by increasing its scale length or using multiple reflections can be overcome by operating the galvanometer in its equilibrium position by using a negative-feedback network. In this system the beam of light reflected from the galvanometer mirror is directed onto a pair of photodiodes connected in series opposition (see illustration). As the galvanometer coil rotates, the light received on one photodiode increases while the other decreases, and an amplified output current is produced whose sign and magnitude depend on the direction and amount of the coil deflection, respectively. The photodiode output current is monitored by an external indicator and is approximately 1800 times the galvanometer input current. This photodiode output also provides a negative-feedback current to servo the galvanometer at its equilibrium position, so that the linearity and input resistance of the system are increased. In such an arrangement it is frequently possible to approach rather closely the theoretical limit of resolution of angular motion imposed by the brownian motion of the coil, or by the Johnson noise of the circuit connected to the galvanometer. In a low-resistance galvanometer this theoretical resolution may be about 0.001  $\mu$ V. See BROWNIAN MOVEMENT; ELECTRICAL NOISE; KINETIC THEORY OF MATTER.

A galvanometer is an extremely efficient low-pass filter, and it is still the most sensitive low-level detector at input impedances of 1 k $\Omega$  or less. At higher input impedances, chopper-stabilized amplifiers, called nanovoltmeters, exhibit better resolution, noise, and drift characteristics than galvanometers. These instruments modulate the input dc signal by using a chopper (mechanical contact, transistor, or photodiode switching), then amplify the signal by traditional ac techniques to achieve sensitivities of 10 nV or less. State-of-the-art digital voltmeters are now available with nanovolt resolution and are useful as low-level detectors. See AMMETER; ELECTRIC FILTER; ELECTRICAL INTERFERENCE; ELECTRICAL MEASUREMENTS; ELECTROMETER; VOLTMETER. [F.K.H.; R.F.Dz.]

**Game theory** The theory of games of strategy can briefly be characterized as the application of mathematical analysis to abstract models of conflict situations. The first such models ana-

lyzed by the theory were parlor games such as chess, poker, and bridge. Since then, models arising from the behavioral sciences such as economics, sociology, and political science have been analyzed. Game theory is used in or closely connected to other areas such as linear programming, statistical decisions, management science, operations research, and military planning. In certain areas, the language and concepts of the theory are sometimes used even though the corresponding mathematics is not. See LINEAR PROGRAMMING; OPERATIONS RESEARCH.

**Games in extensive form.** The players of a game are called persons, and such a person may actually consist of one or more people (for instance, in bridge the pairs of partners, east-west and north-south, each make up a player in the game). Chance moves occur when hands are dealt from a shuffled pack, dice are rolled, or pointers are spun. One says that all chance moves are allotted to the chance player—a fiction that is useful in abstracting properties of games.

When specified by a list of rules, a game is said to be in extensive form. For mathematical purposes, it is convenient to have games in normalized form, and for that, the idea of a pure strategy is needed.

A pure strategy for a player (not the chance player) is a complete list of choices of legal moves that he or she will make for every possible situation that can occur during the game. This is a much more complete list of decisions than that commonly called a strategy. The number of pure strategies in a game can be astronomical even for childish games such as tic-tac-toe. Because of the enormous number of pure strategies, the actual applications of game theory even to parlor games have been severely limited by computational difficulties. Simplified versions of the games have been developed for which computations have been completely carried out.

**Games in normalized form.** After players have chosen pure strategies in a game, they need not physically play the game. Instead they could hand their strategies to a neutral person, or umpire, who could then carry out their instructions and make the moves they would have made. This intuitively obvious idea leads naturally to the normalized form of the game.

Assume for the moment there are no chance moves in the game, that is, that there are  $n$  real players but no chance player. Denote by  $s_1, s_2, \dots, s_n$  specific pure strategies for players 1, 2,  $\dots$ ,  $n$ , respectively. Given these, the game must be played in exactly one way and a unique outcome will result. Let  $P_i(s_1, s_2, \dots, s_n)$  be the monetary outcome to player  $i$  for this play of the game.

Before the effect of the chance player can be introduced, the important concept of mathematical expectation must be explained. Suppose that  $O_1, O_2, \dots, O_k$  are mutually exclusive monetary outcomes of a chance event, and suppose further that they happen with probabilities,  $p_1, p_2, \dots, p_k$  where  $p_i > 0$  and  $p_1 + p_2 + \dots + p_k = 1$ . Then the mathematical expectation  $E$  of the chance event is defined to be the sum  $E = p_1O_1 + p_2O_2 + \dots + p_kO_k$ . See PROBABILITY.

If there are chance moves in the game, a set of pure strategies, one for each player, will not determine a unique outcome of the game but merely a set of possible outcomes. These outcomes will be mutually exclusive and have probabilities depending on the chance moves associated with their occurrence. Hence in this case one can let  $P_i(s_1, s_2, \dots, s_n)$  be the expected payoff to player  $i$  for each  $i = 1, 2, \dots, n$ .

Now the normalized form of a game is defined as the list of all expected payoffs to each player for every possible combination of pure strategies. In the case of two-person games it is most convenient to list these in tables called matrices. See MATRIX THEORY.

**Classification of games.** A game is called zero-sum if, for every possible  $n$ -tuple of pure strategies  $s_1, \dots, s_n$ , the sum of the payoffs to all players is zero, that is, Eq. (1) holds. If this sum

$$P_1(s_1, \dots, s_n) + P_2(s_1, \dots, s_n) + \dots + P_n(s_1, \dots, s_n) = 0 \quad (1)$$

is not zero for some  $n$ -tuple of pure strategies, the game is called nonzero-sum.

A game in extensive form is said to have perfect information if every player knows and remembers each move of each of her or his opponents as they are made. A game is said to have perfect recall if each player knows and remembers everything he or she did (but not necessarily what the opponent did). Bridge does not have perfect recall, because the personality of a player (=team) is divided between two actual persons and, for instance, north does not see what is in south's hand (except when south is dummy) even though they are members of the same team.

Games can then be classified according to the number of players they have, whether or not they are zero-sum, and whether or not they have perfect information or perfect recall.

**Nonzero-sum games.** By far the most satisfactory part of the theory of games consists of the zero-sum two-person cases, that is, in matrix games. Applications of the theory to such areas as economics, sociology, and political science almost invariably lead to many-person nonzero-sum games. Although no universally accepted theory has been developed to cover these games, many interesting and useful attempts have been made to deal with them.

When more than two persons are involved in a conflict situation, the important feature of the game becomes the coalition structure of the game. A coalition is a group of players who band together and, in effect, act as a new player in the game. There are two extremes to be considered. One is the noncooperative game in which such coalitions are banned by some means. Equilibrium-point solutions, discussed below, provide reasonably satisfactory solutions to such games. The other extreme is that in which all the players join together in a coalition to maximize jointly their total payoff. A game in which coalitions are permitted is called a cooperative game.

In the noncooperative game, each player is solely interested in his or her own payoff. By an equilibrium point in such a game is meant a set of mixed strategies  $s_1, \dots, s_n$  such that Eq. (2) holds

$$P_i(s_1, \dots, s_i, \dots, s_n) = P_i(s_i, \dots, s_i', \dots, s_n) \quad (2)$$

for each  $i = 1, \dots, n$  for all strategies  $s_i$  of player  $i$ . What this means is that no player can, by changing strategy and assuming that the other strategies stay fixed, improve the payoff. By a theorem of J. Nash, every game has at least one equilibrium-point solution (commonly there are several).

**Simple games.** An important class of  $n$ -person games for application to political behavior are the so-called simple games. Each coalition in such a game can be either winning, losing, or blocking. For instance, a winning coalition may be a set of voters who can elect their candidate, or a group of lawmakers who can pass their bill. The players not in a given winning coalition form a losing coalition. Finally, a coalition is blocking if neither it nor the players not in it can enforce their wishes.

**Continuous games.** If, in the normalized form of the game, each player is permitted to have a continuous range of pure strategies and the payoff function is permitted to be a function of the two real variables that range over each player's strategies, the result is a continuous game.

**Game-playing machines.** One of the first applications of large electronic computers to numerical problems was in solving large matrix games. Several methods have been devised for finding such solutions. One such method is the simplex method. So-called decomposition methods can extend these methods to certain problems having thousands or even millions of variables and constraints. The principal application of the method is to solve linear programming problems, which can be shown to be equivalent to matrix games.

Computers have also been programmed to play board games such as checkers and chess. Strictly speaking they do not use the theory of games at all at present, but instead use some of the game sense of the people who devised the codes. See DECISION THEORY; INFORMATION THEORY; STOCHASTIC PROCESS. [G.L.T.]

**Gametogenesis** The production of gametes, either eggs by the female or sperm by the male, through a process involving meiosis. In animals, the cells which will ultimately differentiate into eggs and sperm arise from primordial germ cells set aside from the potential somatic cells very early in the formation of the embryo.

The final products of gametogenesis are the large, sedentary egg cells, and the smaller, motile sperm cells. Each type of gamete is haploid; that is, it contains half the chromosomal complement and thus half as much deoxyribonucleic acid (DNA) as the somatic cells, which are diploid. Reduction of the DNA content is accomplished by meiosis, which is characterized by one cycle of DNA replication followed by two cycles of cell division. See CHROMOSOME; MEIOSIS.

The production of sperm differs from that of oocytes in that each primary spermatocyte divides twice to produce four equivalent spermatozoa which differ only in the content of sex chromosomes (in XY sex determination, characteristic of mammals, two of the sperm contain an X chromosome and two contain a Y). The morphology of sperm is highly specialized, with distinctive organelles forming both the posterior motile apparatus and the anterior acrosome, which assists in penetration of the oocyte at fertilization. See SPERMATOGENESIS.

The cytoplasm of the primary oocyte increases greatly during the meiotic prophase and often contains large quantities of yolk accumulated from the blood. Meiotic divisions in the oocyte are often set in motion by sperm entry, and result in the production of one large egg and three polar bodies. The polar bodies play no role, or a very subordinate one, in the formation of the embryo. See OOGENESIS.

After fertilization and the formation of the polar bodies, the haploid sperm and egg nuclei (pronuclei) fuse, thus restoring the normal diploid complement of chromosomes. See FERTILIZATION; REPRODUCTION (ANIMAL). [S.J.B.]

Meiosis in flowering plants, or angiosperms, is essentially similar to that in animals. However, the cells produced after meiosis are spores, and these do not develop directly into gametes. Female spores (megaspores) and male spores (microspores) develop into gametophytes, that is, female and male haploid plants that bear within them the egg and sperm, respectively. There is a wide range in the details of development and structure of gametes among the different groups of plants other than angiosperms. See REPRODUCTION (PLANT). [J.P.M.]

**Gamma function** A particular mathematical function that can be used to express many definite integrals. There are, however, no significant applications where the gamma function by itself constitutes the essence of the solution. Instead it occurs usually in connection with other functions, such as Bessel functions and hypergeometric functions.

A special case of the gamma function is the factorial  $n! = 1 \cdot 2 \cdot 3 \cdot \dots \cdot n$  (for example,  $1! = 1$ ,  $2! = 2$ ,  $3! = 6$ ,  $4! = 24$ ). It is defined only for integral positive values of  $n$ . The factorial occurs, for instance, in the expansion

$$\exp z = 1 + z/1! + z^2/2! + z^3/3! + \dots$$

The binomial coefficient  $(N/n)$  can be expressed in terms of factorials as  $N!/n!(N-n)!$ . Many occurrences of the factorial are found in combinatorial theory (for instance,  $n!$  is the number of permutations of  $n$  different elements), in probability theory, and in the applications of this theory to statistical mechanics. For large values of  $n$ , the factorial can be easily, although only approximately, computed with Stirling's formula,

$$n! \approx (n/e)^n (2\pi n)^{1/2}$$

See BESSEL FUNCTIONS.

[J.Meix.]

**Gamma-ray astronomy** The study of gamma rays of cosmic origin. This vast spectral domain extends from an energy of 0.05 MeV (wavelength of  $2.5 \times 10^{-11}$  m), the adopted

boundary between x-ray and gamma-ray photons, to  $10^{11}$  MeV ( $10^{-23}$  m), an experimental barrier imposed by the extreme scarcity of ultrahigh-energy photons. See GAMMA RAYS.

Low-energy (or soft) gamma-ray astronomy (up to a few megaelectronvolts) deals mainly with processes in dense media, such as plasmas confined close to neutron stars and black holes. It also concerns cosmic sites where monoenergetic photons are released either by deexcitation of atomic nuclei (nuclear lines) or by positron annihilation (the 0.511-MeV line). Gamma-ray astronomy at higher energies relates to emissions induced by relativistic particles throughout the whole interstellar medium, as well as in the vicinity of some neutron stars and in the powerful jets beamed by active galactic nuclei. The penetration power of gamma-ray photons enables exploration of regions that are hidden at other wavelengths, such as the galactic center region, as well as of the first stages of the universe, since the cosmos is particularly transparent to gamma rays (with the exception of photons whose energy exceeds  $10^6$  MeV).

Because photons in the gamma-ray regime are completely absorbed by the Earth's atmosphere, gamma-ray detectors are placed on board high-altitude balloons or, better still, artificial satellites. Ground-based telescopes, making use of the upper atmospheric layers as a detector, operate successfully in the very high energy gamma-ray band. See SATELLITE (ASTRONOMY).

**Instrumentation.** In other regions of the electromagnetic spectrum, sensitivity is increased by the straightforward method of gathering large numbers of photons and concentrating them to form an image, by means of arrangements of reflectors or lenses. Such a method does not apply to gamma-ray telescopes, since gamma-ray photons can be neither reflected nor refracted. However, gamma-ray concentrators based on Laue diffraction have become feasible, and signal-to-noise ratio could be dramatically improved.

Soft gamma-ray telescopes use the coded-aperture technique to image celestial sources. A coded mask is a pattern of tungsten blocks that absorb gamma-ray photons and are arranged so that a given point source at infinity projects on a position-sensitive detector a pattern that is characteristic of the direction of arrival of the photons. The position of the source in the sky is determined by comparing the observed pattern with all possible projection patterns.

High-energy gamma-ray observations are performed with devices derived from particle-physics detectors. High-energy gamma-ray photons interact almost exclusively via electron-positron pair production. After passing undetected through an anticoincidence shield sensitive to charged particles, a photon is converted to an electron-positron pair in one of the conversion foils. Trajectories of the resulting electron and positron are measured by particle tracking detectors. The energy deposited in an underlying calorimeter is used with the trajectory data to determine the arrival direction and total energy of the gamma rays.

As the gamma-ray energy approaches  $10^5$  MeV, the intensities of celestial gamma rays become too low for them to be seen with space telescopes. However, at energies above a few thousand megaelectronvolts (wavelengths of less than  $10^{-15}$  m), a gamma-ray photon induces in the upper atmosphere a shower of secondary relativistic particles whose propagation through the air produces a narrow beam of Cerenkov visible light which can be detected on the ground by a large parabolic mirror. Detailed studies of the Cerenkov light beam enable the determination of the arrival direction of the generating gamma ray to within  $0.1^\circ$  while discriminating gamma-ray-induced events from much more numerous events induced by interactions of very high energy cosmic-ray protons and nuclei. See CERENKOV RADIATION; COSMIC RAYS.

**Stellar sources.** Other than the Sun, all stellar sources of gamma rays relate to massive stars in their final stages of evolution. Major contributions to the theoretical understanding of explosive nucleosynthesis have come from the data obtained on

supernova SN 1987A, which appeared on February 24, 1987, in the Large Magellanic Cloud, a nearby galaxy. See NUCLEOSYNTHESIS; SUPERNOVA.

Attested by the discovery of radio pulsars in 1967, the capability of neutron stars to accelerate relativistic electrons was confirmed a few years later by the discovery of the gamma-ray emission of the Crab and Vela pulsars. Six or more pulsars were detected by the *Compton Gamma-Ray Observatory*. The energy spectrum of the Crab pulsar suggests that the gamma radiation results from the synchrotron emission of relativistic electrons in the intense magnetic fields which prevail in the close vicinity of newly formed neutron stars. It is generally agreed that the ultimate source of the radiated energy is the rotational energy of the neutron star. Electrons are accelerated to very high energies by the huge electric fields induced by the pulsar rotation. See CRAB NEBULA; NEUTRON STAR; PULSAR.

Almost all the known accreting black-hole systems produce strong and variable gamma-ray emission. In systems with low-mass (less than one solar mass) companion stars, huge outbursts called x-ray novae are observed, such as Nova Muscae 1991, which for one week was the brightest source in the soft gamma-ray sky. Several accreting black holes have been observed in the central region of the Milky Way Galaxy. See ASTROPHYSICS, HIGH-ENERGY; BLACK HOLE.

**Other galactic sources.** A large fraction of the cosmic gamma-ray photons originates in interstellar sites. Cosmic-ray-induced interstellar emission results mostly from the interaction of cosmic rays (electrons and protons) with the interstellar gas. The high-energy gamma-ray sky is dominated by radiation from the galactic plane whose spatial distribution and intensity can be reliably modeled from knowledge of the interstellar gas distribution. A large fraction of the pointlike sources observed at medium galactic latitude may be related to the local interstellar medium, and more specifically to the giant cloud complexes of Gould's Belt.

Spectroscopic observations of the whole galactic center region have demonstrated the presence of a large-scale component of 0.511-MeV radiation due to the annihilation of positrons in the interstellar medium. The source of such interstellar positrons is thought to be the  $\beta^+$ -decay products from radioactive nuclides produced by novae, red giants, Wolf-Rayet stars, and supernovae. See GIANT STAR; NOVA; POSITRON; WOLF-RAYET STAR.

**Extragalactic sources.** With the exception of the Large Magellanic Cloud, all localized extragalactic sources of gamma rays are active galactic nuclei, the most energetic and distant objects in the universe. These include radio sources such as Seyfert galaxies and quasars, all with different properties depending on the observing wavelength. The ultimate source of active galactic nuclei activity is believed to be massive ( $10^6$ – $10^9$ -solar-mass) black holes, accreting 10–100 solar masses per year to account for their overall luminosity. An accretion disk with a collimated perpendicular jet is the favored model for explaining the luminous, broadband radiation emitted from the central engines of active galactic nuclei. See GALAXY, EXTERNAL; QUASAR. [J.Pa.]

**Gamma-ray bursts.** Gamma-ray bursts were first detected by means of the *Vela* spacecraft in 1967, and their discovery was announced in 1973. More than 2700 bursts were detected by the *Compton Gamma-Ray Observatory*. Its observations give strong evidence for an isotropic distribution of bursts; that is, the burst directions appear to be random and show no preference for the galactic plane, in particular. The nearest reasonable source location is probably in an extended halo surrounding the Milky Way Galaxy; a great many astrophysicists now favor greater (cosmological) distances.

Knowledge about gamma-ray bursts has increased rapidly in recent years due to the launch of spacecraft such as *BeppoSAX*, and to the development of a very rapid alert network (the Gamma-Ray Burst Coordinate Network) to allow follow-up observations by ground observers. Optical, x-ray, and radio afterglows have been detected for a number of

gamma-ray bursts, and in a few cases redshifts have been reported for optical sources in the gamma-ray burst error boxes.

The arguments for cosmological distances of most gamma-ray bursts include the highly isotropic distribution of sources and the redshifts reported for a small number of gamma-ray bursts, at least for optical sources within the error boxes for the bursts. To account for the enormous amounts of energy required for such cosmological distances (greater than  $10^{54}$  ergs or  $10^{47}$  J) models have been developed based on "hypernovae" (much brighter than supernovae), collisions between two neutron stars, narrow searchlight beams of emission aimed at the Earths, and even gravitational lensing to increase the intensity. [J.Te.]

**Gamma-ray detectors** Instruments that register the presence of gamma ( $\gamma$ ) radiation. Such detectors convert some or all of the energy of gamma radiation into an electrical signal. Most instruments are capable of detecting individual gamma-ray photons (or quanta), each of which produces a short (0.1–5-microsecond) current pulse at the detector output. The output pulses may be made visible on an oscilloscope, made audible through a speaker (such as the familiar Geiger counter), or be electronically processed further, depending on the application. See GAMMA RAYS; OSCILLOSCOPE.

In common with most radiation detectors, gamma-ray detectors respond not to the radiation but to its secondary effects, in this case energetic electrons. Photons have neither mass nor charge and pass through matter rather easily. In so doing, they lose energy by (1) elastic scattering of electrons (Compton effect), (2) electron-positron ( $\beta^+\beta^-$ ) pair production, and (3) at lower energies by photoabsorption. In these processes the energy of the photon is converted to the kinetic energy of the few electrons with which it interacts. Since electrons are much less penetrating than gamma-ray photons, their energy is largely trapped within the detector, where their ionizing effect creates a response convertible to an electrical output. In a gas-ionization device, such as Geiger counter, this occurs by the production of ion-electron pairs and in a solid-state device, such as a germanium detector, by production of electron-hole pairs. In a scintillation device, for example, a sodium iodide (NaI) detector, the response is caused by the emission of optical photons from atoms excited by the passage of energetic electrons. See COMPTON EFFECT; ELECTRON-POSITRON PAIR PRODUCTION; GEIGER-MÜLLER COUNTER; IONIZATION CHAMBER; SCINTILLATION COUNTER.

In accurate instruments the magnitude of the current pulse created by a single gamma-ray photon is closely proportional to the energy within the detector volume. However, gamma radiation is so penetrating that any particular event may involve only partial absorption of the photon. For example, a single Compton scattering may be followed by the escape of the scattered photon (now reduced in energy) from the detector, leaving behind only the energy of the scattered electron.

Gamma-ray detectors range from hand-held devices capable of giving some indication of the intensity of a radiation field, to devices that accurately measure the energy and event time of individual photons reaching detectors assembled into a single complex instrument. These diverse detectors are widely used in industry, medicine, and research. [D.Wa.]

**Gamma rays** Electromagnetic radiation emitted from excited atomic nuclei as an integral part of the process whereby the nucleus rearranges itself into a state of lower excitation (that is, energy content). See NUCLEAR STRUCTURE; RADIOACTIVITY.

The gamma ray is an electromagnetic radiation pulse—a photon—of very short wavelength. The electric (E) and magnetic (H) fields associated with the individual radiations oscillate in planes mutually perpendicular to each other and also the direction of propagation with a frequency  $\nu$  which characterizes the energy of the radiation. The E and H fields exhibit various specified phase-and-amplitude relations, which define the character of the radiation as either electric (EL) or magnetic (ML).

The second term in the designation indicates the order of the radiation as  $2^L$ -pole, where the orders are monopole ( $2^0$ ), dipole ( $2^1$ ), quadrupole ( $2^2$ ), and so on. The most common radiations are dipole and quadrupole. Gamma rays range in energy from a few kiloelectronvolts to 100 MeV, although most radiations are in the range 50–6000 keV. As such, they lie at the very upper high-frequency end of the family of electromagnetic radiations, which include also radio waves, light rays, and x-rays. See ELECTROMAGNETIC RADIATION; MULTIPOLE RADIATION; PHOTON.

The dual nature of gamma rays is well understood in terms of the wavelike and particlelike behavior of the radiations. For a gamma ray of intrinsic frequency  $\nu$ , the wavelength is  $\lambda = c/\nu$ , where  $c$  is the velocity of light; energy is  $E = h\nu$ , where  $h$  is Planck's constant. The photon has no rest mass or electric charge but, following the concept of mass-energy equivalence set forth by Einstein, has associated with it a momentum given by  $p = h\nu/c = E/c$ . See LIGHT; QUANTUM MECHANICS; RELATIVITY.

Various nuclear species exhibit distinctly different nuclear configurations; the excited states, and thus the  $\gamma$ -rays which they produce, are also different. Precise measurements of the  $\gamma$ -ray energies resulting from nuclear decays may therefore be used to identify the  $\gamma$ -emitting nucleus. This has ramifications for nuclear research and also for a wide variety of more practical applications. One of the most useful studies of the nucleus involves the bombardment of target nuclei by energetic nuclear projectiles to form final nuclei in various excited states. Measurements of the decay  $\gamma$ -rays are routinely used to identify the various final nuclei according to their characteristic  $\gamma$ -rays.

In practical applications, the presence of  $\gamma$ -rays is used to detect the location or presence of radioactive atoms which have been deliberately introduced into the sample. In irradiation studies, for example, the sample is activated by placing it in the neutron flux from a reactor. The resultant  $\gamma$ -rays are identified according to isotope, and thus the composition of the original sample can be inferred. Such studies have been used to identify trace elements found as impurities in industrial production, or in ecological studies of the environment, such as minute quantities of tin or arsenic in plant and animal tissue. See ACTIVATION ANALYSIS.

In tracer studies, a small quantity of radioactive atoms is introduced into fluid systems (such as the human blood stream), and the flow rate and diffusion can be mapped out by following the radioactivity. Local concentrations, as in tumors, can also be determined. See RADIOACTIVE TRACER.

For the three types of interaction with matter which together are responsible for the observable absorption of  $\gamma$ -rays, namely, Compton scattering, the photoelectric effect, and pair production, see COMPTON EFFECT; ELECTRON-POSITRON PAIR PRODUCTION; PHOTOEMISSION. [J.W.OI.]

**Gammaridea** A suborder of Amphipoda. These crustaceans are commonly known as scuds in aquatic environments, and as sandhoppers on beaches. In 1956 the suborder comprised 3200 species in 672 genera and 57 families. The majority of the species is marine but more than 500 species are limnetic, to an altitude of 13,000 ft (4000 m), or are subterranean; 80 species are terrestrial (family Talitridae). The terrestrial species are confined mainly to beaches in high latitudes, but in the Indo-Pacific insular region they penetrate far inland and to an altitude of 10,000 ft (3000 m) in moist environments.

Gammaridea are usually compressed laterally and are poor walkers, unlike the Isopoda, except for the families Corophiidae and Cheluridae, which have depressed bodies (see illustration). The head and segments are free, lacking a carapace. The head bears two pairs of antennae and six kinds of mouthparts, some of them paired. The mandibles usually bear cutting and trituration surfaces for chewing, but a few species lack these devices or have the mouthparts modified for sucking the tissues of animals such as compound ascidians.

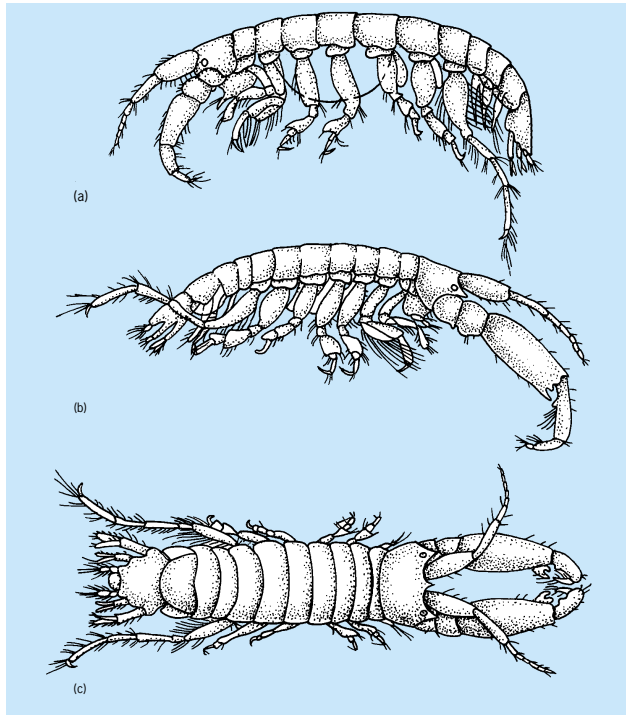

*Corophium crassicorne* (Corophiidae). (a) Female. (b) Male. (c) Male, dorsal view. (After G. O. Sars, *An Account of the Crustacea of Norway*, vol. 1, 1895)

Gammaridea are largely scavengers, feeding on organic debris or detritus which falls to the ocean bottom. Species in the families Ampeliscidae, Photidae, and Corophiidae build nesting tubes attached to solid intertidal objects or lying on the sea bottom. The tubes are spun either from secreting glands on the first two pairs of pereopods or from cuticular glands on the body. These animals use their well-developed antennae to strain food particles. Species in the Phoxocephalidae and Haustoriidae have strongly spinose appendages for burrowing into bottom sediments. Some of these ingest mud, while others are selective deposit feeders. Semiparasitic and commensal species with sucking or lapping mouthparts are known in the families Stenothoidae, Leucothoidae, and Dexaminidae. They inhabit coelenterates, ascidians, and sponges, or grasp lobsters and fish. See AMPHIPODA. [J.L.B.]

**Ganglion** A group of nerve cell bodies, usually located outside the brain and spinal cord. A ganglion located inside the central nervous system is called a nucleus.

The dorsal root ganglia are rounded clusters of cell bodies and fibers, surrounded by a connective tissue covering, located on the dorsal, or sensory, root of each spinal nerve. Other ganglia are given specific names which indicate their function or location, such as acoustic, cardiac, carotid, jugular, celiac, and sympathetic ganglia. Sympathetic ganglia, lying on either side of the vertebral column, unite by fiber strands to form a sympathetic chain. See SYMPATHETIC NERVOUS SYSTEM.

The term ganglion may be applied to a tumorlike, often cystic growth found on tendons, joints, and other connective tissues, but this usage is rare. See BRAIN; SPINAL CORD. [W.B.]

**Gangrene** A form of tissue death, or necrosis, usually occurring in an extremity and due to insufficient blood supply.

If no bacterial contamination is present, the part becomes dry, greenish-yellow, and finally turns brown or black. This is known as mummification. A sharp inflammatory border marks the edge of the adjacent viable tissue. This dry gangrene is seen most often in small portions of the extremities, such as the fingers

and toes. Senile gangrene is the form caused by deterioration of blood supply in the elderly, usually as the result of progressive arteriosclerosis. Similar types are often present in diabetes, Reynaud's disease, and Buerger's disease (thromboangiitis obliterans). See ARTERIOSCLEROSIS; DIABETES.

When bacterial infection intervenes, putrefaction ensues, thus producing the moist or wet type of gangrene. Moist gangrene may occur anywhere in the body that the blood supply is blocked and bacterial contamination occurs.

Gas gangrene is a localized, but rapidly spreading, necrotizing wound infection, characterized by extensive edema with gas production and discoloration of the tissue, and often accompanied by a putrefactive odor. The disease commonly arises following septic abortion or dirt contamination of deep wounds. The microbial flora of the gangrenous wound usually comprises one or more species of toxigenic anaerobic bacteria mixed with nontoxic anaerobic species, aerobic species, or both. [E.G.St.; N.K.M.]

Gangrene does not necessarily follow the presence of bacteria in a wound, as initiation of the disease depends on the virulence of the organisms and other factors relating to the resistance of the host. The virulence of the gangrene-producing organisms depends on the toxins produced and the same species may produce several immunologically different toxins. See TOXIN; VIRULENCE.

The rapidly spreading nature of the disease precludes extensive laboratory diagnostic aids because therapeutic measures, possibly including amputation, usually must be instituted before laboratory results are available. The effectiveness of antibiotic therapy seems to depend on the species involved in the infection and the elapsed time between injury and treatment. Hyperbaric oxygen therapy is beneficial for individuals who are diagnosed early. [L.S.McC.]

**Gantt chart** A graphic device that depicts tasks, machines, personnel, or whatever resources are required to accomplish a job on a calendar-oriented grid. Charts may be provided for various managerial levels and responsibilities, but detailed planning occurs at the lowest organizational level. Performance may be monitored and controlled throughout the organization.

The Gantt chart is an effective tool for planning and scheduling operations involving a minimum of dependencies and interrelationships among the activities. The technique is best applied to activities for which time durations are not difficult to estimate, since there is no provision for treatment of uncertainty. On the other hand, the charts are easy to construct and understand, even though they may contain a great amount of information. In general, the charts are easily maintained provided the task requirements are somewhat static.

An initial step in development of a Gantt chart may be to specify the tasks or activities making up a project, as shown in the illustration. The amount of time required for each activity is represented as a horizontal bar on the chart, with open triangles designating original start and finish dates in this example. The

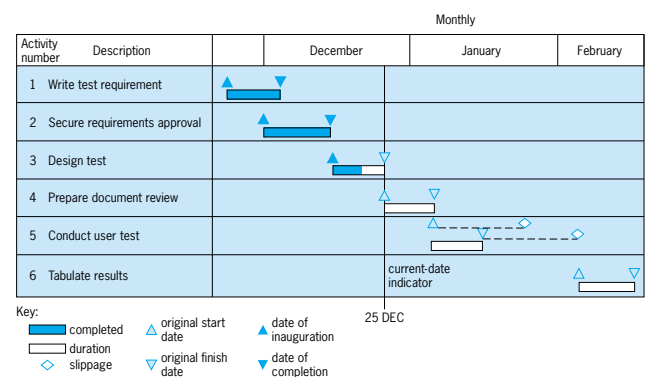

Example of a Gantt bar chart.

open start triangle is changed to a filled triangle upon inauguration of the activity, and the bar is filled in with vertical lines to indicate progress and completion. The open finish triangle is also filled upon completion. Slippage times are documented on the chart by broken lines, and the diamond symbols are employed to indicate rescheduled work. The vertical line on the chart is the current-date indicator and indicates present and future status of the project as of that date.

Updating of a Gantt chart will reveal difficulties encountered in the conduct of a project. Possible solutions include rescheduling, overtime, multishift operations, use of additional equipment and facilities, and changes in method.

An outgrowth of the bar chart technique is the milestone chart. A milestone is an important activity in the sequence of project completion. The most significant activities may be designated major milestones. The primary difference in this concept is the graphic display, since the method and collection of data are the same. The milestone approach offers no intrinsic improvement over the basic Gantt chart but provides a means for focusing resources on critical items. See PERT. [L.S.H.]

**Garlic** A hardy perennial, *Allium sativum*, of Asiatic origin and belonging to the plant order Liliales. Garlic is grown for its pungent bulbs, segments of which are used primarily for seasoning. Europeans have grown it for more than 200 years. Propagation is commonly by bulb segments, sometimes called cloves; seeds are seldom produced. Cultural practices are similar to those used for onions. Popular varieties are Italian, Tahiti, and Creole or Mexican. Harvest of the mature dry bulbs is 7–8 months after planting. Garlic salt is made from dehydrated cloves. California is the most important producing state; smaller acreages are planted to garlic in Louisiana and Texas. See LILIALES; ONION. [H.J.C.]

**Garnet** A hard, dense silicate mineral which occurs as crystals of cubic symmetry in a wide range of geologic environments. The general chemical formula of the silicate garnet group is  $A_3B_2(SiO_4)_3$  where, in natural occurrences, the A cations are dominantly  $Fe^{2+}$ ,  $Mn^{2+}$ ,  $Mg$ , and  $Ca$ , and the B cations are  $Al$ ,  $Fe^{3+}$ , and  $Cr^{3+}$ .

The garnet mineral group is generally divided into a number of individual species on the basis of chemical composition. The more common of these species are pyrope, almandine, spessartine, grossular, andradite, and uvarovite.

Garnets are substantially denser than most chemically analogous silicates, with specific gravities ranging between 3.58 (pyrope) and 4.32 (almandine). They also have high refractive indices (1.71–1.89) and hardness, on Mohs scale, of  $6\frac{1}{2}$  to  $7\frac{1}{2}$ . The relative hardness, coupled with the absence of cleavage, has led to the use of garnet as an abrasive. The color of garnet is primarily controlled by its chemical composition. Uvarovite is emerald green; gem varieties of garnet are generally clear, deep red pyrope. See GEM; SILICATE MINERALS.

Garnets are widespread in their occurrence, particularly in rocks which formed at high temperatures and pressures. Because of the large, readily identifiable crystals which form, the first appearance of garnet is commonly used by geologists as an index of the intensity, or grade, of metamorphism. Garnets are strongly resistant to weathering and alteration and are hence widespread constituents of sands and sediments in areas of garnetiferous primary rocks. See METAMORPHIC ROCKS. [B.J.Wo.]

**Gas** A phase of matter characterized by relatively low density, high fluidity, and lack of rigidity. A gas expands readily to fill any containing vessel. Usually a small change of pressure or temperature produces a large change in the volume of the gas. The equation of state describes the relation between the pressure, volume, and temperature of the gas. In contrast to a crystal, the molecules in a gas have no long-range order.

At sufficiently high temperatures and sufficiently low pressures, all substances obey the ideal-gas, or perfect-gas, equation of state below, where  $p$  is the pressure,  $T$  is the absolute temperature,

$$p\bar{V} = RT$$

$\bar{V}$  is the molar volume, and  $R$  is the gas constant. Absolute temperature  $T$  is expressed on the Kelvin scale. The gas constant is 8.314 joules/(mole K). The molar volume is the molecular weight divided by the gas density.

At lower temperatures and higher pressures, the equation of state of a real gas deviates from that of a perfect gas. Various empirical relations have been proposed to explain the behavior of real gases. See GAS DYNAMICS. [C.F.C.; J.O.H.]

**Gas absorption operations** The separation of solute gases from gaseous mixtures of noncondensables by transfer into a liquid solvent. This recovery is achieved by contacting the gas stream with a liquid that offers specific or selective solubility for the solute gas or gases to be recovered. The operation of absorption is applied in industry to purify process streams or recover valuable components of the stream. It is used extensively to remove toxic or noxious components (pollutants) from effluent gas streams. See ABSORPTION.

The absorption process requires the following steps: (1) diffusion of the solute gas molecules through the host gas to the liquid boundary layer based on a concentration gradient, (2) solvation of the solute gas in the host liquid based on gas-liquid solubility, and (3) diffusion of the solute gas based on concentration gradient, thus depleting the liquid boundary layer and permitting further solvation. The removal of the solute gas from the boundary layer is often accomplished by adding neutralizing agents to the host liquid to change the molecular form of the solute gas. This process is called absorption accompanied by chemical reaction. See DISTILLATION. [A.J.T.]

**Gas and atmosphere analysis** Qualitative identifications and quantitative determinations of substances essential for the evaluation of the air quality in the ambient air and in the industrial workplace. See AIR POLLUTION; INDUSTRIAL HEALTH AND SAFETY.

**Qualitative identification.** The qualitative identification of air pollutants may require the use of several instruments which provide complementary information about composition and structure. Since the entire sample is often limited to milligram or microgram quantities, the classical identification methods, such as boiling point and refractive index determinations, functional group tests, combustion analyses, and derivative preparations, have been largely replaced by instrumental methods. Information for identification purposes is now generally obtained from instruments such as mass, nuclear magnetic resonance, infrared, and ultraviolet spectrometers that rely upon the response of a molecule to an energy probe.

Mass spectroscopy is probably the single most powerful technique for the qualitative identification of volatile organic compounds, and has been particularly useful in the identification of many environmental contaminants. When a sample is introduced into the mass spectrometer, electron bombardment causes the parent molecule to lose an electron and form a positive ion. Some of the parent ions are also fragmented into characteristic daughter ions, while other ions remain intact. All of the ions are accelerated, separated, and focused on an ion detector by means of either a magnetic field or a quadrupole mass analyzer. Using microgram quantities of pure materials, the mass spectrometer yields information about the molecular weight and the presence of other atoms, such as nitrogen, oxygen, and halogens, within the molecule. In addition, the fragmentation pattern often provides a unique so-called fingerprint of a molecule, allowing positive identification. If the gas is a mixture, interpretation of the mass spectral data is difficult since the fragmentation patterns are superimposed. However, interfacing the mass spectrometer to a

gas chromatograph provides an elegant solution to this problem. See MASS SPECTROMETRY.

A gas chromatograph is essentially a highly efficient apparatus for separating a complex mixture into individual components. When a mixture of components is injected into a gas chromatograph equipped with an appropriate column, the components travel down the column at different rates and therefore reach the end of the column at different times. The mass spectrometer located at the end of the column can then analyze each component separately as it leaves the column. In essence, the gas chromatograph allows the mass spectrometer to analyze a complex mixture as a series of pure components. More than 100 compounds have been identified and quantified in automobile exhaust by using a gas chromatograph-mass spectrometer combination. See GAS CHROMATOGRAPHY.

**Quantitative analysis.** The methods employed chiefly for quantification can be classified for convenience into direct and indirect procedures. Direct-reading instruments are generally portable and may analyze and display their results in a few seconds or minutes, and can operate in a continuous or semicontinuous mode. Indirect methods are those involving collection and storage of a sample for subsequent analysis.

Direct methods utilize colorimetric indicating devices and instrumental methods. Three types of direct-reading colorimetric indicators have been utilized: liquid reagents, chemically treated papers, and glass tubes containing solid chemicals (detector tubes). The simplest of these methods is the detector tube. Detector tubes are constructed by filling a glass tube with silica gel coated with color-forming chemicals. For use, the ends of the sealed tube are broken and a specific volume of air, typically 6 in.<sup>3</sup> (100 cm<sup>3</sup>), is drawn through the tube at a controlled rate. Detector tubes for analyzing approximately 400 different gases are commercially available. Accuracy is sometimes low, and detector tubes for only 25 gases meet the National Institute for Occupational Safety and Health (NIOSH) accuracy requirement of  $\pm 25\%$ . For some gases, semicontinuous analyzers have been developed that operate by pulling a fixed volume of air through a paper tape impregnated with a color-forming reagent. The intensity of the color is then measured for quantification. Phosgene, arsine, hydrogen sulfide, nitric oxide, chlorine, and toluene diisocyanate have been analyzed by indicating tapes. See COLORIMETRY.

With the availability of stable and sensitive electronics, direct-reading instruments capable of measuring gases directly at the parts-per-billion range were developed. Most direct-reading instruments contain a sampling system, electronics for processing signals, a portable power supply, a display system, and a detector. The detector or sensor is a component that is capable of converting some characteristic property of the gas into an electrical signal. While there are dozens of properties for the bases of operation of these detectors, the most sensitive and popular detectors are based on electrical or thermal conductivity, ultraviolet or infrared absorption, mass spectrometry, electron capture, flame ionization, flame photometry, heat of combustion, and chemiluminescence. Many of these detectors respond to the presence of  $10^{-9}$  g quantities, and even to  $10^{-12}$  g levels. In addition to improved accuracy, precision, and analysis time, another advantage is that most instruments produce an electrical signal which can be fed into a computer for process control, averaging, and record keeping. Rapid fluctuations and hourly, daily, and yearly averages are readily obtained.

For indirect methods of quantification, the main collection devices are freeze traps, bubblers, evacuated bulbs, plastic bags, and solid sorbents. Because of their convenience, solid sorbents dominate collection procedures. NIOSH developed a versatile method for industrially important vapors, based on the sorption of the vapors on activated charcoal or, to a lesser extent, on other solid sorbents such as silica gel and porous polymers. Typically, in this technique a few liters of air are pulled through a glass tube containing about 0.004 oz (100 mg) of charcoal.

The charcoal tube is only 7 cm  $\times$  6 mm (3 in.  $\times$  0.2 in.), and has the advantage that it can be placed on the worker's lapel. A battery-operated pump small enough to fit into a shirt pocket is connected by a plastic tube to the collecting device, so that the contaminants are continuously collected from the breathing zone of the worker. Many solvent vapors and gases are efficiently trapped and held on the charcoal. The ends of the sample tube are then capped, and the tube is returned to a laboratory for analysis. In the laboratory the tube is broken open, and the charcoal is poured into carbon disulfide to desorb the trapped vapors. Following desorption, a sample of the solution is injected into a gas chromatograph for quantification.

This technique has been highly successful for several classes of compounds, such as aromatics, aliphatics, alcohols, esters, aldehydes, and chlorinated compounds. Sulfur- and nitrogen-containing compounds can also be analyzed by using a gas chromatograph which is equipped with a sulfur- or nitrogen-sensitive detector. [W.R.Bu.; M.Gl.; L.S.Be.]

**Gas chromatography** A method for the separation and analysis of complex mixtures of volatile organic and inorganic compounds. Most compounds with boiling points less than about 250°C (480°F) can be readily analyzed by this technique. A complex mixture is separated into its components by eluting the components from a heated column packed with sorbent by means of a moving-gas phase. See CHROMATOGRAPHY.

Gas chromatography may be classified into two major divisions: gas-liquid chromatography, where the sorbent is a non-volatile liquid called the stationary-liquid phase, coated as a thin layer on an inert, granular solid support, and gas-solid chromatography, where the sorbent is a granular solid of large surface area. The moving-gas phase, called the carrier gas, is an inert gas such as nitrogen or helium which flows through the chromatographic column packed with the sorbent. The solute partitions, or divides, itself between the moving-gas phase and the sorbent and moves through the column at a rate dependent upon its partition coefficient, or solubility, in the liquid phase (gas-liquid chromatography) or upon its adsorption coefficient on the packing (gas-solid chromatography) and the carrier-gas flow rate.

The apparatus used in gas chromatography consists of four basic components: a carrier-gas supply and flow controller, a sample inlet system providing a means for introduction of the sample, the chromatographic column and associated column oven, and the detector system.

Qualitative and quantitative information is obtained from analyzing the peaks appearing on a chromatogram. Combination of gas chromatography with mass spectrometry provides the ultimate in qualitative information and has been used extensively in research. See MASS SPECTROMETRY; QUALITATIVE CHEMICAL ANALYSIS. [R.S.J.]

**Gas constant** The universal constant  $R$  that appears in the ideal gas law, Eq. (1), where  $P$  is the pressure,  $V$  the volume,

$$PV = nRT \quad (1)$$

$n$  the amount of substance, and  $T$  the thermodynamic (absolute) temperature. The gas constant is universal in that it applies to all gases, providing they are behaving ideally (in the limit of zero pressure). The gas constant is related to the more fundamental Boltzmann constant,  $k$ , by Eq. (2), where  $N_A$  is the Avogadro

$$R = N_A k \quad (2)$$

constant (the number of entities per mole). The best modern value in SI units is  $R = 8.314\,472\,(15)\text{ J/K} \cdot \text{mol}$ , where the number in parentheses represents the uncertainty in the last two digits. See BOLTZMANN CONSTANT; GAS.

According to the equipartition principle, at a temperature  $T$ , the average molar energy of each quadratic term in the expression for the energy is  $(1/2)RT$ ; as a consequence, the translational

contribution to the molar heat capacity of a gas at constant volume is  $(3/2)R$ ; the rotational contribution of a linear molecule is  $R$ . See KINETIC THEORY OF MATTER.

Largely because  $R$  is related to the Boltzmann constant, it appears in a wide variety of contexts, including properties unrelated to gases. Thus, it occurs in Boltzmann's formula for the molar entropy of any substance, Eq. (3), where  $W$  is the number of

$$S = R \ln W \quad (3)$$

arrangements of the system that are consistent with the same energy; and in the Nernst equation for the potential of an electrochemical cell, Eq. (4), where  $E^\circ$  is a standard potential,  $F$  is

$$E = E^\circ - (RT/nF) \ln Q \quad (4)$$

the Faraday constant, and  $Q$  is a function of the composition of the cell. The gas constant also appears in the Boltzmann distribution for the population of energy levels when the energy of a level is expressed as a molar quantity. See BOLTZMANN STATISTICS; ELECTRODE POTENTIAL; ENTROPY. [P.W.A.]

**Gas discharge** A system made up of a gas, electrodes, and an enclosing wall in which an electric current is carried by charged particles in response to an electric field, the gradient of the electric potential, or the voltage between two surfaces. The gas discharge is manifested in a variety of modes (including Townsend, glow, arc, and corona discharges) depending on parameters such as the gas composition and density, the external circuit or source of the voltage, electrode geometry, and electrode material. See ARC DISCHARGE; CORONA DISCHARGE; ELECTRICAL BREAKDOWN; GLOW DISCHARGE; TOWNSEND DISCHARGE.

Gas discharges are useful both as tools to study the physics existing under various conditions and in technological applications such as in the lighting industry and in electrically excited gas lasers. New applications in gas insulation, in high-power electrical switching, and in materials reclamation and processing will assure a continuing effort to better understand all aspects of gas discharges. See GAS TUBE; LASER; VAPOR LAMP.

Electrons, rather than ions, are the main current carriers in gas discharges because their mass is smaller and their mobility is correspondingly much higher than that of ions. Electrons are produced by ionization of the gas itself, or they originate at the electrodes present in the system. Gas ionization can be accomplished in several ways, including electron impact ionization, photoionization, and associative ionization. Bombardment by photons, energetic ions or electrons, and excited neutral particles can cause secondary emission from the electrodes. A high-energy-per-unit electrode surface area can induce thermionic or field emission of electrons. Each of these means of producing electrons leads to a different response of the gas discharge as a circuit element. See ELECTRICAL CONDUCTION IN GASES; ELECTRON EMISSION; FIELD EMISSION; IONIZATION; PHOTOEMISSION; SECONDARY EMISSION; THERMIONIC EMISSION. [L.C.P.]

**Gas dynamics** The study of gases in motion. In general, matter exists in any of three states: solid, liquid, or gas. Liquids are incompressible under normal conditions; water is a typical example. In contrast, gases are compressible fluids; that is, their density varies depending on the pressure and temperature. The air surrounding a high-speed aircraft is an example. See GAS; LIQUID.

Gas dynamics can be treated in a variety of ways. One such way deals with gases as a continuum. The structure of gases on the particle level is called rarefied gas dynamics. See AEROTHERMODYNAMICS; COMPRESSIBLE FLOW; FLUID FLOW.

Gases in motion are subject to certain fundamental laws. These are the laws of the conservation of mass, momentum, and energy. In the case of the dynamics of incompressible fluids, it is usually sufficient to satisfy only the laws of conservation of mass and momentum. This distinction constitutes the fundamental difference between high-speed gas dynamics and hydrodynamics.

If irreversibilities are involved, a fourth equation called the entropy balance equation may be considered. Whereas mass, momentum, and energy are conserved, the entropy is not. Real problems are irreversible; that is, losses such as friction are involved. However, as a first approximation such effects are generally not considered. See CONSERVATION LAWS (PHYSICS); CONSERVATION OF ENERGY; CONSERVATION OF MASS; CONSERVATION OF MOMENTUM.

The mass, momentum, and energy equations are higher-order, nonlinear equations that have no general solution, and only a limited number of special cases can be solved. Another approach is to resort to numerical solutions using high-speed digital computers. While this approach has proven to be very useful, it limits the degree to which flow phenomena can be conceptualized. Accordingly, it is frequently permissible to write the equations in one-dimensional form. By one-dimensional flow is meant that the properties of gas such as its velocity and density are assumed to be constant in the direction perpendicular to the direction of the gas flow. Generally, the one-dimensional approach gives excellent insights into understanding the physical behavior of the flow. It is also very useful in setting up the computer algorithm for numerical solutions. See COMPUTATIONAL FLUID DYNAMICS; DIFFERENTIAL EQUATION.

One other matter must be considered, namely whether the flow is steady or unsteady. In steady flow, the flow characteristics do not vary with time, whereas unsteady flow implies that the flow assumes different configurations over time. Thus, unsteady flow is broader in scope. In this case the continuity equations for conservation of mass may be written as Eq. (1). In this equation,

$$\frac{\partial(\rho V)}{\partial x} + \frac{\partial \rho}{\partial t} = 0 \quad (1)$$

the first term defines the mass-flow changes with respect to the space coordinates, whereas the second term indicates the changes with time. Here,  $\partial$  is the partial differential operator;  $x$  denotes the space coordinate, in this case the direction of flow;  $\rho$  is the gas density;  $V$  is the gas velocity; and  $t$  is the time.

If the flow is steady, there is no time-dependent term, and hence the continuity equation can be written in integrated form as Eq. (2), where  $A$  denotes the area in the direction perpendicular to the flow direction.

$$\rho V A = \text{constant} \quad (2)$$

The momentum equation is the mathematical representation of the law of conservation of momentum. It is a statement of the forces acting on the gas. Different types of forces must be recognized. Body forces, such as gravitation and electromagnetic forces, act at a distance. The so-called surface forces may assume different forms, such as normal stresses and viscosity. The simple form of the momentum equation is Eq. (3), which, in spite

$$\frac{p}{\rho} + \frac{V^2}{2} = \text{constant} \quad (3)$$

of its simplicity, is very powerful. Called Bernoulli's theorem, this equation makes a crucial statement that when the velocity increases, the pressure  $p$  decreases. See BERNOULLI'S THEOREM.

The energy equation expresses the first law of thermodynamics and accounts for the changes in energy as the gas moves about its path. It can also take into consideration energy exchanges between the gas and its environment, such as radiation. Its simplest form is Eq. (4), where  $c_p$  denotes the specific heat at constant pressure.

$$c_p \frac{p}{\rho} + \frac{V^2}{2} = \text{constant} \quad (4)$$

The speed of sound or the acoustic velocity is a very important term in gas dynamics because it serves as a criterion to identify flow regimes. Being able to do so is crucial because the designer must know the conditions that the gas will generate or, conversely, experience. In prescribing flow regimes, the flow



velocity of the gas is compared with the acoustic velocity. This ratio, called the Mach number ( $M$ ), is defined by Eq. (5).

$$M = \frac{V}{a} \quad (5)$$

Using the Mach number the following flow regimes are described:

$M < 1$	subsonic flow
$M = 1$	sonic flow
$0.9 < M < 1.1$	transonic flow
$M > 1$	supersonic flow
$M > 5$	hypersonic flow

High-speed aircraft are categorized by the Mach number. See MACH NUMBER; SOUND.

Flows can be classified as internal flow and external flow. Internal flow refers to the cases where the gas is constrained by a duct of some sort. Characteristically external flow is flow over an airplane or missile. Internal flows are conveniently characterized by (1) the shape of the duct and its variation, (2) the heat transfer through the walls of the duct and internal heat sources, and (3) frictional effects. By varying one of these characteristics at a time, the essential features of internal flow can be discussed most simply.

Boundary layers and wakes are the centers of interest in external flows. Here the effects of compressibility are substantially more difficult to analyze than in internal flows, if for no other reason than the inapplicability of a one-dimensional approach. See BOUNDARY-LAYER FLOW; WAKE FLOW. [J.Men.; A.B.C.]

Rarefied gas dynamics is that branch of gas dynamics dealing with the flow of gases under conditions where the molecular mean free path is not negligibly small compared to some characteristic dimension of the flow field. Rarefied flows occur when the gas density is extremely low, as in the cases of vacuum systems and high-altitude flight, but also when gases are at normal densities if the characteristic dimension is sufficiently small, as in the case of very small particles suspended in the atmosphere.

The dimensionless parameter which describes the degree of rarefaction existing in a flow is the Knudsen number,  $Kn = \lambda/L$ , defined as the ratio of the mean free path  $\lambda$  to some characteristic dimension  $L$  of the flow field. Depending on the situation,  $L$  might be chosen, for example, as the diameter of a duct in a vacuum system, the wavelength of a high-frequency sound wave, the diameter of a suspended submicrometer-size particle, the length of a high-altitude rocket, or the thickness of a boundary layer or a shock wave. The mean free path  $\lambda$ , which is the average distance traveled by a gas molecule between successive collisions with other molecules, is equal to the molecular mean speed, given by Eq. (6) [where  $R$  is the gas constant and  $T$  is

$$\bar{C} = \sqrt{\frac{8}{\pi} RT} \quad (6)$$

the gas temperature], divided by the collision frequency  $\nu_c$ ; thus, Eq. (7) is satisfied. However, it is often more convenient in eval-

$$\lambda = \frac{\bar{C}}{\nu_c} \quad (7)$$

uating the Knudsen number to use the viscosity-based mean free path given by Eq. (8), where  $\nu$  is the kinematic viscosity.

$$\lambda \simeq \frac{2\nu}{\bar{C}} \quad (8)$$

See VISCOSITY.

It is convenient to divide rarefied flows into three flow regimes, according to the range of values of the appropriate Knudsen numbers. The regime of highly rarefied flow, which obtains for  $Kn$  much greater than 1 (typically greater than 10), is called collisionless or free-molecule flow, while the regime of slight rarefaction, where  $Kn$  is much less than 1 (typically less than 0.1),

is called slip flow. Flows at Knudsen numbers intermediate to these limiting values are termed transition flows. The phenomena and methods of analysis associated with the three regimes are in general quite dissimilar. [L.T.]

**Gas field and gas well** The term gas field refers to a geographical area which is underlain by one or more commercial reservoirs of petroleum. This commercially valuable gas, primarily methane but with smaller amounts of ethane, propane, and butanes and in some cases containing significant concentrations of carbon dioxide, hydrogen sulfide, and nitrogen, is produced through wells which penetrate subterranean reservoirs, composed of porous rock. The gas in the reservoir may be free or dissolved in crude oil.

About one-third of the gross production of natural gas in the United States is produced from reservoirs in which there is no substantial amount of crude oil (mixture of higher-molecular-weight pentanes plus hydrocarbons) in contact with the gas. The gas in such reservoirs is called nonassociated gas. Associated gas is that produced from reservoirs in which there is a substantial contact of free gas (in the gas cap) with crude oil or gas dissolved in crude oil. See NATURAL GAS; OIL AND GAS FIELD EXPLOITATION; OIL AND GAS WELL DRILLING; PETROLEUM; PETROLEUM GEOLOGY; PETROLEUM RESERVOIR ENGINEERING. [T.M.D.]

**Gas furnace** An enclosure in which a gaseous fuel is burned. Domestic heating systems may have gas furnaces. Some industrial power plants are fired with gases that remain as a by-product of other plant processes. Utility power stations may use gas as an alternate fuel to oil or coal, depending on relative cost and availability. Some heating processes are carried out in gas-fired furnaces. Among the gaseous fuels are natural gas, producer gas from coal, blast furnace gas, and liquefied petroleum gases such as propane and butane. See FUEL GAS; FURNACE; STEAM-GENERATING FURNACE. [R.M.H.]

**Gas thermometry** A method of measuring temperatures with gas as the thermometric fluid. Gas thermometry is the primary source of information about a fundamental physical parameter, temperature, over the range from about 3 to 900 K (−454 to 1160°F).

In principle, gas thermometry consists of using the ideal gas law, Eq. (1), where  $P$  is the pressure,  $V$  the volume,  $n$  the number

$$PV = nRT \quad (1)$$

of moles of gas,  $R$  the molar gas constant, and  $T$  the thermodynamic temperature, to evaluate an unknown temperature by reference to the single defining temperature of the Kelvin thermodynamic temperature scale, namely the triple-point temperature of water. This reference temperature, achievable within about one part in  $10^7$  by standard laboratory practice, has the value 273.16 K (0.01°C or 32.018°F). Determination of the unknown temperature requires two sets of measurements of the pressure  $P$  and the volume  $V$  of  $n$  moles of an ideal gas. One set of measurements usually is performed while the gas is maintained at the water triple-point temperature; the second set is obtained with the gas at the unknown temperature. The unknown temperature can readily be evaluated by rewriting Eq. (1) as  $n = (PV)/(RT)$ , which has the same value for both sets of measurements. The desired result is given by Eq. (2), where the primed quantities

$$T' = \frac{273.16(P'V')}{(PV)} \quad (2)$$

refer to the unknown temperature. In Eq. (2) the precise values of the gas constant  $R$  and of  $n$  need not be considered. See GAS; TRIPLE POINT.

Constant-volume gas thermometry is by far the most commonly used of the gas-thermometry methods. The name is somewhat misleading because no gas bulb truly exhibits constant

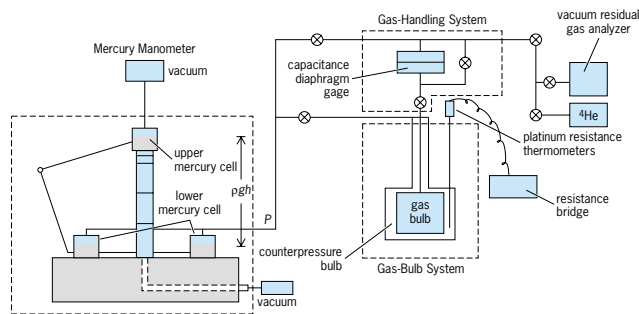

Typical constant-volume gas thermometer. (After J. F. Schooley, *Thermometry*, CRC Press, 1986)

volume over any substantial temperature range. Several steps are involved: inserting a fixed mass of a working gas into a rigid container or bulb; determining the pressure of the gas at the triple-point temperature of water; heating or cooling the container to a new temperature whose value is to be determined; and measuring the gas pressure at the new temperature.

A typical constant-volume gas thermometer (see illustration) includes a mercury manometer, used for the measurement of pressure; a gas-bulb system; and a gas-handling system. The part-per-million accuracy achievable in manometric pressure measurements is central to the thermometric accuracy of this instrument. The entire manometer is operated in a temperature-controlled environment. The distance between the surface of the mercury in an upper cell and mercury surfaces in two lower cells is measured by the use of wrung stacks of calibrated end gage blocks. Axial holes through the gage blocks permit detection of the quality of the wringing process by measurement of the internal vacuum of the stack. The pressure exerted by the column of mercury is given by the product  $\rho gh$ , where  $\rho$  is the density of the mercury,  $g$  is the acceleration due to gravity at the manometer, and  $h$  is the height of the gage-block stack.

The gas bulb is completely enclosed by a second bulb in which a so-called counterpressure of helium gas equal to the gas-bulb pressure is maintained at all times. The counterpressure gas minimizes pressure-induced changes in the gas-bulb volume and helps to reduce contamination of the working gas from impurities in the gas-bulb thermostat.

It is possible to determine the thermodynamic temperature of a gas bulb by repeatedly adding measured quantities of a working gas to it and measuring the resulting pressures. The repeated measurements at a single temperature are known as an isotherm. The virial equation (3) can be used to obtain both

$$PV = nRT(1 + BP + CP^2 + \dots) \quad (3)$$

the unknown gas-bulb temperature and the value of the second virial coefficient. See VIRIAL EQUATION.

Two variations on the technique can be used, the absolute isotherm and the relative isotherm. In absolute isothermal gas thermometry, measured quantities of working gas are introduced into a gas bulb at the unknown temperature from a known volume that is maintained at 273.16 K. In the relative isotherm method, the working gas is added stepwise to a gas bulb while it is maintained at another, more convenient reference temperature. See LOW-TEMPERATURE THERMOMETRY; PHYSICAL MEASUREMENT; TEMPERATURE MEASUREMENT. [J.F.Sc.]

**Gas tube** An electron tube that contains gas or vapor at low pressure in which an electrical discharge takes place. Gas tubes are of two general types: cold-cathode tubes, in which the phenomenon known as glow discharge serves to maintain a conducting path between the electrodes, and hot-cathode tubes, in which an arc discharge conducts the current. The cold-cathode glow tubes are characterized by a relatively high voltage drop and a low current, while the hot-cathode arc tubes are characterized

by a low voltage drop and relatively high current. See ELECTRON TUBE.

Cold-cathode gas tubes, or glow tubes, require no cathode heater power and are therefore always ready for instant service. Glow tubes are commonly constructed as two-element (diode) or three-element (triode) tubes.

Three representative types of hot-cathode gas tubes may be distinguished: the Tungar (sometimes called a Rectigon), the phanotron, and the thyratron. The first two are simple rectifier tubes while the third is a control tube having one or two grids between cathode and anode. Both phanotrons and thyratrons may be built with glass, ceramic, or metal envelopes. [J.D.Co.]

**Gas turbine** One of a class of heat engines which use fuel energy to produce mechanical output power, either as torque through a rotating shaft (industrial gas turbines) or as jet power in the form of velocity through an exhaust nozzle (aircraft jet engines). The fuel energy is added to the working substance, which is gaseous in form and most often air, either by direct internal combustion or indirectly through a heat exchanger. The heated working substance, air co-mixed with combustion products in the usual case of internal combustion, acts on a continuously rotating turbine to produce power. The gas turbine is thus distinguished from heat engine types where the working substance produces mechanical power by acting intermittently on an enclosed piston, and from steam turbine engines where the working substance is water in liquid and vapor form. See INTERNAL COMBUSTION ENGINE; STEAM TURBINE.

Gas turbine engines depend on the principle of the air cycle, where, ambient air is first compressed to a maximum pressure level, at which point fuel heat energy is added to raise its temperature, also to a maximum level. The air is then expanded from high to low pressure through a turbine. The expansion process through the turbine extracts energy from the air, while the compression process requires energy input.

As the air moves through the engine, the turbine continuously provides energy sufficient to drive the compressor. In addition, because the turbine expansion process starts from a high temperature that comes from the fuel energy released by combustion, surplus energy beyond that required for compression can be extracted from the air by further expansion. At the point where the turbine has provided sufficient energy to power the compressor, the air pressure remains higher than the outside ambient level. This higher pressure represents available energy in the air that can be turned into useful output power by a final expansion process that returns the air pressure to ambient. The exhaust air leaves the engine with pressure equal to the outside, but at a higher temperature. As with any heat engine, the high exhaust temperature represents wasted energy that will dissipate into the outside atmosphere. See COMPRESSOR.

From an energy accounting standpoint, the sequence of processes acting on the air from front to rear constitutes a full cycle. It starts with the outside air entering at its initial state, and is completed when the air returns again to both ambient pressure and temperature levels. The series of cycle processes includes the final outside dissipation of the wasted exhaust energy, inevitable for every heat engine according to Carnot's principle. The ideal version of the gas turbine cycle is known as the Brayton cycle. See BRAYTON CYCLE; CARNOT CYCLE.

For any completed cycle, the total energy added from the fuel sources will always be equal to the sum of the useful output energy and the wasted exhaust energy. The thermal efficiency, which is the ratio of net output energy to fuel input energy for the cycle, measures the engine's ability to minimize wasted energy. A thermal efficiency of 60% means that for every 100 units of added energy 60 units will be available as useful output while 40 units will leave the engine as high-temperature exhaust.

Another performance measure is the specific power, which is the ratio of output power to quantity of working substance mass flow rate. Gas turbine engines, in comparison with other

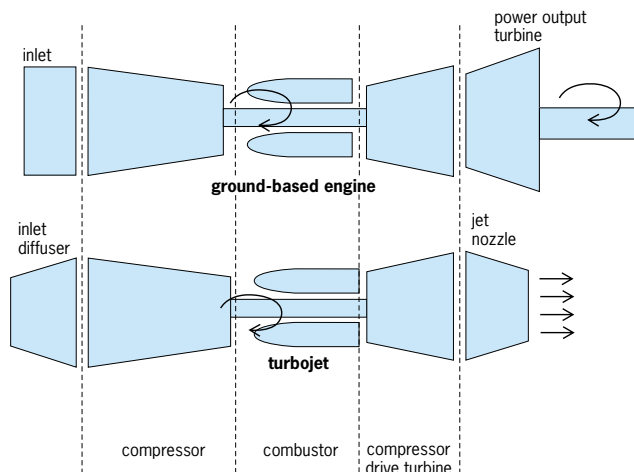

Simple gas turbine component arrangements.

types of heat engines, are characterized not only by high levels of efficiency but also by very high levels of specific power. They are especially useful for applications that need compact power.

By far the most common mechanical arrangement for the gas turbine is an in-line axial flow positioning of all components (see illustration). In the ground-based engine, the inlet at the front guides the incoming air into the compressor, which in turn delivers high-pressure air into the combustor section. The combustor burns the injected fuel at a high reaction temperature, using some of the air itself as an oxygen source. The combustion products in the combustor mix with the remaining unused air to reach a uniform equilibrium temperature, still high but diluted down from the reaction temperature. The hot, high-pressure combustor exit air enters the compressor drive turbine, where it expands down in pressure toward, but stays higher than, ambient level. This expansion process results in output shaft power that can be delivered directly to the compressor through a connecting rotating shaft. Starting from the exit of the compressor drive turbine, net output power remains available. This power can be realized through the process of further pressure expansion completely down to the ambient level. For ground-based applications, the final expansion takes place through a power turbine whose output shaft is connected to the external load. In the single-spool arrangement the power turbine and compressor drive turbine are indistinguishably combined into one unit which, together with the compressor and the output load, is connected to a common shaft. For aircraft applications, either a power turbine extracts useful power to drive a propeller through a separate shaft (turbo-prop), or the expansion process takes place through a nozzle which acts to convert some of the thermal energy into velocity energy to be used for jet propulsion. See AIRCRAFT ENGINE; JET PROPULSION.

Gas turbines characteristically produce smooth and linear throttle response over their entire operating range. Rotor speeds normally vary continuously over this range without the need for the gear shifting and clutch mechanisms found in piston engines. The governing fuel control senses rotor speeds, pressures, and temperatures to maintain stable, steady power or thrust output and, when needed, ensure rapid accelerations and decelerations. The control is programmed, normally by electronic input, to guard against harming the engine during throttle changes by governing the appropriate fuel input rate. Most important, during throttle transients the control functions to prevent turbine overheating, burner blowout, and compressor surge. [J.H.Le.; W.H.D.]

**Gasket** Deformable material used to make a pressure-tight joint between stationary parts, such as cylinder head and cylinder, that may require occasional separation. Gaskets are known

as static seals, as compared with packing or dynamic seals. In packings the parts are frequently in motion, as in piston rods and valve stems.

Gaskets are made of sheet materials such as natural or synthetic rubber, cork, vegetable fiber such as paper, asbestos and plastic pastes, or of soft metallic materials such as lead and copper. Rubber in the form of O-rings is used for light pressure. See PRESSURE SEAL. [P.H.B.]

**Gasoline** A mixture of hydrocarbons whose boiling point is below 200°C (390°F), obtained in the fractional distillation of petroleum. Gasoline is a liquid at ambient temperature, but it volatilizes readily in air to form a flammable mixture. The hydrocarbon fuel is used to power the internal combustion engine. Gasoline is composed primarily of the alkanes (paraffins) hexane, heptane, and octane, plus smaller amounts of higher-boiling alkanes. See ALKANE; INTERNAL COMBUSTION ENGINE.

Gasoline is usually produced by catalytic cracking or by reforming processes. In catalytic cracking, the petroleum (or petroleum-derived feedstock) is fed into a reaction vessel containing a catalyst. In reforming, naphtha (refined or unrefined) is heated with hydrogen in the presence of a catalyst. Reforming causes a rearrangement of the structures of the molecular constituents and creates a gasoline product. See CRACKING; PETROLEUM PROCESSING AND REFINING; REFORMING PROCESSES.

The hydrocarbon constituents in the boiling range of gasoline are those that have 4–12 carbon atoms in their molecular structure. Thus, gasoline can vary widely in composition; even gasolines with the same octane number may be quite different. For example, low-boiling distillates with high (above 20%) aromatics contents can be obtained from some crude oils. The variation in aromatics content as well as the variation in the content of normal paraffins, branched paraffins, cyclopentanes, and cyclohexanes is dependent upon the characteristics of the petroleum feedstock, and influence the octane number of the gasoline. See AROMATIC HYDROCARBON; DISTILLATION.

The differences in composition of gasoline dictate that, in order to produce a uniform product, blending of the products from several component streams is necessary. The properties of each stream may vary considerably, significantly affecting the product gasoline. The blending process is relatively straightforward, but the determination of the amount of each component to include in a blend is much more difficult. The operation is carried out by simultaneously pumping all the components of a gasoline blend into a pipeline that leads to the gasoline storage. The pumps adjust for the correct proportion of each component, while baffles in the pipeline are often used to mix components as they flow to the storage tank.

Volatility is an important property of gasoline and is a necessity to ensure engine starting in cold weather. In winter, volatility is raised and the flash point is lowered by adding the more volatile butanes and pentanes. To prevent vapor lock in warm weather, the amounts of the more volatile constituents are reduced to produce mixtures that will not vaporize in the fuel lines.

Additives are incorporated into commercial gasoline blends, for example to inhibit oxidation and gum formation during storage. Dyes may be added for identification purposes. Alcohol and surfactants are used to reduce carburetor icing and corrosion. Detergent additives remove from the engine and fuel injector some of the deposits produced by gasoline combustion.

Before they are ignited by a spark plug, the hydrocarbons in a gasoline blend may ignite spontaneously under the high temperature and pressure conditions inside an engine cylinder. This preignition causes a characteristic engine knock. The octane number is a measure of the ability of a hydrocarbon fuel to resist preignition. It is obtained by comparing the antiknock performance of the gasoline with that of a mixture of isooctane and heptane: a gasoline blend with an octane number of 90 equals in performance a mixture of 90% octane and 10% heptane. The octane number of a gasoline can be increased by the

use of reforming techniques and by alkylation, where gasoline components are recombined to build a larger molecule with a high octane number. See OCTANE NUMBER. [J.G.S.]

**Gasteromycetes** An artificial class of fungi in the phylum Basidiomycota in which basidiospores are produced in a mass (gleba) and enclosed within a membrane called the peridium. Such enclosed fruit bodies evolved many times; hence the class is heterogeneous. Most Gasteromycetes have lost the ability to discharge spores ballistically off basidia directly into air. Since internal sporulation prevents normal spore drop into air currents, these fungi have developed other dispersal mechanisms.

Gasteromycetes are either saprophytic or mycorrhizal. Historically, mature dry spores of puffballs were used to clot wounds. Young puffballs are edible, but false puffballs are poisonous. Because of their phallic shape, stinkhorns have been associated with witchcraft. See ASCOMYCOTA; BASIDIOMYCOTA; EUMYCOTA; FUNGI. [S.A.R.]

**Gasterosteiformes** An order of actinopterygian fishes which includes the groups Solenichthyes, Thoracostei, Hemibranchii, Lophobranchii, and Syngnathiformes of other classifications. Members of this order, commonly known as sticklebacks, tube-snouts, snipefishes, pipefishes, and seahorses, may be classified in 3 suborders, 7–9 families, 50–55 genera, and 200 or more species. The group dates from the Eocene.

Common characters include a swim bladder without a duct; pelvic fin, if present, with or without a spine and abdominal to subthoracic in position; pelvic girdle not in contact with the cleithrum; and articulation of the quadrate with the lower jaw in advance of the orbit. Fin spines are present or absent. The snout is commonly produced, the mouth opening at the end of a long tube (see illustration).



Trumpetfish (*Aulostomus maculatus*). (After D. S. Jordan and B. W. Evermann, *The Fishes of North and Middle America*, U.S. Nat. Mus. Bull. no. 47, 1900)

Most species are inhabitants of warm seas, but some sticklebacks live in fresh waters of northern continents, and a few tropical pipefishes enter or reside permanently in rivers. See ACTINOPTERYGII; TELEOSTEI. [R.M.B.]

**Gastornithiformes** An order of extinct flightless birds known from Paleocene and Eocene deposits in North America and Europe. These were giant, 2-m-tall (7-ft) birds with large heads, huge laterally compressed bills, broad cervical vertebrae, wide pelvis, massive legs with relatively short tarsi and heavy toes suggestive of a slow-moving gait, and reduced wings that were evidently too short to permit flight. Gastornithiforms have been depicted as fast-running predators that evolved to fill the bipedal carnivore niche vacated by theropod dinosaurs at the end of the Cretaceous Period. However, their jaw and hindlimb anatomy indicates that they were primarily herbivorous and incapable of sustained rapid running. Various skull and postcranial characters suggest that gastornithiforms are related to the waterfowl (Anseriformes) and, more distantly, to the true fowl (Galliformes).

Three genera have been reported. The type-genus, *Gastornis*; an apparently confamilial form, *Diatryma*; and third genus, *Zhongyuanus*, of uncertain phylogenetic affinity.



*Diatryma steini* (reconstruction). (American Museum of Natural History)

Gastornithiforms are most abundant in alluvial sediments of the Bighorn Basin of Wyoming, where the most complete known skeleton, the holotype of *Diatryma steini* Matthew and Granger (= *D. gigantea* Cope; see illustration), was discovered, and in lake and swamp deposits of the Geiseltal of Germany. See AVES. [A.V.A.]

**Gastrointestinal tract disorders** Malfunctions of the organs of digestion from the esophagus to the rectum. The gastrointestinal tract usually functions unnoticed, intruding into consciousness only in the form of specific sensations of hunger, intestinal motion, or the need to defecate. However, it is subject to a wide array of pathologic states.

**Esophagus.** The esophagus is the site of two principal disorders: disturbance of the muscular contractions, and mechanical interference with the passage of food caused by a narrowed lumen. Carcinoma of the esophagus produces mechanical obstructions to swallowing; the long-term prognosis is poor. Excessive acid reflux or regurgitation from the stomach may result in inflammation of the lower esophagus with heartburn and indigestion. Changes in diet and eating habits may bring relief.

The prime example of muscular or neuromuscular disorder is achalasia, a condition of unknown etiology characterized by degeneration of the nervous mechanisms that coordinate contractions of the esophagus and relaxation of the lower esophageal sphincter. Swallowing solids and liquids is difficult, and nutritional consequences usually result.

Other disorders that affect the esophagus include connective tissue diseases such as scleroderma or dermatomyositis. Scleroderma is characterized by weakening of the smooth musculature, which is present in the lower two-thirds of the esophagus, and the lower esophageal sphincter. Dermatomyositis affects the striated musculature present in the upper third of the esophagus. See CONNECTIVE TISSUE DISEASE.

Mechanical problems include stricture or scarring of the lower esophagus, which usually develops from acid reflux. Swallowing is also impeded mechanically by a lower esophageal, or Schatzki, ring, which is a mucosal constriction at the junction of the esophagus and stomach in the presence of a hiatus hernia. See HERNIA.

Carcinoma of the esophagus causes mechanical obstructions to swallowing.

Reflux esophagitis is an inflammation of the lower esophagus that results from excessive acid reflux or regurgitation from the stomach.

**Stomach.** The stomach is the site of secretion of the highly concentrated hydrochloric acid. The lining of the stomach and duodenal both need to be protected against the effects of the acid.

Peptic ulcer disease is characterized by breaks in the mucosa of the proximal duodenum (duodenal ulcer) or stomach (gastric ulcer). Duodenal ulcer is one of the most common maladies, but for unknown reasons its incidence seems to be declining. It is associated with high concentrations of hydrochloric acid caused by excessive gastrin secretion. In persons with a gastric ulcer, acid concentrations are usually normal or low. The cause of gastric ulcer is not known but may involve increased reflux of bile and other constituents of the small intestine.

Inflammation of the stomach lining, known as gastritis, ranges in severity from acute to chronic and can ultimately lead to atrophy of the tissues and loss of function.

The typical symptoms of gastric cancer include early satiety after eating small amounts of food, abdominal pain, anemia from blood loss, and difficulty in swallowing. Benign stomach tumors are usually asymptomatic but may cause bleeding.

**Small intestine.** The small intestine is normally resistant to disease. When nutrition is adequate, structure and function remain intact into old age with only slight changes if no specific diseases occur. A prototypical disease of malabsorption is gluten enteropathy, or nontropical sprue. Probably due in part to genetic abnormalities, gluten enteropathy is characterized by inflammation and loss of the normal architecture of the small intestine following ingestion of some proteins. The causative substance is contained in gluten, the protein of cereal grains; a gluten fraction, gliadin, contains the toxin that is responsible. A gluten-free diet, once it has been adopted, is usually maintained for life. Other conditions may also interfere with the absorptive function of the small intestine. Tropical sprue, found in tropical and subtropical climates, resembles gluten enteropathy in its manifestations. It may, however, be an infectious diarrhea; it can be treated with antibiotics and high doses of folic acid. A gluten-free diet does not cure the condition. Infections within the small intestine, particularly those of the parasite *Giardia lamblia*, may also cause malabsorption. Bacterial infection by *Escherichia coli* causes most cases of traveler's diarrhea. Among the many other diseases that may lead to malabsorption is regional enteritis, or Crohn's disease. See INFLAMMATORY BOWEL DISEASE.

Of all the body's organs, the small intestine is one of the most resistant to neoplastic disease. Benign tumors are rare, as are cancer and lymphoma. (In some familial conditions, however, benign polyps may develop.)

**Colon.** The colon, or large intestine, is subject to malfunction of widely varying degrees, ranging from mild irritation to life-threatening diseases.

Disturbance of bowel function is among the most common complaints. Constipation probably predominates, particularly with advancing age, but loose stool and diarrhea are also frequent and troublesome. A familiar condition associated with altered function is irritable bowel syndrome, a nonspecific label for an intestinal disturbance without known anatomic cause. See DIARRHEA.

In diverticulosis, small pouches appear along the wall of the colon. Diverticulosis is associated with high pressures within the colon and particularly its narrowest segment, the sigmoid colon. The pressure pushes the mucosa through the weakest points in the wall, leading to formation of the diverticuli.

The second most common internal cancer is that of the colon and rectum. Cancers frequently arise in benign polyps of the colon, which are stalklike or leafed structures (villous adenomas). A high intake of red meat and low fiber and low vitamin A consumption may be contributing factors; a genetic predisposition has been suggested.

Hemorrhoids are veins near the anus that have become distended or occluded. The cause is not fully understood but may be related to straining at stool.

**Appendix.** Appendicitis, that is, inflammation of the vermiform appendix, was once common among young people but is now relatively rare; the reason for the sharp drop in frequency is unclear. Appendicitis seems to result when a hardened piece of fecal matter known as a fecolith becomes trapped within the appendix and causes infection that can lead to gangrene. If the condition persists, the appendix may perforate, resulting in widespread infection in the abdomen. See APPENDICITIS; CANCER (MEDICINE); DIGESTIVE SYSTEM; GASTROINTESTINAL TRACT; TUMOR. [L.A.Ka.]

**Gastrolith** Any of the pebbles swallowed by animals and retained for a time in the gizzard or stomach, where they serve to grind up the food and in so doing become rounded and highly polished. Birds generally use such pebbles, as do some living reptiles, notably the crocodile and certain lizards. Some of the Mesozoic reptiles also used gastroliths. [C.O.D.]

**Gastropoda** The largest and most varied class in the phylum Mollusca, possibly numbering over 74,000 species and commonly known as snails.

**General characteristics.** The shell is in one piece which, in the majority of forms, grows along a turbinated (equiangular) spiral (see illustration), but which is modified into an open cone in various limpets or is secondarily lost in various slugs.

All gastropods, at some time in their phylogeny and at some stage in their development, have undergone torsion. The process does not occur in any other mollusks. It implies that the visceral mass and the mantle shell covering it have become twisted through 180° in relation to the head and foot. As a result of torsion, all internal organs are twisted into a loop. Similarly in gastropods, the mantle cavity (the semi-internal space enclosed by the pallium or mantle) containing the characteristic molluscan gills (ctenidia) has become anterior and placed immediately above and behind the head. The most primitive gastropods retain a pair of aspidobranch (bipectinate or featherlike) gills, each with alternating ctenidial leaflets on either side of a ctenidial axis in which run afferent and efferent blood vessels. Lateral cilia on the faces of the leaflets create a respiratory water current (toward the midline and anteriorly) in the direction opposite to the flow of blood through the gills, to create the physiological efficiency of a countercurrent exchange system.



Longitudinal section ground through the shell of a specimen of *Conus spurius* to reveal the central columella and spiral of whorls expanding to the aperture. (From W. D. Russell-Hunter, *A Life of Invertebrates*, Macmillan, 1979)

**Classification and diversity.** The usual systematic arrangement of the class Gastropoda involves three somewhat unequal subclasses. The first, the largest and most diverse, is the subclass Prosobranchia, which is made up largely of marine snails all retaining internal evidence of torsion. Prosobranchs are divided into at least four orders: Archaegastropoda, Caenogastropoda, Neritida, and Patellogastropoda; three superfamilies remain to be assigned to one of the four orders, and may each comprise a distinct order. The other two subclasses (Opisthobranchia and Pulmonata) are each considerably more uniform than the subclass Prosobranchia and, in both, the effects of torsion are reduced or obscured by secondary processes of development and growth. See OPISTHOBRANCHIA; PROSOBRANCHIA; PULMONATA.

More than half of all molluscan species are gastropods, and they encompass a range from marine zygobranchs, which can be numbered among the most primitive of all living mollusks, to the highly evolved terrestrial air-breathing slugs and snails. Pulmonates and certain mesogastropod families are the only successful molluscan colonizers of land and fresh waters.

[W.D.R.H.]

**Fossils.** Fossil gastropods have a long geologic history, being common throughout the Paleozoic and increasingly abundant in the Mesozoic and Cenozoic. All three subclasses are known in the fossil record; many superfamilies, particularly prosobranchs, are extinct. Average duration of a genus has been estimated to range from 30,000,000 to 90,000,000 years.

Marine gastropods are important stratigraphic indicators in Cenozoic strata and locally are abundant in Cretaceous rocks. They are less common and less useful in the Jurassic and Triassic. Although individual genera have stratigraphic utility within the Paleozoic, it is only in the Ordovician that they are significant for correlation. See MOLLUSCA.

[E.L.Y.]

**Gastrotricha** A phylum of minute metazoan animals (formerly placed in the aschelminth group) numbering 500 described species worldwide. Some 300 species have been reported from the marine habitat, with new ones being described every year.

Gastrotrichs comprise two orders, the Macrotrichida and the Chaetonotida. The term Gastrotricha refers to the ventral locomotor cilia by which the animals glide gracefully over the substratum or through its interstices; unlike many other ciliated animals, they cannot move in reverse. Gastrotrichs have a complete digestive tract, with a sucking pharynx, a simple intestine with a wall only a single cell thick, and an anus. They appear to be selective feeders on bacteria, very small protozoa, and yeasts. Most have protonephridia, accounting in part for their broad salinity tolerances.

Gastrotrichs appear to be regionally cosmopolitan, with 20–30% having broad distributions within continents, and 10–15% between continents; endemism probably does not exceed 20%.

The phylum Gastrotricha is the most primitive in the aschelminth group of phyla. Gastrotrichs and nematodes probably share a common ancestor, which in turn was descended from a stock that included gnathostomulids and turbellarianoid animals. See CHAETONOTIDA; GNATHOSTOMULIDA; MACROTRICHIDA; NEMATA; TURBELLARIA.

[W.D.Hu.]

**Gastrulation** The formation of the primordial gut, the archenteron, or digestive cavity of an early animal embryo. More generally, and originally, the term gastrulation referred to the process by which the gastrula stage of the embryo is formed. Thus to nineteenth-century embryologists, gastrulation was the process by which the single-layered blastula, a hollow ball of cells, is converted into the double-layered gastrula. The term has now come to have a still more general meaning, namely, the process by which the three germ layers, or primordial tissues of the embryo, are brought into the positions and relations characteristic of the late gastrula stage, with ectoderm (outer skin), mesoderm (middle skin), and endoderm (inner skin) from the outside to the

inside. The terms epiblast, mesoblast, and hypoblast are also used to denote ectoderm, mesoderm, and endoderm, respectively. See BLASTULATION.

Two general but not mutually exclusive methods of gastrulation have been recognized: epiboly and emboly. Epiboly is the growing or extending of one part, such as the upper hemisphere of a spherical blastula, over and around another part, such as the lower hemisphere. Emboly is the pushing or growing of one part into another. In many embryos, both types of cell movement may occur; in certain invertebrate embryos, one type may predominate almost to the exclusion of the other. Generally speaking, epiboly tends to be the major, but not the only, method of gastrulation in forms with large, yolky eggs. See GERM LAYERS.

[N.T.S.]

**Gate circuit** An electronic circuit that consists of elements, which may be transistors, diodes, or resistors, combined in such a manner that they perform a logic operation. Gate circuits are the most basic building blocks of a digital system. These circuits have one or more inputs and one output which is a boolean function of the inputs. The input and output signals can have only two discrete values, low (for example, 0 V) and high (for example, 3.3 V). These values are usually represented as 0 and 1, or “false” and “true,” respectively.

Whereas the early gate circuits consisted of diodes, resistors, and transistors, the majority of gate circuits nowadays are built exclusively with transistors. The dominant technology for fabricating gate circuits is the metal oxide semiconductor (MOS) silicon method, followed by the silicon bipolar and gallium arsenide (GaAs) techniques. The manufacturing process has become so sophisticated that transistors smaller than 1 square micrometer can be fabricated, allowing the placement of millions of gate circuits on a silicon chip the size of a fingernail. The main advantage of MOS technology is that it gives rise to very low power circuits that can still operate at relatively high clock speed. It is these characteristics that have allowed the fabrication of very complex digital systems such as microprocessors and memories. See INTEGRATED CIRCUITS; MICROPROCESSOR; SEMICONDUCTOR MEMORIES.

The transistors in a gate circuit are used as ON-OFF switches. By combining these transistors in a certain way, it is possible to realize logical, arithmetical, and memory functions. There are two types of MOS transistors: NMOS and PMOS field-effect transistors (FETs), corresponding to a normally-OFF or normally-ON switch, respectively. Circuits in which both types of transistors are used are called CMOS (complementary MOS) circuits. CMOS circuits now constitute the majority of gate and logic circuits.

In switch circuits an MOS transistor is used to pass or block the flow of information in a similar fashion to a mechanical switch. By placing these switches in a network, it is possible to realize different logic functions. A transistor used in this fashion is often called a pass-transistor. In order to improve the switching characteristics, an NMOS switch and a PMOS switch are placed in parallel, each clocked at opposite clock signals. Such a combination is called a CMOS transmission gate. Several transmission gates can be combined to form a logic AND circuit. See SWITCHING CIRCUIT.

An alternative way to realize logic functions is to make use of logic gates. The simplest gate circuit, the inverter, takes an input signal and presents the inverted signal at the output. See LOGIC CIRCUITS; TRANSISTOR.

[J.V.S.]

**Gauge theory** The theoretical foundation of the four fundamental forces of nature, the electromagnetic, weak, strong, and gravitational interactions. Gauge symmetry lies at the heart of gauge theory. A gauge symmetry differs from an ordinary symmetry in two important respects:

1. Gauge symmetry is a local symmetry rather than a global symmetry. For a local symmetry, the element of the symmetry

group ( $G$ ) that acts on the fields of a theory at a space-time point  $(\mathbf{x}, t)$  depends on the position  $\mathbf{x}$  and time  $t$ , whereas for a global symmetry a fixed group element acts on fields at different space-time points.

2. A gauge transformation leaves a physical state invariant. Gauge symmetry reflects a redundancy in the variables used to describe a physical state. By contrast, a global symmetry acting on a physical state in general produces a new, distinct physical state. See FUNDAMENTAL INTERACTIONS; SPACE-TIME.

The simplest example of a gauge theory is electromagnetism. In classical electrodynamics, gauge invariance reflects the arbitrariness that exists in choosing the potentials  $\mathbf{A}(\mathbf{x}, t)$  and  $\phi(\mathbf{x}, t)$  to represent the electric and magnetic fields,  $\mathbf{E}$  and  $\mathbf{B}$ , according to Eqs. (1), where  $c$  is the speed of light. If  $\Lambda(\mathbf{x}, t)$  is an arbitrary scalar field, Eqs. (2) define a gauge transformation.

$$\begin{aligned}\mathbf{E}(\mathbf{x}, t) &= -\nabla\phi - \frac{1}{c} \frac{\partial \mathbf{A}}{\partial t} \\ \mathbf{B}(\mathbf{x}, t) &= \nabla \times \mathbf{A}\end{aligned}\quad (1)$$

$$\begin{aligned}\phi &\rightarrow \phi' = \phi - \frac{1}{c} \frac{\partial \Lambda}{\partial t} \\ \mathbf{A} &\rightarrow \mathbf{A}' = \mathbf{A} + \nabla \Lambda\end{aligned}\quad (2)$$

The potentials  $\mathbf{A}'$  and  $\phi'$  may equally well be used to represent the electromagnetic fields  $\mathbf{E}$  and  $\mathbf{B}$ . See MAXWELL'S EQUATIONS; POTENTIALS; RELATIVISTIC ELECTRODYNAMICS.

In nonrelativistic quantum mechanics, gauge invariance is realized as follows. The Schrödinger equation for a particle with an electromagnetic charge  $q$  and mass  $m$  is Eq. (3), where  $\hat{H}$  is

$$\begin{aligned}\hat{H}\Psi &= \frac{1}{2m} \left( \hat{\mathbf{p}} - \frac{q}{c} \mathbf{A} \right)^2 \Psi + q\phi\Psi \\ &= \frac{1}{2m} \left( -i\hbar\nabla - \frac{q}{c} \mathbf{A} \right)^2 \Psi + q\phi\Psi \\ &= i\hbar \frac{\partial}{\partial t} \Psi\end{aligned}\quad (3)$$

the hamiltonian operator,  $\hat{\mathbf{p}}$  is the momentum operator,  $\Psi$  is the wave function of the particle, and  $\hbar$  is Planck's constant divided by  $2\pi$ . Equation (3) is invariant under the gauge transformation given by Eqs. (4). Electromagnetism is a  $U(1)$  gauge symmetry

$$\begin{aligned}\Psi &\rightarrow \Psi' = \exp\left(\frac{iq\Lambda}{\hbar c}\right) \cdot \Psi \\ \phi &\rightarrow \phi' = \phi - \frac{1}{c} \frac{\partial \Lambda}{\partial t} \\ \mathbf{A} &\rightarrow \mathbf{A}' = \mathbf{A} + \nabla \Lambda\end{aligned}\quad (4)$$

[where  $U(1)$  is the one-dimensional unitary group, which is represented by the complex numbers  $e^{i\varphi}$  with  $0 \leq \varphi < 2\pi$ ] because a gauge transformation rotates the phase of the wave function in a space-time-dependent manner and adjusts the potentials  $A$  and  $\phi$  accordingly. See NONRELATIVISTIC QUANTUM THEORY; QUANTUM MECHANICS; SCHRÖDINGER'S WAVE EQUATION; UNITARY SYMMETRY.

The concept of a gauge theory may be generalized to larger, nonabelian Lie groups, such as  $G = SU(2)$ ,  $SU(3)$ ,  $SU(5)$ , or  $SO(10)$ . In 1954 C. N. Yang and R. L. Mills suggested gauging the  $SU(2)$  isospin symmetry, thus developing the first nonabelian gauge theory, also known as Yang-Mills theory. In 1971 G. 't Hooft demonstrated the renormalizability of nonabelian gauge theory. Nonabelian gauge theory is the foundation of the electroweak and strong interactions. In the electroweak theory, formulated by S. Weinberg and A. Salam in 1967, the gauge group  $G = SU(2)_L \times U(1)_Y$  is spontaneously broken to  $U(1)_Q$ , the gauge group of ordinary electromagnetism, by the condensation of a Higgs field. There are four kinds of particles that mediate the gauge interactions, called gauge bosons: two massive charged weak gauge bosons, the  $W^+$  and  $W^-$ , with a mass of 80.4 GeV; a

neutral gauge boson, the  $Z$ , with a mass of 91.2 GeV; and finally a massless photon ( $\gamma$ ). The  $W^\pm$  and the  $Z$  are responsible for the charged and neutral weak interactions, respectively, and the photon is the gauge particle responsible for the electromagnetic interaction. In quantum chromodynamics (QCD) the symmetry group is  $SU(3)_{\text{color}}$ , which remains unbroken. There are eight gauge bosons called gluons. Quarks, which come in three colors, carry a color charge, and the quark field forms an  $SU(3)$  triplet. See ELECTROWEAK INTERACTION; SYMMETRY BREAKING.

One remarkable property of quantum chromodynamics is that color charge is antiscreened rather than screened, a feature arising from the nonabelian character of the gauge symmetry. This situation is opposite to that in QED. Consequently, as shorter distance scales are probed, the coupling constant  $\alpha_{\text{QCD}}$  decreases, so that at very short distances QCD approaches a free (noninteracting) field theory. This feature, pointed out in 1973 by D. Gross and F. Wilczek and by H. D. Politzer, is known as asymptotic freedom. Although on large scales QCD is a strongly coupled theory, at very small scales, which may be probed by scattering at very high energies, the constituents of hadrons (quarks and gluons) behave almost as if they were free particles, originally called partons. Similarly, at larger distances scales  $\alpha_{\text{QCD}}$  becomes larger, and perturbation theory breaks down. This increase in the coupling constant at large distances leads to a phenomenon known as confinement, which prevents colored objects (such as quarks or gluons) from being isolated. See GLUONS; QUANTUM CHROMODYNAMICS; QUARKS. [M.Bu.]

**Gauss' theorem** The assertion, under certain light restrictions, that the volume integral through a volume  $V$  of the divergence of vector function  $\mathfrak{F}(x, y, z)$  is equal to the surface integral of the exterior normal component of  $\mathfrak{F}$  over the boundary surface  $S$  of  $V$ , or in symbols  $\iiint_V \nabla \cdot \mathfrak{F} dV = \iint_S \mathfrak{F} \cdot \mathbf{v} dS$ , with  $\mathbf{v}$  the unit exterior normal to  $S$ . This theorem is also known as the divergence theorem and as Green's theorem.

The divergence theorem plays an important role in a variety of subjects such as electricity and magnetism, mechanics of continuous media (including fluid dynamics), heat flow, partial differential equations, and potential theory. See CALCULUS OF VECTORS; GREEN'S THEOREM. [H.V.C.]

**Gavial** The name of two species of reptiles which form the family Gavialidae in the order Crocodylia. The Indian gavial (*Gavialis gangeticus*) is confined to the Ganges River and its tributaries, while the Malayan gavial (*Tomistoma schlegelii*) is found in Borneo and Sumatra.

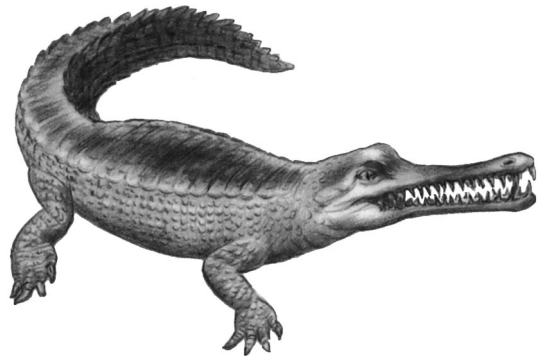

The Indian gavial, which may attain a length of 30 ft (9 m).

The gavial is distinguished from other members of the order by its extremely long, slender snout (see illustration). The tip of the snout is enlarged, and fleshy elevations surround the openings of the nostrils. The females lay about 30–40 eggs in nests which they have prepared on the riverbanks. The newly hatched young are about 1 ft (30 cm) long and quite active. See ALLIGATOR; CROCODILE; REPTILIA. [C.B.C.]

**Gaviiformes** A small order of aquatic birds that contains a single living family, the Gaviidae (loons), whose five species are restricted to the Northern Hemisphere, and a fossil family, the Colymboididae. Loons are large swimming and diving birds that catch fish with their strong bills in underwater pursuits. They are foot-propelled swimmers, with short legs placed far back on the body and webbed feet; land locomotion is awkward. Loons take wing with difficulty but are strong fliers. Sexes are similar in plumage, which is white below and checked black and white above. Loons are monogamous, have a strong pair bond, and engage in elaborate courtship rituals that include loud, quavering calls often given in flight. Breeding is solitary and takes place on freshwater lakes. The young are downy, leave the nest after hatching, and are cared for by both parents. Because all flight features are molted simultaneously, the birds are rendered temporarily flightless. Loons migrate south to wintering areas, which are mostly along ocean coasts. See AVES; CHARADRIIFORMES; HESPERORNITHIFORMES; PODICIPEDIFORMES. [W.J.B.]

**Gear** A machine element used to transmit motion between rotating shafts when the center distance of the shafts is not too large. Toothed gears provide a positive drive, maintaining exact velocity ratios between driving and driven shafts, a factor that may be lacking in the case of friction gearing which is subject to slippage. See BELT DRIVE; CHAIN DRIVE; ROLLING CONTACT.

The application of gears for power transmission between shafts falls into three general categories: those with parallel shafts, those for shafts with intersecting axes, and those whose shafts are neither parallel nor intersecting but skew. See GEAR TRAIN. [J.R.Z.]

**Gear train** A combination of two or more gears used to transmit motion between two rotating shafts or between a shaft and a slide. In theory two gears can provide any speed ratio in connecting shafts at any center distance, but it is often not practical to use only two gears. If the ratio is large or if the center distance is relatively great, the larger of the two gears may be excessively large. Moreover, an additional gear may be necessary simply to give the proper direction to the output gear. Belt, rope, and chain drives are frequently used in conjunction with gear trains. See BELT DRIVE; CHAIN DRIVE; GEAR; PLANETARY GEAR TRAIN.

The most important distinction in classifying gear trains is that between ordinary and epicyclic gear trains. In ordinary trains (illustration a), all axes remain stationary relative to the frame. But in epicyclic trains (illustration b), at least one axis moves relative to the frame. In illustration b, gear B, whose axis is in motion, is called a planet. The gears A and C are sun gears.

A simple gear train is one in which each gear is fastened to a separate shaft, as in illustration a. If at least one shaft has two or more gears fastened to it, the train is said to be compound. The train is a reverted gear train when the input and output shafts are

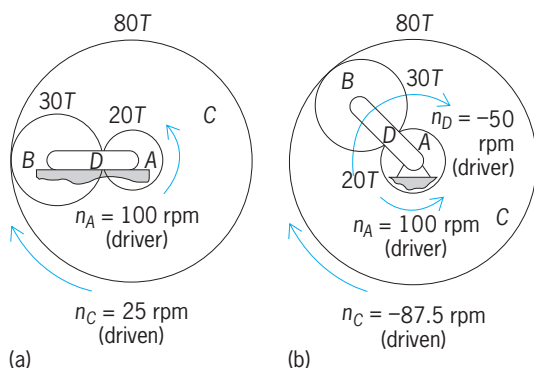

Gear trains. (a) Ordinary. (b) Epicyclic.

in line. If the input shaft does not line up with the output shaft, the train is said to be nonreverted.

If a machine must be operated at any one of several output speeds, a multiple-speed gearbox, or transmission, may be used as a component part. Machine tools and motor vehicles are familiar instances of the need for transmissions. The speed of the output shaft of a transmission can be varied by sliding gears in and out of contact or by connecting gears in continual mesh to shafts by means of clutches. See AUTOMOTIVE TRANSMISSION. [J.R.Z.]

**Gecko** The name for about 300 species of reptiles that form the family Gekkonidae in the order Squamata. They are small lizards, primarily arboreal and nocturnal, which occur in the warm regions of the world. The body is flattened; most species have five digits, while some have only four; the toes often have adhesive pads to assist the animal when climbing on smooth surfaces. Geckos feed on small animals, especially insects, and all species have a long sensitive tongue to aid in capturing their prey. Most species of gecko are oviparous.

The largest, most aggressive species is the orange-spotted Tokay (*Gekko gekko*), which is indigenous to Southeast Asia. Another species is the flying gecko (*Ptychozoon homalocephalum*), which is essentially arboreal and is well adapted to leaping and gliding because it has folds of skin on either side of the body that can be opened out to form a planing surface. The banded gecko (*Coelonyx variegatus*) of the southwestern United States is one of the few species with movable eyelids, and with claws instead of pads on the toes. See SQUAMATA. [C.B.C.]

**Geiger-Müller counter** A detector of ionizing radiation. When a fast-moving charged particle traverses a Geiger-Müller counter, an electrical impulse is produced. These impulses can readily be counted by electronic circuits. Geiger-Müller (GM) counters, usually referred to simply as Geiger counters, are widely used to indicate the presence and intensity of nuclear radiations.

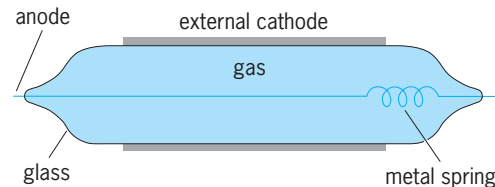

Cylindrical external-cathode Geiger-Müller counter, with thin soda glass and central wire of 0.003-in.-diameter (0.008-cm) tungsten. Metal spring keeps central wire taut.

A GM counter consists of a gas between two electrodes (see illustration). One electrode, usually cylindrical and hollow, is the cathode. The other electrode, a fine "wire stretched along the axis of the cylinder, is the anode. A potential of about 1000 volts is placed on the wire. When an atom of the gas between the two electrodes is ionized by collision with a charged particle passing through the gas, the electron produced in the collision is drawn toward the central wire. The electron then collides with the atoms of the gas. Near the central wire the electric field is very intense, and the electron may acquire enough energy between two collisions to allow it to ionize another atom. A second electron is then set free, and by successive collisions, an avalanche of electrons is produced which is then collected as charge on the central wire. This charge produces an electrical impulse which in typical cases may be 50 volts. See IONIZATION CHAMBER; PARTICLE DETECTOR. [W.B.Fr.]

**Gel** A continuous solid network enveloped in a continuous liquid phase; the solid phase typically occupies less than 10 vol % of the gel. Gels can be classified in terms of the network structure.



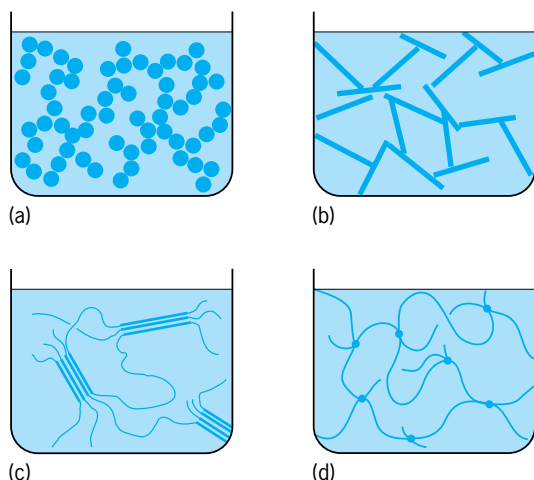

**Gel structures.** (a) Agglomerated particles. (b) Framework of fibers or plates. (c) Polymers linked by crystalline junctions. (d) Polymers linked by covalent bonds. (After M. Djabourov, *Architecture of gelatin gels*, *Contemp. Phys.*, 29(3):273–297, 1988)

The network may consist of agglomerated particles (formed, for example, by destabilization of a colloidal suspension; illus. a); a “house of cards” consisting of plates (as in a clay) or fibers (illus. b); polymers joined by small crystalline regions (illus. c); or polymers linked by covalent bonds (illus. d).

In a gel the liquid phase does not consist of isolated pockets, but is continuous. Consequently, salts can diffuse into the gel almost as fast as they disperse in a dish of free liquid. Thus, the gel seems to resemble a saturated household sponge, but it is distinguished by its colloidal size scale: the dimensions of the open spaces and of the solid objects constituting the network are smaller (usually much smaller) than a micrometer. This means that the interface joining the solid and liquid phases has an area on the order of  $1000 \text{ m}^2$  per gram of solid. As a result, the properties of a gel are controlled by interfacial and short-range forces, such as van der Waals, electrostatic, and hydrogen-bonding. Factors that influence these forces, such as introduction of salts or another solvent, application of an electric field, or changes in pH or temperature, affect the interaction between the solid and liquid phases. Variations in these parameters can induce huge changes in volume as the gel imbibes or expels liquid, and this phenomenon is exploited to make mechanical actuators or hosts for controlled release of drugs from gels. For example, a polyacrylamide gel (a polymer linked by covalent bonds) shrinks dramatically when it is transferred from a dish of water (a good solvent) to a dish of acetone (a poor solvent), because the polymer chains tend to favor contact with one another rather than with acetone, so the network collapses onto itself. Conversely, the reason that water cannot be gently squeezed out of such a gel is that the network has a strong affinity for the liquid, and virtually all of the molecules of the liquid are close enough to the solid-liquid interface to be influenced by those attractive forces. See HYDROGEN BOND; INTERMOLECULAR FORCES.

The most striking feature of a gel is its elasticity: if the surface of a gel is displaced slightly, it springs back to its original position. If the displacement is too large, gels, except those with polymers linked by covalent bonds, may suffer some permanent plastic deformation, because the network is weak. The process of gelation, which transforms a liquid into an elastic gel, may begin with a change in pH that removes repulsive forces between the particles in a colloidal suspension, or a decrease in temperature that favors crystallization of a solution of polymers or the initiation of a chemical reaction that creates or links polymers. See PH.

Many inorganic gels can be made from solutions of salts or metallorganic compounds, and this offers several advantages in

ceramics processing: the reactants are readily purified; the components can be intimately mixed in the solution or sol stage; the sols can be applied as coatings, drawn into fibers, emulsified or spray-dried to make particles, or molded and gelled into shapes. Hybrid materials can be made by combining organic and inorganic components in the gel. Many hybrids have such compliant networks that they collapse completely during drying, leaving a dense solid; therefore, they can be used as protective coatings (on plastic eyeglass lenses, for example) without heat treatment. Hybrid gels show great promise for active and integrated optics, because optically active organic molecules retain their activity while encapsulated in the gel matrix. [G.W.Sc.]

**Gel permeation chromatography** A separation technique involving the transport of a liquid mobile phase through a column containing the separation medium, a porous material. Gel permeation chromatography (GPC), also called size exclusion chromatography and gel filtration, affords a rapid method for the separation of oligomeric and polymeric species. The separation is based on differences in molecular size in solution. It is of particular importance for research in biological systems and is the method of choice for determining molecular weight distribution of synthetic polymers.

The separation medium is a porous solid, such as glass or silica, or a cross-linked gel which contains pores of appropriate dimensions to effect the separation desired. The liquid mobile phase is usually water or a buffer for biological separations, and an organic solvent that is appropriate for the sample and is compatible with the column packing for synthetic polymer characterization. Solvent flow may be driven by gravity, or by a high-pressure pump to achieve the desired flow rate through the column. The sample to be separated is introduced at the head of the column (see illustration). As it progresses through the column, small molecules can enter all pores larger than the molecule, while larger molecules can fit into a smaller number of pores, again only those larger than the molecule. Thus, the larger the molecule, the smaller is the amount of pore volume available into which it can enter. The sample emerges from the column in the inverse order of molecular size; that is, the largest molecules emerge first followed by progressively smaller molecules. In order to determine the amount of sample emerging, a concentration detector is located at the end of the column. Additionally, detectors may be used to continuously determine the molecular

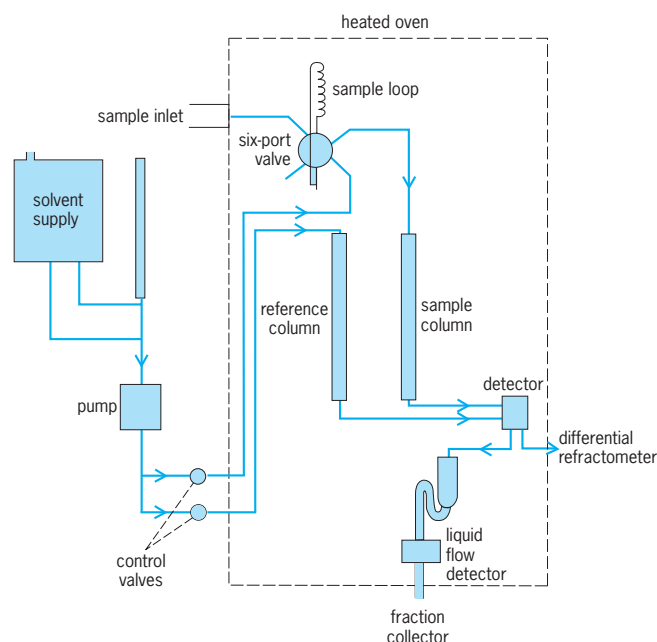

**Gel permeation chromatography.**

weight of species eluting from the column. The volume of solvent flow is also monitored to provide a means of characterizing the molecular size of the eluting species.

As the sample emerges from the column, a concentration detector signal increases above the baseline, passes through a maximum, and returns to the baseline. This signal provides a relative concentration of emerging species and is recorded as a function of elution volume. Molecular-weight detectors based on light scattering or viscometry produce a signal, independent of molecular weight, that increases with increasing molecular weight for a given sample concentration. The molecular-weight chromatograms therefore are skewed with respect to the concentration detector signal. Typically, constant-volume pumps are used, and the time axis is transformed into a volume axis. Devices such as siphons that empty after a known volume of solvent has collected, or electronic circuitry that measures the transit time of a thermal pulse between two points in the flowing solvent, have been used to provide a measurement of the volumetric flow rate.

Gel permeation chromatography has had widespread applications. For determining the molecular weight of synthetic polymers, at least 50 types of polymers have been characterized. These include alkyd resins, natural and synthetic rubbers, cellulose esters, polyolefins, polyamides, polyesters, polystyrenes, polyacrylates, uncured epoxy, urethane and phenolic resins, and a wide variety of oligomeric materials. Additionally, the ability to determine the molecular-weight distribution and changes in distribution has led to many applications in areas such as blending distributions, chain-length studies in semicrystalline polymers, interactions in solution, radiation studies, mechanical degradation studies, mechanisms of polymerization research, polymerization reactor control, and evaluation of the processing of polymers. In the field of natural and biological polymers, numerous systems have been separated and analyzed. Among these are acid phosphatases, adrenalin, albumin, amino acids and their derivatives, enzymes, blood group antibodies, collagen and related compounds, peptides, and proteins.

Additionally, gel permeation chromatography is capable of making separations of low-molecular-weight compounds. This is particularly important when both low- and high-molecular-weight species are present in the same sample. See CHROMATOGRAPHY; POLYMER. [A.R.C.]

**Gelatin** A protein extracted after partial hydrolysis of collagenous raw material from the skin, white connective tissue, and bone of animals. It is a linear polymer of amino acids, most often with repeating glycine-proline-proline and glycine-pro-line-hydroxyproline sequences in the polypeptide linkages. See COLLAGEN; PROTEIN.

The unique characteristics of gelatin are: reversible sol-to-gel formation, amphoteric properties, swelling in cold water, film-forming properties, viscosity-modifying properties, and protective colloid properties. Gelatin contains 26.4–30.5% glycine, 14.8–18% proline, 13.3–14.5% hydroxyproline, 11.1–11.7% glutamic acid, 8.6–11.3% alanine, and in decreasing order arginine, aspartic acid, lysine, serine, leucine, valine, phenylalanine, threonine, isoleucine, hydroxylysine, histidine, methionine, and tyrosine. Absence of only two essential amino acids—tryptophan and methionine—makes gelatin a good dietary food supplement.

The principal uses of gelatin are in foods, pharmaceuticals, and photographic industries. Other uses of industrial gelatin are in the field of microencapsulation, health and cosmetics, and plastics. [F.V.]

**Gem** A mineral or other material that has sufficient beauty for use as personal adornment and has the durability to make this feasible. With the exception of a few materials of organic origin,

such as pearl, amber, coral, and jet, and inorganic substances of variable composition, such as natural glass, gems are lovely varieties of minerals.

**Natural gems.** Each distinct mineral is called a species by the gemologist. Two stones that have the same essential composition and crystal structure but that differ in color are considered varieties of the same species. Thus ruby and sapphire are distinct varieties of the mineral species corundum, and emerald and aquamarine are varieties of beryl. See MINERAL; MINERALOGY.

Most gemstones are crystalline (that is, they have a definite atomic structure) and have characteristic properties, most of which are related directly to either beauty or durability. Each mineral has a characteristic hardness (resistance to being scratched) and toughness (resistance to cleavage and fracture). With few exceptions, the most important gemstones are those at the top of the Mohs hardness scale; for example, diamond is 10, ruby and sapphire are 9, chrysoberyl is  $8\frac{1}{2}$ , and topaz, beryl (emerald and aquamarine), and spinel are 8.

Optical properties are particularly important to the beauty of the various gem materials. The important optical properties include color; dispersion (or “fire”); refractive index (relating the breaking up of white light into colors—a rough measure of brilliancy); and pleochroism (the property of some doubly refractive materials of absorbing light unequally in the different directions of transmission, resulting in color differences). Gemstones usually are cherished for their color, brilliancy, fire, or one of the several optical phenomena, such as asterism (the star effect caused by certain reflections of light); chatoyancy, or a cat’s-eye effect; play of color, such as displayed by an opal; and adularescence (the billowy light effect seen in adularia or moonstone varieties of orthoclase feldspar).

Gemstones are commonly designated as precious or semiprecious. This is a somewhat meaningless practice, however, and often misleading, since many of the so-called precious gem varieties are inexpensive and many of the more attractive varieties of the semiprecious stones are exceedingly expensive and valuable. For example, a piece of fine-quality jadeite may be valued at approximately 100 times the price per carat of a low-quality star ruby. Fine black opals, chrysoberyl cat’s-eyes, and alexandrites are often much more expensive than many sapphires of certain colors. See PRECIOUS STONES.

More than 100 natural materials have been fashioned at one time or another for ornamental purposes. Of these, however, only a relatively small number are likely to be encountered in jewelry articles.

The table lists the important gem minerals and the properties most useful in identification. For further information on the individual species or groups see AMBER; AMETHYST; AZURITE; BERYL; CAMEO; CHRYSOBERYL; CORUNDUM; DIAMOND; EMERALD; FELDSPAR; GARNET; INTAGLIO (GEMOLOGY); JADE; JET (GEMOLOGY); LABRADORITE; LAZURITE; MALACHITE; OLIVINE; ONYX; OPAL; ORTHOCLASE; PEARL; QUARTZ; RUBY; SAPPHIRE; SPINEL; SPODUMENE; TOPAZ; TOURMALINE; TURQUOISE; ZIRCON.

**Manufactured gems.** A mineral or other material that has sufficient beauty and durability for use as a personal adornment can be manufactured. The term “manufactured,” as used here, does not include such processes as shaping, faceting, and polishing, but only the processes that affect the material from which the finished gem is produced. These processes are (1) those that change the mineral in some fundamental characteristic, such as color, called a treated gem; (2) those by which a material is made that is identical with the naturally occurring mineral, called a synthetic gem; and (3) those that produce a simulated material with the appearance but not both the composition and structure of the natural gem, called an imitation gem.

**Treated gems.** There are four basic methods of treatment: (1) dyeing and staining, (2) plastic or other impregnation, (3) heat treatment, and (4) radiation. When the process to which a gem material is subjected changes its structure or adds something, such as a dye or a plastic binder, an effect on value takes

**Hardness, specific gravity, and refractive indices of gem materials**

Gem material	Hardness	Specific gravity	Refractive index
Amber	2–2½	1.05	1.54
Beryl	7½–8	2.67–2.85	1.57–1.58
Chrysoberyl	8½	3.73	1.746–1.755
Corundum	9	4.0	1.76–1.77
Diamond	10	3.52	2.42
Feldspar	6–6½	2.55–2.75	1.5–1.57
Garnet			
Almandite	7½	4.05	1.79
Pyrope	7–7½	3.78	1.745
Rhodolite	7–7½	3.84	1.76
Andradite	6½–7	3.84	1.875
Grossularite	7	3.61	1.735
Spessartite	7–7½	4.15	1.80
Hematite	5½–6½	5.20	
Jade			
Jadeite	6½–7	3.34	1.66–1.68
Nephrite	6–6½	2.95	1.61–1.63
Lapis lazuli	5–6	2.4–3.05	1.50
Malachite	3½–4	3.34–3.95	1.66–1.91
Opal	5–6½	2.15	1.45
Pearl	4	2.7	
Peridot	6½–7	3.34	1.654–1.690
Quartz			
Crystalline	7	2.65	1.54–1.55
Chalcedonic	6½–7	2.60	1.535–1.539
Spinel	8	3.60	1.72
Spodumene	6–7	3.18	1.66–1.676
Topaz	8	3.53	1.61–1.62
Tourmaline	7–7½	3.06	1.624–1.644
Turquoise	5–6	2.76	1.61–1.65
Zircon			
Blue and colorless	7½	4.7	1.92–1.98
Green	6	4.0	1.81

place. When such changes are made, the nature of the alteration must be disclosed. An example of the second category of treatment, wherein there is no obvious effect on value, is gentle heating of amethyst to even its color, or stronger heating to change it to yellow or brown citrine. The change is permanent and nothing but temporary heat has been added. Many colored stones, including most green tourmaline, aquamarine, and colorless and flame-colored zircon and all pink topaz and blue zircon have been heated to improve their color.

**Synthetic gems.** The U.S. Federal Trade Commission has restricted the term synthetic gems to manufactured materials that have the same chemical, physical, and optical properties as their naturally occurring counterparts. Many gem materials, including diamond, have been synthesized, but in such small crystals or poor quality that they are unsatisfactory as gemstones. Some attempts to make gemstones have resulted in producing substances hitherto not known, many of which are of great importance industrially. Others have resulted in significant improvements in existing processes.

**Imitation gems.** Since prehistoric times glass has been the most widely used gem imitation. Since World War II colored plastics have replaced glass to a great extent in the least expensive costume jewelry.

**Identification.** Materials made by a flame-fusion process almost always contain gas bubbles, which are usually spherical or nearly so. Those with medium to dark tones of color often show color banding, or striae, with a curvature corresponding to that of the top of the boule. Natural gem materials are characterized by angular inclusions and straight color bands, if any are present.

Flux-fusion synthetic emeralds have distinctly lower refractive indices and specific gravities than natural emeralds and are characterized by wisplike or veillike flux inclusions. They show a red fluorescence under ultraviolet light, whereas most natural emeralds are inert.

Hydrothermally made synthetic emeralds have properties similar to many natural emeralds, but their inclusions differ and they

are characterized by a very strong red fluorescence under ultraviolet.

The cheaper forms of glass are cast in molds and, under a hand lens, show rounded edges at the intersections of facets; the facets are often concave. The better grades, known as cut glass, have been cut and polished after first being molded approximately into the desired form. Cut glass has facets that intersect in sharp edges. Both types may contain gas bubbles or have a roiled appearance in the heart or have both, in contrast to most of the colored stones they imitate. [R.T.L.]

**Geminga** A nearby neutron star that emits pulsed x-rays and gamma rays, steady optical radiation, and possibly radio and optical pulsations. Since the 1970s, it has been studied at a level of detail very unusual for a neutron star. As a result, not only are its nature and distance well known, but also a good understanding has been reached of the physical processes responsible for its multiwavelength emission.

Owing to their large, rapidly spinning magnetic fields, neutron stars emit significant nonthermal luminosity, that is, radiation produced by the interaction of accelerated particles and electromagnetic fields, or by the spinning fields themselves. This radiation was first detected at radio frequencies with the discovery of pulsars in 1968. Subsequently, notably with the launch of COS-B in 1975 and of the *Compton Gamma-Ray Observatory* in 1991, came the observation of gamma-ray pulsars. These are radio pulsars that emit a large flux of high-energy (100-MeV) gamma-ray photons. At the same time, a gamma-ray source was discovered that had all the markings of being connected with a radio pulsar but had no such object in its positional error box in the sky. See GAMMA-RAY ASTRONOMY; RADIO ASTRONOMY; SATELLITE (ASTRONOMY).

The object, named Geminga, is indeed a rotating neutron star. It was the first unidentified gamma-ray source in the sky, and subsequently became the first isolated neutron star to be discovered through its x-ray and gamma-ray emission, without the help of radio astronomy. High-precision positional measurements using the *Hipparcos* satellite and the Hubble Space Telescope allowed, for the first time, the absolute astrometry of an object this faint. Through a delicate space-time correlation, this work has made it possible to count every single rotation of the neutron star (at the rate of about 4 per second) throughout a period of over 25 years. See ASTROMETRY; X-RAY ASTRONOMY.

Optical and ultraviolet observations, carried out from the ground and from space, have allowed the measurement of Geminga's annual parallax, defining its distance to be about 150 parsecs (450 light-years), and thus determining with accuracy the star's absolute energy output at each wavelength. Detailed spectral data have also shown evidence for a thin atmosphere (a few centimeters thick), the first such detection on a neutron star. In the optical domain, a proton cyclotron feature has been detected, which enabled the first direct measurement of the magnetic field of an isolated neutron star. See PARALLAX (ASTRONOMY); PARTICLE ACCELERATOR.

Wide-band data have shown that both thermal and nonthermal processes are at work in this neutron star, which is approximately 350,000 years old. Such processes originate on its surface as well as in the extremely intense stellar magnetic field. See NEUTRON STAR; PULSAR. [G.F.Bi.]

**Gemini** The Twins, in astronomy, is a winter zodiacal constellation. Gemini is the third sign of the zodiac. It is conspicuous, containing first-, second-, and third-magnitude stars. These stars,  $\alpha$ ,  $\beta$ ,  $\gamma$ , and  $\mu$ , form a rough quadrilateral figure (see illustration). The constellation is pictured as the figures of the twin heroes Castor and Pollux, with the two brightest stars of the same names representing the heroes' heads. Pollux, slightly brighter than

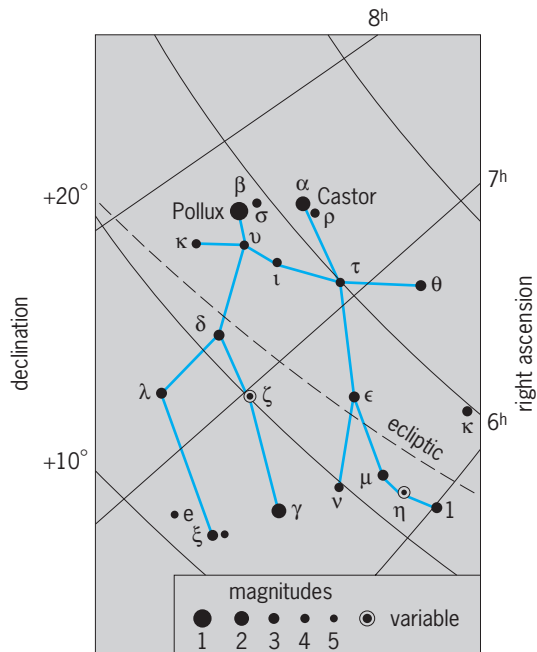

Line pattern of the constellation Gemini. Grid lines represent coordinates of the sky. Apparent brightness, or magnitudes, of stars is shown by sizes of dots graded by appropriate numbers as indicated.

Castor, is a navigational star. The Sun is in this constellation at the time of the summer solstice. See CONSTELLATION.

[C.-S.Y.]

**Gemology** The science of those minerals and other materials which possess sufficient beauty and durability to make them desirable as gemstones. It is concerned with the identification, grading, evaluation, fashioning, and other aspects of gemstones. See GEM.

[R.T.L.]

**Gene** The basic unit in inheritance. There is no general agreement as to the exact usage of the term, since several criteria that have been used for its definition have been shown not to be equivalent.

The facts of mendelian inheritance indicate the presence of discrete hereditary units that replicate at each cell division, producing remarkably exact copies of themselves, and that in some highly specific way determine the characteristics of the individuals that bear them. The evidence also shows that each of these units may at times mutate to give a new equally stable unit (called an allele), which has more or less similar but not identical effects on the characters of its bearers. These hereditary units are the genes, and the criteria for the recognition that certain genes are alleles have been that they (1) arise from one another by a single mutation, (2) have similar effects on the characters of the organism, and (3) occupy the same locus in the chromosome. It has long been known that there were a few cases where these criteria did not give consistent results, but these were explained by special hypotheses in the individual cases. However, such cases have been found to be so numerous that they appear to be the rule rather than the exception. See ALLELE; GENE ACTION; MENDELISM; MUTATION; RECOMBINATION (GENETICS).

The term gene, or cistron, may be used to indicate a unit of function. The term is used to designate an area in a chromosome made up of subunits present in an unbroken unit to give their characteristic effect. See CHROMOSOME.

Every gene consists of a linear sequence of bases in a nucleic acid molecule. Genes are specified by the sequence of bases in DNA in prokaryotic, archaeal, and eukaryotic cells, and in DNA

or ribonucleic acid (RNA) in prokaryotic or eukaryotic viruses. The ultimate expressions of gene function are the formation of structural and regulatory RNA molecules and proteins. These macromolecules carry out the biochemical reactions and provide the structural elements that make up cells. See DEOXYRIBONUCLEIC ACID (DNA); NUCLEIC ACID; RIBONUCLEIC ACID (RNA); VIRUS.

One goal of molecular biology is to understand the function, expression, and regulation of a gene in terms of its DNA or RNA sequence. The genetic information in genes that encode proteins is first transcribed from one strand of DNA into a complementary messenger RNA (mRNA) molecule by the action of the RNA polymerase enzyme. Many kinds of eukaryotic and a limited number of prokaryotic mRNA molecules are further processed by splicing, which removes intervening sequences called introns. In some eukaryotic mRNA molecules, certain bases are also changed posttranscriptionally by a process called RNA editing. The genetic code in the resulting mRNA molecules is translated into proteins with specific amino acid sequences by the action of the translation apparatus, consisting of transfer RNA (tRNA) molecules, ribosomes, and many other proteins. The genetic code in an mRNA molecule is the correspondence of three contiguous (triplet) bases, called a codon, to the common amino acids and translation stop signals; the bases are adenine (A), uracil (U), guanine (G), and cytosine (C). There are 61 codons that specify the 20 common amino acids, and 3 codons that lead to translation stopping. See GENETIC CODE; INTRON. [A.H.St.]

In many cases, the genes that mediate a specific cellular or viral function can be isolated. The recombinant DNA methods used to isolate a gene vary widely depending on the experimental system, and genes from RNA genomes must be converted into a corresponding DNA molecule by biochemical manipulation using the enzyme reverse transcriptase. The isolation of the gene is referred to as cloning, and allows large quantities of DNA corresponding to a gene of interest to be isolated and manipulated.

After the gene is isolated, the sequence of the nucleotide bases can be determined. The goal of the large-scale Human Genome Project is to sequence all the genes of several model organisms and humans. The sequence of the region containing the gene can reveal numerous features. If a gene is thought to encode a protein molecule, the genetic code can be applied to the sequence of bases determined from the cloned DNA. The application of the genetic code is done automatically by computer programs, which can identify the sequence of contiguous amino acids of the protein molecule encoded by the gene. If the function of a gene is unknown, comparisons of its nucleic acid or predicted amino acid sequence with the contents of huge international databases can often identify genes or proteins with analogous or related functions. These databases contain all the known sequences from many prokaryotic, archaeal, and eukaryotic organisms. Putative regulatory and transcript-processing sites can also be identified by computer. These putative sites, called consensus sequences, have been shown to play roles in the regulation and expression of groups of prokaryotic, archaeal, or eukaryotic genes. However, computer predictions are just a guide and not a substitute for analyzing expression and regulation by direct experimentation. See GENETIC ENGINEERING; HUMAN GENOME PROJECT; MOLECULAR BIOLOGY. [M.E.Wi.]

**Gene action** The functioning of genes (hereditary units) in determining the structural and functional characteristics of an individual, that is, its phenotype. Gene action is studied by two somewhat different, but complementary, approaches: (1) the analysis of changes which occur in the phenotype when a gene mutates, or is changed in dosage, or in position relative to other genes; this is frequently called the study of phenogenetics; and (2) the more direct approach, which attempts to determine the actual means by which genes exert their control over metabolism and the processes of development in multicellular, differentiated organisms. The more direct approach is best described as study

of primary gene action, but includes study of the interaction of primary or secondary products of gene action. See GENE.

All genes, with the exception of those in ribonucleic acid (RNA) viruses, are constituted of deoxyribonucleic acid (DNA), and the primary action of the great majority of them is to initiate a series of events leading directly or indirectly to the determination of the amino acid sequences of specific polypeptides. See DEOXYRIBONUCLEIC ACID (DNA); PROTEIN; VIRUS.

The base sequence of one of the chains of the DNA double helix constituting the gene is transcribed into an RNA molecule with a chain of complementary bases in the presence of RNA polymerases. This RNA molecule may then frequently become a messenger RNA (mRNA) by some alteration of the original transcript, or it may become a transfer RNA (tRNA) or a ribosomal RNA (rRNA). See RIBONUCLEIC ACID (RNA).

The primary action of a gene is transcription, but the expression of this action lies in the next step—translation—for many genes. The mRNAs are translated into polypeptides in what may be considered the culmination of the primary process of gene action. The proteins so formed may act as enzymes, structural units, regulators of various metabolic processes by interacting with other proteins and genes, and essential agents in guiding and directing the processes of development.

The actual effects of gene action are recognized for the most part by noting the effects of gene mutation on the phenotype, but in complex multicellular organisms the final phenotypic effect observed superficially may be far removed from the initial action of the gene itself, for example, a change in shape of the ear or a change in eye color. Studies of a wide variety of different genetic strains of organisms ranging over phages and bacteria, plants and animals, including humans, have shown that the mutations of some genes are reflected in the qualitative alteration of the proteins they code for. These kinds of genes are called structural genes. Frequently the protein changes resulting from their mutation are simple substitutions of a single amino acid in the chain by another. The cause for this substitution can be traced back to a change in the genetic code. If a codon in the DNA of a gene coding for a specific polypeptide is altered by a base, for example, AAA → CAA, this mutation will result in the substitution of valine for the phenylalanine originally present at the specific site in the polypeptide chain coded for by this codon. A protein so changed, even though it may involve only one amino acid residue out of more than 100, may have no noticeable effects on the phenotype, or it may have drastic effects. See GENETIC CODE.

If there is no noticeable effect of mutation on a protein's action in forming the phenotype, the mutant allele may be called a neutral allele. However, even a single amino acid substitution may cause a protein to be completely inactive and, if the protein is an enzyme, create a genetic metabolic block. Over 100 different inherited blocks are known in humans, including phenylketonuria. The mutant protein may also be active, but its activity is altered so that it is less active than the wild type, or more active, or only active at certain temperatures or pH, or may be inhibited by substances not inhibitory to the wild-type enzyme. The range of possible effects is considerable, and by no means are all recognized and cataloged. See PHENYLKETONURIA.

Some genes code for RNA that is not translated. The obvious ones are those that code for tRNA and rRNA, but other RNAs are also transcribed that do not appear to be transcribed and may have a role in the regulation of the activity of other genes. Finally, some genes code for proteins that act as regulators of the processes of metabolism and development. As yet, little is known about this class of genes in the eukaryotes, but they have been studied intensively in bacteria and phages. Mutations of genes coding for regulators may have profound effects on the course of development and, if they do not cause early lethality, they may result in the birth of a malformed individual. See BACTERIAL GENETICS; OPERON.

Under certain conditions, an increase in the number of times a particular gene is present has a direct quantitative effect on one or more aspects of the phenotype. This effect is considered to be a manifestation of quantitative gene activity or gene dosage. It means that the gene does something, and that the higher the dose with which it is present, the greater the physiological or chemical end result. The best examples of this are found in the genetics of polyploid plants. In these plants, it is possible to increase the dosage of a particular allele from zero to four or more, when this is done, for example, with certain genes which control the production of the flower pigments of *Dahlia*, there is a demonstrable increase in the amount of pigment in the petals. See POLYPLIIDY.

An increase in the dose of an active allele of a gene does not always cause an increase in the manifestation of a particular aspect of the phenotype. It may have quite the opposite effect, and cause a decrease. Plants and animals are also subject to aneuploidy, in which not all of the chromosomes of the genome are increased in number proportionately. Instead, only one of the chromosomes of the diploid set may be increased or decreased in number. In humans these conditions usually lead to the early death of the embryo. If the fetus reaches term and is born, it is always abnormal. A relatively common occurrence in humans is trisomy-21, which leads to Down syndrome. See DOWN SYNDROME.

Some heterozygous combinations of mutant alleles do not produce the phenotype expected from the phenotypes of the homozygotes. This is defined as a manifestation of allelic interaction. It is in contrast to those situations in which one allele is dominant over the other, so that the phenotype of the heterozygote is very similar or identical to that of the homozygous dominant. Also, it is different from those situations in which the two alleles show an additive effect, and the phenotype of the heterozygote is intermediate between those expected from the homozygotes. Diploid organisms heterozygous for two mutant alleles will produce two polypeptide species, one for each allele. The two proteins may interact and form hybrid multimers, which may be more or less active than the homomultimers formed by the polypeptides of each of the two genes alone. See DOMINANCE.

The final phenotype of an organism is the resultant of the action of all the active genes in its cell or cells. These genes may act independently in producing their respective primary products, but the primary products, and the products of their activity, that is, enzymes and other macromolecules, interact at the level of extragenic metabolism to give the final phenotype. Thus, there is really no one gene determining the shape of an organ, or even the production of a certain pigment. These end products are determined by many genes acting together through their respective immediate and then succeeding interrelated products. The manifestation of these interactions, as determined initially by the results from breeding experiments and in a few cases from biochemical analysis, is called gene interaction. This term does not necessarily imply that the genes themselves interact. In general, the term is applied to apparent interactions between genes. Examples include: complementary genes, in which nonallelic genes are so directly involved in the formation of the same end product, or phenotype, that the mutation of any one of them to an inactive state will result in no end product or type effect; epistasis, in which one gene masks the effects of other genes that may be present; and suppressor genes, which cause a wild-type or normal phenotype despite the presence of nonallelic mutant genes.

The environment must be considered in any analysis of gene action, if it is desired to arrive at an understanding of how genes act toward the production of the phenotype. Practically, this is best done by keeping the environment as constant as possible while making studies of gene action. However, much also can be learned by varying the environmental conditions and keeping the genotype as constant as possible. See GENETICS.

The environment of genes is a complex one. For convenience, two areas can be defined: (1) that immediately around the genes, the intracellular environment of the rest of the cell; and (2) the extracellular and extraorganismal environment. The intracellular environment can be changed by the mutation of other genes, which may then modify the action of a gene under study. Gene interaction is thus seen to be in part an aspect of the study of the internal environment of the cell. Extracellular environmental factors, such as light and heat, may also influence the action of genes greatly.

Changes in phenotype which occur against a constant genetic background are in reality responses to the environment by the extragenic part of the living system. The genes themselves are not changed, as can be readily demonstrated by changing the environment back to the original condition, or by breeding the individual and showing that the offspring inherit the original parental genotype. See DEVELOPMENTAL GENETICS; GENE. [R.P.W.]

**Gene amplification** The process by which a cell specifically increases the copy number of a particular gene to a greater extent than it increases the copy number of genes composing the remainder of the genome (all the genes which make up the genetic machinery of an organism). It is therefore distinguished from duplication, which is a precise doubling of the genome preparatory to cell division, and endoreduplication, which leads to endopolyploidy.

Gene amplification results from the repeated replication of the deoxyribonucleic acid (DNA) in a limited portion of the genome, in the absence of or to a much greater extent than replication of DNA composing the remainder of the genome. Thus is formed a cell in which the genes composing a limited portion of the genome are present in relatively high copy number, while the genes composing the remainder of the genome are present in approximately normal copy number. See DEOXYRIBONUCLEIC ACID (DNA).

Since gene amplification increases the copy number of a specific region of the genome without altering the copy number of genes composing the remainder of the genome, it would appear to offer an alternative method for developmental control of gene expression. By increasing the number of copies of a particular gene, the number of gene copies available for transcription could thereby be increased.

In a number of instances of gene amplification, the amplification phenomenon appears to be developmentally regulated, and the amplified copies of the gene are subsequently lost from the cell. Studies on cells in culture have demonstrated "amplification" of genes involved in resistance to specific drugs. See GENE; GENE ACTION. [M.D.C.]

**General aviation** All aircraft activity not associated with major airlines or the military. Among all classifications of aviation in the United States, general aviation consists of the largest number of aircraft and pilots and accounts for the largest number of flying hours.

Of the more than 220,000 active general aviation aircraft registered by the Federal Aviation Administration (FAA), almost 80% are single-engine vehicles powered by intermittent-combustion engines. Although many of these aircraft carry fewer than three passengers at speeds below 150 mi/h (240 km/h), most can carry four to six passengers at speeds up to 200 mi/h (320 km/h). Approximately 11% of the general aviation fleet are twin-engine aircraft, powered by intermittent-combustion engines and capable of cruising at speeds of 180–250 mi/h (290–400 km/h) with six to ten passengers. See AIRPLANE; RECIPROCATING AIRCRAFT ENGINE.

In addition, approximately 6000 multiengine aircraft are powered by turboprop engines and 4500 by turbojet or turbofan power plants. Jet aircraft employed within general aviation usually carry from five to fifteen passengers, depending on the model, with a crew of two pilots. Turboprop aircraft may also

be flown by two pilots, although this is not required for all models; passenger capacity typically ranges from six to nine. See JET PROPULSION; TURBOFAN; TURBOJET; TURBOPROP.

Rotorcraft number about 7000. There are also approximately 7000 gliders in the general aviation fleet. See GLIDER; HELICOPTER.

Business travel accounts for more flying hours than any other branch of general aviation. Approximately 70% of all general aviation is associated with some commercial activity, such as business travel, construction, aerial application of fertilizer and pesticides, or flight instruction.

Because of the characteristics of hub-and-spoke systems, business people have increased their demand for general aviation, which also offers more control over travel arrangements. With a small single-engine aircraft accommodating four or five passengers, a business person with a private license and perhaps an instrument rating can escape many of the limitations of airline schedules based on the hub-and-spoke system.

Commuter and regional airlines supplement the hub-and-spoke scheduling typical of commercial air travel since deregulation. Small airlines offer the only scheduled service in some communities, and often cooperate with major airlines by sharing code designations used in computer reservation systems and by travel agencies. Air taxis provide on-demand air transportation for hire in a wide variety of aircraft. General aviation is widely used in agriculture; aerial seeding, fertilizing, and spraying are efficient and widely used by farmers. Flight instruction represents about 15% of all general aviation activity and is the principal source of professional pilots. See AGRICULTURAL AIRCRAFT.

About 30% of general aviation involves the personal use of small aircraft for transportation and leisure purposes as well as some of the proficiency flying required by the Federal Aviation Administration of pilots who wish to maintain their licenses. Most personal flying employs small single-engine craft.

General aviation has often been the testing ground for innovation. *Voyager* (see illustration) was designed and constructed to circumnavigate the globe by air without refueling, a feat that had never been accomplished. *Voyager* carried nearly 9000 lb (4000 kg) of fuel in a structure that was built of advanced composite materials and weighed less than 1000 lb (450 kg) when empty. *Voyager* took off from Edwards Air Force Base, California, on December 14, 1986, and landed there 9 days later without refueling, the crew having completed their global circumnavigation without mishap or physical injury.

Modern attempts to achieve human-powered flight were stimulated in 1959 when H. Kremer posted a prize for the first British aircraft to fly solely by means of human power, without the aid of power storage or buoyancy, around a figure-eight course. (The prize was later opened to all nationalities.) In 1977, the Kremer prize was won by the *Gossamer Condor* aircraft, which was designed by P. D. MacCready, Jr., and flown by B. Allen. The team

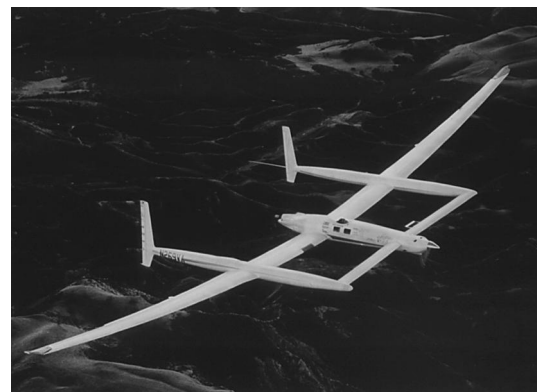

*Voyager* after takeoff on world flight. (Jeffrey Vock/Visions)

of MacCready and Allen subsequently accomplished many significant events in human-powered flight, including the 1979 flight of the *Gossamer Albatross* across the English Channel. [J.W.O.]

**Generator** A machine in which mechanical energy is converted to electrical energy. Generators are made in a wide range of sizes, from very small machines with a few watts of power output to very large central-station generators providing 1000 MW or more. All electrical generators utilize a magnetic field to produce an output voltage which drives the current to the load. The electric current and magnetic field also interact to produce a mechanical torque opposing the motion supplied by the prime mover. The mechanical power input is equal to the electric power output plus the electrical and mechanical losses.

Generators can be divided into two groups, alternating current (ac) and direct current (dc). Each group can be subdivided into machines that use permanent magnets to produce the magnetic field (PM machines) and those using field windings. A further subdivision relates to the type of prime mover and the generator speed. Large generators are often driven by steam or hydraulic turbines, by diesel engines, and sometimes by electric motors. Generator speeds vary from several thousand rotations per minute for steam turbines to very low speeds for hydraulic or wind turbines. See DIESEL ENGINE; HYDRAULIC TURBINE; MOTOR; PRIME MOVER; STEAM TURBINE; WIND POWER.

The field structure of a generator establishes the magnetic flux needed for energy conversion. In small generators, permanent magnets can be used to provide the required magnetic field. In large machines, dc field windings are more economical and permit changes in the magnetic flux and output voltage. This allows control of the generated voltage, which is important in many applications. In dc generators the field structure must be stationary to permit a rotating mounting for the commutator and armature windings. However, since the field windings require low voltage and power and have only two lead wires, it is convenient to place the field on the rotating member in ac generators. See ELECTRIC POWER GENERATION; ELECTRIC ROTATING MACHINERY; WINDINGS IN ELECTRIC MACHINERY. [D.W.N.]

**Genetic algorithms** Search procedures based on the mechanics of natural selection and genetics. Such procedures are known also as evolution strategies, evolutionary programming, genetic programming, and evolutionary computation. Genetic algorithms are increasingly solving difficult search, optimization, and machine-learning problems that have previously resisted automated solution. They can solve hard problems quickly and reliably, are easy to interface to existing simulations and models, are extensible, and are easy to hybridize.

**Motivation.** Just as natural selection and genetics have filled a variety of niches by creating genotypes (sets of chromosomes) that result in well-adapted phenotypes (or organisms), so too can genetic algorithms solve many artificial problems by creating strings (artificial chromosomes) that result in better solutions. Users ultimately turn to genetic algorithms for robustness, that is, for algorithms that are broadly applicable, relatively quick, and sufficiently reliable. This emphasis on robustness contrasts starkly with the philosophy of operations research, where new algorithms must be tailored to specific problems. The need to invent a new method for each new problem class is daunting, and users look for methods that can solve complex problems without this requirement. See GENETICS; OPERATIONS RESEARCH; ORGANIC EVOLUTION.

**Mechanics.** For concrete exposition, the discussion is limited to a simple genetic algorithm that processes a finite population of fixed-length, binary strings. A simple genetic algorithm consists of three operators: selection, crossover, and mutation.

Selection is the survival of the fittest within the genetic algorithm. The key notion is to give preference to better individuals. Of course, for selection to function, there must be some way of determining what is good. This evaluation can come from

a formal objective function, or it can come from the subjective judgment of a human observer or critic.

If genetic algorithms were to do nothing but selection, the trajectory of populations could contain nothing but changing proportions of the strings in the original population. To do something more sensible, the algorithm needs to explore different structures. A primary exploration operator used in many genetic algorithms is crossover. Simple, one-point crossover proceeds in three steps: (1) two individuals are chosen from the population by using the selection operator, and these two structures are considered to be mated; (2) a cross site along the string length is chosen uniformly at random; and (3) position values are exchanged between the two strings following the cross site.

In a binary-coded genetic algorithm, mutation is the occasional (low probability) alteration of a bit position, and with other codes a variety of diversity-generating operators may be used. When used together with selection and crossover, mutation acts both as an insurance policy against losing needed diversity and as a hill-climbing algorithm. [D.E.Go.]

**Genetic code** The rules by which the base sequences of deoxyribonucleic acid (DNA) are translated into the amino acid sequences of proteins. Each sequence of DNA that codes for a protein is transcribed or copied into messenger ribonucleic acid (mRNA). Following the rules of the code, discrete elements in the mRNA, known as codons, specify each of the 20 different amino acids that are the constituents of proteins. During translation, another class of RNAs, called transfer RNAs (tRNAs), are coupled to amino acids, bind to the mRNA, and, in a step-by-step fashion provide the amino acids that are linked together in the order called for by the mRNA sequence. The specific attachment of each amino acid to the appropriate tRNA, and the precise pairing of tRNAs via their anticodons to the correct codons in the mRNA, form the basis of the genetic code. See DEOXYRIBONUCLEIC ACID (DNA); PROTEIN; RIBONUCLEIC ACID (RNA).

The genetic information in DNA is found in the sequence or order of four bases that are linked together to form each strand of the two-stranded DNA molecule. The bases of DNA are adenine, guanine, thymine, and cytosine, which are abbreviated as A, G, T, and C. Chemically, A and G are purines, and C and T are pyrimidines. The two strands of DNA are wound about each other in a double helix that looks like a twisted ladder. Each rung of the ladder is formed by two bases, one from each strand, that pair with each other by means of hydrogen bonds. For a good fit, a pyrimidine must pair with a purine; in DNA, A bonds with T, and G bonds with C. See PURINE; PYRIMIDINE.

Ribonucleic acids such as mRNA or tRNA also comprise four bases, except that in RNA the pyrimidine uracil (U) replaces thymine. During transcription a single-stranded mRNA copy of one strand of the DNA is made.

If two bases at a time are grouped together, then only  $4 \times 4$  or 16 different combinations are possible, a number that is insufficient to code for all 20 amino acids that are found in proteins. However, if the four bases are grouped together in threes, then there are  $4 \times 4 \times 4$  or 64 different combinations. Read sequentially without overlapping, those groups of three bases constitute a codon, the unit that codes for a single amino acid.

The 64 codons can be divided into 16 families of four (see illustration), in which each codon begins with the same two bases. With the number of codons exceeding the number of amino acids, several codons can code for the same amino acid. Thus, the code is degenerate. In eight instances, all four codons in a family specify the same amino acid. In the remaining families, the two codons that end with the pyrimidines U and C often specify one amino acid, whereas the two codons that end with the purines A and G specify another. Furthermore, three of the codons, UAA, UAG, and UGA, do not code for any amino acid but instead signal the end of the protein chain.

On the ribosome, the nucleic acid code of an mRNA is converted into an amino acid sequence with the aid of tRNAs. These

	U	C	A	G
U	UUU } Phe UUC } UUA } Leu UUG }	UCU } Ser UCC } UCA } UCG }	UAU } Tyr UAC } UAA } Stop UAG }	UGU } Cys UGC } UGA } Stop UGG } Trp
C	CUU } Leu CUC } CUA } CUG }	CCU } Pro CCC } CCA } CCG }	CAU } His CAC } CAA } Gln CAG }	CGU } Arg CGC } CGA } CGG }
A	AUU } Ile AUC } AUA } AUG } Met	ACU } Thr ACC } ACA } ACG }	AAU } Asn AAC } AAA } Lys AAG }	AGU } Ser AGC } AGA } Arg AGG }
G	GUU } Val GUC } GUA } GUG }	GCU } Ala GCC } GCA } GCG }	GAU } Asp GAC } GAA } Glu GAG }	GGU } Gly GGC } GGA } GGG }

**Universal (standard) genetic code.** Each of the 64 codons found in mRNA specifies an amino acid (indicated by the common three-letter abbreviation) or the end of the protein chain (*stop*). The amino acids are phenylalanine (Phe), leucine (Leu), isoleucine (Ile), methionine (Met), valine (Val), serine (Ser), proline (Pro), threonine (Thr), alanine (Ala), tyrosine (Tyr), histidine (His), glutamine (Gln), asparagine (Asn), lysine (Lys), aspartic acid (Asp), glutamic acid (Glu), cysteine (Cys), tryptophan (Trp), arginine (Arg), and glycine (Gly).

RNAs are relatively small nucleic acids, varying from 75 to 93 bases in length, that are folded in three dimensions to form an L-shaped molecule to which an amino acid can be attached. At the other end of the tRNA molecule, three bases are free to pair with a codon in the mRNA. These three bases of a tRNA constitute the anticodon. Each amino acid has one or more tRNAs, and because of the degeneracy of the code, many of the tRNAs for a specific amino acid have different anticodon sequences. However, the tRNAs for one amino acid are capable of pairing their anticodons only with the codon or codons in the mRNA that specify that amino acid. The tRNAs act as interpreters of the code, providing the correct amino acid in response to each codon by virtue of precise codon-anticodon pairing. The tRNAs pair with the codons and sequentially insert their amino acids in the exact order specified by the sequence of codons in the mRNA. See RIBOSOMES.

The rules of the genetic code are virtually the same for all organisms, but there are some interesting exceptions. In the microorganism *Mycoplasma capricolum*, UGA is not a stop codon; instead it codes for tryptophan. This alteration in the code is also found in the mitochondria of some organisms. In addition to changes in the meanings of codons, a modified system for reading codons that requires fewer tRNAs is found in mitochondria. See GENE; GENE ACTION; GENETICS. [PSc.; H.E.We.]

**Genetic engineering** The artificial recombination of nucleic acid molecules in the test tube, their insertion into a virus, bacterial plasmid, or other vector system, and the subsequent incorporation of the chimeric molecules into a host organism in which they are capable of continued propagation. The construction of such molecules has also been termed gene manipulation because it usually involves the production of novel genetic combinations by biochemical means. See NUCLEIC ACID.

Genetic engineering provides the ability to propagate and grow in bulk a line of genetically identical organisms, all containing the same artificially recombinant molecule. Any genetic segment as well as the gene product encoded by it can therefore potentially be amplified. For these reasons the process has also been termed molecular cloning or gene cloning. See GENE.

**Basic techniques.** The central techniques of such gene manipulation involve (1) the isolation of a specific deoxyribonucleic

acid (DNA) molecule or molecules to be replicated (the passenger DNA); (2) the joining of this DNA with a DNA vector (also known as a vehicle or a replicon) capable of autonomous replication in a living cell after foreign DNA has been inserted into it; and (3) the transfer, via transformation or transfection, of the recombinant molecule into a suitable host.

**Isolation of passenger DNA.** Passenger DNA may be isolated in a number of ways; the most common of these involves DNA restriction. Restriction endonucleases make possible the cleavage of high-molecular-weight DNA. Although three different classes of these enzymes have been described, only type II restriction endonucleases have been used extensively in the manipulation of DNA. Type II restriction endonucleases are DNAases that recognize specific short nucleotide sequences (usually 4 to 6 base pairs in length), and then cleave both strands of the DNA duplex, generating discrete DNA fragments of defined length and sequence. A number of restriction enzymes make staggered cuts in the two DNA strands, generating single-stranded termini. See RESTRICTION ENZYME.

The various fragments generated when a specific DNA is cut by a restriction enzyme can be easily resolved as bands of distinct molecular weights by agarose gel electrophoresis. Specific sequences of these bands can be identified by a technique known as Southern blotting. In this technique, DNA restriction fragments resolved on a gel are denatured and blotted onto a nitrocellulose filter. The filter is incubated together with a radioactively labeled DNA or RNA probe specific for the gene under study. The labeled probe hybridizes to its complement in the restricted DNA, and the regions of hybridization are detected autoradiographically. Fragments of interest can then be eluted out of these gels and used for cloning. Purification of particular DNA segments prior to cloning reduces the number of recombinants that must later be screened. See ELECTROPHORESIS.

Another method that has been used to generate small DNA fragments is mechanical shearing. Intense sonification of high-molecular-weight DNA with ultrasound, or high-speed stirring in a blender, can both be used to produce DNA fragments of a certain size range. Shearing results in random breakage of DNA, producing termini consisting of short, single-stranded regions. Other sources include DNA complementary to poly(A) RNA, or cDNA, which is synthesized in the test tube, and short oligonucleotides that are synthesized chemically. See OLIGONUCLEOTIDE.

**Joining DNA molecules.** Once the proper DNA fragments have been obtained, they must be joined. When cleavage with a restriction endonuclease creates cohesive ends, these can be annealed with a similarly cleaved DNA from another source, including a vector molecule. When such molecules associate, the joint has nicks a few base pairs apart in opposite strands. The enzyme DNA ligase can then repair these nicks to form an intact, duplex recombinant molecule, which can be used for transformation and the subsequent selection of cells containing the recombinant molecule. Cohesive ends can also be created by the addition of synthetic DNA linkers to blunt-ended DNA molecules.

Another method for joining DNA molecules involves the addition of homopolymer extensions to different DNA populations followed by an annealing of complementary homopolymer sequences. For example, short nucleotide sequences of pure adenine can be added to the 3' ends of one population of DNA molecules and short thymine blocks to the 3' ends of another population. The two types of molecules can then anneal to form mixed dimeric circles that can be used directly for transformation.

The enzyme T4 DNA ligase carries out the intermolecular joining of DNA substrates at completely base-paired ends; such blunt ends can be produced by cleavage with a restriction enzyme or by mechanical shearing followed by enzyme treatment.

**Transformation.** The desired DNA sequence, once attached to a DNA vector, must be transferred to a suitable host. Transformation is defined as the introduction of foreign DNA into a recipient cell. Transformation of a cell with DNA from a virus is usually referred to as transfection.



Transformation in any organism involves (1) a method that allows the introduction of DNA into the cell and (2) the stable integration of DNA into a chromosome, or maintenance of the DNA as a self-replicating entity. See TRANSFORMATION (BACTERIA).

*Escherichia coli* is usually the host of choice for cloning experiments, and transformation of *E. coli* is an essential step in these experiments. *Escherichia coli* treated with calcium chloride are able to take up DNA from bacteriophage lambda as well as plasmid DNA. Calcium chloride is thought to effect some structural alterations in the bacterial cell wall. An efficient method for transformation in *Bacillus* species involves polyethylene glycol-induced DNA uptake in bacterial protoplasts and subsequent regeneration of the bacterial cell wall. Actinomycetes can be similarly transformed. Transformation can also be achieved by first entrapping the DNA with liposomes followed by their fusion with the host cell membrane. Similar transformation methods have been developed for lower eukaryotes such as the yeast *Saccharomyces cerevisiae* and the filamentous fungus *Neurospora crassa*. See LIPOSOMES.

Several methods are available for the transfer of DNA into cells of higher eukaryotes. Specific genes or entire viral genomes can be introduced into cultured mammalian cells in the form of a coprecipitate with calcium phosphate. DNA complexed with calcium phosphate is readily taken up and expressed by mammalian cells. DNA complexed with diethylamino-ethyl-dextran (DEAE-dextran) or DNA trapped in liposomes or erythrocyte ghosts may also be used in mammalian transformation. Alternatively, bacterial protoplasts containing plasmids can be fused to intact animal cells with the aid of chemical agents such as polyethylene glycol (PEG). Finally, DNA can be directly introduced into cells by microinjection. The efficiency of transfer by each of these methods is quite variable.

Introduction of DNA sequences by insertion into the transforming (T)-DNA region of the tumor-inducing (Ti) plasmid of *Agrobacterium tumefaciens* is a method of introducing DNA into plant cells and ensuring its integration. Because of the limitations of the host range of *A. tumefaciens*, however, alternative transformation systems are being developed for gene transfer in plants. They include the use of liposomes, as well as induction of DNA uptake in plant protoplasts. Foreign DNA has been introduced into plant cells by a technique called electroporation. This technique involves the use of electric pulses to make plant plasma membranes permeable to plasmid DNA molecules. Plasmid DNA taken up in this way has been shown to be stably inherited and expressed.

**Cloning vectors.** There is a large variety of potential vectors for cloned genes. The vectors differ in different classes of organisms.

**Prokaryotes and lower eukaryotes.** Three types of vectors have been used in these organisms: plasmids, bacteriophages, and cosmids. Plasmids are extrachromosomal DNA sequences that are stably inherited. *Escherichia coli* and its plasmids constitute the most versatile type of host-vector system known for DNA cloning. Several natural plasmids, such as ColE1, have been used as cloning vehicles in *E. coli*. In addition, a variety of derivatives of natural plasmids have been constructed by combining DNA segments and desirable qualities of older cloning vehicles. The most versatile and widely used of these plasmids is pBR322. Transformation in yeast has been demonstrated using a number of plasmids, including vectors derived from the naturally occurring  $2\mu$  plasmid of yeast.

Bacteriophage lambda is a virus of *E. coli*. Several lambda-derived vectors have been developed for cloning in *E. coli*, and for the isolation of particular genes from eukaryotic genomes. These lambda derivatives have several advantages over plasmids: (1) Thousands of recombinant phage plaques can easily be screened for a particular DNA sequence on a single petri dish by molecular hybridization. (2) Packaging of recombinant DNA in laboratory cultures provides a very efficient means of DNA uptake by the bacteria. (3) Thousands of independently pack-

aged recombinant phages can be easily replicated and stored in a single solution as a "library" of genomic sequences. See BACTERIOPHAGE.

Plasmids have also been constructed that contain the phage cos DNA site, required for packaging into the phage particles, and ColE1 DNA segments, required for plasmid replication. These plasmids have been termed cosmids. The recombinant cosmid DNA is injected into a host and circularizes like phage DNA but replicates as a plasmid. Transformed cells are selected on the basis of a vector drug resistance marker.

**Animal cells.** In contrast to the wide variety of plasmid and phage vectors available for cloning in prokaryotic cells, relatively few vectors are available for introducing foreign genes into animal cells. The most commonly used are derived from simian virus 40 (SV40). Normal SV40 cannot be used as a vector, since there is a physical limit to the amount of DNA that can be packaged into the virus capsid, and the addition of foreign DNA would generate a DNA molecule too large to be packaged. However, SV40 mutants lacking portions of the genome can be propagated in mixed infections in which a "helper" virus supplies the missing function. See ADENO-SV40 HYBRID VIRUS.

**Plant cells.** Two systems for the delivery and integration of foreign genes into the plant genome are the Ti plasmid of the soil bacterium *Agrobacterium* and the DNA plant virion cauliflower mosaic virus. The Ti plasmid is a natural gene transfer vector carried by *A. tumefaciens*, a pathogenic bacterium that causes crown gall tumor formation in dicotyledonous plants. A T-DNA segment present in the Ti plasmid becomes stably integrated into the plant cell genome during infection. This property of the Ti plasmid has been exploited to show that DNA segments inserted in the T-DNA region can be cotransferred to plant DNA. See CROWN GALL.

**Applications.** Recombinant DNA technology has permitted the isolation and detailed structural analysis of a large number of prokaryotic and eukaryotic genes. This contribution is especially significant in the eukaryotes because of their large genomes. The methods outlined above provide a means of fractionating and isolating individual genes, since each clone contains a single sequence or a few DNA sequences from a very large genome. Isolation of a particular sequence of interest has been facilitated by the ability to generate a large number of clones and to screen them with the appropriate "probe" (radioactively labeled RNA or DNA) molecules.

Genetic engineering techniques provide pure DNAs in amounts sufficient for mapping, sequencing, and direct structural analyses. Furthermore, gene structure-function relationships can be studied by reintroducing the cloned gene into a eukaryotic nucleus and assaying for transcriptional and translational activities. The DNA sequences can be altered by mutagenesis before their reintroduction in order to define precise functional regions.

Genetic engineering methodology has provided means for the large-scale production of polypeptides and proteins. It is now possible to produce a wide variety of foreign proteins in *E. coli*. These range from enzymes useful in molecular biology to a vast range of polypeptides with potential human therapeutic applications, such as insulin, interferon, growth hormone, immunoglobins, and enzymes involved in the dynamics of blood coagulation. See BIOTECHNOLOGY.

Finally, experiments showing the successful transfer and expression of foreign DNA in plant cells using the Ti plasmid, as well as the demonstration that whole plants can be regenerated from cells containing mutated regions of T-DNA, indicate that the Ti plasmid system may be an important tool in the genetic engineering of plants. Such a system will help in the identification and characterization of plant genes as well as provide basic knowledge about gene organization and regulation in higher plants. Once genes useful for crop improvement have been identified, cloned, and stably inserted into the plant genome, it will be possible to engineer plants to be resistant to environmental stress, to pests, and to pathogens. See BREEDING (PLANT); GENE; GENE ACTION; SOMATIC CELL GENETICS. [P.K.M.]

**Genetic homeostasis** The tendency of mendelian populations to maintain a constant genetic composition in the face of external pressure. When subjected to such pressures as artificial selection (usually for some quantitative trait) or temporary environmental changes, genetic homeostatic mechanisms tend to restore to equilibrium gene frequencies that may have shifted from mean optimal values. See MENDELISM; POPULATION GENETICS.

The mechanisms responsible for genetic homeostasis are varied. The two most commonly invoked, which are also responsible for maintenance of genetic polymorphisms, are frequency-dependent selection and heterozygote advantage. Under the first, the selective value of a gene depends on its frequency in the gene pool with a loss of selective advantage by an allele which was rare and has become common. Under the second, when either single alleles or blocks of linked genes are involved, the relative fitness of homozygotes is lower than that of heterozygotes. See ALLELE; POLYMORPHISM (GENETICS). [I.M.L.]

**Genetics** The science of biological inheritance, that is, the causes of the resemblances and differences among related individuals.

Genetics occupies a central position in biology, for essentially the same principles apply to all animals and plants, and understanding of inheritance is basic for the study of evolution and for the improvement of cultivated plants and domestic animals. It has also been found that genetics has much to contribute to the study of embryology, biochemistry, pathology, anthropology, and other subjects. See BIOCHEMISTRY; EMBRYOLOGY; PATHOLOGY; PHYSICAL ANTHROPOLOGY.

Genetics may also be defined as the science that deals with the nature and behavior of the genes, the fundamental hereditary units. From this point of view, evolution is seen as the study of changes in the gene composition of populations, whereas embryology is the study of the effects of the genes on the development of the organism. See GENE ACTION; POPULATION GENETICS. [A.H.St.]

The field of molecular genetics describes the basis of inheritance at the molecular level. It focuses on two general questions: how do genes specify the structure and function of organisms, and how are genes replicated and transmitted to successive generations? Both questions have been answered. Genes specify organismal structure and function according to a process described by the central dogma of molecular biology: DNA is made into messenger ribonucleic acid (mRNA), which specifies the structure of a protein; the mRNA molecule then serves as a template for protein synthesis, which is carried out by complex machinery that comprises a particle called a ribosome and special adapter RNA molecules called transfer RNA. See DEOXYRIBONUCLEIC ACID (DNA); RIBONUCLEIC ACID (RNA); RIBOSOMES.

The structure of DNA provides a simple mechanism for genes to be faithfully reproduced: the specific interaction between the nucleotides means that each strand of the double helix carries the information for producing the other strand. See GENETIC CODE; GENETIC ENGINEERING; MOLECULAR BIOLOGY; MUTATION. [M.J.]

**Gentianales** An order of flowering plants (angiosperms) in the euasterid I group of the asterid eudicotyledons. The order consists of five families and approximately 17,500 species. The order is characterized by opposite leaves, frequent occurrence of alkaloids, and the presence of internal phloem in the wood (not in Rubiaceae).

Apocynaceae (including Asclepiadaceae), approximately 5000 species, are mostly tropical and subtropical and have a well-developed latex system, superior ovary, thickened and apically modified style, and carpels that are usually united only by the common style or stigma. Rubiaceae, approximately 11,000 species, are cosmopolitan, but particularly important in the tropics. They have stipulate leaves and an inferior ovary. The widespread occurrence of alkaloids makes the family economically significant; the major products are coffee (*Coffea*) and the

antimalarial drug quinine (*Cinchona*). Gentianaceae, approximately 1200 species, are principally temperate and subtropical. They often contain bitter iridoid compounds, and some are used medicinally or in bitter alcoholic beverages (such as *Gentiana*, gentians). The remaining two families are relatively small but contain some genera of economic importance. *Strychnos* (Loganiaceae) is the source of strychnine and the arrow poison curare, and Gelsemiaceae include the ornamental *Gelsemium* (allspice jasmine). See ASTERIDAE; MAGNOLIOPSIDA; PLANT KINGDOM; RAUWOLFIA; STROPHANTHUS; STRYCHNOS. [M.W.C.]

**Geochemical prospecting** The use of chemical properties of naturally occurring substances (including rocks, glacial debris, soils, stream sediments, waters, vegetation, and air) as aids in a search for economic deposits of metallic minerals or hydrocarbons. In exploration programs, geochemical techniques are generally integrated with geological and geophysical surveys. See GEOCHEMISTRY; GEOPHYSICAL EXPLORATION.

**General principles.** Mineral deposits represent anomalous concentrations of specific elements, usually within a relatively confined volume of the Earth's crust. Most mineral deposits include a central zone, or core, in which the valuable elements or minerals are concentrated, often in percentage quantities, to a degree sufficient to permit economic exploitation. The valuable elements surrounding this core generally decrease in concentration until they reach levels, measured in parts per million (ppm) or parts per billion (ppb), which appreciably exceed the normal background level of the enclosing rocks. These zones or halos afford means by which mineral deposits can be detected and traced; they are the geochemical anomalies being sought by all geochemical prospectors.

The zone surrounding the core deposit is known as a primary halo or anomaly, and it represents the distribution patterns of elements which formed as a result of primary dispersion. Primary dispersion halos vary greatly in size and shape as a result of the numerous physical and chemical variables that affect fluid movements in rocks. Some halos can be detected at distances of hundreds of meters from their related ore bodies; others are no more than a few centimeters in width.

Abnormal chemical concentrations in weathering products are known as secondary dispersion halos or anomalies and are more widespread. They are sometimes referred to as dispersion trains. The shape and extent of secondary dispersion trains depend on a host of factors, of which topography and groundwater movement are perhaps most important. Groundwaters frequently dissolve some of the constituents of mineralized bodies and may transport these for considerable distances before eventually emerging in springs or streams. Further dispersion may ensue in stream sediments when soil or weathering debris that has anomalous metal content becomes incorporated through erosion in stream sediment. Analysis of the fine sand arid silt of stream sediment can be a particularly effective method for detection of mineralized bodies within the area drained by the stream.

**Survey design.** The degree of success of a geochemical survey in a mineral exploration program is often a reflection of the amount of care taken with initial planning and survey design. This phase of activity is often referred to as an orientation survey; its practical importance cannot be overstressed.

When a geochemical prospecting survey is contemplated, four basic considerations must be addressed: the nature of the mineral deposits being sought; the geochemical properties of the elements likely to be present in the target mineral deposit; geological factors likely to cause variations in geochemical background; and environmental, or landscape, factors likely to influence the geochemical expression of the target mineral deposit. Elucidation of these factors in an orientation survey will permit design of a geochemical prospecting survey that is most likely to prove effective under the prevailing conditions. See PROSPECTING.

Geochemical prospecting surveys fall into two broad categories, strategic or tactical, which may be further subdivided

according to the material sampled. Strategic surveys imply coverage of a large area (generally several thousands of square kilometers) where the primary objective is to identify districts of enhanced mineral potential; tactical surveys comprise the more detailed follow-up to strategic reconnaissance. Typically the area covered by a tactical survey is divided into discrete areas of high mineral potential within the general anomalous district.

Soil and glacial till surveys have been used extensively in geochemical prospecting and have resulted in the discovery of a number of ore bodies. Generally, such surveys are of a detailed nature and are run over a closely spaced grid.

Biogeochemical surveys are of two types. One type utilizes the trace-element content of plants to outline dispersion halos, trains, and fans related to mineralization; the other uses specific plants or the deleterious effects of an excess of elements in soils on plants as indicators of mineralization. The latter type of survey is often referred to as a geobotanical survey.

Rock geochemical surveys are reconnaissance surveys carried out on a grid or on traverses of an area, with samples taken of all available rock outcrops or at some specific interval. One or several rock types may be selected for sampling and analyzed for various elements. Geochemical maps are compiled from the analyses, and contours of equal elemental values are drawn. These are then interpreted, often by using statistical methods. Under favorable conditions, mineralized zones or belts may be outlined in which more detailed work can be concentrated. If the survey is executed over a large expanse of territory, geochemical provinces may be outlined.

Isotopic surveys are applicable to elements which exist in two or more isotopic forms. They employ the ratios between isotopes such as  $^{204}\text{Pb}$ ,  $^{206}\text{Pb}$ ,  $^{207}\text{Pb}$ ,  $^{208}\text{Pb}$ , or  $^{32}\text{S}$  and  $^{34}\text{S}$  to "fingerprint" or indicate certain types of mineral deposits which may share a common origin. Isotopic ratios may also be used to determine the ages of minerals or given rock types and may, thus, assist in elucidating questions of ore formation.

Geochemistry applied to hydrocarbon exploration differs from that in the search for metallic mineral deposits; the former chiefly involves detection and study of organic substances found during drilling; the latter, detection and study of inorganic substances at the surface. Once hydrocarbon accumulations have been discovered, their classification into geochemical families is important. The final stages of detailed exploration may involve complex multivariate computer-aided modeling of all available geological, geochemical, geophysical, and hydrological data—to determine the ultimate hydrocarbon potential of a given basin.

[R.F.H.]

**Geochemistry** A field that encompasses the investigation of the chemical composition of the Earth, other planets, and the solar system and universe as a whole, as well as the chemical processes that occur within them. The discipline is large and very important because basic knowledge about the chemical processes involved is critical for understanding subjects as diverse as the formation of economically valuable ore deposits, safe disposal of toxic wastes, and variations in the Earth's climate.

Isotope geochemistry is based on the fact that the isotopic compositions of various chemical elements may reveal information about the age, history, and origin of terrestrial and extraterrestrial materials. Isotopes of an element share the same chemical properties but have slightly different nuclear makeups and therefore different masses. Some naturally occurring isotopes are radioactive and decay at known rates to form daughter isotopes of another element; for example, radioactive uranium isotopes decay to stable isotopes of lead. Radioactive decay is the basis of geochronology, or age determination: the age of a sample can be found by measuring its content of the daughter isotope. Both radioactive decay and the processes that enrich or deplete materials in certain isotopes cause different parts of the Earth and solar system to have different, characteristic isotopic compositions for some elements. These differences serve as fingerprints for tracing the origins of, and characterizing the interactions between,

various geochemical reservoirs. See DATING METHODS; ELEMENTS, GEOCHEMICAL DISTRIBUTION OF; GEOCHRONOMETRY; ISOTOPE; LEAD ISOTOPES (GEOCHEMISTRY).

Cosmochemistry deals with nonearthly materials. Typically, cosmochemists use the same kinds of analytical and theoretical approaches as other geochemists but apply them to problems involving the origin and history of meteorites, the formation of the solar system, the chemical processes on other planets, and the ultimate origin of the elements themselves in stars. See COSMOCHEMISTRY; METEORITE; SOLAR SYSTEM.

Organic geochemistry deals with carbon-containing compounds, largely those produced by living organisms. These are widely dispersed in the outer part of the Earth—in the oceans, the atmosphere, soil, and sedimentary rocks. Organic geochemistry is important for understanding many of the chemical cycles that occur on Earth because biology often plays a major role. Organic geochemists are also active in investigating such areas as the origin of life, the formation of some types of ore deposits that may be biologically mediated, and the origin of coal, petroleum, and natural gas. See BIOGEOCHEMISTRY; COAL; NATURAL GAS; ORGANIC GEOCHEMISTRY; PETROLEUM; PREBIOTIC ORGANIC SYNTHESIS.

In recent years there has been widespread application of geochemical techniques to problems in paleoclimatology and paleoceanography. In this approach, ocean sediments, sedimentary rocks on land, ice cores, and other continuous records of the Earth's history are analyzed for fossil chemical evidence of past climates or seawater composition. As in most areas of geochemistry, precise and accurate analytical methods for determining the isotopic and elemental composition of the samples are critical. See EARTH SCIENCES; PALEOCEANOGRAPHY; PALEOCLIMATOLOGY.

[J.D.MacD.]

**Geochronometry** The measurement of the age of rocks, minerals, water, and biological materials. Measurements are based primarily on the radioactive decay or fission of such naturally occurring isotopes as  $^{238}\text{U}$ ,  $^{235}\text{U}$ ,  $^{232}\text{Th}$ ,  $^{187}\text{Re}$ ,  $^{176}\text{Lu}$ ,  $^{147}\text{Sm}$ ,  $^{87}\text{Rb}$ ,  $^{40}\text{K}$ ,  $^{129}\text{I}$ ,  $^{36}\text{Cl}$ ,  $^{26}\text{Al}$ ,  $^{14}\text{C}$ , and  $^{10}\text{Be}$ . These radioactive isotopes can be divided into two groups: primordial isotopes that are residual from early nucleosynthesis, and cosmogenic isotopes that are continuously produced by cosmic-ray-induced spallation reactions primarily within the Earth's atmosphere or on the surfaces of meteorites. For the first group, the relative amounts of the radioactive parent and radiogenic daughter are used as a measure of age. Age is determined for the second group by the amount of radioactive isotope remaining after the object is isolated from further intake—for example, by death of an organism participating in the carbon-oxygen cycle, or by trapping of the cosmogenic isotope in sediment or ice. Tree-ring dating (dendrochronology), which is based on the counting of annual rings, may also be used and provides a very precise measure of age of the last eight millennia. See DENDROCHRONOLOGY; LEAD ISOTOPES (GEOCHEMISTRY); NUCLEOSYNTHESIS; RADIOCARBON DATING.

There are also methods of establishing the relative sequence of events in time, most importantly, the use of unidirectional biologic evolution upon which the boundaries of the Phanerozoic time scale are based ( $5.5 \times 10^8$  years to the present). The virtues of isotopic dating are its applicability to the full range of geologic time, including the Precambrian for which an adequate paleontologic time scale does not exist; better resolution of events during the Cenozoic ( $6.5 \times 10^7$  years to present); and provision of the fourth physical dimension of astronomic time to quantify rates and energies involved in geologic processes. These isotopic chronometers have been used to measure the age of the Earth, Moon, and meteorites ( $4.5 \times 10^9$  years), the age of the oldest datable rocks ( $3.7 \times 10^9$  years), and many other significant geologic events such as the advance and retreat of continental glaciers. They have also been used to establish a Precambrian time scale, to calibrate the Phanerozoic time scale in solar years, and to provide a chronology for significant biologic, cultural, and environmental events related to the evolution

of the human race. On a much shorter time scale, these methods have been used to determine rates of flow of water through aquifers and rates of material (aerosols) transport through the atmosphere. See AMINO ACID DATING; DATING METHODS; EARTH, AGE OF; GEOLOGIC TIME SCALE; ROCK AGE DETERMINATION. [P.E.Da.]

**Geode** A roughly spheroidal hollow body, lined on the inside with inward-projecting small crystals (see illustration). Geodes are found most frequently in limestone beds but may occur in

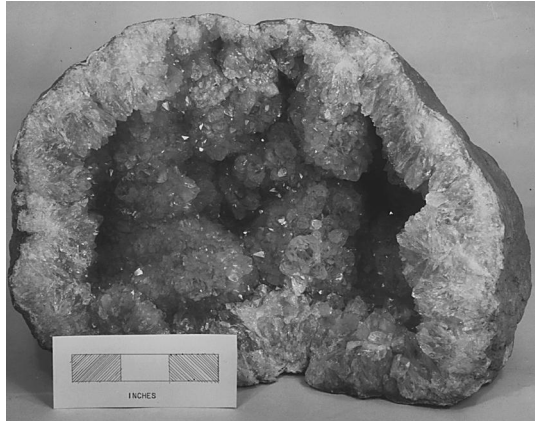

Geode, lined with quartz crystals, keokuk, Iowa. (Brooks Museum, University of Virginia)

some shales. Typically, a geode consists of a thin outer shell of dense chalcedonic silica and an inner shell of quartz crystals. Many geodes are filled with water; others, having been exposed for some time at the surface, are dry. Calcite or dolomite crystals line the interior of some geodes, and a host of other minerals are less commonly found. In some geodes there is an alternation of layers of silica and calcite, but almost all geodes show some banding suggestive of rhythmic precipitation. See CHALCEDONY.

[R.Si.]

**Geodesic dome** A curved lattice grid dome that utilizes the equilateral triangle as the basis of its surface grid geometry. R. Buckminster Fuller, the inventor and champion of the geodesic dome, obtained a patent in 1954 that described a method of

dividing a spherical surface into equilateral triangles. The two regular polyhedra that can be inscribed in a sphere are the dodecahedron (12 faces, each of which is a regular polygon; illus. a) and the more utilized icosahedron (20 faces, each of which is an equilateral triangle; illus. b). See POLYHEDRON.

The geodesic dome has been used for everything from great exhibition spaces and halls to outdoor tent supports and jungle gyms. By utilizing the icosahedron as the basic building block of the geodesic dome, larger domes are possible with additional triangular subdivisions. This subdivision is known as the frequency. The first frequency is to interconnect the projected midpoints of the struts of each equilateral triangle of the icosahedron as they will project on the spherical surface. The result is four almost equilateral triangles where there was one before. The resulting lattice has similar but not exactly equilateral triangles if the grid is to remain on the spherical surface. This subdivision process can continue. The resulting grids have both triangular and hexagonal grids as a by-product within the basic geodesic dome geometry, with pentagons around the apex of the basic underlying icosahedron framework (illus. c). [I.PL.]

**Geodesy** The science of measuring the size, shape, and gravity field of the Earth. Geodesy supplies positioning information about locations on the Earth, and this information is used in a variety of applications, including civil engineering, boundary demarcations, navigation, resource management and exploration, and geophysical studies of the dynamics of the Earth. See EARTH.

The conventional measurement systems in geodesy are triangulation and trilateration for determining horizontal positions, and leveling for determining heights. These techniques depend on the Earth's gravity field, and so a major part of geodesy has been not only position determination but also the measurement of the Earth's gravity field. See EARTH, GRAVITY FIELD OF.

Two major measurement systems were developed in the late 1970s and early 1980s: satellite laser ranging (SLR) systems, which could measure the distance from the ground to a satellite equipped with special corner-cube mirrors; and very long baseline interferometry (VLBI), which could measure the difference in arrival times between radio signals from extragalactic radio sources. With these systems it is possible to measure accurately (within a few centimeters) the distances between points located on different continents, making possible the creation of

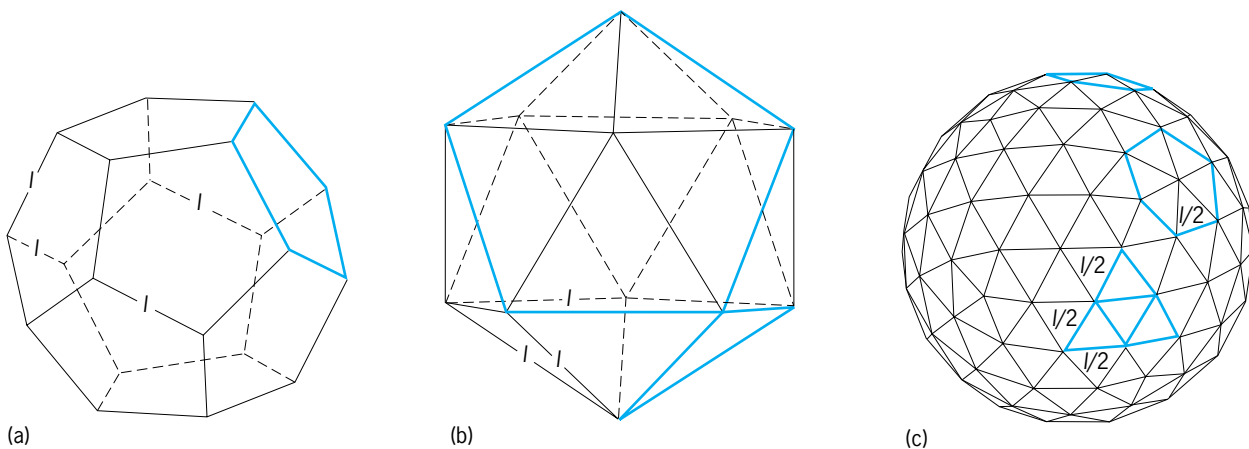

Geometry of geodesic domes. (a) Dodecahedron: a regular pentagon is typical of each face; every point is an apex because all apexes are on the sphere; each strut ( $l$ ) is the same length. (b) Icosahedron: an apex is above the center of each polygon and on the surface of the sphere; the equilateral triangle typical of each face is highlighted; each strut is the same length. (c) Larger dome based on the icosahedron: subdivision is formed by connecting mid points of struts of equilateral triangles (each half strut is labeled  $l/2$ ); the original pentagon is shown at the top, and a formed hexagon is also shown.

truly global coordinate systems. Both systems were deployed around the world to measure not only the positions of locations but also the changes in those positions; and thus it was confirmed that the Earth is not a static but a highly dynamic body, with much of this dynamism causing catastrophic events such as earthquakes and volcanic eruptions. The more recent Global Positioning System (GPS) offers much of the capability of SLR and VLBI. See RADIO ASTRONOMY; SATELLITE NAVIGATION SYSTEMS.

The most recent development in geodetic techniques is interferometric synthetic aperture radar (InSAR). This technique is used to measure heights of the topography or, if the topography is already known, the changes in the topography between two synthetic aperture radar (SAR) images. Heights measured with InSAR are far less accurate than normal geodetic height measurements, but since InSAR is an imaging system, large areas can be measured easily. If the InSAR instrument is on an orbiting spacecraft, global topography can be measured. The measurement of changes in topography with InSAR has been widely used to measure the surface displacements after earthquakes (by comparing before and after SAR images) and for monitoring volcanic deformations. See RADAR.

Some of the major impacts of modern geodetic measurements have been in the study of the dynamics of the Earth. The measurement systems enable the observation of many of the minute motions of the Earth, such as those associated with plate tectonics and other geophysical processes, and changes in the rotation of the Earth. [T.He.]

**Geodynamics** The branch of geophysics that studies the processes leading to deformation of planetary mantle and crust and the related earthquakes and volcanism that shape the structure of the Earth and other planets. On the largest scale, these processes are a consequence of the transfer of heat out of planetary interiors due to cooling at their surfaces. Rock contracts as it cools, so that its density increases. The cool surface layer is heavier than the interior and has a tendency to sink into it. At the same time, cooling and solidification of the metallic core heats the deepest portion of the surrounding rocky mantle, causing it to become buoyant. The resulting flow of the mantle causes deformation at the surface. Volcanism arises from the partial melting of hot mantle that rises toward the surface from the deeper interior, in response either to buoyancy or to surface deformation. Surface deformation also results from external loads, such as the distribution of ice and water, tidal loads due to the gravitational attraction of nearby planetary bodies, and meteor impacts. See EARTH, CONVECTION IN; EARTH, HEAT FLOW IN; GEOPHYSICS; VOLCANO.

A planet's response to its internal heat flow depends largely on the rheology of deforming rock. At low temperatures, near the surface, rock behaves as a brittle-elastic material, allowing the propagation of seismic waves and the support of surface loads by elastic stresses. Deformation occurs by the formation of cracks or faults. On geologic time scales and at the higher temperatures of the deeper interior, thermally activated creep allows the solid, rocky mantle to flow like a viscous fluid. But even at these high temperatures, rock behaves elastically on short time scales so that elastic shear waves propagate through the slowly flowing mantle. In the case of the Earth in its current stage of evolution, plate tectonics describes how the surface behaves: large, cold, relatively rigid plates move laterally across the surface while the deeper mantle flows by creep. In the cold plates, deformation is largely confined to boundary faults between the plates. Faults slip with a stick-slip behavior, giving rise to large earthquakes that occur primarily on the plate boundaries. See EARTHQUAKE; PLATE TECTONICS; RHEOLOGY; ROCK MECHANICS.

Given the difficulty of direct observation and the wide range of scales involved in phenomena of interest, multiple approaches are needed to understand geodynamic processes. Laboratory experiments on relatively small samples of rock are used to characterize the rock's physical properties, such as its rheology, at

high pressures and temperatures. The rate of deformation due to creep in nature is much too slow to measure directly in the laboratory. Field studies of rocks once deep in the interior and brought to the surface by uplift and erosion provide evidence of the processes that have affected them. But the interior of the Earth where the processes of interest are actually occurring is not directly accessible for study. Thus geodynamicists must design large-scale observational experiments that allow them to create conceptual and physical images of the interior, using combinations of seismic, gravitational, electromagnetic, and heat-flow measurements. Variations in global gravity and corresponding surface topography can be remotely sensed from orbiting spacecraft. See EARTH CRUST; EARTH INTERIOR; GEODESY; GEOMAGNETISM; SEISMOLOGY. [E.M.P.]

**Geodynamo** The mechanism thought to be responsible for the generation of the Earth's magnetic field through the convection of conducting fluids in the Earth's core.

Paleomagnetic measurements suggest that the Earth has possessed a magnetic field for at least 3.5 billion years. Geophysicists generally accept that the ambient magnetic field measured at the Earth's surface is due to electric currents flowing in its liquid iron core (see illustration). In the absence of electromotive forces, like those of chemical batteries, electric currents will decay as magnetic energy is converted to heat. Without some regenerative process to offset such natural ohmic dissipation in the Earth's core, any electric currents and the associated magnetic field would vanish in about 15,000 years. Regeneration of the field is necessary. In the Earth it is thought that the magnetic field is maintained by dynamo action, whereby the kinetic energy of convective motion in the Earth's liquid core is converted into magnetic energy. Since this process operates without an external energy source, the geodynamo is said to be self-sustaining. See GEOELECTRICITY; GEOMAGNETISM; PALEOMAGNETISM.

It is not obvious how a simply connected conducting fluid body, like the Earth's core, functions as a dynamo without the induced currents simply short-circuiting and eliminating field generation. In fact, the electric current in a dynamo and the magnetic field that it sustains cannot be too simple; a theorem, due to T. G. Cowling, says that no axisymmetric, or even two-dimensional,

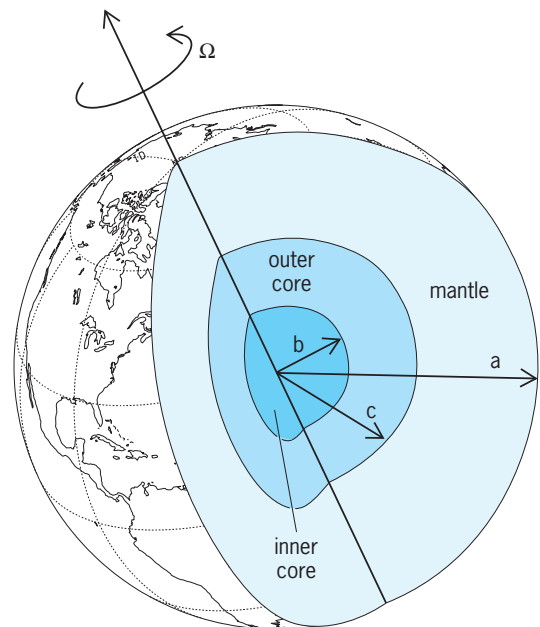

**Anatomy of the Earth.** The rocky mantle has a radius  $a = 6371$  km (3959 mi), the liquid iron outer core has a radius  $c = 3485$  km (2165 mi), and the solid inner core has a radius  $b = 1215$  km (755 mi). The Earth's rotational vector is  $\Omega$ .

dynamo magnetic field can exist. Although the magnetic north and south poles usually are nearly coincident with the geographic poles, indicating that the rotation arising from the Coriolis force plays an important role in the core's dynamics, it is no accident that the compass does not point toward true north everywhere on the Earth's surface—an inherent lack of symmetry. As a result, theoretical progress has been slow since scientists often take advantage of symmetry, should it be present, when solving mathematical equations. See CORIOLIS ACCELERATION; MAGNETO-HYDRODYNAMICS.

Geophysicists do, however, have a good qualitative understanding of how the geodynamo works. In the 1940s and 1950s, W. M. Elsasser and E. N. Parker first elucidated the so-called  $\alpha$ - $\omega$  (alpha-omega) mechanism, by which core fluid motion can act as a dynamo if it consists of a combination of differential rotation and convective helical motion. Since then it has been shown mathematically that dynamo regeneration can arise from the turbulent motion of a rotating fluid. Although the  $\alpha$ - $\omega$  mechanism probably describes how the field is amplified, it is the dynamics that ultimately governs the strength of the field.

There are two possible sources of the energy sustaining the fluid convection in the outer core—thermal and compositional. Thermal convection is perhaps most familiar, with heat sources, such as radioactive potassium, distributed over the volume of the outer core. With sufficient internal heating, the fluid is gravitationally unstable and, as a result, convection is sustained. Compositional convection is currently favored by most geophysicists as the energy source of the geodynamo. Although the core is primarily of iron, there are probably light impurities, such as sulfur. Due to the effects of pressure, as the Earth slowly cools, iron solidifies at the inner-core boundary. This causes the inner core to grow and leaves the lighter constituents behind in the fluid at the base of the outer core, supplying the buoyancy that drives the convection. See CONVECTION (HEAT).

The Sun is a familiar dynamo, and it reverses regularly almost every 11 years. So, why does the Earth's magnetic field not display such regularity? The difference is thought to be due to the presence in the Earth of a solid electrically conducting inner core, where the magnetic field can change only rather slowly by diffusion. Recent calculations suggest that because the inner core is electromagnetically coupled to the outer core, its presence acts to stabilize the magnetic field, so that only particularly large fluctuations of the field in the outer core are sufficient to overcome the damping effect of the inner core. See DIFFUSION; ELECTROMAGNETISM; GEOPHYSICS; MAGNETIC REVERSALS. [J.J.Lo.]

**Geoelectricity** Electromagnetic phenomena and electric currents, mostly of natural origin, that are associated with the Earth. Geophysical methods utilize natural and artificial electric currents to explore the properties of the Earth's interior and to search for natural resources (for example, petroleum, water, and minerals). Geoelectricity is sometimes known as terrestrial electricity. All electric currents (natural or artificial, local or worldwide) in the solid Earth are characterized as Earth currents. The term telluric currents is reserved for the natural, worldwide electric currents whose origins are almost entirely outside the atmosphere. Geoelectromagnetism is a more comprehensive term than geoelectricity. Time variations of any magnetic field are associated with an electric field that induces electric currents in conducting media such as the Earth.

Magnetic fields, electric fields, and electric currents are the constituents of electromagnetism, and are related by Maxwell's equations. For instance, the illustration shows the time variations of the natural magnetic and electric fields simultaneously measured at one location at the surface of the Earth. These two traces are related to each other, not only by Maxwell's equations but also by the physical properties of the subsurface rocks in the vicinity of the measuring site. Either one of the two traces may be computed synthetically from the other if the properties of the subsurface rocks are known. Conversely, the two traces together can yield geologic information; this is a form of geophys-

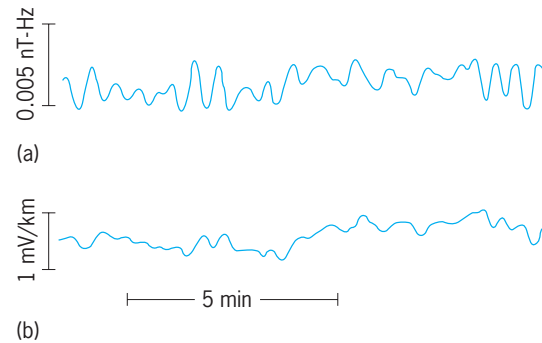

Time variations of the horizontal orthogonal components of the natural (a) magnetic and (b) electric fields, simultaneously measured at one site at the surface.

ical exploration or prospecting. Thus, the terms geoelectricity, geomagnetism, and geoelectromagnetism are essentially interchangeable, although each one may have a somewhat different emphasis. For example, the term geomagnetism is sometimes used for the study of the Earth's quasistationary main magnetic field. See GEOMAGNETISM; GEOPHYSICAL EXPLORATION. [S.H.Y.]

**Geographic information systems** Computer-based technologies for the storage, manipulation, and analysis of geographically referenced information. Attribute and spatial information is integrated in geographic information systems (GIS) through the notion of a data layer, which is realized in two basic data models: raster and vector. The major categories of applications comprise urban and environmental inventory and management, policy decision support, and planning; engineering and defense applications; and scientific analysis and modeling.

A geographic information system differs from other computerized information systems in two major respects. First, the information in this type of system is geographically referenced (geocoded). Second, a geographic information system has considerable capabilities for data analysis and scientific modeling, in addition to the usual data input, storage, retrieval, and output functions.

A geographic information system is composed of software, hardware, and data. The notion of data layer (or coverage) and overlay operation lies at the heart of most software designed for geographic information systems.

Two fundamental data models, the vector and raster models, embody the overlay idea in geographic information systems. In a vector geographic information system, the geometrical configuration of a coverage is stored in the form of points, arcs (line segments), and polygons, which constitute identifiable objects in the database. In a raster geographic information system, a layer is composed of an array of elementary cells of pixels, each holding an attribute value without explicit reference to the geographic feature of which the pixel is a part. See COMPUTER GRAPHICS; ELECTRONIC DISPLAY; IMAGE PROCESSING.

A data layer or coverage integrates two kinds of information: attribute and spatial (geographic). The functionality of a geographic information system consists of the ways in which that information may be captured, stored, manipulated, analyzed, and presented to the user. Spatial data capture (input) may be from primary sources such as remote sensing scanners, radars, or global positioning systems, or from scanning or digitizing images and maps derived from remote sensing. Output (whether as a display on a cathode-ray tube or as hard copy) is usually in map or graph form, accompanied by tables and reports linking spatial and attribute data. The critical data management and analysis functions fall into four categories: retrieval, classification, and measurement; overlay functions; neighborhood operations; and connectivity functions. See DIGITAL COMPUTER; REMOTE SENSING.

[H.Co.]

Business applications of geographic information systems are increasingly widespread and include market analysis, store

location, and agribusiness (for example, determining the correct amount of fertilizers or pesticides needed at each point of a cultivated field). Engineers use geographic information systems when modeling terrain, building roads and bridges, maintaining cadastral maps, routing vehicles, drilling for water, determining what is visible from any point on the terrain, integrating intelligence information on enemy targets, and so forth. Such applications have been facilitated through the integration of geographic information systems with global positioning systems. See COORDINATE SYSTEMS; SATELLITE NAVIGATION SYSTEMS.

Among the earliest and still most widespread applications of the technology are land information and resource management systems (for example, forest and utility management). Other common uses of geographic information systems in an urban policy context include emergency planning, determination of optimal locations for fire stations and other public services, assistance in crime control and documentation, and electoral and school redistricting. Uses of geographic information systems have spread well beyond geography, the source discipline, and now involve most applied sciences, both social and physical, that deal with spatial data. The nature of the applications of geographic information systems in these areas ranges from simple thematic mapping for illustration purposes to complex statistical and mathematical modeling for the exploration of hypotheses or the representation of dynamic processes. [H.Co.]

**Geography** The study of physical and human landscapes, the processes that affect them, how and why they change over time, and how and why they vary spatially. Geographers consider, to varying degrees, both natural and human influences on the landscape, although a common division separates human and physical geography. Physical geographers may study landforms (geomorphology), water (hydrology), climate and meteorology (climatology), the biotic environment (biogeography), or soils (pedology). Human geographers include urban, regional, and environmental planners; cultural geographers; regional and area specialists; economic geographers; political geographers; transportation analysts; location analysts; and specialists in the spatial nature of ethnic or gender issues. See BIOGEOGRAPHY; CLIMATOLOGY; GEOMORPHOLOGY; HYDROLOGY; PEDOLOGY.

Many geographers are involved with the development of techniques and applications that support spatial analytical studies or the display of spatial information and data. Maps, whether printed, digital, or conceptual, are the basic tools of geography. Geographers are involved in map interpretation and use, as well as map production and design. Cartographers supervise the compilation, design, and development of maps, globes, and other graphic representations. See CARTOGRAPHY.

A geographic information system (GIS) is a relatively new technology that combines the advantages of computer-assisted cartography with those of spatial database management. It facilitates the storage, retrieval, and analysis of spatial information in the form of digital map “overlays,” each representing a different landscape component (terrain, hydrologic features, roads, vegetation, soil types, or any mappable factor). Each of these data layers can be fitted digitally to the same map scale and map projection—in any combination—permitting the analysis of relationships among any combination of environmental variables for which data have been input into the geographic information systems. See GEOGRAPHIC INFORMATION SYSTEMS.

Many geographers are applied practitioners, solving problems using a variety of tools, including computer-assisted cartography, statistical methods, remotely sensed imagery, the Global Positioning System (GPS), and geographic information systems. Today, nearly all geographers, regardless of their subdisciplinary emphases, employ some or all of these techniques in their professional endeavors. See EARTH RESOURCE PATTERNS; PHYSICAL GEOGRAPHY; TERRAIN AREAS. [J.F.P.]

**Geologic thermometry** The measurement or estimation of temperatures at which geologic processes take place.

Methods used can be divided into two groups, nonisotopic and isotopic. Nonisotopic methods involve measurements of earth temperatures either directly by surface and near-surface features or indirectly from various properties of minerals and fossils. The isotopic methods involve the determination of distribution of isotopes of the lighter elements between pairs of compounds in equilibrium at various temperatures, and application of these data to problems of the temperature at which these compounds (commonly minerals) form in nature. [E.I.]

**Geologic time scale** An ordered, internally consistent, internationally recognized sequence of time intervals, each distinct in its own history and record of life on Earth, including the assignment of absolute time in years to each geologic period. The geologic time scale (see table) has a relative scale, consisting of named intervals of geologic history arranged in historical sequence; and a numerical (or absolute) time scale, providing absolute ages for the boundaries of these intervals.

**Geologic time scale**

Eon	Age at beginning of interval, 10 <sup>6</sup> years	Interval length, 10 <sup>6</sup> years
Era		
Period [system]		
Epoch [series]		
<b>Phanerozoic</b>		
<b>Cenozoic</b>		
		65
Quaternary (Q)*		1.8
Recent	0.01	0.01
Pleistocene	1.8	1.79
Tertiary (T)	65	63.2
Pliocene (Tpl)	5.3	3.5
Miocene	23.8	18.5
Oligocene (To)	33.7	9.9
Eocene (Te)	54.8	21.1
Paleocene (Tp)	65	10.2
<b>Mesozoic</b>		
	250	185
Cretaceous (K)	144	79
Jurassic (J)	206	62
Triassic (Tr)	250	44
<b>Paleozoic</b>		
	543	297
Permian (P)	290	40
Carboniferous (M, P)	354	64
Devonian	417	63
Silurian	443	26
Ordovician	490	47
Cambrian	543	53
<b>Precambrian</b>		
<b>Proterozoic</b>		
	2500	1957
Late (Z) <sup>†</sup> (Neoproterozoic)	900	357
Middle (Y) (Mesoproterozoic)	1600	700
Early (X) (Paleoproterozoic)	~2500	900
<b>Archean</b>		
	3800	
Late (W)	3000	500
Middle (U)	3400	400
Early (V)	>3800	>400

\*In parentheses are the symbols for the periods and epochs used on geologic maps and figures in North America, as well as other parts of the world.

<sup>†</sup>Letter designations of Precambrian age intervals are used by the U.S. Geological Survey.

In order to establish a geologic time scale, an independent means of dating rocks is required. Before the discovery of radioactivity, crude estimates of the length of a geologic history were made based on the total thicknesses of sedimentary rock and assumed rates of erosion and sedimentation. These estimates varied by as much as a factor of 10.

The modern geologic time scale is based on many measurements of various rock types by quantitative isotopic chronometers such as uranium-lead (U-Pb) and potassium-argon (K-Ar). See ROCK AGE DETERMINATION. [A.R.P.; J.W.Gei.; J.L.K.]

**Geology** The science of the Earth. The study of the Earth's materials and of the processes that shape them is known as physical geology. Historical geology is the record of past events. See EARTH; EARTH SCIENCES.

Geology is an interdisciplinary subject that overlaps and depends on other scientific disciplines. Physical geology is concerned primarily with the Earth's materials (minerals, rocks, soils, water, ice, and so forth) and the processes of their origin and alteration. Chemistry and physics are the two scientific disciplines most closely related—study of the chemistry of the Earth's materials is geochemistry, and study of the physical properties of the Earth is geophysics. See GEOCHEMISTRY; GEOPHYSICS; STRUCTURAL GEOLOGY.

Historical geology is based on two complementary disciplines, stratigraphy and paleontology. Stratigraphy is the systematic study of stratified rocks through geologic time. The stratigraphic record reveals the sequence of events that have affected the Earth through eons of time. Absolute dates for the stratigraphic record are provided from geochemical studies of naturally occurring radioactive isotopes. Paleontology is the study of fossilized plants and animals with regard to their distribution in space and time. Paleontology is closely related to biology. The distinctions between physical and historical geology are more matters of convenience than substance, because it is increasingly clear, within the framework of plate tectonics, that all aspects of geology are interrelated. See PALEONTOLOGY; PLATE TECTONICS; STRATIGRAPHY.

Mineralogy concerns the study of natural inorganic substances (minerals), the basic building blocks of rocks. About 3600 minerals have been identified, but fewer than 50 are common constituents in the types of rocks that are abundant in the Earth. The most common minerals in the crust are feldspars, quartz, micas, amphiboles, pyroxenes, olivine, and calcite. Modern laboratories have effective devices for resolving the mineral content of rock materials; even the ultramicroscopic particles in clays are clearly defined under the electron microscope. See CRYSTAL STRUCTURE; ELECTRON MICROSCOPE; MINERAL; MINERALOGY.

Petrology is the study of rocks, their physical and chemical properties, and their modes of origin. The primary families are igneous rocks, which have solidified from molten matter (magma); sedimentary rocks, made of fragments derived by weathering of preexisting rocks, of chemical precipitates from sea or lake water, and of organic remains; and metamorphic rocks derived from igneous or sedimentary rocks under conditions that brought about changes in mineral composition, texture, and internal structure (fabric). The secondary rock families are pyroclastic rocks, which are partly igneous and partly sedimentary rocks because they are composed largely or entirely of fragments of igneous matter erupted explosively from a volcano; diagenetic rocks are transitional between sedimentary and metamorphic rocks because their textures or compositions were affected by low-temperature, postsedimentation processes below conditions of metamorphism; migmatites are transitional between metamorphic and igneous rocks because they form when metamorphic rocks are raised to temperatures and pressures so that small localized fractions of the rock start to melt but the melting is insufficient for a large body of magma to develop. See PETROGRAPHY; PETROLOGY; ROCK.

A general knowledge of geology has many practical applications, and large numbers of geologists receive special training for service in solving problems met in the mining of metals and nonmetals, in discovering and producing petroleum and natural gas, and in engineering projects of many kinds. Human use of materials has become so great that waste materials are influencing natural geological processes. As a result, a new discipline, environmental geology, is starting to emerge. See ENGINEERING GEOLOGY; PETROLEUM GEOLOGY. [B.J.S.]

**Geomagnetic variations** Variations in the natural magnetic field measured at the Earth's surface. This field changes with periodicities from about 0.3 s to thousands of years. Many of these variations of observed field—the very short-period, daily, seasonal, semiannual, and solar-cycle (11-year) variations—arise from sources that are external to the Earth but are superposed upon the larger main dipolar field of the Earth by the typical measuring instruments. The daily and seasonal atmospheric

motions cause field variations that are smooth in form and relatively predictable, given the time and location of the observation. During occasions of high solar-terrestrial disturbance activity that give rise to auroras at high latitudes, very large geomagnetic variations occur that mask the quiet daily changes. These geomagnetic variations are so spectacular in size and global extent that they have been named geomagnetic storms. See AURORA; GEOMAGNETISM; IONOSPHERE; MAGNETOSPHERE; SOLAR WIND; SUN.

[W.H.Ca.]

**Geomagnetism** The magnetism of the Earth; also, the branch of science that deals with the Earth's magnetism. Formerly called terrestrial magnetism, geomagnetism involves any topic pertaining to the magnetic field observed near the Earth's surface, within the Earth, and extending upward to the magnetospheric boundary. Modern usage of the term is generally confined to historically recorded observations to distinguish it from the sciences of archeomagnetism and paleomagnetism, which deal with the ancient magnetic field frozen respectively in archeological artifacts and geologic structures. See PALEOMAGNETISM; ROCK MAGNETISM.

The primary component of the magnetic field observed at the Earth's surface is caused by electric currents flowing in its liquid core, and is called the main field. Vectorially added to this component are the crustal field of magnetized rocks, transient variations imposed from external sources, and the field from electric currents induced in the Earth from these variations.

The geomagnetic field is specified at any point by its vector  $\mathbf{F}$ . Its direction is that of a magnetized needle perfectly balanced before it is magnetized, and freely pivoted about that point, when in equilibrium. The north pole of such a needle is the one that at most places on the Earth takes the more northerly position. Over most of the Northern Hemisphere, that pole dips downward (see illustration). The elements used to describe the vector  $\mathbf{F}$  are  $H$ , the component of the vector projected onto a horizontal plane; its north and east components  $X$  and  $Y$ , respectively;  $Z$  the vertical component;  $F$  the magnitude of the vector  $\mathbf{F}$ ; the angles  $I$ , the dip of the field vector below the horizontal; and  $D$  the magnetic declination or deviation of the compass from geographic north. By convention,  $Z$  and  $I$  are positive downward, and  $D$  is positive eastward (or may be indicated as east or west of north). These elements can be related to each other by trigonometric equations. See MAGNETIC COMPASS.

A magnetic pole is a location where the field is vertically

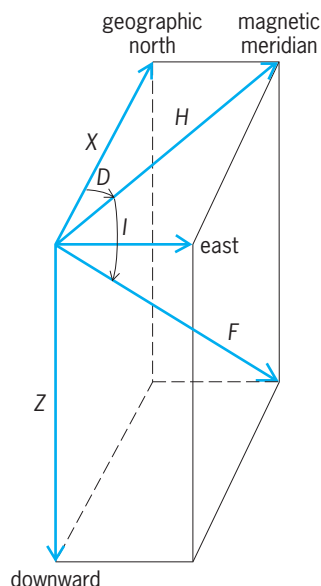

Elements of the geomagnetic field.  $D$  = declination,  $I$  = inclination,  $H$  = horizontal intensity,  $X$  = north intensity,  $Y$  = east intensity,  $Z$  = vertical intensity,  $F$  = total intensity.



aligned,  $H = 0$ . Due to the presence of sometimes strong (for example,  $>1000$  nanoteslas) magnetic anomalies at the Earth's surface, there are a number of locations where the field is locally vertical. However, those field components that extend to sufficient altitude to control charged particles can be accurately located by using the computations from a spherical harmonic expansion using degrees up to only about  $n = 10$ . Indeed, a pole can be defined by using only the main dipole ( $n = 1$ ), or many terms. See AURORA.

The  $n = 1$  poles are sometimes referred to as the geomagnetic poles, and those computed using higher terms as dip poles. The term geomagnetic could also refer to the eccentric geomagnetic pole, which can be computed from  $n = 1$  and  $n = 2$  harmonics so as to be the best representation of a dipole offset from the center of the Earth. The latter has been used as a simplified field model at distances of 3 or 4 earth radii. Due to the more rapid fall-off of the higher terms with distance from the Earth, the two principal poles approach those of the  $n = 1$  term with increasing altitude, until the distortions due to external effects begin to predominate. See MAGNETOSPHERE.

The distribution of the dip angle  $I$  over the Earth's surface can be indicated on a globe or map by contours called isoclines, along which  $I$  is constant. The isocline for which  $I = 0$  (where a balanced magnetized needle rests horizontal) is called the dip equator. The dip equator is geophysically important because there is a region in the ionospheric E layer in which small electric fields can produce a large electric current called the equatorial electrojet. See GEOMAGNETIC VARIATIONS; IONOSPHERE.

A magnetized compass needle can be weighted so as to rest and move in a horizontal plane at the latitudes for which it is designed, thus measuring the declination  $D$ . The lines on the Earth's surface along which  $D$  is constant are called isogonic lines or isogones. The compass points true geographic north on the agonic lines where  $D = 0$ . At nonpolar latitudes,  $D$  is a useful tool for marine and aircraft navigational reference. Indeed, isogones appear on navigation charts, electronic navigational aids are referenced to  $D$ , and airport runways are marked with  $D/10$ . A runway painted with the number 11 indicates that its direction has a compass heading of  $110^\circ$ . The compass needle becomes less reliable in polar regions because the horizontal component  $H$  becomes smaller as the magnetic poles are approached. See NAVIGATION.

The intensity of the field can also be represented by maps, and the lines of equal intensity are called isodynamic lines. The dipole dominates the patterns of magnetic intensity on Earth in that the intensity is about double at the two poles compared to the value near the Equator. However, it can also be seen that the next terms of the spherical harmonic expansion also have a significant effect, in that there is a second maximum in Siberia, and an area near Brazil that is weaker than any other. This so-called Brazilian anomaly allows charged particles trapped in the magnetic field to reach a low altitude and be lost by collisions with atmospheric gases. The highest intensity of this smooth field is about 70 microteslas near the south magnetic pole in Antarctica, and the weakest is about  $23 \mu\text{T}$  near the coast of Brazil.

The term magnetic anomaly has become clearer than it was previously because it is recognized that the geomagnetic field has a continuous spectrum but with two distinct contributors. Originally, the term meant a field pattern that was very local in extent; the modern definition is that portion of the field whose origin is the Earth's crust. The sizes of the strong and easily observable features are generally up to only a few tens of kilometers. Their intensity ranges typically from a few hundred nanoteslas up to several thousand, and they are highly variable depending on the geology of the region.

The main or core component of the geomagnetic field undergoes slow changes that necessitate continual adjustment of the model coefficients and redrawing of the isomagnetic maps. In any magnetic element at a particular place, the variation may be an increase or a decrease and is not constant in either magnitude or sign. This distribution of the rate for any element can

be indicated on isoporic maps by lines (isopors) along which the rate is constant. Typically, the pattern of isopors is more complex than that of the isomagnetic lines for the same element, partly because the spectrum of such change is not dominated by the dipole as is the case of the static field.

Studies indicate that the dipole component of the field 2000 years ago was about 50% stronger than the present. Its average decay rate has averaged about 0.05% per year (15 nanoteslas per year) since about 1840 when absolute measurements were first begun, but accelerated from 1970 to its 1994 value of 0.08% per year (24 nT/yr). However, there is also evidence that the decade of the 1940s showed a rate of only about 10 nT per year. A linear projection of the present rate would have the dipole decreasing to zero in less than 1500 years. Although archeomagnetic evidence indicates that the field has indeed decayed to near zero level within the last 50,000 years with a subsequent return to the present polarity, and paleomagnetic results show that the field has reversed its polarity many times since the Earth's formation (the last time, about a million years ago), there is no model that can predict the future course of field change.

Deriving a suitable model that explains the source of the Earth's magnetic field has been one of the most frustrating problems that theoreticians have faced. Starting with the physical laws that should govern the behavior of a highly conducting, rotating, spherical fluid and coming up with a model of the geomagnetic field is exceedingly difficult. Dynamo means that a current is generated as an electrical conductor is moved through a magnetic field, as in a dynamo supplying electrical power. See GEODYNAMO.

The main source of data for magnetic maps and models before the advent of satellites was fixed magnetic observatories. These stations, numbering about 140, provided the continuous record of changes in the magnetic field at their location. Their data are generally accurate and an excellent indicator of both secular change and the transient variations, but their global coverage is too sparse for a determination of the whole field. Spherical harmonic analyses based only on such data produce distorted results because of the large gaps in coverage, especially because of the sparseness of observing locations in southern oceanic regions. See MAGNETISM. [J.Cai.]

**Geometric phase** A unifying mathematical concept that describes the relation between the history of internal states of a system and the system's resulting orientation in space. Under various aspects, this concept occurs in geometry, astronomy, classical mechanics, and quantum theory. In geometry it is known as holonomy. In quantum theory it is known as Berry's phase, after M. Berry, who isolated the concept (which was already known in special cases) and explained its wide-ranging significance.

A system is envisioned whose possible states can be visualized as points in a suitable abstract space. At the same time, the system has some position or orientation in another space. A history of internal states can be represented by a curve in the first space; and the effect of this history on the disposition of the system, by a curve in the second space. The mapping between these two curves is described by the geometric phase. Especially interesting is the case when a closed curve (cycle) in the first space maps onto an open curve in the second, for then there is no net change in internal state, yet the disposition of the system with respect to the outside world is altered.

The power of the geometric phase ideas is that they make it possible, in complex dynamical problems, to find some simple universal regularities without having to solve the complete equations. Significant uses of these ideas include demonstrations of the fractional electric charge and quantum statistics of the quasiparticles in the quantum Hall effect, and of the occurrence of anomalies in quantum field theory. See ANYONS; HALL EFFECT; QUANTUM FIELD THEORY. [FWil.]

**Geometrical optics** The geometry of light rays and their images, through optical systems. In the modern view of

the wave nature of light, geometrical optics as a model is simply wrong. In spite of this geometrical optics is remarkably robust, remaining as a most practical tool in the solution of optical problems where at first glance it would seem to be totally inappropriate. The principal application of geometrical optics remains in the field of optical design.

Light is a form of energy which flows from a source to a receiver. It consists of particles (corpuscles) called photons. The speed with which the particles travel depends on the medium. In a vacuum this speed is  $3 \times 10^8 \text{ m} \cdot \text{s}^{-1}$  ( $1.86 \times 10^5 \text{ mi} \cdot \text{s}^{-1}$ ) for all colors. In a material medium, whether gas, liquid, or solid, light travels more slowly. Moreover, different colors travel at different rates. The ratio of the speed in a vacuum to the speed in the medium is called the refractive index of the medium. The variation in refractive index with color is called dispersion. See COLOR; DISPERSION (RADIATION); REFRACTION OF WAVES.

The paths that particles take in going from the source to the receiver are called rays. The product of the refractive index and the path length is called the optical path length along the ray. The optical path length is equal to the distance that the particle would have traveled in a vacuum in the same time interval.

A point source is an infinitesimal region of space which emits photons. An extended source is a dense array of point sources. Each point source emits photons along a family of rays associated with it. For each such family of rays there is also a family of surfaces each of which is a surface of constant transit time from the source for all the particles, or alternatively, a surface of constant optical path length from the source. These surfaces are called geometrical wavefronts, because they are often good approximations to the wavefronts predicted by a wave theory.

The ray path which any particle takes as it propagates is determined by Fermat's principle, which states that the ray path between any two points in space is that path along which the optical path length is stationary (usually a minimum) among all neighboring paths. In a homogeneous medium (one with a constant refractive index) the ray paths are straight lines.

In a system that consists of a sequence of separately homogeneous media with different refractive indices and with smooth boundaries between them (such as a lens system), the ray paths are straight lines in each medium, but the directions of the ray paths will change in passing through a boundary surface. This change in direction is called refraction, and is governed by Snell's law, which states that the product of the refractive index and the sine of the angle between the normal to the surface and the ray is the same on both sides of a surface separating two media. The normal in question is at the point where the ray intersects the surface.

The primary area of application of geometrical optics is in the analysis and design of image-forming systems. An optical image-forming system consists of one or more optical elements (lenses or mirrors) which when directed at a luminous (light-emitting) object will produce a spatial distribution of the light emerging from it which more or less resembles the object. The latter is called an image. See OPTICAL IMAGE.

In order to judge the performance of the system, it is first necessary to have a clear idea of what constitutes ideal behavior. Departures from this ideal behavior are called aberrations, and the purpose of optical design is to produce a system in which the aberrations are small enough to be tolerable. See ABERRATION (OPTICS).

In an ideal optical system the rays from every point in the object space pass through the system so that they converge to or diverge from a corresponding point in the image space. This corresponding point is the image of the object point, and the two are said to be conjugate to each other (object and image functions are interchangeable).

The geometry of the object and image spaces must be connected by some mapping transformation. The one generally used to represent ideal behavior is the collinear transformation. If three object points lie on the same straight line, they are said to be collinear. If the corresponding three image points are also

collinear, and if this relationship is true for all sets of three conjugate pairs of points, then the two spaces are connected by a collinear transformation. In this case, not only are points conjugate to points, but straight lines and planes are conjugate to corresponding straight lines and planes.

Another feature usually incorporated in the ideal behavior is the assumption that all refracting or reflecting surfaces in the system are figures of revolution about a common axis, and this axis of symmetry applies to the object-image mapping as well. Every object plane containing the axis, called a meridional plane, has a conjugate which is a meridional plane coinciding with the object plane. In addition, every object plane perpendicular to the axis must have a conjugate image plane which is also perpendicular to the axis, because of axial symmetry. In the discussion below, the terms object plane and image plane refer to planes perpendicular to the axis.

An object line parallel to the axis will have a conjugate line which either intersects the axis in image space or is parallel to it. The first case is called a focal system, and the second an afocal system.

The point of intersection of the image-space conjugate line of a focal system with the axis is called the rear focal point (see illustration). It is conjugate to an object point on axis at infinity. The image plane passing through the rear focal point is the rear focal plane, and it is conjugate to an object plane at infinity. Every other object plane has a conjugate located at a finite distance from the rear focal point, except for one which will have its image at infinity. This object plane is the front focal plane, and its intersection with the axis is the front focal point.

Now take an arbitrary object plane and its conjugate image plane. Select a point off axis in the object plane and construct a line parallel to the axis passing through the off-axis point. The conjugate line in image space will intersect the axis at the rear focal point and the image plane at some off-axis point. The distance of the object point from the axis is called the object height, and the corresponding distance for the image point is the image height. The ratio of the image height to the object height is called the transverse magnification, and is positive or negative according to whether the image point is on the same or the opposite side of the axis relative to the object point.

Every pair of conjugate points has associated with it a unique transverse magnification. The conjugate pair which have a transverse magnification of +1 are called the (front and rear) principal planes. The intersections of the principal plane with the axis are called the principal points. The distance from the rear principal point to the rear focal point is called the rear focal length, and likewise for the front focal length. See FOCAL LENGTH.

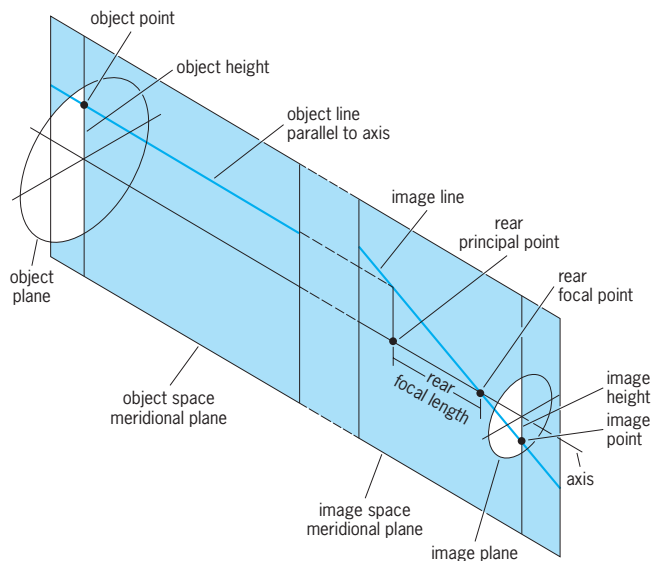

Focal system.

The focal points and principal points are four of the six gaussian cardinal points. The remaining two are a conjugate pair, also on axis, called the nodal points. They are distinguished by the fact that any conjugate pair of lines passing through them make equal angles with the axis. The function of the cardinal points and their associated planes is to simplify the mapping of the object space into the image space.

In addition to the transverse magnification, the concept of longitudinal magnification is useful. If two planes are separated axially, their conjugate planes are also separated axially. The longitudinal magnification is defined as the ratio of the image plane separation to the object plane separation.

In the case of afocal systems, any line parallel to the axis in object space has a conjugate which is also parallel to the axis. The transverse and longitudinal magnifications are constant for the system. Cardinal points do not exist for afocal systems.

The most common use of an afocal system is as a telescope, where both the object and the image are at infinity. The angular magnification is defined as the ratio of the transverse magnification to the longitudinal magnification. The power of a telescope or a pair of binoculars is the magnitude of the angular magnification. *See* MAGNIFICATION; TELESCOPE.

Real optical systems cannot obey the laws of the collinear transformation, and departures from this ideal behavior are identified as aberrations. However, if the system is examined in a region restricted to the neighborhood of the axis, the so-called paraxial region, where angles and their sines are indistinguishable from their tangents, a behavior is found which is exactly congruent with the collinear transformation. Paraxial ray tracing can therefore be used to determine the ideal collinear properties of the system.

The above discussion does not take into account the fact that the sizes of the elements of any optical system are finite, and the light that can get through the system to form the image is limited. A circular aperture which limits the cone of rays from an axial object point that gets through the system and participates in image formation is called the aperture stop of the system. An observer who looks into the front of the system from the axial object point sees not the aperture stop itself (unless it is in front of the system), but the image of it formed by the elements preceding it. This image of the aperture stop is called the entrance pupil, and is situated in the object space on the system. The image of the aperture stop formed by the rear elements is the exit pupil, and is situated in the image space of the system.

[R.V.S.]

**Geometry** A branch of mathematics concerned with the properties of space, including points, lines, curves, planes and surfaces in space, and figures bounded by them. For discussion of various branches of geometry *see* ALGEBRAIC GEOMETRY; DIFFERENTIAL GEOMETRY; EUCLIDEAN GEOMETRY; PROJECTIVE GEOMETRY; RIEMANNIAN GEOMETRY. [J.S.F.]

**Geomorphology** The study of landforms, including the description, classification, origin, development, and history of planetary surface features. Emphasis is placed on the genetic interpretation of the erosional and depositional features of the Earth's surface. However, geomorphologists also study primary relief elements formed by movements of the Earth's crust, topography on the sea floor and on other planets, and applications of geomorphic information to problems in environmental engineering.

Geomorphologists analyze the landscape. Their purview includes the structural framework of landscape, weathering and soils, mass movement and hillslopes, fluvial features, eolian features, glacial and periglacial phenomena, coastlines, and karst landscapes. Processes and landforms are analyzed for their adjustment through time, especially the most recent portions of Earth history. Geomorphologists consider processes from the perspectives of pedology, soil mechanics, sedimentology, geochemistry, hydrology, fluid mechanics, remote sensing, and other

sciences. The complexity of geomorphic processes has required this interdisciplinary approach, but it has also led to a theoretical vacuum in the science. At present many geomorphologists are organizing their studies through a form of systems analysis. The landscape is conceived of as a series of elements linked by flows of mass and energy. Process studies measure the inputs, outputs, and transfers for these systems. Systems analysis provides an organizational framework within which geomorphologists are developing models to predict selected phenomena.

[V.R.B.]

**Geophagia** Soil ingestion by animals. Grazing animals such as sheep and cattle ingest varying amounts of soil when they graze herbage contaminated with it. Pastures become contaminated with soil when livestock walk across the herbage, particularly in wet conditions.

The amount of soil ingested by sheep and cattle is influenced by soil type, stock density, earthworm activity, management practices, and various seasonal factors. Soils that are well drained and have a strong structure do not break up so readily and contaminate the herbage as is the case for poorly drained, weak-structured soils. When the density of stock grazing in a given area of herbage is increased, the amount of treading is increased, while the herbage is grazed more closely. The overall effect is that more soil is transferred to the herbage and ingested.

Geophagia is subject to seasonal variations. The wetter and cooler conditions of autumn and winter result in muddier herbage and an increase in soil ingestion by grazing animals. During the spring and summer, the greater growth of the herbage and drier conditions result in cleaner herbage, and there is a marked decrease in intake of soil.

Soil can be a source of mineral nutrients. Since soils are higher than herbage in iron, manganese, zinc, copper, cobalt, selenium, and iodine, they may contribute to the mineral nutrition of the grazing animals. *See* AGRICULTURE; SOIL CHEMISTRY. [N.D.G.]

**Geophysical exploration** Making, processing, and interpreting measurements of the physical properties of the Earth with the objective of practical application of the findings. Most exploration geophysics is conducted to find commercial accumulations of oil, gas, or other minerals, but geophysical investigations are also employed with engineering objectives, in studies aimed at predicting the nature of the Earth for the foundations of roads, buildings, dams, tunnels, nuclear power plants, and other structures, and in the search for geothermal areas, water resources, archeological ruins, and so on.

Geophysical exploration is also called applied geophysics or geophysical prospecting. The physical properties and effects of subsurface rocks and minerals that can be measured at a distance include density, electrical conductivity, thermal conductivity, magnetism, radioactivity, elasticity, and other properties. Exploration geophysics is often divided into subsidiary fields according to the property being measured, such as magnetic, gravity, seismic, electrical, thermal, or radioactive properties.

**Magnetic exploration.** Rocks and ores containing magnetic minerals become magnetized by induction in the Earth's magnetic field so that their induced field adds to the Earth's field. Magnetic exploration involves mapping variations in the magnetic field to determine the location, size, and shape of such bodies. The magnetic susceptibility of sedimentary rock is generally orders of magnitude less than that of igneous or metamorphic rock. Consequently, the major magnetic anomalies observed in surveys of sedimentary basins usually result from the underlying basement rocks. Determining the depths of the tops of magnetic bodies is thus a way of estimating the thickness of the sediments. *See* GEOMAGNETISM; MAGNETOMETER; ROCK MAGNETISM.

Except for magnetite and a very few other minerals, mineral ores are only slightly magnetic. However, they are often associated with bodies such as dikes that have magnetic expression so that magnetic anomalies may be associated with minerals

empirically. For example, placer gold is often concentrated in stream channels where magnetite is also concentrated.

**Gravity exploration.** Gravity exploration is based on the law of universal gravitation: the gravitational force between two bodies varies in direct proportion to the product of their masses and in inverse proportion to the square of the distance between them. Because the Earth's density varies from one location to another, the force of gravity varies from place to place. Gravity exploration is concerned with measuring these variations to deduce something about rock masses in the immediate vicinity. Gravity surveys are used more extensively for petroleum exploration than for metallic mineral prospecting. The size of ore bodies is generally small; therefore, the gravity effects are quite small and local despite the fact that there may be large density differences between the ore and its surroundings. See GRAVITY METER; PROSPECTING.

**Seismic exploration.** Seismic exploration is the predominant geophysical activity. Seismic waves are generated by one of several types of energy sources and detected by arrays of sensitive devices called geophones or hydrophones. The most common measurement made is of the travel times of seismic waves, although attention is being directed increasingly to the amplitude of seismic waves or changes in their frequency content or wave shape. See SEISMOLOGY.

**Electrical and electromagnetic exploration.** Variations in the conductivity or capacitance of rocks form the basis of a variety of electrical and electromagnetic exploration methods, which are used primarily in metallic mineral prospecting. Both natural and induced electrical currents are measured. Direct currents and low-frequency alternating currents are measured in ground surveys, and ground and airborne electromagnetic surveys involving the lower radio frequencies are made. See GEOELECTRICITY.

**Radioactivity exploration.** Natural radiation from the Earth, especially of gamma rays, is measured both in land surveys and airborne surveys. Natural types of radiation are usually absorbed by a few feet of soil cover, so that the observation is often of diffuse equilibrium radiation. The principal radioactive elements are uranium, thorium, and potassium; radioactive exploration has been used primarily in the search for uranium and other ores, such as columbium, which are often associated with them. The Geiger counter and scintillation counter are instruments generally used to detect and measure the radiation. See GEIGER-MÜLLER COUNTER; SCINTILLATION COUNTER.

**Remote sensing.** Measurements of natural and induced electromagnetic radiation made from high-flying aircraft and earth satellites are referred to collectively as remote sensing. This comprises both the observation of natural radiation in various spectral bands, including both visible and infrared radiation, such as by photography and measurements of the reflectivity of infrared and radar radiation. See REMOTE SENSING.

**Well logging.** A variety of types of geophysical measurements are made in boreholes, including self-potential, electrical conductivity, velocity of seismic waves, natural and induced radioactivity, and temperature variations. Borehole logging is used extensively in petroleum exploration to determine the characteristics of the rocks which the borehole has penetrated, and to a lesser extent in mineral exploration. See WELL LOGGING.

[R.E.Sh.]

**Geophysical fluid dynamics** The branch of physics that studies the dynamics of naturally occurring large-scale flows in the atmosphere and oceans. Examples of such flows are weather patterns, atmospheric fronts, and ocean currents. The fluids are either air or water in a moderate range of temperatures and pressures.

Because of their large scale (from tens of kilometers up to the size of the planet), geophysical flows are strongly influenced by the diurnal rotation of the Earth, which is manifested in the equations of motion as the Coriolis force. Another fundamental characteristic is stratification, that is, density heterogeneity within

the fluid in the presence of the Earth's gravitational field, which is responsible for buoyancy forces. Thus, geophysical fluid dynamics may be considered to be the study of rotating and stratified fluids. It is the common denominator of dynamical meteorology and physical oceanography. See CORIOLIS ACCELERATION; EARTH; METEOROLOGY; OCEANOGRAPHY.

The first of the two distinguishing attributes of geophysical fluid dynamics is the effect of the Earth's rotation. Because geophysical flows are relatively slow and spread over long distances, the time taken by a fluid particle (be it a parcel of air in the atmosphere or water in the ocean) to traverse the region occupied by a certain flow structure is comparable to, and often longer than, a day. Thus, the Earth rotates significantly during the travel time of the fluid, and rotational effects enter the dynamics. Fluid flows viewed in a rotating framework of reference are subject to two additional types of forces, namely the centrifugal force and the Coriolis force. (Properly speaking, these originate not as actual forces but as acceleration terms to correct for the fact that viewing the flow from a rotating frame—the rotating Earth in the case of geophysical fluid dynamics—demands a special transformation of coordinates.) Contrary to intuition, the centrifugal force plays no role on fluid motion because it is statically compensated by the tilting of the gravitational force caused by the departure of the Earth's shape from sphericity. Thus, of the two, only the Coriolis force acts on fluid parcels.

Variations of moisture in the atmosphere, of salinity in the ocean, and of temperature in either can modify the density of the fluid to such an extent that buoyancy forces become comparable to other existing forces. The fluid then has a strong tendency to arrange itself vertically so that the denser fluid sinks under the lighter fluid. The resulting arrangement is called stratification, the second distinguishing attribute of geophysical fluid dynamics. The greater the stratification in the fluid, the greater the resistance to vertical motions, and the more potential energy can affect the amount of kinetic energy available to the horizontal flow.

A quantity central to the understanding of geophysical flows, which are simultaneously rotating and stratified, is the potential vorticity,  $q$ . This quantity incorporates both rotation and stratification. Geophysical flows are replete with vortices, resulting from baroclinic instability. Their interactions generate highly complex flows not unlike those commonly associated with turbulence. Unlike classical fluid turbulence, however, geophysical flows are wide and thin (with, furthermore, a high degree of vertical rigidity as a result of rotational effects), and their turbulence is nearly two-dimensional.

In meteorology, geophysical fluid dynamics has been the key to understanding the essential properties of midlatitude weather systems, including the formation of cyclones and fronts. Geophysical fluid dynamics also explains the dynamical features of hurricanes and tornadoes, sea and land breezes, the seasonal formation and break-up of the polar vortex that is associated with high-latitude stratospheric ozone holes, and a host of other wind-related phenomena in the lower atmosphere. See CYCLONE; HURRICANE; TORNADO.

In oceanography, successes of geophysical fluid dynamics include the explanation of major oceanic currents, such as the Gulf Stream. Coastal river plumes, coastal upwelling, shelf-break fronts, and open-ocean variability on scales ranging from tens of kilometers to the size of the basin are among the many other marine applications. The El Niño phenomenon in the tropical Pacific is rooted in processes that fall under the scope of geophysical fluid dynamics. See EL NIÑO; GULF STREAM. [B.C.R.]

**Geophysics** Those branches of earth sciences in which the principles and practices of physics are used to study the Earth. Geophysics is considered by some to be a branch of geology, by others to be of equal rank. It is distinguished from the other earth sciences largely by its use of instruments to make direct or indirect measurements of the parts of the Earth being studied,

in contrast to the more direct observations which are typical of geology. See GEOLOGY.

Geophysics consists of several principal fields plus parallel and subsidiary divisions. These are commonly considered to include plutology, with geodesy, geothermometry, seismology, and tectonophysics as subdivisions; hydrospheric studies, hydrology (groundwater studies), oceanography, and glaciology; atmospheric studies, meteorology, and aeronomy; and several fields of geophysics which overlap one another, including geomagnetism and geoelectricity, geochronology, geocosmogony, and geophysical exploration and prospecting. Planetary sciences, the study of the planets and satellites aside from the Earth, are usually considered a branch of geophysics because the techniques used have been, until the first landings on each, entirely instrumental rather than directly observational. See GEOCHRONOMETRY; GEODESY; GEOELECTRICITY; GEOLOGIC THERMOMETRY; GEOMAGNETISM; GLACIOLOGY; HYDROLOGY; METEOROLOGY; OCEANOGRAPHY; SEISMOLOGY. [B.F.H.]

**Geostrophic wind** A hypothetical wind based upon the assumption that a perfect balance exists between the horizontal components of the Coriolis force and the horizontal pressure gradient force per unit mass, with the implication that viscous forces and accelerations are negligible. The geostrophic wind blows parallel to the isobars (lines of equal pressure) with lower pressure to the left of the direction of the wind in the Northern Hemisphere and to the right in the Southern Hemisphere. It represents a good approximation to the actual wind at elevations greater than about 3000 ft (900 m), except in instances of strongly curved flow and in the vicinity of the Equator.

The term thermal wind denotes the net change in the geostrophic wind over some specific vertical distance. This change arises because the rate of change of pressure in the vertical is different in two air columns of different air density, so that the horizontal component of the pressure gradient force per unit mass varies in the vertical. The thermal wind is directed approximately parallel to the isotherms of air temperature with cold air to the left and warm air to the right in the Northern Hemisphere, and vice versa in the Southern Hemisphere. Thus, for example, the increasing predominance of westerly winds aloft may be viewed as a consequence of the warmth of tropical latitudes and the coldness of polar regions. See CORIOLIS ACCELERATION; GRADIENT WIND; WIND; WIND STRESS. [F.S.]

**Geosyncline** A linear part of the crust of the Earth that sagged deeply through time, that is, a great trough hundreds of kilometers long and tens of kilometers wide that subsided as it received thousands of meters of sedimentary and volcanic rocks through millions of years. Thicknesses are roughly 10 times greater than synchronous strata in adjacent stable regions. Linear geosynclinal belts were great subsiding tectonic divisions of the crust that lay between more stable parts of continents (cratons) or the deep abyssal ocean basins of their time, or both. Geosynclines generally contain volcanic (eugeosynclinal) and nonvolcanic (miogeosynclinal) zones (see illustration). Although defined on the basis of thickness and types of rocks, the geosyncline has always been so closely linked with the origin of mountains

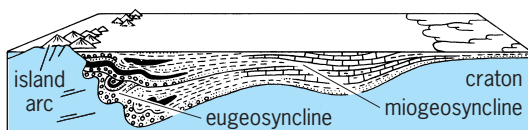

Key: ■ volcanic rocks

Diagrammatic section of Cordilleran geosyncline in southeastern Alaska and British Columbia at the close of Permian time (about 230 million years ago). (After A. J. Eardley, *J. Geol.*, 55:319-342, 1947)

that it has little meaning in any other context. See CORDILLERAN BELT; OROGENY; SYNCLINE. [R.H.Dot.]

**Geosynthetic** Any synthetic material used in geotechnical engineering. See MANUFACTURED FIBER.

Geotextiles are used with foundations, soils, rock, earth, or other geotechnical material as an integral part of a manufactured project, structure, or system. These textile products are made of synthetic fibers or yarns and constructed into woven or nonwoven fabrics that weigh from 3 to 30 oz/yd<sup>2</sup> (100 to 1000 g/m<sup>2</sup>). Geotextiles are more commonly known by other names, for example, filter fabrics, civil engineering fabrics, support membranes, and erosion control cloth.

Permeable geotextiles perform three basic functions in earth structures: separation, reinforcement, and filtration. Such geotextiles can thus be adapted to numerous applications in earthwork construction. The major end-use categories are stabilization (for roads, parking lots, embankments, and other structures built over soft ground); drainage (of subgrades, foundations, embankments, dams, or any earth structure requiring seepage control); erosion control (for shoreline, riverbanks, steep embankments, or other earth slopes to protect against the erosive force of moving water); and sedimentation control (for containment of sediment runoff from unvegetated earth slopes). [R.G.C.]

A geomembrane is any impermeable membrane used with soils, rock, earth, or other geotechnical material in order to block the migration of fluids. These membranes are usually made of synthetic polymers in sheets ranging from 0.01 to 0.14 in. (0.25 to 3.5 mm) thick. Geomembranes are also known as flexible membrane liners, synthetic liners, liners, or polymeric membranes.

Early liners included clay, bentonite, cement-stabilized sand, and asphalt. Modern geomembranes are commonly made of medium-density polyethylenes that are very nearly high-density polyethylenes (HDPE), several types of polyvinyl chloride (PVC), chlorosulfonated polyethylene (a synthetic rubber), ethylene propylene diene monomer (EPDM), and several other materials. Some geomembranes require reinforcement with an internal fabric scrim for added strength, or plasticization with low-molecular-weight additives for greater flexibility. See POLYMER.

Geomembranes are able to contain fluids, thus preventing migration of contaminants or valuable fluid constituents. Since they prevent the dispersal of materials into surrounding regions, geomembranes are often used in conjunction with soil liners, permeable geotextiles, fluid drainage media, and other geotechnical support materials. The major application of geomembranes has been containment of hazardous wastes and prevention of pollution in landfill and surface impoundment construction. They are also used to a large extent in mining to contain chemical leaching solutions and the precious metals leached out of ore, in aquaculture ponds for improved health of aquatic life and improved harvesting procedures, in decorative pond construction, in water and chemical storage-tank repair and spill containment, in agriculture operations, in canal construction and repair, and in construction of floating covers for odor control, evaporation control, or wastewater treatment through anaerobic digestion. See HAZARDOUS WASTE. [M.Cad.; H.P.]

**Geothermal power** Thermal or electrical power produced from the thermal energy contained in the Earth (geothermal energy). Use of geothermal energy is based thermodynamically on the temperature difference between a mass of subsurface rock and water and a mass of water or air at the Earth's surface. This temperature difference allows production of thermal energy that can be either used directly or converted to mechanical or electrical energy.

Commercial exploration and development of geothermal energy to date have focused on natural geothermal reservoirs—volumes of rock at high temperatures (up to 662°F or 350°C) and with both high porosity (pore space, usually filled with

water) and high permeability (ability to transmit fluid). The thermal energy is tapped by drilling wells into the reservoirs. The thermal energy in the rock is transferred by conduction to the fluid, which subsequently flows to the well and then to the Earth's surface.

There are several types of natural geothermal reservoirs. All the reservoirs developed to date for electrical energy are termed hydrothermal convection systems and are characterized by circulation of meteoric (surface) water to depth. The driving force of the convection systems is gravity, effective because of the density difference between cold, downward-moving, recharge water and heated, upward-moving, thermal water. A hydrothermal convection system can be driven either by an underlying young igneous intrusion or by merely deep circulation of water along faults and fractures. Depending on the physical state of the pore fluid, there are two kinds of hydrothermal convection systems: liquid-dominated, in which all the pores and fractures are filled with liquid water that exists at temperatures well above boiling at atmospheric pressure, owing to the pressure of overlying water; and vapor-dominated, in which the larger pores and fractures are filled with steam. Liquid-dominated reservoirs produce either water or a mixture of water and steam, whereas vapor-dominated reservoirs produce only steam, in most cases superheated.

Although geothermal energy is present everywhere beneath the Earth's surface, its use is possible only when certain conditions are met: (1) The energy must be accessible to drilling, usually at depths of less than 2 mi (3 km) but possibly at depths of 4 mi (6–7 km) in particularly favorable environments (such as in the northern Gulf of Mexico Basin of the United States). (2) Pending demonstration of the technology and economics for fracturing and producing energy from rock of low permeability, the reservoir porosity and permeability must be sufficiently high to allow production of large quantities of thermal water. (3) Since a major cost in geothermal development is drilling and since costs per meter increase with increasing depth, the shallower the concentration of geothermal energy the better. (4) Geothermal fluids can be transported economically by pipeline on the Earth's surface only a few tens of kilometers, and thus any generating or direct-use facility must be located at or near the geothermal anomaly.

Equally important worldwide is the direct use of geothermal energy, often at reservoir temperatures less than 212°F (100°C). Geothermal energy is used directly in a number of ways: to heat buildings (individual houses, apartment complexes, and even whole communities); to cool buildings (using lithium bromide absorption units); to heat greenhouses and soil; and to provide hot or warm water for domestic use, for product processing (for example, the production of paper), for the culture of shellfish and fish, for swimming pools, and for therapeutic (healing) purposes.

[J.P.M.]

The use of geothermal energy for electric power generation has become widespread because of several factors. Countries where geothermal resources are prevalent have desired to develop their own resources in contrast to importing fuel for power generation. In countries where many resource alternatives are available for power generation, including geothermal, geothermal has been a preferred resource because it cannot be transported for sale, and the use of geothermal energy enables fossil fuels to be used for higher and better purposes than power generation. Also, geothermal steam has become an attractive power generation alternative because of environmental benefits and because the unit sizes are small (normally less than 100 MW). Moreover, geothermal plants can be built much more rapidly than plants using fossil fuel and nuclear resources, which, for economic purposes, have to be very large in size. Electrical utility systems are also more reliable if their power sources are not concentrated in a small number of large units.

The most common process is the steam flash process, which incorporates steam separators to take the steam from a flashing geothermal well and passes the steam through a turbine that

drives an electric generator. A more efficient utilization of the resource can be obtained by using the binary process on resources with a temperature less than 360°F (180°C). This process is normally used when wells are pumped. The pressurized geothermal brine yields its heat energy to a second fluid in heat exchangers and is reinjected into the reservoir. The second fluid (commonly referred to as the power fluid) has a lower boiling temperature than the geothermal brine and therefore becomes a vapor on the exit of the heat exchangers. It is separately pumped as a liquid before going through the heat exchangers. The vaporized, high-pressure gas then passes through a turbine that drives an electric generator. See ELECTRIC POWER GENERATION.

[T.C.Hi.]

**Geraniales** An order of flowering plants, division Magnoliophyta (Angiospermae), in the superorder Rosidae of Eudicotyledon. The order consists of 6 families (Francoaceae, Geraniaceae, Greyiaceae, Ledocarpaceae, Melianthaceae, Vivianiaceae), 15 genera, and approximately 700 species. The Geraniaceae constitute the vast majority of the order and are temperate herbs or soft shrubs with deeply cleft or compound leaves (see illus.). The other families are mainly woody and are



A common eastern United States species of geranium (*Geranium maculatum*), which is characteristic of the order Geraniales. (A. W. Ambler, National Audubon Society)

found in South America or Africa. Flowers typically have 5 sepals and petals, 10 stamens, and 5 fused carpels that separate from the central axis of the pistil when in fruit. Many of the species possess volatile compounds, as in *Pelargonium* (Geraniaceae) and *Melianthus* (Melianthaceae). See MAGNOLIOPHYTA; PLANT KINGDOM; ROSIDAE.

[K.J.Sy.]

**Gerbil** The common name for 106 species of rodents, known as the sand rats, composing the subfamily Gerbillinae in the family Muridae. They inhabit the more arid regions of Africa and Asia. All species have light, soft fur and hindlegs that are longer than the front ones, enabling them to hop kangaroo fashion, although most frequently they run like typical rodents. These animals are active nocturnally and remain in their burrows during the heat of the day. In captivity they are gregarious and make good pets. See RODENTIA.

[C.B.C.]

**Germ layers** The primitive cell layers, or first tissues, which appear early in the development of animals and from which the embryo body and its auxiliary membranes, when present, are constructed. These are more or less distinct anatomically, but do not necessarily have sharp boundaries of demarcation. Germ layers are almost universal among animal embryos

and appear to establish discontinuities of architectural importance without complete loss of continuity. Three kinds of germ layers are recognizable: (1) the ectoderm or outer skin, (2) the endoderm or inner skin, and (3) the mesoderm or middle skin. The layers have been named in accordance with their positions in the spherical type of gastrula such as that of the sea urchin or amphibian. The terms epiblast, mesoblast, and hypoblast are sometimes used as synonyms for ectoderm, mesoderm, and endoderm, respectively. The three primary germ layers are present as a basic structural plan in all Metazoa with the exception of the coelenterates and the Porifera, in which a distinct mesodermal layer is absent. See GASTRULATION. [N.T.S.]

**Germanium** A brittle, silvery-gray, metallic chemical element, Ge, atomic number 32, atomic weight 72.59, melting point 937.4°C (1719°F), and boiling point 2830°C (5130°F), with properties between silicon and tin. Germanium is distributed widely in the Earth's crust in an abundance of 6.7 parts per million (ppm). Germanium is found as the sulfide or is associated with sulfide ores of other elements, particularly those of copper, zinc, lead, tin, and antimony. See PERIODIC TABLE.

Germanium has a metallic appearance but exhibits the physical and chemical properties of a metal only under special conditions since it is located in the periodic table where the transition from nonmetal to metal occurs. At room temperature there is little indication of plastic flow and consequently it behaves like a brittle material.

As it exists in compounds, germanium is either divalent or tetravalent. The divalent compounds (oxide, sulfide, and all four halides) are easily reduced or oxidized. The tetravalent compounds are more stable. Organogermanium compounds are many in number and, in this respect, germanium resembles silicon. Interest in organogermanium compounds has centered around their biological action. Germanium in its derivatives appears to have a lower mammalian toxicity than tin or lead compounds.

The properties of germanium are such that there are several important applications for this element, especially in the semiconductor industry. The first solid-state device, the transistor, was made of germanium. Single-crystal germanium is used as a substrate for vapor-phase growth of GaAs and GaAsP thin films in some light-emitting diodes. Germanium lenses and filters are used in instruments operating in the infrared region of the spectrum. Mercury-doped and copper-doped germanium are used as infrared detectors; synthetic garnets with magnetic properties may have applications for high-power microwave devices and magnetic bubble memories; and germanium additives increase usable ampere-hours in storage batteries. [P.S.G.]

**GERT** A procedure for the formulation and evaluation of systems using a network approach. Problem solving with the GERT (graphical evaluation and review technique) procedure utilizes the following steps:

1. Convert a qualitative description of a system or problem to a generalized network similar to the critical path method—PERT type of network.
2. Collect the data necessary to describe the functions ascribed to the branches of a network.
3. Combine the branch functions (the network components) into an equivalent function or functions which describe the network.
4. Convert the equivalent function or functions into performance measures for studying the system or solving the problem for which the network was created. These might include either the average or variance of the time or cost to complete the network.
5. Make inferences based on the performance measures developed in step 4.

Both analytic and simulation approaches have been used to perform step 4 of the procedure. GERT was developed to analytically evaluate network models of linear systems through an adaptation of signal flow-graph theory. For nonlinear systems, involving complex logic and queuing situations, Q-GERT was developed. In Q-GERT, a simulation of the network is performed in order to obtain statistical estimates of the performance measures of interest.

GERT networks have been designed, developed, and used to analyze the following situations: claims processing in an insurance company, production lines, quality control in manufacturing systems, assessment of job performance aids, burglary resistance of buildings, capacity of air terminal cargo facilities, judicial court system operation, equipment allocation in construction planning, refueling of military airlift forces, planning and control of marketing research, planning for contract negotiations, risk analysis in pipeline construction, effects of funding and administrative strategies on nuclear fusion power plant development, research and development planning, and system reliability. See DECISION THEORY; PERT; SIMULATION. [A.A.B.P.]

**Gestation period** In mammals, the interval between fertilization and birth. It covers the total period of development of the offspring, which consists of a preimplantation phase (from fertilization to implantation in the mother's womb), an embryonic phase (from implantation to the formation of recognizable organs), and a fetal phase (from organ formation to birth).

There is widespread confusion over the duration of the gestation period in humans because of the way in which it is defined medically. The time of ovulation, and hence the time of fertilization, is difficult to determine in humans, so for purely practical reasons doctors measure the duration of pregnancy as the interval between the last menstrual period and birth, which is typically about 40 weeks or 280 days. For comparison with other mammals, however, the true gestation period between fertilization and birth in humans is about 267 days.

The length of the gestation period in mammals depends primarily on body size and the state of development of the offspring at birth. Large-bodied mothers have big offspring that take longer to develop, and development is also prolonged for offspring that are born at an advanced stage of development. Compared to all other mammals, human beings are found to have one of the longest gestation periods relative to body size.

One remarkable feature of mammalian gestation periods is that they show very little variability within a species. After excluding exceptional cases, departures from the average usually lie in a range of no more than  $\pm 4\%$ . This is one of the smallest degrees of variability found in any biological dimension. See FERTILIZATION; PREGNANCY; REPRODUCTIVE SYSTEM. [R.D.Ma.]

**Geys** A natural spring or fountain which discharges a column of water or steam into the air at more or less regular intervals. Perhaps the best-known area of geysers is in Yellowstone Park, Wyoming, where there are more than 100 active geysers and more than 3000 noneruptive hot springs.

The eruptive action of geysers is believed to result from the existence of very hot rock not far below the surface. The neck of the geyser is usually an irregularly shaped tube partly filled with water which has seeped in from the surrounding rock. Far down the pipe the water is at a temperature much above the boiling point at the surface, because of the pressure of the column of water above it. Its temperature is constantly increasing, because of the volcanic heat source below. Eventually the superheated water changes into steam, lifting the column of water out of the hole. [A.N.S./R.K.Li.]

**Ghost image (optics)** An undesired image appearing at the image plane of an optical system. Each surface of an optical system divides the incoming light into two parts: (1) the reflected light, which returns into the first medium, and (2) the refracted light. The reflected light is again divided into two parts when it

in turn strikes another dividing surface. The light thus reflected twice forms an image which may be near the plane of the primary image. This may be a false image of the object or an out-of-focus image of a bright source of light in the field of the optical system. Thus a large number of undesired or ghost images may appear. See OPTICAL IMAGE; REFLECTION OF ELECTROMAGNETIC RADIATION; REFRACTION OF WAVES.

If the ghost images are far out of focus, they only diminish the contrast in the primary image, a condition known as flare. But if the ghost images are near the focal plane, they are very disturbing. This effect is especially noticeable if there is a bright light source in the field of the instrument, since the ghost image of the light source may have an even greater brightness than the image of the desired object. The coating of lenses with layers of fluorite and other materials has nearly eliminated ghost images from modern optical systems. [M.J.H.]

**Giant nuclear resonances** Elementary modes of oscillation of the whole nucleus, closely related to the normal modes of oscillation of coupled mechanical systems. Giant nuclear resonances occur systematically in most, if not all, nuclei, with oscillation energies typically in the range of 10–30 MeV. Among the best-known examples is the giant electric dipole (E1) resonance, in which all the protons and all the neutrons oscillate with opposite phase, producing a large time-varying electric dipole moment which acts as an effective antenna for radiating gamma rays. See GAMMA RAYS.

Giant resonances are usually classified in terms of three characteristic quantum numbers:  $L$ ,  $S$ , and  $T$ , where  $L$  is the orbital angular momentum,  $S$  is the (intrinsic) spin, and  $T$  is the isospin carried by the resonance oscillation. The number  $L$  is also the multipole order, with possible values  $L = 0$  (monopole),  $L = 1$  (dipole),  $L = 2$  (quadrupole),  $L = 3$  (octupole), and so on. The spin quantum number  $S$  is either 0 or 1. The  $S = 0$  resonances are often called electric, and the  $S = 1$  ones magnetic (EL or ML, where  $L$  is the multipole order), stemming from the fact that these giant resonances have strong decay modes involving the emission of either electric (for EL resonances) or magnetic (for ML resonances) multipole photons of the same multipole order as the resonance. A giant resonance with  $S = 0$  corresponds to a purely spatial oscillation of the nuclear mass (or charge density), while one with  $S = 1$  corresponds to a spin oscillation. The isospin quantum number  $T$ , which is also either 0 or 1, determines the relative behavior of neutrons versus protons; in a  $T = 0$  or isoscalar giant resonance, the neutrons and protons oscillate in phase, whereas in a  $T = 1$  or isovector resonance the neutrons and protons oscillate with opposite phase. See MULTIPOLE RADIATION; NUCLEAR MOMENTS.

These resonances are called giant because of their great strength, 50–100% of the theoretical limit, concentrated in a compact energy region. The oscillation energy is characteristic of the type of giant resonance and is determined by the restoring force and the nuclear mass; the force is due to the nuclear attraction between nucleons, the most important part being the component of the same multipole order as the giant resonance.

The giant electric dipole (E1) resonance is the oldest and best known of the nuclear giant resonances. It is the dominant feature in reactions initiated by gamma rays. The absorption of a gamma ray induces the giant E1 oscillation, which breaks up, in this case, by emitting neutrons. This resonance is also the dominant feature in the reverse process, in which gamma rays are produced by proton and neutron bombardments of nuclei. The resonance is isovector ( $L = 1$ ,  $S = 0$ ,  $T = 1$ ).

The isoscalar giant E0 (electric monopole;  $L = 0$ ,  $S = 0$ ,  $T = 0$ ) resonance lies very close in energy to the giant E1 resonance, whereas the isoscalar giant E2 (electric quadrupole;  $L = 2$ ,  $S = 0$ ,  $T = 0$ ) resonance lies somewhat lower. Both are strongly excited in forward-angle inelastic scattering of energetic alpha particles.

The isoscalar E0 resonance is called the breathing mode, as the whole nucleus undergoes a purely radial oscillation, alternately

expanding and contracting. The isoscalar E0 resonance energy is important in determining the nuclear compressibility.

In ordinary nuclear beta decay, a neutron inside a nucleus is transformed into a proton, and an electron and an antineutrino are produced. In one of the simplest types of beta decay, called Gamow-Teller decay, the transformed neutron is otherwise undisturbed, except that its spin may be reversed. As a result, the nucleus usually gains a small amount of energy. If beta decay involved a higher energy transfer to the nucleus, it would drive the giant Gamow-Teller resonance, which is a pure spin oscillation where the neutron spin and the proton spin oscillate out of phase ( $L = 0$ ,  $S = 1$ ,  $T = 1$ ). A giant Gamow-Teller resonance is a strong feature in the ( $p$ ,  $n$ ) reaction in which neutrons emerge at  $0^\circ$  from nuclei struck by energetic protons. This reaction substitutes a proton for a neutron in the nucleus via a spin-dependent interaction, in a manner analogous to beta decay but with a much larger energy transfer.

The properties of the giant Gamow-Teller resonance are important in certain problems in nuclear astrophysics.

Studies of the giant electric dipole resonance have been extended to highly excited hot nuclei. These studies provide unique information about the properties of such nuclei, in particular their shape. The shape sensitivity arises from the resonance splitting in a deformed nucleus. The size of the splitting gives the magnitude of the deformation, whereas the relative strength of the components determines the sense of the deformation: prolate (football-shaped) or oblate (doorknob-shaped).

Giant resonances play an important role in energetic nuclear reactions occurring in nature. Among the best examples are supernovae explosions. The rate of electron capture reactions, which cool the core of the massive star involved in the explosion and accelerate its gravitational collapse, depends on the properties of the giant Gamow-Teller resonance. The strength of the shock wave created by the collapse is directly related to the nuclear compressibility discussed above in the context of the giant isoscalar E0 resonance. Higher-energy neutrinos from the central region of the star travel outward and heat the nuclei in the mantle via inelastic scattering reactions which excite various giant resonances. Certain elements found in nature may have been produced primarily as giant resonance decay products in these reactions. See also GRAVITATIONAL COLLAPSE; NEUTRINO; NEUTRON STAR; NUCLEAR REACTION; NUCLEAR SPECTRA; NUCLEAR STRUCTURE; RESONANCE (QUANTUM MECHANICS); SUPERNOVA. [K.A.Sn.]

**Giant star** An intermediate state in the evolution of a star in which it swells to enormous proportions before its death. During the longest and most stable phase of a star's life, the star, like the Sun, derives its energy from the thermonuclear fusion of hydrogen into helium deep in its dense, hot core. When the hydrogen fuel is exhausted, the core contracts and heats under the action of gravity, fresh hydrogen is ignited in a shell that surrounds the spent core, and the star becomes much more luminous, larger, and cooler at its surface. The lower surface temperature produces a redder color, hence the common term red giant. Stars like the Sun brighten by a factor of 100 and grow in radius by a factor of nearly 50.

There are actually two separate giant states. The first, described above, is terminated when the core temperature climbs so high that the helium ignites and fuses into carbon. This event stabilizes the star, but when this helium is exhausted, the earlier behavior is repeated. The star then swells to enormous proportions, perhaps two astronomical units ( $1.8 \times 10^8$  mi or  $3 \times 10^8$  km), becoming even redder than before. It may pulsate and loses much or most of its mass through a strong wind. See HERTZSPRUNG-RUSSELL; STELLAR EVOLUTION. [J.B.Ka.]

**Giardiasis** A disease caused by the protozoan parasite *Giardia lamblia*, characterized by chronic diarrhea that usually lasts 1 or more weeks. The diarrhea may be accompanied by one or more of the following: abdominal cramps, bloating, flatulence,



fatigue, or weight loss. The stools are malodorous and have a pale greasy appearance. Infection without symptoms is also common.

Giardiasis occurs worldwide. In community epidemics caused by contaminated drinking water, as many as 50 to 70% of the residents have become infected. Outbreaks also occur among backpackers and campers who drink untreated stream water. Both human and animal (beaver) fecal contamination of stream water has been implicated as the source of *Giardia* cysts in waterborne outbreaks. *Giardia* species in dogs and possibly other animals are also considered infectious for humans. Epidemics resulting from person-to-person transmission occur in day-care centers for preschool-age children and institutions for the mentally retarded. Infants and toddlers in day-care centers are more commonly infected than older children who have been toilet-trained. See EPIDEMIOLOGY. [D.D.J.]

**Gibberellin** Any of the members of a family of higher-plant hormones characterized by the *ent*-gibberellane skeleton. Some of these compounds have profound effects on many aspects of plant growth and development, which indicates an important regulatory role.

There are two classes of gibberellins: the 19-carbon gibberellins and the 20-carbon gibberellins. The 19-carbon gibberellins, formed from 20-carbon gibberellins, are the biologically active forms. Gibberellins also vary according to the position and number of hydroxyl groups linked to the carbon atoms of the *ent*-gibberellane skeleton. Hydroxylation has a profound influence on biological activity.

Probably the best-defined role for gibberellins in regulating the developmental processes in higher plants is stem growth. The cellular basis for gibberellin-induced stem growth can be either an increase in the length of pith cells in the stem or primarily the production of a greater number of cells. Applied gibberellins can often promote germination of dormant seeds, a capability suggesting that gibberellins are involved in the process of breaking dormancy. Gibberellins are intimately involved in other aspects of seed germination as well. Applied gibberellins promote or induce flowering in plants that require either cold or long days for flower induction. Gibberellin is probably not the flowering hormone or floral stimulus, because the floral stimulus appears to be identical or similar in all response types. The application of gibberellins often modifies sex expression, usually causing an increase in the number of male flowers. See DORMANCY; FLOWER; PLANT GROWTH; SEED.

Although gibberellins have limited use in agriculture compared with other agricultural chemicals such as herbicides, several important applications have been developed, including the production of seedless grapes. Application of gibberellin at bloom results in increased berry size and reduced berry rotting. Gibberellins are also used to increase barley malt yields for brewing and to reduce the time necessary for the malting process to reach completion. Gibberellins have found significant applications in plant breeding. Other uses for gibberellin in agriculture include reduction of rind discoloration in citrus fruits, increased yield in sugarcane, stimulation of fruit set in fruit trees, and increased petiole growth in celery. See PLANT HORMONES. [J.D.Me.]

**Ginger** An important spice or condiment; also the plant from which it is obtained, *Zingiber officinale*, of the ginger family (Zingiberaceae). The plant is a native of southeastern Asia. It is an erect perennial herb having thick, scaly, branched rhizomes which contain starch, gums, an oleoresin (gingerin) responsible for the pungent taste, and an essential oil which imparts the aroma. Ginger is used in medicine, in culinary preparations, and for flavoring beverages such as ginger ale and ginger beer. The plant is grown in China, Japan, Sierra Leone, Jamaica, Australia (Queensland), and Indonesia. See ZINGIBEREALES. [PD.St./E.L.C.]

**Ginkgoales** An order of nearly extinct gymnosperms (Pinophyta) having only one living species, the maidenhair tree (*Ginkgo biloba*). The fan-shaped leaves resemble those of the maidenhair fern. The leaves are dichotomously veined (fork-veined) and often more or less lobed (see illustration). The

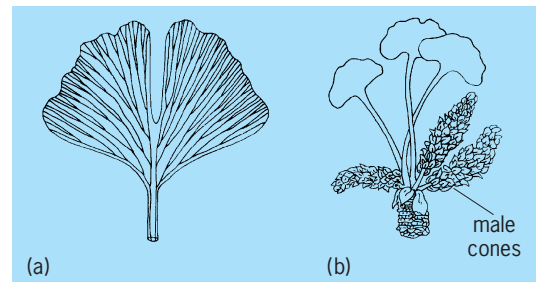

**Essential features of *Ginkgo*.** (a) Leaf showing dichotomous venation of blade. (b) Spur branch with mature male cones. (After G. M. Smith et al., *A textbook of General Botany*, 5th ed., Macmillan, 1953)

species is dioecious; that is, the male and female reproductive structures occur on separate trees. *Ginkgo* is widely planted on street borders, on home grounds, and in city parks. See PINOPHYTA. [A.Cr.]

**Ginkgoopsida** A class of largely extinct gymnosperms (Pinophyta). Included orders are Calamopityales, Callistophytales, Arberiales, Peltaspermales, Ginkgoales, Leptostroboles, Caytoniales, Pentoxylales, and Ephedrales. The most ancient taxa, Calamopityales and Callistophytales, lived during the Carboniferous; the Arberiales, from late Carboniferous into the Triassic; the Peltaspermales, from Permian through Jurassic; the Leptostroboles and Caytoniales, from Triassic into the Cretaceous; and Ginkgoales, predominantly, from Triassic into the Cretaceous periods, with one species, *Ginkgo biloba*, persisting to the present. Ephedrales is the only largely extant group, but has a pollen fossil record beginning in the Upper Triassic. See CAYTONIALES; EPHEDRALES; GINKGOALES.

These taxa, divergent in many characteristics, are unified by the presence in all of platyspermic (bilaterally symmetrical) seeds lacking cupules. In the most primitive, and some other, taxa of ginkgoopsids, the seeds and microsporangia are thought to have been borne on pinnately (featherlike) branched fertile structures. During the evolution of more advanced taxa, the individual microsporangia aggregated, fused to form synangia, and shifted onto leaves, causing additional changes to the microsporophylls and phylloperms (seed-bearing leaves). In particular, the phylloperms became greatly modified, often into peltate structures (as in advanced Peltaspermales) and stemlike structures (as in *Ginkgo*). See PINOPHYTA; PLANT KINGDOM. [C.B.B.]

**Ginseng** The common name of the genus *Panax*, a group of perennial herbs of the aralia family (Araliaceae), native to the woodlands of the North Temperate Zone. *Panax schinseng* of Manchuria, extensively cultivated, was in such demand among the Chinese that the supply became insufficient. Then *P. quinquefolius* of eastern North America was discovered, and soon it was being exported to China in large quantities. The price paid for the dried roots was so high that in a relatively short time the collectors nearly exterminated the plants. Ginseng is used as a general panacea for many ills, but there is no evidence that the drug has therapeutic value. See APIALES. [PD.St.; E.L.C.]

**Giraffe** Member of the family Giraffidae represented by a single species, *Giraffa camelopardalis*. The giraffe occurs in the savanna regions of tropical Africa. Giraffes are ruminants and belong to the mammalian order Artiodactyla (even-toed ungulates). The giraffe is the tallest of all mammals and may reach a

height of 18 ft or 5.5 m. There are two prominent horns on the forehead which are bony outgrowths covered by skin, and there is a short mane along the back of the neck.

The giraffe lives in small herds with many females and usually one mature and several immature males. Gestation for the giraffe lasts about 15 months, and a single young is born. The young is about 6 ft (1.8 m) tall at the time of birth. See ARTIODACTYLA.

[C.B.C.]

**Girvanella** A genus of fossil algae. *Girvanella* is characterized by flexuous, tubular filaments of uniform diameter, composed of thick, calcareous walls (see illus.). External diameters average between 10 and 30 micrometers. Filaments may occur free (unattached), but usually occur in groups, twisted together to form nodules and encrusting masses on various objects. The genus is intergrown with encrusting foraminifers in some Paleozoic limestones.



*Girvanella* in a thin section of Cambrian limestone. Tube diameter is about 20  $\mu\text{m}$ .

*Girvanella* is now generally placed in the bluegreen algae (Cyanophyta). This genus is a very common fossil, with a worldwide distribution. Occurring mainly in marine rocks, it has been reported from the Cambrian to Cretaceous. The apparent absence of *Girvanella* in rocks younger than Cretaceous age has not been satisfactorily explained. See ALGAE.

[J.L.Wr.]

**Glacial epoch** An informal reference to a time during the history of the Earth when there were larger ice sheets (continental size) and mountain glaciers than today. The most recent glacial epoch, better known as the Pleistocene glacial epoch, and also by the older term Quaternary period, encompassed at least the last 3,000,000 years.

Many side effects resulted from the existence of these ice sheets and glaciers, including climate changes, sea-level rise and fall, depressions of the Earth's crust, and large-scale migrations of plants, animals, and humans as well as mass extinctions. Mountain landscapes were sculptured by glaciers, and erosional and depositional landforms were formed. Ocean temperatures were cold during glaciations and warm at times of interglacials. Early human evolution, development, and migrations resulted from the ever-changing climates closely related to glacier advances and retreats.

Glacial epochs seem to recur at intervals of 200,000,000 to 250,000,000 years. In overall occurrence, all the glacial epochs that have ever occurred occupy only 5 to 10% of all geologic time. During major glacial epochs, great ice sheets formed in the high latitudes and spread out to cover as much as 40% of the Earth's land surface. Accompanying drops in temperature during some glacial epochs may have been as much as 25°F (14°C) in the mid-latitudes. During a glacial epoch, major glaciations are short-lived, each lasting less than 10,000 years, with the in-

terglacials persisting for only about 10,000 years, so that for most of an epoch, the ice sheets either grow or diminish in size. The Pleistocene glacial epoch was distinguished by seven or eight glacial advances within the last 700,000 years. Its last glaciation ended about 9000 years ago in Fennoscandia, and less than 8000 years ago in north-central Canada. See GLACIAL GEOLOGY; GLACIOLOGY; PLEISTOCENE.

[S.E.Wh.]

**Glacial geology** The scientific study of the effects of glaciers on the broad land areas, on the oceans, and on climate, of their erosion and deposition, and of their modification of the Earth's surface in detail. Included in the realm of glacial geology is the history of glacial theory, consideration of the origin of glacial ages, extent and times of past glaciations, erosion and sculpturing of plains and mountains, deposition of ice-contact and meltwater sediments, and the consequences of glaciers on worldwide climate, and also on local climate around their edges. Quite distinct from glacial geology, however, is the separate, growing subsience of glaciology, the study of glaciers themselves. See GLACIOLOGY.

Features on the Earth's surface explained by former worldwide glaciation are numerous, embracing, for example, glacially eroded and molded valleys and mountains; ice-transported and deposited sediments and nonglacial sediments; abandoned stream channels with associated floodwater deposits; elevated silts and clays that collected around continental edges when sea level was higher; valleys eroded across and into continental shelves and slopes when sea level was much lower; communities of plants and animals similar to each other but separated by shallow seaways where land bridges once existed; fossil shells and microorganisms in deep-sea sediments reflecting colder or warmer water temperatures than today; vegetated sand dunes aligned to wind systems no longer operating; ancient shorelines and beach ridges ringing dry empty lake basins far inland; and orderly patterns of stones and fine sediments next to glacier margins in polar regions and high mountains. See CIRQUE; DRUMLIN; GLACIAL EPOCH; MORaine.

[S.E.Wh.]

**Glaciology** A broad field encompassing all aspects of the study of ice, specifically glaciers, the largest ice masses on Earth.

Glaciers are classified principally on the basis of size, shape, and temperature. Cirque glaciers occupy spectacular steep-walled, overdeepened basins a few square kilometers (1 km<sup>2</sup> = 0.36 mi<sup>2</sup>) in area, called cirques. Most cirques are in high mountain areas that have been repeatedly inundated by ice. The cirques and the deep valleys leading away from them were, in fact, eroded by larger glaciers over the past 3 million years. See CIRQUE.

As a cirque glacier expands, it is usually constrained, at least initially, to move down such a valley. It then becomes a valley glacier (see illustration). Where such a valley ends in a deep fiord in the sea, the glacier is called a tidewater glacier. See FIORD.

In contrast, some glaciers are situated on relatively flat topography. Such glaciers can spread out in all directions from a central dome. When small, on the order of a few tens of kilometers across, these are called ice caps. Large ones, like those in Antarctica and Greenland, are ice sheets. See ANTARCTICA; ICE FIELD.

Thermally, glaciers are usually classified as either temperate or polar. In the simplest terms, a temperate glacier is one that is at the melting point throughout. The term melting point is used in this context rather than 0°C (32°F), because the temperature at which ice melts decreases as the pressure increases. Thus, the temperature at the base of a temperate glacier that is 500 m (1700 ft) thick will be about -0.4°C (31.2°F), but if heat energy is added to the ice, it can melt without an increase in temperature. Most valley glaciers are temperate.

In polar glaciers the temperature is below the melting point nearly everywhere. The temperature of a polar glacier increases



Storglaciären, a small valley glacier in northern Sweden.

with depth, however, because the deeper ice is warmed by heat escaping from within the Earth and by frictional heat generated by deformation of the ice. Thus, at its base, a polar glacier may be frozen to the substrate or may be at the melting point. Ice caps and ice sheets are normally polar, as are some valley glaciers in high latitudes.

As was the case with the classification based on size and shape, there is a continuum of thermal regimes in glaciers. The most common intermediate type has a surficial layer of cold ice, a few tens of meters (1 m = 3.28 ft) thick in its lower reaches, but is temperate elsewhere. Such glaciers are sometimes called subpolar or polythermal.

Glaciers exist because there are places where the climate is so cold that some or all of the winter snow does not melt during the following summer. The next winter's snow then buries that remaining from the previous winter, and over a period of years a thick snow pack or snowfield develops. Deep in such a snow pack the snow is compacted by the weight of the overlying snow. In addition, evaporation of water molecules from the tips of snowflakes and condensation of this water in intervening hollows results in rounding of grains. These processes of compaction and metamorphism gradually transform the deeper snow, normally known as firn, into ice. Melt water percolating downward into this firn may refreeze, accelerating the transformation. See SNOWFIELD AND NÉVÉ.

When, during a given year, the mass of snow added in the accumulation area of a glacier exceeds the mass of ice lost from the ablation area, the glacier is said to have had a positive mass balance. If such a situation persists for several years, the glacier will advance to lower elevations or more temperate latitudes, thus increasing the size of its ablation area and the mass loss. Conversely, persistent negative mass balances lead to retreat. Contrary to one implication of the word retreat, a retreating glacier does not flow backward. Rather, a glacier retreats when the ice flow toward the terminus is less than the melt rate at the terminus.

Under certain rather rare circumstances, the high subglacial water pressures that develop in the spring do not dissipate quickly but persist for weeks. This occurs under glaciers that have been thickening for several years or decades but have not advanced appreciably as a result of the thickening. On these occasions, the increase in sliding speed resulting from the increased water pressure inhibits development of an integrated subglacial conduit system, so water pressures remain high. The glacier then may advance at speeds of meters to tens of meters per day, in what is known as a surge.

Ice stream flow occurs in some parts of the Antarctic Ice Sheet. These high flow rates occur in streams of ice tens of kilometers wide and hundreds of kilometers long, and are sustained for centuries. These streams are bounded not by valley sides but by ice that is moving much more slowly. Ice Stream B, for

example, which drains to the Ross Ice Shelf in West Antarctica, has a maximum speed of 825 m/yr, while ice on either side of it is moving at only 10–20 m/yr. The high speeds of these ice streams are attributed to slippery conditions at the bed, where high water pressures reduce friction between the ice and the bed. Changes in paths of water flow at the bed are believed to be responsible for the changes in ice stream activity.

Among the hazards associated with glaciers are jökulhlaups, or sudden releases of water from lakes dammed by glaciers. Jökulhlaup is an Icelandic word; it has entered the vocabulary of geology because such floods are common in Iceland where localized volcanic heat is responsible for the presence of deep lakes surrounded by ice. In other regions, the lakes are more commonly formed where a glacier in a trunk valley extends across the open mouth of a tributary valley. See GLACIAL GEOLOGY.

[R.LeB.H.]

**Gland** A structure which produces a substance or substances essential and vital to the existence of the organism and species. Glands are classified according to (1) the nature of the product; (2) the structure; (3) the manner by which the secretion is delivered to the area of use; and (4) the manner of cell activity in forming secretion. A commonly used scheme for the classification of glands follows.

#### I. Morphological criteria

##### A. Unicellular (mucous goblet cells)

##### B. Multicellular

1. Sheets of gland cells (choroid plexus)
2. Restricted nests of gland cells (urethral glands)
3. Invaginations of varying degrees of complexity
  - a. Simple or branched tubular (intestinal and gastric glands)—no duct interposed between surface and glandular portion
  - b. Simple coiled (sweat gland)—duct interposed between glandular portion and surface
  - c. Simple, branched, acinous (sebaceous gland)—glandular portion spherical or ovoid, connected to surface by duct
  - d. Compound, tubular glands (gastric cardia, renal tubules)—branched ducts between surface and glandular portion
  - e. Compound tubular-acinous glands (pancreas, parotid gland)—branched ducts, terminating in secretory portion which may be tubular or acinar

#### II. Mode of secretion

- A. Exocrine—the secretion is passed directly or by ducts to the exterior surface (sweat glands) or to another surface which is continuous with the external surface (intestinal glands, liver, pancreas, submaxillary gland)
- B. Endocrine—the secretion is passed into adjacent tissue or area and then into the bloodstream directly or by way of the lymphatics; these organs are usually circumscribed, highly vascularized, and usually have no connection to an external surface (adrenal, thyroid, parathyroid, islets of Langerhans, parts of the ovary and testis, anterior lobe of the hypophysis, intermediate lobe of the hypophysis, groups of nerve cells of the hypothalamus, and the neural portion of the hypophysis)
- C. Mixed exocrine and endocrine glands (liver, testis, pancreas)
- D. Cytocrine—passage of a secretion from one cell directly to another (melanin granules from melanocytes in the connective tissue of the skin to epithelial cells of the skin)

#### III. Nature of secretion

- A. Cytogenous (testis, perhaps spleen, lymph node, and bone marrow)—gland “secretes” cells
- B. Acellular (intestinal glands, pancreas, parotid gland)—gland secretes noncellular product

- IV. Cytological changes of glandular portion during secretion
  - A. Merocrine (sweat glands, choroid plexus)—no loss of cytoplasm
  - B. Holocrine (sebaceous glands)—gland cells undergo dissolution and are entirely extruded, together with the secretory product
  - C. Apocrine (mammary gland, axillary sweat gland)—only part of the cytoplasm is extruded with the secretory product
- V. Chemical nature of the product
  - A. Mucous goblet cells (submaxillary glands, urethral glands)—the secretion contains mucin
  - B. Serous (parotid gland, pancreas)—the secretion does not contain mucin [O.E.N.]

**Glanders** A contagious zoonosis affecting primarily horses, mules, and donkeys and caused by the bacterium *Burkholderia (Pseudomonas) mallei*. Glanders (farcy) was once common throughout the world but is now found only in parts of Africa, Russia, and Asia. *Burkholderia mallei* is a gram-negative, non-acid-fast, nonsporulating, nonmotile, unencapsulated bacillus occasionally showing bipolar staining; it is obligately aerobic and oxidase-positive. *Burkholderia mallei* is highly infectious for humans, who may acquire it by handling or treating glanders animals or during laboratory investigations. See ZOONOSES.

Glanders is usually contracted by ingestion of contaminated food or water, by contact, and by inhalation of infectious droplets. All equids are highly susceptible. The disease is usually acute and often fatal in donkeys and mules, and chronic in horses, some of which may ultimately recover but continue to carry *B. mallei*. It is characterized by formation of nodules and ulcerations of the skin and respiratory membranes and by granulomatous nodules in the lungs, lymphatic channels, and lymph nodes.

Although *B. mallei* is sensitive to sulfonamides and tetracyclines, affected horses are not usually treated since destruction of cases has been found to be extremely effective in control and eradication. Essential components of diagnosis include clinical examinations at frequent intervals to detect the cutaneous and nasal forms; immunological tests to detect serum antibody; and skin and intradermopalpebral (within the skin of the eyelid) injection of mallein, a glycoprotein of *B. mallei*, to detect hypersensitivity. See AGGLUTINATION REACTION; COMPLEMENT-FIXATION TEST; HYPERSENSITIVITY. [J.F.T.]

**Glass** Materials made by cooling certain molten materials in such a manner that they do not crystallize but remain in an amorphous state, their viscosity increasing to such high values that, for all practical purposes, they are solid. Materials having this ability to cool without crystallizing are relatively rare, silica, SiO<sub>2</sub>, being the most common example. Although glasses can be made without silica, most commercially important glasses are based on it. The most important properties are viscosity; strength; index of refraction; dispersion; light transmission (both total and as a function of wavelength); corrosion resistance; and electrical properties.

Chemically, most glasses are silicates. Silica by itself makes a good glass (fused silica), but its high melting point (1723°C or 3133°F) and its high viscosity in the liquid state make it difficult to melt and work. To lower the melting temperature of silica to a more convenient level, soda, Na<sub>2</sub>O, is added in the form of sodium carbonate or nitrate, for example. This has the desired effect, but unfortunately the resulting glass has no chemical durability and is soluble even in water (water glass). To overcome this problem, lime, CaO, is added to the glass to form the basic soda-lime-silica glass composition which is used for the

bulk of common glass articles, such as bottles and sheet (window) glass. Although these are the main ingredients, commercial glass contains other oxides (aluminum and magnesium oxides) and ingredients to help in oxidizing, fining, or decolorizing the glass batch.

Special kinds of glass have other oxides as major ingredients. For example, boron oxide is added to silicate glass to make a low-thermal-expansion glass for chemical glassware which must stand rapid temperature changes, for example, Pyrex glass. Also, lead oxide is used in optical glass because it gives a high index of refraction. [J.F.McM.]

**Glass switch** A glassy, solid-state device used to control the flow of electric current. Useful solid-state devices can be made from glassy as well as crystalline semiconductors. A glass is a special case of a noncrystalline class of materials, namely, amorphous solids. These do not exhibit long-range order, although they tend to have the same local structure (that is, short-range order) as the corresponding crystal. A glass is an amorphous solid that is formed by cooling rapidly from the liquid phase.

The first applications of glassy semiconductors were switches made from chalcogenide (that is, alloys containing tellurium, selenium, or sulfur) glasses. The two basic structures are known as the Ovonic Threshold Switch (OTS) and the Ovonic Memory Switch (OMS). They are active devices consisting simply of a thin film (about 10–100 nanometers thick) of glass between two metallic contacts. The device characteristics depend on the bulk properties of the semiconductor material rather than on the contacts. Consequently, the switches are symmetrical in that they respond identically to voltages and currents of both polarities. The OMS and OTS differ in terms of the composition of their amorphous semiconductor thin-film materials and their functional performance.

Amorphous semiconductors can be formulated so they can be doped by adding small amounts of impurities to change their electrical properties in the same way as crystalline semiconductors, or they can be designed to be insensitive to the effects of impurities. The glass switches typically use impurity-independent material compositions, and they are also highly resistant to the effects of radiation.

Both the OTS and OMS show a rapid and reversible transition between a highly resistive and a conductive state effected by applied electric fields. The main difference between the two devices is that, after being brought from the highly resistive state to the conducting state, the OTS returns to its highly resistive state when the current falls below a holding current value. On the other hand, the OMS remains in the conducting state until a current pulse returns it to its highly resistive state. The OMS thereby remembers the last applied switching command, and it is from this property that the device receives its name.

Integrated arrays of OMSs can be used as electrically erasable programmable read-only memories (EEPROMs). Readout of these devices is extremely rapid, limited only by the readout circuit's characteristics; and, because of the capability of the OMS to be programmed into a number of selected conductivity states, more than one bit of data can be stored in each memory cell. See COMPUTER STORAGE TECHNOLOGY; SEMICONDUCTOR MEMORIES.

The OMS can be used as an electrically reconfigurable electrical interconnection in neural networks. In this application it provides a simple, high-density means to accomplish the many thousands or millions of programmable electrical interconnections required in practical neural-network circuits that can exhibit artificial intelligence. See NEURAL NETWORK.

A transistor, using an OTS as the emitter, has been developed. This can be used as a threshold amplifier, as a threshold latching amplifier, or as the basis for a computer using ternary logic. Other promising application areas include ac control and

microwave generation. See AMORPHOUS SOLID; GLASS; SEMICONDUCTOR. [S.R.O.; D.A.]

**Glass transition** The transition that occurs when a liquid is cooled to an amorphous or glassy solid. This can occur only if the cooling rate is fast enough to prevent crystallization which would otherwise occur if time had been sufficient for the sample to reach true equilibrium at each temperature. Since the crystal is invariably the thermodynamically stable low-temperature phase, the glass transition corresponds to a transition from a high-temperature liquid into a nonequilibrium metastable low-temperature solid. See AMORPHOUS SOLID; CRYSTAL; VISCOSITY.

For many organic and polymeric systems, the difficulty of molecular packing and the steric hindrances are sufficient to prevent crystallization, and glass formation in these systems is relatively easy. In other systems, for example, metallic systems, rapid quench rates on the order of  $10^6$  K/s ( $2 \times 10^6$  °F/s) may be necessary to avoid crystallization, suggesting that any system can be quenched from the liquid state to an amorphous glassy state assuming that the system can be cooled rapidly enough. See GLASS; METALLIC GLASSES. [G.S.G.]

**Glaucoma** A disease of the eye in which damage is caused by elevated pressure within the eye. The incidence in persons over the age of 40 is about 0.5%, making glaucoma one of the most common and serious eye disorders, surpassed in the United States only by cataracts as a cause of blindness. See CATARACT; VISUAL IMPAIRMENT.

The normal pressure within the eye measures 10–20 mmHg (1.3–2.7 kilopascals) and is maintained by a delicate balance between the inflow and outflow of fluid called aqueous humor. See EYE (VERTEBRATE).

Four major types of glaucoma have been identified: (1) congenital or infantile glaucoma, which is evident at birth or shortly thereafter; (2) primary open-angle glaucoma, the most common kind, which is usually painless and is marked by a blockage in the outflow channels; (3) primary (acute) angle-closure glaucoma, in which the root of the iris interrupts drainage and causes a sudden painful blockage and acute rise in internal pressure; and (4) subacute or chronic angle-closure glaucoma, in which the root or base of the iris falls across the drain temporarily but repeatedly, resulting in transient increases in pressure but with scarring after each episode until the drain can no longer become unblocked. Secondary glaucoma results from inflammation, injury, surgery, or eye diseases such as swollen cataract.

Infantile glaucoma often enlarges the eye because of a lack of rigidity in its white coat, known as the sclera; the condition is called buphthalmos. Angle-closure glaucoma is marked by pain, sudden visual loss, and a steamy or cloudy cornea; the semidilated and fixed pupil does not respond to changes in light intensity. In chronic angle-closure glaucoma, the periodic rises in pressure are accompanied by the above symptoms and also by halo vision, that is, the person sees haloes around a light source. In the most common type of glaucoma, the asymptomatic open-angle form, the chief threat is a gradual, imperceptible loss of vision. The disease is bilateral, with progressive field loss mostly in the periphery where it escapes notice.

Blindness can usually be prevented by early treatment to maintain normal eye pressure. Eye drops or oral medication is usually effective, reducing the flow of aqueous humor into the eye and increasing its outflow. If medication fails, as in angle-closure glaucoma, or if sudden complete blockage occurs, surgery is indicated. [J.Hart.]

**Glauconite** The term glauconite as currently used has a two-fold meaning. It is used as both a mineralogic and morphologic term. The mineral glauconite is defined as an illite type of

clay mineral. A fundamental characteristic of glauconite is that the unit cell is composed of a single silicate layer rather than the double layer of most other dioctahedral micas. See CLAY MINERALS; ILLITE.

Glauconite is known to occur in flakes and as pigmentary materials. When used in the morphological sense, the term glauconite often refers to small, green, spherical, earthy pellets. Some of these pelletiferous varieties are composed solely of the mineral described above, others are a mixed-layer association of this mineral and other three-layer structures.

Glauconite forms during marine diagenesis, in relatively shallow water, and at times of slow or negative deposition. Glauconite has been identified in both recent and ancient sediments. It is a major component in some “greensand” deposits and has been used commercially for the extraction of potassium from such sources. See AUTHIGENIC MINERALS; DIAGENESIS; MARINE SEDIMENTS. [F.M.W.; R.E.Gr.]

**Glaucofanite** A monoclinic sodic amphibole with composition close to  $\text{Na}_2(\text{Mg}_3\text{Al}_2)\text{Si}_8\text{O}_{22}(\text{OH})_2$ . This mineral exhibits a characteristic blue color with distinct pleochroism from colorless to lavender blue when viewed in thin section by plane-polarized light. Outcrops of glaucofanite-rich metamorphic rocks are commonly blue and tend to have good foliation; these rocks are called blueschists. See BLUESCHIST; PLEOCHROISM.

Glaucofanite is an index mineral of blueschist, which is generated under unusually high pressures at low temperatures in a tectonic environment exclusively associated with a subducted lithospheric slab or related tectonic loading. The glaucofanite-bearing assemblages occur in recrystallized graywackes and pelitic rocks and in metabasites and metacherts of oceanic affinity; they are typically found in subduction zone complexes at plate boundaries, a setting first recognized in the Jurassic and Cretaceous Franciscan Complex of northern California. Blueschists are most common and best developed in Mesozoic and Cenozoic terranes: some Paleozoic and even latest Precambrian blueschists have been described in Russia and China. Blueschists formed earlier in geologic time may have been eroded or been recrystallized under normal geothermal conditions. The preservation of glaucofanite in blueschists of continental or island arc margins indicates either rapid uplift or maintenance of low geothermal gradients by steady-state subduction for tens of million years. See GRAYWACKE; SUBDUCTION ZONES. [J.G.L.; R.Y.Z.; S.Maru.]

**Glazing** The application of finely ground glass, or glass-forming materials, or a mixture of both, to a ceramic body and heating (firing) to a temperature where the material or materials melt, forming a coating of glass on the surface of the ware. Glazes are used to decorate the ware, to protect against moisture absorption, to give an easily cleaned sanitary surface, and to hide a poor body color.

Glazes are classified and described by the following characteristics: surface—glossy or matte; optical properties—transparent or opaque; method of preparation—fritted or raw; composition—such as lead, tin, or boron; maturing temperature; and color. Opaque glazes contain small crystals embedded in the glass, but special glazes in which a few crystals grow to recognizable size are called crystalline glazes. See CERAMICS; GLASS. [J.F.McM.]

**Glide-path indicator** An aircraft landing instrument that provides the pilot with a set of vertical and horizontal cross pointers that indicate deviation from a radio-transmitted course to the threshold of the runway. A dual-frequency transmitter sends out one frequency to the right of the runway center line

and a second frequency to the left of the runway center line. The reception of these signals in the aircraft biases the vertical needle to the left or right depending on the position of the aircraft relative to the transmitted 5° localizer path. Simultaneously, another dual-frequency transmitter causes a horizontal needle to indicate high or low as the aircraft descent path is compared to the transmitted 3° glide path. [J.W.A.]

**Glider** An unpowered flying device that attempts to copy the flight of soaring birds. In October 1911, Orville Wright made a gliding flight of nearly 10 min duration, and demonstrated that gliders could stay up for long periods in rising air. This condition of flight, called slope soaring, was the basic method of soaring flight until about 1930. Thermal soaring, the next step, was accomplished by flying in areas of rising convection currents. By the use of thermal flight, the modern glider can fly almost anywhere in the world for extended time and distances over 500 mi (800 km) in one flight. Other methods of soaring make use of clouds and standing-wave phenomena in the atmosphere. High-performance gliders (sailplanes) may be launched by towing behind powered aircraft or by car towing, which is used to a lesser extent. Some gliders have been fitted with a small motor and propeller, which enables them to take off and climb to an altitude where rising air permits them to soar unpowered. [F.M.R.]

Sailplane construction traditionally has been of wood and plywood, although the use of aluminum alloy has become common. The use of fiber glass as primary structure has also come into prominence, since it is possible to produce the external shapes in accurate molds with greater precision, resulting in improved performance. [E.S.]

Modern foot-launched hang gliders with aluminum tube frames have flown over 100 mi (160 km) in straight-line distance, have reached about 20,000 ft (6000 m) altitude, and have remained aloft more than 15 h. But it is not so much their performance that makes hang gliders popular, but their low cost, their convenience of folding into a small package for transport or storage, and the fact that no license is required for glider or pilot. [F.M.R.]

**Global climate change** The periodic fluctuations in global temperatures and precipitation, such as the glacial (cold) and interglacial (warm) cycles of the Pleistocene (a geological period from 1.8 million to 10,000 years ago). Presently, the increase in global temperatures since 1900 is of great interest. Many atmospheric scientists and meteorologists believe it is linked to human-produced carbon dioxide (CO<sub>2</sub>) in the atmosphere.

**Greenhouse effect.** The greenhouse effect is a process by which certain gases (water vapor, carbon dioxide, methane, nitrous oxide) trap heat within the Earth's atmosphere and thereby produce warmer air temperatures. These gases act like the glass of a greenhouse: they allow short (ultraviolet; UV) energy waves from the Sun to penetrate into the atmosphere, but prevent the escape of long (infrared) energy waves that are emitted from the Earth's surface. See ATMOSPHERE; GREENHOUSE EFFECT.

Human-induced changes in global climate caused by release of greenhouse gases into the atmosphere, largely from the burning of fossil fuels, have been correlated with global warming. Since 1900, the amount of two main greenhouse gases (carbon dioxide and methane) in the Earth's atmosphere has increased by 25%. Over the same period, mean global temperatures have increased by about 0.5°C (0.9°F). The most concern centers on carbon dioxide. Not only is carbon dioxide produced in much greater quantities than any other pollutant, but it remains stable in the atmosphere for over 100 years. Methane, produced in the low-oxygen conditions of rice fields and as a by-product of

coal mining and natural gas use, is 100 times stronger than carbon dioxide in its greenhouse effects but is broken down within 10 years.

Chlorofluorocarbon (CFC) pollution, from aerosol propellants and coolant systems, affects the Earth's climate because CFCs act as greenhouse gases and they break down the protective ozone (O<sub>3</sub>) layer. Other pollutants released into the atmosphere are also likely to influence global climate. Sulfur dioxide (SO<sub>2</sub>) from car exhaust and industrial processes, such as electrical generation from coal, cool the Earth's surface air temperatures and counteract the effect of greenhouse gases. Nevertheless, there have been attempts in industrialized nations to reduce sulfur dioxide pollution because it also causes acid rain. See AIR POLLUTION; OZONE.

**Possible impact.** A rise in mean global temperatures is expected to cause changes in global air and ocean circulation patterns, which in turn will alter climates in different regions. Changes in temperature and precipitation have already been detected. In the United States, total precipitation has increased, but it is being delivered in fewer, more extreme events, making floods (and possibly droughts) more likely. See OCEAN CIRCULATION.

Global warming has caused changes in the distribution of a species throughout the world. By analyzing preserved remains of plants, insects, mammals, and other organisms which were deposited during the most recent glacial and interglacial cycles, scientists have been able to track where different species lived at times when global temperatures were either much warmer or much cooler than today's climate. Several studies have documented poleward and upward shifts of many plant and insect species during the current warming trend.

Changes in the timing of growth and breeding events in the life of an individual organism, called phenological shifts, have resulted from global warming. For example, almost one-third of British birds are nesting earlier (by 9 days) than they did 25 years ago, and five out of six species of British frog are laying eggs 2–3 weeks earlier.

Community reassembly, changes in the species composition of communities, has resulted from climate change because not all species have the same response to environmental change.

To date, there have been no extinctions of species directly attributable to climate change. However, there is mounting evidence for drastic regional declines. For example, the abundance of zooplankton (microscopic animals and immature stages of many species) has declined by 80% off the California coast. This decline has been related to gradual warming of sea surface temperatures. See CLIMATE HISTORY; CLIMATE MODIFICATION; CLIMATIC PREDICTION; EXTINCTION (BIOLOGY). [C.Pa.]

**Globe (Earth)** A sphere on the surface of which is a map of the world. The map may be drawn, engraved, or painted directly on the surface but is more commonly prepared as a series of gores, or segments in other designs, to be affixed to the globe ball (see illustration).

Globes are both artistically interesting and scientifically useful. Their principal value is in stimulating sound concepts of worldwide patterns and in rectifying errors induced by the limitations of flat maps. All flat maps distort the Earth's surface patterns, but carefully made globes constitute truer scale models of the Earth, with correct areas, shapes, and distances as well as continuity of surface. Globes have long been used as aids in navigation, in the teaching of earth sciences, and as room ornaments.

Many modern globes have special attachments to improve their utility. A meridian ring, extending from pole to pole, may be calibrated in degrees to measure latitude. The longitude of points directly beneath that ring will be indicated at the intersection of the ring with the equatorial scale. A horizon ring at right angles to the meridian ring may be calibrated in miles or in meters, degrees, and hours to expedite distance and time measurement. A

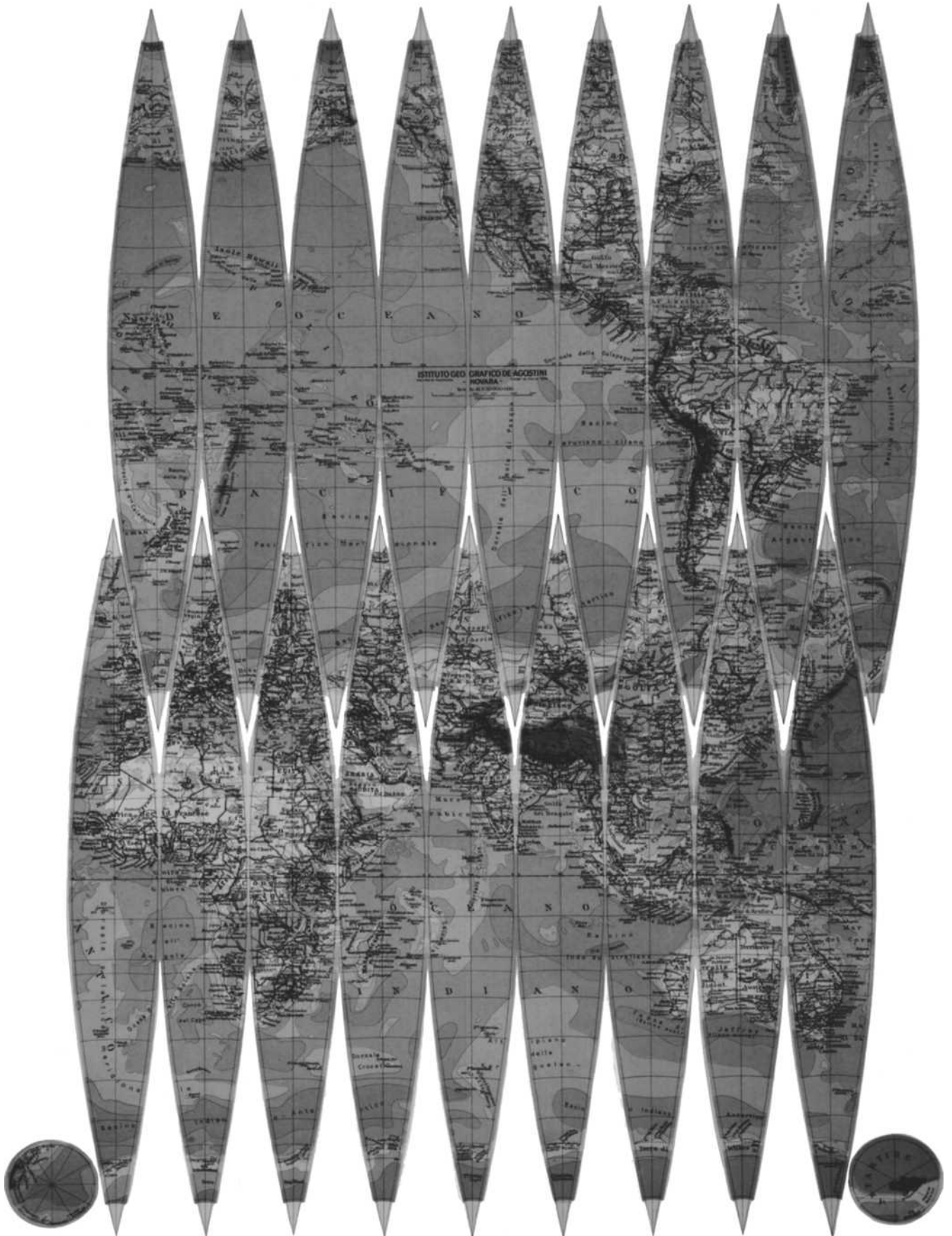

Globe gores from collections of Library of Congress. (*Istituto Geografico de Agostini, Novara, Italy*)

hinged horizon ring may be lifted to serve as a meridian ring, or placed in an oblique position to show great circle routes and distances. [A.C.G.]

**Globule** A small, opaque nebula seen in silhouette against a rich star field or a bright nebula. Globules were first cataloged in the 1920s. In 1947, B. J. Bok called attention to their potential significance for star formation, and since then they have been commonly known as Bok globules. A globule is a region of the interstellar medium containing a high density of interstellar grains that obscure the more distant background stars and cause the region to appear as a dark nebula in optical photographs. Only relatively nearby globules can be identified, because if there are many stars in front of the nebula the contrast with the background is too weak. See NEBULA.

The material contained in interstellar grains represents only a small fraction (about 1%) of the total mass of a globule; most of its mass is in gaseous form. The grains play a key role in shielding the nebular gas from the surrounding starlight, thus creating an environment in which molecules can survive and interact. Radio astronomers have been able to detect carbon monoxide (CO) emission lines in dark nebulae, and in the densest cores of nebulae heavier molecules have been identified. Dark nebulae are now commonly called molecular clouds; the most abundant molecule is molecular hydrogen, but it is difficult to detect directly. See INTERSTELLAR MATTER; MOLECULAR CLOUD; RADIO ASTRONOMY.

A typical (molecular core) globule has a diameter of 0.1 parsec (1 parsec =  $1.9 \times 10^{13}$  mi or  $3.1 \times 10^{13}$  km) and mass four times that of the Sun; larger, more massive globules are also known. The kinetic temperature in a globule is low; it is estimated to be about 10 K ( $-442^\circ\text{F}$ ).

Calculations predict that in the absence of internal support a typical globule undergoes gravitational collapse in less than a million years to produce one or more protostars. Some but not all globules have given birth to protostars, and these probably represent the youngest stars of the Milky Way. See PROTOSTAR; STELLAR EVOLUTION. [B.T.L.]

**Globulin** A general name for any member of a heterogeneous group of serum proteins precipitated by 50% saturated ammonium sulfate. See PROTEIN; SERUM.

The introduction of electrophoresis during the 1930s permitted subdivision of the globulins into alpha, beta, and gamma globulins on the basis of relative mobility at alkaline pH (8.6). However, each of these subgroups, though electrophoretically homogeneous, consists of a great variety of proteins with different biological properties and markedly different sizes and chemical properties other than net charge. Thus the  $\alpha_2$ -globulins, for example, as defined by moving boundary or paper electrophoresis, contain proteins ranging in molecular weight from approximately 50,000 to approximately 1,000,000 ( $\alpha_2$ -macroglobulin), each with differing functions. See ELECTROPHORESIS; IMMUNOGLOBULIN. [H.H.F.]

**Glow discharge** A mode of electrical conduction in gases. Glow discharge commonly occurs under conditions of relatively low pressure and generally in the pressure range of 1–10 mm of mercury ( $10^2$ – $10^3$  pascals). The discharge typically gives off light, so that the region of the discharge appears to glow with considerable intensity. This glow is quite diffuse as contrasted to a higher-pressure discharge, such as a high-pressure arc. Typical currents may be of the order of tens or hundreds of milliamperes, whereas the potential drop may be of the order of 100 volts.

The most important application of the glow discharge is in the so-called voltage regulator or voltage reference tube. This device

maintains a relatively constant difference of potential across itself as the current is varied over an appreciable range, and consequently is very useful in cases where a constant reference potential is required. See ELECTRIC SPARK; ELECTRICAL CONDUCTION IN GASES. [G.H.M.]

**Glucagon** The protein hormone secreted by the pancreas which is known to influence a wide variety of metabolic reactions. Glucagon, along with insulin and other hormones, plays a role in the complex and dynamic process of maintaining adequate supplies of sugar in the blood. Glucagon has often been called the hyperglycemic-glycogenolytic factor because it causes the breakdown of liver glycogen to sugar (a process known as glycogenolysis) and thereby increases the concentration of sugar in the bloodstream (a condition known as hyperglycemia). Glucagon may also be involved in the regulation of protein and fat metabolism, gastric acid secretion and gut motility, excretion of electrolytes (such as sodium, potassium and chloride) by the kidney, contractility of heart muscle, and release of insulin from the pancreas. Glucagon is used in human medicine chiefly in certain diabetic conditions when a dangerously low blood sugar must be rapidly raised. See CARBOHYDRATE METABOLISM; DIABETES; GLYCOGEN; HORMONE; INSULIN; PANCREAS. [W.W.BrO.]

**Glucose** A monosaccharide also known as D-glucose, D-glucopyranose, grape sugar, corn sugar, dextrose, and cerelese. The structure of glucose is shown in the illustration.

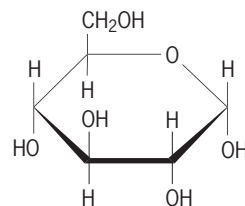

Structural formula for  $\alpha$ -D-glucose.

Glucose in free or combined form is not only the most common of the sugars but is probably the most abundant organic compound in nature. It occurs in free state in practically all higher plants. It is found in considerable concentrations in grapes, figs, and other sweet fruits and in honey. In lesser concentrations, it occurs in the animal body fluids, for example, in blood and lymph. Urine of diabetic patients usually contains 3–5%.

Cellulose, starch, and glycogen are composed entirely of glucose units. Glucose is also a major constituent of many oligosaccharides, notably sucrose, and of many glycosides. It is produced commercially from cornstarch by hydrolysis with dilute mineral acid. The commercial glucose so obtained is used largely in the manufacture of confections and in the wine and canning industries. See CELLULOSE; GLYCOGEN; STARCH.

D-Glucose is the principal carbohydrate metabolite in animal nutrition; it is utilized by the tissues, and it is absorbed from the alimentary tract in greater amounts than any other monosaccharide. Glucose could serve satisfactorily in meeting at least 50% of the entire energy needs of humans and various animals.

Glucose enters the bloodstream by absorption from the small intestine. It is carried via the portal vein to the liver, where part is stored as glycogen, the remainder reentering the circulatory system. Another site of glycogen storage is muscle tissue.

Glucose is readily fermented by yeast, producing ethyl alcohol and carbon dioxide. It is also metabolized by many bacteria, resulting in the formation of various degradation products, such as hydrogen, acetic and butyric acids, butyl alcohol, acetone, and many others. See CARBOHYDRATE; MONOSACCHARIDE.



**Gluons** The hypothetical force particles believed to bind quarks into "elementary" particles. Although theoretical models in which the strong interactions of quarks are mediated by gluons have been successful in predicting, interpreting, and explaining many phenomena in particle physics, free gluons remain undetected in experiments (as do free quarks). According to prevailing opinion, an individual gluon cannot be isolated.

According to quantum chromodynamics (QCD), the mediators of the strong interaction are eight massless vector bosons, which are named gluons because they make up the "glue" that binds quarks together. It is hoped that the infinite range of the forces mediated by the gluons may help to explain why free quarks have not been isolated. The gluons themselves carry color. Hence, strong interactions among gluons will also occur through the exchange of gluons. It is therefore believed that gluons, as well as quarks, may be permanently confined. According to this view, only colorless objects may exist in isolation. See ELEMENTARY PARTICLE; QUANTUM CHROMODYNAMICS; QUARKS. [C.Q.]

**Glycerol** The simplest trihydric alcohol, with the formula  $\text{CH}_2\text{OHCHOHCH}_2\text{OH}$ . The name glycerol is preferred for the pure chemical, but the commercial product is usually called glycerin. It is widely distributed in nature in the form of its esters, called glycerides. The glycerides are the principal constituents of the class of natural products known as fats and oils.

When pure, glycerin is a colorless, odorless, viscous liquid with a sweet taste. It is completely soluble in water and alcohol but is only slightly soluble in many common solvents, such as ether, ethyl acetate, and dioxane. Glycerin is insoluble in hydrocarbons. It boils at  $290^\circ\text{C}$  ( $554^\circ\text{F}$ ) at atmospheric pressure and melts at  $17.9^\circ\text{C}$ . Its specific gravity is 1.262 at  $25^\circ\text{C}$  ( $77^\circ\text{F}$ ) referred to water at  $25^\circ\text{C}$ , and its molecular weight is 92.09. It has a very low mammalian toxicity.

Glycerin is used in nearly every industry. With dibasic acids, such as phthalic acid, it reacts to make the important class of products known as alkyd resins, which are widely used as coating and in paints. It is used in innumerable pharmaceutical and cosmetic preparations; it is an ingredient of many tinctures, elixirs, cough medicines, and anesthetics; and it is a basic medium for toothpaste. In foods, it is an important moistening agent for baked goods and is added to candies and icings to prevent crystallization. It is used as a solvent and carrier for extracts and flavoring agents and as a solvent for food colors. Many specialized lubrication problems have been solved by using glycerin or glycerin mixtures. Many millions of pounds are used each year to plasticize various materials.

Several grades of glycerin are marketed, including high gravity, dynamite, yellow distilled, USP (U.S. Pharmacopoeia), and CP (chemically pure). USP grade is water-white and suitable for use in foods, pharmaceuticals, and cosmetics, or for any purpose where the product is designed for human consumption. See ALCOHOL; FAT AND OIL; POLYOL. [P.H.C.]

**Glycogen** The primary reserve polysaccharide of the animal kingdom. It is found in the muscles and livers of all higher animals, as well as in the cells of lower animals. Because of its close relationship to starch, it is often called animal starch, although glycogen is found in some lower plants, fungi, yeast, and bacteria. See STARCH.

Glycogen is a nonreducing, white, amorphous polysaccharide which dissolves readily in cold water, forming an opalescent, colloidal solution. The molecular weight of glycogen is usually very high, and it varies with the source and the method of preparation; molecular weights of the order of  $1-20 \times 10^6$  have been reported. Chemical studies show glycogen to possess a branched structure similar to the amylopectin starch fraction.

In its biochemical reactions, glycogen is similar to starch. It is attacked by the same plant amylases that attack starch, and

like starch, it is degraded to maltose and dextrans. Both glycogen and starch are broken down by animal or plant phosphorylase enzyme in the presence of inorganic phosphate with the production of  $\alpha$ -D-glucose-1-phosphate. See CARBOHYDRATE METABOLISM.

The metabolic formation of glycogen from glucose in the liver is frequently termed glycogenesis. In fasted animals, glycogen formation can be induced by the feeding, not only of materials that can be hydrolyzed to glucose and other monosaccharides, such as fructose, but also of various other materials. A number of L-amino acids, such as alanine, serine, and glutamic acid, upon deamination in the liver give rise to substances, such as pyruvic acid and  $\alpha$ -ketoglutaric acid, that can be converted in the liver to glucose units which are subsequently converted to glycogen. Furthermore, substances such as glycerol derived from fats, dihydroxyacetone, or lactic acid can all be utilized for glycogen synthesis in the liver. Such noncarbohydrate precursors are termed glycogenic compounds. The process of glycogen formation from these precursors is known as glycogenesis. The term glycogenolysis is used to connote glycogen breakdown. See POLYSACCHARIDE. [W.Z.H.]

**Glycolipid** One of a class of compounds having solubility properties of a lipid and containing one or more molecules of a covalently attached sugar.

Glycosphingolipids, the most abundant and structurally diverse type of glycolipids in animals, are glycosides of ceramide, a fatty acid amide of the amino alcohol sphingosine. Galactosyl ceramide is enriched in brain tissue and is a major component of the myelin sheaths around nerves. Glucosyl ceramide is present in the cell membranes of many cell types and is abundant in serum.

Larger, neutral glycosphingolipids containing more than one sugar include lactosyl ceramide, abundant in leukocyte membranes; globosides; and other oligosaccharyl ceramides, some of which are important antigens defining blood groups. Gangliosides are oligosaccharyl ceramides, abundant in brain, spleen, erythrocytes, liver, and kidney, that contain glucose, galactose, N-acetylglucosamine, and sialic acids.

Glycosphingolipids carry blood group antigens and define tumor-specific or developmental antigens. In addition, they serve as receptors for many microorganisms and toxins, as modulators of cell surface receptors that mediate cell growth, and as mediators of cell adhesion. See ANTIGEN; CELLULAR ADHESION.

Glycosyl phosphatidylinositols are a class of glycolipids that serve as membrane anchors for a multitude of proteins in organisms ranging from yeast to protozoa to humans. Glycosyl phosphatidylinositol-core structures can have many different modifications, depending upon the protein and cell type. Lipophosphoglycans are glycosyl phosphatidylinositols attached to large polysaccharide structures that coat the surfaces of many parasitic protozoa, such as *Leishmania donovani*, the causative agent of visceral leishmaniasis (kala azar). Lipophosphoglycans appear to protect these organisms from host defenses.

Mannosylphosphoryl dolichol, glucosylphosphoryl dolichol, and oligosaccharyl phosphoryl dolichols are glycolipids with sugars attached to large polyisoprenoids by phosphate esters. Dolichols are structurally related to cholesterol. Saccharylphosphoryl dolichols serve as important biosynthetic intermediates in the assembly of both asparagine-linked glycoproteins and glycosyl phosphatidylinositols. See GLYCOPROTEIN.

Glycosyl glycerides are glycolipids that have a structure analogous to phospholipids. They are the major glycolipids of plants and microorganisms but are rare in animals.

Bacteria produce a wide variety of glycolipids not easily categorized. Examples include fatty acid esters of carbohydrates, such as cord factor. Cord factor is a toxic component of the waxy capsular material of virulent strains of *Mycobacterium tuberculosis*, the causative agent of tuberculosis. Mycosides, glycolipids

that are also found in tubercle bacilli, comprise long-chain, highly branched, hydroxylated hydrocarbon terminated by a phenol group, with the sugar glycosidically attached to the phenolic hydroxyl. See LIPID; SPHINGOLIPID; TUBERCULOSIS. [G.W.Ha.]

**Glycoprotein** A compound in which carbohydrate (sugar) is covalently linked to protein. The carbohydrate may be in the form of monosaccharides, disaccharides, oligosaccharides, or polysaccharides, and is sometimes referred to as glycan. The sugar may be linked to sulfate or phosphate groups. In different glycoproteins, 100–200 glycan units may be present. Therefore, the carbohydrate content of these compounds varies markedly, from 1% (as in the collagens), to 60% (in certain mucins), to >99% (in glycogen). See COLLAGEN; GLYCOGEN.

Glycoproteins are ubiquitous in nature, although they are relatively rare in bacteria. They occur in cells, in both soluble and membrane-bound forms, as well as in the intercellular matrix and in extracellular fluids, and include numerous biologically active macromolecules. A number of glycoproteins are produced industrially by genetic engineering techniques for use as drugs; among them are erythropoietin, interferons, colony stimulating factors, and blood-clotting factors. See GENETIC ENGINEERING.

In most glycoproteins, the carbohydrate is linked to the polypeptide backbone by either N- or O-glycosidic bonds. A different kind of bond is found in glycoproteins that are anchored in cell membranes by a special carbohydrate-containing compound, glycosylphosphatidylinositol, which is attached to the C-terminal amino acid of the protein. A single glycoprotein may contain more than one type of carbohydrate-peptide linkage. N-linked units are typically found in plasma glycoproteins, in ovalbumin, in many enzymes (for example, the ribonucleases), and in immunoglobulins. O-linked units are found in mucins; collagens; and proteoglycans (typical constituents of connective tissues), including chondroitin sulfates, dermatan sulfate, and heparin. See ALBUMIN; CARBOHYDRATE; ENZYME; IMMUNOGLOBULIN; MONOSACCHARIDE; OLIGOSACCHARIDE; POLYSACCHARIDE; PROTEIN.

Within any organism, all molecules of a particular protein are identical. In contrast, a variety of structurally distinct carbohydrate units are found not only at different attachment sites of a glycoprotein but even at each single attachment site—a phenomenon known as microheterogeneity. For instance, ovalbumin contains one glycosylated amino acid, but over a dozen different oligosaccharides have been identified at that site, even in a preparation isolated from a single egg of a purebred hen. [N.Sh.]

**Glycoside** A large important class of sugar derivatives in which the sugar is combined with a nonsugar. In their cyclic forms, monosaccharides (simple sugars) possess one carbon (C) atom (the anomeric carbon) that is bonded to two oxygen (O) atoms; one oxygen atom forms a part of the ring, whereas the other is outside the ring (exocyclic) and is part of a hydroxyl (OH) group. If the oxygen atom of the anomeric hydroxyl group becomes bonded to a carbon atom, other than that of a carbonyl (C=O) group, the resulting compound is a glycoside. A glycoside thus consists of two parts (see illustration): the sugar (glycosyl) unit, which provides the anomeric carbon, and the moiety (the aglycon), which is the source of the exocyclic oxygen and carbon atoms of the glycosidic linkage. Such compounds frequently are referred to as O-glycosides to distinguish them from analogs having a sulfur (thio- or S-glycosides), nitrogen (amino- or N-glycosides), or carbon (anomalously called C-glycosides) as the exocyclic atom on the anomeric carbon. See HYDROXYL; MONOSACCHARIDE.

The formation of glycosides is the principal manner in which monosaccharides are incorporated into more complex molecules. For example, lactose (illustration b), the most abundant disaccharide in mammalian milk, has a glycosidic bond

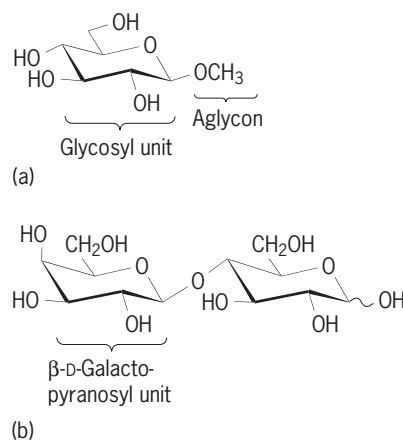

Structural formulas of two glycosides. (a) Methyl  $\beta$ -D-glycopyranoside. (b) Lactose, 4-O- $\beta$ -D-galactopyranosyl-D-glucopyranose; the wavy bond indicates that the group may have various orientations in space.

involving the anomeric carbon of D-galactose and the C-4 hydroxyl of D-glucose. The anomeric carbon atom can exist in either of two stereoisomeric configurations, a fact which is of immense importance to the chemistry and biochemistry of glycosides. For example, the principal structural difference between cellulose and amylose is that cellulose is  $\beta$ -glycosidically linked whereas amylose is  $\alpha$ -linked. Humans are able to digest amylose but are unable to utilize cellulose for food. See CELLULOSE; LACTOSE; STEREOCHEMISTRY.

A very large number of glycosides exist in nature, many of which possess important biological functions. In many of these biologically important compounds the carbohydrate portion is essential for cell recognition, the terminal sugar units being able to interact with specific receptor sites on the cell surface.

One class of naturally occurring glycosides is called the cardiac glycosides because they exhibit the ability to strengthen the contraction of heart muscles. These cardiotoxic agents are found in both plants and animals and contain complex aglycons, which are responsible for most of the drug action; however, the glycoside may modify the biological activity. The best-known cardiac glycosides come from digitalis and include the drug digoxin. See DIGITALIS.

Glycosidic units frequently are found in antibiotics. For example, the important drug erythromycin A possesses two glycosidically linked sugar units. See ANTIBIOTIC.

Perhaps the most ubiquitous group of glycosides in nature is the glycoproteins; in many of them carbohydrates are linked to a protein by O-glycosidic bonds. These glycoproteins include many enzymes, hormones, such antiviral compounds as interleukin-2, and the so-called antifreeze glycoproteins found in the sera of fish from very cold marine environments. See AMINO ACIDS; ANTIFREEZE (BIOLOGY); CARBOHYDRATE; ENZYME; GLYCOPROTEIN; HORMONE.

Glycolipids are a very large class of natural glycosides having a lipid aglycon. These complex glycosides are present in the cell membranes of microbes, plants, and animals. See GLYCOLIPID; LIPID. [G.W.Hay.]

**Gnathiidea** A suborder of the Isopoda. These animals are characterized as having a much reduced second thoracomere which is incorporated with the cephalothorax. The antennules are short and each has a flagellum with four or five joints; the terminal three bear single sensory palps. The antennae are also short, with flagella having five to eight joints, but generally there are seven. Thoracomeres 3–7 have a normal appearance and bear pereopods, while the eighth thoracomere is vestigial and lacks appendages (see illustration).

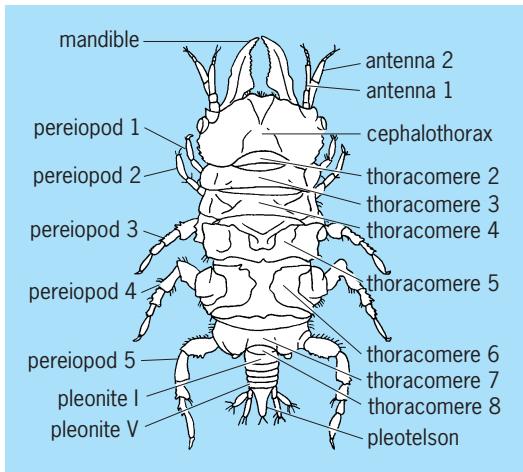

*Gnathia calva*, male specimen, dorsal view. (After W. H. Tattersall, 1921)

The group comprises marine forms exclusively. They are found in all latitudes and at all depths. The larvae are found as parasites on fish. See ISOPODA. [T.M.]

**Gnathostomata** A group of the subphylum Vertebrata which possesses jaws, teeth, paired appendages, and girdles (secondarily lost in some), as well as other advanced features in contrast to the more primitive Agnatha, which lack jaws and paired appendages. The Gnathostomata are divided into two major subdivisions, the superclasses Pisces and Tetrapoda, which respectively constitute roughly the aquatic and the terrestrial vertebrates. See PISCES (ZOOLOGY); TETRAPODA; VERTEBRATA. [W.J.B.]

**Gnathostomulida** Microscopic marine worms of uncertain systematic relationship, mainly characterized by cuticular structures in the pharynx and a monociliated skin epithelium. It is the most recently described phylum of the animal kingdom. The total number of species probably exceeds 1000.

Gnathostomulids are worm-shaped, cylindrical or slightly depressed, and semitransparent (or bright red), and sometimes have the external division of head and tail. The skin is a one-layered epithelium that is completely monociliated; that is, each of the polygonal epidermal cells bears only one cilium. The sensory system usually consists of 1–2 pairs of simple and 3–4 pairs of compound bristles (frontally and laterally), and a bundle of stiff cilia (dorsally on the head). The reproductive system consists of a dorsal ovarium and in most cases two caudolateral groups of testes follicles in the same specimen. Fertilization is internal.

The distribution of gnathostomulids is worldwide, the majority of localities being known from European coasts, some from the North American east coast, and some scattered over the western Pacific. [R.J.R.; W.E.S.]

**Gneiss** Coarse-grained, banded crystalline rock. Gneiss is composed of mineral grains large enough to be seen with the naked eye (see illustration). Banding arises from segregation of the various minerals present, typically into dark- and light-colored layers. Individual bands are commonly 0.04 to 0.4 in. (1 mm to 1 cm) thick. Although individual mineral grains are often flattened parallel to banding, such shape orientation is not present in many gneisses. Sheetlike minerals such as micas may be present but form only a subordinate amount of the rock. Banded rock of coarse grain containing substantial amounts of such minerals is named schist. Crystalline rock which has flattened grains but lacks obvious banding is generally called leptite. See SCHIST.

Gneiss is defined by its texture, or arrangement of mineral grains, rather than by its mineral composition. However, the term gneiss is often taken to imply a mineral composition of granitic type, dominated by quartz and feldspar. Gneisses of other compositions are identified by qualifying terms such as compositional rock names, as in diorite gneiss and amphibolite gneiss, or a partial list of minerals present, as in biotite-plagioclase gneiss and hornblende-plagioclase gneiss. See FELDSPAR; QUARTZ.

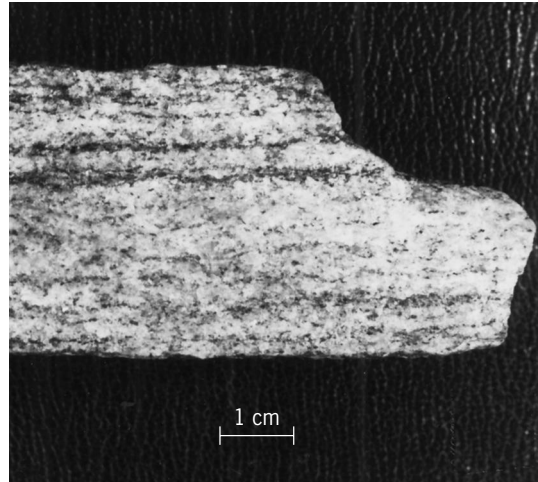

Gneiss formed by metamorphism of preexisting granite. Dark minerals are mica; light-colored minerals are quartz and feldspar. The streaky nature of banding is typical of gneisses. The sample is from the Great Smoky Mountains of North Carolina.

Most gneisses are formed by recrystallization of preexisting rock during intense regional metamorphism. Shear stress present during such metamorphism causes formation of gneissic banding, although the exact mechanisms of this process are not well understood. Gneisses typically occupy large areas within the high-grade cores of regional metamorphic belts. Such terranes are often difficult to understand, because the processes which cause formation of gneissic texture are also sufficient to obscure preexisting rock structures. High temperature and shear are sufficient to cause plastic flow of gneissic rock on a gigantic scale. Such conditions of metamorphism are probably brought about by deep tectonic burial and major regional compression. Thus gneissic terranes may be expected to form in areas of convergent plate tectonics. See METAMORPHIC ROCKS; METAMORPHISM; METASOMATISM; PLATE TECTONICS. [D.W.Mo.]

**Gnetales** The only order of the class Gnetopsida in the division Gnetophyta. There are three living families, each with a single genus: Ephedraceae (*Ephedra*; 65 species in arid regions), Gnetaceae (*Gnetum*; 29 species in the tropics), and Welwitschiaceae (*Welwitschia*; 1 species in Namibia). Among the gymnosperms, Gnetales are usually considered the closest living relatives of the angiosperms. The fossil record is sparse but increasing, perhaps extending back to the Triassic Period.

Each modern genus is quite distinctive. Species of *Ephedra* (Mormon tea) somewhat resemble the spore-bearing horsetails (*Equisetum*), with scale leaves on photosynthetic, jointed stems. Most species of *Gnetum* are lianas, woody vines closely resembling the Australian flowering plant family Austrobaileyaceae. The only species of *Welwitschia* is unlike any other living plant. From its stumplike trunk, just two leaves grow ever wider and longer (upto 7 m (23 ft)), tattering at the tips. All three genera are dioecious, with separate male and female individuals. The pollen and seed cones are compound, with flowerlike buds in the axils of bracts. See CYCADOPSIDA; PINOPHYTA; PLANT KINGDOM. [J.E.E.]

**Gnotobiotics** The science involved with maintaining a microbiologically controlled environment, and with the knowledge necessary to obtain and use biological specimens in this environment. The roots of the word are *gnotos*, meaning well known, and *biota*, the combined flora and fauna of a region.

All exposed surfaces of an animal are teeming with microbes. For example, the contents of the large intestine may contain 3 trillion microbes per ounce (100 billion per gram), belonging to several hundred species. Even if the animal itself is the primary interest of a researcher, there is no direct way to determine how many of an animal's normal characteristics are truly its own, and how many involve interaction with or reaction against resident microbiota. The only way to determine this is comparison with animals that have no microbiota. If differences are found, then the role of individual microbial species can be studied by inoculating pure cultures of these species into the animals without a microbiota.

Thus, gnotobiotics evolved initially to answer questions about what difference the resident microbiota makes, and which members of the microbiota make the difference. Answers become more and more essential in going beyond the effects of pathogenic microbes to the harmful or helpful long-term effects of environmental chemicals, compounds produced in the host's own metabolism, and therapeutic drugs being tested for efficacy, toxicity, or carcinogenicity. The activity of the microbiota is proportionately much greater in laboratory animals than it is in humans, and could have a decisive effect on such chemicals, especially since the chemicals are often received in small doses. For example, intestinal microbes turn a minor component of the cycad bean, a South Pacific foodstuff, into a carcinogen. One of the best drugs against parasitic schistosomes in humans is turned into a carcinogen by a single species of intestinal streptococcus. Gnotobiotic studies are designed to detect such possibilities.

Gnotobiotite is the term applied to an animal (or plant) with a defined microbiota. The most simple of gnotobiotites is the animal with no microbiota. Invertebrate animals of this type are most frequently called axenic. Vertebrate animals may also be called axenic, but are more frequently called germfree. Gnotobiology is a term sometimes used to designate studies involving gnotobiotites, although it tends to suggest that there is a unified body of knowledge which results from studying gnotobiotites. In fact, the gnotobiotite is a more precisely defined laboratory animal which helps elucidate biological phenomena in immunology, nutrition, physiology, oncology, gastroenterology, microbial ecology, gerontology, pathogenic microbiology, parasitology, and so on. [J.R.P.]

**Gobiesociformes** An order of bony fishes, also known as the Xenopterygii, or clingfishes, equipped with a thoracic sucking disk which serves for attachment to the substrate. There are single dorsal and anal fins that lack fin spines (see illustration).

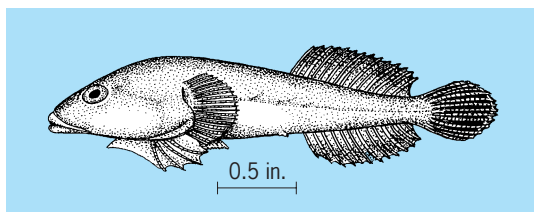

Northern clingfish (*Gobiesox maeandricus*). (After D. S. Jordan and B. W. Evermann, *The Fishes of North and Middle America*, U.S. Nat. Mus. Bull. no. 47, 1900)

The body is scaleless, and there are no ribs and no swim bladder. The order consists of a single family that is classified into 8 subfamilies, 33 genera, and nearly 100 Recent species. See ACTINOPTERYGII. [R.M.B.]

**Gödel's theorem** The result, proved by K. Gödel in 1931, that any sufficiently advanced mathematical system must be incomplete in that there must always be a true sentence that is not provable in the system. Roughly speaking, Gödel showed how, for each such system, a sentence could be constructed that asserted its own nonprovability in the system.

Gödel considered mathematical systems that involve numbers, sets of numbers, and other purely mathematical entities. He demonstrated a still more remarkable result for these same systems, which include the most comprehensive mathematical systems known. He showed that if these systems are consistent, they cannot prove their own consistency. This is known as Gödel's second incompleteness theorem.

Unfortunately, there are widespread misconceptions about this result. For example, Gödel's second theorem is sometimes thought to imply the impossibility of knowing that these systems are consistent. In reality, the fact that a system cannot prove its own consistency does not constitute the slightest grounds for doubting its consistency. Indeed, if a system could in fact prove its own consistency, that of course would not be any guarantee that the system was consistent, since an inconsistent system can prove anything. The consistency of the systems considered by Gödel is known rather by the self-evident nature of the axioms and the obvious correctness of the rules of reasoning. Still, it is of interest that the systems, though obviously consistent, cannot prove their own consistency.

In the eighteenth century, G. Leibniz envisioned a universal calculating machine that could solve all mathematical problems. The impossibility of such a device has been conclusively demonstrated by further ramifications of Gödel's work developed by A. Church and A. Turing. This work shows that mathematics cannot be mechanized, and that creativity and ingenuity will always be required. This is perhaps the most important consequence of Gödel's work. Another way of stating this consequence is that human beings can never eliminate the necessity of using their own intelligence, regardless of how cleverly they try. See LOGIC; RECURSIVE FUNCTION. [R.M.Sm.]

**Goethite** A mineral of composition  $\text{FeO} \cdot \text{OH}$ , crystallizing in the orthorhombic system. Crystals are rare, and the mineral is usually in reniform or stalactitic masses which have a radiating fibrous internal structure. The luster is adamantine to dull, and the color light to dark brown. The Mohs hardness is 5.0–5.5, and the density is 4.28 for crystals and 3.3–4.3 for massive material. Most of the common, yellow-brown, earthy ferric oxides known as limonite are mixtures composed largely of cryptocrystalline goethite.

Goethite is one of the most common minerals. It is the major constituent of the gossan at the surface of metalliferous deposits rich in iron-bearing sulfides, as at Bisbee, Arizona, and of laterites, as in Cuba. Well-formed crystals are found at Pribram, Bohemia, and Cornwall, England. It is an important iron ore in Alsace-Lorraine, in the Lake Superior hematite deposits, and in the southern Appalachians. See LIMONITE. [L.Gr.]

**Gold** A chemical element, Au, atomic number 79 and atomic weight 196.967, a deep yellow, soft, and very dense metal. Gold is classed as a heavy metal and as a noble metal; commercially, it is the most familiar of the precious metals. Copper, silver, and gold are in the same group of the periodic table of elements. The Latin name for gold, *aurum* (glowing dawn), is the source of the chemical symbol Au. There is only one stable isotope of gold, that of mass number 197. See PERIODIC TABLE.

**Uses.** Consumption of gold in jewelry accounts for about three-fourths of the world's production of gold. Industrial applications, especially electronic, consume another 10–15%. The remainder is divided among medical and dental uses, coinage, and bar stock for governmental and private holdings. Gold coins and most decorative gold objects are actually gold alloys,

because the metal itself is too soft (2.5–3 on Mohs scale) to be useful with frequent handling. See GOLD ALLOYS.

Radioactive  $^{198}\text{Au}$  is used in medical irradiation, in diagnosis, and in a number of industrial applications as a tracer. Another tracer use is in the study of movement of sediment on the ocean floor in and around harbors. The properties of gold toward radiant energy have led to development of efficient energy reflectors for infrared heaters and cookers and for focusing and retention of heat in industrial processes.

**Occurrence.** Gold occurs widely throughout the world, but usually very sparsely, so that it is quite a rare element. Sea water contains low concentrations of gold, on the order of  $10\ \mu\text{g}$  per ton (10 parts of gold per trillion parts of water). Somewhat higher concentrations accumulate on plankton or on the ocean bottom. At present, no economically feasible process is visualized for extracting gold from the sea. Native, or metallic, gold and various telluride minerals are the only forms of gold found on land. Native gold may occur in veins among rocks and ores of other metals, especially quartz or pyrite, or it may be scattered in sands and gravel (alluvial gold). See GOLD METALLURGY.

**Properties.** The density of gold is 19.3 times that of water at  $20^\circ\text{C}$  ( $68^\circ\text{F}$ ), so that  $1\ \text{ft}^3$  of gold weighs about 1200 lb ( $1\ \text{m}^3$ , about 19,000 kg). Masses of gold, like those of other precious metals, are measured on the troy scale, which counts 12 oz to the pound. Gold melts at  $1064.43^\circ\text{C}$  ( $1947.97^\circ\text{F}$ ) and boils at  $2860^\circ\text{C}$  ( $5180^\circ\text{F}$ ). It is somewhat volatile well below its boiling point. Gold is a good conductor of heat and electricity. It is the most malleable and ductile metal. It can easily be made into translucent sheets  $0.000039\ \text{in.}$  ( $0.00001\ \text{mm}$ ) thick or drawn into wire weighing only  $0.00005\ \text{oz/ft}$  ( $0.5\ \text{mg/m}$ ). The quality of gold is expressed on the fineness scale as parts of pure gold per thousand parts of total metal, or on the karat scale as parts of pure gold per 24 parts of total metal. Gold readily dissolves in mercury to form amalgams. Gold is one of the least active metals chemically. It does not tarnish or burn in air. It is inert to strong alkaline solutions and to all pure acids except selenic acid.

**Compounds.** Gold may be either unipositive or tripositive in its compounds. So strong is the tendency for gold to form complexes that all the compounds of the 3+ oxidation state are complex. The compounds of the 1+ oxidation state are not very stable and tend to be oxidized to the 3+ state or reduced to metallic gold. All compounds of either oxidation state are easy to reduce to the metal.

In its complex compounds gold forms bonds most readily and stably with halogens and sulfur, less stably with oxygen and phosphorus, and only weakly with nitrogen. Bonds between gold and carbon are fairly stable, as in the cyanide complexes and a variety of organogold compounds. [W.E.C.]

**Gold alloys** Combinations of gold and other metals. Pure gold is soft. The addition of copper hardens the gold, and ultimately gold-copper alloys became standard for coinage. Gold coins in the United States contained 10% copper, the balance gold.

Pure gold is weak, having a tensile strength of less than 20,000 psi (138 megapascals) when annealed; however, by alloying with copper, sometimes in conjunction with silver or nickel, and often a little zinc, gold alloys with strengths of 60,000–100,000 psi (414–690 MPa) may be made. Addition of these metals changes the color of gold so that red, yellow, greenish, and white golds result. The proportion of gold in solid gold jewelry is designated in karats (k); pure gold is 24 k, 18 k is  $18/24$  or 75% pure gold, and 14 k is  $14/24$  or 58.3% pure gold.

Industrial uses of gold depend primarily upon the corrosion resistance and secondarily upon the strength that can be secured by alloying alone or by alloying and heat treating. Many alloys used in dentistry contain gold, silver, and copper, often with small amounts of platinum and palladium; these alloys can be heat-treated to develop strengths above 150,000 psi (1.0 gigapascal). The latter have good spring properties. Alloys of this type find many electrical uses as contacts, particularly where rub-

bing is involved. Gold electroplate, often thin, is employed on high-frequency conductors, such as those in radar equipment, because of the high electrical conductivity and tarnish resistance of gold. For the same reason gold is employed in the construction of many transistors, microcircuits, printed circuits, and integrated circuits. Most such devices are so small that the cost of gold is relatively unimportant.

Because gold does not oxidize when heated in air, appropriate gold compounds can be decomposed by heat to liberate the metal. Compounds of this type are used in the decoration of china and also for the production of printed electrical circuits on ceramics. These materials, known as liquid bright golds, are applied in the form of varnish, which is dried and then heated to redness, leaving a thin film of gold firmly attached to the underlying ceramic. See GOLD; GOLD METALLURGY. [C.R.M.; G.S.]

**Gold metallurgy** Extracting gold from ores, refining it, and preparing it for use. Total world resources of gold are estimated at about 83,000 tons (75,000 metric tons). South Africa has about half of these resources, and Brazil, Russia, and the United States have about 12% each. The United States produces about 330 tons (300 metric tons) per year. In the United States, gold is used for jewelry and arts (70%), industry and electronics (23%), and dentistry (7%). There are only a few dozen placer mines in the United States, nearly all in Alaska. In such mines, gold is processed with the modern equivalent of gold panning—sluicing, tabling, and jigging. In addition, by-product gold from copper mining is only about 10% (historically, this source used to be much larger). There are several hundred lode mines in the United States, where the ore is mined from solid rock. This gold is often difficult to recover because it is associated with sulfide or carbonaceous minerals. As technology has improved, possibilities for processing the more difficult-to-treat (refractory) ores have expanded. A particular ore is more or less refractory depending on its combination of chemical compounds and minerals. See GOLD; PLACER MINING.

In the cyanide leaching process, ore is first crushed dry in a gyratory crusher and ground wet in a semiautogenous grinding mill. During the wet grinding process, cyanide and lime are added. The ore leaves the grinding mill as a slurry of muddy water. The gold gradually leaches out of each tiny ore particle (during its 20–30-h residence time) and dissolves into solution.

Sometimes lower-grade ore ( $<0.05\ \text{oz/ton}$  or  $1.57\ \text{g/metric ton}$  of gold) is simply crushed and placed in heaps where it is slowly leached with cyanide solutions. Even though heap leaching gives lower gold recovery (sometimes lower than 60%), the cost is lower. Heap leaching is a form of solution mining that can also be applied to old tailings piles and mined overburden dumps. See SOLUTION MINING. [K.A.Pr.]

**Goldhaber triangle** The phase space triangle, or Goldhaber triangle, corresponds to the kinematically allowed boundary for a high-energy reaction leading to four or more particles. In a high-energy reaction between two particles  $a$  and  $b$  yielding four particles 1, 2, 3, and 4 in the final state ( $a + b \rightarrow 1 + 2 + 3 + 4$ ), it is convenient to consider the reaction in terms of the production of two intermediate-state quasi-particle composites  $x$  and  $y$ , which then decay into two particles each, as in expression (1).

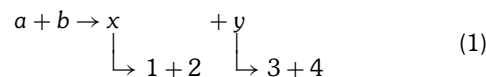

Most high-energy interactions indeed proceed through such intermediate steps, in which, for specific values of the invariant masses  $m_x = M_x^*$  and  $m_y = M_y^*$ , the quasi-particle composites may form resonances. However, the description in terms of the composites  $x$  and  $y$ , with the invariant masses  $m_x$  and  $m_y$  as variables, is valid irrespective of whether or not these composites form resonances.

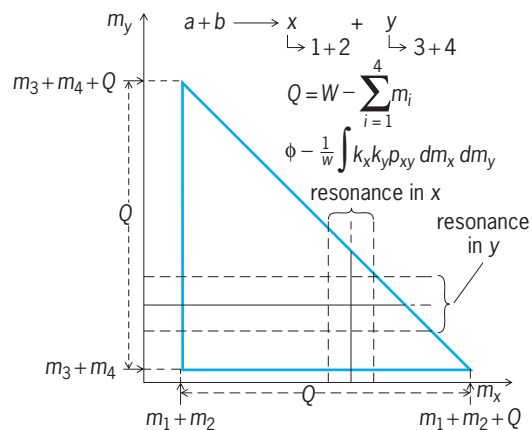

**Definition of the kinematical boundary of the Goldhaber triangle for four particles.**

The kinematical limits in this representation are particularly simple, namely, they form a right-angle isosceles triangle. A Goldhaber triangle plot corresponds to plotting a point  $(m_x, m_y)$  for each event occurring in the above high-energy reaction. Because of the kinematical constraints, these points must all lie inside the triangle.

If one considers the general reaction given in Eq. (1), then the length of each of the two equal sides of the triangle is  $Q$ , defined in Eq. (2). Here  $W$  is the total energy in the center of mass of

$$Q = W - \sum_{i=1}^4 m_i \quad (2)$$

particles  $a$  and  $b$ , and  $m_i$ , for  $i = 1$  to 4, is the mass of the particles 1 to 4. Hence  $Q$  corresponds to the total kinetic energy available in the reaction.

In the triangle corresponding to the general reaction (see illustration), the vertical and horizontal bands indicate resonances at masses  $M_x^*$  and  $M_y^*$  with full width at half-maximum height or  $\Gamma_x$  and  $\Gamma_y$ , respectively. The bands shown of width  $2\Gamma$  represent the regions usually chosen if the events corresponding to a given resonance are selected. [G.G.]

**Golgi apparatus** An organelle, named after the Italian histologist Camillo Golgi, found in all eukaryotic cells but absent from prokaryotes such as bacteria. It consists of flattened membrane-bounded compartments known as cisternae. In most cells, the Golgi cisternae are organized into stacks. Different cell types contain from one to several thousand Golgi stacks. The Golgi apparatus sorts newly synthesized proteins for delivery to various destinations, and modifies the oligosaccharide chains found on glycoproteins and glycolipids. See CELL ORGANIZATION.

The Golgi apparatus acts at an intermediate stage in the secretory pathway. A subset of the proteins synthesized by the cell are inserted into the endoplasmic reticulum. Most such proteins are then delivered to the Golgi apparatus by means of coat protein II (COPII) transport vesicles, which form at endoplasmic reticulum exit sites. Newly synthesized proteins traverse the Golgi stack until they reach the trans-most Golgi compartment, which is termed the trans-Golgi network to connote its extensive tubulation. The trans-Golgi network sorts the proteins into several types of vesicles. Clathrin-coated vesicles carry certain proteins to lysosomes. Other proteins are packaged into secretory vesicles for immediate delivery to the cell surface. Still other proteins are packaged into secretory granules, which undergo regulated secretion in response to specific signals. This sorting function of the Golgi apparatus allows the various organelles to grow while maintaining their distinct identities. See CELL MEMBRANES; ENDOPLASMIC RETICULUM; LYSOSOME.

The best understood of the processing reactions carried out by the Golgi apparatus is the remodeling of oligosaccharides

(chains of six-carbon sugars) that are attached to glycoproteins. During insertion of a newly synthesized protein into the endoplasmic reticulum, one or more copies of a 14-sugar oligosaccharide may be attached to the amino acid asparagine at specific locations in the polypeptide chain. As the protein passes through the Golgi stack, the asparagine-linked oligosaccharides are modified to generate a diverse range of structures. Additional oligosaccharides may become linked to the amino acids serine and threonine. Although the particular oligosaccharide modifications are quite different in animal, plant, and fungal cells, the Golgi apparatus always functions as a "carbohydrate factory." See OLIGOSACCHARIDE.

The Golgi apparatus also carries out other processing events, including the addition of sulfate groups to the amino acid tyrosine in some proteins, the cleavage of protein precursors to yield mature hormones and neurotransmitters, and the synthesis of certain membrane lipids such as sphingomyelin and glycosphingolipids. See LIPID; PROTEIN. [B.S.G.]

**Gonorrhea** A common sexually transmitted disease caused by the bacterium *Neisseria gonorrhoeae*. Humans are the only natural hosts for *N. gonorrhoeae*, which directly infects the epithelium of the mucous membranes of the human genital tract, pharynx, rectum, or conjunctiva. Local epithelial cell destruction usually occurs, but the organisms may spread to adjacent organs or disseminate via the bloodstream. In women, local complications include inflammation of the uterine lining (endometritis), inflammation of the fallopian tube (salpingitis), inflammation of the abdominal wall (peritonitis), and inflammation of Bartholin's glands (bartholinitis); in men, periurethral abscess and inflammation of a duct connected to the testes (epididymitis). Systemic manifestations such as arthritis or dermatitis may develop, and rarely endocarditis or meningitis.

Women are disproportionately affected by the complications of gonorrhea. Acute pelvic inflammatory disease and salpingitis, the most serious complications of gonorrhea, result in ectopic pregnancy and infertility. Gonococcal infection during pregnancy may also predispose women to premature rupture of membranes, delivery in less than full term, and postpartum endometritis. During childbirth, the gonococcus may infect the conjunctiva of the infant and result in the infection ophthalmia neonatorum. This infection is a serious complication that remains common in less developed countries and can lead to permanent damage to the eye and blindness. See INFERTILITY; REPRODUCTIVE SYSTEM DISORDERS.

Gonorrhea continues to be the most commonly reported communicable disease in the United States, although incidence has declined since 1984. Risk factors that may influence the probability of infection include number of sexual partners, lack of barrier contraceptives, and young age.

Gonorrhea is an infection spread by physical contact with the mucosal surfaces of an infected person, usually a sexual partner. The risk of infection depends on the anatomic site, the amount of substance containing bacteria, and the number of exposures. Variations in host susceptibility have not been well defined. In a small but significant proportion of infections, there are no symptoms. These individuals are important in the epidemiology of this disease because gonorrhea is usually spread by carriers who have no symptoms or have ignored symptoms.

Control of gonorrhea depends on early diagnosis, effective treatment, and identification of asymptomatic individuals. The last has been accomplished, in part, through screening programs. However, complete control has not been possible because of the emergence and spread of strains that are resistant to less-expensive antimicrobial treatments such as penicillin and tetracycline.

There is no evidence that infected individuals develop long-lasting immunity to reinfection, and vaccination is not available. Thus, the prevention of gonorrhea relies on behavior modification and risk reduction, use of appropriate screening and diagnostic tests, routine use of highly effective antibiotics, early

identification and treatment of sexual partners of individuals with gonorrhoea, and the appropriate use of barrier methods such as condoms.

An increasing proportion of infections are due to antibiotic-resistant strains of *N. gonorrhoeae*. Chromosomally mediated resistance to multiple antibiotics as well as plasmid-mediated resistance to beta-lactam antibiotics and tetracycline occurs in strains from both developed and developing countries. Nevertheless, infections can be effectively treated with third-generation cephalosporins (for example, ceftriaxone) or fluoroquinolones (for example, ciprofloxacin or ofloxacin). See SEXUALLY TRANSMITTED DISEASES. [S.A.L.; S.A.Mo.]

**Gonorynchiformes** A small order of soft-rayed teleost fishes which at one time were included in the large order Clupeiformes (or Isospondyli). Gonorynchiforms are fusiform or moderately compressed fishes, varying from less than 2 in. (5 cm) to 5 ft (1.5 m) in length. There are single short dorsal and anal fins, and no adipose fin; the caudal fin is usually forked; and the pelvic fins are placed well back. The jaws are weak and toothless.

Modern gonorynchiforms are classified in 2 suborders, 4 families, 6 genera, and about 12 species. They have a wide fossil distribution that goes back to the Lower Cretaceous. *Gonorynchus* lives in marine shore waters of the Indo-Pacific area; the four genera of the Kneriidae and Phractolaemidae live in tropical African fresh waters; and the milkfish (*Chanos chanos*, family Chanidae) lives in marine and estuarine waters of the tropical Indo-Pacific. Milkfish are pond-cultured for food in Southeast Asia. See ACTINOPTERYGII; CYPRINIFORMES; TELEOSTEI. [R.M.B.]

**Gooseberry** A small fruit represented by about six species of the genus *Ribes* of the plant order Rosales. The gooseberry is a thorny, spreading bush which produces red, yellow, or green berries. The most desirable hardier types in the United States are of American parentage, or are hybrids between American and European species. Commercial culture is limited to a few states, notably Oregon, Michigan, and Washington.

The fruit is very acid and only a few European varieties, when fully ripe, are suitable for eating fresh. The fruit may be canned or frozen for use in pies or as preserves. See FRUIT; ROSALES. [J.H.Cl.]

**Gopher** The name for the North American rodents of the family Geomyidae. There are 39 species in 8 genera; 11 species are found in the United States. The distinctive name pocket gopher is applied to these animals, since they have large, furred cheek pouches which open outward on the side of the face. Two common species are the northern pocket gopher (*Thomomys talpoides*), a small burrowing species, most numerous in the western United States and Mexico, and the prairie pocket gopher (*Geomys bursarius*). See RODENTIA. [C.B.C.]

**Gorgonacea** An order of the coelenterate subclass Alcyonaria. The Gorgonacea are the horny corals which often form

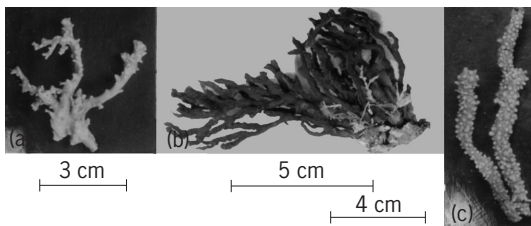

Gorgonacea colonies. (a) Skeleton of *Corallium knojoi*. (b) *Melitodes* sp. (preserved specimen). (c) *Anthoplexaura dimorpha* (preserved specimen).

fanlike or featherlike colonies with branches spread rapidly or oppositely in one plane (see illustration). They attach to objects by somewhat enlarged bases or tufts of stolons. They are more widely distributed than the Alcyonacea and extend from the littoral zone to some great depth. See ALCYONARIA.

[K.At.]

**Gout** A hereditary disease due to abnormal purine metabolism. The disease is characterized by increased amounts of blood uric acid (hyperurilcemia), acute and chronic inflammatory arthritis, tophaceous deposits of uric acid crystals, and renal insufficiency. The increase of uric acid is thought to be caused by increased production or decreased excretion of uric acid from the kidney or both. See ARTHRITIS; PURINE.

Primary gout occurs most frequently in middle-aged males and is passed as a familiar or hereditary trait which for some unknown reason does not appear as often in females. Secondary gout refers to the disease when associated with some underlying disorder causing an elevation in uric acid production (for example, myeloproliferative disorders).

The uric acid becomes deposited as urates in soft tissues, especially around the joints, in the cartilages of the ear, along the shafts of long bones, in the kidney, and occasionally on the heart valves. Such deposits, when superficial, can be seen grossly as reddish, inflamed masses called tophi. See PROTEIN METABOLISM; URIC ACID. [R.Se.]

**Governor** A device used to control the speed of a prime mover. A governor protects the prime mover from overspeed and keeps the prime mover speed at or near the desired revolutions per minute. When a prime mover drives an alternator supplying electrical power at a given frequency, a governor must be used to hold the prime mover at a speed that will yield this frequency. An unloaded diesel engine will fly to pieces unless it is under governor control. See PRIME MOVER.

A governor regulates the speed of a prime mover by properly varying the flow of energy to or from it. In the case of gas and steam turbines and internal combustion engines, the fuel furnishes the energy to the prime mover. For such applications, the governor usually controls the speed of the unit by regulating the rate at which fuel, and hence energy, is furnished to the prime mover. The governor controls the fuel flow so that the speed of the prime mover remains constant regardless of load and other disturbances, or changes in accordance with such operating conditions as changes in speed setting.

The speed of a prime mover is usually measured by a ballhead that contains flyweights driven at a speed proportional to the speed of the prime mover. The force from the flyweights is balanced, at least in part, by the force of compression of a speeder spring (see illustration). The upper end of this spring is positioned according to the speed setting of the governor.

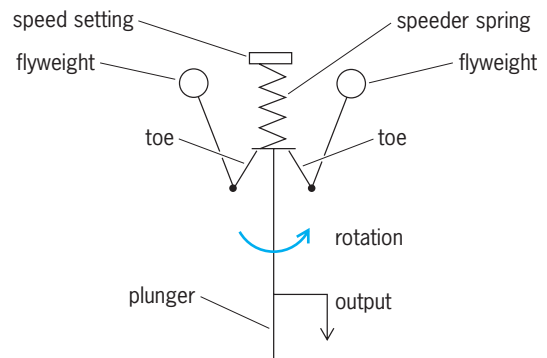

Ballhead governor.

To increase the power output of a governor, a hydraulic amplifier is often employed. A governor that keeps the speed of a prime mover constant is said to be isochronous. In a simple isochronous governor, the ballhead senses the speed and strokes a pilot valve plunger that regulates the flow of fluid to a servomotor. The performance of the simple isochronous governor is often greatly improved by the introduction of a dashpot in the feedback path from the output to the ballhead. If there is little damping in the prime mover, instability often occurs when the simple isochronous governor is used, whereas this instability is removed when the dashpot is incorporated. Acceleration governors are sometimes used in place of governors with dashpots. In such governors a flywheel is employed instead of a dashpot. The prime mover drives the flywheel through a spring. [R.O.]

**Graben** A block of the Earth's crust, generally with a length much greater than its width, that has been dropped relative to the blocks on either side (see illustration). The size of a graben may

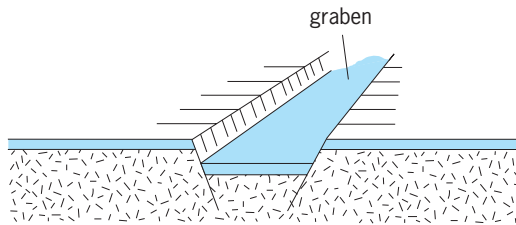

Diagram of simple graben. (After A. K. Lobeck, *Geomorphology*, McGraw-Hill, 1939)

vary. The faults that separate a graben from the adjacent rocks are inclined from 50 to 70° toward the down-thrown block and have displacements ranging from inches to thousands of feet. The direction of slip on these indicates that they are gravity faults. See FAULT AND FAULT STRUCTURES; HORST; RIFT VALLEY. [P.H.O.]

**Gradient of a scalar** The result of the application of the distributive vector differential operator  $\nabla$ ,  $\nabla = i \partial/\partial x + j \partial/\partial y + f \partial/\partial z$ , to a differentiable scalar function  $S(x, y, z)$ ; thus  $\nabla S = i \partial S/\partial x + j \partial S/\partial y + f \partial S/\partial z$ . The letters  $i, j, f$  are symbols for the base vectors associated with  $x, y, z$ . The gradient of  $S$  is also denoted by  $\text{grad } S$ , while the symbol  $\nabla$  is usually called del and less frequently nabla. See CALCULUS OF VECTORS. [H.V.C.]

**Gradient wind** A hypothetical wind based upon the assumption that the sum of the horizontal components of the Coriolis force and the atmospheric pressure gradient force per unit mass is equivalent to a wind acceleration which is normal to the direction of the wind itself (centripetal acceleration), with the implication that there are no viscous forces acting. The direction of the gradient wind is the same as that of the geostrophic wind. The gradient wind speed is less than the geostrophic speed when the air moves in a cyclonically curved path and greater when the air moves in an anticyclonically curved path. The gradient wind is a good approximation of the actual wind and is often superior to the geostrophic wind, particularly when the flow is strongly curved in the cyclonic sense. See CORIOLIS ACCELERATION; GEOSTROPHIC WIND. [F.S.]

**Grain boundaries** The internal interfaces that separate neighboring misoriented single crystals in a polycrystalline solid. Most solids such as metals, ceramics, and semiconductors have a crystalline structure, which means that they are made of atoms which are arranged in a three-dimensional periodic manner within the constituent crystals. Most engineering materials are polycrystalline in nature in that they are made of many small

single crystals which are misoriented with respect to each other and meet at internal interfaces called grain boundaries. These interfaces, which are frequently planar, have a two-dimensionally periodic atomic structure. A polycrystalline cube 1 cm on edge, with grains 0.0001 cm in diameter, would contain  $10^{12}$  crystals with a grain boundary area of several square meters. Thus, grain boundaries play an important role in controlling the electrical and mechanical properties of the polycrystalline solid. It is believed that the properties are influenced by the detailed atomic structure of the grain boundaries, as well as by the defects that are present, such as dislocations and ledges. Grain boundaries generally have very different atomic configurations and local atomic densities than those of the perfect crystal, and so they act as sinks for impurity atoms which tend to segregate to interfaces. See CRYSTAL DEFECTS; CRYSTAL STRUCTURE.

Using electron microscopy and x-ray diffraction, it was determined that the grain boundary structure is frequently periodic in two dimensions. The geometry of a grain boundary is described by the rotation axis and angle,  $\theta$ , that relate the orientations of the two crystals neighboring the interface, and the interface plane (or plane of contact) between the two crystals. Grain boundaries are typically divided into categories characterized by the magnitude of  $\theta$  and the orientation of the rotation axis with respect to the interface plane. When  $\theta$  is less than (arbitrarily) 15°, the boundary is called small-angle, and when  $\theta$  is greater than 15°, the boundary is large-angle. See ELECTRON MICROSCOPE; X-RAY DIFFRACTION.

Because of the large differences in atomic structure and density between the grain boundary region and the bulk solid, the properties of the boundary are also quite different from those of the bulk, and have a strong influence on the bulk properties of the polycrystalline solid. The mechanical behavior of a solid, that is, its response to an applied stress, often involves the movement of dislocations in the bulk, and the presence of boundaries impedes their motion since, in order for deformation to be transmitted from one crystal to its neighbor, the dislocations must transfer across the boundary and change direction. The detailed structure at the interface influences the ease or difficulty with which the dislocations accomplish this change in direction.

Since grain boundaries in engineering materials are not in a high-purity environment, the presence of impurities dissolved in the solid may have a strong influence on their behavior. The presence of one-half of a monolayer of impurity atoms, such as sulfur or antimony in iron, at the grain boundary, can have a drastic effect on mechanical properties, making iron, which is ductile in the high-purity state, extremely brittle, so that it fractures along grain boundaries. The segregation of the impurity atoms to the boundaries has been well documented by the use of Auger electron spectroscopy, and studies have led to the suggestion that the change in properties may be related to a change in the dislocation structure of the grain boundary induced by the presence of these impurities. See METAL, MECHANICAL PROPERTIES OF; PLASTIC DEFORMATION OF METAL.

Since modern electronic devices are fabricated from semiconductors, which may be polycrystalline, the presence of grain boundaries and their effect on electrical properties is of great technological interest. In a semiconductor such as silicon the local change in structure at the interface gives rise to disruption of the normal crystal bonding, or sharing of valence electrons. One consequence can be the charging of the grain boundaries, which produces a barrier to current flowing across them and thus raises the overall resistance of the sample. This polycrystalline effect is exploited in devices such as zinc oxide varistors, which are used as voltage regulators and surge protectors. See SURGE SUPPRESSOR; VARISTOR. [S.L.S.]

**Grain crops** Crop plants that belong to the grass family (Gramineae), generally grown for their edible starchy seeds. They also are referred to as cereal crops and include wheat, rice,



maize (corn), barley, rye, oats, sorghum (jowar), and millet. The grain of all these is used directly for human food and also for livestock, especially maize, barley, oats, and sorghum.

An important attribute of these grain crops is the easy manner in which they can be stored. The grain often dries naturally before harvest to a safe moisture content (10–12%), or can easily be dried with modern equipment. Grain placed in adequate storage facilities can then be protected against insect infestations and maintained in sound condition for years. *See* CORN; MILLET; OATS; RICE; SORGHUM; WHEAT. [E.G.H.]

**Gram-equivalent weight** A quantity of a substance that contains the same number (known as the Avogadro number) of molecules as the number of atoms contained in exactly 12.000 g of carbon-12 ( $^{12}\text{C}$ ). This convention stems from the concept that the central principle guiding chemical calculations is the relation of quantities of reacting substances to the numbers of molecules involved.

An added convenience in stoichiometric calculations is to incorporate the combining capacity ( $n$ ), as well as the number of molecules, so that an equivalence of reacting substances is implicit without the need to examine balanced equations each time. Thus, the gram-equivalent weight of a substance is its gram-molecular weight divided by  $n$ . In acid-base reactions,  $n$  of the acid or base is given by the number of protons released or consumed in the reaction. For hydrochloric acid (HCl), ammonia ( $\text{NH}_3$ ), acetic acid ( $\text{CH}_3\text{COOH}$ ), and the acetate ion [ $\text{CH}_3\text{COO}^-$ ]; as in sodium acetate ( $\text{NaOOCCH}_3$ ),  $n = 1$ . For carbonic acid ( $\text{H}_2\text{CO}_3$ ), sodium carbonate ( $\text{Na}_2\text{CO}_3$ ), and ethylenediamine ( $\text{H}_2\text{NCH}_2\text{CH}_2\text{NH}_2$ ),  $n = 2$ .

In precipitation and other metathetical reactions, the charge (valence) of the ion involved governs the value of  $n$ . Thus,  $n = 3$  for ferric chloride ( $\text{FeCl}_3$ ) and  $n = 6$  for ferric sulfate [ $\text{Fe}_2(\text{SO}_4)_3$ ] when precipitation yields either ferric hydroxide [ $\text{Fe}(\text{OH})_3$ ], barium sulfate ( $\text{BaSO}_4$ ), or silver chloride ( $\text{AgCl}$ ). When oxidation-reduction is involved, the change of valence, rather than the valence itself, defines  $n$ . When the ferric ion ( $\text{Fe}^{3+}$ ) acts as an oxidant [with the ferrous ion ( $\text{Fe}^{2+}$ ) as product],  $n = 1$  for ferric chloride ( $\text{FeCl}_3$ ) and  $n = 2$  for ferric sulfate. When potassium permanganate ( $\text{KMnO}_4$ ) reacts in acid medium,  $n = 5$ , but in neutral or basic solution  $n = 3$ .

Further changes in the definition arise in dealing with metal complex formation, such as  $\text{FeF}_6^{3-}$ ,  $\text{FeCl}_4^-$ ,  $\text{Zn}(\text{EDTA})^{2+}$ , and  $\text{Bi}(\text{EDTA})^-$ ; EDTA is the polydentate metal chelating agent ethylenediaminetetraacetate ion. The combining capacity of metals in complex formation depends on their coordination number, which, as these examples demonstrate, differs with different complexing agents, or ligands. *See* ELECTROCHEMICAL EQUIVALENT; EQUIVALENT WEIGHT; ETHYLENEDIAMINETETRAACETIC ACID; MOLE (CHEMISTRY); STOICHIOMETRY; VALENCE. [H.Frei.]

**Gram-molecular weight** The molecular weight of an element or compound expressed in grams (g), that is, the molecular weight on a scale on which the atomic weight of the  $^{12}\text{C}$  isotope of carbon is taken as 12 exactly. This replaces the earlier scale on which the atomic weight of oxygen was taken as 16.00 g. In the International System of Units, gram-molecular weight is replaced by the mole.

The ratio of the gram-molecular weights of any two elements or compounds must be identical with the ratio of the absolute weights of their individual molecules. Therefore, the gram-molecular weights of all elements or compounds contain the same number of molecules. This number, called the Avogadro number,  $N$ , is  $6.022 \times 10^{23}$ . *See* AVOGADRO NUMBER; MOLE (CHEMISTRY); MOLECULAR WEIGHT; RELATIVE MOLECULAR MASS. [T.C.W.]

**Grand unification theories** Attempts to unify three fundamental interactions—strong, electromagnetic, and weak—with a postulate that the three forces, with the exception of gravity, can be unified into one at some very high energy. The basic

idea is motivated by the incompleteness of the electroweak theory of S. Weinberg, A. Salam, and S. Glashow, which has been extremely successful in the energy region presently accessible with the use of accelerators, and by the observation that the coupling constant for strong nuclear forces becomes smaller as energy increases whereas the fine-structure constant ( $\alpha = 1/137$ ) for electromagnetic interactions is expected to increase with energy. *See* GRAVITATION; STRONG NUCLEAR INTERACTIONS; WEAK NUCLEAR INTERACTIONS.

The simplest grand unification theory (GUT), proposed by H. Georgi and Glashow, is based on the assumption that the new symmetry that emerges when the three forces are unified is given by a special unitary group  $\text{SU}(5)$  of dimension 24. This symmetry is not observable in the low-energy region since it is badly broken. In this model, as in most GUTs, the coupling constants for the three interactions merge into one at an energy of about  $10^{14}$  GeV. Quarks and leptons belong to the same multiplets, implying that distinctions between them disappear at the energy of  $10^{14}$  GeV or above. In addition to the known 12 quanta of strong, electromagnetic, and weak interactions, there appear, in this model, 12 new quanta with the mass of  $10^{14}$  GeV. These generate new but extremely weak interactions that violate baryon- and lepton-number conservation. The most spectacular prediction of GUTs is the instability of the proton, which is a consequence of baryon-number (and lepton-number) violation. *See* LEPTON; PROTON; QUARKS; SYMMETRY BREAKING; SYMMETRY LAWS (PHYSICS).

GUTs, in general, explain why the charge of the electron is precisely that of the proton with the opposite sign. Massive neutrinos are a distinct possibility in GUTs, and the smallness of their mass can also be understood. *See* COSMOLOGY; NEUTRINO.

According to the scenario based on the GUTs, the universe underwent a phase transition when its temperature cooled to  $10^{27}$  K, which corresponds to  $10^{14}$  GeV in energy and to the first  $10^{-35}$  s after the big bang. The phase transition caused an exponential expansion ( $10^{30}$ -fold in  $10^{-32}$  s) of the universe, which explains why the observed 3 K microwave background radiation is uniform (the horizon problem), and why the universe behaves as if space is practically flat (the flatness problem). *See* BIG BANG THEORY; INFLATIONARY UNIVERSE COSMOLOGY; PHASE TRANSITIONS; UNIVERSE.

In spite of its theoretical triumph and spectacular predictions, the simple  $\text{SU}(5)$  model is practically untested by experiment and appears to be incomplete or even incorrect. No experimental evidence of proton decay has been established, and the problems which GUTs leave unsolved are numerous. *See* ELEMENTARY PARTICLE; FUNDAMENTAL INTERACTIONS; SUPERGRAVITY; SUPERSYMMETRY. [C.W.K.]

**Granite** A crystalline igneous rock that consists largely of alkali feldspar (typically perthitic microcline or orthoclase), quartz, and plagioclase (commonly calcic albite or oligoclase). Its average grain size is 0.04–1.0 in. (1–25 mm); finer-grained rocks of this composition include rhyolite and aplite, and coarser-grained ones are granite pegmatite. *See* APLITE; PEGMATITE; RHYOLITE.

The revised nomenclature of the International Union of Geological Sciences (IUGS) subcommission defines granite as containing 80–100% by volume quartz, alkali feldspar, and plagioclase in the proportions given in the illustration, and 20–0% accessory minerals. The three essential minerals must include 20–60% quartz, and alkali feldspar must constitute 65–90% of the total feldspar. The variety alkali feldspar granite is similar except that alkali feldspar constitutes 90–100% of its total feldspar. The term granitic rocks includes granodiorite and tonalite as well as granite, and as used by some geologists may include quartz syenite to quartz diorite (*see* illustration). *See* FELDSPAR; GRANODIORITE; HORNBLLENDE; MUSCOVITE.

Granites may be divided into three major types: calc-alkaline, peraluminous, and alkaline. Calc-alkaline granites typically are

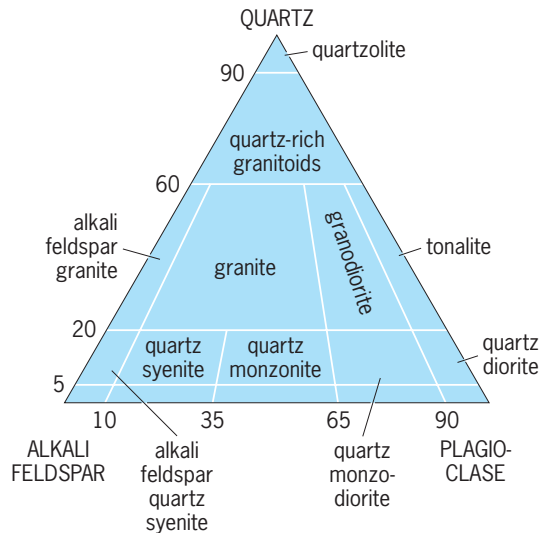

Classification of granitic rocks by the IUGS scheme. All proportions are by volume percentages.

biotite or biotite-hornblende granites, some contain augite, and sphene is a common accessory.

Peraluminous granites, also known as S-type granites, contain aluminum in excess of that contained in feldspars and biotite; thus muscovite is an accessory mineral. Other aluminous minerals such as andalusite, sillimanite, cordierite, or garnet also may be accessory. Subalkaline to alkaline granites are characterized by iron-rich mafic minerals and relatively sodic alkali feldspar. The subalkaline type typically contains ferruginous biotite or hornblende, or both, but varieties containing ferrohedenbergite or fayalite are not uncommon. Allanite and zircon are common accessories. The alkaline type contains the Na-Fe minerals aegirine or riebeckite-arfvedsonite, or all three, and may also contain ferruginous biotite or even astrophyllite, eudialyte, or other rare minerals. See IGNEOUS ROCKS. [F.B.]

**Granodiorite** A phaneritic (visibly crystalline) plutonic rock composed chiefly of sodic plagioclase (oligoclase or andesine), alkali feldspar (microcline or orthoclase, usually perthitic), quartz, and subordinate dark-colored (mafic) minerals (biotite, amphibole, or pyroxene). Granodiorite is intermediate between granite and quartz diorite (tonalite). For convenience granite and granodiorite are commonly grouped and referred to as granite. See GRANITE; IGNEOUS ROCKS. [C.A.C.]

**Granulite** An important class of metamorphic rocks exposed at the surface of the Earth's crust, and inferred to make up a large portion of the deeper crust. Granulites are known to have formed at higher temperatures, and in many cases, higher pressures, than most other crustal rock assemblages. Thus, they are believed to have formed at considerable depths in the crust. See METAMORPHIC ROCKS.

Granulites may be of many different bulk compositions, inherited from precursor sedimentary, igneous, or lower-grade metamorphic rocks. The high temperatures of crystallization have resulted in very low water content, reflected in nearly anhydrous mineralogy. Characteristic minerals of granulite metabasalts are plagioclase, orthopyroxene, clinopyroxene, hornblende, and garnet. These minerals are also characteristic of granulites of intermediate to granitic composition, together with progressively greater amounts of quartz and potassium feldspar. The association of potassium feldspar with orthopyroxene is definitive for charnockite, a granulite of approximately granitic composition characteristic of ancient high-grade terrains. See BASALT; GRANITE.

Granulites characteristically contain CO<sub>2</sub>-rich fluid inclusions in the mineral grains, in contrast to the more aqueous fluid inclusions of other kinds of rock. This has suggested that action of volatiles low in H<sub>2</sub>O and rich in CO<sub>2</sub>, probably of subcrustal origin, were important in crustal metamorphism early in the Earth's history. See METAMORPHISM. [R.C.N.]

**Granuloma inguinale** A mildly infectious, chronic, granulomatous disease principally affecting skin and subcutaneous tissues of the genital and rectal areas. The causative organism is *Calymmatobacterium granulomatis* (*Donovania granulomatis*). Although rare in the United States, the disease is very common in New Guinea, the Caribbean, and other tropical and subtropical areas.

Although the method of transmission is controversial, there is a definite correlation with sexual activity and a frequent association with homosexual behavior. Tetracyclines are the drugs of choice, with streptomycin an effective alternative. [D.S.K.]

**Granuloreticulosis** A subclass of the Rhizopodea. These Protozoa produce reticulopodia which often fuse into networks greatly exceeding the area of the body, as in various Foraminiferida. Such nets are effective food traps and may also be important in construction of tests and cyst walls. A characteristic feature of reticulopodia is the bidirectional flow of cytoplasm. Granuloreticulosis include three orders: Athalamida, Foraminiferida, and Xenophyophorida. See ATHALAMIDA; FORAMINIFERIDA; RHIZOPODEA; XENOPHYOPHORIDA. [R.P.H.]

**Grape** The two genera of grapes are *Vitis* and *Muscadinia*. *Vitis vinifera* has intermittent forked tendrils, bark that sheds, and elongated clusters with berries that adhere to the pedicels at maturity. This species also has thin, smooth, shiny leaves with three, five, or seven lobes. Berries may be round or oval and have edible skins that adhere to the flesh. In the American species skins slip from the pulp. Many American species have a characteristic musky or foxy odor and taste. *Muscadinia* can be easily distinguished from *Vitis* by bark that does not shed and simple tendrils that do not fork.

Viticulture is the science of grape production. In a broad sense, viticulture includes studies of grape varieties; methods of culture such as trellising, pruning, and training; insect and disease control; propagation; and raisin production.

In the United States, *V. vinifera* is grown on the west coast, and most of the grapes cultivated east of the Rocky Mountains have been derived from American native species such as *V. labrusca* and *V. aestivalis*, or from crosses between them and *V. vinifera*. There is also a native Caribbean species and several Asiatic species. There are three main species of *Muscadinia* that are found mostly in the southeast portion of the United States.

Table grapes are utilized for food and decorative purposes. Some of the leading table grapes in California are Emperor, Tokay, Thompson Seedless, Cardinal, and Perlette. Some of the principal commercial American varieties are Concord, Catawba, Delaware, and Niagara. Some of the important varieties of *M. rotundifolia*, the Muscadine grape, are Scuppernong, Thomas, and Hunt.

Important wine grapes in California include Cabernet Sauvignon, Carignane, Chardonnay, Grenache, French Colombard, and Zinfandel. Many of the North American and *rotundifolia* species that are used for eating purposes are also used for wine. [R.J.W.]

**Grapefruit** A citrus fruit, *Citrus paradisi*. It apparently arose as a hybrid of shaddock or pummelo and sweet orange in the West Indies. Its first recorded mention was in Barbados in 1750,

and the first use of the term grapefruit occurred in Jamaica in 1814. It was thought to have been introduced into Florida by Count Odelle Phillipe around 1823. The term grapefruit was derived from the tree's tendency to produce large clusters of fruit, as grape vines do.

The tree is a large evergreen, spreading in habit and becoming larger than most other edible citrus species. Fruit is relatively large and the peel thick compared to sweet oranges. Fruit shape is oblate or flattened at each end unless grown from off-bloom or under growing conditions promoting excessive vigor, in which case the fruit is often pear-shaped or sheep-nosed. The yellow peel color is not related to cool temperature as in the case of sweet oranges, but fruit picked early in the season must be degreened with ethylene to develop a satisfactory peel color. The original grapefruit were white-fleshed and extremely seedy; however, current important commercial cultivars are seedless or contain few seeds. See ETHYLENE; FRUIT.

Grapefruit ripens slowly over an extended period, storing well on the tree after reaching edible quality, with fruit of a given cultivar harvested from early fall to midsummer. Composition is, therefore, important not only for indicating nutritive values but also for determining proper time of harvest. The fresh weight of grapefruit consists of 35–50% juice, with the remainder made up of peel, pulp, and seeds. The edible quality of grapefruit depends in large measure upon the ratio of sugars to acids in juice. The nutritive value of juice is in part related to its vitamin C content. The juice also contains a number of other vitamins and mineral elements required in a well-balanced human diet. The principle giving grapefruit its distinctive bitter flavor is naringin, a glucoside not found in its progenitor the pummelo or in other commercial citrus. See ASCORBIC ACID; CITRIC ACID. [D.P.H.T.]

**Graph theory** A branch of mathematics that belongs partly to combinatorial analysis and partly to topology. Its applications occur (sometimes under other names) in electrical network theory, operations research, organic chemistry, theoretical physics, and statistical mechanics, and in sociological and behavioral research. Both in pure mathematical inquiry and in applications, a graph is customarily depicted as a topological configuration of points and lines, but usually is studied with combinatorial methods. See COMBINATORIAL THEORY; TOPOLOGY.

A graph consists of a set of points, a set of lines, and an incidence relation that designates the end points of each line. In many applications no line starts and ends at the same point. (Such a line would be called a loop.) Also, no two lines have the same pair of end points. A graph whose lines satisfy these conditions is called simplicial. The valence of a point is the number of lines incident on it, calculated so that a loop is twice incident on its only end point. Two graphs are isomorphic if there is one-to-one correspondence from the point set and line set of one onto the point set and line set, respectively, of the other that preserves the incidence relation. An automorphism of a graph is an isomorphism of a graph with itself. Two graphs are homeomorphic if, after smoothing over all points of valence 2, the resulting graphs are isomorphic. See GROUP THEORY.

Drawing a graph on a surface decomposes the surface into regions. One colors the regions so that no two adjacent regions have the same color, rather like a political map of the world. It is a remarkable fact that for a given surface, there is a single number of colors that will always be enough no matter how many regions occur in a decomposition of the surface. The smallest such number is called the chromatic number of that surface. It is easy to draw a plane map that requires four colors. In 1976 K. Appel and W. Haken settled a problem dating back to about 1850, by showing that four colors are always enough for plane maps.

A graph is planar if it can be drawn in the plane so that none of its lines cross each other. Neither of the two graphs in the illustration can be drawn in the plane. K. Kuratowski proved in

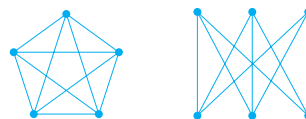

Prototypes of all nonplanar graphs.

1930 that a graph is planar if and only if it contains no subgraph homeomorphic to either of those two graphs.

In a directed graph, or digraph, each line  $ab$  is directed from one end point  $a$  to the other end point  $b$ . There is at most one line from  $a$  to  $b$ .

An oriented graph is obtained from an ordinary graph by assigning a unique direction to every line. If there is one line between every pair of points and no loops, an ordinary graph is called complete. An oriented complete graph is called a tournament. [J.L.Gro.]

**Graphic methods** Procedures and techniques for visually representing on paper or a screen information pertaining to data analysis and decision making or relationships between variables by means of diagrams or charts.

Structural information is usually depicted by a bar graph, also known as a histogram, or a circle graph, also known as a sector-graph or a pie chart. Such charts are commonly used to display data. A graph representing the relation between an independent and a dependent variable is a two-dimensional line, whereas a graph representing the relation between two independent variables and a dependent variable is a three-dimensional surface. Graphical methods are frequently used to solve problems of curve fitting, correlation and regression analysis, nomographs and alignment charts, numerical integration, areas under curves, and interpolation and extrapolation.

Line graphs are by far the most important type because they can be used not only to represent functional relationships but also to solve problems. For example, the roots of an equation in one variable can be found with the help of a graph. If  $f(x)$  is a function which becomes 0 for a certain value of  $x$ , that value is a root of the equation  $f(x) = 0$ . The equation is solved by finding the  $x$  coordinates of points where the graph of  $f(x)$  crosses the  $x$  axis. See ROOT (MATHEMATICS). [V.K.B.]

**Graphic recording instruments** Instruments that make a graphic record of one or more quantities as a function of another variable, usually time. Signals representing information, such as the shape of time-varying electronic waveforms or the movements of a machine, are presented in graphical form by these devices. See TRANSDUCER.

Recorders are of two forms: those that plot an input variable with respect to time (denoted  $x-t$ ) and those that plot two different variables (denoted  $x-y$ ). Graphic recorders can also be classified as being either directly or indirectly driven by the input signal. In addition, they can be classified by their exhibiting means, recording means, number of marking devices or channels, and marking means.

Direct-acting units are suitable when the primary variable exerts sufficient and appropriate force to overcome the frictional loads of the bearings and marking means. Direct-drive recorders lack general-purpose usefulness and are, therefore, more costly to produce than indirect alternatives. In some circumstances, however, they are essential.

In the indirect form an intermediate stage is used to convert the input signal into the equivalent mechanical movements needed. Indirect-acting recorders generally accept voltage or current input signals, converting these into equivalent mechanical positions on a suitable exhibiting medium. Other input variables, such as pressure and temperature, are first transformed into electrical signals.

Such signals may range from microvolts to megavolts or from picoamperes to kiloamperes. Recorders are often supplied with adjustable input stages so that the input signal can be matched to the scale size needed for the graph.

Exhibiting means can be of either circular form or linear form, the latter being continuous strip or a single sheet.

Many different methods are used to produce the permanent trace on the recording medium. They include the use of fluid inks and fiber pens that mark in direct contact with the paper; pressure-forced ink jetting; marking with a heated stylus on heat-sensitive paper; pressure- or voltage-sensitive paper on which the stylus moves in contact; pressure of an inked ribbon onto the paper after the marking head has been positioned; exposure of heat-sensitive or photographically sensitive paper or film; and electrostatically charged images in a laser printer.

Graphic recorders (commonly referred to as plotters) are designed for use with either analog or digital electrical input signals. In the analog variation the input circuitry accepts signals that have the information to be displayed carried in terms of the variable amplitude of a voltage or current. A variable-gain input stage allows input signal magnitudes to be matched, by amplification or attenuation, to the set sensitivity of the positioning system.

In the digital plotter the digital signal (having only two states of existence for each of the bits forming the digital word equivalent to the analog alternative) can be of either serial format or parallel format. In the former a time sequence of serially occurring binary bits represents the signal amplitude. In the latter it is the state of binary signals simultaneously existing on several parallel lines that represents the amplitude. The signal lines carrying these digital signals, for purposes of interconnection, are called the communication interface.

The extensive acceptance of computer-based data logging and the general availability of hard-copy printers have contributed to a shift in usage from dedicated chart recorders to digital printers that provide permanent displays in the form of computer printouts. The plotting mechanisms incorporated within printers are similar to those of conventional graphic recording instruments, the majority being driven with stepping motors and using thermal- or laser-based printing. Dedicated graphic recording devices are still in use because it is often not economical to replace them with modern equivalents. They also find application where records need longer paper lengths than a computer printer can provide. See COMPUTER PERIPHERAL DEVICES; STEPPING MOTOR. [P.H.Sv.]

**Graphite** A low-pressure polymorph of carbon (the common high-pressure polymorph being diamond). Graphite is metallic in appearance and very soft. Crystals of graphite are infrequently encountered since the mineral usually occurs as earthy, foliated, or columnar aggregates often mixed with iron oxide, quartz, and other minerals. See CARBON.

The sheetlike character of the graphite atomic arrangement results in distinctive physical properties. The mineral is very soft, with hardness  $1\frac{1}{2}$ ; it soils the fingers and leaves a black streak on paper, hence its use in pencils. The specific gravity is 2.23, often less because of the presence of pore spaces and impurities. The color is black in earthy material to steel-gray in plates, and thin flakes are deep blue in transmitted light. Graphite is a conductor of electricity.

The major sources of graphite are in gneisses and schists, where the mineral occurs in foliated masses mixed with quartz, mica, and so on. Noteworthy localities include the Adirondack region of New York, Korea, and Sri Lanka (formerly Ceylon). In Sonora, Mexico, graphite occurs as a product of metamorphosed coal beds. Graphite is also observed in meteorites. [P.B.M.]

**Synthetic graphite.** Commercially produced synthetic graphite is a mixture of crystalline graphite and cross-linking intercrystalline carbon. Its physical properties are the result of contributions from both sources. Thus, among engineering materials, synthetic graphite is unusual because a wide variation in

measurable properties can occur without significant change in chemical composition.

At room temperature the thermal conductivity of synthetic graphite is comparable to that of aluminum or brass. An unusual property of graphite is its increased strength at high temperature. Graphite is resistant to thermal shock because of its high thermal conductivity and low elastic modulus. It is one of the most inert materials with respect to chemical reaction with other elements and compounds. It is subject to oxidation, and reaction with and solution in some metals.

Graphite has many uses in the electrical, chemical, metallurgical, nuclear, and rocket fields: electrodes in electric furnaces producing carbon steel, alloy steel, and ferroalloys; anodes for the electrolytic production of chlorine, chlorates, magnesium, and sodium; motor and generator brushes; sleeve-type bearings and seal rings; rocket motor nozzles; missile nose cones; metallurgical molds and crucibles; linings for chemical reaction vessels; and, in a resin-impregnated impervious form, for heat exchangers, pumps, pipings, valves, and other process equipment.

**Graphite (carbon) fibers.** Carbon fibers are filamentary forms of carbon, with a fiber diameter normally in the 6–10-micrometer range. The product is offered in the form of yarns or tows containing from 1000 to 500,000 filaments per strand. The fibers offer a unique combination of properties. They are flexible, lightweight, thermally and to a large extent chemically inert, and are good thermal and electrical conductors. In their high-performance varieties, carbon fibers are very strong and can be extremely stiff.

The principal use of high-performance carbon fibers is as the reinforcing component in structural epoxy matrix composites. Due to initially high cost, the original applications were almost exclusively for lightweight, high-stiffness, and high-strength composites for the aerospace industry. The second major usage of high-performance carbon fibers is in sporting goods, such as golf club shafts, tennis rackets, fishing rods, and sailboat structures. The major matrix material for both applications is epoxy. See COMPOSITE MATERIAL. [H.F.V.]

**Graptolithina** A group of marine organisms that were common in the early Paleozoic (the Late Cambrian to Early Devonian periods). Graptolites became extinct in the late Paleozoic Era. They were minute animals that built communal skeletons. Each graptolite colony contained from two to many hundreds of separate graptolite animals (referred to individually as zooids). All of the zooids within a single colony (a rhabdosome) were formed by asexual budding from the founder zooid, which probably grew from a fertilized egg. Thus, each colony started with a sexually produced animal and then enlarged by budding new zooids from one another. The result was a spreading rhabdosome composed of a few to many hundreds of minute tubes (thecae), each containing its own zooid. The thecae consist of the protein collagen.

With the exception of a small group of living organisms that may be relatives of the graptolites, little is known for sure of the detailed anatomy and ecology of these enigmatic organisms. Based on the shape and patterns of occurrence of their colonies, graptolites were probably suspension feeders that extracted food particles such as bacteria, algae, and other organic matter from the surrounding ocean water. Many graptolite species were very widely distributed throughout the world's oceans during the Ordovician, Silurian, and Early Devonian periods (an interval of about 110 million years in total). Graptolites evolved very rapidly. They are mainly of two sorts: bottom-living (benthic) and free-floating (planktic). Many of these benthic graptolites are grouped by graptolite taxonomists as the Dendroidea. Benthic graptolites also include several other graptolite orders (such as the Tuboidea); however, these are very small and very rare fossils. In contrast to the benthic graptolites, species of the Graptoloidea were planktonic.

Graptoloids lived mostly in the open ocean in relatively off-shore or deep-water locations. Thus, they are most common in

rocks deposited in outer-shelf and deep-sea environments. Most graptoloid graptolites are preserved in gray to black shales as black or silvery films flattened on the surface of the rock. Most understanding of graptolites' detailed structure comes from material of this kind. [C.E.Mi.]

**Grass crops** Members of the family Gramineae cultivated as forage and grain for consumption. The grasses are the most useful of all the plants that cover the Earth. The cereal grasses supply directly three-fourths of the energy and over half of the protein in food consumed by humans. Indirectly, these cereals together with the forage grasses supply most of the food for the domestic animals that provide milk, meat, eggs, and much of the draft power required to grow crops. See BARLEY; CEREAL; CORN; MILLET; OATS; RICE; RYE; SORGHUM; SUGARCANE; WHEAT.

The bamboos are of vast importance in the Indo-Malay region, where they are used in building houses, bridges, furniture, rafts, water pipes, vessels for holding water, and so forth. See BAMBOO.

The grasses protect soil from erosion and help conserve water resources. More than any other family of plants, the sod-forming grasses blanket golf courses, athletic fields, lawns, parks, and cemeteries with a protective covering that beautifies and enhances the environment. No other family of plants in the vast plant kingdom is so useful to humans. See EROSION; LAWN AND TURF GRASSES; SOIL CONSERVATION.

Grass stems have solid joints (nodes) and leaves arranged in two rows, with one leaf at each joint (see illustration). The leaves consist of the sheath, which fits around the stem like a split tube, and the blade, which is commonly long and narrow. Seed heads are made up of minute flowers on tiny branchlets, often several crowded together, but always two-ranked like the leaves. The flowers are generally wind-pollinated. The seeds are enclosed between two bracts, or glumes, which remain on the seed when ripe.

The 600 genera grouped into 14 tribes that make up the grass family may be annual or perennial. Annuals and some perennial

grasses are bunch grasses which spread only by seeding. Others, mostly perennials, also spread by creeping stems called stolons when above ground and rhizomes when below the soil surface. The creeping grasses form the best sods and surpass others for soil conservation; they are also the best turf grasses. All grasses have fine fibrous root systems that permeate the soil extensively to depths ranging from much less than 3 ft to more than 10 ft (1 to 3 m). The roots are short-lived, are continually being replaced, and in the process increase the organic matter content of the soil.

Grasses are distributed throughout the world. Annual species predominate in the adverse environments found in the deserts and the arctic areas. Temperature is the principal factor determining the distribution of perennial grasses. Perennial grasses are frequently classed as cool- or warm-season grasses depending upon the season in which they make their best growth.

Annuals and most perennial grasses reproduce sexually and are propagated by seed. Many of the grasses are cross-pollinated largely by the wind. In some species, cross-pollination is facilitated by self-incompatibility that occurs at variable frequencies. Most grasses produce perfect flowers containing both male and female organs. The male organs (anthers) must be carefully removed before they shed pollen to make controlled hybrids. A few species, largely tropical perennials, reproduce by apomixis, simply defined as vegetative reproduction through the seed. Apomictic seeds produce the same genotype as the plant that produced them. See FLOWER; POLLINATION; REPRODUCTION (PLANT). [G.W.Bur.]

**Grassland ecosystem** A biological community that contains few trees or shrubs, is characterized by mixed herbaceous (nonwoody) vegetation cover, and is dominated by grasses or grasslike plants. Mixtures of trees and grasslands occur as savannas at transition zones with forests or where rainfall is marginal for trees. About  $1.2 \times 10^8$  mi<sup>2</sup> ( $4.6 \times 10^7$  km<sup>2</sup>) of the Earth's surface is covered with grasslands, which make up about 32% of the plant cover of the world. In North America, grasslands include the Great Plains, which extend from southern Texas into Canada. The European meadows cross the subcontinent, and the Eurasian steppe ranges from Hungary eastward through Russia to Mongolia; the pampas cover much of the interior of Argentina and Uruguay. Vast and varied savannas and velds can be found in central and southern Africa and throughout much of Australia. See SAVANNA.

Grasslands occur in regions that are too dry for forests but that have sufficient soil water to support a closed herbaceous plant canopy that is lacking in deserts. Thus, temperate grasslands usually develop in areas with 10–40 in. (25–100 cm) of annual precipitation, although tropical grasslands may receive up to 60 in. (150 cm). Grasslands are found primarily on plains or rolling topography in the interiors of great land masses, and from sea level to elevations of nearly 16,400 ft (5000 m) in the Andes. Because of their continental location they experience large differences in seasonal climate and wide ranges in diurnal conditions. In general, there is at least one dry season during the year, and drought conditions occur periodically. See DROUGHT; PLANT-WATER RELATIONS.

Significant portions of the world's grasslands have been modified by grazing or tillage or have been converted to other uses. The most fertile and productive soils in the world have developed under grassland, and in many cases the natural species have been replaced by cultivated grasses (cereals). See CEREAL; GRASS CROPS.

Different kinds of grasslands develop within continents, and their classification is based on similarity of dominant vegetation, presence or absence of specific dominant species, or prevailing climate conditions.

The climate of grasslands is one of daily and seasonal extremes. Deep winter cold does not preclude grasslands since they occur in some of the coldest regions of the world. However,

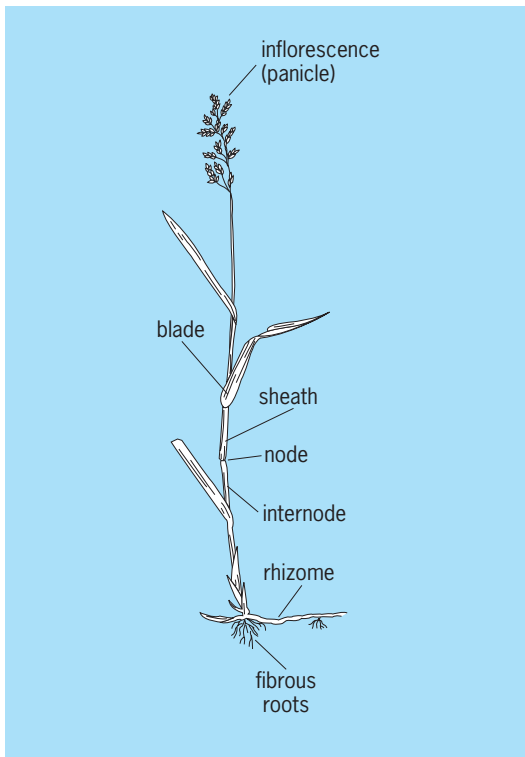

A typical grass plant. (After P. D. Strausbaugh and E. L. Core, *Flora of West Virginia*, West Va. Univ. Bull., ser. 52, no. 12–2, pt. 1, p. 67, 1952)

the success of grasslands in the Mediterranean climate shows that marked summer drought is not prohibitive either. In North America, the rainfall gradient decreases from an annual precipitation of about 40 in. (100 cm) along the eastern border of the tallgrass prairie at the deciduous forest to only about 8 in. (20 cm) in the shortgrass prairies at the foothills of the Rocky Mountains. A similar pattern exists in Europe. Growing-season length is determined by temperature in the north latitudes and by available soil moisture in many regions, especially those adjacent to deserts. Plants are frequently subjected to hot and dry weather conditions, which are often exacerbated by windy conditions that increase transpirational water loss from the plant leaves.

Soils of mesic temperate grasslands are usually deep, about 3 ft (1 m), are neutral to basic, have high amounts of organic matter, contain large amounts of exchangeable bases, and are highly fertile, with well-developed profiles. The soils are rich because rainfall is inadequate for excessive leaching of minerals and because plant roots produce large amounts of organic material. With less rainfall, grassland soils are shallow, contain less organic matter, frequently are lighter colored, and may be more basic. Tropical and subtropical soils are highly leached, have lower amounts of organic material because of rapid decomposition and more leaching from higher rainfall, and are frequently red to yellow.

Grassland soils are dry throughout the profile for a portion of the year. Because of their dense fibrous root system in the upper layers of the soil, grasses are better adapted than trees to make use of light rainfall showers during the growing season. When compared with forest soils, grassland soils are generally subjected to higher temperatures, greater evaporation, periodic drought, and more transpiration per unit of total plant biomass. See BIOMASS; SOIL.

Throughout the year, flowering plants bloom in the grasslands with moderate precipitation, and flowers bloom after rainfall in the drier grasslands. With increasing aridity and temperature, grasslands tend to become less diverse in the number of species; they support more warm-season species; the complexity of the vegetation decreases; the total above-ground and below-ground production decreases; but the ratio of above-ground to below-ground biomass becomes smaller.

There are many more invertebrate species than any other taxonomic group in the grassland ecosystem. Invertebrates play several roles in the ecosystem. For example, many are herbivorous, and eat leaves and stems, whereas others feed on the roots of plants. Earthworms process organic matter into small fragments that decompose rapidly, scarab beetles process animal dung on the soil surface, flies feed on plants and are pests to cattle, and many species of invertebrates are predaceous and feed on other invertebrates. Soil nematodes, small nonarthropod invertebrates, include forms that are herbivorous, predaceous, or saprophagous, feeding on decaying organic matter. See SOIL ECOLOGY.

Most of the reptiles and amphibians in grassland ecosystems are predators. Relatively few bird species inhabit the grassland ecosystem, although many more species are found in the flooding pampas of Argentina than in the dry grasslands of the western United States. Their role in the grassland ecosystem involves consumption of seeds, invertebrates, and vertebrates; seed dispersal; and scavenging of dead animals.

Small mammals of the North American grassland include moles, shrews, gophers, ground squirrels, and various species of mice. Among intermediate-size animals are the opossum, fox, coyote, badger, skunk, rabbit, and prairie dog; large animals include various types of deer and elk. The most characteristic large mammal species of the North American grassland is the bison, although many of these animals were eliminated in the late 1800s. Mammals include both ruminant (pronghorns) and nonruminant (prairie dogs) herbivores, omnivores (opossum), and predators (wolves).

Except for large mammals and birds, the animals found in the grassland ecosystem undergo relatively large population variations from year to year. These variations, some of which are cyclical and others more episodic, are not entirely understood and may extend over several years. Many depend upon predator-prey relationships, parasite or disease dynamics, or weather conditions that influence the organisms themselves or the availability of food, water, and shelter. See POPULATION ECOLOGY.

Within the grassland ecosystem are enormous numbers of very small organisms, including bacteria, fungi, algae, and viruses. From a systems perspective, the hundreds of species of bacteria and fungi are particularly important because they decompose organic material, releasing carbon dioxide and other gases into the atmosphere and making nutrients available for recycling. Bacteria and some algae also capture nitrogen from the atmosphere and fix it into forms available to plants. See NITROGEN FIXATION; SOIL MICROBIOLOGY.

Much of the grassland ecosystem has been burned naturally, probably from fires sparked by lightning. Human inhabitants have also routinely started fires intentionally to remove predators and undesirable insects, to improve the condition of the rangeland, and to reduce cover for predators and enemies; or unintentionally. Thus, grasslands have evolved under the influences of grazing and periodic burning, and the species have adapted to withstand these conditions. If burning or grazing is coupled with drought, however, the grassland will sustain damage that may require long periods of time for recovery by successional processes. See ECOLOGICAL SUCCESSION; ECOSYSTEM. [P.G.Ri.]

**Gravel** An unconsolidated sedimentary aggregate containing more than 50% by weight of gravel-sized particles (mean diameter greater than 0.08 in. or 2 mm). The gravel-sized particles are termed the framework; those less than 0.08 in. in diameter are the matrix. There is an important distinction between framework-supported and matrix-supported gravels. The latter may possess a muddy matrix, in which case they are termed diamictos. Typically, diamictos are unstratified internally, contain subangular framework clasts, and are deposited by mass-flow processes such as debris flow or glacial-ice transport. Water-laid gravels are typically stratified or cross-stratified and are framework-supported, with subangular to rounded clasts in a sand matrix. Less commonly, they may be sand-matrix-supported, or they may lack matrix and then are termed open-work gravels. Water-worn gravel clasts tend to conform to the shape of triaxial ellipsoids and develop preferred orientation, with long axes normal to stream flow and intermediate axes dipping gently upstream.

The consolidated equivalents of gravels are conglomerates and breccias, the latter including only angular particles. Paleoenvironmental indicators for conglomerates include stratification, size grading, particle roundness, particle orientation, and matrix-framework relations. See BRECCIA; CONGLOMERATE; SEDIMENTARY ROCKS. [B.R.R.]

**Gravimetric analysis** That branch of quantitative chemical analysis in which a desired constituent is converted (usually by precipitation) to a pure compound or element of definite, known composition, and is weighed. In a few cases, a compound or element is formed which does not contain the constituent but bears a definite mathematical relationship to it. In either case, the amount of desired constituent can be determined from the weight and composition of the precipitate.

At least two weighings are required for each analysis—the original sample, and the dried or ignited residue. From these weights, the percentage or proportion of the desired constituent may be calculated from the equation below.

$$\%A = \frac{\text{wt of residue} \times \text{factor} \times 100}{\text{wt of sample}}$$

The factor is determined from a knowledge of the chemical relationships between the weight of substance A contained in, or equivalent to, a fixed weight of residue of known composition. See ANALYTICAL CHEMISTRY; QUANTITATIVE CHEMICAL ANALYSIS; STOICHIOMETRY. [S.G.S.]

**Gravitation** The mutual attraction between all masses and particles of matter in the universe. In a sense this is one of the best-known physical phenomena. During the eighteenth and nineteenth centuries gravitational astronomy, based on Newton's laws, attracted many of the leading mathematicians and was brought to such a pitch that it seemed that only extra numerical refinements would be needed in order to account in detail for the motions of all celestial bodies. In the twentieth century, however, A. Einstein shattered this complacency, and the subject is currently in a healthy state of flux.

**Newton's law of gravitation.** Newton's law of universal gravitation states that every two particles of matter in the universe attract each other with a force that acts in the line joining them, the intensity of which varies as the product of their masses and inversely as the square of the distance between them. Or, the gravitational force  $F$  exerted between two particles with masses  $m_1$  and  $m_2$  separated by a distance  $d$  is given by the equation below, where  $G$  is called the constant of gravitation.

$$F = \frac{Gm_1m_2}{d^2}$$

**Gravitational constant.** In 1774,  $G$  was determined by measuring the deflection of the vertical by the attraction of a mountain. This method is much inferior to the laboratory method in which the gravitational force between known masses is measured. In the torsion balance two small spheres, each of mass  $m$ , are connected by a light rod, suspended in the middle by a thin wire. The deflection caused by bringing two large spheres each of mass  $M$  near the small ones on opposite sides of the rod is measured, and the force is evaluated by observing the period of oscillation of the rod under the influence of the torsion of the wire (see illustration). This is known as the Cavendish experiment, in honor of H. Cavendish, who achieved the first reliable results by this method in 1797–1798. More recent determinations using various refinements yield the results: constant of gravitation  $G = 6.67 \times 10^{-11}$  SI (mks) units; mass of Earth =  $5.98 \times 10^{24}$  kg. The result of the best available laboratory measurements, announced in 2002, is  $G = (6.6742 \pm 0.0010) \times 10^{-11}$  in SI (mks) units.

In newtonian gravitation,  $G$  is an absolute constant, independent of time, place, and the chemical composition of the masses involved. Partial confirmation of this was provided before Newton's time by the experiment attributed to Galileo in which different weights released simultaneously from the top of the Tower

of Pisa reached the ground at the same time. Newton found further confirmation, experimenting with pendulums made out of different materials. Early in this century, R. Eötvös found that different materials fall with the same acceleration to within 1 part in  $10^7$ . The accuracy of this figure has been extended to 1 part in  $10^{11}$ , using aluminum and gold, and to  $0.9 \times 10^{-12}$  with a confidence of 95%, using aluminum and platinum.

**Mass and weight.** In the equations of motion of newtonian mechanics, the mass of a body appears as inertial mass, a measure of resistance to acceleration, and as gravitational mass in the expression of the gravitational force. The equality of these masses is confirmed by the Eötvös experiment. It justifies the assumption that the motion of a particle in a gravitational field does not depend on its physical composition. In Newton's theory the equality can be said to be a coincidence, but not in Einstein's theory, where this equivalence becomes a cornerstone of relativistic gravitation.

While mass in newtonian mechanics is an intrinsic property of a body, its weight depends on certain forces acting on it. For example, the weight of a body on the Earth depends on the gravitational attraction of the Earth on the body and also on the centrifugal forces due to the Earth's rotation. The body would have lower weight on the Moon, even though its mass would remain the same. See CENTRIFUGAL FORCE.

**Gravity.** This should not be confused with the term gravitation. Gravity is the older term, meaning the quality of having weight, and so came to be applied to the tendency of downward motion on the Earth. Gravity or the force of gravity is today used to describe the intensity of gravitational forces, usually on the surface of the Earth or another celestial body. So gravitation refers to a universal phenomenon, while gravity refers to its local manifestation. See EARTH, GRAVITY FIELD OF.

**Accuracy of newtonian gravitation.** A discrepancy in newtonian gravitation was discovered by U.J.J. Leverrier in the orbit of Mercury. Because of the action of the other planets, the perihelion of Mercury's orbit advances. But allowance for all known gravitational effects still left an observed motion of about 43 seconds of arc per century unaccounted for by Newton's theory. Attempts to account for this by adding an unknown planet or by drag with an interplanetary medium were unsatisfactory, and a very small change was suggested in the exponent of the inverse square of force. This particular discordance was accounted for by A. Einstein's general theory of relativity in 1916, but the final word on the subject has yet to be said. See RELATIVITY.

**Gravitational lens.** Light is deflected when it passes through a gravitational field, and an analogy can be made to the refraction of light passing through a lens. It has been suggested that a galaxy situated between an observer and a more distant source might have a focusing effect, and that this might account for some of the observed properties of quasi-stellar objects. The multiple images of the quasar (Q0957 + 561 A,B) are almost certainly caused by the light from a single body passing through a gravitational lens. While this is the best-studied gravitational lens, many other examples of this phenomenon have been discovered. See GRAVITATIONAL LENS; QUASAR.

**Relativistic theories.** In spite of his success and the absence of a reasonable alternative, Newton's theory was heavily criticized, not least with regard to its requirement of "action at a distance" (that is, through a vacuum). Newton himself considered this to be "an absurdity," and he recognized the weaknesses in postulating in his system of mechanics the existence of preferred reference systems (that is, inertial reference systems) and an absolute time.

The theory of relativity grew from attempts to describe electromagnetic phenomena in moving systems. No physical effect can propagate with a speed exceeding that of light in vacuum; therefore, Newton's theory must be the limiting case of a field theory in which the speed of propagation approaches infinity. Einstein's field theory of gravitation (general relativity) is based on the identification of the gravitational field with the curvature

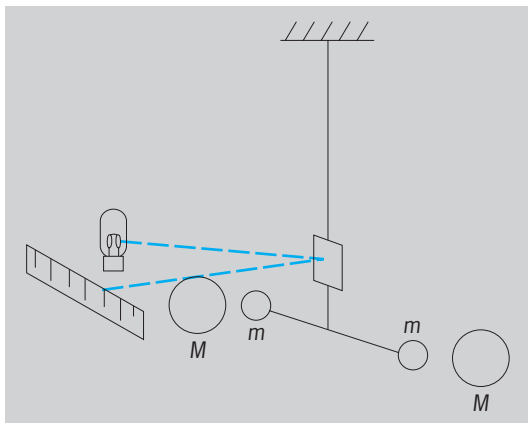

Diagram of the torsion balance.

of space-time. The geometry of space-time is affected by the presence of matter and radiation. The relationship between mass-energy and the space-time curvature is therefore a relativistic generalization of the newtonian law of gravitation. The relativistic theory is mathematically far more complicated than Newton's. Instead of the single newtonian potential described above, Einstein worked with 10 quantities that form a tensor. See TENSOR ANALYSIS.

An important step in Einstein's reasoning is his "principle of equivalence": A uniformly accelerated reference system imitates completely the behavior of a uniform gravitational field. This principle requires that all bodies fall in a gravitational field with precisely the same acceleration, a result that is confirmed by the Eötvös experiment mentioned earlier. Also, if matter and antimatter were to repel one another, it would be a violation of the principle. See FREE FALL.

**Gravitational waves.** The existence of gravitational waves, or gravitational "radiation," was predicted by Einstein shortly after he formulated his general theory of relativity. They are now a feature of any relativity theory. Gravitational waves are "ripples in the curvature of space-time." In other words, they are propagating gravitational fields, or propagating patterns of strain, traveling at the speed of light. They carry energy and can exert forces on matter in their path, producing, for instance, very small vibrations in elastic bodies. The gravitational wave is produced by change in the distribution of some matter. It is not produced by a rotating sphere, but would result from a rotating body not having symmetry about its axis of rotation: a pulsar, perhaps. In spite of the relatively weak interaction between gravitational radiation and matter, the measurement of this radiation is now technically possible. [J.M.A.D.; B.Ma.]

**Gravitational collapse** The stage in the evolution of a star in which the pressure in the star is insufficient to maintain the star at a stable size. The material in the star or in the core of the star then falls inward under its own gravitational attraction. Depending on the mass, composition, and spin of the star, the collapse may proceed to the formation of a neutron star or black hole, possibly accompanied by a supernova explosion. See STELLAR EVOLUTION; SUPERNOVA.

Stars similar to the Sun maintain a stable size by continually burning nuclear fuel. In most stars, as for the Sun, this burning involves the conversion of hydrogen to helium with a release of energy as the nuclear reactions take place. This energy supplies heat to the interior of the star, which in turn keeps the core of the star hot enough so that nuclear reactions can continue. Heat is also continually transferred from the interior to the exterior of the star, where it is lost, primarily in the form of radiation.

Suppose now that the nuclear burning is turned off, as is the case if the hydrogen in the core is used up and only helium remains. Then, no more heat is supplied to the core of the star, and its temperature drops as remaining heat is transported to the surface of the star and is lost. Likewise, since the pressure in the gas depends on the temperature, the pressure in the core also drops, and more importantly, the pressure gradient decreases throughout the star. The various chunks of gas are no longer in equilibrium, and they move inward. This compression of the gas then causes a rise in temperature and the temporary reestablishment of the required temperature gradient. However, as heat is transported outward, the temperature again drops, the gas is further compressed, and so on. In this stage, the star is undergoing contraction, the heating coming from the gravitational potential energy of the star rather than nuclear reactions.

Eventually, the star condenses, and the temperature rises to a sufficiently high value that helium burning can take place. Once again, the star is in stable equilibrium until the reservoir of fuel in the core of the star is used up, after which contraction takes place until conditions are right for nuclear burning of higher elements. The contraction discussed here refers to what is going on in the

core of the star; the atmosphere may actually be expanding in the process.

When the star has a core which is composed of iron, no further nuclear burning can take place, since iron is the most stable element. Continued contraction must then take place. In fact, theoretical calculations indicate that under normal conditions the temperature does not rise high enough for nuclear burning to proceed beyond carbon, at which point the star effectively runs out of fuel, and continued contraction also takes place. If, after ejection of material by the star, the mass of the star is less than about 1.2–1.4 solar masses, the limiting value known as the Chandrasekhar limit, the contraction takes place to a white dwarf. Observations suggest that stars of up to 8 solar masses can eject sufficient matter to become white dwarfs. A white dwarf is stable without any nuclear burning taking place. The pressure gradient is produced by the same kind of quantum interactions among the electrons as those which make atoms stable. See WHITE DWARF STAR.

Theoretical studies indicate that a star of more than about 8 solar masses will not lose enough mass in its evolution to become a white dwarf. The contracting star at some point becomes unstable; that is, the heating as a result of contraction is insufficient to produce the required pressure gradient to support the gas against gravity. This instability occurs first in the core of the star, and the core starts to fall inward on itself. This is the stage of gravitational collapse. In essence, the core is freely falling inward under its own gravitational attraction.

A collapsing core will be too condensed to form a white dwarf, even if its mass is less than the maximum allowed mass. The only other known possibilities are collapse to a neutron star and collapse to a black hole. A neutron star is a highly condensed star in which the predominant constituent of matter is in the form of neutrons. The stability of such stars is a result of the quantum-mechanical interaction of neutrons, the same kind of interaction which, for electrons, leads to stability of white dwarfs. See NEUTRON STAR.

Some collapsing stars are expected to end up with a core which has a mass larger than the maximum mass of a neutron star. In addition, neutron stars (and white dwarfs as well) which had been formed earlier could accrete enough matter to become more massive than the maximum mass of a neutron star. In these cases, the only known alternative is for such stars to collapse to a black hole. A black hole is a region in space in which gravity is so strong that even light cannot escape from its surface. Although black holes had been conjectured earlier, Karl Schwarzschild found the first black-hole solution of general relativity in 1916, although the significance of the solution as a black hole was not realized at the time. After suggestions that black holes might be an end point of stellar evolution, J. R. Oppenheimer and H. Snyder showed in 1939 that a black hole must result from spherically symmetric gravitational collapse if the mass of the collapsing body is large enough. At present, a black hole is believed to be the only result of a collapsing star that cannot lose enough matter to become a white dwarf or neutron star. Black holes are even more condensed than neutron stars. For example, a 1-solar-mass black hole would have a radius of about 2 mi (3 km). See BLACK HOLE.

Because black holes emit no light, they are intrinsically dark and directly unobservable. However, they can still have an effect on nearby matter because their gravitational field is still present. In fact, there is strong evidence that at least one condensed body in a binary star system, Cygnus X-1, is a black hole. Its gravitational field results in matter heating up sufficiently to emit x-rays, which can only be done by a highly condensed body, and its mass is determined from the orbital motion to be larger than 5 solar masses. From theory, the only known body which has these properties is a black hole. Black holes have also been identified by similar evidence in several other x-ray binaries, including LMC X-3 and A0620-00. There is no proof that such black holes came from the gravitational collapse of a star, but that is the



most reasonable hypothesis. See ASTROPHYSICS, HIGH-ENERGY; BINARY STAR; X-RAY ASTRONOMY. [P.C.P.]

**Gravitational lens** A massive body producing distorted, magnified, or multiple images of more distant objects when its gravitational fields bend the paths of light rays. Lenses have been observed when the light from very distant quasars is affected by intervening galaxies and clusters of galaxies, producing several different images of the same quasar. A. Einstein predicted the occurrence of this phenomenon in 1936, but the discovery of real gravitational lenses did not occur until 1979. Gravitational lenses, in addition to being intrinsically interesting, can reveal the intrinsic properties of galaxies, active galaxies, and quasars, and provide information on the universe and its contents, including dark matter.

The lens phenomenon exists because gravity bends the paths of light rays, which is predicted by Einstein's general theory of relativity. Since photons, the carriers of light energy, have no mass, Newton's theory of gravity indicates that light would always travel in a straight line even if there were heavy, massive objects between the source and the observer. (Even if photons are given mass in Newton's theory, the predicted bending of light is different from the result in general relativity.) But in general relativity, gravity acts by producing curvature in space-time, and the paths of all objects, whether or not they have mass, are also curved if they pass near a massive body. See GRAVITATION; RELATIVITY.

The discovery of gravitational lenses affects astronomers' understanding of the universe on the very largest scales. The very existence of this phenomenon indicates that nearly a dozen quasars—the ones that are being lensed—are more distant than the galaxies that are focusing their light. When quasars were first discovered, some astrophysicists argued that their redshifts were produced by exotic new physics and the quasars were just beyond the boundary of the Milky Way Galaxy. This controversy has largely subsided but has not been completely resolved. The lens phenomenon shows that at least some quasars are billions of light-years away, well beyond the edge of the Milky Way. If some quasars are billions of light-years away and others look like them, it is reasonable to conclude that all quasars are billions of light-years away at the edge of the observable universe.

Gravitational lenses can be used to determine the distance scale of the universe. Most quasars change the amount of light that they produce. In the case of a multiply imaged quasar like PG 1115 + 080, observers on Earth could see that change occur at different times because light travels on different paths to get here. The image where light travels on a more direct path would brighten first, and the one taking a more roundabout route would brighten later. The differences in the two path lengths can be used to deduce the distance to the quasar and the lensing object. Astronomers can then measure the redshifts of these distant objects and use the lens as another way to determine how fast the universe is expanding.

This seemingly easy idea is hard to implement in practice. Only one of 500 quasars is lined up in exactly the right way, and the mass distribution in the lensing object must be fully understood in order to interpret the data correctly. Sharp infrared pictures from the Hubble Space Telescope severely constrained possible models of the lens, making the interpretation much more secure. The data indicate a Hubble constant of 70 kilometers per second per megaparsec (the conventional units for measuring the Hubble constant), meaning that, if the universe has a very low density, its age is 14 billion years. See COSMOLOGY; HUBBLE CONSTANT.

Gravitational lenses also enable the discovery of invisible objects. The speed with which stars move in galaxies and galaxies move in galaxy clusters indicates that many galaxies may be surrounded by massive dark halos. Since the matter that composes these halos cannot be seen, the name "dark matter" has been used to describe it. The dark matter could be brown dwarfs (ob-

jects not massive enough to be stars), dead stars, Jupiter-sized objects, or subnuclear particles. The more massive forms of dark matter are termed MACHOs (massive compact halo objects). See BROWN DWARF.

If a MACHO passed directly between a distant star and the Earth, the light from the star could be temporarily brightened as the MACHO focused the starlight toward the Earth. Precise calculations of this event indicate that the brightening should last about a week. Several teams of astronomers have made repeated observations of a nearby galaxy, the Large Magellanic Cloud, in search of this phenomenon, and seven such events have been detected. These events indicate that MACHOs, which are probably low-mass white dwarf stars, make up a sizable fraction of the mass of the halo of the Milky Way Galaxy, probably at least 20% of the dark matter and possibly as much as 100%. See MAGELLANIC CLOUDS; MILKY WAY GALAXY. [H.L.Sh.]

**Gravitational radiation** A type of wave generated by accelerated masses that propagates through vacuum with the speed of light. The existence of gravitational radiation is an inescapable consequence of A. Einstein's general theory of relativity.

**Properties.** The general theory of relativity posits that matter (and energy) introduces curvature into four-dimensional space-time and that matter moves in response to this curvature. The degree of curvature generated by a distribution of matter can be calculated by using the Einstein field equations, which are analogous to the Maxwell field equations of electromagnetism. The Einstein equations admit solutions corresponding to weak, transverse waves that propagate in vacuum with the speed of light just like the electromagnetic waves predicted by Maxwell's equations and demonstrated experimentally by H. Hertz in 1884. However, while electromagnetic waves are fluctuations in the electric field vector which can be measured by the acceleration of a single charged particle, gravitational waves are fluctuations in the tidal gravitational force which is measured by a tensor and can be detected by the relative acceleration induced between two free test masses (see illustration). See ELECTROMAGNETIC RADIATION; MAXWELL'S EQUATIONS.

**Sources.** In 1974, R. Hulse and J. Taylor discovered the first binary pulsar, now known as PSR 1913+16. This is believed to comprise two neutron stars, one of which spins with a period of 59 milliseconds and emits regular radio pulses with an equal period. Radio astronomers on Earth observe a pulse period that varies slightly as the pulsar source traces an elliptical orbit around its companion due to the Doppler effect. This system emits gravitational waves with a fundamental period equal to the orbital period of 7.8 h, and these waves carry energy away from the binary, causing it to become more tightly bound. The orbital period decreases as the two stars approach one another. The fractional change in the measured orbital period agrees with the relativistic prediction to approximately 0.5%, a striking verification of general relativity. See DOPPLER EFFECT; NEUTRON STAR; PULSAR.

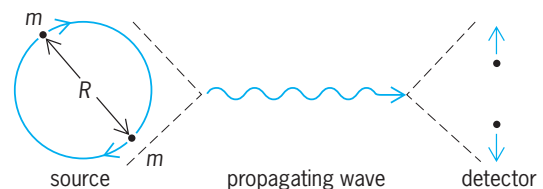

**Generation and detection of gravitational waves.** A powerful source of these waves, such as a neutron star binary with a circular orbit, radiates with a fundamental period equal to half the orbital period. The presence of the wave can be demonstrated conceptually by measuring the relative acceleration between two free masses.

When such binary stars shrink so that their orbital periods are only a few milliseconds, the rate of radiation increases dramatically. The waves emitted by such coalescing stars may be strong enough to measure at Earth even when the stars reside in quite distant galaxies. Other proposed sources of detectable gravitational radiation include supernovae, binary black holes in active galactic nuclei, and cosmic strings. See BLACK HOLE; COSMIC STRING; SUPERNOVA. [R.D.BI.]

**Detectors.** The direct detection of gravitational waves has not yet been achieved, though there is an active research program directed toward the construction of appropriate ultrasensitive detectors. The two classes of detectors are resonant-mass and free-mass antennas. Both types comprise a mechanical element and a transducer that converts mechanical motion to an electronic signal. See TRANSDUCER.

The resonant-mass antennas are commonly cylindrical bars of a few tons mass, although a mass in the shape of an icosahedron (a body with 60 faces, like a soccer ball) would be superior to a cylinder. The material most commonly used is aluminum. To reduce thermal noise, the bar is brought to cryogenic temperatures in a vacuum vessel cooled by liquid helium and is isolated against vibrations from the terrestrial environment by a series of mechanical filters. The lowest-frequency longitudinal mode of the antenna, in which the two end faces of the cylinder are displaced in opposition, is most strongly excited by a passing gravitational wave. An electromechanical transducer is attached to one end face of the bar to detect the bar's vibration.

The free-mass antennas are composed of almost inertial masses which are actually very low frequency pendulums. A common design is the arrangement of three such masses at the vertices of a right triangle with equal legs lying on the surface of the Earth. The passage of a gravitational wave in a direction perpendicular to the plane of the free-mass antenna lengthens one leg of the triangle relative to the perpendicular leg. This change in length can be detected by a laser interferometer which is composed of mirrors mounted on the masses and a high-power visible laser light source. Each mass is rigorously isolated from vibrations in the environment, and the entire system is placed in a high-vacuum chamber to eliminate light scattering by gas and dust particles. See INTERFEROMETRY. [M.F.B.; D.H.D.]

**Gravitational redshift** A shift toward longer wavelengths of spectral lines emitted by atoms in strong gravitational fields. It is also known as the Einstein shift. One of three famous predictions of the general theory of relativity, this shift results from the slowing down of all periodic processes in a gravitational field. The amount of the shift is proportional to the difference in gravitational potential between the source and the receiver. For starlight received at the Earth the shift is proportional to the mass of the star divided by its radius. In the solar spectrum the shift amounts to about 0.001 nanometer at a wavelength of 500 nm. In the spectra of white dwarfs, whose ratio of mass to radius is about 30 times that of the Sun, the shift is about 0.03 nm, which can easily be measured if it can be separated from the Doppler effect. This was first done by W. S. Adams for the companion of Sirius, a white dwarf whose true velocity relative to the Earth can be deduced from the observed Doppler effect in the spectrum of Sirius. The measured shift agreed with the prediction based on Einstein's theory and on independent determinations of the mass and radius of Sirius B. A more accurate measurement was carried out in 1954 by D. M. Popper, who measured the gravitational redshift in the spectrum of the white dwarf 40 Eridani B. Similar measurements, all confirming Einstein's theory, have since been carried out for other white dwarfs. Attempts to demonstrate the gravitational redshift in the solar spectrum have thus far proved inconclusive, because it is difficult to distinguish the gravitational redshift from so-called pressure shifts resulting from perturbations of the emitting atoms by neighboring atoms. See WHITE DWARF STAR.

Gravitational redshift has also been detected as temperature fluctuations in the observed cosmic microwave background. In 1967 R. K. Sachs and A. M. Wolfe showed that large-scale fluctuations in cosmic density should lead to different gravitational redshifts of observed microwave photons; the measurement of angular temperature variations therefore gives direct information about the mass distribution. This effect was observed in 1992 by the *Cosmic Background Explorer (COBE)* satellite, and has become a key tool in measuring the initial density perturbations from which cosmological structures are believed to have formed by gravitational instability. See COSMIC BACKGROUND RADIATION; COSMOLOGY; RELATIVITY. [D.La.; A.A.]

**Graviton** A theoretically deduced particle postulated as the quantum of the gravitational field. According to Einstein's theory of general relativity, accelerated masses (or other distributions of energy) should emit gravitational waves, just as accelerated charges emit electromagnetic waves. And according to quantum field theory, such a radiation field should be quantized; that is, its energy should appear in discrete quanta, called gravitons, just as the energy of light appears in discrete quanta, namely photons. See ELEMENTARY PARTICLE; GRAVITATION; QUANTUM FIELD THEORY; RELATIVITY. [C.J.G.]

**Gravity** The gravitational attraction at the surface of a planet or other celestial body. The quantity  $g$  is often referred to simply as "gravity" or "the force of gravity" of Earth, both of which are incorrect. The force of gravity means the force with which a celestial body attracts an object, that is, the weight of the object. The letter  $g$  represents the acceleration caused by the gravitational force and, of course, has the dimensions of acceleration. See GRAVITATION. [D.Br./G.M.C.]

**Gravity meter** A device that measures local acceleration due to the Earth's gravity; it is also called a gravimeter. Such instruments fall into two categories: relative gravity meters, which are used to determine gravity differences among a number of geographic locations or changes in gravity that occur at a single location over time; and absolute gravity meters, which can measure the true value of the acceleration due to gravity at a given location and time.

The local value of gravity is the acceleration undergone by a freely falling mass upon which gravity is the only force acting. Because the value of gravity at any particular position depends on the distribution of mass throughout the Earth (and also slightly on the Earth's rotation), measurements of the gravity field can yield information on the density of underlying rock. Thus, gravity meters are used for geologic studies and for oil and mineral exploration. Local gravity also depends on the shape of the Earth; the observation of gravity over time, then, provides a measure of deformations in the Earth that can be caused by a wide variety of phenomena, including tides, tectonic activity, and volcanism.

Nowhere on the surface of the Earth does the value of gravity differ from the nominal value of 980 Gal by more than about 0.5%. (The SI unit for gravity is the meter/second<sup>2</sup>; the more commonly used unit is the Gal, defined as 1 cm/s<sup>2</sup>, or the milli-Gal, which equals 0.001 Gal.) Values of gravity predicted with a latitude-and-height-dependent Earth model usually agree with observed values to within about 30 mGal. The gravitational acceleration produced by the mass of a 1-m-thick (3-ft) sheet of water (having infinite lateral extent) is 0.043 mGal.

A number of different instruments are available. One of two methods is used in all gravity meters. The first, employed by absolute gravity meters, is the direct determination of the acceleration of a test mass falling inside a vacuum chamber by using optical interferometry. The second is the observation of variations in the position of a mass supported by a mechanical or magnetic spring. This method, applied in relative gravity meters and shipboard gravity meters, is usually used in conjunction with an additional applied force (nulling force) that maintains

the mass at a null position. The small nulling force is a relative measure of gravity. See GRAVITY. [M.A.Z.]

**Graybody** An energy radiator which has a blackbody energy distribution, reduced by a constant factor, throughout the radiation spectrum or within a certain wavelength interval. The designation "gray" has no relation to the visual appearance of a body but only to its similarity in energy distribution to a blackbody. Most metals, for example, have a constant emissivity within the visible region of the spectrum and thus are graybodies in that region. The graybody concept allows the calculation of the total radiation intensity of certain substances by multiplying the total radiated energy (as given by the Stefan-Boltzmann law) by the emissivity. The concept is also quite useful in determining the true temperatures of bodies by measuring the color temperature. For a discussion of the Stefan-Boltzmann law and color temperature see HEAT RADIATION; BLACKBODY. [H.G.S.; P.J.W.]

**Graywacke** A well-indurated dark gray sandstone that is characterized by abundant dark-colored detrital rock fragments and more than 15% clay matrix minerals between sand grains. Graywacke sands were deposited chiefly in marine basins near the edge of continental margins where plate subduction was taking place. Subsequent compressional deformation and uplift of rocks in the sedimentary basins results in the occurrence of most graywackes in Alpine-type (compressional) mountain ranges. See CLAY MINERALS; CONTINENTAL MARGIN.

Graywackes have a wide range in mineral composition, which reflects the varied source rocks from which the detritus in them was derived. They tend to be quartz-poor (10–50%), to be rich in both feldspar and unstable rock fragments, and to contain several percent of unstable accessory minerals such as micas, pyroxenes, and amphiboles. Feldspathic graywackes (those in which feldspar exceeds rock fragments) are derived chiefly from plutonic cores of denuded island arcs. Lithic graywackes (those in which rock fragments exceed feldspar) are derived either from volcanic island arcs or from sedimentary rocks in adjacent basins that were deformed and uplifted. Volcanic rock fragments characterize the former type of lithic graywackes, whereas sandstone, shale, and their weakly metamorphosed equivalents characterize the latter type.

Most graywackes were deposited in submarine fans and adjacent basin-plain environments by turbidity currents. They commonly display graded bedding, Bouma sequences, and current-formed and biogenic sole marks. The term Bouma sequence refers to five divisions of a single, ideal turbidity current deposit. Graywackes are interbedded with shale beds that were deposited by dilute turbidity currents and other marine processes. Thicknesses of several miles of interbedded turbidite graywacke and shale accumulated in many basins. Burial and subsequent compressional deformation of these sequences resulted in the generation of clay matrix, loss of porosity, and strong induration. The gray color of the sandstone is derived from rock fragments and organic-stained clay minerals. See ARKOSE; SANDSTONE; SEDIMENTARY ROCKS; SHALE; TURBIDITE; TURBIDITY CURRENT. [E.F.McB.]

**Great circle, terrestrial** A circle or near-circle representing a trace on the Earth's surface of a plane that passes through the center of the Earth and divides it into equal halves (see illustration). The Equator is a great circle, the trace of the plane that bisects and is perpendicular to the Earth's axis. Planes through the Poles cut the Earth along meridians. All meridians are great circles; actually, they are not quite circular because of the slightly flattened Earth. The equatorial diameter is 1.0034 times the size of the polar diameter. All parallels other than the Equator are called small circles, being smaller than a great circle.

Two common methods can be used to calculate the distance of a great circle arc. One method uses trigonometric functions:  $\cos D = \sin a \sin b + \cos a \cos b \cos c$ . Here  $D$  is the arc distance between points A and B in degrees,  $a$  is the latitude of A,  $b$  is

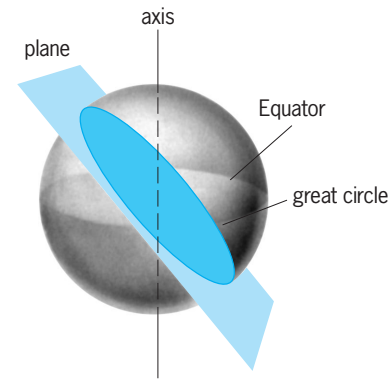

Diagram of a great circle described by a plane through the center of the Earth.

the latitude of B, and  $c$  is the difference in longitude between A and B. After  $D$  is calculated, it can be converted to a linear distance measure by multiplying  $D$  by the length of one degree of the Equator, which is 111.32 km or 69.17 mi.

The other method uses the azimuthal equidistant projection. Unlike the gnomonic projection, the azimuthal equidistant projection can be centered at any point on the Earth's surface and can show the entire sphere. More importantly, a straight line from the center of the projection to any other point is a great circle route and the distances are at a comparable (consistent) scale between the two points. The azimuthal equidistant projection is therefore useful in showing any movement directed toward or away from a center, such as seismic waves, radio transmissions, missiles, and aircraft flights. [K.t.C.]

**Greenhouse effect** The ability of a planetary atmosphere to inhibit heat loss from the planet's surface, thereby enhancing the surface warming that is produced by the absorption of solar radiation. For the greenhouse effect to work efficiently, the planet's atmosphere must be relatively transparent to sunlight at visible wavelengths so that significant amounts of solar radiation can penetrate to the ground. Also, the atmosphere must be opaque at thermal wavelengths to prevent thermal radiation emitted by the ground from escaping directly to space. The principle is similar to a thermal blanket, which also limits heat loss by conduction and convection. In recent decades the term has also become associated with the issues of global warming and climate change induced by human activity. See ATMOSPHERE; SOLAR RADIATION.

Basic understanding of the greenhouse effect dates back to the 1820s, when the French mathematician and physicist Joseph Fourier performed experiments on atmospheric heat flow and pondered the question of how the Earth stays warm enough for plant and animal life to thrive; and to the 1860s, when the Irish physicist John Tyndall demonstrated by means of quantitative spectroscopy that common atmospheric trace gases, such as water vapor, ozone, and carbon dioxide, are strong absorbers and emitters of thermal radiant energy but are transparent to visible sunlight. It was clear to Tyndall that water vapor was the strongest absorber of thermal radiation and, therefore, the most influential atmospheric gas controlling the Earth's surface temperature. The principal components of air, nitrogen and oxygen, were found to be radiatively inactive, serving instead as the atmospheric framework where water vapor and carbon dioxide can exert their influence.

The impact of water vapor behavior was noted by the American geologist Thomas Chamberlin who, in 1905, described the greenhouse contribution by water vapor as a positive feedback mechanism. Surface heating due to another agent, such as carbon dioxide or solar radiation, raises the surface temperature and evaporates more water vapor which, in turn, produces

additional heating and further evaporation. When the heat source is taken away, excess water vapor precipitates from the atmosphere, reducing its contribution to the greenhouse effect to produce further cooling. This feedback interaction converges and, in the process, achieves a significantly larger temperature change than would be the case if the amount of atmospheric water vapor had remained constant. The net result is that carbon dioxide becomes the controlling factor of long-term change in the terrestrial greenhouse effect, but the resulting change in temperature is magnified by the positive feedback action of water vapor.

Besides water vapor, many other feedback mechanisms operate in the Earth's climate system and impact the sensitivity of the climate response to an applied radiative forcing. Determining the relative strengths of feedback interactions between clouds, aerosols, snow, ice, and vegetation, including the effects of energy exchange between the atmosphere and ocean, is an actively pursued research topic in current climate modeling. See CLIMATE MODIFICATION. [A.A.L.]

**Greenhouse technology** Along with low tunnels and high tunnels, greenhouses are structures used to grow plants under protected conditions. The progression of terms shows the level (low to high) of technical sophistication in the plant-growing systems. Low tunnels, also called row covers, primarily advance the growing season for outdoor crops (for example, tomatoes, melons, strawberries, and sweet corn). Low tunnels are created using long, narrow strips of transparent plastic material (often polyethylene) buried in the ground along their outer edges to cover one or several adjacent rows of plants grown directly in the soil. High tunnels are large versions of low tunnels, raised sufficiently above the ground that people can walk within them. Greenhouse (or glass-houses) are relatively permanent structures (usually glass or plastic with aluminum or steel frames) equipped with several means of environmental modification.

**Construction.** Free-standing greenhouses are the most basic structural type. Cross-sectional shapes can be classified as arch, hoop, or gable (see illustration). Multispan greenhouses are typically connected by a series of roof gutters to create a single air space. Large multispan greenhouses can cover several hectares under one roof, and they are the design of choice for larger commercial greenhouse operators. Floors are frequently made of concrete, although gravel floors with concrete walkways may be used to reduce cost.

Light transmittance is important when selecting a covering material. Glass provides the most light to the plants and retains its light transmittance; however, various rigid and film plastic glazing materials are used because of initial lower costs. See GLASS.

**Environment control.** Environment control typically encompasses air temperature, supplemental light, air movement (circulation and mixing), and carbon dioxide concentration. Some degree of relative humidity control may also be included. Integrated control by computer, found in most modern greenhouses, provides the flexibility of zoned control of each environmental parameter without conflicting control signals (for example, ventilating while supplementing carbon dioxide).

Structural insulation opportunities in greenhouses are minimal and heat requirements are high in comparison to most other types of buildings. Efforts to conserve heat, such as insulating the north wall and part of the north roof, have often shown negative benefits by reducing natural light and degrading plant growth and quality. Movable, horizontal, indoor curtain systems (which also double as movable shade systems) can save approximately one-quarter of the yearly heat in a cold climate.

Greenhouses can be heated by oil or natural gas. Heat delivery is either hydronic (hot water) or by steam. See HEAT.

Solar loads in greenhouses are so great that mechanical cooling, as by air conditioning, is prohibitively expensive. Options for greenhouse cooling are thus limited. The most typical cool-

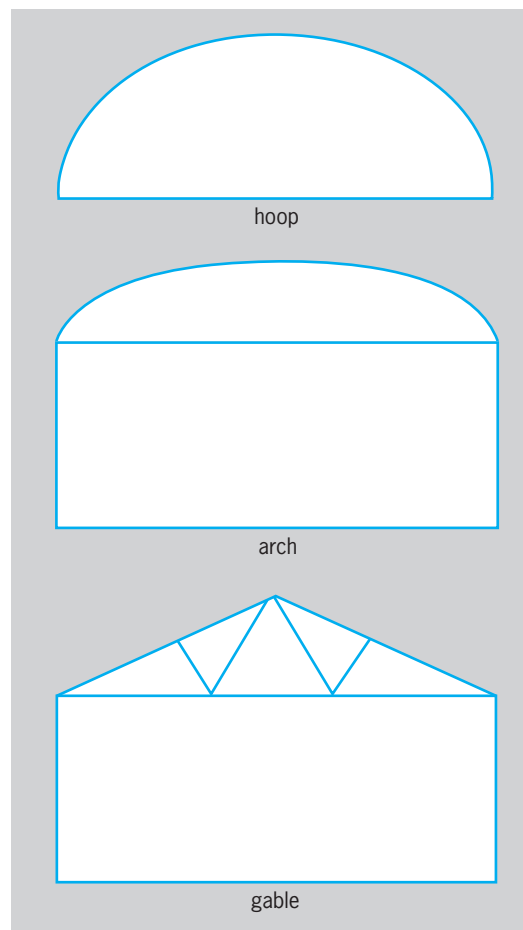

Common commercial greenhouse shapes.

ing mechanism is ventilation, either natural or mechanical. The next step of cooling is to use evaporative means. Cooling can be obtained by spraying a fine mist into the ventilation air or by pulling outside air through matrices or structures that are wetted to cool the air flowing past them.

Greenhouse lighting may be used for photoperiodic reasons, or for enhancing growth. Photoperiodic lighting is a very low intensity light during the night to break the darkness period and induce plant responses representative of summer (short nights and long days). Greenhouse supplemental lighting is usually provided by high-pressure sodium (HPS) lights because of their relatively high energy efficiency. See LIGHT; PHOTOPERIODISM; PHOTOSYNTHESIS.

Optimum concentrations of carbon dioxide are often in the range 800–1000 ppm, which can lead to 25% greater growth provided that other inputs are not limited. Carbon dioxide can be added through carefully controlled flue gases from the greenhouse heating system, or from tanks of liquid carbon dioxide.

**Mechanization and automation.** Many greenhouse operations that were formerly done by hand are now mechanized or automated. Root medium is mixed, fertilized, and placed directly into flats and pots by machine. Seeding and transplanting can be by machine. Plant watering and fertilizing (termed “fertigation” when combined) can now be automated. Automatic material movement at harvest, coordinated by a computer, is no longer unusual.

**Nutrition management and hydroponics.** Plant fertilizers are composed of a mix of salts that are electrically conducting when dissolved into water. This characteristic leads to the use of electrical conductivity as a measure of fertilizer concentration. Computer programs have been developed that are suitable for

balancing a nutrient mix to achieve close approximations to the desired molar ratios of elements. See PLANT MINERAL NUTRITION.

Hydroponics is defined as growing plants without using soil. However, a root medium such as sand, gravel, or rockwool may be used. Two common hydroponics systems that use no root medium are the nutrient film technique (NFT) and deep flow troughs (DFT). See HYDROPONICS.

**Economics.** Modern greenhouse technologies have mirrored developments in most of agriculture in that increased labor efficiency, larger sizes of greenhouse operations, and mass production of a few crops, or even a single crop, have become the rule to be profitable. The current dynamic in the greenhouse industry in the United States is characterized by the entry of many growers in small, specialized operations, and consolidations and mergers of large operations. See FLORICULTURE; PLANT GROWTH; PLANT-WATER RELATIONS. [L.D.A.]

**Greenockite** A mineral having composition CdS (cadmium sulfide). Greenockite usually occurs as earthy coatings with resinous luster and yellow-to-orange color. There is good prismatic cleavage; the hardness is 3 (Mohs scale) and specific gravity is 4.9. Greenockite and wurtzite, ZnS, are isostructural, and a complete solid-solution series exists between the two minerals. Although greenockite is the most common cadmium mineral, no deposits of it are sufficiently large to warrant mining it solely as a source of cadmium. See CADMIUM. [C.S.Hu.]

**Green's function** A solution of a partial differential equation for the case of a point source of unit strength within the region under examination. The Green's function is an important mathematical tool that has application in many areas of theoretical physics including mechanics, electromagnetism, acoustics, solid-state physics, thermal physics, and the theory of elementary particles. The underlying physics in each of these areas is generally described by some linear partial differential equation which relates the physical variable of interest (electrostatic potential or pressure amplitude in a sound wave, for example) to a source function. For present purposes the source may be regarded as an independent entity, although in some applications (for example, particle physics) this view masks an inherent non-linearity. The source may be physically located within the region of interest, it may be simulated by certain boundary conditions on the surface of that region, or it may consist of both possibilities. A Green's function is a solution to the relevant partial differential equation for the particular case of a point source of unit strength in the interior of the region and some designated boundary condition on the surface of the region. Solutions to the partial differential equation for a general source function and appropriate boundary condition can then be written in terms of certain volume and surface integrals of the Green's function. See DIFFERENTIAL EQUATION. [P.Sh.]

**Green's theorem** A term used variously in mathematical literature to denote either (1) the Gauss divergence theorem,

$$\iiint \nabla \cdot \mathfrak{S} dV = \iint \mathfrak{S} \cdot \nu dS$$

or some one of several forms or immediate consequences of this theorem, or (2) the plane case of Stokes' theorem. See CALCULUS OF VECTORS; GAUSS' THEOREM; STOKES' THEOREM. [H.V.C.]

**Gregarinia** A subclass of the class Telosporae. These protozoans occur principally as extracellular parasites in the digestive tracts and body cavities of invertebrates. There are three orders: the Archigregarinida, whose life cycle embraces both sexual and asexual phases; the Eugregarinida, which increases only by sporogony; and the Neogregarinida, whose life cycle involves schizogony and gamont formation. See ARCHIGREGARINIDA; EUGREGARINIDA; NEOGREGARINIDA; TELOSPOREA. [E.R.B./N.D.L.]

**Greisen** A type of hydrothermal wall-rock alteration and a class of tin-tungsten deposits (greisen deposits). Hydrothermal wall-rock alteration is the process whereby rocks on the margins of hydrothermal flow channels are changed from an original assemblage of minerals to a different one. This change occurs because of heat and mass exchange between water and rock.

Granitic rocks altered to greisen are known as apogranites. They are composed mainly of quartz, topaz (fluoroaluminosilicate), and muscovite (white mica), accompanied by accessory minerals such as tourmaline and fluorite. Abundant veins of quartz-topaz are characteristic of intensely greisenized zones. Skarn and limestone on the margins of apogranites may also be altered to greisen (apogranite greisen and apocarbonate greisen, respectively) with abundant fluorite. Apogranite greisen commonly is accompanied by other types of hydrothermal wall-rock alteration, including early feldspathic and late sericitic and lesser argillic.

Tin-tungsten-(beryllium-molybdenum) deposits in peraluminous granites commonly are accompanied by greisen. Ore minerals may include cassiterite, wolframite, scheelite, molybdenite, bismuth, and bismuthinite, accompanied in some deposits by pyrrhotite and sphalerite, in addition to chalcopyrite and other sulfides. See GRANITE.

Tin greisens represent the dominant world source of lode tin, with examples in Southeast Asia (Malaya, Indonesia, Burma, Thailand); southeast China; Tasmania, Australia; Zinnwald and Altenberg (Erzegebirge), Germany; and Cornwall-Devon, southwest England. Greisenized skarn and apocarbonate greisen, also mostly tin deposits (but including beryllium and tungsten), are found in western Tasmania, Australia; Seward Peninsula, Alaska; and Yunnan (tungsten), China. Many of the tungsten deposits of southeast China, the richest tungsten province in the world, occur in greisenized granite. See METASOMATISM; ORE AND MINERAL DEPOSITS; PNEUMATOLYSIS; TIN; TUNGSTEN. [M.T.E.]

**Grignard reaction** A reaction between an alkyl or aryl halide and magnesium metal in a suitable solvent, usually absolute ether. The organomagnesium halides produced by this reaction are known as Grignard reagents and are useful in many chemical syntheses. The structure of a Grignard reagent is usually written RMgX, where X represents a halogen.

The scope of the Grignard reaction is extremely broad, and Grignard reagents have been prepared from many kinds of alkyl and aryl halides. In general, alkyl chlorides, bromides, and iodides and aryl bromides and iodides react readily. A few halides, such as aryl chlorides, react very sluggishly. See ORGANOMETALLIC COMPOUND. [P.E.F.]

**Grimmiales** An order of the true mosses (subclass Bryidae) which consist of two families and about five genera and generally grow in dry, exposed places, especially on rock. They are often dark, even blackish, with erect-ascending and simple or forked stems, or prostrate and freely branched stems. The leaves, in many rows, are often hair-pointed with a single and well-developed costa. The cells are generally smooth but commonly have side walls that are nodulose-thickened. The capsules are immersed to exserted (sometimes on curved setae), and are usually erect, symmetric, and sometimes ribbed. The operculum is differentiated, and the single peristome (rarely lacking) is composed of 16 teeth which are commonly perforated or variously cleft. The calyptrae are cucullate or mitrate. See BRYIDAE; BRYOPSIDA. [H.Cr.]

**Grinding mill** A machine that reduces the size of particles of raw material fed into it. The size reduction may be to facilitate removal of valuable constituents from an ore or to prepare the material for industrial use, as in preparing clay for pottery making or coal for furnace firing. Coarse material is first crushed.

Grinding mills are of three principal types, as shown in the illustration. In ring-roller pulverizers, the material is fed past

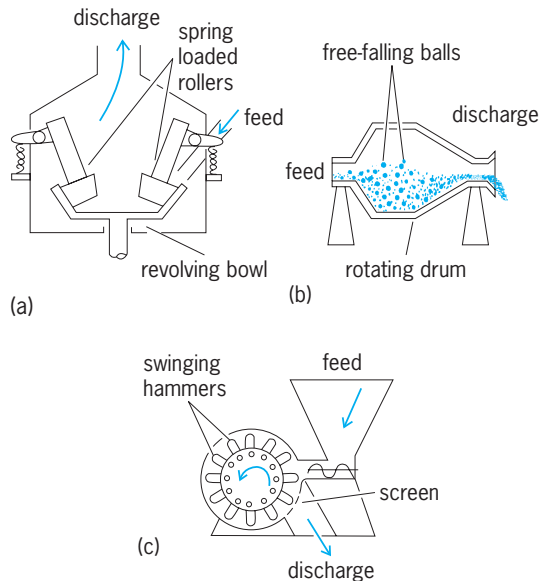

Basic grinding mills. (a) Ring-roller mill. (b) Tumbling mill. (c) Hammer mill.

spring-loaded rollers. The rolling surfaces apply a slow large force to the material as the bowl or other container revolves. The fine particles may be swept by an air stream up out of the mill. In tumbling mills the material is fed into a shell or drum that rotates about its horizontal axis. The attrition or abrasion between particles grinds the material. The grinding bodies may be flint pebbles, steel balls, metal rods lying parallel to the axis of the drum, or simply larger pieces of the material itself. In hammer mills, driven swinging hammers reduce the material by sudden impacts. See CRUSHING AND PULVERIZING; PEBBLE MILL; TUMBLING MILL. [R.M.H.]

**Gromiida** An order of the subclass Filosia. The test of these protozoa is mostly chitinous in some species, rather thin and a bit flexible in others. Siliceous particles of endogenous origin, or sometimes minute platelets, may be embedded in the chitinous layer (see illustration); some species typically reinforce the test

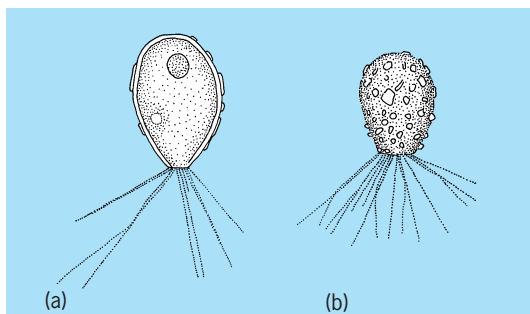

Representative Gromiida. (a) *Plagiophrys parvipunctata*. (b) *Pseudodiffugia tulva*. (After R. P. Hall, *Protozoology*, Prentice-Hall, 1953)

with sand grains or other extraneous particles. A few species are marine, the rest fresh-water types. Little is known about most Gromiida. See FILOSIA. [R.P.H.]

**Ground-probing radar** A nondestructive technique using electromagnetic waves to locate objects or interfaces buried beneath the Earth's surface or located within a visually opaque structure; also termed ground-penetrating, surface-penetrating, or subsurface radar.

Ground-probing radar (GPR) transmits a regular sequence of low power bursts of electromagnetic energy into the ground and detects the weak reflected signal from the buried target. The energy is in the form of either a very short duration impulse or a sweep over a range of frequencies. See MICROWAVE; RADAR.

The buried target can be a conductor of electricity, a nonconducting dielectric, or combinations of both; the surrounding host material can be soil, earth materials, rocks, ice, fresh water, or human-made materials such as concrete or brick. A typical GPR achieves a range of up to a few meters in depth, but some special systems can penetrate up to hundreds of meters. GPR will not penetrate clay or salt water because of the high absorption of electromagnetic energy by these materials. See ABSORPTION OF ELECTROMAGNETIC RADIATION.

GPR can be used on vehicles for rapid survey by means of an array of antennas. Other GPR systems are designed to be inserted into boreholes to provide tomographic images of the intervening rock. Most GPR systems use separate, portable, transmit-and-receive antennas which are placed on the surface of the ground and moved linearly to provide an image of the cross section of the ground traversed.

GPR technology has many applications, some well established and some still undergoing research and development, including forensic investigations, location of abandoned antipersonnel land mines, archeological exploration, and geological surveys. [D.J.Da.]

**Ground proximity warning system** A system carried on many aircraft to warn the pilot that the aircraft may be in danger of inadvertent contact with the ground. It is intended to reduce the occurrence of controlled-flight-into-terrain (CFIT) accidents, in which aircraft with no apparent mechanical difficulty or defect strike the ground while under the direct or indirect control of the pilot. These accidents usually occur in conditions of poor visibility due to atmospheric obscuration such as fog or rain, or darkness of night. Since 1975, federal aviation regulations have required installation of the system on large turbine-powered aircraft in commercial service.

The heart of the ground proximity warning system (GPWS) is a computer which receives inputs from several sensors on the aircraft and issues warnings to the pilot through visual and aural alerting devices. The primary sensors are the radio altimeter, the barometric altimeter, the electronic glideslope of the Instrument Landing System (ILS), and sensors which indicate aircraft configuration such as the position of flaps and landing gear. See ALTIMETER; INSTRUMENT LANDING SYSTEM (ILS).

The system is designed to detect and warn the pilot of excessive descent rate near the ground, excessive terrain closure rate, approaching the ground with landing gear or flaps not in the landing configuration, and descending significantly below the ILS electronic glideslope when on approach to landing. Also, during takeoff and immediately after initiating a missed-approach go-around, the system warns the pilot if the aircraft is descending when it should normally be climbing.

While GPWS has been credited with significantly reducing the incidence of CFIT accidents, it does have limitations. Its sensors cannot detect hazards which may be ahead of the aircraft such as steeply rising terrain or artificial obstacles. In addition, the effectiveness of GPWS is largely dependent on the pilot's prompt reaction to the system's warnings. See AIR NAVIGATION. [G.W.F.]

**Ground state** In quantum mechanics, the stationary state of lowest energy of a particle or a system of particles. The ground state may be bound or unbound; when bound, its energy generally is a finite amount less than the energy of the next higher or first excited state. In the typical circumstance that the potential energy is zero at infinite separation, the magnitude of the negative ground-state energy is the binding energy, that is, the energy required to separate all the particles infinitely. See ENERGY LEVEL (QUANTUM MECHANICS); EXCITED STATE; NUCLEAR BINDING ENERGY. [E.G.]

**Ground-water hydrology** The occurrence, circulation, distribution, and properties of any liquid water residing beneath the surface of the earth. Generally ground water is that fraction of precipitation which infiltrates the land surface and subsequently moves, in response to various hydrodynamic forces, to reappear once again as seeps or in a more obvious fashion as springs. Most of ground-water discharge is not evident because it occurs through the bottoms of surface water bodies. See SPRING (HYDROLOGY).

Ground water can be found, at least in theory, in any geological horizon containing interconnected pore space. Thus a ground-water reservoir (an analogy to an oil reservoir) can be a classical porous medium, such as sand or sandstone; a fractured, relatively impermeable rock, such as granite; or a cavernous geologic horizon, such as certain limestone beds. Ground-water reservoirs which readily yield water to wells are known as aquifers; in contrast, aquitards are formations which do not normally provide adequate water supplies, and aquicludes are considered, for all practical purposes, to be impermeable. These terms are, of course, subjective descriptions; the flow of water which constitutes an economically viable supply depends upon the intended use and the availability of alternative sources. See AQUIFER.

To effectively utilize ground water as a natural resource, it is necessary to be able to forecast the impact of exploitation on water availability. When ground water is used for water supply, a concern is the potential energy in the aquifer as reflected in the water levels in the producing well or neighboring wells. When a ground-water reservoir which does not readily transmit water is tapped, the energy loss associated with flow to the well can be such that the well must be drilled to prohibitively great depths to provide adequate supplies. On the other hand, in a formation able to transmit fluid easily, water levels may drop because the reservoir is being depleted of water. This is generally encountered in reservoirs of limited areal extent or those in which natural infiltration has been reduced either naturally or through human activities.

Problems involving ground-water quantity were once the primary concern of hydrologists; interest is now focused on ground-water quality. Ground-water contamination is a serious problem, particularly in the highly urbanized areas of the United States. See HYDROLOGY; WATER POLLUTION. [G.F.P.]

**Grounding** Intentional electrical connections to a reference conducting plane, which may be earth (hence the term ground), but which more generally consists of a specific array of interconnected electrical conductors, referred to as the grounding conductor. The symbol which denotes a connection to the grounding conductor is three parallel horizontal lines, each of the lower two being shorter than the one above it (Fig. 1). The electric system of an airplane or ship observes specific grounding practices with prescribed points of grounding, but no connection to earth is involved. A connection to such a reference grounding conductor which is independent of earth is denoted by use of the symbol shown in Fig. 2.

The subject of grounding may be conveniently divided into two categories: system grounding and equipment grounding. System grounding relates to a grounding connection from the electric power system conductors for the purpose of securing superior performance qualities in the electrical system. Equipment grounding relates to a grounding connection from the various electric-machine frames, equipment housings, metal raceways containing energized electrical conductors, and closely adjacent conducting structures judged to be vulnerable to contact by an energized conductor. The purpose of such equipment grounding is to avoid environmental hazards such as electric shock to area occupants, fire ignition hazard to the building or contents, and sparking or arcing between building interior metallic members which may be in loose contact with one another. The design of outdoor open-type installations presents special problems.

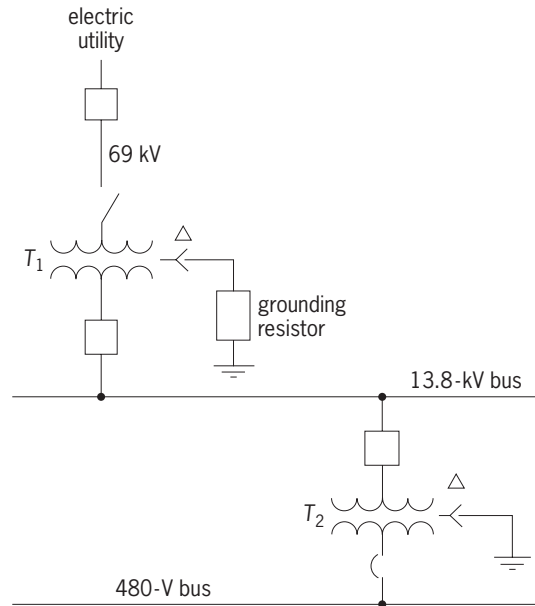

Fig. 1. Each conductively isolated portion of a distribution system requires its ground.

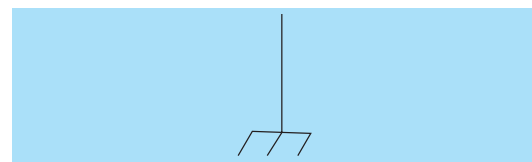

Fig. 2. Symbol to denote connection to a reference ground that is independent of earth.

Installations in which earth is used as a reference ground plane present special problems. To design an earth "floor surface" for an outdoor open-type substation which will be free of dangerous electric shock voltage exposure to persons around the station is a difficult task. [R.H.K.]

**Group theory** Any set of elements which is equipped with an operation (called multiplication) that is associative, has an identity element, and has an inverse element for each element of the set, is called a group. [These requirements are stated explicitly in Eqs. (1), (2), and (3) below.] Group theory is the branch of mathematics devoted to the properties of groups. Group theory has applications in the theories of relativity, quantum mechanics, and crystallography, and also in some branches of algebra and in analytic function theory.

The group operation is supposed to give for every pair of elements, for example,  $g$  and  $h$ , in the group, another element  $gh$  (called their product). Multiplication is supposed to satisfy the following requirements.

1. If  $g_1, g_2$ , and  $g_3$  are any elements of the group, then Eq. (1) is satisfied; that is, in forming a product of three elements one

$$(g_1g_2)g_3 = g_1(g_2g_3) \tag{1}$$

obtains the same result by first multiplying  $g_1$  and  $g_2$  and then multiplying the result and  $g_3$ , as first multiplying  $g_2$  and  $g_3$  and then multiplying  $g_1$  and the result. This is called the associative law.

2. There is in the group an element  $e$  (called the identity) with the property that Eq. (2) is satisfied for every element  $g$  of the group.

$$eg = ge = g \tag{2}$$

3. For each element  $g$  of the group there is an element  $g^{-1}$  (called the inverse of  $g$ ) which satisfies Eq. (3).

$$g^{-1}g = gg^{-1} = e \quad (3)$$

An example of a group is the set of positive real numbers equipped with the operation of ordinary multiplication. The identity element is then the number 1, and the inverse of an element is its reciprocal. Another example of a group is the set of all real numbers equipped with the operation of ordinary addition. The identity element is then the number 0, and the inverse of an element is its negative.

Both these examples are commutative groups (also called abelian groups after the mathematician Niels Abel) because their multiplication law satisfies Eq. (4) for every  $g$  and  $h$  in the group.

$$gh = hg \quad (4)$$

An example of a noncommutative group (also called nonabelian) is the group of rotations of a three-dimensional rigid body around a point.

These three examples are all of groups with an infinite number of elements, that is, infinite groups. There are also finite groups. A simple example is the group with two elements, the identity  $e$  and another  $e_1$  satisfying  $e_1e_1 = e$ .

For infinite groups, it often occurs that a group has a natural geometry. For example, in the group of positive real numbers described above one has the geometry of the real numbers. This geometry is compatible with the group operations in the sense that the product  $gh$  is a continuous function of  $g$  and  $h$ , and the inverse  $g^{-1}$  is a continuous function of  $g$ . Generalizing this scheme to arbitrary groups, one arrives at the notion of a topological group (or less frequently a continuous group) which is a set of elements equipped not only with a group operation but also with a topology, the two notions being required to be compatible in the above sense. See TOPOLOGY.

There is a particular class of topological groups which is of great importance. These are the so-called Lie groups (named after the mathematician Sophus Lie). Most of the topological groups occurring in applications are Lie groups. See LIE GROUP.

The principal applications of group theory outside mathematics itself have to do with the classification and exploitation of symmetries in physical systems. [A.S.W.]

A symmetry may be so powerful that its possible realizations can be classified. To accomplish such classifications is the task of the theory of transformation groups. An outstanding example is the classification of possible forms of crystals. See CRYSTAL STRUCTURE; CRYSTALLOGRAPHY.

If a physical system is invariant under some group of transformations, then its behavior generally depends upon fewer variables than might appear in general. For instance, if the potential energy due to the interaction between two particles depends on their positions, then in general it depends upon six variables, namely three coordinates for the position of each particle. However, if this energy is invariant under both the group of spatial translations and the group of spatial rotations, then it can depend on only one parameter, the distance between the particles. In this simple example, the reduction in complexity entailed by the symmetries can be inferred rather easily, but in more complex cases, it becomes all but essential to use systematic mathematical procedures to carry out similar reductions.

A major problem in many branches of quantum mechanics is to find the energy levels of the system under study. Group theory is invaluable in predicting such energy levels. For if the fundamental laws describing a physical system have a certain symmetry, then states related by symmetry operations will all have the same energy; and if the fundamental laws are only approximately symmetric, or if some external condition breaks the symmetry, then these states will have nearly but not quite the same energy.

In modern physics, symmetry, or group theory, is increasingly used as a guide to formulating new laws. For example, the dis-

covery that the weak interaction is not invariant under spatial inversion or parity was an important clue for formulating the proper theory of this interaction. See PARITY (QUANTUM MECHANICS); WEAK NUCLEAR INTERACTIONS.

A more abstract and wide-ranging symmetry postulate, gauge invariance, plays a central role in the modern theory of fundamental interactions. Roughly speaking, gauge invariance postulates not only that there is an overall symmetry among different entities, but that the symmetry transformations can be made independently at every point of space-time. When applied to the color symmetry of quarks, this powerful hypothesis leads directly to quantum chromodynamics, which is presently accepted as the fundamental theory of the strong interaction. See GAUGE THEORY; QUANTUM CHROMODYNAMICS. [F.Wil.]

The applications of group theory within mathematics itself are numerous and important. The part of mathematics in which the notion of group was first clearly isolated was the theory of algebraic equations. In topology, groups are used to classify the structure of various geometric objects. Group theory also plays a fundamental role in the theory of analytic functions. [A.S.W.]

**Group velocity** The velocity of propagation of a group of waves forming a wave packet; also, the velocity of energy flow in a traveling wave or wave packet. The pure sine waves used to define phase velocity  $v_p$  do not ever really exist, for they would require infinite extent. What do exist are groups of waves, wave packets, which are combined disturbances of a group of sine waves having a range of frequencies and wavelengths. Good approximations to pure sine waves exist, provided the extent of the media is very large in comparison with the wavelength of the sine wave. In nondispersive media, pure sine waves of different frequencies all travel at the same speed  $v_p$ , and any wave packet retains its shape as it propagates. In this case, the group velocity  $v_g$  is the same as  $v_p$ . But if there is dispersion, the wave packet changes shape as it moves, because each different frequency which makes up the packet moves with a different phase velocity. If  $v_p$  is frequency-dependent, then  $v_g$  is not equal to  $v_p$ . See PHASE VELOCITY; SINE WAVE; WAVE MOTION. [S.A.Wil.]

**Grout** A binding or structural agent used in construction and engineering applications. Grout is typically a mixture of hydraulic cement and water, with or without fine aggregate; however, chemical grouts are also produced. See CEMENT.

The type most commonly specified in construction and engineering is cementitious grout, which is used where its more conventional sister material, concrete, is less suited because of placing limitations or restrictions on coarse-aggregate contents. Cementitious grouts are used to fill voids and cracks in pavements, building and dam foundations, and brick and concrete masonry wall assemblies; to construct floor toppings or provide flooring underlayment; to place ceramic tile; and to bind preplaced-aggregate concrete. See CONCRETE.

Grout can be formulated from a variety of cements and minerals and proportioned for specific applications. Neat cement grout refers to formulations without aggregate, containing only hydraulic cement, water, and possibly admixtures. Sanded grout is any mix containing fine aggregate and it is formulated much like masonry mortar. Whether neat or sanded, cementitious grouts derive their strength and other properties from the same calcium silicate-based binding chemistry as concrete. [D.Ma.]

**Growth factor** Any of a group of biologically active polypeptides which function as hormonelike regulatory signals, controlling the growth and differentiation of responsive cells. Indeed, the distinction between growth factors and hormones is frequently arbitrary and stems more from the manner of their discovery than from a clear difference in function. See CELL DIFFERENTIATION; HORMONE.



The sequence of amino acids has been determined for several growth-factor polypeptides. This information permits a number of growth factors to be placed into families, members of which have related amino acid sequences, suggesting that they evolved from a single ancestral protein. The insulin family comprises somatomedins A and C, insulin, insulinlike growth factor (IGF), and multiplication-stimulating factor (MSF). A second family consists of sarcoma growth factor (SGF), transforming growth factors (TGFs), and epidermal growth factor (EGF). In addition, there are growth factors, such as nerve growth factor (NGF), fibroblast growth factor (FGF), and platelet-derived growth factor (PDGF), for which structural homologs have not been identified. See INSULIN; PROTEIN.

The stimulation of cell proliferation by several growth factors is similar in some ways to the rapid cell proliferation characteristic of tumor cells. Furthermore, the growth factor receptors are similar to the tumor-causing proteins produced by several RNA tumor viruses. It has been demonstrated that platelet-derived growth factor is virtually identical to the tumor-causing protein of the RNA tumor virus, simian sarcoma virus. Some forms of cancer involve improper function of growth factors. See CANCER (MEDICINE); ONCOLOGY; TUMOR VIRUSES. [M.Bo.]

**Gruiformes** A highly heterogeneous, worldwide order of field, marsh, and aquatic birds that may be closely related to the shorebirds and their allies. (Some taxonomists divide the gruiforms into a number of separate orders.) The order Gruiformes is arranged in 10 suborders and 20 families. See CHARADRIIFORMES.

The fossil record of some groups within the Gruiformes is well known from the early Eocene, including the cranes, rails, and seriemas. Other living families have either no fossil record or a poor one.

The Gruiformes range from small to very large. Some have short legs and others long, and the bill varies from short and straight to long and decurved. Some have long wings and are strong fliers, whereas others are flightless. Wading, terrestrial, or aquatic, they are usually found in open country, but some inhabit dense forests. The sexes in most species are similar in plumage, and most species are monogamous. The downy young usually leave the nest shortly after hatching and are cared for by both parents. Northern species are migratory. Some forms, including the kagu and a number of rail species, are flightless. See AVES. [W.J.B.]

**Guava** A plant, *Psidium guajava*, of tropical America. It is a shrub or low tree which belongs to the myrtle family (Myrtaceae). The fruit is a berry, yellow when ripe, and quite variable in size depending on variety and growing conditions. The guava is quite aromatic, sweet, and juicy. It is used mostly for jellies and preserves, but also as a fresh fruit. See FRUIT; MYRTALES. [P.D.St./E.L.C.]

**Guayule** A desert plant, *Parthenium argentatum*, of the composite family (Compositae), which produces rubber. It is a native perennial shrub growing in the Chihuahuan Desert of north-central Mexico and southwestern Texas. The plant is bushy with dense branches, thick clusters of silverlike leaves, a strong taproot, and a thick crown.

During the early decades of this century, guayule was cultivated as an alternative source for rubber. With the development of synthetic rubber and the end of World War II, economic and political incentives for guayule production disappeared, and all projects were terminated by 1959. Later, in 1976, research was reinitiated as the rising price of oil and the accompanying political difficulties with oil-producing countries rekindled interest in guayule as a source of natural rubber. See CAMPANULALES; RUBBER. [D.D.Ru.; L.J.Ca.]

**Guidance systems** The algorithms and computers utilized to steer a vehicle along a path. The types of vehicles include airplanes, rockets, missiles, ships, torpedoes, drones, and material transport vehicles within factories and so forth. The means of steering depend on the vehicle and can be the rudder, elevators, and other control surfaces on an airplane, the rudder on a ship, the control surfaces on a missile or on a torpedo, the gimbal angle of the motor on a rocket, and others. In every case the guidance system utilizes knowledge of the difference between where the vehicle should be and where it is. The difference between these two vectors is processed by the guidance algorithm. The output is a steering command intended to reduce the error between the desired and the actual paths. See CONTROL SYSTEMS; DRONE; ELEVATOR (AIRCRAFT); FLIGHT CONTROLS; SHIP POWERING, MANEUVERING, AND SEAKEEPING.

Several important performance attributes contribute to the effectiveness of the system. These attributes are governed by the guidance system and by the other system components, including the vehicle itself and its dynamic behavior.

A primary concern is accuracy. Whether the goal is to insert a satellite into synchronous orbit or to try to intercept an enemy aircraft with an air-to-air missile, the accuracy of the sensor and the properties of the guidance system are the principal factors.

Another concern is speed of response. Here the dynamics of the vehicle itself can be a limiting factor. The guidance system must compensate to the extent possible in providing a fast, responsive system. The system should be able to recover from errors as quickly as possible and return to the desired path. In the case of homing on a target, this is crucial if the target can maneuver. Coupled with the need for a quick response is the simultaneous need for a stable response.

Another important feature of the system is its robustness. The guidance system design is based on a mathematical model of the vehicle, the autopilot, and the sensor. The guidance system must provide good overall performance despite this. See AUTOPILOT.

Reliability is also important. In many cases, backup components are provided for redundancy. This is frequently the case for the digital computer of the guidance system, especially for crewed space flight. See RELIABILITY, AVAILABILITY, AND MAINTAINABILITY. [G.C.]

**Guided missile** A pilotless, controlled-flight vehicle that is guided to a target by guidance and control equipment. This equipment may be carried in the missile vehicle itself, or guidance may be directed from the launch site. The term is generally reserved for aerodynamic, maneuverable missiles that may be guided to predetermined targets for military purposes.

Guided missiles are classified by launch/target mode such as air to air (AAM), air to surface (ASM), surface to air (SAM), surface to surface (SSM), and other possible modes. Missiles may be classified by range (short, medium, long) or by techniques related to tracking and guidance (radar, infrared heat seeker, optical or television, laser, radio, wire control command, acoustical). Some missiles make use of terrain following, which permits the missile to look at the terrain, compare it with a predetermined mapped route, and in effect fly a course as if by following a road map. See GUIDANCE SYSTEMS.

Guided missiles are generally self-propelled, and may use rocket motors (liquid or solid), air-breathing turbojet engines, ramjets, or various types of combined-cycle engines. For some missions, particularly air-to-surface missions, unpowered, gliding guided missiles may be used. See ION PROPULSION; JET PROPULSION; ROCKET PROPULSION.

The kill mechanism for a missile consists of some form of explosive warhead and a system for detonation (fusing and arming). Warheads are typically either high-explosive or nuclear. Warheads may be exploded upon contact with the target, by command from an external source, by a proximity fuse that senses the target, by preset timers, and so on. See MISSILE. [M.L.Sp.]

**Guild** A group of species that utilize the same kinds of resources, such as food, nesting sites, or places to live, in a similar manner. Emphasis is on ecologically associated groups that are most likely to compete because of similarity in ecological niches, even though species can be taxonomically unrelated. The term was derived from the guild in human society composed of people engaged in an activity or trade held in common.

The guild concept focuses attention on the ways in which ecologically related species differ enough to permit coexistence, or avoid competitive displacement. For example, new places to live for some plants are provided by badger mounds in dense tall-grass prairie vegetation.

The guild is also commonly used as the smallest unit in an ecosystem in studies relating to environmental impact, wildlife management, and habitat classification. A representative species of a guild may be selected for study involving the uncertain assumption that environmental impact will influence this species in the same way as other guild members. See ECOSYSTEM. [P.W.P.]

**Gulf of California** A young, elongate ocean basin on the west coast of Mexico. It is flanked on the west by the narrow mountainous peninsula and continental shelf of Baja California, while the eastern margin has a wide continental shelf and coastal plain. The floor of the gulf consists of a series of basins 3300–12,000 ft (1000–3600 m) deep, whereas the northern gulf is dominated by a broad shelf which is the result of deltaic deposition from the Colorado River. The structural depression of the gulf continues northward into the Imperial Valley of California, which is cut off from the ocean by the delta of the Colorado River. See CONTINENTAL MARGIN.

Most of the gulf lies within an arid climate, with 4–6 in. (10–15 cm) of annual rainfall over Baja California and ranging on the eastern side from 4 in. (10 cm) in the north to about 34 in. (85 cm) in the southeast. No year-round streams enter the gulf on the west; a series of intermediate-size rivers flow in on the east side; and the major source of fresh-water sediment came from the Colorado River at the north prior to damming it upstream in the United States.

Water circulation is driven by seasonal wind patterns. Surface water is blown into the gulf in the summer by the southwesterly wind regime. In the winter, surface water is driven out of the gulf by the northwesterly wind regime, and upwelling occurs along the eastern margin, resulting in high organic productivity. Bottom sediments of the gulf range from deltaic sediments of the Colorado River at the north and coalesced deltas of the intermediate-size rivers on the east. A strong oxygen minimum occurs between 990 and 3000 ft (300 and 900 m) water depth, where seasonal influx of terrigenous sediments and blooms of diatoms due to upwelling produce varved sediments consisting of alternating diatom-rich and clay-rich layers. Rates of sediment accumulation are high, and total sediment fill beneath the Colorado River delta at the north may attain thicknesses of greater than 6 mi (10 km), even though the structural depression and the underlying crust are geologically young. See BACILLARIOPHYCEAE; DELTA; MARINE SEDIMENTS; OCEAN CIRCULATION; UPWELLING; VARVE. [J.R.C.]

**Gulf of Mexico** A subtropical semienclosed sea bordering the western North Atlantic Ocean. It connects to the Caribbean Sea on the south through the Yucatan Channel and with the Atlantic on the east through the Straits of Florida. To the north, it is bounded by North America, to the west and south by Mexico and Central America, and on the east and southeast by Florida and Cuba respectively. See INTRA-AMERICAS SEA.

The continental shelves surrounding the gulf are very broad along the eastern (Florida), northern (Texas, Louisiana, Mississippi, Alabama), and southern (Campeche) area, averaging 125–186 mi (200–300 km) wide. The continental shelves along the western and southwestern (Mexico) and southeastern (Cuba) boundaries of the gulf are narrow, often being less

than 12 mi (20 km) wide. Between the continental shelves and the Sigsbee Abyssal Plain are three steep continental slopes: the Florida Escarpment off west Florida, the Campeche Escarpment off Yucatan, and the Sigsbee Escarpment south of Texas and Louisiana. Two major submarine canyons crease the gulf's shelf areas: the De Soto Canyon near the Florida-Alabama border, and the Campeche Canyon west of the Yucatan Peninsula. See CONTINENTAL MARGIN; ESCARPMENT; GLACIAL EPOCH; HOLOCENE; MARINE GEOLOGY.

Compared with the North American rivers, the Mexican rivers are short, but they still provide approximately 20% of the fresh-water input to the gulf because of extensive orographic rainfall from the trade winds that dominate the southern flank of the basin. Meteorologically, the Gulf of Mexico is a transition zone between the tropical wind system (easterlies) and the westerly frontal-passage-dominated weather (in winter particularly) to the north, punctuated with intense tropical storms in summer/autumn called the West Indian Hurricane. Much of the atmospheric moisture supplied to the North American heartland during spring and summer has its origin over the gulf, and thus it is a vital element in the so-called North American Monsoon. See HURRICANE; MONSOON METEOROLOGY; STORM SURGE; TROPICAL METEOROLOGY.

The Gulf Stream System dominates the oceanic circulation in the Gulf of Mexico. The Yucatan Current, flowing northward into the eastern Gulf of Mexico, is the first recognizable western boundary current in the Gulf Stream System. North of the Yucatan Peninsula, the flow penetrates into the eastern gulf (where it is called the Gulf Loop Current) at varying distances with a distinctive chronology, loops around clockwise, and finally exits through the Straits of Florida, where it is called the Florida Current. This intense current reaches to more than 3300 ft (1000 m) depth, and transports  $1.1 \times 10^9$  ft<sup>3</sup>/s ( $3 \times 10^7$  m<sup>3</sup>/s) of water, an amount 1800 times that of the Mississippi River. See GULF STREAM; MEDITERRANEAN SEA; OCEAN CIRCULATION.

Surrounding the Gulf of Mexico are many population centers that exploit the numerous estuaries, lagoons, and oil and gas fields. Coral reefs off Yucatan, Cuba, and Florida provide important fishery and recreational activities. There are extensive wetlands along most coastal boundaries with ecological connections to many seagrass beds nearshore and coastal mangrove forests of Mexico, Cuba, and Florida. This biogeographic confluence creates one of the most productive marine areas on Earth, providing the food web for commercially important species such as lobster, demersal (bottom-dwelling) fish, and shrimp; this same ecology supports large populations of sea turtles and marine mammals. The coastal and nearshore waters also support large phytoplankton populations. The juxtaposition of these enormous marine resources and human activities has led to a distinctive anthropogenic impact on the health of the marine ecosystem. See BIOGEOGRAPHY; ESTUARINE OCEANOGRAPHY; FOOD WEB; MANGROVE; MARINE ECOLOGY; REEF; WETLANDS. [G.A.Ma.]

**Gulf Stream** A great ocean current transporting about 70,000,000 tons (63,000,000 metric tons) of water per second (1000 times the discharge of the Mississippi River) northward from the latitude of Florida to the Grand Banks off Newfoundland. The Gulf Stream is thought of as a portion of a great horizontal circulation in the ocean, where each particle of water executes a closed circuit, sometimes moving slowly in midocean regions and other times rapidly in strong currents like the Gulf Stream. Thus the beginning and end of the Stream have arbitrary geographical limits. See ATLANTIC OCEAN.

The Gulf Stream is a narrow (62 mi or 100 km) and swift (up to 5 knots or 250 cm/s) eastward-flowing current jet which is embedded in a weaker and broader mean westward flow and which is surrounded by intense eddies. As it leaves the coast at Cape Hatteras, the Stream meanders from side to side like a river.

The near-surface Gulf Stream transports warm water from southern latitudes eastward to the Grand Banks, where the flow becomes broader and weaker, separating into several branches and eddies. About half the near-surface flow continues eastward across the Mid-Atlantic Ridge, and half recirculates southwestward, with part of the recirculation consisting of a countercurrent located south of the Stream.

The Gulf Stream is predominantly driven by the large-scale wind pattern, the westerlies in the north and the trades in the south. The winds exert a torque on the ocean that, due to the shape and rotation of the Earth, causes a large western-intensified gyre. Cold, deep water is formed in northern seas and flows southward as a western boundary current; warm water flows northward and replaces it. See OCEAN CIRCULATION. [P.R.]

**Gum** A class of high-molecular-weight molecules, usually with colloidal properties, which in an appropriate solvent or swelling agent are able to produce gels at low dry-substance content. The molecules are either hydrophilic or hydrophobic. The term gum is applied to a wide variety of substances of gummy characteristics, and therefore cannot be precisely defined. See GEL.

Various rubbers are considered to be gums, as are many synthetic polymers, high-molecular-weight hydrocarbons, or other petroleum products. Chicle for chewing gum is an example of a hydrophobic polymer which is termed a gum but is not frequently classified among the gums. Quite often listed among the gums are the hydrophobic resinous saps that often exude from plants and are commercially tapped in balsam (gum balsam) and other evergreen trees (gum resin). Incense gums such as myrrh and frankincense are likewise fragrant plant exudates.

Usually, however, the term gum, as technically employed in industry, refers to plant polysaccharides or their derivatives. Modern usage of the term includes water-soluble derivatives of cellulose and derivatives and modifications of other polysaccharides which in the natural form are insoluble. Usage, therefore, also includes with gums the ill-defined group of plant slimes called mucilages. See CELLULOSE; COLLOID; POLYSACCHARIDE.

Gums are used in foods as stabilizers and thickeners. They form viscous solutions which prevent aggregation of the small particles of the dispersed phase. In this way they aid in keeping solids dispersed in chocolate milk, air in whipping cream, and fats in salad dressings. Gum solutions also retard crystal growth in ice cream (ice crystals) and in confections (sugar crystals). Their thickening and stabilizing properties make them useful in water-base paints, printing inks, and drilling muds. Because of these properties they also are used in cosmetics and pharmaceuticals as emulsifiers or bases for ointments, greaseless creams, toothpastes, lotions, demulcents, and emollients. The adhesive properties of gums make them useful in the production of cardboard, postage stamps, gummed envelopes, and as pill binders. Other applications include the production of dental impression molds, fibers (alginate rayon), soluble surgery films and gauze, blood anticoagulants, plasma extenders, beverage-clarifying agents, bacteriological culture media, half-cell bridges, and tungsten-wire-drawing lubricants. [R.L.Wh.]

**Gunsights** Optical instruments which establish an optical line or axis for the purpose of aiming a weapon. The axis includes the observer's eye, a suitable mark in the instrument, and the target. Most gunsights employ as their basis either a telescope or a partially reflective mirror. See MIRROR OPTICS; TELESCOPE.

A typical rifle sight consists of a terrestrial telescopic system having an objective, an eyepiece, an erector lens, and a reticle. Sometimes a field lens is employed to ensure uniform illumination. Aircraft gunsights are usually of the reflector type (also known as reflex sights) and employ in their simplest form a lamp, a reticle, a collimating lens, and a glass plate or partially reflecting mirror (see illustration). The collimator images the reticle pattern at infinity, and the mirror superimposes this image over the tar-

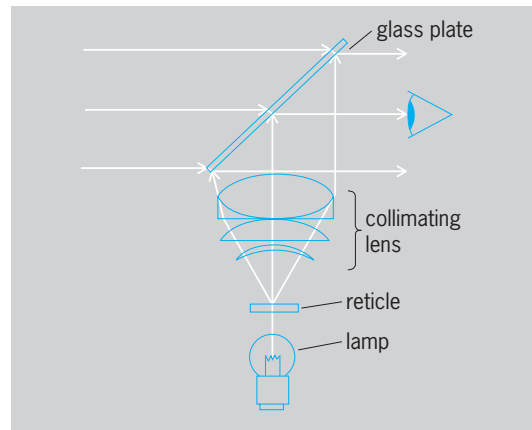

Reflex sight.

get area. Artillery sights can assume various forms, the simplest of which is the collimator sight, consisting of an objective having a reticle at its focus. When the eye is so placed as to receive light simultaneously from the target and the reticle, the latter appears superimposed on the former and a line of sight is established. See LENS (OPTICS). [E.K.K.]

**Gymnolaemata** A class of bryozoans. Predominantly marine, gymnolaemates possess lophophores which are circular in basal outline and zooecia which are short, wide, vasselike or boxlike. Highly diverse in size and shape, most gymnolaemate colonies are small and delicate, but a few are large conspicuous growths. The individual zooids may be relatively isolated or loosely grouped side by side.

The gymnolaemates include several thousand species—mostly marine, some brackish, and a very few fresh-water—belonging to the two orders Ctenostomata and Cheilostomata. Consequently, in line with the recent approach to classification of Bryozoa, there is a tendency now to use the name Eurystomata for this class instead. Appearing early in the Early Ordovician, when they included the possible ectoproct stem group, gymnolaemates remained quite inconspicuous until the Cretaceous, when they rose to the position of dominance among bryozoans which they still maintain. See BRYOZOA; CTENOSTOMATA. [R.J.Cu.]

Members of the extinct order Cheilostomata have body walls that are negligibly to heavily mineralized by calcium carbonate; most are polymorphic. Feeding zooids possess tentacles that form a circular, bell-to-funnel-shaped lophophore centered on the mouth, atop a cuticular tube enclosing the initial portion of the U-shaped digestive tract. The anus is located part of the way up the cuticular tube. When the lophophore is retracted from the feeding position above the colony surface, the cuticular tube inverts and surrounds the lophophore, and the orifice is closed by a protective operculum. The operculum is a proximally hinged cuticular plate that is a thickened, sometimes mineralized part of the body wall.

Polymorphism is more prevalent in cheilostomes than in any other bryozoans. Avicularia are common cheilostome polymorphs that may be larger or much smaller than feeding zooids. They have reduced polypides and hypertrophied opercula called mandibles. Mandibles may have any shape from broad fans to bristles, but many are tapered distally to an acute point.

Colonies can be cemented to a continuous substratum, attached by rhizoids to continuous substrata or sediments, or free-living. Cemented colonies include threadlike, sheet, mound, or various erect branched morphologies; rhizoid-attached colonies are predominantly erect; and most free-living colonies are small, broadly flaring, inverted cones.

Most cheilostomes are marine, some are estuarine, and none live in fresh water. [E.K.K.]

**Gymnostomatida** An order of the Holotrichia which contains a large, widely distributed group of what are believed to be the most primitive ciliate protozoans. These organisms occur abundantly in sands of intertidal zones, as well as in the more usual fresh- and salt-water habitats. The body size is frequently large; ciliation is simple and plentiful; and the oral area lacks buccal ciliature, as the name of the order implies. See HOLOTRICHIA. [J.O.C.]

**Gypsum** The most common sulfate mineral, characterized by the chemical formula  $\text{CaSO}_4 \cdot 2\text{H}_2\text{O}$ ; it shows little variation from this composition.

Gypsum is one of the several evaporite minerals. This mineral group includes chlorides, carbonates, borates, nitrates, and sulfates. These minerals precipitate in seas, lakes, caves, and salt flats due to concentration of ions by evaporation. When heated or subjected to solutions with very large salinities, gypsum converts to bassanite ( $\text{CaSO}_4 \cdot \text{H}_2\text{O}$ ) or anhydrite ( $\text{CaSO}_4$ ). Under equilibrium conditions, this conversion to anhydrite is direct. The conversion occurs above  $108^\circ\text{F}$  ( $42^\circ\text{C}$ ) in pure water. The presence of halite ( $\text{NaCl}$ ) or other sulfates in the solution lowers this temperature, although metastable gypsum exists at higher temperatures. See ANHYDRITE; HALITE.

Crystals of gypsum are commonly tabular, diamond-shaped, or lenticular; swallow-tailed twins are also common. The mineral is monoclinic with symmetry  $2/m$ . The common colors displayed are white, gray, brown, yellow, and clear. Cleavage surfaces show a pearly to vitreous luster. Gypsum is the index mineral chosen for hardness 2 on Mohs scale with a specific gravity of 2.32. In addition to free crystals, the common forms of gypsum are satin spar (fibrous), alabaster (finely crystalline), and selenite (massive crystalline).

Gypsum is used for a variety of purposes, but chiefly in the manufacture of plaster of paris, in the production of wallboard, in agriculture to loosen clay-rich soils, and in the manufacture of fertilizer. Plaster of paris is made by heating gypsum to  $392^\circ\text{F}$  ( $200^\circ\text{C}$ ) in air. A hemihydrate is formed as part of the water of crystallization is driven off. Later, when water is added, rehydration occurs. The interlocking, finely crystalline texture that results forms a uniform hardened mass. The slightly increased volume of the set plaster serves to fill the mold into which it has been poured. See PLASTER OF PARIS.

Gypsum deposits are mined throughout the world, with the United States being a world leader in gypsum production. The majority of United States gypsum is mined in Michigan, Iowa, Texas, California, and Oklahoma. Canada is the world's second largest producer. Most Canadian production is in the province of Nova Scotia. Among the other leading producers are France, Japan, Iran, Russia, Italy, Spain, and the United Kingdom. [M.L.H.; C.Sc.]

**Gyrator** A linear, passive, two-port electric circuit element whose transmission properties are such that it is effectively a half wavelength longer for one direction of transmission than for the other direction of transmission. Thus a gyrator is a device that causes a reversal of signal polarity for one direction of propagation but not for the other. (A two-port element has a pair of input terminals and a pair of output terminals.) This device is novel, since it violates the theorem of reciprocity. See RECIPROCITY PRINCIPLE.

Until the early 1950s, all known linear passive electrical networks obeyed the theorem of reciprocity. However, several different types of nonreciprocal networks are now widely applied, principally at microwave frequencies. These devices are used to control the direction of signal flow and to protect or isolate components from undesired signals. One common application of a three-port nonreciprocal network, called a circulator, is to permit connection of a transmitter and a receiver to the same antenna. This is accomplished with minimum interference and

virtually no power loss of either transmitted or received signal. See CONTINUOUS-WAVE RADAR.

Perhaps the first passive nonreciprocal system was an optical one proposed by Lord Rayleigh, making use of the rotation of the plane of polarization of light when it passed through a transparent material in the presence of a magnetic field. This phenomenon is called Faraday rotation.

The microwave analogy of Lord Rayleigh's device was proposed by C. L. Hogan. The nonreciprocal medium used is ferrite. In such a material, infinitesimal magnetic dipole moments which arise from the electronic structure of the material act gyroscopically when a steady magnetic field is applied. They precess about the applied field direction in a counterclockwise sense, thus permitting strong coupling to the component of a microwave-frequency magnetic field which is circularly polarized in the same sense. The component with the opposite sense of polarization is weakly coupled. Thus energy exchange between the magnetic dipoles and the microwave field is polarization-sensitive. See FERRIMAGNETISM; FERRITE. [E.J.R.]

**Gyrocompass** A north-seeking form of gyroscope used as a directional reference in navigation. Modern gyrocompasses are so reliable and so much more accurate than magnetic compasses that they are now used as the prime navigational instrument on nearly every ship and on major aircraft and missiles. See MAGNETIC COMPASS.

A gyrocompass combines the action of two devices, a pendulum and a gyroscope, to produce alignment with the Earth's spin axis. The principle is demonstrated with the model shown in the illustration, which consists of a rapidly spinning, heavy gyro rotor, a pendulous case which permits the rotor axle to nod up and down (angle  $\theta$ ), and an outer gimbal which permits the axle to rotate in azimuth (angle  $\psi$ ). For a gyroscope positioned at the Equator of the Earth, as the Earth rotates, the gimbal moves with it. So long as the rotor's spin axis is aligned with the Earth's axis, the gyro experiences no torque from Earth rotation. If there is misalignment, however, a sequence of restoring torques is initiated. See GYROSCOPE; PENDULUM.

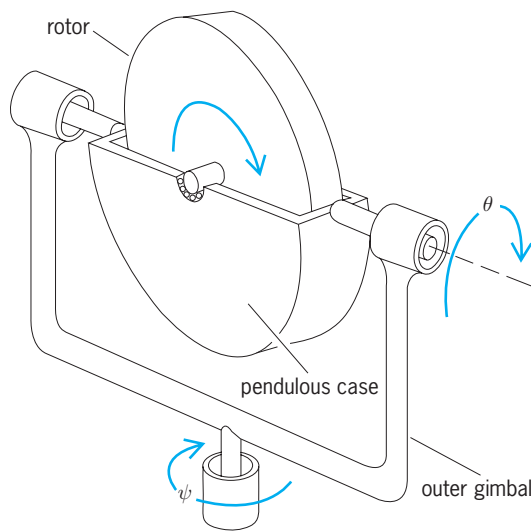

Gyrocompass model.

In a shipboard installation the system must be mounted in a complete set of gimbals to isolate it from rolling, pitching, and yawing motions of the ship. Friction must be minimized. Moreover, Schuler tuning is employed to keep horizontal accelerations of the ship from producing false torques on the pendulum; the unique combination of gyro spin speed and pendulosity is chosen so that no acceleration of the instrument can disturb its vertical reference. See SCHULER PENDULUM. [R.H.C.]

For many years the use of gyrocompasses in aircraft was impractical because of their high speed and large, rapid changes in attitude. The north-south component of vehicle velocity produces an error which depends on the velocity magnitude. Aircraft applications of gyrocompasses therefore use a modified version of the marine gyrocompass. The gyroscopes are mounted on a platform that is stabilized by signals from the gyroscopes. The platform is aligned to the local vertical and to north prior to takeoff by using essentially the same technique as for a marine gyrocompass. The 84-min Schuler period is shortened by amplifying signals from tilt sensors or accelerometers on the platform to rapidly remove platform tilt and align to north. Alignment times range from 5 to 30 min, depending upon the desired accuracy. The heading and vertical, once established, are "remembered" by the gyroscopes during flight. Vehicle velocity can be computed from the accelerometer data and used to correct for vehicle velocity and for dead-reckoning navigation. The need for preflight heading and vertical alignment can be eliminated by "gyrocompassing" this system in-flight by using an independent velocity sensor such as a Doppler radar. See DOPPLER RADAR; INERTIAL GUIDANCE SYSTEM. [H.Bu.]

**Gyrocotylidea** An order of tapeworms of the subclass Cestodaria. All species are intestinal parasites of chimaeroid fishes and have an anterior end with an eversible proboscis and a posterior end with a ruffled adhesive organ. Typically, only one sexually mature worm is found in an individual host. The life history is incompletely known. See CESTODARIA. [C.PR.]

**Gyromagnetic effect** An effect arising from the relation between the angular momentum and the magnetization of a magnetic substance. It is the effect which is exploited in the measurement of the gyromagnetic ratio of magnetic materials. The gyromagnetic effect is demonstrated by a simple experiment in which a freely suspended magnetic substance is subjected to a magnetic field. Upon a change in direction of the magnetic field, the magnetization of the substance must change. In order for this to happen, the atoms must change their angular momentum. Since there are no external torques acting on the system, the total angular momentum must remain constant. Thus the sample must acquire a mass rotation which may be measured. In this way, the gyromagnetic ratio may be determined. See GYROMAGNETIC RATIO. [E.A.; FKe.]

**Gyromagnetic ratio** The ratio of angular momentum to magnetic moment for atomic systems. This ratio is usually expressed in terms of the magnetomechanical factor  $g'$ , as in Eq. (1). The ratio is written here in electromagnetic units; thus,

$$\frac{\text{Angular momentum}}{\text{Magnetic moment}} = \frac{2mc}{g'e} \quad (1)$$

$e/c$  and  $m$  are the charge and mass of the electron. The factor  $g'$  is sometimes loosely called the gyromagnetic ratio.

The magnetomechanical ratio is the inverse of the gyromagnetic ratio. It is usually denoted by  $\gamma$  and is equal to  $g'e/2mc$ . The magnetomechanical ratio of a substance identifies the origin of the magnetic moment. For example, for electron spin the angular momentum is  $1/2\hbar$ , where  $\hbar$  is Planck's constant divided by  $2\pi$ . The magnetic moment is the Bohr magneton  $e\hbar/2mc$ . Thus, the magnetomechanical ratio is given by Eq. (2). Since

$$\gamma = \frac{e\hbar/2mc}{\hbar/2} = \frac{e}{mc} \quad (2)$$

$\gamma = g'e/2mc$ , for electron spin  $g' = 2$ . For orbital angular momentum,  $\gamma = e/mc$  and  $g' = 1$ . The experimental values of  $g'$  for most ferromagnetic materials are in the neighborhood of 2, showing that the major contribution to the magnetization comes from the electron spin. In superconductors, on the other hand, the fact that  $g' = 1$  shows that the diamagnetic currents which

cause the Meissner effect are caused by electrons. See MEISSNER EFFECT; SUPERCONDUCTIVITY. [E.A.; FKe.]

**Gyroscope** A device that is used to define a fixed direction in space or to determine the change in angle or the angular rate of its carrying vehicle with respect to a reference frame. Gyroscopes (also called gyros) respond to vehicle angular rates, that is, rates of change of angles between vehicle axes and reference axes, from which these angles can be computed. Gyros are used for guidance, navigation, and stabilization. See GYROCOMPASS; INERTIAL GUIDANCE SYSTEM; NAVIGATION.

Gyros can be utilized either mounted on a stabilized platform, whose orientation in a moving vehicle remains fixed in space by a means of two, three, or four gimbals, or directly attached to the vehicle's body, so that the gyro experiences the same maneuvering as the vehicle, an operating mode referred to as strapdown. Strapdown operation is desirable because it enables a much less expensive system; it became feasible only in the 1970s and 1980s, when the very high digital computing speed required for the strapdown algorithms became available.

Gyros can be operated closed-loop or open-loop. Closed-loop means that a feedback loop from the gyro output introduces a restoring mechanism either inside the gyro (for example, torquing in mechanical gyros) or counterrotating platform motions to maintain the gyro at its null (initial) setting. In open-loop operation, the gyro is allowed to operate off its null position as it responds to the input angular rates. See CONTROL SYSTEMS; SERVOMECHANISM.

Gyroscopes use different physical phenomena to respond to input angular rates; for example, spinning-mass gyros sense changes in angular momentum from Coriolis acceleration; resonator gyroscopes sense deflections from Coriolis acceleration; and optical gyros sense phase shifts (the Sagnac effect) between counterpropagating beams of light. Instruments that do not have spinning masses are not technically gyros but angular rate sensors. However, the term "gyro" is commonly used for all rate-sensing devices. See CORIOLIS ACCELERATION.

The classical spinning-mass gyroscope is based upon the phenomenon that the spin axis of a spinning mass points in a fixed direction in space unless acted upon by an external influence. However, the spin axis can be made to rotate if a torque (or rotational rate) is applied at right angles to the spin vector. The spin vector then begins to rotate (precess) about a third axis, perpendicular to the spin axis and the applied torque; that is, the spin axis tries to align itself with the applied torque. This is the law of gyroscopic precession; measurement of precession is what makes the spinning-mass gyro useful for knowing the changes in direction of the carrying vehicle.

The free gyroscope's spinning mass is isolated from the rotations of the case or the carrying vehicle so that it remains fixed in space. The relative position of the spinning mass to the gyro case is proportional to the vehicle's angle of rotation.

The rate gyro's spinning mass is forced to rotate with the vehicle rotation rate about one particular axis (for example, pitch or roll). The output torque causing the spinning mass to turn (precess) is opposed by an elastic restraint. The angle, measured by pickoffs, that the spinning mass turns through is proportional to the vehicle rotation rate. Rate gyros are used in applications in which stable errors can be tolerated.

The floated, single-degree-of-freedom, rate-integrating gyro, or floated gyro as it is commonly known, is basically a rate gyro in which the spring restraint is replaced by viscous damping. The spinning mass is contained inside a "float" which is isolated from the case by means of the viscous flotation fluid, low-restraint electromagnetic suspensions, pickoffs, and torque generators. Floated, integrating gyros went from revolutionizing military aircraft navigation in the 1950s to enabling strategic missile guidance, submarine navigation, space flight (for example, the Apollo spacecraft), and satellite stabilization (for example, the Hubble Space Telescope).

In the electrostatically suspended gyroscope (ESG), a spherical rotor is suspended in a spherical chamber in vacuum by electrostatic forces. External motor windings spin the rotor to the desired speed and are then turned off. The rotor will spin for days before requiring motor excitation. Optical or electrical techniques are used to pick off rotor position. The ESG is basically a free gyroscope and does not require a torquer to keep the rotor and case aligned. ESGs are very accurate and are used for long-term navigation of submarines and aircraft and for land surveying. A similar concept is the magnetically suspended gyro (MSG), which uses a magnetic field to suspend the rotor. See ELECTROSTATICS; MAGNETISM; RELATIVITY.

Optical gyros use the Sagnac effect to detect rotation. The Sagnac effect pertains to the postulate of the theory of relativity that the speed of light is constant, and independent of the motion of the source. If two identical light waves circulate in opposite directions along a closed path undergoing a rotation, then the light beam traveling in the same direction as the rotation takes longer to travel around the path than the other beam, resulting in a changed interference pattern. Optical gyroscopes include the ring laser gyro (RLG) and fiber-optic gyros (FOGs).

The ring laser gyro is widely used in tactical and navigation systems. It comprises a closed optical cavity (usually a three- or four-sided block of low-expansion-coefficient material), whose light path is defined by mirrors mounted at the corners. The light travels through holes bored in the block containing a low-pressure gas, usually a helium-neon mixture which lases when the anode and cathode are excited. Thus, the RLG is itself actually a laser (that is, it does not require an external light source), and is thus said to be an active device. See LASER.

The lased light propagates clockwise and counterclockwise so that there are two optical beams, each maintained in resonance (that is, each beam contains an integral number of wavelengths). Under a rotation rate about the gyro input axis, the resonant frequencies of the clockwise and counterclockwise beams change. Some light from both beams is transmitted through one of the mirrors to impinge on a detector. Because the beams have different frequencies, a changing interference pattern (fringes) appears. Measurement of the fringe pattern changes determines the external rotation rate and direction.

Fiber-optic gyros use optical fibers, in place of a lasing block, to define the optical path. The light source is external, and its light is split by a beam splitter or optical coupler to produce clockwise and counterclockwise light beams in the fiber-optic coil. FOGs are called passive devices because the optical source (a laser) is external. There are two principal types: interferometric and resonant. The interferometric fiber-optic gyro (IFOG) has up to 1 km (0.6 mi) of optical fiber wound into a coil with both ends brought into a coupler. The resonant fiber-optic gyro (RFOG) maintains the counterpropagating light beams in resonance, recirculating them in a short fiber-optic coil.

Vibrating gyroscopes use an oscillating mass in place of a spinning mass to sense rates. The mass oscillates (sinusoidally) back and forth through a fixed angle; the amplitude of the oscillation is restrained by the elastic (spring) stiffness of the vibrating structure. Nearly all such gyros oscillate at the resonant frequency of the mass-spring system since the gyro output is maximized at this frequency; hence these gyroscopes are also called resonator gyros. See RESONANCE (ACOUSTICS AND MECHANICS); VIBRATION.

[N.Ba.]

**Gyrotron** One of a family of microwave generators, also called cyclotron resonance masers, in which cyclotron resonance coupling between microwave fields and an electron beam in vacuum is the basis of operation. This type of coupling has the advantage that both the electron beam and the associated microwave structures can have dimensions which are large compared with a wavelength. Thus, cyclotron resonance masers are potentially greatly superior to conventional microwave tubes with respect to power capability at short wavelengths.

The development of these power sources is particularly significant for magnetically confined plasma fusion experiments. Microwave heating is considered an attractive method of supplying the energy needed to bring a reactor to ignition temperature, and gyrotrons provide a potential means of producing sufficient microwave power at the very short wavelength required. Gyrotrons also have potential application in millimeter-wave radar and communications systems. See MICROWAVE TUBE; NUCLEAR FUSION; TRAVELING-WAVE TUBE.

[H.R.J.]

# H

**Hackberry** A medium-sized to large tree, *Celtis occidentalis*. It occurs in the eastern half of the United States, except in the extreme south, and is characterized by corky or warty bark, by alternate, long-pointed serrate leaves unequal at the base, and by a small drupaceous fruit, with thin, sweet, edible flesh. Both species are used for furniture, boxes, and baskets, for shelterbelts, and as shade trees. Sugarberry (*C. laevigata*) is similar to hackberry and grows in the southeast United States.

[A.H.G./K.P.D.]

**Hadean** The eon of geological time extends for several hundred million years from the end of the accretion of the Earth to the formation of the oldest recognized rocks. According to current models, the inner planets formed by the accretion of planetesimals in an environment where gas and volatiles had been swept away by early intense solar activity. The accretion of the Earth appears to have been completed between 50 and 100 million years (m.y.) after the beginning of the solar system ( $T_0$ ) as recorded in the oldest refractory inclusions in the Allende Meteorite, whose age of  $4566 \pm 2$  m.y., ascertained by lead isotope dating, is taken as  $T_0$ . Core formation on the Earth appears to have been coeval with accretion and so preceded the Hadean. Any primitive atmosphere was removed by early collisional events, and the present atmosphere has arisen by a combination of degassing and additions from comets. See EARTH, AGE OF; LEAD ISOTOPES (GEO-CHEMISTRY).

The Acasta Gneiss in the Northwest Territories of Canada, dated at 3960 m.y., is often regarded as the oldest rock. However, that date refers to relict zircon crystals in the rock rather than the age of formation of the rock itself. The oldest definitely dated rocks are at Isua, Greenland, with an age of 3650–3700 m.y. Thus the Hadean Eon begins around 4500–4450 m.y. ago and extends to between 3900 and 3650 m.y. ago depending on the age assigned to the oldest rock.

Conditions on the Hadean Earth bore little resemblance to more recent times. A picture dimly appears of a hot young Earth with a thick basaltic crust, covered by an ocean. Dry land was rare. Plate tectonics had not yet begun. A few remnant zircon crystals indicate the formation of an occasional felsic rock, produced by remelting of the basalt. Sporadic disruption of the surface was caused by the collisions of basin-forming impactors that probably culminated in a spike or cataclysm around 3850–4000 m.y. ago. Such events must have frustrated the origin and development of life, which emerged in post-Hadean time.

[S.R.T.]

**Hadromerida** An order of sponges of the class Demospongiae with monactinal megascleres that usually have a terminal knob at one end. Microscleres in the form of streptasters, asters, sigmas, or small spined diactinals may occur. Spongin is usually sparse in occurrence. In shape, hadromeridan sponges include radially symmetrical forms (see illustration) as well as encrusting, massive, or branching types. They occur in tidal and shallow waters of all seas and extend down to depths of at least 18,000 ft (5500 m). Included in the group are the

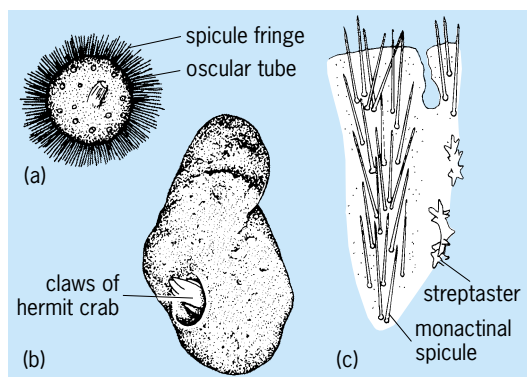

**Hadromerine sponges.** (a) *Radiella sol*, deep-sea species. (b) *Suberites ficus* living on shell occupied by hermit crab. (c) Spicule arrangement of *Spirastrella*.

limestone-excavating clionids. See BORING SPONGES; DEMOSPONGIAE. [W.D.H.]

**Hadron** The generic name of a class of particles which interact strongly with one another. Examples of hadrons are protons, neutrons, the  $\pi$ ,  $K$ , and  $D$  mesons, and their antiparticles. Protons and neutrons, which are the constituents of ordinary nuclei, are members of a hadronic subclass called baryons, as are strange and charmed baryons. Baryons have half-integral spin, obey Fermi-Dirac statistics, and are known as fermions. Mesons, the other subclass of hadrons, have zero or integral spin, obey Bose-Einstein statistics, and are known as bosons. The electric charges of baryons and mesons are either zero or  $\pm 1$  times the charge on the electron. Masses of the known mesons and baryons cover a wide range, extending from the pi meson, with a mass approximately one-seventh that of the proton, to values of the order of 10 times the proton mass. The spectrum of meson and baryon masses is not understood. See BARYON; BOSE-EINSTEIN STATISTICS; FERMI-DIRAC STATISTICS; MESON; NEUTRON; PROTON.

Based on an enormous body of data, hadrons are now thought of as consisting of elementary fermion constituents known as quarks which have electric charges of  $+\frac{2}{3}|e|$  and  $\frac{1}{3}|e|$ , where  $|e|$  is the absolute value of the electron charge. For example, a quark-antiquark pair makes up a meson, while three quarks constitute a baryon. See ELEMENTARY PARTICLE; QUARKS. [A.K.M.]

**Hadronic atom** A hydrogenlike system that consists of a strongly interacting particle (hadron) bound in the Coulomb field and in orbit around any ordinary nucleus. The kinds of hadronic atoms that have been made and the years in which they were first identified include pionic (1952), kaonic (1966),  $\Sigma^-$  hyperonic (1968), and antiprotonic (1970). They were made by stopping beams of negatively charged hadrons in suitable targets of various elements, for example, potassium, zinc, or lead. The lifetime of these atoms is of the order of  $10^{-12}$  s, but this is long enough to identify them and study their characteristics by

means of their x-ray spectra. They are available for study only in the beams of particle accelerators. Pionic atoms can be made by synchrocyclotrons and linear accelerators in the 500-MeV range. The others can be generated only at accelerators where the energies are greater than about 6 GeV. See ELEMENTARY PARTICLE; HADRON; PARTICLE ACCELERATOR.

The hadronic atoms are smaller in size than their electronic counterparts by the ratio of electron to hadron mass. For example, in pionic calcium, atomic number  $Z = 20$ , the Bohr radius of the ground state is about 10 fermis (1 fermi =  $10^{-15}$  m), and in ordinary calcium it is about 2500 fermis. Thus the atomic electrons are practically not involved in the hadronic atoms, and the equations of the hydrogen atom are applicable. The close approach of the hadrons to their host nuclei suggests that hadron-nucleon and hadron-nucleus forces will be in evidence, and this is one of the motivations for studying these relatively new types of atoms.

Antiproton atoms are the latest in the series of hadronic atoms to be observed. The main research effort involving antiproton atoms has been dedicated to the investigation of the x-ray spectra of the antiprotonic hydrogen. The transitions to the ground state depend directly on the elementary antiproton-proton interaction at the threshold. If this interaction turns out to be simple enough, the antiprotonic atoms will be a future tool for measuring the matter distribution of the nuclear surface. Another source of low-energy antiprotons—the Low Energy Antiproton Ring (LEAR), which makes precision measurements on antiprotonic atoms feasible—was put into operation at CERN near Geneva, Switzerland.

There are two additional hadrons with lifetimes that are long enough to be candidates for hadronic atom formation: the negative xi ( $\Xi^-$ ) and the negative omega ( $\Omega^-$ ), but even at the largest accelerators, these particles are too scarce for their atoms to be detected. [C.E.W.; B.Po.]

**Haemophilus** A genus of gram-negative, pleomorphic bacteria that are facultative anaerobes and are nonmotile and non-spore-forming.

*Haemophilus influenzae* was the first of the species to be isolated and is considered the type species. It was originally recovered during the influenza pandemic of 1889 and for a time was believed to be the causative agent of influenza; thus it was called the influenza bacillus. However, when this fallacy became apparent, the organism was renamed, still reflecting the historical association with influenza.

*Haemophilus* species are distinguished by a number of criteria. Strains of *H. influenzae* can be separated into encapsulated and nonencapsulated forms. Encapsulated strains express one of six biochemically and antigenically distinct capsular polysaccharides that are designated serotypes a through f. Nonencapsulated strains are referred to as nontypable. See INFLUENZA; MENINGITIS.

*Haemophilus influenzae* is a human-specific pathogen that inhabits the upper respiratory tract and is acquired by exposure to airborne droplets or contact with respiratory secretions. Nontypable strains can be isolated from the nasopharynx of up to 80% of normal children and adults at any given time, usually in association with asymptomatic colonization. Overall, these organisms are the leading cause of exacerbations of chronic bronchitis, and the second most common etiology of acute otitis media and sinusitis. On occasion, nontypable *H. influenzae* causes invasive disease such as meningitis, septicemia, endocarditis, epiglottitis, or septic arthritis. Invasive disease occurs most often in neonates and in patients with underlying immunodeficiency, especially when abnormalities in humoral immunity are present.

Encapsulated strains of *H. influenzae* are present in the nasopharynx of only 2–5% of children and an even smaller percentage of adults. Historically, *H. influenzae* type b strains were the primary cause of childhood bacterial meningitis and a majority of other bacteremic diseases in children. However, in recent years the incidence of disease due to *H. influenzae* type b has plummeted in the United States and other developed coun-

tries, reflecting the routine use of *H. influenzae* conjugate vaccines. These vaccines provide effective protection against disease due to *H. influenzae* type b but fail to protect against non-type b strains.

*Haemophilus aphrophilus*, *H. haemolyticus*, *H. parahaemolyticus*, *H. parainfluenzae*, and *H. segnis* are members of the normal flora in the human oral cavity and oropharynx and have low pathogenic potential. Among these species, *H. parainfluenzae* is the most common pathogen and has been reported in association with a variety of diseases.

Strains of *H. influenzae* are increasingly resistant to a wide variety of antibiotics. Accordingly, an extended-spectrum cephalosporin is generally recommended for empiric treatment of serious disease. See ANTIBIOTIC; DRUG RESISTANCE; MEDICAL BACTERIOLOGY. [G.P.Kr.; J.W.St.G.]

**Haemosporina** A relatively small and generally rather compact group of protozoans in the subphylum Sporozoa. Authorities differ as to the group's taxonomic status; that assigned it by the Committee on Taxonomy and Taxonomic Problems of the Society of Protozoologists is followed here: a suborder of the order Eucoccidia, subclass Coccidia, class Telosporea, subphylum Sporozoa. The Haemosporina are common protozoan parasites of vertebrates, and some of them are important as causes of illness and death. The best known of the group are the four species (genus *Plasmodium*) of malarial parasites of humans. See MALARIA.

Transmission of these parasites is probably always effected in nature by the bite of some bloodsucking invertebrate. In the vertebrate host they reproduce asexually; sometimes this occurs in the tissues of certain internal organs, such as the lungs, liver, spleen, and brain; sometimes in the red blood cells (erythrocytes), or even in other types of blood and blood-forming cells; and often in both tissues and blood cells. The immature sex cells, gametocytes, always occur in erythrocytes or leukocytes (white blood cells). Gametocytes mature into gametes after ingestion by an intermediate host (arthropod). Fertilization ensues, with a subsequent period of development culminating in the production of numerous sporozoites. These tiny filamentous forms are infective for the vertebrate host. Since they can develop no further in the arthropod, infection in this host is self-limited, in the sense that no further buildup is possible; the insect is seldom harmed by the parasite. However, sporozoites may remain infective for a long time in the invertebrate host, perhaps as long as the insect lives. See SPOROZOA. [R.D.M.]

**Hafnium** A metallic element, symbol Hf, atomic number 72, and atomic weight 178.49. There are five naturally occurring isotopes. It is one of the less abundant elements in the Earth's crust. See PERIODIC TABLE.

Hafnium is a lustrous, silvery metal that melts at about 2222°C (4032°F). Reported values of the boiling point vary greatly, from about 2500 to about 5100°C (4530 to 9200°F). There are virtually no uses of the metal other than in control rods for nuclear reactors.

The chemistry of hafnium is almost identical with that of zirconium. The similarity of hafnium to zirconium is a consequence of the lanthanide contraction, which brings the ionic radii to very nearly identical values. Before (and since) the discovery of hafnium, this element was extracted with zirconium from its ores and passed with zirconium into all derivatives. Since the chemical properties are so similar, there has been no incentive to separate the hafnium except for making nuclear studies and components of nuclear reactors. See ZIRCONIUM. [W.B.B.]

**Hail** Precipitation composed of chunks or lumps of ice formed in strong updrafts in cumulonimbus clouds. Individual lumps are called hailstones. Most hailstones are spherical or oblong, some are conical, and some are bumpy and irregular. Diameters range from 0.2 to 6 in. (5 to 150 mm) or more. That is, the





Cross section of a large hailstone showing the structure of alternating rings of clear and white ice. (Alberta Research Council, Edmonton)

largest stones are grapefruit or softball size, and the smallest are pea size.

Very often hailstones are observed to be made of alternating rings of clear and white ice (see illustration). These rings indicate the growth processes of the hail. The milky or white portion of the growth occurs when small cloud droplets are collected by the hailstone and freeze almost instantaneously, trapping bubbles of air between the droplets and creating a milky appearance. The clear portion is formed when many droplets are collected so rapidly that a film of water spreads over the stone and freezes gradually, giving time for any trapped air bubbles to escape from the liquid.

The most favorable conditions for hail formation occur in the mountainous, high plains regions of the world. Hailstorms normally have relatively high, cool cloud bases and very strong updrafts within the clouds to carry the hailstones into the cooler regions of the cloud, where maximum growth occurs. Both small ice particles and supercooled liquid water (liquid water at temperatures below 32°F or 0°C) are needed for the ice particles to grow into hailstones. See CLOUD PHYSICS; PRECIPITATION (METEOROLOGY). [H.D.O.]

**Hair** Nonliving, specialized epidermal derivatives characteristic only of modern mammals. However, it is now thought that hair was present in at least some therapsid reptiles. It consists of keratinized cells, tightly cemented together, which arise from the matrix at the base of a follicle. A follicle is a tubular epidermal downgrowth that penetrates into the dermis and widens into a bulb (the hair root) at its deep end. The follicle, together with a lateral outgrowth called the sebaceous gland, forms the pilosebaceous system. Rapid cell production in the matrix, and differentiation in the regions immediately above, produces a hair shaft which protrudes from the follicle mouth at the skin surface. See GLAND.

Hairs are not permanent structures but are continually replaced throughout the life of a mammal. In some species, for example, the rat, hamster, mouse, chinchilla, and rabbit, the replacement pattern is undulant, and waves of follicular activity can be traced across the body. In other species, for example, humans, cats, and guinea pigs, each follicle appears to cycle in-

dependently of others in the immediate area. See INTEGUMENT. [P.F.M.]

**Half-life** The time required for one-half of a given material to undergo chemical reactions; also, the average time interval required for one-half of any quantity of identical radioactive atoms to undergo radioactive decay.

The concept of the time required for all of the material to react is meaningless, because the reaction goes very slowly when only a small amount of the reacting material is left and theoretically an infinite time would be required. The time for half completion of the reaction is a definite and useful way of describing the rate of a reaction.

The specific rate constant  $k$  provides another way of describing the rate of a chemical reaction. This is shown in a first-order reaction, Eq. (1), where  $c_0$  is the initial concentration and  $c$  is

$$k = \frac{2.303}{t} \log \frac{c_0}{c} \quad (1)$$

the concentration at time  $t$ . The relation between specific rate constant and period of half-life,  $t_{1/2}$ , in a first-order reaction is given by Eq. (2).

$$t_{1/2} = \frac{2.303}{k} \log \frac{1}{1/2} = \frac{0.693}{k} \quad (2)$$

See CHEMICAL DYNAMICS. [F.D.]

The activity of a source of any single radioactive substance decreases to one-half in 1 half-period, because the activity is always proportional to the number of radioactive atoms present. For example, the half-period of  $^{60}\text{Co}$  (cobalt-60) is  $t_{1/2} = 5.3$  years. Then a  $^{60}\text{Co}$  source whose initial activity was 100 curies will decrease to 50 curies in 5.3 years. In 1 additional half-period this activity will be further reduced by the factor  $1/2$ . Thus, the fraction of the initial activity which remains is  $1/2$  after one half-period,  $1/4$  after two half-periods,  $1/8$  after three half-periods,  $1/16$ , after four half-periods, and so on. The half-period is sometimes also called the half-value time or, with less justification, the half-life. See RADIOACTIVITY. [R.D.E.]

**Halichondrida** A small order of sponges of the class Demospongiae, subclass Ceractinomorpha, with a skeleton of diactinal or monactinal siliceous megascleres or both. Spongin is present in small amounts; microscleres are absent. A skinlike dermis is present and is often reinforced with tangentially placed spicules.

Halichondrid sponges are encrusting, massive, lobate, or branching in shape. Common shallow-water species, such as *Halichondria panicea*, exhibit extensive intraspecific variations in shape associated with environmental conditions (see illustration). Halichondrids inhabit all seas, occurring chiefly in tidal areas and shallow waters of the continental shelf. Some species

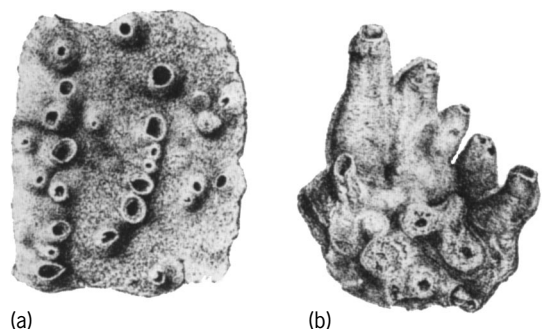

*Halichondria panicea*, shallow-water sponge. (a) Encrusting form. (b) Fistular form.

occur down to depths of at least 4900 ft (1500 m). Fossil species are unknown. See DEMOSPONGIAE. [W.D.H.]

**Halide** A compound containing one of the halogens [fluorine (F), chlorine (Cl), bromine (Br), iodine (I)] and another element or organic group. Halides have the general formula  $M_xX_y$ , where M is a metal or organic group and X is a halogen. Halides are composed of almost every element in the periodic table, and they are referred to as fluorides, chlorides, bromides, or iodides. See HALOGEN ELEMENTS; PERIODIC TABLE.

The halides are divided into classes that reflect the nature of bonding between the halogen and metal or organic species. The bonding of halides ranges from purely ionic to essentially covalent. The classes include ionic halides, molecular halides, halides and halogens that behave as ligands in coordination complexes, and organic halides.

Ionic halides such as sodium chloride (NaCl) and potassium chloride (KCl) are prepared from the vigorous reaction of the alkali and alkaline-earth metals with the halogens. These compounds possess high melting and boiling points and are soluble in very polar solvents. Ionic halides are extremely important to the chemical industry, where they are used to produce commodity chemicals such as sodium hydroxide (NaOH), hydrochloric acid (HCl, a hydrogen halide), and potassium nitrate ( $KNO_3$ ).

The organic halides are divided into the alkyl halides (haloalkanes) and the aryl halides. The alkyl halides have the general formula  $RX$ , where R is any alkyl group and X is one of the halogens; for example, 1-chlorobutane ( $CH_3CH_2CH_2CH_2Cl$ ). Halides are good leaving groups in nucleophilic substitution reactions and are good nucleophiles. The aryl halides are compounds where the halogen is attached directly to an aromatic ring and have the general formula  $ArX$ , where Ar is an aromatic group. See COORDINATION CHEMISTRY; COORDINATION COMPLEXES; ELECTROPHILIC AND NUCLEOPHILIC REAGENTS; HALOGENATED HYDROCARBON; HALOGENATION. [T.J.Me.]

**Halimeda** A genus of marine, benthic, green algae (Chlorophyta) belonging to the family Codiaceae. Plants are attached by a holdfast, generally several centimeters high, and consist of calcareous segments separated by flexible, little-calcified nodes. Most species have a distinct, erect habit (see illustration), but some deep-water species have a vinelike growth form.

*Halimeda* is an exclusively marine algae restricted to tropical waters, except for one or two species known from subtropical

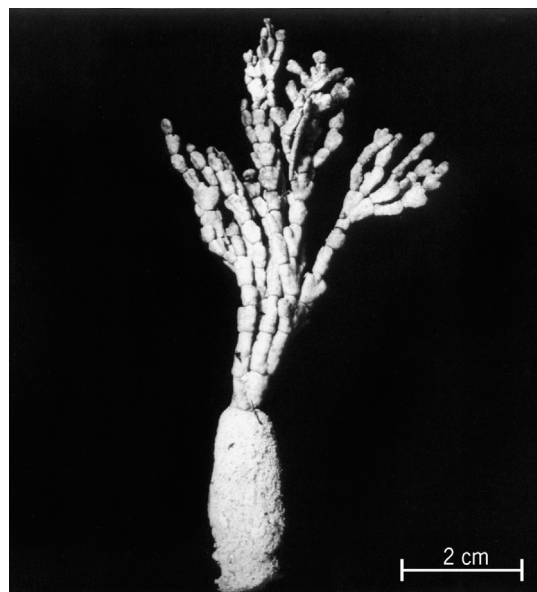

*Halimeda* from southern Florida.

regions. These algae colonize sand and mud substrates, where rhizoids of the plant penetrate the soft bottom to develop holdfasts. They are most common at shallow depths of a few meters, especially in tropical marine shelf and lagoonal environments. See ALGAE; ATOLL. [J.L.Wr.]

**Halite** One of the group of minerals referred to as evaporites, halite is commonly known as salt. Halite is one of many substances that are essential for human life. Evaporite minerals form when ions are concentrated to their saturation point by the progressive evaporation of seawater or saline lake water. Halite precipitates after calcium sulfate, but before the highly soluble salts of potassium and magnesium. See HALOGEN MINERALS; SALINE EVAPORITES.

Halite (chemical formula NaCl) is composed of sodium cations and chlorine anions in equal proportion. It is the most common chloride mineral in natural sequences which proceed beyond the precipitation of sulfates. Even in sequences which contain a high percentage of potassium and magnesium salts, halite is often the most common chloride present.

Crystals of halite are generally cubic or hopper-shaped (skeletal). Although the mineral is colorless generally, impurities can color it gray, red, orange, or brown. Blue or violet halite results from exposure to radioactivity, which produces dislocations and defects in the crystal structure. Halite is characterized by a hardness of 2.5 on Mohs scale and a specific gravity of 2.16.

The deformation of bedded halite deposits is of importance to the petroleum industry. Salt rises, in part as a result of density contrasts, to form domelike structures. Hydrocarbons (oil and gas) are commonly associated with salt domes. Exploration for these structures by geophysical techniques often results in major discoveries by the petroleum industry. See GEOPHYSICAL EXPLORATION; PETROLEUM GEOLOGY; SALT DOME. [M.L.H.; B.C.Sc.]

**Hall effect** An effect whereby a conductor carrying an electric current perpendicular to an applied magnetic field develops a voltage gradient which is transverse to both the current and the magnetic field. It was discovered by E. H. Hall in 1879. Important information about the nature of the conduction process in semiconductors and metals may be obtained through analysis of this effect.

A simple model which accounts for the phenomenon is the following. For a magnetic field of strength  $B$  in the  $z$  direction (see illustration), particles flowing with speed  $v$  in the  $x$  direction suffer a Lorentz force  $F_L$  in the  $y$  direction given by Eq. (1),

$$F_L = -qvB \quad (1)$$

where  $q$  is the charge of the particles. This force deflects the particles so that a charge imbalance develops between opposite sides of the conductor. Deflection continues until the electric field  $E_y$  resulting from this charge imbalance produces a force  $F_y = qE_y$  which cancels the Lorentz force. In practice, the equilibrium condition  $F_L + F_y = 0$  is achieved almost instantaneously, giving a steady-state Hall field as in Eq. (2). The current density is  $J_x = nqv$ , where  $n$  is the carrier density. The Hall resistivity, defined by Eq. (3), is thus given by Eq. (4). The Hall coefficient, defined by Eq. (5), satisfies Eq. (6) and thus  $R_0$  provides a measure of the

$$E_y = vB \quad (2)$$

$$\rho_{yx} = \frac{E_y}{J_x} \quad (3)$$

$$\rho_{yx} = \frac{B}{nq} \quad (4)$$

$$R_0 = \frac{\rho_{yx}}{B} \quad (5)$$

$$R_0 = \frac{1}{nq} \quad (6)$$

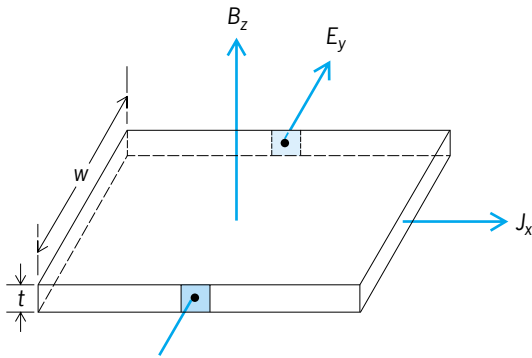

Configuration of fields and currents in the Hall effect experiment.

sign and magnitude of the mobile charge density in a conductor. Within the free-electron theory of simple metals,  $q$  is expected to be the electron charge  $-e$ , and  $n$  is taken to be  $n = Zn_A$ , where  $Z$  is the valence of the metal and  $n_A$  is the density of the atoms. This yields Eq. (7).

$$R_0 = \frac{-1}{n_A Z e} \quad (7)$$

See FREE-ELECTRON THEORY OF METALS.

Equation (7) is approximately valid in simple monovalent metals but fails drastically for other materials, often even giving the wrong sign. The explanation of the failures of Eq. (7) was one of the great early triumphs of the quantum theory of solids. The theory of band structure shows how collisions with the periodic array of atoms in a crystal can cause the current carriers to be holes which have an effective positive charge which changes the sign of the Hall coefficient. Band structure theory also accounts for the observed dependence of  $R_0$  on the orientation of the current and the magnetic field relative to the crystal axes, an effect which is very useful for studying the topology of the Fermi surface. See BAND THEORY OF SOLIDS; FERMI SURFACE; HOLE STATES IN SOLIDS.

In certain special field-effect transistors, it is possible to create an electron gas which is effectively two-dimensional. The Hall resistance for an idealized system in two dimensions is given by Eq. (8), where  $n_S$  is the density of electrons per unit area

$$\rho_{xy} = -\rho_{yx} = \frac{B}{n_S e} \quad (8)$$

(rather than volume). However, if the measured value of  $\rho_{xy}$  for a high-quality (low-disorder) device is plotted as a function of  $B$ , the linear behavior predicted by Eq. (8) is observed only at low fields. At high fields the Hall resistance exhibits plateau regions in which it is a constant independent of  $B$ . Furthermore, the values of  $\rho_{xy}$  on these plateaus are given quite accurately by the universal relation of Eq. (9), where  $h$  is Planck's constant and  $\nu$

$$\rho_{xy} = \frac{h}{e^2 \nu} \quad (9)$$

is an integer or simple rational fraction. The absolute accuracy with which Eq. (9) has been verified is better than 1 part in  $10^6$ .

This extremely accurate quantization of  $\rho_{xy}$  allows the realization of a new standard of resistance based solely on fundamental constants of nature. In addition, the quantum unit of Hall resistance,  $h/e^2 \approx 25,812.80$  ohms, determines the fine-structure constant. See ELECTRICAL UNITS AND STANDARDS; FUNDAMENTAL CONSTANTS.

The explanation of this remarkable phenomenon involves several subtle quantum-mechanical effects. In the quantum regime (small  $\nu$ ),  $\rho_{xx}$ , which is the dissipative (longitudinal) resistivity, approaches zero on the Hall plateaus. The quantization of the Hall resistance is intimately connected with this fact. It is spec-

ulated that at zero temperature the dissipation is zero and that Eq. (9) is then obeyed exactly. See QUANTUM MECHANICS.

The nearly complete lack of dissipation in the quantum Hall regime is reminiscent of superconductivity. In both effects the ability of the current to flow without dissipation has its origin in the existence of a quantum-mechanical excitation gap, that is, a minimum threshold energy needed to disturb the special microscopic order in the system. See ENTROPY; SUPERCONDUCTIVITY.

In the integer quantum Hall effect [where  $\nu$  in Eq. (9) is an integer], this excitation gap is a single-particle effect associated with the quantization by the strong magnetic field of the kinetic energy of the individual electrons into discrete states called Landau levels. In the fractional effect, the gap is associated with the highly collective, many-body ordering of the electrons into a quantum state which minimizes the strong Coulomb repulsion and hence lowers the overall energy. Thus, while the integer and fractional quantum Hall effects look superficially similar on a plot of resistivities versus magnetic field, their physical origins are actually quite different. See DE HAAS-VAN ALPHEN EFFECT; GALVANOMAGNETIC EFFECTS. [S.M.G.]

**Halley's Comet** The most famous of all comets; records of Halley's Comet appear at least as far back as 240 B.C. The comet's size, activity, and favorably placed orbit (with the perihelion roughly halfway between the Sun and the Earth's orbit) ensure its visibility to the naked eye at each apparition (see illustration). See COMET.

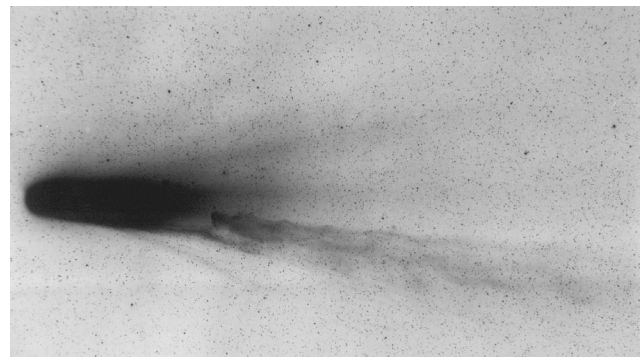

Halley's Comet as photographed by the United Kingdom Schmidt telescope in Australia on March 9, 1986. Dust-tail structures are visible (above), and the plasma tail (below) also shows a completely detached portion called a disconnection event. (Copyright © by Photolabs, Royal Observatory, Edinburgh)

This comet was the first to have its return predicted, a feat accomplished by Edmond Halley in 1705. He computed the orbits of several comets with Isaac Newton's then new gravitational theory. The orbits of comets observed in 1531, 1607, and 1682 were remarkably similar. Halley assumed that the sightings were of a single comet and predicted its return in 1758-1759. The prediction was verified, and the comet was named in his honor. The last perihelion passage of the comet was on February 9, 1986. In March 1986, six uncrewed spacecraft encountered Halley's Comet and produced data that have greatly enhanced the understanding of comets. The comet will return to its perihelion in 2061. [J.C.B.]

**Halloysite** A clay mineral similar in structure to kaolinite, having a 1:1 structure in which a silica tetrahedral sheet is joined to an alumina octahedral sheet. Unlike kaolinite, however, the structure is disordered in both the  $a$  and the  $b$  axis directions in successive layers, and it frequently contains water between the layers. See KAOLINITE.

Two principal modifications exist: a less hydrous form with a composition and structure near to that of kaolinite,

$\text{Al}_2\text{Si}_2\text{O}_5(\text{OH})_4$ ; and a hydrous form with the composition  $\text{Al}_2\text{Si}_2\text{O}_5(\text{OH})_4 \cdot 2\text{H}_2\text{O}$ . The less hydrous form has a *c*-dimension of about 0.72 nanometer, whereas the hydrous form has a *c*-dimension of about 1.01 nm, the difference between them being roughly the thickness of a single sheet of water molecules. The hydrated form converts spontaneously and irreversibly into the less hydrous form when dried.

Electron microscopy reveals that the morphology of halloysite is usually tubular. Because the 1:1 layers in halloysite generally are separated from each other by water, halloysite has a larger cation exchange capacity, surface area, and catalytic activity than does kaolinite.

Halloysite is formed in nature from the weathering of feldspar under intense leaching conditions, and may also form in low-temperature hydrothermal systems. It has not been synthesized in the laboratory beyond doubt, although products resembling halloysite have been obtained by the artificial weathering of feldspar, and by the intercalation of kaolinite. Halloysite may precede kaolinite as a weathering product, and the transformation of halloysite into kaolinite may explain why halloysite is not common in sediments. See FELDSPAR; WEATHERING PROCESSES.

Halloysite is used as a catalyst and in the manufacture of ceramic products. See CLAY MINERALS. [D.Eb.]

**Hallucination** A perceptual experience in the absence of external stimulation. Hallucinations differ from illusions, which are changes in the perception of a real object. Hallucinations tend to fade with fixation or with attention to the content. Except for afterimages, which lie like a film over objects, hallucinations replace objects and object space. A hallucination is not objectlike in its realism. The conviction of reality is due to the loss of an object for comparison and the inability to disprove the image through other sensory modalities.

Hallucinations that are recognized as such by the experiencer include those resulting from sensory deprivation, drug use, and the phantom limb state. See SCHIZOPHRENIA.

Hallucinations may occur in a range of neurologic and psychiatric conditions, although they are usually considered hallmarks of schizophrenia. Delusional misidentification syndromes are a subtype of hallucinations and may also occur in neurological and psychiatric disease. For example, Capgras syndrome, which is commonly seen in schizophrenia, causes the individual to replace a familiar person (usually the spouse) with an imposter with the same or similar physical appearance. Frégoli syndrome is the delusional confusion of an individual as a familiar person in disguise.

Neurotransmitters are directly involved in the regulation of drug-induced and schizophrenic hallucinations, with many accounts pointing to the involvement of serotonin and dopamine. Therefore, it is possible to treat individuals with antipsychotic drugs that stabilize the chemical systems involved.

With localized damage to the brain, hallucinations are usually brief and intermittent, though in some cases, especially neurologic damage involving the brainstem, hallucinations can be chronic and sustained.

Physical input to the eyes and ears constrains and guides the construction of mental images, but the final result—the perception of an object or sound as a meaningful event occurring in the external world—also reflects very complex physiological processes. They begin in the brainstem, pass to the limbic system of the brain, and finally involve the temporal, parietal, and occipital areas of the cerebral cortex. Various types of hallucination are caused by disruptions that occur at different levels along that sequence of brain processes. See COGNITION.

At its earliest phase, damage to the upper brainstem produces peduncular (crepuscular) hallucinations of faces, torsos, and occasionally geometric patterns or landscapes near the viewer at the close of day. The images may be static and immobile or may change in content and affective tonality while being viewed. A smiling young boy, for example, may change into a scowling old

woman. The hallucinations are often vivid and chromatic, and tend to be multimodal: they are seen, heard, and even touched, and occur over the entire visual field. Olfactory and gustatory images have also been described. Peduncular hallucinations are similar to the hypnagogic hallucinations that are experienced when falling asleep. See SLEEP AND DREAMING.

Neurologic damage involving limbic and temporal-lobe structures yields hallucinations of faces or formed scenes laden with meaning and affect. Changes in size (micropsia, macropsia) and shape (metamorphopsia) may occur. Déjà vu, derealization, and dreamy states are common. Auditory hallucinations are usually of speech or music. Microscopic (Lilliputian) and autoscopic (out-of-the-body) hallucinations also occur with temporal-lobe lesions. Exposure to a wide range of drugs and many psychiatric disorders, especially schizophrenia, can lead to hallucinations whose form suggests dysfunction involving limbic or temporal-lobe structures. See PSYCHOTOMIMETIC DRUG.

Damage to the parietal lobe leads to illusory distortions of shape, size, and motion, whereas occipital lesions or stimulation—or migraine—gives elementary hallucinations of sparks, flames, lines, or simple patterns. These hallucinations share features with afterimages. Palinopsia, the hallucinatory persistence of an object after the viewer has turned away, is a form of pathological afterimagery. See PERCEPTION.

[J.W.Br.; K.L.C.]

**Halo** Either of two large circles of light surrounding the Sun or Moon that result from the refraction of sunlight by small, hexagonal ice crystals falling slowly through the air. Light passing through the side faces of a hexagonal prism is refracted by an amount that depends on the orientation of the crystal; but a collection of many crystals refracts light passing through two side faces by an average angle of about 22°. If such crystals tumble randomly as they fall, they will produce the 22° halo, a circle around the Sun with an angular radius of 22°. Rays that pass through a side face and an end face of the prism similarly produce the larger and fainter 46° halo. The halos sometimes have a red inner edge and otherwise appear nearly white.

Many similar effects result from rays passing through ice crystals that assume special orientations as they fall, and from rays undergoing combination of reflection and refraction in an ice crystal. Usually, all of these effects are referred to as halo effects. See METEOROLOGICAL OPTICS; SUN DOG. [R.Gr.]

**Halocyprida** An order of the subclass Myodocopa, class Ostracoda, characterized by biramous antennae with the endopod and exopod of similar size, reduction or absence of the seventh pair of appendages, an unpaired male copulatory organ, and the absence of a median eye. The taxon is subdivided into two suborders, Halocypridina and Cladocopina; each has both Recent and fossil representatives. Extant halocyprids are small ostracods, measuring less than 0.4 in (10 mm).

With the exception of one brackish-water representative, halocyprids are marine, cosmopolitan in all oceans, and found from surface waters to abyssal depths. Most are planktonic species, although a few are epibenthic or benthic, and they include filter feeders, carnivores, and possibly detritus feeders. See CRUSTACEA; MYODOCOPA. [P.A.McL.]

**Halogen elements** The halogen family consists of the elements fluorine, F; chlorine, Cl; bromine, Br; iodine, I; and astatine, At. All the halogen elements except astatine exist in the Earth's crust and atmosphere. See HALOGEN MINERALS.

The halogens are the best-defined family of elements. They have an almost perfect gradation of physical properties. The increase in atomic weight from fluorine through iodine is paralleled by increases in density, melting and boiling points, critical temperature and pressure, heats of fusion and vaporization, and even in progressively deeper color (fluorine is pale yellow; chlorine, yellow-green; bromine, dark red; and iodine, deep violet).

Although all halogens generally undergo the same types of reactions, the extent and ease with which these reactions occur vary markedly. Fluorine in particular has the usual tendency of the lightest member of a family of elements to exhibit reactions not comparable to the other members. Each halogen must be considered individually, both in its preparation and in its reaction. See ASTATINE; BROMINE; CHLORINE; FLUORINE; HALIDE; HALOGENATION; IODINE. [R.J.C.; A.A.G.]

**Halogen minerals** Naturally occurring compounds containing a halogen as the sole or principal anionic constituent. There are over 70 such minerals, but only a few are common and can be grouped according to the following methods of formation.

1. Saline deposition by evaporation of seawater or salt lakes. Halite (rock salt), NaCl, is the most important of this type. Of the other minerals associated with halite, sylvite, KCl, and carnallite,  $\text{KMgCl}_3 \cdot 6\text{H}_2\text{O}$ , are the most important. See SALINE EVAPORITE.

2. Hydrothermal deposition. Fluorite,  $\text{CaF}_2$ , is the chief representative of this type. Cryolite,  $\text{Na}_3\text{AlF}_6$ , may be of primary deposition or may result from the action of fluorine-bearing solutions on preexisting silicates. See CRYOLITE; FLUORITE.

3. Secondary alteration. Chlorides, iodides, or bromides of silver, copper, lead, or mercury may form as surface alterations of ore bodies carrying these metals. The most common are cerargyrite, AgCl, and atacamite,  $\text{Cu}_2(\text{OH})_3\text{Cl}$ . See CERARGYRITE.

4. Deposition by sublimation. Halides formed as sublimation products about volcanic fumaroles include sal ammoniac,  $\text{NH}_4\text{Cl}$ ; malysite,  $\text{FeCl}_3$ ; and cotunnite,  $\text{PbCl}_2$ . At Mount Vesuvius, Italy, is the most noted occurrence of such minerals. See HALIDE.

5. Meteorites. Lawrencite,  $\text{FeCl}_2$ , has been found in iron meteorites. [C.S.H.]

**Halogenated hydrocarbon** An aliphatic or aromatic hydrocarbon in which one or more hydrogen atoms are substituted by halogen. See HALOGEN ELEMENTS; HALOGENATION.

Alkyl halides are compounds in which one hydrogen of an alkane has been replaced by halogen [fluorine (F), chlorine (Cl), bromine (Br), or iodine (I)], for example, bromoethane (ethyl bromide;  $\text{CH}_3\text{CH}_2\text{Br}$ ). Many alkyl halides have been prepared; the chlorides and bromides are most useful and most common. Alkyl halides are important starting materials for the preparation of many other functionally substituted compounds. A general reaction for chlorides, bromides, and iodides is nucleophilic substitution, in which an ion or molecule with an available electron pair (a nucleophile) displaces a halide ion. See QUATERNARY AMMONIUM SALTS.

Compounds with halogen bonded directly to a benzene or other aromatic ring are called aryl halides. Halogen is introduced by electrophilic substitution, with a Lewis acid catalyst such as  $\text{FeCl}_3$  or  $\text{FeBr}_3$  to enhance the positive character of the halogen.

In fluorocarbons, every hydrogen atom is replaced by fluorine. Fluorocarbons can be named simply by using the prefix perfluoro- with the parent name. Because of the small atomic radius and high electronegativity of fluorine, these compounds are chemically inert and have properties quite unlike those of other halogenated organic compounds. See FLUORINE; FLUOROCARBON.

Hydrofluorocarbons contain combinations of fluorine and hydrogen to satisfy the valency requirement of carbon. Hydrofluorocarbons are also known as HFCs. The development of specific molecules for particular applications, previously satisfied by chlorofluorocarbons, has been international in scope. Because they contain hydrogen, hydrofluorocarbons are more likely to be degraded in the lower regions of the atmosphere. Since they do not contain chlorine, these compounds do not contribute to ozone depletion.

Perfluorocarbons contain only carbon and fluorine. They are named by using the prefix perfluoro- along with the name of

the equivalent hydrocarbon. Perfluorocarbons are chemically very inert and also have excellent thermal stability. This inertness and the resulting long atmospheric lifetime is reflected in higher global warming potentials compared to hydrofluorocarbons, hydrochlorofluorocarbons, and chlorofluorocarbons. This is due, partly, to the high strength of the C-F bond. The electronegativity of fluorine shields the carbon backbone from chemical attack. Under normal conditions, perfluorocarbons are unaffected by strong acids or bases and by oxidizing or reducing agents. See ELECTRONEGATIVITY.

A number of compounds with two or more halogen atoms are of special importance. Methane ( $\text{CH}_4$ ) can be substituted with as many as four halogen atoms to give compounds such as  $\text{CH}_2\text{Cl}_2$ ,  $\text{CHI}_3$ , and  $\text{CF}_3\text{Br}$ . Several polyhalomethane, -ethane, and -ethylene derivatives have major uses, and they are industrial chemicals produced in large quantities.

Chlorination of methane leads to mixtures of mono-, di-, tri-, and tetrachloro products. The relative amounts can be controlled by adjusting the ratio of starting materials. Methyl chloride is manufactured by this chlorination process and also by reaction of methanol and HCl. Methylene chloride,  $\text{CH}_2\text{Cl}_2$ , is the major product from methane, and is utilized primarily as a cleaning solvent or as a blowing agent for plastic foam. Methylene chloride is more volatile and much less toxic than  $\text{CHCl}_3$  or  $\text{CCl}_4$ .

Chlorofluorocarbons are methane and ethane derivatives with all hydrogen atoms replaced by combinations of chlorine and fluorine. Chlorofluorocarbons are known collectively as CFCs. The first of these compounds, dichlorofluoromethane ( $\text{CCl}_2\text{F}_2$ ), was introduced as a nontoxic, nonflammable working fluid in refrigeration equipment to replace ammonia and sulfur dioxide. Other compounds were developed to meet the requirements of specific uses such as air-conditioning equipment in buildings and vehicles, and propellants for aerosols.

Hydrochlorofluorocarbons contain combinations of hydrogen, chlorine, fluorine, and carbon to satisfy the valency requirement of carbon. Also known as HCFs, the hydrochlorofluorocarbons have been developed as interim substitutes for chlorofluorocarbons. Since they have at least one hydrogen atom in the molecule, they are more likely to be degraded in the troposphere by reaction with hydroxyl (OH) radicals. Thus, the potential that hydrochlorofluorocarbons have to deplete ozone by migration to the stratosphere is reduced. [J.A.Mo.; V.N.M.R.]

**Halogenation** A chemical reaction or process which results in the formation of a chemical bond between a halogen atom and another atom. Reactions resulting in the formation of halogen-carbon bonds are especially important. The halogenated compounds produced are employed in many ways, for example, as solvents, intermediates for numerous chemicals, plastic and polymer intermediates, insecticides, fumigants, sterilants, refrigerants, additives for gasoline, and materials used in fire extinguishers. See HALOGEN ELEMENTS.

Halogenation reactions can be subdivided in several ways, for example, according to the type of halogen (fluorine, chlorine, bromine, or iodine), type of material to be halogenated (paraffin, olefin, aromatic, hydrogen, and so on), and operating conditions and methods of catalyzing or initiating the reaction.

Halogenation reactions with elemental chlorine, bromine, and iodine are of considerable importance. Because of high exothermicities, fluorinations with elemental fluorine tend to have high levels of side reactions. Consequently, elemental fluorine is generally not suitable for direct fluorination. Two types of reactions are possible with these halogen elements, substitution and addition.

Substitution halogenation is characterized by the substitution of a halogen atom for another atom (often a hydrogen atom) or group of atoms (or functional group) on paraffinic, olefinic, aromatic, and other hydrocarbons. A chlorination reaction of importance that involves substitution is that between methane and chlorine. See SUBSTITUTION REACTION.

Addition halogenation involves a halogen reacting with an unsaturated hydrocarbon. Chlorine, bromine, and iodine react readily with most olefins; the reaction between ethylene and chlorine to form 1,2-dichloroethane is of considerable commercial importance, since it is used in the manufacture of vinyl chloride.

Addition reactions with bromine or iodine are frequently used to measure quantitatively the number of  $-\text{CH}=\text{CH}-$  (or ethylenic-type) bonds in organic compounds. Bromine numbers or iodine values are measures of the degree of unsaturation of the hydrocarbons.

Substitution halogenation on the aromatic ring can be made to occur via ionic reactions. The chlorination reactions with elemental chlorine are similar to those used for addition chlorination of olefins. See HALOGENATED HYDROCARBON. [L.F.A.]

**Halophilism (microbiology)** The requirement of high salt (NaCl) concentrations for growth of microorganisms. Microorganisms (mainly bacteria) can be classified by their physiological tolerance to salt. Most normal eubacteria, such as *Escherichia coli* and *Pseudomonas fluorescens*, and most freshwater microorganisms, are nonhalophiles (best growth at less than 1.2% NaCl). Slight halophiles (1.2–3% NaCl) include many marine microorganisms. Moderate halophiles (3–15% NaCl) include *Vibrio costicola*, *Paracoccus halodenitrificans*, and many others. Borderline extreme halophiles (9–25% NaCl) include the photosynthetic bacterium *Ectothiorhodospira halophila*, the actinomycete *Actinopolyspora halophila*, and the halophylic archaeobacteria *Halobacterium volcanii* and *H. mediterranei*. Extreme halophiles (require at least 10% NaCl; optima 15–30% NaCl) are *Halobacterium salinarium* and *Halococcus morrhuae*. See METHANOGENESIS (BACTERIA).

The halophilic aerobic archaeobacteria give a striking red color to hypersaline waters. They are found in the Dead Sea, the Great Salt Lake, Lake Magadi in Kenya, and other alkaline salt lakes, and in solar salterns where salt is prepared by evaporating seawater. Their red color is due to carotenoid pigments (bacterioruberins), which seem to protect them from strong sunlight in their natural environments. See CAROTENOID.

Microorganisms that live in high concentrations of salt or other solutes do not exclude solutes from the interior of the cell. However, the internal solute composition is quite different from the outside composition. *Dunaliella* species have internal glycerol concentrations corresponding to the external concentration of NaCl. Other salt-tolerant algae and yeasts also have high internal concentrations of glycerol, or other polyols. Solute which maintain osmotic equilibrium between inside and outside of the cell without interfering with the cell's physiological processes are called compatible solutes. See OSMOREGULATORY MECHANISMS.

Mechanisms of adaptation to a highly saline environment have been best characterized in aerobic halophilic bacteria whose enzymes are able to function in high salt concentrations; indeed, most of them require such salt concentrations for activity, stability, or both. For a number of enzyme systems, KCl rather than NaCl is required. Other parts of the cells of these bacteria also require high salt concentrations for function or stability. Halobacteria lyse and their cell walls may completely dissolve unless salt concentrations are high. NaCl is specifically required for active transport of ions and nutrients in all halophilic bacteria. [D.J.K.]

**Haloragales** An order of flowering plants, division Magnoliophyta (Angiospermae), in the subclass Rosidae of the class Magnoliopsida (dicotyledons). The order consists of 2 families, with about 150 species in all. The Haloragales are herbs with perfect or often unisexual, more or less reduced flowers. Many of the species are aquatic. Pollen is commonly distributed by wind or water. The aquarium plant called parrot's feather (*Myriophyllum*, family Haloragaceae) and the very large-leaved plant *Gunnera*, (family Gunneraceae) are well-known members of the

Haloragales. See MAGNOLIOPHYTA; MAGNOLIOPSIDA; PLANT KINGDOM; ROSIDAE. [A.Cr.; T.M.Ba.]

**Hamamelidae** A small subclass of the class Magnoliopsida (dicotyledons) in the division Magnoliophyta (Angiospermae), the flowering plants, consisting of 11 orders (Trochodendrales, Hamamelidales, Daphniphyllales, Didymelales, Eucommiales, Urticales, Leitneriales, Juglandales, Myricales, Fagales, and Casuarinales), 24 families, and about 3400 species. They have strongly reduced, often unisexual flowers with poorly developed or no perianth. With the notable exception of some of the Urticales, they are all woody plants. Pollination is usually by wind. Many of the families formerly grouped under the Amentiferae belong to the Hamamelidae. See articles on each order. See MAGNOLIOPHYTA; MAGNOLIOPSIDA; PLANT KINGDOM. [A.Cr.; T.M.Ba.]

**Hamamelidales** A small order of flowering plants, division Magnoliophyta (Angiospermae), which gives its name to the subclass Hamamelidae in the class Magnoliopsida (dicotyledons). The family Hamamelidaceae contains about 100 species and the Platanaceae about 6 species; the other 3 families have only 2 species each. Within its subclass, the order is more advanced than the Trochodendrales in having vessels in the wood, but less advanced than the other orders in that the gynoecium consists either of separate carpels or of united carpels that open at maturity to release the seeds. Witch hazel (*Hamamelis*; see illustration), sweet gum (*Liquidambar*, family Hamamelidaceae),



American witch hazel (*Hamamelis virginiana*), a characteristic member of the family Hamamelidaceae and order Hamamelidales. The flowers of this species open in the autumn, when the leaves are already beginning to deteriorate. (John H. Gerard, National Audubon Society)

and the plane tree or sycamore (*Platanus*) are familiar members of the Hamamelidales. See HAMAMELIDAE; MAGNOLIOPHYTA; PLANT KINGDOM; TROCHODENDRALES. [A.Cr.; T.M.Ba.]

**Hamilton's equations of motion** The motion of a mechanical system may be described by a set of first-order ordinary differential equations known as Hamilton's equations. Because of their remarkably symmetrical form, they are often referred to as the canonical equations of motion of a system. They are equivalent to Lagrange's equations, but the fact that they are of first order and highly symmetrical makes them advantageous

for general discussions of the motion of systems. See LAGRANGE'S EQUATIONS.

Hamilton's equations can be derived from Lagrange's equations. Let the coordinates of the system be  $q_j$  ( $j = 1, 2, \dots, f$ ), and let the dynamical description of the system be given by the lagrangian  $L(q, \dot{q}, t)$ , where  $q$  denotes all the coordinates and a dot denotes total time derivative. Lagrange's equations are then given by Eq. (1). The momentum  $p_j$  canonically conjugate to  $q_j$  is defined by Eq. (2).

$$\frac{d}{dt} \frac{\partial L}{\partial \dot{q}_j} - \frac{\partial L}{\partial q_j} = 0 \quad (1)$$

$$p_j = \frac{\partial L}{\partial \dot{q}_j} \quad (2)$$

The hamiltonian  $H$  is defined by Eq. (3). Then Hamilton's canonical equations are Eqs. (4).

$$H = \sum_{j=1}^f p_j \dot{q}_j - L(q, \dot{q}, t) \quad (3)$$

$$\dot{q}_j = \frac{\partial H(q, p, t)}{\partial p_j} \quad \dot{p}_j = - \frac{\partial H(q, p, t)}{\partial q_j} \quad (4)$$

As they stand, Hamilton's equations are no easier to integrate directly than Lagrange's. Hamilton's equations are of great advantage in more general discussions, and they permit the making of canonical transformations which can lead to simplifications. See CANONICAL TRANSFORMATIONS.

The hamiltonian function  $H$  of classical mechanics is used to form the quantum-mechanical hamiltonian operator. [P.M.S.]

**Hamilton's principle** A variational principle from which can be derived the equations of motion of a classical dynamical system in which friction or other forms of dissipation of energy do not occur. In the original formulation of Newton's laws of motion, the position of each particle of the system of interest is specified by the cartesian coordinates of that particle. In many cases, these coordinates are not all independent of each other or do not reflect the structure of the system in a convenient way. It is then advantageous to introduce a system of generalized coordinates which are independent of each other and do reflect any special features of the system such as its symmetry about some center. The number of degrees of freedom of the system,  $f$ , is the number of such coordinates required to specify the configuration of the system at any time. See DEGREE OF FREEDOM (MECHANICS).

The problem of determining how a system moves may be formulated in the following way: If the configuration of the system at time  $t_1$  is specified by the generalized coordinates  $q_1(t_1), \dots, q_f(t_1)$  and at the time  $t_2$  by  $q_1(t_2), \dots, q_f(t_2)$ , then it is required to find the trajectory along which the system travels from the initial to the final configuration. Hamilton's principle addresses this problem similarly to the way that a geometer addresses the problem of finding the shortest path lying in a curved surface between two given points on the surface. The geometer specifies the distance  $ds$  between any two close-lying points in terms of the coordinates  $q_i$  of the two points and their differences, the coordinate differentials  $dq_i$ , as in Eq. (1). The path length  $D$  between the two

$$(ds)^2 = \sum_{i,j=1}^f g_{ij}(q_1, \dots, q_f) dq_i dq_j \quad (1)$$

$$D = \int_{t_1}^{t_2} ds \quad (2)$$

specified points, given by the integral in Eq. (2), is then required to be a minimum. Hamilton defined a characteristic function  $\Phi$ , analogous to  $D$ , by Eq. (3), using the lagrangian function

$$\Phi = \int_{t_1}^{t_2} L(q, \dot{q}, t) dt \quad (3)$$

$L(q, \dot{q}, t)$  of the system in a way analogous to the geometer's  $g$ . Hamilton's principle states that the system follows the trajectory that makes the integral in Eq. (3) have a minimum value, provided the time interval between times  $t_1$  and  $t_2$  is not too great. It can be shown that this principle implies Lagrange's equations of motion for the system, and that it follows from Lagrange's equations. See DIFFERENTIAL GEOMETRY; LAGRANGE'S EQUATIONS; LAGRANGIAN FUNCTION; LEAST-ACTION PRINCIPLE; MINIMAL PRINCIPLES; VARIATIONAL METHODS (PHYSICS). [PSt.]

**Hamster** The common name for any of 14 species of rodents in the family Cricetidae. The natural range of most of these species is Asia but a few, such as the common hamster (*Cricetus cricetus*), are found in Europe.

The common hamster is a solitary, aggressive animal with interesting burrowing and hoarding habits. The burrows are not deep, rarely more than 2 ft (0.6 m), and consist of a large central chamber with radiating side chambers for special purposes, such as for hoarding food, for living quarters, and for excretion. A so-called summer chamber is used for breeding. The hamster goes into its burrow in the autumn, closes off the entrance, and goes to sleep. It does not hibernate deeply and wakes up from time to time to eat. See HIBERNATION.

The golden hamster (*Mesocricetus auratus*) is extensively used as a laboratory animal for experimental purposes, especially in studies of the physiological aspects of hibernation. See RODENTIA. [C.B.C.]

**Haplopoda** An order of carnivorous branchiopod crustaceans formerly included in the order Cladocera. Only one species, the fresh-water *Leptodora kindti*, is included.

The body is about 9 mm (0.4 in.) long. *Leptodora* is among the most transparent of multicellular freshwater animals. It swims slowly by means of enormous antennae and seizes its prey with its six pairs of segmented, grasping, thoracic limbs. The mandibles are styliform and of a type unique within the Branchiopoda. There is a single, median sessile eye. The carapace is reduced to a dorsal brood pouch and does not protect the body.

Parthenogenetic eggs and young are carried in the brood pouch in summer. In autumn, fertilized resting eggs are carried there which are shed freely, and the eggs overwinter. They hatch in spring as nauplii, a stage eliminated from the parthenogenetic phase of the life cycle.

*Leptodora* is widely distributed in the plankton of larger lakes of the Holarctic region. See BRANCHIOPODA. [G.Fr.]

**Haplosclerida** An order of sponges of the class Demospongiae, including species with a skeleton made up of a single category of siliceous megascleres embedded in spongin fibers or joined together in a network by a spongin cement. Microscleres (never asters) are present or absent. A modified dermal skeleton is absent. Many species form large upright branching colonies, the branches often being hollow.

Haplosclerid sponges inhabit all seas and are especially abundant in tidal and shallow waters of the continental shelf. Some species occur down to depths of 6600 ft (2000 m). The family Spongillidae is restricted to fresh water except for a few species which have secondarily invaded brackish water. See DEMOSPONGIAE. [W.D.H.]

**Haplosporea** A class of protozoa, often known as Acnidosporidia, in the subphylum Sporozoa. Haplosporea are distinguished from other similar groups by the production of spores lacking polar filaments. The spores are enclosed in a membrane, and each spore contains a single sporozoite.

Two orders make up the class according to the scheme proposed by the Committee on Taxonomy and Taxonomic Problems of the Society of Protozoologists. These are the Haplosporida and Sarcosporida. Haplosporida are parasites of

invertebrates and primitive chordates (Ascidia). Sarcosporida are muscle parasites of vertebrates, particularly warm-blooded ones. See HAPLOSPORIDA; SPOROZOA. [R.D.M.]

**Haplosporida** A group of Protozoa usually regarded as an order within the class Haplosporea. The chief distinguishing characteristic of the Haplosporida, and the one from which their name is derived, is the production of uninucleate spores that lack polar capsules and polar filaments.

Haplosporida are mainly parasites of invertebrates, such as rotifers, annelids, crustacea, insects, and mollusks, but they also occur in the bodies of *Ascidia* (tunicates), which are primitive chordates. If the genus *Icthyosporidium* is properly included in the order, Haplosporida also parasitize fish. One species causes "neon" fish disease.

It is of considerable biological interest that some species of Haplosporida are hyperparasites, that is, parasitic on other parasites. They have been found in gregarines parasitizing annelids, and also in flukes. See HAPLOSPOREA; SPOROZOA. [R.D.M.]

**Harbors and ports** A harbor is any body of water of sufficient depth for ships to enter and find shelter from storms or other natural phenomena. The modern harbor is a place where ships are built, launched, and repaired, as well as a terminal for incoming and outgoing ships. There are four principal classes of harbors; commercial, naval, fishery, and refuge for small craft. Most harbors are situated at the mouth of a river or at some point where it is easy to transfer cargoes inland by river barges, railroads, or trucks. Harbors may be land-locked, natural harbors protected from the sea by a narrow inlet; unprotected harbors at which ships may dock even though subjected to the hazards of changing tides, ocean waves, fogs, and ice; and artificial harbors carved out at sites where the natural features are unfavorable. The latter are fashioned by dredging and by constructing jetties, breakwaters, and sea basins to protect ships against unusually high or low tides. See COASTAL ENGINEERING.

A port is a harbor with the necessary terminal facilities to expedite the moving of cargo and passengers at any stage of a journey. A good harbor must have a safe anchorage and a direct channel to open water, and must be deep enough for large ships. An efficient port must have enough room for docks, warehouses, and loading and unloading machinery. Geographically, a port or harbor is usually limited to a comparatively small area of usable berthing space rather than an extended coastline. Some ports along exposed coastal areas, for example, the western coast of South America, have little harbor area. [B.J.W.]

**Hardness scales** Arbitrarily defined measures of the resistance of a material to indentation under static or dynamic load, to scratch, abrasion, or wear, or to cutting or drilling. Standardized tests compare similar materials according to the particular aspect of hardness measured by the test. Widely used tests for metals are Brinell, Rockwell, and Scleroscope tests, with modifications depending upon the size or condition of the material. Indentation tests compare species of wood or flooring materials, and abrasion tests serve as an index of performance of stones and paving materials.

Hardness tests are important in research and are widely used for grading, acceptance, and quality control of manufactured articles. The hardness designation or scale is associated with the test method or instrument used.

Resistance to scratching is defined by comparison with 10 selected minerals, which are numbered in the order of increasing hardness. This mineralogical scale, called Mohs scale, is 1, talc; 2, gypsum; 3, calcite; 4, fluorite; 5, apatite; 6, orthoclase; 7, quartz; 8, topaz; 9, corundum; and 10, diamond. Minerals lower in the scale are scratched by those with higher numbers.

Materials are differentiated qualitatively according to resistance to scratching or cutting by files especially selected for the purpose. Whether or not a visible scratch is produced on the material indicates its hardness in comparison with a sample of desired hardness.

Resistance to indentation by a hardened steel or tungsten carbide ball under specified load is the basis for Brinell hardness. Brinell hardness number (Bhn), expressed in kilograms per square millimeter, is obtained by dividing the load by the spherical surface area of the impression.

Indentation of a square-based diamond pyramid penetrator with an angle between opposite faces of  $136^\circ$  measures Vickers hardness. Vickers hardness number, also called diamond pyramid hardness, is equal to the load divided by the lateral area of the pyramidal impression.

Depth of indentation of either a steel ball or a  $120^\circ$  conical diamond with rounded point, called a brale, under prescribed load is the basis for Rockwell hardness. The depth of impression is indicated on a dial whose graduations represent the hardness number.

The pressure in kilograms per square millimeter required to embed a 0.75-mm (0.0295-in.) hemispherical diamond penetrator to a depth of 0.046 mm (0.0018 in.), producing an impression 0.36 mm (0.014 in.) in diameter, is the measure of Monotron hardness.

Height of rebound of a diamond-tipped weight or hammer falling within a glass tube from a height of 10 in. (25.4 cm) and striking the specimen surface measures Shore Scleroscope hardness.

Resistance to indentation over very small areas (as on small parts, the constituents of metal alloys, or for exploration of hardness variations) is called microhardness. [W.J.K./W.G.B.]

**Hardy-Weinberg formula** A basic mathematical relation used in population genetics. It gives the proportion of the various genotypes in a randomly mating population in terms of the frequencies of the genes. The formula was discovered independently in 1908 by G. H. Hardy, a British mathematician, and W. Weinberg, a German physician. See HUMAN GENETICS; POPULATION GENETICS.

In its simplest form the Hardy-Weinberg formula may be stated thus: If  $p$  is the proportion of gene  $A$  in the population and  $q (= 1 - p)$  is the proportion of gene  $a$ , then after one generation of random mating the three genotypes  $AA$ ,  $Aa$ , and  $aa$  will occur in the proportions  $p^2$ ,  $2pq$ , and  $q^2$ . In other words the genotypes are given by the appropriate terms in the expansion of the binomial  $(p + q)^2$ . The extension to multiple alleles is direct.

The formula holds only for an infinite population and assumes random mating in the absence of significant mutation pressure or gene transfer between populations. However, it is an accurate approximation in many populations. See GENETICS. [J.F.Cr.]

**Harmonic (periodic phenomena)** A sinusoidal quantity having a frequency that is an integral multiple of the frequency of a periodic quantity to which it is related. See MODE OF VIBRATION.

A harmonic series of sounds is one in which the basic frequency of each sound is an integral multiple of some fundamental frequency. The name exists for historical reasons, even though according to the usual mathematical definition such frequencies form an arithmetic series. An ideal string (or air column) can vibrate as a whole or in a number of equal parts, and the respective periods of vibration are proportional to the lengths. These increasingly shorter lengths or periods form a harmonic series. The name came from the harmonious relation of such sounds, and the science of musical acoustics was once called harmonics. Nowadays, it is customary to deal with ratios of frequency rather than ratios of length and, because frequency is the



reciprocal of period, the definition of harmonic in acoustics becomes that given here. See HARMONIC ANALYZER; MUSICAL ACOUSTICS. [R.W.Y.]

**Harmonic motion** A periodic motion that is a sinusoidal function of time. It is often called simple harmonic motion (SHM). It is the simplest possible type of vibratory motion. The motion is symmetric about its midpoint, at which the velocity is greatest and the acceleration is zero. At the extreme displacements or turning points, the velocity is zero, and the acceleration is a maximum. The motion is characterized by a unique frequency (without overtones).

Harmonic motion may be present in very simple mechanisms. For example, if a wheel is rotating at a constant speed about a fixed axis, the projection on any fixed line of the motion of a point on the wheel is simple harmonic. Harmonic motion may also result from the response of a vibrating system to a periodic—in particular a sinusoidal—force. Harmonic motion is the typical motion of most simple systems that have been displaced from a position of stable equilibrium and then released, provided that the damping is negligible. The motion of a pendulum is approximately simple harmonic for small amplitudes. See PENDULUM.

The realization that atoms are continually vibrating in motions that are nearly harmonic is essential for understanding many properties of matter, including molecular spectra, heat capacity, and heat conduction. See DAMPING; FORCED OSCILLATION; HARMONIC OSCILLATOR; LATTICE VIBRATIONS; MOLECULAR STRUCTURE AND SPECTRA; PERIODIC MOTION; VIBRATION; WAVE MOTION. [J.M.Ke.]

**Harmonic oscillator** Any physical system that is bound to a position of stable equilibrium by a restoring force or torque proportional to the linear or angular displacement from this position. If such a body is disturbed from its equilibrium position and released, and if damping can be neglected, the resulting vibration will be simple harmonic motion, with no overtones. The frequency of vibration is the natural frequency of the oscillator, determined by its inertia (mass) and the stiffness of its restoring force.

The harmonic oscillator is not restricted to a mechanical system, but might, for example, be electric. Typical electronic oscillators, however, are only approximately harmonic.

If a harmonic oscillator, instead of vibrating freely, is driven by a periodic force, it will vibrate harmonically with the period of the force; initially the natural frequency will also be present, but any damping will eventually remove the natural motion. See DAMPING; FORCED OSCILLATION; HARMONIC MOTION.

In both quantum mechanics and classical mechanics, the harmonic oscillator is an important problem. It is one of the few rigorously soluble problems of quantum mechanics. The quantum-mechanical description of electromagnetic, electronic, mesonic, and other fields is usually carried out in terms of a (time) Fourier analysis. The individual Fourier components of noninteracting fields are independent harmonic oscillators. See ANHARMONIC OSCILLATOR. [J.M.Ke.]

**Harmonic speed changer** A mechanical-drive system used to transmit rotary, linear, or angular motion at high ratios and with positive motion. In the rotary version, shown schematically in the illustration, the drive consists of a rigid circular spline, an input wave generator, and a flexible spline. Any one of these can be fixed, used as the input, or used as the output. Any combination (fixed, driver, or driven) may be used. See SPLINES.

The advantages of this drive are (1) high-ratio gearing in small space, (2) speed reduction (or increase) in fixed ratio up to 1000:1 in one unit, (3) negligible wear of teeth, (4) balanced bearing loads, (5) negligible backlash, (6) efficiency of approx-

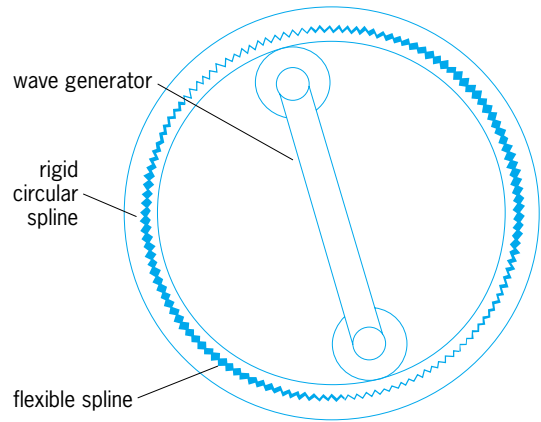

Rotary-to-rotary harmonic speed changer.

imately 80% in a gear ratio of 400:1, and (7) adaptability to rotary-to-rotary, rotary-to-linear, and linear-to-linear drives. See GEAR DRIVE. [P.H.B.]

**Harpacticoida** An order of the Copepoda, with about 1700 species known. Their form is variable but is generally linear and more or less cylindrical (see illustration). These animals are minute and vary in length from 1/64 to 1/8 in. (0.4 to 3 mm). As a rule, the first thoracic segment is incorporated with the cephalothorax, and the last thoracic segment is included in the abdomen.

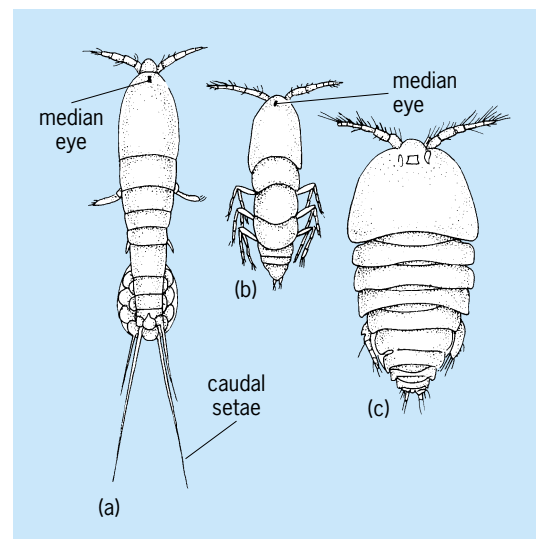

Some typical harpacticoids. (a) *Harpacticus chelifer*. (b) *Parategastes spaericus*. (c) *Alteutha interrupta*.

Harpacticoids have a worldwide distribution. They occur in all kinds of aquatic habitats, especially marine, but also among moss and leaves. In the sea they range from the shore to abyssal depths. In general, they are free-living and benthonic; some species are pelagic, parasitic, or commensal. See COPEPODA. [K.L.]

**Hassium** A chemical element, symbol Hs, atomic number 108. It was synthesized and identified in 1984 by using the Universal Linear Accelerator (UNILAC) at Darmstadt, West Germany, by the same team (led by P. Armbruster and G. Müzenberg) which first identified bohrium and meitnerium. The isotope  $^{265}\text{Hs}$  was produced in a fusion reaction by bombarding a  $^{208}\text{Pb}$  target with a beam of  $^{58}\text{Fe}$  projectiles. See PERIODIC TABLE.

The discovery of bohrium and meitnerium was made by detection of isotopes with odd proton and neutron numbers. In this region, odd-odd nuclei show the highest stability against fission. Elements with an even atomic number are intrinsically less stable against spontaneous fission. The isotopes of hassium were expected to decay by spontaneous fission—which explains why meitnerium was synthesized before hassium.

As in the case of bohrium and meitnerium, the isotope was produced by fusion in a one-neutron deexcitation channel; in this case the compound system was  $^{266}\text{Hs}$ . The reaction mechanism again was cold fusion. The isotope  $^{265}\text{Hs}$  has a half-life of about 2 ms and decays by emission of an alpha particle of 10.36 MeV.

The elements bohrium, hassium, and meitnerium are stabilized by shell effects against spontaneous fission; this special stability may occur because these nuclei may prefer a sausage shape which is predicted to be energetically most favorable for them. See BOHRUM; MEITNERIUM; TRANSURANIUM ELEMENTS. [PAr.]

**Hatchettite** Mountain tallow, a yellow-white to yellow-green hydrocarbon occurring in Belgian coal seams; it is also called hatchettine. Hatchettite is translucent but darkens on exposure to air. It is soft, has no odor, is greasy to the touch, and consists of 85.5% carbon and 14.5% hydrogen. Its index of refraction is 1.47–1.50; it melts at 46–47°C (115–117°F), is sparingly soluble in alcohol or ether, decomposes in concentrated sulfuric acid, and has a specific gravity of 0.89–0.98. [I.A.B.]

**Hausmannite** A mineral with composition  $\text{Mn}^{2+}\text{Mn}_2^{3+}\text{O}_4$ . Hausmannite is most frequently massive-granular and possesses one perfect basal cleavage. The color is black, and streak dark brown. Hardness is 5.5 on Mohs scale, and the specific gravity is 4.81. It is an occasional ore of manganese, and it most frequently occurs in metamorphosed sedimentary manganese ore deposits, such as some small deposits in central Sweden and in the Central Provinces, India. [P.B.M.]

**Hazardous waste** Any solid, liquid, or gaseous waste materials that, if improperly managed or disposed of, may pose substantial hazards to human health and the environment. Every industrial country in the world has had problems with managing hazardous wastes. Improper disposal of these waste streams in the past has created a need for very expensive cleanup operations. Efforts are under way internationally to remedy old problems caused by hazardous waste and to prevent the occurrence of other problems in the future.

A waste is considered hazardous if it exhibits one or more of the following characteristics: ignitability, corrosivity, reactivity, and toxicity. Ignitable wastes can create fires under certain conditions; examples include liquids, such as solvents, that readily catch fire, and friction-sensitive substances. Corrosive wastes include those that are acidic and those that are capable of corroding metal (such as tanks, containers, drums, and barrels). Reactive wastes are unstable under normal conditions. They can create explosions, toxic fumes, gases, or vapors when mixed with water. Toxic wastes are harmful or fatal when ingested or absorbed. When they are disposed of on land, contaminated liquid may drain (leach) from the waste and pollute groundwater. See GROUND-WATER HYDROLOGY; WATER POLLUTION.

Hazardous wastes may arise as by-products of industrial processes. They may also be generated by households when commercial products are discarded. These include drain openers, oven cleaners, wood and metal cleaners and polishes, pharmaceuticals, oil and fuel additives, grease and rust solvents, herbicides and pesticides, and paint thinners.

The predominant waste streams generated by industries in the United States are corrosive wastes, spent acids, and alkaline materials used in the chemical, metal-finishing, and petroleum-refining industries. Many of these waste streams contain heavy metals, rendering them toxic. Solvent wastes are generated in large volumes both by manufacturing industries and by a wide

range of equipment maintenance industries that generate spent cleaning and degreasing solutions. Reactive wastes come primarily from the chemical industries and the metal-finishing industries. The chemical and primary-metals industries are the major sources of hazardous wastes.

There is a growing acceptance throughout the world of the desirability of using waste management hierarchies for solutions to problems of hazardous waste. A typical sequence involves source reduction, recycling, treatment, and disposal. Source reduction comprises the reduction or elimination of hazardous waste at the source, usually within a process. Recycling is the use or reuse of hazardous waste as an effective substitute for a commercial product or as an ingredient or feedstock in an industrial process.

Treatment is any method, technique, or process that changes the physical, chemical, or biological character of any hazardous waste so as to neutralize such waste; to recover energy or material resources from the waste; or to render such waste nonhazardous, less hazardous, safer to manage, amenable for recovery, amenable for storage, or reduced in volume. Disposal is the discharge, deposit, injection, dumping, spilling, leaking, or placing of hazardous waste into or on any land or body of water so that the waste or any constituents may enter the air or be discharged into any waters, including groundwater.

There are various alternative waste treatment technologies, for example, physical treatment, chemical treatment, biological treatment, incineration, and solidification or stabilization treatment. These processes are used to recycle and reuse waste materials, reduce the volume and toxicity of a waste stream, or produce a final residual material that is suitable for disposal. The selection of the most effective technology depends upon the wastes being treated.

There are abandoned disposal sites in many countries where hazardous waste has been disposed of improperly in the past and where cleanup operations are needed to restore the sites to their original state. Cleaning up such sites involves isolating and containing contaminated material, removal and redeposit of contaminated sediments, and in-place and direct treatment of the hazardous wastes involved. As the state of the art for remedial technology improves, there is a clear preference for processes that result in the permanent destruction of contaminants rather than the removal and storage of the contaminating materials. [H.M.F.]

**Head** The region of the body consisting of the skull, its contents, and related structures. Its two principal parts are the cranium, or braincase, and the face.

The skin, hair, and subcutaneous tissues over the top of the skull are collectively known as the scalp. The regions of the cranium take their names from the underlying bones, for example, the temporal, parietal, frontal, and occipital regions.

The intracranial contents include the brain and uppermost portion of the spinal cord with their coverings (meninges), blood vessels, and the important cranial nerves, as well as the cerebrospinal fluid system. Many openings, or foramina, afford means of passage from within the skull for nerves and blood vessels. [T.S.P.]

**Headache** Pain within the head. It is probably the most common complaint for which people seek a physician's help. Headaches can be grouped into three primary categories: vascular, muscle-contraction, and organic.

Vascular headaches include classic and common migraine as well as cluster, toxic, and hypertensive headaches. All are caused by dilation of cerebral blood vessels. Constriction of the blood vessels may also occur in any part of the cerebral vasculature and cause the neurologic symptoms associated with some forms of vascular headache. Migraine affects one side of the head but may be bilateral. Neurologic symptoms, especially visual disturbances, are common. Cluster headache is the occurrence of

migraines in groups or series. The cluster headache is characterized by its one-sided, excruciating attack that is usually localized around one eye. Other forms of vascular headache may be caused by systemic infection or fever, which causes dilation of the blood vessels. The ingestion of alcohol, poisons, or some medications used to treat hypertension or cardiac disease may produce adverse effects, including vascular headaches. See HYPERTENSION.

The most common form of headache is the muscle-contraction or tension headache. It is characterized by dull, constricting pain that can either occur intermittently or continue for days, months, or years. Muscle-contraction headaches usually affect both sides of the head and may be described as having a hat-band distribution of pain.

Very few headaches have an organic cause, such as brain tumor or aneurysm. Headache is not a prominent symptom of brain tumor: if present, headache will become progressively worse and constant, and it may not appear until late in the course of the tumor development. The headache associated with an aneurysm is usually mild until the aneurysm is at the point of rupture. If a patient complains of an exceptionally severe headache, organic disease, such as aneurysm, must be ruled out. See ANEURYSM.

Acute sinus headache is characterized by nasal congestion and fever. The headache is minimal in the morning and increases in severity through the day. Temporomandibular joint (TMJ) disease involves a faulty bite or misalignment of the teeth and can cause a headache. Eye conditions may also cause headache. The increased intraocular pressure of glaucoma, for example, may cause a headache, and so complaints of a recent onset of headache, particularly in the elderly, should prompt a screening for glaucoma. See GLAUCOMA; PAIN. [S.D.]

**Health physics** A branch of the environmental and occupational safety health sciences and professions concerned with the protection of people and the environment from possibly harmful effects of radiation, while providing for the utilization of radiation for the benefit of society. Health physicists are interdisciplinary radiation protection and safety specialists whose expertise draws from environmental science, mathematics, medicine, radiological health, radiation biology, chemistry, and physics. The subject requires understanding of the generation, measurement, and characteristics of radiation; environmental transport of radionuclides; dosimetry; effects of radiation in biological systems; and the regulations and recommendations governing the use of radiation. The field has expanded to include nonionizing as well as ionizing sources of radiation. See DECONTAMINATION OF RADIOACTIVE MATERIALS; DOSIMETER; ENVIRONMENTAL RADIOACTIVITY; NUCLEAR MEDICINE; RADIATION INJURY (BIOLOGY); RADIATION SHIELDING; RADIOACTIVE TRACER; RADIOACTIVITY; RADIOACTIVITY AND RADIATION APPLICATIONS; RADIOECOLOGY; RADIOGRAPHY; RADIOLOGY; RADON. [M.Gol.]

**Hearing (human)** The general perceptual behavior and the specific responses that are made in relation to sound stimuli. The auditory system consists of the ear and the auditory nervous system. The ear comprises outer, middle, and inner ear. The outer ear, visible on the surface of the body, directs sounds to the middle ear, which converts sounds into vibrations of the fluid that fills the inner ear. The inner ear contains the vestibular and the auditory sensory organs. See EAR (VERTEBRATE).

The auditory part of the inner ear, known as the cochlea because of its snaillike shape, analyzes sound in a way that resembles spectral analysis. It contains the sensory cells that convert sounds into nerve signals to be conducted through the auditory portion of the eighth cranial nerve to higher brain centers. The neural code in the auditory nerve is transformed as the information travels through a complex system of nuclei connected by fiber tracts, known as the ascending auditory pathways. They

carry auditory information to the auditory cortex, which is the part of the sensory cortex where perception and interpretation of sounds are believed to take place. Interaction between the neural pathways of the two ears makes it possible for a person to determine the direction of a sound's source. See BINAURAL SOUND SYSTEM; BRAIN.

**Role of the ear.** The pinna, the projecting part of the outer ear, collects sound, but because it is small in relation to the wavelengths of sound that are important for human hearing, the pinna plays only a minor role in hearing. The ear canal acts as a resonator: it increases the sound pressure at the tympanic membrane in the frequency range between 1500 and 5000 Hz. The difference between the arrival time of a sound at each of the two ears and the difference in the intensity of the sound that reaches each ear are used by the auditory nervous system to determine the location of the sound source.

Sound that reaches the tympanic membrane causes the membrane to vibrate, and these vibrations set in motion the three small bones of the middle ear: the malleus, the incus, and the stapes. The footplate of the stapes is located in an opening of the cochlear bone—the oval window. Moving in a pistonlike fashion, the stapes sets the cochlear fluid into motion and thereby converts sound (pressure fluctuations in the air) into motion of the cochlear fluid. Motion of the fluid in the cochlea begins the neural process known as hearing.

There are two small muscles in the middle ear: the tensor tympani and the stapedius muscles. The former pulls the manubrium of the malleus inward, while the latter is attached to the stapes and pulls the stapes in a direction that is perpendicular to its pistonlike motion. The stapedius muscle is the smallest striated muscle in the body, and it contracts in response to an intense sound. This is known as the acoustic middle-ear reflex. The muscle's contraction reduces sound transmission through the middle ear and thus acts as a regulator of input to the cochlea. Perhaps a more important function of the stapedius muscle is that it contracts immediately before and during a person's own vocalization, reducing the sensitivity of the speaker's ears to his or her own voice and possibly reducing the masking effect of an individual's own voice. The role of the tensor tympani muscle is less well understood, but it is thought that contraction of the tensor tympani muscle facilitates proper ventilation of the middle-ear cavity. These two muscles are innervated by the facial (VIIth) nerve for the stapedius and the trigeminal (Vth) nerve for the tensor tympani. The acoustic stapedius reflex plays an important role in the clinical diagnosis of disorders affecting the middle ear, the cochlea, and the auditory nerve.

Vibrations in the cochlear fluid set up a traveling wave on the basilar membrane of the cochlea. When tones are used to set the cochlear fluid into vibration, one specific point on the basilar membrane will vibrate with a higher amplitude than any other. Therefore, a frequency scale can be laid out along the basilar membrane, with low frequencies near the apex and high frequencies near the base of the cochlea.

The sensory cells that convert the motion of the basilar membrane into a neural code in individual auditory nerve fibers are located along the basilar membrane. They are also known as hair cells, because they have hairlike structures on their surfaces. The hair cells in the mammalian cochlea function as mechanoreceptors: motion of the basilar membrane causes deflection of the hairs, starting a process that eventually results in a change in the discharge rate of the nerve fiber connected to each hair cell. This process includes the release of a chemical transmitter substance at the base of the hair cells that controls the discharge rate of the nerve fiber (see illustration).

The frequency selectivity of the basilar membrane provides the central nervous system with information about the frequency or spectrum of a sound, because each auditory nerve fiber is "tuned" to a specific frequency. The frequency of a sound is also represented in the time pattern of the neural code, at least for frequencies up to 5 kHz. Thus, the frequency or spectrum of a

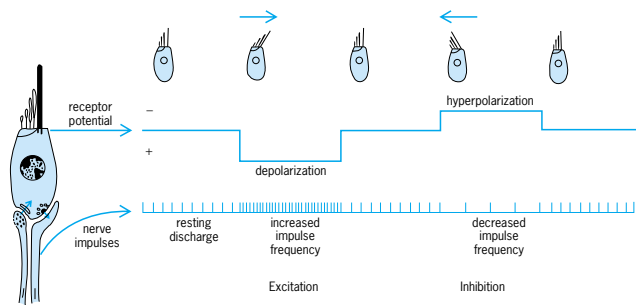

**Schematic illustration of the excitation in hair cells. A deflection of hairs in one direction results in an increase in the neural discharge rate in the nerve fiber associated with the hair cell, whereas a deflection in the opposite direction causes inhibition, or slowing, of this discharge rate. (After A. Flock, *Transducing mechanisms in lateral line canal organ receptors, Proceedings of the Cold Spring Harbor Symposia on Quantitative Biology*, 30:133-146, 1965)**

sound can be coded for place and time in the neural activity in the auditory nervous system. See AUDIOMETRY; PITCH.

**Auditory nervous system.** The ascending auditory nervous system consists of a complex chain of clusters of nerve cells (nuclei), connected by nerve fibers (nerve tracts). The chain of nuclei relays and transforms auditory information from the periphery of the auditory system, the ear, to the central structures, or auditory cortex, which is believed to be associated with the ability to interpret different sounds. Neurons in the entire auditory nervous system are, in general, organized anatomically according to the frequency of a tone to which they respond best, which suggests a tonotopical organization in the auditory nervous system and underscores the importance of representations of frequency in that system. However, when more complex sounds were used to study the auditory system, qualities of sounds other than frequency or spectrum were found to be represented differently in different neurons in the ascending auditory pathway, with more complex representation in the more centrally located nuclei. Thus, the response patterns of the cells in each division of the cochlear nucleus are different, which indicates that extensive signal processing is taking place. Although the details of that processing remain to be determined, the cells appear to sort the information and then relay different aspects of it through different channels to more centrally located parts of the ascending auditory pathway. As a result, some neurons seem to respond only if more than one sound is presented at the same time, others respond best if the frequency or intensity of a sound changes rapidly, and so on.

Another important feature of the ascending auditory pathway is the ability of particular neurons to signal the direction of sound origination, which is based on the physical differences in the sound reaching the two ears. Certain centers in the ascending auditory pathway seem to have the ability to compute the direction to the sound source on the basis of such differences in the sounds that reach the ears.

Knowledge of the descending auditory pathway is limited to the fact that the most peripheral portion can control the sensitivity of the hair cells. See HEARING IMPAIRMENT; LOUDNESS; MASKING OF SOUND; PHONORECEPTION; SIGNAL DETECTION THEORY; SOUND.

[A.R.Mø.]

**Hearing (vertebrate)** The ability to perceive sound arriving from distant vibrating sources through the environmental medium (such as air, water, or ground). The primary function of hearing is to detect the presence, identity, location, and activity of distant sound sources. Sound detection is accomplished using structures that collect sound from the environment (outer ears), transmit sound efficiently to the inner ears (via middle ears), transform mechanical motion to electrical and chemical

processes in the inner ears (hair cells), and then transmit the coded information to various specialized areas within the brain. These processes lead to perception and other behaviors appropriate to sound sources, and probably arose early in vertebrate evolution.

Sound is gathered from the environment by structures that are variable among species. In many fishes, sound pressure reaching the swim bladder or another gas-filled chamber in the abdomen or head causes fluctuations in volume that reach the inner ears as movements. In addition, the vibration of water particles that normally accompany underwater sound reaches the inner ears to cause direct, inertial stimulation. In land animals, sound causes motion of the tympanic membrane (eardrum). In amphibians, reptiles, and birds, a single bone (the columella) transmits tympanic membrane motion to the inner ears. In mammals, there are three interlinked bones (malleus, incus, and stapes). Mammals that live underground may detect ground-borne sound via bone conduction. In whales and other sea mammals, sound reaches the inner ears via tissue and bone conduction.

The inner ears of all vertebrates contain hair-cell mechanoreceptors that transform motion of their cilia to electrochemical events resulting in action potentials in cells of the eighth cranial nerve. Patterns of action potentials reaching the brain represent sound wave features in all vertebrates. All vertebrates have an analogous set of auditory brain centers. See EAR (VERTEBRATE); PHYSIOLOGICAL ACOUSTICS.

Experiments show that vertebrates have more commonalities than differences in their sense of hearing. The major difference between species is in the frequency range of hearing, from below 1 Hz to over 100,000 Hz. In other fundamental hearing functions (such as best sensitivity, sound intensity and frequency discrimination acuity, time and frequency analysis, and source localization), vertebrates have much in common. All detect sound within a restricted frequency range. All species are able to detect sounds in the presence of interfering sounds (noise), discriminate between different sound features, and locate the sources of sound with varying degrees of accuracy.

The sensitivity range is similar among all groups, with some species in all groups having a best sensitivity in the region of -20 to 0 dB. Fishes, amphibians, reptiles, and birds hear best between 100 and 5000 Hz. Only mammals hear at frequencies above 10,000 Hz. Humans and elephants have the poorest high-frequency hearing.

[R.R.F.]

**Hearing aid** A device worn by a person with a hearing loss to amplify sound so that the individual can better recognize the phonetic components of speech, and so communicate orally. A typical hearing aid consists of a microphone, an amplifier, a volume control, an earphone (receiver), a power source, and a coupling to the ear (earmold). When both ears are draining, a vibrator held by a spring headband is utilized to deliver amplified sound by bone conduction. See AMPLIFIER; EARPHONES; MICROPHONE.

Hearing aids are designed in various forms. The body type, also known as the conventional or pocket type, is worn in a garment bag or clipped to the clothing and has a cord connecting the amplifier and receiver. The postauricular or over-the-ear type fits behind the ear; a sound tip attached to plastic tubing conducts sound through an earmold to the ear canal. All components of the in-the-ear type fit into the concha of the ear. This type of hearing aid is normally custom made from an impression taken of the ear. The eyeglass-temple type has all components fitted into the temples of eyeglasses and is made with a receiver and customized earmolds or with vibrators for bone conduction. This type can also be employed for special fittings such as the CROS (contralateral routing of signal) or BICROS (one hearing aid with a microphone in each temple) for people with unilateral profound hearing losses. The components of the all-in-the-canal type fit into a customized shell that is placed in the ear canal. Deep canal fittings are customized canal aids so miniaturized that

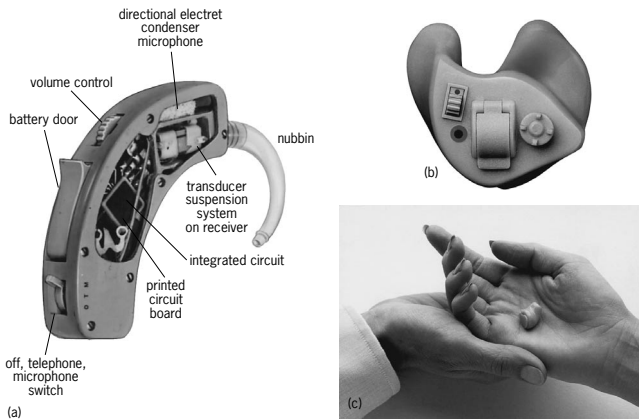

**Hearing aids. (a) Over-the-ear aid with case open to show internal components. (b) In-the-ear aid. (c) In-the-canal aid. (Belltone Electronics Corp.)**

they can be inserted into the bony section of the ear canal close to the eardrum; these hearing aids are completely concealed in the ear canal and provide improved response at high frequencies (see illustration).

The performance characteristics of a hearing aid, namely gain, frequency response, and maximum pressure output, are determined from the audiometric profile of the hearing-impaired individual. Prescriptive procedures have been suggested, based on threshold-of-hearing levels or most-comfortable-loudness levels, for computing the gain and frequency-response characteristics for maximum speech intelligibility for the user. A threshold of uncomfortable loudness at critical frequencies of 500, 1000, 2000, and 4000 Hz is determined so that the selected maximum output of the hearing aid will not exceed discomfort levels. Directional microphones can be employed in hearing aids to reduce background noise and favor speech in the foreground. Speech recognition is enhanced when the hearing aid responds to frequencies in the range 200–6500 Hz and the frequency-response curve is smooth. Potentiometers can be inserted in hearing aids to adjust the gain (amplification factor), frequency response, and maximum pressure output. Compression amplification, a type of automatic gain control, adjusts the gain of the amplifier to amplify weak sounds more than strong ones. The automatic volume control enables the intensity range of speech to be delivered to the hearing-impaired ear within its tolerable or comfortable range of hearing. See AUTOMATIC GAIN CONTROL (AGC); GAIN; POTENTIOMETER; RESPONSE; VOLUME CONTROL SYSTEMS. [E.Z.]

**Hearing impairment** Any alteration of hearing capacity. Hearing impairment can be of various degrees, including mild, moderate, severe, profound, or total. The degree of impairment typically is categorized by the loss of hearing sensitivity, that is, how loud sounds must be for a listener to hear them. The degree of impairment can refer either to the loss of hearing sensitivity for individual pitches of sounds for each ear separately, or to an overall loss of hearing sensitivity for both ears. Hearing impairment is further defined as unilateral if present in only one ear, and as bilateral if present in both ears.

Hearing impairment may be present at birth or acquired later in life. Congenital hearing loss greatly interferes with normal language and speech development if it is bilateral and of severe or greater magnitude over the pitch range that covers speech sounds. Acquired hearing loss can occur gradually or suddenly at any time of life and therefore can also be defined in relation to the development of language and speech. Hearing impairment is often termed prelingual, perilingual, or postlingual if the hearing loss occurred prior to, during, or after the development of language and speech.

The term deafness has two meanings. If it refers only to a total lack of hearing function, a lowercase *d* is used. If it refers to an individual with a bilateral hearing loss who does not use oral language and speech, an uppercase *D* is used.

Hearing loss can be classified by the part of the auditory system that is defective. Conductive hearing loss results from abnormalities or diseases of the outer or middle ear; sensorineural hearing loss results from abnormalities or diseases of the inner ear or auditory nerve; and central hearing impairment results from abnormalities or diseases of the auditory portions of the central nervous system. Combined conductive and sensorineural hearing loss is referred to as mixed hearing loss. See AUDIOMETRY; EAR (VERTEBRATE).

Conductive hearing loss impairs sensitivity to sound; if the sound is amplified, the impairment can usually be overcome. See ACOUSTIC NOISE; LOUDNESS.

In sensorineural hearing loss, the abnormality can affect different portions of the inner ear so that often hearing sensitivity may be normal or nearly so for low-pitched tones but falls off sharply for higher tones. In addition, what is heard may be distorted. The speech of the hearing-impaired person may deteriorate over time because the high-pitched speech sounds cannot be heard. See SPEECH DISORDERS.

In most cases of sensorineural or mixed hearing loss, both sensitivity and clarity are impaired, so the perceived sound is weak and distorted. A hearing aid that amplifies sound fails to correct the distortion, and so the difficulty of understanding speech is only partially remedied. Speech deteriorates for adults who suffer this type of hearing loss after speech has developed normally. For children born with severe or profound bilateral sensorineural hearing loss, special education is required for the acquisition of speech and language. See HEARING AID.

Other symptoms characterize sensorineural hearing loss. Tinnitus—head noise or ringing in the ears that is heard with no related acoustic stimulus—may occur continuously or intermittently, and is described as a rushing or roaring noise. Vertigo and nausea may accompany the hearing deficit if the abnormality affects the vestibular system, as in Ménière's disease. In double hearing, or diplacusis, a single tone is heard at a different pitch in each ear, or simple tones may sound fuzzy or rough. Loudness recruitment, an abnormal increase in perceived loudness as a sound is intensified, may be associated with a low tolerance for loud noises.

Prevention is the best approach to possible loss. Immunization for viral and bacterial diseases, early medical intervention for upper respiratory infections or earaches, keeping both nostrils open when blowing the nose, control of allergies, avoidance of ototoxic drugs, and reduced exposure to loud sounds are desirable preventive measures. Routine hearing tests are also advisable.

Antibiotic control of ear infections is a common treatment for conductive hearing loss, and surgical procedures are also available. Many of these procedures for conductive hearing loss allow hearing to return to normal.

Measures to correct sensorineural deafness are varied. Tranquilizing and antivertiginous drugs, vasodilative agents, and low-salt diets are among the treatments prescribed for the symptomatic management of Ménière's disease, but they have met with only moderate success. The cochlear implant seeks to restore hearing in the completely deaf ear by direct electrical stimulation of the auditory nerve, thereby producing an auditory sensation that can represent environmental sounds and certain speech sounds. Success is not universal, but some with postlingual deafness have improved substantially.

Nonmedical aural rehabilitation for persons with hearing impairment includes the use of hearing aids, special auditory training to use this amplification, and instruction in speech reading (lip reading). Devices that convert sound to skin sensations are sometimes useful when hearing aids fail to provide any benefit.

[G.R.Po.]

**Heart (invertebrate)** Hearts of invertebrates can be categorized according to the source of the electrical rhythmicity that underlies their beat. Rhythmic electrical activity can arise in the muscle itself (myogenic hearts) or in neurons that drive the heart muscle (neurogenic hearts). Most mollusks and some insects appear to have purely myogenic hearts; these hearts beat normally when isolated from neural inputs. Conversely, the hearts of the higher crustaceans and the xiphosuran *Limulus* are usually considered to be purely neurogenic: motor neurons impose their rhythmic electrical activity on heart muscle fibers by means of direct excitatory synapses. Without neural input, the heart ceases to beat. Other invertebrates, including gnathobdellid leeches and some insects, have hearts that can produce a myogenic beat but require rhythmic neural input to coordinate that beat and maintain the proper rate.

In the marine snail *Aplysia*, an organism with a myogenic heart, a muscular heart consisting of an auricle and a ventricle is located in a dorsal pericardial cavity. The rhythmic contractions of the auricle fill the ventricle with hemolymph, which is then pumped through the open circulatory system by the rhythmic contractions of the ventricle. The normal heartbeat period lasts about 3 s. A pair of semilunar valves prevents backflow of hemolymph into the auricle during ventricular contraction. Three arteries issue from the ventricle toward the anterior, and a single semilunar valve prevents backflow from them during ventricular expansion. The arteries carry the hemolymph to the various body organs, where they end in tissue spaces. The hemolymph then collects in the hemocoel and returns to the heart by two parallel veins, one through the kidney and one through the gill. Although the *Aplysia* heart is innervated, its normal beat persists after denervation.

The lobster is an example of an organism with a neurogenic heart. A muscular heart pumps hemolymph through the open circulatory system. This heart is located dorsally along the thoracic midline and is suspended within a pericardial cavity by ligaments. The heartbeat period lasts about 2 s. Large anterior- and posterior-going arteries, which branch extensively to supply various body organs, issue from the heart. Semilunar valves, located at the juncture of each artery with the heart, prevent backflow of blood into the heart when it relaxes. Hemolymph enters the heart from the pericardial sinus through six ostia, which have valves to ensure unidirectional flow. The rhythmic discharge of motor neurons innervating the heart by way of excitatory chemical synapses produces the heartbeat. These motor neurons are located in the cardiac ganglion on the inner dorsal surface of the heart. The cardiac ganglion contains only nine neurons, which generate a simple two-phased rhythm of electrical activity. The four posterior small cells (cells 6–9) are interneurons, and the five anterior large cells (cells 1–5) are the motor neurons. See NERVOUS SYSTEM (INVERTEBRATE). [R.L.Ca.; C.S.Co.]

**Heart (vertebrate)** The muscular pumping organ of the cardiovascular system. The heart typically lies ventrally, near the anterior end of the trunk; it is ventral and medial to the gills in fish and at the base of the neck or in the chest region of tetrapods. In humans it is located behind the breastbone and ribs between the third and fifth costal cartilages. Its anterior portion or base is directed to the right and dorsally and is the area where the great vessels enter and leave the heart. The lower muscular portion ends in a blunt apex which lies behind the fifth costal cartilage on the left.

The muscular wall of the heart, the myocardium, is lined by an inner endocardium and is covered externally by membranous visceral pericardium. There are coronary arteries and veins to and from the heart, which has a specialized neuromuscular conducting system and autonomic nerve supply.

In fishes the heart is basically a simple tube which becomes subdivided into four successive chambers, the sinus venosus, atrium, ventricle, and conus arteriosus. Blood from the body

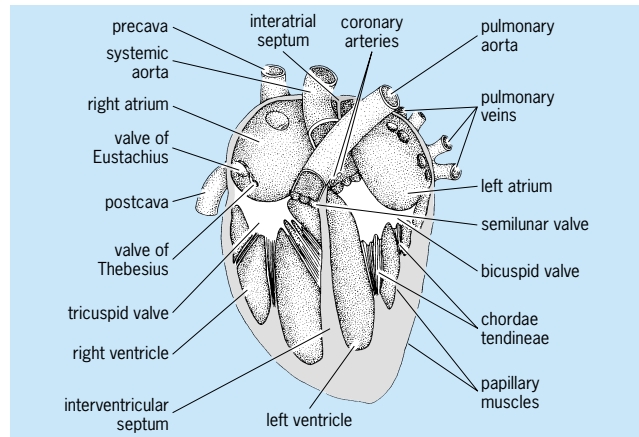

**Internal structure of four-chambered mammalian heart, ventral view. (After C. K. Weichert, *Anatomy of the Chordates*, 2d ed., McGraw-Hill, 1958)**

enters the sinus and leaves the conus to go to the gills to be oxygenated. The ventricle supplies the main pumping force.

When lungs are introduced into the system in lungfish and tetrapods, the mixing of oxygenated and nonoxygenated blood becomes a problem. In brief, the sinus venosus and conus arteriosus disappear, becoming incorporated into the other chambers or the bases of the great vessels. At the same time the atrium and later the ventricle become divided into right and left chambers by a median septum.

In birds and mammals including humans (see illustration) the medial fibromuscular septum divides the heart into two lateral halves, each consisting of a thin-walled receiving chamber or atrium and a thicker, muscular pumping chamber or ventricle. Blood enters the right atrium from the superior and inferior venae cavae which drain most of the body. It passes through the tricuspid valve to the right ventricle and is pumped to the lungs during systole, or contraction of the heart. Blood returns from the lungs by way of the pulmonary veins to the left atrium, passes into the left ventricle through the mitral valve, and during contraction is pumped out into the aorta. See CARDIOVASCULAR SYSTEM. [T.S.P.]

**Heart disorders** Pathologies of the heart and its blood vessels. Almost all cardiovascular disorders eventually progress to serious debilitating stages characterized by heart failure (reduced pumping function), dysrhythmias (abnormal electrical rhythms), and sudden death. Coronary atherosclerosis, a disease causing obstruction of the arteries that supply nutrient blood to heart muscle, is the leading cause of cardiovascular mortality. Hypertension (high blood pressure) is another important cause. Valvular heart disease, cardiomyopathies (disease of heart muscle), and congenital heart disease are less common.

**Coronary disease.** The coronary arteries carry oxygen and nutrients to the heart muscle. Obstructive disease of these arteries is almost always caused by atherosclerosis, a pathologic process that produces a fatty deposition and thickening of the inner surface of the artery, eventually restricting the flow of blood through the artery. The capacity to deliver blood to the heart muscle is increasingly limited. Heart muscle function declines, and the individual experiences characteristic discomfort in the chest called angina pectoris. Angina pectoris is relieved by rest or medications that improve the balance between myocardial oxygen demands and coronary blood (and oxygen) supply. See ARTERIOSCLEROSIS.

Coronary artery disease can be complicated by the abrupt formation of a blood clot (thrombus) at the site of an atherosclerotic plaque. When the artery is incompletely obstructed, unstable angina or angina at rest may develop. This is a dynamic condition that is complicated by spasms of the involved artery. When the artery becomes completely occluded, a myocardial

infarction or heart attack results, causing irreversible injury to the heart muscle (myocardium) supplied by the occluded artery. Complications and deaths are directly related to the size of the infarction. See INFARCTION; THROMBOSIS.

Several characteristics or risk factors are associated with a high likelihood that coronary disease will develop. They include cigarette smoking, elevated levels of blood cholesterol, hypertension, and a family history of the disease. Other risk factors include diabetes, a lack of exercise, and obesity. By modifying or eliminating these factors, the risk of developing coronary disease can be reduced. See CHOLESTEROL; DIABETES; HYPERTENSION; OBESITY.

**Hypertensive heart disease.** High blood pressure results in an excessive cardiac work load. The heart responds to the high pressure through a growth process called hypertrophy. As a result, the mass of the heart muscle is increased, and the work requirement of each unit of heart muscle returns toward normal. Unfortunately, this compensatory increase in cardiac mass eventually results in heart failure and other morbid cardiovascular events. Antihypertensive drugs are effective in the treatment of hypertension and its consequences.

**Valvular heart disease.** Heart valves ensure an efficient forward blood flow through the heart. Disease of these valves can be caused by rheumatic fever or degenerative noninflammatory processes.

**Congenital heart disease.** About 1% of all newborns have a structural abnormality of the heart or adjacent blood vessels. Such congenital heart disease can be caused by maternal rubella, or it may be inherited, as in Down syndrome. However, the cause of most congenital heart disease is unknown. Defects in the walls between the atria and the ventricles are the most common congenital malformations. A blood shunt between the pulmonary artery and the aorta also causes a recirculation of oxygenated blood through the lungs; this defect occurs when there is an abnormal persistence of the fetal connection between the two vessels. See CONGENITAL ANOMALIES; DOWN SYNDROME.

**Cardiomyopathies.** Heart muscle disease that is caused by excessive intake of alcohol, some drugs, or infections may cause depression of myocardial function and cardiac enlargement. The resulting dilated cardiomyopathy causes shortness of breath and fatigue. Less commonly, inappropriate growth of the myocardium has occurred in the absence of enlargement of the chamber. This hypertrophic cardiomyopathy causes anginalike chest pain, shortness of breath, and fainting spells.

**Heart failure.** Congestive heart failure is a clinical syndrome that consists of shortness of breath, fatigue, and retention of fluid. It is caused by failure of the heart as a pump; thus, heart failure can be caused by almost any form of heart disease.

**Sudden cardiac death.** Most cases of sudden death result from inadequate pumping and low cardiac output during a rapid cardiac dysrhythmia, such as ventricular tachycardia or ventricular fibrillation. See HEART (VERTEBRATE). [W.H.Ga.; F.J.V.]

**Heartwater disease** A rickettsial disease, also known as cowdriosis, which is caused by the microorganism *Cowdria ruminantium* and is transmitted by ticks of the genus *Amblyomma*. The disease occurs in wild and domestic ruminants, primarily cattle, sheep, and goats, in sub-Saharan Africa and some Caribbean islands (for example, Guadeloupe, Antigua, and Marie-Galante).

Heartwater disease is characterized by fluid in the pericardium of the heart, high fever, lung edema, and nervous symptoms that range from mild incoordination and exaggerated reflexes to convulsions seen in acute infections. The course of acute heartwater disease is 2–6 days, and recovery is rare. However, young animals have a high rate of natural resistance.

The organism is susceptible to tetracycline antibiotics. However, once marked nervous symptoms have developed, recovery usually does not occur. See ANTIBIOTIC.

Control and prevention of heartwater is achieved by tick control or immunization. [K.M.K.]

**Heartworms** Heartworm (*Dirofilaria immitis*) is a nematode parasite that resides within the host's large pulmonary arteries and right heart chambers. It primarily infests dogs but may also infest foxes, wolves, coyotes, ferrets, sea lions, horses, and cats. A dog can be infested with one to several hundred adult heartworms, which can grow to 12 in. (30 cm). During their 3–5-year life-span, heartworms can cause serious and often life-threatening damage to the heart and lungs. Endemic areas require a reservoir of infected animals (usually dogs) and the presence of mosquitoes, the intermediate host, which transmit the larval stages to a new host.

Adult female heartworms release their microscopic offspring called microfilariae into the bloodstream. A mosquito becomes infested with these circulating microfilariae while taking a blood meal from the dog. The microfilariae develop into mature larvae within the mosquito during the next 10–14 days. As the mosquito feeds again, the mature larvae are injected into the new host. Once in the dog, it takes approximately 6 months for these larvae to complete the cycle by migrating to the large arteries of the lung and right chambers of the heart.

Adult heartworms stimulate a progressive proliferation of the artery lining (endarteritis) that gradually restricts the blood flow to the lungs. The resulting increase in the pulmonary artery blood pressure (pulmonary hypertension) causes the right ventricle to pump harder, eventually leading to right heart failure. In advanced cases the lung fibrosis and heart changes may be permanent. When adult worms die either naturally or with treatment, their fragments become lodged distally in the smaller pulmonary arteries causing an exaggerated proliferation of the vessel lining, the formation of blood clots, and an intense local inflammatory reaction. Blood flow is severely restricted or totally blocked, resulting in severe coughing, coughing up blood, and difficulty in breathing (dyspnea).

Initial signs of disease include coughing, exercise intolerance, and weight loss. As the disease progresses, these symptoms become more pronounced. With advanced disease, dogs begin to exhibit progressive signs of pulmonary disease and associated heart failure, including fainting spells, collapse, difficulty in breathing, coughing up blood, and fluid accumulation around the lungs (hydrothorax) or within the abdominal cavity (ascites). Rarely, a rapidly fatal condition called vena caval syndrome may be observed in young dogs with massive heartworm infestation.

Heartworm infection can usually be determined by examining a blood sample for the presence of circulating microfilariae. Those infestations in which the adults produce no circulating microfilariae are termed occult infections, which can be accurately diagnosed by identifying specific circulating immunologic substances (uterine antigens) released into the blood by adult females.

All but the most advanced cases of heartworm disease can usually be treated successfully. Treatment involves multiple steps to eliminate both adult and microfilariae stages. Daily or monthly heartworm preventive medication is strongly recommended, especially during the mosquito season, in infested areas. The objective is killing the infectious larval stages before they develop into adults. Only dogs that test negative for heartworms should be placed on preventive medication because of the risk of serious reactions. [W.D.F.]

**Heat** For the purposes of thermodynamics, it is convenient to define all energy while in transit, but unassociated with matter, as either heat or work. Heat is that form of energy in transit due to a temperature difference between the source from which the energy is coming and the sink toward which the energy is going. The energy is not called heat before it starts to flow or after it has ceased to flow. A hot object does contain energy, but calling this energy heat as it resides in the hot object can lead to widespread confusion. See ENERGY; INTERNAL ENERGY; TEMPERATURE; THERMODYNAMIC PRINCIPLES. [H.C.W.; W.A.S.]

**Heat balance** An application of the first law of thermodynamics to a process in which any work terms are negligible.

For a closed system, one that always consists of the same material, the first law is  $Q + W = \Delta E$ , where  $Q$  is the heat supplied to the system,  $W$  is the work done on the system, and  $\Delta E$  is the increase in energy of the material forming the system. It is convenient to treat  $\Delta E$  as the sum of changes in mechanical energy, such as kinetic energy and potential energy in a gravitational field, and of internal energy  $\Delta U$  that depends on changes in the thermodynamic state of the material. Because the rates at which any changes occur are usually of interest, heat balances are often written in terms of heat flow rates (heat per unit time), sometimes denoted by a dot over the symbol,  $\dot{Q}$ , so that for a process with negligible work, kinetic energy and potential energy terms,  $\dot{Q} = \dot{Q}_{IN} - \dot{Q}_{OUT} = dU/dt$ , the rate of change of internal energy with time.

Often it is more convenient to apply the first law or a heat balance to an open system, a fixed region or control volume across the boundaries of which materials may travel and inside which they may accumulate, such as a building, an aircraft engine, or a section of a chemical process plant. Then the first law is expressed by the equation below, where  $\dot{W}_S$  is the rate of doing shaft work on the system;  $\dot{m}$  is the mass flow rate of any stream entering or

$$\dot{Q} + \dot{W}_S = \sum \dot{m} (h + c^2/2 + gz)_{OUT} - \sum \dot{m} (h + c^2/2 + gz)_{IN} + dE/dt$$

leaving the control volume;  $h$  is the enthalpy per unit mass;  $c$  is the velocity;  $gz$  is the gravitational potential for each stream at the point of crossing the boundary of the control volume; and  $E$  is the energy of all material inside the control volume. When conditions inside the control volume do not change with time, although they need not be spatially uniform,  $dE/dt = 0$ , and the balance equation is known as the steady-flow energy equation.

Enthalpy is a thermodynamic property defined by  $h = u + pv$ , where  $u$  is the specific internal energy (enthalpy per unit mass),  $p$  the pressure, and  $v$  the specific volume. It is used, along with shaft work, because the derivation of the first-law equation for a control volume from the more fundamental equation for a closed system involves work terms  $pv$  that are not available for use outside the control volume. Changes in enthalpy occur because of changes in temperature, pressure, physical state (for example, from liquid to vapor), and changes in chemical state. See ENTHALPY; THERMODYNAMIC PRINCIPLES; THERMODYNAMIC PROCESSES.

[D.B.R.K.]

**Heat balance, terrestrial atmospheric** The balance of various types of energy in the atmosphere and at the Earth's surface. At the top of the atmosphere, the incoming solar radiation that is absorbed by the Earth-atmosphere system is approximately balanced by the terrestrial radiation emitted from this system over long periods of time. The flux of solar energy (energy per time) across a surface of unit area normal to the solar beam at the mean distance between the Sun and the Earth is referred to as the solar constant. Based on recent satellite measurements, a value of 1365 watts per square meter ( $W/m^2$ ) for the solar constant has been suggested. Because the area of the spherical Earth is four times that of its cross section facing the parallel solar beam, the top of the Earth's atmosphere receives an average of about  $341 W/m^2$ . Based on measurements from satellite radiation budget experiments, about 30% of this is reflected back to space, and is referred to as the global albedo. The reflecting power of the Earth-atmosphere system includes the scattering of molecules, aerosols, and various types of clouds, as well as reflection by different surfaces. Thus, only about 70% of the incoming solar flux, that is, about  $239 W/m^2$ , is absorbed within the Earth-atmosphere system. For this system to be in thermodynamic equilibrium or balance, it must emit the same amount of thermal infrared radiation. See ALBEDO; SOLAR CONSTANT; SOLAR ENERGY.

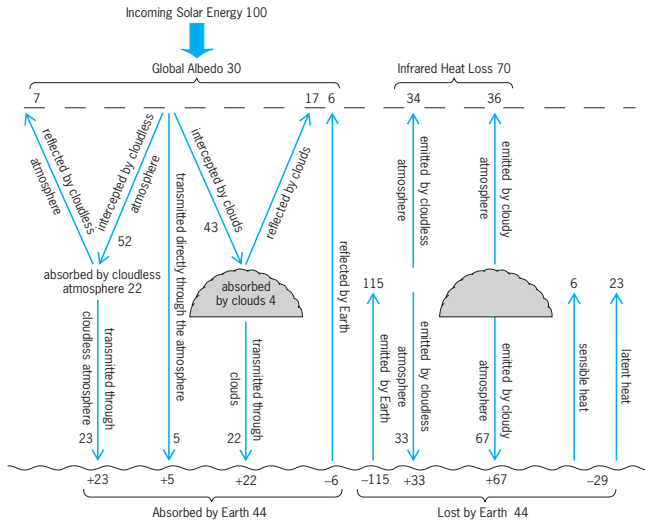

**Heat balance of the Earth-atmosphere system.** The incoming solar energy is taken to be 100 units. On a climatic scale, the incoming solar energy at the top of the atmosphere is approximately balanced by the reflected solar energy and thermal infrared heat loss. At the surface, the heat balance involves sensible and latent heat components, in addition to net radiative energy.

For the presentation of internal heat balance components, the effective solar constant of  $341 W/m^2$  may be arbitrarily represented by 100 units (see illustration). Of these units, roughly 26 are absorbed within the atmosphere, including 22 by clear column and 4 by clouds. A total of 30 units are reflected back to space, including about 7 from clear column, 17 from cloudy atmospheres, and 6 directly from the Earth's surface. The remaining 44 units are absorbed by the surface. The Earth-atmosphere system emits terrestrial radiation according to its temperature and composition distributions. The upward flux from the warmer surface accounts for about 115 units. The colder troposphere emits both upward and downward fluxes, with about 70 and 100 units at the top and surface, respectively. The clear and cloudy portions are 34 and 36 at the top and 33 and 67 at the surface, respectively. The net upward flux at the surface, representing the difference between the flux emitted by the surface and the downward flux from the atmosphere reaching the surface, is about 15 units. See HEAT BALANCE; TERRESTRIAL RADIATION.

As a result of thermal emission, the atmosphere loses 55 units. With absorption of the incoming solar flux contributing only 26 units, the net radiative loss from the atmosphere amounts to about 29 units. This deficit is balanced by convective fluxes of sensible and latent heat associated with temperature gradient and evaporation. Based on statistical analyses, the average annual ratio of sensible to latent heat loss at the surface has a global value of about 0.27. It follows that the latent and sensible heat components are about 23 and 6 units, respectively, in order to produce an overall heat balance at the surface (see illustration). The atmosphere experiences a net radiative cooling that must be balanced by the latent heat of condensation released in precipitation processes and by the convection and conduction of sensible heat from the underlying surface. [K.N.L.]

**Heat capacity** The quantity of heat required to raise a unit mass of homogeneous material one unit in temperature along a specified path, provided that during the process no phase or chemical changes occur, is known as the heat capacity of the material in question. Moreover, the path is so restricted that the only work effects are those necessarily done on the surroundings to cause the change to conform to the specified path. The path is usually at either constant pressure or constant volume.



In accordance with the first law of thermodynamics, heat capacity at constant pressure  $C_p$  is equal to the rate of change of enthalpy with temperature at constant pressure  $(\partial H/\partial T)_p$ . Heat capacity at constant volume  $C_v$  is the rate of change of internal energy with temperature at constant volume  $(\partial U/\partial T)_v$ . Moreover, for any material, the first law yields the relation

$$C_p - C_v = \left[ P + \left( \frac{\partial U}{\partial V} \right) \right]_T \left( \frac{\partial U}{\partial T} \right)_p$$

See ENTHALPY; INTERNAL ENERGY; THERMODYNAMIC PRINCIPLES.  
[H.C.W.]

**Heat exchanger** A device used to transfer heat from a fluid flowing on one side of a barrier to another fluid (or fluids) flowing on the other side of the barrier.

When used to accomplish simultaneous heat transfer and mass transfer, heat exchangers become special equipment types, often known by other names. When fired directly by a combustion process, they become furnaces, boilers, heaters, tube-still heaters, and engines. If there is a change in phase in one of the flowing fluids—condensation of steam to water, for example—the equipment may be called a chiller, evaporator, sublimator, distillation-column reboiler, still, condenser, or cooler-condenser.

Heat exchangers may be so designed that chemical reactions or energy-generation processes can be carried out within them. The exchanger then becomes an integral part of the reaction system and may be known, for example, as a nuclear reactor, catalytic reactor, or polymerizer.

Heat exchangers are normally used only for the transfer and useful elimination or recovery of heat without an accompanying phase change. The fluids on either side of the barrier are usually liquids, but they may also be gases such as steam, air, or hydrocarbon vapors; or they may be liquid metals such as sodium or mercury. Fused salts are also used as heat-exchanger fluids in some applications.

Most often the barrier between the fluids is a metal wall such as that of a tube or pipe. However, it can be fabricated from flat metal plate or from graphite, plastic, or other corrosion-resistant materials of construction.

Heat exchangers find wide application in the chemical process industries, including petroleum refining and petrochemical processing; in the food industry, for example, for pasteurization of milk and canning of processed foods; in the generation of steam for production of power and electricity; in nuclear reaction systems; in aircraft and space vehicles; and in the field of cryogenics for the low-temperature separation of gases. Heat exchangers are the workhorses of the entire field of heating, ventilating, air-conditioning, and refrigeration. See CONDUCTION (HEAT); CONVECTION (HEAT); COOLING TOWER; DISTILLATION; EVAPORATOR; FURNACE; HEAT RADIATION; HEAT TRANSFER; TUBE-STILL HEATER; VAPOR CONDENSER.  
[R.F.F.]

**Heat insulation** Materials whose principal purpose is to retard the flow of heat. Thermal- or heat-insulation materials may be divided into two classes, bulk insulations and reflective insulations. The class and the material within a class to be used for a given application depend upon such factors as temperature of operation, ambient conditions, mechanical strength requirements, and economics.

Examples of bulk insulation include mineral wool, vegetable fibers and organic papers, foamed plastics, calcium silicates with asbestos, expanded vermiculite, expanded perlite, cellular glass, silica aerogel, and diatomite and insulating firebrick. They retard the flow of heat, breaking up the heat-flow path by the interposition of many air spaces and in most cases by their opacity to radiant heat.

Reflective insulations are usually aluminum foil or sheets, although occasionally a coated steel sheet, an aluminized paper, or even gold or silver surfaces are used. Refractory metals, such as tantalum, may be used at higher temperatures. Their effec-

tiveness is due to their low emissivity (high reflectivity) of heat radiation. See EMISSIVITY.

The distinguishing property of bulk thermal insulation is low thermal conductivity. For a given thickness of material exposed to a given temperature difference, the rate of heat flow per unit area is directly proportional to the thermal conductivity of the material. See CONDUCTION (HEAT).  
[H.F.R.]

**Heat pipe** A device for transferring heat efficiently between two locations by using the evaporation and condensation of a fluid contained therein. Heat pipes have many applications in areas where reliable performance and low cost are of prime importance—for example, in electronics and heat exchangers. See HEAT EXCHANGER.

The heat pipe, the idea of which was first suggested in 1942, is similar in many respects to the thermosiphon. A large proportion of applications do not use heat pipes as strictly defined below, but employ thermosiphons (illus. *a*), sometimes known as gravity-assisted heat pipes. A small quantity of liquid is placed in a tube from which the air is then evacuated, and the tube is sealed. The lower end of the tube is heated, causing liquid to vaporize and the vapor to move to the cooler end of the tube, where it condenses. The condensate is returned to the evaporator section by gravity. Since the latent heat of evaporation is generally high, considerable quantities of heat can be transported with a very small temperature difference between the two ends. Thus the structure has a high effective thermal conductance. The thermosiphon, also known as the Perkins tube, has been used for many years. A wide variety of working fluids have been employed, ranging from helium to liquid metals.

One limitation of the basic thermosiphon is that in order for the condensate to be returned by gravitational force to the evaporator region, the latter must be situated at the lowest point. The heat pipe is similar in construction to the thermosiphon, but in this case provision is made for returning the condensate against a gravity head. A wick, for example a few layers of fine gauze, is commonly used. This is fixed to the inside surface of the tube, and capillary forces return the condensate to the evaporator (illus. *b*). Since the evaporator position is not restricted, the heat pipe may be used in any orientation. If the heat pipe evaporator happens to be in the lowest position, gravitational forces will assist the capillary force. Alternative techniques, including centripetal forces and osmosis, may be used for returning the condensate to the evaporator.

Capillary forces are by far the most common form of condensate return employed, but a number of rotating heat pipes are used for cooling of electric motors and other rotating machinery. In some applications a mechanical pump is used to return condensate in two-phase run-around coil heat recovery systems. While this may be regarded as a retrograde step, it is a much

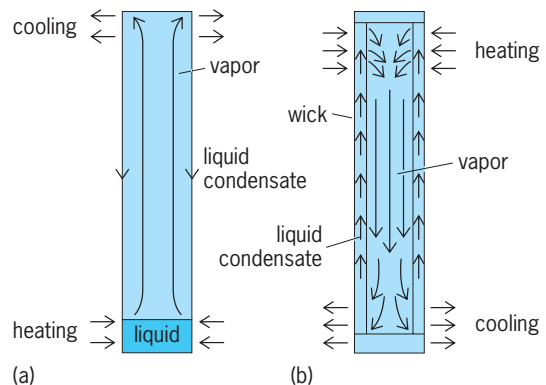

**Heat transfer devices. (a) Thermosiphon. (b) Heat pipe; it can be in any position, not just vertical as shown.**

more effective method for condensate return than reliance on capillary forces.

Applications are related to five principal functions of the heat pipe: separation of heat source and sink, temperature flattening, heat flux transformation, temperature control, and action as a thermal diode or switch. The two major applications, cooling of electronic components and heat exchange, can involve all of these features. In the case of electronics cooling and temperature control, all features can be important. In heat exchangers employing heat pipes, the separation of heat source and sink, and the action as a thermal diode or switch, are most significant.

[D.A.Re.]

**Heat pump** The thermodynamic counterpart of the heat engine. A heat pump raises the temperature level of heat by means of work input. In its usual form a compressor takes refrigerant vapor from a low-pressure, low-temperature evaporator and delivers it at high pressure and temperature to a condenser (see illustration). The pump cycle is identical with the customary vapor-compression refrigeration system. See REFRIGERATION CYCLE.

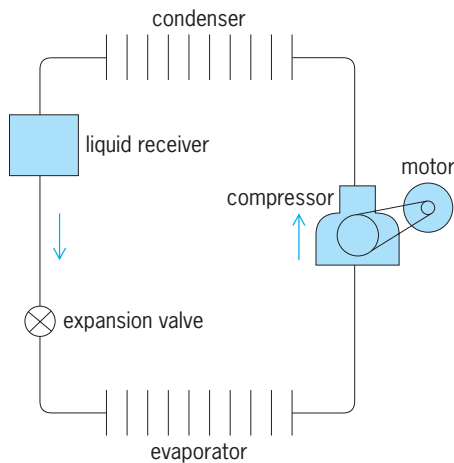

**Basic flow diagram of heat pump with motor-driven compressor. For summer cooling, condenser is outdoors and evaporator indoors; for winter heating, condenser is indoors and evaporator outdoors.**

This dual purpose is accomplished, in effect, by placing the low-temperature evaporator in the conditioned space during the summer and the high-temperature condenser in the same space during the winter. Thus, if 70°F (21°C) is to be maintained in the conditioned space regardless of the season, this would be the theoretical temperature of the evaporating coil in summer and of the condensing coil in winter. The actual temperatures on the refrigerant side of these coils would need to be below 70°F in summer and above 70°F in winter to permit the necessary transfer of heat through the coil surfaces. If the average outside temperatures are 100°F (38°C) in summer and 40°F (4°C) in winter, the heat pump serves to raise or lower the temperature 30° (17°C) and to deliver the heat or cold as required.

The heat pump is also used for a wide assortment of industrial and process applications such as low-temperature heating, evaporation, concentration, and distillation.

[T.Ba.]

**Heat radiation** The energy radiated by solids, liquids, and gases as a result of their temperature. Such radiant energy is in the form of electromagnetic waves and covers the entire electromagnetic spectrum, extending from the radio-wave portion of the spectrum through the infrared, visible, ultraviolet, x-ray, and gamma-ray portions. From most hot bodies on Earth this radiant energy lies largely in the infrared region. See ELECTROMAGNETIC RADIATION; INFRARED RADIATION.

Radiation is one of the three basic methods of heat transfer, the other two methods being conduction and convection. See CONDUCTION (HEAT); CONVECTION (HEAT); HEAT TRANSFER.

A hot plate at 260°F (400 K) may show no visible glow; but a hand which is held over it senses the warming rays emitted by the plate. A temperature of more than 1300°F (1000 K) is required to produce a perceptible amount of visible light. At this temperature a hot plate glows red and the sensation of warmth increases considerably, demonstrating that the higher the temperature of the hot plate the greater the amount of radiated energy. Part of this energy is visible radiation, and the amount of this visible radiation increases with increasing temperature. A steel furnace at 2800°F (1800 K) shows a strong yellow glow. If a tungsten wire (used as the filament in incandescent lamps) is raised by resistance heating to a temperature of 4600°F (2800 K), it emits a bright white light. As the temperature of a substance increases, additional colors of the visible portion of the spectrum appear, the sequence being first red, then yellow, green, blue, and finally violet. The violet radiation is of shorter wavelength than the red radiation, and it is also of higher quantum energy. In order to produce strong violet radiation, a temperature of almost 5000°F (3000 K) is required. Ultraviolet radiation necessitates even higher temperatures. The Sun emits considerable ultraviolet radiation; its temperature is about 10,000°F (6000 K). Such temperatures have been produced on Earth in gases ionized by electrical discharges. The mercury-vapor lamp and the fluorescent lamp emit large amounts of ultraviolet radiation. Temperatures up to 36,000°F (20,000 K), however, are still much too low to produce x-rays or gamma radiation. A gas maintained at temperatures above  $2 \times 10^6$ °F ( $1 \times 10^6$  K), encountered in nuclear fusion experiments, emits x-rays and gamma rays. See NUCLEAR FUSION; SUN; ULTRAVIOLET RADIATION.

A blackbody is defined as a body which emits the maximum amount of heat radiation. Although there exists no perfect blackbody radiator in nature, it is possible to construct one on the principle of cavity radiation. See BLACKBODY.

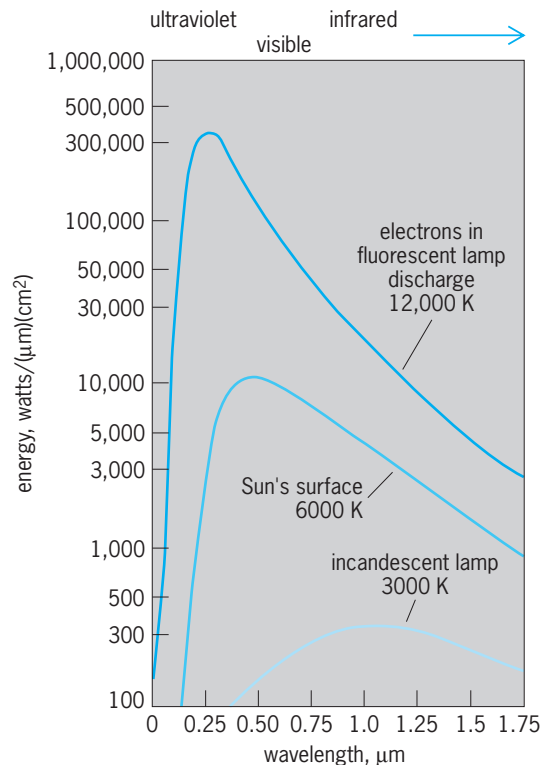

**Graphs of Planck's law for various temperatures.**

A cavity radiator is usually understood to be a heated enclosure with a small opening which allows some radiation to escape or enter. The escaping radiation from such a cavity has the same characteristics as blackbody radiation.

Kirchhoff's law correlates mathematically the heat radiation properties of materials at thermal equilibrium. It is often called the second law of thermodynamics for radiating systems. Kirchhoff's law can be expressed as follows: The ratio of the emissivity of a heat radiator to the absorptivity of the same radiator is a function of frequency and temperature alone. This function is the same for all bodies, and it is equal to the emissivity of a blackbody. A consequence of Kirchhoff's law is the postulate that a blackbody has an emissivity which is greater than that of any other body. See KIRCHHOFF'S LAWS OF ELECTRIC CIRCUITS.

Planck's radiation law represents mathematically the energy distribution of the heat radiation from 1 cm<sup>2</sup> of surface area of a blackbody at any temperature. Formulated by Max Planck early in the twentieth century, it laid the foundation for the advance of modern physics and the advent of quantum theory. Equation (1)

$$R_{\lambda} = 37,418/\lambda^5 [e^{14.388(\lambda T)} - 1] \quad (1)$$

is the mathematical expression of Planck's radiation law, where  $R_{\lambda}$  is the total energy radiated from the body measured in watts per square centimeter per unit wavelength, at the wavelength  $\lambda$ . The wavelength in this formula is measured in micrometers. The quantity  $T$  is the temperature in kelvins, and  $e$  is the base of the natural logarithms. The illustration presents graphs of Planck's law for various temperatures and shows substances which attain these temperatures. It should be noted that these substances will not radiate as predicted by Planck's law since they are not blackbodies themselves.

The Stefan-Boltzmann law states that the total energy radiated from a hot body increases with the fourth power of the temperature of the body. This law can be derived from Planck's law by the process of integration and is expressed mathematically as Eq. (2), where  $R_T$  is the total amount of energy radiated from a

$$R_T = 5.670 \times 10^{-10} T^4 \quad (2)$$

blackbody in watts per square centimeter. When  $R_T$  is multiplied by the total emissivity, the total energy radiated from a real heat radiator is obtained. [H.G.S.; P.J.W.]

**Heat transfer** Heat, a form of kinetic energy, is transferred in three ways: conduction, convection, and radiation. Heat transfer (also called thermal transfer) can occur only if a temperature difference exists, and then only in the direction of decreasing temperature. Beyond this, the mechanisms and laws governing each of these ways are quite different. See CONDUCTION (HEAT); CONVECTION (HEAT); HEAT RADIATION.

By utilizing a knowledge of the principles governing the three methods of heat transfer and by a proper selection and fabrication of materials, the designer attempts to obtain the required heat flow. This may involve the flow of large amounts of heat to some point in a process or the reduction in flow in others. All three methods operate in processes that are commonplace.

In industry, for example, it is generally desired to extract heat from one fluid stream and add it to another. Devices used for this purpose have passages for each of the two streams separated by a heat-exchange surface in the form of plates or tubes and are known as heat exchangers. The automobile radiator, the hot-water heater, the steam or hot-water radiator in a house, the steam boiler, the condenser and evaporator on the household refrigerator or air conditioner, and even the ordinary cooking utensils in everyday use are all heat exchangers. See HEAT; HEAT EXCHANGER. [R.H.L.]

**Heat treatment (metallurgy)** A procedure of heating and cooling a material without melting. Plastic deformation may be included in the sequence of heating and cooling steps,

thus defining a thermomechanical treatment. Typical objectives of heat treatments are hardening, strengthening, softening, improved formability, improved machinability, stress relief, and improved dimensional stability. Heat treatments are often categorized with special names, such as annealing, normalizing, stress relief anneals, process anneals, hardening, tempering, austempering, martempering, intercritical annealing, carburizing, nitriding, solution anneal, aging, precipitation hardening, and thermomechanical treatment.

All metals and alloys in common use are heat-treated at some stage during processing. Iron alloys, however, respond to heat treatments in a unique way because of the multitude of phase changes which can be induced, and it is thus convenient to discuss heat treatments for ferrous and nonferrous metals separately. See IRON; STEEL.

**Ferrous metals.** Annealing heat treatments are used to soften the steel, to improve the machinability, to relieve internal stresses, to impart dimensional stability, and to refine the grain size.

Hardening treatments are used to harden steels by heating to a temperature at which austenite is formed and then cooling with sufficient rapidity to make the transformation to pearlite or ferrite unfavorable.

Some heat treatments are used to alter the chemistry at the surface of a steel, usually to achieve preferential hardening of a surface layer. Carburizing consists of subjecting the steel to an atmosphere of partially combusted natural gas which has been enriched with respect to carbon. In the nitriding treatment, nitrogen diffusing to the surface of the steel forms nitrides. Chromizing involves the addition of chromium to the surface by diffusion from a chromium-rich material packed around the steel or dissolved in molten lead. See SURFACE HARDENING OF STEEL.

**Nonferrous metals.** Many nonferrous metals do not exhibit phase transformations, and it is not possible to harden them by means of simple heating and quenching treatments as in steel. Unlike steels, it is impossible to achieve grain refinement by heat treatment alone, but it is possible to reduce the grain size by a combination of cold-working and annealing treatments.

Some nonferrous alloys can be hardened, but the mechanism is one by which a fine precipitate is formed, and the reaction is fundamentally different from the martensitic hardening reaction in steel. There are also certain ferrous alloys that can be precipitation hardened. However this hardening technique is used much more widely in nonferrous than in ferrous alloys. In titanium alloys, the  $\beta$  phase can transform in a martensitic reaction on rapid cooling, and the hardening of these alloys is achieved by methods which are similar to those used for steels. [B.L.A.]

**Heating system** An apparatus consisting of an energy source, a method of converting that energy to heat, and a transport system to convey the energy and heat to the point of use. Most heating systems include some manual or automatic method of controlling the heat output and delivery.

There are many sources of energy for use in heating. The earliest source, and still most common in developing countries, comprises wood and wood products such as paper, wood chips, and sawdust; peat is used in some cultures. Solar use for heating and electrical generation has become widespread, although economics discourages more general use. The generation of electrical energy requires the use of fossil fuels, water power, geothermal energy, or nuclear energy. Fossil fuels are used directly in furnaces and boilers. See ELECTRIC POWER SYSTEMS; ENERGY SOURCES; HEAT PUMP; SOLAR ENERGY.

The energy source is converted into heat by various means. Wood and fossil fuels are converted by burning, or the combustion process. Electrical energy can be converted directly into heat by resistance heaters. Solar energy requires collectors, with conversion to heat or electricity.

Many methods deliver heat to the point of use. Radiation systems take several forms. Cast-iron column radiators, using steam

or hot water, have largely been superseded by convector radiators using steam, hot water, or electricity. Panel-type radiators are also used in ceilings or in floors. All require a piping or electrical distribution system. Forced-air warm-air heating, using electric motor-driven circulating fans, is common. See CENTRAL HEATING AND COOLING; COMFORT HEATING; DISTRICT HEATING; HOT-WATER HEATING SYSTEM; PANEL HEATING AND COOLING; RADIANT HEATING; SOLAR HEATING AND COOLING; STEAM HEATING; WARM-AIR HEATING SYSTEM.

[R.W.Hai.]

**Heavy minerals** Minerals with a density greater than  $2.9 \text{ g/cm}^3$ . The term is most commonly used to denote high-density components of siliclastic sediments. Most heavy mineral studies are undertaken to determine sediment provenance, because heavy mineral suites provide important information on the mineralogical composition of source areas. Since heavy minerals rarely constitute more than 1% of sandstones, their study normally requires them to be concentrated. This is achieved by disaggregation of the sandstone, followed by mineral separation using dense liquids such as bromoform, tetrabromoethane, or the more recently developed nontoxic polytungstate liquids. See DENSITY; PROVENANCE (GEOLOGY); SANDSTONE.

Geographic and stratigraphic variations in heavy mineral suites within a sedimentary basin can be used to infer differences in sediment provenance. Such differences result either from the interplay between a number of sediment transport systems draining different source regions, or from erosional unroofing within a single source area. Heavy mineral data therefore play an important role in the understanding of depositional history and paleogeography. In some cases, sophisticated mathematical and statistical treatment of heavy mineral data may be required to elucidate the interplay between multiple sediment transport systems. See DEPOSITIONAL SYSTEMS AND ENVIRONMENTS; PALEOGEOGRAPHY; SEDIMENTOLOGY; STRATIGRAPHY.

Heavy minerals have important economic applications. Their use in paleogeographic reconstructions, especially in elucidating sediment transport pathways, is of particular value in hydrocarbon exploration, and their use in correlation has important applications in hydrocarbon reservoir evaluation and production. Recent advances have made it possible to utilize the technique on a real-time basis at the well site, where it is used to help steer high-angle wells within the most productive reservoir horizons. Heavy minerals may become concentrated naturally by hydrodynamic sorting, usually in shallow marine or fluvial depositional settings. Naturally occurring concentrates of economically valuable minerals are known as placers, and such deposits have considerable commercial significance. Cassiterite, gold, diamonds, chromite, monazite, and rutile are among the minerals that are widely exploited from placer deposits. See DATING METHODS; MONAZITE; PLACER MINING; WELL; ZIRCON.

[A.Mor.]

**Heavy water** A form of water in which the hydrogen atoms of mass 1 ( $^1\text{H}$ ) ordinarily present in water are replaced by deuterium (D or  $^2\text{H}$ ), the heavy stable isotope of hydrogen of mass 2. The molecular formula of heavy water is  $\text{D}_2\text{O}$  (or  $^2\text{H}_2\text{O}$ ). See DEUTERIUM.

Because the mass difference between  $^1\text{H}$  and  $^2\text{H}$  is the largest for any pair of stable (nonradioactive) isotopes in the periodic table, many of the physical and chemical properties of the pure isotopic species and their respective compounds differ to a significant extent. Selected physical properties of  $^1\text{H}_2\text{O}$  and  $^2\text{H}_2\text{O}$  are compared in the table.

Heavy water, judging from its higher melting and boiling points, its higher viscosity, and its surprisingly high temperature of maximum density, is a distinctly more structured liquid than is ordinary water. Heavy water is more extensively hydrogen-bonded, and the hydrogen bonds formed by  $^2\text{H}$  are somewhat stronger than are those of  $^1\text{H}$ .

The only large-scale use of heavy water in industry is as a moderator in nuclear reactors. Small amounts of heavy water

Physical properties of ordinary and heavy water

Property	$^1\text{H}_2\text{O}$	$^2\text{H}_2\text{O}$ ( $\text{D}_2\text{O}$ )
Molecular weight, $^{12}\text{C}$ scale	18.015	20.028
Melting point, $^\circ\text{C}$	0.00	3.81
Normal boiling point, $^\circ\text{C}$	100.00	101.42
Temperature of maximum density, $^\circ\text{C}$	3.98	11.23
Density at $25^\circ\text{C}$ , $\text{g/cm}^3$	0.99701	1.1044
Critical constants		
Temperature, $^\circ\text{C}$	374.1	371.1
Pressure, mPa	22.12	21.88
Volume, $\text{cm}^3/\text{mol}$	55.3	55.0
Viscosity at $55^\circ\text{C}$ , mPa-s	0.8903	1.107
Refractive index, $n_D^{20}$	1.3330	1.3283

are used to grow fully deuterated organisms, which serve as a source of fully deuterated compounds of biological importance. These are finding increasing use in research techniques such as small-angle neutron scattering, in high-resolution nuclear magnetic resonance spectroscopy of immobilized samples, and in the study of isotope effects. See ISOTOPE (STABLE); SEPARATION; NUCLEAR REACTOR; WATER.

[J.J.K.]

**Hederellida** A marine bryozoan order in the class Stenolaemata. It is recorded from scattered localities in the Ordovician through Permian systems of the Paleozoic Era but is found prominently in Devonian strata. The colonies comprise tubular zooecia that commonly occur on brachiopod shells, echinoderm plates and columnals, and the outer surfaces of corals. Although usually encrusting, the colonies sometimes may be erect structures. The initial zooecium is a bulbous ancestrula, which gives rise to a tubular zooecium. Succeeding tubular zooecia bud one at a time from the lateral wall of the preceding zooecium. The tubular zooecia have perforated walls, and the distal opening of the zooecium is commonly sealed by a plate (possibly perforate). The zooecial wall apparently consisted of two layers, but it lacks the distinctive laminate structures of the order Trepostomata (Stenolaemata) and shows no additional thickening in the outer parts of the colony.

The simple, perforate tubular zooecia, in which the commonly oval zooecial opening is the same diameter as the zooecial tube, and the lack of accessory tubes or structures separate the hederellids from the Paleozoic cyclostomes. There are six recognized genera, including *Hederella*, *Reptaria*, *Hederopsis*, and *Clonopora*.

[J.R.P.R.]

**Hedgehog** Members of the family Erinaceidae (order Insectivora), which includes 7 genera and 19 species of medium-to large-size animals generally characterized by spines on their back and sides. This family, however, is subdivided into two subfamilies, the spiny hedgehog group which includes the European hedgehog (*Erinaceus europaeus*); and the hairy hedgehog or gymnuras, long-tailed species which lack spines. The typical spiny hedgehog (see illustration) has well-developed eyes and a rudimentary to moderately long tail. In most species, there

Hedgehog (*Erinaceus europaeus*).

are five toes on each foot, although in some species these are reduced to four on the hindfeet. The spines can be erected by strong muscles, and serve as a protection for the naked or hairy belly, head, and limbs when the animal rolls itself into a ball. See INSECTIVORA. [C.B.C.]

**Helicity (quantum mechanics)** A fundamental quantized variable used in quantum mechanics to specify the relative orientations of spin and linear momentum of massless particles. It is a requirement of fundamental Dirac quantum mechanics that such particles have their spins aligned either parallel or antiparallel to their linear momentum. Particles having parallel alignment are arbitrarily assigned helicity +1; those having antiparallel alignment, -1. See MOMENTUM; SPIN (QUANTUM MECHANICS).

In a classic experiment on *K* electron capture by  $^{152}\text{Eu}$ , M. Goldhaber, L. Grodzins, and A. Sunyar first showed that the neutrino emitted in the weak nuclear interaction had negative helicity—that its spin was aligned antiparallel to its momentum. An equivalent description of this situation is that these neutrinos are left-handed. Symmetry requires that antineutrinos be right-handed and have positive helicity. See ELECTRON CAPTURE; ELEMENTARY PARTICLE; NEUTRINO; QUANTUM MECHANICS; SYMMETRY LAWS (PHYSICS). [D.A.B.]

**Helicobacter** A genus of gram-negative bacilli whose members are spiral shaped, showing corkscrewlike motility generated by multiple, usually polar flagella. *Helicobacter* species require low concentrations of oxygen for maximum growth and produce the enzymes oxidase, catalase, and urease.

Different species of *Helicobacter* are found in the stomachs of different animals: *H. felis* in cats and dogs, *H. mustelae* in the domestic ferret, *H. nemestrinae* in the pigtailed macaque, and *H. acinonyx* in captive cheetahs with gastritis. *Helicobacter pylori*, found in the human stomach, is extremely common. In the United States and similarly developed countries, its prevalence increases at about 1% per year of age so that the majority of adults above age 50 are infected. In less developed countries, infection rates are dramatically higher, with up to 80% of children infected.

*Helicobacter pylori* is present in virtually all cases of chronic gastritis, which progresses slowly (years or decades) from asymptomatic to atrophic gastritis with impaired acid secretion. Virtually all individuals with duodenal ulcers are infected with *H. pylori*, which colonizes sites in the duodenum. The termination of treatment for duodenal ulcers leads to a high rate of recurrence of the ulcers, but ulcer treatment plus eradication of *H. pylori* from the stomach usually leads to a permanent cure. A significant proportion of individuals with *H. pylori*-associated atrophic gastritis develop intestinal-cell metaplasia in the stomach, a condition which is known to represent a precancerous state. See CANCER (MEDICINE); ULCER.

*Helicobacter pylori* virulence factors include its shape and its ability to rapidly move into and through the gastric mucous coating, which protects the organism from stomach acid; its surface-associated urease enzyme which neutralizes stomach acid near the organism; a cytotoxin; and a fibrillar adhesin which binds the organism to the surface of gastric epithelial cells. *Helicobacter pylori* can survive in large numbers in spite of antibodies which are secreted into the stomach and the host immune cell response (inflammatory response) characteristic of gastritis. [D.J.Ev.]

**Helicoplacoidea** A small class of spindle-shaped, spirally pleated, primitive echinoderms in the subphylum Echinozoa, from the Early Cambrian (*Nevadella* Zone) in eastern California, western Nevada, and eastern British Columbia. Since their discovery in the early 1960s, three genera and six species have been described based on nearly 600 complete specimens, making helicoplacoids the most diverse and abundant echino-

derm class known from the Early Cambrian. The unusual plating and spiral symmetry of helicoplacoids separate them from all other classes of echinoderms. See ECHINODERMATA; ECHINOZOA.

[J.Sp.]

**Helicopter** An aircraft characterized by its large-diameter, powered, rotating blades. The helicopter can lift itself vertically by the reactive force generated as the rotating blades accelerate air downward. It can both lift and propel itself by accelerating air downward at an angle to the vertical. The helicopter is the most successful vertical takeoff and landing (VTOL) aircraft developed, by virtue of its relatively high efficiency in performing hovering and low-speed flight missions.

The key to understanding the operation and control of a helicopter lies in a knowledge of the forces and resultant motion of each rotor blade as momentum is imparted to the air. Unlike a fixed-wing aircraft, which derives its lift from the translational motion of the fuselage and airfoil-shaped wing relative to the air, the helicopter rotates its wings (or rotor blades) about a vertical shaft and thus is able to generate lift when the fuselage remains stationary.

Many different rotor arrangements have been used, and most of the early attempts at vertical flight were made with machines having multiple or coaxial counterrotating rotors. Most modern helicopters employ the single rotor or the tandem rotor configurations.

In addition to the selection of the number and location of the lifting rotors, designers have developed varied methods for attaching the blades to the rotor hub. Very early experiments conducted with the blades rigidly attached to the hub were unsatisfactory because of the excessive moments applied to the rotor mast. Based on the success achieved by the introduction of hinged attachments for the rotor blades, several configurations have been successfully manufactured. The teetering rotor used on two-bladed configurations has one central hinge which allows the blades to move in unison (one up, one down) like a seesaw. The gimbaled rotor is essentially equivalent to the teetering rotor and has been used on rotors with three or more blades. The articulated rotor has each blade attached to the hub by its own flapping hinge.

The growth of the helicopter industry in the United States is founded in the uses made by the armed forces. The technology which evolved to meet the needs of the military provided the base for an impressive growth in commercial applications. With such diverse operations as crop spraying, logging, construction, police and ambulance service, and passenger and corporate transportation, the industry has responded with a variety of commercial helicopters. See VERTICAL TAKEOFF AND LANDING (VTOL). [J.L.J.]

**Helicosporida** An order of protozoa in the class Myxosporidea (subphylum Cnidospora). It is characterized by production of spores with a relatively thick, single intrasporal filament and three uninucleate sporoplasms. *Helicosporidium parasiticum* is the only species in the order. The parasite infests the body cavity, fat bodies, and ganglia of mites (*Hericia hericia*) and the body cavity of fly larvae (*Dasyhelea obscura* and *Mycetobia pallipes*) found in the sap of horse chestnut and elm trees. See MYXOSPORIDEA. [R.F.N.]

**Helimagnetism** A property possessed by some metals, alloys, and salts of transition elements in which the atomic magnetic moments, at sufficiently low temperatures, are arranged in a spiral or helix. Simple antiferromagnets and ferromagnets can be considered as nonconical helimagnets with helical angles of 180 and 0°, respectively. In the same way, nonconical helimagnets may be considered as conical helimagnets with cone angle of 0°. Some typical helimagnets are listed in the table. The

**Some representative helimagnets**

Substance	Magnetic structure	Temperature, K
MnO <sub>2</sub>	Nonconical helix	0 < T < 84
MnAu <sub>2</sub>	Nonconical helix	0 < T < 363
Dy	Nonconical helix	85 < T < 179
MnCr <sub>2</sub> O <sub>4</sub>	Ferromagnet	0 < T < 85
	Simple ferrimagnet	18 < T < 43
Er	Complex conical helix	0 < T < 18
	Conical helix	0 < T < 20
	Complex oscillation	20 < T < 53
	Sinusoidal antiferromagnet	53 < T < 85

magnetic structures have been detected by neutron diffraction. [F.Ke.]

**Helioseismology** A technique for probing the interior of the Sun, using methods akin to terrestrial seismology. The Sun, although the nearest star by far, is a typical star, so what can be learned of its interior through helioseismology is of broad importance to the stars in general.

Like terrestrial seismology, helioseismology entails the analysis of many "seismic" wave modes to determine the structure of the interior. However, although terrestrial seismic waves are initiated by a singular event such as an earthquake, waves within the Sun are continuously excited, probably by the turbulent convective motions in its outer layers. Thus the solar waves are always present at all points within the Sun and on its surface. The Sun is "ringing" like a bell, but not like one struck by a clapper; it vibrates more like a bell suspended in a sandstorm, continuously struck by tiny grains of sand. See SEISMOLOGY.

The solar waves are seen at the surface as up-and-down motions of the gases with a speed of about 0.3 mi/s (0.5 km/s) and a vertical displacement of about 30 mi (50 km). These waves are detected through the Doppler shift of the wavelength of absorption lines in the solar spectrum. They have periods clustering near 5 min (that is, with a frequency of one cycle in 5 min or about 0.003 cycle per second). As a result, the solar surface undulates up and down in a so-called five-minute oscillation. The oscillation is actually the superposition of as many as 10<sup>7</sup> individual modes of oscillation of the Sun as a whole, where each mode has its own characteristic frequency (near, but not exactly at, 0.003 cycle per second) and spatial pattern on the solar surface.

Precise observations of the solar oscillations are difficult. A nearly continuous stream of data extending over days is needed to separate the many individual modes with nearly identical oscillation frequencies. Ground-based observations are hampered by the day-night cycle. This restriction has been overcome by making observations from near the South Pole during the austral summer, through networks of similar telescopes spaced at several longitudes around the globe, and from spacecraft located in orbits experiencing continuous sunlight.

Helioseismology offers insight into the structure of the solar interior and also into its rotation. Waves propagating with or against the direction of rotation are carried by it, and their effective propagation speed and frequency are increased or decreased. The frequency shift for any mode depends on the average rotation rate within the resonant cavity for that mode, and comparison of the shift for many modes with different cavities makes it possible to determine how the rotation varies with depth.

The surface of the Sun has long been known to rotate differentially with latitude; that is, at the Equator the surface rotation period is about 25 days while near the Poles it is about 34 days. Roughly speaking, the increase of rotation period from Equator to Pole persists throughout the convection zone, which constitutes the outer 30% of the solar radius. However, at all latitudes the rotation period decreases slightly over the outer 10% of the solar radius, and then increases again to approximately its sur-

face value at the bottom of the convection zone. At the bottom of the convection zone there is an abrupt transition to a deeper interior, which seems to rotate nearly uniformly and at the same speed as surface latitudes of about 35°. See STELLAR ROTATION; SUN. [R.W.N.]

**Heliozoia** A subclass of the Actinopodea. Unlike Radiolaria, these protozoans have no central capsule. Most species live in fresh water. Pseudopodia may be either slender with an axial filament surrounded by cytoplasm (axopodia) or filamentous (filopodia). Certain floating species can roll along on the tips of their axopodia and also swim by moving their axopodia. Some species are naked; others have skeletal elements ranging from siliceous scales or spicules embedded in a gelatinous capsule to a reticulate chitinous skeleton often impregnated with

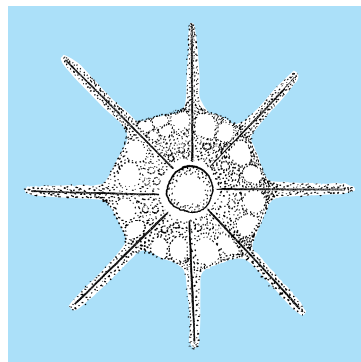

Actinophryida type of Heliozoia. (After R. P. Hall, *Protozoology*, Prentice-Hall, 1953)

silica. A centroplast may or may not be present. The subclass has three orders: Actinophryida (see illustration), Centrohelida, and Desmothoracida. See ACTINOPODEA. [R.P.H.]

**Helium** A gaseous chemical element, He, atomic number 2 and atomic weight 4.0026. Helium is one of the noble gases in group 18 of the periodic table. It is the second lightest element. The world's chief source of helium is a group of natural gas fields in the United States. See INERT GASES; PERIODIC TABLE.

Helium is a colorless, odorless, and tasteless gas. It has the lowest solubility in water of any known gas. It is the least reactive element and forms essentially no chemical compounds. The density and the viscosity of helium vapor is very low. Thermal conductivity and heat content are exceptionally high. Helium can be liquefied, but its condensation temperature is the lowest of any known substance. The properties of helium are given in the table. See LIQUID HELIUM.

Helium was first used as a lifting gas in balloons and dirigibles. This use continues for high-altitude research and for weather balloons. The principal use of helium is in inert gas-shielded

**Properties of helium**

Property	Value
Atomic number	2
Atomic weight	4.0026
Melting point* at 25.2 atm pressure	-272.1°C (1.1 K)
Triple point (solid, helium I, helium II)	-271.37°C (1.78 K)
Triple point = λ-point (helium gas, helium I, helium II)	-270.96°C (2.19 K)
Boiling point at 1 atm pressure	-268.94°C (4.22 K)
Gas density at 0°C and 1 atm pressure, g/liter	0.17847
Liquid density at its boiling point, g/ml	0.1249
Solubility in water at 20°C, ml helium (STP)/1000 g water at 1 atm partial pressure of helium	8.61

\*The melting point varies with the pressure.

arc welding. The greatest potential for helium use continues to emerge from extreme-low-temperature applications. Helium is the only refrigerant capable of reaching temperatures below 14 K ( $-434^{\circ}\text{F}$ ). The chief value of ultralow temperature is the development of the state of superconductivity, in which there is virtually zero resistance to the flow of electricity. Other helium applications include use as a pressurizing gas in liquid-fueled rockets, in helium-oxygen breathing mixtures for divers, as a working fluid in gas-cooled nuclear reactors, and as a carrier gas for chemical analysis by gas chromatography.

Terrestrial helium is believed to be formed in natural radioactive decay of heavy elements. Most of this helium migrates to the surface and enters the atmosphere. The atmospheric concentration of helium (5.25 parts per million at sea level) could be expected to be higher. However, its low molecular weight permits helium to escape into space from the upper atmosphere at a rate roughly equal to its formation. Natural gases contain helium at concentrations higher than in the atmosphere. [A.W.F.]

Helium is an element with a closed electronic shell, a large ionization potential, and a low polarizability, which makes it a very unlikely candidate to form chemical bonds. However, solid helium compounds have been found to form at high pressure, one with nitrogen [ $\text{He}(\text{N}_2)_{11}$ ] and one with neon [ $\text{Ne}(\text{He})_2$ ]. These compounds belong to a class known as van der Waals compounds. See INTERMOLECULAR FORCES.

Other helium compounds have also been observed in a clathrate hydrate,  $\text{He}(\text{H}_2\text{O})_{6+\delta}$ , and helium has been detected inside the carbon molecule buckminsterfullerene ( $\text{C}_{60}$ ), forming  $\text{HeC}_{60}$ . Mixtures of helium and other components prevail under conditions of high pressure in the outer planets of the solar system and their satellites. Therefore, it is believed that helium compounds are important in the modeling of the interiors of such celestial bodies. The formation of helium compounds at high pressures illustrates that under such conditions different chemical behavior occurs compared to that observed under ambient conditions. See CHEMICAL BONDING; CLATHRATE COMPOUNDS; FULLERENE. [W.L.V.]

Helium-3 is a rare stable isotope of helium was discovered by L. W. Alvarez and R. Cornog in 1939. Its concentration in nature is so low, approximately one part per hundred million in well helium, that it was 1951 before sufficient quantities of pure gas became available for experimentation. The gas was then, and continues to be, obtained as a by-product from the decay of tritium, the heavy isotope of hydrogen. Tritium is produced in a nuclear reactor from the reaction between lithium and a neutron.

The  $^3\text{He}$  nucleus is composed of two protons and one neutron, one fewer than for  $^4\text{He}$ ; as a consequence,  $^3\text{He}$  is a fermion whereas  $^4\text{He}$  is a boson. The two isotopes are the exemplars of Fermi-Dirac and Bose-Einstein systems, respectively. It is principally for this reason that helium, an apparently featureless chemical element, has been studied intensively. See BOSE-EINSTEIN STATISTICS; FERMION-DIRAC STATISTICS; TRITIUM. [B.M.A.]

**Helix** Any nonplanar curve all of whose tangents make the same angle with a fixed line. Other characteristic properties are that all principal normals are parallel to a plane and that the ratio of torsion to curvature is constant. If a helix has constant curvature (and hence constant torsion), it is a circular helix; it lies on a circular cylinder whose elements it cuts at a constant angle. See ANALYTIC GEOMETRY; DIFFERENTIAL GEOMETRY. [L.M.B.]

**Helmholtz coils** A pair of flat circular coils with equal numbers of turns and equal diameters, arranged with a common axis, and connected in series to have a common current (see illustration). The purpose of the arrangement is to obtain a magnetic field that is more nearly uniform than that of a single coil without the use of a long solenoid. The optimum arrange-

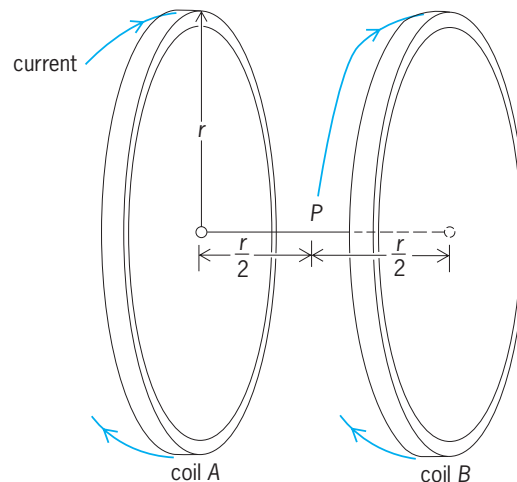

Helmholtz coils separated by distance  $r$ , resulting in a nearly uniform field of point  $P$ . (After L. B. Loeb, *Fundamentals of Electricity and Magnetism*, 3d ed., 1947)

ment is that in which the distance between the two coils is equal to the radius of one of the coils. See SOLENOID (ELECTRICITY). [K.V.M.]

**Hematite** The most important ore of iron, with composition  $\alpha\text{-Fe}_2\text{O}_3$ . The crystals are thick tabular, usually flattened parallel to the base, and are frequently platy in habit. Hematite usually occurs as rouge-red earthy masses of finely divided particles. It is the major red-coloring agent in rocks and is a common interstitial cement in sediments. When mixed with quartzite or finely divided quartz, the mixture is called jasper, jaspilite, or taconite. Botryoidal masses are called "kidney ore," and splinters of these masses are "pencil ore."

The color is steel gray, blood red in thin fragments, and streak and powder are rouge red; hardness is 6 on Mohs scale and specific gravity is 5.25. The mineral is only weakly magnetic.

Hematite is the most widespread iron mineral. The most important ores are in low-to-medium-grade metamorphic rocks of sedimentary origin. Enormous beds occur in the Great Lakes region of the United States. Hematite also occurs in contact metamorphic and metasomatic deposits, often derived from the oxidation of magnetite and frequently associated with limestones.

Nearly every country in the world mines some hematite ore; the most important occurrences outside of the United States include India, Cuba, China, Chile, north African nations, and Russia. See IRON METALLURGY; REDBEDS. [P.B.M.]

**Hematologic disorders** Those disorders marked by aberrations in structure or function of the blood cells or the blood-clotting mechanism. Although many other diseases may be reflected by the blood and its constituents, the abnormalities of red cells, white cells, platelets, and clotting factors are considered to be primary hematologic disorders. See BLOOD.

Red-cell abnormalities are principally represented by the anemias and polycythemias. The anemias are marked by a decrease in the hemoglobin concentration, and may be due to blood loss or decreased production or excessive destruction of red cells. Polycythemias are disorders characterized by an increase in the numbers of circulating red cells and usually by a concomitant increase in hemoglobin. Secondary polycythemias result from a compensatory increase in the formation of red cells following hypoxia of the bone marrow. Primary polycythemia or polycythemia vera is a chronic and ultimately fatal disease of middle and old age in which there is a gradual increase in the number of red cells and usually an increase in the number of platelets and leukocytes. See ANEMIA; HEMOGLOBIN.

In a wide variety of conditions the many forms of white cell present in the circulation, bone marrow, and lymphoid tissues of the body may be altered in form or number. The suffixes -philia and -penia denote increases and decreases, respectively, for the cells named. Leukopenia, neutrophilia, eosinophilia, and pancytopenia are examples of the wide range of possibilities. The absolute or relative increases or decreases of one or more types of leukocytes are often characteristic of certain disease states. There may also be changes in the proportions of the different cells, and immature or atypical forms may be present. The leukemias represent a special kind of malignancy in which there is usually an uncontrolled proliferation of one or more types of leukocytes, often reflected by great increases in the white cell count of the peripheral blood. See LEUKEMIA.

The hemorrhagic disorders result from a large number of known and unknown causes or contributing factors, often of a diverse nature. A decrease or abnormality of the von Willebrand factor, a reduction in the number of platelets, a qualitative defect in platelets, or a defect in the vascular wall can all result in failure of the primary hemostatic mechanism, with spontaneous bleeding; this is referred to as purpura. Blood vessel damage may occur as a result of direct or indirect damage by microorganisms during infections, as the result of vitamin C deficiency (scurvy), and following hereditary defects in blood vessel development. There are several forms of thrombocytopenia, all of which are characterized by a decrease in thrombocytes or platelets in the circulation. A defect in fibrin or clot formation gives rise to the type of bleeding seen in hemophilia, in which the primary hemostatic plug is formed normally but breaks down several hours or days later owing to lack of adequate fortification by fibrin. Defects in the clotting process that result in excessive bleeding may be due to an acquired or hereditary deficiency or abnormality of a clotting factor, as in hemophilia A or B. See HEMOPHILIA; HEMORRHAGE. [C.Ho.]

**Hematopoiesis** The process by which the cellular elements of the blood are formed. The three main types of cells are the red cells (erythrocytes), which serve to carry oxygen, the white cells (leukocytes), which function in the prevention of and recovery from disease, and the thrombocytes, which function in blood clotting. The formation of these cells is one of the most active and important processes in the body. Most of the circulating cells live only for a short time and must be replaced in order to maintain life. For instance, in the human adult a red blood cell has a life of 120 days; 250 billion new red cells have to be produced daily to replace those that are destroyed.

Blood cells originate in the reticuloendothelial tissue, which is a loose, fibrous, highly vascularized mesh of fibers, endothelial cells, and macrophages. Within the spaces of the tissue are found the precursor (blast) cells of the definitive adult types. For the sake of convenience, the reticuloendothelial tissue is divided into two general but imprecise types: lymphoid and myeloid tissue. Lymphoid tissue is primarily localized in the lymph nodes of the lymphatic system and is also in the spleen, thymus, and bone marrow. Several classes of white cells are produced, including the lymphocytes, macrophages, and monocytes. See CELLULAR IMMUNOLOGY; LYMPHATIC SYSTEM.

Myeloid tissue is normally limited in humans to the red bone marrow of the ribs, sternum, vertebrae, and proximal ends of the long bones of the body. It is concerned with the production of the erythrocytes and certain types of leukocytes. The latter are the granular leukocytes (called eosinophils, basophils, and neutrophils on the basis of the affinity of granules in their cytoplasm for certain dyes) and megakaryocytes. Fragments of megakaryocytes form the blood platelets (thrombocytes), which are necessary for blood clotting. See BLOOD. [F.Wi.]

**Hemiascomycetes** A class of the phylum Ascomycota that includes the yeasts and yeastlike fungi. These are morphologically simple fungi; no ascus is formed, and the asci are pro-

duced free on the host or substrate. Asexual reproduction occurs by the formation of blastospores (budding) or, less frequently, by fission arthrospores. Two main orders are recognized, the Saccharomycetales and the Taphrinales. See YEAST.

The vegetative body (thallus) of the Saccharomycetales may be either unicellular (true yeasts) or mycelial. In unicellular species, asci form when two vegetative cells fuse, and then the fused cell undergoes meiosis to form ascospores. In mycelial species, the hyphae are not very extensive. Sexual reproduction occurs when adjacent cells extend short lateral branches that fuse to form the asci. Variations on these modes of ascus formation, however, are common among the yeasts.

The Saccharomycetales are common on substrates high in sugars, such as plant exudates, ripe fruits, and flower parts. Because they are microscopic, they are recognized mainly from cultures that have a homogeneous appearance and a characteristic odor. The most important genus is *Saccharomyces*; *S. cerevisiae* is the common bakery and brewery yeast, and *S. ellipsoideus* is used in winemaking. An important mycelial species is *Nematospira coryli*, which causes yeast spot disease of various crops.

The order Taphrinales includes the leaf curl disease fungi. The most widely recognized species are *Taphrina deformans*, cause of leaf curl of peach and almond trees, and *T. caerulea*, cause of leaf blister of oaks. These fungi produce a well-developed mycelium in the host tissue but, when grown in culture, form only a yeastlike colony of single cells. Asci are produced when special binucleate hyphal cells beneath the host cuticle undergo nuclear fusion and the resulting diploid cell elongates to form an ascus on the leaf surface. The nucleus undergoes meiosis, and ascospores are formed. See ASCOMYCOTA; EUMYCOTA; FUNGI.

On the basis of molecular data, some workers now propose separating the Taphrinales and the fission yeast, *Schizosaccharomyces*, into a new class, Archiascomycetes. These fungi are considered to be more primitive and phylogenetically basal to the rest of the ascomycetes. [R.T.Ha.]

**Hemicellulose** A term designating plant cell components which are made soluble by dilute alkali or which go into solution quite readily in hot dilute mineral acids with the formation of simple sugars. Hemicelluloses constitute about one-fourth of perennial plants and about one-third of annual plants. The term is usually applied to those polysaccharides in the cell wall of land plants which are extractable by dilute alkaline solutions. The term has also been used to include all the polysaccharide components of the cell wall other than cellulose. See CELL WALLS (PLANT); CELLULOSE.

Hemicelluloses extracted from different plant sources are rarely identical. In fact, many different hemicelluloses usually occur intermixed with each molecular type representing different degrees of polymerization. Because of this heterogeneity, few hemicelluloses have been isolated in a homogeneous state. Therefore, relatively little is known of the structure of these compounds that compose almost one-third of the carbohydrates in woody tissue.

D-Xylose is the dominant building unit of the hemicelluloses of most woods and annual plants. D-Mannose is also very abundant in hemicelluloses; the mannose content of softwoods is usually higher than that of hardwood. Often it occurs as a polymer, mannan, or in combination with D-glucose or D-galactose as a glucomannan, galactomannan, or galactoglucomannan. See MANNANS.

Hemicelluloses are important to the paper industry. In chemical wood pulps, hemicellulose is needed for satisfactory pulp quality. Its presence aids the swelling of the pulp, the bonding of the fibers, the bursting strength, tensile strength, tear resistance, folding endurance, opacity, and specific surface of the pulp sheet.

Hemicelluloses also serve as nutrients for yeasts, and they can be used for raw material in the production of furfural and ethyl alcohol. [R.L.Wh.]



**Hemichordata** A group of deuterostome animals that includes the classes Enteropneusta, Pterobranchia, and Planctosphaeroidea. The last, a monospecific class, is represented by *Planctosphaera pelagica*, a planktonic larva that occupies low depths and resembles the larval tornaria of Enteropneusta. See ENTEROPNEUSTA; PTEROBRANCHIA.

The hemichordates have a slender tubular diverticulum that projects forward into the protosome from the roof of the buccal cavity. That organ, also called a stomochord or buccal diverticulum, is a supporting axial rod of the protosome and resembles the notochord of Chordata, but it does not have the same position, structure, origin, or function, and so they are not homologous. See CHORDATA.

The hemichordates are not plentiful animals. All are marine species that live in a wide range of habitats and depths, from intertidal to abyssal, and show a worldwide distribution. They vary in size from a fraction of an inch to 7 ft or more. The members of the phylum differ widely. The enteropneusts are vermiform and solitary, whereas the pterobranchs are sacciform and colonial.

The hemichordates are a primitive group, having a tripartite body and coelom; their embryonic development resembles the echinoderms, with which they also share a primitive nervous system. The Hemichordata, therefore, may be a group at a low level of evolution, between echinoderms and chordates. [J.Ben.]

**Hemicidaroida** An extinct paraphyletic order of regular sea urchins (Echinoidea), identified by having a plain, unsculptured test and tubercles that are perforate and crenulate. They almost certainly include ancestors of later groups that developed imperforate and noncrenulate tuberculation and are thus paraphyletic. Two families are generally placed within the order, Hemicidaridae and Pseudodiadematidae. The oldest hemicidaroid is Late Triassic (Upper Norian) and the youngest comes from the Upper Cretaceous (Campanian). They appear to have been epifaunal grazers. See ECHINOIDEA. [A.Sm.]

**Hemidiscosa** An order of the subclass Amphidiscophora in the class Hexactinellida. These sponges are distinguished from the order Amphidiscosa in that the birotulates are hemidiscs with asymmetrical ends. See AMPHIDISCOPHORA; AMPHIDISCOSA. [W.D.H.]

**Hemimorphite** A mineral sorosilicate having the composition  $Zn_4Si_2O_7(OH)_2 \cdot H_2O$ ; an ore of zinc. Crystals are usually colorless and the aggregates white, but in some cases there are faint shades of green, yellow, and blue. The mineral has a vitreous luster, a hardness of  $4\frac{1}{2}$  to 5 on Mohs scale, and a specific gravity of 3.45.

Hemimorphite has a wide distribution and has been mined in Belgium, Germany, Romania, England, Algeria, and Mexico. In the United States it is found at Sterling Hill, New Jersey; Friedensville, Pennsylvania; and Elkhorn Mountains, Montana. See SILICATE MINERALS. [C.S.Hu.]

**Hemiptera** An order of the class Insecta sometimes referred to as the Heteroptera. Both these names refer to the forewings, which are differentiated into a thickened basal area and a membranous apical region. These are the true bugs. Included in Hemiptera are such common insects as the bedbugs, stink bugs, plant bugs, lace bugs, and backswimmers.

The true bugs number about 25,000 species. They are known from all continents except Antarctica and occur on most islands. Hemiptera range in size from small aquatic and ground-inhabiting forms approximately 0.04–0.08 in. (1–2 mm) in length to giant water bugs 4 in. (100 mm) or more.

In habits, the true bugs range from strictly phytophagous types attached to a single host plant, to general predators on other insects, and even to specialized ectoparasites of bats. Many species are of economic importance as plant pests or vectors of disease.

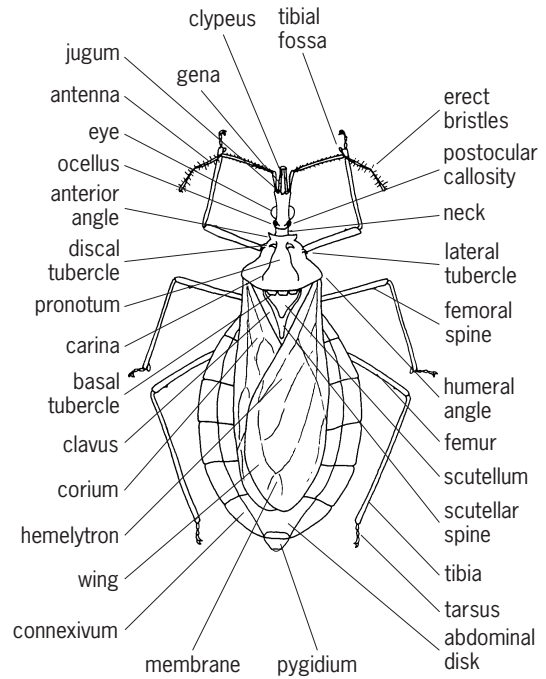

External anatomy of a bug.

They occur in vegetation, on the ground, in and on the water, and in the nests of termites. Most water bugs depend on surface air held to the body by air spaces and hairs on the abdomen. As oxygen is depleted in the air bubble, it is replaced from the surrounding medium by diffusion.

Most Hemiptera are bisexual and oviparous, but parthenogenesis is known. Mating usually takes place on vegetation or on the ground, the pairing being end-to-end in stink bugs, squash bugs, chinch bugs, and similar species, and with the male above the female in most others.

**Morphology.** In Hemiptera the mouthparts are elongate and slender, forming a sucking mechanism. The beak arises from the anterior part of the head and the head is commonly directed forward or downward.

Hemiptera are further characterized (see illustration) by antennae, usually of four or five segments, a pair of compound eyes, and often two ocelli. The thorax consists of a prominent pronotum, a triangular mesothoracic scutellum, and a broad metathorax which is partly fused with the first abdominal segment. The mesothoracic wings, or hemelytra, overlap at their membranous apices when at rest. The hindwings are hitched to the forewings in flight by grooves and pegs. Wings are sometimes reduced to short pads and may be lacking in certain groups or even in members of a single species. The front legs are frequently enlarged and sometimes chelate in predacious forms, and the middle and hindlegs are adapted for swimming in some groups. The abdomen is of 10–11 segments, but only seven are commonly seen.

**Subdivisions.** Families of the Hemiptera and their distinguishing characteristics are listed in the table under the respective subdivisions.

**Hydrocorisae.** This subdivision contains nine families of water bugs with concealed antennae and without a bulbous ejaculator in the male. Many species are predaceous.

Corixoidea is a superfamily which contains the single family Corixidae, or water boatmen. Corixidae lack ocelli and have a unique type of mouthpart. Corixids swim with the dorsal side uppermost, using the oarlike middle and hind legs. Eggs are stalked and there are five nymphal instars. Adults sometimes fly to lights in great numbers.

Families of Hemiptera			
Family	Common name	Distribution	Number of species
<b>Subdivision Hydrocorisae</b>			
Corixidae	Water boatmen	General	300
Nepidae	Water scorpions	General	170
Belostomatidae	Giant water bugs	General	140
Notonectidae	Backswimmers	General	170
Pleidae	None	General	20
Helotrephidae	None	Tropical	20
Naucoridae	Creeping water bugs	General	200
Gelastocoridae	Toad bugs	Tropical and subtropical	80
Ochteridae	Velvety shore bugs	Tropical and subtropical	20
<b>Subdivision Amphibicorisae</b>			
Gerridae	Water striders	General	300
Veliidae	Smaller water striders	General	200
Hydrometridae	Marsh treaders	General	50
Mesoveliidae	Water treaders	General	20
Hebridae	Velvety water bugs	General	40
<b>Subdivision Geocorisae</b>			
<i>Superfamily Leptopodoidea</i>			
Saldidae	Shore bugs	General	200
Leptopodidae	None	Tropical and subtropical	20
Leotichidae	None	Asian	2
<i>Superfamily Dipsocoroidea</i>			
Dipsocoridae	None	General	
Schizopteridae	Jumping ground bugs	Tropical and subtropical	
<i>Superfamily Cimicimorpha</i>			
Cimicidae	Bat, bed, bird bugs	General	80
Anthocoridae	Flower bugs	General	300
Polycetenidae	Bat bugs	Tropical and subtropical	20
Miridae	Plant bugs	General	5000
Microphysidae	None	Palaearctic	30
Plokiophilidae	None	Tropical	20
Nabidae	Damsel bugs	General	250
Tingidae	Lace bugs	General	700
Vianaidae	None	Neotropical	2
Thaumastocoridae	Palm bugs	Tropical	11
<i>Superfamily Enicocephaloidea</i>			
Enicocephalidae	Gnat bugs	General	300
<i>Superfamily Reduvioidae</i>			
Reduviidae	Assassin bugs	General	3500
<i>Superfamily Aradoidea</i>			
Aradidae	Flat bugs	General	800
Termitaphididae	Termite bugs	Tropical	10
<i>Superfamily Pentatomomorpha</i>			
Idiostolidae	None	Chilean	2
Lygaeidae	Lygaeid bugs	General	2000
Thaumastellidae	None	Ethiopian	1
Colobathristidae	None	Tropical	70
Berytidae	Stilt bugs	General	100
Malcidae	None	Ethiopian, Asian	30
Piesmatidae	Ash-gray leaf bugs	General but discontinuous	20
Pyrrhocoridae	Pyrrhocorid bugs	General	300
Largidae	None	General	100
Coreidae	Coreid bugs	General	2000
Rhopalidae	None	General	300
Stenocephalidae	None	Old World, Neotropical	20
Hyocephalidae	None	Australia	1
Pentatomidae	Stink bugs	General	2500
Phloeidae	Bark bugs	Neotropical	5
Plataspidae	None	Old World	400
Lestoniidae	None	Australia	1
Cydnidae	Ground or burrower bugs	General	600
Urostylidae	None	Asian and Australian	50
Aphylidae (not placed)	None	Australian	2
Joppeicidae	None	Mediterranean	1

In the superfamily Nepoidea, the Nepidae, or water scorpions, have a long breathing tube at the tip of the abdomen, through which they obtain air directly from the surface. The beak is short and stout to suck the juices of other insects on which they prey. Belostomatidae, or electric-light bugs, have short, straplike respiratory appendages at the tip of the abdomen. Giant water bugs of the genus *Lethocerus* are pests in fish ponds where they attack fry. They can inflict a painful bite when handled carelessly.

The superfamily Notonectoidea includes the Notonectidae or backswimmers: they swim ventral side uppermost, the hindlegs serving as oars. Breathing is facilitated by an air bubble, obtained by touching the tip of the abdomen to the surface.

The minute bugs of the families Pleidae and Helotrephidae (superfamily Pleoidea) are suboval, with legs not fitted for rowing.

The creeping water bugs (superfamily Naucoroidea) are sometimes separated into the Naucoridae and Aphelocheiridae. They are suboval in body form. Respiration is either by an air bubble or by means of a plastron; in the Old World genus *Aphelocheirus*, the plastron consists of an ultramicroscopic hair pile which acts as a physical gill; the bug is thus able to remain submerged permanently.

In the superfamilies Gelastocoroidea and Ochteroidea, the Gelastocoridae, or toad bugs, and the Ochteridae (or Pelogonidae) are shore-line or mud inhabitants. Both have ocelli. The

former are cryptically colored, resembling the sand or mud background. Ochterids are black with a silky sheen.

*Amphibicorisae*. This subdivision contains surface water bugs with antennae exposed and without a bulbous ejaculatorius in the male. Only the single, diverse superfamily Gerroidea has been proposed for the surface water bugs. All have conspicuous antennae, and the body is clothed with hydrofuge hairs. All Gerroidea are predacious.

Gerridae are the large water striders with long middle and hind legs and a median scent gland opening on the metasternum. The claws are inserted before the tips of the tarsi. The marine forms are always wingless but all others are polymorphic, with fully winged forms occurring together with short-winged or apterous types.

Veliidae are small water striders which have shorter legs and a longitudinal groove between the eyes. The claws are preapical. Like the Gerridae, these are pond inhabitants, stream-riffle bugs, and marine types, but the last are found only near shore in tropical reefs.

Hydrometridae are long, slender marsh treaders in which the head is longer than the thorax. The claws are apical.

Mesoveliidae and Hebridae are two small families which differ from others in having the well-developed ocelli and the single dorsal abdominal scent gland openings of the nymphs.

*Geocorisae*. This subdivision contains the land bugs with conspicuous antennae and an ejaculatory bulb in the male reproductive system. This subdivision can be divided into seven groups, each of which may be equivalent in rank to the Hydrocorisae and Amphibicorisae. Superfamilies that do not fit the above groupings are the Reduvidae, the Saldoidea, the Aradoidea, and the Enicocephaloidea and Dipsocoroidea, of isolated position in the system.

The superfamily Saldoidea comprise the shore bugs which have three pairs of trichobothria on the vertex and a single nymphal scent gland opening. Dipsocoroidea is a group of minute ground inhabitants, of which the Schizopteridae live in leaf mold and the Dipsocoridae are predators on small insects under bark or in rotten wood or amid stones at the edge of streams.

Enicocephaloidea is a unique group in which the head is bilobed, the pronotum trilobed, and the wings completely membranous. They live under stones, beneath bark, and in leaf mold and are predators. Some species are wingless; others can cast off their wings.

Reduvidae includes only the assassin bugs or conenose bugs of the family Reduviidae. Nearly all have a stridulatory furrow on the prosternum, which is scraped by the rostrum to produce a squeaking sound. Ocelli are generally present and the beak is three-segmented.

Among the Aradoidea are flat bugs of the family Aradidae and their specialized relatives, Termitaphididae. They lack ocelli and have four-segmented antennae. Most, if not all, are fungus feeders. The Termitaphididae have no wings. They are known from termite nests in the Old and New World tropics. Aradidae are nearly cosmopolitan and fully winged, brachypterous, stenopterous, or apterous.

Cimicimorpha is the largest group of the Geocorisae and is divided into three superfamilies, the Cimicoidea, Tingoidea, and Thaumastocoroidea.

1. Cimicoidea. Anthocoridae, or the flower bugs, are small predators on thrips, mites, and similar species in vegetation, in stored products, and in the nests of birds. The ocelli are distinct, and the front wings have a marginal fracture. Cimicidae contains the bedbugs, which lack ocelli, and have the short wings reduced to pads. The food consists of blood of birds and mammals. The Polytentidae are bat ectoparasites which lack eyes and have ctenidia and strong claws. The Miridae family contains a majority of the species of Hemiptera. Included are plant bugs of both herbivorous and predacious type. Ocelli are lacking, the anten-

nae are four-segmented, and there is only one dorsal abdominal scent gland opening in nymphs. Two small families, the Plokiophilidae and Microphysidae, are predacious. The Plokiophilids live in the webs of spiders and embiids.

Nabidae are the long "damsel" bugs which are slender predators on other insects. The ocelli are well developed, and the rostrum is four-segmented. The tropical Velocipedidae are related but differ in the broader form and darker coloration.

2. Tingoidea. This superfamily contains the lace bugs of the family Tingidae which have wings with many lacelike areolae. They lack ocelli, have four segments in the antennae and beak, and commonly have one or more bulbous or hoodlike elevations on the thorax. Pests are known on ornamental plants.

3. Thaumastocoroidea. The only family, the Thaumastocoridae, occurs in Australia and the New World tropics; it includes the royal palm bug of Florida.

Pentatomorpha includes the superfamilies Lygaeoidea, Pyrrhocoroidea, Coreoidea, and Pentatomoidea.

1. Lygaeoidea. This is the first of the superfamilies with ventral trichobothria (bristles) on the abdomen. The antennae are four-segmented. Ocelli are present. The Lygaeidae include the chinch bug, the false chinch bugs, and the milkweed bugs. Small families related to the lygaeids are the thread-legged Neididae (Berytidae), the small Piesmididae, and the tropical Colobathristidae. Some of the last have a unique method of stridulation with a filelike arch on the sides of the head.

2. Pyrrhocoroidea. This group includes the cotton stainers, which attack cotton bolls in the southwestern United States and over most of the tropics, and stout, dark bugs with a reddish border.

3. Coreoidea. The squash bugs and their relatives include the Coreidae, Rhopalidae, Alydidae, and Hyocephalidae. They have four-segmented antennae, a beak, distinct ocelli, and many veins in the membrane.

4. Pentatomoidea. This large group has marginal trichobothria. The antennae are usually five-segmented and the beak is four-segmented. Scutelleridae, or shield bugs, are not injurious in the United States. Cydnidae include the ground-burrowing bugs, which attack strawberries in sandy soil, and the negro bugs. Smaller families of little or no economic importance in the United States are the large tropical Tessaratomidae, the Acanthosomatidae, the Dinidoridae, the Aphyllidae, the Urostylidae, the barklike Phloeidae, the shining, oval Plataspidae, and the Lestoniidae. The true stink bugs, Pentatomidae, include the black-and-red harlequin cabbage bug, and several green stink bugs on cotton and other crops. See INSECTA. [P.W.]

**Hemispheric laterality** The human brain is a bilaterally symmetrical structure which is for the most part richly interconnected by two main bridges of neurons called the corpus callosum and anterior commissure. These structures can be surgically sectioned in humans in an effort to control the spread of epileptic seizures. Although there is no apparent change in everyday behavior of these patients, dramatic differences in cognitive function can be demonstrated under specialized testing conditions. In normal humans these cerebral commissures are largely responsible for behavioral unity; the neural mechanism keeps the left side of the body up to date with the activities of the right side, and vice versa.

Changes in behavioral responses of persons whose cerebral commissures have been sectioned are almost undetectable. The person walks, talks, and behaves in a normal fashion. Dramatic effects are observed only under testing conditions which utilize stimuli that are lateralized exclusively to one hemisphere or the other. For example, if a picture of an apple is flashed in the right visual field, the person describes the object normally. However, if the same picture is flashed in the left visual field, in the early days of postoperative testing the person denies that the stimulus

was presented at all. After many test sessions the person may have the impression that something was flashed, but is unable to say what. This disparity of recognition in the two sides of the visual field occurs because the information is projected to the right hemisphere, which is incapable of speech. Because the right hemisphere is now disconnected from the left, information arriving in the right hemisphere cannot be communicated by means of speech.

When tests are used which do not require a spoken response, numerous mental abilities are observed to be present in the "disconnected" right hemisphere. For example, even though the person is unable to describe a picture of an orange flashed to the left field, when the left hand searches through a field of objects placed out of view, it correctly retrieves the orange. If asked what the object is, the person would say he does not know. Here again the left hemisphere controls speech but cannot solve the problem. The right hemisphere solves the problem but cannot elicit speech.

Despite its linguistic superiority, the left hemisphere does not excel over the right in all tasks. Tests have demonstrated that in some specialized functions the right hemisphere is decidedly superior to the left. In the area of emotional reactions there appears to be equal reactivity in the two hemispheres.

Tests have been conducted on subjects in which the cerebral commissure had not been entirely sectioned (because it is now believed total commissure section is not necessary to stop the interhemispheric spread of some kinds of seizure activity). These persons showed dramatic breakdown in interhemispheric transfer. When the posterior part of the callosum is sectioned, visual aspects of the syndrome appear. When it is spared and more interior regions are cut, tactile and auditory communications are blocked, but not visual ones. It also appears that no fundamental reorganization of the interhemispheric transfer system takes place, since years after surgery these same deficits are present and are not compensated for in any way.

There appears to be a large variation in the lateralized talents of each half-brain. While the right hemisphere frequently appears to have some language talent, not all split-brain persons have language skills in the right hemisphere. Similarly, visual spatial skills, which are usually present exclusively in the right hemisphere, are frequently bilaterally represented and sometimes represented only in the left speech hemisphere. There is even some evidence that the commissure system itself varies in what is transferred where. See BRAIN; PSYCHOLOGY. [M.S.G.]

**Hemlock** The genus *Tsuga* of the pine family, characterized by flattened needles with two white lines beneath the needlelike leaves, which have distinct short stalks. The cones are small and pendent.

Eastern hemlock (*T. canadensis*) occurs in eastern Canada, the Great Lakes states, and the Appalachians. Minutely toothed leaves are characteristic of this species. The wood is hard and strong, and is used for construction, boxes, crates, and paper pulp. The bark is one of the principal domestic sources of tannin. The eastern hemlock is a common ornamental tree.

Carolina hemlock (*T. caroliniana*), a species found in the southern Appalachians, has entire needles and is sometimes grown as an ornamental. The western hemlock (*T. heterophylla*) grows in the extreme Northwest and in Alaska. Its needles resemble those of the eastern hemlock, but the white lines beneath are not so distinct. It is an important lumber tree, with uses similar to these of the eastern species. See FINALES. [A.H.G./K.P.D.]

**Hemoglobin** The oxygen-carrying molecule of the red blood cells of vertebrates. This protein represents more than 95% of the solid constituents of the red cell. It is responsible for the transport of oxygen from the lungs to the other tissues of the body and participates in the transport of carbon dioxide in the reverse direction.

Each molecule of hemoglobin comprises four smaller subunits, called polypeptide chains. These are the protein or globin parts

of hemoglobin. A heme group, which is an iron-protoporphyrin complex, is associated with each polypeptide subunit and is responsible for the reversible binding of one molecule of oxygen. The polypeptide chains and the heme are synthesized and combine together in nucleated red cells of the bone marrow. As these cells mature, the nuclei fragment and the cells, now called reticulocytes, begin to circulate in the blood. After sufficient hemoglobin has been formed in the reticulocyte, all nuclear material disappears and the cell is then called an erythrocyte, or red blood cell. Each hemoglobin molecule lasts as long as the red cell, which has an average life of 120 days. See PORPHYRIN.

Normal adult males and females have about 16 and 14 g, respectively, of hemoglobin per 100 ml of blood; each red cell contains about  $29 \times 10^{-12}$  g of hemoglobin. Red cells normally comprise 40–45% of the volume of whole blood.

The reversible combination of hemoglobin and oxygen can be represented by the reaction shown below. The equilibrium

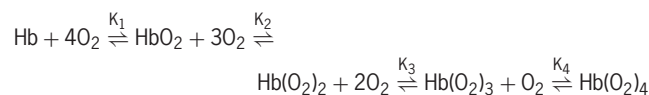

constants for each step are not the same because an oxygen molecule on one heme group changes the affinity of the other hemes for additional oxygen molecules. This alteration in binding affinity during oxygenation is called heme-heme interaction and is due to small changes in the three-dimensional structure of the molecule.

Hemoglobin combines reversibly with carbon monoxide about 210 times more strongly than with oxygen. This strong affinity for carbon monoxide accounts for the poisoning effects of this gas.

Hemoglobin binds carbon dioxide by means of free amino groups of the protein but not by the heme group. The reversible combination with carbon dioxide provides part of the normal blood transport of this gas. Hemoglobin serves also as a buffer by reversible reactions with hydrogen ions. The acidic property of oxyhemoglobin is greater than deoxygenated hemoglobin. The extra binding of hydrogen ion by deoxyhemoglobin promotes the conversion of tissue carbon dioxide into bicarbonate ion and thus increases the amount of total carbon dioxide which can be transported by blood. See BLOOD; RESPIRATION. [R.T.J.]

**Hemophilia** A rare, hereditary blood disorder marked by a tendency toward excessive bleeding. It is almost entirely restricted to males, and is transmitted as a sex-linked mendelian recessive trait passing from an affected male through an unaffected or very mildly affected daughter to appear again in a grandson. Queen Victoria was a carrier, and several of her male descendants were affected. See HUMAN GENETICS; SEX-LINKED INHERITANCE.

Classical hemophilia (hemophilia A) is due to a deficiency of the antihemophilic factor or factor VIII, a clotting factor which is normally present in the blood in trace amounts and is essential for normal fibrin formation. Hemophilia B is a similar sex-linked bleeding disorder affecting males but characterized by a deficiency of another blood clotting factor, factor IX. It can only be distinguished from hemophilia A, which it closely resembles, by laboratory tests. Hereditary deficiencies of other clotting factors may give rise to bleeding disorders similar to hemophilia, but they are inherited as autosomal dominant or recessive characteristics.

Treatment consists in the intravenous administration of potent concentrates of factor VIII or IX prepared from human plasma and they are very effective in the management of hemophilia A and B, respectively. See BLOOD; HEMORRHAGE. [C.Ho.]

**Hemorrhage** The escape of blood from within the vascular system. Hemorrhage may result from either trauma or disease of the vessel wall. The escape of blood following rupture of a vessel wall as a result of trauma is obvious and needs no further

explanation. The causes other than trauma can be divided into three main groups. The first group consists of these conditions in which there is a chronic disease process affecting the vessel wall, such as atherosclerosis or aneurysm formation. Either of these conditions, in association with an elevated blood pressure, can result in a break in the wall and subsequent hemorrhage. An infarct, or tissue death from any cause, may also result in hemorrhage. The second group consists of those causes in which there is an acute process affecting the vessel wall, such as septicemia, bacterial toxins, or anoxia. The third group consists of those hemorrhagic conditions which result from some defect in the blood itself. Under this heading are leukemia, thrombocytopenia, and the clotting disorders. See ANEURYSM; ARTERIOSCLEROSIS; INFARCTION; LEUKEMIA.

Petechiae are hemorrhages no larger than the head of a pin. Hemorrhages of greater size are termed ecchymoses. A localized mass of blood in tissue is a hematoma. Spontaneous hemorrhaging into the skin and mucosal surfaces is termed purpura. This usually denotes a disease of the vascular system or of the blood itself, such as a deficiency of blood platelets. See HEMATOLOGIC DISORDERS.

Cerebrovascular accident, or stroke, is an acute vascular lesion of the brain. This may be the result of hemorrhage from, thrombosis in, or embolism to a cerebral vessel. See EMBOLISM; THROMBOSIS. [R.A.V.; I.N.]

**Hemp** The fiber and the plant *Cannabis sativa*. It should not be confused with Manila hemp, which is not related to true hemp. Hemp contains the drug THC (tetrahydrocannabinol). See ABACA; MARIJUANA.

Hemp fiber, which for many years was the major raw material used in the manufacture of rope, now is used mostly in the production of small twines, linenlike fabrics and canvases, and, to some extent, in making special types of paper. See NATURAL FIBER.

Hemp is an annual crop, most of which is produced in Eastern Europe and mainland China, with some production in South Korea, Turkey, Italy, and Canada. [E.G.N.]

**Henequen** A fiber obtained from the leaves of *Agave fourcroydes*. It is produced only in Mexico, Cuba and El Salvador. Henequen is sometimes incorrectly called sisal, which is a closely related plant grown in Brazil and Africa. See SISAL.

The greatest quantity of henequen fiber goes into farm twine, followed by industrial tying twine and then light-duty rope. Padding for innerspring mattresses is made from the lowest grades of fiber and from flume tow, the short, tangled fiber that can be recovered from the cleaning operation. Henequen is exported as manufactured twine, rope, or padding, not as raw fiber. See NATURAL FIBER. [E.G.N.]

**Heparin** A highly sulfated mucopolysaccharide with blood anticoagulant activity, isolated from mammalian (chiefly beef) tissues. Heparin was first found in abundance in the liver, hence the name, but it is present in substantial amounts in the spleen, muscle, and lung as well. In the blood of most mammals, heparin is an antagonist to thrombin, prothrombin, and thromboplastin. It lessens the tendency of platelets to agglutinate. It is used in the treatment of venous thrombosis, embolism, myocardial infarction, and certain types of cerebral thrombosis. See POLYSACCHARIDE. [F.W.]

**Hepaticopsida** A class of lower green plants called liverworts that belong to the division Bryophyta. The class is divided into approximately 225 genera and 8500 species. Although there is a great diversity of external form, most of the gametophytes (gamete-producing plants) are dorsoventrally differentiated. These plants are considered among the most primitive of the existing land plants. Fossil remains of liverworts have been found in both the Devonian and Carboniferous. Since the fossils found do not differ significantly from modern liverworts,

they are of little value in ascertaining phylogenetic relationships. Liverworts are widely distributed over the world, but have their greatest diversity in the tropics of the Americas and East Indies.

Except when the plants occur in masses, they are quite inconspicuous and are usually confused with mosses, which they resemble somewhat in their external appearance. In the presence of adequate moisture, they grow on soil, rocks, and tree trunks. Usually the plant body is a thin, prostrate thallus, sometimes having a short central axis with leaflike appendages. On the lower surface are rhizoids (rootlike structures) which function in anchorage and absorption. See BRYOPHYTA; BRYOPSIDA.

[P.A.V.]

**Hepatitis** An inflammation of the liver caused by a number of etiologic agents, including viruses, bacteria, fungi, parasites, drugs, and chemicals. The most common infectious hepatitis is of viral etiology. All types of hepatitis are characterized by distortion of the normal hepatic lobular architecture due to varying degrees of necrosis of individual liver cells or groups of liver cells, acute and chronic inflammation, and Kupffer cell enlargement and proliferation. There is usually some degree of disruption of normal bile flow, which causes jaundice. The severity of the disease is highly variable and often unpredictable. See LIVER.

A frequently occurring form of hepatitis is caused by excessive ethyl alcohol intake and is referred to as alcoholic hepatitis. It usually occurs in chronic alcoholics and is characterized by fever, high white blood cell count, and jaundice. Some drugs are capable of damaging the liver and can occasionally cause enough damage to produce clinical signs and symptoms. Among these drugs are tetracycline, methotrexate, anabolic and contraceptive steroids, phenacetin, halothane, chlorpromazine, and phenylbutazone.

Clinical features of hepatitis include malaise, fever, jaundice, and serum chemical tests revealing evidence of abnormal liver function. In most mild cases of hepatitis, treatment consists of bedrest and analgesic drugs. In those individuals who develop a great deal of liver cell necrosis and subsequently progress into a condition known as hepatic encephalopathy, exchange blood transfusions are often used. This is done with the hope of removing or diluting the toxic chemicals thought to be the cause of this condition. Chronic hepatitis is a condition defined clinically by evidence of liver disease for at least 6 consecutive months. See ALCOHOLISM; LIVER DISORDERS. [S.P.H.]

Hepatitis C is a disease of the liver caused by the hepatitis C virus (HCV). The prevalence of HCV infection worldwide is 3% (170 million people), with infection rates in North America ranging from 1 to 2% of the population. A simulation analysis estimated that in the period from 1998 to 2008 there will be an increase of 92% in the incidence of cirrhosis of the liver, resulting in a 126% increase in the incidence of liver, failures and a 102% increase in the incidence of hepatocellular carcinoma (HCC), all attributed to HCV.

Hepatitis C virus can be transmitted only by blood-to-blood contact. With the institution of screening of blood, intravenous drug use has become the major source of transmission in North America. Approximately 89% of people who use intravenous drugs for one year become infected with HCV.

Management strategies can be divided into three main areas: surveillance of patients with chronic HCV infection who have not developed cirrhosis; surveillance of patients with established cirrhosis; and strategies to eradicate HCV. [N.Ar.; N.G.; G.L.]

**Herbarium** A collection of pressed and dried plant specimens, and a description of when, where, and by whom they were collected, arranged in a systematic manner, and serving as a permanent physical record of the occurrence of an individual plant at a specific place and time. Herbaria may contain specimens from the full range of organisms that have classically been considered plants: fungi, lichens, algae, bryophytes, ferns and their allies, gymnosperms, and angiosperms. Many herbaria also accumulate and manage special collections such as

liquid-preserved parts for anatomical studies, wood, seeds, or specially preserved material suitable for extraction of deoxyribonucleic acid (DNA) or other chemical constituents. Many groups of plants, especially those with succulent or fleshy parts, are not suitable for preservation as dry, flat specimens because they lose many of their important features in the drying process. Consequently, these plants are often preserved in liquid. Specimens are used in taxonomic and ecological research, such as morphological studies, and for comparative identification and verification of unknown specimens. See PLANT GEOGRAPHY; PLANT TAXONOMY. [J.C.So.]

**Herbicide** Any chemical used to destroy or inhibit plant growth, especially of weeds or other undesirable vegetation. There are well over a hundred chemicals in common usage as herbicides. Many of these are available in several formulations or under several trade names. The variety of materials are conveniently classified according to the properties of the active ingredient as either selective or nonselective. Selective herbicides are those that kill some members of a plant population with little or no injury to others. Nonselective herbicides are those that kill all vegetation to which they are applied. Further subclassification is by method of application, such as preemergence (soil-applied before plant emergence) or postemergence (applied to plant foliage). Additional terminology sometimes applied to describe the mobility of post-emergence herbicides in the treated plant is contact (nonmobile) or translocated (mobile—that is, killing plants by systemic action).

A rapidly expanding use for nonselective herbicides is the destruction of vegetation before seeding in the practice of reduced tillage or no tillage. Some are also used to kill annual grasses in preparation for seeding perennial grasses in pastures. Additional uses are in fire prevention, elimination of highway hazards, destruction of plants that are hosts for insects and plant diseases, and killing of poisonous or allergen-bearing plants.

Preemergence or postemergence application methods derive naturally from the properties of the herbicidal chemical. The distinction between pre- and postemergence is not always clear-cut. For example, atrazine can exert its herbicidal action either following root absorption from a preemergence application or after leaf absorption from a postemergence treatment. [R.O.R.]

**Herbig-Haro objects** A small, bright, semistellar knot of nebular emission in one of the dark interstellar clouds of gas and dust from which stars form. Herbig-Haro objects are named for G. Herbig and G. Haro, who independently discovered them in the early 1950s. They range in size from 300 to 1000 astronomical units and can vary in intensity over periods of only a few years. Their spectra show the presence of the emission lines characteristically formed behind a radiative shock wave, and suggest masses only about a factor of 10 greater than the mass of the Earth. It is now believed that Herbig-Haro objects are manifestations of the mass-loss phenomenon associated with very young stars. See INTERSTELLAR MATTER; MOLECULAR CLOUD.

Since the late 1970s, evidence of bipolar outflows has been detected in star-forming regions of the interstellar medium. In this dramatic phase of early stellar evolution, oppositely directed jets of high-speed gas are observed emanating from visible, pre-main-sequence T Tauri stars and, more frequently, from objects so young that their presence within their obscuring, parent clouds can be inferred only from infrared measurements. When these visible jets, which have speeds up to 400 km/s (250 mi/s), collide with the ambient interstellar gas, the violent heating and compression known as a shock wave results. Herbig-Haro objects are frequently the hot spots where the jets hit the surrounding material. Their luminous appearance is the result of excitation of the gas by the shock. See PROSTAR; T TAURI STAR.

However, not all Herbig-Haro objects are found at the terminal points of bipolar jets. Particularly when the source of the outflow is a much more luminous star than the Sun, Herbig-Haro objects

can be scattered over a wide angular region rather than restricted to a well-defined outflow axis. Alternatively, several well-known Herbig-Haro objects with characteristic spectral emission lines are the brightest knots within individual jets, and probably reflect the presence of internal shocks. See STELLAR EVOLUTION. [A.I.S.]

**Herbivory** The consumption of living plant tissue by animals. Herbivorous species occur in most of the major taxonomic groups of animals. Herbivorous insects alone may account for one-quarter of all species. The fraction of all plant biomass that is eaten by herbivores varies widely among plants and ecosystems, ranging from less than 1% to nearly 90%. In terms of both the number of species involved and the role that herbivory plays in the flow of energy and nutrients in ecosystems, herbivory is a key ecological interaction between species.

Herbivory usually does not kill the plant outright, although there are striking exceptions (such as bark beetle outbreaks that decimate conifer trees over thousands of square kilometers). Nevertheless, chronic attack by herbivores can have dramatic cumulative effects on the size, longevity, or reproductive output of individual plants. As a consequence, plants have evolved several means to reduce the level of damage from herbivores and to ameliorate the impact of damage.

Many plants possess physical defenses that interfere mechanically with herbivore feeding on or attachment to the plant. In addition, plant tissues may contain chemical compounds that render them less digestible or even toxic to herbivores. Many plant compounds even can cause death if consumed by unadapted herbivores. While natural selection imposed by herbivores was the likely force driving the elaboration of these plant chemicals, humans have subsequently found many uses for the chemicals as active components of spices, stimulants, relaxants, hallucinogens, poisons, and drugs. An exciting recent finding is that some plants possess induced resistance, elevated levels of physical or chemical defenses that are brought on by herbivore damage and confer enhanced resistance to further damage.

Herbivores can either avoid or counteract plant defenses. Many herbivores avoid consuming the plant tissues that contain the highest concentrations of toxic or antinutritive chemicals. Herbivores have also evolved an elaborate array of enzymes to detoxify otherwise lethal plant chemicals. Because few herbivores have the ability to detoxify the chemical compounds produced by all the plant species they encounter, many herbivores have restricted diets; the larvae of more than half of all species of butterflies and moths include only a single genus of plants in their diets. Some insect species that have evolved the means to tolerate toxic plant chemicals have also evolved ways to use them in their own defense. Larvae of willow beetles store plant compounds in glands along their back. When the larvae are disturbed, the glands exude droplets of the foul-smelling compounds, which deter many potential predators.

If a plant evolved the ability to produce a novel chemical compound that its herbivores could not detoxify, the plant and its descendants would be freed for a time from the negative effects of herbivory. A herbivore that then evolved the means to detoxify the new compound would enjoy an abundance of food and would increase until the level of herbivory on the plant was once again high, favoring plants that acquire yet another novel antiherbivore compound. These repeated rounds of evolution of plant defenses and herbivore countermeasures (coevolution) over long periods of time help to explain similar patterns of evolutionary relatedness between groups of plant species and the herbivorous insect species that feed on them.

Plants and their herbivores seldom occur in isolation, and other species can influence the interaction between plants and herbivores. For example, mammalian herbivores often rely on gut microorganisms to digest cellulose in the plant material they consume. Thus, herbivory occurs against a backdrop of multiple interactions involving the plants, the herbivores, and other species in the ecological community. [W.F.Mo.]

**Hermaphroditism** A condition in which components of both testes and ovaries are present in the same individual. Although true hermaphroditism is common among lower forms of animals such as annelids and mollusks, it is rare in humans. A more common condition in humans is pseudohermaphroditism, which simulates hermaphroditism. In female pseudohermaphroditism, or gynandry, the external sexual characteristics are in part or wholly of the male aspect, but internal female genitalia are present. In male pseudohermaphroditism, or androgyny, the individual has external sexual characteristics of female aspect, but has testes (usually undescended). See OVARY; REPRODUCTIVE SYSTEM DISORDERS; TESTIS. [S.P.P.]

**Hernia** The protrusion of an organ, part of an organ, or other structure through the wall of the body cavity normally containing it. Various organs may be involved, including the bladder, brain, esophagus, intestine, ovary, and rectum. The most common location for a hernial bulge to appear is the abdominal wall, particularly the groin.

Among the most infrequent but life-threatening hernias is a cerebral hernia in which part of the brain protrudes through an opening in the skull.

A diaphragmatic hernia, which occurs when a defect is present in the muscular diaphragm separating chest from abdomen, may be present at birth or result from an injury later in life. Abdominal organs, such as the liver, spleen, stomach, and intestine, can pass through the diaphragmatic defect and lodge in the chest cavity, so that the lungs become compressed and breathing is impaired. Hiatal or esophageal hernia results when a portion of the stomach slides into the chest cavity through the normal diaphragmatic opening for the esophagus.

Groin hernias consist of two major types, inguinal and femoral. Inguinal hernias account for 75% of all hernias of the body, and are divided into two anatomic variants, indirect and direct. Indirect inguinal hernias are caused by a weakness in the abdominal wall that corresponds to an area where the testis descended into the scrotum during embryological development. With direct inguinal hernias, the defect results mainly from strain on the abdominal muscles which have been weakened by age. Inguinal hernias are 10 times as common in men as in women. Femoral hernias are more common in women, but are infrequent. The weakness in a femoral hernia originates in the area where the major veins, arteries, and nerves pass from the abdomen into the lower extremities. A femoral hernia bulge is always located in the upper inner part of the thigh, just below the groin crease.

With rare exceptions, all hernias should be corrected surgically to prevent the possibilities of incarceration, intestinal obstruction, and strangulation. [I.M.R.]

**Herpes** Any virus of the herpesvirus group, which comprises a family of 70 species, 5 of which are pathogenic to humans; the term also refers to any infection caused by these viruses. Since these pathogens are ubiquitous in nature, most individuals of all populations are exposed to and thus immunized to these viruses. The five pathogenic groups include herpes simplex I and II, varicella-zoster, cytomegalovirus, and the Epstein-Barr virus.

In nonimmunized hosts, the vast majority of all herpes infections present symptoms of nonspecific viral illnesses which resolve spontaneously. However, the infections that cause clinical disease in fact may cause serious morbidity and mortality in afflicted individuals. Reactivation of herpes infection, characteristic of the immunocompromised host, is an important cause of mortality in the treatment of patients with advanced cancer, and is a potential complication of an otherwise possibly curable systemic disease.

Herpesviruses have a deoxyribonucleic acid (DNA) core and are 150 to 200 nanometers in size with icosahedral symmetry, and are coated by a protein barrier, the capsid, derived from the infected host cells. The surface of the virions in general contains protein-carbohydrate structures which allow cellular attachment

and thus cellular penetration. All viruses require living cells for their replication; the virus may replicate and destroy the cell, or replicate and allow cell survival, or incorporate its viral gene structure into the host gene structure. This incorporation phenomenon is designated as latency. For example, herpes simplex virus exhibits the phenomenon of latency within nerve cells in the area of previous infection. The Epstein-Barr virus characteristically causes latent infection in lymphocytes (white blood cells in the circulating blood), and the cytomegalic virus also causes latent infection within lymphocytes and possibly within nerve cells. Once the viral genome is incorporated into the host cell, antiviral drugs are of no use, since therapeutic agents cannot selectively destroy or inhibit the viral genome. Factors which are possibly involved in the reactivation of latent virus generally revolve around some depression of the host immune response system. Viral genome incorporation into host cells is of great interest as several herpesvirus types are implicated in the development of cancer. See VIRUS INFECTION, LATENT, PERSISTENT, SLOW.

The foundation of therapeutic intervention for all herpesviruses involves a series of chemicals with structures similar to the base pairs which compose the viral DNA structure. The base analogs compete with or inhibit viral enzymes necessary for the assembly of DNA. See VIRUS.

Herpes simplex I and II infections are spread by intimate contact of mucocutaneous surfaces during the period of virus shedding from active lesions. They usually affect the genitalia, but may affect the oral mucosa, causing painful ulcerations which crust and heal. Upon healing, the virus resides in latent form within local nerve cells. Viral reactivation is poorly understood, but may relate in part to the host immune system. The type II virus has been linked to the development of uterine cervical carcinoma, however its precise role remains a question.

Herpes simplex virus I (cold sores, fever blisters) afflicts 20–40% of the population in the United States and usually affects the oropharynx, causing pharyngitis, tonsillitis, gingivostomatitis, or keratitis (eye inflammation) as primary infections. Inflammation of the mouth, eye, or brain may occur as a secondary infection.

Primary infection (airborne) due to herpes varicella-zoster usually affects preschool children, causing chickenpox, with rare complications usually affecting the immunocompromised host. Secondary infection usually afflicts the elderly when latent viral reactivation occurs, presumably due to an immune imbalance in the host, and involves the spread of virus along the skin in the anatomic distribution of nerve (this disorder is known as shingles). See CHICKENPOX AND SHINGLES.

Cytomegalovirus is ubiquitous, with the majority of infections remaining subclinical. Adult syndromes include a mononucleosislike syndrome and hepatitis, both of which are self-limited diseases in the normal host. However, reactivation of latent infection is a major source of morbidity and especially mortality in the compromised host, for example, the patient being treated with chemoradiotherapy for advanced malignant disease. See CYTOMEGALOVIRUS INFECTION; HEPATITIS.

The characteristic clinical syndrome caused by Epstein-Barr virus infection includes generalized lymphadenopathy, hepatosplenomegaly, pharyngitis, tonsillitis, and general fatigue and fever. This disorder affects individuals of all ages, but predominantly adolescents. The majority of children are subclinically infected. This mononucleosis syndrome is usually a self-limited disorder, and investigational drugs in use for prophylaxis of high-risk individuals include interferons and acyclovir. Epstein-Barr virus is suspected to be of etiologic importance in Burkitt's African lymphoma. See ANIMAL VIRUS; EPSTEIN-BARR VIRUS; VIRUS CHEMOPROPHYLAXIS. [D.J.D.]

**Herrings** The common name for a family (Clupeidae) of about 70 genera of fishes in the order Clupeiformes. They are used extensively as food all over the world, and occur in all seas except the Arctic and Antarctic.

These fishes are the most primitive of the higher bony fishes. The fins have no supporting spines and are soft-rayed. There are usually four gill clefts, with the pectoral fins behind the gill openings. Scales are present on the body but absent on the head, and the swim bladder and lateral line may be missing.

The herring *Clupea harengus* has a circumpolar distribution. About eight other species of this genus are recognized, including the sprat or brisling (*C. sprattus*), which occurs in the Mediterranean and seas of western Europe, and the gizzard shad (*Dorosoma cepedianum*), which is a common species in the Potomac River. In Europe the herring is either salted, pickled, or smoked and cured as kippers. In Canada and the United States young herring are canned as "sardines."

The sardine, *Sardina pilchardus*, is a herring known commonly as the pilchard and is found along the European coasts in the Atlantic. The entire fish may be processed and preserved in oil, since the bones are soft and all parts are edible. Shads, herrings of the genus *Alosa*, occur in northern waters on both sides of the Atlantic. Anchovies comprise a family of herringlike fish, the Engraulidae, which together with the Clupeidae belong to the suborder Cluipoidea. These fishes are found in the Mediterranean and range along the European coast as far north as Norway. See CLUPEIFORMES. [C.B.C.]

**Hertzsprung-Russell diagram** A two-dimensional diagram used extensively in astronomy, developed independently by Ejnar Hertzsprung in 1911 and Henry Norris Russell in 1913. In its original form, the Hertzsprung-Russell (H-R) diagram was a plot of absolute visual magnitude versus spectral type (O, B, A, and so on). Variants are now commonly used, avoiding requirements of and uncertainties due to spectral classification. The vertical axis of the diagram is some suitable measure of the power output of the star, while the horizontal axis indicates the temperature (or color) of the star's visible surface, or the corresponding spectral type. Each point in the plot represents a nearby star of known distance. In any of its forms, the diagram reveals the most fundamental correlation among observed stellar properties discovered to date. See MAGNITUDE (ASTRONOMY); SPECTRAL TYPE.

In its observational form, also referred to as a color-magnitude diagram, absolute magnitude is used as ordinate, although apparent magnitude may be used for a collection of stars at a common distance. Brighter stars (that is, those with higher luminosities, and smaller numerical values of the magnitude) appear at the top of the diagram. The color scale is usually a color index constructed as the difference between the magnitudes measured in two chosen spectral bands. For historical reasons, the bluest color index (corresponding to the highest temperatures) appears at the left. See COLOR INDEX.

The illustration shows the Hertzsprung-Russell diagram for about 15,000 single stars from the compilation of nearly 120,000 stellar distances measured by the *Hipparcos* satellite. The absolute visual magnitude scale runs from  $-5$  to  $15$ , corresponding to a range of  $10^8$  in star luminosity. The color index scale corresponds to effective temperatures ranging from around 100,000 K (180,000°F) at the left to about 2500 K (4000°F).

From the upper left (blue, high-luminosity stars) to the lower right (red, low-luminosity stars) a prominent concentration of objects defines the main sequence. Stars located on the main sequence are also called dwarfs. They include stars such as Sirius, and are assigned luminosity class V in the MK stellar classification system. (In this system, two parameters, spectral type and luminosity class, categorize each star.) Along the main sequence, the luminosity of a star and its surface temperature are tightly correlated. Stellar structure theory successfully models this relationship. The main-sequence stars are at the early phases of their lives, and are powered by the fusing of hydrogen to helium in their centers. Masses of the main-sequence stars increase going toward the upper left of the diagram (reaching almost 100 times the Sun's mass) and decrease going to the lower right

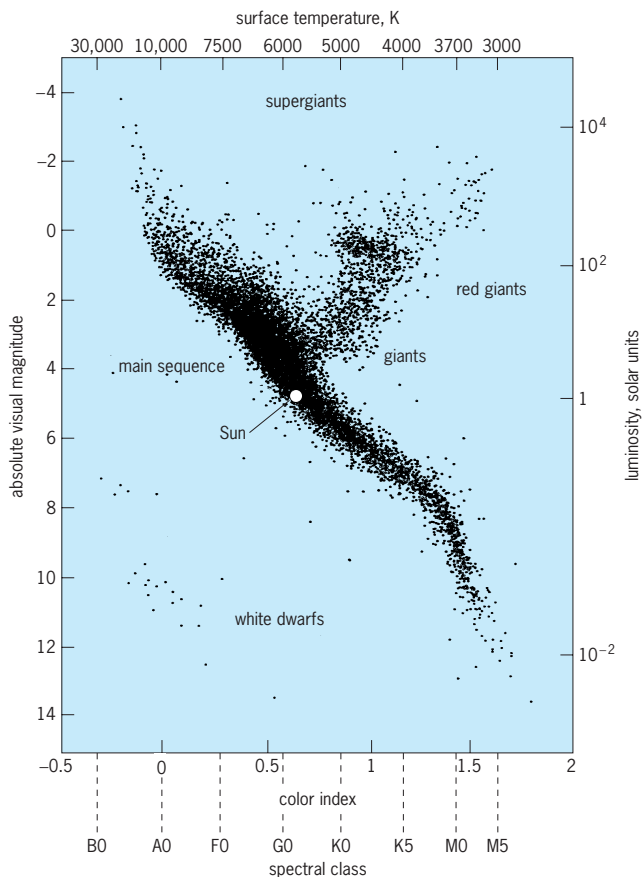

**Hertzsprung-Russell diagram for about 15,000 stars within a sphere of radius 100 parsecs, taken from the *Hipparcos Catalogue*. The color index and absolute visual magnitude scales are directly measured. The spectral class, surface temperature, and luminosity (in terms of solar luminosity) are approximate relationships appropriate for the main sequence.**

(to about one-tenth of the Sun's mass). Due to their higher central temperatures and pressures, the more massive stars are burning hydrogen more rapidly and are therefore brighter. See DWARF STAR.

Extending from the main sequence in the direction toward lower temperatures, and at roughly constant luminosity, are the luminosity class III giant stars (such as Vega) and the clump of more luminous red giants. Even more luminous supergiants, of luminosity class I (such as Arcturus and Procyon), are sparsely represented but occupy a broad range of color index at the very highest luminosities. They reach absolute magnitudes of less than  $-5$ , corresponding to luminosities some  $10^4$  times brighter than the Sun, and with radii around 1000 times that of the Sun. The lower left part of the diagram is not entirely empty and contains the white dwarfs: hotter than the Sun, but much less luminous (typically  $10^4$  times fainter) and of much smaller radius (about 1% of the Sun's radius). See GIANT STAR; SUPERGIANT STAR; WHITE DWARF STAR.

The Hertzsprung-Russell diagram says nothing, at least directly, about the mass, chemical composition, or age and state of evolution of a star. However, comparisons between observations (such as the illustration) and the predictions of stellar evolution theory allow stringent constraints to be placed on models of the structure, chemical composition, and evolution of stars. See STAR; STELLAR EVOLUTION. [M.A.C.P.]

**Hesperornithiformes** A small order of Cretaceous, toothed fossil birds that comprises the families Enaliornithidae, Baptonithidae, and Hesperornithidae. They were mostly



flightless marine birds specialized for diving, whose fossils have been found through most of the Cretaceous of North America and Europe and with one species known from Chile. Although the hesperornithiforms are similar in body form and habits to the living loons, grebes, and penguins, they are not closely related and their resemblances are the result of convergent evolution. Hesperornithiformes is placed in the superorder Odonotognathae with Ichthyornithiformes solely because those two orders comprise the only modern birds still possessing teeth. The relationships of the two orders must still be demonstrated with additional evidence, however. See AVES; GAVIIFORMES; ICHTHYORNITHIFORMES; ODONOTGNATHAE; PODICIPEDIFORMES; SPHENISCIFORMES. [W.J.B.]

**Heterochrony** An evolutionary phenomenon that involves changes in the rate and timing of development. As animals and plants grow from their earliest embryonic stages to the adult, they undergo changes in shape and size. This life history of an individual organism is known as its ontogeny. The amount of growth that an organism experiences during its ontogeny can be more or less than its ancestor. This can apply to the organism as a whole or to specific parts.

Evolution can be viewed as a branching tree of modified ontogenies. Heterochrony that produces these changes in size and shape may be the link between genetics at one extreme and natural selection at the other.

If a character of one species in an evolutionary sequence undergoes less growth than its ancestor, the process is known as pedomorphosis. If it undergoes more growth, the process is known as peramorphosis. Each state can be achieved by varying the timing of onset, offset, or rate of development.

If development is stopped at an earlier growth stage in the descendant than in the ancestor (for example, by earlier onset of sexual maturity), ancestral juvenile features will be retained by the descendant adult (progenesis). If the onset of development of a particular structure is delayed in a descendant, the structure will develop less than in the ancestor (postdisplacement). The third process that produces pedomorphosis is neoteny, whereby the rate of growth is reduced.

For peramorphosis, development can start earlier in the descendant than in the ancestor (predisplacement); or the rate of development can be increased, thus increasing the allometric coefficient (acceleration); or development can be extended by a delay in the onset of sexual maturity (hypermorphosis).

As an organism grows, the number of cells that it produces increases. Ultimately, changes to rate and timing of growth are reflections of changes to the timing of onset and rate of cell development, and the balance between cell growth and cell death. Morphogens and growth hormones play a major role in controlling development in terms of initiation, rate of division, and migration. Therefore, changes to the timing of their expression affect the shape and size of the final adult structure. Inception of hormonal activity is under the control of genes that regulate the timing of its production. [K.J.McN.]

**Heterocorallia** A small, extinct, late Paleozoic order of fossil corals, known from Europe, North Africa, Asia, North America, and Australia, but limited to the Late Mississippian. They are found in calcareous shales and in limestones. Their very elongate skeletons, and the hooks on the outer septal edges of some, suggest a pseudoplanktonic existence attached to seaweeds. There are but rare indications of branching. See COELENTERATA. [D.H.]

**Heterocyclic compounds** Cyclic compounds in which the rings include at least one atom of an element different from the rest. Most types of heterocyclic compounds studied to date are organic compounds. An example of an organic heterocyclic compound is oxazoline (1); an example of an inorganic heterocyclic compound is the phosphonitric chloride (2). The

smallest possible ring is three-membered, for example, ethyl-ene oxide (3), but very large rings are possible, as in the crown ethers, for example, 18-crown-6 (4). The cycle may contain only

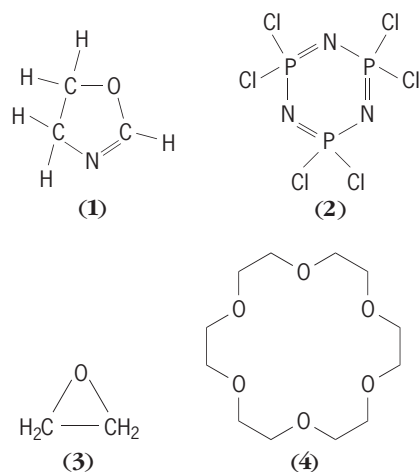

single bonds and is thus saturated; it may include one or more double bonds; or it may possess aromatic unsaturation characteristics of benzene, that is, it is heteroaromatic. Heterocyclic compounds can contain more than one ring, either heterocyclic or homocyclic.

Naturally occurring heterocyclic compounds are extremely common as, for example, most alkaloids, sugars, vitamins, DNA and RNA, enzymic cofactors, plant pigments, many of the components of coal tar, many natural pigments (such as indigo, chlorophyll, hemoglobin, and the anthocyanins), antibiotics (such as penicillin and streptomycin), and some of the essential amino acids (for example, tryptophan), and many of the peptides (such as oxytocin). Some of the most important naturally occurring high polymers are heterocyclic, including starch and cellulose. The major groups of natural products that are not mainly heterocyclic are the fats and most of the terpenes, steroids, and essential  $\alpha$ -amino acids, though exceptions do exist.

Heterocyclic compounds may be named systematically. Many heterocycles, however, have nonsystematic names that are usually preferred by practicing chemists over the systematic ones. In the systematic approach to nomenclature the ring size is denoted by the appropriate stem. For example, three-membered saturated rings without nitrogen would have a name ending in -irane. The nature of the heteroatom is denoted by such prefixes as oxa-, thia-, or aza-, for oxygen, sulfur, or nitrogen, respectively. Thus, ethylene oxide (3) becomes oxirane. A five-membered unsaturated ring would have a name ending in -ole. A six-membered unsaturated ring containing nitrogen would have a name ending in -ine according to this scheme. Actually, the trivial names for many systems are commonly accepted, and the systematic names are not often used.

For details about specific heterocyclic systems see FURAN; HETEROCYCLIC POLYMER; INDOLE; PYRIDINE; PYRIMIDINE; PYRROLE; THIOPHENE. [R.A.A.]

**Heterocyclic polymer** Essentially, linear high polymers comprising heterocyclic rings, or groups of rings, linked together by one or more covalent bonds. As the search has continued for polymeric materials having useful properties at high temperatures (500°C or 930°F, or higher), much attention has been given to heterocyclic polymers. As a group such polymers are often both mechanically rigid and inherently resistant to thermal degradation. See POLYMER.

Some of these polymers form molecules in which the rings are fused together, as shown symbolically in the illustration (ladder

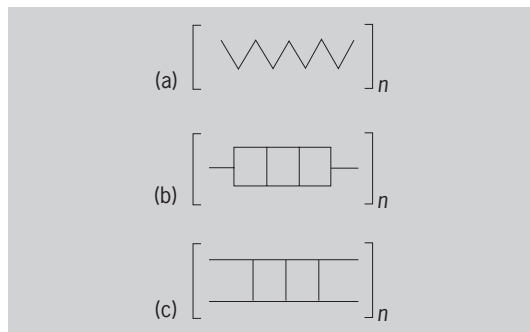

Structural units in linear polymers. (a) Simple linear polymer. (b) Stepladder polymer. (c) Ladder polymer.

polymers), and some form molecules in which fused rings are joined by single bonds (stepladder polymers). Similar considerations hold for simple aromatic systems, for example, linear polymers of benzene, but the heterocyclic systems have, in general, been more useful in application.

Three heterocyclic polymers have been developed to the point of commercial availability; polyimides, polybenzimidazoles, and polybenzothiazoles. At least the first two appear to have established specialized markets.

Major applications for these rather expensive polymers are as metal-to-metal adhesives and as laminating resins for fibrous composites for structural applications in the aerospace industry. Other applications requiring both strength and resistance to oxidation at elevated temperatures have developed, including valve seats, bearings, and turbine blades. See POLYMERIC COMPOSITE.

[J.A.M.]

**Heterodyne principle** The basic principle underlying the operation of a superheterodyne radio, television, or other receiver, wherein two alternating currents that differ in frequency are mixed in a nonlinear device to produce two new frequencies, corresponding to the sum and the difference of the input frequencies. Only the difference frequency is commonly used in a superheterodyne receiver, where it serves as the input to the intermediate-frequency amplifier. See RADIO RECEIVER. [J.Mar.]

**Heterogeneous catalysis** A chemical process in which the catalyst is present in a separate phase. In the usual case, the catalyst is a solid and the reactants and products are in gaseous or liquid phases. See CATALYSIS.

Heterogeneous catalysis proceeds by the formation and subsequent reaction of chemisorbed complexes which can be considered to be surface chemical compounds. A very simple case, where  $A \rightarrow B$  is slow in the absence of catalyst, is shown in the following reaction:



Reaction  $A \rightarrow B$  is fast if the three preceding steps are fast. Here,  $*$  represents a catalytic site on the surface of the catalyst,  $A^* \rightarrow B^*$  is called a surface reaction,  $* + A \rightarrow *A$  represents the chemisorption of  $A$ , and  $B^* \rightarrow B + *$  represents desorption of  $B$ . See ADSORPTION.

With most sets of reactants, more than one reaction will be thermodynamically possible. The degree to which a given catalyst favors one reaction compared with other possible reactions is called the selectivity of the catalyst for the reaction. Two aspects of a catalyst are of particular importance: its selectivity, and its activity, which can be taken as the rate of conversion of reac-

tants by a given amount of catalyst under specified conditions. Ideally, the rate will be proportional to the amount of catalyst.

The first important heterogeneous catalytic process to be used in the chemical industry was the manufacture of sulfuric acid from sulfur trioxide by the contact process in 1875. By the 1950s, heterogeneous catalytic processes had come to dominate the petroleum, petrochemical, and chemical industries. Today, about 70% of the crude oil refined in the United States is exposed to at least one heterogeneous catalytic process. Heterogeneous catalysis is a critical feature in energy conservation and interconversion, and is a key feature in the production of synthetic fuels from coal and oil shale. See COAL GASIFICATION; FISCHER-TROPSCH PROCESS.

Since catalytic activity will ordinarily be proportional to surface area, most catalysts are used in forms with large specific areas. Higher-area metal powders are often used for liquid-phase reactions in batch reactors. For example, finely divided nickel is used for the hydrogenation of unsaturated glycerides in the manufacture of margarine from vegetable oils. Supported catalysts are widely used. In these, the catalytic ingredient is dispersed in the internal porosity of such supports as silica gel,  $\gamma$ -alumina, and charcoals. These supports have large areas in the internal porosity, and their average pore diameters are 2–20 nm. Supported catalysts have the advantage that the area of the catalytic ingredient can be very large.

One important type of catalyst exposes strongly acidic sites in its internal porosity. Such catalysts are used to crack larger molecules of hydrocarbon into smaller ones in petroleum refining. Other catalysts, called dual-functional catalysts, have a hydrogenating catalytic ingredient on an acidic support. These are also of major importance in processing petroleum. See CRACKING; HYDROCRACKING; ZEOLITE.

[R.L.Bu.; G.L.H.]

**Heteronemertini** An order of the class Anopla in the phylum Rhynchocoela, with an unarmed proboscis, a thick partly fibrous dermis, and a three-layered body musculature composed of outer longitudinal, median circular, and inner longitudinal strata. Cerebral organs, cephalic grooves and slits, and eyes are generally present. The alimentary system consists of a mouth, foregut, intestine with regular lateral diverticula but no cecum, and anus. Heteronemertini are mainly marine littoral in habit. See ANOPLA; RHYNCHOCOELA. [J.B.J.]

**Heterophile antigen** The serologic reactions of the tissue and blood-cell antigens of most animals are normally characteristic of the species. Significant serologic cross reactions usually occur only with antisera to the corresponding antigens of closely related species. The numerous groups of heterophile antigens—of which the Forssman antigens are the best studied—constitute significant exceptions. Heterophile antigens link the species hog-ox-human (blood group A), cat-horse, and dog-hog-cat-human, while several heterophile groups link otherwise diverse microorganisms. Similarities between antigens in mammalian hearts and the cell walls of the group A hemolytic streptococcus are also known. The cross reactions between the *Proteus* bacillus and the *Rickettsiae* are important in the diagnosis of typhus fever. See ANTIBODY; ANTIGEN; SEROLOGY. [M.J.Po.]

**Heterosis** Hybrid vigor or increase in size, yield, and performance found in hybrids, especially if the parents have previously been inbred. The application of heterosis has been one of the most important contributions of genetics to scientific agriculture in providing hybrid corn, and vigorous, high-yielding hybrids in other plants and in livestock. See BREEDING (ANIMAL); BREEDING (PLANT); GENETICS; MENDELISM.

There are two principal hypotheses to account for the association of size and vigor with heterozygosity, dominance and overdominance. The dominance hypothesis notes that any non-inbred population carries a number of recessive genes that are harmful to a greater or lesser extent, but which are rendered

ineffective by their dominant alleles. As they become homozygous through inbreeding, they exert their harmful effect. With hybridization, some of the detrimental recessives contributed to the hybrid by one parent are masked by dominant alleles from the other, and an increase in vigor is the result. The alternative hypothesis is that there are loci at which the heterozygote is superior in vigor to either homozygote. This, the overdominance hypothesis, also has the consequence that vigor is proportional to heterozygosity. The dominance hypothesis has been more widely accepted, but the two are very difficult to distinguish experimentally, and it is likely that overdominant loci are playing an appreciable role in heterosis, particularly in determining why one hybrid is better than another. See DOMINANCE. [J.F.Cr.]

**Heterostraci** An extinct group of ostracoderms or armored, jawless vertebrates (Agnatha). The armor has a distinctive microscopic structure, consisting of bone lacking any cavities for bone cells, surmounted by tubercles or ridges of dentine. Fragments of such armor from the Middle Ordovician of Australia and North America are the earliest remains definitely attributable to vertebrates. Heterostraci became more common toward the end of the Silurian and persisted through the Devonian.

The anterior part of the body was covered with plates. The posterior part of the body and the tail were covered with thick scales. There were no jaws, but the mouth was bounded behind by a number of small plates that may have been used for nibbling. [R.H.De.]

**Heterotardigrada** An order of the tardigrades; the majority of genera have widely varied structure. Cephalic appendages having a sensorial function are present, as well as cirrus lateralis and clava. This order of tardigrades is divided into two suborders, Arthrotardigrada and Echiniscoidea.

Members of the suborder Arthrotardigrada have toelike terminations of the legs. The tubular middle part of the leg telescopes into the broad proximal part. These animals are marine organisms found in sand or on algae.

In the suborder Echiniscoidea the legs terminate with claws. The middle part of the leg is partially retractable into the proximal part. At least the fourth pair of legs has a distinct fold. Frequently these animals are red because of the presence of carotenoid pigments. See CAROTENOID; TARDIGRADA. [Ev.M.]

**Heterotrichida** A large order of the Spirotrichia. The buccal ciliature is well developed, although in a number of families the somatic, or body, ciliature is really holotrichous in nature. Heterotrichs have become adapted to all sorts of habitats, including the digestive tracts of a variety of invertebrate and a few vertebrate hosts. Because of their size and amazing regenerative powers, a number of heterotrichs have been widely used in experimental research. Common genera include *Sten-*

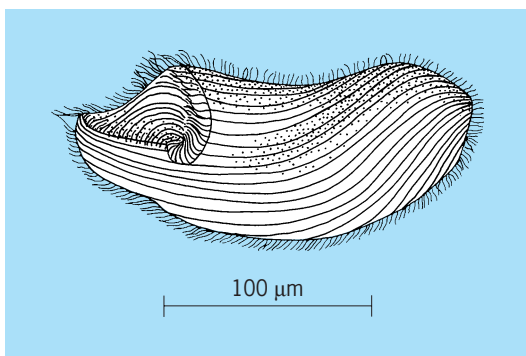

*Climacostomum*, an example of a heterotrich.

*tor*, *Blepharisma*, *Folliculina*, *Condylostoma*, *Climacostomum* (see illustration), and *Spirostomum*. See SPIROTRICHIA. [J.O.C.]

**Heulandite** A mineral belonging to the zeolite family of silicates. It usually occurs in crystals with the prominent side being pinacoid, often having a diamond shape. There is perfect side pinacoid cleavage on which the luster is pearly; elsewhere the luster is vitreous. The hardness is  $3\frac{1}{2}$  to 4 on Mohs scale; specific gravity is 2.18–2.20. The mineral is usually white or colorless but may be yellow or red. See ZEOLITE.

Heulandite is essentially a hydrous calcium aluminum silicate,  $\text{Ca}(\text{Al}_2\text{Si}_7\text{O}_{18}) \cdot 6\text{H}_2\text{O}$ . Heulandite is a secondary mineral found in cavities in basalts associated with other zeolites and calcite. Notable localities are in the Faeroe Islands, India, Nova Scotia, and West Paterson, New Jersey. [C.Fr.; C.S.Hu.]

**Hexactinellida** A class of sponges whose skeletons are made of siliceous hexactine spicules. These exclusively marine sponges are widely distributed in modern oceans. Their fossil record extends from the late Precambrian to the Recent. The basic spicule type of the class is a triaxial hexactine, in which the three pairs of opposed rays are at right angles to each other and lie along one of the three axes of a cube. Proximal ray ends and axial filaments meet at the center of the cube. These principal spicules and variants of that form make up skeletons of the sponges.

Recent hexactinellid sponges are chiefly upper bathyal marine animals and are most common in depths of 200–2000 m (660–6560 ft), although many species are known to inhabit lower bathyal depths. Living hexactinellid sponges are commonly goblet- or vase-shaped, although branched, massive, tubular, or rosy-appearing sponges also occur in the class. Many have root tufts of long spicules that anchor them in place and support them above the sea floor.

The following classification is a combination of ones used in living and fossil sponges. See PORIFERA.

- Class Hexactinellida
  - Subclass Hexasterophora
    - Order Lyssacinosida
    - Order Hexactinosida
    - Order Lychniscosida
  - Subclass Amphidiscophora
    - Order Reticulosa
    - Order Amphidiscosa
    - Order Hemidiscosa

[J.K.Ri.]

**Hexactinosa** An order of the subclass Hexasterophora in the class Hexactinellida. The parenchymal megascleres in this order of sponges are united to form a rigid framework and consist wholly of simple hexactins which are arranged in parallel linear series. The members of each series are united one to another by a secondary envelope of silica. See HEXACTINELLIDA; HEXASTEROPHORA. [W.D.H.]

**Hexasterophora** A subclass of sponges of the class Hexactinellida, in which the parenchymal microscleres are typically hexasters (small, six-rayed spicules, often with branched ends). This is a diverse assemblage of sponges commonly firmly fixed to the substratum by the base, less commonly anchored by means of basal spicule tufts or mats. The spicules of the body are sometimes free and unconnected, but the parenchymal megascleres are often fused to form a rigidly connected skeleton. The following orders are recognized: Hexactinosa, Lychniscosa, Lyssacinosida, and Reticulosa. See HEXACTINOSA; LYCHNISCOSA; LYSSACINOSA; PORIFERA; RETICULOSA. [W.D.H.]

**Hibernation** A term generally applied to a condition of dormancy and torpor found in cold-blooded (poikilotherm) vertebrates and invertebrates. (The term is also applied to relatively

few species of mammals and birds, which are warm-blooded vertebrates.) This rather universal phenomenon can be readily seen when body temperatures of poikilotherm animals drop in a parallel relation to ambient environmental temperatures.

**Poikilotherm animals.** Hibernation occurs with exposure to low temperatures and, under normal conditions, occurs principally during winter seasons when there are lengthy periods of low environmental temperatures. A related form of dormancy is known as estivation. Many animals estivate when they are exposed to prolonged periods of drought or during hot, dry summers. For all practical purposes, hibernation and estivation in animals are indistinguishable, except for the nature of the stimulus, which is either cold or an arid environment.

There is no complete list of animals that hibernate; however, many examples can be found among the poikilotherms, both vertebrate and invertebrate. The poikilotherms are sometimes referred to as ectothermic, because their body temperatures are not internally regulated but follow the rise and fall of environmental temperatures. During hibernation and winter torpor, body temperatures reflect the environmental temperature, often to within a fraction of a degree. Among the classic examples of hibernators or estivators are reptiles, amphibians, and fishes among the vertebrates, and insects, mollusks, and many other invertebrates.

For many ectothermic vertebrates (fishes, amphibians, and reptiles) the ability to avoid seasonal and periodic environmental rigors by entering a state of metabolic inactivity is a crucial element in their survival. Specifically, winter dormancy and summer estivation—the usual context in which these terms are applied to ectotherms—permit these animals to survive and flourish, first, by reducing the impact of seasonal extremes and, second, by significantly lowering the ectotherm's energetic costs during times that would not be favorable for activity (that is, when food is available).

Many terrestrial reptiles, such as lizards, snakes, and turtles, become dormant and hibernate by burrowing in crevices under rocks, logs, and in the ground below the frost line. Terraqueous turtles also become cold-torpid and may often be found completely submerged in mud and in ponds under ice.

Since the hibernating reptile is subject to the caprices of duration of seasonal low temperature, there is no well-defined period of dormancy. The period of hibernation may often be related to latitudinal positions as evidenced by the turtle family Emydæ. Species that inhabit the northern climes will hibernate longer than their southern relatives, thus showing hibernation periods which are proportional to the length of the winter period. Hibernating reptiles show a loss of appetite and discontinue the ingestion of food. Although the metabolic rate is reduced as much as 95% in hibernating turtles, there is some utilization of stored food products. There are two principal types of reserve food: lipids and glycogen, the animal starch, which is less stable and more rapidly used than fats. Glycogen is generally localized in tissues such as liver and muscle. There is evidence that these reserve foods are selectively utilized. In hibernating turtles, the tissue glycogen is used during the initial days and weeks of hibernation; later, the lipids are utilized.

A major hazard to hibernating poikilotherms is death from freezing; ice crystals form in free protoplasmic water and ultimately destroy the cells and tissues, causing the death of the animal. Frogs, salamanders, and turtles are able to survive, despite the reduction in body temperatures to about 32 to 31°F (0 to -1°C). As winter approaches, the water content of the tissues becomes reduced and the blood more concentrated.

Hibernation in fishes does not occur. Many fishes do, however, spend much of the winter in a state of quiescence while partially frozen in mud and ice.

The phenomenon of estivation is best known in the dipnoans, that is, the lungfishes. These fishes are restricted to tropical regions marked by repeated seasons of drought. They survive the dry seasons by becoming dormant and torpid. The lungfishes

are among the more primitive air-breathing animals possessing a lung which utilizes atmospheric oxygen. This lung becomes the primary organ of respiration during the torpidity of estivation. In general, the lungfishes follow a similar behavioral pattern as the dry seasons approach. *Protopterus*, for example, burrows in the bottom mud as the water begins to diminish during the dry season. A lifeline of air is provided by the tunnel from the burrow to the surface. In preparation for estivation, *Protopterus* secretes a slimy mucus around itself which hardens in a tight cocoonlike chamber, preventing the desiccation of the fish. There is but one opening, formed around the mouth. Thus the air from the tunnel enters the mouth and passes to the lung apparatus. At the termination of the dry season, water slowly enters the burrow, softens the contents, and awakens the lungfish. The metabolism of the lungfish is at a low ebb during estivation, with the energy for its modest life processes provided by the utilization of tissue protein.

In some snails estivation may be extended for years at a time, and among the insects and spiders the period of hibernation becomes intimately associated with a phase in the life cycle. During the winter months and during a hot dry summer, the soil contains a remarkable variety of torpid invertebrates, for example, earthworms, snails and slugs, nematodes, insects and spiders, grubs, larvae, and pupae of many insects, egg cases, and cocoons.

Insects overwinter, for the most part, in the egg or larval stage of metamorphosis. Hibernation frequently becomes integrated with the diapause, or arrested development, of the egg or larva which occurs during the winter. The familiar cocoon of the butterfly is the hibernaculum of the larva and pupa. See also INSECT PHYSIOLOGY.

The phenomenon of encystment is commonplace in the protozoa, or single-celled animals. Encystment is remarkably similar to estivation and hibernation, and an encysted protozoon is extremely quiescent and almost nonmetabolizing. See PROTOZOA.

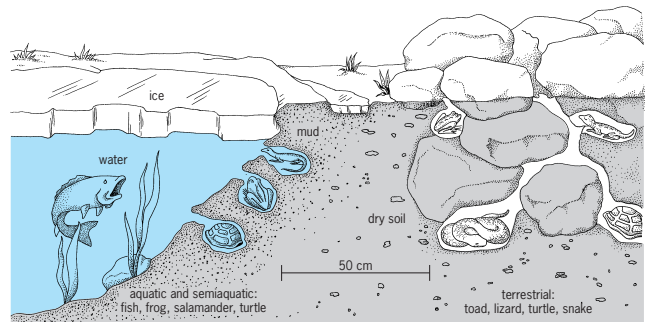

Hibernacula of various cold-blooded vertebrates.

The hibernacula of poikilotherm vertebrates and invertebrates are as varied as the animals themselves (see illustration). The minute cysts in protozoa, the cocoon and egg case of insects and spiders, the burrows and crevices of reptiles, and the dried mucous case of the lungfish, in all instances, protect the animal from evaporation or desiccation and freezing. [X.J.M.]

**Warm-blooded vertebrates.** Many mammals and some birds spend at least part of the winter in hiding, but remain no more drowsy than in normal sleep. On the other hand, some mammals undergo a profound decrease in metabolic rate and physiological function during the winter, with a body temperature near 32°F (0°C). This condition, sometimes known as deep hibernation, is the only state in which the warm-blooded vertebrate, with its complex mechanisms for temperature control, abandons its warm-blooded state and chills to the temperature of the environment. Between the drowsy condition and deep hibernation are gradations about which little is known. The bear, skunk, raccoon, and badger are animals which become drowsy

in winter. Although usually considered the typical hibernator, the bear's body temperature does not drop more than a few degrees.

The deep hibernators are confined to five orders of mammals: the marsupials, the Chiroptera or bats, the insectivores, the rodents, and, probably, the primates. Most, if not all, of the insect-eating bats of temperate climates not only hibernate in the winter, but also drop their body temperature when they roost and sleep. The advantage of this for a small mammal with a disproportionately large heat-losing surface is obvious when conservation of energy is considered. Many rodents are deep hibernators, including ground squirrels, woodchucks, dormice, and hamster. The fat-tailed and mouse lemurs are primates that hibernate or estivate. Among birds, the poorwill (*Phalaenoptilus*) and some hummingbirds and swifts undergo a lowering of body temperature and metabolic rate in cold periods.

With all deep hibernators, except the bats, hibernation is seasonal, usually occurring during the cold winter months. In all cases, it occurs in animals which would face extremely difficult conditions if they had to remain active and search for food. During a preparation period for hibernation, the animals either become fat, like the woodchuck, or store food in their winter quarters, like the chipmunk and hamster. Prior to hibernation, there is a general involution of the endocrine glands, but at least part of this occurs soon after the breeding season and is not directly concerned with hibernation. Animals such as ground squirrels become more torpid during the fall, even when kept in a warm environment, indicating a profound metabolic change which may be controlled by the endocrine glands. In most hibernators lack of food has little if any effect, and the stimulus for hibernation is not known. It has been reported that an extract from the blood of an animal in hibernation will induce hibernation when infused into an active potential hibernator, indicating that the factor which produces hibernation may be bloodborne.

Hibernation in mammals is not caused by an inability to remain warm when exposed to cold, for hibernators are capable of very high metabolic rates and sometimes do not enter hibernation if exposed to cold for months at a time. When the animal is entering hibernation, heart rate and oxygen consumption decline before body temperature, indicating that the animal is actively damping its heat-generating mechanisms. The autonomic nervous system is involved in this process. As normal hibernation deepens, the heart rate, blood pressure, metabolic rate, and body temperature slowly drop, but in some animals periodic bouts of shivering and increased oxygen consumption occur, elevating the body temperature temporarily and causing a stepwise entrance into hibernation. See AUTONOMIC NERVOUS SYSTEM.

In deep hibernation at a steady state the body temperature is 33–35.5°F (0.5–2°C) above that of the environment, and it is a peculiarity of hibernators that the vital processes can function at lower temperatures than those of nonhibernators. The heart rate varies between 3 and 15 beats per minute. The metabolic rate is less than one-thirtieth of the warm-blooded rate at rest, and the main source of energy is fat. In spite of its low body temperature, the hibernating animal retains a remarkably rigid control of its internal environment. If the environmental temperature drops to 32°F (0°C), the hibernating animal may respond either by increasing its metabolic rate and remaining in hibernation or by a complete arousal from the hibernating state.

A hibernating mammal reduces its metabolic rate by nearly 30-fold and shifts from glycogen to lipid (that is, fat stores) as the major fuel source for metabolism. The magnitude of metabolic rate reduction is far in excess of what would be expected solely as a result of a hibernator's lowered body temperature. Moreover, suppression of glycogen metabolism during hibernation must be poised for regular and rapid relaxation during periods of arousal (which are fueled by glycolysis) as well as at the end of the hibernation period.

Mechanisms controlling these aspects of hibernation metabolism appear to be the relative acidification of the intracel-

lular fluids of the hibernator. This is a consequence of the hibernator's tendency to continuously regulate its blood pH (at about pH 7.4, termed pH stat), and of the adoption of a modified breathing pattern that, although variable among species, is typified by periods of apnea lasting up to 2 h that are interspersed between 3–30 min intervals of rapid ventilation.

[J.B.G.]

The hibernator is capable of waking at any time, using self-generated heat, and this characteristic clearly separates the hibernating state from any condition of induced hypothermia. During the total period of hibernation, the hibernator spontaneously wakes from time to time, usually at least once a week. In the period of wakefulness the stored food is evidently eaten, but animals which do not store food rely on their fat for the extra energy during the whole winter. The cause of the periodic arousals has not been definitely determined, but it is theorized that the arousal is due to the effect of the accumulation of a metabolite or other substance which can be neutralized only in the warm-blooded state.

[C.P.L.]

As in hibernating endotherms (birds and mammals), a key factor regulating seasonal torpor in ectotherms is the continuous internal monitoring of environmental cues, such as day length, which in turn triggers temporally precise seasonally adaptive changes in systemic function, metabolism, and behavior. A second important factor is the presence in ectotherms of a bioenergetic metabolic system that, when compared to mammals and birds, operates at a much lower intensity and has less absolute dependence on molecular oxygen. The metabolic energy adaptations for seasonal torpor in ectothermic vertebrates are to a large extent similar to those required by vigorous activity or prolonged diving, and thus involve the processing or storage of intermediate metabolites such as lactic acid, the regulation of intra- and extracellular pH, and enduring periods without access to oxygen. See ENERGY METABOLISM; METABOLISM.

[J.B.G.]

**Hickory** Any species of the genus *Carya*, formerly known botanically as *Hicoria*. Hickories are mostly tall forest trees characterized by strong, terminal, scaly winter buds, pinnately compound leaves (see illustration), solid pith (not chambered), and fruit with an outer husk or exocarp which splits more or less readily into four parts, revealing a nut with a hard shell or endocarp.

The shagbark hickory (*C. ovata*) is found in the eastern half of the United States and adjacent Canada. It is the most important species because of the commercial value of its nuts, the hickory nuts of commerce, and of its wood. The pecan (*C. illinoensis*) is also a valuable species because of its commercially popular, thin-shelled, sweet nuts. Other species are the mockernut, shellbark, and pignut hickories. The remarkably tough and strong wood of



Twigs, buds, and leaves of shagbark hickory (*Carya ovata*).

all species makes it the world's best wood for tool handles. It is also used for parts of furniture, flooring, boxes, and crates, and for smoking meats. See FAGALES. [A.H.G./K.P.D.]

**Hidden variables** Additional variables or parameters that would supplement quantum mechanics so as to make it like classical mechanics. Hidden variables would make it possible to unambiguously predict (as in classical mechanics) the result of a specific measurement on a single microscopic system. In contrast, quantum mechanics can give only probabilities for the various possible results of that measurement. Hidden variables would thus provide deeper insights into the quantum-mechanical probabilities. In this sense the relationship between quantum mechanics and hidden variables could be analogous to the relationship between thermodynamics (for example, temperature) and statistical mechanics (the motions of the individual molecules). See STATISTICAL MECHANICS.

F. J. Belinfante formulated a three-section classification scheme for hidden variable theories—zeroth kind, first kind, and second kind. Most interest, both theoretically and experimentally, has been focused on hidden variable theories of the second kind, also known as local hidden variable theories.

In 1932 J. von Neumann provided an axiomatic basis for the mathematical methods of quantum mechanics. As a sidelight to this work, he rigorously proved from the axioms that any hidden variable theory was inconsistent with quantum mechanics. This was the most famous of a number of proofs, appearing as recently as 1980 and purporting to show the impossibility of any hidden variable theory. In 1966 J. S. Bell pinpointed the difficulty with von Neumann's proof—one of his axioms was fine for a pure quantum theory which makes statistical predictions, but the axiom was inherently incompatible with any hidden variable theory. The other impossibility proofs have also been found to be based on self-contradictory theories. Such theories are called hidden variable theories of the zeroth kind.

Hidden variable theories of the first kind are constructed so as to be self-consistent and to reproduce all the statistical predictions of quantum mechanics when the hidden variables are in an "equilibrium" distribution. Hidden variables of the second kind predict deviations from the statistical predictions of quantum mechanics, even for the "equilibrium" situations for which theories of the first kind agree with quantum mechanics. They are generally called local hidden variable theories because they are required to satisfy a locality condition. Intuitively, this seems to be a very natural condition. Locality requires that an apparatus at one location should operate independently of any settings or actions of a second apparatus at a spatially separated location. In the strict Einstein sense of locality, the two apparatus must be independent during any time interval less than the time required for a light signal to travel from one apparatus to the other.

The focus for much of the discussion of local hidden variable theories is provided by a famous thought experiment (a hypothetical, idealized experiment in which the experimental results are deduced) that was introduced in 1935 by A. Einstein, B. Podolsky, and N. Rosen. Their thought experiment involves an examination of the correlation between measurements on two parts of a single system after the parts have become spatially separated. They used this thought experiment to argue that quantum mechanics was not a complete theory. Although they did not refer to hidden variables as such, these would presumably provide the desired completeness. The Einstein-Podolsky-Rosen (EPR) experiment led to a long-standing philosophical controversy; it has also provided the framework for a great deal of research on hidden variable theories.

New efforts were stimulated in 1952 when Bohm did the "impossible" by designing a hidden variable theory of the first kind. Bohm's theory was explicitly nonlocal, and this fact led Bell to reexamine the Einstein-Podolsky-Rosen experiment. He came to the remarkable conclusion that any hidden variable theory that satisfies the condition of locality cannot possibly reproduce all

the statistical predictions of quantum mechanics. Specifically, in Einstein-Podolsky-Rosen type experiments, quantum mechanics predicts a very strong correlation between measurements on the spatially separated parts. Bell showed that there is an upper limit on the strength of these correlations in the statistical prediction of any local hidden variable theory. Bell's result can be put in the form of inequalities which must be satisfied by any local hidden variable theory but which may be violated by the statistical predictions of quantum mechanics under appropriate experimental conditions.

Experiments performed under conditions in which the statistical predictions of quantum mechanics violate Bell's inequalities can test the entire class of local hidden variable theories. However, all existing experiments have required supplementary assumptions regarding detector efficiencies. Due to the supplementary assumptions, small loopholes still remain, and experiments have been proposed to eliminate them. The overwhelming experimental evidence is against any theory that would supplement quantum mechanics with hidden variables and still retain the locality condition; that is, any hidden variable theory that reproduces all the statistical predictions of quantum mechanics must be nonlocal. The remarkable Einstein-Podolsky-Rosen correlations have defied any reasonable classical kind of explanation. See NONRELATIVISTIC QUANTUM THEORY; QUANTUM MECHANICS. [E.S.F.]

**Higgs boson** An elementary scalar particle in the Glashow-Weinberg-Salam theory of electromagnetic and weak interactions. At present, there is no direct experimental evidence for its existence. It is closely associated with the origin of mass for all known elementary particles, as described in the Glashow-Weinberg-Salam theory. This gives the Higgs boson distinctive properties which shape the search for it. See ELECTROWEAK INTERACTION; STANDARD MODEL.

The mass of the Higgs boson is uncertain theoretically, being determined by the parameters of the scalar self-interactions. It is strongly suspected, however, that the Higgs mass is between about 114 and 200 GeV/ $c^2$  (where  $c$  is the speed of light).

The fact that the Higgs particle is closely related to the origin of mass endows it with special properties crucial in its production and detection. The illustration shows how the decay pattern of a standard-model Higgs boson depends on its mass.

The first extensive searches for the Higgs boson were carried out at the Large Electron Positron Storage Ring (LEP) and Stanford Linear Collider (SLC),  $e^+e^-$  machines with sufficient center-of-mass energy to operate at the  $Z$  resonance. The LEP was subsequently upgraded, and there were signs that experiments at center-of-mass energies up to 208 GeV/ $c^2$  might be seeing the Higgs, but these were not sufficient to delay the machine's

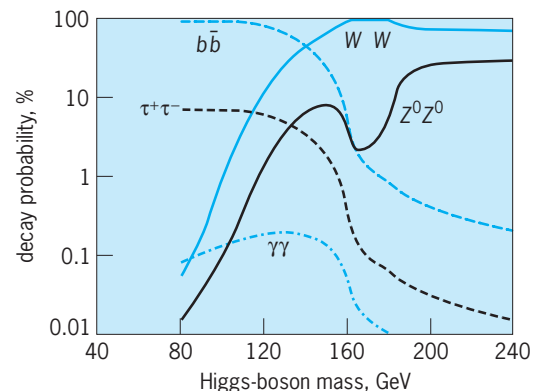

Dependence of the decay probabilities of a standard-model Higgs boson on its mass.

shutdown in November 2000 to make way for the construction of the Large Hadron Collider (LHC) in the same tunnel.

The next particle accelerators to extend the Higgs search will probably be hadron colliders (proton-proton or proton-antiproton), particularly the LHC. See ELEMENTARY PARTICLE; PARTICLE ACCELERATOR. [A.Ch.; M.Sol.]

**High magnetic fields** Magnetic fields that are large enough to significantly alter the properties of objects that are placed in them. Valuable research is conducted at high magnetic fields. See MAGNETISM.

**High-field magnets.** Research and development efforts in magnets and magnet materials have led to gradual increases in the fields available for scientific research to fields near 20 tesla from superconducting magnets, 33 T in copper-core (resistive) magnets, and 45 T for hybrid magnets. Superconducting magnets have the advantage that they use no electrical power once the field is established and the temperature is maintained at liquid-helium temperatures of 4.2 K (−452°F) or below. The disadvantage is that there is a critical magnetic field,  $H_{c2}$ , determined by the type of conductor, that limits the attainable field to about 22 T in superconducting materials currently available. Resistive magnets, which consume enormous amounts of power and are very expensive to build and operate, are confined to a few central facilities worldwide. See MEDICAL IMAGING; SUPERCONDUCTIVITY.

Advanced pulsed magnets that are not self-destructing provide fields beyond 70 T for about 0.1 s. Pulsed magnets using explosive magnetic flux compression have achieved fields above 500 T for periods of 10 microseconds. See MAGNET.

**Materials research.** Research at very high magnetic fields spans a wide spectrum of experimental techniques for studies of materials. These techniques include nuclear magnetic resonance (NMR) in biological molecules utilizing the highest-field superconducting magnets, while the resistive magnet research is primarily in the investigation of semiconducting, magnetic, superconducting, and low-dimensional conducting materials. See NUCLEAR MAGNETIC RESONANCE (NMR).

Much of the progress in semiconductor physics and technology has come from high-field studies. For example, standard techniques for mapping the allowed electronic states (the Fermi surface) of semiconductors and metals are to measure the resistance (in the Shubnikov-de Haas effect) or magnetic susceptibility (in the de Haas-van Alphen effect) as a function of magnetic field and to observe the oscillatory behavior arising from the Landau levels of the electron orbits. Measurements at low fields are limited to low impurity concentrations since the orbits are large and impurity scattering wipes out the oscillations. At high fields of 20–200 T, the orbits are smaller, and higher impurity concentrations (higher carrier concentrations) have been studied. Another area in which very high magnetic fields have an important role is in high-temperature superconductors, which have great potential for high-field applications, from magnetic resonance imaging, to magnetically levitated trains, to basic science. See DE HAAS-VAN ALPHEN EFFECT; FERMI SURFACE; SEMICONDUCTOR.

Studies at high magnetic fields have played an important role in advancing understanding of magnetic materials. For example, in many organic conductors the conduction electrons (or holes) are confined to one or two dimensions, leading to very rich magnetic phase diagrams. High-field phases above 20 T include spin-density waves, a modulation of the electron magnetic moments that can propagate through the crystal, modifying the conduction and magnetic properties. Another area of interest is the magnetic levitation of diamagnetic materials (the most common materials). See MAGNETIC MATERIALS; ORGANIC CONDUCTOR; PHASE TRANSITIONS; SPIN-DENSITY WAVE. [W.G.M.]

**High-pressure chemistry** Chemistry at very high pressures, arbitrarily chosen to be above  $10^4$  bars (1 gigapascal), and mainly concerned with solid and liquid states. At 25°C

(77°F) and  $10^4$  bars (1 GPa), nearly all ordinary gases are liquid or solid, and only a few liquids are not frozen; thus most high-pressure chemistry involves either higher temperatures, at which chemical reactions can occur at appreciable rates, or studies of internal arrangements in solids.

From 1 bar ( $10^2$  kilopascals) to about  $10^5$  bars (10 GPa), normal low-pressure chemical behavior prevails, and only minor departures from the usual valence and coordination rules are found. However, many interesting changes in materials can be effected in this pressure range as atoms are forced into new bonding arrangements. From  $10^5$  to  $10^9$  bars (10 to  $10^5$  GPa), the energy added by compression becomes comparable with chemical bond energies, so that outer-shell electronic orbits are distorted and atoms and molecules change in character. A general tendency toward more metallic behavior is observed as the electrons become less strongly fixed to particular atoms, and chemical bonds may be broken. Upward of about  $10^9$  bars ( $10^5$  GPa), the delocalization of electrons is extensive, and the material consists of a mixture of ions and electrons, so that chemical bonds are of little importance. The boundaries on these three pressure ranges are, of course, only approximate, and show some variation according to the temperature and the atoms involved.

The simplest effect of high pressure is the closer compression of atoms. The noble gases and alkali metals are quite compressible, whereas most oxides and the stronger metals are considerably stiffer. However, at a pressure exceeding about  $10^5$  bars (10 GPa), most of the easily compressed electronic clouds are tightened up, and the compressibilities of most substances approach each other.

Substances which consist of large molecules are easily stiffened or frozen by high pressures. The mobility of the molecules is sharply decreased by a sort of interlocking and tangling effect; thus for the substance to be sheared, chemical bonds must be broken, a process which requires considerable energy. This stiffening phenomenon limits the study of most reactions of organic molecules to low pressures because they are rather large and “freeze” easily, but yet are usually not stable enough to withstand the temperatures necessary for liquefaction or intermolecular reactions. [R.H.W.]

**High-pressure mineral synthesis** A laboratory technique for studying the behavior of minerals under high-pressure conditions.

The nature of minerals as they exist at atmospheric pressure represents only a very limited part of their real nature. The range of pressure and temperature prevailing at the surface of the Earth is very limited compared to the ranges that exist in the other planets of the solar system. The bottom of the ocean, which is at the highest pressure that can be observed directly, is only 0.1 GPa (1 kilobar), while the pressure at the center of the Earth is 390 GPa (3900 kilobars). Pressures at the centers of large planets such as Saturn and Jupiter exceed 1000 GPa (10,000 kilobars). Therefore, to study the formation and structure of the Earth and other planets, it is essential to study the behavior of minerals under high pressure. It has become clear through high-pressure experiments that the minerals constituting the Earth's lower mantle (which extends from 650 to 2900 km or 400 to 1800 mi from the surface and occupies more than 50% of the entire volume of the Earth) are mostly so-called silicate perovskites that can never be formed on the surface of the Earth. See EARTH INTERIOR; JUPITER; SATURN.

Pressure is defined as a force per unit area; therefore, in order to apply a high pressure, it is necessary to concentrate a large force in a small area. Because of the limited strength of materials used to produce sample chambers, many different techniques are required, depending on the pressure range (see illustration).

A large number of phase transformations has been found in minerals under high pressure, but most of these structures have already been observed in other minerals existing under

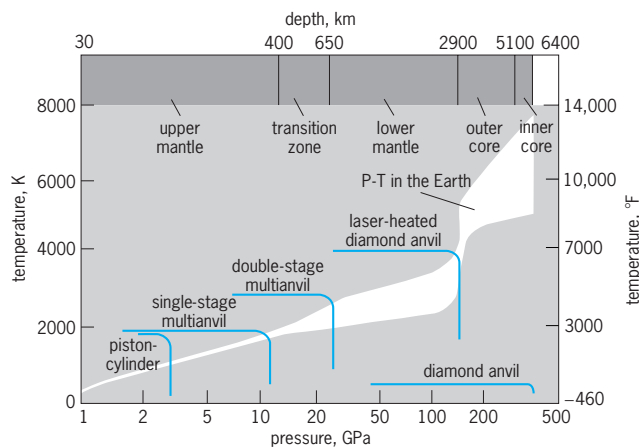

**Diagram of pressure (P) and temperature (T) within the Earth, showing capabilities of various types of high-pressure apparatus. 1 GPa = 10 kilobars. 1 km = 0.6 mi.**

atmospheric pressure. For example, rutile-type  $\text{SiO}_2$  (stishovite) is formed only above 10 GPa (100 kilobars), but the same structure is obtained at atmospheric pressure when the Si ion is replaced by the larger germanium (Ge) ion. This implies that crystal structure is determined mainly by the ratio of the cation radius to that of the anion.

When the very dense structure is compressed further, the bond length becomes shorter and shorter, and the orbitals of the electrons around the ions begin to overlap. This means that the orbital electrons can move freely in the material, which changes into a so-called metallic state. This metallic transition is believed to occur in all materials when they are subjected to high enough pressure. Even hydrogen, helium, and ice are believed to exist in the metallic state in the interiors of Jupiter and Saturn. In the laboratory, however, this transformation into the metallic state under pressure has been confirmed in only a limited number of materials such as Si, Ge, and gallium arsenide (GaAs). See BOND ANGLE AND DISTANCE; FREE-ELECTRON THEORY OF METALS.

It has become clear that many of the major phases of silicate transform into the perovskite structure above 25 GPa (250 kilobars). Therefore it is believed that silicate perovskite is the most abundant mineral within the Earth, although it is an exotic mineral on the surface. In order to clarify the nature of the high-pressure minerals believed to be present in the interior of the Earth many studies have been made using various techniques. For this type of study, it is important to obtain a single crystal. The multianvil apparatus has been widely used for such experiments, and various single crystals of high-pressure minerals such as silicate perovskite, spinel, and stishovite have been synthesized.

High-pressure synthesis is a powerful method not only for use in earth and planetary sciences but also for the creation of new materials. Many industrial diamonds are synthesized by using high-pressure techniques, and some new high-pressure materials, such as cubic boron nitride, have found wide application. Pressure is one of the most fundamental parameters that can alter the state of materials, and research in this field is also expected to expand in the future. See DIAMOND; HIGH-PRESSURE CHEMISTRY; HIGH-PRESSURE PHYSICS; SILICATE PHASE EQUILIBRIA; SOLID-STATE CHEMISTRY; SOLID-STATE PHYSICS; THERMODYNAMIC PROCESSES. [T.Ya.]

**High-pressure physics** The study of the effects of high pressure on the properties of matter. Since most properties of matter are modified by pressure, the field of high-pressure physics encompasses virtually all branches of physics.

The "high" of high-pressure physics connotes experimental difficulty. At liquid-helium temperatures, pressures of several

hundred bars are considered high. In general, however, the high-pressure range may be arbitrarily regarded as extending from about 1 kbar (100 MPa or  $14,500 \text{ lb/in.}^2$ ) upward to the present experimental limit. Prolonged static pressures in excess of 1 megabar (100 gigapascals or  $1.45 \times 10^7 \text{ lb/in.}^2$ ) can be achieved in very small samples weighing about 1 microgram.

Transient pressures as high as about  $10^7$  bars (1000 GPa or  $1.45 \times 10^8 \text{ lb/in.}^2$ ) have been attained in shock waves produced by high explosives or by projectile impact.

The major effects of high pressure on matter include diminution of volume, phase transitions, changes in electrical, optical, magnetic, and chemical properties, increases in viscosity of liquids, and increases in the strength of most solids. In general solids are less compressible than liquids, and the compressibility of both solids and liquids decreases with increasing pressure.

At high pressure many solids exhibit polymorphic phase changes, that is, a rearrangement of the atoms or molecules in the solid. There are no universally applicable rules governing the number of phase changes or the kind of phase change to be expected at high pressure, but there is a thermodynamic requirement that the phase that is stable at high pressure must have a smaller volume than the phase that is stable at low pressure. See THERMODYNAMIC PRINCIPLES.

Frequently, dramatic changes in physical properties result from phase changes. Ferromagnetic iron transforms to a paramagnetic form at pressures somewhat above 100 kbar (10 GPa or  $1.45 \times 10^6 \text{ lb/in.}^2$ ). In the same pressure range, the semiconducting element germanium transforms into a metallic phase that has an electrical conductivity greater than a million times that of the semiconductor. Similar semiconductor-to-metal transitions at high pressure have been observed in the cases of silicon, indium arsenide, gallium antimonide, indium phosphide, aluminum antimonide, and gallium arsenide. See SEMICONDUCTOR.

Many phases that form at high pressure transform back to low-pressure phases as the pressure is released. However, some high-pressure phases may be retained in a metastable condition at low pressures, and some low-pressure phases can persist metastably at high pressure. Diamond, the high-pressure form of carbon, is thermodynamically unstable at room temperature and pressures below about 12 kbar (1.2 GPa or  $1.74 \times 10^5 \text{ lb/in.}^2$ ). Nonetheless diamond persists indefinitely as a metastable phase at low temperatures; it transforms to the stable form, graphite, only when heated to temperature in excess of  $1800^\circ\text{F}$  ( $1000^\circ\text{C}$ ) at low pressure. [R.K.L.; P.S.De.C.]

**High-pressure processes** Changes in the chemical or physical state of matter subjected to high pressure. The earliest high-pressure chemical process of commercial importance were the Haber synthesis of ammonia from hydrogen and nitrogen and the synthesis of diamonds from graphite. Raising the pressure on a system may result in several kinds of change. It causes a gas or vapor to become a liquid, a liquid to become a solid, a solid to change from one molecular arrangement to another, and a gas to dissolve to a greater extent in a liquid or solid. These are physical changes. A chemical reaction under pressure may proceed in such a fashion that at equilibrium more of the product forms than at atmospheric pressure; it may also take place more rapidly under pressure; and it may proceed selectively, forming more of the desired product among multiple possible products.

Pressures higher than that of the atmosphere are expressed in bars and kilobars as well as in other units. A bar is  $10^5$  pascals, or  $10^5$  newtons per square meter, which are the units for pressure in the International System of units. These units are too small for convenient use in high-pressure processes, hence the bar is used. The bar equals 0.9869 standard atmosphere, 760 mmHg.

Increasing the pressure on a gas or vapor compresses it to a higher density and so to a smaller volume. If the pressure exceeds the vapor pressure, the vapor will condense to a liquid which occupies a still smaller volume. A vapor may be condensed at



a higher temperature when it is under pressure; this permits the use of cooling water to remove the latent heat instead of more costly refrigeration.

Solids also change from a less dense phase to a more dense phase under the influence of increases in pressure. The density of diamond is about 1.6 times greater than that of graphite because of a change in the spatial arrangement of the carbon atoms. The temperatures and pressures used in the commercial synthesis of diamond range up to 5000°F (3000 K) and 100,000 atm. A molten metal is required as a catalyst to permit the atomic rearrangement to take place at economical rates of conversion. Metals such as tantalum, chromium, and iron form a film between graphite and diamond.

In a manner similar to its effect during a physical change in which the volume of a system decreases, pressure also favors a chemical change where the volume of the products is less than the volume of the reactants. This is Le Chatelier's principle, which applies to systems in equilibrium. This general principle may be derived more precisely by thermodynamic reasoning, and thermodynamics is used to predict the effect of pressure on physical and chemical changes which lead to an equilibrium state.

Ammonia is formed according to the reaction shown below. At

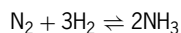

1 atm only a fraction of 1% ammonia is formed. The ammonia content increases greatly when the pressure is raised. At 100 atm and 392°F (200°C) there would be about 80% ammonia at equilibrium. However, a very long time is required to form ammonia under these conditions, and consequently commercial processes operate at higher temperatures and pressures and use a catalyst to obtain higher rates of reaction. Many combinations of pressure and temperature have been used. The largest number of plants now operate in the region of 300 atm and 840–930°F (450–500°C). A higher-pressure process is carried out at about 1000 atm and 930–1200°F (500–650°C).

Methanol is synthesized from hydrogen and carbon monoxide at 200 atm and 600°F (315°C) in a similar manner. The catalyst contains aluminum oxide, zinc oxide, chromium oxide, and copper. Higher alcohols are produced at pressures of 200–1000 atm and temperatures up to 1000°F (538°C) with a similar catalyst to which potassium carbonate or chromate has been added.

Polyethylene has been produced at pressures in the ranges 3–4, 20–30, 40–60, and 1000–3000 atm. The last is probably the highest pressure yet used in the commercial synthesis of an organic chemical product. The ethylene is polymerized in a stainless steel tubular reactor at 375°F (191°C) with small amounts of oxygen as a catalyst.

Phenol can be formed from chlorobenzene mixed with 18% sodium hydroxide solution at a pressure of 330 atm. Pressure is employed in this instance to maintain the mixture in the liquid phase at a temperature high enough for the hydrolysis reaction to proceed at an acceptable rate.

Hydrocracking and hydrodesulfurization in the refining of gasoline and fuel oils are carried out at pressures up to 200 atm and temperatures of 800°F (427°C) and higher. See HYDROCRACKING; HYDROGENATION. [E.W.C.]

**High-temperature chemistry** The study of chemical phenomena occurring above 500 K (227°C or 440°F). High temperatures represent one of the important variables available to scientists for increasing the variety of possible chemical reactions over that expected for classical ground-state atoms and molecules. The relative population of excited rotational, vibrational, and electronic states can be enhanced by increasing the temperature and thus can effectively create new species and new mechanisms for reaction. The potentialities of this approach are well illustrated by the three laws of high-temperature chemistry: (1) At high temperatures everything reacts with everything. (2) The higher the temperature, the faster the reaction. (3) The products may be anything.

High temperatures also provide a common tie among the various options for energy production, conversion, or storage. For maximum thermodynamic efficiency, an energy production cycle should operate with a working fluid at as high a temperature as possible, and exhaust the spent fluid at as low a temperature as possible. Thus, in the combustion of coal to produce electric power or in the combustion of gasoline or diesel fuel to propel a car or an airplane, there is a need for materials of construction which allow operation of such devices at higher temperatures. See HIGH-TEMPERATURE MATERIALS.

It is convenient to discuss temperatures in terms of energy and to note that 11,500 K (20,200°F) corresponds to 1 electronvolt. In this sense, the particles emitted by radioactive nuclei or accelerated in cyclotrons and synchrotrons, which have energies in the keV, MeV, and BeV ranges, are effectively at temperatures of  $\sim 10^7$  K,  $\sim 10^{10}$  K, and  $\sim 10^{13}$  K, respectively, and "high-energy physics" is synonymous with "ultra-high-temperature chemistry."

Traditional high-temperature chemistry in the last several decades has been mainly concerned with phenomena in the range of 500–3000 K, although exotic flames can produce temperatures up to  $\sim 6000$  K, shock waves can generate temperatures up to  $\sim 25,000$  K, electric arcs can be operated in constricted modes to produce temperatures of  $\sim 50,000$  K, and nuclear processes begin to occur at temperatures in the millions-of-degrees range. Laser excitation of selected energy states can produce species with effective temperatures in the range of  $10^8$  K. [J.L.M.]

**High-temperature materials** A metal or alloy which serves above about 1000°F (540°C). More specifically, the materials which operate at such temperatures consist principally of some stainless steels, superalloys, refractory metals, and certain ceramic materials. The giant class of alloys called steels usually see service below 1000°F. The most demanding applications for high-temperature materials are found in aircraft jet engines, industrial gas turbines, and nuclear reactors. However, many furnaces, ductings, and electronic and lighting devices operate at such high temperatures.

In order to perform successfully and economically at high temperatures, a material must have at least two essential characteristics: it must be strong, since increasing temperature tends to reduce strength, and it must have resistance to its environment, since oxidation and corrosion attack also increase with temperature. See CORROSION; HIGH-TEMPERATURE CHEMISTRY.

High-temperature materials, always vital, have acquired an even greater importance because of developing crises in providing society with sufficient energy. The machinery which produces electricity or some other form of power from a heat source operates according to the basic Carnot cycle law, where the efficiency of the device depends on the difference between its highest operating temperature and its lowest temperature. Thus, the greater this difference, the more efficient is the device—a result giving great impetus to create materials that operate at very high temperatures. See CARNOT CYCLE; EFFICIENCY. [C.T.S.]

**Highway engineering** A branch of civil engineering that includes planning, design, construction, operation, and maintenance of roads, bridges, and related infrastructure to ensure effective movement of people and goods. See CIVIL ENGINEERING.

Highway planning involves the estimation of current and future traffic volumes on the road network. For purposes of design, traffic volumes are needed for a representative period of traffic flow. The capacity is the maximum theoretical traffic flow rate that a highway section is capable of accommodating under a given set of environmental, highway, and traffic conditions. The capacity of a highway depends on factors such as the number of lanes, lane width, effectiveness of traffic control systems, frequency and duration of traffic incidents, and efficiency of

collection and dissemination of highway traffic information. Traffic conditions arising from the interplay of volume and capacity are perceived by road users in a way that is quantitatively termed level of service. See TRAFFIC-CONTROL SYSTEMS.

Highway facilities often cause adverse effects on the environment, such as noise pollution, air pollution, water pollution, and ecological impacts. Tire/pavement interaction, vehicle exhausts, and engines cause traffic noise. Highway engineers strive to predict and mitigate all possible impacts of highway systems. See AIR POLLUTION.

Through highway design, the most appropriate location, alignment, and shape of the highway are selected. Highway design involves the consideration of three major factors (human, vehicular, and roadway) and how these factors interact to provide a safe highway. Human factors include reaction time for braking and steering, visual acuity for traffic signs and signals, and car-following behavior. Vehicle considerations include vehicle size and dynamics that are essential for determining lane width and maximum slopes, and for the selection of design vehicles. Engineers design road geometry to ensure stability of vehicles when negotiating curves and grades and to provide adequate sight distances for undertaking passing maneuvers along curves on two-lane, two-way roads.

Location involves fitting the road efficiently onto the surrounding terrain and environment. Horizontal alignment is represented by an aerial view of the highway. It consists of straight lines and curves. Curves are fitted to provide a smooth transition between straight highway sections.

Intersections and interchanges occur where two or more highways cross each other at the same level. Since various vehicle maneuvers (turning, crossing, and through movements) all occur within a limited area as the volumes of these movements increase, there is increased likelihood of traffic conflicts and crashes. One way of reducing such danger is to use channelization to limit each stream to a unique path. In high traffic volume areas, movement of streams can be separated in time using multiphased traffic signals. The vertical alignment of a highway is represented by its longitudinal profile, which gives the elevation of all points along the length of the highway. The purpose of vertical alignment design is to determine the level of the highway at each point in order to ensure adequate safety and drainage.

Highway cross section refers to the profile of the road, perpendicular to the direction of travel and extending to the limits of the right of way within which the facility is constructed. Highway cross-section elements may include driving lanes, bicycle/pedestrian lanes, shoulders, medians, barriers, cross slope for drainage, and superelevation.

Pavement design is the process of selecting pavement layer types and thicknesses in order to withstand expected traffic loads in a cost-effective manner. Each pavement layer usually consists of mineral aggregates such as natural river or pit sand, natural gravel, and crushed rock. For rigid pavements, portland cement is mixed with water and aggregates to produce a viscous concrete mix that is poured into prepared forms and vibrated. See CEMENT.

There are generally three types of pavements specified for pavement design. Gravel pavement is the simplest type of pavement and is often designed for lightly traveled roads. Flexible pavement is a multilayered structure that includes a subbase, a base, and an asphaltic wearing course. Rigid pavement consists of a plain or steel-reinforced portland cement concrete slab laid on a prepared crushed-stone base course. See GRAVEL; PAVEMENT; PRECAST CONCRETE.

Highway construction usually follows planning and design, and involves new or reconstructed facilities such as pavements, drainage structures, and traffic control devices. Road construction is often preceded by detailed stakeout surveys and preparation of the subgrade. See CONSTRUCTION ENGINEERING; CONSTRUCTION EQUIPMENT.

Traffic signals are the most important traffic control devices. The typical traffic signal for an intersection displays a sequence

of green, amber, and red. One complete signal sequence is called a cycle. Traffic signals are either pretimed or demand-actuated. Flow-concentration controllers are capable of sensing detailed demand information and responding to it by revising the cycle length and phasing patterns of the signal.

The performance of highway infrastructure is measured in terms of pavement and bridge condition, level of service, and safety. Pavement condition is monitored over a period of time using a condition index or serviceability rating. Through the development and implementation of bridge management systems, many agencies have in place a decision support tool that supplies analyses and summaries of data, uses mathematical models to make predictions of bridge conditions, and provides the means by which alternative policies and programs may be efficiently evaluated. Congestion management is maintained by implementing measures to mitigate the magnitude and duration of traffic congestion. Safety management is a systematic process that has the goal of reducing the number and severity of traffic crashes by ensuring that all opportunities and identified, considered, implemented as appropriate, and evaluated in all phases of highway planning design, construction, maintenance, and operation. See BRIDGE. [K.C.S.; S.Lab.]

**Hilbert space** Hilbert space is an abstract notion of great power and beauty which has been central to the development of mathematical analysis and forms the backdrop for many applications of analysis to science and engineering. Its essence lies in the fact that the objects of primary interest in analysis (namely, functions) enjoy geometrical properties which are in important ways analogous to the geometry of physical space. Thus the highly developed human visual and spatial intuition can lead to significant truths about functions. See EUCLIDEAN GEOMETRY.

**Generalizations of euclidean space.** Vectors (or directed line segments) in euclidean space have a rich structure. If certain of the desirable properties of euclidean space are isolated and adopted as postulates, a class of spaces is defined that may include spaces of functions that are of concern in analysis. During the early decades of the twentieth century it was gradually realized that it is possible to select a small number of properties in such a way that the resulting spaces possess virtually all the desirable features of euclidean space except those which are closely linked to finite dimensionality. These spaces are named after David Hilbert, who took a decisive step toward their introduction in 1906 when he proved the spectral theorem.

**Role of Hilbert space.** Hilbert's innovation occurred while he was investigating integral equations which arose from mathematical physics. These equations are continuous analogs of the systems of simultaneous linear equations which are encountered in elementary algebra, but the unknown entity, instead of being a finite set of numbers, is a function. Just as graphical methods give insight into the solution of a pair of simultaneous linear equations in two unknowns, so the development of Hilbert-space geometry had great consequences for the understanding of integral equations. Hilbert space is a truly fundamental mathematical structure which appears in widely disparate branches of pure and applied mathematics. A striking instance is quantum mechanics, where observable quantities are modeled by linear transformations of Hilbert space. See INTEGRAL EQUATION; LINEAR SYSTEMS OF EQUATIONS; OPERATOR THEORY; QUANTUM MECHANICS. [N.J.Y.]

**Hill and mountain terrain** Land surfaces characterized by roughness and strong relief. The distinction between hills and mountains is usually one of relative size or height, but the terms are loosely and inconsistently used.

Uplift of the Earth's crust is necessary to give mountain and hill lands their distinctive elevation and relief, but most of their characteristic features—peaks, ridges, valleys, and so on—have been carved out of the uplifted masses by streams and glaciers. Hill lands, with their lesser relief, indicate only lesser uplift, not a fundamentally different course of development. The features of hill and mountain lands are chiefly valleys and divides produced

by sculpturing agents, especially running water and glacier ice. Local peculiarities in the form and pattern of these features reflect the arrangement and character of the rock materials within the upraised crustal mass that is being dissected.

Hill and mountain terrain occupies about 36% of the Earth's land area. The greater portion of that amount is concentrated in the great cordilleran belts that surround the Pacific Ocean, the Indian Ocean, and the Mediterranean Sea. Additional rough terrain, generally low mountains and hills, occurs outside the cordilleran systems in eastern North and South America, northwestern Europe, Africa, and western Australia. Eurasia is the roughest continent, more than half of its total area and most of its eastern portion being hilly or mountainous. Africa and Australia lack true cordilleran belts. The broad-scale pattern of crustal disturbance, and hence of rough lands, is now known to be related to the relative movements of a worldwide system of immense crustal plates. See MOUNTAIN; PLATE TECTONICS. [E.H.Ha.]

**Hippopotamus** The name for two species of even-toed (artiodactylid) ungulates which form the family Hippopotamidae. Both species occur in Africa; the great African hippopotamus (*Hippopotamus amphibius*) inhabits the rivers of tropical Africa, and the pygmy hippopotamus (*Choeropsis liberiensis*) lives near the rivers of western Africa but is more terrestrial.

The great African hippopotamus is the largest living artiodactylid. The ears are small and flexible, and the nostrils and eyes protrude so that they are out of the water as the animal floats. The skin is almost devoid of hair. The feet end in four toes enclosed in round hoofs. The pygmy hippopotamus is about the size of a large pig and is a more solitary species and does not live in large herds, as does the common species.

These animals migrate regularly, following the river upstream during the rainy season and downstream during the dry season to new pastures. They come onto land, especially at night, to feed on vegetation. The males of the common species occupy and maintain territories within which are small herds of females and juveniles. See ARTIODACTYLA. [C.B.C.]

**Hirudinea** A class of the annelid worms commonly known as leeches. These organisms are parasitic or predatory and have

terminal suckers for attachment and locomotion. Most inhabit inland waters, but some are marine and a few live on land in damp places. The majority feed by sucking the blood of other animals, including humans.

Leeches differ from other annelids in having the number of segments in the body fixed at 34, chaetae or bristles lacking, and the coelomic space between the gut and the body wall filled with packing tissue (see illustration). In a typical leech the first six segments of the body are modified to form a head, bearing eyes, and a sucker, and the last seven segments are incorporated into a posterior sucker.

The mouth of a leech opens within the anterior sucker, and there are two main methods of piercing the skin of the host to obtain blood: an eversible proboscis or three jaws, each shaped like half a circular saw, placed just inside the mouth. The process of digestion is very slow, and a meal may last a leech for 9 months. The carnivorous forms have lost most or all of their gut diverticula and resemble earthworms in having a straight, tubular gut. Leeches are hermaphroditic, having a single pair of ovaries and several pairs of testes.

The importance of leeches as a means of making incisions for the letting of blood or the relief of inflammation is declining, and in developed countries the bloodsucking parasites of mammals are declining, because of lack of opportunity for contact with the hosts. In other countries they are still serious pests. See ARHYNCHOBDELLAE; RHYNCHOBDELLAE. [K.H.M.]

**Histamine** A biologically active amine that is formed by the decarboxylation of the amino acid histidine. It is widely distributed in nature and is found in plant and animal tissues as well as in insect venoms. In humans, histamine is a mediator of inflammatory reactions, and it functions as a stimulant of hydrochloric acid secretion in the stomach.

Most tissue histamine is found stored in mast cells, where it can be released by a variety of stimuli. Once released, it can cause many effects, including constriction of bronchiolar, gastrointestinal, uterine smooth muscle, and lowering of blood pressure. If histamine is released in the skin, itching, a flare (area of redness) due to vasodilation, and a wheal due to leaking of fluid into the tissue are observed. The increase in vascular permeability that permits this leakage is due to an action on the endothelial cells of postcapillary venules.

All of these actions of histamine are mediated by the activation of histamine receptors, designated either H-1 or H-2. Anti-histamine drugs exert their effects by blocking the combination of histamine with these receptors. See ANTIHISTAMINE.

Histamine release can be caused by tissue injury, by physical stimuli such as cold or pressure, by drugs such as heroin, and most importantly by immunologic mechanisms. Mast cells in the skin, the lung, the nasal passages, or other sites may become sensitized to antigens such as ragweed or other pollens, and then release histamine and other biologically active substances upon exposure to them. The released histamine may then cause the effects commonly associated with allergic responses. If the allergic reaction becomes generalized and severe, life-threatening anaphylactic shock may ensue. The prompt administration of epinephrine, which exerts effects opposite to those of histamine, can be life-saving in such cases. See ALLERGY; ANTIGEN; EPINEPHRINE; HYPERSENSITIVITY; IMMUNOLOGY. [A.Bu.]

**Histocompatibility** A term used to describe the genes that influence acceptance or rejection of grafts. When grafts of tissue are exchanged between genetically dissimilar individuals, profound immunological rejection generally takes place. In contrast, grafts between genetically similar individuals, such as identical twins, are normally tolerated; they are histocompatible. Most known examples of histocompatibility (or H) genes encode polymorphic (that is, tending to differ between individuals) cell-surface proteins.

The major histocompatibility complex (MHC) contains a set of histocompatibility genes, termed major because mismatching at

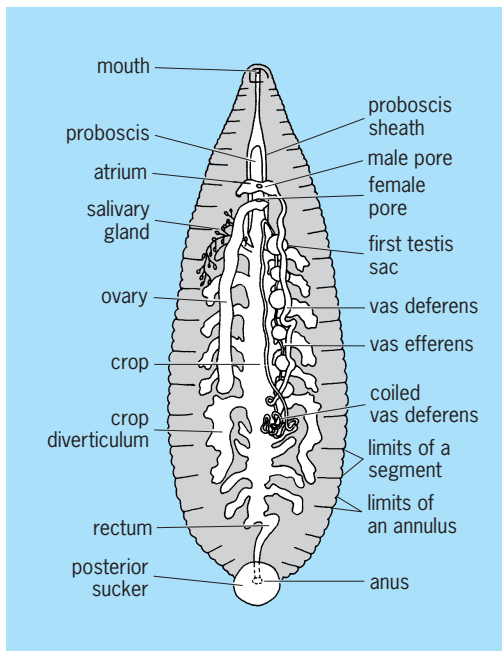

General structure of a leech. Male reproductive system is shown on the right, the female on the left. (After K. H. Mann, *A key to the British freshwater leeches*, *Freshwater Biol. Ass. Sci. Publ.*, 14:3-21, 1954)

these genes invokes rapid rejection. The main function of MHC genes involves distinguishing self from nonself in the immune system, as part of preventing the spread of infectious disease. The body employs special mechanisms to avoid rejection of the fetus, which is effectively an allograft, that is, a graft from a donor to a genetically dissimilar recipient of the same species; in this case, the mechanisms include a diminution of MHC gene expression.

The MHC contains a spectrum of genes, many of which influence processing and presentation of antigens to the immune system. In mice, the MHC is designated the H-2 complex; in humans, it is referred to as the HLA complex (for human leukocyte A system). Mice and other mammals seem to have a similar arrangement of genes in their MHCs. *See* ANTIGEN; CELLULAR IMMUNOLOGY; MENDELISM; TRANSPLANTATION BIOLOGY. [J.Tr.]

**Histogenesis** The developmental processes by which the definite cells and tissues which make up the body of an organism arise from embryonic cells. Among animals, the ectoderm, endoderm, and mesoderm, also known as the primary germ layers, provide the stem cells which gradually transform into distinctive kinds of cells and tissues. In the higher plants, meristematic cells, which occur wherever extensive growth takes place, provide the basis for tissue formation. *See* APICAL MERISTEM; EMBRYOLOGY; GERM LAYERS; HISTOLOGY; LATERAL MERISTEM. [C.B.C.]

**Histology** The study of the structure and chemical composition of tissues of animals and plants as related to their function. The primary aim is to understand how tissues are organized at all structural levels, including the molecular and macromolecular, the entire cell and intercellular substances, and the tissues and organs.

The four tissues of the animal body include cells and intercellular substances. They are (1) epithelium, in which the cells are generally closely applied to each other and separated by very little intercellular substance; (2) connective tissue, in which the cells are usually separated by greater amounts of intercellular substance, which may indeed form the great bulk of the tissue; (3) muscular tissue, whose cells are primarily concerned with contractility; and (4) nervous tissue, whose components are concerned primarily with rapid conduction of impulses. *See* CONNECTIVE TISSUE; EPITHELIUM; MUSCULAR SYSTEM; NERVOUS SYSTEM (VERTEBRATE).

The major fields of histological studies are morphological descriptions; developmental studies; histo- and cytophysiology; histo- and cytochemistry; and (5) fine (or submicroscopic) structure. [I.G.]

**Historadiography** The technique for taking x-ray pictures of cells, tissues, or sometimes the whole animal or plant, if it is a small one. Soft x-rays, those with low penetrating power and relatively long wavelengths, are required for this type of picture. The best pictures are obtained when the tissues contain deposits of metallic elements which have a high absorption capacity for x-rays. *See* X-RAYS.

In applying the technique to tissues, a relatively thin section is placed against an x-ray film and irradiated with a beam of x-rays. When the film is developed, a picture of the object or section of tissue shows on the film. Another method attempts to focus the x-rays after they pass through the specimen. *See* X-RAY MICROSCOPE. [J.H.T.]

**Hodgkin's disease** A malignant lymphoid neoplasm, usually arising in lymph nodes characterized by morphological heterogeneity and bizarre giant tumor cells referred to as Reed-Sternberg cells. The etiology of Hodgkin's disease is unknown, although current epidemiological data suggest an infectious (viral) etiology.

Persons with Hodgkin's disease usually seek medical advice because of enlarged painless lymph nodes. They may also have fever, weight loss, anorexia, pruritus, and anemia. The clinical

extent of the disease is determined by a process of staging based on physical examination, various biopsies, and usually a laparotomy for examination of the spleen and liver.

Hodgkin's disease more commonly affects males than females, except for the nodular sclerosing variety, which occurs with equal frequency in both sexes. It generally is a disease of persons between the ages of 20 and 40, but it may affect the very young and the very old. Characteristically, persons with Hodgkin's disease exhibit a loss of cell-mediated immunity and become susceptible hosts for infection with a variety of microorganisms such as tubercle bacilli.

The treatment of Hodgkin's disease is dependent on its clinical stage and microscopic appearance. A combination of chemotherapy and radiation therapy is commonly used. *See* LYMPHATIC SYSTEM. [S.P.H.]

**Hog cholera** A highly contagious epizootic disease of pigs, also known as classical (or European) swine fever. The causative agent is a virus in the genus *Pestivirus*. This disease is the subject of statutory controls in a majority of countries, and has been eradicated from many areas, including the United States, Canada, Australasia, and parts of Europe. Clinically and pathologically, it closely resembles African swine fever, which is caused by an unrelated virus. *See* ANIMAL VIRUS.

Hog cholera can occur in European wild boar, but among domestic species only pigs are affected. Humans are not susceptible. The primary mode of transmission is by contact or proximity. Infected animals shed virus in all bodily secretions, including aerosols of respiratory mucus. The virus survival time in aerosol is short, and airborne transmission over long distances is not a factor. Virus may also be spread by contact with contaminated equipment and vehicles. It can survive for many months in frozen or refrigerated meat from infected pigs, and is not inactivated by mild forms of curing.

Pigs of any age may be affected. There are typically a high fever, loss of appetite, and dullness. Other symptoms include blotchy discoloration of the skin (particularly the extremities), incoordination and weakness of the hindquarters, constipation followed by diarrhea, gummed-up eyes, and coughing. Death occurs within 4–7 days, and the mortality is usually high.

The chronic form of disease is characterized by dullness, unthriftiness, capricious appetite, and variable degrees of coughing, diarrhea, and emaciation. There may be joint swellings and ulceration of the skin.

Strains vary in virulence, and hog cholera may still be suspected when milder signs occur in epizootic form. Low-virulence strains may produce few signs apart from reproductive failure in sows or congenital tremors in their offspring. [S.E.]

**Hoisting machines** Mechanisms for raising and lowering material with intermittent motion while holding the material freely suspended. Hoisting machines are capable of picking up loads at one location and depositing them at another anywhere within a limited area. In contrast, elevating machines move their loads only in a fixed vertical path, and monorails operate on a fixed horizontal path rather than over a limited area. *See* ELEVATING MACHINES; MONORAIL.

The principal components of hoisting machines are: sheaves and pulleys, for the hoisting mechanisms; winches and hoists, for the power units; and derricks and cranes, for the structural elements.

Sheaves and pulleys or blocks are a means of applying power through a rope, wire, cable, or chain. Sheaves are wheels with a grooved periphery that change the direction or the point of application of a force transmitted by means of a rope or cable. Pulleys are made up of one or more sheaves mounted in a frame, usually with an attaching swivel hook, eye, or similar device at one or both ends. Pulley systems are a combination of blocks. *See* BLOCK AND TACKLE; PULLEY.

Normally, winches are designed for stationary service, while hoists are mounted so that they can be moved about, for example, on wheel trolleys in connection with overhead crane operations. A winch is basically a drum or cylinder around which cordage is coiled for hoisting or hauling. The drum may be operated either manually or by power, using a worm gear and worm wheel, or a spur gear arrangement. A ratchet and pawl prevent the load from slipping; large winches are equipped with brakes, usually of the external band type.

A derrick is distinguished by a mast in the form of a slanting boom pivoted at its lower end and carrying load-supporting tackle at its outer end. In contrast, jib cranes always have horizontal booms. Derricks are standard equipment on construction jobs; they are also used on freighters for loading and unloading cargo, and on barges for dredging operations. Hoisting machines with a bridgelike structure spanning the area over which they operate are overhead-traveling or gantry cranes. See BULK-HANDLING MACHINES; DERRICK. [A.M.P.]

**Holasteroidea** An order of irregular echinoids (sea urchins) of the superorder Atelostomata, with a strongly bilaterally symmetrical test. They have a small oval mouth lacking buccal notches that lies close to the anterior on the lower surface: a lantern is never present.

The 105 Recent species are divided into 13 genera. All are deep-sea forms. Their fossil record indicates that they were much more common and diverse in the past, with 61 genera divided into seven families, most of these being shallow-water forms. They are all deposit feeders, living either epifaunally or shallowly buried in unconsolidated substrata. See ATELOSTOMATA; ECHINODERMATA. [A.Sm.]

**Hole states in solids** Vacant electron energy states near the top of an energy band in a solid are called holes. A full band cannot carry electric current; a band nearly full with only a few unoccupied states near its maximum energy can carry current, but the current behaves as though the charge carriers are positively charged. See BAND THEORY OF SOLIDS.

The process of conduction in such a system may be visualized in the following way. An electron moves against an applied electric field by jumping into a vacant state. This transfers the position of the vacant state, or propagates the hole, in the direction of the field.

Hole conduction is important in many semiconductors, notably germanium and silicon. The occurrence of hole conduction in semiconductors can be favored by alloying with a material of lower valence than the "host." Semiconductors in which the conduction is primarily due to holes are called *p* type. See SEMICONDUCTOR. [J.C.]

**Holectypoida** An extinct order of primitive irregular sea urchins of the class (Echinoidea), which retain a functioning lantern throughout life. Although their periproct opens on the oral surface in the posterior interambulacrum, the test still shows considerable radial symmetry. The mouth is large, circular, and centrally positioned and is indented by sharp buccal notches. The holectypoids are distinguished from other primitive irregular echinoid groups by the presence of a fifth genital plate in the apical disc that may be perforated by a gonopore.

The approximately 130 nominal species are divided into nine genera and two families, Holectypidae and Discoididae. Holectypoids first appeared in the late Lower Jurassic and survived to the end of the Cretaceous (Maastrichtian), when they became extinct. They were mostly infaunal deposit feeders living in relatively coarse, permeable substrata. See ECHINOIDEA. [A.Sm.]

**Holly** The American species of holly (*Ilex opaca*) has evergreen leaves. It grows naturally in the eastern and southeastern United States close to the Atlantic and Gulf coasts, in the Mississippi Valley, and westward to Oklahoma and Missouri. It is best

known for its bright red berries. The heartwood takes a high polish and is used for cabinet work and musical instruments; because it resembles ivory, it is sometimes used for keys for pianos and organs.

The English holly (*I. aquifolium*) is cultivated extensively in the extreme northwestern United States, but is not hardy in the northeastern states. Its spiny leaves are glossier than those of the American holly and have wavier margins. [A.H.G./K.P.D.]

**Holmium** A chemical element, Ho, atomic number 67, atomic weight 164.93, a metallic element belonging to the rare-earth group. The stable isotope <sup>165</sup>Ho makes up 100% of the naturally occurring element. The metal is paramagnetic, but as the temperature is lowered, it changes to antiferromagnetic and then to the ferromagnetic system. See ANTIFERROMAGNETISM; PERIODIC TABLE; RARE-EARTH ELEMENTS. [F.H.Sp.]

**Holocene** That portion of geologic time that postdates the latest episode of continental glaciation. The Holocene Epoch is synonymous with the Recent or Postglacial interval of Earth's geologic history and extends from 10,000 years ago to the present day. It was preceded by the Pleistocene Epoch and is part of the Quaternary Period, a time characterized by dramatic climatic oscillations from warm (interglacial) to cold (glacial) conditions that began about 1.6 million years ago. The term Holocene is also applied to the sediments, processes, events, and environments of the epoch.

As the interval of time closest to us, the Holocene Epoch is very convenient to study. Holocene sediments cover virtually every part of the Earth's surface and represent almost every environment of deposition. With the development of <sup>14</sup>C dating (a method of age determination based on the measurement of radioactive carbon decay), Holocene sediments are relatively easy to date. From a scientific standpoint, the Holocene Epoch is of great interest because it provides a recent analog for past environments and processes. Its sediments and landforms provide important clues to changes that occurred as a result of the last shift from the glacial to the nonglacial climatic mode. See DEPOSITIONAL SYSTEMS AND ENVIRONMENTS; RADIOCARBON DATING.

The Pleistocene/Holocene transition was a time of dramatic environmental change. The huge ice sheets that had developed over the northern and western parts of North America (Laurentide and Cordilleran, respectively) and most of Scandinavia were at their maximum geographic extent about 18,000 <sup>14</sup>C years B.P. (before present, where present is defined as the year 1950) and in full retreat by 14,000 <sup>14</sup>C years B.P. By 10,000 <sup>14</sup>C years B.P., the Laurentide ice sheet had withdrawn from the Great Lakes. The ice sheets survived in the northern latitudes for another 3000 <sup>14</sup>C years or so. The progress of deglaciation was complex, because the overall glacial meltback was interrupted by intervals of glacier readvance. It remains unclear whether these readvances were synchronous on a hemispheric or global scale and what role ice sheet/oceanic interactions played in the deglaciation. See PLEISTOCENE.

The early phase of the Holocene was geologically the most eventful. The periglacial (near the edge of the ice) landscape was unstable and very dynamic. As the Pleistocene ice sheets melted, enormous volumes of water, stored as glacier ice for many thousands of years, returned to the oceans via meltwater streams or by way of ice streams that flowed directly to the ocean.

As the ice sheets shrank, sea level rose an average of 130 m (426 ft), drowning the continental margins and closing many land bridges, including the land bridge across the Bering Strait between Asia and North America that had enabled humans to migrate to the Americas. In parts of Canada and Scandinavia, temporary marine invasions occurred when the ice melted from low areas where the Earth's crust had been depressed by the weight of the ice sheets.

As the ice sheets waned, the Earth's crust rose, rebounding from the release of the weight of thousands of meters of glacier

ice and creating uplifted shoreline features and sediments. Parts of Hudson Bay and Scandinavia were uplifted several hundred meters. Maximum uplift occurred in the early Holocene, but uplift continues even today although at much slower rates.

The middle phase of the Holocene has been called the hypsithermal, a name for the warmest interval of the present interglacial episode. It has also been referred to as the climatic optimum, a term which is more appropriately applied to the peak warmth of the hypsithermal phase. At the climatic optimum, world temperature was probably 2 or 3°C (3.6 or 5.4°F) higher than today. The climate was warm enough to melt much of the sea ice in the Arctic Ocean, as indicated by the occurrence of fossil driftwood (dated at 4000–6000 <sup>14</sup>C years B.P.) on uplifted beaches.

After the climatic optimum, the Earth experienced climatic cooling. The shift to a cooler, moister climate began about 5000–4000 <sup>14</sup>C years B.P. in the midcontinent. In western North America at about 5000 <sup>14</sup>C years B.P., the mountain glaciers began to expand again. This renewed glacial activity is called Neoglaciation. At least three intervals of glacial expansion have occurred in the late Holocene. The glacial advances are cyclic. In the mountains of the western United States, the three advances have been dated at about 5000, 2800, and 300 <sup>14</sup>C years B.P. The most impressive of the three glacial intervals is the last, called the Little Ice Age. It is well documented because it occurred in historic time. Between the intervals of glacier expansion were times of climatic warming. One, called the Little Climatic Optimum to differentiate it from the hypsithermal of the middle Holocene, peaked about 1800 <sup>14</sup>C years B.P.

During the late Holocene, human populations expanded and human culture developed into the complex agricultural, industrial, and technological society of today. The result is that humans have become significant factors in altering the Earth's surface environment, including, most believe, Holocene climate. See GEOLOGIC TIME SCALE; GLACIAL EPOCH; QUATERNARY. [A.K.H.]

**Holocephali** One of two Recent subclasses of the cartilaginous fishes, or Chondrichthyes. The Holocephali, or chimaeras, differ from the other subclass, the Elasmobranchii, in having only four pairs of gill arches and gills that open to the exterior from a single pair of apertures; in the erectile dorsal fin and spine (see illustration); in the naked skin in adults; and in the absence of a cloaca and of ribs.

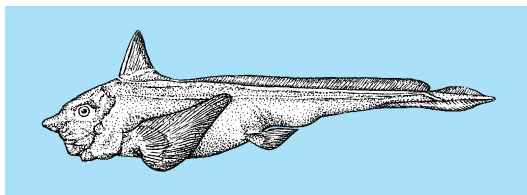

Deepwater chimaera (*Hydrolagus affinis*). (After G. B. Goode and T. H. Bean, *Oceanic Ichthyology*, U.S. Nat. Mus. Spec. Bull. no. 2, 1895)

Chimaeras date from the early Mesozoic. They are classified into a single order, the Chimaeriformes, one family, the Chimaeridae, four or five genera, and about 24 species. All chimaeras are marine, most living in deep water. They are of little economic importance. See CHONDRICHTHYES. [R.M.B.]

**Holography** A technique for recording, and later reconstructing, the amplitude and phase distributions of a coherent wave disturbance. Invented by Dennis Gabor in 1948, the process was originally envisioned as a possible method for improving the resolution of electron microscopes. While this original application has not proved feasible, the technique is widely used as a method for optical image formation, and in addition has been

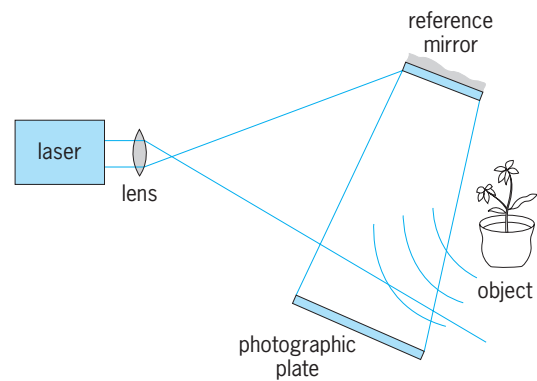

Fig. 1. Recording a hologram.

successfully used with acoustical and radio waves. See ACOUSTICAL HOLOGRAPHY.

The technique is accomplished by recording the pattern of interference between the unknown "object" wave of interest and a known "reference" wave (Fig. 1). In general, the object wave is generated by illuminating the (possibly three-dimensional) subject of concern with a highly coherent beam of light, such as supplied by a laser source. The waves reflected from the object strike a light-sensitive recording medium, such as photographic film or plate. Simultaneously a portion of the light is allowed to bypass the object, and is sent directly to the recording plane, typically by means of a mirror placed next to the object. Thus incident on the recording medium is the sum of the light from the object and a mutually coherent "reference" wave. See LASER.

The photographic recording obtained is known as a hologram (meaning a "total recording"); this record generally bears no resemblance to the original object, but rather is a collection of many fine fringes which appear in rather irregular patterns. Nonetheless, when this photographic transparency is illuminated by coherent light, one of the transmitted wave components is an exact duplication of the original object wave (Fig. 2). This wave component therefore appears to originate from the object (although the object has long since been removed) and accordingly generates a virtual image of it, which appears to an observer to exist in three-dimensional space behind the transparency. The image is truly three-dimensional in the sense that the observer's eyes must refocus to examine foreground and background, and indeed can "look behind" objects in the foreground simply by moving his or her head laterally.

Holography has been demonstrated to offer the capability of several unique kinds of interferometry. This capability is a consequence of the fact that holographic images are coherent; that is, they have well-defined amplitude and phase distributions. Any use of holography to achieve the superposition of two coherent images will result in a potential method of interferometry. See INTERFEROMETRY.

Optical memories for storing large volumes of binary data in the form of holograms have been developed for commercial use. Such a memory consists of an array of small holograms, each

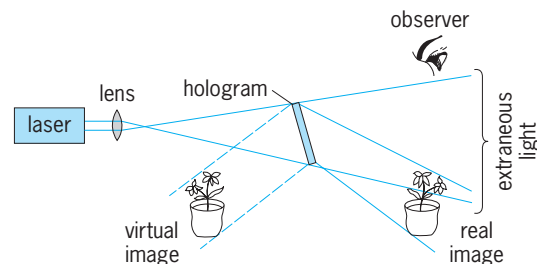

Fig. 2. Obtaining images from a hologram.

capable of reconstructing a different “page” of binary data. When one of these holograms is illuminated by coherent light, it generates a real image consisting of an array of bright or dark spots, each spot representing a binary digit. See COMPUTER STORAGE TECHNOLOGY.

There has been interest in the use of holography for purposes of display of three-dimensional images. Applications have been found in the field of advertising, and there is increased use of holography as a medium for artistic expression. [J.W.Goo.]

Microwave holography is microwave imaging by means of coherent continuous-wave electromagnetic radiation in the wavelength range from 1 mm to 1 m. As a long-wavelength imaging modality, it differs from techniques which employ echo timing (for example, conventional radar) by its requirement for phase information. In this respect it resembles optical holography, from which it has departed significantly. The technique usually involves small-scale systems, that is, systems in which the effective data acquisition aperture is of the order of tens or hundreds of wavelengths. Microwave holographic imaging is characterized by high lateral-resolution capability in comparison with images obtained from echo timing. The natural image format of the data it presents to the human observer enhances its diagnostic potential. In particular, it conveniently produces phase imagery which increases further its diagnostic capability. See MICROWAVE; RADAR.

Microwave holography is useful in applications where images of concealed structure are required. Microwave radiation penetrates a variety of dielectric media to a depth depending on the attenuation of a given wavelength in a particular medium. One such application is the mapping of subsurface pipes and cables. Plastic pipes as well as metal pipes can be imaged. Hence this noninvasive microwave technique has a diagnostic power greater than the normal metal detectors. See NONDESTRUCTIVE EVALUATION.

The major limitation of the microwave holographic techniques is that the images produced are essentially two-dimensional. The reason is that the microwave wavelength is so long ( $10^4$ – $10^6$  times that of light) that the depth of focus of the microwave hologram is prohibitive. This disadvantage is overcome by employing a tomographic mode of imaging which exploits the ability of microwaves to penetrate many materials and thereby characterize their three-dimensional structure more accurately. Microwave holographic tomography requires holograms to be recorded from different views of the object and synthesized. See COMPUTERIZED TOMOGRAPHY. [A.PAn.]

**Holostei** One of three organizational levels (infraclasses) of the subclass Actinopterygii, or rayfin fishes. The holosteans are descended from the older Chondrostei and in turn are ancestral to the great mass of modern bony fishes, the Teleostei. See CHONDROSTEI; TELEOSTEI.

Holosteans made their first appearance in the Upper Permian as the order Semionotiformes; three additional orders arose in the Triassic Period, and the fifth and last order, the Aspidorhynchiformes, evolved in the Middle Jurassic. In the Jurassic and Lower Cretaceous, holosteans dominated actinopterygian fish life, but by the Late Cretaceous they had been largely replaced by teleosts.

Holosteans, although highly varied in body form, were structurally as well as temporally intermediate between chondrosteans, and teleosts, to which group they passed on substantial advances. In living holosteans the swim bladder is highly vascularized, and auxiliary aerial respiration is possible, a sometimes essential faculty in oxygen-poor waters of swamps. See ACTINOPTERYGII; AMIIFORMES; ASPIDORHYNCHIFORMES; PHOLIDOPHORIFORMES; PYCNODONTIFORMES; SEMIONOTIFORMES. [R.M.B.]

**Holothuroidea** A class of Echinozoa characterized by a cylindrical body and smooth leathery skin, and known as sea cucumbers. There are no arms, but a ring of five or more tentacles

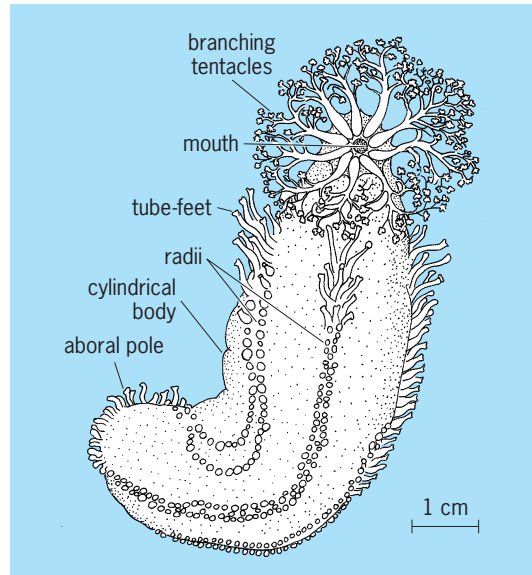

*Cucumaria*, a representative holothurian.

may surround the mouth, which is usually at one end of the body. There are no pedicellariae. Tube feet may be present or lacking. There are no ambulacral grooves. See ECHINOZOA.

Holothurians resemble worms because the pentamerous symmetry is largely concealed by a secondary bilateral symmetry, and the general absence of external spines distinguishes them from the other extant echinoderms (see illustration).

The 1100 living species have been grouped in 170 genera arranged in six orders: the Dendrochirotida, Dactylochirotida, Aspidochirotida, Elaspodida, Molpadida, and Apodida. Colors vary widely; the most brilliant colors are found among the Synaptidae. Yellow, red, violet, and fawn tints occur, but many species are somber shades or black.

Holothurians occur in all seas, from low-tide level down to the greatest depths explored. At depths below 5.5 mi (8.8 km) holothurians comprise 90% of the total mass of living matter, the rest being mainly starfishes. Two pelagic genera are known. [H.B.F.]

**Holotrichia** A major subclass of the class Ciliatea. These protozoans have a fairly uniform body ciliation, as the name implies. Separate articles appear on the groups listed in the following classification:

- Subclass Holotrichia
- Order : Gymnostomatida      Astomatida
- Trichostomatida      Hymenostomatida
- Chonotrichida        Thigmatrichida
- Apostomatida

The cilia are typically arranged in longitudinal rows over the body, although scattered exceptions exist. A mouth is often,

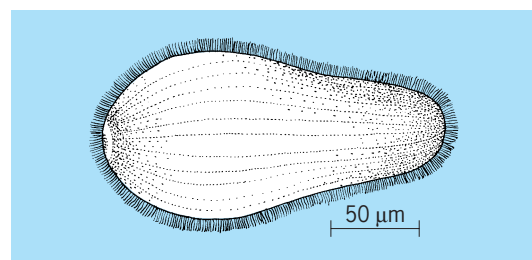

*Prorodon*, a primitive holotrich.

although not always, present. The prototype of the Holotrichia is exemplified by the form portrayed in the illustration. [J.O.C.]

**Homalozoa** A subphylum of echinoderms, made up of members having a flattened theca or body lacking pentamerous symmetry. Homalozoans (also called carpoids) include four extinct classes of relatively uncommon primitive echinoderms ranging in age from the Early or Middle Cambrian to the Late Carboniferous. Homalozoans have a flattened, asymmetrical to bilaterally symmetrical theca often composed of a marginal frame of large elongate plates surrounding top and bottom central areas that had numerous smaller plates and were probably flexible. All homalozoans were apparently mobile, benthic, detritus or suspension feeders that had adopted a flatfish way of life. See CARPOIDS; ECHINODERMATA. [J.Sp.]

**Homeosis** The formation of a normal plant or animal body structure or organ in place of another at an abnormal site. Examples of homeosis (also called homeotic transformation) are most obvious in insect appendages, where an appendage that is characteristic of one segment, for example the antennae on an insect head segment, are transformed into insect legs that normally develop only on trunk segments. Similar examples of homeotic transformations can also occasionally be found in vertebrates where lumbar vertebrae are transformed into thoracic vertebrae which then extend into rib processes, or in floral organs where petals are transformed into sepals. Homeotic transformations rarely occur in nature in living organisms, and are due to genetic defects in a class of proteins called homeotic proteins, the products of homeotic genes. Homeotic transformations may also be induced in the laboratory by the accidental or deliberate manipulation of homeotic gene expression so that homeotic proteins are produced in the wrong place or at the wrong time in developing plants and animals. See CELL DIFFERENTIATION; DEVELOPMENTAL BIOLOGY; DEVELOPMENTAL GENETICS; GENE ACTION; MUTATION. [W.McG.]

**Homeostasis** The relatively constant conditions within organisms, or the physiological processes by which such conditions are maintained in the face of external variation.

Similar homeostatic controls are used to keep factors such as temperature and blood pressure nearly constant despite changes in an organism's activity level or surroundings. Such systems operate by detecting changes in the variable that the system is designed to hold constant and initiating some action that offsets any change. All incorporate a sensor within the system that responds when the actual condition differs from the desired one, a device to ensure that any action taken will reduce the difference between actual and desired, and an effector to take the needed action as directed. The crucial aspect is that information is fed back from effector to sensor and action is taken to reduce any imbalance—hence the term negative feedback.

Blood pressure is, at least on a moment-to-moment basis, regulated by a system for which the sensors are stretch-sensitive cells located in the neck arteries that carry blood from heart to brain. An increase in blood pressure triggers sensor activity; their signal passes to the brain; and, in turn, the nerve supplying the heart (the vagus) is stimulated to release a chemical (acetylcholine) that causes the heart to beat more slowly—which decreases blood pressure.

The volume of the blood is subject to similar regulation. Fluid (mainly plasma) moves between the capillaries and the intercellular fluid in response to changes in pressure in the capillaries. A decrease in blood volume is detected by sensors at the base of the brain; the brain stimulates secretion of substances that cause contraction of tiny muscles surrounding the blood vessels that lead into the capillaries. The resulting arteriolar constriction reduces the flow of blood to, and the pressure within, the capillaries, so fluid moves from intercellular space into capillaries, thus restoring overall blood volume.

Body temperature in mammals is regulated by a sensor that consists of cells within the hypothalamus of the brain. Several effectors are involved, which vary among animals. These include increasing heat production through nonspecific muscle activity such as shivering; increasing heat loss through sweating, panting, and opening more blood vessels in the skin (vasodilation); and decreasing heat loss through thickening of fur (piloerection) and curling up. Humans sweat, but they retain only a vestige of piloerection (“goose flesh”). See THERMOREGULATION.

While the homeostatic mechanisms described involve the neural and endocrine systems of mammals, it is clear that such arrangements pervade systems from genes to biological communities, and that they are used by the simplest and the most complex organisms.

Organisms of every kind develop, mature, and even shift physiological states periodically—between day and night, with seasons, or as internal rhythms. Thus organisms cannot be considered constant except over short periods. However, all such changes appear to involve the same basic sensing of the results of the past activity of the system and the adjusting of future activity in response to that information. Development of an organism from a fertilized egg is far from a direct implementation of a genetic program; probably no program could anticipate all the variation in the external context in which an organism must somehow successfully develop. See BIOLOGICAL CLOCKS; ENDOCRINE MECHANISMS; NERVOUS SYSTEM (VERTEBRATE); SERVOMECHANISM. [S.V.]

**Homing** A process of navigation by which a destination is approached by keeping some navigation parameter constant. In its early uses, the most commonly chosen parameter was the relative bearing from the vehicle to destination as determined from a signal emitted at or near the destination point. The vehicle then steers to travel in the direction of its destination. The signal can be of many forms, ranging from a visual image to a radio wave or even an odor. This simple form of homing requires minimal on-board equipment, but the path taken by the vehicle over the Earth's surface is influenced by vehicle drift due to winds, currents, or other causes. See DIRECTION-FINDING EQUIPMENT.

A higher level of homing is available through certain radio navigation aids (navaids), such as the very high frequency omnidirectional range (VOR) and the aircraft instrument landing system (ILS). While the signals from these aids define a path in space that can be followed by the user, the signals themselves do not indicate the courses that should be selected to remain on the path. In the case of VOR, the signals define the azimuth to or from the station, with the user being required to adjust the vehicle heading to acquire the desired path and to compensate for any drift in order to remain on the path. The ILS signals define a precise fixed path in space, which the user equipment processes to yield deviation indications in the lateral and vertical directions. See ELECTRONIC NAVIGATION SYSTEMS; INSTRUMENT LANDING SYSTEM (ILS).

The advent of affordable on-board digital processing accompanied by extensive geographical databases has resulted in supporting direct-to paths from present position to destinations that need not radiate a signal. The navigation aids used most for establishing direct-to paths include VOR/DME (distance-measuring equipment), DME/DME, Loran-C, and the Global Positioning System (GPS). See DISTANCE-MEASURING EQUIPMENT; LORAN; SATELLITE NAVIGATION SYSTEMS.

One of the most useful navigation features developed after the advent of radionavigation is vehicle-to-vehicle homing, where a vehicle homes on signals radiated by another vehicle. This is especially valuable in rescue operations. In the United States, aircraft are required to carry emergency locator transmitters (ELTs) which automatically turn on when the aircraft crashes.

The most serious military homing mode is that which enables a missile to home on any source of radiation. Typical sources are radio transmitters of all kinds, including radar and navigation



aids, and the infrared exhausts of jet engines, tanks, and ships. See ELECTRONIC WARFARE; GUIDED MISSILE; MISSILE. [E.O.F.]

**Homogeneous catalysis** A process in which a catalyst is in the same phase as the reactant. A homogeneous catalyst is molecularly dispersed (dissolved) in the reactants, which are most commonly in the liquid state. Catalysis of the transformation of organic molecules by acids or bases represents one of the most widespread types of homogeneous catalysis. In addition, the catalysis of organic reactions by metal complexes in solution has grown rapidly in both scientific and industrial importance. See CATALYSIS. [D.F.]

**Homoptera** An order of the class Insecta related to the order Hemiptera. This is a major group of sucking insects, with more than 30,000 species, even though in Asia and Africa the number of undiscovered species probably still exceeds the discovered ones. Common examples are the cicadas, aphids, and leafhoppers. The group is difficult to characterize because of the large number and diverse forms of the species it contains.

The head of these insects is hypognathous or opisthognathous, the beak appearing to arise from the ventral posterior margin of the head or even from the prosternum. The gula is membranous or absent. As in the Heteroptera, the beak consists of two pairs of stylets, formed by the maxillae and the mandibles, ensheathed in the labium. The maxillary stylets fit together to form a double tube, one channel serving for the passage of food and the other for saliva.

Most winged species have four wings, but male scale insects have only two. In most forms both pairs of wings are membranous and transparent, but in some, the forewings are somewhat thickened and may then be either coriaceous and translucent, or opaque, and with or without an apical membranous area. When the insects are at rest, the forewings are usually held, rooflike, over the dorsum, with the apex of one of them slightly overlapping the apex of its complement (Fig. 1).

In most species metamorphosis is gradual, but in a few it is practically holometabolous. Adults and nymphs of most species are terrestrial, but a few species are subterranean in all stages and others are subterranean only in immature stages. A number of species are vectors of virus diseases of plants.

**Series Coleorrhyncha.** This group is characterized by the origin of the beak, formed at the anteroventral extremity of the face, and by the fact that the propleura form a sheath for the base of the beak. The hindwings are absent, and the forewings are held flat over the abdomen in repose. The flight function has been lost. They occur in Tasmania, New Zealand, and South America.

**Series Auchenorrhyncha.** This series and the Sternorrhyncha are the major groups of the Homoptera. In the Auchenorrhyncha the beak arises at the anteroventral extremity of the face and is not sheathed by the propleura. The Auchenorrhyncha includes a large number of species. A number of classifications have been proposed; the classification adopted here is a common one. It divides the series into the superfamily Fulgoroidea

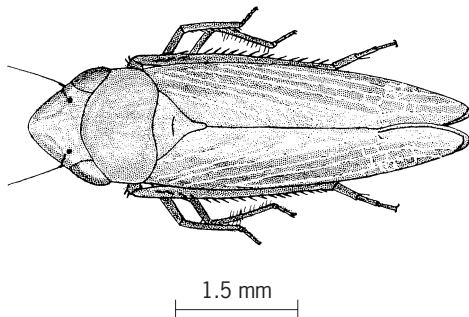

Fig. 1. A cicadellid, dorsal view.

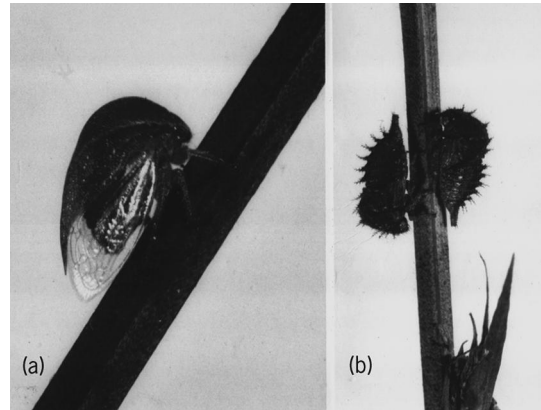

Fig. 2. Membracids on stems. (a) Adult. (b) Nymphs. (Courtesy of C. H. Hanson)

and the families Cicadidae, Cercopidae, Membracidae, and Cicadellidae. These families are not subordinate to the superfamily Fulgoroidea.

Superfamily Fulgoroidea includes insects commonly known as lantern flies. This group is subdivided into 20 families and includes many species which are important because of the economic damage they do while feeding or because they carry virus diseases of plants.

Included in the family Cicadidae are the cicadas, harvest flies, and jar flies. The insects in this family are probably better known to the layperson than any other homopterous family because of their large size and the strident songs of the males. Adults are usually found on trees or shrubs. At least in some species, the songs of the males assemble local populations.

Spittle bugs and froghoppers are common examples of the family Cercopidae. Insects in this group attract attention in the immature stages, during which they surround themselves with a mass of froth or spittle. One species, the meadow spittle bug, is very common in the temperate portion of the Northern Hemisphere, and its masses of spittle are familiar sights. Some species of Australia and the East Indies live within a calcium carbonate tube attached to stems or leaves.

The treehoppers (family Membracidae) are small to medium in size and seldom attract attention (Fig. 2a). Most of them feed on woody plants and are found on the stems in sunny locations. Frequently a number of specimens are arranged in a vertical row on the stem, all with their heads downward.

The greatest number of species occurs in the warmer regions of the world. In many species the enlarged pronotum has adornments, excrescences, and processes which are astonishing in appearance, some of them nearly as large as the remainder of the insect. The nymphs (Fig. 2b) leave the trees and feed on herbaceous plants, often occurring in great numbers in pastures. The adults return to woody plants before oviposition.

The leafhoppers are included in the large family Cicadellidae. These usually small insects are known to many people by sight but not by name, because of their common occurrence in great numbers at night near lights (Fig. 1). Probably the greatest number of species occurs in tropical areas, but the majority of these have not been described. Leafhoppers occasionally bite humans, but apparently they have never been seen taking blood. Several species have been found to be vectors of virus diseases of plants.

**Series Sternorrhyncha.** In this group of families, the beak appears to arise either between the fore coxae or behind them. The antennae are usually long, filamentous, and have no well-differentiated terminal setae. Wingless forms are common.

The Sternorrhyncha includes a large number of species, many of them of great economic importance. The winged forms are not strong flyers, but they are so light that they may be borne considerable distances by air currents.

The family Psyllidae are known as jumping plant lice. Its representatives resemble cicadas in appearance, but are much smaller. About 1000 species are known. Some psyllids produce severe damage to their food plants. This damage may result from the mere feeding by tremendous numbers of individuals, from the resulting yellowing or rolling of leaves, or from galls produced on the leaves. Indirect damage may result from the growth of fungi on leaves which have become coated with the sugary excrement, the honeydew, of the psyllids.

The whiteflies (family Aleyrodidae) are 0.28 in. (7 mm) or less in length and usually lightly covered with a white, powdery, waxy material which has led to their common name. Whiteflies directly damage plants by their feeding. Indirectly, damage results from spotting at the feeding site, growth of fungus on the excreted honeydew, or from increased susceptibility of leaves to winter damage.

Members of the large superfamily Aphidoidea have four wings, or none. The wings are usually membranous or whitish and opaque. The forewings are much larger than the hindwings. Honeydew is usually produced. This superfamily includes the families Aphididae and Chermidae. The true aphids (Aphididae) are very attractive to ants, and colonies of very small aphid species which otherwise might escape notice can often be located by observing the attending ants. In a few species, this relationship has progressed to the point where ants are necessary for the survival of the aphid species, as in the corn root aphid. Many aphid species are important because of damage done in feeding.

Chermidae is a small family of minute insects, the adelgids and phylloxerids. Both winged and wingless forms occur. The grape phylloxera has been a severe pest of cultivated grapes and once threatened the entire wine industry of France.

The scale insects and mealy bugs (superfamily Coccoidea) are usually small. More than 4000 species have been described. In the males, the hindwings are reduced to clublike halteres. The wings are usually held flat over the back in repose, and the venation is greatly reduced. The females are wingless.

Scale insects injure the host plant by their feeding on leaves, stems, or roots, and a number of species are very important economically. Most species produce large quantities of honeydew. A few species have been shown to be vectors of virus diseases of cucumbers, tobacco, and cacao. See ENTOMOLOGY, ECONOMIC; INSECTA. [D.A.H.]

**Homosclerophorida** An order of primitive sponges of the class Demospongiae, subclass Tetractinomorpha, with a skeleton consisting of equirayed, tetraxonid, siliceous spicules and their derivatives formed through reduction in number of rays.

Homosclerophorid sponges are mostly small in size and encrusting to massive in shape. They occur in tidal and shallow waters, down to depths of at least 1640 ft (500 m). Fossil sponges with spicules suggesting homosclerophorid affinities are scattered through the fossil record from Carboniferous strata upward. See DEMOSPONGIAE. [W.D.H.]

**Honey Dew melon** A long-keeping cultivar of muskmelon, *Cucumis melo inodorus*, of the gourd family, Cucurbitaceae. Vines are vigorous and prolific and have large leaves and stems. The fruits are large, slightly oval, (diameter 6–7 in. or 15–18 cm), smooth, creamy yellow to ivory when ripe, and with little or no net. The flesh is thick, light green, tender, juicy, and very sweet with mild aroma and flavor; it contains 10% or more sugar when ripe and is rich in potassium and vitamin C, but not as rich in vitamin A as the orange-fleshed cantaloupe.

Honey Dew is of African origin, has been grown in France for many years, and was introduced into the United States in 1911. Most of the crop is harvested in the summer in California; almost all of the remaining crop is harvested in the spring in Texas, with less than 5% harvested in the fall in Arizona. See MUSKMELON; VIOLALES. [O.A.L.]

**Hookeriales** An order of the mosses, many species of which occur in the tropics. The plants are small to robust, procumbent, and often flaccid, and frequently appear flattened. The stems are irregularly branched, and the cells of the

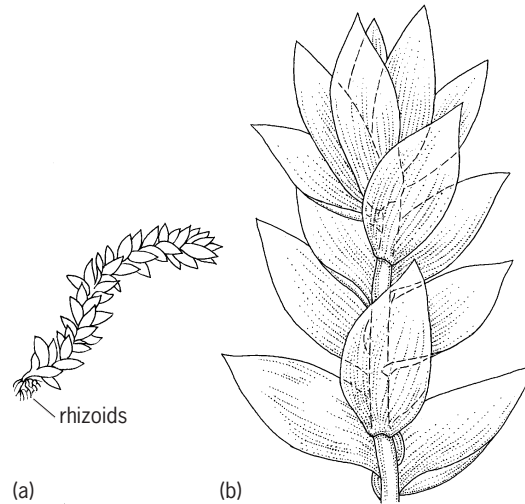

*Hookeria acutifolia*. (a) A portion of an entire plant, (b) Apical portion enlarged. (After W. H. Welch, *Mosses of Indiana*, Indiana Department of Conservation, 1957)

peripheral layer are enlarged. The leaves vary in shape and size. They occur in many rows in some species, four rows in others, and appear to be in one plane (see illustration). See BRYOPSIDA. [W.H.W.]

**Hooke's law** A generalization applicable to all solid materials, stating that stress is directly proportional to strain and expressed as

$$\frac{\text{Stress}}{\text{Strain}} = \frac{S}{\epsilon} = \text{constant} = E$$

where  $E$  is the modulus of elasticity, or Young's modulus, in pounds per square inch. The constant relationship between stress and strain applies only to stress below the proportional limit. See STRESS AND STRAIN; YOUNG'S MODULUS. [W.J.K./W.G.B.]

**Hop** A plant (*Humulus lupulus*) belonging to the family Urticaceae. The plant is perennial, with the clockwise twining vine dying back to the ground each year. The male and female flowers are borne on separate plants.

The mature hop cone—the hop of commerce—consists of papery bracts and bracteoles. As the cone matures, numerous golden-yellow granules (lupulin) develop on the bracteoles. These granules contain the resins and essential oils to which the hop owes its brewing value. See MALT BEVERAGE.

Hops are found primarily in the temperate areas of the world. In the United States the cultivated hop is grown in Washington, Oregon, Idaho, and California. [C.B.S.]

**Hophornbeam** The genus *Ostrya* of the birch family, represented in North America by two species. *Ostrya virginiana* is widely distributed in the eastern half of the United States and in the highlands of southern Mexico and Guatemala. It can be recognized by its fruit, which closely resembles that of the hop vine, and by its very scaly bark. The scales usually occur in narrow, more or less parallel, vertical strips. The leaves are sharply and doubly serrate. This is one of several trees known as ironwood because of its hard, strong wood; it is used for fence posts, tool handles, mallets, and other articles requiring hardness and strength. *Ostrya knowltonii* is a small rare tree of the southwestern United States. See FAGALES. [A.H.G./K.P.D.]

**Hoplocarida** A subclass of Crustacea, with a single extant order, Stomatopoda, commonly known as mantis shrimps. The Hoplocarida was formerly included as a taxon within the Eumalacostraca, and disagreement regarding its independent origin still persists. The controversy is centered on the question of whether those elements of the eumalacostracan caridoid facies observed in hoplocarids represent examples of homology or convergence. Investigations of fossil (Paleostomatopoda) and Recent Stomatopoda suggest that a distinct set of morphological features, sometimes referred to as a hoploid morphotype, clearly delineate the Hoplocarida from the Eumalacostraca. Morphological aspects of feeding observed in modern-day species, as well as features of the digestive system and abdominal musculature, tend to support the hypothesis of a distinct origin. See CRUSTACEA; STOMATOPODA. [P.A.McL.]

**Hoplomertini** An order of the class Enopla of the phylum Rhynchocoela, characterized by possession of an elaborate armed proboscis consisting of an anterior thick-walled tube, a median portion armed with stylets, and a posterior blind tube. In some species the foregut (stomach) can be everted into the prey to achieve extracorporeal digestion prior to ingestion. There are two suborders, the Monostylifera and Polystylifera, separated on the number of stylets in the proboscis. Monostylifera include fresh-water, terrestrial, and symbiotic species, as well as the more common marine littoral forms. See ANOPLA; BDELLONEMERTINI; ENOPLA; RHYNCHOCOELA. [J.B.J.]

**Horizon** The visible horizon is the apparent boundary line between sky and earth or sea. The astronomical horizon is the great circle of the celestial sphere  $90^\circ$  from the zenith and the nadir. See ASTRONOMICAL COORDINATE SYSTEMS. [G.M.C.]

**Hormone** One of the chemical messengers produced by endocrine glands, whose secretions are liberated directly into the bloodstream and transported to a distant part or parts of the body, where they exert a specific effect for the benefit of the body as a whole. The endocrine glands involved in the maintenance of normal body conditions are pituitary, thyroid, parathyroid, adrenal, pancreas, ovary, and testis. However, these organs are not the only tissues concerned in the hormonal regulation of body processes. For example, the duodenal mucosa, which is not organized as an endocrine gland, elaborates a substance called secretin which stimulates the pancreas to produce its digestive juices. The placenta is also a very important hormone-producing tissue. See separate articles on the individual glands.

The hormones obtained from extracts of the endocrine glands may be classified into four groups according to their chemical constitution: (1) phenol derivatives, such as epinephrine, norepinephrine, thyroxine, and triiodothyronine; (2) proteins, such as the anterior pituitary hormones, with the exception of adrenocorticotrophic hormone (ACTH), human chorionic gonadotropin, pregnant-mare-serum gonadotropin, and thyroglobulin; (3) peptides, such as insulin, glucagon, ACTH, vasopressin, oxytocin, and secretin; and (4) steroids, such as estrogens, androgens, progesterone, and corticoids. Hormones, with a few exceptions like pituitary growth hormone and insulin, may also be classified as either tropic hormones or target-organ hormones. The former work indirectly through the organs or glands which they stimulate, whereas the latter exert a direct effect on peripheral tissues. See ENDOCRINE SYSTEM (VERTEBRATE). [C.H.L.]

**Hornbeam** The genus *Carpinus* of the birch family, represented in the United States by *C. caroliniana*, the American hornbeam or blue beech. Hornbeam is a small tree, and it has a smooth, steel-gray, fluted bark. It grows throughout the eastern half of the United States, especially in moist soil along banks of streams; it is sometimes called water beech. When mature, it is easily recognized by its peculiar bark, by the doubly serrate leaves resembling those of sweet birch, and by the small,

pointed, angular winter buds with scales in four rows. The fruit is a small nutlet subtended by a three-lobed serrate bract. The wood is very hard, giving rise to the name iron-wood.

The European hornbeam (*C. betulus*) is often cultivated in parks and estates. It can be distinguished by its larger size, larger winter buds, and larger three-lobed, almost entire fruiting bracts. See FAGALES. [A.H.G./K.P.D.]

**Hornblende** The name that was traditionally assigned to common calcic amphiboles of metamorphic and igneous rocks. However, a nomenclature scheme for amphiboles was introduced in 1997 in which the names now carry strict compositional restrictions. Magnesiohornblende (contains magnesium) and ferrohornblende (contains iron) are monoclinic amphiboles with end-member compositions  $\text{Ca}_2(\text{Mg}_4\text{Al})(\text{Si}_7\text{Al})\text{O}_{22}(\text{OH})_2$  and  $\text{Ca}_2(\text{Fe}^{2+}_4\text{Al})(\text{Si}_7\text{Al})\text{O}_{22}(\text{OH})_2$ , respectively (Ca = calcium, Mg = magnesium, Al = aluminum, Si = silicon, O = oxygen, Fe = iron, OH = hydroxyl). Most natural compositions differ significantly from these ideal end members. Significant deviations from these compositions are denoted by the addition and replacement of prefixes and adjectival modifiers characteristic of the compositions involved. Thus fluorohornblende (contains fluorine, F) has the end-member composition  $\text{Ca}_2(\text{Mg}_4\text{Al})(\text{Si}_7\text{Al})\text{O}_{22}\text{F}_2$ , in which all of the OH in hornblende has been replaced by F. When used to denote an amphibole of known chemical composition, the term hornblende is never used without a prefix or adjectival modifier. The unmodified term hornblende specifically refers to a calcic amphibole identified by physical or optical properties without characterization of the chemical composition.

Hornblende is a common rock-forming mineral in medium- and high-grade metamorphic rocks, particularly those of mafic and ultramafic composition. In mafic rocks, it first appears in the upper part of the low grade by a chemical reaction involving the disappearance of actinolite, a nonaluminous calcic amphibole. This change is extremely noticeable in thin sections, very pale-green actinolite giving way to blue-green hornblende. With prograde metamorphism, the composition of the hornblende gradually changes in a highly complex manner that is a function of temperature, pressure, oxygen fugacity (a measure of the activity of oxygen), and the chemical composition of the rock. This causes a gradual color change from blue-green through various shades of green to olive green and brown. At the middle of the high grade, hornblende becomes unstable and breaks down to form pyroxene (plus other minerals). The prominence of hornblende in medium-grade metabasic rocks has led to these rocks being called amphibolites. See PYROXENE.

Hornblende is commonly found as a minor phase in a wide variety of igneous rocks. Magnesium-rich hornblendes do occur as primary phases in basic and ultrabasic rocks, but this is not common. Igneous amphiboles are most abundant in calcic-alkaline diorites, granodiorites, and granites, becoming more iron-rich with increasing acidity of the host rock. This compositional trend is also characterized by a progressive increase in the alkali content of the amphibole, and hornblende grades into hastingsite, riebeckite, and arfvedsonite in granitic rocks. See GRANITE; GRANODIORITE; IGNEOUS ROCKS.

Due to its complex structure and chemistry, hornblende contains much information on its formation. Its behavior is understood reasonably well, and hornblende is of considerable use in interpreting the geological history of the rocks in which it occurs. See AMPHIBOLITE; METAMORPHISM. [F.C.Ha.]

**Hornfels** A metamorphic rock that has been subjected to heating during contact metamorphism around intrusive igneous rocks. Hornfels is typically fine-grained, although where it is subjected to high temperatures, large crystals called porphyroblasts can form. Mineral grains in hornfels are randomly oriented, with no preferred alignment of crystals to form foliation or cleavage planes. This texture indicates that the hornfels was not subjected to significant stresses during contact metamorphism.

Hornfels generally originates from sediments that undergo mineralogical changes, the nature of which depend on the magnitude of heating. The types of minerals that form are strongly dependent on the bulk composition. Minerals in hornfels formed from metamorphism of limestones, which are rich in calcium oxide (CaO), carbon dioxide (CO<sub>2</sub>), and various amounts of magnesium oxide (MgO), iron oxide (FeO), and aluminum oxide (Al<sub>2</sub>O<sub>3</sub>), include (from high to low temperature) forsterite, diopside, tremolite, talc, and brucite. Other minerals that may be present include wollastonite, vesuvianite, anorthite, and grossular garnet, depending on the bulk composition of the rock. See LIMESTONE.

Pelitic sediments are rich in chemical constituents such as silicon dioxide (SiO<sub>2</sub>), Al<sub>2</sub>O<sub>3</sub>, MgO, FeO, potassium oxide (K<sub>2</sub>O), and water (H<sub>2</sub>O), with relatively minor amounts of CaO, sodium oxide (Na<sub>2</sub>O), manganese oxide (MnO), and titanium dioxide (TiO<sub>2</sub>). Metamorphism of these sediments to form hornfels results in formation of minerals such as chlorite, muscovite, biotite, andalusite, sillimanite, cordierite, garnet, staurolite, and K-feldspar. At extremely high temperatures (>800°C or 1470°F) aluminum-rich minerals such as sapphirine, spinel, and corundum form. Deposits of emery, utilized for abrasives, are aluminum-rich hornfels that are products of high-temperature contact metamorphism. Chemical study of emeries indicates a general lack of alkali elements (K, Na, and Ca), which has been used to argue that they form as a result of extraction of a melt phase during high-temperature contact metamorphism. See EMERY.

During contact metamorphism, hornfels typically forms in the highest-temperature part of aureoles adjacent to the pluton. Further away from the pluton, metamorphism of sediments results in development of schists and phyllites. Around the pluton, low-grade chlorite-bearing slates are progressively metamorphosed, resulting in the systematic appearance from low to higher temperature of cordierite + biotite + muscovite phyllite to cordierite + K-feldspar + biotite hornfels. In hornfels of a slightly different composition, muscovite is preserved, resulting in a hornfels with the composition andalusite + K-feldspar + cordierite + biotite + muscovite. Adjacent to the contact with the pluton, these muscovite-bearing hornfels undergo partial melting, resulting in the segregation of K-feldspar + plagioclase + quartz from the metamorphosed sediment as a result of partial melting. See PLUTON; SLATE.

Metamorphic studies of hornfels provide an important avenue to documenting the temperature and, in particular, the pressure (that is, the depth) during emplacement of the intrusive igneous rock that provides the heat. See METAMORPHIC ROCKS; METAMORPHISM; MINERALOGY. [M.W.N.]

**Horology** Measurement of the time dimension. In practice, horology is the search for a steady or repetitive action, and the design of an instrument to perform that action and to indicate (read out) a measure of the action. Until early in the twentieth century, horology dealt with mechanical instruments, with effort distributed between improving accuracy and decreasing size of timepieces. Increasingly, however, electronic instruments provided means for meeting these objectives. See CHRONOMETER; CLOCK; QUARTZ CLOCK; TIME.

An advance in accurate measurement of time came by replacement of dynamic mechanical oscillators with quantum energy transitions. Two standards in common use are the cesium atomic beam clock and the rubidium gas cell. More recently, trapped ion clocks, which use quantum transitions in elements such as mercury, have been developed. A small cloud of ions is trapped in a quadrupole electric field. The ions' thermal motions are then reduced by a technique called laser cooling. The quantum transitions in these clouds can then be measured with high precision. See ATOMIC CLOCK; LASER COOLING; PARTICLE TRAP. [F.H.R.; D.C.Ba.]

Radio astronomers require precise time for two areas of experimentation: very long-baseline interferometry (VLBI) and pul-

sars. Both areas have the capability of providing precise time information. Very long-baseline interferometry involves multiplying samples of an incident electric field that are recorded independently at telescopes situated around the globe while being trained on the same object in the sky. Solar time, or Coordinated Universal Time (UTC), is offset from International Atomic Time (TAI) to allow for the variable rotation of the Earth. The most precise measurement of Earth rotation comes from VLBI measurements. Pulsars are highly magnetized and rapidly rotating neutron stars that emit intense beams of radio emission. Astronomers keep track of the rotations of these stars by referencing pulse arrival times to TAI, but not even the TAI time scale is sufficiently accurate because of the relativistic effects, gravitational redshift, and time dilation that result from the motion of the Earth. A new time scale, Terrestrial Time (TT), is derived from TAI without the relativistic effects. Timing measurements of the fastest pulsars, which rotate more than 600 times per second, are now as precise as the best Earth clocks over durations of a year or more. Time, which in prehistory was reckoned solely by astronomical events, has again become the province of astronomical observations. See ATOMIC TIME; DYNAMICAL TIME; PULSAR; RADIO ASTRONOMY; RADIO TELESCOPE; TIME. [D.C.Ba.]

**Horseradish** A hardy perennial crucifer, *Armoracia rusticana*, of eastern European origin belonging to the plant order Capparales. Horseradish is grown for its pungent roots, which are generally grated, mixed with vinegar and salt, and used as a condiment or relish. Production in the United States is limited to northern areas; Illinois, Wisconsin, and Missouri are important producing states. See CAPPARALES. [H.J.C.]

**Horst** A segment of the Earth's crust, generally long as compared to its width, that has been upthrown relative to the adjacent rocks (see illustration). Horsts range in size from those

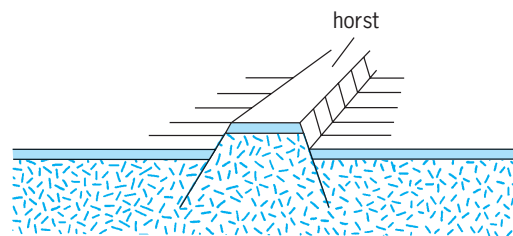

A simple horst with associated faults. (After A.K. Lobeck, *Geomorphology*, McGraw-Hill, 1939)

that have lengths and upward displacement of a few inches to those that are tens of miles long with upward displacements of thousands of feet. The faults bounding a horst on either side commonly have inclinations of 50–70° toward the down-thrown blocks, and the direction of movement on these displacements indicates that they are gravity faults. These relationships suggest that horsts develop in regions where the crust has undergone extension. They may form in the crests of anticlines or domes, or may be related to broad regional warpings. See FAULT AND FAULT STRUCTURES. [P.H.O.]

**Horticultural crops** Intensively managed plants cultivated for food or for esthetic purposes. Plant agriculture is divided traditionally into the fields of agronomy (herbaceous field crops, mainly grains, forages, oilseeds, and fiber crops), forestry (forest trees and products), and horticulture (garden crops, particularly fruits, vegetables, spices and herbs, and all plants grown for ornamental use). Most horticultural plants are utilized in the living state, with water essential to quality; thus most horticultural plants and products are highly perishable. See AGRICULTURAL SCIENCE (PLANT); AGRONOMY; FLORICULTURE; FOREST AND FORESTRY.

Horticultural crops are usually classified as edibles or ornamentals. Edible crops which are used for direct human

consumption are commonly subdivided into fruits or vegetables, but this classification is traditional and difficult to define precisely.

Fruit crops in the horticultural sense are cultivated for tissues associated with the botanical fruit, that is, seed-bearing structures derived from the flower, which are usually pulpy and tasteful. Trees or shrubs bearing nuts, characterized by a hard shell separated by a firm inner kernel (the seed), are often treated as a special category of fruit crops. *See* FRUIT; NUT CROP CULTURE.

Vegetable crops in the horticulture sense are commonly herbaceous plants grown as annuals or biennials and occasionally as perennials that have edible parts (including, confusingly, the botanical fruit). Examples of edible parts include the root (sweet potato), tuber (potato), young shoot (asparagus), leaf (spinach), flower buds (cauliflower), fruit (tomato), and seed (pea).

Plants grown for ornamental use, such as cut flowers, bedding plants, interior foliage plants, or landscape plants, represent an enormous group and include thousands of species. *See* ORNAMENTAL PLANTS. [J.J.]

**Hospital infections** Infections acquired during a hospital stay; also known as nosocomial infections. They may be recognized during or after hospitalization. They usually appear during hospitalization, but as many as 25% of infections related to surgery occur after discharge. Most nosocomial infections (93%) are caused by bacteria; fungi account for about 6%; and viruses, protozoa, and parasites account for the remaining 1%.

Nosocomial infections occur most frequently in the urinary tract, in surgical wounds, as a complication of pneumonia, and in association with bacteremia. *See* PNEUMONIA; SURGERY; URINARY TRACT DISORDERS.

Viral infections, although sometimes difficult to recognize, are becoming an increasing concern in hospitals, particularly because of the possibility of transmitting the human immunodeficiency virus (HIV), the causative organism for acquired immune deficiency syndrome (AIDS). Since the virus is not transmitted by the respiratory route or by casual contact, no one is endangered simply by being in the same hospital with HIV-infected patients. *See* ACQUIRED IMMUNE DEFICIENCY SYNDROME (AIDS); INFECTION; MEDICAL BACTERIOLOGY. [B.B.D.]

**Hot spots (geology)** The surface manifestations of plumes, that is, columns of hot material, that rise from deep in the Earth's mantle. Hot spots are widely distributed around the Earth. One of their characteristics is an abundance of volcanic activity which persists for long time periods (greater than 1 million years). When the lithosphere (the rigid outer layer of the Earth) moves over a plume, a chain of volcanoes is left behind that progressively increases in age along its length. Hot spots are believed to be fixed with respect to each other and the deep mantle so that the age and orientation of these chains provide information on the absolute motions of the tectonic plates. *See* LITHOSPHERE; PLATE TECTONICS.

The Hawaiian-Emperor seamount chain in the central Pacific Ocean is a good example of a volcanic chain that was generated at a hot spot. The 3400-mi-long (5700-km) chain is made up mainly of tholeiitic lavas and ash tuff and pumice deposits. The lavas may have evolved from an initial submarine shield-building stage, through an explosive stage as they build up to sea level, and finally to a subaerial post-erosional stage. *See* LAVA; SEAMOUNT AND GUYOT.

Not all hot-spot volcanism is expressed in terms of highly lined, multistage, volcanic chains. Aseismic ridges that extend up to or close to the axes of mid-oceanic ridges are another example of hot-spot volcanism. When a hot spot (for example, Iceland) is centered on the axis, pairs of ridges such as the Iceland-Faeroes Rise and the Greenland Rise are formed. Sometimes the plate (for example, Africa) has migrated off the hot spot (such as Tristan da Cunha), leaving behind ridge systems that no longer extend to the ridge axis (such as Rio Grande Rise and Western Walvis). *See* MID-OCEANIC RIDGE; VOLCANO; VOLCANOLOGY.

Another characteristic of hot spots is their association with broad swells in the Earth's topography. The Hawaiian hot-spot swell is believed to have been formed in response to either thermal or dynamic effects in an underlying mantle plume. The crustal and upper-mantle structure, which is constrained by seismic refraction data, shows that the oceanic crust is of uniform thickness beneath the swell. The long-wavelength correlation that is observed between the gravity anomaly and the topography (about 37 mGal mi<sup>-1</sup> or 22 mGal km<sup>-1</sup>) indicates that the mass excess of the swell is compensated by a low-density, high-temperature region below the crust. The uplift of hot-spot swells is believed to result from thermal perturbations in the underlying plume. The excess heights of swells suggest, on isostatic grounds, that temperature differences of about 450°F (250°C) occur between the plume and the surrounding mantle. Hot ascending plumes may raise the temperature of the overlying lithosphere, thereby thinning it.

Two classes of models have been proposed to explain hot-spot swells. In the reheating model, uplift is produced by thermal expansion that is confined to the conducting portion of the lithosphere (the thermal boundary layer). In the dynamic model, however, there is a contribution to the uplift that is produced by vertical normal stresses exerted to the seismically defined base of the lithosphere (the mechanical boundary layer) by convection.

The main distinguishing feature between the uplift models is that the reheating model predicts a higher heat flow than the dynamic model. Discrimination between these models therefore depends on how the subsidence history, heat flow, and long-term strength (which is controlled mainly by the temperature) differ from those for unperturbed lithosphere of the same age. [A.B.W.]

**Hot-water heating system** A heating system for a building in which the heat-conveying medium is hot water. A hot-water heating system consists essentially of water-heating or -cooling means and of heat-emitting means such as radiators, convectors, baseboard radiators, or panel coils. A piping system connects the heat source to the various heat-emitting units and includes a method of establishing circulation of the water or other medium and an expansion tank to hold the excess volume of water as it is heated and expands.

In a one-pipe system, radiation units are bypassed around a one-pipe loop. This type of system should only be used in small installations. In a two-pipe system (see illustration), radiation units are connected to separate flow and return mains, which may run in parallel or preferably on a reverse return loop, with no limit on the size of the system. In either type of system, circulation may be provided by gravity or pump.

One outstanding advantage of hot-water systems is the ability to vary the water temperature according to requirements imposed by outdoor weather conditions, with consequent savings in fuel. Radiation units may be above or below water heaters, and piping may run in any direction as long as air is eliminated.

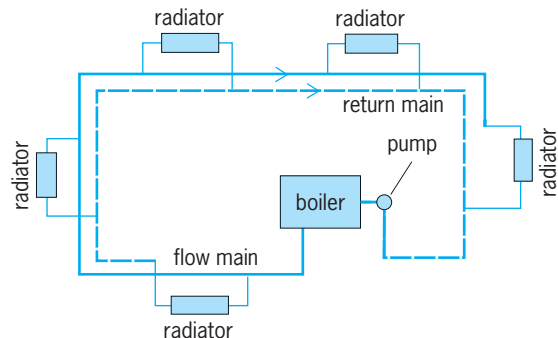

Two-pipe reverse return hot-water heating system.

Hot water is admirably adapted to extensive central heating where high temperatures and high pressures are used and also to low-temperature panel-heating and -cooling systems. See COMFORT HEATING; DISTRICT HEATING; OIL BURNER. [E.L.W.]

**Hubble constant** A number that characterizes the expansion rate of the universe and is required to determine its age. In the standard big bang model, the universe expands uniformly according to the Hubble law,  $v = H_0 d$ , where  $v$  is the velocity of a galaxy at a distance  $d$ , and  $H_0$  is the Hubble constant. The wavelength of radiation is stretched due to the expansion of space so that the spectra of objects become progressively redder at greater distances. (For nearby objects, the observed redshift can be described as a Doppler effect.) The constant is named after Edwin P. Hubble, who discovered that the velocity of recession of a galaxy is proportional to its distance. A reliable and accurate measurement of the Hubble constant, an independent estimate of the ages of the oldest objects in the universe, and a further measurement of the average density in the universe are all separately required in order to test and ultimately provide strong constraints on cosmological models. See DOPPLER EFFECT; REDSHIFT.

Measurement of the Hubble constant is extraordinarily difficult in practice. First, measuring distances has turned out to be immensely challenging. Second, while the velocities can be measured very simply and accurately (from measurements of the positions of spectral lines in galaxies), they are perturbed by the gravitational interactions of galaxies with the neighbors (including what are referred to as peculiar motions superimposed on the general expansion). Hence, an extragalactic distance scale must be established at distances great enough that peculiar motions of galaxies are small compared to the overall cosmic expansion velocity, the Hubble flow. See ASTRONOMICAL SPECTROSCOPY.

In general, the basis for estimating distances in astronomy is the inverse-square radiation law. If objects can be identified whose luminosities are either constant (standard candles), or perhaps related to a quantity that is independent of distance (for example, period of oscillation, rotation rate, velocity dispersion, or color), then, given an absolute calibration, their distances can be gauged.

Primary among the distance indicators are the Cepheid variables, stars whose outer atmospheres pulsate regularly with periods ranging from 2 to about 100 days. Empirically it has been established that the period of pulsation (a quantity independent of distance) is very well correlated with the intrinsic luminosity of the star. High resolution is the key to discovering Cepheids in other galaxies. The resolution of the Hubble Space Telescope is about 10 times better than can be generally obtained through the Earth's atmosphere, and, moreover, it is stable. The reach of Cepheid variables as distance indicators is limited, however, even with the Hubble Space Telescope. For distances beyond 20 megaparsecs or so (1 Mpc =  $3.08 \times 10^{22}$  m =  $3.26 \times 10^6$  light-years), brighter objects than ordinary stars are required, for example, luminous supernovae or the luminosities of entire galaxies. The Cepheid distances from the Hubble Space Telescope Key Project have provided a means of calibrating and comparing a number of relative distance methods, and, to within an uncertainty of  $\pm 10\%$ , all of these methods are consistent with a value of the Hubble constant of about 72 kilometers per second per megaparsec.

The Hubble constant sets the expansion time scale for the universe. In order to measure the time since the big bang, it is necessary to determine the expansion rate, and the average matter-plus-energy density of the universe. Increasing evidence suggests that the total matter density of the universe is about 20–30% of the critical density. (Below a critical density the universe will expand forever, whereas above the critical density the universe will recollapse.) The theory of inflation provides a strong theoretical motivation for a critical-density universe; however, if the mass density is only 20–30% of critical, as observations

suggest, then inflation would require a missing energy component to bring the total energy density up to the critical density. Measurements of type Ia supernovae provide evidence for such a missing energy component, called the cosmological constant. See BIG BANG THEORY; COSMOLOGY; INFLATIONARY UNIVERSE COSMOLOGY; UNIVERSE. [W.L.F.]

**Huebnerite** A mineral with the chemical composition  $MnWO_4$ . Huebnerite is the manganese member of the wolframite solid-solution series. It commonly contains small amounts of iron. It occurs in monoclinic, short, prismatic crystals. Fracture is uneven. Luster varies from adamantine to resinous. Hardness is 4 on Mohs scale and specific gravity is 7.2. Huebnerite is transparent and yellowish to reddish-brown in color; streak is brown. See WOLFRAMITE. [E.C.T.C.]

**Human-computer interaction** An interdisciplinary field focused on the interactions between human users and computer systems, including the user interface and the underlying processes which produce the interactions. The contributing disciplines include computer science, cognitive science, human factors, software engineering, management science, psychology, sociology, and anthropology. Early research and development in human-computer interaction focused on issues directly related to the user interface. Some typical issues were the properties of various input and output devices, interface learnability for new users versus efficiency and extensibility for experienced users, and the appropriate combination of interaction components such as command languages, menus, and graphical user interfaces (GUI). Recently, the field of human-computer interaction has broadened and become more attentive to the processes and context for the user interface. The focus of research and development is now on understanding the relationships among users' goals and objectives, their personal capabilities, the social environment, and the designed artifacts with which they interact. As an applied field, human-computer interaction is also concerned with the development process used to create the interactive system and its value for the human user.

The interfaces and processes that make up human-computer interaction are understood and advanced through a variety of methods. At one level, this interaction can be characterized by the capabilities and processes of the human and the computer to accept input, process that input, and generate output. The computer capabilities include the hardware (input and output devices) such as the monitor, mouse, keyboard, and Internet connection. These devices reflect contributions from computer science and engineering, whereas the human capabilities, both mental and physical, are understood through cognitive science and ergonomics. At another level, the interaction between the computer and the human consists of user interface software which governs the meanings of the inputs and outputs for the computer, as well as the corresponding rules and expectations that the user applies to generate meaningful actions. The user's internal model of the interaction is supported by visual cues in the interface and designed in accordance with principles of human factors. At a higher level, this interaction includes the context of goals, motivations, and other people and resources that determine what the person is doing. Understanding the process at this level requires insights from social and organizational sciences. See HUMAN-FACTORS ENGINEERING.

Advances in computer science have significantly increased the processing power of computers while decreasing their size. These advances have provided the underlying technology for creating a wider variety of human-computer interactions. For example, streaming audio and video over the Internet, now common, would not be possible without the increased processing power and network connectivity of computers. These technological developments were influenced by the discovery of useful applications in human-computer interaction. Increasingly sophisticated software has become available to address input through natural

speech and immersive environments, providing a virtual reality experience. See VIRTUAL REALITY.

Developing human-computer interactions involves design on both sides of the interaction. On the technology side, the designer must have a thorough understanding of the available hardware and software components and tools. On the human side, the designer must have a good understanding of how humans learn and work with computers, including envisioning new modes of working. The designer's task is to create effective, efficient, and satisfying interactions by balancing factors such as cost, benefits, standards, and the environmental constraints in which the interaction will take place.

Modern prototyping tools allow for the use of an iterative development model where a representative portion of the interface is designed and implemented with each iteration. Feedback from testers is used to enhance the design with each iteration. The final design consists of many elements: the resulting artifacts for use by the target population, as well as supporting elements such as an analysis of needs and tasks, descriptions of the dialog rules and users' conceptual models, expected scenarios of use, and the designer's rationale and reflections from the development process. [T.Ca.; K.Ha.]

**Human ecology** The study of how the distributions and numbers of humans are determined by interactions with conspecific individuals, with members of other species, and with the abiotic environment. Human ecology encompasses both the responses of humans to, and the effects of humans on, the environment. Human ecology today is the combined result of humans' evolutionary nature and cultural developments. See BIOSPHERE; ECOLOGICAL COMMUNITIES; ECOSYSTEM.

Humans' strong positive and negative emotional responses to components of the environment evolved because our ancestors' responses to environmental information affected survival and reproductive success. Early humans needed to interpret signals from other organisms and the abiotic environment, and they needed to evaluate and select habitats and the resources there. These choices were emotionally driven. For example, food is one of the most important resources provided by the environment. Gathering food requires decisions of where to forage and what items to select. Anthropologists often use the theory of optimal foraging to interpret how these decisions are made. The theory postulates that as long as foragers have other valuable ways to spend their time or there are risks associated with seeking food, efficient foraging will be favored even when food is not scarce. This approach has facilitated development of simple foraging models and more elaborate models of food sharing and gender division of labor, symbolic communication, long-term subsistence change, and cross-cultural variation in subsistence practices.

Significant modification of the environment by people was initiated by the domestication of fire, used to change vegetation structure and influence populations of food plants and animals. Vegetation burning is still common in the world, particularly in tropic regions. The arrival of humans with sophisticated tools precipitated the next major transformation of Earth, the extinction of large vertebrates. Agriculture drove the third major human modification of environments. Today about 35–40% of terrestrial primary production is appropriated by people, and the percentage is rising.

Humans will continue to exert powerful influences on the functioning of the Earth's ecological systems. The human population is destined to increase for many years. Rising affluence will be accompanied by increased consumption of resources and, hence, greater appropriation of the Earth's primary production. Nevertheless, many future human ecology scenarios are possible, depending on how much the human population grows and how growth is accommodated, the efficiency with which humans use and recycle resources, and the value that people give to preserva-

tion of biodiversity. See ANTHROPOLOGY; ECOLOGY; ENVIRONMENT; SOCIOBIOLOGY. [G.H.O.]

**Human-factors engineering** The application of experimental findings in behavioral science and physiology to the design and operation of technical systems in which humans are users or operators. This includes design of hardware, software, training, and documentation as well as manufacturing and maintenance. Human-factors professionals are trained in some combination of experimental or cognitive psychology, physiology, and engineering—typically industrial, mechanical, electrical, or software engineering. Human-factors engineering seeks to ensure that humans' tools and environment are best matched to their physical size, strength, and speed and to the capabilities of the senses, memory, cognitive skill, and psychomotor preferences. These objectives are in contrast to forcing humans to conform or adapt to the physical environment.

Human-factors engineering has also been termed human factors, human engineering, engineering psychology, applied experimental psychology, ergonomics, and biotechnology. It is related to the field of human-machine systems engineering but is more general, comprehensive, and empirical and not so wedded to formal mathematical models and physical analysis. See HUMAN-MACHINE SYSTEMS.

Among the problems of human-factors engineering are design of visual displays for ease and speed of interpretation; design of tonal signaling systems and voice communication systems for accuracy of communication; design of seats, workplaces, cockpits, and consoles in terms of humans' physical size, comfort, strength, and visibility. Human-factors engineering addresses problems of physiological stresses arising from such environmental factors as heat and cold, humidity, high and low atmospheric pressure, vibration and acceleration, radiation and toxicity, illumination or lack of it, and acoustic noise. Finally, the field includes psychological stresses of work speed and load and problems of memory, perception, decision making, and fatigue.

A fundamental problem of ever-increasing importance for human-factors engineers is what tasks should be assigned to people and what to machines. It is a fallacy to think that any given whole task can be accomplished best either by a human or by a machine without the aid of the other, because often some elements of both provide a mixture superior to either alone. Machines are superior in speed and power; are more reliable for routine tasks, being free of boredom and fatigue; can perform computations at higher rates; and can store and recall specific quantitative facts from memory faster and more dependably. Humans, by contrast, have remarkable sensory capacities which are difficult to duplicate in range, size, and power with artificial instruments (the ratio of the greatest to the least energy which people can either see or hear is about  $10^{13}$ ). Humans' ability to perceive patterns, make relevant associations in memory, and induce new generalizations from empirical data remains far superior to that of any computer existing or planned. Thus, while people's overt information-processing rate in simple skills is low, their information-processing rate for these pattern recognition and inductive-reasoning capabilities (of which little is understood) appears far greater. [T.B.S.]

In cognitive engineering, one of the major issues in human-factors engineering is the concern that modern sophisticated hardware and software technology may be too complex for the people who will eventually use it. Requiring people to perform difficult or cognitively complex tasks is perhaps the leading cause of human-machine errors or accidents. Tasks can be cognitively difficult for a number of reasons. The number of steps required to use the system may exceed people's memory limitations, the user may be required to divide his or her attention between several different sources of information, or the person may be required to perform difficult mental operations. All of these factors

burden an individual's cognitive capacity and, if that capacity is exceeded, errors may occur.

Two major trends have led to increased emphasis on the cognitive complexity of human-machine systems. One of these is the move toward larger and more complex systems where human error can have serious consequences for the systems' users and the general public. The other trend is the rapid development of modern information technology based upon powerful yet inexpensive microcomputers.

An important aspect in addressing this problem is the early identification and control of the cognitive complexity or mental difficulty of performing a task required of the new technology application. The best procedure (in terms of cost and effectiveness) for addressing this problem is to use cognitive analysis to develop specifications or guidelines that can be used during the initial design technology application. Through such design guidance, human cognitive limitations are controlled early in the technology application design when it is easiest and most cost-effective to make changes. If the technology application has developed to the point where design guides would no longer be useful (for example, much design work has already been completed), an alternative approach is to use cognitive engineering to evaluate the design as it exists. The results of the cognitive analysis will indicate which aspects of the design may be too difficult for people to perform and could lead to human-machine errors. The final use of cognitive engineering analysis is in preparing training materials. Cognitive analyses can identify the aspects of a person-machine interface that will be most difficult for people to perform. These aspects can then be given special training aids or more intensive hands-on training in order to reduce the potential of human-machine error. [P.G.Ro.]

**Human genetics** A discipline concerned with genetically determined resemblances and differences among human beings. Technological advances in the visualization of human chromosomes have shown that abnormalities of chromosome number or structure are surprisingly common and of many different kinds, and that they account for birth defects or mental impairment in many individuals as well as for numerous early spontaneous abortions. Progress in molecular biology has clarified the molecular structure of chromosomes and their constituent genes and the ways in which change in the molecular structure of a gene can lead to a disease. Concern about possible genetic damage through environmental agents and the possible harmful effects of hazardous substances in the environment on prenatal development has also stimulated research in human genetics. The medical aspects of human genetics have become prominent as nonhereditary causes of ill health or early death, such as infectious disease or nutritional deficiency, have declined, at least in developed countries.

In normal humans, the nucleus of each normal cell contains 46 chromosomes, which comprise 23 different pairs. Of each chromosome pair, one is paternal and the other maternal in origin. In turn, only one member of each pair is handed on through the reproductive cell (egg or sperm) to each child. Thus, each egg or sperm has only 23 chromosomes, the haploid number; fusion of egg and sperm at fertilization will restore the double, or diploid, chromosome number of 46. See CHROMOSOME; FERTILIZATION.

The segregation of chromosome pairs during meiosis allows for a large amount of "shuffling" of genetic material as it is passed down the generation. Two parents can provide  $2^{23} \times 2^{23}$  different chromosome combinations. This enormous source of variation is multiplied still further by the mechanism of crossing over, in which homologous chromosomes exchange segments during meiosis. See CROSSING-OVER (GENETICS); MEIOSIS.

Twenty-two of the 23 chromosome pairs, the autosomes, are alike in both sexes; the other pair comprises the sex chromosomes. A female has a pair of X chromosomes; a male has a single X, paired with a Y chromosome which he has inherited

from his father and will transmit to each of his sons. Sex is determined at fertilization, and depends on whether the egg (which has a single X chromosome) is fertilized by an X-bearing or a Y-bearing sperm. See SEX DETERMINATION.

Any gene occupies a specific chromosomal position, or locus. The alternative genes at a particular locus are said to be alleles. If a pair of alleles are identical, the individual is homozygous; if they are different, the individual is heterozygous. See ALLELE.

Genetic variation has its origin in mutation. The term is usually applied to stable changes in DNA that alter the genetic code and thus lead to synthesis of an altered protein. The genetically significant mutations occur in reproductive cells and can therefore be transmitted to future generations. Natural selection acts upon the genetic diversity generated by mutation to preserve beneficial mutations and eliminate deleterious ones.

A very large amount of genetic variation exists in the human population. Everyone carries many mutations, some newly acquired but others inherited through innumerable generations. Though the exact number is unknown, it is likely that everyone is heterozygous at numerous loci, perhaps as many as 20%. See MUTATION.

The patterns of inheritance of characteristics determined by single genes or gene pairs depend on two conditions: (1) whether the gene concerned is on an autosome (autosomal) or on the X chromosome (X-linked); (2) whether the gene is dominant, that is, expressed in heterozygotes (when it is present on only one member of a chromosomal pair and has a normal allele) or is recessive (expressed only in homozygotes, when it is present at both chromosomes). See DOMINANCE. [M.W.T.]

A quantitative trait is one that is under the control of many factors, both genetic and environmental, each of which contributes only a small amount to the total variability of the trait. The phenotype may show continuous variation (for example, height and skin color), quasicontinuous variation (taking only integer values—such as the number of ridges in a fingerprint), or it may be discontinuous (a presence/absence trait, such as diabetes or mental retardation). With discontinuous traits, it is assumed that there exists an underlying continuous variable and that individuals having a value of this variable above (or below) a threshold possess the trait.

A trait that "runs in families" is said to be familial. However, not all familial traits are hereditary because relatives tend to share common environments as well as common genes.

The variability of almost any trait is partly genetic and partly environmental. A rough measure of the relative importance of heredity and environment is an index called heritability. For example, in humans, the heritability of height is about 0.75. That is, about 75% of the total variance in height is due to variability in genes that affect height and 25% is due to exposure to different environments. [C.De.]

**Hereditary diseases.** Medical genetics has become an integral part of preventive medicine (that is, genetic counseling, including prenatal diagnostics). Hereditary diseases may be subdivided into three classes: chromosomal diseases; hereditary diseases with simple, mendelian modes of inheritance; and multifactorial diseases.

One out of 200 newborns suffers from an abnormality that is caused by a microscopically visible deviation in the number or structure of chromosomes. The most important clinical abnormality is Down syndrome—a condition due to trisomy of chromosome 21, one of the smallest human chromosomes. This chromosome is present not twice but three times; the entire chromosome complement therefore comprises 47, not 46, chromosomes. Down syndrome occurs one to two times in every 1000 births; its pattern of abnormalities derives from an imbalance of gene action during embryonic development. Down syndrome is a good example of a characteristic pattern of abnormalities that is produced by a single genetic defect. See DOWN SYNDROME.

Other autosomal aberrations observed in living newborns that lead to characteristic syndromes include trisomies 13 and 18



(both very rare), and a variety of structural aberrations such as translocations (exchanges of chromosomal segments between different chromosomes) and deletions (losses of chromosome segments). Translocations normally have no influence on the health status of the individual if there is no gain or loss of chromosomal material (these are called balanced translocations). However, carriers of balanced translocations usually run a high risk of having children in whom the same translocation causes gain or loss of genetic material, and who suffer from a characteristic malformation syndrome.

Clinical syndromes caused by specific aberrations vary, but certain clinical signs are common: low birth weights (small for date); a peculiar face; delayed general, and especially mental, development, often leading to severe mental deficiency; and multiple malformations, including abnormal development of limbs, heart, and kidneys. See CONGENITAL ANOMALIES.

Less severe signs than those caused by autosomal aberrations are found in individuals with abnormalities in number (and, sometimes, structure) of sex chromosomes. This is because in individuals having more than one X chromosome, the additional X chromosomes are inactivated early in pregnancy. For example, in women, one of the two X chromosomes is always inactivated. Inactivation occurs at random so that every normal woman is a mosaic of cells in which either one or the other X chromosome is active. Additional X chromosomes that an individual may have received will also be inactivated; in trisomies, genetic imbalance is thus avoided to a certain degree. However, inactivation is not complete; therefore, individuals with trisomies—for example, XXY (Klinefelter syndrome), XXX (triple-X syndrome), or XYY—or monosomies (XO; Turner syndrome) often show abnormal sexual development, intelligence, or behavior.

In contrast to chromosomal aberrations, the genetic defects in hereditary diseases with simple, mendelian modes of inheritance cannot be recognized by microscopic examination; as a rule, they must be inferred more indirectly from the phenotype and the pattern of inheritance in pedigrees. The defects are found in the molecular structure of the DNA. Often, one base pair only is altered, although sometimes more complex molecular changes, such as deletions of some bases or abnormal recombination, are involved. Approximately 1% of all newborns have, or will develop during their lives, a hereditary disease showing a simple mendelian mode of inheritance.

In medical genetics, a condition is called dominant if the heterozygotes deviate in a clearly recognizable way from the normal homozygotes, in most cases by showing an abnormality. Since such dominant mutations are usually rare, almost no homozygotes are observed.

In some dominant conditions, the harmful phenotype may not be expressed in a gene carrier (this is called incomplete penetrance), or clinical signs may vary in severeness between carriers (called variable expressivity). Penetrance and expressivity may be influenced by other genetic factors; sometimes, for example, by the sex of the affected person, whereas in other instances, the constitution of the “normal” allele has been implicated. Environmental conditions may occasionally be important. In most cases, however, the reasons are unknown.

X-linked modes of inheritance occur when the mutant allele is located on the X chromosome. The most important X-linked mode of inheritance is the recessive one. Here, the males (referred to as hemizygotes since they have only one allele) are affected, since they have no normal allele. The female heterozygotes, on the other hand, will be unaffected, since the one normal allele is sufficient for maintaining function. A classical example is hemophilia A, in which one of the serum factors necessary for normal blood clotting is inactive or lacking. (The disease can now be controlled by repeated substitution of the deficient blood factor—a good example for phenotypic therapy of a hereditary disease by substitution of a deficient gene product.) Male family members are affected whereas their sisters and daughters, while being unaffected themselves, transmit the mutant gene to half their sons. Only in very rare instances, when a hemophilic pa-

tient marries a heterozygous carrier, are homozygous females observed. See SEX-LINKED INHERITANCE.

There are thousands of hereditary diseases with simple mendelian modes of inheritance, but most common anomalies and diseases are influenced by genetic variability at more than one gene locus. Most congenital malformations, such as congenital heart disease, cleft lip and palate, neural tube defects and many others, fall into this category, as do the constitutional diseases, such as diabetes mellitus, coronary heart disease, anomalies of the immune response and many mental diseases, such as schizophrenia or affective disorders. All of these conditions are common and often increase in frequency with advanced age.

[F.V.]

**Biochemical genetics.** Biochemical genetics began with the study of inborn errors of metabolism. These are diseases of the body chemistry in which a small molecule such as a sugar or amino acid accumulates in body fluids because an enzyme responsible for its metabolic breakdown is deficient. This molecular defect is the result of mutation in the gene coding for the enzyme protein. The accumulated molecule, dependent on its nature, is responsible for the causation of a highly specific pattern of disease.

The field of biochemical genetics expanded with the recognition that similar heritable defective enzymes interfere with the breakdown of very large molecules, such as mucopolysaccharides and the complex lipids that are such prominent components of brain substance. The resultant storage disorders present with extreme alterations in morphology and bony structure and with neurodegenerative disease.

The majority of hereditary disorders of metabolism are inherited in an autosomal recessive fashion. In these families, each parent carries a single mutant gene on one chromosome and a normal gene on the other. Most of these mutations are rare. In populations with genetic diversity, most affected individuals carry two different mutations in the same gene. Some metabolic diseases are coded for by genes on the X chromosome. Most of these disorders are fully recessive, and so affected individuals are all males, while females carrying the gene are clinically normal. The disorders that result from mutations in the mitochondrial genome are inherited in nonmendelian fashion because mitochondrial DNA is inherited only from the mother. Those that carry a mutation are heteroplasmic; that is, each carries a mixed population of mitochondria, some with the mutation and some without.

Phenylketonuria (PKU) is a prototypic biochemical genetic disorder. It is an autosomally recessive disorder in which mutations demonstrated in a sizable number of families lead, when present in the genes on both chromosomes, to defective activity of the enzyme that catalyzes the first step in the metabolism of phenylalanine. This results in accumulation of phenylalanine and a recognizable clinical disease whose most prominent feature is severe retardation of mental development. See PHENYLKETONURIA.

The diseases that result from mutation in mitochondrial DNA have been recognized as such only since the 1990s. They result from point mutations, deletions, and other rearrangements. A majority of these disorders express themselves chemically in elevated concentrations of lactic acid in the blood or cerebrospinal fluid. Many of the disorders are known as mitochondrial myopathies (diseases of muscles) because skeletal myopathy or cardiomyopathy are characteristic features. [W.L.Ny.]

**Human Genome Project** An organized international scientific endeavor to determine the complete structure of the human genetic material deoxyribonucleic acid (DNA) and understand its function. See HUMAN GENETICS.

**History.** The idea for the Human Genome Project (HGP) first arose in the mid-1980s. Several scientific groups met to discuss the feasibility, and various reports were published. The most influential report was prepared by the National Research Council

(NRC) of the U.S. National Academy of Sciences. It proposed a detailed scientific strategy that persuaded many scientists that the project was possible. October 1, 1990, was declared the official start time for the HGP in the United States; significant funding had become available and research groups were starting their work. Major contributions to the HGP have been made by the United Kingdom, France, Japan, and Germany, with smaller contributions from many other quarters. Coordination among the countries has been informal, relying largely on scientist-to-scientist collaborations, but has proved to be very effective.

**Scientific strategy.** First, markers are placed on the chromosomes by genetic mapping, that is, observing how the markers are inherited in families. Second, a physical map is created from overlapping cloned pieces of the DNA. Third, the sequence of each piece is determined, and the sequences are lined up by computer until a continuous sequence along the whole chromosome is obtained. The second and third steps can be reversed or done in parallel. As the pieces are sequenced, the sequences at the overlapping ends can be used to help order the pieces. If the sequencing is done before the pieces are mapped, the process is called whole-genome shotgun sequencing. See DEOXYRIBONUCLEIC ACID (DNA); GENE.

Because the human genome is so big (human DNA consists of about 3 billion nucleotides connected end to end in a linear array), it was necessary to break the task down into manageable chunks (see illustration).

**Model organisms.** An important element of the overall strategy was to include the study of model organisms in the HGP. There were two reasons for this: (1) Simpler organisms provide good practice material. (2) Comparisons between model organisms and humans yield very valuable scientific information. The HGP initially adopted five model organisms to have their DNA sequenced: the bacterium *Escherichia coli*, the yeast *Saccharomyces cerevisiae*, the roundworm *Caenorhabditis elegans*, the fruitfly *Drosophila melanogaster*, and the laboratory mouse *Mus musculus*. The mouse genome is just as complex as the human genome, but the mouse offers the advantages that it can be bred and other experiments can be conducted that are not possible on humans.

**Findings.** How many genes are there is probably the most common question regarding the human genome. The first two human chromosomes to be sequenced, chromosomes 22 and 21, provided some interesting observations. Although the two chromosomes are approximately the same length, chromosome 22 has more than twice as many genes as chromosome 21. Extrapolation of the number of genes found on chromosomes 22 and 21 led to the estimate that the whole human genome contains about 36,000 genes. This is quite a surprise because previous estimates were 80,000 to 100,000 genes. Preliminary examination of the draft sequence of the entire human genome

confirmed that the number of genes is much lower than previously thought. This does not necessarily mean that the human genome is less complex, because many genes can produce more than one protein by alternate splicing of their exons (protein-encoding regions of the gene) during translation into the constituents of proteins. See CHROMOSOME; GENETIC CODE.

Another fascinating feature of the human genome sequence is the large fraction that consists of repeated sequence elements; 40% of chromosome 21 and 42% of chromosome 22 are composed of repeats. The function of any of these repeats is not yet known, but elucidating their distribution in the genome may help to reveal it.

Another statistic that is of interest is the base composition, the percent of the DNA that is made of guanine-cytosine (GC) base pairs as opposed to adenine-thymine (AT) base pairs. Chromosome 22 has a 48% GC content, whereas chromosome 21 has 41% and the average over the genome is 42%. Again, the significance of this is not yet known, but higher GC content seems to correlate with higher gene density.

The type of analysis performed initially on chromosomes 21 and 22 has been extended to the entire human sequence. However, a full understanding will take decades to achieve.

**Future research.** With the complete sets of genes of organisms available, how genes are turned on and off and how genes interact with each other can be studied. What the different genes do and how they affect human health must also be learned. Consequently, much effort is now directed to studying the regulation of gene expression and annotating the sequence with useful biological information about function.

Another key challenge is to understand how DNA function varies with differences in the DNA sequence. Each human being has a unique DNA sequence which differs from that of any other human being by about 0.1%, regardless of ethnic origin. Yet this small difference affects characteristics such as how humans look and to what diseases they are susceptible. The differences also provide clues about the evolution of the human species and the historical migration patterns of people across the world. See MOLECULAR BIOLOGY; NUCLEIC ACID. [F.Co.; E.Jor.]

**Human-machine systems** Complex systems that comprise both humans and machines. Human-machine systems engineering is the analysis, modeling, and design of such systems. It is distinguished from the more general field of human factors and from the related fields of human-computer interaction, engineering psychology, and sociotechnical systems theory in three general ways. First, human-machine systems engineering focuses on large, complex, dynamic control systems that often are partially automated (such as flying an airplane, monitoring a nuclear power plant, or supervising a flexible manufacturing system). Second, human-machine systems engineers build quantitative or computational models of the human-machine interaction as tools for analysis and frameworks for design. Finally, human-machine systems engineers study human problem-solving in naturalistic settings or in high-fidelity simulation environments. See HUMAN-COMPUTER INTERACTION; HUMAN-FACTORS ENGINEERING.

Thus, human-machine systems engineering focuses on the unique challenges associated with designing joint technological and human systems. Historically it has grown out of work on cybernetics, control engineering, information and communication theory, and engineering psychology. Subsequently, researchers who focus on cognitive human-machine systems (in which human work is primarily cognitive rather than manual) have also referred to their specialization as cognitive engineering or cognitive systems engineering. See CYBERNETICS; INFORMATION THEORY.

The four major aspects of human-machine systems, in roughly historical order, are systems in which the human acts as a manual controller, systems in which the human acts as a supervisory controller, human interaction with artificial-intelligence systems, and human teams in complex systems. This general progression

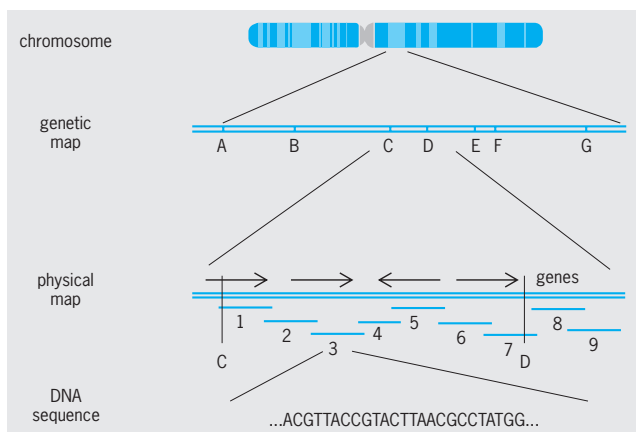

Steps in analyzing a genome.

is related to advances in computer and automation technology. With the increasing sophistication and complexity of such technology, the human role has shifted from direct manual control to supervisory control of physical processes, to supervision of intelligent systems, and finally, with an increasing emphasis on the social and organizational aspects of complex systems, to teamwork in complex environments.

Aviation is an example of a human-machine system in which all of these developments have occurred. Early work in aircraft systems focused on manual control models of pilot performance. With increasing levels of automation, the pilot shifted to a more supervisory role in which tasks such as planning and programming the flight management computer became the predominant form of work. See AIRCRAFT INSTRUMENTATION; AUTOPILOT; FLIGHT CONTROLS. [P.M.J.]

**Human variation** Attempting to describe and explain the manner in which people differ from one another constitutes one of the traditionally central research questions in anthropology. This also affords a classic illustration of the manner in which humans interpret the world by imposing patterns upon it, and of the social functions of science.

The first to suggest that the human species might actually be divisible into a small number of natural groups was a French traveler and physician, Francois Bernier, in 1684. He proposed dividing the human species into the peoples of Europe, North Africa, India, and the Near East; the peoples of sub-Saharan Africa; the people of east Asia; the Lapps (Saami) of Scandinavia; and the Hottentots (Khoi) of southern Africa. The apparent naturalness of this system was so powerful that the father of biological classification, Carolus Linnaeus, formally incorporated it into his *System of Nature* in the eighteenth century. Here, four landmasses became eponymous homes to four formally designated subspecies of humans: red Americans, yellow Asians, white Europeans, and black Africans. Subsequent studies attempted to fine-tune the classification, observing the distinctive physical features of many different peoples, but still failing to question the fundamental assumption that there were indeed a small number of basic types of people to be identified and classified. See TAXONOMY.

Not until the advent of genetic data did the racial paradigm begin to be seriously questioned. It was shown that the vast bulk of the genetic differences in the human species occurred within and between local populations, the differences between continental regions accounting for only about 6% of the total. Thus, racial (continental) differences were found to be quantitatively trivial.

Genetic variation appears to be patterned in two principal ways. Ubiquitous polymorphisms, like the ABO blood group, constitute the majority of detectable genetic variation, where most populations contain most alleles. Private polymorphisms constitute another component of human variation, in which a particular variant is found mostly in a restricted region of the world. Even then, it will be found only in low frequency. See GENE; HUMAN GENETICS.

In the twenty-first century the study of race has been superseded by studies of human variation and ethnicity, reflecting two significant discoveries. First, race (that is, contrasts among the most biologically divergent peoples) amounts to little in the overall biological variation in the human species. Second, "racial" issues transcend biology; they are issues of equality, rights, opportunities, and prejudices.

However, several biological generalizations can be made. First, the continuity found across human populations in nature is precisely what should be expected from microevolutionary processes operating. Second, some differences among populations are adaptations, molded by the action of natural selection on the gene pool. Third, the most divergent peoples are simply the most adapted to different circumstances—not the most primordial. Fourth, specific populations are not reliable as represen-

tatives of large continents. Finally, the observation of consistent differences between populations is not a sufficient basis on which to infer that those differences are innate. It is nearly impossible to control all the relevant social, economic, and developmental variables and to study simply innate biological differences between populations. See PHYSICAL ANTHROPOLOGY; SOCIOBIOLOGY. [J.M.]

**Humidification** The process of increasing the water-vapor content (humidity) of a gas. This process and its reverse operation, dehumidification, are important steps in air conditioning for human comfort and in many industrial operations. See AIR CONDITIONING; COMFORT HEATING; DEHUMIDIFIER; HUMIDITY.

Air (or other gas) can be humidified by direct injection of water vapor (steam) or, more commonly, by the evaporation of liquid water in contact with the airstream. When evaporation occurs, heat is required to provide the latent heat of vaporization. If no external source of heat is provided, either the water or the air, or both, will be cooled. The cooling of water by this process is the basis of operation for industrial cooling towers, whereas evaporative air coolers often used in hot, dry climates depend upon the air-cooling effect. In both these types of apparatus, humidification of the air occurs, although it is not the prime objective of the operation. In units designed primarily for humidification, the incoming air is usually heated to provide the latent heat of evaporation and to permit the air to leave the unit at controlled levels of both temperature and humidity. See COOLING TOWER. [A.L.K.]

**Humidistat** A controller that measures and controls relative humidity. A humidistat may be used to control either humidifying or dehumidifying equipment by the regulation of electric or pneumatic switches, valves, or dampers. Most methods for measuring humidity rely upon the swelling and shrinking of materials, such as human hair, silk, horn, goldbeater's skin, and wood, with increases and decreases in relative humidity.

An electronic humidistat includes a sensing element and a relay amplifier. The sensing element consists of alternate metal conductors on a small, flat plate with a plastic coating. An increase or decrease of the relative humidity causes a decrease or increase in the electrical resistance between the two sets of conductors; the change in resistance is measured by the relay amplifier. See HUMIDITY; PSYCHROMETRICS. [J.E.H./R.L.K.]

**Humidity** Atmospheric water-vapor content, expressed in any of several measures, especially relative humidity, absolute humidity, humidity mixing ratio, and specific humidity.

Relative humidity is the ratio, in percent, of the moisture actually in the air to the moisture it would hold if it were saturated at the same temperature and pressure. It is a useful index of dryness or dampness for determining evaporation, or absorption of moisture. See PSYCHROMETRICS.

Absolute humidity is the weight of water vapor in a unit volume of air expressed, for example, as grams per cubic meter or grains per cubic foot.

Humidity mixing ratio is the weight of water vapor mixed with unit mass of dry air, usually expressed as grams per kilogram. Specific humidity is the weight per unit mass of moist air and has nearly the same values as mixing ratio. [J.R.F.]

**Humidity control** Regulation of the degree of saturation (relative humidity) or quantity (absolute humidity) of water vapor in a mixture of air and water vapor. Humidity is commonly mistaken as a quality of air. See HUMIDITY.

When the mixture of air and water vapor is heated at constant pressure, not in the presence of water or ice, the ratio of vapor pressure to saturation pressure decreases; that is, the relative humidity falls, but absolute humidity remains the same. If the warm mixture is brought in contact with water in an insulated system, adiabatic humidification takes place; the warm

gases and the bulk of the water are cooled as heat is transferred to that portion of the water which evaporates, until the water vapor reaches its saturation pressure corresponding to the resultant water-air-vapor mixture temperature. Relative humidity is then 100% and absolute humidity has increased. Heating of the mixture and use of the heated mixture to evaporate water is typical of many industrial drying processes, as well as such common domestic applications as hair drying. This same sequence occurs when warm furnace air is passed over wetted, porous surfaces to humidify air for comfort conditioning. See AIR CONDITIONING.

To remove moisture from the air-vapor mixture, the mixture is commonly cooled to the required dew point temperature (corresponding to the absolute humidity to be achieved) by passage over refrigerated coils or through an air washer where the mixture is brought in contact with chilled water. The result is a nearly saturated mixture which can be reheated, if required, to achieve the desired relative humidity. See DEHUMIDIFIER.

Moisture is also removed without refrigeration by absorption, a process in which the mixture passes through a spray of liquid sorbent that undergoes physical or chemical change as it becomes more dilute. Typical sorbents include lithium and calcium chloride solutions and ethylene glycol. See also ABSORPTION.

Another means of dehumidification, by adsorption, uses silica gel or activated bauxite which, through capillary action, reduces the vapor pressure on its surface so that the water vapor in its vicinity, being supersaturated, condenses. See ADSORPTION; PSYCHROMETRICS. [R.L.K.]

**Humite** A homologous series of magnesium nesosilicate minerals having the general composition  $Mg_{2n+1}(SiO_4)_n(F, OH)_2$ . The known species include norbergite ( $n = 1$ ), chondrodite ( $n = 2$ ), humite ( $n = 3$ ), and clinohumite ( $n = 4$ ). All are based on hexagonal close-packed oxygen and fluorine atoms, the Mg atoms occupying octahedral interstices and the Si atoms occupying tetrahedral interstices. Forsterite, norbergite, and humite are orthorhombic; chondrodite and clinohumite are monoclinic; brucite is trigonal. Manganese analogs of these minerals occur as pink grains in metamorphosed manganese ores derived from preexisting siliceous carbonates and sedimentary manganese oxides. Other cations which can occur as substituents are  $Fe^{2+}$ ,  $Ca^{2+}$ ,  $Al^{3+}$ , and  $Ti^{4+}$ .

The minerals of the humite group have similar physical properties. The luster is resinous, and the color usually light yellow, brown, orange, or red. The pure synthetic Mg end members are colorless. Hardness is 6–6½ on Mohs scale, specific gravity is 3.1–3.2. They are very difficult to distinguish visually, and x-ray diffraction, electron microprobe, or optical techniques are required. They are found in regionally crystallized marbles, usually the skarn minerals associated with iron ores. See SILICATE MINERALS. [P.B.M.]

**Humus** The amorphous, ordinarily dark-colored, colloidal matter in soil, representing a complex of the fractions of organic matter of plant, animal, and microbial origin that are most resistant to decomposition.

Humus consists of the combined residues of organic materials which have lost their original structure following the rapid decomposition of the simpler ingredients and includes synthesized cell substance as well as by-products of microorganisms. It is not a definite substance and is in a continual state of flux, disappearing by slow decomposition, and being constantly renewed by incorporation of residual matter. With a balance between these processes, humus, though not static, remains relatively uniform in nature and amount in a given soil. It constitutes a reservoir of stabilizing material which imparts beneficial physical, chemical, and biological properties to soil. Fertile soils are rich in humus.

Humus improves the texture of soils. It exerts a binding effect on sandy soils, and loosens the harder, clayey soils, thus increas-

ing their porosity and permeability. It increases the moisture-holding capacity and improves the granular structure by cementing mineral particles into stable crumbs. This helps soils resist the pulverizing and eroding action of wind, water, and cultivation. As a storehouse of elements important to plants, humus functions as a regulator of soil processes by liberating gradually nutrients that would otherwise drain away. A soil rich in humus provides optimum conditions for the development of beneficial microorganisms and constitutes the best medium for growth of plants.

Peat is a type of humus that results from the decomposition of plant material under conditions of excessive moisture or in areas submerged in water. It is an organic deposit formed in marshes and swamps by the partial decomposition of countless generations of a variety of plants. See BOG; PEAT. [A.G.L.]

**Hunger** A term most commonly used to refer to the subjective feelings that accompany the need for food; however, the study of this topic has come to include consideration of the overall control of food intake. More specifically, experimental work on the problem of hunger has been concerned with the sensory cues that give rise to feelings of hunger, the physiological mechanisms that determine when and how much food will be ingested, and the mechanism governing the selection of the food to be eaten.

Food consumption is basically controlled by the organism's nutritional status. Food deprivation leads to eating, and the ingestion of food materials terminates hunger sensations. The issues are to determine which physiological processes vary quantitatively with nutritional status, and to find out if these changes can be detected by the nervous system in a manner that would instigate and terminate food consumption.

Blood-sugar level, which has received more attention than any other factor, can be used as a case in point. The concentration of blood sugar does indeed vary appropriately in a general way with the periodicity of the food cycle. Detailed analyses of normal life variations of blood sugar, however, reveal that the relation between the concentration of blood sugar and hunger is not sufficiently close for this single humoral factor to be able to control hunger in any simple and direct manner. The evaluation of more local tissue utilization of food has proved a more promising approach to this problem. There is now some evidence suggesting that the status of the liver is pivotal in the control of feeding. Depletion of liver glycogen stimulates feeding; its repletion terminates feeding in rats and rabbits. See CARBOHYDRATE METABOLISM; LIVER.

Many stimuli that terminate feeding have been identified. Eating in food-deprived animals is inhibited by the reduction of either cellular water or of plasma fluid. It is also reduced by gastric distension and by infusing nutrients into the intestine and into the systemic, especially venous hepatic, circulation. Satiation produced by nutrient absorption from the intestine may be mediated, in part, by the gut hormone cholecystokinin. It is likely that cholecystokinin is effective because it reduces the rate at which food passes through the stomach. The previously held notions of discrete neural centers for the onset and termination of feeding have been abandoned, as the complexity of the feeding act and its corresponding neural complexity have become more widely appreciated.

Deprivation of certain, specific food substances precipitates an increased appetite for the needed substance. This so-called specific hunger behavior has been demonstrated experimentally with many substances, such as salt, calcium, fats, proteins, and certain vitamins in children and in the lower animals studied. It is now clear that only the hunger for salt in salt-deprived animals appears before the animal has learned about the beneficial consequences of salt ingestion. Specific hungers for other minerals, proteins, and vitamins appear only gradually and reflect the animal's learning that certain foods are no longer beneficial and, in fact, may be harmful. See THIRST AND SODIUM APPETITE. [E.M.B.]

**Huntington's disease** A rare hereditary disorder of the basal ganglia causing progressive motor incoordination, abnormal involuntary movements (chorea), and intellectual decline. The disease, which progresses gradually over 15–20 years, is invariably fatal. Inherited as an autosomal dominant mendelian trait, Huntington's disease inevitably develops in those who carry the gene if they live long enough. Men and women are affected equally. The average age at onset is between 35 and 40 years, but the disease can begin as early as 2 years or as late as 80 years.

Therapy is merely supportive: no medications significantly affect the course of the disease or functional capacity of the sufferer. Depression or psychosis, however, can be temporarily alleviated by antidepressant and antipsychotic medications.

The gene for Huntington's disease, termed IT15, has been localized at the end of the short arm of chromosome 4. The IT15 gene is thought to encode a protein, huntingtin, which does not resemble any known protein. Offspring of individuals suffering from the disease have a 50% risk of developing it, and can be tested by recombinant genetic technology. See CHROMOSOME; HUMAN GENETICS; MUTATION; NERVOUS SYSTEM DISORDERS. [A.Y.]

**Hurricane** A tropical cyclone whose maximum sustained winds reach or exceed a threshold of 119 km/h (74 mi/h). In the western North Pacific ocean it is known as a typhoon. Many tropical cyclones do not reach this wind strength. See CYCLONE.

Maximum surface winds in hurricanes range up to about 200 mi (320 km) per hour. However, much greater losses of life and property are attributable to inundation from hurricane tidal surges and riverine or flash flooding than from the direct impact of winds on structures.

Tropical cyclones of hurricane strength occur in lower latitudes of all oceans except the South Atlantic and the eastern South Pacific, where combinations of cooler sea temperatures and prevailing winds whose velocities vary sharply with height prevent the establishment of a central warm core through a deep enough layer to sustain the hurricane wind system.

In the United States, property losses resulting from hurricanes have climbed steadily because of the increasing number of seashore structures. However, the loss of life, which has been huge in many storms, has decreased markedly. This is due mainly to the fact that warnings, aided by a more complete surveillance from aircraft and satellite, and extensive programs of public education, have become more accurate and more effective. Improvements in methodology for hurricane prediction have reduced the error in pinpointing hurricane landfall and have greatly reduced the probability of larger errors in prediction. See STORM; TROPICAL METEOROLOGY. [R.Sim.; J.Sim.]

**Huygens' principle** An assumption regarding the behavior of light waves, originally proposed by C. Huygens in the seventeenth century to explain the fact that light travels in straight lines and casts sharp shadows. Large-scale waves, such as sound

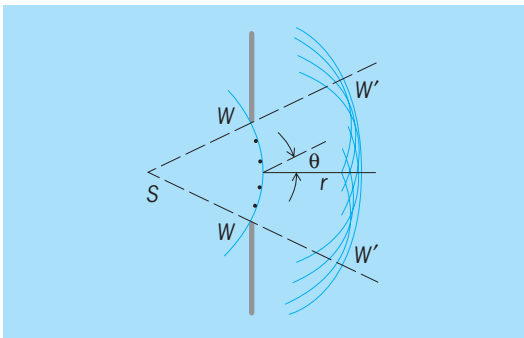

Huygens' principle: the construction for a spherical wave.

waves or water waves, bend appreciably into the shadow. The special behavior of light may be explained by Huygens' principle, which states that "each point on a wavefront may be regarded as a source of secondary waves, and the position of the wavefront at a later time is determined by the envelope of these secondary waves at that time." Thus a wave  $WW$  originating at  $S$  is shown in the illustration at the instant it passes through an aperture. If a large number of circular secondary waves, originating at various points on  $WW$ , are drawn with the radius  $r$  representing the distance the wave would travel in time  $t$ , the envelope of these secondary waves is the heavily drawn circular arc  $W'W'$ . This represents the wave after  $t$ . If, as Huygens' principle requires, the disturbance is confined to the envelope, it will be 0 outside the limits indicated by points  $W'$ .

Careful observation shows that there is a small amount of light beyond these points, decreasing rapidly with distance into the geometrical shadow. This is called diffraction. See DIFFRACTION.

[F.A.J./W.W.W.]

**Hyades** A small cluster of stars that makes up the nearest well-defined open cluster (galactic cluster) to the Earth. With a total mass of about 300 suns and a population of 400–500 mostly low-mass stars, the Hyades is a typical example of the 2000 or so small star clusters in the Milky Way Galaxy. Most of its stars are located in a loose, roughly spherical system approximately 40 light-years ( $2.4 \times 10^{14}$  mi or  $3.8 \times 10^{14}$  km) in diameter. It is located primarily in the constellation Taurus, the Bull. See TAURUS.

For many years the Hyades was the backbone of the stellar distance scale in the Milky Way Galaxy and beyond. However, in 1967, evidence was found suggesting that the distance to the Hyades (and, therefore, almost all other distances in the Milky Way Galaxy and beyond) had been underestimated by 20%. This conclusion was confirmed in 1996, when the European space telescope *Hipparcos* was able to make a more direct and more precise measure of the Hyades distance of 149 light-years ( $8.7 \times 10^{14}$  mi or  $1.4 \times 10^{15}$  km). See ASTROMETRY; PARALLAX (ASTRONOMY).

The age of the cluster is approximately  $6.5 \times 10^8$  years. Thus the Hyades were formed quite recently, after about 95% of the life of the Milky Way Galaxy had already occurred. See MILKY WAY GALAXY; STAR CLUSTERS. [P.H.]

**Hyaluronic acid** A polysaccharide which is an integral part of the gel-like substance of animal connective tissue; it supposedly serves as a lubricant and shock absorbent in the joints. Hyaluronic acid has also been isolated from umbilical cord, synovial fluid, skin, certain fowl tumors, and other sources. Treatment of this polysaccharide with the enzyme hyaluronidase, followed by acid hydrolysis, yields a disaccharide consisting of *N*-acetyl-D-glucosamine and D-glucuronic acid. This disaccharide appears to be the basic repeating structural unit that constitutes the hyaluronic acid molecule. See HYALURONIDASE; POLYSACCHARIDE. [W.Z.H.]

**Hyaluronidase** Any one of a family of enzymes, also known as hyaluronate lyases or spreading factors, produced by mammals, reptiles, insects, and bacteria, which catalyze the breakdown of hyaluronic acid. Some hyaluronidases also attack other similar polysaccharides. Since all liquefy the polysaccharide gel which fills the tissue spaces, they effectively accelerate diffusion so that injected, dissolved, or particulate matter (bacteria, viruses, toxins, or pigments) can diffuse through a larger volume of tissue. See HYALURONIC ACID.

The biological importance of the enzyme depends upon its source. That found in the culture filtrates of many strains of virulent bacteria permits the microorganisms to gain access to a larger volume of the host's tissue and, hence, to additional nutrient. That found in the venom of certain snakes and bees

permits the toxin to produce more extensive damage to the victim. See ENZYME. [R.H.P.]

**Hybrid dysgenesis** A syndrome of abnormal traits that appears in the hybrids between certain strains of the fruit fly *Drosophila melanogaster*. The traits include partial sterility and greatly elevated rates of genetic mutations and chromosome rearrangements. Strains can be classified as P for paternally contributing or M for maternally contributing, so that only the hybrid sons and daughter of M females mated to P males show hybrid dysgenesis.

Hybrid dysgenesis is caused by the action of a family of transposable genetic elements, that is, segments of the genetic material (deoxyribonucleic acid, or DNA) with the special ability to move from one chromosomal site to another. Such elements range in size from a few hundred to a few thousand nucleotide pairs and typically occur in 10–100 genetic locations scattered throughout the chromosomes. Altogether, transposable elements are thought to compose 10–15% of the entire genetic complement of *Drosophila melanogaster* and are probably also common in most animal and plant species. The family of transposable elements that causes most cases of hybrid dysgenesis is called the P family, and the individual elements are called P factors because they occur only in the paternally contributing strains. See GENE; GENE ACTION; MUTATION; TRANSPOSONS. [W.R.E.]

**Hydatellales** An order of flowering plants, division Magnoliophyta (Angiospermae), in the subclass Commelinidae of the class Liliopsida (monocotyledons). The order consists of a single family with five species native to Australia, New Zealand, and Tasmania. The plants are small, submersed or partly submersed aquatic annuals with greatly simplified internal anatomy. The leaves are tufted at the base of the stem, and the inflorescence is a terminal head with two to several bracts, each subtending one to several reduced, unisexual flowers. These plants have sometimes been included within the Restionales, but the structural details of the ovary and seed set them apart. They are of no economic significance. See COMMELINIDAE; PLANT KINGDOM; RESTIONALES. [T.M.B.]

**Hydrate** A particular form of a solid compound which has water in the form of H<sub>2</sub>O molecules associated with it. For example, anhydrous copper sulfate is a white solid with the formula CuSO<sub>4</sub>. When crystallized from water, a blue crystalline solid which contains water molecules as part of the crystals is formed. Analysis shows that the water is present in a definite amount, and the hydrate may be given the formula CuSO<sub>4</sub> · 5H<sub>2</sub>O. Four of the water molecules are attached to the copper ion in the manner of coordination complexes, and the fifth water molecule is related to the sulfate and presumably held by hydrogen bonding. See HYDROGEN BOND.

Water can also be present in definite proportions in the crystal without being associated directly with the anion or cation. The water occupies a definite place in the crystal lattice. Alums, with their 12 molecules of water, are examples of this. See ALUM.

Gas hydrates (gas clathrates) are crystalline compounds in which an isometric (cubic) ice (H<sub>2</sub>O) lattice contains cages that incorporate small guest gas molecules. They are stable at moderate to high pressures and low temperatures, above and below the ice point. These ice lattices are stable only when the cages contain a gas molecule. The pressure and temperature constraints restrict them to oceanic continental margins in the uppermost few hundred meters of slope and rise sediments where water depths exceed 300–500 m (1000–1600 ft), and to permafrost in polar regions. Under the ocean, the amount of gas hydrates is at least an order of magnitude higher than in permafrost.

Methane (CH<sub>4</sub>) hydrate is the dominant natural gas hydrate on Earth. One cubic meter of methane hydrate when dissociated can contain 165–180 m<sup>3</sup> of methane gas. The total amount of

methane in gas hydrates is estimated to be very large; about 10<sup>19</sup> g of methane carbon is stored in them, approximately twice that in fossil fuels.

Recent interest in natural gas hydrates, most of which are methane hydrates, has resulted from the recognition that global warming may destabilize the enormous quantities of methane hydrate in shallow marine slope sediments and permafrost. The environmental impact of releasing large quantities of methane into the ocean and atmosphere could have important consequences. The fossil fuel resource potential of the enormous quantities of marine methane hydrates is being evaluated. See MARINE SEDIMENTS; METHANE; PERMAFROST. [F.W.; M.Ka.]

**Hydration** The incorporation of molecular water into a complex with the molecules or units of another species. The complex may be held together by relatively weak forces or may exist as a definite compound. Many salts form solid hydrates when exposed to water vapor under certain conditions of temperature and pressure. Water is lost from these compounds when they are heated or when the water vapor pressure falls below a minimum value. Solids forming hydrates at low pressures are used as drying agents. See DELIQUESCENCE; DESICCANT; EFFLORESCENCE; HYDRATE; SOLUTION; SOLVATION. [F.J.J.]

**Hydraulic accumulator** A pressure vessel which operates as a fluid source device or shock absorber. It is used to store fluid under pressure or to absorb excessive pressure increases. The hydraulic accumulator is an energy-efficient component, which allows the use of a smaller pump to achieve the same end results in terms of cylinder rod actuation speeds. In certain circuit designs, the accumulator will permit a pump motor to be completely shut down for an extended period of time while the accumulator supplies the necessary fluid to the circuit.

The operation of the hydraulic accumulator is induced by a pressurized gas (usually nitrogen), a spring, or a weighted plunger. The accumulator supplies fluid for actuator movement or to replace fluid lost by leakage. The gas-charged accumulator and the spring-type accumulator discharge their fluid into the system at pressures which are decreasing as the gas or spring expands. The weighted accumulator allows stored fluid to be discharged into the system at a constant pressure for the entirety of its downward stroke. See CONTROL SYSTEMS; HYDRAULICS; PUMP; SHOCK ABSORBER. [J.E.A.]

**Hydraulic actuator** A cylinder or fluid motor that converts hydraulic power into useful mechanical work. The mechanical motion produced may be linear, rotary, or oscillatory. Operation exhibits high force capability, high power per unit weight and volume, good mechanical stiffness, and high dynamic response. These features lead to wide use in precision control systems and

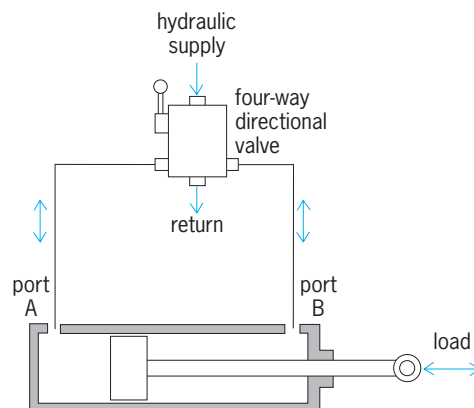

Fig. 1. Function of a hydraulic double-acting cylinder.

in heavy-duty machine tool, mobile, marine, and aerospace applications. See CONTROL SYSTEMS.

Cylinder actuators provide a fixed length of straight-line motion. They usually consist of a tight-fitting piston moving in a closed cylinder. The piston is attached to a rod that extends from one end of the cylinder to provide the mechanical output. The double-acting cylinder (Fig. 1) has a port at each end of the cylinder to admit or return hydraulic fluid. A four-way directional valve functions to connect one cylinder port to the hydraulic supply and the other to the return, depending on the desired direction of the power stroke.

Limited-rotation actuators are used for lifting, lowering, opening, closing, indexing, and transferring movements by producing limited reciprocating rotary force and motion. Rotary actuators are compact and efficient, and produce high instantaneous torque in either direction. Figure 2 shows a piston-rack type of rotary actuator. Hydraulic fluid is applied to either the two end chambers or the central chamber to cause the two pistons to retract or extend simultaneously so that the racks rotate the pinion gear.

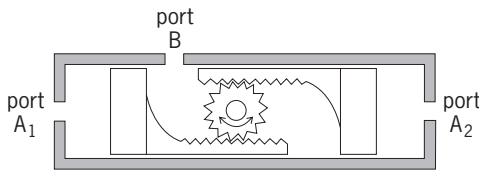

Fig. 2. Piston-rack type rotary actuator.

Rotary motor actuators are coupled directly to a rotating load and provide excellent control for acceleration, operating speed, deceleration, smooth reversals, and positioning. They allow flexibility in design and eliminate much of the bulk and weight of mechanical and electrical power transmissions.

Motor actuators are generally reversible and are of the gear or vane type. [C.M.]

**Hydraulic jump** An abrupt increase of depth in a free-surface liquid flow. A hydraulic jump is characterized by rapid flow and small depths on the upstream side, and by larger depths and smaller velocities on the downstream side. A jump can form only when the upstream flow is supercritical, that is, when the fluid velocity is greater than the propagation velocity  $c$  of a small, shallow-water gravity wave ( $c = \sqrt{gh}$ , where  $g$  is the acceleration of gravity and  $h$  is the depth). A considerable amount of energy is dissipated in the conversion from supercritical to subcritical flow. See OPEN CHANNEL; WAVE MOTION IN LIQUIDS. [D.R.F.H.]

**Hydraulic press** A combination of a large and a small cylinder connected by a pipe and filled with a fluid so that the pressure created in the fluid by a small force acting on the piston

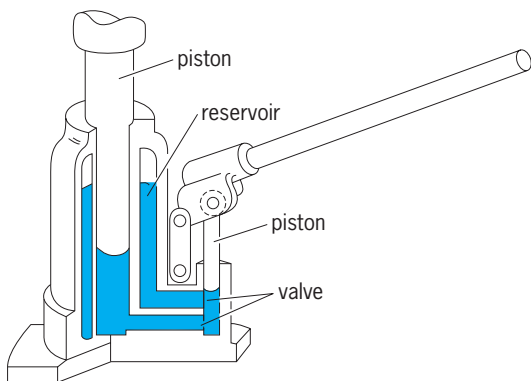

Hydraulic jack.

in the small cylinder will result in a large force on the large piston. The operation depends upon Pascal's principle, which states that when a liquid is at rest the addition of a pressure (force per unit area) at one point results in an identical increase in pressure at all points.

The principle of the hydraulic press is used in lift jacks, earth-moving machines, and metal-forming presses (see illustration). A comparatively small supply pump creates pressure in the hydraulic fluid. The fluid then acts on a substantially larger piston to produce the action force. Heavy objects are accurately weighed on hydraulic scales in which precision-ground pistons introduce negligible friction. See MECHANICAL ADVANTAGE; SIMPLE MACHINE. [R.M.Ph.]

**Hydraulic turbine** A machine which converts the energy of an elevated water supply into mechanical energy of a rotating shaft. Most old-style waterwheels utilized the weight effect of the water directly, but all modern hydraulic turbines are a form of fluid dynamic machinery of the jet and vane type operating on the impulse or reaction principle and thus involving the conversion of pressure energy to kinetic energy. The shaft drives an electric generator, and speed must be of an acceptable synchronous value. See GENERATOR; IMPULSE TURBINE; TURBINE.

Efficiency of hydraulic turbine installations is always high, more than 85% after all allowances for hydraulic, shock, bearing, friction, generator, and mechanical losses. Material selection is not only a problem of machine design and stress loading from running speeds and hydraulic surges, but is also a matter of fabrication, maintenance, and resistance to erosion, corrosion, and cavitation pitting.

Pumped-storage hydro plants have employed various types of equipment to pump water to an elevated storage reservoir during off-peak periods and to generate power during on-peak periods where the water flows from the elevated reservoir through hydraulic turbines. See WATERPOWER. [T.Ba.]

**Hydraulic valve lifter** A device that eliminates the need for mechanical clearance in the valve train of internal combustion engines. Clearance is normally required to prevent the valve's being held open and destroyed as the valve train

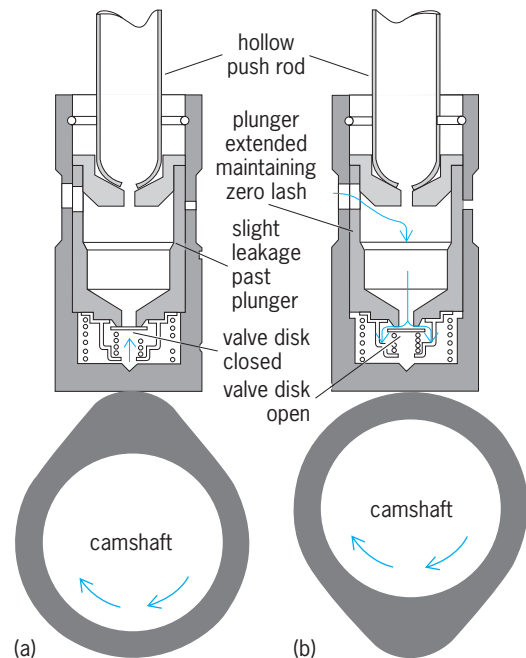

Positions of the hydraulic valve lifter, with engine valve (a) open and (b) closed. (After W. H. Crouse, *Automotive Mechanics*, 5th ed., McGraw-Hill, 1965)

undergoes thermal expansion. However, clearance requires frequent adjustment and is responsible for much operating noise. The hydraulic lifter is a telescoping compression strut in the linkage between cam and valve, consisting of a piston and cylinder (see illustration). When no opening load exists, a weak spring moves the piston, extending the strut and eliminating any clearance. This action sucks oil into the cylinder past a check valve. The trapped oil transmits the valve-opening forces with little deflection. A slight leakage of oil during lift shortens the strut, assuring valve closure. The leakage oil is replaced as the spring again extends the strut at no load. [A.R.R.]

**Hydraulics** The branch of engineering that focuses on the practical problems of collecting, storing, measuring, transporting, controlling, and using water and other liquids. It differs from fluid mechanics, which is more theoretical and includes the study of gases as well as liquids; and from hydrology, which is the study of the properties, distribution, and circulation of the Earth's water. See FLUID MECHANICS; HYDROLOGY.

Many problems in hydraulics involve pipe flow. Pipe flow occurs in the direction of decreasing energy. The primary forms of energy in pipes are position energy (height of the fluid), pressure energy, and kinetic energy according to Bernoulli's theorem. Fluids can be forced to flow uphill if the pressure energy and kinetic energy are large enough to overcome the position energy. This can be accomplished with a pump that adds pressure energy to the fluid. See BERNOULLI'S THEOREM; PUMP.

Liquids in motion produce forces whenever the velocity or flow direction changes. For example, forces develop at the nozzle of a fire hose, at pipe bends, and when flowing water is used to turn a turbine. The force is generally proportional to the flow rate, the mass density, and the velocity change. See FLUID FLOW; HYDRODYNAMICS; JET FLOW; TURBINE.

Liquids are often transported in open channels instead of pipes. An energy imbalance produces flow in open channels, just as it does in pipes. The primary forms of energy are position energy, flow depth, and kinetic energy. Energy balance methods are used to solve many problems in gradually varied flow (that is, the depth changes slowly over short distances), but a momentum balance is required for rapidly varied flow.

Hydraulic principles apply to many other scientific and engineering endeavors. For example, ground-water flow is studied in geology but is governed by the principles of hydraulics. Coastal hydraulics is an important subset of oceanography. The design of certain structures, such as jetties, dams, spillways, locks, piers, levees, dry docks, and tanks, requires an understanding of hydraulic concepts. Scale models are often used to better understand some of the complex forces and currents associated with these large structures. See COASTAL ENGINEERING; DAM; DIMENSIONAL ANALYSIS; GEOLOGY; GROUND-WATER HYDROLOGY; RIVER ENGINEERING. [R.J.Ho.]

**Hydrazine** A colorless liquid,  $\text{H}_2\text{NNH}_2$  (boiling point  $114^\circ\text{C}$  or  $237^\circ\text{F}$ ), with a musty, ammonialike odor. Physically it is similar to water, but chemically it is reducing, decomposable, basic, and bifunctional. Its derivatives range from simple salts to ring compounds, polymers, and coordination complexes. Major uses of hydrazine include such diverse applications as rocket fuels, corrosion inhibition in boilers, syntheses of biologically active materials and in rubber curing and foam-rubber production. [T.H.D.]

**Hydride** The isolated atomic hydrogen anion,  $\text{H}^-$ . It consists of a singly charged positive nucleus and two electrons. The electron-electron repulsion almost overwhelms the nuclear-electron attraction. Thus, the "extra" electron is held weakly and is readily donated. Ionic salts containing this large and easily polarized ion are highly reactive, strongly basic, and powerfully reducing. This makes them important reagents despite the fact that they are readily destroyed by the presence of the relatively

acidic compound water ( $\text{H}_2\text{O}$ ) or by exposure to the relatively oxidizing dioxygen ( $\text{O}_2$ ) as found in air. See ELECTRON CONFIGURATION.

The term hydride also refers to salts containing the  $\text{H}^-$  anion and a highly electropositive alkali or alkaline-earth metal as the cation. The salt names reflect this high ionic character, for example, sodium hydride ( $\text{NaH}$ ). In such salts the ionic radius of  $\text{H}^-$  is comparable to that of  $\text{Cl}^-$ .

There are complex metal hydrides that are formed from the formal reaction of  $\text{H}^-$  salts with some more covalent metal or metalloid hydrogen compound. Among the earliest to be investigated were lithium aluminum hydride ( $\text{LiAlH}_4$ ) and sodium borohydride ( $\text{NaBH}_4$ ).

There are compounds with metal-hydrogen bonds that are also referred to as hydrides. For example, hydridocarbonyl [ $\text{HCo}(\text{CO})_4$ ] and dihydridotetracarbonyl iron [ $\text{H}_2\text{Fe}(\text{CO})_4$ ] are often named cobalt tetracarbonyl hydride and iron tetracarbonyl dihydride by analogy to corresponding halides. See COORDINATION COMPLEXES; METAL HYDRIDES.

Ideally, the term hydride should be reserved for those species that contain  $\text{H}^-$  or that at least formally transfer this ion to another substance in a so-called hydride transfer reaction. Such reactions are found in the industrial synthesis of 2,2,4-trimethylpentane (isooctane) from isobutylene and isobutane, as well as in many of the classical organic chemistry named reactions. Hydride transfer is also important in most of the biologically important oxidation-reduction reactions of the vitamin niacin (nicotinamide) as found in the forms of nicotinamide adenine dinucleotide/hydrogenated nicotinamide adenine dinucleotide ( $\text{NAD}^+/\text{NADH}$ ) and nicotinamide adenine dinucleotide phosphate ( $\text{NADP}^+/\text{NADPH}$ ). See NIACIN; NICOTINAMIDE ADENINE DINUCLEOTIDE ( $\text{NAD}$ ); NICOTINAMIDE ADENINE DINUCLEOTIDE PHOSPHATE ( $\text{NADP}$ ). [J.F.Li.]

**Hydrido complexes** Complex hydrides containing a hydride ligand bonded to a central atom. The prefix hydro instead of hydrido is sometimes used. All are soluble in aromatic hydrocarbons. They are rather expensive, but their specific reducing powers make them attractive for synthesizing high-value products, such as pharmaceuticals, flavorings, fragrances, dyes, and insecticides. See COORDINATION COMPLEXES; METAL HYDRIDES. [J.C.W.]

**Hydroboration** The process of producing organoboranes by the addition of diborane to unsaturated organic compounds. In ether solvents the addition of diborane to such molecules is exceedingly rapid and essentially quantitative. This reaction therefore makes the organoboranes readily available. Such organoboranes are finding increasing application as intermediates for organic synthesis.

Diborane is highly soluble in tetrahydrofuran, where it exists as the addition compound tetrahydrofuran-borane. Such solutions are often used for hydroboration, and merely involve bringing the two reactants together as indicated by reaction (1).

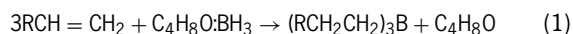

Alternatively, sodium borohydride may be utilized to achieve hydroboration by the addition of boron trifluoride etherate. This is shown by reaction (2). Usually the organoborane is not

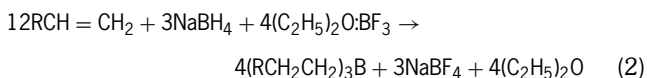

isolated but is utilized in place, similar to applications of the Grignard reagent in synthesis.

Organoboranes are among the most versatile synthetic intermediates that are available to the organic chemist. The hydroboration reaction has made these intermediates readily available. See BORANE. [H.C.B.]



**Hydrocharitales** An order of aquatic flowering plants, division Magnoliophyta (Angiospermae), in the subclass Alismatidae of the class Liliopsida (monocotyledons). The order consists of the single family Hydrocharitaceae, with about 100 species. Within the subclass the order is marked by its inferior, compound ovary with basically laminar placentation. The ovules are scattered over the walls of the individual carpels. The familiar aquarium plant, *Vallisneria spiralis*, called tape grass or eelgrass, is not a grass but belongs to the Hydrocharitaceae. See ALISMATIDAE; FLOWER; LILIOPSIDA. [A.Cr.]

**Hydrocracking** A catalytic, high-pressure process flexible enough to produce either of the two major light fuels—high octane gasoline or aviation jet fuel. It proceeds by two main reactions: adding hydrogen to molecules too massive and complex for gasoline and then cracking them to the required fuels. The process is carried out by passing oil feed together with hydrogen at high pressure (1000–2500 pounds per square inch gage or 7–17 megapascals) and moderate temperatures (500–750°F or 260–400°C) into contact with a bifunctional catalyst, comprising an acidic solid and a hydrogenating metal component. Gasoline of high octane number is produced, both directly and through a subsequent step such as catalytic reforming; jet fuels may also be manufactured simply by changing conditions with the same catalysts.

Generally, the process is used as an adjunct to catalytic cracking. Oils, which are difficult to convert in the catalytic process because they are highly aromatic and cause rapid catalyst decline, can be easily handled in hydrocracking, because of the low cracking temperature and the high hydrogen pressure, which decreases catalyst fouling. However, the most important components in any feed are the nitrogen-containing compounds, because these are severe poisons for hydrocracking catalysts and must be almost completely removed.

The products from hydrocracking are composed of either saturated or aromatic compounds; no olefins are found. In making gasoline, the lower paraffins formed have high octane numbers. The remaining gasoline has excellent properties as a feed to catalytic reforming, producing a highly aromatic gasoline which, with added lead, easily attains 100 octane number. Another attractive feature of hydrocracking is the low yield of gaseous components, such as methane, ethane, and propane, which are less desirable than gasoline. See GASOLINE.

The hydrocracking process is being applied in other areas, notably, to produce lubricating oils and to convert very asphaltic and high-boiling residues to lower-boiling fuels. See AROMATIZATION; CRACKING; HYDROGENATION. [C.P.B.]

**Hydrodynamics** The study of fluids in motion. The study is based upon the physical conservation laws of mass, momentum, and energy. The mathematical statements of these laws may be written in either integral or differential form. The integral form is useful for large-scale analyses and provides answers that are sometimes very good and sometimes not, but that are always useful, particularly for engineering applications. The differential form of the equations is used for small-scale analyses. In principle, the differential forms may be used for any problem, but exact solutions can be found only for a small number of specialized flows. Solutions for most problems must be obtained by using numerical techniques, and these are limited by the computer's inability to model small-scale processes. See CONSERVATION OF ENERGY; CONSERVATION OF MASS; CONSERVATION OF MOMENTUM; FLUID FLOW; FLUID MECHANICS.

Applications of hydrodynamics include the study of closed-conduit and open-channel flow, and the calculation of forces on submerged bodies.

Flow in closed conduits, or pipes, has been extensively studied both experimentally and theoretically. If the pipe Reynolds num-

ber, given by the equation below, where  $V$  is the average velocity

$$Re_D = \frac{VD\rho}{\mu}$$

and  $D$  is the pipe diameter, is less than about 2000, the flow in the pipe is laminar. In this case, the solution to the continuity, momentum, and energy equations is readily obtained, particularly in the case of steady flows. If  $Re_D$  is greater than about 4000, the flow in the pipe is turbulent, and the solution to the continuity, momentum, and energy equations can be obtained only by employing empirical correlations and other approximate modeling tools. The  $Re_D$  region between 2000 and 4000 is the transition region in which the flow is intermittently laminar and turbulent. See LAMINAR FLOW; REYNOLDS NUMBER; TURBULENT FLOW.

Confined flows that have a liquid surface exposed to the atmosphere (a free surface) are called open-channel flows. Flows in rivers, canals, partially full pipes, and irrigation ditches are examples. The difficulty with these flows is that the shape of the free surface is one of the unknowns to be calculated.

In most open-channel flows the bottom slope and the water depth change with position, and the free surface is not parallel to the channel bottom. If the slopes are small and the changes are not too sudden, the flow is called a gradually varied flow. An energy balance between two sections of the channel yields a differential equation for the rate of change of the water depth with respect to the distance along the channel. The solution of this equation, which must be accomplished by using one of many available numerical techniques, gives the shape of the water surface.

Flow over spillways and weirs and flow through a hydraulic jump are examples of rapidly varying flows. In these cases, changes of water depth with distance along the channel are large. Here, because of large accelerations, the pressure distribution with depth may not be hydrostatic as it is in the cases of gradually varied and uniform flows. Solutions for rapidly varying flows are accomplished by using approximation techniques. See HYDRAULIC JUMP; OPEN CHANNEL.

The force exerted by a fluid flowing past a submerged body is calculated by integrating the pressure distribution over the surface of the body. The pressure distribution is determined from the simultaneous solution of the continuity and momentum equations along with the appropriate boundary conditions. In almost all cases, this solution must be accomplished by using an appropriate approximation. See BOUNDARY-LAYER FLOW.

Usually the force exerted on the body is resolved into two components, the lift and the drag. The drag force is the component parallel to the velocity of the undisturbed stream (flow far away from the body), and the lift force is the component perpendicular to the undisturbed stream. [W.M.H.]

**Hydroelectric generator** A low-speed generator driven by water turbines. Hydrogenerators may have a horizontal or vertical shaft. The horizontal units are usually small with speeds of 300–1200 revolutions per minute (rpm). The vertical units are usually larger and more easily adapted to small hydraulic heads. The rotor diameters range from 2 to 62 ft (0.6 to 19 m) and capacities from 50 to 900,000 kVA. The generators are rated in kVA (kilovolts times amperes). The kilowatt output is the product of kVA and power factor. The normal power-factor rating of small synchronous generators is between 0.8 and 1.0 with 0.9 being common. For large generators a rating of 0.9–0.95 is common with the machines able to operate up to 1.0 when the load requires. The generators may also supply reactive power. See ALTERNATING CURRENT; ELECTRIC POWER MEASUREMENT; VOLT-AMPERE.

The turbine shown in the illustration has an adjustable blade propeller, typical of large, low-head units that are common on large river power plants. The water enters the turbine spiral scroll casing, falls down through the turbine, causing rotation, and empties into the river. The shaft transmits the rotation to the



## Properties of hydrogen

Property	Value
Melting point	-259.2°C
Boiling point at 1 atm	-252.8°C
Density of solid at -259.2°C	0.0866 g/cm <sup>3</sup>
Density of liquid at -252.8°C	0.0708 g/cm <sup>3</sup>
Critical temperature	-240.0°C
Critical pressure	13.0 atm
Critical density	0.0301 g/cm <sup>3</sup>

treatment for removal of sulfur. Large quantities of hydrogen are consumed in the catalytic hydrogenation of unsaturated liquid vegetable oils to make solid fats. Hydrogenation is used in the manufacture of organic chemicals. Large quantities of hydrogen are used as a rocket fuel, in conjunction with oxygen or fluorine, and as a propellant for nuclear-powered rockets.

**Properties.** Ordinary hydrogen has a molecular weight of 2.01594. The gas has a density at 0°C and 1 atm of 0.08987 g/liter. Its specific gravity, compared to air, is 0.0695. Hydrogen is the lightest substance known. Some additional properties of hydrogen are listed in the table.

Hydrogen is somewhat more soluble in organic solvents than in water. Many metals adsorb hydrogen. The adsorption of hydrogen in steel may cause "hydrogen embrittlement," which sometimes leads to the failure of chemical processing equipment.

At ordinary temperatures hydrogen is a comparatively unreactive substance unless it has been activated in some manner, for example, by a suitable catalyst. At elevated temperatures it is highly reactive.

Although ordinarily diatomic, molecular hydrogen dissociates at high temperatures into free atoms. Atomic hydrogen is a powerful reducing agent, even at room temperature. It reacts with the oxides and chlorides of many metals, including silver, copper, lead, bismuth, and mercury, to produce the free metals. It reduces some salts, such as nitrates, nitrites, and cyanides of sodium and potassium, to the metallic state. It reacts with a number of elements, both metals and nonmetals, to yield hydrides such as NaH, KH, H<sub>2</sub>S, and PH<sub>3</sub>. With oxygen atomic hydrogen yields hydrogen peroxide, H<sub>2</sub>O<sub>2</sub>. With organic compounds atomic hydrogen reacts to produce a complex mixture of products. With ethylene, C<sub>2</sub>H<sub>4</sub>, for example, the products include ethane, C<sub>2</sub>H<sub>6</sub>, and butane, C<sub>4</sub>H<sub>10</sub>. The heat liberated when hydrogen atoms recombine to form hydrogen molecules is used to obtain very high temperatures in atomic hydrogen welding.

Hydrogen reacts with oxygen to form water. At room temperature this reaction is immeasurably slow, but is accelerated by catalysts, such as platinum, or by an electric spark, and then may take place with explosive violence.

With nitrogen, hydrogen undergoes an important reaction to give ammonia. Hydrogen reacts at elevated temperatures with a number of metals to give hydrides. The oxides of many metals are reduced by hydrogen at elevated temperatures either to the free metal or to lower oxides. Hydrogen reacts at room temperature with the salts of the less electropositive metals and reduces them to the metallic state. In the presence of a suitable catalyst hydrogen reacts with unsaturated organic compounds and adds to the double bond. See HYDROGENATION.

**Principal compounds.** Hydrogen is a constituent of a very large number of compounds containing one or more other elements. Such compounds include water, acids, bases, most organic compounds, and many minerals. Compounds in which hydrogen is combined with a single other element are commonly referred to as hydrides. For additional details on the compounds of hydrogen see ACID AND BASE; HYDRAZINE; HYDRIDE; HYDRIDO COMPLEXES; HYDROGEN FLUORIDE; HYDROGEN PEROXIDE; WATER.

**Preparation.** A large number of methods may be used to prepare hydrogen gas. The choice of method is determined by such factors as the quantity of hydrogen desired, the purity required, and the availability and cost of raw materials. Among

the processes frequently used are the reactions of metals with water or acids, the electrolysis of water, the reaction of steam with hydrocarbons or other organic materials, and the thermal decomposition of hydrocarbons. The principal raw materials for hydrogen production are hydrocarbons, such as natural gas, oil refinery gas, gasoline, fuel oil, and crude oil. [L.K.]

**Hydrogen bomb** A device in which an uncontrolled, self-sustaining, thermonuclear fusion reaction is carried out in heavy hydrogen (deuterium or tritium) to produce an explosion. In a fusion reaction, the collision of two energy-rich nuclei results in a mutual rearrangement of their protons and neutrons to produce two or more reaction products, together with a release of energy of amount  $E$  given by A. Einstein's formula  $E = mc^2$ , where  $m$  is the mass difference between the original and produced nuclei, and  $c$  is the velocity of light. See NUCLEAR FUSION; THERMONUCLEAR REACTION.

For the hydrogen bomb reaction to become self-sustaining, a so-called critical temperature of about  $3.5 \times 10^7$  K ( $6.3 \times 10^7$  °F) must be attained with the aid of the enormous temperature created by a fission explosive. Once this temperature is achieved, the energy released in the initial reaction maintains the temperature, and the chain proceeds either until the supply of fusionable material is exhausted or until sufficient expansion has taken place that the material is cooled below the critical temperature. See ATOMIC BOMB.

There are two ways to use fusion: boosting of fission explosive yields or generating multistage thermonuclear reactions.

In a fusion-boosted warhead (illus. a), when the sphere of fissile materials is compressed (imploded) by the chemical explosion, an uncontrolled fission chain reaction begins. If there is fusionable material inside the device, thermonuclear reactions will boost the fission yield. The fusion reactions do not directly contribute very much to the explosive energy, but instead enhance the fission rate, due to the release of a large number of additional neutrons. See ATOMIC BOMB.

Multistage thermonuclear weapons contain three physically separated components, (illus. b): a small fission or fusion-boosted explosive called a primary or trigger, an assembly of lithium-deuteride fusion material called the secondary, and a massive casing surrounding the primary and secondary. Explosive detonation is generated in three phases: ignition caused by the fission-explosive primary stage, coupling of x-radiation to the secondary fusion stage, and secondary-stage implosion induced by fission x-rays, which compresses the lithium-deuteride.

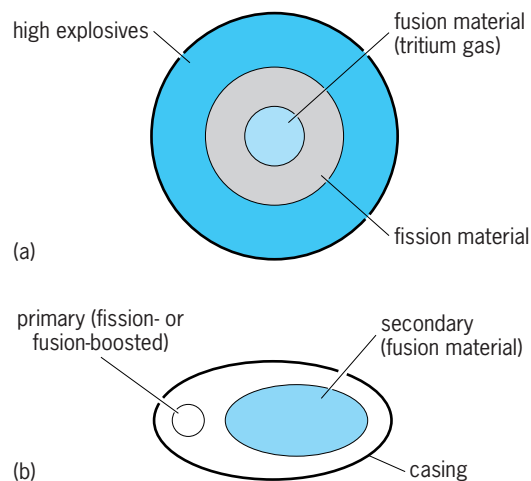

Design configuration of two types of fusion weapons: (a) fusion-boosted atomic bomb, (b) multistage hydrogen bomb. (After A. DeVolpi et al., *Born Secret: The H-Bomb, the Progressive Case and National Security*, Pergamon, 1981)

As neutrons from the primary traverse the compressed lithium-deuteride compound, they are absorbed in enriched lithium-6, which immediately decomposes into tritium and an alpha particle. If the tritium thus created fuses with deuterium, an energetic alpha particle and a 14-MeV neutron are released. Soon the fusion materials reach densities and temperatures where thermonuclear ignition occurs, liberating many times more energy than that which came originally from the trigger. See HEAT RADIATION.

If the massive casing is made mostly of uranium-238 (natural or depleted uranium), neutrons from the thermonuclear reactions will cause the uranium nuclei to undergo fission, giving off still more energy. A device of this sort can be regarded as a three-stage fission-fusion-fission bomb.

The yield, or total energy, of a hydrogen bomb is expressed in megatons (1 megaton equals  $10^{15}$  calories or  $4.18 \times 10^{15}$  joules). Typical fusion-boosted weapons yield hundreds of kilotons (tenths of megatons), and typical multistage weapons yield megatons. See NUCLEAR EXPLOSION. [A.DeV.]

**Hydrogen bond** The interaction which occurs when a hydrogen atom, covalently bonded to an electronegative atom (as in A—H), interacts with another atom to form the aggregate A—H  $\cdots$  Y. The shortest and strongest bond is indicated as A—H, while the secondary and weaker interaction is written as H  $\cdots$  Y. Thus A—H is a proton donor, while (Y) is a proton acceptor which often contains lone pair electrons and can act as a base. The strongest hydrogen bonds are formed between the most electronegative (A) atoms such as fluorine, nitrogen, and oxygen which interact with (Y) atoms having electronegativity greater than that of hydrogen (C, N, O, S, Se, F, Cl, Br, I). The weakest of hydrogen bonds are formed by acidic protons of C—H groups, as in chloroform and acetylene, and by olefinic and aromatic  $\pi$ -electrons acting as (Y).

The weaker the hydrogen bond, the shorter the lifetime of the complex it forms. An important aspect of weak hydrogen bond formation is that the different molecular aggregates which do form can be easily and reversibly transformed. Thus the small energy changes resulting in the rapid making and breaking of hydrogen bonds in biological systems are of great importance; for example, hydrogen bonding determines the configuration of the famous  $\alpha$ -helix of DNA, and the structures of most proteins, thereby serving an important function in determining the nature of all living things. See CHEMICAL BONDING; DEOXYRIBONUCLEIC ACID (DNA); PROTEIN. [J.M.Wi.]

**Hydrogen fluoride** The hydride of fluorine and the first member of the family of halogen acids. Anhydrous hydrogen fluoride is a mobile, colorless liquid that fumes strongly in air. It has the empirical formula HF, melts at  $-83^\circ\text{C}$ , and boils at  $19.8^\circ\text{C}$ . The vapor is highly aggregated, and gaseous hydrogen fluoride deviates from perfect gas behavior to a greater extent than any other gaseous substance known. Aggregate formation in both the vapor and liquid phase arises from unusually strong hydrogen-bond interactions. See HYDROGEN BOND.

Anhydrous hydrogen fluoride is an extremely powerful acid, exceeded in this respect only by 100% sulfuric acid. Because anhydrous hydrogen fluoride is a superacid, many organic solutes dissolve in it to form stable carbonium ions. Alkali metal fluorides and silver fluoride dissolve readily in hydrogen fluoride to form conducting solutions. Anhydrous hydrogen fluoride dissolves a wide variety of organic compounds. Aqueous solutions of hydrogen fluoride (hydrofluoric acid) are relatively weakly acidic as compared to hydrochloric acid.

Hydrogen fluoride is a widely used industrial chemical. The largest use is in making fluorine-containing refrigerants (Freons, Genetrons). An increasingly important use of hydrogen fluoride is in the preparation of organic fluorocarbon compounds.

Both hydrogen fluoride and hydrofluoric acid cause unusually severe burns; appropriate precautions must be taken to prevent

any contact of the skin or eyes with either the liquid or the vapor. See FLUORINE; HALOGENATED HYDROCARBON. [J.J.K.]

**Hydrogen ion** A proton combined with a number of water molecules. It is often written as  $\text{H}_3\text{O}^+$  and called the hydronium ion. However, this species is best considered as an excess proton on a tetrahedral group of four water molecules and so would be designated as  $\text{H}_5\text{O}_4^+$ . For simplicity, it is most commonly written as  $\text{H}^+$  (aq). See PROTON.

Since it is formed by the self-ionization of water, the hydrogen ion is present in all aqueous solutions. This formation also means that  $\text{H}^+$ (aq) is always found in the company of the hydroxide ion,  $\text{OH}^-$  (aq). The equilibrium relationship between the concentrations of these two species is a very important property of water. See IONIC EQUILIBRIUM.

The  $\text{H}^+$ (aq) and  $\text{OH}^-$  (aq) concentrations in pure water are equal to each other with a value of  $10^{-7}$  mole/liter. Any aqueous solution with this concentration of  $\text{H}^+$ (aq) is called a neutral solution. If the  $\text{H}^+$ (aq) concentration is greater than  $10^{-7}$  mole/liter, the solution is called acidic. Basic solutions are those in which the  $\text{H}^+$ (aq) concentration is less than  $10^{-7}$  mole/liter. As the  $\text{H}^+$ (aq) concentration increases the  $\text{OH}^-$  (aq) concentration must decrease, and vice versa. In the most straightforward system, acids are substances that can donate an  $\text{H}^+$ (aq), and bases are substances that can accept one. See ACID AND BASE.

Hydrogen ion concentration determines the course of many chemical reactions that occur in living organisms and in the chemical industry. The control of hydrogen ion concentration is achieved in living organisms and in the laboratory by buffer systems. These are chemical mixtures designed to resist change in hydrogen ion concentration.

Another property of the  $\text{H}^+$ (aq) is important in both theoretical and practical ways.  $\text{H}^+$ (aq) is the best conductor of electricity of any ion in aqueous solution. Its conductance at  $77^\circ\text{F}$  ( $25^\circ\text{C}$ ) is almost five times as large as the next-most-conducting ion. See ELECTROLYTIC CONDUCTANCE; HYDROGEN ELECTRODE.

The hydrogen ion concentration can vary over fourteen powers of 10. To avoid dealing with such exponentials, the concept of pH is used. Since all aqueous solutions contain both hydrogen ion and hydroxide ion, it is possible to define all degrees of acidity and basicity on the pH scale. See pH.

Two general methods are used for the determination of hydrogen ion concentrations. For relatively crude work, colorimetric methods are commonly used. These methods depend on the fact that certain natural and synthetic dyes have colors that depend on the hydrogen ion concentration. At times, paper is impregnated with such an indicator. In most precise work, a potentiometric method is used for the determination of hydrogen ion concentration. This method depends on an electrode whose potential is sensitive to hydrogen ion concentration. The only electrode commonly in use for practical pH measurements is the glass electrode. See ACID-BASE INDICATOR; COLORIMETRY; TITRATION. [G.A.]

**Hydrogen peroxide** A binary compound of hydrogen and oxygen, empirical formula  $\text{H}_2\text{O}_2$ , used mostly in dilute aqueous solutions as an oxidizing agent. Its most remarkable feature is its tendency to decompose readily into water and oxygen.

Anhydrous hydrogen peroxide is a clear, colorless liquid, of nearly the same viscosity and dielectric constant as water, but of greater density. Like water, it is strongly associated through hydrogen bonds. It boils at  $150^\circ\text{C}$  ( $300^\circ\text{F}$ ) with violent, sometimes explosive decomposition. Decomposition by light begins only in the near ultraviolet. As a solvent, hydrogen peroxide resembles water, except that acids and bases show much lower electrical conductivity. Although a fairly strong oxidant, it can act as a mild reducing agent, for example, with permanganates and perchromates.

Hydrogen peroxide is used mainly for bleaching cotton and other fibers, natural or synthetic. Increasing amounts are used in

the pulp and paper industry. Its well-known cosmetic use as hair bleach consumes relatively little of the commercial 10% (30 volume) solution. In medicine it is useful for cleansing wounds and cuts, although its antiseptic action is rather slow. A limited but important use of the concentrated peroxide is for energy production in rockets, submarines (during submersion), airplanes (at takeoff), and the steering of space vessels. See BLEACHING; CHEMICAL FUEL.

Hydrogen peroxide, especially when concentrated, requires great care in handling and storing. When dropped on paper or wood, it can start a fire. Contact with the skin causes blotches that can be painful, but they disappear after a few hours without leaving traces. See HYDROGEN; OXYGEN; PEROXIDE. [P.A.G.]

**Hydrogenation** The chemical reaction of hydrogen with another substance, generally an unsaturated organic compound, and usually under the influence of temperature, pressure, and catalysts. There are several types of hydrogenation reactions. They include: (1) the addition of hydrogen to reactive molecules; (2) the incorporation of hydrogen accompanied by cleavage of the starting molecules (hydrogenolysis); and (3) reactions in which isomerization, cyclization, and so on, result.

Hydrogenation is synonymous with reduction in which oxygen or some other element (most commonly nitrogen, sulfur, carbon, or halogen) is withdrawn from, or hydrogen is added to, a molecule. When hydrogenation is capable of producing the desired reduction product, it is generally the simplest and most efficient procedure.

Hydrogenation is used extensively in industrial processes. Important examples are the synthesis of methanol, liquid fuels, hydrogenated vegetable oils, fatty alcohols from the corresponding carboxylic acids, alcohols from aldehydes prepared by the aldol reaction, cyclohexanol and cyclohexane from phenol and benzene, respectively, and hexamethylenediamine for the synthesis of nylon from adiponitrile. See DEHYDROGENATION; FISCHER-TROPSCH PROCESS; HYDROFORMYLATION; HYDROGEN; OXIDATION-REDUCTION. [R.Le.]

**Hydrography** The measurement and description of the physical features and conditions of navigable waters and adjoining coastal areas, including oceans, rivers, and lakes. It involves geodesy, physical oceanography, marine geology, geophysics, photogrammetry (in coastal areas), remote sensing, and marine cartography. Basic parameters observed during a hydrographic survey are time, geographic position, depth of water, and bottom type. However, observation, analysis, and prediction of tides and currents area are also normally included in order to reduce depth measurements to a common vertical datum. See GEODESY; PHOTOGRAMMETRY.

A principal objective of hydrography is to provide for safe navigation and protection of the marine environment through the production of up-to-date nautical charts and related publications. In addition, hydrographic data are essential to a multitude of other activities such as global studies, for example, shoreline erosion and sediment transport studies; coastal construction; delimitation of maritime boundaries; environmental protection and pollution control; exploration and exploitation of marine resources, both living and nonliving; and development of marine geographic information systems (GIS). See GEOGRAPHIC INFORMATION SYSTEMS; NAVIGATION.

Modern depth information is achieved with sonar measurements. Dual-frequency echo sounders are used, with a high-frequency, narrow beam to measure the depth below the vessel, and a lower-frequency, wider beam to obtain larger coverage of the terrain. Side-scan sonar, an instrument that transmits acoustic signals obliquely through the water, is normally towed behind the survey vessel and displays the returning echoes via an on-board graphic recorder. Although this technique does not allow exact determination of position and depth (both can be approximated), it provides excellent resolution with a depiction with

what lies to either side of the vessel. Multibeam hydrographic survey systems consist of hull-mounted arrays such that a fan-shaped array of sound beams is transmitted perpendicular to the direction of the ship's track. This provides for the possibility of 100% coverage of the sea floor. See ECHO SOUNDER; SONAR.

Laser airborne systems mounted in fixed-wing aircraft or helicopters are also available for hydrographic surveys. The system emits a two-color laser beam, usually green and red, such that a return is received from the surface of the water by the red laser and from the bottom by the lower-frequency green laser, allowing the depth to be determined from the time difference. They can be operated in depths down to 165 ft (50 m), but more normally to 66 ft (20 m), depending on water clarity. Hydrographers use tide-coordinated aerial photography to delineate the high and low water lines for charting, which in turn is used for base-line determination of offshore boundaries. Satellite positioning of the aircraft using the Global Positioning System with carrier phase measurement and postprocessing of the data provides for determination of the position of the aircraft of the decimeter level. See AERIAL PHOTOGRAPHY; LASER. [C.An.; G.An.]

**Hydroida** An order of the coelenterates which includes the fresh-water hydras, the attached and usually colonial hydroids, and many of the smaller jellyfish. It is the largest order of the class Hydrozoa.

The order Hydroida includes two principal suborders, Gymnoblastera and Calyptoblastera. The Gymnoblastera are those hydroids which lack protective cups around the hydranths and gonozoids. Jellyfish produced by these athecate hydroids are Anthomedusae. The Calyptoblastera include the hydroids with protective cups around the hydranths (hydrothecae) and around the gonozoids (gonothecae). Jellyfish of these thecate hydroids are called Leptomedusae. Two minor suborders are Limnomedusae and Chondrophora.

Anthomedusae are typically ovoid jellyfish, often with eyespots. Leptomedusae are usually flattened or saucer-shaped, have statocysts (sense organs of balance), and lack eyespots. The gonads of Anthomedusae are generally on the wall of the

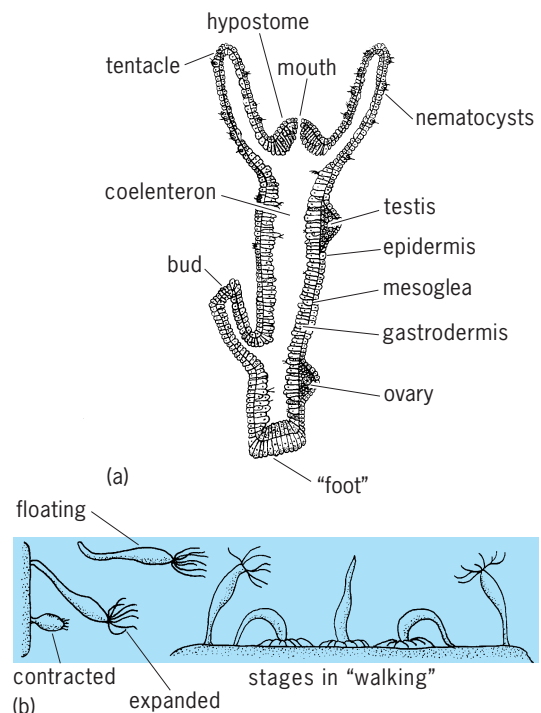

**Hydra.** (a) Longitudinal section. (b) Movements. (After T. I. Storer et al., *General Zoology*, 6th ed., McGraw-Hill, 1979)

stomach just above the mouth, and those of Leptomedusae below the radial canals.

Young hydranths of gymnoblastic hydroids are small with five or more tentacles, but subsequently grow much larger and add more tentacles. Calyptoblastic hydranths, in contrast, emerge from a bud with a full complement of parts; they do not grow, live for only about a week, undergo regression and absorption by the colony, and are then replaced by new hydranths.

The fresh-water hydras are simple, motile polyps which do not produce colonies (see illustration). Buds separate from the parent and become individual polyps. Simple gonads develop on the body and there is no medusa. Hydras are sometimes included in the Gymnoblastera and sometimes placed in a suborder by themselves, the Hydrida.

Hydroids are species in which the polyp stage is usually dominant. Most hydroids are found near the shore attached to various supports such as rocks, wharves, boats, mussels, barnacles, worm tubes, crab and snail shells, and seaweeds. Sometimes the medusa stage is well developed and the hydroid stage may be lacking. Medusae are abundant both in coastal waters and in the open sea.

Hydras and hydroids have been used extensively in research on problems of growth, development, and regeneration. They have a high capacity for reorganization. Missing parts are quickly replaced, a bit of stem can produce a new hydranth, and completely disorganized masses of cells can reconstitute a new polyp. See HYDROZOA; REGENERATION (BIOLOGY). [S.Cr.]

**Hydrology** The study of the waters of the Earth: their occurrence, circulation, and distribution; their chemical and physical properties; and their reaction with the environment, including their relation to living things. See TERRESTRIAL WATER.

Water in liquid and solid form covers most of the crust of the Earth. By a complex process powered by gravity and the action of solar energy, an endless exchange of water, in vapor, liquid, and solid forms, takes place between the atmosphere, the oceans, and the crust. This is known as the hydrologic cycle. Water circulates in the air and in the oceans, as well as over and below the surface of landmasses. The distribution of water in the planet is uneven. General patterns of circulation are present in the atmosphere, the oceans, and the landmasses, but regional features are very irregular and seemingly random in detail. Therefore, while causal relations underlie the overall process, it is believed that important elements of chance affect local hydrological events. See ATMOSPHERIC GENERAL CIRCULATION.

Whereas the global linkages of the hydrologic cycle are recognized, the science of hydrology has traditionally confined its direct concern to the detailed study of the portion of the cycle limited by the physical boundaries of the land; thus, it has generally excluded specialized investigations of the ocean (which is the subject of the science of oceanography) and the atmosphere (which is the subject of the science of meteorology). The heightened interest in anthropogenically induced environmental impacts has, however, underlined the critical role of the hydrologic cycle in the global transport and budgeting of mass, heat, and energy. Hydrology has become recognized as a science concerned with processes at the local, regional, and global scales. This enhanced status has strengthened its links to meteorology, climatology, and oceanography. See CLIMATOLOGY; METEOROLOGY; OCEANOGRAPHY.

A number of field measurements are performed for hydrologic studies. Among them are the amount and intensity of precipitation; the quantities of water stored as snow and ice, and their changes in time; discharge of streams; rates and quantities of infiltration into the soil, and movement of soil moisture; rates of production from wells and changes in their water levels as indicators of ground-water storage; concentration of chemical elements, compounds, and biological constituents in surface and ground waters; amounts of water transferred by evaporation and evapotranspiration to the atmosphere from snow, lakes,

streams, soils, and vegetation; and sediment lost from the land and transported by streams.

In addition, hydrology is concerned with research on the phenomena and mechanisms involved in all physical and biological components of the hydrologic cycle, with the purpose of understanding them sufficiently to permit quantitative predictions and forecasting. The field investigations and measurements not only provide the data whereby the behavior of each component may be evaluated in detail, permitting formulation in quantitative terms, but also give a record of the historical performance of the entire system. Thus, two principal vehicles for hydrological forecasting and prediction become available: a set of elemental processes, whose operations are expressible in mathematical terms, linked to form deterministic models that permit the prediction of hydrologic events for given conditions; and a group of records or time series of measured hydrologic variables, such as precipitation or runoff, which can be analyzed by statistical methods to formulate stochastic models that permit inferences to be made on the future likelihood of hydrologic events. See GROUND-WATER HYDROLOGY; HYDROSPHERE. [M.A.Ma.]

**Hydrolysis** A chemical reaction in which splitting of a molecule by water occurs. Hydrolysis as applied to organic molecules can be considered a reversal of such reactions as esterification and amide formation. The hydrolysis of esters [reaction (1)] and of amides [reaction (2)] is shown. Other classes of

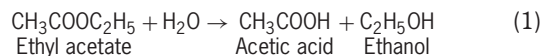

organic compounds that are subject to hydrolysis include acetals, acyl and alkyl halides, ketals, and peptides. While the overall hydrolysis reaction [as in reactions (1) and (2)] appears to involve the addition of the water molecule ( $\text{H}_2\text{O}$ ), the reaction is in fact more complicated. There are several reaction steps, such as the formation of a complex with either a proton ( $\text{H}^+$ ; acid-catalyzed hydrolysis) or a hydroxyl ion ( $\text{OH}^-$ ; base-catalyzed hydrolysis), followed by elimination of these ions to give the overall equation. The hydrolysis reaction is frequently encountered in biological systems. The kinetics of these reactions are greatly enhanced by the action of enzymes (biological catalysts) such as the esterases and the peptidases. See ENZYME; HYDROGEN ION.

In inorganic chemistry, hydrolysis, also called aquation, represents a class of reactions involving metal coordination complexes in which one of the coordinated ligands is displaced by either  $\text{H}_2\text{O}$  or  $\text{OH}^-$ . Hydrolysis is a special case of the class of reactions termed ligand displacement reactions [reaction (3), where M is



a metal, L and X are ligands, and Y is the displacing ligand ( $\text{H}_2\text{O}$  in hydrolytic reactions)]. See COORDINATION COMPLEXES; LIGAND. [H.Frei.]

**Hydrolytic processes** Reactions of both organic and inorganic chemistry wherein water effects a double decomposition with another compound, hydrogen going to one component, hydroxyl to another, as in reactions (1)–(3). Although



the word "hydrolysis" means decomposition by water, cases in which water brings about effective hydrolysis unaided are rare, and high temperatures and pressures are usually necessary. See HYDROLYSIS.

Hydrolytic reactions may be classified as follows: (1) hydrolysis with water alone; (2) hydrolysis with dilute or concentrated acid;

(3) hydrolysis with dilute or concentrated alkali; (4) hydrolysis with fused alkali with little or no water at high temperature.

In the field of organic chemistry, the term "hydrolysis" has been extended to cover the numerous reactions in which alkali or acid is added to water. An example of an alkaline-condition hydrolytic process is the hydrolysis of esters, reaction (4), to



produce alcohol. An example of an acidic-condition process is the hydrolysis of olefin to alcohol in the presence of phosphoric acid, reaction (5). The addition of acids or alkalies hastens such

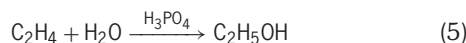

reactions even if it does not initiate the reaction.

Perhaps some of the oldest and largest-volume hydrolysis technology is involved in soap manufacture. In the first step, glyceryl stearate acid, a fat, is hydrolyzed with water to yield stearic acid and glycerin. In the second step, the stearic acid is neutralized with caustic soda to give sodium stearate, the soap, and water. See FAT AND OIL.

Hydrolytic processes account for a huge product volume. Conversion of starch such as corn starch into maltose and glucose (sugar syrups) by treatment with hydrochloric acid is a major industry. Similarly, the production of furfural from pentosans of oat hulls or other cereal by-products such as corn cobs, rice hulls, or cottonseed bran is another commercial hydrolytic process.

[D.L.H.]

**Hydrometallurgy** The extraction and recovery of metals from their ores by processes in which aqueous solutions play a predominant role. Two distinct processes are involved in hydrometallurgy: putting the metal values in the ore into solution via the operation known as leaching; and recovering the metal values from solution, usually after a suitable solution purification or concentration step, or both. The scope of hydrometallurgy is quite broad and extends beyond the processing of ores to the treatment of metal concentrates, metal scrap and revert materials, and intermediate products in metallurgical processes. Hydrometallurgy enters into the production of practically all nonferrous metals and of metalloids, such as selenium and tellurium. Hydrometallurgical and pyrometallurgical processes complement each other. See LEACHING; PYROMETALLURGY.

Hydrometallurgy occupies an important role in the production of aluminum, copper, nickel, cobalt, zinc, gold, silver, platinum, selenium, tellurium, tungsten, molybdenum, uranium, zirconium, and other metals. See METALLURGY.

[W.C.Co.]

**Hydrometeorology** The study of the occurrence, movement, and changes in the state of water in the atmosphere. The term is also used in a more restricted sense, especially by hydrologists, to mean the study of the exchange of water between the atmosphere and continental surfaces. This includes the processes of precipitation and direct condensation, and of evaporation and transpiration from natural surfaces. Considerable emphasis is placed on the statistics of precipitation as a function of area and time for given locations or geographic regions.

Water occurs in the atmosphere primarily in vapor or gaseous form. The average amount of vapor present tends to decrease with increasing elevation and latitude and also varies strongly with season and type of surface. Precipitable water, the mass of vapor per unit area contained in a column of air extending from the surface of the Earth to the outer extremity of the atmosphere, varies from almost zero in continental arctic air to about 6 g/cm<sup>2</sup> in very humid, tropical air.

Although a trivial proportion of the water of the globe is found in the atmosphere at any one instant, the rate of exchange of water between the atmosphere and the continents and oceans is high. Evaporation from the ocean surface and evaporation and transpiration from the land are the sources of water vapor for the

atmosphere. Water vapor is removed from the atmosphere by condensation and subsequent precipitation in the form of rain, snow, sleet, and so on. The amount of water vapor removed by direct condensation at the Earth's surface (dew) is relatively small. See HYDROLOGY; METEOROLOGY; PRECIPITATION (METEOROL-OGY).

[E.M.R.]

**Hydrometer** A direct-reading instrument for indicating the density, specific gravity, or some similar characteristic of liquids. Almost all hydrometers are made of a high-grade glass tubing. The main body is the float section in the bottom of which ballast, such as small shot, is secured. A small-diameter tube, the stem, extends from the upper end of the float section. Inside the stem is the scale, printed on heavy-grade paper, and well-secured within the stem so its position will not change. When the hydrometer is placed in a liquid, the stem extends vertically above the surface for a portion of its length.

Hydrometers may be classified according to the indication provided by graduations of the scale as follows: (1) density hydrometers, to indicate densities at a particular temperature, and usually for a particular liquid; (2) specific gravity hydrometers to indicate specific gravity of a liquid, with reference to water, at a particular temperature; (3) percentage hydrometers to indicate, at a particular temperature, the percentage of a substance such as salt, sugar, or alcohol dissolved in water (alcoholometers are an example); and (4) arbitrary scale hydrometers, indicating the density, specific gravity, or concentration of a liquid in terms of an arbitrarily defined scale, at a defined temperature. The last group includes the saccharimeter (indicates percentage of pure sucrose solutions); the Baumé hydrometer (measures specific gravity of liquids lighter than water); the lactometer (tests milk); and the barkometer (tests tanning extracts). See DENSITY; SPECIFIC GRAVITY.

[H.S.B.]

**Hydrophone** A device which receives underwater sound waves and converts them to essentially equivalent electric waves. A hydrophone is the underwater analog of a microphone. Hydrophones are used in sonar apparatus, sonobuoys, and certain underwater weapons. See ACOUSTIC TORPEDO; MICROPHONE; SONAR; SONOBUOY; UNDERWATER SOUND.

[H.F.O.]

**Hydroponics** Techniques for supplying nutrients and water directly to the roots of plants, without soil or other media. Methods that utilize an inert medium such as sand, gravel, peat, or vermiculite to provide the root environment, with water and nutrients added in solution, are soilless culture but are not hydroponic in the strict sense.

Hydroponic systems range in complexity from a single plant supported above an aerated jar of nutrient solution to thousands of plants supported above a large area of flowing solution in which pH, temperature, and nutrient concentrations are controlled by using a sophisticated computer system and automated chemical analysis. In hydroponic culture, precise control of the pH and the concentrations of elements in the solution is critical; all essential elements must be provided and in the correct ratios for plant growth. See PLANT MINERAL NUTRITION.

Hydroponic systems offer a number of advantages when compared to soil culture. They reduce water, pH, and nutrient stress; yield clean roots and leaves; and facilitate rapid crop turnaround and automation. The disadvantages are that disease may spread more rapidly, pH and nutrient control are required, and initial expenses are higher. In theory, the growth-limiting factors in hydroponic systems are the availability of photosynthetic light and carbon dioxide. See PHOTOSYNTHESIS.

Among typical hydroponic systems are aerated standing culture, intermittent-flow culture, and continuous-flow culture. These techniques require careful preparation of the nutrient solution, continued monitoring, and adjustment or periodic replacement of the solution.

Hydroponic culture is widely used in research on plant nutrition and on the effect of temperature and pH on roots. Hydroponics can also be used to study the effect of microbes on plant health. Hydroponic systems also have obvious value in the field of education and for the amateur horticulturist, who can grow flowers or vegetables in a confined space with an indoor hydroponic garden. See PLANT GROWTH. [T.W.D.]

**Hydrosphere** The water portion of the Earth as distinguished from the solid part and from the gaseous outer envelope (atmosphere). Approximately 74% of the Earth's surface is covered by water, in either the liquid or solid state. These waters, combined with minor contributions from ground waters, constitute the hydrosphere.

The oceans account for about 97% of the weight of the hydrosphere, while the amount of ice reflects the Earth's climate, being higher during periods of glaciation. There is a considerable amount of water vapor in the atmosphere. The circulation of the waters of the hydrosphere results in the weathering of the landmasses. The annual evaporation from the world oceans and from land areas results in an annual precipitation of 320,000 km<sup>3</sup> (76,000 mi<sup>3</sup>) on the world oceans and 100,000 km<sup>3</sup> (24,000 mi<sup>3</sup>) on land areas. The rainwater falling on the continents, partly taken up by the ground and partly by the streams, acts as an erosive agent before returning to the seas.

The unique chemical properties of water make it an effective solvent for many gases, salts, and organic compounds. Circulation of water and the dissolved material it contains is a highly dynamic process driven by energy from the Sun and the interior of the Earth. Each component has its own geochemical cycle or pathway through the hydrosphere, reflecting the component's relative abundance, chemical properties, and utilization by organisms. The introduction of materials by humans has significantly altered the composition and environmental properties of many natural waters. See GROUND-WATER HYDROLOGY; HYDROLOGY; LAKE; TERRESTRIAL WATER. [J.S.H.]

**Hydrostatics** The study of liquids at rest. In the absence of motion, there are no shear stresses; the internal state of stress at any point is determined by pressure alone. Hence, the pressure at a point is the same in all directions. Pressure acts normally to all boundary surfaces. For equilibrium under gravity, regardless of the shape of the containing vessel, the pressure is uniform over any horizontal cross section. Pressure varies with height or depth. Two different reference levels are used in measuring pressure. For many engineering purposes, gage pressure is used with pressure measured relative to atmospheric pressure as zero. For most scientific purposes, pressure is referred to true zero. Normal atmospheric pressure at sea level caused by the weight of the air above is approximately 101 kilopascals or 14.7 pounds per square inch absolute.

The buoyant force is the force exerted vertically upward by a fluid on a body wholly or partly immersed in it. Its magnitude is equal to the weight of the fluid displaced by the body. This value is also the vertical component of the fluid pressure force acting upward against the bottom of the body minus the fluid pressure force component (if any) acting vertically downward against the top of the body. If this buoyant force equals the weight of the body, the body will remain at the given level. If it exceeds the weight of the body, the latter will rise, and vice versa. The buoyant force as a single magnitude acts vertically upward through the center of buoyancy which is the center of gravity of the displaced fluid. See ARCHIMEDES' PRINCIPLE.

Pressure applied to a confined liquid is transmitted with equal intensity throughout the liquid and by it to all surfaces of the confining vessel or piping. Hence, a small force applied to a small area of a confined liquid can create a large force against a large area. If the small and large areas are pistons the device may be a hydraulic press or jack. Because the transmitting liquid is practically incompressible and its volume virtually constant,

the linear movement of the large piston will be to that of the small piston in inverse proportion to their areas. The principle of multiplying a force by means of liquid pressure applies also to hydraulic brakes, power steering, control systems, and the like; the actuating force may be a pump instead of a small piston. See HYDRAULICS. [W.A.]

**Hydrothermal vent** A hot spring on the ocean floor, where heated fluids exit from cracks in the Earth's crust. Most hydrothermal vents occur along the central axes of mid-oceanic ridges, which are underwater mountain ranges that wind through all of the deep oceans. The best-studied vents are at tectonic spreading centers on the East Pacific Rise and at the Mid-Atlantic Ridge. However, vents are also found over hot spots such as the Hawaiian Islands and Iceland, in back-arc basins such as those in the western Pacific, in shallow geothermal systems such as those off the Kamchatka Peninsula, and on the flanks of some underwater volcanoes and seamounts. Hydrothermal vent sites, or closely grouped clusters of vent deposits and exit ports, may cover areas from hundreds to thousands of square feet (tens to hundreds of square meters). Individual vent sites may be separated along mid-ocean ridges by more than 1000 mi (1600 km). See MID-OCEANIC RIDGE; SEAMOUNT AND GUYOT.

All of the hydrothermal vent sites occur in areas where quantities of magma exist below the sea floor. Cold seawater is drawn down into the oceanic crust toward the heat source. As the seawater is heated and reacts with surrounding rock, its composition changes. Sulfate and magnesium are major components of seawater lost during the reactions; sulfide, metals, and gases such as helium and methane are major components gained. This modified seawater is known as hydrothermal fluid. Buoyant, hot hydrothermal fluid rises toward the sea floor in a concentrated zone of upflow to exit from the sea floor at temperatures ranging from 50°F (10°C) to greater than 750°F (400°C), depending on the degree of cooling and of mixing with seawater during the ascent. If the sea floor is shallow enough and the fluid hot enough, the solution may boil; but it usually does not because of the pressure of overlying seawater. See MAGMA.

Hydrothermal fluid that mixes extensively with seawater below the sea floor surface may reach the sea floor as warm springs, with temperatures of 50–86°F (10–30°C). This outflow is usually detectable as cloudy or milky water, but the flow is slow and no mineral deposits accumulate except for some hydrothermal staining or oxidation of sea floor basalts. When hotter, relatively undiluted hydrothermal fluid reaches the sea floor, it is still buoyant with respect to seawater, so that the hot solution rises out of cracks in the sea floor at velocities up to about 6 ft (2 m) per second, mixing turbulently with seawater as it rises. Mixing of hydrothermal fluid with seawater leads to precipitation of minerals from solution, forming mineral deposits at the exit from the sea floor and so-called smoke, tiny mineral particles suspended in the rising plume of fluid. Black smoker vents are distinguished by the presence of such large quantities of minute mineral particles that the plumes become virtually opaque.

Formation and outflow of hydrothermal fluid makes a major contribution to the concentration and balance of elements in the oceans by changing the composition of seawater. The quantities of elements added or removed from the oceans by hydrothermal venting around the world are comparable to quantities contributed by the worldwide flow of rivers into the oceans. Hydrothermal venting also represents a major flow of heat from the Earth's crust and a major mechanism for cooling of new oceanic lithosphere. See LITHOSPHERE; SEAWATER.

Perhaps the most striking feature of sea-floor hydrothermal vents is their dense biologic communities. Vent faunas tend to be dominated by mollusks, annelids, and crustaceans, whereas faunas on nonvent hard-bottom habitats consist predominantly of cnidarians, sponges, and echinoderms. Biologically, vents are among the most productive ecosystems on Earth. Sulfide from hydrothermal fluids provides the energy to drive these produc-



tive systems. Whereas most animal life depends on food of photosynthetic origin (inorganic carbon converted to useful sugars by plants using energy from the Sun), the animals at hydrothermal vents obtain most or all of their food by a process of chemosynthesis. Chemosynthesis is accomplished by specialized bacteria residing in hydrothermal fluids, in mats on the sea floor, or in symbiotic relationships with other organisms. The bacteria convert inorganic carbon to sugars by mediating the oxidation of hydrogen sulfide, thereby exploiting the energy stored in chemical bonds. A few vent animals are also known to use methane gas as a source of energy and carbon. The physical and chemical conditions at hydrothermal vents would be lethal to most marine animals, but vent species have adapted to the conditions there. See DEEP-SEA FAUNA.

In a remarkable discovery, it was shown that chemosynthetic microbes known as Archaea are flushed from cavities deep within the Earth's crust by hydrothermal and volcanic activity. These microbes are hyperthermophilic (hot-water-loving) and thrive at temperatures exceeding 90°C (194°F). It is now suspected that an entire community of such microbes inhabits the rocks deep within the water-saturated portions of the Earth's crust. See MARINE GEOLOGY. [M.Go.]

**Hydroxide** A compound containing the hydroxide ion (OH<sup>-</sup>) and having the general formula M(OH)<sub>n</sub>, where M represents a metal. Hydroxides are a subset of compounds containing the hydroxyl group (—OH) and range in chemical character from strongly basic, to amphoteric (having both acidic and basic characteristics), to essentially acidic. The hydroxide ion has a closed-shell electronic structure with a singlet ground state.

In the Lewis acid-base scheme, where a base is defined as an electron pair donor and an acid as an electron pair acceptor, a typical hydroxide decreases in base strength as attraction for electrons of the cation increases. For example, the hydroxides of electropositive elements such as the alkali metals and alkaline earths tend to be bases. When these ionic compounds are dissolved in water, they form metal ions and hydroxide ions, as in reaction (1), where S represents a solid and aq represents a water

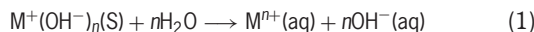

solution. The hydroxides of nonmetals (X) such as boron hydroxide [B(OH)<sub>3</sub>], where the X-O bonds are covalent, are generally acidic, as shown in reaction (2), where H<sub>3</sub>O<sup>+</sup> is the hydronium

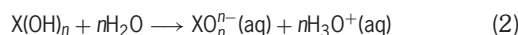

ion. The amphoteric hydroxides may dissociate by either mechanism, depending on the presence of strong acids or bases. See ACID AND BASE; HYDROGEN ION.

The alkali metal hydroxides such as sodium hydroxide (NaOH) are extremely important as reagents in metallurgy and photography and in the manufacture of soaps and detergents. Calcium hydroxide [Ca(OH)<sub>2</sub>], known as slaked lime, is used in the preparation of mortar for brick laying. Minerals such as brucite [Mg(OH)<sub>2</sub>] and pyrochroite [Mn(OH)<sub>2</sub>] are naturally occurring hydroxides. [T.J.Me.]

**Hydroxyl** A chemical group in which oxygen and hydrogen are bonded and act as a single entity. In inorganic chemistry the hydroxyl group is known as the hydroxide ion (OH<sup>-</sup>), and it is frequently bonded to metal cations, for example, sodium hydroxide (NaOH). In organic chemistry it frequently acts as a functional group, for example, in an alcohol (ROH, where R represents an alkyl group). See ACID AND BASE.

Many of the intermediate redox forms of dioxygen are toxic and damage important biomolecules. Much of this toxicity is thought to involve the generation and reactivity of hydroxyl (·OH), which is sometimes called the hydroxy radical. The most common means for producing hydroxyl is the reaction of a reducing agent with hydrogen peroxide (H<sub>2</sub>O<sub>2</sub>). Transition-metal

ions, such as ferrous ion (Fe<sup>2+</sup>), are the most common reducing agents for generating ·OH.

Once generated, hydroxyl is a potent one-electron oxidant that forms the very stable OH<sup>-</sup> ion, and it abstracts hydrogen atoms from organic molecules that contain C-H bonds to form the stronger O-H bond in water. The reaction of a radical, which contains an uneven number of electrons, with a molecule, which contains an even number of electrons paired in bonds, must generate a radical, because the number of electrons cannot change during the reaction. Thus, most reactions of radicals generate new radicals in processes called radical chain reactions. Reactions of radicals with molecules will continue to produce new radicals until other odd-electron species (such as transition-metal ions or other radicals) react with the radicals to produce even-electron molecules via termination reactions. See TRANSITION ELEMENTS. [H.H.T.]

**Hydrozoa** A class of the phylum Coelenterata which includes the fresh-water hydras, the marine hydroids, many of the smaller jellyfish, a few special corals, and the Portuguese man-of-war. The Hydrozoa may be divided into six orders: the Hydroida, Milleporina, Stylasterina, Trachylina, Siphonophora, and Spongiomorphida. See separate article on each order.

The form of the body varies greatly among the hydrozoans. This diversity is due in part to the existence of two body types, the polyp and the medusa. A specimen may be a polyp, a medusa, a colony of polyps, or even a composite of the first two. Polyps are somewhat cylindrical, attached at one end, and have a mouth surrounded by tentacles at the free end. Medusae are free-swimming jellyfish with tentacles around the margin of the discoidal body.

In a representative life cycle, the fertilized egg develops into a swimming larva which soon attaches itself and transforms into a polyp. The polyp develops stolons (which fasten to substrates), stems, and other polyps to make up a colony of interconnected polyps. Medusae are produced by budding and liberated to feed, grow, and produce eggs and sperm.

Most hydrozoans are carnivorous and capture animals which come in contact with their tentacles. The prey is immobilized by poison injected by stinging capsules, the nematocysts. Most animals of appropriate size can be captured, but small crustaceans are probably the most common food. See COELENTERATA. [S.C.]

**Hyena** An African carnivore represented by three species of the family Hyaenidae. Hyenas resemble dogs superficially, but they are more closely related to the felids (cats). They are four-toed digitigrade (walking on the toes) animals with blunt, non-retractile claws that are used for digging and disinterring bodies. The gestation period is about 13 weeks, with two to four young composing the yearly litter. The maximum lifespan of this animal is about 25 years. See CARNIVORA. [C.B.C.]

**Hyeniales** An order of Devonian plants considered to be related to the Sphenopsida. The small dichotomously forked leaves tend to be borne in whorls. Some leaves bear terminal sporangia, but these appendages are neither aggregated into a tight cone nor separated by bracts. See PALEOBOTANY. [H.P.B.]

**Hygrometer** An instrument for giving a direct indication of the amount of moisture in the air or other gas, the indication usually being in terms of relative humidity as a percentage that the moisture present bears to the maximum amount of moisture that could be present at the location temperature without condensation taking place. There are three major types of hygrometers: mechanical, electrical, and cold-spot or dew-point. See DEW POINT; HUMIDITY.

In a simple mechanical type of hygrometer the sensing element is usually an organic material which expands and contracts with changes in the moisture in the surrounding air or gas. The

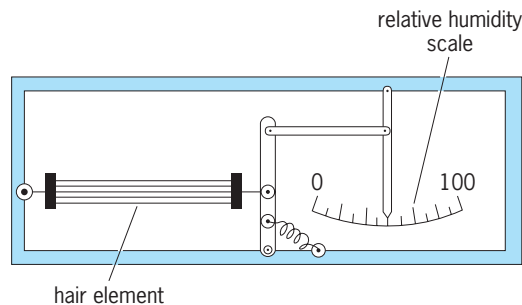

Hygrometer which uses hair as the sensing element. (After D. M. Considine and S. D. Ross, *Process Instruments and Controls Handbook*, 2d ed., McGraw-Hill, 1974)

material used most is human hair. As shown in the illustration, the bundle of hair is held under a slight tension by a spring, and a magnifying linkage actuates a pointer.

In an electrical hygrometer the change in the electrical resistance of a hygroscopic substance is measured and converted to percent relative humidity.

In a third group of hygrometers, commonly called dew-point apparatus, the dew-point temperature is determined; this is the temperature at which the moisture in the gas is at the point of saturation, or 100% relative humidity. The usual procedure is to chill a polished surface until dew or a film of moisture just starts to appear and to measure the temperature of the surface. [H.S.B.]

**Hymenomyces** An artificial class of fungi in the phylum Basidiomycota. It was traditionally divided into two subclasses: Holobasidiomycetidae, delimited by nonseptate basidia and the absence of a yeast phase; and Phragmobasidiomycetidae, frequently with septate basidia and often forming a yeast phase. A typical hymenomyces produces a fruit body or basidiome with spore-bearing basidia organized in a membranous layer called the hymenium. The shape of the hymenium varies from lamellate (gilled as in mushrooms), poroid (as in conk or bracket fungi), toothed (in hedge hog fungi), coralloid (coral fungi), labyrinthoid (daedaleoid fungi), wrinkled (meruloid fungi), or smooth to diffuse (corticoid fungi). Exceptional hymenomyces may be aquatic, lack a mycelial phase, or lack a fruit body.

Antibiotics have been isolated from many species. Commercially grown edible species include the button mushroom (*Agaricus bisporus*), Shiitake (*Lentinula edodes*), Paddy Straw mushroom (*Volvariella volvacea*), and Wood Ear (*Auricularia polytricha*). Wild harvested species include the Matsutake (*Tricholoma matsutake* and *T. magnivelare*), chanterelles (*Cantharellus cibarius* and allies), and the King Boletus (*Boletus edulis*).

Most genera are either saprophytic (for example, *Agaricus* and *Polyporus*), or mycorrhizal with trees (*Albatrellus*, *Cortinarius*, *Ramaria*, and *Thelephora*). Others are parasites. *Heterobasidion* causes destructive tree diseases; *Rhizoctonia* and *Typhula* (snow molds) cause field crop losses; *Mycena citricolor* blights coffee leaves; and *Exobasidium*, an obligate plant pathogen, induces the formation of galls and leaf curls. Other notable pathogens include *Hohenbuehelia* and *Pleurotus*, which capture nematodes; *Serpula*, a major dry-rot agent; *Dictyonema*, a basidiolichen; and *Septobasidium*, which harnesses living scale insects. See BASIDIOMYCOTA; EUMYCOTA; FUNGI; PLANT PATHOLOGY. [S.A.R.]

**Hymenoptera** The third largest order of insects, containing the sawflies, ants, wasps, bees, and related forms. Conservative estimates suggest that the world fauna may comprise well over 100,000 described species of this order, with many thousands still to be described. See INSECTA.

This order is of great importance to humans. Some members such as the sawflies, certain chalcidoids, and most cynipoids, feed during the larval stage on foliage or other plant tissues. Many species, such as the ichneumon flies, most chalcid flies, and wasps, are parasites or predators of other insects or spiders during their larval stage. Bees are indispensable in the pollination of many fruits, vegetables, and forage crops. See BEE.

Hymenoptera occur in all major faunal zones but are more abundant and have greater diversity of species in the tropical and temperate zones.

Adult Hymenoptera usually may be recognized by having two pairs of membranous wings with reduced venation, the hind pair smaller than the front pair, and by mouthparts formed for biting and often for lapping or sucking. In the higher forms, the abdomen is constricted basally, its first segment fused with the hind part of the thorax. Females always have an ovipositor modified for sawing, piercing, or stinging. Metamorphosis is complete.

The first four superfamilies of the Apocrita—the Ichneumonoidea, Chalcidoidea, Cynipoidea, and Proctotrupeoidea—are commonly called the Parasitica, and the remaining superfamilies are known as the Aculeata. The Aculeata are stinging forms and the Parasitica are parasites of other insects. It is impossible to demarcate these two groups sharply because some Aculeata are parasites and some Parasitica are phytophagous. However, except for the phytophagous species of Parasitica, these insects lay their eggs in or on an insect or spider host while the Aculeata place theirs in nests with a provision of food. The table presents the major classification of the order as recognized in North America.

**Morphology.** The adult hymenopteran has a clearly differentiated head, thorax, and abdomen. Wings, when present, and legs are attached to the thorax.

Typically the head is so oriented that mouthparts are directed downward; however, all variations occur, and in some species the mouthparts are directed forward. The large compound eyes occupy much of the sides of the head, though they are reduced in size in many ants and some Parasitica. Three ocelli are typically present on the top of the head, but may be reduced or absent in wingless forms. The paired antennae arise from the face between the eyes, and they may be close to the mouthparts or removed from them.

The thorax consists of three segments, tightly fused together. Each segment bears a pair of legs, and each of the last two segments bears a pair of wings. In flight, the fore- and hind-wings are joined by a row of tiny hooks along the fore margin of the posterior wing, which fit into the downfolded hind margin of the anterior wing. Flightless species with shortened, nonfunctional wings, or no wings at all occur in most major groups, except the sawflies and bees.

The abdomen primitively consists of 10 segments, though the number appears to be less because of modification or loss in the higher forms. The female ovipositor, or sting, is formed from processes of the eighth and ninth sterna.

In the Apocrita there is a pair of acid glands opening into a poison sac connected with the ovipositor. The secretion of these glands produces either a temporary paralysis when injected into their hosts by some Parasitica, or, usually, permanent paralysis when injected into their prey by aculeate wasps. Bees use their stings purely for defense. When a human is stung, the enzymes react with the tissues to release histamine. Death may occasionally result from anaphylactic shock, or from mechanical suffocation due to swelling of the lymphatic system. Medical assistance should be sought if severe swelling occurs following a sting, especially one on the face or throat.

**Biology.** Practically all hymenopterous adults are terrestrial forms, living in, on, or near the Earth's surface. A few species are secondarily aquatic, the adults swimming or walking under water to search out and parasitize aquatic or subaquatic hosts.

Most adults feed on plant nectar or honeydew secretions of various insects. A few sawflies prey on other insects. Some

Families of Hymenoptera					
Classification	Common name	No. of species	Classification	Common name	No. of species
<b>Suborder Symphyta</b>	Sawflies	1009	<b>Suborder Apocrita</b>		
<b>Superfamily</b>			<b>(cont.)</b>		
<b>Megalodontoidea</b>		120	<b>Superfamily</b>		
Xyelidae		33	<b>Proctotrupoidea</b>		985
Pamphiliidae	Web-spinning sawflies	87	Evaniidae	Ensign flies	11
<b>Superfamily</b>			Gasteruptionidae		50
<b>Tenthredinoidea</b>		849	Pelecinidae	Pelecinid wasps	50
Pergidae		13	Vanhorniidae		1
Argidae		32	Roproniidae		3
Cimbicidae	Cimbicid sawflies	12	Heloridae		1
Diprionidae	Conifer sawflies	35	Proctotrupidae		54
Tenthredinidae	Sawflies	757	Ceraphronidae		101
<b>Superfamily</b>			Diapriidae		304
<b>Siricoidea</b>		28	Scelionidae	Scelionid wasps	272
Syntexidae		1	Platygasteridae		182
Siricidae	Horntails	15	Trigonalidae		5
Xiphydriidae		6	<b>Superfamily</b>		
Orussidae		6	<b>Bethylloidea</b>		345
<b>Superfamily</b>			Chrysididae	Cuckoo wasps	124
<b>Cephoidea</b>		12	Bethylidae		100
Cephidae	Stem sawflies	12	Sclerogibbidae		1
<b>Suborder Apocrita</b>		13,346	Dryinidae		120
<b>Superfamily</b>			<b>Superfamily</b>		
<b>Ichneumonoidea</b>		3814	<b>Scolioidea</b>		643
Stephanidae		7	Tiphidae	Tiphid wasps	185
Braconidae	Braconid wasps	1239	Sierolomorphidae		2
Ichneumonidae	Ichneumon flies	2568	Mutillidae	Velvet ants	409
<b>Superfamily</b>			Rhopalosomatidae		2
<b>Chalcidoidea</b>		2032	Scoliidae		26
Mymaridae	Fairy flies	110	Sapygidae		19
Trichogrammatidae	Minute egg parasites	39	<b>Superfamily</b>		
Eulophidae		544	<b>Formicoidea</b>		786
Elasmidae		17	Formicidae	Ants	786
Thysanidae		18	<b>Superfamily</b>		
Eutrichosomatidae		2	<b>Vespoidea</b>		368
Tanaostigmatidae		4	Vespidae	Hornets, yellow jackets, potter wasps	368
Encyrtidae		320	<b>Superfamily</b>		
Eupelmidae		89	<b>Pompiloidea</b>		279
Eucharitidae		27	Pompilidae	Spider wasps	279
Perilampidae		31	<b>Superfamily</b>		
Agaontidae	Fig insects	2	<b>Sphecoidea</b>		1215
Torymidae	Torymids	181	Ampulicidae		3
Ormyridae		17	Sphecidae		1212
Pteromalidae		321	<b>Superfamily</b>		
Eurytomidae	Seed and stem chalcids	203	<b>Apoidea</b>		3304
Chalcididae	Chalcids	101	Colletidae	Bees	149
Leucospidae		6	Andrenidae	Colletid bees	852
<b>Superfamily</b>			Halictidae	Andrenidae bees	472
<b>Cynipoidea</b>		877	Melittidae	Halictid and sweat bees	31
Ibaliidae	Gall wasps	6	Megachilidae	Melittidae	31
Liopteridae		2	Apidae	Leafcutting bees	730
Figitidae		58		Honeybees, bumblebees, and carpenter bees	1076
Cynipidae	Cynipids of gall wasps	811			

species of Parasitica and Aculeata imbibe body juices of the host or prey which they attack primarily for oviposition.

Mating takes place in a variety of situations, but it is always of rather short duration. Most species are represented by both males and females. Males are usually produced from unfertilized eggs and have half the normal number of chromosomes, while females are produced from fertilized eggs and have the normal number of chromosomes.

Hymenoptera exhibit complete metamorphosis during development and pass through an egg, larval, and pupal state. So far as is known, Hymenoptera always lay eggs. These are deposited in a protected situation on or near the supply of larval food. The hymenopterous egg is usually ovoid or sausage-shaped, and many species in some groups have stalked eggs.

Some species have only one generation a year in temperate zones, others have two, and many breed continually during the warmer months. Hymenoptera usually overwinter as prepupae but occasionally ants, social wasps, and some bees overwinter as adults or as larvae, as in some Parasitica.

Sexual dimorphism is often very marked. The two sexes of some species are so dissimilar that earlier students placed them in different genera or families. Even today there are many puzzles, and sexes have not been associated for many of the species having wingless females and winged males. Ordinarily the males are somewhat smaller than females, though the reverse is true in most species having wingless females. See SEXUAL DIMORPHISM; SOCIAL INSECTS. [K.V.K.]

**Hymenostomatida** An order of the Holotrichia which contains many species that often are of small size and fairly uniform ciliation. Primarily, these protozoans are of importance as the first possessors of a definite, though inconspicuous, buccal ciliation. This ciliation consists of an undulating membrane on the right side of the buccal cavity and an adoral zone of membranelles that is primitively composed of three membranelles on the left side. This tetrahymenal, or four-part, buccal ciliary apparatus is considered the fundamental condition from which the

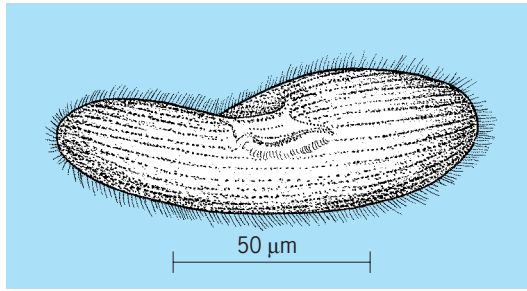

A representative *Paramecium*.

oral ciliature of many subsequent higher groups evolved. See CILIOPHORA.

The majority of hymenostomes are free-living fresh-water forms. *Paramecium* (see illustration) is the best-known genus of ciliates. It is a good-sized, widely distributed ciliate, and is a much-studied form. *Tetrahymena*, beginning to rival *Paramecium* as a favorite ciliate in much experimental work, owes its scientific popularity primarily to its ability to grow axenically, that is, free from all other organisms, in a chemically defined medium. See PROTOZOA. [J.O.C.]

**Hyperbaric oxygen chamber** A specially equipped pressure vessel used in medicine and physiological research to administer oxygen at elevated pressures.

**Basic principle.** Under normal conditions the red blood cells provide the main transport mechanism for distributing oxygen through the bodies of warm-blooded animals. In humans less than 5% of the oxygen in the body is dissolved in body fluids. The transport capacity of red blood cells permits warm-blooded animals to maintain high body temperatures even in cold climates, and to supply the heavy oxygen demand of a large active brain. However, circulation of the red cells through the blood vessels requires a great amount of work by the heart and can be reduced or stopped by damage or blockage of the blood vessels.

The amount of oxygen dissolved in the body fluids is related to the pressure of oxygen in the lungs (Henry's law). When a person breathes pure oxygen, the amount of oxygen dissolved in body fluids is about six times that when breathing air. This is still too low to supply the needs of the human body. However, breathing pure oxygen at three times normal air pressure causes the amount of oxygen dissolved in body fluids to be equal to that normally carried by the red cells. Research animals have been kept alive in a hyperbaric chamber for some time with all the red cells removed from their blood. At the end of the experimental period the red cells were returned and the animals subsequently led perfectly normal lives.

A principal advantage of dissolved oxygen is that it can be transported throughout the body wherever there is fluid of any sort. It is not limited to circulation through blood vessels. A second advantage is that a given volume of blood contains twice the normal amount of oxygen. The high level of oxygen in the body aids the patient in the following ways: (1) Oxygen can be carried past an obstruction in the circulatory system, thus relieving oxygen-starved tissues. (2) The work load on the heart can be reduced, since one-half the normal blood flow will provide the normal amount of oxygen required by the body. (3) Poisons such as carbon monoxide can be eliminated. (4) Anaerobic bacteria such as tetanus can be destroyed. (5) The effectiveness of radiation treatment of cancer is increased. See RADIATION BIOLOGY; TETANUS.

**Equipment.** For physiological studies and for some types of patient treatment chambers just large enough for one person have been built. These chambers are relatively inexpensive to build but have limited usefulness because the patient cannot

be treated or cared for while sealed up inside the oxygen-filled pressure chamber.

In order to give the patient adequate care or to perform surgery, it is necessary to use much larger equipment. The illustration shows a hyperbaric facility consisting of two large chambers. One chamber contains a fully equipped operating room, while the other contains a small medical ward. These large chambers are filled with ordinary air that is compressed to the appropriate pressure. The patients breathe pure oxygen through masks or tents; the attending doctors and nurses breathe the air that fills the chamber.

Each chamber consists of a steel pressure vessel which is roughly 12 ft (4 m) in diameter and about 45 ft (14 m) long. Larger vessels have been employed, but they are extremely difficult to install and require excessively large compressors to provide a fresh air supply.

Inside, the vessel is divided into three areas. In the front area is a large entry lock in which patients on stretchers can be compressed or decompressed while the main section remains at elevated pressure. The main area of the chamber is a room about 30 ft (9 m) wide because of the curvature of the walls. In one of the chambers this room contains a fully equipped surgical operating table. In the other chamber, beds for six patients can be accommodated. Beyond the main section there is a small lavatory and another small lock through which attending personnel can enter or leave quickly during an operation. There is also an instrument lock through which small equipment and supplies can be passed.

In a nearby room outside the chambers air compressors and air conditioning equipment are located. From a central console the operator can monitor all that is happening in each of the chamber areas and can activate any of the mechanical equipment by remote control.

Proper conditioning of the air under a wide variety of operating pressures is necessary for the comfort and safety of the people in the chamber. When air is compressed, that part of the total pressure represented by each component increases to the same extent (Dalton's law). For example, on a comfortable day relative humidity is about 50–75%. This means that the water vapor is 50–75% of the saturation pressure. If this air is compressed to three times its normal pressure, the pressure of each component including the water vapor will be increased threefold. On the other hand, the water vapor saturation pressure will remain constant as long as the temperature remains the same. Therefore, the humidity will rise to 150–225% which means that some of the water vapor must condense as fog or even rain. Without any special provision to remove moisture the hyperbaric chamber

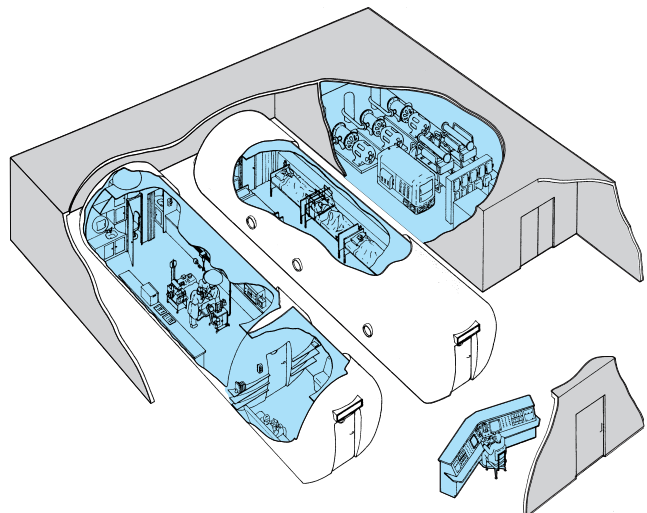

Hyperbaric oxygen treatment facility.

would always be foggy and damp, and the atmosphere would have a very unpleasant effect on the senses. To keep the atmosphere clean and comfortable, the air in the chamber is changed completely every 20 min. The fresh air is dried and cooled after being compressed.

Providing normal facilities in a hyperbaric chamber presents novel problems. For example, normal water pressure may not be sufficient to make the water flow out of a faucet into the high-pressure environment in the chamber. Booster pumps raise the pressure enough to ensure normal flow. Draining wastewater out of the chamber under 3 atm (300 kilopascals) pressure could have rather spectacular results if the drain lines led directly to the sewers. Special waste-receiving tanks are provided which permit the high pressure to bleed off before releasing the wastewater to the normal drainage system.

Changes in pressure must take place rather gradually for the comfort and safety of the people in the chamber. The ear-popping problems that commonly occur in express elevators and airplanes are considerably magnified because the total change in pressure is considerably greater. Normally a period of 5–10 min is required to pressure up or down.

A special problem exists for the attending personnel who breathe the compressed air. This is the well-recognized problem of the elimination of dissolved nitrogen from the body. For working periods in the chamber up to about 1 h no problem is involved, because nitrogen dissolves slowly. However, for periods of more than 1 h enough nitrogen will accumulate to cause formation of gas bubbles in the bloodstream if decompression takes place too fast. These gas bubbles cause the condition known as caisson disease, or the bends. Tables governing the safe decompression schedules for various working times and pressures have been prepared by the U.S. Navy.

For example, if a surgical team conducts an open-heart operation lasting 3 h in a hyperbaric chamber at three times normal pressure, the Navy tables indicate that decompression should include a 19-min hold at  $1\frac{2}{3}$  times normal pressure and another hold of 79 min at  $1\frac{1}{3}$  times normal pressure. Altogether this means that decompression requires almost 2 h after a 3-h working period. This would not be required for the patient, since the pure oxygen administered during the surgery does not present any hazard. See DECOMPRESSION ILLNESS.

Because of the potentially long periods of time which may be required to decompress, the people in the chamber are relatively isolated from the outside world. They are highly dependent on the chamber operator, who remains at the control console continually as long as any person is in the chamber. Communication is maintained by closed-circuit television with the main section and each of the personnel locks. The operator continually observes the pressure, temperature, and gas composition in the chamber.

While loss of electric power would not of itself be dangerous, the chamber would soon become rather uncomfortable without the constant flow of fresh air, and it would soon become necessary to decompress and leave the chamber. This could mean stopping an operation before completion, which could pose serious problems. Emergency power supplies are therefore provided, and clean dry air is stored in high-pressure cylinders so that no interruption disrupts the work of the physicians. During the great power failure that blacked out the Northeast on November 9–10, 1965, the hyperbaric facility at Mount Sinai Hospital in New York City was an island of light in otherwise complete darkness.

**History.** Physicians have long been interested in the medical applications of elevated pressures. Orval Cunningham observed beneficial results from such conditions when treating influenza victims during World War I. However, treatment with oxygen at atmospheric pressure produced the same benefits with much less difficulty. It was not until the 1950s that the combination of elevated pressure and pure oxygen was suggested, especially for open-heart surgery. In 1965 a large chamber was built at

the University of Amsterdam in the Netherlands. Since that time facilities have been constructed at a number of medical schools and large hospitals in the United Kingdom, Canada, and the United States. See OXYGEN; RESPIRATION. [A.W.F.]

**Hyperbola** A curve cut from a cone or revolution by a plane that intersects both nappes of the cone and does not contain the apex. In analytic geometry it is shown (see illustration) that a

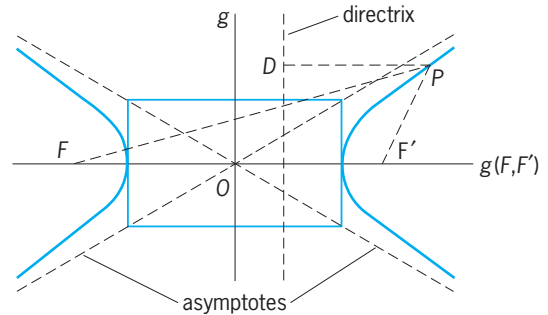

Hyperbola as a locus of points.

hyperbola is the locus of points  $P$  in a plane, such that  $PF = \epsilon \cdot PD$ , where  $PF$  and  $PD$  denote the distances of  $P$  from a fixed point  $F$  (focus) and a fixed line (directrix) of the plane, respectively, and  $\epsilon$  is a constant, greater than 1. A hyperbola is also the locus of points  $P$ , the difference of whose distances from two fixed points  $F, F'$  (foci),  $PF - PF'$ , is a constant  $2a$  that is less than the distance  $2c$  between the foci. The curve is symmetric to the line  $g(F, F')$  determined by  $F, F'$  and to  $O$ , their midpoint. It consists of two branches that are images of each other in the line  $g$  through  $O$ , perpendicular to  $g(F, F')$ . There are two lines through  $O$ , making equal angles with  $g(F, F')$ , and to each of which points on each branch get indefinitely close; that is, if point  $P$  traverses either branch of the hyperbola, its distance from these lines approaches zero. These lines are called asymptotes of the hyperbola. See ANALYTIC GEOMETRY; CONIC SECTION. [L.M.BI.]

**Hyperbolic function** The hyperbolic sine and cosine of a real or complex variable  $z$  are defined by Eqs. (1). Both  $\sinh z$  and  $\cosh z$  have a period  $2\pi i$  of  $e^z$ . From  $De^z = de^z/dz = e^z$ , Eqs. (2) are obtained.

$$\sinh z = \frac{e^z - e^{-z}}{z} \quad \cosh z = \frac{e^z + e^{-z}}{z} \quad (1)$$

$$D \sinh z = \cosh z \quad D \cosh z = \sinh z \quad (2)$$

Since

$$e^z = \sum_{n=0}^{\infty} z^n/n!$$

by definition, Eqs. (3) hold and the series converge for all  $z$  and yield relations (4). Thus relations between the circular functions

$$\sinh z = \sum_{n=0}^{\infty} \frac{z^{2n+1}}{(2n+1)!} \quad \cosh z = \sum_{n=0}^{\infty} \frac{z^{2n}}{(2n)!} \quad (3)$$

$$\begin{aligned} \sinh iz &= i \sin z & \cosh iz &= \cos z \\ \sin iz &= i \sinh z & \cos iz &= \cosh z \end{aligned} \quad (4)$$

become hyperbolic (and vice versa) when  $z$  is replaced by  $iz$ .

The hyperbolic tangent and cotangent are defined by Eqs. (5).

$$\tanh z = \frac{\sinh z}{\cosh z} \quad \coth z = \frac{\cosh z}{\sinh z} \quad (5)$$

They have the period  $\pi i$  and have simple poles at the zeros of

cosh  $z$  and sinh  $z$ , respectively. Moreover Eqs. (6) hold true.

$$D \tanh z = \frac{1}{\cosh^2 z} \quad D \coth z = -\frac{1}{\sinh^2 z} \quad (6)$$

By definition Eqs. (7) hold.

$$\operatorname{sech} z = \frac{1}{\cosh z} \quad \operatorname{csch} z = \frac{1}{\sinh z} \quad (7)$$

See HYPERBOLA; TRIGONOMETRY. [L.Br.]

**Hyperbolic navigation system** A navigation system that produces hyperbolic lines of position (LOPs) through the measurement of the difference in times of reception (or phase difference) of radio signals from two or more synchronized transmitters at fixed points. Such systems require the use of a receiver which measures the time difference (or phase difference) between arriving radio signals. Assuming the velocity of signal propagation is relatively constant across a given coverage area, the difference in the times of arrival (or phase) is constant on a hyperbola having the two transmitting stations as foci (see illustration). Therefore, the receiver measuring time or phase difference between arriving signals must be located somewhere along the hyperbolic line of position corresponding to that time or phase difference. If a third transmitting station is available, the receiver can measure a second time or phase difference and obtain another hyperbolic line of position. The intersection of the lines of position provides a navigational fix (see illustration). User receivers typically convert this navigational fix to latitude and longitude for operator convenience.

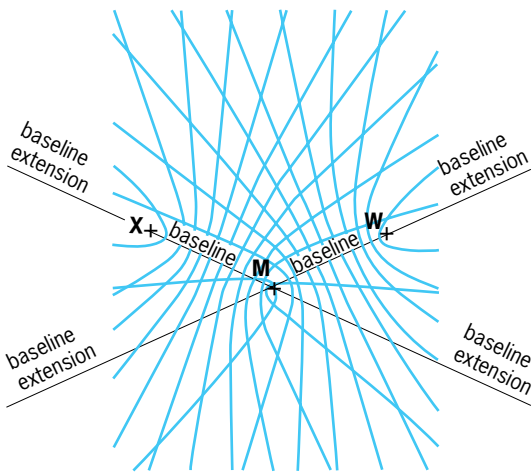

Typical grid of hyperbolic lines of position formed by a master (M) and two secondary stations (W and X).

The choice of frequency and locations of transmitters determines both the utility and the accuracy of hyperbolic navigation systems. In general, longer baselines (see illustration) enhance accuracy; however, transmitter power limitations may constrain a system to shorter baselines in order to maintain accurate synchronism. [B.B.P.; R.J.Ha.]

**Hypercharge** A quantized attribute, analogous to electric charge, introduced in the classification of a subset of elementary particles—the so-called baryons—including the proton and neutron as its lightest members. As far as is known, electric charge is absolutely conserved in all physical processes. Hypercharge was introduced to formalize the observation that certain decay modes of baryons expected to proceed by means of the strong nuclear force simply were not observed. See ELECTRIC CHARGE.

Unlike electric charge, however, the postulated hypercharge was found not to be conserved absolutely; the weak nuclear interactions do not conserve hypercharge—and indeed can change hypercharge by  $\pm 1$  or 0 units.

When the known baryons are classified according to their electric charge and their hypercharge, they naturally group into octets in the scheme first proposed by M. Gell-Mann and K. Nishijima. The quarks, hypothesized as the fundamental building blocks of matter, must have fractional hypercharge as well as electrical charge; the simplest quark model suggests values of 1/3 and 2/3, respectively. See BARYON; ELEMENTARY PARTICLE; QUANTUM MECHANICS; QUARKS; UNITARY SYMMETRY. [D.A.B.]

**Hyperfine structure** A closely spaced structure of the spectrum lines forming a multiplet component in the spectrum of an atom or molecule, or of a liquid or solid. In the emission spectrum for an atom, when a multiplet component is examined at the highest resolution, this component may be seen to be resolved, or split, into a group of spectrum lines which are extremely close together. This hyperfine structure may be due to a nuclear isotope effect, to effects related to nuclear spin, or to both. See ISOTOPE SHIFT; SPIN (QUANTUM MECHANICS).

The measurement of a hyperfine structure spectrum for a gaseous atomic or molecular system can lead to information about the nuclear magnetic and quadrupole moments, and about the atomic or molecular electron configuration. Important methods for the measurement of hyperfine structure for gaseous systems may employ an interferometer, or use atomic beams, electron spin resonance, or nuclear spin resonance. See ELECTRON PARAMAGNETIC RESONANCE (EPR) SPECTROSCOPY; INTERFEROMETRY; MAGNETIC RESONANCE; NUCLEAR MAGNETIC RESONANCE (NMR). [L.D.R.]

**Hypergeometric functions** The analytic continuation of the function defined by the series in Eq. (1), where the shifted factorial  $(a)_n$  is defined by Eq. (2). It satisfies differential

$${}_2F_1(a, b; c; z) = \sum_{n=0}^{\infty} \frac{(a)_n (b)_n}{(c)_n n!} z^n \quad (1)$$

$$|z| < 1$$

$$(a)_n = a(a+1) \cdots (a+n-1) \quad (2)$$

$$n = 1, 2, \dots \quad (a)_0 = 1$$

equation (3), and for  $|z| < 1$ ,  $\operatorname{Re} c > \operatorname{Re} b > 0$ , is given by the integral representation of Eq. (4), where  $\Gamma$  represents the gamma function.

$$z(1-z)y'' + [c - (a+b+1)z]y' - aby = 0 \quad (3)$$

$${}_2F_1(a, b; c; z) = \frac{\Gamma(c)}{\Gamma(b)\Gamma(c-b)} \int_0^1 (1-zt)^{-a} t^{b-1} (1-t)^{c-b-1} dt \quad (4)$$

See COMPLEX NUMBERS; GAMMA FUNCTION; SERIES.

The interest in hypergeometric functions comes from the many important functions which are special cases of the general hypergeometric function, the rich theory which has been developed for the general hypergeometric function, and the many times they occur in applications. Classically hypergeometric functions have arisen in science as solutions to differential equations. As discrete, rather than continuous, models of physical phenomena have become increasingly useful, hypergeometric functions have continued to arise as solutions to the equations governing these models. See DIFFERENTIAL EQUATION. [R.A.]

**Hyperidea** A suborder of amphipod crustaceans. Most hyperiids can be recognized by the large eyes which cover nearly the entire surface of the head. The first maxillae and especially the maxillipeds are greatly reduced in comparison to the suborder Gammaridea. In the prehensile pereopods, the claw is formed by the fifth and sixth segments rather than by the sixth and seventh segments, as in the Gammaridea. The second and third somites of the urosome are always fused, a condition rarely found in the Gammaridea. See AMPHIPODA; GAMMARIDEA.

The Hyperidea are exclusively pelagic and marine. They are found in all the oceans, from the surface to great depths. Most are characteristic of oceanic rather than neritic waters, although there are some species that frequent inshore waters in the tropics. After the Copepoda and Euphausiacea, the Hyperidea are the most abundant planktonic crustaceans. Some species are frequently found in association with other animals. Other species are truly free-living. Some hyperiids are luminescent; the whole body glows with a greenish-yellow light. See BIOLUMINESCENCE. [T.E.B.]

**Hypermastigida** An order of the Protozoa in the class Zoomastigophorea comprising the most complex flagellates, both structurally and in modes of division. All inhabit the alimentary canal of termites, cockroaches, and woodroaches. These organisms are multflagellate. The nucleus is single and the organisms are plastic and slow-moving, generally ovoid to elongate. Flagella occur in spiral rows, in tufts, or over the entire body. These flagellates vary from 15 to 350 micrometers in size. See PROTOZOA; ZOOMASTIGOPHOREA. [J.B.L.]

**Hypernuclei** Nuclei that consist of protons, neutrons, and one or more strange particles such as lambda particles. The lambda particle is the lightest strange baryon (hyperon); its lifetime is  $2.6 \times 10^{-10}$  s. Because strangeness is conserved in strong interactions, the lifetime of the lambda particle remains essentially unchanged in the nucleus also. Lambda hypernuclei live long enough to permit detailed study of their properties. See BARYON; ELEMENTARY PARTICLE; HYPERON; NUCLEAR STRUCTURE; STRONG NUCLEAR INTERACTIONS. [B.Po.]

**Hyperon** A collective name for any baryon with nonzero strangeness number  $s$ . The name hyperon has generally been limited to particles which are semistable, that is, which have long lifetimes relative to  $10^{-22}$  s and which decay by photon emission or through weaker decay interactions. Hyperonic particles which are unstable (that is, with lifetimes shorter than  $10^{-22}$  s) are commonly referred to as excited hyperons. The known hyperons with spin  $\frac{1}{2}\hbar$  (where  $\hbar$  is Planck's constant divided by  $2\pi$ ) are  $\Lambda$ ,  $\Sigma^-$ ,  $\Sigma^0$ , and  $\Sigma^+$  with  $s = -1$ , and  $\Xi^-$  and  $\Xi^0$ , with  $s = -2$ , together with the  $\Omega^-$  particle, which has spin  $\frac{3}{2}\hbar$  and  $s = -3$ . The corresponding antihyperons have baryon number  $B = -1$ , opposite strangeness  $s$ , and charge  $Q$ ; they are all known empirically.

There is no deep distinction between hyperons and excited hyperons, beyond the phenomenological definition above. Indeed, the hyperon  $\Omega(1672)^-$  and the excited hyperons  $\Xi(1530)$  and  $\Sigma(1385)$ , together with the unstable nucleonic states  $\Delta(1236)$ , are known to form a unitary decuplet of states with spin  $\frac{3}{2}\hbar$ . See BARYON; ELEMENTARY PARTICLE; SYMMETRY LAWS (PHYSICS); UNITARY SYMMETRY. [R.H.D.]

**Hypersensitivity** Heightened reactivity to antigens (molecules capable of stimulating an immune response). Many different examples of hypersensitivity have been recognized in animals and humans. These are often referred to collectively as allergies, and clinically may take such forms as asthma, hives, hay fever, anaphylactic reactions to certain foods or insect venoms, some forms of eczema and kidney diseases, and skin reactions to poison ivy antigens and many other substances. See ANTIGEN.

Because molecules foreign to the body are often antigenic, the various forms of hypersensitivity are most commonly induced either by exposure to foreign antigens derived from microorganisms during infections, or by contact with certain noninfectious agents (some plant pollens, some drugs, and certain simple chemicals such as components of poison ivy). However, under certain circumstances, molecules of the body itself can induce an immune response. In these cases, hypersensitivity reactions can be directed against antigens of the body's own organs or tis-

sues. Whether foreign or derived from the body itself, antigenic substances often produce little or no tissue reaction in unsensitized individuals. But once hypersensitivity develops, additional exposure to antigen can give rise to clinically obvious symptoms (hives, sneezing, runny nose), tissue damage, or even (in certain extreme cases) death. See AUTOIMMUNITY.

The development of hypersensitivity in animals or humans may be divided into two phases. During the first phase, induction of hypersensitivity, exposure of the organism to antigen results in (1) recognition of the antigen by cells of the immune system; (2) proliferation (multiplication) of the types of immune cells that recognize and respond to that antigen; and (3) long-term storage of the information required to recognize and respond to the antigen in immune "memory" cells. Although a variety of cell types assist in these processes, all of the three functions are primarily dependent on various types of lymphocytes.

Once the state of hypersensitivity has been induced, reexposure of the organism to the antigen that induced the response usually leads to the second phase, expression of a hypersensitivity reaction. Hypersensitivity reactions historically have been classified according to two characteristics: the delay between the exposure of a previously sensitized (hypersensitive) individual to antigen and the development of a clinically recognizable reaction; and the types of cells and humoral substances thought to be responsible for the induction and expression of the reaction. According to this scheme, classical delayed hypersensitivity reactions differ from other forms of hypersensitivity in first becoming clinically prominent in sensitized individuals approximately 1 day after exposure to the specific antigen against which the individual expresses hypersensitivity; and depending for their expression on the activity of certain lymphocytes (thymic-dependent lymphocytes, or T cells) rather than soluble antibodies. By contrast, immediate hypersensitivity reactions may develop within seconds or minutes of exposure to specific antigen, and require the participation of antibodies. See ANTIBODY.

In addition to its association with certain infections, delayed hypersensitivity has been implicated in a variety of noninfectious disease processes. These include the annoying reactions induced in some individuals by contact with certain plants (for example, poison ivy), detergents, or drugs, as well as certain of the immune responses resulting in the rejection of transplanted tissues such as skin, kidneys, and hearts. In many of these processes, the immunological reactions are thought largely to reflect the activity of T lymphocytes (as in classical delayed hypersensitivity), whereas in others soluble antibodies may also have a role. See CELLULAR IMMUNOLOGY; TRANSPLANTATION BIOLOGY. [S.J.Ga.]

Immediate hypersensitivity reactions, collectively known as allergies, occur usually within minutes or up to a few hours after inhalation, ingestion, or injection of an antigen. Such reactions may be severe, even life-threatening, such as anaphylactic shock and asthma, or relatively minor but uncomfortable, such as hay fever or urticaria (hives). They may be of short duration—hours for anaphylaxis—or prolonged for several days or even weeks, as in immune complex-induced vasculitis. See ALLERGY.

Hypersensitivities have been classified into four main types with different mechanisms: type I, anaphylaxis or atopy; type II, cytotoxic or cytolytic; type III, immune complex or Arthus reaction; and type IV, delayed or cellular-immune; the last type has been described above.

In type I the antigen is recognized immunologically upon first exposure and initiates antibody formation, usually of immunoglobulin E (IgE) or IgG class. IgE-mediated allergy, known as atopy, has a strong hereditary component, and occurs commonly in humans and dogs, while IgG-mediated anaphylaxis can occur in most vertebrates. The antibodies (IgE or IgG) attach or fix to target cells, such as tissue mast cells and blood basophils. Upon subsequent exposure to the antigen, the target cell-fixed antibodies react with antigen to cause degranulation and release of chemical mediators, such as histamine. See HISTAMINE; IMMUNOGLOBULIN.

In cytotoxic or cytolytic (type II) reactions, the antigen may be certain altered body cells themselves; they may be altered physically or by chemicals and drugs attached to the cells. These are usually circulating cells, such as red blood cells coated with penicillin, platelets coated with a drug, or white blood cells coated with sulfonamides. Altered cells are recognized by the body's immune system as foreign or altered self, and IgG or IgM antibodies are formed which react with the altered cells and activate the serum complement enzymatic cascade that culminates in the lysis of the altered cells. Thus, cytotoxic hypersensitivity leads to anemia, bleeding due to low platelet levels, and increased infections from loss of white blood cells (agranulocytosis).

In immune complex or Arthus (Type III) reaction, neither antibody nor antigen is fixed to cells. Rather, they combine in various ratios in blood and tissues. If they are in the proper ratio, they form microprecipitates, or immune complexes, in capillaries and venules. The immune complexes activate complement to form chemoattractants for neutrophils and monocytes. Microprecipitates and phagocytosing neutrophils block the small vessels, resulting in a typical Arthus reaction—lack of blood to the tissue and subsequent tissue necrosis and death. [O.L.F.]

**Hypersonic flight** Flight at speeds well above the local velocity of sound. By convention, hypersonic flight starts at about Mach 5 (five times the speed of sound) and extends upward in speed indefinitely. Supersonic vehicles also fly at speeds greater than the local speed of sound. However, when the Mach number is high, the flow field around an object exhibits a special behavior, which is worth studying separately from supersonic flight. This behavior is characteristic of hypersonic flight.

A body entering the Earth's atmosphere from space (for example, a meteorite, a ballistic reentry vehicle, or a spacecraft) has high velocity and hence large kinetic and potential energy. During reentry, drag forces act upon a reentry vehicle or spacecraft and cause it to decelerate, thus dissipating its kinetic and potential energy. The energy lost by the reentry vehicle is then transferred to the air within the flow field around the reentry vehicle. The flow field around the forward portion of a blunt-nosed vehicle (body of revolution or leading edge of a wing) generally exhibits (1) a distinct bow shock wave, (2) a shock layer of highly compressed hot gas, and (3) a highly sheared boundary layer over the surface. The flow field is defined as the region of disturbed air between the body surface and the shock wave. The temperature of the shock layer is so high that molecules begin to dissociate during collisions at about 4000°F (2500 K), or at Mach 7. At about Mach 12, gas in the stagnation region reaches a temperature of 6700°F (4000 K) and becomes ionized.

In general, at high hypersonic flight speed the characteristic temperature in the shock layer of a blunted body and in the boundary layer of a slender body is proportional to the square of the Mach number. Heat energy is then transferred from the hot gases to the vehicle surface by conduction and diffusion of chemical species in the boundary layer and by radiation from the shock layer near the nose. Heat energy is also radiated from the vehicle surface to space or to adjacent objects. One important problem confronting the designer of reentry vehicles or spacecraft is therefore to design a minimum-weight vehicle able to withstand large heat loads from adjacent hot-gas layers during reentry while retaining the ability to carry a given useful payload. See ATMOSPHERIC ENTRY. [S.-Y.C.]

**Hypertension** High blood pressure. Blood pressure is expressed in two numbers: the higher number is the systolic blood pressure, which is the pressure exerted by the blood against the walls of the blood vessels while the heart is contracting. The lower number is the diastolic blood pressure, which is the residual pressure that exists between heart contractions, or while the heart is relaxing. Normal blood pressure provides sufficient blood flow to the vital organs, including the brain, heart, kidneys, intestine, and skeletal muscle.

It is not entirely accurate to think of high blood pressure as a distinct disease; high blood pressure appears to be both a disease and a risk factor for other diseases. At the highest end of the blood pressure distribution, there is an increased probability of premature death secondary to stroke, heart disease, or kidney failure. Lower on the distribution curve (for example, diastolic blood pressure of 90–104 mmHg, which is referred to as mild hypertension), the absolute risk of premature mortality is lower and continues to decline with further decreases in blood pressure. High blood pressure is thus a disease when its value is very high and a risk factor throughout its distribution. For diagnostic purposes, blood pressure is considered high when persistently above 140/90 mmHg.

Some cases of very high blood pressure are due to specific causes that may be surgically remediable. Most hypertension, however, results from the combination of a genetic predisposition and an environmental factor such as excessive sodium intake, sedentary habits, and stress.

High blood pressure can be controlled. Mild cases are treated by losing excess weight and reducing the intake of sodium and alcohol. More serious cases are treated with drugs such as diuretics, beta blockers, calcium antagonists, angiotensin-converting enzyme inhibitors, alpha blockers, and centrally acting compounds that affect regulatory centers in the brain. Treatment can usually assure a normal life. See HEART DISORDERS. [M.Ho.]

**Hypervalent compounds** Group 1, 2, and 13–18 compounds which contain a number (*N*) of formally assignable electrons of more than eight (octet) in a valence shell directly associated with the central atom (*X*) in direct bonding with a number of ligands (*L*). The designation *N*-*X*-*L* is conveniently used to describe hypervalent molecules. See ELECTRON CONFIGURATION; LIGAND; VALENCE.

In the periodic table, compounds of main group elements in the second row (such as carbon, nitrogen, and oxygen) have eight valence electrons. As such, the fundamental shapes of their atoms are linear (such as acetylene,  $sp$  orbital), triangular (such as ethylene,  $sp^2$  orbital), and tetrahedral (such as methane,  $sp^3$  orbital). In contrast, main group elements in the third row of the periodic table (such as silicon, phosphorus, and sulfur) may contain more than eight electrons in a valence shell. These are called hypervalent compounds. Fundamental shapes of *10*-*X*-*5* molecules (including *10*-*X*-*4* molecules bearing a pair of unshared electrons) are trigonal bipyramid (TBP) or square pyramid (SP), and those of *12*-*X*-*6* (including *12*-*X*-*5* bearing a pair of unshared electrons) are octahedral. Hence, there is an apparent similarity in shape between hypervalent compounds and organotransition metal compounds. See MOLECULAR ORBITAL THEORY.

The hydrogen bond is one of the best examples of a hypervalent bond. The covalent nature of the hydrogen bond of the  $[N-H\cdots N]$  system has recently been established experimentally and theoretically. The structure of  $(HF)_5$ , shown below, is pen-

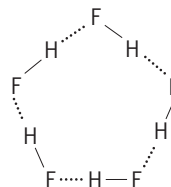

tagonal, with a bond length for  $F-H$  of 1 Å and  $H\cdots F$  of 1.5 Å. The hydrogen atom shifts rapidly between the two fluorines in the range of 0.5 Å. However,  $[F-H-F]^- K^+$ , (*4*-*H*-*2*), is linear, and the two  $F-H$  bond lengths are equal to 1.13 Å, which is typical for a hypervalent bond. See CHEMICAL BONDING.

In order to accept extra electrons in a valence shell, an electron-rich and polarized sigma bond contains an apical bond (three-center, four-electron bond, which is defined as a hypervalent bond by molecular orbital theory) on the central atom. One of



the most unstable hypervalent molecules is  $[F-F-F]^{-}Li^{+}$ , (10-F-2). It is linear and the F—F bond is calculated to be 1.701 Å, which is elongated from that of F—F (1.412 Å) by accepting a fluoride ion. This is essentially the same as that of  $[F-H-F]^{-}Li^{+}$ , (4-F-2). [K.Ak.]

**Hypochytriomycetes** A class of the subdivision Mastigomycotina; a taxonomically small group of about 20 species of fungallike organisms characterized by the presence of a uniflagellate zoospore in the life cycle. In contrast to the Chytridiomycetes, the flagellum is anteriorly directed, with two rows of tripartite hairs. From similarities in ultrastructure and cellular chemistry, and from molecular analysis, it has been determined that hypochytrids are related to the biflagellated Oomycetes and heterokont algae, and they have been classified within the Kingdom Protista, Kingdom Chromista, Kingdom Protoctista, and most recently Kingdom Stramenopila.

Two species, *Rhizidiomyces apophysatus* and *Hypochytrium catenoides*, are widely distributed, possibly cosmopolitan, and occur as saprobes in soil and water. *Rhizidiomyces apophysatus* has a unicellular thallus comprising a single zoosporangium with delicate rhizoids for anchorage and the absorption of nutrients. *Hypochytrium catenoides* is filamentous with numerous intercalary hyphal swellings; under favorable conditions these swellings develop into zoosporangia. Sexual reproduction is unknown in these species and has not been well documented in the class. All species parallel the Chytridiomycetes in morphology and distribution, and they cannot be distinguished except by the position and morphology of the flagellum, the zoospore ultrastructure, and nucleic acid sequence. See EUMYCOTA; FUNGI.

[D.J.S.B.]

**Hypomycetes** A class of mitosporic or anamorphic (asexual or imperfect) fungi belonging to the Deuteromycotina. They lack locular fruit bodies (conidiomata), and so sporulation occurs on separate or aggregated hyphae, which may or may not be differentiated; the thallus consists of septate hyphae. About 1400 genera comprising more than 11,500 species are recognized.

The Hypomycetes, like other groups of Deuteromycetes, is an artificial one composed almost entirely of anamorphic fungi of ascomycete affinity. The majority are known anamorphs of Ascomycetes, although some have basidiomycete affinities. Several of the latter are aquatic or aero-aquatic. Taxa are referred to as form genera and form species, because the absence of a sexual or perfect teleomorph state forces classification and identification by artificial rather than phylogenetic means. The unifying feature of the group is the production of conidia from superficial, exposed conidiogenous cells arising separately from vegetative hyphae or cells (mononematous), or incorporated on conidiophores that may be entirely separate or aggregated in cushion-like sporodochia or stalk-like synnemata. Differences in insertion and arrangement of conidiogenous cells and conidiophores traditionally have been used to separate three orders. In the Hypomycetales they are solitary or at most fasciculate and tufted; in the Tuberculariales they are produced over the outer surface of a cushion-shaped-to-flattened conidioma (sporodochium), and in the Stilbellales they are united into a stipitate conidioma (synnema). An alternative means of classifying hypomycetes is based on differences in the ways that conidia are produced and conidiogenous cells grow before, during, and after conidiogenesis. See ASCOMYCOTA; BASIDIOMYCOTA; COELOMYCETES.

To the naked eye, hypomycete colonies are conspicuous as black, brown, green, gray, and white growths on substrata. In size, hypomycete conidia vary from the minute to extremely long or wide. Shapes vary markedly within and between genera. Many hypomycetes produce conidia in mucilaginous matrices. As in the Coelomycetes, the matrix inhibits or retards germination until the conidia become dispersed, and maintains ger-

minability during periods of environmental stress. Other genera produce conidia in powdery masses, such hydrophobic conidia being more suited for air dispersal. Sterile elements in the form of simple or branched setae are commonly present among conidiophores or on conidiomata, and since they are particularly common among leaf-litter fungi they are thought to function as a form of predator defense.

The Hypomycetes draw nourishment from living or dead organic matter and are adapted to grow, reproduce, and survive in a wide range of ecological situations. They can also be either stress-tolerant or combative. Some species grow among rubbish, and because their thin-walled, hyaline vegetative and reproductive structures make them more prone to attack and decay, they are ephemeral. Their ability to colonize, decompose, and use substrates and to interact with or parasitize other organisms is a result of the enzymes, antibiotics, toxins, and other metabolites they produce, coupled with wide genetic diversity. They are extremely common in soils of all types and on leaf litter and other organic debris of both natural and manufactured origin. They also cause extensive problems in food spoilage and occur in saline, stagnant, and fresh water.

Some hypomycetes are found on or associated with fungi, including pathogens such as *Verticillium*, *Mycogone*, and *Cladobotryum*, and on lichens. Several are of medical importance, being associated with superficial, cutaneous, subcutaneous, and systemic infections. They are often opportunistic organisms that cause infections in immunocompromised patients. Toxic metabolites, or mycotoxins, are formed by many hypomycetes, notably *Aspergillus*, *Fusarium*, and *Penicillium*. Others are nematophagous, capturing or consuming nematodes and other microfauna. *Beauveria*, *Metarhizium*, *Hirsutella*, and *Entomophthora*, for example, have been exploited for insect control. Many also cause economically important diseases in all types of vascular plants, especially agricultural and forestry crops. Hypomycetes are primary pathogens of plants and weeds, causing root, stem, and leaf necrosis; diebacks; cankers; wilts; and blights. By infesting or contaminating seed, they can transmit seed-borne defects or reduce seed viability. See MEDICAL MYCOLOGY; MYCOTOXIN; PLANT PATHOLOGY.

Hypomycetes produce a wide variety of primary and secondary metabolites and are capable of effecting many different chemical and biochemical changes. By harnessing that capability in industrial processes, organic acids, enzymes, antibiotics, growth substances, alcohol, and cheese, among others, can be produced and steroid transformation can take place. See DEUTEROMYCOTINA; FUNGI.

[B.C.S.]

**Hypnales** An order of the true mosses (subclass Bryidae). Also known as the Hypnobryales, this order consists of 14 families and some 135 genera, primarily put together because they share a hypnoid peristome. The families show considerable sporophytic unity; it is gametophyte structure that determines family membership.

Hypnales are often known as feather mosses owing to their freely branched stems, with branches regularly or irregularly arranged in two rows. The plants form mats, especially in woodlands. The leaves are most commonly acute or acuminate, and the costa is generally short and double or nearly lacking. The sporophytes are lateral with elongate, smooth setae, and the capsules are generally inclined and asymmetric with well-developed double peristomes. See BRYIDAE; BRYOPHYTA; BRYOPSIDA. [H.Cr.]

**Hypnosis** A presumed altered state of consciousness in which the hypnotized individual is usually more susceptible to suggestion than in his or her normal state. In this context, a suggestion is understood to be an idea or a communication carrying an idea that elicits a covert or overt response not mediated by the higher critical faculties (that is, the volitional apparatus).

Hypnosis cannot be physiologically distinguished from the normal awake state of an individual, and for this reason its

existence has been questioned by some investigators. There are few phenomena observed in association with hypnosis, if any, that are specific to the hypnotic state. Most are directly or indirectly produced by suggestions. Through suggestions given to hypnotized individuals, it is possible to induce alterations in memory, perception, sensation, emotions, feelings, attitudes, beliefs, and muscular state. Such changes can be, and usually are, incorporated into the complex behavior of the individual, resulting in amnesias and paramnesias, fuguelike conditions, paralysis, loss of sensory functions, changes in attention, personality alterations, hallucinatory and delusional behavior, and even physiological changes. Enhanced recall is sometimes possible. Although sometimes remarkable, the effects produced through hypnosis with the majority of individuals are much less spectacular than popularly believed. [A.M.W.]

**Hypodermis** The outermost cell layer of the cortex, also called the exodermis, of plants. It forms a prominent layer immediately under the epidermis in many but not all plants. Like the endodermis, it develops Casparian strips, suberin deposits, and cellulose deposits impregnated with phenolic or quinoidal substances. The hypodermis may produce substances that act as a barrier to the entry of pathogens, and in some plants it may function in the absorption of water and the selection of ions that enter the plant. See CORTEX (PLANT); ENDODERMIS. [D.S.V.F.]

**Hypohalous acid** An oxyacid of a halogen [fluorine (F), chlorine (Cl), bromine (Br), iodine (I), or astatine (At)] possessing the general chemical formula HOX, where X is the halogen atom. The chemical behavior of hypofluorous acid (HOF) is dramatically different from the heavier hypohalous acids which, as a group, exhibit similar properties. These differences are attributed primarily to the high electronegativity and small size of the fluorine atom, which cause HOF to be an extremely strong oxidant with an anomalously weak O-F bond. Thus, the molecule is highly reactive and relatively unstable. (Gaseous HOF decomposes to HF and O<sub>2</sub> at room temperature with a half-life of about 1 h, and the liquid has a tendency to explode.) Because the most electronegative element in HOF is fluorine, whereas the other halogen atoms are less electronegative than oxygen, the O-X bond polarities are reversed in HOF and the heavier congeners. HOF therefore acts primarily as an oxygenating and hydroxylating agent, whereas the other hypohalous acids are electrophilic halogenating agents. For example, HOF hydroxylates aromatic compounds to form phenols and reacts instantaneously with water to give hydrogen peroxide (H<sub>2</sub>O<sub>2</sub>), whereas hypochlorous acid (HOCl) chlorinates aromatic compounds and is unreactive toward water. See ASTATINE; HALOGEN ELEMENTS.

Hypochlorous, hypobromous, and hypoiodous acid solutions are formed by disproportionation of the corresponding halogen, as in the reaction below.

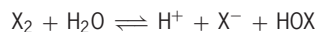

Hypohalous acids are weak acids, that is, HOX  $\rightleftharpoons$  H<sup>+</sup> + OX<sup>-</sup> acids whose dissociation constants increase in the order HOI < HOBr < HOCl. The decomposition mechanisms are complex with rates that vary widely, increasing in the order X = Cl<sup>-</sup> < Br<sup>-</sup> < I<sup>-</sup>. Hypochlorite solutions (for example, commercial bleach) are stable at room temperature and below for months but decompose at elevated temperatures; hypobromite solutions are stable only at reduced temperatures; and hypoiodite generally decays within minutes of its formation.

HOCl and HOBr and their anions are powerful oxidants that react rapidly with a wide range of organic and inorganic reductants. In addition, both acids halogenate aromatic compounds and form halohydrins with unsaturated organic compounds, and N-chloro compound with nitrogen bases. In general, HOCl reacts much more rapidly than OCl<sup>-</sup>.

HOCl and HOBr are potent cytotoxins. Hypochlorite was first used as a disinfectant around the beginning of the nineteenth century, and has subsequently been widely applied to problems in public sanitation. Recent studies with bacteria indicate that death is accompanied by disruption of metabolic functions associated with the plasma membrane, including inactivation of the adenosine triphosphate synthase and proteins involved with active transport of metabolites, and (in aerobes) inhibition of respiration. This pattern of reactivity suggests that toxicity arises from disruption of the energy-transducing capabilities of the cell.

[J.K.Hu.]

**Hypothermia** A condition in which the internal temperature of the (human) body is at least 3.6°F (2.0°C) below an internal temperature of 98.6°F (37°C). Hypothermia represents a continuum of effects that vary with the severity of cold on physiological systems. The human body needs a specific internal temperature that is regulated on a minute-by-minute basis to maintain all normal body functions. The many physiological and behavioral processes involved in maintaining the internal temperature constant are called thermoregulation. See THERMOREGULATION.

Various environmental situations predispose humans to hypothermia, which can occur even in the absence of cold. In fact, hypothermia is more common in temperate regions than in the colder climates. Because of the uniqueness of the situations in which hypothermia can occur, various kinds of hypothermia have been classified, all of which can prove fatal.

**Primary hypothermia.** Primary hypothermia is a decrease in internal temperature that is caused by environmental factors in which the body's physiological processes are normal but thermoregulation capability is overwhelmed by environmental stress.

Air (formerly exposure) hypothermia is thought to be the most common form. A person exposed to cold air experiences the same processes as a person in cold water, but air hypothermia occurs more slowly. The induction of air hypothermia is more subtle and therefore more dangerous since it can occur over a number of weeks. The degree to which a person reacts to a cold air stress is dependent on such factors as age, physical stamina, the intensity of the cold stress, and the responsiveness of the thermoregulatory system. One of the most convenient ways to determine whether someone is suffering from hypothermia is a noted change in personality: Complaints of fatigue, sluggish speech, and confusion are common, and in some cases the behavior resembles that of intoxication.

Initially, skin temperature falls rapidly, blood vessels to the skin constrict, and shivering begins. After 5–10 min, shivering ceases for about 10–15 min, but this is followed by uncontrollable shivering. In a cold situation, the nervous system causes blood to be redistributed away from the skin as the blood vessels of the skin close down to minimize heat transfer to the cold environment. The decrease in skin temperature coupled with vasoconstriction makes the person feel cold, and sometimes the fingers and toes can become painful. Internally, there is an increase in the levels of hormones that control metabolism, and blood is shunted primarily to the lungs, heart, and brain. The person becomes dehydrated as the inspired air is warmed and humidified. If the tense and shivering muscles do not generate enough heat, the hypothermic process begins and progresses for at least 3–5 h. As hypothermia continues, the arms become rigid, and the person loses the ability to make fine movements. During this period of time the heart rate initially increases, then stabilizes and as the person's internal temperature becomes progressively colder, the heart rate and respiration slow. In severely hypothermic persons, it is very difficult to detect a slow heart rate or determine if the person is breathing. A temperature of 95°F (35°C) is only the beginning of mild hypothermia and shivering can continue for hours, depending on the muscle and fat supplies available. Eventually, the environment becomes overwhelming. At 86°F

(30°C), the person loses consciousness and shivering ceases. Death does not occur until the internal temperature drops further: Death results at 68–77°F (20–35°C) because of cardiac standstill.

When a person falls into cold water, a gasping response is triggered by the thermal receptors on the skin. For some individuals, the cold stress may trigger a heart attack. Although as much of the body as possible should be kept out of the water, many victims of immersion hypothermia stay in the cold water because they cannot tell how cold they are. Shivering becomes generalized and, unlike its effect in cold air, may cause a faster drop in internal temperature since the water layer closest to the body is stirred and convective heat loss is promoted. Although the greater conductive property of water relative to air is a major heat sink, physiological and behavioral responses act to minimize the heat loss. Survival in 50°F (10°C) water is possible for several hours at most if the person is dressed in street clothes and a life jacket.

The cooling of the body in submersion hypothermia allows the brain and heart to withstand approximately 45 min of oxygen debt. This is most operative for young children. A child can survive for an extended period of time while completely submerged because the body is undergoing both internal and external cooling. As the child is drowning, cold water is swallowed and enters the lungs, which cools the core. At the same time, the cold water that bathes the skin rapidly cools the periphery. The multiple effects of the internal and external cooling decrease the metabolic rate and give the child a window of safety of approximately 45 min. In warm water, survival is possible for only 5–7 min.

**Secondary hypothermia.** A decrease in core temperature caused by an underlying pathology that prevents the body from generating enough core heat is referred to as secondary hypothermia. If any of the thermoregulatory systems are altered, the body's ability to generate heat decreases and hypothermia can then develop without warning. Insufficient muscle mass to generate heat, medications that interfere with metabolism, an underlying systemic infection, decreased thyroid hormone production, and paralysis predispose to hypothermia. Premature infants with low body fat and a large surface-to-volume ratio lose heat rapidly and are at risk for becoming hypothermic. The elderly are perhaps the most susceptible to secondary hypothermia. However, whether the process of aging with no associated debility also alters the thermoregulatory system in the elderly remains to be determined.

**Clinical hypothermia.** Some cardiac surgical procedures require clinically induced cooling to stop the heart from beating. Induced hypothermia lowers the oxygen demand of the body tissues, so that oxygenated blood need not circulate. In the case of coronary bypass surgery, the entire body is cooled, enabling the surgeons to work for an extended period of time on the cold heart.

**Frostbite.** In hypothermia, the body's internal temperature decreases, but no solid freezing takes place. In frostbite, which is freezing of the digits or the limbs, there is actual formation of ice crystals. Basically the digits go through various stages of cooling. Initially, in the prefreeze phase, the finger temperature is 37.4–50°F (3–10°C). Next, at 24.8°F (–4°C) ice crystals form outside the cells of the digits, circulation is limited, and cell death takes place if the process is allowed to continue. The cells of the digits and limbs can tolerate low temperatures that would be lethal to brain or nerve cells. However, once they are rewarmed and thawed, they develop an increased sensitivity to the cold and become more susceptible to frostbite. Any part of the body can become frostbitten, but the fingers, toes, ears, nose, and cheeks are most often affected. See HOMEOSTASIS.

[R.W.Po.; L.E.W.; J.Ho.]

**Hypothesis** A tentative supposition with regard to an unknown state of affairs, the truth of which is thereupon subject

to investigation by any available method, either by logical deduction of consequences which may be checked against what is known, or by direct experimental investigation or discovery of facts not hitherto known and suggested by the hypothesis.

[P.W.Br./H.Ma.]

**Hypotrichida** An order of Spirotrichia. These protozoans are commonly considered to represent the pinnacle of specialized development in the evolution of ciliates. Somatic ciliature of the ventral surface has been replaced by cirri; on the dorsal surface it is absent or represented by inconspicuous sensory bristles (see illustration). The adoral zone of membranelles is very

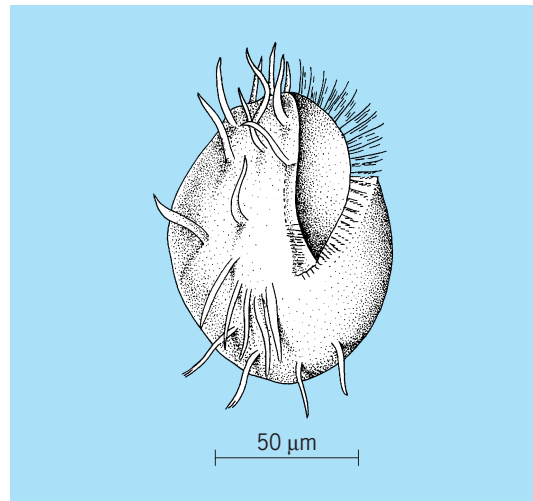

*Euplotes*, an example of a hypotrich.

prominently developed, and the buccal area may occupy a large part of the ventral surface of the body. The whole body is generally rigid. Hypotrichs occur ubiquitously in fresh- and saltwater habitats. See SPIROTRICHIA.

[J.O.C.]

**Hypoxia** The failure of oxygen to gain access to, or to be utilized by, the body. Although the term anoxia is commonly used, a more precise term, hypoxia, is more often applicable because there is seldom a complete oxygen defect.

Oxygen deprivation may result from interference with some stage of the inspiration, lung diffusion, blood transport, cellular absorption, and final utilization by enzyme systems. A defect at any one or more of these major stages quite often induces a decreased ability of other related mechanisms to survive. This is seen most dramatically in any form of hypoxia in which the brain is deprived of the necessary oxygen for more than a few minutes. Nerve cell degeneration begins quickly, and although the original cause of hypoxia is removed, damage to the respiratory centers prevents resumption of breathing. See RESPIRATORY SYSTEM.

The term anoxia is used by many authorities to indicate an oxygen deficiency at the tissue level, and failure of cellular respiration may be designated histotoxic anoxia. There are other terms employed to differentiate the type of oxygen deficiency or the stage in the total respiratory process where defects occur.

[E.G.St./N.K.M.]

**Hyracoidea** An order of mammals closely related to elephants. Hyracoids were a diverse and successful group of mammals in Africa during the Eocene and Oligocene epochs (early part of the Age of Mammals, 55 to 34 million years ago), and they are still represented by a few living species. The early hyracoids ranged from animals as small as rabbits to ones as large as modern Sumatran rhinoceroses. The fossil skeletons of the early hyracoids indicate that some species were active runners

and leapers, while others were heavy, piglike quadrupeds. Their teeth suggest herbivorous diets, ranging from fibrous leaves in some species to pulpy fruits and roots in others. Hyracoids originated in Africa but later extended their range into Europe and Asia, eventually attaining a distribution encompassed by China, Spain, and South Africa. In contrast to the early diversity of the order, the only living species are a few small-bodied animals (1.5–5.5 kg or 3.3–12 lb) that inhabit forests, scrubby brushlands, and rocky deserts in Africa and the Middle East. Hyracoidea represents a classic case of a spectacular adaptive radiation on an isolated continent, now reduced to a few remnant living taxa. See MAMMALIA.

The modern hyracoids, the hyraxes, include about 7 to 12 species classified in three genera, *Procavia*, *Heterohyrax*, and *Dendrohyrax*. All are members of the family Procaviidae. *Gigantohyrax* is a fourth, extinct genus of Procaviidae known from Plio-Pleistocene caves in southern and eastern Africa. All of the remaining fossil hyracoids, representing at least 18 genera, are often classified in a separate, very diverse family, Pliohyracidae, pending better understanding of the phylogenetic relationships among forms.

Morphological and molecular lines of evidence indicate that hyracoids are close relatives of elephants (order Proboscidea) and manatees and dugongs (order Sirenia). Therefore, the orders Hyracoidea, Proboscidea, and Sirenia are best classified together in the superorder Paenungulata. See PROBOSCIDEA; SIRENIA. [D.T.Ra.]

**Hysteriales (lichenized)** An order of the Ascolichenes shared by the Ascomycetes, comprising those species with a so-called ascolocular structure. The hymenium consists of densely interwoven, branched pseudoparaphyses and irregularly scattered locules in which the asci are located.

The growth form of the Hysteriales is either crustose or fruticose. There are five or six families now included here. Arthoniaceae is the largest family, with two genera, *Arthonia* and *Arthothelium*, both widespread on bark, rarely on leaves, in temperate and tropical regions. The Roccellaceae is a family of conspicuous fruticose species that grow profusely on trees and rocks along the coastlines of Portugal, California, Baja California, and parts of western South America. These plants were collected by the ton in the Middle Ages for use as dyestuffs. These same lichens, on a smaller scale, now yield the dye used in litmus paper. [M.E.H.]

**Hysteresis** A phenomenon wherein two (or more) physical quantities bear a relationship which depends on prior history. More specifically, the response  $Y$  takes on different values for an increasing input  $X$  than for a decreasing  $X$ .

If one cycles  $X$  over an appropriate range, the plot of  $Y$  versus  $X$  gives a closed curve which is referred to as the hysteresis loop. The response  $Y$  appears to be lagging the input  $X$ .

Hysteresis occurs in many fields of science. Perhaps the primary example is of magnetic materials where the input variable  $H$  (magnetic field) and response variable  $B$  (magnetic induction) are traditionally chosen. For such a choice of conjugate variables, the area of the hysteresis loop takes on a special significance, namely the conversion of energy per unit volume to heat per cycle. For mechanical hysteresis, it is customary to take the variables stress and strain, where the energy density loss per cycle is related to the internal friction. Thermal hysteresis is characteristic of many systems, particularly those involving phase changes, but here the hysteresis loops are not usually related to energy loss. See FERROELECTRICS; STRESS AND STRAIN. [H.B.H.; R.K.MacC.]

**Hysteresis motor** A type of synchronous motor in which the rotor consists of a central nonmagnetic core upon which are mounted rings of magnetically hard material. The rings form a thin cylindrical shell of material with a high degree of magnetic hysteresis. The cylindrical stator structure is identical to that of conventional induction or synchronous motors and is fitted with a three-phase or a single-phase winding, with an auxiliary winding and series capacitor for single-phase operation. See INDUCTION MOTOR; SYNCHRONOUS MOTOR.

When the motor is running at synchronous speed, the hysteresis material is in a constant state of magnetization and acts as a permanent magnet. Full-speed performance is therefore exactly the same as in a permanent-magnet synchronous motor.

The outstanding special feature of a hysteresis motor is the production of nearly constant, ripple-free torque during starting. Hysteresis motors are widely used in synchronous motor applications where very smooth starting is required, such as in clocks and other timing devices and record-player turntables, where smooth starting torque reduces record slippage. Hysteresis motors are limited to small size by the difficulty of controlling rotor losses caused by imperfections in the stator mmf wave. See ALTERNATING-CURRENT MOTOR; MOTOR. [D.W.N.]

**I-spin** A quantum-mechanical variable or quantum number applied to quarks and their compounds, the strongly interacting fundamental hadrons, and the compounds of those hadrons (such as nuclear states) to facilitate consideration of the consequences of the charge independence of the strong (nuclear) forces. This variable is also known as isotopic spin, isobaric spin, and isospin.

The many strongly interacting particles (hadrons) and the compounds of these particles, such as nuclei, are observed to form sets or multiplets such that the members of the multiplet differ in their electric charge and magnetic moments, and other electromagnetic properties but are otherwise almost identical. For example, the neutron and proton, with electric charges that are zero and plus one (in units of the magnitude of the electron charge), form a set of two such states. The pions, one with a unit of positive charge, one with zero charge, and one with a unit of negative charge, form a set of three. It appears that if the effects of electromagnetic forces and the closely related weak nuclear forces (responsible for beta decay) are neglected, leaving only the strong forces effective, the different members of such a multiplet are equivalent and cannot be distinguished in their strong interactions. The strong interactions are thus independent of the different electric charges held by different members of the set; they are charge-independent. See ELEMENTARY PARTICLE; FUNDAMENTAL INTERACTIONS; HADRON; STRONG NUCLEAR INTERACTIONS.

The I-spin ( $I$ ) of such a set or multiplet of equivalent states is defined such that Eq. (1) is satisfied, where  $N$  is the number of

$$N = 2I + 1 \quad (1)$$

states in the set. Another quantum number  $I_3$ , called the third component of I-spin, is used to differentiate the numbers of a multiplet where the values of  $I_3$  vary from  $+I$  to  $-I$  in units of one. The charge  $Q$  of a state and the value of  $I_3$  for this state are connected by the Gell-Mann-Okubo relation, Eq. (2), where  $Y$ ,

$$Q = I_3 + \frac{Y}{2} \quad (2)$$

the charge offset, is called hypercharge. For nuclear states,  $Y$  is simply the number of nucleons. Electric charge is conserved in all interactions;  $Y$  is observed to be conserved by the strong forces so that  $I_3$  is conserved in the course of interactions mediated by the strong forces. See HYPERCHARGE.

This description of a multiplet of states with I-spin is similar to the quantum-mechanical description of a particle with a total angular momentum or spin of  $j$  (in units of  $\hbar$ , Planck's constant divided by  $2\pi$ ). Such a particle can be considered as a set of states which differ in their orientation or component of spin  $j_z$  in a  $z$  direction of quantization. There are  $2j + 1$  such states, where  $j_z$  varies from  $-j$  to  $+j$  in steps of one unit. To the extent that the local universe is isotropic (or there are no external forces on the states that depend upon direction), the components of angular momentum in any direction are conserved, and states with different values of  $j_z$  are dynamically equivalent.

There is then a logical or mathematical equivalence between the descriptions of (1) a multiplet of states of definite  $I$  and different values of  $I_3$  with respect to charge-independent forces and (2) a multiplet of states of a particle with a definite spin  $j$  and different values of  $j_z$  with respect to direction-independent forces. In

each case, the members of the multiplet with different values of the conserved quantity  $I_3$  on the one hand and  $j_z$  on the other are dynamically equivalent; that is, they are indistinguishable by any application of the forces in question. See ANGULAR MOMENTUM; SPIN (QUANTUM MECHANICS).

The charge independence of the strong interactions has important consequences, defining the intensity ratios of different charge states produced in those particle reactions and decays which are mediated by the strong interactions. I-spin considerations also provide insight into the total energies or masses of nuclear and particle states. The basis for the symmetry described by I-spin is to be found in the quark structure of the strongly interacting particles and the character of the interactions between quarks. See QUARKS; SELECTION RULES (PHYSICS); SYMMETRY LAWS (PHYSICS). [R.K.A.]

**Ice cream** A commercial dairy food made by freezing while stirring a pasteurized mix of suitable ingredients. The product may include milk fat, nonfat milk solids, or milk-derived ingredients; other ingredients may include corn syrup, water, flavoring, egg products, stabilizers, emulsifiers, and other non-milk-derived ingredients. Air incorporated during the freezing process is also an important component.

The composition of ice cream may vary depending on whether it is an economy brand satisfying minimal requirements, a trade brand of average composition, or a premium brand of superior composition. The components by weight of an average-composition ice cream are 12% fat, 11% nonfat milk solids, 15% sugar, and 0.3% vegetable gum stabilizer.

Ice cream manufacturing ranges from small-batch operations, in which the ingredients are weighed or measured by hand, to large automated operations, where the ingredients are metered into the mix-making equipment. The liquid materials, including milk, cream, concentrated milk, liquid sugar syrup, and water, are mixed. The dry solids, such as nonfat dry milk, dried egg yolk, stabilizer, and emulsifier, are blended with the liquid ingredients. This liquid blend is known as the mix. Following the blending operation, the mix is pasteurized, homogenized, cooled, and aged. Pasteurization destroys all harmful microorganisms and improves the storage properties of the ice cream. Soluble flavoring materials are usually added to the mix just before the freezing process, but fruits, nuts, and candies are not added until the ice cream is discharged from the freezer. See PASTEURIZATION. [W.S.A.; R.T.M.]

**Ice field** A network of interconnected glaciers or ice streams, with common source area or areas, in contrast to ice sheets and ice caps. (An ice sheet is a broad, cakelike glacial mass with a relatively flat surface and gentle relief. Ice caps are properly defined as domelike glacial masses, usually at high elevation.) Being generally associated with terrane of substantial relief, ice-field glaciers are mostly of the broad-basin, cirque, and mountain-valley type. Thus, different sections of an ice field are often separated by linear ranges, bedrock ridges, and nunataks. [M.M.Mi.]

**Ice point** The temperature at which liquid and solid water are in equilibrium under atmospheric pressure. The ice point is

by far the most important "fixed point" for defining temperatures scales and for calibrating thermometers. A closely related point is the triple point, which has gained favor as the primary standard since it can be attained with great accuracy in a simple closed vessel, isolated from the atmosphere. See TEMPERATURE; TRIPLE POINT. [R.A.Bu.]

**Iceberg** A large mass of glacial ice broken off and drifted from parent glaciers or ice shelves along polar seas. Icebergs should be distinguished from polar pack ice which is sea ice, or frozen sea water, though rafted or hummocked fragments of the latter may resemble small bergs. See GLACIOLOGY; SEA ICE.

Icebergs are classified by shape and size. The terms used are arched, blocky, dome, pinnacled, tabular, valley, and weathered for berg description, and bergy-bit and growler for berg fragments ranging smaller than cottage size above water. The lifespan of an iceberg may be indefinite while the berg remains in cold polar waters, eroding only slightly during summer months. But under the influence of ocean currents, an iceberg that drifts into warmer water will disintegrate rapidly.



Arctic iceberg, eroded to form a valley or dry-dock type: grotesque shapes are common to the glacially produced icebergs of the North.

In the Arctic, icebergs (see illustration) originate chiefly from glaciers along Greenland coasts. It is estimated that a total of about 16,000 bergs are calved annually in the Northern Hemisphere, of which over 90% are of Greenland origin; but only about half of these have a size or source location to enable them to achieve any significant drift. No icebergs are discharged or drift into the North Pacific Ocean or its adjacent seas, except a few small bergs each year that calve from the piedmont glaciers along the Gulf of Alaska.

In the Southern Ocean, bergs originate from the giant ice shelves all along the Antarctic continent. These result in huge, tabular bergs or ice islands several hundred feet high and often over a hundred miles in length, which frequent the entire waters of the Antarctic seas. [R.PD.]

**Icebreaker** A ship designed to break floating ice. Since the 1960s, potential resource development in the Arctic regions has led to the construction of icebreaking ships that can transit to all areas of the world, including the North Pole. Icebreakers provide the platforms from which polar science and research can be conducted on a year-round basis. See ANTARCTIC OCEAN; ARCTIC OCEAN.

Icebreakers may be classed as polar or subpolar, depending on their primary geographic area of operation. Polar icebreakers can operate independently in first-year, second-year, and multiyear ice in the Arctic or the Antarctic. Subpolar icebreakers operate in the ice-covered waters of coastal seas and lakes outside the polar regions. See MARITIME METEOROLOGY; SEA ICE.

The combined shapes of the bow, midbody, and stem con-

stitute the hull form. The icebreaker's bow must be designed to break ice efficiently, and it consists of an inclined wedge that forms an angle of about 20° with the ice surface. As the icebreaker advances, the bow rides up on the edge of the ice until the weight of the ship becomes sufficiently large that the downward force causes the ice to fail. The broken ice pieces move under the hull, and the process is repeated. Traditionally, icebreakers have sloped sides of 5–20° to reduce the frictional resistance. The stern of the icebreaker is designed in a manner similar to the bow so that the ship can break ice while going astern. See SHIP DESIGN.

The hull of a polar icebreaker is built very strong so that it can withstand tremendous ice forces. Because frequent and high loads occur at very low air temperatures, specialty steels are used on polar icebreakers. It is common to have bow and stern plating of 1.5–2.0 in. (4–5 cm) in thickness.

Most icebreakers are powered with diesel engines. However, when the horsepower required for icebreaking is sufficiently great, gas turbines or nuclear steam turbines are needed. See MARINE ENGINE.

Many auxiliary methods have been developed to improve the performance of icebreakers by reducing the friction between the hull and the ice. One widely used method is to roll or heel the ship from side to side. In addition, most icebreakers use a low-friction coating or a stainless-steel ice belt to reduce ice-breaking resistance. [R.PV.]

**Ichneumon** The common name for medium- to large-sized insects (wasps) comprising 25,000 species and belonging to the family Ichneumonidae (Hymenoptera); together with the Braconidae (with an additional 15,000 species) they form the superfamily Ichneumonoidea. The majority of ichneumons are slender wasps with long filiform antennae, freely rotating head, and permanently extruded ovipositor. The ichneumons, found worldwide, are most abundant in heavy vegetational areas such as the edges of woodlands, hedgerows, and in secondary growth vegetation, and are often seen in the woodland canopy or in the litter of the forest floor. Ichneumons are more commonly seen in the spring and fall, as these wasps avoid hot, dry weather. See HYMENOPTERA; INSECTA.

All members of the family Ichneumonidae are parasitic during their immature stages. They attack a wide variety of insects, usually the larval stages of beetles, butterflies, moths, flies, and other Hymenoptera. Since many of their insect hosts are considered pests of forest and agricultural crops, ichneumons are beneficial and important in biological control. See ENTOMOLOGY; ECONOMIC. [S.B.V.]

**Ichthyopterygia** A subclass of Mesozoic reptiles consisting of the highly specialized aquatic order Ichthyosauria. Ichthyosaurs are known from the Lower Triassic to near the end of the Cretaceous. Their body form broadly resembles that of living dolphins. Advanced ichthyosaurs have a spindle-shaped trunk, a narrow caudal peduncle, and a lunate tail with a high aspect ratio. This configuration corresponds closely to that of the fastest swimming modern sharks and bony fish such as the tuna and swordfish. See REPTILIA. [R.L.C.]

**Ichthyornithiformes** A small order of flying, toothed fossil birds that dates from the Cretaceous and contains only the family Ichthyornithidae of North America. Placement of the Ichthyornithiformes in the superorder Odontognathae, together with the Hesperornithiformes, is based only on their common possession of teeth; the relationship must still be supported with additional evidence. See HESPERORNITHIFORMES; ODONTOGNATHAE.

The original finds of *Ichthyornis* were from the Niobrara chalk beds of Kansas, but recent discoveries have extended the range of those birds over much of North America as well as into the Early Cretaceous. *Ichthyornis* disappeared in the Late Cretaceous Period, perhaps with the loss of the extensive inland seas

that covered much of central North America during that period. See AVES. [W.J.B.]

**Ichthyostega** Four-legged vertebrates (basal tetrapods) that evolved from their lobe-finned fish ancestors during the later Devonian Period (400–350 million years ago) [see illus.]. *Ichthyostega* was the first Devonian tetrapod to be described and was found in East Greenland during the 1930s. For many decades it remained the only representative of the “fish-tetrapod transition” which was known from articulated skeletal fossils. Subsequently, a second genus from the same beds, *Acanthostega*, was more fully described, and during the 1990s Devonian tetrapod genera were recognized in other parts of the world.

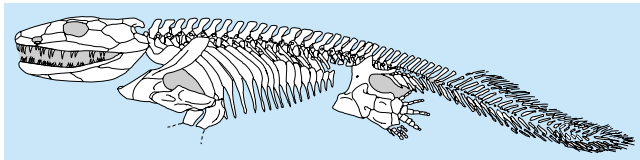

Reconstruction of the skeleton of *Ichthyostega* based on recent information. The animal was about 1 m (3 ft) long.

Like other very early tetrapods, *Ichthyostega* had a skull composed of an outer casing of bone (the skull roof) with a separate box containing the brain (the braincase) inside it. The braincase shows some highly unusual features, especially in the ear region, which are difficult to interpret and do not resemble those of any other early tetrapod.

The postcranial skeleton shows some primitive and some very specialized features. The tail bore a fringe of fin-rays like those of a fish; these are lost in all other known early tetrapods except *Acanthostega*. The neural arches supporting the spinal cord articulated with one another via well-developed joint surfaces (zygapophyses). The ribs were massive overlapping blades which formed a corset around the body and gave it rigidity.

The massive shoulder girdle bore the large complex humerus which articulated with the shoulder at right angles to the body. The large pelvic girdle was attached to the vertebral column only by ligaments and muscles—no bony joint surfaces were involved as they are in modern tetrapods. The femur appears to have been about half the length of the humerus, and the hindlimb was paddlelike with tibia, fibula, and ankle bones all broad and flattened. The foot bore seven toes, which seems were enclosed in a web of skin. See AMPHIBIA; LABYRINTHODONTIA. [J.A.Cla.]

**Igneous rocks** Those rocks which have congealed from a molten mass. They may be composed of crystals or glass or both depending on the conditions of formation. The molten matter from which they come is called magma; where erupted to the surface, it is commonly known as lava. Solidification of the hot rock melt occurs in response to loss of heat. Generated at depth the magma tends to rise. It commonly breaks through the Earth's crust and spills out on the Earth's surface or ocean floor to form volcanic or extrusive rocks. At the surface where cooling is rapid, fine-grained or glassy rocks are formed.

Where unable to reach the surface, magma cools more slowly, insulated by the overlying rocks; and a coarser texture develops. The resulting igneous rocks appear intrusive relative to adjacent rocks. In general, deeply formed (plutonic) rocks display the coarsest texture. Igneous rocks formed at shallow depths (hypabyssal) display features somewhat intermediate between those of volcanic and plutonic types. See MAGMA; PLUTON; VOLCANO; VOLCANOLOGY.

Texture refers to the mutual relation of the rock constituents within a uniform aggregate. It is dependent upon the relative amounts of crystalline and amorphous (glassy) matter as well as the size, shape, and arrangement of the constituents. Rock

textures are highly significant; they shed light on the problem of rock genesis, and tell much about the conditions and environment under which the rock formed.

Schemes for classifying igneous rocks are numerous. Three principal methods of classification are used. (1) Megascopic schemes are based on the appearance of the rock-in-hand specimen or as seen with a magnifying glass (hand lens). Such schemes are useful in the field study of rocks. (2) Microscopic schemes (largely mineralogical) are employed in laboratory investigations where more detailed information is needed. (3) Chemical schemes are very useful but have more limited application. The mineral content and texture of a rock generally tell much more about the rock's origin than does a bulk chemical analysis. Igneous rocks show great variations chemically, mineralogically, texturally, and structurally with few if any natural boundaries.

Plutonic rocks occur in large intrusive masses (batholiths, stocks, and other large plutons). They form at great depth and are often referred to as abyssal rocks. They are generated from large bodies of magma which cooled slowly.

Volcanic rocks are formed as lava flows or as pyroclastic rocks (heterogeneous accumulations of volcanic ash and coarser fragmental matter). They have solidified rapidly, and expanding gas bubbles formed by escaping volatiles frequently create highly porous rocks.

Hypabyssal rocks exhibit characteristics more or less intermediate between those of volcanic and plutonic types. They differ from volcanic rocks in that they are intrusive and generally free from glass and vesicular structures. They differ from plutonic rocks in that they occur in small bodies (dikes and sills) or in larger bodies formed at shallow depths (laccoliths) and they have textures characteristically resulting from more rapid cooling. See ANORTHOSITE; BASALT; FELDSPAR; FELDSPATHOID; GABBRO; GRANITE; GRANODIORITE; LABRADORITE; LEUCITE ROCK; PYROXENITE; QUARTZ; RHYOLITE; SYENITE; TRACHYTE.

Igneous rock-forming minerals may be classed as primary or secondary. The primary minerals are those formed by direct crystallization from the magma. Secondary minerals may form at any subsequent time. The principal primary minerals are relatively few and may be classed as light-colored (felsic) or dark-colored (mafic) varieties. Felsic is a mnemonic term for feldspathic minerals (feldspar and feldspathoids) and silica (quartz, tridymite, and cristobalite). Mafic is mnemonic for magnesium and iron-rich minerals (biotite, amphibole, pyroxene, and olivine). Felsic minerals are composed largely of silica, alumina, and alkalis. Mafics are rich in iron, magnesium, and calcium.

Secondary minerals include minerals formed by addition of material subsequent to solidification of the rock or by alteration of minerals already present in the rock. Alteration in which certain minerals become more or less reconstituted is common and widespread. The common alteration products derived from the essential primary minerals are as follows.

<i>Primary mineral</i>	<i>Secondary mineral</i>
Quartz	Not altered
Potash feldspar	Kaolinite, sericite
Plagioclase	Kaolinite, sericite (paragonite), epidote, zoisite, calcite
Nepheline	Cancrinite, analcite, natrolite
Leucite	Nepheline and potash feldspar
Sodalite	Analcite, cancrinite
Biotite	Chlorite, sphene, epidote, rutile, iron oxide
Hornblende	Actinolite, biotite, chlorite, epidote, calcite
Orthopyroxene	Antigorite, actinolite, talc
Clinopyroxene	Hornblende, actinolite, biotite, chlorite, epidote, antigorite
Olivine	Serpentine, magnetite, talc, magnesite

See PETROLOGY.

[C.A.C.]

**Ignimbrite** A pyroclastic rock deposit formed by one or more ground-hugging flows of hot volcanic fragments and particles, essentially synonymous with pyroclastic-flow deposit, ash-flow tuff, flood tuff, or welded tuff.

Ignimbrites are commonly produced during explosive eruptions and are associated with most of the world's volcanic systems. They vary in size by orders of magnitude ( $10^{-3}$  to  $10^3$  km<sup>3</sup> of erupted material) and have chemical compositions that span the entire range commonly exhibited by igneous rocks (basaltic to rhyolitic). An ignimbrite can be of any form and size, but most deposits have sheetlike shapes and cover many thousands of square kilometers.

Ignimbrite deposits are characterized by a poorly sorted aggregate of ash (crystals and glass shards) and pumice. In the larger deposits, the pumice fragments may be flattened and stretched to yield ovoid-to-lenticular shapes, reflecting the compaction and welding of the deposit after or during emplacement. See IGNEOUS ROCKS; PUMICE; PYROCLASTIC ROCKS; TUFF; VOLCANIC GLASS; VOLCANO. [R.I.T.]

**Ignition system** The system in an internal combustion engine that initiates the chemical reaction between fuel and air in the cylinder charge by producing a spark. An ignition system for a multicylinder internal combustion engine has three basic functions: (1) to provide a sufficiently energetic spark to initiate the burning of the fuel-air mixture within each cylinder; (2) to control spark timing for optimum efficiency so that cylinder pressure reaches its maximum value shortly after the piston reaches the top of its compression stroke; and (3) to select the correct cylinder fired.

In an inductive ignition system, there are three possible types of control—vacuum-mechanical, electronic spark, or full electronic engine. Prior to spark discharge, electrical energy is stored inductively in the coil primary. The current to the coil primary winding is turned on and off by the ignition module in response to the spark-timing trigger signal. The current-off time marks the beginning of the sparking event. An accurate spark-timing schedule is a complex function of many engine variables, such as fuel-air composition, engine revolutions per minute (rpm), temperature, cylinder pressure, exhaust gas recirculation rate, knock tendency, and engine design.

The ignition coil stores electrical energy during the dwell (current-on) period and acts as a transformer at the end of dwell by converting the low-voltage-high-current energy stored in the primary to high-voltage-low-current energy in the secondary. The distributor selects the fired spark plug by positioning the rotor opposite the terminal connected to one spark plug. The plug selected depends on the cylinder firing order, which in turn depends on the engine design. The distributor is driven at one-half engine speed from the camshaft. See SPARK PLUG.

When high voltage (10–30 kV) is created in the coil secondary, a spark jumps from the rotor to a distributor cap terminal, establishing a conducting path from the ignition coil high-voltage terminal along a high-voltage wire to the spark plug. Each cylinder usually has one spark plug. (High-efficiency engines may have two spark plugs per cylinder and two complete ignition systems.) The plug electrodes project as far into the cylinder as possible. After high voltage is applied to the plug, an electrical discharge is generated between its two electrodes. The energy and temperature of this discharge must be sufficient to reliably ignite the fuel-air mixture under all encountered conditions of composition, temperature, and pressure.

Among the several other types of ignition systems for internal combustion engines are capacitive discharge, multiple-firing capacitive discharge, continuous sustaining, magneto, and distributorless ignitions. The input energy for capacitive discharge systems is stored on a capacitor at several hundred volts (generated by a dc-dc converter). A semiconductor switch (thyristor) controls the discharge of the capacitor into the primary winding. In a multiple-firing capacitive discharge ignition, the ignition

module repetitively fires a capacitive discharge ignition during one spark event, increasing both the energy and effective time duration of the spark. In a continuous sustaining ignition, supplemental electrical power is added to the spark after it is established, resulting in electronically controlled extended duration rather than uncontrolled duration as for conventional ignitions. In a magneto ignition, electric current and energy are generated in the primary by relative rotational motion between a magnet and a coil (electromagnetic induction). High voltage is generated in the secondary when a set of contacts in the primary circuit is mechanically opened. Magnetos require no external source of electrical power.

The distributorless ignition system eliminates the need for mechanical distribution of spark energy by using a single coil for one, two, or four cylinders. For the two-cylinder-single-coil system, a double-ended ignition coil simultaneously fires a cylinder in a compression stroke together with a second in an exhaust stroke. The exhaust stroke cylinder accepts the waste spark to complete the electrical circuit through the engine block. A design variation uses alternating polarity high voltage from a special type of double-ended coil and four high-voltage rectifiers to fire four plugs. The rectifiers steer the voltage to the correct pair of plugs.

In diesel or compression ignition engines, sparkless ignition occurs almost immediately after fuel injection into the cylinder due to high in-cylinder air temperatures. High temperatures result from the high compression ratio of diesel engines. Mechanical or electronic injection timing systems determine ignition timing. See COMBUSTION CHAMBER; DIESEL ENGINE; INTERNAL COMBUSTION ENGINE. [J.R.As.]

**Illiciales** An order of flowering plants, division Magnoliophyta (Angiospermae), in the subclass Magnoliidae of the class Magnoliopsida (dicotyledons). The order consists of two families, Illiciaceae and Schisandraceae, with fewer than a hundred species in all. They are all woody, with scattered spherical cells containing volatile oils. The leaves are alternate and simple. The flowers are solitary or a few clustered together, regular, and hypogynous; the perianth has five to many segments that are not clearly differentiated into sepals and petals. The Illiciales are related to the Magnoliales and have sometimes been included in that order, but they are apparently more advanced in having fundamentally triaperturate pollen. See MAGNOLIOPSIDA. [T.M.Ba.]

**Illite** A clay-size, micaceous mineral; a common component of soil, sediments, sedimentary rocks, and hydrothermal deposits. Illite is considered to possess a smaller layer charge and potassium (K) content than muscovite. It is characterized by the ideal formula  $Al_2(Si_{3.2}Al_{0.8})O_{10}(OH)_2K_{0.8}$ .

Illite frequently is interlayered with smectite, and can be considered the nonswelling end member in an illite-smectite mixed-layer clay series. Pure end-member illite, with no interlayer smectite, is rare.

Illitic clays are used for manufacturing structural clay products such as brick and tile. Some degraded illites (vermiculites) are used for molding sands. Illite may also be useful for storing certain types of radioactive wastes, because it is less subject to transformation by heat than are other common clays and because it is highly specific for the sorption of cesium. See CLAY, COMMERCIAL; CLAY MINERALS. [D.D.E.]

**Illuminance** A term expressing the density of luminous flux incident on a surface. This word has been proposed by the Colorimetry Committee of the Optical Society of America to replace the term illumination. The definitions are the same. The symbol of illumination is  $E$ , and the equation is  $E = dF/dA$ , where  $A$  is the area of the illuminated surface and  $F$  is the luminous flux. See ILLUMINATION; LUMINOUS FLUX; PHOTOMETRY. [R.C.Pu.]



**Illumination** In a general sense, the science of the application of lighting. Radiation in the range of wavelengths of 0.38–0.76 micrometer produces the visual effect, commonly called light, by the response of the average human eye for normal (photopic) brilliance levels. Illumination engineering pertains to the sources of lighting and the design of lighting systems which distribute light to produce a comfortable and effective environment for seeing. In a specific quantitative sense, illumination is the combination of the spatial density of radiant power received at a surface and the effectiveness of that radiation in producing a visual effect. *See* ILLUMINANCE. [W.B.Bo.]

**Ilmenite** A rhombohedral mineral with composition  $\text{Fe}^{2+}\text{Ti}^{4+}\text{O}_3$ . The hardness is  $5\frac{1}{2}$  on Mohs scale, specific gravity 4.72. Color is black, and there is no cleavage. The mineral usually occurs massive or in thin plates. Two other minerals belonging to the ilmenite structure type are geikielite,  $\text{MgTiO}_3$ , and pyrophanite,  $\text{MnTiO}_3$ .

Ilmenite is the most abundant titanium mineral in igneous rocks and the most important ore of titanium. Important occurrences include the Ilmen Mountains, Russia (whence the name); Kragerø, Norway; and Allard Lake, Quebec, Canada. *See* TITANIUM. [P.B.M.]

**Image processing** Manipulating data in the form of an image through several possible techniques. An image is usually interpreted as a two-dimensional array of brightness values, and is most familiarly represented by such patterns as those of a photographic print, slide, television screen, or movie screen. An image can be processed optically, or digitally with a computer.

To digitally process an image, it is first necessary to reduce the image to a series of numbers that can be manipulated by the computer. Each number representing the brightness value of the image at a particular location is called a picture element, or pixel. A typical digitized image may have  $512 \times 512$  or roughly 250,000 pixels, although much larger images are becoming common. Once the image has been digitized, there are three basic operations that can be performed on it in the computer. For a point operation, a pixel value in the output image depends on a single pixel value in the input image. For local operations, several neighboring pixels in the input image determine the value of an output image pixel. In a global operation, all of the input image pixels contribute to an output image pixel value. These operations, taken singly or in combination, are the means by which the image is enhanced, restored, or compressed.

An image is enhanced when it is modified so that the information it contains is more clearly evident, but enhancement can also include making the image more visually appealing. An example is noise smoothing. To smooth a noisy image, median filtering can be applied with a  $3 \times 3$  pixel window. This means that the value of every pixel in the noisy image is recorded, along with the values of its nearest eight neighbors. These nine numbers are then ordered according to size, and the median is selected as the value for the pixel in the new image. As the  $3 \times 3$  window is moved one pixel at a time across the noisy image, the filtered image is formed.

Another example of enhancement is contrast manipulation, where each pixel's value in the new image depends solely on that pixel's value in the old image; in other words, this is a point operation. Contrast manipulation is commonly performed by adjusting the brightness and contrast controls on a television set, or by controlling the exposure and development time in printmaking. Another point operation is that of pseudocoloring a black-and-white image, by assigning arbitrary colors to the gray levels. This technique is popular in thermography (the imaging of heat), where hotter objects (with high pixel values) are assigned one color (for example, red), and cool objects (with low pixel values) are assigned another color (for example, blue), with other colors assigned to intermediate values.

The aim of restoration is also to improve the image, but unlike enhancement, knowledge of how the image was formed is used in an attempt to retrieve the ideal (uncorrupted) image. Any image-forming system is not perfect, and will introduce artifacts (for example, blurring, aberrations) into the final image that would not be present in an ideal image. A point spread function, called a filter, can be constructed that undoes the blurring. By imaging the blurred image with the filter point spread function, the restored image results. The filter point spread function is spread out more than the blurring point spread function, bringing more pixels into the averaging process. This is an example of a global operation, since perhaps all of the pixels of the blurred image can contribute to the value of a single pixel in the restored image. This type of deblurring is called inverse filtering, and is sensitive to the presence of noise in the blurred image. By modifying the deblurring filter according to the properties of the noise, performance can be improved. An example of the need to deblur images from an optical system is the Hubble Space Telescope before its spherical aberration was corrected with new optics. *See* SATELLITE ASTRONOMY.

Compression is a way of representing an image by fewer numbers, at the same time minimizing the degradation of the information contained in the image. Compression is important because of the large quantities of digital imagery that are sent electronically and stored. Digital high-definition television relies heavily on image compression to enable transmission and display of large-format color images. Once the image is compressed for storage or transmission, it must be uncompressed for use, by the inverse of the compression operations. There is a trade-off between the amount of compression and the quality of the uncompressed image. High compression rates are acceptable with television images, for example. However, where high image quality must be preserved (as in diagnostic medical images), only compression rates as low as three to four may be acceptable. *See* DATA COMPRESSION.

Image processing is an active area of research in such diverse fields as medicine, astronomy, microscopy, seismology, defense, industrial quality control, and the publication and entertainment industries. The concept of an image has expanded to include three-dimensional data sets (volume images), and even four-dimensional volume-time data sets. An example of the latter is a volume image of a beating heart, obtainable with x-ray computed tomography (CT). CT, PET, single-photon emission computed tomography (SPECT), MRI, ultrasound, SAR, confocal microscopy, scanning tunneling microscopy, atomic force microscopy, and other modalities have been developed to provide digitized images directly. Digital images are widely available from the Internet, CD-ROMs, and inexpensive charge-coupled-device (CCD) cameras, scanners, and frame grabbers. Software for manipulating images is also widely available. *See* CHARGE-COUPLED DEVICES; COMPACT DISK; COMPUTER STORAGE TECHNOLOGY; COMPUTERIZED TOMOGRAPHY; CONFOCAL MICROSCOPY; DATA COMMUNICATIONS; DIGITAL COMPUTER; ELECTRON MICROSCOPE; MEDICAL ULTRASONIC TOMOGRAPHY; NUCLEAR MEDICINE; SCANNING TUNNELING MICROSCOPE; TELEVISION CAMERA. [W.E.Sm.]

**Immittance** The impedance or admittance of an alternating-current circuit. It is sometimes convenient to use the term immittance when referring to a complex number which may be either the impedance (ratio of voltage to current) or the admittance (ratio of current to voltage) of an electrical circuit. The units of impedance and admittance are, of course, different and so units cannot be assigned to an immittance. However, in certain theoretical work it may be necessary to deal with general functions which afterward will be specialized to become either an impedance or an admittance by the assignment of suitable units; in such cases it is convenient to refer to the functions as immittances. *See* ADMITTANCE; ALTERNATING CURRENT; ELECTRICAL IMPEDANCE. [J.O.S.]

**Immune complex disease** Local or systemic tissue injury caused by the vascular deposition of products of antigen-antibody interaction, termed immune complexes. Immune complex formation with specific antibodies causes the inactivation or elimination of potentially harmful consequences only when immune complexes deposit in tissues, inciting various mediators of inflammation. When the reaction takes place in the extravascular fluids near the site of origin of the antigen (by injection, secretion, and such), focal injury can occur, as exemplified by the Arthus reaction or such conditions as experimental immune thyroiditis. Systemic disease may occur when soluble antigens combine with antibodies in the vascular compartment, forming circulating immune complexes that are trapped nonspecifically in the vascular beds of various organs, causing such clinical diseases as serum sickness or systemic lupus erythematosus with vasculitis and glomerulonephritis. The term immune complex disease usually signifies this systemic immune complex formation and vascular deposition. See ANTIGEN-ANTIBODY REACTION; CONNECTIVE TISSUE DISEASE.

Circulating immune complex disease occurs when the host's antibody production, relative to the amount of antigens, is inadequate for prompt elimination of antigen. Normally, excess amounts of antibody are formed which generate large immune complexes that are removed very rapidly from the circulation and are disposed of by the mononuclear phagocytic system. If the antibody response is very poor, only a few very small complexes are formed which are not prone to vascular deposition. When the relative antibody production is such that complexes of intermediate size form, vascular trapping can occur and injury results from the effects of inflammation. In addition to immune complex size, other factors influence vessel deposition, including the efficiency of systemic clearance of immune complexes, the hemodynamics of blood flow, and vasoactive amine-influenced changes in vascular permeability. Through dynamic equilibrium, continual modification of the deposits occurs as antigen and antibody fluctuate in the body fluids.

Treatment of immune complex disease can be divided into nonspecific and more specific modalities. Primary among the specific measures is the identification and elimination of the offending antigen. This may be possible with some infections when specific therapies are available, and in certain instances where the antigenic source can be removed, such as a neoplasm. More frequently, nonspecific anti-inflammatory (corticosteroids) and immunosuppressive agents (such as cyclophosphamide and azathioprine) are used to attempt to blunt the person's immune response, thereby lessening the amount of immune complexes produced. See AUTOIMMUNITY; IMMUNOLOGY. [E.H.C.; C.B.W.]

**Immunity** A state of resistance to an agent, the pathogen, that normally produces an infection. Pathogens include microorganisms such as bacteria and viruses, as well as larger parasites. The immune response that generates immunity is also responsible in some situations for allergies, delayed hypersensitivity states, autoimmune disease, and transplant rejection. See ALLERGY; AUTOIMMUNITY; HYPERSENSITIVITY; TRANSPLANTATION BIOLOGY.

Immunity is engendered by the host immune system, reacting in very specific ways to foreign components (such as proteins) of particular parasites or infective agents. It is influenced by many factors, including the environment, inherited genes, and acquired characteristics. Reaction to a pathogen is through a nonadaptive or innate response as well as an adaptive immune response. The innate response is not improved by repeated encounters with the pathogen. An adaptive response is characterized by specificity and memory: if reinfection occurs, the host will mount an enhanced response.

The components of the pathogen that give rise to an immune response, to which antibodies are generated, are called antigens. There are two types of specific responses to an antigen, antibodies and the cellular response. Antibodies help to neu-

tralize the infectious agent by specifically binding it. A series of proteins in the blood (called complement) act in conjunction with antibodies to destroy pathogenic bacteria. In the cellular response, cytotoxic T cells are recruited to kill cells infected with intracellular agents such as viruses. Helper T cells may also be generated, which influence B cells to produce appropriate antibodies. Inflammatory responses and activation of other kinds of cells, such as macrophages, in conjunction with lymphocytes, is another important aspect of the immune response, as in delayed hypersensitivity. This kind of response seems to be common in certain chronic infections. See ANTIBODY; ANTIGEN; COMPLEMENT.

Complex immune systems (antibody and specific cellular responses) have been demonstrated in mammals, birds, amphibians, and fish, and are probably restricted to vertebrates.

**Natural or innate immunity.** There are natural barriers to infection, both physical and physiological, which are known collectively as innate immunity, and include the effects of certain cells (macrophages, neutrophils and natural killer cells) and substances such as serum proteins, cytokines, complement, lectins, and lipid-binding proteins. The skin or mucous membranes of the respiratory tract are obvious barriers and may contain bacteriostatic or bactericidal agents (such as lysozyme and spermine) that delay widespread infection until other defenses can be mobilized.

If organisms manage to enter tissues, they are often recognized by molecules present in serum and by receptors on cells. Bacterial cell walls, for example, contain substances such as lipopolysaccharides that activate the complement pathway or trigger phagocytic cells. Host range is dramatic in its specificity. Animals and plants are generally not susceptible to each other's pathogens. Within each kingdom, infectious agents are usually adapted to affect a restricted range of species. For example, mice are not known to be susceptible to pneumococcal pneumonia under natural conditions. The health of the host and environmental conditions may also make a difference to susceptibility. This is readily apparent in fish that succumb to fungal infections if their environment deteriorates. Genetic factors have an influence on susceptibility. Some of these genes have been identified, in particular the genes of the major histocompatibility complex which are involved in susceptibility to autoimmune diseases as well as some infectious disorders. See HISTOCOMPATIBILITY.

Once parasites gain entry, phagocytic cells attack them. They may engulf and destroy organisms directly, or they may need other factors such as antibody, complement, or lymphokines, secreted by lymphocytes, which enhance the ability of the phagocytes to take up antigenic material. In many cases these cells are responsible for alerting cells involved in active immunity so there is two-way communication between the innate and adaptive responses. See PHAGOCYTOSIS.

**Adaptive immune response.** Adaptive immunity is effected in part by lymphocytes. Lymphocytes are of two types: B cells, which develop in the bone marrow or fetal liver and may mature into antibody-producing plasma cells, and T cells, which develop in the thymus. T cells have a number of functions, which include helping B cells to produce antibody, killing virus-infected cells, regulating the level of immune response, and controlling the activities of other effector cells such as macrophages.

Each lymphocyte carries a different surface receptor that can recognize a particular antigen. The antigen receptor expressed by B cells consists of membrane-bound antibody of the specificity that it will eventually secrete; B cells can recognize unmodified antigen. However, T cells recognize antigen only when parts of it are complexed with a molecule of the major histocompatibility complex. The principle of the adaptive immune response is clonal recognition: each lymphocyte recognizes only one antigenic structure, and only those cells stimulated by antigen respond. Initially, in the primary response, there are few lymphocytes with the appropriate receptor for an antigen, but these cells

proliferate. If the antigen is encountered again, there will be a proportionally amplified and more rapid response. Primed lymphocytes either differentiate into immune effector cells or form an expanded pool of memory cells that respond to a secondary challenge with the same antigen.

The acquired or adaptive immune response is characterized by exquisite specificity such that even small pieces of foreign proteins can be recognized. This specificity is achieved by the receptors on T cells and B cells as well as antibodies that are secreted by activated B cells. The genes for the receptors are arranged in multiple small pieces that come together to make novel combinations, by somatic recombination. Each T or B cell makes receptors specific to a single antigen. Those cells with receptors that bind to the foreign protein and not to self tissues are selected out of a large pool of cells. For T cells, this process takes place in the thymus. The extreme diversity of T- and B-cell receptors means that an almost infinite number of antigens can be recognized. It has been calculated that potentially about  $3 \times 10^{22}$  different T-cell receptors are made in an individual. Even if 99% of these are eliminated because they bind to self tissues,  $3 \times 10^{20}$  would still be available.

Inflammation takes place to activate immune mechanisms and to eliminate thoroughly the source of infection. Of prime importance is the complement system, which consists of tens of serum proteins. A variety of cells are activated, including mast cells and macrophages. Inflammation results in local attraction of immune cells, increased blood supply, and increased vascular permeability. See CELLULAR IMMUNOLOGY.

**Autoimmunity.** The immune system is primed to react against foreign antigens while avoiding responses to self tissue by immunological tolerance. Although most T cells which might activate against host proteins are deleted in the thymus, these self-reactive cells are not always destroyed. These exceptions to self tolerance are frequently associated with disease, the autoimmune diseases, which are widespread pathological conditions, including Addison's disease, celiac disease, Goodpasture's syndrome, Hashimoto's thyroiditis, juvenile-onset diabetes mellitus, multiple sclerosis, myasthenia gravis, pemphigus vulgaris, rheumatoid arthritis, Sjögren's disease, and systemic lupus erythematosus. In these diseases, antibodies or T cells activate against self components. See AUTOIMMUNITY.

**Immunization.** Adaptive immunity is characterized by the ability to respond more rapidly and more intensely when encountering a pathogen for a second time, a feature known as immunological memory. This permits successful vaccination and prevents reinfection with pathogens that have been successfully repelled by an adaptive immune response. Mass immunization programs have led to the virtual eradication of several very serious diseases, although not always on a worldwide scale. Living attenuated vaccines against a variety of agents, including poliomyelitis, tuberculosis, yellow fever, and bubonic plague, have been used effectively. Nonliving vaccines are commonly used for prevention of bacterial diseases such as pertussis, typhoid, and cholera as well as some viral diseases such as influenza and bacterial toxins such as diphtheria and tetanus. See CANCER (MEDICINE); VACCINATION.

**Passive immunization.** Protective levels of antibody are not formed until some time after birth, and to compensate for this there is passive transfer of antibody across the placenta. Alternatively, in some animals antibody is transferred in the first milk (colostrum). Antibody may also be passively transferred artificially, for example, with a concentrated preparation of human serum gamma globulin containing antibodies against hepatitis. Protection is temporary. Horse serum is used for passive protection against snake venom. Serum from the same (homologous) species is tolerated, but heterologous serum is rapidly eliminated and may produce serum sickness. On repeated administration, a sensitized individual may experience anaphylactic shock, which in some cases is fatal. Cellular immunity can also be transferred, particularly in experimental animal situations when graft and

host reactions to foreign tissue invariably occur unless strain tissue types are identical. [J.Tr.]

**Immunoassay** An assay that quantifies antigen or antibody by immunochemical means. The antigen can be a relatively simple substance such as a drug, or a complex one such as a protein or a virus. See ANTIBODY; ANTIGEN.

The reactants are first mixed so that a varying quantity of one (A) is added to a constant amount of the other (B). The formation of an immune (antigen-antibody) complex is measured as a function of the varied reactant (A). The result is represented by a "standard curve" for reactant A. An unknown sample is tested by adding it to reactant B. The extent of the measured change is referred to the standard curve, and thereby is obtained the amount of reactant A which produces a comparable change. The amount is represented as the content of reactant A in the unknown sample. See IMMUNOFLUORESCENCE; IMMUNOLOGY; IMMUNONEPHELOMETRY; RADIOIMMUNOASSAY. [A.B.]

**Immunochemistry** A discipline concerned both with the structure of antibody (immunoglobulin) molecules and with their ability to bind an apparently limitless number of diverse chemical structures (antigens); with the structure, organization, and rearrangement of the genes coding for the immunoglobulin molecules; and with the structure and function of molecules on the surface of animal cells, such as the transplantation (histocompatibility) antigens, which recognize antibodies and the thymus-derived lymphocytes mediating the cellular immune response. See ANTIGEN; IMMUNOASSAY; IMMUNOGLOBULIN; RADIOIMMUNOASSAY; TRANSPLANTATION BIOLOGY. [W.H.K.; F.F.R.]

**Immuno-electrophoresis** A combination of the techniques of electrophoresis and immunodiffusion used to separate the components of a mixture of antigens and make them visible by reaction with specific antibodies. See ELECTROPHORESIS.

A medium such as agar is deposited on a convenient base, for example, a microscopic slide. A small well is cut in the medium. A test solution is deposited in the well, and the contained substances are separated by electrophoresis along one axis of the plate. A trough is then cut in the medium parallel to, but at some distance from, the line of the separated substances. The trough is filled with antiserum which contains antibodies to one or more of the separated substances. The antiserum and substances diffuse toward one another and, where they meet, form curvilinear patterns of precipitation. These can be seen directly in clear media or can be visualized after washing out unreacted materials and staining in opaque media. See IMMUNOASSAY. [A.B.]

**Immunofluorescence** A technique that uses a fluorochrome to indicate the occurrence of a specific antigen-antibody reaction. The fluorochrome labels either an antigen or an antibody. The labeled reactant is then used to detect the presence of the unlabeled reactant. The use of a labeled reactant (such as an antibody which both detects and indicates the antigen) to reveal the presence of an unlabeled one is termed direct immunofluorescence. The use of a labeled indicator antibody, which reacts with an unlabeled detector antibody that has previously reacted with an antigen, is termed indirect immunofluorescence. Substitution of a light meter for the human eye permits a quantitative measurement in immunofluorometry. See FLUORESCENCE; IMMUNOASSAY. [A.B.]

**Immunogenetics** A scientific discipline that uses immunological methods to study the inheritance of traits. Traditionally, immunogenetics has been concerned with moieties that elicit immune response, that is, with antigens (antigenic determinants). It has now broadened its scope to study also the genetic control of the individual's ability to respond to an antigen. See ANTIGEN.

The immunological methods used in immunogenetics are of two principal kinds, serological and histogenetical. In serological methods, antibodies are used to detect antigens, either in solution or on a cell surface. In histogenetical methods, immune cells (lymphocytes) are used to detect antigens on the surface of other cells. In modern immunogenetics research, the serological and histogenetical methods are combined with molecular methods in which the researcher isolates and works with the genes that code for the traits. This approach of going back and forth from classical to molecular methods has proved to be very successful and has led to the elucidation of several complex genetic systems. See ANTIBODY.

Animal immunogenetics relies heavily on the use of inbred, congenic, and recombinant inbred strains. Inbred lines result when individuals that are more closely related to each other than randomly chosen individuals mate together, for many generations. The advantage in working with inbred strains rather than outbred animals is that inbred strains restrict the variability of the conditions of an experiment. However, when two strains are compared and it is found that they respond differently to a treatment, it is not known to what gene this difference should be attributed. The strains may differ at as many genetic loci as two unrelated individuals in an outbred population do. To study the effect of single, defined genes, immunogeneticists have developed congenic lines. These lines always come in groups, the smallest group being a pair, which consists of a congenic line and its inbred partner strain. The two are homozygous at more than 97% of their loci (that is, they are inbred) and are identical except, ideally, at one locus—the locus that is to be studied. To find out whether two loci are on the same or on different chromosomes, two individuals that differ in the traits controlled by these loci are mated and then the  $F_1$  hybrids are intercrossed. In the  $F_2$  generation that results from this intercross, the genes assort either independently, if they are on different chromosomes, or nonrandomly, if they are the same chromosome—that is, when they are linked. Each time the strains are tested for linkage, this laborious procedure must be repeated. To avoid this repetition, immunogeneticists have prepared a “frozen”  $F_2$  generation by establishing separate inbred lines from the different  $F_2$  individuals. Such lines are called the recombinant inbred strains.

Contemporary immunogenetic research concentrates on two main categories of antigenic substances—those present in body fluids, primarily blood serum or plasma, and those expressed on surfaces of various cells. In the body-fluid antigens category, a prominent position is occupied by immunoglobulins. Although antibodies are usually used to detect antigens, they themselves may also serve as antigens, and antibodies can be produced against them. These antibodies against antibodies detect three principal kinds of antigenic determinants: isotypic, allotypic, and idiotypic. The main categories of cell-surface molecules studied by immunogenetical methods are blood-group antigens, histocompatibility antigens, tissue-restricted antigens, and receptors. Blood-group antigens are alloantigens found on erythrocytes. Histocompatibility antigens are antigens capable of inducing cellular immune responses and hence are detectable by histogenetical methods. Tissue-restricted antigens are expressed on some tissues but not on others and therefore serve as markers for cell sorting. Receptors are molecules that are capable of specifically interacting with certain other molecules. The interaction often leads to activation or inhibition of the receptor-bearing cell. See BLOOD GROUPS; GENETICS; HISTOCOMPATIBILITY; IMMUNOGLOBULIN; IMMUNOLOGY. [J.K.]

**Immunoglobulin** Any of the glycoproteins in the blood serum that are induced in response to invasion by foreign antigens and that protect the host by eradicating pathogens. Antibodies belong to this group of proteins. An antigen is any substance capable of inducing an immune response. Intact antigens are able to specifically interact with the induced immunoglobulins. Normally, the immune system operates in a state known

as self-tolerance, and does not attack the host's own tissues, but occasionally the immune system targets host-specific antigens, resulting in autoimmune disease. See AUTOIMMUNITY.

Immunoglobulins are composed of two identical heavy (H) and two identical light (L) polypeptide chains. Each H and L chain has an amino-terminal variable (V) region and a carboxyl-terminal constant (C) region. Although V regions from different antibodies exhibit considerable sequence variation, there is a large degree of sequence similarity among C regions of different antibodies. In the living animal, antibodies first bind to antigen at the antigen combining site and then, ideally, eliminate it as a threat to the host.

Immunoglobulins are heterogeneous with respect to charge, size, antigenicity, and function. There are three categories of antigenic determinants present on immunoglobulins: isotypes are found in all individuals, allotypes are found in some individuals, and idiotypes are associated with the amino-terminal variable region. Isotypic determinants are located on the carboxyl-terminal constant region and are used to group immunoglobulin H and L chains into isotypes or classes. In total, there are five human H-chain classes. IgM contains mu ( $\mu$ ) H chains, IgG contains gamma ( $\gamma$ ) H chains, IgA contains alpha ( $\alpha$ ) H chains, IgD contains delta ( $\delta$ ) H chains, and IgE contains epsilon ( $\epsilon$ ) H chains. IgG has four subclasses, IgG1, IgG2, IgG3, and IgG4, while IgA has two subclasses, IgA1 and IgA2. There are two L-chain isotypes named kappa ( $\kappa$ ) and lambda ( $\lambda$ ). Kappa and lambda chains may be associated with H chains of any isotype, and a complete description of an immunoglobulin molecule requires identification of both H and L chains.

IgG is the most abundant immunoglobulin class in the serum. IgG isotypes are associated with complement fixation, opsonization (that is, rendering more susceptible to phagocytosis), fixation to macrophages, and membrane transport. Of the two IgA subclasses, IgA1 is the predominant subclass of IgA in human serum. IgA1 is the dominant subclass in all external secretions, including milk, saliva, tears, and bronchial fluids. The percentage of subclass IgA2 is higher in these fluids than in serum. IgM is the first immunoglobulin to appear during the primary immune response. IgD and IgE are present in minute amounts in normal human serum. No function has been clearly attributed to IgD. IgE is active against parasites and acts as a mediator of immediate hypersensitivity. See ANAPHYLAXIS; ANTIBODY; ANTIGEN; ANTIGEN-ANTIBODY REACTION; HYPERSENSITIVITY; IMMUNOLOGY; PROTEIN. [J.D.C.; K.N.P.]

**Immunologic cytotoxicity** The mechanism by which the immune system destroys or damages foreign or abnormal cells. Immunologic cytotoxicity may lead to complete loss of viability of the target cells (cytolysis) or an inhibition of the ability of the cells to continue growing (cytostasis). Immunologic cytotoxicity can be manifested against a wide variety of target cells, including malignant cells, normal cells from individuals unrelated to the responding host, and normal cells of the host that are infected with viruses or other microorganisms. In addition, the immune system can cause direct cytotoxic effects on some microorganisms, including bacteria, parasites, and fungi.

Immunologic cytotoxicity is a principal mechanism by which the immune response copes with, and often eliminates, foreign materials or abnormal cells. Cytotoxic reactions are frequently observed as a major component of an immune response that develops following exposure to foreign cells or microorganisms. In addition, there is increasing evidence that cytotoxic reactions represent a major mechanism for natural immunity and resistance to such materials. In most instances, cytotoxicity by immune components involves the recognition of particular structures on the target cells; also, the targets need to be susceptible to attack by the immune components. Some cells are quite resistant to immunologic cytotoxicity, and this appears to represent a major mechanism by which they can escape control by the immune system.

There are a variety of mechanisms for immunologic cytotoxicity. The two main categories are antibody- and cell-mediated cytotoxicity. Within cell-mediated cytotoxicity, there is a multiplicity of effector cell types and mechanisms that can be involved, including cytotoxic T lymphocytes, macrophage-mediated cytotoxicity, natural killer cells, granulocyte cytotoxicity, and antibody-dependent cell-mediated cytotoxicity. See IMMUNOLOGY.

[R.B.He.]

**Immunological deficiency** A state wherein the immune mechanisms are inadequate in their ability to perform their normal function, that is, the elimination of foreign materials (usually infectious agents such as bacteria, viruses, and fungi). Immune mechanisms are also responsible for the rejection of transplanted organs. These processes are accomplished by white blood cells known as lymphocytes, of which there are two major types, T lymphocytes (thymus-derived) and B lymphocytes (bone marrow-derived). See CELLULAR IMMUNOLOGY; TRANSPLANTATION BIOLOGY.

Immunological deficiency states result from a failure at any point in the complex set of interactions involving lymphocytes and immunoglobulins. In general, the diseases are due to absence of cell populations; failure of cells to mature; failure to secrete the products necessary for effective cell interactions; or failure of accessory cell populations or protein systems (for example, complement) which are necessary for the complete competence of B-cell immune function. Some of the diseases are carried on the X-chromosome and affect only males, being carried by females. See COMPLEMENT; SEX-LINKED INHERITANCE.

The prime symptom of immunodeficiency is an increased susceptibility to infections. Many of the organisms to which people are constantly exposed do not ordinarily have the capability to cause infections in immunocompetent individuals because these organisms are so weak that they cannot establish themselves in normals. In immunodeficients, however, they can cause fatal infections.

In general, immunodeficiency states are inherited. Immunodeficiency can also be acquired as a complication of other disease processes. One of the most common forms of deficiency is caused by aggressive treatment of leukemia. Another cause of induced immunodeficiency is seen with transplant rejection therapy. To prevent organ rejection, drugs which destroy lymphocytes must be administered. Certain viruses, such as the Epstein-Barr virus (EBV), which causes infectious mononucleosis, infect lymphocytes. Involvement of the lymphoid system is nearly always only temporary, but in a small number of individuals the virus cannot be eliminated, and a chronic infection of B cells leads to the loss of normal lymphocyte function. Another immunodeficiency disorder caused by virus infection is acquired immune deficiency syndrome (AIDS). Immunodeficiency can also be observed secondary to dietary deficiency. Two main varieties are seen. In protein-calorie malnutrition, serious deficiency primarily involving the T-cell system predisposes affected individuals to overwhelming infection by the agents of measles or tuberculosis. In the second variety, deficiency of single substances is the cause; the two most commonly observed deficiencies are those of zinc and biotin. See ACQUIRED IMMUNE DEFICIENCY SYNDROME (AIDS); TRANSPLANTATION BIOLOGY. [Ri.H.]

**Immunological ontogeny** The origin and development (ontogeny) of the lymphocyte system, from its earliest stages to the two major populations of mature lymphocytes: the thymus-dependent or T lymphocytes, and the thymus-independent or B lymphocytes. The T lymphocytes carry out those aspects of function which are called cell-mediated immunity, including graft rejection, elimination of tumor cells, and delayed hypersensitivity. B cells are responsible for humoral or antibody-mediated immunity. See CELLULAR IMMUNOLOGY; IMMUNITY.

For both systems, development or differentiation proceeds in discrete stages. In the first stage, pluripotent hematopoietic stem cells, which originate in the yolk sac in the embryo and then successively in fetal liver and fetal bone marrow, develop into precursor cells committed to becoming T or B cells. Hematopoiesis in human fetal liver begins at about 4 weeks of gestational age and in fetal bone marrow after 20 weeks. See HEMATOPOIESIS.

The thymus plays a strategic role in the development of T lymphocytes. Precursor cells are attracted into the thymus where, under the influence of this microenvironment, they undergo rapid proliferation and maturation. These maturing T cells also begin to express a variety of cell-surface markers, which parallels developing immunocompetence. From the thymus, the maturing T cells are exported to the peripheral lymphoid tissues. See THYMUS GLAND.

The earliest B cells identified in fetal liver are pre-B cells. As the cells mature, they express immunoglobulin M (IgM) and subsequently IgD on their surface. At this stage, the cell is a specific, competent B cell ready to interact with an antigen. In the course of B-lymphocyte differentiation, diversity of immunoglobulin classes is generated by an orderly switch from IgM to IgG to IgA with expression of the respective immunoglobulin on the cell surface. See ANTIGEN; IMMUNOGLOBULIN. [E.W.Ge.]

**Immunological phylogeny** The study of immunology and the immune system in evolution. All vertebrates can recognize and respond to nonself-molecular configurations on microorganisms, cells, or organic molecules by utilizing a complex recognition system termed the immune response. The presence of lymphocytes and circulating antibodies has been documented in all extant vertebrate species. However, the existence of induced, specific reactions directly homologous to the immune repertoire of vertebrates has not been clearly established in invertebrates.

The role of phagocytic cells in engulfing foreign pathogens has been documented in virtually all metazoan organisms. Phagocytic cells possess a limited capacity to discriminate self from nonself, and this is due in part to the presence of lectins (molecules capable of binding specifically to various sugars) on their surface. Although there is no evidence to suggest that invertebrate lectins and vertebrate immunoglobulins are homologous structures, sufficient diversity exists within lectins of certain species to indicate that these types of molecules and their cellular expression on phagocytes might serve as a primitive and universal recognition mechanism. See IMMUNOGLOBULIN; LECTINS.

All true vertebrates possess cells clearly recognizable as lymphocytes and can carry out T-cell functions, such as graft rejection, and show the capacity of B cells to synthesize and secrete immunoglobulins. True lymph nodes are not present in vertebrate species more primitive than mammals, but birds possess aggregates of lymphoid tissue probably serving a similar function. See CELLULAR IMMUNOLOGY; LYMPHATIC SYSTEM.

Humans possess five major classes or isotypes of immunoglobulin: IgG, IgM, IgA, IgE, and IgD. The IgM molecule is the first immunoglobulin to appear in ontogeny, and the first to appear in phylogeny. Immunoglobulins of cyclostomes, elasmobranchs (sharks and rays), and many teleost fishes consist only of IgM polymers. Immunoglobulins possessing heavy chains distinct from the  $\mu$ -like heavy chains of those groups are present in some lungfish (Dipnoi) and in anuran amphibians (frogs and toads). Dipnoi have a low-molecular-weight non-IgM immunoglobulin (termed IgN). Birds possess IgM and IgA immunoglobulins, but also possess a non-IgM immunoglobulin similar to that of amphibians as their major immunoglobulin class. This immunoglobulin has been termed IgY. IgG immunoglobulins containing gamma chains clearly homologous to those of the humans and of true mammals are found only within the three subclasses of living mammals, namely, eutherians, metatherians (marsupials), and monotremes (for example, the echidna). See IMMUNOLOGICAL ONTOGENY.

Although the precise nature of the precursors of the specific elements of the immune system in evolution remains to be determined, the genetic and cellular events which lead to the capacity for specific immune recognition, diversification, and reactivity occurred early in vertebrate evolution. See IMMUNITY; IMMUNOLOGY. [J.J.Ma.]

**Immunology** The division of biological science concerned with the native or acquired response of complex living organisms to the intrusion of other organisms or foreign substances. The immune system allows the host organism to distinguish between self and nonself and to respond to a target (termed an antigen).

It was not until the germ theory of infectious disease was established that the full implication of immunology was realized. First came the recognition that certain bacteria caused corresponding diseases. Second came the recognition that it was a specific resistance to that bacterium or its toxins that prevented recurrence of the same disease. Third came the discovery that after recovery from an infectious disease, protective substances called antibodies could be found in the blood of animals and humans. Antigens, such as bacteria and their products, triggered the production of antibodies and indeed all kinds of chemical and biological molecules. The action of these effector mechanisms, however, has come to be recognized as being not always protective or conferring immunity, but sometimes becoming grossly exaggerated or inappropriate, or capable of turning upon the host in a destructive fashion that causes disease. These responses are classified as allergies. Illnesses associated with a misguided response of the immune system that is directed against the self and results from a breakdown in the normal immunological tolerance of, or unresponsiveness to, self antigens are termed autoimmune. The mechanisms responsible for these disorders are unknown but probably include the intervention of factors such as viruses that either modify or naturally resemble self molecules. Subsequently, the immune response, in seeking out what is foreign, proceeds to attack the self. See ALLERGY; AUTOIMMUNITY.

Immunology is also concerned with assaying the immune status of the host through a variety of serological procedures, and in devising methods of increasing host resistance through prophylactic vaccination. There has also been much important investigation of induced resistance and tolerance to transplants of skin and organs, including tumors. See BLOOD GROUPS; HYPERSENSITIVITY; IMMUNITY; IMMUNOASSAY; ISOANTIGEN; PHAGOCYTOSIS; PRECIPITIN; SEROLOGY; TRANSPLANTATION BIOLOGY; VACCINATION.

[A.B.; M.J.Po.]

**Immunonephelometry** An application of nephelometry to the quantification of antigen or antibody. The technique depends on the light-scattering properties of microparticles. The initial antigen-antibody complexes are macromolecular in size and do not scatter light. However, such complexes have the ability to aggregate. The size of the aggregates increases with time until they do scatter light. This process takes from several minutes to hours before it attains maximum, depending on various properties of the reactants. If other aspects are kept constant, including, for example, the concentration of one reactant, then both the rate at which the scatter of light increases and its maximal value increase with the concentration of the other reactant. Either the increase in the rate of scatter or its maximal value can be calibrated for various concentrations of a reactant to yield a concentration-response calibration curve. Unknown concentrations of that reactant can then be quantified by measuring the response and comparing it with the calibration curve. See ANTIBODY; ANTIGEN; IMMUNOASSAY. [A.P.]

**Immunosuppression** The natural or induced active suppression of the immune response, as contrasted with deficiency or absence of components of the immune system.

Like many other complex biological processes, the immune response is controlled by a series of regulatory factors. A variety of suppressor cells play a role in essentially all of the known immunoregulatory mechanisms, such as maintenance of immunological tolerance; limitation of antibody response to antigens of both thymic-dependent and thymic-independent types, as well as to antigens that stimulate reaginic antibody (antibodies involved in allergic reactions); genetic control of the immune response; idiotype suppression; control of contact and delayed hypersensitivity; and antigenic competition. All of the major cell types involved in the positive side of cellular interactions required for an immune response have also been found capable of functioning as suppressors in different regulatory systems. See IMMUNOLOGICAL DEFICIENCY.

**Suppressor cells.** Some suppressor functions are antigen- or carrier-specific. (A carrier is a molecule that can be chemically bound to another small molecule, called a hapten, in such a way that the combination induces an immune response that the hapten alone would not induce.) Others may not be carrier-specific, but may be specific for the type of response, such as immunoglobulin production but not delayed hypersensitivity. In the case of immunoglobulin production, the suppressor T cell may regulate the production of all immunoglobulin classes, a single class of immunoglobulins, or molecules that bind only a given antigen. Other suppressors may affect only cellular immunity and not humoral immunity. See CELLULAR IMMUNOLOGY; IMMUNOGLOBULIN.

Suppressor cells are critical in the regulation of the normal immune response. Immunological tolerance refers to the ability of an individual's immune system to distinguish between its own and foreign antigens and to mount a response only to foreign antigens. A major role has been established for suppressor T lymphocytes in this phenomenon. Suppressor cells also play a role in regulating the magnitude and duration of the specific antibody response to an antigenic challenge.

Reagin, or IgE, is the class of immunoglobulin that mediates allergic reactions such as asthma and urticaria. The reaginic antibody response depends heavily on nonspecific cooperator T cells and specific helper T cells as well as the B cells that produce the antibody. In a negative direction, IgG-blocking antibodies regulate the response, but antigen-specific and antigen-nonspecific suppressor T cells also play a critical role in regulating this response. See ALLERGY.

T cells are the major cells involved in immunosuppression, although activated phagocytic mononuclear cells are also significant as nonspecific suppressors in many systems. Helper T cells and suppressor T cells are different cell populations that are distinguished to a considerable extent by surface antigens that react with monoclonal antibodies or receptors for specific substances such as histamine.

No single model explains the entire array of cellular suppressor phenomena. In different systems, other T cells, macrophages, or even B cells may be the immediate targets of the suppressor cells and their secretions. Some suppression requires direct cell-cell interaction, whereas other suppression may be mediated by suppressor lymphokines. Both antigen-specific and antigen-nonspecific factors are known, and they may be secreted to act upon other cells, or especially in the case of antigen-specific factors, they may be integral parts of the cell membrane. The soluble immune-response suppressor factor, produced by activated T cells and then activated by monocytes, inhibits B-cell proliferation and immunoglobulin production in response to antigens. Macrophages also secrete suppressor factors, including prostaglandins that act on T cells and other soluble factors that are B-cell-specific.

There is a variety of disorders of immunoglobulin production in humans. In many cases these involve intrinsic defects in the bone marrow stem cells that normally mature into immunoglobulin-producing plasma cells. Defects in cell-mediated immunity occur in individuals who are infected with

various fungal organisms. Suppressor T cells have been implicated, although it is not clear whether the appearance of suppressor cells is the initial event allowing development of the fungal infection or whether they develop secondarily after infection. Those individuals found to have suppressor T cells are at high risk for dissemination of the fungal infection and relapse following therapy. Although probably only one of many mechanisms, suppressor cells interfere with the host tumor-growth-inhibiting immune response to the foreign tumor-specific transplantation antigens that occur on malignant cells, thus allowing the tumors to progress. Both animal and human studies indicate a major role for both an activation of immunoglobulin-producing B cells as well as the absence or reduced numbers or function of suppressor T cells in autoimmune disorders such as Coombs-positive hemolytic anemia, systemic lupus erythematosus, rheumatoid disorders, and thyroid disorders in which antithyroid antibodies appear in the serum. See AUTOIMMUNITY.

[K.S.W.; T.A.Wa.]

**Immunosuppressors.** Suppression of the immune response may be specific to a particular antigen or may be a response to a wide range of antigens encountered. The whole immune response may be depressed, or a particular population of immunologically active lymphocytes may be selectively affected. In some cases, the effect may be preferentially on T cells rather than B cells. If B cells are affected, it may be on a specific subclass of antibody-producing cells. Antigen-specific immunosuppression may be the result of deletion or suppression of a particular clone of antigen-specific cells, or the result of enhanced regulation of the immune response by antigen-specific suppressor cells. It can also be the result of increased production of antiidiotypic antibody.

Nonspecific suppression of the immune response occurs in a number of rare immunological deficiency diseases of childhood. Acquired deficiency states affecting mainly T-cell function occur in states of malnutrition and in the presence of tumors, particularly those of the lymphoreticular system. Acquired deficiencies may also occur secondary to a number of infectious diseases. The acquired immune deficiency syndrome (AIDS) is probably of similar origin; its manifestations are similar although more severe and more dramatic. See ACQUIRED IMMUNE DEFICIENCY SYNDROME (AIDS); IMMUNE COMPLEX DISEASE.

There are a number of compounds capable of suppressing the immune response. The main stimulus for studies designed to identify these substances has been to devise means for controlling organ graft rejection. However, there has also been considerable activity in looking for compounds that will suppress the immune response and reduce the inflammatory process in experimental models of rheumatoid arthritis. The ideal immunosuppressive drug should fulfill five main requirements: (1) There should be a wide margin of safety between a toxic and a therapeutic dose. (2) The drug should have a selective effect on lymphoid cells and not cause damage to the rest of the body. (3) If possible, this effect should be only on those cells which are involved in the specific immune process to be suppressed. (4) The drug should need to be administered for only a limited period until the immunological processes become familiar with the foreign antigen and begin to recognize it as part of "self." (5) The drug should be effective against immune processes once they have developed. See TRANSPLANTATION BIOLOGY.

The result of any immune response is a balance between the action of effector cells mediating the phenomenon and suppressor cells regulating the response. Anything that reduces the regulatory function of suppressor cells will functionally increase the immune response. As suppressor cells are derived from rapidly turning-over precursor cells, and effector cells of T-cell-mediated immunity are derived from slowly dividing precursors, it is possible preferentially to depress the action of suppressor cells without affecting effector cells. This may be done by the use of alkylating agents such as cyclophosphamide given before immunization. Cyclophosphamide used in this way can increase a

normal cell-mediated immune response, reverse immunological tolerance caused by increased regulatory activity of suppressor cells, and even reverse antigenic competition. It is likely that the chemotherapeutic effect of alkylating agents which are used extensively in the treatment of cancer in humans is partially due to these agents modifying the biological response to the tumor, producing an immunopotentiating action. See CHEMOTHERAPY; IMMUNITY; IMMUNOLOGY. [J.L.T.]

**Immunotherapy** The treatment of cancer by improving the ability of a tumor-bearing individual (the host) to reject the tumor immunologically. There are molecules on the surface of tumor cells, and perhaps in their interior, that are recognized as different from normal structures by the immune system and thus generate an immune response. The two components of the immune response are cell-mediated and antibody-mediated immunity, which must work in concert to overcome tumor cells. One type of thymus-derived lymphocyte (also called a cytotoxic T cell) can destroy tumor cells directly, while another recruits other white blood cells, the macrophages, that do the killing. Natural killer cells and perhaps other white blood cells may also participate. However, elements that normally regulate immunity, such as suppressor T cells, are stimulated excessively by the tumor, which leads to an immune response that is deficient and unable to reject the growing tumor. Thus the strategy of immunotherapy is to stimulate within or transfer to the tumor-bearing individual the appropriate antitumor elements while avoiding further stimulation of suppressor elements. See CELLULAR IMMUNOLOGY; IMMUNOLOGIC CYTOTOXICITY; IMMUNOSUPPRESSION.

There are four broad categories of immunotherapy: active, adoptive, restorative, and passive. Active immunotherapy attempts to stimulate the host's intrinsic immune response to the tumor, either nonspecifically or specifically. Nonspecific active immunotherapy utilizes materials that have no apparent antigenic relationship to the tumor, but have modulatory effects on the immune system, stimulating macrophages, lymphocytes, and natural killer cells. Specific active immunotherapy attempts to stimulate specific antitumor responses with tumor-associated antigens as the immunizing materials. Adoptive immunotherapy involves the transfer of immunologically competent white blood cells or their precursors into the host. Bone marrow transplantation, while performed principally for the replacement of hematopoietic stem cells, can also be viewed as adoptive immunotherapy. Restorative immunotherapy comprises the direct and indirect restoration of deficient immunological function through any means other than the direct transfer of cells. Passive immunotherapy means the transfer of antibodies to tumor-bearing recipients. This approach has been made feasible by the development of hybridoma technology, which now permits the production of large quantities of monoclonal antibodies specific for an antigenic determinant on tumor cells. See CANCER (MEDICINE); GENETIC ENGINEERING; IMMUNOLOGY; MONOCLONAL ANTIBODIES. [J.K.M.; M.S.Mi.]

**Impact** A force, also known as impulsive force, which acts only during a short time interval but which is sufficiently large to cause an appreciable change in the momentum of the system on which it acts. The momentum change produced by the impulsive force is described by the momentum-impulse relation. See COLLISION (PHYSICS); IMPULSE (MECHANICS). [P.W.S.]

**Impedance matching** The use of electric circuits and devices to establish the condition in which the impedance of a load is equal to the internal impedance of the source. This condition of impedance match provides for the maximum transfer of power from the source to the load. See ELECTRICAL IMPEDANCE.

The maximum power transfer theorem of electric network theory states that at any given frequency the maximum power is transferred from the source to the load when the load impedance

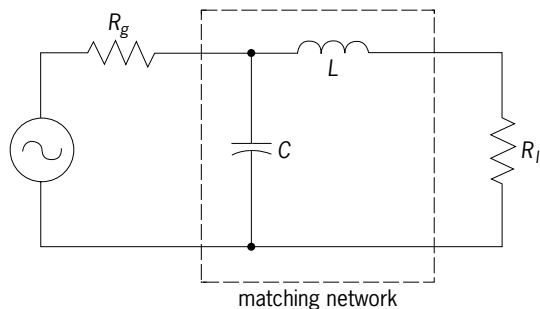

**L-section impedance matching network with inductor  $L$  and capacitor  $C$  used in radio-frequency circuits.  $R_l$  = load resistance;  $R_g$  = generator resistance.**

is equal to the conjugate of the generator impedance. When these conditions are satisfied, the power is delivered with 50% efficiency; that is, as much power is dissipated in the internal impedance of the generator as is delivered to the load. In general, the load impedance will not be the proper value for maximum power transfer. A network composed of inductors and capacitors may be inserted between the load and the generator to present to the generator an impedance that is the conjugate of the generator impedance (see illustration). [C.C.H.]

**Impsonite** A black, naturally occurring carbonaceous material having specific gravity 1.10–1.25 and fixed carbon 50–85%. The origin of impsonite is not well understood, but it appears to be derived from a fluid bitumen that polymerized after it filled the vein in which it is found. See ASPHALT AND ASPHALTITE. [I.A.B.]

**Impulse (mechanics)** The integral of a force over an interval of time. For a force  $\mathbf{F}$ , the impulse  $\mathbf{J}$  over the interval from  $t_0$  to  $t_1$  can be written as Eq. (1). The impulse thus

$$\mathbf{J} = \int_{t_0}^{t_1} \mathbf{F} dt \quad (1)$$

represents the product of the time interval and the average force acting during the interval. Impulse is a vector quantity with the units of momentum.

The momentum-impulse relation states that the change in momentum of a mass  $m$  over a given time interval equals the impulse of the resultant force acting during that interval. The momentum change can be expressed in terms of the velocities  $\mathbf{v}_1$  and  $\mathbf{v}_0$  at times  $t_1$  and  $t_0$ , respectively, giving Eq. (2).

$$\mathbf{J} = m(\mathbf{v}_1 - \mathbf{v}_0) \quad (2)$$

See IMPACT; MOMENTUM. [P.W.S.]

**Impulse generator** An electrical apparatus which produces very short high-voltage or high-current surges. Such devices can be classified into two types: impulse voltage generators and impulse current generators. High impulse voltages are used to test the strength of electric power equipment against lightning and switching surges. Also, steep-front impulse voltages are sometimes used in nuclear physics experiments. High impulse currents are needed not only for tests on equipment such as lightning arresters and fuses but also for many other technical applications such as lasers, thermonuclear fusion, and plasma devices. See FUSE (ELECTRICITY); LASER; LIGHTNING AND SURGE PROTECTION; NUCLEAR FUSION; PARTICLE ACCELERATOR; PLASMA (PHYSICS).

An impulse voltage generator (sometimes called a Marx generator, after E. Marx who first proposed it in 1923) consists of capacitors, resistors, and spark gaps. The capacitors are first charged in parallel through charging resistors by a high-voltage, direct-current source and then connected in series and discharged through a test object by a simultaneous spark-over of

the spark gaps. The impulse current generator comprises many capacitors that are also charged in parallel by a high-voltage, low-current, direct-current source, but it is discharged in parallel through resistances, inductances, and a test object by a spark gap. [C.Wa.; T.C.C.]

**Impulse turbine** A turbine in which fluid is deflected without a pressure drop in the blade passages. A turbine is a power-producing machine fitted with shaft-mounted wheels. Turbine blades, attached to the wheels' periphery, are driven by the through-flow of water, steam, or gas. The rotary motion of the wheel is maintained by forces imparted to the blades by the impingement against them of high-speed fluid streams. Before the stream of fluid reaches the moving turbine blades, it is accelerated in stationary passages called nozzles. The nozzles are shaped to convert mechanical or thermal energy of the fluid into kinetic energy; that is, the nozzles increase the fluid's velocity while decreasing its pressure and temperature. Upon leaving the nozzles the high-speed fluid strikes the moving blades, and a force is imparted to the blades as the fluid is deflected by them. If the fluid's deflection in the blade passage is accompanied by a pressure drop and a relative velocity rise, the turbine is called a reaction turbine; if the fluid is deflected without a pressure drop in the blade passages, it is called an impulse turbine. See NOZZLE; REACTION TURBINE. [E.Lo.]

**Inadunata** One of three Paleozoic subclasses of the Crinoidea consisting of over 350 genera ranging from the Ordovician to the Permian. Its members generally lack fixed brachials such that the arms are free above the level of the radials. The calyx may be monocyclic, consisting of a circllet of basal and a circllet of radial plates, or dicyclic, having an additional circllet of infrabasal plates (see illustration). The arms, constructed of serially arranged brachials, may be simple or branched.

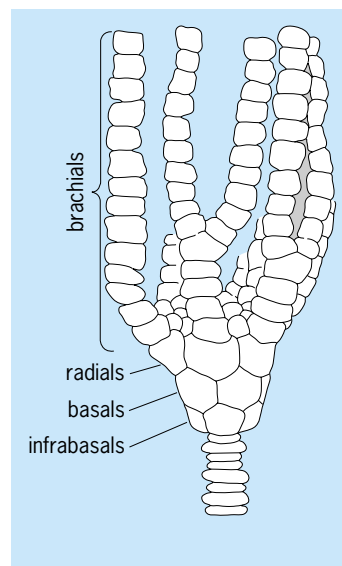

**Dicyclic Inadunate.**

The generic diversity of the Inadunata reached its peak during the Late Paleozoic, when it became the dominant crinoid group; all post-Paleozoic crinoids, members of the subclass Articulata, descended from one of the clades of the Inadunata. See CRINOIDEA; ECHINODERMATA. [T.K.B.]

**Inarticulata** A class of phylum Brachiopoda. It is presently divided into four orders: Paterinida, Obolellida, Acrotretida, and Lingulida. See LINGULIDA; OBOLELLIDA; PATERINIDA.

The two valves of the shell are typically not articulated and are held together only by soft tissue of the living animal. A few genera



developed hinge mechanisms posteriorly. The posterior sector of one or both valves is commonly flattened. Internally, muscle scars and mantle canal impressions are usually the only features present; a median ridge or elevated septum may be developed, particularly in the brachial valve. In all inarticulates, the fibrous secondary layer characteristic of the Articulata is undeveloped. See BRACHIOPODA. [A.J.R.]

**Incandescence** The emission of visible radiation by a hot body. A theoretically perfect radiator, called a blackbody, will emit radiant energy according to Planck's radiation law at any temperature. Prediction of the visual brightness requires additional consideration of the sensitivity of the eye, and the radiation will be visible only for temperatures of the blackbody which are above some minimum. The relation between brightness and temperature is plotted in the illustration. As shown, the minimum

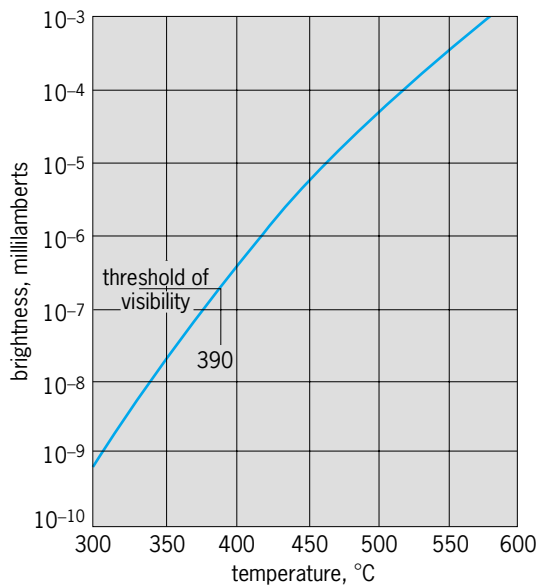

Relation between brightness of blackbody and temperature.

temperature for incandescence for the dark-adapted eye is about 390°C (730°F). Under these ideal observing conditions, the incandescence appears as a colorless glow. The dull red light commonly associated with incandescence of objects in a lighted room requires a temperature of about 500°C (930°F). See BLACKBODY; HEAT RADIATION; INCANDESCENT LAMP; VISION. [H.W.Ru./G.R.H.]

**Incandescent lamp** A lamp that creates radiant energy when its metallic filament is heated by an electric current. The filament is designed to produce radiant energy in the visible portion of the electromagnetic spectrum (light). The filament is of a special material that is supported in an envelope (bulb) that has been evacuated or filled with an inert gas such as argon, nitrogen, or krypton. In addition to light, the heated filament emits infrared and ultraviolet energy. When either of these radiations is accentuated, the lamp may be used as a source of that energy.

The important parts of an incandescent lamp are the bulb (envelope), the filament, and the base. The bulb may be clear, colored, inside-frosted, or coated with diffusing or reflecting material. Most lamps have soft-glass bulbs; hard glass is used when the lamp will be subjected to sudden and severe temperature changes. Lamps have a variety of bulb shapes, base types, and filament structures.

The efficient design of an incandescent lamp centers on obtaining a high temperature at the filament without the loss of heat or disintegration of the filament. The early selection of carbon,

which has the highest melting point of any element (3872 K or 6510°F) was a natural one. However, carbon evaporates from its solid phase (sublimates) below this temperature, so carbon filaments must be operated at relatively low temperatures to obtain reasonable life. Ductile tungsten is a nearly perfect filament material, with a tensile strength four times that of steel, high melting point (3655 K or 6120°F), and relatively low evaporation.

Most lamps are rated in watts at a specified voltage. The most common voltage is 120 V for lamps to be used for general lighting service. General-service lamps are also available with voltage ratings of 125, 130, 230, 250, and 277. Lamps for special lighting service where the voltage may not be relatively constant may have ratings such as 115–125 V. Typical of such lamps are the rough-service lamps for use on extension cords where supplementary lighting is needed. Lamps for various special uses have voltage ratings which range from 1.5 V for flashlight lamps, 6 V for projector lamps, 12 V for automotive lamps, to 300 V for mines and special industrial usage.

Incandescent lamps have been developed for many services. Most common are those used in general service and the miniature lamp. Special types have been developed for rough service applications, bake-oven use, severe vibration applications, showcase lamps, multiple lights (three-way lamp), sign lamps, spotlights, floodlights, and insect-control lamps.

Tungsten-halogen lamps are made with a fill gas that includes a small amount of one of the halogen elements such as iodine, bromine, or chlorine. The special changes that result from the halogen addition are: (1) the filament temperature can be increased, giving a whiter light output; (2) the depreciation in light output with time is greatly decreased; and (3) the lumen output and the life are increased. The filament is enclosed in a small-diameter tubing made of fused quartz instead of glass to withstand the 500°F or 260°C bulb wall temperature required for proper functioning of the halogen gas fill.

For other types of incandescent lamps see ARC LAMP; INFRARED LAMP. [G.R.P.; R.L.Sm.]

**Inclined plane** A plane surface inclined at an angle with the line of action of the force that is to be exerted or overcome. In the free-body diagram shown here, three forces act on the

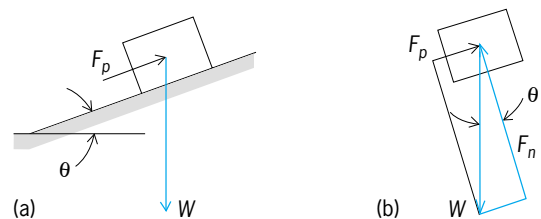

Weight resting on an inclined plane (a) with principal forces applied, and (b) their resolution into normal force.

object when no friction is present. The forces are its weight  $W$ , the force  $F_p$  parallel to the surface, and a force  $F_n$  normal to the surface. The summation of the forces acting in any direction on a body in static equilibrium equals zero; therefore, the summation of forces parallel to and forces normal to the surface are given by Eqs. (1) and (2). A force slightly greater than  $W \sin \theta$  moves the

$$F_p - W \sin \theta = 0 \quad (1)$$

$$F_n - W \cos \theta = 0 \quad (2)$$

object up the incline, but the inclined plane supports the greater part of the weight of the object. The principal use of the inclined plane is as ramps for moving goods from one level to another. See SIMPLE MACHINE. [R.M.Ph.]

**Incompressible flow** Fluid motion with negligible changes in density. No fluid is truly incompressible, since even liquids can have their density increased through application of sufficient pressure. But density changes in a flow will be negligible if the Mach number,  $Ma$ , of the flow is small. This condition for incompressible flow is given by the equation below, where  $V$

$$Ma = \frac{V}{a} < 0.3$$

is the fluid velocity and  $a$  is the speed of sound of the fluid. It is nearly impossible to attain  $Ma = 0.3$  in liquid flow because of the very high pressures required. Thus liquid flow is incompressible. See MACH NUMBER.

Gases may easily move at compressible speeds. Doubling the pressure of air—from, say, 1 to 2 atm—may accelerate it to supersonic velocity. In principle, practically any large Mach number may be achieved in gas flow. As Mach number increases above 0.3, the four compressible speed ranges occur: subsonic, transonic, supersonic, and hypersonic flow. Each of these has special characteristics and methods of analysis.

Air at 68°F (20°C) has a speed of sound of 760 mi/h (340 m/s). Thus inequality indicates that air flow will be incompressible at velocities up to 228 mi/h (102 m/s). This includes a wide variety of practical air flows: ventilation ducts, fans, automobiles, baseball pitches, light aircraft, and wind forces. The result is a wide variety of useful incompressible flow relations applicable to both liquids and gases. See COMPRESSIBLE FLOW; FLUID FLOW.

[F.M.Wh.]

**Index fossil** The ancient remains and traces of a plant or animal that lived during a particular span of geologic time and that geologically dates the containing rocks. Index fossils are almost exclusively confined to sedimentary rocks which originated in such diverse environments as open oceans, tropical lagoons, coral reefs, beaches, lakes, and rivers.

The choice of a fossil as an index depends on several criteria. In general, the fossil represents a group that evolved rapidly. The greater the rate of evolution, the shorter the period of time represented by any given index fossil and the narrower the limits of relative age assigned to the rocks containing the index. Commonly, the span of geologic time during which a fossil lived is referred to as its range, and the thickness of rocks through which a particular index fossil or selected group of fossils occurs is referred to as a faunal zone. An index fossil also must be present in the rocks in sufficient numbers to be found with reasonable effort, must be relatively easy to collect or identify, and must be geographically extensive so that the zone it defines is widely applicable.

The fossil groups most useful as index fossils are generally marine and either floaters or open ocean swimmers, such as cephalopods, or bottom dwellers that had a floating or swimming stage in their life cycles, such as the medusa stage in the brachiopods. Such characteristics are necessary for rapid dispersal of newly evolved forms. On land, such mobile forms as the horses or wind-borne pollen and spores were relatively unrestricted by environmental barriers and became widely dispersed. All of these groups have provided biochronological zones of worldwide extent.

During the Cambrian Period ( $5.7 \times 10^8$  years before present) the oldest highly developed animals appeared; among them the trilobites provide the first important group of index fossils. Small plantlike floating colonial animals called graptolites have proved useful in correlating Ordovician ( $4.75 \times 10^8$  years B.P.) and Silurian ( $4.25 \times 10^8$  years B.P.) rocks. Ammonoids are a classic example of the internationally useful index fossil and are important beginning in the Devonian Period ( $4.13 \times 10^8$  years B.P.) and extending to the end of the Cretaceous Period ( $6.5 \times 10^8$  years B.P.). From the Pennsylvanian Period ( $3.1 \times 10^8$  years B.P.), fusulinids, a family of Foraminiferida, and pollen and spores from the coal forests are important indices. Small phos-

phatic teethlike fossils known as conodonts have been useful for detailed zonation throughout the Paleozoic Era as well as the early part of the Mesozoic. Closer to present time, the bones and teeth of vertebrate animals serve as index fossils for the Tertiary Era, while the remains of primitive humans have been used to date the Recent past. See BRACHIOPODA; CEPHALOPODA; CONODONT; FORAMINIFERIDA; FOSSIL; FUSULINACEA; GEOLOGIC TIME SCALE; GRAPTOLITHINA; STRATIGRAPHY. [C.C.]

**Indian Ocean** The smallest and geologically the most youthful of the three oceans. It differs from the Pacific and Atlantic oceans in two important aspects. First, it is landlocked in the north, does not extend into the cold climatic regions of the Northern Hemisphere, and consequently is asymmetrical with regard to its circulation. Second, the wind systems over its equatorial and northern portions change twice each year, causing an almost complete reversal of its circulation.

The eastern and western boundaries of the Indian Ocean are 147 and 20°E, respectively. In the southeastern Asian waters the boundary is usually placed across Torres Strait, and then from New Guinea along the Lesser Sunda Islands, across Sunda Strait and Singapore Strait.

The ocean floor is divided into a number of basins by a system of ridges. The largest is the Mid-Ocean Ridge, the greater part of which has a rather deep rift valley along its center. It lies like an inverted Y in the central portions of the ocean and ends in the Gulf of Aden. The Sunda Trench, stretching along Java and Sumatra, is the only deep-sea trench in the Indian Ocean. East of the Mid-Ocean Ridge, deep-sea sediments are chiefly red clay; in the western half of the ocean, globigerina ooze prevails and, near the Antarctic continent, diatom ooze.

Atmospheric circulation over the northern and equatorial Indian Ocean is characterized by the changing monsoons. In the southern Indian Ocean atmospheric circulation undergoes only a slight meridional shift during the year. The surface circulation is caused largely by winds and changes in response to the wind systems. In addition, strong boundary currents are formed, especially along the western coastline, as an effect of the Earth's rotation and of the boundaries created by the landmasses.

North of 10°S the changing monsoons cause a complete reversal of surface circulation twice a year. In February, during the Northeast Monsoon, flow north of the Equator is mostly to the west and the North Equatorial Current is well developed. Its water turns south along the coast of Somaliland and returns to the east as the Equatorial Countercurrent between about 2 and 10°S. In August, during the Southwest Monsoon, the South Equatorial Current extends to the north of 10°S; most of its water turns north along the coast of Somaliland, forming the strong Somali Current. North of the Equator flow is from west to east and is called the Monsoon Current. Parts of this current turn south along the coast of Sumatra and return to the South Equatorial Current. During the two transition periods between the Northeast and the Southwest monsoons in April–May and in October, a strong jetlike surface current flows along the Equator from west to east in response to the westerly winds during these months. See OCEAN CIRCULATION.

Both semidiurnal and diurnal tides occur in the Indian Ocean. The semidiurnal tides rotate around three amphidromic points situated in the Arabian Sea, southeast of Madagascar, and west of Perth. The diurnal tide also has three amphidromic points: south of India, in the Mozambique Channel, and between Africa and Antarctica. It has more the character of a standing wave, oscillating between the central portions of the Indian Ocean, the Arabian Sea, and the waters between Australia and Antarctica. See TIDE. [K.W.]

**Indium** A chemical element, In, atomic number 49, a member of group III and the fifth period of the periodic table. Indium has a relative atomic weight of 114.82. Indium occurs in the

Earth's crust to the extent of about 0.000001% and is normally found in concentrations of 0.1% or less. It is widely distributed in many ores and minerals but is largely recovered from the flue dusts and residues of zinc-processing operations. See PERIODIC TABLE.

Indium is used in soldering lead wires to germanium transistors and as a component of the intermetallic semiconductor used for germanium transistors. Indium arsenide, antimonide, and phosphide are semiconductors with unique properties. Other uses of indium are sleeve-type bearings to reduce corrosion and wear, glass-sealing alloys, and dental alloys. See GERMANIUM. [E.M.L.]

**Indole** The parent compound of a group of organic heterocyclic compounds containing the indole nucleus, which is a benzene ring fused to a pyrrole ring as in indole itself (**1**). The importance of the indole ring lies in its presence in a large number of naturally occurring compounds. See PYRROLE.

Indole can exist in two tautomeric forms, the more stable enamine form (**1**) and the 3-H-indole or imine form (**2**). Unsubstituted 3-H-indoles (sometimes called indolenines) and a structural isomer of indole, isoindole (**3**), are not stable, but have

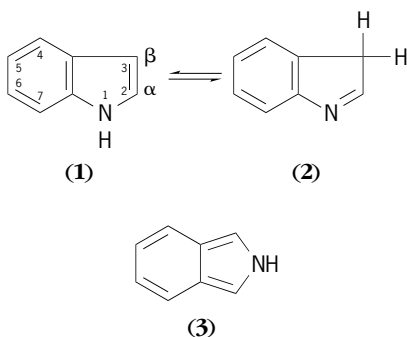

been shown to be reaction intermediates. They are isolable when properly substituted.

Indole (**1**) is a steam-volatile, colorless solid, melting point 52.5°C (126.5°F), boiling point 253°C (487°F). It is found in small amounts in coal tar, feces, and flower oils. Despite the presence of nitrogen, indole is not basic in the sense that it dissolves in aqueous acid or turns litmus blue. In fact, the hydrogen on the nitrogen is about as acidic as an aliphatic alcohol hydrogen. Indole is an aromatic compound and undergoes electrophilic substitutions much like benzene, although it is much more reactive than benzene. Its reactivity is comparable to that of phenol, and it undergoes a number of reactions similar to those of phenol. Indole itself reacts slowly with air and rapidly with most oxidizing agents to give intractable polymeric tars.

The indole alkaloids are a large group of substances containing the indole nucleus and can be isolated from plants. They contain a number of physiologically active materials, such as strychnine, reserpine, some forms of curare poison, and the rye-fungus drug, ergot. Lysergic acid diethylamide (LSD) is a synthetic, and not a naturally occurring, substance. There are many hundreds of other indole alkaloids. See ALKALOID; HETEROCYCLIC COMPOUNDS.

[J.M.Bo.]

**Inductance** That property of an electric circuit or of two neighboring circuits whereby an electromotive force is induced (by the process of electromagnetic induction) in one of the circuits by a change of current in either of them. The term inductance coil is sometimes used as a synonym for inductor, a device possessing the property of inductance. See ELECTROMAGNETIC INDUCTION; ELECTROMOTIVE FORCE (EMF); INDUCTOR.

For a given coil, the ratio of the electromotive force of induction to the rate of change of current in the coil is called the self-inductance of the coil. An alternative definition of self-inductance is the number of flux linkages per unit current. Flux linkage is the product of the flux and the number of turns in

the coil. Self-inductance does not affect a circuit in which the current is unchanging; however, it is of great importance when there is a changing current, since there is an induced emf during the time that the change takes place. For example, in an alternating-current circuit, the current is constantly changing and the inductance is an important factor.

The mutual inductance of two neighboring circuits is defined as the ratio of the emf induced in one circuit to the rate of change of current in the other circuit.

The International System (SI) unit of mutual inductance is the henry, the same as the unit of self-inductance. The same value is obtained for a pair of coils, regardless of which coil is the starting point.

The mutual inductance of two circuits may also be expressed as the ratio of the flux linkages produced in a circuit by the current in a second circuit to the current in the second circuit. See INDUCTANCE MEASUREMENT. [K.V.M.]

**Inductance measurement** The measurement of self- or mutual inductance. An electrical reactance such as the angular frequency ( $2\pi f$ , where  $f$  is the frequency) times self- or mutual inductance is the ratio of the alternating voltage having the appropriate phase, which appears across specified terminals, to the current through the device. Commercial instruments often measure inductance from this ratio by comparing it with the voltage-to-current ratio associated with a noninductive resistor. See ELECTRICAL IMPEDANCE.

Some practical precautions must be taken if accurate results are to be obtained. Any magnetic field associated with the inductor must not interact significantly with magnetic or conducting material in the vicinity of the inductor, since the field, and therefore the inductance, would be altered. The varying magnetic field of an inductor will induce eddy currents in any nearby conducting material, which will in turn produce a magnetic field which interacts with the inductor and measuring system. Errors in a measurement of inductance may also arise from the interaction of the magnetic field of an inductor with the rest of the measuring circuit. Capacitance to other parts or to the surroundings of an inductor arising from its associated electric field will inevitably affect the impedance or apparent inductance of an inductor by a frequency-dependent amount but capacitive currents associated with screening of the measuring circuit can be routed in such a way as not to affect the measurement. See EDDY CURRENT; INDUCTOR.

If the magnetic circuit of an inductor includes magnetic material whose permeability depends on its previous magnetic history, or the magnetic flux caused by a direct current flowing simultaneously in the coil, its inductance will also be current- or history-dependent, and these conditions must be specified if the measurement is to be meaningful.

The electrical property of self- or mutual inductance is only defined for complete circuits. Since a measuring device or network forms part of the complete circuit when it is connected to an inductor to perform a measurement, it is necessary to ensure that either the inductance associated with the measuring circuit is negligible or that the measured quantity is defined as the change in inductance occurring when the unknown is replaced by a short circuit. The former procedure is usual for mutual inductors, and the latter for self-inductors. See ELECTRICAL MEASUREMENTS; INDUCTANCE. [B.P.K.]

**Induction coil** A device for producing a high-voltage alternating current or high-voltage pulses from a low-voltage direct current. The largest modern use of the induction coil is in the ignition system of internal combustion engines, such as automobile engines. Devices of similar construction, known as vibrators, are used as rectifiers and synchronous inverters. See IGNITION SYSTEM.

The illustration shows a typical circuit diagram for an induction coil. The primary coil, wound on the iron core, consists of only a

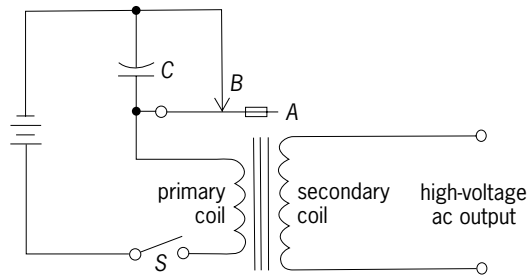

Typical circuit for an induction coil.

few turns. The secondary coil, wound over the primary, consists of a large number of turns.

Induction coils of a different type are used in telephone circuits to step up the voltage from the transmitter and match the impedance of the line. The direct current in the circuit varies in magnitude at speech frequencies; therefore, no interrupter contacts are necessary. Still another type of induction coil, called a reactor, is really a one-winding transformer designed to produce a definite voltage drop for a given current. See REACTOR (ELECTRICITY). [N.R.B.]

**Induction heating** The heating of a nominally electrical conducting material by eddy currents induced by a varying electromagnetic field. The principle of the induction heating process is similar to that of a transformer. In the illustration, the inductor coil can be considered the primary winding of a transformer, with the workpiece as a single-turn secondary. When an alternating current flows in the primary coil, secondary currents will be induced in the workpiece. These induced currents are called eddy currents. The current flowing in the workpiece can be considered as the summation of all of the eddy currents.

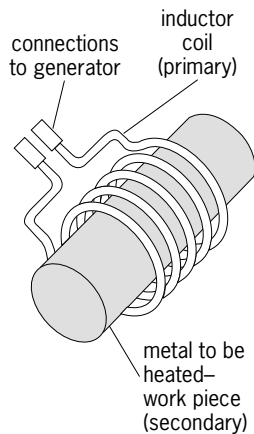

Basic elements of induction heating.

In the design of conventional electrical apparatus, the losses due to induced eddy currents are minimized because they reduce the overall efficiency. However, in induction heating, their maximum effect is desired. Therefore close spacing is used between the inductor coil and the workpiece, and high coil currents are used to obtain the maximum induced eddy currents and therefore high heating rates. See CORE LOSS.

Induction heating is widely employed in the metalworking industry for a variety of industrial processes. While carbon steel is by far the most common material heated, induction heating is also used with many other conducting materials such as various grades of stainless steel, aluminum, brass, copper, nickel, and titanium products. See BRAZING; HEAT TREATMENT (METALLURGY); SOLDERING.

The advantages of induction heating over the conventional processes (like fossil furnace or salt-bath heating) are the following: (1) Heating is induced directly into the material. It is therefore an extremely rapid method of heating. It is not limited by the relative slow rate of heat diffusion in conventional processes using surface-contact or radiant heating methods. (2) Because of skin effect, the heating is localized and the heated area is easily controlled by the shape and size of the inductor coil. (3) Induction heating is easily controllable, resulting in uniform high quality of the product. (4) It lends itself to automation, in-line processing, and automatic-process cycle control. (5) Startup time is short, and standby losses are low or nonexistent. (6) Working conditions are better because of the absence of noise, fumes, and radiated heat. See ELECTRIC HEATING. [G.F.B.]

**Induction motor** An alternating-current motor in which the currents in the secondary winding (usually the rotor) are created solely by induction. These currents result from voltages induced in the secondary by the magnetic field of the primary winding (usually the stator). An induction motor operates slightly below synchronous speed and is sometimes called an asynchronous (meaning not synchronous) motor.

Induction motors are the most common electric motors due to their simple construction, efficiency, good speed regulation, and low cost. Polyphase induction motors come in all sizes and find wide use where polyphase power is available. Single-phase induction motors are found mainly in fractional-horsepower (1 horsepower = 746 W) sizes, and those up to 25 hp are used where only single-phase power is available.

There are two principal types of polyphase induction motors: squirrel-cage and wound-rotor machines. The difference in these machines is in the construction of the rotor. The stator construction is the same and is also identical to the stator of a synchronous motor. Both squirrel-cage and wound-rotor machines can be designed for two- or three-phase current.

Single-phase induction motors display poorer operating characteristics than polyphase machines, but are used where polyphase voltages are not available. They are most common in small sizes ( $1/2$  hp or less) in domestic and industrial applications. Their particular disadvantages are low power factor, low efficiency, and the need for special starting devices. [A.G.C.]

**Inductive coordination** The avoidance of inductive interference. Electric power systems, like almost everything run by electricity, depend on internal electric and magnetic fields; some of these fields find their way into the environment. The strongest of these fields can then induce voltages and currents in nearby devices and equipment and, in some cases, can interfere with the internal fields being used by electrical equipment in the vicinity. These induced voltages and currents, which are due to the coupling between the energized source and the electrical equipment, are called inductive interference. See ELECTRIC FIELD; ELECTROMAGNETIC INDUCTION.

Overhead power lines cause practically all of the problems due to inductive coupling. For this reason and for safety

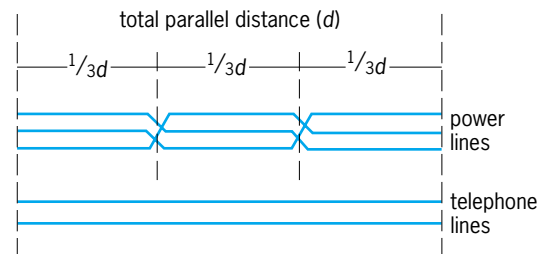

Transposition: the induced voltage and currents are canceled by transposing the power line as shown.

considerations, power lines are restricted as far as possible to specific corridors or rights of way. Spacing between them and the requirements of their surroundings are considered and carefully calculated to minimize possible interference. These corridors are often shared by telephone lines, communication circuits, railroads, and sometimes trolley buses, each of which must be considered for possible inductive coupling.

Modern telephone and communication circuits are well shielded and rarely encounter interference from nearby power lines. However, where a long parallel exposure exists, inductive coupling can be reduced by balancing the operation of the power line and by transposition of power and communication lines (see illustration). Fences, long irrigation pipes, and large ungrounded objects within the right of way may experience considerable inductive coupling and must be grounded for safety. See ELECTRICAL INTERFERENCE; ELECTRICAL SHIELDING; GROUNDING; TRANSMISSION LINES. [A.A.M.]

**Inductive voltage divider** An autotransformer that has its winding divided into a number of equal-turn sections (usually 10) so that when an alternating voltage  $V$  is applied to the whole winding, the voltage across each section is nominally  $V/10$ . The progressive voltages from one end to the section junctions are thus  $V/10, 2V/10, 3V/10, \dots$ , and  $9V/10$ . This voltage division can be realized with errors considerably less than 1 part per million of  $V$ , and such units therefore find wide use as standards of ac voltage ratio in the discipline of electrical measurements. See TRANSFORMER.

The division of voltage will be in error if there are differences of resistance and leakage inductance from section to section, and these errors will be significant if the differences are significant in relation to the input impedance of the winding. Leakage inductance is caused by that very small fraction of the flux from one section's winding which fails to thread the rest of the windings. The most commonly used constructional technique for minimizing such errors is to take 10 equal lengths of insulated copper wire and twist them into a "rope". The rope is wound onto a toroidal core made of thin, high-permeability, low-iron-loss magnetic material. The strands of the winding are then connected in series so that each strand forms the winding of one section of the 10-section divider (see illustration). The resistances of the sections are very nearly equal since the strands are the same length, and the leakage inductances are also closely equal and small because of the close flux coupling of this type of winding. The low-reluctance magnetic path of the core ensures a very high value of input impedance. Thus, voltage division at low audio frequencies can be accurate to a few parts in  $10^8$  of  $V$ .

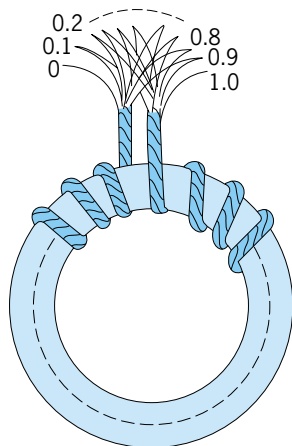

Rope winding on toroidal core making single-decade inductive voltage divider.

Inductive voltage dividers operate most accurately in the frequency range 20–1592 Hz but can be constructed to operate at frequencies up to 1 MHz. They are usually designed to accept an input voltage of up to about 0.25 times the frequency in hertz. See VOLTAGE MEASUREMENT. [T.A.D.; B.P.K.]

**Inductor** A device for introducing inductance into a circuit. The term covers devices with a wide range of uses, sizes, and types, including components for electric-wave filters, tuned circuits, electrical measuring circuits, and energy storage devices.

Inductors are classified as fixed, adjustable, and variable. All are made either with or without magnetic cores. Inductors without magnetic cores are called air-core coils, although the actual core material may be a ceramic, a plastic, or some other nonmagnetic material. Inductors with magnetic cores are called iron-core coils. A wide variety of magnetic materials are used, and some of these contain very little iron.

In fixed inductors coils are wound so that the turns remain fixed in position with respect to each other. Adjustable inductors have either taps for changing the number of turns desired, or consist of several fixed inductors which may be switched into various series or parallel combinations. Variable inductors are constructed so that the effective inductance can be changed. Means for doing this include (1) changing the permeability of a magnetic core; (2) moving the magnetic core, or part of it, with respect to the coil or the remainder of the core; and (3) moving one or more coils of the inductor with respect to one or more of the other coils, thereby changing mutual inductance. See INDUCTANCE. [B.L.R.; W.S.P.]

**Industrial ecology** The multidisciplinary study of industrial and economic systems and their linkages with fundamental natural systems. Industrial ecology incorporates research involving energy supplies, materials, technologies, and technological systems; physical, biological, and social sciences; economics; law; and business management. Industrial and economic systems are viewed not in isolation but in their cultural and ecological context. Both demand-side (consumer) and supply-side (producer) activities are included, as are all sectors of economic activity, such as mining, agriculture, forestry, fisheries, manufacturing, and service activities. Industrial ecology also includes subsistence activities at the fringes of formal economic systems, which generate a number of important impacts on natural systems. Industrial ecology provides the understanding to support the reasoned improvement of the economic, environmental, and social efficiency of current industrial systems.

Some of the obvious principles of industrial ecology can be illustrated by analogy to biological communities. For example: (1) Creation of economic systems where material flows are reused rather than becoming waste is a critical element of industrial ecology (see illustration). (2) The focus is on systems and integrative analysis rather than specific elements. Key techniques which support such an approach are a focus on material stocks and flows, and energy consumption, throughout the system. (3) Industrial ecology is concerned not just with static analyses of systems but with their responses over time, and particularly with their resilience (how well they maintain system coherence and function when stressed).

Five key concepts of industrial ecology are:

1. Design of products, processes, facilities, infrastructure, services, and technology systems so that they can be easily adapted to environmentally preferable innovation with minimal waste. Modular design of complex technologies is an example.

2. Minimization of waste production and energy consumption in all activities.

3. Use of the least toxic alternatives whenever possible, particularly when the materials may be dispersed into the environment. This principle would have argued against adding lead to gasoline, since predictably the pollutant subsequently would be dispersed throughout the environment.

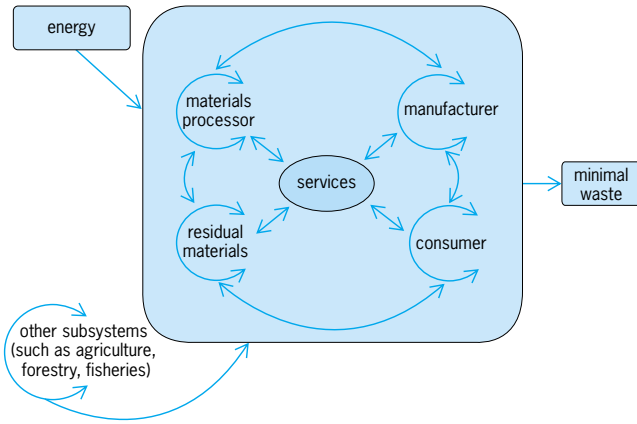

**Energetically open, low-waste economy. Materials are cycled through the economy at different scales and in different sectors to minimize overall waste production while quality of life is enhanced.**

4. Design of products, facilities, infrastructure, and technology systems to preserve the embedded utility of materials and energy used in initial manufacture. Thus, in many cases designs which extend the life of products and support the recycling of subassemblies or components, rather than materials, are preferable.

5. Design of physical products at all scales not just to perform their intended function but also to be used in creating other useful products at the end of their current life. See CLIMATE MODIFICATION; CONSERVATION OF RESOURCES; ECOLOGY; ECOLOGY, APPLIED; ENVIRONMENT; ENVIRONMENTAL ENGINEERING; HUMAN ECOLOGY; SYSTEMS ENGINEERING. [B.R.A.]

**Industrial engineering** A branch of engineering dealing with the design, development, and implementation of integrated systems of humans, machines, and information resources to provide products and services. Industrial engineering encompasses specialized knowledge and skills in the physical, social, engineering, and management sciences, such as human and cognitive sciences, computer systems and information technologies, manufacturing processes, operations research, production, and automation. The industrial engineer integrates people into the design and development of systems, thus requiring an understanding of the physical, physiological, psychological, and other characteristics that govern and affect the performance of individuals and groups in working environments.

Industrial engineering is a broad field compared to other engineering disciplines. The major activities of industrial engineering stem from manufacturing industries and include work methods analysis and improvement; work measurement and the establishment of standards; machine tool analysis and design; job and workplace design; plant layout and facility design; materials handling; cost reduction; production planning and scheduling; inventory control, maintenance, and replacement; statistical quality control; scheduling; assembly-line balancing, systems, and procedures; and overall productivity improvement. Computers and information systems have necessitated additional activities and functions, including numerically controlled machine installation and programming; manufacturing systems design; computer-aided design/computer-aided manufacturing, design of experiments, quality engineering, and statistical process control; computer simulation, operations research, and management science methods; computer applications, software development, and information technology; human-factors engineering and ergonomics; systems design and integration; and robotics and automation.

The philosophy and motivation of the industrial engineering profession is to find the most efficient and effective methods, procedures, and processes for an operating system, and to seek continuous improvement. Thus, industrial engineering helps organizations grow and expand efficiently during periods of prosperity, and streamline costs and consolidate and reallocate resources during austere times. Industrial engineers, particularly those involved in manufacturing and related industries, work closely with management. Therefore, some understanding of organizational behavior, finance, management, and related business principles and practices is needed. See COMPUTER-AIDED DESIGN AND MANUFACTURING; HUMAN-FACTORS ENGINEERING; OPERATIONS RESEARCH; PRODUCTION PLANNING. [M.U.T.]

**Industrial health and safety** An interdisciplinary field that focuses on preventing occupational illnesses and injuries. The disciplines of engineering, epidemiology, toxicology, medicine, psychology, and sociology provide the methods for study and prevention.

Tens of thousands of occupational hazards exist. Occupational hazards can be organized in terms of plants and equipment, the physical work environment, hazards of materials, and task demands. Significant interactions occur between these categories. For example, equipment can modify the work environment by producing noise, potentially hazardous materials, or heat, but will be hazardous only if inappropriate procedures are followed.

Plant hazards are often associated with energy sources and power transmission, processes at the point of operation, vehicles and materials-handling systems, walking and climbing surfaces, ingress-egress, and confined spaces. Hazards in the physical work environment include vibration and noise, thermal extremes, pressure extremes, and ionizing or nonionizing radiation.

Materials used in industrial processes vary greatly in nature and form. Mists, vapors, gases, liquids, dusts, and fumes from certain materials may be hazardous. Some materials pose fire and explosion hazards. Others are chemically or biologically active when they contact or enter the human body. Even chemically inert materials can cause injuries or illness.

The task performed by a worker can be hazardous. Lifting, pushing, pulling, and other physical activity can cause injury when applied or reactive forces, pressures, or torques exceed the tolerance of the body. Repeated performance of manual tasks over prolonged periods, excessive reaches, twisting motions, rapid movements, and postures that concentrate forces can significantly increase the risk of injury. Tasks that are stressful or monotonous can also contribute to human error. Changes in work conditions requiring deviations from ordinary routines, such as when equipment is being repaired, are particularly likely to increase the chance of errors.

A fundamental safety and health activity is to identify potential hazards and then to analyze them in terms of severity and probability. This process allows the cost of control measures to be compared with expected loss reduction and helps justify choices between control alternatives.

Hazard identification is guided by past experience, codes and regulations, checklists, and other sources. This process can be organized by separately considering each step in the making of a product. Numerous complementary hazard analysis methods are available, including failure modes and effects analysis, work safety analysis, human error analysis, and fault tree analysis. Failure mode and effects analysis systematically documents the effects of malfunctions on work sheets that list the components of a system, their potential failure modes, the likelihood and effects of each failure, and potential countermeasures. Work safety analysis and human error analysis are related techniques that organize the analysis around tasks rather than system components.

This process involves an initial division of tasks into subtasks. For each subtask, potential effects of product malfunctions and human errors are then documented. Fault tree analysis takes an approach that begins with a potential accident and then works down to its fundamental causes. Fundamental causes may be system malfunctions, human errors, or ordinary nonmalfunction states. Probabilities are often assigned to the fundamental causes, allowing the probability of accidents to be calculated. See OPERATIONS RESEARCH; RISK ASSESSMENT AND MANAGEMENT; SYSTEMS ANALYSIS.

Determining which standards, codes, and regulations are relevant and then ensuring compliance are essential health and safety activities. In the United States the best-known governmental standards are the general industry standards specified by the Occupational Safety and Health Administration (OSHA). OSHA also specifies standards for the construction, maritime, and agriculture industries. Other standards include those specified by the Environmental Protection Agency (EPA) on disposal and cleanup of hazardous materials, the Federal Aviation Administration (FAA) standards on worker safety in air travel, the Federal Highway Administration (FHWA) standards regarding commercial motor carriers, the Mine Safety and Health Administration (MSHA) standards for mine workers, the Nuclear Regulatory Commission's and Department of Energy's standards regarding employees working with radioactive materials, and the U.S. Coast Guard standards regarding safety of workers on tank and passenger vessels. State and local governments may also implement safety and health standards.

Methods of controlling or eliminating hazards include plant or process design; job design; employee selection, training, and supervision; personal protective equipment; and warnings. Accident investigations, plant inspections, and environmental monitoring are complementary ways of ensuring that implemented control strategies are fulfilling their intended function. They can uncover deficiencies in existing controls and help formulate needed changes. [M.R.L.]

**Industrial meteorology** The application of meteorological information to industrial, business, or commercial problems. Generally, industrial meteorology is a branch of applied meteorology, which is the broad field where weather data, analyses, and forecasts are put to practical use. The term "private sector meteorology" has taken on the broader context of traditional industrial meteorology, expanding to include the provision of weather instrumentation/remote sensing devices, systems development and integration, and various consulting services to government and academia as well as value-added products and services to markets in industry (such as media, aviation, and utilities). Some areas in which industrial meteorology may be applied include environmental health and air-pollution control, weather modification, agricultural and forest management, and surface and air transportation. See AERONAUTICAL METEOROLOGY; AGRICULTURAL METEOROLOGY; METEOROLOGICAL INSTRUMENTATION.

Specific examples of the uses of industrial meteorology include many in the public sphere. For example, electric utilities need hourly predictions of temperature, humidity, and wind to estimate system load. In addition, they need to know when and where thunderstorms will impact their service area, so that crews can be deployed to minimize or correct disruptions to their transmission and distribution systems. Highway departments need to know when and where frozen precipitation will affect their service areas so that crews can be alerted, trucks loaded with sand and salt, and, if necessary, contractors hired to assist. Since a few degrees' change in temperature, or a slight change in intensity of snow or ice, determines the type of treatment required, early prediction and close monitoring of these parameters are critical.

Agricultural enterprises, from farmers to cooperatives to food manufacturers, rely on precise weather information and forecasts. Weather is the single most important factor in determining crop growth and production. Thus, monitoring and prediction of drought, floods, heat waves, and freezes are of extreme importance. See WEATHER FORECASTING AND PREDICTION.

Professionals involved with the meteorological aspects of air pollution are generally concerned with the atmospheric transport, distribution, transformation, and removal mechanisms of air pollutants. They are often called upon to evaluate the effectiveness of pollution control technologies or regulatory (policy) actions used to achieve and maintain air-quality goals. See AIR POLLUTION. [T.S.G.]

**Industrial microbiology** A field concerned with the development of technologies to control and manipulate the growth and activities of selected biological agents to create desirable products and economic gain or to prevent economic loss. In addition to bacteria and yeasts, animal and plant cell cultures are now used to produce sophisticated products such as monoclonal antibodies, immunomodulating compounds, and complex plant metabolites.

Although fermented products have been consumed for thousands of years, only in the nineteenth century was microbial activity associated with the fermentation process. Soon after that discovery, microorganisms, especially bacteria, were selectively introduced on the commercial level. Techniques were developed gradually for pure-culture fermentation and strain improvement, but the major advance in industrial microbiology occurred during World War II with the large-scale production of penicillin by submerged-culture fermentation. In the 1950s, industrial microbiology shifted its focus to the production of therapeutic agents, especially antibiotics. Advances in molecular biology have greatly increased the potential applications of industrial microbiology in areas such as therapeutics, diagnostics, environmental protection, and agriculture. The techniques of genetic engineering, along with technology developments in bioprocessing, make possible large-scale production of complex natural compounds that would otherwise be very difficult to obtain.

With the exception of the food industry, few commercial fermentation processes use wild strains of microorganisms. Of the many thousands of microbial species, few are used commercially, and fewer still are used as hosts for genetically engineering genes. Process development occurs in large part by strain improvement directed at increasing product yield, enhancing growth on cheaper substrates, and simplifying purification.

Strain development is achieved by either a traditional mutation and selection program or direct genetic manipulation. The recombinant DNA approach has succeeded in introducing new genetic material into a convenient host microorganism and amplifying genetic material. About 20% of the synthesizing capacity of a bacterium can be devoted to a single polypeptide or protein. See RECOMBINATION (GENETICS).

Commercial microbial compounds are produced in two distinct phases: fermentation and product recovery. Production usually occurs in a batch fermentor, where gas of controlled composition and flow is bubbled through a stirred pure microbial culture suspended in a liquid medium of optimum nutrient composition. Product recovery and purification involves a series of operations. The first steps usually involve cell disruption or the separation of the cell or cellular debris from the fluid medium, typically through centrifugation and filtration. Later stages of purification include finer membrane filtration, extraction, precipitation, and chromatography. See CENTRIFUGATION; FERMENTATION; FILTRATION; FOOD FERMENTATION; STERILIZATION.

The production of certain foods and beverages was an early application of industrial microbiology. Now, the fields of mineral

recovery, medicine, environmental protection, and food and agriculture are using similar techniques.

Bacterial leaching reactions have been used to alter metal-bearing minerals, usually converting them to more soluble forms before the metals are extracted. Such operations can result in improved extraction rates in comparison to those of conventional processes, which are usually conducted on ore waste dumps and heaps. Large-scale commercial applications of biochemical mining and extraction have been limited mainly to copper and uranium. Besides enhancing or inhibiting the recovery of metal values from ores, bacteria are being used to precipitate or accumulate metal. The process, known as bioaccumulation, normally involves the adsorption of metal ions on the bacteria, which are then chemically transformed to an insoluble precipitate.

The most visible products of industrial microbiology are therapeutics for human health. Microbial synthesis is the preferred method of production for most health care drugs with complex chemistry. Microorganisms still have a remarkable ability for producing new commercial antibiotics, the largest class of drugs, and for continued yield improvement. With recombinant DNA technology, many proteins and polypeptides that are present naturally in the human body in trace amounts can be produced in large amounts during fermentation of recombinant microorganisms. See ANTIBIOTIC; INSULIN.

Microbial activities have long been the basis for sewage treatment facilities, and industrial and hazardous waste cleanup, or bioremediation, has become important. Bioremediation successes have been achieved by using native bacteria to degrade petroleum products, toxic chlorinated herbicides, and toxic biocides. See HAZARDOUS WASTE; SEWAGE.

Some of the oldest and most established areas of industrial microbiology concern food and beverage products, such as the production and use of brewer's yeast and baker's yeast. The food industry and the detergent industry are the major users of industrial enzymes produced by microbial fermentation. Detergents, especially in Europe, often contain protein-degrading enzymes (proteases). In the food industry, amylases convert starch to glucose, and glucose isomerase converts glucose to fructose. See DETERGENT; FOOD MANUFACTURING. [R.Kor.]

**Industrial trucks** Manually propelled (handtrucks) or powered carriers for transporting materials over level, slightly inclined, or slightly declined running surfaces. Some industrial trucks can lift and lower their loads, and others can also tier them. In any event, all such trucks maintain contact with the running surface over which they operate and, except when towed by a chain conveyor, follow variable paths of travel as distinct from conveying machines or monorails.

In industry the principle of handling materials in unit loads has developed in parallel with the increased use of powered industrial trucks, particularly the forklift type. These mobile mechanical handling aids have removed the limitations that existed when the weight and size of a load for movement and stacking depended mainly on the ability of a person to lift it manually. The unit-load principle of materials handling underlies the skid-platform and the pallet-forklift methods of operation. Both methods, especially the latter, have revolutionized handling techniques and equipment and even production equipment. [A.M.P.]

**Industrial wastewater treatment** A group of unit processes designed to separate, modify, remove, and destroy undesirable substances carried by wastewater from industrial sources. United States governmental regulations have been issued that involve volatile organic substances, designated priority pollutants; aquatic toxicity as defined by a bioassay; and in some

cases nitrogen and phosphorus. As a result, sophisticated technology and process controls have been developed for industrial wastewater treatment.

Wastewater streams that are toxic or refractory should be treated at the source, and there are a number of technologies available. For example, wet air oxidation of organic materials at high temperature and pressure (2000 lb/in. or 14 kilopascals and 550°F or 288°C) is restricted to very high concentrations of these substances. Macroreticular (macroporous) resins are specific for the removal of particular organic materials, and the resin is regenerated and used again. Membrane processes, particularly reverse osmosis, are high-pressure operations in which water passes through a semipermeable membrane, leaving the contaminants in a concentrate. See HAZARDOUS WASTE; MEMBRANE SEPARATIONS.

Pretreatment and primary treatment processes address the problems of equalization, neutralization, removal of oil and grease, removal of suspended solids, and precipitation of heavy metals. See ELECTROCHEMICAL PROCESS; ION EXCHANGE; pH; SEDIMENTATION (INDUSTRY).

Aerobic biological treatment is employed for the removal of biodegradable organics. An aerated lagoon system is applicable (where large land areas are available) for treating nontoxic wastewaters, such as generated by pulp and paper mills. Fixed-film processes include the trickling filter and the rotating biological contactor. In these processes, a biofilm is generated on a surface, usually plastic. As the wastewater passes over the film, organics diffuse into the film, where they are biodegraded. Anaerobic processes are sometimes employed before aerobic processes for the treatment of high-strength, readily degradable wastewaters. The primary advantages of the anaerobic process is low sludge production and the generation of energy in the form of methane (CH<sub>4</sub>) gas. See BIODEGRADATION; SEWAGE DISPOSAL; SEWAGE TREATMENT.

Biological processes can remove only degradable organics. Nondegradable organics can be present in the influent wastewater or be generated as oxidation by-products in the biological process. Many of these organics are toxic to aquatic life and must be removed from the effluent before discharge. The most common technology to achieve this objective is adsorption on activated carbon. See ACTIVATED CARBON; ADSORPTION.

In some cases, toxic and refractory organics can be pretreated by chemical oxidation using ozone, catalyzed hydrogen peroxide, or advanced oxidation processes. In this case the objective is not mineralization of the organics but detoxification and enhanced biodegradability.

Biological nitrogen removal, both nitrification and denitrification, is employed for removal of ammonia from wastewaters. While this process is predictable in the case of municipal wastewaters, many industrial wastewaters are inhibitory to the nitrifying organisms.

Volatile organics can be removed by air or steam stripping. Air stripping is achieved by using packed or tray towers in which air and water counterflow through the tower. In steam stripping, the liquid effluent from the column is separated as an azeotropic mixture. See AZEOTROPIC MIXTURE; STRIPPING.

Virtually all of the processes employed for industrial wastewater treatment generate a sludge that requires some means of disposal. In general, the processes employed for thickening and dewatering are the same as those used in municipal wastewater treatment. Waste activated sludge is usually stabilized by aerobic digestion in which the degradable solids are oxidized by prolonged aeration. See SEWAGE SOLIDS.

Most landfill leachates have high and variable concentrations of organic and inorganic substances. All municipal and most industrial landfill leachates are amenable to biological treatment and can be treated anaerobically or aerobically, depending on the effluent quality desired. Activated carbon has been employed to remove nondegradable organics. In Europe, some plants



employ reverse osmosis to produce a high-quality effluent. See WATER POLLUTION. [W.W.E.]

**Inert gases** The inert gases, listed in the table, constitute group 18 of the periodic table of the elements. They are now better known as the noble gases, since stable compounds of xenon have been prepared. The noble gases are all monatomic.

All these gases occur to some extent in the Earth's atmosphere, but the concentrations of all but argon are exceedingly low. Argon is plentiful, constituting almost 1% of the air.

**The inert gases**

Name	Symbol	Atomic number	Atomic weight
Helium	He	2	4.0026
Neon	Ne	10	20.183
Argon	Ar	18	39.948
Krypton	Kr	36	83.80
Xenon	Xe	54	131.30
Radon	Rn	86	(222)

All the gases are colorless, odorless, and tasteless. They are all slightly soluble in water, the solubility increasing with increasing molecular weight. They can be liquefied at low temperatures, the boiling point being proportional to the atomic weight. All but helium can be solidified by reducing the temperature sufficiently, and helium can be solidified at temperatures of less than 2°F above absolute zero (0–1 K) by the application of an external pressure of 25 atm (2.5 megapascals) or more. See ARGON; HELIUM; KRYPTON; NEON; RADON; XENON. [A.W.F.]

**Inertia** That property of matter which manifests itself as a resistance to any change in the motion of a body. Thus when no external force is acting, a body at rest remains at rest and a body in motion continues moving in a straight line with a uniform speed (Newton's first law of motion). The mass of a body is a measure of its inertia. See MASS. [L.N.]

**Inertia welding** A welding process used to join similar and dissimilar materials at very rapid speed. It is, therefore, a very attractive welding process in mass production of good-quality welds. The ability to join dissimilar materials provides further flexibility in the design of mechanical components. The automotive and truck industry is the major user of this process.

Inertia welding is a type of friction welding which utilizes the frictional heat generated at the rubbing surfaces to raise the temperature to a degree that the two parts can be forged together to form a solid bond. The energy required for inertia welding comes from a rotating flywheel system built into the machine. Like an engine lathe, the inertia welding machine has a headstock and a tailstock. One workpiece held in the spindle chuck (usually with an attached flywheel) is accelerated rapidly, while the other is clamped in a stationary holding device of the tailstock. When a predetermined spindle speed is reached, the drive power is cut and the nonrotating part on the tailstock is pushed against the rotating part under high pressure. Friction between the rubbing surfaces quickly brings the spindle to a stop. At the same time the stored kinetic energy in the flywheel is converted into frictional heat which raises the temperature at the interface high enough to forge the two parts together without melting. [K.K.W.]

**Inertial guidance system** A self-contained system which can automatically determine the position, velocity, and attitude of a moving vehicle for the purpose of directing its future course. Based on prior knowledge of time, gravitational field, initial position, initial velocity, and initial orientation relative to

a known reference frame, an inertial guidance system is capable of determining its present position, velocity, and orientation without the aid of external information. The generated navigational data are used to determine the future course for a vehicle to follow in order to bring it to its destination. Such systems have found application in the guidance and control of submarines, ships, aircraft, missiles, and spacecraft. See GUIDANCE SYSTEMS. [W.E.H.]

**Infant diarrhea** Diarrhea and its complications are the most important causes of infant death in most developing regions. The causes of the illness vary from dietary incompatibilities to intestinal infection. The most important infectious causes are, in approximate order of importance: rotavirus, the bacteria *Shigella* (causing dysentery) and *Salmonella*, the parasite *Giardia lamblia*, and enteropathogenic *Escherichia coli* bacteria (a common cause of hospital nursery outbreaks). Breast-feeding is associated with a decreased occurrence of diarrhea and represents a major means of preventing infantile diarrhea in the developing world. See DIARRHEA. [H.L.D.]

**Infant respiratory distress syndrome** A common disorder of premature (or preterm) birth, defined by respiratory difficulty (including rapid respiration, retractions of the rib cage, nasal flaring, grunting or whining upon exhaling, and a bluish discoloration of the skin and mucous membranes), which requires oxygen or assisted ventilation, and a characteristic on chest x-ray showing a uniform, diffuse haziness of both lungs due to their poor aeration. It is primarily the result of deficiency in surface-active lipids (contained within pulmonary surfactant) which serve to stabilize the air spaces (alveoli) within the lung. Although cases of infant respiratory distress syndrome rarely result in a fatal outcome in developed countries, all require specialized care in a neonatal intensive care unit. The incidence of respiratory distress syndrome increases with greater prematurity as well as with maternal diabetes and asphyxia around the time of delivery.

Prevention of prematurity and administration of good prenatal care reduce the incidence of infant respiratory distress syndrome. Corticosteroids given before birth to the mother at risk for premature delivery is a well-established therapy for reducing the incidence of respiratory distress syndrome; this treatment enhances pulmonary maturation in the infant.

Surfactant therapy is now widely used for treatment of infants with moderate or severe respiratory distress syndrome. This requires introducing a tube into the trachea for direct placement of surfactant into the infant's lungs; this is done one or more times over the first 48 h of life. Surfactant therapy must be performed in conjunction with conventional treatment such as maintenance of an optimal-temperature environment and use of intravenous fluids. See RESPIRATORY SYSTEM DISORDERS. [R.J.Ma.]

**Infarction** The process of anoxic tissue death. The usual cause is occlusion of an artery by a thrombus or embolus and sometimes by severe atherosclerosis. The development of the infarct depends to a great extent on the collateral circulation. If the collateral blood supply is inadequate or if the vessel is the sole source of blood supply to the region, an infarct results. See ARTERIOSCLEROSIS; THROMBOSIS.

Infarcts commonly occur in the lungs, heart, brain (see illustration), spleen, and kidneys. The common cause of infarcts of the heart is thrombosis of the coronary artery, usually secondary to atherosclerosis. Hemorrhage into an atherosclerotic plaque can also result in thrombosis of an artery. Myocardial infarcts usually involve the left ventricle or interventricular septum and only rarely involve the right ventricle or atria. The location of the infarct usually depends on the coronary artery occluded. See HEART DISORDERS.

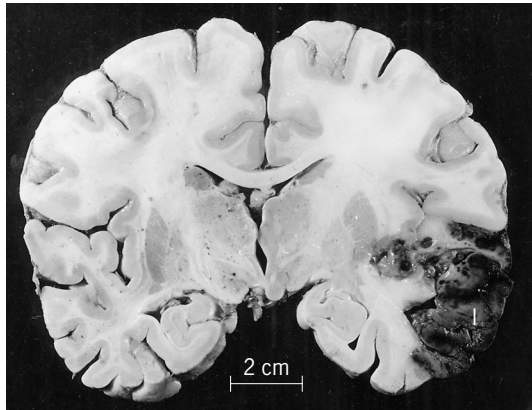

Gross photograph of a brain section, showing a wedge-shaped infarct that resulted from a thrombus. Secondary hemorrhage has occurred.

Infarction of a portion of bowel will result in death unless surgical intervention is forthcoming. Embolization to the lungs is a rather frequent occurrence. However, because of the collateral blood supply of the lungs, infarction follows only when there is some interference with the circulation, such as chronic pulmonary venous congestion. An extensive collateral circulation also exists in the liver, hence the rarity of infarcts in this organ. See CIRCULATION DISORDERS. [R.A.V.; I.N.]

**Infection** A term considered by some to mean the entrance, growth, and multiplication of a microorganism (pathogen) in the body of a host, resulting in the establishment of a disease process. Others define infection as the presence of a microorganism in host tissues whether or not it evolves into detectable pathologic effects. The host may be a bacterium, plant, animal, or human being, and the infecting agent may be viral, rickettsial, bacterial, fungal, or protozoan.

A differentiation is made between infection and infestation. Infestation is the invasion of a host by higher organisms such as parasitic worms. See EPIDEMIOLOGY; HOSPITAL INFECTIONS; MEDICAL BACTERIOLOGY; MEDICAL MYCOLOGY; MEDICAL PARASITOLOGY; OPPORTUNISTIC INFECTIONS; PATHOGEN; VIRUS. [D.N.La.]

**Infectious disease** A pathological condition spread among biological species. Infectious diseases, although varied in their effects, are always associated with viruses, bacteria, fungi, protozoa, multicellular parasites and aberrant proteins known as prions. A complex series of steps, mediated by factors contributed by both the infectious agent and the host, is required for microorganisms or prions to establish an infection or disease. Worldwide, infectious diseases are the third leading cause of human death.

The most common relationship between a host and a microorganism is a commensal one, in which advantages exist for both organisms. For example, hundreds of billions of bacteria of many genera live in the human gastrointestinal tract, coexisting in ecological balance without causing disease. These bacteria help prevent the invasion of the host by more virulent organisms. In exchange, the host provides an environment in which harmless bacteria can readily receive nutrients. There are very few microorganisms that cause disease every time they encounter a host. Instead, many factors of both host and microbial origin are involved in infectious disease. These factors include the general health of the host, previous exposure of the host to the microorganism, and the complement of molecules produced by the bacteria.

Spread of a pathogenic microorganism among individual hosts is the hallmark of an infectious disease. This process,

known as transmission, may occur through four major pathways: contact with the microorganism, airborne inhalation, through a common vehicle such as blood, or by vector-borne spread.

The manner in which an infectious disease develops, or its pathogenesis, usually follows a consistent pattern. To initiate an infection, there must be a physical encounter as which the microorganism enters the host. The most frequent portals of entry are the respiratory, gastrointestinal, and genitourinary tracts as well as breaks in the skin. Surface components on the invading organism determine its ability to adhere and establish a primary site of infection. The cellular specificity of adherence of microorganisms often limits the range of susceptible hosts. For example, although measles and distemper viruses are closely related, dogs do not get measles and humans do not get distemper. From the initial site of infection, microorganisms may directly invade further into tissues or travel through the blood or lymphatic system to other organs.

Microorganisms produce toxins that can cause tissue destruction at the site of infection, can damage cells throughout the host, or can interfere with the normal metabolism of the host. The damage that microorganisms cause is directly related to the toxins they produce. Toxins are varied in their mechanism of action and host targets. See CHOLERA; STAPHYLOCOCCUS; TETANUS.

The host's reaction to an infecting organism is the inflammatory response, the body's most important internal defense mechanism. Although the inflammatory response is also seen as secondary to physical injury and nonspecific immune reactions, it is a reliable indicator of the presence of pathogenic microorganisms. Immune cells known as lymphocytes and granulocytes are carried by the blood to the site of infection. These cells either engulf and kill, or secrete substances which inhibit and neutralize, microorganisms. Other white blood cells, primarily monocytes, recognize foreign organisms and transmit chemical signals to other cells of the host's immune system, triggering the production of specific antibodies or specialized killer cells, both of which are lethal to the infecting microorganism. Any influence that reduces the immune system's ability to respond to foreign invasion, such as radiation therapy, chemotherapy, or destruction of immune cells by an immunodeficiency virus such as HIV, increases the likelihood that an organism will cause disease within the host. See INFLAMMATION.

Chemical compounds that are more toxic to microorganisms than to the host are commonly employed in the prevention and treatment of infectious disease; however, the emergence of drug-resistant organisms has led to increases in the morbidity and mortality associated with some infections. Other methods for controlling the spread of infectious diseases are accomplished by breaking a link in the chain of transmission between the host, microorganism, and mode of spread by altering the defensive capability of the host. Overall, the three most important advances to extend human life are clean water, vaccination, and antibiotics (in that order of importance).

Water-borne infections are controlled by filtration and chlorination of municipal water supplies. Checking food handlers for disease, refrigeration, proper cooking, and eliminating rodent and insect infestation have markedly reduced the level of food poisonings. The transmission of vector-borne diseases can be controlled by eradication of the vector. Blood-borne infections are reduced by screening donated blood for antibodies specific for HIV and other viruses and by rejecting donations from high-risk donors. For diseases such as tuberculosis, the airborne spread of the causative agent, *Mycobacterium tuberculosis*, can be reduced by quarantining infected individuals. The spread of sexually transmitted diseases, including AIDS, syphilis, and herpes simplex, can be prevented by inhibiting direct contact between the pathogenic microorganism and uninfected hosts. See ACQUIRED IMMUNE DEFICIENCY SYNDROME (AIDS); FOOD POISONING; VACCINATION; WATER-BORNE DISEASE. [P.J.McN.]

**Infectious mononucleosis** A disease of children and young adults, characterized by fever and enlarged lymph nodes and spleen. EB (Epstein-Barr) herpesvirus is the causative agent.

Onset of the disease is slow and nonspecific with variable fever and malaise; later, cervical lymph nodes enlarge, and in about 50% of cases the spleen also becomes enlarged. The disease lasts 4–20 days or longer. Epidemics are common in institutions where young people live. EB virus infections occurring in early childhood are usually asymptomatic. In later childhood and adolescence, the disease more often accompanies infection—although even at these ages inapparent infections are common. See EPSTEIN-BARR VIRUS. [J.L.Me.]

**Infectious myxomatosis** A viral disease of European rabbits (*Oryctolagus*) and domestic rabbits, spread mainly by biting insects (mosquitoes and rabbit fleas) and characterized by edematous swellings of the skin, particularly on the head and anogenital area. The disease is caused by infection with myxoma virus, a pox virus, which occurs naturally in certain species of the genus *Sylvilagus* in North, Central, and South America. In these rabbits, infection results generally in localized, nonmalignant tumors that disappear in weeks or months. There is no effective treatment once clinical signs have appeared. Preventive measures include restriction of contact with insect vectors and vaccination with active or inactivated myxoma virus or with Shope fibroma virus. See ANIMAL VIRUS. [J.Ro.]

**Infectious papillomatosis** A nonfatal viral disease that occurs naturally in cottontail rabbits in states bordering the Mississippi River as well as in Oklahoma and Texas, and in brush rabbits in California. Cottontail rabbits from other parts of the United States and domestic rabbits (*Oryctolagus*) are also susceptible. The disease is caused by infection with Shope papilloma virus; it is spread naturally by contamination of broken skin or by the rabbit tick. The disease is characterized by cutaneous warts (papillomas) which can persist for months or years, sometimes becoming very prominent. Rabbits can be immunized against papillomatosis by injection of active or inactivated virus. See ANIMAL VIRUS. [J.Ro.]

**Infertility** Inability to conceive or induce conception. Of all cases of infertility, 35% may be attributed to the male and 55% to the female; the remaining 10% is undetermined.

The principal cause of increasing rates of infertility is the postponement of pregnancy: adverse effects of increasing age on reproductive capacity include decreased conception rates and increased pregnancy losses. The increasing incidence of pelvic inflammatory disease is also thought to be a major cause. Pelvic infections lead to scar formation around the ovaries and the fallopian tubes, thereby impeding the transport of oocytes for fertilization.

Ovulatory dysfunction accounts for approximately 20% of cases of infertility. Ovulation is dependent on the timely secretion of the two gonadotropic hormones from the pituitary gland, follicle-stimulating hormone (FSH) and luteinizing hormone (LH). Gonadotropic hormone release can be impeded by certain medications and by many disease states, including stress, anorexia nervosa, weight loss, and thyroid disease. Anovulation can be treated by replacing the deficient gonadotropins with human menopausal gonadotropin, a mixture of follicle-stimulating and luteinizing hormones. In addition, the drug clomiphene citrate increases the endogenous secretion of those hormones from the pituitary gland. See ENDOCRINE MECHANISMS; PITUITARY GLAND.

Fallopian tube and uterine abnormalities account for 25% of the cases of infertile couples. These abnormalities include defective development as well as scar formation after surgery or infec-

tion. Not uncommonly the region of the fallopian tube closest to the uterus may be obstructed by scar tissue, but the obstruction can be microscopically removed or the fallopian tube can be surgically cut and reconnected.

In endometriosis, tissue that normally lines the uterus is found on the pelvic lining. Severe forms of endometriosis involve the ovaries and fallopian tubes, which doubles the likelihood of infertility in those women. The condition is treated either by surgical excision of the aberrant tissue or by subsequent medical treatment. See OVARIAN DISORDERS.

Abnormalities in cervical mucus production may result from trauma, surgery, and diethylstilbestrol (DES) exposure before birth. The treatment of cervical abnormalities remains controversial, but may include estrogen; or another approach is to bypass this obstruction by using intrauterine transfer of semen (artificial insemination).

Male infertility resulting from abnormal semen may be due to developmental defects, genitourinary infections, or varicocele. An evaluation of sperm count, motility, and morphology is helpful, but in most cases the cause of the abnormality remains undetermined. No treatment other than donor insemination is available for these couples.

In approximately 10% of infertile couples, a thorough evaluation reveals no cause, and unexplained infertility is diagnosed. In nearly 50% of women with unexplained infertility, pelvic abnormalities are found and are most often caused by endometriosis and scar formation.

One method of assisted reproduction is in vitro fertilization, which takes place through the controlled hyperstimulation of ovulation followed by surgical extraction of mature oocytes from the ovaries. In another method of assisted reproduction, gamete intrafallopian tube transfer (GIFT), ovulation is stimulated, as with in vitro fertilization, but the extracted oocytes are placed directly into the fallopian tube with the semen specimen. Incubation occurs within the fallopian tube rather than outside the body. See FERTILIZATION; PREGNANCY; REPRODUCTIVE SYSTEM; REPRODUCTIVE SYSTEM DISORDERS; REPRODUCTIVE TECHNOLOGY. [R.E.Le.; R.D.K.]

**Infinity** The terms infinity and infinite have a variety of related meanings in mathematics. The adjective finite means “having an end,” so infinity may be used to refer to something having no end. In order to give a precise definition, the mathematical domain of discourse must be specified.

Set theory provides a simple and basic example of an infinite collection—the class of natural numbers, or positive integers. A fundamental property of positive integers is that after each integer there follows a next one, so that there is no last integer. Now it is necessary in mathematics to treat the collection of all positive integers as an entity, and this entity is the simplest infinity, or infinite collection.

The term infinity appears in mathematics in a different sense in connection with limits of functions. For example, consider the function defined by  $y = 1/x$ . When  $x$  tends to 0,  $y$  approaches infinity, and the expression may be written as shown below.

$$\lim_{x \rightarrow 0} y = \infty$$

Precisely, this means that for an arbitrary number  $a > 0$ , there exists a number  $b > 0$  such that when  $0 < x < b$ , then  $y > a$ , and when  $-b < x < 0$ , then  $y < -a$ . This example indicates that it is sometimes useful to distinguish  $+\infty$  and  $-\infty$ . The points  $+\infty$  and  $-\infty$  are pictured at the two ends of the  $y$  axis, a line which has no ends in the proper sense of euclidean geometry.

In geometry of two or more dimensions, it is sometimes said that two parallel lines meet at infinity. This leads to the conception of just one point at infinity on each set of parallel lines and of a line at infinity on each set of parallel planes. With such agreements, parts of euclidean geometry can be discussed in the

terms of projective geometry. For example, one may speak of the asymptotes of a hyperbola as being tangent to the hyperbola at infinity. [L.M.G.]

**Inflammation** The local response to injury, involving small blood vessels, the cells circulating within these vessels, and nearby connective tissue.

The early phases of the inflammatory response are stereotyped: A similar sequence of events occurs in a variety of tissue sites in response to a diversity of injuries. The response characteristically begins with hyperemia, edema, and adherence of the circulating white blood cells to endothelial cells. The white cells then migrate between the endothelial cells of the blood vessel into the tissue. The subsequent development of the inflammatory process is determined by factors such as type and location of injury, immune state of the host, and the use of therapeutic agents. See CIRCULATION; EDEMA.

A local inflammatory response is usually accompanied by systemic changes: fever, malaise, an increase in circulating leukocytes (leukocytosis), and increases in specific circulating proteins called acute-phase reactants. Such signals and symptoms are often helpful to the physician, first as clues to the presence of inflammation and later as an indication of its course.

The process of inflammation, both vascular and cellular, is orchestrated by an array of molecules produced locally. These mediators include histamine, leukotrienes, prostaglandins, complement components, kinins, antibodies, and interleukins. Many anti-inflammatory drugs function by preventing the formation of those mediators or by blocking their actions on the target cells whose behavior is modified by the mediators.

Inflammation is basically a protective mechanism. The leakage of water and protein into the injured area brings humoral factors, including antibodies, into the locale and may serve to dilute soluble toxic substances and wash them away. The adherence and migration of leukocytes brings them to the local site to deal with infectious agents. There are also instances in which no causative toxic substance or infectious agent can be found to account for the inflammation. This is the case in rheumatoid arthritis and rheumatic fever. Such diseases may be examples in which an uncontrolled or misdirected inflammatory response with an autoimmune component is turned against the host. See ARTHRITIS; AUTOIMMUNITY; INFECTION; RHEUMATIC FEVER. [D.L.]

**Inflammatory bowel disease** Inflammatory bowel disease is a general term for two closely related conditions, ulcerative colitis and Crohn's disease. The diseases can affect the colon, distal, small intestine and sometimes other portions of the gastrointestinal tract as well as several sites outside the gastrointestinal tract. In 15–25% of cases limited to the colon, ulcerative colitis and Crohn's disease cannot be distinguished by clinical manifestations, x-ray examination, or even pathology. For this reason the broad term inflammatory bowel diseases is useful. The cause of these diseases is unknown.

Ulcerative colitis, an inflammatory condition limited to the colon, primarily affects the mucosa or lining of the colon. Marked inflammation gives rise to small ulcerations and microscopic abscesses that produce bleeding. The condition tends to be chronic, alternating between periods of complete remission and episodes of active and even life-threatening disease.

Crohn's disease, also known as regional enteritis, granulomatous colitis, and terminal ileitis, affects the colon and small intestine, and rarely the stomach or esophagus. Like ulcerative colitis, it is chronic and of unknown etiology. See DIGESTIVE SYSTEM. [L.A.Ka.]

**Inflationary universe cosmology** A theory of the evolution of the early universe, motivated by considerations from elementary particle physics as well as certain paradoxes of standard big bang cosmology, which asserts that at some early time

the observable universe underwent a period of exponential, or otherwise superluminal, expansion. During this inflationary epoch the scale of the universe increased by at least 28 orders of magnitude.

**"Old" inflationary model.** The suggestion of an inflationary period during the early universe, in connection with a specific model, was first made in 1980 by A. Guth. Guth reasoned that if grand unified symmetries are broken at some large energy scale, then a phase transition could occur in the early universe as the temperature cooled below the critical temperature where symmetry breaking occurs. According to the standard big bang model of expansion, the time at which this would occur would be about  $10^{-35}$  s after the initial expansion had begun. See GRAND UNIFICATION THEORIES; PHASE TRANSITIONS; SYMMETRY BREAKING; SYMMETRY LAWS (PHYSICS).

As Guth demonstrated, the effects of such a phase transition in the early universe could be profound. In order to calculate the dynamics of a phase transition it is necessary to follow the behavior of the relevant order parameter for the transition. This is done by determining the free energy of a system as a function of the order parameter, and following the changes in this energy as the temperature changes. The illustration shows a typical example of what might be expected for the case of symmetry breaking in grand unification theories. At some high temperature  $T$  the minimum of the relevant function is at zero value of the order parameter, the vacuum expectation value of a certain field. Thus the ground state of the system, which occurs when this energy is a minimum, will be the symmetric ground state. As the temperature is decreased, however, at a certain critical temperature  $T_c$ , a new minimum of the energy appears at a nonzero value of the order parameter. This is the symmetry-breaking ground state of the system. See FREE ENERGY.

In the illustration it is seen that there is a barrier between the two minima. This means that classically the system cannot make a transition between the two states. However, it is a well-known property of quantum mechanics that the system can, with a certain very small probability, tunnel through the barrier and arrive in the new phase. Such a transition is called a first-order phase transition. Because the probability of such a tunneling process is small the system can remain for a long time in the symmetric phase before the transition occurs. This phenomenon is called supercooling. When the transition finally begins, "bubbles" of new phase locally appear throughout the original phase. As more and more bubbles form, and the original bubbles grow, eventually they combine and coalesce until all of the system is in the new phase. See QUANTUM MECHANICS.

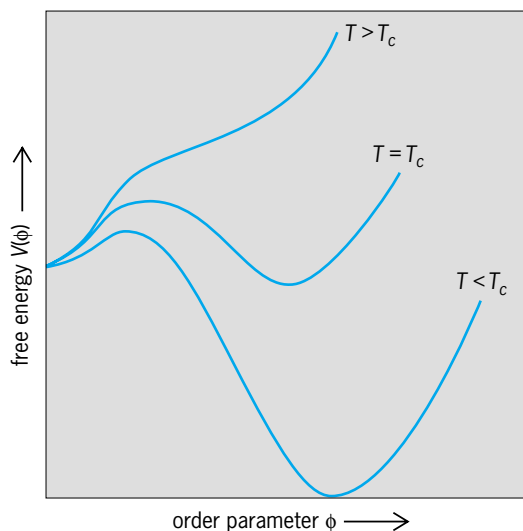

Free energy as a function of the order parameter for the case of a first-order transition.

The metastable symmetric phase has a higher energy than the lower energy symmetry breaking phase. Until the transition occurs, this means that the symmetric phase has associated with it a large constant energy density, independent of temperature. When this constant energy density is placed on the right hand side of Einstein's equations, where the energy density of matter appears, it is found that the resultant Hubble parameter describing expansion is a constant. Mathematically this implies that the scale size of the universe increases exponentially during this supercooling phase. This rapid expansion is what is referred to as inflation. See HUBBLE CONSTANT; RELATIVITY.

**Successes of inflation.** Guth pointed out that a period of exponential expansion at some very early time could solve a number of outstanding paradoxes associated with standard big bang cosmology.

Present observations seem to imply that either the present era is a unique time in the big bang expansion, or else the initial conditions of expansion had to be fine-tuned to an incredible degree. Measurements of the observed expansion rate combined with measurements of the observed mass density of the universe yield a value for the density parameter  $\Omega$  which rapidly approaches zero for an open universe, infinity for a closed universe, and is exactly equal to one for a flat universe. All measurements of  $\Omega$  yield values between about 0.1 and 2. However, theory suggests that once the value of  $\Omega$  deviates even slightly from one, it very quickly approaches its asymptotic value far away from one for open or closed universes. Thus, it is difficult to understand why, after  $10^{10}$  years of expansion, the value of  $\Omega$  is now so close to one.

Inflation naturally explains why  $\Omega$  should exactly equal one in the observable universe today. During inflation  $\Omega(t)$  is driven arbitrarily close to one within the inflated region. If there are some 28 orders of magnitude of exponential expansion, then  $\Omega(t)$  need not have been finely tuned to be close to one.

An equally puzzling problem which inflationary cosmology circumvents has to do with the observed large-scale uniformity of the universe. In particular, the 3-K microwave radiation background is known to be uniform in temperature to about one part in 10,000. However, in the standard big bang model the sources of this radiation observed coming from opposite directions in the sky were separated by more than 90 times the horizon distance (the distance a light ray could have travelled since the big bang explosion) at the time of emission. Since these regions could not possibly have been in physical contact, it is difficult to see why the temperature at the time of emission was so uniform in all directions. See COSMIC BACKGROUND RADIATION.

Inflation solves the horizon problem very simply. If the observed universe expanded by 28 orders of magnitude, then it originated from a region  $10^{28}$  times smaller than the comparable region in the standard big-bang model. This makes it quite possible that at early times the entire observed universe was contained in a single horizon volume.

Unfortunately, the original inflationary scenario was fundamentally flawed. The phase transition began by the formation of bubbles of one phase nucleating amidst the initial metastable phase of matter. While these bubbles grow at the speed of light once they form, the space in between the bubbles is expanding exponentially. Thus, it is extremely difficult for bubbles to eventually occupy all of space, as is required for the completion of the transition.

**"New" inflationary cosmology.** In 1981, it was suggested that if the energy function (potential) of the illustration were slightly changed then it might be possible to maintain the successful phenomenology of the old inflationary model while avoiding its problems. In particular a special form of the potential was considered which is extremely flat at the origin. Such functions have essentially no barrier separating the metastable from the stable phase at low temperature. When the universe cooled down below the critical temperature, the order parameter could continuously increase from zero instead of tunnelling discretely

to a large nonzero value. As long as the potential is sufficiently flat near the origin, however, it can take a long time before the order parameter approaches its value at the true minimum of the potential (a so-called slow-rollover transition). During this time the region of interest can again be expanding exponentially. Thus, in some sense a single bubble can undergo inflation in this scenario.

New inflation, too, is not without its problems. In order to have such a slow-rollover transition, the parameters of particle physics models must be finely tuned to some degree. No clear candidate model for new inflation has emerged from particle physics.

Another potential problem for any inflationary scenario concerns initial conditions. As discussed above, if an inflationary phase precedes the standard big bang expansion, then it is possible to resolve problems of the standard big bang model related to the unphysical fine tunings that seem necessary at time zero in order for the big bang to evolve into its presently observed form. However, if the initial preinflationary conditions are unphysical, then inflation may not have really solved any fundamental problems.

In 1983, Linde proposed a version of inflation, which he called chaotic inflation, that may in principle address this issue. He argued that the early universe may have been arbitrarily inhomogeneous. In some regions, inflation may have successfully taken place, even without the spontaneous symmetry breaking associated with a grand unified theory, and in other regions it may not have. He then suggested that the regions in which inflation did take place are in fact most probable. In addition, he pointed out that life would form only in those regions that became sufficiently isotropic so that, if many different regions of the universe now exist, it is not surprising that humans live in one that has undergone inflation. The issue of initial conditions for inflation remains the subject of much research, but may require an understanding of quantum gravity for its eventual resolution. See CHAOS; QUANTUM GRAVITATION.

**Primordial fluctuations.** It has been demonstrated that new inflationary cosmology naturally allows a derivation from first principles of the spectrum of primordial energy density fluctuations responsible for galaxy formation. The spectrum that emerges from inflationary models is a so-called scale-invariant spectrum of perturbations. The first observation of anisotropies in the microwave background was announced in 1992, based on the analysis of data from the differential microwave radiometer experiment aboard the *Cosmic Background Explorer (COBE)* satellite. A quadrupole anisotropy in the background was observed at a level of about  $5 \times 10^{-6}$ , just in the range that might be expected for primordial fluctuations from inflation that might also result in the observed distribution of galaxies. Moreover, the correlation of temperature deviations observed across the sky on scales greater than about  $10^\circ$  is remarkably consistent with the scale-invariant spectrum predicted by inflationary models. While neither of these observations conclusively proves the existence of an inflationary phase in the early universe, the fact that they are clearly consistent with such a possibility, and at present with no other scenario, gives great confidence that inflationary models may provide the correct description of the universe in the era preceding the present observed isotropic expansion.

**Open inflation and a cosmological constant.** Since 1995 it has been increasingly clear, based on measurements of the total clustered mass in the universe in galaxies and clusters of galaxies, that there is not sufficient matter to result in a flat universe today. There are two possibilities. The first possibility is that the universe is not flat but open. While this would deal a severe blow to standard inflationary models, a number of groups have proposed inflationary models, called open inflation models, which are tuned so that there is sufficient inflation to solve the horizon problem but not enough to result in a flat universe. The second possibility is that matter accounts for only part of the total energy density of the universe, with the remainder being

associated with some new form of energy, possibly energy stored in the ground state of empty space, called a cosmological constant. This energy is in fact identical to the energy which is stored during the inflationary phase itself. If this is true, then we live in an inflationary universe today. Preliminary measurements of the expansion rate of the universe as a function of cosmic time, by observing the recession velocities of certain types of exploding stars, called type 1a supernovae in very distant galaxies, in fact argue that this is precisely the case. Other current data favors the second possibility, including ground-based measurements of the cosmic microwave background anisotropies on small scales, the distribution of which suggests a flat universe rather than an open one. See BIG BANG THEORY; COSMOLOGY; SUPERNOVA; UNIVERSE. [L.M.Kr.]

**Inflorescence** A flower cluster segregated from any other flowers on the same plant, together with the stems and bracts (reduced leaves) associated with it. Certain plants produce inflorescences, whereas others produce only solitary flowers. See FLOWER. [G.J.W.]

**Influenza** An acute respiratory viral infection characterized by fever, chills, sore throat, headache, body aches, and severe cough. The term flu, which is frequently used incorrectly for various respiratory and even intestinal illnesses (such as stomach flu), should be used only for illness with these classic symptoms. The onset is typically abrupt, in contrast to common colds which begin slowly and progress over a period of days. Influenza is usually epidemic in occurrence. The first documented pandemic, or global epidemic, of influenza is considered to have been in 1580. The influenza pandemic of 1918, the most famous occurrence, was responsible for at least 20 million deaths worldwide.

The three types of influenza viruses, types A, B, and C, are classified in the virus family Orthomyxoviridae, and they are similar, but not identical, in structure and morphology. Types A and B are more similar in physical and biologic characteristics to each other than they are to type C. Influenza viruses may be spherical or filamentous in shape, and they are of medium size among common viruses of humans. See ANIMAL VIRUS.

When a cell is infected by two similar but different viruses of one type, especially type A, various combinations of the original parental viruses may be packaged or assembled into the new progeny; thus, a progeny virus may be a mixture of gene segments from each parental virus and therefore may gain a new characteristic, for example, a new surface protein. This phenomenon is called genetic reassortment, and the frequency with which it occurs and leads to viruses with new features is a significant cause of the constant appearance of new variants of the virus. In the laboratory, reassortment occurs between animal and human strains as well as between human strains. It probably occurs in nature also, and is thought to contribute to the appearance of new strains that infect humans. Generally, if a new variant is sufficiently different from the vaccine currently in use, the vaccine will provide limited or no protection.

The influenza virus has a short incubation period; that is, there is only a period of 1–3 days between infection and symptoms, and this leads to the abrupt development of symptoms that is a hallmark of influenza infections. The virus is typically shed in the throat for 5–7 days. Complete recovery from uncomplicated influenza usually takes several days, and the individual may feel weak and exhausted for a week or more after the major symptoms disappear. The two main complications of influenza are primary influenza virus pneumonia and secondary bacterial pneumonia. Primary influenza pneumonia is relatively infrequent, occurring in less than 1% of cases during an epidemic, although mortality may be 25–30%. The damage to epithelial cells and subsequent loss of the ability to clear particles from the respiratory tract can lead to secondary bacterial pneumonia. This problem commonly occurs in elderly individuals or those with underlying chronic lung disease or similar problems. Influenza-

induced pneumonia may cause as many as 20,000 deaths in a typical influenza season. Another complication, known as Reye's syndrome, may follow influenza, and is more common in children. This disease of the brain develops within 2–12 days of a systemic viral infection, and can result in vomiting, liver damage, coma, and sometimes death.

All three types of influenza viruses can cause disease in humans, but there are significant differences in severity of the disease and the range of hosts. In contrast to the large number of animal species infected by type A virus, types B and C are only rarely isolated from animals and infect predominantly humans.

The presence or absence of antibodies is very important in the epidemiology of influenza. In individuals with no immunity, attack rates may reach 70% and severe illness may result. Even low levels of antibody may provide partial protection in an individual and decrease the severity of the illness to only coldlike symptoms.

During an epidemic, one strain of influenza is predominant, but it is not unusual for two or more other strains to be present as minor infections in a population. Outbreaks of influenza occur during cold-weather months in temperate climates, and typically most cases cluster on a period of 1–2 months, in contrast to broader periods of illness with many other respiratory viruses. An increased death rate due to primary pneumonia and bacterial superinfection is common and is one of the ways that public health authorities monitor an epidemic.

Control and prevention of influenza are attempted through the use of drugs and vaccines. Inactivated viral vaccines are used to prevent influenza, although use of attenuated live strains of the virus may better stimulate the cell-mediated immune response and provide higher-quality and longer-lasting immunity. The makeup of the vaccine is modified annually, based upon predictions of the expected prevalent strain for each flu season, but usually contains antigens of two type A viruses and one type B virus. These vaccines take advantage of the natural ability of the viral nucleic acid to reassort and form new strains. The vaccines utilize strains that are not virulent and will replicate at lower temperatures, as found in the nasopharynx, but not at higher temperatures as found in the lower respiratory tract. The techniques of modern biotechnology are employed to clone copies of parts of the virus or to provide oligonucleotides corresponding to crucial functional areas of the virus, to obtain improved protection and reduced side effects. See BIOTECHNOLOGY; VACCINATION. [J.M.Q.]

**Information management** The functions associated with managing the information assets of an enterprise, typically a corporation or government organization. Increasingly, companies are taking the view that information is an asset of the enterprise in much the same way that a company's financial resources, capital equipment, and real estate are assets. Properly employed, assets create additional value with a measurable return on investment. Forward-looking companies carry this view a step further, considering information as a strategic asset that can be leveraged into a competitive advantage in the markets served by the company.

The scope of the information management function may vary between organizations. As a minimum, it will usually include the origination or acquisition of data, its storage in databases, its manipulation or processing to produce new (value-added) data and reports via application programs, and the transmission (communication) of the data or resulting reports. Many companies include the management of voice communications (telephone systems, voice messaging, and, increasingly, computer-telephony integration or CTI), and even intellectual property and other knowledge assets.

There is a significant difference between the terms "data" and "information." Superficially, information results from the processing of raw data. However, the real issue is getting the right information to the right person at the right time and in a usable

form. In this sense, information may be a perishable commodity. Thus, perhaps the most critical issue facing information managers is requirements definition, or aligning the focus of the information systems with the mission of the enterprise. The best technical solution is of little value if the final product fails to meet the needs of users.

One formal approach to determining requirements is information engineering. By using processes identified variously as business systems planning or information systems planning, information engineering focuses initially on how the organization does its business, identifying the lines from where information originates to where it is needed, all within the context of a model of the organization and its functions. While information systems personnel may be the primary agents in the information engineering process, success is critically dependent on the active participation of the end users, from the chief executive officer down through the functional staffs.

A major advantage of the application of information engineering is that it virtually forces the organization to address the entire spectrum of its information systems requirements, resulting in a functionally integrated set of enterprise systems. In contrast, ad hoc requirements may result in a fragmented set of systems (islands of automation), which at their worst may be incompatible, contain duplicate (perhaps inconsistent) information, and omit critical elements of information. [A.B.Sa.]

**Information systems engineering** The process by which information systems are designed, developed, tested, and maintained. The technical origins of information systems engineering can be traced to conventional information systems design and development, and the field of systems engineering. Information systems engineering is by nature structured, iterative, multidisciplinary, and applied. It involves structured requirement analyses, functional modeling, prototyping, software engineering, and system testing, documentation, and maintenance.

Modern information systems solve a variety of data, information, and knowledge-based problems. In the past, most information systems were exclusively data-oriented; their primary purpose was to store, retrieve, manipulate, and display data. Application domains included inventory control, banking, personnel record keeping, and the like. The airline reservation system represents the quintessential information system of the 1970s. Since then, expectations as to the capabilities of information systems have risen considerably. Information systems routinely provide analytical support to users. Some of these systems help allocate resources, evaluate personnel, and plan and simulate large events and processes. The users expect information systems to perform all the tasks along the continuum shown in the illustration.

Systems engineering extends over the entire life cycle of systems, including requirement definitions, functional designs, development, testing, and evaluation. The systems engineer's perspective is different from that of the product engineer, software

designer, or technology developer. The product engineer deals with detail, whereas the systems engineer takes an overall viewpoint. Systems engineering is based upon the traditional skills of the engineer combined with additional skills derived from applied mathematics, psychology, management, and other disciplines. The systems engineering process is a logical sequence of activities and decisions that transform operational needs into a description of system performance configuration. The process is by nature iterative and multidisciplinary. See SYSTEMS ENGINEERING. [S.J.A.]

**Information technology** The field of engineering involving computer-based hardware and software systems, and communication systems, to enable the acquisition, representation, storage, transmission, and use of information. Successful implementation of information technology (IT) is dependent upon being able to cope with the overall architecture of systems, their interfaces with humans and organizations, and their relationships with external environments. It is also critically dependent on the ability to successfully convert information into knowledge.

Information technology is concerned with improvements in a variety of human and organizational problem-solving endeavors through the design, development, and use of technologically based systems and processes that enhance the efficiency and effectiveness of information in a variety of strategic, tactical, and operational situations. Ideally, this is accomplished through critical attention to the information needs of humans in problem-solving tasks and in the provision of technological aids, including electronic communication and computer-based systems of hardware and software and associated processes. Information technology complements and enhances traditional engineering through emphasis on the information basis for engineering.

The knowledge and skills required in information technology come from the applied engineering sciences, especially information, computer, and systems engineering sciences, and from professional practice. Professional activities in information technology and in the acquisition of information technology systems range from requirements definition or specification, to conceptual and functional design and development of communication and computer-based systems for information support. They are concerned with such topics as architectural definition and evaluation. These activities include integration of new systems into functionally operational existing systems and maintenance of the result as user needs change over time. This human interaction with systems and processes, and the associated information processing activities, may take several diverse forms. See REENGINEERING; SYSTEMS ARCHITECTURE; SYSTEMS ENGINEERING.

The hardware and software of computing and communications form the basic tools for information technology. These are implemented as information technology systems through use of systems engineering processes. While information technology and information systems engineering does indeed enable better designs of systems and existing organizations, it also enables the design of fundamentally new organizations and systems such as virtual corporations. Thus, efforts in this area include not only interactivity in working with clients to satisfy present needs but also awareness of future technological, organizational, and human concerns so as to support transition over time to new information technology-based services. [A.P.Sa.]

**Information theory** A branch of communication theory devoted to problems in coding. A unique feature of information theory is its use of a numerical measure of the amount of information gained when the contents of a message are learned. Information theory relies heavily on the mathematical science of probability. For this reason the term information theory is often applied loosely to other probabilistic studies in communication theory, such as signal detection, random noise, and prediction. See ELECTRICAL COMMUNICATIONS; PROBABILITY.

Data-Oriented Computing		Analytical Computing	
Physical tasks	Communicative tasks	Perceptual tasks	Mediational tasks
<ul style="list-style-type: none"> <li>• file</li> <li>• store</li> <li>• retrieve</li> <li>• sample</li> </ul>	<ul style="list-style-type: none"> <li>• instruct</li> <li>• inform</li> <li>• request</li> <li>• query</li> </ul>	<ul style="list-style-type: none"> <li>• search</li> <li>• identify</li> <li>• classify</li> <li>• categorize</li> </ul>	<ul style="list-style-type: none"> <li>• plan</li> <li>• evaluate</li> <li>• prioritize</li> <li>• decide</li> </ul>
Analytical Complexity Continuum →			

Data-oriented and analytical computing, suggesting the range of information systems applications.

In designing a one-way communication system from the standpoint of information theory, three parts are considered beyond the control of the system designer: (1) the source, which generates messages at the transmitting end of the system, (2) the destination, which ultimately receives the messages, and (3) the channel, consisting of a transmission medium or device for conveying signals from the source to the destination. The source does not usually produce messages in a form acceptable as input by the channel. The transmitting end of the system contains another device, called an encoder, which prepares the source's messages for input to the channel. Similarly the receiving end of the system will contain a decoder to convert the output of the channel into a form that is recognizable by the destination. The encoder and the decoder are the parts to be designed. In radio systems this design is essentially the choice of a modulator and a detector. See MODULATION.

A source is called discrete if its messages are sequences of elements (letters) taken from an enumerable set of possibilities (alphabet). Thus sources producing integer data or written English are discrete. Sources which are not discrete are called continuous, for example, speech and music sources. The treatment of continuous cases is sometimes simplified by noting that signal of finite bandwidth can be encoded into a discrete sequence of numbers.

The output of a channel need not agree with its input. For example, a channel might, for secrecy purposes, contain a cryptographic device to scramble the message. Still, if the output of the channel can be computed knowing just the input message, then the channel is called noiseless. If, however, random agents make the output unpredictable even when the input is known, then the channel is called noisy. See COMMUNICATIONS SCRAMBLING; CRYPTOGRAPHY.

Many encoders first break the message into a sequence of elementary blocks; next they substitute for each block a representative code, or signal, suitable for input to the channel. Such encoders are called block encoders. For example, telegraph and teletype systems both use block encoders in which the blocks are individual letters. Entire words form the blocks of some commercial cablegram systems. It is generally impossible for a decoder to reconstruct with certainty a message received via a noisy channel. Suitable encoding, however, may make the noise tolerable.

Even when the channel is noiseless, a variety of encoding schemes exists and there is a problem of picking a good one. Of all encodings of English letters into dots and dashes, the Continental Morse encoding is nearly the fastest possible one. It achieves its speed by associating short codes with the most common letters. A noiseless binary channel (capable of transmitting two kinds of pulse 0, 1, of the same duration) provides the following example. Suppose one had to encode English text for this channel. A simple encoding might just use 27 different five-digit codes to represent word space (denoted by #), A, B, . . . , Z; say # 00000, A 00001, B 00010, C 00011, . . . , Z 11011. The word #CAB would then be encoded into 00000000110000100010. A similar encoding is used in teletype transmission; however, it places a third kind of pulse at the beginning of each code to help the decoder stay in synchronism with the encoder. [E.N.G.]

**Infrared astronomy** The field of astronomical observations specializing in detecting photons from the infrared portion of the electromagnetic spectrum. The infrared portion of the spectrum spans the range from the red limit of human vision (approximately 0.7 micrometer) to the shortest wavelengths accessible to heterodyne radio receivers (several hundred micrometers). See ELECTROMAGNETIC RADIATION; INFRARED RADIATION.

Astronomers observing the universe with infrared light encounter a number of fundamental differences relative to those observing with visible light:

1. Infrared observations are more sensitive to cooler objects than visible-wavelength observations. Blackbodies at a temperature cooler than 2000 kelvins (3100°F) radiate virtually all of their light in the infrared part of the spectrum. Infrared observa-

tions are particularly well suited to detect both forming stars and evolved stars (that is, stars in the final stages of their lives) since both classes of objects are cool. Since starlight often heats nearby dust grains to temperatures of tens or hundreds of degrees, reprocessing the visible starlight into exclusively infrared radiation, warm dust is also a common target for infrared observations. See HEAT RADIATION.

2. Interstellar dust is substantially more transparent at infrared wavelengths than at visible wavelengths. Infrared observations thus enable astronomers to view distant objects through the obscuring dust that permeates the Milky Way Galaxy. Forming and evolved stars often reside in dense clouds of interstellar dust grains and can be observed only at infrared and even longer radio wavelengths. See INTERSTELLAR EXTINCTION; INTERSTELLAR MATTER; SCATTERING OF ELECTROMAGNETIC RADIATION.

3. The quantized energies of molecular rotational and vibrational transitions, which give rise to molecular spectral lines, fall largely in the infrared part of the spectrum, as do many hyperfine lines of individual atoms. See INFRARED SPECTROSCOPY.

In addition to these astrophysical differences, the technology and practice of infrared astronomy differs from visible-wavelength astronomy in fundamental ways:

1. The Earth's atmosphere is opaque to infrared radiation through a substantial fraction of the spectrum. This opacity arises largely from water in the Earth's lower atmosphere.

2. Planck's law dictates that only photons with wavelength shorter than about 1  $\mu\text{m}$  can induce chemical reactions or liberate free electrons. Thus physics limits photography and photon-counting photomultiplier tubes to operation mainly in the visible-wavelength domain. Infrared detection technology relies largely on either mimicking the photoelectric effect inside a crystalline semiconductor material or monitoring the temperature change of a semiconductor under the influence of infrared radiation. See PHOTOEMISSION.

3. Objects at room temperature (300 K or 80°F) emit radiation throughout most of the infrared spectrum. This glow interferes with the detection of faint astronomical sources, limiting the sensitivity of observations. Cooling of the entire telescope—impractical on the ground but possible in the vacuum of space—can substantially reduce the thermal glow of the telescope optics and result in unprecedented sensitivity to faint astronomical sources.

**Infrared technology.** Detectors of infrared radiation divide into two classes: bolometers and photovoltaic or photoconductive devices. Bolometer detectors have temperature-sensitive electrical conductivity. Incident radiation warms the detector, and the resulting subtle change in the electrical resistance of the detector is measured. Infrared photodetectors are crystalline semiconductors in which some electrons in the crystal lattice lie only a short distance in energy away from becoming unbound and behaving like metallic conducting electrons. Infrared light with energy in excess of the binding energy creates free charge carriers, either changing the bulk conductivity of the device (photoconductors) or charging or discharging a semiconductor junction (photovoltaics). See BOLOMETER; PHOTOCONDUCTIVITY; PHOTOVOLTAIC EFFECT.

Since the mid-1980s, large-scale integration of semiconductor components has permitted the production of arrays of infrared detectors. These arrays now exist in formats as large as 2048  $\times$  2048 elements (4 million detectors on a single device). Each detector on such an array is also substantially more sensitive than its 1980s counterpart.

**Astronomical targets.** The targets of infrared observations include ordinary stars and galaxies, planets, brown dwarfs, young stellar objects, evolved stars, starburst galaxies, and redshifted radiation.

Although popular interest in infrared astronomy focuses on exotic objects observable only using infrared light, infrared observations continue to play a fundamental role in understanding the more pedestrian stars and galaxies that constitute most of the visible-wavelength universe. At infrared wavelengths longer



than  $10\ \mu\text{m}$ , infrared light emitted from dust warmed by stars in normal galaxies begins to dominate the infrared light from stars, making dusty spiral galaxies prime targets for mid-infrared observations. See GALAXY, EXTERNAL; HERTZSPRUNG-RUSSELL DIAGRAM; MILKY WAY GALAXY; STAR.

At infrared wavelengths longer than  $3\ \mu\text{m}$ , thermal radiation from the planets begins to dominate over reflected sunlight. Jupiter, still cooling from its initial formation, emits twice as much energy as it receives from the Sun—nearly all of it at infrared wavelengths. See ASTEROID; JUPITER; PLANET; PLANETARY PHYSICS.

An object with a mass less than 8% that of the Sun (equivalent to 80 times the mass of Jupiter) is incapable of fusing hydrogen in its core to sustain its luminosity—the hallmark of being a star. At the time of their formation, the interiors of such substellar objects are warmed by their gravitational contraction from an initially diffuse interstellar cloud of gas. Even at this most luminous point in their evolution, most of the light emerges in the infrared part of the spectrum. Infrared surveys of the entire sky are beginning to reveal large numbers of these brown dwarfs, and they appear to be more common than ordinary stars in the Milky Way Galaxy. See BROWN DWARF.

Young stellar objects (YSOs) are newly formed or forming stars. These stars are being assembled by gravity out of dense (1000 atoms per cubic centimeter) interstellar clouds. The environment surrounding the forming star is naturally very dusty, and the slight rotation of the natal cloud combined with gravity drives the infalling material to form a thin flattened disk around the star. Virtually all of the disk emission emerges at infrared wavelengths. Planets accrete within these disks, and infrared observations provide the primary astrophysical insight into the process of planetary formation. See PROTOSTAR.

After exhausting the initial supply of hydrogen in the stellar core, stars reconfigure themselves to liberate the energy of hydrogen shell burning around the core and helium burning within the core. Stellar physics dictates that the star must grow to large size and become cool at its surface in order to dissipate the energy being produced within. Dust grains condensing in the expanding envelope can completely enshroud the star. Under these circumstances, the observed radiation emerges entirely in the infrared part of the spectrum. These evolved stars are ideal tracers of the structure of the Galaxy. See GIANT STAR; STELLAR EVOLUTION.

Starburst galaxies, which are undergoing active bursts of star formation, can produce most of their radiation at wavelengths of  $10\ \mu\text{m}$  or longer. The radiation emerges in this part of the spectrum because the star-forming regions are embedded in dust clouds which absorb the starlight and, having been warmed to temperatures of tens of kelvins, reradiate energy largely in the infrared portion of the spectrum. See STARBURST GALAXY.

The gravitational interaction between two gas-rich galaxies can induce both objects to undergo an extensive burst of star formation. The resulting energy release can augment the flux of the galaxy by a factor of 10 or more with most of the radiation arising in the infrared part of the spectrum. Such “ultraluminous” infrared galaxies are among the most luminous galaxies in the universe.

The apparent Doppler shift due to the expansion of the universe causes the ultraviolet and visible light originally emitted by extremely distant stars and galaxies to be shifted into the infrared part of the spectrum. Redshifts this large originate from objects at distances of  $10^{10}$  light-years or more. Since the light collected from these objects was emitted by them  $10^{10}$  years ago, these observations probe the state of the universe at the earliest times. See BIG BANG THEORY; COSMOLOGY; REDSHIFT.

**Ground-based infrared astronomy.** Telescopes dedicated to visible-wavelength astronomy are also effective collectors of infrared radiation. Equipped with infrared focal-plane-array imagers and spectrographs, these telescopes can observe the infrared universe through the accessible atmospheric windows. Such observations are particularly effective shortward of  $2\ \mu\text{m}$ ,

where thermal emission from the telescope is negligible relative to other backgrounds.

**Infrared space missions.** The opacity of the Earth’s atmosphere at most infrared wavelengths and the need to place a telescope in an environment where the entire telescope structure can be cooled to cryogenic temperatures have motivated a number of extremely successful satellite missions largely devoted to infrared astronomy, including the *Infrared Astronomy Satellite (IRAS)*, launched in 1983; the *Infrared Space Observatory (ISO)*, launched in 1995; and the *Space Infrared Telescope Facility (SIRTF)*, renamed the *Spitzer Space Telescope*, following its launch in 2003. [M.F.S.]

**Infrared imaging devices** Devices that convert an invisible infrared image into a visible image. The radiation available for imaging may be emitted from objects in the scene of interest (usually at the longer wavelengths called thermal radiation) or reflected. Reflected radiation may be dominated by sunlight or may be from controlled sources such as lasers used specifically as illuminators for the imaging device. The latter systems are called active, while those relying largely on emitted radiation are called passive. Active optical imaging systems were developed to achieve a nighttime aerial photographic capability, and work during World War 11 pushed such systems into the near-infrared spectral region. Development of passive infrared imaging systems came after the war, but only the advent of lasers allowed creation of active infrared imagers at wavelengths much longer than those of the photographic region. See INFRARED RADIATION; LASER.

Although developed largely for military purposes, infrared imaging devices have been valuable in industrial, commercial, and scientific applications. These range from nondestructive testing and quality control to earth resources surveys, pollution monitoring, and energy conservation. Infrared images from aerial platforms are used to accomplish “heat surveys,” locating points of excessive heat loss. Calibration allows association of photographic tones with values of apparent (that is, equivalent black-body) temperatures. Dark areas are “colder” than light ones. See REMOTE SENSING. [G.J.Z.]

**Infrared lamp** A special type of incandescent lamp that is designed to produce energy in the infrared portion of the electromagnetic spectrum. The lamps produce radiant thermal energy which can be used to heat objects that intercept the radiation. An infrared lamp with a filament operating at  $4000^\circ\text{F}$  ( $2500\ \text{K}$ ) will release about 85% of its energy in the form of thermal

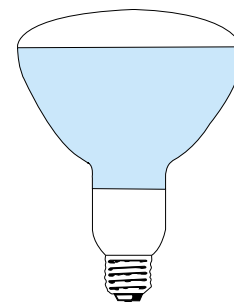

(a)

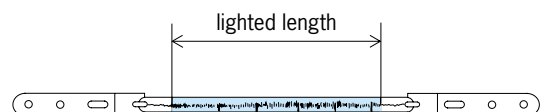

(b)

Typical shapes of infrared lamps. (a) R lamp, with built-in reflector unit. (b) Tubular configuration with a quartz bulb.

radiant energy, about 15% as visible light, and a tiny fraction of a percent as ultraviolet energy. See HEAT RADIATION.

The lamps are supplied in two shapes. The most common shape, for general use, is the R lamp (illus. a), since the reflector unit is built in and the lamp needs only a suitable socket to form an infrared heating system. The other type of infrared lamp, the tubular quartz bulb lamp (illus. b), is used with a separate external reflector designed to distribute the heat as desired.

The major advantage of infrared heating is that it is possible to heat a surface that intercepts the radiation without heating the air or other objects that surround the surface. Infrared lamps have many uses, including paint drying, evaporative drying, farm heating of animals, heating of food, control heating, and therapeutic heating of portions of the body to relieve muscle strains. See INCANDESCENT LAMP; INFRARED RADIATION; THERMOTHERAPY. [G.R.P.]

**Infrared radiation** Electromagnetic radiation in which wavelengths lie in the range from about 1 micrometer to 1 millimeter. This radiation therefore has wavelengths just a little longer than those of visible light and cannot be seen with the unaided eye. The radiation was discovered in 1800 by William Herschel.

An infrared source can be described by the spectral distribution of power emitted by an ideal body (a blackbody curve). This distribution is characteristic of the temperature of the body. A real body is related to it by a radiation efficiency factor or emissivity which is the ratio at every wavelength of the emission of a real body to that of a blackbody under identical conditions. The illustration shows curves for these ideal blackbodies radiating at a number of different temperatures. The higher the temperature, the greater the total amount of radiation. See EMISSIVITY.

Infrared detectors are based either on the generation of a change in voltage due to a change in the detector temperature resulting from the power focused on it, or on the generation of a change in voltage due to some photon-electron interaction in the detector material. This latter effect is sometimes called the internal photoelectric effect.

Infrared techniques have been applied in military, medical, industrial, meteorological, ecological, forestry, agricultural, chemical, and other disciplines. Weather satellites use infrared imaging devices to map cloud patterns and provide the imagery seen in many weather reports. Infrared imaging devices have also been used for breast cancer screening and other medical diagnostic applications. In most of these applications, the underlying princi-

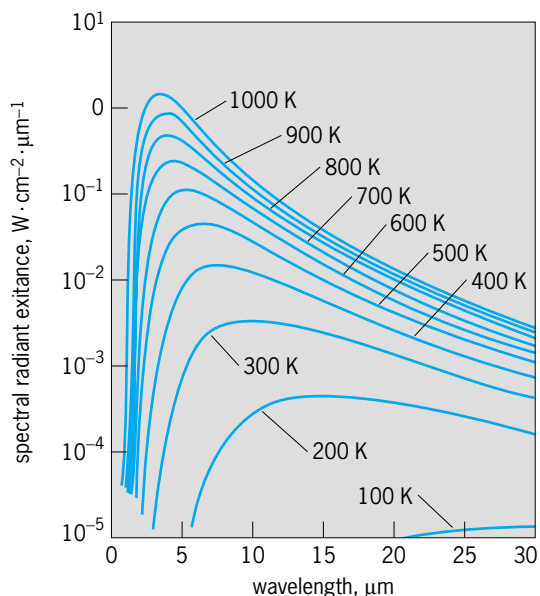

Radiation from blackbodies at different temperatures, shown on a logarithmic scale.

ple is that pathology produces inflammation, and these locations of increased temperature can be found with an infrared imager. Airborne infrared imagers have been used to locate the edge of burning areas in forest fires. See INFRARED IMAGING DEVICES; REMOTE SENSING. [W.L.Wo.]

**Infrared spectroscopy** The spectroscopic study of the interaction of matter with infrared radiation. Electromagnetic waves from the long-wavelength limit of visible light at 800 nanometers to the shortest microwaves at 1 mm are used. In the wave-number units usually employed (oscillations per centimeter, read as reciprocal centimeters), this corresponds to 12,500–10 cm<sup>-1</sup>. See INFRARED RADIATION.

The broad wavelength range of infrared radiation, and the few transparent optical materials available, require that infrared instruments be designed with reflecting optics: radiation is focused with front-surface aluminized mirrors rather than lenses. Because of strong infrared absorption by water vapor and carbon dioxide, operation takes place in a vacuum or the optical path is purged with dry nitrogen. Absorption spectroscopy is the principal method, where attention centers on the frequencies absorbed by the sample from a broadly emitting source. However, spectrometers and interferometers can easily be adapted to emission spectroscopy.

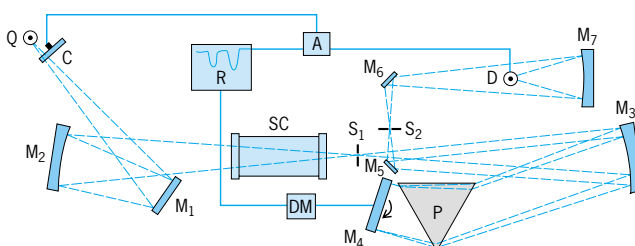

Basic single-beam recording infrared prism spectrometer. The monochromator (the portion from the entrance slit S<sub>1</sub> to the exit slit S<sub>2</sub>) is a Littrow mounting, a common arrangement for infrared instruments.

In a dispersive spectrometer (see illustration), infrared radiation from the source Q is focused by a spherical mirror M<sub>2</sub> onto the entrance slit S<sub>1</sub> of the monochromator, after passing through the sample cell SC. The beam is collimated by the off-axis paraboloid mirror M<sub>3</sub>, dispersed by refraction through the prism P, and focused in the plane of the exit slit S<sub>2</sub> by a second reflection from M<sub>3</sub>. A narrow spectral region of the dispersed radiation passes the exit slit and is focused by the ellipsoidal mirror M<sub>7</sub> onto the detector D, which converts the radiant energy into an electrical signal. Since the beam has been chopped at constant frequency by a rotating mechanical chopper C, this signal is an alternating current that is amplified by the lock-in amplifier A, controlling the pen of the chart recorder R. To scan the spectrum, M<sub>4</sub> is rotated by the drive mechanism DM, which also drives the recorder. Successive frequencies are thus moved across the exit slit, producing a record of signal intensity as a function of mirror position; with a proper mechanical linkage, this record is made linear in wavelength or wave number. The same arrangement can be used with a diffraction grating as the dispersive element; the prism is removed and mirror M<sub>4</sub> is replaced by the grating.

In the near-infrared, quartz prisms are used, and in the mid-infrared, alkali-metal halide or calcium fluoride (CaF<sub>2</sub>) prisms, but no prism material is suitable beyond about 50 μm. Diffraction gratings can be used in all regions with the advantage, for equivalent optical configurations, of significantly higher resolving power than prisms. Prism instruments have resolutions of little better than 1 cm<sup>-1</sup> near wavelengths of maximum dispersion, and much poorer than this elsewhere. Grating resolution can be several tenths of a reciprocal centimeter for commercial spectrometers; some specially built instruments can resolve a few hundredths of a reciprocal centimeter. In most laboratories

these instruments are being replaced by other techniques, although inexpensive double-beam grating spectrometers are still manufactured. See DIFFRACTION GRATING; OPTICAL PRISM; RESOLVING POWER (OPTICS).

In a Michelson interferometer, light from the source strikes a thin, partially reflecting beam splitter at an angle of  $45^\circ$  and is divided into two beams that are returned by mirrors and recombined at the beam splitter. The intensity of the recombined and interfering beams, recorded as a function of the optical path difference (or retardation) as one mirror is moved, yields an interferogram. From this, the desired spectrum (that is, the source intensity as a function of wave number) can be recovered by the mathematical procedure known as a Fourier transform. See FOURIER SERIES AND TRANSFORMS; INTEGRAL TRANSFORM; INTERFEROMETRY.

Fourier-transform spectroscopy offers several advantages over dispersive methods; these are especially important for effective use of the limited radiant power available from most infrared sources. Whereas a spectrometer samples only one small frequency range at any given instant and must scan these frequencies sequentially to produce a spectrum, an interferometer processes information from all frequencies simultaneously (multiplex or Fellgett advantage). Furthermore, an interferometer passes a much greater light flux for a given resolving power than a spectrometer, which can accept only a very limited solid angle of source radiation because of the narrow slits required (throughput or Jacquinot advantage). These advantages can be translated into improvements of orders of magnitude in any one of the three interrelated important parameters of resolution, signal-to-noise ratio, and scan time. Another advantage is that the mirror movement is monitored to high precision with a fixed-frequency laser, so that the wave-number scale of the transformed spectrum is highly accurate compared with spectrometer readings.

Commercial Fourier-transform spectrometers are marketed with resolutions from a few reciprocal centimeters for routine qualitative analyses to research instruments that can resolve better than  $0.002\text{ cm}^{-1}$ . Typically, they operate from  $4000$  to  $400\text{ cm}^{-1}$  on one beam splitter such as germanium-coated potassium bromide (KBr); this range can be extended broadly in either direction with different beam-splitter materials. For the far-infrared, Mylar films in various thicknesses are used. These instruments are controlled by microprocessors and include a digital computer to handle the Fourier transform. This computing power allows data manipulation such as repetitive scanning and signal averaging; background subtraction; spectral smoothing, fitting, and scaling; and searching digitized spectral libraries and databases to identify unknowns. Although backgrounds can be subtracted with software, some Fourier-transform instruments are designed for true optical double-beam operation. Many offer rapid-scan capability for the study of short-lived species and can be adapted to recording Fourier-transform Raman spectra. See MICROPROCESSOR; RAMAN EFFECT.

Infrared spectra are usually plotted as percent transmittance  $T$  or absorbance  $A$  on a scale linear in wave number  $\nu$  (less commonly, in wavelength  $\lambda$ ). Transmittance is the ratio of the intensity of radiation transmitted by the sample ( $I$ ) to that incident on the sample ( $I_0$ ), expressed as a percentage, so that  $T = 100I/I_0$ .

Infrared spectra are ideal for identifying chemical compounds because every molecule [except homonuclear diatomics such as nitrogen ( $\text{N}_2$ ), oxygen ( $\text{O}_2$ ), and chlorine ( $\text{Cl}_2$ )] has an infrared spectrum. Since the vibrational frequencies depend upon the masses of the constituent atoms and the strengths and geometry of the chemical bonds, the spectrum of every molecule is unique (except for optical isomers). Pure unknowns can thus be identified by comparing their spectra with recorded spectra; catalogs are available in digitized versions, and searches can be made rapidly by computer.

Simple mixtures can be identified with the help of computer software that subtracts the spectrum of a pure compound from that of the unknown mixture. More complex mixtures may require fractionation first. This has led to the development of com-

binations of analytical techniques, such as gas chromatography used together with Fourier-transform infrared spectroscopy; instruments that combine these functions are available commercially.

Many functional groups have characteristic infrared frequencies that are relatively independent of the molecular environment. Often, specific conclusions can be drawn from frequencies, and it may be possible to identify even a new compound from its spectrum. Group frequencies are most useful above about  $1500\text{ cm}^{-1}$ ; below this the absorptions are due to, or are influenced more by, the skeletal vibrations of the molecule. This is the "fingerprint" region, where even similar molecules may have quite different spectra. See QUALITATIVE CHEMICAL ANALYSIS.

Many details of molecular structure and dynamics can be extracted from an infrared spectrum, especially for light molecules that can be examined in the gas phase and therefore exhibit rotational structure.

Other applications include calculation of thermodynamic quantities from vibrational and rotational energy levels; studies of intermolecular forces in condensed phases; distinguishing between free or hindered internal rotation (as of methyl groups); quantitative intensity measurements to obtain bond dipole moments; studies of molecular interactions in adsorption, surface chemistry, and catalytic processes; time-resolved monitoring of transient species and chemical reaction kinetics; characterization of reactive molecules isolated at cryogenic temperatures in rare-gas lattices (matrix isolation); electronic energy states in semiconductors and superconductors; studies of biological molecules and membranes (effects of hydrogen bonding); and analysis of energy levels in laser systems. Double-resonance techniques, in which molecules are excited by an intense pulse of ultraviolet, infrared, or microwave energy, and simultaneously probed by infrared or microwave spectroscopy, are useful in monitoring population changes in molecular energy levels, energy transfer and relaxation, and multiphoton absorption processes. See ADSORPTION; CATALYSIS; CHEMICAL DYNAMICS; HYDROGEN BOND; INTERMOLECULAR FORCES; SEMICONDUCTOR; SPECTROSCOPY; SUPERCONDUCTIVITY. [R.S.McD.]

**Infrasound** Sound waves, particularly in the atmosphere, whose frequencies of pressure variation and of vibration are below the audible range, that is, lower than about 20 Hz. Earthquake and seismic waves are elastic waves which occur at infrasonic frequencies in the Earth's crust and in the oceans and seas. The physical laws of propagation in the atmosphere are essentially the same as for audible sound. The local speed of infrasound in air at ambient temperatures near  $20^\circ\text{C}$  ( $68^\circ\text{F}$ ) is about  $340\text{ m/s}$  ( $1115\text{ ft/s}$ ), the same as for audible sound.

At frequencies less than about 1.0 Hz, infrasound propagates through the atmosphere for distances of thousands of kilometers without substantial loss of energy. Sounds at these frequencies are almost always present at measurable intensities. Those of natural origin have many causes, including tomadoes, volcanic explosions, earthquakes, the aurora borealis, waves on the seas, large meteorites, and lightning discharges. When the wind blows, turbulent pressure fluctuations in the atmosphere occur at amplitudes up to tens of pascals, at infrasonic frequencies. People are unaware of these pressures via the sensation of hearing.

Sufficiently strong infrasound is "audible," contrary to simple acoustic tradition. The threshold sound pressure level (the least intensity for audibility) is about 92 dB at 16 Hz, and increases 12 dB per octave to about 140 dB at 1.0 Hz. However, there is no sensation of tone. Listeners variously describe audible infrasound as pumping, popping effect, or chugging. For vibration at very low frequencies, motion sickness of people in boats must have been one of the earliest noticeable effects. The human body is particularly sensitive to vibrations and infrasound near 7 Hz, at which frequency there is an overall mechanical resonance of organs in the abdominal and chest cavities. See ATMOSPHERIC ACOUSTICS; SOUND. [R.K.C.]

**Inhibitor (chemistry)** A substance which is capable of stopping or retarding a chemical reaction. To be technically useful, such compounds must be effective in low concentrations, usually under 1%. The type of reaction which is most easily inhibited is the free-radical chain reaction. Vinyl polymerization and autoxidation are two important examples of the class. Another reaction type for which inhibitors have been found is corrosion, particularly in aqueous systems. See ANTIOXIDANT; CORROSION; FREE RADICAL; POLYMERIZATION. [L.R.M.]

**Ink** A dispersion of a pigment or a solution of a dye in a carrier vehicle, yielding a fluid, paste, or powder to be applied to and dried on a substrate. Printing, writing, marking, and drawing inks are applied by several methods to paper, metal, plastic, wood, glass, fabric, or other substrates. Inks perform communicative, decorative, and even protective functions.

Printing inks can be classified according to their characteristic properties, the method of application, or other considerations such as end use or manner of drying. The composition of an ink can be oil-, solvent-, or water-based; the ink may be a high-viscosity paste or a low-viscosity liquid. The most important printing methods that utilize inks are lithography, flexography, letterpress, and gravure. The inks can be applied in four-color process (screen), as spot colors (solid or screen), or as line work. The end uses are news, publication, commercial, folding carton, book, corrugated box, paper bag, wrapper, label, metal container, plastic container, plastic film, foil, laminating, food insert, sanitary paper, and textile. The various drying manners are oxidizing, evaporating, penetrating, precipitating, polymerizing, reactive, including radiation-cured, gelling, cold-setting or quick-setting, and thermosetting. Some 900,000 ink formulations exist to meet the various needs and conditions.

Fundamentally, inks are composed of four major material categories: (1) Colorants (which include pigments, toners, and dyes) provide the color contrast with the substrate. (2) Vehicles, or varnishes, act as carriers for the colorants during the printing operation. Upon drying, the vehicles bind the colorants to the substrate. (3) Additives influence the printability, film characteristics, drying speed, and end-use properties. (4) Solvents (including water), besides participating in formation of the vehicles, are used to reduce ink viscosity and adjust drying ease and resin compatibility. Ingredients from these four classes are weighed, mixed, and ground (dispersed) together or separately, according to the formulas preestablished in the laboratory. See PRINTING.

Inks developed for ball-point pens are newtonian fluids of high tinctorial strength. These must be free of particles and premature drying so as to continue the feed to the paper without clogging. Rapid penetration into the paper accomplishes drying. They are dye solutions or pigment dispersions in oleic acid, castor oil, sulfonamide, or in aqueous solutions of gums or glues. See NEWTONIAN FLUID. [F.Ci.; N.Im.; T.M.De.]

**Inland waterways transportation** The movement of cargo on inland and intracoastal waterways by barge. About 14% of the bulk movement of commerce in the United States moves by barge, amounting to over  $6 \times 10^8$  tons ( $5.4 \times 10^8$  metric tons) annually. Barges directly serve 87% of all major United States cities, accounting for 65% of all domestic waterborne traffic.

Barges move on the 25,543-mi (41,107-km) network of commercially navigable inland and intracoastal waterways. Generally, barges are either pushed or towed by towboats on the inland waters. Barges require standard operating depths of at least 9 ft (about 3 m). Certain sections of the inland waterways are deep enough to support ocean-going vessels, including the Hudson River to Albany, New York, the Lower Mississippi north to Baton Rouge, Louisiana, the Houston Ship Channel, the Delaware River, the James River, and portions of the Columbia-Snake River.

Three major types of barges are used on the inland and intracoastal waterways: the open hopper, the covered dry cargo, and the tank barge. The open hopper barge is used to transport cargo that does not need to be protected from the elements, such as coal, sand, and gravel. Cargoes that need protection, such as grain, are shipped on covered dry cargo barges. Tank barges carry liquid commodities, such as petroleum and chemicals.

Towboats with barge flotillas commonly operate on the inland waterways, where they are fully protected by land on either side. The barges are kept together by wire rigging and are lashed against the towing knees of the towboat which pushes them ahead. On open channels, such as the Atlantic and Gulf intracoastal waterways, tugboats are used, which pull barges on a hawser.

With the exception of the New York State Barge Canal, which is state-run, the inland waterways of the United States are maintained on a federal level by the Army Corps of Engineers. Since 1980, barge operators have paid a fuel tax that pays for a percentage of the construction, operation, and maintenance costs for inland waterway projects. Before this time, all projects were entirely federally funded with appropriations from Congress.

[J.Fa.]

**Inoculation** The process of introducing a microorganism or suspension of microorganism into a culture medium. The medium may be (1) a solution of nutrients required by the organism or a solution of nutrients plus agar; (2) a cell suspension (tissue culture); (3) embryonated egg culture; or (4) animals, for example, rat, mouse, guinea pig, hamster, monkey, birds, or human being. When animals are used, the purpose usually is the activation of the immunological defenses against the organism. This is a form of vaccination, and quite often the two terms are used interchangeably. Both constitute a means of producing an artificial but active immunity against specific organisms, although the length of time given by such protection may vary widely with different organisms. See IMMUNITY; VACCINATION. [E.G.St./N.K.M.]

**Inorganic chemistry** The chemical reactions and properties of all the elements in the periodic table and their compounds, with the exception of the element carbon. The chemistry of carbon and its compounds falls in the domain of organic chemistry. The boundaries of inorganic chemistry with the other major areas of chemistry are not precisely defined, and it is often a matter of taste as to whether a particular topic is to be included in the field of inorganic chemistry or is to be considered physical or even organic chemistry. Investigations into theoretical inorganic chemistry or the study of problems in inorganic chemistry by quantitative and sophisticated physical methods may be considered either inorganic or physical chemistry quite arbitrarily. In similar fashion, organometallic compounds may be considered to be in the sphere of either inorganic or organic chemistry. To an increasing extent, the inorganic chemist is concerned with problems that once were considered the prerogative of physical chemists, organic chemists, or even biochemists. See BIOINORGANIC CHEMISTRY; CHEMICAL DYNAMICS; COORDINATION CHEMISTRY; GEOCHEMISTRY; NUCLEAR CHEMISTRY; ORGANOMETALLIC COMPOUND; PHYSICAL CHEMISTRY; SOLID-STATE CHEMISTRY. [J.J.K.]

**Inorganic photochemistry** The study of the light-induced behavior of various metal compounds. The physical and chemical properties of substances are generally altered by the absorption of light. Typical metal compounds have a characteristic number (coordination number) of molecules or ions (ligands) directly bonded to the metal center. For example a six-coordinate compound has the general formula  $ML_6^{n+}$ . Many of these compounds are colored, and much interest has been aroused by speculation that some metal compounds could mediate the transformation of solar radiation into useful chemical or electrical energy.



major strategy for control of pest insects may involve the use of genetic engineering to introduce traits into natural enemies that enhance their performance, or mortality-causing traits of natural enemies, such as insect pathogens, into plants. See BREEDING (PLANT); GENETIC ENGINEERING. [P.B.]

**Insect pathology** A biological discipline embracing the general principles of pathology (disease in the broadest sense) as applied to insects. It refers to human observations and actions concerning the cause, symptomatology, gross pathology, histopathology, pathogenesis, and epizootiology of the diseases of insects; it is concerned with whatever can go wrong or become abnormal in an insect. A diseased insect may be suffering from an infectious disease caused by a microorganism or a noninfectious disease, such as metabolic disturbance, a genetic abnormality, a fetal malformation, a nutritional deficiency, a physical or chemical injury, or an injury caused by parasites or predators.

Insect pathology draws upon and contributes to the general field of microbiology and provides understanding of certain of the biological relationships existing between insects and microorganisms not pathogenic to them. Insect pathology finds applications in agriculture, medicine, and biology generally. Microbial control, the use of microorganisms in biological control, is one area of applied insect pathology. Microorganisms are introduced to control insect pests for the protection of humans and other animals and agricultural crops. However, the suppression of disease in beneficial insects, such as the silkworm, honeybee, and ladybird beetle, is also of significant practical importance. See INSECT CONTROL, BIOLOGICAL.

An important facet of insect pathology is concerned with the epizootiology of diseases, which involves the study of disease in populations of insects rather than in individual animals. Any epizootic affecting an insect population is concerned with three primary natural entities: the infectious agent, the insect host, and the environment. Each of these factors has certain attributes that, when properly related to the attributes of the others, play their appropriate role in determining the initiation, rise, and decline of an epizootic. Knowledge concerning the nature of epizootics is extremely important in insect ecology generally and in an understanding of insect-microbe ecosystems. The degree to which disease-producing microorganisms are dependent upon the density of the host population, the susceptibility of the host insect to the disease, the influence of weather and other environmental conditions on epizootics, the mode of transmission of insect pathogens, the success of the microorganism remaining alive, and other factors are important aspects of the epizootiology of insect disease. In the microbial control of an injurious insect, humans can initiate and increase the rapid rate of development of an epizootic by controlling the amount, method of distribution, and time of introduction of an effective microorganism.

Most of the activity in insect pathology has been with the infectious diseases. The infectious agents responsible for diseases in insects belong to the same major groups as those that cause such diseases in other organisms: the bacteria, fungi, viruses, rickettsiae, protozoa, and nematodes. In general, however, insects are not normally susceptible to those particular microorganisms that cause diseases of humans, other animals, and plants. Moreover, most of the microorganisms that cause fatal diseases in insects are harmless to plants and to higher animals. Insects often can resist infection by humoral and cellular types of immunity; acquired humoral immunity is manifested in the hemolymph. However, it appears that the antibody immunity characteristic of higher animals does not occur in insects.

*Bacillus thuringiensis* is one of the most intensively studied bacterial pathogens of insects because it has proved to be an effective microbial control agent against a number of insect pests, such as the alfalfa caterpillar, larvae of the cabbage butterfly,

and larval forms of certain mosquitoes, black flies, and beetles. A number of closely related species of this bacillus are known to cause diseases of beneficial insects, such as silkworms. Several different strains or varieties of *B. thuringiensis* are known. Certain types affect only Lepidoptera, others only Diptera or Coleoptera. These bacteria are characterized by the formation of a protein crystal in the sporangium at the time of spore formation. The protein material comprising the crystal is highly toxic for certain insects, but apparently harmless for other forms of life. *Bacillus thuringiensis* and related species also produce a heat-stable, water-soluble substance, distinct from the crystal and from lecithinase, that is toxic for certain insects when injected, and to larval Diptera when they are exposed to it in a rearing medium. Preparations containing the spores and crystals of *B. thuringiensis* or its varieties may be sprayed or dusted on crops or into aquatic habitats to destroy lepidopterous, dipterous, or coleopterous pests. Commercial products containing the bacillus are available. One of the primary advantages of this type of control is that this and other entomophilic microorganisms are nontoxic and noninfectious for plants and higher animals. See INSECT PHYSIOLOGY; INSECTA; INSECTICIDE. [J.D.Br.]

**Insecta** A class of the phylum Arthropoda, sometimes called the Hexapoda. In fact, Hexapoda is a superclass consisting of both Insecta and the related class Parainsecta (containing the springtails and proturans). Class Insecta is the most diverse group of organisms, containing about 900,000 described species, but there are possibly as many as 5 million to perhaps 20 million actual species of insects. Like other arthropods, they have an external, chitinous covering. Fossil insects dating as early as the Early Devonian have been found. See PARAINSECTA.

**Classification.** The class Insecta is divided into orders on the basis of the structure of the wings and the mouthparts, on the type of metamorphosis, and on various other characteristics. There are differences of opinion among entomologists as to the limits of some of the orders. The orders of insects (and their relatives the parainsects) are shown below.

#### Superclass Hexapoda

##### Class Parainsecta

Order: Protura; proturans  
Collembola; springtails

##### Class Insecta

##### Subclass Monocondylia

Order: Diplura; tselontails  
Archaeognatha; bristletails

##### Subclass Dicondylia

##### Infraclass Apterygota

Order: Zygentoma; silverfish, firebrats

##### Infraclass Pterygota

##### Section Palaeoptera

Order: Ephemeroptera; mayflies  
Odonata; damselflies and dragonflies

##### Section Neoptera

##### Hemimetabola

Order: Plecoptera; stoneflies  
Grylloblattodea; rockcrawlers  
Orthoptera; grasshoppers, katy-dids, crickets  
Phasmatodea; walkingsticks  
Mantodea; mantises  
Blattodea; cockroaches  
Isoptera; termites  
Dermaptera; earwigs  
Embioptera; webspinners  
Zoraptera; zorapterans  
Psocoptera; psocids, booklice  
Phthiraptera; lice  
Thysanoptera; thrips  
Hemiptera; cicadas, hoppers, aphids, whiteflies, scales

## Holometabola

Order: Megaloptera; dobsonflies, alderflies  
 Raphidioidea; snakeflies  
 Neuroptera; lacewings, antlions  
 Coleoptera; beetles  
 Strepsiptera; twisted-wing parasites  
 Mecoptera; scorpionflies  
 Siphonaptera; fleas  
 Diptera; true flies  
 Trichoptera; caddisflies  
 Lepidoptera; moths, butterflies  
 Hymenoptera; sawflies, wasps, ants, bees

**Morphology.** Insects are usually elongate and cylindrical in form, and are bilaterally symmetrical. The body is segmented, and the ringlike segments are grouped into three distinct regions: the head, thorax, and abdomen. The head bears the eyes, antennae, and mouthparts; the thorax bears the legs and wings, when wings are present; the abdomen usually bears no locomotor appendages but often bears some appendages at its apex. Most of the appendages of an insect are segmented.

The skeleton is primarily on the outside of the body and is called an exoskeleton. However, important endoskeletal structures occur, particularly in the head. The body wall of an insect serves not only as a covering, but also as a supporting structure to which many important muscles are attached. The body wall of an insect is composed of three principal layers: the outer cuticula, which contains, among other chemicals, chitin; a cellular layer, the epidermis, which secretes the chitin; and a thin non-cellular layer beneath the epidermis, the basement membrane. The surface of an insect's body consists of a number of hardened plates, or sclerites, separated by sutures or membranous areas, which permit bending or movement. See CHITIN.

A pair of compound eyes usually cover a large part of the head surface. In addition most insects also possess two or three simple eyes, the ocelli, usually located on the upper part of the head between the compound eyes; each of these has a single lens. See EYE (INVERTEBRATE).

Insect mouthparts typically consist of a labrum, or upper lip; a pair each of mandibles and maxillae; a labium, or lower lip; and a tonguelike structure, the hypopharynx. These structures are variously modified in different insect groups and are often used in classification and identification. The type of mouthparts an insect has determines how it feeds and what type of damage it is capable of causing.

Several forms of antennae are recognized, to which various names are applied; they are used extensively in classification. The antennae are usually located between or below the compound eyes and are often reduced to a very small size. They are sensory in function and act as tactile organs, organs of smell, and in some cases organs of hearing.

Insects are the only winged invertebrates, and their dominance as a group is probably due to their wings. Immature insects do not have fully developed wings, except in the mayflies. The wings may be likened to the two sides of a cellophane bag that have been pressed tightly together. The form and rigidity of the wing are due to the stiff chitinous veins which support and strengthen the membranous portion. At the base are small sclerites which serve as muscle attachments and produce consequent wing movement. The wings vary in number, placement, size, shape, texture, and venation, and in the position at which they are held at rest. Adult insects may be wingless or may have one pair of wings on the mesothorax, or, more often two pairs. There is a common basic pattern of wing venation in insects which is variously modified and in general quite specific for different large groups of insects. Much of insect classification depends upon these variations. A knowledge of fossil insects depends largely upon the wings, because they are among the more readily fossilized parts of the insect body.

**Internal anatomy.** The intake of oxygen, its distribution to the tissues, and the removal of carbon dioxide are accomplished by means of an intricate system of tubes called the tracheal system. The principal tubes of this system, the tracheae, open externally at the spiracles. Internally they branch extensively, extend to all parts of the body, and terminate in simple cells, the tracheoles. Many adaptations for carrying on respiration are known.

Insects possess an alimentary tract consisting of a tube, usually coiled, which extends from the mouth to the anus. It is differentiated into three main regions: the foregut, midgut, and hindgut. Valves between the three main divisions of the alimentary canal regulate the passage of food from one region to another.

The excretory system consists of a group of tubes with closed distal ends, the Malpighian tubules, which arise as evaginations of the anterior end of the hindgut. They vary in number from 1 to over 100, and extend into the body cavity. Various waste products are taken up from the blood by these tubules and passed out via the hindgut and anus.

The circulatory system of an insect is an open one. The only blood vessel is a tube located dorsal to the alimentary tract and extending through the thorax and abdomen. The posterior portion of this tube, the heart, is divided into a series of chambers, each of which has a pair of lateral openings called ostia. The anterior part of the tube is called the dorsal aorta.

The nervous system consists of a brain, often called the supraesophageal ganglion, located in the head above the esophagus; a subesophageal ganglion, connected to the brain by two commissures that extend around each side of the esophagus; and a ventral nerve cord, typically double, extending posteriorly through the thorax and abdomen from the subesophageal ganglion. In the nerve cords there are enlargements, called ganglia. Typically, there is a pair to each body segment. From each ganglion of the chain, nerves extend to each adjacent segment of the body, and also extend from the brain to part of the alimentary canal.

Reproduction in insects is nearly always sexual, and the sexes are separate. Variations from the usual reproductive pattern occur occasionally. In many social insects, such as the ants and bees, certain females, the workers, may be unable to reproduce because their sex organs are undeveloped; in some insects, individuals occasionally occur that have characters of both sexes, called gynandromorphs. Also, parthenogenesis—the process of females giving rise to females—is known in some species.

**Metamorphosis.** After insects hatch from an egg, they begin to increase in size and will also usually change, to some degree at least, in form and often in appearance. This developmental process is metamorphosis. The growth of an insect is accompanied by a series of molts, or ecdyses, in which the cuticle is shed and renewed.

The molt involves not only the external layers of the body wall, the cuticula, but also the cuticular linings of the tracheae, foregut, and hindgut; the cast skins often retain the shape of the insects from which they were shed. The shedding process begins with a splitting of the old cuticle. This split grows and the insect eventually wriggles out of the old cuticle. The new skin, remains soft and pliable long enough for the body to expand to its fullest capacity before hardening.

Insects differ regarding the number of molts during their growing period. Many have as few as four molts; a few species have 40 or more, and the latter continue to molt throughout life.

Insects have been grouped or classified on the basis of the type of metamorphosis they undergo. Although all entomologists do not agree upon the same classification, the following outline is presented:

1. Ametabolous or primitive: No distinct external changes are evident with an increase in size.
2. Hemimetabolous: Direct metamorphosis that is simple and gradual; immature forms resemble the adults except in size, wings, and genitalia. Immatures are referred to as nymphs or naiads if aquatic.

3. Holometabolous: Complete, or indirect, metamorphosis; stages in this developmental type are: egg→larva→pupa→adult (or imago). [D.M.DeL.]

**Fossils.** Insects and parainsects have a rich fossil record that extends to 415 million years, representing all taxonomic orders and 70% of all families that occur today. Insect deposits are characterized by an abundance of exceptionally well-preserved deposits known as Lagerstätten. Lagerstätten refer not only to the familiar amber deposits that entomb insects in hardened tree resin, but more importantly to a broad variety of typically laminar, sedimentary deposits. These deposits, formed in lake basins, are the most persistent of insect-bearing deposits and document the evolution of insect biotas during the past 300 million years. By contrast, the oldest amber is approximately 120 million years old and extends modern lineages and associated taxa to the Early Cretaceous. Other major types of insect deposits include terrestrial shales and fine-grained sandstones marginal to marine deposits during the Early and Middle Devonian, a proliferation of nodular ironstone-bearing strata of late Carboniferous age from the equatorial lowlands of the paleocontinent Euramerica, and distinctive lithographic limestones worldwide from the Middle Jurassic to Early Cretaceous. More modern deposits are Miocene to Recent sinter deposits created by hydrothermal zones with mineral-rich waters, and similarly aged asphaltum, representing the surface accumulation of tar. Lastly, insects are abundant in many Pleistocene glacial deposits of outwash and stranded lake sediments, formed by the waxing and waning of alpine and continental glaciers.

Various types of fossil documentation are important for understanding insect paleobiology, such as the body-fossil history of mouthparts. A recent study of insect mouthparts reveals a five-fold phase of increasing mouthpart disparity through time. This geochronologic deployment of the 34 basic types of modern insect mouthparts began during the Early Devonian with a few generalized types, was expanded during the late Carboniferous to early Permian to include major modifications of mandibulate and piercing-and-sucking types, and increased significantly again during the Late Triassic to Early Jurassic to include filter-feeding mouthpart types and others involved in the ecologic penetration of aquatic ecosystems, and also intricate interactions with other animal and seed-plant hosts. During the Late Jurassic, there was expansion of mouthpart types involved in fluid-feeding on plant, fungal, and animal tissues and during the Early Cretaceous mouthpart innovation was completed by the addition of a few specialized mouthpart types involved in blood-feeding and other specialized associations. A comparison of taxonomic diversity and mouthpart disparity reveals that the generation of taxa has proceeded overall in a semilogarithmic increase reflected in a concave curve, whereas morphologic innovation, as revealed by mouthpart disparity, is a logistic process evidenced by a convex curve. This suggests that the deployment of basic morphologic types typically precedes taxonomic diversification in insect fossil history. [C.C.La.]

**Insecticide** A material used to kill insects and related animals by disruption of vital processes through chemical action. Insecticides may be inorganic or organic chemicals. The principal source is from chemical manufacturing, although a few are derived from plants.

Insecticides are classified according to type of action as stomach poisons, contact poisons, residual poisons, systemic poisons, fumigants, repellents, attractants, insect growth regulators, or pheromones. Many act in more than one way. Stomach poisons are applied to plants so that they will be ingested as insects chew the leaves. Contact poisons are applied in a manner to contact insects directly, and are used principally to control species which obtain food by piercing leaf surfaces and withdrawing liquids. Residual insecticides are applied to surfaces so that insects touching them will pick up lethal dosages. Systemic insecticides are applied to plants or animals and are absorbed

and translocated to all parts of the organisms, so that insects feeding upon them will obtain lethal doses. Fumigants are applied as gases, or in a form which will vaporize to a gas, so that they can enter the insects' respiratory systems. Repellents prevent insects from closely approaching their hosts. Attractants induce insects to come to specific locations in preference to normal food sources. Insect growth regulators are generally considered to act through disruption of biochemical systems or processes associated with growth or development, such as control of metamorphosis by the juvenile hormones, regulation of molting by the steroid molting hormones, or regulation of enzymes responsible for synthesis or deposition of chitin. Pheromones are chemicals which are emitted by one sex, usually the female, for perception by the other, and function to enhance mate location and identification; pheromones are generally highly species-specific.

Formulation of insecticides is extremely important in obtaining satisfactory control. Common formulations include dusts, water suspensions, emulsions, and solutions. Accessory agents, including dust carriers, solvents, emulsifiers, wetting and dispersing agents, stickers, deodorants or masking agents, synergists, and antioxidants, may be required to obtain a satisfactory product.

Proper timing of insecticide applications is important in obtaining satisfactory control. Whatever the technique used, the application of insecticides should be correlated with the occurrence of the most susceptible or accessible stage in the life cycle of the pest involved. By and large, treatments should be made only when economic damage by a pest appears to be imminent.

Among problems associated with insect control are the development of strains of insects resistant to insecticides; the assessment of the significance of small, widely distributed insecticide residues in and upon the environment; the development of better and more reliable methods for forecasting insect outbreaks; the evolution of control programs integrating all methods—physical, physiological, chemical, biological, and cultural—for which practicality was demonstrated; the development of equipment and procedures to detect chemicals much below the part-per-million and microgram levels. As a consequence of the provisions of the Federal Insecticide, Fungicide, and Rodenticide Act as amended by the Federal Environmental Pesticide Control Act of 1972, there have been increased efforts to obtain data delineating mammalian toxicology, persistence in the environment, and immediate chronic impact of pesticides upon non-target invertebrate and vertebrate organisms occupying aquatic, terrestrial, and arboreal segments of the environment. See FUMIGANT; INSECT CONTROL, BIOLOGICAL; INSECT PHYSIOLOGY; INSECTA; PESTICIDE. [G.F.L.]

**Insectivora** An order of placental mammals including shrews, moles, and hedgehogs. The tree shrews (Tupaiaidae) and elephant shrews (Macroscelididae) are now recognized as unrelated, and they are placed in separate orders (Scandentia and Macroscelidea). Formerly thought to be the basal placental order, from which other orders were derived, the Insectivora is now restricted to members of the former suborder Lipotyphla. It evolved side by side with the other placental orders, with a fossil record going back to the Paleocene. A number of fossil families from the Cretaceous and early Tertiary, formerly included in the Insectivora, are classified as Proteutheria. See MACROSCELIDEA.

Living lipotyphlous insectivores are small animals: the largest (*Potamogale*) weighs about 1 kg (2 lb). Most eat insects, worms, and other invertebrates, for which they search in ground litter and vegetation, using their highly developed olfactory sense and their mobile, sensitive snouts. Some burrow, such as moles; some are aquatic, such as the desman. Anatomically, they are distinguished by the absence of a cecum in the intestine, reduction of the pubic symphysis, and characters of the skull. The cheek teeth typically have sharp cusps and crests, and the incisors are often enlarged to act as forceps. Insectivores are found on all



continents except Australia and Antarctica, but only one genus (*Cryptotis*, a shrew) has reached South America.

Three suborders can be distinguished: Erinaceomorpha, Soricomorpha, and Chrysochloromorpha. Living erinaceomorphs belong to the family Erinaceidae, comprising the spiny hedgehogs (Erinaceinae) of Eurasia and Africa and the hairy moonrats (Echinosoricinae) of Southeast Asia.

Four living families are included in the Soricomorpha: Soricidae (shrews), Talpidae (moles, desman), Tenrecidae (Madagascan tenrecs and African otter shrews), and Solenodontidae (*Solenodon*, confined to Cuba and Hispaniola). True moles did not reach North America until the Miocene; they were preceded in the Oligocene by the Proscalopidae. The living *Solenodon*, in the West Indies, is one of the largest insectivores, but nevertheless shrewlike. The Tenrecidae are far removed geographically from other soricomorphs. They probably evolved in Africa, where their fossil history goes back to the early Miocene, and the otter shrews (Potamogalinae) survive on the continent of Africa today. The remainder are in Madagascar where, like the lemurs, they have evolved in diverse directions during a long time of isolation. In some ways, for example brain size, they have remained more primitive than other insectivores.

The golden moles (Chrysochloridae) are put into a separate suborder, Chrysochloromorpha. They are highly specialized burrowers, using large claws on the forefoot. They are confined to Africa, where fossils show that they were already specialized in the early Miocene. See MAMMALIA; MOLE (ZOOLOGY); SHREW; SOLENDON; TENREC. [P.M.B.; M.C.McK.]

**Insectivorous plants** Plants having variously modified, highly specialized leaves which capture and digest insects. The proteins of the digested insect bodies supply nitrogen, which otherwise may be unavailable to these plants in the places where they grow. Sometimes they are also called carnivorous (flesh-eating) plants. See NEPENTHALES; PITCHER PLANT; SECRETORY STRUCTURES (PLANT); SUNDEW; VENUS' FLYTRAP. [P.D.St./E.L.C.]

**Insolation** The incident radiant energy emitted by the Sun, which reaches a unit horizontal area of the Earth's surface. The term is a contraction of incoming solar radiation. About 99.9% of the Sun's energy is in the spectral range of 0.15–4.0 micrometers. About 95% of this energy is in the range of 0.3–2.4  $\mu\text{m}$ ; 1.2% is below 0.3  $\mu\text{m}$  and 3.6% is above 2.4  $\mu\text{m}$ . The bulk of the insolation (99%) is in the spectral region of 0.25–4.0  $\mu\text{m}$ . About 40% is found in the visible region of 0.4–0.7  $\mu\text{m}$  and only 10% is in wavelengths shorter than the visible. Energy of wavelengths shorter than 0.29  $\mu\text{m}$  is absorbed high in the atmosphere by nitrogen, oxygen, and ozone.

Insolation depends on several factors: (1) the solar constant—that is, the amount of energy that in a unit time reaches a unit plane surface perpendicular to the Sun's rays outside the Earth's atmosphere, when the Earth is at its mean distance from the Sun; (2) the Sun's elevation in the sky; (3) the amount of solar radiation returned to space at the Earth-atmosphere boundary; and (4) the amount of solar radiation absorbed by the atmosphere and the amount of solar radiation reflected at the lower boundary of the Earth. Insolation is commonly expressed in units of watts per square meter, or calories per square centimeter per minute, also known as langley/min. For instance, the mean value of the solar constant has been estimated as 1368  $\text{W}/\text{m}^2$  (~1.96 ly/min), and the average insolation in summer for a midlatitude clear region could be 340  $\text{W}/\text{m}^2$  (700 ly/day), while for a cloudy region it is only about 120  $\text{W}/\text{m}^2$  (250 ly/day). See ALBEDO; ATMOSPHERE; SOLAR RADIATION; TERRESTRIAL RADIATION. [R.T.P.]

**Inspection and testing** Industrial activities which ensure that manufactured products, individual components, and multicomponent systems are adequate for their intended purpose. Inspection and testing are the operational parts of quality control, which is the most important factor to the survival of

any manufacturing company. Quality control directly supports the other factors of cost, productivity, on-time delivery, and market share. Therefore, all quality standards needed to produce the components of a product and perform its assembly must be specified in a manner such that customers' expectations are met. Global competitive pressures force manufacturing companies to become more customer-oriented and focused in terms of offering higher-quality products and services. See QUALITY CONTROL.

Inspection and testing are performed before, during, and after manufacturing to ensure that the quality level of the product is within acceptable design standards.

Whereas inspection is the activity of examining the product or its components to determine if they meet the design standards, testing is a procedure in which the item is observed during operation in order to determine whether it functions properly for a reasonable period of time. See DESIGN STANDARDS.

In statistical quality control, inferences are made about quality based on a sample taken from the population of the items. The sample of items is generated randomly from the population. Each item in the sample is inspected or tested for certain quality characteristics. For example, the diameter of a cylindrical part is measured after the turning operation that generated the part is completed.

The objective of statistical quality control is to determine when the process has gone out of statistical control, so that corrective action can be taken. The two principal techniques in statistical quality control are acceptance sampling and control charts. In acceptance sampling, a sample is taken from a batch of parts and, depending on the number of parts that pass the inspection or testing, the batch is accepted or rejected. A control chart is designed to be a simple graphical technique to monitor and control a single characteristic of the process output. The objective is to obtain an estimate of the principal parameter that describes the variability of this characteristic and then to use a test of hypothesis to determine if the process is in control. A control chart contains three horizontal lines: the central line represents the mean of the process output, and the upper and lower control limits indicate extreme statistical values of the process output. If a measured value of the output is outside these limits, the process is out of control and needs to be examined to determine the reason. The natural tolerance limits ( $\pm 3$  standard deviations) are normally used to specify the upper and lower limits in a control chart. See CONTROL CHART; STATISTICS.

Sensor technologies for automated inspection can be divided into two broad categories: contact and noncontact inspection methods. Contact inspection methods involve the use of a mechanical probe or another device that makes contact with the object being inspected. The purpose of the probe is to measure or gage some physical dimension of the object. These methods are used predominantly in the mechanical manufacturing industries. Coordinate measurement machines, flexible inspection systems, and inspection probes represent the high end of this technology. Noncontact inspection methods involve the use of a sensor located at a certain distance from the object to measure or gage the desired features. Two significant advantages of noncontact inspection methods are shorter inspection times and avoidance of damage to the object. Noncontact inspection methods include machine vision, electrical field techniques, radiation techniques, and ultrasonics. [J.A.V.]

**Instinctive behavior** A relatively complex response pattern which is usually present in one or both sexes of a given species. These responses have a genetic basis, are essentially unlearned, and are generally adaptive.

Instinctive behavior occurs when an animal has a particular internal state while it is in the presence of a specific external stimulation called a releaser or a sign stimulus. Neither the internal state nor the external stimulus alone is adequate for the elicitation of the response. Many animals show particular instinctive

behaviors only during the mating season, when hormonal changes associated with sexual behavior sensitize specific portions of the central nervous system, which will then be active in the presence of the releaser. The external stimulus may be relatively simple or incredibly complex.

Within limits, the instinctive behaviors can be modified by learning. There is evidence, for example, that some predators learn to attack their prey at the back of the neck because when held in that position the prey cannot counterattack. See MIGRATORY BEHAVIOR; REPRODUCTIVE BEHAVIOR. [K.E.M.]

**Instrument landing system (ILS)** A collection of discrete radio navigation aids used by pilots of all types of aircraft for approach guidance to a specific airport runway, especially during times of limited visibility. Typically, three components constitute the instrument landing system: a localizer, which provides lateral guidance; a glide slope, which gives vertical guidance; and one to three marker beacons, which give position fixes along the approach path (see illustration). A distance-measuring-equipment (DME) readout or a non-directional, low-frequency radio beacon (NDB) is sometimes substituted for the outer marker beacon, usually located about 5 mi (8 km) from the runway. See DISTANCE-MEASURING EQUIPMENT.

The localizer, glide slope, and markers function by radiating continuous-wave, horizontally polarized, fixed beams of radio-frequency energy into the air space. The localizer operates in the band of 108–112 MHz, the glide slope in the band of 329–335 MHz, and the marker beacons on the discrete frequency of 75 MHz. The localizer and glide-slope frequencies are paired; for example, every localizer operating at 109.5 MHz has a glide slope operating at 329.6 MHz. If there is a DME present, it is also paired. Only the localizer receiver in the aircraft needs to be tuned.

Over 1000 instrument landing systems operate in the United States, with an additional 300 systems in use worldwide. A major contender for ultimate replacement of the instrument landing system appears to be a Global Navigation Satellite System

(GNSS), in which the Global Positioning System (GPS) would play a major role. See SATELLITE NAVIGATION SYSTEMS. [R.H.McF.]

**Instrument science** The systematically organized body of general concepts and principles underlying the design, analysis, and application of instruments and instrument systems.

Instruments are very diverse in function and form. They differ according to measurands, range of magnitudes and the dynamic variations of the measurand, required accuracy, and nature and environment of application. Equally diverse is the range of technologies that can be used to realize a particular instrument function. To enable this information to be handled in such a way that it can be usefully applied to the design, analysis, or application of instruments, it must be organized on the basis of a systematic framework of general concepts and principles. This framework is termed instrument science.

The basis of instrument science is: first, the consideration of instruments as members of the general class of information machines; and second, an analysis and synthesis of the instruments as systems, applying the principles of system engineering.

There exists a wide class of machines whose function is to acquire, process, and feed out information. This class includes measuring instruments, control apparatus, communication equipment, and computers. These machines function by the transformation of an input physical variable into an output variable in such a way that the output is functionally related to the input. Thus the output carries information about the input. This basic principle of functioning determines the general features of the analysis and synthesis of information machines. See COMPUTER; CONTROL SYSTEMS; ELECTRICAL COMMUNICATIONS.

Instruments and indeed other forms of information machines are conveniently analyzed and synthesized as systems. A system is a set of interconnected components functioning as a unit. There is a set of general principles and techniques for treating complex entities as systems. It is known as the systems approach, and is based on the decomposition of the complex whole into

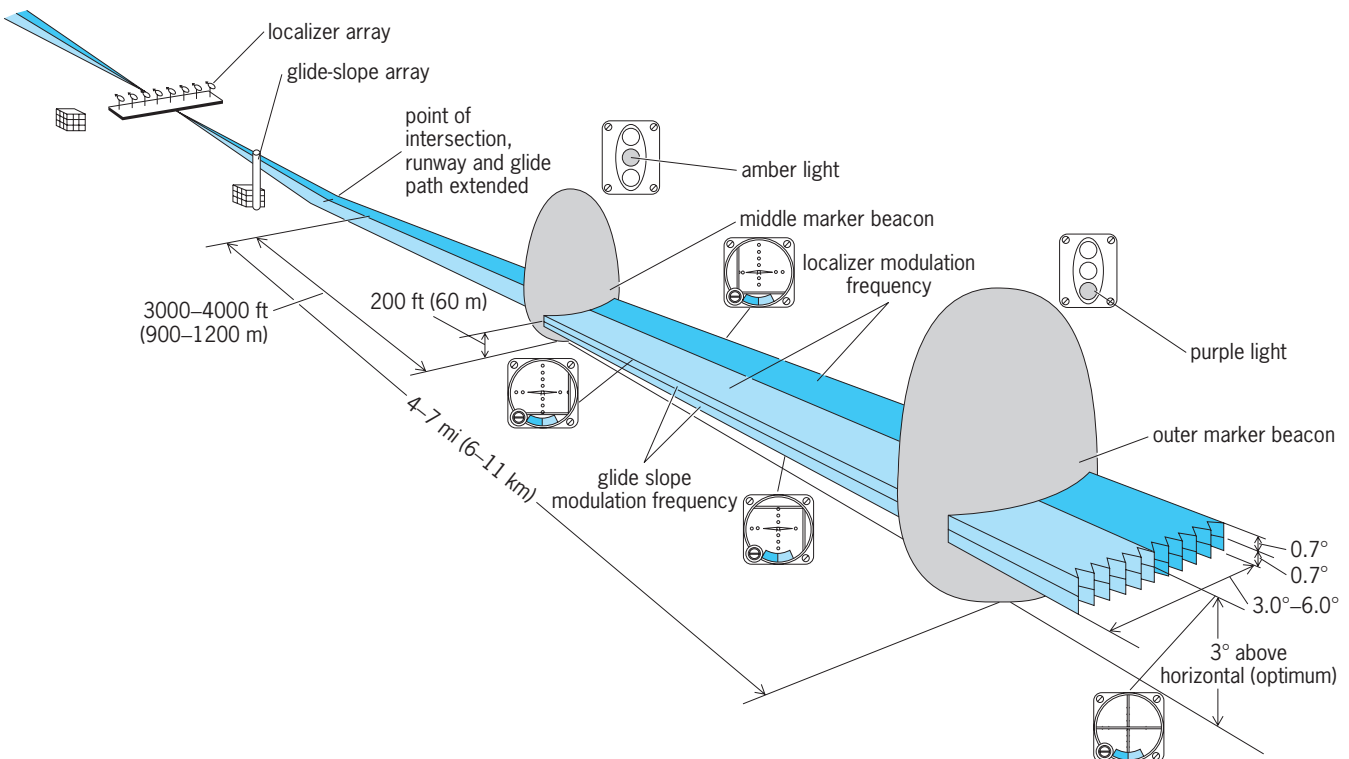

Components of instrument landing system (ILS), and resulting signals used by the pilot. (Federal Aviation Administration)

individual components. The individual components are considered in the first instance in terms of function rather than form.

Considering systems, such as instruments, as structures of functional building blocks makes clear that a very wide variety of instruments can be constructed from a much smaller variety of building blocks organized into a small variety of basic structures, such as a chain or loop connection. Further, it makes clear that apparently different systems—say, electrical and mechanical, or physical and biological—are essentially analogous. See INSTRUMENTATION; SYSTEMS ANALYSIS; SYSTEMS ENGINEERING. [L.Fi.]

**Instrument transformer** A device that serves as an input source of currents and voltages from an electric power system to instruments, relays, meters, and control devices. The basic design is that of a transformer with the primary winding connected to the power system, and the secondary winding to the sensing and measuring equipment. Data from these devices are necessary for the operation, control, and protection of the power system. The primary reason for setting up the instrument-transformer interface is to provide analog information at low voltage levels, insulated from the higher system voltages. The range of use is from 480 V through the maxima of the 765–1000-kV power systems. See ELECTRIC POWER SYSTEMS; TRANSFORMER.

Current transformers are connected in series with the power conductor. In many cases this conductor serves as the one-turn primary. The principal types are the window type, where the power conductor is passed through a hole in the center of the current transformer; the bar type, where the power conductor is fastened to a one-turn bar which is part of the current transformer; and the bushing type, a toroidal core and winding that is slipped over the insulating bushings of circuit breakers, transformers, and so forth.

Voltage transformers and coupling capacitor voltage transformers are connected in parallel from one conductor to another or to ground. The coupling capacitor voltage transformer is widely used at the higher system voltages of 115 kV and above. It is a voltage transformer tapped across part of a capacitor unit connected from the conductor to ground. [J.L.Bl.]

**Instrumental conditioning** Learning based upon the consequences of behavior. For example, a rat may learn to press a lever when this action produces food. Instrumental or operant behavior is the behavior by which an organism changes its environment. The particular instances of behavior that produce consequences are called responses. Classes of responses having characteristic consequences are called operant classes; responses in an operant class operate on (act upon) the environment. For example, a rat's lever-press responses may include pressing with the left paw or with the right paw, sitting on the lever, or other activities, but all of these taken together constitute the operant class called lever pressing.

Consequences of responding that produce increases in behavior are called reinforcers. For example, if an animal has not eaten recently, food is likely to reinforce many of its responses. Whether a particular event will reinforce a response or not depends on the relation between the response and the behavior for which its consequences provide an opportunity. Some consequences of responding called punishers produce decreases in behavior. The properties of punishment are similar to those of reinforcement, except for the difference in direction.

The consequences of its behavior are perhaps the most important properties of the world about which an organism can learn, but few consequences are independent of other circumstances. Organisms learn that their responses have one consequence in one setting and different consequences in another. Stimuli that set the occasion on which responses have different consequences are called discriminative stimuli (these stimuli do not elicit responses; their functions are different from those that are simply followed by other stimuli). When organisms learn that responses have consequences in the presence of one but not

another stimulus, their responses are said to be under stimulus control. For example, if a rat's lever presses produce food when a light is on but not when it is off and the rat comes to press only when the light is on, the rat's presses are said to be under the stimulus control of the light. See CONDITIONED REFLEX; LEARNING MECHANISMS. [A.C.Ca.]

**Instrumentation amplifier** A special-purpose linear amplifier, used for the accurate amplification of the difference between two (often small) voltages, often in the presence of much larger common-mode voltages, and having a pair of differential (usually high-impedance) input terminals, connected to sources  $V_{in1}$  and  $V_{in2}$ ; a well-defined differential-mode gain  $A_{DM}$ ; and a voltage output  $V_{out}$ , satisfying the relationship given in the equation below. It differs from an operational amplifier

$$V_{out} = A_{DM}(V_{in1} - V_{in2})$$

(op-amp), which ideally has infinite open-loop gain and must be used in conjunction with external elements to define the closed-loop transfer function. At one time built in discrete or hybrid form using operational amplifier and resistor networks, instrumentation amplifiers are readily available as inexpensive monolithic integrated circuits. Typical commercial amplifiers provide present gains of 1, 10, 100, and 1000. In some cases, the gain may be set to a special value by one or more external resistors. The frequency response invariably is flat, extending from 0 (dc) to an upper frequency of about 1 kHz to 1 MHz. See INTEGRATED CIRCUITS; OPERATIONAL AMPLIFIER; RESISTOR.

Instrumentation amplifiers are used to interface low-level devices, such as strain gages, pressure transducers, and Hall-effect magnetic sensors, into a subsequent high-level process, such as analog-to-digital conversion. See AMPLIFIER; DIFFERENTIAL AMPLIFIER; HALL EFFECT; PRESSURE TRANSDUCER; STRAIN GAGE. [B.Gi.]

**Instrumented buoys** Unattended, floating structures equipped with systems for collecting, processing, and transmitting meteorological and oceanographic data. Such information is useful for many purposes, including storm warnings and forecasts, coastal engineering, climatology, and oceanographic and atmospheric research.

Moored systems, anchored to the ocean bottom, record currents and water properties as the flow passes the buoy (the eulerian framework). Drifting buoys move with the waters, indicating where they go (the lagrangian framework). In both cases, additional sensors may record a variety of parameters, such as temperature, pressure, acceleration, and water properties.

Surface moorings come in many shapes and sizes depending upon a number of factors, such as research versus operational requirements, duration of deployment, surface versus subsurface measurements, strength of currents, and weather considerations. To operate for a long time, moored buoys require highly reliable components, including a strong mooring line to prevent failure due to wear and tear in heavy seas. This in turn requires large buoys with substantial surface flotation to support the weight of the line. These buoys support a suite of atmospheric sensors and power systems for their operation and data telemetry.

Studies of the subsurface ocean typically employ moorings with flotation below the surface. Subsurface moorings experience much less fatigue of the hardware and mooring line due to the absence of wave motion, permitting the use of lighter-weight, less expensive hardware. More importantly, the absence of surface wave motion results in a much calmer mooring line, greatly facilitating accurate current measurements. Subsurface moorings also eliminate the risk of piracy and entanglement with fishing nets, a major source of equipment and data loss for surface moorings. However, these moorings require costly subsurface flotation devices because they must have the strength to withstand the higher hydrostatic pressure. Large steel spheres are used for near-surface flotation applications, and glass balls are used at greater pressures. Syntactic foam, consisting of a

matrix of glass microspheres embedded in epoxy, has proven very effective in applications where the flotation must have a special shape to support instruments, yet remain streamlined to minimize drag forces in strong currents.

Drifting buoys drift with the waters, either as surface drifters or as subsurface floats. In order to follow the waters while minimizing the effect of winds, surface drifters have very little exposure at the surface but have large drag elements hanging beneath. Today, the nearly universal drifter design includes a spherical flotation element and a long, large-diameter canvas tube with large holes, known as a holey sock. Its large size guarantees that the drifter moves with the waters around the sock, readily pulling the small surface sphere with it. Depending upon the application, the sock might hang just to 10 m or as deep as 100 m. The movement of the drifters are tracked by satellites. These drifters have made major contributions to our knowledge of the surface circulation of all the oceans. Some new designs come equipped with temperature sensors, and increasingly, with barometric pressure gauges. They also telemeter valuable sea surface weather information, including acoustic measurements of winds. These buoys cost-effectively complement the functions of the surface buoys.

Buoy sensors can be categorized according to whether they measure scalar or vector properties. Scalar sensors measure the state of a fluid, such as temperature, pressure, humidity, salinity, and light intensity. Vector sensors measure speed and direction of winds and currents. In the past, precipitation measurement presented formidable problems, but the tropical moorings across the Pacific have successfully measured rainfall. An acoustic method that measures the noise generated by raindrops as they hit the surface also shows promise. *See* OCEAN CIRCULATION. [H.T.R.]

**Insulation resistance testing** The measurement of direct current or voltage drop across an electrical insulating material to determine its resistance by the application of Ohm's law. Insulation resistance testing is performed either on samples of the insulation material or on the electrical equipment which uses the insulation.

Insulation resistance in solids is made up of a combination of volume resistance and surface resistance. These two types of resistances arise because the current can physically flow through the volume of the insulation material or it can find other parallel paths over the surface of the insulation. Volume resistance can be used as an indirect measure of the quality of the material with regard to processing or to detect impurities. Surface resistance measurements can be used to characterize the condition of the insulation surface, such as deposition of contaminants and insulation breakdown strength.

In all cases, the conditions under which resistance measurements on insulators are performed must be fully specified. Several factors can significantly affect the test results. Among them are the geometry of the electrode system, the nonuniformity of the material, the time period that the sample is energized, the magnitude and polarity of the voltage, the time required for charge to build up or decay in the sample, and the contour of the specimen. The measured value of insulation resistance will be most useful when the test samples and the electrodes have the same arrangement and are tested in a similar environment as that expected under actual use. Modern electronic instrumentation has simplified and improved insulation resistance measurements because of the high input impedance available with these devices, their fast response time, their memory storage capability, and their ease of operation. [T.C.C.]

**Insulin** Produced and secreted by the beta cells of the islets (insulae) of Langerhans of the pancreas, the hormone which regulates the use and storage of foodstuffs, especially the carbohydrates. Chemically insulin is a small, simple protein. Insulins from various species differ in the composition; these differences account for the fact that diabetics treated with animal insulins develop antibodies which may sometimes interfere with the action

of the hormone. The structure has been verified by synthesis of insulin from pure amino acids in the laboratory. *See* CARBOHYDRATE METABOLISM; IMMUNOLOGY; PANCREAS.

Insulin, being a polypeptide, can also be broken down by many proteolytic enzymes to its constituent amino acids. Because of these breakdown systems, the turnover of insulin in the body is rapid; its "half-life" has been estimated to be 10–30 min. The liver alone is capable of destroying about 50% of the insulin passing through it on its way from the pancreas to the bodily tissues.

The role played by insulin in the body is most clearly approached by considering the abnormalities resulting from removing insulin from an organism by surgical excision of the pancreas or by the chemical destruction of the insulin-producing cells: A state of severe diabetes is produced. Normally the blood glucose level is about 100 mg/100 ml. A carbohydrate meal raises the blood sugar to about 150 mg and the premeal value is reached again within 1.5 h. The normal organism manages to dispose of food by storage and oxidation within this period because insulin is present. When food (carbohydrate and protein) reaches the upper intestine, a substance is liberated which in turn stimulates the beta cells to secrete extra insulin. Insulin acts on most tissues to speed the uptake of glucose. In the cells the glucose is burned for energy, stored as glycogen, or transformed to and stored as fat. The human pancreas probably produces 1–2 mg of the hormone per day. This is sufficient to regulate the metabolism of more than 250 g of carbohydrate, 70 g of protein, and 75 g of fat, the usual composition of an ordinary 2000-calorie diet.

In diabetes the rate of glucose uptake is slowed, the level of circulating blood sugar rises, and sugar spills over into the excreted urine. Calories are wasted, more water is excreted, and there is muscular weakness and weight loss; hence urinary frequency, hunger, thirst, and fatigue. Whenever glucose metabolism is defective, stored fat is broken down to fatty acids because of the actions of adrenaline and the pituitary growth hormone. Insulin is able to reverse all these phenomena by favoring storage and swift intake of glucose into the tissues, by decreasing the breakdown of stored fat, and by promoting protein synthesis. *See* DIABETES.

When insulin is secreted or given in excess, it may lower the blood sugar level much below its normal value, causing hypoglycemia. Hypoglycemia is dangerous because the metabolism in the brain cells depends primarily upon an adequate supply of glucose.

The precise molecular mechanisms of insulin action are still not known. The initial step is the binding of the hormone to a specific receptor on the cell membrane. This event somehow activates a set of transport molecules, so that glucose, potassium, and amino acids enter cells more freely. At the same time, fat breakdown is slowed and glycogen storage increased. All these actions depend upon the integrity of the outer cell membrane. *See* CELL PERMEABILITY.

Not all the cells of the body require or respond to insulin. The insulin-responsive tissues are the liver, skeletal muscle, the heart, and the adipose tissue. Sensitivity to insulin is affected by many conditions. Obesity, antibodies to the hormone or its receptor, oversecretion of growth hormone or adrenal steroids, ketosis, and unknown genetic factors all cause insulin resistance. Muscular exercise, correction of obesity, and a deficiency of pituitary or adrenal hormones are associated with an increased sensitivity to the hormone. *See* ENDOCRINE MECHANISMS. [R.Lev.; B.F.]

**Intaglio (gemology)** The name given to the type of carved gemstone in which the figure is engraved into the surface of the stone, rather than left in relief by cutting away the background, as in a cameo. Intaglios are almost as old as recorded history, for this type of carving was popular in ancient Egypt in the form of cylinders. Intaglios have been carved in a variety of gem materials, including emerald, crystalline quartz, hematite, and the various forms of chalcedony. *See* CAMEO. [R.T.L.]

**Integral equation** An equation of the form typified by Eq. (1). The major problem is to decide when there is a function

$$\int_a^b K(x, y, \phi(y)) dy + f(x) = a(x)\phi(x) \quad (1)$$

$\phi(x)$  which is a solution to the equation. Equations such as (1) arise from the analysis of ordinary differential equations. Integral equation (1) is an equation of the first kind if  $a(x) \equiv 1$ , and an equation of the second kind if  $a(x) \equiv 0$ .

If  $K(x, y, \phi) = 0$  for  $x \leq y \leq b$ , Eq. (1) is called a Volterra equation. Under mild assumptions the Volterra equation of the second kind can be solved by the method of successive approximations (also known as the method of Picard).

A special case of some interest is that of linear integral equations. The function  $K(x, y, \phi)$  is a linear function of  $\phi$ . The linear equations of the first and second kind are shown in Eqs. (2) and (3) respectively. The function  $K(x, y)$  is called the kernel, and

$$f(x) = \int_a^b K(x, y)\phi(y) dy \quad (2)$$

$$\phi(x) = f(x) + \lambda \int_a^b K(x, y)\phi(y) dy \quad (3)$$

the complex number  $\lambda$  is called the parameter. The equation of the second kind, Eq. (3), is homogeneous if  $f(x) \equiv 0$ . In typical cases, the homogeneous equations will have only the trivial solution  $\phi(x) \equiv 0$ . For some values of the parameter  $\lambda$ , however, there will be nontrivial solutions. Such a value of the parameter  $\lambda$  is called a characteristic value for  $K$ , and the corresponding function  $\phi$  is called a characteristic function for  $K$ . These concepts are related to corresponding concepts in linear algebra and operator theory. See EIGENVALUE (QUANTUM MECHANICS); MATRIX THEORY; OPERATOR THEORY.

The integral equation, Eq. (2) or (3), is called a Fredholm equation, and  $K(x, y)$  is called a Fredholm kernel if  $\|K\| < \infty$ , where  $\|K\|$ , the norm of  $K$ , is defined by Eq. (4). This is certainly true

$$\|k\|^2 = \int_a^b \int_a^b |K(x, y)|^2 dx dy \quad (4)$$

if  $K$  is continuous or even bounded. Even some infinite discontinuities are allowable. Fredholm equations of the second kind for which the parameter satisfies the inequality  $|\lambda| \|K\| < 1$  can be shown to have unique solutions by the method of Picard. As a result there are no characteristic values for which  $|\lambda| \lesssim 1/\|K\|$ . In general, for any constant  $M > 0$  there are only finitely many characteristic values which satisfy  $|\lambda| \lesssim M$ . Further, only finitely many linearly independent characteristic functions are associated with each characteristic value. See INTEGRAL TRANSFORM; INTEGRATION. [J.P.]

**Integral transform** An integral relation between two classes of functions. For example, a relation such as Eq. (1) is

$$f(x) = \int_{-\infty}^{\infty} G(x, y)\phi(y) dy \quad (1)$$

said to define an integral transform. More generally, the integral may be a multiple integral, and the functions  $f$ ,  $G$ , and  $\phi$  may depend on a larger number of variables. Equation (1) is thought of as transforming a whole class, or space, of functions  $\phi(y)$  into another class of functions  $f(x)$ . The function  $G(x, y)$  is the kernel of the transform. One of the important uses of such a transform is based on the fact that a problem posed in one of the two spaces in question may be more easily solved in the other. For example, a differential equation to be solved for the function  $\phi(y)$  may become an algebraic equation for the unknown function  $f(x)$ . See LAPLACE TRANSFORM.

The two basic problems for any integral transform are inversion and representation. In inversion the aim is to recover  $\phi(y)$  from  $f(x)$ , the kernel  $G(x, y)$  being known. That is, Eq. (1) is

thought of as an integral equation (of the first kind) to be solved for the unknown function  $\phi(y)$ . A means of calculating  $\phi(y)$  from  $f(x)$  is called an inversion formula, and in its presence the transform achieves maximum utility, since explicit passage from each space to the other is thus assured. In representation the question is which functions  $f(x)$  may be written or represented in the form (1). That is, one asks which functions  $f(x)$  will make Eq. (1) solvable for  $\phi(y)$ . Usually this problem becomes more tractable when the solutions  $\phi(y)$  are restricted to some subspace such as the class of positive or bounded functions. See INTEGRAL EQUATION.

An important special case of Eq. (1) is the convolution transform, when the kernel is a function of  $(x - y)$ , Eq. (2). An equivalent form of Eq. (2) is Eq. (3), since the change of variable

$$f(x) = \int_{-\infty}^{\infty} G(x - y)\phi(y) dy \quad (2)$$

$$F(x) = \int_0^{\infty} K(xy)\phi(y) dy \quad (3)$$

$x = e^t$ ,  $y = e^{-u}$  carries Eq. (3) into Eq. (2) after a suitable change in notation. See INTEGRATION. [D.V.W.]

**Integrated-circuit filter** An electronic filter implemented as an integrated circuit, as contrasted with filters made by interconnecting discrete electrical components. The design of an integrated-circuit filter (also called simply an integrated filter) is constrained by the unavailability of certain types of components, such as piezoelectric resonators, that are often valuable in filtering. However, integrated filters can benefit from small size, close integration with other parts of a system, and the low cost of manufacturing very complex integrated circuits.

Filters have many applications. An important one is to smooth signal waveforms sufficiently to allow accurate sampling or to interpolate smoothly between given samples of a signal. Since the analog-to-digital converters that sample signals are usually made as integrated circuits (chips), it is often convenient to put the associated filters on the same chip. See ANALOG-TO-DIGITAL CONVERTER.

Passive filters, made by interconnecting inductors and capacitors, are not easily integrated because integrated-circuit inductors are usually of poor quality. This problem is less serious at frequencies above 1 GHz, so microwave filters can be passive. See MICROWAVE FILTER.

Because amplifiers are very cheap in integrated-circuit technology, active filters are widely implemented. The five main types of active filter—active-RC, MOSFET-C, transconductance-C, switched-capacitor (or switched-C), and active-RLC—are distinguished by their frequency-sensitive components. The switched-capacitor filters operate on samples of signals, while the other types operate without sampling (in continuous time). There is also a trend toward digital filters, which are easily integrated but require that analog signals be converted to digital form, which in turn requires filtering. See DIGITAL FILTER.

Discrete active-RC filters were widely used in the 1970s, and modern integrated filters are derived from them. The frequency-sensitive mechanism in active-RC filters is the charging of a capacitor  $C$  through a resistor  $R$ , giving a characteristic frequency  $\omega_0 = 1/RC$  radians per second, at which the impedances of the resistor and capacitor are equal. Unfortunately, integrated-circuit manufacturing techniques do not control the product  $RC$  at all accurately, with variations of 20–50% being possible. This limits active-RC filtering to those applications where accuracy is unimportant, where external passive components are tolerable, or where tuning circuitry is available.

MOSFET-C filters replace the resistors of an active-RC filter with metal-oxide-semiconductor (MOS) transistors, in which a conducting channel along the surface can be enhanced or depleted by applying an electrical field from a gate electrode,

thereby changing the resistance of the channel. The result is a tunable variant of an active-RC filter. See TRANSISTOR.

Transconductance-C filters combine the functions of the amplifier and the simulated resistor into a transconductance amplifier, whose output current (rather than output voltage) is proportional to its input voltage. Transconductance amplifiers can be very simple and hence are capable of high-frequency operation (up to approximately 1 GHz) but tend to have poor linearity when designed for high speeds.

A technique known as active-RLC filtering combines the ideas of active filtering with the use of physical inductors (made as spirals of metallization on the top layer of the chip). In this method, amplifiers, connected to simulate negative resistors, are used to enhance the performance of the inductors, whose losses can be modeled (to a first approximation) as being caused by a parallel positive resistance.

The primary advantage of switched-capacitor filters is that they can be very accurate, since critical frequencies are determined by the product of a clock frequency and a ratio of capacitors (rather than a single capacitor). Switched-capacitor filters are probably the most prevalent integrated filters. Most telephone systems, for example, use them to smooth signals before sampling them for digital transmission. See ELECTRIC FILTER; INTEGRATED CIRCUITS; SWITCHED CAPACITOR. [M.Sn.]

**Integrated circuits** Miniature electronic circuits produced within and upon a single semiconductor crystal, usually silicon. Integrated circuits range in complexity from simple logic circuits and amplifiers, about  $\frac{1}{20}$  in. (1.3 mm) square, to large-scale integrated circuits up to about  $\frac{1}{2}$  in. (12 mm) square. They can contain millions of transistors and other components that provide computer memory circuits and complex logic subsystems such as microcomputer central processor units. See SEMICONDUCTOR; SILICON.

Integrated circuits consist of the combination of active electronic devices such as transistors and diodes with passive components such as resistors and capacitors, within and upon a single semiconductor crystal. The construction of these elements within the semiconductor is achieved through the introduction of electrically active impurities into well-defined regions of the semiconductor. The fabrication of integrated circuits thus involves such processes as vapor-phase deposition of semiconductors and insulators, oxidation, solid-state diffusion, ion implantation, vacuum deposition, and sputtering.

Generally, integrated circuits are not straightforward replacements of electronic circuits assembled from discrete components. They represent an extension of the technology by which silicon planar transistors are made. Because of this, transistors or modifications of transistor structures are the primary devices of integrated circuits. Methods of fabricating good-quality resistors and capacitors have been devised, but the third major type of passive component, inductors, must be simulated with complex circuitry or added to the integrated circuit as discrete components. See TRANSISTOR.

Integrated circuits can be classified into two groups on the basis of the type of transistors which they employ: bipolar integrated circuits, in which the principal element is the bipolar junction transistor; and metal oxide semiconductor (MOS) integrated circuits, in which the principal element is the MOS transistor. Both depend upon the construction of a desired pattern of electrically active impurities within the semiconductor body, and upon the formation of an interconnection pattern of metal films on the surface of the semiconductor.

Bipolar circuits are generally used where highest logic speed is desired, and MOS for largest-scale integration or lowest power dissipation. High-performance bipolar transistors and complementary MOS (CMOS) transistors have been combined on the same chip (BiCMOS) to obtain circuits combining high speed and high density.

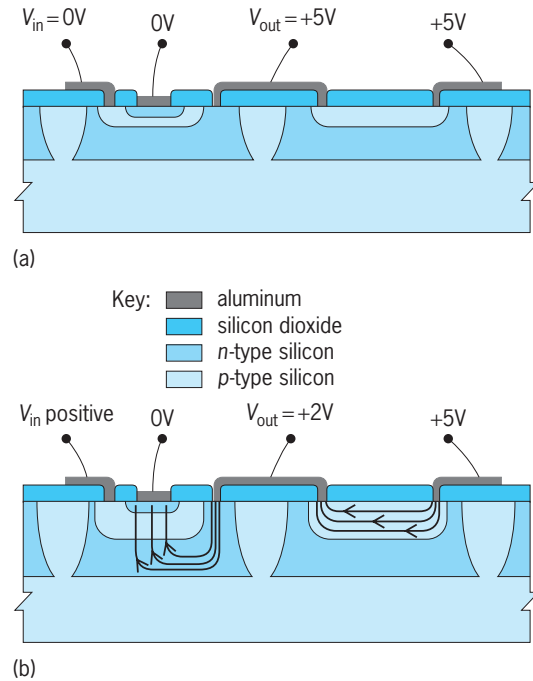

**Fig. 1. Operation of bipolar inverter circuit (cross-sectional view). (a) Input voltage  $V_{in}$  is zero. (b) Positive input voltage applied; arrows indicate direction of current flow.**

**Bipolar integrated circuits.** A simple bipolar inverter circuit using a diffused resistor and an *n*pn transistor is shown in Fig. 1. The input voltage  $V_{in}$  is applied to the base of the transistor. When  $V_{in}$  is zero or negative with respect to the emitter, no current flows. As a result, no voltage drop exists across the resistor, and the output voltage  $V_{out}$  will be the same as the externally applied biasing voltage, +5 V in this example. When a positive input voltage is applied, the transistor becomes conducting. Current now flows through the transistor, hence through the resistor: as a result, the output voltage decreases. Thus, the change in input voltage appears inverted at the output.

The tendency toward increased complexity is dictated by the economics of integrated circuit manufacturing. Because of the nature of this manufacturing process, all circuits on a slice are fabricated together. Consequently, the more circuitry accommodated on a slice, the cheaper the circuitry becomes. Because testing and packaging costs depend on the number of chips, it is desirable, in order to keep costs down, to crowd more circuitry onto a given chip rather than to increase the number of chips on a wafer.

Integrated circuits based on amplifiers are called linear because amplifiers usually exhibit a linearly proportional response to input signal variations. However, the category includes memory sense amplifiers, combinations of analog and digital processing functions, and other circuits with nonlinear characteristics. Some digital and analog combinations include analog-to-digital converters, timing controls, and modems (data communications modulator-demodulator units). See ANALOG-TO-DIGITAL CONVERTER; DATA COMMUNICATIONS.

In the continuing effort to increase the complexity and speed of digital circuits, and the performance characteristics and versatility of linear circuits, a significant role has been played by the discovery and development of new types of active and passive semiconductor devices which are suitable for use in integrated circuits. Among these devices is the *pnp* transistor which, when used in conjunction with the standard *n*pn transistors described above, lends added flexibility to the design of integrated circuits.

**MOS integrated circuits.** The other major class of integrated circuits is called MOS because its principal device is a

metal oxide semiconductor field-effect transistor (MOSFET). It is more suitable for very large-scale integration (VLSI) than bipolar circuits because MOS transistors are self-isolating and can have an average size of less than  $10^{-7}$  in.<sup>2</sup> ( $10^{-5}$  mm<sup>2</sup>). This has made it practical to use millions of transistors per circuit. Because of this high-density capability, MOS transistors are used for high-density random-access memories (RAMs), read-only memories (ROMs), and microprocessors. See COMPUTER STORAGE TECHNOLOGY; MICROPROCESSOR; SEMICONDUCTOR MEMORIES.

Several major types of MOS device fabrication technologies have been developed since the mid-1960s. They are (1) metal-gate *p*-channel MOS (PMOS), which uses aluminum for electrodes and interconnections; (2) silicon-gate *p*-channel MOS, employing polycrystalline silicon for gate electrodes and the first interconnection layer; (3) *n*-channel MOS (NMOS), which is usually silicon gate; and (4) complementary MOS (CMOS), which employs both *p*-channel and *n*-channel devices.

Both conceptually and structurally the MOS transistor is a much simpler device than the bipolar transistor. In fact, its principle of operation has been known since the late 1930s, and the research effort that led to the discovery of the bipolar transistor was originally aimed at developing the MOS transistor. What kept this simple device from commercial utilization until 1964 is the fact that it depends on the properties of the semiconductor surface for its operation, while the bipolar transistor depends principally on the bulk properties of the semiconductor crystal. Hence MOS transistors became practical only when understanding and control of the properties of the oxidized silicon surface had been perfected to a very great degree.

A simple CMOS inverter circuit is shown in Fig. 2. The gates of the *n*-channel and *p*-channel transistors are connected together as are the drains. The common gate connection is the input node while the common drain connection is the output node. A capacitor is added to the output node to model the loading expected from the subsequent stages on typical circuits.

When the input node is in the "low state," at 0 V, the *n*-channel gate to source voltage is 0 V while the *p*-channel gate to source voltage is  $-5$  V. The *n*-channel transistor requires a positive gate-to-source voltage, which is greater than the transistor threshold voltage (typically 0.5–1 V), before it will start conducting current between the drain and source. Thus, with a 0-V gate-to-source voltage it will be off and no current will flow through the drain and source regions. The *p*-channel transistor, however, requires a negative voltage between the gate and source which is less than its threshold voltage (typically  $-0.5$  to  $-1.5$  V). The  $-5$ -V gate-to-source potential is clearly less than the threshold voltage, and the *p*-channel will be turned on, conducting current from the source to the drain, and thereby charging up the loading capacitor. Once the capacitor is charged to the "high state" at 5 V, the transistor will no longer conduct because there will no longer be a potential difference between the source and drain regions.

When the input is now put to the "high state" at 5 V, just the opposite occurs. The *n*-channel transistor will be turned on while the *p*-channel will be off. This will allow the load capacitor to discharge through the *n*-channel transistor resulting in the output voltage dropping from a "high state" at 5 V to a "low state" at 0 V. Again, once there is no potential difference between the drain and source (capacitor discharged to 0 V), the current flow will stop, and the circuit will be stable.

This simple circuit illustrates a very important feature of CMOS circuits. Once the loading capacitor has been either charged to 5 V or discharged back to 0 V, there is no current flow, and the standby power is very low. This is the reason for the high popularity of CMOS for battery-based systems. None of the other MOS technologies offers this feature without complex circuit techniques, and even then will typically not match the low standby power of CMOS. The bipolar circuits discussed above require even more power than these other MOS technologies. The price for CMOS's lower power are the additional

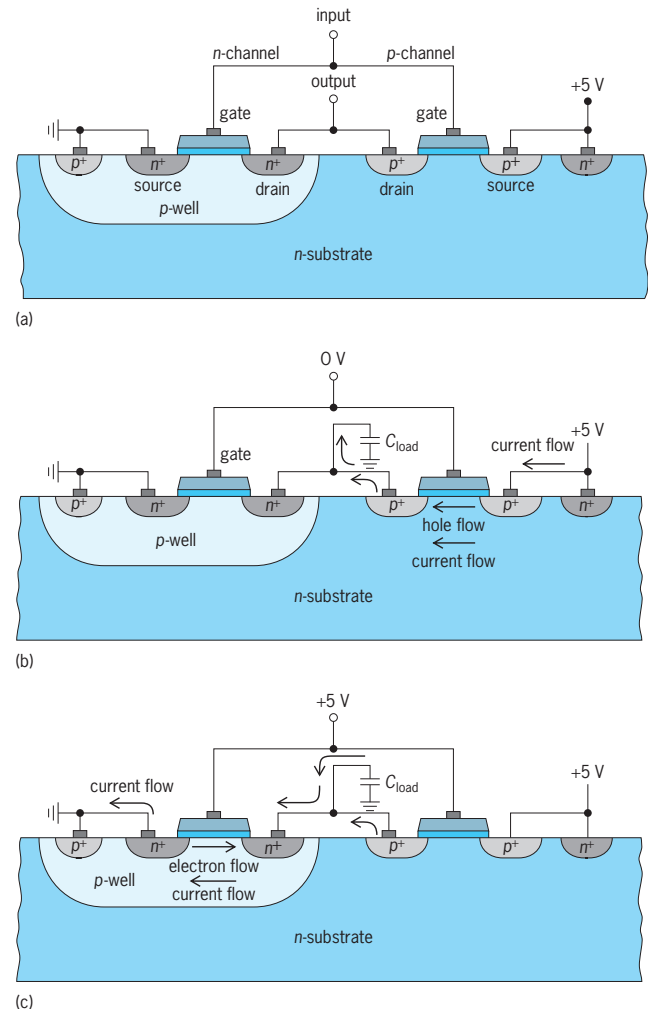

Fig. 2. Simple CMOS inverter circuit. (a) Schematic cross section. (b) Current flow when input is "low" at 0 V. (c) Current flow when input is "high" at 5 V.

fabrication steps required (10–20% more) when compared to NMOS.

**BiCMOS integrated circuits.** There is a strong interest in combining high-performance bipolar transistors and high-density CMOS transistors on the same chip (BiCMOS). This concept originated with work on bipolar circuits when power limitations became important as more functionality (and thus more transistors) was added to the chip. It is possible to continue adding more circuits on a chip without increasing the power by combining the low-power CMOS circuits with the bipolar circuits. This is done with both memory circuits and logic circuits, resulting in speeds somewhere between those of typical CMOS and bipolar-only circuits, but with the functional density of CMOS. The disadvantage of BiCMOS is its additional cost over plain CMOS or bipolar circuits, because the number of processing steps increases 20–30%. However, this increased complexity is expected to be used when either the additional functionality over bipolar circuits or the increased speed over CMOS circuits justifies the cost. [R.Bu.; Y.E.M.; N.Be.]

**Fabrication.** Integrated-circuit fabrication begins with a thin, polished slice of high-purity, single-crystal semiconductor (usually silicon) and employs a combination of physical and chemical processes to create the integrated-circuit structures described above. Junctions are formed in the silicon slice by the processes of thermal diffusion or high-energy ion implantation. Electrical isolation between devices on the integrated circuit is achieved with insulating layers grown by thermal oxidation or deposited

by chemical deposition. Conductor layers to provide the necessary electrical connections on the integrated circuit are obtained by a variety of deposition techniques. Precision lithographic processes are used throughout the fabrication sequence to define the geometric features required.

[B.L.G.; E.A.I.]

**Design.** VLSI chips containing  $10^6$  transistors and operating at tens of megahertz have been designed and fabricated and are commercially available. Projections indicate that silicon chips containing as many as  $10^8$  transistors may be feasible for digital applications and that perhaps even a  $10^9$  transistor chip is feasible for dynamic random access memories (DRAMs) before fundamental limits constrain the growth of complexity. (The limits beyond which the size of a transistor cannot be reduced are thought to depend on the degradation of its material properties when it is operated at high-field conditions and the general degradation of its performance and reliability.) Computer-aided engineering (CAE) systems provide the environment, specific computer tools, data management, and other services that are intended to support the design of these very complex, high-performance products. In many cases, the design of complex chips requires the cooperative endeavors of large design teams; thus the CAE system must also manage the design process to ensure that proper documentation has occurred, needed changes in the design database are made, and a chosen design methodology is enforced. The design process must be adapted to the very short design cycle times from product conception to production of a salable product that are characteristic of the semiconductor industry.

[R.K.Ca.]

**Gallium arsenide circuits.** Integrated circuits based on gallium arsenide (GaAs) have come into increasing use since the late 1970s. The major advantage of these circuits is their fast switching speed.

The gallium arsenide field-effect transistor (GaAs FET) is a majority carrier device in which the cross-sectional area of the conducting path of the carriers is varied by the potential applied to the gate. Unlike the MOSFET, the gate of the GaAs FET is a Schottky barrier composed of metal and gallium arsenide. Because of the difference in work functions of the two materials, a junction is formed. The depletion region associated with the junction is a function of the difference in voltage of the gate and the conducting channel, and the doping density of the channel. By applying a negative voltage to the gate, the electrons under the gate in the channel are repelled, extending the depletion region across the conducting channel. The variation in the height of the conducting portion of the channel caused by the change in the extent of the depletion region alters the resistance between the drain and source. Thus the negative voltage on the gate modulates the current flowing between the drain and the source. As the height of the conducting channel is decreased by the gate voltage or as the drain voltage is increased, the velocity of charge carriers (electrons for *n*-type gallium arsenide) under the gate increases (similar to water in a hose when its path is constricted by passing through the nozzle). The velocity of the carriers continues to increase with increasing drain voltage, as does the current, until their saturated velocity is obtained (about  $10^7$  cm/s or  $3 \times 10^5$  ft/s for gallium arsenide). At that point the device is in the saturated region of operation; that is, the current is independent of the drain voltage.

[P.T.G.]

**Integrated optics** The study of optical devices that are based on light transmission in planar waveguides, that is, dielectric structures that confine the propagating light to a region with one or two very small dimensions, on the order of the optical wavelength. The principal motivation for these studies is to combine miniaturized individual devices through waveguides or other means into a functional optical system incorporated into a small substrate. The resulting system is called an integrated optical circuit (IOC) by analogy with the semiconductor type of integrated circuit. An integrated optical circuit could include lasers, integrated lenses, switches, interferometers, polarizers, modula-

tors, detectors, and so forth. Important uses envisioned for integrated optical circuits include signal processing (for example, spectrum analysis and analog-to-digital conversion) and optical communications through glass fibers, which are themselves circular (or elliptical) waveguides. Integrated optical circuits could be used in such systems as optical transmitters, switches, repeaters, and receivers. See INTEGRATED CIRCUITS; OPTICAL COMMUNICATIONS; OPTICAL FIBERS.

The advantages of having an optical system in the form of an integrated optical circuit rather than a conventional series of components include (apart from miniaturization) reduced sensitivity to air currents and to mechanical vibrations of the separately mounted parts, low driving voltages and high efficiency, robustness, and (potentially) reproducibility and economy. As in the case of semiconductor integrated circuits, an integrated optical circuit might be fabricated on or just within the surface of one material (the substrate) modified for the different components by shaping structures (using etching, for example) or incorporating suitable substitutes or dopants, or alternatively, by depositing or epitaxially growing additional layers. It is also possible to construct independent components which are then attached to form the integrated optical circuit. This option, called hybrid, has the advantage that each component could be optimized, for example, by using gallium aluminum arsenide lasers as sources for an integrated optical circuit and silicon detectors. In the former case, the integrated optical circuit is called monolithic, and is expected to have the advantage of ease of processing, similar to the situation for monolithic semiconductor integrated circuits. Perhaps the most promising materials for monolithic integrated optical circuits are direct band-gap semiconductors composed of III-V materials such as gallium aluminum arsenide [(GaAl)As] and indium gallium arsenide phosphide [(InGa)(AsP)] since with suitable processing they may perform almost all necessary operations as lasers, switches, modulators, detectors, and so forth. See ELECTROOPTICS; LASER; OPTICAL MODULATORS; SEMICONDUCTOR HETEROSTRUCTURES; SPECTRUM ANALYZER; WAVEGUIDE.

[W.Str.]

### Integrated services digital network (ISDN)

A generic term referring to the integration of communications services transported over digital facilities such as wire pairs, coaxial cables, optical fibers, microwave radio, and satellites. ISDN provides end-to-end digital connectivity between any two (or more) communications devices. Information enters, passes through, and exits the network in a completely digital fashion.

Since the introduction of pulse-code-modulation (PCM) transmission in 1962, the worldwide communications system has been evolving toward use of the most advanced digital technology for both voice and nonvoice applications. Pulsecode modulation is a sampling technique which transforms a voice signal with a bandwidth of 4 kHz into a digital bit stream, usually of 64 kilobits per second (kbps). See PULSE MODULATION.

Many aspects of telecommunications are improved with digital technology. For example, digital technology lends itself to very large-scale integration (VLSI) technology and its associated benefits of miniaturization and cost reduction. In addition, computers operate digitally. Digital transport provides for human-to-human, computer-to-computer, and human-to-computer interactions. The ISDN is capable of transporting voice, data, graphics, text, and even video information over the same equipment. See DATA COMMUNICATIONS; DIGITAL COMPUTER; INTEGRATED CIRCUITS.

The customer has access to a wide spectrum of communications services by way of a single access link. This is in contrast to existing methods of service access, which segregate services into specialized lines.

Associated with integrated access and ISDN is the concept of a standard interface. The objective of a standard interface is to allow any ISDN terminal to be plugged into any ISDN interface,



resulting in terminal portability, flexibility, and ease in operation. See ELECTRICAL COMMUNICATIONS. [R.M.Wi.; A.E.J.]

**Integration** An operation of the infinitesimal calculus which has two aspects. The roots of one go back to antiquity, for Archimedes and other Greek mathematicians used the “method of exhaustion” to compute areas and volumes. A simple example of this is the approximation to the area of a circle obtained by inscribing a regular polygon of known area, and then repeatedly doubling the number of sides. The areas of the successive polygons are computable with the help of elementary geometry. The limit of the sequence of these areas gives the area of the circle. The area of each polygon can be regarded as being made up of the sum of the areas of triangles with vertices at the center of the circle, and so the process described is a constructive definition of an integral which is the limit of a sum. Modern definitions of integrals as limits of sums are discussed in this article.

The other aspect of integration is the process of finding antiderivatives, that is, for a given function  $f(x)$  to find another function  $g(x)$  whose derivative is  $f(x)$ . This aspect is related to the first by the fundamental theorem of integral calculus, so both processes are called integration.

In the early 19th century A. L. Cauchy gave a clear-cut definition of the definite integral for continuous functions and a proof of its existence. Later, G. F. B. Riemann discussed the integral for discontinuous functions and gave a necessary and sufficient condition for its existence. Thus the most generally used definition of the integral as the limit of a sum has come to be called the Riemann integral.

The precise definition of the Riemann integral for a real function  $f$  of one real variable  $x$  on a finite interval  $a \leq x \leq b$  may be formulated as follows. Let  $P$  be a partition of the interval  $[a, b]$  into  $n$  subintervals by points  $t_i$  where  $t_{i-1} < t_i$ ,  $t_0 = a$ ,  $t_n = b$  and consider a sum  $S$  of the form of Eq. (1), where  $t_{i-1} \leq x_i \leq t_i$ . The

$$S = \sum_{i=1}^n f(x_i)(t_i - t_{i-1}) \tag{1}$$

sum  $S$  depends not only on the partition  $P$  but on the choice of the intermediate points  $x_i$ . It may happen that the sum  $S$  approaches a definite limit  $I$  when the maximum of the numbers  $(t_i - t_{i-1})$  tends to zero, and in this case  $I$  is called the Riemann integral (or the definite integral) of  $f$  from  $a$  to  $b$ , and is denoted by the Leibnizian symbol (2).

$$\int_a^b f(x)dx \tag{2}$$

Also,  $f$  is said to be integrable on  $[a, b]$ . When  $f$  is a continuous function with positive values on the interval  $[a, b]$ , the integral has a simple geometrical interpretation as the area bounded by the  $x$  axis, the ordinates  $x = a$  and  $x = b$ , and the graph of  $y = f(x)$  (Fig. 1).

It can be proved that a function  $f$  is integrable on  $[a, b]$  if and only if the following two conditions are satisfied:  $f$  is bounded on  $[a, b]$ ; and the set of points where  $f$  is discontinuous can be

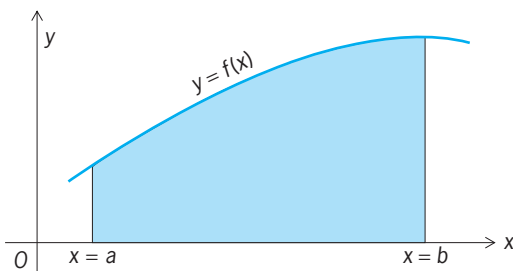

Fig. 1. Graph of  $y = f(x)$ .

enclosed in a series (possibly infinite) of intervals, the sum of whose lengths is arbitrarily near to zero.

To develop the fundamental theorem of integral calculus let  $u$  be a variable in the interval  $[a, b]$ , on which  $f$  is integrable; then formula (3) defines a function of  $u$  which may be noted by

$$\int_a^u f(x)dx \tag{3}$$

$I(u)$ . If  $f$  is continuous on  $[a, b]$ , then  $f$  is integrable, and it is also true that  $I(u)$  has a derivative  $I'(u) = f(u)$ . Now let  $h$  be any antiderivative of  $f$ , that is,  $h'(u) = f(u)$  on  $[a, b]$ . Then  $I'(u) - h'(u) = 0$ , so  $I(u) - h(u) = \text{constant} = -h(a)$ , by the theorem of the mean for derivatives and the fact that  $I(a) = 0$ , so relation (4) can be

$$I = I(b) = h(b) - h(a) \tag{4}$$

written, This is the fundamental theorem of integral calculus, and it shows that definite integrals may be calculated by the process of finding antiderivatives. For this reason antiderivatives are frequently called indefinite integrals and denoted by  $\int f(x) dx$ , and special methods of finding indefinite integrals for frequently occurring functions occupy a large part of elementary calculus. The standard notation for an indefinite integral of  $f(x)$  is formula (5).

$$\int f(x)dx \tag{5}$$

The term improper integral refers to an extension of the notion of definite integral to cases in which the integrand is unbounded or the domain of integration is unbounded.

The concept called the Riemann integral can be extended to functions of several variables. The case of a function of two variables illustrates sufficiently the additional features which arise. To begin with, let  $f(x, y)$  denote a real function defined on a rectangle of the form (6). Let  $P$  be a partition of  $R$  into  $n$  nonoverlapping

$$R: a \leq x \leq b \quad c \leq y \leq d \tag{6}$$

rectangles  $R_i$  with areas  $A_i$ , and let  $(x_i, y_i)$  be a point of  $R_i$ . Define  $S$  by Eq. (7). In case the sum  $S$  tends to a definite limit  $I$  when

$$S = \sum_{i=1}^n f(x_i, y_i)A_i \tag{7}$$

the maximum diagonal of a rectangle  $R_i$  tends to zero, then  $f$  is said to be integrable over  $R$ , and the limit  $I$  is called the Riemann integral of  $f$  over  $R$ . It will be denoted here by the abbreviated symbol  $\iint_R f$ .

To define the integral of a function  $f(x, y)$  over a more general domain  $D$  where it is defined, suppose that  $D$  is enclosed in a rectangle  $R$ , and define  $F(x, y)$  by Eqs. (8). Then  $f$  is said to be integrable over  $D$  in case  $F$  is integrable over  $R$ , and Eq. (9) holds, by definition.

$$\begin{aligned} F(x, y) &= f(x, y) \text{ in } D \\ F(x, y) &= 0 \text{ outside } D \end{aligned} \tag{8}$$

$$\iint_D f = \iint_R F \tag{9}$$

When the function  $f(x, y)$  is continuous on  $D$ , and  $D$  is defined by inequalities of the form (10), where the functions  $\alpha(x)$  and

$$a \leq x \leq b \quad \alpha(x) \leq y \leq \beta(x) \tag{10}$$

$\beta(x)$  are continuous, the double integral of  $f$  over  $D$  always exists, and may be represented in terms of two simple integrals by Eq. (11). In many cases, this formula makes possible the evaluation of the double integral.

$$\iint_D f = \int_a^b \left[ \int_{\alpha(x)}^{\beta(x)} f(x, y)dy \right] dx \tag{11}$$

In the study of the “space” of real functions defined, for example, on the interval  $a \leq x \leq b$ , it is frequently useful to take

formula (12) as the distance between the functions  $f$  and  $g$ . This

$$\int_a^b |f(x) - g(x)| dx \tag{12}$$

distance already has a meaning when  $f$  and  $g$  are Riemann-integrable, that is, bounded and not too discontinuous, in the sense specified for the Riemann integral. There is no generally useful extension of the concept of integral to apply to all real functions on  $[a,b]$ , but is desirable to extend it to apply to the functions obtained from the continuous ones by certain limiting processes. In particular, it is desirable to have correspond to each sequence  $(f_n)$  of functions satisfying the Cauchy condition for convergence in terms of the distance (12), namely Eq. (13),

$$\lim_{m \rightarrow \infty} \lim_{n \rightarrow \infty} \int_a^b |f_m(x) - f_n(x)| dx = 0 \tag{13}$$

a function  $g$  which is integrable (in the extended sense), and for which Eq. (14) holds. An extended definition of integral having

$$\lim_{n \rightarrow \infty} \int_a^b |f_n(x) - g(x)| dx = 0 \tag{14}$$

this property was given by H. L. Lebesgue.

F. Riesz devised an equivalent definition which can be stated quite simply, at least for the case of a bounded function  $g(x)$ . As a first definition, a point set  $S$  in the interval  $[a,b]$  has measure zero in case it can be enclosed in a sequence (finite or infinite) of intervals, the sum of whose lengths is arbitrarily small. Also, a step function  $f(x)$  is defined as one which is constant on each interval of a partition of  $[a,b]$ , as in Fig. 2. The Riemann integral

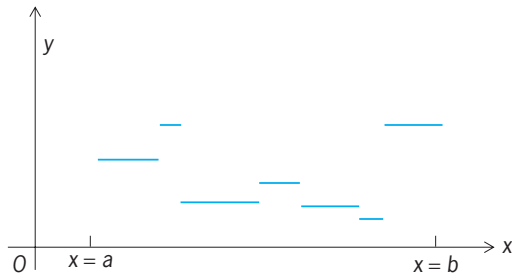

Fig. 2. Step function  $f(x)$ .

of a step function is expressible as a finite sum. Then a bounded function  $g(x)$  is integrable in Lebesgue's sense in case it is the limit of a uniformly bounded sequence of step functions  $f_n(x)$ , at each point of  $[a,b]$  except those in a set  $S$  with measure zero, and by definition Eq. (15) can be written. In case the step functions  $f_n$  in

$$\int_a^b g(x) dx = \lim_{n \rightarrow \infty} \int_a^b f_n(x) dx \tag{15}$$

Eq. (15) are replaced by Lebesgue-integrable functions forming a uniformly bounded sequence, no new functions  $g$  are obtained.

The integral of Lebesgue is also defined for unbounded functions, but the points of infinite discontinuity do not need to be considered one by one. For each function  $g(x)$  and each positive integer  $N$  let  $g_N(x)$  denote the lesser of  $g(x)$  and  $N$ . If each  $g_N(x)$  is Lebesgue-integrable in the sense already defined, expressed (16) forms a nondecreasing sequence, and so if expression (16)

$$\int_a^b g_N(x) dx \tag{16}$$

is bounded, it tends to a finite limit, which is taken as the value of integral (17).

$$\int_a^b g(x) dx \tag{17}$$

If  $\alpha(x)$  is a fixed function defined on the interval  $[a,b]$ , the sum  $S$  defined by Eq. (1) may be replaced by that in Eq. (18).

$$S = \sum_{i=1}^n f(x_i) [\alpha(t_i) - \alpha(t_{i-1})] \tag{18}$$

Then if the limit  $I$  of  $S$  exists in this case, it is called the stieltjes integral of  $f$  with respect to  $\alpha$ , and is denoted by integral (19).

$$\int_a^b f(x) d\alpha(x) \tag{19}$$

It has many of the properties of the Riemann integral, especially in case the function  $\alpha$  is nondecreasing. See CALCULUS; FOURIER SERIES; SERIES. [L.M.G.]

**Integumentary patterns** All the features of the skin and its appendages that are arranged in designs, both in humans and other animals. Examples are scales, hairs, and feathers; coloration; and epidermal ridges of the fingers, palms, and feet. In its common usage, the term applies to the configurations of epidermal ridges, collectively named dermatoglyphics. Dermatoglyphics are characteristic of primates. See EPIDERMAL RIDGES; FEATHER; HAIR; SCALE (ZOOLOGY).

The superficial ridges are associated with a specific inner organization of skin. Skin is composed of two chief layers, the epidermis on the outside and the dermis underlying it. These two layers are mortised by pegs of dermis, a double row of pegs corresponding to each ridge; these pegs accordingly form a patterning like that of the ridges.

The patterning of ridges, including that of the epidermal-dermal mortising, is determined during the third and fourth fetal months. All characteristics of single ridges and of their alignments are then determined definitively. Ridge alignments reflect directions of stress in growth of the hand and foot at the critical period of ridge differentiation. An important element in the production of localized patterns, for example, on the terminal segment of each digit, is the development in the fetus of a series of elevations, the volar pads.

The pads are homologs of the prominent pads on the paws of some mammals, but in primates they attain little elevation and soon tend to subside. The volar pads are disposed in a consistent topographic plan. Localized patterns have the same placement because growth of the pad is the determiner of the specific local pattern. When a pad has subsided before ridges are formed, its area does not present a localized pattern, and the ridges follow essentially straight, parallel courses. Variations in contours of the pads are accompanied by wide variations in the designs formed by the ridges overlying them.

Variability of patterning is a major feature of dermatoglyphics and the basis for various applications. In personal identification, prints, customarily of fingers, are classified for filing in accordance with variables of pattern type and counts of ridges. In anthropological and medical investigations, groups of individuals are compared statistically in reference to the occurrence of these variables. Deductions may be drawn in accordance with likeness or unlikeness in the directions of variation. See FINGERPRINT; SKIN. [H.Cu.]

**Intelligence** General mental ability due to the integrative and adaptive functions of the brain that permit complex, un-stereotyped, purposive responses to novel or changing situations, involving discrimination, generalization, learning, concept formation, inference, mental manipulation of memories, images, words and abstract symbols, education of relations and correlates, reasoning, and problem solving.

Intelligence tests are diverse collections of tasks (or items), graded in difficulty. The person's performance on each item can be objectively scored (for example, pass or fail); the total number of items passed is called the raw score. Raw scores are converted

to some form of scaled scores which can be given a statistical interpretation.

The first practical intelligence test for children, devised in 1905 by the French psychologist Alfred Binet, converted raw scores to a scale of "mental age," defined as the raw score obtained by the average of all children of a given age. Mental age (MA) divided by chronological age (CA) yields the well known intelligence quotient or IQ. When multiplied by 100 (to get rid of the decimal), the average IQ at every age is therefore 100, with a standard deviation of approximately 15 or 16. Because raw scores on mental tests increase linearly with age only up to about 16 years, the conversion of raw scores to a mental-age scale beyond age 16 must resort to statistical artifices. Because of this problem and the difficulty of constructing mental-age scales which preserve exactly the same standard deviation of IQs at every age, all modern tests have abandoned the mental-age concept and the calculation of IQ from the ratio of MA to CA. Nowadays the IQ is simply a standardized score with a population mean of 100 and a standard deviation ( $\sigma$ ) of 15 at every age from early childhood into adulthood. The middle 50%, considered "average," fall between IQs of 90 and 110. IQs below 70 generally indicate "mental retardation," and above 130, "giftedness." [A.R.J.]

**Intelligent machine** Any machine that can accomplish its specific task in the presence of uncertainty and variability in its environment. The machine's ability to monitor its environment, allowing it to adjust its actions based on what it has sensed, is a prerequisite for intelligence. The term intelligent machine is an anthropomorphism in that intelligence is defined by the criterion that the actions would appear intelligent if a person were to do it. A precise, unambiguous, and commonly held definition of intelligence does not exist.

Examples of intelligent machines include industrial robots equipped with sensors, computers equipped with speech recognition and voice synthesis, self-guided vehicles relying on vision rather than on marked roadways, and so-called smart weapons, which are capable of target identification. These varied systems include three major subsystems: sensors, actuators, and control. The class of computer programs known as expert systems is included with intelligent machines, even though the sensory input and output functions are simply character-oriented communications. The complexity of control and the mimicking of human deductive and logic skills makes expert systems central in the realm of intelligent machines. See COMPUTER VISION; EXPERT SYSTEMS; GUIDANCE SYSTEMS; ROBOTICS; SPEECH RECOGNITION; VOICE RESPONSE.

Since the physical embodiment of the machine or the particular task performed by the machine does not mark it as intelligent, the appearance of intelligence must come from the nature of the control or decision-making process that the machine performs. Given the centrality of control to any form of intelligent machine, intelligent control is the essence of an intelligent machine. The control function accepts several kinds of data, including the specification for the task to be performed and the current state of the task from the sensors. The control function then computes the signals needed to accomplish the task. When the task is completed, this also must be recognized and the controller must signal the supervisor that it is ready for the next assignment (see illustration). See ADAPTIVE CONTROL; CONTROL SYSTEMS.

Automatic, feedback, or regulatory systems such as thermostats, automobile cruise controls, and photoelectric door openers are not considered intelligent machines. Several important concepts separate these simple feedback and control systems from intelligent control. While examples could be derived from any of the classes of intelligent machines, robots will be used here to illustrate five concepts that are typical of intelligent control. (1) An intelligent control system typically deals with many sources of information about its state and the state of its environment. (2) An intelligent control system can accommodate incomplete or inconsistent information. (3) Intelligent control is

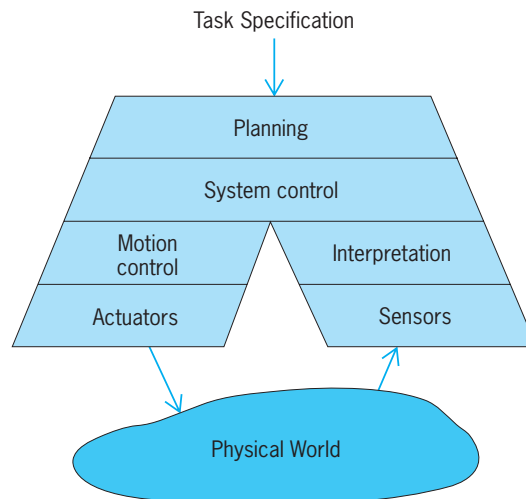

Flow of information and data in a typical intelligent machine.

characterized by the use of heuristic methods in addition to algorithmic control methods. (A heuristic is a rule of thumb, a particular solution or strategy to be used for solving a problem that can be used for only very limited ranges of the input parameters.) (4) An intelligent machine has a builtin knowledge base that it can use to deal with infrequent or unplanned events. (5) An algorithmic control approach assumes that all relevant data for making decisions is available. [J.F.Ja.]

**Intercalation compounds** Crystalline or partially crystalline solids consisting of a host lattice containing voids into which guest atoms or molecules are inserted. Candidate hosts for intercalation reactions may be classified by the number of directions (0 to 3) along which the lattice is strongly bonded and thus unaffected by the intercalation reaction. Isotropic, three-dimensional lattices (including many oxides and zeolites) contain large voids that can accept multiple guest atoms or molecules. Layer-type, two-dimensional lattices (graphite and clays) swell up perpendicular to the layers when the guest atoms enter. The chains in one-dimensional structures (polymers such as polyacetylene) rotate cooperatively about their axes during the intercalation reaction to form channels that are occupied by the guest atoms. In the intercalation family based on solid  $C_{60}$  (buckminsterfullerene), the zero-dimensional host lattice consists of 60-atom carbon clusters with strong internal bonding but weak intercluster bonding. These clusters pack together like hard 1-nm-diameter spheres, creating interstitial voids which are large enough to accept most elements in the periodic table. The proportions of guest and host atoms may be varied continuously in many of these materials, which are therefore not true compounds. Many ternary and quaternary substances, containing two or three distinct guest species, are known. The guest may be an atom or inorganic molecule (such as an alkali metal, halogen, or metal halide), an organic molecule (for example, an aromatic such as benzene, pyridine, or ammonia), or both. See CRYSTAL STRUCTURE; FULLERENE; GRAPHITE; POLYMER; ZEOLITE.

Many applications of intercalation compounds derive from the reversibility of the intercalation reaction. The best-known example is pottery: Water intercalated between the silicate sheets makes wet clay plastic, while driving the water out during firing results in a dense, hard, durable material. Many intercalation compounds are good ionic conductors and are thus useful as electrodes in batteries and fuel cells. A technology for lightweight rechargeable batteries employs lithium ions which shuttle back and forth between two different intercalation electrodes as the battery is charged and discharged: vanadium oxide (three-dimensional) and graphite (two-dimensional). Zeolites containing metal atoms remain sufficiently porous to serve as

catalysts for gas-phase reactions. Many compounds can be used as convenient storage media, releasing the guest molecules in a controlled manner by mild heating. See BATTERY; CLAY, COMMERCIAL; FUEL CELL; SOLID-STATE BATTERY. [J.E.F.]

**Intercommunicating system** A privately owned system that allows voice communication between a limited number of locations, usually within a relatively small area, such as a building, office, or residence. Intercommunicating systems are generally known as intercoms. Intercom systems can vary widely in complexity, features, and technology. Though limited in size and scope, intercom systems can provide easy and reliable communication for their users.

An extremely simple intercom is a two-station arrangement in which one station is connected to the other via a dedicated wire. Other systems have multiple stations, as many as 10 to 20, any of which can connect with any other station. The user must dial a one- or two-digit code to signal the intended destination.

Still other intercom systems work in conjunction with key and hybrid key telephone/private branch exchange telephone systems. They support internal station-to-station calling rather than access to outside lines. Normally the telephone intercom is incorporated in the same telephone instrument that is used to access the public switched network. See KEY TELEPHONE SYSTEM; PRIVATE BRANCH EXCHANGE.

A third type of intercom is the wireless intercom system for intrabuilding communications, which consists of a base unit radio transmitter, equipped with an antenna, and a number of roving units tuned to different frequencies. The base can selectively communicate with individual roving units by dialing the code corresponding to each roving unit's specific frequency. See MOBILE RADIO. [B.W.B.; V.F.R.]

**Interface of phases** The boundary between any two phases. Among the three phases—gas, liquid, and solid—five types of interfaces are possible: gas-liquid, gas-solid, liquid-liquid, liquid-solid, and solid-solid. The abrupt transition from one phase to another at these boundaries, even though subject to the kinetic effects of molecular motion, is statistically a surface only one or two molecules thick.

A unique property of the surfaces of the phases that adjoin at an interface is the surface energy which is the result of unbalanced molecular fields existing at the surfaces of the two phases. Within the bulk of a given phase, the intermolecular forces are uniform because each molecule enjoys a statistically homogeneous field produced by neighboring molecules of the same substance. Molecules in the surface of a phase, however, are bounded on one side by an entirely different environment, with the result that there are intermolecular forces that then tend to pull these surface molecules toward the bulk of the phase. A drop of water, as a result, tends to assume a spherical shape in order to reduce the surface area of the droplet to a minimum.

At an interface, there will be a difference in the tendencies for each phase to attract its own molecules. Consequently, there is always a minimum in the free energy of the surfaces at an interface, the net amount of which is called the interfacial energy in units of joules/cm<sup>2</sup>. The interfacial energy can also be expressed as surface tension in units of millinewtons per meter.

The surface energy at an interface may be altered by the addition of solutes that migrate to the surface and modify the molecular forces there, or the surface energy may be changed by converting the planar interfacial boundary to a curved surface.

At liquid-solid interfaces, where the confluence of the two phases is usually termed wetting, a critical factor called the contact angle is involved. A drop of water placed on a paraffin surface, for example, retains a globular shape, whereas the same drop of water placed on a clean glass surface spreads out into a thin layer. In the first instance, the contact angle is practically 180°, and in the second instance, it is practically 0°. The study of contact angles reveals the interplay of interfacial energies at

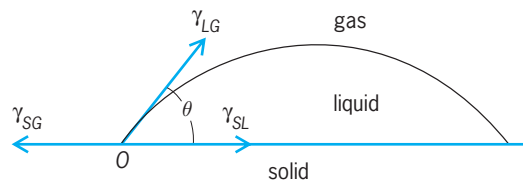

Contact angle at interface of three phases.

three boundaries. The illustration is a schematic representation of the cross section of a drop of liquid on a solid. There are solid-liquid, solid-gas, and liquid-gas interfaces that meet in a linear zone at O.

The measurement of interfacial energies is made directly only upon liquid-gas and liquid-liquid interfaces. In measuring the liquid-gas interfacial energy (surface tension), the methods of capillary rise, drop weight on pendant drop, bubble pressure, sessile drops, Du Nuoy ring, vibrating jets, and ultrasonic action are among those used. There is a small but appreciable temperature effect upon surface tension, and this property is used to determine small differences in the surface tension of a liquid by placing the two ends of a liquid column in a capillary tube whose two ends are at different temperatures. The determination of interfacial energies at other types of interfaces can be inferred only by indirect methods. See FLOTATION; FOAM; FREE ENERGY; PHASE EQUILIBRIUM; SURFACE TENSION. [W.H.S.]

**Interference filter** An optical filter in which the wavelengths that are not transmitted are removed by interference phenomena rather than by absorption or scattering. In addition to being able to duplicate most of the spectral characteristics of absorption color filters, these devices can be made to transmit a very narrow band of wavelengths. They can thus be used as monochromators to examine a radiation source at the wavelength of a single spectrum line. For example, the solar disk can be observed in light of the hydrogen line H $\alpha$  and thus the distribution of excited hydrogen over the disk can be determined. Most narrow-band interference filters are based on the Fabry-Perot interferometer. See INTERFERENCE OF WAVES; INTERFEROMETRY. [B.H.Bi.]

**Interference microscope** An instrument for visualizing and measuring differences in the phase of light transmitted through or reflected from microscopic specimens. It is closely allied to the phase-contrast microscope. See PHASE-CONTRAST MICROSCOPE.

A microscopic image is formed by the interaction of all light waves passing through the optical system. In a phase-contrast microscope, light diffracted by a transparent object is spatially separated from nondiffracted light in the back focal plane of the objective, where a phase plate alters the relative phases of the diffracted and nondiffracted beams so that they interfere in the image plane to produce a visible, intensity-modulated image. In an interference microscope, the diffracted and nondiffracted waves are not spatially separated, but light (the object beam) that passes through or is reflected from the object interferes with light (the reference beam) that passes through or is reflected from a different region of the specimen plane or is reflected from a comparison (reference) surface. For interference to be visible, the light beams must be coherent; in other words, the beams must maintain a constant relationship of wavelength, phase, and polarization over a relatively long period. The easiest way to achieve coherence is by using a device such as a semireflecting mirror, which splits a light beam into two beams. Random changes in the properties of successive photons from a given point in the source then affect both beams simultaneously. Differences in optical path introduced by various parts of the object can be seen as variations in intensity or color. See INTERFERENCE OF WAVES.

[D.J.G.]

**Interference of waves** The process whereby two or more waves of the same frequency or wavelength combine to form a wave whose amplitude is the sum of the amplitudes of the interfering waves. The interfering waves can be electromagnetic, acoustic, or water waves, or in fact any periodic disturbance.

The most striking feature of interference is the effect of adding two waves in which the trough of one wave coincides with the peak of another. If the two waves are of equal amplitude, they can cancel each other out so that the resulting amplitude is zero. This is perhaps most dramatic in sound waves; it is possible to generate acoustic waves to arrive at a person's ear so as to cancel out disturbing noise. In optics, this cancellation can occur for particular wavelengths in a situation where white light is a source. The resulting light will appear colored. This gives rise to the iridescent colors of beetles' wings and mother-of-pearl, where the substances involved are actually colorless or transparent.

To observe interference with waves generated by atomic or molecular transitions, it is necessary to use a single source and to split the light from the source into parts which can then be recombined. In this case, the amplitude and phase changes occur simultaneously in each of the parts at the same time.

The simplest technique for producing a splitting from a single source was done by T. Young in 1801 and was one of the first demonstrations of the wave nature of light. In this experiment, a narrow slit is illuminated by a source, and the light from this slit is caused to illuminate two adjacent slits. The light from these two parallel slits can interfere, and the interference can be seen by letting the light from the two slits fall on a white screen. The screen will be covered with a series of parallel fringes. The location of these fringes can be derived approximately as follows: In the illustration,  $S_1$  and  $S_2$  are the two slits separated by a distance

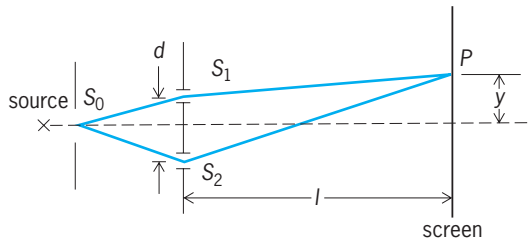

Young's two-slit interference.

$d$ . Their plane is a distance  $l$  from the screen. Since the slit  $S_0$  is equidistant from  $S_1$  and  $S_2$ , the intensity and phase of the light at each slit will be the same. The light falling on  $P$  from slit  $S_1$  can be represented by Eq. (1) and from  $S_2$  by Eq. (2), where

$$A = A_0 \sin 2\pi f \left( t - \frac{x_1}{c} \right) \quad (1)$$

$$B = A_0 \sin 2\pi f \left( t - \frac{x_2}{c} \right) \quad (2)$$

$f$  is the frequency,  $t$  the time,  $c$  the velocity of light;  $x_1$  and  $x_2$  are the distances of  $P$  from  $S_1$  and  $S_2$ , and  $A_0$  is the amplitude. This amplitude is assumed to be the same for each wave since the slits are close together, and  $x_1$  and  $x_2$  are thus nearly the same. The square of the amplitude or the intensity at  $P$  can then be written as Eq. (3).

$$I = 4A_0^2 \cos^2 \frac{2\pi f}{c} (x_1 - x_2) \quad (3)$$

In general,  $l$  is very much larger than  $y$  so that Eq. (3) can be simplified to Eq. (4).

$$I = 4A_0^2 \cos^2 \pi \left( \frac{yd}{l\lambda} \right) \quad (4)$$

Equation (4) is a maximum when Eq. (5) holds and a mini-

mum when Eq. (6) holds, where  $n$  is an integer.

$$y = n\lambda \frac{l}{d} \quad (5)$$

$$y = (n + 1/2)\lambda \frac{l}{d} \quad (6)$$

Accordingly, the screen is covered with a series of light and dark bands called interference fringes. If the source behind slit  $S_0$  is white light and thus has wavelengths varying perhaps from 400 to 700 nanometers, the fringes are visible only where  $x_1 - x_2$  is a few wavelengths, that is, where  $n$  is small. At large values of  $n$ , the position of the  $n$ th fringe for red light will be very different from the position for blue light, and the fringes will blend together and be washed out.

The energy carried by a wave is measured by the intensity, which is equal to the square of the amplitude. The total energy falling on the screen is not changed by the presence of interference. The energy density at a particular point is, however, drastically changed. This fact is most important for those waves of the electromagnetic spectrum which can be generated by vacuum-tube oscillators. The sources of radiation or antennas can be made to emit coherent waves which will undergo interference. This makes possible a redistribution of the radiated energy. Quite narrow beams of radiation can be produced by the proper phasing of a linear antenna array. See ANTENNA (ELECTROMAGNETISM); INTERFEROMETRY. [B.H.Bi.]

**Interferometry** The design and use of optical interferometers. Optical interferometers based on both two-beam interference and multiple-beam interference of light are extremely powerful tools for metrology and spectroscopy. A wide variety of measurements can be performed, ranging from determining the shape of a surface to an accuracy of less than a millionth of an inch (25 nanometers) to determining the separation, by millions of kilometers, of binary stars. In spectroscopy, interferometry can be used to determine the hyperfine structure of spectrum lines. By using lasers in classical interferometers as well as holographic interferometers and speckle interferometers, it is possible to perform deformation, vibration, and contour measurements of diffuse objects that could not previously be performed. There are two basic classes of interferometers: division of wavefront and division of amplitude.

**Michelson interferometer.** The Michelson interferometer (Fig. 1) is based on division of amplitude. Light from an extended source  $S$  is incident on a partially reflecting plate (beam splitter)  $P_1$ . The light transmitted through  $P_1$  reflects off mirror  $M_1$  back to plate  $P_1$ . The light which is reflected proceeds to  $M_2$  which reflects it back to  $P_1$ . At  $P_1$ , the two waves are again partially reflected and partially transmitted, and a portion of each wave proceeds to the receiver  $R$ , which may be a screen, a photocell, or a human eye. Depending on the difference between the distances from the beam splitter to the mirrors  $M_1$  and  $M_2$ ,

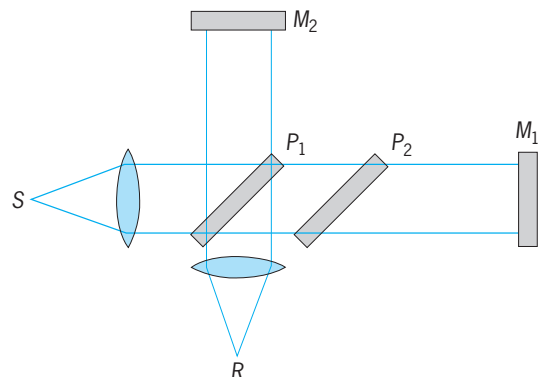

Fig. 1. Michelson interferometer.

the two beams will interfere constructively or destructively. Plate  $P_2$  compensates for the thickness of  $P_1$ .

The function of the beam splitter is to superimpose (image) one mirror onto the other. When the mirrors' images are completely parallel, the interference fringes appear circular. If the mirrors are slightly inclined about a vertical axis, vertical fringes are formed across the field of view. These fringes can be formed in white light if the path difference in part of the field of view is made zero. Just as in other interference experiments, only a few fringes will appear in white light.

**Twyman-Green interferometer.** If the Michelson interferometer is used with a point source instead of an extended source, it is called a Twyman-Green interferometer. The use of the laser as the light source for the Twyman-Green interferometer has made it an extremely useful instrument for testing optical components. The great advantage of a laser source is that it makes it possible to obtain bright, good-contrast, interference fringes even if the path lengths for the two arms of the interferometer are quite different. See LASER.

The Twyman-Green interferometer can be used to test a flat mirror. In this case,  $M_1$  in Fig. 1 is a reference surface and  $M_2$  is the flat surface being tested. If the test surface is perfectly flat, then straight, equally spaced fringes are obtained. Departure from the straight, equally spaced condition shows directly how the surface differs from being perfectly flat. A height change of half a wavelength will cause an optical path change of one wavelength and a deviation from fringe straightness of one fringe. Thus, the fringes give surface height information, just as a topographical map gives height or contour information.

The basic Twyman-Green interferometer can be modified to test concave-spherical mirrors. In the interferometer, the center of curvature of the surface under test is placed at the focus of a high-quality diverger lens so that the wavefront is reflected back onto itself. Likewise, a convex-spherical mirror can be tested. Also, if a high-quality spherical mirror is used, the high-quality diverger lens can be replaced with the lens to be tested.

**Fizeau interferometer.** One of the most commonly used interferometers in optical metrology is the Fizeau interferometer, which can be thought of as a folded Twyman-Green interferometer. In the Fizeau, the two surfaces being compared, which can be flat, spherical, or aspherical, are placed in close contact. The light reflected off these two surfaces produces interference fringes. For each fringe, the separation between the two surfaces is a constant. If the two surfaces match, straight, equally spaced fringes result. Surface height variations between the two surfaces cause the fringes to deviate from straightness or equal separation.

**Mach-Zehnder interferometer.** The Mach-Zehnder interferometer (Fig. 2) is a variation of the Michelson interferometer and, like the Michelson interferometer, depends on amplitude splitting of the wavefront. Light enters the instrument and is reflected and transmitted by the semitransparent mirror  $M_1$ . The reflected portion proceeds to  $M_3$ , where it is reflected through the cell  $C_2$  to the semitransparent mirror  $M_4$ . Here it combines with the light transmitted by  $M_1$  to produce interference. The light transmitted by  $M_1$  passes through a cell  $C_1$ , similar to  $C_2$ , and is used to compensate for the windows of  $C_2$ . The major application of this instrument is in studying airflow around models of aircraft, missiles, or projectiles.

**Shearing interferometers.** In a lateral-shear interferometer a wavefront is interfered with a shifted version of itself. A bright fringe is obtained at the points where the slope of the wavefront times the shift between the two wavefronts is equal to an integer number of wavelengths. That is, for a given fringe the slope or derivative of the wavefront is a constant. For this reason a lateral-shear interferometer is often called a differential interferometer. Another type of shearing interferometer is a radial-shear interferometer. Here, a wavefront is interfered with an expanded version of itself. This interferometer is sensitive to radial slopes.

**Michelson stellar interferometer.** A Michelson stellar interferometer can be used to measure the diameter of stars which

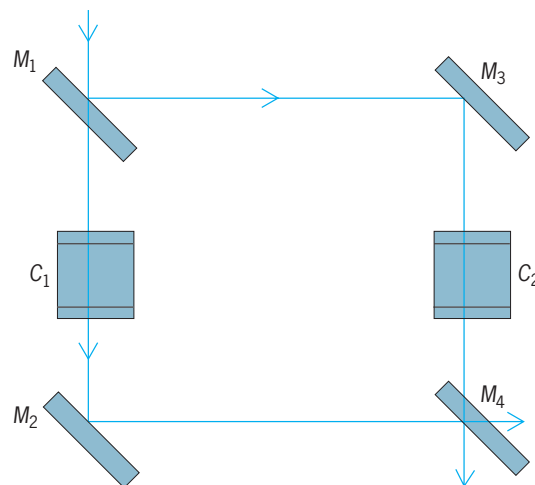

Fig. 2. Mach-Zehnder interferometer.

are as small as 0.01 second of arc. This task is impossible with a ground-based optical telescope since the atmosphere limits the resolution of the largest telescope to not much better than 1 second of arc.

**Fabry-Perot interferometer.** All the interferometers discussed above are two-beam interferometers. The Fabry-Perot interferometer is a multiple-beam interferometer since the two glass plates are partially silvered on the inner surfaces, and the incoming wave is multiply reflected between the two surfaces. The position of the fringe maxima is the same for multiple beam interference as two-beam interference; however, as the reflectivity of the two surfaces increases and the number of interfering beams increases, the fringes become sharper.

**Holographic interferometry.** A wave recorded in a hologram is effectively stored for future reconstruction and use. Holographic interferometry is concerned with the formation and interpretation of the fringe pattern which appears when a wave, generated at some earlier time and stored in a hologram, is later reconstructed and caused to interfere with a comparison wave. It is the storage or time-delay aspect which gives the holographic method a unique advantage over conventional optical interferometry. See HOLOGRAPHY.

**Speckle interferometry.** A random intensity distribution, called a speckle pattern, is generated when light from a highly coherent source, such as a laser, is scattered by a rough surface. The use of speckle patterns in the study of object displacements, vibration, and distortion is becoming of more importance in the nondestructive testing of mechanical components. See SPECKLE.

**Phase-shifting interferometry.** Electronic phase-measurement techniques can be used in interferometers such as the Twyman-Green, where the phase distribution across the interferogram is being measured. Phase-shifting interferometry is often used for these measurements since it provides for rapid precise measurement of the phase distribution. In phase-shifting interferometry, the phase of the reference beam in the interferometer is made to vary in a known manner. This can be achieved, for example, by mounting the reference mirror on a piezoelectric transducer. By varying the voltage on the transducer, the reference mirror is moved a known amount to change the phase of the reference beam a known amount. A solid-state detector array is used to detect the intensity distribution across the interference pattern. This intensity distribution is read into computer memory three or more times, and between each intensity measurement the phase of the reference beam is changed a known amount. From these three or more intensity measurements, the phase across the interference pattern can be determined to within a fraction of a degree. [J.C.Wy.]

**Interhalogen compounds** The elements of the halogen family (fluorine, chlorine, bromine, and iodine) possess an

Known interhalogen compounds				
	XY	XY <sub>3</sub>	XY <sub>5</sub>	XY <sub>7</sub>
mp	ClF	ClF <sub>3</sub>	ClF <sub>5</sub>	IF <sub>7</sub>
bp	-154°C	-76°C	-103°C	4.77 (sublimes)
	-101°C	12°C	-14°C	
mp	BrF	BrF <sub>3</sub>	BrF <sub>5</sub>	
bp	≈-33°C	8.77°C	-62.5°C	
	≈20°C	125°C	40.3°C	
mp	IF	IF <sub>3</sub>	IF <sub>5</sub>	
bp	-	-28°C	10°C	
		-	101°C	
mp	BrCl	ICl <sub>3</sub> <sup>*</sup>		
bp	≈-54°C	101°C		
		-		
mp	ICl <sup>†</sup>			
bp	27.2°C(α)			
	≈100°C			
mp	I <sub>2</sub>			
bp	40°C			
	119°C			

\*In the solid state the compound forms a dimer.  
<sup>†</sup>Unstable β-modification exists, mp 14°C.

ability to react with each other to form a series of binary interhalogen compounds (halogen halides) of general composition given by XY<sub>n</sub>, where n can have the values 1, 3, 5, and 7, and where X is the heavier (less electronegative) of the two elements. All possible diatomic compounds of the first four halogens have been prepared. In other groups a varying number of possible combinations is absent. Although attempts have been made to prepare ternary interhalogens, they have been unsuccessful; there is considerable doubt that such compounds can exist. A list of known interhalogen compounds and some of their physical properties is given in the table. See HALOGEN ELEMENTS.

The reactivity of the polyhalides reflects the reactivity of the halogens they contain. In general, they behave as strong oxidizing and halogenating agents. Most halogen halides (especially halogen fluorides) readily attack metals, yielding the corresponding halide of the more electronegative halogen. All halogen halides readily react with water. Such reactions can be quite violent and, with halogen fluorides, they may be explosive. They readily react with aliphatic and aromatic hydrocarbons and with oxygen- or nitrogen-containing compounds. [T.Su.]

**Intermediate-frequency amplifier** An amplifying circuit in a radio-frequency (RF) receiver that processes and enhances a downconverted or modulated signal. Signal frequency spectrum downconversion is achieved by multiplying the radio-frequency signal by a local oscillator signal in a circuit known as a mixer. This multiplication produces two signals whose frequency content lies about the sum and difference frequencies of the center frequency of the original signal and the oscillator frequency. A variable local oscillator is used in the receiver to hold the difference-signal center frequency constant as the receiver is tuned. The constant frequency of the downconverted signal is called the intermediate frequency (IF), and it is this signal that is processed by the intermediate-frequency amplifier.

Unfortunately, radio-frequency signals both higher and lower than the local oscillator frequency by a difference equal to the intermediate frequency will produce the intermediate frequency. One of these is the desired signal; the undesired signal is called an image. See MIXER; OSCILLATOR.

Aside from demodulation and conversion, the purpose of each stage of a radio receiver is to improve the signal-to-noise ratio (SNR) through a combination of signal amplification and noise/interference suppression. Unlike the broadband tunable radio-frequency amplifier, the intermediate-frequency amplifier is designed to operate over a narrow band of frequencies centered about a dedicated fixed frequency (the intermediate frequency); therefore, the intermediate-frequency amplifier can be an extremely efficient stage. If the intermediate frequency is on

the order of a few megahertz, the undesirable images may be efficiently rejected, but narrow-band filtering for noise and adjacent-channel-signal rejection is difficult and expensive because of the high ratio of the intermediate frequency to the bandwidth of the intermediate-frequency amplifier. If the intermediate frequency is much smaller, say, on the order of a few hundred kilohertz, then inexpensive and more selective filters are possible that can separate the desired signal from closely packed adjacent signals, but they do not reject images very well. A high-quality double-conversion receiver combines the best of both approaches by cascading both high- and low-frequency intermediate-frequency stages that are separated by a second fixed-frequency mixer.

The superheterodyne structure is common for television, ground-based and satellite communications, cell phones, ground-based and airborne radar, navigation, and many other receivers. The intermediate-frequency amplifier function is ubiquitous. See AMPLIFIER; HETERODYNE PRINCIPLE; RADIO-FREQUENCY AMPLIFIER; RADIO RECEIVER; TELEVISION RECEIVER. [S.A.Wh.]

**Intermediate vector boson** One of the three fundamental particles that transmit the weak force. (An example of a weak interaction process is nuclear beta decay.) These elementary particles—the W<sup>+</sup>, W<sup>-</sup>, and Z<sup>0</sup> particles—were discovered in 1983 in very high-energy proton-antiproton collisions. It is through the exchange of W and Z bosons that two particles interact weakly, just as it is through the exchange of photons that two charged particles interact electromagnetically. The intermediate vector bosons were postulated to exist in the 1960s; however, their large masses prevented their production and study at accelerators until 1983. Their discovery was a key step toward unification of the weak and electromagnetic interactions. See ELECTROWEAK INTERACTION; ELEMENTARY PARTICLE; FUNDAMENTAL INTERACTIONS; WEAK NUCLEAR INTERACTIONS.

The W and Z particles are roughly 100 times the mass of a proton. Therefore, the experiment to search for the W and the Z demanded collisions of elementary particles at the highest available center-of-mass energy. Such very high center-of-mass energies capable of producing the massive W and Z particles were achieved with collisions of protons and antiprotons at the laboratory of the European Organization for Nuclear Research (CERN) near Geneva, Switzerland. See PARTICLE ACCELERATOR; PARTICLE DETECTOR.

Striking features of both the charged W and the Z<sup>0</sup> particles are their large masses. The charged boson (W<sup>+</sup> and W<sup>-</sup>) mass is measured to be about 80 GeV/c<sup>2</sup>, and the neutral boson (Z<sup>0</sup>) mass is measured to be about 91 GeV/c<sup>2</sup>. (For comparison, the proton has a mass of about 1 GeV/c<sup>2</sup>.) Prior to the discovery of the W and the Z, particle theorists had met with some success in the unification of the weak and electromagnetic interactions. The electroweak theory as it is understood today is due largely to the work of S. Glashow, S. Weinberg, and A. Salam. Based on low-energy neutrino scattering data, which in this theory involves the exchange of virtual W and Z particles, theorists made predictions for the W and Z masses. The actual measured values are in agreement (within errors) with predictions. The discovery of the W and the Z particles at the predicted masses is an essential confirmation of the electroweak theory.

Only a few intermediate vector bosons are produced from 10<sup>9</sup> proton-antiproton collisions at a center-of-mass energy of 540 GeV. This small production probability per p $\bar{p}$  collision is understood to be due to the fact that the bosons are produced by a single quark-antiquark annihilation. The other production characteristics of the intermediate vector bosons, such as longitudinal and transverse momentum distributions (with respect to the p $\bar{p}$  colliding beam axis), all provide support for this theoretical picture. See QUARKS. [J.W.R.]

**Intermetallic compounds** Materials composed of two or more types of metal atoms, which exist as homogeneous, composite substances and differ discontinuously in structure from that of the constituent metals. They are also called,

preferably, intermetallic phases. Their properties cannot be transformed continuously into those of their constituents by changes of composition alone, and they form distinct crystalline species separated by phase boundaries from their metallic components and mixed crystals of these components; it is generally not possible to establish formulas for intermetallic compounds on the sole basis of analytical data, so formulas are determined in conjunction with crystallographic structural information.

The term "alloy" is generally applied to any homogeneous molten mixture of two or more metals, as well as to the solid material that crystallizes from such a homogeneous liquid phase. Alloys may also be formed from solid-state reactions. In the liquid phase, alloys are essentially solutions of metals in one another, although liquid compounds may also be present. Alloys containing mercury are usually referred to as amalgams. Solid alloys may vary greatly in range of composition, structure, properties, and behavior. See ALLOY; NONSTOICHIOMETRIC COMPOUNDS; SEMICONDUCTOR; SOLID-STATE CHEMISTRY. [J.L.T.W.]

**Intermolecular forces** Attractive or repulsive interactions that occur between all atoms and molecules. Intermolecular forces become significant at molecular separations of about 1 nanometer or less, but are much weaker than the forces associated with chemical bonding. They are important, however, because they are responsible for many of the physical properties of solids, liquids, and gases. These forces are also largely responsible for the three-dimensional arrangements of biological molecules and polymers.

Intermolecular forces can be classified into several types, of which two are universal. The attractive force known as dispersion arises from the quantum-mechanical fluctuation of the electron density around the nucleus of each atom. At distances greater than 1 nm or so, the electrons of each atom move independently of the other, and the charge distribution is spherically symmetric. At shorter distances, an instantaneous fluctuation of the charge density in one atom can affect the other. If the electrons of one atom move briefly to the side nearer the other, the electrons of the other atom are repelled to the far side. In this configuration, both atoms have a small dipole moment, and they attract each other electrostatically. At another moment, the electrons may move the other way, but their motions are correlated so that an attractive force is maintained on average. Molecular orbital theory shows that the electrons of each atom are slightly more likely to be on the side nearer to the other atom, so that each atomic nucleus is attracted by its own electrons in the direction of the other atom.

At small separations the electron clouds can overlap, and repulsive forces arise. These forces are described as exchange-repulsion, and are a consequence of the Pauli exclusion principle, a quantum-mechanical effect which prevents electrons from occupying the same region of space simultaneously. To accommodate it, electrons are squeezed out from the region between the nuclei, which repel each other as a result. Each element can be assigned, approximately, a characteristic van der Waals radius; that is, when atoms in different molecules approach more closely than the sum of their radii, the repulsion energy increases sharply. It is this effect that gives molecules their characteristic shape, leading to steric effects in chemical reactions. See EXCLUSION PRINCIPLE; STERIC EFFECT (CHEMISTRY).

The other important source of intermolecular forces is the electrostatic interaction. When molecules are formed from atoms, electrons flow from electropositive atoms to electronegative ones, so that the atoms become somewhat positively or negatively charged. In addition, the charge distribution of each atom may be distorted by the process of bond formation, leading to atomic dipole and quadrupole moments. The electrostatic interaction between these is an important source of intermolecular forces, especially in polar molecules, but also in molecules that are not normally thought of as highly polar. The electrostatic field of a molecule may cause polarization of its neighbors, and this leads to a further induction contribution to the intermolecu-

lar interaction. An induction interaction can often polarize both molecules in such a way as to favor interactions with further molecules, leading to a cooperative network of intermolecular attractions. This effect is important in the network structure of water and ice. See WATER.

Intermolecular forces are responsible for many of the bulk properties of matter in all its phases. A realistic description of the relationship between pressure, volume, and temperature of a gas must include the effects of attractive and repulsive forces between molecules. The viscosity, diffusion, and surface tension of liquids are examples of physical properties which depend strongly on intermolecular forces. Intermolecular forces are also responsible for the ordered arrangement of molecules in solids, and account for their elasticity and properties (such as the velocity of sound in materials). [A.J.S.]

**Internal combustion engine** A prime mover, the fuel for which is burned within the engine, as contrasted to a steam engine, for example, in which fuel is burned in a separate furnace. See ENGINE.

The most numerous of internal combustion engines are the gasoline piston engines used in passenger automobiles, outboard engines for motor boats, small units for lawn mowers, and other such equipment, as well as diesel engines used in trucks, tractors, earth-moving, and similar equipment. For other types of internal combustion engines see GAS TURBINE; ROCKET PROPULSION; ROTARY ENGINE; TURBINE PROPULSION.

The aircraft piston engine is fundamentally the same as that used in automobiles but is engineered for light weight and is usually air cooled. See RECIPROCATING AIRCRAFT ENGINE.

Characteristic features common to all commercially successful internal combustion engines include (1) the compression of air, (2) the raising of air temperature by the combustion of fuel in this air at its elevated pressure, (3) the extraction of work from the heated air by expansion to the initial pressure, and (4) exhaust. In 1862 Beau de Rochas proposed the four-stroke engine cycle as a means of accomplishing these conditions in a piston engine (see illustration). The engine requires two revolutions of the crankshaft to complete one combustion cycle. The first engine to use this cycle successfully was built in 1876 by N. A. Otto. See OTTO CYCLE.

Two years later Sir Dougal Clerk developed the two-stroke engine cycle by which a similar combustion cycle required only one revolution of the crankshaft. In 1891 Joseph Day simplified the two-stroke engine cycle by using the crankcase to pump the required air. Engines using this two-stroke cycle today have been further simplified by use of a third cylinder port which dispenses with the crankcase check valve used by Day. Such engines are in wide use for small units where fuel economy is not as important as mechanical simplicity and light weight. They do not need mechanically operated valves and develop one combustion cycle per crankshaft revolution. Nevertheless they do not develop twice the power of four-stroke cycle engines with the same size working cylinders at the same number of revolutions per minute (rpm). The principal reasons for this are (1) the reduction in effective cylinder volume due to the piston movement required to cover the exhaust ports, (2) the appreciable mixing of burned (exhaust) gases with the combustible mixture, and (3) the loss of some combustible mixture with the exhaust gases.

About 20 years after Otto first ran his engine, Rudolf Diesel successfully demonstrated an entirely different method of igniting fuel. Air is compressed to a pressure high enough for the adiabatic temperature to reach or exceed the ignition temperature of the fuel. Because this temperature is 1000°F (538°C) or higher, compression ratios of 12:1 to 23:1 are used commercially with compression pressures from about 440 to 800 psi (3 to 5.5 megapascals). The fuel is injected into the cylinders shortly before the end of the compression stroke, at a time and rate suitable to control the rate of combustion. See DIESEL ENGINE; FUEL INJECTION.



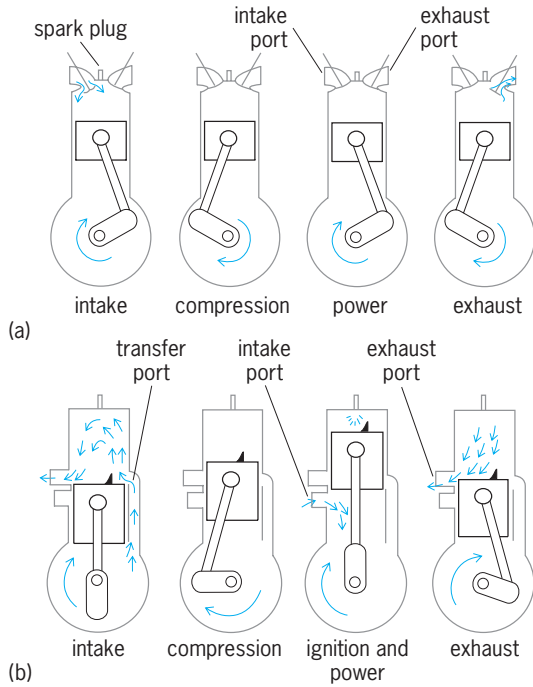

**Engine cycles** (a) The four strokes of a four-stroke engine cycle. On intake stroke, the intake valve (left) has opened and the piston is moving downward, drawing air and gasoline vapor into the cylinder. On compression stroke, the intake valve has closed and the piston is moving upward, compressing the mixture. On power stroke, the ignition system produces a spark that ignites the mixture. As it burns, high pressure is created, which pushes the piston downward. On exhaust stroke, the exhaust valve (right) has opened and the piston is moving upward, forcing the burned gases from the cylinder. (b) Three-port two-cycle engine. The same action is accomplished without separate valves and in a single rotation of the crankshaft.

There are many characteristics of the diesel engine which are in direct contrast to those of the Otto engine. The higher the compression ratio of a diesel engine, the less the difficulties with ignition time lag. Too great an ignition lag results in a sudden and undesired pressure rise which causes an audible knock. In contrast to an Otto engine, knock in a diesel engine can be reduced by use of a fuel of higher cetane number, which is equivalent to a lower octane number. See CETANE NUMBER; OCTANE NUMBER.

The larger the cylinder diameter of a diesel engine, the simpler the development of good combustion. In contrast, the smaller the cylinder diameter of the Otto engine, the less the limitation from detonation of the fuel.

High intake-air temperature and density materially aid combustion in a diesel engine, especially of fuels having low volatility and high viscosity. Some engines have not performed properly on heavy fuel until provided with a supercharger. The added compression of the supercharger raised the temperature and, what is more important, the density of the combustion air. For an Otto engine, an increase in either the air temperature or density increases the tendency of the engine to knock and therefore reduces the allowable compression ratio.

Diesel engines develop increasingly higher indicated thermal efficiency at reduced loads because of leaner fuel-air ratios and earlier cutoff. Such mixture ratios may be leaner than will ignite in an Otto engine. Furthermore, the reduction of load in an Otto engine requires throttling, which develops increasing pumping losses in the intake system. [N.MacC.; D.L.An.]

**Internal energy** A characteristic property of the state of a thermodynamic system, introduced in the first law of thermodynamics. For a static, closed system (no bulk motion, no transfer of matter across its boundaries), the change in internal energy

for a process is equal to the heat absorbed by the system from its surroundings minus the work done by the system on its surroundings. Only a change in internal energy can be measured, not its value for any single state. For a given process, the change in internal energy is fixed by the initial and final states and is independent of the path by which the change in state is accomplished. See THERMODYNAMIC PRINCIPLES. [P.J.B.]

**International Date Line** The 180° meridian, where each day officially begins and ends. As a person travels eastward, against the apparent movement of the Sun, 1 h is gained for

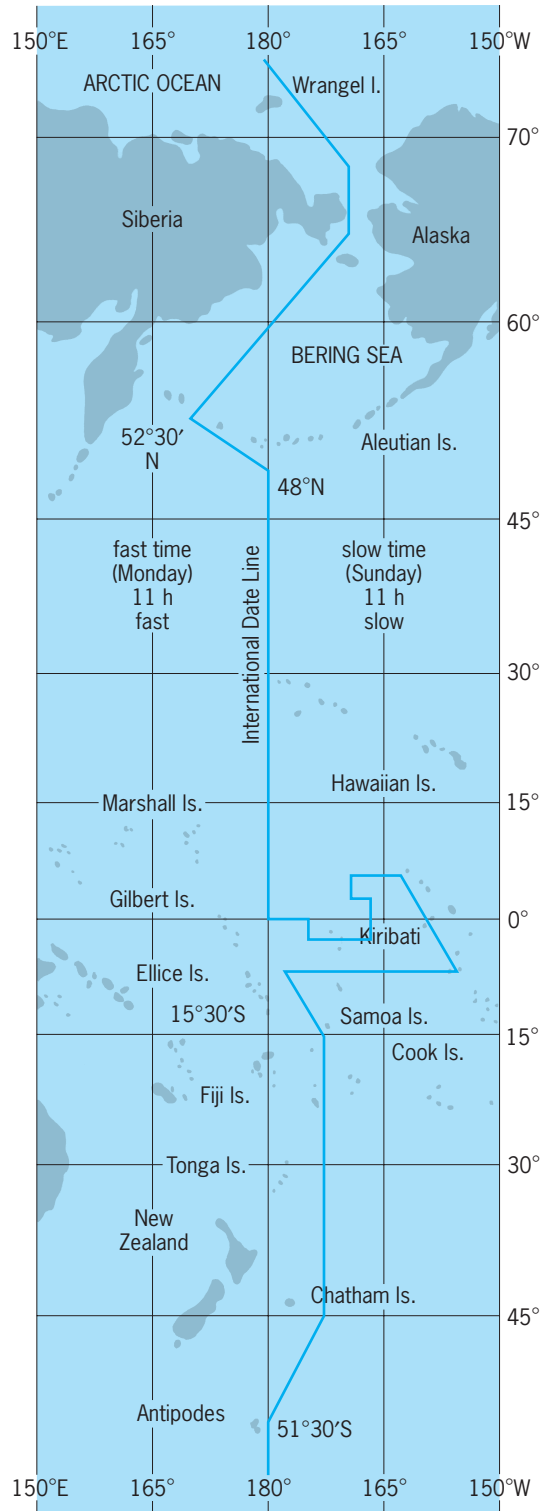

The International Date Line.

every 15° of longitude; traveling westward, time is lost at the same rate. Two people starting from any meridian and traveling around the world in opposite directions at the same speed would have the same time when they meet, but would be 1 day apart in date. When a traveler goes west across the line, a day is lost; if it is Monday to the east, it will be Tuesday immediately as the traveler crosses the International Date Line.

The 180° meridian is ideal for serving as the International Date Line (see illustration). It is exactly halfway around the world from the zero, or Greenwich, meridian, from which all longitude is reckoned. It also falls almost in the center of the largest ocean; consequently there is the least amount of inconvenience as regards population centers. A few deviations in the alignment have been made, such as swinging the line east around Siberia to keep that area all in the same day, and westward around the Aleutian Islands so that they will be within the same day as the rest of Alaska. Other variations for the same purpose have been made near Kiribati, at the Equator, and the Fiji Islands, in the South Pacific. See MATHEMATICAL GEOGRAPHY. [V.H.E.]

**Internet** A worldwide system of interconnected computer networks. The origins of the Internet can be traced to the creation of ARPANET (Advanced Research Projects Agency Network) as a network of computers under the auspices of the U.S. Department of Defense in 1969. Today, the Internet connects millions of computers around the world in a nonhierarchical manner unprecedented in the history of communications. The Internet is a product of the convergence of media, computers, and telecommunications. It is not merely a technological development but the product of social and political processes, involving both the academic world and the government (the Department of Defense). From its origins in a nonindustrial, noncorporate environment and in a purely scientific culture, it has quickly diffused into the world of commerce.

The Internet is a combination of several media technologies and an electronic version of newspapers, magazines, books, catalogs, bulletin boards, and much more. This versatility gives the Internet its power.

**Technological features.** The Internet's technological success depends on its principal communication tools, the Transmission Control Protocol (TCP) and the Internet Protocol (IP). They are referred to frequently as TCP/IP. A protocol is an agreed-upon set of conventions that defines the rules of communication. TCP breaks down and reassembles packets, whereas IP is responsible for ensuring that the packets are sent to the right destination.

Data travels across the Internet through several levels of networks until it reaches its destination. E-mail messages arrive at the mail server (similar to the local post office) from a remote personal computer connected by a modem, or a node on a local-area network. From the server, the messages pass through a router, a special-purpose computer ensuring that each message is sent to its correct destination. A message may pass through several networks to reach its destination. Each network has its own router that determines how best to move the message closer to its destination, taking into account the traffic on the network. A message passes from one network to the next, until it arrives at the destination network, from where it can be sent to the recipient, who has a mailbox on that network. See ELECTRONIC MAIL; LOCAL-AREA NETWORKS; WIDE-AREA NETWORKS.

**TCP/IP.** TCP/IP is a set of protocols developed to allow cooperating computers to share resources across the networks. The TCP/IP establishes the standards and rules by which messages are sent through the networks. The most important traditional TCP/IP services are file transfer, remote login, and mail transfer.

The file transfer protocol (FTP) allows a user on any computer to get files from another computer, or to send files to another computer. Security is handled by requiring the user to specify a user name and password for the other computer.

The network terminal protocol (TELNET) allows a user to log in on any other computer on the network. The user starts a

remote session by specifying a computer to connect to. From that time until the end of the session, anything the user types is sent to the other computer.

Mail transfer allows a user to send messages to users on other computers. Originally, people tended to use only one or two specific computers. They would maintain "mail files" on those machines. The computer mail system is simply a way for a user to add a message to another user's mail file.

Other services have also become important: resource sharing, diskless workstations, computer conferencing, transaction processing, security, multimedia access, and directory services.

TCP is responsible for breaking up the message into datagrams, reassembling the datagrams at the other end, resending anything that gets lost, and putting things back in the right order. IP is responsible for routing individual datagrams. The datagrams are individually identified by a unique sequence number to facilitate reassembly in the correct order. The whole process of transmission is done through the use of routers. Routing is the process by which two communication stations find and use the optimum path across any network of any complexity. Routers must support fragmentation, the ability to subdivide received information into smaller units where this is required to match the underlying network technology. Routers operate by recognizing that a particular network number relates to a specific area within the interconnected networks. They keep track of the numbers throughout the entire process.

**Domain Name System.** The addressing system on the Internet generates IP addresses, which are usually indicated by numbers such as 128.201.86.290. Since such numbers are difficult to remember, a user-friendly system has been created known as the Domain Name System (DNS). This system provides the mnemonic equivalent of a numeric IP address and further ensures that every site on the Internet has a unique address. For example, an Internet address might appear as crito.uci.edu. If this address is accessed through a Web browser, it is referred to as a URL (Uniform Resource Locator), and the full URL will appear as <http://www.crito.uci.edu>.

The Domain Name System divides the Internet into a series of component networks called domains that enable e-mail (and other files) to be sent across the entire Internet. Each site attached to the Internet belongs to one of the domains. Universities, for example, belong to the "edu" domain. Other domains are gov (government), com (commercial organizations), mil (military), net (network service providers), and org (nonprofit organizations).

**World Wide Web.** The World Wide Web (WWW) is based on technology called hypertext. The Web may be thought of as a very large subset of the Internet, consisting of hypertext and hypermedia documents. A hypertext document is a document that has a reference (or link) to another hypertext document, which may be on the same computer or in a different computer that may be located anywhere in the world. Hypermedia is a similar concept except that it provides links to graphic, sound, and video files in addition to text files.

In order for the Web to work, every client must be able to display every document from any server. This is accomplished by imposing a set of standards known as a protocol to govern the way that data are transmitted across the Web. Thus data travel from client to server and back through a protocol known as the HyperText Transfer Protocol (http). In order to access the documents that are transmitted through this protocol, a special program known as a browser is required, which browses the Web. See WORLD WIDE WEB.

**Commerce on the Internet.** Commerce on the Internet is known by a few other names, such as e-business, Etailing (electronic retailing), and e-commerce. The strengths of e-business depend on the strengths of the Internet. Internet commerce is divided into two major segments, business-to-business (B2B) and business-to-consumer (B2C). In each are some companies that have started their businesses on the Internet, and others that

have existed previously and are now transitioning into the Internet world. Some products and services, such as books, compact disks (CDs), computer software, and airline tickets, seem to be particularly suited for online business. [A.V.]

**Interplanetary matter** Low-density dust or gas that fills the space in a planetary system around or between the planets. Most interplanetary matter in the inner solar system is dust created by collisions among asteroids or released by comets as they pass by the Sun. Ionized gas, launched at high speeds from the Sun as the solar wind, also permeates the solar system and creates a variety of important electromagnetic effects where it interacts with planets.

A cloud of dust, called zodiacal dust, fills the plane of the solar system interior to the asteroid belt. An observer on the Earth can see this dust with the unaided eye on some clear moonless nights because it scatters sunlight in the Earth's direction. See ZODIACAL LIGHT.

Two satellites, the *Infrared Astronomical Satellite (IRAS)* and the *Cosmic Background Explorer (COBE)*, made detailed maps of the zodiacal cloud as seen from Earth orbit, using detectors that were sensitive at a wide range of infrared wavelengths (1–200 micrometers). Prominent families of asteroids, groups of asteroids that appear to have fragmented from a single larger body, create bands of dust that both *IRAS* and *COBE* detected. *IRAS* and *COBE* also detected trails of dust left by individual comets, mixing into the background cloud. See ASTEROID; COMET; INFRARED ASTRONOMY.

The solar wind flows supersonically in all directions out of the corona of the Sun at typical speeds of  $450 \text{ km s}^{-1}$  (280 mi/s) and temperatures of 100,000 K. Like the corona, the solar wind consists mostly of ionized hydrogen. At the Earth's orbit, the density of the wind is roughly 5 particles/cm<sup>3</sup> (80 particles/in.<sup>3</sup>), or about  $8 \times 10^{-24} \text{ g cm}^{-3}$ . See SOLAR WIND.

The region between the asteroid belt and the orbit of Neptune appears to be relatively devoid of interplanetary dust. Beyond Neptune, a ring of comet-sized icy bodies, called the Kuiper Belt, orbits the Sun. Undoubtedly, Kuiper Belt Objects collide with one another and produce a disklike cloud of dust. Dust so far from the Sun is cold, so that it radiates most of its thermal energy at far-infrared wavelengths (30–200  $\mu\text{m}$ ). The low temperature makes the cloud too dim to detect from near the Earth, even though it may be just as massive as the zodiacal cloud. See KUIPER BELT.

However, other stars have circumstellar clouds of dust that may be analogous to the Kuiper Belt dust in the solar system. The *IRAS* made many observations of individual stars, and detected far-infrared emission from some of them greatly in excess of what the star alone should produce. The first object discovered to be in this category was the bright, nearby star Vega, so this class of objects is called Vega-excess stars. Vega-excess stars have hundreds or thousands of times as much dust as the solar system. However, even the relatively small amount of dust in the solar system emits and reflects at least six times as much light as the Earth.

Several Vega-excess stars, notably Beta Pictoris, HR 4796, and Epsilon Eridani, appear to be surrounded by rings or disks of dust in images taken at a variety of wavelengths from the ground and with the Hubble Space Telescope. These disks generally have an inner edge at distances greater than 10 AU from the stars. Some stars also appear to have clouds of dust orbiting within a few astronomical units of the star. This dust, called exozodiacal dust, may be analogous to the zodiacal dust in the solar system. See SPACE TELESCOPE, HUBBLE.

Many Vega-excess stars probably harbor planetary systems. Some have planets that have been detected by close monitoring of the radial velocity of the star to look for the wobble caused by gravitational pull of an orbiting body. Other Vega-excess stars have disks that show structure and central clearings that may indicate the existence of a planet. See PLANET. [M.J.Kuc.]

**Interplanetary propulsion** Means of providing propulsive power for flight to the Moon or to a planet. A variety of different propulsion systems can be used. The space vehicles for these missions consist of a series of separate stages, each with its own set of propulsion systems. When the propellants of a given stage have been expended, the stage is jettisoned to prevent its mass from needlessly adding to the inertia of the vehicle. Although all propulsion systems actually used in interplanetary flight have been chemical rockets, several basically different propulsion systems have been studied. See ION PROPULSION; ROCKET PROPULSION; ROCKET STAGING; SPACECRAFT PROPULSION. [G.P.S.]

**Interpolation** A process in mathematics used to estimate an intermediate value of one (dependent) variable which is a function of a second (independent) variable when values of the dependent variable corresponding to several discrete values of the independent variable are known.

Suppose, as is often the case, that it is desired to describe graphically the results of an experiment in which some quantity  $Q$  is measured, for example, the electrical resistance of a wire, for each of a set of  $N$  values of a second variable  $v$  representing, perhaps, the temperature of the wire. Let the numbers  $Q_i$ ,  $i = 1, 2, \dots, N$ , be the measurements made of  $Q$  and the numbers  $v_i$  be those of the variable  $v$ . These numbers representing the raw data from the experiment are usually given in the form of a table with each  $Q_i$  listed opposite the corresponding  $v_i$ . The problem of interpolation is to use the above discrete data to predict the value of  $Q$  corresponding to any value of  $v$  lying between the above  $v_i$ . If the value of  $v$  is permitted to lie outside these  $v_i$ , the somewhat more risky process of extrapolation is used. See EXTRAPOLATION. [K.S.K.]

**Interstellar extinction** Dimming of light from the stars due to absorption and scattering by grains of dust in the interstellar medium. In the absorption process the radiation disappears and is converted into heat energy in the interstellar dust grains. In the scattering process the direction of the radiation is altered. Interstellar extinction produces a dimming of the light from stars situated beyond interstellar clouds of dust. Measures of the radiation from pairs of stars of similar intrinsic properties but with differing amounts of interstellar extinction can be used to obtain information about the dependence of extinction on wavelength, which can then be used to provide clues about the nature of the interstellar dust grains. See SCATTERING OF ELECTROMAGNETIC RADIATION.

A detailed interpretation of this dependence and other data relating to interstellar dust suggests that the interstellar grains of dust range in size from about 0.01 to 1  $\mu\text{m}$  and are composed of silicate grains and probably some type of carbon grain, and that the interstellar dust acquires coatings of water ice and ammonia ice in the densest regions of interstellar space. A comparison of interstellar extinction with the absorption by interstellar atomic hydrogen reveals that the dust contains about 1% of the mass of the interstellar medium. See INTERSTELLAR MATTER. [B.D.S.]

**Interstellar matter** The material between the stars, constituting several percent of the mass of stars in the Milky Way Galaxy. Being the reservoir from which new stars are born in the Galaxy, interstellar matter is of fundamental importance in understanding both the processes leading to the formation of stars, including the solar system, and ultimately the origin of life in the universe. Among the many ways in which interstellar matter is detected, perhaps the most familiar are attractive photographs of bright patches of emission-line or reflection nebulosity. However, these nebulae furnish an incomplete view of the large-scale distribution of material, because they depend on the proximity of one or more bright stars for their illumination. Radio observations of hydrogen, the dominant form of interstellar matter, reveal a widespread distribution throughout the thin disk of the

Galaxy, with concentrations in the spiral arms. The disk is very thin (scale height 135 parsecs for the cold material, where 1 pc is equal to 3.26 light-years,  $1.92 \times 10^{13}$  mi, or  $3.09 \times 10^{13}$  km) compared to its radial extent (the distance from the Sun to the galactic center is about 8000 pc, for example). Mixed in with the gas are small solid particles, called dust grains, of characteristic radius 0.1 micrometer. Although by mass the grains constitute less than 1% of the material, they have a pronounced effect through the extinction of starlight. Striking examples of this obscuration are the dark rifts seen in the Milky Way. On average, the density of matter is only 15 hydrogen atoms per cubic inch (1 hydrogen atom per cubic centimeter; in total,  $2 \times 10^{-24}$  g · cm<sup>-3</sup>), but because of the long path lengths over which the material is sampled, this tenuous medium is detectable. Radio and optical observations of other spiral galaxies show a similar distribution of interstellar matter in the galactic plane.

A hierarchy of interstellar clouds, concentrations of gas and dust, exists within the spiral arms. Many such clouds or cloud complexes are recorded photographically. However, the most dense, which contain interstellar molecules, are often totally obscured by the dust grains and so are detectable only through their infrared and radio emission. These molecular clouds, which account for about half of the interstellar mass, contain the birthplaces of stars. See GALAXY, EXTERNAL; MILKY WAY GALAXY.

**Molecules.** The presence of molecules in interstellar space was first revealed by optical absorption lines. Unfortunately, most species produce no lines at optical wavelengths, and so the discovery of large numbers of molecules had to await advances in radio astronomy, for it is in this spectral band that molecular rotational transitions take place.

An intriguing phenomenon seen in some molecular emission lines is maser amplification to very high intensities. The relative populations of the energy levels of a particular molecule are determined by a combination of collisional and radiative excitation. The population distribution is often not in equilibrium with either the thermal gas or the radiation field, and if a higher energy sublevel comes to have a higher population than a lower one, the electromagnetic transition between the states is amplified through the process of stimulated emission. The best-understood masers are the hydroxyl (OH), water (H<sub>2</sub>O), and silicon monoxide (SiO) masers in the circumstellar envelopes of cool mass-losing red supergiant stars. The other masers are found in dense molecular clouds, in particular near compact sources of infrared and radio continuum emission identified as massive stars just being formed. See MASER. [P.G.M.]

At present, 119 interstellar molecular species are identified. The known molecules are largely organic. Only 21 are inorganic and stable. There are 32 stable organic species, and 66 unstable species, mostly organic, including carbon chains as complex as HC<sub>11</sub>N. Most of the unstable species were unknown terrestrially before their interstellar identification.

**Astrochemistry.** Because of the very low temperatures and densities of the interstellar medium, molecules cannot form from atoms by normal terrestrial processes. The most important interstellar formation process involves gas-phase chemistry, particularly involving molecular ions. Ion-molecule reactions satisfy the requirements of minimal activation energy and of rapid two-body rates. The (positive) ions are initiated by the cosmic-ray ionization of H<sub>2</sub>, producing H<sub>3</sub><sup>+</sup>, which then reacts with other abundant species such as carbon monoxide (CO) and N<sub>2</sub> to produce a large number of the observed species such as HCO<sup>+</sup> and N<sub>2</sub>H<sup>+</sup>. Ion fragments themselves react rapidly at low temperatures to form larger ions, which eventually recombine with electrons or neutralize by reaction with easily ionized metals. Slower reactions involving neutral atoms and molecules also produce several species.

Interstellar grains can act as passive repositories of frozen molecular material while a cloud is in a cold dense phase. The same frozen material can undergo chemical reactions within the icy mantle, modifying the chemical composition before subse-

quent evaporation. Finally, molecules may be catalyzed from interstellar atoms arriving on dust grains. The ubiquitous H<sub>2</sub> molecule is the best example of a species that cannot form in the gas phase at sufficient rate but that catalyzes on grains and desorbs efficiently because of its high volatility.

Strong shocks abound in the interstellar medium, resulting from supernovae and expanding H II regions. These shocks briefly heat and compress the gas, producing required conditions for many high-temperature chemical reactions. [B.E.T.]

**Intestine** The tubular portion of the digestive tract, usually between the stomach and the cloaca or anus. The detailed functions vary with the region, but are primarily digestion and absorption of food.

The structure of the intestine varies greatly in different vertebrates, but there are several common modifications, mainly associated with increasing the internal surface area. One, seen in many fishes, is the development of a spiral valve; this turns the intestine into a structure resembling a spiral staircase. Another, seen in some fish and most tetrapods, is simply elongating and then coiling the intestine. This can reach extremes in large herbivores: Oxen have intestinal lengths of over 150 ft (45 m). In numerous forms there are blind pouches, or ceca, off part of the intestine. In fish these are commonly at the anterior end; in tetrapods they generally lie at the junction between the large and small intestines. In all vertebrates the inner surface of the intestine is irregular, with ridges and projections of various sorts; these reach their maximum development in the extremely fine and numerous finger-shaped villi found in mammals.

In humans the intestine consists of the small and large intestines. The small intestine is further divided into three major parts: the duodenum, the jejunum, and the ileum. The duodenum, 10–12 in. (25–30 cm) long, begins at the pyloric sphincter of the stomach and curves around the head of the pancreas on the right side of the anterior part of the abdomen. It receives the ducts of the biliary system and the pancreas. The jejunum and ileum are about 19 ft (6 m) long and form a much-coiled tube that empties at right angles into the large intestine through the ileocolic valve (see illustration). The large intestine, or colon, consists of five parts: the ascending, transverse, descending, and sigmoid regions, and the terminal rectum which empties into the anal canal.

The microscopic structure of the intestine comprises an inner glandular mucosa, a muscular coat, and an outer serosa of connective tissues which is covered in most areas by peritoneum.

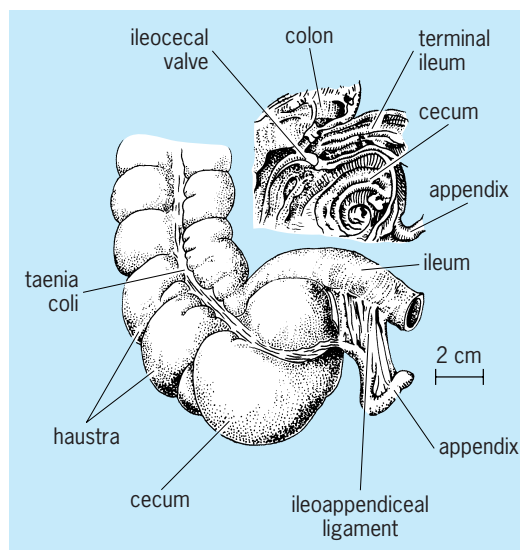

Junction of ileum with large intestine in humans.

The intestine is supported by dorsal mesenteries of varying extent, which contain an extensive system of arteries, veins, lymphatics, and nerves to the various regions. See DIGESTIVE SYSTEM.

[T.S.P.]

**Intra-Americas Sea** That area of the tropical and subtropical western North Atlantic Ocean encompassing the Gulf of Mexico, the Caribbean Sea, the Bahamas and Florida, the northeast coast of South America, and the juxtaposed coastal regions, including the Antillean Islands.

Meteorologically, the Intra-Americas Sea is a transition zone between truly tropical conditions in the south and a subtropical climate in the north. The Sea is also the region that either spawns or interacts with the intense tropical storms known locally as the West Indian Hurricane. Air flowing over the Sea acquires moisture that is the source of much of the precipitation over the central plains of North America. See HURRICANE.

Ocean currents of the Intra-Americas Sea are dominated by the Gulf Stream system. Surface waters flow into the Sea through the passages of the Lesser Antilles, and to a lesser extent through the Windward Passage between Cuba and Haiti, and the Anegada Passage between Puerto Rico and Anguilla. These inflowing waters form the Caribbean Current, which flows westward and northward into the Gulf of Mexico through the Yucatán Channel. See OCEAN CIRCULATION.

River discharge from several South American rivers, notably the Orinoco and Amazon, drifts through the Intra-Americas Sea and carries materials thousands of kilometers from the deltas. The large deltas are heavily impacted by anthropogenic activities, but they remain the source of rich fisheries and plankton communities. Because of the small tidal range in the Sea, most deltas are wind-dominated geological features. See DELTA; EARTHQUAKE; MARINE FISHERIES; PLATE TECTONICS; TIDE. [G.A.Ma.]

**Intron** In split genes, a portion that is included in ribonucleic acid (RNA) transcripts but is removed from within a transcript during RNA processing and is rapidly degraded. Split genes are those in which portions appearing in messenger RNAs (mRNAs) or in structural RNAs, termed exons, are not contiguous in a gene but are separated by lengths of deoxyribonucleic acid (DNA) encoding parts of transcripts that do not survive the maturation of RNA (introns). Most genes in eukaryotes, and a few in prokaryotes, are split. These include not just a large number of different protein-coding genes but also genes encoding transfer RNAs (tRNAs) in such diverse eukaryotes as yeast and frogs, and genes encoding structural RNAs of ribosomes in some protozoa. Introns are also found in mitochondrial genes of lower eukaryotes and in some chloroplast genes. See EXON.

The number of introns in a gene varies greatly, from 1 in the case of structural RNA genes to more than 50 in collagen. The lengths, locations, and compositions of introns also vary greatly among genes. However, in general, sizes and locations—but not DNA sequence—are comparable in homologous genes in different organisms. The implication is that introns became established in genes early in the evolution of eukaryotes, and while their nucleotide sequence is not very important, their existence, positions, and sizes are significant.

Speculation on the roles and the evolution of introns is mostly based on correlations that have been seen between domains of protein structure and the exons of genes that are defined by intervening introns. For example, the enzyme alcohol dehydrogenase (ADH) has two domains, one portion of the protein that binds alcohol, and another that binds the enzyme cofactor nicotinamide adenine dinucleotide (NAD). The ADH gene has an intron that cleanly separates the nucleotide sequences which encode each domain, and gene-sequence arrangements such as this are not uncommon. It has been suggested that introns became established in the genes of eukaryotes (and to a limited extent in bacteria) because they facilitate a genetic shuffling or rearrangement of portions of genes which encode various units of function, thus

creating new genes with new combinations of properties. The introns allow genetic recombination to occur between the coding units rather than within them, thus providing a means of genetic evolution via wholesale reassortments of functional subunits or building blocks, rather than by fortuitous recombinations of actual protein-coding DNA sequences. See GENE; GENETIC CODE; RECOMBINATION (GENETICS). [P.M.M.R.]

**Invasion ecology** The study of the establishment, spread, and ecological impact of species translocated from one region or continent to another by humans. Biological invasions have gained attention as a tool for basic research, used to study the ecology and evolution of populations and of novel biotic interactions; and as a conservation issue tied to the preservation of biodiversity. The invasion of nonindigenous (also called exotic, alien, or nonnative) species is a serious concern for those charged with managing and protecting natural as well as managed ecosystems. See ECOLOGY; POPULATION ECOLOGY.

Ecologists make a distinction between introduced species, meaning any species growing outside its natural habitat including cultivated or domesticated organisms, and invasive species, meaning the subset of introduced species that establish free-living populations in the wild. The great majority of introduced species (approximately 90% as estimated from some studies) do not become invasive. While certain problem invaders, such as the zebra mussel (*Dreissena polymorpha*), exact enormous economic and ecological costs, other introduced species are generally accepted as beneficial additions, such as most major food crops.

Intentional plant introductions have been promoted primarily by the horticulture industry to satisfy the public's desire for novel landscaping. However, plants have also been introduced for agriculture, for silviculture, and for control of soil erosion. Intentional animal introductions include game species brought in for sport hunting or fishing. Unlike these examples, intentional introductions can also include species that are not necessarily intended to form self-sustaining populations, such as those promoted by the aquarium or pet trade.

Species introduced accidentally are "hitchhikers." Shipping ballast has been a major vector, first in the form of soil carrying terrestrial invertebrates and plant seeds or rhizomes, and more recently in the form of ballast water carrying planktonic larvae from foreign ports. While many species are introduced in ballast or by similar means, hitchhikers can also be unwanted parasites that bypass importation and quarantine precautions. For example, many nonindigenous agricultural weeds have been imported in contaminated seed lots.

Certain types of habitats seem to have higher numbers of established nonindigenous species than others. The characteristics that make a site open to invasion must be determined. For example, islands are notably vulnerable to invasions. Islands usually have fewer resident species to begin with, leading to the conjecture that simpler systems have less biotic resistance to invaders. That is, an introduced species is less likely to be met by a resident competitor, predator, or pathogen capable of excluding it. The idea of biotic resistance is also consistent with the idea that complexity confers stability in natural systems. See INVASION ECOLOGY.

A second generalization about invasibility is that ecosystems with high levels of anthropogenic disturbance, such as agricultural fields or roadsides, seem to be more invaded. Increased turnover of open space in these sites could provide more opportunities for the establishment of new species. An alternative explanation is that many species that adapted to anthropogenic habitats in Europe simply tagged along as humans re-created those habitats in new places. Those species would naturally have an advantage over native species at exploiting human disturbances. A final suggestion by proponents of ecosystem management is that disturbance (including, in this context, a disruption of natural disturbance regimes, for example, fire suppression)

weakens the inherent resistance of ecosystems and promotes invasion.

Invasive species can have several different types of impacts. First, they can affect the traits and behavior of resident organisms (for example, causing a shift in diet, size, or shape of the native species they encounter). Second, impacts can occur at the level of the population, either by changing the abundance of a native population or by changing its genetic composition. Hybridization between an invader and a closely related native can result in introgression and genetic pollution. The endpoint can be the de facto extinction of the native species when the unique aspects of its genome are overwhelmed. Third, impacts can occur at the level of ecological communities. When individual populations are reduced or even driven extinct by competition or predation by an invasive species, the result is a decrease in the overall biodiversity of the invaded site. Finally, invaders can impact not only other species but the physical characteristics of an ecosystem as well.

There are two main contributing factors in determining which species have the biggest impacts: abundance and special characteristics. Invaders that reach extremely high density simply overwhelm all other organisms. Other species have special traits that result in an impact out of proportion to their numbers.

Because of the economic and conservation importance of nonindigenous species, much of invasion ecology focuses on the prevention, eradication, and control of invaders, and the restoration of sites after control. Research has emphasized the importance of early detection and eradication of problem species. Biological control has been touted as an environmentally friendly alternative to herbicides and pesticides. See ALLELOPATHY; ECOLOGICAL COMMUNITIES; ECOLOGICAL SUCCESSION; SPECIATION; SPECIES CONCEPT. [I.M.P.]

**Inventory control** The process of managing the timing and the quantities of goods to be ordered and stocked, so that demands can be met satisfactorily and economically. Inventories are accumulated commodities waiting to be used to meet anticipated demands. Inventory control policies are decision rules that focus on the trade-off between the costs and benefits of alternative solutions to questions of when and how much to order for each different type of item.

The possible reasons for carrying inventories are: uncertainty about the size of future demands; uncertainty about the duration of lead time for deliveries; provision for greater assurance of continuing production, using work-in-process inventories as a hedge against the failure of some of the machines feeding other machines; and speculation on future prices of commodities. Some of the other important benefits of carrying inventories are: reduction of ordering costs and production setup costs (these costs are less frequently incurred as the size of the orders are made larger which in turn creates higher inventories); price discounts for ordering large quantities; shipping economies; and maintenance of stable production rates and work-force levels which otherwise could fluctuate excessively due to variations in seasonal demand.

The benefits of carrying inventories have to be compared with the costs of holding them. Holding costs include the following elements: cost of capital for money tied up in the inventories; cost of owning or renting the warehouse or other storage spaces; materials handling equipment and labor costs; costs of potential obsolescence, pilferage, and deterioration; property taxes levied on inventories; and cost of installing and operating an inventory control policy. Inventories, when listed with respect to their annual costs, tend to exhibit a similarity to Pareto's law and distribution. A small percentage of the product lines may account for a very large share of the total inventory budget (they are called class A items).

Continuous-review and fixed-interval are two different modes of operation of inventory control systems. The former means the records are updated every time items are withdrawn from stock. When the inventory level drops to a critical level called reorder

point, a replenishment order is issued. Under fixed-interval policies, the status of the inventory at each point in time does not have to be known. The review is done periodically.

Uncertainties of future demand play a major role in the cost of inventories. That is why the ability to better-forecast future demand can substantially reduce the inventory expenditures of a firm. Conversely, using ineffective forecasting methods can lead to excessive shortages of needed items and to high levels of unnecessary ones.

Material requirements planning (MRP) systems (which are production-inventory scheduling softwares that make use of computerized files and data-processing equipment) are receiving widespread application. MRP systems have not yet made use of mathematical inventory theory. They recognize the implications of dependent demands in multiechelon manufacturing (which includes lumpy production requirements). Integrating the bills of materials, the given production requirements of end products, and the inventory records file, MRP systems generate a complete list of a production-inventory schedule for parts, subassemblies, and end products, taking into account the lead-time requirements. MRP has proved to be a useful tool for manufacturers, especially in assembly operations. [A.Do.]

**Inverse scattering theory** A theory whose objective is to determine the scattering object, or an interaction potential energy, from the knowledge of a scattered field. This is the opposite problem from direct scattering theory, where the scattering amplitude is determined from the equations of motion, including the potential. The equations of motion are usually linear (operator-valued) equations. See SCATTERING EXPERIMENTS (ATOMS AND MOLECULES); SCATTERING EXPERIMENTS (NUCLEI).

Inverse scattering theories can be divided into two types: (1) pure inverse problems, when the data consist of complete, noise-free information of the scattering amplitude; and (2) applied inverse problems, when incomplete data which are corrupted by noise are given. Many different applied inverse problems can be obtained from any pure inverse problem by using different band-limiting procedures and different noise spectra.

The difficulty of determining the exact object which produced a scattering amplitude is evident. It is often a priori information about the scatterer that makes the inversion possible.

Much of the basic knowledge of systems of atoms, molecules, and nuclear particles is obtained from inverse scattering studies using beams of different particles as probes. For the Schrödinger equation with spherical symmetry or in one dimension, there is an exact solution of the inverse problem.

A number of high-technology areas (nondestructive evaluation, medical diagnostics including acoustic and ultrasonic imaging, x-ray absorption and nuclear magnetic resonance tomography, radar scattering and geophysical exploration) use inverse scattering theory. Several classical waves including acoustic, electromagnetic, ultrasonic, x-rays, and others are used. See BIOACOUSTICS; COMPUTERIZED TOMOGRAPHY.

All of the inverse scattering technologies require the solution to ill-posed or improperly posed problems. A model equation is well posed if it has a unique solution which depends continuously on the initial data. It is ill posed otherwise. The ill-posed problems which are amenable to analysis, called regularizable ill-posed problems, are those which depend discontinuously upon the data. This destroys uniqueness, although solutions (in fact, many solutions) exist. [B.DeF.]

**Inverse-square law** Any law in which a physical quantity varies with distance from a source inversely as the square of that distance. When energy is being radiated by a point source (see illustration), such a law holds, provided the space between source and receiver is filled with a nondissipative, homogeneous, isotropic, unbounded medium.

Similar reasoning shows that the same law applies to mechanical shear waves in elastic media and to compressional sound

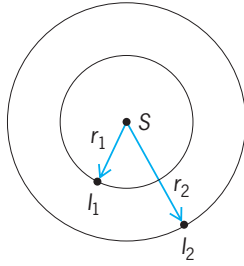

Point source *S* emitting energy of intensity *I*. The inverse-square law states that  $I_1/I_2 = r_2^2/r_1^2$ , where *r* = distance from *S*.

waves. The term is also used for static field laws such as the law of gravitation and Coulomb's law in electrostatics. [W.R.Sm.]

**Invertebrate embryology** The study of the development or morphogenesis and growth of the invertebrates. The same general principles of development apply to the invertebrates as do to the vertebrates. Much of the basic knowledge of embryology has been the result of studies on the invertebrates. A common phenomenon in the invertebrates is the release of a free and independent form, the larva, before development is completed. The larvae vary considerably and are characteristic of the different animal groups.

Embryonic development begins with the formation of the gametes in a specialized cell bearing the haploid or *N* number of chromosomes. The process of spermatogenesis consists of a stage of cell proliferation, followed by a period of progressive concentration and streamlining. The essential, heredity-determining material of the chromosomes is packed tightly into a tiny nucleus. The cytoplasm forms the locomotor apparatus, usually a single long flagellum with a centriole at its base and a mitochondrion nearby, as well as an organelle (acrosome) for penetrating the egg coverings. Millions upon millions of such cells are produced in the testis, where they remain quiescent until they are spawned. See SPERM CELL; SPERMATOGENESIS.

The egg is specialized for large size and protection of its contents, with less concern for numbers and none at all for motility. In addition, its cytoplasm possesses intrinsic capacities for differentiation and building in exact accordance with the specifications contained in its chromosomes, so that a spider egg, for example, always produces a spider and never a fly. The reserve building and energy-yielding materials are stored in the egg cytoplasm as minute spheres or platelets of yolk, a stable lipoprotein substance. Eggs are large cells even without this inert material. At the end of their growth period, when they have accumulated the full amount of yolk, they are huge in comparison to the body cells of the parent animal. The largest are found among the arthropods, while some marine animals have very small eggs.

During the growth period, while the egg cell is actively synthesizing yolk and increasing the amount of cytoplasm, it has a very large nucleus, the germinal vesicle. When it reaches full size, however, and this synthetic activity subsides, the nuclear membrane breaks down, releasing its contents into the cytoplasm. The two successive nuclear divisions of meiosis follow, but the cytoplasm, instead of dividing equally, pushes out one of the daughter nuclei each time as a polar body. These two minute bodies have no further function in development. The chromosome material left in the egg forms the egg pronucleus, which is ready to unite with the sperm pronucleus. The zygote nucleus, formed by their union, is comparable in size to those of the body cells.

The eggs of invertebrates are always surrounded by a protective covering. In some forms the eggs are laid in batches which may be enclosed in a leathery sac or embedded in a mass of jelly. In other cases each egg has its own separate membranous case, a layer of jelly, or a more complex system of protective structures. Sperm and egg of each individual species have been

shown by light and electron microscopy to be characteristic of its particular species. Mechanisms have evolved which normally prevent the egg of one species from being fertilized by the sperm of another. Reproduction among the invertebrates takes place in a variety of ways which differ widely from phylum to phylum.

Fertilization has been studied in several invertebrates, but especially in the sea urchin. Egg and sperm of the sea urchin are released into the seawater. The eggs are covered with a jelly coat to which a receptor on the plasma membrane of the fertilizing sperm binds. The plasma and outer acrosomal membranes of the sperm break down and fuse with each other as a  $Ca^{2+}$  influx occurs; the hydrolytic enzymes within the acrosome are released to lyse the egg coat. Next the inner acrosomal membrane everts by the polymerization beneath it of actin, and forms the acrosomal process which makes contact and fuses with the egg plasma membrane. The egg responds to the sperm by forming a fertilization cone. The sperm nucleus enters the egg, and its DNA swells to form the male pronucleus. As the sperm binds to the receptors on the egg plasma membrane, the electrical potential of the egg membrane changes and establishes a rapid block to prevent further sperm from making contact and fusing with the egg. With sperm-egg membrane fusion,  $Ca^{2+}$  is released to activate a series of changes in the egg. As changes occur at the egg surface, the egg pronucleus and the sperm pronucleus with associated astral rays move toward the center of the egg, where they fuse.

The union of the two pronuclei (syngamy) marks the completion of the fertilization process. The fusion forms the zygote nucleus, with the full complement of chromosomes, and the dormant egg cell has been aroused to start the series of changes which will produce a new sea urchin. With different time schedules and allowance for the individual characteristics of each species, these basic processes of sperm entry, aster formation, and syngamy make up the complex phenomenon of the fertilization reaction as it occurs in all animals.

The fertilized egg, or zygote, sets about at once to divide the huge mass of the egg into many small cells in order to restore the usual ratio between the amounts of nuclear and cytoplasmic substances. The energy for these repeated mitoses comes from the yolk, which also furnishes at least part of the materials required for synthesis of new nuclear structures. During this cleavage period, which commonly occurs during the first 12 h after fertilization, the blastomeres, as the cleavage stage cells are called, divide more or less synchronously. Generally, cleavage follows one of several patterns characteristic for large groups of animals and often correlated with the amount and mode of distribution of the yolk. Small eggs, which contain little yolk, divide completely and usually very regularly, forming a mass of cells that shows spiral, bilateral, or radial symmetry.

Insect eggs contain a large store of yolk. Following fertilization, the nuclei alone divide and move apart in the layer of cytoplasm after each division so that they distribute themselves all around the egg. After nine such nuclear divisions have taken place (producing 512 nuclei), the cytoplasm also cleaves at the next division, forming a single layer composed of about 1000 cells surrounding the central yolk mass. See CLEAVAGE (EMBRYOLOGY).

Among all the invertebrate forms except the insects, the result of 6–10 successive cleavage cycles is the formation of a sphere (blastula) composed of small cells which lie in a single compact layer around a central cavity (blastocoele).

The end of the brief blastula stage occurs when the process of gastrulation begins. In its simplest form, this consists in an indenting (invagination) of the blastula wall in the vegetal region. Meanwhile cell division is going on steadily, and since the larva has as yet no way of taking in solid food from the outside, all the form changes which occur during this period are accomplished with the material originally present in the fertilized egg. The only addition is water (blastocoele fluid) and such dissolved substances, mostly salts, from the environment as can enter through the cell membranes. As the blastomeres become

smaller and the blastular wall becomes correspondingly thinner, cells are provided to extend the vegetal indentation into a pocket. With the appearance of this structure (primitive digestive tract) the larva becomes two-layered, possessing an outer layer, the ectoderm, which will later produce the nervous system as well as the outermost body covering, and an inner layer, the endoderm, from which will be formed the lining of the functional digestive tract and its associated organs and glands. As the primitive digestive tract extends into the blastocoel, its opening to the outside becomes smaller and is known as the blastopore. See BLASTULATION; GASTRULATION.

At this time the first few cells belonging to a third body layer, the mesoderm, make their appearance. This mesodermal tissue spreads out between the ectoderm and endoderm, and in all phyla more advanced than the flatworms it splits through its center into an inner and an outer layer. The cavity thus formed within the mesoderm is the true body cavity in which the various internal organs lie. The outer layer of mesoderm becomes closely applied to the inner side of the ectoderm, forming body-wall muscles and other supporting layers, while the inner layer of mesoderm surrounds the endoderm with layers of muscle. The organs of circulation, excretion, and reproduction, as well as all muscles and connective tissue, are eventually formed from this mesodermal layer which surrounds the endoderm.

So far it is possible to summarize the development of invertebrate animals as a group but beyond this point each subgroup follows its own course, and these are so widely divergent that every one must be considered separately. Meaningful generalizations are not even possible within a single class in some cases, as attested to by the various modes of development occurring among the Insecta, some of which proceed directly from egg to adult form, while others go through an elaborate series of changes. In very many species there is a sharp break in the life history when the larva, after passing through a number of morphological phases which lead from one to the next with a steady increase in size and complexity, abruptly forms a whole new set of rudimentary adult organs which take over the vital functions. This metamorphosis represents the end of the larval period. The tiny animal which it produces is for the first time recognizable as the offspring of its parents. See INSECT PHYSIOLOGY; INSECTA.

[G.H.I.]

**Invertebrate pathology** The study of diseases affecting invertebrate animals, including etiology, pathogenesis, symptomatology, pathology, histopathology, physiopathology, and epizootiology. Interactions between invertebrates and their diverse pathogens, such as bacteria, viruses, and protozoa, range from obligate parasitism to various associations that may result in disease. Disease is usually described as a disturbance of the equilibrium between the invertebrate animal and the environment, and it should be understood as a process and not a thing. The disease process represents the response of an invertebrate organism to injury. Its occurrence is a normal biological phenomenon, and it has been recognized as a balancing factor in nature. Understanding invertebrate pathology is essential to understanding invertebrate life and behavior.

Infectious diseases of invertebrates have been thoroughly studied, while less attention has been devoted to noninfectious diseases. The latter involve mechanical and physiological injuries caused by chemicals, nutritional disturbances, inherited abnormalities (genetic diseases), tumors, predation, and the actions of other invertebrates.

Numerous diseases and pathogens of invertebrate animals have been described throughout the world. By 1999, in Mollusca as many as 46 diseases of oysters, 20 of clams and cockles, 19 of scallops, and 9 of abalone had been described. Diseases of Crustacea included 17 lobster diseases, 35 diseases of shrimp and prawns, 17 of crabs, and 13 of crayfish.

Immune reactions of invertebrates can be cellular or humoral. In cellular immunity, several types of hemocytes have been

demonstrated. Three defense reactions have been recognized: phagocytosis, encapsulation, and hemostasis (coagulation and wound healing). Phagocytosis is localized in the plasma membrane and the cytoskeleton. Encapsulation occurs when bacteria, fungi, nematodes, or protozoa, as well as nonliving objects that are too large to be phagocytized, are encapsulated by plasmatocytes or granulocytes. Wound healing and coagulation in invertebrates differs from hemostasis in vertebrate animals.

All types of hemocytes involved in invertebrate immunity are called immunocytes. The recognition of foreign antigens is affected by surface receptors and molecules located on the plasma membrane of immunocytes. Parasitoids and parasites of invertebrates often possess defensive mechanisms that can overcome immunological reactions of their hosts. Humoral immunity of invertebrates provides the second line of defense against massive invasion, when immunocytes become depleted.

The immune system of invertebrate animals produces antimicrobial proteins in immunocytes or in the fat body. Arthropods do not possess antibodies, but they synthesize lectins that can agglutinate microorganisms. Cytokine-like molecules have been found in mollusks, worms, echinoderms, and arthropods. In many invertebrate animals, a prophenoloxidase-activating system can contribute to humoral immunity. Neuropeptides and opiates mediate phagocytosis in the earthworm, mollusks, arthropods, starfishes, and sea urchins. Complement-like molecules have been detected in all invertebrates, and in some the C-reactive protein has been reported. Obviously the immune system of invertebrates is very sophisticated, sharing many fundamental mechanisms with vertebrates.

Invertebrate pathology has applications in agriculture, medicine, general biology, and biotechnology. In agriculture the prevention of diseases affecting honeybees and silkworm, and the use of bacterial toxins and baculoviruses for microbial control of insect pests, constitute the most important applications of invertebrate pathology. See ANNELIDA; ANTIBODY; ARTHROPODA; ECHINODERMATA; IMMUNITY; INSECTA; MOLLUSCA; NEMATODA; PORIFERA.

[K.M.]

**Involute** A term applied to a curve  $C'$  that cuts at right angles all tangents of a curve  $C$  (see illustration). Each curve  $C$  has

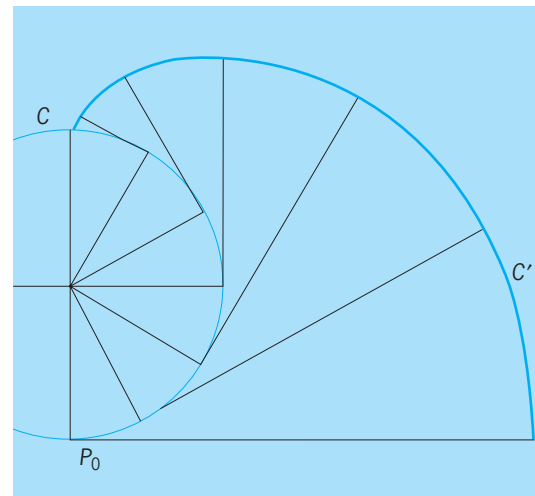

An involute  $C'$  of curve  $C$ .

infinitely many involutes and the distance between corresponding points of any two involutes is constant. Let a length of string be coincident with a curve  $C$ , with one end fastened at a point  $P_0$  of  $C$ . If the string is unwound, remaining taut, the other end of the string traces an involute  $C'$  of  $C$ . By varying the length of the string, all involutes of  $C$  are obtained. See ANALYTIC GEOMETRY.

[L.M.B.I.]



**Iodine** A nonmetallic element, symbol I, atomic number 53, relative atomic mass 126.9045, the heaviest of the naturally occurring halogens. Under normal conditions iodine is a black, lustrous, volatile solid; it is named after its violet vapor. See HALOGEN ELEMENTS; PERIODIC TABLE.

The chemistry of iodine, like that of the other halogens, is dominated by the facility with which the atom acquires an electron to form either the iodide ion  $I^-$  or a single covalent bond  $-I$ , and by the formation, with more electronegative elements, of compounds in which the formal oxidation state of iodine is +1, +3, +5, or +7. Iodine is more electropositive than the other halogens, and its properties are modulated by: the relative weakness of covalent bonds between iodine and more electropositive elements; the large sizes of the iodine atom and iodide ion, which reduce lattice and solvation enthalpies for iodides while increasing the importance of van der Waals forces in iodine compounds; and the relative ease with which iodine is oxidized. Some properties of iodine are listed in the table. See ASTATINE; BROMINE; CHEMICAL BONDING; CHLORINE; FLUORINE.

Iodine occurs widely, although rarely in high concentration and never in elemental form. Despite the low concentration of iodine in sea water, certain species of seaweed can extract and accumulate the element. In the form of calcium iodate, iodine is found in the caliche beds in Chile. Iodine also occurs as iodide ion in some oil well brines in California, Michigan, and Japan.

The sole stable isotope of iodine is  $^{127}I$  (53 protons, 74 neutrons). Of the 22 artificial isotopes (masses between 117 and 139), the most important is  $^{131}I$ , with a half-life of 8 days. It is widely used in radioactive tracer work and certain radiotherapy procedures. See RADIOACTIVE TRACER.

Iodine exists as diatomic  $I_2$  molecules in solid, liquid, and vapor phases, although at elevated temperatures ( $>200^\circ C$  or  $390^\circ F$ ) dissociation into atoms is appreciable. Short intermolecular  $I \dots I$  distances in the crystalline solid indicate strong intermolecular van der Waals forces. Iodine is moderately soluble in nonpolar liquids, and the violet color of the solutions suggests that  $I_2$  molecules are present, as in iodine vapor.

Although it is usually less vigorous in its reactions than the other halogens, iodine combines directly with most elements. Important exceptions are the noble gases, carbon, nitrogen, and some noble metals. The inorganic derivatives of iodine may be grouped into three classes of compounds: those with more electropositive elements, that is, iodides; those with other halogens; and those with oxygen. Organoiodine compounds fall into two categories: the iodides; and the derivatives in which iodine is in a formal positive oxidation state by virtue of bonding to another, more electronegative element. See GRIGNARD REACTION; HALOGENATED HYDROCARBON; HALOGENATION.

Iodine appears to be a trace element essential to animal and vegetable life. Iodide and iodate in sea water enter into the metabolic cycle of most marine flora and fauna, while in the higher mammals iodine is concentrated in the thyroid gland, being converted there to iodinated amino acids (chiefly thyroxine and iodotyrosines). They are stored in the thyroid as thyroglobulin, and thyroxine is apparently secreted by the gland. Iodine

deficiency in mammals leads to goiter, a condition in which the thyroid gland becomes enlarged. See THYROID GLAND.

The bactericidal properties of iodine and its compounds bolster their major uses, whether for treatment of wounds or sterilization of drinking water. Also, iodine compounds are used to treat certain thyroid and heart conditions, as a dietary supplement (in the form of iodized salt), and for x-ray contrast media. See ANTIMICROBIAL AGENTS; ANTISEPTIC; SALT (FOOD).

Major industrial uses are in photography, where silver iodide is a constituent of fast photographic film emulsions, and in the dye industry, where iodine-containing dyes are produced for food processing and for color photography. See DYE; PHOTOGRAPHIC MATERIALS. [C.A.]

**Ion** An atom or group of atoms that bears an electric charge. Positively charged ions are called cations, and negatively charged ions are called anions. When a single atom gains or loses an electron, monoatomic ions are formed. For example, reaction of the element sodium (Na) with the element chlorine (Cl) leads to the transfer of electrons from Na to Cl to form  $Na^+$  cations and  $Cl^-$  anions. In general, atoms of metallic elements (on the left side of the periodic table) lose electrons to form cations, while atoms of nonmetallic atoms (on the right side of the periodic table) gain electrons to form anions. Ions can bear multiple charges, as in the magnesium ion ( $Mg^{2+}$ ) or the nitride ion ( $N^{3-}$ ). The charge on monoatomic ions is usually the same for elements in the same column of the periodic table; for example, hydrogen (H), Na, lithium (Li), potassium (K), rubidium (Rb), and cesium (Cs) all form +1 ions. See PERIODIC TABLE.

Ions can also comprise more than one atom and are then called polyatomic ions. For example, the ammonium ion ( $NH_4^+$ ) carries a positive charge and is composed of one nitrogen atom and four hydrogen atoms. The nitrate ion ( $NO_3^-$ ) is composed of one nitrogen atom and three oxygen atoms and carries a single negative charge. Polyatomic ions are usually depicted inside brackets with superscripted charges, as shown in the structure below.

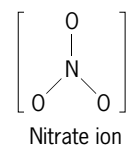

Anions and cations can combine to form solid materials called salts, which are named by the cation name followed by the anion name. For a salt composed of the polyatomic ions ammonium and nitrate, the formula is  $NH_4NO_3$  and the name is ammonium nitrate. For monoatomic ions, the cation name is the same as the element and the anion name is the element name with the ending -ide. Thus, common table salt,  $NaCl$ , is called sodium chloride. The ratio of anions to cations must always be such that an electrically neutral material is produced. Thus, magnesium nitrate must contain one magnesium for every two nitrates, giving the formula  $Mg(NO_3)_2$ . See SALT (CHEMISTRY). [H.H.T.]

Some important properties of iodine

Property	Value
Electronic configuration	[Kr]4d105s25p5
Relative atomic mass	126.9045
Electronegativity (Pauling scale)	2.66
Electron affinity, eV	3.13
Ionization potential, eV	10.451
Covalent radius, $-I$ , nm	0.133
Ionic radius, $I^-$ , nm	0.212
Boiling point, $^\circ C$	184.35
Melting point, $^\circ C$	113.5
Specific gravity (20/4)	4.940

**Ion beam mixing** A process in which bombardment of a solid with a beam of energetic ions causes the intermixing of the atoms of two separate phases originally present in the near-surface region. In the well-established process of ion implantation, the ions are incident instead on a homogeneous solid, into which they are incorporated over a range of depths determined by their initial energy. In the simplest example of ion beam mixing, the solid is a composite consisting of a substrate and a thin film of a different material (illus. a). Ions with sufficient energy pass through the film into the substrate, and this causes mixing of the film and substrate atoms (illus. b). If the ion dose is large enough, the original film will completely disappear (illus. c). This process may result in the impurity doping of the substrate, in the formation of an alloy or two-phase mixture, or in the production

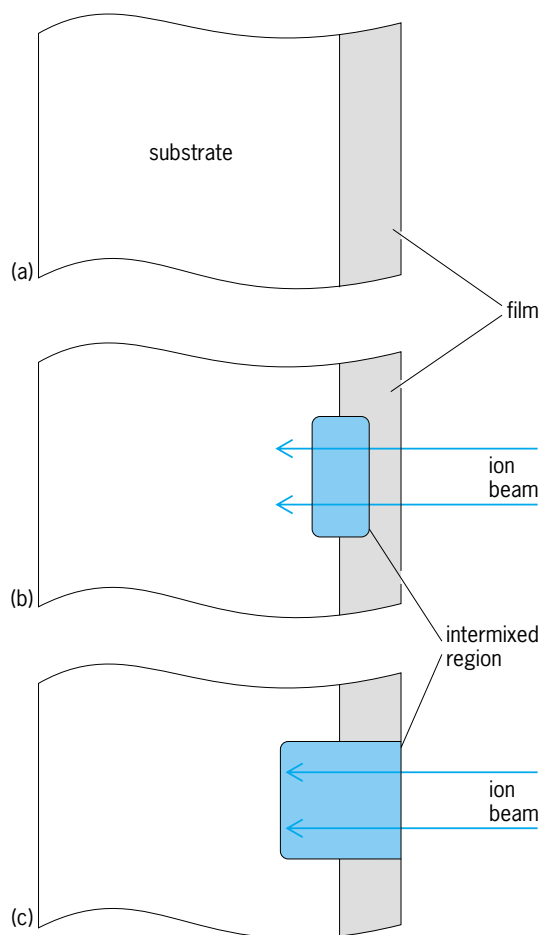

**Ion beam mixing of film and substrate. (a) Before ion bombardment. (b) Partial intermixing. (c) Complete intermixing.**

of a stable or metastable solid phase that is different from either the film or the substrate. See ION IMPLANTATION.

Like ion implantation, ion beam mixing is a solid-state process that permits controlled change in the composition and properties of the near-surface region of solids. Although not yet employed commercially, it is expected to be useful for such applications as the surface modification of metals and semiconductor device processing. In conjunction with thin-film deposition technology, ion beam mixing should make it possible to introduce many impurity elements at concentrations too high for ion implantation to be practical.

[B.Y.T.]

**Ion exchange** The reversible exchange of ions of the same charge between a solution and an insoluble solid in contact with it; or between two immiscible solvents, one of which contains a soluble material with immobilized ionic groups. Ions are atoms or molecules containing charge-bearing groups. Their interactions are dominated by the electrostatic forces between charge centers. These interactions are attractive when the ions are of opposite charge, or repulsive when the ions have the same charge. Ions with a net negative charge are called anions, and those with a net positive charge are cations.

A unique property of ions is their capacity to render gases and liquids conducting, and conductivity is a universal method of detecting ions. Ions in solution are in rapid motion and have no distinct partners. Ions in an electric field migrate to the electrode of opposite charge with a velocity roughly proportional to their charge-to-size ratio. This process is known as electrophoresis, and it is one method used to separate and identify ions. See ELECTROPHORESIS.

Ions can also be separated on the basis of their equilibrium with a system containing immobilized ions of opposite charge. Ions can be immobilized by virtue of their location in a rigid matrix. Associated with these fixed ionic sites are mobile counterions of opposite charge. Solution ions with a higher affinity than the counterions for the fixed sites will displace them from the fixed sites and remain localized in the vicinity of the fixed sites. Simultaneously the solution is enriched in the counterions originally localized at the fixed sites. This exchange process for ions of the same charge type is called ion exchange. In a column containing the immobilized ions as part of the stationary phase and the solution of competing ions as the mobile phase, the sample ions can be separated by the repeated equilibrium steps involved as they are transported through the column until they exit it, and are detected. This is an example of ion-exchange chromatography, an important method of separating and identifying ions.

**Ion-exchange materials.** Ion-exchange polymers are based on styrene and divinylbenzene and, to a lesser extent, polymers prepared from divinylbenzene, or a similar cross-linking agent, and acrylic, methacrylic, or hydroxyalkyl methacrylic acids and esters. These are usually prepared in bead form.

Ion exchangers prepared for the isolation or separation of cations must have negatively charged functional groups incorporated into the polymer backbone. The most common groups are sulfonic and carboxylic acids. Sulfonic acid groups are introduced by reacting the polymer beads with fuming sulfuric acid or a similar reagent. Similarly, carboxylic acid groups can be introduced by a number of common chemical reactions or by hydrolysis of the ester group or oxidation of hydroxyalkyl groups in methyl methacrylate or hydroxyalkyl methacrylate polymers, respectively. Other common functional groups used in cation exchangers include phosphoric acid and phenol and, to a lesser extent, phosphinic, arsonic, and selenonic acids.

A common approach for the preparation of anion exchangers is to react the styrene-divinylbenzene polymer with chloromethylmethyl ether in the presence of a catalyst, which adds the side chain,  $-\text{CH}_2\text{Cl}$ ; then this chloromethylated product is treated with an amine to introduce the charged functional group. A tertiary amine produces a quaternary ammonium group, while primary and secondary amines give products that are charged only in contact with solutions of low pH. As well as simple alkyl and benzyl amines, hydroxyalkyl amines are used to introduce functional groups of the type  $[-\text{CH}_2\text{N}(\text{CH}_3)_2\text{C}_2\text{H}_4\text{OH}]^+$ . See QUATERNARY AMMONIUM SALTS.

Silica-based materials are used primarily in chromatography because of the favorable mechanical and physical properties of the silica ( $\text{SiO}_2$ ) gel support matrix. Ion-exchange groups are introduced by reacting the surface silanol groups of the porous silica particles with silanizing reagents containing the desired functional group (R).

Hydrous oxides of elements of groups 14, 15, and 16 of the periodic table can be used as selective ion exchangers. The most important hydrous oxides used for the separation of organic and inorganic ions are alumina ( $\text{Al}_2\text{O}_3 \cdot n\text{H}_2\text{O}$ ), silica ( $\text{SiO}_2 \cdot n\text{H}_2\text{O}$ ), and zirconia ( $\text{ZrO}_2 \cdot n\text{H}_2\text{O}$ ). Silica, by virtue of the presence of surface silanol groups, is used as a cation exchanger at  $\text{pH} > 2$ . Alumina is amphoteric and can be used as an anion exchanger at low pH and a cation exchanger at high pH. Alumina has the advantage over silica of being chemically stable over a wide pH range. The ion-exchange capacity of silica and alumina is controlled by the pH of the solution in contact with the oxides, since this controls the number of ionized surface functional groups. Alumina is used to isolate nitrogen-containing drugs and biochemically active substances from biological fluids, thus minimizing matrix interferences in their subsequent chromatographic analysis.

**Applications.** Ion exchange has numerous applications for industry and for laboratory research. By the quantity of materials used, water conditioning is the most important. Ion exchange is

one of the primary analytical methods used to identify and quantify the concentration of ions in a wide range of environmental, biological, and industrial samples.

Natural water from rivers and wells is never pure; it is usually hard, that is, it contains calcium and magnesium salts that form curds with soap and leave hard crusts in pipes and boilers. Hard water is softened by passage through a cartridge or bed of cation exchanger in the sodium form (the mobile counterions are sodium in this case).

Many industrial and laboratory processes require a supply of pure water with a very low concentration of salts. This can be achieved by passing water through a bed of mixed strong cation exchanger in the hydrogen form and a strong anion exchanger in the hydroxide form. The cation exchanger removes all the cations from the water by replacing them by hydrogen ions. The anions are removed by the anion exchanger and replaced by hydroxide ions. The hydrogen and hydroxide ions combine to form water.

Toxic ions such as mercury ( $\text{Hg}^{2+}$ ), lead ( $\text{Pb}^{2+}$ ), chromate ( $\text{CrO}_4^{2-}$ ), and ferrocyanide [ $\text{Fe}(\text{CN})_6^{4-}$ ] are removed by ion exchange from industrial wastewaters prior to their discharge into the environment. Ion exchangers are used to recover precious metals such as gold ( $\text{Au}^+$ ), platinum ( $\text{Pt}^+$ ), and silver ( $\text{Ag}^+$ ) in a useful form from mine workings and metalworking factories. Ion exchange is frequently used to decontaminate waste and concentrate radioactive elements from the nuclear industry.

Ion exchange is used on the laboratory scale for isolation and preconcentration of ions prior to instrumental analysis and to obtain preparative scale quantities of material for use in laboratory studies. Ion exchange is often employed in conjunction with activation analysis to isolate individual elements for quantification by radiochemical detection. Modern chromatographic techniques employ ion exchangers of small particle size and favorable mass-transfer characteristics, and operate at high pressures, providing better resolution of mixtures in a shorter time than with conventional gravity-flow-controlled separations.

Biotechnology requires reliable, efficient methods to purify commercial-scale quantities of proteins, peptides, and nucleic acids for use in the pharmaceutical, agricultural, and food industries. Ion exchange is widely used in the isolation and purification of these materials. Typical applications include the removal of ionic compounds used in the production process, the elimination of endotoxins and viruses, the removal of host-cell proteins and deoxyribonucleic acid (DNA), and the removal of potentially hazardous variants of the main product. [C.F.P.]

**Membranes.** Ion-exchange membranes are a class of membranes that bear ionic groups and therefore have the ability to selectively permit the transport of ions through themselves. In biological systems, cell membranes and many other biological membranes contain ionic groups, and the conduction of ions is essential to their function. Synthetic ion-exchange membranes are used in fuel cells, electrochemical processes for chlorine manufacture and desalination, membrane electrodes, and separation processes. Ion-exchange membranes typically consist of a thin-film phase, usually polymeric, to which have been attached ionizable groups. Numerous polymers have been used, including polystyrene, polyethylene, polysulfone, and fluorinated polymers. Ionic groups attached to the polymer include sulfonate ( $-\text{SO}_3^-$ ), carboxylate ( $-\text{COO}^-$ ), tetralkylammonium ( $-\text{N}(\text{CH}_3)_4^+$ ), phosphonate ( $-\text{PO}_3\text{H}^-$ ), and many others. [N.N.Li; S.F.Y.]

**Ion implantation** A process that utilizes accelerated ions to penetrate a solid surface. The implanted ions can be used to modify the surface composition, structure, or property of the solid material. This surface modification depends on the ion species, energy, and flux. The penetration depth can be controlled by adjusting the ion energy and the type of ions used. The total number of ions incorporated into the solid is determined by the ion flux and the duration of implantation. This

technique allows for the precise placement of ions in a solid at low temperatures. It is used for many applications such as modifying the electrical properties of semiconductors and improving the mechanical or chemical properties of alloys, metals, and dielectrics. See ALLOY; DIELECTRIC MATERIALS; METAL; SEMICONDUCTOR.

Wide ranges of ion energy and dose are applied. For ion energy ranging from 1 keV to 10 MeV, the ion penetration depth varies from 10 nanometers to 50 micrometers. In general, it is difficult to get deeper penetration since extremely high energy ions are required. As such, ion implantation is a surface modification technique and not suitable for changing the entire bulk property of a solid. Ion dosage also varies depending on the applications. Doses ranging from  $10^{10}$  to  $10^{18}$  ions/cm<sup>2</sup> are typically applied. For high-dose applications, ion sources providing high ion currents are needed to keep the implantation time reasonable for production purposes. See ION.

Ion implantation is used extensively in the semiconductor industry. The fabrication of integrated circuits in silicon often requires many steps of ion implantation with different ion species and energies. The implanted ions serve as dopants in semiconductors, changing their conductivity by more than a factor of  $10^8$ . See INTEGRATED CIRCUITS.

Ion implantation is also used to change the surface properties of metals and alloys. It has been applied successfully to improve wear resistance, fatigue life, corrosion protection, and chemical resistance of different materials. Even though the ion projected range is less than 1  $\mu\text{m}$ , surface treatment by ion implantation can extend the lives of metal or ceramic tools by 80 times or more. Ion implantation can form new compounds such as nitrides on the surface, and the implanted ions can be found at much greater depths than the projected range due to diffusion or mechanical mixing. See CERAMICS. [S.W.P.]

**Ion propulsion** Vehicular propulsion caused by the high-speed discharge of a beam of electrically charged minute particles. These particles, usually positive ions, are generated and accelerated in an electrostatic field produced within an ion thruster attached to a spacecraft. Because positive ions cannot be ejected from the thruster without leaving a substantial negative charge on the thruster and spacecraft, electrons must be ejected at the same rate. Ion propulsion systems are attractive because they expel the ions at very high speeds and, therefore, require much less propellant than other thrusters, such as chemical rockets.

The three principal components of an ion propulsion system are the power-generation and -conditioning subsystem, the propellant storage and feed subsystem, and one or more ion thrusters.

The power source can be a nuclear reactor or a radiant-energy collector. In the former, thermal power is released by fission or fusion reactions. Solar radiation can be used to provide electric power directly through photovoltaic (solar) cells or indirectly through a solar collector-heat exchanger system similar to that for a nuclear system. See SOLAR CELL; SOLAR ENERGY.

If the power-generation system involves a nuclear reactor or a solar-thermal subsystem, thermal-to-electric conversion subsystems are required. Those most highly developed involve thermodynamic conversion cycles based on turbine generators. Although most traditional systems have operated on the Brayton gas cycle or the Rankine vapor cycle, more recent efforts include the Stirling gas-cycle system.

Ion-thruster propellants that have been investigated include argon, xenon, cesium, mercury, and fullerenes such as  $\text{C}_{60}$ . Although mercury received most of the early attention, xenon is now being used on all space missions because of toxicity concerns with mercury.

Ion or electrostatic thrust devices contain three functional elements: an ionizer that generates the ions; an accelerator providing an electric field for accelerating the ions and forming them into a well-focused beam; and a neutralizer or electron emitter

that neutralizes the electrical charge of the exhaust beam of ions after they have been ejected.

The positive ions needed for acceleration are produced in a strong electric field, by contact with a surface having a work function greater than the ionization potential of the propellant, or by electron-bombardment ionization. The last method has received the most attention and appears to be the most promising.

Some of the ions produced are directed toward the ion-accelerating subsystem which typically consists of two plates containing large numbers of aligned hole pairs. The upstream plate and the body of the ionizer are maintained at a positive potential with respect to the space downstream from the thruster, whereas the downstream plate is biased negative at a smaller value. For a high extracted ion current density, the plates should be as close together as possible.

Ion propulsion is characterized by high specific impulse and low thrust. Because high specific impulse means low propellant consumption, ion propulsion is attractive for a wide variety of applications.

One functional category includes the use of ion thrusters on satellites for orbit control (against weak perturbation forces) and for station keeping (position maintaining of satellite in a given orbit). Substantial commercial use of ion thrusters in this application began at the end of the twentieth century. An ion propulsion system can also be used advantageously for changing the satellite's position in a given orbit, especially shifting a satellite to different longitudes over the Earth in an equatorial geostationary orbit. See SATELLITE (SPACECRAFT); SPACECRAFT PROPULSION.

A major functional application of ion propulsion is interplanetary transfer. Here, thrust has to overcome only very weak solar gravitational forces. Because of this, and the long powered flight times of which ion propulsion is capable, transfer times to Venus or Mars need not be longer than transfer times in comparable flights with high thrust drives capable only of short powered flight. At the very large distances to objects in the outer solar system, ion propulsion would yield shorter transfer times than chemical and most high-thrust nuclear concepts. The National Aeronautics and Space Administration (NASA) *Deep Space 1* mission, launched in 1998, used a 30-cm-diameter (12-in.) xenon ion thruster to propel a spacecraft to encounters with the asteroid Braille and the comet Borrelly. See ELECTROTHERMAL PROPULSION; INTERPLANETARY PROPULSION; PLASMA PROPULSION; SPACE PROBE. [P.J.Wi.]

### **Ion-selective membranes and electrodes**

Membrane-based devices, involving permselective, ion-conducting materials, used for measurement of activities of species in liquids or partial pressures in the gas phase. Permselective means that ions of one sign may enter and pass through a membrane.

Ion-selective electrodes are classified mainly according to the physical state of the ion-responsive membrane material, and not with respect to the ions sensed.

Glass membrane electrodes are mainly used for hydrogen ion activity measurements. They predate the wider variety of membrane electrodes developed after 1960. Electrodes based on water-insoluble inorganic salts include sensors for  $F^-$ ,  $Cl^-$ ,  $Br^-$ ,  $I^-$ ,  $CN^-$ ,  $SCN^-$ ,  $S^{2-}$ ,  $Ag^+$ ,  $Cu^{2+}$ ,  $Cd^{2+}$ , and  $Pb^{2+}$ . The compounds used are silver salts, mercury salts, sulfides of Cu, Pb, and Cd, and rare-earth salts. All of these are so-called white metals whose aqueous cations (except  $La^{3+}$ ) are labile. Electrodes using liquid-ion exchangers are supported in the voids of inert polymers such as cellulose acetate, or in transparent films of polyvinyl chloride, and provide extensive examples of devices for sensing. Electrodes with chemical reactions interposed between the sample and the sensor surface permit a new degree of freedom in design of sensors for species which do not directly respond at an electrode surface. Two primary examples are the categories of gas sensors and of electrodes which use enzyme-catalyzed reactions. See ELECTRODE; ION EXCHANGE.

Electrodes for many species are, for the most part, commercially available. Applications may be batch or continuous. Important batch examples are potentiometric titrations with ion-selective electrode end-point detection, determination of stability constants of complexes and speciation identity, solubility and activity coefficient determinations, and monitoring of reaction kinetics, especially for oscillating reactions. Ion, selective electrodes serve as liquid chromatography detectors and as quality-control monitors in drug manufacture. Applications occur in air and water quality (soil, clay, ore, natural-water, water-treatment, sea-water, and pesticide analyses); medical and clinical laboratories (serum, urine, sweat, gastric-juices, extra-cellular-fluid, dental-enamel, and milk analyses); and industrial laboratories (heavy-chemical, metallurgical, glass, beverage, and household-product analyses). See ANALYTICAL CHEMISTRY; CHROMATOGRAPHY; TITRATION. [R.P.B.]

**Ion-solid interactions** Physical processes resulting from the collision of energetic ions, atoms, or molecules with condensed matter. These include elastic and inelastic backscattering of the projectile, penetration of the solid by the projectile, emission of electrons and photons from the surface, sputtering of neutral atoms and ions, production of defects in crystals, creation of nuclear tracks in insulating solids, and electrical, chemical, and physical changes to the irradiated matter resulting from the passage or implantation of the projectile.

When an energetic ion impinges upon the surface of condensed matter, it experiences a series of elastic and inelastic collisions with the atoms which lie in its path. These collisions occur because of the electrical forces between the nucleus and electrons of the projectile and those of the atoms which constitute the solid target. They result in the transformation of the kinetic energy of the projectile into internal excitation of the solid.

One of the most simple interactions occurs when the projectile collides with a surface atom and bounces back in generally the opposite direction from which it came. This process is known as backscattering. Its observation in 1911 led Ernest Rutherford to conclude that most of the matter in atoms is concentrated in a small nucleus. Now it is used as an analytical technique to measure the masses and locations of atoms on and near a surface. This technique for surface characterization is appropriately named Rutherford backscattering analysis, and is most commonly performed with alpha particles of about 2 MeV. Another backscattering technique, known as ion-scattering spectrometry, uses projectiles with energies of perhaps 2 keV.

Although backscattering events are well enough understood to be used as analytical tools, they are relatively rare because they represent nearly head-on collisions between two nuclei. Far more commonly, a collision simply deflects the projectile a few degrees from its original direction and slows it somewhat, transferring some of its kinetic energy to the atom that is struck. Thus, the projectile does not rebound from the surface but penetrates deep within the solid, dissipating its kinetic energy in a series of grazing collisions.

The capacity of a solid to slow a projectile is called the stopping power, and is defined as the amount of energy lost by the projectile per unit length of trajectory in the solid. Stopping power is of central importance for many phenomena because it measures the capacity of a projectile to deposit energy within a thin layer of the solid and this energy drives secondary processes associated with penetration. In many insulating solids (including mica, glasses, and some plastics) the passage of an ion with a large electronic stopping power creates a unique form of radiation damage known as a nuclear track. When the substance is chemically etched, conical pits visible under an ordinary microscope are produced where ionizing particles have penetrated. The passage of single projectiles may thereby be observed. See PARTICLE TRACK ETCHING.

In the nuclear stopping region it is relatively likely that the projectile will transfer significant amounts of energy to individual

target atoms. These atoms will subsequently strike others, and eventually a large number of atoms within the solid will be set in motion. This disturbance is known as a collision cascade. Collision cascades may cause permanent damage to materials, induce mixing of layers in the vicinity of interfaces, or cause sputtering if they occur near surfaces. See ION BEAM MIXING; SPUTTERING.

Ion implantation is used in the manufacture of integrated circuits and in the improvement of surface properties of metals. Ion-solid processes permit highly sensitive analyses for trace elements, the characterization of materials and surfaces, and the detection of ionizing radiation. Techniques employing them include secondary ion mass spectrometry (SIMS) for elemental analysis and imaging of surfaces, proton-induced x-ray emission (PIXE), ion-scattering spectrometry (ISS), and Rutherford backscattering analysis (RBS). They are also fundamental to the operation of silicon surface-barrier detectors which are used for the measurement of particle radiation, and of nuclear track detectors which are used in research as diverse as the dating of meteorites and the search for magnetic monopoles. See ACTIVATION ANALYSIS; BEAM-FOIL SPECTROSCOPY; ION IMPLANTATION; MAGNETIC MONOPOLES; PARTICLE DETECTOR; PROTON-INDUCED X-RAY EMISSION (PIXE); SECONDARY ION MASS SPECTROMETRY (SIMS); SURFACE PHYSICS. [R.A.We.]

**Ion sources** Devices which produce positive or negative electrically charged atoms or molecules. See ION.

In general, ion sources fall into three major categories: those designed for positive-ion generation, those for negative-ion generation, and a highly specialized type of source designed to produce a polarized ion beam. The positive-ion source category may further be subdivided into sources specifically designed to generate singly charged ions and those designed to produce very highly charged ions.

Ion sources have acquired a wide variety of applications. They are used in a variety of different types of accelerators for nuclear research; have application in the field of fusion research; and are used for ion implantation, in isotope separators, in ion microprobes, as a means of rocket propulsion, in mass spectrometers, and for ion milling. See ION IMPLANTATION; ION PROPULSION; MASS SPECTROSCOPE; NUCLEAR FUSION; PARTICLE ACCELERATOR; SECONDARY ION MASS SPECTROMETRY (SIMS). [R.M.]

**Ion transport** Movement of salts and other electrolytes in the form of ions from place to place within living systems.

Ion transport may occur by any of several different mechanisms: electrochemical diffusion, active-transport requiring energy, or bulk flow as in the flow of blood in the circulatory system of animals or the transpiration stream in the xylem tissue of plants. The best-known system for transporting ions actively is the sodium/potassium (Na/K) exchange pump, which occurs in plasma membranes of virtually all cells.

Experimental studies revealed that many transport processes, such as in bacterial cells and in the mitochondria of eukaryotic cells, are associated with a transport of protons (hydrogen ions,  $H^+$ ). This fact led to the concept of proton pumps, in which the coupling or transfer of energy between oxidation processes and synthesis of ATP and between hydrolysis of ATP and transport or other cellular work is explained in terms of a flow of protons as the means of energy transfer.

The processes of oxidation in the citric acid cycle of reactions in mitochondria are known to be coupled with the synthesis of adenosine triphosphate (ATP), which is formed from adenosine diphosphate (ADP) and inorganic orthophosphate ( $P_i$ ), through the system of enzymes and cytochromes known as the electron transfer chain or electron transport system. This system transports electrons, removed in dehydrogenation from the organic molecules of the citric acid cycle on one side of the mitochondrial membrane, to the site of their incorporation into water, formed from two hydrogen ions and an atom of oxygen on the other side

of the membrane. The flow of electrons from a relatively high potential level in the organic substrate to a level of lower potential in water constitutes, in effect, a current of negative electricity, and it was proposed that the flow drives a flow of protons in the opposite direction, as a current of positive electricity. This proton flow in turn is proposed as the force that drives the synthesis of three molecules of ATP for every two electrons flowing through the electron transport system. In effect, this is the machinery of the cellular power plant.

The Na/K ATPase pump then provides an example of a way in which a proton pump may transfer energy between the hydrolysis of ATP and a process of cellular work. The enzyme which is the basis of the pump is known to be bound to the lipid bilayer of the plasma membrane through phosphatides and to function only when so bound. The binding of  $Na^+$ ,  $K^+$ ,  $H^+$ , and ATP to active sites on the enzyme presumably has an allosteric effect, changing the shape of the enzyme molecule, activating the hydrolysis of ATP, and opening pathways of exchange of  $Na^+$  and  $K^+$ . [B.T.S.]

Transport processes are involved in uptake and release of inorganic ions by plants and in distribution of ions within plants, and thus determine ionic relations of plants. The cell wall and the external lipid-protein membrane (plasmalemma) have to be passed by the ions. Intracellular distribution and compartmentation are determined by transport across other membranes within the cells. The most important one is the tonoplast separating the cell vacuole from the cytoplasm.

Within tissues the continuous cell walls of adjacent cells form an apoplastic pathway for ion transport. A symplastic pathway is constituted by the cytoplasm extending from cell to cell via small channels of about 40 nanometers diameter (plasmodesmata) crossing the cell walls. Transport over longer distances is important in organs (roots, shoots, leaves, fruits), which are composed of different kinds of tissues, and in the whole plant. Xylem and phloem serve as pathways for long-distance transport. Roots take up ions from the soil and must supply other plant organs. The nutritional status of roots and shoots regarding both inorganic anions and organic substrates plays a large role in regulation of ionic relations of whole plants. Phytohormones affect transport mechanisms; they are produced in particular tissues, are distributed via the transport pathways, and thus exert a signaling function. See PHLOEM; PLANT HORMONES; PLANT TISSUE SYSTEMS; XYLEM.

The pipe system of the xylem in its mature transporting state is composed of rows of dead cells (tracheids, tracheary elements) whose cross-walls are perforated or removed entirely. The driving force for long-distance transport in the xylem is very largely passive. Transport is caused by transpiration, the loss of water from the aerial parts of the plant, driven by the water potential gradient directed from soil to roots, leaves, and atmosphere. A normally much smaller component driving the ascent of sap in the xylem is osmotic root pressure due to the pumping mechanisms concentrating ions in the root xylem, with water following passively. In a simplifying way the xylem can be considered as pathway for long-distance transport of ions from root to shoot, and the phloem for metabolite transport from photosynthesizing source leaves to various sinks in the plant. The long-distance transport pathways of the phloem are the sieve tubes, pipe systems with porous structures in the cross-walls (sieve plates) but, in contrast to vessels of the xylem, having living cytoplasm. Concentration and pressure gradients built up by active loading and unloading of sieve tubes in the source and sink regions, respectively, are the driving forces for transport. See PLANTS, SALINE ENVIRONMENTS OF. [U.L.]

**Ionic crystals** A class of crystals in which the lattice-site occupants are charged ions held together primarily by their electrostatic interaction. Such binding is called ionic binding. Empirically, ionic crystals are distinguished by strong absorption of infrared radiation, good ionic conductivity at high temperatures,

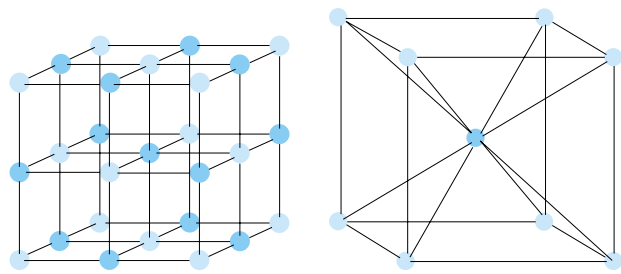

(a) Lattices of (a) sodium chloride and (b) cesium chloride. The darker circles represent positive ions and the lighter circles negative ions. (After F. Seitz, *The Modern Theory of Solids*, Dover, 1987)

and the existence of planes along which the crystals cleave easily. See CRYSTAL STRUCTURE.

Compounds of strongly electropositive and strongly electronegative elements form solids which are ionic crystals, for example, the alkali halides, other monovalent metal halides, and the alkaline-earth halides, oxides, and sulfides. Crystals in which some of the ions are complex, such as metal carbonates, metal nitrates, and ammonium salts, may also be classed as ionic crystals.

As a crystal type, ionic crystals are to be distinguished from other types such as molecular crystals, valence crystals, or metals. The ideal ionic crystal as defined is approached most closely by the alkali halides (see illustration). Other crystals often classed as ionic have binding which is not exclusively ionic but includes a certain admixture of covalent binding. Thus the term ionic crystal refers to an idealization to which real crystals correspond to a greater or lesser degree, and crystals exist having characteristics of more than one crystal type. See CHEMICAL BONDING.

Ionic crystals, especially alkali halides, have played a very prominent role in the development of solid-state physics. They are relatively easy to produce as large, quite pure, single crystals suitable for accurate and reproducible experimental investigations. In addition, they are relatively easy to subject to theoretical treatment since they have simple structures and are bound by the well-understood Coulomb force between the ions. This is in contrast to metals and covalent crystals, which are bound by more complicated forces, and to molecular crystals, which either have complicated structures or are difficult to produce as single crystals. Being readily available and among the simplest known solids, they have thus been a frequent and profitable meeting place between theory and experiment. These same features of ionic crystals have made them attractive as host crystals for the study of crystal defects: deliberately introduced impurities, vacancies, interstitials, and color centers. See COLOR CENTERS; CRYSTAL DEFECTS. [B.G.D.]

Most ionic crystals have large band gaps, and are therefore generally good electronic insulators. However, electrical conduction occurs by the motion of ions through these crystals. The presence of point defects, that is, deviations from ideal order in the crystalline lattice, facilitates this motion, thus giving rise to transport of electric charge. In an otherwise perfect lattice where all lattice sites are fully occupied, ions cannot be mobile.

Many so-called normal ionic crystals possess conductivities of about  $10^{-10}$  ( $\text{ohm} \cdot \text{cm}$ ) $^{-1}$  or lower at room temperature. However, a relatively small number of ionic materials, called superionic conductors or fast ionic conductors, display conductivities of the order of  $10^{-1}$  to  $10^{-2}$  ( $\text{ohm} \cdot \text{cm}$ ) $^{-1}$ , which imply ionic liquidlike behavior. In most of these crystals, only one kind of ionic species is mobile, and its diffusion coefficient and mobility attain values such as found otherwise only in liquids. Due to their high value of ionic conductivity as well as their ability to selectively transport ionic species, superionic conductors have successfully

been employed as solid electrolytes in many applications. See DIFFUSION; SOLID-STATE BATTERY. [T.M.Gü.]

**Ionic equilibrium** An equilibrium in a chemical reaction in which at least one ionic species is produced, consumed, or changed from one medium to another.

The wide variety of types of ionic equilibrium possible include: dissolution of an un-ionized substance, for example, the dissolution of hydrogen chloride (a gas) in water (an ionizing solvent), reactions (1)–(3); dissolution of a crystal in water, such as the

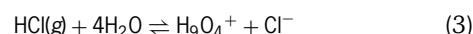
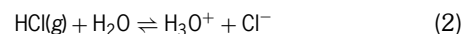

dissociation of solid silver chloride, reaction (4); dissociation of a strong acid, for example, nitric acid,  $\text{HNO}_3$ , dissociates as it dissolves in water, as in reaction (5); dissociation of an ion in water, for example, the bisulfate ion,  $\text{HSO}_4^-$ , dissociates in water, as in reaction (6); and dissociation of water itself, is represented by reaction (7).

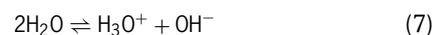
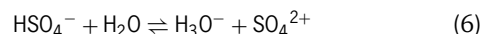
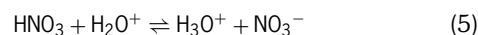
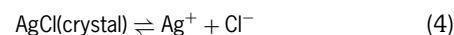

See ACID AND BASE; CHEMICAL EQUILIBRIUM; HYDROLYSIS. [T.F.Y.]

**Ionization** The process by which an electron is removed from an atom, molecule, or ion. It is of basic importance to electrical conduction in gases and liquids. In the simplest case, ionization may be thought of as a transition between an initial state consisting of a neutral atom and a final state consisting of a positive ion and a free electron. In more complicated cases, a molecule may be converted to a heavy positive ion and a heavy negative ion which are separated. [G.H.M.]

**Ionization chamber** An instrument for detecting ionizing radiation by measuring the amount of charge liberated by the interaction of ionizing radiation with suitable gases, liquids, or solids.

While the gold leaf electroscope is the oldest form of ionization chamber, instruments of this type are still widely used as monitors of radiations by workers in the nuclear or radiomedical professions. However, for many purposes it is useful to measure the ionization pulse produced by a single ionizing particle. See ELECTROSCOPE.

The simplest form of a pulse ionization chamber consists of two conducting electrodes in a container filled with gas (see illustration). A battery, or other power supply, maintains an electric field between the positive anode and the negative cathode. When

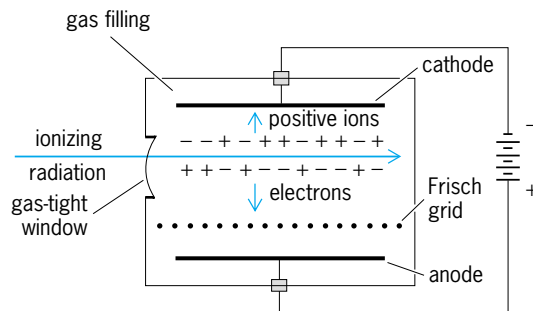

Parallel-plate ionization chamber.

ionizing radiation penetrates the gas in the chamber—entering, for example, through a thin gas-tight window—this radiation liberates electrons from the gas atoms leaving positively charged ions. The electric field present in the gas sweeps these electrons and ions out of the gas, the electrons going to the anode and the positive ions to the cathode.

In a chamber, such as that represented in the illustration, the current begins to flow as soon as the electrons and ions begin to separate under the influence of the applied electric field. The time it takes for the full current pulse to be observed depends on the drift velocity of the electrons and ions in the gas. Because the ions are thousands of times more massive than the electrons, the electrons always travel several orders of magnitude faster than the ions. As a result, virtually all pulse ionization chambers make use of only the relatively fast electron signal.

One of the most important uses of an ionization chamber is to measure the total energy of a particle or, if the particle does not stop in the ionization chamber, the energy lost by the particle in the chamber. In addition to energy information, ionization chambers are now routinely built to give information about the position within the gas volume where the initial ionization event occurred. This information can be important not only in experiments in nuclear and high-energy physics where these position-sensitive detectors were first developed, but also in medical and industrial applications.

Foremost among the other applications is the use of gas ionization chambers for radiation monitoring. Portable instruments of this type usually employ a detector containing approximately 60 in.<sup>3</sup> (1 liter) of gas, and operate by integrating the current produced by the ambient radiation. Another application of ionization chambers is the use of air-filled chambers as domestic fire alarms. Yet another development in ion chamber usage is that of two-dimensional imaging in x-ray medical applications to replace the use of photographic plates.

Gaseous ionization chambers have also found application as total-energy monitors for high-energy accelerators. Such applications involve the use of a very large number of interleaved thin parallel metal plates immersed in a gas inside a large container.

Ionization chambers can be made where the initial ionization occurs, not in gases, but in suitable liquids or solids. In the solid-state ionization chamber (or solid-state detector) the gas filling is replaced by a large single crystal of suitably chosen solid material. In this case the incident radiation creates electron-hole pairs in the crystal, and this constitutes the signal charge. Silicon and germanium detectors have proved to be highly successful and have led to detectors that have revolutionized low-energy nuclear spectroscopy. The use of a liquid in an ionization chamber combines many of the advantages of both solid and gas-filled ionization chambers; most importantly, such devices have the flexibility in design of gas chambers with the high density of solid chambers. During the 1970s a number of groups built liquid argon ionization chambers and demonstrated their feasibility. [W.A.L.]

**Ionization gage** An instrument for measuring vacuum by ionizing the gas present and measuring the ion current. There are two types of ionization gages.

In the hot-filament ionization gage (see illustration), electrons emitted by a filament are attracted toward a positively charged grid electrode. Collisions of electrons with gas molecules produce ions, which are then attracted to a negatively charged electrode. The current measured at this electrode is directly proportional to the pressure or gas density.

In the cold-cathode (Philips or Penning) ionization gage, a high voltage is applied between two electrodes. Fewer electrons are emitted, but a strong magnetic field deflects the electron stream, increasing the length of the electron path which increases the

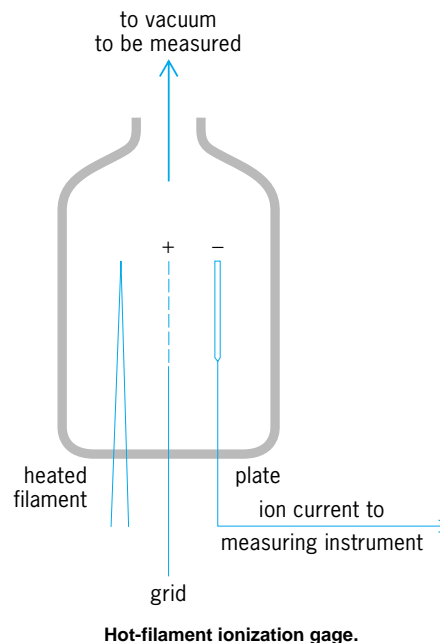

chance for ionizing collisions of electrons with gas molecules. See VACUUM MEASUREMENT. [R.C.]

**Ionization potential** The potential difference through which a bound electron must be raised to free it from the atom or molecule to which it is attached. In particular, the ionization potential is the difference in potential between the initial state, in which the electron is bound, and the final state, in which it is at rest at infinity.

The ionization potential for the removal of an electron from a neutral atom other than hydrogen is more correctly designated as the first ionization potential. The potential associated with the removal of a second electron from a singly ionized atom or molecule is then the second ionization potential, and so on. [G.H.M.]

**Ionophore** A substance that can transfer ions from a hydrophilic medium, such as water, into a hydrophobic medium, such as hexane or a biological membrane, where the ions typically would not be soluble; also known as an ion carrier. The ions transferred are usually metal ions, for example, lithium (Li<sup>+</sup>), sodium (Na<sup>+</sup>), potassium (K<sup>+</sup>), magnesium (Mg<sup>2+</sup>), and calcium (Ca<sup>2+</sup>); but there are ionophores that promote the transfer of other ions, such as ammonium ion (NH<sub>4</sub><sup>+</sup>) or amines of biological interest. See ION.

There are two mechanisms by which ionophores promote the transfer of ions across hydrophobic barriers: ion-ionophore complex formation and ion channel formation. In complex formation, the ion forms a coordination complex with the ionophore in which there is a well-defined ratio (typically 1:1) of ion to ionophore. The ionophore wraps around the ion so that the ion exists in the polar interior of the complex, while the exterior is predominantly hydrophobic in character and as such is soluble in nonpolar media. The ion is coordinated by oxygen atoms present in the ionophore molecule through ion-dipole interactions. The ionophore molecule essentially acts as the solvent for the ion, replacing the aqueous solvation shell that normally surrounds the ion. See COORDINATION COMPLEXES.

Ionophores that act via ion channel formation are found in biological environments. The molecule forms a polar channel in an otherwise nonpolar cell membrane, allowing passage of small ions either into or out of the cell.

Naturally occurring ionophores fall into four classes, each of which has antibiotic activity: peptide, cyclic depsipeptide,

macrotetrolide, and polyether ionophores. The biological activity of ionophore antibiotics is due to their ability to disrupt the flow of ions either into or out of cells. Under normal conditions, cells have a high internal concentration of potassium ions but a low concentration of sodium ions. The concentration of ions in the extracellular medium is just the reverse, high in sodium ions but low in potassium ions. This imbalance, which is necessary for normal cell function, is maintained by a specific transport protein (sodium-potassium adenosine triphosphatase) in the cell membrane that pumps sodium ions out of the cell in exchange for potassium ions. Ionophore antibiotics can disrupt this ionic imbalance by allowing ions to penetrate the cell membrane as ion-ionophore complexes or via the formation of ion channels. Gram-positive bacteria appear to be particularly sensitive to the effect of ionophores perturbing normal ion transport. See ANTIBIOTIC; ION TRANSPORT. [C.A.V.]

**Ionosphere** The part of the upper atmosphere that is sufficiently ionized that the concentration of free electrons affects the propagation of radio waves. Existence of the ionosphere was suggested simultaneously in 1902 by O. Heaviside in England and A. E. Kennelly in the United States to explain the transatlantic radio communication that was demonstrated the previous year by G. Marconi; and for many years it was commonly referred to as the Kennelly-Heaviside layer. The existence of the ionosphere as an electronically conducting region had been postulated earlier by B. Steward to explain the daily variations in the geomagnetic field. See ATMOSPHERE; IONIZATION; RADIO-WAVE PROPAGATION.

The ionosphere is highly structured in the vertical direction. It was first thought that discrete layers were involved, referred to as the D, E, F<sub>1</sub>, and F<sub>2</sub> layers; however, the layers actually merge with one another to such an extent that they are now referred to as regions rather than layers. The very high temperatures in the Earth's upper atmosphere are collocated with the upper ionosphere, since both are related to the effect of x-rays from the Sun. That is, the x-rays both ionize and heat the very uppermost portion of the Earth's atmosphere. Tremendous variations occur in the ionosphere at high latitudes because of the dynamical effects of electrical forces and because of the additional sources of plasma production. The most notable is the visual aurora, one of the most spectacular natural sights.

The aurora has a poleward and equatorward limit during times of magnetic storms. A resident of the arctic regions of the Northern Hemisphere see the "northern" lights in their southern sky, for example. The aurora forms two rings around the poles of the Earth. The size of the rings waxes and wanes while wave-like disturbances propagate along its extent. See AURORA; UPPER-ATMOSPHERE DYNAMICS. [M.C.K.; F.S.J.]

**Iridium** A chemical element, Ir, atomic number 77, relative atomic weight 192.22. Iridium is a transition metal and shares similarities with rhodium as well as the other platinum metals, including palladium, platinum, ruthenium, and osmium. The atom in the gas phase has the electronic configuration 1s<sup>2</sup>, 2s<sup>2</sup>, 2p<sup>6</sup>, 3s<sup>2</sup>, 3p<sup>6</sup>, 3d<sup>10</sup>, 4s<sup>2</sup>, 4p<sup>6</sup>, 4d<sup>10</sup>, 4f<sup>14</sup>, 5s<sup>2</sup>, 5p<sup>6</sup>, 5d<sup>7</sup>, 6s<sup>2</sup>. The ionic radius for Ir<sup>3+</sup> is 0.068 nanometer and its metallic radius is 0.1357 nm. Metallic iridium is slightly less dense than osmium, which is the densest of all the elements. See PERIODIC TABLE.

The abundance of iridium in the Earth's crust is very low, 0.001 ppm. For mining purposes, it is generally found alloyed with osmium in materials known as osmiridium and iridosmium, with iridium contents ranging from 25 to 75%.

Solid iridium is a silvery metal with considerable resistance to chemical attack. Upon atmospheric exposure the surface of the metal is covered with a relatively thick layer of iridium dioxide (IrO<sub>2</sub>). Important physical properties of metallic iridium are given in the table.

Physical properties of iridium metal

Property	Value
Crystal structure	Face-centered cubic
Lattice constant <i>a</i> at 25°C, nm	0.38394
Thermal neutron capture cross section, barns	440
Density at 25°C, g/cm <sup>3</sup>	22.560
Melting point	2443°C (4429°F)
Boiling point	4500°C (8130°F)
Specific heat at 0°C, cal/g	0.0307
Thermal conductivity 0–100°C, cal/cm <sup>2</sup> s °C	0.35
Linear coefficient of thermal expansion	
20–100°C, μin./in./°C	6.8
Electrical resistivity at 0°C, microhm-cm	4.71
Temperature coefficient of electrical resistance	
0–100°C/°C	0.00427
Tensile strength (1000 lb/in. <sup>2</sup> )	
Soft	160–180
Hard	300–360
Young's modulus at 20°C	
lb/in. <sup>2</sup> , static	75.0 × 10 <sup>6</sup>
lb/in. <sup>2</sup> , dynamic	76.5 × 10 <sup>6</sup>
Hardness, diamond pyramid number	
Soft	200–240
Hard	600–700
Δ <i>H</i> <sub>fusion</sub> , kJ/mol	26.4
Δ <i>H</i> <sub>vaporization</sub> , kJ/mol	612
Δ <i>H</i> <sub>f</sub> monoatomic gas, kJ/mol	669
Electronegativity	2.2

Because of its scarcity and high cost, applications of iridium are severely limited. Although iridium metal and many of its complex compounds are good catalysts, no large-scale commercial application for these has been developed. In general, other platinum metals have superior catalytic properties. The high degree of thermal stability of elemental iridium and the stability it imparts to its alloys does give rise to those applications where it has found success. Particularly relevant are its high melting point (2443°C or 4429°F), its oxidation resistance, and the fact that it is the only metal with good mechanical properties that survives atmospheric exposure above 1600°C (2910°F). Iridium is alloyed with platinum to increase tensile strength, hardness, and corrosion resistance. However, the workability of these alloys is decreased. These alloys find use as electrodes for anodic oxidation, for containing and manipulating corrosive chemicals, for electrical contacts that are exposed to corrosive chemicals, and as primary standards for weight and length. Platinum-iridium alloys are used for electrodes in spark plugs that are unusually resistant to fouling by antiknock lead additives. Iridium-rhodium thermocouples are used for high-temperature applications, where they have unique stability. Very pure iridium crucibles are used for growing single crystals of gadolinium gallium garnet for computer memory devices and of yttrium aluminum garnet for solid-state lasers. The radioactive isotope, <sup>192</sup>Ir, which is obtained synthetically from <sup>191</sup>Ir by irradiation of natural sources, has been used as a portable gamma source for radiographic studies in industry and medicine. See HIGH-TEMPERATURE MATERIALS; PLATINUM. [A.L.Ba.]

**Iron** A chemical element, Fe, atomic number 26, and atomic weight 55.847. Iron is the fourth most abundant element in the crust of the Earth (5%). It is a malleable, tough, silver-gray, magnetic metal. It melts at 1540°C, boils at 2800°C, and has a density of 7.86 g/cm<sup>3</sup>. The four stable, naturally occurring isotopes have masses of 54, 56, 57, and 58. The two main ores are hematite, Fe<sub>2</sub>O<sub>3</sub>, and limonite, Fe<sub>2</sub>O<sub>3</sub> · 3H<sub>2</sub>O. Pyrites, FeS<sub>2</sub>, and chromite, Fe(CrO<sub>2</sub>)<sub>2</sub>, are mined as ores for sulfur and chromium, respectively. Iron is found in many other minerals, and it occurs in groundwaters and in the red hemoglobin of blood. See PERIODIC TABLE.

The greatest use of iron is for structural steels; cast iron and wrought iron are made in quantity, also. Magnets, dyes (inks, blueprint paper, rouge pigments), and abrasives (rouge) are



among the other uses of iron and iron compounds. See CAST IRON; IRON ALLOYS; IRON METALLURGY; STAINLESS STEEL; STEEL MANUFACTURE; WROUGHT IRON.

There are several allotropic forms of iron. Ferrite or  $\alpha$ -iron is stable up to 760°C (1400°F). The change of  $\beta$ -iron involves primarily a loss of magnetic permeability because the lattice structure (body-centered cubic) is unchanged. The allotrope called  $\gamma$ -iron has the cubic close-packed arrangements of atoms and is stable from 910 to 1400°C (1670 to 2600°F). Little is known about  $\delta$ -iron except that it is stable above 1400°C (2600°F) and has a lattice similar to that of  $\alpha$ -iron.

The metal is a good reducing agent and, depending on conditions, can be oxidized to the 2+, 3+, or 6+ state. In most iron compounds, the ferrous ion, iron(II), or ferric ion, iron(III), is present as a distinct unit. Ferrous compounds are usually light yellow to dark green-brown in color; the hydrated ion,  $\text{Fe}(\text{H}_2\text{O})_6^{2+}$ , which is found in many compounds and in solution, is light green. This ion has little tendency to form coordination complexes except with strong reagents such as cyanide ion, polyamines, and porphyrins. The ferric ion, because of its high charge (3+) and its small size, has a strong tendency to hold anions. The hydrated ion,  $\text{Fe}(\text{H}_2\text{O})_6^{3+}$ , which is found in solution, combines with  $\text{OH}^-$ ,  $\text{F}^-$ ,  $\text{Cl}^-$ ,  $\text{CN}^-$ ,  $\text{SCN}^-$ ,  $\text{N}_3^-$ ,  $\text{C}_2\text{O}_4^{2-}$ , and other anions to form coordination complexes. See COORDINATION CHEMISTRY.

An interesting aspect of iron chemistry is the array of compounds with bonds to carbon. Cementite,  $\text{Fe}_3\text{C}$ , is a component of steel. The cyanide complexes of both ferrous and ferric iron are very stable and are not strongly magnetic in contradistinction to most iron coordination complexes. The cyanide complexes form colored salts. See TRANSITION ELEMENTS. [J.O.E.]

**Iron alloys** Solid solutions of metals, one metal being iron. A great number of commercial alloys have iron as an intentional constituent. Iron is the major constituent of wrought and cast iron and wrought and cast steel. Alloyed with large amounts of silicon, manganese, chromium, vanadium, molybdenum, niobium (columbium), selenium, titanium, phosphorus, or other elements, singly or sometimes in combination, iron forms the large group of materials known as ferroalloys that are important as addition agents in steelmaking. Iron is also a major constituent of many special-purpose alloys developed to have exceptional characteristics with respect to magnetic properties, electrical resistance, heat resistance, corrosion resistance, and thermal expansion. See ALLOY; FERROALLOY; STEEL. [H.E.McG.]

**Iron metabolism** A nearly continuous cycle whereby iron from organic and inorganic sources is converted to form iron-porphyrin compounds, which can be utilized by the body. One such compound, termed a heme, is hemoglobin; more than 60% of the iron in the body is used in hemoglobin metabolism. Iron is also essential for other heme compounds, such as myoglobin and cytochromes, and for a wide variety of nonheme enzymes, including many in the citric acid cycle.

Hemoglobin metabolism involves formation and breakdown. Formation is initiated by the process of absorption. Unlike most elements, iron has no specific mechanism for excretion so that absorption must be closely monitored to control body content and ensure replacement of the daily loss. Absorption occurs best from animal and plant hemes and less from inorganic ferric salts; different mechanisms are involved for the two types. Many factors influence absorption, especially gastric acid, which can solubilize iron salts and prevent their precipitation in the duodenum.

In the duodenum, iron rapidly enters the mucosal cells of the intestinal villi, where the iron is released from heme by the enzyme heme oxygenase. There, the ferrous iron destined for the formation of hemoglobin in the developing red cells of the marrow (the erythroblasts) is converted to ferric ions by ceruloplasmin and is attached to the transport glycoprotein transferrin. The nonassimilated iron remains in the intestinal cell and is combined

with the storage protein apoferritin to form ferritin, which is lost by the body when the mucosal cells are shed after their 3–5-day life cycle. The mechanism by which the mucosal cell knows what to discard and what to assimilate is unknown.

Once ferric iron is attached to transferrin, it circulates in the blood until it attaches to transferrin receptors on immature red blood cells in the marrow. Once attached, the transferrin receptor complex is taken in by endocytosis, and the iron is released and reduced to ferrous ions. The transferrin receptor complex returns to the cell surface, and the transferrin reenters the blood plasma. The iron enters the mitochondria and is inserted into protoporphyrin by the enzyme ferrochetalase to form heme, which when combined with the protein globin forms the respiratory pigment hemoglobin.

Mature red blood cells cannot take up iron; at the end of their 120-day life span they are engulfed by the monocyte-macrophage cells in liver and spleen, where the iron is released by the enzyme heme oxygenase. Sixty percent of this iron is rapidly returned to the marrow to produce red blood cells, while the remainder is stored as ferritin in the labile pool for release as needed. Iron excessively absorbed from the gut or released from the labile pool and not destined for the formation of red blood cells may enter the storage compartment as ferritin or hemosiderin. Apoferritin, the iron-free storage protein, exists in most living cells, and ferric ions can be stored in its hollow sphere to form a growing crystal of ferric oxyhydroxide ( $\text{FeOOH}$ ). Hemosiderin occurs in the monocyte macrophages of the liver and spleen as  $\text{FeOOH}$  stripped of its apoferritin shell. See BLOOD; HEMOGLOBIN. [J.Mu.]

**Iron metallurgy** Extracting iron from ores and preparing it for use. Extraction involves the conversion of naturally occurring iron-bearing minerals into metallic iron. The term iron-making is commonly used to include all of the industrial processes that convert raw materials into iron. The major process for the production of iron is the iron blast furnace. However, since 1970 the growth of alternative direct-reduction processes has been very significant. The principal difference between the blast furnace process and the direct-reduction processes is the temperature of operation. In the blast furnace, high operating temperatures enable the production of molten iron. At the lower operating temperatures of the direct-reduction processes, solid or sponge iron is produced. Most of the iron produced in the world is used in the production of steel. The remainder is converted to iron castings, ferroalloys, and iron powder. See FERROALLOY; IRON; PRESSURIZED BLAST FURNACE; PYROMETALLURGY; STEEL MANUFACTURE. [G.R.St.P.]

**Ironwood** The name given to any of at least 10 kinds of tree in the United States, including the American hornbeam (*Carpinus caroliniana*), eastern hophornbeam (*Ostrya virginiana*), buckthorn bumelia (*Bumelia lycioides*), tough bumelia (*B. tenax*), buckwheat tree (*Cliftonia monophylla*), and swamp cyrilla or swamp ironwood (*Cyrilla racemiflora*). Leadwood (*Krugiodendron ferreum*), a native of southern Florida, has the highest specific gravity of all woods native to the United States and is also known as black ironwood. See HOPHORNBEAM; HORNBEAM. [A.H.G./K.P.D.]

**Irregularia** The name given by G. Cuvier in 1817 to an assemblage of echinoids in which the anus and periproct lie outside the apical system, the ambulacral plates remain simple, the primary radioles are hollow, and the rigid test shows more or less bilateral symmetry. The Irregularia are an artificial assemblage of similar but unrelated forms, and the name has no taxonomic validity. See DIADEMATAEA; ECHINOIDEA; PYGASTEROIDA; REGULARIA. [H.B.F.]

**Irrigation (agriculture)** The artificial application of water to the soil to produce plant growth. Irrigation also cools

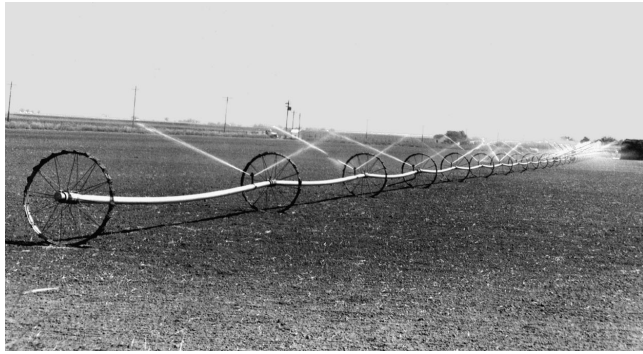

A side-roll sprinkler system which uses the main supply line (often more than 1000 ft, or 300 m, long) to carry the sprinkler heads and as the axle for wheels.

the soil and atmosphere, making the environment favorable for plant growth. Water is applied to crops by surface, subsurface, sprinkler, and drip irrigation.

Surface irrigation includes furrow and flood methods. The furrow method is used for row crops. Corrugations or rills are small furrows used on close-growing crops. The flow, carried in furrows, percolates into the soil. Flow to the furrow is usually supplied by siphon tubes, spiles, gated pipe, or valves from buried pipe. In the flood method, controlled flooding is done with border strips, contour or bench borders, and basins.

Subirrigation is a type of irrigation accomplished by raising the water table to the root zone of the crop or by carrying moisture to the root zone by perforated underground pipe. Either method requires special soil conditions for successful operation.

A sprinkler system consists of pipelines which carry water under pressure from a pump or elevated source to lateral lines along which sprinkler heads are spaced at appropriate intervals. Laterals are moved from one location to another by hand or tractor, or they are moved automatically. The side-roll wheel system, which utilizes the lateral as an axle (see illustration), is very popular as a labor-saving method.

Drip irrigation is a method of providing water to plants almost continuously through small-diameter tubes and emitters. It has the advantage of maintaining high moisture levels at relatively low capital costs. It can be used on very steep, sandy, and rocky areas and can utilize saline waters better than most other systems. The system has been most popular in orchards and vineyards, but is also used for vegetables, ornamentals, and for landscape plantings. See LAND DRAINAGE (AGRICULTURE); TERRACING (AGRICULTURE). [M.A.H.]

**Isentropic flow** Compressible flow in which entropy remains constant throughout the flowfield. A slight distinction is sometimes made, especially in Europe, as follows. If the entropy of a fluid element moving along a streamline in a flow remains constant, the flow is isentropic along a streamline. However, the value of the entropy may be different along different streamlines, thus allowing entropy changes normal to the streamlines. An example is the flowfield behind a curved shock wave; here, streamlines that pass through different locations along the curved shock wave experience different increases in entropy. Hence, downstream from this shock, the entropy can be constant along a given streamline but differs from one streamline to another. This type of flow, with entropy constant along streamlines, is sometimes defined as isentropic. Flow with entropy constant everywhere is then called homentropic. See COMPRESSIBLE FLOW; ENTROPY; ISENTROPIC PROCESS.

Because of the second law of thermodynamics, an isentropic flow does not strictly exist. From the definition of entropy, an isentropic flow is both adiabatic and reversible. However, all real flows experience to some extent the irreversible phenomena

of friction, thermal conduction, and diffusion. Any nonequilibrium, chemically reacting flow is also irreversible. However, there are a large number of gas dynamic problems with entropy increase negligibly slight, which for the purpose of analysis are assumed to be isentropic. Examples are flow through subsonic and supersonic nozzles, as in wind tunnels and rocket engines; and shock-free flow over a wing, fuselage, or other aerodynamic shape. For these flows, except for the thin boundary-layer region adjacent to the surface where friction and thermal conduction effects can be strong, the outer inviscid flow can be considered isentropic. If shock waves exist in the flow, the entropy increase across these shocks destroys the assumption of isentropic flow, although the flow along streamlines between shocks may be isentropic. See ADIABATIC PROCESS; BOUNDARY-LAYER FLOW; NOZZLE; SHOCK WAVE; SUBSONIC FLIGHT; THERMODYNAMIC PRINCIPLES; THERMODYNAMIC PROCESSES. [J.D.A.]

**Isentropic process** In thermodynamics, a process involving change without any increase or decrease of entropy. Since the entropy always increases in a spontaneous process, one must consider reversible or quasistatic processes. During a reversible process the quantity of heat transferred is directly proportional to the system's entropy change. Systems which are thermally insulated from their surroundings undergo processes without any heat transfer; such processes are called adiabatic. Thus during an isentropic process there are no dissipative effects and the system neither absorbs nor gives off heat. For this reason the isentropic process is sometimes called the reversible adiabatic process. See ADIABATIC PROCESS; ENTROPY; THERMODYNAMIC PROCESSES. [P.E.B.]

**Isentropic surfaces** Surfaces along which the entropy and potential temperature of air are constant. Potential temperature, in meteorological usage, is defined by the relationship

$$\Theta = T \left( \frac{1000}{P} \right)^{(c_p - c_v)/c_p}$$

in which  $T$  is the air temperature,  $P$  is atmospheric pressure expressed in millibars,  $C_p$  is the heat capacity of air at constant pressure, and  $C_v$  is the heat capacity at constant volume. Since the potential temperature of an air parcel does not change if the processes acting on it are adiabatic (no exchange of heat between the parcel and its environment), a surface of constant potential temperature is also a surface of constant entropy. The slope of isentropic surfaces in the atmosphere is of the order of 1/100 to 1/1000. An advantage of representing meteorological conditions on isentropic surfaces is that there is usually little air motion through such surfaces, since thermodynamic processes in the atmosphere are approximately adiabatic. See ADIABATIC PROCESS; ATMOSPHERIC GENERAL CIRCULATION. [F.S.]

**Ising model** A model which consists of a lattice of "spin" variables with two characteristic properties: (1) each of the spin variables independently takes on either the value +1 or the value -1; and (2) only pairs of nearest neighboring spins can interact. The study of this model in two dimensions forms the basis of the modern theory of phase transitions and, more generally, of cooperative phenomena.

A macroscopic piece of material consists of a large number of atoms, the number being of the order of Avogadro's number (approximately  $6 \times 10^{23}$ ). Thermodynamic phenomena all depend on the participation of such a large number of atoms. Even though the fundamental interaction between atoms is short-ranged, the presence of this large number of atoms can, under suitable conditions, lead to an effective interaction between widely separated atoms. Phenomena due to such effective long-range interactions are referred to as cooperative phenomena. The simplest examples of cooperative phenomena are phase transitions. The most familiar phase transition is either the

condensation of steam into water or the freezing of water into ice. Only slightly less familiar is the ferromagnetic phase transition that takes place at the Curie temperature, which, for example, is roughly 1043 K for iron. See CURIE TEMPERATURE; FERROMAGNETISM; PHASE TRANSITIONS. [B.M.McC.; T.T.W.]

**Island biogeography** The distribution of plants and animals on islands. Islands harbor the greatest number of endemic species. The relative isolation of many islands has allowed populations to evolve in the absence of competitors and predators, leading to the evolution of unique species that can differ dramatically from their mainland ancestors.

Plant species produce seeds, spores, and fruits that are carried by wind or water currents, or by the feet, feathers, and digestive tracts of birds and other animals. The dispersal of animal species is more improbable, but animals can also be carried long distances by wind and water currents, or rafted on vegetation and oceanic debris. Long-distance dispersal acts as a selective filter that determines the initial composition of an island community. Many species of continental origin may never reach islands unless humans accidentally or deliberately introduce them. Consequently, although islands harbor the greatest number of unique species, the density of species on islands (number of species per area) is typically lower than the density of species in mainland areas of comparable habitat. See POPULATION DISPERSAL.

Once a species reaches an island and establishes a viable population, it may undergo evolutionary change because of genetic drift, climatic differences between the mainland and the island, or the absence of predators and competitors from the mainland. Consequently, body size, coloration, and morphology of island species often evolve rapidly, producing forms unlike any related species elsewhere. Examples include the giant land tortoises of the Galápagos, and the Komodo dragon, a species of monitor lizard from Indonesia. See POLYMORPHISM (GENETICS); POPULATION GENETICS; SQUAMATA.

If enough morphological change occurs, the island population becomes reproductively isolated from its mainland ancestor, and it is recognized as a unique species. Because long-distance dispersal is relatively infrequent, repeated speciation may occur as populations of the same species successively colonize an island and differentiate. The most celebrated example is Darwin's finches, a group of related species that inhabit the Galápagos Islands and were derived from South American ancestors. The island species have evolved different body and bill sizes, and in some cases occupy unique ecological niches that are normally filled by mainland bird species. The morphology of these finches was first studied by Charles Darwin and constituted important evidence for his theory of natural selection. See ANIMAL EVOLUTION; SPECIATION.

Island biogeography theory has been extended to describe the persistence of single-species metapopulations. A metapopulation is a set of connected local populations in a fragmented landscape that does not include a persistent source pool region. Instead, the fragments themselves serve as stepping stones for local colonization and extinction. The most successful application of the metapopulation model has been to spotted owl populations of old-growth forest fragments in the northwestern United States. See BIOGEOGRAPHY; ECOLOGICAL COMMUNITIES; ECOSYSTEM. [N.J.Go.]

**Isoantigen** An immunologically active protein or polysaccharide present in some but not all individuals in a particular species. These substances initiate the formation of antibodies when introduced into other individuals of the species that genetically lack the isoantigen. Like all antigens, they are also active in stimulating antibody production in heterologous species. The ABO, MN, and Rh blood factors in humans constitute important examples. Consequently, elaborate precautions for typing are required in blood transfusion. See ANTIBODY; ANTIGEN; BLOOD GROUPS. [M.J.Po.]

**Isobar (meteorology)** A curve along which pressure is constant. Leading examples of its uses are in weather forecasting and meteorology. The most common weather maps are charts of weather conditions at the Earth's surface and mean sea level, and they contain isobars as principal information. Areas of bad or unsettled weather are readily defined by roughly circular isobars around low-pressure centers at mean sea level. Likewise, closed isobars around high-pressure centers define areas of generally fair weather. See AIR PRESSURE.

A principal use of isobars stems from the so-called geostrophic wind, which approximates the actual wind on a large scale. The direction of the geostrophic wind is parallel to the isobars, in the sense that if an observer stands facing away from the wind, higher pressures are to the person's right if in the Northern Hemisphere and to the left if in the Southern. Thus, in the Northern Hemisphere, flow is counterclockwise about low-pressure centers and clockwise about high-pressure centers, with the direction of the flow reversed in the Southern Hemisphere. See GEOSTROPHIC WIND; WEATHER MAP. [F.B.Sh.]

**Isobar (nuclear physics)** One of two or more atoms which have a common mass number  $A$  but which differ in atomic number  $Z$ . Thus, although isobars possess approximately equal masses, they differ in chemical properties; they are atoms of different elements. Isobars whose atomic numbers differ by unity cannot both be stable; one will inevitably decay into the other. See ELECTRON CAPTURE; RADIOACTIVITY. [H.E.D.]

**Isobaric process** A thermodynamic process during which the pressure remains constant. When heat is transferred to or from a gaseous system, a volume change occurs at constant pressure. This thermodynamic process can be illustrated by the expansion of a substance when it is heated. The system is then capable of doing an amount of work on its surroundings. The maximum work is done when the external pressure of the surroundings on the system is equal to the pressure of the system. See ISOMETRIC PROCESS; POLYTROPIC PROCESS; THERMODYNAMIC PROCESS. [P.E.Bl.]

**Isobryales** An order of the true mosses (subclass Bryidae). This order is difficult to define precisely, but includes plants that generally grow from a creeping primary stem with leaves reduced or essentially lacking and plants that have spreading to ascending secondary stems which may be pinnately branched. The leaves may have single or double and sometimes short costae. The sporophytes are lateral, usually with elongate setae and capsules. The double peristome, sometimes reduced, consists of 16 teeth which are papillose on the outer surface, or less often cross-striate at the base, and an endostome with narrow segments and a low basal membrane or none at all. The calyptrae are cucullate and naked, or mitrate and hairy.

The order is heterogeneous in composition. It consists of about 19 families and 124 genera, some of which may be better placed in the Hypnales. See BRYIDAE; BRYOPHYTA; BRYOPSIDA; HYPNALES. [H.Cr.]

**Isocyanate** A derivative of isocyanic acid. Isocyanates are represented by the general formula  $R-N=C=O$ , where  $R$  is predominantly alkyl or aryl; however, stable isocyanates in which the  $N=C=O$  group is linked to elements such as sulfur, silicon, phosphorus, nitrogen, or the halogens have also been prepared. Most members of this class of compounds are liquids that are sensitive to hydrolysis and are strong lacrimators. Isocyanates are extremely reactive, especially toward substrates containing active hydrogen. They have found wide use in the commercial manufacture of polyurethanes, which are used in making rigid and flexible foam, elastomers, coatings, and adhesives.

Diisocyanates react with difunctional reagents, such as diols, to form addition polymers with a wide variety of properties. The flexibility in the choice of starting materials (diisocyanate, diol,

diamine, diacid, and so forth) and consequently in the multitude of possible adducts makes this product group unique in the field of polymeric materials.

Two aromatic diisocyanates, tolylene diisocyanate [TDI; reaction (1)] and di(4-isocyanatophenyl)methane [MDI; reaction (2)], have become the major starting materials for a family

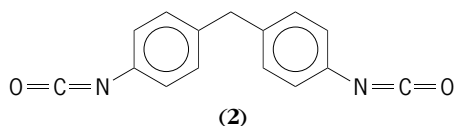
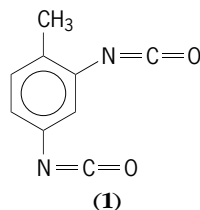

of polymeric products, such as flexible and rigid polyurethane foams used in construction and appliance insulation, automotive seating, and furniture. Elastomers based on MDI, polyols, and polyamines are widely used in the automotive industry, where reaction injection molding technology is used for the manufacture of exterior parts such as body panels and bumpers. See POLYOL.

Thermoplastic polyurethane elastomers (TPU) are used in the molding and extrusion of many industrial and consumer products with superior abrasion resistance and toughness. See POLYURETHANE RESINS.

The trimerization to polyisocyanurates and the formation of polyamides from dicarboxylic acids have been used to synthesize polymers with excellent thermal properties. Aliphatic diisocyanates, notably 1,6-diisocyanatohexane (HDI), fully hydrogenated MDI (H<sub>12</sub>MDI), and isophorone diisocyanate (IPDI) have become building blocks for color-stable polyurethane coatings and elastomers with high abrasion resistance. See POLYAMIDE RESINS; POLYMER. [R.H.R.]

**Isoelectric point** The pH of a dispersion medium of a colloidal suspension or an ampholyte at which the solute does not move in an electrophoretic field. The term isoelectric point is abbreviated pI.

Ampholytes are molecules with acid as well as basic functional groups. When dissolved in a suitable medium, ampholytes may acquire positive and negative charges by dissociation or by accepting or losing protons, thereby becoming bipolar ions (zwitterions). Ampholytes may be as small as glycine and carry just one chargeable group each; or as large as polyampholytes (polyelectrolytes that carry positive charges, negative charges, or both). They may possess molecular weights in the hundreds of thousands like proteins or in the millions like nucleic acids, and carry many hundreds of chargeable groups. See ION; NUCLEIC ACID; pH; PROTEIN.

An example of establishing the isoelectric point is shown by the course of the pH changes during the titration of alanine [NH<sub>2</sub>CH(CH<sub>3</sub>)COOH], a 1:1 ampholyte, meaning a molecule that carries one positively and one negatively ionizable group. Starting from acid solution (see illustration), relatively small pH changes (with alkali as the titrant) are observed between pH 2 and 3 (acidic), and again between pH 9.5 and 10.5 (alkaline), caused by the buffering capacity of the carboxyl (-COOH) and amine (-NH<sub>2</sub>) groups as weak electrolytes. The pH for 1/2 equivalence corresponds to the pK of the acid function (a value related to the equilibrium constant), where one-half of the alanine molecules still carry only a positive charge (-NH<sub>3</sub><sup>+</sup>), while the other half are also negatively charged (-COO<sup>-</sup>). Thus alanine exists in the form of zwitterions. See PK.

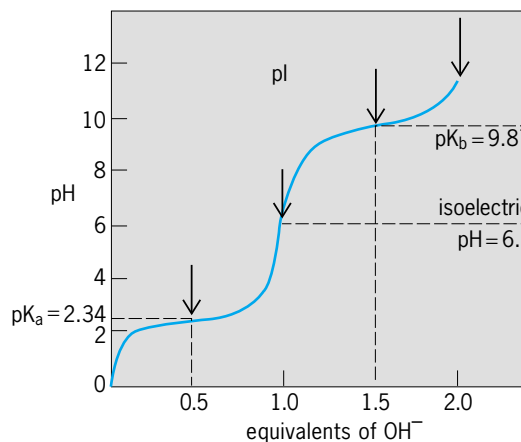

Titration of alanine with sodium hydroxide (NaOH), showing the course of pH with added fractional equivalents. The four arrows show, from left to right, the pK<sub>a</sub> [<sup>1</sup>/<sub>2</sub> cations: NH<sub>3</sub><sup>+</sup>(CH<sub>3</sub>)COOH, and <sup>1</sup>/<sub>2</sub> zwitterions: NH<sub>3</sub><sup>+</sup>(CH<sub>3</sub>)CHCOO<sup>-</sup>]; the pI (all zwitterions); the pK<sub>b</sub> (<sup>1</sup>/<sub>2</sub> zwitterions, <sup>1</sup>/<sub>2</sub> anions); and the end of titration, when all alanine molecules are in the anionic form: NH<sub>2</sub>(CH<sub>3</sub>)CHOO<sup>-</sup>.

For molecules that carry four or more chargeable groups, that is, for polyelectrolytes, the courses of the overall titration curves may no longer reflect the individual dissociation steps clearly, as the dissociation areas usually overlap. The isoelectric point then becomes an isoelectric range, such as for pigskin (parent) gelatin, a protein that exhibits an electrically neutral isoelectric range from pH 7 to pH 9.

Since ampholytes in an electric field migrate according to their pI with a specific velocity to the cathode or anode, the blood proteins, for example, can be separated by the techniques of gel or capillary-zone electrophoresis. See ELECTROPHORESIS; TITRATION.

The notion that some ampholytes may pass with changing pH through a state of zero charge (zero zeta potential) on their way from the positively to the negatively charged state has become so useful for specifying and handling polyampholytes that it was extended to all kinds of colloids, and to solid surfaces that are chargeable in contact with aqueous solutions. Practically all metal oxides, hydroxides, or hydroxy-oxides become charged by the adsorption of hydrogen ions (H<sup>+</sup>) or hydroxide ions (OH<sup>-</sup>), while remaining neutral at a specific pH. Strictly speaking, the isoelectric point of electrophoretically moving entities is given by the pH at which the zeta potential at the shear plane of the moving particles becomes zero. The point of zero charge at the particle (solid or surface) is somewhat different but often is not distinguished from the isoelectric point. It is determined by solubility minima or, for solid surfaces, is found by the rate of slowest adsorption of colloids (for example, latexes) of well-defined charge.

The important separation technique of ion-exchange chromatography is based on the selective adsorption of ampholytes on the resins with which the column is filled, at a given pH. For example, the larger the net positive charge of an ampholyte, the more strongly will it be bound to a negative ion-exchange resin and the slower will it move through the column. By rinsing with solutions of gradually increasing pH, the ampholytes of a mixture can be eluted and made to emerge separately from the column and be collected. Automated amino acid analyzers are built on this principle. See AMINO ACIDS; COLLOID; ELECTROKINETIC PHENOMENA; ION EXCHANGE; ION-SELECTIVE MEMBRANES AND ELECTRODES. [F.R.E.]

**Isoelectronic sequence** A term used in spectroscopy to designate the set of spectra produced by different chemical elements ionized in such a way that their atoms or ions contain the same number of electrons. The sequence in the table is an

**Example of isoelectronic sequence**

Designation of spectrum	Emitting atom or ion	Atomic number, Z
CaI	Ca	20
ScII	Sc <sup>+</sup>	21
TiIII	Ti <sup>2+</sup>	22
VIV	V <sup>3+</sup>	23
CrV	Cr <sup>4+</sup>	24
MnVI	Mn <sup>5+</sup>	25

example. Since the neutral atoms of these elements each contain *Z* electrons, removal of one electron from scandium, two from titanium, and so forth, yields a series of ions all of which have 20 electrons. Isoelectronic sequences are useful in predicting unknown spectra of ions belonging to a sequence in which other spectra are known. See ATOMIC STRUCTURE AND SPECTRA.

[F.A.J./W.W.W.]

**Isoetales** An order in the class Lycopsidea that diverged from the Lepidodendrales in the Late Devonian. These two groups have several characters that are not found in other lycopsids, notably a centralized, shootlike rooting structure (rhizomorph) that allows finite growth, wood production, and tree-sized dimensions. Isoetales evolved from trees as an increasingly specialized and reduced lineage; all but the earliest are small-bodied shrubs and pseudoherbs. A reduced morphology characterizes the only living isoetalean genus, *Isoetes*, which is globally distributed and contains approximately 150 species. See LEPIDODENDRALES; LYCOPHYTA; LYCOPSIDA.

[R.A.Ba.; W.A.DiM.]

**Isolaimida** An order of nematodes comprising the single superfamily Isolaimoidea. The order consists of one family and one genus. They are rather large for free-living soil nematodes (0.1–0.2 in. or 3–6 mm) and are found in seldom-cultivated sandy soils. Some forms have anterior annulations, while others have posterior transverse rows of punctations. The diagnostic characteristics of this superfamily are the presence of six hollow tubes around the oral opening and two whorls of six circumoral sensilla. Amphids are apparently absent, though some authors speculate that their function is taken over by the dorsolateral papillae of the second whorl. The triradiate stoma is elongate and has thickened walls anteriorly. The esophagus is clavate. Paired caudal papillae are large in males, small in females. See NEMATATA.

[A.R.M.]

**Isomerization** Rearrangement of the atoms within hydrocarbon molecules. Isomerization processes of practical significance in petroleum chemistry are (1) migration of alkyl groups, (2) shift of a single-carbon bond in naphthenes, and (3) double-bond shift in olefins. See ALKYLATION; AROMATIZATION; CRACKING; MOLECULAR ISOMERISM.

[G.E.L.]

**Isometric process** A constant-volume thermodynamic process in which the system is confined by mechanically rigid boundaries. No direct mechanical work can be done on the surroundings by a system with rigid boundaries; therefore the heat transferred into or out of the system equals the change of internal energy stored in the system. This change in the internal energy, in turn, is a function of the specific heat and the temperature change in the system. See POLYTROPIC PROCESS.

[P.E.Bl.]

**Isopoda** An order of malacostracan crustaceans characterized by a cephalon, or head, bearing one pair of maxillipeds in addition to the antennae, mandibles, and maxillae (see illustration). A carapace is lacking. The peraeon, or thorax, consists of seven distinct somites each bearing a pair of peraeopods, the legs. The pleon, or abdomen, has six somites. The first five pairs

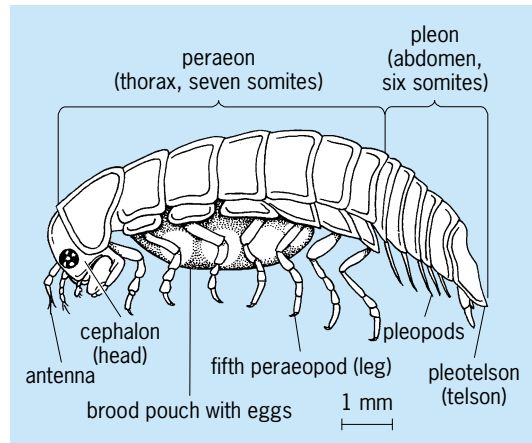

*Limnoria*, female. (After R. J. Menzies, *The comparative biology of the wood-boring isopod crustacean Limnoria*, *Museum of Comparative Zoology, Harvard Coll. Bull.*, 112(5):363–388, 1954)

of pleonal appendages are foliaceous. The last pair is modified into hardened appendages called uropods and the last somite is fused with the telson into a pleotelson.

The most familiar isopods are the terrestrial sow bugs or pill bugs. Many of the animals roll up into a compact ball when disturbed. Land isopods are usually found in moist environments, under decaying leaves and wood, and under rocks. The destructive marine wood-boring isopod *Limnoria*, the gribble, causes extensive damage to wharf piling in the United States, and one species is reported to attack treated timbers.

About 3000 species of isopods are known today, but it may be estimated that only one-half of the existing species have been described. See CRUSTACEA.

[R.J.Me.]

**Isoptera** An order of the Insecta, commonly called termites, with the general characteristics and stages of other exopterygote insects. Some authorities consider them a suborder of the Dictyoptera, or cockroaches, and they are certainly closely related to that group.

Approximately 2000 species of termites have been described and these are placed in six or seven families: Mastotermitidae, Hodotermitidae, Termopsidae (sometimes included in the Hodotermitidae), Kalotermitidae, Rhinotermitidae, Serritermitidae and the Termitidae. The latter family represents the higher termites and includes over 80% of all known termite species. See EXOPTERYGOTA; ORTHOPTERA.

The termite group is typically a tropical one, but certain genera do occur outside the tropics and may be found as far north in North America as British Columbia and Ontario. The group is distinguished by the fact that all species are eusocial and all feed on cellulose. The castes, apart from the imagos and primary reproductives, are drawn from the larval forms. In this respect they differ from the Hymenoptera where the castes are all variants of adults. Termites live in nests of varying degrees of complexity, ranging from large exiguous mounds to diffuse or temporary galleries in wood or soil. See HYMENOPTERA.

The mature termite (alate or imago) has membranous wings which extend beyond the end of the abdomen. There is a pair of compound eyes, and a pair of ocelli is present in most groups. The wings are superimposed flat on the abdomen when the insect is not in flight. Flight is weak and fluttering and is usually short. When the alate alights, the wings are shed along a basal suture with the base of each wing (the wing scale) being retained. The alates vary in color from yellow, through brown, to coal black.

In almost all termite species a second type of individual is produced in the colony. This is the soldier, which lacks wings, is

nonreproductive, and is variously modified for defense. There are four rather distinct types of soldiers: mandibulate, phragmotic, nasutoid, and nasute.

In the more advanced termites there is a third caste, the worker. True workers usually have some pigmentation as opposed to the immature termites, which are generally white. Workers lack wings, are nonreproductive, and have mandibles which resemble those of the imagos; they are usually blind.

In addition to the definitive castes (alate, soldier, and worker) another type of individual may occur in the colony under certain circumstances. These individuals are the supplementary or replacement reproductives. Although the original pair (king and queen) may live for two or three decades, the life of the colony itself is not limited by their survival. If one or both are lost, other individuals in the colony become reproductive. If these new reproductives have wing buds, they are termed nymphoid (or brachypterous or second-form) reproductives. If they lack wing buds, they are termed ergatoid (or apterous or third-form) reproductives. See INSECTA; SOCIAL INSECTS. [A.M.S.]

**Isopycnic** The line of intersection of an atmospheric isopycnic surface with some other surface, for instance, a surface of constant elevation or pressure. An isopycnic surface is a surface in which the density of the air is constant. Since specific volume is the reciprocal of density, isosteric surfaces coincide with isopycnic surfaces. On a surface of constant pressure, isopycnics coincide with isotherms, because on such a surface, density is a function solely of temperature. On a constant-pressure surface, isopycnics lie close together when the field is strongly baroclinic and are absent when the field is barotropic. See BAROCLINIC FIELD; BAROTROPIC FIELD; SOLENOID (METEOROLOGY). [F.S.; H.B.B.]

**Isostasy** The application of Archimedes' principle to the layered structure of the Earth. The elevated topography of Earth is roughly equivalent to an iceberg that floats in the surrounding, denser water. Just as an iceberg extends beneath the exposed ice, the concept of isostasy proposes that topography is supported, or compensated, by a deep root. The buoyant outer shell of the Earth, the crust, displaces the denser, viscous mantle in proportion to the surface elevation. Isostasy implies the existence of a level surface of constant pressure within the mantle, the depth of compensation. Above this surface the mass of any vertical column is equal. Equal pressure at depth can also be achieved by varying density structure or by the regional deflection of the lithosphere. See ARCHIMEDES' PRINCIPLE; EARTH CRUST.

Local isostasy achieves equilibrium directly beneath a load by varying either the density or thickness of that mass column. This model attributes no inherent strength to the crust and assumes that the mantle is a simple fluid, redistributing mass to minimize pressure differences at depth. From studies of seamounts, oceanic trenches, foreland basins, and glacial rebound, it has become known that the outer shell of the Earth is rigid, responding to loads over a region broader than the load itself, and that the mantle is a viscous fluid with a time-dependent response to loads.

The simplest method of examining the response of the Earth is to study an area influenced by a discrete load such as a seamount or a continental glacier. If local isostasy (illus. a, b) is applicable, the region surrounding the load will be horizontal, unaffected by the load. In contrast, if the lithosphere has finite strength and regional or flexural isostasy (illus. c) is applicable, the surrounding regions will be deflected down toward the load. Gravity, bathymetry, and seismic studies of the crust surrounding Hawaii and other seamounts have demonstrated that the crust is downwarped beneath seamounts. The implication of this regional response is that the oceanic lithosphere has some

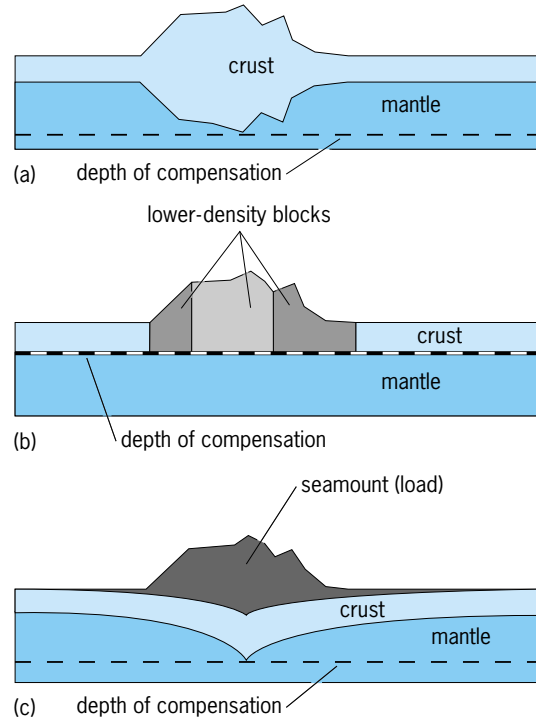

Three major modes of isostatic compensation. (a) Airy isostasy, where the crustal density is constant beneath both the elevated topography and the level region; a large root extends beneath the elevated topography, and the depth of compensation is at the base of the crust where the pressure is constant. (b) Pratt isostasy, where the density of the crust varies inversely with the height of the topography; the depth of compensation is at the base of the horizontal crust-mantle boundary. (c) Flexural or regional isostasy, where the crust has some strength and is deflected beneath the elevated topography; the depth of compensation is a horizontal surface beneath the lowest extent of the crust.

strength and that the Earth's outer shell behaves elastically. See EARTH; EARTH, GRAVITY FIELD OF; GEODESY; LITHOSPHERE.

[R.E.Bel.; B.J.C.]

**Isotach** A line along which the speed of the wind is constant. Isotachs are customarily represented on surfaces of constant elevation or atmospheric pressure, or in vertical cross sections. The closeness of spacing of the isotachs is indicative of the intensity of the wind shear on such surfaces. In the region of a jet stream the isotachs are approximately parallel to the streamlines of wind direction and are closely spaced on either side of the core of maximum speed. See JET STREAM; WIND.

[F.S.; H.B.B.]

**Isothermal chart** A map showing the distribution of air temperature (or sometimes sea surface or soil temperature) over a portion of the Earth's surface, or at some level in the atmosphere. On it, isotherms are lines connecting places of equal temperature. The temperatures thus displayed may all refer to the same instant, may be averages for a day, month, season, or year, or may be the hottest or coldest temperatures reported during some interval.

Isothermal charts are drawn daily in major weather forecasting centers; 5-day, 2-week, and monthly charts are used regularly in long-range forecasting; mean monthly and mean annual charts are compiled and published by most national weather services, and are presented in standard books on, for example, climate, geography, and agriculture. See AIR TEMPERATURE; WEATHER MAP.

[A.Cou.]

**Isothermal process** A thermodynamic process which occurs with a heat addition or removal rate just adequate to maintain constant temperature. The change in the internal energy per mole  $U$  accompanying a change in volume in an isothermal process is given by the equation below, where  $T$  is the

$$U_2 - U_1 = \int_{V_1}^{V_2} \left[ T \left( \frac{\partial P}{\partial T} \right)_V - P \right] dV$$

temperature,  $P$  is the pressure, and  $V$  is the volume per mole. The integral in the equation is zero for an ideal gas, and approximately zero for a condensed phase (solid or liquid) for which the volume changes vary little with pressure. Thus, in both these cases,  $U_2 = U_1$ . For real gases, the integral is nonzero, and the internal energy change is computed using the equation of state of the gas in the equation. See CHEMICAL THERMODYNAMICS; THERMODYNAMIC PROCESSES. [S.I.S.]

**Isotone** One of two or more atoms which display a constant difference  $A - Z$  between their mass number  $A$  and their atomic number  $Z$ . Thus, despite differences in the total number of nuclear constituents, the numbers of neutrons in the nuclei of isotones are the same. The numbers of naturally occurring isotones provide useful evidence concerning the stability of particular neutron configurations. For example, the relatively large number (six and seven, respectively) of naturally occurring 50- and 82-neutron isotones suggests that these nuclear configurations are especially stable. On the other hand, from the fact that most atoms with odd numbers of neutrons are anisotonic, one may conclude that odd-neutron configurations are relatively unstable. See NUCLEAR STRUCTURE. [H.E.D.]

**Isotope** One member of a (chemical-element) family of atomic species which has two or more nuclides with the same number of protons ( $Z$ ) but a different number of neutrons ( $N$ ). Because the atomic mass is determined by the sum of the number of protons and neutrons contained in the nucleus, isotopes differ in mass. Since they contain the same number of protons (and hence electrons), isotopes have the same chemical properties. However, the nuclear and atomic properties of isotopes can be different. The electronic energy levels of an atom depend upon the nuclear mass. Thus, corresponding atomic levels of isotopes are slightly shifted relative to each other. A nucleus can have a magnetic moment which can interact with the magnetic field generated by the electrons and lead to a splitting of the electronic levels. The number of resulting states of nearly the same energy depends upon the spin of the nucleus and the characteristics of the specific electronic level. See ATOMIC STRUCTURE AND SPECTRA; HYPERFINE STRUCTURE; ISOTOPE SHIFT.

Of the 12 elements confirmed thus far, 81 have at least one stable isotope whereas the others exist only in the form of radioactive nuclides. Some radioactive nuclides (for example,  $^{115}\text{In}$ ,  $^{232}\text{Th}$ ,  $^{235}\text{U}$ ,  $^{238}\text{U}$ ) have survived from the time of formation of the elements. Several thousand radioactive nuclides produced through natural or artificial means have been identified. See RADIOISOTOPE.

Of the 83 elements which occur naturally in significant quantities on Earth, 20 are found as a single isotope (mononucleidic), and the others as admixtures containing from 2 to 10 isotopes. Isotopic composition is mainly determined by mass spectroscopy. See MASS SPECTROSCOPE.

Nuclides with identical mass number (that is,  $A = N + Z$ ) but differing in the number of protons in the nucleus are called isobars. Nuclides having different mass number but the same number of neutrons are called isotones. See ISOBAR (NUCLEAR PHYSICS); ISOTONE.

Isotopic abundance refers to the isotopic composition of an element found in its natural terrestrial state. The isotopic composition for most elements does not vary much from sample to sample. This is true even for samples of extraterrestrial origin

such as meteorites and lunar materials brought back to Earth by space missions. However, there are a few exceptional cases for which variations of up to several percent have been observed. There are several phenomena that can account for such variations, the most likely being some type of nuclear process which changes the abundance of one isotope relative to the others. For some of the lighter elements, the processes of distillation or chemical exchange between different chemical compounds could be responsible for isotopic differences. See NUCLEAR REACTION; RADIOACTIVITY.

The areas in which separated (or enriched) isotopes are utilized have become fairly extensive, and a partial list includes nuclear research, nuclear power generation, nuclear weapons, nuclear medicine, and agricultural research. For many applications there is a need for separated radioactive isotopes. These are usually obtained through chemical separations of the desired element following production by means of a suitable nuclear reaction. Separated radioactive isotopes are used for a number of diagnostic studies in nuclear medicine, including the technique of positron tomography. See ISOTOPE SEPARATION; NUCLEAR MEDICINE.

Studies of metabolism, drug utilization, and other reactions in living organisms can be done with stable isotopes such as  $^{13}\text{C}$ ,  $^{15}\text{N}$ ,  $^{18}\text{O}$ , and  $^2\text{H}$ . Molecular compounds are "spiked" with these isotopes, and the metabolized products are analyzed by using a mass spectrometer to measure the altered isotopic ratios. See ISOTOPE DILUTION TECHNIQUES; RADIOISOTOPE (BIOLOGY). [D.J.Ho.]

**Isotope dilution techniques** Analytical techniques that involve the addition to a sample of an isotopically labeled compound. Soon after the discovery of the stable heavy isotopes of hydrogen, carbon, nitrogen, and oxygen, their value in analytical chemistry was recognized. Stable isotopes were particularly useful in the analysis of complex mixtures of organic compounds where the isolation of the desired compound with satisfactory purity was difficult and effected only with low or uncertain yields. The addition of a known concentration of an isotopically labeled compound to a sample immediately produces isotope dilution if the particular compound is present in the sample. After thorough mixing of the isotopically labeled compound with the sample, any technique that determines the extent of the isotopic dilution suffices to establish the original concentration of the compound in the mixture. Isotope dilution techniques exploit the difficulty in the separation of isotopes, with the isotopically labeled "spike" following the analytically targeted compound through a variety of separation procedures prior to isotopic analysis. See ISOTOPE.

The technique depends on the availability of a stable or radioisotope diluent with isotope abundance ratios differing markedly from those of the naturally occurring elements. With monoisotopic elements, such as sodium or cesium, radioactive elements of sufficiently long life can be used in isotope dilution techniques.

The original applications of isotope dilution were by biochemists interested in complex mixtures of organic compounds. In these studies care had to be taken to ensure the stability of the labeled compound and its resistance to isotopic exchange reactions. Nitrogen-15-labeled glycine for example, could be used to determine glycine in a mixture of amino acids obtained from a protein. Deuterium-labeled glycine could not be used reliably if the deuterium isotopes were attached to the glycine amino or carboxyl group, because in these locations deuterium is known to undergo exchange reactions with hydrogens in the solvent or in other amino acids. Deuterium is very useful in elemental isotopic analysis where total hydrogen or exchangeable hydrogen concentrations are desired. See BIOCHEMISTRY; DEUTERIUM.

Applications of isotope dilution techniques have also been found in geology, nuclear science, and materials science. These applications generally focus on the very high sensitivity attainable with these techniques. Isotopes of argon, uranium, lead,

thorium, strontium, and rubidium have been used in geologic age determinations of minerals and meteorites. Taking the estimated error as a measurement of sensitivity, isotopic dilution analyses of uranium have been done down to 4 parts in  $10^{12}$  and on thorium to 8 parts in  $10^9$ . Studies in geology and nuclear science require the determination of trace amounts of radiogenic products. If the half-life and decay scheme of the parent nuclide is known, then isotopic dilution determinations of parent and daughter isotopes provide a basis for the calculation of the age of the sample. If the age or history of the sample is known, then determination of the trace concentrations of isotopes provides information on pathways of nuclear reactions. See RADIOACTIVITY; ROCK AGE DETERMINATION. [L.Fr.]

**Isotope separation** The physical separation of different isotopes of an element from one another. The different isotopes of an element as it occurs in nature may have similar chemical properties but completely different nuclear reaction properties. Therefore, nuclear physics and nuclear energy applications often require that the different isotopes be separated. However, similar physical and chemical properties make isotope separation by conventional techniques unusually difficult. Fortunately, the slight mass difference of isotopes of the same element makes separation possible by using especially developed processes, some of which involve chemical industry distillation concepts. See ISOTOPE.

Isotope separation depends on the element involved and its industrial application. Uranium isotope separation has by far the greatest industrial importance, because uranium is used as a fuel for nuclear power reactors. The two main isotopes found in nature are  $^{235}\text{U}$  and  $^{238}\text{U}$ , which are present in weight percentages (w/o) of 0.711 and 99.283, respectively. In order to be useful as a fuel the weight percentage of  $^{235}\text{U}$  must be increased to between 2 and 5. The process of increasing the  $^{235}\text{U}$  content is known as uranium enrichment, and the process of enriching is referred to as performing separative work. See NUCLEAR FUELS; NUCLEAR REACTOR; URANIUM.

The production of heavy water is another example of isotope separation. Heavy water is obtained by isotope separation of light hydrogen ( $^1\text{H}$ ) and heavy hydrogen ( $^2\text{H}$ ) in natural water. Heavy hydrogen is usually referred to as deuterium (D). All natural waters contain  $^1\text{H}$  and  $^2\text{H}$ , in concentrations of 99.985 and 0.015 w/o, respectively, in the form of  $\text{H}_2\text{O}$  and  $\text{D}_2\text{O}$  (deuterium oxide). Isotope separation increases the concentration of the  $\text{D}_2\text{O}$ , and thus the purity of the heavy water. See DEUTERIUM; HEAVY WATER.

The development of laser isotope separation technology provided a range of potential applications from space-flight power sources ( $^{238}\text{Pu}$ ) to medical magnetic resonance imaging ( $^{13}\text{C}$ ) and medical research ( $^{15}\text{O}$ ).

The isotope separation process that is best suited to a particular application depends on the state of technology development as well as on the mass of the subject element and the quantities of material involved. Processes such as electromagnetic separation, thermal diffusion, and the Becker Process which are suited to research quantities of material are generally not suited to industrial separation quantities. However, the industrial processes that are used, gaseous diffusion, gas centrifugation, and chemical exchange, are not suited to separating small quantities of material. See CENTRIFUGATION; DIFFUSION.

Three experimental laser isotope separation technologies for uranium are the atomic vapor laser isotope separation (AVLIS) process, the uranium hexafluoride molecular laser isotope separation (MLIS) process, and the separation of isotopes by laser excitation (SILEX) process. The AVLIS process, which is more experimentally advanced than the MLIS and SILEX processes, exploits the fact that the different electron energies of  $^{235}\text{U}$  and  $^{238}\text{U}$  absorb different colors of light (that is, different wavelengths). AVLIS technology is inherently more efficient than either the gaseous diffusion or gas centrifuge processes. It can

enrich natural uranium to  $^{235}\text{U}$  in a single step. In the United States, the AVLIS process is being developed to eventually replace the gaseous diffusion process for commercially enriching uranium. See LASER; PHOTOIONIZATION. [J.J.St.]

**Isotope shift** A small difference between the different isotopes of an element in the transition energies corresponding to a given spectral line transition. For a spectral line transition between two energy levels  $a$  and  $b$  in an atom or ion with atomic number  $Z$ , the small difference  $\Delta E_{ab} = E_{ab}(A') - E_{ab}(A)$  in the transition energy between isotopes with mass numbers  $A'$ , and  $A$  is the isotope shift. It consists largely of the sum of two contributions, the mass shift (MS) and the field shift, also called the volume shift. The mass shift is customarily divided into a normal mass shift and a specific mass shift; each is proportional to the fractional mass difference  $(A' - A)/A$ . The normal mass shift is a reduced mass correction that is easily calculated for all transitions. The specific mass shift is produced by the correlated motion of different pairs of atomic electrons and is, therefore, absent in one-electron systems. The field shift is produced by the change in the finite size and shape of the nuclear charge distribution when neutrons are added to the nucleus. See ATOMIC STRUCTURE AND SPECTRA; NUCLEAR STRUCTURE. [P.M.K.]

**Isotopic irradiation** The uses of the radiation emitted by radioactive isotopes (radioisotopes), principally in industry and medicine. The radiation from radioisotopes produces essentially the same effect as the radiation from electron linear accelerators and other high-voltage particle accelerators, and the choice of which to use is based primarily on convenience and cost. Although the radioisotope radiation source does not require the extensive and complex circuitry necessary for a high-voltage radiation source, its radiation is always present and requires elaborate shielding for health protection and specialized mechanisms for bringing the irradiated objects into and out of the radiation beam. Further, the radiation output decreases with time according to the half-life of the radioisotope, which must therefore be replaced periodically. See PARTICLE ACCELERATOR.

The two main radioisotopes for industrial processing are cobalt-60 with a half-life of 5.271 years and an average gamma-ray energy of 1.25 MeV, and cesium-137 with a half-life of 30.07 years and a gamma-ray energy of 0.662 MeV. The application of industrial irradiation is increasing, with sterilization of medical disposables using cobalt-60 gamma rays being the most common. A promising application is food preservation, including the reduction of postharvest losses by the elimination of pests with irradiation. The biocidal effect of the gamma-irradiation process is effective for the control of microbiological contamination in many raw materials used by the pharmaceutical and cosmetic industries. Other applications include irradiation of male insects for pest control, sterilization of corks, sterilization of laboratory animal bedding, preparation of vaccines, degradation of Teflon scraps used in lubricants, cross-linking of polyethylene for shrink films, and production of wood-polymer and concrete-polymer composites.

Radioisotopes are used in the treatment of cancer by radiation. Encapsulated sources are used in two ways: the radioisotopes may be external to the body and the radiation allowed to impinge upon and pass through the patient (teletherapy), or the radiation sources may be placed within the body (brachytherapy). For teletherapy purposes cobalt-60 is the most commonly used isotope. Some cesium-137 irradiators have been built, but cesium-137 radiation is not as penetrating as that from cobalt-60. Radium-226 is now being replaced with cesium-137 sources as a brachytherapy encapsulated source. Iridium-192 is also being used for brachytherapy applications. Iodine-125 or gold-198 seeds are put directly in a tumor and permanently left in place.

For some medical applications the radioisotope is dispersed



in the body; the most commonly used is iodine-131. When the radioisotope is administered either orally or intravenously in a highly purified form, it goes to the thyroid, where certain forms of thyroid disorders and cancers can be treated by the radiation. See RADIOACTIVITY AND RADIATION APPLICATIONS; RADIOISOTOPE; RADIOLOGY. [P.R.A.]

**Ixodides** A suborder of the Acarina comprising the ticks. Ticks differ from mites, their nearest relatives, in their larger size and in having a pair of breathing pores, or spiracles, behind the third or fourth pair of legs. They have a gnathosoma, or head, which consists of a base, a pair of palps, and a rigid, elongated, ventrally toothed hypostome which anchors the parasite to its host. They also have a pair of protrusible cutting organs, or chelicerae, which permit the insertion of the hypostome. The 600 or so known species are all bloodsucking, external parasites of vertebrates including amphibians, reptiles, birds, and mammals. Ticks are divided into three families, Argasidae, Ixodidae (see illustration), and Nuttalliellidae.

In contrast to argasids, Ixodidae have a scutum covering most of the dorsal surface of the male but only the anterior portion of females, nymphs, and larvae. They are known as the hard ticks. The sexes are thus markedly dissimilar.

The numerous tick-borne diseases of animals cause vast economic losses, especially in tropical and subtropical regions. Aside from carrying disease, several species are extremely important



Ixodid tick, *Dermacentor andersoni*, female, enlarged to about 18 times natural size.

pests of humans and animals. Heavy infestations of ticks produce severe anemia in livestock, and even death, from loss of blood alone. See ACARI; TICK PARALYSIS. [G.M.K.]





**J/psi particle** An elementary particle with an unusually long lifetime or, from the Heisenberg uncertainty principle, with an extremely narrow width  $\Gamma = 91.0 \pm 3.2$  keV, and a large mass  $m = 3096.916 \pm 0.011$  MeV. It is a bound state containing a charm quark and an anticharm quark. The discovery of the J/psi particle is one of the cornerstones of the standard model.

Since its discovery in 1974, more than  $10^9$  J/psi particles have been produced. More than 100 different decay modes and new particles radiating from the J/psi particle have been observed. The J/psi particle has been shown to be a bound state of charm quarks. The long lifetime of the J/psi results from its mass being less than the masses of particles which separately contain a charm and an anticharm quark. This situation permits the J/psi to decay only into noncharm quarks, and empirically this restriction was found to lead to a suppression of the decay rate resulting in a long lifetime and narrow width. The subsequent discovery of the *b* quark and the intermediate vector bosons  $Z^0$  and  $W^\pm$ , and studies of  $Z^0$  decays into charm, *b*, and other quarks, show that the theory of the standard model is in complete agreement with experimental data to an accuracy of better than 1%. See CHARM; ELEMENTARY PARTICLE; INTERMEDIATE VECTOR BOSON; QUARKS; STANDARD MODEL; UPSILON PARTICLES. [S.C.C.T.]

**Jade** A name that may be applied correctly to two distinct minerals. The two true jades are jadeite and nephrite. In addition, a variety of other minerals are incorrectly called jade. Idocrase is called California jade, dyed calcite is called Mexican jade, and green grossularite garnet is called Transvaal or South African jade. The most commonly encountered jade substitute is the mineral serpentine. It is often called "new jade" or "Korean jade." The most widely distributed and earliest known true type is nephrite, the less valuable of the two. Jadeite, the most precious of gemstones to the Chinese, is much rarer and more expensive. See JADEITE. [R.T.L.]

**Jadeite** The monoclinic sodium aluminum pyroxene,  $\text{NaAlSi}_2\text{O}_6$ . Free crystals are rare. Jadeite usually occurs as dense, felted masses of elongated blades or as fine-grained granular aggregates. It has a Mohs hardness of 6.5 and a density of 3.25–3.35. It has a vitreous or waxy luster, and is commonly green but may also be white, violet, or brown.

Jadeite is always found in metamorphic rocks. It is associated with serpentine at Tawmaw, Burma; Kotaki, Japan; and San Benito County, California. It occurs in metasedimentary rocks of the Franciscan group in California and in Celebes. It is found in Tibet; Yunnan Province, China; and Guatemala.

Jadeite is the more cherished of the two jade minerals, because of the more intense colors it displays. It is best known in the lovely intense green color resembling that of emerald. See JADE; PYROXENE. [L.Gr.]

**Jahn-Teller effect** A distortion of a highly symmetrical molecule, which reduces its symmetry and lowers its energy. The effect occurs for all nonlinear molecules in degenerate electronic states, the degeneracy of the state being removed by the effect. It was first predicted in 1937 by H. A. Jahn and E. Teller. In early experimental work, the effect often "disappeared" or was

masked by other molecular interactions. This has surrounded the Jahn-Teller effect with a certain mystery and allure, rarely found in science today. However, there are now a number of clear-cut experimental examples which correlate well with theoretical predictions. These examples range from the excited states of the most simple polyatomic molecule,  $\text{H}_3$ , through moderate-sized organic molecules, like the ions of substituted benzene, to complex solid state phenomena involving crystals or localized impurity centers. See CRYSTAL DEFECTS; DEGENERACY (QUANTUM MECHANICS); MOLECULAR STRUCTURE AND SPECTRA; QUANTUM MECHANICS.

With the exception of linear molecules which suffer Renner-Teller effects, all polyatomic molecules of sufficiently high symmetry to possess orbitally degenerate electronic states will be subject to the Jahn-Teller instability. However, in cases other than molecules with fourfold symmetry, the proof is somewhat involved and requires the use of the principles of group theory. See GROUP THEORY; RENNER-TELLER EFFECT. [V.E.B.; T.A.M.]

**Jamming** Intentional generation of interfering signals by powerful transmitters as a countermeasure intended to block a communication or radar system or to impair its effectiveness appreciably. For example, radio broadcasts or radio messages can be jammed by beaming a more powerful signal on the same frequency at the area in which reception is to be impaired, using carefully selected noise modulation to give maximum impairment of intelligibility of reception. See ELECTRONIC WARFARE. [J.Mar.]

**Jasper** An opaque, impure type of massive fine-grained quartz that typically has a tile-red, dark-brownish-red, brown, or brownish-yellow color. Jasper has been used since ancient times as an ornamental stone, chiefly of inlay work, and as a semiprecious gem material. See GEM; QUARTZ.

Jasper has a smooth conchoidal fracture with a dull luster. The specific gravity and hardness are variable; both values approach those of quartz. The color of jasper often is variegated in banded, spotted, or orbicular types. [C.Fr.]

**Jaundice** The yellow staining of the skin and mucous membranes associated with the accumulation of bile pigments, such as bilirubin, in the blood plasma. Bile pigments are the normal result of the metabolism of blood pigments, and are normally excreted from the blood into the bile by the liver. An increase in circulating bile pigments can, therefore, come about through increased breakdown of blood (hemolytic jaundice), through lack of patency of the bile ducts (obstructive jaundice), through inability or failure of the liver to clear the plasma (parenchymal jaundice), or through combinations of these. Jaundice occurs when the level of these circulating pigments becomes so high that they are visible in the skin and mucous membranes. See GALLBLADDER; LIVER.

Hemolytic jaundice results from certain morbid states that include various hemolytic anemias, hemolysis resulting from incompatible blood transfusion, severe thermal or electric injuries, or introduction of hemolytic agents into the blood-stream. Similar jaundice occurs in pulmonary infarction.

Chronic obstructive jaundice may be brought about through a variety of means. In the infant there may be a severe maldevelopment of the bile ducts, while in the adult obstructive jaundice is most commonly caused by impaction of a gallstone in the ducts, or benign and malignant tumors of the gallbladder, bile ducts, pancreas, or lymph nodes.

A wide variety of diseases exists in which part of the jaundice can be accounted for by actual damage to liver cells. This group comprises such conditions as inflammations of the liver, including viral hepatitis, Weil's disease, syphilis, parasitic infestations, and bacterial infections; toxic conditions, including poisoning and in a broader sense the toxemias associated with severe systemic diseases; tumorous conditions; and other miscellaneous conditions, the most common of which is congestive heart failure. [R.B.H.]

**Jawless vertebrates** Jawless vertebrates (Agnatha) include the modern Cyclostomata (lampreys and hagfishes) as well as extinct armored fishes known colloquially as ostracoderms ("bony-skinned"). They lived in the Ordovician, Silurian, and Devonian periods. Agnathans have pouchlike gills opening through small pores, rather than slits as in jawed vertebrates (Gnathostomata). Primitively, agnathans lack jaws, they show a persistent notochord, and most have no paired fins.

Lampreys (Petromyzontiformes; 42 species) and hagfishes (Myxiniiformes; 43 species) are scaleless, eel-shaped fishes with round mouths, inside which there are keratinized teeth carried upon a complex tongue. Most species of lampreys live as adults in the sea, where they attach to host fishes by a sucker and use the tongue to rasp away flesh and blood. Hagfishes are exclusively marine, are blind, and live most of their lives buried in mud, emerging to eat polychaete worms or the abdominal contents of dead or dying fishes. Lampreys and hagfishes show a bipolar distribution and prefer cool waters.

Ostracoderms were very variable in shape and were covered with a superficial bony armor made up of solid shields or scales. One of the best known was the osteostracans (cephalaspids) of Europe and North America, with a solid semicircular head shield pierced by dorsally placed eyes and a small circular mouth on the undersurface. The head shield is also marked by sensory fields (lacunae filled with small plates) which were specialized parts of the lateral line system. Osteostracans probably lived on, or partly buried in, mud and sand, where they sucked in small food particles.

Modern ideas of the interrelationships of agnathan fishes suggest that they are not a natural group; that is, some such as the osteostracans and galeaspids are more closely related to jawed vertebrates than to other agnathans. Similarly, lampreys share many specializations with jawed vertebrates not seen in hagfishes, such as neural arches along the notochord, eye muscles, nervous control of heartbeat, and the capability to osmoregulate and adapt to fresh water. These attributes suggest that lampreys are more closely related to jawed vertebrates than to hagfishes and that the Cyclostomata is not a natural group.

Members of the Conodonta may be jawless vertebrates, but their classification is still under discussion. See CEPHALASPIDOMORPHA; FOSSIL; PTERASPIDOMORPHA.

A classification of jawless vertebrates is given below.

- Subphylum Craniata (complex brain and sensory organs)
  - Class Hyperotreti
    - Order Myxiniiformes
  - Class Vertebrata (with neural arches in backbone)
    - Order: Petromyzontiformes
      - Anaspida
      - Thelodonti
      - Heterostraci (pteraspids)

Galeaspida  
Osteostraci (cephalaspids)  
Class incertae sedis Conodonta

See MYXINIFORMES; PETROMYZONTIDA.

[P.L.F.]

**Jerboa** The common name for 25 species of rodents which make up the family Dipodidae. All species occur in desert or semiarid regions of Asia; three species extend into North Africa. All of these animals are adapted for jumping, and the hindlegs and feet are extremely long (see illustration). The most common

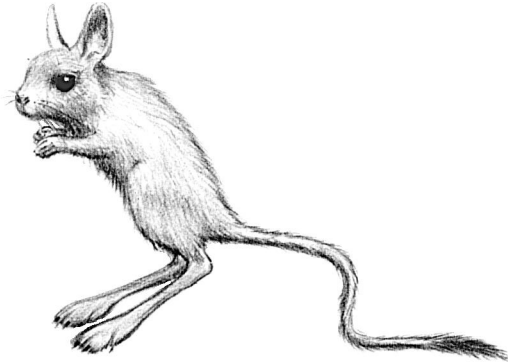

Typical jerboa, with long hindlegs and a tail that terminates in a tuft of hair.

species is *Jaculus jaculus*, the lesser Egyptian jerboa. See RODENTIA. [C.B.C.]

**Jet (gemology)** A black, opaque material that takes a high polish. Jet has been used for many centuries for ornamental purposes. It is a compact variety of lignite coal. It has a refractive index of 1.66, a hardness of 3–4 on Mohs scale, and a specific gravity of 1.30–1.35. Jet is compact and durable, and can be carved or even turned on a lathe. The main source is Whitby, England, in hard shales. See GEM; LIGNITE. [R.T.L.]

**Jet flow** A fluid flow in which a stream of one fluid mixes with a surrounding medium, at rest or in motion. Such flows occur in a wide variety of situations, and the geometries, sizes, and flow conditions cover a large range. Jet flows vary greatly, depending on the values of two numbers. The first is the Reynolds number, defined in Eq. (1), where  $\rho$  is the density,

$$\text{Re} \equiv \frac{\rho VL}{\mu} \quad (1)$$

$V$  is a characteristic velocity (for example, the jet exit velocity),  $L$  is a characteristic length (for example, the jet diameter), and  $\mu$  is the viscosity. The second is the Mach number, defined in Eq. (2), where  $a$  is the speed of sound.

$$\text{M} \equiv \frac{V}{a} \quad (2)$$

See MACH NUMBER; REYNOLDS NUMBER.

For conditions where  $\text{Re} < 2300$  and  $\text{M} \ll 1$ , jet flows take on a simple character. An example is the water jet formed by a household tap when the valve is partially opened to produce a low flow. If the flow or the diameter is increased or the viscosity is decreased so that  $\text{Re} > 2300$ , the jet will change dramatically. For example, a water jet exiting into water at rest with  $\text{Re} \approx 2300$  is initially in the simple laminar state, but at this Reynolds number that state is unstable and the flow undergoes a transition to the more chaotic turbulent state. Turbulent structures called eddies are formed with a large range of sizes. The large-scale structures

are responsible for capturing fluid from the surroundings and entraining it into the jet. However, the jet and external fluids are not thoroughly mixed until diffusion is completed by the small-scale structures. See DIFFUSION; LAMINAR FLOW; TURBULENT FLOW.

When the velocities in the jet are greater than the speed of sound ( $M > 1$ ) the flow is said to be supersonic, and important qualitative changes in the flow occur. The most prominent change is the occurrence of shock waves. For example, a supersonic air jet exhausting from a nozzle at low pressure into higher-pressure air at rest is said to be overexpanded. As the jet leaves the nozzle, it senses the higher pressure around it and adjusts through oblique shock waves emanating from the edges of the nozzle. See SHOCK WAVE; SUPERSONIC FLOW.

Another class of jet flows is identified by the fact that the motion of the jet is induced primarily by buoyancy forces. A common example is a hot gas exhaust rising in the atmosphere. Such jet flows are called buoyant plumes, or simply plumes, as distinct from the momentum jets, or simply jets, discussed above. See FLUID FLOW. [J.A.Sc.]

**Jet fuel** Fuel blended from the light distillates fractionated from crude petroleum. All jet fuels must meet the stringent requirements of aircraft turbine engines and fuel systems, which demand extreme cleanliness and freedom from oxidation deposits in high-temperature zones. Combustors require fuels that atomize and ignite at low temperatures, burn with adequate heat release and controlled radiation, and neither produce smoke nor attack hot turbine parts. The operation of the aircraft in long-duration flights at high altitude imposes a special requirement of good low-temperature flow behavior. [W.G.D.]

**Jet propulsion** Propulsion of a body by means of force resulting from discharge of a fluid jet. This fluid jet issues from a nozzle and produces a reaction (Newton's third law) to the force exerted against the working fluid in giving it momentum in the jet stream. Turbojets, ramjets, and rockets are the most widely used jet-propulsion engines. See RAMJET; TURBOJET.

In each of these propulsion engines a jet nozzle converts potential energy of the working fluid into kinetic energy. Hot high-pressure gas escapes through the nozzle, expanding in volume as it drops in pressure and temperature, thus gaining rearward velocity and momentum. This process is governed by the laws of conservation of mass, energy, and momentum and by the pressure-volume-temperature relationships of the gas-state equation. See JET FLOW; NOZZLE. [J.W.Bl.]

**Jet stream** A relatively narrow, fast-moving wind current flanked by more slowly moving currents. Jet streams are observed principally in the zone of prevailing westerlies above the lower troposphere and in most cases reach maximum intensity, with regard both to speed and to concentration, near the tropopause. At a given time, the position and intensity of the jet stream may significantly influence aircraft operations because of the great speed of the wind at the jet core and the rapid spatial variation of wind speed in its vicinity. Lying in the zone of maximum temperature contrast between cold air masses to the north and warm air masses to the south, the position of the jet stream on a given day usually coincides in part with the regions of greatest storminess in the lower troposphere, though portions of the jet stream occur over regions which are entirely devoid of cloud. The jet stream is often called the polar jet, because of the importance of cold, polar air. The subtropical jet is not associated with surface temperature contrasts, like the polar jet. Maxima in wind speed within the jet stream are called jet streaks. See ATMOSPHERIC GENERAL CIRCULATION. [F.S.; H.B.B.]

**Jet velocity** The velocity of the engine exhaust gases relative to the exhaust nozzle. In ideal air-breathing cycles, it is assumed that the exhaust gas mass rate equals the inlet air mass

rate, the mass of fuel burned being neglected, and that the exhaust gases are expanded to ambient pressure in the nozzle. Under these conditions the thrust of an engine is directly proportional to the airflow rate and to the difference between the jet and vehicle velocities; thrust is greatest at zero flight speed and becomes zero when the flight speed is the same as the jet velocity.

In the non-air-breathing rocket cycle, thrust of a rocket is independent of flight speed. Rather, at constant mass flow, thrust is directly proportional to nozzle exhaust velocity plus a pressure-times-area term. See PROPULSION; ROCKET PROPULSION. [R.R.H.]

**Jewel bearing** A bearing used in quality timekeeping devices, gyros, and instruments, usually made of synthetic corundum (crystallized  $Al_2O_3$ ) which is more commonly known as ruby or sapphire. The extensive use of such bearings in the design of precision devices is mainly due to the outstanding qualities of the material. Sapphire's extreme hardness imparts to the bearing excellent wear resistance, as well as the ability to withstand heavy loads without deformation of shape or structure. The crystalline nature of sapphire lends itself to very fine polishing and this, combined with the excellent oil- and lubricant-retention ability of the surface, adds to the natural low-friction characteristics of the material. Ruby has the same properties as sapphire. See ANTIFRICTION BEARING; GEM; GYROSCOPE; WATCH. [R.M.Sch.]

**Johne's disease** Chronic inflammation of the mucosa of the ileocecal valve and adjacent tissues of the gastrointestinal tract of cattle, sheep, goats, and captive wild ruminants, caused by the bacterium *Mycobacterium paratuberculosis*. Transmission of *M. paratuberculosis* is primarily by ingestion of feces from animals shedding the organism. The incubation period varies from 2 to 3 years or more. Diseased animals in advanced stages have intermittent or persistent diarrhea without fever and often become emaciated.

Johne's disease is diagnosed by serologic tests and mycobacteriologic examinations conducted on feces or tissues collected by biopsy or at necropsy. To confirm a diagnosis of Johne's disease, it is necessary to isolate and identify the etiologic agent.

Therapeutic drugs are not available for routine treatment of animals. A killed whole-cell vaccine is available for use in calves 1–35 days of age. Live attenuated strains of *M. paratuberculosis* have been used for vaccinating cattle in a few countries, but are not approved for use in the United States or Canada. *Mycobacterium paratuberculosis* has not been shown to cause disease in humans; however, a *M. paratuberculosis*-like organism has been isolated from a few individuals with Crohn's disease. See MYCOBACTERIAL DISEASES. [C.O.T.]

**Joint (anatomy)** The structural component of an animal skeleton where two or more skeletal elements meet, including the supporting structures within and surrounding it. The relative range of motion between the skeletal elements of a joint depends on the type of material between these elements, the shapes of the contacting surfaces, and the configuration of the supporting structures.

In bony skeletal systems, there are three general classes of joints: synarthroses, amphiarthroses, and diarthroses. Synarthroses are joints where bony surfaces are directly connected with fibrous tissue, allowing very little if any motion. Synarthroses may be further classified as sutures, syndesmoses, and gomphoses. Sutures are joined with fibrous tissue, as in the coronal suture where the parietal and frontal bones of the human skull meet. Syndesmoses are connected with ligaments, as are the shafts of the tibia and fibula. The roots of a tooth that are anchored in the jaw bone with fibrous tissue form a gomphosis. Amphiarthroses are joints where bones are directly connected with fibrocartilage or hyaline cartilage and allow only limited motion. An amphiarthrosis joined with fibrocartilage, as found

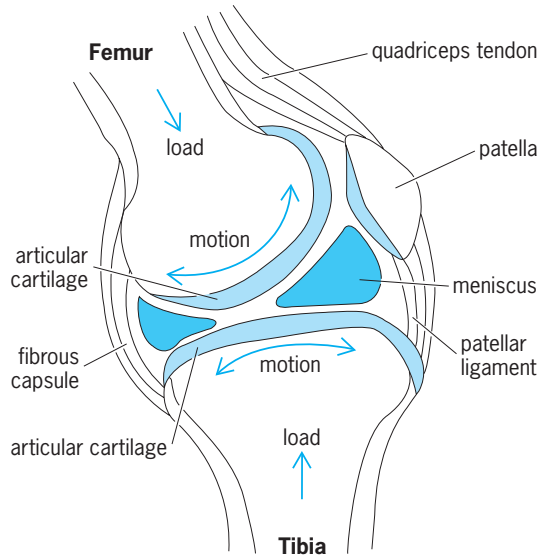

**Cross section of the human knee showing its major components. This diarthrodial joint contains contacting surfaces on the tibia, femur, meniscus, and patella (knee cap). The patella protects the joint and also serves to redirect the force exerted by the quadriceps muscles to the tibia. (After R. Skalak and S. Chien, eds., *Handbook of Bioengineering*, McGraw-Hill, 1987)**

between the two pubic bones of the pelvis, is known as a symphysis; but when hyaline cartilage joins the bones, a synchondrosis is formed, an example being the first sternocostal joint. The greatest range of motion is found in diarthrodial joints, where the articulating surfaces slide and to varying degrees roll against each other. See **LIGAMENT**.

The contacting surfaces of the bones of a diarthrodial joint are covered with articular cartilage, an avascular, highly durable hydrated soft tissue that provides shock absorption and lubrication functions to the joint (see illustration). Articular cartilage is composed mainly of water, proteoglycans, and collagen. The joint is surrounded by a fibrous joint capsule lined with synovium, which produces lubricating synovial fluid and nutrients required by the tissues within the joint. Joint motion is provided by the muscles that are attached to the bone with tendons. Strong flexible ligaments connected across the bones stabilize the joint and may constrain its motion. Different ranges of motion result from several basic types of diarthrodial joints: pivot, gliding, hinge, saddle, condyloid, and ball-and-socket. See **COLLAGEN**; **SKELETAL SYSTEM**. [V.C.M.; R.J.F.]

**Joint (structures)** The surface at which two or more mechanical or structural components are united. Whenever parts of a machine or structure are brought together and fastened into position, a joint is formed. See **STRUCTURAL CONNECTIONS**.

Mechanical joints can be fabricated by a great variety of methods, but all can be classified into two general types, temporary (screw, snap, or clamp, for example), and permanent (brazed, welded, or riveted, for example). [W.H.Gr.]

**Jjoba** *Simmondsia chinensis*, the only plant known to produce and store a liquid wax in its seed. The jjoba plant is native to the southwestern United States and Mexico. It is tolerant of some of the highest temperatures and most arid regions, and is being domesticated as a crop for hot low-rainfall regions around the world. A broadleaf evergreen shrub that is typically 3–10 ft (1–3 m) in height, it can grow as tall as 20 ft (6 m).

The seed-storage lipid of jjoba is a straight-chain ester. A majority of the wax molecules of jjoba are formed from acids and alcohols with 20 or 22 carbon atoms and one double bond. Many

modifications can be made at the double bond, which results in the plant's versatility as an ingredient in a wide range of chemical products. Jjoba wax, used in cosmetics and lubricants, has the potential to serve as a basic feedstock if seed production costs are reduced. Jjoba is being developed simultaneously in many places around the world, and cultivation methods are variable and change rapidly. See **FAT AND OIL (FOOD)**; **WAX, ANIMAL AND VEGETABLE**. [D.A.P.]

**Josephson effect** The passage of paired electrons (Cooper pairs) through a weak connection (Josephson junction) between superconductors, as in the tunnel passage of paired electrons through a thin dielectric layer separating two superconductors.

Quantum-mechanical tunneling of Cooper pairs through a thin insulating barrier (on the order of a few nanometers thick) between two superconductors was theoretically predicted by Brian D. Josephson in 1962. Josephson found that a current of paired electrons (supercurrent) would flow in addition to the usual current that results from the tunneling of single electrons. Josephson predicted that if the current did not exceed a limiting value (the critical current), there would be no voltage drop across the tunnel barrier. This zero-voltage current flow is known as the dc Josephson effect. Josephson also predicted that if a constant nonzero voltage were maintained across the tunnel barrier, an alternating supercurrent would flow through the barrier in addition to the dc current produced by the tunneling of unpaired electrons. This phenomenon is known as the ac Josephson effect. See **TUNNELING IN SOLIDS**.

Josephson pointed out that the magnitude of the maximum zero-voltage supercurrent would be reduced by a magnetic field. In fact, the magnetic field dependence of the magnitude of the critical current is one of the more striking features of the Josephson effect. Circulating supercurrents flow through the tunnel barrier to screen an applied magnetic field from the interior of the Josephson junction just as if the tunnel barrier itself were weakly superconducting. The screening effect produces a spatial variation of the transport current, and the critical current goes through a series of maxima and minima as the field is increased.

Josephson junctions, and instruments incorporating Josephson junctions, are used in applications for metrology at dc and microwave frequencies, frequency metrology, magnetometry, measurement of absolute temperatures below about 1 K, detection and amplification of electromagnetic signals, and other superconducting electronics such as high-speed analog-to-digital converters and computers. A Josephson junction, like a vacuum tube or a transistor, is capable of switching signals from one circuit to another; a Josephson tunnel junction is the fastest switch known. Josephson junction circuits are capable of storing information. Finally, because a Josephson junction is a superconducting device, its power dissipation is extremely small, so that Josephson junction circuits can be packed together as tightly as fabrication techniques permit. All the basic circuit elements required for a Josephson junction computer have been developed. See **LOW-TEMPERATURE THERMOMETRY**; **SUPERCONDUCTING DEVICES**; **SUPERCONDUCTIVITY**. [L.B.H.]

**Joule's law** A quantitative relationship between the quantity of heat produced in a conductor and an electric current flowing through it. As experimentally determined and announced by J. P. Joule, the law states that when a current of voltaic electricity is propagated along a metallic conductor, the heat evolved in a given time is proportional to the resistance of the conductor multiplied by the square of the electric intensity. Today the law would be stated as  $H = RI^2$ , where  $H$  is rate of evolution of heat in watts, the unit of heat being the joule;  $R$  is resistance in ohms; and  $I$  is current in amperes. This statement is more general than the one sometimes given that specifies that  $R$  be independent of  $I$ . Also,

it is now known that the application of the law is not limited to metallic conductors. See ELECTRIC HEATING. [L.G.H./J.W.St.]

**Juglandales** An order of flowering plants, division Magnoliophyta (Angiospermae), in the subclass Hamamelidae of the class Magnoliopsida (dicotyledons). The order consists of 2 families: the Juglandaceae with a little over 50 species and the Rhoipteleaceae with only 1 species. Within its subclass the order is sharply set off by its compound leaves. *Juglans* (walnut and butternut) and *Carya* (hickory, including the pecan, *C. illinoensis*) are familiar genera of the Juglandaceae. See HAMAMELIDAE; HICKORY; MAGNOLIOPHYTA; MAGNOLIOPSIDA; PLANT KINGDOM. [A.Cr.; T.M.B.]

**Juncales** An order of flowering plants, division Magnoliophyta (Angiospermae), in the subclass Commelinidae of the class Liliopsida (monocotyledons). The order consists of the family Juncaceae, with about 300 species, and the family Thurniaceae, with only 3. Within its subclass the order is marked by its reduced, mostly wind-pollinated flowers and capsular fruits with one to many anatropous ovules per carpel. The flowers have six sepals arranged in two more or less similar whorls, both sets chaffy and usually brown or green. See COMMELINIDAE; FLOWER; LILIOPSIDA. [A.Cr.]

**Junction detector** A device in which detection of radiation takes place in or near the depletion region of a reverse-biased semiconductor junction. The electrical output pulse is linearly proportional to the energy deposited in the junction depletion layer by the incident ionizing radiation. See IONIZATION CHAMBER.

Introduced into nuclear studies in 1958, the junction detector, or more generally, the nuclear semiconductor detector, revolutionized the field. In the detection of both charged particles and gamma radiation, these devices typically improved experimentally attainable energy resolutions by about two orders of magnitude over that previously attainable. To this they added unprecedented flexibility of utilization, speed of response, miniaturization, freedom from deleterious effects of extraneous electromagnetic (and often nuclear) radiation fields, low-voltage requirements, and effectively perfect linearity of output response. They are now used for a wide variety of diverse applications. They are used for general analytical applications, giving both qualitative and quantitative analysis in the microprobe and the scanning transmission electron microscopes. They are used in medicine, biology, environmental studies, and the space program. In the last category they continue to play a very fundamental role, ranging from studies of the radiation fields in the solar system to the composition of extraterrestrial surfaces. See PARTICLE DETECTOR; SEMICONDUCTOR. [J.M.McK.]

**Junction diode** A semiconductor rectifying device in which the barrier between two regions of opposite conductivity type produces the rectification. Junction diodes are used in computers, radio and television, brushless generators, battery chargers, and electrochemical processes requiring high direct current and low voltage. Lower-power units are usually called semiconductor diodes, and the higher-power units are usually called semiconductor rectifiers. See SEMICONDUCTOR.

Junction diodes are classified by the method of preparation of the junction, the semiconductor material, and the general category of use of the finished device. By far the great majority of modern junction diodes use silicon as the basic semiconductor material. Germanium material was used in the first decade of semiconductor diode technology, but has given way to the all-pervasive silicon technology, which allows wider temperature limits of operation and produces stable characteristics more easily. Other materials are the group III-V compounds, the most

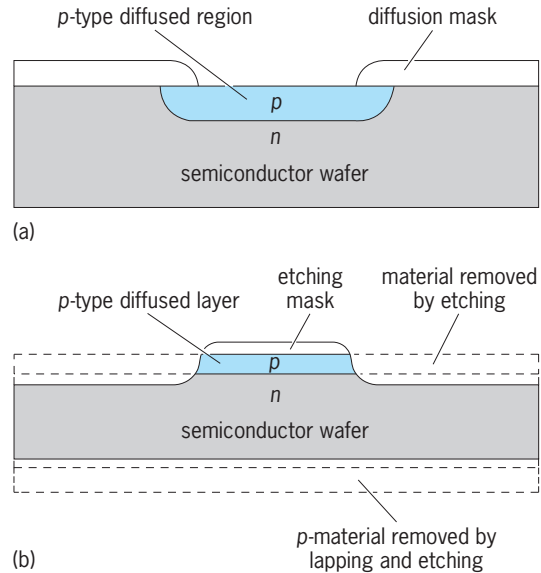

**High-speed diffused silicon diodes. (a) Mesaless structure. (b) Mesa structure.**

common being gallium arsenide, which is used where its relatively large band-gap energy is needed.

In silicon units nearly all categories of diodes are made by self-masked diffusion, as shown in illus. a. Exceptions are diodes where special control of the doping profile is necessary. In such cases, a variety of doping techniques may be used, including ion implantation, alloying with variable recrystallization rate, silicon transmutation by neutron absorption, and variable-impurity epitaxial growth. The mesa structure shown in illus. b is used for some varactor and switching diodes if close control of capacitance and voltage breakdown is required. See ELECTRONIC SWITCH; ION IMPLANTATION; RECTIFIER. [L.P.H.]

**Junction transistor** A transistor in which emitter and collector barriers are formed by *pn* junctions between semiconductor regions of opposite conductivity type. These junctions are separated by a distance considerably less than a minority-carrier diffusion length, so that minority carriers injected at the emitter junction will not recombine before reaching the collector barrier and therefore be effective in modulating the collector-barrier impedance. Junction transistors are widely used both as discrete devices and in integrated circuits. The discrete devices are found in the high-power and high-frequency applications. Silicon is the most widely used semiconductor material, although germanium is still used for some applications. See TRANSISTOR.

Most modern transistors are fabricated by the silicon self-masked planar double-diffusion technique. The structure of a planar diffused epitaxial transistor is shown in section in the illustration. In this structure both collector and emitter junctions are formed by diffusion of impurities from the top surface. In modern technology the base and emitter diffusions are carried out in two steps: a predeposition step, in which a very thin layer of heavily doped oxide is chemically deposited over the open surface of the silicon in the hole opened in the masking oxide; and a drive-in diffusion step, in which the deposited dopant is diffused into the silicon at a higher temperature than that used for the predeposition. The chemical predeposition step is being replaced by ion implantation directly through the oxide. See ION IMPLANTATION.

Silicon planar technology is used in fabricating integrated circuit chips. The general form of the transistor structure displayed in the illustration is used in integrated circuits. Such a structure

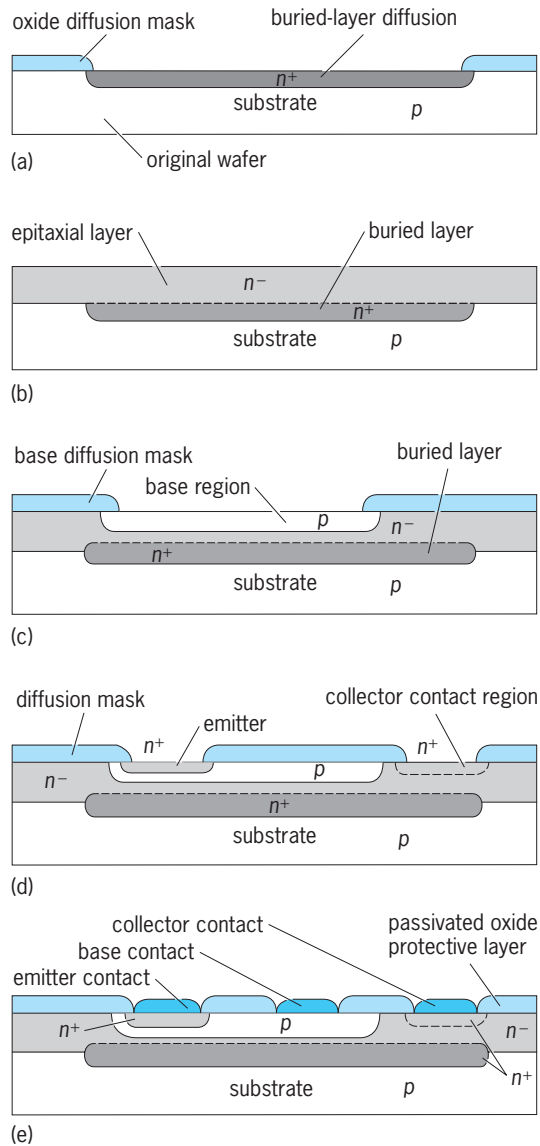

**Double-diffused planar epitaxial transistor structure and method of fabrication. (a) Buried layer. (b) Epitaxial layer. (c) Collector junction formation. (d) Emitter junction. (e) Contact stripe placement.**

is used for diodes as well as transistors since, for example, it is necessary only to connect the base and collector contacts to use the collector junction as a diode. See INTEGRATED CIRCUITS. [L.PH.]

**Jungermanniales** The largest order of liverworts, often called the leafy liverworts; it consists of 43 families. The leaves are in three rows, with the underleaves usually reduced or lacking. Other distinctive features include a perianth formed by a fusion of modified leaves, a short-lived seta, and a four-valved capsule. The leaves have an embryonic bilobed phase which may be lost on further development.

The plants of this order are dorsiventrally organized and leafy. They grow by means of an apical cell with three cutting faces, resulting in two rows of lateral leaves and a third row of underleaves which are generally reduced, and sometimes lacking. The stems lack a central strand. Rhizoids are usually present, all smooth. The leaves pass through a primordial two-lobed stage but may become two- to several-lobed, or unlobed (owing to obliteration of one primordial lobe). A midrib is lacking. Asexual reproduction by gemmae is common. Antheridia occur in

leaf axils, sometimes also in axils of underleaves. Archegonia are terminal. The sporophyte is usually protected by a perianth (in addition to a calyptra) formed by the fusion of leaves. The seta, usually long, consists of delicate, hyaline cells. The capsule is four-valved. See BRYOPHYTA; JUNGERMANNIIDAE. [H.Cr.]

**Jungermanniiidae** One of the two subclasses of liverworts (class Hepaticopsida). The plants may be thallose, with little or no tissue differentiation, or they may be organized into erect or prostrate stems with leafy appendages. The leaves, generally one cell in thickness, are mostly arranged in three rows, with the third row of underleaves commonly reduced or even lacking. Oil bodies are usually present in all cells. The rhizoids are smooth. The capsules, generally dehiscing by four valves, are usually elevated on a long, delicate, short-lived seta. The spore mother cells are deeply lobed.

The subclass consists of the orders Takakiales, Calobryales, and Jungermanniales, which are leafy, and the Metzgeriales, which are mostly thallose. See BRYOPHYTA; CALOBRYALES; JUNGERMANNIALES; METZGERIALES; TAKAKIALES. [H.Cr.]

**Jupiter** The largest planet in the solar system, and the fifth in the order of distance from the Sun. It is visible to the naked eye, except for short periods when in near conjunction with the Sun. Usually it is the second brightest planet in the sky; only Mars at its maximum luminosity and Venus appear brighter.

**Telescopic appearance.** Through an optical telescope Jupiter appears as an elliptical disk, strongly darkened near the limb and crossed by a series of bands parallel to the equator (Fig. 1). Even fairly small telescopes show a great deal of complex structure in the bands and disclose the rapid rotation of the planet. The period of rotation is very short, about 9 h 55 m, the shortest of any planet. The features observed, however, do not correspond to the solid body of a planet but to clouds in its atmosphere, and the rotation period varies markedly with latitude.

**Red Spot.** Apart from the constantly changing details of the belts, some permanent or semipermanent markings have been observed to last for decades or even centuries, with some fluctuations in visibility. The most conspicuous and permanent marking is the great Red Spot (Fig. 2), intermittently recorded since the seventeenth century and observed continually since

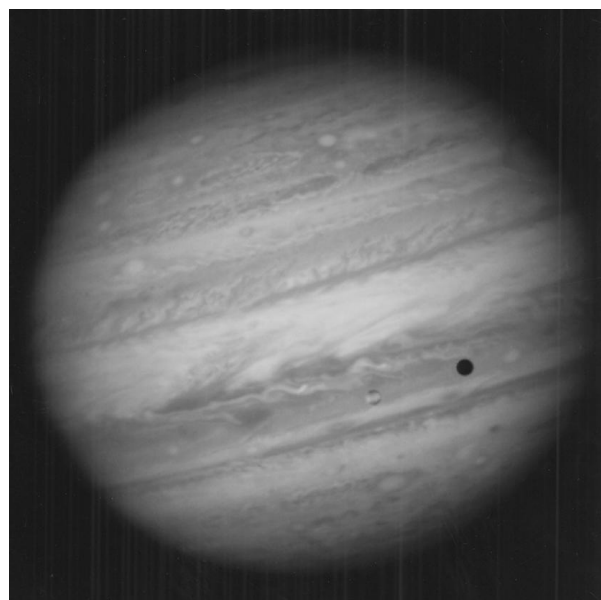

**Fig. 1. Telescopic appearance of Jupiter from the Hubble Space Telescope (Space Telescope Science Institute; Jet Propulsion Laboratory; NASA).**



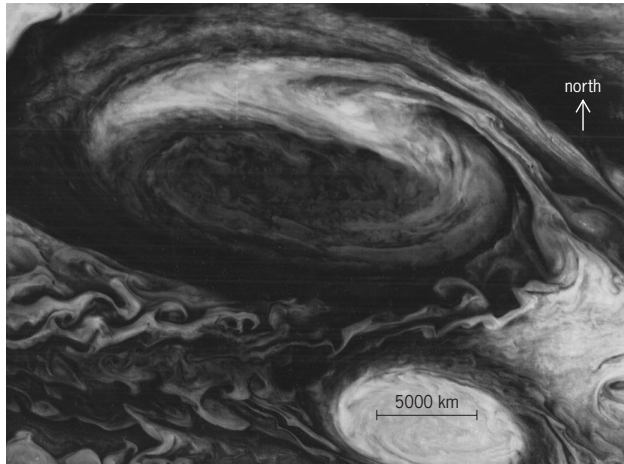

Fig. 2. Details of the Red Spot as seen by the *Voyager 1* flyby. 5000 km = 3000 mi. (NASA)

1878. At times it has been conspicuous and strongly colored; at other times it has been faint and only slightly colored. The Spot's distinctive coloration is probably due to chemical compounds (perhaps containing phosphorus) transported from deep within the atmosphere. The origin and longevity of the Great Red Spot remain difficult to explain.

**Atmosphere.** Jupiter's visible belts and zones reflect the complicated vertical atmospheric structure. The atmosphere consists primarily of hydrogen ( $H_2$ ), helium (He), ammonia ( $NH_3$ ), methane ( $CH_4$ ), water ( $H_2O$ ), hydrogen sulfide ( $H_2S$ ), and other trace compounds. In the simplest model, the deepest cloud layer consists of water vapor and ammonia cumulus clouds. These form a cloud bank about 16 mi (25 km) thick which is overlain by a 6-mi-thick (10-km) clear region probably saturated with gaseous ammonia. Above this are ammonium hydrosulfide ( $NH_4SH$ ) clouds, the tops of which perhaps receive a constant liquid ammonia rain from a higher level of ammonia clouds nearly 12 mi (20 km) in vertical extent. A high-altitude smog layer obscures the entire planet.

The belts and zones represent regions of differing cloud altitudes and compositions. The atmosphere is divided by a series of prograding and retrograding jet streams. Convection is strong since the bright zones are cooler and higher by 9–12 mi (15–20 km) than the dark belts, with their higher albedos arising from solid ammonia crystals.

Individual vortices form within the zones and belts, some persisting for decades. The major white ovals are hot-spot regions of strong infrared emission and are consistent with convective motion from the deep water-cloud layers, while other features such as the plumes observed in the equatorial region may be surface phenomena.

During July 16–22, 1994, 21 observable fragments of Comet Shoemaker-Levy 9 impacted the Jovian atmosphere at nearly 120,000 mi/h (200,000 km/h), the first time such an event had been witnessed. Though occurring on Jupiter's nonvisible side, each strike was clearly visible as a dark area in the south temperate zone as the planet's rapid rotation brought it into view. In addition, ejecta and impact plumes were seen to rise approximately 1860 mi (3000 km) above the planetary limb. The event provided a first probe into the Jovian atmosphere. See COMET.

**Interior composition and structure.** Jupiter primarily consists of liquid and metallic hydrogen. Early measures of the ratios of helium, carbon, and nitrogen to hydrogen gave values resembling those of the Sun, and therefore, the primordial composition of the solar system. However, later analyses of the methane spectrum showed a two- to threefold overabundance of carbon as compared to solar values, a result confirmed by gravity analyses

of the rocky core. Still in a late phase of its gravitational contraction, the planet converts the released gravitational energy into heat, emitting 1.668 times as much thermal energy as it receives from the Sun.

The cloud zone thickness actually extends only 0.1–0.3% of the Jovian radius. Beneath that, the atmosphere is clear and gradually metamorphoses into the liquid hydrogen molecular fluid envelope which makes up approximately the outer 20% of the radius. The transition at lower depths to metallic hydrogen is abrupt. See HYDROGEN.

Observations suggest that the planet could be homogeneous (that is, it has no core) or else it has a dense central core with a mass less than or equal to 12 earth masses. The large abundance of carbon suggests that gases other than those from the solar nebula contributed to the composition of Jovian volatile gases. Probably the entire planet holds 11–45 earth masses of elements other than hydrogen and helium.

**Jovian magnetosphere.** Jupiter possesses the strongest magnetic field and most complex magnetosphere of any planet in the solar system. This field rotates with the rotational period of the planet and contains an embedded plasma trapped in the field. At the distance of the satellite Io, the field revolves faster than the satellite, and so numerous collisions occur with the atmospheric gas of that body, resulting in the stripping away of  $10^{28}$ – $10^{29}$  ions per second. The energy involved slows the magnetic field, and so, beyond Io, the magnetic field no longer rotates synchronously with the planet. The ions removed from Io spiral around the magnetic lines of force, oscillating above and below the plane of Io's orbit. This ring of ions is known as the Io plasma torus and emits strongly in the ultraviolet. The motion of Io through the magnetosphere creates a 400,000-V,  $2 \times 10^{12}$  W circuit, sufficient to cause pronounced aurorae in both the equatorial and polar regions of the satellite.

**Jovian ring.** *Voyager 1* and *2* detected a faint ring encircling Jupiter. It appears to have three parts, which interact in a complicated, dynamic way with the planet's magnetic field and several embedded satellites.

**Satellites.** Jupiter has 63 known satellites of which the four largest, I Io, II Europa, III Ganymede, and IV Callisto, discovered by Galileo in 1610, are by far the most important.

The four Galilean satellites are of fifth and sixth stellar magnitudes and would be visible to the naked eye if they were not so close to the much brighter parent planet. They are easily visible in binoculars. All the others are faint telescopic objects.

The close approaches of the *Voyager* and *Galileo* spacecraft as well as the superior imaging capabilities of the Hubble Space Telescope have shown the four galilean satellites to be very different. I Io is probably the most geologically active body in the solar system. Its surface landforms include active shield volcanoes, calderas, mountains, plateaus, flows, grabens, and scarps. Spacecraft have shown that Io possesses over 80 separate volcanoes. The source of this volcanism is thought to be the transformation of tidal energy into heat as Jupiter's gravity deforms the satellite surface by several hundred feet.

Europa, primarily a rocky body, may be rich in silicates and lightweight water ices. The surface displays a satellite-wide system of cracks, and ridges, running for thousands of miles, about 10–25 mi (16–40 km) in width. There are few elevations, and the surface is remarkably free from craters. The ice surface makes the satellite one of the most reflective bodies in the solar system. Geologic activity is thought to heat the ice under the surface to near-liquid state, allowing it to gush through in volcanoes of slush and water.

It is likely that liquid oceans exist on Europa at depths more than 6 mi (10 km) below the surface, kept liquid by geothermal activity and tidal action. This is suggested by the variable European magnetic field observed by the *Galileo* spacecraft. It is not inconceivable that simple life may exist in the European oceans, much in the same way as in Earth's oceans lifeforms congregate near thermal vents.

The density of III Ganymede suggests that it is composed largely of ice. It has a metallic core approximately the size of Io, surrounded by a 500-mi (800-km) shell of rock and a similarly sized overmantle of ice. The surface formed recently since there are few large impact craters, but those that exist may have crater caps of frost.

Since it is similar in radius and density, IV Callisto should have a geological history resembling that of Ganymede, but does not. In fact, it seems to have been geologically dead for millions of years. It is the most heavily cratered of the galilean satellites and has not undergone extensive resurfacing since the time of impacts. [E.M.Ha.]

**Jurassic** The system of rocks deposited during the middle part of the Mesozoic Era, and encompassing an interval of time between about 208 and 145 million years ago, based on radiometric dating. It takes its name from the Jura Mountains, which run along the border of France and Switzerland.

The main continental masses were grouped together as the supercontinent Pangaea, with a northern component, Laurasia, separated from a southern component, Gondwana, by a major seaway, Tethys, which expanded in width eastward (see illustration). From about Middle Jurassic times onward, this supercontinent began to split up, with a narrow ocean being created between eastern North America and northwestern Africa, corresponding to the central sector of the present Atlantic Ocean. At about the same time, and continuing into the Late Jurassic, separation began between the continents that now surround the Indian Ocean, namely Africa, India, Australia, and Antarctica. As North America moved westward, it collided with a number of oceanic islands in the eastern part of the Paleo-Pacific.

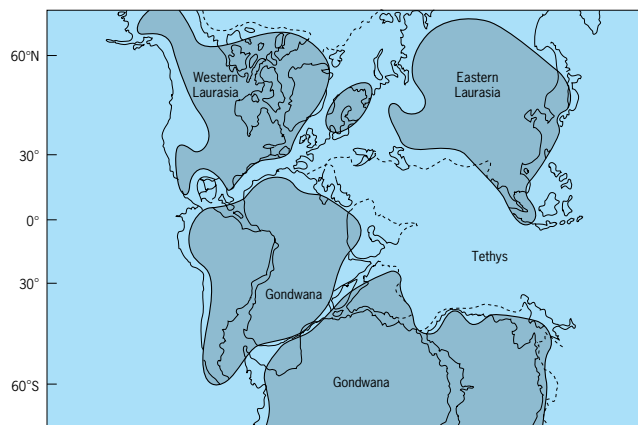

Approximate distribution of land and sea in the Oxfordian stage, the first stage of the late Jurassic. Small islands are excluded, but boundaries of modern continents are included as a reference.

The climate of Jurassic times was clearly more equable than at present. A number of ferns whose living relatives cannot tolerate frost are distributed over a wide range of paleolatitudes, sometimes as far as 60° N and S. Similarly, coral reefs, which are at present confined to the tropics, occur in Jurassic strata in western and central Europe, beyond the paleotropical zone. Many other groups of organisms had wide latitudinal distribution, and there was much less endemism (restriction to a particular area) with respect to latitude than there is today. In addition, there is a lack of evidence for polar icecaps.

The vertebrate terrestrial life of the Jurassic Period was dominated by the reptiles. The dinosaurs had first appeared late in the Triassic from a thecodont stock, which also gave rise to pterosaurs and, later, birds. From small bipedal animals

such as *Coelophysis*, there evolved huge, spectacular creatures. These include the herbivorous *Apatosaurus*, *Brontosaurus*, *Brachiosaurus*, *Diplodocus*, and *Stegosaurus* as well as the carnivorous, bipedal *Allosaurus*. See DINOSAUR.

Flying animals include the truly reptilian pterosaurs and the first animals that could be called birds as distinct from reptiles, as represented by the pigeon-sized *Archaeopteryx*. There were two important groups of reptiles that lived in the sea, the dolphin-like ichthyosaurs and the long-necked plesiosaurs. Both of these groups had streamlined bodies and limbs beautifully adapted to marine life. Turtles and crocodiles are also found as fossils in Jurassic deposits. See ARCHAEOORNITHES; PTEROSAURIA.

Jurassic mammals, known mainly from their teeth alone, were small and obviously did not compete directly with the dinosaurs. The fish faunas were dominated by the holosteans, characterized by heavy rhombic scales. Their evolutionary successors, the teleosts, probably appeared shortly before the end of the period. See HOLOSTEI; TELEOSTEI.

Because they are far more abundant, the invertebrate fossil faunas of the sea are of more importance to stratigraphers and paleoecologists than are the vertebrates. By far the most useful for stratigraphic correlation are the ammonites, a group of fossil mollusks related to squids. They were swimmers that lived in the open sea, only rarely braving the fluctuating salinity and temperature of inshore waters. They are characteristically more abundant in marine shales and associated fine-grained limestones. From a solitary family that recovered from near extinction at the close of the Triassic, there radiated an enormous diversity of genera. Many of these were worldwide in distribution, but increasingly throughout the period these was a geographic differentiation into two major realms. The Boreal Realm occupied a northern region embracing the Arctic, northern Europe, and northern North America. The Tethyan Realm, with more diverse faunas, occupied the rest of the world. See LIMESTONE; SHALE.

With regard to the plant kingdom, the Jurassic might well be called the age of gymnosperms, the nonflowering "naked seed" plants, forests of which covered much of the land. They included the conifers, ginkgos, and their relatives, the cycads. Ferns and horsetails made up much of the remainder of the land flora. These and others of the Jurassic flora are still extant in much the same forms. See CYCADALES; GINKGOALES.

Jurassic source rocks in the form of organic-rich marine shale and associated rocks contain a significant proportion of the world's petroleum reserves. A familiar example is the Upper Jurassic Kimmeridge Clay of the North Sea, and its stratigraphic equivalents in western Siberia. Some of the source rocks of the greatest petroleum field of all, in the Middle East, are also of Late Jurassic age. See MESOZOIC; PETROLEUM GEOLOGY. [A.Ha.]

**Jute** A natural fiber obtained from two Asiatic species, *Corchorus capsularis* and *C. olitorius*, of the plant family Tiliaceae. These are tall, slender, half-shrubby annuals, 8–12 ft (2.5–3.5 m) tall. The fibers are not very strong and deteriorate quickly in the presence of moisture, especially salt water. Despite these weaknesses, jute is much used. It is inexpensive and easily spun and converted into coarse fabrics. It is made into gunny, burlap bags, sacks for wool, potato sacks, covers for cotton bales, twine, carpets, rug cushions, curtains, and a linoleum base. It is also used in making coarse, cheap fabrics, such as novelty dress goods. Most of the commercial supply comes from plants grown in the Ganges and Brahmaputra valleys in Bangladesh and India. See FIBER CROPS; MALVALES; NATURAL FIBER.

A number of diseases that affect jute cause losses in yield and reduce fiber quality. "Runner" and "specky" fiber are primarily due to disease-producing organisms. The fungus *Macrophomina phaseolina* is believed to cause the most serious disease of the two species of jute. See PLANT PATHOLOGY. [E.G.N.; T.E.S.]

# K

**Kale** Either of two cool-season biennial crucifers, *Brassica oleracea* var. *acephala* and *B. fimbriata*, of Mediterranean origin and belonging to the plant order Capparales. Kale is grown for its nutritious green curled leaves which are cooked as a vegetable. Distinct varieties (cultivars) are produced in Europe for stock feed. Kale is a minor vegetable in the United States. Virginia is an important producing state. See CAPPARALES. [H.J.C.]

**Kaliophilite** A rare mineral tectosilicate found in volcanic rocks high in potassium and low in silica. Kaliophilite is one of three polymorphic forms of  $KAlSiO_4$ . It crystallizes in the hexagonal system in prismatic crystals. The hardness is 6 on Mohs scale, and the specific gravity is 2.61. The principal occurrence of kaliophilite is at Monte Somma, Italy. See KALSILITE; SILICATE MINERALS. [C.S.Hu.]

**Kalsilite** A rare mineral found in volcanic rocks at Mafuru, in southwest Uganda. It is one of the three polymorphic forms of  $KAlSiO_4$ . The mineral is hexagonal. The specific gravity is 2.59. In index of refraction and general appearance in thin section it resembles nepheline and is difficult to distinguish from it. See KALIOPHILITE; SILICATE MINERALS. [C.S.Hu.]

**Kame** A round hill or small knoll of sand and gravel, a few meters to more than 100 m high (330 ft). It is one of a family of stratified glacial sediments formed by meltwater in contact with a disintegrating ice sheet. Melting stagnant ice produces large volumes of water carrying boulders, sand, silt, and clay into holes melted in the wasting glacier. When the ice melts completely, the sediment is left standing as small hills. Mixtures of loose rock debris (till) carried above in the melting ice may be lowered onto the kame. Kames are common wherever ice sheets melted, as in New England, New York, the midwestern United States, the British Isles, and Sweden. [S.E.Wh.]

**Kangaroo** The name for a number of Australian marsupials that are members of the family Macropodidae. This family also includes the wallabies. The kangaroos and their relatives occur principally in Australia, but are found in Tasmania and New Guinea as well.

Kangaroos have a long, thick tail that is used as a balancing organ, and enlarged hindlegs that are adapted for jumping in many species. The forelimbs are quite short, except in arboreal species such as the blacktree kangaroo (*Dendrolagus ursinus*) and its relatives, in which all four limbs are about the same length. The two largest species are the red kangaroo (*Macropus rufus*) and the great gray kangaroo (*M. giganteus*).

Kangaroos usually have one offspring each year. After the uterine gestation period of about 6 weeks, the very immature young is born and crawls into the marsupium. After an uninterrupted period of 2 months, it ventures out to find food and then returns to the safety of the marsupium. It may seek the protection of the pouch for up to 9 months. See MARSUPIALIA. [C.B.C.]

**Kaolinite** A common hydrous aluminum silicate mineral found in sediments, soils, hydrothermal deposits, and sedimentary rocks. It is a member of a group of clay minerals called the kaolin group minerals, which include dickite, halloysite, nacrite,

ordered kaolinite, and disordered kaolinite. These minerals have a theoretical chemical composition of 39.8% alumina, 46.3% silica, and 13.9% water [ $Al_2Si_2O_5(OH)_4$ ], and they generally do not deviate from this ideal composition. They are sheet silicates comprising a single silica tetrahedral layer joined to a single alumina octahedral layer. Although the kaolin group minerals are chemically the same, each is structurally unique as a result of how these layers are stacked on top of one another. Kaolinite is the most common kaolin group mineral and is an important industrial commodity used in ceramics, paper coating and filler, paint, plastics, fiberglass, catalysts, and other specialty applications. See CLAY MINERALS; SILICATE MINERALS. [J.E.K.]

**Kapitza resistance** A resistance to the flow of heat across the interface between liquid helium and a solid. A temperature difference is required to drive heat from a solid into liquid helium, or vice versa; the temperature discontinuity occurs right at the interface. The Kapitza resistance, discovered by P. L. Kapitza, is defined in the equation below, where  $T_S$  and  $T_H$

$$R_K = \frac{T_S - T_H}{\dot{Q}/A}$$

are the solid and helium temperatures and  $\dot{Q}/A$  is the heat flow per unit area across the interface. See CONDUCTION (HEAT).

In principle, the measured Kapitza resistance should be easily understood. In liquid helium and solids (such as copper), heat is carried by phonons, which are thermal-equilibrium sound waves with frequencies in the gigahertz to terahertz region. The acoustic impedance of helium and solids can differ by up to 1000 times, which means that the phonons mostly reflect at the boundary, like an echo from a cliff face. This property together with the fact that the number of phonons dies away very rapidly at low temperatures means that at about 1 K there are few phonons to carry heat and even fewer get across the interface. The prediction is that the Kapitza resistance at the interface is comparable to the thermal resistance of a 10-m (30-ft) length of copper with the same cross section. See ACOUSTIC IMPEDANCE; PHONON; QUANTUM ACOUSTICS.

The reality is that above 0.1 K and below 0.01 K (10 mK) more heat is driven by a temperature difference than is predicted. Above 0.1 K this is now understood to be a result of imperfections such as defects and impurities at the interface, which scatter the phonons and allow greater transmission. See CRYSTAL DEFECTS.

The enormous interest in ultralow-temperature (below 10 mK) research generated by the invention of the dilution refrigerator and the discovery of superfluidity in liquid helium-3 ( $^3\text{He}$ ) below 0.9 mK also regenerated interest in Kapitza resistance, because heat exchange between liquid helium and solids was important for both the dilution refrigerator and superfluidity research. An ingenious technique was invented to overcome the enormous Kapitza resistance at 1 mK: The solid is powdered, and the powder is packed and sintered to a spongelike structure to enhance the surface area. In this way a  $1\text{-cm}^3$  (0.06-in.<sup>3</sup>) chamber can contain up to  $1\text{ m}^2$  (10 ft<sup>2</sup>) of interface area between the solid and the liquid helium.

It was found that at 1 mK the Kapitza resistance is 100 times smaller than predicted by the phonon model. There have been

two explanations for the anomaly, and probably both are relevant. One is that energy is transferred by magnetic coupling between the magnetic  $^3\text{He}$  atoms and magnetic impurities in the solid or at the surface of the solid; the other is that the spongelike structure has quite different, and many more, phonons than a bulk solid and that these can transfer heat directly to the  $^3\text{He}$  atoms. Whatever its cause, this anomaly has had a major impact on ultralow-temperature physics. See ADIABATIC DEMAGNETIZATION; LIQUID HELIUM; LOW-TEMPERATURE PHYSICS; SUPERFLUIDITY.

[J.P.Ha.]

**Kapok tree** Also called the silk-cotton tree (*Ceiba pentandra*), a member of the bombax family (Bombacaceae). The tree has a bizarre growth habit and produces pods containing seeds covered with silky hairs called silk cotton. It occurs in the American tropics, and has been introduced into Java, Philippine Islands, and Ceylon. The silk cotton is the commercial kapok used for stuffing cushions, mattresses, and pillows. See MALVALES.

[P.D.St./E.L.C.]

**Kármán vortex street** A double row of line vortices in a fluid. Under certain conditions a Kármán vortex street is shed in the wake of bluff cylindrical bodies when the relative fluid velocity is perpendicular to the generators of the cylinder, as illustrated.

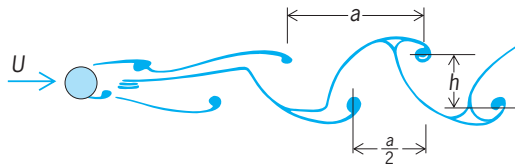

Kármán vortex street.  $U$  = stream speed;  $a$  = spacing between vortices;  $h$  = distance between two rows of vortices.

This periodic shedding of eddies occurs first from one side of the body and then from the other, an unusual phenomenon because the oncoming flow may be perfectly steady. Vortex streets can often be seen, for example, in rivers downstream of the columns supporting a bridge. They can be created by steady winds blowing past smokestacks, transmission lines, bridges, missiles about to be launched vertically, and pipelines aboveground in the desert. See VORTEX.

[A.E.Br.]

**Karst topography** Distinctive associations of third-order, erosional landforms indented into second-order structural forms such as plains and plateaus. They are produced by aqueous dissolution, either acting alone or in conjunction with (and as the trigger for) other erosion processes. Karst is largely restricted to the most soluble rocks, which are salt, gypsum and anhydrite, and limestone and dolostone. See DOLOMITE ROCK; GYPSUM; LIMESTONE.

The essence of the karst dynamic system is that meteoric water (rain or snow) is routed underground, because the rocks are soluble, rather than flowing off in surface river channels. It follows that dissolutional caves develop in fracture systems, resurging as springs at the margins of the soluble rocks or in the lowest places. A consequence is that most karst topography is "swallowing topography," assemblages of landforms created to deliver meteoric water down to the caves.

Karst landforms develop at small, intermediate, and large scales. Karren is the general name given to small-scale forms—varieties of dissolutional pits, grooves, and runnels. Individuals are rarely greater than 10 m (30 ft) in length or depth, but assemblages of them can cover hundreds of square kilometers. On bare rock, karren display sharp edges; circular pits or runnels extending downslope predominate. Beneath soil, edges are rounded and forms more varied and intricate.

Sinkholes, also known as dolines or closed depressions, are the diagnostic karst (and pseudokarst) landform. They range from shallow, bowl-like forms, through steep-sided funnels, to vertical-walled cylinders. Asymmetry is common. Individual sinkholes range from about 1 to 1000 m (3 to 3300 ft) in diameter and are up to 300 m (1000 ft) deep. Many may become partly or largely merged.

Dry valleys and gorges are carved by normal rivers, but progressively lose their water underground (via sinkholes) as the floors become entrenched into karst strata. Many gradations exist, from valleys that dry up only during dry seasons (initial stage) to those that are without any surface channel flow even in the greatest flood periods (paleo-valleys). They are found in most plateau and mountain karst terrains and are greatest where river water can collect on insoluble rocks before penetrating the karst (allogenic rivers).

Poljes, a Serbo-Croatian term for a field, is the generic name adopted for the largest individual karst landform. This is a topographically closed depression with a floor of alluvium masking an underlying limestone floor beveled flat by planar corrosion.

Karst plains and towers are the end stage of karst topographic development in some regions, produced by long-sustained dissolution or by tectonic lowering. The plains are of alluvium, with residual hills (unconsumed intersinkhole limestone) protruding through. Where strata are massively bedded and the hills are vigorously undercut by seasonal floods or allogenic rivers, they may be steepened into vertical towers.

[D.Fo.]

**Kelvin bridge** A specialized version of the Wheatstone bridge network designed to eliminate, or greatly reduce, the effect of lead and contact resistance and thus permit accurate measurement of low resistance. The circuit shown in the illustration accomplishes this by effectively placing relatively high-resistance-ratio arms in series with the potential leads and contacts of the low-resistance standards and the unknown resistance. In this circuit  $R_A$  and  $R_B$  are the main ratio resistors,  $R_a$  and  $R_b$  the auxiliary ratio,  $R_x$  the unknown,  $R_s$  the standard, and  $R_y$  a heavy copper yoke of low resistance connected between the unknown and standard resistors.

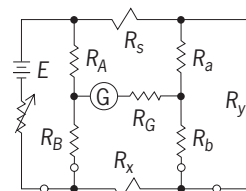

A Kelvin bridge used to measure an unknown low resistance.

As with the Wheatstone bridge, the Kelvin bridge for routine engineering measurements is constructed using both adjustable-ratio arms and adjustable standards. However, the ratio is usually continuously adjustable, over a short span, and the standard is adjustable in appropriate steps to cover the required range. See BRIDGE CIRCUIT; RESISTANCE MEASUREMENT; WHEATSTONE BRIDGE.

[C.E.A.]

**Kelvin's circulation theorem** A theorem in fluid dynamics that pertains to the dynamics of vortices and the use of ideal-fluid potential-flow equations. The theorem states that the circulation (defined as the line integral of the component of velocity tangential to the closed contour) in an inviscid and incompressible fluid subject to only conservative forces is constant. By using Stokes' theorem of integral calculus, it may be shown that the circulation is also related to the flux of vorticity (defined as the curl of the velocity field) normal to the area transcribed by the contour. See CALCULUS OF VECTORS; STOKES' THEOREM.

The principal use of Kelvin's theorem is in the study of incompressible, inviscid fluid flows. If a body is moving through such a fluid, the vorticity far from the body is, by definition, zero. Then according to Kelvin's theorem, the vorticity in the fluid will everywhere be zero and the flow will be irrotational. This permits the reduction of the governing equations from the Euler equations to the Laplace equation and presents the many mathematical techniques of potential theory for solving fluid-flow problems. See LAPLACE'S IRRATIONAL MOTION; VORTEX. [E.Pa.; F.Ste.]

**Kelvin's minimum-energy theorem** A theorem in fluid dynamics that pertains to the kinetic energy of an ideal fluid (that is, inviscid, incompressible, and irrotational) and provides uniqueness statements concerning the solution of potential-flow problems. The theorem states that the irrotational motion of a liquid occupying a simply connected region has less kinetic energy than any other motion consistent with the same normal motion of the boundary  $S$ . See GREEN'S THEOREM; POTENTIALS.

The implications of the minimum-energy of irrotational motion are: (1) irrotational motion is impossible in a simply connected region bounded by fixed walls since in this case the normal derivative of the velocity potential vanishes at all points on the boundary, and therefore, according to the energy theorem, the kinetic energy is zero, or the system is at rest; (2) irrotational motion is impossible in a fluid in which the velocity at infinity vanishes if the internal boundaries are also at rest; (3) if the velocity at infinity vanishes, then the irrotational motion due to prescribed motion of an internal boundary is unique; and (4) if a fluid is in motion with uniform velocity at infinity, then the irrotational motion due to prescribed motion of an internal boundary is unique. See FLUID-FLOW PRINCIPLES; LAPLACE'S IRRATIONAL MOTION. [E.Pa.; F.Ste.]

**Kenaf** An annual, short-day, herbaceous plant (*Hibiscus cannabinus*) of the Malvaceae family, cultivated for its stem fibers. The genus *Hibiscus* has approximately 200 species, of which one, roselle (*H. sabdariffa* var. *altissima*), also is occasionally referred to as kenaf.

Kenaf usually grows up to 15 ft (5 m) in height, and is cylindrical and either branched or unbranched. The stem is composed of two fibers, bast and core. The bast fibers, located in the bark, are long compared to the core fibers, produced in the stem interior. The leaves either are entirely heart shaped or display radiating lobes. Flowers are typically yellow with deep red centers. Wild forms of kenaf are found in east and central Africa, where for several centuries kenaf has been used for both fiber and food. Selection and breeding have developed varieties with higher fiber yields, improved disease resistance, and reduced branching.

Kenaf is grown commercially for fiber production in many areas of the world, with the largest producer being the People's Republic of China. In the United States, kenaf production is located in Texas, Louisiana, Mississippi, and California. Kenaf is used in the manufacturing of various paper and pulp products, and as poultry litter, potting soil amendments, chemical- and oil-spill absorbents, animal and horse bedding, and packing materials. Potential uses include the manufacturing of filters, particle boards, and insulation boards. Kenaf leaves, which contain 20–30% crude protein, also may have potential as a livestock feed source.

Kenaf can adapt to a wide range of climates and soils. However, because it cannot tolerate frost, planting should not occur at temperatures below 32°F (0°C). Optimum yields are generally obtained on well-drained soils with fertility levels to meet the nutritional requirements. Most varieties of kenaf are photoperiod sensitive, and vegetative growth increases until the daylight period becomes less than 12 h 30 min. Flowering is then initiated and the vegetative growth rate declines. Early planting maximizes yields by increasing the growing season. Kenaf is propagated by seed and must be replanted annually. Dense plant populations generally produce greater total and bast fiber

yields, reduce weed populations, and improve harvesting efficiency. [C.G.C.]

**Kennel cough** A common, highly contagious respiratory disease of dogs, also known as canine infectious tracheobronchitis. Several different bacteria and viruses are usually associated with the disease. Symptoms are generally mild but may vary widely depending on the agent, the host, and environmental factors. The main feature of the disease is sudden onset of violent coughing in dogs that had a recent exposure to other, infected dogs. The disease is easily transmitted between dogs by droplets in the air or direct contact, and often occurs as outbreaks or as a seasonal infection. Most dogs completely recover within 2 weeks; however, chronic and severe forms of the disease sometimes occur.

Infectious agents commonly associated with the disease are the bacterium *Bordetella bronchiseptica* and canine parainfluenza virus. Each agent is capable of producing a mild form of the disease; however, most single-agent infections probably show no symptoms of disease. Several species of mycoplasmas have been isolated from the lower respiratory tract of dogs with kennel cough, but always in combination with another agent (for example, bordetella or canine parainfluenza virus). These mycoplasmas are normally found in the upper respiratory tract of healthy dogs. See BORDETELLEA; MYCOPLASMAS.

Close contact with other dogs is usually required for transmission of kennel cough. Each of the viral agents of the disease, and possibly some of the mycoplasmas, has host ranges restricted to dogs. Because infections that show no symptoms of disease are also common, it is sometimes difficult to determine the source of the infection. Canine parainfluenza virus and *B. bronchiseptica* do not usually persist longer than a few weeks or a few months, respectively, in an individual dog.

Treatment of kennel cough is often unwarranted. However, antitussives, bronchodilators, and corticosteroids are used to relieve coughing, and antimicrobials are used to treat or prevent bronchopneumonia. The risk of acquiring kennel cough can be reduced by minimizing exposure to infectious agents. [D.A.Be.]

**Kepler's laws** The three laws of planetary motion discovered by Johannes Kepler during the early years of the seventeenth century.

**First law.** The first law of Kepler states that a planet moves in an elliptical orbit around the Sun that is located at one of the two foci of the ellipse. An ellipse is one of the conic curves originally studied by Greek geometers. See CONIC SECTION; ELLIPSE.

In 1687, Isaac Newton demonstrated that any body, moving in an orbit around another body that attracts it with a force that varies inversely as the square of the distance between them, must move in a conic section. This path will be an ellipse when the velocity is below a certain limit in relation to the attracting force. Thus the first law is a general law that applies to all satellites held in orbit by an inverse-square force.

**Second law.** Kepler needed some method by which to predict the locations of planets at given times, and this he provided with his second law. It states that the radius vector of the ellipse (the imaginary line between the planet and the Sun) sweeps out areas that are proportional to time (see illustration). A planet moves more swiftly when it is closer to the Sun and more slowly when it is farther removed.

Again Newton demonstrated the dynamic cause behind Kepler's second law. In this case, it is not restricted to forces that vary inversely as the square of the distance; rather it is valid for all forces of attraction between the two bodies. The second law expresses the principle of the conservation of angular momentum. See ANGULAR MOMENTUM.

**Third law.** Kepler's third law defines the relations that hold within the system of planets. It states that the ratio between the square of a planet's period (the time required to complete one orbit) to the cube of the mean radius (the average distance from

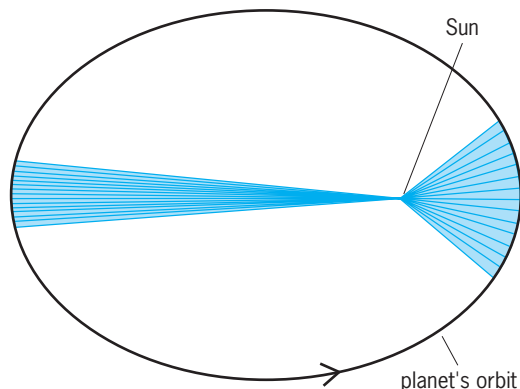

**Demonstration of Kepler's first and second laws.** The planet moves along an elliptical orbit at a nonuniform rate, so that the radius vector drawn to the Sun, which is located at one focus of the ellipse, sweeps out areas that are proportional to time. Thus, the planet would take equal times (corresponding to the equal areas) to traverse the unequal distances along the ellipse that correspond to the two shaded areas. The diagram greatly exaggerates the eccentricity of any orbital ellipse in the solar system.

the Sun during one orbit) is a constant. The four satellites that Galileo had discovered around Jupiter were found to obey the third law, as did the satellites later found around Saturn. Newton demonstrated once again that the third law is valid for every system of satellites around a central body that attracts them, as the Sun attracts the planets, with a force that varies inversely as the square of the distance. See GRAVITATION; ORBITAL MOTION.

[R.S.We.]

**Kernite** A hydrated borate mineral with chemical composition  $\text{Na}_2\text{B}_4\text{O}_6(\text{OH})_2 \cdot 3\text{H}_2\text{O}$ . It occurs only very rarely in crystals but is found most commonly in coarse, cleavable masses and aggregates. It is colorless to white; colorless and transparent specimens tend to become chalky white on exposure to air.

Boron compounds are used in the manufacture of glass, especially in glass wool used for insulation purposes. They are also used in soap, in porcelain enamels for coating metal surfaces, and in the preparation of fertilizers and herbicides. See BORATE MINERALS.

[C.K.]

**Kerogen** The complex, disseminated organic matter present in sedimentary rocks that remains undissolved by sequential treatment with common organic solvents followed by treatment with nonoxidizing mineral hydrochloric acid and hydrofluoric acid. See SEDIMENTARY ROCKS.

Kerogen is considered to be the major starting material for most oil and gas generation as sediments are subjected to geothermal heating in the subsurface. It is the most abundant form of organic carbon on Earth—about 1000 times more abundant than coal, which forms primarily from terrigenous remains of higher plants. Kerogen is formed from the remains of marine and lacustrine microorganisms, plants and animals, and variable amounts of terrigenous debris in sediments. The terrestrial portions of kerogen have elemental compositions similar to coal. See COAL.

Kerogens are classified according to their atomic ratios of hydrogen to carbon (H/C) and oxygen to carbon (O/C), with oil-prone kerogens being generally higher in H/C and lower in O/C than the gas-prone kerogens. With increasing length of exposure to subsurface temperatures, all kerogens show decreases in the O/C and H/C ratios as they generate preferentially carbon dioxide and water, then oil, and finally only gas (methane) at progressively higher subsurface depths and temperatures. See NATURAL GAS; PETROLEUM.

[J.K.W.]

**Kerosine** A refined petroleum fraction used as a fuel for heating and cooking, jet engines, lamps, and as a base for insecticides. Kerosine, known also as lamp oil, is recovered from crude oil by distillation. Specifications are established for specific grades of kerosine by government agencies and by refiners. For use in lamps, for example, a highly paraffinic oil is desired because aromatics and naphthenes give a smoky flame. In order to avoid atmospheric pollution, sulfur content must be low; and a minimum flash point of  $100^\circ\text{F}$  ( $38^\circ\text{C}$ ) is desirable to reduce explosion hazards. See JET FUEL.

[H.C.R.]

**Kerr effect** Electrically induced birefringence that is proportional to the square of the electric field. When a substance (especially a liquid or a gas) is placed in an electric field, its molecules may become partly oriented. This renders the substance anisotropic and gives it birefringence, that is, the ability to refract light differently in two directions. This effect, which was discovered in 1875 by John Kerr, is called the electrooptical Kerr effect, or simply the Kerr effect.

When a liquid is placed in an electric field, it behaves optically like a uniaxial crystal with the optical axis parallel to the electric lines of force. The Kerr effect is usually observed by passing light between two capacitor plates inserted in a glass cell containing the liquid. Such a device is known as a Kerr cell or optical Kerr shutter. Light passing through the medium normal to the electric lines of force (that is, parallel to the capacitor plates) is split into two linearly polarized waves.

In certain crystals there may be an electrically induced birefringence that is proportional to the first power of the electric field. This is called the Pockels effect. In these crystals the Pockels effect usually overshadows the Kerr effect, which is nonetheless present. In crystals of cubic symmetry and in isotropic solids (such as glass) only the Kerr effect is present. See ELECTROOPTICS.

[M.A.D.]

**Ketene** A member of a class of organic compounds with the  $\text{C}=\text{C}=\text{O}$  group as a common structural element. Ketenes are derivatives of carboxylic acids, from which they are (hypothetically) formed by abstraction of water; they can therefore be considered to be inner anhydrides of acids, as opposed to the common carboxylic acid anhydrides formed from two molecules of a carboxylic acid.

Like real anhydrides, ketenes are acylating agents which readily undergo reactions with many compounds containing active hydrogens. They are relatively labile compounds, and only a limited number have been prepared and isolated. Many ketenes have been prepared in place and reacted immediately. See ACID ANHYDRIDE.

[R.H.Ri.]

**Ketone** One of a class of chemical compounds of the general formula

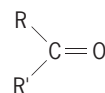

R and R' are alkyl, aryl, or heterocyclic radicals. The groups R and R' may be the same or different or incorporated into a ring as in cyclopentanone:

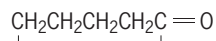

The ketones acetone and methyl ethyl ketone are used as solvents. Ketones are important intermediates in the syntheses of organic compounds.

By common nomenclature rules, the R and R' groups are named, followed by the word ketone—for example,  $\text{CH}_3\text{CH}_2\text{COCH}_2\text{CH}_3$  (diethyl ketone),  $\text{CH}_3\text{COCH}(\text{CH}_3)_2$  (methyl isopropyl ketone), and  $\text{C}_6\text{H}_5\text{COC}_6\text{H}_5$  (diphenyl ketone). The nomenclature of the International Union of Pure and Applied Chemistry uses the hydrocarbon name corresponding

to the maximum number of carbon atoms in a continuous chain in the ketone molecule, followed by “-one,” and preceded by a number designating the position of the carbonyl group in the carbon chain. The first two ketones above are named 3-pentanone and 3-methyl-3-butanone.

The lower-molecular-weight ketones are colorless liquids. Acetone and methyl ethyl ketone are miscible with water; the water solubility of the higher homologs decreases with increasing number of carbon atoms. Because of their characteristic odors, various ketones are of use in the flavoring and perfumery industry.

Addition to the carbonyl group is the most important type of ketone reaction. Ketones are generally less reactive than aldehydes in addition reactions. Methyl ketones are more reactive than the higher ketones because of steric group effects. [P.E.F.]

**Key telephone system** A communications system that allows users to access more than one central office line, answer or access a central office line from more than one telephone, and place a line on hold in order to answer or initiate calls on other lines. The system usually includes an intercom capability that allows users on different telephones in the system to communicate with one another. See INTERCOMMUNICATING SYSTEM.

The main functional parts of a key telephone system are (1) the central service unit, also called the key service unit (KSU), which serves as an interface and switching center between incoming central office lines and system telephones; (2) station cabling to connect each telephone to the key service unit; (3) multibutton telephone sets, or key telephones, on which separate buttons provide access to the central office lines, intercom, and special features; and (4) a power supply, which converts available electrical power to the specifications required by the key telephone system.

The number of station lines and central office lines served by a key telephone system is limited by the size of the key service unit. On a typical key telephone system, each incoming central office line appears on a separate button on every key telephone set that is allowed to make or receive calls on that line. Usually, a visual indicator, such as a small incandescent lamp or light-emitting diode, allows the user to tell if the line is in use. The same lamp flashes at a certain rate when an incoming call is ringing on the line, and flashes at a different rate when a call is on hold. The number of lines that appear on every key telephone set varies with the capacity of buttons on each set. Such capacities vary from a low of 5 buttons to over 30 buttons, depending on the make and model of the key telephone system.

Key telephone systems are either electromechanical or electronic in design. Electronic key telephone systems use microprocessors and integrated circuits to accomplish the switching, voice amplification, and feature activation. See INTEGRATED CIRCUITS; MICROPROCESSOR; SWITCHING SYSTEMS (COMMUNICATIONS); TELEPHONE SERVICE. [S.R.R.; V.F.R.]

**Kidney** An organ involved with the elimination of water and waste products from the body. In vertebrates the kidneys are paired organs located close to the spine dorsally in the body cavity. They consist of a number of smaller functional units called urinary tubules or nephrons. The nephrons open to large ducts, the collecting ducts, which open into a ureter. The two ureters run backward to open into the cloaca or into a urinary bladder. In mammals, the kidneys are bean-shaped and found between the thorax and the pelvis. The number, structure, and function of the nephrons vary with evolution and, in certain significant ways, with the adaptation of the animals to their various habitats.

In its most primitive form, found only in invertebrates, the nephron has a funnel opening into the coelomic cavity followed by a urinary tubule leading to an excretory pore. In amphibians, some of the tubules have this funnel, but most of the tubules have a Bowman capsule (see illustration). In all higher vertebrates,

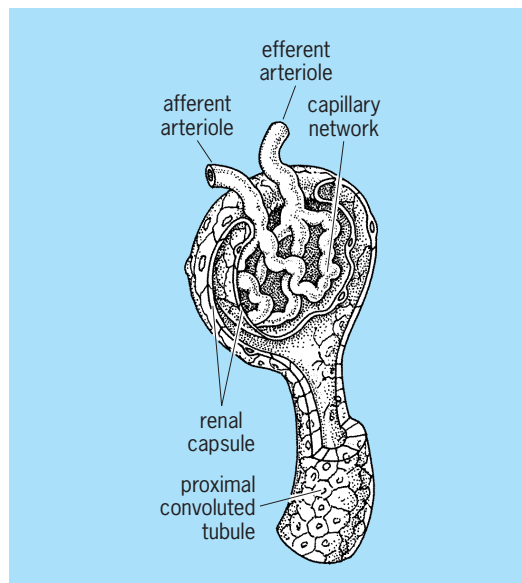

Nephron from frog kidney, dissected to show glomerulus within Bowman capsule.

the nephron has the Bowman capsule, which surrounds a tuft of capillary loops, called the glomerulus, constituting the closed end of the nephron. The inner epithelial wall of the Bowman capsule is in intimate contact with the endothelial wall of the capillaries. The wall of the capillaries, together with the inner wall of the Bowman capsule, forms a membrane ideally suited for filtration of the blood.

The blood pressure in the capillaries of the glomerulus causes filtering of blood by forcing fluid, small molecules, and ions through the membrane into the lumen of Bowman's capsule. This filtrate contains some of the proteins and all of the smaller molecules in the blood. As the filtrate passes down through the tubule, the walls of the tubule extract those substances not destined for excretion and return them to the blood in adjacent capillaries. Many substances which are toxic to the organism are moved in the opposite direction from the blood into the tubules. The urine thus produced by each nephron is conveyed by the collecting duct and ureter to the cloaca or bladder from which it can be eliminated.

In all classes of vertebrates the renal arteries deliver blood to the glomeruli and through a second capillary net to the tubules. The major blood supply to the kidney tubules comes, however, from the renal portal vein, which is found in all vertebrates except mammals and cyclostomes. Waste products from the venous blood can thus be secreted directly into the urinary tubules. See URINARY SYSTEM. [B.S.N.]

**Kidney disorders** Disorders of the kidney are classified by both their etiology and their anatomic location along the nephron. Disorders other than those arising from tumors become evident when the kidney is unable to regulate the volume and composition of the extracellular fluids, resulting in edema and hypertension. Kidney disorders may be divided into the following categories: congenital, inflammatory, hereditary, infection-related, or associated with metabolic diseases (such as diabetes mellitus), toxins or drugs, circulatory collapse, and cancer.

The absence of kidneys at birth, which is quite rare, is incompatible with life. A slightly more common condition, however, is the presence of only one kidney or the presence of one kidney in an abnormal location. The most common congenital disorders are abnormalities in the peristaltic passage of urine, which normally flows from the kidneys into the ureters, where it is moved by a rhythmic peristaltic motion to the bladder. In many

cases, diseases that inhibit the normal peristaltic flow of urine down the ureters because of a neuromuscular abnormality gradually run their course and do not require surgery. See CONGENITAL ANOMALIES.

The most common hereditary kidney disorder is adult polycystic kidney disease. It is an autosomal dominant disease that is found in all racial and ethnic groups and is characterized by the formation of cysts along the length of the nephron. As the cysts enlarge, the kidneys likewise enlarge—resulting in kidney failure in midadulthood. Alport's syndrome, a very rare genetic disease of the glomeruli, results in glomerular scarring and eventual renal failure within the second or third decade of life that cannot be reversed. See HUMAN GENETICS.

The kidneys are subject to infection from both local and remote sources and from a variety of causative organisms. The most common cause of pyelonephritis, a bacterial infection of the kidney, is obstruction of the bladder or ureters by a tumor or kidney stones that interrupt urine flow. The kidney may also be subject to infections originating at distant sites. Examples include bacterial products, such as endotoxins, that are released into the bloodstream and antibodies that are formed in response to bacterial invasion. See STREPTOCOCCUS.

The most common metabolic disorder to affect the kidney is diabetes mellitus. Of those persons with the insulin-dependent form of diabetes, 30–40% develop renal disease. Kidney dysfunction is one of the most life-threatening complications of diabetes. See DIABETES.

The two most common systemic diseases to affect the kidneys are systemic lupus erythematosus and vasculitis. Systemic lupus erythematosus is essentially a disease of young women and is characterized by the deposition of immunoglobulins and other immune substances in the glomeruli. Systemic vasculitis can affect either the medium-sized arteries or the arterioles. Involvement of the former leads to infarcts in various organs but seldom causes kidney failure. When the arterioles are affected, the lesions are diffuse, because the kidney is highly vascular and the arterioles, the smallest of the arteries, are abundant. Kidney failure often occurs.

The kidney is a major site for the excretion of waste products as well as heavy metals, the acids and alkalis of metabolism, and drugs. Because the urine becomes concentrated (100-fold) as it travels the length of the tubule, the concentration of otherwise-innocuous, or even therapeutic, substances may reach levels that are toxic to the kidneys. See TOXICOLOGY.

If systemic blood pressure drops to levels at which the kidneys are no longer perfused, the tubules become deprived of oxygen and suffer severe injury. The most common causes of underperfusion are blood loss and cardiac failure. If bloodflow to the kidneys is restored, epithelial cell damage is rapidly reversed and renal function returns to normal.

Cancer of the kidney occurs mainly in two age groups—the very young and those over 50 years of age. Tumors found in the young, the most common type being Wilms' tumor, are often bilateral, composed of fetal tissues, and may grow to a large size before detection. Some cancerous tumors of the kidney in children are responsive to radiation or chemotherapy. Tumors in the adult kidney, adenocarcinomas or hypernephromas, usually metastasize to the lungs and bones. See CANCER (MEDICINE); KIDNEY; URINARY SYSTEM. [G.S.]

**Kiln** A device or enclosure to provide thermal processing of an article or substance in a controlled temperature environment or atmosphere, often by direct firing, but occasionally by convection or radiation heat transfer. Kilns are used in many different industries, and the type of device called a kiln varies with the industry.

“Kiln” usually refers to an oven or furnace which operates at sufficiently high temperature to require that its walls be constructed of refractory materials. The distinction between a kiln and a furnace is often based more on the industry than on the

design of the device. Generally the word “kiln” is used when referring to high-temperature treatment of nonmetallic materials such as in the ceramic, the cement, and the lime industries. When melting is involved as in steel manufacture, the term “furnace” is used, as in blast furnace and basic oxygen furnace. See FURNACE. [B.B.Cr.]

**Kimberlite** A variety of peridotite, an igneous rock containing at least 35% olivine. Kimberlite is richer in carbon dioxide than most peridotites, and has crystals larger in diameter than 0.5 mm of olivine, garnet, clinopyroxene, phlogopite, and orthopyroxene. All of these silicate minerals have high Mg/Fe ratios in kimberlites. Diamonds are the only economically significant mineral extracted from kimberlite. They form deeper than 150 km (93 mi) in the Earth's mantle and are carried upward as “accidental tourists” in kimberlite.

The magmatic liquid that forms kimberlite is generated by the melting of small amounts of the Earth's upper mantle containing water and carbonate. The liquid moves upward, gathering crystals (including diamond) and rock fragments along the way. During the violent injection of kimberlites into the upper crust, some detached fragments from the crust move downward and others from the lower crust and mantle move upward. Kimberlite bodies are important scientifically because they contain fragments of rocks that were once above the present-day erosion surface as well as fragments of the Earth's mantle.

Kimberlites usually occur in regions of thick and stable continental crust, in southern Africa (including the Kimberley district), India, Siberia, Canada, Colorado-Wyoming, Venezuela, and Brazil. Most kimberlite outcrops appear on the surface as small, roughly circular areas less than 1 km (0.6 mi) in diameter; they are usually not well exposed because kimberlite weathers rapidly. In three dimensions, kimberlite bodies are dikes or, more commonly, downward-tapering cylinders (pipes). See DIAMOND; IGNEOUS ROCKS; OLIVINE; PERIDOTITE. [D.S.Ba.]

**Kinematics** That branch of mechanics which deals with the motion of a system of material particles without reference to the forces which act on the system. Kinematics differs from dynamics in that the latter takes these forces into account. See DYNAMICS.

For a single particle moving in a straight line (rectilinear motion), the motion is prescribed when the position of the particle is known as a function of the time. Plane kinematics of a particle is concerned with the specification of the position of a particle moving in a plane by means of two independent variables. The kinematics of a particle in space is concerned with the ways in which three independent coordinates may be chosen to specify the position of the particle at a given time, and with the relations between the first and second time derivatives of these coordinates and the components of velocity and acceleration of the particle.

Among the coordinate systems studied in kinematics are those used by observers who are in relative motion. In nonrelativistic kinematics the time coordinate for each such observer is assumed to be the same, but in relativistic kinematics proper account must be taken of the fact that lengths and time intervals appear different to observers moving relative to each other. See RELATIVITY. [H.C.Co./B.G.]

**Kinetic methods of analysis** The measurement of reaction rates for the analytical determination of the initial concentrations of the species taking part in chemical reactions. This technique can be used since, in most cases, the rates or velocities of chemical reactions are directly proportional to the concentrations of the species taking part in the reactions.

The rate of a chemical reaction is measured by experimentally following the concentration of some reactant or product as a function of time as the mixture proceeds from a nonequilibrium to an equilibrium or static state (steady state). Kinetic techniques



of analysis have the inherent problem of the difficulty of making measurements on a dynamic system. However, kinetic methods often have advantages over equilibrium techniques in spite of the increased experimental difficulty. For example, the equilibrium differentiations or distinctions attainable for the reactions of very closely related compounds are often very small and not sufficiently separated to resolve the individual concentrations of a mixture without prior separation. But the kinetic differentiations or distinctions obtained when such compounds are reacted with a common reagent are often quite large and permit simultaneous analysis. See CHEMICAL EQUILIBRIUM.

A further advantage of kinetic methods is that they permit a larger number of chemical reactions to be used analytically. Many reactions, both inorganic and organic, are not sufficiently well behaved to be employed analytically by equilibrium or thermodynamic techniques. Many reactions attain equilibrium too slowly; side reactions occur as the reactions proceed to completion, or the reactions are not sufficiently quantitative (do not go to completion) to be applicable. However, a kinetic-based technique can often be employed in these cases simply by measuring the reaction rate of these reactions during the early or initial portion of the reaction period. Also, the measurement of the rates of catalyzed reactions generally is a considerably more sensitive analytical method for the determination of trace amounts of a large number of species than equilibrium methods. See CATALYSIS. [H.B.Ma.]

**Kinetic theory of matter** A theory which states that the particles of matter in all states of aggregation are in vigorous motion. In computations involving kinetic theory, the methods of statistical mechanics are applied to specific physical systems. The atomistic or molecular structure of the system involved is assumed, and the system is then described in terms of appropriate distribution functions. The main purpose of kinetic theory is to deduce, from the statistical description, results valid for the whole system. The distinction between kinetic theory and statistical mechanics is thus of necessity arbitrary and vague. Historically, kinetic theory is the oldest statistical discipline. Today a kinetic calculation refers to any calculation in which probability methods, models, or distribution functions are involved. See STATISTICAL MECHANICS.

Kinetic calculations are not restricted to gases, but occur in chemical problems, solid-state problems, and problems in radiation theory. Even though the general procedures in these different areas are similar, there are a sufficient number of important differences to make a general classification useful.

In classical ideal equilibrium problems there are no interactions between the constituents of the system. The system is in equilibrium, and the mechanical laws governing the system are classical. The basic information is contained in the Boltzmann distribution  $f$  (also called Maxwell or Maxwell-Boltzmann distribution) which gives the number of particles in a given momentum and positional range ( $d^3x = dx dy dz$ ,  $d^3v = dv_x dv_y dv_z$ , where  $x$ ,  $y$ , and  $z$  are coordinates of position, and  $v_x$ ,  $v_y$ , and  $v_z$  are coordinates of velocity). In Eq. (1)  $\epsilon$  is the energy,  $\beta = 1/kT$  (where  $k$  is the

$$f(xyz, v_x v_y v_z) = Ae^{-\beta\epsilon} \quad (1)$$

Boltzmann constant and  $T$  is the absolute temperature), and  $A$  is a constant determined from Eq. (2). The calculations of gas

$$\int \int \int d^3x d^3v f = N \quad \text{total number of particles} \quad (2)$$

pressure, specific heat, and the classical equipartition theorem are all based on these relations. See BOLTZMANN STATISTICS.

Many important physical properties refer not to equilibrium but to nonequilibrium states. Phenomena such as thermal conductivity, viscosity, and electrical conductivity all require a discussion starting from the Boltzmann transport equation. If one deals with states that are near equilibrium, the exact Boltzmann equation need not be solved; then it is sufficient to describe the

nonstationary situation as a small perturbation superimposed on an equilibrium state.

The basic classical procedure for arbitrary systems (systems with interactions taken into account) that allows the calculation of macroscopic entities is that using the partition function.

Classical nonideal nonequilibrium theory is the most general situation that classical statistics can describe. In general, very little is known about such systems.

There are quantum counterparts to the classifications just described. In a quantum treatment a distribution function is also used for an ideal system in equilibrium to describe its general properties. For systems of particles which must be described by symmetrical wave functions, such as helium atoms and photons, one has the Bose distribution, Eq. (3), where  $\beta = 1/kT$ , and  $A$  is determined by Eq. (2).

$$f(v_x v_y v_z) = \frac{1}{(1/A)e^{\beta\epsilon} - 1} \quad (3)$$

See BOSE-EINSTEIN STATISTICS.

For systems of particles which must be described by antisymmetrical wave functions, such as electrons, protons, and neutrons, one has the Fermi distribution, Eq. (4). The application

$$f(v_x v_y v_z) = \frac{1}{(1/A)e^{\beta\epsilon} + 1} \quad (4)$$

to electrons as an (ideal) Fermi-Dirac gas in a metal is the basis of the Sommerfeld theory of metals. See FERMI-DIRAC STATISTICS; FREE-ELECTRON THEORY OF METALS; QUANTUM STATISTICS. [M.Dr.]

**Kinetics (classical mechanics)** That part of classical mechanics which deals with the relation between the motions of material bodies and the forces acting upon them. It is synonymous with dynamics of material bodies. See DYNAMICS.

Kinetics proceeds by adopting certain intuitively acceptable concepts which are associated with measurable quantities. These essential concepts and the measurable quantities used for their specification are as follows:

1. Space configuration refers to the positions and orientations of bodies in a reference frame adopted by the observer. It is expressed quantitatively by an arbitrarily chosen set of space coordinates, of which cartesian and polar coordinates are examples. All space coordinates rest on the notion of distance measurement.

2. Duration is expressed quantitatively by time measured by a clock or comparable mechanism.

3. Motion refers to change of configuration with time and is expressed by time rates of coordinate change called velocities and time rates of velocity change called accelerations. The classical assumption that coordinates behave as analytic functions of time permits representation of velocities and accelerations as first and second derivatives, respectively, of the space coordinates with respect to time.

4. Inertia is an attribute of bodies implying their capacity to resist changes of motion. A body's inertia with respect to linear motion is denoted by its mass.

5. Momentum is an attribute proportional to both the mass and velocity of a body. Momentum of linear motion is expressed as the product of mass and linear velocity.

6. Force serves to designate the influence exercised upon the motion of a particular body by other bodies, not necessarily specified. A quantitative connection between the motion of a body and the force applied to it is expressed by Newton's second law of motion, which is discussed later.

Distance, time, and mass are commonly regarded as fundamental, all other dynamical quantities being definable in terms of them.

A primary objective of classical kinetics is the prediction of the behavior of bodies which are subject to known forces when only initial values of the coordinates and momenta are available. This

is accomplished by use of a principle first recognized by Isaac Newton. Newton's statement of the principle was restricted to the linear motion of an idealized body called a mass particle, having negligible extension in space.

The basic dynamical law set forth by Newton and known as his second law states that the time rate of change of a particle's linear momentum is proportional to and in the direction of the force applied to the particle. Stated analytically, Newton's second law becomes the differential equation, Eq. (1), in which  $m$  represents the particle's mass,  $v$  its velocity,

$$\frac{d(mv)}{dt} = F \quad (1)$$

$F$  the applied force, and  $t$  the time. Equation (1) provides a definition of force and of its units if units of mass, distance, and time have previously been adopted. The classical assumption of constancy of mass permits Eq. (1) to be expressed as Eq. (2), where  $a$  represents the linear acceleration.

$$ma = F \quad (2)$$

The behavior of systems composed of two or more interacting particles is treated by Newtonian dynamics augmented by Newton's third law of motion which states that when two bodies interact, the forces they exert on one another are equal and oppositely directed. The important laws of momentum and energy conservation are derivable for such systems (the latter only for forces of special type) and useful in solution of problems. See ACCELERATION; FORCE; GRAVITATION; HARMONIC MOTION; MASS; MOMENTUM; RIGID-BODY DYNAMICS; VELOCITY. [R.A.F.]

**Kinetoplastida** An order of the class Zoomastigophorea in the phylum Protozoa, also known as Protomastigida, containing a heterogeneous group of colorless flagellates possessing one or two flagella in some stage of their life cycle. These small organisms (5–89  $\mu\text{m}$  in length) typically have pliable bodies. Some species are holozoic and ingest solid particles, while others are saprozoic and obtain their nutrition by absorption.

There is disagreement on the division of the order into families. However, the five or more families can be divided into two general groups (see illustration). The first group contains simple organisms with no distinctive features save one or two flagella of equal or unequal length (includes the families Oikomonadidae, Amphimonadidae, Monadidae, and Bodonidae). The second group contains organisms which have an undulating membrane in addition to one or two flagella (includes Trypanosomatidae

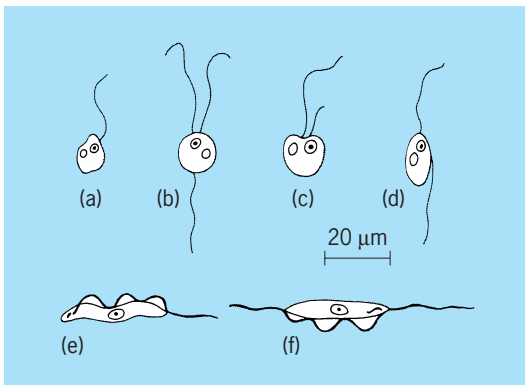

Representative genera of families of order Kinetoplastida. (a) *Oikomonas* (family Oikomonadidae), one anterior flagellum. (b) *Amphimonas* (family Amphimonadidae), two equally long anterior flagella. (c) *Monas* (family Monadidae), two unequally long anterior flagella. (d) *Bodo* (family Bodonidae), two unequally long flagella, one of them trailing. (e) *Trypanosoma* (family Trypanosomatidae), one flagellum with undulating membrane. (f) *Cryptobia* (family Cryptobiidae), two flagella, one free and one with undulating membrane.

and Cryptobiidae). The most important family is the Trypanosomatidae, since it includes several species that infect humans and domestic animals with serious diseases, such as African sleeping sickness. See CILIA AND FLAGELLA; TRYPANOSOMATIDAE. [M.M.B.]

**Kinorhyncha** A phylum of free-living marine invertebrates less than 0.04 in. (1 mm) long. They are segmented and lack external ciliation (see illustration). Kinorhynchs are benthonic, so-called because they generally dwell in mud or sand from intertidal to deep-sea habitats. Two orders are generally recognized, Cyclorhagida and Homalorhagida.

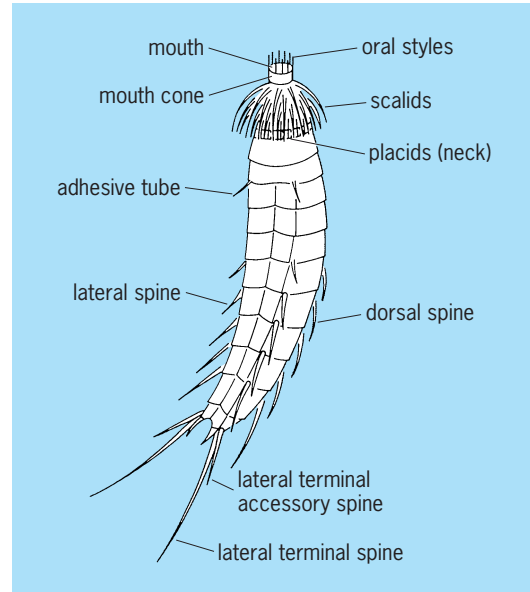

*Echinoderes* sp., a cyclorhagid kinorhynch (ventrolateral view).

The body is covered by a transparent cuticle secreted by an underlying epidermis. The cuticle is molted only in the process of juvenile growth. Three body regions are recognized: a head segment, a neck segment and an 11-segment trunk. The head is completely retractable. When everted, it extends its five to seven circles of recurved spines called scalids. The neck consists of plates called placids which function to close the anterior opening of the trunk when the head is retracted. Most kinorhynchs have a pair of adhesive tubes on the ventral surface of the third or fourth segment. [R.P.H.]

**Kirchhoff's laws of electric circuits** Fundamental natural laws dealing with the relation of currents at a junction and the voltages around a loop. These laws are commonly used in the analysis and solution of networks. They may be used directly to solve circuit problems, and they form the basis for network theorems used with more complex networks.

One way of stating Kirchhoff's voltage law is: "At each instant of time, the algebraic sum of the voltage rise is equal to the algebraic sum of the voltage drops, both being taken in the same direction around the closed loop."

Kirchhoff's current law may be expressed as follows: "At any given instant, the sum of the instantaneous values of all the currents flowing toward a point is equal to the sum of the instantaneous values of all the currents flowing away from the point." See CIRCUIT (ELECTRICITY). [K.Y.T./R.T.W.]

**Kite** A tethered flying device that supports itself and the cable that connects it to the ground by means of the aerodynamic forces created by the relative motion of the wind. This relative wind may arise merely from the natural motions of the air or may

be caused by towing the kite through the agency of its connecting cable.

The lifting force of all kites is produced by deflecting the air downward, the resulting change in momentum producing an upward force. To be successful, a kite must have an extremely low wing loading (weight/area) so that it can fly even on days when the wind velocity is not high. It must be completely stable, since the only controls available to the operator are the length of cable and the rate at which it is taken in or let out. Efficient design requires that its lift-to-drag ratio be as high as possible. See AERODYNAMIC FORCE; AERODYNAMICS. [D.C.H.]

**Kiwifruit** A vigorous deciduous fruiting vine (family Actinidaceae) that is native to central China, where it commonly grows in moist and sheltered areas on the forest edges. Kiwifruit requires both the female cultivar and a male pollinizer for successful fruit production. The kiwifruit industry depends on a single female cultivar, Hayward, the fruit having a creamy-white central core, black-brown seeds, and a bright translucent green outer flesh surrounded by a light-brown fuzzy skin. It is adapted to moderate climates in the temperate zone and requires 600–850 h of winter chilling (temperatures between 32 and 45°F or 0 and 7°C) to ensure uniform bud-break. Kiwifruit wood is susceptible to winter injury at temperatures below 14°F (–10°C), and flower buds can be damaged by frost below 29°F (–1.5°C).

The kiwifruit (*Actinidia deliciosa*) was introduced into cultivation in New Zealand with seed brought from China in 1904, making it one of the most recently domesticated fruiting plants. It appears that all vines now in New Zealand descended from one male and two female plants. The principal kiwifruit-growing countries are Italy, New Zealand, Japan, Chile, France, Greece, United States (California), and Australia.

Kiwifruit is a source of vitamin C, minerals such as potassium, calcium, and phosphorus, and dietary fiber. The primary use is for the fresh market, although culled fruit is processed into canned and frozen fruit slices, wine, jam, juice, and dried products. See FRUIT; THEALES. [J.K.Ha]

**Klebsiella** A genus of gram-negative, nonmotile bacteria. Characteristic large mucoid colonies are due to production of a large amount of capsular material. Species of *Klebsiella* are commonly found in soil and water, on plants, and in animals and humans. Harmless strains of *Klebsiella* are beneficial because they fix nitrogen in soil. Pathogenic species include *K. pneumoniae*, *K. rhinoscleromatis*, and *K. ozaenae*, also known as *K. pneumoniae* subspecies *pneumoniae*, *rhinoscleromatis*, and *ozaenae*.

*Klebsiella pneumoniae* is the second most frequently isolated colon-related bacterium in clinical laboratories. The carbohydrate-containing capsule of *Klebsiella* promotes virulence by protecting the encased bacteria from ingestion by leukocytes; nonencapsulated variants of *Klebsiella* do not cause disease. Capsular types 1 and 2 cause pneumonia; types 8, 9, 10, and 24 are commonly associated with urinary tract infections. See ESCHERICHIA; PNEUMONIA.

*Klebsiella* accounts for a large percentage of hospital-acquired infections, mostly skin infections (in immunocompromised burn patients), bacteremia, and urinary tract infections. It is also the most common contaminant of intravenous fluids such as glucose solutions and other medical devices. See HOSPITAL INFECTIONS.

*Klebsiella* may produce *E. coli*-like enterotoxins and cause acute gastroenteritis in infants and young children. Enteric illnesses due to *Klebsiella* are more predominant where populations are more crowded and conditions less sanitary. Other virulence factors of *Klebsiella* include a relatively high ability to survive and multiply outside the host in a variety of environments, and its relatively simple growth requirements. See ENDOTOXIN.

*Klebsiella rhinoscleromatis* causes rhinoscleroma, a chronic destructive granulomatous disease of the upper respiratory tract

that is most common in eastern Europe, central Africa, and tropical South America. *Klebsiella ozaenae* is one cause of chronic rhinitis (ozena), a destructive atrophy of the nasal mucosa, and is infrequently isolated from urinary tract infections and bacteremia. See MEDICAL BACTERIOLOGY. [D.J.Ev.]

**Klystron** An evacuated electron-beam tube in which an initial velocity modulation imparted to electrons in the beam results subsequently in density modulation of the beam. A klystron is used either as an amplifier in the microwave region or as an oscillator.

For use as an amplifier, a klystron receives microwave energy at an input cavity through which the electron beam passes. The microwave energy modulates the velocities of electrons in the beam, which then enters a drift space. Here the faster electrons overtake the slower to form bunches. In this manner, the uniform current density of the initial beam is converted to an alternating current. The bunched beam with its significant component of alternating current then passes through an output cavity to which the beam transfers its ac energy. See MICROWAVE.

Klystrons may be operated as oscillators by feeding some of the output back into the input circuit. More widely used is the reflex oscillator in which the electron beam itself provides the feedback. The beam is focused through a cavity and is velocity-modulated there, as in the amplifier. The cavity usually has grids to concentrate the electric field in a short space so that the field can interact with a slow, low-voltage electron beam. Leaving the cavity, the beam enters a region of dc electric field opposing its motion, produced by a reflector electrode operating at a potential negative with respect to the cathode. The electrons do not have enough energy to reach the electrode, but are reflected in space and return to pass through the cavity again. The points of reflection are determined by electron velocities, the faster electrons going farther against the field and hence taking longer to get back than the slower ones. Reflex oscillators are used as signal sources from 3 to 200 GHz. They are also used as the transmitter tubes in line-of-sight radio relay systems and in low-power radars. [R.B.N.]

**Knudsen number** In gas dynamics, the ratio of the molecular mean free path  $\lambda$  to some characteristic length  $L$ :  $Kn = \lambda/L$ . The length chosen will depend on the problem under consideration. It may be, for example, the diameter of a pipe or an object immersed in a flow, or the thickness of a boundary layer or a shock wave. See MEAN FREE PATH.

The magnitude of the Knudsen number determines the appropriate gas dynamic regime. When the Knudsen number is small compared to unity, of the order of  $Kn \leq 0.1$ , the fluid can be treated as a continuous medium and described in terms of the macroscopic variables: velocity, density, pressure, and temperature. In the transition flow regime, for Knudsen numbers of the order of unity or greater, a microscopic approach is required, wherein the trajectories of individual representative molecules are considered, and macroscopic variables are obtained from the statistical properties of their motions. In both internal and external flows, for  $Kn \geq 10$ , intermolecular collisions in the region of interest are much less frequent than molecular interactions with solid boundaries, and can be ignored. Flows under such conditions are termed collisionless or free molecular. In the range  $0.1 \leq Kn \leq 1.0$ , termed the slip flow regime, it is sometimes possible to obtain useful results by treating the gas as a continuum, but allowing for discontinuities in velocity and temperature at solid boundaries. See GAS DYNAMICS; KINETIC THEORY OF MATTER; RAREFIED GAS FLOW. [L.T.]

**Koala** A single species, *Phascolarctos cinereus*, which is a member of the family Phalangeridae in the mammalian order Marsupialia (pouch-bearing animals). It is a small animal that weighs from 11 to 17 lb (5 to 8 kg) when mature. They are restricted to eastern Australia. Not only do they have a specialized

diet of eucalyptus leaves, but the leaves must be of a certain age from a specific species of tree, and the tree must grow upon a certain type of soil.

The koala breeds once each season, and the usual number of offspring is one. It remains in the pouch for 6 months; then it clings to the back of its mother and is carried around in this manner until 1 year old. See MAMMALIA; MARSUPIALIA. [C.B.C.]

**Kohlrabi** A cool-season biennial crucifer, *Brassica caulorapa* and *B. oleracea* var. *caulo-rapa*, of northern European origin belonging to the plant order Capparales. Kohlrabi is grown for its turniplike enlarged stem, which is usually eaten as a cooked vegetable (see illustration). A common cooked vegetable in



Kohlrabi (*Brassica caulorapa*), cultivar Early White Vienna. (Joseph Harris Co., Rochester, New York.)

Europe, especially Germany, kohlrabi is of minor importance in the United States. See CAPPARALES; TURNIP. [H.J.C.]

**Kondo effect** An unusual, temperature-dependent effect displayed in the thermal, electrical, and magnetic properties of nonmagnetic metals containing very small quantities of magnetic impurities. A striking example is the anomalous, logarithmic increase in the electrical resistivity with decreasing temperature. Other properties, such as heat capacity, magnetic susceptibility, and thermoelectric power, also display anomalous behavior because of the Kondo effect. For these properties, the temperature dependence of a typical dilute magnetic metal (Kondo alloy) differs greatly from the behavior expected of an ordinary metal containing no magnetic impurities.

The Kondo effect has been observed in a wide variety of dilute magnetic alloys. Usually these alloys are made from a nonmagnetic host such as copper, silver, gold, magnesium, or zinc and a small amount of a magnetic metal impurity such as chromium, manganese, iron, cobalt, nickel, vanadium, or titanium. Typical concentrations range from about one to a few hundred magnetic atoms per million host atoms. At higher concentrations, the dilute magnetic alloys may display spin-glass behavior. See SPIN GLASS.

The Kondo effect is used in thermometry applications, especially thermocouple thermometers at very low temperatures (that is, millikelvin temperatures). In other applications where the properties of pure metals are studied, the Kondo effect serves as a useful indicator of the metal's magnetic-impurity level.

The problem of understanding the Kondo effect is considered important since it is recognized to be a simpler version of the more complex problem of understanding ferromagnetism in magnetic materials, which is one of the great challenges in physics. Basically the Kondo effect is an example of the most simple possible magnetic system—a single magnetic atom in a nonmagnetic environment. (The alloys used are so dilute that the interaction between different magnetic impurities can be safely

ignored.) Although this involves a simple physical model, the problem has required some of the most sophisticated mathematical techniques known to advance its understanding.

An important step in this direction was the development of a partial mathematical solution of the Kondo problem using renormalization field theory techniques. Information gained in this step helped with the final development of a mathematically exact solution of the Kondo problem. The exact solution permits a systematic calculation of all properties (resistivity, thermal conductivity, thermopower, specific heat, magnetic susceptibility, neutron scattering behavior, and so forth) and provides a physical understanding of these properties. The theoretical work on the Kondo problem has been connected with new understanding in a variety of other scientific disciplines such as condensed-matter physics, surface physics, critical phenomena, elementary particle physics, magnetism, molecular physics, and chemistry, where parallels and analogs to the Kondo problem can be identified and utilized. See CRITICAL PHENOMENA; FERROMAGNETISM; RENORMALIZATION. [W.P.K.]

**Kronig-Penney model** An idealized, one-dimensional model of a crystal which exhibits many of the basic features of the electronic structure of real crystals. Consider the potential energy  $V(x)$  of an electron shown in the illustration with an

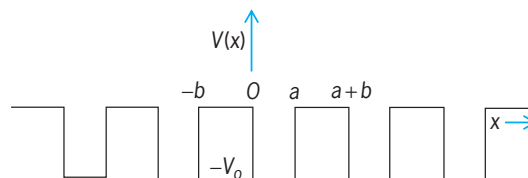

Potential energy which is assumed for the one-dimensional Kronig-Penney model.

infinite sequence of potential wells of depth  $-V_0$  and width  $a$ , arranged with a spacing  $b$ . The width and the curvatures of the allowed bands increase with energy. The Kronig-Penney model has been extended to include the effects of impurity atoms. See BAND THEORY OF SOLIDS. [J.C.]

**Krypton** A gaseous chemical element, Kr, atomic number 36, and atomic weight 83.80. Krypton is one of the noble gases in group 18 of the periodic table. Krypton is a colorless, odorless, and tasteless gas. The table gives some physical properties of krypton. The principal use for krypton is in filling electric lamps and electronic devices of various types. Krypton-argon mixtures are widely used to fill fluorescent lamps. See INERT GASES; PERIODIC TABLE.

#### Physical properties of krypton

Property	Value
Atomic number	36
Atomic weight (atmospheric krypton only)	83.80
Melting point, triple point °C	-157.20
Boiling point at 1 atm pressure, °C	-153.35
Gas density at 0°C and 1 atm pressure, g/liter	3.749
Liquid density at its boiling point, g/ml	2.413
Solubility in water at 20°C, ml krypton (STP) per 1000 g water at 1 atm partial pressure krypton	59.4

The only commercial source of stable krypton is the air, although traces of krypton are found in minerals and meteorites.

A mixture of stable and radioactive isotopes of krypton is produced in nuclear reactors by the slow-neutron fission of uranium. It is estimated that about  $2 \times 10^{-8}\%$  of the weight of the Earth is krypton. Krypton also occurs outside the Earth. [A.W.F.]

**Kudzu** A perennial vine legume, capable of rapid growth in a warm temperate, humid subtropical climate. The name kudzu has a Japanese origin. Kudzu (*Pueraria thunbergiana*) was introduced into the United States in 1876 and used as a shade plant until 1906, when a few enthusiastic growers in the southeastern United States began to use it as a forage crop, a practice that continued for 30 years. It was then promoted as a soil-conserving plant. However, much prejudice developed against its use because of its spread into forest borders, drainage ditches, and other areas.

Tropical kudzu (*P. phaseolides*) is one of the most important and widely planted cover and green manure crops of the tropics. It makes rapid vigorous growth, providing quick ground cover and suppressing most other vegetative growth. It is used as a forage crop although careful management is required to prevent complete domination of mixtures with grasses and other species. See LEGUME FORAGES; ROSALES. [P.T.]

**Kuiper Belt** A vast reservoir of icy bodies in the region of the solar system beyond the orbit of the planet Neptune. Until the discovery, in 1992, of the Kuiper Belt object 1992 QB<sub>1</sub> by David Jewitt and Jane Luu, the trans-Neptunian region of the solar system was thought to contain only the small planet Pluto and its satellite Charon. Members of the belt (Kuiper Belt objects) are the remnants of the original solid building blocks (planetesimals) that went into the formation of the outer planets. They were left behind because they were not incorporated into the planets and, owing to their location far beyond the giant planets, escaped being ejected from the solar system. They are thus relics from the solar nebula, the original disk of gas and dust that gave rise to everything in the solar system, and should preserve records of this early stage of the solar system's evolution. See NEPTUNE; PLANET; PLUTO.

In 1951 Gerard Kuiper proposed that perhaps distant planetesimals that did not agglomerate into planets might still exist beyond the planets. (This idea of a trans-Neptunian comet belt was actually first mentioned by K. E. Edgeworth in 1949, and then elaborated by Kuiper.) In the 1980s the concept of the Kuiper Belt was revived as a possible source for the short-period comets, which take less than 200 years to complete one orbit around the Sun. [The long-period comets, whose orbits take longer than 200 years, have long been recognized to come from the Oort Cloud, a large spherical cloud of comets at roughly 10,000 astronomical units (AU) from the Sun.]

**Population.** The Kuiper Belt starts just beyond Neptune and extends to some as yet unknown outer limit. These objects are not distributed uniformly throughout the belt, but lie in clumps separated by empty space. Based on their orbits, Kuiper Belt objects can be classified into resonance, classical, or scattered.

The Kuiper Belt contains several special areas called mean motion resonances, which are best explained by an example: Located at 39.4 AU, Pluto lies in the 3:2 resonance with Neptune. This means that every time Neptune completes three orbits around the Sun, Pluto completes two orbits around the sun. Resonances act as stable oases in space where members can survive for the age of the solar system. Just as the 3:2 resonance protects Pluto from close encounters with Neptune, it protects other members of the resonance, now called plutinos to highlight their dynamical similarity with Pluto.

The classical Kuiper Belt objects lie outside the resonances and are characterized by near-circular orbits almost in the ecliptic plane. These orbits are what would be expected from the first-generation planetesimals in the solar nebula, suggesting that the classical Kuiper Belt objects are indeed primordial planetesimals that have managed to preserve their original orbits.

The scattered Kuiper Belt objects stand out from the rest of the Kuiper Belt with their very large, very elliptical orbits. The origin of the scattered Kuiper Belt is unknown, but may be a by-product of the scattering process that produced the Oort Cloud.

**Physical properties.** The properties of Kuiper Belt objects are of intense interest since these bodies are primordial survivors from the early solar nebula. Unfortunately, most Kuiper Belt objects are so faint that detailed investigations of their properties are extremely difficult. Nothing is currently known besides their colors. See PLANETARY PHYSICS; SOLAR SYSTEM. [J.Lu.]

**Kumquat** Shrubs or small trees that are members of the genus *Fortunella*, which is one of the six genera in the group of true citrus fruits. Kumquats are believed to have originated in China and the Malay Peninsula, but are now widely grown in all citrus areas of the world. Of the several species the most common are *F. margarita*, which has oval-shaped fruit, and *F. japonica*, which has round fruit.

Kumquats, with their brilliant orange-colored fruits and dense green foliage, are highly ornamental and are most frequently grown for this reason. Kumquat fruits can be eaten whole without peeling; they are also used in marmalades and preserves and as candied fruits. See SAPINDALES. [F.E.G.]

**Kuroshio** A swift, intense current flowing northeastward off the coasts of China and Japan in the upper waters of the North Pacific Ocean. The Kuroshio is the western portion of a giant clockwise, horizontal circulation known as the North Pacific subtropical gyre. This circulation extends from 15° to 45°N across the entire width of the Pacific Ocean. It is driven by the large-scale winds—the trades in the south and the westerlies in the north. As with all other western boundary currents, such as the Gulf Stream, the effect of the Earth's rotation and its spherical shape is to concentrate the Kuroshio flow into a current that is only about 100 km (62 mi) wide with speeds up to 2 m/s (4 mi/h). See CORIOLIS ACCELERATION; GULF STREAM; PACIFIC OCEAN.

The Kuroshio (Japanese, meaning "Black Current") has an apparent blackness resulting from the water clarity, which is a consequence of the low biological productivity of seawater in the area. It originates off the southeast coast of Luzon, the main island of the Philippines. For the first 1000 km (620 mi), the Kuroshio flows northward along the east coasts of Luzon and Taiwan, until it enters the East China Sea. For the next 1000 km, it flows northeastward near the edge of the continental shelf off eastern China, until it exits the East China Sea through the Tokara Strait. During its final 1000 km, it flows east-northeastward off the southern coast of Japan (where it is sometimes called the Japan Current). Finally, it leaves the Asian coast near Tokyo and travels into the interior of the North Pacific Ocean as a slowly expanding jetlike current known as the Kuroshio Extension. Here it merges with the Oyashio, a cold current with high biological productivity, and becomes the North Pacific Current.

Like the Gulf Stream in the North Atlantic, the Kuroshio rapidly carries large quantities of warm water from the tropics into mid-latitude regions. It is consequently an important agent in redistributing global heat. North of 30°N, where prevailing winds are westerlies, the North American climate is strongly affected by the warmth of these waters. [M.Wi.]

**Kutorginida** An extinct order of brachiopods whose class assignment is uncertain. Members occur in rocks of Early Cambrian and questionably Middle Cambrian age. The shell has a primarily calcareous composition. The valves may have articulation of paired furrows or sockets and ridges, but these do not appear to be homologous to the teeth and sockets of articulate brachiopods. Both valves resemble articulate brachiopod valves in having the true hinge line coincident with the hinge axis, elongate muscle tracks, and well-defined interareas. See BRACHIOPODA. [M.W.F.]

**Kyanite** A nesosilicate mineral, Al<sub>2</sub>SiO<sub>5</sub>, crystallizing in the triclinic system and occurring in metamorphic rocks. It is essentially a pure phase, but minor amounts of iron (Fe<sup>3+</sup>), chromium

## 1220 Kyanite

(Cr<sup>3+</sup>), and titanium (Ti<sup>4+</sup>) may substitute for aluminum (Al). The structure of kyanite is based on cubic close-packed oxygens (O). Ten percent of the tetrahedral (fourfold) interstices are filled with silicon (Si), and 40 percent of the octahedral (sixfold) interstices are filled with Al. The Al, with O at the corners, occurs in zigzag edge-sharing chains of Al-O octahedra. Si-O tetrahedra share corners with Al-O octahedra along the sides. This structure is about 10 percent denser than that of the other two Al<sub>2</sub>SiO<sub>5</sub> polymorphs, sillimanite and andalusite, making kyanite the high-pressure polymorph.

Kyanite occurs in well-formed bladed crystals and aggregates. Luster is vitreous to pearly. It is usually light blue because of minor Fe and Ti, and, rarely, light green because of Fe only. Kyanite may also be white or gray. Hardness is 5 (Mohs scale) along the length of crystals and 7 at right angles to the length. Kyanite has a single perfect cleavage parallel to the bladed face of crystals. *See* HARDNESS SCALES.

Kyanite is a source of material for the manufacture of highly refractory porcelains such as those used for spark plugs. *See* ANDALUSITE; MINERALOGY; SILICATE MINERALS; SILLIMANITE. [M.J.H.]

# L

**Labradorite** A plagioclase feldspar with composition range  $Ab_{50}An_{50}$  to  $Ab_{30}An_{70}$  ( $Ab = NaAlSi_3O_8$ ;  $An = CaAl_2Si_2O_8$ ). In some labradorite samples brilliant colors, much like those seen in oil films on water, result from the interference of light reflected at successive lamellar interfaces. See FELDSPAR; IGNEOUS ROCKS.

[P.H.R.]

**Labyrinthodontia** An important subclass of fossil amphibians, first known in the Late Devonian, common in the Carboniferous and Permian, and persisting to the Late Triassic. They are named for infoldings of the enamel of their teeth, a primitive feature which is not universally present in labyrinthodonts and which is shared with rhipidistian crossopterygian fishes. It is generally accepted that the labyrinthodonts are descended from rhipidistians. Labyrinthodonts are usually fairly large (up to 6.5 ft or 2 m long). Some were totally aquatic (in fresh water). Most were probably semiaquatic, while some (especially the Dissorophidae) appeared to be terrestrial, at least as adults. See AMPHIBIA.

[R.E.DeM.]

**Labyrinthulia** Protozoa forming a subclass of Rhizopodea with obscure relationships to rest of the class. There is one order, Labyrinthulida. The mostly marine, ovoid to spindle-shaped, uninucleate organisms secrete a network of filaments (slime tubes) along which they glide, usually singly. This network inspired the name "net slime molds" sometimes applied to them. The mechanism of locomotion is unknown. See RHIZOPODEA.

[R.P.H.]

**Lacquer** A fast-drying, hard, high-gloss surface coating. Lacquers are made by dissolving a cellulose derivative and other modifying materials in a solvent and adding pigment if desired. The cellulose derivative most commonly used is nitrocellulose, but a cellulose ester such as cellulose acetate or cellulose butyrate, or a cellulose ether such as ethyl cellulose is often used in formulation. Lacquers dry by evaporation of the solvent. They usually are applied by spray because of their rapid drying properties.

Lacquers have been used extensively as fast-drying, weather-resistant finishes for automobiles and as coatings for furniture and other factory-finished items. Their use diminished, however, as less expensive coating materials with improved properties appeared on the market. See SURFACE COATING.

[C.R.Ma.; C.W.Si.]

**Lacrimal gland** A tubuloalveolar or acinous skin gland, also known as the tear gland. Two types occur among the vertebrates, the lacrimal proper and the Harderian. The eye glands drain into the nasal cavity by means of the lacrimal duct.

In land mammals the lacrimal gland proper is highly developed as a complex tubuloalveolar structure with several ducts which pour their copious fluid into the outer, upper part of the conjunctival sac or cavity. The tear substance washes across the eyeball and eventually passes through two small openings, one on the margin of each lid, into the lacrimal ducts. The latter converge to form the lacrimal sac, from which the nasolacrimal duct leads into the nasal passageway. Tears contain a considerable quantity of the common salt, sodium chloride. See EYE (VERTEBRATE); GLAND.

[O.E.N.]

**Lactam** A cyclic amide that is the nitrogen analog of a lactone. For example, a  $\gamma$ -aminobutyric acid readily forms  $\gamma$ -butyrolactam (also known as 2-pyrrolidinone) upon heating, as in the reaction below. The tautomeric enol form of a lactam is known as a lactim.

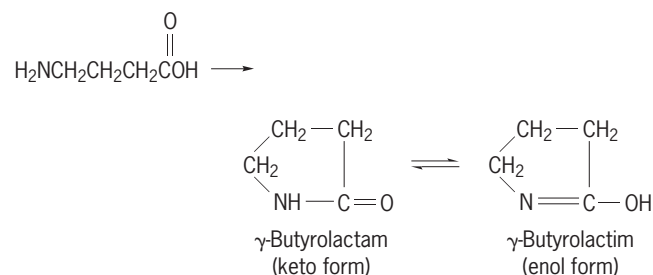

The  $\delta$ -amino acids similarly form  $\delta$  (six-membered-ring) lactams upon heating, but larger- and smaller-ring lactams must be made by indirect methods.

Several lactams are of considerable industrial importance. 2-Pyrrolidinone and 1-methyl-2-pyrrolidinone are made by heating  $\gamma$ -butyrolactone with ammonia and methylamine, respectively. They are useful specialty solvents. Vinylation of 2-pyrrolidinone with acetylene gives 1-vinyl-2-pyrrolidinone, which is polymerized to a substance commonly used in aerosol hair sprays.

The  $\beta$ -lactam antibiotics comprise two groups of clinically important therapeutic agents, the penicillins and the cephalosporins. In both cases they contain a four-membered or  $\beta$ -lactam ring which has its nitrogen atom and a carbon atom in common with another ring. Such substances are derived commercially from fermentation processes, followed usually by chemical manipulation of the functional groups. See AMINO ACIDS; ANTIBIOTIC; BIOCHEMICAL ENGINEERING; LACTONE.

[P.E.F.]

**Lactase** An enzyme found in mammals, honeybee larvae, and some plants. It is a  $\beta$ -galactosidase which hydrolyzes lactose to galactose and glucose. In mammals, lactase appears in the intestinal secretion from the intestinal villi, and exerts its effect on lactose in chyme. See ENZYME; GLUCOSE.

[D.N.La.]

**Lactate** A salt or ester of lactic acid ( $\text{CH}_3\text{CHOHCOOH}$ ). In lactates, the acidic hydrogen of the carboxyl group has been replaced by a metal or an organic radical. Lactates are optically active, with a chiral center at carbon 2. Commercial fermentation produces either the dextrorotatory (*R*) or the levorotatory (*S*) form, depending on the organism involved. See OPTICAL ACTIVITY.

The *R* form of lactate occurs in blood and muscle as a product of glycolysis. Lack of sufficient oxygen during strenuous exercise causes enzymatic (lactate dehydrogenase) reduction of pyruvic acid to lactate, which causes tiredness, sore muscles, and even muscle cramps. During renewed oxygen supply (rest) the lactate is reoxidized to pyruvic acid and the fragments enter the Krebs (citric acid) cycle. The plasma membranes of muscle and liver are permeable to pyruvates and lactates, permitting the blood

to transport them to the liver (Cori cycle). Lactates also increase during fasting and in diabetics. See BIOLOGICAL OXIDATION; CARBOHYDRATE METABOLISM; CITRIC ACID CYCLE.

Lactates are found in certain foods (sauerkraut), and may be used for flour conditioning and in food emulsification. Alkali-metal salts act as blood coagulants and are used in calcium therapy, while esters are used as plasticizers and as solvents for lacquers. See ESTER; SALT (CHEMISTRY). [E.H.H.]

**Lactation** The function of the mammary gland providing milk nourishment to the newborn mammal. This process is under the control of the endocrine and nervous systems. It involves transformation of an inactive duct system to a lobuloalveolar glandular structure during pregnancy, cellular production of the components of milk (galactopoiesis), secretion into the ducts, and ejection under the stimulus of milking or suckling.

Lactation makes demands on the maternal regulation of calcium metabolism. Resorption of bone increases in lactating rats and women, and there is a marked increase in the absorption of calcium from the intestine. The elevated need for calcium results in an increased role for parathyroid hormone, calcitonin, and vitamin D in the regulation of the absorption and utilization of calcium. In humans a concomitant phenomenon frequently associated with lactation is amenorrhea. Consequently in some societies prolonged nursing is used as a birth control technique. See MAMMARY GLAND; MILK. [H.J.L.]

**Lactone** A cyclic, intramolecular ester derived from a hydroxy acid. Simple lactones are designated  $\alpha$ ,  $\beta$ ,  $\gamma$ ,  $\delta$  and so forth. Five- and six-membered lactones are very readily obtained by cyclization of a hydroxy acid or precursor as shown in reactions (1)–(3). Lactones with three- and four-membered rings are also known. See ESTER.

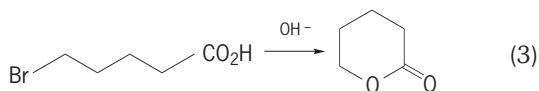
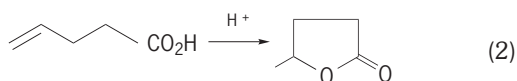
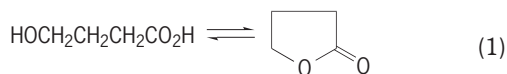

Lactones in various forms are found in numerous naturally occurring compounds. Unsaturated  $\gamma$ -lactone rings (**1** and **2**) are present in many components of essential oils. Ascorbic acid [vitamin C; **3**] is a carbohydrate lactone. See ASCORBIC ACID; ESSENTIAL OILS.

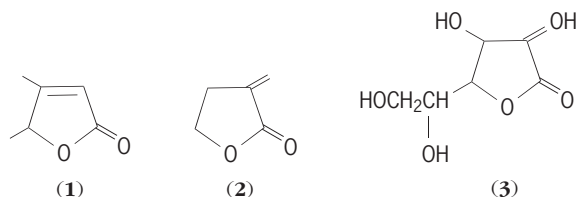

A major development in the chemistry of naturally occurring compounds has been the isolation from microorganisms of a number of macrocyclic lactones with rings containing from 12 to more than 30 atoms. These substances include immunosuppressive agents and antibiotics such as erythromycin. Although they represent some of the most complex organic compounds known, several of these macrocyclic lactones have been synthesized. See ANTIBIOTIC; ORGANIC CHEMISTRY. [P.E.F.; J.A.Mo.]

**Lactose** Milk sugar or 4-O- $\beta$ -D-galactopyranosyl-D-glucose. This reducing disaccharide is obtained as the  $\alpha$ -D anomer (see formula, where the asterisk indicates a reducing group); the melting point is 202°C (396°F). Lactose is found in the milk of mam-

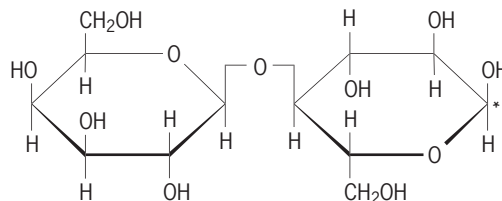

mals to the extent of approximately 2–8%. It is usually prepared from whey, which is obtained by a by-product in the manufacture of cheese. Upon concentration of the whey, crystalline lactose is deposited. [W.Z.H.]

**Laevicaudata** An order of fresh-water branchiopod crustaceans formerly included in the order Conchostraca. The body is up to about 7 mm (0.3 in.) in length; females have 12 trunk segments, males have 10. The trunk terminates in a feebly developed telson that lacks claws and is covered ventrally by an opercular lamella. The head is free, articulated with the trunk, and can be swung forward. It is covered by a headshield and has paired, sessile eyes. It bears large antennae that are used for swimming. The mandibles, while of the rolling, crushing type, have narrow masticatory surfaces and stout teeth.

Clumps of small drought-resistant eggs are carried by the female and shed at the next molt. They hatch as a late nauplius of distinctive type. The Laevicaudata are inhabitants of temporary water bodies and are almost worldwide in distribution. Although they can swim, they are usually associated with the bottom. See BRANCHIOPODA. [G.Fr.]

**Lagomorpha** The order of mammals including rabbits, hares, and pikas. Lagomorphs have two pairs of upper incisors (the second pair minute), and enamel surrounds the tooth, which does not form a sharp chisel. Motion of the jaw is vertical or transverse. Lagomorphs have three upper and two lower premolars, the earliest fossil rodents have one less of each. The tibia and fibula are fused, the fibula articulating with the calcaneum as in artiodactyls. There is a spiral valve in the cecum, and the scrotum is prepenial.

The order includes three families: Leporidae (rabbits and hares); Ochotonidae (pikas, whistling hares, or American coney); and Eurymylidae, an extinct family from the Paleocene of Mongolia. See MAMMALIA.

Leporidae are the most familiar members of the order. There are, in general, two kinds: rabbits (such as the American cottontail), which are relatively small, with shorter hindlegs, shorter ears, and short tails; and hares, larger forms with longer legs, ears, and tails. Rapid locomotion is by leaps, using the hindlegs, combined (especially in rabbits) with abrupt changes of direction. Both types occur in the same region, with rabbits inhabiting brush, scrub, or woods and hares living in open grassland. In North America, hares are usually called jackrabbits. [A.E.Wo.]

**Lagrange's equations** Equations of motion of a mechanical system for which a classical (non-quantum-mechanical) description is suitable, and which relate the kinetic energy of the system to the generalized coordinates, the generalized forces, and the time. If the configuration of the system is specified by giving the values of  $f$  independent quantities  $q_1, \dots, q_f$ , there are  $f$  such equations of motion.

In their usual form, these equations are equivalent to Newton's second law of motion and are differential equations of the second order for the  $q$ 's as functions of the time  $t$ . [P.M.S.]



**Lagrangian function** A function of the generalized coordinates and velocities of a dynamical system from which the equations of motion in Lagrange's form can be derived. The Lagrangian function is denoted by  $L(q_1, \dots, q_f; \dot{q}_1, \dots, \dot{q}_f; t)$ . For systems in which the forces are derivable from a potential energy  $V$ , if the kinetic energy is  $T$ , the equation below holds.

$$L = T - V$$

See LAGRANGE'S EQUATIONS.

[P.M.S.]

**Lake** An inland body of water, small to moderately large in size, with its surface exposed to the atmosphere. Most lakes fill depressions below the zone of saturation in the surrounding soil and rock materials. Generically speaking, all bodies of water of this type are lakes, although small lakes usually are called ponds, tarns (in mountains), and less frequently pools or meres. The great majority of lakes have a surface area of less than 100 mi<sup>2</sup> (259 km<sup>2</sup>). More than 30 well-known lakes, however, exceed 1500 mi<sup>2</sup> (3885 km<sup>2</sup>) in extent, and the largest freshwater body, Lake Superior, North America, covers 31,180 mi<sup>2</sup> (80,756 km<sup>2</sup>). Most lakes are relatively shallow features of the Earth's surface. Because of their shallowness, lakes in general may be considered evanescent features of the Earth's surface, with a relatively short life in geological time.

Lakes differ as to the salt content of the water and as to whether they are intermittent or permanent. Most lakes are composed of fresh water, but some are more salty than the oceans. Generally speaking, a number of water bodies which are called seas are actually salt lakes; examples are the Dead, Caspian, and Aral seas. All salt lakes are found under desert or semiarid climates, where the rate of evaporation is high enough to prevent an outflow and therefore a discharge of salts into the sea.

Lakes with fresh waters also differ greatly in the composition of their waters. Because of the balance between inflow and outflow, fresh lake water composition tends to assume the composite dissolved solids characteristics of the waters of the inflowing streams—with the lake's age having very little influence. Under a few special situations, as crater lakes in volcanic areas, sulfur or other gases may be present in lake water, influencing color, taste, and chemical reaction of the water. See FRESH-WATER ECOSYSTEM; HYDROSPHERE; MEROMICTIC LAKE; SURFACE WATER.

Both natural and artificial lakes are economically significant for their storage of water, regulation of stream flow, adaptability to navigation, and recreational attractiveness. A few salt lakes are significant sources of minerals. See EUTROPHICATION. [E.A.A.]

**Lamellibranchia** The largest subclass of the class Bivalvia in the phylum Mollusca. Lamellibranchs are ciliary filter feeders with greatly enlarged ctenidia, in each of which the elongated gill filaments are held together in parallel series to form folded lamellae. The 30,000 living species constitute the most successful of molluscan groups, in terms both of individual numbers with their biomass and of ecological bioenergetics (calorie transfer in food chains).

There are several proposed systems of ordinal classification for the subclass Lamellibranchia, but little agreement on the best structural bases. One system frequently employed comprises six orders: Anisomyaria, Taxodonta, Heterodonta, Schizodonta, Anomalodesmata, and Adapedonta. There is more general acceptance of the (possibly 18) superfamilies of lamellibranchs, each with characteristic shell structure, hinge dentition, ligament, and degree of fusion of the mantle lobes involving the origin of the siphons. The more important superfamilies include Mytilacea (mussels), Ostreacea (true oysters), Cardiacea (true cockles), Unionacea and Corbiculacea (fresh-water clams), Myacea (including softshell clams), Mactracea (surf clams), Tellinacea, and Pholadacea (=Adesmacea). Within each larger superfamily there is a wide range of adaptive radiation, with different genera

living as shallow or deep burrowers or as sessile attached forms. There can be considerable evolutionary convergence shown by genera from different superfamilies, and deep burrowers with massive fused siphons are found in five superfamilies. See BIVALVIA; BORING BIVALVES; MOLLUSCA. [W.D.R.H.]

**Lamiales** An order of flowering plants (Magnoliophyta, or angiosperms), in the subclass Asteridae (Eudicotyledons). The order consists of some 22 families with approximately 1100 genera and over 21,000 species. Seven families (Acanthaceae, Gesneriaceae, Lamiaceae, Orobanchaceae, Plantaginaceae, Scrophulariaceae, Verbenaceae) have more than 1000 species. Members of the Lamiales are distributed worldwide with some families being predominantly tropical and some being predominantly temperate. Lamiaceae, the largest family, is well represented in both tropical and temperate floras.

A basal split in the evolutionary relationships within the order sets off the family Oleaceae, with tetramerous flowers, which are radially symmetric, from the rest of the Lamiales. Pentamerous flowers with fewer stamens (two or four) than petals and bilateral symmetry predominate among the other families. Flowers of all families are characterized by petals fused into a tubular corolla, a single whorl of stamens (typically four), and ovaries consisting of two fused carpels. Iridoid compounds are found in most members of the Lamiales and are thought to function in deterring herbivory by insects. However, iridoids are not universal in the order and, for example, the large subfamily Nepetoideae in family Lamiaceae lacks iridoids but exhibits a diverse array of volatile oils that may serve a similar function.

The volatile oils in the Lamiaceae have made many species valuable as scents and herbs, including lavender (*Lavandula*), mint (*Mentha*), sage (*Salvia*), catnip (*Nepeta*), basil (*Ocimum*), and oregano (*Oreganum*). Additional economically important plants in the Lamiales include those grown for food: sesame (*Sesamum*, Pedaliaceae) and olives (*Olea*, Oleaceae); wood: teak (*Tectona*, Verbenaceae) and ash (*Fraxinus*, Oleaceae); houseplants: African violets and relatives (Gesneriaceae); and many ornamental plants from a wide variety of families. The order also contains some plants with specialized habits, including parasitic plants (Orobanchaceae), insectivorous plants (Byblidaceae, Lentibulariaceae), mangroves (Avicenniaceae), and aquatic plants, such as *Callitriche* and *Hippuris* (Plantaginaceae). See ASTERIDAE; MAGNOLIOPHYTA; MAGNOLIOPSIDA; PLANT KINGDOM. [R.OI.]

**Laminar flow** A smooth, streamline type of viscous fluid motion characteristic of flow at low-to-moderate deformation rates. The name derives from the fluid's moving in orderly layers or laminae.

The chief criterion for laminar flow is a relatively small value for the Reynolds number,  $Re = \rho VL/\mu$ , where  $\rho$  is fluid density,  $V$  is flow velocity,  $L$  is body size, and  $\mu$  is fluid viscosity. Laminar flow may be achieved in many ways: low-density flows as in rarefied gases; low-velocity or "creeping" motions; small-size bodies such as microorganisms swimming in the ocean; or high-viscosity fluids such as lubricating oils. At higher values of the Reynolds number, the flow becomes disorderly or turbulent, with many small eddies, random fluctuations, and streamlines intertwining. See CREEPING FLOW; REYNOLDS NUMBER; TURBULENT FLOW; VISCOSITY.

Nearly all of the many known exact solutions of the equations of motion of a viscous fluid are for the case of laminar flow. These mathematically accurate descriptions can be used to give insight into the more complex turbulent and transitional flow patterns for which no exact analyses are known. See NAVIER-STOKES EQUATION.

The theory of viscous lubricating fluids in bearings is a highly developed area of laminar flow analysis. Even large Reynolds number flows, such as aircraft in flight, have regions of laminar

flow near their leading edges, so that laminar flow analysis can be useful in a variety of practical and scientifically relevant flows. See ANTI-FRICTION BEARING; BOUNDARY-LAYER FLOW; FLUID FLOW; LUBRICANT. [F.M.W.]

**Laminariales** An order of large brown algae (Phaeophyceae) commonly called kelps. Four families are recognized: Chordaceae, Laminariaceae, Alariaceae, and Lessoniaceae. Definitive features include a life history in which microscopic, filamentous, dioecious gametophytes alternate with a massive, parenchymatous sporophyte; growth of the sporophyte effected by meristems; and production of unilocular zoosporangia in extensive sori on blades of the sporophyte. See PHAEOPHYCEAE.

A mature sporophyte consists typically of a holdfast, stipe, and one or more blades. The holdfast usually comprises a cluster of rootlike structures (haptera); in a few species it is discoid or conical. The stipe, which varies in length from a few millimeters in *Hedophyllum* to more than 100 ft (30 m) in *Macrocystis* (giant kelp), may be branched or unbranched and may bear one or more blades.

Kelps are largely confined to cold waters of both hemispheres, displaying a peak of diversity, abundance, and luxuriance all around the North Pacific. Only *Lessonia* and *Ecklonia* (both Lessoniaceae) are characteristic of the Southern Hemisphere, but *Macrocystis* is bipolar, occurring abundantly in subantarctic waters. Kelps are lacking in Antarctica, where their ecological niche is filled by members of the brown algal family Desmarestiaceae. Some kelps are found in the intertidal zone, usually on rocks exposed to heavy waves, but most are subtidal.

The principal use of kelps is in the alginate industry. Various kelps are used extensively for human food in Japan. In China *Laminaria japonica* has been established as an important maricultural crop plant. Ecologically, such kelps as *Macrocystis* and *Nereocystis* are particularly important because they form protective canopies harboring special communities of smaller seaweeds, invertebrates, fishes, and the sea otter. See ALGAE; ALGINATE. [P.C.Si.; R.L.Moe]

**Lamp** A generic term for a device designed to produce electromagnetic radiation in the form of light, heat, ultraviolet energy, or a combination of the three. The term lamp is applied to the entire range of sources, including flame sources (such as kerosene lamps or gas lamps with Welsbach mantles), incandescent sources, and electric arc discharge sources. Used with a modifier, such as ultraviolet, infrared, or sun, the term lamp is used to indicate sources that radiate energy in the ultraviolet or infrared portions of the electromagnetic spectrum (plus some radiation in the visible part of the spectrum).

Electric lamps are the most common and useful types of light-producing sources. These devices convert electrical energy into light (radiant energy in the visible portion of the spectrum). The most widely used lamps for lighting buildings and areas, such as parking lots, stadia, and streets, are incandescent lamps, fluorescent lamps, and high-intensity arc discharge lamps (HID lamps). See ARC LAMP; FLUORESCENT LAMP; INCANDESCENT LAMP; INFRARED LAMP; SUN; ULTRAVIOLET LAMP; VAPOR LAMP. [G.R.P.; R.L.Sm.]

**Lampridiformes** An order of teleost fishes including the ribbonfishes, oarfishes, opah, and their allies, also known as the Allotriognathi. Although these fishes are diverse in form, they share characters that define this order. In most, the body is notably compressed, often ribbonlike (see illustration). The fins are composed of soft rays, or the dorsal has one or two anterior spines; the pelvic fin, if present, is thoracic, with 1–17 spineless rays; the pelvic girdle is inserted between the coracoids, or attached to them, or is lost; scales are small and cycloid or, commonly, absent; and the swim bladder is without a duct. Most

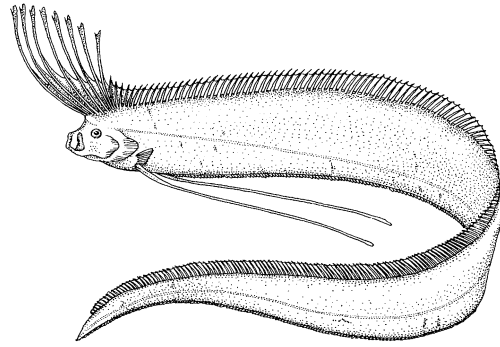

Oarfish (*Regalecus glesne*). (After D. S. Jordan and B. W. Evermann, *The Fishes of North and Middle America*, U.S. Nat. Mus. Bull. no. 47, 1900)

species are large and colorful. They are all oceanic. See ACTINOPTERYGII. [R.M.B.]

**Lamprophyre** Any of a heterogeneous group of gray to black, mafic igneous rocks characterized by a distinctive panidiomorphic and porphyritic texture in which abundant euhedral, dark-colored ferromagnesian (femic) minerals (dark mica, amphibole, pyroxene, olivine) occur in two generations—both early as phenocrysts and later in the matrix or groundmass—while felsic minerals (potassium feldspar, plagioclase, analcime, melilite) are restricted to the groundmass.

Many varieties of lamprophyre are known. Minettes, kersantites, vogesites, and spessartites are the most common and are sometimes collectively called calcalkaline lamprophyres. Camp-tonites and monchiquites are less common; alnoites are rare. These varieties, along with some others, are referred to as alkaline lamprophyres.

Lamprophyres are widespread but volumetrically minor rocks that apparently are restricted to the continents and are the last manifestation of igneous activity in a given area. They usually occur as subparallel or radial swarms of thin (~1.6–160 ft or ~0.5–50 m) dikes or, less commonly, sills, volcanic neck fillings, or diatremes, or, rarely, lava flows. See IGNEOUS ROCKS. [S.W.B.]

**Land drainage (agriculture)** The removal of water from the surface of the land and the control of the shallow groundwater table improves the soil as a medium for plant growth. The sources of excess water may be precipitation, snowmelt, irrigation water, overland flow or underground seepage from adjacent areas, artesian flow from deep aquifers, floodwater from channels, or water applied for such special purposes as leaching salts from the soil or for achieving temperature control.

The purpose of agricultural drainage can be summed up as the improvement of soil water conditions to enhance agricultural use of the land. Such enhancement may come about by direct effects on crop growth, by improving the efficiency of farming operations or, under irrigated conditions, by maintaining or establishing a favorable salt regime. Drainage systems are engineering structures that remove water according to the principles of soil physics and hydraulics. The consequences of drainage, however, may also include a change in the quality of the drainage water. Agricultural drainage is divided into two broad classes; surface and subsurface. Some installations serve both purposes. [J.N.Lu.]

**Land reclamation** The process by which seriously disturbed land surfaces are stabilized against the hazards of wind and water erosion. Surface mining for coal is responsible for almost one-half of the total land area disturbed in the United States. The drastic disturbance of the overburden severely changes the chemical and physical properties of the resulting

spoils. These altered properties often create a hostile environment for seed germination and subsequent plant growth. Unless vegetative cover is established almost immediately, the denuded areas are subject to both wind and water erosion that pollute surrounding streams with sediment.

In the United States the Federal Strip Mine Law requires that topsoil be removed and reapplied on the spoil surface during regrading and reclamation. This practice alone has aided materially in reclamation of surface mine spoil areas throughout the United States. Even when topsoil is reapplied, the surface may contain coarse-textured materials and rock fragments, making it difficult to establish vegetative cover. Many of the eastern mine spoils are derived from sandstone and shales and have a low water-holding capacity. These spoils tend to form crusts and thus create a water-impermeable layer. Practically all of these topsoils have low fertility and thus require extensive fertilization for reclamation and seedling establishment. See SURFACE MINING.

[O.L.B.]

**Land-use planning** The long-term development or conservation of an area and the establishment of a relationship between local objectives and regional goals. Land-use planning is often guided by laws and regulations. The major instrument for current land-use planning is the establishment of zones that divide an area into districts which are subject to specified regulations. Although land-use planning is sometimes done by private property owners, the term usually refers to permitting by government agencies. Land-use planning is conducted at a variety of scales, from plans by local city governments to regulations by federal agencies. The United States has never developed a national land-use plan because land use is considered a local concern.

A major part of local planning is zoning, the division of areas into districts. Zones cover most potential uses, such as residential, commercial, light industry, heavy industry, open space, or transportation infrastructure (such as rail lines or highways). Detailed regulations guide how each zone can be used. As a result of pressures from rapid growth, some cities have begun to write growth management plans that limit the pace of growth. Comprehensive city plans aimed to limit the pace of growth have been accepted by the courts. See LANDSCAPE ARCHITECTURE.

Very few plans have been undertaken at a statewide scale. Each state plan differs by the needs and philosophy of the state. The state plans represent a balance of regional structures that address widespread growth with local powers that keep specific decision-making at the local level.

Environmental regulations are among the few national-level policies that have direct implications for land-use planning. Four of the major types of environmental laws that impact land-use planning are wetland laws, clean-air laws, clean-water laws, and laws for the protection of endangered species. See ENDANGERED SPECIES; WETLANDS.

Land-use planning, in large part, has focused on urban planning. Increasingly, land-use planning is done at larger scales and involves multiple issues. Awareness of environmental concerns, coupled with the wide availability of technical tools that include digital maps at all scales, has led to new approaches to land-use planning. These approaches often use ideas from landscape ecology, such as the concepts of patches; edges, boundaries, and fragmentation; buffer zones; and corridors and connectivity. See ECOLOGY, APPLIED; LANDSCAPE ECOLOGY.

[C.Sc.]

**Landing gear** That portion of an aircraft consisting of the wheels, tires, brakes, energy absorption mechanism, and drag brace. The landing gear is also referred to as the aircraft undercarriage. Additional components attached to and functioning with the landing gear may include retracting mechanisms, steering devices, shimmy dampers, and door panels.

The landing gear supports the aircraft on the ground and provides a means of moving it. It also serves as the primary means

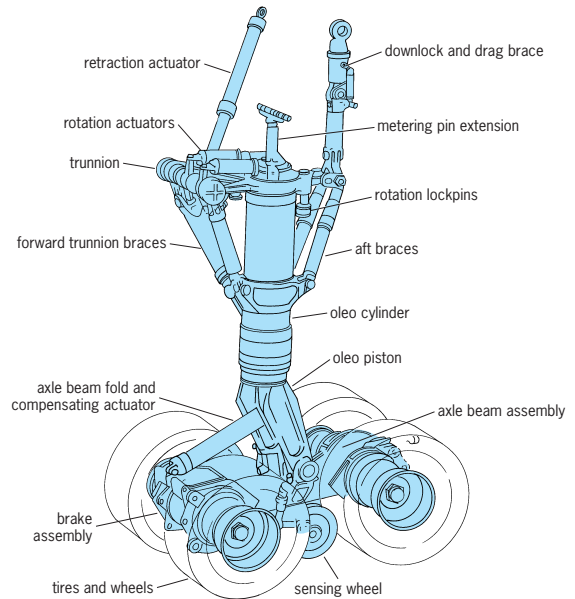

**Main-wheel bogie for the XB-70A aircraft.** (After S. Pace, *North American Valkyrie XB-70A*, Aero Series vol. 30, Tab Books, 1984)

of absorbing the large amounts of energy developed in the transition from flight to ground roll during a landing approach. The brakes, normally located in the main wheels, are used to retard the forward motion of the aircraft on the ground and may provide some control in the steering of the aircraft. In most modern aircraft the landing gear is designed to retract into the aircraft so that it is out of the airstream and drag is thus reduced.

Early aircraft and many small aircraft use a tail-wheel (or skid) in a conventional, or tail-dragger arrangement, in which the main landing gear is located ahead or forward of the center of gravity of the aircraft. The popular arrangement on modern aircraft is a tricycle landing gear, with the main gear located behind or aft of the center of gravity, and a nose gear located forward which carries about 20% of the static weight of the aircraft. Large aircraft such as the wide-body commercial aircraft and military aircraft like the C-5A employ multiple-wheeled bogies to support their huge weight and, in the case of the C-5A, to provide soft terrain landing and takeoff capability. See MILITARY AIRCRAFT.

The most accepted method of absorbing the energy due to landing is an air-oil strut called an oleo. The basic components are an outer cylinder which contains the air-oil mixture and an inner piston that compresses the oil through an orifice. The flow of oil through the orifice is metered by a variable-diameter pin that passes through the orifice as the gear strokes. The flow of oil in effect varies the stiffness of the compression of the gear. [R.R.De.]

**Landscape architecture** The art and profession of designing and planning landscapes. Landscape architects are concerned with improving the ways in which people interact with the landscape, as well as with reducing the negative impacts that human use has upon sensitive landscapes. Landscape architects are involved in such diverse areas as landscape and urban design, community and regional planning, interior and exterior garden design, agricultural and rural land-use planning, parks and recreation, historic site and natural area preservation, landscape restoration and management, research and academic programs, energy and water conservation, and environmental planning.

Landscape architects are generalists in that their educational and professional experience is very broad. Many environmental and cultural factors affect landscape design and planning, and landscape architects have to know how these factors relate.

Design process is the main area of specialization for landscape architects, and decision-making related to design process is fundamental. See CIVIL ENGINEERING; ENVIRONMENTAL ENGINEERING; FORESTRY, URBAN; LAND-USE PLANNING. [K.J.D.]

**Landscape ecology** The study of the distribution and abundance of elements within landscapes, the origins of these elements, and their impacts on organisms and processes. A landscape may be thought of as a heterogeneous assemblage or mosaic of internally uniform elements or patches, such as blocks of forest, agricultural fields, and housing subdivisions. Biogeographers, land-use planners, hydrologists, and ecosystem ecologists are concerned with patterns and processes at large scale. Landscape ecologists bridge these disciplines in order to understand the interplay between the natural and human factors that influence the development of landscapes, and the impacts of landscape patterns on humans, other organisms, and the flows of materials and energy among patches. Much of landscape ecology is founded on the notion that many observations, such as the persistence of a small mammal population within a forest patch, may be fully understood only by accounting for regional as well as local factors.

Factors that lead to the development of a landscape pattern include a combination of human and nonhuman agents. The geology of a region, including the topography and soils along with the regional climate, is strongly linked to the distribution of surface water and the types of vegetation that can exist on a site. These factors influence the pattern of human settlement and the array of past and present uses of land and water. One prevalent effect of humans is habitat fragmentation, which arises because humans tend to reduce the size and increase the isolation among patches of native habitat.

The pattern of patches on a landscape can in turn have direct effects on many different processes. The structure and arrangement of patches can affect the physical movement of materials such as nutrients or pollutants and the fate of populations of plants and animals. Many of these impacts can be traced to two factors, the role of patch edges and the connectedness among patches.

The boundary between two patches often act as filters or barriers to the transport of biological and physical elements. As an example, leaving buffer strips of native vegetation along stream courses during logging activities can greatly reduce the amount of sediment and nutrients that reach the stream from the logged area. Edge effects can result when forests are logged and there is a flux of light and wind into areas formerly located in the interior of a forest. In this example, edges can be a less suitable habitat for plants and animals not able to cope with drier, high-light conditions. When habitats are fragmented, patches eventually can become so small that they are all edge. When this happens, forest interior dwellers may become extinct. When patch boundaries act as barriers to movement, they can have pronounced effects on the dynamics of populations within and among patches. In the extreme, low connectivity can result in regional extinction even when a suitable habitat remains. This can occur if populations depend on dispersal from neighboring populations. When a population becomes extinct within a patch, there is no way for a colonist to reach the vacant habitat and reestablish the population. This process is repeated until all of the populations within a region disappear. Landscape ecologists have promoted the use of corridors of native habitat between patches to preserve connectivity despite the fragmentation of a landscape. [D.Sk.]

**Landslide** The perceptible downward sliding, falling, or flowing of masses of soil, rock, and debris (mixtures of soil and weathered rock fragments). Landslides range in size from a few cubic meters to over  $10^9 \text{ m}^3$  ( $3.5 \times 10^{10} \text{ ft}^3$ ), their velocities range from a few centimeters per day to over 100 m/s (330 ft/s), and their displacements may be several centimeters to several kilometers. See MASS WASTING.

The U.S. Highway Research Board classification divides land-sliding of rock, soil, and debris, on the basis of the types of movement, into falls, slides, and flows. Other classifications consider flows, along with creep and other kinds of landslides, as general forms of mass wasting.

Falls occur when soil or rock masses free-fall through air. Falls are usually the result of collapse of cliff overhangs which result from undercutting by rivers or simply from differential erosion. Slides invariably involve shear displacement or failure along one or more narrow zones or planes. Internal deformation of the sliding mass after initial failure depends on the kinetic energy of the moving mass (size and velocity), the distance traveled, and the internal strength of the mass. Flows have internal displacement and a shape that resemble those of viscous fluids. Relatively weak and wet masses of shale, weathered rock, and soil may move in the form of debris flows and earthflows; water-soaked soils or weathered rock may displace as mudflows.

Mining and civil engineering works have induced myriads of landslides, a few of them of a catastrophic nature. Open-pitmines and road cuts create very high and steep slopes, often quite close to their stability limit. Local factors (weak joints, fault planes) or temporary ones (surges of water pressure inside the slopes, earthquake shocks) induce the failure of some of these slopes. The filling of reservoirs submerges the lower portion of natural, marginally stable slopes or old landslides. Water lowers slope stability by softening clays and by buoying the lowermost portion, or toe, of the slope.

Advances in soil and rock engineering have improved the knowledge of slope stability and the mechanics of landsliding. Small and medium-sized slopes in soil and rock can be made more stable. Remedial measures include lowering the slope angle, draining the slope, using retaining structures, compressing the slope with rock bolts or steel tendons, and grouting. See ENGINEERING GEOLOGY; EROSION; SOIL MECHANICS. [A.S.N.]

**Langevin function** A mathematical function which is important in the theory of paramagnetism and in the theory of the dielectric properties of insulators. The analytical expression for the Langevin function is shown in the equation below. If

$$L(x) = \coth x - 1/x$$

$x \ll 1$ ,  $L(x) \simeq x/3$ . The paramagnetic susceptibility of a classical (non-quantum-mechanical) collection of magnetic dipoles is given by the Langevin function, as is the polarizability of molecules having a permanent electric dipole moment. See PARAMAGNETISM. [E.A.; F.Ke.]

**Langmuir circulation** A form of motion found in the near-surface water of lakes and oceans under windy conditions. When the wind is stronger than 5–8 m/s (10–15 knots), streaks of bubbles, seaweed, or flotsam form lines running roughly parallel to the wind, called windrows. Windrows are seen at one time or another on all bodies of water, from ponds to oceans. In the 1920s, Irving Langmuir hypothesized that they are produced by convergences in the water rather than by a direct action of the wind. Langmuir proposed that as the surface water is blown downwind it moves in a spiral fashion, first angling toward the streaks along the surface, next sinking to some depth, then diverging out from under the streaks, and finally rising again in between the streaks (see illustration). In a series of observations and experiments conducted in the North Atlantic and on Lake George in New York, he was able to confirm this basic form of the circulation.

In the ocean, the downwelling under windrows can be strong enough to pull bubbles, seaweed, and other buoyant particles down tens to hundreds of meters below the surface. The downward motion is eventually halted by a subtle increase in the water density with depth, associated with colder temperatures and/or higher salinity. The mixed surface layer typically spans most or all of the depth that light penetrates (the euphotic zone). This

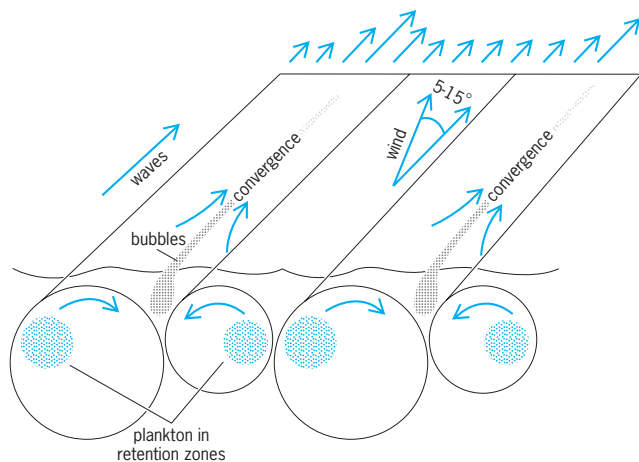

**Langmuir circulation** consists of a set of alternating rolls of water nearly aligned with the wind. Downwelling zones tend to be narrow and intense compared to the broader, gentler upwelling in between. The rolls may be asymmetric, with stronger flows to the right of the wind at the surface (in the Northern Hemisphere). Details of the lower part of the motion are not yet clear.

layer acts like the skin of the sea, through which heat, water vapor, oxygen, carbon dioxide, and all other materials must pass as they enter and leave the air and the sea. The mixing at the bottom of this layer also brings up nutrients and colder water from below.

[J.A.Smi.]

**Lanolin** A soft, waxy material derived from the greasy coating on raw wool. In the processing of wool, the fleece is scoured with an aqueous alkaline solution to remove debris, wax, water-soluble material, and free acids. The insoluble fraction, which constitutes about 15–20% of the weight of the original wool, is crude lanolin.

Lanolin is a very complex mixture of esters, similar to the skin lipids of birds and other animals. Analysis gives equal weights of acids and alcohols. The acids consist of 50–60% saturated fatty acids with chains up to C<sub>38</sub>–C<sub>40</sub>. Another group (30–35%) comprises  $\alpha$ -hydroxy acids and a small amount of  $\omega$ -hydroxy acids. See ESTER.

The major alcohol components are 35% cholesterol and 35–40% lanosterol. The latter is a key intermediate in the biosynthesis of steroids from squalene. See CHOLESTEROL; SQUALENE; STEROID.

A particularly useful property of lanolin is the formation of stable water-in-oil emulsions containing up to 25% water (hydrous lanolin). Major uses are as an emollient and skin moisturizer in lotions and cosmetic products, and in medicinal ointments. Unrefined lanolin has some use in inks and as a corrosion and rust preventative. See FAT AND OIL; WOOL.

[J.A.Mo.]

**Lanthanide contraction** The name given to an unusual phenomenon encountered in the rare-earth series of elements. The radii of the atoms of the members of this series decrease slightly as the atomic number increases. As the charge on the nucleus increases across the rare-earth series, all electrons are pulled in closer to the nucleus so that the radii of the rare-earth ions decrease slightly as the compounds go across the rare-earth series. Any given compound of the rare earths is very likely to crystallize with the same structure as any other rare earth. However, the lattice parameters become smaller and the crystal denser as the compounds proceed across the series. This contraction of the lattice parameters is known as the lanthanide contraction. See RARE-EARTH ELEMENTS.

[F.H.Sp.]

**Lanthanum** A chemical element, La, atomic number 57, atomic weight 138.91. Lanthanum, the second most abundant element in the rare-earth group, is a metal. The naturally occurring element is made up of the isotopes <sup>138</sup>La, 0.089%, and <sup>139</sup>La, 99.91%. <sup>138</sup>La is a radioactive positron emitter with a half-life of  $1.1 \times 10^{11}$  years. The element was discovered in 1839 by C. G. Mosander and occurs associated with other rare earths in monazite, bastnasite, and other minerals. It is one of the radioactive products of the fission of uranium, thorium, or plutonium. Lanthanum is the most basic of the rare earths and can be separated rapidly from other members of the rare-earth series by fractional crystallization. Considerable quantities of it are separated commercially, since it is an important ingredient in glass manufacture. Lanthanum imparts a high refractive index to the glass and is used in the manufacture of expensive lenses. The metal is readily attacked in air and is rapidly converted to a white powder. Lanthanum becomes a superconductor below about 6 K (–449°F) in both the hexagonal and face-centered crystal forms. See RARE-EARTH ELEMENTS.

[F.J.Sp.]

**Laplace transform** An integral transform extensively used by P. S. Laplace in the theory of probability. In simplest form it is expressed as the equation below. It is thought of as

$$f(s) = \int_0^{\infty} e^{-st} \phi(t) dt$$

transforming the determining function  $\phi(t)$  into the generating function  $f(s)$ . The variable  $t$  is real, the variable  $s$  may be real or complex,  $s = \sigma + i\tau$ . As an example, if  $\phi(t) = 1$  the integral converges for  $\sigma > 0$ , and  $f(s) = 1/s$ .

The Laplace transform is used for the solution of differential and difference equations, for the evaluation of definite integrals, and in many branches of abstract mathematics (functional analysis, operational calculus, and analytic number theory). See INTEGRAL TRANSFORM.

[D.V.W.]

**Laplace's differential equation** Laplace's equation in two independent variables  $x$  and  $y$  is given as Eq. (1) and

$$\frac{\partial^2 u(x, y)}{\partial x^2} = \frac{\partial^2 u(x, y)}{\partial y^2} = 0 \quad (1)$$

is of central importance in both pure mathematics and mathematical physics. A function  $u(x, y)$  having continuous first and second partial derivatives and satisfying Laplace's equation in a neighborhood of a point is called harmonic at that point. If a plane piece of tinfoil has its edges kept at a temperature which varies from point to point but does not change with time, and if the flow of heat in the tinfoil is steady (that is, independent of the time), the temperature  $u(x, y)$  at interior points of the foil is harmonic. Likewise Laplace's equation dominates the flow of electricity (the potential is similarly harmonic) and the flow of any incompressible fluid.

Many properties of Laplace's equation with two independent variables apply also in three or more dimensions. Thus, in three dimensions, a point distribution of matter of masses  $m_k$  at points  $(x_k, y_k, z_k)$  has a potential defined by Eq. (2), which is harmonic

$$u(x, y, z) \equiv \sum m_k [(x - x_k)^2 + (y - y_k)^2 + (z - z_k)^2]^{-1/2} \quad (2)$$

except in the points  $(x_k, y_k, z_k)$ . Except at such points, the force (Newtonian law of gravitation) exerted by the distribution on a unit exploratory particle at  $(x, y, z)$  has the components  $(\partial u/\partial x, \partial u/\partial y, \partial u/\partial z)$  and the component of the force in any direction is the directional derivative of  $u(x, y)$  in that direction. See POTENTIALS; SPHERICAL HARMONICS.

[J.L.W.]

**Laplace's irrotational motion** Laplace's equation for irrotational motion of an inviscid, incompressible fluid is

partial differential equation (1), where  $x_1, x_2, x_3$  are rectangular cartesian coordinates in an inertial reference frame, and Eq. (2) gives the velocity potential. The fluid velocity compo-

$$\partial^2\phi/\partial x_1^2 + \partial^2\phi/\partial x_2^2 + \partial^2\phi/\partial x_3^2 = 0 \quad (1)$$

$$\mathbf{v} = \text{grad } \phi \quad (2)$$

nents,  $u_1, u_2, u_3$  in the three respective rectangular coordinate directions are given by  $u_i = \partial\phi/\partial x_i, i = 1, 2, 3$ . More generally, in any inertial coordinate system, the equation is  $\text{div}(\text{grad } \phi) = 0$  and the velocity vector is  $\mathbf{v} = \text{grad } \phi$ . Irrotational motion implies that the fluid particles translate without rotation (like the cars on a ferris wheel). See FLUID FLOW. [A.E.Br.]

**Laplacian** The differential operator  $\partial^2/\partial x^2 + \partial^2/\partial y^2 + \partial^2/\partial z^2$ , in which the symbols  $x, y, z$  denote the variables of a rectangular cartesian coordinate system. The laplacian is frequently denoted by the symbol  $\nabla^2$  (read del square) in accordance with the fact that the laplacian of a scalar function  $S(x, y, z)$  is the divergence of the gradient of  $S$ , that is, the equation below applies.

$$\partial^2 S/\partial x^2 + \partial^2 S/\partial y^2 + \partial^2 S/\partial z^2 = \nabla \cdot (\nabla S)$$

The laplacian operator is involved in some of the most fundamental equations of mathematical physics, namely, Laplace's equation ( $\nabla^2 u = 0$ ), Poisson's equation, various wave equations, and the heat flow and diffusivity equations. See CALCULUS OF VECTORS; GAUSS' THEOREM; GRADIENT OF A SCALAR; GREEN'S THEOREM; WAVE EQUATION. [H.V.C.]

**Larch** A genus, *Larix*, of the pine family, with deciduous needles and short spurlike branches, which annually bear a crown of needles. The cones are small and persistent, varying by species in size, number, and form of the cone scales. The tamarack (*L. laricina*), also called hackmatack, is a native species. It has an erect, narrowly pyramidal habit, and grows in the northeastern United States, west to the Lake states, and across Canada to Alaska. The tough resinous wood is durable in contact with the soil and is used for railroad ties, posts, sills, and boats. Other uses include the manufacture of excelsior, cabinet work, interior finish, and utility poles. See PINALES.

The western larch (*L. occidentalis*), the most important and largest of all the species, grows in the northwestern United States and southeastern British Columbia. [A.H.G./K.P.D.]

**Large systems control theory** A branch of control theory concerned with large-scale systems. The three commonly accepted definitions of a large-scale system are based on notions of decomposition, complexity, and centrality. A system is sometimes considered to be large-scale if it can be partitioned or decomposed into small-scale subsystems. Another definition is that a system is large-scale if it is complex; that is, conventional techniques of modeling, analysis, control, design, and computation do not give reasonable solutions with reasonable effort. A third definition is based on the notion of centrality. Until the advent of large-scale systems, almost all control systems analysis and design procedures were limited to components and information grouped in one geographical location or center. Thus, by another definition, a system in which the concept of centrality fails is large-scale. This can be due to a lack of either centralized computing capability or a centralized information structure. Large-scale systems appear in such diversified fields as sociology, management, the economy, the environment, computer networks, power systems, transportation, aerospace, robotics, manufacturing, and navigation. Some examples of large-scale systems are the United States economy, the global telephone communication network, and the electric power generation system for the western United States. See CONTROL SYSTEMS; SYSTEMS ENGINEERING. [M.Ja.]

**Larmor precession** A precession in a magnetic field of the motion of charged particles or of particles possessing magnetic moments.

The Larmor theorem states that, for electrons moving in a single central field of force, the motion in a uniform magnetic field  $H$  is, to first order in  $H$ , the same as a possible motion in the absence of  $H$  except for the superposition of a common precession of angular frequency given by Eq. (1). Here  $e/c$  is

$$\omega_L = \frac{eH}{2mc} \quad (1)$$

the magnitude of the electronic charge in electromagnetic units, and  $m$  is the electronic mass. The frequency  $\omega_L$  is called the Larmor frequency and is numerically equal to  $2\pi$  times 1.40 MHz per oersted or  $2\pi$  times 111 MHz per SI unit of magnetic field strength (ampere-turn per meter). See PRECESSION.

In stating the Larmor theorem, use was made of the phrase "a possible motion." If  $H$  is applied sufficiently slowly, it can be proved that the motion is the same as in the absence of  $H$ , except for the superposition of the Larmor precession. However, a sudden application of  $H$  may change, for example, a circular orbit into an elliptical one.

According to elementary electromagnetic theory, a current loop of area  $A$  and of current  $I$  possesses a magnetic moment  $\mu$  of magnitude  $IA$  and of direction normal to the loop. Thus an electron moving in a circular orbit has an orbital magnetic moment.

The electron also has orbital angular momentum, which by quantum theory must equal  $\hbar J$ , where  $J$  is an integer and  $\hbar$  is Planck's constant  $h$  divided by  $2\pi$ . In terms of the equivalent magnetic moment, Eq. (1) may be written in the form of Eq. (2).

$$\omega_L = -\frac{\mu}{\hbar J} H \quad (2)$$

In this form the Larmor precession is exhibited by any magnetic moment  $\mu$  including magnetic moments associated with spin angular momentum as well as those associated with orbital angular momentum. In this form the Larmor precession applies to experiments in molecular beams, electron paramagnetic resonance (EPR), and nuclear magnetic resonance (NMR). See ANGULAR MOMENTUM; ELECTRON PARAMAGNETIC RESONANCE (EPR) SPECTROSCOPY; ELECTRON SPIN; MAGNETIC RESONANCE. [E.A.; F.Ke.]

**Larnite** The alpha polymorph of calcium silicate ( $\text{Ca}_2\text{SiO}_4$ ). Larnite is a mineral which crystallizes at high temperature. Its occurrences are practically confined to limestone or chalk zones in contact with semimolten basalts. At room temperature, larnite is metastable and inverts to its low-temperature polymorph calcio-olivine through shock. This leads to "fall," or disintegration of slags with time, and presents problems in the cement industry. The mineral is very rare, known from its type locality at Scawt Hill, County Antrim, Ireland, and from Crestmore, near Riverside, California. See SILICATE MINERALS. [P.B.M.]

**Larynx** The complex of cartilages and related structures at the opening of the trachea, or windpipe, into the pharynx, or throat. In humans and most other mammals, the signet-shaped cricoid cartilage forms the base of the larynx and rests upon the trachea. The thyroid cartilage, which forms the prominent Adam's apple ventrally, lies anterior to the cricoid. Dorsally there are paired pivoting cartilages, the arytenoids. Each is pyramid-shaped and acts as the movable posterior attachment for the vocal cords and the laryngeal muscles that regulate the cords. Two other small paired cartilages, the cuneiform and the corniculate, also lie dorsal to the thyroid cartilage. The epiglottis, a leaf-shaped elastic cartilage with its stem inserted into the thyroid notch, forms a lid to the larynx. [T.S.P.]

**Larynx disorders** Diseases of the larynx manifest themselves by hoarseness and by stridor, a form of noisy breathing caused by localized narrowing in the larynx or trachea.

Laryngitis is an inflammation of the mucous membrane of the larynx always associated with hoarseness. It frequently occurs with common colds and as a complication of other inflammatory diseases of the upper respiratory system. In diphtheria, the formation of a membrane of fibrin, leukocytes, destroyed tissue, and bacteria can cause severe respiratory difficulties, which may demand tracheotomy. The development of chronic laryngitis is favored by a chronic irritation such as that caused by smoking.

Hoarseness is also a manifestation of paralysis of the recurrent laryngeal nerve of the vagus, which is easily damaged upon surgical removal of a goiter.

Benign tumors of the larynx occur in the younger age group. A tumorlike formation of the vocal cord, known as singer's node, often accounts for the hoarseness of people who abuse the voice. Cancer of the larynx is not uncommon in humans, but is frequently of a slowly growing type and the outlook is often good. [E.R.W.]

**Laser** A device that uses the principle of amplification of electromagnetic waves by stimulated emission of radiation and operates in the infrared, visible, or ultraviolet region. The term laser is an acronym for light amplification by stimulated emission of radiation, or a light amplifier. However, just as an electronic amplifier can be made into an oscillator by feeding appropriately phased output back into the input, so the laser light amplifier can be made into a laser oscillator, which is really a light source. Laser oscillators are so much more common than laser amplifiers that the unmodified word "laser" has come to mean the oscillator, while the modifier "amplifier" is generally used when the oscillator is not intended. See AMPLIFIER; MASER; OSCILLATOR.

The process of stimulated emission can be described as follows: When atoms, ions, or molecules absorb energy, they can emit light spontaneously (as with an incandescent lamp) or they can be stimulated to emit by a light wave. This stimulated emission is the opposite of (stimulated) absorption, where unexcited matter is stimulated into an excited state by a light wave. If a collection of atoms is prepared (pumped) so that more are initially excited than unexcited (population inversion), then an incident light wave will stimulate more emission than absorption, and there is net amplification of the incident light beam. This is the way the laser amplifier works.

A laser amplifier can be made into a laser oscillator by arranging suitable mirrors on either end of the amplifier. These are called the resonator. Thus the essential parts of a laser oscillator are an amplifying medium, a source of pump power, and a resonator. Radiation that is directed straight along the axis bounces back and forth between the mirrors and can remain in the resonator long enough to build up a strong oscillation. (Waves oriented in other directions soon pass off the edge of the mirrors and are lost before they are much amplified.) Radiation may be coupled out by making one mirror partially transparent so that part of the amplified light can emerge through it (see illustration).

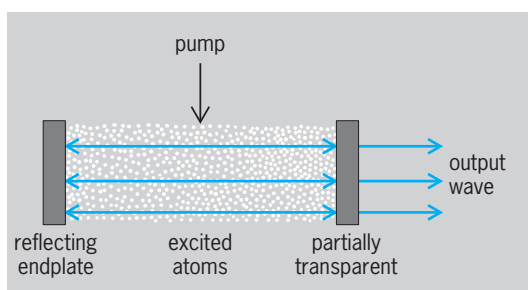

Structure of a parallel-plate laser.

The output wave, like most of the waves being amplified between the mirrors, travels along the axis and is thus very nearly a plane wave. See OPTICAL PUMPING.

**Continuous-wave gas lasers.** Perhaps the best-known gas laser is the neutral-atom helium-neon (HeNe) laser, which is an electric-discharge-excited laser involving the noble gases helium and neon. The lasing atom is neon. The wavelength of the transition most used is 632.8 nanometers; however, many helium-neon lasers operate at longer and shorter wavelengths including 3390, 1152, 612, 594, and 543 nm. Output powers are mostly around 1 milliwatt.

A useful gas laser for the near-ultraviolet region is the helium-cadmium (HeCd) laser, where lasing takes place from singly ionized cadmium. Wavelengths are 325 and 442 nm, with powers up to 150 mW.

The argon ion laser provides continuous-wave (CW) powers up to about 50 W, with principal wavelengths of 514.5 and 488 nm, and a number of weaker transitions at nearby wavelengths. The argon laser is often used to pump other lasers, most importantly tunable dye lasers and titanium:sapphire lasers. For applications requiring continuous-wave power in the red, the krypton ion laser can provide continuous-wave lasing at 647.1 and 676.4 nm (as well as 521, 568, and other wavelengths), with powers somewhat less than those of the argon ion laser.

The carbon dioxide (CO<sub>2</sub>) molecular laser has become the laser of choice for many industrial applications, such as cutting and welding.

**Short-pulsed gas lasers.** Some lasers can be made to operate only in a pulsed mode. Examples of self-terminating gas lasers are the nitrogen laser (337 nm) and excimer lasers (200–400 nm). The nitrogen laser pulse duration is limited because the lower level becomes populated because of stimulated transitions from the upper lasing level, thus introducing absorption at the lasing wavelength. Peak powers as large as 1 MW are possible with pulse durations of 1–10 nanoseconds. Excimer lasers are self-terminating because lasing transitions tear apart the excimer molecules and time is required for fresh molecules to replace them.

**Solid-state lasers.** The term solid-state laser should logically cover all lasers other than gaseous or liquid. Nevertheless, current terminology treats semiconductor (diode) lasers separately from solid-state lasers because the physical mechanisms are somewhat different. With that reservation, virtually all solid-state lasers are optically pumped.

Historically, the first laser was a single crystal of synthetic ruby, which is aluminum oxide (Al<sub>2</sub>O<sub>3</sub> or sapphire), doped with about 0.05% (by weight) chromium oxide (Cr<sub>2</sub>O<sub>3</sub>). Three important rare-earth laser systems in current use are neodymium:YAG, that is, yttrium aluminum garnet (Y<sub>3</sub>Al<sub>5</sub>O<sub>12</sub>) doped with neodymium; neodymium:glass; and erbium:glass. Other rare earths and other host materials also find application.

**Semiconductor (diode) lasers.** The semiconductor laser is the most important of all lasers, both by economic standards and by the degree of its applications. Its main features include rugged structure, small size, high efficiency, direct pumping by low-power electric current, ability to modulate its output by direct modulation of the pumping current at rates exceeding 20 GHz, compatibility of its output beam dimensions with those of optical fibers, feasibility of integrating it monolithically with other semiconductor optoelectronic devices to form integrated circuits, and a manufacturing technology that lends itself to mass production. See INTEGRATED OPTICS.

Most semiconductor lasers are based on III–V semiconductors. The laser can be a simple sandwich of *p*- and *n*-type material such as gallium arsenide (GaAs). The active region is at the junction of the *p* and *n* regions. Electrons and holes are injected into the active region from the *p* and *n* regions respectively. Light is amplified by stimulating electron-hole recombination. The mirrors comprise the cleaved end facets of the chip (either uncoated

or with enhanced reflective coatings). See ELECTRON-HOLE RECOMBINATION; SEMICONDUCTOR; SEMICONDUCTOR DIODE.

**Monochromaticity.** When lasers were first developed, they were widely noted for their extreme monochromaticity. They provided far more optical power per spectral range (as well as per angular range) than was previously possible. It has since proven useful to relate laser frequencies to the international time standard (defined by an energy-level difference in the cesium atom), and this was done so precisely, through the use of optical heterodyne techniques, that the standard of length was redefined in such a way that the speed of light is fixed. In addition, extremely stable and monochromatic lasers have been developed, which can be used, for example, for optical communication between remote and moving frames, such as the Moon and the Earth. See FREQUENCY MEASUREMENT; HETERODYNE PRINCIPLE; LASER SPECTROSCOPY; LIGHT.

**Tunable lasers.** Having achieved lasers whose frequencies can be monochromatic, stable, and absolute (traceable to the time standard), the next goal is tunability. Most lasers allow modest tuning over the gain bandwidth of their amplifying medium. However, the laser most widely used for wide tunability has been the (liquid) dye laser. This laser must be optically pumped, either by a flash lamp or by another laser, such as the argon ion laser. Considerable engineering has gone into the development of systems to rapidly flow the dye and to provide wavelength tunability. About 20 different dyes are required to cover the region from 270 to 1000 nm.

**Free-electron lasers.** The purpose of the free-electron laser is to convert the kinetic energy in an electron beam to electromagnetic radiation. Since it is relatively simple to generate electron beams with peak powers of  $10^{10}$  W, the free-electron laser has the potential for providing high optical power, and since there are no prescribed energy levels, as in the conventional laser, the free-electron laser can operate over a broad spectral range.

[S.F.J.; A.L.S.; R.Pan.]

**Laser alloying** A material processing method which utilizes the high power density available from focused laser sources to melt metal coatings and a portion of the underlying substrate. Since the melting occurs in a very short time and only at the surface, the bulk of the material remains cool, thus serving as an intimate heat sink. Large temperature gradients exist across the boundary between the melted surface region and the underlying solid substrate. The result is rapid selfquenching and resolidification.

For all laser sources, the exposure time (dwell time or pulse length) strongly influences the depth that will be melted. Longer exposure times result in deeper melting. Since deeper melting means a longer total time in the molten state, that means more time available for diffusion of the one or more alloying elements into the molten portion of the substrate. Deeper melting and longer melt times therefore result in more dilute surface alloys, while shallow melting and shorter melt times result in more concentrated surface alloys.

In making laser alloys, many other processing variables need to be considered. In addition to the exposure time, these include the laser power, the thickness of the film put down prior to laser melting, and in some instances the nature of the gaseous ambient during the laser processing. The processing variables are interrelated, and one variable cannot be freely changed without affecting another. Another consideration is that laser alloying is a liquid state-rapid quenching phenomenon. The near-surface region must be melted and yet vaporization avoided. Different minimum and maximum energy densities are thus defined for each laser exposure time. Laser alloying also involves very large temperature gradients and quenching from the liquid state. In this way it resembles other rapid-solidification technologies. The thermodynamic constraints which limit the conventional metallurgist do not necessarily apply. See ALLOY; LASER; METAL COATINGS.

[C.W.D.]

**Laser cooling** Reducing the thermal motion of atoms with the force exerted by a laser beam. Typically, such cooling is used to reduce the temperature of a gas of atoms, or the velocity spread of atoms in an atomic beam.

Light affects atomic motion when the atoms absorb or emit photons, the particles or quanta that make up light. Photons carry momentum  $p = h/\lambda$ , where  $h$  is Planck's constant and  $\lambda$  is the light's wavelength. By conservation of momentum, when an atom absorbs or emits a photon, the atom's momentum must change by an amount equal to the photon momentum. Each absorption or emission thus gives the atom a tiny kick, changing its velocity. For most atoms this change is only a few millimeters to a few centimeters per second, while atoms in a gas at room temperature have velocities of a few hundred to a few thousand meters per second. Nevertheless, repeated absorption and emission of photons can have a significant effect on even hot atomic gases or beams. See CONSERVATION OF MOMENTUM; LIGHT; MOMENTUM; PHOTON.

The keys to using such repeated kicks to reduce the random, thermal motion of a gas of atoms are the monochromatic nature of laser light, the selectivity of absorption of light by atoms, and the Doppler effect. Light is an oscillating electromagnetic wave whose frequency of oscillation determines its color. The energy of each photon is  $E = h\nu$ , where  $\nu$  is the frequency. Laser light can have nearly a single frequency or color, so that all the photons have almost identical energies. Atoms absorb only photons whose energy is equal, within a small range, to the difference in energy between two of its quantum states or energy levels. For sodium atoms this resonance frequency is  $\nu_0 \equiv 5 \times 10^{14}$  Hz (wavelength  $\lambda \equiv 589$  nanometers), but the absorption is efficient only over a range  $\Delta\nu = 10^7$  Hz. Moving atoms, however, experience a Doppler shift so that, depending on their speed and whether they are moving along the direction of the laser beam or against it, the light appears to room-temperature atoms to have a frequency shifted up or down by a hundred or more times the natural absorption width  $\Delta\nu$ . See DOPPLER EFFECT; LASER.

If the frequency  $\nu$  of the laser is tuned to be slightly lower than  $\nu_0$ , those atoms moving against the laser beam see the laser upshifted, closer to  $\nu_0$ . These atoms are more likely to absorb photons, receive kicks opposite to the direction of their velocity, and slow down. After absorbing a photon, the atoms are in an excited state and return to the original state by spontaneously emitting a photon. Such photons are radiated in random directions, so the effect of their kicks averages to zero. For atoms held in a trap, as ions generally are, any trapped atom will at some time be traveling against the laser beam and be cooled. Laser cooling was first demonstrated in 1978 with such trapped ions. For free atoms, another, similarly tuned laser beam is added, aimed in the opposite sense, to cool those atoms moving in the opposite direction. More generally, one uses three pairs of mutually perpendicular, counterpropagating laser beams, all tuned below  $\nu_0$ . Then, no matter the direction of an atom's velocity, there are one or more laser beams that oppose the velocity and slow the atom.

Improving atomic clocks, where the thermal motion of atoms reduces the precision and accuracy, was a major motivation to developing laser cooling. Laser cooling is also used in atom optics, where well-collimated, monoenergetic atomic beams are more easily and effectively manipulated. In addition, laser cooling has been used to study collisions between very slow atoms. See ATOMIC CLOCK; SCATTERING EXPERIMENTS (ATOMS AND MOLECULES).

Laser cooling is intimately connected with trapping of atoms, because atoms must often be slowed down before they can be held in a trap and because atoms must often be trapped in order to observe laser cooling or its effects. Such effects include cold, trapped ions arranging themselves into a crystal because of the electric repulsion between the charged ions. Neutral atoms can become arrayed on an optical lattice of tiny traps formed by interference between the laser beams used to cool them. In both



cases, the spacing between atoms is thousands of times larger than the spacing in solid crystals. Another effect is Bose-Einstein condensation, wherein a gas of atoms whose de Broglie wavelength is comparable to the spacing between atoms has a transition to a state where a significant fraction of the atoms are in the lowest kinetic energy state possible. See BOSE-EINSTEIN CONDENSATION; PARTICLE TRAP; QUANTUM MECHANICS. [W.D.P.]

**Laser photobiology** The interaction of laser light with biological molecules, and the applications to biology and medicine. See LASER.

Microirradiation is a useful technique for the study of cell function by alteration of a specific organelle or part of a cell. The laser beam is focused through the objective of a microscope onto the cell. Practically speaking, it is easy to obtain spots of about 1 micrometer in diameter. Ruby, neodymium, and argon lasers are used for this purpose.

Laser spectroscopy is used to probe biological processes in which very fast reactions are involved or to study structural changes of complex molecules. The two techniques used are flash photolysis (in the nanosecond and picosecond range) and Raman spectroscopy. See LASER SPECTROSCOPY; RAMAN EFFECT.

Continuous-wave lasers have been employed as a "light knife," that is as a surgical cutting and coagulation tool. Generally, CO<sub>2</sub> lasers, emitting in the infrared, are used for this purpose. When the laser energy is focused onto a tissue surface, a small volume of tissue is heated, and thus only this area is "cut off." An advantage of this procedure is that small capillaries are coagulated, preventing hemorrhage resulting from cut blood vessels. Argon lasers are the most commonly used for treating retinopathies, but also for glaucoma and cataract. Laser irradiation is used for removal of foreign pigments in the skin (tattoos), for treatment of vascular disorders ("wine marks"), and for removal of various pigmented skin lesions. [G.Mo.]

**Laser photochemistry** A branch of chemistry in which reactions are induced or altered by laser light. The initial part of any photochemical reaction involves an optical transition to some excited state of molecule. These excited states could involve electronic, vibrational, and rotational excitation. The particular photochemical product that results from the absorption of light depends on the specific excited state species created during the irradiation. Thus the properties of the light source often determine the photochemical product. Lasers have had an immense impact on the field of photochemistry by providing scientists with an intense, polarized, and nearly monochromatic source of light. There are lasers that extend from wavelengths of less than 110 nanometers (vacuum ultraviolet) to more than 100,000 nm (far-infrared); for comparison, the entire visible spectrum extends from only 400 nm (violet) to 700 nm (red).

Use of lasers in photochemical applications provides three main advantages over conventional light sources such as discharge or arc lamps. First, lasers are generally more powerful than conventional light sources. A continuous-wave argon ion laser can produce 10 W at 514.5 nm. Pulsed lasers, which compress the light energy into very short time periods ( $10^{-6}$  to  $10^{-12}$  s), can generate correspondingly higher peak powers, typically from  $10^3$  to  $10^9$  W. These very short, intense pulses of light are used by the photochemist to monitor the time evolution of excited-state species or the appearance rate of products in a photochemical reaction.

Second, laser light can be collimated into a beam with a very small divergence angle, routinely less than 1/100 of a degree. The high degree of collimation of laser light permits efficient illumination at a chosen point within the sample, which could be far from the light source. This collimation permits the photochemist to confine the photochemical activation to some very small and precisely located area, such as in the fabrication and repair of microelectronic devices. In addition, the photochemical event, which has a very low absorption cross section, can be induced

by photolyzing a very small region of the chemical sample with the total laser output power.

Third, laser light is exceptionally pure in color. The spectral purity of light can be described by a band width measured in wavenumbers ( $\text{cm}^{-1}$ ), defined as the frequency width divided by the speed of light. While the full visible spectrum is  $10,000 \text{ cm}^{-1}$  wide, a typical laser may be as narrow as a few  $\text{cm}^{-1}$ . When conventional sources are used to irradiate molecules that have many possible excited-state transitions, a distribution of excited molecules results. These molecules may have been excited to several different electronic states with many possible vibrational or rotational energies. Under such conditions, it is often impossible to identify the excited electronic states that produced the various photochemical products. The high spectral purity of the laser obviates this problem, and the identity of the excited electronic state is almost always known to the laser photochemist.

The two general areas of laser-induced photochemistry are vibrational photochemistry and electronic photochemistry. In vibrational photochemistry the chemical reaction occurs entirely on the ground electronic state of the molecule, whereas electronic photochemistry occurs via some excited electronic state, usually involving the first excited singlet state (all electrons spin-paired) and possibly the lowest-lying triplet state (two electrons spin-unpaired) for most polyatomic molecules. Although electronic photochemistry has been profoundly affected by the advent of lasers, vibrational photochemistry, which requires intense light sources, is not even possible without lasers. See ELECTRON SPIN; TRIPLET STATE.

Because of the advantages of lasers, there is a constant demand for the development of lasers that will serve in new regions of the spectrum. In spite of the advantages of lasers, conventional light sources are still widely used in most photochemical investigations and commercial processes because of their simplicity and low cost. [D.Sn.]

**Laser-solid interactions** Interactions of laser light with solids. The term usually refers to the thermal effects of absorption of high-intensity laser beams. For nonthermal laser interactions with matter see LASER PHOTOCHEMISTRY; LASER SPECTROSCOPY; NONLINEAR OPTICS.

The high power densities attainable with lasers allow melting and even vaporization of any solid material that is sufficiently opaque at a given wavelength or photon energy. This has led to a number of applications involving cutting and drilling of ceramics and other brittle materials, even diamonds. Welding of components from the smallest wires to huge steel plates is done commercially with high-power lasers. Metal alloying in surface regions is also a domain of lasers. See LASER ALLOYING; LASER WELDING.

Ion implantation has become a dominant method of introducing controlled quantities of impurities near the surface of silicon and other semiconductors. The implanted layers need a heat treatment to repair the displacement damage caused by bombardment with energetic ions and to move the implanted impurity ions into lattice locations where they replace host atoms and become electrically active. Laser heating is particularly suitable for annealing since only the implanted regions are heated. See ION IMPLANTATION.

Thin films of single-crystalline silicon over an insulating substrate are very attractive for high-speed integrated circuits. An important approach to the formation of such films is the controlled melting of thin polycrystalline layers deposited over fused silica substrates or over oxidized silicon wafers. Through a careful control of temperature gradients around the molten spot, by shaping the laser beam or patterning the film, single-crystalline regions can be obtained. The formation of silicon-on-insulator structures will lead in the future to three-dimensional circuits, with several levels of transistors on the same chip. See INTEGRATED CIRCUITS; LASER. [G.K.C.]

**Laser spectroscopy** Spectroscopy with laser light or, more generally, studies of the interaction between laser radiation and matter. Lasers have led to a rejuvenescence of classical spectroscopy, because laser light can far surpass the light from other sources in brightness, spectral purity, and directionality, and if required, laser light can be produced in extremely intense and short pulses. The use of lasers can greatly increase the resolution and sensitivity of conventional spectroscopic techniques, such as absorption spectroscopy, fluorescence spectroscopy, or Raman spectroscopy. Moreover, interesting new phenomena have become observable in the resonant interaction of intense coherent laser light with matter. Laser spectroscopy has become a wide and diverse field, with applications in numerous areas of physics, chemistry, and biology. See LASER; SPECTROSCOPY. [T.W.Ha.]

**Laser welding** Welding with a laser beam. The primary apparatus is the continuous-wave, convectively cooled CO<sub>2</sub> laser with either oscillator/amplifier (gaussian output beam) or unstable resonator (hollows output beam) optics. These lasers, available in output powers ranging from approximately 1000 to 15,000 W, have been used to demonstrate specific welding accomplishments in a variety of metals and alloys. Substantial advances in laser technology made possible the production of fully automated multikilowatt industrial laser systems which can be operated on a continuous production basis. These systems can be used for a variety of development programs and on-line production applications. See LASER. [E.M.Br.]

**Latent image** An invisible image produced by a physical or chemical effect of light on the individual crystals (usually silver halide) of photographic emulsions. This image can be rendered visible by the process known as development. See PHOTOGRAPHY; PHOTOLYSIS. [R.H.N.]

**Lateral line system** A primitive vertebrate sensory system that is present in all larval and adult fishes, in larval amphibians (such as tadpoles), and in some adult amphibians that retain an aquatic lifestyle. The lateral line system consists of 100 or more sensory organs (neuromasts) that are typically arranged in lines on or just under the skin of the head and body. Neuromasts are composed of sensory hair cells, which are also found in the auditory system of all vertebrates. The lateral line system responds to water flowing past the skin surface and uses different flow patterns over the body to form hydrodynamic images of the animal's nearby surroundings, just as the visual system forms visual images of the environment using different light patterns on the retina.

Neuromasts are found just under the skin in fluid-filled canals that communicate with the skin surface through a series of pores (canal neuromasts, found in fishes only), or on the skin surface (superficial neuromasts, found in fishes and amphibians). A prominent canal that often forms a visible line along the trunk of most fishes is probably the origin of the term "lateral line," but in reality the lateral line system includes neuromasts that are distributed all over the head and body of the animal.

A neuromast contains up to hundreds of mechanosensory hair cells that are surrounded by support cells. Hair cells function as directional sensors that convey information to the brain about both the strength and direction of water currents. The ciliary bundle of each hair cell contains one long cilium (kinocilium) and a cluster of shorter cilia (stereocilia). The ciliary bundles of the hair cells are embedded in a gelatinous cupula. Hair cells are activated when water flows past the skin surface, causing the cupula to move, thus causing the cilia to bend. The neural response of each hair cell is proportional to both the degree of cilia displacement and the direction in which the stereocilia are displaced relative to the eccentrically placed kinocilium of each hair cell.

Information from neuromasts is transmitted to the brain by sensory (afferent) nerve fibers, which form five cranial nerves

(the lateral line nerves) that terminate in distinct medullary regions of the brainstem (medulla oblongata). Distinct regions and pathways in the brain are dedicated to processing information from the lateral line system. These are similar in overall organization, and in proximity to regions of the brain dedicated to processing information from two other closely allied sensory systems, the auditory system and the electrosensory system. Information is also carried from the brain to the sense organs by efferent nerve fibers, which can modulate the sensitivity of the organs to certain stimuli (for example, to reduce sensitivity when water flows are produced by the animal's own movements). See AMPHIBIA.

The lateral line system is thought to have a function that is intermediate between touch and hearing, and is best described as a sense of touch-at-a-distance. In general, large-scale water movements such as oceanic currents, tides, and river flows that are strong enough to carry a fish with them are not by themselves very effective lateral line stimuli. Smaller-scale movements, such as those produced by a slowly moving (less than 8 cm or 0.25 ft/s) stream or by nearby animals (less than one or two body lengths away), can be effective lateral line stimuli.

Fishes can use different types of water flows to form hydrodynamic images of their surroundings. They can form images passively by remaining still and simply detecting the water currents created by other moving animals, or by detecting current distortions or turbulent wakes created by a stationary obstacle in moving water. Alternatively, fishes can actively form images by swimming past a stationary obstacle and then detecting the distortions in their own self-generated flows due to the presence of the obstacle.

Fishes and amphibians can also use their lateral line system to orient themselves relative to a water current (rheotaxis), hold a stationary position in a stream, capture prey, avoid predators, and communicate with intraspecifics. Many stream-dwelling fishes (such as trout and salmon) show rheotactic and station-holding behaviors by orienting their bodies upstream and holding positions behind stationary rocks or boulders. These behaviors are important for the upstream spawning migrations of these fishes and for capturing prey that are being carried downstream. See ELASMOBRANCHII; NERVOUS SYSTEM (VERTEBRATE).

[S.Co.; J.F.Web.]

**Lateral meristem** Strips or cylinders of dividing cells located parallel to the long axis of the organ in which they occur. Radial enlargement of the cells derived from these meristems increases the diameter of the organ. The lateral meristem is concerned with secondary growth in the sense that its meristematic activity adds cells to the primary body which was derived from the apical meristems. See APICAL MERISTEM. [V.I.C.]

**Laterite** Originally the name for the iron-rich weathering product of basalt in southern India. The term is now used in a compositional sense for weathering products composed principally of the oxides and hydrous oxides of iron, aluminum, titanium, and manganese. Clay minerals of the kaolin group are typically associated with, and are genetically related to, laterite. Laterites range from soft, earthy, porous material to hard, dense rock. Concretionary forms of varying size and shape commonly are developed. The color depends on the content of iron oxides and ranges from white to dark red or brown, commonly variegated. See BAUXITE; CLAY MINERALS; KAOLINITE; WEATHERING PROCESSES.

Mature lateritic soils lack fertility for most systems of agriculture. Savannas or parklike grasslands are typical on laterite. Clay, not laterite, is found beneath rainforests and jungle vegetation.

[S.S.G.]

**Latitude and longitude** The latitude of a location specifies the angle between an imaginary line directed generally toward the center of the Earth and the Equator. The longitude

measures the angle between the meridian (the plane defined by the Earth's axis and this local reference direction) and the plane of the Greenwich meridian.

Astronomical (or astronomic) latitude and longitude use the direction of gravity for the reference direction. This direction, known as the astronomical vertical, is perpendicular to the equipotential surface of the Earth's gravitational field at the location of the observer.

A particular geopotential surface approximating mean sea level in the open ocean is called the geoid. A mathematical surface in the form of an oblate ellipsoid may be constructed to approximate the geoid. The direction perpendicular to this reference ellipsoid at the observer's location is used as the reference direction in defining geodetic latitude and longitude. See GEODESY.

Geocentric latitude and longitude are defined by a reference direction which passes precisely through the center of mass of the Earth. These coordinates are determined mathematically from the geodetic latitude and longitude, assuming a fixed relationship between the center of the geodetic datum and the center of mass and knowing the mathematical shape of the ellipsoid. [D.D.McC.]

**Lattice (mathematics)** Lattice theory deals with properties of order and inclusion, much as group theory treats symmetry. As a generalization of Boolean algebra, lattice theory was first applied to algebraic number theory; however, it was later recognized as a major branch of mathematics, unifying various aspects of algebra, geometry, and functional analysis, as well as of set theory, logic, and probability. See BOOLEAN ALGEBRA; GROUP THEORY; SET THEORY.

The most basic concept of lattice theory is that of a partial ordering of a set  $S$  of elements  $x, y, z, \dots$ . By this is meant a binary relation, usually denoted  $\leq$  (or  $\geq$ ), with the following properties:

- (P1)  $x \leq x$  for all  $x \in S$   
 (P2) If  $x \leq y$  and  $y \leq x$ , then  $x = y$   
 (P3) If  $x \leq y$  and  $y \leq z$ , then  $x \leq z$

If  $\leq$  is any partial ordering of  $S$ , then its converse or dual  $\geq$  defined by statement (1), is also a partial ordering of  $S$ . This easily

$$x \geq y \text{ if and only if } y \leq x \quad (1)$$

verified fact provides a fundamental Duality Principle, which is useful in many connections.

A lattice is defined as a partially ordered set in which any two elements  $x$  and  $y$  have a meet  $x \cap y$  and a join  $x \cup y$ . These binary operations satisfy the four basic identities:

- (L1)  $x \cap x = x \cup x = x$   
 (L2)  $x \cap y = y \cap x$  and  $x \cup y = y \cup x$   
 (L3)  $x \cap (y \cap z) = (x \cap y) \cap z$  and  $x \cup (y \cup z) = (x \cup y) \cup z$   
 (L4)  $x \cap (x \cup y) = x$  and  $x \cup (x \cap y) = x$

The operations  $\cap$  and  $\cup$  are connected with the relation  $\leq$  by the condition that  $x \leq y$ ,  $x \cap y = x$ , and  $x \cup y = y$  are three equivalent statements. Conversely, if  $L$  is an algebraic system with operations  $\cap$  and  $\cup$  satisfying (L1) to (L4) for all  $x, y, z$ , then the preceding condition defines  $\leq$  as a partial ordering of  $L$ , with respect to which  $\cap$  and  $\cup$  have the meanings defined above. [G.Bi.]

**Lattice vibrations** The oscillations of atoms in a solid about their equilibrium positions. In a crystal, these positions form a regular lattice. Because the atoms are bound not to their average positions but to the neighboring atoms, vibrations of neighbors are not independent of each other. In a regular lattice with harmonic forces between atoms, the normal modes of vibrations are lattice waves. These are progressive waves, and at low frequencies they are the elastic waves in the corresponding anisotropic continuum. The spectrum of lattice waves ranges

from these low frequencies to frequencies of the order of  $10^{13}$  Hz, and sometimes even higher. The wavelengths at these highest frequencies are of the order of interatomic spacings. See CRYSTAL STRUCTURE; VIBRATION; WAVE MOTION.

At room temperature and above, most of the thermal energy resides in the waves of highest frequency. Because of the short wavelength, the motion of neighboring atoms is essentially uncorrelated, so that for many purposes the vibrations can be regarded as those of independently vibrating atoms, each moving about its average position in three dimensions with average vibrational energy of  $3kT$ , where  $k$  is the Boltzmann constant and  $T$  the absolute temperature. The wave character of the vibrations is needed, however, to describe heat transport by lattice waves. Also, lattice vibrations interact with free electrons in a conducting solid and give rise to electrical resistance. The temperature variation at low temperatures provides evidence that this interaction is with waves. See ELECTRICAL RESISTIVITY.

Scattering of lattice waves by defects increases with increasing frequency ( $f$ ); its variation depends on the nature of the defect. Scattering by external and internal boundaries is almost independent of frequency, thus dominating at low frequencies and hence at low temperatures. A study of the thermal conductivity of nonmetallic crystals as function of temperature yields information about the defects present, and about the anharmonic nature of the interatomic forces in the crystal lattice. See CRYSTAL DEFECTS; THERMAL CONDUCTION IN SOLIDS. [P.G.Kl.]

**Launch complex** The composite of facilities and support equipment needed to assemble, check out, and launch a rocket-propelled vehicle. The term usually is applied to the facilities and equipment required to launch larger vehicles for which a substantial amount of prelaunch preparation is needed. Small operational rockets may require similar but highly simplified resources on a much smaller scale. For these, the term launcher is usually used. See SPACE FLIGHT. [K.Kr.]

**Laurales** An order of flowering plants composed of seven eumagnoliid families of tropical tree species that are important ecologically; some are shrubs. They include in total about 2500 species. They are most closely related to Magnoliales, from which they differ in their partly inferior ovaries and their biaperturate or inaperturate pollen, and then to Winterales and Piperales. Lauraceae (the laurel or cinnamon family) are the best known and largest, but Monimiaceae and its segregates are also important. Nearly all species have aromatic oils, which are important spices, perfumes, and medicines; their flowers are for the most part small and often arranged in distinct whorls, but some such as those of Calycanthaceae are large and much like those of Magnoliales in that parts are arranged spirally and intergrade.

Many species are important as timbers. Cinnamon and camphor come from *Cinnamomum* species, sassafras tea was formerly made from the roots of *Sassafras albidum* (now discouraged due to its suspected carcinogenic nature), and avocado comes from *Persea americana*; several genera are cultivated as ornamentals, such as *Calycanthus* (Carolina allspice) and *Chimonanthus* (wintersweet; both Calycanthaceae); and *Laurus* (bay laurel) and *Lindera* (spice bush; both Lauraceae). See AVOCADO; CAMPHOR TREE; EUMAGNOLIIDS; MAGNOLIALES; MONOCOTYLEDONS; PIPERALES; SASSAFRAS. [M.Ch.]

**Lava** Molten rock material that is erupted by volcanoes through openings (volcanic vents) in the Earth's surface. Volcanic rock is formed by the cooling and solidification of erupted lava. Beneath the Earth's surface, molten rock material is called magma. All magmas and lavas consist mainly of a liquid, along with much smaller amounts of solid and gaseous matter. The liquid is molten rock that contains some dissolved gases or gas bubbles; the solids are suspended crystals of minerals or incorporated fragments of preexisting rock. Rapid cooling (quenching) of

this liquid upon eruption forms a natural volcanic glass, whereas slower cooling allows more minerals to crystallize from the liquid and preexisting minerals to grow in size. The dissolved gases, a large proportion of which are lost on eruption, are mostly water vapor, together with lesser amounts of carbon, sulfur, chlorine, and fluorine gases. With very rare exception, the chemical composition of the liquid part of magmas and lavas is dominated by silicon and oxygen, which form polymers or compounds with other common rock-forming elements, such as aluminum, iron, magnesium, calcium, sodium, potassium, and titanium.

Viscosity is the principal property which determines the form of erupted lava. It is mainly dependent on chemical composition, temperature, gas content, and the amount of crystals in the magma. Liquid lava with basaltic composition (such as in Hawaii)—relatively low in silicon and aluminum and high in iron, magnesium, and calcium—has higher fluidity (lower viscosity) compared with lava of rhyolitic or dacitic composition (such as at Mount St. Helens, Washington), with higher abundance of silicon and aluminum but lower amounts of iron, magnesium, and calcium. High temperature and gas content of the liquid lava, combined with low crystal abundance, also contribute to increased lava fluidity. Measured maximum temperatures of basaltic lava (1150–1200°C; 2100–2190°F) are higher than those for andesitic and more silicic lavas (720–850°C; 1330–1560°F). Very fluid basaltic lavas can flow great distances, tens to hundreds of kilometers, from the eruptive vents; in contrast, more silicic lavas travel much shorter distances, forming stubby flows or piling up around the vent to form lava domes.

Volcanic products formed by erupted lava vary greatly in size and appearance, depending on volcano type, lava composition, and eruptive style. Most lava products are either lava flows, formed during nonexplosive eruptions by cooling and hardening of flowing lava; or fragmental (pyroclastic) products, formed during explosive eruptions by the shredding apart and ejection into the air of liquid lava. See ANDESITE; DACITE; MAGMA; PYROCLASTIC ROCKS; RHYOLITE; VISCOSITY; VOLCANIC GLASS; VOLCANO.

[R.I.T.]

**Lawrencium** A chemical element, symbol Lr, atomic number 103. Lawrencium, named after E. O. Lawrence, is the eleventh transuranium element; it completes the actinide series of elements. See ACTINIDE ELEMENTS; PERIODIC TABLE; TRANSURANIUM ELEMENTS.

The nuclear properties of all the isotopes of lawrencium from mass 255 to mass 260 have been established. <sup>260</sup>Lr is an alpha emitter with a half-life of 3 min and consequently is the longest-lived isotope known.

[A.Gh.]

**Lawson criterion** A necessary but not sufficient condition for the achievement of a net release of energy from nuclear fusion reactions in a fusion reactor. As originally formulated by J. D. Lawson, this condition simply stated that a minimum requirement for net energy release is that the fusion fuel charge must combust for at least enough time for the recovered fusion energy release to equal the sum of energy invested in heating that charge to fusion temperatures, plus other energy losses occurring during combustion. The Lawson criterion is to be thought of as only a rule of thumb for measuring fusion progress; detailed evaluation of all energy dissipative and energy recovery processes is required in order properly to evaluate any specific system. See NUCLEAR FUSION.

[R.F.P.]

**Lawsonite** A metamorphic silicate mineral related chemically and structurally to the epidote group of minerals. Its composition is CaAl<sub>2</sub>(H<sub>2</sub>O)(OH)<sub>2</sub>[Si<sub>2</sub>O<sub>7</sub>]. It possesses two perfect cleavages; crystals are orthorhombic prismatic to tabular, and colorless to pale blue; specific gravity is 3.1, and hardness is 6.5 on Mohs scale. See EPIDOTE; SILICATE MINERALS.

[P.B.M.]

**Layered intrusion** In geology, an igneous rock body of large dimensions, 5–300 mi (8–480 km) across and as much

as 23,000 ft (7000 m) thick, within which distinct subhorizontal stratification, or layering, is apparent and may be continuous over great distances, in some cases more than 60 mi (100 km). Although conspicuous layering may be found in other rocks of syenitic to granitic composition that are richer in silica, the great layered complexes of the world are, in an overall sense, of tholeiitic basaltic composition. (They may be viewed as intrusive analogs to continental flood basalts.) Indeed, their basaltic composition is of paramount significance to their origin. Only basaltic melts, originating in the mantle beneath the crust of the Earth, are both voluminous enough to occupy vast magma chambers and fluid enough for mineral layering to develop readily. The relatively low viscosity of basaltic melt is a consequence of its high temperature, 2100–2200°F (1150–1200°C), derived from the mantle source region, and its silica-poor, magnesium- and iron-rich (mafic) composition. See BASALT; EARTH; MAGMA.

Layered mafic complexes develop upon intrusion of large volumes of basaltic magma (120–24,000 mi<sup>3</sup> or 500–100,000 km<sup>3</sup>) into more or less funnel-shaped (smaller complexes) or dish-shaped (larger complexes) chambers 3–5 mi (5–8 km) beneath the Earth's surface. It is widely held that such layering is dominantly produced by gravitational settling of early-formed (cumulus) crystals. These crystals begin to grow as the magma cools and, on reaching a critical size, begin to sink because of their greater density relative to that of the hot silicate melt. Although the sequential order of mineral crystallization can vary depending on subtle differences in magma chemistry, a classic sequence of crystallization from basaltic magma is olivine, (Mg,Fe)SiO<sub>4</sub>; orthopyroxene, (Mg,Fe)SiO<sub>3</sub>; clinopyroxene, (Ca,Mg,Fe)SiO<sub>3</sub>; plagioclase (Ca,Na)(Si,Al)<sub>4</sub>O<sub>8</sub>.

While layers containing only one cumulus mineral may form under special circumstances, coprecipitation of two or three cumulus minerals—for example, olivine + orthopyroxene; orthopyroxene + plagioclase; or orthopyroxene + clinopyroxene + plagioclase—is more common. Under the influence of gravity and current movements in the cooling, tabular magma chamber, the cumulus minerals accumulate on the ever-rising floor of the chamber. The solid rock formed is known as a cumulate, a term that emphasizes its mode of origin and predominant content of cumulus minerals.

Lithologic layering within a complex is typically displayed on a variety of scales. On the broadest scale, a layered mafic complex may contain ultramafic cumulates rich in olivine and orthopyroxene at its base; mafic pyroxene- and plagioclase-rich cumulates at intermediate levels; and more evolved plagioclase-rich cumulates, or even granitic (granophyric) rocks, near its top.

Study of layered mafic complexes is of far more than academic interest because many of them host important deposits of chromium, copper, nickel, titanium, vanadium, and the platinum-group elements platinum, palladium, iridium, osmium, and rhodium. Each of these elements has a relatively high initial concentration in mafic magmas, but all must be dramatically concentrated within restricted layers to be recoverable economically. See IGNEOUS ROCKS.

[G.K.Cz.]

**Layout drawing** A design drawing or graphical statement of the overall form of a component or device, which is usually prepared during the innovative stages of a design. Since it lacks detail and completeness, a layout drawing provides a faithful explanation of the device and its construction only to individuals such as designers and drafters who have been intimately involved in the conceptual stage. In a sense, the layout drawing is a running record of ideas and problems posed as the design evolves. In most cases the layout drawing ultimately becomes the primary source of information from which detail drawings and assembly drawings are prepared by other drafters under the guidance of the designer. See DRAFTING; ENGINEERING DRAWING.

[R.W.M.]

**Lazurite** The chief mineral constituent in the ornamental stone lapis lazuli. Lazurite is a feldspathoid. It crystallizes in the isometric system, but well-formed crystals, usually dodecahedral, are rare. Most commonly, it is granular or in compact masses. The hardness is 5–5.5 on Mohs scale, and the specific gravity is 2.4–2.5. There is vitreous luster and the color is a deep azure, more rarely a greenish-blue. Lazurite is a tectosilicate, the composition of which is expressed by the formula  $\text{Na}_4\text{Al}_3\text{Si}_3\text{O}_{12}\text{S}$ .

Lapis lazuli is a mixture of lazurite with other silicates and calcite and usually contains disseminated pyrite. It has long been valued as an ornamental material. Localities of occurrence are in Afghanistan; Lake Baikal, Siberia; Chile; and San Bernardino County, California. See FELDSPATHOID; SILICATE MINERALS. [C.S.Hu.]

**Leaching** The removal of a soluble fraction, in the form of a solution, from an insoluble, permeable solid with which it is associated. The separation usually involves selective dissolving, with or without diffusion, but in the extreme case of simple washing it consists merely of the displacement (with some mixing) of one interstitial liquid by another with which it is miscible. The soluble constituent may be solid (as the metal leached from ore) or liquid (as the oil leached from soybeans).

Leaching is closely related to solvent extraction, in which a soluble substance is dissolved from one liquid by a second liquid immiscible with the first. Both leaching and solvent extraction are often called extraction. Because of its variety of applications and its importance to several ancient industries, leaching is known by a number of other names: solid-liquid extraction, lixiviation, percolation, infusion, washing, and decantation-settling. The liquid used to leach away the soluble material (the solute) is termed the solvent. The resulting solution is called the extract or sometimes the miscella.

Leaching processes fall into two principal classes: those in which the leaching is accomplished by percolation (seeping of solvent through a bed of solids), and those in which particulate solids are dispersed into the extracting liquid and subsequently separated from it. In either case, the operation may be a batch process or continuous. See EXTRACTION; FILTRATION; SOLVENT EXTRACTION. [S.A.M.]

**Lead** A chemical element, Pb, atomic number 82 and atomic weight 207.19. Lead is a heavy metal (specific gravity 11.34 at 16°C or 61°F), of bluish color, which tarnishes to dull gray. It is pliable, inelastic, easily fusible, melts at 327.4°C (621.3°F), and boils at 1740°C (3164°F). The normal chemical valences are 2 and 4. It is relatively resistant to attack by sulfuric and hydrochloric acids but dissolves slowly in nitric acid. Lead is amphoteric, forming lead salts of acids as well as metal salts of plumbic acid. Lead forms many salts, oxides, and organometallic compounds. See PERIODIC TABLE.

Industrially, the most important lead compounds are the lead oxides and tetraethyllead. Lead forms alloys with many metals and is generally employed in the form of alloys in most applications. Alloys formed with tin, copper, arsenic, antimony, bismuth, cadmium, and sodium are all of industrial importance. See LEAD ALLOYS.

Lead compounds are toxic and have resulted in poisoning of workers from misuse and overexposure. However, lead poisoning is presently rare because of the industrial application of modern hygienic and engineering controls. The greatest hazard arises from the inhalation of vapor or dust. In the case of organolead compounds, absorption through the skin may become significant. Some of the symptoms of lead poisoning are headaches, dizziness, and insomnia. In acute cases there is usually stupor, which progresses to coma and terminates in death. The medical control of employees engaged in lead usage involves precise clinical tests of lead levels in blood and urine. With such control and the proper application of engineering control, industrial lead poisoning may be entirely prevented.

Lead rarely occurs in its elemental state. The most common ore is the sulfide, galena. The other minerals of commercial importance are the carbonate, cerussite, and the sulfate, anglesite, which are much more rare. Lead also occurs in various uranium and thorium minerals, arising directly from radioactive decay. Commercial lead ores may contain as little as 3% lead, but a lead content of about 10% is most common. The ores are concentrated to 40% or greater lead content before smelting. See LEAD METALLURGY.

The largest single use of lead is for the manufacture of storage batteries. Other important applications are for the manufacture of tetraethyllead, cable covering, construction, pigments, solder, and ammunition.

Organolead compounds are being developed for applications such as catalysts for polyurethane foams, marine antifouling paint toxicants, biocidal agents against gram-positive bacteria, protection of wood against marine borers and fungal attack, preservatives for cotton against rot and mildew, molluscicidal agents, anthelmintic agents, wear-reducing agents in lubricants, and corrosion inhibitors for steel.

Because of its excellent resistance to corrosion, lead finds extensive use in construction, particularly in the chemical industry. It is resistant to attack by many acids because it forms its own protective oxide coating. Because of this advantageous characteristic, lead is used widely in the manufacture and handling of sulfuric acid.

Lead has long been used as protective shielding for x-ray machines. Because of the expanded applications of atomic energy, radiation-shielding applications of lead have become increasingly important.

Lead sheathing for telephone and television cables continues to be a sizable outlet for lead. The unique ductility of lead makes it particularly suitable for this application because it can be extruded in a continuous sheath around the internal conductors.

The use of lead in pigments has been a major outlet for lead but is decreasing in volume. White lead,  $2\text{PbCO}_3 \cdot \text{Pb(OH)}_2$ , is the most extensively used lead pigment. Other lead pigments of importance are basic lead sulfate and lead chromates.

A considerable variety of lead compounds, such as silicates, carbonates, and salts of organic acids, are used as heat and light stabilizers for polyvinyl chloride plastics. Lead silicates are used for the manufacture of glass and ceramic frits, which are useful in introducing lead into glass and ceramic finishes. Lead azide,  $\text{Pb(N}_3)_2$  is the standard detonator for explosives. Lead arsenates are used in large quantities as insecticides for crop protection. Litharge (lead oxide) is widely employed to improve the magnetic properties of barium ferrite ceramic magnets. Also, a calcined mixture of lead zirconate and lead titanate, known as PZT, is finding increasing markets as a piezoelectric material. [H.S.; J.D.J.]

**Lead alloys** Substances formed by the addition of one or more elements, usually metals, to lead. Lead alloys may exhibit greatly improved mechanical or chemical properties as compared to pure lead. The major alloying additions to lead are antimony and tin. The solubilities of most other elements in lead are small, but even fractional weight percent additions of some of these elements, notably copper and arsenic, can alter properties appreciably.

Lead is used as a sheath over the electrical components to protect power and telephone cable from moisture. Lead alloy grids are used in the lead-acid storage battery (the type used in automobiles) to support the active material composing the plates. Chemical-resistant alloys are used extensively in many applications requiring resistance to water, atmosphere, or chemical corrosion. Lead bearing metals (babbitt metals) find frequent application in cast sleeve bearings, and are used extensively in freight-car journal bearings. Lead-base solder contains large amounts of tin with selected minor additions to provide specific benefits. See ALLOY; LEAD; LEAD METALLURGY; SOLDERING; TIN ALLOYS. [D.Wi.]

**Lead isotopes (geochemistry)** The study of the isotopic composition of stable and radioactive lead in geological and environmental materials to determine their ages or origins. See LEAD.

Lead isotope geochemistry provides the principal method for determining the ages of old rocks and the Earth itself, as well as the sources of metals in mineral deposits and the evolution of the mantle. Lead (Pb) has four stable isotopes of mass 204, 206, 207, and 208. Three are produced by the radioactive decay of uranium (U) and thorium (Th) [reactions (1)–(3), where  $t_{1/2}$  is

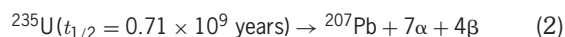
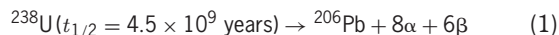

the half-life of the isotope and  $\alpha$  and  $\beta$  denote alpha and beta particles, respectively].

The lead produced by the decay of uranium and thorium is termed radiogenic. Since  $^{204}\text{Pb}$  is not produced by the decay of any naturally occurring radionuclide, it can be used as a monitor of the amount of initial (nonradiogenic) lead in a system. This will include all of the  $^{204}\text{Pb}$  and variable amounts of  $^{206}\text{Pb}$ ,  $^{207}\text{Pb}$ , and  $^{208}\text{Pb}$ . See ALPHA PARTICLES; BETA PARTICLES; RADIOACTIVITY; THORIUM; URANIUM.

It is possible to calculate the isotopic composition of lead at any time  $t$  in the past by calculating and deducting the amount of radiogenic lead that will have accumulated, provided a mineral or rock represents a closed system. A closed system is one in which there has been no chemical transfer of uranium, thorium, or lead in or out of the mineral or rock since it formed. All calculations for uranium-lead dating should yield the same age; this is a unique and powerful property. The ratio of radiogenic  $^{207}\text{Pb}$  to  $^{206}\text{Pb}$  is simply a function of age, not the U/Pb ratio. Certain minerals such as zircon, monazite, and uraninite are particularly well suited for dating because of extremely high concentrations of uranium or thorium relative to initial lead. However, the degree to which they behave as closed systems can vary. See ROCK AGE DETERMINATION.

Even if a rock or mineral contains appreciable initial lead, it may still be dated by using isochron methods. Since the amount of radiogenic lead relative to nonradiogenic lead is a function of the U/Pb ratio and time, the slope on a plot of  $^{206}\text{Pb}/^{204}\text{Pb}$  against  $^{238}\text{U}/^{204}\text{Pb}$  is proportional to age. An isochron is a line on a graph defined by data for rocks of the same age with the same initial lead isotopic composition, the slope of which is proportional to the age. In practice, the  $^{238}\text{U}/^{204}\text{Pb}$  ratio may well have been disturbed by recent alteration of the rock because uranium is highly mobile in near-surface environments. For this reason it is more common to combine the two uranium decay schemes and plot  $^{207}\text{Pb}/^{204}\text{Pb}$  against  $^{206}\text{Pb}/^{204}\text{Pb}$ ; the slope of an isochron on this plot is a function of age.

Isochron dating has been used to determine an age of 4.55 billion years for the Earth and the solar system by dating iron and stony meteorites. The position of data along the isochron is a function of the U/Pb ratio. The iron meteorites are particularly important for defining the initial lead isotopic composition of the solar system since they contain negligible uranium. The meteorite isochron is commonly termed the geochron. See EARTH, AGE OF; GEOCHRONOMETRY; METEORITE.

Lead isotopes can serve as tracers in the lithosphere, atmosphere, and hydrosphere. Lead isotopes are commonly used to trace the sources of constituents in continental terranes, granites, ore deposits, and pollutants. For example, some granites such as those of the Isle of Skye in northwest Scotland have very unradiogenic lead, indicating that the magmas were derived by melting portions of the lower continental crust that were depleted in uranium about 3 billion years ago. See ORE AND MINERAL DEPOSITS.

While there are at least 11 known radioactive isotopes of lead, only  $^{212}\text{Pb}$ ,  $^{214}\text{Pb}$ , and especially  $^{210}\text{Pb}$  have been of interest geo-

chemically. Unlike their noble-gas parents, the radioactive lead isotopes as well as other daughter products have a strong affinity for atmospheric aerosols. Both  $^{212}\text{Pb}$  and  $^{214}\text{Pb}$  have been used to study the process of diffusion of ions in gases and the mechanism of attachment of small ions to aerosols. Measurement of the distribution of radon (Rn) daughter product activities with respect to aerosol size has been important in the development of theoretical models of ion-aerosol interactions. The short half-lives of  $^{212}\text{Pb}$  and  $^{214}\text{Pb}$  also make these isotopes suitable for studies of near-ground atmospheric transport processes.  $^{210}\text{Pb}$ , because of its longer half-life, is removed mainly by precipitation and dry deposition. Its horizontal and vertical distributions are the result of the integrated effects of the distribution and intensity of sources, the large-scale motions of the atmosphere, and the distribution and intensity of removal processes. See AEROSOL; AIR MASS; ATMOSPHERIC CHEMISTRY; RADON.

One of the most important uses of  $^{210}\text{Pb}$  is for dating recent coastal marine and lake sediments. As the isotope is rapidly removed from water to underlying deposits, surface sediments often have a considerable excess of  $^{210}\text{Pb}$ . The excess is defined as that present in addition to the amount produced by the decay of radium in the sediments. When the sedimentation rate is constant and the sediments are physically undisturbed, the excess  $^{210}\text{Pb}$  decreases exponentially with sediment depth as a result of radioactive decay during burial. The reduction in activity at a given depth, compared with that at the surface, provides a measure of the age of the sediments at that depth. Typically, excess  $^{210}\text{Pb}$  can be measured for up to about five half-lives or about 100 years, and it is therefore ideally suited for dating sediments that hold records of human impact on the environment. See RADIOISOTOPE (GEOCHEMISTRY); SEDIMENTOLOGY. [A.N.H.; J.A.R.]

**Lead metallurgy** The extraction of lead from ore, its subsequent purification and processing, and its alloying with other metals to achieve desired properties.

There are many types and several specifications for lead. Primary lead is lead which is extracted and refined from ore. Secondary lead, recycled mostly from old storage batteries, can be refined to meet the same specifications as the primary metal, but the remelting, drossing, and recasting involved may have a negative impact on composition.

In the United States most lead ore is smelted and refined to a minimum purity of 99.85%. At and above this level of purity, four different grades of lead are recognized by the American Society for Testing and Materials: corroding, chemical, acid-copper, and common desilverized lead. The major differences among these grades are the allowable concentrations of copper, silver, and bismuth. Even trace amounts of these elements can have a significant effect on the properties or cost of the lead and justify having the four grades.

The first step in the beneficiation of ores to raise the lead content and to separate the lead from the zinc and iron minerals is concentrating. The standard processing begins with crushing the raw ore, followed by wet grinding, and then by mixing with flotation chemicals that collect the lead minerals in a froth, which is thickened and filtrated. The lead concentrate produced in this first processing step has a lead metal content of around 70%.

Before smelting, lead concentrates are frequently blended with high-grade raw ores or returned intermediates (flue dusts, lime-rock, and so forth) drawn from proportioning bins. These materials are pelletized so that a homogeneous and carefully sized smelter feed is provided. The feed is then sintered. The sinter product is charged into the top of a blast furnace. As the charge descends in the furnace, the molten metal flows to the bottom, from where it is withdrawn for refining. See LEAD. [A.L.P.]

**Leaf** A lateral appendage which is borne on a plant stem at a node (joint) and which usually has a bud in its axil. In most plants, leaves are flattened in form, although they may be nearly cylindrical with a sheathing base as in onion. Leaves usually

contain chlorophyll and are the principal organs in which the important processes of photosynthesis and transpiration occur.

**Morphology.** A complete dicotyledon leaf consists of three parts: the expanded portion or blade; the petiole which supports the blades; and the leaf base. Stipules are small appendages that arise as outgrowths of the leaf base and are attached at the base of the petiole. The leaves of monocotyledons may have a petiole and a blade, or they may be linear in shape without differentiation into these parts; in either case the leaf base usually encircles the stem. The leaves of grasses consist of a linear blade attached to the stem by an encircling sheath.

Leaves are borne on a stem in a definite fixed order, or phyllotaxy, according to species (Fig. 1). For identification purposes, leaves are classified according to type (Fig. 2) and shape (Fig. 3), and types of margins (Fig. 4), tips, and bases (Fig. 5). The arrangement of the veins, or vascular bundles, of a leaf is called venation (Fig. 6). The main longitudinal veins are usually interconnected with small veins. Reticulate venation is most common in dicotyledons, parallel venation in monocotyledons.

Surfaces of leaves provide many characteristics that are used in identification. A surface is glabrous if it is smooth or free

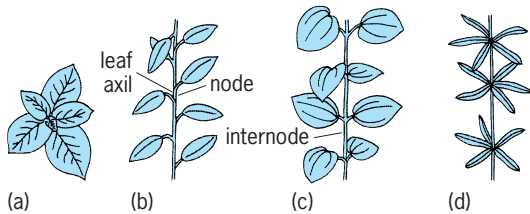

Fig. 1. Leaf arrangement. (a) Helical (top view). (b) Helical with elongated internodes (alternate). (c) Opposite (decussate). (d) Whorled (verticillate).

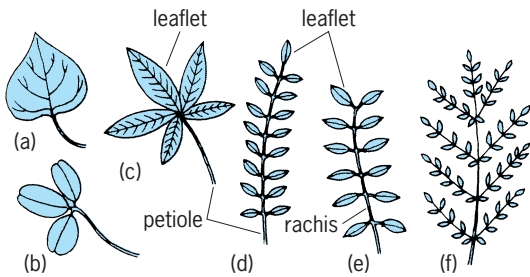

Fig. 2. Leaf types. (a) Simple. (b) Trifoliate. (c) Palmately compound. (d) Odd-pinnately compound. (e) Even-pinnately compound. (f) Decomound.

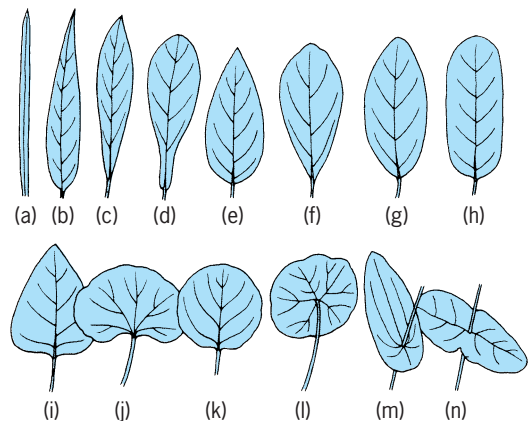

Fig. 3. Leaf shapes. (a) Linear. (b) Lanceolate. (c) Oblanceolate. (d) Spatulate. (e) Ovate. (f) Obovate. (g) Elliptic. (h) Oblong. (i) Deltoid. (j) Reniform. (k) Orbicular. (l) Peltate. (m) Perfoliate. (n) Connate.

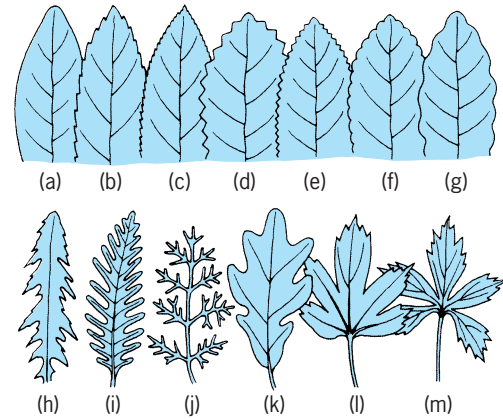

Fig. 4. Leaf margins of various types. (a) Entire. (b) Serrate. (c) Serrulate. (d) Dentate. (e) Denticulate. (f) Crenate. (g) Undulate. (h) Incised. (i) Pinnatifid. (j) Dissected. (k) Lobed. (l) Cleft. (m) Parted.

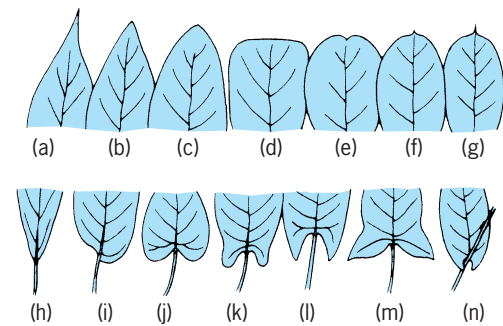

Fig. 5. Leaf tips and bases. (a) Acuminate. (b) Acute. (c) Obtuse. (d) Truncate. (e) Emarginate. (f) Mucronate. (g) Cuspidate. (h) Cuneate. (i) Oblique. (j) Cordate. (k) Auriculate. (l) Sagittate. (m) Hastate. (n) Clasping.

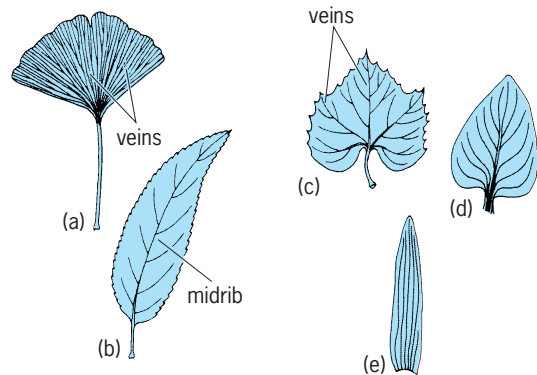

Fig. 6. Leaf venation. (a) Dichotomous. (b) Pinnate reticulate. (c) Palmate reticulate. (d) Parallel (expanded leaf). (e) Parallel (linear leaf).

from hairs; glaucous if covered with a whitish, waxy material, or "bloom"; scabrous if rough or harsh to the touch; pubescent, a general term for surfaces that are hairy; puberulent if covered with very fine, downlike hairs; villous if covered with long, soft, shaggy hairs; hirsute if the hairs are short, erect, and stiff; and hispid if they are dense, bristly, and harshly stiff.

The texture may be described as succulent when the leaf is fleshy and juicy; hyaline if it is thin and almost wholly transparent; chartaceous if papery and opaque but thin; scarious if thin and dry, appearing shriveled; and coriaceous if tough, thickish, and leathery.





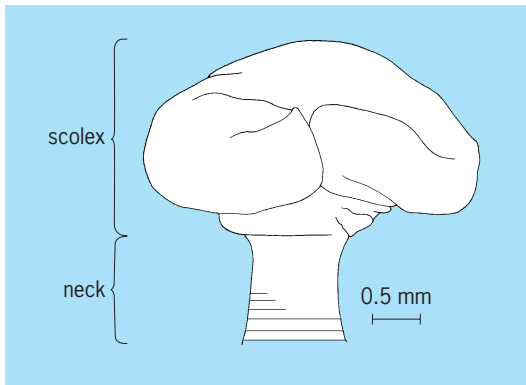

Anterior end of a lecanicephaloid tapeworm.

scolex divided into two portions. The lower portion is collarlike and bears four small suckers; the upper portion may be discoid or tentacle-bearing and is provided with glandular structures (see illustration). The scolex is usually buried in the intestinal wall of the host and may produce local pathology. The anatomy of the segments is very similar to that of the Proteocephaloidea. See CESTODA. [C.PR.]

**Lecanorales** An order of the Ascolichenes, also known as the Discolichenes. Lecanorales is the largest and most typical order of lichens and parallels closely the fungal order Helotiales. The apothecia are open and discoid, with a typical hymenium and hypothecium. There are four growth forms—crustose, squamulose, foliose, and fruticose—all showing greater variability than any other order of lichens.

The Lecanorales is divided into 25 families, about 160 genera, and 8000–10,000 species. Family divisions are based on growth form of the thallus, structure of the apothecia, the species of symbiotic algae present, and spore characters. Species are separated by such characters as isidia, soredia, rhizines, and pores, and by chemistry. The larger families include: Cladoniaceae, Lecanoraceae, Lecideaceae, Parmeliaceae, Umbilicariaceae, and Usneaceae. [M.E.H.]

**Le Chatelier's principle** A description of the response of a system in equilibrium to a change in one of the variables determining the equilibrium.

For any chemical reaction equilibrium or phase equilibrium, an increase in temperature at constant pressure shifts the equilibrium in the direction in which heat is absorbed by the system. See CHEMICAL EQUILIBRIUM; PHASE EQUILIBRIUM.

For any reaction equilibrium or phase equilibrium, an increase in pressure at constant temperature shifts the equilibrium in the direction in which the volume of the system decreases.

For a reaction equilibrium in a dilute solution, addition of a small amount of a solute species that participates in the reaction will shift the equilibrium in the direction that uses up some of the added solute.

For an ideal-gas reaction equilibrium, addition at constant temperature and volume of a species that participates in the reaction will shift the equilibrium in the direction that consumes some of the added species. For an ideal-gas reaction equilibrium, addition at constant temperature and pressure of a species that participates in the reaction might shift the equilibrium to produce more of the added species or might shift the equilibrium to use up some of the added species; the direction of the shift depends on the reaction, on which species is added, and on the initial composition of the equilibrium mixture. [I.N.L.]

**Lectins** A class of proteins of nonimmune origin that bind carbohydrates reversibly and noncovalently without inducing

any change in the carbohydrate. Lectins bind a variety of cells having cell-surface glycoproteins (carbohydrate bound proteins) or glycolipids (carbohydrate bound lipids). The presence of two or more binding sites for each lectin molecule allows the agglutination of many cell types, and the agglutination reaction has been used extensively to detect the presence of lectins in extracts from different organisms. Although lectins are ubiquitous in nature, their biological role is not well understood. See CARBOHYDRATE.

Hemagglutinating activity has been found in more than 1000 plant taxa. However, knowledge on distribution of well-characterized lectins covers only 4–5% of flowering plant families. Moreover, most of the best-characterized lectins come from a single family, Leguminosae.

Animal lectins have also been characterized in only a small number of species, but they have been found in almost all of the invertebrate and vertebrate phyla. Invertebrate lectins occur in body fluids or secretions, such as fish serum, snake venom, seminal and coelomic fluids, and hemolymph. Vertebrate lectins occur as soluble or integral membrane proteins in embryonic and adult fluids, organs, and tissues.

Microbial lectins have been isolated mainly from bacteria, but they are also found in viruses, slime molds, protozoa, green algae, and fungi.

From the few known examples, it seems clear that lectins are involved in recognition phenomena and their ability to bind particular carbohydrate structures is the key to their biological functions. These recognition functions include their involvement in interactions with cells or extracellular materials from the same organism (self-recognition) and interactions with foreign particles or cells (non-self recognition). Among the best-known examples of self-recognition mediated by lectins are the hepatic lectins involved in the recognition of glycoproteins that must be cleared from circulation. Specific lectins recognize and internalize the target proteins into lysosomes, where they are destroyed. See LYSOSOME.

Examples of lectin-mediated non-self-recognition are seen in the involvement of bacterial surface lectins in infection. Numerous bacterial strains produce surface lectins that recognize specific sugars in the surface of host cells and thus initiate the infection process. Another example is the symbiotic interaction between nitrogen-fixing bacteria and plant roots. The lectins present in the roots of legumes are localized at the surface of root hairs and in the root exudates, where they recognize the appropriate *Rhizobium* strain and account for part of the specificity in the initiation of nodulation.

Lectins are very useful reagents for the study of complex carbohydrates and cell surfaces, for the separation and identification of particular cells, and for the stimulation of cell proliferation. Lectins covalently attached to insoluble matrices are used to separate glycoproteins or glycopeptides that contain different carbohydrates. Labeled lectins are also used in histochemical and cytochemical studies to localize glyconjugates that carry particular sugars. This technique is particularly interesting, since changes in lectin-binding patterns occur during embryonic differentiation, malignant transformation, aging, and some pathological conditions. See PROTEIN. [R.PLe.]

**Lecythidales** An order of flowering plants, division Magnoliophyta (Angiospermae), in the subclass Dilleniidae of the class Magnoliopsida (dicotyledons). The order consists of the single family Lecythidaceae, with about 400 species. They are tropical, woody plants with alternate, entire leaves, valvate sepals, separate petals, numerous centrifugal stamens, and a syncarpous, inferior ovary with axile placentation. Brazil nuts are the seeds of *Bertholletia excelsa*, a member of the Lecythidaceae. See BRAZIL NUT; DILLENIIDAE; MAGNOLIOPHYTA. [A.Cr.]

**Legendre functions** Solutions to the differential equation  $(1 - x^2)y'' - 2xy' + \nu(\nu + 1)y = 0$ .

The most elementary of the Legendre functions, the Legendre polynomial  $P_n(x)$  can be defined by the generating function in Eq. (1). More explicit representations are Eq. (2), and the hypergeometric function, Eq. (3). See HYPERGEOMETRIC FUNCTIONS.

$$(1 - 2xr + r^2)^{-1/2} = \sum_{n=0}^{\infty} P_n(x)r^n \quad (1)$$

$$P_n(x) = \frac{(-1)^n}{2^n n!} \frac{d^n}{dx^n} (1 - x^2)^n \quad (2)$$

$$P_n(x) = {}_2F_1[-n, n + 1; 1; (1 - x)/2] \quad (3)$$

Generating function (1) implies Eq. (4). The function  $(a^2 - 2ar \cos \theta + r^2)^{-1/2}$  represents the potential in an inverse square field at a point  $P$  of a source at  $A$ , where  $r$  and  $a$  are the

$$(a^2 - 2ar \cos \theta + r^2)^{-1/2} = \frac{1}{a} \sum_{n=0}^{\infty} P_n(\cos \theta)(r/a)^n \quad (4)$$

$$0 < r < a$$

distances from  $P$  and  $A$  to a fixed point  $O$ , and  $\theta$  is the angle between the segments  $PO$  and  $OA$ . See DIFFERENTIAL EQUATION; ORTHOGONAL POLYNOMIALS; POTENTIALS. [R.A.]

**Legionnaires' disease** A type of pneumonia usually caused by infection with the bacterium *Legionella pneumophila*, but occasionally with a related species (such as *L. micdadei* or *L. dumoffii*). The disease was first observed in an epidemic among those attending an American Legion convention in Philadelphia, Pennsylvania, in 1976. The initial symptoms are headache, fever, muscle aches, and a generalized feeling of discomfort. The fever rises rapidly, reaching 102–105°F (32–41°C), and is usually accompanied by cough, shortness of breath, and chest pains. Abdominal pain and diarrhea are often present. The mortality rate can be as high as 15% in untreated or improperly diagnosed cases. Erythromycin, new-generation fluoroquinolones, and rifampicin are considered highly effective medications, whereas the penicillins and cephalosporins are ineffective.

While epidemics of Legionnaires' disease (also referred to as legionellosis) can often be traced to a common source (cooling tower, potable water, or hot tub), most cases seem to occur sporadically. It is estimated that *Legionella* spp. account for approximately 4% of all community- and hospital-acquired pneumonia. Legionnaires' disease is most frequently associated with persons of impaired immune status. *Legionella* bacteria are commonly found in fresh water and moist soils worldwide and are often spread to humans through inhalation of aerosols containing the bacteria. Legionnaires' disease is not a communicable disease, indicating that human infection is not part of the survival strategy of these bacteria. Therefore, the legionellae are considered opportunistic pathogens of humans. It is technology (air conditioning) and the ability to extend life through medical advances (such as transplantation and treatments for terminal diseases) that have brought these bacteria into proximity with a susceptible population.

For most humans exposed to *L. pneumophila*, infection is asymptomatic or short-lived. This is attributed to a potent cellular immune response in healthy individuals. Recovery from Legionnaires' disease often affords immunity against future infection. However, no vaccine exists at the present time. See MEDICAL BACTERIOLOGY; PNEUMONIA. [P.S.H.]

**Legume** A member of the plant family Leguminosae, and the name for the fruit produced by members of that family, as idealized in a bean or pea pod. The legume and grass families are by far the world's most important sources of food. Legumes, which include beans, soybeans, peas, and alfalfa, supply protein and fats. Through their root nodules, which are inhabited by *Rhizobium* bacteria, the legumes also preserve the nitrogen

balance in the soil. Legumes comprise one of the largest plant families in the world, with perhaps 18,000 species. Most species are tropical and include trees, woody vines, and herbaceous plants. All legume plants bear the same type of fruit, the pod or legume, which is diversely modified within the family. Most have compound leaves, and many, particularly tropical legumes, have spectacular flowers, some of which are grown as ornamentals. See FABALES; GRASS CROPS; NITROGEN FIXATION.

The three major groups of Leguminosae differ in the appearance of their flowers, and some botanists consider them to be three separate families. Others, as here, regard them as a single diverse family because all have the same kind of fruit and because the groups intergrade. The first group is the Mimosoids, in which the flowers have reduced petals and usually have conspicuous, long stamens that give color to the flower clusters. The Mimosoid group, which is almost entirely tropical, includes the so-called sensitive plant and the silk tree, or mimosa, a widely planted ornamental in the southern United States. The second group, the Caesalpinioids, is characterized by well-developed petals and includes ornamentals such as the redbud and honey locust in temperate regions and the orchid trees of the tropics. The third and largest group is the Papilionoids, whose members bear a flower that resembles the sweet pea, with a big petal at the top, a wing on either side, and a "keel" of two fused petals that enclose the stamens at the bottom. Many important agricultural plants are members of the Papilionoid group, including peanuts, garden beans, soybeans, garden peas, lentils, chickpeas, cowpeas, clovers, and alfalfa. See ALFALFA; BEAN; CLOVER; COWPEA; LENTIL; PEA; PEANUT; SOYBEAN. [D.I.]

**Legume forages** Plants of the legume family used for livestock feed, grazing, hay, or silage. Legume forages are usually richer in protein, calcium, and phosphorus than other kinds of forages; such as grass. The production, preservation, and use of forage legumes require special skills on most soils. One important requirement is a supply of the needed symbiotic nitrogen-fixing bacteria if these are not already in the soil. Protection from weeds, injurious insects, diseases, and other harmful influences is often required. See LEGUME; NITROGEN FIXATION.

Alfalfa is the most important legume forage crop in the United States; it is used mainly for hay but is often grazed. White clover and the annual lespedezas are the most extensively grown legumes for grazing particularly in the southeastern United States. Red clover was an important crop prior to 1930 but is minor now. About a dozen other species of legumes are used for cultivated forage in the United States, and a large number are grown for range grazing. See ALFALFA; CLOVER; COVER CROPS; COWPEA. [P.T.]

**Leitneriales** An order of flowering plants, division Magnoliophyta (Angiospermae) in the subclass Hamamelidae of the class Magnoliopsida (dicotyledons). The order consists of a single family, genus, and species (*Leitneria floridana*) of the southeastern United States. The plants are simple-leaved, dioecious shrubs with the flowers in catkins. The ovary is superior and pseudomonomerous, with a single ovule ripening into a small drupe. See HAMAMELIDAE; MAGNOLIOPHYTA. [A.Cr.; T.M.Ba.]

**Lemming** The name applied to 11 species of rodents in the subfamily Microtinae, family Muridae. These animals have a northern circumpolar distribution.

The Norway lemming (*Lemmus lemmus*) is found in the mountainous wastelands of northern Norway and Lapland. It is usually nocturnal and timid in its habits, except when a population explosion occurs with its resultant migration, of which the causative factors are not known. Cyclic variations in fertility may be a factor. Usually there are two litters of five offspring each year, but often four litters of two to eight offspring occur. See RODENTIA. [C.B.C.]

**Lemniscate of Bernoulli** A curve shaped like the figure eight (see illustration), referred to by Jacques Bernoulli in

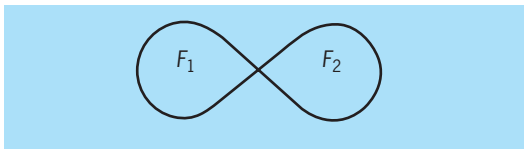

Curve known as lemniscate.

1694. Let  $F_1, F_2$  be points of a plane  $\pi$  with  $F_1F_2 = 2a, a > 0$ . The locus of a point  $P$  of  $\pi$  which moves so that  $PF_1 \cdot PF_2 = b^2$ , where  $b$  is a positive constant, is called an oval of Cassini. The lemniscate is obtained when  $b = a$ . Its equation in rectangular coordinates is  $(x^2 + y^2)^2 = a^2(x^2 - y^2)$  and in polar coordinates  $\rho^2 = a^2 \cos 2\theta$ . See ANALYTIC GEOMETRY. [L.M.Bl.]

**Lemon** The fruit *Citrus limon*. The yellow fruits are medium-sized and elongate with a prominent nipple. The lemon is more sensitive to cold than other major citrus fruits, and thus its commercial culture is restricted to areas with mild winter temperatures.

The lemon is grown primarily for its acid flavor. Lemon juice, very high in vitamin C, is used in beverages and has many culinary uses. It is also used widely in proprietary soft drinks. The principal by-products are citric acid from the juice and lemon oil from the peel. See ASCORBIC ACID.

Commercial lemon production developed first in Italy, mainly in Sicily. Italy is the largest producer, followed by California. Spain, Greece, and Argentina are also significant producers. [R.K.So.]

**Length** A one-dimensional extension in space. Length is one of the three fundamental physical quantities, the others being mass and time. It can be measured by comparison with an arbitrary standard; the specific one in most common usage is the international meter. In 1983, at the meeting of the Conférence Générale des Poids et Mesures, the meter was redefined in terms of time and the speed of light: "The meter is the length of the path traveled by light in vacuum during a time interval of 1/299 792 458 of a second." This definition defines the speed of light to be exactly 299 792 458 m/s, and defines the meter in terms of the most accurately known quantity, the second. See LIGHT; MASS; TIME. [D.A.J.]

**Lens (optics)** A curved piece of ground and polished or molded material, usually glass, used for the refraction of light. Its two surfaces have the same axis. Usually this is an axis of rotation symmetry for both surfaces; however, one or both of the surfaces can be toric, cylindrical, or a general surface with double symmetry (see illustration). The intersection points of

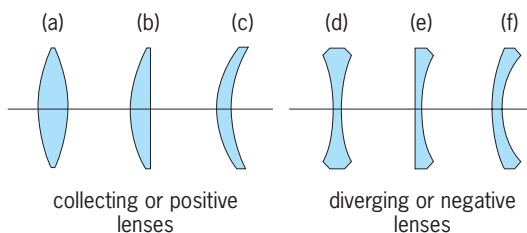

Common lenses. (a) Biconvex. (b) Plano-convex. (c) Positive meniscus. (d) Biconcave. (e) Plano-concave. (f) Negative meniscus. (After F. A. Jenkins and H. E. White, *Fundamentals of Optics*, 4th ed., McGraw-Hill, 1976)

the symmetry axis with the two surfaces are called the front and back vertices and their separation is called the thickness of the lens. There are three lens types, namely, compound, single, and cemented. A group of lenses used together is a lens system. Such systems may be divided into four classes: telescopes, oculars (eyepieces), photographic objectives, and enlarging lenses.

**Lens types.** A compound lens is a combination of two or more lenses in which the second surface of one lens has the same radius as the first surface of the following lens and the two lenses are cemented together. Compound lenses are used instead of single lenses for color correction, or to introduce a surface which has no effect on the aperture rays but large effects on the principal rays, or vice versa. Sometimes the term compound lens is applied to any optical system consisting of more than one element, even when they are not in contact.

The diameter of a simple lens is called the linear aperture, and the ratio of this aperture to the focal length is called the relative aperture. This latter quantity is more often specified by its reciprocal, called the  $f$ -number. Thus, if the focal length is 50 mm and the linear aperture 25 mm, the relative aperture is 0.5 and the  $f$ -number is  $f/2$ . See FOCAL LENGTH.

A compound lens made of two or more simple thin lenses cemented together is called a cemented lens.

**Lens systems.** A lens system consisting of two systems combined so that the back focal point of the first (the objective) coincides with the front focal point of the second (the ocular) is called a telescope. Parallel entering rays leave the system as parallel rays. The magnification is equal to the ratio of the focal length of the first system to that of the second. See TELESCOPE.

A photographic objective images a distant object onto a photographic plate or film. The amount of light reaching the light-sensitive layer depends on the aperture of the optical system, which is equivalent to the ratio of the lens diameter to the focal length. The larger the aperture (the smaller the  $f$ -number), the less adequate may be the scene luminance required to expose the film. Therefore, if pictures of objects in dim light are desired, the  $f$ -number must be small. On the other hand, for a lens of given focal length, the depth of field is inversely proportional to the aperture.

In general, photographic objectives with large fields have small apertures; those with large apertures have small fields.

The basic type of enlarger lens is a holosymmetric system consisting of two systems of which one is symmetrical with the first system except that all the data are multiplied by the enlarging factor  $m$ . When the object is in the focus of the first system, the combination is free from all lateral errors even before correction. A magnifier in optics is a lens that enables an object to be viewed so that it appears larger than its natural size. The magnifying power is usually given as equal to one-quarter of the power of the lens expressed in diopters. See DIOPTRER; MAGNIFICATION. [M.J.H.]

**Lentil** A semiviny annual legume with slender tufted and branched stems. The lentil plant (*Lens esculenta*) was one of the first plants brought under cultivation. The world's lentil production is centered in Asia, with nearly two-thirds of the production from India, Pakistan, Turkey, and Syria. Whitman and Spokane counties in Washington, and Latah, Benewah, and Nez Perce counties in Idaho grow about 95% of the lentils produced in the United States.

The seeds grow in short broad pods, each pod producing two or three thin lens-shaped seeds. Seed color varies from yellow to brown and may be mottled, although mottled seeds are not desirable for marketing.

Lentil seed is used primarily for soups but also in salads and casseroles. Lentils are more digestible than meat and are used as a meat substitute in many countries. See LEGUME. [K.J.M.]

**Lenz's law** A law of electromagnetism which states that, whenever there is an induced electromotive force (emf) in a conductor, it is always in such a direction that the current it would produce would oppose the change which causes the induced emf. If the change is the motion of a conductor through a magnetic field, the induced current must be in such a direction as to produce a force opposing the motion. If the change causing the emf is a change of flux threading a coil, the induced current must produce a flux in such a direction as to oppose the change.

Lenz's law is a form of the law of conservation of energy, since it states that a change cannot propagate itself. See CONSERVATION OF ENERGY; ELECTROMAGNETIC INDUCTION. [K.V.M.]

**Leo** The Lion, in astronomy, is a magnificent zodiacal constellation appearing during spring and early summer. It is the fifth sign of the zodiac. Leo is well defined and bears a close resemblance to the creature it represents (see illustration).

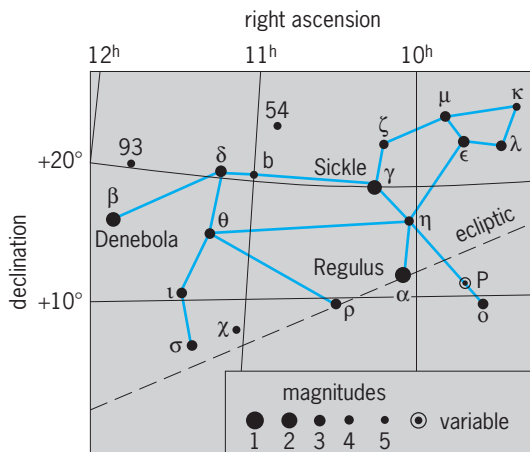

Line pattern of the constellation Leo. The grid lines represent the coordinates of the sky. Right ascension (E-W) in hours, and declination (N-S) in degrees, corresponding to the longitude and latitude of the Earth. The apparent brightness, or magnitudes, of the stars is shown by the sizes of the dots, which are graded by appropriate numbers as indicated.

Associated with this constellation are the famous Leonids shower of meteors, which can be seen radiating from Leo in November of each year and appearing especially brilliant at intervals of about 33 years. See CONSTELLATION. [C.-S.Y.]

**Lepadomorpha** A suborder of the Thoracica. These barnacles have a stalk or peduncle, which morphologically is the elongated, anterior, preoral region of the body, and a capitulum

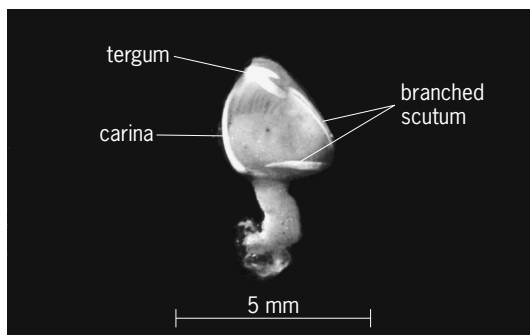

Morphology of *Octolasmis lowei*.

comprising the bivalved mantle enclosing the rest of the body (see illustration). The mantle folds are usually protected by a varying number of calcareous plates. The peduncle also may be protected by small calcareous scales or granules. Caudal furca and filamentary appendages are often present. These barnacles are hermaphroditic, or with separate sexes.

Several families are distinguished, the most primitive being Scalpellidae. See THORACICA. [H.G.St.]

**Lepidodendrales** An extinct order of the class Lycopsidea which, together with Isoetales, forms the monophyletic rhizomorphaleans, the most derived and diverse group of clubmosses. The lepidodendraleans are best known as the scale trees that dominate most reconstructions of Upper Carboniferous swamps, where they were the main constituent of many coal-forming peats.

Lepidodendraleans are represented most frequently in the fossil record as characteristic "tire-track" bark fragments, which reflect the regular geometric arrangements of leaves, although taxonomic revisions have focused on the more complete information obtained from fossils preserved three-dimensionally in petrified peats. Reconstruction of the plants from their component organs has revealed that the classic trees possessed a wide range of growth architectures and shared lowland habitats with other smaller-bodied genera, reflecting a major radiation that occurred in the Late Devonian and perhaps Early Carboniferous.

Rhizomorphic lycopsids are distinguished by their centralized rootstock (rhizomorph), which permitted bipolar growth; both aerial and subterranean axes could branch, unlike the unipolar rhizomes of other, more primitive lycopsids. This trait and the newly acquired ability to produce wood allowed many rhizomorphic lycopsids to form large upright trees, with trunks up to 115 ft (35 m) tall and 3 ft (1 m) in diameter.

Unlike most seed plants, branches functioned primarily for reproduction and propagule dispersal rather than light capture; even when mature, they formed open canopies that cast little shade.

The warming and drying of the global climate toward the end of the Late Carboniferous greatly reduced the diversity of the rhizomorphic lycopsids, beginning with the most derived and specialized genera such as *Lepidophloios* and eventually leaving only the increasingly reduced and ecologically specialized isoetales to survive to present day. See ISOETALES; LYCOPHYTA; LYCOPSIDA. [R.M.Ba.; W.A.DIM.]

**Lepidolite** A mineral of variable composition which is also known as lithium mica and lithionite,  $K_2(Li,Al)_{5-6}(Si_{6-7}, Al_{2-1})O_{20-21}(F,OH)_{3-4}$ . Rubidium (Rb) and cesium (Cs) may replace potassium (K); small amounts of Mn, Mg, Fe(II), and Fe(III) normally are present; and the OH/F ratio varies considerably. Polithionite is a silicon- and lithium-rich, and thus aluminum-poor, variety of lepidolite.

Lepidolite usually forms small scales or fine-grained aggregates. Its colors, pink, lilac, and gray, are a function of the Mn/Fe ratio. Hardness is 2.5–4.0 on Mohs scale; specific gravity is 2.8–3.0. See MICA; SILICATE MINERALS.

Lepidolite is uncommon, occurring almost exclusively in structurally complex granitic pegmatites, commonly in replacement units. Common associates are quartz, cleavelandite, alkali beryl, and alkali tourmaline. It is a commercial source of lithium, commonly used directly in lithium glasses and other ceramic products. [E.W.H.]

**Lepidoptera** The order of scaly-winged insects, including the butterflies, skippers, and moths. This is one of the largest orders in the class Insecta. It has more than 100,000 species, about 10,000 in North America, and between 125 and 175 families. The adults have a covering of hairs and scales on the wings, legs, and body, and are often beautifully colored. With minor

exceptions, the adults are also characterized by two pairs of membranous wings and sucking mouthparts, featuring a prominent, coiled proboscis. Butterflies and skippers usually fly in the daytime, and most moths are nocturnal. The adults usually take liquid food, such as nectar and juices of fruits. The caterpillars are almost always herbivorous.

**Morphology.** The most unusual feature of the head of the adult animal is the form of the mouthparts. The proboscis is extended by blood pressure created by the retraction of the stipites of the maxillae. Diagonal muscles within each proboscis unit cause the proboscis to coil. The liquid food is sucked up by means of a muscular pump, formed from the pharynx, buccal cavity, and cibarium, a food pocket of the mouth cavity. Ocelli are absent in many groups. Antennae are quite variable in form.

The prothorax is well developed in some lower groups but it is considerably smaller than the pterothoracic, or wing-bearing, segments, and is largely membranous in most Lepidoptera. The most prominent feature of the dorsum of the prothorax, in most groups, is a pair of protuberant sclerotized lobes.

The scales are very variable in form. Generally, they are flat, thin, sclerotized sacks, with striated outer surfaces. The vast spectrum of colors seen in the Lepidoptera can be grouped into two categories, pigmentary and structural colors. Pigmentary colors result from pigments which are present in the scales. Structural colors are the result of either fine surface ridges on the scales or layers within the cuticle, which interfere with or diffract the light. The structural colors are generally metallic or iridescent.

In most moths, the wings are coupled by a single spine formed by fused setae which project forward from the base of the hindwing and are held by a clasp on the forewing. The spine is known as the frenulum and the clasp is the retinaculum. In the *Homoneura*, there is a lobe, the jugum, at the base of the forewing, which engages the hindwing, or the frenulum, when it is present.

The form of the external genitalia, especially that of the male, has been widely used in the separation of species.

**Developmental stages.** Metamorphosis is complete. The larvae, commonly called caterpillars, are mandibulate and cylindrical, with short thoracic legs and a variable number of abdominal prolegs. They have one pair of thoracic and eight pairs of abdominal spiracles. Pupae are variable in form and have appendages that are usually firmly cemented down (obtect), though they are sometimes partly or completely free (exarate). Pupae often are enclosed in a silken cocoon.

**Classification.** Unfortunately, the classification of the Lepidoptera is the subject of considerable controversy; much will doubtless be resolved when more is known of the anatomy and life history of many groups.

A rather conservative classification has been used here. In many superfamilies only the more important families are mentioned. The table lists the important families.

*Homoneura (Jugatae).* Fore- and hindwings are similar in shape and venation. They are connected by a jugum and, sometimes, also by a frenulum. Mouthparts are mandibulate, with mandibles vestigial or absent, and the galeae forms a rudimentary proboscis. The female has a single genital opening. The pupae are free or partially free.

This small suborder, including less than 1% of the species in the order, contains a diverse group of primitive forms showing certain features in common with the Trichoptera, or caddis flies.

The superfamily Micropterygoidea includes one small family, the Micropterygidae, minute moths possessing toothed, functional mandibles and lacking even the most rudimentary proboscis. The larvae, which feed on mosses, are unusual in having eight pairs of abdominal prolegs.

Superfamily Eriocranioidea is a group of tiny moths; the mandibles are greatly reduced and untoothed. Three families, the Eriocraniidae, Neopseustidae, and Mnesarchaeidea, have been recognized within the superfamily. The leaf-mining larva

lacks legs. The adults reportedly do not feed. The females have a piercing ovipositor. Superfamily Hepialoidea contains medium- to large-sized moths which possess rudimentary mouth-parts. The larvae are borers. The rapid flying adults are mostly crepuscular, thus the common name swift, or ghost, moths. The only family of importance is the Hepialidae.

*Heteroneura (Frenatae).* Fore- and hindwings are markedly different in shape and venation. Usually they are connected by a frenulum and retinaculum. Mouthparts are formed for sucking or, rarely, are vestigial. Adults with functional mouthparts feed on nectar of flowers, juices of rotten fruits, and other liquids. The female usually has two genital openings. Pupae are usually obtect.

One family, the Incurvariidae, comprises the superfamily Incurvarioidea. The wings are covered with microscopic spines and the females have a single genital opening. The venation is almost complete.

Superfamily Nepticuloidea includes one family, the Nepticulidae. These tiny moths have wing spines and the females have a single genital opening, but they differ from the Incurvarioidea in having a reduced venation. The larvae are generally miners in leaves, bark, and rarely, in fruits.

Superfamily Cossioidea includes one family, the Cossidae, commonly called the carpenter or goat moths. These are heavy-bodied moths, with the abdomen extending well beyond the hindwings. Mouthparts are rudimentary except for labial palpi.

Superfamily Tineoidea contains 16–39 families; the number varies with the author. This is a very large group, of uncertain composition. These moths are of small size, usually with well-developed maxillary palpi. The labial palpi have a slender, pointed third segment. Venation may be reduced, and the wings may be divided into plumes.

The small, wide-winged moths of the superfamily Torticoidea belong to two families, the Olethreutidae and the Tortricidae. The maxillary palpi are vestigial or absent, and the third segment of the labial palpus is short and usually obtuse. The hair fringes of the wings are always shorter than the width of the wing.

The family contains a number of agriculturally undesirable species. Paramount among these is the codling moth (*Carpocapsa pomonella* L.), which is a very serious pest of apples and other fruits. The large genus *Laspeyresia* contains the interesting Mexican jumping bean moth (*L. saltitans* Westwood). The violent movements of the larvae of this moth are responsible for the action of the beans which they inhabit.

Tortricidae is a family which generally lacks the fringe of long hairs along the cubitus, characteristic of the Olethreutidae. The spruce budworm (*Choristoneura fumiferana* Clemens) is probably the most important injurious tortricid. In many places, especially in eastern Canada, it has defoliated vast areas of coniferous forest.

The superfamily Pyralidoidea is comprised of moths that are moderately small to medium-sized, long-legged, and slender-bodied. The maxillary palpi are usually well developed. Pyralidae is the second largest family of moths. They are small and medium-sized, and a wing expanse of 20–35 mm is not uncommon. The legs are usually long and slender. Pterophoridae is the family known as the plume moths. The wings are divided into featherlike plumes, of which there are usually two in the forewing and three in the hindwing. The moths lack maxillary palpi and have slender bodies and long legs. The larvae feed exposed or are borers.

Superfamily Zygaenoidea includes moderately small- to medium-sized moths that have complete venation, rudimentary palpi and, usually, a rudimentary proboscis. The wings are broad with short fringes. The larvae are short and more or less sluglike and are exposed feeders.

Superfamily Castnioidea includes one family, the Castniidae. They are large, diurnal, butterflylike moths with clubbed antennae, upright eggs, and boring larvae. A proboscis may be either

## Size, distribution, and common names of some families of Lepidoptera

Classification	Common name	Distribution	No. of species*
<b>Suborder Homoneura</b>			
Micropterygidae	Micropterygids	Holarctic and Australia	3 (35)
Eriocraniidae	Ericocraniids	Holarctic	5 (20)
Mnesarchaeidae	Mnesarchaeids	New Zealand	
Hepialidae	Swift or ghost moths	Cosmopolitan	18 (200)
<b>Suborder Heteroneura</b>			
Incurvariidae	Yucca moths and relatives	Cosmopolitan	60
Nepticulidae	Serpentine leaf miners	Cosmopolitan	75
Cossidae	Goat or carpenter moths	Cosmopolitan	45
Aegeriidae	Clearwing moths	Cosmopolitan	120
Coleophoridae	Case bearers	Cosmopolitan	110 (900)
Gelechiidae	Gelechiids	Cosmopolitan	590 (3800)
Gracilariidae	Gracilariids	Cosmopolitan	235
Heliodinidae	Heliodinids	Cosmopolitan	21
Oecophoridae	Oecophorids	Cosmopolitan; largely Australian	225 (3000)
Orneodidae	Many-plume moths	Cosmopolitan	1
Psychidae	Bagworms	Cosmopolitan	25
Tineidae	Clothes moths and relatives	Cosmopolitan	135 (2500)
Yponomeutidae	Ermine moths	Cosmopolitan	65 (800)
Olethreutidae	Olethreutids	Cosmopolitan	715 (2500)
Tortricidae	Tortricids	Cosmopolitan	210 (1500)
Thyrididae	Window-winged moths	Tropical	10
Pyralidae	Pyralids; snout moths	Cosmopolitan	1135 (12,000)
Pterophoridae	Plume moths	Cosmopolitan	130
Eucleidae	Slug moths	Cosmopolitan	50 (900)
Megalopygidae	Flannel moths	Mostly American; a few African	11
Zygaenidae	Foresters and burnets	Palaearctic, African, and Indo-Australian	—
Castniidae	Castniids	Neotropical and Indo-Australian	
Drepanidae	Hooktips	Holarctic	6
Geometridae	Measuring worms, loopers, cankerworms, carpets, waves, and pupgs	Cosmopolitan	1200 (4000)
Uraniidae	Uraniids	Tropical	—
Sphingidae	Sphinx, hawk, or hummingbird moths	Cosmopolitan	106 (1000)
Lasiocampidae	Tent caterpillars, lappet moths	Cosmopolitan except New Zealand; mainly tropical	30 (1400)
Saturniidae	Giant silkworms	Cosmopolitan	60
Bombycidae	Silkworm and allies	Tropical	1 (introduced)
Arctiidae	Tiger moths	Cosmopolitan	200 (3600)
Lymantriidae	Tussock moths	Largely African and Indo-Malayan, but with important Holarctic species	27
Notodontidae	Prominents, puss moths	Cosmopolitan except New Zealand	120
Noctuidae	Noctuids, owlets, underwings, millers	Cosmopolitan	2700 (20,000)
Hesperiidae	Skippers, agave worms	Cosmopolitan	240 (3000)
Papilionidae	Swallowtails, bird-wings, parnassians	Cosmopolitan	27 (600)
Pieridae	Whites, sulfurs, orangetips	Cosmopolitan	61 (1000)
Nymphalidae	Four-footed butterflies	Cosmopolitan	211 (5000)
Libytheidae	Snout butterflies	Cosmopolitan	1 (17)
Lycaenidae	Blues, coppers, hairstreaks, metal marks	Cosmopolitan	138 (3500)

\*The first figure is the number of described species in North America north of Mexico. This figure is reasonably accurate. The second figure, in parentheses, is a rough estimate of the number of described species in the world. It is difficult to postulate the actual total of Lepidoptera species from these figures since in some groups, such as the Papilionidae, probably more than 90% of the existing species have been described, while in others, such as many families of microlepidoptera, the figure may be well under 25%.

present or absent. These moths are considered by some to be distantly related to the butterflies, but the resemblances may very well be due to convergence.

Members of the superfamily Geometroidea are small to large moths with reduced maxillary palpi and tympanal organs at the base of the abdomen. The frenulum may be present or absent.

Geometridae includes the measuring worms, loopers, and cankerworms, which make up a very large family of small- and medium-sized moths with slender bodies and relatively broad wings. The females are occasionally apterous. The larvae have the anterior prolegs reduced or absent; usually only those on segments 6 and 10 are well developed. They proceed with a characteristic looping motion, which is the basis for the scientific name. The larvae ordinarily are exposed feeders.

Sphinx, hawk, or hummingbird moths constitute the one family Sphingidae of the superfamily Sphingoidea. These medium-sized to very large, heavy-bodied moths have extremely rapid flight. The adults are mostly crepuscular or nocturnal, but a few genera are diurnal. The antennae are thickened and have a pointed apex. The proboscis is well developed and often extremely long. The wings are narrow, with the hindwing much shorter than the forewing. The larvae are external feeders and

usually have a characteristic caudal horn. The pupa is in a cell in the ground or in a loose cocoon at the surface, and its long proboscis is often in a projecting case resembling a pitcher's handle.

Moths of the superfamily Saturnioidea are medium-sized to very large moths with the frenulum almost always reduced or absent. There is no tympanum and the mouthparts are usually reduced. The antennae are ordinarily pectinate, especially in the males.

Noctuoidea is a large, rather uniform superfamily of more than 20,000 species. Most of them are moderately large moths with reduced maxillary palpi. Tympanal organs are present in the metathorax.

The superfamily Hesperioidea includes one rather large family, the Hesperidae. The skippers are small to moderately large, heavy-bodied, mostly diurnal insects with a clubbed antenna, which is bent, curved, or reflexed at the tip. The larvae have a prominent constriction, or neck, behind the head, and often live in leaves drawn together by silk. Those of the giant skippers are borers in yucca and agave. The pupa is usually enclosed in a slight cocoon.

Butterflies of the superfamily Papilionoidea are small to large

diurnal insects with clubbed antennae, which are rounded at the tip and not bent or reflexed. The forewings always have two or more veins, which are stalked.

**Biological aspects.** The Lepidoptera are a group of insects on which much biological research remains to be done. A great deal is still unknown about the genetics, physiology, and ecology of this group. Moreover, butterflies and moths have proved useful as experimental animals in genetical research. The larvae of many species are injurious to certain crops, causing severe economic losses. Lepidoptera of all stages are subject to the attacks of a large number of predators, including birds, mammals, lizards, frogs, spiders, and certain other insects.

The Lepidoptera penetrate almost every section of the globe, with the major exception of Antarctica. Arctic and alpine tundra areas normally support a lepidopteran fauna which, although relatively poor in species, is rich in numbers. After rains, deserts are often alive with butterflies and moths. Tropical areas are by far the richest in species. One of the strangest habitats occupied by a lepidopteran is the hair of the neotropical three-toed sloth, where the sloth moth (*Bradypodicola hahneli*), a pyralid, passes its entire life cycle presumably feeding on algae which grow in the hair.

Migration is the most spectacular behavior occurring in the order. It is most frequent in the butterflies *Phoebis*, *Danaus*, *Libytheana*, and others, but is also known in moths such as *Chrysidia*. Huge migratory swarms are frequently reported in many parts of the world, but this phenomenon, as well as the related communal roosting of adults, daily use of flyways, hill-topping, and so forth, is poorly understood.

Aggregations of butterflies at a mud puddle are a frequent sight, and moths have been observed "pumping," an act which consists of sipping water steadily from a puddle and ejecting it as a stream of drops or fine spray from the anus.

The phenomena of mimicry and protective resemblance are widespread in the Lepidoptera. Eyespot patterns in certain species elicit escape responses in passerine birds. Thus, they are an effective protective device. The appearance of dark forms of various moths in heavily industrialized, and thus heavily sooted, areas is a widespread phenomenon. This "industrial melanism" is doubtless due to shifting selection pressures and is one of the best-known examples of evolution in action. See INSECTA; PROTECTIVE COLORATION. [P.R.E.]

**Lepidosauria** A subclass of reptiles, both living and extinct, in which the structure of the skull is characterized by two temporal openings (diapsid condition) on each side (see illustration). Lepidosauria differ from Archosauria, which are also diapsid, in that the bony arcades bordering their temporal openings may suffer reduction or loss, causing the apparent disap-

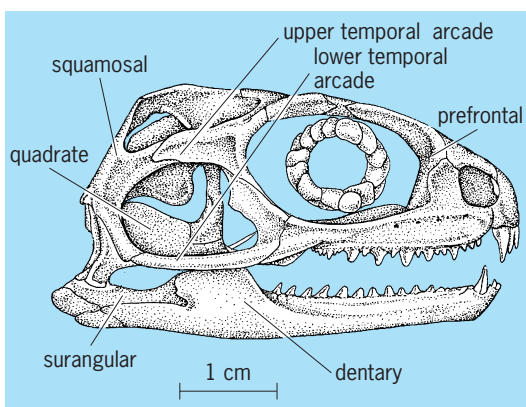

Skull of a living rhynchocephalian, *Sphenodon*, a typical diapsid. (After A. S. Romer, *Vertebrate Paleontology*, 3d ed., University of Chicago Press, 1966)

pearance of one or both openings. They differ also in that no lepidosaur skull has any antorbital opening in front of the orbit, and in that their teeth are typically fused to the jaw (acrodont or pleurodont) rather than implanted in sockets (thecodont). See ARCHOSAURIA.

In the classification adopted here the Lepidosauria include three orders: Eosuchia, Rhynchocephalia, and Squamata. See EOSUCHIA; REPTILIA; SQUAMATA. [A.J.C.]

**Lepospondyli** A group of Paleozoic amphibians commonly recognized as one of the three amphibian subclasses, equivalent to its approximate contemporary, the Labyrinthodontia, and to the modern amphibians, the Lissamphibia. They include a diverse array of extinct aquatic, terrestrial and, possibly, subterranean species, all of which were only a few centimeters long or rarely as much as a meter. For most of the Carboniferous and much of the Permian periods (340–225 million years ago), they seem to have filled niches similar to those held by modern salamanders, apodans, and lizards. See LABYRINTHODONTIA.

The term lepospondyl refers to the single-piece, spoollike vertebral centra present in many forms, which contrasts with the typically multipiece centra in the Labyrinthodontia. Other lepospondyl skeletal features include the absence of labyrinthine infolding of dental enamel, of large teeth on the palatal bones, and of otic notches, all of which are generally present in labyrinthodonts. Exceptions exist within both the Lepospondyli and Labyrinthodontia. The absence of consistent patterns in lepospondyl skeletal anatomy has obscured relationships within the subclass and between the lepospondyls and other amphibians.

The orders Adelospondyli, Aistopoda, Lysorophia, Microsauria, and Nectridea are generally considered to compose the Lepospondyli. See AISTOPODA; AMPHIBIA; LYSOROPHIA; MICROSAURIA; NECTRIDEA. [C.F.W.]

**Leprosy** A chronic infectious disease caused by *Mycobacterium leprae* that primarily affects the skin and peripheral nerves and, to a lesser extent, the eyes and mucous membranes. Leprosy, or Hansen's disease, has been known for more than 2000 years. It afflicts at least 3 million people worldwide and is most common in developing countries. There are about 200 new cases yearly in the United States. Its epidemiology is not fully understood, but transmission probably takes place by the respiratory route. The bacillus is very slow-growing, and the incubation period is usually 3–5 years. Less than 5% of any population is susceptible, and these individuals have a deficient cell-mediated immune response specifically to *M. leprae*, which may be genetic in origin. Epidemics have occurred, but are rare. See MYCOBACTERIAL DISEASES.

A skin rash and loss of feeling due to nerve damage by *M. leprae* are the hallmarks of leprosy. Usually the nerve damage is mild, but when severe the inability to feel, particularly in the hands and feet, predisposes the individuals to frequent injuries. Nerve involvement may also lead to a loss of muscle function that produces clawing of the fingers and toes as well as other neuromuscular dysfunctions. Manifestations of the disease depend upon the degree of the immune defect. Initially, most patients develop one or several depigmented areas of skin that may have decreased sensation, a stage referred to as indeterminate disease. The condition may self-heal. If treatment or self-healing does not halt the disease, it may progress to one of three advanced types. The mildest of these, tuberculoid disease, is usually manifested as a single large depigmented, scaly, numb area. The most severe type, lepromatous leprosy, usually involves most of the skin to varying degrees, with variously sized nodules or other changes. Between the two extremes immunologically is borderline disease, with skin changes of both types. The World Health Organization's simplified classification labels indeterminate and tuberculoid patients paucibacillary (few bacilli) and borderline and lepromatous patients multibacillary.

Paucibacillary disease is treated with dapsone plus rifampin for 6–12 months. Clofazimine is added for multibacillary individuals and the treatment continued for 2 or more years. Isolation is unnecessary, since patients become noninfectious within days of starting treatment. See INFECTIOUS DISEASE. [R.R.J.]

**Leptolepiformes** An order of small ray-finned fishes of the Mesozoic that are important to the understanding of the early evolution of the Teleostei. The principal family included in this order, the Leptolepidae, has been reported from the Middle Triassic of Europe and ranges into the Cretaceous. Leptolepids represent the first teleosts as defined on the structure of the caudal skeleton. They were either derived from the earliest Pholidophoridae (known from the European Middle Triassic sediments) or shared a common ancestry with them. In size, body shape, fin position, structure of head and jaws, and general habitat, leptolepids are similar to the pholidophorids. In many ways these two families appear to parallel one another. See TELEOSTEI. [T.M.C.]

**Lepton** An elementary particle having no internal constituents which interacts through the electromagnetic, weak, and gravitational forces, but does not interact through the strong (nuclear) force. Leptons are very small, less than  $10^{-18}$  m in size. This is less than  $10^{-3}$  the size of a nucleus and less than  $10^{-8}$  the size of an atom. Indeed, existing measurements are consistent with leptons being point particles.

These properties of the lepton family of particles are to be contrasted with the properties of the quark family of particles. Quarks interact through the strong force as well as through the electromagnetic, weak, and gravitational forces. By means of the strong force, quark-antiquark pairs bind together to form hadrons such as the  $\pi$  meson, and the quarks bind together to form hadrons such as the proton. In contrast, leptons act as individual particles and can be studied as isolated particles whereas, as far as is known, quarks are always inside hadrons and cannot be studied as isolated particles. See FUNDAMENTAL INTERACTIONS; HADRONS; QUARKS.

Six leptons are known. There are three known charged leptons: the electron ( $e$ ), muon ( $\mu$ ), and tau ( $\tau$ ). Associated with each charged lepton is a neutral lepton called a neutrino. A charged lepton and its associated neutrino is said to form a lepton generation. Thus there are three known lepton generations. See ELECTRON; NEUTRINO. [M.L.P.]

**Leptospirosis** An acute febrile disease of humans produced by spirochetes of many species of *Leptospira*. The incubation period is 6–15 days. Among the prominent features of the disease are fever, jaundice, muscle pains, headaches, hepatitis, albuminuria, and multiple small hemorrhages in the conjunctiva or skin. Meningeal involvement often occurs. The febrile illness subsides after 3–10 days. Fatal cases show hemorrhagic lesions in the kidney, liver, skin, muscles, and central nervous system.

Wild rodents are the principal reservoirs, although natural infection occurs in swine, cattle, horses, and dogs and may be transmitted to humans through these animals. Humans are infected either through contact with the urine or flesh of diseased animals, or indirectly by way of contaminated water or soil, the organisms entering the body through small breaks in the skin or mucous membrane. [T.B.T.]

**Leptostraca** The only extant order of the crustacean subclass Phyllocarida. The Leptostraca is represented by one fossil and a small number of living genera. These malacostracans are unique in having the carapace laterally compressed to such an extent that it forms a bivalvelike shell held together by a strong adductor muscle. The carapace covers only the thorax, leaving exposed the head, with its uniquely movable rostrum, stalked eyes, paired antennules, and antennae.

Leptostracans use the thoracopods to produce a feeding cur-

rent and, in females, to form a brood pouch. That secondary brooding function suggests that egg-bearing females generally do not feed. Locomotion in leptostracans is accomplished by use of the first four pairs of pleopods. Most leptostracans are bottom dwellers, living on or slightly under the substrate, but one species is holopelagic, one inhabits hydrothermal vents, and still another is a marine cave dweller. See CRUSTACEA; PHYLLOCARIDA. [P.A.McL.]

**Lespedeza** A warm-season legume with trifoliolate leaves, small purple pea-shaped blossoms, and one seed per pod. There are 15 American and more than 100 Asiatic species; two annual species and a perennial from Asia are grown as field crops in the United States. The American species are small shrubby perennials found in open woods and on idle land, rarely in dense stands; they are harmless weeds. See LEGUME. [P.T.]

**Lethal dose 50** One special form of the effective dose 50, or median effective dose. The lethal dose 50, or median lethal dose ( $LD_{50}$ ), is used when the response that is being investigated is the death of the experimental animal. The median lethal dose is therefore the dose which is fatal to 50% of the test animals. See EFFECTIVE DOSE 50. [C.W.]

**Lethal gene** A gene which brings about the death of the organism carrying it. Lethal genes constitute the most common class of mutations and are reflections of the fact that the fundamental function of genes is the control of processes essential to the growth and development of organisms. In higher diploid forms lethals are usually recessive and expressed only in homozygotes. Dominant lethals, expressed in heterozygotes, are rapidly eliminated and thus rarely detected. Recessive zygotic lethals are retained with considerable frequency in natural populations of cross-fertilizing organisms, while gametic lethals (those affecting normal functioning of eggs and sperm among animals, or the pollen and ovules of plants) are subject to stringent selection and are accordingly rare. See GENE; MOLECULAR BIOLOGY; MUTATION. [D.F.P.]

**Lettuce** A cool-season annual, *Lactuca sativa*, of Asian origin and belonging to the tribe Cichorium of the Compositae family. Lettuce is grown for its succulent leaves, which are eaten raw as a salad. Four varieties of this leading salad crop are head lettuce (*L. sativa* var. *capitata*), leaf or curled lettuce (*L. sativa* var. *crispa*) cos or romaine lettuce (*L. sativa* var. *longifolia*), and stem or asparagus lettuce (*L. sativa* var. *asparagina*). There are two types of head lettuce: butterhead, and crisphead or iceberg.

California raises more lettuce than any other state; Arizona, Florida, and Texas are next in importance. See ASTEREALES. [R.G.Gr.]

**Leucettida** An order of the subclass Calcinea in the class Calcarea. These sponges have either a radiate arrangement of the flagellated chambers or a leuconoid structure. A distinct dermal membrane or cortex is present. The spongocoel is not lined with choanocytes; these cells are restricted to the flagellated chambers. Two families are recognized, the Leucascidae and Leucaltidae. See CALCAREA. [W.D.H.]

**Leucite** A framework structure silicate of the feldspathoidal mineral group with the chemical composition  $(K,Na)AlSi_2O_6$ . Leucite found in the natural environment is usually nearly pure  $KAlSi_2O_6$ . The crystals are typically white, and the luster varies from dull to vitreous. Mohs hardness lies between 5.5 and 6. Density ranges from 2.45 to 2.5.

Crystals are common in the lavas of Nyiragongo volcano, Zaire. Other well-known areas include: West Kimberley, Australia; Mount Vesuvius, Italy; Highwood Mountains and Bearpaw Mountains, Montana; and the Leucite Hills, Wyoming. See SILICATE MINERALS. [W.Lu.]



**Leucite rock** Igneous rocks rich in leucite but lacking or poor in alkali feldspar. Those types with essential alkali feldspar are classed as phonolites, feldspathoidal syenite, and feldspathoidal monzonite. The group includes an extremely wide assortment both chemically and mineralogically.

The rocks are generally dark-colored and aphanitic types of volcanic origin. They consist principally of pyroxene and leucite and may or may not contain calcic plagioclase or olivine. Leucite rocks are rare. They occur principally as lava flows and small intrusives (dikes and volcanic plugs). See IGNEOUS ROCKS; LEUCITE.

[C.A.C.]

**Leucosoleniida** An order of the subclass Calcarenea in the class Calcarea. These sponges have an asconoid structure. A true dermal membrane or cortex does not develop in this order, and the spongocoel is lined with choanocytes. Leucosoleniidae is the one family recognized. See CALCAREA.

[W.D.H.]

**Leukemia** A disease characterized by a progressive and abnormal accumulation of white blood cells, or leukocytes. Leukemic cells are malignant because they have three characteristics common to all cancers: (1) they exhibit uncontrolled growth that is frequently associated with an inability to mature normally; (2) they arise from a single precursor cell; and (3) they disregard anatomic boundaries and metastasize to organs or tissues where leukocytes are not normally found. The expanding clone of leukemic cells infiltrates organs and tissues, particularly the bloodstream and bone marrow, where they disrupt the production of normal cells. The resulting symptoms include fatigue, pallor, infections, bruising and bleeding, and discomfort caused by enlarged organs. In humans, the term leukemia encompasses more than 20 distinct malignancies. See BLOOD; HEMATOPOIESIS.

Normal leukocytes are grouped into two primary types or lineages, myeloid and lymphoid, and virtually any cell of either lineage can become leukemic. Leukemias are also divided into broad categories that are based on the cell involved (myeloid or lymphoid) and disease aggressiveness (either acute or chronic). Subclassifications are based on morphologic, cytochemical, immunologic, cytogenetic, and molecular criteria.

Although many agents are suspected of inducing leukemia, for the great majority of cases the etiology is unknown. It appears that no single factor is causative but a number of events must take place before leukemia occurs. The evidence for ionizing radiation as a leukemogenic cofactor is virtually irrefutable. Chronic exposure to high levels of benzene and perhaps related compounds is associated with a tenfold higher risk of developing myeloid leukemia. A clear, strong association has been demonstrated between pharmaceuticals (particularly alkylating agents) that are administered as therapy for a primary cancer and the subsequent development of secondary leukemia, virtually always acute myeloblastic leukemia. A strong association has been shown between the rare adult T-cell leukemia and a retrovirus called human T-cell leukemia virus I, or HTLV-I. Persons with the Down syndrome are 30 times more likely to develop acute, usually lymphoid, leukemia than the rest of the population. In the primary immunodeficiency states, malignancies develop 10,000 times faster than in unaffected persons, and each of the immunodeficiencies is associated with a distinct leukemia. The myelodysplastic syndromes are characterized by ineffective production of normal blood cells and result in low blood cell counts due to abnormal precursor cells in the bone marrow. The abnormal cells are clonal and manifest a spectrum of morphologic and cytogenetic abnormalities. Most have a tendency to evolve into acute leukemia, with the myeloid type predominating. See DOWN SYNDROME; RADIATION INJURY (BIOLOGY); TUMOR VIRUSES.

The two major types of leukemia usually differ in signs and symptoms. Acute leukemias have a relatively rapid onset, and those with the disease often experience problems immediately.

Chronic leukemias have an insidious course and are frequently discovered during an examination for an unrelated problem. For both types, the most consistent symptoms are nonspecific and include weakness, fatigue, mild weight loss, and low-grade fever.

Practical therapeutic goals for the acute and chronic leukemias are distinct. Without prompt, intensive, in-hospital therapy, the acute leukemias usually cause death within a few months. In acute leukemia, the object of therapy is to totally obliterate the leukemic clone and allow normal bone marrow cells to recover. In the chronic leukemias, standard therapeutic principles are completely different. Many patients who initially require no therapy begin mild forms of outpatient treatment as the disease progresses. The intent is not to cure but to control the disease with minimal toxicity.

Many effective antileukemic agents have been synthesized. Combination therapy incorporates drugs that have different modes of action and different toxicities in order to increase cytotoxic potency, account for leukemic cells that may be resistant to a single agent, and lessen cumulative toxicity in any particular organ or tissue. Most antileukemic drugs act by perturbing enzymes or substrates that are related to deoxyribonucleic acid (DNA) or ribonucleic acid (RNA) synthesis and thus largely affect actively dividing cells. Any treatment must be repeated since the number of leukemic cells may exceed one trillion and a single course of antileukemic drugs will destroy only some of them. See CHEMOTHERAPY.

Perhaps the most dramatic and toxic treatment, bone marrow transplantation has had the most positive impact on the leukemia cure rate. Chemotherapy is administered alone or with radiation therapy in doses much higher than those used in standard antileukemic regimens to abolish the leukemic clone at the expense of the normal stem cells in the bone marrow. Patients would die following such treatment unless "rescued" with cryopreserved stem cells. The stem cells must come from a donor whose human leukocyte antigens match those of the patient's cells as closely as possible. Marrow transplantation is the therapy of choice for eligible patients with chronic myelocytic, relapsed acute lymphoid and acute myeloblastic, and other high-risk leukemias.

The search for therapies that are less toxic and more specific for leukemic cells has focused on substances that are derived from natural (biologic) sources or that affect biologic reactions, some of which are thought to be part of the body's natural defense against cancer. Examples include monoclonal antibodies, cell products manufactured by recombinant DNA technology, and the patient's own killer cells expanded and activated in the laboratory before reinfusion. Although such techniques have proved effective in other cancers, only alpha-interferon is commonly used in leukemia. See MONOCLONAL ANTIBODIES.

Despite the differences between the acute and chronic leukemias, and despite the fact that the great majority of patients can be brought into a remission or quiescent phase of the disease, leukemia is one of the most lethal malignancies. If cure is considered to be the absence of disease 3 to 5 years after cessation of therapy, only a small fraction of all leukemias are curable. An exception is acute lymphoid leukemia in children, where therapeutic advances have resulted in the attainment of a complete remission in almost all and cures in the majority. See CANCER (MEDICINE); ONCOLOGY.

[L.V.; K.A.F.]

**Level measurement** The determination of the linear vertical distance between a reference point or datum plane and the surface of a liquid or the top of a pile of divided solids.

**Liquid level measurement.** Satisfactory measurements are possible only when the liquid is undisturbed by turbulence or wave action. When a liquid is too turbulent for the average level to be read, a baffle or stilling chamber is inserted in the tank or vessel to provide a satisfactory surface.

Stick, hook, and tape gages are used in open vessels where the surface of the liquid can readily be observed. The stick gage is a

suitably divided vertical rod, or stick, anchored in the vessel so that the magnitude of the rise and fall of the liquid level may be observed directly. The hook gage provides a needle point, which is adjusted to produce a very tiny pimple in the liquid surface at the level reading, thereby minimizing the meniscus error. The tape gage reads the correct elevation when the point of a bob just touches the liquid surface.

Many forms of gage glass are available for the measurement of liquid level. Liquid in a tank or vessel is connected to the gage glass by a suitable fitting, and when the tank is under pressure the upper end of the glass must be connected to the tank vapor space. Thus the liquid rises to substantially the same height in the glass as in the tank, and this height is measured by suitable scale.

Various types of float mechanism are also used for liquid level measurement. The float, tape, and pulley gage provides an excellent method of measuring large changes in level with accuracy. It has the advantage that the scale can be placed for convenient reading at any point within a reasonable distance of the tank or vessel.

The change in buoyancy of a solid as its immersion in a liquid is varied is used to measure liquid level. This principle is used only when the densities of the liquid and vapor are substantially constant. Temperature changes will produce errors of greater magnitude than with the float mechanisms.

Hydrostatic head may also be used to measure liquid level. The pressure exerted by a column of liquid varies directly with its density as well as with its height, and thus this method of measurement requires that density be substantially constant. Densities of liquids vary with temperature; errors are therefore introduced with temperature changes, or the measuring element must be temperature compensated.

Electrode or probe systems are used in various forms for level indication and control. The number of electrodes and their design depend upon the characteristics of the liquid and the application. Fundamentally, a circuit through a relay coil is closed (or opened) when the liquid contacts a probe.

Capacitance-measuring devices can be used to measure levels of both dielectric (insulating) and conducting liquids. If the liquid being measured is a dielectric, one or two probes or rods, extending nearly to the bottom of the tank, are supported in an insulating mounting. The probes may be bare or covered with insulation. If the liquid is a conductor of electricity, only one probe is necessary but it must be covered with an insulating coating.

Nuclear level gages are used for difficult applications. Basically, all of the units involve a source of gamma ( $\gamma$ ) radiation and a detector separated by the vessel or a portion of the vessel in which a liquid level varies. As the level rises, the detector receives less  $\gamma$ -radiation and thus the level is measured.

The sonic level detector is based on the time increment between the emission of a sound wave pulse and its reflection from liquid surface. The sound wave pulse is generated electronically, and its time in transit is measured very accurately by electronic means. If the speed of sound in the liquid or vapor is known accurately, the liquid level is known.

**Solids level measurement.** Solids level detectors are used to locate the top of a pile of divided solids in large vessels or processing equipment. The instruments are designed for the different solids handled, and the installation must be carefully made to ensure proper measurements. Because solids funnel, cone, and vary in average density with the particle size, shape, distribution, moisture content, and other factors, these detectors provide only an approximate indication of the volume present or the top of the pile. Solids level detectors are classified as continuous or fixed point. Continuous detectors provide a continuous measurement of the level over the range for which they were designed. Their output is an analog representation of the level of the solids. Fixed-point detectors indicate when a specific level has been reached and are used mainly for actuating alarm signals. By installing a

number of these, however, at different points, the combined response can be made to approach that of a continuous detector. [H.S.B.]

**Lever** A pivoted rigid bar used to multiply force or motion, sometimes called the lever and fulcrum (see illustration). The lever uses one of the two conditions for static equilibrium, which is that the summation of moments about any point equals zero. The other condition is that the summation of forces acting in any direction through a point equals zero. See INCLINED PLANE.

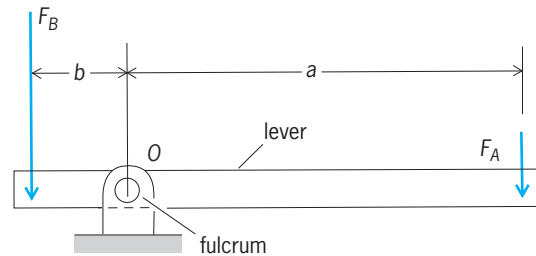

The lever pivots at the fulcrum.

If moments acting counterclockwise around the fulcrum of a lever are positive, then, for a frictionless lever,  $F_B b - F_A a = 0$ , which may be rearranged to give Eq. (1). If  $F_B$  represents the

$$F_B = \frac{a}{b} F_A \quad (1)$$

output and  $F_A$  represents the input, the mechanical advantage, MA, is then given by Eq. (2).

$$MA = \frac{F_B}{F_A} = \frac{a}{b} \quad (2)$$

Applications of the lever range from the simple nutcracker and paper punch to complex multiple-lever systems found in scales and in testing machines used in the study of properties of materials. See SIMPLE MACHINE. [R.M.Ph.]

**Libra** The Balance, in astronomy, appearing during the spring. It is the seventh sign of the zodiac. The constellation consists of faint stars and is not conspicuous. It lies just west of the claws of Scorpius. The principal stars,  $\alpha$ ,  $\beta$ ,  $\gamma$ , and  $\sigma$ , outline

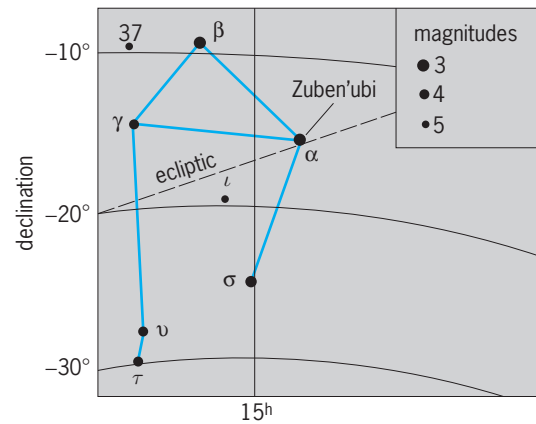

Line pattern of the constellation Libra. The grid lines represent the coordinates of the sky. The apparent brightness, or magnitude, of the stars is shown by the sizes of the dots, graded by appropriate numbers.

a four-sided figure resembling a balance with beam and pans (see illustration). See CONSTELLATION. [C.-S.Y.]

**Lichens** Symbiotic associations of fungi (mycobionts) and photosynthetic partners (photobionts). These associations always result in a distinct morphological body termed a thallus that may adhere tightly to the substrate or be leafy, stalked, or hanging. A thallus consists of layers, that is, a cortex and medulla made up of the fungus, and a photosynthetic layer of algal or cyanobacterial cells that are closely associated with fungal hyphae. Rhizoids anchor thalli to their substrates. See CYANOBACTERIA.

Lichens are formed from specialized groups of parasitic fungi; this association is one of a controlled parasitism rather than mutualism. Thus, the photobionts that lichen fungi slowly parasitize should be considered victims and not partners. Lichen-forming fungi share two characteristics with fungi that parasitize plants: concentric bodies and specialized branches of hyphae (haustoria) that penetrate host cells and absorb nutrients from them.

Lichens have a worldwide distribution and grow on almost any inanimate object. They are among the hardiest of organisms and thrive in some of the Earth's harshest environments, such as polar regions, deserts, and high mountains.

The name given to a lichen applies only to the mycobiont, while the photobiont has a separate name. Most of the 15,000 lichen-forming fungi are in the fungal class Ascomycotina (ascolichens). Approximately a dozen species of basidiomycetes form lichens. Lichens that do not have sexual reproduction (*Lepraria*) are placed in the Lichenes Imperfecti.

Photobionts of lichens are either green algae or cyanobacteria. The most common photobiont is *Trebouxia*. This unicellular green algae has never been found in the free-living state. It is believed that *Trebouxia* is a lichenized and highly modified form of the filamentous alga *Pleurastrum terrestre*.

The basic metabolic processes of lichens are photosynthesis, respiration, and nitrogen fixation. Lichens have adapted these processes to different conditions of light, temperature, day length, and water. The mycobiont causes the photobiont to excrete most of the carbon that it fixes during photosynthesis. Only a single type of compound is excreted. The mycobiont absorbs these compounds and converts them to mannitol, its own storage compound. See PLANT RESPIRATION.

Nitrogen-fixing lichens are common and contribute nitrogen to different ecosystems when they decay. In cyanolichens the mycobiont inhibits the nitrogen-assimilating enzymes of the cyanobiont, causing it to release most of the ammonia it produces. The ammonia is absorbed by the mycobiont and used to make proteins and nucleic acids. See NITROGEN FIXATION.

Lichens produce several hundred secondary compounds that accumulate as crystals in the thalli, often at high concentrations. These compounds may protect the slow-growing thalli from harmful bacteria, fungi, and insects and may play a regulatory role in the interactions between bionts. Lichen secondary compounds represent a new class of antibiotics in an age where standard antibiotics such as penicillin are becoming ineffective against antibiotic-resistant microbes. Secondary compounds are used extensively by taxonomists to characterize new taxa of lichens (chemotaxonomy). [V.Ah.]

**Lidar** The optical analog of radar. The term lidar is an acronym for light detection and ranging. Lidar systems employ intense pulses of light, typically generated by lasers, and large telescopes and sensitive optical detectors to receive the reflected pulses. They are most commonly used to measure the composition and structure of the atmosphere. The very narrow beamwidth, narrow linewidth, and ultrashort pulses of the laser make it possible to optically probe the atmosphere with exceptional sensitivity and resolution. When used to measure the range and velocity of hard targets, lidars are usually called laser ranging systems or laser radars. See LASER; OPTICAL DETECTORS; RADAR.

**Ranging and altimeter systems.** The most common lidar configuration is the monostatic system. The laser beam is either projected through the receiving telescope or propagates parallel

to the optical axis of the telescope. If the system is designed for ranging or altimetry, the receiver measures the round-trip propagation time of the laser pulse between the lidar and the target.

The most sophisticated systems are used for ranging to retroreflector-equipped satellites and to the retroreflector arrays placed on the Moon by the Apollo astronauts. Accuracies of a few centimeters are achieved routinely. Data from these measurements are used to monitor geophysical phenomena such as continental drift, crustal dynamics, and the Earth's rotation rate. Airborne laser altimeters provide maps of surface topography, coastal water depth, forest canopies, sea ice distribution, volcanic landforms, impact craters, and ocean wave heights. See REMOTE SENSING.

**Atmospheric lidars.** The targets of atmospheric lidars are either suspended dust and aerosols or gas molecules which are continuously distributed in the atmosphere along the propagation path of the laser beam. Atmospheric lidar systems are used to measure density profiles of the scatterers. Profile measurements are accomplished by pulsing the laser and then periodically sampling the detector output. The sampling process is called range gating.

Atmospheric lidars are classified according to the type of scattering mechanism exploited to make the measurement. Aerosol lidars measure scattering from atmospheric dust and aerosols. Rayleigh lidars are designed to measure the molecular scattered signal, which is proportional to atmospheric density. Resonance fluorescence lidars are used to measure the density profiles of specific molecular species such as sodium in the upper atmosphere. The differential absorption lidar (DIAL) measures species concentrations in the lower atmosphere using two lasers, one tuned to an absorption line of the species of interest and the other tuned just off the absorption line. Raman lidars measure the scattered signal at the Raman shifted wavelength, and have provided excellent measurements of atmospheric density, temperature, and water vapor concentration at altitudes below 10 km (6 mi). Doppler lidars are used to measure tropospheric winds. See DOPPLER EFFECT; DOPPLER RADAR; RAMAN EFFECT; SCATTERING OF ELECTROMAGNETIC RADIATION. [C.S.G.]

**Lie detector** A device intended to detect an involuntary physiological response that all persons exhibit when lying but never when telling the truth. Because there is no such specific lie response, actual "lie detector" tests used in the United States record breathing movements, blood pressure changes, and electrodermal responses on a polygraph while the respondent answers "yes" or "no" to a series of questions. From the recordings, one can determine whether "relevant" questions had greater impact on the respondent than the interpolated "control" questions. See ELECTRODERMAL RESPONSE. [D.T.L.]

**Lie group** A topological group with only countably many connected components whose identity component is open and is an analytic group. An analytic group or connected Lie group is a topological group with the additional structure of a smooth manifold such that multiplication and inversion are smooth. Many groups that arise naturally as groups of symmetries of physical or mathematical systems are Lie groups. The study of Lie groups has applications to analytic function theory, differential equations, differential geometry, Fourier analysis, algebraic number theory, algebraic geometry, quantum mechanics, relativity, and elementary particle theory. See GROUP THEORY; TOPOLOGY. [A.W.K.]

**Ligament** A strong, flexible connective tissue band usually found between two bony prominences. Most ligaments are composed of dense fibrous tissue formed by parallel bundles of collagen fibers. They have a shining white appearance and are pliable, strong, and noncompliant. A second kind of ligament, composed either partly or almost entirely of yellow elastic fibers,

is extensible or compliant, thereby allowing the connected bones to move apart. See CONNECTIVE TISSUE; JOINT (ANATOMY). [W.J.B.]

**Ligand** A molecule with an affinity to bind to a second atom or molecule. This affinity can be described in terms of noncovalent interactions, such as the type of binding that occurs in enzymes that are specific for certain substrates; or of a mode of binding where an atom or groups of atoms are covalently bound to a central atom, as in the case of coordination complexes and organometallic compounds. Ligands of the latter type can be further distinguished by the nature of the orbitals used in bond formation. See ENZYME.

When a protein binds to another molecule, that molecule may be referred to as a ligand. The site where the ligand is bound is known as the binding or active site of the protein. In order for a molecule to be classified as a ligand for a protein, several weak interactions such as hydrophobic, van der Waals, and hydrogen bonding must take place simultaneously. Therefore, the binding of a ligand by a protein is generally quite specific. See CHEMICAL BONDING; COORDINATION CHEMISTRY. [T.J.Me.]

**Ligand field theory** An essentially ionic approach to chemical bonding which is often used with coordination compounds. These compounds consist of a central transition-metal ion that is surrounded by a regular array of coordinated atoms or ligands. Accordingly, the ligands are assumed to be sources of negative charge which perturb the energy levels of the central metal ion. In this respect the ligands subject the metal ion to an electric field which is analogous to the electric or crystal field produced by the regular distribution of nearest neighbors within an ionic crystalline lattice. For example, the crystal field produced by the Cl ion ligand in octahedral  $TiCl_6^{3-}$  is considered to be similar to that produced by the octahedral array of the six Cl ions about each Na ion in NaCl. The Na ion with its rare-gas configuration has an electronic charge distribution which is spherically symmetric both within and without the crystal field. The paramagnetic Ti(III) ion, which possesses one 3d electron ( $d^1$ ), has a spherically symmetric charge distribution only in the absence of the crystal field produced by the ligands. The presence of the ligands destroys the spherical symmetry and produces a more complex set of energy levels within the central metal ion. The crystal field theory allows the energy levels to be calculated and related to experimental observation. See COORDINATION CHEMISTRY. [R.A.D.W.]

**Light** The term light, as commonly used, refers to the kind of radiant electromagnetic energy that is associated with vision. In a broader sense, light includes the entire range of radiation known as the electromagnetic spectrum. The branch of science dealing with light, its origin and propagation, its effects, and other phenomena associated with it is called optics. Spectroscopy is the branch of optics that pertains to the production and investigation of spectra. See OPTICS; SPECTROSCOPY.

**Principal effects.** The electromagnetic spectrum is a broad band of radiant energy that extends over a range of wavelengths running from trillionths of inches to hundreds of miles; wavelengths of visible light are measured in hundreds of thousandths of an inch. Arranged in order of increasing wavelength, the radiation making up the electromagnetic spectrum is termed gamma rays, x-rays, ultraviolet rays, visible light, infrared waves, microwaves, radio waves, and very long electromagnetic waves. See ELECTROMAGNETIC RADIATION.

The fact that light travels at a finite speed or velocity is well established. In round numbers, the speed of light in vacuum or air may be said to be 186,000 mi/s or 300,000 km/s. Measurements of the speed of light,  $c$ , which had attracted physicists for 308 years, came to an end in 1983 when the new definition of the meter fixed the value of the speed of light. Highly precise values of  $c$  were obtained by extending absolute frequency measurements into a region of the electromagnetic spectrum where

wavelengths can be most accurately measured. These advances were facilitated by the use of stabilized lasers and high-speed tungsten-nickel diodes which were used to measure the lasers' frequencies. The measurements of the speed of light and of the frequency of lasers yielded a value of the speed of light limited only by the standard of length which was then in use. This permitted a redefinition of the meter in which the value of the speed of light assumed an exact value, 299,792,458 m/s. The meter is defined as the length of the path traveled by light in vacuum during a time interval of  $1/299\,792\,458$  of a second. See LASER. [K.M.E.]

One of the most easily observed facts about light is its tendency to travel in straight lines. Careful observation shows, however, that a light ray spreads slightly when passing the edges of an obstacle. This phenomenon is called diffraction. The reflection of light is also well known. Reflection of light from smooth optical surfaces occurs so that the angle of reflection equals the angle of incidence, a fact that is most readily observed with a plane mirror. When light is reflected irregularly and diffusely, the phenomenon is termed scattering. The scattering of light by gas particles in the atmosphere causes the blue color of the sky. See DIFFRACTION; REFLECTION OF ELECTROMAGNETIC RADIATION.

The type of bending of light rays called refraction is caused by the fact that light travels at different speeds in different media—faster, for example, in air than in either glass or water. Refraction occurs when light passes from one medium to another in which it moves at a different speed. Familiar examples include the change in direction of light rays in going through a prism, and the bent appearance of a slick partially immersed in water. See REFRACTION OF WAVES.

In the phenomenon called interference, rays of light emerging from two parallel slits combine on a screen to produce alternating light and dark bands. This effect can be obtained quite easily in the laboratory, and is observed in the colors produced by a thin film of oil on the surface of a pool of water. Polarization of light is usually shown with Polaroid disks. Such disks are quite transparent individually. When two of them are placed together, however, the degree of transparency of the combination depends upon the relative orientation of the disks. It can be varied from ready transmission of light to almost total opacity, simply by rotating one disk with respect to the other. See INTERFERENCE OF WAVES; POLARIZED LIGHT.

When light is absorbed by certain substances, chemical changes take place. This fact forms the basis for the science of photochemistry.

**Theory.** Phenomena involving light may be classed into three groups: electromagnetic wave phenomena, corpuscular or quantum phenomena, and relativistic effects. The relativistic effects appear to influence similarly the observation of both corpuscular and wave phenomena. See RELATIVITY.

**Wave phenomena.** Interference and diffraction are the most striking manifestations of the wave character of light. Their fundamental similarity can be demonstrated in a number of experiments. The wave aspect of the entire spectrum of electromagnetic radiation is most convincingly shown by the similarity of diffraction pictures produced on a photographic plate, placed at some distance behind a diffraction grating, by radiations of different frequencies, such as x-rays and visible light. The interference phenomena of light are, moreover, very similar to interference of electronically produced microwaves and radio waves.

Polarization demonstrates the transverse character of light waves. Further proof of the electromagnetic character of light is found in the possibility of inducing, in a transparent body that is being traversed by a beam of plane-polarized light, the property of rotating the plane of polarization of the beam when the body is placed in a magnetic field. See FARADAY EFFECT.

The fact that the velocity of light had been calculated from electric and magnetic parameters (permittivity and permeability) was at the root of Maxwell's conclusion in 1865 that "light, including heat and other radiations if any, is a disturbance in

the form of waves propagated. . . according to electromagnetic laws." Finally, the observation that electrons and neutrons can give rise to diffraction patterns quite similar to those produced by visible light has made it necessary to ascribe a wave character to particles. See ELECTRON DIFFRACTION; NEUTRON DIFFRACTION.

**Corpuscular phenomena.** In its interactions with matter, light exchanges energy only in discrete amounts, called quanta. This fact is difficult to reconcile with the idea that light energy is spread out in a wave, but is easily visualized in terms of corpuscles, or photons, of light.

The radiation from theoretically perfect heat radiators, called blackbodies, involves the exchange of energy between radiation and matter in an enclosed cavity. The observed frequency distribution of the radiation emitted by the enclosure at a given temperature of the cavity can be correctly described by theory only if one assumes that light of frequency  $\nu$  is absorbed in integral multiples of a quantum of energy equal to  $h\nu$ , where  $h$  is a fundamental physical constant called Planck's constant.

When a monochromatic beam of electromagnetic radiation illuminates the surface of a solid (or less commonly, a liquid), electrons are ejected from the surface in the phenomenon known as photoemission or the external photoelectric effect. It is found that the emission of these photoelectrons, as they are called, is immediate, and independent of the intensity of the light beam, even at very low light intensities. This fact excludes the possibility of accumulation of energy from the light beam until an amount corresponding to the kinetic energy of the ejected electron has been reached.

The scattering of x-rays of frequency  $\nu_0$  by the lighter elements is caused by the collision of x-ray photons with electrons. Under such circumstances, both a scattered x-ray photon and a scattered electron are observed, and the scattered x-ray has a lower frequency than the impinging x-ray. The kinetic energy of the impinging x-ray, the scattered x-ray, and the scattered electron, as well as their relative directions, are in agreement with calculations involving the conservation of energy and momentum. See COMPTON EFFECT; HEAT RADIATION; PHOTON.

**Quantum theories.** The need for reconciling Maxwell's theory of the electromagnetic field, which describes the electromagnetic wave character of light, with the particle nature of photons, which demonstrates the equally important corpuscular character of light, has resulted in the formulation of several theories which go a long way toward giving a satisfactory unified treatment of the wave and the corpuscular picture. These theories incorporate, on one hand, the theory of quantum electrodynamics, first set forth by P. A. M. Dirac, P. Jordan, W. Heisenberg, and W. Pauli, and on the other, the earlier quantum mechanics of L. de Broglie, Heisenberg, and E. Schrödinger. Unresolved theoretical difficulties persist, however, in the higher-than-first approximations of the interactions between light and elementary particles.

Dirac's synthesis of the wave and corpuscular theories of light is based on rewriting Maxwell's equations in a Hamiltonian form resembling the Hamiltonian equations of classical mechanics. Using the same formalism involved in the transformation of classical into wave-mechanical equations by the introduction of the quantum of action  $h\nu$ , Dirac obtained a new equation of the electromagnetic field. The solutions of this equation require quantized waves, corresponding to photons. The superposition of these solutions represents the electromagnetic field. The quantized waves are subject to Heisenberg's uncertainty principle. The quantized description of radiation cannot be taken literally in terms of either photons or waves, but rather is a description of the probability of occurrence in a given region of a given interaction or observation. See HAMILTON'S EQUATIONS OF MOTION; QUANTUM ELECTRODYNAMICS; QUANTUM FIELD THEORY; QUANTUM MECHANICS; RELATIVISTIC QUANTUM THEORY; UNCERTAINTY PRINCIPLE. [G.W.S.]

**Light amplifier** In the broadest sense, a device which produces an enhanced light output when actuated by incident

light. A simple photocell relay-light source combination would satisfy this definition. To make the term more meaningful, common usage has introduced two restrictions: (1) a light amplifier must be a device which, when actuated by a light image, reproduces a similar image of enhanced brightness; and (2) the device must be capable of operating at very low light levels without introducing spurious brightness variations (noise) into the reproduced image. The term is used synonymously with image intensifier. The light amplifier increases the brightness of an image which is below the visual threshold to a level where it can be readily seen with the unaided eye. It is, of course, impossible to see under conditions of complete darkness. Indeed, there is a fundamental lower limit of illumination under which an image of a given quality can be recognized. This limitation arises because of the corpuscular nature of light. See LIGHT; PHOTON.

In addition to their application for night vision, light amplifiers have been useful in many fields of science, such as astronomy, nuclear physics, and microbiology. [D.R.Co.]

**Light curves** Graphs of the intensity of radiation from astronomical objects as they change with time. Variations may be caused by the changing perspective from the Earth of two stars in orbit around each other, by pulsations that change an individual star's size and surface temperature, by mass ejection or accretion, by explosions, by beams of radiation sweeping across the line of sight from the Earth, or by clouds of very high-energy electrons in powerful magnetic fields. The information contained in the light curve includes the timing of events, such as eclipses or pulses, and the amplitude of changes in the radiation received at Earth.

Each data point in a light curve is a photometric measurement, recorded at a particular time. These points represent measurements of the amount of radiation from the source received at Earth per second per area in a particular bandpass, for example, through a blue filter. In optical light, photometry is affected by the varying transparency of the atmosphere, so that light curves are often obtained as ratios to the intensities of nearby comparison stars. Simultaneous measurements can be made visually, with photometers that have two channels or with imagers, such as charge-coupled devices (CCDs) or photographic emulsions. These relative light curves are put on an absolute scale by means of calibrating measures of the comparison stars taken on clear nights. See ASTRONOMICAL PHOTOGRAPHY; CHARGE-COUPLED DEVICES; MAGNITUDE (ASTRONOMY); PHOTOMETRY. [R.F.Gr.]

**Light-emitting diode** A rectifying semiconductor device which converts electrical energy into electromagnetic radiation. The wavelength of the emitted radiation ranges from the near-ultraviolet to the near-infrared, that is, from about 400 to over 1500 nanometers.

Most commercial light-emitting diodes (LEDs), both visible and infrared, are fabricated from III-V semiconductors. These compounds contain elements such as gallium, indium, and aluminum from column III (or group 13) of the periodic table, as well as arsenic, phosphorus, and nitrogen from column V (or group 15) of the periodic table. There are also LED products made of II-VI (or group 12-16) semiconductors, for example ZnSe and related compounds. Taken together, these semiconductors possess the proper band-gap energies to produce radiation at all wavelengths of interest. Most of these compounds have direct band gaps and, as a consequence, are efficient in the conversion of electrical energy into radiation. With the addition of appropriate chemical impurities, called dopants, both III-V and II-VI compounds can be made *p*- or *n*-type, for the purpose of forming *pn* junctions. All modern-day LEDs contain *pn* junctions. Most of them also have heterostructures, in which the *pn* junctions are surrounded by semiconductor materials with larger band-gap energies. See ACCEPTOR ATOM; DONOR ATOM; ELECTROLUMINESCENCE; ELECTRON-HOLE RECOMBINATION; JUNCTION DIODE; JUNCTION TRANSISTOR; LASER; SEMICONDUCTOR; SEMICONDUCTOR DIODE.

Conventional low-power, visible LEDs are used as solid-state indicator lights in instrument panels, telephone dials, cameras, appliances, dashboards, and computer terminals, and as light sources for numeric and alphanumeric displays. Modern high-brightness, visible LED lamps are used in outdoor applications such as traffic signals, changeable message signs, large-area video displays, and automotive exterior lighting. General-purpose white lighting and multielement array printers are applications in which high-power visible LEDs may soon displace present-day technology. Infrared LEDs, when combined in a hybrid package with solid-state photodetectors, provide a unique electrically isolated optical interface in electronic circuits. Infrared LEDs are also used in optical-fiber communication systems as a low-cost, high-reliability alternative to semiconductor lasers.

[J.M.Woo.; L.J.G.]

**Light panel** A surface-area light source that employs the principle of electroluminescence to produce light. Light panels are composed of two sheets of electrically conductive material, one a thin conducting backing and the other a transparent conductive film, placed on opposite sides of a plastic or ceramic sheet impregnated with a phosphor, such as zinc sulfide, and small amounts of compounds of copper or manganese. When an alternating voltage is applied to the conductive sheets, an electric field is applied to the phosphor. Each time the electric field changes, it dislodges electrons from the edges of the phosphor crystals. As these electrons fall back to their normal atomic state, they affect the atoms of the slight "impurities" of copper or manganese, and radiation of the wavelength of light is emitted. See ELECTROLUMINESCENCE.

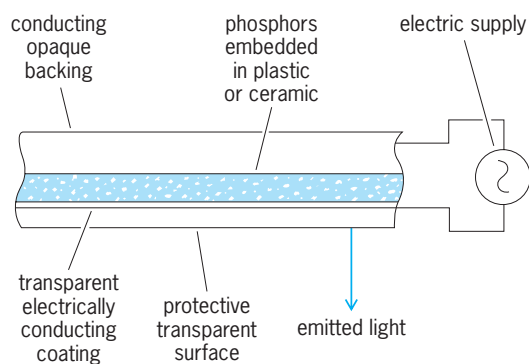

Simplified diagram of an electroluminescent cell.

In contrast to incandescent, vapor-discharge, and fluorescent lamps, which are essentially point or line sources of light, the electroluminescent light panel is essentially a surface source of light. Complete freedom of size and shape is a fascinating aspect of luminescent cells (see illustration). See ILLUMINATION. [W.B.Bo.]

**Light-scattering photometry** Optical methods used to measure the extent of scattering of light by particles suspended in fluids or by macromolecules in solution. Two different approaches are employed. The photometric measurement of the extent of attenuation of an incident light beam as it passes through the scattering medium is known as turbidimetry. The measurement of the intensity of light scattered to a detector which is not in the path of the incident light (often at right angles to it) is known as nephelometry—literally, the measurement of cloudiness.

Nephelometry and turbidimetry are also used for quantitative analytical chemical measurements. These methods were formerly considered relatively nonprecise and were used only to obtain approximate concentration information. With the advent of microprocessor-based instrumentation, however, it has been possible to overcome such prior limitations as nonlinearity of response with concentration, and these methods have become

increasingly popular, particularly in the field of clinical chemistry. See SCATTERING OF ELECTROMAGNETIC RADIATION.

Turbidimetric analysis involves measurement of the intensity of light that is transmitted through a solution or suspension. For strongly turbid samples containing many particles or particles that are large compared with the wavelength of visible light, turbidimetry is the method of choice, and it is most often performed on a colorimeter or spectrophotometer. For a limited range of particle concentrations in suspensions, this method of measurement gives fairly good precision. See COLORIMETRY; SPECTROSCOPY.

The relative ease of discriminating the presence of scattered light from the dark background present in the absence of scattering makes nephelometric measurement an extremely sensitive tool for analytical purposes. For a relatively clear solution, where the light is only weakly scattered because of a low concentration of particles or the presence of particles which are extremely small compared with the wavelength of the incident light, nephelometry is generally the tool best suited to measurement. In principle, nephelometric measurements can be made at the detection angle and with the wavelength of light most suitable for a particular application. The most notable analytical application of nephelometry is in the quantitative analysis of specific human serum proteins. See IMMUNOASSAY; PHOTOMETRY. [J.C.St.; A.F.T.C.]

**Light-year** A unit of measurement of astronomical distance. A light-year is the distance light travels in 1 sidereal year. One light-year is equivalent to  $9.461 \times 10^{12}$  km, or  $5.879 \times 10^{12}$  mi. Distances to some of the nearer celestial objects, measured in units of light time, are shown in the table.

Distances from the Earth to some celestial objects

Object	Distance from Earth (in light time)
Moon (mean)	1.3 s
Sun (mean)	8.3 min
Mars (closest)	3.1 min
Jupiter (closest)	33 min
Pluto (closest)	5.3 h
Nearest star (Proxima Centauri)	4.3 years
Andromeda Nebula (M31)	2,300,000 years

This unit, while useful for its graphic presentation of the enormous scale of stellar distances, is seldom used technically except in cosmology. See ASTRONOMICAL UNIT; PARALLAX (ASTRONOMY); PARSEC. [J.L.Gr.]

**Lighthouse** A distinctive structure, built on or near a shore, which exhibits a light of distinctive characteristics to serve as an aid to navigation. Lesser lights may be displayed from fixed structures called beacons or from floating buoys or lightships.

The characteristics of the lights displayed by lighthouses are given in light lists available to mariners and, in abbreviated form, on charts. Some lights have one or more sectors in which the light appears red, usually to warn of some danger in this sector. In other sectors most lights are white. See PILOTING. [A.B.M.]

**Lightning** An abrupt, high-current electric discharge that occurs in the atmospheres of the Earth and other planets and that has a path length ranging from hundreds of feet to tens of miles. Lightning occurs in thunderstorms because vertical air motions and interactions between cloud particles cause a separation of positive and negative charges. See ATMOSPHERIC ELECTRICITY.

The vast majority of lightning flashes between cloud and ground begin in the cloud with a process known as the preliminary breakdown. After perhaps a tenth of a second, a highly branched discharge, the stepped leader, appears below the cloud base and propagates downward in a succession of intermittent steps. The leader channel is usually negatively charged, and when the tip of a branch of the leader gets to within about 30 m (100 ft) of the ground, the electric field becomes large enough

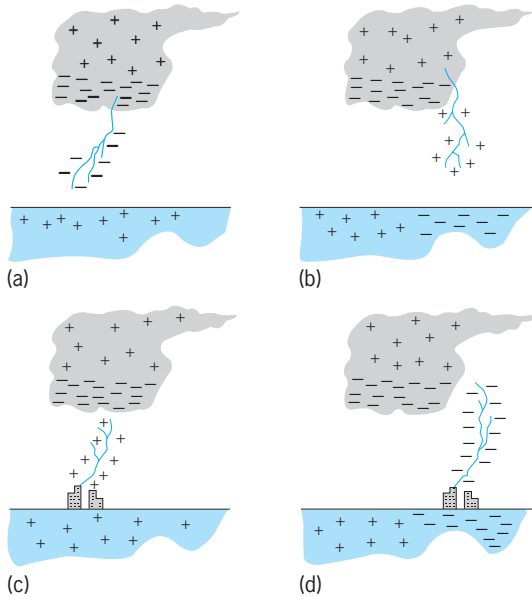

Sketches of the different types of lightning between an idealized cloud and the ground: (a) type 1, (b) type 2, (c) type 3, and (d) type 4. Channel development within the cloud is not shown. Type 1 is the most common form of cloud-to-ground lightning, and type 4 is very rare. (After M. A. Uman, *The Lightning Discharge*, Academic Press, 1987)

to initiate one or more upward connecting discharges, usually from the tallest objects in the local vicinity of the leader. When contact occurs between an upward discharge and the stepped leader, the first return stroke begins. The return stroke is basically a very intense, positive wave of ionization that propagates up the partially ionized leader channel into the cloud at a speed close to the speed of light. After a pause of 40–80 milliseconds, another leader, the dart leader, forms in the cloud and propagates down the previous return-stroke channel without stepping. When the dart leader makes contact with the ground, a subsequent return stroke propagates back to the cloud. A typical cloud-to-ground flash lasts 0.2–0.3 s and contains about four return strokes; lightning often appears to flicker because the human eye is capable of just resolving the interval between these strokes.

Lightning between cloud and ground is usually classified according to the direction of propagation and polarity of the initial leader. For example, in the most frequent type of cloud-to-ground lightning a negative discharge is initiated by a downward propagating leader as described above (illus. a). In this case, the total discharge will effectively lower negative charge to ground or, equivalently, will deposit positive charge in the cloud.

A discharge can be initiated by a downward-propagating positive leader (illus. b). Positive discharges occur less frequently than negative ones, but positive discharges are often quite deleterious. Another type of lightning is a ground-to-cloud discharge that begins with a positive leader propagating upward (illus. c); this type is relatively rare and is usually initiated by a tall structure or a mountain peak. The rarest form of lightning is a discharge that begins with a negative leader propagating upward (illus. d).

The electric currents that flow in return strokes have been measured during direct strikes to instrumented towers. The peak current in a negative first stroke is typically 30 kiloamperes, with a zero-to-peak rise time of just a few microseconds. This current decreases to half-peak value in about 50 microseconds, and then low-level currents of hundreds of amperes may flow for a few to hundreds of milliseconds. The long-continuing currents produce charge transfers on the order of tens of coulombs and are frequently the cause of fires. Subsequent return strokes have peak currents that are typically 10–15 kA, and somewhat faster current rise times. Five percent of the negative discharges to ground gen-

erate peak currents that exceed 80 kA, and 5% of the positive discharges exceed 250 kA. Positive flashes frequently produce very large charge transfers, with 50% exceeding 80 coulombs and 5% exceeding 350 coulombs. [E.P.K.]

Red sprites, elves, and blue jets are upper atmospheric optical phenomena associated with thunderstorms and have only recently been documented using low-light-level television technology. Sprites are massive but weak luminous flashes appearing directly above active thunderstorms coincident with cloud-to-ground or intracloud lightning. They extend from the cloud tops to about 95 km (59 mi) and are predominantly red. High-speed photometer measurements show that the duration of sprites is only a few milliseconds. Their brightness is comparable to a moderately bright auroral arc. Elves are associated with sprites. They are optical emissions of approximately 1 millisecond, with a fast lateral, horizontal expansion that emits more red than blue light. They occur at altitudes of 75–95 km (47–59 mi). Blue jets are optical ejections from the top of the electrically active core regions of thunderstorms. Following the emergence from the top of the thundercloud, they typically propagate upward in narrow cones of about 15° full width at vertical speeds of roughly 100 km/s (60 mi/s), fanning out and disappearing at heights of about 40–50 km (25–30 mi). [R.E.O.]

**Lightning and surge protection** Means of protecting electrical systems, buildings, and other property from lightning and other high-voltage surges. From studies of lightning, two conclusions emerge: (1) Lightning will not strike an object if it is placed in a grounded metal cage. (2) Lightning tends to strike, in general, the highest objects on the horizon. See ATMOSPHERIC ELECTRICITY; LIGHTNING.

One practical approximation of the grounded metal cage is the well-known lightning rod or mast. The effectiveness of this device is evaluated on the cone-of-protection principle. The protected area is the space enclosed by a cone having the mast top as the apex of the cone and tapering out to the base. If the radius



(a)

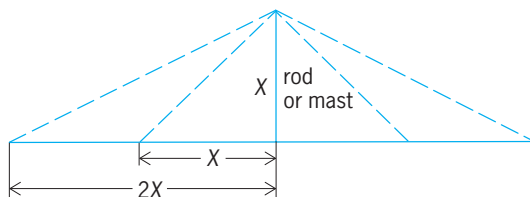

(b)

Lightning rod cone of protection. (a) Configuration of rods on a house. (b) Geometry of the principle.

of the base of the cone is equal to the height  $X$  of the mast, equipment inside this cone will rarely be struck. A radius equal to twice the height of the mast ( $2X$ ) gives a cone of shielding within which an object will be struck occasionally. The cone-of-protection principle is shown in the illustration.

The probability that an object will be struck by lightning is considerably less if it is located in a valley. Therefore, electric transmission lines which must cross mountain ranges often will be routed through the gaps to avoid the direct exposure of the ridges.

There are a number of protective devices to limit or prevent lightning damage to electric power systems and equipment. The word protective is used to connote either one of two functions: the prevention of trouble, or its elimination after it occurs. Various protective means have been devised either to prevent lightning from entering the system or to dissipate it harmlessly if it does. Overhead ground wires and lightning rods are used to prevent lightning from striking the electrical system. Lightning arresters are protective devices for reducing the transient system overvoltages to levels compatible with the terminal-apparatus insulation. See SURGE SUPPRESSOR.

Immediate reclosure is a practice for restoring service after the trouble occurs by immediately reclosing automatically the line power circuit breakers after they have been tripped by a short circuit. The protective devices involved are the power circuit breaker and the fault-detecting and reclosing relays. See CIRCUIT BREAKER; ELECTRIC PROTECTIVE DEVICES. [G.D.B.]

**Lignin** A polymer found extensively in the cell walls of all woody plants, Lignin, one of the most abundant natural polymers, constitutes one-fourth to one-third of the total dry weight of trees. It combines with hemicellulose materials to help bind the cells together and direct water flow. See CELL WALLS (PLANT); HEMICELLULOSE; POLYMER.

Several methods have been devised for isolating lignin from wood. Some isolation methods are based on acid treatments in which the carbohydrate components (cellulose and hemicelluloses) are hydrolyzed to water-soluble materials. However, with such procedures, serious doubts exist as to whether the isolated lignin is representative of the "native" lignin. Enzymatic digestion of the carbohydrate in wood meal is a lengthy, tedious procedure but offers the greatest promise of leaving lignin unaltered during isolation.

Structural studies on lignin have been hampered by the random, cross-linked nature of the polymer. The relative proportions of the monomers which make up lignin (**1** and **2**) vary with the

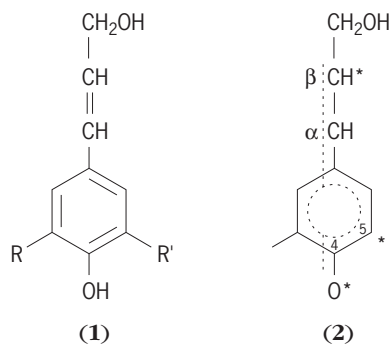

plant species. Lignin is formed in the plant by an enzymatic dehydrogenation of the monomers. The \* designations shown on the structure **(2)** indicate the principal sites for coupling monomers.

In general, the markets for lignin products are not large or attractive enough to compensate for the cost of isolation and the energy derived from its burning. An exception is lignosulfonate, which is obtained during paper production either directly from sulfite pulping liquors or by sulfonation of acid-precipitated kraft lignin; its markets include a dispersant in carbon black slurries, clay products, dyes, cement, oil drilling muds, an asphalt emul-

sifier, a binder for animal feed pellets, a conditioner for boiler water or cooling water, and an additive to lead-acid storage battery plate expanders. See PAPER; WOOD CHEMICALS. [D.R.D.]

**Lignite** A brownish-black, low-rank coal, with a heating value of less than 8300 Btu/lb (4611 kcal/kg) on a moist, mineral-matter-free basis. Lignite occurs in two subclasses: lignite A [8300–6300 Btu/lb (4611–3500 kcal/kg)] and lignite B [less than 6300 Btu/lb (3500 kcal/kg)]. Outside North America, low-rank coal is classified as brown coal, which includes lignite, subbituminous, and most high-volatile C bituminous coal of the North American classification system. Brown coal is divided into soft and hard coal; hard coal is subdivided into dull and bright coal. See COAL.

Because lignite has undergone less coalification than higher-rank coals, the organic precursor constituents are more easily recognized than those in high-rank coals, and lignite serves as an invaluable link between peat and high-rank coals in studying the coal origin. See COAL PALEOBOTANY; PEAT.

Lignite is used primarily to generate electricity at mine-mouth power plants. Lignite has been successfully used as a feedstock for gasification, liquefaction, and pyrolysis. Minor uses of lignite are montan wax, activated carbon, firing kilns, and home heating. See ACTIVATED CARBON; COAL CHEMICALS. [W.B.A.]

**Lignumvitae** A tree, *Guaicum sanctum*, also known as holywood lignumvitae, which is cultivated to some extent in southern California and tropical Florida. Lignumvitae is native in the Florida Keys, Bahamas, West Indies, and Central and South America. It is an evergreen tree of medium size with abruptly pinnate leaves. The tree yields a resin or gum known as gum guaiac or resin of guaiac which is used in medicine. The very heavy black heartwood is used in bowling balls, blocks and pulleys, and parts of instruments. See SAPINDALES. [A.H.G./K.P.D.]

**Liliales** An order of monocotyledons, the well-known lilies or family Liliaceae of many previous botanists, actually consisting of 9 families and about 1600 species. Liliales are clearly circumscribed in deoxyribonucleic acid (DNA) sequence analyses, but are difficult to define on the basis of morphological characters, resulting in varying family composition in different classifications. Nearly all features marking the families of Liliales are micromorphological (for example, perigonal nectaries, nuclear endosperm formation).

Many members of the order are herbaceous perennials, but there are also some vines. Many taxa are extremely poisonous. Most Colchicaceae, for example, possess colchicine-type alkaloids. *Lilium* (lilies), *Tulipa* (tulips), and *Fritillaria* (fritillaries) in Liliaceae, *Colchicum* (autumn crocuses, Colchicaceae), and *Alstroemeria* (Peruvian lilies, Alstroemeriaceae) are well-known horticultural plants. See ASPARAGUS; COLCHICINE; GARLIC; LILIACEAE; LILIOPSIDA; ONION; SISAL. [M.F.F.; M.W.C.]

**Liliidae** A subclass of the class Liliopsida (monocotyledons) of the division Magnoliophyta (Angiospermae), the flowering plants, consisting of 2 orders (Liliales and Orchidales), 19 families, and about 25,000 species. The Liliidae are syncarpous monocotyledons with both the sepals and the petals usually petaloid. The flowers generally have well-developed nectaries, and pollination is usually by insects or other animals. See LILIALES; LILIOPSIDA; MAGNOLIOPHYTA; ORCHIDALES. [A.C.; T.M.Ba.]

**Liliopsida** One of the two classes which collectively make up the division Magnoliophyta (Angiospermae), the flowering plants. The Liliopsida, often known as Monocotyledoneae, or monocotyledons, embrace 5 subclasses (Alismatidae, Commelinidae, Arecidae, Zingiberidae, and Liliidae), 18 orders, 61 families, and about 55,000 species.



All of the characters which collectively distinguish the Liliopsida from the Magnoliopsida (dicotyledons) are subject to exception, but most of the Liliopsida have parallel-veined leaves, and when the embryo is differentiated into recognizable parts, there is only a single cotyledon. The vascular bundles are generally scattered or borne in two or more rings, so the stems and roots do not have a well-defined pith and cortex. Monocotyledons never have an intrafascicular cambium, and most of them have no secondary growth at all. The mature root system of monocots is wholly adventitious. The floral parts of monocots, when of definite number, are most often borne in sets of 3, seldom 4, never 5. The pollen is uniapecturate or of uniapecturate-derived type. See ALISMATIDAE; ARECIDAE; COMMELINIDAE; LILIIDAE; MAGNOLIOPHYTA; ZINGIBERIDAE. [A.Cr.; T.M.Ba.]

**Lime (botany)** An acid citrus fruit, *Citrus aurantifolia*, usually grown in tropical or subtropical regions because of its low resistance to cold. The two principal groups of limes are the West Indian or Mexican and the Tahiti or Bearss. The fruit of West Indian lime is very small (walnut size) and strongly acid, and drops when fully colored. The Tahiti lime is seedless and its aroma is less pronounced.

Except in the United States, the commercial lime industry is restricted to the West Indian group. The major producing areas are India, Mexico, Egypt, and the West Indies. Commercial production of the Tahiti lime is largely confined to the United States. It is grown mainly in Florida, with some plantings in the warmer areas of southern California. See FRUIT; FRUIT, TREE. [R.K.So.]

**Lime (industry)** A general term for burned (or calcined) limestone, also known as quicklime, hydrated lime, and unslaked or slaked lime. Its predominant usage (90%) is as a basic industrial chemical. It still enjoys its traditional building uses. In order of decreasing size uses are: steel fluxing, water treatment, non-ferrous metals (alumina, magnesium, copper, and others), pulp and paper, refractories, soil stabilization, sewage and trade waste treatment, chemicals, and glass manufacture. See LIMESTONE.

Lime is not a mineral; it is manufactured from a mineral—limestone, coral, oystershell, all being sources of calcium carbonate. Dolomite, a calcium-magnesium carbonate, is used to produce dolomitic (magnesium) lime. Only the purest types of stone or shell are used for lime. [R.S.B.]

**Limestone** A common sedimentary rock composed predominantly of carbonates of calcium and magnesium. Limestones are the most voluminous of the nonsiliciclastic sedimentary rocks. In the strict sense, limestones refer to sedimentary rocks composed of the calcium carbonate mineral calcite ( $\text{CaCO}_3$ ). Those rocks, dominated by the magnesium-calcium carbonate mineral dolomite [ $\text{CaMg}(\text{CO}_3)_2$ ], are known as dolomites or dolostones. Although most limestones are similar in chemical and mineralogical composition, the complex organic and chemical origins of carbonate sediments lead to a wide range of textures and fabrics in the resulting limestones. These textures and fabrics share significant parallels with those found in siliciclastic rocks, and they are quite useful for the classification and determination of depositional environments for limestones. Limestones and dolomites are used commercially as building materials and as a source for industrial and agricultural lime. In addition, limestones and dolomites are important reservoirs for oil and gas and are the hosts for important mineral deposits, including lead, zinc, silver, and fluorite. See LIME (INDUSTRY); ORE AND MINERAL DEPOSITS; PETROLEUM GEOLOGY; STONE AND STONE PRODUCTS.

Most marine limestones (perhaps 90% or more) originate as calcium carbonate skeletal elements of various organisms, including both plants (marine algae such as *Lithothamnion* and phytoplankton such as coccoliths) and animals (such as corals, clams, snails, and oysters). The larger organisms are broken down into cobble-to-silt-sized sediments by biological processes,

such as boring, browsing, and grazing, in the environment. Once formed, these sediments react to environmental processes as do their siliciclastic counterparts. See ALGAE; CHALK; DEPOSITIONAL SYSTEMS AND ENVIRONMENTS; MARINE SEDIMENTS; STRATIGRAPHY.

Some limestones and limestone components are formed by direct chemical precipitation from marine and meteoric waters. Most modern, tropical, marine surface water is supersaturated with respect to calcium carbonate. If carbon dioxide is removed from this water by warming, agitation, or photosynthesis, there is a tendency for calcium carbonate to be precipitated. This precipitation can take several forms: an aragonite or magnesian calcite cement, which lithifies carbonate sediment, such as the beach rock commonly found along tropical beaches; an aragonite precipitate on a moving nucleus in a high-energy environment, forming highly polished, round, sand-sized particles termed ooids; or clouds of spontaneously precipitated, clay-sized aragonite, forming on shallow carbonate platforms or in restricted bays. See OOLITE.

Finally, some limestones are formed in fresh-water environments associated with caves (speleothems, such as stalactites and stalagmites), springs (tufa and travertine), and lakes (almost always chemically precipitated fine muds of calcite, dolomite, or alkali-carbonates). See CAVE; STALACTITES AND STALAGMITES; TRAVERTINE; TUFA.

Textures and fabrics in limestones are much more difficult to interpret than in siliciclastics, because of the organic origin of most carbonate grains. While grain size distribution in siliciclastics is controlled by the flow velocity at the site of deposition, grain size distribution in carbonates may be controlled by the types of organisms present in the environment that furnishes the grains. As an example, an environment dominated by large mollusks will tend to produce a sediment characterized by coarse grain sizes, whereas a benthic foraminiferal community will tend to produce grain sizes that are much finer. Roundness in siliciclastic deposits may be used to infer transport and depositional processes. Roundness in the individual grains of a limestone, however, may reflect only the original shape of the organism or the architecture of its skeleton. [C.H.Mo.]

**Limiter circuit** A device whose purpose is to ensure that the amplitude of a sensed variable (referred to as a signal) is constrained or limited to lie within prescribed maximum and minimum values. It is more properly termed an amplitude limiter, although convention usually dispenses with the important modifier. Also, unless specified otherwise, the limiting is applied to voltage.

Strictly speaking, the limiter should behave as a perfectly linear device (such as an ideal amplifier or even a piece of wire) until the amplitude of the input signal reaches the upper or lower limit values. In other words, the output of an ideal limiter matches the input perfectly when the input is between the limit values. If the input is greater than the upper limit, the output equals the upper limit; if the input is less than the lower limit, the output equals the lower limit. If the upper and lower limits are equal in magnitude, the limiting is symmetrical. In the past, one or two stages of high-gain amplification would often precede a limiter in order to obtain clean limiting. See LINEARITY.

The term limiter is often used to mean sign detector, so that when the input is greater than zero, the output equals some fixed positive value; when the input is less than zero, the output is the negative of this value. This usage is sometimes employed in discussing frequency-modulation (FM) radio receivers.

Discrete-component limiters have become rare. The cost/performance ratio of integrated circuits makes them the only rational choice for commercial applications. Most often, integrated circuits now contain limit operations that are both functionally and physically integrated with companion operations to form a higher-level function. The isolated need for a limit-only function is almost never encountered. Limiting within an integrated circuit is usually obtained by designing

an amplifier to be heavily overdriven and therefore to quickly enter the saturation (limiting) range. See AMPLIFIER; INTEGRATED CIRCUITS. [J.S.A.Wh.]

**Limits and fits** The extreme permissible values of a dimension are known as limits. The degree of tightness or looseness between two mating parts that are intended to act together is known as the fit of the parts. The character of the fit depends upon the use of the parts. Thus, the fit between members that move or rotate relative to each other, such as a shaft rotating in a bearing, is considerably different from the fit that is designed to prevent any relative motion between two parts, such as a wheel attached to an axle.

In selecting and specifying limits and fits for various applications, the interests of interchangeable manufacturing require that (1) standard definitions of terms relating to limits and fits be used; (2) preferred basic sizes be selected wherever possible to reduce material and tool costs; (3) limits be based upon a series of preferred tolerances and allowances; and (4) a uniform system of applying tolerances (bilateral or unilateral) be used. See DESIGN STANDARDS; ENGINEERING DESIGN; MACHINE. [J.E.I.]

**Limnology** The study of lakes, ponds, rivers, streams, swamps, and reservoirs that make up inland water systems. Each of these inland aquatic environments is physically and chemically connected with its surroundings by meteorologic and hydrogeologic processes (see illustration).

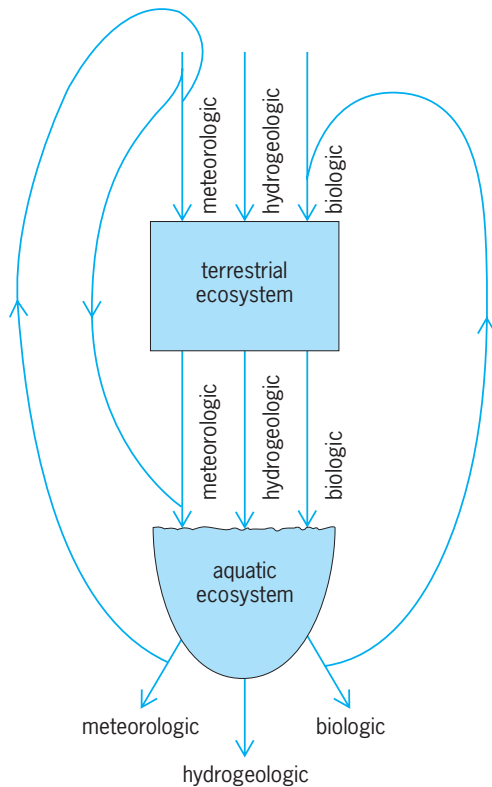

Diagrammatic model of the functional linkages between terrestrial and aquatic ecosystems. Vectors may be meteorologic, hydrogeologic, or biologic components moving nutrients or energy along the pathway shown.

Aquatic systems with excellent physical conditions for production of organisms and high nutrient levels may show signs of eutrophication. Eutrophic lakes are generally identified by large numbers of phytoplankton and aquatic macrophytes and by low oxygen concentrations in the profundal zone. See ECOLOGY; EUTROPHICATION; FRESH-WATER ECOSYSTEM; HYDROLOGY; LAKE; RIVER. [J.E.S.]

**Limonite** A field or generic term for natural hydrous iron oxides, the most common phase being the mineral goethite,  $\alpha\text{-FeO(OH)}$ . Limonite includes the so-called bog iron ores. It is the characteristic brown stain which coats rocks containing sulfide ores, such as pyrite and pyrrhotite, in the zone of weathering of these ores referred to as a gossan. It is formed by biogenic or inorganic precipitation in bog, spring, lacustrine, or marine deposits. [P.B.M.]

**Limpet** Name given to a variety of species of aquatic gastropod mollusks, all with a characteristic conical shell (see illustration) and a suckerlike foot. Limpets (like chitons) are well adapted for life on rocky surfaces exposed to wave action and, in the higher levels of the littoral zone, to alternating tidal submergence and aerial drying. All limpets move relatively slowly over rock or other hard surfaces, protecting themselves (against wave action or desiccation or predation) by clamping down the shell opening against the substrate by contraction of the enlarged shell muscles. There is never an operculum on the foot, and limpets are defenseless once detached.

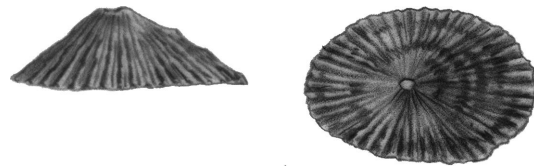

*Diodora aspera*, the rough-keyhole limpet of the Pacific coast of North America, viewed from the side and top.

Limpets usually graze slowly and continuously by radular scraping of attached algae and diatoms from rock surfaces. The structural and functional adaptations of the limpet form have arisen in many distinct groups of gastropods. See GASTROPODA; MOLLUSCA. [W.D.R.H.]

**Linales** An order of flowering plants, division Magnoliophyta (Angiospermae), in the subclass Rosidae of the class Magnoliopsida (dicotyledons). The order is a coherent group of 5 families and about 550 species. They are simple-leaved herbs or woody plants, with hypogynous, regular, syncarpous flowers that have five to many stamens which are connate at the base. The pollen is trinucleate. *Linum usitatissimum* (the source of flax fibers and linseed oil) and *Erythroxylon coca* (the source of cocaine) are well-known members of the Linales. See COCA; FLAX; MAGNOLIOPHYTA; MAGNOLIOPSIDA; ROSIDAE. [A.Cr.; T.M.Ba.]

**Line integral** The line integral of a vector function  $\mathbf{F}$  of position over a path  $C$  is represented by Eq. (1), where  $F_x, F_y, F_z$

$$\int \mathbf{F} \cdot d\mathbf{r} = \int_C F_x(x, y, z) dx + \int_C F_y(x, y, z) dy + \int_C F_z(x, y, z) dz \quad (1)$$

are the scalar components of  $\mathbf{F}$  along the coordinate axes. The path  $C$  is supposed to be a curve, smooth at least in part, defined parametrically by equations of form (2) for each smooth

$$x = x(p) \quad y = y(p) \quad z = z(p) \quad (2)$$

portion. The functions  $F_x(x, y, z)$ , etc., must be defined at all points of  $C$ .

When  $C$  is a closed curve, the line integral is called a circuit integral, and is written as notation (3).

$$\oint \mathbf{F} \cdot d\mathbf{r} \quad (3)$$

See INTEGRATION.

[McA.H.H.]

**Line spectrum** A discontinuous spectrum characteristic of excited atoms, ions, and certain molecules in the gaseous

phase at low pressures. If an electric arc or spark between metallic electrodes, or an electric discharge through a low-pressure gas, is viewed through a spectroscope, images of the spectroscope slit are seen in the characteristic colors emitted by the atoms or ions present. See ATOMIC STRUCTURE AND SPECTRA; SPECTROSCOPY. [G.R.H.]

**Linear algebra** That branch of mathematics which deals with solutions of systems of linear equations and the related geometric notions of vector spaces and linear transformations. It is fundamental in the theory of the calculus of functions of several variables and hence is of great importance in the application of mathematics to physical and biological sciences, economics, and so on.

The word linear is derived from the fact that the equation of a line in two-dimensional analytic geometry has the form shown in Eq. (1) and a system of linear equations has the corresponding form shown in Eq. (2), where  $i = 1, 2, \dots, m$ . The  $a_{ij}$  and  $b_i$  are

$$ax + by = c \tag{1}$$

$$a_{i1}x_1 + a_{i2}x_2 + \dots + a_{in}x_n = b_i \tag{2}$$

fixed quantities belonging to a specified field, for example, the field of real numbers, and solutions  $(x_1, x_2, \dots, x_n)$  are sought in the same field. [N.J.]

**Linear programming** An area of mathematics concerned with the minimization (or maximization) of a linear function of several variables subject to linear equations and inequalities. The subject in its present form was created in 1947, when G. B. Dantzig defined the general model and proposed the first, and still the most widely used, method for its solution: the simplex method.

Although the linearity assumptions are restrictive, many algorithms for extensions of linear programming, such as problems with nonlinear or integer restrictions, involve successively solving linear programming problems. With a result in 1979 giving a polynomially bounded ellipsoid method, an alternative to the simplex method, linear programming became the focus of work by computer scientists, and nonlinear methods have been re-focused on solving the linear programming problem. Work by N. K. Karmarkar announced in 1984 attracted much attention because of claims of vastly improved performance of a new interior method. The relative merits of Kamarkar's method and the simplex method remain to be determined, but there seems to be a place for both methods. Karmarkar's work stimulated considerable activity in linear programming methodology. See NONLINEAR PROGRAMMING; OPTIMIZATION.

The linear programming problems is to minimize linear objective function (1) subject to restrictions (2). The variables  $x_1,$

$$c_1x_1 + \dots + c_nx_n \tag{1}$$

$$x_1 \geq 0, \dots, x_n \geq 0$$

$$a_{11}x_1 + \dots + a_{1n}x_n = b_1$$

$$\vdots \tag{2}$$

$$a_{m1}x_1 + \dots + a_{mn}x_n = b_m$$

$\dots, x_n$  are required to take on real values, and the coefficients  $a_{ij}, c_j,$  and  $b_i$  are real constants. The objective could be to maximize rather than minimize, and among constraints (2) the equations could be replaced by inequalities of the form less-than-or-equal-to or greater-than-or-equal-to. The set of  $x_j$ 's satisfying constraints (2) form a convex polyhedron, and the optimum value of the objective function will always be assumed at a vertex of the polyhedron unless the objective function is unbounded. The simplex method works by moving from vertex to vertex until the vertex yielding the optimum value of the objective function is reached, while interior methods stay inside the polyhedron.

An important extension in practice is to integer programming, where some of the  $x_j$ 's are required to take on integral values.

The most common case in practice is where the integer  $x_j$  must be 0 or 1, representing decision choices such as to whether to switch from production of one product to another or whether to expand a warehouse to allow for larger throughput. Whereas linear programming solution times tend to be less than an hour, adding the constraint that some or all of the  $x_j$ 's must be integral may cause the running time to be very long. See DECISION THEORY.

Early work on computer programs was done in the 1950s. Commercial computer codes implementing the simplex method have been used in industry since the mid-1960s. Efficient methods for handling the structures encountered have been developed. In particular, the matrices tend to be very sparse, that is, most (usually over 99%) of the  $a_{ij}$ 's are zeroes. In the 1980s, intense development in software was begun because of changed hardware and new algorithmic developments.

Following the early work on codes, the petroleum industry quickly became the major user of linear programming, and still is an important user, especially for blending models in petroleum refining. Commercial codes are used in industry and government for a variety of applications involving planning, scheduling, distribution, manufacturing, and so forth. In universities, linear programming is taught in most business schools, industrial engineering departments, and operations research departments, as well as some mathematics departments. The model is general enough to be useful in the physical and social sciences. The improved computational efficiency achieved in the 1980s has gone hand-in-hand with expanded applications, particularly in manufacturing, transportation, and finance. See OPERATIONS RESEARCH. [E.L.J.]

**Linear system analysis** The study of properties and behavior of a system using a body of mathematical techniques based on linear system theory. A system can be defined as a set or arrangement of things related in such a way as to form a whole. Linear system analysis is concerned with the study of equilibrium and change in dynamical systems, that is, in systems that contain variables that may change with time. These variables include system inputs (external causes of change or excitation), outputs (measurable results or effects of the behavior, response, or dynamics of the system), as well as variables describing internal states of the system. To perform the analysis, relationships between these variables are described by a set of equations known as the model. In order for linear system analysis to be applicable, the model must possess the linearity property: it must be a linear model. Linearity simplifies the analysis of systems significantly, and hence there is a large body of mathematical techniques and results, referred to as linear system theory, that can be used to study linear systems. See LINEARITY; SYSTEMS ENGINEERING.

Examples of systems studied include both natural (biological or environmental) systems and artificial or engineered systems, such as spacecraft, aircraft, and electronic circuits. Models describing such systems can be derived from the laws of physics or fitted empirically by using input and output data. The linearity property implies that the response of a system to the sum of several inputs is equal to the sum of its responses due to each of the individual inputs, and that the response of a system to an input multiplied by a scale factor is equal to the same scale factor times the response of the system to that input. Although most systems in reality are nonlinear, it is possible to study their behavior in a limited range of values of inputs and outputs around an operating point with the help of linear approximations. An electronic amplifier, for example, can be approximated by a linear model for analysis of response to small signals around an operating point defined by dc bias voltages. See AMPLIFIER. [H.K.E.]

A discrete-time system is one whose input and output responses evolve at discrete time instants rather than in continuous time. A discrete-time linear system is a discrete-time system that obeys the superposition property; that is, its response to a linear



related to the lifetime  $\tau$  of the excited level through Eq. (3). This

$$(\Delta\nu)(\tau) = \frac{1}{2\pi} \quad (3)$$

is a manifestation of the quantum-mechanical uncertainty principle, and the linewidth  $\Delta\nu$  is referred to as the natural linewidth. See ENERGY LEVEL (QUANTUM MECHANICS); QUANTUM MECHANICS; UNCERTAINTY PRINCIPLE.

Another major source of line broadening for atomic and molecular transitions is the Doppler shift due to thermal motion. For most situations the Doppler width is greater than the natural linewidth. See DOPPLER EFFECT.

A third major source of line broadening is collisions of the radiating molecule with other molecules. This broadens the line, shifts the center of the line, and shortens the lifetime of the radiating state.

For radiating atoms in a liquid or solid the width is usually dominated by the strong interaction of the radiator with the surrounding molecules. The net result is a broad line profile with a complex structure. See BAND THEORY OF SOLIDS. [F.M.P.]

**Linguistics** The science, that is, the general and universal properties, of language. The middle of the twentieth century saw a shift in the principal direction of linguistic inquiry from one of data collection and classification to the formulation of a theory of generative grammar, which focuses on the biological basis for the acquisition and use of human language and the universal principles that constrain the class of all languages. Generative grammar distinguishes between the knowledge of language (linguistic competence), which is represented by mental grammar, and the production and comprehension of speech (linguistic performance).

If grammar is defined as the mental representation of linguistic knowledge, then a general theory of language is a theory of grammar. A grammar includes everything one knows about a language; its phonetics and phonology (the sounds and the sound system), its morphology (the structure of words), its lexicon (the words or vocabulary), its syntax (the structure of sentences and the constraints on well-formed sentences), and its semantics (the meaning of words and sentences). See PSYCHOACOUSTICS; SPEECH; SPEECH PERCEPTION.

Linguistics is not limited to grammatical theory. Descriptive linguistics analyzes the grammars of individual languages; anthropological linguistics, or ethnolinguistics, and sociolinguistics focus on languages in relation to culture, social class, race, and gender; dialectologists investigate how these factors fragment one language into many. In addition, sociolinguists and applied linguists examine language planning, literacy, bilingualism, and second-language acquisition. Computational linguistics encompasses automatic parsing, machine processing, and computer simulation of grammatical models for the generation and parsing of sentences. If viewed as a branch of artificial intelligence, computational linguistics has as its goal the modeling of human language as a cognitive system. A branch of linguistics concerned with the biological basis of language development is neurolinguistics. The form of language representation in the mind, that is, linguistic competence and the structure and components of the mental grammar, is the concern of theoretical linguistics. The branch of linguistics concerned with linguistic performance, that is, the production and comprehension of speech (or of sign language by the deaf), is called psycholinguistics. Psycholinguists also investigate how children acquire the complex grammar that underlies language use. See INFORMATION PROCESSING; PSYCHOLINGUISTICS. [V.A.F.]

**Lingulida** An order of inarticulated brachiopods consisting of a group of semisessile, suspension-feeding, marine, benthic, infaunal bivalves with representatives occurring throughout the Phanerozoic Era (from the Early Cambrian to the present). Most

extant members of this group originated in the Ordovician Period, when the order achieved maximum diversity.

Shells are tongue shaped, equivalve, and slightly convex. The valves are separate and do not articulate about a hinge but possess a complex arrangement of muscles. Lingulids have a pair of anterior adductor muscles and one laterally placed posterior adductor muscle, two pairs of oblique muscles (three in *Lingula*), an elevator, and three pairs of minor muscles: the lophophore (tentacular feeding organ) protractors, retractors, and elevators. All extant members of this order have a relatively long, fleshy retractable pedicle and burrow in soft sediments.

Two superfamilies are recognized: Lingulacea, which have thin chitinophosphatic shell and no muscle platforms, and Trimerelacea, which have thick aragonite shells and muscle platforms. Important genera in this order include *Lingula*, "a living fossil" which appears to have changed little for 450 million years, and *Glottidia*. See BRACHIOPODA; INARTICULATA. [M.A.J.]

**Link** An element of a mechanical linkage. A link may be a straight bar or a disk, or it may have any other shape, simple or complex. It is assumed, for simple analysis, to be made of unyielding material; that is, its shape does not change. The frame, or fixed member, of a linkage is one of the links.

Two links of a kinematic chain meet in a joint, or pair, by which these links are held together. Just as each joint is a pair having two elements, one from each link, so a link in a kinematic chain is the rigid connector of two or more elements belonging to different pairs. See LINKAGE (MECHANISM); MECHANISM. [D.PAD.]

**Linkage (genetics)** Failure of two or more genes to recombine at random as a result of their location on the same chromosome pair. Among the haploid products of a cell which has gone through meiosis, two genes located in the same chromosome pair remain in their two original combinations of alleles ("parental") unless an odd number of exchanges of homologous segments occurred within the interval bounded by their loci. The incidence of exchanges of homologous segments at meiosis is roughly proportional to the length of the chromosome segment between two loci. The percentage of recombinants thus provides an estimate of this length and a basis for constructing gene maps on which linked loci are arranged in linear order and spaced out in proportion to the recombination percentages between them. See MEIOSIS. [G.Po.]

**Linkage (mechanism)** A set of rigid bodies, called links, joined together at pivots by means of pins or equivalent devices. A body is considered to be rigid if, for practical purposes, the distances between points on the body do not change. Linkages are used to transmit power and information. They may be employed to make a point on the linkage follow a prescribed curve, regardless of the input motions to the linkage. They are also used to produce angular or linear displacement. See LINK; MECHANISM.

If the links are bars the linkage is termed a bar linkage. A common form of bar linkage is one for which the bars are restricted to a given plane, such as a four-bar linkage. A commonly occurring variation of the four-bar linkage is the linkage used in reciprocating engines (see illustration). Slider C is the piston in a cylinder,

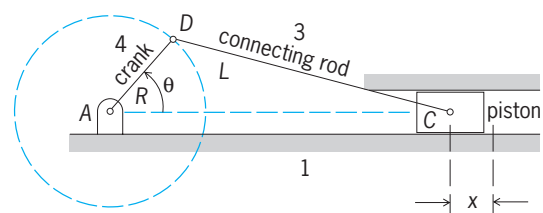

Slider crank mechanism.

link 3 is the connecting rod, and link 4 is the crank. (Link 1 is the fixed base, *A* and *D* are pivots, *R* is the length of the crank, *L* is the length of the connecting rod, and  $\theta$  denotes the angle of the crank.) This mechanism transforms a linear into a circular motion, or vice versa. The straight slider in line with the crank center is equivalent to a pivot at the end of an infinitely long link. See FOUR-BAR LINKAGE; PANTOGRAPH; SLIDER CRANK MECHANISM. [R.O.]

**Lipid** One of a class of compounds which contains long-chain aliphatic hydrocarbons (cyclic or acyclic) and their derivatives, such as acids (fatty acids), alcohols, amines, amino alcohols, and aldehydes. The presence of the long aliphatic chain as the characteristic component of lipids confers distinct solubility properties on the simpler members of this class of naturally occurring compounds.

The lipids are generally classified into the following groups:

#### A. Simple lipids

1. Triglycerides or fats and oils are fatty acid esters of glycerol. Examples are lard, corn oil, cottonseed oil, and butter.
2. Waxes are fatty acid esters of long-chain alcohols. Examples are beeswax, spermaceti, and carnauba wax.
3. Steroids are lipids derived from partially or completely hydrogenated phenanthrene. Examples are cholesterol and ergosterol.

#### B. Complex lipids

1. Phosphatides or phospholipids are lipids which contain phosphorus and, in many instances, nitrogen. Examples are lecithin, cephalin, and phosphatidyl inositol.
2. Glycolipids are lipids which contain carbohydrate residues. Examples are sterol glycosides, cerebrosides, and plant phytyglycolipids.
3. Sphingolipids are lipids containing the long-chain amino alcohol sphingosine and its derivatives. Examples are sphingomyelins, ceramides, and cerebrosides.

Lipids are present in all living cells, but the proportion varies from tissue to tissue. The triglycerides accumulate in certain areas, such as adipose tissue in the human being and in the seeds of plants, where they represent a form of energy storage. The more complex lipids occur closely linked with protein in the membranes of cells and of subcellular particles. More active tissues generally have a higher complex lipid content; for example, the brain, liver, kidney, lung, and blood contain the highest concentration of phosphatides in the mammal. See FAT AND OIL; FAT AND OIL (FOOD); GLYCOLIPID; SPHINGOLIPID; STEROID; TERPENE; TRIGLYCERIDE; VITAMIN; WAX, ANIMAL AND VEGETABLE. [R.H.G.]

**Lipid metabolism** The assimilation of dietary lipids and the synthesis and degradation of lipids; this article is restricted to mammals.

The principal dietary fat is triglyceride. This substance is not digested in the stomach and passes into the duodenum, where it causes the release of enterogastrone, a hormone which inhibits stomach motility. The amount of fat in the diet, therefore, regulates the rate at which enterogastrone is released into the intestinal tract. Fat, together with other partially digested foodstuffs, causes the release of hormones, secretin, pancreaticozym, and cholecystokinin from the wall of the duodenum into the bloodstream.

Secretin causes the secretion of an alkaline pancreatic juice rich in bicarbonate ions, while pancreaticozym causes secretion of pancreatic enzymes. One of these enzymes, important in the digestion of fat, is lipase. Cholecystokinin, which is a protein substance chemically inseparable from pancreaticozym, stimulates the

gallbladder to release bile into the duodenum. Bile is secreted by the liver and concentrated in the gallbladder and contains two bile salts, both derived from cholesterol: taurocholic and glycocholic acids. These act as detergents by emulsifying the triglycerides in the intestinal tract, thus making the fats more susceptible to attack by pancreatic lipase. In this reaction, which works best in the alkaline medium provided by the pancreatic juice, each triglyceride is split into three fatty acid chains, forming monoglycerides. The fatty acids pass across the membranes of the intestinal mucosal (lining) cells. Enzymes in the membranes split monoglyceride to glycerol and fatty acid, but triglycerides are reformed within the mucosal cells from glycerol and those fatty acids with a chain length greater than eight carbons: Short- and medium-chain fatty acids are absorbed directly into the bloodstream once they pass through the intestinal mucosa. See CHOLESTEROL; DIGESTIVE SYSTEM; GALLBLADDER; LIVER; PANCREAS; TRIGLYCERIDE.

Obesity is a condition in which excessive fat accumulates in the adipose tissue. One factor responsible for this condition is excessive caloric intake. In starvation, uncontrolled diabetes, and many generalized illnesses the opposite occurs and the adipose tissue becomes markedly depleted of lipid. See ADIPOSE TISSUE; DIABETES; LIPID; METABOLIC DISORDERS; OBESITY. [M.A.R.]

**Lipoprotein** Classes of conjugated proteins consisting of a protein combined with a lipid. The normal functioning of higher organisms requires movement of insoluble lipids, such as cholesterol, steroid hormones, bile, and triglycerides, between tissues. To accomplish this movement, lipids are incorporated into macromolecular complexes called lipoproteins.

All major types of lipoproteins share a general structure. The core of these spherical particles contains primarily cholesteryl ester and triglyceride. These insoluble molecules are surrounded by a coating of proteins and phospholipids that are amphipathic; that is, they have both polar and nonpolar regions. Lipoproteins vary by size and density. The largest lipoproteins, chylomicrons, are up to 500 nanometers in diameter, and since they contain primarily triglyceride they are so buoyant that they float in plasma. Very low density lipoproteins (VLDL) also primarily transport triglyceride. Low-density lipoproteins (LDL) and the smallest, most dense lipoproteins, high-density lipoproteins (HDL), transport cholesterol. The interactions of these particles with cell surface receptors and with metabolic enzymes are mediated by the protein components of the particles, termed apolipoproteins. See CHOLESTEROL; TRIGLYCERIDE.

Chylomicrons contain triglyceride (fat) from the diet. In addition, they carry fat-soluble vitamins, such as vitamin A and E, into the circulation. Chylomicrons are produced in the intestine, enter the body via the lymphatic system, and then enter the bloodstream.

Very low density lipoproteins are made in the liver and contain triglyceride that is synthesized either from excess carbohydrate sources of calories or from fatty acids that enter the liver and are reassembled into triglyceride. Lipoprotein lipase (LpL) is an enzyme found on the surface of blood vessels that is responsible for the breakdown of triglyceride in lipoproteins. The partially degraded lipoproteins are termed remnants. They are ultimately removed from the circulation by the liver.

Low-density lipoproteins result after triglyceride is removed from very low density lipoproteins. This leaves a smaller, denser particle that primarily contains cholesteryl ester as its core lipid and a single protein called apoB. Cells throughout the body contain an LDL receptor that recognizes apoB. This allows the uptake of low-density lipoproteins into cells, supplying them with cholesterol. When sufficient low-density lipoproteins and cholesterol are available, cells use them in preference to synthesizing new cholesterol from precursors. In contrast, high-density lipoproteins both deliver and remove cholesterol from tissues.

Blood levels of lipoproteins are major factors regulating risk for development of coronary artery atherosclerosis. Via unknown

mechanisms, low-density lipoproteins and remnant lipoproteins infiltrate and then become attached to extracellular matrix molecules within the artery. Some of the lipoproteins are internalized by macrophages and smooth muscle cells. This might first require chemical modification such as oxidation of the lipids. The resulting pathological findings are deposition of cholesterol in cells and matrix within the vessel wall, leading to a decrease in the diameter of the artery.

In contrast, high-density lipoproteins appear to prevent atherosclerosis formation. The reasons are not entirely understood. Most likely, high-density lipoproteins remove excess cholesterol that accumulates in the artery, or prevent the oxidation of low-density lipoproteins. See ARTERIOSCLEROSIS. [I.J.Go.]

**Liposomes** Aqueous compartments enclosed by lipid bilayer membranes; liposomes are also known as lipid vesicles. Phospholipid molecules consist of an elongated nonpolar (hydrophobic) structure with a polar (hydrophilic) structure at one end. When dispersed in water, they spontaneously form bilayer membranes, also called lamellae, which are composed of two monolayer layer sheets of lipid molecules with their nonpolar (hydrophobic) surfaces facing each other and their polar (hydrophilic) surfaces facing the aqueous medium. The membranes enclose a portion of the aqueous phase much like the cell membrane which encloses the cell; in fact, the bilayer membrane is essentially a cell membrane without its protein components.

Liposomes are often used to study the characteristics of the lipid bilayer. Properties of liposomes have been characterized by a variety of techniques: molecular organization by x-ray diffraction, nuclear magnetic resonance, electron paramagnetic resonance, and Raman spectroscopy; melting behavior (that is, crystal to liquid-crystal transition) by calorimetry; net electric surface charge by microelectrophoresis; size by light scattering and electron microscopy. See LIPID.

Liposomes have numerous uses as biochemical and biophysical tools: (1) as vehicles for the delivery of both water- and of oil-soluble materials to the cell; (2) as immunological adjuvants; (3) as substrates for the study of membrane properties such as rotational or translational diffusion in the plane of the membrane; and (4) as intermediates in the construction of bilayers large enough for the study of electrical properties of membranes. See CELL MEMBRANES. [R.C.MacD.; R.I.MacD.]

**Liquefaction of gases** The process of refrigerating a gas to a temperature below its critical temperature so that liquid can be formed at some suitable pressure, also below the critical pressure.

Gas liquefaction is a special case of gas refrigeration. The gas is first compressed to an elevated pressure in an ambient-temperature compressor. This high-pressure gas is passed through a countercurrent heat exchanger to a throttling valve or expansion engine. Upon expanding to the lower pressure, cooling may take place, and some liquid may be formed. The cool, low-pressure gas returns to the compressor inlet to repeat the cycle. The purpose of the countercurrent heat exchanger is to warm the low-pressure gas prior to recompression, and simultaneously to cool the high-pressure gas to the lowest temperature possible prior to expansion. Both refrigerators and liquefiers operate on this same basic principle. See COMPRESSOR; CRITICAL PHENOMENA; GAS; HEAT EXCHANGER; REFRIGERATION.

An important distinction between refrigerators and liquefiers is that in a continuous refrigeration process, there is no accumulation of refrigerant in any part of the system. This contrasts with a gas-liquefying system, where liquid accumulates and is withdrawn. Thus, in a liquefying system, the total mass of gas that is warmed in the countercurrent heat exchanger is less than the gas to be cooled by the amount that is liquefied, creating an unbalanced flow in the heat exchanger. In a refrigerator, the warm and cool gas flows are equal in the heat exchanger. This results in balanced flow condition. The thermodynamic principles of re-

frigeration and liquefaction are identical. However, the analysis and design of the two systems are quite different due to the condition of balanced flow in the refrigerator and unbalanced flow in liquefier systems.

The prerequisite refrigeration for gas liquefaction is accomplished in a thermodynamic process when the process gas absorbs heat at temperatures below that of the environment. A process for producing refrigeration at liquefied gas temperatures usually involves equipment at ambient temperature in which the gas is compressed and heat is rejected to a coolant. During the ambient-temperature compression process, the enthalpy and entropy, but usually not the temperature of the gas, are decreased. The reduction in temperature of the gas is usually accomplished by heat exchange between the cooling and warming gas streams followed by an expansion of the high-pressure stream. This expansion may take place either through a throttling device (isenthalpic expansion) where there is a reduction in temperature only (when the Joule-Thomson coefficient is positive) or in a work-producing device (isentropic expansion) where both temperature and enthalpy are decreased. See ENTHALPY; ENTROPY; ISENTROPIC PROCESS; THERMODYNAMIC PRINCIPLES; THERMODYNAMIC PROCESSES. [T.M.F.]

**Liquefied natural gas (LNG)** A product of natural gas which consists primarily of methane. Its properties are those of liquid methane, slightly modified by minor constituents. One property which differentiates liquefied natural gas (LNG) from liquefied petroleum gas (LPG) is the low critical temperature, about  $-100^{\circ}\text{F}$  ( $-73^{\circ}\text{C}$ ). This means that natural gas cannot be liquefied at ordinary temperatures simply by increasing the pressure, as is the case with LPG; instead, natural gas must be cooled to cryogenic temperatures to be liquefied and must be well insulated to be held in the liquid state. See LIQUEFACTION OF GASES; LIQUEFIED PETROLEUM GAS (LPG). [A.W.F.]

**Liquefied petroleum gas (LPG)** A product of petroleum gases, principally propane and butane, which must be stored under pressure to keep it in a liquid state. At atmospheric pressure and above freezing temperature, these substances would be gases. Large quantities of propane and butane are now available from the gas and petroleum industries. These are often employed as fuel for tractors, trucks, and buses and mainly as a domestic fuel in remote areas. Because of the low boiling point ( $-47.2$  to  $32^{\circ}\text{F}$  or  $-44$  to  $0^{\circ}\text{C}$ ) and high vapor pressure of these gases, their handling as liquids in pressure cylinders is necessary. Owing to demand from industry for butane derivations, LPG sold as fuel is made up largely of propane.

LPG has a high octane rating, making it useful in engines having compression ratios above 10:1. Another factor of importance in internal combustion engines is that LPG leaves little or no engine deposit in the cylinders when it burns. See INTERNAL COMBUSTION ENGINE; PETROLEUM PRODUCTS. [M.Sou.]

**Liquid** A state of matter intermediate between that of crystalline solids and gases. Macroscopically, liquids are distinguished from crystalline solids in their capacity to flow under the action of extremely small shear stresses and to conform to the shape of a confining vessel. Liquids differ from gases in possessing a free surface and in lacking the capacity to expand without limit. On the scale of molecular dimensions liquids lack the long-range order that characterizes the crystalline state, but nevertheless they possess a degree of structural regularity that extends over distances of a few molecular diameters. In this respect, liquids are wholly unlike gases, whose molecular organization is completely random.

Liquids possess important transport properties, notably their capacity to transmit heat (thermal conductivity), to transfer momentum under shear stresses (viscosity), and to attain a state of homogeneous composition when mixed with other miscible liquids (diffusion). These nonequilibrium properties of liquids

are well understood in macroscopic terms and are exploited in large-scale engineering and chemical-process operations. See GAS. [N.H.N.]

**Liquid chromatography** A method of chemical separation that involves passage of a liquid phase through a solid phase and relies on subtle chemical interactions to resolve complex mixtures into pure compounds. A small amount of the sample to be separated is injected onto the top of a column that is densely packed with spherical particles of small diameter, that is, the stationary phase. A liquid solvent, the mobile phase, flows through the column continuously to carry the sample from the top to the bottom of the column. During passage through the column, the components of the sample are transferred back and forth continuously between the two phases, and small thermodynamic differences in the chemical interactions of the various sample components with the mobile and stationary phases slow the passage of some solutes more than others and lead to their separation. The technique can be performed on very small scales for chemical analysis, dealing with micrograms or even nanograms of sample, or it can be performed on an industrial scale for purification of commercial products. The technique has great resolving power.

In the late 1960s, workers realized that to achieve maximum performance they needed to make the stationary-phase particles very small. As the stationary-phase particles became smaller, they packed too densely to permit gravity-driven flow of the mobile phase. It was necessary to force the mobile phase through the column under high pressure, and the technique was named high-pressure liquid chromatography (HPLC). The meaning of the acronym has been changed to high-performance liquid chromatography, for the elegant separations that are possible. Typical stationary-phase particles are monodisperse, macroporous silica particles either 3 or 5 micrometers in diameter, and the column lengths for analytical scale separations are on the order of 2–10 in. (5–25 cm), with inside diameters of about 0.16 in. (4 mm). The columns are made of stainless steel, which is relatively inert chemically and able to withstand the high pressures applied to the top of the column. Since these columns require pressures of a few hundred to a few thousand pounds per square inch, depending on the mobile-phase flow velocity desired, a high-pressure metering pump is an integral part of a modern liquid chromatograph. Most instruments include a means of performing gradient elution, that is, making a continuous change in the composition of the liquid mobile phase during the separation process. Gradient elution can be performed by using a separate pump for each solvent and changing the relative proportions during the separation, or by using a proportioning valve between the solvent reservoirs and the pump. An injector valve is used to introduce a small volume of sample, typically 5–100 microliters, onto the top of the column without interrupting the mobile-phase flow. These valves can be operated manually, or they can be programmed to perform injections from a tray of samples for routine analyses. After the sample traverses the column, a flow-through detector is employed to generate the chromatogram, which is the visual representation of the separation. Detectors can provide both quantitative and qualitative information about the separated components. Temperature control of the column and detector is important; they are generally operated at or near room temperature, and temperature fluctuations can adversely affect the reproducibility of the separation and detection steps.

Liquid chromatography very much depends on the highly selective chemical interactions that occur in both the mobile and stationary phases. Rapid separations have become possible for compounds whose difference in free energy of transfer between the two phases is only a few calories per mole. Columns exhibiting virtually every type of possible selectivity exist, including selectivity by shape, charge, size, and optical activity. Additional selectivity can be generated through manipulations of the mobile phase; additives that interact with the solute in the mobile phase

can create unique selectivities in columns that do not normally show that type of selectivity.

In addition to facilitating chemical analysis, liquid chromatography can be used to obtain physicochemical information. Diffusion coefficients, kinetic parameters, critical micelle concentrations of surfactants, and other information have been estimated from chromatographic data. The most common application is the estimation of hydrophobic parameters, especially as models of biological or environmental partitioning processes (most frequently, of octanol-water partitioning). Bioavailability, bioaccumulation, soil sorption, and various other factors are estimated based on linear free-energy relationships. See CHROMATOGRAPHY. [J.G.D.]

**Liquid crystals** A state of matter that mixes the properties of both the liquid and solid states. Liquid crystals may be described as condensed fluid states with spontaneous anisotropy. They are categorized in two ways: thermotropic liquid crystals, prepared by heating the substance, and lyotropic liquid crystals, prepared by mixing two or more components, one of which is rather polar in character, for example, water. Thermotropic liquid crystals are divided, according to structural characteristics, into two classes, nematic and smectic.

**Nematic structure.** Nematic liquid crystals are subdivided into the ordinary nematic and the chiral-nematic (or cholesteric). The molecules in the ordinary nematic structure maintain a parallel or nearly parallel arrangement to each other along the long molecular axes (illus. *a*). They are mobile in three directions and can rotate about one axis. This structure is one-dimensional.

When the nematic structure is heated, it is generally transformed into the isotropic liquid where the completely disordered motion of the molecules produces a phase in which all directions are equivalent. The nematic structure is the highest-temperature mesophase in thermotropic liquid crystals. The energy required to deform a nematic liquid crystal is so small that even the slightest perturbation caused by a dust particle can distort the structure considerably.

In the chiral-nematic structure (illus. *b*), the direction of the long axis of the molecule in a given layer is slightly displaced from the direction of the molecular axes of the molecules in an adjacent layer. If a twist is applied to this molecular packing, a helical structure is formed. The helix has a pitch that is temperature-sensitive. The helical structure serves as a diffraction grating for visible light.

**Smectic structure.** The term smectic includes all thermotropic liquid crystals that are not nematics. In the smectic phase, not only is the small amount of orientational order of nematic liquid crystals present, but there is also a small amount of positional order. In most smectic structures, the molecules are free to bounce around randomly; but they tend to point along a specific direction and arrange themselves in layers, either in neat rows or randomly distributed. The molecules can move in two directions in the plane and rotate about one axis.

Smectic liquid crystals may have structured or unstructured strata. Structured smectic liquid crystals have long-range order in the arrangement of molecules in layers to form a regular two-dimensional lattice. The most common of the structured liquid crystals is smectic B. Molecular layers are in well-defined order, and the arrangement of the molecules within the strata is also well ordered. The long axes of the molecules lie perpendicular to the plane of the layers. In the smectic A (illus. *c*) structure, molecules are also packed in strata, but the molecules in a stratum are randomly arranged. The long axes of the molecules in the smectic A structure lie perpendicular to the plane of the layers. Molecular packing in a smectic C (illus. *d*) is the same as that in smectic A, except the molecules in the stratum are tilted at an angle to the plane of the stratum.

**Applications.** Liquid crystals are a state of matter that combines a kind of long-range order (in the sense of a solid) with the ability to form droplets and to pour (in the sense of waterlike



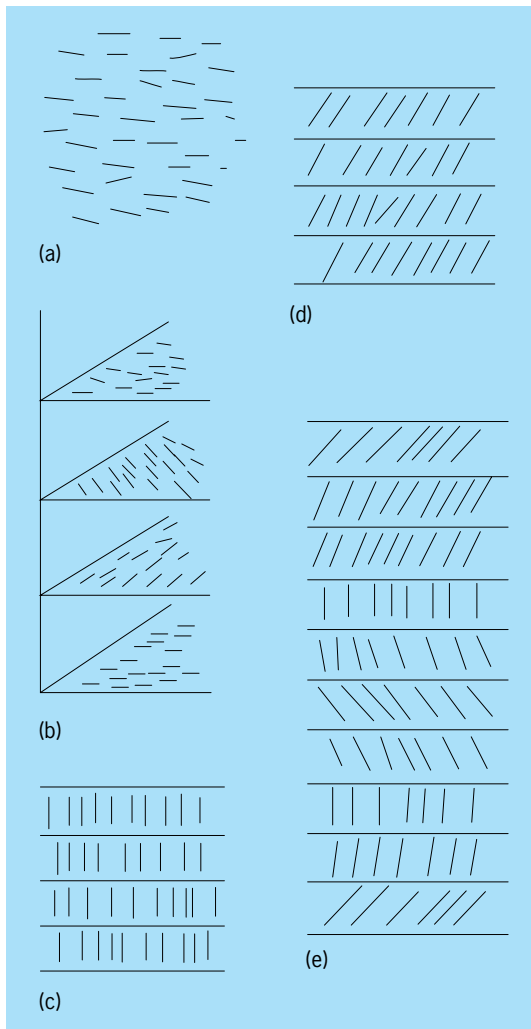

**Molecular arrangement in liquid crystals.** (a) Nematic. (b) Chiral-nematic. (c) Smectic A. (d) Smectic C. (e) Smectic C\* ( $S_C^+$ ). (After R. Blinc, *Solid and liquid crystalline ferroelectrics and antiferroelectrics*, *Condensed Matter News* 1(1):17–23, 1991)

liquids). They also exhibit properties of their own such as the ability to form monocrystals with the application of a normal magnetic or electric field; an optical activity of a magnitude without parallel in either solids or liquids; and a temperature sensitivity that results in a color change in certain liquid crystals. As such, liquid crystals have many applications. They are used as displays in digital wristwatches, calculators, and panel meters. They can be used to record, store, and display images which can be projected onto a large screen. Direct and active-matrix liquid-crystal displays (LCDs) are used in several areas from laptop computers to communication equipment such as television teleconferencing systems, portable and high-definition television (HDTV), and video games. [G.H.B.; J.W.D.; D.Fi.]

**Liquid helium** Helium boils at a substantially lower temperature, 4.2 K ( $-452^\circ\text{F}$  or  $-269^\circ\text{C}$ ), than any other substance; and below 2.172 K ( $-455.76^\circ\text{F}$ ) the liquid exhibits the extraordinary properties of superfluidity, notably the ability to flow through narrow channels with complete absence of friction. In addition to the common isotope of atomic weight 4, helium has a rare isotope of atomic weight 3 with a normal boiling point of 3.2 K ( $-454^\circ\text{F}$ ) and a superfluid transition at a very much lower temperature near 0.001 K. Both forms of helium remain in a liquid state at absolute zero. All of these characteristics are

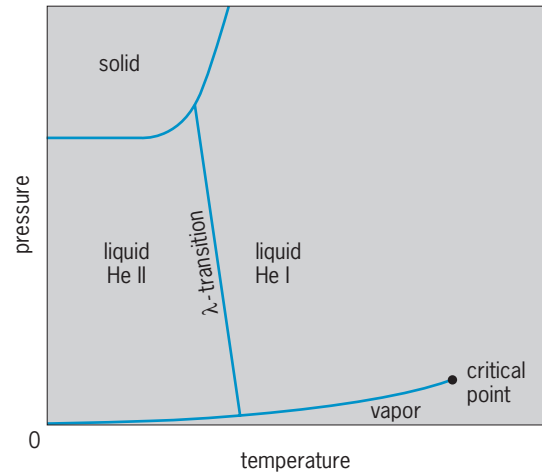

**Phase diagram for  $^4\text{He}$ .** The critical point is at  $T_c = 5.20\text{ K}$  ( $-450.3^\circ\text{F}$ ),  $P_c = 229\text{ kPa}$  (2.26 atm or 33.2 lb/in. $^2$ ).

due to the weakness of the attractive force between two helium atoms and to the small atomic mass, which according to the laws of quantum mechanics makes the atoms difficult to localize.

At 4.2 K ( $-452^\circ\text{F}$ ) liquid  $^4\text{He}$  is colorless and of low refractive index ( $n = 1.024$ ), with a density of  $0.125\text{ g/cm}^3$  (0.125 times that of water). The latent heat of vaporization, 5 cal/g (21 J/g), is very small, and so care must be taken to reduce the heat input by conduction and radiation into the storage container. The classical container consists of two vacuum-insulated vessels of silvered glass (Dewar flask) or metal, with the inner vessel containing the liquid helium immersed in a larger outer vessel filled with liquid nitrogen. Modern superinsulated Dewars are able to dispense with the liquid nitrogen.

The phase diagram of  $^4\text{He}$  (see illustration) shows several remarkable characteristics. Helium remains a liquid down to absolute zero unless a pressure greater than 2.53 megapascals (25.0 atm or 367 lb/in. $^2$ ) is applied. A more subtle feature is a transition between two different liquid phases. This  $\lambda$ -transition is so named because the specific heat has a singularity resembling the Greek letter lambda. There is no latent heat; such a transition is called second-order. The high-temperature liquid phase, called helium I, is a rather ordinary liquid. The  $\lambda$ -transition at 2.172 K or  $-455.76^\circ\text{F}$  (at vapor pressure) marks the onset of superfluidity, which is the characteristic property of the low-temperature phase, helium II. See HELIUM; SUPERFLUIDITY. [B.S.S.]

**Lissajous figures** Plane curves traced by a point which executes two independent harmonic motions in perpendicular

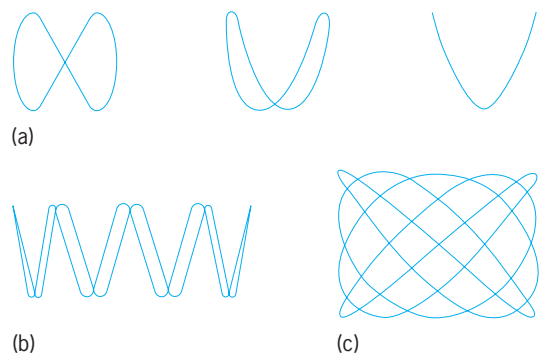

**Typical Lissajous figures for ratios of vertical frequency to horizontal frequency.** (a) 2:1, with various phase relations. (b) 8:1. (c) 5:4. (After F. E. Terman, *Radio Engineers' Handbook*, McGraw-Hill, 1943)

directions, the frequencies of the motion being in the ratio of two integers. Such figures are widely used in frequency and phase measurements (see illustration). See HARMONIC MOTION.

The cathode-ray oscilloscope furnishes the most important and practical means for the generation of the figures. The x-deflection plates of the tube are supplied with one alternating voltage, and the y-deflection plates with another. If the frequencies are incommensurable, the figure is not a closed curve and, except for very low frequencies, will appear as a patch of light because of the persistence of the screen. On the other hand, if the frequencies are commensurable, the figure is closed and strictly periodic; it is a true Lissajous figure, stationary on the screen and, if the persistence is sufficient, visible continuously as a complete pattern. See FREQUENCY MEASUREMENT; OSCILLOSCOPE; PHASE-ANGLE MEASUREMENT. [M.Gr.]

**Lissamphibia** The subclass of Amphibia including all living amphibians (frogs, toads, salamanders, and apodans). The other two subclasses are the Labyrinthodontia and the Lepospondyli. See LABYRINTHODONTIA; LEPOSONDYLI.

Living amphibians are grouped together by possession of a unique series of characters, the most important of which are (1) pedicellate teeth, consisting of two segments, a crown and a pedicel; (2) an operculum-plectrum complex of the middle ear; (3) the papilla amphibiorum, a special sensory area of the inner ear; (4) green rods in the retina of the eye; (5) similar skin glands; and (6) a highly vascular skin used in respiration (cutaneous respiration). See AMPHIBIA; ANURA; URODELA. [R.E.]

**Listeriosis** An infectious disease of humans and animals caused by the bacteria *Listeria monocytogenes* and *L. ivanovii*. Both humans and animals can be carriers, which excrete the bacterium in feces. Sheep, goats, and cattle can excrete the bacteria in milk, without clinical symptoms of mastitis. The most important pathway of infection is probably through food. *Listeria monocytogenes* has frequently been isolated from grass silage (fermented fodder), especially from silage of inferior quality, which is an important source of infection in ruminants. Relatively few animals develop clinical disease, but a high proportion can be latent carriers. Humans most likely ingest the bacteria with contaminated food, such as meat and meat products, raw milk and milk products, and unwashed vegetables. See FOOD MICROBIOLOGY.

Encephalitis is the most common form of disease in ruminants, and septicemia with involvement of several organs, including the pregnant uterus, occurs most commonly in monogastric animals, including very young sheep, goats, and calves.

Most human cases are sporadic, but food-borne epidemics occur. Abortions, perinatal disease, and disease in immunosuppressed individuals are most common. Perinatal disease is dominated by septicemia, widespread microscopic abscesses, and meningitis. In adults, meningitis is by far the most common manifestation, but in immunosuppressed individuals encephalitis occurs, possibly with a pathogenesis similar to encephalitis in ruminants.

Clinical diagnosis is based on symptoms, on isolation of *L. monocytogenes*, and on histopathological examination of affected tissue, especially brain tissue. See MEDICAL BACTERIOLOGY. [H.Gro.]

**Lithium** A chemical element, Li, atomic number 3, and atomic weight 6.939. Lithium heads the alkali metal family in the periodic table. In nature it is a mixture of the isotopes  $^6\text{Li}$  and  $^7\text{Li}$ . Lithium, the lightest solid element, is a soft, low-melting, reactive metal. In many physical and chemical properties it resembles the alkaline-earth metals as much as, or more than, it does the alkali metals. See ALKALINE-EARTH METALS; PERIODIC TABLE.

The major industrial use of lithium is in the form of lithium stearate as a thickener for lubricating greases. Other important

uses of lithium compounds are in ceramics, specifically in porcelain enamel formulation; as an additive to give longer life and higher output in alkaline storage batteries; and in welding and brazing fluxes.

Lithium is a moderately abundant element and is present in the Earth's crust to the extent of 65 parts per million (ppm). This places lithium a little below nickel, copper, and tungsten, and a little above cerium and tin in abundance.

Noteworthy among lithium's physical properties are the high specific heat (heat capacity), large temperature range of the liquid phase, high thermal conductivity, low viscosity, and very low density. Lithium metal is soluble in liquid ammonia and is slightly soluble in the lower aliphatic amines, such as ethylamine. It is insoluble in hydrocarbons.

Lithium undergoes a large number of reactions with both organic, and inorganic, reagents. It reacts with oxygen to form the monoxide,  $\text{Li}_2\text{O}$ , and the peroxide,  $\text{Li}_2\text{O}_2$ . Lithium is the only alkali metal that reacts with nitrogen at room temperature to form a nitride,  $\text{Li}_3\text{N}$ , which is black. Lithium reacts readily with hydrogen at about 930°F (500°C) to form lithium hydride, LiH. The reaction of lithium metal with water is exceedingly vigorous. Lithium reacts directly with carbon to form the carbide,  $\text{Li}_2\text{C}_2$ . Lithium combines readily with the halogens, forming halides with the emission of light. While lithium does not react with paraffin hydrocarbons, it does undergo addition reactions with arylated alkenes and with dienes. Lithium also reacts with acetylenic compounds, forming lithium acetylides, which are important in the synthesis of vitamin A.

The most important lithium compound is lithium hydroxide. It is a white powder, and the material of commerce is actually lithium hydroxide monohydrate,  $\text{LiOH} \cdot \text{H}_2\text{O}$ . Lithium carbonate,  $\text{LiCO}_3$ , finds application in the ceramic industries and in medicine as an antidepressant. Both lithium halides, lithium chloride and lithium bromide, form concentrated brines with ability to absorb moisture over a wide temperature range; these brines are used in commercial air conditioning systems. [M.Si.]

**Lithosphere** The rigid or mechanically strong outer layer of the Earth that can support stress. The lithosphere is divided into 12 major plates, the boundaries of which are zones of intense activity that produce many of the large-scale geological features that characterize the Earth. These plates move as coherent units with velocities of up to several centimeters per year, and their relative movement and interaction form the foundation for the theory of plate tectonics.

The lithosphere comprises the crust (either continental or oceanic) and a portion of the upper mantle that together overlie a zone of relative weakness termed the asthenosphere. The boundary between the crust and the mantle is known as the Mohorovičić discontinuity (Moho), and is compositional in origin—that is, the crust and mantle are distinguished by fundamental differences in rock chemistry. In contrast, the boundary between the lithosphere and the asthenosphere represents an isotherm that separates a conductively cooling lithosphere from a quasi-isothermal convecting asthenosphere. The asthenosphere differs from the overlying lithosphere principally in its ability to flow on geological time scales. These differences arise from the fact that temperature (and thus the fluid or flow properties of rocks) increases as a function of depth in the Earth. Whereas the lithosphere tends to be resistant to deformation, the asthenosphere deforms by flowing. The lithosphere is either oceanic or continental, each type being fundamentally different in terms of the formation and composition of the rocks that constitute the crust and upper mantle. While the most common definition of the lithosphere is in terms of its temperature structure, there exist a whole range of alternative definitions that consider the seismic, mechanical, rheological, and chemical characteristics of the crust and mantle. See ASTHENOSPHERE; EARTH CRUST; MOHO (MOHOROVİČIĆ DISCONTINUITY); PLATE TECTONICS.

The chemical lithosphere is defined as a chemical boundary layer between the surface of the Earth and the asthenosphere that cools by conduction and contains both the material differentiated or extracted from the mantle (for example, oceanic and continental crust) and mantle material modified by various degrees of depletion. [G.D.K.]

**Litopterna** Hoofed herbivores confined to the Cenozoic of South America. The order was well represented from the Paleocene to the Pleistocene, and apparently arose on that continent from a condylarth ancestry. By later Paleocene time two main lines of descent were clearly demarcated. The Protheriidae displayed a remarkable evolutionary convergence with the horses in their dentition and in reduction of the lateral digits of their feet. In one group the foot was reduced to a single median toe by early Miocene time. The members of the Macraucheniiidae were proportioned much as in the camels and by late Tertiary time had similarly lost the vertebral arterial canal of the cervical vertebrae. See MAMMALIA. [R.H.T.]

**Liver** A large gland found in all vertebrates. It consists of a continuous parenchymal mass arranged to form a system of walls through which venous blood emanating from the gut must pass. This strategic localization between nutrient-laden capillary beds and the general circulation is associated with hepatic regulation of metabolite levels in the blood through storage and mobilization mechanisms controlled by liver enzymes.

**Function.** The large size of the liver is matched by its functional complexity and involvement in a diverse array of regulatory mechanisms. The liver plays a key role in assuring carbohydrate homeostasis (dynamic steady-state conditions) by removing simple sugars from the general circulation after ingestion of food and storing them as glycogen. In the intervals between ingestion of food, liver glycogen is broken down. This process tends to maintain blood sugar levels between 80 and 100 mg per 100 ml of blood. Under conditions of prolonged fast, where glycogen stores are exhausted, the liver is capable of converting noncarbohydrate metabolites such as amino acids and fats into glucose to maintain blood sugar levels. The complex steps involved in maintaining carbohydrate metabolism are subject to endocrine control, with the liver serving as a particularly sensitive target organ of hormone regulators such as insulin. See CARBOHYDRATE METABOLISM; GLUCOSE; GLYCOGEN; INSULIN.

The liver is key in the interconversion of many metabolites. It is a major site of production of fatty acids, triglycerides, phospholipids, ketone bodies, and cholesterol. Steroid hormones are degraded in the liver. See CHOLESTEROL; KETONE; LIPID; STEROID.

The liver is the sole source of such necessary constituents of the blood as fibrinogen, serum albumin, and cholinesterase. In the embryonic stage of most vertebrates the liver serves as the major manufacturing site of erythrocytes, a process known as erythropoiesis. The liver also removes toxins from the systemic circulation and degrades them, as well as excess hormones. Particulate material may be removed through a phagocytic action of specialized cells (Kupffer cells) lining the lumen of the hepatic "capillary spaces," or sinusoids. In addition to the products which the liver delivers directly to the general circulation (endocrine function), it secretes bile through a duct system which, involving the gallbladder as a storage chamber, eventually passes into the duodenum (exocrine function). Bile functions as an emulsifier of fats to facilitate their digestion by fat-splitting lipases, and may also activate the lipase directly. See GALLBLADDER.

**Anatomy.** The human liver is a massive wedge-shaped organ divided into a large right lobe and a smaller left lobe. Its anterior surface underlies the diaphragm. The upper portion of the liver is partially covered ventrally by the lungs, whereas the lower portion overhangs the stomach and intestine. The entire liver is covered by Glisson's capsule, an adherent membranous sheet of collagenous and elastic fibers.

Venous blood from the intestine, and to a lesser extent from spleen and stomach, converges upon a short broad vessel, called the hepatic portal vein, which enters the liver through a depression in the dorsocaudal surface termed the porta hepatis. There the hepatic portal vein divides into a short right branch and a longer left branch. These vessels then ramify into the small branches which actually penetrate the functional parenchymal mass as the inner tubes of the portal canals.

The hepatic artery also enters at the porta hepatis and ramifies into smaller branches, which flank the portal venules within the portal canals. The branches of the portal vein and hepatic artery then empty into sinusoids, which are major regions of hepatovascular exchange. They communicate with small branches of the hepatic veins and, through the hepatic vein, the blood is returned to the heart by way of the vena cava.

The tiny bile canaliculi, which lie between grooves in adjacent parenchymal cells, communicate with tiny intralobular bile ducts. These intralobular bile ducts empty into increasingly larger interlobular bile ducts which lie within the portal canals and make up the third element of the so-called portal triad. [G.H.F.]

**Liver disorders** A heterogeneous group of diseases that are of particular importance because of the many essential functions of the liver. Persons with liver disorders can develop a number of different signs and symptoms. One common symptom is fatigue, although some people are entirely asymptomatic. A striking sign of liver disease is jaundice (yellowing of the skin and eyes) due to abnormal production or transport of bile. The presence of liver disease can be confirmed by performing liver function tests on the blood. A needle biopsy can help determine the type of liver disorder and the extent of organ damage. See JAUNDICE; LIVER.

Fatty metamorphosis is a common condition characterized by accumulation of fat (lipid) within the liver cells. In the United States the most common cause of a fatty liver is excessive alcohol intake. In the developing areas of the world, malnutrition is the major cause of a fatty liver. Some obese persons also develop a fatty liver. See ALCOHOLISM; MALNUTRITION; OBESITY.

Hepatitis, an inflammation of the liver, has a variety of causes. The specific type of hepatitis present is usually determined by studies of serum, which identify the type of antibody directed against a component of the causative virus, or by liver biopsy. See HEPATITIS.

Cirrhosis is a disease in the liver characterized by scarring, which produces a marked nodularity of the liver. Cirrhosis has a variety of causes, although in the United States the most common by far is excessive alcohol intake. Cirrhosis may also result from almost any type of injury to the liver that does not heal but instead leads to progressive inflammation and scarring. See CIRRHOSIS.

Most neoplasms in the liver are malignant and are metastatic from a primary site. Usually their cause is unknown, but in the United States primary malignant tumors are most frequently associated with cirrhosis. Primary liver cancers are difficult to treat because they usually grow rapidly and involve other structures, preventing total surgical removal. See CANCER (MEDICINE); ONCOLOGY.

Reye's syndrome is a liver disorder that affects primarily infants and young children; it usually occurs during or after an episode of viral influenza and it has been causally related to the ingestion of aspirin for treatment of influenza. Wilson's disease, also called hepatolenticular degeneration, is a rare inherited disorder of copper metabolism in which cirrhosis of the liver is associated with degeneration of certain regions of the brain. Hemochromatosis, another hereditary disease, is marked by excessive deposition of iron in the liver because of faulty iron metabolism. It causes cirrhosis and is frequently associated with primary cancer of the liver. In alpha-1 antitrypsin deficiency, a disease characterized by an absence of an antienzyme in the blood, the liver can show extensive fibrosis and even cirrhosis. [S.P.H.]

**Living fossils** Living species very closely resembling fossil relatives in most anatomical details. The term is a relative one and, applied loosely, could embrace nearly all extant animals and plants. In its more restricted usage, the term applies to living species with four additional characteristics: (1) truly close anatomical similarity to (2) an ancient fossil species—generally at least 100,000,000 years old; (3) living members of the group are represented by only a single or at best a few species, which are (4) often found in a very limited geographic area. Examples are horseshoe crabs, ginkgo trees, and coelacanth fish.

[N.E.]

**Llama** A member of the camel family (Camelidae) found only in South America. The llama is an artiodactyl, or even-toed ungulate, with two toes on each foot. The upper lip is cleft and prehensile. The animal has a long neck, and attains a maximum length of less than 8 ft (2.4 m) and a maximum weight of nearly 300 lb (135 kg; see illustration). A single young is born after a gestation period of about 11 months. The maximum life-span is about 20 years. Like other members of the family, the llama is herbivorous. It has 36 teeth with the dental formula  $I \frac{1}{3} C \frac{1}{1} Pm \frac{3}{3} M \frac{3}{3}$ . These animals lack a gallbladder. Many interesting crosses have occurred among the different breeds in South America. See ARTIODACTYLA.



The llama of South America.

*Lama glama* has been domesticated since the Inca civilization by the Peruvian Indians, who still keep large herds. While the fur provides material for rugs, rope, and cloth, the main use of this animal is as a beast of burden, especially in mining areas. Another race is the alpaca, which is more restricted in its distribution and is specialized in wool production.

There are two species of wild llama, the guanaco or huanaco (*L. guanicoe*) and the vicuña (*L. vicugna*). The most widespread is the guanaco, which stands about 4 ft (1.2 m) at the shoulder and just over 5 ft (1.5 m) at the top of the head. See ALPACA; VICUÑA.

[C.B.C.]

**Loads, dynamic** Forces which are derived from moving loads such as wind, earthquakes, machinery, vehicles, trains, cranes, and hoists. Analysis techniques which take into account the vibrations of the structures are required for loads which are repeated many times, such as machinery in motion, and produce harmonic motions of equal amplitude and constant frequency (cyclic loading); loads such as the motion produced by earthquakes (random motion); and varied loads, such as that of the wind, which produce gusts or short-duration impulses.

Repeated loads applied to a structural member can cause failure by fracture of the material. This fracture can occur at various stress levels depending upon the amplitude or acceleration of the motion, frequency, and duration. Often the stress level is below that of the design level for statically applied loads, and is referred to as the fatigue strength of the material for that application. See STRESS AND STRAIN.

[J.B.S.]

**Loads, transverse** Forces applied perpendicularly to the longitudinal axis of a member. Transverse loading causes the member to bend and deflect from its original position, with internal tensile and compressive strains accompanying change in curvature.

Concentrated loads are applied over areas or lengths which are relatively small compared with the dimensions of the supporting member. Examples are a heavy machine occupying limited floor area, wheel loads on a rail, or a tie rod attached locally. Loads may be stationary or they may be moving, as with the carriage of a crane hoist or with truck wheels.

Distributed loads are forces applied continuously over large areas with uniform or nonuniform intensity. Closely stacked contents on warehouse floors, snow, or wind pressures are considered to be uniform loads. Variably distributed load intensities include foundation soil pressures and hydrostatic pressures.

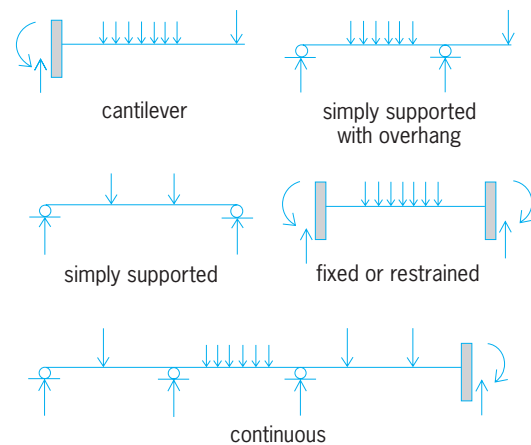

Types of beams.

Members subjected to bending by transverse loads are classed as beams. The span is the unsupported length. Beams may have single or multiple spans and are classified according to type of support, which may permit freedom of rotation or furnish restraint (see illustration).

[J.B.S.]

**Lobata** An order of the phylum Ctenophora (comb jellies) comprising the families Bathocyroidae, Bolinopsidae, Eurhamphaeidae, Kiyohimeidae, Leucotheidae, and Ocyropsidae. Lobate ctenophores are characterized by large winglike lobes on the oral end of the body that are used for capturing food. All species are predators on zooplankton. Lobates are among the largest ctenophores; some epipelagic species attain an oral-aboral height of 8 in. (20 cm), and some deep-sea species have lobes nearly 39 in. (1 m) across. Most species are transparent, but some have conspicuous brown, blue, or purple

spots on the lobes. Deep-sea forms often have red pigment surrounding the stomodeum. Lobates are bioluminescent, like other ctenophores. Bright blue-green light is produced in the meridional canals, and some species also release a cloud of luminous material into the water when disturbed, probably as part of an escape response.

The upper body is usually compressed in the tentacular plane. The comb (ctene) rows in this plane are short, but the sub-stomodeal comb rows extend onto the outer surface of the lobes. Pendant structures called auricles extend from the oral end of the body into the space enclosed by the oral lobes. Locomotion is produced by the comb rows, but some genera (*Ocyropsis*, *Bathocyroe*) can also swim by flapping the oral lobes.

Except for the genus *Ocyropsis*, all lobate ctenophores are simultaneous hermaphrodites. Eggs develop into the cydippid larva typical of most ctenophores. After a variable length of time of swimming and feeding as a cydippid, the larva metamorphoses into the adult form, passing through intermediate larval stages in some species. Metamorphosis from the cydippid form involves loss of the primary tentacles, development of the oral lobes and auricles, and growth of secondary tentacles near the mouth. See CTENOPHORA. [L.P.M.]

**Lobosia** A subclass of Rhizopodea characterized by lobopodia predominantly, although certain of these protozoan species also may form slender pseudopodia, or even develop several different kinds. Lobosia are divided into two orders, Amoebida and Arcellinida, which differ in presence or absence of a test. Pseudopodia emerge through the aperture of the test. See AMOEBIDA; ARCELLINIDA; PROTOZOA; SARCODINA. [R.P.H.]

**Local-area networks** Computer networks that usually cover a limited range, say, within the boundary of a building. A computer network is two or more computers that communicate with each other through some medium. The primary usage of local-area networks (LANs) is the sharing of hardware, software, or information, such as data files, multimedia files, or electronic mail. Resource sharing provided by local-area networks improves efficiency and reduces overhead. See DIGITAL COMPUTER; ELECTRONIC MAIL; MULTIMEDIA TECHNOLOGY.

Four basic types of media are used in local-area networks: coaxial cable, twisted-pair wires, fiber-optic cable, and wireless. Each medium has its advantages and disadvantages relative to cost, speed, and expandability. Coaxial cables provide high speed and low error rates. Twisted-pair wires are cheaper than coaxial cables, can sustain the speeds common to most personal computers, and are easy to install. Fiber-optic cable is the medium of choice for high-speed local-area networks. Wireless local-area networks have the advantage of expandability. See COAXIAL CABLE; COMMUNICATIONS CABLE; FIBER-OPTIC CIRCUIT; OPTICAL COMMUNICATIONS; OPTICAL FIBERS.

The topology of a local-area networks is the physical layout of the network. For wired local-area networks, there are four basic topologies: bus, ring, star, and mesh. The most widely used local-area network topology is the bus, where the medium consists of a single wire or cable to which nodes are attached. A message transmitted over a bus propagates in both directions along the bus, passing each tap until it is finally absorbed at the ends.

There are a number of ways in which nodes can communicate over a network. The simplest is to establish a dedicated link between the transmitting and receiving stations. This technique is known as circuit switching. A better way of communicating is to use a technique known as packet switching, in which a dedicated path is not reserved between the source and the destination. Data are wrapped up in a packet and launched into the network. In this way, a node only has exclusive access to the medium while it is sending a packet. During its inactive period, other nodes can transmit. A typical packet is divided into preamble, address, control, data, and error-check fields. See PACKET SWITCHING.

An access protocol is a set of rules observed by all the nodes in a local-area network so that one node can get the attention of another and its data packet can be transferred. Two common protocols are carrier sense multiple access with collision detection (CSMA/CD) and token passing.

With the CSMA/CD protocol, a node that wants to transmit its data must first listen to the medium to hear if any other node is using the medium. If not, the node may transmit immediately. However, while the transmission is taking place, the transmitting node must continue listening to ascertain if anyone else has begun transmitting. If the transmitting node detects that someone else is also transmitting, the node aborts its own transmission, waits for a random amount of time, and then restarts the process until its data transmission succeeds.

With the token-passing protocol, the right to transmit is granted by a token, a predefined bit pattern that is recognized by each node. The token is passed for one node to another in a predetermined order. [W.Zh.]

**Local Group** The small cluster of galaxies that contains the Milky Way Galaxy. Galaxies exhibit a pronounced tendency to clump together on a variety of scales. It is assumed that gravitational attraction draws galaxies together. On a very large scale, this attractive process may still be at an early stage. On a smaller scale, the process has led to collapse. Galaxies have fallen together, though with enough angular momentum that they usually orbit each other rather than collide.

Collapsed structures that contain a few dozen to a few thousand substantial galaxies are called clusters; collapsed structures that contain a few but less than 10 or 20 big galaxies are called groups. The Milky Way Galaxy is a large but not exceptional spiral galaxy and one of two dominant members of a small assemblage referred to as the Local Group.

On successively larger scales, the Local Group is a member of the Coma-Sculptor Cloud and the Local Supercluster. The closest galaxies beyond the Local Group are at a distance of  $7 \times 10^6$  light-years.

The Local Group has 36 known or suspected members. The only system larger than the Milky Way Galaxy is M31, the Andromeda Nebula. These two giant galaxies generate 80% of the light of the group. There are also two intermediate-scale galaxies: M33, the Triangulum Nebula near Andromeda, and the Large Magellanic Cloud, a close companion of the Milky Way and a conspicuous feature of the night sky in the Southern Hemisphere. Fainter than these are 32 small systems. The smallest among them are identified only because they are so close. Many would not be detected in even the nearest adjacent groups. The census of Local Group members may be very incomplete at the faint end and in the zones obscured by the plane of the Milky Way. See ANDROMEDA GALAXY; MAGELLANIC CLOUDS; MILKY WAY GALAXY. [R.B.T.]

**Location fit** Mechanical sizes of mating parts such that, when assembled, they are accurately positioned in relation to each other. Locational fits are intended only to determine the orientation of the parts. For normally stationary parts that require ease of assembly or disassembly, for parts that fit snugly, and for parts that move yet fit closely as in spigots, slight clearance is provided between parts. Where accuracy of location is important, transition fits are used. In these fits the holes and shafts are normally nearly the same diameter. For greater accuracy of location, the shafts are made slightly larger than the holes; such fits are termed location interference fits. See ALLOWANCE. [P.H.B.]

**Locomotive** A machine mounted on flanged wheels which converts some form of potential energy into the mechanical work of propelling itself and other, nonpowered vehicles over a railroad track. The dimensions and weight of a locomotive are restricted by the presence of stationary structures adjacent to and

above the track, such as overhead bridges and tunnels, and by the strength of the track and bridges that support it.

Economics demands that locomotives use an available and plentiful form of potential energy; that they convert it to useful work efficiently; that they be capable of applying sufficient force to overcome the resistance of the loaded vehicles they are to move, and they do so in the time allotted; and that they be durable, reliable, and relatively easy to maintain.

The first locomotives (around 1830) were steam propelled. Because of the many advantages of other forms of motive power, steam locomotives began to be replaced shortly after World War II and had virtually disappeared in the United States by the late 1950s. See STEAM ENGINE.

Electric locomotives draw electricity from a third rail set alongside the running rails of track through a sliding shoe that transmits electric power to the locomotive, or from a configuration of overhead wires known as a catenary by means of a pantograph that raises or lowers to compensate for wire height variations. The cost of these electric distribution systems has restricted the use of electric motive power to only very high traffic routes such as the Northeast Corridor of Amtrak in the United States, commuter lines, and some routes in Japan, Russia, England, and continental Europe.

Diesel-electric locomotive units are produced in a number of sizes, with corresponding power. Switching or shunting locomotives are of approximately 1000 hp and low maximum speed, while mainline passenger and freight units are being designed to produce 5000–6000 hp. Several diesel-electric units are most often coupled together to produce a single locomotive of as much as 15,000 hp or more. In such cases the entire locomotive assembly is controlled from the leading unit.

Diesel engines turn an alternator, which produces the electricity to power the traction motors. The traction motors are mounted in the truck assemblies with their armature shafts parallel to the locomotive's driving axles. A pinion gear on the armature shaft turns a bull gear on the axle to propel the locomotive. Traction motors are cooled by fan-driven air through ducts. There may be four or six such motor-driven axles per locomotive unit, and the gear ratio between pinion and bull gear teeth is varied according to the locomotive's intended use. See DIESEL ENGINE.

Both diesel-electric and straight electric locomotives can be equipped with dynamic brakes where traction motors act as generators resisting rotation, thus slowing the train. In the straight electric locomotive the current produced is fed back into the catenary, while in the diesel-electric the generated current is fed to high-resistance grids, which must be cooled by fan-driven air. Dynamic braking can be advantageous in reducing wear and tear on train brakes and wheels, but it must be used judiciously to avoid excessive longitudinal train forces. See BRAKE; DYNAMIC BRAKING; GAS TURBINE; RAILROAD ENGINEERING; TURBINE PROPULSION. [G.H.W.]

**Loculoascomycetes** A class in the phylum Ascomycota. The Loculoascomycetes form a well-developed mycelium which bears the sexual (ascus) and asexual (conidium) states, and are distinguished from other ascomycetes by their method of ascoma formation and their ascus structure. Ascoma formation is ascolocular, a type of development in which certain cells of the vegetative hyphae undergo numerous divisions to form a small mass of homogeneous tissue (stroma). As the stroma enlarges, internal differentiation occurs to form the ascogenous cells, from which the asci will form. As the asci develop, they dissolve or crush the internal tissues of the stroma (now an ascostroma), creating a cavity (locule). As the ascostroma matures, a neck with a canal for ascospore discharge usually forms. An ascostroma may have one or several locules with asci. Species with a single locule are termed pseudothecia, and they often resemble the perithecia of the Pyrenomyces. The asci have a two-layered wall (bitunicate). The outer layer (ectotunica) is thin and rigid, whereas the inner layer (endotunica) is thicker

and elastic. At maturity, the ectotunica splits, allowing the endotunica to expand and forcibly discharge the eight ascospores. The ascospores may be hyaline or brown, but they are usually multicelled.

Found primarily on living and dead plant tissues, the fungi in this class include a number of important plant disease fungi. See ASCOMYCOTA; EUMYCOTA; FUNGI; PLANT PATHOLOGY. [R.T.Ha.]

**Locust (forestry)** A name commonly applied to two trees, the black locust (*Robinia pseudoacacia*) and the honey locust (*Gleditsia triacanthos*). Both of these commercially important trees have podlike fruits similar to those of the pea or bean.

The black locust is native in the Appalachian and the Ozark regions and is now widely naturalized in the eastern United States, southern Canada, and Europe. The wood is hard and durable in the soil and is used for fence posts, mine timbers, poles, and railroad ties.

The honey locust is native in the Appalachian and the Mississippi Valley regions, but is also widely naturalized in the eastern United States and southern Canada. The reddish wood is hard, strong, and coarse-grained and takes a high polish. Because it is durable in contact with soil, it is used for fence posts and railroad ties; it is also used for construction, furniture, and interior finish. [A.H.G./K.P.D.]

**Loess** Silt-dominated sediment of eolian (windblown) origin. Loess is a common deposit in and near areas that were glaciated during the Quaternary Period, and most loess deposits are indirectly related to glaciation. See EOLIAN LANDFORMS; GLACIAL EPOCH; QUATERNARY.

Loess is a well-sorted clastic deposit which is unconsolidated, relatively homogeneous, seemingly nonstratified, and extremely porous. Colors range from buff to shades of pink, gray, yellow, or brown. Silt-sized particles, most of which are 0.0002–0.002 in. (0.005–0.05 mm) in diameter, usually make up 60–90% of the deposit, with small amounts of fine sand and small to moderate amounts of clay-sized material. The particles are generally angular to subangular.

Quartz is the dominant mineral, with subordinate amounts of feldspar, calcite, dolomite, clay minerals, and small amounts of other minerals. Clay minerals are primarily smectite, illite, and chlorite. They occur as silt-sized aggregates and, along with calcite, as coatings or fillings on silt grains, in interstices, and in vertical tubes left from the decay of grass roots. These latter characteristics partially bind the particles together and give loess with relatively large dry strength. As a result, many loess deposits maintain near-vertical slopes in both natural and artificial cuts. See CALCITE; CLAY MINERALS; DOLOMITE; FELDSPAR; QUARTZ.

Loess occurs as a relatively thin (generally <90 ft or 30 m), blanket-type deposit which drapes over an irregular landscape. It is common in many areas of the world, but is particularly thick near valleys that served as meltwater drainageways during Quaternary glaciation. Loess also may be derived from desert areas, in which case the particles must be produced by either weathering processes or eolian abrasion. See SEDIMENTOLOGY; SOIL. [W.H.J.]

**Logarithm** An exponent of a suitably chosen positive number (base) larger than unity. Logarithms are of value in mathematical computation and in the equations and formulas used in expressing natural phenomena.

If  $b^l = n$ , where  $b$  is a positive number larger than unity, then  $l$  is called the logarithm of  $n$  to the base  $b$  and is written  $l = \log_b n$ . From this definition it follows at once that all positive numbers larger than unity have positive logarithms, all positive numbers smaller than unity have negative logarithms, and the logarithm of unity is equal to 0. Since  $b^0 = 1$  irrespective of the value of  $b$ , it follows that the logarithm of unity is equal to 0. From the known properties of exponentials expressed by relations (1), it follows

immediately that (1) the logarithm of a product of two or more

$$\begin{aligned} b^1 \cdot b^2 &= b^{1+2} & b^2 \div b^2 &= b^{1-2} \\ (b^1)^m &= b^m & \sqrt[m]{b^1} &= b^{1/m} \end{aligned} \quad (1)$$

factors is equal to the sum of the logarithms of the factors; (2) the logarithm of the ratio of two numbers is equal to the difference between the logarithm of the numerator and the logarithm of the denominator; (3) the logarithm of the *m*th power of a number is the product of *m* and the logarithm of the number; and (4) the logarithm of the *m*th root of a number is equal to the logarithm of the number divided by *m*. See EXPONENT.

Although any positive number *b* larger than unity might have been chosen as the base of a system of logarithms, actually two numbers have been chosen in the construction of tables of logarithms, namely, the number *b* = 10 and the number *e* = 2.718... defined as the sum of infinite series (2). The system of logarithms

$$1 + \frac{1}{1} + \frac{1}{1 \cdot 2} + \frac{1}{1 \cdot 2 \cdot 3} + \dots + \frac{1}{1 \cdot 2 \cdot 3 \cdot \dots \cdot n} + \dots \quad (2)$$

to the base 10 is usually referred to as common logarithms; the system of logarithms to the base *e* is called natural logarithms. See E (MATHEMATICS).

The integral part of the common logarithm of a number larger than unity is one unit less than the number of digits before the decimal point. This integral part is called the characteristic; the decimal part is called the mantissa. Similarly, because the common logarithms of 0.1, 0.01, and 0.001 are -1, -2, and -3, it follows that the logarithm of a number smaller than unity having *p* zeros after the decimal point may be expressed as the sum of a negative characteristic equal to - (*p* + 1) and a positive mantissa. [A.N.L./S.Bo.]

**Logging** Those processes required to bring all or a portion of a tree from the stump to the mill facilities. Logging (tree harvesting) processes are clustered into tree conversion, woods transport (off-road transportation), landing operations (wood transfer), transport from landing to mill facility (truck, water, or rail), and unloading at the mill facility (wood transfer). See FOREST TIMBER RESOURCES; PAPER; PLYWOOD; WOOD PRODUCTS.

The start of harvesting is the cutting down of trees with hand tools, chain saws, or mechanized felling machines. The tree may be further cut into suitable lengths (bucking), or it may be transported whole or in tree-lengths. Tree products may be allocated during bucking with the aid of a computer on the felling and bucking machine or by a faller using a log order list or a handheld computer to help decide the log products to make. The objective of the tree falling operation is to fell the tree with minimum damage, to avoid damaging surrounding trees, to minimize soil and water impacts, and to position the tree or logs for the next phase of harvesting. The goal of bucking is to produce the most valuable assortment of logs from the tree while considering the physical capability of the skidding (log-dragging), yarding (moving of logs to a landing), or forwarding (log-carrying) equipment.

Logs in lengths from about 1 to 10 m (3 to 33 ft) or other products must be transported from the stump to a place where they are further processed (often called a landing). In some cases, entire trees are pulled to the landing. Humans, animals, crawler tractors and wheeled skidders (machines that drag the logs), forwarders (machines that carry loads of logs), farm tractors with winches or trailers, cable logging systems, balloons, or even helicopters transport logs and tree products to landings.

At the landing, the logs or trees may be stored or directly processed for transport. They may be loaded onto trucks, trains, barges, or ships, or prepared for water transport. Whole trees brought to a landing may have limbs and bark removed, and then be chipped and loaded into chip vans for transport to a pulp mill. Tree-length segments may be delimbed and bucked into logs for different market destinations. Trees may be shredded, chunked, or processed through machines for use as fuel.

The allocation process may include measurement by volume or weight of the products.

Because logs are heavy, they are normally loaded mechanically, although some regions still use manual or animal methods involving ramps. There are two general types of mechanical loaders used at roadside: swingboom loaders with grapples, and front-end loaders fitted with a log fork or grapple. Both are mobile, mounted on tracked or rubber-tired carriers. Forwarders usually unload themselves either into log decks for storage or onto setout trailers.

Trucks are most commonly used to transport log products to mill facilities. They vary from small vehicles hauling 5–8 tons on straight beds to large specialized off-highway vehicles hauling 50 tons or more. A variety of truck trailers are used depending upon the type of product. Trees or long logs may be loaded onto pole trailers. Short logs, 2.5 m (8 ft) and less, are often stacked sideways on flat-bed trailers with bunks. Chips or flakes are hauled in specially designed chip vans. Water transport in barges, as log rafts, and as free-floating logs is used in some areas.

Log products can be unloaded from truck trailers by lifting, rolling, or dumping over the side or end, depending upon the type of trailer. Trees and long logs are usually lifted from trailers by a grapple on mobile wheel loaders or overhead cranes (which can unload the entire truck in one pass). Shorter logs are often unloaded using slings. In some cases, short wood for pulp is swept directly off the trailer and fed into a debarking machine to eliminate rehandling. Chip trailers are often tilted and end-dumped on large hydraulic ramps. [J.Ses.; J.Ga.]

**Logic** The subject that investigates, formulates, and establishes principles of valid reasoning.

The first attempt to investigate systematically acceptable modes of reasoning was made by Aristotle, in whose *Organon* reasoning was recognized as the subject of a special science. He formulated three basic “laws of thought”: (1) the law of contradiction (no proposition is both true and false), (2) the law of excluded middle (each proposition is either true or false), and (3) the law of identity (each proposition implies itself). Advanced as his views of logic were, it seems doubtful that the idea of axiomatizing them ever occurred to him, despite the success of his contemporary Euclid in organizing geometry. That aspect of logic which enunciates or establishes valid reasoning (rather than merely investigating it) began with the publication in 1854 of George Boole’s *An Investigation of the Laws of Thought*. The partly abstract treatment of logic presented in this work initiated the completely abstract developments that were to follow. In it the laws of thought are regarded as mere conventions which, like the postulates of euclidean geometry, might be modified or even rejected to create new logics. The only requirement that a “new” logic must satisfy is the one demanded of every deductive system—consistency. Just as different geometries are useful for different purposes, a logic that is appropriate in one environment might not be so in another. There are a growing number of competent individuals, for example, who consider that any logic containing Aristotle’s law of excluded middle is not suitable for mathematics.

**Propositional calculus.** The unit of the propositional calculus is the proposition, which may be defined as the meaning of an indicative or declarative sentence. Each proposition has a truth-value; it is either true or false in the classical logic, but may assume other truth-values (for example, uncertain) in some of the new logics. It is convenient to use letters *p*, *q*, *r*, and so on to denote propositions. Propositions are combined by logical connectives to form other propositions. Chief among these are (1) negation (the negation of a proposition *p*, symbolized by *p*’, may be formed verbally by writing “It is not the case that” before *p*); (2) conjunction (a binary operation symbolized by  $\cdot$  or  $\&$ , for example,  $p \cdot q$ , read “*p* and *q*”); (3) disjunction (a binary operation symbolized by  $+$  or  $\vee$ ; for example,  $p \vee q$ , read “*p* or

q”); (4) implication (a binary operation symbolized by  $\supset$  or  $\rightarrow$ , for example,  $p \rightarrow q$ , read “p implies q”); and (5) equivalence (a binary operation denoted by  $\equiv$ ; for example,  $p \equiv q$ , read “p is equivalent to q,” means that each proposition implies the other). The proposition  $p \cdot q$  asserts that both p and q are true. It is important to note that the disjunctive “or” is always used in the inclusive sense; that is,  $p \vee q$  asserts that at least one, possibly both, of the propositions p and q is true. In addition, the meaning of “implication” in logic differs markedly from the ordinary sense of that term. The proposition  $p \rightarrow q$  asserts merely that it is not the case that p is true and q is false; that is, in classical logic  $p \rightarrow q$  means that either p is false or q is true. The logical connectives introduced above are examples of logical constants. They are not independent notions. Implication may be defined in terms of negation and conjunction, and this is true for all of the connectives. In fact, all the connectives can be defined in terms of one binary operation, the so-called Scheffer stroke function  $p | q$ , which may be read “p is false or q is false.”

The logical connectives, the letters p, q, r, and so on that stand for propositions (propositional variables), and the parentheses, brackets, and braces needed for punctuation are formal concepts. A propositional function is a combination of concepts, formal or nonformal, involving at least one variable, which is not a proposition but becomes one when all the variables are given specified values. Examples are (1) p and q, (2)  $x^2 + y^2 = 1$ , and (3) x is president of the United States. Unlike a proposition, a propositional function has no truth-value. On the other hand, the statement “For every integer x,  $x^2 + 1 = 0$ ” is a proposition (not a propositional function) even though it contains a (bound) variable. A formal function is a propositional function that contains only formal concepts—for example  $[(p \vee q) \cdot r] \supset s$ . A truth function is a propositional function in which only propositional variables occur, and such that the truth value of each proposition obtained from the function by substituting specific propositions for the variables depends only on the truth values of those propositions. Examples are (1)  $(p \cdot q) \vee r'$ , (2) Napoleon was a great general and p (where p is a propositional variable). On the other hand, “Jones stated that p” is not a truth function.

Tautologies are formal truth functions such that every proposition obtained from them by substituting specific values (propositions) for the variables they contain has the truth value T (true). A truth function is contingent provided it assumes both truth values T and F (false)—here only the classical two-valued (aristotelian logic) truth functions are considered—and self-inconsistent provided it has only the value F. The character of a truth function is determined when it is shown to be self-inconsistent, contingent, or a tautology.

A truth function may be analyzed by means of a truth table, or matrix. Such tables are made first for the elementary truth functions  $p' \vee q$ ,  $p \cdot q$ ,  $p \supset q$  as follows:

(I)		(II)		(III)		(IV)				
p	p'	p	q	p ∨ q	p	q	p · q	p	q	p ⊃ q
T	F	T	T	T	T	T	T	T	T	T
F	T	T	F	T	T	F	F	T	F	F
		F	T	T	F	T	F	F	T	T
		F	F	F	F	F	F	F	F	T

In every table each row of the last column gives that truth value of the function which is determined by those truth values (assigned to the variables) that are entered in the preceding columns of that row.

All tautologies can be deduced from a set of just four of them:

- P1  $(p \vee p) \supset p$
- P2  $q \supset (p \vee q)$
- P3  $(p \vee q) \supset (q \vee p)$
- P4  $(q \supset r) \supset [(p \vee q) \supset (p \vee r)]$

These simple tautologies were selected by Alfred North Whitehead and Bertrand Russell in their monumental work *Principia Mathematica* as the basic set from which all tautologies can be derived. This is analogous to what is done in an axiomatic geometry in which all the theorems of the geometry are deduced from a selected set of axioms or postulates that are assumed to be true.

It was proved by E. L. Post that postulates P1–P4 are consistent; that is, it is impossible to deduce from them truth functions X and X'. He also proved that the four postulates form an independent set; that is, no one of the postulates can be deduced from the others.

In nonaristotelian logics the principle of the excluded middle (that is, each proposition is either true or false) is not valid. There are, then, at least three truth values possible for a proposition, and for this reason such logics are known as many-valued. If “true” be interpreted in mathematics to mean “provable,” and a proposition be called false provided its negation is provable, then the law of excluded middle is demonstrably false, since it has been shown that mathematics contains proposition p such that neither p nor its negation p' is provable. See BOOLEAN ALGEBRA; EUCLIDEAN GEOMETRY; MATHEMATICS; SCIENCE. [L.M.B.]

**Mathematical logic.** Mathematical logic is an area of research that has emerged from the study of formal systems. It has its roots in work on the foundations of mathematics in the nineteenth and early twentieth centuries, showing that the customary forms of mathematical reasoning can be adequately expressed in formal (purely symbolic) systems. Mathematical logic contains four areas of research: proof theory, set theory, model theory, and recursion theory.

The original objective of work in the foundations of mathematics was the analysis and precise formulation of mathematical concepts, such as “limit,” “function,” and “differential manifold,” as well as a complete and explicit determination of the valid forms of mathematical argument. This goal was achieved by the formalization of mathematics.

A formal system consists of a symbolic notation (or language) with rules for constructing expressions using the specified notation, axioms (expressions taken as given), and rules of inference used to derive additional expressions from a given set of expressions. To formalize an area of mathematics means to give a procedure for representing proofs in the specified area within a definite formal system. One formal system that is adequate for the formalization of all existing mathematics is the language of set theory, which can be set up in a variety of ways. There are various standard systems of axioms for set theory, notably the axiom system ZFC, consisting of axioms proposed by E. Zermelo and A. Fränkel, with the addition of the axiom of choice.

Proof theoretic research continues the study of formal systems that are adequate for the formalization of various parts of mathematics. Two basic results, due to K. Gödel, relate to the adequacy of formal systems in general: the so-called completeness and incompleteness theorems. The completeness theorem essentially states that the laws of inference are adequately mirrored in the usual formal systems in the sense that any law of inference that is in fact valid in all mathematical contexts is derivable in any of these systems. The incompleteness theorem, on the other hand, can be interpreted as stating that it is impossible to give a completely satisfactory axiom system for any theory that can serve as a formal foundation for mathematics. See GÖDEL'S THEOREM.

Axiomatic set theory was developed in part as a way of obtaining a formalism adequate for all of mathematics, and also for concrete mathematical reasons connected with the development of general topology and measure theory around 1900. Set theory is probably the most active research area within mathematical logic. It has been shown that a variety of problems in analysis, general topology, and algebra (especially homological algebra) cannot be settled within the framework of any of the standard set theoretic systems like ZFC. See SET THEORY.



The development of formal systems in logic is related to the development of axiomatic systems in modern algebra, although the motivation is very different. Model theory combines the algebraic and logical points of view. In applied model theory, the tools of mathematical logic are applied to problems arising in algebra. In pure model theory, axiomatic systems are studied as if they were algebraic systems, and the class of all models of a given axiomatic system is investigated.

Given two functions,  $f$  and  $g$ , from the natural numbers to the natural numbers,  $f$  is said to be reducible to  $g$  if there is an algorithm that will compute  $f$  by using information about  $g$ . Two functions are equivalent if each can be reduced to the other. The equivalence classes are called degrees; they can be thought of as degrees of complexity. Modern recursion theory has produced a very detailed picture of the structure of the degrees and the reducibility relation. See MATHEMATICS; SCIENCE; SCIENTIFIC METHODS. [G.Ch.]

**Logic circuits** Electronic circuits which process information encoded as one of a limited set of voltage or current levels. Logic circuits are the basic building blocks used to realize consumer and industrial products that incorporate digital electronics. Such products include digital computers, video games, voice synthesizers, pocket calculators, and robot controls. See INTEGRATED CIRCUITS.

All logic circuits may be described in terms of three fundamental elements, shown graphically in the illustration. The NOT element has one input and one output; as the name suggests, the output generated is the opposite of the input in binary. In other words, a 0 input value causes a 1 to appear at the output; a 1 input results in a 0 output. (All signals are interpreted to be one of only two values, denoted as 0 and 1.)

The AND element has an arbitrary number of inputs and a single output. As the name suggests, the output becomes 1 if, and only if, all of the inputs are 1; otherwise the output is 0. The AND together with the NOT circuit therefore enables searching for a particular combination of binary signals.

The third element is the OR function. As with the AND, an arbitrary number of inputs may exist and one output is generated. The OR output is 1 if one or more inputs are 1.

The operations of AND and OR have some analogies to the arithmetic operations of multiplication and addition, respectively. The collection of mathematical rules and properties of these operations is called boolean algebra. See BOOLEAN ALGEBRA.

While the NOT, AND, and OR functions have been designed as individual circuits in many circuit families, by far the most common functions realized as individual circuits are the NAND and NOR circuits of the illustration. A NAND may be described as equivalent to an AND element driving a NOT element. Similarly, a NOR is equivalent to an OR element driving a NOT element.

As the names of the logic elements described suggest, logic circuits respond to combinations of input signals. Logic networks which are interconnected so that the current set of output signals is responsive only to the current set of input signals are appropriately termed combinational logic. An important further capability for processing information is memory, or the ability to store information. The logic circuits themselves must provide a memory function if information is to be manipulated at the speeds the logic is capable of. Logic circuit networks that include feedback paths to retain information are termed sequential logic networks, since outputs are in part dependent on the prior input signals applied and in particular on the sequence in which the signals were applied.

Several alternatives exist for the digital designer to create a digital system. Two common realizations are ready-made catalog-order devices, which can be combined as building blocks, and custom-designed devices. Gate-array devices comprise a two-dimensional array of logic cells, each equivalent to one or a few logic gates. Programmable logic arrays have the potential for realizing any of a large number of different sets of logic functions. In table look-up, the collection of input signals are grouped arbitrarily as address digits to a memory device. Finally, the last form of logic network embodiment is the microcomputer. See MICROCOMPUTER.

There are basically two logic circuit families in widespread use: bipolar and metal-oxide-semiconductor (MOS). See TRANSISTOR. [R.R.Sh; W.V.R.]

	Logic Symbol	Truth Table															
Elementary Elements		<table border="1"> <thead> <tr> <th>A</th> <th>C</th> </tr> </thead> <tbody> <tr> <td>0</td> <td>1</td> </tr> <tr> <td>1</td> <td>0</td> </tr> </tbody> </table>	A	C	0	1	1	0									
	A	C															
	0	1															
1	0																
	<table border="1"> <thead> <tr> <th>A</th> <th>B</th> <th>C</th> </tr> </thead> <tbody> <tr> <td>0</td> <td>0</td> <td>0</td> </tr> <tr> <td>0</td> <td>1</td> <td>0</td> </tr> <tr> <td>1</td> <td>0</td> <td>0</td> </tr> <tr> <td>1</td> <td>1</td> <td>1</td> </tr> </tbody> </table>	A	B	C	0	0	0	0	1	0	1	0	0	1	1	1	
A	B	C															
0	0	0															
0	1	0															
1	0	0															
1	1	1															
	<table border="1"> <thead> <tr> <th>A</th> <th>B</th> <th>C</th> </tr> </thead> <tbody> <tr> <td>0</td> <td>0</td> <td>0</td> </tr> <tr> <td>0</td> <td>1</td> <td>1</td> </tr> <tr> <td>1</td> <td>0</td> <td>1</td> </tr> <tr> <td>1</td> <td>1</td> <td>1</td> </tr> </tbody> </table>	A	B	C	0	0	0	0	1	1	1	0	1	1	1	1	
A	B	C															
0	0	0															
0	1	1															
1	0	1															
1	1	1															
		<table border="1"> <thead> <tr> <th>A</th> <th>B</th> <th>C</th> </tr> </thead> <tbody> <tr> <td>0</td> <td>0</td> <td>1</td> </tr> <tr> <td>0</td> <td>1</td> <td>1</td> </tr> <tr> <td>1</td> <td>0</td> <td>1</td> </tr> <tr> <td>1</td> <td>1</td> <td>0</td> </tr> </tbody> </table>	A	B	C	0	0	1	0	1	1	1	0	1	1	1	0
A	B	C															
0	0	1															
0	1	1															
1	0	1															
1	1	0															
		<table border="1"> <thead> <tr> <th>A</th> <th>B</th> <th>C</th> </tr> </thead> <tbody> <tr> <td>0</td> <td>0</td> <td>1</td> </tr> <tr> <td>0</td> <td>1</td> <td>0</td> </tr> <tr> <td>1</td> <td>0</td> <td>0</td> </tr> <tr> <td>1</td> <td>1</td> <td>0</td> </tr> </tbody> </table>	A	B	C	0	0	1	0	1	0	1	0	0	1	1	0
A	B	C															
0	0	1															
0	1	0															
1	0	0															
1	1	0															

Logic elements.

**Lophiiformes** The anglerfishes and their relatives. The first dorsal fin is reduced to a few flexible rays, of which the first is placed on top of the head and bears a terminal bulb or tassel and functions as a fishing lure (see illustration).

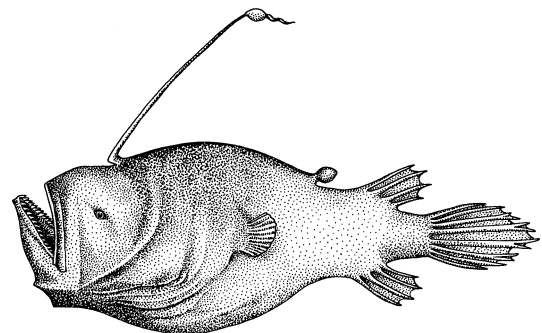

Anglerfish (*Cryptopsaras couesii*). (After G. B. Goode and T. H. Bean, *Oceanic Ichthyology*, U.S. Nat. Mus. Spec. Bull. no. 2, 1895)

Luminescent organs may be present, and in some deep-sea species the males are dwarfed and attached as ectoparasites on the females. There are 3 suborders, 15 families, nearly 60 genera, and about 195 known species. See ACTINOPTERYGII. [R.M.B.]

**Lophophore** The crown of tentacles which surrounds the mouth in the Bryozoa, Phoronida, and Brachiopoda. The numerous ciliated tentacles arise from a circular or horseshoe-shaped fold of the body wall. The tentacles are hollow outgrowths of the body wall, each containing fluid-filled extensions of the body cavity and extended hydraulically. The primary function of the lophophore is to gather food. On the tentacles are ciliary tracts which drive a current of food-particle-bearing water through the lophophore. While the lophophore is primarily a feeding organ, it may also play a role in reproduction, respiration, and larval locomotion. See BRACHIOPODA; BRYOZOA; PHORONIDA.

[J.E.Wi.]

**Loran** A navigation system from which hyperbolic lines of position are determined by measuring the difference in times of arrival of pulses from widely spaced, synchronized transmitting stations. Since radio waves travel at the speed of light, a line of position represents a constant range difference from two transmitters.

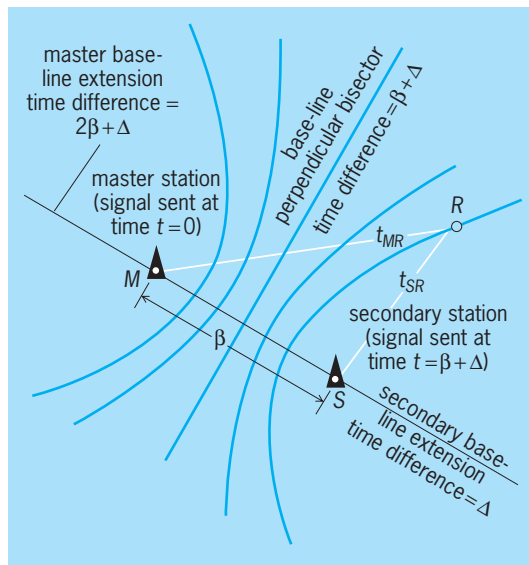

**Principle of position fixing by hyperbolic navigation systems.** (After J. P. Van Etten, *Navigation systems: Fundamentals of low and very-low-frequency hyperbolic techniques*, *Electr. Commun.*, 45(3):192-212, 1970)

In the illustration, it is assumed that the master station *M* transmits a pulse signal at time  $t = 0$ , and that the secondary station *S* transmits a similar pulse signal  $\Delta$  microseconds after receiving the master pulse signal. The secondary station receives the master signal at time  $t = \beta$  microseconds, and therefore transmits its pulse at time  $t = \beta + \Delta$  microseconds. A receiver at *R* measuring the difference in the times of arrival of the signals from the secondary and master stations measures the time difference  $TD = (\beta + \Delta) + t_{SR} - t_{MR}$ . The locus of all points with this common time difference is a hyperbola through the receiver position *R*. Similarly, every hyperbolic line of position is uniquely defined by a time difference. The intersection of two such lines of position gives a navigational fix, or location. Loran is used by commercial and military ships and aircraft. The name is derived from "long range navigation." See HYPERBOLIC NAVIGATION SYSTEM.

[J.P.V.E.]

**Lorentz transformations** The relationship in the special theory of relativity between the sets of coordinates  $(t, x, y, z)$  and  $(t', x', y', z')$  used to label events in spacetime by two inertial observers, *O* and *O'*, who are moving with respect to each other. Many of the effects predicted by special relativity can be derived in a direct manner from the Lorentz transformation formulas.

By definition, an event in spacetime is a point of space at an instant of time. It is an empirical fact that the collection of events in spacetime constitutes a four-dimensional continuum. This means that it takes four numbers to specify a particular event: one number to specify its "time" and three numbers to specify its spatial position.

In both prerelativity physics and in special relativity, an inertial observer, *O*, is one who is not acted upon by any external forces and thus undergoes straight-line motion. It is assumed in prerelativity physics and in special relativity that any inertial observer, *O*, can use a procedure involving the construction of a rigid cartesian grid of meter sticks and the synchronization of clocks placed at each point on the grid, to assign four numbers  $(t, x, y, z)$  to each event in spacetime. Another inertial observer, *O'*, who moves with respect to *O* at velocity  $v$  in the  $x$  direction, may also construct a global inertial coordinate system by using exactly the same procedure as *O*. The observer *O'* can thereby label events in spacetime by the numbers  $(t', x', y', z')$ . It is of interest to compare the way the same events are labeled by *O* and *O'*. For simplicity, it is assumed that *O* and *O'* meet at an event *A*, and that they adjust their clocks so that  $t = t' = 0$  at this event. It is also assumed for simplicity that the axes of the grid of meter sticks carried by *O'* are aligned (that is, not rotated) with respect to the axes of *O* when they meet.

In prerelativistic physics, the relationship between the global inertial coordinate systems of *O* and *O'* is given by a galilean transformation defined by Eqs. (1). Equation (1a) states that *O*

$$t' = t \tag{1a}$$

$$x' = x - vt \tag{1b}$$

$$y' = y \tag{1c}$$

$$z' = z \tag{1d}$$

and *O'* agree on the time labeling of any two events. In particular, if two events are judged to be simultaneous by *O* (that is, if  $t_1 = t_2$  for the two events), they also will be judged to be simultaneous by *O'* (that is,  $t'_1 = t'_2$ ). This reflects the fact that the notion of simultaneity is an absolute one in prerelativistic physics. The observers *O* and *O'* disagree only about the  $x$ -labeling of events, and this disagreement is readily understood as resulting from their relative motion.

In special relativity the corresponding relationship between the global inertial coordinates of *O* and *O'* is a Lorentz transformation, defined by Eqs. (2). The Lorentz transformation differs

$$t' = \frac{t - \frac{xv}{c^2}}{\sqrt{1 - \frac{v^2}{c^2}}} \tag{2a}$$

$$x' = \frac{x - vt}{\sqrt{1 - \frac{v^2}{c^2}}} \tag{2b}$$

$$y' = y \tag{2c}$$

$$z' = z \tag{2d}$$

dramatically from the galilean transformation in that *O* and *O'* disagree over the time labeling of events. In particular, two events judged by *O* to be simultaneous (that is,  $t_1 = t_2$ ) will not, in general, be simultaneous according to *O'*. This reflects the fact that simultaneity is not an absolute notion in special relativity. See RELATIVITY.

[R.M.Wal.]

**Loricifera** A phylum of multicellular invertebrates. These marine organisms are entirely meiobenthic; that is, they never exceed a maximum dimension of 400 micrometers and live in sediments ranging from deep-sea red clay to coarse sand or shell hash. They have some of the smallest known cells in the animal kingdom. Although they have been found throughout the world,

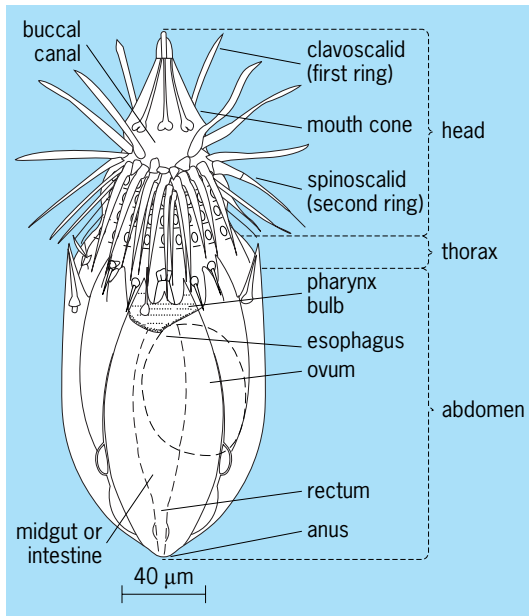

Ventral view of adult female loriferan (*Nannaloricus mysticus*). (After R. M. Kristensen, *Loricifera, a new phylum with Aschelminthes characters from the meiobenthos*, *Z. Zool. Syst. Evolutionsforsch.*, 21(3):163–180, 1983)

only 10 species representing three genera and two families have been described. Well over 50 species thought to represent several additional genera are known but remain undescribed.

Adult loriferans are bilaterally symmetrical. The body is regionated into a mouth cone which telescopically protrudes anteriorly from the center of a spherical, appendage-ringed (up to 400 rings may be present) head; a short, usually plated neck region; and a distinctively loricated (thick-cuticled) thorax-abdomen (see illustration). The head, along with its withdrawn mouth cone, may be inverted into the thorax-abdomen, which is then closed anteriorly by the cuticle of the neck region.

Loriciferans appear to be closely related to the Priapulida and perhaps less so to the Kinorhyncha. Certain structures of the mouth cone suggest affinities to the Tardigrada. Their presence may support the idea that proarthropods could have been developed from aschelminth ancestral stock. See ANIMAL KINGDOM; ARTHROPODA; KINORHYNCHA; PRIAPULIDA; TARDIGRADA. [R.PH.]

**Loudness** The perceptual intensity of sound. Loudness depends importantly on the physical intensity of sound, increasing when physical intensity increases and decreasing when physical intensity decreases. But loudness also depends on other physical properties of sound, such as frequency and duration. Sound waves with frequencies between 1000 and 5000 hertz are louder than sound waves that have the same intensity but lower or higher frequencies. The physical level of sound is expressed in decibels. See DECIBEL.

Because loudness depends on sound frequency as well as sound intensity or pressure, different stimuli with the same sound pressure level (SPL) may not be equally loud. One type of decibel scale, called the phon scale, overcomes this deficiency. The level of a sound in phons is the SPL in decibels of an equally loud 1000-Hz tone. Thus a 1000-Hz tone at 40-dB SPL has a level of 40 phons, as do all other sounds that equal its loudness, even though these other sounds may have SPLs much greater than 40 dB.

The phon scale is often designated as a scale of loudness level. It is a scale of equal loudness, in that all equally loud sounds take the same level in phons, regardless of the SPL. Nevertheless, the phon scale is not a true scale of loudness, because it is a physical (decibel) scale. That is, a sound of 80 phons is not necessarily

Sound pressure level, dB	Loudness, sones
130	512
120 ————— jet plane —————	256
110	128
100 ————— truck —————	64
90	32
80 ————— machinery —————	16
70 ————— street noises —————	8
60	4
50 ————— ordinary conversation —————	2
40	1
30 ————— quiet office —————	.5
20 ————— whisper —————	.2
10	.085
0	threshold

Decibel and loudness scales of common sounds.

twice as loud as a sound of 40 phons. In order to determine a scale of perceived loudness, observers were asked to set the level of one sound to make it appear twice or half as loud as standard sounds. Observers were also asked to make numerical judgments of the degree of loudness. From such judgments a scale of loudness in sones was established. One sone is defined as the loudness of a 1000-Hz tone at 40-dB SPL heard with both ears. (When heard with one ear, loudness is half as great.) Above 40 dB, loudness in sones doubles with every 10-dB increase in the level of sound. Below 40 dB, loudness falls by half with decrements smaller than 10 dB (see illustration). See SOUND; SOUND PRESSURE. [L.E.M.]

**Loudspeaker** A device that converts an electrical signal from an amplifier into sound. A loudspeaker driver is an electromechanical-acoustic device with two electrical input terminals, to which an electrical signal is applied, and a diaphragm which vibrates and radiates sound. An electromechanical motor mechanism exerts a force on the diaphragm to cause it to vibrate. By far the most common type of motor mechanism, the electromagnetic-mechanical transducer employs a coil of wire immersed in a magnetic field; electric current flowing through the coil causes a force to be exerted on the coil which is mechanically coupled to the diaphragm. A less common type of motor mechanism is the electrostatic-mechanical transducer. It uses a capacitor to which an electric voltage is applied, causing a force to be exerted between the capacitor plates, which is mechanically coupled to the diaphragm. Two types of electrostatic transducers are used: the piezoelectric transducer and the condenser transducer. The piezoelectric transducer uses a piezoelectric crystal between the capacitor plates. The condenser transducer uses an air dielectric. One plate of the capacitor is a flexible membrane which serves as the diaphragm. See AUDIO AMPLIFIER.

A loudspeaker system employs one or more loudspeaker drivers in a common enclosure. A one-way loudspeaker system employs a full-range driver to cover the full audio spectrum. A two-way system employs a low-frequency driver called a woofer and a high-frequency driver called a tweeter. An electrical low-pass filter is used in series with the woofer and a high-pass filter

is used in series with the tweeter. These filters are commonly referred to as the crossover networks. A three-way system adds a midfrequency driver called the midrange or squawker. The crossover network for this driver is a band-pass filter. In some systems, a driver called a supertweeter is used to reproduce audio frequencies into the ultrasonic range. A driver called a subwoofer is used to reproduce audio frequencies into the infrasonic range. See ELECTRIC FILTER; NETWORK THEORY.

Loudspeaker drivers can also be operated either as direct-radiator or horn-loaded. A direct-radiator driver is one whose diaphragm radiates directly into the external air load. A horn-loaded driver has an acoustic horn between the diaphragm and the air load. A horn can be used to improve the efficiency and to control the directional pattern of the radiated sound at the expense of frequency response. See DIRECTIVITY; SOUND-REINFORCEMENT SYSTEM. [W.M.L.]

**Louping ill** A viral disease of sheep, capable of producing central nervous system manifestations. It occurs chiefly in the British Isles. Infections have been reported, although rarely, among persons working with sheep. In sheep the disease is usually biphasic with a systemic influenzalike phase, which is followed by encephalitic signs. In infected humans the first phase is generally the extent of the illness. The virus is a member of the Russian tick-borne complex of the group B arboviruses. Characteristics, diagnosis, and epidemiology are similar to those of other viruses of this complex. See ANIMAL VIRUS; ARBOVIRAL ENCEPHALITIDES. [J.L.Me.]

**Low-level counting** The measurement of very small amounts of radioactivity. This can be achieved by measuring radioactivity in large samples or modifying conventional radiation-detection instruments for greater detection sensitivity, or both. All approaches must take into account the characteristics of the radiations, notably the very short range and intense energy deposition of alpha particles, intermediate range and energy deposition of beta particles, and high penetration of matter with low linear energy transfer by gamma rays. These techniques are important for measuring radionuclides from naturally occurring terrestrial and cosmic-ray-produced sources, and anthropogenic radionuclides to characterize the decay schemes of newly formed isotopes and analyze environmental and biological samples. See ALPHA PARTICLES; BETA PARTICLES; GAMMA RAYS.

Accurate measurements are defined by a small statistical error for the net sample count rate. Because the statistical error depends both on the net sample count rate and on the radiation background count rate, the value of the radiation background count rate must be kept as low as possible.

Commonly used radiation detectors are gas-ionization systems operating in the ionization, proportional, or Geiger-Müller regions; scintillation systems with scintillators that are inorganic solids, organic solids, or organic liquids; and solid-state systems with germanium or silicon detectors. See GEIGER-MÜLLER COUNTER; IONIZATION CHAMBER; JUNCTION DETECTOR; PARTICLE DETECTOR; SCINTILLATION COUNTER.

Radionuclides in very large samples may be measured directly by counting the energetic gamma rays they emit, for example in whole-body counting. If such samples emit only alpha particles, beta particles, or weak gamma rays (x-rays), then the radionuclides must be extracted and concentrated by chemical or physical processes. Radionuclides can be concentrated from water on ion-exchange resins or by precipitation, and from air by sorption on materials such as charcoal or molecular sieves. Filtering will collect radioactive solids from both media. Other processes include condensation of gases from air and volatilization from liquids or solids. The radionuclides must then be prepared for counting as thin solids, as solutes in a liquid scintillation cocktail, or as gases that are part of an ionization-detector filling. See ADSORPTION; CHARCOAL; FILTRATION; ION EXCHANGE; MOLECULAR SIEVE; PRECIPITATION (CHEMISTRY); VOLATILIZATION.

To maximize the detection efficiency, the intrinsic efficiency for recording the radiation should be near unity and the detector should view the sample from as large a solid angle as possible. Even relatively thin detectors have intrinsic efficiencies near unity for alpha particles, beta particles, and x-rays, but energetic gamma rays are detected with much lower intrinsic efficiency, except by very thick detectors. In general, the larger the sample, the smaller the angle subtended by the detector, although large detectors have been made for large samples. Relatively small samples can be surrounded more easily by a detector.

Achieving a low and stable radiation background is one basic aim in low-level counting. Stability is necessary because the detector background generally is determined by counting blanks between samples and subtracting these blank counts from the sample count on the assumption that the background is invariant. The counting facility must be situated to avoid fluctuating external radiation fields at nuclear facilities or near radiation sources. Airborne radon and progeny may have to be controlled by air-cleaning processes to avoid radiation background fluctuations. See RADON.

The detector background from ambient radiation is reduced by shielding and by anticoincidence systems. A typical shield consists of 2 in. (5 cm) of a heavy metal such as lead or mercury, or thicker iron, to surround a beta-particle detector, or at least twice that thickness for a gamma-ray detector. This shielding absorbs all beta particles and most gamma rays. Water or paraffin is added to shield against neutrons. For ultralow-level counting, the entire system can be shielded with massive amounts of iron and buried below ground to reduce the cosmic-ray background. See NEUTRON; RADIATION SHIELDING; RADIOACTIVITY. [B.Ka.]

**Low-temperature acoustics** The application of acoustics to research on the properties of condensed matter at low temperatures. Acoustic techniques are readily adaptable to the cryogenic environment and make possible many measurements of the structural and thermodynamic properties of materials at temperatures approaching absolute zero (0 K, which is  $-273^{\circ}\text{C}$ ). The study of sound propagation has also yielded major insights into the low-temperature phenomena of superconductivity in metals and superfluidity in liquid helium.

**Solid materials.** Acoustic measurements have been used to characterize the properties of a wide variety of solid-state materials, such as metals, dielectric crystals, amorphous solids, and magnetic materials. A measurement of the velocity of sound in a substance gives information on its elastic properties, while the attenuation of the sound characterizes the interaction of the lattice vibrations with the electronic and structural properties of the material. Ultrasonic frequencies, in the range from 20 kHz to 100 MHz and above, are commonly employed in these measurements because of the ease of generating and detecting the sound with piezoelectric quartz crystals.

Because the sound velocity effectively measures elastic constants, such measurements are used to characterize phase transitions in crystals where the structure of the lattice changes. The attenuation of sound in many crystals is due to defects and impurities in the crystal lattice and provides information on such structures. In a metal at very low temperatures, the dominant source of attenuation is the interaction of the sound with the conduction electrons. See CRYSTAL; LATTICE VIBRATIONS; PHASE TRANSITIONS; PHONON; SOUND ABSORPTION.

A large variety of magnetoacoustic effects are observed in metals and crystals. In these measurements, changes in the sound attenuation occur as the strength of a magnetic field applied to the sample is increased. One example is the phenomenon of nuclear acoustic resonance, resulting from the interaction of the nuclear spins in a crystal with vibrations of the lattice. There are also a number of other magnetoacoustic effects in metals which are useful in determining the orbits followed by the conduction electrons in the metal. See DE HAAS-VAN ALPHEN EFFECT.

Sound propagation is useful for studying amorphous materials. In materials such as silica glass (amorphous silicon dioxide,  $\text{SiO}_2$ ), only two quantum energy levels are found to be important at low temperatures. These levels correspond to two nearly equivalent arrangements of the atoms, with one arrangement having slightly higher energy. An imposed sound field can cause a transition from one arrangement to the other. If the relaxation rate back to the original configuration is comparable to the sound frequency, there will be a net absorption of energy from the sound wave. A peak in the attenuation in silica glass near 50 K ( $-370^\circ\text{F}$ ) has been identified as being due to this process, and measurements as a function of frequency allow a determination of the relaxation rate. See AMORPHOUS SOLID.

When a metal is cooled below its superconducting transition temperature, there are striking changes in the attenuation of sound. At the transition some of the electrons near the Fermi surface begin to pair together, due to the attractive electron-phonon coupling. Once this occurs, the electrons can no longer exchange momentum with the lattice, and hence have zero resistance. This also means that the paired electrons no longer absorb energy from the sound wave, and the attenuation is from the remaining unpaired normal electrons. As the temperature is lowered well below the transition, the density of the unpaired electrons drops rapidly, and the attenuation becomes very small. See SUPERCONDUCTIVITY.

**Superfluid helium.** Sound propagation has been extensively used to probe many of the unusual properties of superfluid helium. The novel features of the superfluid (zero viscosity and entropy) give rise to a rich variety of different types of sound which can propagate in the superfluid helium. Five distinct sound modes have been identified and observed experimentally. The sound velocities of a number of these modes are shown in the illustration as a function of temperature.

First sound is a pressure wave which propagates in the bulk liquid. It is quite similar to sound in ordinary fluids.

Second sound is an unusual type of wave: it is a temperature wave in the bulk superfluid. In this mode the normal fluid and superfluid move in opposite directions. This keeps the density constant, and hence there are no pressure oscillations in the wave (as in first sound); but because only the normal fluid carries entropy, there are oscillations in the entropy and thus in the temperature of the liquid. See SECOND SOUND.

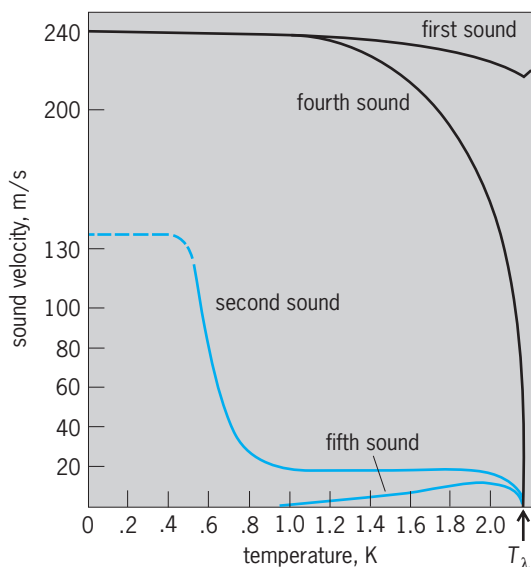

Velocity of the various types of sound in superfluid  $^4\text{He}$  as a function of temperature.  $1 \text{ m/s} = 3.28 \text{ ft/s}$ .  $^\circ\text{F} = (\text{K} \times 1.8) - 459.67$ .

Third sound is a wave which propagates in very thin films of helium. The third sound is a wave in which the thickness of the film varies, somewhat like waves in a tank of water. Because the films are so thin, only the superfluid can move, the normal fluid being immobilized by its viscosity.

Fourth sound is a pressure wave which propagates in superfluid helium when it is confined in a porous material such as a tightly packed powder. In such a situation the normal fluid is immobilized, and only the superfluid can flow freely because of its zero viscosity (the porous materials are often called superleaks for this reason). The fourth sound is analogous to first sound because it involves density and pressure oscillations.

Fifth sound is a temperature wave which can propagate in helium confined in a superleak. It is analogous to second sound, except that again only the superfluid component can flow. See LIQUID HELIUM; SUPERFLUIDITY. [G.A.W.]

**Low-temperature physics** A branch of physics dealing with physical properties of matter at temperatures such that thermal fluctuations are greatly reduced and effects of interactions at the quantum-mechanical level can be observed. As the temperature is lowered, order sets in (either in space or in motion), and quantum-mechanical phenomena can be observed on a macroscopic scale.

Some of the most interesting manifestations of low temperatures have been investigated in the temperature range from 4 K ( $-452^\circ\text{F}$ ) down to less than a nanokelvin above absolute zero. (1 K is equal to  $1.8^\circ\text{F}$  above absolute zero, or  $-459.67^\circ\text{F}$ .) Certain metals become superconducting, losing their electrical resistance entirely; hence persistent currents can flow indefinitely in a superconducting ring or coil, displaying quantum-mechanical coherence over large distances. The liquids helium-3 ( $^3\text{He}$ ) and helium-4 ( $^4\text{He}$ ) remain liquid down to absolute zero under their own vapor pressure due to the large zero-point energy of these light atoms. (To overcome the large zero-point energy in liquid  $^3\text{He}$  and liquid  $^4\text{He}$ , a large pressure, approximately 30 atm or 3 megapascals, must be applied to cause these systems to solidify.) Liquid  $^4\text{He}$  becomes superfluid, exhibiting no resistance to flow under certain conditions; when set in circulation, the fluid current persists indefinitely. Liquid  $^3\text{He}$  also becomes superfluid at a much lower temperature with interesting magnetic and orbital effects. At sufficiently low temperatures, nuclear magnetic ordering has been observed in solid  $^3\text{He}$ , in magnetic insulators, and in metallic systems. Silver becomes a nuclear antiferromagnet in the nanokelvin range as a result of quantum-mechanical exchange interactions. Considerable attention has been addressed to the general problem of ordering in disordered systems leading to studies of spin glasses, localization, and lower dimensionality. Quantum statistics are investigated in atomic hydrogen and deuterium, stabilized in states known as spin-polarized hydrogen ( $\text{H}\downarrow$ ) and spin-polarized deuterium ( $\text{D}\downarrow$ ). Because of its light mass and weak interactions, spin-polarized hydrogen is expected to remain gaseous down to absolute zero, whereas spin-polarized deuterium might liquefy at low temperatures. See HYDROGEN; LIQUID HELIUM; SUPERFLUIDITY.

Low-temperature research also deals with problems of thermometry and heat transfer between systems and within systems. Many practical applications have emerged, including the use of superconductivity for large magnets, ultrafast electronics for computers, and low-noise and high-sensitivity instrumentation. This type of instrumentation has opened new areas of research in biophysics, and in fundamental problems such as the search for magnetic monopoles, gravity waves, and quarks. See LOW-TEMPERATURE THERMOMETRY; SUPERCONDUCTING DEVICES; SUPERCONDUCTIVITY.

The development of low-temperature techniques has revealed a wide range of other phenomena. The behavior of oriented nuclei is studied by observing the distribution of gamma-ray emission of radioactive nuclei oriented in a magnetic field. Other areas of study include surfaces of liquid  $^3\text{He}$  and liquid  $^4\text{He}$ ,

$^3\text{He}$ - $^4\text{He}$  mixtures, cryogenics, acoustic microscopy, phonon spectroscopy, monolayer helium films, molecular hydrogen, determination of the voltage standard, and phase transitions. See ACOUSTIC MICROSCOPE; CRYOGENICS; ELECTRICAL UNITS AND STANDARDS; NUCLEAR ORIENTATION; PHASE TRANSITIONS. [O.G.S.]

**Low-temperature thermometry** The measurement of temperature below  $32^\circ\text{F}$  ( $0^\circ\text{C}$ ). Very few thermometers are truly wide-range, and hence most of the conventional methods of thermometry tend to fail the further one moves below room temperature (see table). The defining instrument for the lower regions of the International Practical Temperature Scale, the platinum resistance thermometer, rapidly loses sensitivity below  $-405^\circ\text{F}$  (30 K), and its official limit is set at  $-434.81^\circ\text{F}$  (13.81 K), the triple point of equilibrium hydrogen. This scale is based upon measurements of thermodynamic temperature made with the gas thermometer; the gas thermometer may be used down to about  $-456^\circ\text{F}$  (2 K). See GAS THERMOMETRY.

The low-temperature region is unique in having available several different types of primary thermometers, all of which are quite practical. The least practical, perhaps, is the acoustic thermometer, which uses the property that, extrapolated to zero pressure, the speed of sound in a gas is proportional to  $T^{1/2}$ . This has been used in the range  $-456$  to  $-424^\circ\text{F}$  (2–20 K) as an alternative to, and check upon, the gas thermometer. The Johnson noise in a resistor can be used with particular advantage at low temperatures when allied with SQUID detector technology. See ELECTRICAL NOISE; SOUND.

#### Ranges and sensitivities of low-temperature thermometers

Thermometer	Temperature range, K
<b>Thermocouples</b>	
300 to 700 ppm Fe in Au/Ag + 0.37 at. % Au	1–25
Chromel/300 to 700 ppm Fe in Au	1–300
Chromel/Constantan	20–1100
<b>Resistance thermometers</b>	
Platinum (capsule)	4–500
Rhodium + 0.5 at. % Fe	0.5–300
Carbon	0.01–300
Germanium	0.01–30
<b>Saturation vapor pressure thermometers</b>	
Hydrogen	14–21
Helium-4	1.0–5.2
Helium-3	0.5–3.3
<b>Noise thermometers*</b>	
<b>Magnetic thermometers</b>	
Gadolinium metaphosphate, $\text{Gd}(\text{PO}_3)_3$	2–100
Cerous magnesium nitrate (CMN), $\text{Ce}_2\text{Mg}_3(\text{NO}_3)_{12} \cdot 24\text{H}_2\text{O}$ ; single crystal	0.003–4
CMN powder sphere or cylinder	0.002–4
Copper (and other nuclear paramagnets)	0.001–0.01
<b>Gamma-ray anisotropy thermometers*</b>	
$^{60}\text{Co}$ in hexagonal close-packed cobalt single crystal	0.002–0.04
$^{54}\text{Mn}$ in iron	0.003–0.03
$^{54}\text{Mn}$ in nickel	0.004–0.045
<b><math>^3\text{He}</math> melting-curve thermometer</b>	0.001–1
<b>Nuclear resonance thermometer</b>	310 nK–2K

\*Primary thermometer.

In suitable systems it is possible to spatially orient atomic nuclei at very low temperatures, and if these nuclei are emitters of gamma rays, the emission pattern is anisotropic to a degree which is a measure of the thermodynamic temperature. Finally the magnetic susceptibility of suitable atomic nuclei may also be employed via the Curie law. Nuclear magnetic resonance or static SQUID-based techniques may be employed, but nuclear magnetic resonance is preferable in being unaffected by magnetic impurities, to which the second method falls hostage. See NUCLEAR MAGNETIC RESONANCE (NMR); SQUID; TEMPERATURE; TEMPERATURE MEASUREMENT; THERMOCOUPLE; THERMOMETER. [R.P.Hu.]

**Lubricant** A gas, liquid, or solid used to prevent contact of parts in relative motion, and thereby reduce friction and wear. In many machines, cooling by the lubricant is equally important. The lubricant may also be called upon to prevent rusting and the deposition of solids on close-fitting parts.

Crude petroleum is an excellent source of lubricants because a very wide range of suitable liquids, varying in molecular weight from 150 to over 1000 and in viscosity from light machine oils to heavy gear oils, can be produced by various refining processes (see table). In order to standardize on nomenclature for oils of differing viscosity, the Society of Automotive Engineers (SAE) has established viscosity ranges for the various SAE designations (see table).

#### Viscosity of oils for various applications

Application	Viscosity in centistokes at $25^\circ\text{C}$ ( $77^\circ\text{F}$ )	Primary function
<b>Engine oils</b>		
SAE 10W	60–90	Lubricate piston rings, cylinders, valve gear, bearings; cool piston; prevent deposition on metal surfaces
SAE 20	90–180	
SAE 30	180–280	
SAE 40	280–450	
SAE 50	450–800	
<b>Gear oils</b>		
SAE 80	100–400	Prevent metal contact and wear of spur gears, hypoid gears, worm gears; cool gear cases
SAE 90	400–1000	
SAE 140	1000–2200	
Aviation engine oils	220–700	Same as engine oils
Torque converter fluid	80–140	Lubricate, transmit power
Hydraulic brake fluid	35	Transmit power
Refrigerator oils	30–260	Lubricate compressor pump
Steam-turbine oil	55–300	Lubricate reduction gearing, cool
Steam cylinder oil	1500–3300	Lubricate in presence of steam at high temperatures

It is often desirable to add various chemicals to lubricating oils to improve their physical properties or to obtain some needed improvement in performance. These include viscosity-index improvers, pour-point depressants, antioxidants, anti-wear and friction-reducing additives, and dispersants.

Synthetic lubricants may be superior to mineral lubricants in some applications. The main advantage of synthetics is that they have a greater operating range than a mineral oil. Included in this class are esters, containing oxidation inhibitors and sometimes mild extreme pressure additives, silicones, and the polyglycols, such as polypropylene and ethylene oxides.

The most useful solid lubricants are those with a layer structure in which the molecular platelets will readily slide over each other. Graphite, molybdenum disulfide, talc, and boron nitride possess this property. A unique type of solid lubricant is provided by the plastic polytetrafluoroethylene (PTFE). The principal difficulty encountered with the use of solid lubricants is that of maintaining an adequate lubricant layer between the sliding metal surfaces.

A lubricating grease is a solid or semifluid lubricant comprising a thickening (or gelling) agent in a liquid lubricant. Other ingredients imparting special properties may be included. An important property of a grease is its solid nature; it has a yield value. This enables grease to retain itself in a bearing assembly without the aid of expensive seals, to provide its own seal against the ingress of moisture and dirt, and to remain on vertical surfaces and protect against moisture corrosion, especially during shut-down periods. [R.G.L.]

**Lubrication** The use of lubricants to reduce friction and wear. Whenever two bodies in contact are made to slide relative to one another, a resistance to the motion is experienced. This resistance, called friction, is present in all machinery. Approximately 30% of the power of an automobile engine is consumed by friction. Friction and wear can be significantly reduced, and thus relative motion of machine parts made possible, by interposing a lubricant at the interface of the contacting surfaces; the machine elements designed to accomplish this are called bearings. Bearings can be lubricated by solids such as graphite or, more commonly, by liquids and gases. See ANTIFRICTION BEARING; FRICTION; GRAPHITE; LUBRICANT; SURFACE AND INTERFACIAL CHEMISTRY; WEAR.

Conventionally, lubrication has been divided into (1) fluid-film lubrication (hydrostatic, hydrodynamic, and elastohydrodynamic), where the sliding surfaces are separated by a relatively thick, continuous film of lubricant; and (2) boundary lubrication, where contact surface separation is but a few molecular layers and asperity contact is unavoidable.

**Hydrostatic bearings.** Hydrostatic films are created when a high-pressure lubricant is injected between opposing (parallel) surfaces (pad and runner), thereby separating them and preventing their coming into direct contact. Hydrostatic bearings require external pressurization. The film is 5–50 micrometers thick, depending on application. Though hydrostatic lubrication does not rely on relative motion of the surfaces, relative motion is permitted and can even be discontinuous. Figure 1 is a schematic of a hydrostatic bearing pad. To handle asymmetric loads, hydrostatic systems generally employ several evenly spaced pads. Hydrostatic bearings find application where relative positioning is of extreme importance. They are also applied where a low coefficient of friction at vanishing relative velocity is required.

**Hydrodynamic bearings.** Hydrodynamic bearings are self-acting. To create and maintain a load-carrying hydrodynamic film, it is necessary only that the bearing surfaces move relative to one another and ample lubricant is available. The surfaces must be inclined to form a clearance space in the shape of a wedge, which converges in the direction of relative motion. The lubricant film is then created as the lubricant is dragged into the clearance by the relative motion. This viscous action results in a pressure build-up within the film (Fig. 2). The fact that hydrodynamic bearings are self-generating and do not rely on auxiliary equipment makes these bearings very reliable. Hydrodynamic journal bearings and thrust bearings are designed to support radial and axial loads, respectively, on a rotating shaft.

**Rolling contact bearings.** Journal and thrust bearings are conformal bearings; that is, the opposing bearing surfaces conform in shape. Ball and roller bearings, also known as rolling contact bearings, are counterformal. Counterformal bearings always operate in the hydrodynamic mode, but because the con-

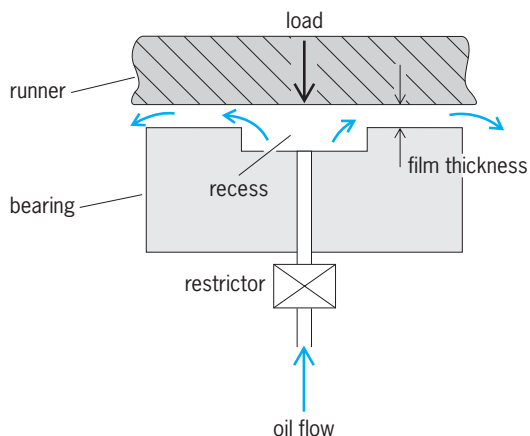

Fig. 1. Hydrostatic bearing pad.

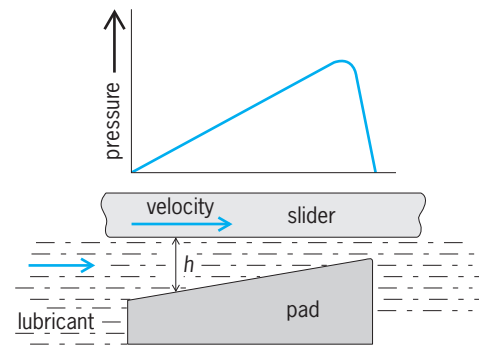

Fig. 2. Hydrodynamic film formation.

tact area in these bearings is small the pressure attains high values, in the range of 1–3 gigapascals (10,000–30,000 atm). In consequence, the surfaces deform elastically and the lubricant viscosity increases by several orders of magnitude.

**Lubricants.** Today, mineral oils manufactured from petroleum are the most common liquid lubricants. The manufacturer of petroleum lubricants can choose from a wide variety of crude oils, and the choice is of great importance because the lubricating oil fraction of crude oils varies widely. See PETROLEUM; VISCOSITY. [A.Z.S.]

**Lumber** Timber sawed or split into planks, boards, and similar products. Lumber can come in many forms, species, and types from a wide variety of commercial sources. Because most lumber is manufactured similarly and graded by standardized rules, it is fairly uniform throughout the United States. See WOOD PRODUCTS.

Lumber is manufactured from round logs primarily in rectangular shapes of different dimensions. Lumber length is recorded in actual dimensions. Width and thickness are traditionally recorded in nominal dimensions, which are somewhat more than actual dimensions. Lumber is classified by thickness into three categories: (1) board, lumber less than 38 mm (nominally 2 in.) thick; (2) dimension, lumber from 38 mm to, but not including, 114 mm (nominally 5 in.) thick; and (3) timber, lumber 114 mm (nominally 5 in.) or more in thickness in the least dimension. See LOGGING.

Lumber can be produced with either a rough or surfaced (dressed) finish. Rough-sawn lumber has surface imperfections caused by the primary sawing operations. Surfaced lumber is smoothed on either one or both sides and one or both edges.

In general, the grade of a piece of lumber is based on the number, character, and location of features that may lower the strength, durability, or utility value of the wood. Lumber grading can be divided into two main categories: remanufacture "shop grade" and structural "stress grade." Sorting of lumber for remanufacture is based on visual inspection. The wood is designated shop grade on the proportion of defect-free or clear cuttings of a certain size that can be made from a piece of lumber. The larger volume and more frequent number of clear cuttings, the higher the grade. Pieces of lumber graded for structural uses are put into classes with similar mechanical properties called stress grades. Stress grades are characterized by (1) one or more sorting criteria, (2) a set of allowable properties for engineering design, and (3) a unique grade name. The allowable properties are inferred through visual grading criteria or are determined nondestructively by machine-grading criteria.

Visual grading is the oldest stress-grading method. It is based on the premise that mechanical properties of lumber differ from mechanical properties of clear wood. Growth characteristics, which affect properties and can be seen and judged by eye, are used to sort the lumber into stress grades. Typical visual sorting criteria include density, decay, proportion of heartwood and

sapwood, slope of grain, knots, shake, checks and splits, wane, and pitch pockets.

Machine-graded lumber is evaluated by a machine using a nondestructive test followed by visual grading to evaluate certain characteristics that the machine cannot or may not properly evaluate. Machine-stress-rated (MSR), machine-evaluated (MEL), and E-rated lumber are three types of machine-graded lumber. Machine-graded lumber allows for better sorting of material for specific applications in engineered structures.

Clear, straight-grained lumber can be about 50% stronger when dry than when wet. For lumber containing knots, the increase in strength with decreasing moisture content is dependent on lumber quality. For timber, often no adjustment for moisture content is made because properties are assigned on the basis of wood in the green condition. See WOOD PRODUCTS; WOOD PROPERTIES. [D.E.Kr.]

**Luminance** The luminous intensity of any surface in a given direction per unit of projected area of the surface viewed from that direction. The International Commission on Illumination defines it as the quotient of the luminous intensity in the given direction of an infinitesimal element of the surface containing the point under consideration, by the orthogonally projected area of the element on a plane perpendicular to the given direction. Simply, it is the luminous intensity per unit area. Luminance is also called photometric brightness.

Since the candela is the unit of luminous intensity, the luminance, or photometric brightness, of a surface may be expressed in candelas/cm<sup>2</sup>, candelas/in.<sup>2</sup>, and so forth.

The stilb is a unit of luminance (photometric brightness) equal to 1 candela/cm<sup>2</sup>. It is often used in Europe, but the practice in America is to use the term candela/cm<sup>2</sup> in its place.

The apostilb is another unit of luminance sometimes used in Europe. It is equal to the luminance of a perfectly diffusing surface emitting or diffusing light at the rate of 1 lumen/m<sup>2</sup>. See LUMINOUS INTENSITY; PHOTOMETRY. [R.C.Pu.]

**Luminescence** Light emission that cannot be attributed merely to the temperature of the emitting body. Various types of luminescence are often distinguished according to the source of the energy which excites the emission. When the light energy emitted results from a chemical reaction, such as in the slow oxidation of phosphorus at ordinary temperatures, the emission is called chemiluminescence. When the luminescent chemical reaction occurs in a living system, such as in the glow of the firefly, the emission is called bioluminescence. In the foregoing two examples part of the energy of a chemical reaction is converted into light. There are also types of luminescence that are initiated by the flow of some form of energy into the body from the outside. According to the source of the exciting energy, these luminescences are designated as cathodoluminescence if the energy comes from electron bombardment; radioluminescence or roentgenoluminescence if the energy comes from x-rays or from  $\gamma$ -rays; photoluminescence if the energy comes from ultraviolet, visible, or infrared radiation; and electroluminescence if the energy comes from the application of an electric field. By attaching a suitable prefix to the word luminescence, similar designations may be coined to characterize luminescence excited by other agents. Since a given substance can frequently be made to luminesce by a number of different external exciting agents, and since the atomic and electronic phenomena that cause luminescence are basically the same regardless of the mode of excitation, the classification of luminescence phenomena into the foregoing categories is only a matter of convenience, not of fundamental distinction.

When a luminescent system provided with a special configuration is excited, or "pumped," with sufficient intensity of excitation to cause an excess of excited atoms over unexcited atoms (a so-called population inversion), it can produce laser action. (Laser is an acronym for light amplification by stimulated emis-

sion of radiation.) This laser emission is a coherent stimulated luminescence, in contrast to the incoherent spontaneous emission from most luminescent systems as they are ordinarily excited and used. See LASER; OPTICAL PUMPING.

A second basis frequently used for characterizing luminescence is its persistence after the source of exciting energy is removed. Many substances continue to luminesce for extended periods after the exciting energy is shut off. The delayed light emission (afterglow) is generally called phosphorescence; the light emitted during the period of excitation is generally called fluorescence. In an exact sense, this classification, based on persistence of the afterglow, is not meaningful because it depends on the properties of the detector used to observe the luminescence. With appropriate instruments one can detect afterglows lasting on the order of a few thousandths of a microsecond, which would be imperceptible to the human eye. The characterization of such a luminescence, based on its persistence, as either fluorescence or phosphorescence would therefore depend upon whether the observation was made by eye or by instrumental means. These terms are nevertheless commonly used in the approximate sense defined here, and are convenient for many practical purposes. However, they can be given a more precise meaning. For example, fluorescence may be defined as a luminescence emission having an afterglow duration which is temperature-independent, while phosphorescence may be defined as a luminescence with an afterglow duration which becomes shorter with increasing temperature. See BIOLUMINESCENCE; CATHODOLUMINESCENCE; CHEMILUMINESCENCE; ELECTROLUMINESCENCE; FLUORESCENCE; PHOSPHORESCENCE; PHOTOLUMINESCENCE; THERMOLUMINESCENCE. (C.C.K.; J.H.S.)

**Luminescence analysis** Methods of chemical analysis in which analyte concentration is related to luminescence intensity or some other property of luminescence. Photoluminescence, particularly fluorescence, is the most widely used type of luminescence for chemical analysis. However, there are also important analytical applications of both chemiluminescence and bioluminescence.

Luminescence is light that accompanies the transition from an electronically excited atom or molecule to a lower energy state. The forms of luminescence are distinguished by the method used to produce the electronically excited species. When produced by absorption of incident radiation, the light emission is known as photoluminescence. Photoluminescence that is short-lived ( $10^{-8}$  s or less between excitation and emission) is known as fluorescence. Photoluminescence that is longer-lived (from  $10^{-6}$  s all the way up to seconds) is known as phosphorescence. The reason for the difference in lifetime is that fluorescence involves an allowed, high-probability, transition while phosphorescence involves a forbidden, low-probability, transition. See FLUORESCENCE; LUMINESCENCE; PHOSPHORESCENCE; PHOTOLUMINESCENCE; SELECTION RULES (PHYSICS).

Chemiluminescence is observed when the electronically excited atom or molecule is formed as the product of a chemical reaction. If the light-producing reaction occurs in nature, such as the light emitted by fireflies, it is known as bioluminescence. See BIOLUMINESCENCE; CHEMILUMINESCENCE.

Photoluminescence excitation spectra are determined by measuring emission intensity at a fixed wavelength while varying the wavelength of the incident light used to produce the electronically excited species responsible for emission. The excitation spectrum is a measure of the efficiency of electronic excitation as a function of excitation wavelength. Photoluminescence emission spectra are determined by exciting at a fixed wavelength and varying the wavelength at which emission is observed. The illustration shows typical excitation and fluorescence and phosphorescence emission spectra for a molecule in solution. Between excitation and emission, electronically excited molecules normally lose some of their energy because of relaxation processes. As a consequence, the emission spectrum is at longer wavelengths,



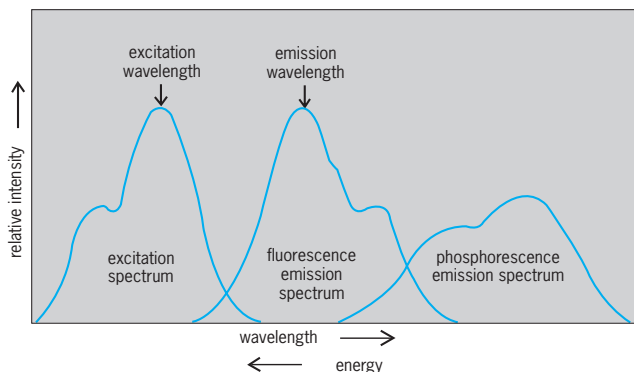

Typical photoluminescence excitation and emission spectra for molecules in solution.

that is, at lower energy, than the excitation spectrum. Because the magnitude of the energy loss due to relaxation processes is greater for phosphorescence than for fluorescence, phosphorescence occurs at longer wavelengths than fluorescence. The spectra extend over a range of wavelengths, because in solution, molecules exist in a continuous distribution of vibrational and rotational energy levels. See ENERGY LEVEL (QUANTUM MECHANICS).

Observed luminescence intensities depend on three factors: (1) the number of electronically excited molecules or atoms produced by the excitation process; (2) the fraction of electronically excited molecules that emit light as they relax to a lower energy state; and (3) the fraction of the emitted luminescence that impinges on the detector and is measured. In the case of photoluminescence, the number of excited molecules is proportional to incident excitation intensity, the concentration of the luminescent species, and the efficiency with which the luminescence species absorbs the incident radiation. In the case of chemiluminescence and bioluminescence, the number of excited molecules depends on reactant concentrations and the efficiency with which the reaction pathway leads to production of the excited state. The dependence of intensity on concentration is the basis for chemical analysis based on luminescence.

By far the most important advantage of luminescence methods of chemical analysis is their ability to measure extremely low concentrations. This advantage arises because luminescence is measured relative to weak background signals. In contrast, methods based on the absorption of light require that a small difference between two large signals be measured. [W.R.Se.]

**Luminous efficacy** There are three ways this term can be used: (1) The luminous efficacy of a source of light is the quotient of the total luminous flux emitted divided by the total lamp power input. Light is visually evaluated radiant energy. Luminous flux is the time rate of flow of light. Luminous efficacy is expressed in lumens per watt. (2) The luminous efficacy of radiant power is the quotient of the total luminous flux emitted divided by the total radiant power emitted. This is always somewhat larger for a particular lamp than the previous measure, since not all the input power is transformed into radiant power. (3) The spectral luminous efficacy of radiant power is the quotient of the luminous flux at a given wavelength of light divided by the radiant power at that wavelength. A plot of this quotient versus wavelength displays the spectral response of the human visual system. It is, of course, zero for all wavelengths outside the range from 380 to 760 nanometers. It rises to a maximum near the center of this range. Both the value and the wavelength of this maximum depend on the degree of dark adaptation present. However, an accepted value of 683 lumens per watt maximum at 555 nanometers represents a standard observer in a light-adapted condition. See ILLUMINATION; LUMINOUS EFFICIENCY; LUMINOUS FLUX; PHOTOMETRY. [G.A.Ho.]

**Luminous efficiency** Visual efficacy of visible radiation, a function of the spectral distribution of the source radiation in accordance with the "spectral luminous efficiency curve," usually for the light-adapted eye or photopic vision, or in some instances for the dark-adapted eye or scotopic vision.

The spectral luminous efficiency of radiant flux is the ratio of luminous efficacy for a given wavelength to the value of maximum luminous efficacy. It is a dimensionless ratio. See ILLUMINATION; LUMINOUS EFFICACY; PHOTOMETRY. [G.A.Ho.]

**Luminous energy** The radiant energy in the visible region or quantity of light. It is in the form of electromagnetic waves, and since the visible region is commonly taken as extending 380–760 nanometers in wavelength, the luminous energy is contained within that region. It is equal to the time integral of the production of the luminous flux. See PHOTOMETRY. [R.C.Pu.]

**Luminous flux** The time rate of flow of light. It is radiant flux in the form of electromagnetic waves which affects the eye or, more strictly, the time rate of flow of radiant energy evaluated according to its capacity to produce visual sensation. The visible spectrum is ordinarily considered to extend from 380 to 760 nanometers in wavelength; therefore, luminous flux is radiant flux in that region of the electromagnetic spectrum. The unit of measure of luminous flux is the lumen. See PHOTOMETRY. [R.C.Pu.]

**Luminous intensity** The solid angular luminous flux density in a given direction from a light source. It may be considered as the luminous flux on a small surface normal to the given direction, divided by the solid angle (in steradians) which the surface subtends at the source of light. Since the apex of a solid angle is a point, this concept applies exactly only to a point source. The size of the source, however, is often extremely small when compared with the distance from which it is observed, so in practice the luminous flux coming from such a source may be taken as coming from a point. See CANDLEPOWER; PHOTOMETRY. [R.C.Pu.]

**Luminous paint** A type of paint that glows in the dark. Luminous paints may be either of the self-luminous type (energized by a radioactive salt) or of the type that requires preexcitation by an outside energy source such as light. Both types are made by incorporating luminescent material into the paint formulation. See LUMINESCENCE; PAINT. [C.C.K.; J.H.S.]

**Lung** Paired, air-filled respiratory sacs, usually in the anterior or anteroventral part of the trunk of most tetrapods. They lie within the coelom and are covered by peritoneum. In mammals they are within special chambers of the coelom known as pleural cavities and the peritoneum is termed pleura.

Amphibian lungs are often simple sacs, with only small ridges on the internal walls. In higher forms the lungs become more and more subdivided internally, thus increasing greatly the surface areas across which the respiratory exchange takes place. However, even in many reptiles the lungs may be quite simple. Birds have especially complex lungs with a highly differentiated system of tubes leading into and through them to the air sacs which are contained in many parts of the bird's body. Mammalian lungs are simpler, but in them the internal subdivision into tiny sacs or alveoli is extreme; there may be over 350,000,000 of them in one human lung.

In humans the two lungs lie within the chest, separated by the heart and mediastinum. The right lung has three lobes and the left lung two. A bronchus, an artery, and a vein enter each lung medially at the hilum; each branches again and again as it enters the lobules and smaller divisions of the lungs (see illustration). The terminal airways or bronchioles expand into small clusters of grapelike air cells, the alveoli. The alveolar walls consist of a single layer of epithelium and collectively present a huge surface.

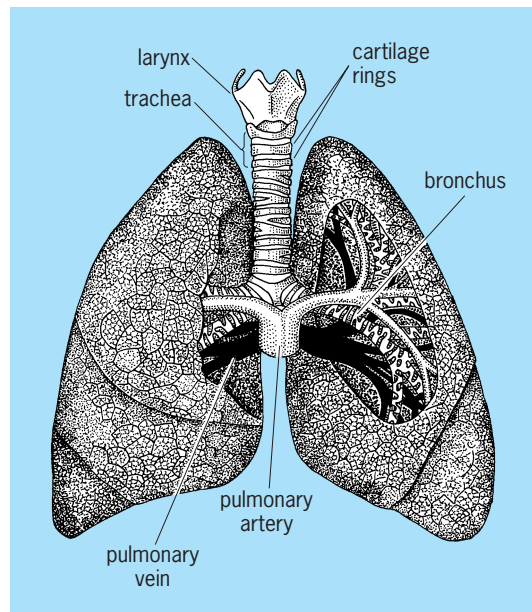

The human lung. (After T. I. Storer and R. L. Usinger, *General Zoology*, 4th ed., McGraw-Hill, 1965)

A small network of blood capillaries in the walls of the alveoli affords surfaces for the actual exchange of gases. See RESPIRATION; RESPIRATORY SYSTEM. [T.S.P.]

**Lupine** A cool-season legume with an upright stem, leaves divided into several digitate leaflets, and terminal racemes of pea-shaped blossoms. Three species, yellow, blue, and white, each named for the color of its blossoms, are cultivated as field crops; several hybrids are grown as ornamentals; and many species occur as wild plants. The yellow crop varieties are usually the earliest and smallest, the whites latest and largest. Field crop lupines have been grown in Europe since early Roman times as a soil-improving crop. The older varieties could not be used as forage since the plants contained a bitter, water-soluble, toxic alkaloid. However, since 1912, plant breeders have developed "sweet" varieties with only traces of alkaloid. The ornamental lupines are perennials unsuited to areas with hot summers. See BREEDING (PLANT); COVER CROPS; LEGUME; LEGUME FORAGES. [P.T.]

**Lutetium** A chemical element, Lu, atomic number 71, atomic weight 174.97, a very rare metal and the heaviest member of the rare-earth group. The naturally occurring element is made up of the stable isotope  $^{175}\text{Lu}$ , 97.41%, and the long-life  $\beta$ -emitter  $^{176}\text{Lu}$  with a half-life of  $2.1 \times 10^{10}$  years. See PERIODIC TABLE.

Lutetium, along with yttrium and lanthanum, is of interest to scientists studying magnetism. All of these elements form trivalent ions with only subshells which have been completed, so they have no unpaired electrons to contribute to the magnetism. Their radii with regard to the other rare-earth ions or metals are very similar so they form at almost all compositions either solid solutions or mixed crystals with the strongly magnetic rare-earth elements. Therefore, the scientist can dilute the magnetically active rare earths in a continuous manner without changing appreciably the crystal environment. See MAGNETOCHEMISTRY; RARE-EARTH ELEMENTS. [F.H.Sp.]

**Lychee** The plant *Litchi chinensis*, also called litchi, a member of the soapberry family (Sapindaceae). The fruit is a one-seeded berry. The thin, leathery, rough shell or pericarp of the ripe fruit is bright red in most varieties. Beneath the shell, completely surrounding the seed, is the edible aril or pulp.

It is a native of southern China, where it has been cultivated for more than 2000 years. It is grown in India, Union of South Africa, Hawaii, Burma, Madagascar, West Indies, Brazil, Honduras, Japan, Australia, and the southern United States. See SAPINDALES. [P.D.S./E.L.C.]

**Lychniscosa** An order of the subclass Hexasterophora in the class Hexactinellida. The parenchymal megascleres of these sponges are united to form a rigid framework. Examples of this order are *Aulocystis* and *Dactylocalyx*. See HEXACTINELLIDA; HEXASTEROPHORA. [W.D.H.]

**Lycophyta** A division (formerly Lycopodiophyta) of the subkingdom Embryobionta which represents one of two main lineages that evolved during the Early Devonian from the earliest land plants to develop vascular tissue and multiple sporangia. Integration of living and fossil taxa has allowed tentative reconstruction of the evolutionary history of the lycophyte group, which is generally regarded as monophyletic (includes all the descendants of a single putative ancestor). The division Lycophyta contains two classes: the extinct Zosterophyllopsida (zosterophylls) and the Lycopsidea (club-mosses), which contains 10 extant genera. See LYCOPSIDA; ZOSTEROPHYLLOPSIDA.

Living lycophytes are confined to the Lycopsidea and are of far less phenotypic diversity and ecological significance than the fossils; most are small-bodied rhizomatous herbs or tuberous pseudohierbs occupying moist niches of low interspecific competition. Their economic significance is confined to various industrial applications of the abundant, small, and unusually uniformly sized spores of *Lycopodium*. The extant genera represent perhaps half of the major lycopsid groups known in the fossil record.

The lycophytes have a small gametophyte that is morphologically distinct from, and physically independent of, the larger sporophyte. Gametophytes are either supraterranean and photosynthetic or subterranean and saprophytic. The primitive growth habit is unipolar; rhizomes periodically generate adventitious roots and aerial branches. Vegetative branches are small, nonwoody, dichotomously branched, and either naked or, more commonly, scattered with cortical projections. The primary xylem undergoes external maturation. Other key features of the Lycophyta are unvascularized, kidney-shaped eusporangia that are positioned laterally rather than terminating axes. The spores are released through distal lateral dehiscence slits.

The evolutionary history of the lycophytes generally is documented by increases in body size, vegetative complexity, and reproductive sophistication. [R.M.Ba.; W.A.DiM.]

**Lycopdiales** An order of the class Lycopsidea (club-mosses) that is evolutionarily positioned between two extinct orders. The Lycopdiales are more advanced than the Asteroxylales because their sporangia are unequivocally positioned on the upper surface of modified leaves, but less advanced than the Protolpidodendrales because they lack a uniquely lycopsid feature termed the ligule. All have steles with metaxylem toward the center of the axis, but otherwise show considerable variation. All are perennial nonwoody herbs. See ASTEROXYLALES; PROTOLEPIDODENDRALES.

The fossil record of lycopodialeans begins with *Baragwanathia*. Its earliest occurrence, in Australia, has been controversially dated as Late Silurian or Early Devonian. Unlike most other lycopsid orders, the range of variation observed among the fossils is well reflected by the extant genera. Eight genera (of approximately 350 extant species) are recognized: the widespread *Huperzia*, *Phlegmariurus*, *Lycopodium*, *Diphasiastrum*, *Pseudolycopodiella*, *Lycopodiella*, and *Palhinhaea*, together with the enigmatic antipodean endemic *Phylloglossum*.

*Huperzia* and *Phlegmariurus* are the most primitive of the living genera. They have non-rhizomatous aerial axes with undivided, star-shaped actinosteles. Sporangia are simple in construction and positioned on sporophylls that resemble leaves;

they do not form cones. In contrast, the remainder of the genera have rhizomatous growth and possess thin-walled sporangia and sporophylls that are aggregated into cones. *Lycopodium* and *Diphasiastrum* gametophytes share an annular meristem, and the stem vascular system is partially dissected into a plectostele. In *Pseudolycopodiella*, *Lycopodiella*, and *Palhinhaea*, the vascular system is further dissected into an annulus of apparently discrete but actually interconnected strands, and axial branching is more complex. Because gametophytes are lobed and occur on the soil surface, they are able to photosynthesize, thus reducing their dependence for nutrition on symbiotic mycorrhizal fungi. Also, the deciduous sporophytes of *Lycopodiella* and *Palhinhaea* develop from a protocorm and produce globose sporangia.

*Phlegmariurus* species grow hanging from other plants; *Pseudolycopodiella* and *Lycopodiella* are semiaquatics. The remaining genera are dominantly terrestrial. Lycopodiales tend to prefer habitats where interspecific competition is low; few club-moss species form a major proportion of the biomass in their preferred communities. Nonetheless, together they have a global distribution. Species-level diversity is greatest in the tropics, although a few species reach the Arctic Circle.

Lycopodiales have a large and long-lived diploid sporophyte, which alternates with the wholly physiologically independent, smaller, and generally shorter-lived haploid gametophyte. The sporophyte produces spores that are released from the sporangium and germinate to produce gametophytes, which in most genera are subterranean and rely for nutrition on mycorrhizal fungi. See LYCOPHYTA; LYCOPSIDA. [R.M.Ba.; W.A.DiM.]

**Lycopsida** A class (formerly Lycopodiopsida) of the division Lycopphyta. It probably evolved in the Early Devonian from a zosterophyllopid ancestor; all six constituent taxonomic orders had probably evolved by the end of the Devonian. See LYCOPHYTA; ZOSTEROPHYLLOPSIDA.

Since this early and rapid radiation, lycopsids have always been globally distributed, with peak diversity in the tropics. In terms of both species diversity and biomass, lycophytes dominated many Devonian and Carboniferous plant communities, including the classic coal-swamp forests. Living lycopsids are of far less phenotypic diversity and ecological significance than the fossils; most are small-bodied rhizomatous perennial herbs or tuberous pseudoherbs occupying moist niches of low interspecific competition. Many are polyploids.

Extant genera are relatively evenly distributed from a phylogenetic viewpoint. Fourteen representative genera of lycopsids belong to six orders, which either lack living species (Asteroxylales, Protolpidodendrales, Lepidodendrales) or possess them (Lycopodiales, Selaginellales, Isoetales). See ASTEROXYLALES; ISOETALES; LEPIDODENDRALES; LYCOPODIALES; PROTOLEPIDODENDRALES; SELAGINELLALES. [R.M.Ba.; W.A.DiM.]

**Lyme disease** A multisystem illness caused by the tick-borne spirochete *Borrelia burgdorferi*. The disease, also known as Lyme borreliosis, generally begins with a unique expanding skin lesion, erythema migrans, which is often accompanied by symptoms resembling those of influenza or meningitis. During the weeks or months following the tick bite, some individuals may develop cardiac and neurological abnormalities, particularly meningitis or inflammation of the cranial or peripheral nerves. If the disease is untreated, intermittent or chronic arthritis and progressive encephalomyelitis may develop months or years after primary infection. See NERVOUS SYSTEM DISORDERS.

The causative agent, *B. burgdorferi*, is a helically shaped bacterium with dimensions of 0.18–0.25 by 4–30 micrometers. Once thought to be limited to the European continent, Lyme borreliosis and related disorders are now known to occur also in North America, Russia, Japan, China, Australia, and Africa, where *B. burgdorferi* is maintained and transmitted by ticks of the genus *Ixodes*, namely *I. dammini*, *I. pacificus*, and possibly *I. scapularis* in the United States, *I. ricinus* in Europe, and *I. per-*

*sulcatus* in Asia. Reports of Lyme disease in areas where neither *I. dammini* nor *I. pacificus* is present suggest that other species of ticks or possibly other bloodsucking arthropods such as biting flies or fleas may be involved in maintaining and transmitting the spirochetes. See IXODIDES.

All stages of Lyme borreliosis may respond to antibiotic therapy. Early treatment with oral tetracycline, doxycycline, penicillin, amoxicillin, or erythromycin can shorten the duration of symptoms and prevent later disease. See ANTIBIOTIC.

Prevention and control of Lyme borreliosis must be directed toward reduction of the tick population. This can be accomplished through reducing the population of animals that serve as hosts for the adult ticks, elimination of rodents that are not only the preferred hosts but also the source for infecting immature ticks with *B. burgdorferi*, and application of tick-killing agents to vegetation in infested areas. Personal use of effective tick repellents and toxins is also recommended. See INFECTIOUS DISEASE; INSECTICIDE.

Lyme disease affects not only humans but also domestic animals such as dogs, horses, and cattle that serve as hosts for the tick vectors. Animals affected show migratory, intermittent arthritis in some joints similar to that observed in humans.

[W.Ba.; J.J.Ka.]

**Lymphatic system** A system of vessels in the vertebrate body, beginning in a network of exceedingly thin-walled capillaries in almost all the organs and tissues except the brain and bones. This network is drained by larger channels, mostly coursing along the veins and eventually joining to form a large vessel, the thoracic duct, which runs beside the spinal column to enter the left subclavian vein at the base of the neck. The lymph fluid originates in the tissue spaces by filtration from the blood capillaries. While in the lymphatic capillaries it is clear and watery. However, at intervals along the larger lymphatic vessels, the lymph passes through spongelike lymph nodes, where it receives great numbers of cells, the lymphocytes, and becomes turbid.

The lymph nodes of mammals vary in number, size, form, and structure in different species. The amount of connective tissue of the lymph nodes, that is, the degree of development of the capsule and trabeculae, also varies in different mammals. Other lymphoid organs include the tonsils, thymus gland, and spleen, and in certain classes and groups of animals, structures which are confined to such groups, for instance, the bursa of Fabricius in the birds, a diverticulum from the lower end of the alimentary canal. See SPLEEN; THYMUS GLAND; TONSIL.

The functions of the lymphatics are to remove particulate materials such as molecular proteins and bacteria from the tissues; to transport fat from the intestine to the blood; to supply the blood with lymphocytes; to remove excess fluid; also to return to the bloodstream the protein which has escaped from the blood capillaries. Basically, the composition of lymph closely resembles that of the plasma; lymph contains all of the types of protein found in plasma, but in lower concentration. The composition of lymph varies to some extent from one part of the body to another. Thus, the lymph from the liver contains more protein than that from the skin.

The lymph nodes serve as filtering-out places for foreign particles, including microorganisms, because the lymph comes into intimate contact with the many phagocytic cells of the sinusoids. These macrophages are of both the fixed and free wandering types. In addition to the phagocytic function, lymphoid tissue produces antibodies, although the actual process of antibody formation is not well understood. See CELLULAR IMMUNOLOGY; PHAGOCYTOSIS. [W.An.]

**Lymphoma** Any of a group of malignant neoplasms derived from cells endogenous to lymphoid tissue. Lymphomas are grouped into two major categories: Hodgkin's disease and non-Hodgkin's lymphomas. Lymphomas usually originate in the lymph nodes located throughout the body, but they can arise

from lymphoid tissue that does not form distinct nodes, such as that in the gastrointestinal tract or lung. Determination of the specific variety of Hodgkin's disease or non-Hodgkin's lymphoma was formerly based on the appearance of the cells when examined under a light microscope. Identification now relies on the nature of the cells with respect to certain substances (antigens) that they have on their surface or within their cytoplasm. For clinical purposes, lymphomas are categorized into three grades, low, intermediate, and high, with low-grade lymphomas having the best prognosis. See HODGKIN'S DISEASE.

The etiology of most lymphomas is unknown. In experimental and domestic animals, viruses can cause lymphomas. Burkitt's lymphoma, a type of lymphoma that is rare in the United States but relatively common in children of central Africa, is thought to be caused by Epstein-Barr virus, a member of the herpes virus group. A form of T-cell lymphoma that has been identified in southern Japan has been attributed to a retrovirus referred to as human T-cell lymphoma-leukemia virus type 1 (HTLV-1). See EPSTEIN-BARR VIRUS; RETROVIRUS.

Patients with lymphomas may have painless swelling of various lymph nodes, such as those in the neck or near the armpit. Some patients, especially those with Hodgkin's disease, are referred to as B symptoms (fever, malaise, and weight loss). If the lymphoma originates in lymphoid tissue outside the lymph nodes, abdominal pain will signal lymphoma of the gastrointestinal tract and a cough will point to lymphoma of the lung.

Lymph nodes involved by lymphoma are characteristically enlarged. They may be firm and have a consistency resembling fish flesh. In rare cases they are rock hard and they may show areas of cellular death (necrosis).

By using modern immunologic techniques, most lymphomas can be identified as B-cell, T-cell, or M-cell type; about 90% of lymphomas are of B-lymphocyte origin. A T-cell lymphoma that occurs in the skin, referred to as mycosis fungoides, is a lymphoma of a specific subtype of lymphocyte labeled a T-helper/inducer lymphocyte. It is that subtype that is depleted in patients with acquired immune deficiency syndrome (AIDS). See ACQUIRED IMMUNE DEFICIENCY SYNDROME (AIDS); CELLULAR IMMUNOLOGY; IMMUNOLOGY.

Most diagnoses of lymphoma are made by surgical removal of a lymph node. Once a diagnosis of lymphoma is established, the patient usually must undergo a series of staging studies. These include a liver-spleen scan to determine if those organs are involved as well as a bone marrow biopsy to check for the presence of malignant cells. See ONCOLOGY.

The treatment of lymphomas depends on the type of lymphoma diagnosed. Lymphomas in the low-grade group are usually not treated, since treatment does not increase life expectancy. Patients who have Hodgkin's disease or who have intermediate or high-grade non-Hodgkin's lymphoma are usually treated with chemotherapy with or without concurrent radiation. Most cases of Hodgkin's disease and more than half the cases of intermediate and high-grade non-Hodgkin's lymphomas are potentially curable. Persons with low-grade non-Hodgkin's lymphomas usually have a life expectancy of 7-10 years, although some live considerably longer. Treatment protocols are now being developed for the low-grade lymphomas in the hope of increasing life expectancy. See CHEMOTHERAPY; LYMPHATIC SYSTEM. [S.P.H.]

**Lyophilization** Solvent removal from the frozen state by sublimation; commonly referred to as freeze-drying. Lyophilization is accomplished by freezing the material to be dried below its eutectic point and then providing the latent heat of sublimation. Precise control of heat input permits drying from the frozen state without product melt-back. In practical application, the process is accelerated and more precisely controlled under reduced pressure conditions. [S.C.T.]

**Lyra** The Lyre, in astronomy, a summer constellation, small but important. Lyra has a first-magnitude star, Vega, a naviga-

tional star and the most brilliant star in this part of the sky. Vega forms, with two faint stars to the east, an almost perfect equilateral triangle. The southern one in turn forms, with three brighter stars to the south, an approximate parallelogram. The resulting overall figure resembles a tortoise more than a stringed musical instrument. However, according to legend, Mercury made the first lyre from a turtleshell by placing strings across it. Hence the two different representations are not incompatible. See CONSTELLATION. [C.-S.Y.]

**Lysenkoism** A school of pseudoscience that flourished in the Soviet Union from the early 1930s to the mid-1960s, in violent opposition to traditional biology. The founder was T. D. Lysenko. He proclaimed a revolutionary fusion of agronomy and biological science, and therefore called his creation agrobiolgy, not Lysenkoism, the term that was used by his opponents.

A coherent outline of Lysenko's doctrines is hardly possible. The inheritance of acquired characters is often considered his central doctrine, though he came to it belatedly, as an offshoot of his original concept: "vernalization," or *iarovizatsiia*, a word that he coined. At first he used the word to describe the transformation of winter-habited wheat into spring habit as a result of moistening and chilling the seed before planting. He denounced the specialists who told him that the phenomenon had been observed and studied long before he put a new name on it, and he went on to extend the new term to almost any kind of seed treatment, and also to a stage in plant development that he claimed to have discovered. Lysenko came into conflict with scientific plant breeders and geneticists when he applied his concept of vernalization to hybridization and the selection of improved varieties. He came to endorse some of the crudest versions of the ancient belief in the inheritance of acquired characters. For example, he declared that domesticated plants are transformed into weeds by the hostile environment of poorly tended fields. See GENETICS; ORGANIC EVOLUTION; VERNALIZATION. [D.J.]

**Lysin** A term used to describe substances that will disrupt a cell, with the release of some of its constituents. Unless the damage is minor, this action leads to the death of the cell. Lysins vary in the range of host species whose cells they will attack and in their requirements for accessory factors for lysis; the immune lysins are strictest in their requirements. Erythrocytes are lysed by a wide variety of chemicals, including water and hypertonic salt solutions, which displace the osmotic pressure from that of isotonicity. They are also susceptible to surface-active substances, such as saponin. Many bacteria, such as the staphylococcus and the streptococcus, elaborate one or more hemolysins that will lyse erythrocytes from certain, although not all, species of animals. See LYTIC REACTION. [H.P.T.]

**Lysogeny** Almost all strains of bacteria are lysogenic; that is, they have the capacity on rare occasions to lyse with the liberation of particles of bacteriophage (see illustration). Such particles can be detected by their ability to form plaques (colonies of bacteriophage) on lawns of sensitive (indicator) bacteria. The genetic determinant of the capacity of lysogenic bacteria to produce bacteriophage is a repressed phage genome (provirus) which exists in the bacterium in one of two states: (1) integrated into the bacterial chromosome (most cases), or (2) occupying some extra-chromosomal location (rare cases).

Bacteriophages which have the potential to exist as provirus are called temperate phages. When the provirus is integrated into the bacterial genome, it is called prophage. When the germinal substance (deoxyribonucleic acid or deoxyribonucleoprotein) of certain temperate phages enters a sensitive bacterium, the outcome may be death (lysis) for the bacterium as a result of phage multiplication, or it may result in the integration of the phage nucleic acid into the host genome (as a prophage), with the formation of a stable lysogenic bacterium. The lysogenic strain is designated by the name of the sensitive strain followed, in

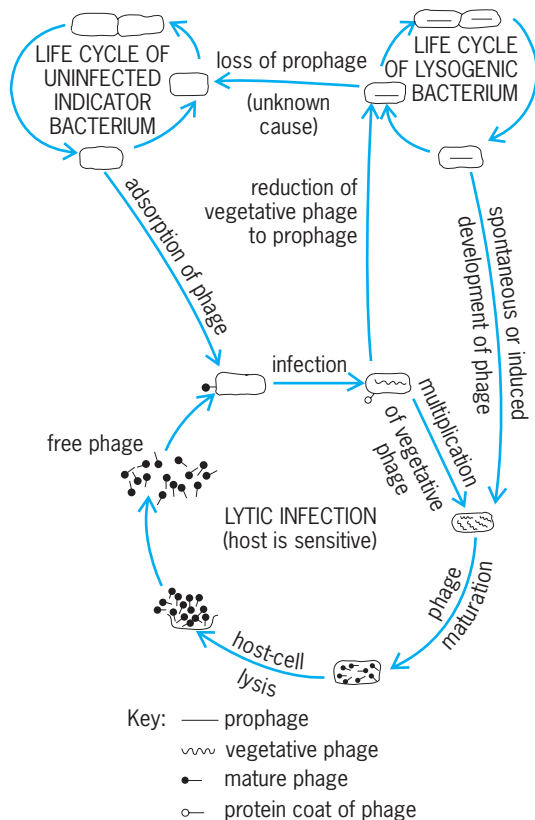

**Life cycles of phage and bacterial host.** (After E. Jawetz, J. L. Melnick, and E. A. Adelberg, *Review of Medical Microbiology*, 2d ed., Lange, 1956)

parentheses, by the strain of lysogenizing phage, for example, *Escherichia coli* ( $\lambda$ ). Such a bacterium differs from its nonlysogenic ancestor in one very special way: It is immune to lysis by phage homologous to its carried prophage. See BACTERIOPHAGE.

[L.B.]

**Lysorophia** An order of elongated, swimming, and burrowing extinct lepospondylous amphibians. The single family Lysorophidae is best known from the upper Carboniferous and lower Permian genus *Lysorophus*. Fossils of this animal commonly are found in clusters of 100 or more individuals, which represent the burrowing, estivating, and possibly reproductive phases of the life cycle.

Body lengths of individuals found in these clusters range from about 3 to 30 in. (7.5 to 75 cm) and appear to represent different growth stages. The trunk consisted of about 100 vertebrae and was followed by a short flattened tail of about 15 more. Ribs were stout, long, and recurved, giving the trunk a robust snakelike appearance. Limbs were vestigial. The skull was small relative to the trunk. The jaws were set with a small number of sharp, conical teeth. Large branchial elements were present, suggesting the presence of external gills.

The closest living counterpart of *Lysorophus* is *Amphiuma*, a predaceous, aquatic urodele. Like *Amphiuma*, *Lysorophus* probably fed on small vertebrates and invertebrates, but the small gape of its mouth likely limited prey size severely. *Lysorophus* lived in areas subject to strong seasonality, to which its habit of estivation was an adaptation. See AMPHIBIA; LEPOSPONDYLI.

[E.C.O.]

**Lysozyme** A digestive structure found within virtually all types of animal cells. Lysozyme sizes, microscopic appearances, and other properties vary among different cell types and circumstances owing, in part, to differences in their functions and

states. Typical lysosomes are roughly spherical or elongate bodies with largest dimensions of 0.1–1 micrometer or greater; tens to hundreds are present in a single cell.

Each lysosome is bounded by a membrane and contains several dozen different species of digestive enzymes, each of which can sever particular chemical bonds found in natural materials. Most lysosomal enzymes function best in an acid environment. This acidification is accomplished by a proton pump, built into the membrane surrounding the lysosome, which effects the transport of hydrogen ions into the lysosomes. See CELL MEMBRANES; ENZYME; ION TRANSPORT.

Lysozymes digest materials taken into the cell from the outside (a process known as heterophagy) as well as other materials that originate in the cell's own cytoplasm (autophagy). The materials to be digested are ultimately incorporated into the same membrane-bounded compartments as the lysosomal enzymes. Selective degradative products can pass out of the lysosome by crossing the membrane, but the enzymes cannot. This sequestration, which protects the cell, persists because the admixture of the enzymes and the materials to digest takes place through fusion of membrane-bounded compartments.

In heterophagy, the cell takes up particles or molecules by the process of endocytosis, engulfing them in membrane-bounded vesicles or vacuoles that are formed at the cell surface. The endocytosed material enters lysosomes via intermediate membrane-bounded compartments known as endosomes. In higher animals, heterophagy is most prominently used by leukocytes and macrophages. These specialized cells endocytose invasive microorganisms and use endocytosis in clearing debris and disposing of dead or senescent cells. See CELL SENESCENCE AND DEATH; ENDOCYTOSIS; PHAGOCYTOSIS.

In autophagy, cells segregate regions of their own cytoplasm within compartments that come to be bounded by single membranes and to receive lysosomal enzymes. Autophagic lysosomes take part in the remodeling of cells as part of the processes of development and during stressful circumstances. They also participate, along with nonlysosomal enzymes and heterophagic lysosomes, in normal turnover of the body's constituents—the balanced synthesis and destruction through which most molecules of most cells are replaced by new molecules.

Genetic defects in lysosomal enzymes and related proteins are known to be associated with a large number of rare disorders in humans and animals (such as Tay-Sachs disease and Niemann-Pick disease type C). Defective lysosomal function leads to storage of particular classes of molecules that cannot be degraded and, in long-lived cells such as neurons, to complex pathogenic cascades with widespread impact on endosomal-lysosomal function, membrane trafficking, and signal transduction. Such disorders are most often fatal. Lysosomes or prelysosomal structures also have been “adopted” as intracellular homes by certain pathogenic microorganisms that avoid or survive the attacks of the lysosomal system. Some strains of viruses, and toxins such as the one responsible for diphtheria, may use endosomes as their route of entry into the cell, penetrating through the endosomal membrane into the surrounding cytoplasm. [E.Ho.; S.U.W.]

**Lysozyme** An enzyme that was first identified and named by Alexander Fleming, who recognized its bacteriolytic properties. It has been designated muramidase, since it is known to facilitate the hydrolysis of a  $\beta$ -1-4-glycosidic bond between *N*-acetylglucosamine and *N*-acetylmuramic acid in bacterial cell walls; it also hydrolyzes similar glycosidic bonds in fragments of chitin. The most detailed studies have been performed on hen egg-white lysozyme, because this product is readily available. However, enzymes possessing lysozyme activity have been found in bacteria, bacteriophages, and plants and in human leukocytes, nasal secretions, saliva, and tears. The three-dimensional structure of the protein has been defined by x-ray crystallography. Additional data are available for the amino acid sequence of human lysozyme and also for a bacteriophage

lysozyme. These results have given rise to speculation concerning the origin of the lysozyme gene during evolution.

Certain enzyme functions appear to be widely distributed in nature. The amino acid sequences of proteins possessing these functions reflect changes that have occurred in the course of evolution. The structures of lysozymes from three sources, distant in evolution, have been carefully examined. Hen egg lysozyme has no structural elements in common with bacteriophage lysozyme. Thus it must be concluded that these two enzymes emerged in evolution completely independent of each other. Preliminary studies of the structure of human lysozyme reveal considerable similarity to the structure of hen egg lysozyme. In fact, the resemblance is so great that it can be concluded that these proteins evolved from the same gene and have an essentially identical mechanism of action.

The amino acid composition of  $\alpha$ -lactalbumin, a protein in cow's milk, is quite similar to that of hen egg lysozyme; nearly half of the amino acid positions in these two proteins are identical. It is postulated from a comparison of the amino acid sequences of hen egg lysozyme, human lysozyme, and  $\alpha$ -lactalbumin that a "deletion" occurred during evolution in the  $\alpha$ -lactalbumin gene with a resulting loss of information for two amino acids near position 13. In addition, positions 10, 12, and 19 in human lysozyme and  $\alpha$ -lactalbumin are identical, so it is possible to see remnants of a common ancestral gene in all three proteins. These data illustrate the manner in which amino acid sequence information is being used as a molecular reflection of the paths of evolution. See ENZYME; PROTEINS, EVOLUTION OF.

[R.E.Ca.]

**Lyssacinosa** An order of the subclass Hexasterophora in the class Hexactinellida. In these sponges the parenchymal megascleres are typically free and unconnected but are sometimes secondarily united. *Asconema*, *Euplectella*, *Rossella*, and *Rhabdocalyptus* are examples of this order. See HEXACTINELLIDA; HEXASTEROPHORA. [W.D.H.]

**Lytic infection** Infection of a bacterium by a bacteriophage with subsequent production of more phage particles and lysis, or dissolution, of the cell. The viruses responsible are commonly called virulent phages. Lytic infection is one of the two major bacteriophage-bacterium relationships, the other being lysogenic infection. See BACTERIOPHAGE; LYSOGENY. [P.B.C.]

**Lytic reaction** A term used in serology to describe a reaction that leads to the disruption or lysis of a cell. The best example is the lysis of sheep red blood cells by specific antibody and complement in the presence of  $\text{Ca}^{2+}$  by (calcium ion) and  $\text{Mg}^{2+}$  (magnesium ion), a reaction that forms the indicator system of the standard Wassermann test for syphilis, as well as other complement-fixation reactions. In this example lysis results in the release of cellular hemoglobin into the medium; the reaction may be followed by visual or instrumental estimation of the decreased cell turbidity or the increased color of the medium due to the free hemoglobin. The initiation of lysis by complement can apparently proceed after the attachment of only one molecule of IgM or two molecules of IgG antibody to the red blood cell. IgM and IgG are both immunoglobulins. See ANTIBODY; COMPLEMENT; COMPLEMENT-FIXATION TEST; SEROLOGY. [H.P.T.]

# M

**Macadamia nut** The fruit of a tropical evergreen tree, *Macadamia ternifolia*, native to Queensland and New South Wales and now grown commercially in Australia and Hawaii. The trees bear many small white or pinkish flowers in drooping racemes, each of which may mature from 1 to 20 fruits. These

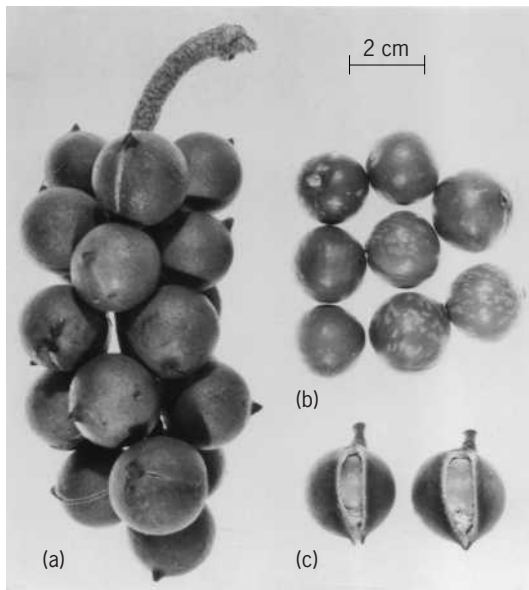

*Macadamia integrifolia*. (a) Mature nuts. (b) Nuts without husks. (c) Nuts in husk showing method of dehiscence. (After R. A. Jaynes, ed., *Handbook of North American Nut Trees*, Humphrey Press, 1969)

consist of a leathery outer husk (pericarp) which splits along one side at maturity, freeing the very hard-shelled, nearly round seed or nut. Two types of nuts are recognized, the most important commercially having a smooth shell and the other having a rough shell and sometimes referred to another species, *M. integrifolia* (see illustration). [L.H.MacD.]

**Mach number** In the flow of a fluid, the ratio of the flow velocity,  $V$ , at a given point in the flow to the local speed of sound,  $a$ , at that same point. That is, the Mach number,  $M$ , is defined as  $V/a$ . In a flowfield where the properties vary in time and/or space, the local value of  $M$  will also vary in time and/or space. In aeronautics, Mach number is frequently used to denote the ratio of the airspeed of an aircraft to the speed of sound in the freestream far ahead of the aircraft; this is called the freestream Mach number. The Mach number is a convenient index used to define the following flow regimes: (1) subsonic, where  $M$  is less than 1 everywhere throughout the flow; (2) supersonic, where  $M$  is greater than 1 everywhere throughout the flow; (3) transonic, where the flow is composed of mixed regions of locally subsonic and supersonic flows, all with local Mach numbers near 1, typically between 0.8 and 1.2; and (4) hypersonic, where (by arbitrary definition)  $M$  is 5 or greater.

Perhaps the most important physical aspect of Mach number is in the completely different ways that disturbances propagate in subsonic flow compared to that in a supersonic flow. Shock waves are a ubiquitous aspect of supersonic flows. See COMPRESSIBLE FLOW; SHOCK WAVE; SONIC BOOM; SUPERSONIC FLIGHT. [J.D.A.]

**Machine** A combination of rigid or resistant bodies having definite motions and capable of performing useful work. The term mechanism is closely related but applies only to the physical arrangement that provides for the definite motions of the parts of a machine. For example, a wristwatch is a mechanism, but it does no useful work and thus is not a machine. Machines vary widely in appearance, function, and complexity from the simple hand-operated paper punch to the ocean liner, which is itself composed of many simple and complex machines. See MACHINERY; SIMPLE MACHINE. [R.M.Ph.]

**Machine key** Generally, a device used to prevent relative rotation of a shaft and the member to which it is connected, such as the hub of a gear, pulley, or crank. Many types of keys (see illustration) are available, and the choice in any installation depends on such factors as power requirements, tightness of fit, stability of connection, and cost.

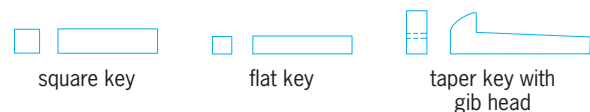

Types of keys. (After P. H. Black and O. E. Adams, Jr., *Machine Design*, McGraw-Hill, 3d ed., 1968)

Square keys are common in general industrial machinery. Flat keys are used where added stability of the connection is desired, as in machine tools. Square or flat keys may be of uniform cross section or they may be tapered. In tapered keys the width is uniform and the height of the key tapers. Tapered keys may have gib heads to facilitate removal. Other types of keys have been developed for special applications. [P.H.B.]

**Machinery** A group of parts arranged to perform a useful function. Normally some of the parts are capable of motion; others are stationary and provide a frame for the moving parts. The terms machine and machinery are so closely related as to be almost synonymous; however, machinery has a plural implication, suggesting more than one machine. Common examples of machinery include automobiles, clothes washers, and airplanes; machinery differs greatly in number of parts and complexity.

Some machinery simply provides a mechanical advantage for human effort. Other machinery performs functions that no human being can do for long-sustained periods. See MACHINE; MECHANICAL ENGINEERING; SIMPLE MACHINE. [R.S.S.]

**Machining** An operation that changes the shape, surface finish, or mechanical properties of a material by the application of special tools and equipment. Machining almost always is a process where a cutting tool removes material to effect the

desired change in the workpiece. Typically, powered machinery is required to operate the cutting tools. See PRODUCTION METHODS.

Although various machining operations may appear to be very different, most are very similar: they make chips. These chips vary in size from the long continuous ribbons produced on a lathe to the microfine sludge produced by lapping or grinding. These chips are formed by shearing away the workpiece material by the action of a cutting tool. Cylindrical holes can be produced in a workpiece by drilling, milling, reaming, turning, and electric discharge machining. Rectangular (or nonround) holes and slots may be produced by broaching, electric discharge machining, milling, grinding, and nibbling. Cylinders may be produced on lathes and grinders. Special geometries, such as threads and gears, are produced with special tooling and equipment utilizing the turning and grinding processes mentioned above. Polishing, lapping, and buffing are variants of grinding where a very small amount of stock is removed from the workpiece to produce a high-quality surface.

In almost every case, machining accuracy, economics, and production rates are controlled by the careful evaluation and selection of tooling and equipment. Speed of cut, depth of cut, cutting-tool material selection, and machine-tool selection have a tremendous impact on machining. In general, the more rigid and vibration-free a machining tool is, the better it will perform. Jigs and fixtures are often used to support the work-piece. Since it relies on the plastic deformation and shearing of the workpiece by the cutting tool, machining generates heat that must be dissipated before it damages the workpiece or tooling. Coolants, which also acts as lubricants, are often used.

To increase the life and speed of cutting tools, they are often coated with a thin layer of extremely hard material such as titanium nitride or zirconium nitride. These materials, which are applied over the cutting edges, provide excellent wear resistance. They are also brittle, so they rely on the toughness of the underlying cutting tool to support them. Coated tools are more expensive than conventional tools, but they can often cut at much higher rates and last significantly longer. When used properly on sufficiently rigid machine tools, they are far more economical than conventional tooling. See METAL COATINGS. [J.R.C.B.]

**Mackerel** A fish which is a member of the order Perciformes, family Scombridae. There are about 50 carnivorous species found in the middle layer or near the surface of tropical and temperate seas. Mackerel are characterized by a long slender body, pointed head, and large mouth.

*Scomber scombrus*, the common mackerel, is an important fish commercially. It is a migratory species found on both sides of the North Atlantic. The Pacific mackerel (*Pneumatophorus diego*) is also an important commercial fish but differs from the common mackerel in having a swim bladder. The American Spanish mackerel (*Scomberomorus maculatus*) is a choice food fish. See PERCIFORMES. [C.B.C.]

**Macrocyclic compound** An organic compound that contains a large ring. In the organic chemistry of alicyclic compounds, a closed chain of 12 carbon (C) atoms is usually regarded as the minimum size for a large ring; crown ethers are similarly defined. Macrocyclic compounds may be a single, continuous thread of atoms, as in cyclododecane  $[(CH_2)_{12}]$ , or they may incorporate more than one strand or other ring systems (subcyclic units) within the macrocycle or macroring. In addition, macrocycles may be composed of aromatic rings that confer considerable rigidity upon the cyclic system. These aromatic rings may be joined together or coupled by spacer units consisting of one or more carbon atoms. See AROMATIC HYDROCARBON.

**Classes of macrocyclic polyethers.** Crown ethers are generally composed of repeating ethylene ( $CH_2CH_2$ ) units separated by noncarbon atoms such as oxygen (O), nitrogen (N), sulfur (S), phosphorus (P), or silicon (Si). By far, the most common het-

eroatom present in the macrorings of crowns  $[X \text{ in } (XCH_2CH_2)_n]$  is oxygen; but as more intricate structures are prepared, nitrogen, sulfur, phosphorus, silicon, or siloxy residues are becoming much more common.

By adding a third strand to the simple macrocyclic polyethers, three-dimensional compounds based on the crown framework are formed. Typically, two of the oxygen atoms across the ring from each other are replaced by nitrogens, and a third ethyleneoxy chain is attached to them. Known as cryptands, these structures completely encapsulate cations smaller than their internal cavities and strongly bind the most similar in size.

Two crown ether rings may be held together by a crown-ether-like strand to give a bicyclic cryptand. These have sometimes been referred to as ditopic receptors because they possess two distinct binding sites.

Lariat ethers, spherands, calixarenes, cavitands, and carcerands are other types of macrocyclic compounds, all of which are capable of encapsulating "guest" molecules in their interior cavities.

Cyclophane is the name given to macrocyclic compounds that contain organic (usually aromatic) rings as part of a cavity-containing structure. The first such compound was [2.2]-paracyclophane. In it, two benzene rings are joined by ethylene ( $CH_2CH_2$ ) chains in their para positions. See CYCLOPHANE.

**Complexation phenomena.** It is the ability of these macrocyclic host compounds to complex a variety of guest species that makes these structures interesting. A crown ether can be described as a doughnut with an electron-rich and polar hole and a greasy or lipophilic (hydrophobic) exterior. As a result, these compounds are usually quite soluble in organic solvents but accommodate positively charged species in their holes.

A variety of organic cations have been found to complex with crown ethers and related hosts. It has been suggested that for a host-guest interaction to occur, the host must have convergent binding sites and the guest must have divergent sites. This is illustrated by the interaction between optically active dibinaphtho-22-crown-6 and optically active phenethylammonium chloride. The crown ether oxygen atoms converge to the center of a hole and the ammonium hydrogens diverge from nitrogen. Three complementary O—H—N hydrogen bonds stabilize the complex. In this particular case, different steric interactions between the optically active crown and the enantiomers of the complex permit resolution of the salt.

Other organic cations have also been complexed, either by insertion of the charged function in the crown's polar hole or by less distinct interactions observed in the solid state. See COORDINATION CHEMISTRY; COORDINATION COMPLEXES.

**Applications.** The striking ability of neutral macrocyclic polyethers to complex with alkali and alkaline-earth cations as well as a variety of other species has proved of considerable interest to the chemistry community. Crown ethers may complex the cation associated with an organic salt and cause separation of the ions. In the absence of cations to neutralize them, many anions show considerably enhanced reactivity. See ORGANIC REACTION MECHANISM.

One of the important modern developments in synthetic chemistry was the use of the phase-transfer technique. Nucleophiles such as cyanide are often insoluble in media that dissolve organic compounds with which they react. Thus 1-bromooctane may be heated in the presence of sodium cyanide for days with no product formation. When a crown ether is added, two things change. First, solubility is enhanced because the crown wraps about the cation, making it more lipophilic. This, in turn, makes the entire salt more lipophilic. Second, by solvating the cation, the association between cation and anion and the interactions with solvent are weakened, thus activating the anion for reaction. This approach has been used to assist the dissolution of potassium permanganate ( $KMnO_4$ ) in benzene in which solvent permanganate is a powerful oxidizing agent. One striking example of solubilization is the displacement of chloride ( $Cl^-$ ) by



fluoride (F<sup>-</sup>) in dimethyl 2-chloroethylene-1,1-dicarboxylate by using the KF complex of dicyclohexano-18-crown-6. In this reaction, a crown provides solubility for an otherwise insoluble or marginally soluble salt. Use of crowns to transfer a salt from the solid phase into an organic phase is often referred to as solid-liquid phase-transfer catalysis. See CATALYSIS; PHASE-TRANSFER CATALYSIS.

Since crown ethers and related species complex cations selectively, they can be used as sensors. Crowns have been incorporated into electrodes for this purpose, and crowns having various appended chromophores have been prepared. When a cation is bound within the macroring, a change in electron density is felt in the chromophore. The chromophores are often nitroaromatic residues and therefore highly colored. The color change that accompanies complexation can be easily detected and quantitated. See ION-SELECTIVE MEMBRANES AND ELECTRODES. [G.W.G.]

**Macrodasyida** An order of the phylum Gastrotricha. They inhabit marine or brackish waters, seldom fresh waters. Some do not exceed 0.5 mm (0.02 in.) in length, and most are not more than 1–1.5 mm (0.04–0.06 in.); these live in clean to detritus-rich marine sands of littoral or sublittoral areas. All have front and rear groups of adhesive tubes; most also have tubes along their sides. Some have cuticular thickenings or scales or hooks. *Turbanella* and *Tetranchyroderma* are the most common and most abundant of macrodasyids, with numbers of 50–100 per cubic centimeter of sand (800–1600 per cubic inch) not being unusual. See GASTROTRICHA. [W.D.Hu.]

**Macroevolution** Large-scale patterns and processes in the history of life, including the origins of novel organismal designs, evolutionary trends, adaptive radiations, and extinctions. Macroevolutionary research is based on phylogeny, the history of common descent among species. The formation of species and branching of evolutionary lineages mark the interface between macroevolution and microevolution, which addresses the dynamics of genetic variation within populations. Phylogenetic reconstruction, the developmental basis of evolutionary change, and long-term trends in patterns of speciation and extinction among lineages constitute major foci of macroevolutionary studies.

**Phylogenetic reconstruction.** Phylogenetic relationships are revealed by the sharing of evolutionarily derived characteristics among species, which provides evidence for common ancestry. Shared derived characteristics are termed synapomorphies, and are equated by many systematists with the older concept of homology. Characteristics of different organisms are homologous if they descend, with some modification, from an equivalent characteristic of their most recent common ancestor. Closely related species share more homologous characteristics than do species whose common ancestry is more distant. Species are grouped into clades according to patterns of shared homologies. The clades form a nested hierarchy in which large clades are subdivided into smaller, less inclusive ones, and are depicted by a branching diagram called a cladogram. A phylogenetic tree is a branching diagram, congruent with the cladogram, that represents real lineages of past evolutionary history.

A cladogram or phylogenetic tree is necessary for constructing a taxonomy, but the principles by which higher taxa are recognized remain controversial. The traditional evolutionary taxonomy of G. G. Simpson recognizes higher taxa as units of adaptive evolution called adaptive zones. Species of an adaptive zone share common ancestry, and distinctive morphological or behavioral characteristics associated with use of environmental resources. Higher taxa receive Linnean categorical ranks (genus, family, order, and so forth) reflecting the breadth and distinctness of their adaptive zones. All taxa must have a single evolutionary origin, which means that the taxon must include the most recent common ancestor of all included species. A taxon is monophyletic if it contains all descendants of the group's most

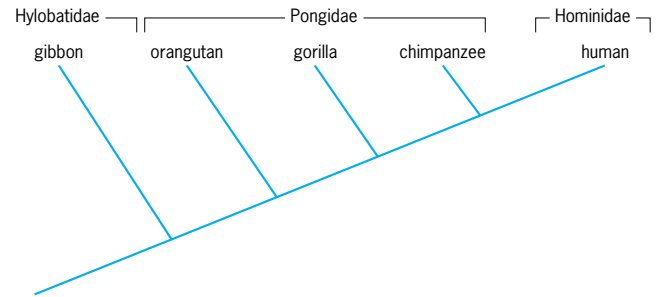

**Phylogenetic relationships of anthropoid primates showing traditional family-level taxa. All apes and humans together form a monophyletic group. The family Pongidae is paraphyletic, and therefore considered invalid by cladistic taxonomists. (After C. P. Hickman, Jr., L. S. Roberts, and A. Larson, *Integrated Principles of Zoology*, 9th ed., 1993)**

recent common ancestor, or paraphyletic if some descendants of the group's most recent common ancestor are excluded because they have evolved a new adaptive zone. For example, evolutionary taxonomy of the anthropoid primates groups the orangutan, gorilla, and chimpanzee in the paraphyletic family Pongidae and the humans in the monophyletic family Hominidae. Although the humans and chimpanzees share more recent common ancestry than either does with the gorilla or orangutan, the chimpanzees are grouped with the latter species at the family level and the humans are placed in a different family because they are considered to have evolved a new adaptive zone. The Hominidae and Pongidae together form a monophyletic group at a higher level (see illustration). See ANIMAL SYSTEMATICS.

Cladistic taxonomy or phylogenetic systematics accepts only monophyletic taxa because these alone are considered natural units of common descent. Linnean rankings are considered unimportant. Taxa recognized using both the Simpsonian and cladistic taxonomies are standardly used in macroevolutionary analyses of extinction and patterns of diversity through time. The Simpsonian versus cladistic taxonomies often lead to fundamentally different interpretations, however. For example, extinction of a paraphyletic group, such as dinosaurs, would be considered pseudoextinction by cladists because some descendants of the group's most recent common ancestor survive. Birds are living descendants of the most recent common ancestor of all dinosaurs. The dinosaurs as traditionally recognized, therefore, do not form a valid cladistic taxon. See AVES; DINOSAUR; PHYLOGENY.

**Developmental processes.** Comparative studies of organismal ontogeny are used to find where in development the key features of higher taxa appear and how developmental processes differ between taxa. Evolutionary developmental biologists denote the characteristic body plans of taxa by the term Bauplan. The major characteristics of animal phyla and their developmental and molecular attributes appear to have arisen and stabilized early in the history of life, during the Cambrian Period. Subsequent evolutionary diversification builds upon the Bauplan established early in animal evolution. See CAMBRIAN.

Particularly important to the evolutionary diversification of life are historical processes that generate change by altering the timing of organismal development, a phenomenon called heterochrony. Heterochronic changes can produce either pedomorphic or paeramorphic results. Pedomorphosis denotes the retention of preadult characteristics of ancestors in the adult stages of descendants; peramorphosis is the opposite outcome, in which the descendant ontogeny transcends that of the ancestor, adding new features at the final stages. Heterochronic changes can be produced by changing the rates of developmental processes or the times of their onset or termination.

Developmental dissociation occurs when different kinds of heterochronic change alter the development of different parts

of the organism independently. Extensive dissociation can fundamentally restructure organismal ontogeny, producing ontogenetic repatterning. However, it is rare that a single heterochronic transformation affects all parts of the organism simultaneously. For most taxa, novel morphologies are produced by a mosaic of different heterochronic processes and by changes in the physical location of developmental events within the organism.

**Long-term trends.** Traditional Darwinian theory emphasizes natural selection acting on varying organisms within populations as the main causal factor of evolutionary change. Over many generations, the accumulation of favorable variants by natural selection produces new adaptations and new species. Macroevolutionary theory postulates two additional processes analogous to natural selection that act above the species level and on much longer time scales. An evolving lineage ultimately experiences one of two fates, branching speciation or extinction. Lineages that have a high propensity to produce new species and an ability to withstand extinction will dominate evolutionary history.

The higher-level process of differential speciation and extinction caused by the varying characteristics of species or lineages has been called species selection. Because the precise meaning of the term species is controversial, the more neutral terms lineage selection and clade selection are sometimes substituted for species selection. Most species show an evolutionary duration from a few million to approximately 10 million years in the fossil record between geologically instantaneous events of branching speciation. Species selection therefore generally occurs on a time scale of millions of years, rather than the generational time scale of natural selection. Species selection may be the primary factor underlying morphological evolutionary trends at this scale if lineages evolve by punctuated equilibrium, in which most morphological evolutionary change accompanies branching speciation, and species remain morphologically stable between speciation events. See SPECIATION.

The fossil record reveals mass extinctions in which enormous numbers of species from many different taxa are lost within a relatively short interval of geological time. Some lineages may be better able to survive mass extinction events than others, and the characteristics that make a lineage prone to survive mass extinction may be very different from those that influence species selection between events of mass extinction. Catastrophic species selection denotes differential survival and extinction of lineages during events of mass extinction as determined by character variation among lineages. Prior to the Cretaceous mass extinction, dinosaur taxa dominated mammalian taxa, whereas mammals survived the mass extinction and then diversified extensively. The characteristics of the ancestral mammals may have permitted them to survive environmental challenges to which dinosaurs were susceptible. See EXTINCTION (BIOLOGY); FOSSIL; MAMMALIA; PALEONTOLOGY; PERMIAN.

Because natural selection, species selection, and catastrophic species selection can differ in the biological characteristics they promote, higher-level processes may undo or reverse evolutionary trends arising from lower-level processes. See ORGANIC EVOLUTION. [A.Lar.]

**Macroscelidea** A mammalian order, the elephant shrews and their allies, which consists of a single African family, Macroscelididae. They are mostly hopping and scampering mammals, divided among several subfamilies, some of which resemble rodents and ungulates in certain features. Characteristic of all these animals is an intestinal cecum and the arrangement of bones in the ear region. The long proboscis of the first living macroscelidids to be discovered led to the name elephant shrews. See MAMMALIA. [M.C.McK.]

**Madelung constant** A numerical constant  $\alpha_M$  in terms of which the electrostatic energy  $U$  of a three-dimensional

**Madelung constants for some common ionic crystals**

Crystal structure	Madelung constant, $\alpha_M$
Sodium chloride, NaCl	1.7476
Cesium chloride, CsCl	1.7627
Zinc blende, $\alpha$ -ZnS	1.6381
Wurtzite, $\beta$ -ZnS	1.641
Fluorite, CaF <sub>2</sub>	5.0388
Cuprite, CuO <sub>2</sub>	4.1155
Rutile, TiO <sub>2</sub>	4.816
Anatase, TiO <sub>2</sub>	4.800
Corundum, Al <sub>2</sub> O <sub>3</sub>	25.0312

periodic crystal lattice of positive and negative point charges  $q_+$ ,  $-q_-$ ,  $N$  in number, is given by the equation below, where  $d$

$$U = -\frac{1}{2} \frac{Nq_+q_-}{d} \alpha_M$$

is the nearest-neighbor distance between positive and negative charges and  $N$  is large. Knowledge of such electrostatic energies as given by the Madelung constant is of importance in the calculation of the cohesive energies of ionic crystals and in many other problems in the physics of solids. See IONIC CRYSTALS.

The Madelung constants for a number of common ionic crystal structures are given in the table. For these cases  $d$  is chosen as the nearest-neighbor distance. See CRYSTAL. [B.G.D.]

**Magellanic Clouds** Two small, irregular galaxies that are close companions of the Milky Way Galaxy. Both are nearby galaxies that are located in the southern sky, not far from the south celestial pole. When viewed without a telescope, they resemble small sections of the Milky Way that might have drifted away from the main arc. The Large Magellanic Cloud (LMC) subtends an angular extent of about 5° in the sky, and the Small Magellanic Cloud (SMC) is about 3° across. Telescopic studies show, however, that each is really much larger than it appears. See MILKY WAY GALAXY.

The Magellanic Clouds are rather small irregular-type galaxies. The Large Magellanic Cloud is at a distance of 160,000 light-years ( $1.5 \times 10^{18}$  km or  $9 \times 10^{17}$  mi), and the Small Cloud is about 10% farther away. The explosion of Supernova 1987A in the Large Magellanic Cloud was seen in February 1987. The galaxies are satellites of the Milky Way Galaxy. See SUPERNOVA.

It was shown in 1998, using Hubble Space Telescope measurements, that the oldest globular clusters in the Large Magellanic Cloud have the same ages as the oldest such clusters in the Milky Way Galaxy, indicating that both galaxies must have formed at nearly the same time. The Small Magellanic Cloud may have formed more recently, as no very old clusters have yet been identified among its several hundred star clusters. Both Magellanic Clouds have large numbers of very young stars, most of which are located in stellar associations, each of which contains several hundred recently formed stars in loose aggregates about 200 light-years ( $2 \times 10^{15}$  km or  $1.2 \times 10^{15}$  mi) across. See STAR CLUSTERS.

Both objects also are rich in gas, mostly neutral hydrogen gas. In certain areas the gas is heated by nearby bright stars, producing brilliant glowing nebulae. The brightest and biggest is the 30 Doradus nebula, one of the most remarkable objects of the nearby universe, which includes a "nursery" for the formation of supergiant stars. See INTERSTELLAR MATTER; NEBULA; SUPERGIANT STAR. [P.Hod.]

**Magic numbers** The number of neutrons or protons in nuclei which are required to fill major quantum shells. They occur at particle numbers 2, 8, 20, 50, and 82.

In atoms, the electrons that orbit the nucleus fill quantum electron shells at atomic numbers of 2 (helium), 10 (neon), 18 (argon), 36 (krypton), and 54 (xenon). These elements are chem-

ically inert and difficult to ionize because the energies of orbits are grouped in bunches or shells with large gaps between them. In nuclei, an analogous behavior is found; quantum orbits completely filled with neutrons or protons result in extra stability. The neutrons and protons fill their quantum states independently, so that both full neutron and full proton shells can occur as magic nuclei. In a few cases, for example oxygen-16 ( $^{16}_8\text{O}_8$ ) and calcium-40 ( $^{40}_{20}\text{Ca}_{20}$ ), doubly magic nuclei have full neutron and proton shells. Between the major shell gaps, smaller subshell gaps cause some extra stabilization and semimagic behavior is found at particle numbers 14, 28, 40, and 64. See ATOMIC STRUCTURE AND SPECTRA; ELECTRON CONFIGURATION.

In very heavy nuclei the Coulomb repulsion between the protons results in a different sequence of states for neutrons and protons and different major shell gaps. For neutrons the magic sequence continues at  $N = 126$ ; the next shell gap is predicted at  $N = 184$ . For protons the next major shell gap is anticipated at  $Z = 114$ . The latter shell gaps lie beyond the heaviest nuclei known, but calculations indicate that the extra stability gained by producing nuclei with these particle numbers may result in an island of long-lived superheavy nuclei.

The closing of nuclear quantum shells has many observable consequences. The nuclei are more tightly bound than average, and the extra stability leads to anomalously high abundances of magic nuclei in nature. The full shells require unusually high energies to remove the least bound neutron or proton, and the probability of capturing extra particles is lower than expected. Furthermore, the full shells are spherically symmetric, and the nuclei have very small electric quadrupole moments. Many of these properties were known before the nuclear shell model was developed to account for quantum-level ordering and gaps between major shells. The different shell closures for atomic and nuclear systems reflect the differences between the Coulomb force that binds electrons to nuclei and the strong force that holds the nucleus together. An important component of the strong force in nuclei is the spin-orbit term, which makes the energy of a state strongly dependent on the relative orientation of spin and orbital angular momentum. See ANGULAR MOMENTUM; ELEMENTS, COSMIC ABUNDANCE OF; ISOTOPE; NUCLEAR MOMENTS; NUCLEAR STRUCTURE; STRONG NUCLEAR INTERACTIONS. [C.J.Li.]

**Magma** The hot material, partly or wholly liquid, from which igneous rocks form. Besides liquids, solids and gas may be present in magma. Most observed magmas are silicate melts with associated crystals and gas, but some inferred magmas are carbonate, phosphate, oxide, sulfide, and sulfur melts.

Strictly, any natural material which contains a finite proportion of melt (hot liquid) is a magma. However, magmas which contain more than about 60% by volume of solids generally have finite strength and fracture like solids.

Hypothetical, wholly liquid magmas which develop by partial melting of previously solid rock and segregation of the liquid into a volume free of suspended solids and gas are called primary magmas. Hypothetical, wholly liquid magmas which develop by crystallization of a primary magma and isolation of rest liquid free of suspended solids are called parental (or secondary) magmas. Although no unquestioned natural examples of either primary or parental magmas are known, the concepts implied by the definitions are useful in discussing the origins of magmas.

Bodies of flowing lava and natural volcanic glass prove the existence of magmas. Such proven magmas include the silicate magmas corresponding to such rocks as basalt, andesite, dacite, and rhyolite as well as rare carbonate-rich magmas and sulfur melts. Oxide-rich and sulfide-rich magmas are inferred from textural and structural evidence of fluidity as well as mineralogical evidence of high temperature, together with the results of experiments on the equilibrium relations of melts and crystals. See IGNEOUS ROCKS; LAVA.

Magma is presumed to underlie regions of active volcanism and to occupy volumes comparable in size and shape to plutons

of eroded igneous rocks. However, it is not certain that individual plutons existed wholly as magma at one time. Magma may underlie some regions where no volcanic activity exists, because many plutons appear not to have vented to the surface. See PLUTON.

Diverse origins are probable for various magmas. Basaltic magmas because of their high temperatures probably originate within the mantle several tens of kilometers beneath the surface of the Earth. Rhyolitic magmas may originate through crystallization of basaltic magmas or by melting of crustal rock. Intermediate magmas may originate within the mantle or by crystallization of basaltic magmas, by melting of appropriate crustal rock, and also by mixing of magmas or by assimilation of an appropriate rock by an appropriate magma. See IGNEOUS ROCKS; VOLCANO. [A.T.A.]

**Magnesite** A member of the calcite-type carbonates having the formula  $\text{MgCO}_3$ . It forms dolomite [ $\text{CaMg}(\text{CO}_3)_2$ ] with calcite ( $\text{CaCO}_3$ ) in the system  $\text{CaCO}_3\text{—MgCO}_3$ . Pure magnesite is not common in nature because there exists a complete series of solid solutions between  $\text{MgCO}_3$  and  $\text{FeCO}_3$ , which is constantly present in magnesite in its natural occurrence. See CARBONATE MINERALS; MAGNESIUM.

Magnesite is usually white, but it may be light to dark brown if iron-bearing. The hardness of magnesite is  $3\frac{1}{2}$  to  $4\frac{1}{2}$  on the Mohs scale, and the specific gravity is 3.00. See HARDNESS SCALES.

Magnesite deposits are of two general types: massive and crystalline. Massive magnesite is an alteration product of serpentine which has been subjected to the action of carbonate waters. Crystalline magnesite is usually found in association with dolomite. It is generally thought to be a secondary replacement of magnesite in preexisting dolomite by magnesium-rich fluids.

Magnesite is an important industrial mineral. Various types of magnesite or magnesia ( $\text{MgO}$ ) are produced by different thermal treatments. The caustic-calcined magnesite or magnesia is used in the chemical industry for the production of magnesium compounds, while dead-burned or sintered magnesite or magnesia is used in refractory materials. Fused magnesia is used as an insulating material in the electrical industry because of its high electrical resistance and high thermal conductivity. [L.L.Y.C.]

**Magnesium** A metallic chemical element, Mg, in group 2 of the periodic system, atomic number 12, atomic weight 24.312. Magnesium is silvery white and extremely light in weight. The specific gravity is 1.74, and the density is  $1740 \text{ kg/m}^3$  ( $0.063 \text{ lb/in.}^3$  or  $108.6 \text{ lb/ft}^3$ ). Because of this lightness combined with alloy strength suitable for many structural uses, magnesium has long been known as industry's lightest structural metal. See PERIODIC TABLE.

With a density only two-thirds that of aluminum, magnesium is used in countless applications where weight saving is an important consideration. The metal also has, however, many desirable chemical and metallurgical properties which account for its extensive use in a variety of nonstructural applications.

Magnesium is very abundant in nature, occurring in substantial amounts in many rock-forming minerals such as dolomite, magnesite, olivine, and serpentine. In addition, magnesium is also found in sea water, subterranean brines, and salt beds. It is the third most abundant structural metal in the Earth's crust, exceeded only by aluminum and iron.

Some of the properties of magnesium in metallic form are listed in Table 1. Magnesium is very active chemically. It will actually displace hydrogen from boiling water, and a large number of metals can be prepared by thermal reduction of their salts and oxides with magnesium. The metal will combine with most nonmetals and with practically all acids. Magnesium reacts only slightly or not at all with most alkalis and many organic chemicals, including hydrocarbons, aldehydes, alcohols,

**Table 1. Physical properties of primary magnesium (99.9% pure)**

Property	Value
Atomic number	12
Atomic weight	24.312
Atomic volume, cm <sup>3</sup> /g-atom	14.0
Crystal structure	Close-packed hexagonal
Electron arrangement in free atoms	(2) (8) 2
Mass numbers of the isotopes	24, 25, 26
Percent relative abundances of <sup>24</sup> Mg, <sup>25</sup> Mg, <sup>26</sup> Mg	77, 11.5, 11.5
Density, g/cm <sup>3</sup> at 20°C	1.738
Specific heat, cal/g°C at 20°C (1 cal = 4.2 joules)	0.245
Melting point, °C	650
Boiling point, °C	1110 ±10

**Table 2. Principal magnesium compounds and uses**

Compound	Uses
Magnesium carbonate	Refractories, production of other magnesium compounds, water treatment, fertilizers
Magnesium chloride	Cell feed for production of metallic magnesium, oxychloride cement, refrigerating brines, catalyst in organic chemistry, production of other magnesium compounds, flocculating agent, treatment of foliage to prevent fire and resist fire, magnesium melting and welding fluxes
Magnesium hydroxide	Chemical intermediate, alkali, medicinal
Magnesium oxide	Insulation, refractories, oxychloride and oxysulfate cements, fertilizers, rayon-textile processing, water treatment, papermaking, household cleaners, alkali, pharmaceuticals, rubber filler catalyst
Magnesium sulfate	Leather tanning, paper sizing, oxychloride and oxysulfate cements, rayon delustrant, textile dyeing and printing, medicinal, fertilizer ingredient, livestock-food additive, ceramics, explosives, match manufacture

phenols, amines, esters, and most oils. As a catalyst, magnesium is useful for promoting organic condensation, reduction, addition, and dehalogenation reactions. It has long been used for the synthesis of complex and special organic compounds by the well-known Grignard reaction. Principal alloying ingredients include aluminum, manganese, zirconium, zinc, rare-earth metals, and thorium. *See* MAGNESIUM ALLOYS

Magnesium compounds are used extensively in industry and agriculture. Table 2 lists the major magnesium compounds and indicates some of their more significant applications.

[W.H.Gr.; S.C.E.]

**Magnesium alloys** The most important alloying ingredients used in magnesium alloys are aluminum, zinc, manganese, silicon, zirconium, rare-earth metals, and thorium. The specific gravity of magnesium alloys ranges from 1.74 to 1.83. It has led to a great many structural applications in the aircraft, transportation, materials-handling, and portable-tool and -equipment industries. Magnesium alloys are commonly used in the form of die castings, which account for 75% of their usage in structural applications. *See* MAGNESIUM.

[T.E.L.]

**Magnet** An object or device that produces a magnetic field. Magnets are essential for the generation of electric power and are used in motors, generators, labor-saving electromechanical devices, information storage, recording, and numerous specialized applications, for example, seals of refrigerator doors. The magnetic fields produced by magnets apply a force at a distance on other magnets, charged particles, electric currents, and magnetic materials. *See* GENERATOR; MAGNETIC RECORDING; MOTOR.

Magnets may be classified as either permanent or excited. Permanent magnets are composed of so-called hard magnetic material, which retains an alignment of the magnetization in the presence of ambient fields. Excited magnets use controllable energizing currents to generate magnetic fields in either electro-

magnets or air-cored magnets. *See* ELECTROMAGNET; FERROMAGNETISM; SUPERCONDUCTIVITY.

The essential characteristic of permanent-magnet materials is an inherent resistance to change in magnetization over a wide range of field strength. Resistance to change in magnetization in this type of material is due to two factors: (1) the material consists of particles smaller than the size of a domain, a circumstance which prevents the gradual change in magnetization which would otherwise take place through the movement of domain wall boundaries; and (2) the particles exhibit a marked magnetocrystalline anisotropy. During manufacture the particles are aligned in a magnetic field before being sintered or bonded in a soft metal or polyester resin. Compounds of neodymium, iron, and boron are used. *See* IRON ALLOYS.

Electromagnets rely on magnetically soft or permeable materials which are well annealed and homogeneous so as to allow easy motion of domain wall boundaries. Ideally the coercive force should be zero, permeability should be high, and the flux density saturation level should be high. Coincidentally the hysteresis energy loss represented by the area of the hysteresis curve is small. This property and high electrical resistance (for the reduction of eddy currents) are required where the magnetic field is to vary rapidly. This is accomplished by laminating the core and using iron alloyed with a few percent silicon that increases the resistivity.

Electromagnets usually have an energizing winding made of copper and a permeable iron core. Applications include relays, motors, generators, magnetic clutches, switches, scanning magnets for electron beams (for example, in television receivers), lifting magnets for handling scrap, and magnetic recording heads. *See* CATHODE-RAY TUBE; CLUTCH; ELECTRIC SWITCH; RELAY.

Special iron-cored electromagnets designed with highly homogeneous fields are used for special analytical applications in, for example, electron or nuclear magnetic resonance, or as bending magnets for particle accelerators. *See* MAGNETIC RESONANCE; PARTICLE ACCELERATOR.

Air-cored electromagnets are usually employed above the saturation flux density of iron (about 2 T); at lower fields, iron-cored magnets require much less power because the excitation currents needed then are required only to generate a small field to magnetize the iron. The air-cored magnets are usually in the form of a solenoid with an axial hole allowing access to the high field in the center. The conductor, usually copper or a copper alloy, must be cooled to dissipate the heat generated by resistive losses. In addition, the conductor and supporting structure must be sufficiently strong to support the forces generated in the magnet. *See* SOLENOID (ELECTRICITY).

In pulsed magnets, higher fields can be generated by limiting the excitation to short pulses (usually furnished by the energy stored in a capacitor bank) and cooling the magnet between pulses. The highest fields are generally achieved in small volumes. A field of 75 T has been generated for 120 microseconds.

Large-volume or high-field magnets are often fabricated with superconducting wire in order to avoid the large resistive power losses of normal conductors. The two commercially available superconducting wire materials are (1) alloys of niobium-titanium, a ductile material which is used for generating fields up to about 9 T; and (2) a brittle alloy of niobium and tin (Nb<sub>3</sub>Sn) for fields above 9 T. Practical superconducting wires use complex structures of fine filaments of superconductor that are twisted together and embedded in a copper matrix. The conductors are supported against the electromagnetic forces and cooled by liquid helium at 4.2 K (−452°F). A surrounding thermal insulating enclosure such as a dewar minimizes the heat flow from the surroundings.

Superconducting magnets operating over 20 T have been made with niobium-titanium outer sections and niobium-tin inner sections. Niobium-titanium is used in whole-body nuclear magnetic resonance imaging magnets for medical diagnostics. Other applications of superconducting magnets include their use

in nuclear magnetic resonance for chemical analysis, particle accelerators, containment of plasma in fusion reactors, magnetic separation, and magnetic levitation. See MAGNETIC LEVITATION; MAGNETIC SEPARATION METHODS; MEDICAL IMAGING; NUCLEAR FUSION; NUCLEAR MAGNETIC RESONANCE (NMR); SUPERCONDUCTING DEVICES.

The highest continuous fields are generated by hybrid magnets. A large-volume (lower-field) superconducting magnet that has no resistive power losses surrounds a water-cooled inner magnet that operates at the highest field. The fields of the two magnets add. Over 35 T has been generated continuously. [S.Fo.]

**Magnet wire** Insulated copper or aluminum wire used in the coils of all types of electromagnetic machines and devices. It is single-strand wire insulated with enamel, varnish, cotton, glass, asbestos, or combinations of these. To meet the immense variety of uses and to gain competitive advantage, a great number of kinds of enamel and fiber insulations are widely available. See ELECTRICAL INSULATION; MAGNET. [P.L.A.; C.J.Her.]

**Magnetic compass** A compass depending for its directive force upon the attraction of the Earth's magnetism for a magnet free to turn in any horizontal direction. A compass is an instrument used for determining horizontal direction.

The magnetic compass operates on the principle that like magnetic poles repel each other whereas unlike poles attract each other. The Earth has internal magnetism similar to that which would result from a short, powerful bar magnet at the center of the Earth. The lines of force connecting the two poles are vertical at two points on the surface of the Earth, called magnetic poles, and horizontal along the magnetic equator, a line approximating a great circle nearly midway between the magnetic poles. The horizontal component of the Earth's magnetic field varies from a maximum on or near the magnetic equator to zero at the magnetic poles.

A simple magnetic compass consists of a magnetized needle mounted so as to be free to align itself with the horizontal component of the Earth's field. A magnetic compass is unreliable or inoperative in the vicinities of the magnetic poles. [A.B.M.]

**Magnetic ferroelectrics** Materials that display both magnetic order and spontaneous electric polarization. Research on these materials has enabled considerable advances to be made in understanding the interplay between magnetism and ferroelectricity. The existence of both linear and higher-order coupling terms has been confirmed, and their consequences studied. They have given rise, in particular, to a number of magnetically induced polar anomalies and have even provided an example of a ferromagnet whose magnetic moment per unit volume is totally induced by its coupling via linear terms to a spontaneous electric dipole moment.

Most known ferromagnetic materials are metals or alloys. Ferroelectric materials, on the other hand, are nonmetals by definition. It therefore comes as no surprise to find that there are no known room-temperature ferromagnetic ferroelectrics. In fact, there are no well-characterized materials which are known to be both strongly ferromagnetic and ferroelectric at any temperature.

Somewhat unaccountably, antiferromagnetic ferroelectrics are also comparative rarities in nature. Nevertheless, a few are known, and among them the barium-transition-metal fluorides are virtually unique in providing a complete series of isostructural examples. They have the chemical composition  $BaXF_4$  in which X is a divalent ion of one of the 3d transition metals, manganese, iron, cobalt, or nickel. These materials are orthorhombic and all spontaneously polar (that is, pyroelectric) at room temperature. For all except the iron and manganese materials, which have a higher electrical conductivity than the others, the polarization has been reversed by the application of an electric field, so that they are correctly classified as ferroelectric. Long-range antiferromag-

netic ordering sets in at temperatures somewhat below 100 K ( $-280^\circ\text{F}$ ). Structurally the materials consist of  $XF_6$  octahedra which share corners to form puckered xy sheets which are linked in the third dimension z by the barium atoms. See CRYSTAL.

The importance of these magnetic ferroelectrics is the opportunity they provide to study and to separate the effects of a variety of magnetic and nonmagnetic excitations upon the ferroelectric properties and particularly upon the spontaneous polarization. Measurements are often made via the pyroelectric effect, which is the variation of polarization with temperature. This effect is an extremely sensitive indicator of electronic and ionic charge perturbations in polar materials. Through these perturbations the effects of propagating lattice vibrations (phonons), magnetic excitations (magnons), electronic excitations (excitons), and even subtle structural transitions can all be probed with precision. See PYROELECTRICITY.

Of all the X ions present in the series  $BaXF_4$ , the largest is  $Mn^{2+}$ . As the temperature is reduced from room temperature, the fluorine cages contract and eventually the divalent manganese ion becomes too big for its cage, precipitating a complicated structural transition at 250 K ( $-10^\circ\text{F}$ ). One interesting effect of this phase transition is that it produces a lower-temperature phase with a crystal symmetry low enough to support the existence of the linear magnetoelectric effect, a linear coupling between magnetization and polarization. Below the antiferromagnetic transition at 26 K in  $BaMnF_4$  this linear coupling produces a canting of the antiferromagnetic sublattices through a very small angle (of order 0.2 degree of arc). The result is a spontaneous, polarization-induced magnetic moment. At low temperatures  $BaMnF_4$  is therefore technically a weak ferromagnet, although the resultant magnetic moment is extremely small, and it is more usually referred to as a canted antiferromagnet. This is the only well-categorized example of pyroelectrically driven ferromagnetism. See ANTIFERROMAGNETISM; FERROELECTRICS; FERROMAGNETISM; MAGNETISM. [M.E.L.]

**Magnetic instruments** Instruments designed for the measurement of magnetic field strength or magnetic flux density, depending on their principle of operation.

**Hall-effect instruments.** Often called gaussmeters, these instruments measure magnetic field strength. They have a useful working range from 10 A/m to 2.4 MA/m (0.125 oersted to 30 kilooersteds). When a magnetic field,  $H_z$ , is applied in a direction at right angles to the current flowing in a conductor (or semiconductor), a voltage proportional to  $H_z$  is produced across the conductor in a direction mutually perpendicular to the current and the applied magnetic field. This phenomenon is called the Hall effect. The output voltage of the Hall probe is proportional to the Hall coefficient, which is a characteristic of the Hall-element material, and is inversely proportional to the thickness of this material. For a sensitive Hall probe, the material is thin with a large Hall coefficient. The semiconducting materials indium arsenide and indium antimonide are particularly suitable. See HALL EFFECT.

**Fluxgate magnetometer.** This instrument is used to measure low magnetic field strengths. It is usually calibrated as a gaussmeter with a useful range of 0.2 millitesla to 0.1 nanotesla (2 gauss to 1 microgauss).

**Fluxmeter.** This instrument is designed to measure magnetic flux. A fluxmeter is a form of galvanometer in which the torsional control is very small and heavy damping is produced by currents induced in the coil by its motion. This enables a fluxmeter to accurately integrate an emf produced in a search coil when the latter is withdrawn from a magnetic field, almost independently of the time taken for the search coil to be moved. See GALVANOMETER; MAGNETIC FLUX.

**Electronic charge integrators.** Often termed an integrator or gaussmeter, an electronic charge integrator, in conjunction with a search coil of known effective area, is used for the measurement of magnetic flux density. Integrators have almost

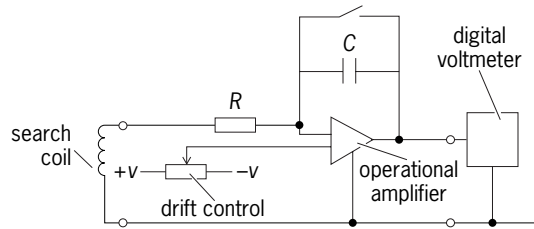

Arrangement of an electronic charge integrator.

exclusively replaced fluxmeters because of their independence of level and vibration. The instrument (see illus.) consists of a high-open-loop-gain ( $10^7$  or more) operational amplifier with a capacitive feedback and resistive input. See OPERATIONAL AMPLIFIER.

**Rotating-coil gaussmeter.** This instrument measures low magnetic field strengths and flux densities. It comprises a coil mounted on a nonmagnetic shaft remote from a motor mounted at the other end. The motor causes the coil to rotate at a constant speed, and in the presence of a magnetic field or magnetic flux density a voltage is induced in the search coil. The magnitude of the voltage is proportional to the effective area of the search coil and the speed of rotation. See MAGNETIC FIELD; MAGNETIC INDUCTION; MAGNETOMETER. [A.E.D.]

**Magnetic lens** A magnetic field with axial symmetry capable of converging beams of charged particles of uniform velocity and of forming images of objects placed in the path of such beams. Magnetic lenses are employed as condensers, objectives, and projection lenses in magnetic electron microscopes, as final focusing lenses in the electron guns of cathode-ray tubes, and for the selection of groups of charged particles of specific velocity in velocity spectrographs.

Magnetic lenses may be formed by solenoids or helical coils of wire traversed by electric current, by axially symmetric pole pieces excited by a coil encased in a high-permeability material such as soft iron, or by similar pole pieces excited by permanent magnets. In the last two instances the armatures and pole pieces serve to concentrate the magnetic field in a narrow region about the axis.

Magnetic lenses are always converging lenses. Their action differs from that of electrostatic lenses and glass lenses in that they produce a rotation of the image in addition to the focusing action. For the simple uniform magnetic field within a long solenoid the image rotation is exactly  $180^\circ$ . Thus a uniform magnetic field forms an erect real image of an object on its axis. [E.G.R.]

**Magnetic levitation** A method of supporting and transporting objects or vehicles which is based on the physical property that the force between two magnetized bodies is inversely proportional to their distance. By using this magnetic force to counterbalance the gravitational pull, a stable and contactless suspension between a magnet (magnetic body) and a fixed guideway (magnetized body) may be obtained. In magnetic levitation (maglev), also known as magnetic suspension, this basic principle is used to suspend (or levitate) vehicles weighing 40 tons or more by generating a controlled magnetic force. By removing friction, these vehicles can travel at speeds higher than wheeled trains, with considerably improved propulsion efficiency (thrust energy/input energy) and reduced noise. In maglev vehicles, chassis-mounted magnets are either suspended underneath a ferromagnetic guideway (track) or levitated above an aluminum track. See MAGNET; MAGNETISM.

In the attraction-type system, a magnet-guideway geometry is used to attract a direct-current electromagnet toward the track. This system, also known as the electromagnetic suspension (EMS) system, is suitable for low- and high-speed passenger-carrying vehicles and a wide range of magnetic bearings. The

electromagnetic suspension system is inherently nonlinear and unstable, requiring an active feedback to maintain an upward lift force equal to the weight of the suspended magnet and its payload (vehicle).

In the repulsion-type system, also known as the electrodynamic levitation system (EDS or EDL), a superconducting coil operating in persistent-current mode is moved longitudinally along a conducting surface (an aluminum plate fixed on the ground and acting as the guideway) to induce circulating eddy currents in the aluminum plate. These eddy currents create a magnetic field which, by Lenz's law, oppose the magnetic field generated by the travelling coil. This interaction produces a repulsion force on the moving coil. At lower speeds, this vertical force is not sufficient to lift the coil (and its payload), so supporting auxiliary wheels are needed until the net repulsion force is positive. The speed at which the net upward lift force is positive (critical speed) is dependent on the magnetic field in the airgap and payload, and is typically around 80 km/h (50 mi/h). To produce high flux from the traveling coils, hard superconductors (type II) with relatively high values of the critical field (the magnetic field strength of the coil at 0 K) are used to yield airgap flux densities of over 4 tesla. With this choice, the strong eddy-current induced magnetic field is rejected by the superconducting field, giving a self-stabilizing levitation force at high speeds (though additional control circuitry is required for adequate damping and ride quality). See EDDY CURRENT.

Due to their contactless operation, linear motors are used to propel maglev vehicles: linear induction motors for low-speed vehicles and linear synchronous motors for high-speed systems. Operationally they are the unrolled versions of the conventional rotary motors. See INDUCTION MOTOR; SYNCHRONOUS MOTOR.

Suspending the rotating part of a machine in a magnetic field may eliminate the contact friction present in conventional mechanical bearings. Magnetic bearings may be based on either attractive or repulsive forces. Although well developed, radial magnetic bearings are relatively expensive and complex, and are used in specialized areas such as vibration dampers for large drive shafts for marine propellers. In contrast, the axial versions of magnetic bearings are in common use in heavy-duty applications, such as large pump shafts and industrial drums. See ANTIFRICTION BEARING. [P.K.Si.]

**Magnetic materials** Materials exhibiting ferromagnetism. The magnetic properties of all materials make them respond in some way to a magnetic field, but most materials are diamagnetic or paramagnetic and show almost no response. The materials that are most important to magnetic technology are ferromagnetic and ferrimagnetic materials. Their response to a field  $H$  is to create an internal contribution to the magnetic induction  $B$  proportional to  $H$ , expressed as  $B = \mu H$ , where  $\mu$  the permeability, varies with  $H$  for ferromagnetic materials. Ferromagnetic materials are the elements iron, cobalt, nickel, and their alloys, some manganese compounds, and some rare earths. Ferrimagnetic materials are spinels of the general composition  $MFe_2O_4$ , and garnets,  $M_3Fe_5O_{12}$ , where  $M$  represents a metal. See FERRIMAGNETISM; FERROMAGNETISM; MAGNETISM; MAGNETIZATION.

Ferromagnetic materials are characterized by a Curie temperature, above which thermal agitation destroys the magnetic coupling giving rise to the alignment of the elementary magnets (electron spins) of adjacent atoms in a crystal lattice. Below the Curie temperature, ferromagnetism appears spontaneously in small volumes called domains. In the absence of a magnetic field, the domain arrangement minimizes the external energy, and the bulk material appears unmagnetized. See CURIE TEMPERATURE.

Magnetic materials are further classified as soft or hard according to the ease of magnetization. Soft materials are used in devices in which change in the magnetization during operation is desirable, sometimes rapidly, as in ac generators and transformers. Hard materials are used to supply a fixed field either to act alone, as in a magnetic separator, or to interact with

others, as in loudspeakers and instruments. See ELECTRIC ROTATING MACHINERY; ELECTRICAL MEASUREMENTS; GENERATOR; INDUCTOR; LOUDSPEAKER; MAGNETIC SEPARATION METHODS; MICROPHONE; TRANSFORMER. [F.E.Lu.]

**Magnetic monopoles** Magnetically charged particles. Such particles are predicted by various physical theories, but so far all experimental searches have failed to demonstrate their existence.

The fundamental laws governing electricity and magnetism become symmetric if particles exist that carry magnetic charge. Current understanding of electromagnetic physical phenomena is based on the existence of electric monopoles, which are sources or sinks of electric field lines (illus. a), and which when set into motion generate magnetic fields. The magnetic field lines produced by such a current have no beginning or end and form closed loops. All magnetic fields occurring in nature can be explained as arising from currents. However, theories of electromagnetism become symmetric if magnetic charges also exist. These would be sources or sinks of magnetic field and when set into motion would generate electric fields whose lines would be closed without ends (illus. b). See ELECTRIC FIELD.

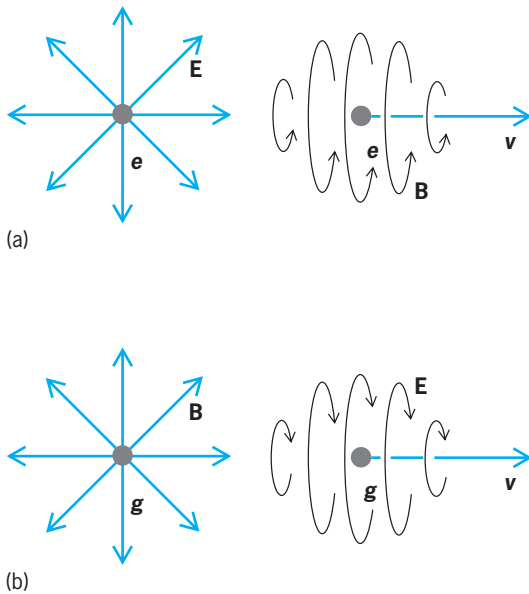

Electric (E) and magnetic (B) field lines generated by monopoles and by their motion with velocity  $v$ . (a) Electric monopole with electric charge  $e$ . (b) Magnetic monopole with magnetic charge  $g$ .

In 1931 P. A. M. Dirac found a more fundamental reason for hypothesizing magnetic charges, when he showed that this would explain the observed quantization of electric charge. He showed that all electric and magnetic charges  $e$  and  $g$  must obey Eq. (1), where  $k$  must be an integer and  $\hbar$  is Planck's constant

$$eg = k^{(1/2)}\hbar c \quad (1)$$

divided by  $2\pi$ . Equation (1) can be satisfied only if all electric and magnetic charges are integer multiples of an elementary electric charge  $e_0$  and an elementary magnetic charge  $g_0$ . Since the size of the elementary electric charge, the charge carried by an electron or proton, is known experimentally, Dirac's equation predicts the size of the elementary magnetic charge to be given by Eq. (2). Since the fine structure constant  $\alpha$  is given by Eq. (3), the

$$g_0 = \frac{1}{2} \frac{\hbar c}{e_0} \quad (2)$$

$$\alpha = \frac{e_0^2}{\hbar c} \approx \frac{1}{137} \quad (3)$$

elementary magnetic charge  $g_0$  is about 68.5 times larger than the elementary electric charge  $e_0$ . See FINE STRUCTURE (SPECTRAL LINES); FUNDAMENTAL CONSTANTS.

In 1983 a successful theoretical unification of the electromagnetic and weak forces culminated in the detection of the  $W^+$ , the  $W^-$ , and the  $Z^0$  particles predicted by the theory. This success has encouraged the search for a grand unification theory that would include the electroweak force and the nuclear or color force under one consistent description. In 1974 G. 'tHooft and independently A. M. Polyakov showed that magnetically charged particles are necessarily present in all true unification theories (those based on simple or semisimple compact groups). These theories predict the same long-range field and thus the same charge  $g_0$  as the Dirac solution; now, however, the near field is also specified, leading to a calculable mass. The SU(5) model predicts a monopole mass of  $10^{16}$  GeV/ $c^2$ , while theories based on supersymmetry or Kaluza-Klein models yield even higher masses up to the Planck mass of  $10^{19}$  GeV/ $c^2$ . See ELECTROWEAK INTERACTION; FUNDAMENTAL INTERACTIONS; GRAND UNIFICATION THEORIES; QUANTUM GRAVITATION; SUPERGRAVITY; SUPERSYMMETRY.

There are two classes of magnetic monopole detectors, superconducting and conventional. On February 14, 1982, a prototype superconducting detector operating at Stanford University observed a single candidate event. Since then a number of groups have operated larger second- and third-generation detectors, and their combined data have placed a limit on the monopole flux more than 3000 times lower than the value from the data set that included the original event. Thus the possibility that this event was caused by the passage of a magnetic monopole has been largely discounted. [B.Ca.]

**Magnetic reception (biology)** Sensitivity to magnetic stimuli, especially the very weak ones occurring naturally in the environment.

Evidence of magnetic detection has been found in a variety of invertebrates, including protozoa, flatworms, snails, and insects. In 1968 Martin Lindauer and Herman Martin first published extensive data showing that the Earth's geomagnetic field influences the orientation of the waggle-run dance by which a scout honeybee communicates the distance and direction of a food source to the forager bees. Later, Lindauer and Martin showed that fluctuations of less than  $10^{-4}$  gauss (roughly 1/10,000 of the Earth's field) can influence these bees' behavior. Other investigators found evidence of magnetic detection in other kinds of insects, including termites, beetles, and fruit flies (*Drosophila*).

Most of the evidence for magnetic detection by birds has come from studies of their migratory and homing behavior. Results strongly suggest that birds possess a magnetic compass, that is, they can determine compass bearings from the geomagnetic field. Evidence indicates that birds' sensitivity to magnetic stimuli is roughly similar to the honeybees'. It appears that the tiny fluctuations in the Earth's magnetic field caused by solar flares and other solar disturbances have a detectable effect on birds' navigation. The detection system probably has a narrow range of sensitivity; magnetic fields much stronger or weaker than the Earth's probably cannot be detected. See MIGRATORY BEHAVIOR.

Although behavioral effects of magnetic stimuli have been found in many kinds of animals, no one has yet succeeded in conditioning an animal to a magnetic stimulus in the laboratory. There is abundant evidence that the detection process is not quick, usually taking 15 min or more; hence, the flash stimuli presented in most classical conditioning attempts may be undetectable.

The physical mechanism for magnetic detection by living organisms is unknown, though a variety of possibilities have been put forward. [W.T.K.]

**Magnetic recording** The technique of storing information as a magnetic pattern on a moving magnetic medium. The medium may be a disk, either flexible (floppy) or rigid, or a tape.

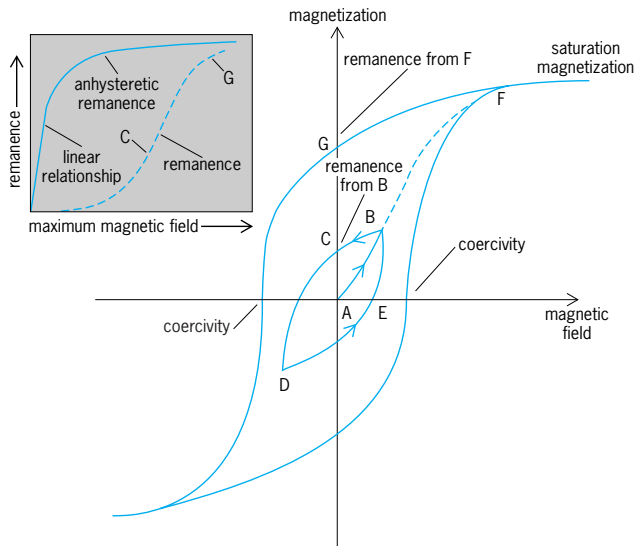

**Fig. 1. Typical magnetization curves.** At A, material is completely demagnetized. If the magnetic field is increased to B and then reversed, the minor loop BCDE is obtained. The inset shows remanence as a function of maximum field; points C and G correspond to the hysteresis loops shown.

All materials respond in some way to an applied magnetic field, but the term “magnetic material” generally means one that maintains a magnetic polarization in the absence of an applied field. This remanence depends upon the magnetic field history to which the material was exposed. This history can be plotted on a graph of magnetization versus magnetic field, giving rise to hysteresis loops (Fig. 1). If the material is initially completely demagnetized (A in Fig. 1, sometimes referred to as the ac erase state), and the applied field is increased to some intermediate value and then reversed, a minor loop (BCDE) is obtained. At zero magnetic field there is a remanence. If the field is increased to the point that further increases in the field result in no further increases in magnetization, the material is said to be saturated. The remanence, at zero magnetic field, is a function of the maximum magnetic field to which the material has been exposed. Also, it takes a finite field in the reverse direction to drive the magnetization to zero. This field is called the coercivity of the material, and is an important parameter in magnetic recording. See MAGNETIC HYSTERESIS; MAGNETIC MATERIALS; MAGNETIZATION.

The hysteretic behavior of magnetic materials, and in particular, the field dependence of the remanence, is the basis for recording sound. The basic idea is to use the electric current from a microphone to generate a magnetic field (Ampère’s law) that magnetizes portions of a magnetic medium in proportion to this current. The resulting magnetic pattern along the medium can then be read back as a voltage induced in a pick-up coil (Faraday’s induction law) as the fringing fields from the magnetic medium pass by. See AMPÈRE’S LAW; FARADAY’S LAW OF INDUCTION; MAGNETIC FIELD.

The writing field associated with a coil can be enhanced by filling the coil with a magnetic material. The reason is that the magnetic flux density generated by an electric current is proportional to the current through a constant of proportionality called the permeability. In free space, this quantity is usually denoted by  $\mu_0$ . The permeability of a magnetic material,  $\mu$ , however, is much larger. For example, the nickel-iron alloy permalloy has a relative permeability,  $\mu/\mu_0$ , of the order of 10,000. Therefore, the magnetic flux density inside a permalloy core would be 10,000 times that of an air core.

A high-permeability core also serves to confine the flux density. The field in a very narrow gap in the magnetic material can therefore be relatively large. Thus, recording generally employs

an electromagnet with a narrow gap (Fig. 2). The writing and reading element is referred to as the head.

The relationship between the remanence and the field is very nonlinear (Fig. 1), which led to a good deal of distortion in early recorders. However, if an alternating current (ac) is added to the signal current, the resulting remanence, called the anhysteretic remanence, becomes linear at low fields. The amplitude of this bias must be sufficient to produce a field greater than the coercivity, and the bias frequency must be higher than the highest signal frequency. See SOUND RECORDING.

To extend magnetic recording to video recording with signals as high as 5 MHz requires increasing the speed between the tape and the recording head. Video recording is based on an approach in which a number of heads are mounted on the face of a drum that rotates rapidly in a direction transverse to the direction of the tape motion. See TELEVISION.

Magnetic recording was applied to the storage of data in the early 1950s. Data generally means information represented in a digital form, that is, a sequence of 0’s and 1’s. In the first tape system for data storage, the data were recorded longitudinally along seven tracks. In a disk system, data are stored along concentric tracks. The figure of merit is the areal bit density, which is the product of the linear density along a track and the track density. See COMPUTER STORAGE TECHNOLOGY.

Early tapes and disks utilized particulate media in which the magnetic ingredient consisted of microscopic particles of a magnetic oxide. These particles were immersed in a polymeric binder that served to separate the particles from one another and bind them to the substrate. The particles first used were the gamma form of iron oxide. Higher levels of magnetization and coercivity can be obtained in particles made of the ferromagnetic elements, iron and cobalt, and their alloys than is possible with oxide particles. However, metal particles tend to corrode in the atmosphere and to react with binders and so must be passivated at some cost in saturation magnetization. The particles are also difficult to disperse and are much more expensive than particles of iron oxide. Metal particles having coercivities in the range 700–1150 Oe

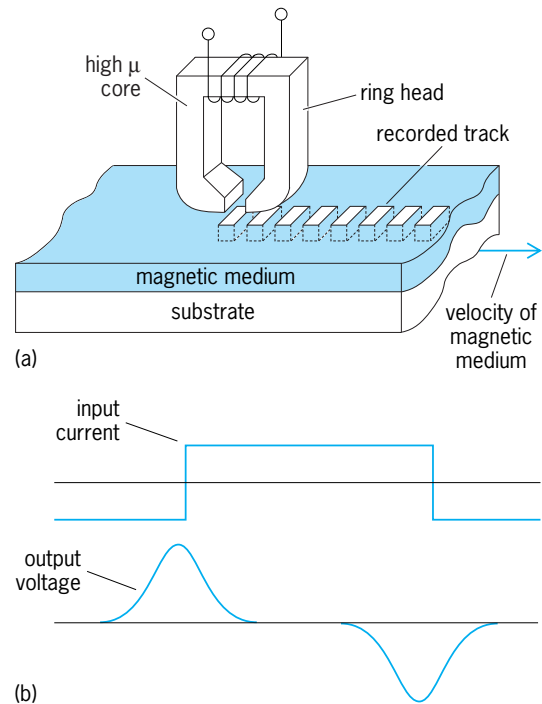

**Fig. 2. Writing and reading process.** (a) Motion of the magnetic medium past the electromagnet in the form of a ring head. (b) Variation with time of input current and output voltage.



(56–92 kA/m) are used in premium audio tapes, and particles with coercivities of 1350–1550 Oe (107–123 kA/m) are used in 8-mm video tapes.

Metallic films are used on magnetic disks to reduce the thickness of the magnetic medium and retain a large magnetization. Among the magnetic elements (iron, cobalt, and nickel), cobalt has a hexagonal crystalline structure that leads to a large coercivity. Therefore, many metallic media consist of cobalt with additional elements to stabilize the hexagonal phase, and also, for longitudinal recording, to ensure that the hexagonal axis lies in the plane of the film. [R.M.Wh.]

**Magnetic relaxation** The relaxation or approach of a magnetic system to an equilibrium or steady-state condition as the magnetic field is changed. This relaxation is not instantaneous but requires time. The characteristic times involved in magnetic relaxation are known as relaxation times. Relaxation has been studied for nuclear magnetism, electron paramagnetism, and ferromagnetism.

Magnetism is associated with angular momentum called spin, because it usually arises from spin of nuclei or electrons. The spins may interact with applied magnetic fields, the so-called Zeeman energy; with electric fields, usually atomic in origin; and with one another through magnetic dipole or exchange coupling, the so-called spin-spin energy. Relaxation which changes the total energy of these interactions is called spin-lattice relaxation; that which does not is called spin-spin relaxation. (As used here, the term lattice does not refer to an ordered crystal but rather signifies degrees of freedom other than spin orientation, for example, translational motion of molecules in a liquid.) Spin-lattice relaxation is associated with the approach of the spin system to thermal equilibrium with the host material; spin-spin relaxation is associated with an internal equilibrium of the spins among themselves. See MAGNETISM; SPIN (QUANTUM MECHANICS). [C.P.S.]

**Magnetic resonance** A phenomenon exhibited by the magnetic spin systems of certain atoms whereby the spin systems absorb energy at specific (resonant) frequencies when subjected to alternating magnetic fields. The magnetic fields must alternate in synchronism with natural frequencies of the magnetic system. In most cases the natural frequency is that of precession of the bulk magnetic moment of constituent atoms or nuclei about some magnetic field. Because the natural frequencies are highly specific as to their origin (nuclear magnetism, electron spin magnetism, and so on), the resonant method makes possible the selective study of particular features of interest. For example, it is possible to study weak nuclear magnetism unmasked by the much larger electronic paramagnetism or diamagnetism which usually accompanies it.

Nuclear magnetic resonance (that is, resonance exhibited by nuclei) reveals not only the presence of a nucleus such as hydrogen, which possesses a magnetic moment, but also its interaction with nearby nuclei. It has therefore become a most powerful method of determining molecular structure. The detection of resonance displayed by unpaired electrons, called electron paramagnetic resonance, is also an important application. See ELECTRON-NUCLEAR DOUBLE RESONANCE; MAGNETIC RESONANCE; MAGNETISM; NUCLEAR MAGNETIC RESONANCE (NMR). [C.P.S.]

**Magnetic reversals** The Earth's magnetic field has reversed polarity hundreds of times. That is, at different times in Earth's past, a compass would have pointed south instead of north. Recognition that the geomagnetic field has repeatedly reversed polarity played a key role in the revolution that transformed the geological sciences in the 1960s—the acceptance of the theory of plate tectonics. It is generally accepted that the geomagnetic field is generated by motion of electrically conducting molten metal in Earth's outer core. However, the mechanism by which the field decays and reverses polarity remains one of the

great unknowns in geophysics. See GEODYNAMO; GEOMAGNETISM; PLATE TECTONICS.

The last magnetic field reversal occurred long before humans were aware of the geomagnetic field (780,000 years ago), so it is necessary to study geological records to understand the process by which the field reverses. The ability of rocks to act as fossilized compasses, which record a permanent “memory” of Earth's magnetic field at the time of rock formation, makes them suitable for detailed studies of ancient geomagnetic field behavior. See PALEOMAGNETISM; ROCK MAGNETISM. [A.P.R.]

**Magnetic separation methods** All materials possess magnetic properties. Substances that have a greater permeability than air are classified as paramagnetic; those with a lower permeability are called diamagnetic. Paramagnetic materials are attracted to a magnet; diamagnetic substances are repelled. Very strongly paramagnetic materials can be separated from weakly or nonmagnetic materials by the use of low-intensity magnetic separators. Minerals such as hematite, limonite, and garnet are weakly magnetic and can be separated from nonmagnetics by the use of high-intensity separators.

Magnetic separators are widely used to remove tramp iron from ores being crushed, to remove contaminating magnetics from food and industrial products, to recover magnetite and ferrosilicon in the float-sink methods of ore concentration, and to upgrade or concentrate ores. Magnetic separators are extensively used to concentrate ores, particularly iron ores, when one of the principal constituents is magnetic. See MECHANICAL SEPARATION TECHNIQUES; ORE DRESSING. [F.D.DeV.]

**Magnetic susceptibility** The magnetization of a material per unit applied field. It describes the magnetic response of a substance to an applied magnetic field. See MAGNETISM; MAGNETIZATION.

All ferromagnetic materials exhibit paramagnetic behavior above their ferromagnetic Curie points. The general behavior of the susceptibility of ferromagnetic materials at temperatures well above the ferromagnetic Curie temperature follows the Curie-Weiss law. The paramagnetic Curie temperature is usually slightly greater than the temperature of transition. See CURIE TEMPERATURE; CURIE-WEISS LAW; FERROMAGNETISM.

Most paramagnetic substances at room temperature have a static susceptibility which follows a Langevin-Debye law. Saturation of the paramagnetic susceptibility occurs when a further increase of the applied magnetic field fails to increase the magnetization, because practically all the magnetic dipoles are already oriented parallel to the field. See PARAMAGNETISM.

The susceptibility of diamagnetic materials is negative, since a diamagnetic substance is magnetized in a direction opposite to that of the applied magnetic field. The diamagnetic susceptibility is independent of temperature. Diamagnetic susceptibility depends upon the distribution of electronic charge in an atom and upon the energy levels. See DIAMAGNETISM.

The susceptibility of antiferromagnetic materials above the Néel point, which marks the transition from antiferromagnetic to paramagnetic behavior, follows a Curie-Weiss law with a negative paramagnetic Curie temperature. [E.A.; FKe.]

**Magnetic thermometer** A thermometer whose operation is based on Curie's law, which states that the magnetic susceptibility of noninteracting (that is, paramagnetic) dipole moments is inversely proportional to absolute temperature. Magnetic thermometers are typically used at temperatures below 1 K (–458°F). The magnetic moments in the thermometric material may be of either electronic or nuclear origin. Generally the magnetic thermometer must be calibrated at one (or more) reference temperatures. See ELECTRON; NUCLEAR MOMENTS; PARAMAGNETISM.

At temperatures from a few millikelvins upward, the thermometric material is preferably an electronic paramagnet, typically

a nonconducting hydrous rare-earth salt. For higher temperatures, an ion is selected with a large magnetic moment in a crystalline environment with a high density of magnetic ions. In contrast, for low temperature use the magnetic exchange interactions between the magnetic ions should be small, which is accomplished by selecting an ion with a well-localized moment and by maintaining a large separation between the magnetic ions by means of diamagnetic atoms. This is the case in cerium magnesium nitrate (CMN)  $[2\text{Ce}(\text{NO}_3)_3 \cdot 3\text{Mg}(\text{NO}_3)_3 \cdot 24\text{H}_2\text{O}]$ . Here, the  $\text{Ce}^{3+}$  ion is responsible for the magnetic moment, which is well localized within the incompletely filled 4f shell relatively deep below the outer valence electrons. To reduce the magnetic interactions between the  $\text{Ce}^{3+}$  ions further,  $\text{Ce}^{3+}$  may be partly substituted with diamagnetic  $\text{La}^{3+}$  ions. Lanthanum-diluted CMN has been used for thermometry to below 1 mK. See EXCHANGE INTERACTION.

A mutual-inductance bridge, originally known as the Hartshorn bridge, has been the most widely employed measuring circuit for precision thermometry. The bridge is driven by a low-frequency alternating-current source. The inductance at low temperatures consists of two coils, which are as identical as possible. The voltages induced across them by the drive current are compared by means of a high-input-impedance ratio transformer. The output level of this voltage divider is adjusted to equal that of the midpoint between the two coils, using as null indicator a narrow-band preamplifier and a phase-sensitive (lock-in) detector. Thus, without a paramagnetic specimen, the bridge is balanced with the decade divider adjusted at its midpoint, while with the specimen inside one of the coils the change in the divider reading at bridge balance is proportional to the sample magnetization. For high-resolution thermometry it has become standard practice to replace the room-temperature zero detector with a SQUID magnetometer circuit. This also allows the mass of the sample to be reduced from several grams to the 1-mg level. See INDUCTANCE MEASUREMENT; SQUID.

Nuclear magnetic moments are smaller by a factor of  $10^3$  and are used for thermometry only in the ultralow-temperature region. For this the Curie-law behavior is generally sufficient down to the lowest temperatures. The nuclear paramagnetic thermometer loses adequate sensitivity for calibration purposes above 50–100 millikelvins, unless it is operated in a high polarizing field ( $H$  greater than 0.1 tesla). It can be utilized as a self-calibrating primary thermometer if the spin-lattice relaxation time is measured in parallel with the nuclear Curie susceptibility. Pulsed NMR measurement on the  $^{195}\text{Pt}$  isotope in natural platinum metal provides presently the most widely used thermometry at temperatures below 1 mK. In the Curie-susceptibility measuring mode, it has been extended down to 10  $\mu\text{K}$ . See LOW-TEMPERATURE THERMOMETRY; MAGNETIC RELAXATION; NUCLEAR MAGNETIC RESONANCE (NMR). [M.K.]

**Magnetic thin films** Sheets of magnetic material with thicknesses of a few micrometers or less, used in the electronics industry. Magnetic films can be single-crystal, polycrystalline, amorphous, or multilayered in the arrangement of their atoms. Applications include magneto-optic storage, inductive recording media, magnetoresist sensors, and thin-film heads. See COMPUTER STORAGE TECHNOLOGY.

Both ferro- and ferrimagnetic films are used. The ferromagnetic films are usually transition-metal-based alloys. For example, permalloy is a nickel-iron alloy. The ferrimagnetic films, such as garnets or the amorphous films, contain transition metals such as iron or cobalt and rare earths. The ferrimagnetic properties are advantageous in magneto-optic applications where a low overall magnetic moment can be achieved without a significant change in the Curie temperature. See FERRIMAGNETISM; FERROMAGNETISM.

The change in electrical properties, such as the electrical resistance, with a magnetic field is used in sensor elements. The most notable of these in semiconductor technology is the magne-

toresist head used in disk storage technology. Very large magnetoresist signals (called giant magnetoresistance) are observed in magnetic multilayers and composites containing a magnetic and nonmagnetic material. See MAGNETIC MATERIALS; MAGNETISM; MAGNETIZATION. [P.C.]

**Magnetism** The branch of science that describes the effects of the interactions between charges due to their motion and spin. These interactions may appear in various forms, including electric currents and permanent magnets. They are described in terms of the magnetic field, although the field hypothesis cannot be tested independently of the electrokinetic effects by which it is defined. The magnetic field complements the concept of the electrostatic field used to describe the potential energy between charges due to their relative positions. Special relativity theory relates the two, showing that magnetism is a relativistic modification of the electrostatic forces. The two together form the electromagnetic interactions which are propagated as electromagnetic waves, including light. They control the structure of materials at distances between the long-range gravitational actions and the short-range “strong” and “weak” forces most evident within the atomic nucleus. See ELECTROMAGNETIC RADIATION; RELATIVITY.

The magnetic field can be visualized as a set of lines (Fig. 1) illustrated by iron filings scattered on a suitable surface. The intensity of the field is indicated by the line spacing, and the direction by arrows pointing along the lines. The sign convention is chosen so that the Earth’s magnetic field is directed from the north magnetic pole toward the south magnetic pole. The field can be defined and measured in various ways, including the forces on the equivalent magnetic poles, and on currents or moving charges. Bringing a coil of wire into the field, or removing it, induces an electromotive force (emf) which depends on the rate at which the number of field lines, referred to as lines of magnetic flux, linking the coil changes in time. This provides a definition of flux,  $\Phi$ , in terms of the emf,  $e$ , given by Eq. (1) for a

$$e = -N d\Phi/dt \quad \text{volts} \quad (1)$$

coil of  $N$  turns wound sufficiently closely to make the number of lines linking each the same. The International System (SI) unit of  $\Phi$ , the weber (Wb), is defined accordingly as the volt-second. The symbol  $B$  is used to denote the flux, or line, density, as in Eq. (2), when the area of the coil is sufficiently small to sample

$$B = \Phi/\text{area} \quad (2)$$

conditions at a point, and the coil is oriented so that the induced emf is a maximum. The SI unit of  $B$ , the tesla (T), is the  $\text{Wb}/\text{m}^2$ . The sign of the emf,  $e$ , is measured positively in the direction of a right-hand screw pointing in the direction of the flux lines. It is often convenient, particularly when calculating induced emfs, to describe the field in terms of a magnetic vector potential function instead of flux.

**Magnetic circuits.** The magnetic circuit provides a useful method of analyzing devices with ferromagnetic parts, and

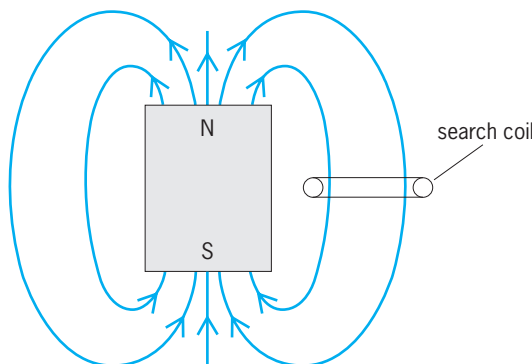

Fig. 1. Magnetic lines of a bar magnet.

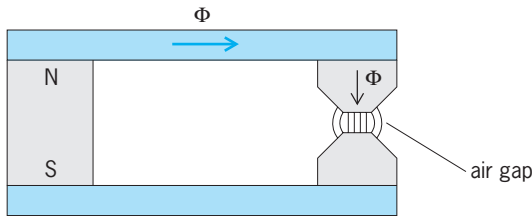

Fig. 2. Magnetic circuit with an air gap.

introduces various quantities used in magnetism. It describes the use of ferromagnetic materials to control the flux paths in a manner analogous to the role of conductors in carrying currents around electrical circuits. For example, pieces of iron may be used to guide the flux which is produced by a magnet along a path which includes an air gap (Fig. 2), giving an increase in the flux density,  $B$ , if the cross-sectional area of the gap is less than that of the magnet. See MAGNET; MAGNETIC MATERIALS.

The magnet may be replaced by a coil of  $N$  turns carrying a current,  $i$ , wound over a piece of iron, or ferromagnetic material, in the form of a ring of uniform cross section. The flux linking each turn of the coil, and each turn of a secondary coil wound separately from the first, is then approximately the same, giving the same induced emf per turn [according to Eq. (1)] when the supply current,  $i$ , and hence the flux,  $\Phi$ , changes in time. The arrangement is typical of many different devices. It provides, for example, an electrical transformer whose input and output voltages are directly proportional to the numbers of turns in the windings. Emf's also appear within the iron, and tend to produce circulating currents and losses. These are commonly reduced by dividing the material into thin laminations. See EDDY CURRENT; TRANSFORMER.

The amount of flux produced by a given supply current is reduced by the presence of any air gaps which may be introduced to contribute constructional convenience or to allow a part to move. The effects of the gaps, and of different magnetic materials, can be predicted by utilizing the analogy between flux,  $\Phi$ , and the flow of electric current through a circuit consisting of resistors connected in series (Fig. 3). Since  $\Phi$  depends on the product,  $iN$ , of the winding current and number of turns, as in Eq. (3),

$$iN = \Phi \mathfrak{R} \quad (3)$$

the ratio between them, termed the reluctance,  $\mathfrak{R}$ , is the analog of electrical resistance. It may be constant or may vary with  $\Phi$ . The quantity  $iN$  is the magnetomotive force (mmf), analogous to voltage or emf in the equivalent electrical circuit. The relationship between the two exchanges the potential and flow quantities, since the magnetic mmf depends on current,  $i$ , and the electrical emf on  $d\Phi/dt$ . Electric and magnetic equivalent circuits are referred to as duals. See RELUCTANCE.

Any part of the magnetic circuit of length  $l$ , in which the cross section,  $a$ , and flux density,  $B$ , are uniform has a reluctance given

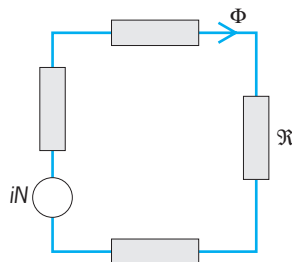

Fig. 3. Circuit analogy. Components of a magnetic circuit carrying a flux  $\Phi$  analogous to current. The reluctances of the components are analogous to resistance.

by Eq. (4). This equation parallels Eq. (5) for the resistance,  $R$ ,

$$\mathfrak{R} = l/(a\mu) \quad (4)$$

$$R = l/(a\sigma) \quad (5)$$

of a conduct of the same dimensions. The permeability,  $\mu$ , is the magnetic equivalent of the conductivity,  $\sigma$ , of the conducting material. Using a magnet as a flux source (Fig. 2) gives an mmf which varies with the air gap reluctance. In the absence of any magnetizable materials, as in the air gaps, the permeability is given by Eq. (6) in SI units (Wb/A-m). The quantity  $\mu_0$  is

$$\mu = \mu_0 = 4\pi \times 10^{-7} \quad (6)$$

sometimes referred to as the permeability of free space. Material properties are described by the relative permeability,  $\mu_r$  in accordance with Eq. (7). The materials which are important in

$$\mu = \mu_r \mu_0 \quad (7)$$

magnetic circuits are the ferromagnetics and ferrites characterized by large value of  $\mu_r$ , sometimes in excess of 10,000 at low flux densities.

**Magnetic field strength.** It is convenient to introduce two different measures of the magnetic field: the flux density,  $B$ , and the field strength, or field intensity,  $H$ . The field strength,  $H$ , can be defined as the mmf per meter. It provides a measure of the currents and other magnetic field sources, excluding those representing polarizable materials. It may also be defined in terms of the force on a unit pole.

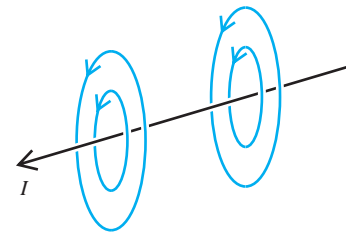

Fig. 4. Magnetic field of a straight wire.

A straight wire carrying a current  $I$  sets up a field (Fig. 4) whose intensity at a point at distance  $r$  is given by Eq. (8). The field

$$H = \frac{I}{2\pi r} \quad (8)$$

strength,  $H$ , like  $B$ , is a vector quantity pointing in the direction of rotation of a right-hand screw advancing in the direction of current flow. The intensity of the field is shown by the number of field lines intersecting a unit area. The straight wire provides one example of the circuital law, known as Ampère's law, given by Eq. (9). Here,  $\theta$  is the angle between  $H$  and the element  $dl$

$$\oint H \cos \theta dl = I \quad (9)$$

of any closed path of summation, or integration, and  $I$  is the current which links this path. Choosing a circular path, centered on a straight wire, reduces the integral to  $H(2\pi r)$ .

A long, straight, uniformly wound coil (Fig. 5), for example, produces a field which is uniform in the interior and zero outside. The interior magnetic field,  $H$ , points in the direction parallel to the coil axis. Applying Eq. (14) to the rectangle  $pqrs$  of unit length in the axial direction shows that the only contribution is from  $pq$ , giving Eq. (10), where  $n$  is the number of turns, per unit length,

$$H = In \quad (10)$$

carrying the current,  $I$ . The magnetic field strength,  $H$ , remains the same, by definition, whether the interior of the coil is empty or is filled with ferromagnetic material of uniform properties. The interior forms part of a magnetic circuit in which  $In$  is the mmf

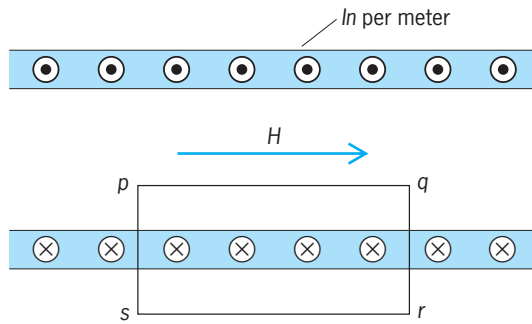

Fig. 5. Cross section of part of a long, straight uniformly wound coil. Black circles indicate current out of the plane of the page, and crosses indicate current into the plane of the page. Rectangle pqrs is used to calculate magnetic field strength,  $H$ , within the coil.

per unit length, where mmf is the magnetic analog of electric voltage, or scalar potential, in an electric circuit. The magnetic field strength,  $H$ , is the analog of the electric field vector,  $E$ , as a measure of potential gradient, pointing down the gradient. The flux density,  $B$ , describes the effect of the field, in the sense of the voltage which is induced in a search coil by changes in time [Eq. (1)]. The ratio of  $H$  to  $B$  is the reluctance of a volume element of unit length and unit cross section in which the field is uniform, so that, from Eq. (4), the two quantities are related by Eq. (11). The permeability,  $\mu$ , is defined by Eq. (11). The

$$B = \mu H \quad (11)$$

relative permeability,  $\mu_r$ , of polarizable materials is measured accordingly by subjecting a sample to a uniform field inside a long coil such as that shown in Fig. 5 and using the emf induced in a search coil wound around the specimen to observe the flux in it.

**Magnetic flux and flux density.** Magnetic flux is defined in terms of the forces exerted by the magnetic field on electric charge. The forces can be described in terms of changes in flux with time [Eq. (1)], caused either by motion relative to the source or by changes in the source current, describing the effect of charge acceleration.

Since the magnetic, or electrokinetic, energy of current flowing in parallel wires depends on their spacing, the wires are subject to forces tending to change the configuration. The force,  $dF$ , on an element of wire carrying a current,  $i$ , is given by Eq. (12),

$$dF = Bi \, dl \quad \text{newtons} \quad (12)$$

and this provides a definition of the flux density,  $B$ , due to the wires which exert the force. The SI unit of  $B$ , called the tesla, or  $\text{Wb/m}^2$ , is the  $\text{N/A}\cdot\text{m}$ . The flux density,  $B$ , equals  $\mu_0 H$  in empty space, or in any material which is not magnetizable [Eq. (11)]. An example is the force,  $F$ , per meter (length) which is exerted by a long straight wire on another which is parallel to it, at distance  $r$ . From Eq. (8), this force is given by Eq. (13), when the wires carry

$$F = \frac{\mu_0 I i}{2\pi r} = 2 \times 10^{-7} I i / r \quad \text{newtons} \quad (13)$$

currents  $I$  and  $i$ . The force,  $F$ , is accounted for by the electrokinetic interactions between the conduction charges, and describes the relativistic modification of the electric forces between them due to their relative motion.

In general, any charge,  $q$ , moving at velocity  $u$  is subject to a force given by Eq. (14), where  $\mathbf{u} \times \mathbf{B}$  denotes the cross-product

$$\mathbf{f} = q \mathbf{u} \times \mathbf{B} \quad \text{newtons} \quad (14)$$

between vector quantities. That is, the magnitude of  $\mathbf{f}$  depends on the sine of the angle  $\theta$  between the vectors  $\mathbf{u}$  and  $\mathbf{B}$ , of mag-

nitudes  $u$  and  $B$ , according to Eq. (15). The force on a positive

$$f = quB \sin \theta \quad (15)$$

charge is at right angles to the plane containing  $\mathbf{u}$  and  $\mathbf{B}$  and points in the direction of a right-hand screw turned from  $\mathbf{u}$  to  $\mathbf{B}$ .

The same force also acts in the axial direction on the conduction electrons in a wire moving in a magnetic field, and this force generates an emf in the wire. The emf in an element of wire of length  $dl$  is greatest when the wire is at right angles to the  $\mathbf{B}$  vector, and the motion is at right angles to both. The emf is then given by Eq. (16). More generally,  $u$  is the component

$$\text{emf} = uB \, dl \quad (16)$$

of velocity normal to  $\mathbf{B}$ , and the emf depends on the sine of the angle between  $d\mathbf{l}$  and the plane containing the velocity and the  $\mathbf{B}$  vectors. The sign is given by the right-hand screw rule, as applied to Eq. (15).

**Magnetic flux linkage.** The magnetic flux linking any closed path is obtained by counting the number of flux lines passing through any surface,  $s$ , which is bounded by the path. Stated more formally, the linkage depends on the sum given in Eq. (17),

$$\Phi = \int \int B_n \, ds \quad \text{webers} \quad (17)$$

where  $B_n$  denotes the component of  $B$  in the direction normal to the area element,  $ds$ . The rate of change of linkage gives the emf induced in any conducting wire which follows the path [Eq. (1)].

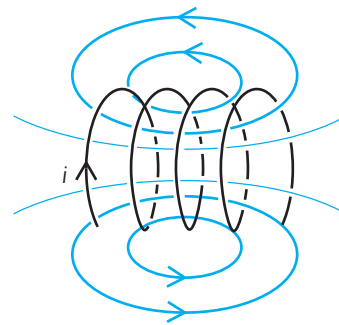

Fig. 6.  $B$  (magnetic flux) field of a short coil.

The flux linkage with a coil (Fig. 6) is usually calculated by assuming that each turn of the coil closes on itself, giving a flux pattern which likewise consists of a large number of separate closed loops. Each links some of the turns, so that the two cannot be separated without breaking, or "tearing," either the loop or the turn. The total linkage with the coil is then obtained by adding the contributions from each turn.

The inductance,  $L$ , is a property of a circuit defined by the emf which is induced by changes of current in time, as in Eq. (18).

$$e = -L \, di / dt \quad (18)$$

The SI unit of inductance is the henry (H), or  $\text{V}\cdot\text{s}/\text{A}$ . The negative sign shows that  $e$  opposes an increase in current (Lenz's law). From Eq. (1) the inductance of a coil of  $N$  turns, each linking the same flux,  $\Phi$ , is given by Eq. (19), so that the henry is also the

$$L = N \Phi / i \quad \text{henrys} \quad (19)$$

$\text{Wb}/\text{A}$ . When different turns, or different parts of a circuit, do not link the same flux, the product  $N\Phi$  is replaced by the total flux linkage,  $\Phi$ , with the circuit as a whole.

The mutual inductance,  $M$ , between any two coils, or circuit parts, is defined by emf which is induced in one by a change of current in the other. Using 1 and 2 to distinguish between them, the emf induced in coil 1 is given by Eq. (20a), where the

$$e_1 = -M_{12} \, di_2 / dt \quad (20a)$$

$$e_2 = -M_{21} \, di_1 / dt \quad (20b)$$

sign convention is consistent with that used for  $L$ , referred to as the self-inductance. Likewise, the emf induced in coil 2 when the roles of the windings are reversed is given by Eq. (20b). The interaction satisfies the reciprocity condition of Eq. (21), so that the suffixes may be omitted.

$$M_{21} = M_{12} \quad (21)$$

**Magnetostatics.** The term “magnetostatics” is usually interpreted as the magnet equivalent of the electrostatic interactions between electric charges. The equivalence is described most directly in terms of the magnetic pole, since the forces between poles, like those between charges, vary inversely with the square of the separation distance. Although no isolated poles, or monopoles, have yet been observed, the forces which act on both magnets and on coils are consistent with the assumption that the end surfaces are equivalent to magnetic poles.

**Magnetic moment.** The magnetic moment of a small current loop, or magnet, can be defined in terms of the torque which acts on it when placed in a magnetic flux density,  $B$ , which is sufficiently uniform in the region of the loop. For a rectangular loop with dimensions  $a$  and  $b$  and with  $N$  turns, carrying a current,  $i$ , equal but opposite forces act on the opposite sides of length  $a$  (Fig. 7). The force is  $iNBa$  [Eq. (12)], and the torque, given by Eq. (22), depends on the effective distance,  $b \sin \theta$ , between

$$T = iNBa b \sin \theta \quad \text{N-m} \quad (22)$$

the wires. It is proportional to the area  $ab$ , and is a maximum when the angle  $\theta$  between  $B$  and the axis of the loop is  $90^\circ$ . A current loop of any other shape can be replaced by a set of smaller rectangles placed edge to edge, and the torques of these added to give the total on the loop. The magnetic moment of any loop of area  $s$  is defined as the ratio of the maximum torque to the flux density, so its magnitude is given by Eq. (23). It is a

$$m = iNs \quad (23)$$

vector quantity pointing in the direction of a right-hand screw turned in the direction of current flow. It is expressed in vector cross-product notation by Eq. (24).

$$\mathbf{T} = \mathbf{m} \times \mathbf{B} \quad (24)$$

See TORQUE.

An electron orbiting at frequency  $f$  is the equivalent of a current  $i = qf$ , giving Eq. (25) for the moment, where  $s$  is the area

$$m_0 = qfs \quad (25)$$

of the orbit. The permissible values are determined by the quantum energy levels. The electron spin is a quantum state which can likewise be visualized as a small current loop. Atomic nuclei also possess magnetic moments. See ELECTRON SPIN; MAGNETON; NUCLEAR MOMENTS.

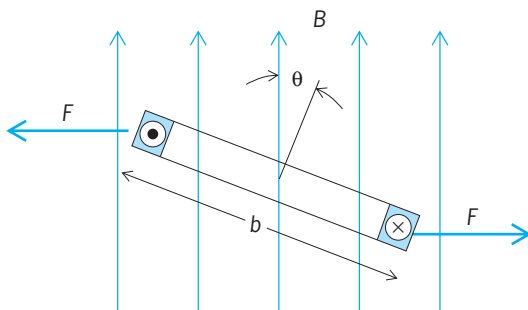

Fig. 7. Cross section of a rectangular current loop placed in magnetic flux density  $B$ . Equal but opposite forces,  $F$ , act on opposite sides of the loop carrying current into the plane of the page (indicated by a cross) and out of the plane of the page (indicated by black circle). These forces give rise to a torque on the loop.

**Magnetic polarization.** Materials are described as magnetic when their response to the magnetic field controls the ratio of  $B$  to  $H$ . The behavior is accounted for by the magnetic moments produced mainly by the electron spins and orbital motions. These respond to the field and contribute to it in a process referred to as magnetic polarization. The effects are greatest in ferromagnetics and in ferrites, in which the action is described as ferrimagnetic. See FERRIMAGNETISM; FERRITE; FERROMAGNETISM.

The sources are the equivalent of miniature “Ampèrian currents” whose sum, in any volume element, is equivalent to a loop of current flowing along the surface of the element. The flux density,  $B$ , depends on the field intensity,  $H$ , which is defined so that its value inside a long ferromagnetic rod of uniform cross section placed inside a long coil (Fig. 5) is the same as in the annular gap between the rod and the coil, in accordance with Eq. (10). If the field is not sufficiently uniform,  $H$  can be measured by using a search coil to observe the flux density,  $\mu_0 H$ , in the gap. The flux density inside the rod is given by Eq. (26), where  $B_0$  denotes

$$B = \mu_r B_0 \quad (26)$$

$\mu_0 H$ , and  $\mu_r$  is the relative permeability [Eqs. (7) and (11)]. The same flux,  $B$ , is obtained by replacing the material by a coil in which the current in amperes per unit length is given by Eq. (27).

$$J_s = (B - B_0)/\mu_0 = (1 - 1/\mu_r)B/\mu_0 \quad (27)$$

The magnetic moment,  $dm$ , of a volume element of length  $dz$  is due to the current flowing over the surface enclosing the area,  $dydz$ ; from Eq. (23), it is given by Eq. (28). The moment per unit volume defines the magnetic polarization, as in Eq. (29).

$$dm = (J_s dx) dy dz \quad (28)$$

$$M = dm/dx dy dz \quad (29)$$

The polarization,  $\mathbf{M}$ , is a vector pointing in the direction of  $d\mathbf{m}$  with magnitude  $J_s$ . The surface current produces an  $\mathbf{H}$ -like, or

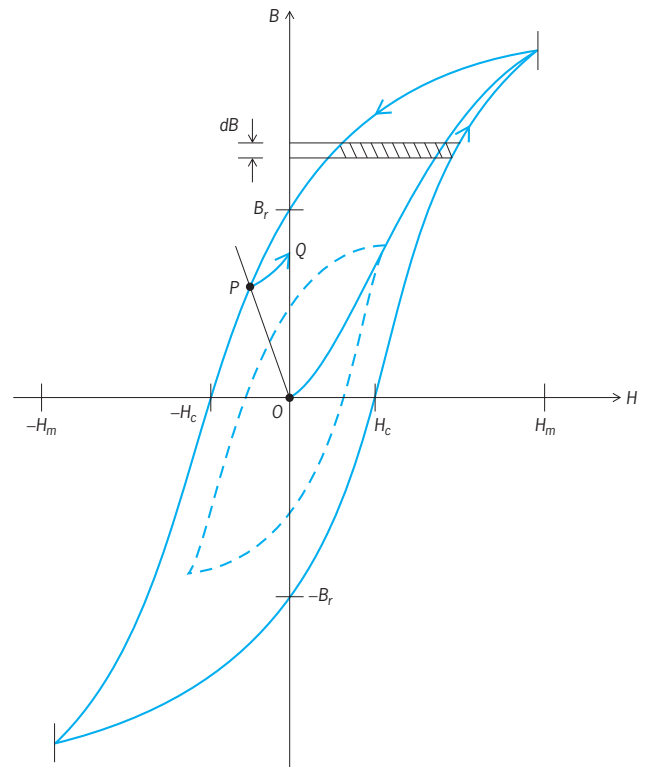

Fig. 8. Hysteresis behavior of a ferromagnetic material.

$\mathbf{B}/\mu_0$ , field which is entirely different from  $\mathbf{H}$  in the material. Substituting from Eq. (27) gives Eq. (30). This model of the material

$$\mathbf{H} = \frac{\mathbf{B}}{\mu_0} - \mathbf{M} \quad (30)$$

accounts for the flux field,  $\mathbf{B}$ , as observed by the voltage induced in a search coil wound around the specimen, and  $\mathbf{H}$ , becomes an auxiliary quantity representing the sum of the polarization,  $\mathbf{M}$ , and the magnetizing field,  $\mathbf{B}/\mu_0$ , to which  $\mathbf{M}$  responds. The polarization,  $\mathbf{M}$ , also makes the largest contribution to that field, since the equivalent surface current is in the same direction as the current in the magnetizing coil.

**Magnetic hysteresis.** The relationship between the flux density,  $B$ , and the field intensity,  $H$ , in ferromagnetic materials depends on the past history of magnetization. The effect is known as hysteresis. It is demonstrated by subjecting the material to a symmetrical cycle of change during which  $H$  is varied continuously between the positive and negative limits  $+H_m$  and  $-H_m$  (Fig. 8). The path that is traced by repeating the cycle a sufficient number of times is the hysteresis loop. The sequence is counterclockwise, so that  $B$  is larger when  $H$  is diminishing than when it is increasing, in the region of positive  $H$ . The flux density,  $B_r$ , which is left when  $H$  falls to zero is called the remanence, or retentivity. The magnetically "hard" materials used for permanent magnets are characterised by a high  $B_r$ , together with a high value of the field strength,  $-H_c$ , which is needed to reduce  $B$  to zero. The field strength,  $H_c$ , is known as the coercive force, or coercivity. Cycling the material over a reduced range in  $H$  gives the path in Fig. 12 traced by the broken line, lying inside the larger loop. The locus of the tips of such loops is known as the normal magnetization curve. The initial magnetization curve is the  $B$ - $H$  relationship which is followed when  $H$  is progressively increased in one direction after the material has first been demagnetized ( $B = H = 0$ ). [C.J.C.]

**Magnetite** A cubic mineral and member of the spinel structure type with composition  $[\text{Fe}^{3+}]^{\text{IV}}[\text{Fe}^{2+}\text{Fe}^{3+}]^{\text{VI}}\text{O}_4$ . The color is opaque iron-black and streak black, the hardness is 6 (Mohs scale), and the specific gravity is 5.20. The habit is octahedral, but the mineral usually occurs in granular to massive form, sometimes of enormous dimensions. Magnetite is a natural ferrimagnet, but heated above 1072°F (578°C; the Curie temperature) it becomes paramagnetic.

The major magnetic ore of iron, magnetite may be economically important if it occurs in sufficient quantities. The most spectacular ore body occurs at Kiruna in northern Sweden. Other important occurrences are in Norway, Russia, and Canada. See IRON; SPINEL. [P.B.M.]

**Magnetization** The process of becoming magnetized; also the property and in particular the extent of being magnetized. Magnetization has an effect on many of the physical properties of a substance. Among these are electrical resistance, specific heat, and elastic strain. See MAGNETOCALORIC EFFECT; MAGNETORESISTANCE; MAGNETOSTRICTION.

The magnetization  $\mathbf{M}$  of a body is caused by circulating electric currents or by elementary atomic magnetic moments, and is defined as the magnetic moment per unit volume of such currents or moments. In the mks (SI) system of units,  $\mathbf{M}$  is measured in webers per square meter. For  $\mathbf{M}$ , 1 weber/m<sup>2</sup> = 10<sup>4</sup>/4 $\pi$  gauss.

The magnetic induction or magnetic flux density  $\mathbf{B}$  is given by the equation below, where  $\mathbf{B}$  and  $\mathbf{M}$  are in webers/m<sup>2</sup>,  $\mathbf{H}$ , the

$$\mathbf{B} = \mu_0\mathbf{H} + \mathbf{M} \text{ (mks)}$$

applied magnetic field, is in ampere-turns/m, and  $\mu_0$ , the permeability of free space, is defined as 4 $\pi \times 10^{-7}$  henry/m, that is, webers/(ampere-turn)(m). See ELECTRICAL UNITS AND STANDARDS.

The topic of magnetization is generally restricted to materials exhibiting spontaneous magnetization, that is, magnetization in the absence of  $\mathbf{H}$ . All such materials will be referred to as

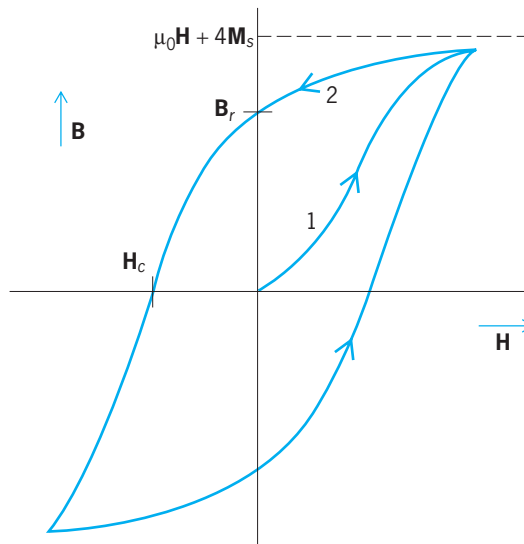

Magnetization or  $B$ - $H$  curves.

ferromagnets, including the special category of ferrimagnets. A ferromagnet is composed of an assemblage of spontaneously magnetized regions called domains. Within each domain, the elementary atomic magnetic moments are essentially aligned, that is, each domain may be envisioned as a small magnet. An unmagnetized ferromagnet is composed of numerous domains, oriented in some fashion.

The process of magnetization in an applied field  $\mathbf{H}$  consists of growth of those domains oriented most nearly in the direction of  $\mathbf{H}$  at the expense of others, followed by rotation of the direction of magnetization against anisotropy forces. See FERROMAGNETISM.

On removal of the field  $\mathbf{H}$ , some magnetization will remain, called the remanence  $\mathbf{M}_r$ .

Curves, sometimes called  $B$ - $H$  curves, are used to describe magnetic materials. They are plotted with  $\mathbf{H}$  as abscissa and with either  $\mathbf{M}$  or  $\mathbf{B}$  as ordinate. In the illustration,  $\mathbf{B}_r$  is the remanent induction ( $\mathbf{B}_r = \mathbf{M}_r$ );  $\mathbf{H}_c$  is the coercive force, or reverse field required to bring the induction  $\mathbf{B}$  back to zero; and  $\mathbf{M}_s$  is the saturation magnetization, or magnetization when all domains are aligned. The saturation magnetization is equal to the spontaneous magnetization of a single domain, except that it is possible to increase this magnetization slightly by application of an extremely large field. Saturation magnetization is temperature dependent, and disappears completely above the Curie temperature  $T_c$  where a ferromagnet changes into a paramagnet. See CURIE TEMPERATURE.

The irreversible nature of magnetization is shown most strikingly by the fact that the path of demagnetization does not retrace the path of magnetization—path 2 of the illustration does not retrace path 1. There is a tendency for the magnetization to show hysteresis, that is, to lag behind the applied field, and the loop of the illustration is called a hysteresis loop. [E.A.; FKe.; K.V.M.]

**Magneto** A type of permanent-magnet alternating-current generator frequently used as a source of ignition energy on tractor, marine, industrial, and aviation engines. See ALTERNATING-CURRENT GENERATOR.

Modern induction-type magnetos consist of a permanent-magnet rotor and stationary low- and high-tension windings, also called the primary and secondary windings. The energy output of a magneto is obtained as a result of a rapid rate of change of flux through the stationary windings. The primary winding has comparatively few turns and the secondary winding has many thousand turns of fine wire. One end of the secondary winding is connected to an end of the primary winding and grounded to the frame of the magneto. The primary winding is closed on

itself through a breaker mechanism actuated by a cam on the magneto shaft. The breaker is mechanically set to interrupt the primary circuit each time the flux through the winding is changing at its greatest rate. The sudden collapse of the primary current induces a very high voltage in the secondary winding. See IGNITION SYSTEM; INTERNAL COMBUSTION ENGINE. [R.T.W.]

**Magnetocaloric effect** The reversible change of temperature accompanying the change of magnetization of a ferromagnetic or paramagnetic material. This change in temperature may be of the order of 1°C (2°F), and is not to be confused with the much smaller hysteresis heating effect, which is irreversible. See THERMAL HYSTERESIS. [E.A.; F.Ke.]

**Magnetochemistry** The branch of chemistry which studies the interrelationship between a magnetic field and atomic and molecular structures.

A substance in a magnetic field acquires an intensity of magnetization which may be either smaller or larger than that induced in a vacuum by the same field. In the first case, the substance is said to be diamagnetic. In the second case, the substance may be paramagnetic, ferromagnetic, or antiferromagnetic.

Diamagnetism, a universal property of matter, is usually of the order of magnitude  $10^{-6}$  to  $10^{-5}$ . Temperature-dependent paramagnetism, on the other hand, arises only when an atom, ion, or molecule possesses a permanent magnetic moment either in the ground state or in an excited state. A permanent magnetic moment is the result of the presence of one or more unpaired electrons. Paramagnetic susceptibilities are of the order of magnitude  $10^{-4}$  to  $10^{-3}$ .

A substance composed of atoms with permanent magnetic moments which are very near to one another (for example, iron metal) may display ferromagnetism. This phenomenon occurs when large numbers of the atoms with permanent magnetic moments interact so that their individual moments align in a parallel fashion, giving rise to a large resultant moment.

On the other hand, a similar substance (for example, manganese metal) may display antiferromagnetism. Here, the magnetic moments align in an antiparallel fashion, thus largely canceling the individual magnetic moments of the atoms. Parallel versus antiparallel alignment depends, among other factors, upon interatomic distances. See ANTIFERROMAGNETISM; ATOMIC STRUCTURE AND SPECTRA; ELECTRON PARAMAGNETIC RESONANCE (EPR) SPECTROSCOPY; MAGNETIC RESONANCE; MAGNETISM; MOLECULAR STRUCTURE AND SPECTRA. [D.M.Gr.]

**Magnetohydrodynamic power generator** A system for the generation of electrical power through the interaction of a flowing, electrically conducting fluid with a magnetic field. As in a conventional electrical generator, the Faraday principle of motional induction is employed, but solid conductors are replaced by an electrically conducting fluid. The interactions between this conducting fluid and the electromagnetic field system through which power is delivered to a circuit are determined by the magnetohydrodynamic (MHD) equations, while the properties of electrically conducting gases or plasmas are established from the appropriate relationships of plasma physics. Major emphasis has been placed on MHD systems utilizing an ionized gas, but an electrically conducting liquid or a two-phase flow can also be employed. See ELECTROMAGNETIC INDUCTION; GENERATOR; MAGNETOHYDRODYNAMICS; PLASMA (PHYSICS).

Electrical conductivity in an MHD generator can be achieved in a number of ways. At the heat-source operating temperatures of MHD systems (1300–5000°F or 1000–3000 K), the working fluids usually considered are gases derived from combustion, noble gases, and alkali metal vapors. In the case of combustion gases, a seed material such as potassium carbonate is added in small amounts, typically about 1% of the total mass flow. The seed material is thermally ionized and yields the electron number density required for adequate electrical conductivity above about

4000°F (2500 K). With monatomic gases, operation at temperatures down to about 2200°F (1500 K) is possible through the use of cesium as a seed material. In plasmas of this type, the electron temperature can be elevated above that of the gas (nonequilibrium ionization) to provide adequate electrical conductivity at lower temperatures than with thermal ionization. In so-called liquid metal, MHD electrical conductivity is obtained by injecting a liquid metal into a vapor or gas stream to obtain a continuous liquid phase.

The conversion process in the MHD generator itself occurs in a channel or duct in which a plasma flows usually above the speed of sound through a magnetic field. High power densities are one of the attractive features of MHD power generators.

Under the magnetic field strengths required for MHD generators, the plasma displays a pronounced Hall effect. To permit the basic Faraday motional induction interaction and simultaneously support the resulting Hall potential in the flow direction, a linear channel requires segmented walls comprising alternately electrodes (anode or cathode) and insulators. From an electrical machine viewpoint, both individual cells and the complete generator may be regarded as a gyrator. The optimum loading of the MHD channel is achieved by extracting power from both the Faraday and Hall terminals, and this is most readily accomplished through consolidation of the dc outputs of individual electrode pairs using power electronics. See GYRATOR; HALL EFFECT.

For most applications, a superconducting magnet system is needed to provide the 4–6-T field, which is at least twice the value utilized in conventional machines. See MAGNET; SUPERCONDUCTING DEVICES.

Improvement of the overall thermal efficiency of central station power plants has been the continuing objective of power engineers. Conventional plants based on steam turbine technology are limited to about 40% efficiency, imposed by a combination of working-fluid properties and limits on the operating temperatures of materials. When combined with a steam turbine system to serve as the high-temperature or topping stage of a binary cycle, an MHD generator has the potential for increasing the overall plant thermal efficiency to around 50%, and values higher than 60% have been predicted for advanced systems. See ELECTRIC POWER GENERATION; STEAM TURBINE.

MHD power generation also has important potential environmental advantages. These are of special significance when coal is the primary fuel, for it appears that MHD systems can utilize coal directly without the cost and loss of efficiency resulting from the processing of coal into a clean fuel required by competing systems. [W.D.J.]

**Magnetohydrodynamics** The interaction of electrically conducting fluids with magnetic fields. The fluids can be ionized gases (commonly called plasmas) or liquid metals. Magnetohydrodynamic (MHD) phenomena occur naturally in the Earth's interior, constituting the dynamo that produces the Earth's magnetic field; in the magnetosphere that surrounds the Earth; and in the Sun and throughout astrophysics. In the laboratory, magnetohydrodynamics is important in the magnetic confinement of plasmas in experiments on controlled thermonuclear fusion. Magnetohydrodynamic principles are also used in plasma accelerators for ion thrusters for spacecraft propulsion, for light-ion-beam powered inertial confinement, and for magnetohydrodynamic power generation. See COSMIC RAYS; GEOMAGNETISM; ION PROPULSION; MAGNETOHYDRODYNAMIC POWER GENERATOR; MAGNETOSPHERE; NUCLEAR FUSION; PLASMA (PHYSICS); SOLAR WIND; SUN.

The conducting fluid and magnetic field interact through electric currents that flow in the fluid. The currents are induced as the conducting fluid moves across the magnetic field lines. In turn, the currents influence both the magnetic field and the motion of the fluid. Qualitatively, the magnetohydrodynamic interactions

tend to link the fluid and the field lines so as to make them move together. See ELECTRIC CURRENT; MAGNETIC FIELD.

The generation of the currents and their subsequent effects are governed by the familiar laws of electricity and magnetism. The motion of a conductor across magnetic lines of force causes a voltage drop or electric field at right angles to the direction of the motion and the field lines; the induced voltage drop causes a current to flow as in the armature of a generator.

The currents themselves create magnetic fields which tend to loop around each current element. The currents heat the conductor and also give rise to mechanical ponderomotive forces when flowing across a magnetic field. (These are the forces which cause the armature of an electric motor to turn.) In a fluid, the ponderomotive forces combine with the pressure forces to determine the fluid motion. See ELECTRICITY; GENERATOR; MAGNETISM; MOTOR.

Magnetohydrodynamic phenomena involve two well-known branches of physics, electrodynamics and hydrodynamics, with some modifications to account for their interplay. The basic laws of electrodynamics as formulated by J. C. Maxwell apply without any change. However, Ohm's law, which relates the current flow to the induced voltage, has to be modified for a moving conductor. See ELECTRODYNAMICS; HYDRODYNAMICS; MAXWELL'S EQUATIONS; OHM'S LAW.

It is useful to consider first the extreme case of a fluid with a very large electrical conductivity. Maxwell's equations predict, according to H. Alfvén, that for a fluid of this kind the lines of the magnetic field move with the material. The picture of moving lines of force is convenient but must be used with care because such a motion is not observable. It may be defined, however, in terms of observable consequences by either of the following statements: (1) a line moving with the fluid, which is initially a line of force, will remain one; or (2) the magnetic flux through a closed loop moving with the fluid remains unchanged.

If the conductivity is low, this is not true and the fluid and the field lines slip across each other. This is similar to a diffusion of two gases across one another and is governed by similar mathematical laws.

As in ordinary hydrodynamics, the dynamics of the fluid obeys theorems expressing the conservation of mass, momentum, and energy. These theorems treat the fluid as a continuum. This is justified if the mean free path of the individual particles is much shorter than the distances that characterize the structure of the flow. Although this assumption does not generally hold for plasmas, one can gain much insight into magnetohydrodynamics from the continuum approximation. The ordinary laws of hydrodynamics can then easily be extended to cover the effect of magnetic and electric fields on the fluid by adding a magnetic force to the momentum-conservation equation and electric heating and work to the energy-conservation equation. [M.G.H.]

**Magnetometer** A device used to measure the intensity and direction of a magnetic field. Magnetometers may be classified as either scalar or vector instruments. A scalar magnetometer measures the strength of the total magnetic field, whereas a vector magnetometer measures one or more vector components of the magnetic field. Most magnetometers are relative instruments that must be calibrated with respect to a known magnetic field. A few magnetometers are absolute instruments that yield accurate magnetic field values without the need for calibration. Three modern devices in regular use are the nuclear magnetometer, fluxgate magnetometer, and SQUID magnetometer.

Two general classes of nuclear magnetometers are the proton precession magnetometer and the optically pumped magnetometer. Both are absolute instruments that measure total field strength without the need for calibration using a known magnetic field.

The fluxgate (saturable-core) magnetometer employs a sensor constructed from an identical pair of cores made from high-magnetic-permeability material. All fluxgate magnetometers are

relative vector instruments that require calibration in a known magnetic field to produce accurate results. Orthogonal sets of fluxgate sensors can be used to measure all three field components and thereby the total field vector. Like proton magnetometers, fluxgate pairs can be configured as vector field gradiometers.

The cryogenic or SQUID magnetometer uses one or more Josephson junctions as a magnetic field sensor. A Josephson junction is a zone of weak magnetic coupling (a weak link) between two regions of superconducting material in which current will flow without resistance. A change in the magnetic field applied to the weak link produces a proportional change in magnetic flux within the Josephson junction. The SQUID is the most sensitive magnetometer in use, capable of measuring flux changes only a small fraction of a flux quantum  $\Phi_0$  ( $2.07 \times 10^{-15}$  weber). See JOSEPHSON EFFECT.

Two types of SQUID are in common use. The radio-frequency SQUID employs a single weak link, whereas the direct-current SQUID uses a pair of Josephson junctions. All SQUID magnetometers are relative, vector instruments. The principal advantages of the SQUID magnetometer over proton, optically pumped, and fluxgate magnetometers are sensitivity and frequency response. The principal disadvantage of the SQUID magnetometer is that it must be kept in a superconducting state. See SQUID. [M.O.McW.]

**Magnetomotive force** The magnetomotive force (mmf) around a magnetic circuit is the work per unit magnetic pole required to carry the pole once around the circuit. It is the analog of electromotive force.

It is expressed mathematically in the equation below, where

$$\text{mmf} = \oint H \cos \theta \, ds$$

$H \cos \theta$  is the component of magnetic field strength in the direction of a length of path  $ds$ . The line integral is taken around any closed path in the field. [K.V.M.]

**Magneton** A unit of magnetic moment used to describe atomic, molecular, or nuclear magnets. More precisely, one unit, the Bohr magneton, is used at the atomic and molecular levels, and another unit, the nuclear magneton, is used at the nuclear level. Still another unit (which might be called the muon magneton, but is usually not named) is used to describe the magnetic moment of the muon. See MAGNETIC MOMENT.

The Bohr magneton  $\mu_B$  is defined and its value given in Eq. (1), where  $-e$  and  $m$  are the charge and mass of the elec-

$$\mu_B = \frac{e\hbar}{2m} = (9.274\,009\,49 \pm 0.000\,000\,80) \times 10^{-24} \text{ joule/tesla}$$

tron respectively and  $\hbar$  is Planck's constant divided by  $2\pi$ . In Dirac's theory the magnetic moment of the electron is exactly  $-\mu_B$ , but according to the theory of quantum electrodynamics the electron has a small anomalous magnetic moment. The experimental value of the electron magnetic moment  $\mu_e$  is given by Eq. (2), in agreement with the prediction of quantum electrodynamics within the errors.

$$\mu_e = -(1.001\,159\,652\,1883 \pm 0.000\,000\,000\,0042)\mu_B$$

The unit of magnetic moment to describe the muon is obtained from the Bohr magneton by replacing  $m$  in Eq. (1) by the muon mass  $m_\mu$ . The experimental value of the muon magnetic moment is given in Eq. (3). The deviation of the muon magnetic moment

$$\mu_\mu = (1.001\,165\,9203 \pm 0.000\,000\,0007) \frac{e\hbar}{2m_\mu}$$

from its Dirac value can also be accounted for by the theory of quantum electrodynamics. See LEPTON.

The nuclear magneton is obtained from the Bohr magneton by replacing  $m$  by the proton mass  $m_p$ . The value of the



nuclear magneton is given in Eq. (4). The nuclear magneton is

$$\mu_N = (5.050\ 783\ 43 \pm 0.000\ 000\ 43) \times 10^{-27} \text{ joule/tesla}$$

used not only as the unit for the magnetic moment of the proton but also for the neutron and other hadrons and for atomic nuclei. If the proton and neutron were Dirac particles, the proton's magnetic moment would be one nuclear magneton (except for a small correction arising from quantum electrodynamics) and the neutron's magnetic moment would be zero (because the neutron is uncharged). However, the proton and neutron have large anomalous magnetic moments, given in Eqs. (5).

$$\mu_p = (2.792\ 847\ 351 \pm 0.000\ 000\ 028)\mu_N$$

$$\mu_n = (-1.913\ 042\ 73 \pm 0.000\ 000\ 45)\mu_N$$

See NEUTRON; NUCLEAR MOMENTS; PROTON.

According to present theory, the proton, neutron, and other hadrons have large anomalous magnetic moments because these particles are not elementary but composite. In the theory of quantum chromodynamics, the principal constituents of a baryon, such as the proton or neutron, are three quarks. See BARYON; ELEMENTARY PARTICLE; FUNDAMENTAL CONSTANTS; QUANTUM CHROMODYNAMICS; QUARKS. [D.B.L.]

**Magneto-optics** That branch of physics which deals with the influence of a magnetic field on optical phenomena. Considering the fact that light is electromagnetic radiation, an interaction between light and a magnetic field would seem quite plausible. It is, however, not the direct interaction of the magnetic field and light that produces the known magneto-optic effects, but the influence of the magnetic field upon matter which is in the process of emitting or absorbing light. See COTTON-MOUTON EFFECT; FARADAY EFFECT; MAGNETO-OPTIC KERR EFFECT; MAJORANA EFFECT; VOIGT EFFECT; ZEEMAN EFFECT. [G.H.Di.; W.W.W.]

**Magnetoresistance** The change of electrical resistance produced in a current-carrying conductor or semiconductor on application of a magnetic field  $H$ . Magnetoresistance is one of the galvanomagnetic effects. It is observed with  $H$  both parallel to and transverse to the current flow. The change of resistance usually is proportional to  $H^2$  for small fields, but at high fields it can rise faster than  $H^2$ , increase linearly with  $H$ , or tend to a constant (that is, saturate), depending on the material. In most nonmagnetic solids the magnetoresistance is positive. See GALVANOMAGNETIC EFFECTS.

In semiconductors, the magnetoresistance is unusually large and is highly anisotropic with respect to the angle between the field direction and the current flow in single crystals. When the magnetoresistance is measured as a function of field, it is the basis for the Shubnikov-de Haas effect, much as the field dependence of the magnetization gives rise to the de Haas-van Alphen effect. Measurement of either effect as the field direction changes with respect to the crystal axes serves as a powerful probe of the Fermi surface. Magnetoresistance measurements also yield information about current carrier mobilities. Important to practical applications is the fact that the geometry of a semiconductor sample can generate very large magnetoresistance, as in the Corbino disk. See DE HAAS-VAN ALPHEN EFFECT; FERMI SURFACE; SEMICONDUCTOR.

Multilayered structures composed of alternating layers of magnetic and nonmagnetic metals, such as iron/chromium or cobalt/copper, can feature very large, negative values of magnetoresistance. This effect, called giant magnetoresistance, arises from the spin dependence of the electron scattering which causes resistance. When consecutive magnetic layers have their magnetizations antiparallel (antiferromagnetic alignment), the resistance of the structure is larger than when they are parallel (ferromagnetic alignment). Since the magnetic alignment can be changed with an applied magnetic field, the resistance of the structure is sensitive to the field. Giant magnetoresistance can

also be observed in a simpler structure known as a spin valve, which consists of a nonmagnetic layer (for example, copper) sandwiched between two ferromagnetic layers (for example, cobalt). The magnetization direction in one of the ferromagnetic layers is fixed by an antiferromagnetic coating on the outside, while the magnetization direction in the other layer, and hence the resistance of the structure, can be changed by an external magnetic field. Films of nonmagnetic metals containing ferromagnetic granules, such as cobalt precipitates in copper, have been found to exhibit giant magnetoresistance as well. See ANTIFERROMAGNETISM; FERROMAGNETISM; MAGNETIC FIELD; MAGNETIZATION.

Magnetoresistors, especially those consisting of semiconductors such as indium antimonide or ferromagnets such as permalloy, are important to a variety of devices which detect magnetic fields. These include magnetic recording heads and position and speed sensors. See MAGNETIC MATERIALS; MAGNETIC RECORDING.

[J.FHe.]

**Magnetosphere** A comet-shaped cavity or bubble around the Earth, carved in the solar wind. This cavity is formed because the Earth's magnetic field represents an obstacle to the solar wind, which is a supersonic flow of plasma blowing away from the Sun. As a result, the solar wind flows around the Earth, confining the Earth and its magnetic field into a long cylindrical cavity with a blunt nose. Since the solar wind is a supersonic flow, it also forms a bow shock a few earth radii away from the front of the cavity. The boundary of the cavity is called the magnetopause. The region between the bow shock and the magnetopause is called the magnetosheath. The Earth is located about 10 earth radii from the blunt-nosed front of the magnetopause. The long cylindrical section of the cavity is called the magnetotail, which is on the order of a few thousand earth radii in length, extending approximately radially away from the Sun. See SOLAR WIND; SUN.

The magnetosphere has been extensively explored by a number of satellites carrying sophisticated instruments. The satellite observations have indicated that the cavity is not an empty one, but is filled with plasmas of different characteristics. The Earth's dipolar magnetic field is considerably deformed by these plasmas and the electric currents generated by them. See VAN ALLEN RADIATION.

All other magnetic planets, such as Mercury, Jupiter, and Saturn, have magnetospheres which are similar in many respects to the magnetosphere of the Earth. [S.-I.A.]

**Magnetostriction** The change of length of a ferromagnetic substance when it is magnetized. More generally, magnetostriction is the phenomenon that the state of strain of a ferromagnetic sample depends on the direction and extent of magnetization. The phenomenon has an important application in devices known as magnetostriction transducers. See FERROMAGNETISM.

The magnetostrictive effect is exploited in transducers used for the reception and transmission of high-frequency sound vibrations. Nickel is often used for this application. See SONAR; ULTRASONICS. [E.A.; FKe.]

**Magnetron** The oldest of a family of crossed-field microwave electron tubes wherein electrons, generated from a heated cathode, move under the combined force of a radial electric field and an axial magnetic field. By its structure a magnetron causes moving electrons to interact synchronously with traveling-wave components of a microwave standing-wave pattern in such a manner that electron potential energy is converted to microwave energy with high efficiency. Magnetrons have been used since the 1940s as pulsed microwave radiation sources for radar tracking. Because of their compactness and the high efficiency with which they can emit short bursts of megawatt peak

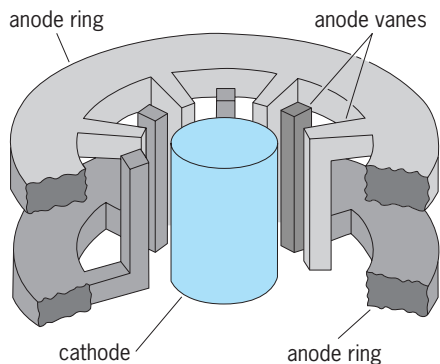

An interdigital-vane anode circuit and cathode, indicating the basic cylindrical geometry of the magnetron. (After G. D. Sims and I. M. Stephenson, *Microwave Tubes and Semiconductor Devices*, Blackie and Son, London, 1963)

output power, they have proved excellent for installation in aircraft as well as in ground radar stations. In continuous operation, a magnetron can produce a kilowatt of microwave power which is appropriate for rapid microwave cooking. See ELECTRON TUBE.

The magnetron is a device of essentially cylindrical symmetry (see illustration). On the central axis is a hollow cylindrical cathode. The outer surface of the cathode carries electronemitting materials, primarily barium and strontium oxides in a nickel matrix. Such a matrix is capable of emitting electrons when current flows through the heater inside the cathode cylinder. See VACUUM TUBE.

At a radius somewhat larger than the outer radius of the cathode is a concentric cylindrical anode. The anode serves two functions: (1) to collect electrons emitted by the cathode and (2) to store and guide microwave energy. The anode consists of a series of quarter-wavelength cavity resonators symmetrically arranged around the cathode.

A radial dc electric field (perpendicular to the cathode) is applied between cathode and anode. This electric field and the axial magnetic field (parallel and coaxial with the cathode) introduced by pole pieces at either end of the cathode provide the required crossed-field configuration. [R.J.Co.]

**Magnification** A measure of the effectiveness of an optical system in enlarging or reducing an image. For an optical system that forms a real image, such a measure is the lateral magnification  $m$ , which is the ratio of the size of the image to the size of the object. If the magnification is greater than unity, it is an enlargement; if less than unity, it is a reduction.

The angular magnification is the ratio of the angles formed by the image and the object at the eye. In telescopes the angular magnification (or, better, the ratio of the tangents of the angles under which the object is seen with and without the lens, respectively) can be taken as a measure of the effectiveness of the instrument.

Magnifying power is the measure of the effectiveness of an optical system used in connection with the eye. The magnifying power of a spectacle lens is the ratio of the tangents of the angles under which the object is seen with and without the lens, respectively. The magnifying power of a magnifier or an ocular is the ratio of the size under which an object would appear when seen through the instrument at a distance of 10 in. or 250 mm (the distance of distinct vision) divided by the object size. See LENS (OPTICS); OPTICAL IMAGE. [M.J.H.]

**Magnitude (astronomy)** The brightness of an astronomical object, expressed on a unique numerical scale. The stel-

lar magnitude scale is logarithmic and is inverted in that fainter objects have numerically larger magnitudes. Although used primarily for stars, the stellar magnitude scale can also be used to express the brightness of the Sun, planets, asteroids, comets, nebulae, galaxies, and even background radiation.

Since the brightness of any object varies with wavelength, many different magnitude scales have been defined corresponding to different spectral regions, bandwidths, and methods of observation. Visual magnitudes, corresponding to the sensitivity of the human eye centered in the yellow part of the spectrum, are usually implied if the type is unspecified.

The star catalog of Hipparchus (about 150 B.C.) is thought to have contained approximately 850 naked-eye stars classified according to brightness. The 15 or so brightest stars were referred to as stars of the first magnitude, while second-magnitude stars were on the average two or three times fainter, and so on. The scale is logarithmic because intervals that are perceived as equal intervals are, in fact, equal brightness ratios.

Measurements of brightness ratios in the nineteenth century showed that, on average, stars of the sixth magnitude (near the limit of naked-eye vision) were about 100 times fainter than those of the first. On the scale introduced by N. R. Pogson in 1856 and universally adopted, an interval of 5 magnitudes corresponds to a factor of exactly 100, so that each magnitude corresponds to a factor of  $100^5 \approx 2.512 \dots$ . The zero point of the Pogson scale was set so that most stars retained their customary magnitudes.

An attractive feature of the magnitude scale is the ease with which fractional magnitudes can be interpreted. Each change of 1% in the brightness of an object corresponds to a change of 0.01 in the magnitude, and this numerical correspondence holds to good accuracy for changes up to about 30%.

A distinction is made between the apparent magnitude of an object viewed from the Earth and its absolute magnitude, which measures the object's intrinsic luminosity by indicating its apparent magnitude as seen from a standard distance. The absolute magnitude may be defined as the apparent magnitude an object would have if viewed from a distance of 10 parsecs (1 pc = 3.26 light-years =  $1.92 \times 10^{13}$  mi =  $3.09 \times 10^{13}$  km). See PARSEC. [R.F.W.]

**Magnolia** A genus of trees with large, chiefly white flowers, and simple, entire, usually large alternate leaves. In the winter the twigs may be recognized by their aromatic odor when bruised.

The most important species commercially is *Magnolia acuminata*, commonly called cucumber tree, which grows in the Appalachian and Ozark mountains. The fruit is red when ripe and resembles a small cucumber in shape.

The wood of the magnolia is similar to that of the tulip tree and is rather soft, but it is of such wide natural dimensions that it is valued for furniture, cabinetwork, flooring, and interior finish.

Magnolia species occur naturally in a broad belt in the eastern United States and Central America, with a similar region in eastern Asia and the Himalayas. See MAGNOLIALES. [A.H.G./K.P.D.]

**Magnoliales** An order of flowering plants consisting of six families, the best known of which are Magnoliaceae (220 species) and Annonaceae (2200 species). The others contain some botanically interesting and peculiar plants (305 species), but none besides Myristicaceae (300 species) are commonly encountered. Previously, many authors have considered these families as among the most primitive of the flowering plants, but in all cases the plants exhibit some highly derived traits. Studies of sequences of deoxyribonucleic acid (DNA) demonstrate that Magnoliales are closely related to Laurales, Piperales, and Winterales, and then more distantly to the monocotyledons.

Some species are of minor economic importance in various parts of the tropics: Annonaceae contain the custard apple, soursop, and sweetsop (*Annona* species), ylang-ylang (an aromatic

oil is produced by the flowers of *Canaga odorata*), and *Mkilua fragrans* is the source of a perfume. *Myristica fragrans* (Myristicaceae) is the source of nutmeg and mace, and seeds of several species in this family are used locally to produce consumable oils that are sometimes also used for candle making. Of Magnoliaceae, many species of *Magnolia* (tulip trees) are used as ornamental trees in the temperate and tropical zones, and *Liriodendron* (yellow poplar or green tulip tree) is a commonly planted shade tree throughout the north temperate region. The latter is also a valuable timber-producing genus. See LAURALES; PIPERALES; TULIP TREE. [M.W.C.]

**Magnoliidae** A subclass of the class Magnoliopsida (dicotyledons) in the division Magnoliophyta (Angiospermae), the flowering plants. The subclass consists of 8 orders, 39 families, and more than 12,000 species. The Magnoliidae are the most primitive subclass of flowering plants. In general, they have a well-developed perianth, which may or may not be numerous, centripetal stamens, and they are apocarpous. See ARISTOLOCHIALES; ILLICIALES; LAURALES; MAGNOLIALES; MAGNOLIOPHYTA; MAGNOLIOPSIDA; NYMPHAEALES; PAPAVERALES; PIPERALES; PLANT KINGDOM; RANUNCULALES. [A.Cr.; T.M.Ba.]

**Magnoliophyta** A division of seed plants consisting of about 250,000 species, which form the bulk and most conspicuous element of the land plants. Often called flowering plants or angiosperms, they have several unique characteristics, the most prominent of which are their reproductive structure, flowers, and covered seeds. The other obvious woody land plants are the gymnosperms, which have cones instead of flowers and have naked seeds. Another trait distinguishing the angiosperms is the presence of double fertilization, which results in the production of stored food (starch or oils) within their seeds. See FLOWER.

Angiosperms range from some of the smallest plants known to large forest trees, and they occur in all habitats, including the oceans, where they are only a minor element in most marine ecosystems. Some are capable of growing directly on rock surfaces as well as on the limbs of trees. The angiosperms are usually considered to be the most highly evolved division of the subkingdom Embryobionta. Their highly specialized and relatively efficient conducting tissues, combined with the protection of their ovules in an ovary, give them a competitive advantage over most other groups of land plants in most regions. See EMBRYOBIONTA.

The angiosperms may be characterized as vascular plants with roots, stems, and leaves, usually with well-developed vessels in the xylem and with companion cells in the phloem. The central cylinder has leaf gaps or scattered vascular bundles; the ovules are enclosed in an ovary; and the female gametophyte is reduced to a few-nucleate embryo sac without an archegonium. The male gametophyte is reduced to a tiny pollen grain that gives rise to a pollen tube containing a tube nucleus and two sperms; one sperm fuses with the egg in the embryo sac to form a zygote, and the other fuses with two nuclei of the embryo sac to form a triple fusion nucleus that is typically the forerunner of the endosperm of the seed. See LEAF; PHLOEM; POLLEN; REPRODUCTION (PLANT); ROOT (BOTANY); SEED; STEM; XYLEM. [M.W.C.]

Among plants with alternation of sporophyte and gametophyte generations, the angiosperms represent the most extreme stage in reduction of the gametophyte, which in effect is reduced to a mere stage in the reproduction of the sporophyte. The pollen grain, with its associated pollen tube, and the embryo sac represent the male and female gametophyte generations; the endosperm is a new structure not referable to either generation; and the remainder of the plant throughout its life cycle is the sporophyte. Many angiosperms can also propagate asexually by means of creeping stems or roots or by other specialized vegetative structures such as bulbils.

It is obvious to biologists that the angiosperms must have evolved from gymnosperms, but beyond this the facts are obscure. They appear in the fossil record early in the Cretaceous Period as obvious angiosperms, without any hint of a connection to any particular group of gymnosperms. Many believe that among the gymnosperms the seed ferns provide the most likely ancestors. See PALEOBOTANY; PINOPHYTA.

The Magnoliophyta consist of two large groups that have not been formally named: the eudicots and the magnoliids. The eudicots are characterized by flowers that are highly organized in terms of the number and orientation of parts whereas the magnoliids have many parts without any particular fixed patterns among the parts—except for the monocots, in which the most developed groups, like the eudicots, exhibit developed flowers with highly organized patterns. See LILIOPSIDA; MAGNOLIOPSIDA. [A.Cr.; T.M.Ba.; M.W.C.]

**Magnoliopsida** One of the two classes of flowering plants which collectively make up the division Magnoliophyta (Angiospermae). The Magnoliopsida, often known as Dicotyledoneae or dicotyledons, embrace 6 subclasses, 64 orders, 318 families, and about 165,000 species.

All of the characters which collectively distinguish the Magnoliopsida from the Liliopsida (monocotyledons) are subject to exception, but in general the Magnoliopsida have two cotyledons and net-veined leaves. The vascular bundles are typically borne in a ring (or cylinder) enclosing a pith. Increase in thickness of stems and roots, after the primary tissues have matured, results from meristematic activity of a cambial layer which passes through the vascular bundles. In about half of the species of the group, the cambium of the stem forms a continuous cylinder which produces a new layer of wood (secondary xylem) and bark (secondary phloem) each growing season for year after year. Such plants become trees or shrubs.

It is widely agreed that the most existing angiosperms belong to the dicotyledons (especially the order Magnoliales) and that most of the characters which distinguish the monocotyledons as a group are derived rather than primitive. See ASTERIDAE; CARYOPHYLLIDAE; DILLENIIDAE; HAMAMELIDAE; LILIOPSIDA; MAGNOLIALES; MAGNOLIIDAE; MAGNOLIOPHYTA; PLANT KINGDOM; ROSIDAE. [A.Cr.; T.M.Ba.]

**Magnon** A quantum of a spin wave; an elementary excitation of a magnetic system which is usually long-range-ordered, such as a ferromagnet. See ANTIFERROMAGNETISM; FERRIMAGNETISM; FERROMAGNETISM.

In the lowest energy state of a simple ferromagnet, all the magnetic moments of the individual atoms are parallel (say, to the  $z$  axis). Each atomic moment derives mainly from the electron spin angular momentum of the atom. In the next-to-lowest energy state (first excited state), the total  $z$  component of spin angular momentum,  $S_z$ , is reduced by one unit of  $\hbar = h/2\pi$ , where  $h$  is Planck's constant. In the case of a crystalline material, this unit is shared equally by all the spins, each of which lies on a cone (see illustration), precessing at an angular rate  $\omega$ . These spins form a wave, known as a spin wave, having a repeat distance or wavelength,  $\lambda$ . The wave amplitude (that is, the cone angle) is extremely small, because of the sharing among all the spins whose number  $N$  is very large, roughly  $10^{23}$ . Thus, each atom's share of the reduction in  $S_z$ , labeled  $\Delta$ , is only  $\hbar/N$ , whereas the  $z$  component of the atomic spin in the fully aligned state is typically 1–10 times  $\hbar$ . It follows from simple geometry that the cone half-angle is of order  $10^{-11}$  to  $10^{-12}$  radian. The state with this value of the amplitude is said to be a one-magnon state with wave number  $k = 1/\lambda$ . If  $\Delta$  is doubled to  $2\hbar/N$ , the state is a two-magnon state, and so forth. The integer values of  $N\Delta/\hbar$  correspond to the possible changes in  $S_z$  being integral multiples of  $\hbar$ . See ELECTRON SPIN; WAVE MOTION.

While the spin waves associated with energy states, that is, stationary states, in crystals vary sinusoidally in space (see

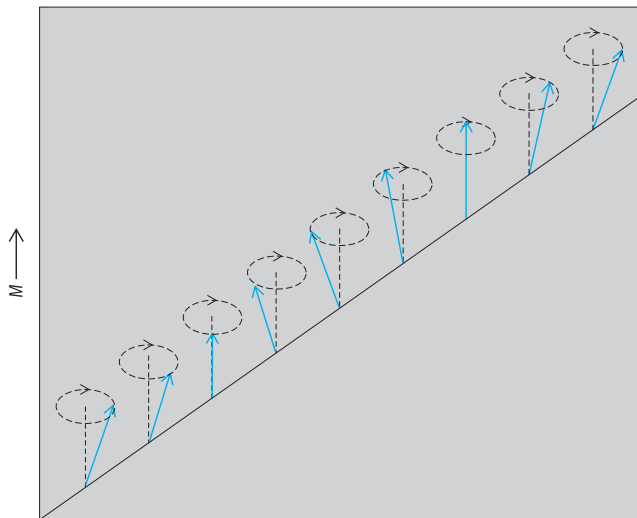

Spin wave in a linear ferromagnetic array of precessing atomic spins of equal magnitude, represented as arrows (vectors) in perspective. The axis of precession is along the vertical direction of the total magnetization,  $M$ .

illustration), magnons can be associated, instead, with nonstationary states (wave packets) in some situations. Closely analogous to magnons are phonons and photons, quanta of mass-density waves and electromagnetic waves, respectively. See ELECTROMAGNETIC WAVE; PHONON; PHOTON; QUANTUM MECHANICS. [T.A.K.]

**Mahogany** A hard, red or yellow-brown wood which takes a high polish and is extensively used for furniture and cabinetwork. The West Indies mahogany tree (*Swietenia mahagoni*), a native of tropical regions in North and South America, is a large evergreen tree with smooth pinnate leaves. Together with other species it yields the world's most valuable cabinet wood. In the United States it occurs naturally only in the extreme southern tip of Florida, but it is planted elsewhere in the state as an ornamental and shade tree. [A.H.G./K.P.D.]

**Maillard reaction** A nonenzymatic chemical reaction involving condensation of an amino group and a reducing group, resulting in the formation of intermediates which ultimately polymerize to form brown pigments (melanoidins). The reaction was named for the French biochemist Louis-Camille Maillard. It is of extreme importance to food chemistry, especially because of its ramifications in terms of food quality. See AMINE; REACTIVE INTERMEDIATES.

There are three major stages of the reaction. The first comprises glycosylamine formation and rearrangement *N*-substituted-1-amino-1-deoxy-2-ketose (Amadori compound). The second phase involves loss of the amine to form carbonyl intermediates, which upon dehydration or fission form highly reactive carbonyl compounds through several pathways. The third phase occurring upon subsequent heating involves the interaction of the carbonyl flavor compounds with other constituents to form brown nitrogen-containing pigments (melanoidins). These are highly desirous compounds in certain foods browned by heating in the presence of oxygen.

The Maillard reaction is considered undesirable in some biological and food systems. The interaction of carbonyl and amine compounds might damage the nutritional quality of proteins by reducing the availability of lysine and other essential amino acids and by forming inhibitory or antinutritional compounds. The reaction is also associated with undesirable flavors and colors in some foods, particularly dehydrated foods. See AMINO ACIDS; CARBONYL. [M.E.B.]

**Malachite** A bright-green, basic carbonate of copper [ $\text{Cu}_2\text{CO}_3(\text{OH})_2$ ]. Malachite is the most stable copper mineral in natural environments in contact with the atmosphere and hydrosphere. It occurs as an ore mineral in oxidized copper sulfide deposits; as a stain on fractures in rock outcrops; as a corrosion product of copper and its alloys (except in industrial-urban environments, where the basic copper sulfate dominates); as suspended particles in streams and in alluvial sediments; and as encrustations on bronze artifacts in seawater and on coccoliths floating in the oceans. It can be distinguished from other green copper minerals by its effervescence in acid. The combination of hardness (3.5–4 on Mohs scale) ideal for carving, color variation in concentric layers, and adamantine-to-silky luster has made malachite a highly prized ornamental stone. Its rare blocky-tabular crystals up to 5 mm (0.2 in.), its pseudomorphs after azurite crystals to 2 cm (0.8 in.), and its more common felty tufts perched on bright blue azurite are eagerly sought by mineral collectors. Malachite is an important copper ore mineral in supergene copper oxide deposits formed by weathering of primary copper sulfide deposits. See AZURITE; CARBONATE MINERALS; COPPER. [M.T.E.]

**Maintenance, industrial and production** The actions taken to preserve the operation of devices, particularly of electromechanical equipment, to ensure that the devices can perform their intended functions when needed. The field of maintenance science is an interdisciplinary research area that employs techniques from physics, engineering, and decision analysis. Traditionally, the focus of maintenance has been on equipment availability—the ratio of operating time less downtime to total available time. Modern maintenance practices focus on increasing equipment effectiveness, that is, making sure that the equipment is both available and capable of producing superior-quality products. See SYSTEMS ENGINEERING.

It has been estimated that up to 50% of all life-cycle equipment costs are attributable to operation and maintenance. Equipment buyers are now requiring better information on time to failure and repair. Suppliers have responded by including such things as failure mode and effects analysis, statistical information on failure times, cost-effective maintenance procedures, and better customer training with their products. Additionally, many companies emphasize design enhancements to improve maintainability, such as built-in diagnostics, greater standardization and modularity, and improved component accessibility. See ENGINEERING DESIGN; MACHINE DESIGN.

Maintenance activities can be classified into several broad categories, depending on whether they respond to failures that have occurred or whether they attempt to prevent failures. The simplest and least sophisticated maintenance strategy still used by many companies is reactive maintenance or breakdown maintenance. Equipment is operated until it fails, then repaired or replaced. No effort is expended on activities that monitor the ongoing "health" of the equipment, and maintenance is focused on quick repairs that return the equipment to production as soon as possible. A slightly more sophisticated maintenance strategy is preventive maintenance, also known as calendar-based maintenance. This system involves detailed, planned maintenance activities on a periodic basis, usually monthly, quarterly, semi-annually, or annually. As in reactive maintenance, preventive maintenance does not monitor information on equipment status. Rather, it attempts to avoid unplanned failures through planned repairs or replacements. Predictive maintenance is based on an ongoing (continuous or periodic) assessment of the actual operating condition of equipment. The equipment is monitored while in operation, and repair or replacement is scheduled only when measurements indicate that it is required. Predictive maintenance programs seek to control maintenance activities to avoid both unplanned equipment outages and unnecessary maintenance and overhauls. [G.A.K.]

**Malacostraca** The largest and most diversified class of the Crustacea; includes the shrimps, lobsters, crabs, sow bugs, beach hoppers, and their allies. The shell or carapace may be large, small, vestigial, or absent; the tail or abdomen is long or short; the eyes are generally set on movable stalks but may be sessile or even coalesced. Despite this diversity, the unity of the group is demonstrated by the following characteristics which all share. The maximum number of appendages is 19 pairs. The trunk limbs are sharply differentiated into a thoracic series of eight pairs and an abdominal series of six pairs. The female genital duct always opens at the level of the sixth thoracic segment, whereas those of the male open at the level of the eighth.

Malacostraca are divided into three subclasses, the Phyllocarida, Hoplocarida, and Eumalacostraca. Central to the classification of the Eumalacostraca has been the concept of the "caridoid facies" (see illustration). This term refers to a series of

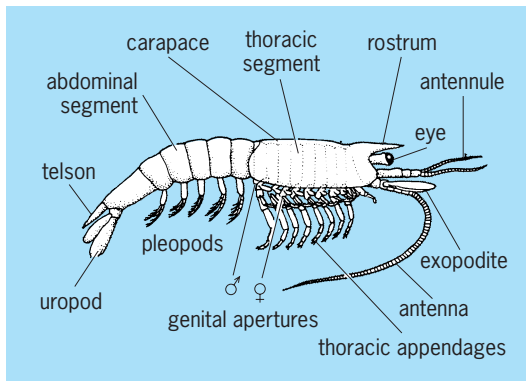

Caridoid facies. (After E. R. Lankester, ed., *A Treatise on Zoology*, pt. 7. fasc. 3, A. and C. Black, 1909)

morphological attributes generally common to the four orders, Syncarida, Pancarida, Peracarida, and Eucarida. See EUCARIDA; EUMALACOSTRACA; HOPLOCARIDA; PERACARIDA; PHYLLOCARIDA; SYNCARIDA. [P.A.McL.]

**Malaria** A disease caused by members of the protozoan genus *Plasmodium*, a widespread group of sporozoans that parasitize the human liver and red blood cells. Four species can infect humans: *P. vivax*, causing vivax or benign tertian malaria; *P. ovale*, a very similar form found chiefly in central Africa that causes ovale malaria; *P. malariae*, which causes malariae or quartan malaria; and *P. falciparum*, the highly pathogenic causative organism of falciparum or malignant tertian malaria. Malaria is characterized by periodic chills, fever, and sweats, often leading to severe anemia, an enlarged spleen, and other complications that may result in loss of life, especially among infants whose deaths are almost always attributed to falciparum malaria. The infective agents are inoculated into the human bloodstream by the bite of an infected female *Anopheles* mosquito, more than 60 species of which can carry the infection to humans. The disease is found in all tropical and some temperate regions, but it has been eradicated in North America, Europe, and Russia. Despite control efforts, malaria has probably been the greatest single killer disease throughout human history and continues to be a major infectious disease. See EPIDEMIC.

The vast reproductive capacity of *Plasmodium* parasites is illustrated by their life cycle, which begins as a series of asexual divisions in human liver and then red blood cells. Transfer of the parasites to the mosquito host depends on the rate of sexual multiplication that begins in the infected human red blood cells and is completed in the mosquito stomach, followed by asexual

multiple division of the product of sexual fusion. Clinical malaria usually begins 7–18 days after infection with sporozoites. Red cell infections tend to follow a remarkably synchronous division cycle. The parasite progresses from merozoite to a vegetative phase (trophozoite) to a division stage (schizont), ending with the new generation of merozoites ready to break out in a burst of parasite releases and initiate the chills-fever-sweat phase of the disease. The sequence of chills, fever, and sweats is the result of simultaneous red cell destruction at 48- or 72-h intervals. See SPOOROZOA.

Chloroquine remains the drug of choice for prevention as well as treatment of vivax, ovale, and malariae malaria. However, most strains of falciparum malaria have become strongly chloroquine-resistant. For prevention of chloroquine-resistant falciparum malaria (and in some areas vivax malaria is now chloroquine-resistant as well) a weekly dose of mefloquine beginning a week before, then during, and for 4 weeks after leaving the endemic area is recommended. Chloroquine-resistant malaria is chiefly treated with the oldest known malaricide, quinine, in the form of quinine sulfate, plus pyrimethamine-sulfadoxine. See DRUG RESISTANCE; QUININE.

Failure of earlier efforts to eradicate malaria and the rapid spread of resistant strains of both parasites and their mosquito vectors necessitated renewed interest in prevention of exposure by avoidance of mosquito bites using pyrethrin-treated bednets, coverage of exposed skin during active mosquito periods (usually dawn, dusk, and evening hours), and use of insect-repellent lotions. A balance between epidemiological and immunological approaches to prevention, and the continued development of new drugs for prophylaxis and treatment are recognized as the most effective means to combat one of the most dangerous and widespread threats to humankind from an infectious agent. See MEDICAL PARASITOLOGY. [D.He.]

**Mallophaga** A comparatively small order of insects numbering perhaps 3000 known species which are commonly called the bird lice or, more correctly, the biting lice. Most of them occur among the feathers of birds. Only a comparatively small number, perhaps 300 species, occur on mammals. The group can be distinguished from the sucking lice by the fact that they always possess mandibles. Unlike sucking lice, they never have claws enlarged or modified to close about a hair or a feather. The significant difference between biting and sucking lice is the fact that the Mallophaga rarely transmit any disease of their host, while the sucking lice are well-known vectors of organisms that cause certain diseases.

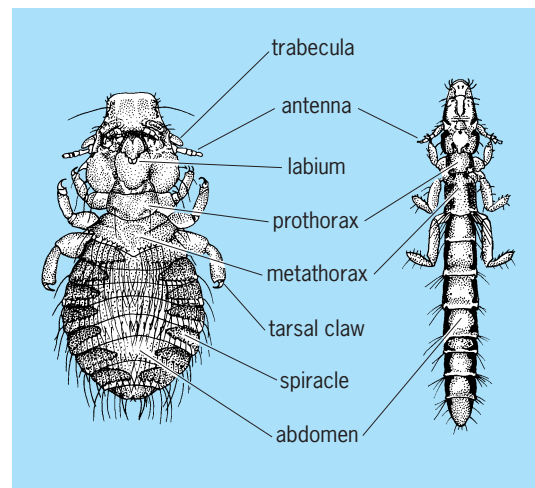

Morphology of two typical mallophagans.

The group may be technically defined as follows (see illustration): relatively small insects, much flattened and permanently without wings. The antennae are five-segmented; mandibles are distinctly developed and their apices cross. The prothorax is developed as a distinct segment, while the mesothorax and metathorax at times are closely fused. Legs possess either one or two terminal claws. The ovipositor is greatly reduced in size.

Like the sucking lice, the Mallophaga are closely adapted to life upon a single host species or, at most, upon a group of closely related hosts. The physical adaptation is not as close as in the sucking lice. There is enough adaptation, however, to preclude the ready passage of a mallophagan from one host species to another, particularly at times other than in the nest or when the hosts are in close bodily contact. The result is that they are usually passed from an animal to its offspring as a sort of racial inheritance, and the insects live as upon an "island" which is the host. Because of this, the classification of the Mallophaga reflects in a way the classification of their hosts. *See ANOPLURA; INSECTA.*

[D.M.DeL.]

**Malnutrition** Impaired health caused by a dietary deficiency, excess, or imbalance. To support human life, energy (from fat, carbohydrate, and protein), water, and more than 40 different food substances must be obtained from the diet in appropriate amounts. Malnutrition can result from the chronic intake of any of these substances at levels above, as well as below, ranges that are adequate and safe, but commonly the term refers only to deficient intake.

The number of people throughout the world who suffer from nutritional deficiencies as a result of inadequate dietary intake is uncertain, but even the most conservative estimates place that figure at hundreds of millions; many experts consider the actual number to approach 1 billion. Most malnourished people live in developing countries where income, education, and housing are inadequate to buy, transport, store, and prepare food and where nutritional deficiencies are almost always related to poverty. In industrialized countries, chronic conditions of deficient dietary intake occur far less frequently but are reported occasionally among people who are dieting to lose weight, fasting, or on an unusually restrictive ("fad") diet. Pregnant women, infants, and children are most at risk for inadequate dietary intake because their nutritional requirements are relatively high.

Nutritional deficiencies also occur as a result of illness, injury, or alcohol or drug abuse that interferes with appetite; the inability to eat; defective digestion, absorption, or metabolism of food molecules; or disease states that increase nutrient losses. Secondary malnutrition has been observed frequently among medical and surgical patients who are treated in hospitals for prolonged periods of time. Regardless of cause, the effects of malnutrition can range from minor symptoms to severe syndromes of starvation, protein-calorie malnutrition, or single-nutrient deficiencies. *See METABOLIC DISORDERS.*

The chronic intake of energy below the level of expenditure induces rapid losses in body weight and muscle mass accompanied by profound changes in physiology and behavior. Together, these effects cause a starving person to become weak, apathetic, depressed, and unable to work productively and to do whatever is necessary to reverse the malnutrition. The consequences of nutritional deficiencies are seen first in tissues that are growing rapidly. These changes are most evident in the gastrointestinal tract, skin, blood cells, and nervous system as indigestion, malabsorption, skin lesions, anemia, or neurologic and behavior changes. Of special concern is the loss of immune function that accompanies severe malnutrition.

The combined effects of malnutrition and infection in young children are referred to as protein-calorie malnutrition. It is classified into two entities, marasmus and kwashiorkor, on the basis of physical appearance and the relative proportions of protein and

calories in the diet. Children with the marasmus form appear generally wasted as a result of diets that are chronically deficient in calories as well as protein and other nutrients. Children with kwashiorkor are also very thin but have characteristically bloated bellies due to fluid retention and accumulation of fat in the liver, symptoms attributed to diets relatively deficient in protein. *See ADIPOSE TISSUE; PROTEIN METABOLISM.*

Deficiency conditions due to lack of a single vitamin or mineral occur rarely and usually reflect the lack of the most limiting nutrient in a generally deficient diet. In industrialized countries, single-nutrient deficiencies are most evident in individuals who abuse alcohol or drugs. Classic conditions of deficiency of niacin (pellagra), thiamine (beriberi), vitamin C (scurvy), and vitamin D (rickets) have virtually disappeared as a result of food fortification programs and the development of food distribution systems that provide fresh fruits and vegetables throughout the year. Iron-deficiency anemia also has declined in prevalence, although children in low-income families remain at risk. In developing countries, however, such conditions are still observed among people whose diets depend on one staple food as the major source of calories. A condition of substantial current public health importance is vitamin A deficiency, which is the principal cause of blindness and a major contributor to illness and death among children in developing countries. *See ANEMIA; VITAMIN.*

[M.N.]

**Malpighiales** One of the largest orders of the rosoid eudicotyledons, comprising more than 30 families distributed worldwide. Recent analyses of deoxyribonucleic acid (DNA) sequences, both plastid and nuclear, led to its recognition, even though the group is highly heterogeneous and difficult to characterize. The largest families are Euphorbiaceae (8000 species), Clusiaceae (1400), Malpighiaceae (1100), Flacourtiaceae (900), and Violaceae (850). Most of the order is composed of woody species, many of regional importance as timber and medicines. Several of the smaller families are significant as well, including Salicaceae (used as coppice, and the original source of aspirin) and Rhizophoraceae (the ecologically significant mangroves). *See MAGNOLIOPHYTA.*

[M.W.C.]

**Malt beverage** A fermented beverage produced from grain. Beer is a generic term used to describe alcoholic beverages made from cereal grains, especially barley, in the form of malt. Ale, lager, porter, and stout are different kinds of beer made by recognizably similar processes. The United States is the largest producer of beer in the world.

The manufacture of beer is a complex natural process of three general parts: the preparation of barley by germination, or the malting process; the actual digestion of barley (now malt) starch to produce a solution of sugars (called wort) and the adjustment of flavor with hops, which are the brewhouse processes; and the fermentation of these sugars by yeast to yield alcohol, carbon dioxide gas, and flavor compounds to produce beer. [M.J.L.]

**Maltase** An enzyme which breaks down (hydrolyzes) the disaccharide maltose into glucose. Maltase has been found in the pancreas, intestine, liver, kidney, and blood serum of animals. It has also been found in the bacteria, fungi, and monocotyledonous and dicotyledonous plants. *See CARBOHYDRATE METABOLISM; ENZYME.*

[D.N.La.]

**Maltose** An oligosaccharide, known as malt sugar, a reducing disaccharide (see illustration). It is fermentable by yeast in the presence of D-glucose.

The action of animal (salivary and pancreatic) as well as plant (germinating cereals, sweet potato) amylases on starch, dextrin,

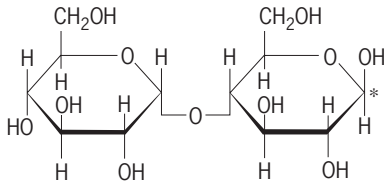

Formula for maltose ( $\alpha$  form; \* indicates reducing group).

and glycogen produces maltose as the main end product. Maltose is hydrolyzed by acids and the enzyme maltase to two molecules of D-glucose. See GLUCOSE; MALTASE; OLIGOSACCHARIDE. [W.Z.H.]

**Malvales** An order of flowering plants in the core eudicots. The order consists of 10 families and more than 5500 species. The circumscription of the order has been altered greatly in recent years, largely on the basis of deoxyribonucleic acid (DNA) sequence data. Of the five families in the traditional concept (Bombacaceae, Malvaceae, Sterculiaceae, Tiliaceae, and Elaeocarpaceae), the first four have been combined as Malvaceae, due to lack of monophyly of three of these families in their traditional circumscription; and Elaeocarpaceae are included in Oxalidales. In addition, other families have been transferred to Malvales, including Dipterocarpaceae and Thymelaeaceae. The expanded order is characterized by the presence of mucilage in epidermal cells and cavities; and of palmate leaves, stellate hairs, and numerous stamens with partially fused filaments occur frequently.

Malvaceae are cosmopolitan and include economic crops such as cotton (*Gossypium*), cocoa (*Theobroma*), and durian (*Durio*) and horticultural plants such as hollyhocks (*Althaea*) and rose of Sharon (*Hibiscus*). Dipterocarpaceae are important elements of tropical forests, especially in Southeast Asia, and provide hardwood timbers. Other horticultural genera in the order include *Cistus* and *Helianthemum* (Cistaceae) and *Daphne* (Thymelaeaceae). Several genera of Thymelaeaceae provide fibers used for making paper, and *Bixa* (Bixaceae) is the source of the orange dyestuff anatto. See CACAO; COTTON; EUDICOTYLEDONS. [M.W.C.]

**Mammalia** The class Mammalia has been the dominant group of vertebrates since the extinction of the dinosaurs 65 million years ago. There are over 4200 living species, classified into over 1000 genera, 140 families, and 18 orders. The number of extinct mammals is at least five times that. Most living mammals are terrestrial. However, many groups of mammals moved to the water from land-dwelling ancestors. These included manatees and dugongs (which are distantly related to elephants), otters (which are related to weasels), seals, sea lions, and walruses (which are distantly related to bears), and whales (which are distantly related to even-toed hoofed mammals), as well as numerous extinct groups. Mammals have also taken to the air, with over 920 living species of bats, as well as numerous gliding forms such as the flying squirrels, phalangerid marsupials, and flying lemurs or colugos. Mammals are even more successful at small body sizes, with hundreds of small species of rodents, rabbits, and insectivores.

Mammals are distinguished from all other animals by a number of unique characteristics. These include a body covered with hair or fur (secondarily reduced in some mammals, particularly aquatic forms); mammary glands in the female for nursing the young; a jaw composed of a single bone, the dentary; and three middle ear bones, the incus, malleus, and stapes. All mammals maintain a constant body temperature through metabolic heat. Their four-chambered heart (two ventricles and two atria) keeps the circulation of the lungs separate from that of the rest of the

body, resulting in more efficient oxygen transport to the body tissues. They have many other adaptations for their active lifestyle, including specialized teeth (incisors, canines, molars, and premolars) for biting, tearing, and grinding up food for more efficient digestion. These teeth are replaced only once in the lifetime of the animal (rather than continuous replacement, found in other toothed vertebrates). Mammals have a unique set of muscles that allow the jaw to move in many directions for chewing and for stronger bite force. Their secondary palate encloses the internal nasal passage and allows breathing while they have food in the mouth. Ribs (found only in the thoracic region) are firmly attached to the breastbone (sternum), so that expansion of the lung cavity is accomplished by a muscular wall in the abdominal cavity called the diaphragm. See CARDIOVASCULAR SYSTEM; DENTITION; EAR (VERTEBRATE); HAIR; LACTATION; MAMMARY GLAND; THERMOREGULATION; TOOTH.

All mammals have large brains relative to their body size. Most mammals have excellent senses, and some have extraordinary senses of sight, smell, and hearing. To accommodate their large brains and more sophisticated development, mammals are born alive (except for the platypus and echidnas, which lay eggs), and may require considerable parental care before they are ready to fend for themselves. Juvenile mammals have separate bony caps (epiphyses) on the long bones, separated from the shaft of the bone by a layer of cartilage. This allows the long bones to grow rapidly while still having a strong, bony articulation at the end. When a mammal reaches maturity, these epiphyses fuse to the shaft, and the mammal stops growing (in contrast to other vertebrates, which grow continuously through their lives). See BRAIN; NERVOUS SYSTEM (VERTEBRATE); SKELETAL SYSTEM.

The living mammals are divided into three major groups: the monotremes (platypus and echidnas), which still lay eggs, retain a number of reptilian bones in their skeletons, and have other primitive features of their anatomy and physiology; the marsupials (opossums, kangaroos, koalas, wombats, and their relatives), which give birth to an immature embryo that must crawl into the mother's pouch (marsupium), where it finishes development; and the placentals (the rest of the living mammals), which carry the young through a long gestation until they give birth to relatively well-developed progeny. In addition to these three living groups, there were many other major groups, such as the rodentlike multituberculates, now extinct. The most recent classification of the mammals can be summarized as follows:

#### Class Mammalia

Subclass Prototheria (monotremes)

Subclass Theriiformes

  Infraclass Holotheria

    Cohort Marsupialia (marsupials or pouched mammals)

    Cohort Placentalia (placentals)

    Magnorder Xenarthra (sloths, anteaters, armadillos)

    Magnorder Epitheria

      Grandorder Anagalida (= Glires) (rodents, rabbits, elephant shrews)

      Grandorder Ferae (carnivores, pangolins, many extinct groups)

      Grandorder Lipotyphla (hedgehogs, shrews, moles, tenrecs, and kin)

      Grandorder Archonta

        Order Chiroptera (bats)

        Order Primates (lemurs, monkeys, apes, humans)

        Order Scandentia (tree shrews)

      Grandorder Ungulata (hoofed mammals)

        Order Tubulidentata (aardvarks)

        Order Artiodactyla (even-toed hoofed mammals: pigs, hippos, camels, deer, antelopes, cattle, giraffes, pronghorns, and relatives)

## 1310 Mammary gland

- Order Cete (whales and their extinct land relatives)
- Order Perissodactyla (odd-toed hoofed mammals: horses, rhinos, tapirs, and extinct relatives)
- Order Hyracoidea (hyraxes)
- Order Tethytheria (elephants, manatees, and extinct relatives)

This classification does not list all the extinct groups, which include at least a dozen more ordinal-level taxa. See separate articles on each group. See REPRODUCTIVE SYSTEM.

Mammals evolved from the Synapsida, an early branch of the terrestrial amniotes that has been erroneously called the mammal-like reptiles. (This name is inappropriate because synapsids were never related to reptiles.) The first undoubted mammals appeared in the Late Triassic (about 210 million years ago), and were tiny insectivorous forms much like living shrews. Through the rest of the age of dinosaurs, a number of different groups evolved over the next 145 million years of the Jurassic and Cretaceous. Most remained tiny, shrewlike animals, hiding from the dinosaurs in the underbrush and coming out mostly at night. The first two-thirds of mammalian history had passed before the dinosaurs became extinct 65 million years ago, and this allowed mammals to emerge from their shadow. Between 65 and 55 million years ago, a rapid adaptive radiation yielded all the living orders of placental mammals and many extinct forms as well. [D.R.Pr.]

**Mammary gland** A unique anatomical structure of mammals that secretes milk for the nourishment of the newborn. The mammary gland contains thousands of milk-producing units called alveoli, each of which consists of a unicellular layer of epithelial cells arranged in a spheroid structure. The alveolar epithelial cells take up a variety of nutrients from the blood that perfuses the outer surface of the alveolar structures. Some of the nutrients are then secreted directly into the alveolar lumen; other nutrients are used to synthesize the unique constituents of milk which are then secreted. Each alveolus is connected to a duct through which milk flows. The ducts from many alveoli are connected via a converging ductal system which opens externally by way of the lactiferous pore.

Surrounding each alveolus and its associated small ducts are smooth muscle cells called myoepithelial cells. These cells contract in response to the posterior pituitary hormone oxytocin; milk is thus forced out of the alveoli, through the ductal system, and out the lactiferous pore for the nourishment of the newborn. The release of oxytocin is a neuroendocrine reflex triggered by the stimulation of sensory receptors by the suckling of the newborn. See ENDOCRINE MECHANISMS.

Mammary glands are basically highly modified and specialized sebaceous glands which derive from ectoderm. In the embryo, mammary lines, formed on both sides of the midventral line, mark the location of future mammary glands. Along the mammary lines discrete ectodermal ingrowths, called mammary buds, produce a rudimentary branched system of ducts at birth. In all species (except the monotremes) a nipple or teat develops in concert with the mammary buds. In the most primitive mammal (the duckbill or platypus), which lacks nipples or teats, milk simply oozes out of the two mammary gland areas and is lapped up by the young.

From birth to sexual maturity the mammary gland consists of a nipple and a rudimentary ductal system in both males and females. At the onset of puberty in the female, the enhanced secretion of estrogen causes a further development of the mammary ductal system and an accumulation of lipids in fat cells. After puberty in women, the mammary gland consists of about 85% fat cells and a partially developed ductal system. See ESTROGEN.

During pregnancy the mammary gland comes under the influence of estrogen and progesterone which are derived from

both the ovary and placenta. These hormones cause a further branching of the ductal system and the development of milk-secreting structures, the alveoli. In humans, approximately 200 alveoli are surrounded by a connective tissue sheath forming a structure called a lobule. About 26 lobules are packaged via another connective tissue sheath into a larger structure called a lobe. Each of 15–20 lobes is exteriorized into the nipple via separate lactiferous pores. See PROGESTERONE.

A complement of hormones maximizes the development of the ductal and lobuloalveolar elements in the mammary gland. Optimal ductal growth is attained with estrogen, a glucocorticoid, prolactin, and insulin. Maximal lobuloalveolar growth is obtained with estrogen, progesterone, growth hormone, prolactin, a glucocorticoid, and insulin. During pregnancy estrogen and progesterone stimulate mammary development but inhibit milk production.

During the final third of pregnancy, the alveolar epithelial cells begin secreting a fluid called colostrum. This fluid fills the alveoli and causes a gradual enlargement of the breast or udder. At parturition, the inhibitory influence of estrogen and progesterone is removed, and the gland can secrete milk under the influence of a further complement of hormones including prolactin, a glucocorticoid, insulin, and the thyroid hormones. See GLAND; LACTATION; MAMMALIA; MILK; PREGNANCY. [J.A.Ri.]

**Mammography** The radiological imaging of breast tissue. This procedure is used to identify cancer, preferably when still palpable. Because of improved resolution in high-contrast film, only minor exposure of skin to x-rays is required, so that national screening programs have been set up in many western industrialized countries.

Mammography depends on the tumor being reflected as a dense focus in contrast to surrounding tissue or less dense glandular and ductal parts of the structure. Discrimination between benign and malignant lesions may sometimes be difficult, but may be aided by increased magnification of the image and by spot compression to confirm otherwise equivocally benign lesions. In addition, ultrasonography may be used to distinguish between cystic (mainly benign) and solid (possibly malignant) masses. Many women with palpable cancers discovered through mammography have microcalcifications as the diagnostic feature; others are diagnosed by the presence of a distinct mass, architectural asymmetry of the glandular and ductal tissue, or tissue distortion.

Mammography has recognized limitations: the possibility exists that in some postmenopausal women it will fail to reveal cancer that is present. Similarly, in premenopausal women in whom the breast tissue is often dense, mammography can be falsely negative in some women with subsequently proven cancers. However, the ability of mammography to reflect breast changes over time and its value in the surveillance of women with breast cancer treated by conservation techniques (lumpectomy and radiation) has made mammography an invaluable clinical tool. See BREAST DISORDERS; CANCER (MEDICINE); MEDICAL ULTRASONIC TOMOGRAPHY; RADIOGRAPHY. [A.J.W.]

**Mandarin** A name used to designate a large group of citrus fruits in the species *Citrus reticulata* and some of its hybrids. This group is variable in the character of trees and fruits since the term is used in a general sense to include many different forms, such as tangerines, King oranges, Temple oranges, tangelos (hybrids between grapefruit and tangerine), Satsuma oranges, and Calamondin, presumably a hybrid between a mandarin and a kumquat. See KUMQUAT; ORANGE; TANGERINE.

Although tangerines are the most extensively planted of the mandarin group, others, particularly the Temple orange, the Murcott orange, and the tangelos, of which there are several varieties, are important commercial fruits in the United States. See FRUIT; FRUIT, TREE; SAPINDALES. [F.E.G.]



**Mandibulata** A subphylum of the phylum Arthropoda in the long-established classification scheme which comprises three groups at subphylum level; it is almost certainly not a natural assemblage. Mandibulata, defined as those arthropods possessing mandibles (lateral jaws) and antennae, includes the six classes Insecta, Chilopoda, Diplopoda, Symphyla, Pauropoda, and Crustacea. In fact, neither in their development nor in their functional morphology are the mandibles of crustaceans homologous with the mandibles of insects. The available fossil evidence for primitive crustaceans also supports a different phyletic origin for these appendages. In addition, insects have a single pair of antennae, while crustaceans have two pairs. See ARTHROPODA; CHILOPODA; CRUSTACEA; DIPLOPODA; INSECTA; PAUROPODA; SYMPHYLA. [W.D.R.H.]

**Manganese** A metallic element, Mn, atomic number 25, and atomic weight 54.9380 g/mole. Manganese is one of the transition elements of the first long period of the periodic table, falling between chromium and iron. The principal properties of manganese are given in the table. It is the twelfth most abundant element in the Earth's crust (approximately 0.1%) and occurs naturally in several forms, primarily as the silicate ( $\text{MnSiO}_3$ ) but also as the carbonate ( $\text{MnCO}_3$ ) and a variety of oxides, including pyrolusite ( $\text{MnO}_2$ ) and hausmannite ( $\text{Mn}_3\text{O}_4$ ). Weathering of land deposits has led to large amounts of the oxide being washed out to sea, where they have aggregated into the so-called manganese nodules containing 15–30% Mn. Vast deposits, estimated at over  $10^{12}$  metric tons, have been detected on the seabed, and a further  $10^7$  metric tons is deposited every year. The nodules also contain smaller amounts of the oxides of other metals such as iron (Fe), cobalt (Co), nickel (Ni), and copper (Cu). The economic importance of the nodules as a source of these important metals is enormous. See HAUSMANNITE; MANGANESE NODULES; PERIODIC TABLE; PYROLUSITE.

#### Properties of manganese

Property	Value
Atomic number	25
Atomic weight, g/mole	54.9380
Naturally occurring isotope	$^{55}\text{Mn}$ (100%)
Electronic configuration	$[\text{Ar}]3d^54s^2$
Electronegativity	1.5
Metal radius, picometers	127
Melting point, °C (°F)	$1244 \pm 3$ ( $2271 \pm 5.4$ )
Boiling point, °C (°F)	1962 (3563)
Density (25 °C or 77 °F), g/cm <sup>3</sup> (oz/in. <sup>3</sup> )	7.43 (4.30)
Electrical resistivity, ohm-cm	$185 \times 10^{-6}$

Manganese is more electropositive than its near neighbors in the periodic table, and consequently more reactive. The bulk metal undergoes only surface oxidation when exposed to atmospheric oxygen, but finely divided metal is pyrophoric.

Manganese is a trace element essential to a variety of living systems, including bacteria, plants, and animals. In contrast to iron (Fe), its neighbor in the periodic table, the exact function of the manganese in many of these systems was determined only recently. The manganese superoxide dismutases have been isolated from bacteria, plants, and animals, and are relatively small enzymes with molecular weights of approximately 20,000. The function of the enzyme is believed to be protection of living tissue from the harmful effects of the superoxide ion ( $\text{O}_2^-$ ), a radical formed from partial reduction of  $\text{O}_2$  in the cells of respiring ( $\text{O}_2$ -utilizing) cells.

The most important biological role yet recognized for manganese is in the enzyme responsible for photosynthetic water oxidation to oxygen in plants and certain photosynthetic bacteria. This reaction represents the source of oxygen gas on the Earth and is therefore responsible for the development of the most common forms of life.

All steels contain some manganese, the major advantage being an increase in hardness, although it also serves as a scavenger of oxygen and sulfur impurities that would induce defects and consequent brittleness in the steel. Manganese even has some use in the electronics industry, where manganese dioxide, either natural or synthetic, is employed to produce manganese compounds possessing high electrical resistivity; among other applications, these are utilized as components in every television set. See ELECTROLYSIS; GLASS; METAL; TRANSITION ELEMENTS. [G.Ch.]

**Manganese nodules** Concentrations of manganese and iron oxides found on the floors of many oceans. The origin of these potato-shaped metal-rich deposits has been elucidated; their complex growth histories are revealed by the textures of nodule interiors shown in the illustration.

Marine manganese nodules from certain regions are significantly enriched in nickel, copper, cobalt, zinc, molybdenum, and other elements so as to make them important reserves for these strategic metals.

Although manganiferous nodules and crusts have been sampled or observed on most sea floors, attention has focused on the nickel-plus-copper-rich nodules (2–3 wt% metals) from the north equatorial Pacific in a belt stretching from southeast Hawaii to Baja California, as well as the high-cobalt nodules from seamounts in the Pacific Ocean. Manganese nodules from the Atlantic Ocean and from higher latitudes in the Pacific Ocean have significantly lower concentrations of the minor strategic metals. However, surveys of the Indian Ocean have revealed metal-enrichment trends comparable to those found in the Pacific Ocean nodules; high Ni + Cu-bearing nodules are found adjacent to the Equator.

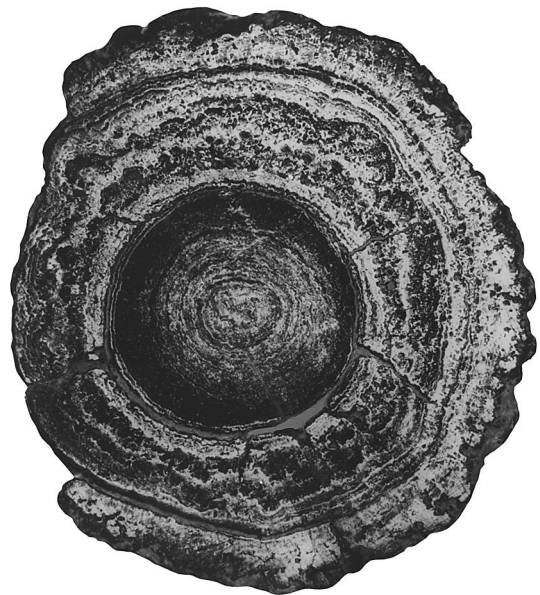

Reflected-light photograph of the polished surface of a sectioned manganese nodule showing the complex growth history of the concretionary deposit (diameter 1.6 in. or 4 cm).

Microchemical analyses have revealed that chemical differences exist between the outermost top (exposed to sea water) and bottom (immersed in sediment) layers of manganese nodules. Surfaces buried in underlying sediments are generally higher in Mn, Ni, and Cu contents, compared to the more Fe + Co-rich surfaces exposed to sea water. Episodic rolling-over of a nodule accounts for fluctuating concentrations of Mn, Fe, Ni, Cu, Co, and other metals across sectioned manganese nodules. [R.G.Bu.]

**Manganese oxide minerals** Minerals that contain manganese (Mn) and oxygen (O) or the hydroxyl ion (OH) as principal components. Over 20 manganese oxide minerals have been identified. They can be broadly categorized by the primary oxidation state of manganese in the mineral as tetravalent ( $Mn^{4+}$ ), trivalent ( $Mn^{3+}$ ), or divalent ( $Mn^{2+}$ ) manganese oxides. Tetravalent and trivalent manganese oxides occur in widespread continental and marine environments. They are the primary constituents of manganese nodules and crusts that occur in vast quantities on the ocean floors. Manganese oxide minerals are of economic importance as a source of manganese for the manufacture of steel, and some are used as the cathodic material in dry-cell batteries. See HYDROXYL; MANGANESE.

The basic structural unit for many of the manganese oxide minerals is an octahedron formed from a manganese cation surrounded by six oxygens ( $MnO_6$ ). Octahedra in these structures are linked to one another by sharing either corners (one oxygen atom) or edges (two oxygen atoms). The octahedra are then linked in some minerals to form chains of different widths, and in other minerals to form layers or sheets of octahedra. See CRYSTAL.

The manganese oxides are black and opaque with the exception of manganosite (emerald green) and pyrochroite (colorless to pale green or blue). Both manganosite and pyrochroite become black on exposure to air. Most of the manganese oxides have a specific gravity of 4–5 and a hardness of 5–7 or less. Some of the minerals have a wide range of hardness. Many of the manganese oxides commonly are poorly crystalline and occur in irregular masses or grains. Many manganese oxides are intimately intergrown with other manganese oxides or other minerals on a fine scale. See HAUSMANNITE; MANGANITE; PYROLUSITE. [S.T.]

**Manganite** A mineral having composition  $MnO(OH)$  and crystallizing in the orthorhombic system in prismatic crystals with deep vertical striations. The hardness is 4 on Mohs scale, and the specific gravity is 4.3. The luster is metallic and the color iron black. Fine crystals have been found in the Harz Mountains; in Cornwall, England; and in the United States at Negaunee, Michigan. Manganite is a minor ore of manganese. See MANGANESE. [C.S.Hu.]

**Mango** A tree (*Mangifera indica*) of the family Anacardiaceae that originated in the Indo-Burma region and is now grown throughout the world. The mango is a medium to large evergreen tree; it produces a dense, round canopy, with leaves which are reddish brown when young and dark green when mature.

In the United States, mangoes are grown only in Florida and on a small scale in Hawaii, usually as backyard trees. Their greatest importance is in India, where almost 2,000,000 acres (800,000 hectares) are grown constituting 75% of the world area devoted to mango production. The ripe fruit is eaten raw as a dessert or used in the manufacture of juice, jams, jellies, and preserves. Unripe fruit can be made into pickles or chutneys. Mangoes are a good source of vitamins A and C. See FRUIT, TREE; SAPINDALES. [R.M.Wa.]

**Mangrove** A taxonomically diverse assemblage of trees and shrubs that form the dominant plant communities in tidal, saline wetlands along sheltered tropical and subtropical coasts. The development and composition of mangrove communities depend largely on temperature, soil type and salinity, duration and frequency of inundation, accretion of silt, tidal and wave energy, and cyclone or flood frequencies. Extensive mangrove communities seem to correlate with areas in which the water temperature of the warmest month exceeds 75°F (24°C), and they are absent from waters that never exceed 75°F (24°C) dur-

ing the year. Intertidal, sheltered, low-energy, muddy sediments are the most suitable habitats for mangrove communities, and under optimal conditions, forests up to 148 ft (45 m) in height can develop. Where less favorable conditions are found, mangrove communities may reach maturity at heights of only 3 ft (1 m). See ECOSYSTEM.

Plants of the mangrove community belong to many different genera and families, many of which are not closely related to one another phylogenetically. However, they do share a variety of morphological, physiological, and reproductive adaptations that enable them to grow in an unstable, harsh, and salty environment. Approximately 80 species of plants belonging to about 30 genera in over 20 families are recognized throughout the world as being indigenous to mangroves. About 60 species occur on the east coasts of Africa and Australasia, whereas about 20 species are found in the Western Hemisphere. At the generic level, *Avicennia* and *Rhizophora* are the dominant plants of mangrove communities throughout the world, with each genus having several closely related species in both hemispheres. At the species level, however, only a few species, such as the portia tree (*Thespesia populnea*), the mangrove fern (*Acrostichum aureum*), and the swamp hibiscus (*Hibiscus tiliaceus*), occur in both hemispheres.

The mangrove community is often strikingly zoned parallel to the shoreline, with a sequence of different species dominating from open water to the landward margins. These zones are the response of individual species to gradients of inundation frequency, waterlogging, nutrient availability, and soil salt concentrations across the intertidal area, rather than a reflection of ecological succession, as earlier studies had suggested. See ECOLOGICAL SUCCESSION.

Most plants of the mangrove community are halophytes, well adapted to salt water and fluctuations of tide level. Many species show modified root structures such as stilt or prop roots, which offer support on the semiliquid or shifting sediments, whereas others have erect root structures (pneumatophores) that facilitate oxygen penetration to the roots in a hypoxic environment. Salt glands, which allow excess salt to be extruded through the leaves, occur in several species; others show a range of physiological mechanisms that either exclude salt from the plants or minimize the damage excess salts can cause by separating the salt from the sensitive enzyme systems of the plant. Several species have well-developed vivipary of their seeds, whereby the hypocotyl develops while the fruit is still attached to the tree. The seedlings are generally buoyant, able to float over long distances in the sea and rapidly establish themselves once stranded in a suitable habitat. See PLANTS, SALINE ENVIRONMENTS OF.

A mangrove may be considered either a sheltered, muddy, intertidal habitat or a forest community. The sediment surface of mangrove communities abounds with species that have marine affinities, including brightly colored fiddler crabs, mound-building mud lobsters, and a variety of mollusks and worms, as well as specialized gobiid fish (mudskippers). The waterways among the mangroves are important feeding and nursery areas for a variety of juvenile finfish as well as crustaceans. Animals with forest affinities that are associated with mangroves include snakes, lizards, deer, tigers, crab-eating monkeys, bats, and many species of birds.

Economically, mangroves are a major source of timber, poles, thatch, and fuel. The bark of some trees is used for tanning materials, whereas other species have food or medicinal value. See ECOLOGICAL COMMUNITIES; FOREST MANAGEMENT. [PSae.]

**Manifold (mathematics)** A Hausdorff topological space with an  $n$ -dimensional atlas of charts for some integer  $n$ . The integer  $n$  is called the dimension of the manifold. If  $M$  is a Hausdorff space, an  $n$ -chart on  $M$  is a pair  $(U, \varphi)$  with  $U$  an open subset of  $M$  and  $\varphi$  a homeomorphism of  $U$  onto an open subset  $\varphi(U)$  of  $n$ -dimensional euclidean space  $\mathbf{R}^n$ . An  $n$ -dimensional

atlas for  $M$  is a system of  $n$ -charts  $(U, \varphi)$  such that the union of the sets  $U$  is all of  $M$ . See TOPOLOGY.

The terminology “charts” and “atlases” comes from the geographer’s way of viewing the surface of the Earth. The manifold described in this case is the two-dimensional sphere  $M = S^2$ .

Many mathematicians include an additional restriction in the definition of manifold—sometimes the underlying topological space is connected, sometimes the topology is given by a metric, sometimes both.

With an appropriate additional structure on a manifold, it is possible to speak of differentiability or smoothness of real-valued functions. In this setting, the notion of a smooth mapping between smooth manifolds can be defined, and the differential of a smooth mapping, which is a generalization of the derivative, can be introduced.

Two charts  $(U_1, \varphi_1)$  and  $(U_2, \varphi_2)$  in an atlas for an  $n$ -dimensional manifold  $M$  are compatible (for defining smoothness) if the mapping  $\varphi_2 \circ \varphi_1^{-1}$  from the open set  $\varphi_1(U_1 \cap U_2)$  in  $\mathbf{R}^n$  to the open set  $\varphi_2(U_1 \cap U_2)$  is infinitely differentiable and has an infinitely differentiable inverse function. If all the charts in an atlas are compatible with one another, the atlas is said to determine a differentiable structure on  $M$ , and  $M$  with its atlas is then called a smooth manifold. Two atlases determine the same differentiable structure if all the charts in question are compatible with one another. Smooth manifolds are called also differentiable manifolds, differential manifolds, and  $C^\infty$  manifolds.

Alternate definitions of compatibility of charts lead to other classes of manifolds. Thus a manifold with its atlas is said to be piecewise linear (PL) or real analytic if all the mappings  $\varphi_2 \circ \varphi_1^{-1}$  have the corresponding property.

If the dimension  $n$  is even, say  $2m$ , then the open sets in  $\mathbf{R}^n$  can be regarded as open sets in the complex space  $\mathbf{C}^m$ . The manifold with its atlas is called a complex manifold of dimension  $m$  if the mappings  $\varphi_2 \circ \varphi_1^{-1}$  are analytic functions of several variables. Complex manifolds are used in studying varieties in algebraic geometry. See ALGEBRAIC GEOMETRY; COMPLEX NUMBERS AND COMPLEX VARIABLES; SERIES. [A.W.K.]

**Manometer** A double-leg liquid-column gage used to measure the difference between two fluid pressures. Micro-manometers are precision instruments which typically measure from very low pressures to 50 mm of mercury (6.7 kilopascals). The barometer is a special case of manometer with one pressure at zero absolute. See BAROMETER.

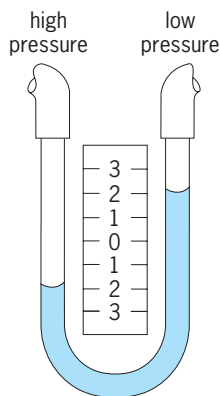

U-tube manometer.

The various types of manometers have much in common with the U-tube manometer, which consists of a hollow tube, usually glass, a liquid partially filling the tube, and a scale to measure the height of one liquid surface with respect to the other (see illustration). If the legs of this manometer are connected to sep-

arate sources of pressure, the liquid will rise in the leg with the lower pressure and drop in the other leg. The difference between the levels is a function of the applied pressure and the specific gravity of the pressurizing and fill fluids.

A well-type manometer has one leg with a relatively small diameter, and the second leg is a reservoir. The cross-sectional area of the reservoir may be as much as 1500 times that of the vertical leg, so that the level of the reservoir does not change appreciably with a change of pressure. Mercurial barometers are commonly made as well-type manometers.

The inclined-tube manometer is used for gage pressures below 10 in. (250 mm) of water differential. The leg of the well-type manometer is inclined from the vertical to elongate the scale. Inclined double-leg U-tube manometers are also used to measure very low differential pressures. See PRESSURE MEASUREMENT.

[J.H.Z.]

**Manufactured fiber** Any of a number of textile fibers produced from chemical substances of natural origin or synthetic origin; the latter are also known as synthetic fibers. Among the natural sources of manufactured fibers are plant cellulose and protein, rubber, metals, and nonmetallic inorganics. The synthetic fibers are produced from organic intermediates derived from petroleum, coal, and natural gas. See NATURAL FIBER; TEXTILE.

With the exceptions of glass and metal fibers, the manufactured fibers are made from very long chainlike molecules called linear polymers. These polymers may be naturally occurring (cellulose from cotton or wood pulp) or may be synthetic (polyester). Irrespective of their chemical nature, fiber-forming polymers must possess the following characteristics: (1) great length—at least 200 monomer units must be joined in a chain; (2) a high degree of intramolecular and intermolecular attraction, whether through primary chemical bonds or other attractive forces; (3) the ability to be oriented along the axis of the fiber; and (4) the ability to form well-ordered crystals or pseudocrystals. All of these parameters are sensitive to the chemical nature of the polymer and the processes of manufacture of the fiber. In turn, they establish the properties of the fiber, such as strength, flexibility, resilience, and abrasion resistance, which contribute to their usefulness in various end uses for apparel, home furnishings, and commercial and industrial applications. See POLYMER.

Only a fraction of those substances capable of forming fibers prove to have all of the characteristics necessary for commercial success. The fiber types of major importance in the United States are classified by composition as follows: cellulosic (composed of regenerated cellulose, cellulose diacetate, and cellulose triacetate); synthetic (composed of polyamide, polyester, polyacrylic, polyvinyl, and polyolefin resins); and inorganic (composed of glass and metal).

All of the manufactured fibers are produced according to the same principles: (1) the fiber-forming material must first be made fluid; (2) the fluid is forced under pressure (extruded) through tiny holes into a medium which causes it to solidify; and (3) the solid fibers are further processed to obtain their optimum properties.

Typically one of three procedures is used to produce fibers. In wet spinning, (for example, the production of rayon by the viscose process), the polymer is dissolved in an applicable reagent to form the fluid (dope). The fluid is then pumped through metal plates (spinnerets) containing many small holes into a liquid bath of appropriate composition. A chemical reaction between the spinning dope and the bath causes the fiber to solidify. In dry spinning, the polymer is again dissolved in an appropriate solvent and extruded through a spinneret. However, the liquid bath is replaced by a stream of warm gas (usually air) which evaporates the solvent and allows the polymer to solidify as a filament. Cellulose diacetate and triacetate are produced in this manner. In melt spinning, Nylon, polyester, and the other thermoplastic

fibers are produced by melt spinning. No solvents or reagents are required since the polymer can be melted without appreciable decomposition. Thus, the fluid consists of hot molten polymer which, upon extrusion into a stream of cold air, solidifies into a filament. Depending upon the end use, filaments may be produced in various sizes ranging from finer than a human hair to thick bristles for toothbrushes. They may also be produced with different cross-sectional shapes, such as round, lobed, square, or dogbone.

After extrusion, filaments are usually stretched (drawn). Drawing causes an increase in order (crystallinity) by extending the molecules of the fiber so that they pack more closely together, and orients the molecules along the longitudinal axis of the fiber. Higher orientation and increased crystallinity raise the strength of the fiber, decrease its stretch, and improve its elasticity.

Often, the manufactured fibers are textured to improve their comfort properties. Fabrics made from smooth, straight filament yarns are not as comfortable as those made from yarns spun from the shorter natural fibers. Texturing introduces irregularities (crimp) along the length of the filament and leads to bulkier filament yarns which are closer to spun yarns in their performance.

Advances in polymer and fiber technology have led to the development of fibers with exceptionally high temperature resistance and extremely high strength. These properties are desirable in applications such as upholstery and floor coverings in aircraft and other mass-transit vehicles, protective clothing for fire fighters and other emergency personnel, body armor for soldiers and police officers, tire cords, and industrial belting.

Metallic fibers of silver and gold have been used for millennia to decorate fabrics. Today metallic fibers serve useful as well as decorative purposes. These fibers are formed by drawing metal wires through successively finer dies to achieve the desired diameter. Although gold and silver are the easiest to draw, modern methods have allowed the manufacture of steel, tantalum, and zirconium fibers. Because they are electrical conductors, metal fibers have been blended into fabrics to reduce the tendency to develop static electrical charges.

Glass fibers are prepared by the melt spinning of previously formed glass marbles, and the molten filaments are drawn down to very fine dimensions. It is the fineness of the fibers that gives them their flexibility and allows them to be used in textiles. Unfortunately, the fibers are so stiff that when broken they can penetrate human skin. Thus, they are not well suited to use in apparel or upholstery. Glass is widely used in curtains and drapery because of its total resistance to the degrading effects of sunlight, its low cost, and its flame resistance. It provides a nonrotting, nonsettling insulating material for homes and industrial uses. See GLASS.

Fiber properties include the physical, mechanical, chemical, biological, and geometrical characteristics of fibers. Some of the more important ones are tensile strength, elongation at break, modulus of elasticity or stiffness, fatigue under repeated stress, resilience or ability to recover from deformation, moisture absorption and wettability, electrostatic properties, friction, color, luster, density, and resistance to light, heat, weathering, abrasion, laundering, mildew, insects, chemicals, and solvents; and finally a number of geometric features, such as diameter, cross-sectional shape, and crimp. Such properties play an important part in determining whether or not the fiber can be made into a fabric that will be wrinkle-resistant, pleasing to the touch, comfortable, easy to clean, durable, and attractive in color, luster, drape, and general appearance. With a knowledge of the physical properties of the available fibers, the textile engineer can choose the best fiber or best blend of several fibers to fit the intended use. The final result, however, is also dependent upon the proper choice and control of additional factors such as the yarn and fabric structure, the weave pattern, and the finishing of the cloth.

[I.B.I.]

**Manufacturing engineering** Engineering activities involved in the creation and operation of the technical and economic processes that convert raw materials, energy, and purchased items into components for sale to other manufacturers or into end products for sale to the public. Defined in this way, manufacturing engineering includes product design and manufacturing system design as well as operation of the factory. More specifically, manufacturing engineering involves the analysis and modification of product designs so as to assure manufacturability; the design, selection, specification, and optimization of the required equipment, tooling, processes, and operations; and the determination of other technical matters required to make a given product according to the desired volume, timetable, cost, quality level, and other specifications. See PROCESS ENGINEERING; PRODUCTION.

The formulation of a process plan for a given part has seven aspects: (1) a thorough understanding of processing techniques, their yield and their reliability, precedences, and constraints (both economic as well as technical); (2) the material and tolerances of the part; (3) proper definition of machinability or process data; (4) proper work-holding design of the stock or piece part during the fabrication process, a key consideration in generating piece parts of consistent quality; (5) proper tool selection for the task; (6) the capability of the equipment selected; and (7) personnel skills required and available.

Process planning aids based on computer programs that incorporate a type of spread sheet can be used to reduce significantly the time required to generate individual process plans. For example, systems have been developed that calculate the cycle time for each part as well as the number of tools used per part, the number of unique tools per part set, and the total time for cutting operations per tool type. See COMPUTER-AIDED DESIGN AND MANUFACTURING.

In parallel with the definition of process equipment, the manufacturing system designer must determine the most appropriate materials-handling techniques for the transfer of parts from machine to machine of each family of parts. During the manufacture of pieces, the parts are organized by the type of feature desired. The parts are then grouped and manufactured as a family, a method known as group technology. This includes the selection of storage devices appropriate for raw material, work in process, and finished-goods inventory as well as fixtures, gages, and tooling. Materials-handling equipment may be very different for each family, depending on part size and weight, aggregate production volume, part quality considerations during transfer, and ease of loading and unloading candidate machines. Different materials-handling approaches may also be appropriate within individual fabrication systems. See MATERIALS-HANDLING EQUIPMENT.

A quality assurance philosophy must be developed that emphasizes process control as the means to assure part conformance rather than emphasizing the detection of part nonconformance as a means of detecting an out-of-control process. The success of any fabrication process is based on rigid work-holding devices that are accurately referenced to the machine, accurate tool sizing, and tool position control. The basic way to determine if these three factors are functioning together acceptably is to measure a feature they produce as they produce it or as soon as possible after that feature is machined. The primary objective of this measurement is to determine that the combination is working within acceptable limits (statistical process control); the fact that the part feature is in conformance to print (conformance to tolerance specified on the print/drawing) is a by-product of a process that is in control. See QUALITY CONTROL.

In a modern manufacturing environment an organization's strategies for highly automated systems and the role of workers in these systems are generally based on one of two distinct philosophical approaches. One approach views workers within the plant as the greatest source of error. This approach uses computer-integrated manufacturing technology to reduce the

workers' influence on the manufacturing process. The second approach uses computer-integrated manufacturing technology to help the workers make the best product possible. It implies that workers use the technology to control variance, detect and correct error, and adapt to a changing marketplace. See *COMPUTER-INTEGRATED MANUFACTURING*.

The best approach utilizes the attributes of employees in the factory to produce products in response to customer demand. This viewpoint enables the employees to exert some control over the system, rather than simply serving it. The employees can then use the system as a tool to achieve production goals.

As technology and automation have advanced, it has become necessary for manufacturing engineers to gain a much broader perspective. They must be able to function in an integrated activity involving product design, product manufacture, and product use. They also have to consider how the product will be destroyed as well as the efficient recovery of the materials used in its manufacture.

Manufacturing engineers must also be able to use an increasing array of computerized support tools, ranging from process planning and monitoring to total factory simulation—and in some cases, including models of the total enterprise. See *SIMULATION*. [J.L.N.]

**Map design** The systematic process of arranging and assigning meaning to elements on a map for the purpose of communicating geographic knowledge in a pleasing format. Careful design is crucial to map effectiveness to avoid distorted or inaccurately represented information.

The first design stage involves determining the type of map to be created for the problem at hand. Decisions must be made about the map's spatial format in terms of size and shape, the basic layout, and the data to be represented. In this step, the experience, cultural background, and educational attainment of the intended audience must be considered. The second stage involves the exploration of preliminary ideas through the manipulation of design parameters such as symbols, color, typography, and line weight. In the third step, alternatives are evaluated and may be accepted or rejected. Under some circumstances, prototype maps may be developed for sample readers as a means of evaluating design scenarios. The last step involves the selection of a final design.

Design considerations include the selection of scale (the relationship between the mapping media format and the area being mapped), symbols to represent geographic features, the system of projection (the method used to translate Earth coordinates to flat media), titles, legends, text, borders, and credits. The process of arranging each map element is referred to as map composition. Success in map composition is achieved when design principles are applied to create a pleasing image with a high degree of information content and readability.

Computers now duplicate all capabilities of manual map design. Design iterations can be explored and evaluated faster and with lower cost, compared to manual drafting methods. The digital environment facilitates the independent storage of map elements that can be combined to form composite images. Other computer innovations such as interactive mapping allow a map user to act as map creator in exploring geographic relationships by selecting and tailoring data sets available through software or the World Wide Web. In addition to its benefits to the design process, mapping software has brought challenges to the mapping sciences, including the proliferation of poorly designed maps constructed by persons untrained in cartography. See *CARTOGRAPHY*; *COMPUTER GRAPHICS*; *MAP PROJECTIONS*; *MAP REPRODUCTION*. [T.A.Wi.]

**Map projections** Systematic methods of transforming the spherical representation of parallels, meridians, and geographic features of the Earth's surface to a nonspherical sur-

face, usually a plane. Map projections have been of concern to cartographers, mathematicians, and geographers for centuries because globes and curved-surface reproductions of the Earth are cumbersome, expensive, and difficult to use for making measurements. Although the term "projection" implies that transformation is accomplished by projecting surface features of a sphere to a flat piece of paper using a light source, most projections are devised mathematically and are drawn with computer assistance. The task can be complex because the sphere and plane are not applicable surfaces. As a result, each of the infinite number of possible projections deforms the geometric relationships among the points on a sphere in some way, with directions, distances, areas, and angular relationships on the Earth never being completely recreated on a flat map.

It is impossible to transfer spherical coordinates to a flat surface without distortion caused by compression, tearing, or shearing of the surface (see illustration). Conceptually, the transformation may be accomplished in two ways: (1) by geometric transfer to some other surface, such as a tangent or intersecting cylinder, cone, or plane, which can then be developed, that is, cut apart and laid out flat; or (2) by direct mathematical transfer to a plane of the directions and distances among points on the sphere. Patterns of deformation can be evaluated by looking at different projection families. Whether a projection is geometrically or mathematically derived, if its pattern of scale variation is like that which results from geometric transfer, it is classed as cylindrical, conic, or in the case of a plane, azimuthal or zenithal. See *CARTOGRAPHY*; *TERRESTRIAL COORDINATE SYSTEM*.

Cylindrical projections result from symmetrical transfer of the spherical surface to a tangent or intersecting cylinder. True or correct scale can be obtained along the great circle of tangency or the two homothetic small circles of intersection. If the axis of the cylinder is made parallel to the axis of the Earth, the parallels and meridians appear as perpendicular lines. Points on the Earth equally distant from the tangent great circle (Equator) or small circles of intersection (parallels equally spaced on either side of the Equator) have equal scale departure. The pattern of deformation therefore parallel the parallels, as change in scale occurs in a direction perpendicular to the parallels. A cylinder turned 90° with respect to the Earth's axis creates a transverse projection with a pattern of deformation that is symmetric with respect to a great circle through the Poles. Transverse projections based on the Universal Transverse Mercator grid system are commonly used to represent satellite images, topographic maps, and other digital databases requiring high levels of precision. If the turn of the cylinder is less than 90°, an oblique projection results. All cylindrical projections, whether geometrically or mathematically derived, have similar patterns of deformation. See *GREAT CIRCLE*, *TERRESTRIAL*.

Transfer to a tangent or intersecting cone is the basis of conic projections. For these projections, true scale can be found along one or two small circles in the same hemisphere. Conic projections are usually arranged with the axis of the cone parallel to the Earth's axis. Consequently, meridians appear as radiating straight lines and parallels as concentric angles. Conical patterns of deformation parallel the parallels; that is, scale departure is uniform along any parallel. Several important conical projections are not true conics in that their derivation either is based upon more than one cone (polyconic) or is based upon one cone with a subsequent rearrangement of scale variation. Because conic projections can be designed to have low levels of distortion in the midlatitudes, they are often preferred for representing countries such as the United States.

Azimuthal projections result from the transfer to a tangent or intersecting plane established perpendicular to a right line passing through the center of the Earth. All geometrically developed azimuthal projections are transferred from some point on this line. Points on the Earth equidistant from the point of tangency

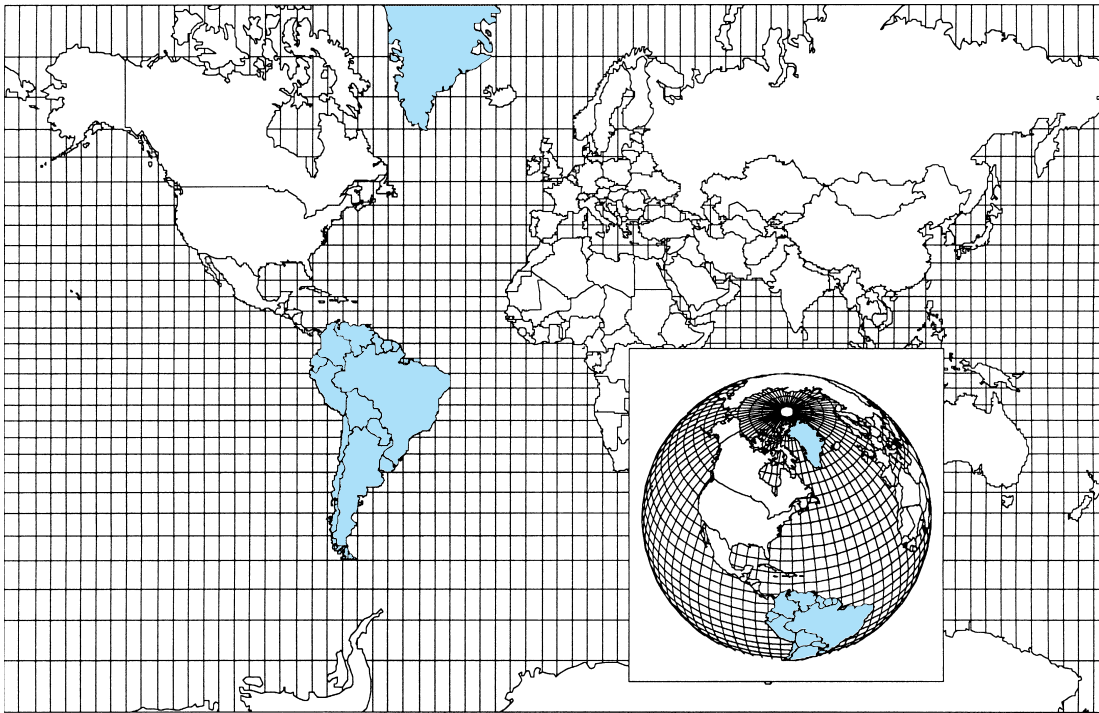

On this Mercator projection, (mathematically derived, cylindrical type), Greenland and South America appear similar in size. The inset map shows that South America is actually about 15 times larger than Greenland.

or the center of the circle of intersection have equal scale departure. Hence the pattern of deformation is circular and concentric to the Earth's center. All azimuthal projections, whether geometrically or mathematically derived, have two aspects in common: (1) all great circles that pass through the center of the projection appear as straight lines; and (2) all azimuths from the center are truly displayed.

[A.H.Ro.; T.A.Wi.]

**Maple** A genus, *Acer*, of broad-leaved, deciduous trees including about 115 species in North America, Asia, Europe, and North Africa. This genus is characterized by simple, opposite, usually palmately lobed (rarely pinnate) leaves, generally inconspicuous flowers, and a fruit consisting of two longwinged samaras or keys (see illustration).

The most important commercial species is the sugar or rock maple (*A. saccharum*), called hard maple in the lumber market. This tree grows in the eastern half of the United States and adjacent Canada. It can be recognized by its gray furrowed bark, sharp-pointed scaly winter buds, and symmetrical oval outline of the crown.

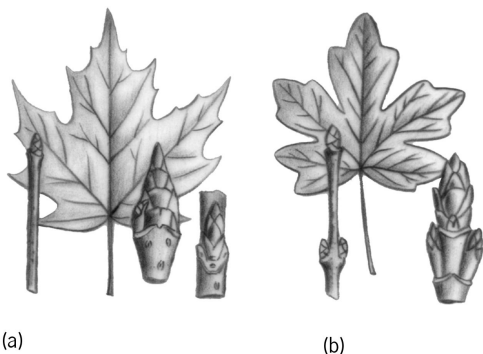

Characteristic maple leaves, twigs, and buds. (a) Sugar maple (*Acer saccharum*). (b) Hedge maple (*A. campestre*).

Maples rank third in the production of hardwood lumber. Hard maple is used for flooring, furniture, boxes, crates, woodenware, spools, bobbins, motor vehicle parts, veneer, railroad ties, and pulpwood. It is the source of maple sugar and syrup and is planted as a shade tree. See SAPINDALES.

[A.H.G./K.P.D.]

**Marattiales** An order (class Polypodiopsida) of primitive ferns that consists of about seven living genera and 150 species. They exist mostly in tropical regions. These large, coarse, sappy ferns usually have large, highly divided fronds. Stems of living genera (*Angiopteris* and *Marattia*) are short and bulbous, often a foot or more in diameter. Other genera have smaller, mostly horizontal, and somewhat more elongated stems. The internal vascular system (food and water conduction tissue) of the stems and fronds can be quite complex, apparently as a function of size. Marattiales are included among the primitive ferns primarily because of the way that the sporangia (spore-bearing organs) arise from a mass of cells rather than from a single cell as in more highly evolved ferns. See PALEOBOTANY; POLYPODIOPHYTA.

[B.M.St.]

**Marble** A term applied commercially to any limestone or dolomite taking polish. Marble is extensively used for building and ornamental purposes. See DOLOMITE; LIMESTONE.

In petrography the term marble is applied to metamorphic rocks composed of recrystallized calcite or dolomite. Schistosity, often controlled by the original bedding, is usually weak except in impure micaceous or tremolite-bearing types. Calcite (marble) deforms readily by plastic flow even at low temperatures. Therefore, granulation is rare, and instead of schistosity there develops a flow structure characterized by elongation and bending of the grains concomitant with a strong development of twin lamellae. See METAMORPHIC ROCKS; MINERALOGY; SCHIST.

Pure marbles attaining 99% calcium carbonate,  $\text{CaCO}_3$ , are often formed by simple recrystallization of sedimentary limestone. Dolomite marbles are usually formed by metasomatism. See CALCITE; DOLOMITE; METASOMATISM.

[T.F.W.B.]

**Marcasite** A mineral having composition  $\text{FeS}_2$  and crystallizing in the orthorhombic system. Marcasite frequently has a radiating structure and may be globular or stalactitic. There is poor prismatic cleavage. The hardness is 6–6.5 on Mohs scale and the specific gravity is 4.89. The luster is metallic and the color pale bronze-yellow to nearly white on a fresh fracture. Marcasite and pyrite are dimorphous; both have the composition  $\text{FeS}_2$ . Because marcasite is whiter, it is called white iron pyrite.

Marcasite is found in metalliferous deposits associated with lead and zinc ores, as replacement deposits in limestone, and in concretions in clays and shales. The nodular and lenticular masses in coal known as brasses are in part marcasite and in part pyrite. See PYRITE. [C.S.Hu.]

**Marchantiales** An order of the liverwort subclass Marchantiidae. Characteristic features include the differentiation of upper and lower tissues of the gametophyte, ventral scales, and rhizoids of two kinds. The sporophyte is considerably reduced, and the capsule dehisces irregularly. The archegonia, though dorsal, come to be pendant from an elevated receptacle because of differential growth resulting in decurved margins. The stalks of the receptacles are modified branches often with rhizoids in one, two, or rarely four furrows along their length. The order consists of 12 families grouped in two suborders, the more complex Marchantiineae and the simplified Ricciineae. See BRYOPHYTA; MARCHANTIIDAE. [H.Cr.]

**Marchantiidae** One of the two subclasses of liverworts (class Hepaticopsida). The gametophytes are ribbonlike or rosette-shaped thalli, usually showing considerable internal tissue differentiation. The rhizoids may be both smooth and internally pegged on the same thalli. Oil bodies, if present, are restricted to scattered cells that lack chloroplasts. The antheridia are usually ovoid, and the archegonia usually consist of six rows of cells. The sporophytes are generally reduced.

The subclass differs from the thallose Metzgeriales of the subclass Jungermanniidae in the internal differentiation of the thallose gametophytes, the smooth and pegged rhizoids, and the variation in the way the capsules dehisce. The subclass is divided into three orders, the Marchantiales, the Monocleales, and the Sphaerocarpaceles. See BRYOPHYTA; JUNGERMANNIIDAE; MARCHANTIALES; METZGERIALES; MONOCLEALES; SPHAEROCARPALES. [H.Cr.]

**Margarine** An emulsified fatty food product used as a spread and a baking and cooking fat, consisting of an aqueous phase dispersed in the fat as a continuous phase. Developed originally as a butter substitute, margarine is now considered a food in its own right and is manufactured in forms unknown to butter, such as plastic, soft, or fluid. However, margarine is colored, flavored, fortified with vitamins, and otherwise formulated to have the same or similar taste, appearance, and nutritional value as butter. See BUTTER.

Currently, margarine produced in the United States must contain not less than 80% fat. The fats and oils must be edible but may be from any vegetable or animal carcass source, natural or hydrogenated. The required aqueous phase may be water, milk, or solutions of dairy or vegetable protein, and must be pasteurized. Vitamin A must be added to yield a finished margarine with not less than 15,000 international units per pound (0.45 kg). Optional ingredients include salt or potassium chloride for low-sodium diets, nutritive sweeteners, fatty emulsifiers, antioxidants, preservatives, edible colors, flavors, vitamin D, acids, and alkalis. See FAT AND OIL (FOOD). [T.J.W.]

**Marijuana** The Spanish name for the dried leaves and flowering tops of the hemp plant, *Cannabis sativa* (Cannabaceae). The narcotic ingredients allegedly have stimulating effects, and after smoking two or three cigarettes, the smoker often has a feeling of well-being and increased power and ability. After excessive amounts of the drug, illusions are often common,

as well as pleasing, fanciful hallucinations. Sometimes the excessive user experiences disorientation and even delirium. See HEMP. [P.D.St./E.L.C.]

**Marine biological sampling** The collection and observation of living organisms in the sea, including the quantitative determination of their abundance in time and space. The biological survey of the ocean depends to a large extent on specially equipped vessels. Sampling in intertidal regions at low tide is one of the few instances where it is possible to observe and collect marine organisms without special apparatus.

A primary aim of marine biology is to discover how ocean phenomena control the distribution of organisms. Sampling is the means by which this aim is accomplished. Traditional techniques employ the use of samplers attached to wires lowered over the side of a ship by means of hydraulic winches. These samplers include bottles designed for enclosing seawater samples from particular depths, fine-meshed nets that are towed behind the ship to sieve out plankton and fish, and grabs or dredges that are used to collect animals inhabiting the ocean bottom. These types of gear are relied upon in many circumstances; however, they illustrate some of the problems common to all methods by which the ocean is sampled. First, sampling is never synoptic, which means that it is not possible to sample an area of ocean so that conditions can be considered equivalent at each point. Usually, it is assumed that this is so. Second, there are marine organisms for which there exists no sampling methodology. For example, knowledge of the larger species of squid is confined to the few animals that have been washed ashore. A third problem concerns the representativeness of the samples collected. The open ocean has no easily definable boundaries, and organisms are not uniformly distributed. The actual sampling is regularly done out of view of the observer; thus, sampling effectiveness is often difficult to determine. Furthermore, navigational systems are not error-free, and therefore the position of the sample is never precisely known. All developments in methods for sampling the ocean try to resolve one or more of these difficulties by improving synopticity, devising more efficient sampling gear, or devising methods for observation such that more meaningful samples can be obtained.

Direct and remote observation methods provide valuable information on the undersea environment and thus on the representativeness of various sampling techniques. Personnel-operated deep-submergence research vessels (DSRVs) are increasingly being employed to observe ocean life at depth and on the bottom, and for determining appropriate sampling schemes. The deep-submergence research vessels are used with cameras and television recording equipment and are also fitted with coring devices, seawater samplers, and sensors of various types. Cameras are deployed from surface ships on a wire. Other cameras are operated unattended at the bottom for months at a time, recording changes occurring there. Scuba diving is playing a larger role, especially in open-ocean areas, and is used to observe marine organisms in their natural habitat as well as to collect the more fragile marine planktonic forms such as foraminifera, radiolaria, and jellyfish. Remotely piloted vehicles (RPVs) will continue to assume greater importance in sampling programs since they can go to greater depths than can divers, and they overcome a limitation in diving in that remotely piloted vehicles can be operated at night. Optical sensors carried aboard Earth-orbiting satellites can provide images of ocean color over wide areas. Ocean color is related to the turbidity and also to the amount of plant material in the seawater. This thus establishes a means by which sampling programs carried out from ships can be optimized. See DIVING; SEAWATER FERTILITY; UNDERWATER PHOTOGRAPHY; UNDERWATER TELEVISION; UNDERWATER VEHICLE. [J.Marr.]

**Marine boiler** A steam boiler designed to suit the marine environment and generally arranged to supply steam to the main

propulsion machinery, ship's service electric generators, feed-pump drivers, and other auxiliary services.

Marine boilers are usually of the two-drum water-tube type with water-cooled furnaces, superheaters, desuperheaters, and heat recovery equipment of the economizer or air-heater type. The majority of ships are fitted with two boilers, although some large passenger ships may have three or more. Some cargo ships are fitted with only one boiler, and in some of these cases a smaller auxiliary boiler may be fitted for emergency or in-port steaming use.

Marine boilers are generally arranged for oil firing. Oil is used extensively because of its simplicity of handling and storing and the fact that it can be stored in spaces that often cannot be used for carrying cargo. See BOILER; MARINE MACHINERY; STEAM-GENERATING UNIT. [R.P.G.]

**Marine conservation** The management of marine species and ecosystems to prevent their decline and extinction. As in terrestrial conservation, the goal of marine conservation is to preserve and protect biodiversity and ecosystem function through the preservation of species, populations, and habitats. The importance of conserving marine species and ecosystems is growing as a consequence of human activities. Negative impacts on marine biological systems are caused by such actions as overfishing; overutilization, degradation, and loss of coastal and marine habitats; introduction of nonnative species; and intensification of global climate change, which alters oceanic circulation and disrupts existing trophic relationships. Marine conservation biologists seek to reduce the negative effects of all these actions by conducting directed research and helping to develop management strategies for particular species, communities, habitats, or ecosystems.

A variety of approaches and tools are used in marine conservation. These include population assessment; mitigation, recovery, and restoration efforts; establishment of marine protected areas; and monitoring programs. Many of these approaches overlap with those in terrestrial conservation. However, fundamental differences between terrestrial and marine environments in spatial dimension, habitat type, and organismal life history require that basic conservation techniques be modified for application to the marine environment. See BIODIVERSITY; ECOSYSTEM; MARINE ECOLOGY; OCEANOGRAPHY.

Effective management requires knowledge of the size and status of populations. Trends in abundance can be detected through stock assessment methods first developed for marine fisheries and subsequently modified for application to other marine organisms. These methods use estimates of population size, reproduction, survivorship, and immigration to determine whether populations are increasing, decreasing, or stable. Population viability analysis is a specialized statistical assessment in which demographic and environmental information is used to determine the probability that a population will persist in a particular environment for a specified period of time. This method can be used to guide management decisions, and has been used in efforts to manage marine mammals, turtles, seabirds, and other species. See ECOLOGICAL COMMUNITIES; ECOLOGICAL METHODS; POPULATION ECOLOGY.

Depleted, threatened, or endangered populations are often subject to mitigation or recovery efforts. The purpose of these efforts is to reduce the immediate threat of extinction or extirpation. This is typically achieved by direct human intervention to increase the size of a population or to prevent further decline in population size. Methods used to achieve recovery for fish and marine invertebrates include reducing fishing quotas, restricting the use of certain types of fishing gear, restricting the seasonal or annual distribution of a fishery, or closing fisheries altogether.

Recovery efforts can be most successful if they are based on multispecies or ecosystem-level management strategies. These strategies take into account positive and negative interactions between species, such as facilitation, competition, and predation.

They further take into account interactions between species and their environment. Key to the success of assessment and recovery programs is identification of the appropriate biological unit for conservation (for example, population, subspecies, stock, or evolutionarily significant unit). Maintaining genetic diversity is an important goal of conservation biology, because genetic diversity confers evolutionary potential. Thus, conservation efforts often are aimed at populations that are genetically distinct from other populations of the same species.

Restoration efforts are aimed at returning habitats to an ecologically functional condition, usually consistent with some previous, more pristine condition. See ENDANGERED SPECIES; FISHERIES ECOLOGY; MARINE FISHERIES.

Marine protected areas are set aside for the protection or recovery of species, habitats, or ecosystems. They include marine parks, marine reserves, marine sanctuaries, harvest refugia, and voluntary or legislated no-take areas. Some marine protected areas allow for consumptive use (such as fishing) or extraction of resources (for example, oil drilling), while others are closed to most human activities.

Monitoring programs are necessary to determine the outcome of specific conservation actions and to guide future conservation decisions. Monitoring programs vary according to the objectives of specific conservation projects but typically include such activities as long-term surveys of population size and status, and the development of mathematical models to help predict specific outcomes. [T.KI.]

**Marine containers** Standardized rectangular boxes for the transport of marine cargo. Since 1960, the ocean transportation of general cargo or freight has undergone a revolutionary technological change. The innovation was containerization—the development of standard marine cargo containers for consolidating packages into units of interchange between ships, docks, trucks, and railcars, and the development of special ships and handling systems to transport these containers at sea. This innovation brought economies of scale to marine cargo-handling operations, introduced capital-intensive processes to the labor-oriented stevedoring tasks, reduced cargo theft and damage,



Container crane and straddle carrier.



reduced the time a ship spent in port, and provided the means for efficient intermodal transport of cargoes.

Basic to the change to containerization was a new approach to loading and unloading cargoes. Instead of using nets or slings to lift individual bales, boxes, sacks, or pallets of cargo in and out of the ship's holds, the new systems employ standard cargo containers and special handling equipment to place the containers aboard (see illustration). The containers are loaded or stuffed at an inland factory or terminal and usually are never opened until they reach their ultimate destination. The ship carrying these containers becomes an extension of a truckline or a railroad.

Intermodality, moving containerized cargo by more than one mode of transport without the need for intermediate reloading, is the essence of this technology. The containers can be moved to the ship via regular highway trailers or trailer chassis, or by flatbed railcar or rail piggyback. Once at the marine terminal, they can be lifted or rolled on the ships. Upon arrival at the discharge port, all land and water modes are again available to move them, with cargo undisturbed, to the consignee. [J.C.C.]

**Marine ecology** An integrative science that studies the basic structural and functional relationships within and among living populations and their physical-chemical environments in marine ecosystems. Marine ecology draws on all the major fields within the biological sciences as well as oceanography, physics, geology, and chemistry. Emphasis has evolved toward understanding the rates and controls on ecological processes that govern both short- and long-term events, including population growth and survival, primary and secondary productivity, and community dynamics and stability. Marine ecology focuses on specific organisms as well as on particular environments or physical settings. See ENVIRONMENT.

**Marine environments.** Classification of marine environments for ecological purposes is based very generally on two criteria, the dominant community or ecosystem type and the physical-geological setting. Those ecosystems identified by their dominant community type include mangrove forests, coastal salt marshes, submersed seagrasses and seaweeds, and tropical coral reefs. Marine environments identified by their physical-geological setting include estuaries, coastal marine and nearshore zones, and open-ocean-deep-sea regions. See DEEP-SEA FAUNA; ECOLOGICAL COMMUNITIES; HYDROTHERMAL VENT; PHYTOPLANKTON; ZOOPLANKTON.

An estuary is a semienclosed area or basin with an open outlet to the sea where fresh water from the land mixes with seawater. The ecological consequences of fresh-water input and mixing create strong gradients in physical-chemical characteristics, biological activity and diversity, and the potential for major adverse impacts associated with human activities. Because of the physical forces of tides, wind, waves, and fresh-water input, estuaries are perhaps the most ecologically complex marine environment. They are also the most productive of all marine ecosystems on an area basis and contain within their physical boundaries many of the principal marine ecosystems defined by community type. See ESTUARINE OCEANOGRAPHY; MANGROVE; SALT MARSH.

Coastal and nearshore marine ecosystems are generally considered to be marine environments bounded by the coastal land margin (seashore) and the continental shelf 300–600 ft (100–200 m) below sea level. The continental shelf, which occupies the greater area of the two and varies in width from a few to several hundred kilometers, is strongly influenced by physical oceanographic processes that govern general patterns of circulation and the energy associated with waves and currents. Ecologically, the coastal and nearshore zones grade from shallow water depths, influenced by the adjacent landmass and input from coastal rivers and estuaries, to the continental shelf break, where oceanic processes predominate. Biological productivity and species diversity and abundance tend to decrease in an offshore direction as the food web becomes supported only by planktonic production. Among the unique marine ecosystems associated with coastal

and nearshore water bodies are seaweed-dominated communities (for example, kelp “forests”), coral reefs, and upwellings. See CONTINENTAL MARGIN; REEF; UPWELLING.

Approximately 70% of the Earth's surface is covered by oceans, and more than 80% of the ocean's surface overlies water depths greater than 600 ft (200 m), making open-ocean-deep-sea environments the largest, yet the least ecologically studied and understood, of all marine environments. The major oceans of the world differ in their extent of landmass influence, circulation patterns, and other physical-chemical properties. Other major water bodies included in open-ocean-deep-sea environments are the areas of the oceans that are referred to as seas. A sea is a water body that is smaller than an ocean and has unique physical oceanographic features defined by basin morphology. Because of their circulation patterns and geomorphology, seas are more strongly influenced by the continental landmass and island chain structures than are oceanic environments.

Within the major oceans, as well as seas, various oceanographic environments can be defined. A simple classification would include water column depths receiving sufficient light to support photosynthesis (photic zone); water depths at which light penetration cannot support photosynthesis and which for all ecological purposes are without light (aphotic zone); and the benthos or bottom-dwelling organisms. Classical oceanography defines four depth zones; epipelagic, 0–450 ft (0–150 m), which is variable; mesopelagic, 450–3000 ft (150–1000 m); bathypelagic, 3000–12,000 ft (1000–4000 m); and abyssopelagic, greater than 12,000 ft (4000 m). These depth strata correspond approximately to the depth of sufficient light penetration to support photosynthesis; the zone in which all light is attenuated; the truly aphotic zone; and the deepest oceanic environments.

**Marine ecological processes.** Fundamental to marine ecology is the discovery and understanding of the principles that underlie the organization of marine communities and govern their behavior, such as controls on population growth and stability, quantifying interactions among populations that lead to persistent communities, and coupling of communities to form viable ecosystems. The basis of this organization is the flow of energy and cycling of materials, beginning with the capture of radiant solar energy through the processes of photosynthesis and ending with the remineralization of organic matter and nutrients.

Photosynthesis in seawater is carried out by various marine organisms that range in size from the microscopic, single-celled marine algae to multicellular vascular plants. The rate of photosynthesis, and thus the growth and primary production of marine plants, is dependent on a number of factors, the more important of which are availability and uptake of nutrients, temperature, and intensity and quality of light. Of these three, the last probably is the single most important in governing primary production and the distribution and abundance of marine plants. Considering the high attenuation of light in water and the relationships between light intensity and photosynthesis, net autotrophic production is confined to relatively shallow water depths. The major primary producers in marine environments are intertidal salt marshes and mangroves, submersed seagrasses and seaweeds, phytoplankton, benthic and attached microalgae, and—for coral reefs—symbiotic algae (zooxanthellae). On an areal basis, estuaries and nearshore marine ecosystems have the highest annual rates of primary production. From a global perspective, the open oceans are the greatest contributors to total marine primary production because of their overwhelming size.

The two other principal factors that influence photosynthesis and primary production are temperature and nutrient supply. Temperature affects the rate of metabolic reactions, and marine plants show specific optima and tolerance ranges relative to photosynthesis. Nutrients, particularly nitrogen, phosphorus, and silica, are essential for marine plants and influence both the rate of photosynthesis and plant growth. For many phytoplankton-based marine ecosystems, dissolved inorganic nitrogen is

considered the principal limiting nutrient for autotrophic production, both in its limiting behavior and in its role in the eutrophication of estuarine and coastal waters. See PHOTOSYNTHESIS.

Marine food webs and the processes leading to secondary production of marine populations can be divided into plankton-based and detritus-based food webs. They approximate phytoplankton-based systems and macrophyte-based systems. For planktonic food webs, current evidence suggests that primary production is partitioned among groups of variously sized organisms, with small organisms, such as cyanobacteria, playing an equal if not dominant role at times in aquatic productivity. The smaller autotrophs—both through excretion of dissolved organic compounds to provide a substrate for bacterial growth and by direct grazing by protozoa (microflagellates and ciliates)—create a microbially based food web in aquatic ecosystems, the major portion of autotrophic production and secondary utilization in marine food webs may be controlled, not by the larger organisms typically described as supporting marine food webs, but by microscopic populations.

Macrophyte-based food webs, such as those associated with salt marsh, mangrove, and seagrass ecosystems, are not supported by direct grazing of the dominant vascular plant but by the production of detrital matter through plant mortality. The classic example is the detritus-based food webs of coastal salt marsh ecosystems. These ecosystems, which have very high rates of primary production, enter the marine food web as decomposed and fragmented particulate organics. The particulate organics of vascular plant origin support a diverse microbial community that includes bacteria, flagellates, ciliates, and other protozoa. These organisms in turn support higher-level consumers.

Both pelagic (water column) and benthic food webs in deep ocean environments depend on primary production in the overlying water column. For benthic communities, organic matter must reach the bottom by sinking through a deep water column, a process that further reduces its energy content. Thus, in the open ocean, high rates of secondary production, such as fish yields, are associated with areas in which physical-chemical conditions permit and sustain high rates of primary production over long periods of time, as is found in upwelling regions.

Regardless of specific marine environment, microbial processes provide fundamental links in marine food webs that directly or indirectly govern flows of organic matter and nutrients that in turn control ecosystem productivity and stability. See BIOLOGICAL PRODUCTIVITY; ECOLOGY; ECOSYSTEM; SEAWATER FERTILITY.

[R.We.]

**Marine engine** An engine that propels a waterborne vessel. In all except the smallest boats, the engine is but part of an integrated power plant, which includes auxiliary machinery for propulsion engine support, ship services, and cargo, trade, or mission services. Marine engines in common use are diesel engines, steam turbines, and gas turbines. Gasoline engines are widely used in pleasure craft. See BOAT PROPULSION; INTERNAL COMBUSTION ENGINE; MARINE MACHINERY.

Diesel engines of all types and power outputs are in use for propulsion of most merchant ships, most service and utility craft, most naval auxiliary vessels, and most smaller surface warships and shorter-range submarines. The diesel engines most commonly used fall into either a low-speed category or the medium- and high-speed category. Low-speed engines are generally intended for the direct drive of propellers without any speed reduction, and therefore are restricted to a range of rotative speeds for which efficient propellers can be designed, generally below 300 revolutions per minute (rpm). The largest engines are rated for power output of over 5000 kW (almost 7500 horsepower) per cylinder at about 100 rpm. Because of their higher rotative speeds, medium- and high-speed engines drive propellers through speed-reduction gears, but they are directly connected for driving generators in diesel-electric installations. Large medium-speed engines are capable of over 1500 kW

(2000 hp) per cylinder at about 400 rpm. The upper limit of the medium-speed category, and the start of the high-speed category, is generally placed in the range of 900–1200 rpm. See DIESEL ENGINE.

While steam-turbine plants cannot achieve the thermal efficiency of diesel engines, steam turbines of moderately high power levels (above about 7500 kW or 10,000 hp) offer efficient energy conversion from steam, which can in turn be produced by combustion of low-quality fuel oil, coal, or natural gas in boilers, or from a nuclear reactor. For high efficiency, high turbine speeds are required, typically 3000–10,000 rpm, with reduction gearing or electric drive used to achieve low propeller rotative speeds. The combination of turbine and reduction gear or electric drive has usually proven robust and durable, so that most oil-fueled steamships currently in service are held over from an earlier era. Others, more recently built, are capitalizing on the availability, in their trade, of a fuel unsuitable for diesel engines. See STEAM TURBINE.

Aircraft-derivative gas turbines have become the dominant type of propulsion engine for medium-sized surface warships, including frigates, destroyers, cruisers, and small aircraft carriers. In all cases the turbines are multishaft, simple-cycle engines, with the power turbine geared to the propeller. In some installations, two to four turbines are the sole means of propulsion; in other cases, one or two turbines provide high-speed propulsion, while diesel engines or smaller gas turbines are used for cruising speeds. Factors favoring the aircraft-derivative gas turbine in this application are low weight, compact dimensions, high power, rapid start and response, standardization of components, and maintenance by replacement. See GAS TURBINE.

In the electric drive arrangement, the engine is directly coupled to a generator, and the electricity produced drives an electric motor, which is most often of sufficiently low rotative speed to be directly connected to the propeller shaft. Any number of engine-generator sets may be connected to drive one or more propulsion motors. Electric drive has been used with engines of all types, including low-speed diesels. Advantages of electric drive include flexibility of machinery arrangement, elimination of gear noise, high propeller torque at low speed, and inherent reversing capability. In ships with high electric requirements for cargo, mission, or trade services—for example, passenger ships, tankers with electric-motor-driven cargo pumps, or warships with laser weapons—there is an advantage in integrating propulsion and ship service support through a common electric distribution system. However, electric drive is usually heavier, higher in initial cost, and less efficient than direct or geared drive. [A.L.R.]

**Marine engineering** The engineering discipline concerned with the machinery and systems of ships and other marine vehicles and structures. Marine engineers are responsible for the design and selection of equipment and systems, for installation and commissioning, for operation, and for maintenance and repair. They must interface with naval architects, especially during design and construction.

Marine engineers are likely to have to deal with a wide range of systems, including diesel engines, gas turbines, boilers, steam turbines, heat exchangers, and pumps and compressors; electrical machinery; hydraulic machinery; refrigeration machinery; steam, water, fuel oil, lubricating oil, compressed gas, and electrical systems; equipment for automation and control; equipment for fire fighting and other forms of damage control; and systems for cargo handling. Many marine engineers become involved with structural issues, including inspection and surveying, corrosion protection, and repair.

Marine engineers are generally mechanical engineers or systems engineers who have acquired their marine orientation through professional experience, but programs leading to degrees in marine engineering are offered by colleges and universities in many countries. See BOAT PROPULSION; MARINE BOILER; MARINE ENGINE; MARINE MACHINERY; MARINE REFRIGERATION; NAVAL

ARCHITECTURE; PROPELLER (MARINE CRAFT); SHIP DESIGN; SHIP POWERING, MANEUVERING, AND SEAKEEPING. [A.L.R.]

**Marine fisheries** The harvest of animals and plants from the ocean to provide food and recreation for people, food for animals, and a variety of organic materials for industry. It is now generally agreed that the world catch is approaching a maximum, which may be less than 100,000,000 metric tons per year. If methods can be devised to harvest smaller organisms not heretofore used because they have been too costly to catch and process, it has been estimated that the yield could perhaps be increased severalfold. Russia is said to have succeeded in developing an acceptable human food product from Antarctic krill. [J.L.McH.]

**Marine geology** The study of the portion of the Earth beneath the oceans. Approximately 70% of the Earth's surface is covered with water. Marine geology involves the study of the sea floor; of the sediments, rocks, and structures beneath the sea floor; and of the processes that are responsible for their formation. The average depth of the ocean is about 3800 m (12,500 ft), and the greatest depths are in excess of 11,000 m (36,000 ft; the Marianas Trench). Hence, the study of the sea floor necessitates employing a complex suite of techniques to measure the characteristic properties of the Earth's surface beneath the oceans. Contrary to popular views, only a minority of marine geological investigations involve the direct observation of the sea floor by scuba diving or in submersibles. Rather, most of the ocean floor has been investigated by surface ships using remote-sensing geophysical techniques, and more recently by the use of satellite observations.

The oceanic crust is relatively young, having been formed entirely within the last 200 million years (m.y.), a small fraction of the nearly 5-billion-year history of the Earth. The process of renewing or recycling the oceanic crust is the direct consequence of plate tectonics and sea-floor-spreading processes. It is therefore logical that the geologic history of the sea floor be outlined within the framework of plate tectonic tenets. Where plates move apart, molten lava reaches the surface to fill the voids, creating new oceanic crust. Where the plates come together, oceanic crust is thrust back within the interior of the Earth, creating the deep oceanic trenches. These trenches are located primarily around the rim of the Pacific Ocean. The material can be traced by using the distribution of earthquakes to depths of about 700 km (420 mi). At that level, the character of the subducted lithosphere is lost, and this material is presumably remelted and assimilated with the surrounding upper-mantle material. See EARTHQUAKE; GEODYNAMICS; LITHOSPHERE; PLATE TECTONICS.

**Mid-oceanic ridges.** Most of the ocean floor can be classified into three broad physiographic regions, one grading into the other (see illustration). The approximate centers of the ocean basin are characterized by spectacular, globally encircling mountain ranges, the mid-oceanic ridge (MOR) system, which formed as the direct consequence of the splitting apart of oceanic lithosphere. The detailed morphologic characteristics of these mountain ranges depend somewhat upon the rate of separation of the plates involved. Abyssal hill relief, especially within 500 km (300 mi) of ridge crest, is noticeably rougher on the slow-spreading Mid-Atlantic Ridge than on the fast-spreading East Pacific Rise. The profile of the East Pacific Rise is also broader and shallower than for the Mid-Atlantic Ridge. If the entire mid-oceanic ridge system were spreading rapidly, the expanded volume of the ridge system would displace water from the ocean basins onto the continents.

The broad cross-sectional shape of this mid-ocean mountain range can be related directly and simply to its age. The depth of the mid-oceanic ridge at any place is a consequence of the steady conduction of heat to the surface and the associated cooling of the oceanic crust and lithosphere. As it cools, contracts, and becomes more dense, the oceanic crust plus the oceanic lithosphere

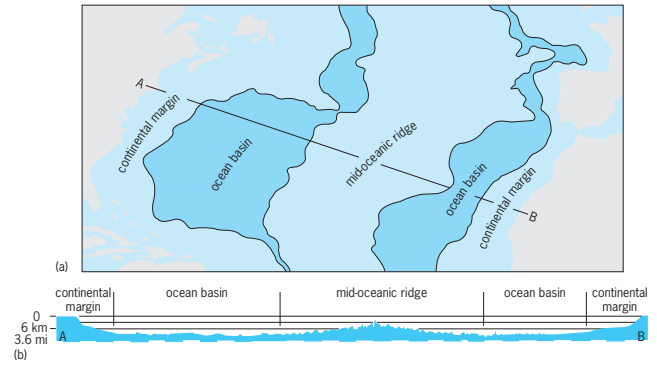

**Geology of the North Atlantic Ocean. (a) Physiographic divisions of the ocean floor. (b) Principal morphologic features along the profile between North America and Africa.**

sink isostatically (under its own weight) into the more fluid substrate (the asthenosphere). Hence, the depth to the top of the oceanic crust is a predictable function of the age of that crust; departures from such depth predictions represent oceanic depth anomalies. These depth anomalies are presumably formed as a consequence of processes other than lithospheric cooling, such as intraplate volcanism. The Hawaiian island chain and the Polynesian island groups are examples of this type of volcanism. See ASTHENOSPHERE; MID-OCEANIC RIDGE; OCEANIC ISLANDS; VOLCANOLOGY.

**Basins.** The deep ocean basins, which lie adjacent to the flanks of the mid-oceanic ridge, represent the older portions of the sea floor that were once the shallower flanks of the ridge (see illustration). The bulk of sediments found on the ocean floor can be broadly classified as terrigenous or biogenic. Terrigenous sediments are derived from adjacent landmasses and are brought to the sea through river systems. This sediment load is sometimes transported across the continental shelves, often utilizing, as pathways, submarine canyons that dissect the shelves, the continental slope, and the continental rise. Biogenic sediments are found in all parts of the ocean, either intermixed with terrigenous sediments or in near "pure form" in those areas inaccessible to terrigenous sedimentation.

Biogenic sediments are composed mostly of the undissolved tests of siliceous and calcareous microorganisms, which settle slowly to the sea floor. This steady so-called pelagic rain typically accumulates at rates of a few centimeters per thousand years. The composition and extent of the input to the biogenic sediment depend upon the composition and abundances of the organisms, which in turn are largely reflective of the water temperature and the available supply of nutrients. The Pacific equatorial zones and certain other regions of deep ocean upwelling are rich in nutrients and correspondingly rich in the microfauna and flora of the surface waters. Such regions are characterized by atypically high pelagic sediment rates. See UPWELLING.

**Continental margins.** The continental margins lie at the transition zone between the continents and the ocean basins and mark a major change from deep water to shallow water and from thin oceanic crust to thick continental crust. Rifted margins are found bounding the Atlantic Ocean (see illustration). These margins represent sections of the South American and North American continents that were once contiguous to west Africa and northwest Africa, respectively. These supercontinents were rifted apart 160–200 m.y. ago as the initial stages of sea-floor spreading and the birth of the present Atlantic Ocean sea floor. See CONTINENTS, EVOLUTION OF.

Continental margins are proximal to large sources of terrestrial sediments that are the products of continental erosion. The margins are also the regions of very large vertical motions through time. This vertical motion is a consequence of cooling of the rifted continental lithosphere and subsidence. During initial rifting of the continents, fault-bound rift basins are formed that serve as

sites of deposition for large quantities of sediment. These sedimented basins constitute significant loads onto the underlying crust, giving rise to an additional component of margin subsidence. The continental margins are of particular importance also because, as sites of thick sediment accumulations (including organic detritus), they hold considerable potential for the eventual formation and concentration of hydrocarbons. As relatively shallow areas, they are also accessible to offshore exploratory drilling and oil and gas production wells. See OIL AND GAS, OFFSHORE.

Many sedimentary aprons or submarine fans are found seaward of prominent submarine canyons that incise the continental margins. Studies of these sedimentary deposits have revealed a number of unusual surface features that include a complex system of submarine distributary channels, some with levees. The channel systems control and influence sediment distribution by depositional or erosional interchannel flows. Fans are also effected by major instantaneous sediment inputs caused by large submarine mass slumping and extrachannel turbidity flows. See SUBMARINE CANYON.

In contrast to the rifted margins, the continental margins that typically surround the Pacific Ocean represent areas where plates are colliding. As a consequence of these collisions, the oceanic lithosphere is thrust back into the interior of the Earth; the loci of underthrusting are manifest as atypically deep ocean sites known as oceanic trenches. The processes of subducting the oceanic lithosphere give rise to a suite of tectonic and morphologic features characteristically found in association with the oceanic trenches. An upward bulge of the crust is created seaward of the trench that represents the flexing of the rigid oceanic crust as it is bent downward at the trench. The broad zone landward of most trenches is known as the accretionary prism and represents the accumulation of large quantities of sediment that was carried on the oceanic crust to the trench. Because the sediments have relatively little strength, they are not underthrust with the more rigid oceanic crust, but they are scraped off. In effect, they are plastered along the inner wall of the trench system, giving rise to a zone of highly deformed sediments. These sediments derived from the ocean floor are intermixed with sediments transported downslope from the adjacent landmass, thus creating a classic sedimentary melange. See CONTINENTAL MARGIN; SEDIMENTOLOGY.

**Anomalous features.** In addition to the major morphologic and sediment provinces, parts of the sea floor consist of anomalous features that obviously were not formed by fundamental processes of sea-floor spreading, plate collisions, or sedimentation. Examples are long, linear chains of seamounts and islands. Many of these chains are thought to reflect the motion of the oceanic plates over hot spots that are fixed within the mantle. See MAGMA; SEAMOUNT AND GUYOT.

The presence of large, anomalously shallow regions known as oceanic plateaus may also represent long periods of anomalous regional magmatic activity that may have occurred either near divergent plate boundaries or within the plate. Alternatively, many oceanic plateaus are thought to be small fragments of continental blocks that have been dispersed through the processes of rifting and spreading, and have subsequently subsided below sea level to become part of the submarine terrain.

Other important features of the ocean floor are the so-called scars represented by fracture zone traces that were formed as part of the mid-oceanic ridge system, where the ridge axis is initially offset. Oceanic crusts on opposite sides of such offsets have different ages and hence they have different crustal depths. A structural-tectonic discontinuity exists across this zone of ridge axis offset known as a transform zone. Although relative plate motion does not occur outside the transform zone, the contrasting properties represented by the crustal age differences create contrasting topographic and subsurface structural discontinuities, which can sometimes be traced for great distances. Fracture zone traces define the paths of relative motion between the two plates involved. Those mapped by conventional methods of ma-

rine survey have provided fundamental information that allows rough reconstructions of the relative positions of the continents and oceans throughout the last 150–200 m.y. The study that deals with the relative motions of the plates is known as plate kinematics. See TRANSFORM FAULT.

**Marginal seas.** The sea-floor features described so far are representative of the main ocean basins and reflect their evolution mostly through processes of plate tectonics. Other, more complicated oceanic regions, typically found in the western Pacific, include a variety of small, marginal seas (back-arc basins) that were formed by the same general processes as the main ocean basins. These regions define a number of small plates whose interaction is also more or less governed by the normal tenets of plate tectonics. One difficulty in studying these small basins is that they are typified by only short-lived phases of evolution. Frequent changes in plate motions interrupt the process, creating tectonic overprints and a new suite of ocean-floor features. Furthermore, conventional methods of analyzing rock magnetism or depths of the sea floor to date the underlying crust do not work well in these small regions. The small dimensions of these seas bring into play relatively large effects of nearby tectonic boundaries and render invalid key assumptions of these analytical techniques. The number of small plates that actually behave as rigid pieces is not well known, but it is probably only 10–20 for the entire world. [D.E.H.]

**Marine machinery** All machinery installed on waterborne craft, including engines, transmissions, shafting, propellers, generators, motors, pumps, compressors, blowers, educators, centrifuges, boilers and other heat exchangers, winches, cranes, steering gear, and associated piping, tanks, wiring, and controls, used for propulsion, for ship services, and for cargo, trade, or mission services.

Practically all marine machinery elements have nonmarine counterparts; in some cases, the latter were developed from marine applications, while in other cases specific equipment was “marinized.” For marine service, machinery may have to meet higher standards of reliability and greater demands for weight and volume reduction and access for maintenance. Marine machinery must be capable of withstanding the marine environment, which tends toward extreme ambient conditions, high humidity, sea-water corrosion, vibration, sea motions, shock, variable demand, and fluctuating support services. Even higher standards may apply for warship machinery. To improve system reliability, essential equipment may be fitted in duplicate or provided with duplicated or alternative support or control systems, while nonessential equipment may be fitted with bypasses, to permit continued operation of a system following a component failure. Isolation valves or circuit breakers are common, enabling immediate repair.

Machinery on modern ships is highly automated, with propulsion usually directly controlled from the wheelhouse, and auxiliary machinery centrally controlled from an air-conditioned, sound-proofed control room, usually in the engine room. In the typical modern merchant ship (but not in passenger ships), the machinery operates automatically, and the controls are unattended at sea, with engineers called out by alarm in the event of malfunctions.

Propulsion machinery comprises an engine, usually a diesel engine, steam turbine, or gas turbine, with required gearing or other transmission system, and, for steam plants, steam generators. See BOAT PROPULSION; MARINE BOILER; MARINE ENGINE; PROPELLER (MARINE CRAFT); SHIP NUCLEAR PROPULSION. [A.L.R.]

**Marine microbiology** An independent discipline applying the principles and methods of general microbiology to research in marine biology and biogeochemistry. Marine microbiology focuses primarily on prokaryotic organisms, mainly bacteria. Because of their small size and easy dispersability, bacteria are virtually ubiquitous in the marine environment. Furthermore,

natural populations of marine bacteria comprise a large variety of physiological types, can survive long periods of starvation, and are able to start their metabolic activity as soon as a substrate becomes available. As a result, the marine environment, similar to soil, possesses the potential of a large variety of microbial processes that degrade (heterotrophy) but also produce (autotrophy) organic matter. Considering the fact that the marine environment represents about 99% of the biosphere, marine microbial transformations are of tremendous global importance. See BIOSPHERE.

**Heterotrophic transformations.** Quantitatively, the most important role of microorganisms in the marine environment is heterotrophic decomposition and remineralization of organic matter. It is estimated that about 95% of the photosynthetically produced organic matter is recycled in the upper 300–400 m (1000–1300 ft) of water, while the remaining 5%, largely particulate matter, is further decomposed during sedimentation. Only about 1% of the total organic matter produced in surface waters arrives at the deep-sea floor in particulate form. In other words, the major source of energy and carbon for all marine heterotrophic organisms is distributed over the huge volume of pelagic water mass with an average depth of about 3800 m (2.5 mi). In this highly dilute medium, particulate organic matter is partly replenished from dissolved organic carbon by microbial growth, the so-called microbial loop.

Of the large variety of organic material decomposed by marine heterotrophic bacteria, oil and related hydrocarbons are of special interest. Other environmentally detrimental pollutants that are directly dumped or reach the ocean as the ultimate sink by land runoff are microbiologically degraded at varying rates. Techniques of molecular genetics are aimed at encoding genes of desirable enzymes into organisms for use as degraders of particular pollutants.

A specifically marine microbiological phenomenon is bacterial bioluminescence, which may function as a respiratory bypass of the electron transport chain. Free-living luminescent bacteria are distinguished from those that live in symbiotic fashion in light organelles of fishes or invertebrates. See BIOLUMINESCENCE.

**Photoautotrophs and chemoautotrophs.** The type of photosynthesis carried out by purple sulfur bacteria uses hydrogen sulfide (instead of water) as a source of electrons and thus produces sulfur, not oxygen. Photoautotrophic bacteria are therefore limited to environments where light and hydrogen sulfide occur simultaneously, mostly in lagoons and estuaries. In the presence of sufficient amounts of organic substrates, heterotrophic sulfate-reducing bacteria provide the necessary hydrogen sulfide where oxygen is depleted by decomposition processes. Anoxygenic photosynthesis is also carried out by some blue-green algae, which are now classified as cyanobacteria. See CYANOBACTERIA; PHOTOSYNTHESIS.

Chemoautotrophic bacteria are able to reduce inorganic carbon to organic carbon (chemosynthesis) by using the chemical energy liberated during the oxidation of inorganic compounds. Their occurrence, therefore, is not light-limited but depends on the availability of oxygen and the suitable inorganic electron source. Their role as producers of organic carbon is insignificant in comparison with that of photosynthetic producers (exempting the processes found at deep-sea hydrothermal vents). The oxidation of ammonia and nitrite to nitrate (nitrification) furnishes the chemically stable and biologically most available form of inorganic nitrogen for photosynthesis. See NITROGEN CYCLE.

The generation of methane and acetic acid from hydrogen and carbon dioxide stems from anaerobic bacterial chemosynthesis, and is common in anoxic marine sediments. See METHANOGENESIS (BACTERIA).

**Marine microbial sulfur cycle.** Sulfate is quantitatively the most prominent anion in seawater. Since it can be used by a number of heterotrophic bacteria as an electron acceptor in respiration following the depletion of dissolved oxygen, the resulting

sulfate reduction and the further recycling of the reduced sulfur compounds make the marine environment microbiologically distinctly different from fresh water and most soils. The marine anaerobic, heterotrophic sulfate-reducing bacteria are classified in three genera; *Desulfovibrio*, *Desulfotomaculum*, and *Clostridium*.

The marine aerobic sulfur-oxidizing bacteria fall into two groups: the thiobacilli and the filamentous or unicellular organisms. While the former comprise a wide range from obligately to facultatively chemoautotrophic species (requiring none or some organic compounds), few of the latter have been isolated in pure culture, and chemoautotrophy has been demonstrated in only a few.

**Hydrothermal vent bacteria.** Two types of hydrothermal vents have been investigated: warm vents (8–25°C or 46–77°F) with flow rates of 1–2 cm (0.4–0.8 in.) per second, and hot vents (260–360°C or 500–600°F) with flow rates of 2 m (6.5 ft) per second. In their immediate vicinity, dense communities of benthic invertebrates are found with a biomass that is orders of magnitude higher than that normally found at these depths and dependent on photosynthetic food sources. This phenomenon has been explained by the bacterial primary production of organic carbon through the chemosynthetic oxidation of reduced inorganic compounds. The chemical energy required for this process is analogous to the light energy used in photosynthesis and is provided by the geothermal reduction of inorganic chemical species. The specific compounds contained in the emitted vent waters and suitable for bacterial chemosynthesis are mainly hydrogen sulfide, hydrogen, methane, and reduced iron and manganese. The extremely thermophilic microorganisms isolated from hydrothermal vents belong, with the exception of the genus *Thermotoga*, to the Archaeobacteria. Of eight archaeal genera, growing within a temperature range of about 75–110°C (165–230°F), three are able to grow beyond the boiling point of water, if the necessary pressure is applied to prevent boiling. These organisms are strictly anaerobic. However, unlike mesophilic bacteria, hyperthermophilic marine isolates tolerate oxygen when cooled below their minimum growth temperature. See ARCHAEBACTERIA; HYDROTHERMAL VENT. [H.W.J.]

**Marine mining** The process of recovering mineral wealth from sea water and from deposits on and under the sea floor. While mineral resources to the value of trillions of dollars do exist in and under the oceans, their exploitation is not simple. Many environmental problems must be overcome and many technical advances must be made before the majority of these deposits can be mined in competition with existing land resources.

The mineral resources of the marine environment are of three basic types: the dissolved minerals of the ocean waters; the unconsolidated mineral deposits of marine beaches, continental shelf, and deep-sea floor; and the consolidated deposits contained within the bedrock underlying the seas. As with land deposits, the initial stages preceding the production of a marketable commodity include discovery, characterization of the deposit to assess its value and exploitability, and mining, including beneficiation of the material to a salable product. [M.J.Cru.]

**Marine navigation** The process of directing a watercraft to a destination in a safe and expeditious manner. From a known present position, a course is determined that avoids dangers, and on this course estimates are made of time schedules. The task is to periodically effect en route checks and to make required adjustments.

The method used will depend on the type of vessel and on its role or mission. The devices available range from a simple compass to a host of sophisticated electronic systems. In all cases, the navigator must plan and prepare by setting instruments in order and by checking for predictable current and tidal effects and hazards to navigation en route. This preparation includes

having the latest correct charts and reviewing pertinent sections of sailing directions, light lists, and tide and current tables.

The methods used to fulfill the requirements of these phases come after one of the following broad categories of navigation: dead reckoning, piloting, celestial navigation, and electronic navigation. The first three categories have become somewhat standardized; the fourth category has been under constant and innovative development.

While the navigator is occupied primarily with courses, speeds, distances, and position determination, the safety of the craft is not to be neglected. Integrated navigation-conning systems have the basic function of helping reduce the number of accidents between ships by having the computer correlate most of the data available during crowded conditions and thus help unburden the navigator by presenting these data in more usable form for better and quicker decision making. The system generally includes a collision avoidance device plus a general-purpose computer. The computer receives inputs from navigation sensors and from ship propulsion and ship status stations. The integrated console is designed to optimize the human engineering aspects of ship control and navigation.

Collision avoidance systems (CAS), also known as automatic radar plotting aids (ARPA), of varying degrees of sophistication have been developed to reduce the work load of the navigator and eliminate human error. Typically, such a system consists of a digital computer that receives inputs from the ship's radar, compass, and log, and determines and displays collision threats, and in some installations provides a recommended avoiding action.

Vessel traffic services (VTS) have been established in a number of heavily trafficked ports throughout the world in an attempt to reduce the number of collisions and strandings and safeguard the environment. Generally the service provides marine traffic management of an advisory nature, but in an especially hazardous situation it may be necessary for the VTS to exercise emergency control of vessel movements. See VESSEL TRAFFIC SERVICE.

Traffic-separation schemes have been established in a number of high-traffic density areas throughout the world, primarily to decrease the risk of collision at sea. A typical scheme consists of the establishment of parallel traffic lanes separated by an intervening buffer zone, analogous to a divided freeway on land.

[A.B.M.; R.Gre.]

An electronic chart displays on a video screen the same type of hydrographic information that mariners seek in a traditional nautical chart. Electronic charts integrated with a range of information, and with hardware and software that can process a hydrographic database to support decision making, are classified as electronic chart display and information systems (ECDIS). In addition to displaying a real-time picture of the vessel's position in the waterway, an ECDIS manages navigational and piloting information (typically, vessel-route-monitoring, track-keeping, and track-planning information) to support navigational decision making.

There are a variety of intelligent systems deployed aboard automated ship's bridges: piloting expert systems, engineering and vibration expert systems, neural network systems for adaptive and intelligent steering control, and automated intelligent docking systems. See EXPERT SYSTEMS; NEURAL NETWORK.

Integrated bridge systems are designed to allow the wheelhouse to function as the operational center for navigational and supervisory tasks aboard the ship. These bridges in many cases become ship's operations centers, incorporating controls and monitors for all essential vessel functions, including navigation, engine control, and communications. See NAVIGATION. [M.R.Gr.]

**Marine refrigeration** Marine refrigerating equipment is used for shipboard refrigeration of products as well as for air conditioning the quarters of passengers and crew. Shipboard refrigeration is necessary for the preservation of perishables in transit and foodstuffs to be used by passengers and crew. Marine

refrigeration is also used for maintaining certain cargo products in liquid form that would otherwise evaporate when stored at ambient conditions. See AIR CONDITIONING; REFRIGERATION.

The common refrigerants that have been in use for years, known as CFCs (chlorofluorocarbons) and HCFCs (hydrochlorofluorocarbons), are still being phased out because they contain chlorine, which depletes Earth's stratospheric ozone layer. Replacements for these refrigerants known as hydrofluorocarbons (HFCs), which are non-ozone-depleting, have been developed. These refrigerants contain fluorine in place of chlorine, and do not destroy the ozone layer. For some systems, the cargo itself is used as the refrigerant, such as when carrying ammonia or petroleum products such as propane or butane.

For refrigerating systems using insulated holds, liquid refrigerant is delivered to cooling coils, where the refrigerant is expanded, and enters the evaporator as a low-pressure liquid. There it evaporates by absorbing heat from the space being cooled. The refrigerant vapor is then drawn from the evaporator by a compressor, which delivers the refrigerant to a condenser as a high-pressure, high-temperature vapor. The condenser, normally a shell-and-tube heat exchanger cooled by seawater flowing through the tubes, removes the heat absorbed in the evaporator and the heat of compression from the refrigerant as it condenses to a high-pressure liquid. The refrigerating cycle is then repeated. For the container system, each container has its own refrigeration system consisting of a compressor, air-cooled condenser, cooling coil, and circulating fan. For liquid cargoes in insulated tanks, the latent heat of vaporization is released as the evaporating liquid changes state to a gas. [J.H.Me.]

**Marine sediments** The accumulation of minerals and organic remains on the sea floor. Marine sediments vary widely in composition and physical characteristics as a function of water depth, distance from land, variations in sediment source, and the physical, chemical, and biological characteristics of their environments. The study of marine sediments is an important phase of oceanographic research and, together with the study of sediments and sedimentation processes on land, constitutes the subdivision of geology known as sedimentology. See OCEANOGRAPHY.

Traditionally, marine sediments are subdivided on the basis of their depth of deposition into littoral 0–66 ft (0–20 m), neritic 66–660 ft (20–200 m), and bathyal 660–6600 ft (200–2000 m) deposits. This division overemphasizes depth. More meaningful, although less rigorous, is a distinction between sediments mainly composed of materials derived from land, and sediments composed of biological and mineral material originating in the sea. Moreover, there are significant and general differences between deposits formed along the margins of the continents and large islands, which are influenced strongly by the nearness of land and occur mostly in fairly shallow water, and the pelagic sediments of the deep ocean far from land.

**Sediments of continental margins.** These include the deposits of the coastal zone, the sediments of the continental shelf, conventionally limited by a maximum depth of 330–660 ft (100–200 m), and those of the continental slope. Because of large differences in sedimentation processes, a useful distinction can be made between the coastal deposits on one hand (littoral), and the open shelf and slope sediments on the other (neritic and bathyal). Furthermore, significant differences in sediment characteristics and sedimentation patterns exist between areas receiving substantial detrital material from land, and areas where most of the sediment is organic or chemical in origin.

Coastal sediments include the deposits of deltas, lagoons, and bays, barrier islands and beaches, and the surf zone. The zone of coastal sediments is limited on the seaward side by the depth to which normal wave action can stir and transport sand, which depends on the exposure of the coast to waves and does not usually exceed 66–100 ft (20–30 m); the width of this zone is normally a few miles. The sediments in the coastal zone are

usually land-derived. The material supplied by streams is sorted in the surf zone; the sand fraction is transported along the shore in the surf zone, often over long distances, while the silt and clay fractions are carried offshore into deeper water by currents. Consequently, the beaches and barrier islands are constructed by wave action mainly from material from fairly far away, although local erosion may make a contribution, while the lagoons and bays behind them receive their sediment from local rivers.

The types and patterns of distribution of the sediments are controlled by three factors and their interaction: (1) the rate of continental runoff and sediment supply; (2) the intensity and direction of marine transporting agents, such as waves, tidal currents, and wind; and (3) the rate and direction of sea level changes. The balance between these three determines the types of sediment to be found. See DELTA; ESTUARINE OCEANOGRAPHY.

On most continental shelves, equilibrium has not yet been fully established and the sediments reflect to a large extent the recent rise of sea level. Only on narrow shelves with active sedimentation are present environmental conditions alone responsible for the sediment distribution. Sediments of the continental shelf and slope belong to one or more of the following types: (1) biogenic (derived from organisms and consisting mostly of calcareous material); (2) authigenic (precipitated from sea water or formed by chemical replacement of other particles, for example, glauconite, salt, and phosphorite); (3) residual (locally weathered from underlying rocks); (4) relict (remnants of earlier environments of deposition, for example, deposits formed during the transgression leading to the present high sea level stand); (5) detrital (products of weathering and erosion of land, supplied by streams and coastal erosion, such as gravels, sand, silt, and clay).

Much of the fine-grained sediment transported into the sea by rivers is not permanently deposited on the shelf but kept in suspension by waves. This material is slowly carried across the shelf by currents and by gravity flow down its gentle slope, and is finally deposited either on the continental slope or in the deep sea. If submarine canyons occur in the area, they may intercept these clouds, or suspended material, channel them, and transport them far into the deep ocean as turbidity currents. If the canyons intersect the nearshore zone where sand is transported, they can carry this material also out into deep water over great distances. See CONTINENTAL MARGIN; REEF. [T.H.V.A.]

**Deep-sea sediments.** In general, classifications are difficult to apply because so many deep-sea sediments are widely ranging mixtures of two or more end-member sediment types. However, they can be divided into biogenic and nonbiogenic sediments.

Biogenic sediments, those formed from the skeletal remains of various kinds of marine organisms, may be distinguished according to the composition of the skeletal material, principally either calcium carbonate or opaline silica. The most abundant contributors of calcium carbonate to the deep-sea sediments are the planktonic foraminiferids, coccolithophorids and pteropods. Organisms which extract silica from the sea water and whose hard parts eventually are added to the sediment are radiolaria, diatoms, and to a lesser degree, dilicoflagellates and sponges. The degree to which deep-sea sediments in any area are composed of one or more of these biogenic types depends on the organic productivity of the various organisms in the surface water, the degree to which the skeletal remains are redissolved by sea water while setting to the bottom, and the rate of sedimentation of other types of sediment material. Where sediments are composed largely of a single type of biogenic material, it is often referred to as an ooze, after its consistency in place on the ocean floor.

The nonbiogenic sediment constituents are principally silicate materials and, locally, certain oxides. These may be broadly divided into materials which originate on the continents and are transported to the deep sea (detrital constituents) and those which originate in place in the deep sea, either precipitating from solution (authigenic minerals) or forming from the alteration of volcanic or other materials. The coarser constituents of detri-

tal sediments include quartz, feldspars, amphiboles, and a wide spectrum of other common rock-forming minerals. The finer-grained components also include some quartz and feldspars, but belong principally to a group of sheet-silicate minerals known as the clay minerals, the most common of which are illite, montmorillonite, kaolinite, and chlorite. The distributions of several of these clay minerals have yielded information about their origins on the continents and, in several cases, clues to their modes of transport to the oceans. [P.E.Bi.]

**Maritime meteorology** Those aspects of meteorology that occur over, or are influenced by, ocean areas. Maritime meteorology serves the practical needs of surface and air navigation over the oceans. Phenomena such as heavy weather, high seas, tropical storms, fog, ice accretion, sea ice, and icebergs are especially important because they seriously threaten the safety of ships and personnel. The weather and ocean conditions near the air-ocean interface are also influenced by the atmospheric planetary boundary layer, the ocean mixed layer, and ocean fronts and eddies.

To support the analysis and forecasting of many meteorological and oceanographic elements over the globe, observations are needed from a depth of roughly 1 km (0.6 mi) in the ocean to a height of 30 km (18 mi) in the atmosphere. In addition, the observations must be plentiful enough in space and time to keep track of the major features of interest, that is, tropical and extratropical weather systems in the atmosphere and fronts and eddies in the ocean. Over populated land areas, there is a fairly dense meteorological network; however, over oceans and uninhabited lands, meteorological observations are scarce and expensive to make, except over the major sea lanes and air routes. Direct observations in the ocean, especially below the sea surface, are insufficient to make a synoptic analysis of the ocean except in very limited regions. Fortunately, remotely sensed data from meteorological and oceanographic satellites are helping to fill in some of these gaps in data. Satellite data can provide useful information on the type and height of clouds, the temperature and humidity structure in the atmosphere, wind velocity at cloud level and at the sea surface, the ocean surface temperature, the height of the sea, and the location of sea ice. Although satellite-borne sensors cannot penetrate below the sea surface, the height of the sea can be used to infer useful information about the density structure of the ocean interior. See REMOTE SENSING.

The motion of the atmosphere and the ocean is governed by the laws of fluid dynamics and thermodynamics. These laws can be expressed in terms of mathematical equations that can be put on a computer in the form of a numerical model and used to help analyze the present state of the fluid system and to forecast its future state. This is the science of numerical prediction, and it plays a very central role in marine meteorology and physical oceanography.

The first step in numerical prediction is known as data assimilation. This is the procedure by which observations are combined with the most recent numerical prediction valid at the time that the observations are taken. This combination produces an analysis of the present state of the atmosphere and ocean that is better than can be obtained from the observations alone. Data assimilation with a numerical model increases the value of a piece of data, because it spreads the influence of the data in space and time in a dynamically consistent way.

The second step is the numerical forecast itself, in which the model is integrated forward in time to predict the state of the atmosphere and ocean at a future time. Models of the global atmosphere and world ocean, as well as regional models with higher spatial resolution covering limited geographical areas, are used for this purpose. In meteorology and oceanography the success of numerical prediction depends on collecting sufficient data to keep track of meteorological and oceanographic features of interest (including those in the earliest stages of development), having

access to physically complete and accurate numerical models of the atmosphere and ocean, and having computer systems powerful enough to run the models and make timely forecasts. See WEATHER FORECASTING AND PREDICTION. [R.L.Han.]

**Marjoram** The aromatic herb *Majorana hortensis*, a common plant in Mediterranean areas. The spicy camphora-ceous odor of marjoram has long been cherished as an addition to a wide variety of foods; in the Middle Ages marjoram was used as an air freshener. Marjoram is in the mint family (Lamiaceae) and is a close relative of European or Greek oregano, with which it is often confused. There is still controversy concerning the proper taxonomic classification of this plant. Some authors place it in the genus *Origanum*, while others continue to separate it into its own genus *Majorana*. See OREGANO.

Marjoram is a small perennial (1–2 ft or 30–60 cm tall), and has ovate leaves to 1 in. (2.5 cm) long. The leaves are slightly hairy, as are the erect somewhat woody stems. Marjoram flowers are white to very light lavender or pink in color but are very small and usually go unnoticed; the entire flower spike or inflorescence is, however, easily noticeable.

The dried and fresh leaves are used as flavoring for meats (sausage), vegetables, cheeses, poultry stuffing blends, and sauces, especially tomato-based sauces. See LAMIALES; SPICE AND FLAVORING. [S.Kir.]

**Marl** A sediment that consists of a mixture of calcium carbonate ( $\text{CaCO}_3$ ) and any other constituents in varying proportions. Marls usually are fine-grained, so that most consist of  $\text{CaCO}_3$  mixed with silt and clay. The dominant carbonate mineral in most marls is calcite ( $\text{CaCO}_3$ ), but other carbonate minerals such as aragonite (another form of  $\text{CaCO}_3$ ), dolomite [ $\text{Ca, Mg}(\text{CO}_3)_2$ ], and siderite ( $\text{FeCO}_3$ ) may be present. See ARAGONITE; CALCITE; CARBONATE MINERALS; DOLOMITE; SIDERITE.

In North America, the name marl may be limited to a lake deposit that is rich in  $\text{CaCO}_3$ , but usually the term is extended to include marine deposits. Deep-sea marls consist of mixtures of clay and the  $\text{CaCO}_3$  skeletons of microscopic planktonic animals (foraminiferans) and plants (coccoliths and discoasters). Marls deposited in the deeper parts of lakes consist of fine-grained  $\text{CaCO}_3$ , but marls deposited in shallow water may contain  $\text{CaCO}_3$  in the form of shells of mollusks and fragments of calcareous algae such as *Chara* (stonewort) mixed with fine-grained  $\text{CaCO}_3$  that is precipitated on the leaves of rooted aquatic vegetation. The  $\text{CaCO}_3$  from these various sources is then mixed with sand, silt, or clay brought in by streams from the surrounding drainage basin. See MARINE SEDIMENTS.

Although the term marl has been applied to sediments with a greatly variable content of  $\text{CaCO}_3$ , strictly speaking the  $\text{CaCO}_3$  content should range between 30 and 70%. Because of the high  $\text{CaCO}_3$  content, most marls are light to medium gray, although they can be almost any color. The high  $\text{CaCO}_3$  content also tends to make dried marl earthy and crumbly.

The indurated rock equivalent of marl is marlstone. Equivalent terms range from calcareous claystone to argillaceous or impure limestone, depending on the amount of  $\text{CaCO}_3$  that is present. Marlstone is common in marine sequences of all ages, and is particularly common in ancient lake sequences of Tertiary age in the western United States. For example, the famous "oil shale" of the Green River Formation of Wyoming, Colorado, and Utah is not a shale at all but a marlstone in which the dominant carbonate mineral is dolomite. See LIMESTONE; OIL SHALE; SEDIMENTARY ROCKS. [W.E.De.]

**Marmot** Several species of rodents of the genus *Marmota* which are members of the squirrel family, Sciuridae. These mammals are found in Europe, Asia, and North America.

One of the best-known marmots is the alpine marmot (*Marmota marmota*). It has a broad round head, a short furry tail, prominent eyes, and medium-sized ears; it is covered

with thick, coarse, dull-colored fur. Other marmots are the red marmot (*M. caudata*) of Central Asia, the red-bellied marmot (*M. flaviventris*), ranging from New Mexico to British Columbia, and the woodchuck, or groundhog (*M. monax*), of North America. All species seem to prefer high altitudes except the woodchuck, which lives in woodlands and on farms. In many ways the marmots resemble the prairie dog. See PRAIRIE DOG; RODENTIA. [C.B.C.]

**Mars** The planet that is fourth outward from the Sun. Mars has a mean heliocentric distance (semimajor axis) of 1.524 astronomical units, equivalent to  $141.6 \times 10^6$  mi ( $227.9 \times 10^6$  km). Its orbital eccentricity of 0.093, one of the largest of the major planets, causes the distance between Mars and the Sun to vary from  $128 \times 10^6$  mi ( $207 \times 10^6$  km) at perihelion to  $155 \times 10^6$  mi ( $249 \times 10^6$  km) at aphelion. The mean diameter of Mars is 4212 mi (6780 km), or about 53% that of the Earth. The planet has a mass of  $7.08 \times 10^{20}$  tons ( $6.42 \times 10^{23}$  kg), about 11% of Earth's. The sidereal rotation period is 24h 37m 22.7s, corresponding to a mean solar day of 24h 39m 35.2s.

Mars appears to the unaided eye as a bright, slightly reddish star. Having a mean (synodic) period between oppositions of 780 days, Mars is in conjunction with the Sun every other year. Viewed through a telescope, Mars usually appears as a bright reddish disk marked by complex, semipermanent dark regions and variable white polar caps.

**Interior.** Accurate measurements of the planet's gravitational field made by orbiting spacecraft have shown that Mars has a dense core and thus is differentiated into a core, mantle, and crust. The crust, composed of silicate rocks, enriched in silicon and aluminum and deficient in magnesium, is believed to be about 30 mi (50 km) thick. Over geologic time, partial melting of the crust or upper mantle has caused lower-density materials to float to the surface, creating the observed lava plains and volcanic structures.

At present Mars does not have a global magnetic field of appreciable strength. However, early in its history Mars must have had a more substantial magnetic field, because its near-surface rocks exhibit strong remanent magnetism. See ROCK MAGNETISM.

**Geology.** The Martian surface has been modified extensively by the processes of impact cratering, volcanism, faulting, and fluvial erosion. The terrain in the southern hemisphere is very heavily cratered and thus quite old, having formed some  $3.8 \times 10^9$  years ago. Much of it stands 1–2 mi (1–4 km) higher than the planet's mean radius. By contrast, the northern hemisphere is dominated by vast, lava-covered plains with relatively few impact craters and an average elevation of about 3 mi (5 km) below the mean radius.

The Tharsis rise, or bulge, is an uplifted portion of the surface that stands several kilometers above the mean elevation of the planet. Most of Mars's tectonic features are associated with Tharsis, which affects approximately one-quarter of the entire surface.

The Martian surface exhibits several enormous shield volcanoes. The largest and perhaps the youngest is Olympus Mons, which is nearly 370 mi (600 km) across at its base and stands approximately 16 mi (26 km) above the surrounding terrain. Three other large shield volcanoes, Ascraeus Mons, Pavonis Mons, and Arsia Mons, lie along the nearby Tharsis rise. In shape and structure the Martian shield volcanoes bear a strong resemblance to their Hawaiian counterparts. At the summit of each shield is a complex of calderas, collapsed craterlike features that were once vents for lava.

Perhaps the most spectacular features on the Martian surface are the huge canyons located primarily in the equatorial regions. Valles Marineris, actually a system of canyons, extends for over 3000 mi (5000 km) along the equatorial belt. In places, the canyon complex is as much as 300 mi (500 km) wide and drops to more than 4 mi (6 km) below the surrounding surface. Dwarfing the Earth's Grand Canyon, Valles Marineris is



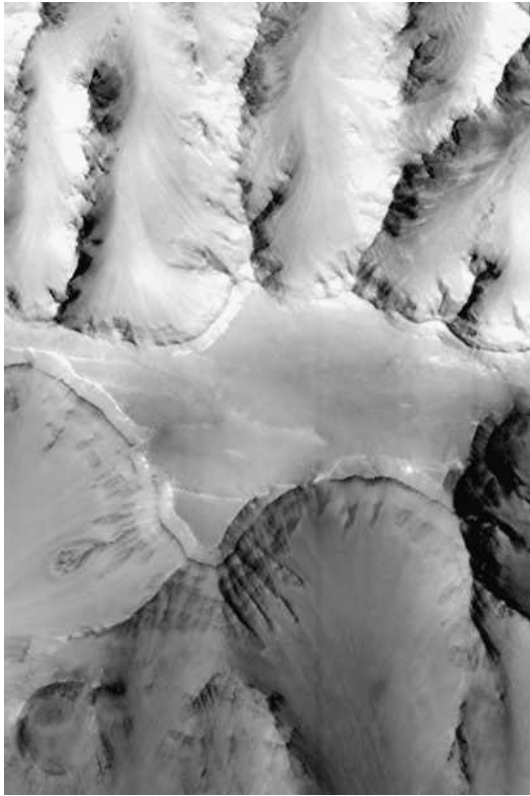

**Fig. 1.** An image from the *Mars Global Surveyor* resolves features as small as 20 ft (6 m) in a 10-km-wide portion of Coprates Chasma, which is located in the middle of Mars's vast Valles Marineris canyon complex. The high-standing plateau is underlain by multiple rock layers that may be volcanic or sedimentary in nature. (NASA/Malin Space Science Systems)

comparable in size to the great East African Rift Valley. In general, the walls of the canyon are precipitous, have well-defined edges, and show evidence of slumping and landslide activity (Fig. 1).

An astonishing class of features on the Martian surface is a widespread network of channels that bear a very strong resemblance to dry river beds. Ranging in size from broad, sinuous features nearly 40 mi (60 km) wide to small, narrow networks less than 300 ft (100 m) wide, the channels appear to have been created by water erosion. The largest channels must have been formed by enormous torrents of water, presumably released in some catastrophic manner (Fig. 2).

**Surface exploration.** Five spacecraft have landed safely on the Martian surface and returned significant scientific data about its properties. Two American *Viking* landers arrived in 1976. *Mars Pathfinder* which landed in 1997, carried a small, instrumented rover, *Sojourner*, which was directed from Earth via remote control to several rocks and fine-grained drifts in the lander's immediate vicinity. The *Mars Exploration Rovers*, *Spirit* and *Opportunity*, which landed in 2004, had far greater mobility.

**Meteorites from Mars.** A small number of meteorites have reached Earth after being violently ejected from the planet Mars during the collision of sizable asteroids or comets. The meteorites are thus samples from Mars itself. The first of these Martian meteorites was recognized in 1982, and 14 such samples were known by the end of 1999. They are sometimes collectively termed the SNC meteorites, representing the first letters of their three subclasses: shergottites, nakhlites, and chassignites. The Martian meteorites contain a distinctive ratio of the isotopes of oxygen found nowhere on Earth, on the Moon, or in other meteorites. With one exception, they crystallized from molten rock

within the last  $1.3 \times 10^9$  years, far more recently than the usual  $4.6 \times 10^9$  years (the age of the solar system) found in all other meteorites. The lone exception to date, designated ALH 84001, crystallized  $4.5 \times 10^9$  years ago during the planet's infancy. See METEORITE.

**Atmosphere.** The Martian atmosphere is very thin, with surface pressure averaging about 6.5 millibars (650 pascals), or less than 1% of the pressure at the Earth's surface. It is composed principally of carbon dioxide (95.3%), but contains nitrogen, argon, oxygen, and a trace of water vapor, totaling 4.7%. Both carbon dioxide and water form clouds in the Martian atmosphere.

**Dust storms.** Localized dust storms appear quite frequently on Mars. Because the Martian atmosphere is extremely thin, wind velocities greater than 90–110 mi/h (40–50 m/s) are needed to set surface dust grains in motion. Some dust storms develop with such intensity that their total extent may be hemispheric or even global.

**Water inventory.** The seasonal cycle of growth and decay of the bright polar caps has long been taken as evidence of the presence of water on Mars. However, evidence from the *Mariner* spacecraft identified carbon dioxide as the principal constituent of the polar snow, with lesser amounts of water ice also present. Formed during autumn and winter by condensation and deposition of the icy mist covering the polar regions, the polar caps at the end of winter cover a vast area extending down to latitude  $60^\circ$  in the southern hemisphere and  $70^\circ$  in the northern hemisphere. The residual caps, which never completely disappear, are believed to be composed almost entirely of water ice. It is estimated that if all the water present in the polar caps were distributed uniformly over the surface of Mars, it would produce a layer 70–110 ft (22–33 m) deep. A far greater amount of water may exist as subsurface ice trapped elsewhere in areas of heavily cratered and fractured terrain.

Even though at present liquid water cannot exist on the Martian surface, the planet's numerous large flood channels suggest that vast amounts of water flowed on the surface early in Martian history. There is strong circumstantial evidence that much of the low-lying northern hemisphere was covered with an ocean roughly  $4 \times 10^9$  years ago. Although unproven, this hypothesis suggests that  $10^7$  mi<sup>2</sup> ( $27 \times 10^6$  km<sup>2</sup>) of the northern plains were also inundated.

**Possibility of life.** The ample evidence that early Mars had an abundance of liquid water, a thicker atmosphere, and a more clement environment has raised speculation that the planet may have once been, or may still be, an abode for primitive life forms. In 1976, the twin *Viking* landers conducted experiments on the Martian surface to test for the existence of life. One of the

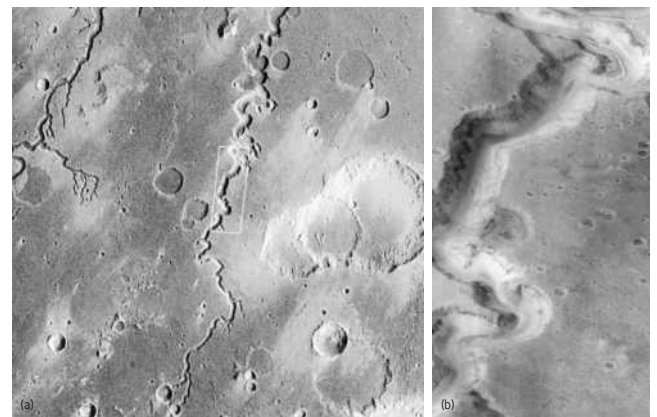

**Fig. 2.** Nanedi Vallis, a long, water-cut canyon on Mars, which is 1.5 mi (2.5 km) wide. (a) Canyon and surrounding terrain. (b) Detailed view of area in white rectangle in part a. Rocky outcrops jut from the canyon's walls, and a secondary rivulet is seen in its floor. (NASA/Malin Space Science Systems)

biological experiments gave a positive result—the release of oxygen from a soil sample when humidified—but there is no consensus as to the source of this reaction.

Twenty years later, a scientific team claimed that it had found evidence of fossilized microbes within a known Martian meteorite (ALH 84001). After years of intensive study, scientists have reached no consensus. The mineral associations within ALH 84001 and other Martian meteorites neither confirm the presence of once-living organisms nor exclude it.

**Satellites.** Mars has two small satellites, Phobos and Deimos. Neither satellite is massive enough to be gravitationally contracted to a spherical shape. Both satellites are saturated with impact craters. Both satellites have the same low albedo, approximately 0.05. This low reflectivity suggests that the Martian satellites may have originated in the asteroid belt. *See* ASTEROID.

[J.K.B.]

**Marsileales** A small order of heterosporous, leptosporangiate ferns (division Polypodiophyta) which grow in water or wet places and are rooted to the substrate. The leaves arise on long stalks from the rhizome and typically have floating blades with four leaflets, suggesting a four-leaved clover. The order contains a single family and only 3 genera, about 50 species in all, most of them belonging to the widespread genus *Marsilea* (water clover). *See* POLYPODIOPHYTA.

[A.Cr.]

**Marsupialia** An order of animals, long considered the only order of the mammalian infraclass Metatheria.

The marsupials are characterized by the presence of a pouch (marsupium) in the female, a skin pocket whose teat-bearing abdominal wall is supported by epipubic bones. The young are born in the embryonic state and crawl unaided to the marsupium, where they attach themselves to the teats and continue their development. In a few species the pouch is vestigial or has disappeared completely.

A wide variety of terrestrial adaptations are found among the 82 genera of living marsupials. Some spectacular examples of evolution convergent upon placental modes of life are exemplified by the Australian marsupial “moles” (*Notoryctes*), “wolves” (*Thylacinus*), and “flying squirrels” (*Petaurus*). For the most part, the adaptive radiation of the marsupials has paralleled that of the placentals, yielding many ecological analogs, such as kangaroos and wallabies, which are the counterparts of the placental deer and antelopes, although these groups differ widely in structure. *See* ANTEATER; EUTHERIA; KANGAROO; KOALA; MAMMALIA; METATHERIA; OPOSSUM.

[R.H.T.]

**Marten** The name applied to seven species of carnivores which are members of the family Mustelidae. This family also includes the skunk, weasel, otter, badger, and wolverine.

The American marten (*Martes americana*) inhabits the cooler forests of North America. Its brown pelt, known as the American sable, is highly prized. It is small and has scent glands, as do most members of the family. Other species are the pine marten (*M. martes*), yellow-throated marten (*M. flavigula*), stone marten (*M. foina*), Japanese marten (*M. melampus*), and South Indian yellow-throated marten (*M. gwatkinsi*). These are all found in Asia; the pine and stone martens occur in Europe as well.

The adult weighs a maximum of 3 lb (1.4 kg), and for the size of the animal, the gestation period of about 38 weeks is unusually long. This is apparently because these species, as many other members of the family do, have delayed implantation of the fertilized egg; that is, after fertilization there is a lapse of several months before embryonic activation is initiated. Mating occurs in the summer and the litter of three or four is born the following spring. *See* BADGER; CARNIVORA; FISHER; MAMMALIA; OTTER; SABLE; SKUNK; WEASEL; WOLVERINE.

[C.B.C.]

**Maser** A device for coherent amplification or generation of electromagnetic waves by use of excitation energy in resonant

atomic or molecular systems. “Maser” is an acronym for microwave amplification by stimulated emission of radiation. The device uses an unstable ensemble of atoms or molecules that may be stimulated by an electromagnetic wave to radiate energy at the same frequency and phase as the stimulating wave, thus providing coherent amplification. Amplifiers and oscillators operating on the same principle as the maser exist in many regions of the electromagnetic spectrum. Those operating in the optical region were once called optical masers, but they are now universally called lasers (the “l” stands for “light”). Amplification by maser action is also observed arising naturally from interstellar gases. *See* COHERENCE; LASER.

Maser amplifiers can have exceptionally low internally generated noise, approaching the limiting effective input power of one-half quantum of energy per unit bandwidth. Their inherently low noise makes maser oscillators that use a narrow atomic or molecular resonance extremely monochromatic, providing a basis for frequency standards. The hydrogen maser, which uses a hyperfine resonance of a gas of hydrogen atoms as the amplification source, is the prime example of this use. Also because of their low noise and consequent high sensitivity, maser amplifiers are particularly useful for reception and detection of very weak signals in radio astronomy, microwave radiometry, and the like. A maser amplifier was used in the experiments that detected the cosmic microwave radiation left over from the big bang that created the universe. *See* COSMIC BACKGROUND RADIATION; ELECTRICAL NOISE; FREQUENCY MEASUREMENT; RADIO ASTRONOMY; UNCERTAINTY PRINCIPLE.

The quantum theory describes discrete particles such as atoms or molecules as existing in one or more members of a discrete set of energy levels, corresponding to the various possible internal motions of the particle (vibrations, rotations, and so forth). Thermal equilibrium of an ensemble of such particles requires that the number of particles  $n_1$  in a lower energy level 1 be related to the number of particles  $n_2$  in a higher energy level 2 by the Boltzmann distribution, given by the equation below, where  $E_1$

$$\frac{n_1}{n_2} = \exp \frac{(E_2 - E_1)}{kT}$$

and  $E_2$  are the respective energies of the two levels,  $k$  is Boltzmann’s constant, and  $T$  is the absolute (Kelvin) temperature. *See* BOLTZMANN STATISTICS; NONRELATIVISTIC QUANTUM THEORY; QUANTUM MECHANICS.

Particles may be stimulated by an electromagnetic wave to make transitions from a lower energy level to a higher one, thereby absorbing energy from the wave and decreasing its amplitude, or from a higher energy level to a lower one, thereby giving energy to the wave and increasing its amplitude. These two processes are inverses of each other, and their effects on the stimulating wave add together. The upward and downward transition rates are the same, so that, for example, if the number of particles in the upper and lower energy states is the same, the stimulated emission and absorption processes just cancel. For any substance in thermal equilibrium at a positive (ordinary) temperature, the Boltzmann distribution requires that  $n_1$  be greater than  $n_2$  resulting in net absorption of the wave. If  $n_2$  is greater than  $n_1$ , however, there are more particles that emit than those that absorb, so that the particles amplify the wave. In such a case, the ensemble of particles is said to have a negative temperature  $T$ , to be consistent with the Boltzmann condition. If there are not too many counterbalancing losses from other sources, this condition allows net amplification. This is the basic description of how a maser amplifies an electromagnetic wave. An energy source is required to create the negative temperature distribution of particles needed for a maser. This source is called the pump.

**Gas masers.** In the first known maser of any kind, the amplifying medium was a beam of ammonia ( $\text{NH}_3$ ) molecules, and the molecular resonance used was the strongest of the rotation-inversion lines, at a frequency near 23.87 GHz (1.26-cm

wavelength). Molecules from a pressurized tank of ammonia issued through an array of small orifices to form a molecular beam in a meter-long vacuum chamber. Spatially varying electric fields in the vacuum chamber created by a cylindrical array of electrodes formed a focusing device, which ejected from the beam the molecules in the lower energy level and directed the molecules in the upper energy level into a metal-walled electromagnetic cavity resonator. When the cavity resonator was tuned to the molecular transition frequency, the number of molecules was sufficiently large to produce net amplification and self-sustained oscillation. This type of maser is particularly useful as a frequency or time standard because of the relative sharpness and invariance of the resonance frequencies of molecules in a dilute gas. *See* CAVITY RESONATOR; MOLECULAR BEAMS.

**Solid-state masers.** Solid-state masers usually involve the electrons of paramagnetic ions in crystalline media immersed in a magnetic field. At least three energy levels are needed for continuous maser action. The energy levels are determined both by the interaction of the electrons with the internal electric fields of the crystal and by the interaction of the magnetic moments of the electrons with the externally applied magnetic field. The resonant frequencies of these materials can be tuned to a desired condition by changing the strength of the applied magnetic field and the orientation of the crystal in the field. An external oscillator, the pump, excites the transition between levels 1 and 3 [at the frequency  $\nu_{31} = (E_3 - E_1)/h$ ], equalizing their populations. Then, depending on other conditions, the population of the intermediate level 2 may be greater or less than that of levels 1 and 3. If greater, maser amplification can occur at the frequency  $\nu_{21}$ , or if less, at the frequency  $\nu_{32}$ . Favorable conditions for this type of maser are obtained only at very low temperature, as in a liquid-helium cryostat. A typical material is synthetic ruby, which contains paramagnetic chromium ions ( $\text{Cr}^{3+}$ ), and has four pertinent energy levels. The important feature of solid-state masers is their sensitivity when used as amplifiers. *See* PARAMAGNETISM.

**Astronomical masers.** Powerful, naturally occurring masers have probably existed since the earliest stages of the universe, though that was not realized until a few years after masers were invented and built on Earth. Their existence was first proven by discovery of rather intense 18-cm-wavelength microwave radiation of the free radical hydroxyl (OH) molecule coming from very localized regions of the Milky Way Galaxy.

Masers in astronomical objects differ from those generally used on Earth in that they involve no resonators or slow-wave structures to contain the radiation and so increase its interaction with the amplifying medium. Instead, the electromagnetic waves in astronomical masers simply travel a very long distance through astronomical clouds of gas, far enough to amplify the waves enormously even on a single pass through the cloud. It is believed that usually these clouds are large enough in all directions that a wave passing through them in any direction can be strongly amplified, and hence astronomical maser radiation emerges from them in all directions.

Naturally occurring masers have been important tools for obtaining information about astronomical objects. Since they are very intense localized sources of microwave radiation, their positions around stars or other objects can be determined very accurately with microwave antennas separated by long distances and used as interferometers. This provides information about the location of stars themselves as well as that of the masers often closely surrounding them. The masers' velocity of motion can also be determined by Doppler shifts in their wavelengths. The location and motion of masers surrounding black holes at the centers of galaxies have also provided information on the impressively large mass of these black holes. Astronomical masers often vary in power on time scales of days to years, indicating changing conditions in the regions where they are located. Such masers also give information on likely gas densities, temperature, motions, or other conditions in the rarefied gas of which they are a part. *See* BLACK HOLE; DOPPLER EFFECT. [C.H.T.; J.P.G.]

**Masking of sound** Interference with the audibility of a sound caused by the presence of another sound. More specifically, the number of decibels (dB) by which the intensity level of a sound (signal) must be raised above its threshold of audibility, to be heard in the presence of a second sound (masker), is called the masking produced by the masker on the signal. The masker and the signal may be identical or may differ in frequency, complexity, or time.

When both the masker and signal are pure tones and the tonal signal and masker have the same frequency, a very low level masker is required to mask the signal, indicating significant masking. As the difference in the frequency between the signal and masker increases, the signal is easier to detect, requiring a higher-level masker to mask the signal. Results from these psychophysical tuning curve measures of masking agree very well with data obtained from single auditory neurons in the auditory periphery, suggesting that tonal masking is mediated by the activity of these peripheral neurons.

The most widely studied complex masking sound is random noise which has energy at all frequencies and is said to be flat if the level for each 1-Hz bandwidth of the noise is the same. When random-flat noise is used to mask a pure tone, only a narrow frequency band (critical band) of the noise centered at the tonal frequency causes masking. If the bandwidth of the noise is narrower than this critical bandwidth, the tone's intensity can be lowered before the tone is masked. If the bandwidth is wider than this critical bandwidth, further widening of the bandwidth causes no changes in the detectability of the signal. The width of the critical band increases proportionally to its center frequency, that is, to the signal frequency. When noise masks speech, either the detectability of speech or speech intelligibility can be measured. The level for speech intelligibility is about 10–14 dB higher than for speech detectability.

Masking can occur when the signal either precedes or follows the masker in time. In backward masking the signal precedes the masker, while in forward masking the signal follows the masker. The physiological basis for this effect, as well as its implications for auditory processing of complex stimuli, is of great interest to the auditory scientist. *See* ACOUSTIC NOISE; HEARING (HUMAN); SOUND. [W.A.Y.]

**Masonry** Construction of natural building stone or manufactured units such as brick, concrete block, adobe, glass block, or cast stone that is usually bonded with mortar. Masonry can be used structurally or as cladding or paving. It is strong in compression but requires the incorporation of reinforcing steel to resist tensile and flexural stresses. Masonry veneer cladding can be constructed with adhesive or mechanical bond over a variety of structural frame types and backing walls.

Masonry is noncombustible and can be used as both structural and protective elements in fire-resistive construction. It is durable against wear and abrasion, and most types weather well without protective coatings. The mass and density of masonry also provide efficient thermal and acoustical resistance.

Brick, concrete block, and stone are the most widely used masonry materials for both interior and exterior applications in bearing and nonbearing construction. Stone masonry can range from small rubble or units of ashlar (a hewn or squared stone) embedded in mortar, to mechanically anchored thin slabs, to ornately carved decorative elements. Granite, marble, and limestone are the most commonly used commercial building stones. Glass block can be used as security glazing or as elements to produce special daylighting effects. *See* BRICK; CONCRETE; GLASS; GRANITE; MARBLE; LIMESTONE; STONE AND STONE PRODUCTS.

Masonry mortar is made from cement, sand, lime, and water. Masonry grout, a more fluid mixture of similar ingredients, is used to fill hollow cores and cavities and to embed reinforcing steel. Anchors and ties are usually of galvanized or stainless steel. Flashing may be of stainless steel, coated copper, heavy rubber sheet, or rubberized asphalt. *See* GROUT; MORTAR. [C.Bea.]

**Mass** The quantitative or numerical measure of a body's inertia, that is, of its resistance to being accelerated.

Because it is often necessary to compare masses of such dissimilar bodies as a sample of sugar, a sample of air, an electron, and the Moon, it is necessary to define mass in terms of a property that not only is inherent and permanent but is also universal in that it is possessed by all known forms of matter. All matter possesses two properties, gravitation and inertia. The property of gravitation is that every material body attracts every other material body. The property of inertia is that every material body resists any attempt to change its motion. A body's motion is said to change if the body is accelerated, that is, if it increases or decreases its speed or changes the direction of its motion. Because of its inertia a body cannot be accelerated unless a force is exerted on it. The greater the inertia of a body, the less will be the acceleration produced by a given force. See GRAVITATION; INERTIA.

The present definition of mass is in terms of inertia. The masses of two bodies are compared by applying equal forces to the bodies and measuring their accelerations. For example, the two bodies may be allowed to collide. According to Newton's third law, each body will then experience an equally strong force. If there are no external forces, and if  $a_1$  and  $a_2$  are the measured accelerations of the two bodies, the ratio of the masses of the two bodies is by definition given by the equation

$$\frac{m_1}{m_2} = \frac{a_2}{a_1}$$

This equation gives only ratios of masses; it is therefore necessary to designate the mass of some one body as the standard mass to which the masses of all other bodies can be compared. The body that has been chosen for this purpose is a cylinder of platinum-iridium alloy. It is known as the international standard of mass; its mass is called 1 kilogram (kg), and it is kept at the International Bureau of Weights and Measures near Paris, France. Replicas of the standard mass, kept at various national laboratories, are periodically compared with this standard.

Einstein's special theory of relativity predicts that the inertia of a body should increase if the energy of the body increases. This prediction has been conclusively verified experimentally. It follows that the mass of a body will increase if, for example, the body gains speed (addition of kinetic energy), or its temperature rises (addition of heat energy), or the body is compressed (addition of elastic energy). See CONSERVATION OF MASS. [L.N.]

**Mass defect** The difference between the mass of an atom and the sum of the masses of its individual components in the free (unbound) state. The mass of an atom is always less than the total mass of its constituent particles; this means, according to Albert Einstein's well-known formula, that an energy of  $E = mc^2$  has been released in the process of combination, where  $m$  is the difference between the total mass of the constituent particles and the mass of the atom, and  $c$  is the velocity of light.

The mass defect, when expressed in energy units, is called the binding energy, a term which is perhaps more commonly used. See NUCLEAR BINDING ENERGY. [W.W.W.]

**Mass-luminosity relation** The relation, observed or predicted by theory, between the quantity of matter a star contains (its mass) and the amount of energy generated in its interior (its luminosity). Because of the great sensitivity of the rate of energy production in a stellar interior to the mass of the star, the mass-luminosity relation provides an important test of theories of stellar interiors.

For a family of stars with different masses but with the same mixture of chemical elements uniformly distributed throughout the stellar volumes, there will be a unique mass-luminosity relation. Since most of the stars in the solar neighborhood have about the same chemical composition, the observed relation, obtained from binary stars for which masses and luminosities

can be observationally evaluated, conforms reasonably well with theory. See BINARY STAR; STAR. [D.M.P.]

**Mass number** The mass number  $A$  of an atom is the total number of its nuclear constituents, or nucleons, as the protons and neutrons are collectively called. The mass number is placed before and above the elemental symbol, thus  $^{238}\text{U}$ . The mass number gives a useful rough figure for the atomic mass; for example,  $^1\text{H} = 1.00814$  atomic mass units (amu),  $^{238}\text{U} = 238.124$  amu, and so on. See ATOMIC NUMBER. [H.E.D.]

**Mass spectrometry** An analytical technique for identification of chemical structures, determination of mixtures, and quantitative elemental analysis, based on application of the mass spectrometer. Determination of organic and inorganic molecular structure is based on the fragmentation pattern of the ion formed when the molecule is ionized; further, because such patterns are distinctive, reproducible, and additive, mixtures of known compounds may be analyzed quantitatively. Quantitative elemental analysis of organic compounds requires exact mass values from a high-resolution mass spectrometer; trace analysis of inorganic solids requires a measure of ion intensity as well. See MASS SPECTROSCOPE.

For analysis of organic compounds the principal methods are electron impact, chemical ionization, field ionization, field desorption, particle bombardment, laser desorption, and electro-spray.

In electron impact, when a gaseous sample of a molecular compound is ionized with a beam of energetic (commonly 70-V) electrons, part of the energy is transferred to the ion formed by the collision, as shown in the reaction below.

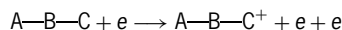

For most molecules the production of cations is favored over the production of anions by a factor of about  $10^4$ , and the following discussion pertains to cations. The ion corresponding to the simple removal of the electron is commonly called the molecular ion and normally will be the ion of greatest  $m/e$  ratio in the spectrum. In the ratio,  $m$  is the mass of the ion in atomic mass units (daltons) and  $e$  is the charge of the ion measured in terms of the number of electrons removed (or added) during ionization. Occasionally the ion is of vanishing intensity, and sometimes it collides with another molecule to abstract a hydrogen or another group. In these cases an incorrect assignment of the molecular ion may be made unless further tests are applied. Proper identification gives the molecular weight of the sample.

The remaining techniques were devised generally to circumvent the problem of the weak or vanishingly small intensity of a molecular ion.

In chemical ionization the ions to be analyzed are produced by transfer of a heavy particle ( $\text{H}^+$ ,  $\text{H}^-$ , or heavier) to the sample from ions produced from a reactant gas.

Field ionization and field desorption is used for less volatile material. The sample is ionized when it is in a very high field gradient (several volts per angstrom) near an electrode surface. The molecular potential well is distorted so that an electron tunnels from the molecule to the anode. The ion thus formed is repelled by the anode. Typically, the lifetime of the ion in the mass spectrometer source is much less ( $10^{-12}$  to  $10^{-9}$  s) than in electron impact. Because little energy is transferred as internal energy and the ion is removed rapidly, little fragmentation occurs, and the molecular weight is more easily determined.

In electrohydrodynamic ionization, a high electric-field gradient induces ion emission from a droplet of a liquid solution, that is, the sample and a salt dissolved in a solvent of low volatility. An example is the sample plus sodium iodide (NaI) dissolved in glycerol. The spectra include peaks due to cationized molecules of  $\text{MNa}^+$ ,  $\text{MNa}(\text{C}_3\text{H}_8\text{O}_3)_n^+$ , and  $\text{Na}(\text{C}_3\text{H}_8\text{O}_3)_n^+$ .

A sample heated very rapidly may vaporize before it pyrolyzes. Techniques for heating by raising the temperature of a source probe on which the sample is coated by 200 K (360°F)/s have been developed. Irradiation of an organic sample with laser radiation can move ions of mass up to 1500 daltons into the gas phase for analysis. This technique is the most compatible with analyzers that require particularly low pressures such as ion cyclotron resonance. Time-resolved spectra of surface ejecta are proving to be the most useful kinds of laser desorption spectra available.

A solid sample or a sample in a viscous solvent such as glycerol may have ions sputtered from its surface by bombardment with accelerated electrons, ions, or neutrals. Bombardment by electrons is achieved simply by inserting a probe with the sample directly into the electron beam of an electron impact source (in-beam electron ionization).

In laser desorption, the energy of laser photons may be used to remove an analyte from a surface and ionize it for mass-spectrometric analysis. In virtually all cases involving polar compounds of high molecular weight, the analyte is prepared in or on an organic matrix that is coated on the surface to be irradiated. The matrix material assists in the ionization process; the technique is known as matrix-assisted laser desorption ionization (MALDI). Numerous organic materials have been investigated. Molecular weights in excess of 700,000 have been measured with this technique, and the technique is particularly suited for the molecular-weight determination of large polar biological molecules; for example, enzymes and intact antibodies have been analyzed.

In electrospray ionization, a solution sprayed through a nozzle of very small diameter into a vacuum with an electric field having a gradient of several hundred to a thousand volts per centimeter produces gaseous ions from solutes effectively. Electrospray ionization is the only mass-spectrometric technique that produces a large fraction of multiply charged ions from an organic or biological analyte. Since mass spectrometers measure mass-to-charge ratios of ions, not simply their mass, electrospray ionization has the advantage of permitting ions of very high mass to be analyzed without special mass-analysis instrumentation; for example, an ion of mass 120,000 daltons carrying 60 positive charges appears at mass-to-charge 2000, within the range of many mass analyzers. This technique has been used to measure the masses of ions from molecules of masses up to about 200,000 daltons. Since the distribution of charged species reflects to some extent the degree of protonation in solution, a signal that reflects the folding of a protein, there is evidence that solution conformations of proteins can be studied by electrospray ionization mass spectrometry.

Measurement using a mass spectrometer takes advantage of the mass dependency in the equations of motion of an ion in an electric or magnetic field. Three common mass analyzers are magnetic-sector, quadrupole, and time-of-flight. An ion traversing the magnetic field of a sector instrument successfully reaches the detector when its mass,  $m$ , corresponds to  $m/z = r^2 B^2 / 2V$ , where  $z$  is the charge of the ion,  $r$  is the radius of the flight tube,  $B$  is the magnetic field strength, and  $V$  is the acceleration voltage. A mass spectrum can be recorded by varying  $B$  or  $V$ . A quadrupole is an array of four parallel rods electronically connected such that a radio frequency (RF) is applied to opposing rods, and the waveforms applied to adjacent rods are out of phase. In addition, a direct-current (DC) component is added to the rods such that one opposing pair has +DC and the other -DC. Ions entering the quadrupole follow complex sinusoidal paths. An ion successfully traversing the rods to the detector is mass-selected by the amplitude of the applied radio frequency and the amount of resolution from adjacent masses by the DC/RF ratio. A spectrum is detected by scanning the RF amplitude and the DC voltage in a fixed ratio. The time-of-flight analyzer is a tube with an acceleration field at one end and a detector at the other. Ions are pulsed and accelerated down the tube, starting a clock. Arrival times

at the detector are converted to mass by solving the equation  $m/z = 2V/(t/L)^2$ , where  $V$  is the acceleration potential,  $t$  is the arrival time, and  $L$  is the flight tube length.

The mass analyzers are characterized by their mass resolving power (RP), scan or acquisition rate, and mass range. Sector instruments are usually assembled with an additional energy filter and can be operated up to 100,000 RP. Resolving power is defined as  $M/\Delta M$ , where  $M$  is the mass number of the observed mass and  $\Delta M$  is the mass difference in two signals with a 10% valley between them. Increased resolution in sectors comes at the sacrifice of sensitivity. To increase resolution, the slits are narrowed on the ion beam. It is typical to lose 90% of the signal going from 1000 to 10,000 RP. Magnetic instruments are available with mass ranges up to 10,000 atomic mass units (amu) for singly charged ions at full acceleration potential. To obtain good quality, data sectors are scanned relatively slowly—a practical rate is 5 s per decade (1000–100 amu). Quadrupoles are usually operated at unit resolution. For example, 100 is resolved from 101, or 1000 from 1001. Quadrupoles can be scanned at 2000 amu/s and are available with mass range up to 4000 amu. Fast scanning and high-gas-pressure tolerance make quadrupoles popular for mass spectrometer–chromatographic hybrid systems. Modern time-of-flight analyzers are capable of 10,000 RP, 50% valley definition of  $\Delta M$ . Acquisition rates can be 100 spectra per second. The time-of-flight mass range is theoretically unlimited, and singly charged ions over 100,000 amu have been observed. See ATOMIC NUMBER; MASS NUMBER.

[T.D.Wi.]

The analysis of solid inorganic samples can be made either by vaporization in a Knudsen cell arrangement at very high temperatures or by volatilization of the sample surface so that particles are atomized and ionized with a high-energy spark (for example, 20,000 eV). The wide range of energies given to the particles requires a double-focusing mass spectrometer for analysis. Detection in such instruments is by photographic plate; exposures for different lengths of time are recorded sequentially, and the darkening of the lines on the plate is related empirically to quantitative composition by calibration charts. The method is useful for trace analysis (parts per billion) with accuracy ranging from 10% at higher concentration levels to 50% at trace levels. Methods for improving accuracy, including interruption and sampling of the ion beam, are under development.

Secondary ion mass spectrometry is most commonly used for surface analysis. A primary beam of ions accelerated through a few kilovolts is focused on a surface; ions are among the products sputtered from this surface, and they may be directly analyzed in a quadrupole filter. Sputtered material may also be analyzed by ionization of the neutrals in an inductively coupled plasma and subsequent mass analysis. This method produces ions with a lower energy spread than spark source mass spectrometry and, since detection then becomes less of a problem, has been supplanting spark source methods. See LASER SPECTROSCOPY; SECONDARY ION MASS SPECTROMETRY (SIMS); SPECTROSCOPY.

[M.M.Bu.]

**Mass spectroscope** An instrument used for determining the masses of atoms or molecules found in a sample of gas, liquid, or solid. It is analogous to the optical spectroscope, in which a beam of light containing various colors (white light) is sent through a prism to separate it into the spectrum of colors present. In a mass spectroscope, a beam of ions (electrically charged atoms or molecules) is sent through a combination of electric and magnetic fields so arranged that a mass spectrum is produced (see illustration). If the ions fall on a photographic plate which after development shows the mass spectrum, the instrument is called a mass spectrograph; if the spectrum is allowed to sweep across a slit in front of an electrical detector which records the current, it is called a mass spectrometer.

Mass spectroscopes are used in both pure and applied science. Atomic masses can be measured very precisely. Because of the equivalence of mass and energy, knowledge of nuclear structure

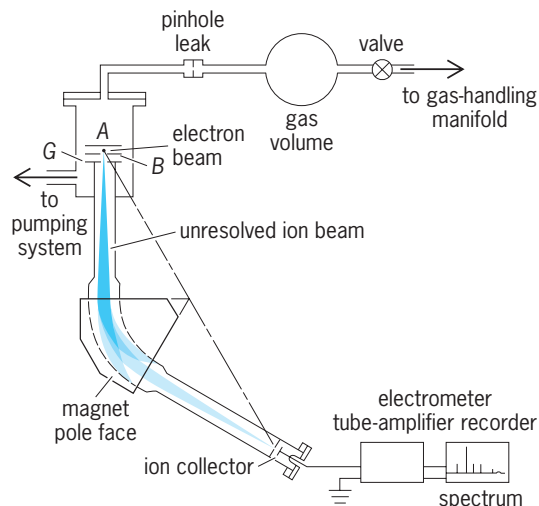

**Schematic drawing of mass spectrometer tube.** Ion currents are in the range  $10^{-10}$  to  $10^{-15}$  ampere and require special electrometer tube amplifiers for their detection. In actual instruments the radius of curvature of ions in a magnetic field is 4–6 in. (10–15 cm).

and binding energy of nuclei is thus gained. The relative abundances of the isotopes in naturally occurring or artificially produced elements can be determined.

Empirical and theoretical studies have led to an understanding of the relation between molecular structure and the relative abundances of the fragments observed when a complex molecule, such as a heavy organic compound, is ionized. When a high-resolution instrument is employed, the masses of the molecular or fragment ions can be determined so accurately that identification of the ion can frequently be made from the mass alone.

Because chemical compounds may have mass spectra as unique as fingerprints, mass spectrometers are widely used in industries such as oil refineries, where analyses of complex hydrocarbon mixtures are required. See BETA PARTICLES. [A.O.N.]

**Mass wasting** A generic term for downslope movement of soil and rock, primarily in response to gravitational body forces. Mass wasting is distinct from other erosive processes in which particles or fragments are carried down by the internal energy of wind, running water, or moving ice and snow.

The stability of slope-making materials is lost when their shear strength (or sometimes their tensile strength) is overcome by shear (or tensile) stresses, or when individual particles, fragments, and blocks are induced to topple or tumble. The shear and tensile strength of earth materials depends on their mineralogy and structure. Processes that generally decrease the strength of earth materials include one or more of the following: structural changes, weathering, groundwater, and meteorological changes. Stresses in slopes are increased by steepening, heightening, and external loading due to static and dynamic forces. Processes that increase stresses can be natural or result from human activities. Although other classifications exist, these movements can be conveniently classified according to their velocity into two types: creep and landsliding. See SOIL MECHANICS.

Geologically, creep is the imperceptible downslope movement at rates as slow as a fraction of millimeter per year; its cumulative effects are ubiquitously expressed in slopes as the downhill bending of bedded and foliated rock, bent tree trunks, broken retaining walls, and tilted structures. There are two varieties of geologic creep. Seasonal creep is the slow, episodic movement of the uppermost several centimeters of soil, or fractured and weathered rock. It is especially important in regions of permanently frozen ground. Rheologic creep, sometimes called continuous creep, is a time-dependent deformation at relatively con-

stant shear stresses of masses of rock, soil, ice, and snow. This type of creep affects rock slopes down to depths of a few hundred meters, as well as the surficial layer disturbed by seasonal creep. Continuous creep is most conspicuous in weak rocks and in regions where high horizontal stresses (several tens of bars or several megapascals) are known to exist in rock masses at depths of 330 to 660 ft (100 to 200 m).

Landsliding includes all perceptible mass movements. Three types are generally recognized on the basis of the type of movement: falls, slides, and flows. Falls involve free-falling material; in slides the moving mass displaces along one or more narrow shear zones; and in flows the distribution of velocities within the moving mass resembles that of a viscous flow. See LANDSLIDE.

Mass wasting is an important consideration in the interaction between humans and the environment. Deforestation accelerates soil creep. Engineering activities such as damming and open-pit mining are known to increase landsliding. On the other hand, enormous natural rock avalanches have buried entire villages and claimed tens of thousands of lives. [A.S.N.]

**Massif** A block of the Earth's crust commonly consisting of crystalline gneisses and schists, the textural appearance of which is generally markedly different from that of the surrounding rocks. Common usage indicates that a massif has limited areal extent and considerable topographic relief. Structurally, a massif may form the core of an anticline or may be a block bounded by faults or even unconformities. In any case, during the final stages of its development a massif acts as a relatively homogeneous tectonic unit which to some extent controls the structures that surround it. Numerous complex internal structures may be present; many of these are not related to its development as a massif but are the mark of previous deformations. [P.H.O.]

**Mastigomycotina** A subdivision of true fungi (Division Eumycota of the Kingdom Fungi), comprising three classes: Chytridiomycetes, Hyphochytriomycetes, and Oomycetes. It is an artificial grouping of zoosporic fungi with all members, except a few advanced ones, able to produce free-living zoospores in some part of their life cycle. The thallus may be unicellular, multicellular, or mycelial. The thallus has a chitinous or cellulosic wall. In a few endoparasitic species the thallus is naked (lacks a wall). Forms of sexual reproduction are many and varied. Distribution is cosmopolitan; many are aquatic, occurring in fresh water or brackish water, and a few are marine. They are also abundant in soils, and some have part of their life cycles on vascular plants. Many are saprobes, but some are parasitic on insects or fish, and some are destructive plant pathogens. See CHYTRIDIOMYCETES; EUMYCOTA; FUNGI; HYPHOCHYTRIOMYCETES; OOMYCETES. [D.J.S.B.]

**Mastigophora** A superclass of the Protozoa also known as the Flagellata. The common morphological flagellate type is spherical to cylindrical on an anteroposterior axis. Despite their common morphological plan, based on the flagellum as a means of locomotion, Flagellata are very diverse in shape, colony formation, internal structure, external shell or test, color, physiology, reproduction, and choice of environment.

The Mastigophora exhibit marked plantlike characteristics, so that texts and references in botany always treat at least some of them. Some workers include all colorless flagellates in the algae; however, flagellates display many distinctly animal features and sometimes are treated as Protozoa. Thus, flagellates are regarded as a link between the plant and animal kingdoms. See PHYTAMASTIGOPHOREA; ZOOMASTIGOPHOREA.

Mastigophora possess one common feature, locomotion by means of one or more whiplike protoplasmic extrusions termed flagella. The flagellate body is typically monaxial and elongate to some degree. Cells are practically spherical in *Monas*, but ovoid, cordiform, pyriform, fusiform, acicular, tubular, or flattened cells are more common. Flattened species typically glide

along a surface rather than swim. A particular shape is normally maintained by *Ochromonas*, whereas *Mastigamoeba* and some others form pseudopodia, and certain species (*Euglena agilis*) undergo frequent distortions termed euglenoid or metabolic changes of shape.

Structurally the flagellate cell is not simple. The cytoplasm is sometimes quite vacuolated (*Collodictyon* or *Trepomonas*) and occasionally colored, although color is generally confined to chromatophores when these are present. One or more contractile vacuoles may be located near the flagellar base.

Most flagellates are single-celled but colony formation is frequent. Cells may be naked (*Oicomonas*), enclosed in a thick cellulose cell wall or pellicle (*Euglena spirogyra*), or in a chitinous, calcareous, or silicious test, the lorica or shell (*Trachelomonas*, *Distephanus speculum*).

Flagellates adjust to wide ranges of pH, osmotic pressure, light, and temperature but optima are found upon investigation. Some flagellate species occur in both fresh and sea water, but cannot be transferred directly from fresh to sea water. Almost any aqueous ecological niche contains Flagellata.

Flagellata are near the base of the food pyramid, probably next to bacteria. Their varied synthetic abilities, fast reproductive rate, and huge numbers in both fresh and salt water compensate for their usual small size. The oceanic blooms which kill fish and other animals are principally flagellates, but green flagellates reareate polluted water. They often cause tastes and odors in potable water, but they readily attack organic matter in natural water as do bacteria. They include many parasites dangerous to humans and animals and are themselves frequently parasitized. See PROTOZOA. [J.B.L.]

**Mastitis** Inflammation of the mammary gland. This condition is most frequently caused by infection of the gland with bacteria that are pathogenic for this organ. It has been described in humans, cows, sheep, goats, pigs, horses, and rabbits. Mastitis causes lactating women to experience pain when nursing the child, it damages mammary tissue, and the formation of scar tissue in the breast may cause disfigurement.

The mammary gland is composed of a teat and a glandular portion. The gland has defensive mechanisms to prevent and overcome infection with bacteria. Nonspecific defense mechanisms include teat duct keratin, lactoferrin, lactoperoxidase, and complement. Specific defense mechanisms are mediated by antibodies and include opsonization, direct lysis of pathogens, and toxin neutralization. Milk contains epithelial cells, macrophages, neutrophils, and lymphocytes. To induce mastitis, a pathogen must first pass through the teat duct to enter the gland, survive the bacteriostatic and bactericidal mechanisms, and multiply. Bacteria possess virulence factors such as capsules and toxins which enable them to withstand these protective mechanisms. See LACTATION.

When bacteria multiply within the gland, there is a release of inflammatory mediators and an influx of neutrophils. The severity of mammary infection is classified according to the clinical signs. In humans, infection occurs during lactation, with clinical episodes most frequent during the first 2 months of lactation. In acute puerperal mastitis the tissue becomes hot, swollen, red, and painful, and a fever may be present. In the absence of treatment, this may progress to a pus-forming mastitis, with the development of breast abscesses.

In acute puerperal mastitis of humans, suitable antibiotics are administered by the intravenous or intramuscular route, while in the abscess form surgical drainage is provided in addition to antibacterial therapy. Penicillins, cephalosporins, and erythromycin are administered locally into the infected gland after milking for 1–2 days. Additional antibiotics are given systemically, that is, intravenously or intramuscularly, in severe cases of mastitis, and also to improve bacteriologic cure rates. See ANTIBIOTIC. [N.L.N.]

**Matched-field processing** A signal-processing technique based on comparison of measured data with predictions for the data that are calculated from a propagation model. Signal-processing techniques have always been of interest for squeezing information out of various kinds of data. In the past, the processing of sonar signals has often been based on beamforming, in which data are examined relative to a variety of plane waves coming from different directions, thereby calculating “beams” of energy. Matched-field processing encompasses conventional plane-wave beamforming but goes beyond it by considering far more accurate and appropriate models for complicated signal behavior.

Some signal-processing methods such as matched filtering can be applied to received data to transform what appears to be nearly random, unpatterned noise into meaningful signals. Other signal-processing methods, such as matched-field processing, can be applied to strong signals to reveal details about the original direction of a signal (to locate the source) or about source characterization (for example, to determine whether the source is a living organism or a particular type of military threat). Matched-field processing has been used to extract environmental information from acoustic data in an effort (1) to address concerns such as global warming (to determine whether the oceans are showing deep, that is, below-surface, changes in temperature patterns) or (2) to search for buried minerals or oil in the ocean bottom. Electromagnetic signals passing through the ionosphere or elastic waves transmitted through the earth also contain a wealth of information about the media through which those signals pass, and those signals can be used in a similar fashion to obtain information about ionospheric or terrestrial parameters. Thus, all types of signals (acoustic, electromagnetic, seismic) can be analyzed via matched-field processing to learn about environments and sources.

Matched-field processing has been studied extensively in underwater acoustics. The process was first suggested by M. J. Hinich in 1973 and H. P. Bucker in 1976. Matched-field processing is usually a passive rather than an active approach; that is, it uses the sound generated by the target itself rather than ensonifying (the acoustic equivalent to illuminating with light) that target from some other source. [A.Tol.]

**Material resource planning** A formal computerized approach to inventory planning, manufacturing scheduling, supplier scheduling, and overall corporate planning. The material requirements planning (MRP) system provides the user with information about timing (when to order) and quantity (how much to order), generates new orders, and reschedules existing orders as necessary to meet the changing requirements of customers and manufacturing. The system is driven by change and constantly recalculates material requirements based on actual forecast orders. It makes adjustments for possible problems prior to their occurrence, as opposed to traditional control systems which looked at more historical demand and reacted to existing problems. See MANUFACTURING ENGINEERING.

The logic of the material requirements planning system is based on the principle of dependent demand, a term describing the direct relationship between demand for one item and demand for a higher-level assembly part or component. For example, the demand for the number of wheel assemblies on a bicycle is directly related to the number of bicycles planned for production; further, the demand for tires is directly dependent on the demand for wheel assemblies. In most manufacturing businesses, the bulk of the raw material and in-process inventories are subject to dependent demand. Dependent demand quantities are calculated, while independent demand items are forecast. Independent demand is unrelated to a higher-level item which the company manufactures or stocks. Generally, independent demand items are carried in finished goods inventory and subject to uncertain end customer demand. Spare parts or

replacement requirements for a drill press are an example of an independent demand item.

By use of the computer, material requirements planning is able to manipulate massive amounts of data to keep schedules up to date and priorities in order. The technological advances in computing and processing power, the benefits of on-line capabilities, and reduction in computing cost make computerized manufacturing planning and control systems such as material requirements planning powerful tools in operating modern manufacturing systems productively. See INDUSTRIAL ENGINEERING; INVENTORY CONTROL; SYSTEMS ENGINEERING. [L.C.G.]

**Materials handling** The loading, moving, and unloading of materials. The hundreds of different ways of handling materials are generally classified according to the type of equipment used. For example, the International Materials Management Society has classified equipment as (1) conveyor, (2) cranes, elevators, and hoists, (3) positioning, weighing, and control equipment, (4) industrial vehicles, (5) motor vehicles, (6) railroad cars, (7) marine carriers, (8) aircraft, and (9) containers and supports. See MATERIALS-HANDLING EQUIPMENT. [R.Mu.]

**Materials-handling equipment** Devices used for handling materials in an industrial distribution activity. The equipment moves products as discrete articles, in suitable containers, or as solid bulk materials which are relatively free-flowing.

Many different types of machines result from combinations and permutations of the following factors: (1) The route over which the product is moved may be fixed or variable; (2) the path of travel may be horizontal, inclined, declined, or vertical; (3) motion may be imparted to the product manually, by the force of gravity, by air pressure, by vacuum, by vibration, or by power-actuated components of the machine; (4) the motion may be continuous or intermittent (reciprocating); and (5) the product may be supported or carried suspended during the handling operation. Based upon their most common characteristics, materials-handling machines can be grouped into six broad categories, listed in the following cross references. See BULK-HANDLING MACHINES; ELEVATING MACHINES; HOISTING MACHINES; INDUSTRIAL TRUCKS; MONORAIL. [A.M.P.]

**Materials science and engineering** A multidisciplinary field concerned with the generation and application of knowledge relating to the composition, structure, and processing of materials to their properties and uses. The field encompasses the complete knowledge spectrum for materials ranging from the basic end (materials science) to the applied end (materials engineering). It forms a bridge of knowledge from the basic sciences (and mathematics) to various engineering disciplines.

The study of metallic materials constitutes a major division of the materials science and engineering field. Most metals have a crystalline structure of closely packed atoms arranged in an orderly manner. In general they are good electrical and thermal conductors. Many are relatively strong at room temperature and retain good strength at elevated temperatures. Metals and alloys are often cast into the nearly final shape in which they will be used (castings). Ferrous metals and alloys contain iron as their major metallic element; nonferrous metals and alloys contain elements other than iron as their major metallic element. See ALLOY; ALUMINUM ALLOYS; CAST IRON; COPPER ALLOYS; IRON ALLOYS; METAL; METAL CASTING; NICKEL ALLOYS; STAINLESS STEEL; STEEL; ZINC ALLOYS.

The study of ceramic materials forms a second major division of the field of materials science and engineering. Ceramics are inorganic materials consisting of metallic and nonmetallic elements chemically bonded together. Most ceramic materials have high hardness, high-temperature strength, and good chemical resistance; however, they tend to be brittle. Ceramics in general have low electrical and thermal conductivities, which makes

them useful for electrical and thermal insulative applications. Most ceramic materials can be classified into three groups: traditional ceramics, technical ceramics, and glasses. See CERAMICS; GLASS; PORCELAIN.

The study of polymeric materials forms a third major division of materials science and engineering. Most of these materials consist of carbon-containing long molecular chains or networks. Structurally, most of them are noncrystalline, but some are partly crystalline. The strength and ductility of polymeric materials vary greatly. Most polymers have low densities and relatively low softening or decomposition temperatures. Many are good thermal and electrical insulators. Polymeric materials have replaced metals and glasses for many applications. See POLYMER.

A fourth major division of materials science and engineering comprises the study of composite materials. A composite material is a mixture of two or more materials that differ in form and chemical composition and are essentially insoluble in each other, and most are produced synthetically by combining various types of fibers with different matrices to increase strength, toughness, and other properties. Three important types of composite materials have polymeric, metallic, or ceramic matrices. See COMPOSITE MATERIAL.

In addition to metallic, ceramic, polymeric, and composite materials, materials science and engineering is also concerned with the research and development of other special classes of materials that are based on applications. Some major types of these materials are electronic materials, optical materials, magnetic materials, superconducting materials, dielectric materials, nuclear materials, biomedical materials, and building materials. See INTEGRATED CIRCUITS; MAGNETIC MATERIALS; OPTICAL FIBERS; SUPERCONDUCTING DEVICES; SUPERCONDUCTIVITY. [W.F.S.]

**Maternal behavior** The pattern of care given an offspring by its mother. Many species reproduce generation after generation without receiving or providing any parental care. Insects and fish commonly produce vast numbers of offspring that they neither feed nor defend, resulting in the loss of many offspring to predators and to other hazards. Their great numbers, however, ensure that some will survive and reproduce. Also, if the young of a species are self-sufficient at birth or if they mature very rapidly after birth, they can often survive and reproduce with little parental care.

Parental behavior is most highly developed in species that produce only a few offspring at once, mature slowly, and have complex behavior patterns that can be learned only through extended practice. Parental behavior can involve as little as hiding the young and never seeing them again or it can involve years of feeding, defending, and teaching. In most species that care for their young after birth, the female does most or all of the work. The biological explanation for this arises from the fact that a male can father vast numbers of offspring, whereas a female can bear only a few. Each offspring that fails to survive or reproduce can represent a significant proportion of the female's lifetime reproductive output. Thus, the females that pass their genes on to subsequent generations in greatest numbers are not those that bear the most young but those that invest more in caring for the few young they produce. Active care of the young by the male is most common when males of a species limit themselves to one or a few female partners. See REPRODUCTIVE BEHAVIOR.

Factors that influence the onset of maternal behavior include physiological and psychological factors related to pregnancy, hormonal influences associated with childbirth, the behavior of the newborn, and cultural factors such as learning and social traditions. Although hormones play necessary roles in recovery from pregnancy and in milk production, there is no evidence that they play a critical role in any other aspect of human maternal behavior. Cultural factors and the behavior of the newborn are the primary cues that prompt human mothers to care for their young. [E.Wa.; G.Pos.]



**Mathematical biology** The application of mathematics to biological systems. Mathematical biology spans all levels of biological organization and biological function, from the configuration of biological macromolecules to the entire ecosphere over the course of evolutionary time.

The influence of physics on mathematical biology has been twofold. On the one hand, organisms simply are material systems, and presumably can be analyzed in the same terms as any other material system. Reductionism, the theory that biological processes find their resolution in the particularities of physics, finds its practical embodiment in biophysics. Thus, one of the roots of mathematical biology is what was originally called mathematical biophysics. On the other hand, other early investigations in mathematical biology, such as population dynamics (mathematical ecology), exploited the form of such analyses, such as using differential rate equations, but they expressed their analyses in strictly biological terms. Such approaches were guided by analogy with mathematical physics rather than by reduction to physics and so rest on the form rather than the substance of physics. See BIOPHYSICS; PHYSICS.

Both of these approaches are important, especially since organisms possess characteristics that have no obvious counterpart in inorganic systems. As a result, mathematical biology has acquired an independent and unique character. In several important cases, these characteristics have required a reconsideration of physics itself, as in the impact of open systems on classical thermodynamics.

**Surrogacy and models.** The idea that something can be learned about a system by studying a different system, or surrogate, is central to all science. The relation between a system and its surrogates is embodied in the concept of a model. The basic idea of mathematical biology is that an appropriate formal or mathematical system may similarly be used as a surrogate for a biological system. The use of mathematical models offers possibilities that transcend what can be done on the basis of observation and experiment alone. See MODEL THEORY.

For example, morphological differences between related species can be made to disappear by means of relatively simple coordinate transformations of the space in which the forms are embedded. Surrogacy explicitly becomes a matter of intertransformability, or similarity, and what is true for morphology also holds true for other functional relationships that are characteristic of organisms, whether they be chemical, physical, or evolutionary. These assertions of surrogacy and modeling can be restated: closely related implies similar. This is a nontrivial assertion: "closely related" is a metric relation pertaining to genotypes, whereas "similar" is an equivalence relation based on phenotypes. It is the similarity relation between phenotypes that provides the basis for surrogacy. Thus the question immediately arises: given a genotype, how far can it be varied or changed or mutated, and still preserve similarity?

Such questions fall mathematically into the province of stability theory, particularly structural stability. Under very general conditions, there exist many genomes that are unstable (bifurcation points) in the sense that however high a degree of metric approximation is chosen, the associated phenotypes may be dissimilar, that is, not intertransformable. That observation by R. Thom provides the basis for his theory of catastrophes and demonstrates the complexity of the surrogacy relationship. The fundamental importance of such ideas for phenomena of development, for evolution (particularly for macroevolution), and for the extrapolation of data from one species to another, or the relation between health and disease, is evident. See CATASTROPHE THEORY; MACROEVOLUTION.

**Metaphor.** A closely related group of ideas that are characteristic of mathematical biology may be described as metaphoric. One example of a metaphoric approach is the study of brain activities through the application of the properties of neural networks, that is, networks of interconnected boolean (binary-state) switches. Appropriately configured switching networks are

known to exhibit behaviors that are analogous to those that characterize the brain, such as learning, memory, and discrimination. That is, networks of neuronlike units can automatically manifest brainlike behaviors and can be regarded as metaphorical brains. Such boolean neural nets also underlie digital computation, a relationship which is explored in the hybrid area of artificial intelligence. The same mathematical formulation of switching networks arises in genetic and developmental phenomena, such as the concept of operon, and in other physiological systems, such as the immune system. See ARTIFICIAL INTELLIGENCE; NEURAL NETWORK; OPERON.

Another important example of metaphor in biology is morphogenesis, or pattern generation, through the coupling of chemical reactions with physical diffusion. Chemical reactions tend to make systems heterogeneous, diffusion tends to smooth them out, and combining the two can lead to highly complex behaviors. Since reactions and diffusions typically occur together in biological systems, exploring the general properties of such systems can illuminate pattern generation in general.

Such ideas turn out to be closely related to those of bifurcation and catastrophe and have a profound impact on physics itself, since they are inherently associated with systems that are thermodynamically open and hence completely outside the realm of classical thermodynamics. The behavior of such open systems can be infinitely more complicated than those that are commonly explored in physics. Open systems may possess large numbers of stable and unstable steady states of various types, as well as more complicated oscillatory steady-state behaviors (limit cycles) and still more general behaviors collectively called chaotic. Changes in initial conditions or in environmental circumstances can result in dramatic switching (bifurcations) between these modes of behavior. See CHAOS.

**Applications.** Perhaps the biotechnology that has affected everyone most directly is medicine. Medicine can be regarded as a branch of control theory, geared to the maintenance or restoration of a state of health. It is unique in that the systems needed for control are themselves control systems that are far more intricate and complex than any that can be fabricated. In addition to the light it sheds on the processes needed for control, mathematical biology is indispensable for designing the controls themselves and for assessing their costs, benefits, safety, and efficacy.

In general, the object of any theory of control is to produce an algorithm, or protocol, that will achieve optimal results. Mathematical biology allows one to relate systems of different characters through the exploitation of their mathematical commonalities. Biology has many optimal designs and optimal controls, which are the products of biological evolution through natural selection. The design of optimal therapies in medicine is analogous to the generation of optimal organisms. Thus the mathematical theory appropriate for analyzing one discipline of biology, such as evolution, itself becomes transmuted into a theory of control in an entirely different realm. The same holds true for other biotechnologies, such as the efficient exploitation of biological populations. See MATHEMATICAL ECOLOGY. [R.Ro.]

**Mathematical ecology** The application of mathematical theory and technique to ecology. The earliest studies in ecology were by naturalists interested in organisms and their relationships to the environment. Such investigations continue to this day as a central part of the subject, and have focused attention on understanding the ecological and evolutionary relationships among species. For the most part, such approaches are retrospective, designed to help in understanding how current ecological relationships developed, and to place that development within appropriate evolutionary context. The second major branch is applied ecology, and derives from the need to manage the environment and its resources. Here the necessity for rigorous mathematical treatments is obvious, but the goals are quite different from those in evolutionary ecology. Management and

control are the objectives, and the relevant time horizon lies in the future. The focus is no longer simply to derive understanding and explanation; rather, one seeks methods for prediction and algorithms for control.

There has been a dramatic increase in mathematical activity concerning the modeling and control of epidemics, and an increasing recognition of the need to view such problems in their proper ecological context as host-parasite interactions. Researchers are using mathematical models to help to understand the factors underlying disease outbreaks, and to develop methods for control such as vaccination strategies. See EPIDEMIOLOGY.

Finally, the need for environmental protection in the face of threats from such competing stresses as toxic substances, acid precipitation, and power generation has led to the development of more sophisticated models that address the responses to stress of community and ecosystem characteristics, for example, succession, productivity, and nutrient cycling. See ECOLOGY; ECOLOGY, APPLIED; ENVIRONMENTAL ENGINEERING. [S.A.L.]

**Mathematical geography** The branch of geography that examines human and physical activities on the Earth's surface using models and statistical analysis. The primary areas in which mathematical methods are used include the analysis of spatial patterns, the processes that are responsible for creating and modifying these patterns, and the interactions among spatially separated entities.

What sets geographic methods apart from other quantitative disciplines is geography's focus on place and relative location. Latitude and longitude provide an absolute system of recording spatial data, but geographic databases also typically contain large amounts of relative and relational data about places. Thus, geographers have devoted much effort to accounting for spatial interrelations while maintaining consistency with the assumptions of mathematical models and statistical theory. See GEOGRAPHY; MODEL THEORY; STATISTICS.

Spatial pattern methodologies attempt to describe the arrangement of phenomena over space. In most cases these phenomena are either point or area features, though computers now allow for advanced three-dimensional modeling as well. Point and area analyses use randomness (or lack of pattern) as a dividing point between two opposite pattern types—dispersed or clustered.

An important innovation in geographic modeling has been the development of spatial autocorrelation techniques. Unlike conventional statistics, in which many tests assume that observations are independent and unrelated, very little spatial data can truly be considered independent. Soil moisture or acidity in one location, for example, is a function of many factors, including the moisture or acidity of nearby points. Because most physical and human phenomena exhibit some form of spatial interrelationships, several statistical methods, primarily based on the Moran Index, have been developed to measure this spatial autocorrelation. Once identified, the presence and extent of spatial autocorrelation can be built into the specification of geographical models to more accurately reflect the behavior of spatial phenomena. [J.C.Co.]

**Mathematical physics** An area of science concerned with the application of mathematical concepts to the physical sciences and the development of mathematical ideas in response to the needs of physics. Historically, the concept of mathematical physics was synonymous with that of theoretical physics. In present-day terminology, however, a distinction is made between the two. Whereas most of theoretical physics uses a large amount of mathematics as a tool and as a language, mathematical physics places greater emphasis on mathematical rigor, and devotes attention to the development of areas of mathematics that are, or show promise to be, useful to physics. The results obtained by pure mathematicians, with no thought to applica-

tions, are almost always found to be both useful and effective in formulating physical theories.

Mathematical physics forms the bridge between physics as the description of nature and its structure on the one hand, and mathematics as a construction of pure logical thought on the other. This bridge between the two disciplines benefits and strengthens both fields enormously. See MATHEMATICS; PHYSICS; THEORETICAL PHYSICS.

The methods employed in mathematical physics range over most of mathematics, the areas of analysis and algebra being the most commonly used. Partial differential equations and differential geometry, with heavy use of vector and tensor methods, are of particular importance in the formulation of field theories, and functional analysis as well as operator theory in quantum mechanics. Group theory has become an especially valuable tool in the construction of quantum field theories and in elementary-particle physics. There has also been an increase in the use of general geometrical approaches and of topology. For solution methods and the calculation of quantities that are amenable to experimental tests, of particular prominence are Fourier analysis, complex analysis, variational methods, the theory of integral equations, and perturbation theory. See ABSTRACT ALGEBRA; COMPLEX NUMBERS AND COMPLEX VARIABLES; DIFFERENTIAL GEOMETRY; FOURIER SERIES AND TRANSFORMS; GROUP THEORY; INTEGRAL EQUATION; OPERATOR THEORY; TOPOLOGY; VARIATIONAL METHODS (PHYSICS); VECTOR METHODS (PHYSICS). [R.G.Ne.]

**Mathematical software** The collection of computer programs that can solve equations or perform mathematical manipulations. The developing of mathematical equations that describe a process is called mathematical modeling. Once these equations are developed, they must be solved, and the solutions to the equations are then analyzed to determine what information they give about the process. Many discoveries have been made by studying how to solve the equations that model a process and by studying the solutions that are obtained.

Before computers, these mathematical equations were usually solved by mathematical manipulation. Frequently, new mathematical techniques had to be discovered in order to solve the equations. In other cases, only the properties of the solutions could be determined. In those cases where solutions could not be obtained, the solutions had to be approximated by using numerical calculations involving only addition, subtraction, multiplication, and division. These methods are called numerical algorithms. These algorithms are often straightforward, but they are usually tedious and require a large number of calculations, usually too many for a human to perform. There are also many cases where there are too many equations to write down. See ALGORITHM; NUMERICAL ANALYSIS.

The advent of computers and high-level computer languages has allowed many of the tedious calculations to be performed by a machine. In the cases where there are too many equations, computer programs have been written to manipulate the equations. A numerical algorithm carried out by a computer program can then be applied to these equations to approximate their solutions. Mathematical software is usually divided into two categories: the numerical computation environment and the symbolic computation environment. However, many software packages exist that can perform both numerical and symbolic computation.

Mathematical software that does numerical computations must be accurate, fast, and robust. Accuracy depends on both the algorithm and the machine on which the software is run. Most mathematical software uses the most advanced numerical algorithms. Robustness means that the software checks to make sure that the user is inputting reasonable data, and provides information during the performance of the algorithm on the convergence of the calculated numbers to an answer. Mathematical software packages can approximate solutions to a large range of problems in mathematics, including matrix equations, nonlinear

equations, ordinary and partial differential equations, integration, and optimization. Mathematical software libraries contain large collections of subroutines that can solve problems in a wide range of mathematics. These subroutines can easily be incorporated into larger programs.

Early computers were used mainly to perform numerical calculations, while the mathematical symbolic manipulations were still done by humans. Now software is available to perform these mathematical manipulations. Most of the mathematical software packages that perform symbolic manipulations can also perform numerical calculations. Software can be written in the package to perform the numerical calculations, or the calculations can be performed after the symbolic manipulations by putting numbers into the symbolic formulas. Mathematical software that is written to solve a specific problem using a numerical algorithm is usually computationally more efficient than these software environments. However, these software environments can perform almost all the commonly used numerical and symbolic mathematical manipulations. See SYMBOLIC COMPUTING.

Parallel computers have more than one processor that can work on the same problem at the same time. Parallel computing allows a large problem to be distributed over the processors. This allows the problem to be solved in a smaller period of time. Many numerical algorithms have been converted to run on parallel computers. See COMPUTER PROGRAMMING; CONCURRENT PROCESSING; DIGITAL COMPUTER; DISTRIBUTED SYSTEMS (COMPUTERS); MULTIPROCESSING; SOFTWARE. [J.So.]

**Mathematics** Mathematics is frequently encountered in association and interaction with astronomy, physics, and other branches of natural science, and it also has deep-rooted affinities to the humanities. It is a realm of knowledge entirely unto itself, and one of considerable scope.

**Relation to science.** Mathematics is not a branch of natural science itself. It does not deal with phenomena and objects of the external world and their relations to each other but, strictly speaking, only with objects and relations of its own imagery. One can practice meaningful mathematics without being concerned with science at all, and philosophical attempts to reduce all origin of mathematics to utilitarian motives are wholly unconvincing. However, mathematics is the language of science in a deep sense. Mathematics is an indispensable medium by which and within which science expresses, formulates, continues, and communicates itself. And just as the language of true literacy not only specifies and expresses thoughts and processes of thinking but also creates them in turn, so does mathematics not only specify, clarify, and make rigorously workable concepts and laws of science, but also at certain crucial instances becomes an indispensable constituent of their creation and emergence as well.

**Creative formulas.** A formula is a string of mathematical symbols subject only to certain general rules of composition. To a working mathematician a string of symbols is a formula if it is something worth remembering. Much mathematics is concentrated in and propelled by certain formulas of unusual import.

**Foundations—mathematical logic.** A prime demand on mathematics is that it be deductively rigorous, and a traditional model for intended rigor is Euclid's presentation of mathematical assertions in theorems. A theorem is a proposition which has been proved, excepting certain first theorems called axioms, which are admitted without proof; and to prove a theorem means to obtain it from other theorems by certain procedures of deduction or inference. It had long been commonplace that each branch of mathematics was based on its own axioms, but during the 19th century, mathematicians arrived at the insight that even the same branch might have alternate axioms. Specifically, there were envisaged alternate versions of two- and three-dimensional geometry, the axiom varied being the axiom on parallels. It was also recognized that a set of axioms becomes mathematically possible if it is logically consistent, that is, if one cannot deduce

from the axioms to theorems one of which, as a proposition, is the negation of the other. See EUCLIDEAN GEOMETRY.

At the same time certain developments led to the realization that not only the axioms but the rules of inference themselves might be, and even ought to be, subjected to variations. Now if axioms and rules of inferences are both viewed as subject to change, it is customary to speak of a mathematical system or also a formal system, and, of course, an irreducible first requirement is that the system be consistent after the manner just stated. Consistency alone is a somewhat negative property. There is a further property, called completeness, which is more positive, and which, if present, is very welcome. A system is complete if for any proposition which can be formulated it either can be proved that it holds or that its negation holds.

Some of the developments that led to doubt as to whether the traditional rules of inference are inviolate were the following.

1. G. Boole had found in 1854 that the classical Aristotelian connectives "and," "or," "negation of" for propositions follow rules similar to those which the operations addition, multiplication, "the negative of" obey in ordinary algebra (Boole's algebra of propositions); his conclusions took from rules of inference the status of untouchability.

2. G. Cantor, the founder of the theory of sets and operations between them, defined a set (intuitively or naively) as the collection of all objects having a certain property which is verbally expressible. Especially, "the set of all sets" is again a set and it has the peculiarity of being a set which contains itself as one of its elements. But this leads to the following contradictory situation (Russell's paradox): Divide the totality of all possible sets into two categories. A set shall belong to category I if it does not contain itself as an element, and to category II if it does contain itself as an element. Now form the set  $M$  whose elements are the sets of category I. It can now be reasoned by deductive steps admissible in Cantor's own theory that the set  $M$  cannot belong to either of the two categories, although the original division into categories did assign each set to one of them.

3. In 1904 E. Zermelo formulated the following axiom of choice: Given any family of nonvacuous sets  $\{S\}$ , no matter how (infinitely) large the family may be, it is possible to choose simultaneously an element  $x = x_s$  from each given set  $S$  and thus to consider the set  $M$  consisting of precisely these elements. By the use of this axiom some striking theorems in classical mathematics could be proved which, without the use of the axiom, seemed to be logically out of reach entirely. Mathematicians began to wonder whether a theorem based on the axiom of choice is indeed valid or, at any rate, whether it has the same level of validity as one without it, and as a consequence, theorems employing the axiom of choice were frequently labeled as such. See SET THEORY.

Some of the doubts were resolved eventually; the most striking results are the following ones of K. Gödel. (1) Any consistent mathematical system which is sufficient for classical arithmetic must be incomplete. (2) Any such system remains consistent if one adds to it the axiom of choice, so that working mathematics cannot disprove the axiom of choice. In 1963 P. Cohen showed that the axiom cannot be proved, either. See LOGIC.

**Constructiveness.** Some mathematicians object to mere existence proofs, and they demand that any proof also be constructive. The interpretations of this demand differ widely. Some proofs closely approach what a practical mathematician welcomes; if, for instance, a theorem asserts the existence of a number or a function, then the proof must also embody a procedure for actual computation of the solution, approximately, at least. Other versions are little more than the negative requirement that certain combinations of inference be avoided. There are also views which combine both; the best known among the last is the intuitionist view. It firmly demands a certain kind of constructiveness, which, however, does not necessarily guarantee the calculation by present-day computing machines. However, the actual stricture by which intuitionism became widely known

is that proof by contradiction is not admissible. Proof by contradiction is also called proof by double negation, and it is equivalent to the Aristotelian law of the excluded middle. It assumes tentatively that the proposition to be proved is false and from this assumption deduces a contradiction to a previously established theorem.

**Space in mathematics.** If geometry is the mathematics of space, then, in a superficial sense, all mathematics began with geometry, because apparently it began with measurements of figures: length, area, volume, and size of angles. It did not concern itself with questions of shape but with clarifying and deciding when figures are equal or substantially equal with regard to form. The first true theory of geometry was that of the Greeks, whose primary concern was study of the basic concept of equality of figures—their congruence and similarity—and the Greeks were so determined to dissociate their theory from the preceding phase of merely making measurements that Euclid's extensive work, for instance, avoids to a fault any kind of actual measurements. But, for all its lofty purposes, Greek geometry was too rigid and circumscribed to be able really to cope with the mathematical problem of space. Geometry did not progress further until, with the advent of coordinate systems, introduced by Descartes and his predecessors, a better mathematics of space could be initiated.

If a cartesian coordinate system is etched into two- or three-dimensional euclidean space, then the space becomes a point set, each point being a pair  $(x^1, x^2)$  or a triple  $(x^1, x^2, x^3)$  of real numbers, and any figure a suitable subset of it. This is a deliberate process of arithmetization of space which unifies space and number at the base. It does not hamper geometry in its task of pursuing problems of shape but instead aids it. In the cartesian plane, two figures are similar if the points of one can be obtained from the points of the other by means of a transformation, Eqs. (1), where Eq. (2) applies and where, for some  $\rho < 0$ , Eq. (3) can

$$\begin{aligned} y^1 &= a^1 + \alpha_1^1 x^1 + \alpha_2^1 x^2 \\ y^2 &= a^2 + \alpha_1^2 x^1 + \alpha_2^2 x^2 \end{aligned} \quad (1)$$

$$\alpha_1^1 \cdot \alpha_1^2 + \alpha_2^1 \cdot \alpha_2^2 = 0 \quad (2)$$

$$(\alpha_1^1)^2 + (\alpha_2^1)^2 = (\alpha_1^2)^2 + (\alpha_2^2)^2 = \rho^2 \quad (3)$$

be written. The similarity is a congruence if, and only if,  $\rho = 1$  (orthogonal transformation). Now this analytic representation of congruence and similarity suggests a geometric examination of the most general linear transformations, Eqs. (1), which are nonsingular, that is, for which the determinant  $|\alpha_i^j| \neq 0$ . They were virtually unknown to the Greeks, although they highlight the axiom of parallels of Euclid's geometry. A one-to-one transformation of the cartesian plane is such a linear transformation if, and only if, it carries a straight line onto a straight line and parallel straight lines into parallel straight lines.

The family of all linear transformations constitutes a transitive group, and the subfamily of orthogonal transformations is already a transitive group. F. Klein made the pronouncement, which is generally accepted, that there arises a geometry on a space if on the space there is given a transitive group of transformations; two figures are considered equal whenever one figure can be carried into the other figure by one of the transformations.

The arithmetization of space led to a purely mathematical creation of  $n$ -dimensional space, euclidean and other, for any integer dimension  $n$ , by defining its points generally as  $n$ -tuples of real numbers  $(x^1, \dots, x^n)$  with suitable definitions for various geometrical relations between such points. The best-known application of this was the four-dimensional space of the theory of relativity, but actually multidimensional geometry had been playing a part in physics before that. If a mechanical system involves  $M$  mass points, it was customary in effect to introduce the space of dimension  $n = 3M$ , whose points are the states of the system, that is, the  $n$ -tuples of coordinates  $\{x_m^1, x_m^2, x_m^3\}$ ,

$m = 1, \dots, M$ , at any one time point. Also, if there are restraints operative in the system, then the Lagrange-Hamilton theory suitably reduced the dimension of the space by the use of the free parameters of the system instead of the original  $n$  coordinates themselves. The use of free parameters spread from mechanical systems to other systems in physics and chemistry, and all so-called equations of state are geared to this. Finally, in quantum theory a state of a system has infinitely many coordinates and the infinitely dimensional space representing it is a Hilbert space. Also, partly under the influence of Hilbert space, mathematicians have become fascinated with infinitely dimensional spaces in general. They are being studied intensively, and large parts of mathematics are being pressed into these new frames of reference.

The arithmetization of space is also reflected in the ever-widening use of graphs and charts. See ALGEBRA; CALCULUS OF VECTORS; GEOMETRY; TOPOLOGY. [S.Bo.]

**Matrix isolation** A technique for providing a means of maintaining molecules at low temperature for spectroscopic study. This method is particularly well suited for preserving reactive species in a solid, inert environment. Elusive molecular fragments, such as free radicals that may be postulated as important controlling intermediates for chemical transformations used in industrial reactions, high-temperature molecules that are in equilibrium with solids at very high temperatures, and molecular ions that are produced in plasma discharges or by high-energy radiation all can be examined by using absorption (infrared, visible, and ultraviolet), electron-spin resonance, and laser-excitation spectroscopes.

The experimental apparatus for matrix isolation experiments is designed with the method of generating the molecular transient and performing the spectroscopy in mind. The illustration shows the cross section of a vacuum vessel used for absorption spectroscopic measurements. The matrix sample is introduced through the spray-on line; argon is the most widely used matrix gas, although neon, krypton, xenon, and nitrogen are also used. The reactive species can be generated in a number of ways: mercury-arc photolysis of a trapped precursor molecule through the quartz window, evaporation from a Knudsen cell in the heater, chemical reaction of atoms evaporated from the Knudsen cell with molecules deposited through the spray-on line, and vacuum-ultraviolet photolysis of molecules deposited from the spray-on line by radiation from discharge-excited atoms flowing through the tube. For laser excitation studies, the sample is deposited on a tilted copper wedge which is grazed by the laser beam, and light emitted or scattered at approximately  $90^\circ$  is examined by a spectrograph. In electronspin resonance studies, the sample is condensed on a sapphire rod that can be lowered into the necessary waveguide and magnet.

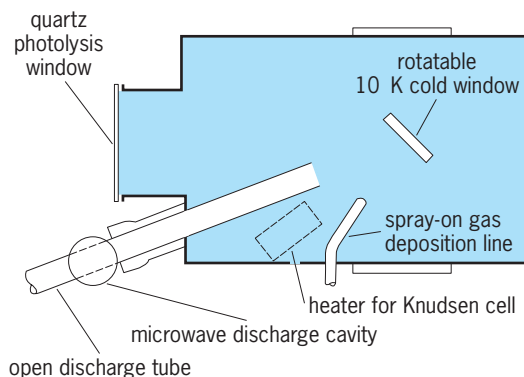

**Vacuum-vessel base cross section for matrix photoionization experiments.**

The matrix isolation technique enables spectroscopic data to be obtained for reactive molecular fragments, many of which cannot be studied in the gas phase. [L.A.]

**Matrix mechanics** A formulation of quantum theory in which the operators are represented by time-dependent matrices. See MATRIX THEORY.

Matrix mechanics is not useful for obtaining quantitative solutions to actual problems; on the other hand, because it is concisely expressed in a form independent of special coordinate systems, matrix mechanics is useful for proving general theorems. [E.G.]

**Matrix theory** The study of matrices and their properties, and of linear transformations on vector spaces, which can be represented by matrices.

A matrix is a rectangular array of numbers, with the numbers that appear in the matrix being called entries. For example,  $A$ , given by Eq. (1), is a  $2 \times 3$  matrix (that is, it has 2 rows and 3

$$A = \begin{bmatrix} 1 & 2 & 3 \\ 4 & 5 & 6 \end{bmatrix} \quad (1)$$

columns). The entry in the  $i$ th row and  $j$ th column of a matrix is denoted by  $a_{ij}$ . For example, in the matrix  $A$ ,  $a_{21} = 4$  and  $a_{12} = 2$ .

In general, if  $X$  is an  $m \times n$  matrix and  $Y$  is an  $n \times q$  matrix, then the product  $P = XY$  is an  $m \times q$  matrix whose entry in row  $i$  and column  $j$  is given by Eq. (2) for  $i = 1, \dots, m$  and  $j = 1, \dots, q$ .

$$p_{ij} = x_{i1}y_{1j} + x_{i2}y_{2j} + \dots + x_{in}y_{nj} \quad (2)$$

The number of columns of  $X$  must be the same as the number of rows of  $Y$  in order that the product matrix  $P$  can be defined. In general,  $XY$  and  $YX$  need not be the same matrix; that is, matrix multiplication is not always commutative. Multiplication of a matrix  $X$  by the  $n \times n$  matrix with 1 in row  $i$  and column  $i$  for  $i = 1, \dots, n$ , and 0 elsewhere, does not change the matrix  $X$ . Finally, the product of two matrices can have every entry 0 without this being the case for either factor.

Vectors in the plane can be added and multiplied (scaled) by constants. For example, if the vectors  $u$  and  $v$  and the number  $c$  are given by Eq. (3), then  $u + v$  is given by Eq. (4) and  $cu$  is given by Eq. (5).

$$u = \begin{bmatrix} 1 \\ 2 \end{bmatrix} \quad v = \begin{bmatrix} 3 \\ 4 \end{bmatrix} \quad c = -3 \quad (3)$$

$$u + v = \begin{bmatrix} 1 + 3 \\ 2 + 4 \end{bmatrix} = \begin{bmatrix} 4 \\ 6 \end{bmatrix} \quad (4)$$

$$cu = \begin{bmatrix} -3 \cdot 1 \\ -3 \cdot 2 \end{bmatrix} = \begin{bmatrix} -3 \\ -6 \end{bmatrix} \quad (5)$$

There are a number of simple axioms that are satisfied by vector addition and scalar multiplication. A set of vectors  $V$  together with a set of numbers  $F$  that satisfy these rules is called a vector space over  $F$ . The set of numbers  $F$  is a field. This means that  $F$  has many of the properties associated with rational numbers (fractions), real numbers (decimals), or complex numbers. There are many important mathematical systems that satisfy the axioms for a vector space. Some examples are the two-dimensional space of plane geometry, the three-dimensional space of solid geometry, and polynomials with coefficients from  $F$ . See FIELD THEORY (MATHEMATICS); LINEAR ALGEBRA.

If  $V$  and  $W$  are vector spaces over  $F$ , then a linear transformation  $T$  on  $V$  to  $W$  is a function that assigns to each vector  $v$  in  $V$  a unique vector  $w$  in  $W$ , as in Eq. (6). Moreover, if  $u$  and  $v$  are any

$$Tv = w \quad (6)$$

vectors in  $V$ , and  $c$  and  $d$  are any scalars in  $F$ , then  $T$  satisfies Eq. (7).

$$T(cu + dv) = cTu + dTv \quad (7)$$

A basis of the vector space  $V$  is an ordered sequence of vectors  $v_1, \dots, v_n$  in  $V$  such that any vector  $v$  in  $V$  can be written in only one way as in Eq. (8) for appropriate scalars  $c_1, \dots, c_n$ .

$$v = c_1v_1 + c_2v_2 + \dots + c_nv_n \quad (8)$$

Once bases  $v_1, \dots, v_n$  and  $w_1, \dots, w_m$  for  $V$  and  $W$  respectively have been chosen, any linear transformation  $T$  on  $V$  to  $W$  can be completely and uniquely described in terms of the entries in an  $m \times n$  matrix  $A$  by Eq. (9). In other words, each  $Tv_j$ , as a vector

$$Tv_j = a_{1j}w_1 + a_{2j}w_2 + \dots + a_{mj}w_m \quad (9)$$

$$j = 1, 2, \dots, n$$

in  $W$ , can be expressed uniquely as a sum of scalar multiples of the basis  $w_1, \dots, w_m$ . The scalars  $a_{1j}, \dots, a_{mj}$  are the entries in column  $j$  of  $A$ . This observation is fundamental because it shows that the study of linear transformations is coextensive with the study of matrices.

There are a number of important questions about linear transformations that have been studied extensively. In particular:

1. Given  $w$  in  $W$ , the problem of determining all vectors  $v$  in  $V$  (if any) for which Eq. (10) is satisfied.

$$Tv = w \quad (10)$$

2. If  $V = W$ , the problem of determining all scalars  $\lambda$  and nonzero vectors  $v$  for which Eq. (11) is satisfied.

$$Tv = \lambda v \quad (11)$$

The set of all vectors  $Tv$  obtained as  $v$  varies over  $V$  is called the range of  $T$ . The range of  $T$  is always a vector space. Thus the first problem above is equivalent to determining the range of a linear transformation  $T$ . Once bases of  $V$  and  $W$  have been selected, Eq. (10) is readily seen to be equivalent to solving a system of linear equations of the form of Eqs. (12) for the determination of the numbers  $x_1, \dots, x_n$ .

$$\begin{aligned} a_{11}x_1 + \dots + a_{1n}x_n &= b_1 \\ a_{21}x_1 + \dots + a_{2n}x_n &= b_2 \\ &\vdots \\ a_{m1}x_1 + \dots + a_{mn}x_n &= b_m \end{aligned} \quad (12)$$

Finding the numbers  $\lambda$  and vectors  $v$  that satisfy Eq. (11) is called the eigenvalue problem; the number  $\lambda$  in (11) is called an eigenvalue of  $T$ , and the corresponding vector  $v$  in Eq. (11) is called an eigenvector of  $T$ . Equation (11) leads to a system similar to Eqs. (12), but  $m = n$  and each  $b_i$  must be replaced by  $\lambda x_i$  for  $i = 1, \dots, n$ . Moreover, both the eigenvalue  $\lambda$  and  $x_1, \dots, x_n$  must be determined. Because of the importance of Eqs. (10) and (11) in many areas of applied mathematics, special-purpose computer programs have been developed to deal with them. See EIGENFUNCTION; EIGENVALUE (QUANTUM MECHANICS).

Because of their applications in the physical and social sciences, certain special classes of linear transformations and matrices have been studied extensively. If  $A$  is an  $m \times n$  matrix, then the transpose of  $A$  is the  $n \times m$  matrix whose rows, in succession, are columns of  $A$  written as rows. The transpose of  $A$  is denoted by  $A^T$ . If  $A$  has complex number entries, then  $A^*$  is the matrix obtained from  $A^T$  by replacing each entry by its complex conjugate. An  $n \times n$  matrix  $A$  is said to be nonsingular (or invertible) if there is a unique  $n \times n$  matrix  $A^{-1}$  for which  $AA^{-1} = A^{-1}A = I_n$ ; the matrix  $I_n$  is the identity matrix:  $a_{ii} = 1$  for  $i = 1, \dots, n$ , and  $a_{ij} = 0$  if  $i \neq j$ . If  $A^* = A$ , then  $A$  is hermitian; if  $A^* = A^{-1}$ , then  $A$  is unitary; if  $A^*A = AA^*$ , then  $A$  is normal.

The singular-value decomposition theorem states that any  $m \times n$  matrix  $A$  can be factored into a product  $A = UDV$ , in which  $U$  is  $m \times m$  unitary,  $V$  is  $n \times n$  unitary, and  $D$  is an

$m \times n$  matrix whose only (possibly) nonzero entries are  $d_{11} \geq \dots > d_{pp} \geq 0$ , where  $p$  is the smaller of  $m$  and  $n$ . The numbers  $d_{11}, \dots, d_{pp}$  are called the singular values of  $A$ . The singular-value decomposition theorem is used extensively in solving least-squares problems.

Matrices whose entries are nonnegative real numbers are important in many applications of matrix theory to problems in the social sciences. Matrices with polynomial entries have been studied extensively because of their importance in control theory, systems theory, and other areas of applied mathematics and engineering. [M.Ma.]

**Matter (physics)** A term that traditionally refers to the substance of which all bodies consist. Matter in classical mechanics is closely identified with mass. Modern analyses distinguish two types of mass: inertial mass, by which matter retains its state of rest or uniform rectilinear motion in the absence of external forces; and gravitational mass, by which a body exerts forces of attraction on other bodies, and by which it reacts to those forces. Expressed in appropriate units, these two properties are numerically equal—a purely experimental fact, unexplained by theory. Albert Einstein made the equality of inertial and gravitational mass a fundamental principle (principle of equivalence), as one of the two postulates of the theory of general relativity. See GRAVITATION; INERTIA; MASS; RELATIVITY; WEIGHT.

In quantum mechanics, mass is only one among many properties (quantum numbers) that a particle can have, for example, electric charge, spin, and parity. The nearest quantum-mechanical analogs of traditional matter are fermions, having half-integral values of spin. Forces are mediated by exchange of bosons, particles having integral spins. Fermions correspond to classical matter in exhibiting impenetrability (a consequence of the exclusion principle), but the correspondence is only rough. For example, fermions can also be exchanged in interactions (a photon and an electron can exchange an electron), and they also exhibit wavelike (nonlocalized) behavior. States of classical matter-particles were given by their positions and momenta, but in quantum mechanics it is impossible to assign simultaneous precise positions and momenta to particles. See EXCLUSION PRINCIPLE; NONRELATIVISTIC QUANTUM THEORY; QUANTUM ELECTRODYNAMICS; QUANTUM MECHANICS; QUANTUM STATISTICS.

The primary constituents of ordinary matter are baryonic, consisting of quarks. However it is possible that as much as 99% (by mass) of the matter in the universe consists of nonbaryonic “dark matter” whose nature is yet to be discovered. See BARYON; BIG BANG THEORY; COSMOLOGY; INFLATIONARY UNIVERSE COSMOLOGY; QUARKS; UNIVERSE. [D.Sha.]

**Matthiessen's rule** An empirical rule which states that the total resistivity of a crystalline metallic specimen is the sum of the resistivity due to thermal agitation of the metal ions of the lattice and the resistivity due to the presence of imperfections in the crystal. This rule is a basis for understanding the resistivity behavior of metals and alloys at low temperatures.

The resistivity of a metal results from the scattering of conduction electrons. Lattice vibrations scatter electrons because the vibrations distort the crystal. Imperfections such as impurity atoms, interstitials, dislocations, and grain boundaries scatter conduction electrons because in their immediate vicinity the electrostatic potential differs from that of the perfect crystal. [F.J.B.]

**Maxillopoda** A class of Crustacea whose application is gaining moderately widespread use, despite the fact that its validity is not universally accepted by researchers. The constituent subclasses of the Maxillopoda also remain unsettled.

The class Maxillopoda was proposed for those taxa with six thoracic somites (with some exceptions), a well-developed mandibular palp in adults, well-developed maxillules and maxillae adapted for filtering in filter feeders, and the lack of gnathobases on the appendages of the thorax. The Recent taxa

included were the Copepoda, Branchiura, Mystacocarida, and provisionally, the Cirripedia. Subsequently the Cirripedia (subdivided into Cirripedia sensu stricto and Ascothoracida) were unequivocally incorporated. The Ostracoda are now included by some but excluded by others. More recent suggestions have included the Tantulocarida, and even the probably noncrustacean Pentastomida, within the Maxillopoda. See BRANCHIURA; CIRRIPIEDIA; COPEPODA; CRUSTACEA; OSTRACODA; PENTASTOMIDA; TANTULOCARIDA. [P.A.McL.]

**Maxwell's demon** An imaginary being whose action appears to contradict the second law of thermodynamics, which identifies the natural direction of change with the direction of increasing entropy. There has always been a certain degree of discomfort associated with the acceptance of the law, particularly in relation to the time reversibility of physical laws and the role of molecular fluctuations. In 1867, J. C. Maxwell considered, in this connection, the action of “a finite being who knows the paths and velocities of all the molecules by inspection.” This being was later referred to as a demon by Lord Kelvin, and the usage has been generally adopted. See ENTROPY; THERMODYNAMIC PRINCIPLES; TIME, ARROW OF.

The activity of Maxwell's demon can be modeled by a trapdoor in a partition between two regions full of gas at the same pressure and temperature. The trapdoor needs to be restrained by a light spring to ensure that it is closed unless it is struck by molecules traveling from the left (see illustration). Its hinging is such that molecules traveling from the right cannot open it. The essential point of Maxwell's vision was that molecules striking the trapdoor from the left would be able to penetrate into the right-hand region but those present on the right would not be able to escape back into the left-hand region. Therefore, the initial equilibrium state of the two regions, that of equal pressures, would be slowly replaced by a state in which the two regions acquired different pressures as molecules accumulated in the right-hand region at the expense of the left-hand region. Only a slightly more elaborate mechanical arrangement is needed to change the apparatus to one in which the temperatures of the two regions move apart. In each case, the demonic trapdoor appears to be contriving a change that is contrary to the second law, for an implication of that law is that systems in either mechanical equilibrium (at the same pressure) or thermal equilibrium (at the same temperature) cannot spontaneously diverge from equilibrium.

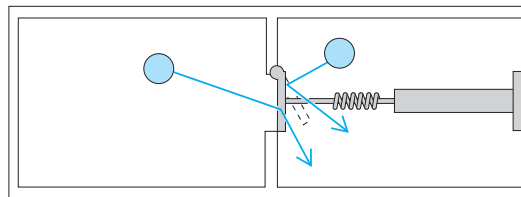

Type of device that emulates mechanically the actions of Maxwell's demon. Molecules traveling to the right can open the trapdoor and enter the right-hand compartment, but those striking it from the right cannot open it, so do not move into the left-hand compartment.

As frequently occurs in science, the resolution of a paradox or the elimination of an apparent conflict with a firmly based law depends on a detailed analysis of the proposed arrangement. Numerous analyses of this kind have shown that the activities of Maxwell's demon do not in fact result in the overthrow of the second law. [P.W.A.]

**Maxwell's equations** Four differential equations proposed by James Clerk Maxwell in 1864 as the basis of the theory of electromagnetic waves. They may be written, in vector nota-

tion, as Eqs. (1)–(4), where  $\mathbf{D}$  is the electric displacement,  $\mathbf{B}$  the

$$\nabla \cdot \mathbf{D} = \rho \quad (1)$$

$$\nabla \cdot \mathbf{B} = 0 \quad (2)$$

$$\nabla \times \mathbf{E} = -\frac{\delta \mathbf{B}}{\delta t} \quad (3)$$

$$\nabla \times \mathbf{H} = \mathbf{i} + \frac{\delta \mathbf{D}}{\delta t} \quad (4)$$

magnetic flux density,  $\mathbf{E}$  the electric field strength or intensity,  $\mathbf{H}$  the magnetic field strength or intensity,  $\rho$  the charge density, and  $\mathbf{i}$  the current density.

The first equation states that electric flux lines, if they end at all, will do so on electric charges. The second states that magnetic flux lines never terminate. The third is a form of Faraday's law of induction, which states that the rate of change of the magnetic flux threading a circuit equals the electromotive force or line integral of  $\mathbf{E}$  around the circuit. The fourth integral is based partially on A. M. Ampère's experiments on steady currents which show that the line integral of the magnetic intensity  $\mathbf{H}$  (or  $\mathbf{B}/\mu$ , where  $\mu$  is the permeability) around a closed curve equals the current encircled. See DISPLACEMENT CURRENT; EQUATION OF CONTINUITY; STOKES' THEOREM. [W.R.Sm.]

**McLeod gage** A type of instrument used to measure vacuum by application of the principle of Boyle's law. A known volume of a gas whose pressure is to be measured is trapped by raising the level of a fluid (mercury or oil) by means of a plunger, by lifting a reservoir, by using pressure, or by tipping the apparatus. As the fluid level is further raised, the gas is compressed into the capillary tube (see illustration). Obeying Boyle's

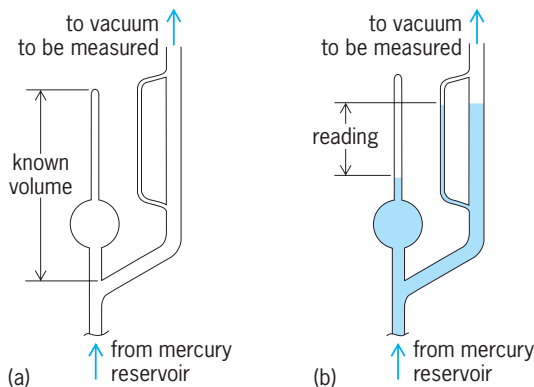

**McLeod gage.** (a) Filling (charging) position. (b) Measuring position.

law, the compressed gas now exerts enough pressure to support a column of fluid high enough to read. Readings are somewhat independent of the composition of the gas under pressure. See VACUUM MEASUREMENT. [R.C.]

**Mean effective pressure** A term commonly used in the evaluation for positive displacement machinery performance which expresses the average net pressure difference in pounds per square inch (psi) on the two sides of the piston in engines, pumps, and compressors. It is also known as mean pressure and is abbreviated as mep or mp.

In an engine (prime mover) it is the average pressure which urges the piston forward on its stroke. In a pump or compressor it is the average pressure which must be overcome, through the driver, to move the piston against the fluid resistance.

The criterion of mep is a vitally convenient device for the evaluation of a reciprocating engine, pump, or compressor design as judged by initial cost, space occupied, and deadweight. See COMPRESSOR; DIESEL CYCLE; THERMODYNAMIC CYCLE; VAPOR CYCLE. [T.Ba.]

**Mean free path** The average distance traveled between two similar events. The concept of mean free path is met in all fields of science and is classified by the events which take place. The concept is most useful in systems which can be treated statistically, and is most frequently used in the theoretical interpretation of transport phenomena in gases and solids, such as diffusion, viscosity, heat conduction, and electrical conduction. The types of mean free paths which are used most frequently are for elastic collisions of molecules in a gas, of electrons in a crystal, of phonons in a crystal, and of neutrons in a moderator. See KINETIC THEORY OF MATTER. [W.D.W.]

**Measles** An acute, highly infectious viral disease with cough, fever, and maculopapular rash. It is of worldwide endemicity.

The virus enters the body via the respiratory system, multiplies there, and circulates in the blood. Cough, sneezing, conjunctivitis, photophobia, and fever occur, with Koplik's spots (small red spots containing a bluish-white speck in the center) in the mouth.

A rash appears after 14 days' incubation and persists 5–10 days. Serious complications may occur in 1 out of 15 persons; these are mostly respiratory (bronchitis, pneumonia), but neurological complications are also found. Encephalomyelitis occurs rarely. Permanent disabilities may ensue for a significant number of persons. Measles is one of the leading causes of death among children in the world, particularly in the developing countries.

In unvaccinated populations, immunizing infections occur in early childhood during epidemics which recur after 2–3 years' accumulation of susceptible children. Transmission is by coughing or sneezing. Measles is infectious from the onset of symptoms until a few days after the rash has appeared. Second attacks of measles are very rare. Treatment is symptomatic.

Killed virus vaccine should not be used, as certain vaccinees become sensitized and develop local reactions when revaccinated with live attenuated virus, or develop a severe illness upon contracting natural measles. Live attenuated virus vaccine effectively prevents measles; vaccine-induced antibodies persist for years. See BIOLOGICALS; HYPERSENSITIVITY; SKIN TEST. [J.L.Me.]

**Measure** A reference sample used in comparing lengths, areas, volumes, masses, and the like. The measures employed in scientific work are based on the international units of length, mass, and time—the meter, the kilogram, and the second—but decimal multiples and submultiples are commonly employed. Prior to the development of the international metric system, many special-purpose systems of measures had evolved and many still survive, especially in the United Kingdom and the United States. See METRIC SYSTEM; PHYSICAL MEASUREMENT; TIME; UNITS OF MEASUREMENT; WEIGHT. [D.Wi.]

**Measure theory** A branch of mathematical analysis connected with the theory of integration. In order to discuss this subject, a formal definition of the term measure must be given.

Let  $X$  be an arbitrary set. Let  $m$  be a fixed collection of subsets of  $X$  satisfying the following conditions:

1.  $\phi \in m$ . ( $\phi$  is the empty set. The symbol  $\in$  indicates that  $\phi$  is an element of  $m$ .)
2. If  $A \in m$ , then  $A^c \in m$ . ( $A^c$  is the complement of  $A$ . It consists of those elements of  $X$  which do not belong to  $A$ .)
3. If  $A_1, A_2, \dots \in m$ , then (1) is valid. (This set is the union of

$$\bigcup_{k=1}^{\infty} A_k \in m \quad (1)$$

$A_1, A_2, \dots$ . It consists of those elements of  $X$  which belong to at least one of the sets  $A_1, A_2, \dots$ .)

In this situation the collection  $m$  is called a  $\sigma$ -algebra. Here the term algebra refers to the various set operations (complementation, union, intersection), and the prefix  $\sigma$  to the fact that countably many such operations can be performed with sets in  $m$  and still result in sets in  $m$ . For example, the three properties mentioned above imply another property:

4. If  $A_1, A_2, \dots \in m$ , then (2) is valid. (This set is the intersec-

$$\bigcap_{k=1}^{\infty} A_k \in m \quad (2)$$

tion of  $A_1, A_2, \dots$ . It consists of those elements of  $X$  which belong to all of the sets  $A_1, A_2, \dots$ .)

Now suppose that  $X$  is a set and  $m$  is a particular  $\sigma$ -algebra of subsets of  $X$ . A measure  $\mu$  is a function which assigns to each set in  $m$  a certain nonnegative real number (or  $+\infty$ ) and which satisfies the following conditions:

1.  $\mu(\phi) = 0$ .

2. If  $A$  and  $B \in m$  and are disjoint ( $A \cap B = \phi$ ), then Eq. (3) holds.

$$\mu(A \cup B) = \mu(A) + \mu(B) \quad (3)$$

3. If  $A_1, A_2, \dots \in m$ , then Eq. (4) holds.

$$\mu\left(\bigcup_{k=1}^{\infty} A_k\right) \leq \sum_{k=1}^{\infty} \mu(A_k) \quad (4)$$

Various other properties can be derived from these conditions, such as:

4. If  $A$  and  $B \in m$  and  $A \subset B$  (that is,  $A$  is a subset of  $B$ ), then  $[\mu](A) \leq \mu(B)$ .

5. If  $A_1, A_2, \dots \in m$  and are mutually disjoint ( $A_i \cap A_j = \phi$  if  $i \neq j$ ), then Eq. (5) holds.

$$\mu\left(\bigcup_{k=1}^{\infty} A_k\right) = \sum_{k=1}^{\infty} \mu(A_k) \quad (5)$$

The last property is of crucial importance and is called the countable additivity property of the measure  $\mu$ .

Measure theory has a great number of important applications. Undoubtedly, the most important is the application to integration. See INTEGRATION. [B.F.J.]

**Measured daywork** A tool used primarily in manufacturing facilities as a control device to measure productive output in relation to labor input within a specific time period. The measurement of the work content is accomplished through the use of time standards which are usually the result of a stopwatch time study, predetermined time standards (methods-time measurement, the work-factor system), or some other form of work-measurement technique designed to measure tasks of labor under normal and average conditions.

A measured daywork plan is similar to incentive pay plans inasmuch as in both plans, time standards are used as a device to measure operator performance and also for various forms of management planning. However, in a measured daywork plan, worker income is based on a fixed hourly rate established by management, and is usually affected only by job classification, shift premiums, and overtime adjustments. Because of the fixed hourly rate in a measured daywork plan, there is little incentive for a worker to exceed a normal or standard level of performance or productivity. On the other hand, time standards are more readily acceptable, and become less an item of contention to the employee and bargaining unit (union).

The term daywork as used in industry denotes a fixed hourly rate that is not raised or lowered by varying worker performance levels. The hourly rate for a particular job should be a fair one relative to other jobs in the shop, and should also be comparable to rates of pay for similar jobs in the industrial community.

Once measured labor time standards have been established for shop operations, in addition to evaluating operator performance and identifying labor costs, new-product costs can also be determined prior to release to production, worker-power planning and scheduling can be done, equipment capacity requirements can be identified, and planning and make/buy decisions can be facilitated. See PERFORMANCE RATING; PRODUCTIVITY; WAGE INCENTIVES; WORK MEASUREMENT. [D.S.]

**Mechanical advantage** Ratio of the force exerted by a machine (the output) to the force exerted on the machine, usually by an operator (the input). The term is useful in discussing a simple machine, where it becomes a figure of merit. It is not particularly useful, however, when applied to more complicated machines, where other considerations become more important than a simple ratio of forces. See EFFICIENCY; SIMPLE MACHINE. (R.M.Ph.)

**Mechanical alloying** A materials-processing method that involves the repeated welding, fracturing, and rewelding of a mixture of powder particles, generally in a high-energy ball mill, to produce a controlled, extremely fine microstructure. The mechanical alloying technique allows alloying of elements that are difficult or impossible to combine by conventional melting methods. In general, the process can be viewed as a means of assembling metal constituents with a controlled microstructure. If two metals will form a solid solution, mechanical alloying can be used to achieve this state without the need for a high-temperature excursion. Conversely, if the two metals are insoluble in the liquid or solid state, an extremely fine dispersion of one of the metals in the other can be accomplished. The process of mechanical alloying was originally developed as a means of overcoming the disadvantages associated with using powder metallurgy to alloy elements that are difficult to combine. See CRUSHING AND PULVERIZING; POWDER METALLURGY; SOLID SOLUTION.

Some oxides are insoluble in molten metals. Mechanical alloying provides a means of dispersing these oxides in the metals. Examples are nickel-based superalloys strengthened with dispersed thorium oxide or yttrium oxide ( $Y_2O_3$ ). These superalloys have excellent strength and corrosion resistance at elevated temperatures, making them attractive candidate materials for use in applications such as jet-engine turbine blades, vanes, and combustors. A number of other potential applications for mechanical alloying material are being explored, including powders for coating applications, alloys of immiscible systems, amorphous alloys, intermetallics, cermets, and organic-ceramic-metallic material systems in general. See AMORPHOUS SOLID; CERMET; HIGH-TEMPERATURE MATERIALS; INTERMETALLIC COMPOUNDS; METAL COATINGS.

Liquids or solid immiscible systems are difficult to process by conventional pyrometallurgy; mechanical alloying provides a route to obtain a homogeneous distribution in the solid phase. See PYROMETALLURGY. [F.H.Fr.]

**Mechanical classification** A sorting operation in which mixtures of particles of mixed sizes, and often of different specific gravities, are separated into fractions by the action of a stream of fluid. Water is ordinarily used as the sorting fluid, but other liquids or air or other gases may be used (see illustration).

The main objective of classification is to separate the particles according to size. This function is identical to that of screening, but classification is applicable to smaller particles, especially those that are undersize. For small particles it is more economical than screening. In classification the oversize and undersize are called sands and slimes, respectively.

Material also may be mechanically classified by specific gravity, a method that separates substances differing in chemical composition. This is called hydraulic separation. Such classification is based on the fact that, in a fluid, particles of the same specific gravity but of different size or shape settle at different constant speeds. Large, heavy, round particles settle faster than



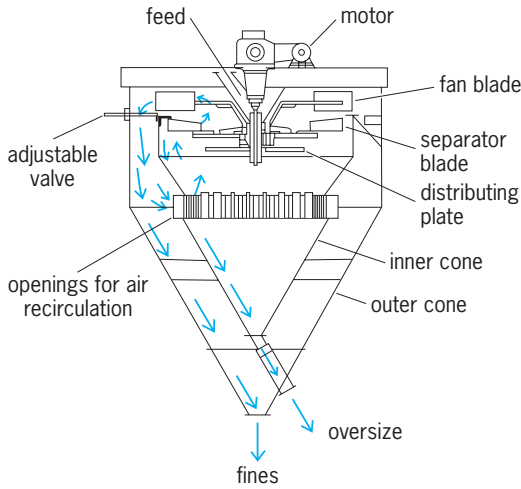

The double-cone air separator. (After W. L. McCabe and J. C. Smith, *Unit Operations of Chemical Engineering*, McGraw-Hill, 3rd ed., 1975)

small, light, needlelike ones. If the particles also differ in specific gravity, the speed of settling is further affected. This is the basis for the separation of particles by kind rather than by size alone. See FLOTATION; MECHANICAL SEPARATION TECHNIQUES; UNIT OPERATIONS. [W.L.McC.]

**Mechanical engineering** One of several recognized fields of engineering. To grasp the meaning of mechanical engineering, it is desirable to take a close look at what engineering really is. The Engineers' Council for Professional Development has defined engineering as the profession in which a knowledge of the mathematical and physical sciences gained by study, experience, and practice is applied with judgment to develop ways to utilize economically the materials and forces of nature for the progressive well-being of mankind. It is a profession in which study in mathematics and science is blended with experience and judgment for the production of useful things.

Formal training of a mechanical engineer includes mastery of mathematics through the level of differential equations. Training in physical science embraces chemistry, physics, mechanics of materials, fluid mechanics, thermodynamics, statics, and dynamics. See ENGINEERING; MACHINERY; TECHNOLOGY. [R.S.S.]

**Mechanical impedance** For a system executing simple harmonic motion, the mechanical impedance is the ratio of force to particle velocity. If the force is that which drives the system and the velocity is that of the point of application of the force, the ratio is the input or driving-point impedance. If the velocity is that at some other point, the ratio is the transfer impedance corresponding to the two points.

Mechanical impedance is a complex quantity. The real part, the mechanical resistance, is independent of frequency if the dissipative forces are proportional to velocity; the imaginary part, the mechanical reactance, varies with frequency, becoming zero at the resonant and infinite at the antiresonant frequencies of the system. See FORCED OSCILLATION; HARMONIC MOTION. [M.Gr.]

**Mechanical rectifier** A device which uses a synchronously operated mechanical switch to convert a single-phase or polyphase alternating voltage to a direct voltage. Single-phase mechanical rectifiers are made for small current output and are normally called vibrators. For large values of power where low voltages (less than 600 volts) are desired, the polyphase mechanical rectifier is used. This low-voltage device has higher efficiency than electronic rectifiers, which have appreciable voltage drop across the arc. These devices are not commonly used in power system applications. See RECTIFIER. [A.G.C.]

**Mechanical separation techniques** A group of laboratory and production operations whereby the components of a polyphase mixture are separated by mechanical methods into two or more fractions of different mechanical characteristics. The separated fractions may be homogeneous or heterogeneous, particulate or nonparticulate.

**Types of mechanical separator**

Materials separated	Separators
Liquid from liquid	Settling tanks, liquid cyclones, centrifugal decanters, coalescers
Gas from liquid	Still tanks, deaerators, foam breakers
Liquid from gas	Settling chambers, cyclones, electrostatic precipitators, impingement separators
Solid from liquid	Filters, centrifugal filters, clarifiers, thickeners, sedimentation centrifuges, liquid cyclones, wet screens, magnetic separators
Liquid from solid	Presses, centrifugal extractors
Solid from gas	Settling chambers, air filters, bag filters, cyclones, impingement separators, electrostatic and high-tension precipitators
Solid from solid	
By size	Screens, air and wet classifiers, centrifugal classifiers
By other characteristics	Air and wet classifiers, centrifugal classifiers, jigs, tables, spiral concentrators, flotation cells, dense-medium separators, magnetic separators, electrostatic separators

The techniques of mechanical separation are based on differences in phase density, in phase fluidity, and in such mechanical properties of particles-as size, shape, and density; and on such particle characteristics as wettability, surface charge, and magnetic susceptibility. Obviously, such techniques are applicable only to the separation of phases in a heterogeneous mixture. They may be applied, however, to all kinds of mixtures containing two or more phases, whether they are liquid-liquid, liquid-gas, liquid-solid, gas-solid, solid-solid, or gas-liquid-solid.

Methods of mechanical separations fall into four general classes: (1) those employing a selective barrier such as a screen or filter cloth; (2) those depending on difference in phase density alone (hydrostatic separators); (3) those depending on fluid and particle mechanics; and (4) those depending on surface or electrical characteristics of particles. A wide variety of separation devices have been devised and are in use. The more important kinds of equipment are listed in the table, grouped according to the phases involved. See CENTRIFUGATION; CLARIFICATION; DUST AND MIST COLLECTION; FILTRATION; FLOTATION; MAGNETIC SEPARATION METHODS; MECHANICAL CLASSIFICATION; SCREENING; SEDIMENTATION (INDUSTRY); THICKENING. [S.A.M.]

**Mechanical vibration** The continuing motion, repetitive and often periodic, of a solid or liquid body within certain spatial limits. Vibration occurs frequently in a variety of natural phenomena such as the tidal motion of the oceans, in rotating and stationary machinery, in structures as varied in nature as buildings and ships, in vehicles, and in combinations of these various elements in larger systems. The sources of vibration and the types of vibratory motion and their propagation are subjects that are complicated and depend a great deal on the particular characteristics of the systems being examined. Further, there is strong coupling between the notions of mechanical vibration and the propagation of vibration and acoustic signals through both the ground and the air so as to create possible sources of discomfort, annoyance, and even physical damage to people and structures adjacent to a source of vibration.

**Mass-spring-damper system.** Although vibrational phenomena are complex, some basic principles can be recognized in a very simple linear model of a mass-spring-damper system (see illustration). Such a system contains a mass *M*, a spring with spring constant *k* that serves to restore the mass to a neutral position, and a damping element which opposes the motion of

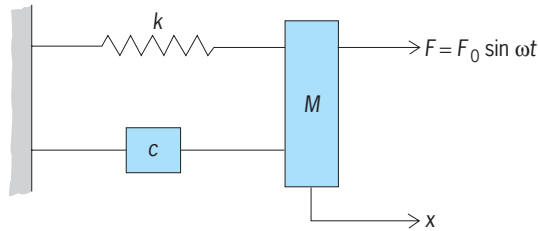

Vibrating linear system (mass-spring-damper) with one degree of freedom.

the vibratory response with a force proportional to the velocity of the system, the constant of proportionality being the damping constant  $c$ . This damping force is dissipative in nature, and without its presence a response of this mass-spring system would be completely periodic. See DAMPING.

**Complex systems.** The foregoing model of the linear spring-mass-damper system contains within it a number of simplifications that do not reflect conditions of the real world in any obvious way. These simplifications include the periodicity of both the input and, to some extent, the response; the discrete nature of the input, that is, the assumption that it is temporal in nature with no reference to spatial distribution; and the assumption that only a single resonant frequency and a single set of parameters are required to describe the mass, the stiffness, and the damping. The real world is far more complex. Many sources of vibration are not periodic. These include impulsive forces and shock loading, wherein a force is suddenly applied for a very short time to a system; random excitations, wherein the signal fluctuates in time in such a way that its amplitude at any given instant can be expressed only in terms of a probabilistic expectation; and aperiodic motions, wherein the fluctuation in time may be some prescribed nonperiodic function or some other function that is not readily seen to be periodic.

**Sources of vibration.** There are many sources of mechanical and structural vibration that the engineer must contend with in both the analysis and the design of engineering systems. The most common form of mechanical vibration problem is motion induced by machinery of varying types, often but not always of the rotating variety. Other sources of vibration include: ground-borne propagation due to construction; vibration from heavy vehicles on conventional pavement as well as vibratory signals from the rail systems common in many metropolitan areas; and vibrations induced by natural phenomena, such as earthquakes and wind forces. Wave motion is a source of vibration in mechanical and structural systems associated with offshore structures.

**Effect of vibrations.** The most serious effect of vibration, especially in the case of machinery, is that sufficiently high alternating stresses can produce fatigue failure in machine and structural parts. Less serious effects include increased wear of parts, general malfunctioning of apparatus, and the propagation of vibration through foundations and buildings to locations where the vibration of its acoustic realization is intolerable either for human comfort or for the successful operation of sensitive measuring equipment. See ACOUSTIC NOISE; SOUND; VIBRATION; WEAR. [C.L.D.; J.P.D.H.]

**Mechanics** In its original sense, mechanics refers to the study of the behavior of systems under the action of forces. Mechanics is subdivided according to the types of systems and phenomena involved.

An important distinction is based on the size of the system. Those systems that are large enough can be adequately described by the newtonian laws of classical mechanics; in this category, for example, are celestial mechanics and fluid mechanics. On the other hand, the behavior of microscopic systems such as molecules, atoms, and nuclei can be interpreted only by the concepts and mathematical methods of quantum mechanics.

Mechanics may also be classified as nonrelativistic or relativistic mechanics, the latter applying to systems with material velocities comparable to the velocity of light. This distinction pertains to both classical and quantum mechanics.

Finally, statistical mechanics uses the methods of statistics for both classical and quantum systems containing very large numbers of similar subsystems to obtain their large-scale properties. See CLASSICAL FIELD THEORY; CLASSICAL MECHANICS; DYNAMICS; FLUID MECHANICS; QUANTUM MECHANICS; STATICS; STATISTICAL MECHANICS. [B.G.]

**Mechanism** Classically, a mechanical means for the conversion of motion, the transmission of power, or the control of these. Mechanisms are at the core of the workings of many machines and mechanical devices. In modern usage, mechanisms are not always limited to mechanical means. In addition to mechanical elements, they may include pneumatic, hydraulic, electrical, and electronic elements. In this article, the discussion of mechanism is limited to its classical meaning. See MACHINE.

Most mechanisms consist of combinations of a relatively small number of basic components. Of these, the most important are cams, gears, links, belts, chains, and logical mechanical elements. The last include such devices as ratchets, trips, detents, and interlocks. In order to understand how any mechanism works, their degree of freedom, structure, and kinematics must be considered. See BELT DRIVE; CAM MECHANISM; CHAIN DRIVE; ESCAPEMENT; GEAR; LINKAGE (MECHANISM); RATCHET.

Degree of freedom is conveniently illustrated for mechanisms with rigid links. The discussion is limited to mechanisms which obey the general degree-of-freedom equation,

$$F = \lambda(l - j - 1) + \sum f_i$$

where  $F$  = degree of freedom of mechanism,  $l$  = number of links of mechanism,  $j$  = number of joints of mechanism,  $f_i$  = degree of freedom of relative motion at  $i$ th joint,  $\sigma$  = summation symbol (summation over all joints), and  $\lambda$  = mobility number (the most common cases are  $\lambda = 3$  for plane mechanisms and  $\lambda = 6$  for spatial mechanisms). See DEGREE OF FREEDOM (MECHANICS).

The kinematic structure of a mechanism refers to the identification of the joint connection between its links. Just as chemical compounds can be represented by an abstract formula and electric circuits by schematic diagrams, the kinematic structure of mechanisms can be usefully represented by abstract diagrams. The structure of mechanisms for which each joint connects two links can be represented by a structural diagram, or graph, in

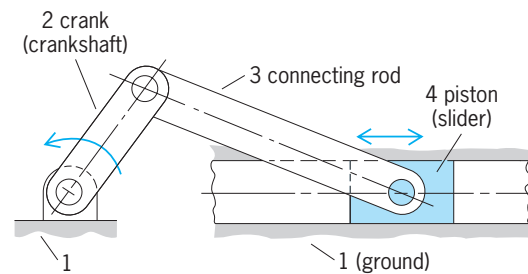

(a)

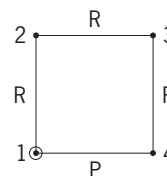

(b)

Slider-crank mechanism, (a) Mechanism, (b) Graph of mechanism.  $R$  = pin joint;  $P$  = sliding joint.

which links are denoted by vertices, joints by edges, and in which the edge connection of vertices corresponds to the joint connection of links; edges are labeled according to joint type, and the fixed link is identified as well. Thus the graph of the slider-crank mechanism of illustration *a* is as shown in illustration *b*. In this figure the circle around vertex 1 signifies that link 1 is fixed.

Kinematics is divided into kinematic analysis (analysis of a mechanism of given dimensions) and synthesis (determination of the proportions of a mechanism for given motion requirements). It includes the investigation of finite as well as infinitesimal displacements, velocities, accelerations and higher accelerations, and curvatures and higher curvatures in plane and three-dimensional motions. See KINEMATICS.

The design of mechanisms involves many factors. These include their structure, kinematics, dynamics, stress analysis, materials, lubrication, wear, tolerances, production considerations, control and actuation, vibrations, critical speeds, reliability, costs, and environmental considerations. Modern trends in the design of mechanisms emphasize economical design analysis by means of computer-aided design techniques. [F.F.]

**Mechanoreceptors** Sensory receptors that provide the organism with information about such mechanical changes in the environment as movement, tension, and pressure. In higher animals receptors are actually the only means by which information of the surroundings is gained and by which reactions to environmental changes are started. See SENSATION.

Mechanoreceptors are excited by mechanical disturbances of their surroundings through deformation of their structure, through pressure or tension, or through a combination of these. In general, little energy is required for mechanical stimuli to cause a detectable excitation in mechanoreceptors.

From a physical point of view, mechanoreceptors are energy transducers; they convert mechanical into electrical energy, which in turn triggers the nerve impulse. Deformation leads to a sequence of events which may be summarized by the following scheme:

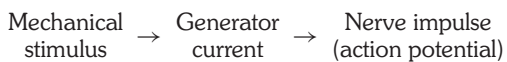

The generator current is the earliest detectable sign of excitation. The most salient characteristic of the generator current is its graded nature; its amplitude increases continuously, without visible steps, if the stimulus strength is progressively increased. When the generator current reaches a certain critical amplitude, an all-or-nothing potential is discharged in the sense organ which may then propagate as an all-or-nothing nerve impulse along the afferent axon of the receptor. See NERVOUS SYSTEM (INVERTEBRATE); NERVOUS SYSTEM (VERTEBRATE). [W.R.L.]

**Mecoptera** A small order of insects called the scorpion flies. Characteristic of the adult insect is the peculiar prolongation of the head into a beak, which bears chewing mouthparts. They are small to medium in size. The insects either have two pairs of large, net-veined wings of equal size, often with dark areas, or have short and aborted wings. The legs are long and slender. In some species, the male abdomen has a terminal enlargement which is held recurved over the back so that he resembles a scorpion, thus the common name. The Mecoptera are found in moist habitats within densely wooded areas. The adults are omnivorous but feed chiefly on small insects. See INSECTA. [B.E.R.]

**Medical bacteriology** The study of bacteria that cause human disease. The field encompasses the detection and identification of bacterial pathogens, determination of the sensitivity and mechanisms of resistance of bacteria to antibiotics, the mechanisms of virulence, and some aspects of immunity to infection. See VIRULENCE.

The clinical bacteriology laboratory identifies bacterial pathogens present in specimens such as sputum, pus, blood, and

spinal fluid, or from swabs of skin, throat, rectal, or urogenital surfaces. Identification involves direct staining and microscopic examination of these materials, and isolation of bacteria present in the material by growth in appropriate media. The laboratory must differentiate bacterial pathogens from harmless bacteria that colonize humans. Species and virulent strains of bacteria can be identified on the basis of growth properties, metabolic and biochemical tests, and reactivity with specific antibodies.

Recent advances in the field of diagnostic bacteriology have involved automation of biochemical testing; the development of rapid antibody-based detection methods; and the application of molecular biology techniques. Once a bacterial pathogen has been identified, a major responsibility of the diagnostic bacteriology laboratory is the determination of the sensitivity of the pathogen to antibiotics. This involves observation of the growth of the bacteria in the presence of various concentrations of antibiotics. The process has been made more efficient by the development of automated instrumentation.

An increasingly serious problem in the therapy of infectious diseases is the emergence of antibiotic-resistant strains of bacteria. An important area of research is the mechanisms of acquisition of antibiotic resistance and the application of this knowledge to the development of more effective antibiotics. See ANTIBIOTIC; ANTIGEN-ANTIBODY REACTION; BACTERIAL PHYSIOLOGY AND METABOLISM; BACTERIAL TAXONOMY; IMMUNOCHEMISTRY.

The study of bacterial pathogenesis involves the fields of molecular genetics, biochemistry, cell biology, and immunology. In cases where the disease is not serious and easily treated, research may involve the deliberate infection of human volunteers. Otherwise, various models of human disease must be utilized. These involve experimental infection of animals and the use of tissue cell culture systems. Modern molecular approaches to the study of bacterial pathogenesis frequently involve the specific mutation or elimination of a bacterial gene thought to encode a virulence property, followed by observation of the mutant bacteria in a model system of human disease. In this way, relative contributions of specific bacterial traits to different stages of the disease process can be determined. This knowledge permits the design of effective strategies for intervention that will prevent or cure the disease. See BACTERIAL GENETICS.

The presence of specific antibodies is frequently useful in the diagnosis of bacterial diseases in which the pathogen is otherwise difficult to detect. An example is the sexually transmitted disease syphilis; the diagnosis must be confirmed by the demonstration of antibodies specific for *T. pallidum*. See ANTIBODY; BIOLOGICALS.

Immunity to some bacteria that survive intracellularly is not mediated by antibodies but by immune effector cells, known as T cells, that activate infected cells to kill the bacteria that they contain. An active area of research is how bacterial components are presented to the immune system in a way that will induce effective cell-mediated immunity. This research may lead to the development of T-cell vaccines effective against intracellular bacterial pathogens.

For disease entities caused by specific bacteria see ANTHRAX; BOTULISM; BRUCELLOSIS; CHOLERA; DIPHTHERIA; GANGRENE, GAS; GLANDERS; GONORRHEA; GRANULOMA INGUINALE; JOHNE'S DISEASE; LEPROSY; LISTERIOSIS; PLAGUE; PSEUDOTUBERCULOSIS; TETANUS; TUBERCULOSIS; TULAREMIA. For disease entities caused by more than one microorganism see FOOD POISONING; INFANT DIARRHEA; MENINGITIS; PNEUMONIA. For groups of disease-producing bacteria see GANGRENE, GAS; HAEMOPHILUS; IMMUNOLOGY; MEDICAL BACTERIOLOGY; PNEUMOCOCCUS; SEPTICEMIA; SPIROCHETE; STREPTOCOCCUS. [S.L.M.]

**Medical control systems** Physiological and artificial systems that control one or more physiological variables or functions of the human body. Regulation, control processes, and system stability are at the heart of the survival of living organisms, both unicellular and multicellular. In the nineteenth century,

C. Bernard concluded that the higher animals, far from being indifferent to their surroundings, must be in close and intimate relation to them. The equilibrium they maintain is the result of compensation established as continually and exactly as if by a very sensitive balance. W. B. Cannon (1929) differentiated the stability properties of biological systems from those of physical systems, and introduced the term homeostasis to describe the steady states in the body that are maintained by complex, coordinated physiological reactions. The condition of homeostasis is achieved either by regulation of supplies (for example, control of blood sugar level) or by regulation of processes (for example, control of body temperature and control of voluntary movements). See HOMEOSTASIS.

Medical control systems may be classified into two groups: (1) the physiological control systems in normal or pathological conditions (for example, control of electrolytes, arterial pressure, respiration, body temperature, blood sugar, endocrinal functions, neuromuscular and motor activity, and sensory functions), and (2) the external (artificial) control systems that interface with physiological systems (for example, artificial kidneys or hemodialyzers, blood oxygenators or heart-lung machines used during open-heart surgery, external prosthetics and orthotics, cardiac pacemakers, ventilators, implantable defibrillators, and implantable pumps for drug delivery). For the development and proper functioning of artificial devices, the underlying control mechanisms of the normal and of the disabled physiological systems with which the external devices must interface must be adequately understood. Thus, in its broadest sense, the area of medical control systems encompasses all branches of engineering, mathematical biology, biophysics, physiology, and medicine. See BIOMECHANICS; BIOMEDICAL CHEMICAL ENGINEERING; BIOMEDICAL ENGINEERING; CONTROL SYSTEMS; MATHEMATICAL BIOLOGY.

The importance of control systems engineering in medical applications has grown because of the inherent complexity of medical control systems. H. A. Simon's concept of complexity is very appropriate for medical control systems: complex systems are composed of subsystems that in turn have their own subsystems, and so on; and the large number of parts interact in a complicated way so that it is sometimes impossible to infer the properties of the whole from the properties of the parts and their laws of interaction. Indeed, the analytical models developed, using control systems engineering, of the components of a medical system have had limited success in predicting the behavior of the overall system.

Examples of medical control systems include myoelectric prostheses, which are replacement devices for lost limbs; external orthoses, which are used for rehabilitation of patients with acquired disabilities; and implantable devices such as defibrillators and pumps for drug delivery. Numerous other devices, such as cardiac pacemakers, artificial kidneys, heart-lung machines, and artificial ventilators, have been in routine clinical use for many years. [G.C.A.]

**Medical imaging** A medical specialty that uses x-rays, gamma rays, high-frequency sound waves, and magnetic fields to produce images of organs and other internal structures of the body. In diagnostic radiology the purpose is to detect and diagnose disease, while in interventional radiology, imaging procedures are combined with other techniques to treat certain diseases and abnormalities. See RADIOLOGY.

Film x-ray studies, the most common radiologic procedures, are made up of still pictures of the various organs and tissues in the body. In these procedures, x-rays are passed through the body to expose the photographic film that is placed on the opposite side of the body. The changes in film density that result from exposure allow the radiologist to distinguish between normal and abnormal tissue and to diagnose many different disease types. See X-RAYS.

Fluoroscopy is a dynamic x-ray imaging technique that produces a moving image over time. It is essential for evaluating organ movement such as the beating of the heart or movement of the diaphragm. The gastrointestinal series and the barium enema are the most common fluoroscopic studies. These procedures begin with the administration of a barium mixture either by ingestion or by an enema that fills the stomach or large intestine. The barium mixture, known as a contrast medium, like dense tissues, blocks the x-ray beam. Fluoroscopy then reveals the location of the barium-coated lining of the stomach and intestine and enables the radiologist to observe as they contract and distend.

Angiography is the radiologic study of blood vessels. Because arteries and veins are not normally visible in conventional x-ray studies, an iodinated compound, which is opaque to the x-ray, must be injected into the bloodstream. An arteriogram is an x-ray study of the arteries; a venogram is an x-ray study of the veins. Arteriography is most often used to show the presence and extent that arteries have become clogged and narrowed by arteriosclerosis, which can lead to strokes and heart attacks.

Computed tomography (CT), also called computed axial tomography (CAT), is a scanning technique that combines computer and x-ray technologies. The computer constructs a two-dimensional anatomic image that represents a cross-sectional slice through the body. Three-dimensional images can be generated by using special computer software. These are especially useful in planning reconstructive orthopedic or plastic surgery. See COMPUTERIZED TOMOGRAPHY.

Ultrasound imaging, or sonography, is a diagnostic imaging procedure that uses high frequency sound waves instead of ionizing radiation. During an ultrasound examination, a lightweight transducer is placed on the patient's skin over the part to be imaged. The transducer produces sound waves that penetrate the skin to reach tissues and organs. When the sound waves strike specific tissue surface, echoes are produced. The echoes are detected by the transducer and are then electronically converted into an anatomic image that is displayed on a video screen. The image can also be recorded on film or videotape. Ultrasound imaging is commonly used in obstetrics to monitor the position and development of the fetus and also to detect any fetal abnormalities or problems in the pregnancy. Ultrasound is also used to show problems in other internal structures, including the gallbladder, kidney, and heart. Doppler ultrasound can monitor blood flow through veins and arteries. It is commonly used to study kidney transplants and blood flow to the brain and also to diagnose blocked arteries. See MEDICAL ULTRASONIC TOMOGRAPHY.

Magnetic resonance imaging (MRI) is a diagnostic procedure that uses a large, high-strength magnet, radio-frequency signals, and a computer to produce images. The technique of MRI is extremely useful in evaluating diseases of the brain and spine. It is also used to evaluate joints, bone and soft tissue abnormalities, as well as abnormalities of the chest, abdomen, and pelvis. See NUCLEAR MAGNETIC RESONANCE (NMR).

Nuclear medicine imaging studies use radioactive compounds called radionuclides of radiopharmaceuticals that emit gamma rays, or some emit beta particles. The chemicals are formulated so that they collect temporarily in the parts of the body to be studied. For most nuclear imaging studies, the radionuclide is injected into the patient and the images are taken with a gamma camera suspended above the patient who lies on a table. The camera detects the gamma rays emitted from the radionuclide in the patient's body and uses this information to produce an image that shows the distribution of the radionuclide within the body. The image is recorded on film and is called a scintigram or scan. Scintigrams of the heart and bone are the two most common nuclear medicine examinations.

The single-photon emission computed tomography (SPECT) examination uses a computer to obtain two-dimensional images that are thin slices of internal organs such as the heart, brain, and

liver. The SPECT images can display organs with much greater detail than conventional scintigrams.

Positron emission tomography (PET) is a more refined radiologic technique that is used to study the metabolic activity inside an organ. The technique has been shown to be useful in the study of brain-related disorders, such as epilepsy and Alzheimer's disease, and of the vitality of heart tissue.

Interventional radiology combines imaging procedures with various injection and catheter techniques to treat tumors, blockages, bleeding vessels, and other abnormalities without extensive surgery. Among the more common interventional procedures is angioplasty, which is used to treat blocked or narrowed arteries. See RADIOGRAPHY. [M.Lo.; R.DeIF.]

**Medical mycology** The study of fungi (molds and yeasts) that cause human disease. Fungal infections are classified according to the site of infection on the body or whether an opportunistic setting is necessary to establish disease. Fungal infections that occur in an opportunistic setting have become more common due to conditions that compromise host defenses, especially cell-mediated immunity. Such conditions include acquired immunodeficiency syndrome (AIDS), cancer, and immunosuppressive therapy to prevent transplant rejection or to control inflammatory syndromes. Additionally, opportunistic fungal infections have become more significant as severely debilitated individuals live longer because of advances in modern medicine, and nosocomial (hospital-acquired) fungal infections are an increasing problem. Early diagnosis with treatment of the fungal infection and control of the predisposing cause are essential. See OPPORTUNISTIC INFECTIONS.

Antifungal drug therapy is extremely challenging since fungi are eukaryotes, as are their human hosts, leading to problems with toxicity or cross-reactivity with host molecules. Most antifungal drugs target the fungal cell membrane or wall. The "gold standard" for therapy of most severe fungal infections is amphotericin B, which binds to ergosterol, a membrane lipid found in most fungi and some other organisms but not in mammals. Unfortunately, minor cross-reactive binding of amphotericin B to cholesterol in mammalian cell membranes can lead to serious toxicity, especially in the kidney where the drug is concentrated. Recent advances in antifungal therapy include the use of liposomal amphotericin B and newer azoles such as fluconazole and itraconazole, which show reduced toxicity or greater specificity. Conversely, drug resistance in pathogenic fungi is an increasing problem, as it is in bacteria.

Candidiasis is the most common opportunistic fungal infection, and it has also become a major nosocomial infection in hospitalized patients. *Candida albicans* is a dimorphic fungus with a yeast form that is a member of the normal flora of the surface of mucous membranes. In an opportunistic setting, the fungus may proliferate and convert to a hyphal form that invades these tissues, the blood, and other organs. The disease may extend to the blood or other organs from various infected sites in patients who are suffering from a grave underlying disease or who are immunocompromised. Other important opportunistic fungal diseases include aspergillosis, mucormycosis, and cryptococcosis.

Healthy persons can acquire disease from certain pathogenic fungi following inhalation of their fungal spores. The so-called deep or systemic mycoses are all caused by different species of soil molds; most infections are unrecognized and produce no or few symptoms. However, in some individuals infection may spread to all parts of the body from the lung, and treatment with amphotericin B or an antifungal azole drug is essential.

Other fungal infections develop when certain species of soil molds are inoculated deep into the subcutaneous tissue, such as by a deep thorn prick or other trauma. A specific type of lesion develops with each fungus as it grows within the tissue. Proper wound hygiene will prevent these infections.

Ringworm, also known as dermatophytosis or tinea, is the most common of all fungal infections. Some species of pathogenic molds can grow in the stratum corneum, the dead outermost layer of the skin. Disease results from host hypersensitivity to the metabolic products of the infecting mold as well as from the actual fungal invasion. Tinea corporis, ringworm of the body, appears as a lesion on smooth skin and has a red, circular margin that contains vesicles. The lesion heals with central clearing as the margin advances. On thick stratum corneum, such as the interdigital spaces of the feet, the red, itching lesions, known as athlete's foot or tinea pedis, become more serious if secondary bacterial infection develops. The ringworm fungi may also invade the hair shaft (tinea capitis) or the nail (onychomycosis). Many pharmaceutical agents are available to treat or arrest such infections, but control of transmission to others is important. See FUNGAL INFECTIONS; FUNGI; YEAST. [C.Ha.; J.P.W.]

**Medical parasitology** The study of diseases of humans caused by parasitic agents. It is commonly limited to parasitic worms (helminths) and the protozoa. Current usage places the various nonprotozoan microbes in distinct disciplines, such as virology, rickettsiology, and bacteriology.

**Nematodes.** The roundworms form an extremely large yet fairly homogeneous assemblage, most of which are free-living (nonparasitic). Some parasitic nematodes, however, may cause disease in humans (zoonosis), and others cause disease limited to human hosts (anthroponosis). Among the latter, several are enormously abundant and widespread. See NEMATATA.

The giant roundworm (*Ascaris lumbricoides*) parasitizes the small intestine, probably affecting over a billion people; and the whipworm (*Trichuris trichiura*) infects the human colon, probably affecting a half billion people throughout the tropics. Similarly, the hookworms of humans, *Necator americanus* in the Americas and the tropical regions of Africa and Asia, and *Ancylostoma duodenale* in temperate Asia, the Mediterranean, and Middle East, suck blood from the small intestine and cause major debilitation, especially among the undernourished. The human pinworm (*Enterobius vermicularis*) infects the large intestine of millions of urban dwellers. Most intestinal nematodes, which require a period of egg maturation outside the human host before they are infective, are associated with fecal contamination of soil or food crops and are primarily rural in distribution.

The nonintestinal nematodes are spread by complex life cycles that usually involve bloodsucking insects. One exception is the guinea worm (*Dracunculus medinensis*), a skin-infecting 2–3-ft (0.6–1-m) worm transmitted by aquatic microcrustaceans that are ingested in drinking water that has been contaminated by larvae that escape from the skin sores of infected humans. Such bizarre life cycles are typical of many helminths. Other nematodes of humans include (1) the filarial worms, which are transmitted by mosquitoes and may induce enormously enlarged fibrous masses in legs, arms, or genitalia (elephantiasis), and (2) *Onchocerca volvulus*, which is transmitted by blackflies (genus *Simulium*) and forms microscopic embryos (microfilariae) in the eyes causing high incidence of blindness in Africa and parts of central and northern South America.

A more familiar tissue-infecting nematode of temperate regions is *Trichinella spiralis*, the pork or trichina worm, which is the agent of trichinosis. The tiny spiraled larvae encyst in muscle and can carry the infection to humans and other carnivorous mammals who eat raw or undercooked infected meat.

**Trematodes.** Parasites of the class Trematoda vary greatly in size, form, location in the human host, and disease produced, but all go through an initial developmental period in specific kinds of fresh-water snails, where they multiply as highly modified larvae of different types. Ultimately, an infective larval stage (cercaria) escapes in large numbers from the snail and continues the life cycle. Each trematode species follows a highly specific pathway from snail to human host, usually by means of another host or

transport mechanism. These include the intestinal, liver, blood, and lung flukes. See SCHISTOSOMIASIS; TREMATODA.

**Cestodes.** Tapeworms, the other great assemblage of parasitic flatworms, parasitize most vertebrates, with eight or more species found in humans. Their flat ribbonlike body form consists of a chain of hermaphroditic segments. Like the trematodes, their life cycles are complex, although not dependent on a snail host. The enormous beef tapeworm of humans, *Taenia saginata*, is transmitted by infected beef ("measly beef") from cattle that grazed where human feces containing egg-filled tapeworm segments contaminated the soil. Other tapeworms include the pork, dog, and broad (or fish) tapeworms. See CESTODA.

**Protozoa.** Of the many protozoa that can reside in the human gut, only the invasive strain of *Entamoeba histolytica* causes serious disease. This parasite, ingested in water contaminated with human feces containing viable cysts of *E. histolytica*, can cause the disease amebiasis, which in its most severe form is known as amebic dysentery. Another common waterborne intestinal protozoon is the flagellate *Giardia lamblia*, which causes giardiasis, a mild to occasionally serious or long-lasting diarrhea. See GIARDIASIS; PROTOZOA.

Other flagellate parasites infect the human skin, bloodstream, brain, and viscera. The tsetse fly of Africa carries to humans the blood-infecting agents of trypanosomiasis, or African sleeping sickness, *Trypanosoma brucei gambiense* and *T. brucei rhodesiense*. The infection can be fatal if the parasites cross the blood-brain barrier. In Latin America, the flagellate *T. cruzi* is the agent of Chagas' disease, a major cause of debilitation and premature heart disease among those who are poorly housed. The infection is transmitted in the liquid feces of a conenose bug (genus *Triatoma*) and related insects. The infective material is thought to be scratched into the skin or rubbed in the eye, especially by sleeping children. See TRYPANOSOMATIDAE.

Another group of parasitic flagellates includes the macrophage-infecting members of the genus *Leishmania*, which are transmitted by blood-sucking midges or sand flies. Cutaneous leishmaniasis is characterized by masses of infected macrophages in the skin, which induce long-lasting dermal lesions of varying form and severity. The broad spectrum of host-parasite interactions is well exemplified by leishmaniasis. The various manifestations of the disease are the result of the particular species of agent and vector, the immunological status of the host, the presence or absence of reservoir hosts, and the pattern of exposure.

Two remaining major groups of protozoa are the ciliates and the sporozoans. The former group is largely free-living, with only a single species, *Balantidium coli*, parasitic in humans (and pigs). This large protozoon is found in the large intestine, where it can cause balantidiasis, an ulcerative disease. The sporozoans, on the other hand, are all parasitic and include many parasites of humans. The most important are the agents of malaria. Other disease agents are included in the genera *Iso spor a*, *Sarcocystis*, *Cryptosporidium*, and *Toxoplasma*. *Pneumocystis*, a major cause of death among persons with acquired immune deficiency syndrome (AIDS), was formerly considered a protozoon of uncertain relationship, but now it is thought to be a member of the Fungi. See ACQUIRED IMMUNE DEFICIENCY SYNDROME (AIDS); MALARIA; SPOROZOA.

*Toxoplasma gondii*, the agent of toxoplasmosis, infects as many as 20% of the world's population. It can penetrate the placenta and infect the fetus if the mother has not been previously infected and has no antibodies. As with most medically important parasites, the great majority of *Toxoplasma* infections remain undetected and nonpathogenic. The parasite primarily affects individuals lacking immune competence—the very young, the very old, and the immunosuppressed. See MEDICAL BACTERIOLOGY; MEDICAL MYCOLOGY; PARASITOLOGY; ZOONOSES. [D.He.]

**Medical ultrasonic tomography** A mapping or imaging technique, used to obtain clinically useful information about the structure and functioning of tissues and organs, in

which acoustic pulses are emitted from an acoustoelectric transducer, and echoes are received from acoustic impedance discontinuities along the assumed line-of-sight axial propagation path. A number of different modes of operation have emerged, each having areas of usefulness.

The A (amplitude) mode uses acoustic pulse emissions and echo reception along a single line-of-sight axial propagation path, and thus provides a one-dimensional mapping. This mode of operation cannot provide identification of structural features. It is, however, a most accurate method of measuring time delays and, therefore, distances between echo-producing structures or distances of structures from transducers, provided the speed of sound propagation in the medium is known.

The M mode of operation is used to display the movement of time-varying, echo-producing structures by intensity-modulating the trace as it is swept slowly across the oscilloscope screen in a direction at right angles to the fast time-base sweep. This mode of operation is used extensively in diagnosing disorders of the heart. See ECHOCARDIOGRAPHY; HEART DISORDERS.

For a two-dimensional picture to be obtained, the line-of-sight propagation path must be scanned and the position and direction of the path monitored and used to form a two-dimensional picture. Typically, the B-mode display is formed by moving the transducer so that the line-of-sight path remains in a single plane. The time-base trace of the cathode-ray oscilloscope screen is moved to correspond, in position and direction, to the ultrasonic line-of-sight propagation path, and echoes are displayed as intensity modulations of the trace.

The C (constant-range) mode provides a two-dimensional image display at constant time delay, and presumed constant distance, from the ultrasonic transducer. The scanning is arranged so that the point at constant depth along the propagation path (beam axis) traverses a plane. See MEDICAL IMAGING; ULTRASONICS. [FDu.]

**Medical waste** Any solid waste that is generated in the diagnosis, treatment, or immunization of human beings or animals, in research pertaining thereto, or in the production or testing of biologicals. Since the development of disposable medical products in the early 1960s, the issue of medical waste has confronted hospitals and regulators. Previously, reusable products included items such as linen, syringes, and bandages; they were sterilized or disinfected prior to reuse, and the principal waste product was limited to human pathological tissue.

Most hazardous substances are described by their relevant properties, such as corrosive, poison, or flammable. Medical waste was originally defined in terms of its infectious properties, and thus it was called infectious waste. However, given the difficulty of identifying pathogenic organisms in waste that might cause disease, it has become standard practice to define medical waste by types or categories. While definitions differ somewhat under different regulations, in the United States the Centers for Disease Control and Prevention (CDC) cite four categories of infective wastes that should require special handling and treatment: laboratory cultures and stocks, pathology wastes, blood, and items that possess sharp points such as needles and syringes (sharps). These categories require that the generator of these wastes exercise judgment in identifying the material to be included.

The waste category that has generated a great deal of interest is sharps. Needles and syringes, in particular, pose risks, since the instruments can penetrate into the body, increasing the potential for disease transmission. Improper disposal of these items in the past has been the catalyst for increased regulation and tighter management control.

Treatment of medical waste constitutes a method for rendering it noninfectious prior to disposal in a landfill or other solid-waste site. The treatment technologies currently used for medical waste include incineration, sterilization, chemical disinfection, and microwave, as well as others under development. See HAZARDOUS WASTE. [R.A.Sp.]

**Medicine** The field of science devoted to healing. Many subdivisions exist and more ramifications appear almost daily. Included in the area of medicine are the clinical specialties of surgery, pediatrics, psychiatry, obstetrics, and others. Internal medicine is the specialization which deals with internal diseases of a nonsurgical nature.

Related to the clinical specialties, particularly in regard to medical education and research, are the basic medical sciences. These include, among others, anatomy, physiology, psychology, pharmacology, biochemistry, and microbiology. Midway between the basic and the clinical sciences lies pathology, the study of the structural and functional alterations caused by diseases or abnormal states.

An important area in all specialties is preventive medicine and public health. This form of medicine supplies a necessary link with the community, state, or large geographic region in matters of prevention, mass treatment, and statistical appraisals of health matters. It is also concerned with socioeconomic factors related to physical and mental well-being. See PUBLIC HEALTH.

Socialized medicine is that form which exists under the direct control and financing of the state. The National Health Service of Great Britain is the best-known example, and other systems exist.

Other subdivisions of medicine, with names that are largely self-explanatory, include veterinary, legal, tropical, and military medicine. See FORENSIC MEDICINE.

Although medicine is based primarily upon scientific information and method, an important feature is the relationship between the physician and the patient. It is at this point that the necessary scientific background of medicine gives way to the art of healing. See SURGERY. [E.G.St./N.K.M.]

**Mediterranean Sea** The Mediterranean Sea lies between Europe, Asia Minor, and Africa. It is completely landlocked except for the Strait of Gibraltar, the Bosphorus, and the Suez Canal. The Mediterranean is conveniently divided into an eastern basin and a western basin, which are joined by the Strait of Sicily and the Strait of Messina.

The total water area of the Mediterranean is 965,900 mi<sup>2</sup> (2,501,000 km<sup>2</sup>), and its average depth is 5040 ft (1536 m). The greatest depth in the western basin is 12,200 ft (3719 m), in the Tyrrhenian Sea. The eastern basin is deeper, with a greatest depth of 18,140 ft (5530 m) in the Ionian Sea about 34 mi (55 km) off the Greek mainland. The Atlantic tide disappears in the Strait of Gibraltar. The tides of the Mediterranean are predominantly semidiurnal. [J.Ly.]

**Meiosis** The set of two successive cell divisions that serve to separate homologous chromosome pairs prior to the formation of gametes (sperm and eggs). The major purpose of meiosis is the precise reduction in the number of chromosomes by one-half, so that a diploid cell can create haploid gametes. Meiosis is therefore a critical component of sexual reproduction. See GAMETOGENESIS.

The basic events of meiosis are actually quite simple. As the cell begins meiosis, each chromosome has already duplicated its deoxyribonucleic acid (DNA) and carries two identical copies of the DNA molecule. These are visible as two lateral parts, called sister chromatids, which are connected by a centromere. Homologous pairs of chromosomes are first identified and matched. This process, which occurs only in the first of the two meiotic divisions, is called pairing. The matched pairs are then physically interlocked by recombination, which is also known as exchange or crossing-over. After recombination, the homologous chromosomes separate from each other, and at the first meiotic division are partitioned into different nuclei. As a consequence, the second meiotic division begins with half of the original number of chromosomes. During this second meiotic division, the sister chromatids of each chromosome separate and migrate to different daughter cells. See CHROMOSOME.

The patterns by which genes are inherited are determined by the movement of the chromosomes during the two meiotic divisions. It is a fundamental tenet of Mendelian inheritance that each individual carries two copies of each gene, one derived from its father and one derived from its mother. Moreover, each of that individual's gametes will carry only one copy of that gene, which is chosen at random. The process by which the two copies of a given gene are distributed into separate gametes is referred to as segregation. Thus, if an individual is heterozygous at the A gene for two different alleles, A and a, his or her gametes will be equally likely to carry the A allele or the a allele, but never both or neither. The fact that homologous chromosomes, and thus homologous genes, segregate to opposite poles at the first meiotic division explains this principle of inheritance. See CELL CYCLE.

**Meiotic divisions.** The two meiotic divisions may be divided into a number of distinct stages. Meiotic prophase refers to the period after the last cycle of DNA replication, during which time homologous chromosomes pair and recombine. The end of prophase is signaled by the breakdown of the nuclear envelope, and the association of the paired chromosomes with the meiotic spindle. The spindle is made up of microtubules that, with associated motor proteins, mediate chromosome movement. In some cases (such as human sperm formation), the spindle is already formed at the point of nuclear envelope breakdown, and the chromosomes then attach to it. In other systems (such as human female meiosis), the chromosomes themselves organize the spindle.

Metaphase I is the period before the first division during which pairs of interlocked homologous chromosomes, called bivalents, line up on the middle of the meiotic spindle. The chromosomes are primarily (but not exclusively) attached to the spindle by their centromeres such that the centromere of one homolog is attached to spindle fibers emanating from one pole, and the centromere of its partner is attached to spindle fibers from the other pole (see illustration). The bivalents are physically held together by structures referred to as chiasmata that are the result of meiotic recombination events. In most meiotic systems, meiosis will not continue until all of the homolog pairs are properly oriented at the middle of the spindle, the metaphase plate. The orientation of each pair of homologs on the spindle occurs in a random fashion, such that the paternally derived homolog of one bivalent may point toward one pole of the spindle, while in the adjacent bivalent the maternally derived homolog is oriented toward the same pole.

Anaphase I refers to the point at which homologous chromosome pairs separate and move to opposite poles. Depending on the organism, there may or may not be a true telophase, or a time in which nuclei reform. In most organisms, the first cell division occurs after the completion of anaphase I.

Following the completion of the first meiotic division, the chromosomes recondense and align themselves on a new pair of spindles, with their sister chromatids oriented toward opposite poles. The stage at which each chromosome is so aligned is referred to as metaphase II. In some, but not all, organisms, metaphase II is preceded by a brief prophase II. DNA replication does not occur during prophase II; each chromosome still consists of the two sister chromatids. Nor are there opportunities for pairing or recombination at this stage due to the prior separation of homologs at anaphase I.

The start of anaphase II is signaled by the separation of sister centromeres, and the movement of the two sister chromatids to opposite poles. At telophase II, the sisters have reached opposite poles and the nuclei begin to reform. The second cell division usually occurs at this time. Thus, at the end of the second meiotic division, there will be four daughter cells, each with a single copy of each chromosome.

**Details of meiotic prophase.** Because pairing and recombination occur during the first meiotic prophase, much attention has been focused on this stage of the process. The prophase of the first meiotic division is subdivided into five stages: leptotene,

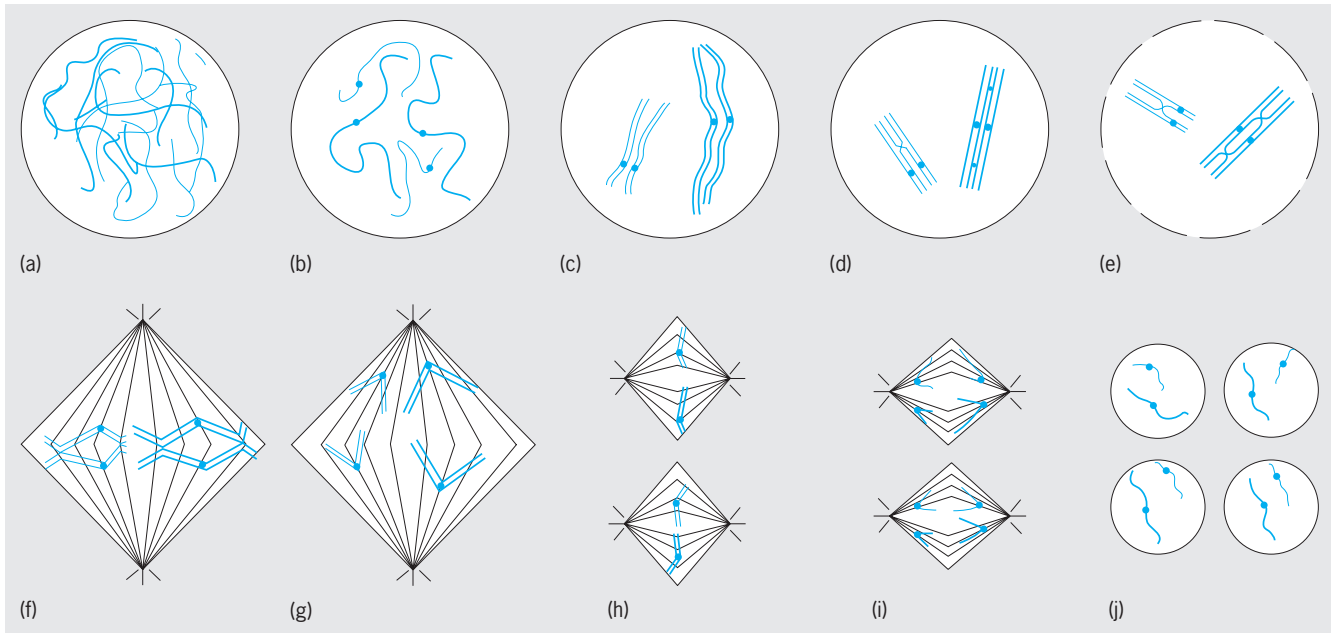

**Stages of meiosis. (a) Pre-meiotic interphase. (b) Leptotene. (c) Zygotene. (d) Pachytene. (e) Diplotene/ diakinesis. (f) Metaphase I. (g) Anaphase I. (h) Metaphase II. (i) Anaphase II. (j) Telophase II.**

zygotene, pachytene, diplotene, and diakinesis (see illustration). Homolog recognition, alignment, and synapsis occur during leptotene and zygotene. In the leptotene, initial homolog alignments are made. By zygotene, homologous chromosomes have become associated at various points along their length. These associations facilitate a more intimate pairing that results in the homologous chromosomes lying abreast of a tracklike structure called the synaptonemal complex. The beginning of pachytene is signaled by the completion of a continuous synaptonemal complex running the full length of each bivalent. During diplotene, the attractive forces that mediated homologous pairing disappear, and the homologs begin to repel each other. However, homologs virtually always recombine, and those recombination events can be seen as chiasmata that tether the homologs together. The final stage in meiotic prophase is diakinesis, during which the homologs shorten and condense in preparation for nuclear division.

**Recombination.** Meiotic recombination involves the physical interchange of DNA molecules between the two homologous chromosomes, thus allowing the creation of new combinations of alleles for genes located on that pair of chromosomes. Recombination involves the precise breakage and rejoining of two nonsister chromatids. The result is the formation of two recombinant chromatids, each of which carries information from both of the original homologs. The number and position of recombination events is very precisely controlled. Exchange occurs only in the gene-rich euchromatin that makes up most of the chromosome arms, never in the heterochromatin that surrounds the centromeres. Moreover, as a result of a process known as interference, the occurrence of one exchange in a given chromosomal region greatly decreases the probability of a second exchange in that region. See RECOMBINATION (GENETICS).

**Errors of meiosis.** The failure of two chromosomes to segregate properly is called nondisjunction. Nondisjunction occurs either because two homologs failed to pair and/or recombine or because of a failure of the cell to properly move the segregating chromosomes on the meiotic spindle. The result of nondisjunction is the production of gametes that are aneuploid, carrying the wrong number of chromosomes. When such a gamete is involved in a fertilization event, the resulting zygote is also ane-

uploid. Those cases where the embryo carries an extra copy of a given chromosome are said to be trisomic, while those that carry but one copy are said to be monosomic for that chromosome. Most aneuploid zygotes are not viable and result in early spontaneous abortion. There are no viable monosomies for the human autosomes; however, a few types of trisomic zygotes are capable of survival. These are trisomies for the sex chromosomes (XXX, XXY, XYY), trisomy 21 (Down syndrome), trisomy 18, and trisomy 13. See CROSSING-OVER (GENETICS).

**Meiosis versus mitosis.** The fundamental difference between meiosis and mitosis is that at the first meiotic division, sister chromatids do not separate; rather, homologous chromosomes separate from each other with their sister chromatids still attached to each other. Recombination is frequent in most meiotic cells; however, it occurs only rarely in mitotic cells, usually as part of DNA repair events. Most critically, DNA synthesis occurs only once within the two meiotic divisions, while there is a complete replication before every mitotic division. This allows mitosis to produce two genetically identical daughter cells, while meiosis produces four daughter cells, each of which have only one-half the number of chromosomes present prior to meiosis. See CELL DIVISION; GENE; MITOSIS. [M.Y.W.; R.S.H.]

**Meissner effect** The expulsion of magnetic flux from the interior of a superconducting metal when it is cooled in a magnetic field to below the critical temperature, near absolute zero, at which the transition to superconductivity takes place. It was discovered by Walther Meissner in 1933, when he measured the magnetic field surrounding two adjacent long cylindrical single crystals of tin and observed that at  $-452.97^{\circ}\text{F}$  ( $3.72\text{ K}$ ) the Earth's magnetic field was expelled from their interior. This indicated that at the onset of superconductivity they became perfect diamagnets. This discovery showed that the transition to superconductivity is reversible, and that the laws of thermodynamics apply to it. The Meissner effect forms one of the cornerstones in the understanding of superconductivity, and its discovery led F. London and H. London to develop their phenomenological electrodynamics of superconductivity. See DIAMAGNETISM; THERMODYNAMIC PRINCIPLES.



The magnetic field is actually not completely expelled, but penetrates a very thin surface layer where currents flow, screening the interior from the magnetic field.

The Meissner effect is subject to limitations. Full diamagnetism is not observed in polycrystalline samples, and the effect is not observed in impure samples or samples with certain geometries, such as a round flat disk, with the magnetic field parallel to the axis of rotation. See SUPERCONDUCTIVITY. [H.W.M.]

**Meitnerium** The seventeenth of the synthetic transuranium elements. Element 109 falls in column 9 of the periodic table under the elements cobalt, rhodium, and iridium. It is expected to have chemical properties similar to those of iridium. See IRIDIUM; PERIODIC TABLE; TRANSURANIUM ELEMENTS.

Element 109 was discovered in 1982 by a team under P. Armbruster and G. Münzenberg at the Gesellschaft für Schwerionenforschung (GSI) at Darmstadt, Germany. In a sequence of bombardments of bismuth-209 targets with beams of ions of titanium-50, chromium-54, and iron-58, the compound systems  $^{259}105$ ,  $^{263}107$ , and  $^{267}109$  were produced. The decay analysis of the isotopes produced showed in the case of elements 105 and 107 the production of  $^{258}105$  and  $^{262}107$  by reaction channels in which one neutron is emitted. These isotopes have odd neutron and proton numbers and possess a special stability against spontaneous fission. It was shown that alpha-particle decay dominated the decay chains. Spontaneous fission occurs through a 30% electron capture branch of  $^{256}105$  in  $^{258}104$ . Three decay chains were observed for the three reactions ending by fission of  $^{258}104$ , and the decay of the first atom of element 109 was observed. See ALPHA PARTICLES; DUBNIUM; NUCLEAR FISSION; NUCLEAR REACTION; RADIOACTIVITY; RUTHERFORDIUM.

The single atom of element 109 was produced at a bombarding energy of 299 MeV in the reaction between iron-58 and bismuth-209. A total dose of  $7 \times 10^{17}$  ions was used to bombard thin layers of bismuth during a 250-h irradiation time. [P.Ar.]

**Melanterite** A mineral having composition  $\text{FeSO}_4 \cdot 7\text{H}_2\text{O}$ . Melanterite occurs mainly in green, fibrous or concretionary masses, or in short, monoclinic, prismatic crystals. Luster is vitreous, hardness is 2 on Mohs scale, and specific gravity is 1.90.

Melanterite is a common secondary mineral derived from oxidation and hydration of iron sulfide minerals such as pyrite and marcasite. Its occurrence is widespread. It is not an ore mineral. See MARCASITE. [E.C.T.C.]

**Melilite** A complete solid solution series ranging from gehlenite,  $\text{Ca}_2\text{Al}_2\text{SiO}_7$ , to akermanite,  $\text{Ca}_2\text{MgSi}_2\text{O}_7$ , often containing appreciable Na and Fe. The Mohs hardness is 5–6, and the density increases progressively from 2.94 for akermanite to 3.05 for gehlenite. The luster is vitreous to resinous, and the color is white, yellow, greenish, reddish, or brown. Akermanite-rich varieties occur in thermally metamorphosed siliceous limestones and dolomites, but more gehlenite-rich ones result if Al is present. Melilites are found instead of plagioclase in silica-deficient, feldspathoid-bearing basalts. See SILICATE MINERALS. [L.Gr.]

**Melting point** The temperature at which a solid changes to a liquid. For pure substances, the melting or fusion process occurs at a single temperature, the temperature rise with addition of heat being arrested until melting is complete.

Melting points reported in the literature, unless specifically stated otherwise, have been measured under an applied pressure of 1 atm ( $10^5$  pascals), usually 1 atm of air. (The solubility of air in the liquid is a complicating factor in precision measurements.) Upon melting, all substances absorb heat, and most substances expand; consequently an increase in pressure normally raises the melting point. A few substances, of which water is the most notable example, contract upon melting; thus, the application of pressure to ice at  $32^\circ\text{F}$  ( $0^\circ\text{C}$ ) causes it to melt. Large changes in

pressure are required to produce significant shifts in the melting point.

For solutions of two or more components, the melting process normally occurs over a range of temperatures, and a distinction is made between the melting point, the temperature at which the first trace of liquid appears, and the freezing point, the higher temperature at which the last trace of solid disappears, or equivalently, if one is cooling rather than heating, the temperature at which the first trace of solid appears. See PHASE EQUILIBRIUM; SOLUTION; SUBLIMATION; TRIPLE POINT. [R.L.S.]

**Membrane distillation** A separation method in which a nonwetting, microporous membrane is used with a liquid feed phase on one side of the membrane and a condensing, permeate phase on the other side. Separation by membrane distillation is based on the relative volatility of various components in the feed solution. The driving force for transport is the partial pressure difference across the membrane. Separation occurs when vapor from components of higher volatility passes through the membrane pores by a convective or diffusive mechanism. See CONVECTION (HEAT).

Membrane distillation shares some characteristics with another membrane-based separation known as pervaporation, but there also are some vital differences. Both methods involve direct contact of the membrane with a liquid feed and evaporation of the permeating components. However, while membrane distillation uses porous membranes, pervaporation uses nonporous membranes.

Membrane distillation systems can be classified broadly into two categories: direct-contact distillation and gas-gap distillation. These terms refer to the permeate or condensing side of the membrane; in both cases the feed is in direct contact with the membrane. In direct-contact membrane distillation, both sides of the membrane contact a liquid phase; the liquid on the permeate side is used as the condensing medium for the vapors leaving the hot feed solution. In gas-gap membrane distillation, the condensed permeate is not in direct contact with the membrane.

Potential advantages of membrane distillation over traditional evaporation processes include operation at ambient pressures and lower temperatures as well as ease of process scale-up. See CHEMICAL SEPARATION TECHNIQUES; MEMBRANE SEPARATIONS. [S.S.K.; N.N.L.]

**Membrane mimetic chemistry** The study of processes and reactions whose developments have been inspired by the biological membrane. Faithful modeling of the biomembrane is not an objective of membrane mimetic chemistry. Rather, only the essential components of natural systems are recreated from relatively simple, synthesized molecules. (The term membrane mimetic is more restrictive than the term biomimetic. Biomimetic chemistry is directed at the mechanistic elucidation of biochemical reactions and at the development of new compounds modeled on specific biological systems.) See CELL MEMBRANES.

Various surfactant aggregate systems have been used in membrane mimetics.

Surfactants (detergents) contain distinct hydrophobic (apolar) and hydrophilic (polar) regions. Depending on the chemical structure of their hydrophilic polar head groups, surfactants can be neutral, positively charged, or negatively charged. See DETERGENT.

Aqueous micelles are spherical aggregates, 4–8 nanometers in diameter, formed dynamically from surfactants in water above a characteristic concentration, the critical micelle concentration. See MICELLE.

Monomolecular layers are formed by spreading naturally occurring lipids or synthetic surfactants, dissolved in volatile solvents, over water in a trough. The polar head groups of the surfactants are in contact with water, the subphase, while their hydrocarbon tails protrude above it. See MONOMOLECULAR FILM.

Other systems used in membrane mimetics are multilayer assemblies (Langmuir-Blodgett films), bilayer lipid membranes, and vesicles prepared by sonication from naturally occurring lipids. See SONOCHEMISTRY.

Membrane mimetic chemistry has become a versatile chemical tool. Applications of compartmentalization of reactants in membrane mimetic systems involve altered reaction rates, products, stereochemistries, and isotope distributions. Monolayers and organized multilayers can be employed profitably as molecular electronic devices. Opportunities also exist for using different surfactant aggregates with polymeric membranes for the control and regulation of reverse osmosis and ultrafiltration. See SURFACTANT; ULTRAFILTRATION. [J.H.Fe.]

**Membrane separations** Processes for separating mixtures by using thin barriers (membranes) between two miscible fluids. A suitable driving force across the membrane, for example concentration or pressure differential, leads to the preferential transport of one or more feed components.

Membrane separation processes are classified under different categories depending on the materials to be separated and the driving force applied: (1) In ultrafiltration, liquids and low-molecular-weight dissolved species pass through porous membranes while colloidal particles and macromolecules are rejected. The driving force is a pressure difference. (2) In dialysis, low-molecular-weight solutes and ions pass through while colloidal particles and solutes with molecular weights greater than 1000 are rejected under the conditions of a concentration difference across the membrane. (3) In electro dialysis, ions pass through the membrane in preference to all other species, due to a voltage difference. (4) In reverse osmosis, virtually all dissolved and suspended materials are rejected and the permeate is a liquid, typically water. (5) For gas and liquid separations, unequal rates of transport can be obtained through nonporous membranes by means of a solution and diffusion mechanism. Pervaporation is a special case of this separation where the feed is in the liquid phase while the permeate, typically drawn under subatmospheric conditions, is in the vapor phase. (6) In facilitated transport, separation is achieved by reversible chemical reaction in the membrane. High selectivity and permeation rate may be obtained because of the reaction scheme. Liquid membranes are used for this type of separation. See DIALYSIS; ION-SELECTIVE MEMBRANES AND ELECTRODES; OSMOSIS; TRANSPORT PROCESSES; ULTRAFILTRATION. [N.N.L.; S.S.K.]

**Memory** The ability to store and access information that has been acquired through experience. Memory is a critical component of practically all aspects of human thinking, including perception, learning, language, and problem solving. See PERCEPTION; PROBLEM SOLVING (PSYCHOLOGY).

**Stages.** The information-processing approach divides memory into three general stages: sensory memory, short-term memory, and long-term memory. Sensory memory refers to the sensations that briefly continue after something has been perceived. Short-term memory includes all of the information that is currently being processed in a person's mind, and is generally thought to have a very limited capacity. Long-term memory is where all the information that may be used at a later time is kept.

A number of interesting facts are known about sensory memory, including the following: (1) sensory memories appear to be associated with mechanisms in the central nervous system rather than at the sensory receptor level, and (2) the amount of attention that a person pays to a stimulus can affect the duration of the sensory memory. Although all of the functions of sensory memory are not understood, one of its most important purposes is to provide people with additional time to determine what should be transferred to the next stage in the memory system, that is, short-term memory.

Information obtained from either sensory memory or long-term memory is processed in short-term memory in order for a

person to achieve current goals. In some situations, short-term memory processing simply involves the temporary maintenance of a piece of information, such as remembering a phone number long enough to dial it. Other times, short-term memory can involve elaborate manipulations of information in order to generate new forms. For example, when someone reads  $27 + 15$ , the person manipulates the symbols in short-term memory in order to come up with the solution. One useful manipulation that can be done in short-term memory is to reorganize items into meaningful chunks. For example, it is a difficult task to keep the letters S K C A U Q K C U D E H T in mind all at once. However, if they are rearranged in short-term memory, in this case reversing them, they can be reduced to a single simple chunk: THE DUCK QUACKS. Short-term memory can accommodate only five to seven chunks at any one time. However, the amount of information contained in each chunk is constrained only by one's practice and ingenuity. In order to increase the amount of information that can be kept in short-term memory at one time, people need to develop specific strategies for organizing that information into meaningful chunks. In addition, many studies have also demonstrated that the transfer of information from short-term to long-term memory is much greater when the information is manipulated rather than simply maintained.

One can keep massive amounts of information in long-term memory. In general, recall from long-term memory simply involves figuring out the heading under which a memory has been filed. Many tricks for effective retrieval of long-term memories involve associating the memory with another more familiar memory that can serve as an identification tag. This trick of using associations to facilitate remembering is called mnemonics. Long-term memory stores related concepts and incidents in close range of one another. This logical association of memories is indicated by subjects' reaction times for identifying various memories. Generally, people are faster at recalling memories if they have recently recalled a related memory. One good way to locate a long-term memory is to remember the general situation under which it was stored. Accordingly, techniques that reinstate the context of a memory tend to facilitate remembering.

Sometimes information may not have been filed in long-term memory in the first place, or if it has, is inaccessible. In these situations, the long-term memory system often fills in the gaps by using various constructive processes. One common component to memory constructions is a person's expectations. Countless studies have also indicated that memories tend to systematically change in the direction of a prior expectation or inference about what is likely to have occurred.

**Physiology.** A number of physiological mechanisms appear to be involved in the formation of memories, and the mechanisms may differ for short-term and long-term memory. There is both direct and indirect evidence suggesting that short-term memory involves the temporary circulation of electrical impulses around complex loops of interconnected neurons. A number of indirect lines of research indicate that short-term memories are eradicated by any event that either suppresses neural activity (for example, a blow to the head or heavy anesthesia) or causes neurons to fire incoherently (for example, electroconvulsive shock). More direct support for the electric circuit model of short-term memory comes from observing electrical brain activity. By implanting electrodes in the brain of experimental animals, researchers have observed that changes in what an animal is watching are associated with different patterns of circulating electrical activity in the brain. These results suggest that different short-term memories may be represented by different electrical patterns. However, the nature of these patterns is not well understood. See ELECTROENCEPHALOGRAPHY.

Long-term memories appear to involve some type of permanent structural or chemical change in the composition of the brain. This conclusion is derived both from general observations of the imperviousness of long-term memories and from physiological studies indicating specific changes in brain com-

position. Even in acute cases of amnesia where massive deficits in long-term memory are reported, often, with time, all long-term memories return. Similarly, although electroconvulsive therapy is known to eliminate recent short-term memories, it has practically no effect on memories for events occurring more than an hour prior to shocking. Thus the transfer from a fragile short-term memory to a relatively solid long-term memory occurs within an hour. This process is sometimes called consolidation. See ELETROCONVULSIVE THERAPY.

The nature of the "solid" changes associated with long-term memories appears to involve alterations in both the structural (neural connections) and chemical composition of the brain. One study compared the brains of rats that had lived either in enriched environments with lots of toys or in impoverished environments with only an empty cage. The cerebral cortices of the brains of the rats from the enriched environment were thicker, heavier, endowed with more blood vessels, and contained significantly greater amounts of certain brain chemicals (such as the neurotransmitter acetylcholine). Other researchers have observed that brief, high-frequency stimulation of a neuron can produce long-lasting changes in the neuron's communications across synapses.

Researchers believe that different brain structures may be involved in the formation and storage of long-term memories. The hippocampus, thalamus, and amygdala are believed to be critical in the formation of long-term memories. Individuals who have had damage to these structures are able to recall memories prior to the damage, indicating that long-term memory storage is intact; however, they are unable to form new long-term memories, indicating that the long-term memory formation process has been disrupted. It is not known where long-term memories are stored, but they may be localized in the same areas of the brain that participated in the actual learning. See BRAIN. [J.Sc.; E.F.Lo.]

**Mendelevium** A chemical element, Md, atomic number 101, the twelfth member of the actinide series of elements. Mendelevium does not occur in nature; it was discovered and is prepared by artificial nuclear transmutation of a lighter element. Known isotopes of mendelevium have mass numbers from 248 to 258 and half-lives from a few seconds to about 55 days. They are all produced by charged-particle bombardments of more abundant isotopes. The amounts of mendelevium which are produced and used for studies of chemical and nuclear properties are usually less than about a million atoms; this is of the order of a million times less than a weighable amount. Studies of the chemical properties of mendelevium have been limited to a tracer scale. The behavior of mendelevium in ion-exchange chromatography shows that it exists in aqueous solution primarily in the 3+ oxidation state characteristic of the actinide elements. However, it also has a dipositive (2+) and a monopositive (1+) oxidation state. See ACTINIDE ELEMENTS; PERIODIC TABLE; TRANSURANIUM ELEMENTS. [G.T.S.]

**Mendelism** Fundamental principles governing the transmission of genetic traits, discovered by an Augustinian monk Gregor Mendel in 1856. Mendel performed his first set of hybridization experiments with pea plants. Although the pea plant is normally self-fertilizing, it can be easily crossbred, and grows to maturity in a single season. True breeding strains, each with distinct characteristics, were available from local seed merchants. For his experiments, Mendel chose seven sets of contrasting characters or traits. For stem height, the true breeding strains tall (7 ft or 2.1 m) and dwarf (18 in. or 45 cm) were used. He also selected six other sets of traits, involving the shape and color of seeds, pod shape and color, and the location of flowers on the plant stem.

The most simple crosses performed by Mendel involved only one pair of traits; each such experiment is known as a monohybrid cross. The plants used as parents in these crosses are known as the P<sub>1</sub> (first parental) generation. When tall and dwarf

plants were crossed, the resulting offspring (called the F<sub>1</sub> or first filial generation) were all tall. When members of the F<sub>1</sub> generation were self-crossed, 787 of the resulting 1064 F<sub>2</sub> (second filial generation) plants were tall and 277 were dwarf. The tall trait is expressed in both the F<sub>1</sub> and F<sub>2</sub> generations, while the dwarf trait disappears in the F<sub>1</sub> and reappears in the F<sub>2</sub> generation. The trait expressed in the F<sub>1</sub> generation Mendel called the dominant trait, while the recessive trait is unexpressed in the F<sub>1</sub> but reappears in the F<sub>2</sub>. In the F<sub>2</sub>, about three-fourths of the offspring are tall and one-fourth are dwarf (a 3:1 ratio). Mendel made similar crosses with plants exhibiting each of the other pairs of traits, and in each case all of the F<sub>1</sub> offspring showed only one of the parental traits and, in the F<sub>2</sub>, three-fourths of the plants showed the dominant trait and one-fourth exhibited the recessive trait. In subsequent experiments, Mendel found that the F<sub>2</sub> recessive plants bred true, while among the dominant plants one-third bred true and two-thirds behaved like the F<sub>1</sub> plants. See DOMINANCE.

**Law of segregation.** To explain the results of his monohybrid crosses, Mendel derived several postulates. First, he proposed that each of the traits is controlled by a factor (now called a gene). Since the F<sub>1</sub> tall plants produce both tall and dwarf offspring, they must contain a factor for each, and thus he proposed that each plant contains a pair of factors for each trait. Second, the trait which is expressed in the F<sub>1</sub> generation is controlled by a dominant factor, while the unexpressed trait is controlled by a recessive factor. To prevent the number of factors from being doubled in each generation, Mendel postulated that factors must separate or segregate from each other during gamete formation. Therefore, the F<sub>1</sub> plants can produce two types of gametes, one type containing a factor for tall plants, the other a factor for dwarf plants. At fertilization, the random combination of these gametes can explain the types and ratios of offspring in the F<sub>2</sub> generation (see illustration). See FERTILIZATION; GENE.

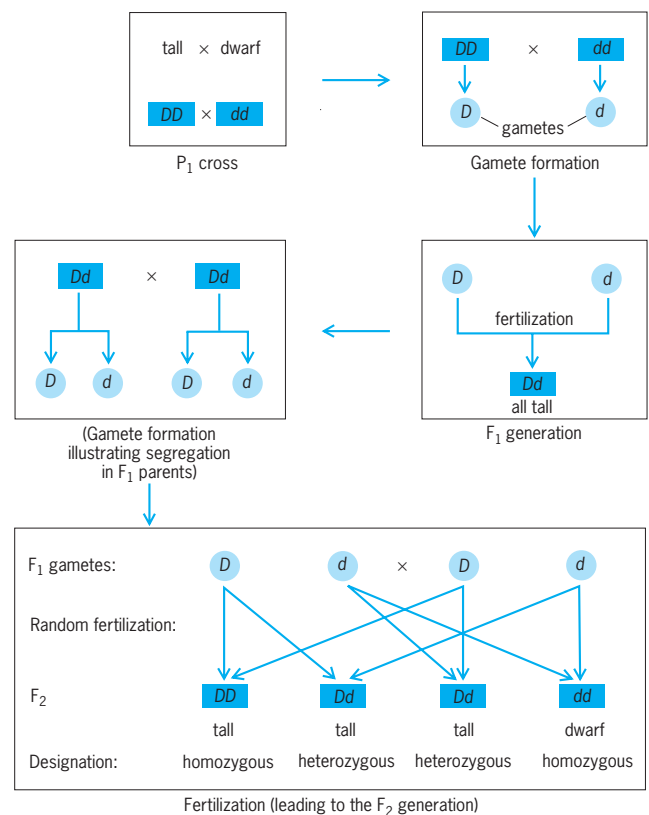

**Schematic representation of a monohybrid cross. Pure-bred tall and dwarf strains are crossed, and yield typical 3:1 ratio in the F<sub>2</sub> generation. D and d represent the tall and dwarf factors (genes), respectively. (After W. S. Klug and M. R. Cummings, *Concepts of Genetics*, Charles E. Merrill, 1983)**

**Independent assortment.** Mendel extended his experiments to examine the inheritance of two characters simultaneously. Such a cross, involving two pairs of contrasting traits, is known as a dihybrid cross. For example, Mendel crossed plants with tall stems and round seeds with plants having dwarf stems and wrinkled seeds. The  $F_1$  offspring were all tall and had round seeds. When the  $F_1$  individuals were self-crossed, four types of offspring were produced in the following proportions: 9/16 were tall, round; 3/16 were tall, wrinkled; 3/16 were dwarf, round; and 1/16 were dwarf, wrinkled. On the basis of similar results in other dihybrid crosses, Mendel proposed that during gamete formation, segregating pairs of factors assort independently of one another. As a result of segregation, each gamete receives one member of every pair of factors [this assumes that the factors (genes) are located on different chromosomes]. As a result of independent assortment, all possible combinations of gametes will be found in equal frequency. In other words, during gamete formation, round and wrinkled factors segregate into gametes independently of whether they also contain tall or dwarf factors. See GAMETOGENESIS; MEIOSIS.

It might be useful to consider the dihybrid cross as two simultaneous and independent monohybrid crosses. In this case, the predicted  $F_2$  results are 3/4 tall, 1/4 dwarf, and 3/4 round, 1/4 wrinkled. Since the two sets of traits are inherited independently, the number and frequency of phenotypes can be predicted by combining the two events:

$$\begin{array}{l} 3/4 \text{ tall} \left\{ \begin{array}{l} 3/4 \text{ round} \quad (3/4)(3/4) = 9/16 \text{ tall, round} \\ 1/4 \text{ wrinkled} \quad (3/4)(1/4) = 3/16 \text{ tall, wrinkled} \end{array} \right. \\ 1/4 \text{ dwarf} \left\{ \begin{array}{l} 3/4 \text{ round} \quad (1/4)(3/4) = 3/16 \text{ dwarf, round} \\ 1/4 \text{ wrinkled} \quad (1/4)(1/4) = 1/16 \text{ dwarf, wrinkled} \end{array} \right. \end{array}$$

This 9:3:3:1 ratio is known as a dihybrid ratio and is the result of segregation, independent assortment, and random fertilization. See GENETICS. [M.R.C.]

**Meninges** In mammals, the three membranes that cover the brain and spinal cord: the dura mater, the arachnoid membrane, and the pia mater. The outermost, the dura mater, is a tough, fibrous, double-layered structure that is adherent to the skull. The inner layer of the dura mater sends separating sheets between the cerebral hemispheres and between the cerebrum and cerebellum. It also contains large venous sinuses and forms sheaths for nerves leaving the skull. The middle layer, the arachnoid, is a delicate serous layer loosely investing the brain. Below this is the spongy subarachnoid cavity which contains the circulating cerebrospinal fluid. The innermost layer, the pia mater, is a vascular layer which closely follows each convolution of the brain. Together the meninges furnish protection, blood supply, drainage, and cerebrospinal channels for the brain. See NERVOUS SYSTEM (VERTEBRATE). [T.S.P.]

**Meningitis** Inflammation of the meninges. Certain types of meningitis are associated with distinctive abnormalities in the cerebrospinal fluid. With certain types of meningitis, especially bacterial, the causative organism can usually be recovered from the fluid. See MENINGES.

Meningeal inflammation in most cases is caused by invasion of the cerebrospinal fluid by an infectious organism. Noninfectious causes also occur. For example, in immune-mediated disorders antigen-antibody reactions can cause meningeal inflammation. Other noninfectious causes of meningitis are the introduction into the cerebrospinal fluid of foreign substances such as alcohol, detergents, chemotherapeutic agents, or contrast agents used in some radiologic imaging procedures. Meningeal inflammation brought about by such foreign irritants is called chemical meningitis. Inflammation also can occur when cholesterol-containing

fluid or lipid-laden material leaks into the cerebrospinal fluid from some intracranial tumors.

Bacterial meningitis is among the most feared of human infectious diseases because of its possible seriousness, its rapid progression, its potential for causing severe brain damage, and its frequency of occurrence. Most cases of bacterial meningitis have an acute onset. Common clinical manifestations are fever, headache, vomiting, stiffness of the neck, confusion, lethargy, and coma. Symptoms of brain dysfunction are caused by transmission of toxic materials from the infected cerebrospinal fluid into brain tissue and the disruption of arterial perfusion and venous drainage from the brain because of blood vessel inflammation. These factors also provoke cerebral swelling, which increases intracranial pressure. Before antibiotics became available, bacterial meningitis was almost invariably fatal. See ANTIBIOTIC.

Most types of acute bacterial meningitis are septic-borne in that they originate when bacteria in the bloodstream (bacteremia, septicemia) gain entrance into the cerebrospinal fluid. Meningitis arising by this route is called primary bacterial meningitis. Secondary meningitis is that which develops following direct entry of bacteria into the central nervous system, which can occur at the time of neurosurgery, in association with trauma, or through an abnormal communication between the external environment and the cerebrospinal fluid.

Many viruses can cause meningeal inflammation, a condition referred to as viral aseptic meningitis. The most common viral causes include the enteroviruses, the various herpesviruses, viruses transmitted by arthropods, the human immunodeficiency virus type I (HIV-1), and formerly, the mumps virus. If the virus attacks mainly the brain rather than the spinal cord, the disorder is termed viral encephalitis. See ANIMAL VIRUS; ARBOVIRAL ENCEPHALITIDES; ENTEROVIRUS; HERPES.

Fungal, parasitic, and rickettsial meningitis are less common in the United States than are bacterial and viral. These infections are more likely to be subacute or chronic than those caused by bacteria or viruses; in most cases, the meningeal inflammation is associated with brain involvement. An acute form of aseptic meningitis can occur in the spirochetal diseases, syphilis and Lyme disease. See LYME DISEASE; MEDICAL MYCOLOGY; MEDICAL PARASITOLOGY; RICKETTSIOSES; SYPHILIS. [W.E.B.]

**Meningococcus** A major human pathogen belonging to the bacterial genus *Neisseria*, and the cause of meningococcal meningitis and meningococcemia. The official designation is *N. meningitidis*. The meningococcus is a gram-negative, aerobic, nonmotile diplococcus. It is fastidious in its growth requirements and is very susceptible to adverse physical and chemical conditions.

Humans are the only known natural host of the meningococcus. Transmission occurs by droplets directly from person to person. Fomites and aerosols are probably unimportant in the spread of the organism. The most frequent form of host-parasite relationship is asymptomatic carriage in the nasopharynx.

The most common clinical syndrome caused by the meningococcus is meningitis, which is characterized by fever, headache, nausea, vomiting, and neck stiffness and has a fatality rate of 15% (higher in infants and adults over 60). Disturbance of the state of consciousness quickly occurs, leading to stupor and coma. Many cases also have a typical skin rash consisting of petechiae or purpura. See MENINGITIS. [R.Go.]

**Menopause** The irreversible cessation of regular monthly uterine bleeding in the adult human female, marking the end of her ability to become pregnant. Menopause commonly occurs in the United States between the ages of 47 and 53. It probably occurs because the ovary runs out of eggs and the cyclic rise and fall of brain and ovarian hormones designed to prepare the uterus to receive and nourish pregnancy no longer occur.

Menopause is one event in the climacteric, the period of time during which the reproductive machinery slows down and finally stops. The biochemical hallmark of this period is a reduction in estrogen production by the ovary. Some estrogen continues to be produced by the adrenal gland and the fatty tissues throughout the body, but this amount is very small compared with premenopausal levels. Estrogen has widespread effects on both genital and extragenital systems, and the withdrawal of estrogen accounts for many of the signs and symptoms attributed to menopause, although these are influenced by both hereditary and social factors. Many psychological problems have been attributed to estrogen deprivation, but well-documented proof of those relationships is lacking.

While estrogen can reverse or halt many of the physical changes described, it will not prevent aging or restore reproductive ability. Treatment of menopausal symptoms should be undertaken on an individual basis, with careful discussion of the risks and benefits currently known. See ESTROGEN; MENSTRUATION. [G.Gu.]

**Menstruation** Periodic sloughing of the uterine lining in women of reproductive age. Menstrual bleeding indicates the first day of the menstrual cycle, which lasts an average of 27–30 days, although ranges of 21–60 days have been recorded. Menarche, the onset of menstruation, occurs between the ages of 9 and 16. The majority of females begin menstruating at ages 12–14. During the first few years, the duration and intensity of menstrual flow and the total cycle length may be quite variable, but regularity is gradually established. Cessation of menses, or menopause, occurs at an average age of 51, with a range of 42–60 years.

The menstrual cycle consists of cyclic changes in both the ovary and the uterus. These changes are controlled by the interaction of several hormones including follicle-stimulating hormone (FSH) and luteinizing hormone (LH), which are secreted by the anterior pituitary, and the steroid hormones estrogen and progesterone, which are secreted by follicles in the ovary. At the beginning of the cycle, the follicle is stimulated by FSH. In response, it grows and secretes estrogen. The amount of estrogen secretion increases rapidly near the middle of the cycle. Estrogen, in turn, stimulates growth of the uterine lining (mucosa), which becomes thicker and fills with blood vessels. In midcycle, the rapid increase in estrogen causes a massive surge of LH release and a smaller release of FSH from the pituitary. This surge causes ovulation, which is the release of the ovum from the follicle. After ovulation, the follicle undergoes rapid changes and is then called a corpus luteum, which secretes progesterone in response to LH stimulation. Progesterone and estrogen together cause a further thickening of the uterine mucosa, preparing the uterus for pregnancy. If pregnancy does not occur, the corpus luteum degenerates, the uterine mucosa sloughs off, and the cycle begins again.

There is no menstrual bleeding during pregnancy, as the uterine mucosa is needed for the maintenance of pregnancy. This amenorrhea, or lack of normal ovarian function, sometimes continues during nursing. [J.M.Ba.]

**Mental retardation** A developmental disability characterized by significantly subaverage general intellectual functioning, with concurrent deficits in adaptive behavior. The causes are many and include both genetic and environmental factors as well as interactions between the two. In most cases the diagnosis is not formally made until children have entered into school settings. In the preschool years, the diagnosis is more likely to be established by evidence of delayed maturation in the areas of sensory-motor, adaptive, cognitive, social, and verbal behaviors. By definition, evidence of mental retardation must exist prior to adulthood, where vocational limitation may be evident, but the need for supervision or support may persist beyond the usual age of social emancipation.

From the aspect of etiology, mental retardation can be classified by prenatal, perinatal, or postnatal onset. Prenatal causes include genetic disorders, syndromal disorders, and developmental disorders of brain formation. Upward of 700 genetic causes have been suggested as associated with the development of mental retardation. Many environmental influences on the developing fetus, for example, infection, and other unknown errors of development may account for mental retardation.

Perinatal causes include complications at birth, extreme prematurity, infections, and other neonatal disorders. Postnatal causes include trauma, infections, demyelinating and degenerative disorders, consequences of seizure disorders, toxic-metabolic disorders, malnutrition, and environmental deprivation. Often no specific cause can be identified for the mental retardation of a particular individual.

Individuals with mental retardation are typically subclassified in terms of the manifest severity of cognitive disability as reflected by the ratio of mental age to chronological age, or intelligence quotient (IQ). Subaverage intellectual functioning is defined as an IQ score of at least two standard deviations below the mean, or approximately 70 to 75 or below. Mild, moderate, severe, and profound degrees of mental retardation refer to two, three, four, or five standard deviations below the normal IQ for the general population.

Limitations in adaptive behavior must also be demonstrable in order to satisfy diagnostic criteria for mental retardation. This criterion is important because certain artistic or other gifts may not be revealed by formal IQ testing, and different levels of learning difficulty may be accentuated by the demands of specific environments. Outside such environments, an individual may navigate a normal course in life.

A specific genetic or other cause of mental retardation may also predispose to other medical or neurologic conditions. In these circumstances, the comorbid medical conditions may increase the likelihood of emotional or behavioral problems, or contribute to the challenges with which a given child must contend. Thus, the identification of cause can be important in planning for the medical, educational, and treatment needs of a particular individual.

Considerable progress has been made in both prevention and treatment. Diet is a method of treatment following early detection of phenylketonuria; warnings regarding alcohol consumption during pregnancy, lead exposure in infancy, and disease immunization and therapy are measures for prevention of retardation. Advances in prenatal, obstetrical, and neonatal care and genetic counseling have had the effect of reducing the incidence or the severity of various conditions. Energetic training and the application of psychosocial techniques have resulted in improved social performance and adaptive behavior in many persons with mental retardation. [B.H.Ki.]

**Menthol** A monocyclic, saturated, secondary terpene alcohol with the formula below. Menthol contains three asymmetric carbon atoms (starred in the formula). It can exist in four

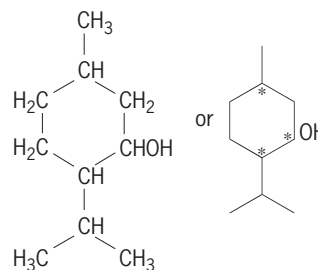

externally compensated and eight optically active forms. The only forms encountered in nature are the L-menthol and D-neomenthol. Commercial l-menthol is isolated principally from the oil of *Mentha arvensis*. It possesses a distinct peppermint flavor

and gives the impression of cooling the mouth and skin. See TERPENE. [W.Mos.]

**Mercaptan** One of a group of organosulfur compounds which are also called thiols or thio alcohols and which have the general structure RSH. Aromatic thiols are called thiophenols, and biochemists often refer to thiols as sulfhydryl compounds. The unpleasant odor of volatile thiols causes them to be classed as stenches, but the odors of many solid thiols are not unpleasant.

Mercaptans (1) form salts with bases, (2) are easily oxidized to disulfides and higher oxidation products such as sulfonic acids, (3) react with chlorine (or bromine) to form sulfenyl chlorides (or bromides), and (4) undergo additions to unsaturated compounds, such as olefins, acetylenes, aldehydes, and ketones. The insoluble mercury salts (mercaptides) are used to isolate and identify mercaptans. See ORGANOSULFUR COMPOUND. [N.K.]

**Merchant ship** A power-driven ship employed in commercial transport on the oceans and large inland bodies of water such as the Great Lakes. The relatively small craft used for inland waterway transportation are not commonly referred to as ships.

Commodities transported by water are classified as break-bulk, unitized, or bulk (dry or liquid) cargoes. Generally, water cargo transportation is cheaper per ton-mile than land or air transportation; approximately 90% of the United States overseas trade revenue is waterborne, while the rest is airborne. See MARINE CONTAINERS.

A passenger ship, as defined by International Safety of Life at Sea (SOLAS) rules, carries more than 12 passengers on international voyages. Passenger vessels that also transport cargo are called passenger-cargo ships. [A.M.D'A.]

**Mercury (element)** A chemical element, Hg, atomic number 80 and atomic weight 200.59. Mercury is a silver-white liquid at room temperature (melting point  $-38.89^{\circ}\text{C}$  or  $-37.46^{\circ}\text{F}$ ); it boils at  $357.25^{\circ}\text{C}$  ( $675.05^{\circ}\text{F}$ ) under atmospheric pressure. It is a noble metal that is soluble only in oxidizing solutions. Solid mercury is as soft as lead. The metal and its compounds are very toxic. With some metals (gold, silver, platinum, uranium, copper, lead, sodium, and potassium, for example) mercury forms solutions called amalgams. See AMALGAM; PERIODIC TABLE; TRANSITION ELEMENTS.

In its compounds, mercury is found in the 2+, 1+, and lower oxidation states, for example,  $\text{HgCl}_2$ ,  $\text{Hg}_2\text{Cl}_2$ , or  $\text{Hg}_3(\text{AsF}_6)_2$ . Often the mercury atoms are doubly covalently bonded, for example,  $\text{Cl}-\text{Hg}-\text{Cl}$  or  $\text{Cl}-\text{Hg}-\text{Hg}-\text{Cl}$ . Some mercury(II) salts, for example,  $\text{Hg}(\text{NO}_3)_2$ , or  $\text{Hg}(\text{ClO}_4)_2$ , are quite soluble in water and dissociate normally. The aqueous solutions of these salts react as strong acids because of hydrolysis. Other mercury(II) salts, for example,  $\text{HgCl}_2$  or  $\text{Hg}(\text{CN})_2$ , also dissolve in water, but exist in solution as only slightly dissociated molecules. There are compounds in which mercury atoms are bound directly to carbon or nitrogen atoms, for example,  $\text{H}_3\text{C}-\text{Hg}-\text{CH}_3$  or  $\text{H}_3\text{C}-\text{CO}-\text{NH}-\text{Hg}-\text{NH}-\text{CO}-\text{CH}_3$ . In complex compounds, for example,  $\text{K}_2(\text{HgI}_4)$ , mercury often has three or four bonds.

Metallic mercury is used as a liquid contact material for electrical switches, in vacuum technology as the working fluid of diffusion pumps, for the manufacture of mercury-vapor rectifiers, thermometers, barometers, tachometers, and thermostats, and for the manufacture of mercury-vapor lamps. It finds application for the manufacture of silver amalgams for tooth fillings in dentistry. Of importance in electrochemistry are the standard calomel electrode, used as the reference electrode for the measurement of potentials and for potentiometric titrations, and the Weston standard cell.

Mercury is commonly found as the sulfide,  $\text{HgS}$ , frequently as the red cinnabar and less often as the black metacinnabar. A less common ore is the mercury(I) chloride. Occasionally the mercury ore contains small drops of metallic mercury. See CINNABAR.

The surface tension of liquid mercury is 484 dynes/cm, six times greater than that of water in contact with air. Hence, mercury does not wet surfaces with which it is in contact. In dry air metallic mercury is not oxidized. After long standing in moist air, however, the metal becomes coated with a thin layer of oxide. In air-free hydrochloric acid or in dilute sulfuric acid, the metal does not dissolve. Conversely, it is dissolved by oxidizing acids (nitric acid, concentrated sulfuric acid, and aqua regia). [K.B.]

**Mercury (planet)** The planet closest to the Sun. It is visible to the unaided eye only shortly after sunset or shortly before sunrise, when it is near its greatest angular distance from the Sun ( $28^{\circ}$ ). Its diameter is 3031 mi (4878 km), and its mass is 0.055 times the mass of the Earth. Most detailed knowledge of Mercury is derived from data returned by the *Mariner 10* spacecraft, which flew by the planet three times in 1974 and 1975. The coverage and resolution is somewhat comparable to Earth-based telescopic coverage and resolution of the Moon before the advent of space flight.

Mercury has the most eccentric (0.205) and inclined ( $7^{\circ}$ ) orbit of any planet in the solar system except Pluto. The rotation period is 58.646 Earth days, and the orbital period, 87.969. Therefore, Mercury makes exactly three rotations around its axis for every two orbits around the Sun. Thus, a solar day (sunrise to sunrise) lasts two Mercurian years (176 Earth days).

Mercury experiences the greatest range in surface temperature ( $1130^{\circ}\text{F}$  or  $627^{\circ}\text{C}$ ) of any planet or satellite in the solar system because of its proximity to the Sun, its long solar day, and its lack of an insulating atmosphere. Its maximum surface temperature

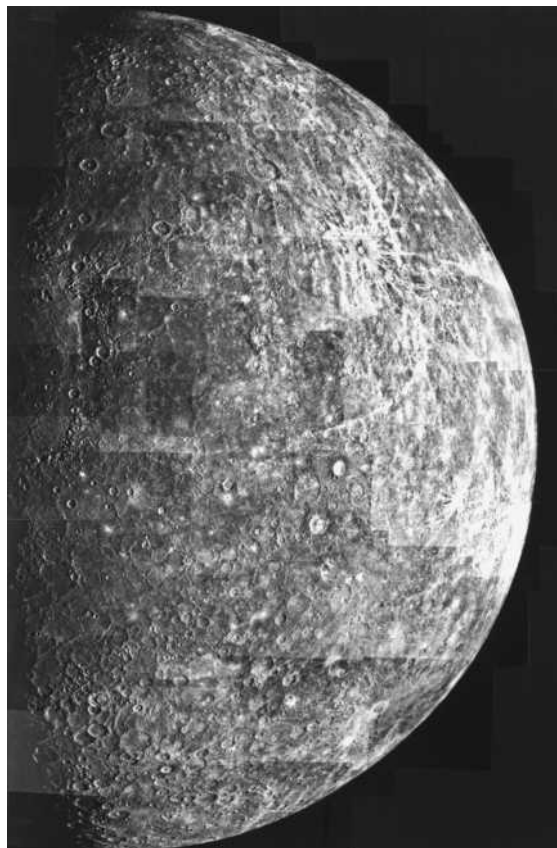

Photomosaic of Mercury as seen by the outgoing *Mariner 10* spacecraft in March 1974. The terminator, the boundary between the lighted and unlighted halves of the planet, runs vertically along the left side of the photograph. The Caloris Basin is on the terminator, slightly above the middle. It is surrounded and filled by younger smooth plains. (Jet Propulsion Laboratory)

is 800°F (427°C) at perihelion on the equator, hot enough to melt zinc. At night, however, the unshielded surface plunges to below -300°F (-183°C).

Mercury's internal structure is unique in the solar system. The planet's mean density is 5.44 g/cm<sup>3</sup> (5.44 times that of water), which is larger than that of any other planet or satellite except Earth (5.52 g/cm<sup>3</sup>). Because of Earth's large internal pressures, however, its uncompressed density is only 4.4 g/cm<sup>3</sup> compared to Mercury's uncompressed density of 5.3 g/cm<sup>3</sup>. This means that Mercury contains a much larger fraction of iron than any other planet or satellite in the solar system. The iron core must be about 75% of the planet diameter, or 42% of Mercury's volume. It is surrounded by a silicate mantle and crust only about 370 mi (600 km) thick. *Mariner 10* discovered an intrinsic dipole magnetic field with a dipole moment equal to about 0.004 that of the Earth, which indicates that the core is at least partly molten at present. A light alloying element in the core must have lowered the melting point and retained a partially molten core over geologic history ( $4.5 \times 10^9$  years); otherwise the core would have solidified long ago. Sulfur is the most reasonable candidate for this alloying element. Mercury probably has between about 0.2 and 7% sulfur in its core. The origin of Mercury and how it acquired such a large percentage of iron is a major unsolved problem. See EARTH.

Mercury's atmosphere is very tenuous and is essentially exospheric in that its atoms rarely collide with each other. The atmospheric surface pressure is  $10^{12}$  times less than Earth's. *Mariner 10*'s ultraviolet spectrometer identified hydrogen, helium, oxygen, and argon in the atmosphere, all of which are probably derived largely from the solar wind. Earth-based telescopic observations in 1985 discovered that Mercury is surrounded by a tenuous atmosphere of sodium and potassium that is probably derived from its surface.

The surface of Mercury superficially resembles that of the Moon (see illustration). It is heavily cratered, with large expanses of younger smooth plains (similar to the lunar maria) that fill and surround major impact basins. Unlike the Moon surface, Mercury's heavily cratered terrain is interspersed with large regions of gently rolling intercrater plains, the major terrain type on the planet. Also unlike the Moon surface, a system of thrust faults, unique in the solar system, transects the surface viewed by *Mariner 10*. The largest structure viewed by *Mariner 10* is the 800-mi-diameter (1300-km) Caloris impact basin. Infrared temperature measurements from *Mariner 10* indicate that the surface is a good thermal insulator and, therefore, must be covered with porous soil or rock powder like the lunar regolith. This is expected on a planet whose surface is shattered and stirred by meteorite impacts. See PLANET; PLANETARY PHYSICS. [R.G.S.]

**Mercury-vapor lamp** A vapor or gaseous discharge lamp in which the arc discharge takes place in mercury vapor. This lamp is widely used for roadway and all other forms of illumination, and as a source of ultraviolet radiation for industrial applications.

The arc discharge takes place in a transparent tube of fused silica, or quartz, and this quartz tube is usually mounted inside a larger bulb of glass (see illustration). The outer bulb reduces the ultraviolet radiation of the inner arc tube, encloses and protects the mount structure, and can be coated with phosphors that greatly improve the color of the light emitted.

The arc tube has electrode assemblies mechanically sealed into each end. At one end of the arc tube, a smaller starting electrode is located close to the main electrode. The starting electrode is connected through a high resistance to the opposite electric polarity of the adjacent main electrode. The arc tube itself is filled with argon gas and a small amount of pure mercury before being sealed.

Radiation from the mercury arc is confined to four specific wavelengths in the visible portion of the spectrum and several strong lines in the ultraviolet. The visible radiation from clear

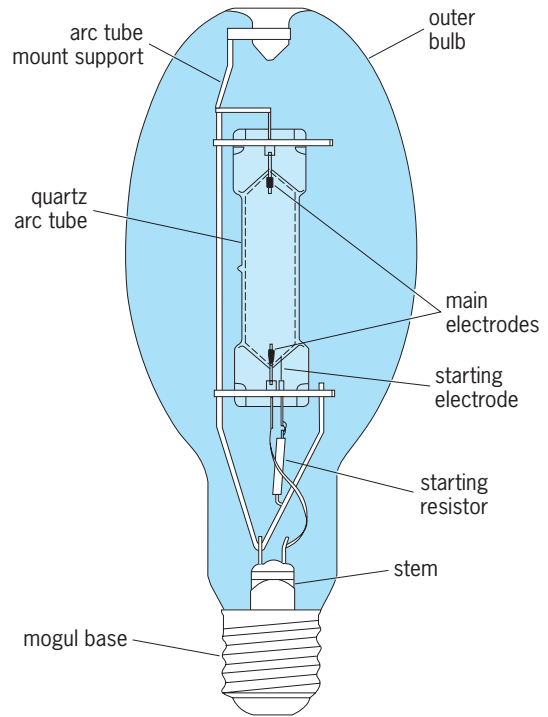

High-pressure mercury-vapor lamp.

mercury lamps provides light with a distinct blue-green appearance and poor color rendition. Red objects, for example, look brown or black, and human skin looks unattractive. For this reason, most mercury lamps have a phosphor color-correcting coating, and clear bulbs are used only where appearance of colors is secondary to some gain in efficiency. See ILLUMINATION; LAMP; ULTRAVIOLET LAMP; VAPOR LAMP. [T.F.N.]

**Meridian** A line of longitude on Earth or in the sky, perpendicular to the Equator, and extending between the North and South poles.

A meridian of longitude on Earth marks a system of location and timekeeping whose zero was set at Greenwich, England, in the nineteenth century, when it was necessary to regularize time signals in the era of railway transportation. See LATITUDE AND LONGITUDE; TIME.

Meridians of celestial longitude are the extensions into space of meridians of longitude on Earth. Each celestial meridian is the half of a great circle that goes between the north and south celestial poles and crosses the celestial equator perpendicularly. The unique line known as the celestial meridian is the great circle going from north pole to south pole through a given observer's zenith, the point directly overhead. It thus marks the north-south line, and celestial objects going through it are said to be at their meridian transits or at their culminations. See ASTRONOMICAL COORDINATE SYSTEMS. [J.M.P.]

**Merogony** The normal or abnormal development of a part of an egg following cutting, shaking, or centrifugation of the egg before or after fertilization. Depending on the character of the nucleus present in the egg fragment, the following types of merogony are recognized: (1) diploid merogony, the nucleus being the normal fusion product of the egg and sperm nuclei and thus diploid; (2) andromerogony, development with the haploid sperm nucleus; (3) gynomerogony, development of a fragment of a fertilized egg with the haploid egg nucleus; (4) parthenomerogony, development of a nucleated fragment of an unfertilized egg following parthenogenetic stimulation. [G.Fa.]

**Meromictic lake** A lake whose water is permanently stratified and therefore does not circulate completely throughout the basin at any time during the year. Normally lakes in the temperate zone mix completely during the spring and autumn when water temperatures are approximately the same from top to bottom. In meromictic lakes there are no periods of overturn or complete mixing because seasonal changes in the thermal gradient are either small or overridden by the stability of a chemical gradient, or the deeper waters are physically inaccessible to the mixing energy of the wind. Most commonly, the vertical stratification is stabilized by a chemical gradient in meromictic lakes.

The upper stratum of water in a meromictic lake is mixed by the wind and is called the mixolimnion. The bottom, denser stratum, which does not mix with the water above, is referred to as the monimolimnion. The transition layer between these strata is called the chemocline.

Of the hundreds of thousands of lakes on the Earth, only about 120 are known to be meromictic. In general, meromictic lakes in North America are restricted to: sheltered basins that are proportionally very small in relation to depth and that often contain colored water, basins in arid regions, and isolated basins in fiords. See FRESH-WATER ECOSYSTEM; LAKE; LIMNOLOGY. [G.E.LI.]

**Merostomata** A class of the phylum Arthropoda, subphylum Chelicerata. Merostomes are aquatic chelicerates, characterized by abdominal appendages bearing respiratory organs. Most merostomes are extinct; only the horseshoe crabs, comprising four species and three genera (*Carcinoscorpio* and *Tachyplesus* of eastern Asia and *Limulus polyphemus* of eastern North America) survive.

The body of a merostome consists of a prosoma, or head, which lacks antennae, has a pair of compound eyes and a pair of simple median eyes, and bears the chelicerae (pincers) and five pairs of uniramous walking legs with gnathobases for mastication. The opisthosoma, or trunk, consists of 12 or fewer segments which may be freely articulating or partly or entirely fused into a solid shield; the opisthosoma bears the respiratory appendages. The telson (tail) is a solid, usually spikelike, structure. See CHELICERATA; LIVING FOSSILS. [N.E.]

**Mesogastropoda** The largest and most diverse order of gastropod mollusks in the subclass Prosobranchia. Mesogastropods are all single-gilled and thus monocardiac, that is, with only one auricle and asymmetry of other cardiac, renal, and genital structures. Mesogastropods with a wide variety of marine lifestyles are found burrowing in soft muds and living exposed to air near high-tide level. There are also estuarine, fresh-water, and terrestrial species in the order. The anatomical asymmetry makes possible a functional separation of genital from renal ducts, which in turn allows the development of internal fertilization, of large eggs, of ovoviviparity, and of true viviparity (all features advantageous for the evolution of nonmarine stocks).

Mesogastropods are structurally diverse, and most classifications divide them into 13 superfamilies, 4 of which number several thousand species and encompass some of the world's most abundant, ubiquitous, and cosmopolitan marine snails. See GASTROPODA; PROSOBRANCHIA. [W.D.R.-H.]

**Meso-ionic compound** A member of a class of five-membered ring heterocycles (and their benzo derivatives) which possess a sextet of  $\pi$  electrons in association with the atoms composing the ring but which cannot be represented satisfactorily by any one covalent or polar structure.

Two main types, depending formally upon the origin of the electrons in the  $\pi$  system, have been identified; they are exemplified by compounds (1) and (2). In structure (1) the nitrogen and oxygen atoms, 1,3 to each other, are shown as donating two electrons each to the total of eight electrons in the whole  $\pi$

system, whereas in structure (2) the two middle nitrogen atoms, 1,2 to each other, are the two-electron donors.

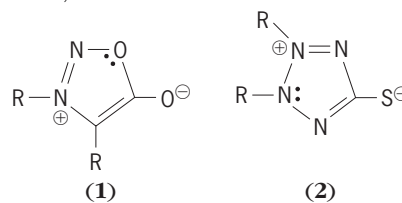

The term "satisfactorily" in the definition refers to the fact that the charge in the ring cannot be associated exclusively with one ring atom. Thus, these compounds are in sharp contrast with other dipolar structures, such as ylides, and such compounds are not considered meso-ionic.

There has been considerable interest in the pharmacological activity of meso-ionic compounds, and derivatives have shown a variety of antibiotic, anthelmintic, antidepressant, and anti-inflammatory properties. See HETEROCYCLIC COMPOUNDS. [J.P.Fr.]

**Mesometeorology** That portion of meteorology comprising the knowledge of intermediate-scale atmospheric phenomena, that is, in the size range of approximately 1–1200 mi (2–2000 km) and with time periods typically, but not always, less than 1 day. Unlike the larger weather systems on synoptic scales (the scales resolved by current weather reporting station networks) which typically produce significant changes over periods of days, most mesoscale phenomena have interdiurnal periods (less than 1 day), and consequently their changes are often more startling. In addition to time and space criteria for defining mesoscale, dynamical considerations can be used.

For observing mesoscale phenomena over midlatitude land masses, the average spacing between atmospheric sounding stations is about 180–360 mi (300–600 km) and soundings are taken twice each day. Consequently, only the largest mesoscale phenomena, with wavelengths greater than about 600 mi (1000 km), are routinely observed (resolved) by this network. Information with higher time-and-space resolution is available from aircraft observations and networks of radar stations, profilers, and satellite imagery. The profiler is a ground-based hybrid observing system of vertically pointing radar and microwave radiometry. The remote-sensing platforms often show that mesoscale weather systems are distinct components of larger synoptic-scale cyclones (low-pressure systems) and anticyclones (high-pressure systems).

Although the satellite imagery and radar data provide extensive areal coverage and clearly reveal the presence of the mesoscale systems, they do not provide measurements of certain atmospheric parameters (such as temperature, moisture, and pressure) in a form in which mesoscale structures and circulations can be readily quantified and understood. Thus, while mesoscale phenomena can be "observed," they cannot be studied and predicted (in the conventional manner) as easily as synoptic-scale systems. See METEOROLOGICAL SATELLITES; RADAR METEOROLOGY; WEATHER FORECASTING AND PREDICTION.

Mesoanalysis is the analysis of meteorological data in a manner that reveals the presence and characteristics of mesoscale phenomena. Because sounding stations are so widely spaced, only the largest of mesoscale systems can be resolved by the free-air (sounding) data. On the other hand, the density of surface observing stations is often satisfactory for identifying mesoscale features or circulations. Probably the most common application of mesoanalysis is for forecasting convective (thunderstorm) weather systems. See THUNDERSTORM.

Modern weather-forecasting techniques rely heavily upon predictions made from computers. These predictions, commonly called numerical model forecasts, require as input the three-dimensional initial state of the atmosphere. Normally, this initial condition is produced from the previous forecast and the most recent observations from the network of atmospheric



soundings. For many mesoscale phenomena, it has been possible to develop relationships between the large-scale (synoptic) environment and the occurrence of particular types of mesoscale events. By using these relationships, the prediction of the synoptic-scale environment by the numerical models is then used to infer the likelihood of specific mesoscale events. Using satellite, radar, and conventional surface observations, the onset of an event is readily detected and appropriate adjustments to local forecasts are implemented. These adjustments usually come in the form of very short-term forecasts, commonly called nowcasts, and typically are valid for only about 3 h. However, depending upon the particular mesoscale phenomena, longer-term (3–12 h) forecasts sometimes are possible. See METEOROLOGY; NOWCASTING; STORM DETECTION. [J.M.I.F.]

**Meson** The generic name for any hadronic particle with baryon number zero. Such particles were first envisaged in 1935 by H. Yukawa, who pointed out that the main features of nuclear forces would be explained if these forces were transmitted between nucleons through an intermediate field coupled with nucleons, provided that its quanta (nuclear force mesons) were massive [200–300 electron masses ( $m_e$ )] and could carry electric charge between the nucleons. See BARYON; HADRON; NUCLEAR STRUCTURE; QUANTUM FIELD THEORY.

All mesons are unstable. Those with relatively long lifetimes are referred to as semistable. Nearly 200 highly unstable mesons are established, with lifetimes shorter than  $10^{-22}$  s, and more continue to be discovered. These mesons decay to lighter mesons through the strong nuclear (hadronic) interactions, whereas the hadronic decays of the semistable mesons are forbidden or strongly suppressed. Alternative decay modes involve the weak interactions or the electromagnetic interactions, which are much weaker than the strong interactions and therefore lead to much smaller decay rates and longer lifetimes. The longest-lived mesons are those that decay only through the weak interactions; these include the charged  $\pi$  mesons (pions) and the  $K$  mesons (kaons), with lifetimes of about  $10^{-8}$  to  $10^{-10}$  s. See FUNDAMENTAL INTERACTIONS; WEAK NUCLEAR INTERACTIONS.

Hadrons are now considered to be composite, consisting of spin-quarks ( $q$ ), corresponding antiquarks ( $\bar{q}$ ), and some number of gluons ( $g$ ), the last being the quanta of the intermediate field which binds the quarks and antiquarks to form hadrons. Baryon number  $B = +1/3$  holds for a quark  $q$ ,  $B = -1/3$  for antiquark  $\bar{q}$ , while  $B = 0$  holds for a gluon. In this view, the simplest possibility is that each meson is a quark-antiquark ( $q\bar{q}$ ) pair bound together by the gluon field, and this model does account quite well for most of the known mesons and their properties. However, more complicated systems (for example, consisting of two quarks with two antiquarks) can be considered and may even be required by some of the present data. The quarks must be assigned fractional charge values, relative to the proton charge. See GLUONS; QUARKS. [R.H.D.; C.G.]

**Mesosauria** An order of extinct aquatic reptiles, also known as Proganosauria, of latest Carboniferous or earliest Permian time, about 280,000,000 years ago. The best-known genus is *Mesosaurus*. Like many aquatic reptiles, mesosaurs have a very long snout. The teeth are numerous and long, and appear very delicate. They may have served for filter feeding on soft-bodied invertebrates.

Mesosaurs, an early offshoot of the Carboniferous “stem reptiles” or captorhinomorphs, were the first reptiles to invade marine waters, but apparently soon became extinct, leaving no descendants. See REPTILIA. [R.L.C.]

**Mesosopic physics** A subdiscipline of condensed-matter physics that focuses on the properties of solids in a size range intermediate between bulk matter and individual atoms or

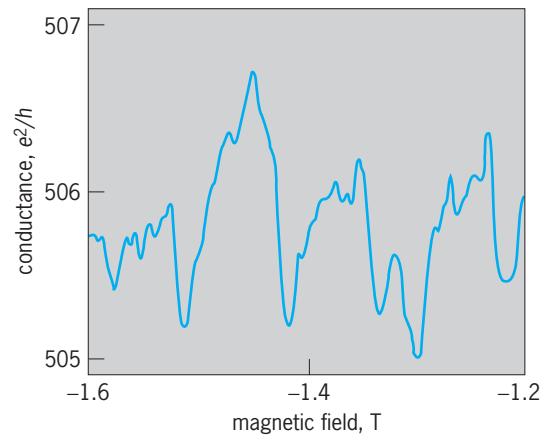

Conductance of 2000-nm gold wire as a function of magnetic field measured at a temperature of 0.04 K. The pattern observed is reproducible over a period of days. (After R. A. Webb and S. Washburn, *Quantum interference fluctuations in disordered materials*, *Phys. Today*, 41(12):46–55, December 1988)

molecules. The size scale of interest is determined by the appearance of novel physical phenomena absent in bulk solids and has no rigid definition; however, the systems studied are normally in the range of 100 nanometers (the size of a typical virus) to 1000 nm (the size of a typical bacterium). Other branches of science, such as chemistry and molecular biology, also deal with objects in this size range, but mesoscopic physics has dealt primarily with artificial structures of metal or semiconducting material which have been fabricated by the techniques employed for producing microelectronic circuits. Thus mesoscopic physics has a close connection to the fields of nanofabrication and nanotechnology. Three categories of new phenomena in such systems are interference effects, quantum size effects, and charging effects. See ARTIFICIALLY LAYERED STRUCTURES; NANOSTRUCTURE; QUANTIZED ELECTRONIC STRUCTURE (QUEST); SEMICONDUCTOR HETEROSTRUCTURES.

**Interference effects.** In the mesoscopic regime, scattering from defects induces interference effects which modulate the flow of electrons. The experimental signature of mesoscopic interference effects is the appearance of reproducible fluctuations in physical quantities. For example, the conductance of a given specimen oscillates in an apparently random manner as a function of experimental parameters (see illustration). However, the same pattern may be retraced if the experimental parameters are cycled back to their original values; in fact, the patterns observed are reproducible over a period of days.

**Quantum size effects.** Another prediction of quantum mechanics is that electrons confined to a particular region of space may exist only in a certain set of allowed energy levels. The spacing between these levels increases as the confining region becomes smaller. One striking phenomenon which arises from these quantum size effects is the steplike increase of the conductance of electrons flowing through a constriction of several hundred nanometers' width. See ENERGY LEVEL (QUANTUM MECHANICS).

Another mesoscopic system that shows quantum size effects consists of isolated islands of electrons that may be formed at the appropriately patterned interface between two different semiconducting materials. The electrons typically are confined to disk-shaped regions termed quantum dots. The confinement of the electrons in these systems changes their interaction with electromagnetic radiation significantly. See QUANTIZED ELECTRONIC STRUCTURE (QUEST).

**Charging effects.** Isolated mesoscopic solids such as quantum dots or metallic grains on an insulating substrate also show novel effects associated with the discreteness of the charge on

the electron. Devices known as single-electron transistors (SETs) are by far the most sensitive electrometers (instruments for measuring electrical charge) presently known. See ELECTROMETER; TRANSISTOR. [A.D.S.]

**Mesosphere** A layer within the Earth's atmosphere that extends from about 50 to 85 km (31 to 53 mi) above the surface. The mesosphere is predominantly characterized by its thermal structure. On average, mesospheric temperature decreases with increasing height.

Temperatures range from as high as 12°C (53°F) at the bottom of the mesosphere to as low as -133°C (-208°F) at its top. The top of the mesosphere, called the mesopause, is the coldest area of the Earth's atmosphere. Temperature increases with increasing altitude above the mesopause in the layer known as the thermosphere, which absorbs the Sun's extreme ultraviolet radiation. In the stratosphere, the atmospheric layer immediately below the mesosphere, the temperature also increases with height. The stratosphere is where ozone, which also absorbs ultraviolet radiation from the Sun, is most abundant. The transition zone between the mesosphere and the stratosphere is called the stratopause. Mesospheric temperatures are comparatively cold because very little solar radiation is absorbed in this layer. Meteorologists who predict weather conditions or study the lowest level of the Earth's atmosphere, the troposphere, often refer to the stratosphere, mesosphere, and thermosphere collectively as the upper atmosphere. However, scientists who study these layers distinguish between them; they also refer to the stratosphere and mesosphere as the middle atmosphere. See ATMOSPHERE; METEOROLOGY; STRATOSPHERE; THERMOSPHERE; TROPOSPHERE.

In the lower part of the mesosphere, the difference between the temperature at the summer and winter poles is of order 35°C (63°F). This large temperature gradient produces the north-south or meridional winds that blow from summer to winter. Temperatures in the upper mesosphere are colder in summer and warmer in winter, resulting in return meridional flow from the summer to the winter hemisphere. Although the temperature gradient in the upper part of the mesosphere remains large, additional complications result in wind speeds that are much slower than they are in the lower part of the mesosphere. Winds in the east-west or zonal direction are greatest at mesospheric middle latitudes. Zonal winds blow toward the west in summer and toward the east in winter. Like their meridional counterparts, zonal winds are comparatively strong near the bottom of the mesosphere and comparatively weak near the top. Thus, on average both temperature and wind speed decrease with increasing height in the mesosphere. See ATMOSPHERIC GENERAL CIRCULATION.

Meteors which enter the Earth's atmosphere vaporize in the upper mesosphere. These meteors contain significant amounts of metallic atoms and molecules which may ionize. Metallic ions combined with ionized water clusters make up a large part of the D-region ionosphere that is embedded in the upper mesosphere. See IONOSPHERE.

The upper mesosphere is also where iridescent blue clouds can be seen with the naked eye and photographed in twilight at high summer latitudes when the Sun lights them up in the otherwise darkening sky. These clouds are called noctilucent clouds (NLC). Noctilucent clouds are believed to be tiny ice crystals that grow on bits of meteoric dust.

Large-scale atmospheric circulation patterns transport tropospheric air containing methane and carbon dioxide from the lower atmosphere into the middle atmosphere. While carbon dioxide warms the lower atmosphere, it cools the middle and upper atmosphere by releasing heat to space. Methane breaks down and contributes to water formation when it reaches the middle atmosphere. If the air is sufficiently cold, the water can freeze and form noctilucent clouds. Temperatures must be below -129°C (-200°F) for noctilucent clouds to form. These conditions are common in the cold summer mesopause region at high latitudes. [M.Hag.]

**Mesostigmata** A suborder of the Acarina, commonly referred to as the mites. Mesostigmata are characterized by a single pair of breathing pores, or stigmata, located laterally in the middle of the idiosoma between the second and third, or third and fourth, legs. A two- or three-tined palpal claw and a tritosternum, which is located ventrally on the idiosoma just behind the gnathosoma, are also characteristic for most mesostigmatid mites. The Mesostigmata range from less than 0.008 in. (0.2 mm) to more than 0.16 in. (4 mm) in length and are cosmopolitan in distribution.

Mesostigmatid mites generally pass through an egg stage, a six-legged larval stage, two eight-legged nymphal stages, and an adult stage. In one group of these mites there is a nymphal stage which serves as a means of dispersal for the species. These nymphs attach themselves to insects and other arthropods by means of an anal pedicel and "hitchhike" to the next suitable habitat.

Many of the Mesostigmata are predacious on other small arthropods or are scavengers and fungus-feeders that make up an important segment of the soil fauna. Some members of the family Phytoseiidae are beneficial to humans as predators of the destructive spider mites, Tetranychidae. Other forms are parasitic on insects and other invertebrates. Terrestrial arthropods are the only invertebrate hosts affected by mesostigmatid mites. As a rule, phoresy is the predominant reason for the association. Vertebrate hosts are restricted to mammals, birds, and reptiles. The Mesostigmata that parasitize them are of two main sorts: They are either internal parasites of the respiratory passages, or they are ectoparasitic nidicoles; that is, they reproduce in the nests of their hosts. See PHORESIS. [J.H.C.; R.W.St.]

**Mesozoa** A division of the animal kingdom sometimes ranked as intermediate between the Protozoa and the Metazoa. These animals are unassignable to any of the better-known phyla, as usually defined. In the absence of proof concerning their relationships, and in view of the disagreement among zoologists relative to their affinities and even with respect to the facts and interpretation of their structure and life cycle, they are treated as a small phylum somewhere between Protozoa and Platyhelminthes. No particular phylogenetic interpretation should be attached to this placement.

The Mesozoa comprise two orders of small, wormlike organisms, the Dicyemida and the Orthonectida. Both are parasitic in marine invertebrates. The body consists of a single layer of ciliated cells enclosing one or more reproductive cells. These body cells are rather constant in number and arrangement for any given species. The internal cells do not correspond to the entoderm of other animals, as they have no digestive function. The life cycles are complex, involving both sexual and asexual generations (metagenesis). [B.H.Mc.]

**Mesozoic** The middle era of the three major divisions of the Phanerozoic Eon (Paleozoic, Mesozoic, and Cenozoic eras) of geologic time, encompassing an interval from 245 to 65 million years ago (Ma) based on various isotopic age dates. The Mesozoic Era is also known as the Age of the Dinosaurs and the interval of middle life. The Mesozoic Erathem (the largest recognized time-stratigraphic unit) encompasses all sedimentary rocks, body and trace fossils of organisms preserved, metamorphic rocks, and intrusive and extrusive igneous rocks formed during the Mesozoic Era. See GEOCHRONOMETRY.

The Mesozoic Era records dramatic changes in the geologic and biologic history of the Earth. At the beginning of the Mesozoic Era, all the continents were amassed into one large supercontinent (Pangaea), with both the marine and continental biotas impoverished from the mass extinction that marked the end of the Paleozoic Era. During the Mesozoic Era, many significant events were recorded in the geologic and fossil record of the Earth, including the breakup of Pangaea and the evolution of modern ocean basins by continental drift, the rise of the di-

nosaurus, the ascension of the angiosperms (flowering plants), and the appearance of the mammals. The end of the Mesozoic Era is marked by a major mass extinction (at the Cretaceous-Tertiary boundary) that records numerous meteorite impacts, the extinction of the dinosaurs, the rise to dominance of the mammals, and the beginning of the Cenozoic Era and the advanced life forms dominant today. See CONTINENTAL DRIFT; PLATE TECTONICS.

The Mesozoic Era comprises three periods of geologic time: the Triassic Period (245–208 Ma), the Jurassic Period (208–146 Ma), and the Cretaceous Period (146–65 Ma). These periods are each subdivided into epochs, formal designations of geologic time designated as Early, Middle, and Late (except for the Cretaceous, which has no middle epoch). The packages of rock themselves are subdivided into series designated Lower, Middle, and Upper (except for Cretaceous). Each epoch is subdivided into ages. Likewise, each series is subdivided into stages, which are time-stratigraphic units whose boundaries are based on unconformities (erosional surfaces), on correlations to a type section (place where rocks are first described), or preferably on changes in the biota that depict true measurable time (for example, evolutionary changes). See CRETACEOUS; JURASSIC; TRIASSIC; UNCONFORMITY. [S.T.H.; R.F.Du.]

**Messier catalog** An early listing of nebulae and star clusters. Charles Messier (1730–1817) was primarily interested in discovering comets, so he compiled a list of objects that might be confused with comets in small telescopes. His first catalog was published in the Royal Academy of Sciences of France in 1771. The compilation contains both open and globular star clusters, diffuse galactic nebulae, so-called planetary nebulae, and external galaxies.

The New General Catalog (NGC) and the supplementary Index Catalogs (IC) published by J. L. E. Dreyer at the end of the 19th century were far more extensive than that of Messier. Consequently the NGC numbers are generally used for all except a few objects whose Messier numbers had become firmly established. See GALAXY, EXTERNAL; NEBULA; STAR CLUSTERS. [L.H.AL.]

**Metabolic disorders** Disorders of metabolism principally involve an imbalance in nucleic acids, proteins, lipids, or carbohydrates. They are usually associated with either a deficiency or excess resulting in an imbalance in a particular metabolic pathway. All metabolic disorders have a genetic background, and some of them are expressed as specific genetic diseases. Other factors affecting metabolism include internal control mechanisms that are superimposed on the genetic background. One of the most important mechanisms is the hormonal control system, which consists of the endocrine, paracrine, and autocrine systems. The second control system that has a significant effect on metabolism is the neural control system. The third control system is the immune control system, which relates to both the endocrine and neural systems. Genetic background, environmental factors, and the three major control mechanisms, in conjunction with age and sex, bring about profound changes in metabolism, which ultimately result in structural and functional alterations. See ENDOCRINE MECHANISMS; IMMUNOLOGY; NERVOUS SYSTEM (VERTEBRATE).

**Nucleic acids.** Abnormalities of nucleic acid metabolism are associated with several diseases, including gout and lupus erythematosus. All genetic disease implies a defect in nucleic acids, and although some genetic diseases are classified as protein abnormalities there is always an inherent defect in the nucleotide. This is either a deficiency, an excess, or a mutation that results in an abnormal protein being formed. Similarly, although lipid storage disease results in an abnormal metabolism of lipids, it is the result of a deficiency of a particular enzyme, which also means a defect in the particular nucleic acid code. In some carbohydrate genetic storage diseases, there is a deficiency of a

particular enzyme, which again results from a nucleotide defect. Certain congenital defects that result in malformations of organ systems are the result of either germ cell or somatic cell deficiencies involving differentiation genes composed of nucleic acid.

The genetic disease severe combined immunodeficiency syndrome (SCIDS) results in a deficiency of B lymphocytes, which produce antibody, and T lymphocytes, which are responsible for graft and tumor rejection as a result of their cytotoxic effect. This abnormality is associated with a deficiency of the enzyme adenosine deaminase. See ARTHRITIS; CONNECTIVE TISSUE; DISEASE; GOUT; HUMAN GENETICS; NUCLEIC ACID.

**Proteins.** The diseases associated with protein abnormalities include those associated with increased production of proteins, decreased production of proteins, production of abnormal proteins, and excretion of unusual amounts of amino acids.

Often called macroglobulinemia, hyperproteinemia results in an increase in beta or gamma globulins, but possibly with less total protein. Hyperglobulinemia diseases include multiple myeloma, kala-azar, Hodgkin's disease, lymphogranuloma inguinale, sarcoidosis, cirrhosis, and amyloid disease. They usually involve stem cell lines of the bone marrow macrophages or B cells. See CIRRHOSIS; HODGKIN'S DISEASE.

A decrease in the amount of protein (hypoproteinemia) can result from a lack of amino acids for protein synthesis, a metabolic block, or other interference with normal protein synthesis. Increased excretion of protein, particularly in chronic renal disease with a loss of albumin in the urine (albuminuria), is another common cause of hypoproteinemia. Kwashiorkor is the best example of hypoproteinemia resulting from dietary deficiency. In hypogammaglobulinemia and agammaglobulinemia, which may also be classified under hypoproteinemia, the total serum albumin and globulin are not markedly depressed, but the gamma globulins may fall from a normal of 15–20% of total protein to 0.4%. See AGAMMAGLOBULINEMIA.

Many diseases are characterized by abnormal proteins, including multiple myeloma, the hemoglobinopathies, and the various amyloid disturbances. Multiple myeloma, a neoplastic growth of plasma cells, particularly in the bone marrow and lymph nodes, is representative of a disease in which an abnormal protein is produced. Another large group of abnormal proteins includes the hemoglobinopathies. Hemoglobin functions in the transport of oxygen in the blood. Scores of different hemoglobins have been identified, but sickle cell in the United States and thalassemia (Mediterranean anemia) in Europe are two of the most common hemoglobin abnormalities. A third type of abnormal protein is found in amyloid disease, of which there are many variations. See AMYLOIDOSIS; HEMOGLOBIN; SICKLE CELL DISEASE.

A fourth group with abnormal protein metabolism is associated with a change in particular amino acids resulting either from an overflow mechanism, where the concentration of amino acids in the serum surpasses the renal threshold of the glomerular membrane, or from defective absorption of amino acids in renal tubules. Tyrosine appears to be one of the most critical amino acids, and its metabolism is related to four key diseases including phenylketonuria, hypothyroidism, albinism, and alkaptonuria. The liver plays a major role in the deamination of amino acids. Advanced hepatitis and cirrhosis may lead to increased levels of amino acids in the blood and excretion in the urine. Other diseases with amino aciduria that are believed to be the result of defective kidney function include cystinuria (the failure to reabsorb cystine, lysine, arginine, and ornithine), Wilson's disease (a degeneration involving copper metabolism in the liver and brain), Fanconi's syndrome, galactosemia, scurvy, rickets, and lead, cresol, or benzene poisoning. See KIDNEY DISORDERS; LIVER DISORDERS; PHENYLKETONURIA; PROTEIN METABOLISM; SICKLE CELL DISEASE.

**Lipids.** Although lipid stores remain a secondary energy reserve in starvation, the breakdown of lipids associated with diabetes and starvation results in the production of ketone bodies in the urine with general acidosis (ketosis) in the serum. Of concern

to many people is an increase in lipids associated with obesity. See OBESITY.

Hyperlipemia, an excess of lipid in the blood, is often secondary to uncontrollable diabetes, hypothyroidism, biliary cirrhosis, and lipid nephrosis. Excess proliferation of fat cells is known as a lipoma, which occasionally becomes malignant, producing a liposarcoma. See ARTERIOSCLEROSIS.

In a large group of genetic lipid storage diseases, lipid accumulates because of a disturbance in lipid metabolism that is independent of external stimuli. These genetic diseases are inherent nucleic acid defects that result in abnormal enzymatic proteins, which then result in abnormal lipid metabolism. In these diseases, a large accumulation of lipid appears in many cells, but particularly the reticuloendothelial cells of the lymph nodes, liver, spleen, and bone marrow. Abnormal lipid storage occurs in Niemann-Pick, Gaucher's, and Tay-Sachs diseases.

The heterozygous form of the genetic disease familial hypercholesteremia results in cholesterol levels two to four times normal, and is characterized by arteriosclerotic lesions of the coronary vessels that cause myocardial infarct and death in the 35-50-year age range. In the homozygous condition, with cholesterol levels eight to ten times normal, death occurs usually before the age of 15. The defect resides in the receptor for low-density lipoprotein (LDL). See CHOLESTEROL; HEART DISORDERS; LIPID METABOLISM.

**Carbohydrates.** Abnormal carbohydrate diseases include the genetic diseases that represent a deficiency in nucleotide and eventually protein enzymatic activity. Of the six common carbohydrate storage diseases, two examples are von Gierke's disease, marked by glycogen storage in the heart, and Pompe's disease, in which the carbohydrate is stored in the liver. Variants of carbohydrate disease involve storage of mucopolysaccharides, as in Hurler's disease, and storage of galactose, as in galactosemia.

The most important disease associated with carbohydrate metabolism is diabetes mellitus. See CARBOHYDRATE METABOLISM; DIABETES; METABOLISM. [D.W.Ki.]

**Metabolism** All the physical and chemical processes by which living, organized substance is produced and maintained and the transformations by which energy is made available for use by an organism.

In defining metabolism, it is customary to distinguish between energy metabolism and intermediary metabolism, although the two are, in fact, inseparable. Energy metabolism is primarily concerned with overall heat production in an organism, while intermediary metabolism deals with chemical reactions within cells and tissues. In general, the term metabolism is interpreted to mean intermediary metabolism. See ENERGY METABOLISM.

Metabolism thus includes all biochemical processes within cells and tissues which are concerned with their building up, breaking down, and functioning. The synthesis and maintenance of tissue structure generally involves the union of smaller into larger molecules. This part of metabolism, the building of tissues, is termed anabolism. The process of breaking down tissue, of splitting larger protoplasmic molecules into smaller ones, is termed catabolism. Growth or weight gain occurs when anabolism exceeds catabolism. On the other hand, weight loss results if catabolism proceeds more rapidly than anabolism, as in periods of starvation, serious injury, or disease. When the two processes are balanced, tissue mass remains the same.

The metabolism of the three major foodstuffs, carbohydrates, fats, and proteins, is intimately interrelated, so any clearcut division of the three is arbitrary and inaccurate. Thus the metabolism of protoplasm is concerned with all three of these foodstuffs. The metabolic pathways of carbohydrates, fats, and proteins cross at many points; thus certain pathways of metabolism are shared in common by fragments of these different classes of foodstuffs.

Some of the metabolic processes of the protoplasm of both plant and animal cells occur along common pathways; carbohydrate metabolism in plants is similar in many details to carbohy-

drate metabolism in animals. Therefore the study of metabolism in any organism is, in a sense, the study of metabolism in all protoplasm. See CARBOHYDRATE METABOLISM; KREBS CYCLE; LIPID METABOLISM; PROTEIN METABOLISM. [M.B.McC.]

**Metal** An electropositive chemical element. Physically, a metal atom in the ground state contains a partially filled band with an empty state close to an occupied state. Chemically, upon going into solution a metal atom releases an electron to become a positive ion. Consequently in biotic systems metal atoms function prominently in ionic transport and electron exchange. In bulk a metal has a high melting point and a correspondingly high boiling temperature; except for mercury, metals are solid at standard conditions. Direct observation shows a metal to be relatively dense, malleable, ductile, cohesive, highly conductive both electrically and thermally, and lustrous. When crystals of the elements are classified along a scale from plastic to brittle, metals fall toward the plastic end. Furthermore, molten metals mixed with each other over wide ranges of proportions form, upon slowly cooling, homogeneous close-packed crystals. In contrast, a metal mixed with a nonmetal completely combines into a homogeneous crystal only in one or a few discrete stoichiometric proportions.

For detailed discussions of metals, in particular, exceptions to generic behavior, see separate articles on each metal. See ELEMENTS; PERIODIC TABLE. [F.H.R.]

**Metal, mechanical properties of** Commonly measured properties of metals (such as tensile strength, hardness, fracture toughness, creep, and fatigue strength) associated with the way that metals behave when subjected to various states of stress. The properties are discussed independently of theories of elasticity and plasticity, which refer to the distribution of stress and strain throughout a body subjected to external forces.

**Stress states.** Stress is the internal resistance, per unit area, of a body subjected to external forces. The forces may be distributed over the surface of a body (surface forces) or may be distributed over the volume (body forces); examples of body forces are gravity, magnetic forces, and centrifugal forces. Forces are generally not uniformly distributed over any cross section of the body upon which they act; a complete description of the state of stress at a point requires the magnitudes and directions of the force intensities on each surface of a vanishingly small body surrounding the point. All forces acting on a point may be resolved into components normal and parallel to faces of the body surrounding the point. When force intensity vectors act perpendicular to the surface of the reference body, they are described as normal stresses. When the force intensity vectors are parallel to the surface, they describe a state of shear stress. Normal stresses are positive, when they act to extend a line (tension). Shear stresses always occur in equal pairs of opposite signs.

A complete description of the state of stress requires knowledge of magnitudes and directions of only three normal stresses, known as principal stresses, acting on reference faces at right angles to each other and constituting the bounding faces of a reference parallelepiped. Three such mutually perpendicular planes may always be found in a body acted upon by both normal and shear forces; along these planes there is no shear stress, but on other planes either shear or shear and tensile forces will exist.

The shear stress is a maximum on a plane bisecting the right angle between the principal planes on which act the largest and smallest (algebraic) principal stresses. The largest normal stress in the body is equal to the greatest principal stress. The magnitude and orientation of the maximum shear stress determine the direction and can control the rate of the inelastic shear processes, such as slip or twinning, which occur in metals. Shear stresses also play a role in crack nucleation and propagation, but the magnitude and direction of the maximum normal stress more often control fracture processes in metals capable only of limited plastic deformation.

It is often useful to characterize stress or strain states under boundary conditions of either plane stress (stresses applied only in the plane of a thin sheet) or plane strain (stresses applied to relatively thick bodies under conditions of zero transverse strain). These two extreme conditions illustrate that strains can occur in the absence of stress in that direction, and vice versa.

**Tension and torsion.** In simple tension, two of the three principal stresses are reduced to zero, so that there is only one principal stress, and the maximum shear stress is numerically half the maximum normal stress. Because of the symmetry in simple tension, every plane at  $45^\circ$  to the tensile axis is subjected to the maximum shear stress. For other kinds of loading, the relationship between the maximum shear stress and the principal stresses are obtained using the same method, with the results depending upon the loading condition.

For example, in simple torsion, the maximum principal stress is inclined  $45^\circ$  to the axis of the bar being twisted. The least principal stress (algebraically) is perpendicular to this, at  $45^\circ$  to the bar axis, but equal to and opposite in sign to the first principal stress—that is, it is compressive. Both of these are in a plane perpendicular to the radial direction, the direction of the intermediate principal stress, which in this case has the magnitude zero. Every free external surface of a body is a principal plane on which the principal stress is zero. In torsion, the maximum shear stress occurs on all planes perpendicular to and parallel with the axis of the twisted bar. But because the principal stresses are equal but of opposite sign, the maximum shear stress is numerically equal to the maximum normal stress, instead of to half of it, as in simple tension. This means that in torsion one may expect more ductility (the capacity to deform before fracture) than in tension. Materials that are brittle (exhibiting little capacity for plastic deformation before rupture) in tension may be ductile in torsion. This is because in tension the critical normal stress for fracture may be reached before the critical shear stress for plastic deformation is reached; in torsion, because the maximum shear stress is equal to the maximum normal stress instead of half of it as in tension, the critical shear stress for plastic deformation is reached before the critical maximum normal stress for fracture.

**Tension test.** To achieve uniformity of distribution of stress and strain in a tension test requires that the specimen be subjected to no bending moment. This is usually accomplished by providing flexible connections at each end through which the force is applied. The specimen is stretched at a controllable rate, and the force required to deform it is observed with an appropriate dynamometer. The strain is measured by observing the extension between gage marks adequately remote from the ends, or by measuring the diameter and calculating the change in length by using the constancy of volume that characterizes plastic deformation. Diameter measurements are applicable even after necking-down has begun. The elastic properties are seldom determined since these are structure-insensitive.

**Yield strength.** The elastic limit is rarely determined. Metals are seldom if ever ideally elastic, and the value obtained for the elastic limit depends on the sensitivity of strain measurement. The proportional limit, describing the limit of applicability of Hooke's law of linear dependence of stress on strain, is similarly difficult to determine. Modern practice is to determine the stress required to produce a prescribed inelastic strain, which is called the yield strength.

**Tensile strength.** Tensile strength, usually called the ultimate tensile strength, is calculated by dividing the maximum load by the original cross-sectional area of the specimen. It is, therefore, not the maximum value of the true tensile stress, which increases continuously to fracture and which is always higher than the nominal tensile stress because the area continuously diminishes. For ductile materials the maximum load, upon which the tensile strength is based, is the load at which necking-down begins. Beyond this point, the true tensile stress continues to increase, but the force on the specimen diminishes. This is because the rate of strain hardening has fallen to a value less than the rate

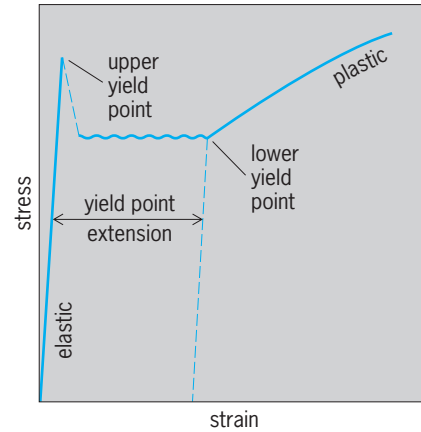

Yield point, mild steel.

at which the stress is increasing because of the diminution of area.

**Yield point.** A considerable number of alloys, including those of iron, molybdenum, tungsten, cadmium, zinc, and copper, exhibit a sharp transition between elastic and plastic flow. The stress at which this occurs is known as the upper yield point. A sharp drop in load to the lower yield point accompanies yielding, followed, in ideal circumstances, by a flat region of yield elongation; subsequently, normal strain hardening is observed (see illustration).

**Elongation.** The tensile test provides a measure of ductility, by which is meant the capacity to deform by extension. The elongation to the point of necking-down is called the uniform strain or elongation because, until that point on the stress-strain curve, the elongation is uniformly distributed along the gage length. The strain to fracture or total elongation includes the extension accompanying local necking. Since the necking extension is a fixed amount, independent of gage length, it is obvious that the total elongation will depend upon the gage length, and will be greater for short gage lengths and less for long gage lengths.

**Ductile-to-brittle transition.** Many metals and alloys, including iron, zinc, molybdenum, tungsten, chromium, and structural steels, exhibit a transition temperature, below which the metal is brittle and above which it is ductile. The transition temperature very clearly is sensitive to alloy content, but it will vary even for the same material, depending upon such external test conditions as stress state and strain rate, and microstructural variables such as purity and grain size. The ductility transition frequently is accompanied by a change in the mechanism of fracture (as in iron and steels or zinc), but this need not be so.

**Notch tensile test.** Notch sensitivity in metals cannot be detected by the ordinary tension test on smooth bar specimens. Either a notched sample may be used in a tension test or a notched-bar impact test may be conducted. Notches produce triaxial stresses under the notch root as tensile forces are applied, thereby decreasing the ratio of shear stress to normal stress and increasing the likelihood of fracture. Materials are evaluated by a quantity, notch strength, which is the analog of the ultimate tensile strength in an ordinary tensile test. The notch strength is defined as the maximum load divided by the original cross-sectional area at the notch root.

**Compression test.** Very brittle metals, or metals used in products which are formed by compressive loading (rolling, forging), often are tested in compression to obtain yield strength or yield point information. Compression test specimens are generally in the form of solid circular cylinders. The ratio of specimen length to diameter is critical in that high ratios increase the likelihood of buckling during a test, thereby invalidating the test results. Proper specimen alignment is important for the same reason. In addition, care must be taken to lubricate specimen

ends to avoid spurious effects from friction between the specimen ends and the testing machine. In the case of a metal which fails in compression by a shattering fracture (for example, cast iron), a quantity known as the compressive strength may be reproducibly obtained by dividing the maximum load carried by the specimen by its cross-sectional area. For materials which do not fail in compression by shattering, the compressive strength is arbitrarily defined as the maximum load at or prior to a specified compressive deformation.

**Notched-bar impact test.** Notched-bar impact tests are conducted to estimate the resistance to fracture of structures which may contain defects. The common procedure is to measure the work required to break a standardized specimen, and to express the results in work units, such as foot-pounds or newton-meters. The notched-bar impact test does not provide design information regarding the resistance of a material to crack propagation. Rather, it is a comparative test, useful for preliminary screening of materials or evaluation of processing variables. The notch behavior indicated in a single test applies only to the specimen size, notch geometry, and test conditions involved and is not generally applicable to other specimen sizes and conditions. The test is most useful when conducted over a range of temperatures so that the ductile-to-brittle transition can be determined.

Notched-bar tests are usually made in either a simple beam (Charpy) or a cantilever beam (Izod) apparatus, in both of which the specimen is broken by a freely swinging pendulum; the work done is obtained by comparing the position of the pendulum before it is released with the position to which it swings after striking and breaking the specimen. In the Izod test, the specimen is held in a vise, with the notch at the level of the top of the vise, and broken as a cantilever beam in bending with the notch on the tension side. In the Charpy test, the specimen is laid loosely on a support in the path of the pendulum and broken as a beam loaded at three points; the tup (striking edge) strikes the middle of the specimen, with the notch opposite the tup, that is, on the tension side. Both tests give substantially the same result with the same specimen unless the material is very ductile, a situation in which there is little interest.

**Hardness testing.** When the only information that is needed is the comparison of the resistance to deformation of a particular sample or lot with a standard material, indentation hardness tests are used. They are relatively inexpensive and fast. They tell nothing about ductility and little about the relationship between stress and strain, for in making the indent the stress and strain are nonuniformly distributed.

In all hardness tests, a standardized load is applied to a standardized indenter, and the dimensions of the indent are measured. This applies to such methods as scratch hardness testing, in which a loaded diamond is dragged across a surface to produce, by plastic deformation, a furrow whose width is measured, and the scleroscope hardness test, in which an indent is produced by dropping a mass with a spherical tup onto a surface. The dimensions of the indent are proportional to the work done in producing it, and the ratio of the height of rebound to the height from which the tup was dropped serves as an indirect measure of the hardness.

**Fatigue.** Fatigue is a process involving cumulative damage to a material from repeated stress (or strain) applications (cycles), none of which exceed the ultimate tensile strength. The number of cycles required to produce failure decreases as the stress or strain level per cycle is increased. The fatigue strength or fatigue limit is defined as the stress amplitude which will cause failure in a specified number of cycles. For a few metals, notably steels and titanium alloys, an endurance limit exists, below which it is not possible to produce fatigue failures no matter how often stresses are applied.

**Creep and stress rupture.** Time-dependent deformation under constant load or stress is measured in a creep test. Creep tests are those in which the deformation is recorded with time, while stress rupture tests involve the measurement of time for

fracture to occur. Closely related are stress relaxation tests, in which the decay of load with time is noted for a body under a fixed state of strain. Test durations vary from seconds or minutes to tens of thousand of hours. Appreciable deformation occurs in structural materials only at elevated temperatures, while pure metals may creep at temperatures well below room temperature.

Since creep deformation and rupture time are temperature- and stress-dependent, it is usually necessary to test a material at several stresses and temperatures in order to establish the creep or stress-rupture properties in adequate detail. See METAL; METALLURGY. [N.S.S.]

**Metal-base fuel** A fuel containing a metal of high heat of combustion as a principal constituent. High propellant performance in either a rocket or an air-breathing engine is obtained when the heat of combustion of the fuel is high. Chemically, high heats of combustion are attained by the oxidation of the low-atomic-weight metals in the upper left-hand corner of the periodic table. The generally preferred candidates are lithium, beryllium, boron, carbon, magnesium, and aluminum.

The metallized additive can be used in either a liquid or solid propellant. When the pure metal is added to liquid fuels, an emulsifying or gelling agent is employed which maintains the particles in uniform suspension. When used in composite solid rocket propellants, the metal powder is usually mixed with the oxidizer and unpolymerized fuel, and the propellant is then processed in the usual way.

Early compounding of metallized propellants employed the free metal itself. As a result of extensive research in metalloorganic compounds, however, several classes of metallic compounds have been employed. Two major reasons for the use of such compounds are that the solubility of the metal in the fuel can be realized, resulting in a homogeneous propellant, and performance higher than that for the pure metal can be obtained in some cases.

The major classes of metallic compounds of interest as high-performance propellants include the hydrides, amides, and hydrocarbons. Additional classes include mixtures either of two metals or of two chemical groups, such as an amine hydrocarbon.

Most metallic fuels are costly and many, because of particle-size requirements or synthesis in a specific compound, are in limited supply. The combustion gases all produce smoky exhausts which may be objectionable in use. Engine development problems are also increased because of the appearance of smoke and deposits in the engine. [D.AL.]

**Metal carbonyl** A complex of a transition metal combined with carbon monoxide (CO). In a metal carbonyl, the CO groups form sigma bonds to the metal through lone pairs of electrons on carbon; the metal, in turn, donates electrons to antibonding pi orbitals on CO. In so doing, the metal usually attains the electronic configuration of an inert gas (the 18-electron rule). Thus elemental chromium ( $\text{Cr}^0$ ), with six valence electrons, combines with six molecules of CO, each donating two electrons, to afford chromium hexacarbonyl [ $\text{Cr}(\text{CO})_6$ ], in which Cr has 18 valence electrons and is isoelectronic to krypton (Kr). See CHEMICAL BONDING; COORDINATION COMPLEXES; VALENCE.

Metal carbonyls usually are electrically neutral and nonpolar, exhibiting many of the physical properties of organic compounds. Typically they are volatile solids or liquids, soluble in common organic solvents but insoluble in water. They are highly toxic.

Anionic and cationic species also are known. Metal carbonyls also may contain one (mononuclear) or more (polynuclear) metal atoms. Polynuclear metal carbonyls may exhibit covalent metal-metal bonds, and in them CO also may function as bridging or capping ligands, forming bonds to two or three metal atoms, respectively. Mononuclear metal carbonyls tend to exhibit geometries expected on the basis of minimization

of interligand repulsions (valence shell electron-pair repulsion model); their polynuclear analogs often may be envisioned structurally as arising from the fusion of mononuclear polyhedra. Thus nickel tetracarbonyl  $[\text{Ni}(\text{CO})_4]$ , iron pentacarbonyl  $[\text{Fe}(\text{CO})_5]$ , and chromium hexacarbonyl  $[\text{Cr}(\text{CO})_6]$  exhibit tetrahedral, trigonal bipyramidal, and octahedral geometries, respectively [structures (1)–(3)]. The polynuclear manganese carbonyl

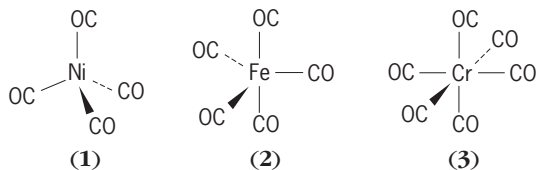

$[\text{Mn}_2(\text{CO})_{10}]$  has a structure obtained by joining two octahedra at a vertex [structure (4)], and the structure of diiron enneacarbonyl  $[\text{Fe}_2(\text{CO})_9]$  is viewed as two octahedra sharing three bridging carbonyls at a face [structure (5)].

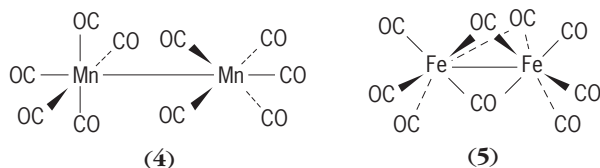

Metal carbonyls react in solution under relatively mild conditions to form a variety of substitution products, with Lewis bases such as amines, phosphines, sulfides, and nitric oxide and with organic molecules such as alkenes, alkynes, arenes, and other aromatic compounds. Reactions of metal carbonyls can also afford derivatives containing alkyl, acyl, allyl, halide, hydride, carbene, carbyne, and other substituents. They thus are the most important precursors to the synthesis of organotransition metal complexes. Their thermal decomposition can afford pure metals and CO. [G.R.B.]

**Metal casting** A metal-forming process whereby molten metal is poured into a cavity or mold and, when cooled, solidifies and takes on the characteristic shape of the mold. Casting offers several advantages over other methods of metal forming: it is adaptable to intricate shapes, to extremely large pieces, and to mass production; it can provide parts with uniform physical and mechanical properties throughout; and depending on the particular material being cast, the design of the part, and the quantity being produced, it can be more economical.

The two broad categories of metal-casting processes are ingot casting and casting to shape. Ingot castings are produced by pouring molten metal into a permanent or reusable mold. Following solidification, the ingots (bars, slabs, or billets) are processed mechanically into many new shapes. Casting to shape involves pouring molten metal into molds in which the cavity provides the final useful shape, followed by heat treatment and machining or welding, depending upon the specific application.

While design factors are important for producing sound castings with proper dimensions, factors such as the pouring temperature, alloy content, mode of solidification, gas evolution, and segregation of alloying elements control the final structure of the casting and therefore its mechanical and physical properties. Typically, pouring temperatures are selected within 100–300°F (60–170°C) of an alloy's melting point. Exceedingly high pouring temperatures can result in excessive mold metal reactions, producing numerous casting defects.

Almost all metals and alloys used by engineering specialists have at some point been in the molten state and cast. Metallurgists have in general lumped these materials into ferrous and nonferrous categories. Ferrous alloys, cast irons and steels, constitute the largest tonnage of cast metals. Aluminum-, copper-, zinc-, titanium-, cobalt-, and nickel-base alloys are also cast into many forms, but in much smaller quantity than cast iron and

steel. Selection of a given material for a certain application will depend upon the physical and chemical properties desired, as well as cost, appearance, and other special requirements. See METAL, MECHANICAL PROPERTIES OF; METAL FORMING. [K.R.]

**Metal cluster compound** A compound in which two or more metal atoms are bonded to one another. Metal cluster compounds bridge the gap between the solid-state chemistry of the metals—or their lower-valent oxides, chalcogenides, and related salts—and the complexes of the metals in which each metal ion is completely surrounded by and bonded to a set of ligands or ions. The latter group comprises the classical coordination chemistry of metal ions. See COORDINATION CHEMISTRY; COORDINATION COMPLEXES; SOLID-STATE CHEMISTRY.

Interest in metal cluster compounds arises from unique features of their chemistry: (1) Cluster compounds provide models for studying fundamental reactions on surfaces. (2) There is a hope that cluster compounds may provide entry to new classes of catalysts that may be tailored to specific syntheses and may thus be more selective than existing processes. (3) The nature of the bonding in cluster compounds is an area wherein experiment and theory are continuously challenging each other. (4) The systematic synthesis of mixed metal clusters may provide for the development of new types of supported catalysts (the discrete clusters are deposited on supports such as alumina, silica, or zeolites). See ATOM CLUSTER; NANOSTRUCTURE. [M.H.Ch.]

**Metal coatings** Thin films of material bonded to metals in order to add specific surface properties, such as corrosion or oxidation resistance, color, attractive appearance, wear resistance, optical properties, electrical resistance, or thermal protection. This article discusses various methods of applying either metallic coatings or nonmetallic coatings, such as vitreous enamel and ceramics, and the conversion of surfaces to suitable reaction-product coatings. For other methods for the protection of metal surfaces see CLADDING; ELECTROLESS PLATING; ELECTROPLATING OF METALS; LACQUER; PAINT.

Hot-dipped coatings of low-melting metals provide inexpensive protection to the surfaces of a variety of steel articles. Thoroughly cleaned work is immersed in a molten bath of the coating metal. The coating consists of a thin alloy layer together with relatively pure coating metal that adheres to the work as it is withdrawn from the bath.

Sprayed coating permits the coating of assembled steel structures to obtain corrosion resistance, the building up of worn machine parts for rejuvenation, and the application of highly refractory coatings with melting points in excess of 3000°F (1650°C).

Cementation coatings are surface alloys formed by diffusion of the coating metal into the base metal, producing little dimensional change. Parts are heated in contact with powdered coating material that diffuses into the surface to form an alloy coating, whose thickness depends on the time and the temperature of treatment.

In vapor deposition a thin specular coating is formed on metals, plastics, paper, glass, and even fabrics. Coatings form by condensation of metal vapor originating from molten metal, from high-voltage discharge between electrodes (cathode sputtering), or from chemical means such as hydrogen reduction or thermal decomposition (gas plating) of metal halides.

Immersion coatings are produced either by direct chemical displacement or for thicker coatings by chemical reduction (electroless coating). Metal ions plate out of solution onto the workpiece.

Vitreous enamel coatings are glassy but noncrystalline coatings for attractive durable service in chemical, atmospheric, or moderately high-temperature environments. In wet enameling, a slip is prepared of a water suspension of crushed glass, flux, suspending agent, refractory compound, and coloring agents or opacifiers. The slip is applied by dipping or flow coating; it is then fired at a temperature at which it fuses into a continuous vitreous coating. Dry enameling is used for castings, such as

bathtubs. The casting is heated to a high temperature, and then dry enamel powder is sprinkled over the surface, where it fuses. See FRET.

Essentially crystalline, ceramic coatings are used for high-temperature protection above 1100°C (2000°F). The coatings may be formed by spraying refractory materials such as aluminum oxide or zirconium oxide, or by the cementation processes for coatings of intermetallic compounds such as molybdenum disilicide. See CERMET.

Surface-conversion coatings provide an insulating barrier of low solubility formed on steel, zinc, aluminum, or magnesium without electric current. The article to be coated is either immersed in or sprayed with an aqueous solution, which converts the surface into a phosphate, an oxide, or a chromate.

Anodic coatings of protective oxide may be formed on aluminum or magnesium by making them the anode in an electrolytic cell. If permanent color is required, the coating is impregnated with a dye before sealing. See CORROSION. [W.W.Br.]

Powder coating is a process whereby organic polymers such as acrylic, polyester, and epoxies are applied to substrates for protection and beautification. It is essentially an industrial painting process which uses a powdered (25–50- $\mu\text{m}$  particle size) resin rather than the solvent solution. The powders are applied to electrically grounded substrates, usually by means of an electrostatic spray gun. The powder particles are attracted to and adhere to the substrate until it can be transported to an oven, where the powder particles melt, coalesce, flow, and form a smooth coating. Outdoor lawn and patio furniture coated in this process display good weathering and abuse resistance. Powder-coated electrical transformers are insulated electrically and provided with corrosion protection. Powder coatings have also been developed for finishing major appliances and for automotive coatings. See SURFACE COATING. [R.Fa.]

**Metal forming** Manufacturing processes by which parts or components are fabricated from metal stock. In the specific technical sense, metal forming involves changing the shape of a piece of metal. In general terms, however, it may be classified roughly into five categories: mechanical working, such as forging, extrusion, rolling, drawing, and various sheet-forming processes; casting; powder and fiber metal forming; electroforming; and joining processes. See DRAWING OF METAL; EXTRUSION; FORGING; METAL CASTING; METAL ROLLING; POWDER METALLURGY; SHEET-METAL FORMING. [S.Ka.]

**Metal halide lamp** A high-pressure discharge lamp that is enclosed in a quartz envelope containing metal halides, usually iodides, and produces high-efficacy white light. These lamps are widely used for sports stadiums, roadways, commercial interiors, and industrial applications. The singular lamp feature is the compact geometry and high efficacy of nearly white light. See LUMINOUS EFFICACY.

The metal halide lamp requires a high voltage in order to start. Once the arc discharge is ignited, the internal vapor pressure begins to increase until it reaches a preset value, usually around 5 atm (500 kilopascals). These lamps are always connected to an auxiliary power supply called the ballast which supplies the proper voltage and current for starting and operating the lamps. The light output gradually increases over approximately 2 min as the various ingredients begin to vaporize and emit light. The light from the arc discharge comes from the metal components of the iodide compounds, which are typically a mixture of sodium, thallium, indium, scandium, dysprosium, and occasionally tin iodide. A combination of these metals produces a pleasing white light of very high efficiency, between 80 and 120 lumens per watt or even higher. See ARC DISCHARGE.

Special ingredients can be used inside these lamps to make them suitable for plant growth, photocopying, and scientific usages. Certain types of compact metal halide lamps are ideal for use with movie and slide projection. In these cases, the ingredi-

ents chosen (usually indium) are used because they produce a small, intense high-brightness arc. The spectra of these lamps are nearly continuous and approach the spectra found in an incandescent lamp. See CINEMATOGRAPHY; INCANDESCENT LAMP; OPTICAL PROJECTION SYSTEMS.

In cases where a more diffuse light source is desired, the outer jacket of the lamp can be coated with a white phosphor in order both to diffuse the light and to change the color of the output and in some cases actually improve the efficiency. [G.H.R.]

**Metal hydrides** A compound in which hydrogen is bonded chemically to a metal or metalloid element. The compounds are classified generally as ionic, transition metal, and covalent hydrides. Covalent hydrides are of two subtypes, binary and complex. Certain hydrides have achieved a position of modest industrial importance, but most are of theoretical interest only.

Under extreme conditions such as in electric discharges, many metals form volatile, short-lived transient hydrides of the general formula type MH. Although some of these can be prepared experimentally, most are observed only by their spectra. They are important in studying molecular bonding. The action of atomic hydrogen at low temperatures forms surface films of unstable hydrides with many metals. See HYDRIDO COMPLEXES; HYDROGEN. [J.C.W.]

**Metal matrix composite** A material in which a continuous metallic phase (the matrix) is combined with another phase (the reinforcement) that constitutes a few percent to around 50% of the material's total volume. In the strictest sense, metal matrix composite materials are not produced by conventional alloying. This feature differentiates most metal matrix composites from many other multiphase metallic materials, such as pearlitic steels or hypereutectic aluminum-silicon alloys. See ALLOY.

The particular benefits exhibited by metal matrix composites, such as lower density, increased specific strength and stiffness, increased high-temperature performance limits, and improved wear-abrasion resistance, are dependent on the properties of the matrix alloy and of the reinforcing phase. The selection of the matrix is empirically based, using readily available alloys; and the major consideration is the nature of the reinforcing phase.

A large variety of metal matrix composite materials exist. The reinforcing phase can be fibrous, platelike, or equiaxed (having equal dimensions in all directions); and its size can also vary widely, from about 0.1 to more than 100 micrometers. Matrices based on most engineering metals have been explored, including aluminum, magnesium, zinc, copper, titanium, nickel, cobalt, iron, and various aluminides. This wide variety of systems has led to an equally wide spectrum of properties for these materials and of processing methods used for their fabrication. Reinforcements used in metal matrix composites fall in five categories: continuous fibers, short fibers, whiskers, equiaxed particles, and interconnected networks.

Composite properties depend first and foremost on the nature of the composite; however, certain detailed microstructural features of the composite can exert a significant influence on its behavior. Physical properties of the metal, which can be significantly altered by addition of a reinforcement, are chiefly dependent on the reinforcement distribution. A good example is aluminum-silicon carbide composites, for which the presence of the ceramic increases substantially the elastic modulus of the metal without greatly affecting its density. However, the level of improvement depends on the shape and alignment of the silicon carbide. Also, it depends on the processing of the reinforcement: for the same reinforcement shape (continuous fibers), microcrystalline polycarbosilane-derived silicon carbide fibers yield much lower improvements than do crystalline  $\beta$ -silicon carbide fibers. Other properties, such as the strength of metal matrix composites, depend in a much more complex manner on composite



microstructure. The strength of a fiber-reinforced composite, for example, is determined by fracture processes, themselves governed by a combination of microstructural phenomena and features. These include plastic deformation of the matrix, the presence of brittle phases in the matrix, the strength of the interface, the distribution of flaws in the reinforcement, and the distribution of the reinforcement within the composite. Consequently, predicting the strength of the composite from that of its constituent phases is generally difficult. See BRITTLENESS; PLASTIC DEFORMATION OF METAL.

The combined attributes of metal matrix composites, together with the costs of fabrication, vary widely with the nature of the material, the processing methods, and the quality of the product. In engineering, the type of composite used and its application vary significantly, as do the attributes that drive the choice of metal matrix composites in design. For example, high specific modulus, low cost, and high weldability of extruded aluminum oxide particle-reinforced aluminum are the properties desirable for bicycle frames. High wear resistance, low weight, low cost, improved high-temperature properties, and the possibility for incorporation in a larger part of unreinforced aluminum are the considerations for design of diesel engine pistons. See COMPOSITE MATERIAL; HIGH-TEMPERATURE MATERIALS. [M.M.S.]

**Metal rolling** Reducing or changing the cross-sectional area of a workpiece by the compressive forces exerted by rotating rolls. The original material fed into the rolls is usually an ingot from a foundry. The largest product in hot rolling is called a bloom; by successive hot- and then cold-rolling operations the bloom is reduced to a billet, slab, plate, sheet, strip, and foil, in decreasing order of thickness and size. The initial breakdown of the ingot by rolling changes the coarse-grained, brittle, and porous structure into a wrought structure with greater ductility and finer grain size.

A schematic presentation of the rolling process, in which the thickness of the metal is reduced as it passes through the rolls, is shown in illus. *a*. The speed at which the metal moves during rolling changes, as shown in illus. *b*, to keep the volume rate of flow constant throughout the roll gap. Hence, as the thickness decreases, the velocity increases; however, the surface speed of a point on the roll is constant, and there is therefore relative sliding between the roll and the strip. The normal pressure distribution on the roll and hence on the strip is of the form shown in illus. *c*.

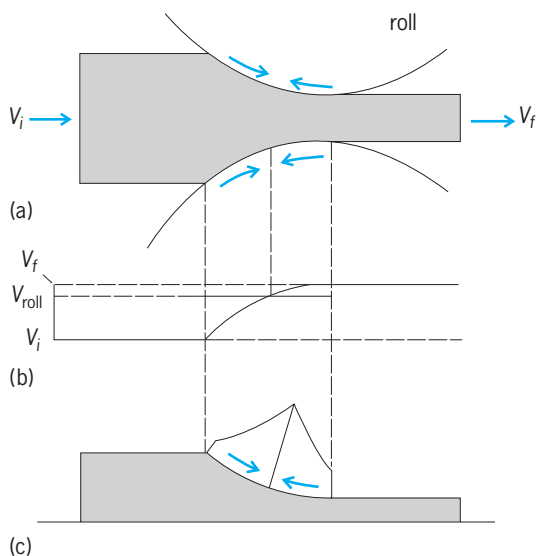

The rolling process, (a) Direction of friction forces in the roll gap, (b) Velocity distribution, (c) Normal pressure acting on the strip in the roll gap.  $V_i$  = initial velocity,  $V_f$  = final velocity,  $V_{roll}$  = velocity during rolling operation.

Because of its particular shape this pressure distribution is known as the friction hill.

A great variety of roll arrangements and equipment are used in rolling. The proper reduction per pass in rolling depends on the type of material and other factors; for soft, nonferrous metals, reductions are usually high, while for high-strength alloys they are small. Requirements for roll materials are mainly strength and resistance to wear. Common roll materials are cast iron, cast steel, and forged steel. [S.Ka.]

**Metallic glasses** Alloys having amorphous or glassy structures. A glass is a solid material obtained from a liquid which does not crystallize during cooling. It is therefore an amorphous solid, which means that the atoms are packed in a more or less random fashion similar to that in the liquid state. The word glass is generally associated with the familiar transparent silicate glasses containing mostly silica and other oxides of aluminum, magnesium, sodium, and so on. These glasses are not metallic; they are electrical insulators and do not exhibit ferromagnetism. Glass having metallic properties is obtained from a melt containing metallic elements instead of oxides. However, liquid metals and alloys crystallize so rapidly on cooling that it was not until 1960 that the first true metallic glass, an alloy of gold and silicon ( $\text{Au}_{80}\text{Si}_{20}$ ), containing 80 at. % Au and 20 at. % Si, was obtained. See AMORPHOUS SOLID.

The effect of adding solute atoms to a pure metal, especially if they are of a size and chemical character different from those of the host atoms, is to suppress the freezing temperature, so that the probability of solidifying the melt without crystallization is increased. Accordingly, the alloy systems for which glass formation occurs most readily are those manifesting either one or more eutectics. Those compositions with the lowest liquidus temperature, that is, near eutectic compositions, thus form a glass most easily. The known glass-forming families are alloys of transition metals or noble metals that contain about 10–30% semimetal [for example, platinum/phosphorus ( $\text{Pt}_{75}\text{P}_{25}$ ) or iron/boron ( $\text{Fe}_{80}\text{B}_{20}$ )], alloys of early-transition metals only [for example, zirconium/palladium ( $\text{Zr}_{70}\text{Pd}_{30}$ ) or niobium/rhodium ( $\text{Nb}_{60}\text{Rh}_{40}$ )], alloys containing metals from group 2 in the periodic table [for example, magnesium/zinc ( $\text{Mg}_{70}\text{Zn}_{30}$ ) or calcium/magnesium ( $\text{Ca}_{70}\text{Mg}_{30}$ )], and alloys of rare-earth metals and transition metals [for example, gadolinium/cobalt ( $\text{Gd}_{70}\text{Co}_{30}$ ) or yttrium/iron ( $\text{Y}_{60}\text{Fe}_{40}$ )]. In a few cases, the glass-forming composition does not fall at the eutectic point but in a composition range richer in the minor element, such as alloys of aluminum (Al) and rare-earth metals (for example,  $\text{Al}_{90}\text{Y}_{10}$  or  $\text{Al}_{90}\text{Gd}_{10}$ ). Binary alloy glasses can be obtained only as thin foils about 0.002 in. (50  $\mu\text{m}$ ) thick, because a critical quenching rate of  $1.8 \times 10^5$  °F/s (10<sup>5</sup> K/s) is required to retain the glassy phase. When further solute is substituted, the stability and glass-forming tendency can be drastically enhanced. Ternary alloy glasses, for example, palladium/copper/silicon ( $\text{Pd}_{77}\text{Cu}_6\text{Si}_{17}$ ), palladium/nickel/phosphorus ( $\text{Pd}_{40}\text{Ni}_{40}\text{P}_{20}$ ), and platinum/nickel/phosphorus ( $\text{Pt}_{60}\text{Ni}_{15}\text{P}_{25}$ ), have been prepared as cylindrical rods of 0.100 in. (2.5 mm) in diameter at a quenching rate of  $1.8 \times 10^2$  °F/s (10<sup>2</sup> K/s) or less. See PHASE EQUILIBRIUM.

The electrical properties of crystalline metals and alloys are generally well understood. The absence of a crystal lattice in metallic glasses results in substantial changes in their electrical properties and has theoretical applications in studies of transport properties in solids.

The electrical resistivity of metallic glasses is high, for example 100  $\mu\Omega\text{-cm}$  and higher, which is in the same range as the familiar nichrome alloys widely used as resistance elements in electric circuits. Another interesting characteristic of the electrical resistivity of metallic glasses is that it does not vary much with temperature. Because of their insensitivity to temperature variations, metallic glasses are suitable for applications in electronic circuits for which this property is an essential requirement.

The first superconducting metallic glass was reported in 1975. This was an alloy containing 80 at. % lanthanum (La) and 20 at. % Au. Some superconducting metallic glasses contain only two metals, such as  $Zr_{75}Rh_{25}$ , and some are more complex alloys in which there is approximately 20% of metalloid elements, mostly B, Si, or P. One of the main reasons for continuing research on new superconducting glasses is their projected usefulness in high-field electromagnets, which will be required to contain the high-temperature plasma in fusion reactors. See SUPERCONDUCTIVITY.

The ferromagnetic properties of metallic glasses have received a great deal of attention, probably because of the possibility that these materials can be used as transformer cores.

Ferromagnetic amorphous alloys had been prepared before the technique of rapid cooling from the liquid state was developed. Electrolytic deposits of NiP alloys are slightly ferromagnetic for P concentrations less than 17 at. %. Amorphous CoP alloys can be electrodeposited in the amorphous state for P concentrations from 18 to 25 at. % Co and are also ferromagnetic. Ferromagnetism was also measured in alloys of Co with Au in the form of vapor-deposited thin films. These results suggested that it should be possible to obtain a ferromagnetic metallic glass from a liquid alloy containing a high enough percentage of ferromagnetic metals. The choice of alloying elements was guided by trying to satisfy the low-melting-point eutectic composition of the original AuSi glass, and Fe was the most obvious choice for the metal constituent.

The interest in the mechanical properties of metallic glasses is motivated by their high rupture strength and toughness. The fracture strength of metallic glasses approaches a theoretical strength that is about 1/50 of Young's modulus. Iron-based glasses have a fracture strength of  $5 \times 10^5$  lb/in.<sup>2</sup> (3.4 GPa), which is comparable to the best hard-drawn piano wires. Remarkably, despite their high strength, metallic glasses exhibit a high toughness contrary to the brittle behavior inherent in nonmetallic and high-strength crystalline metals. The ductility and toughness of Fe-based glasses, however, are very sensitive to thermal annealing. A complete loss in ductility of Fe glasses may occur after annealing without crystallization. In contrast, glass-forming alloys of Ni, Pd, and Pt as well as metal-metal alloys (Nb-Ni,Zr-Cu) remain ductile even in a partially crystalline state. The causes of embrittlement are still not clear. See YOUNG'S MODULUS.

Possible applications of metallic glasses have already been demonstrated on audio and video magnetic tape recording heads, sensitive and quick-response magnetic sensors or transducers, security systems, motors, and power transformer cores. The combination of excellent strength, resistance to corrosion and wear, and magnetic properties may lead to interesting applications, for example, the use of such glasses as inductors in magnetic separation equipment. [P.E.D.; H.S.C.]

**Metallocene catalyst** A transition-metal atom sandwiched between ring structures having a well-defined single catalytic site and well-understood molecular structure used to produce uniform polyolefins with unique structures and physical properties. See CATALYSIS; COORDINATION CHEMISTRY; COORDINATION COMPLEXES; METALLOCENES; ORGANOMETALLIC COMPOUND.

In the early 1980s, W. Kaminsky discovered that an appropriate co-catalyst activated metallocene compounds of group 4 metals, that is, titanium, zirconium, and hafnium, for alpha-olefin polymerization, attracting industrial interest. This observation led to the synthesis of a great number of metallocene compounds for the production of polymers already made industrially, such as polyethylene and polypropylene, and new materials. Polymers produced with metallocene catalysts represent a small fraction of the entire polyolefin market, but experts agree that such a fraction will increase rapidly in the future. See POLYMER; POLYMERIZATION; POLYOLEFIN RESINS.

The simplest metallocene precursor has the formula  $Cp_2MX_2$ , where M is one of the group 4 metals (mainly Zr and Ti) and X are halogen atoms (mainly chlorine, Cl). The latter are known

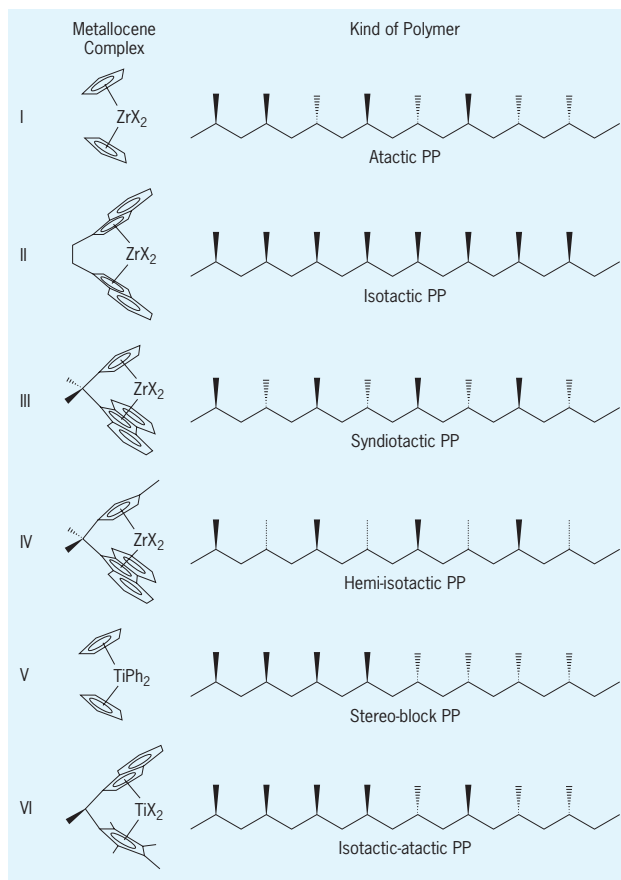

Correlation between the metallocene structure and the obtained polymer microstructure. PP = polypropylene.

as mobile ligands because during polymerization they are substituted or removed. A typical co-catalyst, in the absence of which the activity is very low, is methylaluminoxane (MAO), an oligomeric compound described by the formula  $(CH_3AlO)_n$ , whose structure is not yet fully understood. MAO plays several roles: it alkylates the metallocene precursor by replacing chlorine atoms with methyl groups; it produces the catalytic active ion pair  $Cp_2MCH_3^+/MAO^-$ , where the cationic moiety is considered responsible for polymerization and  $MAO^-$  acts as weakly coordinating anion.

The simplest metallocene structures are easily modified by replacing the Cp ligands with other variously substituted derivatives. In this way, a great number of catalysts with different steric and electronic properties are generated. The catalysts contain two C5 ring derivatives, always lying on tilted planes, which can be bridged or unbridged. Some examples are shown in the illustration, where the influence of the metallocene structure on the microstructure of the polymer product is also shown.

Because activity, stereospecificity, regiospecificity, and relative reactivity toward different monomers depend on the catalysts' characteristics, the metallocene systems offer the advantage of controlling the product through modifications of their chemical structure. [R.F.; F.G.; L.Lo.]

**Metallocenes** Bis-cyclopentadienyl derivatives of transition metals whose bonding involves overlap of  $ns$ ,  $(n-1)d$ , and  $np$  orbitals of the metal with molecular orbitals of appropriate symmetry of each cyclopentadienyl ring. The resulting complexes often possess two parallel rings (sandwich structure), but in some cases, for example those involving the titanium subgroup of metals, the rings are canted (see illustration). Metals in the periodic table commonly known to form metallocene complexes

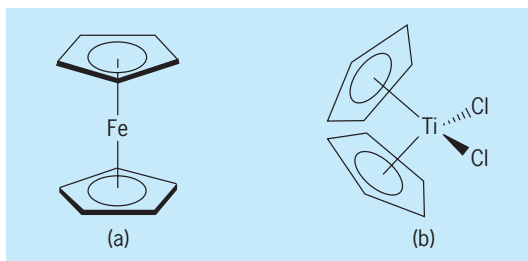

**Metallocene structures.** (a) Staggered sandwich structure of ferrocene. (b) Canted cyclopentadienyl ring structure of titanocene dichloride. The distribution of the ligands about the Ti atom is tetrahedral.

are titanium, zirconium, hafnium, vanadium, chromium, molybdenum, tungsten, manganese, iron, ruthenium, osmium, cobalt, rhodium, and nickel. See COORDINATION COMPLEXES.

The reactions of metallocenes can be divided into two classes: the first is typified by the iron triad, and comprises essentially the reactions of aromatic molecules; the second consists of the reactions of the other metallocenes where the 18-electron rare-gas configuration is not found. Reactions in these latter systems often lead to a product where the 18-electron rule is obeyed.

Ferrocene is a very electron-rich system, and undergoes electrophilic substitution with great rapidity. For example, acylation proceeds about  $10^6$  times faster than that of benzene under similar conditions. Ferrocene also undergoes several other typical aromatic substitution reactions besides acylation, including sulfonation, dimethylaminomethylation (Mannich reaction), metalation, and the like. Bis substitution tends to factor a product where each ring is monosubstituted, although several cases are known where two substituents are introduced into one ring. Ferrocene is oxidized and deactivated under conditions for nitration and halogenation.

Uses of metallocenes include reaction of chromocene with alumina to make a polymerization catalyst for ethylene. Ferrocene and some alkyl-substituted ferrocenes have been used as moderators in high-temperature combustions such as occur in solid rocket fuels. A cyclopentadienyl complex,  $\text{CH}_3\text{C}_5\text{H}_4\text{Mn}(\text{CO})_3$ , briefly replaced tetraethyllead as an octane booster and anti-knock agent in liquid fuels. See ORGANOMETALLIC COMPOUND.

[D.W.S.I.]

**Metallochaperones** A family of proteins that shuttle metal ions to specific sites within a cell. The target sites for metal delivery include a number of metalloenzymes, or proteins that bind metal ions, such as copper, zinc, or iron, and use these ions as cofactors to carry out essential biochemical reactions. Metallochaperones escort the ion to a specific intracellular location and facilitate incorporation of the metal into designated metalloenzymes. See BIOINORGANIC CHEMISTRY; CELL (BIOLOGY).

The bulk of current knowledge on metallochaperones is restricted to copper, although it is reasonable to assume that a distinct class of proteins is responsible for the incorporation of other metal ion cofactors into metalloenzymes. Among the metallochaperones that have been studied in detail are a family of three copper chaperones. These molecules operate in eukaryotic (nucleated) cells to direct copper to distinct intracellular locations: the mitochondria, the secretory pathway, and the cytosol. The first copper chaperone identified, COX17, is a small protein that specifically directs copper to the mitochondria. The copper delivered by COX17 is inserted into the metalloenzyme cytochrome oxidase, needed for respiration. A second copper chaperone identified was ATX1, which carries copper to the secretory pathway, a cellular compartment that functions to shuttle proteins toward the cell surface. The metal delivered by ATX1 is incorporated into copper enzymes destined for the cell surface or the extracellular milieu. The most recently identified copper

chaperone is CCS, which specifically delivers copper to a single metalloenzyme, superoxide dismutase. This copper-requiring enzyme is located in the soluble cytosolic compartment of the cell and acts to detoxify harmful reactive oxygen species. See MITOCHONDRIA.

Intracellular copper is normally present at exquisitely low levels, and activation of copper enzymes is wholly dependent upon copper chaperones. Copper not only is an essential nutrient but also is quite toxic to living cells, and elaborate detoxification mechanisms prevent the free metal ion from accumulating to any substantial degree. The copper-requiring metalloenzymes cannot compete for these vanishingly low levels of available metal, explaining the requirement for the copper metallochaperones. [V.C.C.]

**Metallography** The study of the structure of metals and alloys by various methods, especially light and electron microscopy. Light microscopy of metals is conducted with reflected light on surfaces suitably prepared to reveal structural features. The method is often called optical microscopy or light optical microscopy. A resolution of about 200 nanometers and a linear magnification of at most  $2000\times$  can be obtained. Electron microscopy is generally carried out by the scanning electron microscope (SEM) on specimen surfaces or by the transmission electron microscope (TEM) on electron-transparent thin foils prepared from bulk materials. Magnifications can range from  $10\times$  to greater than  $1,000,000\times$ , sufficient to resolve individual atoms or planes of atoms.

Metallography serves both research and industrial practice. Light microscopy has long been a standard method for observing the morphology of phases resulting from industrial processes that involve phase transformations, such as solidification and heat treatment, and plastic deformation and annealing. Microscopy, both light and electron, is also indispensable for the analysis of the causes of service failures of components and products.

In light microscopy, microstructural features observed in photomicrographs include the size and shape of the grains (crystals) in single-phase materials (see illustration), the structure of alloys containing more than one phase such as steel, the effects of deformation, microcracking, and the effects of heat treatment. Other structural features investigated by light microscopy include the morphology and size of precipitates, compositional inhomogeneities (microsegregation), microporosity, corrosion, thickness and structure of surface coatings, and microstructure and defects in welds.

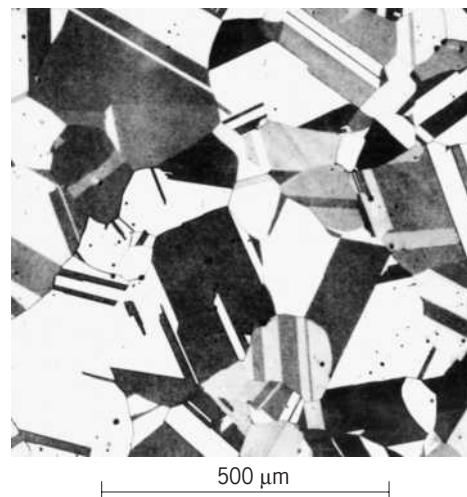

Photomicrographs of typical microstructures of annealed brass (70% Cu–30% Zn). (Courtesy of W. R. Johnson)

The electron microscope offers improved depth of field and higher resolution than the light microscope, as well as the possibility of in-place spectroscopy techniques. The scanning electron microscope images the surface of a material, while the transmission electron microscope reveals internal microstructure. Images produced by the scanning electron microscope are generally easier to interpret; in addition, the instrument operates at lower voltages, offers lower magnification, and requires less specimen preparation than is necessary for the transmission electron microscope. Consequently it is important to view a specimen with light microscopy and often with the scanning electron microscope before embarking on transmission electron microscopy.

However there are some disadvantages. Electron microscope specimens are viewed under vacuum, the instruments cost significantly more than light microscopes, electron beam damage is always a danger, and representative sampling becomes more difficult as the magnification increases. See ELECTRON MICROSCOPE.

The ionizing nature of electron irradiation means that x-ray spectrometry and electron spectrometry, both powerful tools in their own right, can be performed in both scanning electron microscopy and transmission electron microscopy. The various signals detected spectroscopically can also be used to form images of the specimen, which reveal elemental distribution among other information. In particular, the characteristic x-ray signal can be detected and processed to map the elemental distribution quantitatively on a micrometer scale in the scanning electron microscope and a nanometer scale in the transmission electron microscope. Electron spectroscopic signals permit not only elemental images to be formed but also images that reveal local changes in bonding, dielectric constant, thickness, band gap, and valence state. See ELECTRON SPECTROSCOPY; METALLURGY.

[D.A.T.; D.B.W.]

**Metalloid** An element which exhibits the external characteristics of a metal but behaves chemically both as a metal and as a nonmetal. Arsenic and antimony, for example, are hard crystalline solids that are definitely metallic in appearance. They may, however, undergo reactions that are characteristic of both metals and nonmetals. However, only when this dualistic chemical behavior is very marked and the external appearance metallic is the element commonly called a metalloid. See METAL; NONMETAL.

[F.J.J.]

**Metallurgy** The technology and science of metallic materials. Metallurgy as a branch of engineering is concerned with the production of metals and alloys, their adaptation to use, and their performance in service. As a science, metallurgy is concerned with the chemical reactions involved in the processes by which metals are produced and the chemical, physical, and mechanical behavior of metallic materials.

The field of metallurgy may be divided into process metallurgy (production metallurgy, extractive metallurgy) and physical metallurgy. In this system metal processing is considered to be a part of process metallurgy and the mechanical behavior of metals a part of physical metallurgy.

Process metallurgy, the science and technology used in the production of metals, employs some of the same unit operations and unit processes as chemical engineering. These operations and processes are carried out with ores, concentrates, scrap metals, fuels, fluxes, slags, solvents, and electrolytes. Different metals require different combinations of operations and processes, but typically the production of a metal involves two major steps. The first is the production of an impure metal from ore minerals, commonly oxides or sulfides, and the second is the refining of the reduced impure metal, for example, by selective oxidation of impurities or by electrolysis. See ELECTROMETALLURGY; HYDROMETALLURGY; IRON METALLURGY; ORE DRESSING; PYROMETALLURGY; STEEL MANUFACTURE.

Physical metallurgy investigates the effects of composition and treatment on the structure of metals and the relations of the struc-

ture to the properties of metals. Physical metallurgy is also concerned with the engineering applications of scientific principles to the fabrication, mechanical treatment, heat treatment, and service behavior of metals. See ALLOY; HEAT TREATMENT (METALLURGY).

The structure of metals consists of their crystal structure, which is investigated by x-ray, electron, and neutron diffraction, their microstructure, which is the subject of metallography, and their macrostructure. Crystal imperfections, which provide mechanisms for processes occurring in solid metals, are investigated by x-ray diffraction and metallographic methods, especially electron microscopy. The microstructure is determined by the constituent phases and the geometrical arrangement of the microcrystals (grains) formed by those phases. Macrostructure is important in industrial metals. It involves chemical and physical inhomogeneities on a scale larger than microscopic. Examples are flow lines in steel forgings and blowholes in castings. See METALLOGRAPHY; X-RAY DIFFRACTION.

Phase transformations occurring in the solid state underlie many heat-treatment operations. The thermodynamics and kinetics of these transformations are a major concern of physical metallurgy. Physical metallurgy also investigates changes in the structure and properties resulting from mechanical working of metals.

For more information on metallurgy and some associated techniques see articles on individual metals and their metallurgy. See ELECTROPLATING OF METALS; METAL COATINGS; METAL FORMING.

[M.B.B.]

**Metameres** The serial repetition of parts along the length of the body axis in bilaterally symmetrical animals. The successive subdivisions are called metameres, somites, or segments, hence the synonym, segmentation. Common examples are the muscles and spinal nerves in the human body and in the body and tail of many mammals, snakes and lizards, salamanders, and fishes. It also occurs in other chordates, and in arthropods and annelid worms. It never involves reproductive organs, and thus differs from strobilization in tapeworms and certain jellyfish. Metamerism arises either from a bilateral series of coelomic pouches which form the segmental muscles, kidneys, and body cavities of lower forms, or from mesoblastic somites which form the skeletal and muscular segments of vertebrates. Repetitive features of the nervous system are acquired secondarily through the influence of mesodermal metameres upon adjoining ectodermal tissues. Several primitive embryonic somites become fused in the heads of adult arthropods and vertebrates. See ANIMAL SYMMETRY; COELOM; MUSCULAR SYSTEM; NEURULATION. [H.L.Ha.]

**Metamict state** The state of a special class of amorphous materials that were initially crystalline. W. C. Broegger first used the term *metamikte* in 1893 to describe minerals that were optically isotropic with a "glasslike" fracture but still retained well-formed crystal faces. In 1914 A. Hamburg correctly attributed the transition from the periodic, crystalline state to the aperiodic, metamict state as induced by alpha-decay damage. In minerals, this damage is the result of the decay of naturally occurring radionuclides and their daughter products in the uranium and thorium ( $^{238}\text{U}$ ,  $^{235}\text{U}$ , and  $^{232}\text{Th}$ ) decay series. A wide variety of complex oxides, silicates, and phosphates are reported as occurring in the metamict state. All of these structures can accommodate uranium and thorium. See ALPHA PARTICLES; AMORPHOUS SOLID; RADIOACTIVITY.

The presence of uranium and thorium distinguishes metamict minerals from other naturally occurring amorphous materials that have not experienced this radiation-induced transformation. Lanthanide elements are also common (in some cases over 50 wt %) and water of hydration may be high (up to 70 mol %).

The radiation damage caused by the alpha-decay event is the result of two separate but simultaneous processes: (1) An alpha particle with an energy of approximately 4.5 MeV and a range of

10,000 nanometers dissipates most of its energy by ionization; however, at low velocities near the end of its track, it displaces several hundred atoms, creating Frenkel defect pairs. (2) The alpha-recoil atom with an energy of approximately 0.09 MeV and a range of 10 to 20 nm produces several thousand atomic displacements, creating tracks of disordered material. These two damaged areas are separated by thousands of unit cell distances and have different effects on the crystalline structure. Local point defects cause an increase in the distortion; therefore, there is an increase in the strain in the structure. Alpha-recoil tracks create regions of aperiodic material that at high enough alpha-decay doses (usually  $10^{24}$  to  $10^{25}$  alpha-decay events/m<sup>3</sup>) overlap and finally lead to the metamict state. The former causes broadening of x-ray diffraction maxima and an increase in unit cell volume (and a decrease in the density); the latter causes a decrease in diffraction peak intensities. The radiation-induced transition from the crystalline to the metamict state occurs over a narrow range of alpha-decay dose ( $10^{24}$ – $10^{25}$  alpha decays/m<sup>3</sup>), which corresponds to 0.1 to 1.0 displacements per atom (dpa). See CRYSTAL DEFECTS; RADIATION DAMAGE TO MATERIALS.

A renewed interest in the metamict state has been stimulated by concern for the long-term stability of crystalline materials (nuclear waste forms) that will serve as hosts for actinides (for example, plutonium, americium, curium, and neptunium). Various crystalline materials (phases) may appear in a single waste form; each phase may or may not suffer radiation damage. For some nuclear waste-form phases, the radiation-induced transformation to the metamict state has been stimulated by doping phases with highly radioactive plutonium-238 or curium-244. [R.C.Ew.]

**Metamorphic rocks** Preexisting rock masses in which new minerals, textures, or structures are formed at higher temperatures and greater pressures than those normally present at the Earth's surface. See IGNEOUS ROCKS; SEDIMENTARY ROCKS.

Two groups of metamorphic rocks may be distinguished; cataclastic rocks, formed by the operation of purely mechanical forces; and recrystallized rocks, or the metamorphic rocks properly so called, formed under the influence of metamorphic pressures and temperatures. Cataclastic rocks are mechanically sheared and crushed. They represent products of dynamometamorphism, or kinetic metamorphism. Chemical and mineralogical changes generally are negligible. The rocks are characterized by their minute mineral grain size. Each mineral grain is broken up along the edges and is surrounded by a corona of debris or strewn fragments. See METAMORPHISM.

Metamorphic rocks, properly so called, are recrystallized rocks. The laws of recrystallization are not the same as those of simple crystallization from a liquid, because the crystals can develop freely in a liquid, but during recrystallization the new crystals are encumbered in their growth by the old minerals. Consequently, the structures which develop in metamorphic rocks are distinctive and of great importance, because in many ways they reflect the physiochemical environment of recrystallization and thereby the genesis and history of the metamorphic rock.

The metamorphic minerals may be arranged in an idioblastic series (crystalloblastic series) in their order of decreasing force of crystallization as follows: (1) sphene, rutile, garnet, tourmaline, staurolite, kyanite; (2) epidote, zoisite; (3) pyroxene, hornblende; (4) ferrogmagnesite, dolomite, albite; (5) muscovite, biotite, chlorite; (6) calcite; (7) quartz, plagioclase; and (8) orthoclase, microcline. Crystals of any of the listed minerals tend to assume idioblastic outlines at surfaces of contact with simultaneously developed crystals of all minerals of lower position in the series.

Igneous magma at high temperature may penetrate into sedimentary rocks, it may reach the surface, or it may solidify in the form of intrusive bodies (plutons). Heat from such bodies spreads into the surrounding sediments, and because the mineral assemblages of the sediments are adjusted to low temperatures, the heating-up will result in a mineralogical and textural

reconstruction known as contact metamorphism. See CONTACT AUREOLE; PLUTON.

The effects produced do not depend only upon the size of the intrusive. Other factors are amount of cover and the closure of the system, composition and texture of the country rock, and abundance of gaseous and hydrothermal magmatic emanations. The heat conductivity of rocks is so low that gases and vaporous emanations become chiefly responsible for transportation and transfer of heat into the country rock.

Crystalline schists, gneisses, and migmatites are typical products of regional metamorphism and mountain building. If sediments accumulate in a slowly subsiding geosynclinal basin, they are subject to down-warping and deep burial, and thus to gradually increasing temperature and pressure. They become sheared and deformed, and a general recrystallization results. However, subsidence into deeper parts of the crust is not the only reason for increasing temperature. It is not known what happens at the deeper levels of a live geosyncline, but obviously heat from the interior of the Earth is introduced regionally and locally, partly associated with magmas, partly in the form of "emanations" following certain main avenues, determined by a variety of factors. From this milieu rose the lofty mountain ranges of the world, with their altered beds of thick sediments intercalated with tuffs, lava, and intrusives, all thrown into enormous series of folds and elevated to thousands of feet. Thus were born the crystalline schists with their variants of gneisses and migmatites. See OROGENY.

Well-defined series of mineral facies have been singled out. Sedimentary rocks of the lowest metamorphic grade have recrystallized to give rocks of the zeolite facies. At slightly higher temperatures the greenschist facies develops—chlorite, albite, and epidote being characteristic minerals. A higher degree of metamorphism produces the epidote-amphibolite facies, and a still higher degree the true amphibolite facies in which hornblende and plagioclase mainly take the place of chlorite and epidote. Representative of the highest regional metamorphic grade is the granulite facies, in which most of the stable minerals are water-free, for example, pyroxenes and garnets. Any sedimentary unit will recrystallize according to the rules of the several mineral facies, the complete sequence of events being a progressive change of the sediment by deformation, recrystallization, and alteration in the successive stages: greenschist facies→epidote-amphibolite facies→amphibolite facies→granulite facies. See FACIES (GEOLOGY); GRANULITE.

The normal continental crust is entirely made up of metamorphic rocks; where thermal, mechanical, and geochemical equilibrium prevails, there are only metamorphic rocks. Border cases of this normal situation occur in the depths where ultrametamorphism brings about differential melting and local formation of magmas. When equilibrium is restored, these magmas congeal and recrystallize to (metamorphic) rocks. At the surface, weathering processes oxidize and disintegrate the rocks superficially and produce sediments as transient products. Thus the cycle is closed; petrology is without a break. All rocks that are found in the continental crust were once metamorphites. See AMPHIBOLITE; GREISEN; MARBLE; MIGMATITE; PHYLLITE; QUARTZITE; SCAPOLITE; SERPENTINITE; SOAPSTONE. [T.F.W.B.; R.C.N.]

**Metamorphism** The alterations and transformations in preexisting rock masses effected by temperature and pressure, but excluding changes produced by weathering and sedimentation. The changes may include the production of new minerals, structures, or textures, or all three. They give a distinctive new character to the rock as a whole, but they do not involve the loss of individuality of a rock mass, such as changes brought about by fusion. Quantitatively, the metamorphic rocks, including gneisses and migmatites, are the most important group of rocks in the crust of the continents. See GNEISS; METAMORPHIC ROCKS; MIGMATITE.

Different kinds of metamorphism may be defined according to genetic criteria, such as the geologic processes that were assumed to have caused the metamorphism, or the physical and chemical conditions that appear to have been predominant in determining the course of metamorphism. Using these criteria three general kinds of metamorphism are noted below.

1. Dislocation, mechanical, or dynamic metamorphism is the result of pressure (or stress) along dislocations in the Earth's crust. The deformed rocks commonly show marked zones of extremely fine-grained rocks, such as mylonites, whose structures are determined by crushing and movement of the grains without important recrystallization of old, or growth of new, minerals. This type of metamorphism is local and restricted in occurrence.

2. Contact or thermal metamorphism occurs in response to increased temperature induced by adjacent intrusions of magma. Chemical reconstitution of the rocks is due to magmatic exhalation; other conditions, such as confining pressure, exert subordinate influence.

3. Regional metamorphism, the most widespread type, is brought about by an increase in both temperature and pressure in orogenic regions, which are vast segments of the crust represented by the folded mountain ranges. Heat and pressure are mainly consequences of downwarping and deep burial. Pressure is also generated by shearing stresses accompanying the orogenic movements. *See* OROGENY. [T.F.W.B./R.C.N.]

A fluid phase plays an important role during metamorphism as an agent of heat and mass transfer. The presence of a static film of fluid around mineral grains greatly facilitates chemical reactions because the fluid film speeds the movement of matter from reactant to product minerals. Flowing fluid carries substantial quantities of materials in solution that may be precipitated far from their source. Heated rocks are cooled more rapidly, and cool rocks are more quickly heated, by flowing fluids than would otherwise be possible by heat conduction. Fluids of metamorphic rocks consist primarily of water (H<sub>2</sub>O), variable amounts of carbon dioxide (CO<sub>2</sub>) and methane (CH<sub>4</sub>), and minor quantities of hydrogen sulfide (H<sub>2</sub>S), carbon monoxide (CO), hydrogen (H<sub>2</sub>), and sulfur dioxide (SO<sub>2</sub>). [D.Rum.]

**Metamorphosis** A pronounced change in both the internal and external morphology of an animal that takes place in a short amount of time, triggered by some combination of external and internal cues. The extent of morphological change varies considerably among species. Even when morphological changes are relatively slight, metamorphosis typically brings about a pronounced shift in habitat and lifestyle. The precise morphological, physiological, and biochemical changes that constitute metamorphosis; the neural, hormonal, and genetic mechanisms through which those changes are controlled; and the ecological consequences of those changes and when they take place continue to be studied in a wide variety of animals. The hormonal and genetic control of metamorphosis has been best examined in a few species of insect, amphibian, and fish (such as flounder), but other aspects of metamorphosis have been investigated for other insect, amphibian, and fish species as well as for marine invertebrates and, indeed, representatives of essentially every animal phylum.

Amphibians exhibit extensive tissue remodeling during metamorphosis, including resorption of the tail musculature and skeletal system; major reconstruction of the digestive tract; degeneration of larval skin and pronounced alteration in skin chemical composition; growth of the hind and fore limbs; degeneration of the gills and associated support structures; shifts in mode of nitrogen excretion, from ammonia to urea; alteration in visual system biochemistry; replacement of larval hemoglobin with adult hemoglobin; and differential growth of the cerebellum. *See* AMPHIBIA.

Metamorphosis among insects is associated primarily with wing development. Bristletails and other species that do not develop wings and are not descended from winged ancestors

exhibit no pronounced metamorphosis. Metamorphosis is most dramatic among holometabolous species, which pass through a distinctive and largely inactive pupal stage; in such species, all of the transformations separating the larval morphology and physiology from that of the adult take place in the pupa. Wings, compound eyes, external reproductive parts, and thoracic walking legs develop from discrete infolded pockets of tissue (imaginal discs) that form during larval development. *See* INSECTA; MOLTING (ARTHROPODA).

The most dramatic metamorphic changes in fish are seen among flounder and other flatfish: in such species, during metamorphosis a symmetrical fish larva becomes an asymmetrical adult, with both eyes displaced to the dorsal surface. The transformation of leptocephalus larvae into juvenile eels is also dramatic; such transformation includes a shift in the position of the urinary and digestive tracts from posterior to anterior. *See* EEL; PLEURONECTIFORMES.

The control of metamorphosis among crabs, barnacles, gastropods, bivalves, bryozoans, echinoderms, sea squirts, and other marine invertebrates is poorly understood, partly due to the very small size of the larvae—they rarely exceed 1 mm in length, and most are less than 0.5 mm. The larvae of some marine invertebrate species are triggered to metamorphose by specific substances associated with adults of the same species, or with the algae or animals on which they prey. *See* ANNELIDA; BIVALVIA; CRAB; DECAPODA (CRUSTACEA); ECHINODERMATA; GASTROPODA; MOLLUSCA.

Among insects, the timing of metamorphosis is influenced by environmental factors such as temperature, humidity, photoperiod, pheromone production by neighboring individuals, and the nutritional quality of the diet. In a number of species, larvae can undergo developmental arrest (a diapause) in response to unfavorable environmental conditions, so that metamorphosis can be delayed for many months or even years. The hormonal basis for such effects has been at least partly worked out for a number of insect species.

Among marine invertebrates and in at least some fish species, there is also considerable flexibility in the timing of metamorphosis. At some point in the development of marine invertebrates and apparently also in the development of some coral reef fishes, individual larvae become "competent" to metamorphose. It is not yet clear what makes larvae competent; the development of external receptor cells, or the completion of specific neural pathways, or the activation of hormonal systems or their receptors are likely possibilities. *See* ENDOCRINE MECHANISMS; ENDOCRINE SYSTEM (INVERTEBRATE); INVERTEBRATE EMBRYOLOGY. [J.A.Pe.]

**Metasomatism** The process by which the bulk chemical composition of a rock is changed from some previous state by the introduction of components from an external source. In contrast with metamorphism, where rocks are converted to a new set of minerals with little or no change in bulk composition, metasomatism involves the import and export of chemical components through the agency of a chemically active fluid.

Clastic rocks and mafic-to-felsic igneous rocks react in similar ways with metasomatic fluids by exchange of alkalis, alkaline earths, and hydrogen. Hydrolytic alteration dominates lower-temperature metasomatic processes. Hydrolysis involves hydrogen-ion metasomatism—exchange of hydrogen ion for potassium, sodium, and calcium.

Metasomatism of aluminum-poor rocks carbonate and ultramafic rocks generally involves addition of silica, metals, and alumina.

Metasomatism is best developed in environments characterized by extreme physical and chemical gradients and high fluid flux. At the centimeter scale, chemical contrasts along shale-limestone contacts lead to diffusive exchange of components on heating during regional or contact metamorphism. At the kilometer scale in mid-ocean rifts, island arcs, and continental-margin plutonic arcs, metasomatism results from emplacement

of magma at depths of a few kilometers and infiltration of hot, saline, aqueous fluids through fractured rocks. At global scales, metasomatism accompanies mass fluxing between the crust and the mantle, such as on emplacement of mantle plumes into the lower crust or subduction of oceanic crust into the mantle. See ASTHENOSPHERE; EARTH CRUST; MAGMA; METAMORPHISM. [M.T.E.]

**Metastable state** In quantum mechanics, a state that is not truly stationary but is almost stationary.

In practice, especially in atomic and nuclear physics applications, the designation metastable state usually is reserved for states whose lifetimes are unusually long. For example, the excited states of atoms usually decay with the emission of a single photon, in a time of the order of  $10^{-8}$  s. However, the necessity for angular momentum and parity conservation forces the second excited state ( $2S_{1/2}$ ) of atomic hydrogen to decay by simultaneous emission of two photons; consequently, the lifetime is increased to an estimated value of 0.15 s. Thus, the  $2S_{1/2}$  state of atomic hydrogen is usually termed metastable, but most other hydrogenic states are not. Similarly, emission of a gamma-ray photon by an excited nucleus usually occurs in  $10^{-13}$  s or less; however, the lifetime of one excited state of the  $^{113}\text{In}$  nucleus, the state that customarily is termed metastable, is about 100 min. Since radiative transition probabilities for emission of photons generally decrease rapidly with decreasing frequency, a low-lying atomic or nuclear excited state may have a lifetime longer than most excited states of atoms and nuclei and yet not be metastable in the practical sense just described, because photon emission from the state may not be hindered by any general requirement or selection rule, such as is invoked for the  $2S_{1/2}$  state of hydrogen. See EXCITED STATE; NUCLEAR ISOMERISM; RADIOACTIVITY. [E.G.]

**Metatheria** An infraclass of therian mammals including a single order, the Marsupialia. The Metatheria are distinguished from the Eutheria (the placental mammals) by numerous characters. The braincase is small, the angular process of the mandible is inflected, and a pair of marsupial bones articulates with the pelvis. Almost all living marsupials have a pouch on the belly of the female in which the young are carried after birth. The early marsupials were unable to compete with the more progressive later placental forms and died out except in South America and Australia, where they were isolated by water barriers. See EUTHERIA; MAMMALIA; THERIA. [D.D.D./F.S.S.]

**Metazoa** The kingdom (or subkingdom) comprising all many-celled animals, whether constructed of simple tissue layers or of complex organs. In some five-kingdom systems and in the six-kingdom systems of classification for living organisms, metazoans constitute a separate kingdom, while in the older two-kingdom and some three-kingdom systems the subphylum Metazoa made up the greater part of the kingdom Animalia. Most usual classifications subdivide the Metazoa into about 30 phyla of many-celled animals (such as Arthropoda or Mollusca), each representing a major kind of body design. In all classifications, the only animal forms not included in the Metazoa are the single-celled protozoa (Protista) and the independently evolved sponges (Parazoa). See ANIMAL KINGDOM; EUKARYOTAE; PROTIFERA; PROTISTA.

Metazoans are made up of eukaryotic cells, each with a membrane surrounding the nuclear material and with the mechanics of cell multiplication always involving the mitotic division of chromosomes. Cellular specialization is common. In addition to increasing functional interdependence and specialization of cells, the evolution of the higher phyla of Metazoa has involved the potentialities and penalties of increasing size, particularly those associated with the surface-mass ratio. Despite differing grades of structural and functional complexity, interdependence of organs, tissues, and cell types is diagnostic of the phyla of animals

making up the kingdom (or subkingdom) Metazoa. See CLASSIFICATION, BIOLOGICAL; HOMEOSTASIS. [W.D.R.H.]

**Meteor** The luminous streak lasting seconds or fractions of a second and seen at night when a solid, natural body plunges into the Earth's (or another planet's) atmosphere. The entering object is called a meteoroid and, if any of it survives atmospheric passage, the remainder is called a meteorite. Cosmic dust particles (with masses of micrograms) entering the atmosphere and leaving very brief, faint trails are called micrometeoroids, with the surviving pieces known as micrometeorites. If the apparent brightness of a meteor exceeds that of the planet Venus as seen from Earth, it is called a fireball, and when a bright meteor is seen to explode, it is called a bolide. See METEORITE; MICROMETEORITE.

Under normal, clear atmospheric conditions and dark skies (no moonlight or artificial lights), an observer will see an average of five meteors per hour. The spatial distribution of meteoroid orbits relative to the Sun and the circumstances of their intersections with the moving Earth are responsible for pronounced variations in meteor rates.

The average meteor seen by the unaided eye starts with a meteoroid velocity of 18 mi/s (30 km/s) and leaves a luminous trail from 67 to 50 mi (110 to 80 km) high. The meteor trails are rapidly expanding columns of atoms, ions, and electrons dislodged from the meteoroid by collisions with air molecules, and can be excited to temperatures of several thousand degrees Celsius. For a time after trail formation, the free electrons are dense enough to reflect radio waves in the very high frequency range, and therefore can be used to transmit radio messages. See RADIO-WAVE PROPAGATION.

Under the right circumstances, particularly with high-power ultrahigh-frequency (UHF) radars, the ionization right around and moving with the meteoroid itself is seen. This is known as the head echo, and a determination of its velocity is the most accurate way to determine radar meteor speeds. See RADAR; RADAR ASTRONOMY.

The Earth moves around the Sun with an average speed of 18 mi/s (30 km/s). According to the laws of celestial mechanics, if a meteoroid comes from beyond the solar system, its velocity at the Earth's distance from the Sun must be greater than 26 mi/s (42 km/s). If such a meteoroid hits the Earth head-on, indications of preatmospheric speeds in excess of 45 mi/s (72 km/s) would be observed. The fact that the vast majority of observed meteoroids have orbits with Earth-approaching velocities of less than 45 mi/s indicates that most of these are comet and asteroid fragments, and are therefore long-term members of the solar system. However, in the 1980s and 1990s, a combination of spacecraft and high-power radar observations indicated that hypervelocity micrometeoroids do indeed exist with seeming interstellar dust connections. See INTERSTELLAR MATTER.

A combination of the meteoroid's and Earth's velocities of travel around the Sun make the meteor itself seem to originate from a specific direction in the sky called the radiant. If there are numerous meteoroids in nearly the same orbit (sometimes incorrectly called meteor streams), the Earth sweeps them up at specific times of the year and a so-called meteor shower is observed. Meteor showers are named after the constellation or single star in the sky from which they appear to radiate. While shower meteoroids are really moving nearly parallel through space and result in nearly parallel meteor trails, the effects of perspective make the meteors appear to diverge from the radiant. Meteors that cannot be shown to be associated with a known shower are termed sporadic meteors.

A number of meteor showers have been observed to be in orbits that are similar to those traveled by known comets. Thus an association between shower meteors and comets has gradually become a firmly entrenched concept. There are numerous theoretical scenarios where vaporization of the more volatile cometary ices ejects small solid particles from the surface of the

nucleus. A fair proportion of these fragments, particularly the smaller dust-sized ones, escape and take up their own orbits as meteoroids. Cometary nuclei have been known to split into two or more pieces and, when this occurs, it is likely that particles larger than dust size are released as well.

The strategy of photographic or electronic measurements is to place at least two cameras 10–52 mi (15–85 km) apart over a known baseline, but arranged to examine the same volume of space at a height of about 56 mi (90 km). Each camera has a rotating shutter so that the meteor trail consists of a line of bright dashes. Meteor imaging is one of the most difficult areas of astronomical detection, even with ultrafast cameras. Meteor spectroscopy is even more difficult since the light is spread out over areas hundreds of times larger than the meteor trail itself. See ASTRONOMICAL PHOTOGRAPHY; ASTRONOMICAL SPECTROSCOPY.

Radio and radar observations depend on the fact that the initial ion-electron densities in a meteor trail are considerably higher than the average for the ionosphere at an altitude of 56 mi (90 km). For a very high frequency (VHF) or somewhat lower-frequency radar system, the maximum reflected signal occurs when the meteor trail is at right angles to the outgoing wave, with head echoes rarely seen. At ultrahigh frequencies (UHF), radar reflections from the head-echo predominate. From these, high-accuracy radial velocities are determined directly, using the Doppler effect. See DOPPLER EFFECT; RADIO ASTRONOMY.

The parent comet of the Leonid stream, 1866 I, made another of its periodic (33-year intervals) approaches to the Sun in 1999. With the appearance of the comet, it was expected that the strong meteor storm that happened last in 1966 would again make a brief but spectacular appearance. However, perturbations by the outer planets (particularly by Neptune) once again played a significant role in this shower's behavior. The perturbations moved a number of thin meteoroid streams produced by the comet many orbit periods in the past into intersection range of the Earth. This produced a unique succession of strong peaks covering a span of seven years (1996–2003). The scientific yield of this extended display was much more than anyone had hoped. While meteor trails had been previously recorded from the space shuttle and other spacecraft, in 1997 the first above-atmosphere, far-ultraviolet spectrum of a bright meteor was recorded during the Leonid shower. Spectra obtained from the ground also yielded new information. The large number of fireballs in the Leonid streams enabled many details of the ablation processes at higher than average meteoroid incoming velocities to be recorded with high-speed cameras. [D.D.M.]

**Meteorite** A naturally occurring solid object from interplanetary space that survives impact on a planetary surface. While in space, the object is called a meteoroid, and a meteor if it produces light or other visual effects as it passes through a planetary atmosphere. Explosive surface impacts by large meteorites are believed to have created the plethora of craters on the solid planets and moons of the solar system. See METEOR; MICROMETEORITE.

A meteorite seen to strike a surface is known as a fall, whereas a meteorite discovered by chance is known as a find. In both cases, meteorites are named after their geographic places of recovery.

Meteorites have been broadly classified into stony, stony-iron, and iron varieties in recognition of their compositions that are dominated by silicate minerals and iron-nickel alloys either alone or as admixtures. Within each of the three categories, detailed classifications are based on distinctive mineralogical and chemical compositions and physical structures.

Meteorites represent the most ancient rocks known. Their ages, as determined by radiometric dating, extend to more than  $4.5 \times 10^9$  years, which is thought to be near the time of solar system formation. As samples of primordial material, stony meteorites known as chondrites are studied for clues about how the solar system formed. In contrast, achondrites, stony-irons, and irons are samples of melt products formed during processing of

solid material in planetary or preplanetary bodies. See DATING METHODS; SOLAR SYSTEM.

Asteroids are believed to be the sources of most meteorites. In 1982, however, it was conclusively demonstrated that a small achondrite found in Antarctica in 1981 was from the Moon. Even more exciting is the prospect that several closely related achondrites (shergottites, nakhlites, and the Chassigny meteorite), from various recovery locations around the world, are from Mars; one of them contains trapped gases that are nearly identical to those measured for the Martian atmosphere by the Viking lander in 1976. See ASTEROID; MARS; MOON.

**Stony meteorites.** Stony meteorites include a large class known as chondrites and a smaller class known as achondrites.

The stony meteorites called chondrites, which are the most abundant class of known meteorites, constitute approximately 92% of all meteorite falls. Chondrites are divided into three major categories: ordinary, carbonaceous, and enstatite. All chondrites contain various amounts of small (generally 0.5–2 mm) beadlike objects known as chondrules.

Ordinary chondrites are the most abundant chondrites, constituting 93% of all chondrite falls. They are composed mainly of the minerals olivine, low-calcium pyroxene, plagioclase, iron-nickel (Fe-Ni) metal, and troilite. They may contain silicate glass. See FELDSPAR; OLIVINE; PYROXENE; PYRRHOTITE.

Chondrules are contained in a matrix of the same minerals that make up the chondrites. The difference is in texture. Chondrule minerals crystallized within molten droplets, and they show a variety of shapes consistent with a molten origin. Matrix minerals are granular and of small grain sizes. [J.L.Go.]

Carbonaceous chondrites are the most primitive of all meteorites. In addition to the major chemical elements that occur in all of the chondrite meteorites, carbonaceous chondrites contain significant amounts of carbon, hydrogen, and nitrogen, which are present in only trace amounts in ordinary chondrites. In addition to chondrules, they have a large number of other types of inclusions. Most important is the fact that the minerals that make up chondrules and inclusions are different in composition and kind from minerals that make up the surrounding matrix.

Enstatite chondrites consist of 60–80 vol % enstatite (FsO) with 10–30 vol % metal and 5–15 vol % troilite. Enstatite chondrites range from those with many chondrules to those that are free of chondrules. See ENSTATITE.

Chondrites contain components from two environments of origin: as results of processes that occurred under dispersed conditions in space, known as nebular; and as results of processes that occurred within parent bodies, known as planetary.

The carbonaceous chondrites have the most evident nebular components in the form of refractory mineral inclusions. These minerals formed by direct condensation from a gas cloud surrounding the primitive Sun. The minerals were accreted into small asteroidal bodies and never subjected to subsequent heat or pressure, that is, metamorphism that would have erased their primitive characteristics. The early formation and accretion histories of the ordinary chondrites and enstatite chondrites into asteroidal bodies are unknown. [E.O.]

Chondrules are the most abundant particles in chondrites, generally being ~1 mm (0.04 in.) in diameter. They contain iron-magnesium silicates that crystallized from a melt.

It has become widely agreed that chondrules were formed by nebular melting of solid precursors, consisting of randomly assembled condensates, presolar relics, and chondrule debris. They were hot for only a few hours in an environment with a low ambient temperature. This requires a local heating event, rather than a nebula-wide process. Specific suggestions for melting mechanisms have ranged from lightning to frictional heating of infalling interstellar grains. [R.H.Hew.]

Achondrites are stony meteorites that have few, if any, chondrules and differ chemically from chondrites. They constitute about 8% of all meteorite falls and 1% of all finds. Although achondrites can be divided into several distinct groups based



on chemical and isotopic composition, they are generally believed, based on aspects of their textures and composition, to have formed as the result of igneous processes on asteroidal or planetary bodies. Much of the interest in these meteorites derives from the fact that they provide clues into the nature of igneous processes and planetary differentiation early in the history of the solar system on planetary bodies outside the Earth-Moon system and on bodies presumed to be much smaller than the Earth and Moon.

The eucrites, howardites, and diogenites—often collectively referred to as the basaltic achondrites—are the most abundant achondritic meteorites. They appear to be samples of a series of related igneous rocks and of regolith breccias composed of fragments of these igneous rocks. They define a coherent group in terms of their oxygen isotope compositions, suggesting they are closely related. With ages near 4.5 billion years, they are products of igneous activity from the earliest history of planetary bodies in the solar system.

It is clear that igneous processes as they are known from study of terrestrial and lunar rocks were active on small bodies very soon after their formation. The heat source for such igneous activity is still under investigation, but it could be the decay of the aluminium isotope  $^{26}\text{Al}$  or perhaps heating by electric currents induced in small planets by the passage of an intense solar wind associated with a very active early Sun (T-Tauri phase). The reflectance spectrum of the surface of the asteroid 4 Vesta closely resembles those of eucritic meteorites, and it has been suggested that this could be the source of the basaltic achondrites, although there are dynamical difficulties with such a source. See BASALT; IGNEOUS ROCKS; SOLAR WIND.

Shergottites, nakhlites, and chassignites (often referred to as the SNC group) are rare meteorites. Their young crystallization ages ( $\sim 1.3 \times 10^9$  years), plus the similarity of the bulk compositions of the shergottites to that of the Martian soil as determined by the Viking landers, first led to the suggestion that these meteorites could be derived from Mars. It is difficult to conceive of a heat source for endogenous igneous activity (these meteorites have no features resembling known impact melts) on an asteroidal parent body at about  $1.3 \times 10^9$  years ago; and given the limited choice of available larger planets, Mars seemed the most likely choice. The similarity of relative noble gas and nitrogen abundances and isotopic ratios in the Martian atmosphere and shock-produced glass in one shergottite provide strong support for this hypothesis. The very low paleomagnetic intensities of the shergottites are also consistent with a Martian origin. It is still a subject of controversy whether fragments of sufficient size to explain measured cosmic-ray exposure ages could be ejected more or less intact from Mars by impact and subsequently delivered to Earth. It is generally accepted that the question of whether or not these meteorites are from Mars will be resolved only after a sample-return mission to Mars. See PALEOMAGNETISM. [E.St.]

**Iron meteorites.** Iron meteorites are pieces of once molten metallic cores and pools in asteroids that were subsequently eroded and fragmented by impacts after slow cooling. About 650 different iron meteorites have been identified; 30 were seen to fall, and the rest fell during the last million years. The smallest iron meteorites, which weigh only 5–30 g (0.18–1.1 oz), were found in Antarctica and are aerodynamically shaped to resemble buttonlike tektites. The largest single iron meteorite weighs about 60 metric tons (66 tons) and still lies in Namibia. See TEKTITE.

Nine much larger iron masses also hit the Earth during the last million years, forming craters 100 to 1200 m (330 to 3900 ft) in diameter. However, each of the fragments surviving from these meteoroids weighs less than a ton. The largest and most famous crater, which is in Arizona, was formed about 50,000 years ago by the impact of a meteoroid weighing around 300,000 metric tons (330,000 tons) and measuring about 40 m (130 ft) across. The impact released energy equivalent to about 15 megatons of TNT.

Chemical and mineralogical evidence shows that iron meteorites formed from molten pools of metal that solidified and then cooled over many millions of years. This evidence is consistent with an origin for iron meteorites in the cores of asteroids that melted and differentiated. When an asteroid is partly melted, iron-nickel and iron sulfide, being denser than the associated silicates, will begin to sink to the center. With sufficient heating, a core of molten sulfur-rich metal will form. Since most iron meteorites contain no silicates and most achondrites have only trivial amounts of metal, it is likely that metallic cores are the source of many iron meteorites. [E.R.D.S.]

**Isotopic anomalies.** In contrast to materials from differentiated planetary bodies such as the Earth and the Moon, primitive meteorites exhibit isotopic anomalies, that is, deviations from the average solar system composition (= “normal” composition) that are not the result of processes taking place in the solar system but are of presolar origin. These anomalies provide information about the nucleosynthetic sources of the material that formed the solar system. See NUCLEOSYNTHESIS.

Carbon and all heavier elements are produced in stars, and their isotopic compositions reflect different nucleosynthetic reactions taking place in different stellar sources. Many different stars must have contributed to the mixture of gas and dust from which the solar system formed, and it is assumed that this mixture was originally chemically and isotopically heterogeneous. Before 1970 it was generally believed that presolar material had been completely vaporized and isotopically homogenized before the condensation of minerals and the accretion of planets. This dogma of a homogeneous solar nebula was shattered by the discovery of isotopic anomalies in an increasing number of different elements. Ample evidence has been found for the incomplete mixing of distinct isotopic components and for the survival of presolar matter in primitive meteorites.

Isotopically anomalous material constitutes only a small fraction of primitive meteorites. The largest isotopic variations are found through the analysis of small samples where the effects are not diluted by isotopically normal material.

Isotopic effects in meteorites can be divided into four classes: (1) mass-dependent fractionation due to physicochemical processes (diffusion, evaporation, condensation), although certain chemical processes can also lead to non-mass-dependent fractionation that mimics isotopic effects of nuclear origin; (2) effects due to the decay of radioactive isotopes—while effects from the decay of long-lived isotopes are also seen in terrestrial samples, meteorites in addition exhibit effects from the decay of short-lived, now extinct isotopes; (3) nuclear effects reflecting different nucleosynthetic processes in stellar sources; and (4) effects due to the irradiation of meteoritic samples by galactic and solar cosmic rays, which provide information on the exposure history of samples on their parent bodies and in interplanetary space. [E.Zi.]

**Meteorite impact.** The process of impact cratering was of fundamental importance for the accumulation of planets in the early solar system, the formation of planetary landscapes, and the Archean geology of the Earth. In addition, meteorite impacts have been implicated in such events as the Moon’s origin and the extinction of the dinosaurs.

The precise outcome of a planetary collision depends on the size of the meteorite and conditions on the target planet. Small meteorites striking planets such as the Earth or Venus dissipate most of their energy in the atmosphere and do not strike the surface at high speed. In general, if the mass of the meteorite is small compared to the mass of atmospheric gases displaced during its entry, the meteorite will not create an impact crater. On airless bodies such as the Moon, there seems to be no lower limit on impact crater size: craters as small as a few micrometers in diameter have been discovered on the lunar rocks. On Earth, the atmosphere prevents stony meteorites or comets from making craters smaller than a few kilometers in diameter, and even iron meteorites cannot make high-speed impact craters smaller than a few hundred meters in diameter.

When a large meteorite does penetrate a planet's atmosphere, it initiates a series of swift but orderly processes that eventually create a characteristic landform, an impact crater. Three principal stages are recognized in this process.

(1) The meteorite first plunges into the surface rocks at high speed, compressing the underlying rocks and converting its initial kinetic energy into both heat and kinetic energy of the surface rocks. The high pressures produce a series of characteristic mineralogical changes in the surrounding rocks that often permits verification of the impact origin of a suspected crater. The duration of this compression state is short, however, lasting only as long as it takes the meteorite to travel a distance equal to its own diameter.

(2) Subsequently, the pent-up pressures in the compressed rocks essentially create an explosion, blasting aside the surrounding rocks as a strong shock wave radiates away from the impact site. The nearly hemispherical shock wave from the impact expands and weakens as time passes, leaving behind outward-moving rock debris that eventually excavates the crater. The maximum depth of excavation is only about 10% of the crater's diameter. The immediate result of crater excavation is called the transient crater. This is a relatively deep, steep-walled crater than beings to collapse as soon as it forms.

(3) Small transient craters are quickly filled by a lens of broken rock that forms from debris that slides down from the rim and pools at the bottom of the crater. Such bowl-shaped craters floored by broken rock are called simple craters.

In larger craters the floor rises as the rim sinks, producing central mounds that are thinly veneered with broken and melted rock. The rims of such craters, termed complex craters, are scalloped and terraced with great blocks of slumped rock. Still larger craters exhibit circular mountainous rings instead of central peaks.

The very largest impact structures, particularly on the Moon, are surrounded by inward-facing, roughly circular (but often incomplete) mountain rings that probably formed well outside the crater cavity by a process of inward flow and slumping in the fluid asthenosphere beneath the crater. They are termed multi-ring basins. These enormous structures dominate the Moon's surface and form the principal stratigraphic markers on that body. See ASTHENOSPHERE. [H.J.M.]

**Meteorological instrumentation** Devices that measure or estimate properties of the Earth's atmosphere. Meteorological instruments take many forms, from simple mercury thermometers and barometers to complex observing systems that remotely sense winds, thermodynamic properties, and chemical constituents over large volumes of the atmosphere.

Weather station measurements provide a description of conditions near the ground. In addition to the average regional conditions, these measurements also provide local information on mesoscale phenomena such as cold fronts, sea breezes, and disturbed conditions resulting from nearby thunderstorms. Traditional thermodynamic instruments are mechanical or heat-conductive devices relying on the expansion and contraction of metallic and nonmetallic liquids or solid materials as a function of temperature, pressure, and humidity. Among these are the mercury, alcohol, and bimetallic thermometers for measurement of temperature, mercury and metallic bellow (aneroid) barometers for measurement of pressure, human hair hygrometers, and wet/dry-bulb thermometers (called psychrometers) for measurement of relative humidity. Mercury barometers are simply weighing devices that balance the mass of the atmospheric column against the mass of a mercury column. On average, a column of atmosphere weighs the same as 76 cm (29.92 in.) of mercury. Psychrometers measure humidity by means of the wet-bulb depression technique. A moist thermometer is cooled by evaporation when relative humidity is less than 100%. The temperature difference between wet and dry thermometers is referred to as the wet-bulb depression, a well-known function of relative

humidity at standard airflow speeds. A related method of humidity measurement is the chilled mirror technique (dewpointer). A polished surface is cooled to the temperature of water vapor saturation, at which point the cooled surface becomes fogged. Dewpoint saturation uniquely defines humidity at a known temperature and pressure. See BAROMETER; DEW POINT; HYGROMETER; PSYCHROMETER; TEMPERATURE MEASUREMENT; THERMOMETER.

Precipitation measurement devices may be described as precision buckets, which measure the depth or weight of that which falls into them. These gages work best for rainfall, but they are also used in an electrically heated mode for weighing snow. Rulers are routinely used for measurement of snow depth. Time-resolved measurements of rainfall are traditionally made by counting quantum amounts (0.01 in. or 0.25 mm) of rain with a small, mechanically controlled tipping bucket located beneath a large collecting orifice. Modern rain measuring is sometimes performed along short paths via drop-induced scintillations of infrared radiation, which is emitted by a laser. When the raindrop size distribution is needed, optical-shadowing spectrometers are employed, as are momentum-measuring impact distrometers, devices that measure the number density versus the size distribution of raindrops or other hydrometeors. See SNOW GAGE.

Wind measurements are performed by anemometers, some of which use wind-driven spinning cups for wind speed determination. Vanes are used in conjunction with cups for indication of wind direction. Alternatively, three-axis propeller anemometers may be employed to provide orthogonal components of the three-dimensional wind vector. Many hybrids of these basic approaches continue to be successfully employed. Fast-response sonic anemometers employ ultrasound transmission, where the apparent propagation speed of sound is measured. The difference between this measured speed and the actual speed for a fluid at rest is the wind speed. Such measurements are made on a time scale of 0.01 s and are used to determine the fluxes of momentum, water vapor, sensible heat, and other scalars in the planetary boundary layer. See ANEMOMETER; WIND MEASUREMENT.

Balloon-borne vertical profiles or soundings of temperature, humidity, and winds are central to computerized (numerical) weather prediction. Such observations are made simultaneously or synoptically worldwide on a daily basis. The temperature and humidity sensors are lightweight expendable versions of traditional surface station instruments. Balloon drift during ascent provides the wind measurement. The preferred method of tracking these rawinsondes is to use global navigation aid systems such as Omega, Loran-C, and the Global Positioning System. Parachute-borne dropsondes are often released from aircraft in data-sparse regions. See LORAN; SATELLITE (ASTRONOMY).

Remote sensing, principally via electromagnetic radiation, is a mainstay of modern meteorology. Such devices typically operate in the optical, infrared, millimeter-wave, microwave, and high-frequency radio regions of the electromagnetic spectrum. Passive radiometers typically operate at infrared and microwave frequencies; they are used for estimates of temperature, water vapor, cloud heights, cloud liquid water mass, and trace-gas concentrations. These observations are made from the ground, aircraft, and satellites, usually measuring naturally emitted radiation. Radarlike, active remote-sensing devices are among the most powerful tools available to meteorology. Collectively, these instruments are capable of measuring kinematic, microphysical, chemical, and thermodynamic properties of the troposphere at high spatial and temporal resolution. Active meteorological remote sensors are principally deployed on land, ships, and aircraft platforms, as well as aboard satellites. Unlike passive instruments, active remote sensors can precisely resolve the distance at which a measurement is located.

At optical frequencies, lidars measure conditions in relatively clear air. Capabilities include determining the properties of tenuous clouds; determining concentrations of aerosol, ozone, and water vapor; and measuring winds through the Doppler

frequency-shift effect. Millimeter-wave radars are used to probe opaque, nonprecipitating clouds. Polarimetric and Doppler techniques reveal hydrometeor type, water mass, and air motions. See LIDAR.

The best-known meteorological remote sensor is the microwave weather radar. In addition to measuring rainfall and tracking movement of storms, powerful and sensitive meteorological radars can measure detailed flow fields in and around storms by using hydrometeors, insects, and blobs of water vapor as reflective targets. These radars can also distinguish between rain, hail, and snow. When Doppler measurements are combined with the atmospheric equations of motion, thermodynamic perturbation fields, such as buoyancy, are revealed inside violent convective storms. At ultrahigh and very high radio frequencies, radars known as wind profilers measure the mean wind as a function of height in the clear and cloudy air. Superior to infrequent weather balloons, radio wind profiling methods permit continuous measurement of winds with regularity and high accuracy. When radio wind profilers are colocated with acoustic transponders, the speed of sound is easily measured through radar tracking of the acoustic wave. This permits the computation of atmospheric density and temperature profiles, on which the speed of sound is strongly dependent. See DOPPLER RADAR; METEOROLOGY; RADAR METEOROLOGY; REMOTE SENSING. [R.E.Car.]

**Meteorological optics** The study of optical phenomena occurring in the atmosphere. Many light effects can be seen by looking skyward, and all of them, resulting from the interaction of light with the atmosphere, lie in the province of atmospheric optics or meteorological optics. The subject also includes the effect of light waves too long or too short to be detected by the human eye—light-type radiation in the infrared or ultraviolet regions of the spectrum. Light interacts with the different components of the atmosphere by a variety of physical processes, the most important being scattering, reflection, refraction, diffraction, absorption, and emission. See ABSORPTION OF ELECTROMAGNETIC RADIATION; ATMOSPHERE; OPTICS; REFLECTION OF ELECTROMAGNETIC RADIATION; SCATTERING OF ELECTROMAGNETIC RADIATION. [R.Gr.]

**Meteorological radar** A remote-sensing device that transmits and receives microwave radiation for the purpose of detecting and measuring weather phenomena. Radar is an acronym for radio detection and ranging. Today, many types of sophisticated radars are used in meteorology, ranging from Doppler radars, which are used to determine air motions (for example, to detect tornadoes), to multiparameter radars, which provide information on the phase (ice or liquid), shape, and size of hydrometeors. Airborne Doppler radars play a vital role in meteorological research. Radars are also used to detect hail, estimate rainfall rates, probe the clear-air atmosphere to monitor wind patterns, and study the electrification processes in thunderstorms that generate lightning discharges.

Commonly used, pulsed Doppler radar operates in the microwave region, with standard wavelengths of 10, 5, and 3 cm, referred to as S-, C-, and X-band radars, respectively. The electromagnetic radiation is focused into a narrow beam by illuminating a parabolic dish reflector with microwave energy provided by the radar transmitter. S-band radars require the use of large antennas (see illustration) to generate a narrow beam of microwave energy; transmit high power (peak power of 1 megawatt); and suffer relatively little attenuation as the radar beam passes through regions of heavy rain and hail. X-band radars use much smaller antennas to achieve similar narrow beams, and are highly portable. However, X-band radars suffer from attenuation when used to probe precipitation, which significantly limits their range. Attenuation results when the radar energy is either absorbed by the raindrops or reemitted from the raindrops in directions other than toward the radar. See ANTENNA (ELECTROMAGNETISM); DOPPLER RADAR; MICROWAVE.

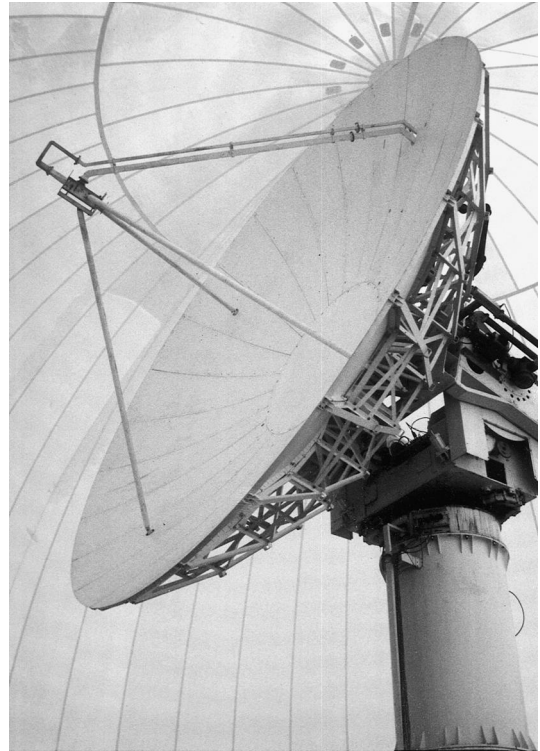

Parabolic dish antenna of the CSU-CHILL 11-cm multiparameter Doppler radar operating at Colorado State University. The antenna is housed within a large, inflatable radome. (P. Kennedy, Colorado State University)

A pulsed Doppler radar typically emits 1000 electromagnetic pulses per second. These individual pulses are typically 1 microsecond ( $10^{-6}$  s) in duration. The Doppler radar provides information on the target's velocity, either toward or away from the radar when viewed along the radar beam. The Doppler shift, which is measured as a small difference between the frequency of the transmitted pulse and the frequency of the energy backscattered to the radar, provides a measure of the scatterer's radial motion. Scatterers in the case of meteorological radar include raindrops, ice particles (snowflakes), hailstones, and even insects, providing clear air returns. A Doppler radar also detects the amplitude of the backscattered signal, which can be used as a measure of storm intensity and as a means of estimating rainfall rates. See PRECIPITATION (METEOROLOGY); SCATTERING OF ELECTROMAGNETIC RADIATION; STORM; STORM DETECTION.

Dual-wavelength radar transmits electromagnetic energy at two wavelengths, and it also receives energy at both wavelengths. Typically, S- and X-band wavelengths are used. Dual-wavelength techniques were originally proposed to detect large hail. At S-band, hail is usually a Rayleigh target, whereas at X-band, hail is considered a Mie scatterer. Since radar energy is scattered in various directions by a Mie target, the power returned at the X-band wavelength is reduced relative to that at S-band. The presence of large hail is interpreted on the basis of the ratio of backscattered power at X-band to that at S-band. Dual-wavelength techniques are also used to estimate rainfall rates by comparing the backscattered power at a nonattenuating wavelength (S-band) to that at attenuating wavelengths (X-band). See HAIL.

Dual-polarization radar is able to transmit and receive both horizontally and vertically polarized radiation (the polarization of a radar beam is defined by the orientation of the electric field vector that comprises an electromagnetic wave). These radars are now used in meteorological research and have largely superseded dual-wavelength radars. A suite of multiparameter

variables is being used to infer information on particle phase (ice or water), size, orientation, and shape.

Radar operating at a wavelength of 2 cm is in low Earth orbit (350 km or 210 m above the surface) and is used for mapping tropical precipitation. Understanding the amount and distribution of tropical rainfall is crucial for better understanding the Earth's climate. This space-borne radar and associated satellite was jointly developed by the United States (NASA) and Japan (National Space Development Agency); it is known as the *Tropical Rainfall Measuring Mission (TRMM)* satellite. Space-borne radar presents many challenging problems, including cost, size constraints, reliability issues, and temporal sampling. It is obviously impossible to continuously sample every precipitating cloud in the tropics from radar orbiting the Earth. But the *TRMM* satellite will help scientists develop a statistical distribution of rain rates within a certain area, and calculate the probability of a specific rain rate occurring. Based on this information, it will be possible to generate monthly mean rain amounts within areas of  $10^5 \text{ km}^2$ . Such information will be vital for the verification of climate models. See *SATELLITE METEOROLOGY*.

Radars used to probe the clear air, or regions devoid of clouds, are known as profilers. A profiler is essentially a Doppler radar that operates at much longer wavelengths compared to weather radar. Wavelengths of 6 m, 70 cm, and 33 cm are commonly used. In the case of a profiler, the reflected power is not only from hydrometeors but also from gradients in the index of refraction of air, which are caused by turbulent motions in the atmosphere. These turbulent motions in turn cause small fluctuations in air temperature and moisture content, which also change the index of refraction. A profiler can determine the airflow in the cloud-free atmosphere, roughly up to 10 km above the Earth's surface. Optical radars, called lidars, use lasers as the radiation source. At these short wavelengths (0.1–10  $\mu\text{m}$ ), the laser beam is scattered by small aerosol particles and air molecules, allowing air motions to be determined, especially in thin, high tropospheric clouds and in the Earth's boundary layer (approximately the lowest 1 km or 0.6 mi of the Earth's atmosphere). See *AEROSOL; HYDROMETEOROLOGY; LASER; LIDAR*.

In the late 1990s, the weather radars used by the National Weather Service to provide warnings of impending severe weather were updated from antiquated WSR-57 and WSR-74 noncoherent radars to NEXRADs (Next Generation Weather Radars). NEXRAD (WSR-88D) radars are state-of-the-art Doppler radars operating at a wavelength of 10 cm. Using NEXRAD's Doppler capability, weather forecasters are able to warn the public sooner of approaching tornadoes and other severe weather. In severe storms, a mesocyclone first develops within the storm. The mesocyclone may be 10 km (6 mi) or more wide, and represents a deep rotating column of air within the storm. Severe and long-lasting tornadoes are often associated with mesocyclones. The mesocyclone is readily detected by a Doppler radar such as NEXRAD. The entire continental United States is covered by the NEXRAD network, consisting of more than 100 radars. NEXRADs along the Gulf Coast, in Florida, and along the eastern seaboard provide warning information on land-falling hurricanes. About 60 of the nation's busiest airports are also equipped with Doppler radars. These radars (operating at a wavelength of 5 cm, known as Terminal Doppler Weather Radars) provide weather-related warnings to air-traffic controllers and pilots. One particularly dangerous weather condition is wind shear, which often occurs as a microburst or intense downdraft. Microbursts can severely affect the flight of landing and departing aircraft, and have been identified as a factor in many aircraft accidents. See *RADAR; RADAR METEOROLOGY; TORNADO; WEATHER FORECASTING AND PREDICTION*.

[S.A.Ru.]

**Meteorological rocket** A small rocket system used for extending observations of the atmosphere above feasible limits for balloon-borne and telemetering instruments. Synoptic exploration of the middle-atmospheric circulation (20–95 km or

12–60 mi altitude) through use of these systems (also known as rocketsondes) matured in the 1960s into a highly productive source of information on atmospheric structure and dynamics. Many thousands of small meteorological rockets have been launched in a coordinated investigation of the wind field and the temperature and ozone structures in the middle atmosphere region at 25–55 km (16–34 mi) altitude. These data produced dramatic changes in the scientific view of this region of the atmosphere, with a resulting alteration of the structural concepts into an atmospheric model that is primarily characterized by intense dynamics.

The development of the small meteorological rocket began in 1959 with a rocketsonde system known as ARCAS. The maximum altitude reached by this system was about 60 km (37 mi). A less wind-sensitive rocketsonde system, the Loki-Datasonde (PWN-8B), replaced the ARCAS system during the early 1970s. It was soon replaced with the Super Loki-Datasonde (PWN-11D). The PWN-11D rocketsonde motor burns for 2 s before separation from its inert dart and payload, which are thereby propelled to about 80 km (50 mi) altitude, where the payload is ejected. The payload consists of a small bead thermistor temperature sensor attached to a radio transmitter that sends the temperature data to a ground receiver, and a Starute parachute. The meteorological measurements are made during payload descent. At launch, the Super Loki-Datasonde has an overall weight of 31 kg (68 lb), and its length is approximately 4 m (13 ft).

Synoptic-scale circulation systems in the upper atmosphere are demonstrated by rocketsonde data to be very obviously keyed to the geographic and orographic structures of the Earth's surface. In winter, oceanic regions characteristically have poleward extensions of ridges of high pressure, and continental regions have shifty troughs of low pressure extending equatorward over them. This intimate relationship between the surface and 50 km (31 mi) is most likely the direct result of turbulent energy transport in the vertical direction, and a total understanding of the entire atmospheric system cannot be realized until these factors are incorporated. See *ATMOSPHERIC GENERAL CIRCULATION; STRATOSPHERE; UPPER-ATMOSPHERE DYNAMICS*. [W.L.W.; F.J.Sc.]

**Meteorological satellites** Satellites dedicated to the observation of meteorological phenomena and atmospheric or surface properties used for weather forecasting. Operational meteorological satellites provide routine observations of weather conditions as well as an ever expanding range of environmental properties, such as aerosol, dust and ash clouds from volcanic eruptions, ozone, and land vegetation cover. For this reason, they are known in the United States as operational environmental satellites. See *METEOROLOGY; SATELLITE (SPACECRAFT); SATELLITE METEOROLOGY*.

**Optical imaging sensors.** The first recognized application of orbital observation was the visual exploitation of cloud images associated with weather systems. Recent instruments, such as the Advanced Very High Resolution Radiometer (AVHRR) on NOAA satellites, use a variety of quantitative applications, such as remote sensing of sea surface temperature, monitoring changes in land vegetation, and discriminating between different kinds of clouds. There is a pervasive trend to increase the number of spectral bands in imaging sensors, from 5 channels in the current AVHRR to 36 channels in the experimental Moderate-resolution Imaging Spectroradiometer (MODIS) developed by NASA. These channels sample the full spectrum of backscattered solar radiation in the visible, near-infrared, and longwave infrared, and a good part of the emitted terrestrial radiation spectrum (thermal infrared). This multiplicity of spectral bands allows the detection of a wide variety of features, from aerosols and smoke in the atmosphere to chlorophyll in the ocean. See *CLOUD; REMOTE SENSING; TERRESTRIAL RADIATION; WEATHER*.

Except for observing polar regions, or providing meteorological support to operations in remote locations worldwide, the ideal platforms for cloud imaging are those in geosynchronous

equatorial orbit, also known as geostationary orbit, at the precise altitude (35,900 km) where the orbital period matches the period of rotation of the Earth, so that the satellite appears to hover over a fixed location at the Equator. The international system of four to six geostationary meteorological satellites provides uninterrupted visibility of the global tropics and midlatitudes (up to 60° north and south at the satellite longitude) with the ability to monitor fast-developing weather systems that often are the most dangerous. The sharpness of cloud images (1-km picture elements in the visible), as well as the ability to scan the same scene repeatedly at time intervals as short as 5 minutes, allow for tracking the apparent motion of clouds, deducing wind velocity, and instantaneously assessing the strength of developing storms, a valuable capability in warm climate regions. See EARTH ROTATION AND ORBITAL MOTION; TROPICAL METEOROLOGY.

**Imaging microwave radiometers.** Also interesting is the detection of diverse atmospheric properties and surface features using multifrequency microwave radiometers with small antenna beams. Water molecule absorption of microwave radiation emitted by the ocean provides an accurate estimation of total precipitable water in the atmospheric column. Microwave radiation emitted by the relatively homogeneous moist atmosphere below is scattered in a recognizable way by waterdrops and ice particles in rain clouds, thus providing an indirect means to estimate precipitation rates. Microwave radiation contrast discriminates ice floes from open ocean water, and wet from dry soil. Microwave radiometry enables diagnostics of sea state and wind strength over the surface of the ocean, or the sea surface temperature. The principal design constraint of imaging microwave radiometers is the diffraction limit of the sensor—large apertures are desirable, but bulky antennas are a problem because mechanical scanning is needed to preserve radiometric accuracy. In order to achieve reasonably small footprints, microwave sensors are currently deployed in low Earth orbit. See MICROWAVE; PRECIPITATION (METEOROLOGY); RADIOMETRY.

**Sounding sensors.** The retrieval of temperature profile and water vapor information from spectral data is a difficult and not a fully determined mathematical problem. The solutions are highly sensitive to spectral resolution and small errors in radiometric measurements. The latest Atmospheric Infra-Red Sounder (AIRS) instrument developed by NASA is expected to yield temperature profiles as accurate as balloon measurements, 1°C within each successive 1-km-thick layer of the lower atmosphere. See HYDROMETEOROLOGY; INFRARED RADIATION.

Atmospheric sounders operate in the thermal infrared, using the absorption bands of carbon dioxide molecules (3.7–4.9  $\mu\text{m}$  and 13–15  $\mu\text{m}$ ), and in the microwave spectrum, using the 54-GHz absorption band of oxygen. Emitted radiation is much weaker and atmospheric sounders correspondingly less sensitive in the microwave region. However, nonprecipitating clouds are largely transparent to such relatively long wavelengths, thus allowing all-weather albeit less accurate observations.

Measurements of temperature and moisture are used mainly to update numerical weather prediction computations that forecast the circulation of the global atmosphere several days in advance. For this quantitative application, a delay of a few hours is immaterial but homogeneous global coverage is essential. Thus, atmospheric sounders are principally deployed on Sun-synchronous polar orbits. The parameters of these circular low Earth orbits are selected from a discrete set of altitudes (800–1000 km) and inclinations (retrograde quasi-polar) that allow the orbital plane to drift by about 1° of longitude per day and match the change in Sun-Earth direction. Thus, a Sun-synchronous satellite crosses the Equator at (nearly) the same local time on every successive orbit.

**Active sensors.** Orbital systems are now powerful enough to probe the atmospheric medium or the surface with beams of electromagnetic radiation generated in space. The first operational sensor of this kind was a coarse radar or scatterometer that measured microwave radiation backscattered by the ocean surface. Backscatter is sensitive to surface roughness and thus

provides a measurement of vector wind speed over the ocean (as well as a coarse all-weather mapping of sea ice).

Various radar altimeters have been used to map the changing topography of the ocean surface (principally to reconstruct the oceanic circulation from measured altitude gradients). Higher-frequency experimental radar and lidar systems are being tested to profile the distribution and optical properties of aerosol and cloud ice particles and waterdrops. The first demonstration of a space-borne precipitation radar is being conducted with the United States-Japan Tropical Rain Measuring Mission (TRMM) launched in 1997. Rain rate can be deduced from the three-dimensional distribution of ice particles and water in rain clouds, as observed by the TRMM satellite. See LIDAR; METEOROLOGICAL RADAR; RADAR METEOROLOGY.

Yet another promising technology will determine wind velocity in clear air from direct measurements of the frequency shift (Doppler effect) of multiple laser pulses backscattered by aerosol and other diffusive particles. Global wind measurements will provide an invaluable enhancement of the worldwide meteorological observing network, especially at low latitudes where the wind field cannot be deduced from atmospheric pressure. See DOPPLER RADAR. [P.Mo.]

**Meteorology** A discipline involving the study of the atmosphere and its phenomena. Meteorology and climatology are rooted in different parent disciplines, the former in physics and the latter in physical geography. They have, in effect, become interwoven to form a single discipline known as the atmospheric sciences, which is devoted to the understanding and prediction of the evolution of planetary atmospheres and the broad range of phenomena that occur within them. The atmospheric sciences comprise a number of interrelated subdisciplines. See CLIMATOLOGY.

Atmospheric dynamics (or dynamic meteorology) is concerned with the analysis and interpretation of the three-dimensional, time-varying, macroscale motion field. It is a branch of fluid dynamics, specialized to deal with atmospheric motion systems on scales ranging from the dimensions of clouds up to the scale of the planet itself. The activity within dynamic meteorology that is focused on the description and interpretation of large-scale (greater than 1000 km or 600 mi) tropospheric motion systems such as extratropical cyclones has traditionally been referred to as synoptic meteorology, and that devoted to mesoscale (10–1000 km or 6–600 mi) weather systems such as severe thunderstorm complexes is referred to as mesometeorology. Both synoptic meteorology and mesometeorology are concerned with phenomena of interest in weather forecasting, the former on the day-to-day time scale and the latter on the time scale of minutes to hours. See DYNAMIC METEOROLOGY; MESOMETEOROLOGY.

The complementary field of atmospheric physics (or physical meteorology) is concerned with a wide range of processes that are capable of altering the physical properties and the chemical composition of air parcels as they move through the atmosphere. It may be viewed as a branch of physics or chemistry, specializing in processes that are of particular importance within planetary atmospheres. Overlapping subfields within atmospheric physics include cloud physics, which is concerned with the origins, morphology, growth, electrification, and the optical and chemical properties of the droplets within clouds; radiative transfer, which is concerned with the absorption, emission, and scattering of solar and terrestrial radiation by aerosols and radiatively active trace gases within planetary atmospheres; atmospheric chemistry, which deals with a wide range of gas-phase and heterogeneous (that is, involving aerosols or cloud droplets) chemical and photochemical reactions on space scales ranging from individual smokestacks to the global ozone layer; and boundary-layer meteorology or micrometeorology, which is concerned with the vertical transfer of water vapor and other trace constituents, as well as heat and momentum across the interface between the atmosphere and the underlying surfaces and their redistribution

within the lowest kilometer of the atmosphere by motions on scales too small to resolve explicitly in global models. Aeronomy is concerned with physical processes in the upper atmosphere (above the 50-km or 30-mi level). See AERONOMY; ATMOSPHERIC CHEMISTRY; ATMOSPHERIC ELECTRICITY; ATMOSPHERIC GENERAL CIRCULATION; ATMOSPHERIC WAVES, UPPER SYNOPTIC; CLOUD PHYSICS; METEOROLOGICAL OPTICS; MICROMETEOROLOGY; RADIATIVE TRANSFER; TERRESTRIAL RADIATION.

Although atmospheric dynamics and atmospheric physics in some circumstances can be successfully pursued as separate disciplines, important problems such as the development of numerical weather prediction models and the understanding of the global climate system require a synthesis. Physical processes such as radiative transfer and the condensation of water vapor onto cloud droplets are ultimately responsible for the temperature gradients that drive atmospheric motions, and the motion field, in turn, determines the evolving, three-dimensional setting in which the physical processes take place.

The atmospheric sciences cannot be completely isolated from related disciplines. On time scales longer than a month, the evolution of the state of the atmosphere is influenced by dynamic and thermodynamic interactions with the other elements of the climate system, that is, the oceans, the cryosphere, and the terrestrial biosphere. A notable example is the El Niño-Southern Oscillation phenomenon in the equatorial Pacific Ocean, in which changes in the distribution of surface winds force anomalous ocean currents; the currents can alter the distribution of sea-surface temperature, which in turn can alter the distribution of tropical rainfall, thereby inducing further changes in the surface wind field. On a time scale of decades or longer, the cycling of chemical species such as carbon, nitrogen, and sulfur between these same global reservoirs also influences the evolution of the climate system. Human activities represent an increasingly significant atmospheric source of some of the radiatively active trace gases that play a role in regulating the temperature of the Earth. See BIOSPHERE; MARITIME METEOROLOGY; TROPICAL METEOROLOGY.

Throughout the atmospheric sciences, prediction is a unifying theme that sets the direction for research and technological development. Prediction on the time scale of minutes to hours is concerned with severe weather events such as tornadoes, hail, and flash floods, which are manifestations of intense mesoscale weather systems, and with urban air-pollution episodes; day-to-day prediction is usually concerned with the more ordinary weather events and changes that attend the passage of synoptic-scale weather systems such as extratropical cyclones; and seasonal prediction is concerned with regional climate anomalies such as drought or recurrent and persistent cold air outbreaks. Prediction on still longer time scales involves issues such as the impact of human activity on the temperature of the Earth, regional climate, the ozone layer, and the chemical makeup of precipitation. See CLIMATE MODELING; DROUGHT; HAIL; TORNADO.

The evolution of the atmospheric sciences from a largely descriptive field to a mature, quantitative physical science discipline is apparent in the development of vastly improved predictive capabilities based upon the numerical integration of specialized versions of the Navier-Stokes equations, which include sophisticated parametrizations of physical processes such as radiative transfer, latent heat release, and microscale motions. The so-called numerical weather prediction models have largely replaced the subjective and statistical prediction methods that were widely used as a basis for day-to-day weather forecasting. The state-of-the-art numerical models exhibit significant skill for forecast intervals as long as about a week. See NAVIER-STOKES EQUATION.

A distinction is often made between weather prediction, which is largely restricted to the consideration of dynamic and physical processes internal to the atmosphere, and climate prediction, in which interactions between the atmosphere and other elements of the climate system are taken into account. The importance and complexity of these interactions tend to increase with the time scale of the phenomena of interest in the forecast. Weather

prediction involves shorter time frames (days to weeks), in which the information contained in the initial conditions is the dominant factor in determining the evolution of the state of the atmosphere; and climate prediction involves longer time frames (seasons and longer), for boundary forcing is the dominant factor in determining the state of the atmosphere.

Atmospheric prediction has benefited greatly from major advances in remote sensing. Geostationary and polar orbiting satellites provide continuous surveillance of the global distribution of cloudiness, as viewed with both visible and infrared imagery. These images are used in positioning of features such as cyclones and fronts on synoptic charts. Cloud motion vectors derived from consecutive images provide estimates of winds in regions that have no other data. Passive infrared and microwave sensors aboard satellites also provide information on the distribution of sea-surface temperature, sea state, land-surface vegetation, snow and ice cover, as well as vertical profiles of temperature and moisture in cloud-free regions. Improved ground-based radar imagery and vertical profiling devices provide detailed coverage of convective cells and other significant mesoscale features over land areas. Increasingly sophisticated data assimilation schemes are being developed to incorporate this variety of information into numerical weather prediction models on an operational basis. See ATMOSPHERE; CLIMATIC PREDICTION; CYCLONE; FRONT; RADAR METEOROLOGY; SATELLITE METEOROLOGY; WEATHER FORECASTING AND PREDICTION. [J.M.Wa.]

**Metering orifice** A thin plate that is mounted inside a pipe and has a sharp-edged aperture through which the fluid in the pipe is accelerated. The acceleration causes the local static pressure to decrease. The flow rate is sensed by taking one pressure reading upstream and one downstream of the orifice.

The orifice plate is commonly used as an instrument to meter or control the rate of flow of the most common or newtonian fluids. These comprise all gases, including air and natural gas, and many liquids, such as water, and most hydrocarbons. With no moving parts and a simple design, the orifice is easily machined, and thus has been a popular flow-measuring device. However, its pressure loss is large compared to more expensive devices such as the venturi tube.

The metering orifice is one of a class of differential-pressure-sensing devices that are used to indicate flow rate. Others in this category include flow nozzles, venturis, elbow meters, target meters, and wedge meters. In open-channel flow, such as occurs in streams and canals, the weir serves the same purpose as the orifice; however, because the flow occurs at constant pressure, the height of the fluid over the weir, rather than the pressure, is used to sense the flow rate. See NOZZLE; PITOT TUBE; VENTURI TUBE. [M.P.W.]

**Methane** A member of the alkane or paraffin series of hydrocarbons with the formula shown below. Methane is called

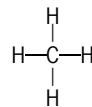

marsh gas because it forms by anaerobic bacterial decomposition of vegetable matter in swampy land. Coal miners know it as firedamp because mixtures with air are combustible. It is a major constituent of natural gas (50–90%) and of coal gas. It forms in large amounts in sewage disposal processes, especially in anaerobic digestion. As a liquid it freezes at  $-182.6^{\circ}\text{C}$  ( $-296.7^{\circ}\text{F}$ ) and boils at  $-161.6^{\circ}\text{C}$  ( $-258.9^{\circ}\text{F}$ ).

In addition to its use as a fuel, methane is important as a source of organic chemicals and of hydrogen. Its reaction with steam at high temperatures in the presence of catalysts yields carbon monoxide and hydrogen (synthesis gas), which can be catalytically converted to liquid alkanes (Fischer-Tropsch process) or to methanol and other alcohols. See ALKANE; FISCHER-TROPSCH PROCESS; HYDROFORMYLATION; NATURAL GAS. [L.S.]

**Methanogenesis (bacteria)** The microbial formation of methane, which is confined to anaerobic habitats where occurs the production of hydrogen, carbon dioxide, formic acid, methanol, methylamines, or acetate—the major substrates used by methanogenic microbes (methanogens). In fresh-water or marine sediments, in the intestinal tracts of animals, or in habitats engineered by humans such as sewage sludge or biomass digesters, these substrates are the products of anaerobic bacterial metabolism. Methanogens are terminal organisms in the anaerobic microbial food chain—the final product, methane, being poorly soluble, anaerobically inert, and not in equilibrium with the reaction which produces it.

Two highly specialized digestive organs, the rumen and the cecum, have been evolved by herbivores to delay the passage of cellulose fibers so that microbial fermentation may be complete. In these organs, large quantities of methane are produced from hydrogen and carbon dioxide or formic acid by methanogens. From the rumen, an average cow may belch 26 gallons (100 liters) of methane per day.

Methanogens are the only living organisms that produce methane as a way of life. The biochemistry of their metabolism is unique and definitively delineates the group. Two reductive biochemical strategies are employed: an eight-electron reduction of carbon dioxide to methane or a two-electron reduction of a methyl group to methane. All methanogens form methane by reducing a methyl group. The major energy-yielding reactions used by methanogens utilize substrates such as hydrogen, formic acid, methanol, acetic acid, and methylamine. Dimethyl sulfide, carbon monoxide, and alcohols such as ethanol and propanol are substrates that are used less frequently. See ARCHAEBACTERIA; BACTERIAL PHYSIOLOGY AND METABOLISM; METHANE. [R.S.W.]

**Methanol** The first member of the homologous series of aliphatic alcohols, with the formula  $\text{CH}_3\text{OH}$ . It is produced commercially from a mixture of carbon monoxide ( $\text{CO}$ ) and hydrogen ( $\text{H}_2$ ). Methanol is a highly flammable liquid, boiling point  $64.7^\circ\text{C}$  ( $149^\circ\text{F}$ ), and is miscible with water and most organic liquids. It is a highly poisonous substance; sublethal amounts can cause permanent blindness. See ALCOHOL.

Methanol is one of the major industrial organic chemicals. Its major derivatives are methyl tertiary butyl ether (MTBE), formaldehyde, and acetic acid. Other derivatives and uses include chloromethanes, methyl methacrylate, methylamines, dimethyl terephthalate, solvents (such as glycol methyl ethers), antifreeze, and fuels. [J.A.Mo.]

**Methods engineering** A technique used by progressive management to improve productivity and reduce costs in both direct and indirect operations of manufacturing and non-manufacturing business organizations. Methods engineering is applicable in any enterprise wherever human effort is required. It can be defined as the systematic procedure for subjecting all direct and indirect operations to close scrutiny in order to introduce improvements that will make work easier to perform and will allow work to be done smoother in less time, and with less energy, effort, and fatigue, with less investment per unit. The ultimate objective of methods engineering is profit improvement. See OPERATIONS RESEARCH; PRODUCTIVITY.

Methods engineering includes five activities: planning, methods study, standardization, work measurement, and controls. Methods engineering, through planning, first identifies the amount of time that should be spent on a project so as to get as much of the potential savings as is practical. Invariably the most profitable jobs to study are those with the most repetition, the highest labor content (human work as distinguished from mechanical or process work), the highest labor cost, or the longest life-span. Next, through methods study, methods are improved by observing what is currently being done and then by developing better ways of doing it. The standardization phase includes the training of the operator to follow the standard method.

Then the number of standard hours in which operators working with standard performances can do their job is determined by measurement. Finally, the established method is periodically audited, and various management controls are adjusted with the new time data. The system may include a plan for compensating labor that encourages attaining or surpassing a standard performance. (B.W.N.)

**Metric system** A system of units used in scientific work throughout the world and employed in general commercial transactions and engineering applications in most of the developed nations of the world except for the United Kingdom and the United States. The basic units of the metric system define length (meter), mass (kilogram), and time (second).

The chief advantage of the metric system is that it is based on standards that have been accepted by international agreement, and it therefore provides a common basis for all scientific measurements. A second advantage of the metric system lies in the fact that only decimal multiples and submultiples of the fundamental length and mass units and of other derived units are employed. See PHYSICAL MEASUREMENT; TIME; UNITS OF MEASUREMENT. [D.Wi.]

**Metzgeriales** An order of liverworts in the subclass Jungermanniidae. Twelve families make up the Metzgeriales, which are also known as the Anacrogynae because of archegonia produced behind the growing apex. The gametophyte plant body is flat, elongated, and usually thallose, with no tissue differentiation or surface pores; less commonly there is a stem with two rows of leaves. Capsules dehisce by valves. See BRYOPHYTA; JUNGERMANNIADA. [H.Cr.]

**Mica** Any one of a group of hydrous aluminum silicate minerals with platy morphology and perfect basal (micaceous) cleavage. The most common micas are muscovite [ $\text{KAl}_2(\text{AlSi}_3\text{O}_{10})(\text{OH})_2$ ], paragonite [ $\text{NaAl}_2(\text{AlSi}_3\text{O}_{10})(\text{OH})_2$ ], phlogopite [ $\text{K}(\text{Mg},\text{Fe})_3(\text{AlSi}_3\text{O}_{10})(\text{OH})_2$ ], biotite [ $\text{K}(\text{Fe},\text{Mg})_3(\text{AlSi}_3\text{O}_{10})(\text{OH})_2$ ], and lepidolite [ $\text{K}(\text{Li},\text{Al})_{2.5-3.0}(\text{Al}_{1.0-0.5}\text{Si}_{3.0-3.5}\text{O}_{10})(\text{OH})_2$ ]. Calcium (Ca), barium (Ba), rubidium (Rb), and cesium (Cs) can substitute for sodium (Na) and potassium (K); manganese (Mn), chromium (Cr), and titanium (Ti) for magnesium (Mg), iron (Fe), and lithium (Li); and fluorine (F) for hydroxyl (OH). The three major species, muscovite, biotite, and phlogopite, are widely distributed rock-forming minerals, occurring as essential constituents in a variety of igneous, metamorphic, and sedimentary rocks and in many mineral deposits.

Mica is commonly found as small flakes or lamellar plates without a crystal outline. Muscovite and biotite sometimes occur in thick books, tabular prisms with a hexagonal outline that can be up to several feet across. The prominent basal cleavage is a consequence of the layered crystal structure. Thin cleavage sheets of micas, particularly muscovite and phlogopite, are flexible, elastic, tough, and translucent to transparent (isingslass). They have low electrical and thermal conductivity and high dielectric strength.

Micas have Mohs hardnesses of 2–3 and specific gravities of 2.8–3.2. Upon heating in a closed tube, they evolve water. They have a vitreous-to-pearly luster. Muscovite is colorless to pale shades of brown, green, or gray. Paragonite is colorless to pale yellow. Phlogopite is pale yellow to brown. Biotite is dark green, brown, or black. Lepidolite is most often pale lilac, but it can also be colorless, pale yellow, or pale gray. See BIOTITE; HARDNESS SCALES.

Commercial mica is of two main types: sheet, and scrap or flake. Sheet muscovite, mostly from pegmatites, is used as a dielectric in capacitors and vacuum tubes in electronic equipment. Lower-quality muscovite is used as an insulator in home electrical products such as hot plates, toasters, and irons. Scrap and flake mica is ground for use in coatings on roofing materials and

waterproof fabrics, and in paint, wallpaper, joint cement, plastics, cosmetics, well drilling products, and a variety of agricultural products. See CAPACITOR; ELECTRIC INSULATOR; SILICATE MINERALS.

[L.Gr.; S.Sim.]

**Micelle** A colloidal aggregate of a unique number (50→100) of amphipathic molecules, which occurs at a well-defined concentration called the critical micelle concentration. In polar media such as water, the hydrophobic part of the amphiphiles forming the micelle tends to locate away from the polar phase while the polar parts of the molecule (head groups) tend to locate at the polar micelle solvent interface. A micelle may take several forms, depending on the conditions and composition of the system, such as distorted spheres, disks, or rods (see illustration). Micelles are formed in nonpolar media such as benzene, where the amphiphiles cluster around small water droplets in the system, forming an assembly known as a reversed micelle.

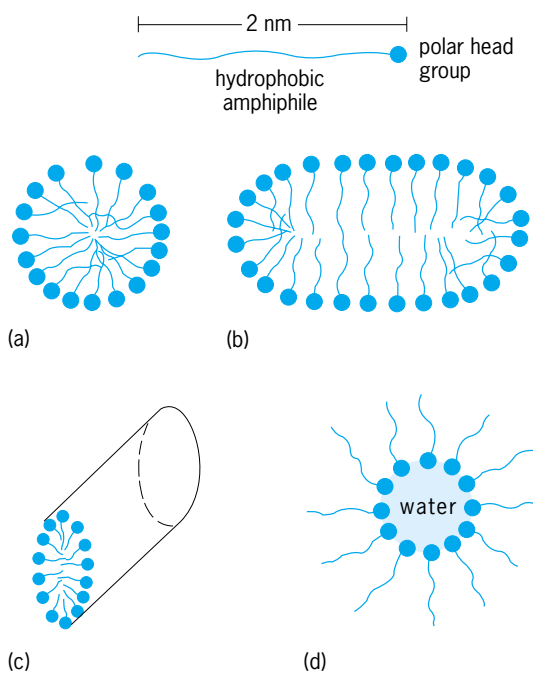

Form of an amphiphile and several forms of micelle: (a) spherical, (b) disk, (c) rod, and (d) reversed.

Micellar systems have the unique property of being able to solubilize both hydrophobic and hydrophilic compounds. They are used extensively in industry for detergency and as solubilizing agents. See DETERGENT; SOAP.

[J.K.T.]

**Microbial ecology** The study of interrelationships between microorganisms and their living and nonliving environments. Microbial populations are able to tolerate and to grow under varying environmental conditions, including habitats with extreme environmental conditions such as hot springs and salt lakes. Understanding the environmental factors controlling microbial growth and survival offers insight into the distribution of microorganisms in nature, and many studies in microbial ecology are concerned with examining the adaptive features that permit particular microbial species to function in particular habitats.

Within habitats some microorganisms are autochthonous (indigenous), filling the functional niches of the ecosystem, and others are allochthonous (foreign), surviving in the habitat for a period of time but not filling the ecological niches. Because of their diversity and wide distribution, microorganisms are extremely important in ecological processes. The dynamic interactions between microbial populations and their surroundings and the metabolic activities of microorganisms are essential for

supporting productivity and maintaining environmental quality of ecosystems. Microorganisms are crucial for the environmental degradation of liquid and solid wastes and various pollutants and for maintaining the ecological balance of ecosystems—essential for preventing environmental problems such as acid mine drainage and eutrophication. See ECOSYSTEM; EUTROPHICATION.

The various interactions among microbial populations and between the microbes, plants, and animals provide stability within the biological community of a given habitat and ensure conservation of the available resources and ecological balance. Interactions between microbial populations can have positive or negative effects, either enhancing the ability of populations to survive or limiting population densities. Sometimes they result in the elimination of a population from a habitat. See RHIZOSPHERE.

The transfer of carbon and energy stored in organic compounds between the organisms in the community forms an integrated feeding structure called a food web. Microbial decomposition of dead plants and animals and partially digested organic matter in the decay portion of a food web is largely responsible for the conversion of organic matter to carbon dioxide. See BIOMASS; FOOD WEB.

Only a few bacterial species are capable of biological nitrogen fixation. In terrestrial habitats, the microbial fixation of atmospheric nitrogen is carried out by free-living bacteria, such as *Azotobacter*, and by bacteria living in symbiotic association with plants, such as *Rhizobium* or *Bradyrhizobium* living in mutualistic association within nodules on the roots of leguminous plants. In aquatic habitats, cyanobacteria, such as *Anabaena* and *Nostoc*, fix atmospheric nitrogen. The incorporation of the bacterial genes controlling nitrogen fixation into agricultural crops through genetic engineering may help improve yields. Microorganisms also carry out other processes essential for the biogeochemical cycling of nitrogen. See BIOGEOCHEMISTRY; NITROGEN CYCLE; NITROGEN FIXATION.

The biodegradation (microbial decomposition) of waste is a practical application of microbial metabolism for solving ecological problems. Solid wastes are decomposed by microorganisms in landfills and by composting. Liquid waste (sewage) treatment uses microbes to degrade organic matter, thereby reducing the biochemical oxygen demand (BOD). See ESCHERICHIA; SEWAGE TREATMENT; WATER PURIFICATION.

[R.M.A.]

**Microbiology** The multidisciplinary science of microorganisms. The prefix micro generally refers to an object sufficiently small that a microscope is required for visualization. In the seventeenth century, Anton van Leeuwenhoek first documented observations of bacteria by using finely ground lenses. Bacteriology, as a precursor science to microbiology, was based on Louis Pasteur's pioneering studies in the nineteenth century, when it was demonstrated that microbes as minute simple living organisms were an integral part of the biosphere involved in fermentation and disease. Microbiology matured into a scientific discipline when students of Pasteur, Robert Koch, and others sustained microbes on various organic substrates and determined that microbes caused chemical changes in the basal nutrients to derive energy for growth. Modern microbiology continued to evolve from bacteriology by encompassing the identification, classification, and study of the structure and function of a wide range of microorganisms including protozoa, algae, fungi, viruses, rickettsia, and parasites as well as bacteria. The comprehensive range of organisms is reflected in the major subdivisions of microbiology, which include medical, industrial, agricultural, food, and dairy. See ALGAE; BACTERIOLOGY; BIOTECHNOLOGY; FUNGI; IMMUNOLOGY; INDUSTRIAL MICROBIOLOGY; MEDICAL BACTERIOLOGY; MEDICAL MYCOLOGY; MEDICAL PARASITOLOGY; MICROSCOPE; PROTOZOA; RICKETTSIOSES; VIRUS.

[E.W.V.]

**Microbiota (human)** Microbial flora harbored by normal, healthy individuals. A number of microorganisms have



become adapted to a particular site or ecologic niche in or on their host. Some are normal residents that are regularly found, and if disturbed will rapidly reestablish themselves; others are transient microorganisms that may colonize the host for short periods but are unable to permanently colonize. The normal fetus is sterile, but during and after birth the infant is exposed to an increasing number of microorganisms. Subsequently, those organisms best adapted to survive and colonize particular sites establish themselves and become predominant. Physiologic factors such as the availability of nutrients, temperature, moisture, pH, oxidation-reduction potential, and resistance to local antibacterial substances play an important role in determining the ability of a microorganism to become established at a particular site. The normal indigenous microbial flora is exceedingly complex, consisting of many different species of bacteria, fungi, viruses, and protozoa. The great majority of these commensal and symbiotic organisms are bacteria and fungi.

The indigenous microorganisms play an important role by protecting the normal host from invasion by microorganisms with a greater potential for causing disease. They compete with the pathogens for essential nutrients and for receptors on host cells by producing bacteriocins and other inhibitory substances, making the environment inimical to colonization by pathogens.

In the healthy individual the morphologic integrity of the body surface provides a very effective first line of defense. The intact skin is an efficient physical barrier that can be penetrated by very few microorganisms. The secretion of specific antimicrobial substances and bactericidal fatty acids by the sebaceous glands also retards microbial invasion.

Mucosal surfaces also provide a mechanical barrier in the respiratory, gastrointestinal, and genitourinary tracts. These surfaces are bathed in secretions with antimicrobial activity. In the respiratory tract, mechanical cleansing is accomplished by the cough and mucociliary action. Recurrent infections of the sinuses, middle ear, bronchial tract, and lungs occur in individuals who have an impairment of ciliary activity. These infections are usually caused by *Staphylococcus pneumoniae* and *Haemophilus influenzae*, the more virulent pus-forming organisms found in the nasopharynx. Defects in ciliary activity also cause bacterial respiratory infections in cigarette smokers and heavy alcohol drinkers. See STAPHYLOCOCCUS.

Once the natural barriers of the skin and mucous membranes are breached, the next major line of defense is the polymorphonuclear leukocytes. Individuals with disorders of these phagocytic cells have an increased incidence of serious infections with their indigenous microflora.

The complement system is another nonspecific mechanism of the body for the elimination of invading microorganisms. Complement proteins in conjunction with organs of the reticuloendothelial system (spleen, liver, and bone marrow) play a key role in the removal of encapsulated bacteria from the bloodstream. Splenectomized individuals and those with a nonfunctioning spleen because of sickle cell disease have an increased incidence of fulminating infections caused by *S. pneumoniae*, *H. influenzae*, *Neisseria meningitidis*, and recently recognized unusual organisms. See COMPLEMENT. [H.P.W.]

**Microcline** Triclinic potassium feldspar,  $KAlSi_3O_8$ , that usually contains a few percent sodium feldspar ( $Ab = NaAlSi_3O_8$ ) in solid solution. Its hardness is 6; specific gravity, 2.56; mean refractive index, 1.52; color, white (green varieties are called amazon stone or amazonite). Microcline is found in some relatively high-grade regional metamorphic rocks, but is much more common in pegmatites, granites, and related plutonic igneous rocks. In the last, it often occurs as a microcline perthite, containing exsolved low albite intergrowths. See FELDSPAR; PERTHITE. [P.H.R.]

**Microcomputer** A digital computer whose central processing unit consists of a microprocessor, a single semiconductor

integrated circuit chip. Once less powerful than larger computers, microcomputers are now as powerful as the minicomputers and superminicomputers of just several years ago. This is due in part to the growing processing power of each successive generation of microprocessor, plus the addition of mainframe computer features to the chip, such as floating-point mathematics, computation hardware, memory management, and multiprocessing support. See INTEGRATED CIRCUITS; MICROPROCESSOR; MULTIPROCESSING.

Microcomputers are the driving technology behind the growth of personal computers and workstations. The capabilities of today's microprocessors in combination with reduced power consumption have created a new category of microcomputers: hand-held devices. Some of these devices are actually general-purpose microcomputers: They have a liquid-crystal-display (LCD) screen and use an operating system that runs several general-purpose applications. Many others serve a fixed purpose, such as telephones that provide a display for receiving text-based pager messages and automobile navigation systems that use satellite-positioning signals to plot the vehicle's position. See LIQUID CRYSTALS; MOBILE RADIO; RADIO PAGING SYSTEMS; SATELLITE NAVIGATION SYSTEMS.

The microprocessor acts as the microcomputer's central processing unit (CPU), performing all the operations necessary to execute a program (see illustration).

A memory subsystem uses semiconductor random-access memory (RAM) for the temporary storage of data or programs. The memory subsystem may also have a small secondary memory cache that improves the system's performance by storing frequently used data objects or sections of program code in special high-speed RAM.

The graphics subsystem consists of hardware that displays information on a color monitor or LCD screen: a graphics memory buffer stores the images shown on the screen, digital-to-analog convertors (DACs) generate the signals to create an image on an analog monitor, and possibly special hardware accelerates the drawing of two- or three-dimensional graphics. (Since LCD screens are digital devices, the graphics subsystem sends data to the screen directly rather than through the DACs.) See DIGITAL-TO-ANALOG CONVERTER.

The storage subsystem uses an internal hard drive or removable media for the persistent storage of data.

The communications subsystem consists of a high-speed modem or the electronics necessary to connect the computer to a network.

Microcomputer software is the logic that makes microcomputers useful. Software consists of programs, which are sets of

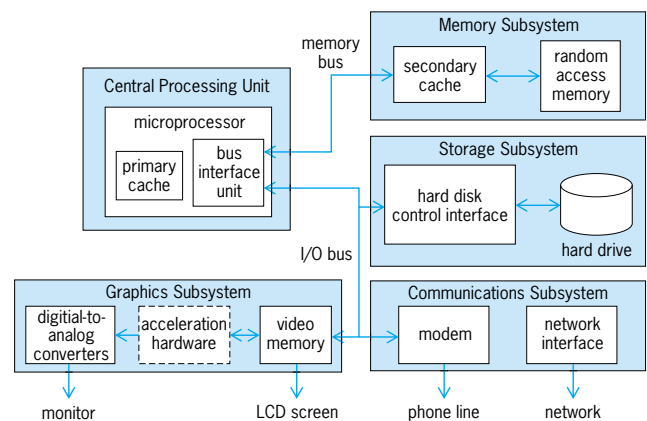

**Elements of a microcomputer.** The various subsystems are controlled by the central processing unit. Some designs combine the memory bus and bus input/output into a single system bus. The graphics subsystem may contain optional graphics acceleration hardware.

instructions that direct the microcomputer through a sequence of tasks. A startup program in the microcomputer's ROM initializes all of the devices, loads the operating system software, and starts it. All microcomputers use an operating system that provides basic services such as input, simple file operations, and the starting or termination of programs. While the operating system used to be one of the major distinctions between personal computers and workstations, today's personal computer operating systems also offer advanced services such as multitasking, networking, and virtual memory. All microcomputers exploit the use of bit-mapped graphics displays to support windowing operating systems. See OPERATING SYSTEM; SOFTWARE. [T.T.]

**Microdialysis sampling** An approach for sampling the extracellular space of essentially any tissue or fluid compartment in the body. Continuous sampling can be performed for long periods with minimal perturbation to the experimental animal. Microdialysis provides a route for sampling the extracellular fluid without removing fluid, and administering compounds without adding fluid. The resulting sample is clean and amenable to direct analysis.

Microdialysis sampling is performed by implanting a short length of hollow-fiber dialysis membrane at the site of interest. The fiber is slowly perfused with a sampling solution (the perfusate) having an ionic composition and pH that closely matches the extracellular fluid of the tissue being sampled. Low-molecular-weight compounds in the extracellular fluid diffuse into the fiber and are swept to a collection vial for subsequent analysis. The system is analogous to an artificial blood vessel that can deliver compounds and remove the resulting metabolites. See DIALYSIS; MEMBRANE SEPARATIONS.

Microdialysis is a diffusion-controlled process. The perfusion rate through the probe is generally in the range of 0.5 to 5.0 ml/min. At this flow rate, there is no net flow of liquid across the dialysis membrane. The driving force for mass transport is the concentration gradient between the extracellular fluid and the fluid in the probe. See DIFFUSION; TRANSPORT PROCESSES.

The greatest use of microdialysis sampling has been in the neurosciences. Microdialysis probes can be implanted in specific brain regions of conscious animals in order to correlate neurochemical activity with behavior. Most studies have focused on determining dopamine or the other monoamine neurotransmitters. See NEUROBIOLOGY.

Microdialysis probes have been implanted in the skin of experimental animals and humans to determine the transdermal delivery of drugs from ointments. Delivery of anticancer drugs to tumors has been studied using microdialysis. See DRUG DELIVERY SYSTEMS; PHARMACOLOGY.

Microdialysis sampling has also been used to study the metabolism of compounds in vivo. Metabolic organs such as the liver and kidneys have been studied by microdialysis sampling. By also sampling the bile by microdialysis, complete metabolic profiles can be obtained from a single experimental animal. This approach dramatically decreases the number of experimental animals needed to assess the metabolism of a new drug. [C.E.Lu.]

### Micro-electro-mechanical systems (MEMS)

Systems that couple micromechanisms with microelectronics. Such systems are also referred to as microsystems, and the coupling of micromechanisms with microelectronics is also termed break micromechatronics. Micromechanics refers to the design and fabrication of micromechanisms that predominantly involve mechanical components with submillimeter dimensions and corresponding tolerances of the order of 1 micrometer or less. The types of systems encompassed by MEMS represent the need for transducers that act between signal and information processing functions, on the one hand, and the mechanical world, on the other. This coupling of a number of engineering areas leads to a highly interdisciplinary field that is commensurately impacting nearly all branches of science and technology in fields such as bi-

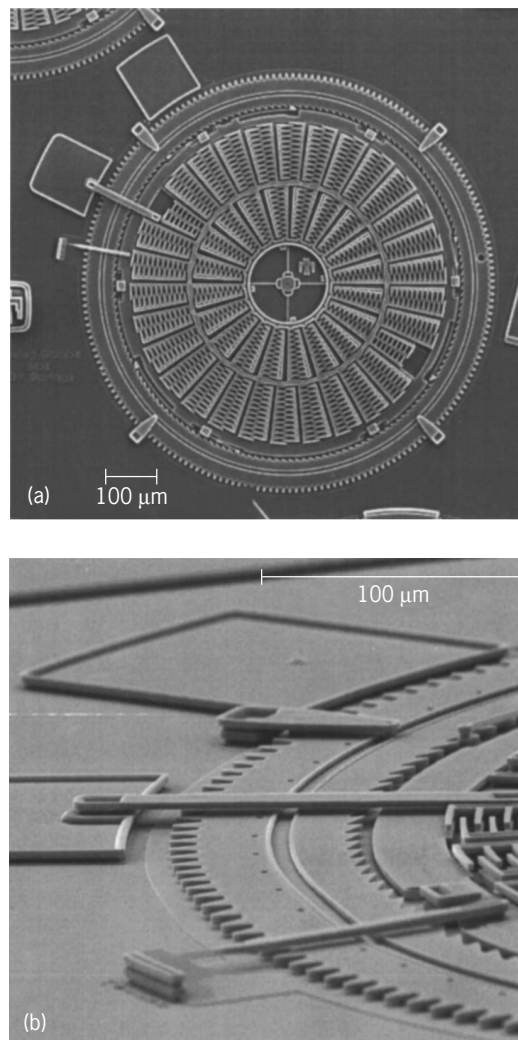
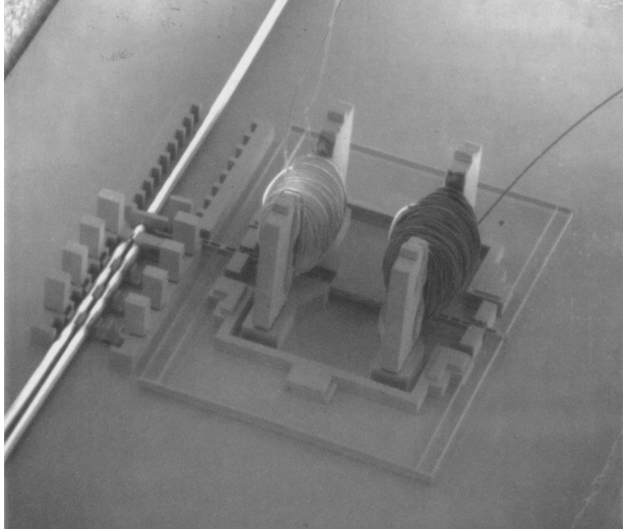

Fig. 1. Torsional ratcheting actuator fabricated by surface micromachining. (a) Overview. (b) Close-up. (J. Jakubczala, Sandia National Laboratories)

ology and medicine, telecommunications, automotive engineering, and defense. Ultimately, realization of a "smart" MEMS may be desired for certain applications whereby information processing tasks are integrated with transduction tasks, yielding a device that can autonomously sense and accordingly react to the environment. See TRANSDUCER.

Motivating factors behind MEMS include greater independence from packaging shape constraints due to decreased device size. In addition, the advantages of repeatable manufacturing processes as well as economic advantages can follow from batch fabrication schemes such as those used in integrated circuit processing, which has formed the basis for MEMS fabrication. Many technical and manufacturing trade-offs, however, come into play in deciding whether an integrated approach is beneficial. In some cases, the device design with the greatest utility is based on a hybrid approach, where mechanical processing and electronic processing are separated until a final packaging step. Two broad categories of devices follow from the transduction need addressed by MEMS: the input transducer or microsensor, and the output transducer or microactuator. See INTEGRATED CIRCUITS.

**Microfabrication technology.** The development of process tools and materials for MEMS is the pivotal enabler for integration success. A material is chosen and developed for its mechanical attributes and patterned with a process amenable to co-electronic fabrication. Two basic approaches to patterning a



**Fig. 2. Magnetic 1 × 2 optical fiber switch fabricated by deep-x-ray lithography. Total device size is approximately 4 mm × 4 mm. (Henry Guckel, University of Wisconsin)**

material are used. Subtractive techniques pattern via removal of unwanted material, while additive techniques make use of temporary complementary molds within which the resulting structure conforms. Both approaches use a mask to transfer a pattern to the desired material. For batch processes, this step typically occurs via photolithography and may itself entail several steps. The basic process is to apply a photoresist, a light-sensitive material, and use a photomask to selectively expose the photoresist in the desired pattern. A solvent chemically develops the photoresist-patterned image, which then may be used as a mask for further processing.

Subtractive processing is accomplished via chemical etching. Wet etching occurs in the liquid phase, and dry etching or gas-phase etching may occur in a vapor phase or plasma. See PLASMA (PHYSICS).

A primary microfabrication technology that has been used for most commercial devices is bulk micromachining, which is the process of removing, or etching, substrate material. The important aspect of precision bulk micromachining is etch directionality. The two limiting cases are isotropic, or directionally insensitive, and anisotropic, or directionally dependent, up to the point of being unidirectional.

An alternative processing approach to bulk microfabrication was driven by the desire to reduce the fraction of the substrate area that had to be devoted to the mechanical components, thereby allowing a larger number of device dies per wafer. The approach, termed surface micromachining (SMM), realizes mechanical structures by depositing and patterning mechanical material layers in conjunction with sacrificial spacer material layers.

**Applications.** A highly successful device that is fabricated with both bulk and surface micromachining is the integrated pressure transducer. The process sequence uses surface micromachining techniques to form a polysilicon-plate-covered cavity. Application areas include air pressure sensing in automobile engines, environmental monitoring, and blood pressure sensing. Similar processing has resulted in the integration of surface-micromachined polysilicon inertial reference proof masses with microelectronic processing, yielding single-chip force-feedback accelerometers. See ACCELEROMETER.

The use of surface micromachining technology to implement microactuators has resulted in steerable micromirror arrays with as many as 1024 × 768 pixels on a chip. These arrays have revolutionized digital display technology. Further electrostatic microactuator designs are possible and may be extremely intricate, such as a torsional ratcheting actuator fabricated with five

polysilicon levels (Fig. 1). These types of devices are suited for a variety of micropositioning applications. Processing based on deep-x-ray lithography has been used to produce precision magnetic microactuators. One such microactuator directly switches a single-mode optical fiber in a 1 × 2 switch configuration (Fig. 2).

[T.R.C.]

**Micromanipulation** The technique or practice involving manipulation of objects too small to be easily seen with the unaided eye. When a microscope is used to allow the operator to visually guide the microtools used in the manipulation, the technique is called micurgy. When an object that is not extremely small needs to be positioned with extreme precision, as when aiming a laser to make a surgical lesion, the technique is called micropositioning.

To manipulate microscopic objects, it is necessary to use a tool called a micromanipulator, which allows relatively coarse hand movements to execute proportionately slower and smaller movements of a probe or microtool. Micromanipulators are used to probe and test integrated circuit chips, to align fiber-optic communication cables, as well as to accomplish techniques in biological research.

The simplest and most common micromanipulators consist of three orthogonal mechanical slides whose position is controlled by a threaded screw or a rack and pinion. Such devices are relatively inexpensive and adequate for magnifications up to 150 power. However, the imperfections of simple machines are revealed by magnifications greater than 150 power.

There has been increasing use of electrically powered micromanipulators. The three types are direct-current-motorized, stepper-motorized, and piezoelectric. Direct-current-motor-driven micromanipulators may be operated by remote control with a joystick or single-step push button, which allows for precise control of pulse length. It is easy to adjust the ratio of movement reduction electrically. At highest magnification, however, the slight vibration of the motors begins to interfere with visualization, making direct-current-motor-driven micromanipulators best suited to medium magnifications. Micromanipulators with stepper-motor drives are the only micromanipulators capable of fast, direct movements to a specific set of coordinates, and can be directed by a computer over a preplanned route. Specialized piezoelectric micromanipulators, called cell penetrators, provide movements over a very short range of 1–10 μm. They move very abruptly but are excellent for puncturing small and hard-to-penetrate cell membranes.

[C.W.Sc.]

**Micrometeorite** A submillimeter extraterrestrial particle that has survived entry into the atmosphere without melting. Meteoroids are natural interplanetary objects that orbit the Sun, and they range in size from small dust grains to objects that are miles in diameter. Particles below 0.04 in. (1 mm) in diameter are considered micrometeoroids, and the micrometeoroids that enter the atmosphere without melting are called micrometeorites. Micrometeorites survive entry without severe heating because they are small and they totally decelerate from cosmic velocity at high altitudes near 55 mi (90 km). Most of the mass of extraterrestrial matter that annually collides with the Earth is in the micrometeoroid size range, a total of about 10<sup>4</sup> tons (10<sup>7</sup> kg), but only a small fraction survives as micrometeorites. Usually only the particles smaller than 0.1 mm survive as true unmelted micrometeorites, although the survival of an individual micrometeorite depends on entry velocity, angle of entry, melting point, and density as well as size. See METEORITE.

Micrometeorites are of particular interest because they are samples of comets and asteroids, small primitive bodies that have survived without major change since the earliest history of the solar system. Some of these particles are generated by collisions in the asteroid belt, while others are released from comets when these bodies approach the Sun and ice volatilization releases dust grains and propels them into space. Once released from a

parent comet or asteroid, particles survive only for a few thousand to a hundred thousand years, depending on size, before they are either destroyed or collide with a planet. Particles are destroyed either when they collide with other particles or when they spiral into the Sun because of the Poynting-Robertson drag, an effect of sunlight that causes the orbits of small particles to decay. During exposure in space, the small particles accumulate large amounts of helium implanted by the solar wind, and they also are riddled with radiation damage tracks produced by solar cosmic rays, high-energy particles accelerated from solar flares. See ASTEROID; COMET; COSMIC RAYS; SOLAR WIND; SUN.

The collection and laboratory analysis of micrometeorites provide an important source of information on the nature of materials in comets and asteroids. Most micrometeorites are collected in the stratosphere with aircraft such as the U2, which is capable of flying at an altitude of 12 mi (20 km) where terrestrial particles as large as 10  $\mu\text{m}$  are rare. Micrometeorites are collected from the stratosphere by direct impact onto sticky plates that are extended from aircraft wings into the ambient airstream. After a cumulative exposure of many hours, the plates are returned to a clean room where the microscopic particles are picked off with needles and placed onto mounts where they can be studied by electron microscopes, mass spectrometers, and other instruments. The collection of micrometeorites in the stratosphere is usually limited to the size range from 2 to 100  $\mu\text{m}$  in diameter. Most particles larger than this limit melt to form cosmic spherules during atmospheric entry and are not true micrometeorites. See COSMIC SPHERULES.

[D.E.Br.]

**Micrometeorology** The study of small-scale meteorological processes associated with the interaction of the atmosphere and the Earth's surface. The lower boundary condition for the atmosphere and the upper boundary condition for the underlying soil or water are determined by interactions occurring in the lowest atmospheric layers. Momentum, heat, water vapor, various gases, and particulate matter are transported vertically by turbulence in the atmospheric boundary layer and thus establish the environment of plants and animals at the surface. These exchanges are important in supplying energy and water vapor to the atmosphere, which ultimately determine large-scale weather and climate patterns. Micrometeorology also includes the study of how air pollutants are diffused and transported within the boundary layer and the deposition of pollutants at the surface.

In many situations, atmospheric motions having time scales between 15 min and 1 h are quite weak. This represents a spectral gap that provides justification for distinguishing micrometeorology from other areas of meteorology. Micrometeorology studies phenomena with time scales shorter than the spectral gap (time scales less than 15 min to 1 h and horizontal length scales less than 2–10 km or 1–6 mi). Some phenomena studied by micrometeorology are dust devils, mirages, dew and frost formation, evaporation, and cloud streets. See AIR POLLUTION; ATMOSPHERE; MESOMETEOROLOGY.

Much of the early understanding of micrometeorology was obtained by studying conditions in large, flat, uniform areas that are relatively simple situations. Micrometeorologists have turned their attention to more complex situations that represent conditions over more of the Earth's surface. The micrometeorology of complex terrain, that is, hills and mountains, is important for air pollution in many towns and cities and for visibility in national parks and for locating wind generators. Another interest is the study of micrometeorology in areas of widely varied surface conditions. For instance, several different crops, dry unirrigated lands, lakes, and rivers may be located near one another. In these cases it is important to understand how the micrometeorology associated with each of these surfaces interacts to produce the overall heat and moisture fluxes of the region so that these areas can be correctly included in weather and climate forecast computer programs. See CLIMATOLOGY; MOUNTAIN METEOROLOGY; WEATHER FORECASTING AND PREDICTION.

Microscale meteorological features are too small to be observed by the standard national and international weather observing network. Generally, micrometeorological phenomena must be studied during specific experiments by using specially designed instruments. Instruments used to study turbulent fluxes must be able to respond to very rapid fluctuations. Special cup anemometers are made from very light materials, and high-quality bearings are used to minimize drag. Other anemometers use the speed of sound waves or measure the temperature of heated wires to measure wind. Tiny thermometers are used, so that time constants are short. Instruments are usually placed on towers or in aircraft, or are suspended in packages from tethered balloons. Instruments have been developed that can measure turbulence remotely. Wind speed and boundary-layer convection can be measured with Doppler radar, lidar devices using lasers, and sodar (sound detection and ranging) using sound waves. See ATMOSPHERIC ACOUSTICS; LIDAR; METEOROLOGICAL INSTRUMENTATION; METEOROLOGICAL RADAR; METEOROLOGY. [S.A.St.]

**Micrometer** A precision instrument used to measure small distances and angles. A common use is on a machinist's caliper, as in the illustration. See CALIPER.

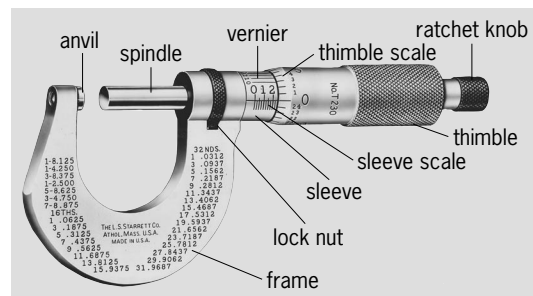

Machinist's outside caliper with micrometer reading 0.250 in. (L. S. Sfarrett Co.)

The spindle of the caliper is an accurately machined screw, which is rotated by the thimble or the ratchet knob until the object to be measured is in contact with both spindle and anvil. The ratchet slips after correct pressure is applied, ensuring consistent, accurate gaging. The number 1 on the sleeve represents 0.1 in.; the smallest divisions are 0.025 in. A vernier scale allows accurate reading to 0.0001 in. See VERNIER.

[F.H.R.]

**Micro-opto-electro-mechanical systems (MOEMS)** A class of microsystems that combine the functions of optical, mechanical, and electronic components in a single, very small package or assembly. MOEMS devices can vary in size from several micrometers to several millimeters. MOEMS may be thought of as an extension of micro-electro-mechanical systems (MEMS) technology by the provision of some optical functionality. This optical functionality may be in the form of moving optical surfaces such as mirrors or gratings, the integration of guided-wave optics into the device, or the incorporation of optical emitters or detectors into the system. The term may be confused with micro-opto-mechanical systems (MOMS), which more properly refers to microsystems that do not include electronic functions at the microsystem location. MOEMS is a rapidly growing area of research and commercial development with great potential to impact daily life. The basic concept is the miniaturization of combined optical, mechanical, and electronic functions into an integrated assembly, or monolithically integrated substrate, through the use of micromachining processes derived from those used by the microelectronics industry. These processes, utilizing microlithography and various etch (subtractive) or deposition (additive) steps on a planar substrate, enable the production of extremely precise shapes, structures, and patterns in various

materials. See INTEGRATED CIRCUITS; INTEGRATED OPTICS; MICRO-ELECTRO-MECHANICAL SYSTEMS (MEMS); MICRO-OPTO-MECHANICAL SYSTEMS (MOMS).

The microsystems realized by these techniques can have many unique capabilities. The miniaturization that is realized is useful in itself, allowing the systems to be utilized as sensors or actuators in environments that were not previously accessible, including inside living organisms, in hand-held instruments, or in small spacecraft. The miniaturization also allows for high-speed operation of the system, as the operating speed of mechanical systems is related to their inertial and frictional properties as well as the actuating forces. Optomechanical systems have been historically constrained in this area because of the mass required for stable optical elements and the extremely precise alignment requirements of most opto-mechanical systems, which limits the forces that can be tolerated for rapid motion. In the more integrated forms of MOEMS, the systems are prealigned by the precise fabrication processes, eliminating one of the more expensive aspects of assembling conventional optical systems. The miniaturization along with the scalability of microfabrication processes allows the development of massively parallel opto-mechanical systems, with millions of moving parts, that would not be possible in conventional technologies. MOEMS can incorporate detection and drive electronics in close proximity to provide improvements in signal-to-noise ratio for sensors and simplified interfaces for actuated systems. Ultimately, these electronics may be monolithically integrated in some technologies. Because of the production volumes achievable with micromachining techniques, MOEMS are potentially much less expensive than their conventional counterparts. [M.E.Wa.]

### Micro-opto-mechanical systems (MOMS)

Miniaturized optomechanical devices or assemblies that are typically formed using micromachining techniques that borrow heavily from the microelectronics industry. The term may be used to distinguish devices and microsystems that combine optical and mechanical functions without the use of internal electronic devices or signals. Systems that use electronic devices as part of the microsystem may be referred to as MOEMS (micro-opto-electro-mechanical systems). In some cases, these terms may be used synonymously. A related area is MEMS (micro-electro-mechanical systems), in which electronic and mechanical functions are combined in a miniature device or system, but not necessarily implementing optical functions. The progress of MOMS technology has been greatly enabled by the simultaneous development of microelectronics and optical fiber-based telecommunications technology. See INTEGRATED CIRCUITS; MICRO-ELECTRO-MECHANICAL SYSTEMS (MEMS); MICRO-OPTO-ELECTRO-MECHANICAL SYSTEMS (MOEMS); OPTICAL COMMUNICATIONS.

**Advantages.** Although similar in concept to MOEMS technologies, MOMS has unique advantages for some applications. The use of only optical energy and signals gives MOMS an inherent immunity to electromagnetic interference (EMI) that is important for applications in electrically noisy or high-voltage environments. The absence of semiconductor electronic devices greatly increases the high-temperature tolerance of the system. MOMS devices can be designed to work immersed in liquids, which is of great importance for chemical sensing and biomedical applications. The fact that the power and signal sources can be remotely provided via an optical fiber, allowing the sensor to be passive, is of great utility and reduces the impact of a MOMS sensor on its local environment. MOMS can be used safely in flammable and explosive environments, making them uniquely valuable in the petrochemical industry.

**Applications.** Some examples of MOMS technology include optical pressure transducers—microphones or hydrophones that have a thin mechanical membrane that is one surface in a Fabry-Perot interferometer formed by the reflection from the membrane surface and the reflection from the end of the fiber. (A similar

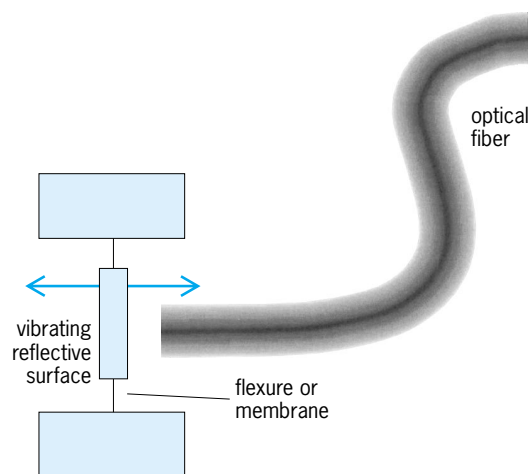

A simplified MOMS sensor using a reflecting surface on a flexible mount or membrane and the end face of an optical fiber to form an optical interferometer that can sense vibration. The vibration of the flexible membrane allows the reflecting surface to move, changing the resonance wavelength of the interferometer, modulating the intensity of the light that is reflected back into the interferometer. At the other end of the interferometer is a light source and a detector.

arrangement for sensing vibration is shown in the illustration.) Other versions have a planar optical waveguide on the surface of a sensitive membrane that is one arm of a two-beam Mach-Zehnder interferometer. Another example is an accelerometer in which a small mass is suspended from flexure attachments to the substrate. Optical fibers are positioned with a small gap in which the moving mass can interrupt the transfer of light from one fiber to another to modulate the light intensity transmitted through the fibers. One of the most well developed MOMS applications is optical sensing of the position of small cantilevers used in scanning tip microscopy processes such as atomic force microscopy. See ACCELEROMETER; MICROPHONE; PRESSURE TRANSDUCER; SCANNING TUNNELING MICROSCOPE. [M.E.Wa.]

**Micropaleontology** A branch of paleontology dealing with the fossilized microscopic organic remains (microfossils) of the geologic past, their structure, biology, phylogenetic relations, and distribution in space and time. The study of these microfossils has become an independent scientific field largely because: (1) The size of these fossils requires special methods for collection and examination. (2) Their abundance in geologic formations makes it possible to analyze their spatial distribution and the rates of morphological changes during the course of evolution by means of statistical methods which can be used only under exceptional circumstances in the study of larger fossils. (3) Microfossils have become indispensable tools in certain branches of applied geology, especially in the exploration for oil-bearing strata, because countless numbers of these minute fossils may be obtained from small pieces of subsurface rock recovered from drill holes. (4) The diversity of microfossils, their wide spatial distribution in varied environments, and their distinctive steps in evolution and the ease of studying them have contributed to make micropaleontology one of the most actively studied branches of the earth sciences.

The material subjected to micropaleontological studies forms a spectrum from primitive plants to advanced vertebrates (see illustration). The only prerequisite for organisms to become the subject of micropaleontological studies is their possession of resistant skeletal components ensuring their preservation in sedimentary strata as fossilized remains even after biological, chemical, or mechanical processes have destroyed the organisms' soft parts.

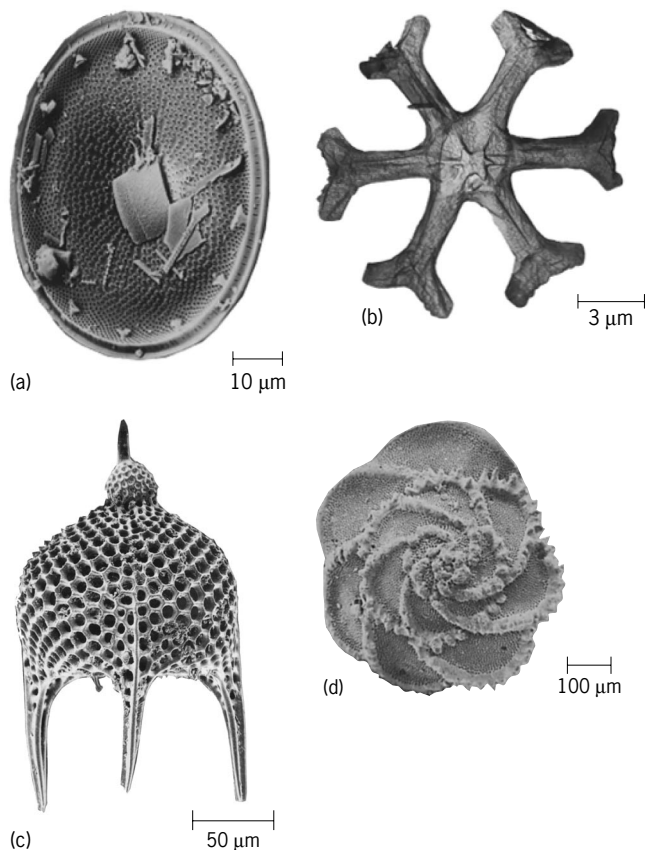

**Representative microfossils.** (a) Diatom; (b) asterolith, a calcareous nannoplankton; (c) radiolarian; and (d) planktonic foraminiferan.

Most major groups of organisms incorporate, besides organic compounds, hard resistant materials that serve for structural support or protection. The more common substances found among the microfossils are calcium carbonate, silicon dioxide (or silica), calcium phosphate in the form of the mineral apatite (typical of bones and teeth), sporonine (principal constituent of pollen and spore walls), and various complex organic compounds. [T.S.]

**Microphone** An electroacoustic device containing a transducer which is actuated by sound waves and delivers electric signals proportional to the sound pressure. Microphones are usually classified with respect to the transducer principle used. Their directional characteristics are also of interest, that is, the voltage output as a function of the direction of incidence for constant sound pressure. See *DIRECTIVITY*; *SOUND*; *SOUND PRESSURE*; *TRANSDUCER*.

In addition to directional characteristics, some other important characteristics of microphones include open-circuit sensitivity, equivalent noise level, dynamic range, and vibration sensitivity.

Open-circuit sensitivity is defined as the ratio of open-circuit output voltage and sound pressure. The pressure sensitivity refers to the actual pressure acting upon the diaphragm of the microphone, while the free-field sensitivity refers to the pressure that existed in the sound field before insertion of the microphone. Pressure sensitivity and free-field sensitivity are equal at low frequencies. Sensitivities are measured in volts/pascal (V/Pa).

Equivalent noise level is equal to the level of a sound pressure which generates an output voltage of the microphone corresponding to its inherent A-weighted noise voltage. It is measured in dB(A).

Dynamic range is defined as the range of sound pressure levels in decibels (dB) extending from the equivalent noise level to the level where the nonlinear distortion reaches 3%.

Vibration sensitivity is defined as the ratio of the output voltage of the microphone as a result of acceleration of its case to the magnitude of the acceleration. Vibration sensitivities are measured in volts/g, where  $g$  is the acceleration of the Earth's gravity, or in volts/(m/s<sup>2</sup>).

**Electrostatic (condenser) microphones.** These consist of a fixed electrode (the backplate), a movable electrode (the diaphragm), and an air gap between the electrodes. To decrease the acoustic stiffness of the airgap, which is generally about 20 to 30 micrometers (0.8 to 1.2 mils) thick, the backplate is often perforated with holes connecting the air gap to a larger air cavity. The diaphragm is a thin [typically 4 to 6 μm thick (0.16 to 0.24 mil)] foil under mechanical tension. See *CAPACITANCE*; *CAPACITOR*; *ELECTRICAL IMPEDANCE*.

Condenser microphones are renowned for their excellent acoustic qualities such as flat frequency response, high sensitivity, large dynamic range, and small vibration sensitivity. Also important is their suitability for miniaturization, with the smallest units having dimensions of only about 0.12 × 0.12 × 0.08 in. (3 × 3 × 2 mm). They can be designed as precision instruments and as such are widely used in measurement and in high-fidelity sound production. See *HEARING AID*; *MAGNETIC RECORDING*; *SOUND RECORDING*; *TELEPHONE*.

**Piezoelectric microphones.** These consist of a material having piezoelectric properties. A deformation of the material leads to the generation of a voltage which corresponds to the deformation. Piezoelectric materials can be crystals, polycrystalline ceramics, or semicrystalline polymers. The best-known piezoelectric crystals are quartz and ammonium dihydrogen phosphate (ADP). Representative of polycrystalline ceramics are lead zirconate titanate (PZT) and barium titanate, which are initially electrostrictive; they have to be poled, that is, exposed to a high electric field at elevated temperatures, to become piezoelectric. An example of a semicrystalline polymer is poly(vinylidene fluoride) [PVDF]. It is also made piezoelectric by poling. See *ELECTRET*; *ELECTROSTRICTION*; *PIEZOELECTRICITY*.

Well-designed piezoelectric microphones have acceptable quality. A drawback is the relatively high vibration sensitivity. They are still in occasional use in telephones in some countries and are also employed in the near-ultrasonic range at frequencies up to about 100 kHz.

**Dynamic microphones.** These consist of a conductor located in the gap of a permanent magnet. Motion of the conductor produces a voltage proportional to its velocity. In the moving-coil microphone the coil, often referred to as voice coil, is connected to a diaphragm actuated by the sound waves. Motion of the coil induces a voltage proportional to its velocity. To obtain a frequency-independent sensitivity, the coil must respond to the sound pressure with frequency-independent velocity. This is accomplished by resistance-controlling the system: the acoustical resistance is made larger in magnitude than the acoustical reactance due to the mass of the diaphragm and coil and due to the compliance of the suspension. A silk cloth or a piece of felt placed behind the voice coil is used for this purpose. In modern moving-coil microphones, the diaphragm is made of a plastic film. The impedance of the voice coil is typically 200 to 1000 ohms. See *ACOUSTIC IMPEDANCE*.

Dynamic microphones are relatively complicated systems. If well designed, they are of good quality. Drawbacks are the difficulties encountered in miniaturization and the relatively high vibration sensitivity. Moving-coil microphones are still widely used in high-fidelity, radio, television, and concert applications. In many other areas they have been replaced by electret-based condenser microphones.

**Magnetic microphones.** These consist of a diaphragm connected to an armature which, when vibrating, varies the reluctance in a magnetic field. The variation in reluctance leads to a variation in the magnetic flux through a surrounding coil and therefore to an induced voltage. This voltage is proportional to the velocity of the armature. To obtain a frequency-independent

sensitivity, the velocity of the armature in response to the sound pressure must be independent of frequency. As in dynamic microphones, this is accomplished by resistance-controlling the system, for example, by placing an acoustic resistance behind the diaphragm.

Magnetic microphones are relatively complicated and have poor frequency response and high vibration sensitivity. While never extensively used, they have now disappeared completely. However, the magnetic principle is still used in telephone receivers and in earphones employed in hearing aids. See EARPHONES.

**Silicon microphones.** The methods of silicon technology make it possible to fabricate batch-processed, high-performance microphones. Utilizing the transducer principles outlined above, many types of such micromachined acoustic sensors have been built. In addition, new concepts of transducer design, such as the modulation of the drain current of a field-effect transistor or the modulation of light propagation in an optical waveguide by the sound waves, have been realized in silicon. Closest to commercial application are the silicon microphones based on the condenser and piezoelectric principles. See FIBER-OPTIC SENSOR; TRANSISTOR.

Silicon microphones have several advantages as compared to conventional microphones. They can be made considerably smaller with membrane areas of only about 1 mm<sup>2</sup>, as opposed to about 5 mm<sup>2</sup> for the smallest conventional transducers. They also have very low vibration sensitivity due to the use of thin diaphragms. They are thus not susceptible to pickup from vibration sources such as motors in cassette recorders or camcorders. Furthermore, they can be produced together with proper signal-processing electronics on the same chip with the same semiconductor methods. Finally, they can be made inexpensively through batch-processing techniques. [G.M.Se.]

**Microprocessor** A device that integrates the functions of the central processing unit (CPU) of a computer onto one semiconductor chip or integrated circuit (IC). In essence, the microprocessor contains the core elements of a computer system, its computation and control engine. Only a power supply, memory, peripheral interface ICs, and peripherals (typically input/output and storage devices) need be added to build a complete computer system. See COMPUTER PERIPHERAL DEVICES.

A microprocessor consists of multiple internal function units. A basic design has an arithmetic logic unit (ALU), a control unit, a memory interface, an interrupt or exception controller, and an internal cache. More sophisticated microprocessors might also contain extra units that assist in floating-point match calculations, program branching, or vector processing (see illustration).

The ALU performs all basic computational operations: arithmetic, logical, and comparisons.

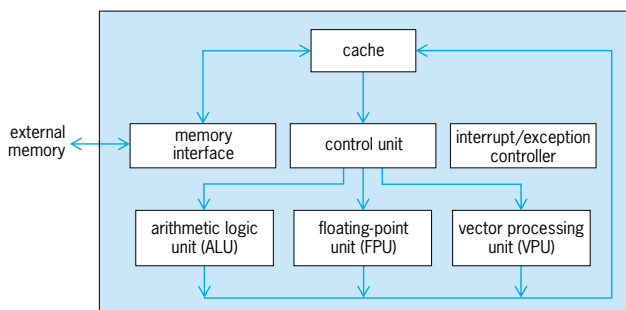

**A microprocessor consists of multiple independent function units. The memory interface fetches instructions from, and writes data to, external memory. The control unit issues one or more instructions to other function units. These units process the instructions in parallel to boost performance.**

The control unit orchestrates the operation of the other units. It fetches instructions from the on-chip cache, decodes them, and then executes them. Each instruction has the control unit direct the other function units through a sequence of steps that carry out the instruction's intent. The execution path taken by the control unit can depend upon status bits produced by the arithmetic logic unit or the floating-point unit (FPU) after the instruction sequence completes. This capability implements conditional execution control flow, which is a critical element for general-purpose computation. See BIT.

The memory interface enables the microprocessor to maintain two-way communication with off-chip semiconductor memory, which stores programs and data. This interface typically supports memory reads and writes in blocks of words (the number of bits that the processor operates on at one time). The block size facilitates burst data transfers to and from the chip's internal cache. See SEMICONDUCTOR MEMORIES.

The interrupt or exception controller enables the microprocessor to respond to requests from the external environment or to error conditions by allowing interruptions of the ongoing operation. An interrupt might be an external peripheral requesting service, while an exception typically consists of a floating-point math error or an unrecognized instruction. The interrupt controller can prioritize and selectively handle these interrupts.

The internal cache is an on-chip memory storage area that holds recently used data values or instruction sequences that are likely to be used again in the near future. Since this information is already on-chip, it can be accessed rapidly, thereby accelerating the computation rate. Items not in the cache can take several or more extra operations to access, which significantly degrades the computation rate. Software writers often organize a program's code and data structures so that the most frequently used elements often occupy the cache, thus maintaining a high level of computational throughput. See COMPUTER STORAGE TECHNOLOGY; COMPUTER SYSTEMS ARCHITECTURE.

The design of instruction sets (the commands that produce basic work when executed by the microprocessor) often influences the design of the microprocessor itself. Instruction sets—and as a consequence, the microprocessor architecture—are of two types: reduced instruction set computers (RISC) and complex instruction set computers (CISC). Because of the limits of early computer technology, most computers were by necessity RISC machines. Since most of the software was written in assembly language (that is, a programming language that represented the program's intent in actual machine instructions), there was a drive to build instruction sets of greater sophistication and complexity. These new CISC instruction sets made assembly language programming easier, but they also made it difficult to build high-speed computer hardware. First, CISC instructions were harder to decode. In addition, since CISC instructions involved long and complex operation sequences, they incurred a major cost by requiring more complicated logic to implement. Second, such instructions were also difficult to interrupt or abort if an exception occurred. Finally, such instructions usually carried many data dependencies that made it more difficult to support advanced architectural techniques. By returning to a RISC design, much faster computers can be built. In fact, an enhancement in performance by a factor of 2 to 3 has been attributed to this simple organizational change. To achieve these efficiencies, most of the RISC microprocessor's function units must be kept as busy as possible. This requires optimizing compilers that can translate a program's high-level source code and then reorder the resulting low-level instructions in such a way as to ensure the high throughput. See COMPUTER PROGRAMMING; PROGRAMMING LANGUAGES.

Microprocessors are found in virtually every consumer product that requires electric power, such as microwave ovens, automobiles, video recorders, cellular telephones, digital cameras, and hand-held computers. High-performance microprocessors implement the servers that store and distribute Web content, such as streaming audio and video, desktop computers, and

the high-speed network switches that constitute the Web's infrastructure. More modest-powered microprocessors are at the heart of notebook computers and electronic games. Low-power microprocessors provide the control and flow logic of hand-held devices, digital cameras, cellular and cordless phones, pagers, and the diagnostic and pollution control of automobile engines. See INTERNET; VIDEO GAMES; WIDE-AREA NETWORKS; WORLD WIDE WEB. [T.T.]

**Micropygoida** An order of regular echinoids belonging to the Diadematacea, established for the two recognized species of *Micropyga*. They have an aulodont lantern with grooved teeth. Test plating is imbricate, and ambulacra are composed of trigeminate compound plates in which upper and lower elements are reduced to demiplates. Pore pairs are biserially arranged in ambulacral columns, and there are unique umbrellalike aboral tube feet. *Micropyga* is a deep-water echinoid, found between 480 and 4290 ft (150 and 1340 m) depth in the Indo-West Pacific. There are no fossils that can be placed in this taxon with certainty, but it is possible that the Upper Jurassic *Pedinothuria* may belong here. See DIADEMATACEA; ECHINODERMATA. [A.B.S.]

**Microradiography** The process of producing enlarged images of the interior of thin, usually small specimens by penetration of low-energy (0.1–10 keV) x-rays. The magnification can be obtained geometrically during the exposure by subsequent enlargement of the initial image by optical or electronic means, or by a combination of both processes. As with radiography on other size scales, microradiography shows the spatial distribution of mass and elemental composition of the sample. If a pulsed (flash) source or time-gated detector is employed, radiographs also provide stop-motion details of fast-changing objects. Microradiography has numerous applications in biology, material science, the characterization of fabricated microstructures, and assessment of plasma-driven compression of thermonuclear fuel.

Microradiography is largely synonymous with x-ray microscopy, both techniques being concerned with producing enlarged images of opaque objects by using x-rays. However, x-ray microscopy of defects in crystals can be performed by using diffraction, rather than simple absorption, in a technique termed x-ray topography. Microradiography by x-ray absorption is complementary, or related to a variety of other techniques for characterization of microstructures. See X-RAY DIFFRACTION; X-RAY MICROSCOPE.

There are three classes of sources employed for microradiography: electron-impact devices, storage ring sources of synchrotron radiation, and multimillion-degree plasmas. The first microradiography measurements, and most studies since then, have been done with electron-impact sources. These contain an electron-emitting cathode and an anode in a high vacuum, between which a high voltage is applied. See X-RAY TUBE.

High-energy (of the order of gigaelectronvolts) electrons orbiting within an evacuated toroid, called a storage ring, produce intense continuum radiation which is tightly collimated and polarized. Such synchrotron radiation is emitted in nanosecond pulses at MHz rates, and can be 1000 or more times as intense as the x-rays from electron-impact sources. The use of synchrotron radiation for microradiography began in 1977 and has rapidly expanded. See SYNCHROTRON RADIATION.

Very high-temperature plasmas can be heated by high-power lasers or electrical discharges. They are typically 10  $\mu\text{m}$  to 1 mm in size. Multimillion-degree plasmas emit uncollimated line and continuum spectra predominantly in the soft x-ray region, below a few kiloelectronvolts, with pulse lengths of 0.1–100 ns. Stop-motion microradiographs were first made with plasma x-radiation in 1980. See PLASMA (PHYSICS).

X-ray micrographs may be obtained by four geometrically different techniques (see illustration). Two of them, the contact and

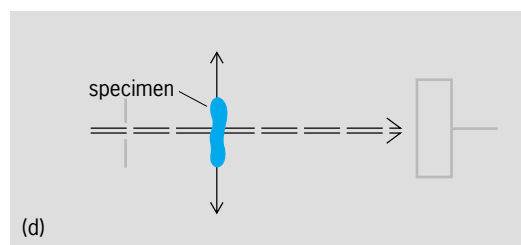
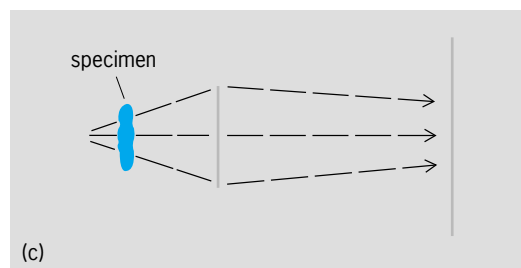
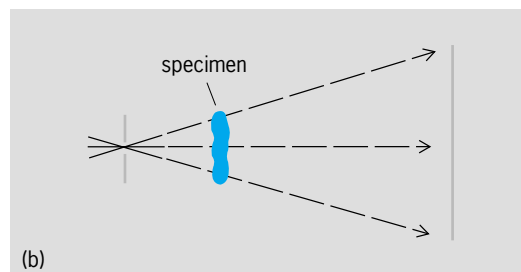
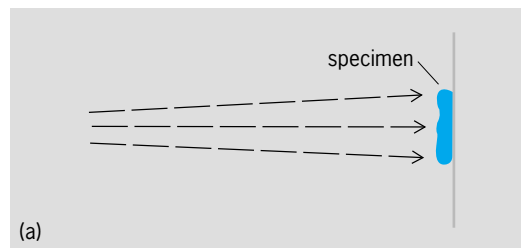

**Schematics of techniques for x-ray microradiography. X-ray paths are indicated by broken lines. (a) Contact. (b) Projection. (c) Imaging. (d) Scanning.**

the projection methods, have been in use for decades. However, they have undergone significant development because of the availability of bright synchrotron radiation and plasma radiation sources. The other two techniques, the true imaging and the scanning methods, require the bright sources.

Microradiography was developed in order to observe fine details in the interior of opaque natural (for example, biological) and manufactured (for example, metallurgical) samples. Optical microscopy has long been available to observe the surfaces of opaque specimens, or the interior of clear samples, with spatial resolutions approaching 200 nm. Early interest in microradiography waned for two reasons: weak sources required long exposure times, and electron beam techniques which provide sub-micrometer details were developed. The availability of bright soft x-ray sources, especially synchrotron radiation, has led to a resurgence of interest in microradiography, especially for cellular samples. Sub-100-nm resolution of live specimens is needed to understand biological structures with sizes between those observable with light microscopes (down to about 200 nm) and the molecular level (about 1 nm) probed by diffraction from ordered



arrays of molecules. Microradiography of inorganic natural, manufactured, and dynamic structures remains of interest. See ELECTRON MICROSCOPE; OPTICAL MICROSCOPE. [D.J.Na.]

**Microsauria** A diverse order of small, extinct amphibians, known only from the Pennsylvanian and lower Permian of North America and Europe. They range from obligatorily aquatic, perennibranchiate genera with lateral-line canal grooves, to fully terrestrial lizardlike forms. Several families include long-bodied, possibly burrowing, species. Limbs are always retained, and the tail is never specialized as a swimming organ. Microsaurians are recognized by the possession of a broad, strap-shaped occipital condyle, and no more than a single bone in the temporal series. The trunk vertebrae are spool-shaped.

The specific origin of the group remains unknown. Although intermediate forms are not known, microsaurians appear to be the most probable group of Paleozoic amphibians from which two modern amphibian orders, the apodans and the salamanders, have evolved. See AMPHIBIA; LEPOSPONDYLII. [R.L.C.]

**Microscope** An instrument used to obtain an enlarged image of a small object. The image may be seen, photographed, or sensed by photocells or other receivers, depending upon the nature of the image and the use to be made of the information of the image.

A simple microscope, hand lens, or magnifier usually is a round piece of transparent material, ground thinner at the edge than at the center, which can form an enlarged image of a small object. Commonly, simple microscopes are double convex or planoconvex lenses, or systems of lenses acting together to form the image.

The compound microscope utilizes two lenses or lens systems. One lens system forms an enlarged image of the object and the second magnifies the image formed by the first. The total magnification is then the product of the magnifications of both lens systems (see illustration).

The typical compound microscope consists of a stand, a stage to hold the specimen, a movable body-tube containing the two lens systems, and mechanical controls for easy movement of the body and the specimen. The lens system nearest the specimen is called the objective; the one nearest the eye is called the eyepiece or ocular. A mirror is placed under the stage to reflect light into the instrument when the illumination is not built into the stand. For objectives of higher numerical aperture than 0.4, a condenser is provided under the stage to increase the illumination of the specimen. Various optical and mechanical attachments may be added to facilitate the analysis of the information in the doubly enlarged image. See ELECTRON MICROSCOPE; FLUO-

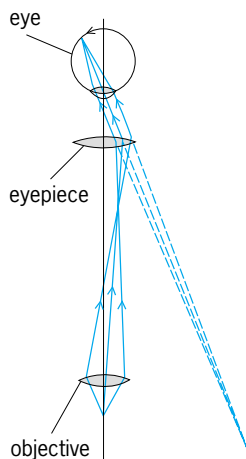

Compound microscope diagram. (After F. A. Jenkins and H. E. White, *Fundamentals of Optics*, 4th ed., McGraw-Hill, 1976)

RESCENCE MICROSCOPE; INTERFERENCE MICROSCOPE; LENS (OPTICS); OPTICAL MICROSCOPE; PHASE-CONTRAST MICROSCOPE; REFLECTING MICROSCOPE; X-RAY MICROSCOPE. [O.W.R.]

**Microsensor** A very small sensor with physical dimensions in the submicrometer to millimeter range. A sensor is a device that converts a nonelectrical physical or chemical quantity, such as pressure, acceleration, temperature, or gas concentration, into an electrical signal. Sensors are an essential element in many measurement, process, and control systems, with countless applications in the automotive, aerospace, biomedical, telecommunications, environmental, agricultural, and other industries. The stimulus to miniaturize sensors lies in the enormous cost benefits that are gained by using semiconductor processing technology, and in the fact that microsensors are generally able to offer a better sensitivity, accuracy, dynamic range, and reliability, as well as lower power consumption, than their larger counterparts.

Mechanical microsensors form perhaps the largest family of microsensors because of their widespread availability. Microsensors have been produced to measure a wide range of mechanical properties, including force, pressure, displacement, acceleration, rotation, and mass flow. Force sensors generally use a sensing element that converts the applied force into the deformation of the elastic element.

Applications for chemical and biochemical microsensors are environmental monitoring and medicine. Applications in the medical industry may involve monitoring blood, urine, and breath, which contain a wealth of information about the patient's state of health. Only a few such devices now exist. Examples include a glucose biochemical microsensor and ion-selective field-effect devices used to measure blood pH. The use of microsensors to gather medical diagnostic information is an attractive proposition, and eventually there may even be implanted microsensors to diagnose health problems, using smell-sensitive array devices. See BIOELECTRONICS. [A.C.P.; C.J.W.; J.W.Ga.]

**Microsporidea** A class of Cnidosporea characterized by the production of minute spores with a single intrasporal or one or two intracapsular filaments and a single sporoplasm. The spore membrane of these protozoans is usually a single piece. Microsporidians are mainly intracellular parasites of arthropods and fishes. Microsporidia is the only order of this class. See CNIDOSPORA. [R.F.N.]

**Microtechnique** The art of preparing objects for examination under the microscope and of preserving objects so prepared. Few objects yield useful information if examined without such preparation, which may involve, in addition to preliminary preservation, hardening, rendering transparent, selective coloration of parts, and cutting into thin slices.

The four types of microscope slide commonly made are whole-mounts, smears, squashes, and sections. The last three methods are merely devices to make thinner, or smaller, objects unsuitable for the first method. In all four methods, the objects are permanently preserved in a mounting medium between a glass slide, about 0.04 in. (1 mm) thick, and a glass cover slip 0.04 to 0.008 in. (1 to 0.2 mm) thick. Preliminary fixation and preservation, staining, and the final mounting media are common to all four types. [PGr.]

**Microwave** Electromagnetic energy with wavelengths in free space ranging roughly from 0.3 to 30 cm. Corresponding frequencies range from 1 to 100 GHz. Frequency and wavelength are related by  $f\lambda = c$ , where  $f$  is the frequency,  $\lambda$  is the free-space wavelength, and  $c$  is the velocity of light in vacuum, approximately  $3 \times 10^8$  m/s. See ELECTROMAGNETIC RADIATION; FREQUENCY (WAVE MOTION); WAVE MOTION; WAVELENGTH.

Characteristic transmission media for microwaves are hollow-pipe waveguides, where the cross-sectional dimensions are of the

order of the wavelength and thus are of convenient size. Coaxial transmission lines are also used, however, especially in the lower-frequency bands, and various stripline techniques are used on microwave integrated circuits. Resonant cavities are commonly used as circuit elements, and radiation or reception of the energy is typically by horns, parabolic reflectors, or arrays. See ANTENNA (ELECTROMAGNETISM); CAVITY RESONATOR; COAXIAL CABLE; ELECTROMAGNETIC WAVE TRANSMISSION; TRANSMISSION LINES; WAVEGUIDE.

**Generation.** For most applications, microwaves are generated in electronic devices that produce oscillations at microwave frequencies. The devices may be single-frequency or tunable, and continuous-wave (cw) or pulsed. Vacuum-tube generators include klystrons, magnetrons, and backward-wave oscillators; solid-state generators include tunnel diodes, Gunn diodes, IMPATT diodes, transistor oscillators, masers, and harmonic generators using varactor diodes. The vacuum-tube generators are used to produce higher powers, which can be as much as thousands of kilowatts. Solid-state generators were formerly limited in power to a few watts, but their power capabilities are continually increasing and now may reach hundreds of watts. See GYROTRON; KLYSTRON; MAGNETRON; MICROWAVE SOLID-STATE DEVICES; MICROWAVE TUBE; TRAVELING-WAVE TUBE.

**Circuit elements.** Physical elements which produce specific effects on microwaves are called circuit elements.

The most common method of microwave transmission within a system is through hollow circular or rectangular metal tubes of uniform cross section called waveguides. The microwave energy is confined within these tubes and guided along them.

Various forms of stripline are used in interconnecting components on a dielectric or semiconductor substrate when microwave devices are integrated. One important example is the microstrip, in which a metallic strip or ribbon is placed on a thin dielectric, which is in turn backed by a conducting ground plane. Striplines have more losses than hollow-pipe waveguides but are generally used over very short distances.

Filters are needed in communication or information-processing systems for blocking of high frequencies (low-pass), blocking of low frequencies (high-pass), elimination of undesired bands (band elimination), or passing of desired bands while attenuating others (band pass). All of these may be made for microwaves by adding periodic perturbations, such as posts, irises, diaphragms, or dimensional variations, to the waveguide or other transmission system. See ELECTRIC FILTER; MICROWAVE FILTER.

A thin sheet of plastic can be used to alter the amplitude or phase of microwaves. If the sheet is coated with powdered carbon with appropriate electrical conductivity and placed in a waveguide with the lossy material parallel to the lines of electrical intensity, it will absorb microwave power. Variable attenuation can be achieved by mechanically inserting more or less of the lossy strip into the path of the wave. See ATTENUATION (ELECTRICITY).

A phase shifter changes the phase of a microwave without changing its amplitude. It can be constructed in the same manner as an attenuator without the lossy material.

An attenuator which has a very large loss and is closed at one end is called a termination; it absorbs all the power transmitted into it, reflecting none.

The most common microwave detector is a silicon diode designed for high frequencies and mounted in a waveguide or a stripline. The diode rectifies the microwave signal, producing an average current which can be indicated by a direct-current meter connected between the diode terminals. If the microwave signal is modulated in amplitude, the modulation will appear in the output current. See AMPLITUDE MODULATION; SEMICONDUCTOR DIODE.

The bolometer is a detector which absorbs microwave power, causing a temperature increase and a corresponding change in resistance. The bolometer does not respond fast enough to detect

high-frequency modulation. It is often used as one arm of a resistance bridge circuit in microwave power meters. See BOLOMETER; MICROWAVE POWER MEASUREMENT.

A transmitting antenna takes microwave power from a waveguide and converts it into a plane wave that propagates through space to a distant receiving antenna. Two important characteristics of antennas are efficiency and directivity, efficiency being the ratio of the power delivered into space to the power available in the waveguide. High directivity is accomplished by large antennas which focus the microwave energy in the same way a searchlight focuses a beam of light.

The gyrator is a lossless, nonreciprocal, two-port circuit which has 180° more phase shift in one direction than in the other. This principle is used in the broadband microwave circulator. The three-port circulator has the property that all the power into port 1 exits at port 2, all the power into port 2 exits at port 3, and all the power into port 3 exits at port 1. The nonreciprocal phase shift is achieved in a magnetic ferrite placed in the waveguide junction and magnetized with an external permanent magnet. An isolator is a circulator with one port terminated, resulting in a circuit which transmits power in one direction and not the other. The input circuit is thus isolated from the output circuit. When the terminated port is internal, the isolator appears to be a two-port element. See GYRATOR.

A varactor is a solid-state diode whose capacitance changes with applied voltage. Varactors are used as harmonic generators to obtain microwave power efficiently from lower-frequency sources such as quartz crystal-controlled oscillators in the 10–100-MHz range. Varactors are also used in up-converters and down-converters performing the same functions as similar circuits using resistive diodes, but more efficiently and at the expense of narrower bandwidth. See OSCILLATOR; VARACTOR.

A microwave amplifier converts a low-power input signal to a higher-power output signal while preserving one or more characteristics. A linear amplifier preserves the amplitude, frequency, and phase of the input signal. When a linear amplifier is overloaded, it becomes saturated: the output amplitude tends to remain constant and the envelope of the input signal becomes distorted.

High power output is achieved with klystron and traveling-wave tube (TWT) amplifiers, both of which can be operated in the linear or saturated modes. Moderate power can be achieved with transistor amplifiers, and these are continually being extended in their frequency range of usefulness. Very low noise levels are achieved in the maser and the parametric amplifier, both of which require power at a single frequency to pump the active element. See AMPLIFIER; MASER; PARAMETRIC AMPLIFIER.

**Microwave integrated circuits.** Microwave integrated circuits (MICs) are of two types, hybrid MICs and monolithic microwave integrated circuits (MMICs). In the hybrid circuits, some or all of the active and passive devices are added to a dielectric or semiconducting substrate and interconnected by striplines as discussed above. For MMICs, all of the active and passive devices of the functional unit are formed on the substrate, and interconnected by striplines through a variety of microfabrication techniques, including photolithography, epitaxy, ion implantation, etching, diffusion, sputtering, and evaporation. See INTEGRATED CIRCUITS.

**Receiver.** The first active element in nearly all microwave receivers is a silicon diode operated as a down-converter. In this type of receiver, a strong, continuous-wave local oscillator signal is used to pump the diode over its nonlinear resistance range. In this manner, the local oscillator and the input signal are mixed, shifting the input signal down to an intermediate frequency, which is the difference between the frequencies of the local oscillator signal and the received signal. Intermediate frequencies of a few tens of megahertz are common. Frequency, phase, or amplitude modulation on the received signal appears in the detector output at the intermediate frequency. A bandpass

intermediate-frequency amplifier, providing most of the gain of the receiver, follows the detector, after which a demodulator converts the modulation on the intermediate-frequency signal to usable form, for example, an audio or a television signal. See RADIO RECEIVER.

**Transmitter.** The main components of a microwave transmitter are a microwave power source, a modulator, and, if necessary, a power amplifier. The modulation can be done directly at microwave frequencies or it can be performed at intermediate frequency and shifted to the microwave frequency in an up-converter, which is very much like a down-converter.

**Propagation.** In free space, microwaves travel in straight lines as do optical waves. Near the Earth, however, the atmosphere has an index of refraction which normally decreases with distance above the Earth and causes the wave to travel in a circular path which bends slightly toward the Earth. Microwaves are reflected and refracted by objects just as are optical waves. See MICROWAVE OPTICS.

Occasionally during the summer, atmospheric conditions cause microwaves transmitted from an antenna to travel to a receiver via two or more paths. These waves interfere at the receiver and may cause large decreases in the received signal amplitude. This phenomenon, called multipath fading, is a serious problem in microwave transmission parallel to the surface of the Earth. Other atmospheric conditions can result in what is known as earth-bulge fading. When microwaves are directed well above the horizon, neither of these two problems occurs. Thus satellite microwave systems do not suffer from either multipath or earth-bulge fading.

At frequencies above about 10 GHz, rain absorbs microwave energy, resulting in large signal losses. Both satellite and point-to-point microwave systems are seriously affected by rain attenuation. For most frequencies the attenuation of microwaves by the Earth's atmosphere is very small. See RADIO-WAVE PROPAGATION.

**Applications.** Areas in which microwave radiation is applied include radar, communications, radiometry, medicine, physics, chemistry, and cooking food.

Radar is used in military applications, commercial aviation, remote sensing of the atmosphere, and astronomy. The high antenna directivity and the excellent propagation characteristics of microwaves in the atmosphere make this the preferred band for radar applications. Microwaves are also used in electronic countermeasures to radar. See ELECTRONIC WARFARE; RADAR.

There is at least 100 times as much frequency space available for communications in the microwave band as in the entire spectrum below microwaves. In addition, the high directivity obtainable at microwave frequencies allows reuse of these frequencies many times in the same area, a practice not possible at lower frequencies. The high directivity also makes possible communication to satellites and deep-space probes. See COMMUNICATION SATELLITE; RADIO SPECTRUM ALLOCATIONS; SPACE COMMUNICATIONS.

All objects, including liquids and gases, emit electromagnetic radiation in the form of noise, the amount of the noise being proportional to the absolute temperature of the object. A noise temperature can be assigned to the object corresponding to the amount of noise radiating from it. A microwave radiometer is a sensitive receiver which measures the noise power received by an antenna; from this measurement, the noise temperature of the source object can be determined. Radiometers are used extensively for remote sensing. Microwave radiometers are used to study astronomical sources of noise and to observe planets from deep space probes. See PASSIVE RADAR; RADIOMETRY; REMOTE SENSING.

Applications of microwaves in medicine include (1) thermography, the measurement of tissue temperature; (2) hyperthermia, microwave heating used in the treatment of cancer and in the treatment of hypothermic subjects; and (3) biomedical imaging, the use of microwaves to study the structure of tissue beneath the skin. See RADIOLOGY.

**Physics and chemistry.** Microwave energy is used in large particle accelerators to accelerate charged particles such as electrons and protons to very high energies and cause them to collide. Knowledge of the structure of matter is also obtained from microwave spectroscopy. See MICROWAVE SPECTROSCOPY; PARTICLE ACCELERATOR.

Microwave energy is absorbed in most foods and has been found to be a source of quick, uniform heating or cooking. Microwave ovens based upon this principle are now widely used. Microwaves are also used for the industrial heating of foodstuffs and other materials. [C.L.Ru.; J.R.W.]

**Microwave filter** A two-port component used to provide frequency selectivity in satellite and mobile communications, radar, electronic warfare, metrology, and remote-sensing systems operating at microwave frequencies (1 GHz and above). Microwave filters perform the same function as electric filters at lower frequencies, but differ in their implementation because circuit dimensions are on the order of the electrical wavelength at microwave frequencies. Thus, in the microwave regime, distributed circuit elements such as transmission lines must be used in place of the lumped-element inductors and capacitors used at lower frequencies. This can make microwave filter design more difficult, but it also introduces a variety of useful coupling and transmission effects that are not possible at lower frequencies.

The majority of modern microwave filters are designed by using the insertion-loss method, whereby the amplitude response of the filter is approximated by using network synthesis techniques that have been extended to accommodate microwave distributed circuit elements. A general four-step procedure is followed: determination of filter specifications, design of a low-pass prototype filter, scaling and transforming the filter, and implementation (conversion of lumped elements to distributed elements).

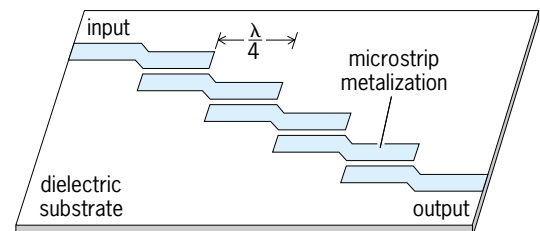

(a)

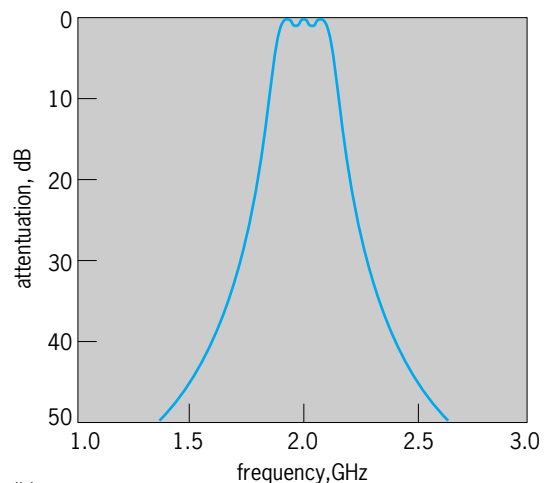

(b)

**Third-order (four-section) microwave band-pass filter.** (a) Layout of the parallel coupled stripline filter. (b) Calculated frequency response of the filter, with center frequency of 2 GHz and 0.5-dB equal-ripple passband.

Microwave filters are implemented in many ways. Waveguide cavity band-pass filters have very low insertion loss, making them preferred for frequency multiplexing in satellite communication systems. Coaxial low-pass filters, made with sections of coaxial line with varying diameters, are compact and inexpensive. Planar filters in microstrip or stripline form (see illus.) are important for integration with hybrid or monolithic microwave integrated circuits. While planar filters are usually more cost effective than waveguide versions, their insertion loss is usually greater. Computer-aided design procedures are used in the synthesis of more sophisticated amplitude and phase responses, and active microwave devices (field-effect transistors) are used to provide filters with gain or tunable response characteristics. See COAXIAL CABLE; COMPUTER-AIDED DESIGN AND MANUFACTURING; ELECTRIC FILTER; MICROWAVE SOLID-STATE DEVICES; TRANSMISSION LINES; WAVEGUIDE. [D.M.Po.]

**Microwave free-field standards** The means for setting up electromagnetic fields of precisely determined intensity at microwave frequencies in unbounded regions of space. Such standards are used to evaluate field probes and antennas for measuring field strength and power density. The standardization of these devices is necessary before they are used for determining the performance of radar and communications systems or for assessing such systems for health and safety risks or electromagnetic compatibility. See ELECTROMAGNETIC RADIATION; MICROWAVE.

Antennas used in free-field standards are usually either half-wave dipoles or wave-guide horns. The half-wave dipole is a collinear device with a length of approximately one-half of the free-space wavelength of the radiated wave. The gain and pattern characteristics of a pyramidal horn can be calculated to accuracies of about  $\pm 2$  dB; however, the reflections at the throat and aperture discontinuities significantly influence the gain-frequency characteristic and calibration is usually necessary. See WAVEGUIDE.

The ideal environment for making measurements on antennas is a large unobstructed volume which is free of reflecting objects and electromagnetically interfering signals—that is, a free-space condition. A practical solution is to use an anechoic chamber to set up simulated free-space conditions in a bounded environment. Low reflection of electromagnetic signals from the walls of such a chamber is achieved by the use of an electromagnetic wave absorbent layer covering all of the reflecting surfaces within the room or chamber, the outer shell of which is a metallic structure to give shielding against interfering signals encroaching on the test region.

Clear open sites can be used at low frequencies, or for high-gain antennas where far-field measurements require such large distances that enclosed or anechoic environments are impractical. However, since electromagnetic waves are strongly reflected by a ground plane, this effect must be accommodated, and one of two courses can be adopted. One is to do measurements as far above the ground as possible. The alternative is to make use of the ground plane by working close to it—if necessary, enhancing its reflection with a metal ground plane or grid—and by making allowance for the reflection in the analysis of performance. See ANECHOIC CHAMBER.

Probably the single most important parameter of a standard antenna, when considered for metrological applications, is the boresight or maximum gain, and a number of methods of determining this parameter have been devised. The three-antenna method involves measurement of the transmission between two polarization-matched antennas. Only the product of the antenna gains can be obtained from this measurement; however, with three antennas the measured combinations will yield the gain of each antenna uniquely. The extrapolation method involves determining the transmission characteristic between two antennas as the transmission path is increased through about 4 to 10 Rayleigh distances. With good metrology it is possible to get a sufficiently accurate characterization to allow extrapolation to

the true far-field range. Antenna metrology has increasingly concentrated on near-field scanning techniques with the objective of improving antenna characterization. In this method a probe antenna is used to sample the magnitude and phase, for orthogonal polarizations, of the radiated fields over a well-defined surface, which can be a plane, a cylinder, or a sphere, a few wavelengths from the antenna under test.

The essential requirement for the calibration of devices for measuring power flux density or field strength is the creation of a substantially plane wave of known power density which encompasses the effective aperture of the device to be tested. This is effected by launching a known power through an antenna or transverse-electromagnetic cell of known characteristics and calculating the field strength or power density from the appropriate equation. [R.W.Ye.]

**Microwave landing system (MLS)** An aircraft landing-guidance system that operates at microwave frequencies and provides deviations from the landing runway centerline using time-referenced scanning beam (TRSB) technology. The MLS was standardized in 1988 and approved for use in international civil aviation. The instrument landing system (ILS) is also standardized internationally and approved for use. Standards for a third landing system, based on Global Positioning System (GPS) technology, are expected. See INSTRUMENT LANDING SYSTEM (ILS); SATELLITE NAVIGATION SYSTEMS.

The operating frequencies for MLS lie in a portion of the C-band (5030–5091 MHz) designated for use in aeronautical telecommunications. This frequency choice allows a 12-ft (3.6-m) antenna to generate the  $1^\circ$  beamwidth pattern needed to exclude most reflections.

As with ILS, the MLS equipment is sited near the primary runway, with the azimuth transmitter and distance-measuring equipment (DME) transponder located near the runway stop end, and the elevation transmitter located alongside the runway near landing threshold. With this geometry, the approach course and glide path, generated by the ground equipment, are monitored at the landing runway. Also, the aircraft lateral and vertical displacements due to guidance errors become vanishingly small as the runway is approached and the angular guidance converges to its origin. Unlike ILS, the 50-times higher frequency of the MLS allows generation of narrow beams by relatively small equipment. Because of this 50:1 scale factor, a  $1^\circ$  beamwidth antenna for MLS requires a 12-ft (3.6-m) antenna, while for ILS a 600-ft (180-m) antenna would be required. See ANTENNA (ELECTROMAGNETISM); DISTANCE-MEASURING EQUIPMENT.

The large coverage volume of MLS is provided by scanning the narrow beams clockwise then counterclockwise for azimuth functions and up then down for elevation functions. This scanning is electronically controlled at a precise rate of  $20,000^\circ/s$  and fills a lateral sector of  $60^\circ$  (maximum) on each side of the runway center line and a vertical sector of  $30^\circ$  (maximum). The angular position of the aircraft is decoded by the airborne receiver, which measures the time elapsed between successive passages of azimuth or elevation beams.

The antennas typically used are phased arrays where beam scanning is accomplished by a stored set of commands which, at the appropriate time in the transmission sequence, are directed to variable signal-delay devices (phase shifters) associated with each radiating element of the array. See AIR NAVIGATION; ELECTRONIC NAVIGATION SYSTEMS. [D.B.V.]

**Microwave measurements** A collection of techniques particularly suited for development of devices and monitoring of systems where physical size of components varies from a significant fraction of an electromagnetic wavelength to many wavelengths. See MICROWAVE.

Virtually all microwave devices are coupled together with a transmission line having a uniform cross section. The concept of traveling electromagnetic waves on that transmission line is

fundamental to the understanding of microwave measurements. See MICROWAVE TRANSMISSION LINES.

At any reference plane in a transmission line there are considered to exist two independent traveling electromagnetic waves moving in opposite directions. One is called the forward or incident wave, and the other the reverse or reflected wave. The electromagnetic wave is guided by the transmission line and is composed of electric and magnetic fields with associated electric currents and voltages. Any one of these parameters can be used in considering the traveling waves, but the measurements in the early development of microwave technology made principally on the voltage waves led to the custom of referring only to voltage. One parameter in very common use is the voltage reflection coefficient  $\Gamma$ , which is related to the incident,  $V_i$ , and reflected,  $V_r$  voltage waves by Eq. (1).

$$\Gamma = \frac{V_r}{V_i} \quad (1)$$

**Impedance.** The voltage reflection coefficient  $\Gamma$  is related to the impedance terminating the transmission line and to the impedance of the line itself. If a wave is launched to travel in only one direction on a uniform reflectionless transmission line of infinite length, there will be no reflected wave. The input impedance of this infinitely long transmission line is defined as its characteristic impedance  $Z_0$ . An arbitrary length of transmission line terminated in an impedance  $Z_0$  will also have an input impedance  $Z_0$ . See ELECTRICAL IMPEDANCE.

If the transmission line is terminated in the arbitrary complex impedance load  $Z_L$ , the complex voltage reflection coefficient  $\Gamma_L$  at the termination is given by Eq. (2).

$$\Gamma = \frac{Z_L - Z_0}{Z_L + Z_0} \quad (2)$$

Even when there is no unique expression for  $Z_L$  and  $Z_0$  such as in the case of hollow uniconductor waveguides, the voltage reflection coefficient  $\Gamma$  has a value because it is simply a voltage ratio. In general, the measurement of microwave impedance is the measurement of  $\Gamma$ . Both amplitude and phase of  $\Gamma$  can be measured by direct probing of the voltage standing wave set up along a transmission line by the two opposed traveling waves, but this is a slow technique. Directional couplers have been used for many years to perform much faster swept frequency measurement of the magnitude of  $\Gamma$ , and more recently the use of automatic network analyzers under computer control has made possible rapid, accurate measurements of amplitude and phase of  $\Gamma$  over very broad frequency ranges. See DIRECTIONAL COUPLER.

**Power.** A required increase in microwave power is expensive whether it be the output from a laboratory signal generator, the power output from a power amplifier on a satellite, or the cooking energy from a microwave oven. To minimize this expense, absolute power must be measured. Most techniques involve con-

version of the microwave energy to heat energy which, in turn, causes a temperature rise in a physical body. This temperature rise is measured and is approximately proportional to the power dissipated. The whole device can be calibrated by reference to low-frequency electrical standards and application of appropriate corrections. See RADIOMETRY.

The power sensors are simple and can be made to have a very broad frequency response. A power meter can be connected directly to the output of a generator to measure available power  $P_A$ , or a directional coupler may be used to permit measurement of a small fraction of the power actually delivered to the load.

**Scattering coefficients.** While the measurement of absolute power is important, there are many more occasions which require the measurement of relative power which is equivalent to the magnitude of voltage ratio and is related to attenuation. Also there arises frequently the need to measure the relative phase of two voltages. Measurement systems having this capability are referred to as vector network analyzers, and they are used to measure scattering coefficients of multi-port devices. The concept of scattering coefficients is an extension of the voltage reflection coefficient applied to devices having more than one port. The most simple is a two-port. Its characteristics can be specified completely in terms of a  $2 \times 2$  scattering matrix, the coefficients of which are indicated in the illustration. The incident voltage at the reference plane of each port is defined as  $a$ , and the reflected voltage is  $b$ . Voltages  $a$  and  $b$  are related by matrix equation (3), where  $(S_{nm})$  is the scattering matrix of the junction. Writing Eq. (3) out for a two-port device gives Eqs. (4) and (5). Examina-

$$(b_n) = (S_{nm})(a_m) \quad (3)$$

$$b_1 = S_{11}a_1 + S_{12}a_2 \quad (4)$$

$$b_2 = S_{21}a_1 + S_{22}a_2 \quad (5)$$

tion of Eq. (4) shows, for example, that  $S_{11}$  is the voltage reflection coefficient looking into port 1 if port 2 is terminated with a  $Z_0$  load ( $a_2 = 0$ ). See MATRIX THEORY.

**Heterodyne.** The heterodyne principle is used for scalar attenuation measurements because of its large dynamic range and for vector network analysis because of its phase coherence. The microwave signal at frequency  $f_s$  is mixed with a microwave local oscillator at frequency  $f_{LO}$ , in a nonlinear mixer. The mixer output signal at frequency  $f_s - f_{LO}$  is a faithful amplitude and phase reproduction of the original microwave signal but is at a low, fixed frequency so that it can be measured simply with low-frequency techniques. One disadvantage of the heterodyne technique at the highest microwave frequencies is its cost. Consequently, significant effort has been expended in development of multiport network analyzers which use several simple power detectors and a computer analysis approach which allows measurement of both relative voltage amplitude and phase with reduced hardware cost. See HETERODYNE PRINCIPLE.

**Noise.** Microwave noise measurement is important for the communications field and radio astronomy. The measurement of thermal noise at microwave frequencies is essentially the same as low-frequency noise measurement, except that there will be impedance mismatch factors which must be carefully evaluated. The availability of broadband semiconductor noise sources having a stable, high, noise power output has greatly reduced the problems of source impedance mismatch because an impedance-matching attenuator can be inserted between the noise source and the amplifier under test. See ELECTRICAL NOISE; ELECTRICAL NOISE GENERATOR; MICROWAVE NOISE STANDARDS.

**Use of computers.** The need to apply calculated corrections to obtain the best accuracy in microwave measurement has stimulated the adoption of computers and computer-controlled instruments. An additional benefit of this development is that measurement techniques that are superior in accuracy but too tedious to perform manually can now be considered. For a discussion of attenuation in microwave circuits see ATTENUATION (ELECTRICITY).

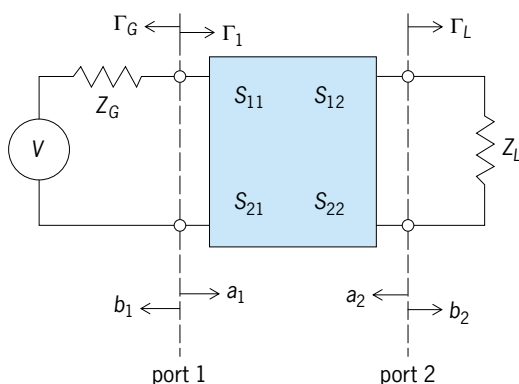

A two-port inserted between a load and a generator.  $S_{nm}$  are the scattering coefficients of the two-port.

**Microwave noise standards** Electrical noise generators which produce calculable noise intensities at microwave frequencies, and which are used to calibrate other noise sources by using comparison methods. Noise standards are based upon the blackbody or thermal radiator and generate noise power according to Planck's radiation law. The practical realization of a blackbody in the microwave region consists of a microwave absorber with unity absorptivity. This can be achieved by using a transmission line terminated in its characteristic impedance, or in microwave terminology a matched termination. See HEAT RADIATION; MICROWAVE TRANSMISSION LINES; TRANSMISSION LINES.

The range of sources which require calibration and the desire to obtain low uncertainties dictate that microwave thermal noise standards are required with temperatures both above and below the ambient temperature. Sources have been developed with temperatures in the range from 4 to 1300 K (−452 to 1900°F). The low temperatures are normally achieved by immersion of the matched termination in a cryogenic liquid of which liquid nitrogen (77 K or −321°F) is the most common. Standards for measurement of high-temperature sources have the termination in a heated oven. A transition section supports the temperature gradient from the thermal termination to the ambient temperature output which connects to the measurement system. See MICROWAVE; MICROWAVE MEASUREMENTS; RADIOMETRY. [M.W.S.]

**Microwave optics** The study of those properties of microwaves which are analogous to the properties of light waves in optics. The fact that microwaves and light waves are both electromagnetic waves, the major difference being that of frequency, already suggests that their properties should be alike in many respects. But the reason microwaves behave more like light waves than, for instance, very low-frequency waves for electrical power (50 or 60 Hz) is primarily that the microwave wavelengths are usually comparable to or smaller than the ordinary physical dimensions of objects interacting with the waves.

As is the case with light, a beam of microwaves propagates along a straight line in a perfectly homogeneous infinite medium. This phenomenon follows directly from a general solution of the wave equation in which the direction of a wave normal does not change in a homogeneous medium. See WAVE EQUATION.

With some modification the laws of reflection and refraction can be applied to the propagation of microwaves inside a dielectric-filled metallic waveguide. Another interesting application is associated with the microwave analog of total internal reflection in optics. A properly designed dielectric rod (without metal walls) can serve as a waveguide by totally reflecting the elementary plane waves. Still another case of interest is that of a microwave lens. See ANTENNA (ELECTROMAGNETISM); REFLECTION OF ELECTROMAGNETIC RADIATION; REFRACTION OF WAVES; WAVEGUIDE.

In an analogous manner to light, a microwave undergoes diffraction when it encounters an obstacle or an opening which is comparable to or somewhat smaller than its wavelength. See MICROWAVE. [C.K.J.]

**Microwave solid-state devices** Semiconductor devices used for the detection, generation, amplification, and control of electromagnetic radiation with wavelengths from 30 cm to 1 mm (frequencies from 1 to 300 GHz). The number and variety of microwave semiconductor devices, used for wireless and satellite communication and optoelectronics, have increased as new techniques, materials, and concepts have been developed and applied. Passive microwave devices, such as *pn* and PIN junctions, Schottky barrier diodes, and varactors, are primarily used for detecting, mixing, modulating, or controlling microwave signals. Step-recovery diodes, transistors, tunnel diodes, and transferred electron devices (TEDs) are active microwave devices that generate power or amplify microwave signals. See MICROWAVE; SEMICONDUCTOR DIODE.

Typical high-frequency semiconductor materials include silicon (Si), germanium (Ge), and compound semiconductors, such as gallium arsenide (GaAs), indium phosphide (InP), silicon germanium (SiGe), silicon carbide (SiC), and gallium nitride (GaN). In general, the compound semiconductors work best for high-frequency applications due to their higher electron mobilities. See GALLIUM; GERMANIUM; SEMICONDUCTOR; SILICON.

**Passive devices.** A PIN (*p*-type/intrinsic/*n*-type) diode is a *pn* diode that has an undoped (intrinsic) region between the *p*- and *n*-type regions. The use of an intrinsic region in PIN diodes allows for high-power operation and offers an impedance at microwave frequencies that is controllable by a lower frequency or a direct-current (DC) bias. The PIN diode is one of the most common passive diodes used at microwave frequencies. PIN diodes are used to switch lengths of transmission line, providing digital increments of phase in individual transmission paths, each capable of carrying kilowatts of peak power. PIN diodes come in a variety of packages for microstrip and stripline packages, and are used as microwave switches, modulators, attenuators, limiters, phase shifters, protectors, and other signal control circuit elements. See JUNCTION DIODE.

A Schottky barrier diode (SBD) consists of a rectifying metal-semiconductor barrier typically formed by deposition of a metal layer on a semiconductor. The SBD functions in a similar manner to the antiquated point contact diode and the slower-response *pn*-junction diode, and is used for signal mixing and detection. The point contact diode consists of a metal whisker in contact with a semiconductor, forming a rectifying junction. The SBD is more rugged and reliable than the point contact diode. The SBD's main advantage over *pn* diodes is the absence of minority carriers, which limit the response speed in switching applications and the high-frequency performance in mixing and detection applications. SBDs are zero-bias detectors. Frequencies to 40 GHz are available with silicon SBDs, and GaAs SBDs are used for higher-frequency applications. See SCHOTTKY EFFECT.

The variable-reactance (varactor) diode makes use of the change in capacitance of a *pn* junction or Schottky barrier diode, and is designed to be highly dependent on the applied reverse bias. The capacitance change results from a widening of the depletion layer as the reverse-bias voltage is increased. As variable capacitors, varactor diodes are used in tuned circuits and in voltage-controlled oscillators. For higher-frequency microwave applications, silicon varactors have been replaced with GaAs. Typical applications of varactor diodes are harmonic generation, frequency multiplication, parametric amplification, and electronic tuning. Multipliers are used as local oscillators, low-power transmitters, or transmitter drivers in radar, telemetry, telecommunication, and instrumentation. See VARACTOR.

**Active devices.** Transistors are the most widely used active microwave solid-state devices. At very high microwave frequencies, high-frequency effects limit the usefulness of transistors, and two-terminal negative resistance devices, such as transferred-electron devices, avalanche diodes, and tunnel diodes, are sometimes used. Two main categories of transistors are used for microwave applications: bipolar junction transistors (BJTs) and field-effect transistors (FETs). In order to get useful output power at high frequencies, transistors are designed to have a higher periphery-to-area ratio using a simple stripe geometry. The area must be reduced without reducing the periphery, as large area means large interelectrode capacitance. For high-frequency applications the goal is to scale down the size of the device. Narrower widths of the elements within the transistor are the key to superior high-frequency performance. See TRANSISTOR.

A BJT consists of three doped regions forming two *pn* junctions. These regions are the emitter, base, and collector in either an *npn* or *pnp* arrangement. Silicon *npn* BJTs have an upper cutoff frequency of about 25 GHz (varies with manufacturing improvements). The cutoff frequency is defined as the frequency at which the current amplification drops to unity as the frequency is raised. The primary limitations to higher frequency are base and

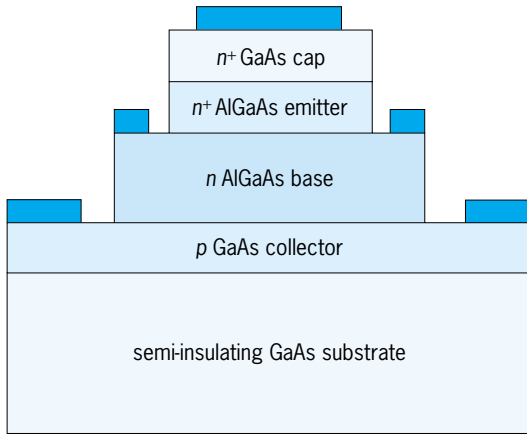

Fig. 1. Materials composition for a heterojunction bipolar transistor (HBT).

emitter resistance, capacitance, and transit time. To operate at microwave frequencies, individual transistor dimensions must be reduced to micrometer or submicrometer size. To maintain current and power capability, various forms of internal paralleling on the chip are used. Three of these geometries are interdigitated fingers that form the emitter and base, the overlaying of emitter and base stripes, and the matrix approach. Silicon BJTs are mainly used in the lower microwave ranges. Their power capability is quite good, but in terms of noise they are inferior to GaAs metal semiconductor field-effect transistors (MESFETs) at frequencies above 1 GHz and are mainly used in power amplifiers and oscillators. They may also be used in small-signal microwave amplifiers when noise performance is not critical. See ELECTRICAL NOISE.

Heterojunction bipolar transistors (HBTs) have been designed with much higher maximum frequencies than silicon BJTs. HBTs are essentially BJTs that have two or more materials making up the emitter, base, and collector regions (Fig. 1). In HBTs, the major goal is to limit the injection of holes into the emitter by using an emitter material with a larger bandgap than the base. The difference in bandgaps manifests itself as a discontinuity in the conduction band or the valence band, or both. For *npn* HBTs, a discontinuity in the valence band is required. In general, to make high-quality heterojunctions, the two materials should have matching lattice constants. For very thin layers, lattice matching is not absolutely necessary as the thin layer can be strained to accommodate the crystal lattice of the other material. Fortunately, the base of a bipolar transistor is designed to be very thin and thus can be made of a strained layer material. Combinations such as AlGaAs/InGaAs and Si/SiGe are possible. See BAND THEORY OF SOLIDS; ELECTRICAL CONDUCTIVITY OF METALS; HOLE STATES IN SOLIDS; SEMICONDUCTOR HETEROSTRUCTURES.

Field-effect transistors (FETs) operate by varying the conductivity of a semiconductor channel through changes in the electric field across the channel. The three basic forms of FETs are the junction FET (JFET), the metal semiconductor FET (MESFET), and the metal oxide semiconductor FET (MOSFET). All FETs have a channel with a source and drain region at each end and a gate located along the channel, which modulates the channel conduction (Fig. 2). Microwave JFETs and MESFETs work by channel depletion. The channel is *n*-type and the gate is *p*-type for JFETs and metal for MESFETs. FET structures are well suited for microwave applications because all contacts are on the surface to keep parasitic capacitances small. The cutoff frequency is mainly determined by the transit time of the electrons under the gate; thus short gate lengths (less than 1  $\mu\text{m}$ ) are used.

Power devices consist of a number of MESFETs in parallel with air bridges connecting the sources. GaAs MESFET devices are used in low-noise amplifiers (LNAs), Class C amplifiers, os-

illators, and monolithic microwave integrated circuits. The performance of a GaAs FET is determined primarily by the gate width and length. The planar structure of a MESFET makes it straightforward to add a second gate which can be used to control the amplification of the transistor. Dual-gate MESFETs can be used as mixers (with conversion gain) and for control purposes. Applications include heterodyne mixers and amplitude modulation of oscillators. See AMPLIFIER; HETERODYNE PRINCIPLE; MIXER; OSCILLATOR.

The MOSFET has a highly insulating silicon dioxide ( $\text{SiO}_2$ ) layer between the semiconductor and the gate; however, silicon MOSFETs are not really considered microwave transistors. Compared with the GaAs MESFET, MOSFETs have lower electron mobility, larger parasitic resistances, and higher noise levels. Also, since the silicon substrate cannot be made semi-insulating, larger parasitic capacitances result. MOSFETs therefore do not perform very well above 1 GHz. Below this frequency, MOSFETs find application mainly as radio-frequency (RF) power amplifiers.

A disadvantage of the MESFET is that the electron mobility is degraded since electrons are scattered by the ionized impurities in the channel. By using a heterojunction consisting of *n*-type AlGaAs with undoped GaAs, electrons move from the AlGaAs to the GaAs and form a conducting channel at the interface. The electrons are separated from the donors and have the mobility associated with undoped material. A heterojunction transistor made in this fashion has many different names: high electron mobility transistor (HEMT), two-dimensional electron gas FET (TEGFET), modulation-doped FET (MODFET), selectively doped heterojunction transistor (SDHT), and heterojunction FET (HFET). The HEMT has high power gain at frequencies of 100 GHz or higher with low noise levels.

A monolithic microwave integrated circuit (MMIC) can be made using silicon or GaAs technology with either BJTs or FETs. For high-frequency applications, GaAs FETs are the best choice. A MMIC has both the active and passive devices fabricated directly on the substrate. MMICs are typically used as low-noise amplifiers, as mixers, as modulators, in frequency conversion, in phase detection, and as gain block amplifiers. Silicon MMIC devices operate in the 100-MHz to 3-GHz frequency range. GaAs FET MMICs are typically used in applications above 1 GHz.

**Active microwave diodes.** Active microwave diodes differ from passive diodes in that they are used as signal sources to generate or amplify microwave frequencies. These include step-recovery, tunnel, Gunn, avalanche, and transit time diodes, such as impact avalanche and transit-time (IMPATT), trapped plasma avalanche triggered transit-time (TRAPATT), barrier injection transit-time (BARITT), and quantum well injection transit time (QWITT) diodes.

A step recovery diode is a special PIN type in which charge storage is used to produce oscillations. When a diode is switched from forward to reverse bias, it remains conducting until the stored charge has been removed by recombination or by the electric field. A step recovery diode is designed to sweep out the carriers by an electric field before any appreciable recombination has taken place. Thus, the transition from the conducting to the nonconducting state is very fast, on the order of picoseconds. Because of the abrupt step, this current is rich in

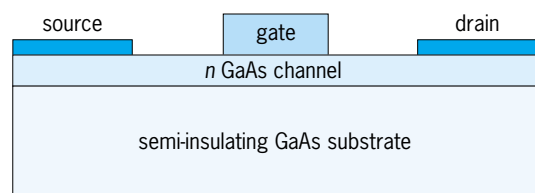

Fig. 2. Gallium arsenide metal semiconductor field-effect transistor (MESFET).

harmonics, so these diodes can be used in frequency multipliers. See FREQUENCY MULTIPLIER.

For microwave power generation or amplification, a negative differential resistance (NDR) characteristic at microwave frequencies is necessary. NDR is a phenomenon that occurs when the voltage ( $V$ ) and current ( $I$ ) are  $180^\circ$  out of phase. NDR is a dynamic property occurring only under actual circuit conditions; it is not static and cannot be measured with an ohmmeter. Transferred electron devices (TEDs), such as Gunn diodes, and avalanche transit-time devices use NDR for microwave oscillation and amplification. TEDs and avalanche transit-time devices today are among the most important classes of microwave solid-state devices. See NEGATIVE-RESISTANCE CIRCUITS.

The tunnel diode uses a heavily doped abrupt  $pn$  junction resulting in an extremely narrow junction that allows electrons to tunnel through the potential barrier at near-zero applied voltage. This results in a dip in the current-voltage ( $I$ - $V$ ) characteristic, which produces NDR. Because this is a majority-carrier effect, the tunnel diode is very fast, permitting response in the millimeter-wave region. Tunnel diodes produce relatively low power. The tunnel diode was the first semiconductor device type found to have NDR. See TUNNEL DIODE; TUNNELING IN SOLIDS.

Avalanche diodes are junction devices that produce a negative resistance by appropriately combining impact avalanche breakdown and charge-carrier transit time effects. Avalanche breakdown in semiconductors occurs if the electric field is high enough for the charge carriers to acquire sufficient energy from the field to create electron-hole pairs by impact ionization. The avalanche diode is a  $pn$ -junction diode reverse-biased into the avalanche region. By setting the DC bias near the avalanche threshold, and superimposing on this an alternating voltage, the diode will swing into avalanche conditions during alternate half-cycles. The hole-electron pairs generated as a result of avalanche action make up the current, with the holes moving into the  $p$  region, and the electrons into the  $n$  region. The carriers have a relatively large distance to travel through the depletion region. At high frequencies, where the total time lag for the current is comparable with the period of the voltage, the current pulse will lag the voltage. By making the drift time of the electrons in the depletion region equal to one-half the period of the voltage, the current will be  $180^\circ$  out of phase. This shift in phase of the current with respect to the voltage produces NDR, so that the diode will undergo oscillations when placed in a resonant circuit.

A Gunn diode is typically an  $n$ -type compound semiconductor, such as GaAs or InP, which has a conduction band structure that supports negative differential mobility. Although this device is referred to as a Gunn diode, after its inventor, the device does not contain a  $pn$  junction and can be viewed as a resistor below the threshold electric field ( $E_{\text{thres}}$ ). For applied voltages that produce electric fields below  $E_{\text{thres}}$ , the electron velocity increases as the electric field increases according to Ohm's law. For applied voltages that produce electric fields above  $E_{\text{thres}}$ , conduction band electrons transfer from a region of high mobility to low mobility, hence the general name "transferred electron device." Beyond  $E_{\text{thres}}$ , the velocity suddenly slows down due to the significant electron transfer to a lower mobility band producing NDR. For GaAs,  $E_{\text{thres}}$  is about 3 kV/cm. The Gunn effect can be used up to about 80 GHz for GaAs and 160 GHz for InP. Two modes of operation are common: nonresonant bulk (transit-time) and resonant limited space-charge accumulation (LSA). See ELECTRIC FIELD.

Impact avalanche and transit-time diodes (IMPATTs) are NDR devices that operate by a combination of carrier injection and transit time effects. There are several versions of IMPATT diodes, including simple reverse-biased  $pn$  diodes, complicated reverse-biased multidoped  $pn$  layered diodes, and reverse-biased PIN diodes. The IMPATT must be connected to a resonant circuit. At bias turn-on, noise excites the tuned circuit into a natural oscillation frequency. This voltage adds algebraically across the diode's reverse-bias voltage. Near the peak positive half-cycle,

the diode experiences impact avalanche breakdown. When the voltage falls below this peak value, avalanche breakdown ceases. A  $90^\circ$  shift occurs between the current pulse and the applied voltage in the avalanche process. A further  $90^\circ$  shift occurs during the transit time, for a total  $180^\circ$  shift which produces NDR. An IMPATT oscillator has higher output power than a Gunn equivalent. However, the Gunn oscillator is relatively noise-free, while the IMPATT is noisy due to avalanche breakdown.

A trapped plasma avalanche triggered transit-time (TRAPATT) diode is basically a modified IMPATT diode in which the holes and electrons created by impact avalanche ionization multiplication do not completely exit from the transit domain of the diode during the negative half-cycle of the microwave signal. These holes and electrons form a plasma which is trapped in the diode and participates in producing a large microwave current during the positive half-cycle.

A barrier injection transit-time diode (BARRITT) is basically an IMPATT structure that employs a Schottky barrier formed by a metal semiconductor contact instead of a  $pn$  junction to create similar avalanche electron injection.

A variety of approaches have been investigated to find alternative methods for injecting carriers into the drift region without relying on the avalanche mechanism, which is inherently noisy. Quantum well injection transit-time diodes (QWITT) employ resonant tunneling through a quantum well to inject electrons into the drift region. The device structure consists of a single GaAs quantum well located between two AlGaAs barriers in series with a drift region of made of undoped GaAs. This structure is then placed between two  $n^+$ -GaAs regions to form contacts. [L.P.S.]

**Microwave spectroscopy** The study of the interaction of matter and electromagnetic radiation in the microwave region of the spectrum. See MICROWAVE; SPECTROSCOPY.

The interaction of microwaves with matter can be detected by observing the attenuation or phase shift of a microwave field as it passes through matter. These are determined by the imaginary or real parts of the microwave susceptibility (the index of refraction). The absorption of microwaves may also trigger a much more easily observed event like the emission of an optical photon in an optical double-resonance experiment or the deflection of a radioactive atom in an atomic beam. See MOLECULAR BEAMS.

At room temperature, the relative population difference between the states involved in a microwave transition is a few percent or less. The population difference can be close to 100% at liquid helium temperatures, and microwave spectroscopic experiments are often performed at low temperatures to enhance population differences and to eliminate certain line-broadening mechanisms. The population differences between the states involved in a microwave transition can also be enhanced by artificial means. When the molecules or atoms with inverted populations are placed in an appropriate microwave cavity, the cavity will oscillate spontaneously as a maser (microwave amplification by stimulated emission of radiation). See MASER.

The magnetic dipole and electric quadrupole interactions between the nuclei and electrons in atoms and molecules can lead to energy splittings in the microwave region of the spectrum. Thus, microwave spectroscopy has been used extensively for precision determinations of spins and moments of nuclei. See HYPERFINE STRUCTURE; MOLECULAR BEAMS; NUCLEAR MOMENTS.

The rotational frequencies of molecules often fall within the microwave range, and microwave spectroscopy has contributed a great deal of information about the moments of inertia, the spin-rotation coupling mechanisms, and other physical properties of rotating molecules. See MOLECULAR STRUCTURE AND SPECTRA.

The magnetic resonance frequencies of electrons in fields of a few thousand gauss (a few tenths of a tesla) lie in the microwave region. Thus, microwave spectroscopy is used in the study of electron-spin resonance or paramagnetic resonance. See ELECTRON PARAMAGNETIC RESONANCE (EPR) SPECTROSCOPY; MAGNETIC RESONANCE.



The cyclotron resonance frequencies of electrons in solids at magnetic fields of a few thousand gauss (a few tenths of a tesla) lie within the microwave region of the spectrum. Microwave spectroscopy has been used to map out the dependence of the effective mass on the electron momentum.

For other applications see ATOMIC CLOCK; COSMIC BACKGROUND RADIATION; RADIO ASTRONOMY. [W.Hap.]

**Microwave tube** A high-vacuum tube designed for operation in the frequency region from approximately 3000 to 300,000 MHz. Two considerations distinguish a microwave tube from vacuum tubes used at lower frequencies: the dimensions of the tube structure in relation to the wavelength of the signal that it generates or amplifies, and the time during which the electrons interact with the microwave field. See VACUUM TUBE.

In the microwave region wavelengths are in the order of centimeters; resonant circuits are in the forms of transmission lines that extend a quarter of a wavelength from the active region of the microwave tube. With such short circuit dimensions the internal tube structure constitutes an appreciable portion of the circuit. For these reasons a microwave tube is made to form part of the resonant circuit. Leads from electrodes to external connections are short, and electrodes are parts of surfaces extending through the envelope directly to the external circuit that is often a coaxial transmission line or cavity. See CAVITY RESONATOR; TRANSMISSION LINES.

At microwaves the period of signal is in the range of 0.001–1 nanosecond. Only if transit time is less than a quarter of the signal period do significant numbers of electrons exchange appreciable energy with the signal field. Transit time is reduced in several ways. Electrodes are closely spaced and made planar in configuration, and high interelectrode voltages are used.

Tubes designed by the foregoing principles are effective for wavelengths from a few meters to a few centimeters. At shorter wavelengths different principles are necessary. To obtain greater exchange of energy between the electron beam and the electromagnetic field several alternative designs have proved practical.

Instead of collecting the electron beam at a plate formed by the opposite side of the resonant circuit, the beam is allowed to pass into a field-free region before reacting further with an external circuit. The electron cloud can be deflected by a strong static magnetic field so as to revolve and thereby react several times with the signal field before reaching the plate. See KLYSTRON; MAGNETRON.

Instead of producing the field in one or several resonant circuits, the field can be supported by a distributed structure along which it moves at a velocity comparable to the velocity of electrons in the beam. The electron beam is then directed close to this structure so that beam and field interact over an extended interval of time. See MICROWAVE; TRAVELING-WAVE TUBE. [F.H.R.]

**Mictacea** A proposed order of the Peracarida established for two small crustacean species, *Hirsutia bathyalis* and *Mictocaris halope*. The two species share many features common to other peracaridans but differ sufficiently to justify their assignment to a distinct order with two monotypic families. Common peracaridan features include a brood pouch formed by basal lamellae of the pereopods (oöstegites) in the female; a small movable process (lacinia mobilis) on the mandible; free thoracic somites not fused to a carapace shield; a single maxilliped of typical peracarid form; and partially immobile pereopodal basal segments.

*Mictocaris* is a cave-dwelling species, whereas *Hirsutia* has been found only in soft muddy sediment of the deep sea. Nothing is known about the feeding habits of these crustaceans, but with its spined first pereopod and fossorial second, *Hirsutia* is thought to be carnivorous. In contrast, the feeding appendages in *Mictocaris* resemble those of thermosbaenaceans, which scrape food particles from the substrate.

Mictacea appear to be most closely related to the Thermosbaenacea, Spelaeogriphacea, and Mysidacea. See CRUSTACEA; MYSIDACEA; PERACARIDA; SPELAEOGRIPHACEA; THERMOSBAENACEA.

[P.A.McL.]

**Middle-atmosphere dynamics** The motion of that portion of the atmosphere that extends in altitude roughly from 10 to 100 km (6 to 60 mi). The Earth's climate is determined by a balance between incoming solar and outgoing Earth thermal radiative energy, both of which must necessarily pass through the middle atmosphere. The lower portion, the stratosphere, contains many greenhouse gases (ozone, water vapor, carbon dioxide, methane, nitrous oxide, chlorofluorocarbons, and others); and it is predicted to cool at the same time as the lower atmosphere is warmed by the greenhouse effect. The middle atmosphere is also a focus for effects of emissions from proposed commercial fleets of stratospheric aircraft. In addition to the chemistry involved, dynamical transport modeling and measurements are needed to predict the widespread transport of these important trace gases and emissions over the globe. See ATMOSPHERE; STRATOSPHERE; TERRESTRIAL RADIATION.

The stratosphere constitutes the lower part of the middle atmosphere, from about 10 to 50 km (6 to 30 mi) altitude; from about 50 to 80 km (30 to 48 mi) or so lies the mesosphere. The location of the base of the stratosphere (called the tropopause) depends on meteorological conditions, varying on average from about 10 km (6 mi) in altitude at the poles to about 16 km (10 mi) at the Equator.

Atmospheric gravity waves result from combined gravitational and pressure gradient forces. Typical characteristics are transverse polarization, vertical wavelengths of 0.1–0 km (0.06–6 mi), horizontal wavelengths of 1–100 km (0.6–60 mi) or more, and periods in the range of 5 min to several hours. These waves may be excited by airflow over orography (mountains) as standing lee waves, by growing clouds, and by large-scale storm complexes in the lower atmosphere; and then they propagate up into the middle atmosphere.

Planetary-scale Rossby waves are large and slowly moving waves affected by the Coriolis effect due to the Earth's rotation. Rossby waves are common at middle latitudes in winter, where they can propagate up into the middle atmosphere from excitation regions below. Near the Equator, hybrid Rossby-gravity waves and also Kelvin waves (a special class of eastward-propagating internal gravity waves having no north-south velocity component) have been observed in the middle atmosphere. See CORIOLIS ACCELERATION.

A variety of global-scale normal-mode oscillations are also found in the middle atmosphere, prominent examples being wave 1, westward-moving waves with periods of about 5 and 16 days, and wave 3, a westward-moving feature with a period of about 2 days. Another observed oscillation in the middle atmosphere has been found with periods in the range 1–2 months (propagating up from the lower atmosphere).

Waves resulting from fluid dynamical instabilities are also observed: medium-scale (waves 4–7) eastward-moving waves, which are actually the tops of tropospheric storm systems, can dominate the circulation of the summer Southern Hemisphere lower stratosphere. The medium-scale waves have periods of 10–20 days. See DYNAMIC INSTABILITY; DYNAMIC METEOROLOGY.

[J.L.Sta.]

**Midnight sun** The phenomenon occurring when the Sun does not set, but only approaches the horizon at midnight. The effect occurs near the time of the summer solstice, on June 21, for latitudes north of the Arctic Circle. The same effect occurs near the time of the winter solstice, on December 21, for latitudes south of the Antarctic Circle. (Here "summer" and "winter" refer to the Northern Hemisphere; seasons are reversed in the Southern Hemisphere.)

The Earth orbits the Sun on a plane called the ecliptic. The Earth's Equator is inclined with the ecliptic by  $23^{\circ}26'$ . As a result, the North and South poles are in turn inclined toward the Sun for 6 months. Close to the summer solstice, on June 21, the Northern Hemisphere reaches its maximum inclination toward the Sun and the Sun illuminates all the polar area down to latitude  $+66^{\circ}34'$ . As seen from the polar area, the Sun does not set, but only reaches its lowest altitude in the north at midnight. Latitude  $+66^{\circ}34'$  defines the Arctic Circle, which is the southernmost latitude in the Northern Hemisphere where the midnight sun can be observed near the summer solstice. However, atmospheric refraction raises objects on the horizon by about  $34'$ , and the midnight sun can therefore be seen for a few days from locations 80 km (50 mi) south of the Arctic Circle. Observers at latitudes above the Arctic Circle see the midnight sun higher above the northern horizon, or correspondingly, see the midnight sun before the summer solstice. See EARTH ROTATION AND ORBITAL MOTION; ECLIPTIC; METEOROLOGICAL OPTICS; REFRACTION OF WAVES; SEASONS. [P.P.]

**Mid-Oceanic Ridge** An interconnected system of broad submarine rises totaling about 60,000 km (36,000 mi) in length, the longest mountain range system on the planet. The origin of the Mid-Oceanic Ridge is intimately connected with plate tectonics. Wherever plates move apart sufficiently far and fast for oceanic crust to form in the void between them, a branch of the Mid-Oceanic Ridge will be created. In plan view the plate boundary of the Mid-Oceanic Ridge comprises an alternation of spreading centers (or axes or accreting plate boundaries) interrupted or offset by a range of different discontinuities, the most prominent of which are transform faults. As the plates move apart, new oceanic crust is formed along the spreading axes, and the ideal transform fault zones are lines along which plates slip past each other and where oceanic crust is neither created nor destroyed. See PLATE TECTONICS; TRANSFORM FAULT.

Separation of plates causes the hot upper mantle to rise along the spreading axes of the Mid-Oceanic Ridge; partial melting of this rising mantle generates magmas of basaltic composition that segregate from the mantle and rise in a narrow zone at the axis of the Mid-Oceanic Ridge to form the oceanic crust. The partially molten mantle "freezes" to the sides and bottoms of the diverging plates to form the mantle lithosphere that, together with the overlying "rind" of oceanic crust, comprises the lithospheric plate. At the axis of the Mid-Oceanic Ridge the underlying column of crust and mantle is hot and thermally expanded; this thermal expansion explains why the Mid-Oceanic Ridge is a ridge. With time, a column of crust plus mantle lithosphere cools and shrinks as it moves away from the ridge axis as part of the plate. The gentle regional slopes of the Mid-Oceanic Ridge therefore represent the combined effects of sea-floor spreading (divergent plate motion) and thermal contraction. See LITHOSPHERE; MAGMA.

The height and thermal contraction rate of the ridge crest are relatively independent of the rate of sea-floor spreading; thus the width and regional slopes of the Mid-Oceanic Ridge depend primarily on the rate of plate separation (spreading rate). Where the plates are separating at 2 cm (0.8 in.) per year, the Mid-Oceanic Ridge has five times the regional slope but only one-fifth the width of a part of the ridge forming where the plates are separating at 10 cm (4 in.) per year. One consequence of the relation between the width and plate separation rate of the Mid-Oceanic Ridge is that more ocean water is displaced, thereby raising sea level, during times of globally faster plate motion.

Although the Mid-Oceanic Ridge exhibits little systematic depth variation along much of its length, there are several bulges (swells) of shallower sea floor. For reasons not well understood, the sea-floor bulges are more prominent along parts of the Mid-Oceanic Ridge where the rate of plate separation (spreading rate) is slower, for example, along the northern Mid-Atlantic Ridge and the Southwest Indian Ridge.

The axis of the Mid-Oceanic Ridge—that is, the active plate boundary between two separating plates—is a narrow zone only a few kilometers wide, characterized by frequent earthquakes, intermittent volcanism, and scattered clusters of hydrothermal vents where seawater, percolating downward and heated by proximity to hot rock, is expelled back into the ocean at temperatures as high as  $350^{\circ}\text{C}$  ( $660^{\circ}\text{F}$ ). Surrounding such vents are deposits of hydrothermal minerals rich in metals, as well as exotic animal communities including, in some vent fields, giant tube-worms and clams. See HYDROTHERMAL VENT; MARINE GEOLOGY; VOLCANO. [P.R.V.]

**Migmatite** Rocks originally defined as of hybrid character due to intimate mixing of older rocks (schist and gneiss) with granitic magma. Now most plutonic rocks of mixed appearance, regardless of how the granitic phase formed, are called migmatites. Commonly they appear as veined gneisses.

Several modes of origin have been proposed. (1) Granitic magma may be intercalated between thin layers of schist (lit-par-lit injection) to form a banded rock called injection gneiss. (2) The granitic magma may form in place by selective melting of the rock components. (3) The granitic layers may develop by metamorphic differentiation (redistribution of minerals in solid rock by recrystallization). (4) The granitic layers may represent selectively replaced or metasomatized portions of the rock. See METAMORPHISM; METASOMATISM. [C.A.C.]

**Migratory behavior** Regularly occurring, oriented seasonal movements of individuals of many animal species. The term migration is used to refer to a diversity of animal movements, ranging from short-distance dispersal and one-way migration to round-trip migrations occurring on time scales from hours (the vertical movements of aquatic plankton) to years (the return of salmon to their natal streams following several years and thousands of kilometers of travel in the open sea).

Many temperate zone species, including many migrants, are known to respond physiologically to changes in the day length with season (photoperiodism). For example, many north temperate organisms are triggered to come into breeding condition by the interaction between the lengthening days in spring and their biological clocks (circadian rhythms). Similar processes, acting through the endocrine system, bring animals into migratory condition.

To perform regular oriented migrations, animals need some mechanism for determining and maintaining compass bearings. Animals use many environmental cues as sources of directional information. Work with birds has shown that species use several compasses.

Many species of vertebrates and invertebrates possess a time-compensated Sun compass. With such a system, the animal can determine absolute compass directions at any time of day; that is, its internal biological clock automatically compensates for the changing position of the Sun as the Earth rotates during the day. Many arthropods, fish, salamanders, and pigeons can perceive the plane of polarization of sunlight, and may use that information to help localize the Sun even on partly cloudy days.

Only birds that migrate at night have been shown to have a star compass. Unlike the Sun compass, it appears not to be linked to the internal clock. Rather, directions are determined by reference to star patterns which seem to be learned early in life.

Evidence indicates that several insects, fish, a salamander, certain bacteria, and birds may derive directional information from the weak magnetic field of the Earth. See MAGNETIC RECEPTION (BIOLOGY).

Many kinds of animals show the ability to return to specific sites following a displacement. The phenomenon can usually be explained by familiarity with landmarks near "home" or sensory contact with the goal. For example, salmon are well known for their ability to return to their natal streams after spending several years at sea. Little is known about their orientation at sea, but

they recognize the home stream by chemical (olfactory) cues in the water. The young salmon apparently imprint on the odor of the stream in which they were hatched. Current evidence indicates that birds imprint on or learn some feature of their birthplace, a prerequisite for them to be able to return to that area following migration. On its first migration, a young bird appears to fly in a given direction for a programmed distance. Upon settling in a wintering area, it will also imprint on that locale and will thereafter show a strong tendency to return to specific sites at both ends of the migratory route.

Only in birds can an unequivocal case be made for the existence of true navigation, that is, the ability to return to a goal from an unfamiliar locality in the absence of direct sensory contact with the goal. This process requires both a compass and the analog of a map. Present evidence suggests that the map is not based on information from the Sun, stars, landmarks, or magnetic field. Other possibilities such as olfactory, acoustic, or gravitational cues are being investigated, but the nature of the navigational component of bird homing remains the most intriguing mystery in this field. [K.P.A.]

**Military aircraft** Aircraft that are designed for highly specialized military applications. Fixed-wing aircraft, rotary-wing aircraft, free-flight balloons, and blimps have all been used in both crewed and crewless flight modes for military purposes. See DRONE.

Bombers are usually characterized by relatively long range, low maneuverability, and large weapon-carrying capability. The use of aerial refueling by tanker aircraft gives most bombers a global range. Bombers may be equipped to deliver conventional or nuclear weapons in day, night, or adverse weather.

Aircraft that provide airborne early warning and control include a variant of the Russian Ilyushin IL-76 and the United States E-3A. Increasing numbers of the airborne early warning and control variant of the Russian Ilyushin IL-76 aircraft (NATO codename Mainstay) have been produced for early warning against low-altitude penetration and for air battle management. The U.S. Air Force Airborne Warning and Control System (AWACS), designated E-3A, is a versatile surveillance, command, and control center, designated to provide battle management in the conduct of air warfare.

Unlike bombers and AWACS aircraft, fighters are relatively short-range, highly maneuverable, fast aircraft, designed to destroy enemy aircraft and to attack ground targets. They can carry machine guns, cannons, rockets, guided missiles, and bombs, depending upon the mission. They may be interceptor fighters, designed to shoot down enemy airplanes or missiles during day, night, or adverse weather conditions. Other fighters may be designated for close-in attack of mobile enemy ground forces to provide close support for friendly ground troops. Some fighters, called fighter-bombers, can carry conventional or nuclear weapons several hundreds of kilometers behind enemy lines to strike priority ground targets.

The United States reconnaissance program provides capabilities to meet many peacetime and wartime information collection requirements. Reconnaissance resources include strategic, tactical standoff, and penetration aircraft systems that are flexible and responsive. Reconnaissance aircraft carry photographic, infrared, radar, and television sensors. These aircraft may be specially designed or may be modified from a basic fighter or bomber type. Some are equipped with special electronic gear for such purposes as submarine detection; others serve as picket planes for early warning of an enemy approach.

Transport aircraft provide dedicated logistic support to all types of military operations. Transport aircraft carry troops and war supplies. Many are adaptations of airplanes used by commercial airlines. The aerial tanker is a special-purpose transport aircraft. Fighters, bombers, and helicopters can refuel from tankers while in flight by means of special probe and drogue fittings. Another special-purpose transport is a gunship. This air-

craft is equipped with rapid-fire weapons for saturation attack on ground targets.

Helicopters deserve special mention as military aircraft. They are unexcelled for rescue work and for delivery of people and material to otherwise inaccessible areas. Some helicopters are armed and serve as attack aircraft, providing gun and rocket fire against ground targets. Other helicopters deliver assault troops to advanced combat areas and supply them with ammunition and other needs. See HELICOPTER.

Special-purpose research aircraft are occasionally designed, assembled, and tested in order to experiment with advanced aerodynamic, structural, avionic, or propulsion concepts that must be validated before they can be applied to other aircraft designs. Research aircraft are usually well instrumented, with performance data telemetered on radio-frequency data links to ground stations located at the test ranges where they are flown. See AIRCRAFT TESTING. [R.J.St.]

**Military satellites** Artificial satellites used for a variety of military purposes. Of approximately 4000 satellites successfully launched between 1957 and 1999, about 50% have been either specifically military or usable for military purposes. Major functions of military satellites include communications, positioning and navigation, meteorology, reconnaissance and surveillance, early warning, remote sensing, geodesy, and research.

Although only certain satellites are used continuously for military purposes, all communication satellites, including commercial, may find use during conflict. All contain the necessary equipment to transmit a signal over great distances to assist in the command, control, administration, and logistic support of military forces. Military communication satellites differ from commercial satellites only in that they contain specialized components, certain capabilities, and multiple redundant systems designed to make them less vulnerable and more effective in a hostile environment. See COMMUNICATIONS SATELLITE.

Military forces must be able to quickly and precisely determine their position on the ground, in the air, or at sea. The Navstar Global Positioning System (GPS) is the most accurate and reliable satellite navigation system available. It includes 25 spacecraft in semisynchronous (12-h) orbits inclined at 55° to the Equator at 11,600 mi (18,700 km) altitude. Of these, 21 are operational and 4 are spares. The inclined orbits provide worldwide coverage, including the Poles. Russia also maintains global navigation satellite systems. Its Tsikada/Nadezhda low-Earth-orbit system functions similar to the United States' decommissioned Transit system. In addition, Russia operates the GLONASS navigation system. Similar to GPS, the system is less complex, but its satellites have proven less reliable than the United States' version. Receivers are available that will accept navigational data from either GPS or GLONASS. See SATELLITE NAVIGATION SYSTEMS.

From orbit, it is possible to obtain a wide-field-of-view image of the Earth, its cloud formations, and their movements. This meteorological information is valuable for military planning and operations.

The *Television Infrared Observation Satellites (TIROS)* have, for decades, traveled in Sun-synchronous, low Earth orbits providing images of cloud cover, snow, ice, and the sea surface. The Defense Meteorological Satellite Program (DMSP) consists of several satellites in low Earth, Sun-synchronous, polar orbits at an altitude of 517 mi (833 km), spaced to provide complete coverage of the Earth at various times of the day and night.

Russia operates the Meteor system of satellites. As many as five satellites are in low Earth orbit similar to *TIROS* with an orbital inclination of 81.2°. They image in the infrared spectrum. Several other countries maintain a meteorological satellite capability that provides useful information for military operations, although not specifically designed for military use. See METEOROLOGICAL SATELLITES.

Military reconnaissance and surveillance satellites offer near-real-time unrestricted access over almost any area on Earth.

Operating in many parts of the electromagnetic spectrum, they can be used to observe weapons development and deployment of forces, and to provide warning of attack by ground forces as well as targeting intelligence, technical intelligence on enemy capabilities, electronic intelligence, and bomb damage assessment.

Early warning satellites provide information on missile launch and nuclear detonation that give governments time to make strategic military decisions.

Remote-sensing satellites afford a unique view of Earth, providing vital information to military forces. The images produced by these satellites are used to conduct routine reconnaissance, analyze waterways, assist in exercise and strike planning, and provide up-to-date maps for forces deploying to unfamiliar areas. Important information is gathered not only in the visible spectrum but in other bands of the spectrum. See REMOTE SENSING.

**Geodesy.** Geodesy is the study of the Earth's size and shape. Geodetic data are important to the military in that the data affect position determination, navigation, map making, and a variety of other missions. Almost all satellites can be used for geodesy, provided their position in space can be accurately determined by optical or electronic means from the Earth.

In addition to the missions discussed above, there have been hundreds of military research and technology spacecraft, as well as thousands of experimental investigations for military purposes on space vehicles launched by all space-faring nations. [D.F.M.]

**Milk** The lacteal secretion, practically free from colostrum, obtained by the complete milking of one or more healthy cows and containing not less than 8.25% milk solids (not fat) and not less than 3.25% milk fat. Among mammals, humans utilize milk as a source of food. The dairy cow supplies the vast majority of milk for human consumption, particularly in the United States; however, milk from goats, water buffalo, and reindeer is also consumed in other countries. Without qualification, the general term milk refers to cow's milk.

Average composition of milk is 87.2% water, 3.7% fat, 3.5% protein, 4.9% lactose, and 0.7% ash. Whole milk and skim milk are classified as excellent sources of calcium, phosphorus, and riboflavin because 10% of the daily nutritional requirement is supplied by not over 100 kcal (420 kilojoules). These two beverages are also classified as good sources of protein and thiamine; and whole milk is a good source of vitamin A. To be classified as good, the source must contribute 10% of a nutrient in not over 200 kcal (840 kilojoules). Milk is a good source of protein rich in all the essential amino acids.

**Processing.** Most raw milk collected at farms is pumped from calibrated and refrigerated stainless steel tanks into tank trucks for delivery to processing plants. The actual processing of raw milk begins with either separation or clarification. These machines are essentially similar except that in the clarifier the cream and skim milk fractions are not separated. Many processors have units called standardizer-clarifiers which separate only a small fraction of the fat from the raw whole milk; the amount of fat removed can be regulated. This facilitates the production of milk of standard fat content even though that in the raw product may vary.

Milk is rendered free of pathogenic bacteria by pasteurization. This is accomplished in a manner so that every particle of milk is heated to a specified temperature and held at that temperature for a specified time. See PASTEURIZATION.

Fat globules in fluid milk products are broken by homogenization into sizes that are 2 micrometers or less and thus are relatively unaffected by gravitational forces. The U.S. Public Health Service specifies that the fat content of the upper 6 in. (100 ml) of a quart of homogenized milk that has been undisturbed for 48 h cannot differ by more than 10% from that of the remainder.

Most milk is fortified with 400 international units (IU) of vitamin D per quart, and some skim milk is fortified also with 2000 IU of vitamin A per quart. These vitamins as concentrates are added

either by automatic dispensing into a continuous flow of milk prior to pasteurization or as a single quantity in a batch operation.

**Products.** Many fermented or cultured products are produced from milk. These fermentations require the use of bacteria that ferment lactose or milk sugar.

Cultured buttermilk consists of skim milk or low-fat milk which is pasteurized at 180°F (82°C) for 30 min, cooled to 72°F (22°C), and inoculated with an active starter culture containing *Streptococcus lactis* and *Leuconostoc citrovorum*. The mixture is incubated at 70°F (21°C) and cooled when acidity is developed to approximately 0.8%. This viscous product is then agitated, packaged, and cooled. The desired flavor is created by volatile acids and diacetyl; the latter is produced by *L. citrovorum*.

One of the oldest fermented milks known is yogurt. Yogurt is prepared using whole or low-fat milk with added nonfat milk solids. The milk is heated to approximately 180°F (82°C) for 30 min, homogenized, cooled to 115°F (46°C), inoculated with an active culture, and packaged. Yogurt cultures are mixtures of *Streptococcus thermophilus* and *Lactobacillus bulgaricus* in a 1:1 ratio. Balance of these organisms in the culture is important for production of a quality product.

**Concentrated and dried milk products.** To reduce costs of transportation and handling, either part or all of the water is removed from milk. Moreover, the partly dehydrated milk can either be sterilized or dried to permit unrefrigerated storage for prolonged periods. Many different milk products (such as dry whole milk, evaporated milk, and condensed milk) are produced for these specific reasons. The composition of some of these is controlled by standards of identity and some by request of the commercial buyer. [R.L.Br.]

**Milky Way Galaxy** The large disk-shaped aggregation of stars, gas, and dust in which the solar system is located. The term "Milky Way" is used to refer to the diffuse band of light visible in the night sky emanating from the Milky Way Galaxy. Although the two terms are frequently used interchangeably, Milky Way Galaxy, or simply the Galaxy, refers to the physical object rather than its appearance in the night sky.

**Structure and contents.** The Milky Way Galaxy contains about  $2 \times 10^{11}$  solar masses of visible matter. Roughly 96% is in the form of stars, and about 4% is in the form of interstellar gas. The gas both inside the stars and in the interstellar medium is primarily hydrogen and helium with a small admixture of all of the heavier atoms. The mass of dust is about 1% of the interstellar gas mass and is an insignificant fraction of the total mass of the Galaxy. Its presence, however, limits the view from the Earth in the plane of the Galaxy to a small fraction of the Galaxy's diameter in most directions. See INTERSTELLAR MATTER.

The Milky Way Galaxy contains four major structural subdivisions: the nucleus, the bulge, the disk, and the halo. The Sun is located in the disk about half way between the center and the indistinct outer edge of the disk of stars. The currently accepted value of the distance of the Sun from the galactic center is 8.5 kiloparsecs, although some measurements suggest that the distance may be as small as 7 kpc. See PARSEC.

The nucleus of the Milky Way is a region within a few tens of parsecs of the geometric center and is totally obscured at visible wavelengths. The nucleus is the source of very energetic activity detected by means of radio waves and infrared radiation.

At the galactic center, there is a very dense cluster of hot stars observed by means of its infrared radiation. In 1997, astronomers confirmed the existence of a black hole with a mass of about 2.5 million times the mass of the Sun at the position of an unresolved source of radio emission known as Sgr A\* in the middle of the central star cluster. The black hole appears to be the dynamical center of the Milky Way. See BLACK HOLE; INFRARED ASTRONOMY; RADIO ASTRONOMY.

The bulge is a thick distribution of stars centered on the nucleus which extends to a distance of about 3 kpc from the cen-

ter. It contains a relatively old population of stars, nearly as old as the Milky Way itself. Direct imaging with infrared satellites has demonstrated that the bulge is actually an elongated barlike structure with a length about two to three times its width. The Milky Way is thus classified as a barred spiral galaxy, a classification that includes about half of all disk-shaped galaxies. See STELLAR POPULATION.

The disk is a thin distribution of stars and gas orbiting the nucleus of the Galaxy. The disk of stars begins near the end of the bar and can be identified to about 16 kpc from the center of the Galaxy; the disk of gas can be identified to about twice this distance, about 35 kpc from the center. The faint, low-mass stars make up most of the mass of the disk. There is also a thick disk of stars and gas. The thin disk of stars contains most of the mass and has a thickness relative to its diameter similar to that of a commercial compact disk. The disk is the location of the spiral arms that are characteristic of most disk-shaped galaxies, as well as most of the present-day star formation.

The halo is a rarefied spheroidal distribution of stars nearly devoid of the interstellar gas and dust that surrounds the disk. The stars found in the halo are the oldest stars in the Galaxy. The stars are found individually as “field” stars as well as in globular clusters: spherical clusters of up to about a million stars with very low abundances of elements heavier than helium. The extent of the halo is not well determined, but globular clusters with distances of about 40 kpc from the center have been identified. Dynamical evidence suggests that the halo contains nonluminous matter in some unknown form, commonly referred to as dark matter. The dark matter contains most of the mass of the Galaxy, dominating even that in the form of stars. See STAR CLUSTERS.

Evidence suggests that the ages of the oldest stars in the Milky Way are within about 10% of the age of the universe as a whole; thus parts of the Milky Way must have formed early in the history of the universe, about 12–16 billion years ago. There is increasing evidence that the Milky Way formed as a result of the coalescence of small galaxies and protogalaxies, objects with the masses of small dwarf galaxies that are thought to have been among the first objects to form in the universe. The coalescence would have proceeded rapidly at first and then more irregularly as relatively large pieces merged to form the Milky Way. According to this picture, the formation of the Milky Way is not yet complete, and both small galaxies and clouds of gas are continuing to rain in on the Milky Way. [L.B.I.]

**Milleporina** An order of the class Hydrozoa of the phylum Coelenterata. These are the “string corals” of shallow trop-

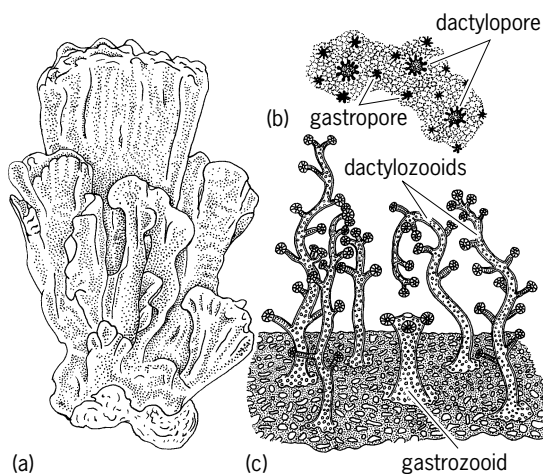

**Milleporina.** (a) Piece of dry *Millepora*, showing typical flabellate shape. (b) Same, magnified, showing pores. (c) Polyps of *Millepora*. (After L. H. Hyman, *The Invertebrates*, vol. 1, McGraw-Hill, 1940)

ical seas. Their structure is similar to that of hydroids except for the addition of a calcareous exoskeleton (illus. a). Because of this skeleton, they resemble true corals (Anthozoa). The skeleton is covered by a thin layer of tissue, is penetrated by interconnecting tubes, and is perforated by tiny holes through which the bodies of the “coral animals,” or polyps, are extended (illus. b).

The polyps are of two types (illus. c): nutritive gastrozooids with tentacles and mouth; and protective polyps, which are long and armed with stinging cells but have no mouth. Millepores produce medusae, or jellyfish, in which sex cells develop. See HYDROZOA. [S.Cr.]

**Millerite** A mineral having composition NiS and crystallizing in the hexagonal system. Millerite usually occurs in hair-like tufts and radiating groups of slender to capillary crystals. The hardness is 3–3.5 (Mohs scale) and the specific gravity is 5.5. The luster is metallic and the color pale brass yellow. Millerite is found in many localities in Europe, notably in Germany and Czechoslovakia. In the United States it is found with pyrrhotite at the Gap Mine, Lancaster County, Pennsylvania; with hematite at Antwerp, New York; and in geodes in limestone at Keokuk, Iowa. In Canada large cleavable masses are mined as a nickel ore in Lamotte Township, Quebec. [C.S.Hu.]

**Millet** A common name applied to at least five related members of the grass family grown for their edible seeds: foxtail millet (*Setaria italica*), proso millet (*Panicum miliaceum*), pearl or cat-tail millet (*Pennisetum typhoideum*), Japanese barnyard millet (*Echinochloa frumentacea*), raggee or finger millet (*Eleusine coracana*), and koda millet (*Paspalum scrobiculatum*).

As a crop for human food, pearl millet is grown widely in the tropics and subtropics in regions of limited rainfall where there is a growing season of 90 to 120 days. The naked seeds are yellowish to whitish in color and about the size of wheat grain. The dried grain is usually pulverized to make a meal or flour and then cooked in soups, in porridge, or as cakes. [H.B.S.]

**Mineral** A naturally occurring homogeneous solid with a definite (but generally not fixed) chemical composition and a highly ordered atomic arrangement; it is usually formed by inorganic chemical processes. The fact that a mineral has a definite chemical composition implies that it can be expressed by a specific chemical formula. For example, the chemical composition of quartz (silicon dioxide) is expressed as SiO<sub>2</sub>; its formula is definite because quartz contains no chemical elements other than silicon and oxygen. Most minerals, however, do not have such a well-defined composition. Dolomite [CaMg(CO<sub>3</sub>)<sub>2</sub>], for example, is not always a pure calcium-magnesium carbonate. It may contain considerable amounts of iron and manganese in place of magnesium, and because these amounts vary, the composition of dolomite is said to range between certain limits and is, therefore, not fixed. The description of mineral structure as a highly ordered atomic arrangement indicates that a mineral possesses an internal structural framework of atoms (or ions) arranged in a regular geometric pattern. Minerals are crystalline because this is the criterion of a crystalline solid. Under favorable conditions, crystalline materials may express their ordered internal structure by well-developed external form, also known as crystal form, or morphology. See APATITE; ARAGONITE; CRYSTAL STRUCTURE.

**Classification.** Chemical composition has been the basis for the classification of minerals, whereby they are divided into classes depending on the dominant anion or anionic group (such as oxides, halides, sulfides, or silicates). However, it was recognized early in the development of mineralogy that chemistry alone does not adequately characterize a mineral. A full appreciation of the nature of minerals evolved only after x-rays were used to determine internal structures. It has become

clear that mineral classification must be based on chemical composition and internal structure, because these together represent the essence of a mineral and determine its physical properties. Major groups in the mineral classification are native elements, sulfides, sulfosalts, oxides, hydroxides, halides, carbonates, nitrates, borates, phosphates, sulfates, tungstates, and silicates. These groups are subdivided on the basis of chemical types, and may be refined further on the basis of structural similarity. See BORATE MINERALS; CARBONATE MINERALS; HALOGEN MINERALS; HYDROXIDE; NATIVE ELEMENTS; NITRATE MINERALS; PHOSPHATE MINERALS; SILICATE MINERALS; X-RAY CRYSTALLOGRAPHY.

**Names.** Minerals may be given names on the basis of some physical property or chemical aspect; or they may be named after a locality, a public figure, a mineralogist, or almost any other subject considered appropriate. Some examples of mineral names and their derivations are as follows: albite ( $\text{NaAlSi}_3\text{O}_8$ ) from the Latin albus (white) in allusion to its color; rhodonite ( $\text{MnSiO}_3$ ) from the Greek rhodon (a rose) in allusion to its characteristically pink color; chromite ( $\text{FeCr}_2\text{O}_4$ ) because of the presence of a large amount of chromium in the mineral; magnetite ( $\text{Fe}_3\text{O}_4$ ) because of its magnetic properties; franklinite ( $\text{ZnFe}_2\text{O}_4$ ) after Franklin, New Jersey, where it occurs as the dominant zinc mineral; sillimanite ( $\text{Al}_2\text{SiO}_5$ ) after Professor Benjamin Silliman of Yale University.

**Occurrence and formation.** Minerals form in all geological environments, reflecting a wide range of chemical and physical conditions, such as temperature and pressure. The main categories of mineral formation are (1) igneous, or magmatic, in which minerals form as crystallization products from a melt; (2) sedimentary, in which minerals are the result of the processes of weathering, erosion, and sedimentation; (3) metamorphic, in which new minerals form at the expense of earlier ones, as a result of changing (usually increasing) temperatures, pressures, or both, on some earlier rock type; metamorphic minerals are the result of new mineral growth in the solid rock, without the intervention of a melt (as in igneous processes); and (4) hydrothermal, in which minerals are chemically precipitated from hot solutions. The first three processes generally lead to rock types in which different mineral grains are closely intergrown in an interlocking fabric. Hydrothermal solutions, and even solutions at very low temperatures such as ground water, tend to follow fracture zones in rocks that may provide open spaces for chemical precipitation of minerals from solution. It is from such open spaces, partially filled by minerals deposited from solutions, that most of the spectacular mineral specimens, seen in mineral museums worldwide, have been collected. If a mineral in the process of its growth (as a result of precipitation) is allowed to grow in a free space, it will commonly exhibit a well-developed crystal form, which adds to a specimen's esthetic beauty. Similarly, geodes, which are rounded, hollow, or partially hollow bodies, commonly found in limestones, may contain very well-formed crystals lining the central cavity. Geodes are the result of mineral deposition from solutions such as ground water. See GEODE; PRECIPITATION (CHEMISTRY).

**Economic importance.** Society today depends on minerals in countless ways—from the construction of skyscrapers to the manufacture of televisions. A few minerals such as talc, asbestos, and sulfur are used essentially as they come from the ground, but most are first processed to obtain a usable material such as bricks, glass, cement, plaster, and a score of metals ranging from iron to gold. Both forests and farms are dependent upon soils, which are composed chiefly of minerals. See ASBESTOS; SOIL; SULFUR; TALC.

Metallic ores and industrial minerals are mined on every continent, wherever specific minerals are sufficiently concentrated to be extracted economically. The location of minable metal and industrial mineral deposits, and the study of the origin, size, and ore grade of these deposits are the domain of economic geologists, but a knowledge of the chemistry, occurrence, and physical

properties of minerals is basic to pursuits in economic geology. See MINERALOGY. [C.K.]

**Mineralogy** The science which concerns the study of natural inorganic substances, whether of terrestrial or extraterrestrial origin, called minerals. Mineralogy is a science that cannot be easily defined. It is most properly a branch of inorganic chemistry, but the discipline concentrates on the origin, description, and classification of minerals. See MINERAL.

Thus, four main categories may be considered: crystal chemistry (composition and atomic arrangement of minerals); paragenetic mineralogy (the study of mineral association and occurrence both in natural and synthetic systems); descriptive mineralogy (the study of the physical properties of minerals and the means for their identification); and taxonomic mineralogy (mineral classification, systematization, and nomenclature).

**Crystal chemistry.** This is the most vital aspect of mineralogy because it is the basis for the other studies. The fields of mineralogy, crystallography, inorganic chemistry, geochemistry, petrology, and geology are connected in the domain of crystal chemistry (Fig. 1).

A particular mineral, called a mineral species, is defined on the basis of a specified chemical composition and a specified crystal structure (atomic arrangement). These two criteria provide almost sufficient knowledge for characterization of a mineral since in principle all other properties can be derived from them.

Crystalline substances, that is, periodic arrangements of matter in three dimensions, can be divided into six crystal systems: triclinic, monoclinic, orthorhombic, tetragonal, hexagonal (including the trigonal and rhombohedral subdivisions), and cubic. These crystal systems can be considered as structure cells, each of which contains a certain integral number of atoms of a substance. Figure 2 depicts these systems and offers the criteria for distinguishing them. See CRYSTALLOGRAPHY.

Any crystalline substance has a certain integral number of its essential chemical formula units loosely called molecules) in its structure cell. Thus, each unique atomic position in the structural unit can be occupied by a particular kind (or kinds) of atom(s). Consider the ideal cell formula  $(A_a)(B_b) \dots (P_p)$ . Each of

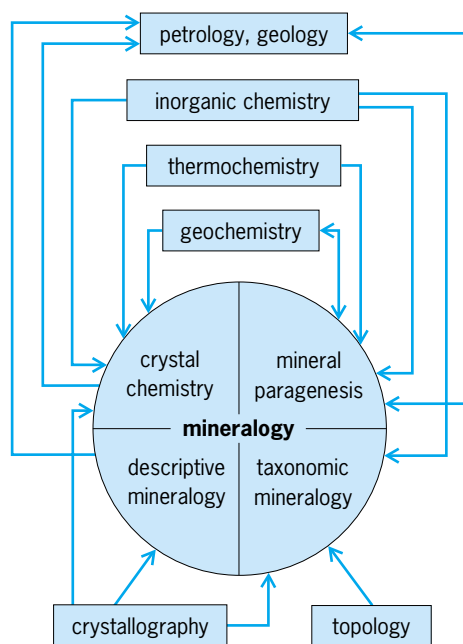

Fig. 1. Diagram showing the transmission of information between mineralogy and some other sciences. Arrows imply the direction of information.

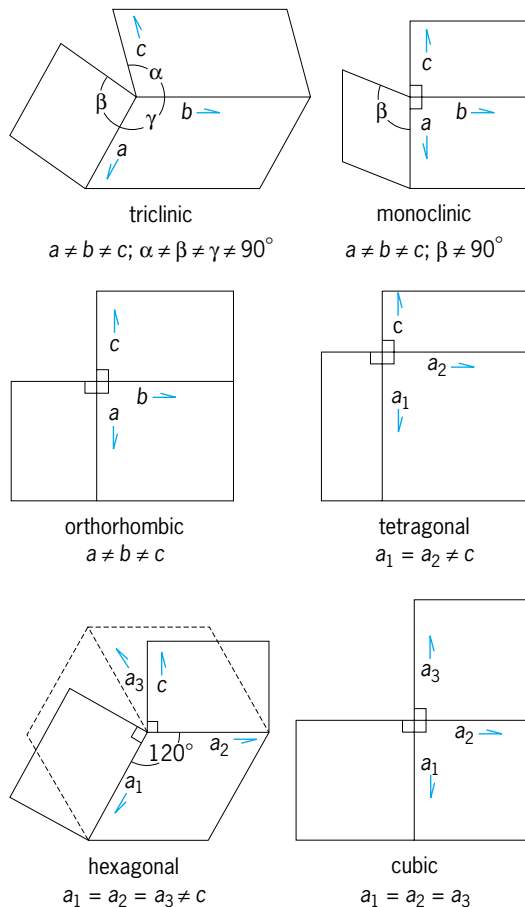

Fig. 2. The cell shapes of the six crystal systems shown as their principal projections.

the parentheses specifies a unique atomic position. The capital letters specify the element present and the small subscripts the number of times it occurs in the cell. If the small subscripts have a factor in common, it is factored out and what remains is the formula unit. The ideal formula is further defined in terms of the atomic element which occurs in excess of 50 mole % within each of the parentheses. The structure type, along with the ideal formula unit, defines a mineral species.

This strict definition of a species is required since a particular mineral may have a range of compositions. The range of compositions is called a series. The ideal limiting compositions are called end members and each of the end members has a specific name.

**Paragenetic mineralogy.** Paragenetic mineralogy is the study of mineral paragenesis, or the association and order of crystallization of minerals. The problem may concern mineral association within a single hand specimen or may embrace a much larger region, such as an entire ore body, in which case many representative specimens are judiciously collected. This study usually accompanies the analysis of the general geological structures within and around the ore body, such as the bedding, folding, and faulting. Included among the important aspects of paragenetic mineralogy are ore mineralogy, the mineralogy of a sequence of phases crystallized from a parent magma, the sequence of minerals crystallized in a vein, and so forth. See GEOLOGY; PETROLOGY.

Mineral paragenesis is usually considered in relative time and the absolute difference in time between the oldest and youngest minerals is often not known. Absolute age differences can be

obtained in some instances, for example, by lead isotope age dating of a sequence of crystallized lead-bearing minerals.

**Descriptive mineralogy.** Mineral recognition directly by the senses is very subjective and requires considerable experience. Gross features of a mineral such as color, form, hardness, and specific gravity are important criteria for identification in the field where a well-equipped laboratory is usually not available. More objective criteria such as the optical properties and x-ray powder diffraction spectra of a mineral require specialized equipment, but the results are usually certain since these data are known for most mineral species and are extensively tabulated. Older methods such as fusibility, flame tests, and blowpipe analysis have been largely abandoned.

**Taxonomic mineralogy.** There are approximately 3000 distinct mineral species known to science. About 60 new mineral species are discovered each year. For a new species to be properly defined, the chemical analysis, structure cell and space group, crystal morphology, powder pattern, optical data, all physical properties, and paragenesis must be given as completely as possible. [P.B.M.]

**Minimal principles** In the treatment of physical phenomena, it can sometimes be shown that, of all the processes or conditions which might occur, the ones actually occurring are those for which some characteristic physical quantity assumes a minimum value. These processes or conditions are known as minimal principles. The application of minimal principles provides a powerful method of attacking certain problems that would otherwise prove formidable if approached directly from first principles.

One simple minimal principle asserts that the state of stable equilibrium of any mechanical system is the state for which the potential energy is a minimum. Other general theorems of classical dynamics that are related to minimal principles are Hamilton's principle and the principle of least action. See HAMILTON'S PRINCIPLE; LEAST-ACTION PRINCIPLE. [D.Wi.]

**Minimal surfaces** A branch of mathematics belonging to the calculus of variations, differential geometry, and geometric measure theory. A surface, interface, or membrane is called minimal when it has assumed a geometric configuration of least area among those configurations into which it can readily deform. Soap films spanning wire frames or compound soap bubbles enclosing volumes of trapped air are common examples. See DIFFERENTIAL GEOMETRY; MEASURE THEORY.

Geometrically, the mean curvature of a surface  $S$  at a point is the difference between the maximum upward curvature there and the maximum downward curvature; in particular, a surface of zero mean curvature has such principal curvatures equal and opposite and hence typically appears "saddle-shaped." It turns out that  $S$  is a minimal surface; that is, it cannot be perturbed to less area leaving its boundary fixed, provided the mean curvature is zero at each of its points; such a surface could occur, for example, as a soap film spanning a wire frame. The corresponding minimal surface equation is partial differential equation. If, alternatively,  $S$  were part of a soap bubble enclosing trapped air, the mean curvature of  $S$  would be proportional to the difference in air pressure between the two sides of  $S$ . In the calculus of variations, typically area-minimizing properties of minimal surfaces are emphasized. In differential geometry, minimal surfaces are defined as surfaces of zero mean curvature; surfaces of constant mean curvature are also extensively studied.

The two-dimensional surface is dominant in determining shape whenever the energy of a system is changed significantly by a displacement or a change in area of the surface. Such surfaces include the interfaces between crystals in a typical rock or metal, the film of soapy water between the air cells in a soap froth, the membrane separating the cells in living tissue, and the

cracks separating basalt columns. Minimization of surface area plays a role in determining the shape of many living organisms. See FOAM; GRAIN BOUNDARIES. [F.J.A.]

**Mining** The taking of minerals from the earth, including production from surface waters and from wells. Usually the oil and gas industries are regarded as separate from the mining industry. The term mining industry commonly includes such functions as exploration, mineral separation, hydrometallurgy, electrolytic reduction, and smelting and refining, even though these are not actually mining operations. See HYDROMETALLURGY; METALLURGY; ORE DRESSING.

Mining is broadly divided into three basic methods: opencast, underground, and fluid mining. Opencast mining is done either from pits or gouged-out slopes or by surface mining, which involves extraction from a series of successive parallel trenches. Dredging is a type of surface mining, with digging done from barges. Hydraulic mining uses jets of water to excavate material.

Underground mining involves extraction from beneath the surface, from depths as great as 10,000 ft (3 km), by any of several methods.

Fluid mining is extraction from natural brines, lakes, oceans, or underground waters; from solutions made by dissolving underground materials and pumping to the surface; from underground oil or gas pools; by melting underground material with hot water and pumping to the surface; or by driving material from well to well by gas drive, water drive, or combustion. Most fluid mining is done by wells. In one experimental type of well mining, insoluble material is washed loose by underground jets and the slurry is pumped to the surface. See COAL MINING; OPEN PIT MINING; PETROLEUM ENGINEERING; PLACER MINING; SOLUTION MINING; SURFACE MINING; UNDERGROUND MINING.

The activities of the mining industry begin with exploration, which, since accidental discoveries or surficially exposed deposits are no longer sufficient, has become a complicated, expensive, and highly technical task. After suitable deposits have been found and their worth proved, development, or preparation for mining, is necessary. For opencast mining, this involves stripping off overburden; and for underground mining, the sinking of shafts, driving of adits and various other underground openings, and providing for drainage and ventilation. For mining by wells, drilling must be done. For all these cases, equipment must be provided for such purposes as blasthole drilling, blasting, loading, transporting, hoisting, power transmission, pumping, ventilation, storage, or casing and connecting wells. Mines may ship their crude products directly to reduction plants, refiners, or consumers, but commonly, concentrating mills are provided to separate useful from useless (gangue) minerals. See PROSPECTING.

A unique feature of mining is the circumstance that mineral deposits undergoing extraction are "wasting assets," meaning that they are not renewable as are other natural resources. This depletability of mineral deposits requires that mining companies must periodically find new deposits and constantly improve their technology in order to stay in business. Depletion means that the supplies of any particular mineral, except those derived from oceanic brine, must be drawn from ever-lower-grade sources. [E.Ju.]

**Mink** Any of three species of aquatic carnivorous mammals that are members of the family Mustelidae in the genus *Mustela*. They are found in the forested areas of North America, Europe, and Siberia. The mink is an excellent swimmer, aided by its slightly webbed hindfeet, and feeds on crayfish, frogs, snakes, and fish. The body is elongate and the legs are short (see illustration).

There is one litter each year, with three or four young being born in April or May after a gestation period of about 8 weeks. The young are mature the following season. The pelts of these animals are valuable; many mink farms have been established



The American mink (*Mustela vison*) is the largest species of mink.

throughout the world. This animal is a natural predator on the muskrat, over whose numbers it exerts a control. See BADGER; CARNIVORA; MARTEN; OTTER; SKUNK; WEASEL. [C.B.C.]

**Miocene** The second subdivision of the Tertiary Period (Eocene, Miocene, and Pliocene) by Charles Lyell in 1833; the fourth in a more modern sevenfold subdivision (epochs) of the Cenozoic Era; and the first epoch of the Neogene Period (which includes in successive order the Miocene, Pliocene, Pleistocene, and Holocene). The Miocene represents the interval of time from the end of the Oligocene to the beginning of the Pliocene and the rocks (series) formed during this epoch. See CENOZOIC; HOLOCENE; OLIGOCENE; PLEISTOCENE; PLIOCENE; TERTIARY.

The Miocene spans the time interval between 23.8 and 5.32 million years ago (Ma) based on integrated astronomical and radioisotopic dating. The Miocene/Pliocene boundary is located in Sicily, just above a major unconformity separating the youngest late Miocene (Messinian) deposits (of the Great Terminal Miocene Salinity Crisis) and the overlying white chalks of the Zanclean. See UNCONFORMITY.

Major orogenic and volcanic events characterize the Miocene. Plate-tectonic motions, originating in the Mesozoic, resulted in the gradual dismemberment of the Tethyan Ocean and the upthrusting of the Alpine-Himalayan orogenic belt in three major phases: the late Eocene (about 40 Ma) and the early (21–17 Ma) and mid-late Miocene (10–7 Ma). Along the eastern margins of the Pacific Ocean, the ocean crust was subducted under the North and South American continents, giving rise to major orogenic movements stretching from the Aleutians to Tierra del Fuego. The Andes range was thrust up during the later part of the Miocene. The Pacific Coast developed as a result of westward drift of North America over, and partial consumption by, the Farallon plate and collision with the Farallon Ridge. Only two relatively minor plates remain as remnants of the Farallon plate: the Juan de Fuca and Cocos plates between Mexico and Alaska. The plate margin was bounded by transform faults rather than a subduction zone, and northwestern propagation of a major transform fault issuing from the Cocos plate formed the Gulf of California in the late Miocene, and its continued extension northward is familiar to residents of the west coast as the San Andreas Fault System. The latter was responsible for the formation of many of the off- and onshore basins of southern California, some of which contain prolific petroleum resources. Subduction of the Pacific plate at the Middle America Trench during the late Paleogene and Neogene resulted in arc magmatism and eventual uplift of the Central American Isthmus into a series of archipelagos in the late Miocene (about 7 Ma) and eventual fusion into a continuous land bridge in the early Pliocene (about 3 Ma) that resulted in the separation of the Atlantic and Pacific oceans and concomitant disruption in marine faunal communities as well as transcontinental migration of vertebrate animals in the Great



American Faunal Interchange. See OROGENY; PLATE TECTONICS; SUBDUCTION ZONES; TRANSFORM FAULT.

Ocean circulation essentially assumed its modern form during the Miocene as enhanced refrigeration in the form of growth of the Antarctic Ice Sheet plunged the Earth inexorably deeper into an icehouse state, although there were some details that were completed during the succeeding Pliocene and Pleistocene epochs. An ice cap has been present on Antarctica, at least intermittently, since at least the early Oligocene (about 34 Ma). The opening of the Drake Passage between South America and Antarctica took place during the latest Oligocene–early Miocene (about 25–23 Ma), allowing the unhindered circulation of ocean currents around the Antarctic continent. The development of the Circum-Antarctic Current thermally isolated high southern latitude waters and the continent of Antarctica from the warmer, low-latitude waters and resulted in the replacement of calcareous oozes (comprising planktonic foraminifera and calcareous nannoplankton) by biosiliceous oozes (diatoms and radiolarians). See GLACIAL EPOCH.

During the Miocene, life assumed much of its modern aspect. The spread of grasses and weeds throughout this epoch, but particularly in the late Miocene, and concomitant reduction in and thinning of forests reflected the global Neogene cooling as the Earth entered deeper into an ice house state. In this environment, snakes, frogs, and murids (rats, mice) expanded in diversity and habitat; songbirds reflect the expansion of seed-bearing herbs and, like frogs, the concomitant diversification of insects, many of which are found entombed in middle Miocene amber from the Dominican Republic. Grazing animals (elephants, rodents, horses, camelids, and rhinos, for example) developed high crowned teeth to resist significant wear caused by silicon fragments in the developing grasses. Some animals assumed gigantic proportions such as *Baluchitherium*, a Eurasian rhino that stood 16 ft (5 m) at the shoulders, and the tallest camel known, a giraffelike form that was over 12 ft (3.5 m) tall.

The relatively free interchange between Eurasia and Africa between 18 and 12 Ma appears to have come to an end in the late Miocene, after which (about 8 Ma) the hominoids of Eurasia and Africa appear to have followed separate and independent lines of evolution: the pongids in Asia, and the panids and hominoids leading eventually to the true hominids in (predominantly East) Africa. This scenario has been linked, in turn, with the development of the East African Rift (and its northward extension into the Red Sea and Gulf of Suez), which would have served as a geographic barrier allowing independent evolution toward forest (panid) and savannah (hominid) adapted forms. With the late Miocene change in climate (7–5 Ma) to cooler, drier conditions and the spread of open savannah and grasslands, monkeys came to dominate the African forest at the expense of dryomorphs. There is a gap in the terrestrial fossil record during this interval of time, and it is only in the early Pliocene (about 4 Ma) that the story of human evolution resumes with the discovery of the earliest true hominids (australopithecines) in East Africa, about 1 million years older than the australopithecine footprints of *Laeotili* and the skeletons of Lucy and other australopithecines at Hadar in Ethiopia at about 3 million years. See AUSTRALOPITHECINE; FOSSIL HUMANS.

In the marine realm, major radiation of mammals including walrus, seals, sea lions, and whales occurred during the early Miocene. On the sea floor, large bivalve mollusks of the scallop family thrived in the early Miocene, and a distinct horizon of large pectenids occurs in lower Miocene rocks of Europe and North America and in corresponding levels in the deposits of the Paratethyan Sea in east-central Europe and at least as far to the east as Iran, attesting to an interval of global climatic amelioration. Among the protozoa, planktonic foraminifera experienced a major radiation in the early and middle Miocene following the drastic reduction in diversity during the middle and late Eocene, some 15–20 million years earlier. Mangroves and coral reefs

flourished in a circumequatorial belt spanning the Indo-Pacific and Caribbean regions, but the latter were eliminated from the Mediterranean during the terminal Miocene Salinity Crisis, never to return with early Pliocene flushing from the Atlantic. See FORAMINIFERIDA; MANGROVE; MOLLUSCA; REEF. [W.A.Ber.]

**Mira** The first star recognized to have a periodic brightness variation. Mira (officially designated Omicron Ceti, in the constellation Cetus, the Whale) was discovered in 1596 by David Fabricius.

Mira is the prototype of an entire class of Mira-type pulsating long-period variables. Although it once resembled the Sun, Mira has evolved into a cool red giant star that is at the end of its life. See GIANT STAR; STELLAR EVOLUTION.

Contracting and expanding every 332 days, Mira varies in visual brightness from about magnitude 3.4 (brightest) to about 9.3 (faintest). However, an individual maximum can sometimes be as bright as second magnitude, while at other times its maximum may reach barely fifth magnitude. See MAGNITUDE (ASTRONOMY).

Mira is one of the few long-period variable stars with a close companion star. The companion, VZ Ceti, is also a variable star. It is a hotter, bluer, burned-out star, called a white dwarf, surrounded by material captured from Mira's wind. See BINARY STAR; WHITE DWARF STAR.

Hubble Space Telescope visible light images show that Mira has an odd, asymmetrical shape. In ultraviolet light, the Hubble Space Telescope has resolved a small hooklike appendage extending from Mira in the direction of the companion. The diameter of Mira is measured to be 700 times larger than the Sun. See STAR; ULTRAVIOLET ASTRONOMY; VARIABLE STAR. [J.A.Ma.]

**Mirage** A name for a variety of unusual images of distant objects seen as a result of the bending of light rays in the atmosphere during abnormal vertical distribution of air density. If the air closer to the ground is much warmer than the air above, the rays are bent in such a way that they enter the observer's eyes along a line lower than the direct line of sight. The object is then seen below the horizon, the inferior mirage. If the air closer to the ground is much colder than the air above, the rays are bent in the opposite direction, arriving at the observer's eyes above the line of sight; the object then seems to be elevated or floating in the air, the superior mirage. Mirages can be seen most frequently along an overheated highway surface; the inferior mirage of the sky gives the impression of water reflection over a wet pavement, which disappears upon a closer viewing. [Z.S.]

**Mirror optics** The use of plane or curved reflecting surfaces for the purpose of reverting, directing, or forming images. An optical surface which specularly reflects the largest fraction of the incident light is called a reflecting surface. Such surfaces are commonly fabricated by polishing of glass, metal, or plastic substrates, and then coating the surface of the substrate with a thin layer of metal, which may be covered in addition by a single or multiple layers of thin dielectric films. The law of reflection states that the incident and reflected rays will lie in the plane containing the local normal to the reflecting surface and that the angle of the reflected ray from the normal will be equal to the angle of the incident ray from the normal. See GEOMETRICAL OPTICS.

The formation of images in the plane mirrors is easily understood by applying the law of reflection. The illustration shows the formation of the image of a point formed by a plane mirror. Each of the reflected rays appears to come from a point image located a distance behind the mirror equal to the distance of the object point in front of the mirror. The face of the observer can be considered as a set of points, each of which is imaged by the plane mirror. Since the observer is viewing the facial image from the object side of the mirror, the face will appear to be reversed left for right in the virtual image formed by the mirror. The illustration also indicates the redirection of light by a plane

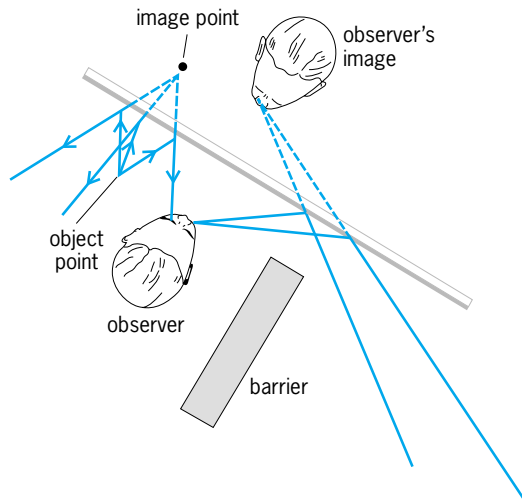

Formation of images by a plane mirror.

mirror, in that a viewer who cannot observe the object point directly can observe the virtual image of the point formed by the mirror. A simple optical device which is based on this principle is the simple mirror periscope, which uses two mirrors to permit viewing of scenes around an obstacle. See PERISCOPE.

A curved mirror, either spherical or conic in form, will produce a real or virtual image in much the same manner as a lens, but generally with reduced aberrations. There will be no chromatic aberrations since the law of reflection is independent of the color or wavelength of the incident light. See ABERRATION (OPTICS); OPTICAL IMAGE.

Both concave and convex spherical mirrors are commonly encountered. Convex mirrors are commonly used as wide-angle rearview mirrors in automobiles or on trucks. A common application of concave mirrors is the magnifying shaving mirror frequently found in bathrooms.

A spherical mirror will form an image which is not perfect, except for particular conjugate distances. The use of a mirror which has the shape of a rotated conic section, such as a parabola, ellipsoid, or hyperboloid, will form a perfect image for a particular set of object-image conjugate distances and will have reduced aberrations for some range of conjugate relations. The most familiar applications for conic mirrors are in reflecting telescopes. See OPTICAL PRISM; OPTICAL SURFACES; OPTICAL TELESCOPE; REFLECTION OF ELECTROMAGNETIC RADIATION; TELESCOPE.

[R.R.S.]

**Misophrioida** A small but evolutionarily significant order of the subclass Copepoda, containing only a few species. Misophrioids have two subdivisions of the body, the anterior prosome and posterior urosome, articulated immediately behind the fifth thoracic somite. This feature immediately distinguishes misophrioids from calanoids. Like calanoids, some misophrioids have a dorsal heart, a character that distinguishes the taxon from both cyclopoids and harpacticoids. The misophrioids have four unique characteristics: a carapacelike posterior extension of the head region (cephalosome) that encloses the first leg-bearing segment; the absence of the nauplius eye in all life stages; the retention of the antennary gland as the functional excretory system of adults; and a single naupliar developmental stage.

The unique characteristics of the misophrioids are interpreted as having resulted from the adaptation to a bathypelagic mode of life and gorging as a feeding strategy. However, species of three newly described genera also exhibit a number of characteristics that approach those attributed to a hypothetical copepod ancestor. See CALANOIDA; COPEPODA; CRUSTACEA; CYCLOPOIDA; HARPACTICOIDA.

[P.A.McL.]

**Missile** An object capable of being projected or hurled, usually with the intent of striking some distant object. More particularly, a missile is usually a weapon that is self-propelled after leaving the launching device. The term thus excludes projectiles fired from guns as well as free-falling bombs. The propulsion criterion is not an absolute test, however, since gliding bombs, especially those guided after launch, are also frequently classed as missiles.

There are two primary categories of modern missiles; unguided and guided. All missiles, to be effective, must be directed in some sense, but those subject to no further control after leaving the launching device are usually classed as unguided.

Typical of unguided missiles are the ground-launched and air-launched free-flying rockets used in enormous number in World War II.

The growth of the sciences of instrumentation, electronics, and automatic control has led to the development of devices for the guidance of missiles in flight. Certain targets contrast with their surroundings by emitting or reflecting radiation in a distinctive manner. (Airplanes and ships are typical of the targets falling into this class.) The direction, and sometimes the distance, of targets of this kind can frequently be sensed by radiation receiving instruments. These instruments, located either in the missile or on the ground, can be used to guide the missile continuously toward the target.

Other targets cannot be readily distinguished from their surroundings by nonhuman means. Guided missiles used against these are frequently directed to the predetermined geographical location of such targets. Guidance errors are likely to be substantial, particularly as the distance from the guidance station to the target becomes great. In these cases, use of nuclear warheads becomes mandatory on economic grounds.

Missiles are classified in many ways. A common classification is according to the medium from which the missile is launched and to which it is directed. Thus, there are surface-to-air missiles, surface-to-surface missiles, air-to-surface missiles, and so on. They may also be classified according to range.

Missiles are also classified according to flight profile. The two categories are aerodynamic missiles (sometimes called cruise missiles) and ballistic missiles. Cruise missiles usually have wings or enlarged fins to give lift and maneuverability. A ballistic missile has no wings. It must be aimed sufficiently high to permit it to fall freely under the influence of gravity until it reaches the target. See BALLISTIC MISSILE.

High-speed missiles present problems of protecting sensitive components from the high temperatures produced by aerodynamic drag and sometimes from the high inertial forces produced by high accelerations. Only during the reentry phase is heat protection necessary.

The shape of the reentering body is sometimes quite blunt. This shape causes a greater fraction of the kinetic energy of the missile to be transferred to the surrounding atmosphere. However, blunt bodies slow down greatly before striking the ground, and they also have large radar reflectivity. These qualities are undesirable if antiballistic missiles are defending the target. As a consequence, the trend is toward sharper cones, accepting the greater heat transfer by providing greater protection. The ablative heat shield has almost entirely superseded the heat-sink type. See NOSE CONE.

[R.C.Tr.]

**Mississippian** The fifth period of the Paleozoic Era. The Mississippian System (referring to rocks) or Period (referring to time during which these rocks were deposited) is employed in North America as the lower (or older) subdivision of the Carboniferous, as used on other continents. The name Mississippian is derived from rock exposures on the banks of the Mississippi River between Illinois and Missouri.

The limits of the Mississippian Period are radiometrically dated. Its start (following the Devonian) is dated as 345–360 million years before the present (Ma). Its end (at the start of the next

younger North American period, the Pennsylvanian) is dated as 320–325 Ma. The duration of the Mississippian is generally accepted as 40 million years (m.y.). Biochronologic dating within the Mississippian, based on a combination of conodont (phosphatic teeth of eel- or hagfish-like primitive fish), calcareous foraminiferan, and coral zones permits a relative time resolution to within about 1 m.y. See CARBONIFEROUS; PENNSYLVANIAN.

The Mississippian is divided, in ascending order, into the Lower Mississippian, comprising the Kinderhookian and Osagean, and the Upper Mississippian, comprising the Meramecian and Chesterian. Kinderhookian, Osagean, Meramecian, and Chesterian are used in North America as series (for rocks) and as stages (for time). In Illinois, Valmeyeran is commonly used for the Osagean and Meramecian combined.

During much of Mississippian time, the central North American craton (stable part of the continent) was the site of an extensive marine carbonate platform on which mainly limestones and some dolostones and evaporites were deposited. This platform extended either from the present Appalachian Mountains or Mississippi Valley to the present Great Basin. The craton was covered by shallow, warm, tropical epicontinental seas that had maximum depths of only about 60 m (200 ft) at the shelf edge.

Mississippian North America was subjected to a number of sea-level rises, associated with transgressions, and sea-level falls, associated with regressions. The two major rises, which were probably eustatic (referring to worldwide change of sea level), took place during the late Kinderhookian and at the start of the middle Osagean zone. These sea-level rises caused progradation or seaward migration of carbonate platforms as organisms produced buildups that maintained their niches relative to sea level. The rises also caused stratification of the water column in deeper basins, so that bottom conditions became deficient to lacking in oxygen. See ANOXIC ZONES; BASIN.

Crinoids were probably the most abundant biota in Mississippian seas, but are only uncommonly used for correlation because most specific identifications require study of calyxes, which generally disarticulated after death. Corals are probably the most widely preserved Mississippian megafossil group, and they are one of the most useful biochronologic tools for constructing biostratigraphic zones for carbonate-platform rocks. The earliest Mississippian is characterized mainly by solitary corals and tubular colonial corals known as *Syringopora*, which had survived the late Frasnian mass extinction. Other colonial corals began a gradual return late in the Kinderhookian. The Late Mississippian was a heyday for reef-building colonial corals and large solitary corals. See CORALLINALES; CRINOIDEA; REEF.

Forests flourished during the Mississippian, and tree trunks, plant stems, roots, and spores occur commonly in terrestrial and peritidal rocks, particularly in coal beds. *Lepidodendron* trunks and *Stigmaria* roots are among the best-known plant remains. See GEOLOGIC TIME SCALE; PALEONTOLOGY; PALEOZOIC. [C.A.Sa.]

**Mistletoe** The name given to several species of the mistletoe family (Loranthaceae). The true mistletoe of Europe is *Viscum album*, and among the early nations this was an important ceremonial plant, which probably accounts for the origin of the custom of kissing under the mistletoe. In the United States, the common representative of the group is *Phoradendron flavescens*. All of the mistletoes are green hemiparasites; that is, they obtain water and minerals from the host plant but manufacture their own food. See SANTALALES. [PD.St./E.L.C.]

**Mitochondria** Specialized organelles of all eukaryotic cells that use oxygen (see illustration). Often called the powerhouses of the cell, mitochondria are responsible for energy generation by the process of oxidative phosphorylation. In this process, electrons produced during the oxidation of simple organic compounds are passed along a chain of four membrane-



Electron micrograph of a thin section through the pancreas of a bat, showing a typical mitochondrion in profile. Note how the cristae are formed by extensive folding of the inner membrane. (Courtesy of K. R. Porter)

bound enzymes (the electron transport or respiratory chain), finally reacting with and reducing molecular oxygen to water. The movement of the electrons releases energy that is used to build a gradient of protons across the membrane in which the electron transport chain is situated. Like a stream of water that drives the turbines in a hydroelectric plant, these protons flow back through adenosine triphosphate (ATP) synthase, a membrane-bound enzyme that acts as a molecular turbine. Rotation of part of ATP synthase results in storage of energy in the form of ATP, the universal energy currency of the cell.

Besides their role in energy generation, mitochondria house numerous enzymes that carry out steps essential to metabolism. Defects in mitochondrial assembly or function generally have serious consequences for survival of the cell. In humans, mitochondrial dysfunction is the underlying cause of a wide range of degenerative diseases, with energy-demanding cells such as those of the central nervous and endocrine systems, heart, muscle, and kidney being most severely affected.

Mitochondria are bounded by two concentric membranes referred to as the outer and the inner. This creates two distinct compartments, the matrix and the intermembrane space. The outer membrane consists of a bilayer containing about 80% lipid. It is freely permeable to molecules smaller than about 5000 daltons. The inner membrane is also a lipid bilayer. It is extremely rich in protein (about 75%) and is impermeable to even the smallest of ions. The inner membrane contains the enzymes of the electron transport chain and the ATP synthase, together with a set of transporter proteins that regulate the movement of metabolites in and out of the matrix space. Mitochondria of cells that depend on a high level of ATP production are usually extensively folded to produce structures called cristae (see illustration). These greatly increase the surface area of the inner membrane, allowing many more copies of the enzymes of oxidative phosphorylation.

The intermembrane space contains enzymes capable of using some of the ATP that is transported out of the matrix to phosphorylate other nucleotides. The matrix space is packed with a hundred or so water-soluble proteins that form a sort of semisolid gel. They include enzymes of the tricarboxylic acid (Krebs) cycle and enzymes required for the oxidation of pyruvate and fatty acids, comprising steps in the biosynthesis or degradation of amino acids, nucleotides, and steroids.

Both mitochondria and chloroplasts contain DNA and the machinery necessary to express the information stored there. In both cases, the DNAs are relatively small and simple compared with DNA in the nucleus. While chloroplast DNA tends to be very similar in size in all organisms examined, mtDNA varies widely in complexity, from 16–18 kilobases in metazoa to upward of 2000 kilobases in some higher plants. In the case of higher-plant mtDNAs, some extra sequences appear to have been picked up from chloroplast and nuclear DNAs. MtDNA is generally circular, although some linear exceptions are known among the yeasts, algae, and protozoa.

The information content of most mtDNA is limited. This means that most of the several hundred proteins found in these organelles are encoded by genes located in nuclear DNA. These proteins are synthesized in the cytosol and subsequently transported specifically to the respective organelles. The contributions of the two genetic systems are usually closely coordinated, so that cells synthesize organelles of more or less constant composition.

Many organisms, including humans, show uniparental inheritance of mitochondrial genes because one parent contributes more cytoplasm to the zygote than the other. In humans, it is the egg cell provided by the mother that contributes the cytoplasm. Human mitochondrial genes are thus inherited maternally.

Recent years have seen a growing interest in human diseases that result from mitochondrial dysfunction. A number of these result from mutations in mtDNA. Others are linked to nuclear genes, whose mutation disturbs oxidative phosphorylation or impairs mitochondrial assembly. Mutations in mtDNA are remarkably frequent and lead to a wide range of degenerative, mainly neuromuscular diseases. Most of these diseases are maternally inherited, but some appear to be spontaneous, possibly resulting from error-prone replication of mtDNA. A striking feature of mtDNA-related diseases is the enormous diversity in clinical presentation. This diversity is attributable to two main factors: (1) Heterogeneity in the mtDNA population. Most human tissues contain many thousands of mtDNA molecules per cell. The severity of clinical symptoms depends on the number of mutated molecules present. (2) Dependence of a particular cell type on mitochondrial function (mainly ATP production). Cells with a high requirement for mitochondrially generated ATP are more severely affected than cells with alternative sources of ATP.

Besides their role in metabolism and energy-linked processes, mitochondria have recently been identified as important players in the initiation of apoptosis (programmed cell death). On one hand, the mitochondrial outer membrane houses a number of members of the Bcl-2 family of apoptosis regulatory proteins. On the other hand, release of certain mitochondrial proteins from the intermembrane space is instrumental in activating specialized proteases called caspases. These catalyze a degradative cascade in the cytoplasm that eventually ends in cell death.

Mammalian mtDNAs accumulate mutations at high rates and evolve correspondingly fast (up to 12–15 times faster than single-copy genes in nuclear DNA and up to 100 times faster for rRNA and tRNA genes). This behavior reflects both a high incidence of mutations and a high probability of their fixation. The first is probably related to oxidative damage to mtDNA by oxygen free radicals produced as by-products of electron transfer through the respiratory chain. The second has been attributed to the lack of efficient DNA repair (mitochondria lack nucleotide-excision repair) and to a relatively high tolerance of many mitochondrial gene products to mutational change.

The rapid rate of sequence evolution of mammalian mtDNAs makes these genomes highly sensitive indicators of recent evolutionary relationships. Unlike their nuclear counterparts, mtDNAs do not undergo recombination during sexual transmission and are strictly maternally inherited. Sequence changes in mtDNA therefore provide a clear record of the history of the female lineages through which this DNA has been transmitted. [L.A.Gr.]

**Mitosis** The series of visible changes that occur in the nucleus and chromosomes of non-gamete-producing plant and animal cells as they divide. During mitosis the replicated genes, packaged within the nucleus as chromosomes, are precisely distributed into two genetically identical daughter nuclei (see illustration). The series of events that prepare the cell for mitosis is known as the cell cycle. When viewed in the context of the cell cycle, the definition of mitosis is often expanded to include cytokinesis, the process by which the cell cytoplasm is partitioned during cell division.

Chromosome segregation is mediated in all nonbacterial cells (that is, eukaryotes) by the transient formation of a complex structure known as the mitotic spindle. During mitosis in most higher plants and animals, the nuclear membrane surrounding the replicated chromosomes breaks down, and the spindle is formed in the region previously occupied by the nucleus (open mitosis). In lower organisms, including some protozoa and fungi, the spindle is formed and functions entirely within the nucleus which remains intact throughout the process (closed mitosis).

All spindles are bipolar structures, having two ends or poles. In animal cells, each spindle pole contains an organelle, the centrosome, onto which the spindle focuses and terminates. The polar regions of plant spindles lack centrosomes and, as a result, are much broader. In animals the bipolar nature of the spindle is established by the separation of the centrosomes, which is critical for successful mitosis; the presence of only one pole produces a monopolar spindle in which chromosome segregation is inhibited. The presence of more than two poles produces multipolar spindles which distribute the chromosomes unequally among three or more nuclei. Centrosomes are duplicated during interphase near the time that the DNA is replicated, but then act as a single functional unit until the onset of mitosis. In plants, and during meiosis in some animals, the two spindle poles are organized by the chromosomes and by molecular motors that order randomly nucleated microtubules into parallel bundles. See CENTROSOME; PLANT CELL.

Microtubules are the primary structural components of the mitotic spindle and are required for chromosome motion. These are 25-nanometer-diameter, hollow, tubelike structures. During interphase, microtubules are distributed throughout the cytoplasm, where they serve to maintain cell shape and also function as polarized roadways for transporting organelles and cell products. As the cell enters mitosis, the cytoplasmic microtubule network is disassembled and replaced by the mitotic spindle. The microtubules in animal cells originate from the centrosome which, like the chromosomes, was inherited during the previous mitosis where it functioned as a spindle pole. The motion associated with microtubules is mediated by several families of molecular motors which bind to and move along the wall of the microtubule. See CYTOSKELETON.

As mitosis begins, each replicated chromosome consists of two identical sister chromatids that are joined along their length. In most cells, chromosomes possess a unique region of highly condensed chromatin (DNA plus protein), known as the centromere, which forms an obvious constriction on the chromosome, referred to as the primary constriction. Spindle microtubules attach to a small specialized structure on the surface of the centromere known as the kinetochore. Fragments of chromosomes lacking a kinetochore do not move poleward; it is always the kinetochore that leads in the poleward motion of the chromosome. The centromere region of each replicated chromosome contains two sister kinetochores, one attached to each chromatid, that lie on opposite sides of the primary constriction.

Once initiated, mitosis is a continuous process that, depending on the temperature and organism, requires several minutes to many hours to complete. Traditionally it has been subdivided into five consecutive stages that are distinguished primarily by chromosome structure, position, and behavior. These stages are prophase, prometaphase, metaphase, anaphase, and telophase. In prophase, cell chromosomes condense within the nucleus. By

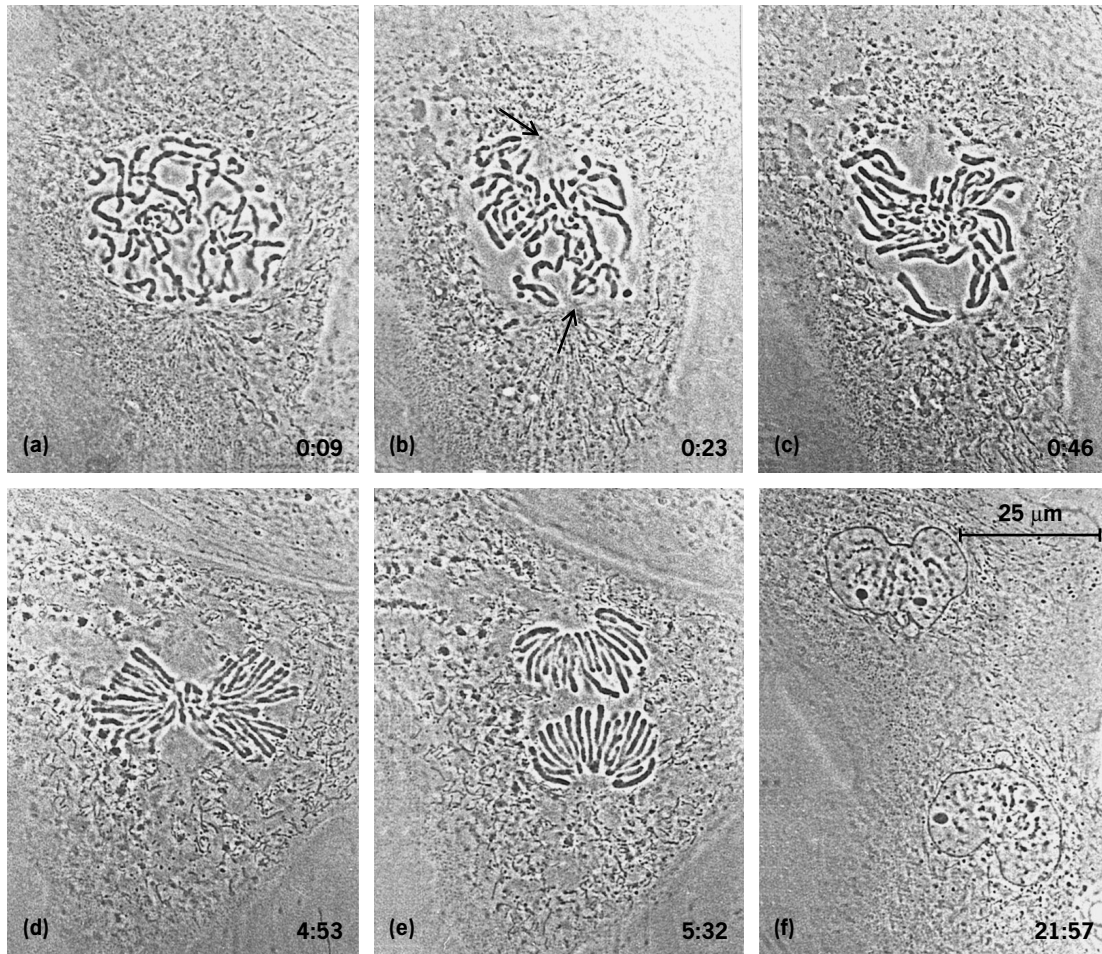

Selected phase-contrast light micrographs showing changes in chromosome position during mitosis in a living newt lung epithelial cell. (a) Late prophase. (b) Prometaphase. (c) Mid-prometaphase. (d) Metaphase. (e) Anaphase. (f) Telophase.

late prophase/early prometaphase, the nuclear envelope breaks down; kinetochore-containing primary constrictions are sometimes visible; the cytoplasmic microtubule complex is replaced by two radial astral microtubule arrays; centrosomes separate; and microtubules in each aster grow and shorten at their ends away from the centrosome. By mid-prometaphase, the kinetochores on the chromosomes interact with the asters to form the spindle. In metaphase, all of the chromosomes are aligned on the spindle equator; sister kinetochores are attached to opposite poles by kinetochore fibers. In anaphase, the sister chromatids separate and move toward their respective spindle poles; at the same time the spindle poles move farther apart. In telophase, the two groups of sister chromosomes become two well-separated sister nuclei, and the cytoplasm of the cell divides (cytokinesis). See CELL (BIOLOGY); CELL DIVISION; CELL NUCLEUS. [C.L.R.]

**Mitteniales** An order of true mosses (subclass Bryidae) found in Australia and New Zealand. The order consists of a single species, *Mittenia plumula*, which is adapted for growth in caves or cavelike places. Branches of the persistent protonema consist of spherical cells which reflect light from a backing of chloroplasts, thus providing a glow. The stems are simple and erect, and the leaves are 2–4-ranked and oblonglingulate and blunt or apiculate. The midrib ends above the midleaf, and the cells are short and smooth.

The order is remarkably similar to the Schistostegales of North Temperate distribution in protonema and habitat, but the other features of gametophyte and sporophyte are quite different. A

distinctive feature is the double peristome with 32 segments derived in part from the outermost cell walls of the endothecium (that is, the inner portion of the embryonic capsule). See BRYIDAE; BRYOPHYTA; BRYOPSIDA; SCHISTOSTEGALES. [H.Cr.]

**Mixer** A device with two or more signal inputs and one common output. The two primary classes are linear (additive) and nonlinear (multiplicative) mixers. Linear mixers are used to add or blend together two or more signals, nonlinear mixers mainly to shift the spectrum (center frequency) of one signal by the frequency of a second signal.

Linear mixing is the process of combining signals additively, such as the summing of audio signals in a recording studio. This operation can be accomplished passively by simply using a resistive summing network. Although this approach appears very economical, there is a loss in signal strength and an interaction of the signal amplitudes as the gains are adjusted.

Inexpensive integrated circuits have improved this application dramatically. Operational amplifiers of reasonably high quality that will eliminate the adjustment interactions and also provide gain are readily available. The input signals are summed into the virtual ground summing node at the input of the operational amplifier. There is a sign change in the output, but that is a small drawback compared to the advantage of having the virtual ground provided by the operational amplifier. See AMPLIFIER; INTEGRATED CIRCUITS; LINEARITY; OPERATIONAL AMPLIFIER.

Perhaps the most familiar application of nonlinear mixers is in radio and television receivers. They are widely used in such

applications as amplitude modulation (AM) and demodulation, frequency demodulation, phase detection, frequency multiplication, and single-sideband (SSB) generation. The incoming information to a receiver has been transmitted and received at a frequency far too high to permit efficient amplification and processing. Therefore the signal is translated or frequency-shifted or heterodyned by a mixer to a lower frequency, known as the intermediate frequency (IF), where amplification and processing are performed efficiently by an IF processor, sometimes referred to as the IF strip. See AMPLITUDE-MODULATION DETECTOR; AMPLITUDE MODULATOR; FREQUENCY-MODULATION DETECTOR; FREQUENCY MODULATOR; FREQUENCY MULTIPLIER; PHASE-ANGLE MEASUREMENT; RADIO RECEIVER; SINGLE SIDEBAND; TELEVISION RECEIVER.

A second application of a nonlinear mixer is frequency synthesis, where a stable but not easily changed signal at a high frequency is made tunable by mixing it with an easily tunable signal at a low frequency, which, perhaps, can be varied in precise increments of any size. The utility of the method is limited by the ability to filter or separate one frequency term from another, thereby determining the minimum practical value of low frequency for the application.

A mixer is an integral part of an AM-radio integrated circuit which contains virtually all AM-radio functions except filters. A particular type of mixer, the quadrature detector, is included in the frequency-modulation (FM)-radio integrated circuit. [S.A.Wh.]

**Mixing** A common operation to effect distribution, intermingling, and homogeneity of matter. Actually the operation is called agitation, with the term mixing being applicable when the goal is blending, that is, homogeneity. Other processes, such as reaction, mass transfer (includes solubility and crystallization), heat transfer, and dispersion, are also promoted by agitation. The type, extent, and intensity of agitation determine both the rates

and adequacy of a particular process result. The agitation is accomplished by a variety of equipment.

Most liquid mixing is done by rotating impellers in vertical cylindrical vessels. A typical impeller-type liquid mixer with a variety of features is shown in the illustration. The internal features, including the vessel itself, are considered as a whole, that is, as the agitated system. The forces applied by the impeller develop overall circulation or bulk flow. Superimposed on this flow pattern, there is molecular diffusion, and if turbulence is present, also turbulent eddies. These provide micromixing. Solids, granular to powder, are mixed in a variety of contrivances.

Solids of different density and size are mixed in tumblers (a double cone turning end on end) or with agitators (a helical ribbon rotating in a horizontal trough). The duration of mixing is an important additional variable because classification and separation often occur after attainment of the desired distribution if the operation is carried on too long. [V.W.U.]

**Mizar** The second-magnitude star that marks the bend in the handle of the Big Dipper,  $\zeta$  Ursae Majoris. Mizar was the first telescopic visual binary to be discovered (1650), the first ever to be photographed (1857), and the first star discovered to be a spectroscopic binary (1889). Its distance to the Sun is 24 parsecs ( $7.5 \times 10^{14}$  km or  $4.7 \times 10^{14}$  mi). See BINARY STAR; CONSTELLATION; URSA MAJOR.

Mizar (the Horse) forms a wide visual binary with the fourth-magnitude star Alcor (the Rider), at a separation of  $12'$ . The two stars have nearly the same proper motion, and the pair is visible to the naked eye. Mizar itself is a close visual pair, with bluish-white components of apparent magnitude 2.27 and 3.95, approximately  $14''$  apart. The spectrum of the primary star, Mizar A, shows periodic doubling of the absorption lines due to the Doppler effect, caused by the motion of two stars around their common center of mass. The orbital period of this spectroscopic binary is 20.5 days, and the stars have been resolved with an interferometer, the mean angular separation being only  $0.012''$ . Mizar B is also a spectroscopic binary with a period of 176 days. See DOPPLER EFFECT; SPECTRAL TYPE. [D.W.L.]

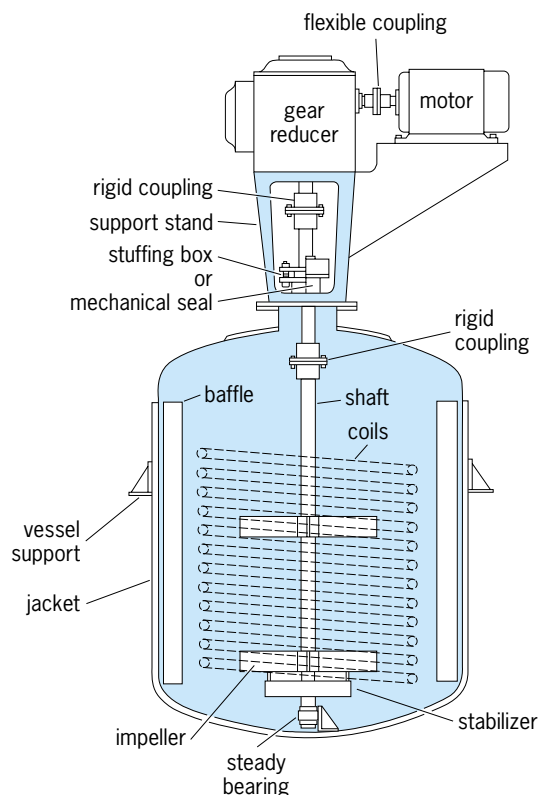

Typical impeller-type liquid mixer. (After V. W. Uhl and J. B. Gray, *Mixing: Theory and Practice*, vol. 2, Academic Press, 1967)

**Mobile radio** Radio communication in which one or both ends of the communication path are movable. The term mobile refers to movement of the radio rather than association with a vehicle (for example, hand-held portable radios are included by the definition). The Federal Communications Commission (FCC) licenses and regulates nonfederal government radio activity in the United States, while the National Telecommunications and Information Administration (NTIA) oversees federal government users. Other countries have similar agencies. International coordination is afforded through the International Telecommunication Union (ITU) and international treaty.

Users who lease or purchase radio equipment for personal communication fall into this category. Examples are public safety, special emergency, industrial, land transportation, and radiolocation radio services. Spectrum over a wide range of frequency bands is allocated; for example, low band (30–50 MHz), high band (150–174 MHz), ultrahigh frequency or UHF (450–512 MHz), the 800 band (806–824 MHz, paired with 851–869 MHz), and the 900 band (896–901 MHz, paired with 935–940 MHz). Dispatch is the normal mode of operation; that is, all members of the group hear all communications. To accomplish this high-power, high-site base, repeaters are generally used so that the entire area of interest is covered by a single site. Coverage radius varies with frequency band, local terrain, and permissible power levels, but values on the order of 20 mi (32 km) are commonplace. Where areas to be covered are even larger (for example, statewide police systems) or where coverage reliability must be greater than that possible from a single site (for example, for ambulance communications), multiple sites can simulcast the communications. Current

technology allows for data exchanges, vehicle location, and secure, digitized voice. See RADIO SPECTRUM ALLOCATIONS.

Specialized mobile radio (SMR) is a type of mobile radio service in which individual users with business interests are licensed to operate their mobiles, portables, and control stations on channel pairs repeated by specialized mobile radio base stations. Full interconnection to the public switched telephone network (PSTN) is possible. To boost the spectrum efficiency of specialized mobile radios relative to shared repeaters already in use, the FCC requires that channels be trunked. Trunking in the context of radio systems means not only sharing equipment but sharing frequencies as well. Trunking channels means that when a user wishes to place a call it can be served by any one of the channel pairs that is available.

Although paging is primarily a one-way radio system, two-way operation with such functions as page acknowledgment and short message reply are available. Some types of paging receivers display digits and letters (alphanumeric displays) that allow the calling party's number or a brief message to be displayed, and a message operator becomes unnecessary. Since display of paging messages involves little information, thousands of users can share each paging channel, thus making the service extremely spectrum efficient. Other types of paging receivers provide for brief voice messages following the alert (tone and voice). See RADIO PAGING SYSTEMS.

Cellular technology allows hundreds of thousands of users to be handled in a single metropolitan area. Rather than link into the telephone system from a single high-power, high site that covers the entire metropolitan area, users are linked via many low-power, low sites. A single low site, of course, can cover only a limited area, termed a cell, but many low sites taken together can cover the entire metropolitan area. Spectrum efficiency stems from reusing the same frequency at all sites that are sufficiently separated. To further limit interference caused by frequency reuse, each cell may be divided into sectors and directive antenna patterns may be used.

An attractive feature of cellular radio is the ability to vary the size of the cells in accordance with user density; hence, cell size can increase away from city centers. To sustain the reuse pattern with mixed cell sizes, power levels are tailored to produce comparable signal levels at all cell boundaries. Also, as more customers are added, radio channels can be created to serve them by constructing new base stations (hence, new cells) in geographical locations between existing cells. This concept is called cell splitting. Geographical coverage of the system can be expanded as well by constructing new base stations on the periphery of the existing system and assigning frequencies consistent with the original reuse pattern.

Automatic, continuous coverage as users move across cell boundaries is provided by the call handoff feature of cellular (also termed handover and automatic link transfer). Calls in need of handoff are recognized by monitoring call quality and comparing it to some required threshold. Handoff control procedures for first-generation analog frequency-modulation cellular systems are in operation.

The great demand for cellular phones and related wireless services has been addressed to some extent by the addition of new spectrum, by the introduction of narrow-band and digital cellular systems, and by cell splitting where practical. Acknowledging that these techniques for increasing capacity would quickly be exhausted, most countries allocated additional spectrum for mobile and portable communication. Since these frequency bands have much more spectrum than those previously allocated to cellular service, a greater variety of services are possible.

A spectrum of 120 MHz in the 1850–1910 and 1930–1990 MHz bands was allocated for licensed personal communication system (PCS) operation in the United States, and 20 MHz of spectrum in the 1910–1930 MHz band for unlicensed operation, split evenly between voice (isochronous) and data (asynchronous) applications. The spectrum allocated for licensed PCS

operation is divided into six frequency blocks, three of which contain 30 MHz of spectrum and the other three, 10 MHz. It is thus possible in a given region to have as many as six competing service providers, in addition to the two 900-MHz cellular service providers. See DATA COMMUNICATIONS; TELEPHONE SERVICE.

[G.C.H.; J.R.Hau.]

**Mode of vibration** A characteristic manner in which vibration occurs. In a freely vibrating system, oscillation is restricted to certain characteristic frequencies; these motions are called normal modes of vibration.

An ideal string, for example, can vibrate as a whole with a characteristic frequency  $f = (1/2L)\sqrt{T/m}$ , where  $L$  is the length of string between rigid supports,  $T$  the tension, and  $m$  the mass per unit length of the string. The displacements of different parts of the string are governed by a characteristic shape function. The frequency of the second mode of vibration is twice that of the first mode. Similarly, modes of higher order have frequencies that are integral multiples of the fundamental frequency.

Because the frequencies are in the ratios 1:2:3 . . . , the modes of vibration of an ideal string are properly called harmonics. Not all vibrating bodies have harmonic modes of vibration, however. See HARMONIC (PERIODIC PHENOMENA); VIBRATION. [R.W.Y.]

**Model theory** The body of knowledge that concerns the fundamental nature, function, development, and use of formal models in science and technology. In its most general sense, a model is a proxy. A model is one entity used to represent some other entity for some well-defined purpose. Examples of models include: (1) An idea (mental model), such as the internalized model of a person's relationships with the environment, used to guide behavior. (2) A picture or drawing (iconic model), such as a map used to record geological data, or a solids model used to design a machine component. (3) A verbal or written description (linguistic model), such as the protocol for a biological experiment or the transcript of a medical operation, used to guide and improve procedures. (4) A physical object (scale model, analog model, or prototype), such as a model airfoil used in the wind-tunnel testing of a new aircraft design. (5) A system of equations and logical expressions (mathematical model or computer simulation), such as the mass- and energy-balance equations that predict the end products of a chemical reaction, or a computer program that simulates the flight of a space vehicle. Models are developed and used to help hypothesize, define, explore, understand, simulate, predict, design, or communicate some aspect of the original entity for which the model is a substitute.

Formal models are a mainstay of every scientific and technological discipline. Social and management scientists also make extensive use of models. Indeed, the theory of models and modeling cannot be divorced from broader philosophical issues that concern the origins, nature, methods, and limits of human knowledge (epistemology) and the means of rational inquiry (logic and the scientific method). See LOGIC; SCIENTIFIC METHODS.

Models are usually more accessible to study than the system modeled. Changes in the structure of a model are easier to implement, and changes in the behavior of a model are easier to isolate, understand, and communicate to others. A model can be used to achieve insight when direct experimentation with the actual system is too dangerous, disruptive, or demanding. A model can be used to answer questions about a system that has not yet been observed or built, or even one that cannot be observed or built with present technologies.

Specific models developed in different disciplines may differ in subject, form, and intended use. However, basic concepts such as model description, validation, simplification, and simulation are not unique to any particular discipline. Model theory seeks a formal logical and axiomatic understanding of the underlying concepts that are common to all modeling endeavors.

General and mathematical systems theory have stimulated many of the important developments in model theory.

Mathematical models are particularly useful, because of the large body of mathematical theory and technique that exists for the study of logical expressions and the solution of equations. The power and accessibility of digital computers have increased the use and importance of mathematical models and computer simulation in all branches of modern science and technology. A great variety of programming languages and applications software are now available for modeling, computational analysis, and system simulation. See DIGITAL COMPUTER; SIMULATION; SYSTEMS ANALYSIS; SYSTEMS ENGINEERING. [K.P.W.]

**Modem** A device that converts the digital signals produced by terminals and computers into the analog signals that telephone circuits are designed to carry. Despite the availability of several all-digital transmission networks, the analog telephone network remains the most readily available facility for voice and data transmission. Since terminals and computers transmit data using digital signaling, whereas telephone circuits are designed to transmit analog signals used to convey human speech, a device is required to convert from one to the other in order to transmit data over telephone circuits. The term modem is a contraction of the two main functions of such a unit, modulation and demodulation. The device is also called a data set. See INTEGRATED SERVICES DIGITAL NETWORK (ISDN); MODULATION.

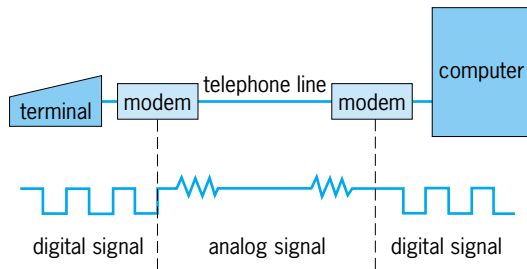

Signal conversion performed by modems. A modem converts a digital signal to an analog tone (modulation) and reconverts the analog tone into its original digital signal (demodulation).

In its most basic form a modem consists of a power supply, transmitter, and receiver. The power supply provides the voltage necessary to operate the modem's circuitry. The transmitter section contains a modulator as well as filtering, wave-shaping, and signal control circuitry that converts digital pulses (often input as a direct-current signal with one level representing a digital one and another level a digital zero) into analog, wave-shaped signals that can be transmitted over a telephone circuit. The receiver section contains a demodulator and associated circuitry that is used to reverse the modulation process by converting the received analog signals back into a series of digital pulses (see illustration). See DATA COMMUNICATIONS; DEMODULATOR; ELECTRIC FILTER; ELECTRICAL COMMUNICATIONS; ELECTRONIC POWER SUPPLY; MODULATOR; WAVE-SHAPING CIRCUITS. [G.He.]

**Modulation** A technique employed in telecommunications transmission systems whereby an electromagnetic signal (the modulating signal) is encoded into one or more of the characteristics of another signal (the carrier signal) to produce a third signal (the modulated signal), whose properties are matched to the characteristics of the medium over which it is to be transmitted. The encoding preserves the original modulating signal in that it can be recovered from the modulated signal at the receiver by the process of demodulation. The main purpose of modulation is to overcome any inherent incompatibilities between the electromagnetic properties of the modulating signal and those of the transmission medium. Of primary importance in this respect is the spectral distribution of power in the modulating signal relative to the passband of the medium. Modulation provides the

means for shifting the power of the modulating signal to a part of the frequency spectrum where the medium's transmission characteristics, such as its attenuation, interference, and noise level, are favorable. See ELECTROMAGNETIC WAVE TRANSMISSION; RADIO-WAVE PROPAGATION.

Two forms of modulation are generally distinguished, although they have many properties in common: If the modulating signal's amplitude varies continuously with time, it is said to be an analog signal and the modulation is referred to as analog. In the case where the modulating signal may vary its amplitude only between a finite number of values and the change may occur only at discrete moments in time, the modulating signal is said to be a digital signal and the modulation is referred to as digital.

In most applications of modulation the carrier signal is a sine wave, which is completely characterized by its amplitude, its frequency, and its phase relative to some point in time. Modulating the carrier then amounts to varying one or more of these parameters in direct proportion to the amplitude of the modulating signal. In analog modulation systems, varying the amplitude, frequency, or phase of the carrier signal results in amplitude modulation (AM), frequency modulation (FM), or phase modulation (PM), respectively. Since the frequency of a sine wave expressed in radians per second equals the derivative of its phase, frequency modulation and phase modulation are sometimes subsumed under the general term "angle modulation" or "exponential modulation." The illustration shows an example of an unmodulated sine-wave carrier signal and the signal resulting from modulating its amplitude, phase, or frequency with the amplitude of an analog modulating signal, which is also taken to be a sine wave.

If the modulating signal is digital, the modulation is termed amplitude-shift keying (ASK), frequency-shift keying (FSK), or phase-shift keying (PSK), since in this case the discrete amplitudes of the digital signal can be said to shift the parameter of the carrier signal between a finite number of values. For a mod-

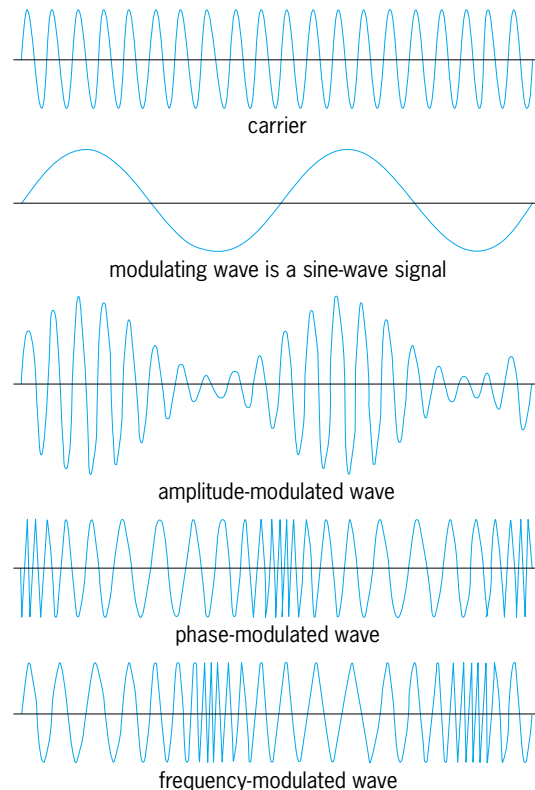

Amplitude, phase, and frequency modulation of a sine-wave carrier by a sine-wave signal. (After H. S. Black, *Modulation Theory*, Van Nostrand, 1953)



ulating signal with only two amplitudes, “binary” is sometimes added before these terms.

Digital modulating signals with more than two amplitudes are sometimes encoded into both the amplitude and phase of the carrier signal. For example, if the amplitude of the modulating signal can vary between four different values, each such value can be encoded as a combination of one of two amplitudes and one of two phases of the carrier signal. Quadrature amplitude modulation (QAM) is an example of such a technique.

In certain applications of modulation the carrier signal, rather than being a sine wave, consists of a sequence of electromagnetic pulses of constant amplitude and time duration, which occur at regular points in time. Changing one or the other of these parameters gives rise to three modulation schemes known as pulse-position modulation (PPM), pulse-duration modulation (PDM), and pulse-amplitude modulation (PAM), in which the time of occurrence of a pulse relative to its nominal occurrence, the time duration of a pulse, or its amplitude are determined by the amplitude of the modulating signal. See PULSE MODULATION. [H.J.He.]

**Modulator** Any device or circuit by means of which a desired signal is impressed upon a higher-frequency periodic wave known as a carrier. The process is called modulation. The modulator may vary the amplitude, frequency, or phase of the carrier. See MODULATION.

There are many ways to accomplish amplitude modulation, but in all cases a nonlinear element or device must be employed. The modulating signal controls the characteristics of the nonlinear device and thereby controls the amplitude of the carrier. See AMPLITUDE MODULATION; AMPLITUDE-MODULATION DETECTOR; AMPLITUDE MODULATOR.

The frequency modulator usually changes the effective capacitance or inductance in the frequency-determining LC circuit of the oscillator. However, other techniques can be used. For example, a multivibrator can be used to generate carrier frequencies up to a few megahertz, and the multivibrator frequency can be modulated by controlling the base, gate, or grid bias supply voltage. See FREQUENCY MODULATION; FREQUENCY-MODULATION RADIO; FREQUENCY MODULATOR. [C.L.A.]

**Mohair** The long, lustrous hair of the Angora goat, which originated in the area around Ankara (Angora), Turkey. Mohair is a smooth, strong, durable, and resilient fiber. It enhances softness and luster in fabrics. Mohair absorbs dye evenly and brilliantly, retains color well, and permits unusual decorative effects. It is mainly used as an apparel fiber but may be used in upholstery, draperies, wigs, hairpieces, and rugs. Leather produced from the skin is useful for gloves, purses, and novelties. See WOOL. [C.E.T.]

**Moho (Mohorovičić discontinuity)** The level in the Earth where the velocity of sonic waves first increases rapidly or discontinuously to a value between 4.7 and 5.3 mi/s (7.6 and 8.6 km/s). A. Mohorovičić discovered this boundary while investigating seismograms of the Zagreb (in former Yugoslavia) earthquake of October 8, 1909. He recognized that low-velocity waves traveling directly from the earthquake source were overtaken at large distances by refracted waves traveling through the deeper, high-velocity layer. Modern determinations of the depth and nature of the Moho are commonly made in seismic refraction studies that use artificial seismic sources, such as explosions, rather than earthquakes. This method allows identification of the wave traveling in the high-velocity medium ( $P_n$ ) and a wide-angle reflection ( $P_nP$ ) from the boundary. The Moho is generally assumed to mark the boundary between the crust and mantle, although this need not always be the case. See EARTH INTERIOR. [D.M.Fo.]

While the definition of Moho in the continents is based solely on seismic refraction observations, the term has been utilized to describe a range of observations pertaining to the oceanic envi-

ronment. In the strictest sense, Moho refers to the depth where material velocities, as determined from seismic refraction methods, exceed 5 mi/s (8 km/s). From geological studies of ocean crust and ophiolites (ancient oceanic sections subsequently emplaced on continents), oceanic crust is understood to originate from partial melting of mantle that upwells and decompresses in response to sea-floor spreading. The eruption and intrusion of this melt, and the formation of Moho, occurs in a very narrow zone at the axis of sea-floor spreading. Different mantle conditions can lead to different volumes of melting, accounting for most of the observed variations in crustal thickness (depth to the Moho). Very slow spreading centers, while rare, are expected to form somewhat thinner crust, largely reflecting the magma-starved nature of these areas. The Moho is a proxy for the transition from crustal materials (for example, basalts, diabase dikes, or gabbros) formed by mafic melts extracted from the mantle to the ultramafic residual mantle (for example, peridotite) that has remained at depth. See BASALT; DOLERITE; GABBRO; OPHIOLITE; PLATE TECTONICS. [C.Z.M.]

**Moiré pattern** When one family of curves is superposed on another family of curves, a new family called the moiré pattern appears.

To produce moiré patterns, the lines of the overlapping figures must cross at an angle of less than about  $45^\circ$ . The moiré lines are then the locus of points of intersection. The illustration shows the case of two identical figures of simple gratings of alternate black and white bars of equal spacing. When the figures are crossed at  $90^\circ$ , a checkerboard pattern with no moiré effect is seen. At crossing angles of less than  $45^\circ$ , however, one sees a moiré pattern of equispaced lines, the moiré fringes. The spacing of the fringes increases with decreasing crossing angle. This provides one with a simple method for measuring extremely small angles (down to 1 second of arc). As the angle of crossing approaches zero, the moiré fringes approach  $90^\circ$  with respect to the original figures.

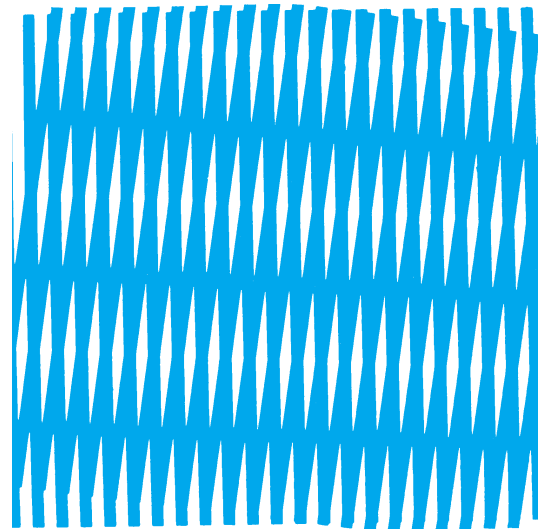

Two simple gratings crossed at a small angle.

Even when the spacings of the original figures are far below the resolution of the eye, the moiré fringes will still be readily seen. This phenomenon provides a means of checking the fidelity of a replica of a diffraction grating. See DIFFRACTION GRATING.

Moiré techniques are widely used in the stress analysis of metals, in the examination of large optical surfaces, in investigating aberrations of lenses, and in determining a refractive index gradient (for example, that of sugar molecules diffusing into water). [G.O.]

**Moisture-content measurement** Measurement of the ratio or percentage of water present in a gas, a liquid, or a solid (granular or powdered) material. Nearly all materials contain free water, the relative amount being dependent upon the physical and chemical properties of the material. The primary purpose of determining and maintaining moisture contents within specified limits can usually be traced to economic factors, trade practices, or legal requirements.

Moisture content has a number of synonymous terms, many of which are specific to certain industries, types of product, or material. The water content in solid, granular, or liquid materials is usually referred to as moisture content on either the wet or dry basis; the wet basis is common to most industries. Specifically, moisture content on the wet basis refers to the quantity of water per unit weight or volume of the wet material. A weight basis is preferred. The textile industry uses the dry basis for moisture content of textile fibers. Often referred to as regain moisture content, the dry basis or regain refers to the quantity of water in a material expressed as a percentage of the weight of the bone-dry (thoroughly dried) material.

The moisture content in air is referred to as humidity, either absolute or relative. Absolute humidity is the number of pounds of water vapor associated with 1 lb (0.5 kg) of dry air, also called just humidity. Relative humidity is the ratio, usually expressed as a percentage, of the partial pressure of water vapor in the actual atmosphere to the vapor pressure of water at the prevailing temperature. Relative humidity is customarily reported by the U.S. Weather Bureau because it essentially describes the degree of saturation of the air. However, air which is saturated (100% RH) at 50°F (10°C) is quite dry (19% RH) when heated to 100°F (38°C). A changing basis of this type is not convenient for many purposes such as computations used in air conditioning, combustion, or chemical processing; therefore absolute units, such as dew point or grains of water per pound of dry air, are more acceptable. Dew point is the temperature at which a given mixture of air and water vapor is saturated with water vapor. See DEW POINT; HUMIDITY.

**Gases.** The measurement of water content in gases and mixtures of air and gases is important in industry. A number of commercially manufactured instruments are available for these measurements; their principles of operation include condensation, used in dew- or fog-point indicators; dimensional change, used by hygrometers; thermodynamic equilibrium, used by wet-bulb psychrometers; and absorption methods, which serve as the basic principle for gravimetric and electric conductivity or dielectric types. See HYGROMETER; PSYCHROMETER; PSYCHROMETRICS.

The importance of humidity in relation to personal comfort is well known. The air conditioning industry produces equipment to maintain comfortable conditions of temperature and humidity. Considerable industrial air conditioning is also done for process reasons. Control of humidity is also important in the preservation of materials, especially those which are hygroscopic, and in the storage of food products.

**Liquids and solids.** The development of instrumentation for the measurement and control of moisture in liquids and solids has been due in a large part to the great need that exists in many processes where the control of a precise moisture is critical. The desirability of a specific moisture content in a product during its preliminary manufacturing process is often required. In general, however, the rigid control of moisture content occurs most frequently in the final product to assure its quality and the fulfillment of legal or trade practices for the individual product.

Instruments suitable for the measurement of moisture content may be classified as periodic and continuous. In general, only those instruments offering continuous measurement are practical for the automatic control of moisture content in a product. The periodic instrument types are generally automated versions of conventional laboratory moisture-analysis procedures.

Moisture measuring instruments may also be classified by operating principle. Those instruments employing electrical conductivity (either dc or ac), absorption of electromagnetic energy (radio-frequency regions), electrical capacitance (dielectric constant change), and infrared energy radiations are more readily adapted to continuous measurements inasmuch as the response of these instruments to moisture changes is very fast. Those instruments employing automatic oven drying, chemical titrations, equilibrium hygrometric methods, distillation methods, and so forth are usually of the intermittent, or periodic, type. [L.E.C.]

**Mole (chemistry)** A unit (symbolized mol) used to measure the amount of material in a chemical sample. The mole is defined by international agreement as the amount of substance (chemical amount) of a chemical system that contains as many molecules or entities as there are atoms in 12 g of carbon-12 (<sup>12</sup>C). When the mole is used, the elementary entities need not be molecules, but they must always be specified. They may be atoms, molecules, ions, electrons, or specified groups of such particles.

Three obvious ways of measuring the amount of material in a given sample are to measure the mass of the sample, to measure the volume, or to count the number of molecules in the sample. Although it is more difficult to devise an experiment to count molecules, this third way of measuring amount is of special interest to chemists because molecules react in simple rational proportions (for example, one molecule of A may react with one, or two, or three molecules of B, and so forth). However, to count molecules is inconvenient in practice because the numbers are so large. For any chemical, a mass of 1 kilogram of the sample contains a large number of molecules, of the order 10<sup>23</sup>–10<sup>24</sup>. The mole is defined so that 1 mole of any substance always contains the same number of molecules. This number approximately 6.02 × 10<sup>23</sup>, and is known as the Avogadro number. The mole is a more convenient unit in which to measure the amount of a chemical than counting the number of molecules, and it has the same advantages. See AVOGADRO NUMBER.

The amount of substance (chemical amount) of a sample,  $n$ , may be determined in practice by one of three methods.

The value of  $n$  (the amount of substance) may be determined from the mass  $m$  by dividing by the molar mass  $M$  of the sample, as in Eq. (1). If  $m$  is expressed in g and  $M$  in g/mol, then the value of  $n$  will be obtained in mol.

$$n = \frac{m}{M} \quad (1)$$

For a gas, the value of  $n$  may be determined from the volume  $V$ , pressure  $p$ , and absolute temperature  $T$  by using the ideal gas equation (2), where  $R$  is the gas constant ( $R = 8.3145 \text{ J K}^{-1}$

$$n = \frac{pV}{RT} \quad (2)$$

mol<sup>-1</sup>). If  $pV$  is expressed in (N m<sup>-2</sup>) × (m<sup>3</sup>) = J, and  $RT$  in J mol<sup>-1</sup>, then  $pV/RT$  gives the value of  $n$  in mol.

For a solution, the amount of solute (or the amount concentration of solution) is frequently determined by titration: if  $\nu_A$  molecules of A react with  $\nu_B$  molecules of B in the titration, then at the end point the amount of A used ( $n_A$ ) is related to the amount of B ( $n_B$ ) by Eq. (3), so that if one is known the other may be determined.

$$n_A = \frac{\nu_A}{\nu_B} n_B \quad (3)$$

See TITRATION.

The concentration of a solution may be recorded as (mass of solute)/(volume of solution), in units gram/liter; or as (chemical amount of solute)/(volume of solution) in units mol/liter. Because of the proportionality of chemical amount to number of molecules, the latter is the more useful measure of concentration and is generally used in chemistry and biochemistry. See CONCENTRATION SCALES. [I.M.M.]

**Mole (zoology)** A mammal belonging to the family Talpidae. There are 19 species distributed on all continents except Australia. Moles are insectivores, feeding mainly on earthworms and insect larvae, and are highly specialized for their burrowing habits.

The body is stout and cylindrical and with a short neck (see illustration). The eyes and external ears are small or vestigial, and the conical head terminates in a long naked muzzle. The forelimbs are especially adapted for digging, having very powerful muscles and a spadelike bony structure. Mating occurs in the spring; after a gestation period of 30–40 days a litter of 3–7 young are born.



The European mole, *Talpa europaea*.

Moles are solitary animals and rarely come aboveground. Molehills are seen where temporary burrows are made, but permanent runs are made by compressing the earth so there are no molehills to betray their presence. Each mole lives in its own fortress constructed as a central chamber around which are two circular passages, one at a higher and the other at a lower level, connected by short passages. The upper passage connects with the central chamber and the lower one leads to the main exit. There is also an emergency exit leading to the main exit from below the central chamber. See INSECTIVORA; MAMMALIA. [C.B.C.]

**Molecular adhesion** The tendency of dissimilar solids or liquids to cling together as a result of the interatomic forces which they exert upon each other across their common interface. Some factors affecting molecular adhesion are the physical state of the materials, the composition and the topology of the surfaces in contact, the temperature, and the presence of foreign materials such as adsorbed gases on one or both surfaces.

Mutual forces of attraction, electrical in origin, exist between virtually all atoms and molecules. It is these forces which, under proper conditions of temperature and pressure, compel isolated atoms or molecules to condense into solids and liquids. On average, these forces are approximately equally strong in all directions and result in an atom or molecule achieving its lowest possible energy, that which is thermodynamically favored, when it is surrounded on all sides by other atoms. The presence of a real surface breaks the three-dimensional continuity of the substance, leaving atoms at the surface with an unfulfilled capacity for bonding. It is this capacity for bonding that is responsible for the phenomena of surface tension, adsorption of gases, and adhesion. See ADSORPTION; COHESION (PHYSICS); INTERMOLECULAR FORCES; SURFACE TENSION.

Molecular adhesion plays an especially significant role in the deposition of thin films on substrates of dissimilar composition. A particularly important example is the use of such films to form conducting paths—microscopic wires only a few tens of nanometers thick—in integrated circuits. These films must both adhere well to the underlying substrate and produce contacts with appropriate electrical properties. At present the understanding of adhesion is not sufficiently detailed to be able to predict such properties in advance of experiments. See INTEGRATED CIRCUITS; SPUTTERING. [R.A.We.]

**Molecular anthropology** The study of primate phylogeny and human evolution through the genetic information in the deoxyribonucleic acid (DNA) of genomes and in the pro-

teins that genes encode. The first studies in molecular anthropology used immunological and biochemical methods to obtain information from proteins on the degrees of genetic similarity of humans and other primates. These results not only placed chimpanzees and gorillas closest to humans rather than to orangutans but also indicated that the very close kinship between chimpanzees and gorillas was not any closer than the relation of each to humans. Subsequent studies that extracted genetic information directly from DNA extended this original finding. Indeed, the accumulating comparative DNA sequence data provide mounting evidence that the closest genetic kinship is between chimpanzees and humans rather than chimpanzees and gorillas.

The results gathered in DNA studies of primate phylogeny challenge the traditional anthropological view that humans are very different from all other animals. DNA results show that, genetically, humans are only slightly remodeled apes. Humans share with their closest relatives, the chimpanzees and bonobos (pygmy chimpanzees), more than 98.3% identity in typical noncoding DNA and probably about 99.5% identity in the active coding sequences of functional nuclear genes. Humans share about 98.0% identity in nuclear genomic DNA with gorillas, 96.5% identity with orangutans, and 95.0% identity with the most distant ape relatives, the gibbons and siamangs. Apes and humans share with the other branch of catarrhines, the Old World monkeys, about 92% identity in nuclear genomic DNA, and with the platyrrhines, the New World monkeys, about 87% identity. Even with nonanthropoid primates, the tarsiers and strepsirhines (lemurs and loriforms, such as bushbabies), the anthropoids (platyrrhines and catarrhines) share a DNA identity in the range of 76–71%. See DEOXYRIBONUCLEIC ACID (DNA).

Traditional primate classifications use the vague concept of grades of evolutionary advancement to place the smaller-brained primates in the suborder Prosimii (the primitive grade) and the larger-brained primates in the suborder Anthropoidea (the advanced grade). Moreover, on viewing humans as the most advanced primates, traditional primate classifications have humans as the sole living members of family Hominidae, while the great apes of Africa (chimpanzees, bonobos, gorillas) and Asia (orangutans) are members of subfamily Ponginae of family Pongidae. In contrast, a strictly objective view based on molecular evidence, but also congruent morphological evidence from both living and fossil primates, not only places apes with humans within the family Hominidae but also within this family places chimpanzees and bonobos with humans in the genus *Homo*. See APES; FOSSIL APES; FOSSIL HUMANS; FOSSIL PRIMATES; MAMMALIA.

After the divergence of *Homo* (*Homo*) from *Homo* (*Pan paniscus* (bonobos, or pygmy chimpanzees), humankind's emergence was marked by mutations (such as DNA sequence changes) that spread to fixation in the ancestors of all modern humans. These mutations are the human-specific factors which distinguish the human species genetically from all other species. Ongoing evolution involves mutations that have not spread to fixation, either because they occurred too recently or because natural selection has maintained a polymorphic state. These mutations occur at frequencies that occasionally differ from one human group to another. They account for the genetic diversity found in the human species. Extensive comparative data now exist on the genetic diversity due to mitochondrial genetic variants (which arise from mutations in the DNA carried by mitochondria). The species-wide distribution of mitochondrial haplotypes in present-day human populations compared to the distribution in chimpanzees reveals that humans show less DNA diversity than chimpanzees. Human populations in different ethnic groups (European Norwegians and South African hottentots) and even within the same group share 85–90% of the total species diversity. The human genetic diversity due to mutations in nuclear DNA (the DNA carried by the chromosomes of cells) also shows this same pattern in which most of the variation within the human species as a whole is contained within single populations. These findings argue that all living humans are biologically not

only members of the same species but also the same subspecies and even the same race, the human race. A further inference from the data on mitochondrial genetic diversity is that the birth of the human race took place in Africa about 200,000 years ago. See MITOCHONDRIA. [M.Goo.]

**Molecular beams** Well-directed streams of atoms or molecules in vacuum. Utilization of molecular beams is a cornerstone technique in the investigation of molecular structure and interactions. Molecular beams are usually formed at sufficiently low particle density for the interaction of one beam molecule with another to be negligible. This ensemble of truly isolated molecules is available for the spectroscopic study of molecular energy levels using photon probes from the radio-frequency to optical portions of the electromagnetic spectrum. Some of the best-determined fundamental knowledge of physics comes from spectroscopic molecular-beam experiments. Beyond this, beams can be applied as probes of the multifaceted nature of gases, plasmas, surfaces, and even the structure of solids. An application intermediate in complexity is the study of molecular interactions by means of two colliding beams, where one might be a beam of charged particles such as ions or electrons. See SCATTERING EXPERIMENTS (ATOMS AND MOLECULES).

One simple means of forming a beam is to permit gas from an enclosed chamber to escape through a small orifice into a second chamber maintained at high vacuum by means of large pumps (illus. a). A useful number of molecules passes forward along the horizontal axis of the apparatus. A well-collimated beam is then formed by requiring that those molecules entering the test chamber where an experiment is to be performed pass not only through the orifice but also through a second small hole separating the collimating and test chambers.

If higher velocities are desired, a charge-exchange beam system can be used. In this scheme (illus. b), ions are produced by some ionizing process such as electron impact on atoms within a gas discharge. Since the ions are electrically charged, they can be accelerated to the desired velocity and focused into a beam using electric or magnetic fields. The last step in neutrally charged beam formation is to pass the ions through a neutralizing gas where electrons from the gas molecules are transferred to the beam ions in charge-exchange molecular collisions. See ION SOURCES.

Much of molecular spectroscopy involves the absorption or emission of light by molecules in a gas sample. The frequency of the light photon is proportional to the separation of molecular energy levels involved in the spectroscopic transition. However, the molecule density in typical gas samples is so high that the energy levels are slightly altered by collisions between molecules, with the transition frequency no longer characteristic of the free molecule. The use of low-density molecular beams with their sensitive detection techniques can reduce this collision alteration problem, with the result that atomic properties can be measured to accuracies of parts per million or even better. If the very simplest atoms or molecules are employed, the basic electromagnetic interactions holding the component electrons and nuclei together can be precisely studied. This is of great importance to fundamental physics, since theoretical understanding of electromagnetic interactions through quantum electrodynamics represents the most successful application of quantum field theory to elementary particle physics problems. See QUANTUM ELECTRODYNAMICS; QUANTUM FIELD THEORY.

The development of tunable, strong laser sources of single-frequency light beams has added another dimension to molecular-beam experiments. With laser radiation resonantly tuned to excite a molecule from its normal ground state to one of its infinite number of vibrationally, rotationally, and electronically excited states, the number of possible studies and applications of excited molecular beams becomes enormous. See LASER SPECTROSCOPY; MOLECULAR STRUCTURE AND SPECTRA; NUCLEAR STRUCTURE. [J.E.B.]

**Molecular biology** The study of structural and functional properties of biological systems, pursued within the context of understanding the roles of the various molecules in living cells and the relationship between them. Molecular biology has its roots in biophysics, genetics, and biochemistry. A prime focus of the field has been the molecular basis of genetics, and with the demonstration in the mid-1940s that deoxyribonucleic acid (DNA) is the genetic material, emphasis has been on structure, organization, and regulation of genes. Initially, molecular biologists restricted their studies to bacterial and viral systems, largely because of their genetic and biochemical simplicity. *Escherichia coli* has been extensively examined because of its limited number of cellular functions and the corresponding restricted amount of genetic information encoded in the bacterial chromosome. Simple eukaryotic cells, such as protozoa and yeast, offer similar advantages and also have been studied. For these same reasons, bacteriophage and animal viruses have provided molecular biologists with the ability to study the structural and functional properties of molecules in intact cells. However, a series of conceptual and technological developments occurred rapidly during the late 1970s that permitted molecular biologists to approach a broad spectrum of plant and animal cells with experimental techniques. One of the major factors has been the development and applications of genetic engineering. Recombinant DNA technology allowed the isolation and selective modification of specific genes, thereby reducing both their structural and functional complexity and facilitating the study of gene expression in higher cells. The concepts and techniques used by molecular biologists have been rapidly and effectively employed to resolve numerous cellular, biological, and biochemical problems—becoming routine at both the basic and applied levels.

The recognition of DNA as the genetic material coupled with the discovery that genes reside in chromosomes resulted in an intensive effort to map genes to specific chromosomes. Initially genes were assigned to chromosomes on the basis of correlations between modifications in cellular function, particularly biochemical defects, and the addition, loss, or modification of specific chromosomes. See CHROMOSOME ABERRATION; MUTATION.

A major breakthrough was the development of somatic cell genetics. This is an approach in which, for example, human and hamster cells are fused, resulting in a hybrid cell initially

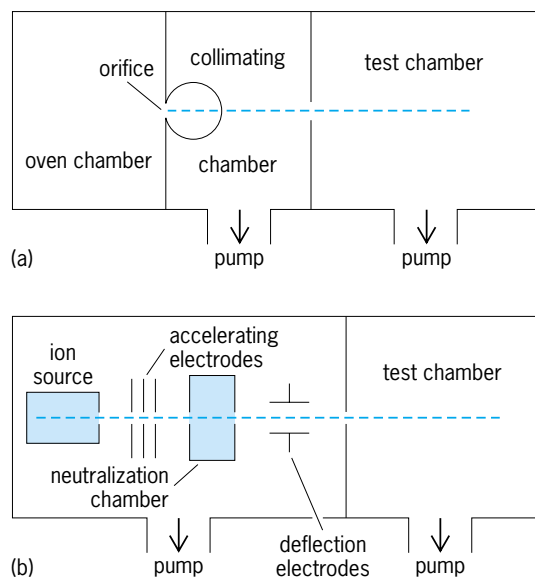

**Schematic diagrams of systems for producing molecular beams. (a) Conventional oven-beam system. (b) Charge-exchange beam system.**

containing the complement of human and hamster chromosomes. As the cells grow and divide in culture, the hamster chromosomes are retained while there is a progressive loss of human chromosomes. By correlating the loss of human biological or biochemical traits with the loss of specific human chromosomes, a number of human genes have been successfully mapped. *See* SOMATIC CELL GENETICS.

The development of methods for isolating genes and for determining the genetic sequences of the DNA in which the genes are encoded, led to rapid advances in gene mapping at several levels of resolution. Localization of specific genes to chromosomes is routinely carried out with cloned genes as probes. Further information about the segment of a chromosome in which a specific gene resides can be obtained by directly determining the DNA sequences of both the gene itself and the surrounding region.

Chromosome localization of specific genes has numerous applications at both the basic and clinical levels. At the basic level, knowledge of the positions of various genes provides insight into potentially functional relationships. At the clinical level, chromosome aberrations are now routinely used in prenatal diagnosis of an extensive series of human genetic disorders, and several chromosomal modifications have been linked to specific types of cancer. Knowledge of genetic defects at the molecular level has permitted the development of diagnostic procedures that in some instances, such as sickle cell anemia, are based on a single nucleotide change in the DNA.

**Recombinant DNA.** Recombinant DNA technology has provided molecular biology with an extremely powerful tool. In broad terms, applications of recombinant DNA technology can be divided into four areas—biomedical, basic biological, agricultural, and industrial. Biomedical applications include the elucidation of the cellular and molecular bases of a broad spectrum of diseases, as well as both diagnostic and therapeutic applications in clinical medicine.

In a strictly formal sense, the term recombinant DNA designates the joining or recombination of DNA segments. However, in practice, recombinant DNA has been applied to a series of molecular manipulations whereby segments of DNA are rearranged, added, deleted, or introduced into the genomes of other cells.

The ability to manipulate or “engineer” genetic sequences is based on several developments.

1. *Methods for breaking and rejoining DNA.* The precise breaking and rejoining of DNA has been made possible by the discovery of restriction endonucleases, enzymes that have the ability to recognize specific DNA sequences and to cleave the double helix precisely at these sites. Also important are the ability to join fragments of DNA together with the enzyme DNA ligase, and the techniques to determine the nucleotide sequence of genes and thereby confirm the identity and location of structural and regulatory sequences.

2. *Carriers for genetic sequences.* Bacterial plasmids, that is, circular double-stranded DNA molecules that replicate extrachromosomally, have been modified so that they can serve as efficient carriers for segments of DNA, complete genes, regions of genes, or sequences contained within several different genes. Bacteriophage and animal viruses, retroviruses, and bovine papilloma virus have also been successfully utilized as DNA carriers. These carriers are referred to as cloning vectors. Host cells in which vectors containing cloned genes can replicate range from bacteria to numerous other cells, including normal, transformed, and malignant human cells.

3. *Introduction of recombinant DNA molecules.* Genetic sequences in the form of isolated DNA fragments, or chromosomes, or of DNA molecules cloned in plasmid vectors can be introduced into host cells by a procedure referred to as transfection or DNA-mediated gene transfer—a technique that renders the cell membrane permeable by a brief treatment with calcium phosphate, thereby facilitating DNA uptake. Genes cloned in viruses can also be introduced by infection of host cells.

4. *Selection of cells containing cloned sequences.* Bacterial cells containing plasmids with cloned genes can be detected by selective resistance or sensitivity to antibiotics. In addition, the presence of introduced genes in bacterial, plant, or animal cells can be assayed by a procedure known as nucleic acid hybridization.

5. *Amplification.* Amplification of genetic sequences cloned in bacterial plasmids is efficiently achieved by treatment of host cells with antibiotics which suppress replication of the bacterial chromosome, yet do not interfere with replication of the plasmid with its cloned gene. Sequences cloned in bacterial or animal viruses are often amplified by virtue of the ability of the virus to replicate preferentially. *See* GENE AMPLIFICATION.

6. *Expression.* Expression of cloned human genes can be mediated by regulatory sequences derived from the natural gene, from exogenous genes, or by host cell sequences.

Two clinically important genes, human insulin and human growth hormone, have been cloned and introduced into bacteria under conditions where biologically active hormones can be produced.

Progress has been made in applications of recombinant DNA technology to the resolution of agricultural problems, especially for the improvement of both crops and livestock. *See* ADENOPHYSIS HORMONE; BREEDING (ANIMAL); BREEDING (PLANT); GENETIC ENGINEERING; INSULIN.

**Biophysical analysis.** Understanding of the structural properties of molecules and the interaction between molecules that constitute biologically important complexes has been facilitated by biophysical analysis. For example, developments in the resolution offered by techniques such as electron microscopy, x-ray diffraction, and neutron scattering have provided valuable insight into the structure of chromatin, the protein-DNA complex which constitutes the genome of eukaryotic cells. These techniques have also provided clues about modifications in chromatin structure that accompany functional changes. One possible application of biophysical analysis is the diagnosis of human disorders by adaptation of nuclear magnetic resonance for tissue and whole body evaluation of soft tissue tumors, blood flow, and cardiac function. *See* ELECTRON MICROSCOPE; NUCLEAR MAGNETIC RESONANCE (NMR); X-RAY DIFFRACTION.

**Flow of molecular information.** Information for all cellular activities is encoded in DNA; selective elaboration of this information is prerequisite to meeting both structural and biochemical requirements of the cell. In this regard, there are three major areas of investigations by molecular biologists: (1) the composition, structure, and organization of chromatin, the protein-DNA molecular complex in which genetic information is encoded and packaged; (2) the molecular events associated with the expression of genetically encoded information so that specific cellular biochemical requirements can be met; and (3) the molecular signals that trigger the expression of specific genes and the types of communication and feedback operative to monitor and mediate gene control. *See* CHROMOSOME; DEOXYRIBONUCLEIC ACID (DNA); GENE; GENETIC CODE; NUCLEIC ACID. [G.S.S.; J.L.St.]

**Molecular cloud** A large and relatively dense cloud of cold gas and dust in interstellar space from which new stars are born. Molecular clouds consist primarily of molecular hydrogen (H<sub>2</sub>) gas, with temperatures in the range 10–100 K. Molecular hydrogen is not directly observable under most conditions in molecular clouds. Therefore, almost all current knowledge about the properties of molecular clouds has been deduced from observations of trace constituents, mostly simple molecules such as carbon monoxide (CO), which have strong emission lines in the centimeter-, millimeter-, and submillimeter-wavelength portions of the electromagnetic spectrum. The majority of clouds lie in a broad Molecular Ring encircling the galactic center with an inner radius of about 3 kiloparsecs and an ill-defined outer radius extending to beyond 20 kpc. *See* RADIO ASTRONOMY.

Molecular clouds are the principal sites of ongoing star formation. Therefore, they tend to be associated with young stars and star-forming regions. The nearest star-forming clouds are found in the constellations Ophiuchus, Taurus, and Perseus, at distances of 125, 140, and 300 parsecs ( $1 \text{ parsec} = 3 \times 10^{13} \text{ km}$  or  $2 \times 10^{13} \text{ mi}$ ), where the nearest regions of active low- and intermediate-mass star formation are found. These cloud complexes have masses ranging from several thousand to perhaps over 10,000 times the mass of the Sun. However, most of the molecular gas in the Milky Way Galaxy is concentrated into giant clouds with masses more than 100,000 times the mass of the Sun. The nearest giant molecular clouds are located at a distance of 460 parsecs toward the constellation Orion where, over the last  $10^7$  years, they gave birth to tens of thousands of stars, including several dozen relatively rare high-mass stars. See ORION NEBULA; PROTOSTAR.

Most molecular clouds have temperatures of only 10 K. Molecular clouds are orders of magnitude more dense than the general interstellar medium, with gas densities ranging from about 10 molecules per cubic centimeter on large scales to over  $10^6$  molecules per cubic centimeter in cloud cores. The sizes of individual clouds range from less than 0.1 parsec for small clouds and dense cores to over 100 parsecs for giant molecular clouds. In addition to star-forming molecular clouds concentrated toward the plane of the Milky Way, there are many smaller and lower-density molecular clouds visible most clearly far away from the galactic plane, with the closest ones only about 50 parsecs from the Sun.

Molecular clouds have a very complex internal structure consisting of clumps and filaments of dense gas surrounded by interclump gas of much lower density. Individual clumps usually have supersonic internal motions with a velocity of several kilometers per second. The powerful outflows produced by young stars during the first 100,000 years of their existence may be a major source of these chaotic motions. Magnetic fields which thread molecular clouds may play a role in the longevity of turbulent motions and may support clouds against gravitational collapse.

About 100 different chemical species have been so far identified within molecular clouds, indicating that there is a rich chemistry taking place. See INTERSTELLAR EXTINCTION. [J.Ba.]

**Molecular isomerism** The property of compounds (isomers) which have the same molecular formula but different physical and chemical properties. The difference in properties is caused by a difference in molecular structure (that is, molecular architecture). A typical example is dimethyl ether,  $\text{CH}_3\text{OCH}_3$ , a chemically quite inert gas which condenses at  $-24^\circ\text{C}$ , and ethyl alcohol,  $\text{CH}_3\text{CH}_2\text{OH}$ , a liquid of substantial chemical reactivity which boils at  $78^\circ\text{C}$ ; both compounds have the molecular formula  $\text{C}_2\text{H}_6\text{O}$ .

Isomers may be classified as constitutional isomers or stereoisomers. Constitutional isomers differ in constitution or connectedness, relating to the question as to which atoms are linked to which others and how. Dimethyl ether and ethanol (Fig. 1) are constitutional isomers. In dimethyl ether each carbon is connected to three hydrogen atoms and the one oxygen atom; the two carbon atoms are thus equivalent. In ethyl alcohol (ethanol) one carbon is linked to three hydrogen atoms and the other carbon; the second carbon is linked to the first carbon, two hydrogens, and the oxygen atom which, in turn, is linked to the sixth hydrogen atom; the two carbon atoms are not equivalent. Stereoisomers, in contrast, have the same constitution but differ in the three-dimensional array of the atoms in space, called configuration.

**Constitutional isomers.** Constitutional isomers have been subdivided into functional isomers, positional isomers, and chain isomers.

Functional isomers (Fig. 1) differ in functional group, that is, the group (or groups) most material in determining chemical behavior. In the third example shown in Fig. 1 (propionaldehyde)

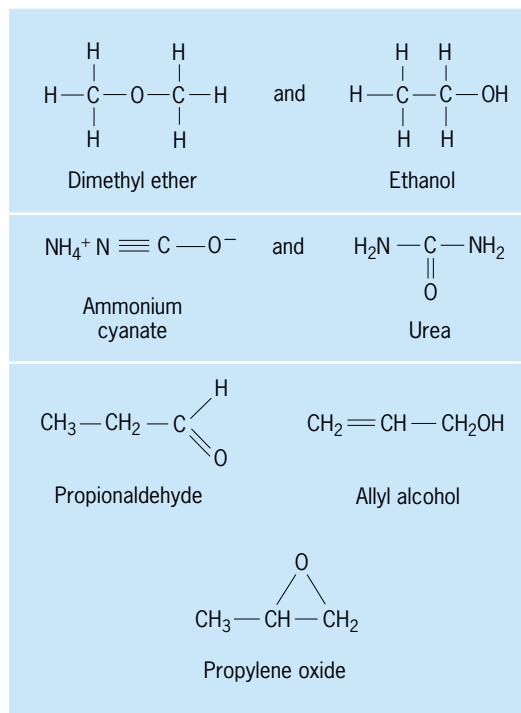

Fig. 1. Functional isomers.

the three compounds all correspond to the molecular formula  $\text{C}_3\text{H}_6\text{O}$ , but the first one has an aldehyde function, the second combines a double bond with an alcohol function, and the third one has an epoxide function.

Positional isomers (Fig. 2) have the same functional group but differ in its position along a chain or in a ring. Closely related are chain isomers which also have the same functional group or groups but differ in the shape of the carbon chain (Fig. 3a); quite

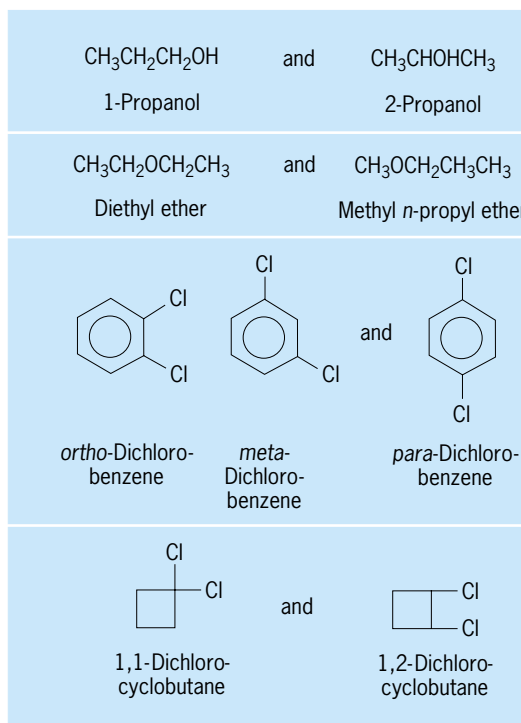

Fig. 2. Positional isomers.

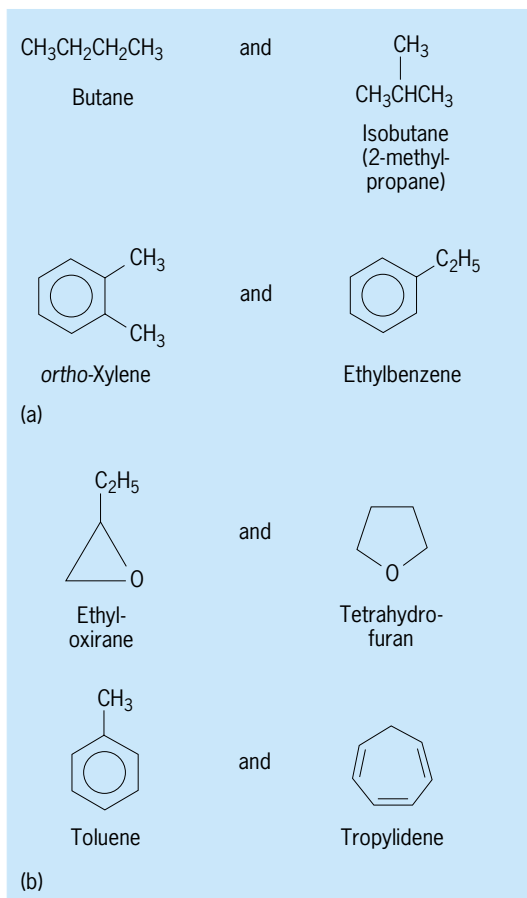

Fig. 3. Skeletal isomers. (a) Chain. (b) Ring.

similar are ring isomers (Fig. 3b) which differ in the size of one or more rings. Ring and chain isomers together are sometimes called skeletal isomers.

**Stereoisomers.** Compounds which have not only the same molecular formula but also the same constitution (connectivity of atoms) but which differ in the disposition of the atoms in space are called Stereoisomers. Stereoisomers, in turn, are subdivided into two types: those that are mirror images of each other, called enantiomers, and those which are not mirror images, called diastereomers or diastereoisomers.

Enantiomers are unique in that they always come in pairs. Either a molecule is superposable with its mirror image, in which case it does not have an enantiomer, or it is not superposable with its mirror image, in which case it has one and only one enantiomer (since an object can have only one mirror image). Molecules which are not superposable with their mirror images are called chiral; those which are so superposable are called achiral. Enantiomers are much more alike than are other sets of isomers (constitutional isomers or diastereomers); thus they have the same melting point, boiling point, free energy, spectral properties, x-ray diffraction pattern, and so on.

Diastereomers have the same constitution but different spatial arrangement and are not mirror images. They resemble constitutional isomers in that there may be more than two isomers in a set and that their physical, energetic, and spectral properties are generally quite distinct. See CONFORMATIONS; ANALYSIS; STEREOCHEMISTRY; TAUTOMERISM. [E.L.E.]

**Molecular machine** A molecular device is an assemblage of a discrete number of molecular components (that is, a supramolecular structure) designed to achieve a specific function. Each molecular component performs a single act, while the

entire supramolecular structure performs a more complex function, which results from the cooperation of the various molecular components. Molecular devices operate via electronic or nuclear rearrangements. Like any device, they need energy to operate and signals to communicate with the operator. The extension of the concept of a device, so common on a macromolecular level, to the molecular level is of interest not only for basic research but also for the growth of nanoscience and nanotechnology. See NANOTECHNOLOGY; SUPRAMOLECULAR CHEMISTRY.

A molecular machine is a particular type of molecular device in which the component parts can display changes in their relative positions as a result of some external stimulus. Such molecular motions usually result in changes of some chemical or physical property of the supramolecular system, resulting in a "readout" signal that can be used to monitor the operation of the machine. The reversibility of the movement, that is, the possibility to restore the initial situation by means of an opposite stimulus, is an essential feature of a molecular machine. Although there are a number of chemical compounds whose structure or shape can be modified by an external stimulus (for example, photoinduced cis-trans isomerization processes), the term "molecular machines" is used only for systems showing large-amplitude movements of molecular components.

The human body can be viewed as a very complex ensemble of molecular-level machines that power motions, repair damage, and orchestrate an inner world of sense, emotion, and thought. Among the most studied natural molecular machines are those based on proteins such as myosin and kinesin, whose motions are driven by adenosine triphosphate (ATP) hydrolysis. One of the most interesting molecular machines of the human body is ATP synthase, a molecular-level rotatory motor. In this machine, a proton flow through a membrane spins a wheel-like molecular structure and the attached rod-like species. This changes the structure of catalytic sites, allowing uptake of adenosine diphosphate (ADP) and inorganic phosphate, their reaction to give ATP, and then the release of the synthesized ATP. See ADENOSINE TRIPHOSPHATE (ATP).

An artificial molecular machine performs mechanical movements analogous to those observed in artificial macroscopic machines (for example, tweezers, piston/cylinder, and rotating rings). Analogously to what happens for macroscopic machines, the energy to make molecular machines work (that is, the stimulus causing the motion of the molecular components of the supramolecular structure) can be supplied as light, electrical energy, or chemical energy. In most cases, the machine-like movement involves two different, well-defined and stable states, and is accompanied by on/off switching of some chemical or physical signal [absorption and emission spectra, nuclear magnetic resonance (NMR), redox potential, or hydronium ion (H<sub>3</sub>O<sup>+</sup>) concentration]. For this reason, molecular machines can also be regarded as bistable devices for information processing (Fig. 1). See ACID AND BASE.

The interest in molecular machines arises not only from their mechanical movements but also from their switching aspects. Computers are based on sets of components constructed by the top-down approach. This approach, however, is now close to its intrinsic limitations. A necessary condition for further miniaturization to increase the power of information processing and computation is the bottom-up construction of molecular-level components capable of performing the functions needed (chemical computer). The molecular machines described above operate according to a binary logic and therefore can be used for switching processes at the molecular level. It has already been shown that suitable designed machine-like systems can be employed to perform complex functions such as multipole switching, plug/socket connection of molecular wires, and XOR logic operation. See LOGIC. [V.B.]

**Molecular mechanics** A non-quantum-mechanical way of computing structures, energies, and some properties

of molecules. While quantum mechanics treats electrons explicitly, molecular mechanics treats electrons implicitly. For this reason, molecular mechanics calculations are much faster than quantum calculations, and this method is heavily used by scientists who need to quickly determine shapes of molecules. The goal of molecular mechanics is to build a computer model of reality. This is done with potential energy functions. Parameters are then selected for those potential functions so that molecules whose structures, energies, and properties are known can be reproduced with a specified degree of precision. Once that has been accomplished, the molecular mechanics model may be used to compute structures, energies, and properties of unknown molecules. See ENERGY.

Molecular mechanics considers molecules as a collection of atomic masses held together by “sticky” forces. These forces represent the electrons holding the atoms together to form molecules. A simple conception is to consider the atoms as balls connected by springs. In this model, as in all real molecules, the atoms migrate toward their lowest-energy, most stable positions. Anything that moves the atoms from their equilibrium positions increases the internal energy of the molecule. This energy, like that of a mechanical spring model, is the potential energy. If one of the bonds were elongated (or compressed) by pulling (or pushing) it from its resting length, the potential energy would increase, and a restoring force would return it to equilibrium position. The magnitude of this restoring force depends on the strength of the spring connecting the masses. This, in turn, is proportional to the strength of the bond connecting the atoms.

Molecular mechanics has several limitations. Most important, it is necessary to have access to a dataset of known, related molecules to use for parametrization. Thus the discovery of completely new molecular species with this computational method is not possible. Also, molecular mechanics cannot account for bond making or bond breaking (the essence of chemical reactions) because of the way it implicitly treats electrons. Finally, the motionless structure computed is not very realistic, so many scientists implement molecular dynamics to achieve better model molecules. See COMPUTATIONAL CHEMISTRY. [K.B.L.]

**Molecular orbital theory** A quantum-mechanical model concerned with the description of the discrete energy levels associated with electrons in molecules. One useful way to generate such levels is to assume that the molecular orbital wave function ( $\psi_j$ ) may be written as a simple weighted sum of the constituent atomic orbitals ( $\chi_i$ ) [Eq. (1)]; this is called

$$\psi_j = \sum c_{ij} \chi_i \quad (1)$$

the linear combination of atomic orbitals approximation. The  $c_{ij}$  coefficients may be determined numerically by substitution of Eq. (1) into the Schrödinger equation and application of the variational theorem. The theorem states that an approximate wave function will always be an upper bound to the true energy; thus minimization of the energy of the system given by the wave function of Eq. (1) will provide the best values of  $c_{ij}$ . Once the wave function is known, its associated energy may be calculated. The energies of the occupied orbitals in molecules may be probed by using photoelectron spectroscopy, which gives a good check on the accuracy of the theory. There are some simple concepts that contribute to a qualitative understanding of these molecular orbital energy levels and hence an insight into chemical bonding in molecules. They may be illustrated with reference to the hydrogen molecule. See CHEMICAL BONDING; ELECTRON SPECTROSCOPY; QUANTUM MECHANICS; SCHRÖDINGER'S WAVE EQUATION.

First, the basis orbitals ( $\chi_i$ ) used in the expansion of Eq. (1) can usefully be restricted to include the valence orbitals only. For molecular hydrogen ( $H_2$ ) the 1s orbitals on the two hydrogen atoms are then the only two orbitals to be included. Second, since hydrogen atoms are chemically identical, any observable characteristic whose value might be computed with Eq. (1) must be the same for both atoms. This leads to the requirement that

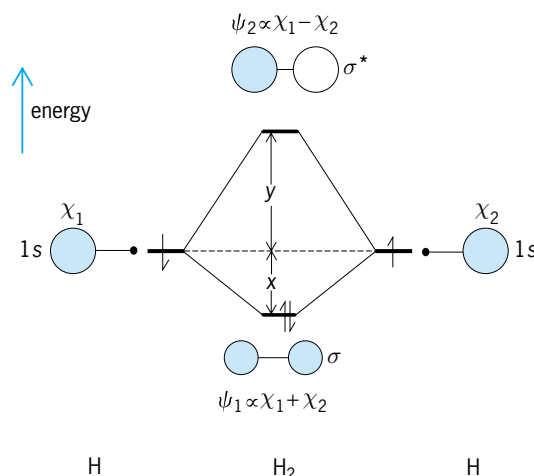

Fig. 1. Molecular orbital diagram of  $H_2$ .

$c_{1j}^2 = c_{2j}^2$ , where the labels 1,2 refer to hydrogen atoms 1 and 2. As a consequence  $c_{1j} = \pm c_{2j}$ .

When the signs of the two coefficients are the same, the two hydrogen orbitals are mixed in phase; when they are different, the two hydrogen orbitals are mixed out of phase. When the atomic orbitals are mixed in phase, electron density is built up between the two hydrogen nuclei and the potential energy of the nuclei and electrons is lowered. In fact, a reduction of kinetic energy also occurs. An electron lying in the molecular orbital is then of lower energy than an electron associated with an isolated hydrogen 1s orbital. It is called a bonding orbital. The increase in electron density between the two nuclei is the electronic “glue” holding the nuclei together. When the atomic orbitals are mixed out of phase, the opposite behavior occurs. Electron density is removed from the region between the two nuclei, resulting in an increase of both potential and kinetic energy of the electrons. An electron lying in such a molecular orbital would experience an energetic destabilization relative to an electron associated with an isolated hydrogen 1s orbital.

Such a molecular orbital is called an antibonding orbital. Figure 1 shows this information as a molecular orbital diagram. The shading convention of the orbitals has been adopted to indicate the in-phase and out-of-phase mixing of the basis orbitals. Just as the energy levels of atoms are filled in an Aufbau process, so the orbitals of the molecule may be analogously filled up with electrons, each level accommodating two electrons of opposite spin. In  $H_2$  there are two electrons to be accounted for. They lie in the bonding orbital, and the stabilization energy relative to two isolated hydrogen atoms (the bond energy) is  $2x$ . Antibonding orbitals are invariably destabilized more than their bonding counterparts are stabilized. This is shown in Fig. 1 by making  $y > x$ . With four electrons to be accommodated in this collection of orbitals (this would correspond to the hypothetical case of the  $He_2$  molecule), one electron pair resides in the bonding orbital and one pair in the antibonding orbital. Since  $y > x$ , this molecule is less stable relative to two isolated helium atoms, and as a result the molecule does not exist as a stable entity.  $He_2^+$ , however, with only three electrons is known.

The size of the interaction energy associated with two atomic orbitals ( $x$  in Fig. 1) is controlled by the extent of their spatial overlap. This overlap integral clearly depends upon the internuclear separation. The equilibrium bond length in the hydrogen molecule (and indeed in all molecules) is then a balance between the attractive forces associated with bonding orbital formation and the electrostatic repulsion between the nuclei. Such a molecular parameter is amenable to numerical calculation.

The description of the bonding in the  $H_2$  molecule using this model is one where two electrons occupy a bonding orbital and



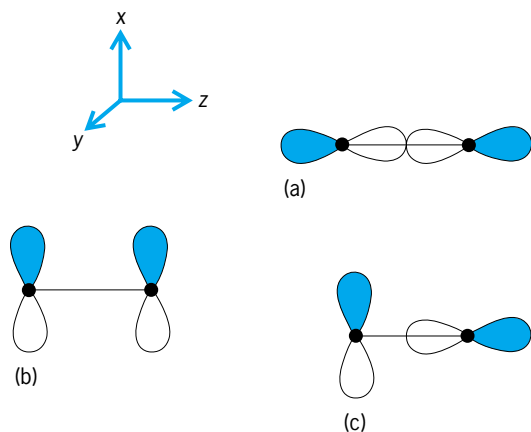

Fig. 2. Possible orientations of the  $p$  orbitals on adjacent atomic centers. (a) End-on overlap. (b) Sideways overlap. (c) Zero overlap.

give rise to a simple two-center–two-electron bond traditionally written as  $H-H$ . Since the electron density associated with the bonding orbital is cylindrically and symmetrically located about the  $H-H$  axis, this bond is called a  $\sigma$  bond. In Fig. 1 the bonding orbital is labeled with a  $\sigma$  and the corresponding antibonding orbital with a  $\sigma^*$ .

Ideas similar to those above are readily extended to diatomic molecules from the first row of the periodic table, such as  $N_2$  and  $O_2$ , where the valence orbitals to be considered are the one  $2s$  and the three  $2p$  orbitals of the atoms. The  $2s$  orbitals lie deeper in energy than the triply degenerate  $2p$  orbitals. The atomic  $2s$  orbitals form bonding and antibonding orbitals ( $s\sigma$  and  $s\sigma^*$ ) just as in the case of elemental hydrogen described above, but the behavior of the  $2p$  orbitals is a little different. Here there are three possible types of interaction between the  $p$  orbitals on one center and those on the other. The end-on overlap of two  $p$  orbitals gives rise to a  $\sigma$  interaction (Fig. 2a), and the sideways overlap of two  $p$  orbitals gives rise to a  $\pi$  interaction (Fig. 2b). The interaction in Fig. 2c can be ignored since the overlap between the two orbitals in this orientation can be seen to be identically zero. The result is a  $\sigma$ -bonding orbital and a  $\sigma$ -antibonding orbital ( $p\sigma$  and  $p\sigma^*$ ), and a pair of  $\pi$ -bonding and a pair of  $\pi$ -antibonding orbitals ( $\pi$  and  $\pi^*$ ). A larger interaction energy is associated with  $p\sigma$  compared to  $p\pi$ , due to the larger  $\sigma$  overlap compared to  $\pi$  overlap in Fig. 2.

Filling these orbitals with electrons allows comment on the stability of the resulting diatomics. The molecule  $Li_2$  ( $s\sigma$ )<sup>2</sup> is known and, like  $H_2$ , may be written as  $Li-Li$  to emphasize the single, two-center, two-electron bond between the nuclei. The molecule  $Be_2$  which would have the configuration  $(s\sigma)^2(s\sigma^*)^2$  is unknown since, just as in  $He_2$ ,  $s\sigma^*$  is destabilized more than  $s\sigma$  is stabilized relative to an atomic  $2s$  level. If the molecular orbital bond order is written as expression (2), then the bond order in  $Li_2$  is one but

$$\text{Molecular bond order} = \left( \frac{\text{number of bonding electron pairs}}{\text{electron pairs}} \right) - \left( \frac{\text{number of antibonding electron pairs}}{\text{electron pairs}} \right) \quad (2)$$

the bond order in  $Be_2$  is zero.

By filling up the molecular orbital levels derived from the  $2p$  orbitals, the bond order associated with the other diatomics may be generated:  $B_2(1)$ ,  $C_2(2)$ ,  $N_2(3)$ ,  $O_2(2)$ ,  $F_2(1)$ , and  $Ne_2(0)$ . All of these species are known except  $Ne_2$ , which is predicted, like  $He_2$  and  $Be_2$ , to have a zero bond order and therefore not to exist as a stable molecule. The molecular orbital bond orders for the three best-known diatomics are consistent with their traditional formulation as  $N\equiv N$ ,  $O=O$ , and  $F-F$ .  $N_2$ , for example, would be described as having one  $\sigma$  and two  $\pi$  bonds. With the

configuration  $(s\sigma)^2(s\sigma^*)^2(p\sigma)^2-(\pi)^4(\pi^*)^2$ , there are four bonding pairs of electrons and two antibonding pairs giving rise to a net bond order of two. The pair of  $\pi^*$  orbitals is only doubly occupied, whereas there is space for four electrons. Hund's rules (which for the electronic ground state maximize the number of electrons with parallel spins) identify the lowest-energy arrangement as the one where each of the degenerate  $\pi^*$  components is singly occupied, the spins of the two electrons being parallel. Unpaired electrons give rise to paramagnetic behavior, and gaseous oxygen is indeed paramagnetic. [J.K.Bu.]

**Molecular pathology** A discipline that deals with the origins and mechanisms of diseases at their most fundamental level, that of macromolecules such as deoxyribonucleic acid (DNA) and protein, in order to provide precise diagnoses and discover possible avenues for treatment. It is interdisciplinary, including infectious disease, oncology, inherited genetic disease, and legal issues such as parentage determination or forensic identity testing. While a variety of biophysical and biochemical techniques can be applied to study the molecular basis of disease, antibodies and nucleic acid probes are two of the principal approaches. See ANTIBODY; NUCLEIC ACID; ONCOLOGY.

When monoclonal antibodies are either tagged to permit their detection or immobilized on a chromatographic column to purify their specific target molecule, they serve as powerful tools for analyzing pathologic processes. A monoclonal antibody conjugated to an enzyme generating a colored reaction product is the basis of the enzyme-linked immunosorbent assay (ELISA), which is widely applied in many diagnostic tests. Autoantibodies from the sera of individuals with autoimmune diseases are often used as highly specific reagents for understanding the nature of these diseases and the role that the affected molecules or organelles normally perform in the cell. These autoantibodies can be detected in tissues by using fluorescently tagged antibodies directed against human immunoglobulins. See AUTOIMMUNITY; MONOCLONAL ANTIBODIES.

In an analogous manner to immunohistochemistry, traditional histopathology can be enhanced by using in situ hybridization. With this technique, an infectious agent such as a virus or a specific messenger ribonucleic acid (mRNA) can be localized within a specific cell or tissue.

Diseases often result from germline or somatic mutations in the individual's DNA, such as are seen in sickle cell disease or cancer, respectively. These abnormalities can be detected by using two basic techniques of molecular genetics: the Southern blot and the polymerase chain reaction (PCR). For the Southern blot, high-molecular-weight DNA isolated from a specimen (most commonly peripheral-blood white cells) is digested by using an appropriate restriction endonuclease. The resulting fragments are then separated by gel electrophoresis and transferred to a nylon membrane, which is incubated with a solution containing a specific, labeled probe, also in single-stranded form. Probe-target hybrids formed by annealing of their complementary sequences can be detected by autoradiography or a colorimetric reaction. The Southern blot technique can detect DNA polymorphisms, mutations, or the presence of viral, bacterial, or specific sex chromosomes. In the polymerase chain reaction, short oligonucleotide primers flank the specific gene region or RNA sequence to be amplified and are combined with the target specimen and free nucleotides, which are synthesized into new DNA. An automated thermal cycler repeatedly alters the temperature to denature the target DNA, to allow the primers to reanneal to the target, and then to synthesize the product. This amplified polymerase chain reaction product is typically detectable as a band in a gel.

Understanding diseases at the genetic level has several advantages. Even when the gene's protein product is not expressed, definitive diagnoses can be made by using DNA-based techniques. Diseases that are similar clinically (phenotypically) can,

in fact, be due to different mutations (genotypes) within a single gene or due to mutations in different genes, often related in an enzyme complex or as a portion of a group of structural proteins. Another advantage of molecular diagnosis is the ability to detect phenotypically normal carriers of genetic diseases in order to provide information for appropriate genetic counseling and prenatal diagnosis. See HUMAN GENETICS; MUTATION; PATHOLOGY.

[M.A.Lo.]

**Molecular physics** The study of the physical properties of molecules. Molecules possess a far richer variety of physical and chemical properties than do isolated atoms. This is attributable primarily to the greater complexity of molecular structure, as compared to that of the constituent atoms. Molecules also possess additional energy modes because they can vibrate; that is, the constituent nuclei oscillate about their equilibrium positions and rotate when unhindered. These modes give rise to additional spectroscopic properties, as compared to those of an atom; molecular spectroscopy in the optical, infrared, and microwave regions is one of the physical chemist's most powerful means of identifying and understanding molecular structure. Molecular spectroscopy has also given rise to the rapidly growing field of molecular astronomy.

Molecular physics is primarily concerned with the study of properties of isolated molecules, as contrasted to the more general study of molecular reactions, which is the domain of physical chemistry. Such properties, in addition to the broad field of spectroscopy, include electron affinities (for the formation of molecular negative ions); polarizabilities (the "distortability" of the molecule along its various symmetry axes by external electric fields); magnetic and electric multipole moments, attributable to the distributions of electric charge; currents and spins of the molecule; and the (nonreactive) interactions of molecules with other molecules, atoms, and ions. See COSMO-CHEMISTRY; INFRARED SPECTROSCOPY; INTERMOLECULAR FORCES; MICROWAVE SPECTROSCOPY; MOLECULAR BEAMS; MOLECULAR STRUCTURE AND SPECTRA; SPECTROSCOPY.

[B.B.]

**Molecular recognition** The ability of biological and chemical systems to distinguish between molecules and regulate behavior accordingly. How molecules fit together is fundamental in disciplines such as biochemistry, medicinal chemistry, materials science, and separation science. A good deal of effort has been expended in trying to evaluate the underlying intermolecular forces. The weak forces that act over short distances (hydrogen bonds, van der Waals interactions, and aryl stacking) provide most of the selectivity observed in biological chemistry and permit molecular recognition. The recognition event initiates behavior such as replication in nucleic acids, immune response in antibodies, signal transduction in receptors, and regulation in enzymes. Most studies of recognition in organic chemistry have been inspired by these biological phenomena. It has been the task of bioorganic chemistry to develop systems capable of such complex behavior with molecules that are comprehensible and manageable in size, that is, with model systems. See ANTIBODY; CHEMORECEPTION; ENZYME; HYDROGEN BOND; INTERMOLECULAR FORCES; NUCLEIC ACID; SYNAPTIC TRANSMISSION.

The advantage of cyclic structures lies in their ability to restrict conformation or flexibility. A rigid matrix of binding sites, that is, preorganized sites, is usually associated with high selectivity in binding. A flexible matrix tends to accept several binding partners. Although sacrificing selectivity, this has the advantage of transmitting conformational information and is relevant to biological signaling events.

Macrocyclic (crown) ethers can bind and transport ions and imitate biological processes involving macrolides. Large ring structures that are lined with oxygen present an inner surface which is complementary to the spherical outer surface of positively charged ions.

Cyclophane-type structures offer considerable rigidity because of the aromatic nuclei. Binding forces between host and guest are largely hydrophobic. A typical system is a cyclophane-naphthalene complex (**1**), in which a naphthalene guest is bound

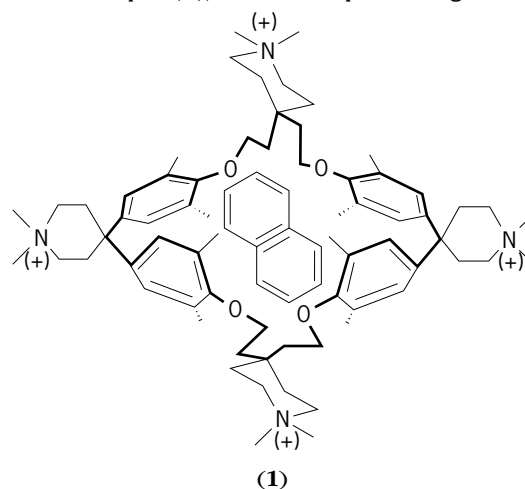

by a water-soluble cyclophane derivative. Other macrocyclic structures include the cyclodextrins and hybrid structures assembled from macrocyclic subunits. See AROMATIC HYDROCARBON; COORDINATION COMPLEXES; NAPHTHALENE.

Because the encircling of larger, more complex molecules with macrocycles poses structural problems, other molecular shapes have been explored. Cleft molecules offer advantages in this regard. The principle underlying these systems involves the shape of the small organic target molecules: convex in surface and bearing functional groups that diverge from their centers. Accordingly, designing a trap for such targets requires molecules of a concave surface in which functional groups converge. This complementarity is also a feature of the immune system: the "hot spots" of an antigen tend to be convex, whereas the binding sites of the antibody are concave.

Systems featuring a cleft have been developed to bind adenine derivatives and other heterocyclic systems through chelation, as shown in (**2**). See CHELATION.

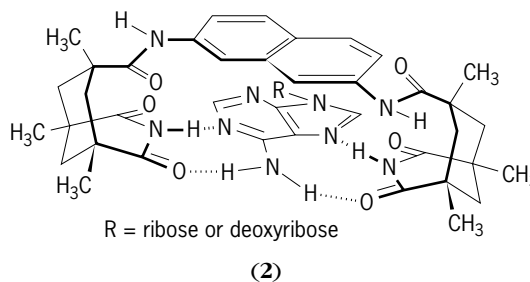

Apart from the abstract questions concerning articulation of molecules, some practical applications in the pharmaceutical industry may be envisioned. Many of the target structures are biologically active, and the use of synthetic sequestering agents for metabolic substrates can represent a novel approach to biochemical methods and drug delivery.

[J.Reb.]

**Molecular sieve** Any one of the crystalline metal aluminosilicates belonging to a class of minerals known as zeolites. An important characteristic of the zeolites is their ability to undergo dehydration with little or no change in crystal structure. The dehydrated crystals are honeycombed with regularly spaced cavities interlaced by channels of molecular dimensions which offer a very high surface area for the absorption of foreign molecules.

The basic formula for all crystalline zeolites can be represented as

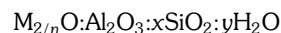

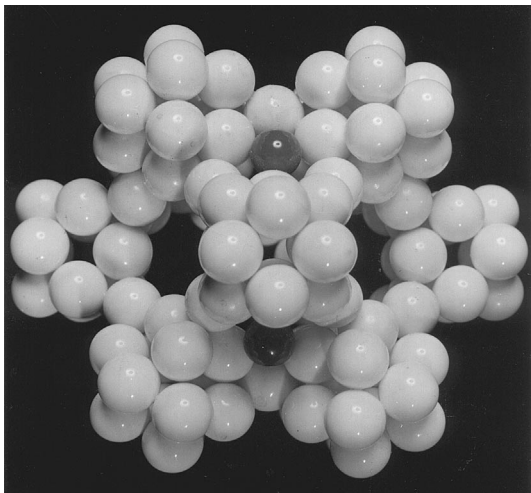

**Molecular sieve type-A crystal model.** Dark spheres represent the included cations, and light spheres the  $\text{SiO}_4$  or  $\text{AlO}_4$  tetrahedrons.

where  $M$  represents a metal ion and  $n$  its valence. The crystal structure consists basically of a three-dimensional framework of  $\text{SiO}_4$  and  $\text{AlO}_4$  tetrahedrons (see illustration). The tetrahedrons are cross-linked by the sharing of oxygen atoms, so that the ratio of oxygen atoms to the total of silicon and aluminum atoms is equal to 2. The electrovalence of the tetrahedrons containing aluminum is balanced by the inclusion of cations in the crystal. One cation may be exchanged for another by the usual ion-exchange techniques. The size of the cation and its position in the lattice determine the effective diameter of the pore in a given crystal species.

The properties of molecular sieves as adsorbents which distinguish them from nonzeolitic adsorbents are (1) the relatively strong coulomb fields generated by the adsorption surface and (2) the uniform pore size; the pore size is controlled, in a given crystal species, by the associated cation.

The basic characteristics of molecular sieves are utilized commercially in several production and research applications. Their absorption properties make them useful for drying, purification, and separations of gases and liquids. Conversely, molecular sieves can be preloaded with chemical agents, which are thereby isolated from the reactive system in which they are dispersed until released from the adsorbent either thermally or by displacement by a more strongly adsorbed compound. They are also used as cation exchange media and as novel catalysts and catalyst supports. See ADSORPTION; GAS CHROMATOGRAPHY; ION EXCHANGE; ZEOLITE. [R.L.Ma.]

**Molecular simulation** A tool for predicting entirely computationally many useful functional properties of systems of interest in the chemical, pharmaceutical, materials, and related industries. Included are thermodynamic, thermochemical, spectroscopic, mechanical, and transport properties, and morphological information (such as location and shape of binding sites on a biomolecule and crystal structure).

The two main molecular simulation techniques are molecular dynamics and Monte Carlo simulation, both of which are rooted in classical statistical mechanics. Given mathematical models for the internal structure of each molecule (the intramolecular potential which describes the energy of each conformation of the molecule) and the interaction between molecules (the intermolecular potential which describes the energy associated with molecules being in a particular conformation relative to each other), classical statistical mechanics provides a formalism for predicting properties of a macroscopic collection of such molecules based on statistically averaging over the possible mi-

croscopic states of the system as it evolves under the rules of classical mechanics. Thus, the building blocks are molecules, the dynamics are described by classical mechanics, and the key concept is statistical averaging. In molecular dynamics, the microscopic states of the system are generated by solving the classical equations of motion as a function of time (typically over a period limited to tens of nanoseconds). Thus, one can observe the relaxation of a system to equilibrium (provided the time for the relaxation falls within the time accessible to molecular dynamics simulation), and so molecular dynamics permits the calculation of transport properties which at the macroscopic scale describe the relaxation of a system in response to inhomogeneities. In Monte Carlo simulation, equilibrium configurations of systems are generated stochastically according to the probabilities rigorously known from classical statistical mechanics. Thus, Monte Carlo simulation generates equilibrium states directly (which has many advantages, including bypassing configurations which are not characteristic of equilibrium but which may be difficult to escape dynamically) and so can be used to study equilibrium configurations of systems which may be expensive or impossible to access via molecular dynamics. The drawback of Monte Carlo simulation is that it cannot yield the kind of dynamical response information that leads directly to transport properties. See CHEMICAL DYNAMICS; COMPUTATIONAL CHEMISTRY; MONTE CARLO METHOD; SIMULATION; STOCHASTIC PROCESS.

Computational quantum chemistry and molecular simulation methods can be used to predict properties that once were only accessible experimentally, resulting in several significant applications in basic and industrial research. These applications include providing estimates of properties for systems for which little or no experimental data are available, which is especially useful in the early stages of chemical process design; yielding insight into the molecular basis for the behavior of particular systems, which is very useful in developing engineering correlations, design rules, or quantitative structure-property relations; and providing guidance for experimental studies by identifying the interesting systems or properties to be measured. [P.T.C.]

**Molecular structure and spectra** Until the advent of quantum theory, ideas about the structure of molecules evolved gradually from analysis and interpretation of the facts of chemistry. Chemists developed the concept of molecules as built from atoms in definite proportions, and identified and constructed (synthesized) a great variety of molecules. Later, when the structure of atoms as built from nuclei and electrons began to be understood with the help of quantum theory, a beginning was made in seeing why atoms can combine in definite ways to form molecules; also, infrared spectra began to be used to obtain information about the dimensions and the nuclear motions (vibrations) in molecules. However, a fundamental understanding of chemical bonding and molecular structure became possible only by application of the present form of quantum theory, called quantum mechanics. This theory makes it possible to obtain from the spectra of molecules a great deal of information about the nature of molecules in their normal as well as excited states, and about dissociation energies and other characteristics of molecules. See CHEMICAL BONDING.

**Molecular sizes.** The size of a molecule varies approximately in proportion to the numbers and sizes of the atoms in the molecule. Simplest are diatomic molecules. These may be thought of as built of two spherical atoms of radii  $r$  and  $r'$ , flattened where they are joined. The equilibrium value  $R_e$  of the distance  $R$  between their nuclei is then smaller than the sum of the atomic radii. However, the nuclei of atoms in two different molecules cannot normally approach more closely than a distance  $r + r'$ ;  $r$  and  $r'$  are called the van der Waals radii of the atoms.

To describe a polyatomic molecule, one must specify not merely its size but also its shape or configuration. For example, carbon dioxide ( $\text{CO}_2$ ) is a linear symmetrical molecule, the

O—C—O angle being  $180^\circ$ . The H—O—H angle in the nonlinear water ( $\text{H}_2\text{O}$ ) molecule is  $105^\circ$ . Many molecules which are essential for life contain thousands or even millions of atoms. Proteins are often coiled or twisted and cross-linked in ways which are important for their biological functioning.

**Dipole moments.** Most molecules have an electric dipole moment. In atoms, the electron cloud surrounds the nucleus so symmetrically that its electrical center coincides with the nucleus, giving zero dipole moment; in a molecule, however, these coincidences are disturbed, and a dipole moment usually results.

Thus, when the atoms of HCl come together, there is some shifting of the H-atom electron toward the Cl. A complete shift would give  $\text{H}^+\text{Cl}^-$ , which would constitute an electric dipole of magnitude  $eR_e$ , where  $e$  is the electronic charge. But in fact the dipole moment is only  $0.17 eR_e$ . This is because the actual electronic shift is only fractional. See ELECTRONEGATIVITY.

**Molecular polarizability.** In the preceding consideration of dipole moments, the discussion has been in terms of atoms and molecules free from external forces. An electric field pulls the electrons of an atom or molecule toward it and pushes the nuclei away, or vice versa. This action creates a small induced dipole moment, whose magnitude per unit strength of the field is called the polarizability.

**Molecular energy levels.** The states of motion of nuclei and electrons in a molecule, or of electrons in an atom, are restricted by quantum mechanics to special forms with definite energies. The state of lowest energy is called the ground state; all others are excited states. In analogy to water levels, one speaks of energy levels. Excited states exist only momentarily, following an electrical or other stimulus. See QUANTUM CHEMISTRY; QUANTUM MECHANICS.

Excitation of an atom consists of a change in the state of motion of its electrons. Electronic excitation of molecules can also occur, but alternatively or additionally, molecules can be excited to discrete states of vibration and rotation.

The total energy of any molecule can be written as Eq. (1). Both the electronic energy  $E_{el}$  and vibration energy  $E_v$  can be

$$E = E_{el} + E_v + (E_r + E_{fs} + E_{hfs} + E_{ext}) \quad (1)$$

discrete or continuous. The quantities  $E_r$ ,  $E_{fs}$ , and  $E_{hfs}$  denote rotational, fine-structure, and hyperfine-structure energies. The last two appear as small or minute splittings of the rotation levels. The spacings  $\Delta E$  of adjacent discrete levels of each type are usually in the order given in notation (2). The  $E_{ext}$  term in

$$\Delta E_{el} \gg \Delta E_v \gg \Delta E_r \gg \Delta E_{fs} \gg \Delta E_{hfs} \quad (2)$$

Eq. (1) refers to additional fine structure which appears on subjecting molecules to external magnetic fields (Zeeman effect) or electric fields (Stark effect). See FINE STRUCTURE (SPECTRAL LINES); HYPERFINE STRUCTURE; STARK EFFECT; ZEEMAN EFFECT.

Polyatomic molecules have much more complicated patterns of vibrational and (usually) rotational energy levels than diatomic molecules.

**Molecular spectra.** The frequencies  $\nu$  ( $c$  = speed of light) of electromagnetic spectra obey the Einstein-Bohr equation (3),

$$h\nu = E' - E'' \quad (3)$$

where  $h$  is Planck's constant. Molecular emission spectra accompany jumps in energy from higher to lower levels; absorption spectra accompany jumps from lower to higher levels.

Molecular spectra can be classified as fine-structure or low-frequency spectra, rotation spectra, vibration-rotation spectra, and electronic spectra. See ELECTRON PARAMAGNETIC RESONANCE (EPR) SPECTROSCOPY; MAGNETIC RESONANCE; MICROWAVE SPECTROSCOPY; MOLECULAR BEAMS; SPECTROSCOPY.

Transitions between energy levels differing only in rotational state give rise to pure rotation spectra. These typically consist of a sequence of lines spaced almost equidistantly, and lying in the far infrared or the microwave region.

Spectra involving only vibrational and rotational state changes consist of bands which lie mainly in the infrared. Each band consists of two sets of closely spaced rotational lines, one on each side of a central frequency. Vibration-rotation absorption bands of liquids and solutions are widely used in chemical analysis. Here the rotational structure is blurred out, and only an "envelope" is seen. See INFRARED SPECTROSCOPY.

Electronic band spectra are the most general type of molecular spectra. For any one electronic transition, the spectrum consists typically of many bands. See ATOMIC STRUCTURE AND SPECTRA; INTERMOLECULAR FORCES; MOLECULAR WEIGHT; RAMAN EFFECT; RESONANCE (MOLECULAR STRUCTURE); SCATTERING EXPERIMENTS (ATOMS AND MOLECULES); VALENCE. [R.S.M.]

**Molecular weight** The sum of the atomic weights of all atoms making up a molecule. Actually, what is meant by molecular weight is molecular mass. The use of this expression is historical, however, and will be maintained. The atomic weight is the mass, in atomic mass units, of an atom. It is approximately equal to the total number of nucleons, protons and neutrons composing the nucleus. Since 1961 the official definition of the atomic mass unit (amu) has been that it is  $1/12$  the mass of the carbon-12 isotope, which is assigned the value 12.000 exactly. See ATOMIC MASS; ATOMIC MASS UNIT; RELATIVE ATOMIC MASS; RELATIVE MOLECULAR MASS.

A mole is an amount of substance containing the Avogadro number,  $N_A$ , approximately  $6.022 \times 10^{23}$ , of molecules or atoms. Molecule, in this definition, is understood to be the smallest unit making up the characteristic compound. Originally, the mole was interpreted as that number of particles whose total mass in grams was numerically equivalent to the atomic or molecular weight in atomic mass units, referred to as gram-atomic or gram-molecular weight. This is how the above value for  $N_A$  was calculated. As the ability to make measurements of the absolute masses of single atoms and molecules has improved, however, modern metrology is tending to alter its approach and define the Avogadro number as an exact quantity, thereby changing slightly the break definition of the atomic mass unit and removing the need to define atomic weight with respect to a particular isotopic species. The latest and most accurate value for the Avogadro number is  $6.0221415(10) \times 10^{23} \text{ mol}^{-1}$ . See AVOGADRO NUMBER; MOLE (CHEMISTRY).

As the masses of all the atomic species are now well known, masses of molecules can be determined once the composition of the molecule has been ascertained. Alternatively, if the molecular weight of the molecule is known and enough additional information about composition is available, such as the basic atomic constituents, it is possible to begin to assemble structural information about the molecule. Thus, the determination of the molecular weight is one of the first steps in the analysis of an unknown species. Given the increasing emphasis on the study of biologically important molecules, particular attention has been focused on the determination of molecular weights of larger and larger units. There are a number of methods available, and the one chosen will depend on the size and physical state of the molecule. All processes are physical macroscopic measurements and determine the molecular weight directly. Connection to the absolute mass scale is straightforward by using the Avogadro number, although, for extremely large molecules, this connection is often unnecessary or impossible, as the accuracy of the measurements is not that good. The main function of molecular weight determination of large molecules is elucidation of structure.

Molecular weight determination of materials which are solid or liquid at room temperature is best achieved by taking advantage of one of the colligative properties of solutions, boiling-point elevation, freezing-point lowering, or osmotic pressure, which depend on the number of particles in solution, not on the nature of the particle. The choice of which to use will depend on a number of properties of the substance, the most important of which will be the size. All require that the molecule be small enough

to dissolve in the solution but large enough not to participate in the phase change or pass through a semipermeable membrane. Freezing-point lowering is an excellent method for determining molecular weights of smaller organic molecules, and osmometry, as the osmotic pressure determination is called, for determining molecular weights of larger organic molecules, particularly polymeric species. Boiling-point elevation is used less frequently. See POLYMER.

The basis of all the methods involving colligative properties of solutions is that the chemical potentials of all phases must be the same. (Chemical potential is the partial change in energy of a system as matter is transferred into or out of it. For two systems in contact at equilibrium, the chemical potentials for each must be equal.) See CHEMICAL EQUILIBRIUM; CHEMICAL THERMODYNAMICS.

Another measurement from which molecular weights can be obtained is based on the scattering of light from the molecule. A beam of light falling on a molecule will induce in the molecule a dipole moment which in its turn will radiate. The interference between the radiated beam and the incoming beam produces an angular dependence of the scattered radiation which depends on the molecular weight of the molecule. This occurs whether the molecule is free or in solution. While the theory for this effect is complicated and varies according to the size of the molecule, the general result for molecules whose size is considerably less than that of the wavelength  $\lambda$  of the radiation (less than  $\lambda/50$ ) is given by the equation below;  $I(\theta)$  is the intensity of radiation at

$$\frac{I(\theta)}{I_0} = \text{constant} (1 + \cos^2\theta) Mc$$

angle  $\theta$ ,  $I_0$  the intensity of the incoming beam,  $M$  the molecular weight, and  $c$  the concentration in grams per cubic centimeter of the molecule. If the molecules are much larger than  $\lambda/50$  (about 9 nanometers for visible light), this relationship in this simple form is no longer valid, but the method is still viable with appropriate adjustments to the theory. In fact, it can be used in its extended version even for large aggregates. See SCATTERING OF ELECTROMAGNETIC RADIATION. [C.D.C.]

**Molecule** A molecule may be thought of either as a structure built of atoms bound together by chemical forces or as a structure in which two or more nuclei are maintained in some definite geometrical configuration by attractive forces from a surrounding swarm of negative electrons. Besides chemically stable molecules, short-lived molecular fragments called free radicals can be observed under special circumstances. See CHEMICAL BONDING; FREE RADICAL; MOLECULAR STRUCTURE AND SPECTRA. [R.S.M.]

**Mollusca** A major phylum of the animal kingdom comprising an extreme diversity of external body forms (oysters, clams, chitons, snails, slugs, squid, and octopuses among others), all based on a remarkably uniform basic plan of structure and function. The phylum name is derived from *mollis*, meaning soft, referring to the soft body within a hard calcareous shell, which is usually diagnostic. Soft-bodied mollusks make extensive use of ciliary and mucous mechanisms in feeding, locomotion, and reproduction. Most molluscan species are readily recognizable as such.

The Mollusca constitute a successful phylum; there are probably over 110,000 living species of mollusks, a number second only to that of the phylum Arthropoda, and more than double the number of vertebrate species. More than 99% of living molluscan species belong to two classes: Gastropoda (snails) and Bivalvia. Ecologically, these two classes can make up a dominant fraction of the animal biomass in many natural communities, both marine and fresh-water.

**Classification.** The phylum Mollusca is divided into seven distinct extant classes, three of which (Gastropoda, Bivalvia, and Cephalopoda) are of major significance in terms both of species

numbers and of ecological bioenergetics, and one extinct class. An outline of their classification follows.

- Class Monoplacophora (mainly fossil; but one living genus *Neopilina*)
- Class Aplacophora
  - Subclass Neomeniomorpha
  - Subclass Chaetodermomorpha
- Class Polyplacophora
- Class Scaphopoda
- Class Rostroconchia (fossil only)
- Class Gastropoda
  - Subclass Prosobranchia
    - Order: Archaeogastropoda
    - Mesogastropoda
    - Neogastropoda
  - Subclass Opisthobranchia
    - Order: Bullomorpha (or Cephalaspidea)
    - Aplysiomorpha (or Anaspidea)
    - Thecosomata
    - Gymnosomata
    - Pleurobranchomorpha (or Notaspidea)
    - Acochliidae
    - Sacoglossa
    - Nudibranchia (or Acoela)
  - Subclass Pulmonata
    - Order: Systellommatophora
    - Basommatophora
    - Stylommatophora
- Class Bivalvia (or Pelecypoda)
  - Subclass Protobranchia
  - Subclass Lamellibranchia
    - Order: Taxodonta
    - Anisomyaria
    - Heterodonta
    - Schizodonta
    - Adapedonta
    - Anomalodesmata
  - Subclass Septibranchia
- Class Cephalopoda
  - Subclass Nautiloidea
  - Subclass Ammonoidea (fossil only)
  - Subclass Coleoidea
    - Order: Belemnoida
    - Sepioidea
    - Teuthoidea
    - Vampyromorpha
    - Octopoda

**Functional morphology.** The unique basic plan of the Mollusca involves the different modes of growth and of functioning of the three distinct regions of the molluscan body (see illustration). These are the head-foot with some nerve concentrations, most of the sense organs, and all the locomotory organs; the visceral mass (or hump) containing organs of digestion, reproduction, and excretion; and the mantle (or pallium) hanging from the visceral mass and enfolding it and secreting the shell. In its development and growth, the head-foot shows a bilateral symmetry with an anterior-posterior axis of growth. Over and around the visceral mass, however, the mantle-shell shows a biradial symmetry, and always grows by marginal increment around a dorsoventral axis. It is of considerable functional importance that a space is left between the mantle-shell and the visceral mass forming a semi-internal cavity; this is the mantle cavity or pallial chamber within which the typical gills of the mollusk, the ctenidia, develop. This mantle cavity is almost diagnostic of the phylum; it is primarily a respiratory chamber housing the ctenidia, but with alimentary, excretory, and genital systems all discharging into it.

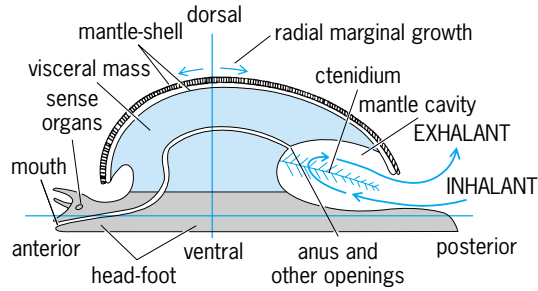

**Generalized model of a stem mollusk (or archetype) in side view. There are three distinct regions in the molluscan body: head-foot, visceral mass, and mantle-shell. Water circulation through the mantle cavity, gills (ctenidia), and pallial complex is from ventral inhaled to dorsal exhalant. (After W. D. Russell-Hunter, *A Life of Invertebrates*, Macmillan, 1979)**

In looking at any mollusk, it is important to realize that whatever the shape of the shell, it is always underlain by the mantle, a fleshy fold of tissues which has secreted it. The detailed structure of the shell and of the mantle edge (with three functionally distinct lobes) is also consistent throughout the Mollusca. The shell is made up of calcium carbonate crystals enclosed in a mesh-work of tanned proteins. It is always in three layers: the outer periostracum, the prismatic layer and the innermost or nacreous layer.

Each of the eight classes of the Mollusca has a characteristic body form and shell shape. Two classes are enormous (Gastropoda and Bivalvia), one of moderate extent (Cephalopoda), the others being minor by comparison. The Gastropoda constitute a diverse group with the shell usually in one piece. This shell may be coiled as in typical snails—that is, helicoid or turbanate—or it may form a flattened spiral, or a short cone as in the limpets, or it may be secondarily absent as in the slugs. Most gastropods are marine, but many are found in fresh waters and on land; in fact, they are the only successful nonmarine mollusks.

The Bivalvia are a more uniform group, with the shell in the form of two calcareous valves united by an elastic hinge ligament. Mussels, clams, and oysters are familiar bivalves. The group is mainly marine with a few genera in estuaries and in fresh waters. There can be no land bivalves since their basic functional organization is as filter feeders. The third major group, the Cephalopoda, includes the most active and most specialized mollusks. There is a chambered, coiled shell in *Nautilus* and in many fossil forms; this becomes an internal structure in cuttlefish and squids, and is usually entirely absent in octopods.

A diversity of gill patterns have evolved in the major molluscan groups, paralleling the evolution of the mantle-shell patterns. The more advanced gastropods show reduction from a pair of aspidobranch ctenidia to a single one, and from that to a one-sided pectinibranch ctenidium (or comb gill), and subsequently to no gill at all in the pulmonate snails. The bivalves show enlargement of gill leaflets to longer filaments and their subsequent folding into the true lamellibranch condition, used in filter feeding. The gills in the cephalopods, while still structurally homologous, are modified with new skeletal elements to resist the stresses of water pumping by muscles.

Besides the gills, the other organs of the mantle cavity (termed collectively the pallial complex) again show morphological and functional consistency throughout the main groups of the Mollusca. The ctenidia form a certain functionally dividing the mantle cavity into an inhalant part (usually ventral) containing the osphradia (pallial sense organs which sample the incoming water), and an exhalant part (usually dorsal) containing hypobranchial glands and both the anus and the openings of the kidney and genital ducts.

The cardiac structures of mollusks are also closely linked to the pallial complex. If there is a symmetrical pair of ctenidia, there will be a symmetrical pair of auricles on either side of the

muscular ventricle of the heart; if one ctenidium, one auricle; if four ctenidia, four auricles. Note that body fluids in mollusks are almost all blood, just as body cavities are almost all hemocoel.

The respiratory pigment is usually hemocyanin in solution, so that neither circulatory efficiency nor blood oxygen-carrying capacity is high. However, mollusks are mostly sluggish animals with low metabolic (and hence respiratory) rates.

Uniquely molluscan is the use of cilia in “sorting surfaces,” which can segregate particles into different size categories and send them to be disposed of in different ways in several parts of the organism. In a simpler type of sorting surface, the epithelium is thrown into a series of ridges and grooves, the cilia in the grooves beating along them and the cilia on the crests of the ridges beating across them. Thus, fine particles impinging on the surface can be carried in the direction of the grooves, while larger particles are carried at right angles. Such sorting surfaces occur both externally on the feeding organs and internally in the gut of many mollusks. For example, on the labial palps of bivalves, they are used to separate the larger sand grains (which are rejected) from the smaller microorganisms which then pass to the mouth.

The range in levels of complexity of molluscan nervous systems is comparable to that found in the phylum Chordata. The four-strand nervous system with one pair of tiny ganglia found in chitons is not dissimilar to the neural plan in turbellarian flatworms. In contrast, the nervous system and sense organs of a cephalopod like an octopus are equaled and exceeded only by those of some birds and mammals. In the majority of mollusks the nervous system is in an intermediate condition. In mollusks other than cephalopods, the main effectors controlled by the nervous system are cilia and mucous glands. In fact, apart from the muscles which withdraw it into its shell, the typical mollusk is a slow-working animal with little fast nervous control or quick reflexes. In the brain of modern cephalopods, paired ganglia have been fused into a massive structure, with over 300 million neurons and extensive “association” centers providing considerable mnemonic and learning capacities. See OCTOPUS.

In all primitive mollusks, the sexes are separate, and external fertilization follows the spawning of eggs and sperm into the sea.

In more advanced mollusks, eggs are larger (and fewer), fertilization may become internal (with complex courtship and copulatory procedures), and larval stages may be sequentially suppressed. A remarkably large number of mollusks (including many higher snails) are hermaphroditic. Although some are truly simultaneous hermaphrodites, many more show various kinds of consecutive sexuality. Most often the male phase occurs first, and these species are said to show protandric hermaphroditism.

**Distributional ecology.** Mollusks are largely marine. The extensive use of ciliary and mucous mechanisms in feeding, locomotion, reproduction, and other functions demands a marine environment for the majority of molluscan stocks. Apart from a small number of bivalve genera living in brackish and fresh waters, all nonmarine mollusks are gastropods.

Despite the soft, hydraulically moved bodies and relatively permeable skins typical of all mollusks, some snails are relatively successful as land animals, although they are largely limited to more humid habitats. The primary physiological requirements for life on land concern water control, conversion to air breathing, and temperature regulation.

In the sea, all classes of mollusks are found, and all habitats have mollusks. Protobranchiate bivalves are found at depths of over 30,000 ft (9000 m). Although ecologically cephalopod mollusks are limited to the sea, there are sound reasons for claiming modern cephalopods as the most highly organized invertebrate animals. The functional efficiencies of jet propulsion and of massive brains in squid, cuttlefish, and octopuses have not been paralleled in their other physiological systems.

In addition to the extreme diversity of external body form exhibited by different mollusks, they show a remarkable

diversity in their ecological distribution and life styles. However, the basic molluscan plan of structure and function always remains recognizable. See APLACOPHORA; BIVALVIA; CEPHALOPODA; GASTROPODA; LAMELLIBRANCHIA; MONOPLACOPHORA; POLYPLACOPHORA; SCAPHOPODA; SNAIL. [W.D.R.H.]

**Molting (Arthropoda)** In arthropods, the shedding of the cuticle. Arthropods, such as insects and crustaceans, owe a large part of their evolutionary success to their exoskeleton. It serves as a rigid attachment site for muscles and also provides a barrier against microbial invasion from the outside and water and ion loss from within. A rigid body covering, however, is not readily expandable. Consequently, at periodic intervals a new exoskeleton is formed and the old one shed to allow increases in body size or changes in morphology. Most of this process, termed molting, is hidden since the new exoskeleton forms underneath the old one. See ARTHROPODA.

Molting begins with the detachment of the epidermis from the overlying cuticle, forming a space between the two structures. Cell divisions may then occur in the epidermis followed by the initiation of secretion of the new cuticle. The epicuticle is first laid down, followed by the exocuticle. Consequently, toward the end of a molt, one finds the animal with a new exoskeleton consisting of epicuticle, exocuticle, and some endocuticle, inside the partially digested old exoskeleton. The events that surround the escape from this old cuticle can be divided into three discrete phases: preparatory, ecdysis, and postecdysis.

The preparatory phase includes the behavioral and physiological changes that lead up to ecdysis. A key physiological event is the activation of the molting fluid and the resulting digestion of the inner layers of the old endocuticle, a major store of protein and chitin. The preparatory phase also involves behavior that brings the animal to an appropriate site for ecdysis.

The ecdysial movements bring about the shedding of the old exoskeleton. These are very stereotyped behaviors that are due to central motor programs whose output is modified to a greater or lesser extent by sensory feedback as the behavior progresses. Ecdysis is often accompanied by the activation of dermal glands that pour their secretion onto the surface of the new cuticle as the old one is being shed. These secretions make up an outer cement layer which further aids in waterproofing the cuticle.

The postecdysial phase is devoted to the expansion and hardening of the new exo-skeleton. Typically, the new exoskeleton is larger than the old one, so it needs to be inflated to its proper size. After its expansion, the new cuticle is tanned and acquires its new pigmentation. In crustaceans, the new cuticle is gradually mineralized through deposition of calcium into it.

In all arthropods, molting is caused by a class of steroid hormones, the ecdysteroids, the most prominent of which is 20-hydroxyecdysone. The ecdysteroid profile during a molt is characterized by initial high titers of the steroid followed by a gradual decline in levels as the molt progresses. Activation of the enzymes in the molting fluid, the digestion of the endocuticle, and molting fluid resorption all occur as the steroid titer drops. Importantly, the decline in ecdysteroids is also necessary for the release and action of the neuropeptide, eclosion hormone, that triggers ecdysis itself. Other neuropeptides are then released as a consequence of eclosion hormone action. Bursicon is the tanning hormone, and its primary target is the epidermis. Other peptides released at this time cause the circulatory changes that direct the blood into the expanding appendages. See ENDOCRINE SYSTEM (INVERTEBRATE); INSECT PHYSIOLOGY. [J.W.Tr.]

**Molybdenite** A mineral having composition  $\text{MoS}_2$ . Molybdenite is the chief ore of molybdenum. It crystallizes in the hexagonal system, but crystals are rare and when found are hexagonal plates. It is commonly in scales or foliated masses. The mineral has a greasy feel. The hardness is 1.5 (Mohs scale) and the specific gravity is 4.7. The luster is metallic and the color lead gray. Molybdenite and graphite have long been confused

because of their nearly identical physical properties. They can be distinguished by the streak left on glazed paper, black for graphite and green for molybdenite. Molybdenite has been used as a lubricant.

Molybdenite occurs in various places in Norway, Sweden, Australia, England, China, and Mexico. In the United States, molybdenite is found in small amounts at many localities but the most important occurrence is at Climax, Colorado. See MOLYBDENUM. [C.S.Hu.]

**Molybdenum** A chemical element, Mo, atomic number 42, and atomic weight 95.94, in the periodic table in the triad of transition elements that includes chromium (atomic number 24) and tungsten (atomic number 74). Research has revealed it to be one of the most versatile chemical elements, finding applications not only in metallurgy but also in paints, pigments, and dyes; ceramics; electroplating; industrial catalysts; industrial lubricants; and organometallic chemistry. Molybdenum is an essential trace element in soils and in agricultural fertilizers. Molybdenum atoms have been found to perform key functions in enzymes (oxidases and reductases), with particular interest being directed toward its role in nitrogenase, which is employed by bacteria in legumes to convert inert nitrogen ( $\text{N}_2$ ) of the air into biologically useful ammonia ( $\text{NH}_3$ ). See NITROGEN FIXATION; PERIODIC TABLE.

Molybdenum is widely distributed in the Earth's crust at a concentration of 1.5 parts per million by weight in the lithosphere and about 10 parts per billion in the sea. It is found in at least 13 minerals, mainly as a sulfide [molybdenite ( $\text{MoS}_2$ )] or in the form of molybdates [for example, wulfenite ( $\text{PbMoO}_4$ ) and magnesium molybdate ( $\text{MgMoO}_4$ )].

Although molybdenum is closer to chromium in atomic weight and atomic number, its chemical behavior is usually very similar to that of tungsten, which has nearly the same atomic radius. (This is due to the so-called lanthanide contraction in which atomic radii decrease for elements 57 to 71 found in the period between molybdenum and tungsten.) See CHROMIUM; LANTHANIDE CONTRACTION; TUNGSTEN.

Molybdenum atoms contain six valence electrons ( $4d^55s^1$ ), which are employed with great versatility in forming compounds and complexes in which electronic configurations vary from  $d^0$  (no  $d$  electrons in oxidation state + 6) to  $d^8$  (8  $d$  electrons in oxidation state -2). The +6 state is preferred, but all states from -2 to +6 are known. States usually exhibit a variety of coordination numbers (4 to 9), and include polynuclear complexes and metal-metal bonds in metallic clusters with two to six metal atoms in their metallic cores. Molybdenum forms a very large number of compounds with oxygen. Low-valent molybdenum [for example,  $\text{Mo}(\text{CO})_6$  and  $\text{Mo}_2$ ,  $\text{Mo}_3$ , and  $\text{Mo}_6$  clusters] has a very rich organometallic chemistry, including clusters that are being studied as models for molybdenum metal surfaces that catalyze organic reactions employed in industrial syntheses and oil refining. The ability of molybdenum atoms to vary oxidation state, coordination number, and coordination geometry and to form metal-metal bonds in clusters accounts in part for the large number of industrial catalysts and biological enzymes in which Mo atoms are found at the active site for catalysis. See CHEMICAL BONDING; COORDINATION CHEMISTRY; ELECTRON CONFIGURATION.

Molybdenum is a high-melting silver-gray metal, strong even at high temperatures, hard, and resistant to corrosion (see table). It also exhibits high conductivity, a high modulus of elasticity, high thermal conductivity, and a low coefficient of expansion. Its major use is in alloy steels, for example, as tool steels ( $\leq 10\%$  molybdenum), stainless steel, and armor plate. Up to 3% molybdenum is added to cast iron to increase strength. Up to 30% molybdenum may be added to iron-, cobalt-, and nickel-based alloys designed for severe heat- and corrosion-resistant applications. It may be used in filaments for light bulbs, and it has many applications in electronic circuitry. See ALLOY; IRON ALLOYS; STAINLESS STEEL.

**Physical properties of molybdenum metal**

Property	Value
Density	10.22 g/cm <sup>3</sup> (5.911 oz/in. <sup>3</sup> )
Heat of vaporization	491 kJ/mol
Heat of fusion	28 kJ/mol
Specific heat	0.267 J/g °C
Thermal conductivity	1.246 J/s/cm <sup>2</sup> /cm °C (200 °C) 0.923 J/s/cm <sup>2</sup> /cm °C (2200 °C)
Electrical conductivity	34% International Copper Standard
Electrical resistivity	5.2 microhm-cm, 20 °C 78.2 microhm-cm, 2525 °C
Magnetic susceptibility	0.93 × 10 <sup>-6</sup> emu, 25 °C 1.11 × 10 <sup>-6</sup> emu, 1825 °C
Mean linear expansion coefficient	6.65 × 10 <sup>-6</sup> /°C, 20–1600 °C
Modulus of elasticity	0.324 N/m <sup>2</sup>
Lattice parameter	0.314767 nm (body-centered cube)

Molybdenum trioxide, molybdates, sulfo-molybdates, and metallic molybdenum are found in thousands of industrial catalysts used in oil refining, ammonia synthesis, and industrial syntheses of organic chemicals. Monomeric molybdenum (IV) in aqueous solution is a powerful catalyst for the reduction of inert oxo-anions such as perchlorate (ClO<sub>4</sub><sup>-</sup>) or nitrate (NO<sub>3</sub><sup>-</sup>) as well as other oxidized nonmetals such as azide ion (N<sub>3</sub><sup>-</sup>) and dinitrogen (N<sub>2</sub>). The trinuclear cation MO<sub>3</sub>O<sub>4</sub><sup>4+</sup> is inert, unreactive, and noncatalytic. See CATALYSIS; HOMOGENEOUS CATALYSIS.

The molybdenum enzymes comprise two major categories. The first category contains the single, highly important enzyme nitrogenase, which is responsible for biological nitrogen fixation. The second category contains all other known molybdenum enzymes, which are crucial for the metabolism of bacteria, plants, and animals, including humans. [E.I.S.]

**Monazite** A rare mineral that incorporates the light rare-earth elements (lanthanum, cerium, praseodymium, neodymium, promethium, samarium, europium, gadolinium) and also yttrium. Monazite has a general formula of (La,Ce,Nd)PO<sub>4</sub>, but Pr, Sm, Eu, Gd, and Y substitute for La, Ce, and Nd in solid solution in minor amounts. The dominant rare-earth element in a particular monazite is denoted by the atomic suffix, such as monazite-(Ce) in which cerium exists in amounts greater than other rare-earth atoms. Monazite-(Ce), monazite-(La), and monazite-(Nd) are officially recognized by the International Mineralogical Association. See CERIUM; MINERAL; RARE-EARTH ELEMENTS; YTTRIUM.

The atomic arrangement of monazite is formed of a packing arrangement of (PO<sub>4</sub>) tetrahedra and distorted (REO<sub>9</sub>) polyhedra, where RE = the rare-earth elements in the particular monazite mineral. The arrangement is formed of chains of alternating phosphate tetrahedra and RE polyhedra, parallel to the *c* axis. Monazite is similar in structure and chemistry to the tetragonal mineral xenotime, Y(PO<sub>4</sub>), that selectively incorporates the heavy rare-earth elements. See PHOSPHATE MINERALS.

Monazite is variably green, yellow, brown, or red-brown, and rarely occurs in crystals large enough to discern with the unaided eye. Mohs hardness is 5–5.5, and the specific gravity is 4.6–5.5, varying with substitution of different elements.

Monazite is one of the main ore minerals for the rare-earth elements that are used in the manufacture of television and computer screens, fluorescent light bulbs, and highly efficient batteries, among other industrial applications. [J.M.Hu.; J.Ra.]

**Molybdenum alloys** Solid solutions of molybdenum and other metals. Molybdenum is classified as a refractory metal by virtue of its high melting point (2623 °C or 4750 °F), and many of its applications result from its strength at high temperatures. A number of other physical and mechanical properties make it attractive for use in a wide variety of applications. Molybdenum is used extensively as electrodes in electric-boost furnaces because it erodes very slowly and does not contaminate the glass

bath. Its high-temperature strength allows it to support significant structural loads imposed during operation of the furnaces. See MOLYBDENUM; REFRACTORY.

Four main classes of commercial molybdenum-base alloys exist. The most common of the carbide-strengthened alloys is known as TZM, containing about 0.5% titanium, 0.08% zirconium, and 0.03% carbon. Other alloys in this class include TZC (1.2% titanium, 0.3% zirconium, 0.1% carbon), MHC (1.2% hafnium, 0.05% carbon), and ZHM (1.2% hafnium, 0.4% zirconium, 0.12% carbon). The high-temperature strength imparted by these alloys is their main reason for existence. Both TZM and MHC have found application as metalworking tool materials. Their high-temperature strength and high thermal conductivity make them quite resistant to the collapse and thermal cracking that are common failure mechanisms for tooling materials.

Tungsten and rhenium are the two primary solid-solution alloys. The most common compositions are 30% tungsten (Mo-30W), 5% rhenium (Mo-5Re), 41% rhenium (Mo-41Re), and 47.5% rhenium (Mo-50Re). With the exception of the Mo-30W alloy which is available as a vacuum-arc-cast product, these alloys are normally produced by powder metallurgy. The tungsten-containing alloys find application as components in systems handling molten zinc, because of their resistance to this medium. They were developed as a lower-cost, lighter-weight alternative to pure tungsten and have served these applications well over the years. The 5% rhenium alloy is used primarily as thermocouple wire, while the 41% and 47.5% alloys are used in structural aerospace applications. See RHENIUM; TUNGSTEN.

The beneficial effects of solid-solution hardening and dispersion hardening found in the carbide-strengthened alloys have been combined in the HWM-25 alloy (25% tungsten, 1% hafnium, 0.07% carbon). This alloy offers high-temperature strength greater than that of carbide-strengthened molybdenum, but it has not found wide commercial application because of the added cost of tungsten and the expense of processing the material.

Dispersion-strengthened alloys rely exclusively on powder metallurgy manufacturing techniques. This allows the production of fine stable dispersions of second phases that stabilize the wrought structure against recrystallization, resulting in a material having improved high-temperature creep strength as compared to pure molybdenum. Once recrystallization occurs, the dispersoids also stabilize the interlocked recrystallized grain structure. This latter effect produces significant improvements in the ductility of the recrystallized material.

The potassium- and silicon-doped alloys such as MH (150 ppm potassium, 300 ppm silicon) and KW (200 ppm potassium, 300 ppm silicon, 100 ppm aluminum) are the oldest of this category; they are analogs to the doped tungsten alloys in common use for tungsten lamp filament. [J.A.Shi.]

**Moment of inertia** A relation between the area of a surface or the mass of a body to the position of a line. The analogous positive number quantities, moment of inertia of area and moment of inertia of mass, are involved in the analysis of problems of statics and dynamics respectively.

The moment of inertia of a figure (area or mass) about a line is the sum of the products formed by multiplying the magnitude of each element (of area or of mass) by the square of its distance from the line. The moment of inertia of a figure is the sum of moments of inertia of its parts.

For a body of mass distributed continuously within volume *V*, the movement of inertia of the mass about the *X* axis is given by either  $I_X = \int r_X^2 dm$  or  $I_X = \int r_X^2 \rho dV$ , where *dm* is the mass included in volume element *dV* at whose position the mass per unit volume is  $\rho$  (see illustration). Similarly  $I_Y = \int r_Y^2 \rho dV$  and  $I_Z = \int r_Z^2 \rho dV$ .

The moments of inertia of a figure about lines which intersect at a common point are generally unequal. The moment is



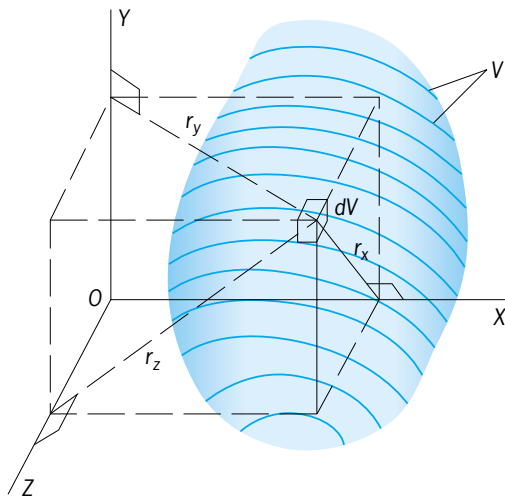

Moment of inertia of a volume.

greatest about one line and least about another line perpendicular to the first one. A set of three orthogonal lines consisting of these two and a line perpendicular to both are the principal axes of inertia of the figure relative to that point. If the point is the figure's centroid, the axes are the central principal axes of inertia. The moments of inertia about principal axes are principal moments of inertia. See CENTROIDS (MATHEMATICS); PRODUCT OF INERTIA; RADIUS OF GYRATION. [N.S.F.]

**Momentum** Linear momentum is the product of the mass and the linear velocity of a body. It is defined by Eq. (1), where  $m$

$$\mathbf{P} = m\mathbf{v} \quad (1)$$

is the mass and  $\mathbf{v}$  is the linear velocity. Since linear momentum is the product of a scalar and a vector quantity, it is a vector and hence has both magnitude and direction.

According to the general statement of Newton's second law, for a force  $\mathbf{F}$ , a momentum  $\mathbf{P}$ , and a time  $t$ , Eq. (2) holds. Thus

$$\mathbf{F} = d\mathbf{P}/dt \quad (2)$$

Newton's second law involves the time rate of change of momentum. Changes of momentum are important in collision processes. See COLLISION (PHYSICS).

When a group of bodies is subject only to forces that members of the group exert on one another, the total momentum of the group remains constant. See ANGULAR MOMENTUM; CONSERVATION OF MOMENTUM; IMPULSE (MECHANICS). [P.W.S.]

**Mongoose** The name for about 39 species of carnivorous mammals which are members of the family Viverridae. This family also includes the civets and genets. Mongooses are restricted in their distribution to the warmer regions of the Old World, ranging from the Mediterranean into Africa and Southeast Asia. These are plantigrade animals about the size of a cat and have a long slender body, short legs, nonretractile claws, and scent glands. Some species are fair climbers even though the claws are nonretractile. Mongooses are predators, feeding on snakes, frogs, fishes, and crabs, and they are especially fond of bird and crocodile eggs. The mongoose cannot legally be brought into the United States because of its destructive habits. See CARNIVORA; CIVET. [C.B.C.]

**Monhysterida** An order of nematodes in which, generally, the stoma is funnel shaped and lightly cuticularized; however, in some families the stoma is spacious and heavily cuticularized, and is armed with protrusible teeth. The amphids vary from simple spirals to circular forms. Usually the second and third circllets of cephalic sensilla are combined, but in some

taxa the third circllet of four distinct setae is separate. The normal pattern of distribution is often disrupted by numerous cervical setae. The near-cylindrical esophagus is sometimes swollen posteriorly. The cuticle may be smooth or may have annuli or ornamentation. When the annuli are distinct, the somatic setae may be long and in four to eight longitudinal rows. The female gonads are outstretched and either single or paired.

There are three monhysterid superfamilies: The Linhomoeoidea and Siphonolaimoidea are primarily marine forms; feeding habits among the groups are unknown. The Monhysteroidea are free-living nematodes found in all environments, from marine waters to fresh waters and soil; feeding habits are unknown. See NEMATODA. [A.R.M.]

**Monkey** An adaptive or evolutionary grade among the primates, represented by members of two of the three modern anthropoid superfamilies. The New World, platyrrhine monkeys (Ateloidea) and Old World, catarrhine forms (Cercopithecoidea) probably reached a monkey level of adaptation independently some time after their separation from a common ancestor, perhaps 40 million years ago. The term monkey is not indicative of taxonomic or phylogenetic relationship: the closest relatives of the cercopithecoids are not the ateloid monkeys but the Old World apes and humans.

The Ateloidea comprise two families, while the living Cercopithecoidea are today considered to comprise only one family, with two subfamilies. A modern classification of the Anthroidea follows:

- Hyporder Anthroidea
  - Infraorder Platyrrhini
    - Superfamily Ateloidea (New World or platyrrhine monkeys)
      - Family Atelidae
        - Subfamily Atelinae (howler and spider monkeys)
        - Subfamily Pitheciinae (saki, owl, and titi monkeys)
      - Family Cebidae
        - Subfamily Cebinae (capuchin and squirrel monkeys)
        - Subfamily Callitrichinae (marmosets and tamarins)
        - Subfamily Branisellinae (extinct early ateloids)
    - Infraorder Catarrhini (Old World anthropoids)
      - Parvorder Eucatarrhini (modern catarrhines)
        - Superfamily Hominoidea (gibbons, great apes, and humans)
        - Superfamily Cercopithecoidea
          - Family Cercopithecidae (Old World or catarrhine monkeys)
            - Subfamily Cercopithecinae (cheek-pouched monkeys: macaques, baboons, guenons, and mangabeys)
            - Subfamily Colobinae (leaf eaters: langurs and colobus)
            - Subfamily Victoriapithecinae (extinct early cercopithecids)
        - Parvorder Eocatarrhini (archaic catarrhines)
          - Family Pliopithecidae (later archaic catarrhines)
          - Family Propithecidae (early archaic catarrhines)
      - Infraorder Paracatarrhini (extinct early anthropoids)
        - Family Parapithecidae (extinct Egyptian monkeys)
        - Family Oligopithecidae (extinct archaic anthropoids)

Monkeys are hard to characterize as a group because of their great diversity, and because much of the discussion reflects a comparison with the apes. Both monkeys and apes contrast with the prosimian grade in that they are typically large, diurnal animals that live in social groups. Monkeys differ from apes in their possession of a tail, a smaller brain, quadrupedal pronograde posture, and a usually longer face. They are generally smaller than apes, but large monkeys outweigh gibbons. Like almost all primates, monkeys are pentadactyl, with nails rather than claws on the digits in most cases. They have pectoral mammary glands and well-developed vision. Monkeys are primarily vegetarian and inhabit forested tropical or subtropical regions of

## Major contrasts between New and Old World monkeys and special features of each

Ateloidea (New World species)	Cercopithecoidea (Old World species)
Nose platyrrhine (nasal septum wide, nostrils open to sides)	Nose catarrhine (septum narrow, nostrils open downward)
Tail long, prehensile in atelines and <i>Cebus</i> only	Tail short to long, nonprehensile
3 premolar teeth in each quadrant	2 premolars in each quadrant
24 deciduous, 36 permanent teeth (4 fewer in Callitrichinae), I 2/2C 1/1 P 3/3 M 3/3/(M 2/2 in Callitrichinae)	20 deciduous, 32 permanent teeth, I 2/2 C 1/1 P 2/2 M 3/3
Jaws and teeth lightly built in Cebidae; more robust in Atelidae, with deep lower jaw	Ischial callosities present
Sacculated stomach in Colobinae	Cheek pouches in Cercopithecinae
Fingers and toes with curved nails (clawlike in Callitrichinae)	All nails tend to be flattened
Big toe opposable, thumb not fully so and sometimes reduced in Cebidae	Thumb and big toe opposable, thumb reduced in colobinae

Africa, Asia, and South America. The differences between the New and Old World monkeys are summarized in the table.

Old World species are found throughout all the warmer regions of the Eastern Hemisphere, except Australia and Madagascar. Many of the familiar monkeys are included in this family, such as the rhesus macaque, Barbary "ape," mangabey, baboon, and mandrill.

The New World monkeys or ateloids occupy forested areas from southern Mexico to Argentina. They are divided into two main groups, or families (their major characteristics are given in the table). All are arboreal, including a few with prehensile tails; there is no living form, nor any evidence of a fossil form, that has come to the ground habitually. Familiar monkeys included in this group are marmosets, capuchins, titis, sakis and nakaris, howler monkeys, and spider and wool monkeys. See APES; PRIMATES.

[E.D.]

**Monoamine oxidase** Either of two enzymes found in the outer membrane of mitochondria that degrade biogenic amines and are thus responsible for the destruction of transmitter substances at neuronal synapses. Nerve cells release neurotransmitter into the synapse in response to stimulation. The neuron must then dispose of this neurotransmitter to stop the signal or a new signal cannot get through. This is accomplished by one of three mechanisms: diffusion; reuptake into the presynaptic area; and degradation by a number of enzymes, including monoamine oxidase. See SYNAPTIC TRANSMISSION.

Monoamine oxidase inhibitors are drugs that block degradation of amine transmitters within the cell; however, not all of their effects can be attributed directly to monoamine oxidase inhibition, since a number of different neuronal effects have been described. The most prominent consequence of monoamine oxidase inhibition is a rapid increase in the intracellular concentrations of monoamines. In addition, the level of serotonin in the brain is raised to a greater extent than that of norepinephrine and dopamine. After these amine concentrations rise, secondary adaptive consequences occur, including a reduction in amine synthesis via an apparent feedback mechanism, which has been most clearly demonstrated for the noradrenergic system. See NEUROBIOLOGY; NORADRENERGIC SYSTEM; SEROTONIN.

Two types of monoamine oxidase have been identified. These are designated A and B and are distinguished by having different substrate specificity. Type A preferentially deaminates norepinephrine, cortical dopamine, and serotonin, and is selectively inhibited by clorgyline. Type B degrades phenylethylamine, dopamine, and benzylamine, and is sensitive to deprenyl or pargyline inhibition. Commonly used monoamine oxidase inhibitors are nonselective inhibitors that affect types A and B. Seventy-five percent of monoamine oxidase in the human is type B.

Monoamine oxidase inhibitors are used in medicine for controlling hypertension and for treating depression and other disorders. Other psychiatric disorders, such as obsessive-compulsive disorder, bulimia, somatoform pain disorder, panic disorder, and schizophrenia, have been reported to occasionally respond to treatment with monoamine oxidase inhibitors. There is also some

evidence that patients with so-called atypical depression preferentially respond to monoamine oxidase inhibitors. See AFFECTIVE DISORDERS; HYPERTENSION.

[M.A.Je.]

**Monocleales** An order of liverworts of the subclass Marchantiidae, consisting of a single genus (*Monoclea*). The gametophyte is among the largest of all liverworts; its thallus consists of homogeneous cells except for scattered oil cells. The rhizoids are smooth and both thick-walled and thin-walled. The sex organs are grouped but not elevated: the antheridia are sunken in cavities and grouped into receptacles, while the archegonia are enclosed in groups by involucre. The very long, massive seta considerably elevates the capsules which dehisce spoonlike by one slit. The lobing of spore mother cells is unique in the subclass Marchantiidae. See BRYOPHYTA; MARCHANTIIDAE.

[H.Cr.]

**Monoclonal antibodies** Antibody proteins that bind to a specific target molecule (antigen) at one specific site (antigenic site). In response to either infection or immunization with a foreign agent, the immune system generates many different antibodies that bind to the foreign molecules. Individual antibodies within this polyclonal antibody pool bind to specific sites on a target molecule known as epitopes. Isolation of an individual antibody within the polyclonal antibody pool would allow biochemical and biological characterization of a highly specific molecular entity targeting only a single epitope. Realization of the therapeutic potential of such specificity launched research into the development of methods to isolate and continuously generate a supply of a single lineage of antibody, a monoclonal antibody (mAb).

In 1974, W. Köhler and C. Milstein developed a process for the generation of monoclonal antibodies. In their process, fusion of an individual B cell (or B lymphocyte), which produces an antibody with a single specificity but has a finite life span, with a myeloma (B cell tumor) cell, which can be grown indefinitely in culture, results in a hybridoma cell. This hybridoma retains desirable characteristics of both parental cells, producing an antibody of a single specificity that can grow in culture indefinitely.

Generation of monoclonal antibodies through the hybridoma process worked well with B cells from rodents but not with B cells from humans. Consequently, the majority of the first monoclonal antibodies were from mice. When administered into humans as therapeutic agents in experimental tests, the human immune system recognized the mouse monoclonal antibodies as foreign agents, causing an immune response, which was sometimes severe. Although encouraging improvements in disease were sometimes seen, this response made murine (mouse) antibodies unacceptable for use in humans with a functional immune system.

Fueled by advances in molecular biology and genetic engineering in the late 1980s, efforts to engineer new generations of monoclonal antibodies with reduced human immunogenicity have come to fruition. Today there are a number of clonal antibodies approved for human therapeutic use in the United States.

Characterization of the structure of antibodies and their genes laid the foundation for antibody engineering. In most mammals,

each antibody is composed of two different polypeptides, the immunoglobulin heavy chain (IgH) and the immunoglobulin light chain (IgL). Comparison of the protein sequences of either heavy or light antibody chain reveals a portion that typically varies from one antibody to the next, the variable region, and a portion that is conserved, the constant region. A heavy and a light chain are folded together in an antibody to align their respective variable and constant regions. The unique shape of the cofolded heavy- and light-chain variable domains creates the variable domain of the antibody, which fits around the shape of the target epitope and confers the binding specificity of the antibody.

Mice genetically engineered to produce fully human antibodies allow the use of established hybridoma technology to generate fully human antibodies directly, without the need for additional engineering. These transgenic mice contain a large portion of human DNA encoding the antibody heavy and light chains. Inactivation of the mouse's own heavy- and light-chain genes forces the mouse to use the human genes to make antibodies. Current versions of these mice generate a diverse polyclonal antibody response, thereby enabling the generation and recovery of optimal monoclonal antibodies using hybridoma technology.

Disease areas that currently are especially amenable to antibody-based treatments include cancer, immune dysregulation, and infection. Depending upon the disease and the biology of the target, therapeutic monoclonal antibodies can have different mechanisms of action. A therapeutic monoclonal antibody may bind and neutralize the normal function of a target. For example, a monoclonal antibody that blocks the activity of the protein needed for the survival of a cancer cell causes the cell's death. Another therapeutic monoclonal antibody may bind and activate the normal function of a target. For example, a monoclonal antibody can bind to a protein on a cell and trigger an apoptosis signal. Finally, if a monoclonal antibody binds to a target expressed only on diseased tissue, conjugation of a toxic payload (effective agent), such as a chemotherapeutic or radioactive agent, to the monoclonal antibody can create a guided missile for specific delivery of the toxic payload to the diseased tissue, reducing harm to healthy tissue. See ANTIBODY; ANTIGEN; GENETIC ENGINEERING; IMMUNOLOGY. [L.Gre.]

**Monocotyledons** This group of flowering plants (angiosperms), with one seed leaf, was previously thought to be one of the two major categories of flowering plants (the other group is dicotyledons). However, deoxyribonucleic acid (DNA) studies have revealed that, although they do constitute a group of closely related families, they are closely related to the magnoliids, with which they share a pollen type with a single aperture. The eudicots are much more distantly related. In general, monocots can also be recognized by their parallel-veined leaves and three-part flowers. Their roots have disorganized vascular bundles, and if they are treelike (yuccas, aloes, dracaenas) their wood is unusually structured. Among the important monocots are grasses (including corn, rice, and wheat), lilies, orchids, palms, and sedges. See DICOTYLEDONS; EUDICOTYLEDONS; FLOWER; GRASS CROPS; LILIALES; MAGNOLIOPHYTA. [M.W.C.; M.EF.]

**Monogenea** A subclass of the Trematoda which are ectoparasites of the gills, skin, and orifices of fishes and, less frequently, of the esophageal tracts and bladders of amphibians and turtles. They have conspicuous anterior and posterior holdfasts, the latter usually armed. The terminal genitalia are frequently sclerotized. The group is characterized by sexual reproduction, direct development, and a single host in the life cycle.

The most widely used classification employs two orders, the Monopisthocotylea, in which the posthaptor is without discrete multiple suckers or clamps, and the Polyopisthocotylea, with suckers or clamps on the posthaptor.

Body shapes of the various genera are distinctive, sometimes bizarre, as in *Vallisia*, which is sickle-shaped. Paired external suckers or buccal cavity suckers and adhesive glands occur an-

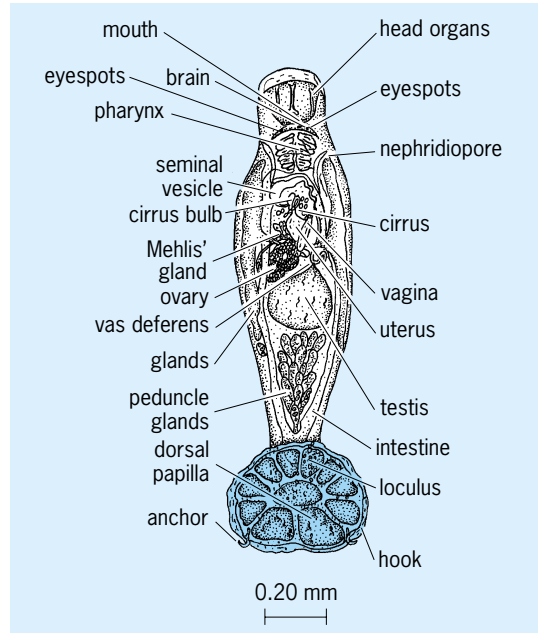

A monogeneid of the superfamily Capsaloidea, *Heterocotyle aetobatis* from the spotted eagle ray, ventral view.

teriorly. The posterior holdfast is either solid and armed with central anchors and marginal hooks (Gyrodactyloidea), sucker-shaped with anchors and hooks (Capsaloidea; see illustration), or solid and bearing suckers or clamps (Polyopisthocotylea).

Monogenea usually have direct development involving simple metamorphosis from the ciliated larval stage to the nonciliated juvenile. Juvenile anchors and hooks may be retained or replaced by adult suckers or clamps. Cross-fertilization or, perhaps less frequently, self-fertilization of hermaphroditic individuals resulting in egg capsules which hatch on the host or in its environment is most common. See TREMATODA. [W.J.Ha.]

**Monogononta** A class of the phylum Rotifera which contains the majority of species in this invertebrate class. The organisms of this order are characterized by the presence of a single gonad in both males and females. There is a striking degree of sexual dimorphism, with the males being small and degenerate. The order is made up of three suborders: Ploima, Flosculariacea, and Collothecacea.

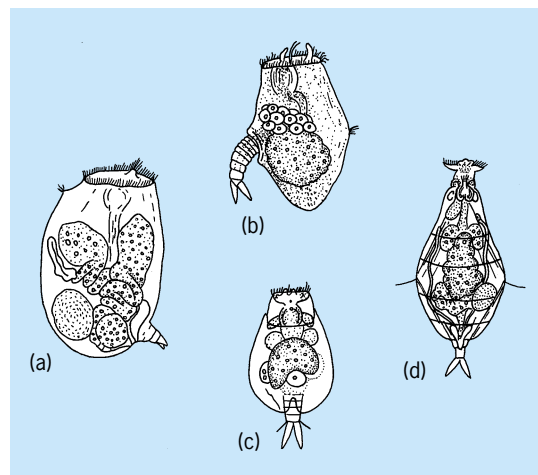

Ploimates. (a) *Asplanchnopus* sp. (b) *Ploesoma* sp. (c) *Eulichlanis dilata*. (d) *Notomata copeus*.

In suborder Ploima there is an exceptional diversity of form, varying from soft-bodied wormlike rotifers to species with variously ornamented, loricated shells (see illustration). Most of the free-swimming benthonic and pelagic rotifers belong to this suborder. Locomotion is by the ciliated corona.

The suborder Flosculariacea contains the spectacular sessile rotifers formerly known as melicertaceans of the family Flosculariidae, as well as a number of equally notable free-swimming forms included in the family Testudinellidae.

The suborder Collotheceacea contains but a single family, the Collotheceidae, made up of five genera. Most species of Collotheceidae are sessile, and many are encased in gelatinous tubes. See ROTIFERA. [E.H.A.]

**Monomolecular film** A film one molecule thick; often referred to as a monolayer. Films that form at surfaces or interfaces are of special importance. Such films may reduce friction, wear, and rust, or may stabilize emulsions, foams, and solid dispersions. The broad field of catalysis, which is basic to petroleum refining and many chemical industries, involves chemical reactions that are accelerated in the thin films of reactants at interfaces. Moreover, thin films containing proteins, cholesterol, and related compounds constitute biological membranes, the internal interfaces that control the complex processes of life. See CATALYSIS; CELL MEMBRANES.

In all of these areas, a single monomolecular layer at the interface is the most important. It is held to the adsorbing surface by forces stronger than those that hold any succeeding layer. On solid surfaces, it is the only layer that can be chemisorbed. It may be the site of enhanced chemical reactivity, or the last line of defense.

Monolayers on solids, or at liquid interfaces, may be formed by adsorption from the adjacent bulk phases; the process may show high specificity for particular chemical species. Measurements of the extent of adsorption have historically provided information on the composition and structure of monolayers formed in this way. A variety of surface-sensitive instrumental techniques, such as diffraction and scattering of low-energy electrons, neutrons, and ions, and spectroscopy of adsorbed species, have been brought to bear to obtain information about the structure of the surface layer and chemical perturbations in it. See ADSORPTION; SPECTROSCOPY.

In addition, monolayers of a wide variety of substantially insoluble substances can be formed at a liquid-gas interface by allowing them to spread over the surface. The properties of such films at the water-air interface can be manipulated, controlled, and measured in simple and elegant ways. A variety of specialized experimental techniques have been developed to study these insoluble monolayers.

In order to form spread monolayers which are sufficiently stable to study, a substance must combine low solubility and volatility with some moiety which attracts it to the liquid surface; for films on water, this generally means one or more polar functional groups. Totally nonpolar substances, such as the higher-molecular-weight paraffin hydrocarbons, will not spread on water (although they can spread on liquids of very high surface tension, such as mercury). Typical among the large group of substances which do form insoluble monolayers on water are the long-chain fatty acids and their derivatives such as glycerides, sterols, and many lipid substances of biological origin, including the fat-soluble vitamins and natural pigments such as chlorophyll. Many polar synthetic polymers, including polyvinyl acetate and polymethyl methacrylate, can be made to spread as monolayers on water; so can many proteins, because their tertiary structure unfolds at the air-water interface. See POLAR MOLECULE. [G.L.G.]

**Mononchida** An order of nematodes having a full complement of cephalic sensilla on the lips in two circlets of 6 and 10. The amphids are small and cuplike, and are located just posterior to the lateral lips; the amphidial aperture is either slit-like or

ellipsoidal. The stoma is globular and heavily cuticularized, and is derived primarily from the cheilostome. The stoma bears one or more massive teeth that may be opposed by denticles in either transverse or longitudinal rows. The esophagus is cylindrical conoid, with a heavily cuticularized luminal lining. The excretory system is atrophied. Males have ventromedial supplements and paired spicules. The gubernaculum may possess lateral accessory pieces. Females have one or two ovaries. Caudal glands and a spinneret are common; however, they may be degenerate or absent.

There are three mononchid superfamilies: The Mononchoidea contain some of the most common and easily recognized free-living nonparasitic nematodes that occur in soils and fresh waters throughout the world. The closely related Bathyodontoida are inhabitants of soil or fresh water and prey on small microorganisms. The nonparasitic Monochuloidea comprise both soil and fresh-water species, all of which are predators of microfauna. See NEMATODA. [A.R.M.]

**Monoplacophora** A class of the phylum Mollusca. Although fossil monoplacophorans had been known since the end of the nineteenth century, it was the discovery of a living species in deep water off Costa Rica in the 1950s that led to universal acceptance of the class. Monoplacophorans are bilaterally symmetrical, univalved mollusks that vanish from the fossil record at the end of the Paleozoic, about 240 million years ago. The living species, such as *Neopilina galathea*, are rare and inhabit deep water, which may explain their absence from Mesozoic and Cenozoic rocks. Living monoplacophorans have a limpet-shaped shell, a circular foot attached by pairs of retractor muscles, and several gills on each side of the body. See GASTROPODA; MOLLUSCA; POLYPLACOPHORA. [B.Ru.]

**Monopulse radar** Radar capable of estimating target position based on the return from a single pulse. In many radars, precise angular position is estimated by conically scanning a single beam around the initial coarse angle estimate; the orderly amplitude variation of echoes during such scanning provides the refinement. Such measurement is limited, however, by pulse-to-pulse fluctuations in echo strength, a property quite common in radar targets.

Monopulse radars use antennas that provide a local cluster of simultaneous beams (instead of scanning just one beam) to make the same precise angle estimate with each pulse transmitted. Since angle information is contained in each return, fluctuations in echo strength do not significantly degrade the measurement. Monopulse radars with mechanically positioned antennas address only a single target, and average the measurements over many pulses for improved accuracy. Radars using electronic beam steering in stationary phased-array antennas may make such a measurement in a single-pulse "dwell," doing so on dozens of targets, returning to each several times a second if necessary. [R.T.H.]

**Monorail** A distinctive type of materials-handling machine that provides an overhead, normally horizontal, fixed path of travel in the form of a trackage system and individually propelled hand or powered trolleys which carry their loads suspended freely with an intermittent motion. Because monorails operate over fixed paths rather than over limited areas, they differ from overhead-traveling cranes, and they should not be confused with such overhead conveyors as cableways. See BULK-HANDLING MACHINES; MATERIALS-HANDLING EQUIPMENT. [A.M.P.]

**Monosaccharide** A class of simple sugars containing a chain of 3–10 carbon atoms in the molecule, known as polyhydroxy aldehydes (aldoses) or ketones (ketoses). They are very soluble in water, sparingly soluble in ethanol, and insoluble in ether. The number of monosaccharides known is approximately 70, of which about 20 occur in nature. The remainder are synthetic. The existence of such a large number of compounds is due

to the presence of asymmetric carbon atoms in the molecules. Aldohexoses, for example, which include the important sugar glucose, contain no less than four asymmetric atoms, each of which may be present in either D or L configuration. The number of stereoisomers rapidly increases with each additional asymmetric carbon atom.

A list of the best-known monosaccharides is given below:

Trioses:	$\text{CH}_2\text{OH} \cdot \text{CHOH} \cdot \text{CHO}$ , glycerose (glyceric aldehyde)
Tetroses:	$\text{CH}_2\text{OH} \cdot \text{CO} \cdot \text{CH}_2\text{OH}$ , dihydroxy acetone $\text{CH}_2\text{OH} \cdot (\text{CHOH})_2 \cdot \text{CHO}$ , erythrose $\text{CH}_2\text{OH} \cdot \text{CHOH} \cdot \text{CO} \cdot \text{CHO}$ , erythrulose
Pentoses:	$\text{CH}_2\text{OH} \cdot (\text{CHOH})_3 \cdot \text{CHO}$ , xylose, arabinose, ribose $\text{CH}_2\text{OH} \cdot (\text{CHOH})_2 \cdot \text{CO} \cdot \text{CH}_2\text{OH}$ , xylulose, ribulose
Methyl pentoses (6-deoxyhexoses):	$\text{CH}_3(\text{CHOH})_4 \cdot \text{CHO}$ , rhamnose, fucose
Hexoses:	$\text{CH}_2\text{OH} \cdot (\text{CHOH})_4 \cdot \text{CHO}$ , glucose, mannose, galactose $\text{CH}_2\text{OH} \cdot (\text{CHOH})_3 \cdot \text{CO} \cdot \text{CHOH}$ , fructose, sorbose
Heptoses:	$\text{CH}_2\text{OH} \cdot (\text{CHOH})_5 \cdot \text{CHO}$ , glucoheptose, galamannoheptose $\text{CH}_2\text{OH} \cdot (\text{CHOH})_4 \cdot \text{CO} \cdot \text{CH}_2\text{OH}$ , sedoheptulose, mannoheptulose

Aldose monosaccharides having 8, 9, and 10 carbon atoms in their chains have been synthesized. See CARBOHYDRATE; KETONE; OPTICAL ACTIVITY; STEREOCHEMISTRY. [W.Z.H.]

**Monosodium glutamate** The single sodium salt of glutamic acid used in foods to accentuate flavors. It is also known as MSG. Molecular structure is represented below.

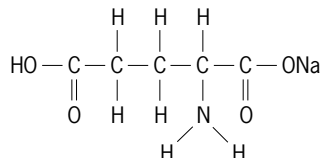

The crystal form available in commerce is the monohydrate, with structure as represented plus one molecule of water of hydration.

Originally produced from seaweed in the Orient, it is now made principally from cereal glutes, such as those of wheat, corn, and soybeans, from solutions evolved in the manufacture of beet sugar, and by microbiological fermentation of carbohydrates. The two raw materials used for the greater proportion of commercial production are wheat gluten and desugared beet-sugar molasses.

Monosodium glutamate is recognized as a standard of identity ingredient in several commercial food preparations. Its principal use is in the preparation of canned and dried soups, but it also enters into the production of some meat, vegetable, fowl, and fish products. It is the so-called secret ingredient used by many of the famous restaurant and hotel chefs. [P.D.V.M.]

**Monotremata** The single order of the mammalian subclass Prototheria. Two living families, the Tachyglossidae and the Ornithorhynchidae, make up this unusual order of quasi-mammals, or mammallike reptiles.

The Tachyglossidae comprise the echidnas (spiny anteaters), which have relatively large brains with convoluted cerebral hemispheres. The known genera, *Tachyglossus* and *Zaglossus*, are terrestrial, feeding on termites, ants, and other insects. They are capable diggers, both to obtain food and to escape enemies. Like hedgehogs, they can erect their spines and withdraw their limbs when predators threaten. Commonly one egg, but occasionally

two or even three, is laid directly into the marsupium (pouch) of the mother where it is incubated for up to 10 days. Species of *Tachyglossus* live in rocky areas, semideserts, open forests, and scrublands. They are found in Australia, Tasmania, New Guinea, and Salawati Island. Species of *Zaglossus* are found in mountainous, forested areas.

The duck-billed platypus, constituting the Ornithorhynchidae, has a relatively small brain with smooth cerebral hemispheres. The young have calcified teeth, but in the adult these are replaced by horny plates which form around the teeth in the gums. The snout is duck-billed. The semiaquatic platypus is a capable swimmer, diver, and digger. Two eggs are usually laid by the female into a nest of damp vegetation. After incubating the eggs for about 10 days the female leaves, returning only when the eggs are hatched. The platypus is found in Australia and Tasmania in almost all aquatic habitats. See MAMMALIA; PROTOTHERIA. [F.S.S.]

**Monsoon meteorology** The study of the structure and behavior of the atmosphere in those areas of the world that have monsoon climates. In lay terminology, monsoon connotes the rains of the wet summer season that follows the dry winter. However, for mariners, the term monsoon has come to mean the seasonal wind reversals.

In true monsoon climates, both the wet summer season that follows the dry winter and the seasonal wind reversals should occur. Winds from cooler oceans blow toward heated continents in summer, bringing warm, unsettled, moisture-laden air and the season of rains, the summer monsoon. In winter, winds from the cold heartlands of the continents blow toward the oceans, bringing dry, cool, and sunny weather, the winter monsoon.

Based on these criteria, monsoon climates of the world include almost all of the Eastern Hemisphere tropics and subtropics, which is about 25% of the surface area of the Earth. The areas of maximum seasonal precipitation straddle or are adjacent to the Equator. Two of the world's areas of maximum precipitation (heavy rainfall) are within the domain of the monsoons: the central and south African region, and the larger south Asia-Australia region. The monsoon surface winds emanate from the cold continents of the winter hemisphere, cross the Equator, and flow toward and over the hot summer-hemisphere land masses.

India presents the classic example of a monsoon climate region, with an annual cycle that brings southwesterly winds and heavy rains in summer (the Indian southwest monsoon) and northeasterly winds and dry weather in winter (the northeast winter monsoon).

Like all weather systems on Earth, monsoons derive their primary source of energy from the Sun. About 30% of the Sun's energy that enters the top of the atmosphere is transmitted back to space by cloud and surface reflections. Little of the remainder is absorbed directly by the clear atmosphere; it is absorbed at the Earth's surface according to a seasonal cycle. The opposition of seasons in the Northern and Southern hemispheres leads to a slow movement of surface air across the Equator from winter hemisphere to summer hemisphere, forced by horizontal pressure gradients and vertical buoyancy forces resulting from differential seasonal heating. Such a seasonally reversing rhythm is most pronounced in the monsoon regions. See ALBEDO; ATMOSPHERE; HEAT BALANCE; INSOLATION; METEOROLOGY; TROPICAL METEOROLOGY. [J.S.Fe.]

**Monstrilloida** A small, aberrant order of the crustacean subclass Copepoda. It comprises two families whose members, as larvae, are parasitic on invertebrates, particularly polychaete worms and prosobranch mollusks. Monstrilloids are characterized by a total absence of mouthparts and gut in the free-swimming, nonfeeding adult phase. Antennae are lacking, but antennules are usually well developed. Thoracopods number four pairs, and females carry two egg sacs on a pair of ovigerous spines. See COPEPODA; CRUSTACEA. [PA.McL.]

**Monte Carlo method** A technique for estimating the solution,  $x$ , of a numerical mathematical problem by means of an artificial sampling experiment. The estimate is usually given as the average value, in a sample, of some statistic whose mathematical expectation is equal to  $x$ . In many of the useful applications, the mathematical problem itself arises in a problem of probability in physics or other sciences, operational research, image analysis, general statistics, mathematical economics, or econometrics. The importance of the method arises primarily from the need to solve problems for which other methods are more expensive or impracticable, and from the increased importance of all numerical methods because of the development of the electronic digital computer.

The main advantage of Monte Carlo is that other methods can be more costly or impracticable. A familiar example is the estimation of the probability of winning a game of pure chance: Sometimes the only reasonably simple method of estimation is to play the game several times. There are also numerical problems that can be solved by deterministic methods but can be more simply solved approximately by the Monte Carlo method. Sometimes poor approximations are satisfactory because the aim is merely to determine the strategic variables of a problem. This is likely to be a fruitful technique in mathematical economics.

Another situation where a poor approximation is satisfactory occurs when there is available an iterative method of calculation, that is, a method of successive approximation, which converges closely to the right answer in a reasonable time provided that the first trial solution is not too far from the truth. The Monte Carlo method may then perhaps be used for obtaining a first trial solution. Modern Monte Carlo techniques are themselves usually iterative.

Sometimes the expense of a Monte Carlo method does not increase as fast as that of other methods when the dimensionality of a problem is increased. This seems to be true for multiple integration when it cannot be done analytically, and for the solution of Schrödinger's equation for several particles. See SCHRÖDINGER'S WAVE EQUATION.

The main disadvantage of some Monte Carlo methods is that for each extra decimal place required, it is necessary to multiply the sample size by 100. Thus, to calculate  $\pi$  to five decimal places by throwing a needle would require about  $10^{10}$  throws, or 1 throw per second for about 300 years. [I.J.G.]

**Month** Any of several units of time based on the revolution of the Moon around Earth.

The calendar month is one of the 12 arbitrary periods into which the calendar year is divided. See CALENDAR.

The synodic month, the period of the lunar phases, is the average period of revolution of the Moon with respect to the Sun, the same as the average interval between successive full moons. Its duration is 29.531 days. See PHASE (ASTRONOMY).

The tropical month is the period required for the mean longitude of the Moon to increase  $360^\circ$ , or 27.322 days.

The sidereal month, 7 s longer than the tropical month, is the average period of revolution of the Moon with respect to a fixed direction in space.

The anomalistic month, 27.555 days in duration, is the average interval between closest approaches of the Moon to Earth. The variation in the Moon's distance from the Earth causes a variation in the apparent size of the Moon and thus in the duration of solar eclipses.

The nodical month, 27.212 days in duration, is the average interval between successive northward passages of the Moon across the ecliptic, points known as nodes. Since eclipses can occur only when the Sun and Moon are near such nodes, this period is also known as a draconic month, after the Chinese mythical dragon that supposedly ate the Sun to cause a solar eclipse. See ECLIPSE; MOON; TIME. [G.M.C.; J.M.P.]

**Montmorillonite** A group name for all clay minerals with an expanding structure, except vermiculite, and also a specific mineral name for the high alumina end member of the group. See CLAY MINERALS; VERMICULITE.

Montmorillonite clays have wide commercial use. The high colloidal, plastic, and binding properties make them especially in demand for bonding molding sands and for oil-well drilling muds. They are also widely used to decolorize oils and as a source of petroleum cracking catalysts. See CLAY.

Members of the montmorillonite group of clay minerals vary greatly in their modes of formation. Alkaline conditions and the presence of magnesium particularly favor the formation of these minerals. Several important modes of occurrence are in soils, in bentonites, in mineral veins, in marine shales, and as alteration products of other minerals. Recent sediments have a fairly high montmorillonite content. See BENTONITE; MARINE SEDIMENTS.

[F.M.W.; R.E.Gr.]

**Moon** The Earth's natural satellite. United States and Soviet spacecraft have obtained lunar data and samples, and American astronauts have orbited, landed upon, and roved upon the Moon.

The Earth and Moon now make one revolution about their barycenter, or common center of mass (a point about 4670 km from the Earth's center), in  $27^d 7^h 43^m 11.6^s$ . This sidereal period is slowly lengthening, and the distance (now about 60.27 earth radii) between centers of mass is increasing, because of tidal friction in the oceans of the Earth.

The Moon's present orbit is inclined about  $5^\circ$  to the plane of the ecliptic. As a result of differential attraction by the Sun on the Earth-Moon system, the Moon's orbital plane rotates slowly relative to the ecliptic (the line of nodes regresses in an average period of 18.60 years) and the Moon's apogee and perigee rotate slowly in the plane of the orbit (the line of apsides advances in a period of 8.850 years). Looking down on the system from the north, the Moon moves counterclockwise. It travels along its orbit at an average speed of nearly 0.6 mi/s (1 km/s) or about 1 lunar diameter per hour.

As a result of the Earth's annual motion around the Sun, the direction of solar illumination changes about  $1^\circ$  per day, so that lunar phases do not repeat in the sidereal period given above but in the synodic period, which averages  $29^d 12^h 44^m$ .

When the lunar line of nodes coincides with the direction to the Sun and the Moon happens to be near a node, eclipses can occur. See ECLIPSE.

The relation between the Moon's shape and its mass distribution is very important to theories of lunar origin and the history of the Earth-Moon system. By radio altimetry, Apollo confirmed that the Moon's surface on the far side is higher on the average than the near side; that is, the center of mass is offset from the center of figure. The offset is about 2 km (1.2 mi) toward the Earth. These observations suggest that the Moon's crust is thicker on the far side than on the near side. The *Clementine* mission in 1994 extended measurements to nearly the whole Moon and revealed the depth of a huge basin on the southern far side.

The Moon's small size and low mean density result in surface gravity too low to hold a permanent atmosphere, and therefore it was to be expected that lunar surface characteristics would be very different from those of Earth. However, the bulk properties of the Moon are also quite different—the density alone is evidence of that. The Moon is too small to have compressed its silicates into a metallic phase by gravity; therefore, if it has a dense core at all, the core should be of nickel-iron. Available data suggest that the Moon's iron core may have a diameter of at most a few hundred kilometers.

As can be seen from the Earth with the unaided eye, the Moon has two major types of surface: the dark, smooth maria and the lighter, rougher highlands. Photography by spacecraft shows that, for some unknown reason, the Moon's far side con-



Aristarchus-Harbinger region of the Moon, photographed from the *Apollo 15* spacecraft in lunar orbit, with the craters Aristarchus and Herodotus and Schroeter's Valley, the largest sinuous rille on the Moon. The impact crater Aristarchus, about 25 mi (40 km) in diameter and more than 2.5 mi (4 km) deep, lies at the edge of a mountainous region that shows evidence of volcanic activity. (NASA)

sists mainly of highlands. Both maria and highlands are covered with craters of all sizes. Numerous different types of craters can be recognized. Most prominent at full moon are the bright ray craters whose grayish ejecta appear to have traveled for hundreds of miles across the lunar surface. Observers have long recognized that some erosive process has been and may still be active on the Moon. Bombardment of the airless Moon by meteoritic matter and solar particles, and extreme temperature cycling, are now considered the most likely erosive agents, but local internal activity is also a possibility.

The lunar mountains, though very high (26,000 ft or 8000 m), are not extremely steep, and lunar explorers see rolling rather than jagged scenery. Though a widespread network of fault traces is visible, there is no evidence on the Moon of the great mountain-building processes seen on the Earth.

Basins on the Moon's near side, namely, Imbrium, Serenitatis, and Crisium, appear fully flooded. These were maria created by giant impacts, followed by subsidence of the ejecta and (probably much later) upwelling of lava from inside the Moon. Examination of small variations in Lunar Orbiter motions has revealed that each of the great circular maria is the site of a positive gravity anomaly (excess mass). The old argument about impact versus vulcanism as the primary agent in forming the lunar relief appears to be entering a new, more complicated phase with the confirmation of extensive flooding of impact craters by lava on the Moon's near side, while on the far side, where the crust is thicker, the great basins remain mostly empty.

In some of the Moon's mountainous regions bordering on the maria are found sinuous rilles (see illustration). These winding valleys were shown in Lunar Orbiter pictures to have an exquisite fineness of detail. No explanation for them yet offered has proved entirely convincing.

The Moon seems to be totally covered, to a depth of at least tens of meters, by a layer of rubble and soil with very peculiar optical and thermal properties. This layer is called the regolith. The observed optical and radio properties all point to a highly porous or underdense structure for at least the top few millimeters

of the lunar surface material. A dark-gray, fine soil appears to mantle the entire Moon, softening most surface contours and covering everything except occasional fields of rocks. This soil, with a slightly cohesive character like that of damp sand and a chemical composition similar to that of some basic silicates on the Earth, is a product of the radiation, meteoroid, and thermal environment at the lunar surface. [J.D.Bu.]

**Moose** An even-toed ungulate (Artiodactyla) which is a member of the deer family, Cervidae. *Alces alces* is the largest member of the family and ranges in the boreal forested areas throughout North America and in northern Eurasia. The moose is known as the elk in Europe and is believed by some authorities to be a race of the American moose (*A. americana*). The legs are long, making the animal well-adapted for its feeding habits of wading for aquatic plants and browsing on trees and bushes. During the rutting season in the early fall, the male gathers a number of cows together, and mating takes place. After a gestation period of about 37 weeks, one or two calves are born. See ARTIODACTYLA. [C.B.C.]

**Moraine** An accumulation of glacial debris, usually till, with distinct surface expression related to some former ice front position. End moraine, the most common form, is an uneven ridge of till built in front of or around the terminus of a glacier margin, and reflects some degree of equilibrium between rate of ice motion, supply of rock debris at the ice front, temperature of the glacier base, and shape and resistance of underlying bedrock (see illustration).



End moraine in Pennsylvania (U.S. Geological Survey).

If an end moraine represents the farthest forward position a glacier ever moved, it is a terminal moraine. It demonstrates a steady-state condition for a period of time within the ice body where constant forward motion is balanced by frontal melting; and a continual supply of debris, as on an endless conveyor belt, is brought forward to the glacier terminus. If the ice front then melts farther back than it moves forward, till is spread unevenly over the land as ground moraine. If a retreatal position of steady-state equilibrium is maintained again, a recessional moraine may be constructed.

Drumlins, produced by glacier streamlining of ground moraine, are probably the best-known moraine forms. [S.E.Wh.]

**Moraxella** A genus of bacteria that are parasites of mucous membranes. Subgenus *Moraxella* is characterized by gram-negative rods that are often very short and plump, frequently resembling a coccus, and usually occurring in pairs. Subgenus *Branhamella* has gram-negative cocci occurring as single cells or in pairs with the adjacent sides flattened. They are usually harmless parasites of humans and other warm-blooded animals and are generally considered not to be highly pathogenic. Most species may be opportunistic pathogens in predisposed or debilitated hosts.

There are presently six species in the subgenus *Moraxella*: *M. (M.) lacunata* (also known as *Diplobacillus moraxaxenfeld* and *liquefaciens*), *M. (M.) bovis*, *M. (M.) nonliquefaciens* (also known as *Bacillus duplex nonliquefaciens*), *M. (M.) atlantae*, *M. (M.) phenylpyruvica*, and *M. (M.) osloensis*. The different species are recognized on the basis of phenotypic properties, including liquefaction of coagulated serum, hemolysis of human blood in liquid agar media, nitrate reduction, phenylalanine deaminase activity, urease activity, and growth on mineral salts medium with ammonium ion and acetate as the sole carbon source.

The subgenus *Branhamella* presently contains four species: *M. (B.) catarrhalis*, *M. (B.) caviae*, *M. (B.) ovis*, and *M. (B.) cuniculi*. The different species are recognized on the basis of hemolysis of human blood in blood agar media, and nitrate and nitrite reduction, among other properties.

*Moraxella (M.) lacunata*, the type species of the subgenus *Moraxella*, was a significant causative agent of human conjunctivitis and keratitis in the past but is only rarely isolated at present. Infectious keratoconjunctivitis in cattle, called pinkeye, is caused by *M. (M.) bovis*. *Moraxella (M.) nonliquefaciens* is considered to be a well-established parasite of humans and rarely causes disease, but it has been associated with endophthalmitis and pneumonitis with pulmonary abscess. *Moraxella (M.) osloensis*, usually a harmless parasite, has been frequently associated with such human infections as osteomyelitis, endocarditis, septicemia, meningitis, stomatitis, and septic arthritis.

*Moraxella (B.) catarrhalis*, the type species of *Branhamella*, is the only species of this subgenus recovered from humans. The organism is considered to be a well-adapted parasite but has been judged the etiologic agent of middle-ear infection, maxillary sinus infection, bronchitis, tracheitis, conjunctivitis, pneumonia, otitis media of infants, respiratory disease in the compromised host, septicemia, meningitis, and endocarditis. The remaining *Branhamella* species (*caviae*, *ovis*, and *cuniculi*) are parasites of guinea pigs, sheep, cattle, and rabbits.

*Moraxella* species are susceptible to most antimicrobial agents with the exception of the lincomycins. Their usually high susceptibility to the penicillins is a feature that separates them from most other gram-negative rods. See CLINICAL MICROBIOLOGY. [G.G.]

**Mordant** A substance or combination of substances that facilitates the fixing of a dye to a fiber. A mordant enables the production of a more permanent and often deeper color. Metallic salts or hydroxides are most frequently used as mordants.

Certain mordants act directly on the fiber, making it more susceptible to the dye. Fabrics are then pretreated with the mordant before exposure to the dye. Other mordants function through the formation of a complex with the dye. The complex acts as the dyeing agent. Mordant and dye in this case are exposed simultaneously to the fabric. See DYE; DYEING. [F.J.J.]

**Mormonilloida** The smallest of seven orders of Copepoda, containing two species in a single genus; their position in the copepod hierarchy has not been determined. Mormonilloids are free-living copepods that, in body form, closely resemble certain cyclopoids. However, they differ significantly in possessing mouthparts typical of the Calanoida. The presence of both gymnoplean and podoplean characteristics suggests a phylogenetic relationship with the Misophrioida. The lack of a heart, the small number of antennal segments, and the absence of fifth thoracic legs immediately distinguish mormonilloids from misophrioids. See CALANOIDA; MISOPHRIOIDA.

Both mormonilloid species are pelagic, primarily occurring in a depth range of 1350–2300 ft (410–700 m) in the eastern North Atlantic. Males have never been observed. See COPEPODA; CRUSTACEA. [P.A.McL.]

**Mortar** A binding agent used in construction of clay brick, concrete masonry, and natural stone masonry walls and, to much less extent, landscape pavements. Modern mortars are improved

versions of the lime and sand mixtures historically used in building masonry walls. See BRICK; MASONRY.

Masonry mortar is composed of one or more cementitious materials, such as masonry cement or portland cement and lime, clean sand, and sufficient water to produce a plastic, workable mixture.

Mortars are closely related to concrete but, like grout, generally do not contain coarse aggregate. Mortars function with the same calcium silicate-based chemistry as concrete and grouts, bonding with masonry units into a contiguous, weatherproof surface in the process. Masonry cement or portland cement-lime mortars can be formulated to address job-specific requirements including setting time, rate of hardening, water retentivity, and extended workability. See CEMENT; CONCRETE; GROUT; LIME (INDUSTRY). [J.Me.]

**Mosaicism** The coexistence of two or more genetically distinct cell populations derived originally from a single zygote. Mosaics may arise at any stage of development, from the two-cell stage onward, or in any tissue which actively proliferates thereafter. The phenomenon is commonly observed in many species of animals and plants and may be caused by somatic mutation or chromosomal nondisjunction. An individual animal or plant may exhibit mosaicism, or it may occur in a culture of a single cell- or tissue-type obtained from an individual.

Chromosome nondisjunction is probably the principal cause of chromosomal aberration, which in turn may lead to the development of mosaicism. During cell division, the two sister chromatids usually separate completely, each chromatid going to opposite poles of the cell guided by the spindle apparatus. In some cases, one chromatid will fail to completely separate, or it may lag behind. This nondisjunction will lead to the presence of both sister chromatids in the same daughter cell instead of one in each of the daughter cells (Fig. 1). Somatic crossing-over leads to the production of a recombinant mosaic where chromosome segments, with their corresponding blocks of genes, are exchanged between homologous chromosomes during mitosis. The occurrence of this process leads to mosaicism, mostly manifested as spots (clones of variant cells) on the cuticle of insects or on leaves, petals, or stamen hairs. See CHROMOSOME.

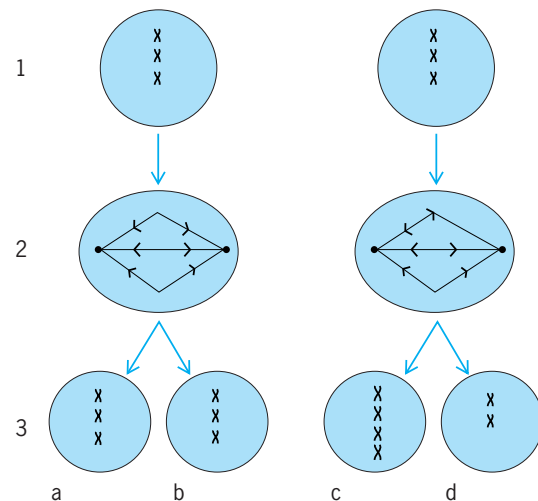

**Fig. 1. Mosaicism caused by chromosome nondisjunction.** (1) Two cells with an identical chromosome complement are in the process of cellular division. (2) In the cell on the left, the sister chromatids have separated normally, whereas in the other cell, one chromatid has remained in the equatorial zone. (3) Two normal daughter cells (a and b) are produced as a result of a normal mitotic division. Two aneuploid cells (c and d) result from the abnormal division. If c and d are viable, a tissue mosaicism may result with a mixture of normal cells and some aneuploid cells (c, d, or c and d).



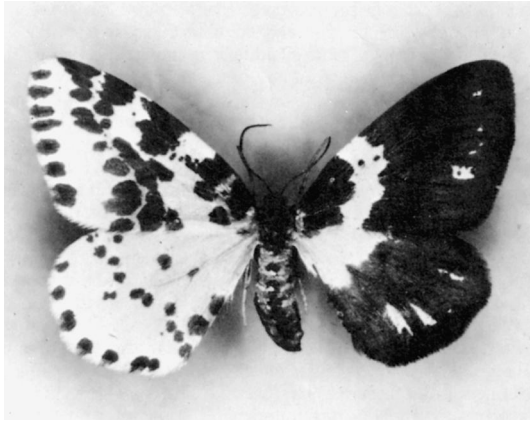

Fig. 2. Bilateral gynandromorphism in the moth *Abraxas grossulariata*. The left side shows the typical male wing patterning, whereas the right side shows a female form.

Sex chromosome mosaicism, the presence of a mixture of cell populations with different X and Y chromosome constitutions, is not uncommon and is often seen in individuals with ovarian dysgenesis. The presence of a significant proportion of chromosomally abnormal cells in any such mosaic will tend to lead to a clinically expressed syndrome. The proportion of each constituent clone may vary from tissue to tissue, but is relatively stable in each individual site throughout adult life. Sex mosaics (gynandromorphs) are particularly striking where a difference in the secondary sexual characteristics exists between the normal sexes. For example, in a butterfly with bilateral gynandromorphism, the left side may show the characteristic wing color and pattern of the male, and the light wing, typical female patterning (Fig. 2). See CHIMERA; GENETICS; SEX-LINKED INHERITANCE.

[A.W.W.]

**Mosquito** Any member of the family Culicidae in the insect order Diptera. Mosquitoes are holometabolous insects and all larval stages are aquatic. Adults are recognized by their long proboscis for piercing and sucking, and characteristic scaled wing venation. This is a relatively large group of well-known flies with nearly 3000 species in 34 genera reported in the world. There are 13 genera and 167 recognized species of mosquitoes in North America north of Mexico. Almost 75% of these species belong to three genera: *Aedes* (78 species), *Culex* (29 species), and *Anopheles* (16 species).

Adult females lay their eggs on or near water. Most larvae, or wrigglers, feed on algae and organic debris that they filter from the water with their oral brushes, although certain genera may be predaceous and feed on other mosquito larvae. Larvae go through three molts and four instars before pupation. Pupae, or tumblers, are active but nonfeeding stages in which metamorphosis to the adult stage occurs. Both larvae and pupae usually breathe through air tubes at the surface of the water.

Adult male mosquitoes are relatively short-lived, and do not suck blood, but feed primarily on nectar and other plant juices. Females also feed on nectar as their primary energy source, but they require a blood meal for egg production in most species. Some mosquito species are very host-specific, blood-feeding only on humans, birds, mammals, or even reptiles and amphibians, although many species will feed on any available host.

Mosquitoes are of major importance in both human and veterinary medicine. They can cause severe annoyance and blood loss when they occur in dense populations, and they act as vectors of three important groups of disease-causing organisms: *Plasmodium*, the protozoan parasite that produces malaria; filarial worms, parasitic nematodes causing elephantiasis in humans and heartworm disease in canines; and arboviruses, which are the causative agents of yellow fever, dengue fever,

LaCrosse encephalitis, St. Louis encephalitis, western equine encephalomyelitis, eastern and Venezuelan equine encephalitis, and several other viral diseases. Human malaria is transmitted exclusively by *Anopheles*, filariasis by *Culex*, *Anopheles*, and *Aedes*, and arboviruses primarily by *Culex* and *Aedes* species. See ARBOVIRAL ENCEPHALITIDES; HEARTWORMS; INSECTA; MALARIA; MEDICAL PARASITOLOGY; YELLOW FEVER.

[B.M.Ch.]

**Mössbauer effect** Recoil-free gamma-ray resonance absorption. The Mössbauer effect, also called nuclear gamma resonance fluorescence, has become the basis for a type of spectroscopy which has found wide application in nuclear physics, structural and inorganic chemistry, biological sciences, the study of the solid state, and many related areas of science.

The fundamental physics of this effect involves the transition (decay) of a nucleus from an excited state of energy  $E_e$  to a ground state of energy  $E_g$  with the emission of a gamma ray of energy  $E_\gamma$ . If the emitting nucleus is free to recoil, so as to conserve momentum, the emitted gamma ray energy is  $E_\gamma = (E_e - E_g) - E_r$ , where  $E_r$  is the recoil energy of the nucleus. The magnitude of  $E_r$  is given classically by the relationship  $E_r = E_\gamma^2/2mc^2$ , where  $m$  is the mass of the recoiling atom and  $c$  is the speed of light. Since  $E_r$  is a positive number, the  $E_\gamma$  will always be less than the difference  $E_e - E_g$ , and if the gamma ray is now absorbed by another nucleus, its energy is insufficient to promote the transition from  $E_g$  to  $E_e$ .

In 1957 R. L. Mössbauer discovered that if the emitting nucleus is held by strong bonding forces in the lattice of a solid, the whole lattice takes up the recoil energy, and the mass in the recoil energy equation given above becomes the mass of the whole lattice. Since this mass typically corresponds to that of  $10^{10}$  to  $10^{20}$  atoms, the recoil energy is reduced by a factor of  $10^{-10}$  to  $10^{-20}$ , with the important result that  $E_r \approx 0$  so that  $E_\gamma = E_e - E_g$ ; that is, the emitted gamma-ray energy is exactly equal to the difference between the nuclear ground-state energy and the excited-state energy. Consequently, absorption of this gamma ray by a nucleus which is also firmly bound to a solid lattice can result in the "pumping" of the absorber nucleus from the ground state to the excited state. See ENERGY LEVEL (QUANTUM MECHANICS); EXCITED STATE; GAMMA RAYS; GROUND STATE.

In a typical Mössbauer experiment the radioactive source is mounted on a velocity transducer which imparts a smoothly varying motion (relative to the absorber, which is held stationary), up to a maximum of several centimeters per second, to the source of the gamma rays. These gamma rays are incident on the material to be examined (the absorber). Some of the gamma rays are absorbed and reemitted in all directions, while the remainder of the gamma rays traverse the absorber and are registered in an appropriate detector.

A typical display of a Mössbauer spectrum, which is the result of many repetitive scans through the velocity range of the transducer, is shown in the illustration. In certain nuclides the

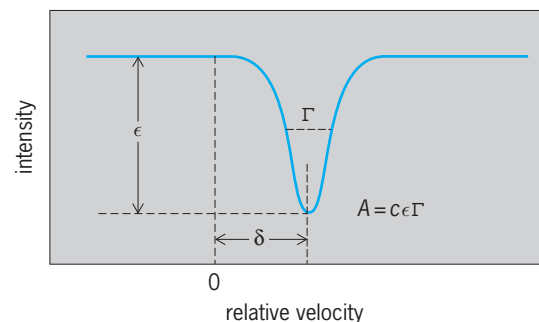

Mössbauer spectrum of an absorber which gives an unsplit resonance line. The spectrum is characterized by a position  $\delta$ , a line width  $\Gamma$ , and an area  $A$  related to the effect magnitude  $\epsilon$ .

Mössbauer resonance line displays splitting that arises from the coupling of the nuclear electric quadrupole moment with the electric field gradient or of the nuclear magnetic dipole moment with the magnetic field at the nucleus, providing information on the magnitude of these interactions.

Mössbauer effect experiments have been used to elucidate problems in a very wide range of scientific disciplines. Applications include the measurement of nuclear magnetic and quadrupole moments and of excited-state lifetimes involved in the nuclear decay process; study of the chemical consequences of nuclear decay; study of the nature of magnetic interactions in iron-containing alloys and of the dependence of the magnetic field in these alloys on various parameters; study of the effects of high pressure on chemical properties of materials; investigation of the relationship between chemical composition and structure on the one hand and the superconductive transition on the other; investigation of the structure of compounds; and study of the structure and bonding properties of metal atoms in complex biological molecules. [R.H.He.]

**Motion** If the position of a material system as measured by a particular observer changes with respect to time, that system is said to be in motion with respect to the observer. Absolute motion, then, has no significance, and only relative motion may be defined; what one observer measures to be at rest, another observer in a different frame of reference may regard as being in motion. See FRAME OF REFERENCE; RELATIVE MOTION.

The time derivatives of the various coordinates used to specify the system may be used to prescribe the motion at any instant of time. How the motion develops in subsequent instants is then determined by the laws of motion. In classical dynamics it is supposed that in principle the motion and configuration of the system may be specified to an arbitrary precision, although in quantum mechanics it is recognized that the measurement of the one disturbs the other.

The most general theory of motion that has yet been developed is quantum field theory, which combines both quantum mechanics and relativity theory, as well as the experimentally observed fact that elementary particles can be created and annihilated. See DEGREE OF FREEDOM (MECHANICS); DYNAMICS; EULER'S EQUATION OF MOTION; HAMILTON'S EQUATIONS OF MOTION; HARMONIC MOTION; KINEMATICS; KINETICS (CLASSICAL MECHANICS); LAGRANGE'S EQUATIONS; NEWTON'S LAWS OF MOTION; OSCILLATION; PERIODIC MOTION; QUANTUM FIELD THEORY; QUANTUM MECHANICS; RECTILINEAR MOTION; RELATIVITY; ROTATIONAL MOTION. [H.C.Co./B.G.]

**Motivation** The intentions, desires, goals, and needs that determine human and animal behavior. An inquiry is made into a person's motives in order to explain that person's actions.

Different roles have been assigned to motivational factors in the causation of behavior. Some have defined motivation as a nonspecific energizing of all behavior. Others define it as recruiting and directing behavior, selecting which of many possible actions the organism will perform. The likely answer is that both aspects exist. More specific determinants of action may be superimposed on a dimension of activation or arousal that affects a variety of actions nonselectively. The situation determines what the animal does; arousal level affects the vigor, promptness, or persistence with which the animal does it.

Early drive theorists saw motivated behavior as adjunct to physiological mechanisms of homeostasis, that is, the mechanisms by which the body regulates internal variables such as temperature, blood sugar level, and the volume and concentration of body fluids. Thus, motivated behavior forms part of a negative-feedback loop, an arrangement characteristic of regulatory systems.

However, the homeostatic model faces difficulties. First, not all "basic biological drives" work this way. Second, motivated behavior can be influenced by external as well as internal factors. Since these external influences are not coupled with the animal's

internal state, they can lead to behavior that does not promote homeostasis and may even threaten it. To add to the complexity, internal and external factors are not independent and additive; rather they interact with each other. In such cases, internal influences affect behavior by setting the animal's responsiveness to certain external signals. The interaction occurs in the opposite direction as well: external signals can affect internal state. Third, especially in humans, vigorous and persistent goal-directed behavior can occur in the absence of any physiological need. See HOMEOSTASIS.

Even relatively simple motives can be influenced by much more than the existing internal and external situation. They respond to potential or expected factors, as registered by cognitive apparatus. Even relatively simple motives such as hunger and thirst are responsive to cognitive factors. See THIRST.

To a hungry rat, food becomes a goal. The rat will make various responses, including arbitrary learned ones or operants, that lead to contact with food. A rat can be trained to do whatever else is necessary (within its capabilities) to attain its goal. It is this flexibility of goal-directed behavior that justifies the concept of motivation. If an animal will do whatever is necessary to obtain food, it must want food. Internal factors then may act by setting the goal status of environmental commodities: the effect of hunger is to make food a goal.

There is a question as to how behavior can be guided by a state or event (goal attainment) that does not yet exist. Modern approaches to this question lean heavily on cognitive concepts. Mammals, birds, and even some insects can represent to themselves a nonexistent state of affairs. They can represent what a goal object is (search images): a chimpanzee may show behavioral signs of surprise if a different food is substituted for the usual one. They can represent where it is (cognitive maps): a digger wasp remembers the location of its nest relative to arbitrary landmarks, and will fly to the wrong place if the landmarks are moved.

If this idea is generalized, motivated behavior can be thought of as guided by a feedback control system with a set point. A set point establishes a goal state which the control system seeks to bring about. Behavior is controlled, not by present external or internal stimuli alone, but by a comparison between the existing state of affairs and a desired state of affairs, that is, the set point or goal, registered or specified within the brain. The animal then acts to reduce the difference between the existing and the desired state of affairs.

This way of looking at motivation helps bridge the gap between simple motives in animals and complex ones in humans. If to be motivated is to do whatever is necessary to bring about an imagined state of affairs, then human motives can literally be as complex, and be projected as far into the future, as human imaginations permit. See COGNITION.

Another approach to motivation comes from ethology, which has formed links with cognitive psychology. The broken-wing display of the piping plover provides an example. If a predator approaches a nest with eggs, the parent bird may behave as if injured (hence easy prey) and thus lead the intruder away from the nest. This action pattern is characteristic of the species and unlearned in its gross topography; yet the bird monitors the intruder's behavior and modulates the display accordingly. It may approach more closely and intensify the display if the intruder is not at first diverted from its path. Thus a species-typical action pattern can be used in ways suggestive of purpose and goal direction: the bird modifies it as necessary to promote the goal of diverting the intruder. See ETHOLOGY.

Motivation and emotion are closely related. Indeed, it has been argued that emotions are the true motivators and that other factors internal, situational, and cognitive take hold of behavior by way of the emotions they evoke. In the simplest case, pleasure and displeasure have been recognized for centuries as having motivational force. In more complex cases, the role of cognitive operations, such as how an individual feels about an event, as

well as what is done about it, can depend heavily on how an individual thinks about it.

The culture in which an individual is raised has a powerful effect on how the individual behaves. It has been argued that culture teaches its members what to believe are the consequences of a specific action (cognitive), and how the individuals should feel about those consequences or about the actions themselves (emotional/motivational). [D.G.M.]

**Motor** A machine that converts electrical into mechanical energy. Motors that develop rotational mechanical motion are most common, but linear motors are also used. A rotary motor delivers mechanical power by means of a rotating shaft extending from one or both ends of its enclosure (see illustration). The shaft is attached internally to the rotor. Shaft bearings permit the rotor to turn freely. The rotor is mounted coaxially with the stationary part, or stator, of the motor. The small space between the rotor and stator is called the air gap, even though fluids other than air may fill this gap in certain applications.

In a motor, practically all of the electromechanical energy conversion takes place in the air gap. Commercial motors employ magnetic fields as the energy link between the electrical input and the mechanical output. The air-gap magnetic field is set up by current-carrying windings located in the rotor or the stator, or by a combination of windings and permanent magnets. The magnetic field exerts forces between the rotor and stator to produce the mechanical shaft torque; at the same time, in accord with Faraday's law, the magnetic field induces voltages in the windings. The voltage induced in the winding connected to the electrical energy source is often called a countervoltage because it is in opposition to the source voltage. By its magnitude and, in the case of alternating-current (ac) motors, its phase angle, the countervoltage controls the flow of current into the motor's electrical terminals and hence the electrical power input. The physical phenomena underlying motor operation are such that the power input is adjusted automatically to meet the requirements of the mechanical load on the shaft. See ELECTROMAGNETIC INDUCTION; MAGNET; WINDINGS IN ELECTRIC MACHINERY.

Both the rotor and stator have a cylindrical core of ferromagnetic material, usually steel. The parts of the core that are subjected to alternating magnetic flux are built up of thin steel laminations that are electrically insulated from each other to impede the flow of eddy currents, which would otherwise greatly reduce motor efficiency. The windings consist of coils of insulated copper or aluminum wire or, in some cases, heavy, rigid insulated conductors. The coils may be placed around pole pieces, called salient poles, projecting into the air gap from one of the cores, or they may be embedded in radial slots cut into the core surface

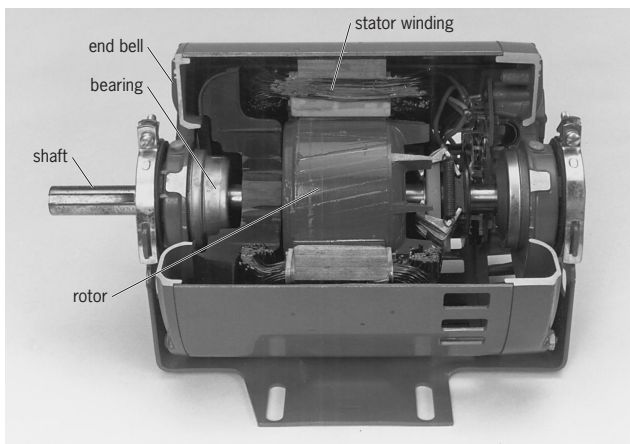

Cutaway view of a single-phase induction motor. (Emerson Motor Division)

facing the air gap. In a slotted core, the core material remaining between the slots is in the form of teeth, which should not be confused with magnetic poles. See EDDY CURRENT.

Direct-current (dc) motors usually have salient poles on the stator and slotted rotors. Polyphase ac synchronous motors usually have salient poles on the rotor and slotted stators. Rotors and stators are both slotted in induction motors. Permanent magnets may be inserted into salient pole pieces, or they may be cemented to the core surface to form the salient poles.

The windings and permanent magnets produce magnetic poles on the rotor and stator surfaces facing each other across the air gap. If a motor is to develop torque, the number of rotor poles must equal the number of stator poles, and this number must be even because the poles on either member must alternate in polarity (north, south, north, south) circularly around the air gap. [G.McP.]

**Motor-generator set** A motor and one or more generators, with their shafts mechanically coupled, used to convert an available power source to another desired frequency or voltage. The motor of the set is selected to operate from the available power supply; the generators are designed to provide the desired output.

The principal advantage of a motor-generator set over other conversion systems is the flexibility offered by the use of separate machines for each function. Since a double energy conversion is involved, electrical to mechanical and back to electrical, the efficiency is lower than in most other conversion methods. See GENERATOR; MOTOR. [A.R.E.]

**Motor systems** Those portions of nervous systems that regulate and control the contractile activity of muscle and the secretory activity of glands. Muscles and glands are the two types of organ by which an organism reacts to its environment; together they constitute the machinery of behavior. Cardiac muscle and some smooth muscle and glandular structures can function independently of the nervous system but in a poorly coordinated fashion. Skeletal muscle activity, however, is entirely dependent on neural control. Destruction of the nerves supplying skeletal muscles results in paralysis, an inability to move. The somatic motor system includes those regions of the central nervous system involved in controlling the contraction of skeletal muscles in a manner appropriate to environmental conditions and internal states. See GLAND; MUSCLE.

**Skeletal muscle.** The nerve supply to skeletal muscles of the limbs and trunk is derived from large nerve cells called motoneurons, whose cell bodies are located in the ventral horn of the spinal cord. Muscles of the face and head are innervated by motoneurons in the brainstem. The axons of the motoneurons traverse the ventral spinal roots (or the appropriate cranial nerve roots) and reach the muscles via peripheral nerve trunks. In the muscle, the axon of every motoneuron divides repeatedly into many terminal branches, each of which innervates a single muscle fiber. The region of innervation, called the neuromuscular junction or motor end plate, is a secure synaptic contact between the motoneuron terminal and the muscle fiber membrane. See SYNAPTIC TRANSMISSION.

Since synaptic transmission at the neuromuscular junction is very secure, an action potential in the motoneuron will produce contraction of every muscle fiber that it contacts. For this reason, the motoneuron and all the fibers it innervates form a functional unit called the motor unit. The number of muscle fibers in a single motor unit may be as small as six (for intrinsic eye muscles) or over 700 (for motor units of large limb muscles). In general, muscles involved in delicate rapid movements have fewer muscle fibers per motor unit than large muscles concerned with gross movements.

**Components of skeletal motor system.** Motoneurons are activated by nerve impulses arriving through many different

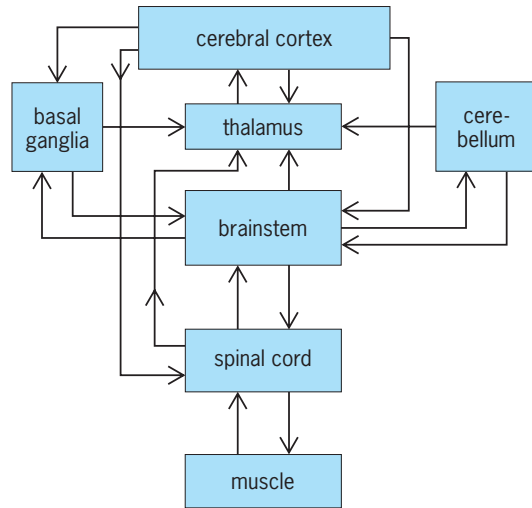

**Schematic diagram of the major components of the vertebrate motor systems. Arrows indicate the main neural connections between regions.**

neural pathways. Some of their neural input originates in peripheral receptor organs located in the muscles themselves, or in receptors in skin or joints. Many muscle receptors discharge in proportion to muscle length or tension; such receptors have relatively potent connections to motoneurons, either direct monosynaptic connections or relays via one or more interneurons. Similarly, stimulation of skin and joints, particularly painful stimulation, can strongly affect motoneurons. Such simple segmental pathways constitute the basis for spinal reflexes. The other major source of input to motoneurons arises from supraspinal centers. The illustration shows the main nervous system centers involved in controlling the input to motoneurons.

**Segmental circuits.** At the spinal level, the motoneurons and muscles have a close reciprocal connection. Afferent connections from receptors in the muscles return sensory feedback to the same motoneurons which contract the muscle. Connections to motoneurons of synergist and antagonist muscles are sufficiently potent and appropriately arranged to subservise a variety of reflexes. In animals with all higher centers removed, these segmental circuits may function by themselves to produce simple reflex responses. Under normal conditions, however, the activity of segmental circuits is largely controlled by supraspinal centers. Descending tracts arise from two major supraspinal centers: the cerebral cortex and the brainstem.

**Brainstem.** The brainstem, which includes the medulla and pons, is a major and complex integrating center which combines signals descending from other higher centers, as well as afferent input arising from peripheral receptors. The descending output from brainstem neurons affects motor and sensory cells in the spinal cord. Brainstem centers considerably extend the motor capacity of an animal beyond the stereotyped reflex reactions mediated by the spinal cord. In contrast to segmental reflexes, these motor responses involve coordination of muscles over the whole body. Another major motor function of the brainstem is postural control, exerted via the vestibular nuclei of the ear.

Besides neurons controlling limb muscles, the brainstem also contains a number of important neural centers involved in regulating eye movements. These include motor neurons of the eye muscles and various types of interneurons that mediate the effects of vestibular and visual input on eye movement.

**Cerebellum.** Another important coordinating center in the motor system is the cerebellum, an intricately organized network of cells closely interconnected with the brainstem. The cerebellum receives a massive inflow of sensory signals from peripheral receptors in muscles, tendons, joints, and skin, as well as from visual, auditory, and vestibular receptors. Higher centers,

particularly the cerebral cortex, also provide extensive input to the cerebellum via pontine brainstem relays. The integration of this massive amount of neural input in the cerebellum somehow serves to smooth out the intended movements and coordinate the activity of muscles. Without the cerebellum, voluntary movements become erratic, and the animal has difficulty accurately terminating and initiating responses. The output of the cerebellum affects primarily brainstem nuclei, but it also provides important signals to the cerebral cortex.

**Basal ganglia.** At another level of motor system are the basal ganglia. These massive subcortical nuclei receive descending input connections from all parts of the cerebral cortex. Their output projections send recurrent information to the cerebral cortex via the thalamus, and their other major output is to brainstem cells.

**Cerebral cortex.** At the highest level of the nervous system is the cerebral cortex, which exerts control over the entire motor system. The cerebral cortex performs two kinds of motor function: certain motor areas exert relatively direct control over segmental motoneurons, via a direct corticospinal pathway, the pyramidal tract, and also through extrapyramidal connections via supraspinal motor centers. The second function, performed in various cortical association areas, involves the programming of movements appropriate in the context of sensory information, and the initiation of voluntary movements on the basis of central states. Cortical language areas, for example, contain the circuitry essential to generate the intricate motor patterns of speech. Limb movements to targets in extrapersonal space appear to be programmed in parietal association cortex. Such cortical areas involved in motor programming exert their effects via corticocortical connections to the motor cortex, and by descending connections to subcortical centers, principally basal ganglia and brainstem.

As indicated in the illustration, the motor centers are all heavily interconnected, so none really functions in isolation. In fact, some of these connections are so massive that they may form functional loops, acting as subsystems within the motor system. For example, most regions of the cerebral cortex have close reciprocal interconnections with underlying thalamic nuclei, and the corticothalamic system may be considered to form a functional unit. Another example is extensive connection from cerebral cortex to pontine regions of the brainstem, controlling cells that project to the cerebellum, which in turn projects back via the thalamus to the cerebral cortex. Such functional loops are at least as important in understanding motor coordination as the individual centers themselves. See BRAIN; NERVOUS SYSTEM (VERTEBRATE). [E.E.F.]

**Mountain** A feature of the Earth's surface that rises high above its base and has generally steep slopes and a relatively small summit area. Commonly the features designated as mountains have local heights measurable in thousands of feet, lesser features of the same type being called hills, but there are many exceptions. See HILL AND MOUNTAIN TERRAIN.

Mountains rarely occur as isolated individuals. Instead they are usually found in roughly circular groups or massifs, such as the Olympic Mountains of northwestern Washington, or in elongated ranges, like the Sierra Nevada of California. An array of linked ranges and groups, such as the Rocky Mountains, the Alps, or the Himalayas, is a mountain system. North America, South America, and Eurasia possess extensive cordilleran belts, within which the bulk of their higher mountains occur. See CORDILLERAN BELT; MASSIF; MOUNTAIN SYSTEMS.

As a rule, mountains represent portions of the Earth's crust that have been raised above their surroundings by upwarping, folding, or buckling, and have been deeply carved by streams or glaciers into their present surface form. Some individual peaks and massifs have been constructed upon the surface by outpourings of lava or eruptions of volcanic ash. See OROGENY. [E.H.Ha.]

**Mountain meteorology** The effects of mountains on the atmosphere, ranging over all scales of motion, including very small (such as turbulence), local (for instance, cloud formations over individual peaks or ridges), and global (such as the monsoons of Asia and North America).

The most readily perceived effects of a mountain, or even of a hill, are related to the blocking of air flow. When there is sufficient wind, the air either goes around the obstacle or over it, causing waves in the flow similar to those in a river washing over a boulder. Since ascending air cools by adiabatic expansion, the saturation point of water vapor may be reached in such waves as they form over an obstacle, and a cloud then forms in the ascending branch of the wave motion. Such a cloud dissipates in the descending branch where adiabatic warming takes place. The shapes and amplitudes of these lee waves (they form over and to the lee of mountains) depend not only on the thermal stability and on the vertical wind shear in the overlying atmosphere but also on the shape of the underlying terrain. See CLOUD; CLOUD PHYSICS; WAVE (PHYSICS).

On a grander scale, mountain ranges, such as the Sierras of North and South America, place an obstacle in the path of the westerly winds (that is, winds from the west), which generally prevail in middle latitudes. Such a blockage tends to generate a high-pressure region upwind from the mountains (this may be viewed as air piling up as it prepares to jump the hurdle), and a low-pressure area downwind. Thus, there is a stronger push against the mountains on the high-pressure western side than on the low-pressure eastern side. The net effect is the slowing down of the atmospheric flow (mountain torque). See TORQUE.

Less subtle than mountain torque effects are the large-scale meanders that develop in the global flow patterns once they have been perturbed, mainly by the North and South American Andes and by the Plateau of Tibet and its Himalayan mountain ranges. These meanders in the large-scale flow are known as planetary waves. They appear prominently in the pressure patterns of hemispheric or global weather maps. See WEATHER MAP.

The major monsoon circulations interact with the global circulation, shaped in part by sea-surface temperature anomalies in the equatorial Pacific. The various aspects of mountain meteorology, therefore, have to be viewed within the larger picture. There is a continuous interaction between the weather effects on all space and time scales generated by the mountains and the weather patterns that prevail elsewhere on the Earth. See METEOROLOGY. [E.R.R.]

**Mountain systems** Long, broad, linear to arcuate belts in the Earth's crust where extreme mechanical deformation and thermal activity have been (or are being) concentrated.

Mountain systems in the general sense occur both on continents and in ocean basins, but the geological properties of the systems in continental as opposed to oceanic settings are distinctly different. The mechanical strain in classical, continental mountain systems is expressed in the presence of major folds, faults, and intensive fracturing and cleavage. Thermal effects are in the form of vast volcanic outpourings, intruded bodies of igneous magma, and metamorphism. Uplift and deformation in young mountain systems are conspicuously displayed in the physiographic forms of topographic relief. Where mountain building is presently taking place, the dynamics are partly expressed in warping of the land surface and significant shallow or deep earthquake activity. Locations of ancient mountain systems in continental regions now beveled flat by erosion are clearly disclosed by the presence of highly deformed, intruded, and metamorphosed rocks.

Two basic classes of oceanic mountain systems exist. A world-encircling oceanic rift mountain system has been built along the extensional tectonic boundary between plates diverging at rates of 0.8–2.4 in. or 2–6 cm per year from the mid-oceanic ridges. This rift mountain system is exposed to partial view in Iceland.

The second type, island arc mountain systems, occur in oceanic basins where the crust dives downward at trench sites, thus underthrusting adjacent oceanic crust. See MARINE GEOLOGY.

The classical, conspicuous mountain systems of the Earth occur at the continent/ocean interface, for this is the site where plate convergence has led to major sedimentation, subduction of oceanic crust under continents, collision of island arc mountain systems with continents, and head-on collision of continents. See OROGENY; PLATE TECTONICS. [G.H.D.]

**Mouse** The name associated with any species of animals which are members of the families Muridae, Heteromyidae, Cricetidae, and Zapodidae in the order Rodentia. Some of the more common species are listed in the table. Many species are used for research in both biology and medicine. In addition to their use in studying the mechanisms of genetics, they are important in the study of carcinogenesis, effects of drugs, and virology. They are also important experimental animals in studying cell physiology, such as for cell and tissue culture research. The familiar white mouse is an albino form of the house mouse and is used extensively in research.

**Classification MI representative species of mice**

Families and subfamilies	Examples
Family: Heteromyidae	
Subfamily: Perognathinae	Pocket and kangaroo mice
Subfamily: Heteromyiinae	Spiny pocket mice
Family: Cricetidae	
Subfamily: Cricetinae	Climbing mice, harvest mice, water mite, white-footed mice, pigmy mice
Family: Muridae	
Subfamily: Murinae	Striped mice, house mice, spiny mice, harvest mice, field mice, forest mice
Subfamily: Dendromurinae	African tree mice
Family: Zapodidae	Jumping mice

The common house mouse is one of the oldest known species of domestic rodent pests. It usually has a maximum lifespan of 4 years with four to six litters of four to eight young each per year. The gestation period is about 3 weeks. These rodents begin to breed at 3 months of age. Adults have a pointed snout, compact body, and an equally long tail. The ears are fairly large, as are the legs. While omnivorous, they have a preference for grains and other vegetable foods. Of the 44 species known, only one species occurs in the United States, and it has become wild in some parts of the country. See RODENTIA. [C.B.C.]

**Mouth** The oral or buccal cavity and its related structures. The oral cavity forms in the embryo from an in-pocketing of the skin, the stomodeum; it is thus lined by ectoderm and is not, properly speaking, part of the digestive tract. Functionally, however, the mouth forms the first portion of both the digestive and respiratory systems. Various special structures are found in, or associated with, the mouths of most vertebrates. See DIGESTIVE SYSTEM; RESPIRATORY SYSTEM.

Teeth may be present to help grasp or grind food. In most vertebrates they are relatively simple cones but in some, especially mammals, they are of diverse shapes. See DENTITION; TOOTH.

Various glands are associated with the mouth. These are of infrequent occurrence in fish but are found in most tetrapods. Humans have three pairs of salivary glands: the parotid, submaxillary, and sublingual. In forms such as some snakes salivary glands may produce a poison used to subdue prey.

Other structures also vary greatly. Most tetrapods have a mobile tongue attached to the floor of the mouth, but few fish do. The structure of the roof of the mouth, or palate, is quite different in different groups. See PALATE; TONGUE.

In mammals, including humans, the margins of the lips mark the junction between the outer skin and the inner mucous lining of the oral cavity. The mucosa of the mouth forms the lining and the gums surrounding the teeth and covers the surface of the tongue. The roof of the mammalian mouth consists of the hard palate and, behind this, the soft palate which merges into the oropharynx. The lateral walls consist of the distensible cheeks, and the floor is formed principally by the tongue and the soft tissues that lie between the two sides of the lower jaw, or mandible.

The posterior limit of the oral cavity of mammals is marked by the fauces, an aperture which leads to the pharynx. On either side of the fauces are two muscular arches covered by mucosa, the glossopalatine and pharyngopalatine arches; between them lie masses of lymphoid tissue, the tonsils. Suspended from the posterior portion of the soft palate is the soft retractable uvula. See MOUTH DISORDERS; TONSIL. [T.S.P.]

**Moving-target indication** A method of presenting pulse-radar echoes in a manner that discriminates in favor of moving targets and suppresses stationary objects. Moving-target indication (MTI) is almost a necessity when moving targets are being sought over a region from which the ground clutter echoes are very strong. The most common presentation of the output of a radar with MTI is a plan-position indicator (PPI) display. The moving targets appear as bright echoes, while ground clutter is suppressed. See RADAR. [J.M.C.]

**Mucilage** A naturally occurring, high-molecular-weight (200,000 and up), organic plant product of unknown detailed structure. The term is loosely used, often interchangeably with the term gum. Chemically, mucilage is closely allied to gums and pectins but differs in certain physical properties. Although gums swell in water to form sticky, colloidal dispersions and pectins gelatinize in water, mucilages form slippery, aqueous colloidal dispersions. Mucilages are formed in normal plant growth within the plant by mucilage-secreting hairs, sacs, and canals, but they are not found on the surface as exudates as a result of bacterial or fungal action after mechanical injury, as are gums. Mucilages occur in nearly all classes of plants in various parts of the plant, usually in relatively small percentages, and are not infrequently associated with other substances, such as tannins. The chief industrial sources of mucilages are Icelandic and Irish moss, linseed, locust bean, slippery elm bark, and quince seed. See ADHESIVE; GUM; PECTIN. [E.H.H.]

**Muffler** A device used to attenuate sound while also allowing fluid (usually gas) to flow through it; also known as silencer in British usage. Mufflers are extensively used to reduce the intake and exhaust noise from pumps, fans, compressors, and internal combustion engines. Although active noise control techniques are emerging, most mufflers continue to use passive silencing methods. Passive mufflers are categorized as reactive or dissipative based on their primary method of attenuation. Reactive mufflers reflect sound back toward the noise source, and dissipative mufflers use porous materials to absorb the sound.

Reactive mufflers reflect acoustic waves at locations where a duct expands, contracts, or branches. Often a combination of reactive elements such as expansion chambers, resonators, and flow reversals is used. Reactive mufflers can be designed to provide better low-frequency attenuation than a dissipative muffler of similar size. Also, reactive mufflers can be used in harsh environments that dissipative or active mufflers might not withstand. In most cases, reactive mufflers are best suited for low-to-moderate frequencies, where acoustic wavelengths are larger than any cross dimension of the muffler. At these frequencies, mufflers can exhibit resonance or broadband attenuation behavior. See RESONANCE (ACOUSTICS AND MECHANICS).

Dissipative mufflers use absorptive materials that dissipate the acoustic energy into heat. A variety of porous media can be used for absorption, with fibrous materials such as fiberglass

being common. The linings and baffles can be flat, contoured, constructed from layers of different materials, or mixed and matched for a particular application. Absorptive materials may face challenges due to harsh conditions such as high temperatures and potential clogging from particulate-laden flows. Dissipative mufflers are best suited for moderate-to-high frequencies, since absorption is less effective at low frequencies. At frequencies where the absorptive materials are effective, the attenuation is broadband, and the passbands exhibited by reactive mufflers are reduced or eliminated. Compared to reactive mufflers of similar size, dissipative mufflers can have higher attenuation (except at resonances for the reactive muffler) and lower pressure drop. At higher frequencies, where the acoustic wavelength is smaller than the duct width, the attenuation of a dissipative muffler may decrease considerably. See SOUND ABSORPTION.

Active mufflers attenuate unwanted noise by adding sound to counteract it. The disturbances add algebraically, resulting in a cancellation of the unwanted sound. An active muffler consists of sensors (such as microphones), a controller, and actuators (such as loudspeakers). The controller unit processes the signals from the sensor, and computes an appropriate signal for the actuator. Numerous control systems and strategies exist, and are under continuous development. Active mufflers are best suited for low frequencies where the sound field is relatively simple. The effectiveness of active mufflers has been demonstrated for a number of situations, but several challenges are the topic of ongoing research. There is a need for rugged sensors and actuators that can withstand high temperatures and harsh environments. Also, high-intensity disturbances at low frequencies require large-displacement, high-power actuators. See ADAPTIVE SOUND CONTROL. [A.Sel.]

**Mulberry** A genus (*Morus*) of trees characterized by milky sap and simple, often lobed, alternate leaves. White mulberry (*M. alba*) was introduced into the United States from China during the 19th century as a source of food for silkworms. The silkworm project was unsuccessful, but the trees remained and are common in cities and on the borders of forests. Red mulberry (*M. rubra*) grows in the eastern half of the United States and in southern Ontario. The wood is used for fence posts, furniture, interior finish, agricultural implements, and barrels. [A.H.G./K.P.D.]

**Mule** A hybrid sired by a male ass (*Equus asinus*) out of a female horse (*E. caballus*). The opposite cross, very seldom made, produces the hinny (a hybrid between a stallion and a female ass). The mule and the hinny are usually sterile, but two authenticated cases of mules producing living progeny are known. Male mules, often called horse mules, are almost always castrated to make them more tractable as work animals. Mules are noted for their endurance, surefootedness, and ability to stand hard work in hot weather. They can safely be self-fed in lots or corrals, whereas horses cannot. Usually steady and free from nervous excitability, mules can be handled by inexperienced or careless farm labor. [J.M.K.]

**Multiaccess computer** A computer system in which computational and data resources are made available simultaneously to a number of users. Users access the system through terminal devices, normally on an interactive or conversational basis. A multiaccess computer system may consist of only a single central processor connected directly to a number of terminals (that is, a star configuration), or it may consist of a number of processing systems which are distributed and interconnected with each other as well as with the user terminals.

The primary purpose of multiaccess computer systems is to share resources. The resources being shared may be simply the data-processing capabilities of the central processor, or they may be the programs and the data bases they utilize. The earliest examples of the first mode of sharing are the general-purpose, time-sharing, computational services. Examples of the latter mode are

airlines reservation systems in which it is essential that all ticket agents have immediate access to current information.

**System components.** The major hardware components of a multiaccess computer system are terminals or data entry/display devices, communication lines to interconnect the terminals to the central processors, a central processor, and on-line mass storage. Terminals may be quite simple, providing only the capabilities for entering or displaying data, or they may have an appreciable amount of "local intelligence" to support simple operations like editing of the displayed text without requiring the involvement of the central processor. The interconnecting communication lines can be provided by utilizing the common-user telephone system or by obtaining leased, private lines from the telephone company or a specialized carrier.

**System operating requirements.** A multiaccess system must include the following functional capabilities: (1) multiline communications capabilities that will support simultaneous conversations with a reasonably large number of remote terminals; (2) concurrent execution of a number of programs with the ability to quickly switch from executing the program of one user to executing that of another; (3) ability to quickly locate and make available data stored on the mass storage devices while at the same time protecting such data from unauthorized access.

The ability of a system to support a number of simultaneous sessions with remote users is an extension of the capability commonly known as multiprogramming. In order to provide such service, certain hardware and software features should be available in the central processor. Primary among these is the ability to quickly switch from executing one program to another while protecting all programs from interference with one another.

Memory sharing is essential to the efficient operation of a multiaccess system. A popular memory management technique is the utilization of paging. The program is broken into a number of fixed-size increments called pages. Similarly, central memory is divided into segments of the same size called page frames. (Typical sizes for pages and page frames are 512 to 4096 bytes.) Under the concept known as demand paging, only those pages that are currently required by the program are loaded into central memory.

**Software capabilities.** The control software component of most interest to an interactive user is the command interpreter. This routine interacts directly with users, accepting requests for service and translating them into the internal form required by the remainder of the operating system, as well as controlling all interaction with the system.

The capability to page the memory as outlined above can be utilized to provide users with the impression that each has available a memory space much larger than is actually assigned. Such a system is said to provide a virtual memory environment. Similarly, the ability of the operating system to quickly change context from one executing program to another will result in users' receiving the impression that each has an individual processor. See DIGITAL COMPUTER. [P.H.E.]

**Multilevel control theory** An approach to the control of large-scale systems based on (1) decomposition of the complex overall control problem into simpler and more easily managed subproblems and (2) coordination of the subproblems so that overall system objectives and constraints are satisfied.

The controllers are organized in a multilevel hierarchical structure according to three basic criteria: functional, plant, and temporal decomposition. Functional and temporal decompositions are often classified as multilayer or vertical structures; plant decomposition is often classified as a multilevel or horizontal structure.

In the functional decomposition approach, the overall control problem is partitioned into a nested set of generic control functions such as the regulatory (or direct control) function, optimizing control function, the adaptive control function, and the self-organizing function.

In the plant decomposition multilevel approach, the controlled system (plant) is partitioned into subsystems along lines of weak interaction. In a two-level control hierarchy, each subsystem has its own (first-level) controller which acts to satisfy local objectives and constraints. A second-level controller (coordinator) influences the actions of the local controllers to compensate for subsystem interactions so that overall objectives and constraints are satisfied.

In the temporal decomposition approach, the control or decision-making problem is partitioned into subproblems based on the different time scales relevant to the associated action functions. These time scales reflect such factors as the response time of the plant, the bandwidth characteristics of the disturbance inputs, and trade-off considerations relating the benefit of control action to its cost. At each layer of the hierarchy, decisions and control actions determined at higher layers (corresponding to lower-frequency events) are treated as constants; disturbances and actions associated with lower layers are treated as noise to be represented by their respective mean values. The temporal hierarchy may embrace a broad spectrum of control and decision-making activities, including process control, production control, scheduling, and planning functions. Time scales may range from seconds to years. See ADAPTIVE CONTROL; OPTIMAL CONTROL THEORY; PROCESS CONTROL; PRODUCTION ENGINEERING.

Hierarchical control has become accepted technology in many industries. It is often implicitly embedded in the design of the system, providing the conceptual framework for integrated (or plant-wide) systems control. Motivating considerations are improved productivity, operating efficiency, product quality, or other economic-based objectives. Hierarchical control has been applied to various nonindustrial systems, such as robotics and air traffic control systems. See AIR-TRAFFIC CONTROL; CONTROL SYSTEMS; DISTRIBUTED SYSTEMS (CONTROL SYSTEMS). [I.L.]

**Multimedia technology** Computer-based, interactive applications having multiple media elements, including text, graphics, animations, video, and sound. Multimedia technology refers to both the hardware and software used to create and run such systems.

The mode of delivery for each application depends on the amount of information that must be stored, the privacy desired, and the potential expertise of the users. Applications that require large amounts of data are usually distributed on CD-ROMs, while personal presentations might be made directly from a computer using an attached projector. Advertising and some training materials are often placed on the WWW for easy public access. Museums make use of multimedia kiosks with touch screens and earphones. See COMPACT DISK; INTERNET; VIDEO GAMES; WORLD WIDE WEB.

Multimedia products may be created and run on the commonly used computer environments. Multimedia system users may employ a variety of input devices in addition to the keyboard and mouse, such as joysticks and trackballs. Touch screens provide both input and display capabilities and are often the choice when potentially large numbers of novices may use the system. Other display devices include high-resolution monitors and computer projectors. Generally the abundance of graphics and video in multimedia applications requires the highest resolution and deepest color capacity possible in display devices.

Input devices for the creation of multimedia applications include graphics tablets, which are pressure-sensitive surfaces for drawing with special pens; digital cameras, which take pictures electronically; and scanners, which convert existing pictures and graphics into digital form. Other hardware devices, such as a video card and video digitizing board, are required both to create and to play digital video elements.

The hardware for incorporating sound elements into multimedia systems includes microphones, voice-recognition systems, sound chips within the computer, and speakers, which come in

a wide variety of forms with varying capabilities and quality. See SPEECH RECOGNITION.

The future of multimedia technology is dependent upon the evolution of the hardware. As storage devices get faster and larger, multimedia systems will be able to expand, and increased use of DVD should result in improved quality. Rising network speeds will increase the possibility of delivering multimedia applications over the WWW. Currently, Virtual Reality Modeling Language (VRML) is used for some WWW applications and may drastically expand the multimedia experience. Virtual reality is becoming more realistic and will stretch the multimedia experience to envelop the user. The one certainty in multimedia technology is that it will continue to change, to be faster, better, and more realistic. See VIRTUAL REALITY. [P.K.C.; R.A.Ko.]

**Multimeter** An instrument designed to measure electrical quantities. A typical multimeter can measure alternating- and direct-current potential differences (voltages), current, and resistance, with several full-scale ranges provided for each quantity. Sometimes referred to as a volt-ohm meter (VOM), it is a logical development of the electrical meter, providing a general-purpose instrument. Many kinds of special-purpose multimeters are manufactured to meet the needs of such specialists as telephone engineers and automobile mechanics testing ignition circuits. See AMMETER; CURRENT MEASUREMENT; OHMMETER; RESISTANCE MEASUREMENT; VOLTAGE MEASUREMENT; VOLTMETER.

Multimeters originated when all electrical measuring instruments used analog techniques. They were generally based on a moving-coil indicator, in which a pointer moves across a graduated scale. Accuracy was typically limited to about 2%, although models achieving 0.1% were available. Analog multimeters are still preferred for some applications. For most purposes, digital instruments are now used. In these, the measured value is presented as a row of numbers in a window. Inexpensive hand-held models perform at least as well as a good analog design. High-resolution multimeters have short-term errors as low as 0.1 part per million (ppm) and drift less than 5 ppm in one year. Many digital multimeters can be commanded by, and send their indications to, computers or control equipment. [R.B.D.K.]

**Multiple cropping** Planting two or more species in the same field in the same year. Preserved through history to maintain biological, economic, and nutritional diversity, multiple-species systems still are used by the majority of the world's farmers, especially in developing countries. Where farm size is small and the lack of capital has made it difficult to mechanize and expand, farm families that need a low-risk source of food and income often use multiple cropping. These systems maintain a green and growing crop canopy over the soil through much of the year, the total season depending on rainfall and temperature. Systems with more than one crop frequently make better use of total sunlight, water, and available nutrients than is possible with a single crop. The family has a more diverse supply of food and more than one source of income, with both spread over much of the year.

Multiple-cropping patterns are described by the number of crops per year and the intensity of crop overlap. Double cropping or triple cropping signifies systems with two or three crops planted sequentially with no overlap in growth cycle. Intercropping indicates that two or more crops are planted at the same time, or at least planted so that significant parts of their growth cycles overlap. Relay cropping describes the planting of a second crop after the first crop has flowered; in this system there still may be some competition for water or nutrients. When a crop is harvested and allowed to regrow from the crowns or root systems, the term ratoon cropping is used. Sugarcane, alfalfa, and sudangrass are commonly produced in this way, while the potential exists for such tropical cereals as sorghum and rice. Mixed cropping, strip cropping, associated cropping, and alternative cropping represent variations of these systems. See AGRICULTURAL

SCIENCE (PLANT); AGRICULTURAL SOIL AND CROP PRACTICES; AGRICULTURE; AGRONOMY. [C.A.F.]

**Multiple proportions, law of** This law states that, when two elements combine together to form more than one compound, the weights of one element that unite with a given weight of the other are in the ratio of small whole numbers. The law can be illustrated by the composition of the five oxides of nitrogen. One gram of nitrogen is combined with 2.85 g of oxygen in nitrogen pentoxide,  $N_2O_5$ ; with 2.28 g in nitrogen dioxide,  $NO_2$ ; with 1.71 g in nitrogen trioxide,  $N_2O_3$ ; with 1.14 g in nitric oxide,  $NO$ ; and with 0.57 g in nitrous oxide,  $N_2O$ . These numbers are in the simple ratio of 5:4:3:2:1. See DEFINITE COMPOSITION, LAW OF. [T.C.W.]

**Multiple sclerosis** A neuromuscular disorder that characteristically involves the destruction of myelin, the insulating material around nerve fibers. The onset of the disease is unusual in persons under 15 or over 60 years of age, and peak incidence is found in people in their 20s and 30s. Multiple sclerosis affects females more frequently than males by approximately 2:1. Distribution is worldwide, but there is an unusual relationship to latitude, with a much higher incidence at northern latitudes than near the Equator.

In multiple sclerosis, only the central nervous system is affected, but both incoming and outgoing processes may be disrupted. Common initial symptoms reflect this underlying disease mechanism. They include blindness in one eye due to disruption of the conduction of the nerve impulse through the optic nerve; weakness of one side of the body due to impairment of the downstream signals from the motor areas of the cerebral cortex through the spinal cord; difficulties with coordination related to problems with cerebellar function; and disturbances in sensation, such as tingling and numbness in an arm or a leg that is related to dysfunction of incoming sensory signals. Multiple sclerosis is a progressive disease, so that over time there is often an accumulation of new symptoms and problems.

In its classic form, the disease spreads both temporally and anatomically. Temporally, there may be a series of acute attacks, but between attacks a person may recover fully and remain well for some time. Anatomically, areas of disruption of myelin (demyelination) are scattered throughout the nervous system and spinal cord. Thus, symptoms depend upon what part of the nervous system is affected at any given time. The course of the disease is unpredictable.

The basic cause of the disease is not known. There clearly are genetic factors in that the incidence of the disease is 20 times higher in first-degree relatives than in the general population. However, other factors must be involved, including infection (presumably viral) or possibly an immunological mechanism. The prevailing hypothesis combines these two possible etiological mechanisms to suggest that some type of viral infection occurs early in life to alter the patient's immune system. Thus, the activity and progression of the disease are related to altered immune functions within the central nervous system. In keeping with this hypothesis, therapy is aimed at altering the immune status of the affected individual. See HUMAN GENETICS; IMMUNOGENETICS; NERVOUS SYSTEM DISORDERS. [G.M.McK.]

**Multiplexing and multiple access** In telecommunications, multiplexing refers to a set of techniques that enable the sharing of the usable electromagnetic spectrum of a telecommunications channel (the channel passband) among multiple users for the transfer of individual information streams. It is assumed that the user information streams join at a common access point to the channel. The term "multiple access" is usually applied to multiplexing schemes by which multiple users who are geographically dispersed gain access to the shared telecommunications facility or channel. Various methods of multiplexing and multiple access are in common use.



In frequency-division multiplexing (FDM) and frequency-division multiple access (FDMA), the passband of a channel is shared among multiple users by assigning distinct and nonoverlapping sections of the electromagnetic spectrum within the passband to individual users. The information stream from a particular user is encoded into a signal whose energy is confined to the part of the passband assigned to that user. See RADIO SPECTRUM ALLOCATIONS.

Time-division multiplexing (TDM) and time-division multiple access (TDMA) permit a user access to the full passband of the channel, but only for a limited time, after which the access right is assigned to another user. Normally the access rights are assigned in a cyclical order to the competing users. However, statistical time-division multiplexing assigns time on the channel on a demand basis, which typically increases the number of users who may be accommodated on the same channel, but may result in delays in accessing the channel during periods when the demand exceeds the supply.

In code-division multiple access (CDMA), all users are assigned the entire passband of the channel and are permitted to transmit their information streams simultaneously. To maintain the ability to recover the individual signals at the receiver, at the transmitter each signal has impressed on it a characteristic signature.

Space-division multiple access (SDMA) refers to the use of the same portion of the electromagnetic spectrum over two or more spatially distinct transmission paths. In most applications of space-division multiple access, the paths are formed by multi-beam antennas, in which each beam is directed toward a different geographic area. See ANTENNA (ELECTROMAGNETISM).

In wavelength-division multiplexing (WDM) schemes, transmission systems that employ the optical portion of the electromagnetic spectrum, such as those using fiber-optic cables as the transmission medium, share the total available passband of the medium by assigning individual information streams to signals of different wavelengths or "colors." See OPTICAL COMMUNICATIONS; OPTICAL FIBERS.

Polarization refers to the direction or geometric orientation of the electric field vector of an electromagnetic field. Polarization-division multiplexing and polarization-division multiple access assign electric fields of different polarization to individual channels or users. See ELECTRICAL COMMUNICATIONS; POLARIZATION OF WAVES; POLARIZED LIGHT. [H.J.He.]

**Multiplication** One of the fundamental operations of arithmetic and algebra. The symbol  $\times$  is commonly employed in arithmetic to denote multiplication. Because of its resemblance to the letter  $x$ , it is rarely used in algebra, where multiplication is frequently denoted by a dot (as in  $a \cdot b$ ) or, most often, merely by juxtaposition of letters (for example,  $ab$ ). Multiplication of numbers (real or complex) is associative,  $a(bc) = (ab)c$ ; commutative,  $ab = ba$ ; and distributive with respect to addition,  $a(b + c) = ab + ac$ ; but the term has been extended to denote binary operations on many other kinds of objects, and these operations need not possess all the properties of ordinary multiplication listed above (for example, multiplication of matrices is not commutative). See ADDITION; ALGEBRA; DIVISION; SUBTRACTION. [L.M.BI.]

**Multipole radiation** Standard patterns of radiation distribution about their source. The term radiation applies primarily to the transport of energy by acoustic, elastic, electromagnetic, or gravitational waves, and extends to the transport of atomic or subatomic particles (as represented by quantum-mechanical wave functions). See ELECTROMAGNETIC RADIATION; GRAVITATIONAL RADIATION; QUANTUM MECHANICS; SOUND; WAVE MOTION.

Each multipole pattern reflects the source's geometrical shape (or the shape of a source component). These geometrical features stand out clearly for the static electric potentials generated by fixed charges as shown by the small set of monopole, dipole, and quadrupole charges (see illustration), elements of

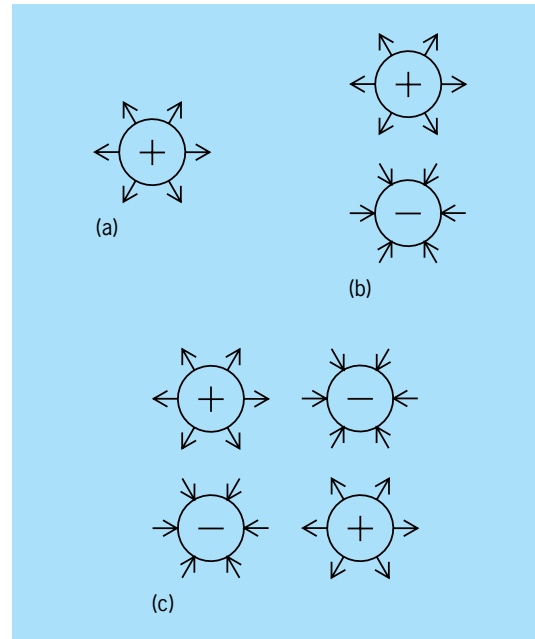

Static electric potentials generated by fixed multipoles. (a) Monopole ( $l = 0$ ). (b) Dipole ( $l = 1$ ). (c) Quadrupole ( $l = 2$ ).

all multipoles being named (in terms of powers of 2)  $2^l$ -poles, with  $l$  equal to any nonnegative integer. A monopole ( $l = 0$ ) acoustic wave radiates from a perfectly spherical bubble with oscillating radius; higher multipoles would arise from bubble distortions. So-called transverse waves, elastic or electromagnetic (including light), have only  $l \geq 1$  components, gravitational waves only  $l \geq 2$ . The angular distributions, in azimuth ( $\varphi$ ) and colatitude ( $\theta$ ), of  $2^l$ -pole waves have amplitudes distributed in directions  $(\theta, \varphi)$  in proportion to the spherical harmonic functions  $Y_l^m(\theta, \varphi)$ . The index  $m$  is a positive or negative integer whose absolute value is equal to less than  $l$ . See COORDINATE SYSTEMS; DIPOLE; SPHERICAL HARMONICS.

The multipolarity index  $l$  also represents the number of angular momentum quanta  $\hbar$  (Planck's constant divided by  $2\pi$ ) radiated together with each energy quantum  $h\nu$  (phonon, photon, graviton, and so forth). Detection and measurement of received energy quanta, together with measurement of their detection rate and mapping of their directional distribution, generally serve to diagnose the mechanics of the radiation source. Energy and momentum conservation underlie this analysis; so does the conservation of angular momentum which states that the initial angular momentum of the source equals the vector sum of the final angular momentum of the source and the angular momentum of the radiation. The quantitative implications of this vector relation are studied by the branch of quantum theory called angular momentum algebra. The balancing of parity, that is, of each variable's sign reversal (or persistence) under reflection through the source's center, also contributes to the analysis of experimental data. Further, more complex angular-momentum considerations play a role in the analysis of the behavior of spin-carrying particles. See ANGULAR MOMENTUM; CONSERVATION LAWS (PHYSICS); GRAVITON; PHONON; SELECTION RULES (PHYSICS); SPIN (QUANTUM MECHANICS). [U.F.]

**Multiprocessing** An organizational technique in which a number of processor units are employed in a single computer system to increase the performance of the system in its application environment above the performance of a single processor of the same kind. In order to cooperate on a single application or class of applications, the processors share a common resource. Usually this resource is primary memory, and the multiprocessor is called

a primary memory multiprocessor. A system in which each processor has a private (local) main memory and shares secondary (global) memory with the others is a secondary memory multiprocessor, sometimes called a multicomputer system because of the looser coupling between processors. The more common multiprocessor systems incorporate only processors of the same type and performance and thus are called homogeneous multiprocessors; however, heterogeneous multiprocessors are also employed. A special case is the attached processor, in which a second processor module is attached to a first processor in a closely coupled fashion so that the first can perform input/output and operating system functions, enabling the attached processor to concentrate on the application workload. See COMPUTER STORAGE TECHNOLOGY; OPERATING SYSTEM.

Multiprocessor systems may be classified into four types: single instruction stream, single data stream (SISD); single instruction stream, multiple data stream (SIMD); multiple instruction stream, single data stream (MISD); and multiple instruction stream, multiple data stream (MIMD). Systems in the MISD category are rarely built. The other three architectures may be distinguished simply by the differences in their respective instruction cycles:

In an SISD architecture there is a single instruction cycle; operands are fetched in serial fashion into a single processing unit before execution. Sequential processors fall into this category.

An SIMD architecture also has a single instruction cycle, but multiple sets of operands may be fetched to multiple processing units and may be operated upon simultaneously within a single instruction cycle. Multiple-functional-unit, array, vector, and pipeline processors are in this category. See SUPERCOMPUTER.

In an MIMD architecture, several instruction cycles may be active at any given time, each independently fetching instructions and operands into multiple processing units and operating on them in a concurrent fashion. This category includes multiple processor systems in which each processor has its own program control, rather than sharing a single control unit.

MIMD systems can be further classified into throughput-oriented systems, high-availability systems, and response-oriented systems. The goal of throughput-oriented multiprocessing is to obtain high throughput at minimal computing cost in a general-purpose computing environment by maximizing the number of independent computing jobs done in parallel. High-availability multiprocessing systems are generally interactive, often with never-fail real-time online performance requirements.

The goal of response-oriented multiprocessing (or parallel processing) is to minimize system response time for computational demands. See COMPUTER SYSTEMS ARCHITECTURE; CONCURRENT PROCESSING; FAULT-TOLERANT SYSTEMS; REAL-TIME SYSTEMS.

[P.C.Pa.]

**Multituberculata** An order in the class Mammalia, subclass Altheria, comprising a major group of early mammals, ranging from Late Jurassic to Late Eocene (about 155 to 35 million years ago). The group is best known from North America, Mongolia, and Europe. Most multituberculates were mouse-like in size, although the North American Paleocene *Taeniolabis* was larger, probably closer to the woodchuck (*Marmota monax*) in its proportions. Multituberculates appear primarily to have been terrestrial creatures, but some were probably arboreal and others fossorial. The Eocene decline and extinction of multituberculates may reflect competition from small placental mammals, especially primates and rodents. See ARCHAIC UNGULATE; RODENTIA.

The most primitive multituberculates are traditionally classified in the suborder Plagiauloidea (Late Jurassic to Early Cretaceous), and the advanced multituberculates are traditionally classified in the suborders Ptilodontioidea and Taeniolabidoidea (both Late Cretaceous to Eocene).

Although clearly mammalian and often characterized as rodent-like, multituberculates are unlike rodents or other living mammals in several important features. The dentition is distinc-

tive and, with associated jaw fragments, it is all that is known for most species. Microscopic wear patterns on multituberculate tooth enamel show that jaw motion differed radically from that in other mammals: during chewing, the mandible moved only in the vertical plane, not transversely, and was strongly retracted during the power stroke. These studies also imply that most multituberculates were probably omnivores, although species having gnawing incisors were likely specialized herbivores feeding on tough plant tissues. See DENTITION.

Attempts to determine multituberculate relationships to other mammals have long been inconclusive. See ALLOThERIA; MAMMALIA.

[R.C.Fo.]

**Multivariable control** The control of systems characterized by multiple inputs, which are usually referred to as the controls; or by multiple outputs, which are often the measured variables to be controlled (see illustration); or by both multiple inputs and outputs. Automobiles, chemical processing plants, aerospace vehicles, biological systems, and the national economy are all examples of multivariable systems which require and receive some form of regulation or control, be it mathematically contrived or not. In many cases, control of such systems is implemented without a previously given design or explicit mathematical model, such as in the manual control of relatively simple motorized vehicles, or in a person's control of arm and leg movements. In more complex tasks, however, such as the manual manipulation of an inherently unstable helicopter, automatic control devices (autopilots) are employed to assist the operator.

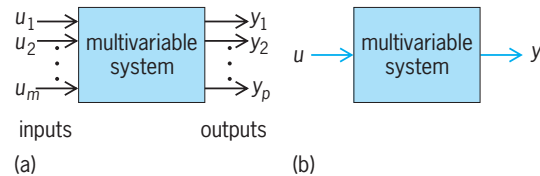

Two multivariable system representations, (a) Input and output variables shown separately as  $u_1, u_2, \dots, u_m$  and  $y_1, y_2, \dots, y_p$ , (b) Input and output variables shown in vector form as  $u$  and  $y$ .

The control objectives to be achieved in the multivariable case include those control objectives which are generally sought in the scalar, that is, single input/output case, and also depend on the particular application involved. In particular, stability is usually a primary concern in the design of any control system, along with various measures of the degree of stability. While controller failure in the scalar case can lead to catastrophic failure of the overall system, such need not be true in the multivariable case due to the interactions between various input/output pairs. More specifically, in certain applications it may be possible to design a multivariable controller "driven" by all  $p$  outputs which performs satisfactorily even when feedback information from one or more outputs is lost. The integrity of such a multivariable controller would be much better than that of its scalar counterpart.

In many control applications, a primary objective is that of tracking, or ensuring that the system output or outputs track a desired input or inputs with little or no steady-state errors. In addition, simultaneous regulation of external disturbances is also often desired; that is, ensuring that any external disturbances affect the plant outputs as little as possible. It is also obvious that simplicity of controller design is a highly desirable design objective both in the scalar and multivariable cases. One final design objective unique to the multivariable case is that of minimizing or eliminating the interaction between loops, which is often referred to as decoupling; that is, perfect decoupling would imply a controlled system where each input affects only one output or, otherwise stated, a system whose compensated transfer matrix is diagonal and nonsingular. See CONTROL SYSTEMS; PROCESS CONTROL.

[W.Wo.]

**Multivibrator** A form of electronic circuit that employs positive feedback to cross-couple two devices so that two distinct states are possible, for example, one device ON and the other device OFF, and in which the states of the two devices can be interchanged either by use of external pulses or by internal capacitance coupling. When the circuit is switched between states, transition times are normally very short compared to the ON and OFF periods. Hence, the output waveforms are essentially rectangular in form.

Multivibrators may be classified as bistable, monostable, or astable. A bistable multivibrator, often referred to as a flip-flop, has two possible stable states, each with one device ON and the other OFF, and the states of the two devices can be interchanged only by the application of external pulses. A monostable multivibrator, sometimes referred to as a one-shot, also has two possible states, only one of which is stable. If it is forced to the opposite state by an externally applied trigger, it will recover to the stable state in a period of time usually controlled by a resistance-capacitance (*RC*) coupling circuit. An astable multivibrator has two possible states, neither of which is stable, and switches between the two states, usually controlled by two *RC* coupling time constants. The astable circuit is one form of relaxation oscillator, which generates recurrent waveforms at a controllable rate.

**Symmetrical bistable multivibrator.** In bistable multivibrators, either of the two devices in a completely symmetrical circuit may remain conducting, with the other nonconducting, until the application of an external pulse. Such a multivibrator is said to have two stable states.

The original form of bistable multivibrator made use of vacuum tubes and was known as the Eccles-Jordan circuit, after its inventors. It was also called a flip-flop or binary circuit because of the two alternating output voltage levels. The junction field-effect transistor (JFET) circuit (Fig. 1) is a solid-state version of the Eccles-Jordan circuit. Its resistance networks between positive and negative supply voltages are such that, with no current flowing to the drain of the first JFET, the voltage at the gate of the second is slightly negative, zero, or limited to, at most, a slightly positive value. The resultant current in the drain circuit of the second JFET causes a voltage drop across the drain load resistor; this drop in turn lowers the voltage at the gate of the first JFET to a sufficiently negative value to continue to reduce the drain current to zero. This condition of the first device OFF and the second ON will be maintained as long as the circuit remains undisturbed. See TRANSISTOR.

If a sharp negative pulse is applied to the gate of the ON transistor, its drain current decreases and its drain voltage rises. A fraction of this rise is applied to the gate of the OFF transistor, causing some drain current to flow. The resultant drop in drain voltage, transferred to the gate of the ON transistor, causes a further rise at its drain. The action is thus one of positive feedback, with nearly instantaneous transfer of conduction from one device to the other. There is one such reversal each time a pulse is applied to the gate of the ON transistor. Normally pulses are ap-

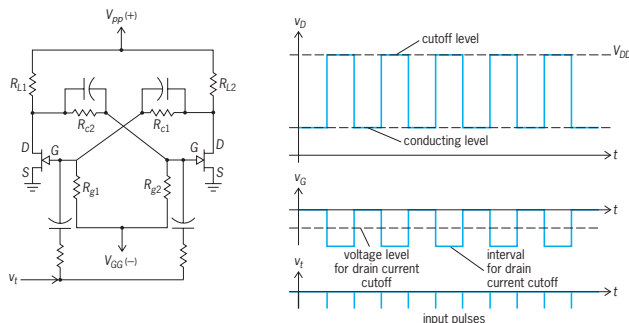

Fig. 1. Bistable multivibrator with triggering, gate, and drain waveforms shown for one transistor.

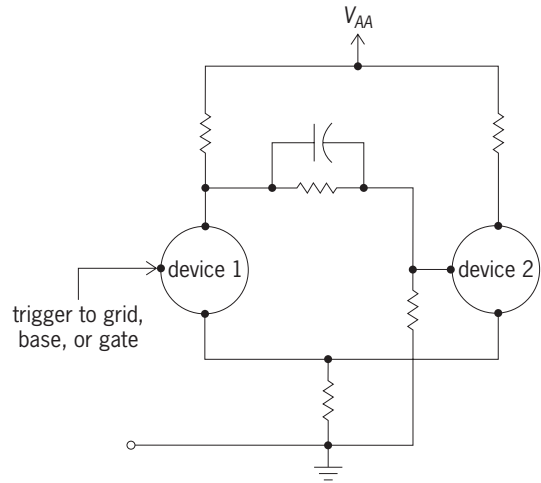

Fig. 2. Unsymmetrical bistable multivibrator.

plied to both transistors simultaneously so that whichever device is ON will be turned off by the action. The capacitances between the gate of one transistor and the drain of the other play no role other than to improve the high-frequency response of the voltage divider network by compensating for the input capacitances of the transistors and thereby improving the speed of transition.

A bipolar transistor counterpart of the JFET bistable multivibrator uses *n*pn bipolar transistors. The base of the transistor corresponds to the gate, the emitter to the source, and the collector to the drain. Although waveforms are of the same polarity and the action is roughly similar to that of the JFET circuit, there are important differences. The effective resistance of the base-emitter circuit, when it is forward-biased and being used to control collector current, is much lower than the input gate resistance of the JFET when the latter resistance is used to control drain current (a few thousand ohms compared to a few megohms). This fact must be taken into account when the divider networks are designed. If *p*np transistors are used, all voltage polarities and current directions are reversed.

**Unsymmetrical bistable circuits.** Bistable action can be obtained in the emitter- or source-coupled circuit with one of the set of cross-coupling elements removed (Fig. 2). In this case, regenerative feedback necessary for bistable action is obtained by the one remaining common coupling element, leaving one emitter or gate free for triggering action. Biases can be adjusted such that device 1 is ON, forcing device 2 to be OFF. In this case, a pulse can be applied to the free input in such a direction as to reverse the states. Alternatively, device 1 may initially be OFF with device 2 ON. Then an opposite polarity pulse is required to reverse states. Such an unsymmetrical bistable circuit, historically referred to as the Schmitt trigger circuit, finds widespread use in many applications.

**Monostable multivibrator.** A monostable or one-shot multivibrator has only one stable state. If one of the normally active devices is in the conducting state, it remains so until an external pulse is applied to make it nonconducting. The second device is thus made conducting and remains so for a duration dependent upon *RC* time constants within the circuit itself. Monostable multivibrators are available commercially in integrated chip form. See INTEGRATED CIRCUITS.

**Astable multivibrator.** The astable multivibrator has capacitance coupling between both of the active devices and therefore has no permanently stable state. Each of the two devices functions in a manner similar to that of the capacitance-coupled half of the monostable multivibrator. It will therefore generate a periodic rectangular waveform at the output with a period equal to the sum of the OFF periods of the two devices.

Astable multivibrators, although normally free-running, can be synchronized with input pulses recurrent at a rate slightly faster than the natural recurrence rate of the device itself. If the synchronizing pulses are of sufficient amplitude, they will bring the internal waveform to the conduction level at an earlier than normal time and will thereby determine the recurrence rate.

**Logic gate multivibrators.** Multivibrators may be formed by using two cross-coupled logic gates, with the unused input terminals used for triggering purposes. The bistable forms of such circuits are usually referred to as flip-flops. See LOGIC CIRCUITS.

[G.M.G.]

**Mumps** An acute contagious viral disease, characterized chiefly by enlargement of the parotid glands (parotitis).

Besides fever, the chief signs and symptoms are the direct mechanical effect of swelling on glands or organs where the virus localizes. One or both parotids may swell rapidly, producing severe pain when the mouth is opened. In orchitis, the testicle is inflamed but is enclosed by an inelastic membrane and cannot swell; pressure necrosis produces atrophy, and if both testicles are affected, sterility may result. The ovary may enlarge, without sequelae.

An attenuated live virus vaccine can induce immunity without parotitis. It is recommended particularly for adults exposed to infected children, for students in boarding schools and colleges, and for military troops.

[J.L.Me.]

**Muonium** An exotic atom, Mu or ( $\mu^+e^-$ ), formed when a positively charged muon ( $\mu^+$ ) and an electron are bound by their mutual electrical attraction. It is a light, unstable isotope of hydrogen, with a muon replacing the proton. Muonium has a mass 0.11 times that of a hydrogen atom due to the lighter mass of the muon, and a mean lifetime of 2.2 microseconds, determined by the spontaneous decay of the muon ( $\mu^+ \rightarrow e^+ \nu_e \bar{\nu}_\mu$ ). Muonium is formed when beams of  $\mu^+$  produced in particle accelerators are stopped in certain nonmetallic targets.

Since muonium is a system consisting only of leptons, it serves as a testing ground for the theory of quantum electrodynamics (QED), which describes the electromagnetic interaction between particles. Muonium chemistry and muonium spin rotation (MSR) are two developing subfields which seek to understand the chemical and physical behavior of a light hydrogen isotope in matter and to probe the structure of materials. See POSITRONIUM; QUANTUM ELECTRODYNAMICS.

[P.O.E.]

**Muscle** The tissue in the body in which cellular contractility has become most apparent. Almost all forms of protoplasm exhibit some degree of contractility, but in muscle fibers specialization has led to the preeminence of this property. In vertebrates three major types of muscle are recognized: smooth, cardiac, and skeletal.

**Smooth muscle.** Smooth muscle, also designated visceral and sometimes involuntary, is the simplest type. These muscles consist of elongated fusiform cells which contain a central oval nucleus. The size of such fibers varies greatly, from a few micrometers up to 0.02 in. (0.5 mm) in length. These fibers contract relatively slowly and have the ability to maintain contraction for a long time. Smooth muscle forms the major contractile elements of the viscera, especially those of the respiratory and digestive tracts, and the blood vessels. Smooth muscle fibers in the skin regulate heat loss from the body. Those in the walls of various ducts and tubes in the body act to move the contents to their destinations, as in the biliary system, ureters, and reproductive tubes.

Smooth muscle is usually arranged in sheets or layers, commonly oriented in different directions. The major physiological properties of these muscles are their intrinsic ability to contract spontaneously and their dual regulation by the autonomic nerves of the sympathetic and parasympathetic systems. See AUTONOMIC NERVOUS SYSTEM.

**Cardiac muscle.** Cardiac muscle has many properties in common with smooth muscle; for example, it is innervated by the autonomic system and retains the ability to contract spontaneously. Presumably, cardiac muscle evolved as a specialized type from the general smooth muscle of the circulatory vessels. Its rhythmic contraction begins early in embryonic development and continues until death. Variations in the rate of contraction are induced by autonomic regulation and by many other local and systemic factors.

The cardiac fiber, like smooth muscle, has a central nucleus, but the cell is elongated and not symmetrical. It is a syncytium, a multinuclear cell or a multicellular structure without cell walls. Histologically, cardiac muscle has cross-striations very similar to those of skeletal muscle, and dense transverse bands, the intercalated disks, which occur at short intervals. See HEART (VERTEBRATE).

**Skeletal muscle.** Skeletal muscle is also called striated, somatic, and voluntary muscle, depending on whether the description is based on the appearance, the location, or the innervation. The individual cells or fibers are distinct from one another and vary greatly in size from over 6 in. (15 cm) in length to less than 0.04 in. (1 mm). These fibers do not ordinarily branch, and they are surrounded by a complex membrane, the sarcolemma. Within each fiber are many nuclei; thus it is actually a syncytium formed by the fusion of many precursor cells.

The transverse striations of skeletal muscle form a characteristic pattern of light and dark bands within which are narrower bands. These bands are dependent upon the arrangement of the two sets of sliding filaments and the connections between them. See MUSCLE PROTEINS; MUSCULAR SYSTEM.

[W.J.B.]

**Muscle proteins** Specialized proteins in muscle cells are the building blocks of the structures constituting the moving machinery of muscle. They are disposed in myofilaments which are discernible by electron microscopy. These myofilaments are of two kinds, and their regular arrangement within the cell gives the striated pattern to skeletal muscle fibers (see illustration). It is recognized that the sliding of the two sets of filaments relative to each other is the molecular basis of muscle contraction. To understand the ultimate mechanism that causes the movement of these filaments (relative to each other), it is necessary to consider the features of the individual molecules making up these filaments. Evidence has been accumulating that practically all nonmuscle cells, although lacking the filaments of muscle, contain proteins similar to those found in muscle; these proteins are likely to be involved in cell motility and in determining properties of cell membranes.

Molecules of myosin, amounting to about 60% of the total muscle protein, are arranged in filaments occupying the central zone of each segment (sarcomere) or the fibril, the A band. Myosin is an elongated molecule made up of two intertwined heavy peptide chains (molecular weight of about 200,000) whose ends form two separate globular structures. The intertwined portion forms a rigid rod; each of the two globular portions (heads) contains a center capable of combining with, and splitting off, the terminal phosphate of adenosine triphosphate

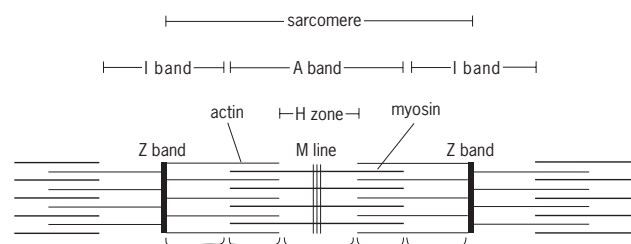

**Banding pattern of a sarcomere, showing arrangement of myosin and actin molecules. A, I, and Z indicate bands.**

(ATP); ATP is the ultimate source of energy for muscle contraction. Each globular head can combine with actin.

The chief constituent of the filaments originating in the Z band of each sarcomere is actin. Actin filaments are made up of globular units in a double helix; there are 13 to 15 of these units in each strand for every complete turn of this helix.

These two proteins, or rather protein complexes, are associated with the actin filaments. Tropomyosin is an  $\alpha$ -helical protein containing two intertwined polypeptide chains that extend over about seven globular actin units. Each tropomyosin molecule is associated with one troponin molecule, which in turn consists of three different types of subunits. In contrast to the tropomyosin molecule, the troponin complex and its subunits are thought to be essentially spherical in shape. Both tropomyosin and troponin are required to make the interaction of actin and myosin sensitive to calcium ions.

A great deal of information has come to light concerning the process by which the interaction between actin and myosin is regulated in the living cell. In higher organisms troponin and tropomyosin participate in this regulation. In the presence of these proteins the combination of actin and myosin cannot take place. However, if a small amount of ionized calcium is present, the inhibitory effect of the tropomyosin-troponin system is reversed, and the interaction with actin and myosin becomes fully effective.

This regulation involves a movement of tropomyosin molecules within the thin filaments from positions in which they block the combination of actin with the myosin moiety. Within the muscle cell the amount of calcium available is regulated by certain membranous structures, collectively the sarcoplasmic reticulum, that appear to have the ability to store calcium in the resting state. Upon excitation, the outer membrane of the muscle cell undergoes a change in permeability. This change spreads inside the muscle through the so-called transverse tubular system and causes a release of calcium within the cell. The calcium ions thus released permit the interaction of actin and myosin, leading to the liberation of chemical energy from ATP and its transformation into mechanical work. See MOTOR SYSTEMS; MUSCLE. [J.Ge.]

**Muscovite** A mineral of the mica group with an ideal composition of  $KAl_2(AlSi_3)O_{10}(OH)_2$ . Sometimes it is referred to as a white mica or potash mica.

Physical properties include specific gravity 2.76–2.88, hardness on the Mohs scale 2–2.5, and luster vitreous to pearly. Thin sheets are flexible and may be colorless, with books (thick crystals) translucent, yellow, brown, reddish, or green. Muscovite occurs commonly in all the major rock types, in igneous rocks (granites, pegmatites, and hydrothermal alteration products), in metamorphic rocks (slates, phyllites, schists and gneisses), and in sedimentary rocks (sandstones and other clastic rocks). As larger flakes, muscovite is used as an electrical insulator, both for its dielectric properties and for its resistance to heat. Ground muscovite is used for fireproofing, as an additive to paint to provide a sheen and for durability, as a filler, and for many other applications. See MICA; SILICATE MINERALS. [S.Gu.]

**Muscular dystrophy** A group of muscle diseases that are hereditary and characterized by progressive muscle weakness and wasting.

The muscular dystrophies are primary diseases of the muscle cells characterized by progressive degeneration and replacement by fibrous tissue, resulting in progressive muscle weakness. In some types of muscular dystrophies, the disease appears to be restricted to the skeletal muscles alone (facioscapulohumeral muscular dystrophy, limb-girdle muscular dystrophy), and in others skeletal-muscle involvement is a part of a more generalized process, with abnormalities in other organ systems as well (Duchenne's muscular dystrophy, myotonic dystrophy). These features as well as the differing patterns of inheritance indicate that the various muscular dystrophies are different diseases

with different genetic and biochemical abnormalities underlying them.

The gene for the Duchenne and the Becker muscular dystrophy has been identified. This gene produces the muscle protein dystrophin, which is absent in Duchenne's dystrophy and qualitatively altered in Becker's dystrophy. Although the gene for myotonic dystrophy has not been identified, it has been found to be closely linked to genetic markers on chromosome 19. See HUMAN GENETICS; MUSCLE PROTEINS.

Duchenne's muscular dystrophy is the most rapidly progressive form of muscular dystrophy. It affects boys before the age of 4, and is characterized initially by progressive weakness of the hip muscles with difficulty in rising from the floor or chair and in climbing stairs. This is accompanied by enlargement of the calf muscles, which are infiltrated by fat and fibrous tissue (pseudohypertrophy). Weakness of the muscles of the upper arms and shoulder muscles follows.

Becker's muscular dystrophy is also characterized by calf pseudohypertrophy but is much more slowly progressive.

Myotonic dystrophy is very slowly progressive and affects the muscles of the face, neck, and hands. It usually begins in early adulthood. In addition to progressive weakness and wasting of the affected muscles, these individuals also exhibit myotonia, that is, a delayed relaxation of a muscle after forceful contraction. Mental retardation, frontal balding, cataracts, and gonadal degeneration are common.

Treatment remains largely symptomatic. See MUSCULAR SYSTEM DISORDERS. [S.M.Su.; T.D.B.]

**Muscular system** The muscular system consists of muscular cells, the contractile elements with the specialized property of exerting tension during contraction, and associated connective tissues. The three morphologic types of muscles are voluntary muscle, involuntary muscle, and cardiac muscle. The voluntary, striated, or skeletal muscles are involved with general posture and movements of the head, body, and limbs. The involuntary, nonstriated, or smooth muscles are the muscles of the walls of hollow organs of the digestive, circulatory, respiratory, and reproductive systems, and other visceral structures. Cardiac muscle is the intrinsic muscle tissue of the heart. See MUSCLE.

**Anatomy.** Muscle groups are particularly distinct in elasmobranchs and other primitive fishes, and they are generally defined on the basis of their embryonic origin in these animals. Two major groups of skeletal muscles are recognized, somatic (parietal) muscles, which develop from the myotomes, and branchiomeric muscles, which develop in the pharyngeal wall from lateral plate mesoderm. The somatic musculature is subdivided into axial muscles, which develop directly from the myotomes and lie along the longitudinal axis of the body, and appendicular muscles, which develop within the limb bud from mesoderm derived phylogenetically as buds from the myotomes.

The vertebrate muscular system is the largest of the organ systems, making up 35–40% of the body weight in humans. The movement of vertebrates is accomplished exclusively by muscular action, and muscles play the major role in transporting materials within the body. Muscles also help to tie the bones of the skeleton together and supplement the skeleton in supporting the body against gravity. See SKELETAL SYSTEM.

Most of the axial musculature is located along the back and flanks of the body, and this part is referred to as trunk musculature. But anteriorly the axial musculature is modified and assigned to other subgroups. Certain of the occipital and neck myotomes form the hypobranchial muscles, and the most anterior myotomes form the extrinsic ocular muscles.

The hypaxial musculature of tetrapods can be subdivided into three groups: (1) a subvertebral (hyposkeletal) group located ventral to the transverse processes and lateral to the centra of the vertebrae, (2) the flank muscles forming the lateral part of the body wall, and (3) the ventral abdominal muscles located on

each side of the midventral line. The subvertebral musculature assists the epaxial muscles in the support and movement of the vertebral column. Most of the flank musculature takes the form of broad, thin sheets of muscle that form much of the body wall and support the viscera. The midventral hypaxial musculature in all tetrapods consists of the rectus abdominis, a longitudinal muscle on each side of the midline that extends from the pelvic region to the anterior part of the trunk.

The hypobranchial musculature extends from the pectoral girdle forward along the ventral surface of the neck and pharynx to the hyoid arch, chin, and into the tongue. It is regarded as a continuation of part of the hypaxial trunk musculature.

Limb muscles are often classified as intrinsic if they lie entirely within the confines of the appendage and girdle, and extrinsic if they extend from the girdle or appendage to other parts of the body. In fishes, movements of the paired fins are not complex or powerful and the appendicular muscles in the strictest sense are morphologically simple. In terrestrial vertebrates, the limbs become the main organs for support and locomotion, and the appendicular muscles become correspondingly powerful and complex. The muscles are too numerous to describe individually, but they can be sorted into dorsal and ventral groups, because tetrapod muscles originate embryonically in piscine fashion from a dorsal and a ventral premuscular mass within the limb bud. In general, the ventral muscles, which also spread onto the anterior surface of the girdle and appendage, act to protract and adduct the limb and to flex its distal segments; the dorsal muscles, which also extend onto the posterior surface of the girdle and appendage, have the opposite effects (retraction, abduction, and extension). The limb muscles also serve as flexible ties or braces that can fix the bones at a joint and support the body.

Flight in birds has entailed a considerable modification of the musculature of the pectoral region. As one example, the ventral adductor muscles are exceedingly large and powerful, and the area from which they arise is increased by the enlargement of the sternum and the evolution of a large sternal keel. Not only does a ventral muscle, the pectoralis, play a major role in the downstroke of the humerus, but a ventral muscle, the supracoracoideus, is active in the upstroke as well.

In a number of terrestrial vertebrates, particularly amniotes, certain of the more superficial skeletal muscles of the body have spread out beneath the skin and inserted into it. These may be described as integumentary muscles. Integumentary muscles are particularly well developed in mammals and include the facial muscles (Fig. 1) and platysma, derived from the hyoid musculature, and often a large cutaneous trunci. The last is derived from the pectoralis and latissimus dorsi and fans out beneath the skin of the trunk. The twitching of the skin of an ungulate is caused by this muscle.

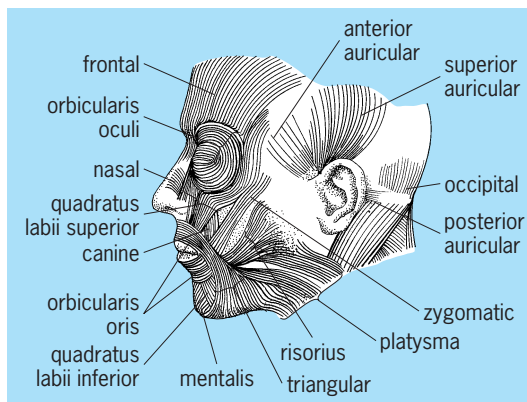

Fig. 1. Human facial muscles. (After H. W. Rand, *The Chordates*, Blakiston, 1950)

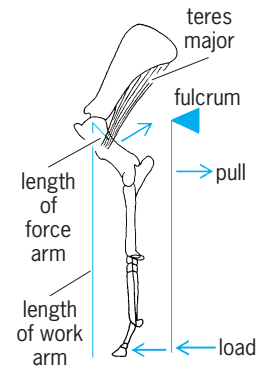

Fig. 2. A typical vertebrate lever system.

**Muscle mechanics.** Many of the bones serve as lever arms, and the contractions of muscles are forces acting on these arms (Fig. 2). The joint, of course, is the fulcrum and it is at one end of the lever. The length of the force arm is the perpendicular distance from the fulcrum to the line of action of the muscle; the length of the work arm is the perpendicular distance from the fulcrum to the point of application of the power generated in the lever. Compactness of the body and physiological properties of the muscle necessitates that a muscle attach close to the fulcrum; therefore, the force arm is considerably shorter than the work arm. Most muscles are at a mechanical disadvantage, for they must generate forces greater than the work to be done, but an advantage of this is that a small muscular excursion can induce a much greater movement at the end of the lever. See SKELETAL SYSTEM.

Slight shifts in the attachments of a muscle that bring it toward or away from the fulcrum, and changes in the length of the work arm, can alter the relationship between force and amount or speed of movement.

In general, the force of a muscle is inversely related to the amount and speed of movement that it can cause. Certain patterns of the skeleton and muscles are adapted for extensive, fast movement at the expense of force, whereas others are adapted for force at the expense of speed. In the limb of a horse, which is adapted for long strides and speed, the muscles that move the limb insert close to the fulcrum and the appendage is long. This provides a short force arm but a very long work arm to the lever system (Fig. 2). In the front leg of a mole, which is adapted for powerful digging, the distance from the fulcrum to the insertion of the muscles is relatively greater and the length of the appendage is less, with the result that the length of the force arm is increased relative to the length of the work arm. [W.F.W.]

**Muscular system disorders** Disorders affecting skeletal (voluntary) muscle. The normal functioning of the skeletal muscle is dependent not only on the integrity of the muscle fibers themselves, but also on that of the motor cortex, the pyramidal tract, and the extrapyramidal system (including the cerebellum). It also depends on innervation by the motoneurons of the brainstem and the spinal cord. In addition, the proper functioning of the other organ systems, such as the endocrine system, and variations in the concentration of various electrolytes may also affect muscle function.

Damage to the motor cortex or the pyramidal tract produces the type of weakness seen in humans after a stroke or spinal cord injury. Although the paralyzed limb may initially be flaccid (hypotonic), spasticity (hypertonia) eventually develops. Despite the weakness, muscle atrophy is usually not striking. When the extrapyramidal system or the cerebellum is the site of damage, instead of weakness there are uncontrolled movements, difficulty with coordination, or both. In either of these situations there is

no characteristic change in the muscle, either grossly or microscopically. At most, atrophy of type 2 fibers is seen.

**Motoneuron damage.** With damage to the spinal motoneuron or its axon, there is flaccid weakness of the muscle with proportionate wasting. Direct involvement of the spinal motoneuron was typically seen in poliomyelitis, but is now seen more commonly in the progressive spinomuscular atrophies of infancy and childhood, and in amyotrophic lateral sclerosis (ALS) in adults. Spontaneous twitching of groups of muscle fibers (fasciculation) innervated by the same motoneuron (motor unit) is frequently seen in these disorders. See POLIOMYELITIS.

Progressive diseases of unknown cause may occur in infancy (Werdnig-Hoffmann disease) or later in childhood (Kugelberg-Wielander disease). Both diseases result from degeneration of the motoneurons and appear to be inherited in an autosomal recessive pattern. In the infantile form, the baby is often floppy from birth with generalized weakness, a poor cry, and difficulty in sucking and breathing. Many children succumb in early childhood. In the later childhood forms, the rate of progression is slower and the outlook better. In these children weakness is more marked in the proximal muscles of the limbs.

Amyotrophic lateral sclerosis is a progressive disease of unknown cause, in which both the brainstem and spinal motoneurons, as well as the corticospinal tracts, undergo degeneration. This is a relatively rapid progressive disease, with death usually occurring within 3 years of diagnosis due to swallowing difficulty and respiratory failure. Although some cases of ALS appear to be inherited, most cases occur sporadically.

**Neuromuscular junction.** The most common example of disease at the neuromuscular junction is myasthenia gravis. Other, less common diseases are the myasthenic Eaton-Lambert syndrome and botulism. See MYASTHENIA GRAVIS.

**Myopathy.** Abnormalities of the muscle itself (myopathy) obviously result in muscle weakness, and muscle diseases fall into two large groups: those with a genetic basis and those which are nongenetic.

Congenital myopathies and the muscular dystrophies constitute the genetic muscle diseases. Congenital myopathies are characterized by a generalized weakness which is present at birth. The weakness is usually not progressive and often improves with time. Muscle fiber necrosis, a characteristic of the muscular dystrophies, is not seen in the congenital myopathies. See MUSCULAR DYSTROPHY.

Nongenetic or acquired diseases are all characterized by rapidly progressive weakness of the proximal muscles of the limbs, and so resemble the limb-girdle form of muscular dystrophy in the distribution of weakness. They are often included as inflammatory myopathies. Individuals with these disorders have difficulty arising from a recumbent or sitting position, in climbing stairs, and in lifting heavy objects onto a shelf. They also often have tender and painful muscles, may be febrile, and may have other manifestations of a systemic illness.

**Metabolic diseases.** A number of metabolic diseases have been associated with muscle symptoms. These include thyroid diseases and certain endocrine diseases, particularly Cushing's syndrome, which are either spontaneous or secondary to therapeutically administered adrenocorticosteroid hormones. No specific histologic changes have been described in the muscle in these disorders. Muscular symptoms are also seen with some of the glycogen storage diseases. Muscle weakness and paralysis may also be associated with alterations in the level of serum potassium.

**Myotonia.** A delayed relaxation of the muscle after forceful contraction (myotonic) is another symptom of muscle disease. This phenomenon is a characteristic feature of myotonic dystrophy and of congenital myotonia. Myotonia is usually present from early life and is often associated with muscle hypertrophy, but muscle weakness is not a feature of this disease. The muscle shows no definite histologic changes. See MUSCULAR SYSTEM.

[S.M.Su.]

**Mushroom** A macroscopic fungus with a fruiting body (also known as a sporocarp). Approximately 14% (10,000) described species of fungi are considered mushrooms. Mushrooms grow aboveground or underground. They have a fleshy or nonfleshy texture. Many are edible, and only a small percentage are poisonous.

Mushrooms reproduce via microscopic spheres (spores) that are roughly comparable to the seeds of higher plants. Spores are produced in large numbers on specialized structures in or on the fruiting body. Spores that land on a suitable medium absorb moisture, germinate, and produce hyphae that grow and absorb nutrients from the substratum. If suitable mating types are present and the mycelium (the threadlike filaments or hyphae that become interwoven) develops sufficiently to allow fruiting, the life cycle will continue. In nature, completion of the life cycle is dependent on many factors, including temperature, moisture and nutritional status of the substratum, and gas exchange capacity of the medium.

Fewer than 20 species of edible mushrooms are cultivated commercially. The most common cultivated mushroom is *Agaricus bisporus*, followed by the oyster mushroom (*Pleurotus* spp.). China is the leading mushroom-producing country; Japan leads the world in number of edible species cultivated commercially.

Mushrooms may be cultivated on a wide variety of substrates. They are grown from mycelium propagated on a base of steam-sterilized cereal grain. This grain and mycelium mixture is called spawn, which is used to seed mushroom substrata.

Mushrooms contain digestible crude protein, all essential amino acids, vitamins (especially provitamin D-2), and minerals; they are high in potassium and low in sodium, saturated fats, and calories. Although they cannot totally replace meat and other high-protein food in the diet, they can be considered an important dietary supplement and a health food.

Fungi have been used for their medicinal properties for over 2000 years. Although there remains an element of folklore in the use of mushrooms in health and medicine, several important drugs have been isolated from mushroom fruiting bodies and mycelium. The best-known drugs obtained are lentinan from *L. edodes*, grifolin from *Grifola frondosa*, and krestin from *Coriolus versicolor*. These compounds are protein-bound polysaccharides or long chains of glucose, found in the cell walls, and function as antitumor immunomodulatory drugs. See FUNGI; MEDICAL MYCOLOGY.

[D.M.C.]

**Musical acoustics** The branch of acoustics that deals with the generation of sound by musical instruments, the transmission of sound to the listener, and the perception of musical sound. A main research activity in musical acoustics is the study of the way in which musical instruments vibrate and produce sound. The most common way of classifying musical instruments is according to the nature of the primary vibrator, into string instruments, wind instruments, and percussion instruments. The vibrations of a plucked string, a struck membrane, or a blown pipe can be described in terms of normal modes of vibration. Determining the normal modes of a complex vibrator is often termed modal analysis. Much of the progress in understanding how musical instruments generate sound is due to new methods of modal analysis, such as holographic interferometry and experimental modal testing. See CAVITY RESONATOR; INTERFEROMETRY; MODE OF VIBRATION; VIBRATION.

In the case of most percussion, plucked string, and struck string instruments, the player delivers energy to the primary vibrator (string, membrane, bar, or plate) and thereafter has little control over the way it vibrates. In the case of wind and bowed string instruments, however, the continuing flow of energy is controlled by feedback from the vibrating system. In brass and reed woodwinds, pressure feedback opens or closes the input valve. In flutes or flue organ pipes, however, the input valve is flow-controlled. In bowed string instruments, pulses on the string control the stick-slip action of the bow on the string.

Four attributes are frequently used to describe musical sound: loudness, pitch, timbre, and duration. Each of the subjective qualities depends on one or more physical parameters that can be measured. Loudness, for example, depends mainly on sound pressure but also on the spectrum of the partials and the physical duration. Pitch depends mainly on frequency, but also shows lesser dependence on sound pressure and envelope. Timbre includes all the attributes by which sounds with the same pitch and loudness are distinguished. Relating the subjective qualities of sound to the physical parameters is a central problem in psychoacoustics, and musical acousticians are concerned with this same problem as it applies to musical sound. See PSYCHOACOUSTICS.

Sound pressure level is measured with a sound level meter and is generally expressed on a logarithmic scale of decibels (dB) using an appropriate reference level and weighting network. From measurements of the sound pressure level at different frequencies, it is possible to calculate a subjective loudness, expressed in sones, which describes the sensation of loudness heard by an average listener. Musicians prefer to use dynamic markings ranging from *ppp* (very soft) to *fff* (very loud). See DECIBEL; LOUDNESS; SOUND; SOUND PRESSURE.

Pitch is defined as that attribute of auditory sensation in terms of which sounds may be ordered on a scale extending from low to high. Pitch is generally related to a musical scale where the octave, rather than the critical bandwidth, is the "natural" pitch interval. See PITCH; SCALE (MUSIC).

Timbre is defined as that attribute of auditory sensation in terms of which a listener can judge two sounds similarly presented and having the same loudness and pitch as dissimilar. Timbre depends primarily on the spectrum of the sound, but it also depends upon the waveform, the sound pressure, the frequency location of the spectrum, and the temporal characteristics of the sound. It has been found impossible to construct a single subjective scale of timbre (such as the sone scale of loudness); multidimensional scales have been constructed. The term "tone color" is often used to refer to that part of timbre that is attributable to the steady-state part of the tone, but the time envelope (and especially the attack) has been found to be very important in determining timbre as well.

Another subject relating to the perception of music is combination tones. When two tones that are close together in frequency are sounded at the same time, beats generally are heard, at a rate that is equal to their frequency difference. When the frequency difference  $\Delta f$  exceeds 15 Hz or so, the beat sensation disappears, and a roughness appears. As  $\Delta f$  increases still further, a point is reached at which the "fused" tone at the average frequency gives way to two tones, still with roughness. The respective resonance regions on the basilar membrane are now separated sufficiently to give two distinct pitches, but the excitations overlap to give a sense of roughness. When the separation  $\Delta f$  exceeds the width of the critical band, the roughness disappears, and the two tones begin to blend. See EAR (VERTEBRATE).

Pythagoras of ancient Greece is considered to have discovered that the tones produced by a string vibrating in two parts with simple ratios such as 2:1, 3:2, or 4:3 sound harmonious. These ratios define the so-called perfect intervals of music, which are considered to have the greatest consonance. Other consonant intervals in music are the major sixth ( $f_2/f_1 = 5/3$ ), the major third ( $f_2/f_1 = 5/4$ ), the major sixth ( $f_2/f_1 = 8/5$ ), and the minor third ( $f_2/f_1 = 6/5$ ). Why are some intervals more consonant than others? H. Helmholtz concluded that dissonance (the opposite of consonance) is greatest when partials of the two tones produce 30 to 40 beats per second (which are not heard as beats but produce roughness). The more the partials of one tone coincide in frequency with the partials of the other, the less chance of roughness. This explains why simple frequency ratios define the most consonant intervals. More recent research has concluded that consonance is related to the critical band. If the frequency difference between two pure tones is greater than a critical band,

they sound consonant; if it is less than a critical band, they sound dissonant. The maximum dissonance occurs when  $\Delta f$  is approximately 1/4 of a critical band, which agrees reasonably well with Helmholtz's criterion for tones around 500 Hz. [T.D.R.]

**Musical instruments** Instruments for producing musical sounds have long been classified as woodwinds, brass, percussion, or strings; to these must be added electrical and electronic instruments. In a sense, all these instruments implement and extend the capability of the original musical instrument, the singing voice. The classes mentioned are useful in grouping instruments in a general way for the kinds of sounds they produce, even though woodwind instruments are not necessarily made of wood, nor are brass instruments always made of metal.

**Woodwind instruments.** Woodwind instruments are distinguished primarily by the fact that the effective length of the vibrating air column is shortened by opening lateral side holes in succession. Two distinctly different means of generating the sound are employed. For the flute, and its half-size version the piccolo, the player blows across the embouchure hole near one end in such a way as to cause periodic puffs of air to enter the tube; after a turbulent turning these puffs excite the air column longitudinally. This method of excitation leaves the tube acoustically open in the sense that the contained air vibrates much as it does in a simple tube with both ends open to the atmosphere.

For the double-reed oboe or bassoon, the player holds between the lips a pair of thin reeds (pieces of cane appropriately thinned, shaped, and bound together) that beat against each other to change the player's breath to puffs of air. For clarinets and saxophones, a single reed attached to a mouthpiece by a ligature functions in a similar way. The portion of the mouthpiece (the lay) against which the reed beats must be appropriately curved; the character of the sound is modified somewhat by the volume of the mouthpiece as well as by the shape and material of the reed.

For both the single- and double-reed instruments, the reeds vibrate under the influence of sound waves reflected back from the distant end of the air column and allow the puffs of air to enter when the sound pressure within the instrument is large. Thus (in contrast to the flute) the air vibration at the reed end is that associated with an acoustically closed end.

**Brass instruments.** The typical brass instrument consists of a cup-shaped mouthpiece, a slightly tapered mouthpipe, cylindrical tubing including valves, and a roughly hyperbolic bell. Puffs of air are introduced by the player via vibrating lips stretched over the mouthpiece. The action is comparable to that of the clarinet, in that the mouthpiece end is nearly closed acoustically. The length of the air column is increased by tubing switched in by use of valves, either piston or rotary: a common arrangement is such that the first valve lowers the intonation by two semitones, the second by one semitone, and the third by three semitones. For a given length of tubing, different tones are produced by tensioning the lips to excite different modes of vibration whose frequencies are approximately in the ratios 2:3:4:5:6:8.

**Percussion instruments.** Instruments such as the timpani (kettledrums) and xylophone are called percussion instruments because the sound is initiated by a blow. Two kinds of sound producers are involved: a membrane under tension, associated with a cavity that can influence the frequency of vibration, as in the case of the timpani; and a rigid bar or plate vibrating transversely, whose frequency is little affected by any resonator that may be attached. Some percussion instruments give a well-defined sound that excites a sensation of definite pitch, such as does a church bell; others, such as drums, cymbals, and triangles, are useful primarily for rhythm effects.

**Stringed instruments.** For the guitar and harp, strings are set into vibration by plucking; for the other stringed instruments the vibration is usually initiated and maintained by bowing. The frequency of vibration is primarily established by the



length, tension, and mass per unit length of the string. A string vibrates not only at the lowest (fundamental) frequency, but also at the same time at higher frequencies which tend toward integer multiples of the fundamental frequency. The sound radiated from the instrument is thus complex.

The radiation of sound from a stringed instrument is enhanced by a resonator consisting of an almost closed air cavity. Some of the energy of the vibrating string is transmitted via the bridge to the walls of the cavity. In a carefully constructed violin the resonances of the air cavity and its vibrating walls are distributed in frequency in order to afford a relatively uniform response throughout the playing range of the instrument.

**Keyboard instruments.** Instruments such as the celesta, pipe organ, accordion, and piano are usually put in a group called keyboard instruments, because the respective vibrating bars, pipes, reeds, and strings in these instruments are selected by use of keys in a keyboard. The celesta and piano could also be described as percussion instruments, because hammers strike the bars and strings; the pipe organ and the accordion, with its wind-driven free reeds, are wind instruments. By its multiple keyboards (and pedal board) the pipe organ puts under the control of a single player thousands of sources whose distinctive sounds can be reproduced on command. [R.W.Y.]

**Electrical, electronic, and software instruments.** Electrical musical instruments produce electrical tone signals for amplification (and loudspeaker listening) without using tuned mechanical vibrators or air columns. Early electrical instruments predated electronics, generating their tone signals by electromagnetic or electrostatic rotating machinery. Later, most of the instruments became electronic, producing their tone waves from vacuum-tube circuits, then transistor circuits, and now integrated electronic circuits. In the 1980s, electronic instruments transitioned from analog to digital, offering much more precise tuning (and alternative tunings) and repeatability of configuration. See INTEGRATED CIRCUITS.

Many different means of sound generation have been used during the evolution of electronic musical instruments. In concept at least, the most simple electronic method would be to substitute directly for each conventional mechanical (string, reed) or acoustical (resonant air column) sound source an electronic circuit source or software algorithm that generates the same complex tone wave. However, in different parts of the musical scale the waveform typically differs for the same instrument. Moreover, keyboard instruments require that a number of tones be produced at the same time. Consequently, the substitution method is less feasible economically than other methods described below. See WAVEFORM.

The additive synthesis method synthesizes each desired complex tone by adding together an appropriate number of simple (sine) waves at harmonically related frequencies, with the relative amplitudes of the harmonic waves adjustable to produce the desired resultant waveform. Additive synthesis has been used extensively in the field of computer music since at least the 1960s, and it has been the basis of a number of limited-production hardware devices. In current music synthesizers, however, there are typically more efficient ways than additive synthesis to achieve desired sounds, and mass-produced electronic musical instruments are generally not based on additive synthesis. However, the concept of additive synthesis remains important, and there are closely related descendants, such as sinusoidal modeling and group additive synthesis.

Subtractive synthesis is similar in principle to that of speech (and singing) sound formation within the human voice system. At each desired musical frequency an electronic circuit produces a standard basic tone waveform (such as a sawtooth wave), which already contains a very large number of harmonics at known relative amplitudes. Then a variety of electric or electronic filters is provided in the instrument wherein switch selection, individually or collectively, converts the basic tone signals into the desired musical tone waveforms. Subtractive synthesis is somewhat the

opposite of additive synthesis, since it practically subtracts undesired harmonics instead of adding desired harmonics. Subtractive synthesis has been the basis for most voice synthesizers for over half a century. See ELECTRIC FILTER; FUNCTION GENERATOR; WAVE-SHAPING CIRCUITS.

The first all-digital synthesizer was based on frequency-modulation (FM) synthesis. Simple FM is carried out using two digital oscillators, with the output of one adding to the frequency (or phase) control of the other. In additive synthesis, two oscillators can provide only two harmonics. In FM synthesis, two oscillators can provide any number of harmonics. It is even possible for the output of a digital oscillator to modulate its own phase, giving so-called feedback FM. A major advantage of FM is the synthesis of a wide variety of complex sounds from an extremely simple digital algorithm. Disadvantages of FM are its extreme sensitivity to its control parameters, and the fact that many parameter settings sound artificial. FM synthesis remains a valuable complexity-reduction technique in the context of additive synthesis. See FREQUENCY MODULATION.

Sampling synthesis can refer to any synthesis method based on playing back digitally recorded and manipulated sounds. Today, ROM-based wavetable synthesizers dominate the field, from single-chip devices used in notebook computers to the most expensive synthesizers. With enough digital recordings of an instrument, it is possible to achieve any sound with sampling synthesis. However, approaching full expressive fidelity for most instruments, particularly bowed strings and solo woodwinds, requires prohibitive amounts of memory, system development, and control complexity.

A more recent approach to the synthesis of acoustic musical instruments, also made possible by digital technology, is known as physical modeling synthesis. In this approach, the algorithms are based directly on the mathematical physics of the instrument. One variant of physical modeling synthesis, which is especially effective for synthesizing string and wind instruments, is waveguide synthesis. Waveguide synthesis explicitly simulates traveling waves on a string or inside a bore or horn using digital delay lines. The theory is analogous to that of sampled (discrete-time) electric transmission lines. Filters are used in conjunction with digital waveguides to simulate losses due to bridge motion, horn radiation, air absorption, and the like. [D.W.Ma.; J.O.Sm.]

**Musk-ox** An even-toed ungulate, *Ovibos moschatus*, which is a member of the family Bovidae in the mammalian order Artiodactyla. This single species is the northernmost representative of the family, ranging through the tundra areas and snowfields of Canada and Alaska, as well as Greenland.



The musk-ox (*Ovibos moschatus*).

The musk-ox derives its name from the musky odor it emits. It is a stoutly built animal (see illustration) and has a coat of long dense hair that is resistant to the extreme cold of the windswept

treeless tundra. They do not hibernate and are usually found in herds of 20–100 animals huddled together for warmth. As protection against its natural enemy, the wolf, the musk-ox will form a circle with the young inside. Since a cow produces a single calf every 2 years, the numbers have been so reduced that they are now protected by the Canadian government. See ARTIODACTYLA. [C.B.C.]

**Muskeg** A term derived from Chippewan Indian for “grassy bog.” In North America ecologists apply diverse usage, but most include peat bogs or tussock meadows, with variable woody vegetation such as spruce or tamarack. Plant remains accumulate when trapped in the water or in media such as sphagnum moss which inhibit decay. The peat might accrue indefinitely or might approach a steady state of raised bogs, blanket bogs, or forest if input became balanced by erosion or by loss as methane and CO<sub>2</sub>.

Organic terrain occurs on every continent. The largest expanses of it are in Russia (especially western Siberia) and Canada. Typical bog or spruce-larch muskeg develops in cool temperature and subarctic to arctic lands. In the subtropics and the tropics there is considerable organic terrain, as in Paraguay, Uruguay, and Guyana in South America. Thus, despite differences in climate or floristics, the phenomenon of peat formation persists if local aeration or biochemical conditions hinder decay. Despite climatic and biotic differences, gross peat structure categories seem comparable the world over. See BOG; PEAT. [N.W.R.]

**Muskmelon** The edible fruit of *Cucumis melo*, belonging to the gourd family, Cucurbitaceae, as do other vine crops such as cucumber, watermelons, pumpkin, and squash. The muskmelon appears to be indigenous to Africa. See CANTALOUPE; HONEY DEW MELON; PERSIAN MELON; VIOLALES.

The plants are annual, trailing vines, with three to five runners. The runners produce short fruiting branches, which bear the perfect flowers and later the fruits. Muskmelons maturing on the vine without becoming overripe are superior in quality to those harvested immature. The sugar content, flavor, and texture of the fresh flesh improves very rapidly as the fruit approaches maturity. When mature, the melon is sweet, averages 6 to 8% sugar, and has a slight to distinctly musky odor and flavor, depending upon cultivar and environment. The flesh is rich in potassium, in vitamin C and, when deep orange, also in vitamin A. [F.W.Z.]

**Muskkrat** The largest member of the rodent subfamily Murinae in the family Muridae, it is also known as the musquash. Also included in this subfamily are the lemmings and voles. *Ondatra zibethica*, the single species, is about the size of a rabbit. It is economically important for its fur, which is shiny, soft, and thick. It received its name because of its inguinal glands which produce a characteristic musky odor.

The muskrat is omnivorous, eating various types of vegetation, such as reeds and tuberous roots of aquatic plants, and animals, such as mussels, insects, and fish. These animals become active in March, when mating occurs. The female has two or three litters of 5–9 young each year, and the last litter of the season remains in the parental abode through winter. See LEMMING; RODENTIA. [C.B.C.]

**Mustard** Any one of a number of annual crucifer species of Asiatic origin belonging to the plant order Capparales. Mustards eaten as greens are *Brassica juncea*, *B. juncea* var. *crispifolia*, and *B. hirta*. Table mustard and oils are obtained from *B. nigra*. Important production centers for mustard greens are in the South, where the crop is popular. Montana and the West Coast states are important sources of mustard seed. See CAPPARALES. [H.J.C.]

**Mutagens and carcinogens** A mutagen is a substance or agent that induces heritable change in cells or or-

ganisms. A carcinogen is a substance that induces unregulated growth processes in cells or tissues of multicellular animals, leading to cancer. Although mutagen and carcinogen are not synonymous terms, the ability of a substance to induce mutations and its ability to induce cancer are strongly correlated. Mutagenesis refers to processes that result in genetic change, and carcinogenesis (the processes of tumor development) may result from mutagenic events. See MUTATION; RADIATION BIOLOGY.

A mutation is any change in a cell or in an organism that is transmitted to subsequent generations. Mutations can occur spontaneously or be induced by chemical or physical agents. The cause of mutations is usually some form of damage to DNA or chromosomes that results in some change that can be seen or measured. However, damage can occur in a segment of DNA that is a noncoding region and thus will not result in a mutation. Mutations may or may not be harmful, depending upon which function is affected. They may occur in either somatic or germ cells. Mutations that occur in germ cells may be transmitted to subsequent generations, whereas mutations in somatic cells are generally of consequence only to the affected individual.

Not all heritable changes result from damage to DNA. For example, in growth and differentiation of normal cells, major changes in gene expression occur and are transmitted to progeny cells through changes in the signals that control genes that are transcribed into ribonucleic acid (RNA). It is possible that chemicals and radiation alter these processes as well. When such an effect is seen in newborns, it is called teratogenic and results in birth defects that are not transmitted to the next generation. However, if the change is transmissible to progeny, it is a mutation, even though it might have arisen from an effect on the way in which the gene is expressed. Thus, chemicals can have somatic effects involving genes regulating cell growth that could lead to the development of cancer, without damaging DNA.

Cancer arises because of the loss of growth control by derangement of regulatory signals. Included in the phenotypic consequences of mutations are alterations in gene regulation brought about by changes either in the regulatory region or in proteins involved with coordinated cellular functions. Altered proteins may exhibit novel interactions with target substrates and thereby lose the ability to provide a regulatory function for the cell or impose altered functions on associated molecules. Through such a complex series of molecular interactions, changes occur in the growth properties of normal cells leading to cancer cells that are not responsive to normal regulatory controls and can eventually give rise to a visible neoplasm or tumor. While mutagens can give rise to neoplasms by a process similar to that described above, not all mutagens induce cancer and not all mutational events result in tumors.

The identification of certain specific types of genes, termed oncogenes, that appear to be causally involved in the neoplastic process has helped to focus mechanistic studies on carcinogenesis. Oncogenes can be classified into a few functionally different groups, and specific mutations in some of the genes have been identified and are believed to be critical in tumorigenesis. Tumor suppressor genes or antioncogenes provide a normal regulatory function; by mutation or other events, the loss of the function of these genes may release cells from normal growth-control processes, allowing them to begin the neoplastic process. See ONCOGENES; ONCOLOGY.

There are a number of methods and systems for identifying chemical mutagens. Mutations can be detected at a variety of genetic loci in very diverse organisms, including bacteria, insects, cultured mammalian cells, rodents, and humans. Spontaneous and induced mutations occur very infrequently, the estimated rate being less than 1 in 10,000 per gene per cell generation. This low mutation rate is probably the result of a combination of factors that include the relative inaccessibility of DNA to damaging agents and the ability of cellular processes to repair damage to DNA.

Factors that contribute to the difficulty in recognizing substances that may be carcinogenic to humans include the prevalence of cancer, the diversity of types of cancer, the generally late-life onset of most cancers, and the multifactorial nature of the disease process. Approximately 50 substances have been identified as causes of cancer in humans, but they probably account for only a small portion of the disease incidence. See CANCER (MEDICINE); HUMAN GENETICS; MUTATION; RADIATION BIOLOGY.

[R.W.T.]

**Mutation** Any alteration capable of being replicated in the genetic material of an organism. When the alteration is in the nucleotide sequence of a single gene, it is referred to as gene mutation; when it involves the structures or number of the chromosomes, it is referred to as chromosome mutation, or rearrangement. Mutations may be recognizable by their effects on the phenotype of the organism (mutant).

**Gene mutations.** Two classes of gene mutations are recognized: point mutations and intragenic deletions. Two different types of point mutation have been described. In the first of these, one nucleic acid base is substituted for another. The second type of change results from the insertion of a base into, or its deletion from, the polynucleotide sequence. These mutations are all called sign mutations or frame-shift mutations because of their effect on the translation of the information of the gene. See NUCLEIC ACID.

More extensive deletions can occur within the gene which are sometimes difficult to distinguish from mutants which involve only one or two bases. In the most extreme case, all the informational material of the gene is lost.

A single-base alteration, whether a transition or a transversion, affects only the codon or triplet in which it occurs. Because of code redundancy, the altered triplet may still insert the same amino acid as before into the polypeptide chain, which in many cases is the product specified by the gene. Such DNA changes pass undetected. However, many base substitutions do lead to the insertion of a different amino acid, and the effect of this on the function of the gene product depends upon the amino acid and its importance in controlling the folding and shape of the enzyme molecule. Some substitutions have little or no effect, while others destroy the function of the molecule completely.

Single-base substitutions may sometimes lead not to a triplet which codes for a different amino acid but to the creation of a chain termination signal. Premature termination of translation at this point will lead to an incomplete and generally inactive polypeptide.

Sign mutations (adding or subtracting one or two bases to the nucleic acid base sequence of the gene) have a uniformly drastic effect on gene function. Because the bases of each triplet encode the information for each amino acid in the polypeptide product, and because they are read in sequence from one end of the gene to the other without any punctuation between triplets, insertion of an extra base or two bases will lead to translation out of register of the whole sequence distal to the insertion or deletion point. The polypeptide formed is at best drastically modified and usually fails to function at all. This sometimes is hard to distinguish from the effects of intragenic deletions. However, whereas extensive intragenic deletions cannot revert, the deletion of a single base can be compensated for by the insertion of another base at, or near, the site of the original change. See GENE; GENETIC CODE.

**Chromosomal changes.** Some chromosomal changes involve alterations in the quantity of genetic material in the cell nuclei, while others simply lead to the rearrangement of chromosomal material without altering its total amount. See CHROMOSOME.

**Origins of mutations.** Mutations can be induced by various physical and chemical agents or can occur spontaneously without any artificial treatment with known mutagenic agents.

Until the discovery of x-rays as mutagens, all the mutants studied were spontaneous in origin; that is, they were obtained without the deliberate application of any mutagen. Spontaneous mutations occur unpredictably, and among the possible factors responsible for them are tautomeric changes occurring in the DNA bases which alter their pairing characteristics, ionizing radiation from various natural sources, naturally occurring chemical mutagens, and errors in the action of the DNA-polymerizing and correcting enzymes.

Spontaneous chromosomal aberrations are also found infrequently. One way in which deficiencies and duplications may be generated is by way of the breakage-fusion-bridge cycle. During a cell division one divided chromosome suffers a break near its tip, and the sticky ends of the daughter chromatids fuse. When the centromere divides and the halves begin to move to opposite poles, a chromosome bridge is formed, and breakage may occur again along this strand. Since new broken ends are produced, this sequence of events can be repeated. Unequal crossing over is sometimes cited as a source of duplications and deficiencies, but it is probably less important than often suggested.

In the absence of mutagenic treatment, mutations are very rare. In 1927 H. J. Muller discovered that x-rays significantly increased the frequency of mutation in *Drosophila*. Subsequently, other forms of ionizing radiation, for example, gamma rays, beta particles, fast and thermal neutrons, and alpha particles, were also found to be effective. Ultraviolet light is also an effective mutagen. The wavelength most employed experimentally is 253.7 nm, which corresponds to the peak of absorption of nucleic acids.

Some of the chemicals which have been found to be effective as mutagens are the alkylating agents which attack guanine principally although not exclusively. The N7 portion appears to be a major target in the guanine molecule, although the O<sup>6</sup> alkylation product is probably more important mutagenically. Base analogs are incorporated into DNA in place of normal bases and produce mutations probably because there is a higher chance that they will mispair at replication. Nitrous acid, on the other hand, alters DNA bases in place. Adenine becomes hypoxanthine and cytosine becomes uracil. In both cases the deaminated base pairs differently from the parent base. A third deamination product, xanthine, produced by the deamination of guanine, appears to be lethal in its effect and not mutagenic. Chemicals which react with DNA to generate mutations produce a range of chemical reaction products not all of which have significance for mutagenesis.

**Significance of mutations.** Mutations are the source of genetic variability, upon which natural selection has worked to produce organisms adapted to their present environments. It is likely, therefore, that most new mutations will now be disadvantageous, reducing the degree of adaptation. Harmful mutations will be eliminated after being made homozygous or because the heterozygous effects reduce the fitness of carriers. This may take some generations, depending on the severity of their effects. Chromosome alterations may also have great significance in evolutionary advance. Duplications are, for example, believed to permit the accumulation of new mutational changes, some of which may prove useful at a later stage in an altered environment.

Rarely, mutations may occur which are beneficial: Drug yields may be enhanced in microorganisms; the characteristics of cereals can be improved. However, for the few mutations which are beneficial, many deleterious mutations must be discarded. Evidence suggests that the metabolic conditions in the treated cell and the specific activities of repair enzymes may sometimes promote the expression of some types of mutation rather than others. See DEOXYRIBONUCLEIC ACID (DNA).

[B.J.K.]

**Mutualism** An interaction between two species that benefits both. Individuals that interact with mutualists experience higher success than those that do not. Hence, behaving

mutualistically is advantageous to the individual, and it does not require any concern for the well-being of the partner. At one time, mutualisms were thought to be rare curiosities primarily of interest to natural historians. However, it is now believed that every species is involved in one or more mutualisms. Mutualisms are thought to lie at the root of phenomena as diverse as the origin of the eukaryotic cell, the diversification of flowering plants, and the pattern of elevated species diversity in tropical forests.

Mutualisms generally involve an exchange of substances or services that organisms would find difficult or impossible to obtain for themselves. For instance, *Rhizobium* bacteria found in nodules on the roots of many legume (bean) species fix atmospheric nitrogen into a form ( $\text{NH}_3$ ) that can be taken up by plants. The plant provides the bacteria with carbon in the form of dicarboxylic acids. The carbon is utilized by the bacteria as energy for nitrogen fixation. Consequently, leguminous plants often thrive in nitrogen-poor environments where other plants cannot persist. Another well-known example is lichens, in which fungi take up carbon fixed during photosynthesis of their algae associates. See NITROGEN FIXATION.

A second benefit offered within some mutualisms is transportation. Prominent among these mutualisms is biotic pollination, in which certain animals visit flowers to obtain resources and return a benefit by transporting pollen between the flowers they visit. A final benefit is protection from one's enemies. For example, ants attack the predators and parasites of certain aphids in exchange for access to the aphids' carbohydrate-rich excretions (honeydew).

Another consideration about mutualisms is whether they are symbiotic. Two species found in intimate physical association for most or all of their lifetimes are considered to be in symbiosis. Not all symbioses are mutualistic; symbioses may benefit both, one, or neither of the partners.

Mutualisms can also be characterized as obligate or facultative (depending on whether or not the partners can survive without each other), and as specialized or generalized (depending on how many species can confer the benefit in question).

Two features are common to most mutualisms. First, mutualisms are highly variable in time and space. Second, mutualisms are susceptible to cheating. Cheaters can be individuals of the mutualist species that profit from their partners' actions without offering anything in return, or else other species that invade the mutualism for their own gain.

Mutualism has considerable practical significance. Certain mutualisms play central roles in humans' ability to feed the growing population. It has been estimated that half the food consumed is the product of biotic pollination. See ECOLOGY; PLANT PATHOLOGY. [J.L.Br.]

**Myasthenia gravis** A disease resulting from an abnormality in neuromuscular transmission, characterized by a fluctuating degree of muscle weakness. The weakness is usually aggravated by activity, and there is partial or complete restoration of strength after a period of rest or the administration of anticholinesterase medications.

It has been shown that the basic defect in myasthenia gravis is a reduction in the number of acetylcholine receptor sites in the postsynaptic membrane of the neuromuscular junction. It has also been shown that many myasthenic patients have immunoglobulins in the serum that partially block acetylcholine receptors. See AUTOIMMUNITY; IMMUNOGLOBULIN.

Abnormalities have been demonstrated in the thymus gland and skeletal muscle in myasthenia gravis. There is an increased incidence of thymoma in myasthenia gravis, and in those without a thymoma, hyperplasia of the germinal centers is a common finding in the thymus gland.

Although the disease affects young women more commonly, usually in the third decade, it can occur in either sex at any age. In the majority of persons, weakness affects muscles of head, neck, and limbs (generalized myasthenia), but in some the weakness

is restricted to the muscles of the eyes (ocular myasthenia), in which case the disease is usually benign.

The standard treatment for myasthenia gravis has been the use of longer-acting anticholinesterase agents; thymectomy and immunosuppressive drugs are reserved for those patients with generalized myasthenia that does not respond sufficiently to these agents. [S.M.Su.]

**Mycobacterial diseases** Diseases caused by mycobacteria, a diffuse group of acid-fast, rod-shaped bacteria in the genus *Mycobacterium*. Some mycobacteria are saprophytes, while others can cause disease in humans. The two most important species are *M. tuberculosis* (the cause of tuberculosis) and *M. leprae* (the cause of leprosy); other species have been called by several names, particularly the atypical mycobacteria or the nontuberculous mycobacteria. See LEPROSY; TUBERCULOSIS.

These bacteria are classified according to their pigment formation, rate of growth, and colony morphology. The most commonly involved disease site is the lungs. Nontuberculous mycobacteria are transmitted from natural sources in the environment, rather than from person to person, and thus are not a public health hazard. Nontuberculous mycobacteria have been cultured from various environmental sources.

The diagnosis of disease caused by nontuberculous mycobacteria can be difficult, since colonization or contamination of specimens may be present rather than true infection.

Pulmonary disease resembling tuberculosis is a most important manifestation of disease caused by nontuberculous mycobacteria. The symptoms and chest x-ray findings are similar to those seen in tuberculosis. *Mycobacterium kansasii* and *M. avium intracellulare* are the most common pathogens. The disease usually occurs in middle-aged men and women with some type of chronic coexisting lung disease. The pathogenic mechanisms are obscure. Pulmonary infections due to *M. kansasii* can be treated successfully with chemotherapy. The treatment of pulmonary infections due to *M. avium intracellulare* complex is difficult.

Chronic infection involving joints and bones, bursae, synovia, and tendon sheaths can be caused by various species.

Localized abscesses due to *M. fortuitum* or *M. chelonae* can occur after trauma, after surgical incision, or at injection sites. The usual treatment is surgical incision. The most common soft tissue infection is caused by *M. marinum*, which may be introduced, following an abrasion or trauma, from handling fish or fish tanks, or around a swimming pool. Treatment is surgical. *Mycobacterium ulcerans* causes a destructive skin infection in tropical areas of the world. It is treated by wide excision and skin grafting.

Disseminated *M. avium intracellulare* is one of the opportunistic infections seen in the acquired immune deficiency syndrome (AIDS). In individuals with AIDS, the organism has been cultured from lung, brain, cerebrospinal fluid, liver, spleen, intestinal mucosa, and bone marrow. No treatment has yet been effective in this setting. See ACQUIRED IMMUNE DEFICIENCY SYNDROME (AIDS). [G.M.L.; L.B.R.]

**Mycology** The study of organisms classified under the kingdom Fungi. Common names for some of these organisms are mushrooms, boletes, bracket or shelf fungi, powdery mildew, bread molds, yeasts, puffballs, morels, stinkhorns, truffles, smuts, and rusts. Fungi are found in every ecological niche. Mycologists estimate that there are 1.5 million species of fungi, with only 70,000 species now described. Fungi typically have a filamentous-branched somatic structure surrounded by thick cell walls known as hyphae. The phyla considered to be true fungi are Chytridiomycota, Zygomycota, Ascomycota, and Basidiomycota. Other phyla that sometimes are included as true fungi are Myxomycota, Dictyosteliomycota, Acrasiomycota, and Plasmodiophoromycota. See FUNGAL BIOTECHNOLOGY; FUNGAL ECOLOGY; FUNGAL GENETICS; FUNGI; MEDICAL MYCOLOGY; PLANT PATHOLOGY. [S.C.Jo.]

**Mycoplasmas** The smallest prokaryotic microorganisms that are able to grow on cell-free artificial media. Their genome size is also among the smallest recorded in prokaryotes, about  $5 \times 10^8$  to  $10^9$  daltons. The mycoplasmas differ from almost all other prokaryotes in lacking a rigid cell wall and in their incapability to synthesize peptidoglycan, an essential component of the bacterial cell wall.

Taxonomically, the mycoplasmas are assigned to a distinct class, the Mollicutes, containing two orders, Mycoplasmatales and Acholeplasmatales. The distinction between the orders is based primarily on differences in nutritional criteria: members of the Mycoplasmatales require cholesterol or other sterols for growth whereas those of the second order do not. The main criteria used for the subdivision of the orders into families and genera are shown:

Class: Mollicutes

Order I: Mycoplasmatales (sterol required for growth; NADH<sub>2</sub> oxidase localized in cytoplasm)

Family I: Mycoplasmataceae (genome size approximately  $5 \times 10^8$  daltons)

Genus I: *Mycoplasma* (70 species; do not hydrolyze urea)

Genus II: *Ureaplasma* (2 species; hydrolyze urea)

Family II: Spiroplasmataceae (helical organisms; genome size approximately  $10^9$  daltons)

Genus I: *Spiroplasma* (4 species)

Order II: Acholeplasmatales (sterol not required for growth; NADH<sub>2</sub> oxidase localized in membrane; genome size approximately  $10^9$  daltons)

Family I: Acholeplasmataceae

Genus I: *Acholeplasma* (9 species)

Genus of uncertain taxonomic position  
*Anaeroplasmata* (2 species)

The term mycoplasmas is generally used as the vernacular or trivial name for all members of the class Mollicutes, irrespective of the classification in a particular genus. See PROKARYOTAE.

The mycoplasmas are almost ubiquitous in nature. Several species are important pathogens of humans, animals and plants, while others constitute part of the normal microbial flora of, for example, the upper respiratory and lower urogenital tracts of humans. *Mycoplasma pneumoniae* was found to be the cause of cold agglutinin-associated primary atypical pneumonia. This disease is particularly frequent in the 5–15-year age group; it is probably endemic almost all over the world and often reaches epidemic proportions at intervals of 4 to 5 years.

Mycoplasmas are generally highly resistant to benzyl penicillin and other antibiotics which act by interfering with the biosynthesis of peptidoglycan. They are usually susceptible to antibiotics that specifically inhibit protein synthesis in prokaryotes, such as tetracyclines and chloramphenicol. Susceptibility to other antibiotics, such as erythromycin and other macrolides, is variable. See ANTI-BIOTIC; BACTERIAL PHYSIOLOGY AND METABOLISM; PLANT PATHOLOGY; PNEUMONIA. [E.A.F.]

**Mycorrhizae** Dual organs of absorption that are formed when symbiotic fungi inhabit healthy absorbing organs (roots, rhizomes, or thalli) of most terrestrial plants and many aquatics and epiphytes.

Mycorrhizae appear in the earliest fossil record of terrestrial plant roots. Roughly 80% of the nearly 10,000 plant species that have been examined are mycorrhizal. Present-day plants that normally lack mycorrhizae are generally evolutionarily advanced. It has been inferred that primitive plants evolved with a symbiosis between fungi and rhizoids or roots as a means to extract nutrients and water from soil. The degree of dependence

varies between species or groups of plants. In absolute dependence, characteristic of perennial, terrestrial plants, the host requires mycorrhizae to survive. Some plants are facultative; they may form mycorrhizae but do not always require them. This group includes many of the world's more troublesome weeds. A minority of plant species characteristically lack mycorrhizae, so far as is known, including many aquatics, epiphytes, and annual weeds.

The three major types of mycorrhizae differ in structural details but have many functions in common. The fungus colonizes the cortex of the host root and grows its filaments (hyphae) into surrounding soil from a few centimeters to a meter or more. The hyphae absorb nutrients and water and transport them to host roots. The fungi thus tap far greater volumes of soil at a relatively lower energy cost than the roots could on their own. Moreover, many, if not all, mycorrhizal fungi produce extracellular enzymes and organic acids that release immobile elements such as phosphorus and zinc from clay particles, or phosphorus and nitrogen bound in organic matter. The fungi are far more physiologically capable in extracting or recycling nutrients in this way than the rootlets themselves.

Mycorrhizal fungi are relatively poorly competent in extracting carbon from organic matter. They derive energy from host-photosynthesized carbohydrates. Hosts also provide vitamins and other growth regulators that the fungi need.

The major types are ectomycorrhizae, vesicular-arbuscular mycorrhizae, and ericoid mycorrhizae. Ectomycorrhizae are the most readily observed type. Ectomycorrhizal hosts strongly depend on mycorrhizae to survive. Relatively few in number of species, they nonetheless dominate most forests outside the tropics. Vesicular-arbuscular mycorrhizae (sometimes simply termed arbuscular mycorrhizae) form with the great majority of terrestrial herbaceous plant species plus nearly all woody perennials that are not ectomycorrhizal. Vesicular-arbuscular mycorrhizal hosts range from strongly mycorrhiza-dependent, especially the woody perennials, to facultative, as are many grasses.

Ericoid mycorrhizae are restricted to the Ericales, the heath order. The hosts are strongly mycorrhiza-dependent. Though relatively few in number, heath species dominate large areas around the world and are common understory plants in many forests. Other mycorrhiza types include those special for the Orchidaceae (orchids) and Gentianaceae (gentians). See ASCOMYCOTA; ERICALES; ZYGOMYCOTINA.

The succession of plants from pioneering through seral to climax communities is governed by availability of mycorrhizal propagules. When catastrophic fire, erosion, or clearcutting reduce the availability of mycorrhizal fungi in the soil, plants dependent on those fungi will have difficulty becoming established. Each mycorrhizal fungus has its own array of physiological characteristics. Some are especially proficient at releasing nutrients bound in organic matter, some produce more effective antibiotics or growth regulators than others, and some are more active in cool, hot, wet, or dry times of year than others. Healthy plant communities or crops typically harbor diverse populations of mycorrhizal fungal species. This diversity, evolved over a great expanse of time, is a hallmark of thriving ecosystems. Factors that reduce this diversity also reduce the resilience of ecosystems.

Mycorrhizal inoculation of plants in nurseries, orchards, and fields has succeeded in many circumstances, resulting in improved survival and productivity of the inoculated plants. Inoculation with selected fungi is especially important for restoring degraded sites or introducing exotics. Because ectomycorrhizal fungi include many premier edibles such as truffles, seedlings can also be inoculated to establish orchards for production of edible fungi. See FOREST SOIL; FUNGI. [J.M.Tr.]

**Mycotoxin** Any of the mold-produced substances that may be injurious to vertebrates upon ingestion, inhalation, or skin contact. The diseases they cause, known as mycotoxicoses, need not involve the toxin-producing fungus. Diagnostic features characterizing mycotoxicoses are the following: the disease is not

transmissible; drug and antibiotic treatments have little or no effect; in field outbreaks the disease is often seasonal; the outbreak is usually associated with a specific foodstuff; and examination of the suspected food or foodstuff reveals signs of fungal activity.

The earliest recognized mycotoxicoses were human diseases. Ergotism, or St. Anthony's fire, results from eating rye infected with *Claviceps purpurea*. Yellow rice disease, a complex of human toxicoses, is caused by several *Penicillium islandicum* mycotoxins. World attention was directed toward the mycotoxin problem with the discovery of the aflatoxins in England in 1961. The aflatoxins, a family of mycotoxins produced by *Aspergillus flavus* and *A. parasiticus*, can induce both acute and chronic toxicological effects in vertebrates. Aflatoxin B<sub>1</sub>, the most potent of the group, is toxic, carcinogenic, mutagenic, and teratogenic. Major agricultural commodities that are often contaminated by aflatoxins include corn, peanuts, rice, cottonseed, and various tree nuts. See AFLATOXIN; ERGOT AND ERGOTISM. [A.Ci.; M.Kl.]

**Myiasis** The infestation of vertebrates by the larvae, or maggots, of numerous species of flies. These larvae may invade different parts of the bodies of these animals or may appear externally. The Diptera of medical and veterinary importance are largely confined to the families Oestridae, Calliphoridae, and Sarcophagidae.

In cutaneous myiasis, the larvae are found in or under the skin. There may be a migration of some species of these larvae through host tissues, resulting in a swelling with intense itching. Such a condition is known as larva migrans, or creeping eruption, and may require surgical treatment.

Intestinal myiasis in humans is usually the result of accidentally swallowing the eggs or larvae of these flies. It occurs commonly in many herbivores who ingest the eggs when feeding on contaminated herbage. The larvae settle in the stomach or intestinal tract of the animal host.

Cavity, or wound, myiasis occurs when the larvae invade natural orifices, such as the nasopharynx, vulva, and sinuses, or artificial openings such as wounds. External myiasis includes infestation by those maggots which are blood feeders. See DIPTERA; MEDICAL PARASITOLOGY. [C.B.C.]

**Mylonite** A rock that has undergone significant modification of original textures by predominantly plastic flow due to dynamic recrystallization. Mylonites form at depth beneath brittle faults in continental and oceanic crust, in rocks from quartzfeldspathic to olivine-pyroxenite composition. Mylonites were once confused with cataclastites, which form by brittle fracturing, crushing, and comminution. Microstructures that develop during mylonitization vary according to original mineralogy and modal compositions, temperature, confining pressure, strain, strain rate, applied stresses, and presence or absence of fluids.

At low to moderate metamorphic grades, mylonitization reduces the grain size of the protolith and commonly produces a very fine-grained, well-foliated rock with a pronounced linear fabric defined by elongate minerals. Lineations may be weak or absent, however, in high-strain zones that lack a significant rotational component. At high metamorphic grades, grain growth during mylonitization can produce a net increase in grain size, and the term mylonitic gneiss is used where there is a preserved or inferred undeformed protolith. See METAMORPHIC ROCKS. [C.Si.]

**Myodocopida** An order of marine organisms that forms an important part of the class Ostracoda (subphylum Crustacea) and comprises three suborders. It has a long geological history that extends back at least to the Early Silurian. However, the lightly calcified carapaces of the species in this order are a factor in their having a sparse fossil record. Indeed, of the sixteen families of myodocopids, three are known only from modern marine environments. Species of those families that have a fossil record are quite rare and discontinuous in their stratigraphical

distribution. Myodocopids are only abundant as fossils from organically rich shale that was deposited in deep, anoxic environments, especially those of the Devonian seas. Such environments were devoid of benthic (bottom-dwelling) life, but the valves and carapaces of the nektonic (free-swimming) myodocopids, both immature forms (termed instars) and adults, sank into such environments and were preserved. See CRUSTACEA; OSTRACODA.

The myodocopids are typically much larger than other ostracodes and may be more than a centimeter long, although adults of most species are unlikely to be longer than 3 mm. As is characteristic of ostracodes, the carapace of the myodocopids comprises two valves that are joined along the animal's dorsum by a hinge and ligament. Among the myodocopids, the anterior portions of both valves are marked by a characteristic notch through which the setaceous antennae or antennules protrude. The appendages of all ostracodes are homologous with those of other crustaceans and, as is characteristic of arthropods in general, have been highly modified during their evolution. The appendages of the myodocopids are especially well adapted for swimming. Sexual dimorphism is not as pronounced among the myodocopids as it is among most smaller, more heavily calcified ostracodes.

Myodocopids are not exclusively planktonic as is often assumed. They are typically strong swimmers, but many are nektonic, swimming in proximity to the substrate. Others, however, live near the surface of the open ocean and are not associated with the environments of deposition that lie far beneath them on the ocean floor, where their valves and carapaces will ultimately be deposited. A fascinating characteristic of the myodocopids is the ability of many species to secrete bioluminescent material into the water. This bioluminescence functions as highly elaborate courtship displays that are species-specific and facilitate recognition of potential mates. See BIOLUMINESCENCE; CRUSTACEA; OSTRACODA. [R.L.Ka.]

**Myricales** An order of flowering plants, division Magnoliophyta (Angiospermae), in the subclass Hamamelidae of the class Magnoliopsida (dicotyledons). The order consists of the single family Myricaceae, with about 50 species. Within its subclass the order is marked by its simple, resinous-dotted, aromatic leaves and unilocular ovary with two styles and a single ovule. The plants are trees or shrubs, and the flowers are much reduced and borne in catkins. The fruit is a small, waxy-coated drupe or nut. Several species of *Myrica* are occasionally cultivated as ornamentals. See FLOWER; HAMAMELIDAE; MAGNOLIOPSIDA. [A.Cr.]

**Myrtales** An order of flowering plants in the core eudicots. The order consists of 10 families and approximately 9300 species. The two largest families are Melastomataceae (approximately 4500 species) and Myrtaceae (approximately 3000 species). Thymelaeaceae are excluded in recent concepts of the order, being related instead to families of Malvales.

Myrtales are chiefly tropical, but Onagraceae and Penaeaceae are predominantly temperate. Myrtales usually have opposite, simple, entire leaves and perigynous to epigynous flowers with a compound pistil and most commonly axile placentation. The seeds have little or no endosperm. The stamens are normally numerous, and many species have tetramerous flowers. Vascular bundles characteristically have internal phloem, which is otherwise rare in the rosid dicots.

Economic crops in Myrtaceae include spice trees such as allspice (*Pimenta*) and cloves (*Syzygium*), and the timber trees *Eucalyptus*. Other important economic crops in the order include evening primrose (*Oenothera*, Onagraceae) and pomegranate (*Punica*, Lythraceae). Purple loosestrife (*Lythrum salicaria*) can be a noxious weed of North American waterways. See EUDICOTYLEDONS. [M.W.C.]

**Myxidacea** An order of free-swimming, shrimplike crustaceans belonging to the class Eumalacostraca; commonly

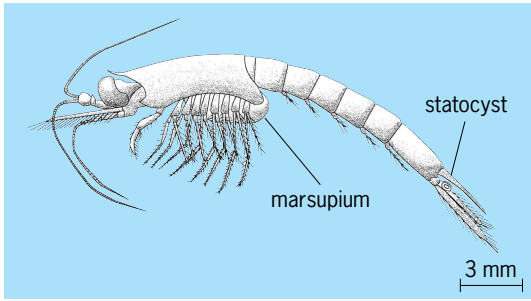

A member of the Mysida, showing the marsupium and the paired uropods with a statocyst in the inner one.

known as opossum shrimps. They occur in vast numbers in coastal and oceanic regions of the world.

The Mysidacea are divided into suborders Lophogastrida and the Mysida. The former contains only 38 species ascribed to six genera; they live predominantly in the deep sea and range in adult body length from 0.6 to 13 in. (17 to 350 mm), except the seven species in the genus *Paralophogaster* which are 0.2–0.8 in. (6–20 mm) in length.

The suborder Mysida contains some 800 species ascribed to four families: the primitive Petalophthalmidae and the advanced Mysidae, Lepidomysidae, and Stygiomysidae. Except for the deep-sea Petalophthalmidae and cave-dwelling Lepidomysidae (some 30 species), all species, in about 130 genera, have statocysts in the uropods (abdominal appendages; see illustration), a feature peculiar to mysids; and have adult body lengths of about 0.6 in. (15 mm) or less. Most mysidans are distributed in shallow coastal and shelf waters, a few have invaded fresh waters, and others live in the surface layers of the oceans or in the deep sea to depths as great as 23,650 ft (7210 m).

The young are carried within a marsupium formed by transparent concave plates attached to the insides of the posterior thoracic legs. These plates have short, strong setae and interlock ventrally to form a closed chamber, the marsupium. The eggs, which are fertilized during laying, are laid directly into the marsupium; develop to miniature adults; and emerge to swim freely in the sea. Mysids, like all crustaceans, increase their body size by molting.

Most species of mysids form aggregations. These are of different types and for different purposes. The functions of these aggregations, except for breeding, are not always clear, although protection of the population from predators is important. These aggregations result in many coastal mysids occurring at high densities, especially in estuarine or sandy beach habitats. Swarms of mysids in coastal waters are exploited commercially in tropical and subtropical regions of the world. See CRUSTACEA; EUMALACOSTRACA. [J.Mau.]

**Mystacocarida** A subclass of primitive Crustacea. The three species are in the genus *Derocheilocaris*. The body is worm-like and about 0.2 in. (5 mm) long. The cephalothorax bears first antennae, second antennae, mandibles, first maxillae, and second maxillae. Maxillipeds are on a separate segment, and four additional free thoracic segments bear platelike appendages. The six abdominal segments are without appendages, but large caudal rami are present. The labrum is enormous, mouthparts and nervous system are primitive, and the genital pore is on the thorax. See CRUSTACEA. [R.W.P.]

**Myxiniformes** The hagfishes, an order of eellike, jawless vertebrates (class Agnatha). They resemble the Petromyzontida in a number of respects. However, they differ from Petromyzontida in having the nasal opening at the tip of the snout and leading to the pharynx so that it can be used in respiration; in having barbels around the mouth; in having 6–15 pairs of gill

pouches which open to the exterior either separately or by a common aperture; in having only one pair of semicircular canals; in having degenerate eyes lacking lens and iris and not visible externally; in having a continuous dorsal-caudal-ventral fin with fin rays only in the caudal portion; in having both male and female organs in one individual, though only one matures; and in being exclusively marine.

Hagfishes live on or near muddy bottoms in fairly deep waters, where they feed largely on dead or disabled fishes and polychaete worms, into which they bore with their rasplike tongues. They are often a considerable nuisance to commercial fishing because of their habit of damaging netted or hooked fishes. They are sometimes called slime eels because of their ability to discharge large quantities of slime from the prominent mucous pores segmentally arranged down each side.

Hagfishes are divided into three genera: *Myxine*, *Paramyxine*, and *Bdellostoma*. See AGNATHA; CYCLOSTOMATA (CHORDATA); PETROMYZONTIDA. [R.H.De.]

**Myxomycota** Organisms that are classified in the kingdom Fungi and given the class name Myxomycetes, following the rules of botanical nomenclature; or classified in the kingdom Protista at various taxonomic ranks, as class Mycetozoa, following the rules of zoological nomenclature. Evolutionary origins are controversial, but many now believe, based on DNA sequencing techniques, that the Myxomycetes diverge early on the tree of life in the region where other protists are found.

The class consists of 3 subclasses, 6 orders, approximately 57 genera, and 600 species. Subclasses Ceratiomyxomycetidae, Myxogastromycetidae, and Stemonitomyxomycetidae are distinguished by the type of sporophore development, type of plasmodium, and method of bearing spores. The various orders, families, genera, and species are distinguished by characteristics of the fruiting bodies such as spore color, peridium, capillitium, calcium carbonate, or columella.

Myxomycetes begin to appear in May and fruit throughout the summer until October in the north temperate regions. Many species are universally distributed and live in moist and dark places on decaying organic matter. Some species are restricted to more specialized habitats.

Spores are released from the fruiting bodies when disturbed and fall onto the substratum where, when water is present, they germinate and release protoplasts. The protoplasts may develop into either a myxamoeba or a flagellated swarm cell, both of which are haploid and behave like gametes (sex cells). The haploid (monoploid) gametes fuse in pairs forming diploid zygotes, which then divide mitotically without subsequent cell division, resulting in the formation of a multinucleated, free-living mass of unvalled protoplasm called the plasmodium. The diploid plasmodium is representative of the slime stage, and hence the common names sometimes used for this group of organisms include plasmodial, acellular, or true slime molds. The plasmodia ingest food as particulate matter (usually bacteria) by engulfment and are capable of growing to over 70 cm in diameter.

The separate stages in their life cycle make myxomycetes ideal organisms to study basic biological problems, ranging through protoplasmic streaming, the mitotic cycle, morphogenesis, aging, and cell division in cancerous cells. See EUMYCOTA. [H.W.K.]

**Myxosporida** An order of the protozoan class Myxosporidea (subphylum Cnidospora). It is characterized by the production of spores with one or more valves and polar capsules, and by possession of a single sporoplasm with or without an iodophilous vacuole. Myxosporidians are mainly parasites of fishes. They infect all parts of the body, including the heart and brain, and often induce considerable pathological changes in the host tissue.

Infection begins with the ingestion of the spore by a host fish. The digestive fluids cause the polar filaments to be extruded, and at the same time the sporoplasm is released from the spore

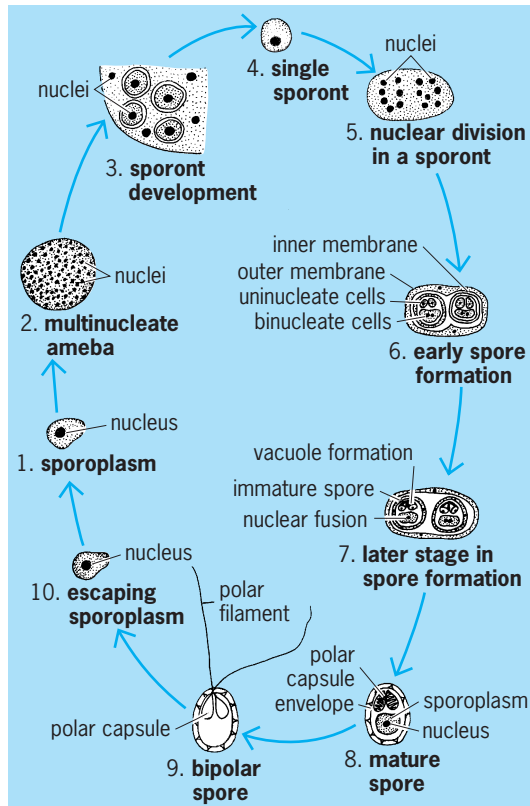

Life cycle of *Myxobolus*, a fish parasite.

(see illustration). The sporoplasm, or amebula, reaches the specific site of infection directly through the gut wall or by way of the bloodstream. The amebula becomes a trophozoite when it starts feeding on the host tissues. The trophozoite then goes through a series of nuclear divisions and, by a process of budding, gives rise to a number of cells, each of which eventually develops into

a sporont. A sporont is a monosporoblast if one spore is produced and a pansporoblast if two or more spores are formed. The sporont undergoes a series of nuclear divisions, in which the number of nuclei produced will determine the number of spores and polar capsules to be formed. That is, in every spore one nucleus is involved in the formation of each valve and each polar capsule. Two nuclei become the gametic nuclei, which then fuse to form the zygotic nucleus of the sporoplasm. See CNIDOSPORA; MYXOSPORIDEA. [R.F.N.]

**Myxosporidea** A class of the protozoan subphylum Cnidospora. Members of this class, which includes the orders Myxosporida, Actinomyxida, and Helicosporida, are parasites in fish, a few amphibians, and invertebrates. The Myxosporida are divided into two suborders, the Unipolarina and Bipolarina.

Unipolarina is characterized by spores with one to six (never five) polar capsules located at the anterior end, except in some genera in which the capsules are widely separated or located in the central part of the spore but in which the polar filament is attached near the anterior end. The Unipolarina contains nine or more families.

Bipolarina, containing a single family with three genera, is characterized by the presence of one capsule at or near each end of a fusiform or ellipsoid spore. See ACTINOMYXIDA; CNIDOSPORA; HELICOSPORIDA; MYXOSPORIDA. [R.F.N.]















**Myzostomaria** An aberrant group of Polychaeta recognized for four families, each with one genus. Myzostomidae with *Myzostomum* comprise about 130 species from worldwide areas. Mesomyzostomidae with *Mesomyzostomum* has two species, from Japan and the Aru Islands. Protomyzostomidae with *Protomyzostomum* is known for three species, from Japan and the Murman Sea, and Stelechopidae with *Stelechopus* has a single species, from Crozet Island, Antarctic Ocean. All are either external or internal parasites of echinoderms, chiefly crinoids, and hence from deep water. Most are greatly depressed, broad and very small, measuring at most a few millimeters. The separation of this group of polychaetes into families and species is based on external and internal characters. See ANNELIDA; POLYCHAETA. [O.H.]

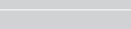
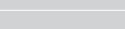

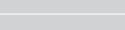
# N

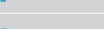
**Nailing** The driving of nails in a manner that will position and hold two or more members, usually of wood, in a desired relationship to each other. The contact pressures between the surfaces of the nails and the surrounding wood fibers hold the nails in position. Some types of nails are shown in the illustration.

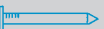
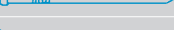
Factors that determine the strength and efficiency of a nailed joint are (1) the type of wood, (2) the nail used, (3) the conditions under which the nailed joint is used, and (4) the number of nails. In general, hard, dense woods hold nails better than soft woods. The better the resistance of a nail to direct withdrawal from a piece of wood, the tighter the joint will remain. To increase resistance to withdrawal or loosening, nails may be coated, etched, spirally grooved, annularly grooved, or barbed, as illustrated.

spiral-threaded, insulated siding, face nail	
annular-ring, gypsum board, dry-wall nail	
asbestos shingle nails: annular-ring, spiral-threaded	
annular-ring, plywood roofing nail for applying wood or asphalt shingles over plywood sheathing	
annular-ring, plywood siding nail for applying asbestos shingles and shakes over plywood sheathing	
spiral-threaded, casing head, wood siding nail	
annular-ring roofing nail for asphalt shingles and shakes	
spiral-threaded roofing nail for asphalt shingles and shakes	
annular-ring roofing nail with neoprene washer	
spiral-threaded roofing nail with neoprene washer	
insulated siding nail	
gypsum lath nail	
wood shake nail	
wood shingle nail	
roofing nail	
general-purpose finish nail	
sinker head, wood siding nail	
casing head, wood siding nail	

Special- and general-purpose nails.

Blunt-pointed nails are often used to prevent the wood from splitting. Using nails of a smaller diameter also tends to prevent splitting but requires a greater number of nails per joint. Beeswax is sometimes applied to nail points to make them drive more easily, but it also reduces the holding power of the nail [A.H.T.]

**Najadales** An order of aquatic and semiaquatic flowering plants, division Magnoliophyta (Angiospermae), in the subclass Alismatidae of the class Liliopsida (monocotyledons). The order consists of 10 families and a little more than 200 species. The Potamogetonaceae, with about 100 species, are the largest family of the order, and the name Potamogetonales is sometimes used instead of Najadales for the group. The Najadales are Alismatidae in which the perianth, when present, is not differentiated into evident sepals and petals. Usually the flowers are not individually subtended by bracts. The Zosteraceae of this order are unique among flowering plants in that they grow submersed in the ocean, albeit in shallow water near the shore. *Zostera marina*, or eelgrass, is a common member of the family. See ALISMATIDAE; FLOWER; LILIOPSIDA; MAGNOLIOPHYTA; PLANT KINGDOM. [A.Cr.; T.M.Ba.]

**Nanochemistry** The study of the synthesis and characterization of materials in the nanoscale size range (1 to 10 nanometers). These materials include large organic molecules, inorganic cluster compounds, and metallic or semiconductor particles. The synthesis of nanoscale inorganic materials is important because the small size endows these particles with unusual structural and optical properties that may find application in catalysis and electrooptical devices. Approaches to the synthesis of these materials have focused on constraining the reaction environment through the use of surface-bound organic additives, porous glasses, zeolites, clays, or polymers. The use of synthetic approaches that are inspired by the biological processes result in the deposition of inorganic materials such as bones, shells, and teeth (biomineralization). This biomimetic approach involves the use of assemblies of biological molecules that provide nanoscale reaction environments in which inorganic materials can be prepared in an organized and controlled manner. Examples of biological assemblies include phospholipid vesicles and the polypeptide micelle of the iron storage protein, ferritin. See MICELLE.

Vesicles are bounded by an organic membrane that provides a spatial limit on the size of the reaction volume. If a chemical reaction is undertaken in this confined space that leads to the formation of an inorganic material, the size of the product will also be constrained to the dimensions of the organic host structure. Provided that the chemical and physical conditions are not too severe to disrupt the organic membrane, these supramolecular assemblies may have advantages over inorganic hosts such as clays and zeolites because the chemical nature of the organic surface can be systematically modified so that controlled reactions can be accomplished. See SUPRAMOLECULAR CHEMISTRY.

One problem encountered with the use of phospholipid vesicles is their sensitivity to changes in temperature and ionic strength. Procedures have been developed in which the biomolecular cage of the iron storage protein, ferritin, has been used as a nanoscale reaction environment for the synthesis of

inorganic materials. In the simplest approach the native iron oxide core is transformed into another material by chemical reaction within the protein shell. [S.Ma.]

**Nanostructure** A material structure assembled from a layer or cluster of atoms with size of the order of nanometers. Interest in the physics of condensed matter at size scales larger than that of atoms and smaller than that of bulk solids (mesoscopic physics) has grown rapidly since the 1970s, owing to the increasing realization that the properties of these mesoscopic atomic ensembles are different from those of conventional solids. As a consequence, interest in artificially assembling materials from nanometer-sized building blocks arose from discoveries that by controlling the sizes in the range of 1–100 nm and the assembly of such constituents it was possible to begin to alter and prescribe the properties of the assembled nanostructures. See MESOSCOPIC PHYSICS.

Nanostructured materials are modulated over nanometer length scales in zero to three dimensions. They can be assembled with modulation dimensionalities of zero (atom clusters or filaments), one (multilayers), two (ultrafine-grained overlayers or coatings or buried layers), and three (nanophase materials), with intermediate dimensionalities (see illustration).

**Multilayers and clusters.** Multilayered materials have had the longest history among the various artificially synthesized nanostructures, with applications to semiconductor devices, strained-layer superlattices, and magnetic multilayers. Recognizing the technological potential of multilayered quantum heterostructure semiconductor devices helped to drive the rapid advances in the electronics and computer industries. A variety of electronic and photonic devices could be engineered by utilizing the low-dimensional quantum states in these multilayers for applications in high-speed field-effect transistors and high-efficiency lasers, for example. Subsequently, a variety of nonlinear optoelectronic devices, such as lasers and light-emitting diodes, have been created by nanostructuring multilayers. See ARTIFICIALLY LAYERED STRUCTURES; LIGHT-EMITTING DIODE; SEMICONDUCTOR HETEROSTRUCTURES; TRANSISTOR.

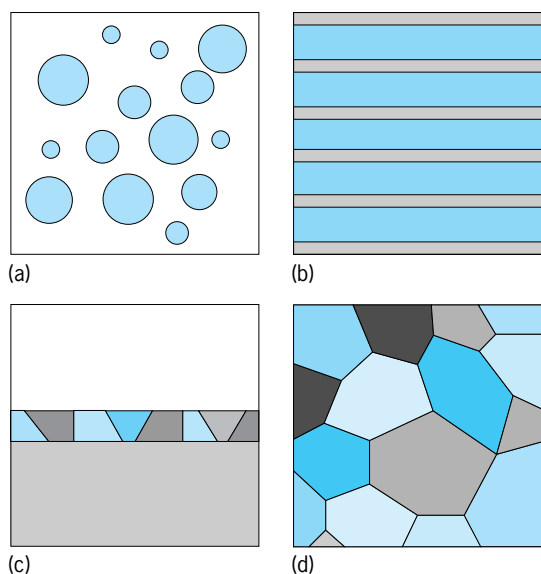

Schematic of four basic types of nanostructured materials, classified according to integral modulation dimensionality. (a) Dimensionality 0: clusters of any aspect ratio from 1 to infinity. (b) Dimensionality 1: multilayers. (c) Dimensionality 2: ultrafine-grained overlayers (coatings) or buried layers. (d) Dimensionality 3: nanophase materials. (After R. W. Siegel, *Nanostructured materials: Mind over matter, Nanostruct. Mat.*, 3:1–18, 1993)

The advent of beams of atom clusters with selected sizes allowed the physics and chemistry of these confined ensembles to be critically explored, leading to increased understanding of their potential, particularly as the constituents of new materials, including metals, ceramics, and composites of these materials. A variety of carbon-based clusters (fullerenes) have also been assembled into materials of much interest. In addition to effects of confinement, interfaces play an important and sometimes dominant role in cluster-assembled nanophase materials, as well as in nanostructured multilayers. See ATOM CLUSTER; CERAMICS; FULLERENE.

**Synthesis and properties.** A number of methods exist for the synthesis of nanostructured materials. They include synthesis from atomic or molecular precursors (chemical or physical vapor deposition, gas condensation, chemical precipitation, aerosol reactions, biological templating), from processing of bulk precursors (mechanical attrition, crystallization from the amorphous state, phase separation), and from nature (biological systems). Generally, it is preferable to synthesize nanostructured materials from atomic or molecular precursors, in order to gain the most control over a variety of microscopic aspects of the condensed ensemble; however, other methodologies can often yield very useful results. See VAPOR DEPOSITION. [R.W.Si.]

**Nanotechnology** Systems for transforming matter, energy, and information, based on nanometer-scale components with precisely defined molecular features. The term nanotechnology has also been used more broadly to refer to techniques that produce or measure features less than 100 nanometers in size; this meaning embraces advanced microfabrication and metrology. Although complex systems with precise molecular features cannot be made with existing techniques, they can be designed and analyzed. Studies of nanotechnology in this sense remain theoretical, but are intended to guide the development of practical technological systems.

Nanotechnology based on molecular manufacturing requires a combination of familiar chemical and mechanical principles in unfamiliar applications. Molecular manufacturing can exploit mechanosynthesis, that is, using mechanical devices to guide the motions of reactive molecules. By applying the conventional mechanical principle of grasping and positioning to conventional chemical reactions, mechanosynthesis can provide an unconventional ability to cause molecular changes to occur at precise locations in a precise sequence. Reliable positioning is required in order for mechanosynthetic processes to construct objects with millions to billions of precisely arranged atoms.

Mechanosynthetic systems are intended to perform several basic functions. Their first task is to acquire raw materials from an externally provided source, typically a liquid solution containing a variety of useful molecular species. The second task is to process these raw materials through steps that separate molecules of different kinds, bind them reliably to specific sites, and then (often) transform them into highly active chemical species, such as radicals, carbenes, and strained alkenes and alkynes. Finally, mechanical devices can apply these bound, active species to a workpiece in a controlled position and orientation and can deposit or remove a precise number of atoms of specific kinds at specific locations.

Several technologies converge with nanotechnologies, the most important being miniaturization of semiconductor structures, driven by progress in microelectronics. More directly relevant are efforts to extend chemical synthesis to the construction of larger and more complex molecular objects. Protein engineering and supramolecular chemistry are active fields that exploit weak intermolecular forces to organize small parts into larger structures. Scanning probe microscopes are used to move individual atoms and molecules. See MOLECULAR RECOGNITION; MONOMOLECULAR FILM; NANOSTRUCTURE; SCANNING TUNNELING MICROSCOPE; SUPRAMOLECULAR CHEMISTRY. [E.Dr.]

**Naphtha** Any one of a wide variety of volatile hydrocarbon mixtures. They are sometimes obtained from coal tar but are more often derived from petroleum. Physical properties vary widely. The initial boiling point may be as low as 27°C (80°F), and end points may reach 260°C (500°F). Boiling ranges are sometimes as narrow as 11°C (20°F) or as wide as 110°C (200°F). Products sold as naphthas find their greatest use as solvents, thinners, or carriers.

There is a fairly sharp differentiation between aliphatic and aromatic naphthas. Aliphatic naphthas are relatively low in odor and toxicity and tend, also, to be low in solvent power. The aromatic naphthas are highly solvent. Their main components are toluene and xylenes; benzene is less desirable because of the extreme toxicity of its vapors. See PETROLEUM PRODUCTS. [J.K.R.]

**Narcotic** A drug which diminishes the awareness of sensory impulses, especially pain, by the brain. This action makes narcotics useful therapeutically as analgesics. While they are the most powerful pain-relieving agents available, their use is complicated by a number of undesirable side actions. See ANALGESIC.

All of the generally used narcotics are in some way related to opium, and the term opiate is sometimes used interchangeably with the term narcotic. Opium is a gummy exudate obtained from the unripe seed capsules of the opium poppy. Crude opium contains over a dozen alkaloids, all of which have been isolated and identified as to their structural chemistry. From this knowledge chemists have developed a number of synthetic chemical compounds, some of which have important advantages over the naturally occurring alkaloids. Therapeutically important natural alkaloids are morphine, codeine, and papaverine. Among the important synthetic narcotics are meperidine (Demerol), dihydromorphine (Dilaudid), oxymorphone (Numorphan), alphaprodine (Nisentil), anileridine (Leritine), piminodine (Alvodine), levorphanol (Levo-Dromoran), methadone (Dolophine), and phenazocine (Prinadol). See ALKALOID; OPIATES; POPPY.

Nalorphine (Nalline) is a narcotic antagonist and is used in the treatment of acute overdosage from narcotics; it is dangerous to drug addicts. Heroin is a highly addicting narcotic, and is so dangerous in this regard that the drug has been completely banned by both federal and state laws under all circumstances.

**Pharmacology.** The pharmacology of narcotics is generally similar to that of morphine, the principal narcotic used for its analgesic effects. Differences among them lie in the potency of their action and in the degree and variety of the side actions which they produce. Effects are those of analgesia, accompanied by a state of euphoria characterized by drowsiness and a change of mood from anxiety and tension to calmness and equanimity. It should be remembered that whatever narcotic is used, the effects are dose-related, and in higher doses all narcotics produce deep sleep and eventually general depression of all brain functions. Death from overdosage is due to depression of the respiratory centers with resultant failure of respiration.

The predominant pharmacological effect of morphine (and the other narcotics) is on the central nervous system. From the standpoint of its medicinal use, its most important action is relief of pain. Along with its valuable medicinal use morphine produces a great many undesirable side actions; the most frequent are depressed respiratory activity, the production of nausea and vomiting, and the inhibition of defecation and urination.

**Drug dependence.** All narcotics have the potential for producing dependence and addiction when used repeatedly over a period of time. Drug dependence results from compulsive, continued use of the drug, and is characterized by one or more of the following conditions: habituation, tolerance, or addiction.

Like any other habit pattern, habitual use of a drug can develop. Common examples are the use of nicotine in the form of cigarettes, or caffeine in the form of coffee or tea. Such habituation is generally regarded as innocuous.

Repeated ingestion of a drug in which the effect produced by the original dose no longer occurs results in tolerance. To produce the original effect, it is necessary to increase the dose.

When the body develops a dependence for the drug, addiction occurs. If the drug is suddenly stopped after a period of frequent use, a withdrawal syndrome develops, which is characterized by physical pain and widespread body reactions. The addict comes to dread the development of such painful and distressing reactions, and is trapped into continuing the drug.

All narcotics can produce habituation, tolerance, and addiction to a greater or less degree. Addiction to codeine is relatively rare but possible. Addiction to heroin develops rapidly, and this narcotic is therefore exceedingly dangerous. [J.M.Di.]

**Native elements** Those elements which occur in nature uncombined with other elements. Aside from the free gases of the atmosphere there are about 20 elements that are found as minerals in the native state. These are divided into metals, semimetals, and nonmetals. Gold, silver, copper, and platinum are the most important metals and each of these has been found abundantly enough at certain localities to be mined as an ore. Rarer native metals are others of the platinum group, lead, mercury, tantalum, tin, and zinc. Native iron is found sparingly both as terrestrial iron and meteoric iron.

The native semimetals can be divided into (1) the arsenic group, including arsenic, antimony, and bismuth; and (2) the tellurium group, including tellurium and selenium.

The native nonmetals are sulfur, and carbon in the forms of graphite and diamond. Native sulfur is the chief industrial source of that element. [C.S.Hu.]

**Natrolite** A fibrous or needlelike mineral belonging to the zeolite family of silicates. Most commonly it is found in radiating fibrous aggregates. The hardness is 5–5½ on Mohs scale, and the specific gravity is 2.25. The mineral is white or colorless with a vitreous luster that inclines to pearly in fibrous varieties. The chemical composition is  $\text{Na}_2(\text{Al}_2\text{Si}_3\text{O}_{10}) \cdot 2\text{H}_2\text{O}$ , but some potassium is usually present substituting for sodium.

Natrolite is a secondary mineral found lining cavities in basaltic rocks. Its outstanding locality in the United States is at Bergen Hill, New Jersey. See ZEOLITE. [C.Fr.; C.S.Hu.]

**Natural fiber** A fiber obtained from a plant, animal, or mineral. The commercially important natural fibers are those cellulosic fibers obtained from the seed hairs, stems, and leaves of plants; protein fibers obtained from the hair, fur, or cocoons of animals; and the crystalline mineral asbestos. Until the advent of the manufactured fibers near the beginning of the twentieth century, the chief fibers for apparel and home furnishings were linen and wool in the temperate climates and cotton in the tropical climates. However, with the invention of the cotton gin in 1798, cheap cotton products began to replace the more expensive linen and wool until by 1950 cotton accounted for about 70% of the world's fiber production. Despite the development of new fibers based on fossil fuels, cotton has managed to maintain its position as the fiber with the largest production volume, although its use has fallen. See COTTON; MANUFACTURED FIBER; WOOL.

The natural fibers may be classified by their origin as cellulosic (from plants), protein (from animals), and mineral. The plant fibers may be further ordered as seed hairs, such as cotton; bast (stem) fibers, such as linen from the flax plant; hard (leaf) fibers, such as sisal; and husk fibers, such as coconut. The animal fibers are grouped under the categories of hair, such as wool; fur, such as angora; or secretions, such as silk. The only important mineral fiber is asbestos, which because of its carcinogenic nature has been banned from consumer textiles. See TEXTILE. [I.Bl.]

**Natural gas** A combustible gas that occurs in porous rock of the Earth's crust and is found with or near accumulations of crude oil. Being in gaseous form, it may occur alone in separate reservoirs. More commonly it forms a gas cap, or mass of gas, entrapped between liquid petroleum and impervious capping rock layer in a petroleum reservoir. Under conditions of greater pressure it is intimately mixed with, or dissolved in, crude oil. See OIL AND GAS STORAGE.

Typical natural gas consists of hydrocarbons having a very low boiling point. Methane (CH<sub>4</sub>) makes up approximately 85% of the typical gas. Ethane (C<sub>2</sub>H<sub>6</sub>) may be present in amounts up to 10%; and propane (C<sub>3</sub>H<sub>8</sub>) up to 3%. Butane (C<sub>4</sub>H<sub>10</sub>); pentane (C<sub>5</sub>H<sub>12</sub>); hexane; heptane; and octane may also be present.

Whereas normal hydrocarbons having 5–10 carbon atoms are liquids at ordinary temperatures, they have a definite vapor pressure and therefore may be present in the vapor form in natural gas. Carbon dioxide, nitrogen, helium, and hydrogen sulfide may also be present.

Types of natural gas vary according to composition and can be dry or lean (mostly methane) gas, wet gas (considerable amounts of so-called higher hydrocarbons), sour gas (much hydrogen sulfide), sweet gas (little hydrogen sulfide), residue gas (higher paraffins having been extracted), and casinghead gas (derived from an oil well by extraction at the surface). Natural gas has no distinct odor. Its main use is for fuel, but it is also used to make carbon black, natural gasoline, certain chemicals, and liquefied petroleum gas. Propane and butane are obtained in processing natural gas. See PETROLEUM PRODUCTS.

Gas occurs on every continent. Wherever oil has been found, a certain amount of natural gas is also present. Successful exploitation of these resources involves drilling, producing, gathering, processing, transporting, and metering the use of the gas. Long before supplies of natural gas run out or become expensively scarce, it is expected that some process of coal gasification will produce a gas which is completely interchangeable with natural gas and at a competitive price. This is important because coal makes up a majority of the world's known fossil fuel reserves. But when energy consumers indicated in the marketplace their preference for fluid and gaseous fuels over the solid forms, coal gasification research, already well under way, was given additional impetus. See COAL GASIFICATION; OIL AND GAS WELL DRILLING. [M.A.A.; M.T.H.]

**Natural language processing** Computer analysis and generation of natural language text. The goal is to enable natural languages, such as English, French, or Japanese, to serve either as the medium through which users interact with computer systems such as database management systems and expert systems (natural language interaction), or as the object that a system processes into some more useful form such as in automatic text translation or text summarization (natural language text processing).

In the computer analysis of natural language, the initial task is to translate from a natural language utterance, usually in context, into a formal specification that the system can process further. Further processing depends on the particular application. In natural language interaction, it may involve reasoning, factual data retrieval, and generation of an appropriate tabular, graphic, or natural language response. In text processing, analysis may be followed by generation of an appropriate translation or a summary of the original text, or the formal specification may be stored as the basis for more accurate document retrieval later. Given its wide scope, natural language processing requires techniques for dealing with many aspects of language, in particular, syntax, semantics, discourse context, and pragmatics.

The first aspect of natural language processing, and the one that has perhaps received the most attention, is syntactic processing, or parsing. Syntactic processing is important because certain aspects of meaning can be determined only from the underlying structure and not simply from the linear string of words. A

second phase of natural language processing, semantic analysis, involves extracting context-independent aspects of a sentence's meaning. Given that most natural languages allow people to take advantage of discourse context, their mutual beliefs about the world, and their shared spatio-temporal context to leave things unsaid or say them with minimal effort, the purpose of a third phase of natural language processing, contextual analysis, is to elaborate the semantic representation of what has been made explicit in the utterance with what is implicit from context. A fourth phase of natural language processing, pragmatics, takes into account the speaker's goal in uttering a particular thought in a particular way—what the utterance is being used to do. [B.W.]

**Nautiloidea** A group of externally shelled cephalopods, represented by the single extant genus *Nautilus*. The formal designation of this group as a subclass is now generally used only for those externally shelled cephalopods that resemble *Nautilus* in having completely coiled shells (and then the subclass includes *Nautilus* itself). In living forms, the basic structural plan includes a shell consisting of a septate phragmocone, a living chamber, and a siphuncle. In fossil nautiloids, this simple pattern is modified in great variety with respect to shell form and size, structure and size of the siphuncle, and the large number of devices to counteract the buoyancy of the phragmocone. The shape of fossil nautiloids may deviate in many ways from the simple *Nautilus* model.

Fossil nautiloids are found on all continents, including Antarctica. Especially noteworthy are the rich Ordovician and Silurian faunas of North America, northern Europe, Czechoslovakia, and central and southern China. Coiled nautiloids almost certainly moved around by jet propulsion like *Nautilus* and lived close to the sea floor, at moderate to intermediate depths in many different environments. Other types may have included agile swimmers as well as slow-moving benthic adaptations. See CEPHALOPODA. [C.T.]

**Naval architecture** An engineering discipline concerned with the design of ships, boats, drill rigs, submarines, and other floating or submerged craft. The naval architect creates the initial overall concept for a new ship, integrates the work of other specialists as the ship design is developed, and is specifically responsible for the hull and superstructure shape, general arrangements, structural design, weights and centers calculations, stability analysis, hydrodynamic performance assessments, propeller and rudder design, and the arrangement and outfit of all living and working spaces, other than machinery spaces. The naval architect's ally, the marine engineer, is responsible for the design of the propulsion plant, the electric plant, and other ship machinery and mechanical systems, including the so-called distributive systems: electric cabling, piping, and ventilation system ducting. The marine engineer also is responsible for ship control systems, including propulsion and electric plant controls and the steering system. See FERRY; HYDROFOIL CRAFT; ICEBREAKER; MERCHANT SHIP; NAVAL SURFACE SHIP; OIL AND GAS, OFFSHORE; SUBMARINE.

In the past, naval architecture was as much an art as a science, but research, coupled with advances in computer-aided design, has greatly enhanced the scientific basis of the profession. Naval architecture is a specialized form of mechanical engineering, as is marine engineering. Thus the education of naval architects is very similar in content to that of mechanical engineers, and the same types of degree programs are offered. Some colleges and universities combine naval architecture and marine engineering education and offer a combined degree. See MARINE ENGINEERING; MECHANICAL ENGINEERING. [PA.Ga.]

**Naval armament** A general term that covers the ordnance and control systems used by naval ships and aircraft. It includes a wide spectrum of weapons designed for use against targets in the air, on land or sea, or under the ocean surface. The spectrum of weaponry used by naval forces runs from small arms to nuclear warheads and includes weapons that are intended for



Fig. 1. Trident missile being fired from a submerged submarine. (U.S. Navy)

use against a particular type of target as well as general-purpose weapons.

Naval armament may be air-, surface-, or submarine-launched. It can be categorized as tactical or strategic, or by its intended primary target: surface attack, air defense, or anti-submarine. Many weapons can be used against different types of targets. Naval weaponry includes guns, guided missiles, rockets, bombs, depth charges, torpedoes, and mines.

**Guided missiles.** In the years since World War II, guided missiles have taken first place among families of naval weapons. Naval missiles may be adaptable to multiple launch modes: from ship, submarine, and aircraft. Modern missiles are more compact, saving critical space and weight, and their guidance systems have steadily become more sophisticated. Shipboard launchers can handle two or three different weapons, eliminating the need for separate launchers.

An *Ohio*-class missile submarine carries 24 Trident fleet ballistic missiles (Fig. 1), developed to replace the earlier Polaris and Poseidon. See SUBMARINE.

Standard, the Navy's principal air defense missile, replaced the first-generation Tartar, Terrier, and Talos. A supersonic solid-fuel weapon, it is produced in medium-range (MR) and extended-range (ER) versions.

Sea Sparrow is an anti-aircraft adaptation of the airborne Sparrow III missile, developed as a relatively uncomplicated basic point-defense missile system (BPDMS) to protect ships without Standard missiles.

Tomahawk, a long-ranged land attack cruise missile, was used in the Gulf War and in Kosovo. Capable of attacking targets at a range up to 1000 mi (1600 km), Tomahawk has greatly increased the striking power of the surface warship, which at one time was thought to have been relegated to a subsidiary role by the aircraft carrier. It is also used by aircraft; submarines can carry them in torpedo tubes, and some submarines have been armed with vertical tube launchers.

Harpoon is a long-range antiship missile, originally designed as an air-to-surface weapon but now used in surface ships and submarines as well.

**Antisubmarine weapons.** ASROC (antisubmarine rocket), launched by surface warships, was originally designed to carry either a nuclear depth charge or a homing torpedo. All nuclear ASROC warheads were taken out of service by 1989. ASROC is an unguided rocket carrying a Mark 46 homing torpedo. Aimed by shipboard computers using target information obtained by sonar, the rocket is fired from a launcher and follows a ballistic trajectory to the target's predicted position. Torpedo and rocket then separate; the torpedo, slowed by a drag parachute, lands in the water and seeks the target. See ANTISUBMARINE WARFARE.

**Rockets.** Naval rockets, as distinguished from guided missiles, are unguided weapons carrying explosive warheads. Their light weight, in proportion to explosive payload, and lack of recoil allow them to be used by attack planes and helicopters. See ROCKET PROPULSION.

**Torpedoes.** Torpedoes travel underwater on their own power to attack the vulnerable hulls of surface ships and submarines. Modern naval torpedoes are fast, far-ranging, and armed with a powerful explosive warhead. Torpedoes may be homing (guiding themselves acoustically to the target); nonhoming (following a preset course); or wire-guided (controlled by signals from the firing ship, transmitted through a trailing wire). They can be launched from surface ships, submarines, or aircraft. Homing torpedoes are used as payload by the ASROC system. Methods for countering the homing torpedo, like the weapons themselves, have been worked on since World War II. It remains a highly effective weapon, and will probably continue in service for a long time. See ACOUSTIC TORPEDO.

**Guns.** Though missiles are widely used by ships and aircraft, guns remain significant naval weapons. Missiles are superior for most long-range attack missions and for defense against supersonic planes and missiles at high altitudes and long ranges; the opposite, however, is often true for such missions as shore bombardment, fire support of land forces, and defense against small attack craft. Renewed attention has been given, both in the United States and in other countries, to lighter guns, with high rates of fire, and to quick-reaction control systems for close-in defense against aircraft and missiles in combination with short-range anti-aircraft missiles (Fig. 2).

**Bombs.** These are free-falling weapons, unlike missiles, which are self-propelled. Bombs take many shapes and sizes, from small antitank and antipersonnel bomblets dispensed from a larger shell or bomb, to heavy weapons designed for blast effect. Most planes and helicopters carry arms externally to accommodate weapon-mix versatility and to keep aircraft size and weight down. High aircraft speeds led to development of

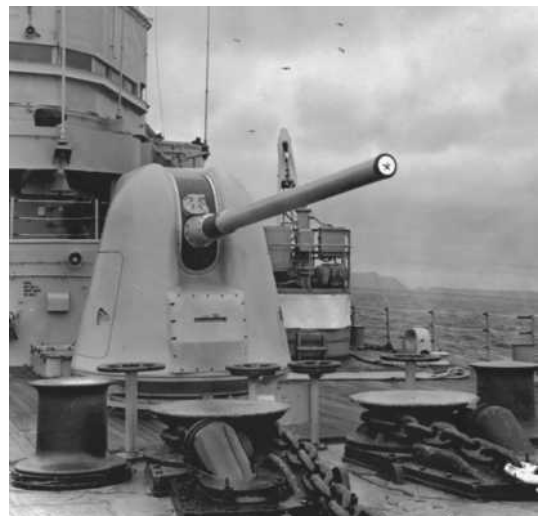

Fig. 2. Mark 45 lightweight 5-in. (127-mm) gun mount. (U.S. Navy)

streamlined, low-drag bombs. Bombs can be “dumb,” that is, uncontrolled, or “smart.” Smart bombs have guidance systems and movable control surfaces, and their trajectory can be adjusted to steer them toward a target.

**Mines.** A mine is a thin-cased, non-self-propelled weapon filled with high explosive and placed underwater, where it is designed to explode when struck, or closely approached, by a ship. Mines can be contact type (fired by actually striking the hull of a passing ship) or influence type (detonated by the close approach of a ship). An influence mine may be magnetic (actuated by a ship’s magnetic field), acoustic (actuated by the underwater sound that a ship generates), or pressure (actuated by the change in water pressure caused by a ship’s passage). It may also be fired by a combination of these influences. Influence mines are thus much harder to sweep than contact mines. Mines are planted by submarines or aircraft; some navies also use surface minelayers.

[J.C.R.]

**Naval surface ship** A surface ship designed primarily for use in warfare, either to operate in direct combat or to provide support to other ships engaged therein. Naval ships can therefore be categorized as either combatants or noncombatants (auxiliaries), both with unique design characteristics.

**Combatant ships.** This category includes battle ships, cruisers, destroyers, frigates, aircraft carriers, amphibious warfare ships, mine warfare ships, and patrol ships.

After World War II, all the surviving battleships of the U.S. Navy were disposed of except for the four most modern ships, which were retained in a decommissioned (standby or “mothball”) status. In 1995 all four battleships were stricken from the naval register, but Congress later directed that two be retained as mobilization assets.

The primary purpose of modern cruisers is to provide anti-air and antisubmarine protection to aircraft carriers and other friendly forces. These highly capable multimission ships can also operate independently. Equipped with anti-air, antisubmarine, anti-ship, and land attack missiles, they are self-contained offensive units in their own right. The dominant cruisers in the world are the U.S. CG 47 *Ticonderoga* class of Aegis guided-missile cruisers (Fig. 1) designed in the 1970s.

If battleships and cruisers are the heavyweights and middleweights, then destroyers are the lightweights with a “go-anywhere, do-anything” outlook. They have tremendous firepower for their size and rely on high speed, dash, and maneuverability. Current destroyers tend either to be multipurpose or to emphasize specific warfare areas. An example of a multipurpose destroyer is the U.S. DDG 51 *Arleigh Burke* class of Aegis guided-missile destroyers. An example of a specialized destroyer is the U.S. DD 963 *Spruance* class designed primarily to detect and destroy submarines.

The smallest and most numerous surface combatants in the U.S. Navy are the *Oliver Hazard Perry* (FFG 7) class of multi-



Fig. 1. Aegis guided-missile cruiser, *Ticonderoga* CG 47 class. USS *Cape St. George* is shown. (U.S. Navy photo)



Fig. 2. Nuclear-powered aircraft carrier, *Nimitz* CVN 68 class. USS *Theodore Roosevelt* (CVN 71) is shown. (U.S. Navy photo)

purpose frigates. Designed in the 1970s, this 50-ship class was expected to protect merchant and military convoys. The speed of FFG-7 is 27–28 knots (13–14 m/s) since carrier operations were not a primary mission. By means of sonars, an embarked ASW helicopter, and shipboard torpedo tubes, it can detect and destroy submarines.

The largest warships in the world are aircraft carriers (Fig. 2), which through the aircraft they support can project power at great distances. An aircraft carrier is a floating mobile air station. Its flight deck provides the runways, its island is the control tower, the large hangar below the flight deck is the garage that contains maintenance and repair shops, and deep in the hull are storage tanks for aviation fuel and magazines for aviation ordnance. These ships, which can operate and maintain up to 80 aircraft, require a length of almost 1100 ft (335 m), a displacement of nearly 100,000 tons (101,600 metric tons), and a crew of 6000.

The ships used to transport, land, support, and control assault troops collectively constitute the amphibious warfare force. Despite the success of Allied amphibious operations in World War II, the need for improvement was recognized. The first major breakthrough came with the advent of the helicopter and its successful adaptation for landing assault troops (called vertical assault). The second was the development of the high-speed (40 knots; 19 m/s) landing craft, air-cushioned (LCAC). The employment of these two new vehicle types permits landing ships to remain offshore, over the horizon, during amphibious assaults. All current United States amphibious warfare ships have both flight decks for operating helicopters and well-decks for operating LCACs and other craft.

Landing craft are used to ferry tanks, vehicles, equipment, ammunition, general cargo, and personnel directly onto the beach from the landing ships offshore.

Amphibious vehicles are capable of being launched directly into the ocean from landing ships, proceeding to the beach, and then moving inland.

Minelayer ships are built in varying sizes, but can be characterized by a mine stowage system, and rails for moving the mines, and dropping them off the stern or side of the ship. Minesweepers can be broadly categorized as having either a hunter role (locate and mark mines) or a hunter/killer role (locate and destroy). Mines can be located by variable-depth sonar and later destroyed by divers or by means of a mine neutralization vehicle (MNV). The MNV is a crewless minisubmarine that lays an explosive charge near the mine, backing off before detonation. Mines can also be located by the minesweeper towing a mechanical sweep that cuts the cable between the bottom anchor and the mine. After the mine surfaces, it is destroyed by divers or gunfire. Mines can also be detonated by towing magnetic and acoustic

cables that trigger them. Minesweepers are often built of wood or composite materials to reduce their magnetic signature.

Patrol ships are small ships that augment conventional surface forces in coastal areas and restricted seas. Their primary mission is coastal patrol and interdiction surveillance—an important aspect of littoral operations. These ships also provide full mission support for Navy SEALs and other special operations forces.

**Noncombatant ships.** Naval auxiliary ships provide services and support naval operations. Floating configurations that provide services but are not ships are called service craft. Service craft include floating dry-docks, harbor tugs, berthing barges, diving support boats, and fuel barges.

Included in the auxiliary category are the tenders for submarines, and the ships that replenish the fleet with supplies of oil, stores, ammunition, and combat support items. Also included are oceangoing salvage rescue ships, acoustic research ships, oceanographic research ships, surveying ships, hospital ships, ocean surveillance ships, cable repair ships, oceangoing tugs, marine prepositioning ships, and even experimental submarines.

[B.T.]

**Navier-Stokes equation** A partial differential equation which describes the conservation of linear momentum for a linearly viscous (newtonian), incompressible fluid flow. In vector form, this relation is written as Eq. (1), where  $\rho$  is fluid density,

$$\rho \left[ \frac{\partial \mathbf{V}}{\partial t} + (\mathbf{V} \cdot \nabla) \mathbf{V} \right] = -\nabla p + \rho \mathbf{g} + \mu \nabla^2 \mathbf{V} \quad (1)$$

$\mathbf{V}$  is fluid velocity,  $p$  is fluid pressure,  $\mathbf{g}$  is the gravitational acceleration,  $\mu$  is fluid viscosity,  $\nabla$  is the del or grad operator, and  $\nabla^2$  is the laplacian operator. The equation is named after its two principal developers, French engineer C. L. M. H. Navier (1823) and Irish scientist George G. Stokes (1845). When coupled with the conservation of mass relation,  $\nabla \cdot \mathbf{V} = 0$ , Eq. (1) can be solved for the space-time distribution of  $\mathbf{V}$  and  $p$  in a given region of viscous fluid flow. Typical boundary conditions are (1) the knowledge of the velocity and pressure in the far field, and (2) the no-slip condition at solid surfaces (fluid velocity equals solid velocity). See CALCULUS OF VECTORS; GRADIENT OF A SCALAR; LAPLACIAN; NEWTONIAN FLUID; VISCOSITY.

Equation (1) correctly models the continuum behavior of all newtonian fluids, including the disorderly fluctuating motion known as turbulence. However, since the left-hand side is highly nonlinear, only a few score of exact solutions are known, mostly for simple geometries. The primary dimensionless parameter which governs Eq. (1) is the Reynolds number, given by Eq. (2), where  $L$  is a characteristic body dimension. For small

$$Re = \frac{\rho V L}{\mu} \quad (2)$$

$Re \ll 1$ , Eq. (1) can be simplified by neglecting the left-hand side, resulting in a linear approximation called Stokes flow, or creeping flow, for which many solutions are known. See CREEPING FLOW; LUBRICATION; REYNOLDS NUMBER.

For large  $Re \gg 1$ , viscous effects are often confined to a thin boundary layer near solid surfaces, with the remaining flow being nearly inviscid. See BOUNDARY-LAYER FLOW. [F.M.Wh.; A.E.Br.]

**Navigation** The process of directing the movement of a craft from one place to another. Navigation involves position, direction, distance, time, and speed.

The process of keeping track of a craft's location by measuring and applying progress from a previous position is called dead reckoning. The location of a craft relative to external reference points such as landmarks or aids to navigation is called piloting. Radio navigation involves determining distances or directions to radio transmitters. Celestial navigation involves the use of celestial bodies. See CELESTIAL NAVIGATION; DEAD RECKONING; PILOTING.

The craft to be navigated may be a ship, small marine craft, land vehicle, aircraft, missile, spacecraft, or any moving object requiring direction or capable of being directed, even an animal or bird. The characteristics of the craft have a significant influence upon the type of navigation and the equipment used. Size, mission, weight and space limitations, and economic factors are important considerations.

Anything used in navigation, whether aboard the craft or external to it, is properly termed a navigational aid. Thus, in addition to onboard navigational equipment, the term includes such external aids as natural landmarks, prominent buildings, or other structures. Although sometimes used synonymously with "navigational aid," the expression "aid to navigation" is generally restricted to an object or device, external to the craft, established expressly to assist navigation. In this restricted sense, aids to navigation for mariners consist of buoys, beacons, light-houses, lightships, and navigation sound and electronic transmitters. Aids to navigation for aviators consist primarily of radio ranges and beacons and radio position-fixing transmitters. See BUOY; ELECTRONIC NAVIGATION SYSTEMS; HYPERBOLIC NAVIGATION SYSTEM; LIGHTHOUSE; MARINE NAVIGATION. [A.B.M.]

**Neanderthals** A group of late archaic humans from Europe, the Near East, and central Asia that immediately preceded the first modern humans in those regions. The Neanderthals are included by some within the species *Homo sapiens*, recognizing their close affinities to modern humans; others place them in their own species, *Homo neanderthalensis*, emphasizing the differences between them and modern humans.

The first recognized Neanderthal remains were found in the Neander Valley near Düsseldorf, Germany, in 1856. Since then the remains of several hundred Neanderthals have been discovered. Since the Neanderthals were the first humans to bury their dead, a number of largely complete skeletons are preserved, providing detailed knowledge of their biology. See EARLY MODERN HUMANS.

In the early twentieth century, when Neanderthals were the only archaic humans known, they were reconstructed as semi-human, dull-witted, and brutish. Hence their popular image was that of the archtypical cavemen. They are now recognized as relatively recent members of the human lineage; they lived between about 125,000 and 36,000 years ago (and as late as 30,000 years ago in certain isolated regions), as compared with earlier members of the genus *Homo* who extend back more than 2 million years. The Neanderthals share many features with modern humans both anatomically and behaviorally. Yet, a number of important contrasts between them and more recent humans are recognized.

Physically, the Neanderthals were about the same height as most modern humans, on the average 5 ft 5 in. (166 cm), but they were much more heavily built. They had heavy necks, broad and muscular shoulders, and extremely muscular arms, hands, and legs. Estimates of their strength show them to have been about as strong as very athletic modern humans. Their leg bones show a marked thickening of their shafts, which is indicative of both marked strength and endurance—a necessary part of their survival.

The Neanderthals are known for their long, low braincases and their projecting faces with large brows and prominent noses. Their brains were larger than those of modern humans. The large brain size was due in part, as with early modern humans, to their large body masses. The length and lowness of their braincases was due to relatively slow brain growth during infancy. There is no evidence that they were less intelligent than modern humans, only that their behavioral system was less elaborate.

The position of the Neanderthals in modern human ancestry remains controversial. Whatever the extent to which Neanderthals can be claimed to be ancestors of modern humans, they represent the most recent phase of premodern humans, one in which people were less efficient than modern humans at

hunting and gathering, and compensated for their cultural limitations with biological attributes such as tremendous strength, large front teeth, and thermal adaptations. Yet they exhibited the beginnings of many of the attributes of modern humans. They were very successful for about 100,000 years, but they were eventually replaced by humans who were better able to exploit their environments. See FOSSIL HUMANS. [E.T.; S.Chu.]

**Nearshore processes** Processes that shape the shore features of coastlines and begin the mixing, sorting, and transportation of sediments and runoff from land. In particular, the processes include those interactions among waves, winds, tides, currents, and land that relate to the waters, sediments, and organisms of the nearshore portions of the continental shelf. The nearshore extends from the landward limit of storm-wave influence, seaward to depths where wave shoaling begins. See COASTAL LANDFORMS.

The energy for nearshore processes comes from the sea and is produced by the force of winds blowing over the ocean by the gravitational attraction of Moon and Sun acting on the mass of the ocean, and by various impulsive disturbances at the atmospheric and terrestrial boundaries of the ocean. These forces produce waves and currents that transport energy toward the coast. The configuration of the landmass and adjacent shelves modifies and focuses the flow of energy and determines the intensity of wave and current action in coastal waters. Rivers and winds transport erosion products from the land to the coast, where they are sorted and dispersed by waves and currents.

In temperate latitudes, the dispersive mechanisms operative in the nearshore waters of oceans, bays, and lakes are all quite similar, differing only in intensity and scale, and are determined primarily by the nature of the wave action and the dimensions of the surf zone. The most important mechanisms are the orbital motion of the waves, the basic mechanism by which wave energy is expended on the shallow sea bottom, and the currents of the nearshore circulation system that produce a continuous interchange of water between the surf zone and offshore areas. The dispersion of water and sediments near the coast and the formation and erosion of sandy beaches are some of the common manifestations of nearshore processes.

Erosional and depositional nearshore processes play an important role in determining the configuration of coastlines. Whether deposition or erosion will be predominant in any particular place depends upon a number of interrelated factors: the amount of available beach sand and the location of its source; the configuration of the coastline and of the adjoining ocean floor; and the effects of wave, current, wind, and tidal action. The establishment and persistence of natural sand beaches are often the result of a delicate balance among a number of these factors, and any changes, natural or anthropogenic, tend to upset this equilibrium. See DEPOSITIONAL SYSTEMS AND ENVIRONMENTS; EROSION. [D.L.I.]

**Nebula** Originally, any fixed, extended, and usually fuzzy luminous object seen in a telescope. Nebulae are now distinguished from star clouds that can be resolved into individual stars, but earlier workers were unable to differentiate between white nebulae, which are stellar systems so remote as to show no individual stars, and gaseous or diffuse nebulae in the Milky Way Galaxy. See STAR CLOUDS.

Extragalactic nebulae are stellar systems comparable with the Milky Way Galaxy or the Magellanic Clouds in size and number of stars, and are more properly termed external galaxies. See GALAXY, EXTERNAL.

This article deals with gaseous nebulae. This class of objects includes diffuse nebulae which contain dust and gas of the interstellar medium, excited and caused to fluoresce by embedded stars. Gaseous nebulae are members of the Milky Way galactic system, and small compared with its overall dimensions. Various

types of gaseous nebulae have been identified. See INTERSTELLAR MATTER.

Diffuse nebulae range in density from a few atoms per cubic centimeter to 10,000 or more atoms per cubic centimeter (as in the Orion Nebula). Some are compact objects less than a parsec in diameter. Both dust and gas are excited by ultraviolet radiation of stars. Some diffuse nebulae such as Orion occur at the edges of large clouds of cool dust and gas, mostly in molecular form. Those of lower density are found from the faint glow in the red hydrogen line produced as hydrogen ions recapture electrons. For this reason they are also called H II regions, indicating regions of ionized hydrogen. They are also found in external galaxies such as the Magellanic Clouds and M33. See MAGELLANIC CLOUDS; ORION NEBULA.

Reflection nebulae show no bright line spectra. Dust grains simply reflect the light of nearby embedded stars. Hydrogen gas is present but mostly neutral. The Pleiades nebulosity is an example of this type. See PLEIADES.

Nebulae associated with star formation include the so-called fan-shaped nebulae associated with T Tauri stars, certain bipolar nebulae, and Herbig-Haro Objects. Some, such as Hubble's variable nebula, associated with the variable star R Monocerotis, show brightness fluctuations. In many instances, a newly formed star excites and ionizes the gas in its immediate neighborhood, although the star itself is quite concealed by its dusty surroundings. See STELLAR EVOLUTION.

Planetary nebulae are so denoted because they often show small greenish disks in the telescope, not unlike the images of the planets Uranus and Neptune. The energy emitted by planetary nebulae is derived mostly from the ultraviolet emission of the central star, although in some objects an important component may be due to shock waves. See PLANETARY NEBULA.

The detonation of a star in a supernova event causes the ejection of the outer layers into the surrounding interstellar medium. In early stages as in the Crab Nebula, the radiating material consists of ejecta from the star. In the later stages this rapidly moving material is slowed down as it mixes with the surrounding dust and gas of the interstellar medium. Heating by shock waves causes the material to radiate optically. Sometimes, the temperature behind the shock front can rise to more than  $10^6$  K, but the gas is so rarefied that the intensity of the emitted radiation is extremely low. Supernovae remnants characteristically emit nonthermal radio-frequency emission, whereby they are often detected in nearby galaxies as well as in the Milky Way system. See CRAB NEBULA; SUPERNOVA.

Cocoon nebulae are associated with very massive stars. At a late stage in its evolution a massive star may eject a dense shell of material that effectively hides it from view temporarily. Although the extended Carina Nebula appears to be a normal H II region,  $\eta$  Carinae itself is a dense, compact object which hides the central star and emits a remarkable spectrum dominated by forbidden lines of ionized iron. [L.H.A.]

**Nectarine** A smooth-skinned, fuzzless form of peach, *Prunus persica*. The nectarine's lack of pubescence is a simple recessive genetic characteristic. Classically, the fruits were thought of as being somewhat smaller, softer, and richer in flavor than those of the peach. More recently developed cultivars, however, approximate fresh-market peaches in size and firmness but are not usually superior in flavor.

California is practically the sole commercial producer of nectarines. There is a considerable number of plantings in irrigated areas in south-central Washington. See FRUIT; FRUIT, TREE; PEACH; ROSALES. [L.F.H.; C.H.B.]

**Nectridea** An order of mostly aquatic lepospondyl amphibians known from Carboniferous and Permian rocks of North America, Europe, and North Africa. They were small, usually less than 20 in. (50 cm) in length, and outwardly newtlike with short



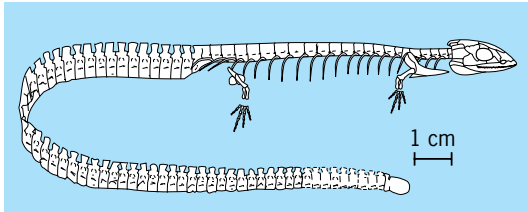

**Urocordylid nectridean *Ptyonius marshii*.** (After R. L. Carroll, *Vertebrate Paleontology and Evolution*, W. H. Freeman, 1988)

trunks and long tails. Limbs were small but well developed. Carpal and tarsal bones were rarely ossified. Their vertebrae exhibit the one-piece centrum characteristic of lepospondyls, but are distinct in bearing spatulate neural spines (see illustration) with crenulated dorsal edges. Three nectridean families are recognized: Urocordylidae, Keraterpetontidae and Scincosauridae. See AMPHIBIA; LEPOSPONDYLI. [C.F.W.]

**Negative ion** An atomic or molecular system with an excess of negative charge. Negative ions, also called anions, are formed in attachment processes in which an additional electron is captured by an atom or molecule. Negative ions were first reported in the early days of mass spectrometry. It was soon learned that even a small concentration of such weakly bound, negatively charged systems had an appreciable effect on the electrical conductivity of gaseous discharges. Negative ions now play a major role in a number of areas of physics and chemistry involving weakly ionized gases and plasmas. Applications include accelerator technology, injection heating of thermonuclear plasmas, material processing, and the development of tailor-made gaseous dielectrics. In nature, negative ions are known to be present in tenuous plasmas such as those found in astrophysical and aeronomical environments. The absorption of radiation by negative hydrogen ions in the solar photosphere, for example, determines the Sun's spectral distribution. See ION; ION SOURCES. [D.J.Pe.]

**Negative-resistance circuits** Electronic circuits or devices that, over some range of voltage  $v$  and current  $i$ , satisfy Eq. (1) for equivalent resistance  $R_{eq}$  (where the voltage and

$$R_{eq} = \frac{dv}{di} < 0 \tag{1}$$

current polarities are defined in Fig. 1a). They are used as building blocks in designing circuits for a wide range of applications, including amplifiers, oscillators, and memory elements. See AMPLIFIER; ELECTRICAL RESISTANCE; OSCILLATOR.

An ideal negative resistor would have the voltage-current relationship (transfer characteristic) shown in Fig. 1b, and thus satisfy Ohm's law with a negative value for the resistance. How-

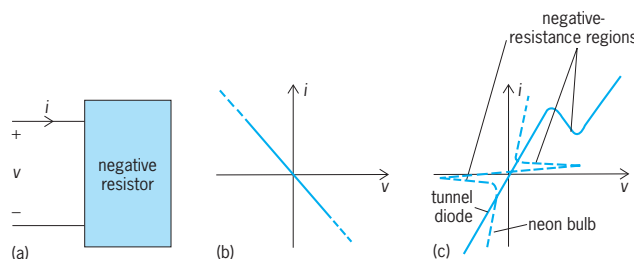

**Fig. 1. Characteristics of negative resistors.** (a) Definition of voltage ( $v$ ) and current ( $i$ ) polarities. (b) Voltage-current transfer characteristic of an ideal negative resistor. (c) Transfer characteristic of practical physical devices with negative-resistance regions: a tunnel diode and a neon bulb (not to the same scale).

ever, the same effect can generally be obtained with any circuit (or physical device) whose voltage-current curve contains a region of negative slope. Figure 1c, for example, shows transfer characteristics typical of a tunnel diode and a neon bulb, which can be operated in the negative-resistance regions indicated. See OHM'S LAW; RESISTOR.

Common generalizations of the negative-resistance idea include negative capacitors, negative inductors, and frequency-dependent negative resistors. Some of the circuits used to implement them are negative impedance converters, negative impedance inverters, and generalized immittance converters. See CAPACITOR; ELECTRICAL IMPEDANCE; IMMITTANCE; INDUCTOR.

The power dissipated in a device, given by Eq. (2), is negative

$$P_{DISS} = vi \tag{2}$$

in the second and fourth quadrants of the  $v$ - $i$  plane of Figs. 1b and c. Thus, the ideal negative resistor whose characteristic is shown in Fig. 1b generates power. Two consequences of this are that an active circuit (a circuit containing a power supply) is required to implement the ideal characteristic of Fig. 1b but is not necessary for the small-signal negative resistances of Fig. 1c; and that for any practical circuit, the characteristic curve must eventually fold over into the power-dissipating quadrants, as shown in Fig. 2a or b. If the curve did not fold but just continued forever, it would be possible to extract an infinite amount of power from the device.

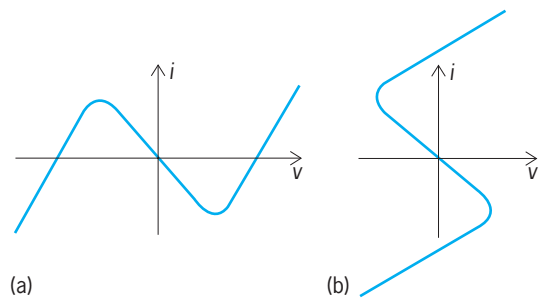

**Fig. 2. Large-signal behavior of a negative resistance having a finite internal power supply.** (a) Voltage-controlled resistance. (b) Current-controlled resistance.

The two types of curve of Fig. 2 correspond to an important dichotomy in types of negative resistance. The N-shaped curve of Fig. 2a allows current to be a single-valued function of voltage (but not vice versa), and circuits with this behavior are therefore called voltage-controlled negative resistors. Dually, the S-curve of Fig. 2b, for which Eq. (3) is appropriate, describes a

$$v = f(i) \tag{3}$$

current-controlled negative resistor. The tunnel-diode characteristic of Fig. 1c can be seen to be voltage-controlled, while the neon tube is current-controlled.

If the terminals of a current-controlled negative resistor are open-circuited, then  $i = 0$  and there is a unique solution  $v = f(0)$ . The voltage-controlled circuit, however, can have any of three voltages in this situation (the three intersections of the N with the horizontal axis). Dually, the S-curve gives a device with multiple equilibrium states when short-circuited. When the dynamic behavior of these circuits is accounted for, it is found that some of these equilibria are stable and some are unstable. These stability considerations are essential to designing a negative-resistance circuit for a particular application.

Negative resistors can be implemented by using amplifiers in positive-feedback configurations. Figure 3a shows how a voltage amplifier with a gain of 2 can be used to simulate a grounded negative resistor, and Fig. 3b shows an operational-amplifier implementation of the same idea. See OPERATIONAL AMPLIFIER.

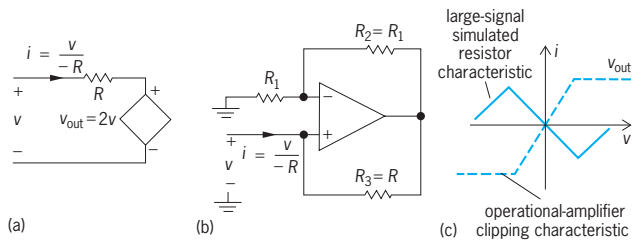

**Fig. 3. Active circuits that simulate a negative resistance.** (a) Circuit that uses an ideal voltage amplifier with a gain of 2. (b) Circuit that uses an operational amplifier. (c) The operational-amplifier clipping characteristic and resulting large-signal voltage-current characteristic of the simulated negative resistor.

In the practical case of a clipping amplifier, which has the input-output characteristics shown in Fig. 3c, the resulting large-signal voltage-current behavior of the simulated resistor is as shown in the figure. This is a voltage-controlled resistor.

The best-known negative-resistance device is the tunnel diode. It is very useful because the phenomenon that it exploits is a quantum-mechanical effect that happens much more rapidly than most others in electronics.

A tunnel diode consists of two very heavily doped regions of a semiconducting material with a very abrupt junction between them. These regions, like any crystalline material, can contain electrons only with energies in certain bands. One side of the junction is doped to have a generous supply of electrons in a certain band of energies, while the other side has a great many vacancies (holes) for electrons in another band. As the applied voltage increases, the bands of electrons and holes on the two sides of the junction start to slide past one another, and eventually their region of overlap starts to decrease. Since quantum tunneling can occur only from an electron in the "supply" to a vacancy at the same energy, this reduction in overlap reduces the amount of charge flowing. Thus, an increasing voltage produces decreasing current, for a negative differential resistance like that shown in Fig. 1c. See BAND THEORY OF SOLIDS; SEMICONDUCTOR RECTIFIER.

A number of other quantum electronic devices have been developed that also have negative-resistance characteristics. In particular, devices have been constructed that have two barriers (instead of the single barrier created by the tunnel-diode junction) and make use of resonant tunneling, where the spacing between the barriers creates a resonance for electrons at certain frequencies. This resonance, in turn, enhances the rate of tunneling. These devices are claimed to be useful at terahertz ( $10^{12}$  Hz) frequencies. See SEMICONDUCTOR HETEROSTRUCTURES; TUNNEL DIODE; TUNNELING IN SOLIDS. [M.Sn.]

**Negative temperature** The property of a thermodynamical system which satisfies certain conditions and whose thermodynamically defined absolute temperature is negative. The essential requirements for a thermodynamical system to be capable of negative temperature are: (1) the elements of the thermodynamical system must be in thermodynamical equilibrium among themselves in order for the system to be described by a temperature at all; (2) there must be an upper limit to the possible energy of the allowed states of the system; and (3) the system must be thermally isolated from all systems which do not satisfy both requirements (1) and (2); that is, the internal thermal equilibrium time among the elements of the system must be short compared to the time during which appreciable energy is lost to or gained from other systems.

The second condition must be satisfied if negative temperatures are to be achieved with a finite energy. Most systems do not satisfy this condition; for example, there is no upper limit to the possible kinetic energy of a gas molecule. Systems of interacting

nuclear spins, however, have the characteristic that under suitable circumstances they can satisfy all three of the conditions, in which case the nuclear spin system can be at negative absolute temperature. See KINETIC THEORY OF MATTER; STATISTICAL MECHANICS.

The transition between positive and negative temperatures is through infinite temperature, not absolute zero; negative absolute temperatures should therefore not be thought of as colder than absolute zero, but as hotter than infinite temperature. See ABSOLUTE ZERO; TEMPERATURE. [N.FR.]

**Nemata** A phylum of unsegmented worms. A classification of nematodes follows:

- Phylum Nemata
  - Class: Adenophorea
    - Subclass: Enoplia
      - Order: Enoplida
        - Oncholaimida
        - Tripylida
        - Isolaimida
        - Mononchida
        - Dorylaimida
        - Stichosomida
    - Subclass: Chromadoria
      - Order: Araeolaimida
        - Chromadorida
        - Desmoscolecida
        - Desmodorida
        - Monhysterida
  - Class: Secernentea
    - Subclass: Rhabditia
      - Order: Rhabditida
        - Strongylida
    - Subclass: Spiruria
      - Order: Spirurida
        - Ascaridida
    - Subclass: Diplogasteria
      - Order: Diplogasterida
        - Tylenchida

**Diagnosis.** The Nemata are unsegmented or pseudosegmented (any superficial annulation limited to the cuticle) bilaterally symmetrical worms with a basically circular cross section. The body is covered by a noncellular cuticle. The cylindrical body is usually bluntly rounded anteriorly and tapering posteriorly. The body cannot be easily divided into head, neck, and trunk or tail, although a region posterior to the anus is generally referred to as the tail. The oral opening is terminal (rarely subterminal) and followed by the stoma, esophagus, intestine, and rectum which opens through a subterminal anus. Females have separate genital and digestive tract openings. In males the tubular reproductive system joins posteriorly with the digestive tract to form a cloaca. The sexes are separate and the gonads may be paired or unpaired. Females may be oviparous or ovoviviparous.

Adult nematodes are extremely variable in size, ranging from less than 0.012 in. (0.3 mm) to over 26 ft (8 m). Nematodes are generally colorless except for food in the intestinal tract or for those few species which have eyespots.

**Life cycle.** Reproduction among nematodes is either amphimictic or parthenogenetic (rarely hermaphroditic). After the completion of oogenesis the chitinous egg shell is formed and a waxy vitelline membrane forms within the egg shell; in some nematodes the uterine cells deposit an additional outermost albuminoid coating. Upon deposition or within the female body, the egg proceeds through embryonation to the eellike first- or second-stage larva, but following eclosion the larva proceeds

through four molts to adulthood. This represents a direct life cycle, but among parasites more diversity occurs.

**Distribution.** Nematoda comprise the third largest phylum of invertebrates, being exceeded only by Mollusca and Arthropoda. In sheer numbers of individuals they exceed all other metazoa. As parasites of animals they exceed all other helminths combined. Nematodes have been recovered from the deepest ocean floors to the highest mountains, from the Arctic to the Antarctic, and in soils as deep as roots can penetrate. [A.R.M.]

**Nematicide** A type of chemical used to kill plant-parasitic nematodes. Nematicides may be classed as soil fumigants or soil amendments, space fumigants, surface sprays, or dips. Soil treatments are commonly used because most plant-pathogenic species spend part or all of their life cycle in the soil, in or about the roots of plants. Nematicides may be liquids, gases, or solids, but on a field scale, liquids are most practical. See NEMATATA; PESTICIDE. [D.J.R.]

**Nematomorpha** A phylum of worms that was formerly considered to be a class of the phylum Aschelminthes; commonly called the hairworms, and closely allied to the nematodes. The adults are free-living in aquatic habitats, while the juveniles are parasitic in arthropods. The nematomorphs are found all over the world. They are divided into two classes, the Nectonematoidea and Gordioidea, with a total of 225 species. See NEMATATA.

The body is long and slender with a maximum length of 5 ft (1.5 m) and a diameter of 0.02–0.12 in. (0.5–3 mm). The females are longer than the males. The posterior end may be rounded with a terminal cloaca, or it may form two or three lobes in a forklike structure. The body color is yellowish, brown, or almost black. The body wall consists of three layers: an outer, rather thick fibrous cuticle; an epidermis consisting of a single layer of cells; and innermost, a muscle layer with longitudinal fibers only.

The body cavity extends the length of the body. It may be filled with tissue so that only minor spaces are left around the digestive system and the gonads.

The sexes are always separate, and the gonads are paired and stringlike extending the length of the body. During copulation the male coils itself around the female and places a drop of sperm near the cloacal opening of the female. The sperm cells actively enter the seminal receptacle. The eggs are laid in water in strings, and the adults die after egg laying. When hatched, the larvae swim to an aquatic arthropod. They penetrate the body wall of the host by means of their characteristic proboscis, which is armed with hooks and three long stylets. The gradual development in the host lasts some months without any metamorphosis. When they are mature, the worms leave the host. [B.J.Mu.]

**Nematophytales** An enigmatic group of fossil plants, in mid-Silurian to lower Upper Devonian rocks, composed of intertwined, branching tubes of two sizes: 10–50 micrometers in diameter, and 1–10 micrometers. Although they are referred to the algae by some authors, the occurrence of this group in inland swamps, coastal plain deposits, and marine deposits close to shore indicates that they were terrestrial organisms, unrelated to any known groups, perhaps at an intermediate level between algae and bryophytes. See PALEOBOTANY. [H.P.B.]

**Neodymium** A metallic chemical element, Nd, atomic number 60, atomic weight 144.24. Neodymium belongs to the rare-earth group of elements. The naturally occurring element includes the six isotopes. The oxide, Nd<sub>2</sub>O<sub>3</sub>, is a light-blue powder. It dissolves in mineral acids to give reddish-violet solutions. See PERIODIC TABLE; RARE-EARTH ELEMENTS.

The salts have found application in the ceramic industry for coloring glass and for glazes. The glass is particularly useful in goggles used by glass blowers, since it absorbs the intense yellow

D line of sodium present in the flame. The element has found commercial application in the manufacture of lasers. [F.H.Sp.]

**Neogastropoda** The most highly specialized order in the subclass Prosobranchia (phylum Mollusca, class Gastropoda). Neogastropods have simplified pallial and cardiac structures involving complete separation of genital from renal organs, and a “half-gill” (that is, a one-sided comb-shaped or pectinibranch ctenidium) with its axis and major blood vessels fused to the mantle wall. The order comprises mainly marine carnivores and carrion feeders, all with a long extensible proboscis bearing a flesh-tearing radula. More efficient hydrodynamically with their simplified mantle cavity and fused ctenidial axis, neogastropods are not limited to clean waters over hard substrata (as are the archaeogastropods) but have successfully invaded all areas of the seashore and sea bottom, whether covered with sand, silt, or mud.

Neogastropods occur in all depths of the world's oceans from the tropics to polar waters, and there are at least 6000 species, mostly in four important superfamilies. The larger whelks of the superfamily Buccinacea are found from the shallow sublittoral and continental shelves down to depths of 9800 ft (3000 m). The flesh of many whelk species provides human food, and almost all species have been used in commercial longline fisheries as resilient and attractive bait. The smaller tangles, dog whelks, and oyster drills of the superfamily Muricacea are the abundant neogastropod predators in inshore and intertidal waters. A third important superfamily, Volutacea, encompasses more beautiful, much collected shells. The most specialized neogastropods are the tropical toxoglossans (superfamily Conacea) belonging to the families Conidae, or cone shells, and Terebridae, or auger shells. Both groups have been prized by shell collectors for centuries.

Despite their large number of species and diversity of habitats, the neogastropods show more anatomical uniformity (efficient mantle cavity, inhalant siphon with chemoreceptive osphradium, extensible proboscis, stenoglossan radula, and simple carnivore gut) than is found in any of the other major orders of gastropods. See GASTROPODA; MOLLUSCA; PROSOBRANCHIA. [W.D.R.H.]

**Neognathae** One of the two recognized superorders making up the subclass Neornithes of the class Aves. They are characterized as flying birds with fully developed wings and sternum with a keel, caudal vertebrae fused into a pygostyle, and absence of teeth in both jaws, or modifications of these conditions in secondary flightless birds.

This superorder includes all living birds and all known fossil birds since the Late Cretaceous; only the ancestral Jurassic *Archaeopteryx* and the specialized Cretaceous *Hesperornis* and its allies do not belong to the Neognathae. See ARCHAEORNITHES; AVES; ODONTOGNATHAE; RATTITES. [W.J.B.]

**Neognathostomata** A superorder of Echinoidea, subclass Euechinoidea. These invertebrates are characterized by having a rigid, exocyclic test and a lantern or jaw apparatus developed sometime during the life history and usually persisting into the adult stage. The included orders are the Holecypoida, Clypeasteroidea, and Cassiduloidea. See ECHINODERMATA; ECHINOIDEA; EUECHINOIDEA; HOLECTYOPOIDA. [H.B.F.]

**Neogregarinida** An order of the protozoan subclass Gregarina, class Telosporea, subphylum Sporozoa. All gregarines are parasites of the digestive tract and body cavity of invertebrates or lower chordates; their large, mature trophozoites (vegetative stages) live outside the host's cells. The Neogregarinida are thought to be relatively advanced gregarines which live in insects. There are only about 29 species of about 12 genera, and 4 families. See GREGARINIA. [N.D.L.]

**Neolampadoida** A group of small, deep-water cassiduloid echinoids with neotenous characteristics, treated as an order

by some workers; possibly polyphyletic. The presence of bourrelets and phylloides, the elongate first ambulacral plates, the undifferentiated tuberculation, and undifferentiated posterior interambulacral plating all indicate their relationships lie with cassiduloids. The only character shared by members of this group is the lack of petals (they have simple ambulacral pores only). Other characteristics, such as apical disc plating, are varied, indicating at least two independent origins from shallow-water cassiduloids.

There are seven genera, each monospecific. Five are living today and are usually found at depths of 430–1280 ft (135–400 m). A Miocene species and an Upper Eocene species are also known. See ECHINODERMATA. [A.B.S.]

**Neolithic** The period of prehistoric culture whose basic defining attributes are the emergence of agriculture, animal domestication, and sedentary farmsteads or villages. This definition has evolved over the last century from the original characterization of this period based on the appearance of polished stone axes. By 1865, when John Lubbock published *Prehistoric Times*, two types of Stone Age had been recognized in Europe: *période de la pierre taillée* (period of chipped stone implements) and *période de la pierre polie* (period of polished stone implements). Lubbock termed the former Palaeolithic and the latter Neolithic. Subsequently, it was realized that the definition of this period based on a single artifact type was spurious, since Neolithic peoples also continued to make chipped stone tools. A more comprehensive view developed that saw the Neolithic as characterized by pottery manufacture, agriculture, livestock, and settled villages, but without the use of metals. Thus the Neolithic formed the final Stone Age precursor to the Bronze Age and the Iron Age in the classic northern European prehistoric sequence, which was soon extended throughout most of Eurasia. See PALEOLITHIC.

As the term Neolithic is presently used, it refers specifically to prehistoric societies in Europe, Asia, and northern Africa that derived the majority of their diet from agriculture and livestock and that lived in sedentary communities, either dispersed farmsteads or villages, but that did not yet know the use of alloyed metals. Outside of this area, the term Neolithic is rarely used, although clearly in most other parts of the world there was also a transition from hunting and gathering to agriculture at some time in prehistory. For the purposes of this article, "Neolithic" will be expanded to include a global consideration of the origins and dispersal of agriculture and sedentary life, what might be called a neolithic cultural pattern.

With the exception of the dog, which was domesticated by late Pleistocene hunter-gatherers in many parts of the world, the domestication of plants appears to have preceded that of animals. Although many parts of the world can claim to have been the location of the domestication of some food plants, the regions where the crop species which underlie the major agricultural systems of the world were domesticated are fairly well delimited. The three foci of domestication include the "Fertile Crescent" area of the Near East (wheat and barley), the Huanghe and Yangzi valleys of China (millet and rice), and Mesoamerica (maize and beans), while the broader areas of where important domestication also occurred include northern and Andean South America (potatoes and other root crops), northern sub-Saharan Africa (sorghum), and southeast Asia and many Pacific islands (various tree and root crops). Other research has added another area to this list: the indigenous domestication in eastern North America of a complex of weedy plants that include chenopod, sunflower, and marsh elder.

Just as wheat and barley were the founder crops of Near Eastern agriculture, sheep and goat can be considered the founder animals of ungulate domestication around 9000 years ago. Cattle and pigs appear to have been domesticated around 8000 years ago, with evidence pointing toward Anatolia as the likely location. The pig and the chicken were the most important

domesticated animals in the Chinese Neolithic, supplemented soon after with the water buffalo.

Not only are the domestication of plants and animals and the establishment of farming settlements the hallmarks of the Neolithic, but also these provided the platform for subsequent cultural developments. The Neolithic in the Old World and its New World parallels were periods of dramatic change in human society, laying the foundation for the socially stratified societies that followed. [PBo.]

**Neomeniomorpha** A subclass of creeping, vermiform mollusks in the class Aplacophora. They are covered by a spicular integument and recognized by the presence of a ventral groove within which lies a narrow foot and by the absence of an oral shield. Neomenioids range in size from less than 0.08 to 12 in. (2 mm to 300 mm) and are found from subtidal areas to the abyss, at depths over 16,000 ft (5000 m). There are 23 families with 70 genera and 193 species worldwide.

Neomenioids creep by means of their ciliated foot along a track of sticky mucus produced from a ciliated, reversible pedal pit at the anterior end of the pedal groove. Anterior to the pedal pit, the head end is held above the substratum and freely moved.

All neomenioids are hermaphroditic. A barrel-shaped, non-feeding larva called a pericalymma either is brooded or swims by means of a ciliated cellular test within which the animal develops; metamorphosis through loss or resorption of the test occurs within 10 days. See APLACOPHORA; MOLLUSCA. [A.H.S.]

**Neon** A gaseous chemical element, Ne, with atomic number 10 and atomic weight 20.183. Neon is a member of the family of noble gases. The only commercial source of neon is the Earth's atmosphere, although traces of neon are found in natural gas, minerals, and meteorites. See INERT GASES; PERIODIC TABLE.

Considerable quantities of neon are used in high-energy physics research. Neon fills spark chambers used to detect the passage of nuclear particles. Liquid neon can be utilized as a refrigerant in the temperature range about 25 to 40 K (−416 to −387°F). Neon is also used in some kinds of electron tubes, in Geiger-Müller counters, in spark-plug test lamps, and in warning indicators on high-voltage electric lines. A very small wattage produces visible light in neon-filled glow lamps; such lamps are used as economical night and safety lights. See NEON GLOW LAMP.

Physical properties of neon

Property	Value
Atomic number	10
Atomic weight (atmospheric neon only)	20.183
Melting point, °C	−248.6
Boiling point at 1 atm pressure, °C	−246.1
Gas density at 0°C and 1 atm pressure, g/liter	0.8999
Liquid density at its boiling point, g/ml	1.207
Solubility in water at 20°C, ml neon (STP)/1000 g water at 1 atm partial pressure neon	10.5

Neon is colorless, odorless, and tasteless; it is a gas under ordinary conditions. Some of the other properties of neon are given in the table. Neon does not form any chemical compounds in the ordinary sense of the word; there is only one atom in each molecule of gaseous neon. [A.W.F.]

**Neon glow lamp** A low-wattage lamp often used as an indicator light or as an electronic circuit component. The neon lamp usually consists of a pair of electrodes sealed within a bulb containing neon gas at a low pressure. Some of the smaller bulbs are equipped with wire leads that are connected directly into the electrical supply circuit; others are equipped with conventional bases that vary with the size of the lamps (see illustration).

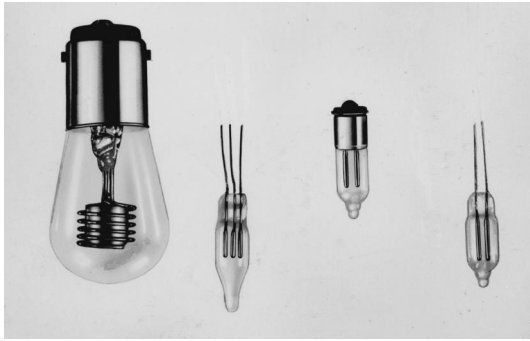

Some examples of glow lamps.

Electrodes sealed in a neon atmosphere will emit electrons if a sufficient voltage difference is impressed across them. In glow lamps the electrodes are usually treated to emit electrons freely. With a sufficiently high voltage between electrodes, the velocity of electron flow is high enough to ionize the neon nearest the negative electrode (cathode). The neon then emits a reddish-orange glow similar to the color of neon sign tubing. With direct current the glow is restricted to the immediate vicinity of the negative electrode. With alternating current, both electrodes act alternately as cathodes, and the glow appears alternately at both surfaces. At usual frequencies, the alternations occur so rapidly that both electrodes appear to glow constantly. In dc circuits, the voltage across the electrodes may be reduced significantly, once the lamp has started, without causing the lamp to go out. [A.M.]

**Neornithes** The subclass of Aves that contains all of the known birds other than those placed in the Archaeornithes. Comprising more than 30 orders, both fossil and living, its members are characterized by a bony, keeled sternum with fully developed powers of flapping flight (secondarily lost in a number of groups); a short tail with the caudal vertebrae fused into a single platelike pygostyle to which all tail feathers attach; a large fused pelvic girdle with a reversed pubis which is fused to a large synsacrum; and a large brain and eyes contained within a fused braincase. The jaws are specialized into a beak covered with a horny rhamphotheca; the upper jaw is kinetic, being either prokinetic or rhynchokinetic. Prokinesis refers to a bending zone at the base of the upper jaw, and rhynchokinesis to one within the upper jaw. A few fossil groups still possess teeth, but most fossil and all Recent birds have lost teeth. See ARCHAEOORNITHES.

The Neornithes contains two superorders, the Odontognathae and the Neognathae. The Odontognathae, alternately known as the Odontornithes, may be an artificial group. Its members, which include the Cretaceous fossil orders Hesperornithiformes and Ichthyornithiformes, are united only by the presence of teeth in all species. The Neognathae contains the remaining modern birds, which have lost the teeth, and includes 26 orders. See AVES; NEOGNATHAE; ODONTOGNATHAE. [W.J.B.]

**Neoteny** A phenomenon among some salamanders, in which larvae of large size, while still retaining the gills and other larval features, become sexually mature, mate, and produce fertile eggs. In certain lakes of Mexico, only the neotenous larvae are present and are called axolotls. Neoteny occurs in certain species of the family Ambystomidae. [T.I.S.]

**Nepenthales** An order of flowering plants, division Magnoliophyta (Angiospermae), in the subclass Dilleniidae of the class Magnoliopsida (dicotyledons). The order (also known as Sarraceniales) consists of 3 well-marked small families: the Droseraceae, with about 90 species; the Nepenthaceae, with about 80 species; and the Sarraceniaceae, with only about 16. The plants characteristically grow in waterlogged soils which are

deficient in available nitrogen. They are herbs or shrubs with alternate, simple leaves that are modified for catching insects, from which they absorb nitrogenous nutrients. The pitcher plants (*Sarracenia*), sundew (*Drosera*), and Venus' flytrap (*Dionaea muscipula*) are well-known members of the order. See MAGNOLIOPSIDA.

[A.Cr.]

**Neper** A unit of attenuation used in transmission-line theory. On a uniform transmission line having waves traveling in only one direction, the magnitudes of voltage  $E$  and of current  $I$  decrease with distance  $x$  traveled, as given by Eq. (1), where

$$\frac{E}{E_0} = \frac{I}{I_0} = e^{-\alpha x} \quad (1)$$

$E_0$ ,  $I_0$ , and  $\alpha$  are constants. The attenuation in nepers between the points where  $E_0$ , and  $I_0$  are measured and where  $E$  and  $I$  are measured is given by Eq. (2), in which  $\ln$  denotes the natural (or

$$\alpha x = \ln \frac{E_0}{E} = \ln \frac{I_0}{I} \quad (2)$$

napierian) logarithm. One neper equals 8.686 dB, the decibel being the practical unit of attenuation. See DECIBEL; TRANSMISSION LINES. [E.W.K.]

**Nepheline** A mineral of variable composition: in its purest state,  $\text{NaAlSi}_3\text{O}_8$ ; often nearly  $\text{Na}_3\text{K}(\text{AlSi}_3\text{O}_8)_4$ ; but generally  $(\text{Na}, \text{K}, \square, \text{Ca}, \text{Mg}, \text{Fe}^{2+}, \text{Mn}, \text{Ti})_8(\text{Al}, \text{Si}, \text{Fe}^{3+})_{16}\text{O}_{32}$ , where  $\square$  represents vacant crystallographic sites, and Ca, Mg,  $\text{Fe}^{2+}$ , Mn, Ti, and  $\text{Fe}^{3+}$  are usually present in only minor or trace amounts. The most important variations in nepheline composition are due to crystalline solution of  $\text{KAlSi}_3\text{O}_8$  (the mineral kalsilite), and substitution of  $\square$  for K. See SILICATE MINERALS.

The salient physical properties of nepheline are: a Mohs scale hardness of 5.5–6.0; a specific gravity between 2.56 and 2.67; a typically dark gray, light gray, or white color, but it can also be colorless (nepheline is colorless in petrographic thin section); and a vitreous or greasy luster. Nepheline occurs as simple hexagonal prisms or, more commonly, as isolated shapeless grains or irregular polycrystalline masses.

Nepheline is the most abundant feldspathoid mineral; it occurs in a wide variety of  $\text{SiO}_2$ -deficient (quartz-free) and alkali-rich volcanic, plutonic, and metamorphic rocks. In volcanic rocks, nepheline occurs chiefly as a primary mineral in phonolites, kenytes, and melilite basalts, and it is the characteristic mineral of nephelinites.

Both "pure" (processed) nepheline and nepheline syenite are used as raw materials for the manufacture of glass, various ceramic materials, alumina, pottery, and tile. See FELDSPATHOID; IGNEOUS ROCKS; NEPHELINITE. [J.G.B.]

**Nephelinite** A dark-colored, aphanitic (very finely crystalline) rock of volcanic origin, composed essentially of nepheline (a feldspathoid) and pyroxene. See KALSILITE.

The texture is usually porphyritic with large crystals (phenocrysts) of augite and nepheline in a very fine-grained matrix. Augite phenocrysts may be diopsidic or titanium-rich and may be rimmed with soda-rich pyroxene (aegirine-augite). Microscopically the matrix is seen to be composed of tiny crystals or grains of nepheline, augite, aegirite, and sodalite with occasional soda-rich amphibole, biotite, and brown glass.

Nephelinite and related rocks are very rare. They occur as lava flows and small, shallow intrusives. A great variety of these feldspathoidal rocks is displayed in Kenya. See FELDSPATHOID; IGNEOUS ROCKS; LEUCITE. [C.A.C.]

**Neptune** The outermost of the four giant planets. Neptune is a near twin of Uranus in size, mass, and composition. Its discovery in 1846 within a degree from the theoretically predicted position was one of the great achievements of celestial mechanics. See CELESTIAL MECHANICS.

Through a small telescope, Neptune appears as a tiny greenish disk. Its linear equatorial diameter of 30,775 mi (49,528 km) is very similar to that of Uranus. The mass of Neptune is 17.20 times the mass of Earth, corresponding to a mean density of 1.62, somewhat above that of its sister planet. This suggests that the enrichment of heavy elements is somewhat greater in Neptune than in Uranus. See URANUS.

Most of what is known about Neptune is the result of the flyby of the planet by the *Voyager 2* spacecraft in August 1989. The cloud features included a large dark oval (about the size of Earth), reminiscent of Jupiter's Great Red Spot, as well as the white clouds of condensed methane whose brilliant contrast with the blue-green atmosphere made them visible from Earth. Unlike the Great Red Spot, Neptune's dark oval proved to have a short lifetime. By following the clouds over several weeks, scientists were able to deduce the presence of currents at different latitudes, with a tendency for the high-latitude winds to be faster than those near the equator. This circulation pattern resembles that of Uranus, despite the fact that the inclinations of the rotational axes of the two planets are very different (that of Neptune is  $29.6^\circ$ , while that of Uranus is  $97.9^\circ$ , and that of Earth is  $23.5^\circ$ ). This active meteorology on Neptune may well be driven by the escaping internal heat, some 2.7 times the magnitude of the heat absorbed from the Sun.

The atmosphere of Neptune, like those of the other giant planets, is composed predominantly of hydrogen and helium. The relative abundance of methane is enhanced by about the same amount as on Uranus, between 20 and 30 times the value corresponding to solar abundances of the elements.

The orientation of Neptune's magnetic field is surprisingly similar to that of Uranus. It can be represented by a bar magnet inclined at an angle of  $46.8^\circ$  with respect to the axis of rotation and offset by 0.55 planetary radius. This field has trapped a plasma of ionized and neutral gases in the planet's magnetosphere.

Before the *Voyager* encounter, only two satellites of Neptune were known, both of them in highly irregular orbits. Triton was discovered visually by W. Lassell in 1846. It is moving in a retrograde direction around Neptune with a period of 5.9 days in a nearly circular orbit. Nereid was found almost 100 years later as a result of a photographic search by G. P. Kuiper. It has the most eccentric orbit of any known satellite. In sharp contrast to these two bodies, the six satellites discovered by the *Voyager* cameras all have very regular orbits: in the plane of the planet's equator and nearly circular. They are all close to the planet.

Triton has a tenuous atmosphere containing nitrogen, methane, and carbon monoxide. These three gases plus carbon dioxide and water are also present as frozen ices on the satellite's surface. *Voyager* revealed that this remarkable object has a diameter of only  $1681 \pm 4$  mi ( $2705 \pm 6$  km), making it considerably smaller than the Earth's Moon (2086 mi or 3476 km). The surface temperature of Triton is  $-391 \pm 7^\circ\text{F}$  ( $38 \pm 4$  K). The size of this satellite, as well as the temperature and composition of its surface, make Triton very similar to Pluto. See PLUTO.

The *Voyager* cameras showed that there are three well-defined, complete rings around Neptune, accompanied by a sheet of material that itself constitutes a broad ring. The outermost discrete ring, the Adams ring, contains three concentrated clumps of material.

The confinement of these narrow rings is commonly assumed to require the presence of small shepherding satellites. Galatea and Despina orbit, respectively, just inside the outer two narrow rings, but the corresponding outer shepherds have not been found. Similarly, the persistence of the three arcs within the outer ring remains an enigma. [T.C.O.]

**Neptunium** A chemical element, symbol Np, atomic number 93. Neptunium is a member of the actinide or *5f* series of elements. It was synthesized as the first transuranium element in 1940 by bombardment of uranium with neutrons to produce

neptunium-239. The lighter isotope  $^{237}\text{Np}$ , a long-lived alpha emitter with half-life  $2.14 \times 10^6$  years, is particularly important chemically. See PERIODIC TABLE.

Neptunium metal is ductile, low-melting ( $637^\circ\text{C}$  or  $1179^\circ\text{F}$ ), and in its alpha form is of high density,  $20.45 \text{ g/cm}^3$  ( $11.82 \text{ oz/in.}^3$ ). The chemistry of neptunium may be said to be intermediate between that of uranium and plutonium. Neptunium metal is reactive and forms many binary compounds, for example, with hydrogen, carbon, nitrogen, phosphorus, oxygen, sulfur, and the halogens. See ACTINIDE ELEMENTS; NUCLEAR CHEMISTRY; TRANSURANIUM ELEMENTS. [R.A.Pe.]

**Nerve** A group of nerve fibers coursing together as a bundle in the peripheral nervous system. The individual fibers are covered by Schwann cells, many of which contain large amounts of myelin, which makes the nerve appear shiny white. The nerve fibers with their Schwann cell sheaths are held together by connective tissue. In most nerves, some of the fibers are sensory (carrying information to the central nervous system) and some are motor (carrying information from the central nervous system to peripheral glands and muscles). When both sensory and motor fibers are in a nerve, it is called a mixed nerve.

In the central nervous system (brain and spinal cord) a group of nerve fibers running together is called a tract. Glial cells, not Schwann cells, form the sheaths of tract fibers, and there is no connective tissue holding the bundle together. Whereas most nerves are mixed, there is functional segregation in the central nervous system so that most tracts have only one functional type of fiber. See MOTOR SYSTEMS; NERVOUS SYSTEM (VERTEBRATE). [D.B.W.]

**Nervous system (invertebrate)** All multicellular organisms have a nervous system, which may be defined as assemblages of cells specialized by their shape and function to act as the major coordinating organ of the body. Nervous tissue underlies the ability to sense the environment, to move and react to stimuli, and to generate and control all behavior of the organism. Compared to vertebrate nervous systems, invertebrate systems are somewhat simpler and can be more easily analyzed. Invertebrate nerve cells tend to be much larger and fewer in number than those of vertebrates. They are also easily accessible and less complexly organized; and they are hardy and amenable to revealing experimental manipulations. However, the rules governing the structure, chemistry, organization, and function of nervous tissue have been strongly conserved phylogenetically. Therefore, although humans and the higher vertebrates have unique behavioral and intellectual capabilities, the underlying physical-chemical principles of nerve cell activity and the strategies for organizing higher nervous systems are already present in the lower forms. Thus neuroscientists have taken advantage of the simpler nervous systems of invertebrates to acquire further understanding of those processes by which all brains function. See NERVOUS SYSTEM (VERTEBRATE).

Invertebrate and vertebrate nerve cells differ more in quantity, or degree, than in qualitative features. Aside from differences in size and numbers, the most striking difference is that invertebrate neurons have a unipolar shape, whereas most vertebrate neurons are multipolar. An additional general contrast between invertebrate and vertebrate nervous systems is that invertebrates tend to have more neurons displaced to the periphery (outside the central nervous system) and to perform more integrative and processing functions in the periphery. Vertebrates perform almost all their integration within the central nervous system, using interneurons. Invertebrate nervous systems also seem to have a greater potential for regrowth, regeneration, or repair after damage than do vertebrate nerve cells. Many invertebrates continue to add new nerve cells to their ganglia with age; vertebrates, in general, do not. Only vertebrate neurons have myelin sheaths, a specialized wrapping of glial membrane around

axons, increasing their conduction speed. Invertebrates tend to enhance conduction velocity by using giant axons, particularly for certain escape responses. [J.E.Bla.]

**Nervous system (vertebrate)** A coordinating and integrating system which functions in the adaptation of an organism to its environment. An environmental stimulus causes a response in an organism when specialized structures, receptors, are excited. Excitations are conducted by nerves to effectors which act to adapt the organism to the changed conditions of the environment.

**Comparative morphology.** The brain of all vertebrates, including humans, consists of three basic divisions: prosencephalon, mesencephalon, and rhombencephalon (Fig. 1). The individual divisions or patterns of the brain do not function separately to bring about a final response; rather, each pattern acts on a common set of connections in the spinal cord.

Spinal patterns are the final common patterns used by all higher brain pathways to influence all organs of the body. These reflexes are divided into two basic patterns: the monosynaptic arc and the multisynaptic arc. The monosynaptic arc, or myotatic reflex, maintains tonus and posture in vertebrates and consists of two neurons, a sensory and a motor neuron.

The multisynaptic arc, or flexor reflex, is the pattern by which an animal withdraws a part of its body from a noxious stimulus. Both sensory neurons and internuncial neurons send information to brain centers. Coordinated limb movement is based on a connective pattern of neurons at the spinal level.

The structure of the spinal cord and its connections are basically similar among all vertebrates. The major evolutionary changes in the spinal cord have been the increased segregation of cells and fibers of a common function from cells and fibers of other functions and the increase in the length of fibers which connect brain centers with spinal centers. See POSTURAL EQUILIBRIUM.

The rhombencephalon of the brain is subdivided into a roof, or cerebellum, and a floor, or medulla oblongata. The medulla is similar to the spinal cord and is divided into a dorsal sensory region and a ventral motor region. It is an integrating and relay area between higher brain centers and the spinal cord. In addition to these nuclei and their connections, the medulla consists of both ascending and descending pathways to and from higher brain centers. The same basic connections occur throughout vertebrates.

In mammals, the cerebellum does not initiate movement; it only times the length of muscle contractions and orders the se-

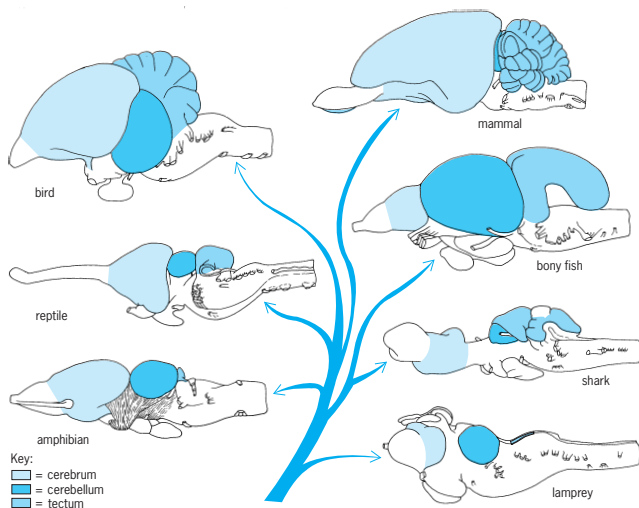

Fig. 1. Lateral views of several vertebrate brains showing evolutionary relationships.

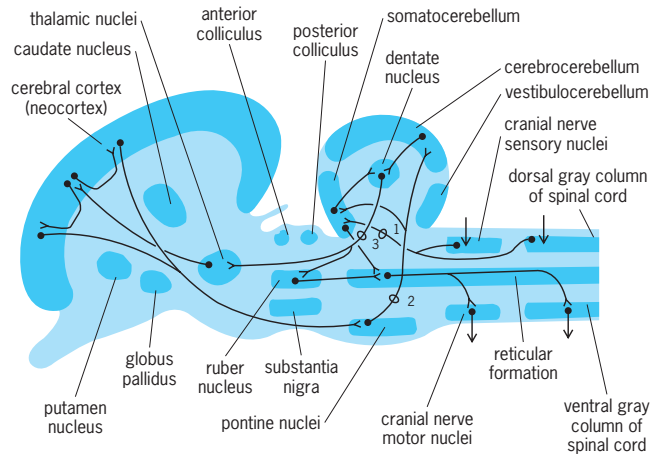

Fig. 2. Mammalian brain in sagittal section. Cerebellar patterns: tract 1, posterior cerebellar peduncle; 2, middle cerebellar peduncle; 3, anterior cerebellar peduncle.

quence in which muscles should contract to bring about a movement. The command to initiate a movement is received from the cerebral cortex (Fig. 2). Similarly, the cerebral cortex receives information regarding limb position and state of muscular contraction to ensure that its commands can be carried out by the cerebellum.

The mesencephalon is divided into a roof or optic tectum and a floor or tegmentum. The tegmentum contains the nuclei of the oculomotor and trochlear cranial nerves and a rostral continuation of the sensory nucleus of the trigeminal cranial nerve.

In the evolution of vertebrates, the prosencephalon develops as two major divisions, the diencephalon and the telencephalon. The diencephalon retains the tubular form and serves as a relay and integrating center for information passing to and from the telencephalon and lower centers. The telencephalon is divided into a pair of cerebral hemispheres and an unpaired telencephalon medium.

There are three divisions of the diencephalon in all vertebrates: an epithalamus which forms the roof of the neural tube, a thalamus which forms the walls of the neural tube, and a hypothalamus which forms the floor of the neural tube. The epithalamus and hypothalamus are primarily concerned with autonomic functions such as homeostasis. The thalamus is subdivided into dorsal and ventral regions. The dorsal region relays and integrates sensory information, and the ventral thalamus relays and integrates motor information. See HOMEOSTASIS; INSTINCTIVE BEHAVIOR.

The telencephalon is the most complex brain division in vertebrates. It is divided into a roof, or pallium, and a floor, or basal region. The pallium is divided into three primary divisions: a medial PI or hippocampal division, a dorsal PII or general pallial division, and a lateral PII division, often called the pyriform pallium.

The most striking change in the telencephalon of land vertebrates involves the PIIIa component. In mammals, it has proliferated with the PIIb component of the dorsal pallium to produce the mammalian neocortex. In all land vertebrates except amphibians, the PIIb and the PIIIa components, along with the corpus striatum (BI and BII), are the highest centers for the analysis of sensory information and motor coordination. The PI, PIIa, PIIb, BIII, and posterior parts of BI and BII form part of the limbic system which is concerned with behavioral regulation. [R.G.No.]

**Comparative histology.** The nervous system is composed of several basic cell types, including nerve cells called neurons, interstitial cells called neurolemma (cells of Schwann), satellite cells, oligodendroglia, and astroglia; and several connective-tissue cell types, including fibroblasts and microglia, blood vessels, and extracellular fluids.

Each neuron possesses three fundamental properties, involving specialized capacity to react to stimuli, to transmit the resulting excitation rapidly to other portions of the cell, and to influence other neurons, muscle, or glandular cells. Each neuron consists of a cell body (soma), one to several cytoplasmic processes called dendrites, and one process called an axon. Cell bodies vary from about 7 to more than 70 micrometers in diameter; each contains a nucleus and several cytoplasmic structures, including Nissl (chromophil) granules, mitochondria, and neurofibrils. The cell body is continuously synthesizing new cytoplasm, especially protein, which flows down the cell processes. The dendrites range from a fraction of a millimeter to a few millimeters in length. An axon may range from about a millimeter up to many feet in length. The site where two neurons come into contact with each other and where influences of one neuron are transmitted to the other neuron is called a synapse. Neurotransmitters are secreted across the presynaptic membrane into the synaptic cleft where they may excite (excitatory synapse) or inhibit (inhibitory synapse) the postsynaptic membrane. See BIOPOTENTIALS AND IONIC CURRENTS; SENSATION; SYNAPTIC TRANSMISSION.

There are three layers of connective tissue membranes, the meninges, covering the brain and spinal cord: the inner, pia mater; the middle layer, the arachnoid; and the outermost, the dura mater. Between the pia mater and the arachnoid is the subarachnoid space; this space and the ventricular cavities within the brain are filled with an extracellular fluid, the cerebrospinal fluid. See MENINGES. [C.No.]

**Comparative embryology.** The anlage of the nervous system is formed in the outer germ layer, the ectoderm, although some later contributions are also obtained from the middle germ layer, the mesoderm. In most vertebrates a neural plate is formed, which later folds into a neural groove, then closes to form a neural tube. The formation of neural tissue within the ectoderm is due to inductive influences from underlying chondromesodermal structures. See DEVELOPMENTAL BIOLOGY; EMBRYONIC INDUCTION; NEURAL CREST.

When the neural tube is developing, a segmentation of the central nervous system occurs by the formation of transverse bulges, neuromeres. At the time of neuromeric segmentation, the brain is subdivided into the so-called brain vesicles by local widenings of its lumen. In the rostral end more or less well-developed hemispheres are formed; in the middle of the brain anlage the mesencephalic bulge develops; and behind the latter the walls of the tube thicken into cerebellar folds. In this way the brain anlage is divided into five sections: the telencephalon, diencephalon, mesencephalon, metencephalon, and myelencephalon, and its cavity is divided into the rudiments of the adult ventricles.

In spite of the extraordinary variation in adult morphology of the vertebrate brain in different species, the early phases of development are essentially similar. The spinal cord remains as a comparatively slightly differentiated tube.

The cranial or cerebral nerves are the peripheral nerves of the head that are related to the brain. Twelve pairs of cranial nerves have been distinguished in human anatomy and these nerves have been numbered rostrally to caudally as follows:

- I. Olfactory nerve, *fila olfactoria*
- II. Optic nerve, *fasciculus opticus*
- III. Oculomotor nerve
- IV. Trochlear nerve
- V. Trigeminal nerve, in most vertebrates divided into three branches: ophthalmic, maxillary, and mandibular
- VI. Abducens nerve
- VII. Facial nerve
- VIII. Statoacoustic nerve
- IX. Glossopharyngeal nerve
- X. Vagus nerve

- XI. Accessory nerve
- XII. Hypoglossal nerve

The spinal ganglia are formed from the neural crest which grows out like a continuous sheet from the dorsal margin of the neural tube and is secondarily split up into cell groups, the ganglia, by a segmentating influence from the somites. Fibers grow out from the ganglionic cells and form the sensory fibers of the spinal nerves. Motor nerve fibers emerge from cells situated in the ventral horns of the spinal cord. The ventral motor fibers and the dorsal sensory fibers fuse to form a common stem, which is again laterally divided into branches, innervating the corresponding segment of the body.

The ganglia of the sympathetic nervous system develop ventrolateral to the spinal cord as neural crest derivatives. At first a continual column of sympathetic nerve cells is formed; it later subdivides into segmental ganglia.

The parasympathetic system is made up of preganglionic fibers emanating as general visceromotor fibers from the brain and from the sacral cord segments. Cells migrate to form the peripheral ganglia along them. See AUTONOMIC NERVOUS SYSTEM.

[B.Kal.]

**Nervous system disorders** A satisfactory classification of diseases of the nervous system should include not only the type of reaction (congenital malformation, infection, trauma, neoplasm, vascular diseases, and degenerative, metabolic, toxic, or deficiency states) but also the site of involvement (meninges, peripheral nerves or gray or white matter of the spinal cord, brainstem, cerebellum, and cerebrum). To these may be added various other correlates, such as age and sex. The nerve cell may be damaged primarily, as in certain infections, but much more commonly the nerve cell is damaged secondarily as the result of metabolic or vascular diseases affecting other important organs, such as the heart, lungs, liver, and kidneys.

**Malformation.** The central nervous system develops as a hollow neural tube by the fusion of the crests of the neural groove, beginning in the cervical area and progressing rostrally and caudally, the last points to close being termed the anterior and posterior neuropores. If the anterior neuropore fails to close (about 24 days of fetal age), anencephaly develops. The poorly organized brain is exposed to amniotic fluid and becomes necrotic and hemorrhagic, with death usually within hours after birth. See CONGENITAL ANOMALIES.

If the posterior neuropore fails to close (about 26 days of fetal age), the lumbosacral neural groove is exposed to amniotic fluid. The nervous tissue becomes partially necrotic and incorporated in a scar. Such a meningocele is readily infected unless buried surgically within a few hours after birth. In addition, in about 95% of such infants hydrocephalus occurs, which usually can be adequately treated by shunting the ventricular fluid into the venous system or peritoneal cavity.

Other developmental disorders of the nervous system may appear as hypoplasia or hyperplasia (decrease or increase in growth of cells, respectively) or as a destruction of otherwise normally developing tissues. Rapidly growing tissues such as the embryonic nervous system are generally rather easily damaged by many toxic agents. The time of onset and the extent of repair rather than the nature of the agent determine the resulting pattern of abnormal development. See BEHAVIORAL TOXICOLOGY.

**Infection.** Infections of the nervous system may occur through a defect in the normal protective coverings caused by certain congenital malformations, as mentioned above, but also through other defects as the result of trauma, especially penetrating wounds or fractures opening into the paranasal sinuses or mastoid air cells. Subsequent infection of the nervous system may be the major complication of such "open head" injuries.

Infections may also spread directly from adjacent structures, as from mastoiditis, sinusitis, osteomyelitis, or subcutaneous abscesses. Such infections usually spread along venous channels



producing epidural abscess, subdural empyema, leptomeningitis, and brain abscess. All of these infections are characteristically caused by pyogenic (pus-forming) bacteria. Other pyogenic bacteria may metastasize by way of the bloodstream from more distant infections, such as bacterial endocarditis, pneumonia, and enteritis.

Infections of the nervous system must be treated promptly as medical emergencies. The diagnosis is easily established by spinal puncture; the microorganisms can be visualized with special stains.

Many other microorganisms can infect the nervous system: *Mycobacterium tuberculosis* (the organism causing tuberculosis), *Treponema pallidum* (the organism causing syphilis), several fungi and rickettsiae, and many viruses.

Viral infections vary widely geographically, generally related to the necessity for intermediate hosts and vectors (animal reservoirs) by which the virus is spread. Poliomyelitis, now largely prevented by effective vaccination of most children, is primarily an intestinal infection which occasionally spreads to the nervous system, infecting and destroying motor nerve cells, thereby producing weakness of certain muscles. Herpes zoster has a similar preference for infecting sensory nerve cells and producing an acute skin eruption in the distribution of the affected sensory cells. Herpes simplex is closely related to herpes zoster, resides in the trigeminal or sacral sensory nerve cells, and intermittently produces eruptions in the distribution of these cells: "fever blisters" in and around the mouth in type I herpes, or similar blisters in the genital area in type II herpes. The latter is increasingly being recognized as a venereal disease. Rabies virus also affects certain nerve cells in the temporal lobe of the brain, as well as in the cerebellum, and is transmitted through the saliva of animals that bite other animals or humans; rabies is the single exception to the rule that immunization must precede infection to be effective, and the immunization must begin promptly after the bite. See ANIMAL VIRUS; HERPES; POLIOMYELITIS.

**Inflammation.** Certain viruses frequently produce a meningitis in humans from whose cerebrospinal fluid the virus is relatively easily grown. Other viruses, such as measles and varicella, occasionally produce meningitis or encephalomyelitis, but the cerebrospinal fluid does not contain the virus. See MENINGITIS.

Allergy to one's own tissue elements is an interesting possibility that has evoked many experimental approaches. Two human diseases, multiple sclerosis, a demyelinating disease affecting the central nervous system, and the Landry-Guillain-Barré syndrome, a demyelinating disease affecting the peripheral nervous system, are considered likely candidates to be related to experimental allergic encephalomyelitis and experimental allergic neuritis, respectively. See AUTOIMMUNITY; MULTIPLE SCLEROSIS.

**Vascular disease.** Vascular diseases of the nervous system are commonly called strokes, a term which emphasizes the suddenness of onset of neurological disability. Such a cataclysmic onset is characteristic of vascular diseases, since the nerve cell can function without nutrients for only a matter of seconds and will die if not renourished within several minutes. See VASCULAR DISORDERS.

Two main types of hemorrhage occur: hemorrhage into the subarachnoid space from rupture of an aneurysm (a focal weakening and dilatation) of a large artery; and hemorrhage into the brain from rupture of an aneurysm of a small artery or arteriole. Both types of hemorrhage occur more commonly in hypertensive adults. See ARTERIOSCLEROSIS; HEMORRHAGE; HYPERTENSION.

Nerve cells require oxygen and glucose for functional activity, and can withstand only brief periods of hypoxia or hypoglycemia. Even a few seconds of hypoxia can block the nerve cell's function, and more than 10 min is almost certainly fatal to most nerve cells. Transient ischemic attacks may result, with temporary impairment of blood flow to a part of the brain and consequent focal neurological dysfunction. These attacks may also be successfully treated with drugs or surgery and the disastrous major stroke prevented. Myocardial infarction, postural

hypotension, and stenosis or narrowing of the carotid or vertebral arteries greater than 60% are common causes of cerebral ischemia. If the ischemia is not rapidly reversed, the neurons undergo selective necrosis; if the ischemia is more severe or prolonged, the glia and blood vessels in the gray matter also undergo necrosis; and if the ischemia is still more severe or prolonged, all the gray and white matter in the ischemic zone becomes necrotic, a condition known as cerebral infarction or encephalomalacia. One of the common ways the brain reacts to small or large hemorrhages or ischemic episodes is by swelling. Such swelling itself may be fatal within a few days to a week or so by a process known as transtentorial herniation, compressing the brainstem, where there are important neural circuits for vital functions, such as breathing and maintenance of blood pressure.

**Degenerative and other diseases.** Degenerative, metabolic, toxic, and deficiency states include the largest numbers of both common and rare diseases of the nervous system. Since neurons in the brain may be destroyed after birth and cannot be replaced, mental deterioration, deafness and blindness, incoordination and adventitious movements, and other neurologic signs that are so typical of these disorders are generally not reversible even if the basic metabolic defect can be corrected. Advances have been made in the early diagnosis and treatment of several diseases usually manifest in infancy with mental retardation. Three examples are phenylpyruvic oligophrenia (phenylketonuria or PKU), which is treatable with a phenylalanine-deficient diet; galactosemia, requiring a galactose-free diet also as early as possible to avoid cataracts and mental retardation; and cretinism, which requires treatment with thyroid. See HUNTINGTON'S DISEASE; METABOLIC DISORDERS; PARKINSON'S DISEASE; PHENYLKETONURIA.

**Neoplasm.** Neoplasms of the nervous system can be divided into primary and metastatic, the primary into gliomas and others, and the metastatic into bronchogenic and others. These four groups each account for about 25% of all intracranial neoplasms. See TUMOR. [E.C.A.; C.M.S.]

**Neural crest** A strip of ectodermal material in the early vertebrate embryo inserted between the prospective neural plate and epidermis. After closure of the neural tube the crest cells migrate into the body and give rise to parts of the neural system: the main part of the visceral cranium, the mesenchyme, the chromaffin cells, and pigment cells. The true nature of the neural crest eluded recognition for many years because this primary organ has a temporary existence; its cells and derivatives are difficult to analyze when dispersed throughout the body. The fact that mesenchyme arises from this ectodermal organ was directly contrary to the doctrine of the specificity of the germ layers.

Neural crest no doubt exists, with similar qualities, in all vertebrate groups, including the cyclostomes. It has been most thoroughly studied in amphibians and the chick. See GERM LAYERS. [S.H.]

**Neural network** An information-processing device that consists of a large number of simple nonlinear processing modules, connected by elements that have information storage and programming functions. The field of neural networks is an emerging technology in the area of machine information processing and decision making. The main thrusts are toward highly innovative machine and algorithmic architectures, radically different from those that have been employed in conventional digital computers. The information-processing elements and components of neural networks, inspired by neuroscientific studies of the structure and function of the human brain, are conceptually simple. Three broad categories of neural-network architectures have been formulated which exhibit highly complex information-processing capabilities. Several generic models have been advanced which offer distinct advantages over traditional digital-computer implementation. Neural networks have created an unusual amount of interest in the engineering and industrial

communities by opening up new research directions and commercial and military applications. See NEUROBIOLOGY.

Automated information processing is achieved by means of modules that in general involve four functions: input/output (getting in and out of the machine), processing (executing prescribed specific information-handling tasks), memory (storing information), and connections between different modules providing for information flow and control. Neural networks contain a very large number of simple processing modules. This contrasts with traditional digital computers, which contain a small number of complex processing modules that are rather sophisticated in the sense that they are capable of executing very large sets of prescribed arithmetic and logical tasks (instructions). In conventional digital computers, the four functions listed above are carried out by separate dedicated machine units. In neural networks information storage is achieved by components which at the same time effect connections between distinct machine units. These key distinctions between the neural-network and the digital computer architectures are of a fundamental nature and have major implications in machine design and in machine utilization.

The information-processing properties of neural networks depend mainly on two factors: the network topology (the scheme used to connect elements or nodes together), and the algorithm (the rules) employed to specify the values of the weights connecting the nodes. While the ultimate configuration and parameter values are problem-specific, it is possible to classify neural networks, on the basis of how information is stored or retrieved, in four broad categories: neural networks behaving as learning machines with a teacher; neural networks behaving as learning machines without a teacher; neural networks behaving as associative memories; and neural networks that contain analog as well as digital devices and result in hybrid-machine implementations that integrate complex continuous dynamic processing and logical functions. Within these four categories, several generic models have found important applications, and still others are under intensive investigation.

Neural-network research is developing a new conceptual framework for representing and utilizing information, which will result in a significant advance in information epistemology. Communication technology is based on the notions of coding and channel capacity (bits per second), which provide the conceptual framework for information representation appropriate to machine-based communication. Neural-network systems (biological or artificial) do not store information or process it in the way that conventional digital computers do. Specifically, the basic unit of neural-network operation is not based on the notion of the instruction but on the connection. The performance of a neural network depends directly on the number of connections per second that it effects, and thus its performance is better understood in terms of its connections-per-second (CPS) capability. See INFORMATION THEORY. [N.DeC.]

**Neurobiology** Study of the development and function of the nervous system, with emphasis on how nerve cells generate and control behavior. The major goal of neurobiology is to explain at the molecular level how nerve cells differentiate and develop their specific connections and how nerve networks store and recall information. Ancillary studies on disease processes and drug effects in the nervous system also provide useful approaches for understanding the normal state by comparison with perturbed or abnormal systems. The functions of the nervous system may be studied at several levels: molecular, subcellular (organelle), cellular, simple multicellular interacting systems, complex systems, and higher functions (whole animal behavior). See BIOPOTENTIALS AND IONIC CURRENTS; MEMORY; MOTOR SYSTEMS; NERVOUS SYSTEM (INVERTEBRATE); NERVOUS SYSTEM (VERTEBRATE); NERVOUS SYSTEM DISORDERS; NEURON; SENSE ORGAN; SYNAPTIC TRANSMISSION. [J.R.B.; M.D.Br.]

**Neurohypophysis hormone** Either of two peptide hormones secreted by the neurohypophysis, or posterior lobe of the pituitary gland, in humans. These hormones, oxytocin and vasopressin, each comprise nine amino acid residues. Vasopressin is responsible for arterial vasoconstriction (pressor action) and inhibition of water excretion through the kidneys (antidiuretic action), and has a weak effect on contraction of smooth muscle including that of the uterus. The principal action of oxytocin is stimulation of smooth muscle contraction, specifically that of the uterine muscle, and milk ejection from the mammary gland.

Oxytocin and vasopressin are synthesized in neurons in the hypothalamus and subsequently packaged into neurosecretory granules, which migrate down the axon of the neuron and are stored in the posterior lobe of the pituitary gland, from where they are secreted into the systemic circulation. These hormones are also secreted directly from the hypothalamus into the third ventricle and into the hypothalamo-hypophysial portal circulation of the anterior pituitary gland. See NEUROSECRETION.

Major stimuli controlling the release of vasopressin include changes in osmolality of the blood, alterations in blood volume, and psychogenic stimuli such as pain, fear, and apprehension. Stimuli evoking release of oxytocin include nipple stimulation or suckling, and stretching of the cervix and vagina (Ferguson reflex).

Oxytocin probably plays an important role in the onset of labor and delivery (parturition) in primates. During lactation, significant amounts of oxytocin are released by the mother during suckling. When there is total destruction of the pituitary or the neurohypophysis, diabetes insipidus may occur. See DIABETES; HORMONE; PITUITARY GLAND. [M.Y.D.]

**Neuroimmunology** The study of basic interactions among the nervous, endocrine, and immune systems during development, homeostasis, and host defense responses to injury. In its clinical aspects, neuroimmunology focuses on diseases of the nervous system, such as myasthenia gravis and multiple sclerosis, which are caused by pathogenic autoimmune processes, and on nervous system manifestations of immunological diseases, such as primary and acquired immunodeficiencies. See AUTOIMMUNITY; IMMUNOLOGICAL DEFICIENCY.

Neuroimmune interactions are dependent on the expression of at least two structural components: immunocytes must display receptors for nervous system-derived mediators, and the mediators must be able to reach immune cells in concentrations sufficient to alter migration, proliferation, phenotype, or secretory or effector functions. More than 20 neuropeptide receptors have been identified on immunocompetent cells.

It has been found that stimuli derived from the nervous system could affect the course of human disease. The onset or progression of tumor growth, infections, or chronic inflammatory diseases, for example, could be associated with traumatic life events or other psychosocial variables such as personality types and coping mechanisms. More direct indications of the influence of psychosocial factors on immune function have been provided by findings that cellular immunity can be impaired in individuals who are exposed to unusually stressful situations, such as the loss of a close relative. See CELLULAR IMMUNOLOGY.

During responses to infection, trauma, or malignancies, cells of the immune system produce some cytokines in sufficiently high quantities to reach organs that are distant from the site of production. These cytokines are known to act on the nervous system. Fever is the classic example of changes in nervous system function induced by products of the immune system; interleukin 1, which is produced by monocytes after stimulation by certain bacterial products, binds to receptors in the hypothalamus and evokes changes via the induction of prostaglandins. Interleukin 1 also induces slow-wave sleep. Both fever and sleep may be regarded as protective behavioral changes. See ENDOCRINE

SYSTEM (VERTEBRATE); IMMUNOLOGY; NERVOUS SYSTEM (VERTEBRATE); NEUROSECRETION. [M.L.; W.Ku.; P.V.]

**Neuron** A nerve cell: the functional unit of the nervous system. Structurally, the neuron is made up of a cell body or soma and one or more long processes: a single axon and dendrites. The cell body contains the nucleus and usual cytoplasmic organelles with an exceptionally large amount of rough endoplasmic reticulum, called Nissl substance in the neuron. The longest cell process is the axon, which is capable of transmitting propagated nerve impulses. There may be none, one, or many dendrites composing part of a neuron. If there is no dendrite, it is a unipolar neuron; with one dendrite, it is a bipolar neuron; if there is more than one dendrite, it is a multipolar neuron. In most neurons only the axon propagates nerve impulses; the dendrites and somas are also irritable but do not propagate nerve impulses. *See* NERVOUS SYSTEM (VERTEBRATE). [D.B.W.]

**Neuroptera** An order of delicate insects having endopterygote development, chewing mouthparts, and soft bodies. Included are the insects commonly termed lacewings, ant lions, dobsonflies, and snake flies. The order consists of about 25 families and is widely distributed.

The adults have long, slender antennae and usually four similar wings, although the front pair is generally slightly larger than the hind pair. The adults of most species are strongly attracted to lights. The larvae are aggressive predators. The larvae of lacewings are especially destructive to aphids, scale insects, and mites. *See* ENDOPTERYGOTA; INSECTA. [F.M.C.]

**Neurosecretion** The synthesis and release of hormones by neurons. Such neurons are called neurosecretory cells, and their products are often called neurohormones. Like conventional (that is, nonglandular or ordinary) neurons, neurosecretory cells are able to receive signals from other neurons. But unlike ordinary neurons that have cell-to-cell communication over short distances at synapses, neurosecretory cells release their product into an extracellular space that may be at some distance from the target cells. In an organism with a circulatory system, the neurohormones are typically sent by the vascular route to their target, whereas in lower invertebrates that lack an organized circulatory system the neurohormones apparently simply diffuse from the release site to the target. It is now clear that the nervous and endocrine systems interact in many ways, as in the suckling reflex of mammals (where the hormone oxytocin, a neurohormone, elicits milk ejection and is reflexly released in response to nerve impulses generated by stimulation of the nipples), and neurosecretory cells form a major link between them. *See* ENDOCRINE MECHANISMS; ENDOCRINE SYSTEM (INVERTEBRATE); ENDOCRINE SYSTEM (VERTEBRATE).

It has been shown that peptides or low-molecular-weight proteins as well as amines, such as octopamine and dopamine, are released from neurosecretory cells into the circulatory systems of various animals, where they function as neurohormones. In classical neurosecretory cells, the secreted material is synthesized in the cell body by the rough-surfaced endoplasmic reticulum and subsequently packaged in the form of membrane-bounded granules by the Golgi apparatus, and is then typically transported along the axon to the axonal terminals, where it is stored until released. The release of neurohormones from axonal terminals into an extracellular space is triggered when the electrical activity (action potential) that is propagated by the axon enters the neurosecretory terminals. Calcium ions are essential for neurohormone release. *See* BIOPOTENTIALS AND IONIC CURRENTS; ENDOPLASMIC RETICULUM; GOLGI APPARATUS.

Neurohormones have a wide variety of functions. The role of the vertebrate hypothalamo-neurohypophysial system has been especially well elucidated. The pars nervosa is the site of release of vasopressin (also called the antidiuretic hormone) and oxytocin, and the median eminence is the release site for several hy-

pothalamic neurohormones that regulate the adenohypophysis, the nonneural portion of the pituitary gland. *See* ADENOHYPOPHYSIS HORMONE; NERVOUS SYSTEM (VERTEBRATE); NEUROHYPOPHYSIS HORMONE; PITUITARY GLAND. [M.F.]

**Neurotic disorders** Mental disorders characterized by symptoms such as phobias, obsessive thoughts, and compulsive actions, or by losses of specific bodily functions. A neurotic disorder, termed neurosis in the psychoanalytic literature, is distinguished from more severe mental disturbances by a continued ability to recognize reality, and from more diffuse character disorders by the relatively specific nature of the symptoms. Neurosis is quite common and treatable through a range of psychological and biological methods.

The three classic neuroses were identified by S. Freud. The first is phobia (anxiety hysteria in Freud's terminology), which is characterized by unreasonable fear of common objects or situations. The second classic neurosis is conversion (conversion hysteria), in which there is loss of function in part of the body that generally does not correspond to an anatomic or physiologic disorder. The third of the original neuroses, obsessive-compulsive neurosis, is characterized by intrusive, repetitive thoughts of a disturbing nature, and a compelling need to perform ritualized, repetitive, and apparently senseless acts. *See* OBSESSIVE-COMPULSIVE DISORDER; PSYCHOSOMATIC DISORDERS.

Historically, neurosis was described and defined by Freud, and the dominant theories of its origin and treatment were psychoanalytic. There have been several generations of psychoanalytic theories, but one generally adopted by classical psychoanalysts holds that each neurotic symptom represents a conflict between an unacceptable impulse and the prohibition against that impulse. In the analytic theory, neurotic symptoms are formed when a frustration in current life prevents direct satisfaction of a wish. The recommended therapy is classical psychoanalysis, or psychoanalytic psychotherapy. This is aimed at making conscious to the patient the nature of the desire that is frustrated, as well as the prohibitions that prevent its direct satisfaction. *See* NEUROBIOLOGY; PSYCHOANALYSIS; PSYCHOTHERAPY. [M.M.]

**Neurulation** The process by which the vertebrate neural tube is formed. The primordium of the central nervous system is the neural plate, which arises at the close of gastrulation by inductive action of the chorda-mesoderm on the overlying ectoderm. The axial mesodermal substratum causes the neural ectoderm to thicken into a distinct plate across the dorsal midline and influences both its size and shape. Its shieldlike appearance, broader anteriorly and narrower posteriorly, presages the areas of brain and spinal cord, respectively. The lateral edges of the neural plate then rise as neural folds which meet first at the level of the future midbrain, above the dorsal midline, then fuse anteriorly and posteriorly to form the neural tube. The body ectoderm becomes confluent above the closing neural tube and separates from it. Upon closure, the cells (known as neural crest cells) which occupied the crest of the neural folds leave the roof of the tube and migrate through the mesenchyme to all parts of the embryo, forming diverse structures. The neural tube thus formed gives rise to the brain and about half of the spinal cord. The remainder of the neural tube is added by the tail bud, which proliferates a solid nerve cord that secondarily hollows into a tube. *See* NERVOUS SYSTEM (VERTEBRATE); NEURAL CREST. [H.L.H.]

**Neutral currents** Exchange currents which carry no electric charge and mediate certain types of electroweak interactions. The discovery of the neutral-current weak interactions and the agreement of their experimentally measured properties with the theoretical predictions were of great significance in establishing the validity of the Weinberg-Salam model of the electroweak forces.

The electroweak forces come in three subclasses: the electromagnetic interactions, the charged-current weak interactions,

and the neutral-current weak interactions. The electromagnetic interaction is mediated by an exchanged photon  $\gamma$ . Since the photon carries no electric charge, there is no change in charge between the incoming and the outgoing particles. The charged-current weak interaction is mediated by the exchange of a charged intermediate boson, the  $W^+$ , and thus, for example, an incoming neutral lepton such as the  $\nu_\mu$  is changed into a charged lepton, the  $\mu^-$ . In the neutral-current weak interactions, the exchanged intermediate boson, the  $Z^0$ , carries no electric charge (hence the name neutral-current interaction), and thus for example, an incident neutral lepton, such as the  $\nu_\mu$ , remains an outgoing neutral  $\nu_\mu$ . See ELECTRON; INTERMEDIATE VECTOR BOSON; LEPTON; NEUTRINO; PHOTON.

The neutral-current interactions were experimentally discovered in 1973, and have since been extensively studied, in neutrino scattering processes. Very important information about the properties of the neutral currents have been obtained by studying the interference effects between the electromagnetic and the neutral-current weak interactions in the scattering of polarized electrons on deuterium. Parity violating effects in atomic physics processes due to the neutral weak currents have been observed, and predicted parity-violating nuclear effects have been searched for. See ELEMENTARY PARTICLE; FUNDAMENTAL INTERACTIONS; PARITY (QUANTUM MECHANICS); SYMMETRY LAWS (PHYSICS); WEAK NUCLEAR INTERACTIONS. [C.B.]

**Neutralization reaction (immunology)** A procedure in which the chemical or biological activity of a reagent or a living organism is inhibited, usually by a specific neutralizing antibody. As an example, the lethal or the dermonecrotic actions of diphtheria toxin on animals may be completely neutralized by an equivalent amount of diphtheria antitoxin.

Antibodies to bacterial, snake-venom, and other enzyme preparations regularly precipitate them from solution so that the supernates are devoid of enzyme activity; however, the neutralization of activity in the precipitate may range from complete to negligible. See IMMUNOLOGY; NEUTRALIZING ANTIBODY; SEROLOGY. [H.P.T.]

**Neutralizing antibody** An antibody that reduces or abolishes some biological activity of a soluble antigen or of a living microorganism. Thus, diphtheria antitoxin is a neutralizing antibody that, in adequate amounts, abolishes the pathological effects of diphtheria toxin in animals. This is only one characteristic; the other general properties of the antibody are those of the immunoglobulin family (IgG, IgA, or IgM) to which it belongs. See ANTIBODY; IMMUNOGLOBULIN. [H.P.T.]

**Neutrino** An elusive elementary particle that interacts with matter principally through the weak nuclear force. Neutrinos are electrically neutral spin- $1/2$  fermions with left-handed helicity. Many weak interaction processes (interactions that involve the weak force), such as radioactive nuclear beta decay and thermonuclear fusion, involve neutrinos. Present experimental knowledge is consistent with neutrinos being point particles that have no internal constituents. Neutrinos are classified as neutral leptons, where leptons are defined as elementary particles that interact with the electroweak (electromagnetic and weak nuclear) and gravitational forces but not with the strong nuclear force. See ELEMENTARY PARTICLE; FUNDAMENTAL INTERACTIONS; HELICITY (QUANTUM MECHANICS); LEPTON; SPIN (QUANTUM MECHANICS); WEAK NUCLEAR INTERACTIONS.

Because the role of gravitational forces is negligible in nuclear and particle interactions and because neutrinos have zero electric charge, neutrinos have the unique property that they interact almost completely via the weak nuclear force. Consequently, neutrinos can be used as sensitive probes of the weak force. As such, neutrino beams at particle accelerators have been employed to study charge-changing (charged current) and charge-preserving (neutral current) weak interactions. However, the extreme weak-

ness (compared to the electromagnetic and strong forces) and short range (of the order of  $10^{-18}$  m) of the weak interaction have made determination of many neutrino properties extremely difficult.

Currently, three distinct flavors (or types) of neutrinos are known to exist: the electron neutrino ( $\nu_e$ ), the muon neutrino ( $\nu_\mu$ ), and the tau neutrino ( $\nu_\tau$ ). Each neutrino flavor is associated with a corresponding charged lepton, the electron ( $e$ ), muon ( $\mu$ ), and tau ( $\tau$ ) particle. The electron, muon, and tau neutrinos (or their antiparticles) have been observed in experiments. Based on present measurements, the lepton flavor families, which comprise the charged and neutral leptons and their antiparticles ( $e^-$ ,  $\nu_e$ ,  $e^+$ ,  $\bar{\nu}_e$ ;  $\mu^-$ ,  $\nu_\mu$ ,  $\mu^+$ ,  $\bar{\nu}_\mu$ ;  $\tau^-$ ,  $\nu_\tau$ ,  $\tau^+$ ,  $\bar{\nu}_\tau$ ), obey laws of conservation of lepton number. These empirical laws state that the number of leptons minus antileptons does not change, both within a flavor family and overall. See ELECTRON; SYMMETRY LAWS (PHYSICS).

The existence of neutrino oscillations (a phenomenon whereby neutrinos change their flavors during the flight from a neutrino source to a detector), seen clearly in observations of atmospheric neutrinos, shows that neutrinos have tiny finite masses which are many orders of magnitude smaller than the masses of their charged lepton counterparts, and also shows that the physical neutrinos do not have pure flavors (quantum-mechanical states) but contain mixtures of two or more neutrino states. This mixing indicates that the empirical laws of lepton number conservation are not exact and that they are violated in some physical processes. It is not known whether neutrinos have magnetic or electric dipole moments. [Y.S.]

**Neutrino astronomy** The detection and study of neutrinos to learn about astronomical objects and the universe. These neutral, weakly interacting particles come almost without any disruption straight from their sources, traveling at very close to the speed of light. A low-energy neutrino in flight would not notice a barrier of lead 50 light-years thick. Neutrino light would provide a wondrous new view of the universe.

**Neutrinos in the universe.** Neutrinos were made in huge numbers at the time of the big bang. Like the cosmic background radiation, they now possess little kinetic energy as a result of the expansion of the universe. The problem with observing these relic neutrinos is that probability of a neutrino interacting within a detector decreases with the square of the neutrino's energy, for low energies. Nobody has been able to detect these lowest-energy neutrinos, and prospects are not good for doing so. See BIG BANG THEORY; COSMIC BACKGROUND RADIATION.

**Stellar neutrinos.** Neutrinos also originate in the nuclear fusion in stars. The Sun close by produces a huge flux of neutrinos, which have been detected in five experiments. However, observations of stellar neutrinos are limited to the Sun. Just as the sky is dark at night despite all the stars, the Sun far outshines all the rest of the cosmos in numbers of detectable neutrinos. See SOLAR NEUTRINOS.

**Supernovae.** On February 23, 1987, two detectors in deep mines in the United States (the IMB experiment) and Japan (the Kamiokande experiment) recorded a total of 19 neutrino interactions over a span of 13 seconds. Two and a half hours later, astronomers in the Southern Hemisphere saw the first supernova to be visible with the unaided eye since 1604. Many deductions followed about the nature of neutrinos, such as limits on mass, charge, gravitational attraction, and magnetic moment.

Supernovae of the gravitational-collapse type occur when elderly massive stars run out of nuclear fusion energy and can no longer resist the force of gravity. The neutrinos carry off most of the in-fall energy. Much can be learned from the final stages of stellar evolution, not only about the process of stellar collapse to a neutron star or black hole (the latter if the progenitor is very massive) but also about properties of neutrinos. Four underground detectors have significant capability for supernova detection from the Milky Way Galaxy. From historical records and from observations of distant spiral galaxies, the rate of

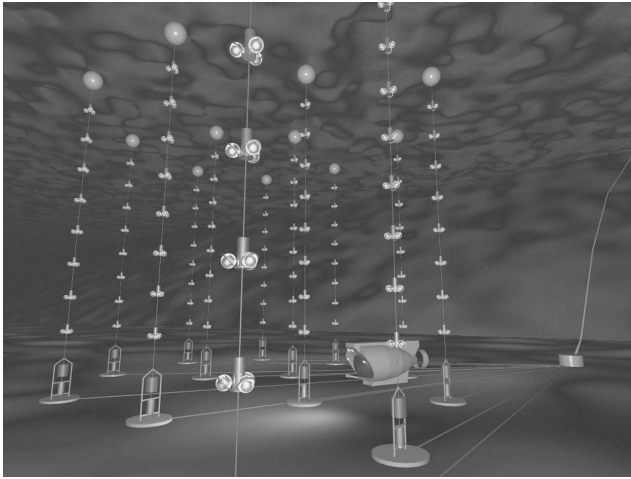

**View of the ANTARES Project from the ocean bottom. The optical detectors consist of modules of a cluster of photomultipliers and electronics, spaced along vertical buoy strings. Spherical floats at the top of each detector string keep the string close to vertical; anchors and releases are at the bottom. Fiber-optic cables go from each string to a junction box, which is serviced by the submarine at the far side of the array. A cable descends the slope from shore in the background. Scales are exaggerated. (ANTARES Collaboration)**

supernovae in the Milky Way Galaxy is expected to be between one and five per century. Thus experimentalists may have to wait a long time before the next observation, and there is no way of predicting when it will occur. *See* SUPERNOVA.

**High-energy cosmic neutrinos.** Higher-energy neutrinos must be made in many of the most luminous and energetic objects in the universe, such as active galactic nuclei and gamma-ray bursters. Two things make prospects brighter in the near future for higher-energy neutrino astronomy than for lower energies: (1) the interaction probability for neutrinos goes up with energy, and (2) the consequences of neutrino interaction with a target (Earth or detector) become more detectable as the energy release is greater. The favored method is to detect muons produced by neutrinos. These charged particles produce Cerenkov radiation, a short flash of light detectable at tens of meters distance by photomultipliers in clear water or ice. *See* CERENKOV RADIATION; PHOTOMULTIPLIER.

**High-energy neutrino telescopes.** Neutrino detectors must be placed deep underground or underwater to escape the backgrounds caused by the rain of cosmic rays upon the atmosphere. The lead project, DUMAND (Deep Underwater Muon and Neutrino Detector), was canceled in 1995, but made great headway in pioneering techniques, studying backgrounds, exploring detector designs, and stimulating interest in astrophysical neutrinos.

Two projects similar to DUMAND are under way in the Mediterranean, the more developed NESTOR (Neutrino Experimental Submarine Telescope with Oceanographic Research) Project, and the ANTARES (Astronomy with a Neutrino Telescope and Abyss Environmental Research) Project (see illustration). These projects employ basically the same method of bottom-anchored cables, with photomultipliers protected in spherical glass pressure housings, as developed for DUMAND. A different type of neutrino telescope, the AMANDA (Antarctic Muon and Neutrino Detector Array) Project, is under construction in ice at the South Pole. [J.G.Le.]

**Neutron** An elementary particle having approximately the same mass as the proton, but lacking a net electric charge. It is indispensable in the structure of the elements, and in the free state it is an important reactant in nuclear research and the prop-

agating agent of fission chain reactions. Neutrons, in the form of highly condensed matter, constitute the substance of neutron stars. *See* NEUTRON STAR.

Neutrons and protons are the constituents of atomic nuclei. The number of protons in the nucleus determines the chemical nature of an atom, but without neutrons it would be impossible for two or more protons to exist stably together within nuclear dimensions, which are of the order of  $10^{-13}$  cm. The protons, being positively charged, repel one another by virtue of their electrostatic interactions. The presence of neutrons weakens the electrostatic repulsion, without weakening the nuclear forces of cohesion. In light nuclei the resulting balanced, stable configurations contain protons and neutrons in almost equal numbers, but in heavier elements the neutrons outnumber the protons; in  $^{238}\text{U}$ , for example, 146 neutrons are joined with 92 protons. Only one nucleus,  $^1\text{H}$ , contains no neutrons. For a given number of protons, neutrons in several different numbers within a restricted range often yield nuclear stability—and hence the isotopes of an element. *See* ISOTOPE; NUCLEAR STRUCTURE; PROTON.

Free neutrons have to be generated from nuclei, and since they are bound therein by cohesive forces, an amount of energy equal to the binding energy must be expended to get them out. Nuclear machines, such as cyclotrons and electrostatic generators, induce many nuclear reactions when their ion beams strike target material. Some of these reactions release neutrons, and these machines are sources of high neutron flux. Neutrons are released in the act of fission, and nuclear reactors are unexcelled as intense neutron sources. *See* NUCLEAR BINDING ENERGY; NUCLEAR FISSION.

Neutrons occur in cosmic rays, being liberated from atomic nuclei in the atmosphere by collisions of the high-energy primary or secondary charged particles. They do not themselves come from outer space. *See* DELAYED NEUTRON; COSMIC RAYS.

Having no electric charge, neutrons interact so slightly with atomic electrons in matter that energy loss by ionization and atomic excitation is essentially absent. Consequently they are vastly more penetrating than charged particles of the same energy. The main energy-loss mechanism occurs when they strike nuclei. The most efficient slowing-down occurs when the bodies that are struck in an elastic collision have the same mass as the moving bodies; hence the most efficient neutron moderator is hydrogen, followed by other light elements: deuterium, beryllium, and carbon. The great penetrating power of neutrons imposes severe shielding problems for reactors and other nuclear machines, and it is necessary to provide walls, usually of concrete, several feet in thickness to protect personnel. The currently accepted health tolerance levels for an 8-h day correspond for fast neutrons to a flux of 20 neutrons/( $\text{cm}^2$ )(s) or 130 neutrons/( $\text{in.}^2$ )(s); for slow neutrons, 700/( $\text{cm}^2$ )(s) or 4500/( $\text{in.}^2$ )(s). On the other hand, fast neutrons are useful in some kinds of cancer therapy. *See* RADIATION DAMAGE TO MATERIALS; RADIATION INJURY (BIOLOGY); RADIATION SHIELDING; RADIOLOGY.

Free neutrons are radioactive, each transforming spontaneously into a proton, an electron ( $\beta^-$  particle), and an antineutrino. This instability is a reflection of the fact that neutrons are slightly heavier than hydrogen atoms. The neutron's rest mass is 1.0086652 atomic mass units on the unified mass scale ( $1.67495 \times 10^{-24}$  g), as compared with 1.0078252 atomic mass units for the hydrogen atom.

Neutrons are, individually, small magnets. This property permits the production of beams of polarized neutrons, that is, beams of neutrons whose magnetic dipoles are aligned predominantly parallel to one direction in space. The magnetic moment is  $-1.913042$  nuclear magnetons. *See* MAGNETON; NUCLEAR MOMENTS; NUCLEAR ORIENTATION; SPIN (QUANTUM MECHANICS).

Despite its overall neutrality, the neutron does have an internal distribution of electric charge, as has been revealed by scattering experiments. On a still finer scale, the neutron can also be presumed to have a quark structure in analogy of that of the proton. *See* QUANTUM CHROMODYNAMICS; QUARKS.

When neutrons are completely slowed down in matter, they have a Maxwellian distribution in energy that corresponds to the temperature of the moderator with which they are in equilibrium. The de Broglie wavelength of these ultracold neutrons is greater than 50 nm, which is so much larger than interatomic distances in solids that they interact with regions of a surface rather than with individual atoms, and as a result they are reflected from polished surfaces at all angles of incidence. Ultracold neutrons are important in basic physics and have applications in studies of surfaces and of the structure of inhomogeneities and magnetic domains in solids. See ELEMENTARY PARTICLE; NEUTRON DIFFRACTION; THERMAL NEUTRONS. [A.H.Sn.]

**Neutron diffraction** The phenomenon associated with the interference processes which occur when neutrons are scattered by the atoms within solids, liquids, and gases. The use of neutron diffraction as an experimental technique is relatively new compared to electron and x-ray diffraction, since successful application requires high thermal-neutron fluxes, which can be obtained only from nuclear reactors. These diffraction investigations are possible because thermal neutrons have energies with equivalent wavelengths near 0.1 nanometer and are therefore ideally suited for interatomic interference studies.

In the scattering of neutrons by atoms, there are two important interactions. One is the short-range, nuclear interaction of the neutron with the atomic nucleus. This interaction produces isotropic scattering because the atomic nucleus is essentially a point scatterer relative to the wavelengths of thermal neutrons. Strong resonances associated with the scattering process prevent any regular variation of the nuclear scattering amplitudes with atomic number. The other important process for the scattering of neutrons by atoms is the interaction of the magnetic moment of the neutron with the spin and orbital magnetic moments of the atom. See SCATTERING EXPERIMENTS (ATOMS AND MOLECULES); SCATTERING EXPERIMENTS (NUCLEI).

Since the nuclear scattering amplitudes for neutrons do not vary uniformly with atomic number, there are certain types of chemical structures which can be investigated more readily by neutron diffraction than by x-ray diffraction. Moreover, since neutron scattering is a nuclear process, when the scattering amplitude of an element is not favorable for a particular investigation, it is frequently possible to substitute an enriched isotope which has scattering characteristics that are markedly different. The most significant application of neutron diffraction in chemical crystallography is the structure determination of composite crystals which contain both heavy and light atoms, and the most important compounds in this general classification are the hydrogen-containing substances.

The interaction of the magnetic moment of the neutron with the orbital and spin moments in magnetic atoms makes neutron scattering a unique tool for the study of a wide variety of magnetic phenomena, because information is obtained on the magnetic properties of the individual atoms in a material. This interaction depends on the size of the atomic magnetic moment and also on the relative orientation of the neutron spin and of the atomic magnetic moment with respect to the scattering vector and with respect to each other. Consequently, detailed information can be obtained on both the magnitude and orientation of magnetic moments in any substance which displays magnetic properties.

The investigation of antiferromagnetic and ferrimagnetic substances is one of the most important applications of the neutron diffraction technique, because detailed information on the magnetic configuration in these systems cannot be obtained by other methods.

One of the most important uses of inelastic neutron scattering is the study of thermal vibrations of atoms about their equilibrium positions, because lattice vibration quanta, or phonons, can be excited or annihilated in their interactions with low-energy neutrons. The measurements provide a direct determination of the

dispersion relations for the normal vibrational modes of the crystal and do not require the large corrections necessary in similar x-ray investigations. These measured dispersion relations furnish the best experimental information available on interatomic forces that exist in crystals. See ELECTRON DIFFRACTION; MAGNON; NEUTRON SPECTROMETRY. [M.K.W.]

**Neutron optics** The general class of experiments designed to emphasize the wavelike character of neutrons. Like all elementary particles, neutrons can be made to display wavelike, as well as particlelike, behavior. They can be reflected and refracted, and they can scatter, diffract, and interfere, like light or any other type of wave. Many classical optical effects, such as Fresnel diffraction, have been performed with neutrons, including even those involving the construction of Fresnel zone plates. See DIFFRACTION; INTERFERENCE OF WAVES; REFLECTION OF ELECTROMAGNETIC RADIATION; REFRACTION OF WAVES; SCATTERING OF ELECTROMAGNETIC RADIATION; WAVE (PHYSICS).

The typical energy of a neutron produced by a moderated nuclear reactor is about 0.02 eV, which is approximately equal to the kinetic energy of a particle at about room temperature (80°F or 300 K), and which corresponds to a wavelength of about  $10^{-10}$  m. This is also the typical spacing of atoms in a crystal, so that solids form natural diffraction gratings for the scattering of neutrons, and much information about crystal structure can be obtained in this way. However, the wavelike properties of neutrons have been confirmed over a vast energy range from  $10^{-7}$  eV to over 100 MeV. See NEUTRON DIFFRACTION.

Neutrons, being uncharged, can be made to interfere over large spatial distances, since they are relatively unaffected by the stray fields in the laboratory that deflect charged particles. This property has been exploited by using the neutron interferometer. This device is made possible by the ability to grow essentially perfect crystals of up to 4 in. (10 cm). The typical interferometer is made from a single perfect crystal cut so that three parallel "ears" are presented to the neutron beam. This allows the incident beam to be split and subsequently recombined coherently. See COHERENCE; INTERFEROMETRY; SINGLE CRYSTAL.

One of the most significant experiments performed with the interferometer involved rotating the interferometer about the incident beam so that one neutron path was higher than the other, creating a minute gravitational potential difference (of  $10^{-9}$  eV) between the paths. This was sufficient to cause a path difference of 20 or so wavelengths between the beams. This remains the only type of experiment that has ever seen a quantum-mechanical interference effect due to gravity. It also verifies the extension of the equivalence principle to quantum theory (although in a form more subtle than its classical counterpart). See GRAVITATION; RELATIVITY.

Many noninterferometer experiments have also been done with neutrons. In one experiment, resonances were produced in transmitting ultracold neutrons (energy about  $10^{-7}$  eV) through several sheets of material. This is theoretically similar to seeing the few lowest states in a square-well potential in the Schrödinger equation. See NEUTRON; NONRELATIVISTIC QUANTUM THEORY; QUANTUM MECHANICS. [D.M.Gre.]

**Neutron spectrometry** A generic term applied to experiments in which neutrons are used as the probe for measuring excited states of nuclides and for determining the properties of these states. The term neutron spectroscopy is also used. The strength of the interaction between a neutron and a target nuclide can vary rapidly as a function of the energy of the incident neutron, and it is different for every nuclide. At particular neutron energies the interaction strength for a specific nuclide can be very strong; these narrow energy regions of strong interactions are called resonances (see illustration). The strength of the interaction, expressing the probability that an interaction of a given kind will take place, can be considered as the effective cross-sectional area  $\sigma$  presented by a nucleus to an incident neutron.

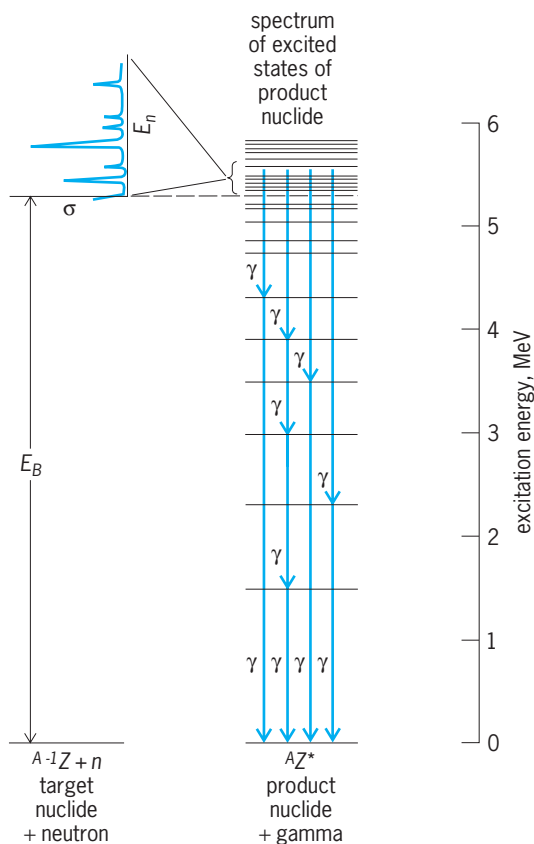

**Energy-level diagram for the product nucleus  $AZ^*$  with mass number  $A$  and charge number  $Z$ . The asterisk emphasizes that the product nucleus is in an excited state, from which it returns to ground state by emitting gamma ( $\gamma$ ) rays. Excitation energy is the sum of the energy of the neutron  $E_n$  and the binding energy  $E_B$  of the neutron which has been added to the target nuclide.**

Neutron spectroscopy can be carried out by two different techniques (or a combination): (1) by the use of a time-pulsed neutron source which emits neutrons of many energies simultaneously, combined with the time-of-flight technique to measure the velocities of the neutrons; this time-of-flight technique can be used for neutron measurements from  $10^{-3}$  eV to about 200 MeV; (2) by the use of a beam of nearly monoenergetic neutrons whose energy can be varied in small steps approximately equal to the energy spread of the neutron beam; however, useful "monoenergetic" neutron sources are not available from about 10 eV to about 10 keV.

Neutron spectroscopy has yielded a mass of valuable information on nuclear systematics for almost all nuclides. The distribution of the spacings between nuclear levels and the average of these spacings have provided valuable tests for various nuclear theories. The properties of these levels, that is, the probabilities that they decay by neutron or gamma-ray emission, or by fission, and the averages and distribution of these probabilities have stimulated much theoretical effort.

In addition, knowledge of neutron cross sections is fundamental for the optimum design of thermal fission power reactors and fast neutron breeder reactors, as well as fusion power reactors now in the conceptual stage. Cross sections are needed for nuclear fuel materials such as  $^{235}\text{U}$  or  $^{239}\text{Pu}$ , for fertile materials such as  $^{238}\text{U}$ , for structural materials such as iron and chromium, for coolants such as sodium, for moderators such as beryllium, and for shielding materials such as concrete. See NUCLEAR STRUCTURE; REACTOR PHYSICS.

[J.A.H.]

**Neutron star** A star containing about  $1\frac{1}{2}$  solar masses of material compressed into a volume approximately 6 mi (10 km) in radius. (1 solar mass equals  $4.4 \times 10^{33}$  lbm or  $2.0 \times 10^{33}$  kg.) Neutron stars are one of the end points of stellar evolution and are the final states of stars that begin their lives with considerably more mass than the Sun. The density of neutron star material is  $10^{14}$  to  $10^{15}$  times the density of water and exceeds the density of matter in the nuclei of atoms. Neutron stars are pulsars (pulsating radio sources) if they rotate sufficiently rapidly and have strong enough magnetic fields. See PULSAR; STELLAR EVOLUTION.

Neutron stars play a role in astrophysics which extends beyond their status as strange, unusual types of stellar bodies. The interior of a neutron star is a cosmic laboratory in which matter is compressed to densities which are found nowhere else in the universe. Precise measurements of the rotation of neutron stars can probe the behavior of matter at such densities. Neutron stars in double-star systems can emit x-rays when matter flows toward the neutron star, swirls around it, and heats up. Neutron stars are probably formed in supernova explosions. A few pulsars are found in double-star systems, and careful timing of the pulses they emit can test Einstein's general theory of relativity. See BINARY STAR; GRAVITATION; RELATIVITY; SUPERNOVA.

Measured values of masses of neutron stars in double star systems range from 1.4 to 1.8 solar masses. If Einstein's theory of gravitation is the correct one, a neutron star with a mass larger than some limiting value will collapse catastrophically, because its internal pressure will be insufficient, and become a black hole. The exact value of this limiting mass is not known precisely, but lies between 3 and 5 solar masses. See BLACK HOLE.

Most of the interior of a neutron star consists of matter which is almost entirely composed of neutrons. In the bulk of the star, this matter is in a superfluid state, where circulation currents can flow without resistance. This material is under pressure, since it must be able to support the tremendous weight of the overlying layers at each point in the neutron star. This pressure, called degeneracy pressure, is caused by the close packing of the neutrons rather than by the motion of the particles. As a result, neutron stars can be stable no matter what the internal temperature is, because the pressure that supports the star is independent of temperature. See SUPERFLUIDITY.

[H.L.Sh.]

**New Zealand** A landmass in the Southern Hemisphere, bounded by the South Pacific Ocean to the north, east, and south and the Tasman Sea to the west, with a total land area of 103,883 mi<sup>2</sup> (269,057 km<sup>2</sup>). The exposed landmass represents about one-quarter of a subcontinent, with three-quarters submerged. This long, narrow, mountainous country, oriented northeast to southwest, consists of two main islands, North Island and South Island, surrounded by a much greater area of crust submerged to depths reaching 1.2 mi (2 km).

South Island lowlands are either alluvial plains as in Otago, Southland, and Nelson, or glacial outwash fans as in Westland and Canterbury. North Island lowlands such as Hawke's Bay, Wairarapa, and Manawatu are alluvial; the Waikato, Hauraki, and Bay of Plenty lowlands occupy structural basins that contain large volumes of reworked volcanic debris from the central volcanic region. The alluvial lowlands of both main islands form the most agriculturally productive areas of the country. See PLAINS.

The climate of New Zealand is influenced by three main factors: a location in latitudes where the prevailing airflow is westerly; an oceanic environment; and the mountain chains, which modify the weather systems as they pass eastward, causing high rainfalls on windward slopes and sheltering effects to leeward.

Weather is determined mostly by series of anticyclones and troughs of low pressure that produce alternating periods of settled and variable conditions. Westerly air masses are occasionally replaced by southerly airstreams, which bring cold conditions with snow in winter and spring to areas south of 39°S, and northerly

tropical maritime air, which brings warm humid weather to the north and east coasts. See METEOROLOGY.

Rainfall on land is 16–470 in. (400–12,000 mm) per year, with the highest rainfall being on the western windward slopes of the mountains, and the lowest on the eastern basins in the lee of the Southern Alps in Central Otago and south Canterbury. Annual rain days are at least 130 for most of North Island, but on South Island the totals are far more variable, with over 200 occurring in Fiordland, 180 on the west coast, and fewer than 80 in Central Otago. Summer droughts are relatively common in Northland, and in eastern regions of both islands. See DROUGHT; PRECIPITATION (METEOROLOGY).

Droughts, springtime air frosts, and hailstorms are the major common climatic hazards for the farming industry, but floods associated with prolonged intense rainstorms are the major general hazard.

The economy is heavily dependent on the natural resources soil, water, and plants. New Zealand has few exploitable minerals, but possesses a climate generally favorable for agriculture, pastoral farming, renewable forestry, and tourism. With a small population (3.4 million), much of its manufacturing is concerned with processing produce from the land and surrounding seas, and supplying the needs of those industries.

Because of its high relief and its location on an active crustal plate boundary in the zone of convergence between Antarctic air masses and tropical air masses, New Zealand is prone to high-intensity and high-frequency natural hazards—earthquakes, volcanic eruptions, large and small landslides, and floods. [M.J.Se.]

**Newcastle disease** A viral infection that affects the digestive, intestinal, and respiratory tracts and the neurological system of birds. The causative agent is an enveloped ribonucleic acid (RNA) virus that is classified as a paramyxovirus. See PARAMYXOVIRUS.

Newcastle disease occurs in five forms based on a virulence in chickens ranging from inapparent infection to severe disease and death. Viscerotropic-velogenic Newcastle disease causes a very severe infection, producing hemorrhagic lesions in the intestinal tract and high mortality. The neurotropic-velogenic type is also highly lethal and produces neurologic and respiratory signs in infected birds. The mesogenic form causes an acute respiratory or neurologic infection that may be lethal only in young birds. The lentogenic type is a mild or inapparent respiratory infection of chickens. The last group includes the viruses causing inapparent or asymptomatic infections of the digestive tract.

The wide susceptibility of avian species to infection with Newcastle disease has complicated control. Newcastle disease is spread worldwide by the international transportation of live birds disseminating the virus. Control of and protection from Newcastle disease can be achieved by the correct use of vaccines. Lentogenic and some mesogenic strains are used to produce vaccines that can be administered by aerosol, intranasal drops, or intramuscular injection, or as an additive to the drinking water. See ANIMAL VIRUS. [M.L.V.]

**Newtonian fluid** A fluid whose stress at each point is linearly proportional to its strain rate at that point. The concept was first deduced by Isaac Newton and is directly analogous to Hooke's law for a solid. All gases are newtonian, as are most common liquids such as water, hydrocarbons, and oils. See HOOKE'S LAW; STRESS AND STRAIN.

A simple example, often used for measuring fluid deformation properties, is the steady one-dimensional flow  $u(y)$  between a fixed and a moving wall (see illustration). The no-slip condition at each wall forces the fluid into a uniform shear strain rate  $\epsilon$ , given by Eq. (1), which is induced by a uniform shear stress  $\tau$ .

$$\epsilon = \frac{\partial u}{\partial y} = \frac{V}{H} \quad (1)$$

Here  $V$  is the speed of the moving wall,  $H$  is the perpendicular

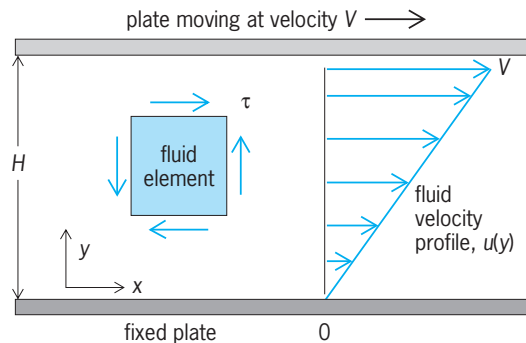

A fluid sheared between two plates. The resulting strain rate equals  $V/H$ .

distance between the walls, and  $u$  is the fluid velocity at distance  $y$  from the fixed wall.

If the fluid is newtonian, the experimental plot of  $\tau$  versus  $\epsilon$  will be a straight line. The constant of proportionality is called the viscosity  $\mu$  of the fluid, as stated in Eq. (2).

$$\tau = \mu \epsilon \quad (2)$$

The viscosity coefficients of common fluids vary by several orders of magnitude. See FLUID FLOW; FLUIDS; VISCOSITY. [F.M.Wh.]

**Newton's laws of motion** Three fundamental principles which form the basis of classical, or newtonian, mechanics. They are stated as follows:

First law: A particle not subjected to external forces remains at rest or moves with constant speed in a straight line.

Second law: The acceleration of a particle is directly proportional to the resultant external force acting on the particle and is inversely proportional to the mass of the particle.

Third law: If two particles interact, the force exerted by the first particle on the second particle (called the action force) is equal in magnitude and opposite in direction to the force exerted by the second particle on the first particle (called the reaction force).

The newtonian laws have proved valid for all mechanical problems not involving speeds comparable with the speed of light and not involving atomic or subatomic particles. See DYNAMICS; FORCE; KINETICS (CLASSICAL MECHANICS). [D.Wi.]

**Niacin** A vitamin also known as nicotinic acid, a component of the vitamin B complex. It is a white water-soluble powder stable to heat, acid, and alkali, with the structure shown below.

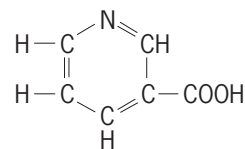

Many animals, including humans, are capable of synthesizing niacin in varying degrees from the amino acid tryptophan. Niacin is widely distributed in foods. Yeasts, wheat germ, and meats, particularly organ meats, are rich sources of the vitamin. Some foods such as milk are relatively poor sources of niacin but contain generous quantities of tryptophan.

Niacin-deficiency disease is known as pellagra and is particularly prevalent among the poor people whose diet is largely corn. The recommended dietary allowance for niacin is 6.6 niacin equivalents per 1000 kcal. See VITAMIN. [S.N.G.]

**Nickel** A chemical element, Ni, atomic number 28, a silver-white, ductile, malleable, tough metal. The atomic mass of naturally occurring nickel is 58.71. See PERIODIC TABLE.

Nickel consists of five natural isotopes having atomic masses of 58, 60, 61, 62, 64. Seven radioactive isotopes have also



been identified, having mass numbers of 56, 57, 59, 63, 65, 66, and 67.

Most commercial nickel goes into stainless steel and other corrosion-resistant alloys. Nickel is also important in coins as a replacement for silver. Finely divided nickel is used as a hydrogenation catalyst. See NICKEL ALLOYS.

Nickel is a fairly plentiful element, making up about 0.008% of the Earth's crust and 0.01% of the igneous rocks. Appreciable quantities of nickel are present in some kinds of meteorite, and large quantities are thought to exist in the Earth's core. Two important ores are the iron-nickel sulfides, pentlandite and pyrrhotite ( $(\text{Ni,Fe})_x\text{S}_y$ ); the ore garnierite,  $(\text{Ni,Mg})\text{SiO}_3 \cdot n\text{H}_2\text{O}$ , is also commercially important. Nickel occurs in small quantities in plants and animals. It is present in trace amounts in sea water, petroleum, and most coal.

Nickel metal is of moderate strength and hardness (3.8 on Mohs scale). When viewed as very small particles, nickel appears black. The density of nickel is 8.90 times that of water at 20°C (68°F). Nickel melts at 1455°C (2651°F) and boils at 2840°C (5144°F). Nickel is only moderately reactive. It resists alkaline corrosion and does not burn in the massive state, although fine nickel wires can be ignited. Nickel is above hydrogen in the electrochemical series, and it dissolves slowly in dilute acids, releasing hydrogen. In metallic form nickel is a moderately strong reducing agent.

Nickel is usually divalent in its compounds, but it can also exist in the oxidation states 0, 1+, 3+, and 4+. Besides the simple nickel compounds, or salts, nickel forms a variety of coordination compounds or complexes. Most compounds of nickel are green or blue because of hydration or other ligand bonding to the metal. The nickel ion present in water solutions of simple nickel compounds is itself a complex,  $[\text{Ni}(\text{H}_2\text{O})_6]^{2+}$ . [W.E.C.]

**Nickel alloys** Combinations of nickel with other metals. Nickel-base alloys may be melted in open-hearth, electric-arc, or induction furnaces in air, under inert gas, or in vacuum. Casting may also be done under these same ambient conditions.

Nickel 211 and Duranickel alloy 301 are essentially binary alloys with 4.75% manganese and 4.5% aluminum, respectively. A characteristic use of nickel 211 is as wire for sparkplug electrodes. Duranickel alloy 301 is well suited to the manufacture of springs and diaphragms.

Monel alloy 400 contains about two-thirds nickel and one-third copper and is the oldest of the commercial nickel-base alloys, dating from about 1905. Nickel-chromium binary alloys are used primarily in specialty high-temperature service. Other nickel alloys contain combinations of other metals in varying quantities. See NICKEL. [E.N.S.; G.Sm.]

**Nickel metallurgy** The extraction and refining of nickel from its ores. Nickel's properties of strength, toughness, and resistance to corrosion have been used to advantage in alloys since ancient times. Although nickel ranks twenty-fourth in order of abundance of the elements, there are relatively few nickel deposits of commercial importance. Nickel ores are of two generic types, sulfides and laterites. Explorations of the ocean bottoms have revealed vast deposits of manganese oxide nodules which contain significant values of nickel, copper, and cobalt.

Selection of processes for nickel extraction is largely determined by the type of ore to be treated. Sulfide ores are amenable to concentration by such methods as flotation or magnetic separation. The state of combination of nickel in the lateritic ores usually precludes such enrichment, thus requiring treatment of the total ore.

Sulfide ores are first crushed and ground to liberate the mineral values and then subjected to froth flotation or magnetic separation to concentrate the valuable constituents and reject the gangue or rock fraction. The nickel concentrate is treated by pyrometallurgical processes. The major portion undergoes partial roasting in multihearth or fluidized-bed furnaces to elim-

inate about half of the sulfur and to oxidize the associated iron. The hot calcine, plus flux, is smelted in natural gas-coal-fired reverberatory furnaces operating at about 1200°C to produce a furnace matte, enriched in nickel, and a slag for discard. The furnace matte is transferred to converters and blown with air in the presence of more flux to oxidize the remaining iron and associated sulfur, yielding Bessemer matte containing nickel, copper, cobalt, small amounts of precious metals, and about 22% sulfur. The molten Bessemer matte is cast into 25-ton (22.5-metric ton) molds in which it undergoes controlled slow cooling. After crushing and grinding, the metallics are removed magnetically and treated in a refining complex for recovery of metal values.

The bulk of the nickel originating from lateritic ores is marketed as ferronickel. The process employed is basically simple and involves drying and preheating the ore usually under reducing conditions. The hot charge is then further reduced and melted in an electric-arc furnace, and the crude metal is refined and cast into ferronickel pigs. A substantial amount of nickel is produced from lateritic ores by the nickel sulfide matte technique. In this process the ore is mixed with gypsum or other sulfur-containing material such as high-sulfur fuel oil, followed by a reduction and smelting operation to form matte. The molten furnace matte is upgraded in either conventional or top-blown rotary converters to a high-grade matte, which can be further refined by roasting and reduction to a metallized product. See NICKEL; PYROMETALLURGY. [A.I.]

**Nickeline** A minor ore of nickel. Nickeline is a mineral having composition  $\text{NiAs}$  and crystallizing in the hexagonal system. Crystals are rare, and nickeline usually occurs in massive aggregates with metallic luster and pale copper-red color. Because of the color, not the composition, it is called copper nickel. The hardness is 5.5 on Mohs scale and the specific gravity is 7.78. Nickeline is frequently associated with other nickel arsenides and sulfides in massive pyrrhotite. It is also found in vein deposits with cobalt and silver minerals, as in the silver mines of Saxony, Germany, and Cobalt, Ontario, Canada. See HARDNESS SCALES; NICKEL; PYRRHOTITE. [C.S.Hu.]

### Nicotinamide adenine dinucleotide (NAD)

An organic coenzyme and one of the most important components of the enzymatic systems concerned with biological oxidation-reduction reactions. It is also known as NAD, diphosphopyridine nucleotide (DPN) coenzyme I, and codehydrogenase I. NAD is found in the tissues of all living organisms. See COENZYME.

The nicotinamide, or pyridine, portion of NAD can be reduced chemically or enzymatically with the formation of reduced or hydrogenated NAD (NADH). NAD functions as the immediate oxidizing agent for the oxidation, or dehydrogenation, of various organic compounds in the presence of appropriate dehydrogenases, which are specific apoenzymes, or protein portions of the enzyme. In the dehydrogenase reactions one hydrogen atom is transferred from the substrate to NAD, while another is liberated as hydrogen ion.

NAD and its reduced form, NADH, serve to couple oxidative and reductive processes and are constantly regenerated during metabolism. Hence, they serve as catalysts and NAD is referred to as a coenzyme. In some enzymatic reactions a different coenzyme, triphosphopyridine nucleotide is required. Dehydrogenases are generally quite specific with respect to the coenzyme which they can utilize. See ENZYME; NICOTINAMIDE ADENINE DINUCLEOTIDE PHOSPHATE (NADP). [M.D.]

### Nicotinamide adenine dinucleotide phosphate (NADP)

A coenzyme and an important component of the enzymatic systems concerned with biological oxidation-reduction systems. It is also known as NAD, triphosphopyridine nucleotide (TPN), coenzyme II, and codehydrogenase II. The

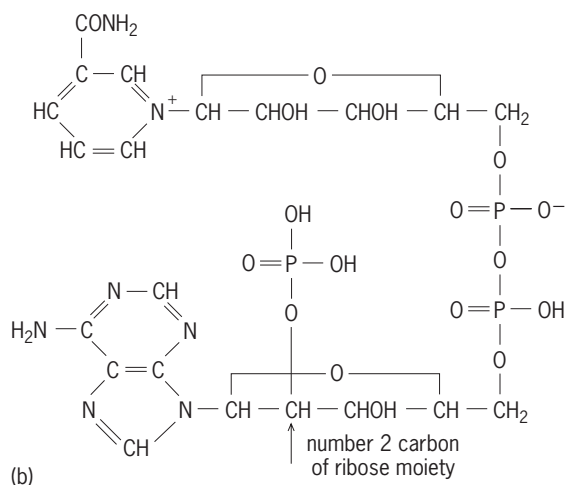
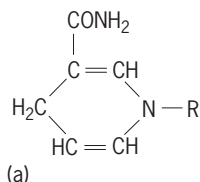

**Triphosphopyridine nucleotide.** (a) Reduced form of the nicotinamide portion of TPNH. (b) Oxidized form of the molecule (TPN).

compound is similar in structure and function to nicotinamide adenine dinucleotide (NAD). It differs structurally from NAD in having an additional phosphoric acid group esterified at the 2' position of the ribose moiety of the adenylic acid portion. In biological oxidation-reduction reactions the NADP molecule becomes alternately reduced to its hydrogenated form (NADPH) and reoxidized to its initial state (see illustration). See CARBOHYDRATE METABOLISM; COENZYME; ENZYME. [M.D.]

**Nicotine alkaloids** Alkaloids found in various species of the genus *Nicotiana*. The species most often used for the production of tobacco because of its high level of nicotine is *N. tabacum*, which is cultivated in many parts of the world for the preparation of cigarettes, cigars, and pipe tobacco. Nicotine is the most abundant alkaloid in *N. tabacum*, occurring to the extent of 2–8% based on the dry weight of the cured leaf. Other alkaloids that are found in this species are nornicotine, anaba-

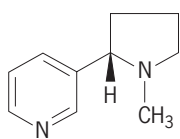

(S)-Nicotine

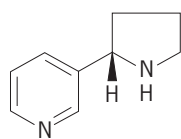

(S)-Nornicotine

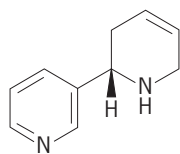

(S)-Anatabine

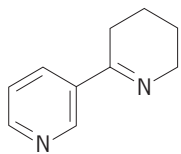

Anabesine

**Structures of nicotine and some other alkaloids found in tobacco.**

sine, and anatabine. The chemical structures of these alkaloids are shown in the illustration. See ALKALOID; TOBACCO. [E.Le.]

**Niobium** A chemical element, Nb, atomic number 41 and atomic weight 92.906. In the United States this element was originally called columbium. The metallurgists and metals industry still use this older name. See PERIODIC TABLE.

Most niobium is used in special stainless steels, high-temperature alloys, and superconducting alloys such as Nb<sub>3</sub>Sn. Niobium is also used in nuclear piles.

Niobium metal has a density of 8.6 g/cm<sup>3</sup> (5.0 oz/in.<sup>3</sup>) at 20°C (68°F), a melting point of 2468°C (4474°F), and a boiling point of 4927°C (8900°F). Metallic niobium is quite inert to all acids except hydrofluoric, presumably owing to an oxide film on the surface. Niobium metal is slowly oxidized in alkaline solution. It reacts with oxygen and the halogens upon heating to form the oxidation state V oxide and halides, with nitrogen to form NbN, and with carbon to form NbC, as well as other elements such as arsenic, antimony, tellurium, and selenium.

The oxide Nb<sub>2</sub>O<sub>5</sub>, melting point 1520°C (2768°F), dissolves in fused alkali to yield a soluble complex niobate, Nb<sub>6</sub>O<sub>19</sub><sup>8-</sup>. Normal niobates such as NbO<sub>4</sub><sup>3-</sup> are insoluble. The oxide dissolves in hydrofluoric acid to give ionic species such as NbOF<sub>5</sub><sup>2-</sup> and NbOF<sub>6</sub><sup>3-</sup>, depending on the fluoride and hydrogen-ion concentration. The highest fluoro complex which can exist in solution is NbF<sub>6</sub><sup>-</sup>. [E.M.L.]

**Nippotaeniidea** An order of tapeworms of the subclass Cestoda. The few known species are intestinal parasites of Eurasian fresh-water fishes. The head bears a single terminal sucker. The segmental anatomy shows relationships to the Pseudophyllidea and Cyclophyllidea. The life history is unknown. It is probable that this order is related to the proteocephalids. See CESTODA; CYCLOPHYLLIDEA; PSEUDOPHYLLIDEA. [C.P.R.]

**Niter** A potassium nitrate mineral with chemical composition KNO<sub>3</sub>. Niter crystallizes in the orthorhombic system, generally in thin crusts and delicate acicular crystals; it occurs in massive, granular, or earthy forms. It is brittle; hardness is 2 on Mohs scale; specific gravity is 2.109. The luster is vitreous, and the color and streak are colorless to white. See NITRATE MINERALS.

Niter is commonly found, usually in small amounts, as a surface efflorescence in arid regions and in caves and other sheltered places. Niter occurs associated with soda niter in the desert regions of northern Chile, and in similar occurrences in Italy, Egypt, Russia, the western United States, and elsewhere. [G.Sw.]

**Nitrate minerals** These minerals are few in number and with the exception of soda niter are of rare occurrence. Normal anhydrous and hydrated nitrates occurring as minerals are soda niter, NaNO<sub>3</sub>; niter, KNO<sub>3</sub>; ammonia niter, NH<sub>4</sub>NO<sub>3</sub>; nitrobarite, Ba(NO<sub>3</sub>)<sub>2</sub>; nitrocalcite, Ca(NO<sub>3</sub>)<sub>2</sub> · 4H<sub>2</sub>O; and nitromagnesite, Mg(NO<sub>3</sub>)<sub>2</sub> · 6H<sub>2</sub>O. In addition there are three known naturally occurring nitrates containing hydroxyl or halogen, or compound nitrates. They are gerhardtite, Cu<sub>2</sub>(NO<sub>3</sub>)(OH)<sub>3</sub>; buttgembachite, Cu<sub>19</sub>(NO<sub>3</sub>)<sub>2</sub>Cl<sub>4</sub>(OH)<sub>32</sub> · 3H<sub>2</sub>O; and darapskite, Na<sub>3</sub>(NO<sub>3</sub>)(SO<sub>4</sub>) · H<sub>2</sub>O. See NITER; SODA NITER.

The natural nitrates are for the most part readily soluble in water. For this reason they occur most abundantly in arid regions, particularly in South America along the Chilean coast. See FERTILIZER; NITROGEN. [G.Sw.]

**Nitration** A process in which a nitro group (—NO<sub>2</sub>) becomes chemically attached to a carbon, oxygen, or nitrogen atom in an organic compound. A hydrogen or halogen atom is often replaced by the nitro group. Three general reactions summarize nitration chemistry:

1. C nitration, in which the nitro group attaches itself to a carbon atom [reaction (1)].

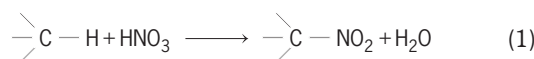

2. O nitration (an esterification reaction), in which an O-N bond is formed to produce a nitrate [reaction (2)].

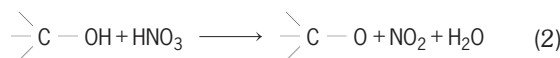

3. N nitration, in which a N-N bond is formed [reaction (3)].

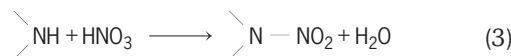

Aromatics, alcohols, glycols, and amines are generally nitrated with mixed acids via an ionic reactions. The mixture includes nitric acid, a strong acid such as sulfuric acid which acts as a catalyst, and a small amount of water. With sulfuric acid, nitric acid is ionized to the nitronium ion,  $\text{NO}_2^+$ , which is the nitrating agent.

Propane is commercially nitrated in relatively large amounts using nitric acid in gas-phase free-radical reactions at temperatures of about 380–420°C. Nitric acid decomposes at these temperatures to produce nitrogen dioxide radicals (actually a mixture of  $\cdot\text{NO}_2$  and  $\cdot\text{ONO}$ ) and a hydroxy radical ( $\cdot\text{OH}$ ). In the free-radical reaction, about 35–40% of the nitric acid reacts to form four  $\text{C}_1$ – $\text{C}_3$  nitroparaffins; C–C bonds are broken during the nitration. The remaining nitric acid acts mainly as an oxidizing agent to form aldehydes, alcohols, carbon monoxide, carbon dioxide, water, and small amounts of other oxidized materials. Commercially, an adiabatic reactor is used, and the heat of reaction is employed to preheat and vaporize the nitric acid feed (containing water).

The product stream from free-radical nitrations is a condensation of mixed nitroparaffins. This liquid mixture is washed to remove the aldehydes, and then is distilled to recover each of the four nitroparaffins—nitromethane, nitroethane, 1-nitropropane, and 2-nitropropane. The unreacted propane is recovered, combined with the feed propane, and returned to the reactor. The oxides of nitrogen are converted back to nitric acid; carbon monoxide, carbon dioxide, and water are discarded.

In the classical Victor Meyer process, an organic halide (often a bromide) is reacted with silver nitrite to produce a nitrohydrocarbon and silver halide. In a modified process, sodium nitrite, dissolved in a suitable solvent, is substituted for the more expensive silver nitrite. The desired nitroalkanes are produced in high yields by these processes, whereas they are produced in rather low yields in free-radical nitrations.

Nitrations can also often be performed by addition reactions using unsaturated hydrocarbons with nitric acid or nitrogen dioxide. [L.F.A.]

**Nitric acid** A strong mineral acid having the formula  $\text{HNO}_3$ . Pure nitric acid is a colorless liquid with a specific gravity of 1.52 at 25°C (77°F); it freezes at –47°C (–53°F). Nitric acid is used in the manufacture of ammonium nitrate and phosphate fertilizers, nitro explosives, plastics, dyes, and lacquers. The principal commercial process for the manufacture of nitric acid is the Ostwald process, in which ammonia,  $\text{NH}_3$ , is catalytically oxidized with air to form nitrogen dioxide,  $\text{NO}_2$ . When the dioxide is dissolved in water, 60% nitric acid is formed. Production of 90–100% nitric acid is based on processes such as the reaction of sulfuric acid with sodium nitrate (an older method of nitric acid manufacture), dehydration of 60% acid, and oxidation of nitrogen dioxide in a solution of dilute nitric acid. See AMMONIA; NITROGEN. [F.J.J.]

**Nitric oxide** An important messenger molecule in mammals and other animals. It can be toxic or beneficial, depending

on the amount and where in the body it is released. Initial research into the chemistry of nitric oxide (NO) was motivated by its production in car engines, which results in photochemical smog and acid rain. In the late 1980s, researchers in immunology, cardiovascular pharmacology, neurobiology, and toxicology discovered that nitric oxide is a crucial physiological messenger molecule. Nitric oxide is now thought to play a role in blood pressure regulation, control of blood clotting, immune defense, digestion, the senses of sight and smell, and possibly learning and memory. Nitric oxide may also participate in disease processes such as diabetes, stroke, hypertension, impotence, septic shock, and long-term depression. See IMMUNOLOGY; NEUROBIOLOGY.

Most cellular messengers are large, unreactive biomolecules that make specific contacts with their targets. In contrast, nitric oxide is a small molecule that contains a free radical—that is, an unpaired electron—making it very reactive. Nitric oxide can freely diffuse through aqueous solutions or membranes, reacting rapidly with metal centers in cellular proteins and with reactive groups in other cellular molecules.

Nitric oxide is produced in the body by an enzyme called nitric oxide synthase, which converts the amino acid L-arginine to nitric oxide and L-citrulline. There are three types of nitric oxide synthase: brain, endothelial, and inducible. Both brain and endothelial enzymes are constitutive, that is, they are always present in cells, while the production of inducible nitric oxide synthase can be turned on or off when a system needs nitric oxide. After nitric oxide is produced in specific areas of the body by nitric oxide synthase, it diffuses to nearby cells. Nitric oxide then reacts preferentially in the interior of these cells with the metal centers of proteins. Nitric oxide binds specifically to the iron (Fe) atom of the heme group in proteins; it can also interact with other metal sites in proteins as well as with the thiol group (SH) of the amino acid cysteine. The interaction of nitric oxide with these proteins causes a cascade of intracellular events that leads to specific physiological changes within cells. For example, nitric oxide causes the smooth muscle cells surrounding blood vessels to relax, decreasing blood pressure. Nitric oxide plays an important role in the central and peripheral nervous systems; the overproduction of nitric oxide in brain tissues has been implicated in stroke and other neurological problems.

Nitric oxide also functions as an important agent in the immune system by killing invading bacterial cells. Nitric oxide released by macrophages can inhibit important cellular processes in the bacteria, including deoxyribonucleic acid (DNA) synthesis and respiration, by binding to and destroying iron-sulfur centers in key enzymes in these pathways.

Although nitric oxide production in the immune system serves a crucial biological function, there can be adverse effects when too much nitric oxide is produced. During a massive bacterial infection, excess nitric oxide can go into the vascular system, causing a dramatic decrease in blood pressure, which may lead to possibly fatal septic shock. Thus, scientists are working on drugs that can selectively inhibit the inducible form of nitric oxide synthase in order to avoid the harmful effects produced by excess nitric oxide without interfering with useful nitric oxide pathways. [J.N.Bu.; M.F.R.]

**Nitrile** One of a group of organic chemical compounds of general formula  $\text{RC}\equiv\text{N}$ . A nitrile is named from the acid to which it can be hydrolyzed by adding the suffix -onitrile to the acid stem, for example, acetonitrile from acetic acid. An alternative system names the group attached to CN, thus  $\text{CH}_3\text{CN}$  is also named methyl cyanide. In more complex structures the CN group is named as a substituent, cyano.

Industrially, nitriles are formed by heating carboxylic acids with ammonia and a dehydration catalyst under pressure. For the preparation of acrylonitrile, which is used on a large scale in the plastics industry, a vapor-phase catalytic ammoxidation of propylene has been developed. See ACRYLONITRILE; AMINE. [P.E.F.]

**Nitro and nitroso compounds** Nitro compounds are derivatives of organic hydrocarbons having one or more  $-\text{NO}_2$  groups with nitrogen-to-carbon bonding. They differ from the oxygen-linked nitrites, which are esters. The group lacks enough electrons to form double bonds with both oxygens. However, both oxygens react alike; hence the bond is regarded as a resonance hybrid of single and double bonds.

Aromatic nitro compounds have been used chiefly as dye intermediates, explosives, and Pharmaceuticals. They are formed readily by the reaction of aromatic compounds with nitric acid; H is replaced by the  $-\text{NO}_2$  group, for example, Aliphatic nitro

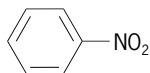

compounds are prepared with difficulty and have grown in importance only since the development of vapor-phase nitration of hydrocarbons with nitric acid vapors at  $420^\circ\text{C}$  ( $788^\circ\text{F}$ ).

Nitroso compounds contain the  $-\text{NO}$  group attached to carbon or nitrogen. Many are unstable intermediates, for example, nitrosobenzene formed during the reduction of nitrobenzene. See NITRATION. [A.L.H.]

**Nitroaromatic compound** A member of the class of organic compounds in which the nitro group ( $-\text{NO}_2$ ) is attached directly to the cyclic, aromatic nucleus. The prototypal compound is nitrobenzene. It is prepared by the reaction of benzene with nitric acid in the presence of sulfuric acid, as shown in the reactions below. The most significant use of nitrobenzene is

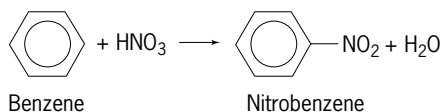

in the manufacture of aniline (**1**). About 97% of the nitrobenzene

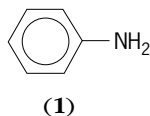

produced in the United States is converted to aniline, which is used in the manufacture of plastics, rubber additives, dyes, drugs, and other products. See BENZENE.

Second to nitrobenzene in commercial importance are the mononitrotoluenes, particularly the ortho and para isomers, (**2**) and (**3**), respectively. Reaction of toluene with a mixture of

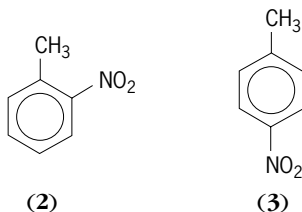

nitric and sulfuric acid at about  $40^\circ\text{C}$  ( $104^\circ\text{F}$ ) gives a high yield of a mixture of the isomers, which are separated by a combination of fractional distillation and crystallization. The nitrotoluenes are important intermediates in the preparation of dyes, rubber chemicals, and agricultural chemicals.

2,4,6-Trinitrotoluene (TNT; **4**) is a military explosive that is

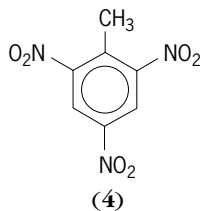

stable, nonhygroscopic, and relatively insensitive to impact, friction, shock, and electric spark. It is produced by nitration of toluene in successive stages at progressively higher temperatures and concentrations of acid.

Although literally thousands of other aromatic ring compounds, including the heterocyclics, have been converted to their nitro derivatives, few such compounds have achieved any significant industrial importance. See AROMATIC HYDROCARBON; NITRATION. [P.E.F.]

**Nitrogen** A chemical element, N, atomic number 7, atomic weight 14.0067. Nitrogen, a gas under normal conditions, is the lightest element of periodic group 5 (nitrogen family). See PERIODIC TABLE.

At standard temperature and pressure, elemental nitrogen exists as a gas with a density of 1.25046 g/liter. This value indicates that the molecular formula is  $\text{N}_2$ . Some physical properties of elemental nitrogen are listed in Table 1.

Table 1. Properties of nitrogen

Property	Value
Heat of transformation ( $\alpha$ - $\beta$ )	54.71 cal/mole
Heat of fusion	172.3 cal/mole
Heat of vaporization	1332.9 cal/mole
Critical temperature	$126.26 \pm 0.04$ K
Critical pressure	$33.54 \pm 0.02$ atm
Density: $\alpha$ form	1.0265 g/ml at $-252.6^\circ\text{C}$
$\beta$ form	0.8792 g/ml at $-210.0^\circ\text{C}$
Liquid	1.1607-0.00457( $T = \text{abs temp}$ )

Elemental nitrogen has a low reactivity toward most common substances at ordinary temperatures. At high temperatures, molecular nitrogen,  $\text{N}_2$ , reacts with chromium, silicon, titanium, aluminum, boron, beryllium, magnesium, barium, strontium, calcium, and lithium (but not the other alkali metals) to form nitrides; with  $\text{O}_2$  to form  $\text{NO}$ ; and at moderately high temperatures and pressures in the presence of a catalyst, with hydrogen to form ammonia. Above  $1800^\circ\text{C}$  ( $3300^\circ\text{F}$ ), nitrogen, carbon, and hydrogen combine to form hydrogen cyanide.

Table 2 lists the principal classes of inorganic nitrogen compounds. Thus, in addition to the typical oxidation states of the family ( $-3$ ,  $+3$ , and  $+5$ ), nitrogen forms compounds with a variety of additional oxidation states. See AMINE; AMMONIA; HYDRAZINE; NITRIC ACID; NITROGEN COMPLEXES; NITROGEN OXIDES.

Molecular nitrogen is the principal constituent of the atmosphere (78% by volume of dry air), in which its concentration is a result of the balance between the fixation of atmospheric nitrogen by bacterial, electrical (lightning), and chemical (industrial) action, and its liberation through the decomposition of organic materials by bacteria or combustion. In the combined state, nitrogen occurs in a variety of forms. It is a constituent of all proteins (both plant and animal) as well as of many other organic materials. Its chief mineral source is sodium nitrate.

The methods for the preparation of elementary nitrogen may be grouped into two classes, separation from the atmosphere and decomposition of nitrogen compounds. The industrial method

Table 2. Compounds of nitrogen

Oxidation state	Examples
+5	$\text{N}_2\text{O}_5$ , $\text{HNO}_3$ , nitrates, $\text{NO}_2\text{X}$
+4	$\text{N}_2\text{O}_4 \rightleftharpoons 2\text{NO}_2$
+3	$\text{N}_2\text{O}_3$ , $\text{HNO}_2$ , nitrites, $\text{NOX}$ , $\text{NX}_3$
+2	$\text{NO}$ , $\text{Na}_2\text{NO}_2$ , nitrohydroxylamates
+1	$\text{N}_2\text{O}$ , $\text{H}_2\text{N}_2\text{O}_2$ , hyponitrites
0	$\text{N}_2$
-1/3	$\text{HN}_3$ , acids
-1	$\text{NH}_2\text{OH}$ , hydroxylammonium salts
-2	$\text{NH}_2\text{NH}_2$ , hydrazinium salts, hydrazides
-3	$\text{NH}_3$ , ammonium salts, amides, imides, nitrides

for the production of nitrogen is the fractional distillation of liquid air. Nitrogen containing about 1% argon and traces of other inert gases may be obtained by the chemical removal of oxygen, carbon dioxide, and water vapor from the atmosphere by appropriate chemical reagents.

Because the importance of nitrogen compounds in agriculture and chemical industry, much of the industrial interest in elementary nitrogen has been in processes for converting elemental nitrogen into nitrogen compounds. The principal methods for doing this are the Haber process for the direct synthesis of ammonia from nitrogen and hydrogen, the electric arc process, which involves the direct combination of  $N_2$  and  $O_2$  to nitric oxide, and the cyanamide process. Nitrogen is also used for filling bulbs of incandescent lamps and, in general, wherever a relatively inert atmosphere is required. [H.H.S.]

**Nitrogen complexes** Compounds containing the dinitrogen molecule,  $N_2$ , bound to a metal (also called dinitrogen complexes). Outstanding in their ability to form coordination compounds with nitrogen are a number of metals which belong to the group 7 transition metal family. For each metal of this group, several nitrogen complexes have been identified. Nitrogen complexes of these metals occur in low oxidation states, such as  $Co(I)$  or  $Ni(0)$ . The other ligands present in these complexes besides  $N_2$  are usually of a type known to stabilize low oxidation states; phosphines appear to be particularly prominent bonding partners in this respect. The illustration shows the structure of a typical  $N_2$  complex, elucidated by a crystal structure determination. The N-N bond axis in this complex is aimed, within the limits of experimental error, directly toward the position of the metal atom. The Co- $N_2$  bond length, 0.18 nanometer, is within the normal range of comparable metal-ligand bonds. See COORDINATION CHEMISTRY.

Even in most favorable cases the binding of the dinitrogen molecule to the metal is fairly labile; all the compounds lose their nitrogen on mild heating. Some of the nitrogen complexes are only metastable to loss of dinitrogen even at room temperature; accordingly, they cannot be obtained by direct uptake of gaseous nitrogen. In the synthesis of these metastable complexes, hydrazine or azide compounds serve as a source of nitrogen molecules within the coordination sphere of the metal. Addition of other coordinating agents to the nitrogen complexes usually results in a displacement of  $N_2$  from the metal. The cobalt compound in the illustration exchanges its  $N_2$  ligand quite reversibly for other ligand molecules, such as  $NH_3$  and  $H_2C=CH_2$ . Whereas these ligands are easily displaced again by an excess of  $N_2$ , an irreversible exchange occurs with carbon monoxide. The bulky organic groups on the phosphine ligands are likely to interfere with the approach to the metal of all but the slimmest ligands and thereby help the "thin" dinitrogen molecule to main-

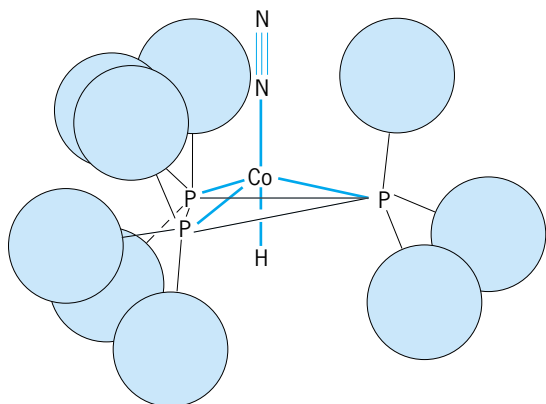

Structure of a coordination compound with  $N_2$  (circles represent phenyl groups).

tain or regain its position on the metal in competition with most other ligands. [H.B.]

**Nitrogen cycle** The collective term given to the natural biological and chemical processes through which inorganic and organic nitrogen are interconverted. It includes the process of ammonification, ammonia assimilation, nitrification, nitrate assimilation, nitrogen fixation, and denitrification.

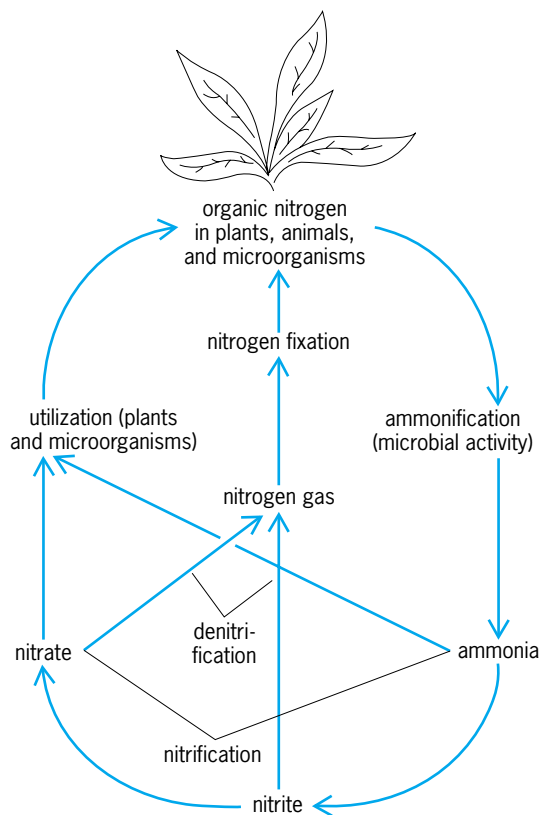

Diagram of the nitrogen cycle.

Nitrogen exists in nature in several inorganic compounds, namely  $N_2$ ,  $N_2O$ ,  $NH_3$ ,  $NO_2^-$ , and  $NO_3^-$ , and in several organic compounds such as amino acids, nucleotides, amino sugars, and vitamins. In the biosphere, biological and chemical reactions continually occur in which these nitrogenous compounds are converted from one form to another. These interconversions are of great importance in maintaining soil fertility and in preventing pollution of soil and water.

An outline showing the general interconversions of nitrogenous compounds in the soil-water pool is presented in the illustration. There are three primary reasons why organisms metabolize nitrogen compounds: (1) to use them as a nitrogen source, which means first converting them to  $NH_3$ , (2) to use certain nitrogen compounds as an energy source such as in the oxidation of  $NH_3$  to  $NO_2^-$  and of  $NO_2^-$  to  $NO_3^-$ , and (3) to use certain nitrogen compounds ( $NO_3^-$ ) as terminal electron acceptors under conditions where oxygen is either absent or in limited supply. The reactions and products involved in these three metabolically different pathways collectively make up the nitrogen cycle.

There are two ways in which organisms obtain ammonia. One is to use nitrogen already in a form easily metabolized to ammonia. Thus, nonviable plant, animal, and microbial residues in soil are enzymatically decomposed by a series of hydrolytic and other reactions to yield biosynthetic monomers such as amino acids and other small-molecular-weight nitrogenous compounds. These amino acids, purines, and pyrimidines are decomposed further to produce  $NH_3$  which is then used by plants and bacteria for biosynthesis, or these biosynthetic monomers

can be used directly by some microorganisms. The decomposition process is called ammonification.

The second way in which inorganic nitrogen is made available to biological agents is by nitrogen fixation (this term is maintained even though  $N_2$  is now called dinitrogen), a process in which  $N_2$  is reduced to  $NH_3$ . Since the vast majority of nitrogen is in the form of  $N_2$ , nitrogen fixation obviously is essential to life. The  $N_2$ -fixing process is confined to prokaryotes (certain photosynthetic and nonphotosynthetic bacteria). The major nitrogen fixers (called diazotrophs) are members of the genus *Rhizobium*, bacteria that are found in root nodules of leguminous plants, and of the cyanobacteria (originally called blue-green algae). See NITROGEN FIXATION. [L.E.Mo.]

**Nitrogen fixation** The chemical or biological conversion of atmospheric nitrogen ( $N_2$ ) into compounds which can be used by plants, and thus become available to animals and humans. In the 1990s, chemical and biological processes together contributed about 260 million tons (230 million metric tons) of fixed nitrogen per year globally. Industrial production of nitrogen fertilizer accounted for about 85 million tons (80 million metric tons) of nitrogen per year, while spontaneous chemical processes, such as lightning, ultraviolet irradiation, and combustion, leading to the synthesis of nitrogen oxides from  $O_2$  and  $N_2$ , may have accounted for 44 million tons (40 million metric tons) per year. The remainder, roughly half of the global input of newly fixed nitrogen, arose from biological processes. World agriculture, which is very dependent on nitrogen fixation, is increasingly reliant on chemical nitrogen sources. See NITROGEN.

**Chemical fixation.** Three chemical processes for fixing atmospheric nitrogen have been developed. All require considerable thermal or electrical energy and yield different products. In arc processes, which are now rarely used, air is passed through an electric arc and about 1% nitric oxide is formed, which can be chemically converted to nitrates. In the cyanamide process, which is now obsolete, heating calcium carbide in nitrogen generates calcium cyanamide, which when moistened hydrolyzes to urea and ammonia. In the widely used Haber process, hydrogen (generated by heating natural gas) is mixed with nitrogen (from air), and burned to yield a nitrogen-hydrogen mixture. The nitrogen-hydrogen mixture is compressed (10–80 megapascals) and heated (200–700°C or 390–1300°F) in the presence of a metal oxide catalyst to give ammonia. The Haber process is the major source of ammonia used for fertilizer. See AMMONIA; CYANAMIDE; ELECTROCHEMICAL PROCESS; FERTILIZER; HIGH-PRESSURE PROCESSES.

**Biological fixation.** Only prokaryotes—bacteria, archaea, and cyanobacteria (earlier called blue-green algae)—fix nitrogen. Nitrogen-fixing microbes, called diazotrophs, fall into two main groups, free-living and symbiotic. See ARCHAEBACTERIA; BACTERIA; CYANOBACTERIA; PROKARYOTAE.

The free-living diazotrophs are subclassified. Aerobic diazotrophs, of which there are over 50 genera, including *Azotobacter*, methane-oxidizing bacteria, and cyanobacteria, require oxygen for growth and fix nitrogen when oxygen is present. *Azotobacter*, some related bacteria, and some cyanobacteria fix nitrogen in ordinary air, but most members of this group fix nitrogen only when the oxygen concentration is low. Free-living diazotrophs, which fix nitrogen only when oxygen is absent or vanishingly low, are widespread. The genera *Bacillus* and *Klebsiella* include many strains of this type, and representatives of symbiotic diazotrophs behave in this way as well. See ALGAE; BACTERIAL PHYSIOLOGY AND METABOLISM.

The best-known symbiotic bacteria belong to the genus *Rhizobium*. Species of *Rhizobium*, or related genera, such as *Bradyrhizobium* and *Sinorhizobium*, colonize the roots of leguminous plants and stimulate the formation of nodules within which they fix nitrogen microaerobically. Both plants and bacteria show specificity; for example, certain types of plants require special strains of rhizobia. Some types of rhizobium, such as *Bradyrhizobium*,

can fix nitrogen in the absence of plant tissue, but require low oxygen, though most rhizobia fix nitrogen only within the nodules. See SOIL MICROBIOLOGY.

The enzymes responsible for nitrogen fixation are called nitrogenases. The most common nitrogenase consists of two proteins, one large containing molybdenum, iron, and inorganic sulfur (the MoFe-protein or dinitrogenase), the other smaller containing iron and inorganic sulfur (the Fe-protein or dinitrogenase reductase). Nitrogenase reduces one molecule of  $N_2$  to two of ammonia ( $NH_3$ ), a reaction which is accompanied by the conversion of 16 molecules of adenosine triphosphate (ATP) to adenosine diphosphate (ADP) and the release of one molecule of  $H_2$  as a by-product. Nitrogenase is irreversibly destroyed by air, so all aerobic diazotrophs have developed means of restricting access of oxygen to the active enzyme. [J.Po.]

**Nitrogen oxides** Chemical compounds of nitrogen and oxygen. Nitrogen and oxygen do not combine when mixed directly (as in air), but they do combine during chemical reactions of compounds containing them. A number of nitrogen oxides can be isolated which differ from one another in the numbers of nitrogen and oxygen atoms present in each molecule. The table gives data for the five nitrogen oxides which are well established.

**Nitrous oxide and nitric oxide.** When inhaled, nitrous oxide has anesthetic effects; in small amounts it produces mild hysteria and hence is sometimes called laughing gas. It is colorless, is the least reactive of the oxides, and dissolves in water without chemical reaction. Some nitric oxide is formed in an electric arc, as in the technical production of nitric acid.

With oxygen or air, nitric oxide is rapidly converted to nitrogen dioxide. Nitric oxide is colorless and is soluble in water without reaction. It is an important messenger molecule in animals. It is one of the few “odd” molecules which contain an odd number of electrons. As an odd molecule, it has the ability to lose or gain one electron, thus giving the electrically charged ions  $NO^+$  and  $NO^-$ . The important nitrosyl compounds contain these ions.

**Trioxide.** Dinitrogen trioxide exists pure only in the solid state. It is the anhydride of nitrous acid; when the oxide is dissolved in an alkaline solution, nitrite ion is produced.

**Dioxide and tetroxide.** The position of the equilibrium between nitrogen dioxide and dinitrogen tetroxide depends upon temperature and physical state. Dinitrogen tetroxide reacts readily with water to give an equimolecular mixture of nitrous and nitric acids. As temperature is raised, the nitrous acid decomposes to nitric acid and nitric oxide. These reactions are important in the technical production of nitric acid by catalytic oxidation of ammonia. Dinitrogen tetroxide is an oxidizing agent comparable in strength to bromine, and is employed as such in the lead-chamber process for sulfuric acid. In organic chemistry the tetroxide finds use as a special oxidizing agent (for example, in the production of sulfoxides and phosphine oxides) and as a nitrating agent.

**Pentoxide.** Solid dinitrogen pentoxide readily volatilizes, and the molecular type of structure found in the gaseous state is observed also in solutions of the oxide in low dielectric solvents such as carbon tetrachloride and chloroform. Sodium metal

Oxides of nitrogen and their properties

Name	Stoichiometric formula	Melting point, °C (°F)	Boiling point, °C (°F)
Nitrous oxide (dinitrogen monoxide)	$N_2O$	-90.8 (-131)	-88.5 (-127.3)
Nitric oxide (nitrogen monoxide)	NO	-163.6 (-262.5)	-151.7 (241.0)
Dinitrogen trioxide	$N_2O_3$	-103 (-155)	3.5 (38.3)
Dinitrogen tetroxide ( $\rightleftharpoons$ nitrogen dioxide)	$N_2O_4$ ( $\rightleftharpoons$ $NO_2$ )	-11.2 (11.8)	21.2 (70.2)
Dinitrogen pentoxide	$N_2O_5$	41 (106)	

reacts with the liquid oxide, liberating nitrogen dioxide and forming sodium nitrate. Gaseous dinitrogen pentoxide decomposes readily, and is a strong oxidizing agent. With water it is converted to nitric acid. See NITRIC OXIDE; NITROGEN; OXYGEN. [C.C.A.]

**Nitroparaffin** Any derivative of an aliphatic hydrocarbon that contains one or more —NO<sub>2</sub> groups bonded via nitrogen to the carbon framework. Nitroparaffins are also known as nitroalkanes.

Low-molecular-weight nitroparaffins are prepared via the vapor-phase nitration of alkanes at >400°C (750°F). However, the process is not generally satisfactory for higher-molecular-weight nitroparaffins because of polynitration and chain cleavage. The direct nitration of propane is used commercially to prepare nitromethane (boiling point 101°C or 214°F), nitroethane (bp 114°C or 237°F), 1-nitropropane (bp 131°C or 268°F), and 2-nitropropane (bp 120°C or 248°F). Nitroparaffins are prepared in the laboratory by the reaction of nitrite salts with alkyl bromides or iodides, from the oxidation of amines or oximes by using peroxy-carboxylic acids, and by the chain homologation of simple nitroparaffins. See NITRATION.

Nitromethane, nitroethane, and the nitropropanes are useful solvents with high dielectric constants that readily dissolve many polymers. In addition, these simple nitroparaffins are versatile intermediates for the synthesis of specialty chemicals. [A.G.M.B.]

**Nobelium** A chemical element, No, atomic number 102. Nobelium is a synthetic element produced in the laboratory. It decays by emitting an alpha particle, that is, a doubly charged helium ion. Only atomic quantities of the element have been produced to date. Nobelium is the tenth element heavier than uranium to be produced synthetically. It is the thirteenth member of the actinide series, a rare-earth-like series of elements. See ACTINIDE ELEMENTS; PERIODIC TABLE; RADIOACTIVITY; RARE-EARTH ELEMENTS; TRANSURANIUM ELEMENTS. [P.R.F.]

**Noeggerathiales** An incompletely known and poorly de-fined group of vascular plants whose geologic range extends from Upper Carboniferous to Triassic. Their taxonomic status and position in the plant kingdom are uncertain since morphological evidence (because of the paucity of the fossil record) does not make it possible to place the group confidently in any recognized major subdivision of the vascular plants. The Noeggerathiales have been proposed in the evolutionary scheme in two remotely related groups of vascular plants, the Pteropsida and the Sphenopsida. See PALEOBOTANY; PLANT KINGDOM. [E.S.B.]

**Noise measurement** The process of quantitatively determining one or more properties of acoustic noise. In noise assessment and control studies, knowledge of the physical properties of the undesirable sound is the initial step toward understanding the situation and what should be done to reduce or eliminate a noise problem.

The most common measures of noise are of the magnitude and frequency content of the noise sound pressure, time-averaged or as a function of time. Of increasing interest are metrics of sound quality (that may include both physical and psychoacoustic factors), such as loudness, pitch strength, and fluctuation strength. To characterize the noise output of a source, sound power level may be determined. To locate a source or to quantify propagation paths, sound intensity level may be measured.

Essentially all noise measurements are performed using electronic equipment. An electroacoustic transducer (a microphone in air and other gases; a hydrophone in water and other liquids) transforms sound (usually the sound pressure) at the point of observation into a corresponding electrical signal. This electrical signal is then operated on by analog or digital means with devices such as signal conditioners, filters, and detectors to de-

termine the value (or values) of interest. This value is then given on an indicating meter or digital display. See ELECTRIC FILTER; HYDROPHONE; MICROPHONE; TRANSDUCER.

For noise measurements in air, a sound-level meter is the most commonly used instrument. The simplest sound-level meter comprises a microphone, a frequency-weighting filter, a root-mean-square (rms) detector, and logarithmic readout of the sound pressure level in decibels relative to 20 micropascals. Standard frequency weightings, designated A and C, were originally developed to approximate human response to noise at low and high levels, respectively, but now are used as specified in standards and legislation without regard to their origin. More sophisticated sound-level meters incorporate standardized octave-band or fractional-octave-band filters, and provide additional metrics and analysis capabilities. See DECIBEL; LOUDNESS.

Selection of a noise metric and measurement instrument generally depends upon the application. Four classes of application are: (1) discrete source emission, (2) hearing conservation, (3) outdoor environmental noise, and (4) indoor room noise. Within these classes there are found additional subclasses, measurements for enforcement of legal limits often being done differently than those for comfort, aircraft sonic boom being measured differently than power plant noise, and so on. [J.Pop.]

**Nomograph** A graphical relationship between a set of variables that are related by a mathematical equation or law. The fundamental principle involved in the construction of a nomographic or alignment chart consists of representing an equation containing three variables,  $f(u, v, w) = 0$ , by means of three scales in such a manner that a straight line cuts the three scales in values of  $u$ ,  $v$ , and  $w$ , satisfying the equation. The cutting line is called the isopleth or index line. Numbers may be quickly and easily read from the scales of such a chart even by one unfamiliar with the construction of the chart and the equation involved. The illustration shows such an example. Assume that it is desired to find the value of  $E$  when  $D = 2$  and  $Q = 50$ . Lay a straightedge through 50 on the  $Q$  scale and through 2 on the  $D$  scale and read 11.8 at its intersection with the  $E$  scale. As another example, it might be desired to know what value or values of  $D$  should be used if  $E$  and  $Q$  are required to be 10 and 60, respectively. A straightedge through  $E = 10$  and  $Q = 60$  cuts the  $D$  scale in two points,  $D = 2.8$  and  $D = 9.4$ . This is equivalent to finding two

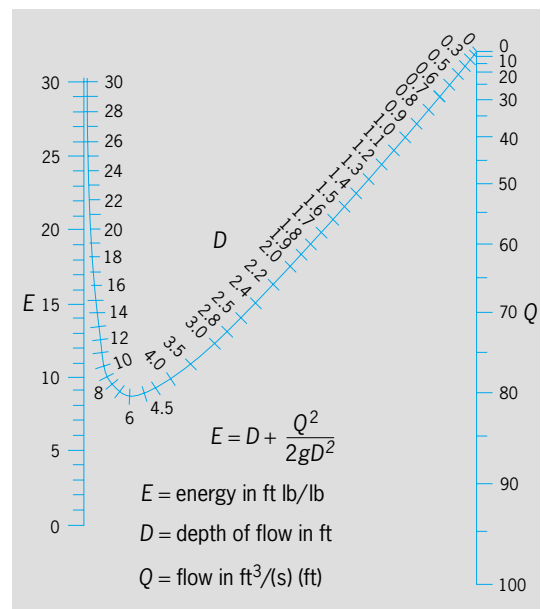

Nomograph for energy content of a rectangular channel with uniform flow.

positive roots of the cubic equation  $D^3 - 10D^2 + 56.25 = 0$ . It is assumed that  $g = 32 \text{ ft/s}^2$  in this equation. [R.D.D.]

**Nondestructive evaluation** Nondestructive evaluation (NDE) is a technique used to probe and sense material structure and properties without causing damage. It has become an extremely diverse and multidisciplinary technology, drawing on the fields of applied physics, artificial intelligence, biomedical engineering, computer science, electrical engineering, electronics, materials science and engineering, mechanical engineering, and structural engineering. Historically, NDE techniques have been used almost exclusively for detection of macroscopic defects (mostly cracks) in structures which have been manufactured or placed in service. Using NDE for this purpose is usually referred to as nondestructive testing (NDT).

A developing use of NDE methods is the nondestructive characterization (NDC) of materials properties (as opposed to revealing flaws and defects). Characterization typically sets out to establish absolute or relative values of material properties such as mechanical strength (elastic moduli), thermal conductivity or diffusivity, optical properties, magnetic parameters, residual strains, electrical resistivity, alloy composition, the state of cure in polymers, crystallographic orientation, and the degree of crystalline perfection. Nondestructive characterization can also be used for a variety of other specialized properties that are relevant to some aspect of materials processing in production, including determining how properties vary with the direction within the material, a property called anisotropy.

Much effort has been directed to developing techniques that are capable of monitoring and controlling (1) the materials production process; (2) materials stability during fabrication, transport, and storage; and (3) the amount and rate of degradation during the postfabrication in-service life for both components and structures. Real-time process monitoring for more efficient real-time process control, improved product quality, and increased reliability has become a practical reality. See MATERIALS SCIENCE AND ENGINEERING.

Visual inspection is the oldest and most versatile NDE tool. In visual inspection, a worker examines a material using only eyesight. The liquid (or dye) penetrant visual method uses brightly colored liquid dye to penetrate and remain in very fine surface cracks after the surface is cleaned of residual dye. The magnetic particle visual method requires that a magnetic field be generated inside a ferromagnetic test object. Flux leakage occurs where there are discontinuities on the surface. Magnetic particles (dry powder or a liquid suspension) are captured at the leakage location and can be readily seen with proper illumination.

The eddy current method uses a probe held close to the surface of a conducting test object. X-rays provide a varied and powerful insight into material, but they are somewhat limited for use in the field. The acoustic emission technique typically uses a broadband piezoelectric transducer to listen for acoustic noise. The thermography technique uses a real-time "infrared camera," much like a home camcorder, except that it forms images using infrared photons instead of visible ones. Contact ultrasonics technique is the workhorse of traditional and mature NDE technology. It uses a transducer held in contact with a test object to launch ultrasonic pulses and receive echoes. See EDDY CURRENT; X-RAY DIFFRACTION.

Many noncontact measurements have been developed that enhance the mature technologies. These include noncontact ultrasonic transducers that involve laser ultrasonics, electromagnetic acoustic transducers, and air- or gas-coupled transducers. Thermal wave imaging uses a main laser beam to scan the surface of the object to be examined. Electronic speckle pattern interferometry is a noncontact, full-field optical technique for high-sensitivity measurement of extremely small displacements in an object's surface. "Speckle" refers to the grainy appearance of an optically rough surface illuminated by a laser. Development

of microwave techniques are under way in such diverse applications as ground-penetrating radar for land-mine detection, locating delaminations in highway bridge decks, and monitoring the curing process in polymers. See INTERFEROMETRY; LASER; TRANSDUCER; ULTRASONICS. [J.M.Win.]

**Noneuclidean geometry** A system of geometry based upon a set of axioms different from those of the euclidean geometry based on the three-dimensional space of experience. Noneuclidean geometries, especially riemannian geometry, are useful in mathematical physics. See DIFFERENTIAL GEOMETRY; EUCLIDEAN GEOMETRY; PROJECTIVE GEOMETRY; RIEMANNIAN GEOMETRY. [J.D.C.]

K. F. Gauss is credited with discovering an "elliptic" noneuclidean geometry in which there are no parallels, but the other euclidean axioms are satisfied. One way to model it is to call each diameter of a sphere a "point," and call each plane through the center (intersecting the sphere in a great circle) a "line." Then each two points determine a unique line and each two lines determine one point.

Another type of noneuclidean geometry, called hyperbolic geometry, was discovered about 1830 by J. Bolyai and N. I. Lobachevski. Through a given point  $P$  not on a line  $l$ , there are many lines that do not meet  $l$ . This geometry may be modeled by defining as "lines" those circular arcs that meet a large circle  $C$  at right angles and restricting the term "points" to those within the absolute circle  $C$ . Then two points determine a unique line, but there are many lines through a point  $P$  not on a line  $l$  that do not intersect  $l$ . Since consistent geometries exist in which the parallel postulate does not hold, this postulate is independent of the others. [J.S.Fra.]

According to whether the geometry is elliptic, euclidean, or hyperbolic, the sum of the angles of a geodesic triangle is greater than  $\pi$ , equal to  $\pi$ , or less than  $\pi$ .

Elliptic geometry of two dimensions may be represented upon a sphere in euclidean space of three dimensions. On the other hand, hyperbolic geometry of two dimensions can be depicted on a pseudosphere in euclidean space of three dimensions. The pseudosphere is obtained by revolving the tractrix about its asymptote. [J.D.C.]

**Nonlinear acoustics** The study of amplitude-dependent acoustical phenomena. The amplitude dependence is due to the nonlinear response of the medium in which the sound propagates, and not to the nonlinear behavior of the sound source. According to the linear theory of acoustics, increasing the level of a source by 10 dB results in precisely the same sound field as before, just 10 dB more intense. Linear theory also predicts that only frequency components radiated directly by the source can be present in the sound field. These principles do not hold in nonlinear acoustics. See AMPLITUDE (WAVE MOTION); LINEARITY; NONLINEAR PHYSICS.

The extent to which nonlinear acoustical effects are strong or even significant depends on the competing influences of energy loss, frequency dispersion, geometric spreading, and diffraction. When conditions are such that nonlinear effects are strong, acoustic signals may experience substantial waveform distortion and changes in frequency content as they propagate, and shock waves may be present. Nonlinear acoustical effects occur in gases, liquids, and solids, and they are observed over a broad range of frequencies. Shock waves present in sonic booms and thunder claps are in the audio frequency range. Principles of nonlinear acoustics form the basis for procedures at megahertz frequencies used in medical ultrasound and nondestructive evaluation of materials. Nonlinearity can also induce changes in nonfluctuating properties of the medium. These include acoustic streaming, which is the steady fluid flow produced by the absorption of sound, and radiation pressure, which results in a steady force exerted by sound on its surroundings. See ACOUSTIC



RADIATION PRESSURE; BIOMEDICAL ULTRASONICS; NONDESTRUCTIVE EVALUATION; SHOCK WAVE; SONIC BOOM; THUNDER.

The principal feature that distinguishes nonlinear acoustics from nonlinear optics is that most acoustical media exhibit only weak dispersion, whereas media in which nonlinear optical effects arise exhibit strong dispersion. Dispersion is the dependence of propagation speed on frequency. In optical media, strong nonlinear wave interactions require that phase-matching conditions be satisfied, which can be accomplished only for several frequency components at one time. In contrast, all frequency components in a sound wave propagate at the same speed and are automatically phase-matched, which permits strong nonlinear interactions to occur among all components in the frequency spectrum. See NONLINEAR OPTICS.

Acoustic streaming is a nonlinear effect because the velocity of the flow depends quadratically on the amplitude of the sound, and the flow is not predicted by linear theory. Absorption due to viscosity and heat conduction results in a transfer of momentum from the sound field to the fluid. This momentum transfer manifests itself as steady fluid flow.

Acoustic streaming produced in sound beams is enhanced considerably when shocks develop. Shock formation generates a frequency spectrum rich in higher harmonics. Because thermoviscous absorption increases quadratically with frequency, attenuation of the wave, and therefore the streaming velocity, increases markedly following shock formation. Streaming is also generated in acoustic boundary layers formed by standing waves in contact with surfaces. Measurements of acoustic streaming have been used to determine the bulk viscosity coefficients of fluids. Thermoacoustic engines and refrigerators are adversely affected by heat transport associated with streaming. See THERMOACOUSTICS.

Phase conjugation refers to wavefront reversal, also called time reversal, at a single frequency. The latter terminologies more clearly describe this procedure. A waveform is captured by a phase conjugation device and reversed in such a way that it propagates back toward the source in the same way that it propagated toward the conjugator. Sound that is radiated from a point source and propagates through an inhomogeneous medium that introduces phase distortion in the wave field is thus retransmitted by the conjugator in such a way as to compensate for the phase distortion and to focus the wave back on the point source.

Phase conjugation is used to compensate for phase distortion in applications involving imaging and retargeting of waves on sources. The most successful techniques for acoustical phase conjugation are based on modulation of acoustical properties of a material that captures the incident sound wave. The modulation is twice the frequency of the incident sound wave, and it is induced by an electric field applied to piezoelectric material, or a magnetic field applied to magnetostrictive material. Often the modulated property of interest is the sound speed in the material. When the incident wave at frequency  $f$  propagates through a medium in which the sound speed fluctuates at frequency  $2f$ , parametric interaction generates a wave at the difference frequency  $f$  that propagates backward as though reversed in time. See MAGNETOSTRICTION; OPTICAL PHASE CONJUGATION; PIEZOELECTRICITY.

Phenomena associated with nonlinear acoustics have proved useful in both diagnostic and therapeutic applications of biomedical ultrasound. A very significant breakthrough in diagnostic imaging, especially for echocardiography and abdominal ultrasound imaging, is based on second-harmonic generation. Medical ultrasound imaging is performed at frequencies of several megahertz. Images constructed from the backscattered second-harmonic component have substantially reduced clutter and haze associated with the propagation of ultrasound through the outer layers of skin, which is the primary cause of phase aberrations. In another technique, microbubbles are injected into the bloodstream to enhance echoes backscattered from blood flow. The microbubbles are fabricated to make them resonant at

diagnostic imaging frequencies, and they become strongly nonlinear oscillators when excited by ultrasound. Imaging is based on echoes at harmonics of the transmitted signal. Frequencies backscattered from the microbubbles differ from those in echoes coming from the surrounding tissue, which highlights the locations of the microbubbles and therefore of the blood flow itself.

A notable therapeutic application is lithotripsy, which refers to the noninvasive disintegration of kidney stones and gallstones with focused shock waves. Nonlinear acoustical effects in lithotripsy are associated not only with propagation of the shock wave but also with the generation of cavitation activity near the stones. Radiation of shock waves due to the collapse of cavitation bubbles is believed to be the dominant cause of stone breakup. An emerging therapeutic application, high-intensity focused ultrasound (HIFU), utilizes the heat dissipated by shock waves that develop in beams of focused ultrasound. The heating is so intense and localized that the potential exists for noninvasive cauterization of internal wounds and removal of tumors and scar tissue. See CAVITATION; ULTRASONICS. [M.F.H.]

**Nonlinear control theory** A control system involves a plant and a controller. Plants are objects as diverse as a satellite, a distillation column, a robot arm, and a colony of bacteria. After measuring actual outputs of the plant, the controller computes signals that are applied at the inputs to the plant to achieve desired outputs. The design of controllers must be based upon mathematical models of plants, which are in most realistic situations composed of nonlinear differential and difference equations. A standard approach is to linearize the equations and use the powerful methods available for the design of linear control systems. See DIFFERENTIAL EQUATION; LINEAR SYSTEM ANALYSIS; OPTIMAL CONTROL (LINEAR SYSTEMS).

When the controlled outputs are allowed to have large deviations from the desired steady-state values, a linearized model will cease to describe the plant accurately, thereby causing erroneous results in the design. Linearized design models also fail in those important situations where nonlinearities are introduced into a controller to achieve a desired performance, generally at reduced cost. Typical examples of nonlinear controllers are on-off relays for temperature regulation in heating and cooling systems, switching elements in robot manipulators, and jet thrusters for the attitude control of space vehicles.

Unlike linear systems, there is no general theory for nonlinear systems. Nonlinear control theory is fragmented into areas centered around those classes of systems that are most prominent in applications.

A simple nonlinear control system is the inverted pendulum (illus. a), where it is required to keep the pendulum in an upright position by applying the torque  $u(t)$  at its base. The pendulum can be considered as a generic model for a rocket booster

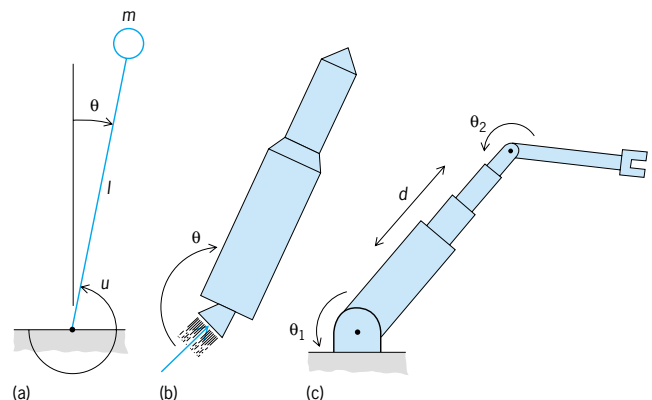

**Nonlinear systems.** (a) Inverted pendulum, which serves as a model for (b) a rocket booster and (c) a robot arm.

balanced on top of a gimbaled thruster engine (illus. *b*), and a controlled robot arm (illus. *c*). Newton's second law of motion for the pendulum is Eq. (1), where  $m$  is the mass of the bob,

$$m\dot{\theta}(t) = \frac{mg}{\ell} \sin \theta(t) + u(t) \quad (1)$$

$\ell$  is the length of the pendulum, and  $g$  is the acceleration due to gravity. By choosing the angular position  $\theta = x_1$  and angular velocity  $\dot{\theta} = x_2$  of the bob as the state of the system, Eq. (1) can be rewritten as two first-order state equations (2).

$$\begin{aligned} \dot{x}_1 &= x_2 \\ \dot{x}_2 &= \frac{g}{\ell} \sin x_1 + u \end{aligned} \quad (2)$$

See PENDULUM.

If the torque is absent ( $u = 0$ ), the upright position of a motionless pendulum ( $\dot{x}_1 = 0$ ,  $\dot{x}_2 = 0$ ) is an equilibrium state:  $x_1 = 0$ ,  $x_2 = 0$ . If the pendulum is slightly perturbed at this state, it will fall down and keep oscillating around the other equilibrium point at  $x_1 = \pi$  and  $x_2 = 0$ , where again,  $\dot{x}_1 = 0$  and  $\dot{x}_2 = 0$ .

To keep the pendulum in the upright position in physically realistic situations involving perturbations, the torque  $u$  is chosen to be a suitable function  $\phi$  of the state  $x_1$ ,  $x_2$ , as in Eq. (3). That

$$u = \phi(x_1, x_2) \quad (3)$$

$u$  should be a feedback control law in terms of the state is one of the most important results of control theory. [D.D.S.]

**Nonlinear optical devices** Devices that use the fact that the polarization in any real medium is a nonlinear function of the optical field strength to implement various useful functions. The nonlinearities themselves can be grouped roughly into second-order and third-order. Materials that possess inversion symmetry typically exhibit only third-order nonlinearities, whereas materials without inversion symmetry can exhibit both second- and third-order nonlinearities. See CRYSTALLOGRAPHY; ELECTRIC SUSCEPTIBILITY; ELECTROMAGNETIC RADIATION; POLARIZATION OF DIELECTRICS.

**Second-order devices.** Devices based on the second-order nonlinearity involve three-photon (or three-wave) mixing. In this process, two photons are mixed together to create a third photon, subject to energy- and momentum-conservation constraints. Different names are ascribed to this mixing process, depending upon the relative magnitudes of the energies of the three photons. See CONSERVATION OF ENERGY; CONSERVATION OF MOMENTUM.

When the two beginning photons are of equal energy or frequency, the mixing process gives a single photon with twice the energy or frequency of the original ones. This mixing process is called second-harmonic generation. Second-harmonic generation is used often in devices where photons of visible frequency are desired but the available underlying laser system is capable of producing only infrared photons. For example, the neodymium-doped yttrium-aluminum-garnet (Nd:YAG) laser produces photons in the infrared with a wavelength of 1.06 micrometers. These photons are mixed in a crystal with a large second-order nonlinearity and proper momentum-conservation characteristics to yield green second-harmonic photons of 0.532- $\mu\text{m}$  wavelength. Under different momentum-conservation constraints, a similar interaction can take place between two photon fields of different frequency, resulting in photons whose energy or frequency is the sum of those of the original photons. This process is called sum-frequency mixing. See LASER.

Optical parametric oscillation/amplification occurs when one of the two initial photons has the largest energy and frequency of the three. A high-energy photon and a low-energy photon mix to give a third photon with an energy equal to the difference between the two initial photons. If initially the third field amplitude is zero, it is possible to generate a third field from nothing; in this case the process is called optical parametric oscillation. If the third field exists but at a low level, it can be amplified through the

optical parametric amplification process. See PARAMETRIC AMPLIFIER.

**Third-order devices.** Devices based on the third-order nonlinearity involve a process called four-photon (or four-wave) mixing. In this process, three photons are mixed together to create a fourth photon, subject to energy- and momentum-conservation constraints. The four-photon mixing nonlinearity is responsible for the existence of so-called self-action effects where the refractive index and absorption coefficient of a light field are modified by the light field's own presence, for third-harmonic generation and related processes, and for phase-conjugation processes.

In a medium with a third-order nonlinearity, the refractive index and absorption coefficient of a light field present in the medium are modified by the strength of the light intensity. Because the field effectively acts on itself, this interaction is termed a self-action effect. The momentum-conservation constraints are automatically satisfied because of the degenerate frequencies involved in the interaction. Such an interaction manifests itself by changing the total absorption experienced by the light field as well as by changing the velocity of propagation of the light field. See ABSORPTION OF ELECTROMAGNETIC RADIATION; REFRACTION OF WAVES.

There are many devices based on the self-action effects. A reverse saturable absorber becomes more opaque because of the nonlinear absorption (also called two-photon adsorption) that it manifests. Refractive-index changes can be used to change the transmission characteristics of resonant cavities and other structures by modifying the effective optical path length (the product of actual structure length times the effective refractive index for the structure) and shifting the cavity resonances to other frequencies. Several nonlinear optical switches have been proposed based upon this resonance-shifting phenomenon. See CAVITY RESONATOR; OPTICAL BISTABILITY.

In a third-harmonic generation process, three photons of like energy and frequency are mixed to yield a single photon with three times the energy and frequency of the initial photons. Applications of third-harmonic generation are typically in the areas of frequency upconversion.

Phase-conjugation devices make use of a property that third-order media possess whereby energy- and frequency-degenerate photons from two counterpropagating fields are mixed with an incoming photon to yield a photon with exactly the opposite propagation direction and conjugate phase. This phase-conjugate field will pass out of the nonlinear optical device in exactly the direction opposite to the incoming field. Such devices are used in phase-conjugate mirrors, mirrors which have the ability to cancel phase variation in a beam due to, for example, atmospheric turbulence. See ADAPTIVE OPTICS; OPTICAL PHASE CONJUGATION.

The suitability of available nonlinear optical materials is a critical factor in the development of nonlinear optical devices. For certain applications, silica glass fibers may be used. Because of the long propagation distances involved in intercontinental transmission systems, the small size of the optical nonlinearity in silica is not a drawback. Other key materials are semiconductors [such as gallium arsenide (GaAs), zinc selenide (ZnSe), and indium gallium arsenide phosphide (InGaAsP)], certain organic polymeric films, hybrid materials such as semiconductor-doped glasses, and liquid crystals. See NONLINEAR OPTICS; OPTICAL MATERIALS. [D.R.A.]

**Nonlinear optics** A field of study concerned with the interaction of electromagnetic radiation and matter in which the matter responds in a nonlinear manner to the incident radiation fields. The nonlinear response can result in intensity-dependent variation of the propagation characteristics of the radiation fields or in the creation of radiation fields that propagate at new frequencies or in new directions. Nonlinear effects can take place in solids, liquids, gases, and plasmas, and may involve one or more electromagnetic fields as well as internal excitations of the

medium. Most of the work done in the field has made use of the high powers available from lasers. The wavelength range of interest generally extends from the far-infrared to the vacuum ultraviolet, but some nonlinear interactions have been observed at wavelengths extending from the microwave to the x-ray ranges. See LASER.

**Nonlinear materials.** Nonlinear effects of various types are observed at sufficiently high light intensities in all materials. It is convenient to characterize the response of the medium mathematically by expanding it in a power series in the electric and magnetic fields of the incident optical waves. The linear terms in such an expansion give rise to the linear index of refraction, linear absorption, and the magnetic permeability of the medium, while the higher-order terms give rise to nonlinear effects. See ABSORPTION OF ELECTROMAGNETIC RADIATION; REFRACTION OF WAVES.

In general, nonlinear effects associated with the electric field of the incident radiation dominate over magnetic interactions. The even-order dipole susceptibilities are zero except in media which lack a center of symmetry, such as certain classes of crystals, certain symmetric media to which external forces have been applied, or at boundaries between certain dissimilar materials. Odd-order terms can be nonzero in all materials regardless of symmetry. Generally the magnitudes of the nonlinear susceptibilities decrease rapidly as the order of the interaction increases. Second- and third-order effects have been the most extensively studied of the nonlinear interactions, although effects up to order 30 have been observed in a single process. In some situations, multiple low-order interactions occur, resulting in a very high effective order for the overall nonlinear process. For example, ionization through absorption of effectively 100 photons has been observed. In other situations, such as dielectric breakdown or saturation of absorption, effects of different order cannot be separated, and all orders must be included in the response. See ELECTRIC SUSCEPTIBILITY; POLARIZATION OF DIELECTRICS.

**Stimulated scattering.** Light can scatter inelastically from fundamental excitations in the medium, resulting in the production of radiation at a frequency that is shifted from that of the incident light by the frequency of the excitation involved. The difference in photon energy between the incident and scattered light is accounted for by excitation or deexcitation of the medium. Some examples are Brillouin scattering from acoustic vibrations; various forms of Raman scattering involving molecular rotations or vibrations, electronic states in atoms or molecules, lattice vibrations or spin waves in solids, spin flips in semiconductors, and electron plasma waves in plasmas; Rayleigh scattering involving density or entropy fluctuations; and scattering from concentration fluctuations in gases. See SCATTERING OF ELECTROMAGNETIC RADIATION.

At the power levels available from pulsed lasers, the scattered light experiences exponential gain, and the process is then termed stimulated, in analogy to the process of stimulated emission in lasers. In stimulated scattering, the incident light can be almost completely converted to the scattered radiation. Stimulated scattering has been observed for all of the internal excitations listed above. The most widely used of these processes are stimulated Raman scattering and stimulated Brillouin scattering.

**Self-action and related effects.** Nonlinear polarization components at the same frequencies as those in the incident waves can result in effects that change the index of refraction or the absorption coefficient, quantities that are constants in linear optical theory. For example, propagation through optical fibers can involve several nonlinear optical interactions. Self-phase modulation resulting from the nonlinear index can be used to spread the spectrum, and subsequent compression with diffraction gratings and prisms can be used to reduce the pulse duration. The shortest optical pulses, with durations of the order of 6 femtoseconds, have been produced in this manner. Linear dispersion in fibers causes pulses to spread in duration and is one of the major limitations on data transmission through fibers. Dispersive pulse spreading can be minimized with solitons, which

are specially shaped pulses that propagate long distances without spreading. They are formed by a combined interaction of spectral broadening due to the nonlinear refractive index and anomalous dispersion found in certain parts of the spectrum. See SOLITON.

**Coherent effects.** Another class of effects involves a coherent interaction between the optical field and an atom in which the phase of the atomic wave functions is preserved during the interaction. These interactions involve the transfer of a significant fraction of the atomic population to an excited state. As a result, they cannot be described with the simple perturbation expansion used for the other nonlinear optical effects. Rather they require that the response be described by using all powers of the incident fields. These effects are generally observed only for short light pulses, of the order of several nanoseconds or less. In one interaction, termed self-induced transparency, a pulse of light of the proper shape, magnitude, and duration can propagate unattenuated in a medium which is otherwise absorbing.

Other coherent effects involve changes of the propagation speed of a light pulse or production of a coherent pulse of light, termed a photon echo, at a characteristic time after two pulses of light spaced apart by a time interval have entered the medium. Still other coherent interactions involve oscillations of the atomic polarization, giving rise to effects known as optical nutation and free induction decay. Two-photon coherent effects are also possible.

**Nonlinear spectroscopy.** The variation of the nonlinear susceptibility near the resonances that correspond to sum- and difference-frequency combinations of the input frequencies forms the basis for various types of nonlinear spectroscopy which allow study of energy levels that are not normally accessible with linear optical spectroscopy.

Nonlinear spectroscopy can be performed with many of the interactions discussed earlier. Multiphoton absorption spectroscopy can be performed by using two strong laser beams, or a strong laser beam and a weak broadband light source. If two counterpropagating laser beams are used, spectroscopic studies can be made of energy levels in gases with spectral resolutions much smaller than the Doppler limit. Nonlinear optical spectroscopy has been used to identify many new energy levels with principal quantum numbers as high as 150 in several elements. See RESONANCE IONIZATION SPECTROSCOPY; RYDBERG ATOM.

Many types of four-wave mixing interactions can also be used in nonlinear spectroscopy. The most widespread of these processes, termed coherent anti-Stokes Raman spectroscopy (CARS), offers the advantage of greatly increased signal levels over linear Raman spectroscopy for the study of certain classes of materials.

**Phase conjugation.** Optical phase conjugation is an interaction that generates a wave that propagates in the direction opposite to a reference, or signal, wave, and has the same spatial variations in intensity and phase as the original signal wave, but with the sense of the phase variations reversed. Several nonlinear interactions are used to produce phase conjugation.

Optical phase conjugation allows correction of optical distortions that occur because of propagation through a distorting medium. This process can be used for improvement of laser-beam quality, optical beam combining, correction of distortion because of mode dispersion in fibers, and stabilized aiming. It can also be used for neural networks that exhibit learning properties. See NEURAL NETWORK; OPTICAL PHASE CONJUGATION. [J.F.R.]

**Photorefractive effect.** The photorefractive effect occurs in many electrooptic materials. A change in the index of refraction in a photorefractive medium arises from the redistribution of charge that is induced by the presence of light. Charge carriers that are trapped in impurity sites in a photorefractive medium are excited into the material's conduction band when exposed to light. The charges migrate in the conduction band until they become retrapped at other sites. The charge redistribution produces an electric field that in turn produces a spatially varying

index change through the electrooptic effect in the material. Unlike most other nonlinear effects, the index change of the photorefractive effect is retained for a time in the absence of the light and thus may be used as an optical storage mechanism. Storage times range from milliseconds to months or years, depending upon the material and the methods employed. See TRAPS IN SOLIDS.

Photorefractive materials are often used for holographic storage. In this case, the index change mimics the intensity interference pattern of two beams of light. Over 500 holograms have been stored in the volume of a single crystal of iron-doped lithium niobate. See HOLOGRAPHY.

Photorefractive materials are typically sensitive to very low light levels. The photorefractive effect is, however, extremely slow by the standards of optical nonlinearity. Because of their sensitivity, photorefractive materials are increasingly used for image and optical-signal processing applications. See IMAGE PROCESSING; NONLINEAR OPTICAL DEVICES. [D.Z.A.]

**Nonlinear physics** The study of situations where, in a general sense, cause and effect are not proportional to each other; in other words, if the measure of what is considered to be the cause is doubled, the measure of its effect is not simply twice as large. Many examples have been known in physics for a long time, and they seemed well understood. Over the last few decades, however, physicists have noticed that this lack of proportionality in some of the basic laws of physics often leads to unexpected complications, if not to outright contradictions. Thus, the term nonlinear physics refers more narrowly to these developments in the understanding of physical reality.

**Linearity in nonlinear systems.** When a large number of particles starts out in a condition of stable equilibrium, the result of small external forces is well-coordinated vibrations of the whole collection, for example, the vibrations of a violin string, or of the electric current in an antenna. Each collective motion acts like an independent oscillator, each with its own frequency. In more complicated systems, many vibrational modes can be active simultaneously without mutual interference. A large dynamical system is, therefore, described in terms of its significant degrees of freedom, thought to be only loosely coupled. The motion of any part of the whole becomes multiperiodic; for example, a water molecule has bending and stretching vibrations with different frequencies, and both are coupled with the rotational motion of the whole molecule. See ANTENNA (ELECTROMAGNETISM); DEGREE OF FREEDOM (MECHANICS); MOLECULAR STRUCTURE AND SPECTRA; VIBRATION.

**Failure of perturbation theory.** H. Poincaré discovered at the end of the nineteenth century that for many problems this perturbation theory is not entirely satisfactory. He showed, in the case of the Moon's motion around the Earth, that the disturbance by the Sun is strong enough that this standard mathematical procedure fails. The main culprits are resonances, which occur when the frequencies of different degrees of freedom are combined through their nonlinear coupling. A key nonperturbative phenomenon is known to engineers as phase lock: When different frequencies arise in simple multiples of one another, the whole dynamical system falls into a dynamical trap; and for a continuous range of initial conditions, the interaction changes the frequencies of the individual degrees of freedom sufficiently to "lock" the motion into the resonance. See ASTEROID; PHASE-LOCKED LOOPS; RESONANCE (ACOUSTICS AND MECHANICS).

**KAM theorem.** In the 1950s, A. N. Kolmogoroff provided a first account of how the addition of a weak coupling generates chaotic regions and islands in phase space. This problem was later worked out in detail by V. Arnold and J. Moser to yield the KAM theorem. This theorem gives detailed information about the loss of the regular structure as the strength of the coupling increases. It does not say anything, however, about the trajectories in the newly created areas of chaotic behavior. These further investigations are the main goal of such fields as chaos or com-

plexity. The impact of Poincaré's general arguments and the KAM theorem reaches into every area of nonlinear physics. The oldest among the areas is hydrodynamics, where the phenomenon of turbulent flow has so far resisted any effective control. This is what makes weather prediction so difficult. Signal propagation along the nerves and transmission of pulses through synaptic connections are other well-known nonlinear processes. See CHAOS; NEUROBIOLOGY; NONLINEAR ACOUSTICS; NONLINEAR OPTICS.

[M.C.G.]

**Nonlinear programming** The area of applied mathematics and operations research concerned with finding the largest or smallest value of a function subject to constraints or restrictions on the variables of the function. Nonlinear programming is sometimes referred to as nonlinear optimization.

A useful example concerns a power plant that uses the water from a reservoir to cool the plant. The heated water is then piped into a lake. For efficiency, the plant should be run at the highest possible temperature consistent with safety considerations, but there are also limits on the amount of water that can be pumped through the plant, and there are ecological constraints on how much the lake temperature can be raised. The optimization problem is to maximize the temperature of the plant subject to the safety constraints, the limit on the rate at which water can be pumped into the plant, and the bound on the increase in lake temperature.

The nonlinear programming problem refers specifically to the situation in which the function to be minimized or maximized, called the objective function, and the functions that describe the constraints are nonlinear functions. Typically, the variables are continuous; this article is restricted to this case.

Researchers in nonlinear programming consider both the theoretical and practical aspects of these problems. Theoretical issues include the study of algebraic and geometric conditions that characterize a solution, as well as general notions of convexity that determine the existence and uniqueness of solutions. Among the practical questions that are addressed are the mathematical formulation of a specific problem and the development and analysis of algorithms for finding the solution of such problems.

The general nonlinear programming problem can be stated as that of minimizing a scalar-valued objective function  $f(\mathbf{x})$  over all vectors  $\mathbf{x}$  satisfying a set of constraints. The constraints are in the form of general nonlinear equations and inequalities. Mathematically, the nonlinear programming problem may be expressed as below, where  $\mathbf{x} = (x_1, x_2, \dots, x_n)$  are the variables of the problem,

$$\begin{aligned} &\text{minimize } f(\mathbf{x}) \text{ with respect to } \mathbf{x} \\ &\text{subject to: } g_i(\mathbf{x}) \leq 0, \quad i = 1, 2, \dots, m \\ &\quad h_j(\mathbf{x}) = 0, \quad j = 1, 2, \dots, p \end{aligned}$$

$f$  is the objective function,  $g_i(\mathbf{x})$  are the inequality constraints, and  $h_j(\mathbf{x})$  are the equality constraints. This formulation is general in that the problem of maximizing  $f(\mathbf{x})$  is equivalent to minimizing  $-f(\mathbf{x})$  and a constraint  $g_i(\mathbf{x}) \geq 0$  is equivalent to the constraint  $-g_i(\mathbf{x}) \leq 0$ .

Since general nonlinear equations cannot be solved in closed form, iterative methods must be used. Such methods generate a sequence of approximations, or iterates, that will converge to a solution under specified conditions. Newton's method is one of the best-known methods and is the basis for many of the fastest methods for solving the nonlinear programming problem.

[P.T.B.]

**Nonmetal** The elements are conveniently, but arbitrarily, divided into metals and nonmetals. The nonmetals do not conduct electricity readily, are not ductile, do not have a complex refractive index, and in general have high ionization potentials.

If the periodic table is divided diagonally from upper left to lower right, all the nonmetals are on the right-hand side of the

diagonal. Examples of elements which do not fit neatly into this useful but arbitrary classification are tin, which exists in two allotropic modifications, one definitely metallic and the other with many properties of a nonmetal, and tellurium and antimony. Such elements are called metalloids. See METAL; METALLOID; PERIODIC TABLE. [T.C.W.]

**Non-newtonian fluid** A fluid that departs from the classic linear newtonian relation between stress and shear rate. In a strict sense, a fluid is any state of matter that is not a solid, and a solid is a state of matter that has a unique stress-free state. A conceptually simpler definition is that a fluid is capable of attaining the shape of its container and retaining that shape for all time in the absence of external forces. Therefore, fluids encompass a wide variety of states of matter including gases and liquids as well as many more esoteric states (for example, plasmas, liquid crystals, and foams). See FLUIDS; FOAM; GAS; LIQUID; LIQUID CRYSTALS; PLASMA (PHYSICS).

A newtonian fluid is one whose mechanical behavior is characterized by a single function of temperature, the viscosity, a measure of the “slipperiness” of the fluid. For the example of Fig. 1, where a fluid is sheared between a fixed plate and a moving plate, the viscosity is given by Eq. (1). Thus, as the viscosity

$$\text{Viscosity} = \frac{\text{force/area}}{\text{velocity/height}} \quad (1)$$

of a fluid increases, it requires a larger force to move the top plate at a given velocity. For simple, newtonian fluids, the viscosity is a constant dependent on only temperature; but for non-newtonian fluids, the viscosity can change by many orders of magnitude as the shear rate (velocity/height in Fig. 1) changes. Typically, the viscosity ( $\eta$ ) of these fluids is given as a function of the shear rate ( $\dot{\gamma}$ ). A common dependence for this function is given in Fig. 2. For other non-newtonian fluids, the viscosity might increase as the shear rate increases (shear-thickening fluids). See NEWTONIAN FLUID; VISCOSITY.

Many of the fluids encountered in everyday life (such as water, air, gasoline, and honey) are adequately described as being newtonian, but there are even more that are not. Common examples include mayonnaise, peanut butter, toothpaste, egg whites, liquid soaps, and multigrade engine oils. Other examples such as molten polymers and slurries are of considerable technological importance. A distinguishing feature of many non-newtonian fluids is that they have microscopic or molecular-level structures that can be rearranged substantially in flow. See PARTICLE FLOW; POLYMER.

Our intuitive understanding of how fluids behave and flow is built primarily from observations and experiences with newtonian fluids. However, non-newtonian fluids display a rich variety of behavior that is often in dramatic contrast to these expectations. For example, an intuitive feel for the slipperiness of fluids can be gained from rubbing them between the fingers. Furthermore, the slipperiness of water, experienced in this way, is expected to be the same as the slipperiness of automobile tires on a wet road. However, the slipperiness (viscosity) of many non-

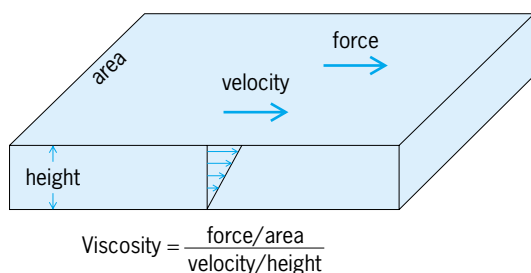

Fig. 1. Steady shear flow of a fluid between a fixed plate and a parallel plate, illustrating the concept of viscosity.

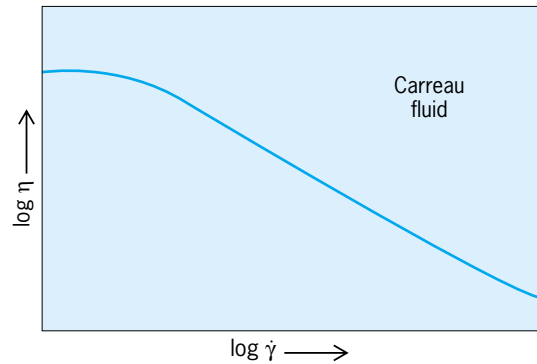

Fig. 2. Typical dependence of the viscosity ( $\eta$ ) on shear rate ( $\dot{\gamma}$ ) for a non-newtonian fluid (Carreau model).

newtonian fluids changes a great deal depending on how fast they move or the forces applied to them.

Intuitive expectations for how the surface of a fluid will deform when the fluid is stirred (with the fluid bunching up at the wall of the container) are also in marked contrast to the behavior of non-newtonian fluids. When a cylindrical rod is rotated inside a container of a newtonian fluid, centrifugal forces cause the fluid to be higher at the wall. However, for non-newtonian fluids, the normal stress differences cause the fluid to climb the rod; this is called the Weissenberg effect. Intuitive understanding about the motion of material when the flow of a fluid is suddenly stopped, for example, by turning off a water tap, is also notably at odds with the behavior of non-newtonian fluids. See CENTRIFUGAL FORCE.

A non-newtonian fluid also displays counterintuitive behavior when it is extruded from an opening. A newtonian fluid tapers to a smaller cross section as it leaves the opening, but the cross section for a non-newtonian fluid first increases before it eventually tapers. This phenomenon is called die swell. See NOZZLE.

When a newtonian fluid is siphoned and the fluid level goes below the entrance to the siphon tube, the siphoning action stops. For many non-newtonian fluids, however, the siphoning action continues as the fluid climbs from the surface and continues to enter the tube. This phenomenon is called the tubeless siphon.

Perhaps the most striking behavior of non-newtonian fluids is a consequence of their viscoelasticity. Solids can be thought of as having perfect memory. If they are deformed through the action of a force, they return to their original shape when the force is removed. This happens when a rubber ball bounces; the ball is deformed as it hits a surface, but the rubber remembers its undeformed spherical shape. Recovery of the shape causes the ball to bounce back. In contrast, newtonian fluids have no memory; when a force is removed, they retain their condition at the time the force is removed (or continue moving as the result of inertia). When a newtonian fluid is dropped onto a surface, it does not bounce. Non-newtonian fluids are viscoelastic in the sense that they have fading memory. If a force is removed shortly after it is applied, the fluid will remember its undeformed shape and return toward it. However, if the force is applied on the fluid for a long time, the fluid will eventually forget its undeformed shape. If a sample of a non-newtonian fluid is dropped onto a surface, it will bounce like a ball. However, if the fluid is simply placed on the surface, it will flow smoothly. Viscoelasticity is frequently the cause of many of the secondary flows that are observed for non-newtonian fluids. These are fluid motions that are small for newtonian fluids (for example, swirling motions) but can become dominant for non-newtonian fluids. See ELASTICITY.

Analysis of fluid flow operations is typically performed by examining local conservation relations—conservation of mass, momentum (Newton’s second law), and energy. This analysis requires material-specific information (for example, the relation

between density, pressure, and temperature) that is collectively known as constitutive relations. The science devoted to obtaining suitable constitutive equations for description of the behavior of non-newtonian fluids is called rheology. The most important constitutive equation for fluid mechanics is that relating the stress in the fluid to the kinematics of the motion (that is, the velocity, the derivatives of the velocity with respect to position, and the time history of the velocity).

Although the non-newtonian behavior of many fluids has been recognized for a long time, the science of rheology is, in many respects, still in its infancy, and new phenomena are constantly being discovered and new theories proposed. Advancements in computational techniques are making possible much more detailed analyses of complex flows and more sophisticated simulations of the structural and molecular behavior that gives rise to non-newtonian behavior. Engineers, chemists, physicists, and mathematicians are actively pursuing research in rheology, particularly as more technologically important materials are found to display non-newtonian behavior. See FLUID FLOW; FLUID-FLOW PRINCIPLES; RHEOLOGY. [J.M.Wie.]

**Nonsinusoidal waveform** The representation of a wave that does not vary in a sinusoidal manner. Electric circuits containing nonlinear elements, such as electron tubes, iron-core magnetic devices, and transistors, commonly produce nonsinusoidal currents and voltages. When these are repetitive functions of time, they are called nonsinusoidal electric waves. Oscillograms, tabulated data, and sometimes mathematical functions for segments of such waves are often used to describe the excursions throughout one cycle. A cycle corresponds to  $2\pi$  electrical radians and covers the time interval  $T$  seconds in which the wave repeats itself.

These electric waves can be represented by a constant term, the average or dc component, plus a series of harmonic terms in which the frequencies of the harmonics are integral multiples of the fundamental frequency. The fundamental frequency  $f_1$ , if it does exist, has the time span  $T = 1/f_1$  seconds for its cycle. The second-harmonic frequency  $f_2$  then will have two of its cycles within  $T$  seconds, and so on.

The series of terms stated above is known as a Fourier series and can be expressed in the form of the equation below, where  $y(t)$ , plotted over a cycle of the fundamental, gives the shape of

$$y(t) = B_0 + C_1 \sin(\omega t + \phi_1) + \dots + C_n \sin(n\omega t + \phi_n) + \dots \\ = \sum_{n=0}^{\infty} C_n \sin(n\omega t + \phi_n)$$

the nonsinusoidal wave. The radian frequency of the fundamental is  $\omega = 2\pi f_1$ , and  $n$  is an integer.  $C_1$  is the amplitude of the fundamental ( $n = 1$ ), and succeeding  $C_n$ 's are the amplitudes of the respective harmonics having frequencies corresponding to  $n = 2, 3, 4$ , and so on, with respect to the fundamental. The phase angle of the fundamental with respect to a chosen time reference axis is  $\phi_1$ , and the succeeding  $\phi_n$ 's are the phase angles of the respective harmonics. See FOURIER SERIES.

The equation for  $y(t)$  shows all its separate components, which, in general, include an infinite number of terms. In practical problems the first several terms usually yield an approximate result sufficiently accurate for portrayal of the actual wave. The degree of accuracy desired in representing faithfully the actual wave determines the number of terms that must be used in any computation. [B.L.R.; W.S.P.]

**Nonstoichiometric compounds** Chemical compounds in which the relative number of atoms is not expressible as the ratio of small whole numbers, hence compounds for which the subscripts in the chemical formula are not rational (for example,  $\text{Cu}_{1.987}\text{S}$ ). Sometimes they are called berthollide compounds to distinguish them from daltonides, in which the ratio of atoms is generally simple. Nonstoichiometry is a property of

the solid state and arises because a fraction of the atoms of a given kind may be (1) missing from the regular structure (for example,  $\text{Fe}_{1-\delta}\text{O}$ ), (2) present in excess over the requirements of the structure (for example,  $\text{Zn}_{1+\delta}\text{O}$ ), or (3) substituted by atoms of another kind (for example,  $\text{Bi}_2\text{Te}_{3\pm\delta}$ ). The resulting materials are generally of variable composition, intensely colored, metallic or semiconducting, and different in chemical reactivity from the parent stoichiometric compounds from which they are derived.

Nonstoichiometry is best known in the binary compounds of the transition elements, particularly the hydrides, oxides, chalcogenides, pnictides, carbides, and borides. It is also well represented in the so-called insertion or intercalation compounds, in which a metallic element or neutral molecule has been inserted in a stoichiometric host. Nonstoichiometric compounds are important in some solid-state devices (such as rectifiers, thermoelectric generators, and photodetectors) and are probably formed as chemical intermediates in many reactions involving solids (for example, heterogeneous catalysis and metal corrosion).

The simplest way to classify nonstoichiometric compounds is to consider which element is in excess and how this excess is brought about. A classification scheme largely based on this distinction but which also includes some examples of ternary systems is as follows.

*Binary compounds:*

- I. Metal nonmetal ratio greater than stoichiometric
  - (a) Metal in excess, for example,  $\text{Zn}_{1+\delta}\text{O}$
  - (b) Missing nonmetal, for example  $\text{UH}_{3-\delta}$ ,  $\text{WO}_{3-\delta}$
- II. Metal: nonmetal ratio less than stoichiometric
  - (a) Metal-deficient, for example,  $\text{Co}_{1-\delta}\text{O}$
  - (b) Nonmetal in excess, for example,  $\text{UO}_{2+\delta}$
- III. Deviations on both sides of stoichiometry, for example,  $\text{TiO}_{1\pm\delta}$

*Ternary compounds (insertion compounds):*

- IV. Oxide "bronzes," for example,  $\text{M}_3\text{WO}_3$ ,  $\text{M}_5\text{V}_2\text{O}_5$
- V. Intercalation compounds, for example,  $\text{K}_{1.5+\delta}\text{MoO}_3$ ,  $\text{LL}_{-\delta}\text{TiS}_2$

Excluded from consideration are the recognized impurity materials, such as  $\text{Na}_{1-2x}\text{Ca}_x\text{Cl}$ , which are best considered as conventional solid solutions wherein ions of one kind and perhaps vacancies have replaced an equivalent number of ions of another kind. [M.J.Si.]

**Noradrenergic system** A neuronal system that is responsible for the synthesis, storage, and release of the neurotransmitter norepinephrine. Norepinephrine, also known as noradrenalin, consists of a single amine group and a catechol nucleus (a benzene ring with two hydroxyl groups) and is therefore referred to as a monoamine or catecholamine. It exists in both the central and peripheral nervous systems. Norepinephrine is the primary neurotransmitter released by the sympathetic nervous system, which mediates the "fight or flight" reaction, preparing the body for action by affecting cardiovascular function, gastrointestinal motility and secretion, bronchiole dilation, glucose metabolism, and so on. Within the central nervous system, norepinephrine has been associated with several brain functions, including sleep, memory, learning, and emotions.

After synthesis, the majority of norepinephrine is transported into synaptic vesicles in the nerve terminals, where it remains until needed. When the nerve terminal is activated by depolarization, calcium flows into it, leading to the release of norepinephrine into the synaptic cleft. Once released into the synaptic cleft, norepinephrine is free to bind to specific receptors located on the presynaptic or postsynaptic terminal, which initiates a chain of events (the effector system) in the target cell that can be mediated by a number of different second messenger systems. The exact effect is determined by the identity of the receptor activated. See EPINEPHRINE; SECOND MESSENGER; SYMPATHETIC NERVOUS SYSTEM; SYNAPTIC TRANSMISSION.

Termination of norepinephrine occurs by a reuptake mechanism in the presynaptic membrane. Once transported back into the presynaptic terminal, norepinephrine can be stored in vesicles for future use or enzymatically degraded by monoamine oxidase.

Certain medications achieve their effect by altering various stages of synthesis, storage, release, and inactivation of norepinephrine. The behavioral manifestations of these alterations have led to a better understanding of norepinephrine's role in various psychiatric disorders. See AFFECTIVE DISORDERS; MONOAMINE OXIDASE; PSYCHOPHARMACOLOGY; SCHIZOPHRENIA; STRESS. [M.My.; D.S.C.; A.Bre.; S.So.]

**Normal (mathematics)** A term generically synonymous with perpendicular, which often refers specifically to a line that goes through a point *P* of a curve *C* and is perpendicular to the tangent to *C* at *P*. If curve *C* is not a plane curve, all normal lines of *C* at point *P* on *C* lie in a plane, the normal plane of *C* at *P*. See ANALYTIC GEOMETRY. [L.M.BI.]

**North America** The third largest continent, extending from the narrow isthmus of Central America to the Arctic Archipelago. The physical environments of North America, like the rest of the world, are a reflection of specific combinations of the natural factors such as climate, vegetation, soils, and landforms. See CONTINENT.

**Location.** North America covers 9,400,000 mi<sup>2</sup> (24,440,000 km<sup>2</sup>) and extends north to south for 5000 mi (8000 km) from Central America to the Arctic. It is bounded by the Pacific Ocean on the west and the Atlantic Ocean on the east. The Gulf of Mexico is a source of moist tropical air, and the frozen Arctic Ocean is a source of polar air. With the major mountain ranges stretching north-south, North America is the only continent providing for direct contact of these polar and tropical air masses, leading to frequent climatically induced natural hazards such as violent spring tornadoes, extreme droughts, subcontinental floods, and winter blizzards, which are seldom found on other continents. See AIR MASS; ARCTIC OCEAN; ATLANTIC OCEAN; GULF OF MEXICO; PACIFIC OCEAN.

**Geologic structure.** The North American continent includes (1) a continuous, broad, north-south-trending western cordilleran belt stretching along the entire Pacific coast; (2) a northeast-southwest-trending belt of low Appalachian Mountains paralleling the Atlantic coast; (3) an extensive rolling region of old eroded crystalline rocks in the north-central and northeastern part of the continent called the Canadian Shield; (4) a large, level interior lowland covered by thick sedimentary rocks and extending from the Arctic Ocean to the Gulf of Mexico; and (5) a narrow coastal plain along the Atlantic Ocean and the Gulf of Mexico. These broad structural geologic regions provide the framework for the natural regions of this continent and affect the location and nature of landform, climatic, vegetation, and soil regions.

**Canadian Shield.** Properly referred to as the geological core of the continent, the exposed Canadian Shield extends about 2500 mi (4000 km) from north to south and almost as much from east to west. The rest of it dips under sedimentary rocks that overlap it on the south and west. The Canadian Shield consists of ancient Precambrian rocks, over 500 million years old, predominantly granite and gneiss, with very complex structures indicating several mountain-building episodes. It has been eroded into a rolling surface of low to moderate relief with elevations generally below 2000 ft (600 m). Its surface has been warped into low domes and basins, such as the Hudson Basin, in which lower Paleozoic rocks, including Ordovician limestones, have been preserved. Since the end of the Paleozoic Era, the Shield has been dominated by erosion. Parts of the higher surface remain at about 1500–2000 ft (450–600 m) above sea level, particularly in the Labrador area. The Shield remained as land throughout the Mesozoic Era, but its western margins were cov-

ered by a Cretaceous sea and by Tertiary terrestrial sediments derived from the Western Cordillera. See CRETACEOUS; ORDOVICIAN; MESOZOIC; PALEOZOIC; PRECAMBRIAN; TERTIARY.

The entire exposed Shield was glaciated during the Pleistocene Epoch, and its surface was intensely eroded by ice and its meltwaters, erasing major surface irregularities and eastward-trending rivers that were there before. The surface is now covered by glacial till, outwash, moraines, eskers, and lake sediments, as well as drumlins formed by advancing ice. A deranged drainage pattern is evolving on this surface with thousands of lakes of various sizes. See DRUMLIN; ESKER; GLACIAL EPOCH; GLACIATED TERRAIN; MORAINES; PLEISTOCENE; TILL.

The Canadian Shield extends into the United States as Adirondack Mountains in New York State, and Superior Upland west of Lake Superior.

**Southeastern Coastal Plain.** The Southeastern Coastal Plain is geologically the youngest part of the continent, and it is covered by the youngest marine sedimentary rocks. This flat plain, which parallels the Atlantic and Gulf coastline, extends for over 3000 mi (4800 km) from Cape Cod, Massachusetts, to the Yucatán Peninsula in Mexico. It is very narrow in the north but increases in width southward along the Atlantic coast and includes the entire peninsula of Florida. As it continues westward along the Gulf, it widens significantly and includes the lower Mississippi River valley. It is very wide in Texas, narrows again southward in coastal Mexico, and then widens in the Yucatán Peninsula and continues as a wide submerged plain, or a continental shelf, into the sea. See COASTAL PLAIN.

Extending from Cape Cod, Massachusetts, to Mexico and Central America, the Coastal Plain is affected by a variety of climates and associated vegetation. While a humid, cool climate with four seasons affects its northernmost part, subtropical air masses affect the southeastern part, including Florida, and hot and arid climate dominates Texas and northern Mexico; Central America has hot, tropical climates.

Varied soils characterize the Coastal Plain, including the fertile alluvial soils of the Mississippi Valley. Broadleaf forests are present in the northeast, citrus fruits grow in Florida, grasslands dominate the dry southwest, and tropical vegetation is present on Central American coastal plains.

**Eastern Seaboard Highlands.** Between the Southeastern Coastal Plain and the extensive interior provinces lies a belt of mountains that, by their height and pattern, create a significant barrier between the eastern seaboard and the interior of North America. These mountains consist of the Adirondack Mountains and the New England Highlands.

The Adirondack Mountains are a domal extension of the Canadian Shield, about 100 mi (160 km) in diameter, composed of complex Precambrian rocks. The New England Highlands consist of a north-south belt of mountains east of the Hudson Valley, including the Taconic mountains in the south and the Green mountains in the north, and continuing as the Notre Dame Mountains along the St. Lawrence Valley and the Chic-Choc Mountains of the Gaspé Peninsula. The large area of New England east of these mountains is an eroded surface of old crystalline rocks culminating in the center as the White Mountains, with their highest peak of the Presidential Range, Mount Washington, reaching over 6200 ft (1880 m). This area has been intensely glaciated, and it meets the sea in a rugged shoreline. Nova Scotia and Newfoundland have a similar terrain.

New England is a hilly to mountainous region carved out of ancient rocks, eroded by glaciers, and covered by glacial moraines, eskers, kames, erratics, and drumlins, with hundreds of lakes scattered everywhere. It has a cool and moist climate with four seasons, thin and acid soils, and mixed coniferous and broadleaf forests.

**Appalachian Highlands.** The Appalachian Highlands are traditionally considered to consist of four parts: the Piedmont, the Blue Ridge Mountains, the Ridge and Valley Section, and the Appalachian Plateau. These subregions are all characterized by

different geologic structures and rock types, as well as different geomorphologies.

The northern boundary of the entire Appalachian System is an escarpment of Paleozoic rocks trending eastward along Lake Erie, Lake Ontario, and the Mohawk Valley. The boundary then swings south along Hudson River Valley and continues southwestward along the Fall Line to Montgomery, Alabama. The western boundary trends northeastward through Cumberland Plateau in Tennessee, and up to Cleveland, Ohio, where it joins the northern boundary. Together with New England, this region forms the largest mountainous province in eastern United States.

**Interior Domes and Basins Province.** The southwestern part of the Appalachian Plateau, overlain mainly by the Mississippian and Pennsylvanian sedimentary rocks, has been warped into two low structural domes called the Blue Grass and Nashville Basins, and a structural basin, drained by the Green River; its southern fringe is called the Pennyroyal Region. The Interior Dome and Basin Province is contained roughly between the Tennessee River in the south and west and the Ohio River in the north.

There is no boundary on the east, because the domes are part of the same surface as the Appalachian Plateau. However, erosional escarpments, forming a belt of hills called knobs, clearly mark the topographic domes and basins. The northern dome, called the Blue Grass Basin or Lexington Plain, has been eroded to form a basin surrounded by a series of inward-facing cuesta escarpments. The westernmost cuesta reaches about 600 ft (180 m) elevation while the central part of the basin lies about 1000 ft (300 m) above sea level, which is higher than the surrounding hills. This gently rolling surface with deep and fertile soils exhibits some solutional karst topography. See FLUVIAL EROSION LANDFORMS.

**Ozark and Ouachita Highlands.** The Paleozoic rocks of the Pennyroyal Region continue westward across southern Illinois to form another dome of predominantly Ordovician rocks, called the Ozark Plateau. This dome, located mainly in Missouri and Arkansas, has an abrupt east side, and a gently sloping west side, called the Springfield Plateau. Its surface is stream eroded into hilly and often rugged topography that is developed mainly on limestones, although shales, sandstone, and chert are present. Much residual chert, eroded out of limestone, is present on the surface. There are some karst features, such as caverns and springs. In the northeast, Precambrian igneous rocks protrude to form the St. Francois Mountains, which reach an elevation of 1700 ft (515 m).

**Central Lowlands.** One of the largest subdivisions of North America is the Central Lowlands province which is located between the Appalachian Plateau on the east, the Interior Domes and Basins Province and the Ozark Plateau on the south, and the Great Plains on the west. It includes the Great Lakes section and the Manitoba Lowland in Canada. This huge lowland in the heart of the continent (whose elevations vary from about 900 ft or 270 m above sea level in the east and nearly 2000 ft or 600 m in the west) is underlain by Paleozoic rocks that continue from the Appalachian Plateau and dip south under the recent coastal plain sediments; meet the Cretaceous rocks on the west; and overlap the crystalline rocks of the Canadian Shield on the northeast.

The present surface of nearly the entire Central Lowlands, roughly north of the Ohio River and east of the Missouri River, is the creation of the Pleistocene ice sheets. When the ice formed and spread over Canada, and southward to the Ohio and Missouri rivers, it eroded much of the preexisting surface. During deglaciation, it left its deposits over the Canadian Shield and the Central Lowlands.

The Central Lowlands are drained by the third longest river system in the world, the Missouri-Mississippi, which is 3740 mi (6000 km) long. This mighty river system, together with the Ohio and the Tennessee, drains not only the Central Lowlands but also parts of the Appalachian Plateau and the Great Plains, before

it crosses the Coastal Plain and ends in the huge delta of the Mississippi. The river carries an enormous amount of water and alluvium and continues to extend its delta into the Gulf. In 1993 it reached a catastrophic level of a hundred-year flood, claimed an enormous extent of land and many lives, and created an unprecedented destruction of property. This flood again alerted the population to the extreme risk of occupying a river floodplain. See FLOODPLAIN; RIVER.

**Great Plains.** The Great Plains, which lie west of the Central Lowlands, extend from the Rio Grande and the Balcones Escarpment in Texas to central Alberta in Canada. On the east, they are bounded by a series of escarpments, such as the Côteau du Missouri in the Dakotas. The dry climate with less than 20 in. (50 cm) of precipitation, and steppe grass vegetation growing on calcareous soils, help to determine the eastern boundary of the Great Plains. On the west, the Great Plains meet the abrupt front of the Rocky Mountains, except where the Colorado Piedmont and the lower Pecos River Valley separate them from the mountains.

The Great Plains region shows distinct differences between its subsections from south to north. The southernmost part, called the High Plains or Llano Estacado, and Edwards Plateaus are the flattest. While Edwards Plateau, underlain by limestones of the Cretaceous age, reveals solutional karst features, the High Plains have the typical Tertiary bare cap rock surface, devoid of relief and streams.

The central part of the Great Plains has a recent depositional surface of loess and sand. The Sand Hills of Nebraska form the most extensive sand dunes area in North America, covering about 24,000 mi<sup>2</sup> (62,400 km<sup>2</sup>). They are overgrown by grass and have numerous small lakes. The loess region to the south provides spectacular small canyon topography. See DUNE.

The northern Great Plains, stretching north of Pine Ridge and called the Missouri Plateau, have been intensely eroded by the western tributaries of the Missouri River into river breaks and interfluvies. In extreme cases, badlands were formed, such as those of the White River and the Little Missouri.

The terrain of the Canadian Great Plains consists of three surfaces rising from east to west: the Manitoba, Saskatchewan, and Alberta Prairies developed on level Cretaceous and Tertiary rocks. Climatic differences between the arid and warm southern part and the cold and moist northern part have resulted in regional differences. The eastern boundary of the Saskatchewan Plain is the segmented Manitoba Escarpment, which extends for 500 mi (800 km) northwestward, and in places rises 1500 ft (455 m) above the Manitoba Lowland. Côteau du Missouri marks the eastern edge of the higher Alberta Plain.

**Western Cordillera.** The mighty and rugged Western Cordillera stretch along the Pacific coast from Alaska to Mexico. There are three north-south-trending belts: (1) Brooks Range, Mackenzie Mountains, and the Rocky Mountains to the north and Sierra Madre Oriental in Mexico; (2) Interior Plateaus, including the Yukon Plains, Canadian Central Plateaus and Ranges, Columbia Plateau, Colorado Plateau, and Basin and Range Province stretching into central Mexico; and (3) Coastal Mountains from Alaska Range to California, Baja California, and Sierra Madre Occidental in Mexico.

This subcontinental-size mountain belt has the highest mountains, greatest relief, roughest terrain, and most beautiful scenery of the entire continent. It has been formed by earth movements resulting from the westward shift of the North American lithospheric plate. The present movements, and the resulting devastating earthquakes along the San Andreas fault system paralleling the Pacific Ocean, are part of this process. See CORDILLERAN BELT; PLATE TECTONICS.

This very high, deeply eroded and rugged Rocky Mountains region comprises several distinct parts: Southern, Middle, and Northern Rockies, plus the Wyoming Basin in the United States, and the Canadian Rockies. The Southern Rockies, extending from Wyoming to New Mexico, include the Laramie Range, the



Front Range, and Spanish Peaks with radiating dikes on the east; Medicine Bow, Park, and Sangre de Cristo ranges in the center; and complex granite Sawatch Mountains and volcanic San Juan Mountains of Tertiary age on the west. Most of the ranges are elongated anticlines with exposed Precambrian granite core, and overlapping Paleozoic and younger sedimentary rocks which form spectacular hogbacks along the eastern front. There are about 50 peaks over 14,000 ft (4200 m) high, while the Front Range alone has about 300 peaks over 13,000 ft (3940 m) high. The southern Rocky Mountains, heavily glaciated into a beautiful and rugged scenery with permanent snow and small glaciers, form a major part of the Continental Divide.

The interior Plateaus and Ranges Province of the Western Cordillera lies between the Rocky Mountains and the Coastal Mountains. It is an extensive and complex region. It begins in the north with the wide Yukon Plains and Uplands; narrows into the Canadian Central Plateaus and Ranges; widens again into the Columbia Plateau, Basin and Range Province, and Colorado Plateau; and finally narrows into the Mexican Plateau and the Central American isthmus.

The coastal Lowlands and Ranges extend along the entire length of North America and include Alaskan Coast Ranges, Aleutian Islands, Alaska Range, Canadian Coast Ranges, and a double chain of the Cascade Mountains and Sierra Nevada on the east, and Coast Ranges on the west, separated by Puget Sound, Willamette Valley, and Great Valley of California. These ranges continue southward as Lower California Peninsula, Baja California, and Sierra Madre Occidental in Mexico.

The basin-and-range type of terrain of the southwest United States continues into northern Mexico and forms its largest physiographic region, the Mexican Plateau. This huge tilted block stands more than a mile above sea level—from about 4000 ft (1200 m) in the north, it rises to about 8000 ft (2400 m) in the south. The Mexican Plateau is separated from the Southern Mexican Highlands (Sierra Madre del Sur) by a low, hot and dry Balsas Lowland drained by the Balsas River. To the east of the Southern Highlands lies a lowland, the Isthmus of Tehuantepec, which is considered the divide between North and Central America. Here the Pacific and Gulf coasts are only 125 mi (200 km) apart. The lowlands of Mexico are the coastal plains. The Gulf Coastal Plain trends southward for 850 mi from the Rio Grande to the Yucatán Peninsula. It is about 100 mi (160 km) wide in the north, just a few miles wide in the center, and very wide in the Yucatan Peninsula. Barrier beaches, lagoons, and swamps occur along this coast. The Pacific Coastal Plains are much narrower and more hilly. North-south-trending ridges of granite characterize the northern part, and islands are present offshore. Toward the south, sandbars, lagoons, and deltaic deposits are common.

East of the Isthmus of Tehuantepec begins Central America with its complex physiographic and tectonic regions. This narrow, mountainous isthmus is geologically connected with the large, mountainous islands of the Greater Antilles in the Caribbean. They are all characterized by east-west-trending rugged mountain ranges, with deep depressions between them. One such mountain system begins in Mexico and continues in southern Cuba, Puerto Rico, and the Virgin Islands. North of this system, called the Old Antillia, lies the Antillian Foreland, consisting of the Yucatán Peninsula and the Bahama Islands. Central American mountains are bordered on both sides by active volcanic belts. Along the Pacific, a belt of young volcanoes extends for 800 mi (1280 km) from Mexico to Costa Rica. Costa Rica and Panama are mainly a volcanic chain of mountains extending to South America. Nicaragua is dominated by a major crustal fracture trending northwest-southeast. [B.Z.B.]

**North Pole** That end of the Earth's axis which points toward the North Star, Polaris (Alpha Ursae Minoris). It is the geographical pole where all meridians converge, and should not be confused with the north magnetic pole, which is in the Canadian Archipelago. The North Pole's location falls near the center

of the Arctic Sea. The North Pole has phenomena unlike any other place except the South Pole. For 6 months the Sun does not appear above the horizon, and for 6 months it does not go below the horizon. As there is a long period (about 7 weeks) of continuous twilight before March 21 and after September 23, the period of light is considerably longer than the period of darkness. [V.H.E.]

**North Sea** A flooded portion of the northwest continental margin of Europe occupying an area of over 200,000 mi<sup>2</sup> (500,000 km<sup>2</sup>). The North Sea has extensive marine fisheries and important offshore oil and gas reserves. In the south, its depth is less than 150 ft (50 m), but north of 58° it deepens gradually to 600 ft (200 m) at the top of the continental slope. A band of deep water down to 1200 ft (400 m) extends around the south and west coast of Norway and is known as the Norwegian Trench.

The nontidal residual current circulation of the southern North Sea is mainly determined by wind velocity, but in the north, well-defined non-wind-driven currents have been identified, especially in the summer. Two of these currents bring in water from outside the North Sea; one flows through the channel between Orkney and Shetland (the Fair Isle current), and the other follows the continental slope north of Shetland and merges with the Fair Isle current southwest of Norway before entering the Skagerrak. The north-flowing Norwegian coastal current provides the exit route for North Sea waters, and is formed from the waters of these two major inflows and from other much smaller inputs such as river runoff, the English Channel, and the Baltic Sea.

There is a rich diversity of zooplankton within the North Sea. Copepods are of particular importance in the food web. There are a wide range of fish stocks in the North Sea and adjacent waters and, in terms of species exploited by commercial fisheries, they constitute the richest area in the northeast Atlantic. The commercially important stocks exploited for human consumption include cod, haddock, whiting, pollock, plaice, sole, herring, mackerel, lobster, prawn, and brown shrimp (*Crangon crangon*). A number of stocks are used for fishmeal and oil; these stocks include sand eel, Norway pout, blue whiting, and sprat. See COPEPODA; MARINE ECOLOGY; ZOOPLANKTON. [H.D.D.]

**Nose** The nasal cavities and the structures surrounding and associated with them. The nose functions primarily as the organ of smell and in most tetrapods also assumes a respiratory function, forming the anterior end of the air passage through which air is drawn in and in which it is warmed and moistened.

In humans the nasal cavities are triangular openings that pass from the external nares back to the dorsal part of the pharynx (see illustration). The lateral walls are composed principally of

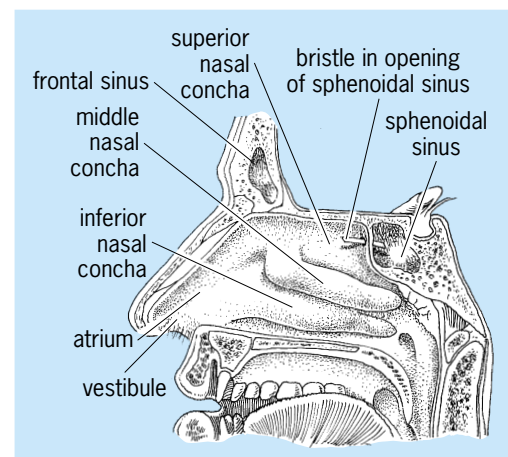

Human nose. (After W. J. Hamilton et al., *Textbook of Human Anatomy*, Macmillan, 1956)

portions of the ethmoid and sphenoid bones and projections of three turbinate bones, or conchae, on each side. The floor of the nose is formed by the palate, which is also the roof of the mouth. The nasal cavities are lined with respiratory epithelium, which also lines the paranasal sinuses. The latter are cavities in the frontal, ethmoid, sphenoid, and maxillary bones which communicate with the nasal passages. The external nose consists of the two nasal bones that form the bony bridge and two pairs of lower nasal cartilages. These together with the tightly adherent skin determine the individual shape and size of the human nose. See OLFACTION. [T.S.P.]

**Nose cone** The forward portion of a spacecraft that is designed for atmospheric entry. Nose cones are utilized for intercontinental ballistic missiles and spacecraft such as Apollo and space shuttles. The nose cone is required to withstand heating encountered during atmospheric entry, maintain the structural integrity of the spacecraft, prevent overheating of the payload, and usually maintain the aerodynamic characteristics of the spacecraft.

Even for a properly designed shape, it is inevitable that some fraction of the spacecraft's initial kinetic energy will finally reach the nose cone in the form of heat. The design of the heat shield for the nose cone is a complex procedure, which is highly dependent on the heating level. There are a variety of surface-protection or cooling systems which have been used. Generally these systems consist of heat sinks of various types: the absorption of heat by virtue of a material's sensible heat capacity, latent heat capacity, or chemical heat capacity. That is, heat absorption is accomplished by a temperature rise, a phase change, or a chemical reaction. Aerodynamic lift is employed by such vehicles as reusable space shuttles to lower heating rates so that the nose cone material can radiate away much of the incident heating.

Ablation is used to provide surface protection. The designer can divert heat from the spacecraft by allowing the nose cone's outer layer of material to melt, vaporize, or sublime. While large ablation rates provide excellent thermal protection, the resulting change in profile due to surface recession can adversely change the aerodynamic characteristics of the spacecraft. The designer must account for this change. See SPACE SHUTTLE; SPACECRAFT STRUCTURE. [P.R.N.]

**Notacanthiformes** An order of actinopterygian fishes known also as the Heteromi (spiny eels or notacanth) and the Lyopomi (halosaurs). The body is elongated, tapers posteriorly, and has no caudal fin (see illustration).

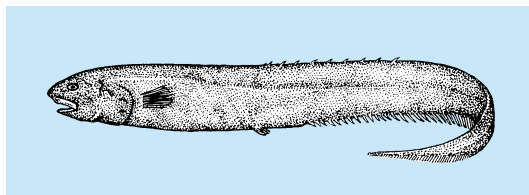

Spiny eel (*Notacanthus nasus*). (After D. S. Jordan and B. W. Evermann, *The Fishes of North and Middle America*, U.S. Nat. Mus. Bull. no. 47, 1900)

This small order, which has a history extending back to the Upper Cretaceous, includes 3 families, about 8 Recent genera, and about 25 species. Spiny eels and halosaurs inhabit deep seas of all oceans; some have photophores. They are like true eels (Anguilliformes) in that they lack a firm suspension of the pectoral girdle from the skull, but some have fin spines like the perciform fishes. See ACTINOPTERYGII; ANGUILLIFORMES. [R.M.B.]

**Nothosauria** An order of extinct aquatic diapsid reptiles in the infraclass Sauropterygia, known from the Triassic System of

Europe, North America, and Asia. Nothosaurs represent a primitive grade of evolution within the infraclass, which also includes the Jurassic and Cretaceous plesiosaurs.

Nothosaurs range approximately 3–13 ft (1–4 m) in length. The neck is long, with at least 15 cervical vertebrae. Like aquatic lizards and crocodiles, early nothosaurs probably swam primarily by lateral undulation of the trunk and tail, with the limbs held to the side to reduce drag. Advanced nothosaurs show modifications of the front limbs to act as paddles; the rear limbs are somewhat reduced.

Nothosaurs are distinguished from other aquatic reptiles by the closure of the openings in the palate that occur in more primitive reptiles, and by the covering of the base of the braincase. The ventral surface of the shoulder girdle is characterized by a wide gap between the base of the scapulae and the coracoids, behind a stout transverse bar formed by the interclavicle and the blades of the clavicles. As in plesiosaurs, part of the scapula is superficial to the clavicle, a reversal of the relationship of these bones in other reptiles. Primitive nothosaurs resemble primitive lepidosauromorphs in the pattern of the skull roof but have lost the lower temporal bar. See DIAPSIDA; PLESIOSAURIA; REPTILIA. [R.L.C.]

**Notomyotina** A suborder of Phanerozoidea (subclass Asteriozoa) in which the upper marginals alternate in position with the lower marginals to impart a degree of flexibility to the arm, and each of the tube feet has a terminal sucking disk. Paxillae are present on the upper surface. Each arm usually contains a pair of dorsal muscles, whose contraction enables the arm to be turned upward over the disk. These are mainly deep-water forms. See ASTEROIDEA; ECHINODERMATA. [H.B.F.]

**Notostraca** An order of branchiopod crustaceans, sometimes called tadpole shrimps. Generally they range from about 20 mm (0.4 in.) to (exceptionally) about 90 mm (3.5 in.) in length. The multisegmented trunk, up to 44 segments in some species, is elongate and cylindrical. Each of the first 11 trunk segments bears a pair of limbs, while a varying number of more posterior segments bear up to six pairs of smaller limbs per segment—a very unusual situation. The trunk terminates in a telson that bears a pair of slender, segmented, caudal filaments. Notostracans feed on a variety of small organisms that are seized by the trunk limbs and passed forward to the mouthparts, but they also collect and eat detritus with the same limbs.

Some species are bisexual, but in some parts of their range some are self-fertilizing hermaphrodites. The highly resistant eggs, which can withstand desiccation if necessary, hatch as nauplii, but in some cases this stage is transient, molting almost at once to a more advanced stage. The two extant genera, *Triops* and *Lepidurus*, are essentially worldwide in distribution and occur mostly in temporary waters. See BRANCHIOPODA. [G.Fr.]

**Notoungulata** An order of dominant, hoofed herbivores of the Cenozoic of South America that are abundantly represented in Paleocene through Pleistocene nonmarine sedimentary rocks of that continent. Diverging from a primitive condylarth ancestry at an early date, they radiated into a wide diversity of forms, some of which were convergent with Northern Hemisphere ungulates.

Notoungulates were characterized by a skull with an expanded temporal region due to the presence of a large sinus in the squamosal and no postorbital bar. The feet were primitive, with five toes (three or two in some advanced forms), and the weight was borne mainly by the third digit. See EUTHERIA. [R.H.T.]

**Nova** The sudden brightening of a previously inconspicuous star. The name, short for nova stella (new star), formerly included objects now classified as supernovae and as other kinds of cataclysmic variables. Classical novae now include only those events where the energy source is hydrogen fusion (burning) on

the surface of a white dwarf in a close binary system and the white dwarf is not destroyed in the process.

A handful of novae are discovered each year in the Milky Way Galaxy, and the total rate is probably 20–50 per year. A comparable number are found in other, nearby galaxies. The system consists of a normal, hydrogen-burning star in a close orbit (periods of a few days or less) around a white dwarf or degenerate star. A stream of gas flows from the normal star into a disk around the white dwarf and then accretes onto its surface. Hydrogen gradually builds up there until it is hot and dense enough for nuclear burning, normally with carbon, oxygen, neon, or magnesium from the white dwarf itself acting as a catalyst. Any nuclear fuel ignited under degenerate conditions explodes, because energy released does not cause the gas to expand, so temperature rises rapidly. See BINARY STAR; WHITE DWARF STAR.

Novae brighten in a few days and fade in months to years. The peak brightness is more than 100 times the solar luminosity, and the total energy release more than  $10^{45}$  ergs ( $10^{38}$  joules). Novae recur every  $10^4$ – $10^5$  years. See CATAclysmic VARIABLE; LIGHT CURVES; VARIABLE STAR. [V.T.]

**Nozzle** A conduit with a variable cross-sectional area in which a fluid accelerates into a high-velocity stream.

The fluid must be compressed to a state of high pressure before it is sent through the nozzle. If the fluid is a gaseous medium, the temperature of the fluid also drops as the fluid accelerates. Since the velocity of sound of the fluid is directly related to the temperature of the fluid, the fluid velocity may exceed the speed of sound of the fluid, so that the fluid is in a state of supersonic flow. Under this condition, the nozzle must have a convergent-divergent geometry, since the supersonic state is realized only in the divergent portion of the nozzle (see illustration). The Mach number, which is the ratio of the velocity of the flowing fluid to the velocity of sound of the fluid, may be employed to characterize the flow. The Mach number is less than unity if the flow is subsonic, unity if the flow is sonic, and larger than unity if the flow is supersonic. If the flow at the throat is sonic, the flow is said to reach the critical state. See FLUID FLOW; MACH NUMBER; SOUND.

A nozzle can be used for a variety of purposes. It is an indispensable piece of equipment in many devices employing fluid as a working medium. The reaction force that results from the fluid acceleration may be employed to propel a jet aircraft or a rocket. In fact, most military jet aircraft employ the simple convergent conical nozzle, with adjustable conical angle, as their propulsive device. If the high-velocity fluid stream is directed to turn a turbine, it may generate electric power or drive an automotive vehicle. The high-velocity stream may also be produced inside a wind tunnel so that the conditions of flight of a missile or an aircraft may be simulated inside the tunnel for research purposes. The nozzle must be carefully designed in this case to provide uniformly flowing fluid with the desired velocity, pressure, and temperature at the test section of the wind tunnel. Nozzles may also be used to disperse fuel into an atomized mist, such as that

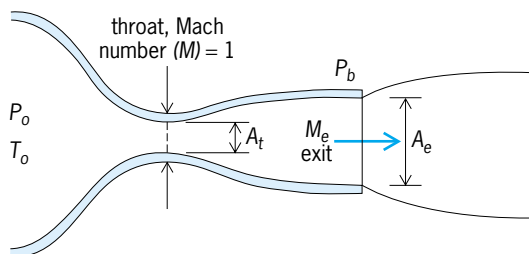

Typical convergent-divergent nozzle with a jet plume.  $P_0$ ,  $T_0$  = pressure and temperature upstream of the nozzle;  $A_t$  = area at the throat;  $P_b$  = backpressure;  $M_e$ ,  $A_e$  = Mach number and area at exit.

in diesel engines, for combustion purposes. See ATOMIZATION; IMPULSE TURBINE; INTERNAL COMBUSTION ENGINE; JET PROPULSION; ROCKET PROPULSION; WIND TUNNEL. [W.L.C.]

**Nuclear battery** A battery that converts the energy of particles emitted from atomic nuclei into electric energy. Two basic types have been developed: (1) A high-voltage type, in which a beta-emitting isotope is separated from a collecting electrode by a vacuum or a solid dielectric, provides thousands of volts but the current is measured in picoamperes (pA); (2) a low-voltage type gives about 1 volt with current in microamperes ( $\mu$ A).

In the high-voltage type, a radioactive source is attached to one electrode, emitting charged particles. The source might be strontium-90, krypton-85, or hydrogen-3 (tritium), all of which are pure beta emitters. An adjacent electrode collects the emitted particles. A vacuum or solid dielectric separates the source and the collector electrodes. The principal use of the high-voltage battery is to maintain the voltage of a charged capacitor. The current output of the radioactive source is sufficient for this purpose.

Three different concepts have been employed in the low-voltage type of nuclear batteries: (1) a thermopile, (2) the use of an ionized gas between two dissimilar metals, and (3) the two-step conversion of beta energy into light by a phosphor and the conversion of light into electric energy by a photocell. See BATTERY. [J.D.;L.R.; K.F.]

**Nuclear binding energy** The amount by which the mass of an atom is less than the sum of the masses of its constituent protons, neutrons, and electrons expressed in units of energy. This energy difference accounts for the stability of the atom. In principle, the binding energy is the amount of energy which was released when the several atomic constituents came together to form the atom. Most of the binding energy is associated with the nuclear constituents (protons and neutrons), or nucleons, and it is customary to regard this quantity as a measure of the stability of the nucleus alone. See NUCLEAR STRUCTURE.

A widely used term, the binding energy (BE) per nucleon, is defined by the equation below, where  ${}_Z M^A$  represents the mass of

$$\text{BE/nucleon} = \frac{[ZH + (A - Z)n - {}_Z M^A]c^2}{A}$$

an atom of mass number  $A$  and atomic number  $Z$ ,  $H$  and  $n$  are the masses of the hydrogen atom and neutron, respectively, and  $c$  is the velocity of light. The binding energies of the orbital electrons, here practically neglected, are not only small, but increase with  $Z$  in a gradual manner; thus the BE/nucleon gives an accurate picture of the variations and trends in nuclear stability.

The binding energy, when expressed in mass units, is known as the mass defect, a term sometimes incorrectly applied to quantity  $M - A$ , where  $M$  is the mass of the atom. See MASS DEFECT.

The term binding energy is sometimes also used to describe the energy which must be supplied to a nucleus in order to remove a specified particle to infinity, for example, a neutron, proton, or alpha particle. A more appropriate term for this energy is the separation energy. This quantity varies greatly from nucleus to nucleus and from particle to particle. For example, the binding energies for a neutron, a proton, and a deuteron in  $^{16}\text{O}$  are 15.67, 12.13, and 20.74 MeV, respectively, while the corresponding energies in  $^{17}\text{O}$  are 4.14, 13.78, and 14.04 MeV, respectively. The usual order of neutron or proton separation energy is 7–9 MeV for most of the periodic table. [H.E.D.; D.H.W.]

**Nuclear chemical engineering** The branch of chemical engineering that deals with the production and use of radioisotopes, nuclear power generation, and the nuclear fuel cycle. A nuclear chemical engineer requires training in both nuclear and chemical engineering. As a nuclear engineer, he or she should be familiar with the nuclear reactions that take place in nuclear fission reactors and radioisotope production, with the

properties of nuclear species important in nuclear fuels, with the properties of neutrons, gamma rays, and beta rays produced in nuclear reactors, and with the reaction, absorption, and attenuation of these radiations in the materials of reactors. See BETA PARTICLES; GAMMA RAYS; NEUTRON; NUCLEAR FUELS.

As a chemical engineer, he or she should know the properties of materials important in nuclear reactors and the processes used to extract and purify these materials and convert them into the chemical compounds and physical forms used in nuclear systems. See CHEMICAL ENGINEERING; NUCLEAR REACTOR.

Aspects of nuclear reactors of concern to nuclear chemical engineers include production and purification of the uranium dioxide fuel, production of the hafnium-free zirconium tubing used for fuel cladding, and control of corrosion and radioactive corrosion products by chemical treatment of coolant. A chemical engineering aspect of heavy-water reactor operation is control of the radioactive tritium produced by neutron activation of deuterium. Aspects of liquid-metal fast-breeder reactors of concern to nuclear chemical engineers include fabrication of the mixed uranium dioxide-plutonium dioxide fuel, purity control of sodium coolant to prevent fouling and corrosion, and reprocessing of irradiated fuel to recover plutonium and uranium for recycle. See NUCLEAR FUEL CYCLE; PLUTONIUM; URANIUM. [M.Be.]

**Nuclear chemistry** An interdisciplinary field that, in general, encompasses the application of chemical techniques to the solution of problems in nuclear physics. The discovery of the naturally occurring radioactive elements and of nuclear fission are classical examples of the work of nuclear chemists.

Although chemical techniques that are employed in nuclear chemistry are essentially the same as those in radiochemistry, these fields may be distinguished on the basis of the aims of the investigation. Thus, a nuclear chemist utilizes chemical techniques as a tool for the study of nuclear reactions and properties, whereas a radiochemist utilizes the radioactive properties of certain substances as a tool for the study of chemical reactions and properties. For the application of radioactive tracers to chemical problems see RADIOCHEMISTRY. For the chemical effects of radiation on various systems see RADIATION CHEMISTRY.

The chemical identification of radioactive nuclides and the determination of their nuclear properties has been one of the major activities of nuclear chemists. Such studies have produced an extensive array of radioisotopes, and present studies are concerned mainly with the more difficult identification of nuclides of very short half-life. Nuclear chemical investigations led to the discovery of the synthetic radioactive elements which do not have any stable isotopes and are not formed in the natural radioactive series (technetium, promethium, astatine, and the transuranium elements). Other major areas of nuclear chemistry include studies of nuclear structure and spectroscopy and of the probability and mechanisms of various nuclear reactions. See NUCLEAR FISSION; NUCLEAR REACTION; NUCLEAR STRUCTURE. [E.P.S.]

**Nuclear engineering** The branch of engineering that deals with the production and use of nuclear energy and nuclear radiation. The multidisciplinary field of nuclear engineering is studied in many universities. In some it is offered in a special nuclear engineering department; in others it is offered in other departments, such as mechanical or chemical engineering. Primarily, nuclear engineering involves the conception, development, design, construction, operation, and decommissioning of facilities in which nuclear energy or nuclear radiation is generated or used.

Examples of facilities include nuclear power plants; nuclear propulsion reactors used for the propulsion of ships and submarines; space nuclear reactors, used to power satellites, probes, and vehicles; nuclear production reactors, which produce fissile or fusile materials used in nuclear weapons; nuclear research reactors, which generate neutrons and gamma rays for scientific research and medical and industrial applications; gamma cells,

which are used for sterilizing medical equipment and food and for manufacturing polymers; particle accelerators, which produce nuclear radiation for use in medical and industrial applications; and nuclear waste repositories. See NUCLEAR MEDICINE; NUCLEAR POWER; NUCLEAR REACTOR; PARTICLE ACCELERATOR; RADIOACTIVE WASTE MANAGEMENT; SHIP NUCLEAR PROPULSION; SPACE POWER SYSTEMS; SUBMARINE.

Many nuclear engineers are also involved in the research and development of future fusion power plants—plants that will be based on the fusion reaction for generating nuclear energy. Many challenging engineering problems are involved, including the development of technologies for heating the fusion fuel to hundreds of millions of degrees; confining this ultrahot fuel; and compressing fusion fuel to many thousand times their natural solid density. See NUCLEAR FUSION. [E.Gre.]

**Nuclear explosion** An explosion whose energy is produced by a nuclear transformation, either fission or fusion. See NUCLEAR FISSION; NUCLEAR FUSION.

The energy of a nuclear explosion is usually stated in terms of the mass of trinitrotoluene (TNT) which would provide the same energy. The complete fissioning of 1 kg of uranium or plutonium would be equivalent to 17,000 metric tons of TNT (17 kilotons); 2 lb would be equivalent to 17,000 short tons. The indicated yield-to-mass ratio of  $1.7 \times 10^7$  cannot be realized, largely because of the ancillary equipment necessary to assemble the nuclear components into an explosive configuration in the very short time required.

Though the size of a typical nuclear explosion is appalling, the most significant feature of a nuclear device derives from its yield-to-weight ratio. The first nuclear weapons (1945) weighed about 5 tons, but with yields of 15 to 20 kT their yield-to-weight ratio was, nevertheless, close to 4000 times larger than that of previous weapons. By 1960 the United States had developed a weapon with a yield of about 1 megaton (MT) in a weight of about 1 ton for use in an intercontinental missile. With this, the yield-to-weight ratio was raised to  $10^6$ .

Although weapons with yields of up to 15 and 60 MT were fired by the United States and Soviet Union respectively, about 1960 the main interest of the major nuclear powers focused on adapting nuclear devices for delivery by missile carriers, and this called for smaller weapons with so-called moderate yields of tens or hundreds of kilotons, up to a few megatons. See MISSILE.

The damage mechanism of a conventional explosion is blast—the pressure, or shock, wave transmitted in the surrounding medium. The blast wave from a nuclear explosion is similar, except for the great difference in scale. A nuclear explosion also produces several kinds of effects not experienced with ordinary explosives.

About one-third of the energy of the explosion is distributed as thermal radiation on line-of-sight trajectories. Exposure to 5–10 cal/cm<sup>2</sup> ( $2\text{--}4 \times 10^5$  J/m<sup>2</sup>) of thermal radiation energy in the short time (a second, or so) during which the thermal pulse is delivered will ignite many combustible materials (fabrics, paper, dry leaves, and so forth). It will cause serious flash burns on exposed skin. Such energy levels will be delivered in clear air to 0.3–0.4 mi (0.5–0.6 km) by an explosion of 1 kT. At Hiroshima, burn injuries alone would have been fatal to almost all persons in the open without protection out to a little over 1 mi (1.6 km), and burns serious enough to require treatment were experienced at distances greater than 2 mi (3.2 km).

During the few tens of seconds before the fireball rises away from the point at which the explosion occurred, it provides an intense source of gamma rays. The radiation emitted during this interval is referred to as prompt radiation. The remaining radioactivity, which is swept upward from the scene of the explosion to the altitude at which the fireball stops rising, and some of which ultimately returns to the surface, constitutes the residual radiation. See ALPHA PARTICLES; NEUTRON; RADIOACTIVITY.

At Hiroshima a dose equal to or greater than 450 rads (4.5 grays) extended to almost 1 mi (1.6 km). About half of the persons exposed to this dose in a short time will die within a few weeks, so that persons in this area who were not protected by heavy building walls experienced severe hazard from radiation. This is about the same distance for severe hazards from blast and thermal effects. The prompt radiation exposure falls off more rapidly with distance than the blast effect which, in turn, falls more rapidly than the intensity of thermal radiation. For an explosion much larger than 15 or 20 kT, the hazard range from thermal radiation or blast will be larger than that from prompt radiation, and prompt radiation will be a relatively unimportant effect. For much smaller yields, this order of importance will be reversed. [J.C.Ma.]

**Nuclear fission** An extremely complex nuclear reaction representing a cataclysmic division of an atomic nucleus into two nuclei of comparable mass. This rearrangement or division of a heavy nucleus may take place naturally (spontaneous fission) or under bombardment with neutrons, charged particles, gamma rays, or other carriers of energy (induced fission). Although nuclei with mass number  $A$  of approximately 100 or greater are energetically unstable against division into two lighter nuclei, the fission process has a small probability of occurring, except with the very heavy elements. Even for these elements, in which the energy release is of the order of 200 megaelectronvolts, the lifetimes against spontaneous fission are reasonably long. See NUCLEAR REACTION.

**Liquid-drop model.** The stability of a nucleus against fission is most readily interpreted when the nucleus is viewed as being analogous to an incompressible and charged liquid drop with a surface tension. Long-range Coulomb forces between protons act to disrupt the nucleus, whereas short-range nuclear forces, idealized as a surface tension, act to stabilize it. The degree of stability is then the result of a delicate balance between the relatively weak electromagnetic forces and the strong nuclear forces. Although each of these forces results in potentials of several hundred megaelectronvolts, the height of a typical barrier against fission for a heavy nucleus, because they are of opposite sign but do not quite cancel, is only 5 or 6 MeV. Investigators have used this charged liquid-drop model with great success in describing the general features of nuclear fission and also in reproducing the total nuclear binding energies. See NUCLEAR BINDING ENERGY; NUCLEAR STRUCTURE; SURFACE TENSION.

**Shell corrections.** The general dependence of the potential energy on the fission coordinate representing nuclear elongation or deformation for a heavy nucleus such as  $^{240}\text{Pu}$  is shown in Fig. 1. The expanded scale used in this figure shows the large decrease in energy of about 200 MeV as the fragments separate to infinity. It is known that  $^{240}\text{Pu}$  is deformed in its ground state, which is represented by the lowest minimum of 7–1813 MeV near zero deformation. This energy represents the total nuclear binding energy when zero of potential energy is the energy of the individual nucleons at a separation of infinity. The second minimum to the right of zero deformation illustrates structure introduced in the fission barrier by shell corrections, that is, corrections dependent upon microscopic behavior of the individual nucleons, to the liquid-drop mass. Although shell corrections introduce small wiggles in the potential-energy surface as a function of deformation, the gross features of the surface are reproduced by the liquid-drop model. Since the typical fission barrier is only a few megaelectronvolts, the magnitude of the shell correction need only be small for irregularities to be introduced into the barrier. This structure is schematically illustrated for a heavy nucleus by the double-humped fission barrier in Fig. 2, which represents the region to the right of zero deformation in Fig. 1 on an expanded scale. The fission barrier has two maxima and a rather deep minimum in between. For comparison, the single-humped liquid-drop barrier is also schematically illustrated. The

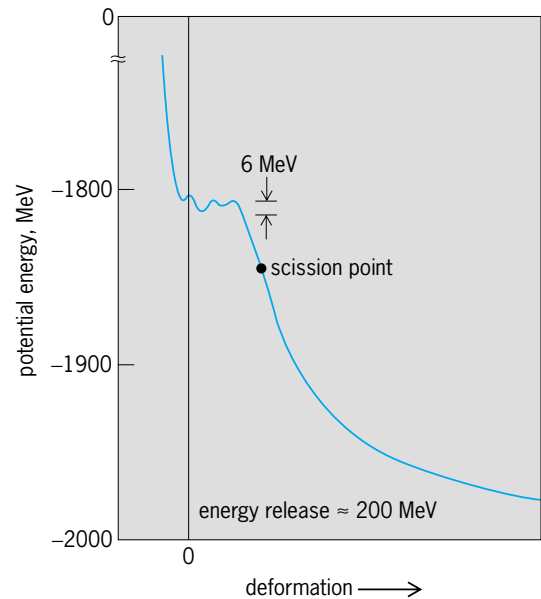

Fig. 1. Plot of the potential energy in MeV as a function of deformation for the nucleus  $^{240}\text{Pu}$ . (After M. Bolsterli et al., New calculations of fission barriers for heavy and superheavy nuclei, *Phys. Rev.*, 5C:1050–1077, 1972)

transition in the shape of the nucleus as a function of deformation is schematically represented in the upper part of the figure.

**Experimental consequences.** The observable consequences of the double-humped barrier have been reported in numerous experimental studies. In the actinide region more than 30 spontaneously fissionable isomers have been discovered between uranium and berkelium, with half-lives ranging from  $10^{-11}$  to  $10^{-2}$  s. These decay rates are faster by 20 to 30 orders of magnitude than the fission half-lives of the ground states, because of the increased barrier tunneling probability (Fig. 2). Several cases in which excited states in the second minimum decay by fission are also known. Normally these states decay within the well by

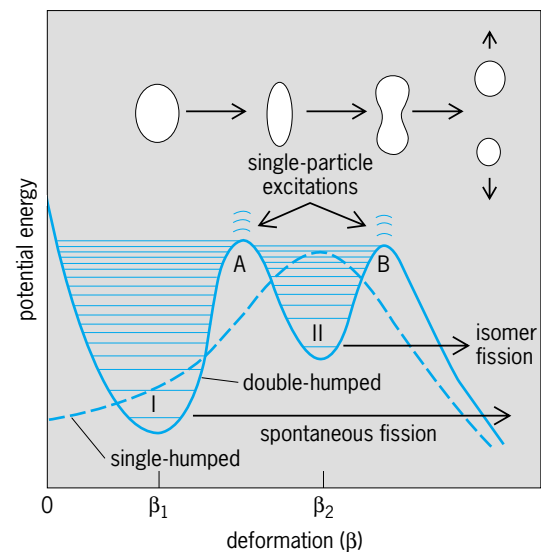

Fig. 2. Schematic plots of single-humped fission barrier of liquid-drop model and double-humped barrier introduced by shell corrections. Humps at A and B result in minima in potential energy at deformation of  $\beta_1$  and  $\beta_2$ . States in these wells are designated class I and class II, respectively. (After J. R. Huizenga, Nuclear fission revisited, *Science*, 168:1405–1413, 1979)

gamma decay; however, if there is a hindrance in gamma decay due to spin, the state (known as a spin isomer) may undergo fission instead.

**Fission probability.** The cross section for particle-induced fission  $\sigma(y, f)$  represents the cross section for a projectile  $y$  to react with a nucleus and produce fission, as shown by the equation below. The quantities  $\sigma_R(y)$ ,  $\Gamma_f$  and  $\Gamma_t$  are the total reaction

$$\sigma(y, f) = \sigma_R(y)(\Gamma_f / \Gamma_t)$$

cross sections for the incident particle  $y$ , the fission width, and the total level width, respectively, where  $\Gamma_t = \Gamma_f + \Gamma_n + \Gamma_\gamma + \dots$  is the sum of all partial-level widths. All the quantities in the above equation are energy-dependent.

When the incoming neutron has low energy, the likelihood of reaction is substantial only when the energy of the neutron is such as to form a compound nucleus in one or another of its resonance levels. The requisite sharpness of the "tuning" of the energy is specified by the total level width  $\Gamma$ . The nuclei  $^{233}\text{U}$ ,  $^{235}\text{U}$ , and  $^{239}\text{Pu}$  have a very large cross section to take up a slow neutron and undergo fission because both their absorption cross section and their probability for decay by fission are large. The probability for fission decay is high because the binding energy of the incident neutron is sufficient to raise the energy of the compound nucleus above the fission barrier. The very large, slow neutron fission cross sections of these isotopes make them important fissile materials in a chain reactor. See CHAIN REACTION (PHYSICS); REACTOR PHYSICS.

**Postscission phenomena.** After the nuclear fragments are separated, they are further accelerated as the result of the large Coulomb repulsion. The initially deformed fragments collapse to their equilibrium shapes, and the excited primary fragments lose energy by evaporating neutrons. After neutron emission, the fragments lose the remainder of their energy by gamma radiation, with a lifetime of about  $10^{-11}$  s. The variation of neutron yield with fragment mass is directly related to the fragment excitation energy. Minimum neutron yields are observed for nuclei near closed shells because of the resistance to deformation of nuclei with closed shells. Maximum neutron yields occur for fragments that are "soft" toward nuclear deformation.

After the emission of the prompt neutrons and gamma rays, the resulting fission products are unstable against  $\beta$ -decay. For example, in the case of thermal neutron fission of  $^{235}\text{U}$ , each fragment undergoes on the average about three  $\beta$ -decays before it settles down to a stable nucleus. For selected fission products (for example,  $^{87}\text{Br}$  and  $^{137}\text{I}$ )  $\beta$ -decay leaves the daughter nucleus with excitation energy exceeding its neutron binding energy. The resulting delayed neutrons amount, for thermal neutron fission of  $^{235}\text{U}$ , to about 0.7% of all the neutrons given off in fission. Though small in number, they are quite important in stabilizing nuclear chain reactions against sudden minor fluctuations in reactivity. See DELAYED NEUTRON; NEUTRON; THERMAL NEUTRONS.

[J.R.Hu.]

**Nuclear fuel cycle** The nuclear fuel cycle typically involves the following steps: (1) finding and mining the uranium ore; (2) refining the uranium from other elements; (3) enriching the uranium-235 content to 3–5%; (4) fabricating fuel elements; (5) interim storage and cooling of spent fuel; (6) reprocessing of spent fuel to recover uranium and plutonium (optional); (7) fabricating recycle fuel for added energy production (optional); (8) cooling of spent fuel or reprocessing waste, and its eventual transport to a repository for disposal in secure long-term storage. See NUCLEAR FUELS; URANIUM.

Steps 6 and 7 are used in Britain, France, India, Japan, and Russia. They are no longer used in the United States, which by federal policy has been restricted to a "once through" fuel cycle, meaning without recycle. Belgium, China, France, Germany, Japan, and Russia, with large and growing nuclear power capacities, use recycled plutonium. Disposal of highly enriched uranium from nuclear weapons is beginning to be undertaken

by blending with natural or depleted uranium to make the 3–5% low-enrichment fuel. Similarly, MOX (mixed oxides) fuel capability can be used to dispose of plutonium stockpiled for nuclear weapons. This option is being planned in Europe and Russia, and is beginning to be considered in the United States. See PLUTONIUM.

Nuclear reactors produce energy using fuel made of uranium slightly enriched in the isotope  $^{235}\text{U}$ . The basic raw material is natural uranium that contains 0.71%  $^{235}\text{U}$  (the only naturally occurring isotope that can sustain a chain reaction). The other isotopes of natural uranium consist of  $^{238}\text{U}$ , part of which converts to plutonium-239, during reactor operation. The isotope  $^{239}\text{Pu}$  also sustains fission, typically contributing about one-third of the energy produced per fuel cycle. See NUCLEAR FISSION; NUCLEAR REACTOR.

Various issues revolve around the type of nuclear fuel cycle chosen. For instance, the question is still being argued whether "burning" weapons materials in recycle reactors is more or less subject to diversion (that is, falling into unauthorized hands) than storing and burying these materials. Another issue involves the composition of radioactive wastes and its impact on repository design. The nuclear fuel cycles that include reprocessing make it possible to separate out the most troublesome long-lived radioactive fission products and the minor actinide elements that continue to produce heat for centuries. The remaining waste decays to radiation levels comparable to natural ore bodies in about 1000 years. The shorter time for the resulting wastes to decay away simplifies the design, management, and costs of the repository. See ACTINIDE ELEMENTS. [E.L.Z.]

**Nuclear fuels** Materials whose ability to release energy derives from specific properties of the atom's nucleus. In general, energy can be released by combining two light nuclei to form a heavier one, a process called nuclear fusion; by splitting a heavy nucleus into two fragments of intermediate mass, a process called nuclear fission; or by spontaneous nuclear decay processes, which are generically referred to as radioactivity. Although the fusion process may significantly contribute to the world's energy production in future centuries and although the production of limited amounts of energy by radioactive decay is a well-established technology for specific applications, the only significant industrial use of nuclear fuel so far utilizes fission. Therefore, the term nuclear fuels generally designates nuclear fission fuels only. See NUCLEAR BATTERY; NUCLEAR FISSION; NUCLEAR FUSION; NUCLEAR POWER; RADIOACTIVITY AND RADIATION APPLICATIONS.

Large releases of energy through a fission or a fusion reaction are possible because the stability of the nucleus is a function of its size. The binding energy per nucleon provides a measure of the nucleus stability. By selectively combining light nuclei together by a fusion reaction or by fragmenting heavy nuclei by a fission reaction, nuclei with higher binding energies per nucleon can be formed. The result of these two processes is a release of energy. The fissioning of one nucleus of uranium releases as much energy as the oxidation of approximately  $5 \times 10^7$  atoms of carbon. See NUCLEAR BINDING ENERGY.

Many heavy elements can be made to fission by bombardment with high-energy particles. However, only neutrons can provide a self-sustaining nuclear fission reaction. Upon capture of a neutron by a heavy nucleus, the latter may become unstable and split into two fragments of intermediate mass. This fragmentation is generally accompanied by the emission of one or several neutrons, which can then induce new fissions. Only a few long-lived nuclides have been found to have a high probability of fission:  $^{233}\text{U}$ ,  $^{235}\text{U}$ , and  $^{239}\text{Pu}$ . Of these nuclides, only  $^{235}\text{U}$  occurs in nature as 1 part in 140 of natural uranium, the remainder being mostly  $^{238}\text{U}$ . The other nuclides must be produced artificially:  $^{233}\text{U}$  from  $^{232}\text{Th}$ , and  $^{239}\text{Pu}$  from  $^{238}\text{U}$ . The nuclides  $^{233}\text{U}$ ,  $^{235}\text{U}$ , and  $^{239}\text{Pu}$  are called fissile materials since they undergo fission with either slow or fast neutrons, while  $^{232}\text{Th}$  and  $^{238}\text{U}$  are called

fertile materials. The latter, however, can also undergo the fission process at low yields with energetic neutrons; therefore, they are also referred to as being fissionable.

The term nuclear fuel applies not only to the fissile materials, but often to the mixtures of fissile and fertile materials as well. Using a mixture of fissile and fertile materials in a reactor allows capture of excess neutrons by the fertile nuclides to form fissile nuclides. Depending on the efficiency of production of fissile elements, the process is called conversion or breeding. Breeding is an extreme case of conversion corresponding to a production of fissile material at least equal to its consumption. See NUCLEAR FUEL CYCLE; NUCLEAR REACTOR. [D.Fr.; A.Mac.]

**Nuclear fuels reprocessing** Nuclear fuels are reprocessed for military or civilian purposes. In military applications, reprocessing is applied to extract fissile plutonium from fuels that are designed and operated to optimize production of this element. In civilian applications, reprocessing is used to recover valuable uranium and transuranic elements that remain in fuels discharged from electricity-generating nuclear power plants, for subsequent recycle in freshly constituted nuclear fuel. This military-civilian duality has made the development and application of reprocessing technology a sensitive issue worldwide and necessitates stringent international controls on reprocessing operations. It has also stimulated development of alternative processes to produce less plutonium and more uranium (or transuranic elements), so that the proliferation of nuclear weapons is held in check. See NUCLEAR POWER; PLUTONIUM; TRANSURANIC ELEMENTS; URANIUM.

Nuclear fuel is removed from civilian power reactors due to chemical, physical, and nuclear changes that make it increasingly less efficient for heat generation as its cumulative residence time in the reactor core increases. The fissionable material in the fuel is not depleted; however, the buildup of fission product isotopes (with strong neutron-absorbing properties) tends to decrease the nuclear reactivity of the fuel. See NUCLEAR FISSION; NUCLEAR FUELS; NUCLEAR REACTOR.

A typical composition of civilian reactor spent fuel at discharge is 96% uranium, 3% fission products, and 1% transuranic elements (generally as oxides, because most commercial nuclear fuel is in the form of uranium oxide). The annual spent fuel output from a 1.2-gigawatt electric power station totals approximately 33 tons (30 metric tons) of heavy-metal content. This spent fuel can be discarded as waste or reprocessed to recover the uranium and plutonium that it contains (for recycle in fresh fuel elements). The governments of France, the United Kingdom, Russia, and China actively support reprocessing as a means for the management of highly radioactive spent fuel and as a source of fissile material for future nuclear fuel supply. The United States forbids the reprocessing of civilian reactor fuel for plutonium recovery and is the only one of the five declared nuclear weapons states with complete fuel recycling capabilities that actively opposes commercial fuel reprocessing.

Decisions to reprocess are not made on economic grounds only, making it difficult to evaluate the economic viability of reprocessing in various scenarios. In the ideal case, a number of factors must be considered, including: (1) cost of uranium/ $U_3O_8$ ; (2) cost of enrichment; (3) cost of fuel fabrication; (4) cost of reprocessing; (5) waste disposal cost; and (6) fissile content of spent fuel.

The once-through fuel cycle (that is, direct disposal/no reprocessing) is favored when fuel costs and waste disposal costs are low and reprocessing costs are high. However, technological advancements and escalating waste disposal costs can swing the balance in favor of reprocessing. See ACTINIDE ELEMENTS; NUCLEAR FUEL CYCLE; RADIOACTIVE WASTE MANAGEMENT.

The technology of reprocessing nuclear fuel was created as a result of the Manhattan Project during World War II, with the purpose of plutonium production. Early reprocessing methods were

refined over the years, leading to a solvent extraction process known as PUREX (plutonium uranium extraction). The PUREX process is an aqueous method that has been implemented by several countries and remains in operation on a commercial basis. A nonaqueous reprocessing method known as pyroprocessing was developed in the 1990s as an alternative to PUREX. It has not been deployed commercially, but promises greatly decreased costs and reduced waste volumes, with practically no secondary wastes or low-level wastes being generated. It also has the important attribute of an inability to separate pure plutonium from irradiated nuclear fuel. See SOLVENT EXTRACTION.

Both the PUREX process and the pyroprocess can be used in a waste management role in support of a once-through nuclear fuel cycle if the economics of this application are favorable. The PUREX process can be operated with a low decontamination factor for plutonium. The pyroprocess can place the transuranic elements in the salt waste stream that leads to a glass-ceramic waste form. Both systems are effective in placing the fission products and actinide elements present in spent nuclear fuel into more durable waste forms that can be safely disposed in a high-level waste repository. [J.J.La.]

**Nuclear fusion** One of the primary nuclear reactions, the name usually designating an energy-releasing rearrangement collision which can occur between various isotopes of low atomic number. See NUCLEAR REACTION.

Interest in the nuclear fusion reaction arises from the expectation that it may someday be used to produce useful power, from its role in energy generation in stars, and from its use in the fusion bomb. Since a primary fusion fuel, deuterium, occurs naturally and is therefore obtainable in virtually inexhaustible supply, solution of the fusion power problem would permanently solve the problem of the present rapid depletion of chemically valuable fossil fuels. As a power source, the lack of radioactive waste products from the fusion reaction is another argument in its favor as opposed to the fission of uranium. See HYDROGEN BOMB; NUCLEAR FISSION.

In a nuclear fusion reaction the close collision of two energy-rich nuclei results in a mutual rearrangement of their nucleons (protons and neutrons) to produce two or more reaction products, together with a release of energy. The energy usually appears in the form of kinetic energy of the reaction products, although when energetically allowed, part may be taken up as energy of an excited state of a product nucleus. In contrast to neutron-produced nuclear reactions, colliding nuclei, because they are positively charged, require a substantial initial relative kinetic energy to overcome their mutual electrostatic repulsion so that reaction can occur. This required relative energy increases with the nuclear charge  $Z$ , so that reactions between low- $Z$  nuclei are the easiest to produce. The best known of these are the reactions between the heavy isotopes of hydrogen, deuterium, and tritium. See DEUTERIUM; TRITIUM.

Nuclear fusion reactions can be self-sustaining if they are carried out at a very high temperature. That is to say, if the fusion fuel exists in the form of a very hot ionized gas of stripped nuclei and free electrons termed a plasma, the agitation energy of the nuclei can overcome their mutual repulsion, causing reactions to occur. This is the mechanism of energy generation in the stars and in the fusion bomb. It is also the method envisaged for the controlled generation of fusion energy.

The cross sections (effective collisional areas) for many of the simple nuclear fusion reactions have been measured with high precision. It is found that the cross sections generally show broad maxima as a function of energy and have peak values in the general range of 0.01 barn ( $1 \text{ barn} = 10^{-24} \text{ cm}^2$ ) to a maximum value of 5 barns, for the deuterium-tritium (D-T) reaction. The energy releases of these reactions can be readily calculated from the mass difference between the initial and final nuclei or determined by direct measurement.

Some of the important simple fusion reactions, their reaction products, and their energy releases are:

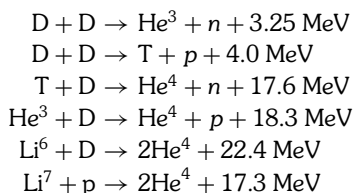

If it is remembered that the energy release in the chemical reaction in which hydrogen and oxygen combine to produce a water molecule is about 1 eV per reaction, it will be seen that, gram for gram, fusion fuel releases more than 1,000,000 times as much energy as typical chemical fuels. [R.F.P.]

**Nuclear isomerism** The existence of excited states of atomic nuclei with unusually long lifetimes. If the lifetime of a specific excited state is unusually long, compared with the lifetimes of other excited states in the same nucleus, the state is said to be isomeric. The definition of the boundary between isomeric and normal decays is arbitrary, and the term is therefore used loosely. See EXCITED STATE; PARITY (QUANTUM MECHANICS); SPIN (QUANTUM MECHANICS).

The predominant decay mode of excited nuclear states is by  $\gamma$ -ray emission. The rate at which this process occurs is determined largely by the spins, parities, and excitation energies of the decaying state and of those to which it is decaying. In particular, the rate is extremely sensitive to the difference in the spins of initial and final states and to the difference in excitation energies. Both extremely large spin differences and extremely small energy differences can result in a slowing of the  $\gamma$ -ray emission by many orders of magnitude, resulting in some excited states having unusually long lifetimes and therefore being termed isomeric.

In addition to spin isomers, two other types of isomers have been identified. The first of these arises from the fact that some excited nuclear states represent a drastic change in shape of the nucleus from the shape of the ground state. In many cases this extremely deformed shape displays unusual stability, and states with this shape are therefore isomeric. A particularly important class of these shape isomers is observed in the decay of heavy nuclei by fission, and the study of such fission isomers has been the subject of intensive effort. See NUCLEAR FISSION.

A more esoteric form of isomer has also been observed, the so-called pairing isomer which results from differences in the microscopic motions of the constituent nucleons in the nucleus. A state of this type has a quite different character from the ground state of the nucleus, and is therefore also termed isomeric. See NUCLEAR STRUCTURE. [R.Bet.]

**Nuclear magnetic resonance (NMR)** A phenomenon exhibited when atomic nuclei in a static magnetic field absorb energy from a radio-frequency field of certain characteristic frequencies. Nuclear magnetic resonance is a powerful analytical tool for the characterization of molecular structure, quantitative analysis, and the examination of dynamic processes. It is based on quantized spectral transitions between nuclear Zeeman levels of stable isotopes, and is unrelated to radioactivity. See ZEEMAN EFFECT.

The format of nuclear magnetic resonance data is a spectrum that contains peaks referred to as resonances. The resonance of an isotope is distinguished by the transition frequency of the nucleus. The intensity of the resonance is directly proportional to the number of nuclei that produce the signal. Although the majority of nuclear magnetic resonance spectra are measured for samples in solution or as neat liquids, it is possible to measure nuclear magnetic resonance spectra of solid samples. Nuclear

magnetic resonance is a nondestructive technique that can be used to measure spectra of cells and living organisms.

**Nuclear magnetic properties.** The nuclei of most atoms possess an intrinsic nuclear angular momentum. The classical picture of nuclear angular momentum is a spherical nucleus rotating about an axis in a manner analogous to the rotation of the Earth. Nuclear angular momentum, like most other atomic quantities, can be expressed as a series of quantized levels.

The transitions that give rise to the nuclear magnetic resonance spectrum are produced when the nuclei are placed in a static magnetic field. The external or applied magnetic field defines a geometric axis, denoted as the  $z$  axis. The external magnetic field orients the  $z$  components of nuclear angular momentum and the magnetic moment with respect to the  $z$  axis. The nuclear magnetic resonance spectrum is produced by spectral transitions between different spin states and is therefore dependent on the value of the nuclear spin. Nuclei for which the nuclear spin value is 0 have a magnetic spin-state value of 0. Therefore, these nuclei do not give rise to a nuclear magnetic resonance spectrum under any circumstances. Many important elements in chemistry have zero values of nuclear spin and are inherently nuclear magnetic resonance inactive, including the most abundant isotopes of carbon-12, oxygen-16, and sulfur-32. Nuclear magnetic resonance spectra are measured most often for nuclei that have nuclear spin values of  $1/2$ . Chemically important spin- $1/2$  nuclei include the isotopes hydrogen-1, phosphorus-31, fluorine-19, carbon-13, nitrogen-15, silicon-29, iron-57, selenium-77, cadmium-113, silver-107, platinum-195, and mercury-199. Nuclear magnetic resonance spectra of nuclei that have nuclear spin values of greater than  $1/2$ , known as quadrupolar nuclei, can be measured; but the measurements are complicated by faster rates of nuclear relaxation. Nuclei that fall into this class include the isotopes hydrogen-2, lithium-6, nitrogen-14, oxygen-17, boron-11, chlorine-35, sodium-23, aluminum-27, and sulfur-33.

The transition frequency in nuclear magnetic resonance depends on the energy difference of the spin states. The intensity of the resonance is dependent on the population difference of the two spin states, which in turn depends directly on the magnitude of the energy difference. For spin- $1/2$  nuclei,  $\Delta E$  is the difference in energy between the + and - values of the magnetic spin state. In contrast to other spectroscopic methods, the nuclear magnetic resonance frequency is variable, depending on the strength of the magnet used to measure the spectrum. Larger magnetic fields produce a greater difference in energy between the spin states. This translates into a larger difference in the population of the spin states and therefore a more intense resonance in the resulting nuclear magnetic resonance spectrum.

Individual nuclei of the same isotope in a molecule have transition frequencies that differ depending on their chemical environment. This phenomenon, called chemical shift, occurs because the effective magnetic field at a particular nucleus in a molecule is less than the applied magnetic field due to shielding by electrons.

An example of resonance chemical shift is observed in the  $^1\text{H}$  nuclear magnetic resonance spectrum of ethyl acetate ( $\text{CH}_3\text{COOCH}_2\text{CH}_3$ ; see illustration). Resonances at several frequencies are observed in this spectrum. The methylene ( $\text{CH}_2$ ) protons are affected by the electron-withdrawing oxygen atoms of the neighboring ester group, and as a result the chemical shift of the methylene proton resonance is significantly different from the chemical shift of the resonances of the protons of the methyl ( $\text{CH}_3$ ) groups of ethyl acetate. The two methyl groups are in different chemical environments and therefore give rise to resonances that have different chemical shifts. Because of the dependence of the transition frequency of a nucleus on its chemical environment, chemical shift is diagnostic of the functional group containing the nucleus of interest. Nuclear magnetic resonance spectroscopy is a frequently employed tool in chemical synthesis studies, because the nuclear magnetic resonance spectrum can confirm the chemical structure of a synthetic product.



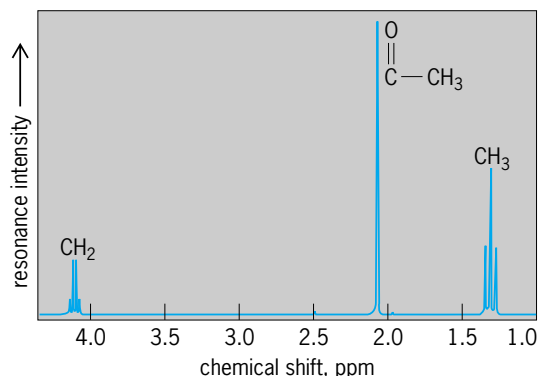

**Proton spectrum of ethyl acetate ( $\text{CH}_3\text{COOCH}_2\text{CH}_3$ ). Chemical shift is relative to the protons of tetramethylsilane. The integrated intensity of the resonances corresponds to the relative number of protons which give rise to each resonance.**

In most nuclear magnetic resonance spectra, rather than frequency units, the spectra are plotted in units of chemical shift expressed as part per million (ppm). The ppm scale calculates the ratio of the resonance frequency in hertz (Hz) to the Larmor frequency of the nucleus at the magnetic field strength of the measurement. The ppm scale allows direct comparison of nuclear magnetic resonance spectra acquired by using magnets of differing field strength. This unit of nuclear magnetic resonance chemical shift should not be confused with the concentration units of ppm (mg/kg), often referred to by analytical chemists in the field of trace analysis.

The chemical shift (either in hertz or ppm) of a resonance is assigned relative to the chemical shift of a standard reference material. The nuclear magnetic resonance community has agreed to arbitrarily set the chemical shift of certain standard compounds to 0 ppm. For  $^1\text{H}$  and  $^{13}\text{C}$  nuclear magnetic resonance, the accepted standard is tetramethylsilane, which is defined to have a chemical shift of 0 ppm. However, any molecule with a resonance frequency in the appropriate chemical shift region of the spectrum that does not overlap with the resonances of the sample can be employed as a chemical shift reference. The use of a chemical shift reference compound other than the accepted standard is particularly common for nuclei that have a very large chemical shift range such as fluorine-19 or selenium-77, since it may be impossible to measure the spectrum of the accepted chemical shift reference compound and the analyte of interest simultaneously because of their very different frequencies.

In addition to the differences in chemical shift, resonances in a given spectrum, for example for ethyl acetate (see illustration), also differ in the number of signals composing the resonance detected for each group of protons. Instead of one resonance resulting from a single transition between two spin states, the methylene group ( $\text{CH}_2$ ) resonance is actually a quartet composed of four lines. Similarly, although the acetate  $\text{CH}_3$  resonance is a single resonance, the ethylene group ( $\text{CH}_3$ ) resonance consists of three lines. This splitting of some resonances, called spin-spin or scalar coupling, arises from interactions between nuclei through their bonding electrons rather than through space. Scalar coupling is a short-range interaction that usually occurs for nuclei separated by one to three bonds.

The effects of spin-spin coupling can be removed from the spectrum by application of a low-strength magnetic field to one of the coupled spins. The effect of this secondary field is to equalize the population of the coupled transitions and to remove the effects of spin-spin coupling. Decoupling can be homonuclear or heteronuclear. Homonuclear decoupling is useful for assigning the resonances of coupled spin systems in the spectrum of a compound or complex mixture. For example, in ethyl acetate, decoupling at the frequency of the methylene group ( $\text{CH}_2$ ) protons would remove the effects of spin-spin coupling, collapsing

the ethylene group ( $\text{CH}_3$ ) resonance into a singlet and confirming the resonance assignments. [C.K.L.]

**Nuclear medicine** A subspecialty of medicine based primarily on the use of radioactive substances in medical diagnosis, treatment, and research. In a typical examination a radioactive tracer is given, usually by injection into an arm vein, and the distribution of the radioactive substance within the body or a part of the body is portrayed in a series of nuclear images. The imaging is based on the emission of gamma rays by the tracer substance that pass out of the body and are recorded by a scintillation camera. The scintillation camera is a radiation detection device consisting of a large sodium iodide crystal (nearly 1 m in diameter in some cases) which detects the gamma rays that interact with the crystal and locates where on the detector face the interaction has occurred. These interactions are used to produce a picture or image of where the gamma rays originated within the body. The methods are related to those in routine x-ray examinations, except that gamma rays are emitted from the body to provide the diagnostic information, rather than being transmitted through the body. Nuclear images depend on specific radioactive elements or compounds labeled with radioactive elements being selectively concentrated in an organ, making it possible to obtain pictures that provide information about regional function within the organ. See GAMMA-RAY DETECTORS; SCINTILLATION COUNTER.

Nuclear imaging techniques make it possible to examine functions of the human body noninvasively, in ways that at times surpass the perception of pathologists at the autopsy table and surgeons at the operating table. The body can be examined as a series of physiologic processes, not simply as static structures. See RADIOACTIVE TRACER; RADIOISOTOPE; RADIOLOGY. [H.N.W.]

**Nuclear molecule** A quasistable entity of nuclear dimensions formed in nuclear collisions and comprising two or more discrete nuclei that retain their identities and are bound together by strong nuclear forces. Whereas the stable molecules of chemistry and biology consist of atoms bound through various electronic mechanisms, nuclear molecules do not form in nature except possibly in the hearts of giant stars; this simply reflects the fact that all nuclei carry positive electrical charges, and that under all natural conditions the long-range electrostatic repulsion prevents nuclear components from coming within the grasp of the short-range attractive nuclear force which could provide molecular binding. But in energetic collisions this electrostatic repulsion can be overcome. See NUCLEAR STRUCTURE. [D.A.B.]

**Nuclear moments** Intrinsic properties of atomic nuclei: electric moments result from deviations of the nuclear charge distribution from spherical symmetry; magnetic moments are a consequence of the intrinsic spin and the rotational motion of nucleons within the nucleus. The classical definitions of the magnetic and electric multipole moments are written in general in terms of multipole expansions. See NUCLEAR STRUCTURE; SPIN (QUANTUM MECHANICS).

In special cases nuclear moments can be measured by direct methods involving the interaction of the nucleus with an external magnetic field or with an electric field gradient produced by the scattering of high-energy charged particles. In general, however, nuclear moments manifest themselves through the hyperfine interaction between the nuclear moments and the fields or field gradients produced by either the atomic electrons' currents and spins, or the molecular or crystalline electronic and lattice structures. See HYPERFINE STRUCTURE. [N.Ko.]

**Nuclear orientation** The directional ordering of an assembly of nuclear spins  $I$  with respect to some axis in space. Under normal conditions nuclei are not oriented; that is, all directions in space are equally probable. For a system of

nuclear spins with rotational symmetry about an axis, the degree of orientation is completely characterized by the relative populations  $a_m$  of the  $2I + 1$  magnetic sublevels  $m$  ( $= I, I - 1, \dots, -I$ ).

Nuclear orientation can be achieved in various ways. The most obvious way is to modify the energies of the  $2I + 1$  magnetic sublevels so as to remove their degeneracy and thereby change the populations of these sublevels. The spin degeneracy can be removed by a magnetic field interacting with the nuclear magnetic dipole moment, or by an inhomogeneous electric field interacting with the nuclear electric quadrupole moment. Significant differences in the populations of the sublevels can be established by cooling the nuclear sample to low temperatures. This means of producing nuclear orientation is called the static method. In contrast, there is the dynamic method, which is related to optical pumping in gases. There are other ways to produce oriented nuclei; for example, in a nuclear reaction such as the capture of polarized neutrons (produced by magnetic scattering) by unoriented nuclei. See DYNAMIC NUCLEAR POLARIZATION; OPTICAL PUMPING.

Oriented nuclei have been used to measure nuclear properties, for example, magnetic dipole and electric quadrupole moments, spins, parities, and mixing ratios of nuclear states. Oriented nuclei have been used to examine some of the fundamental properties of nuclear forces, for example, nonconservation of parity in the weak interaction. Measurement of hyperfine fields, electric-field gradients, and other properties relating to the environment of the nucleus have been made by using oriented nuclei. Nuclear orientation thermometry is one of the few sources of a primary temperature scale at low temperatures. Oriented nuclear targets used in conjunction with beams of polarized and unpolarized particles have proved very useful in examining certain aspects of the nuclear force. See LOW-TEMPERATURE THERMOMETRY; NUCLEAR MOMENTS; NUCLEAR STRUCTURE; PARITY (QUANTUM MECHANICS).

[H.Mar.]

**Nuclear physics** The discipline involving the structure of atomic nuclei and their interactions with each other, with their constituent particles, and with the whole spectrum of elementary particles that is provided by very large accelerators. The nuclear domain occupies a central position between the atomic range of forces and sizes and those of elementary-particle physics, characteristically within the nucleons themselves. As the only system in which all the known natural forces can be studied simultaneously, it provides a natural laboratory for the testing and extending of many fundamental symmetries and laws of nature. Containing a reasonably large, yet manageable number of strongly interacting components, the nucleus also occupies a central position in the universal many-body problem of physics. See ATOMIC NUCLEUS; ATOMIC STRUCTURE AND SPECTRA; ELEMENTARY PARTICLE; SYMMETRY LAWS (PHYSICS).

Nuclear physics is unique in the extent to which it merges the most fundamental and the most applied topics. Its instrumentation has found broad applicability throughout science, technology, and medicine; nuclear engineering and nuclear medicine are two very important areas of applied specialization. See NUCLEAR ENGINEERING; NUCLEAR RADIATION (BIOLOGY); RADIOLOGY.

Nuclear chemistry, certain aspects of condensed matter and materials science, and nuclear physics together constitute the broad field of nuclear science; outside the United States and Canada elementary particle physics is frequently included in this more general classification. See ANALOG STATES; COSMIC RAYS; FUNDAMENTAL INTERACTIONS; ISOTOPE; NUCLEAR CHEMISTRY; NUCLEAR FISSION; NUCLEAR FUSION; NUCLEAR ISOMERISM; NUCLEAR MOMENTS; NUCLEAR REACTION; NUCLEAR REACTOR; NUCLEAR SPECTRA; NUCLEAR STRUCTURE; PARTICLE ACCELERATOR; PARTICLE DETECTOR; RADIOACTIVITY; SCATTERING EXPERIMENTS (NUCLEI); WEAK NUCLEAR INTERACTIONS.

[D.A.B.]

**Nuclear power** Power derived from fission or fusion nuclear reactions. More conventionally, nuclear power is interpreted as the utilization of the fission reactions in a nuclear power reactor to produce steam for electric power production, for ship propulsion, or for process heat. Fission reactions involve the breakup of the nucleus of high-mass atoms and yield an energy release which is more than a millionfold greater than that obtained from chemical reactions involving the burning of a fuel. Successful control of the nuclear fission reactions utilizes this intensive source of energy. See NUCLEAR FISSION.

Fission reactions provide intensive sources of energy. For example, the fissioning of an atom of uranium yields about 200 MeV, whereas the oxidation of an atom of carbon releases only 4 eV. On a weight basis, this  $50 \times 10^6$  energy ratio becomes about  $2.5 \times 10^6$ . Uranium consists of several isotopes, only 0.7% of which is uranium-235, the fissile fuel currently used in reactors. Even with these considerations, including the need to enrich the fuel to several percent uranium-235, the fission reactions are attractive energy sources when coupled with abundant and relatively cheap uranium ore.

Although the main process of nuclear power is the release of energy in the fission process which occurs in the reactor, there are a number of other important processes, such as mining and waste disposal, which both precede and follow fission. Together they constitute the nuclear fuel cycle. See NUCLEAR FUEL CYCLE.

Power reactors include light-water-moderated and -cooled reactors (LWRs), including the pressurized-water reactor (PWR) and the boiling-water reactor (BWR). The high-temperature gas-cooled reactor (HTGR), and the liquid-metal-cooled fast breeder reactor (LMFBR) have reached a high level of development but are not used for commercial purposes. See NUCLEAR REACTOR.

Critics of nuclear power consider the radioactive wastes generated by the nuclear industry to be too great a burden for society to bear. They argue that since the high-level wastes will contain highly toxic materials with long half-lives, such as a few tenths of one percent of plutonium that was in the irradiated fuel, the safekeeping of these materials must be assured for time periods longer than social orders have existed in the past. Nuclear proponents answer that the time required for isolation is much shorter, since only 500 to 1000 years is needed before the hazard posed by nuclear waste falls below that posed by common natural ore deposits in the environment. See RADIOACTIVE WASTE MANAGEMENT.

Nuclear power facilities present a potential hazard rarely encountered with other facilities; that is, radiation. A major health hazard would result if, for instance, a significant fraction of the core inventory of a power reactor were released to the atmosphere. Such a release of radioactivity is clearly unacceptable, and steps are taken to assure it could never happen. These include use of engineered safety systems, various construction and design codes, regulations on reactor operation, and periodic maintenance and inspection.

[F.J.Ra.]

**Nuclear quadrupole resonance** A selective absorption phenomenon observable in a wide variety of polycrystalline compounds containing nonspherical atomic nuclei when placed in a magnetic radio-frequency field. Nuclear quadrupole resonance (NQR) is very similar to nuclear magnetic resonance (NMR), and was originated as an inexpensive (no stable homogeneous large magnetic field is required) alternative way to study nuclear moments. It later gained a modest popularity. See MAGNETIC RESONANCE; NUCLEAR MAGNETIC RESONANCE (NMR).

In the simplest case, for example,  $^{35}\text{Cl}$  in solid  $\text{Cl}_2$ , NQR is associated with the precession of the angular momentum  $I$  (and the nuclear magnetic dipole moment  $\mu$ ) of the nucleus, depicted in the illustration as a flat ellipsoid of rotation, around the symmetry axis (taken as the  $z$  axis) of the  $\text{Cl}_2$  molecule fixed in the crystalline solid. The precession, with constant angle  $\theta$  between the nuclear axis and symmetry axis of the molecule, is due to the torque which the inhomogeneous molecular electric field exerts

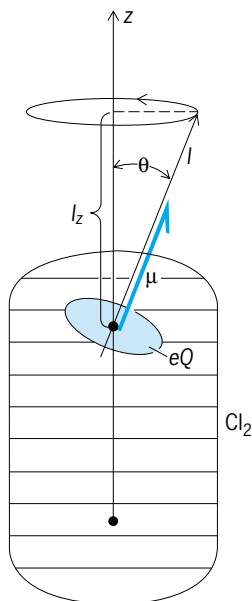

Interaction of  $^{35}\text{Cl}$  nucleus with the electric field of a  $\text{Cl}_2$  molecule.

on the nucleus of electric quadrupole moment  $eQ$ . The absorption occurs classically when the frequency of the rf field and that of the precessing motion of the angular momentum coincide.

NQR spectra have been observed in the approximate range 1–1000 MHz. Most of the NQR work has been on molecular crystals. For such crystals the coupling constants found do not differ very much from those measured for the isolated molecules in microwave spectroscopy. The most precise nuclear information which may be extracted from NQR data are quadrupole moment ratios of isotopes of the same element. If values for the axial gradient of the molecular electric field can be estimated from atomic fine structure data, then fair values of the quadrupole moment may be obtained. However, it has also proved very productive to use the quadrupole nucleus as a probe of bond character and orientation and crystalline electric fields and lattice sites, and extensive data have been accumulated in this area. See MICROWAVE SPECTROSCOPY. [H.De.]

**Nuclear radiation** All particles and radiations emanating from an atomic nucleus due to radioactive decay and nuclear reactions. Thus the criterion for nuclear radiations is that a nuclear process is involved in their production. The term was originally used to denote the ionizing radiations observed from naturally occurring radioactive materials. These radiations were alpha rays (energetic helium nuclei), beta rays (negative electrons), and gamma rays (electromagnetic radiation with wavelength much shorter than visible light). See ALPHA PARTICLES; BETA PARTICLES; GAMMA RAYS.

Nuclear radiations have traditionally been considered to be of three types based on the manner in which they interact with matter as they pass through it. These are the charged heavy particles with masses comparable to that of the nuclear mass (for example, protons, alpha particles, and heavier nuclei), electrons (both negatively and positively charged), and electromagnetic radiation. For all of these, the interactions with matter are considered to be primarily electromagnetic. The behavior of mesons and other particles is intermediate between that of the electron and heavy charged particles.

A striking difference in the absorption of the three types of radiations is that only heavy charged particles have a range. That is, a monoenergetic beam of heavy charged particles, in passing through a certain amount of matter, will lose energy without changing the number of particles in the beam. Ultimately, they

will be stopped after crossing practically the same thickness of absorber. For electromagnetic radiation (gamma rays) and neutrons, on the other hand, the absorption is exponential. The difference in behavior reflects the fact that charged particles are not removed from the beam by individual interactions, whereas gamma radiation photons (and neutrons) are removed. Electrons exhibit a more complex behavior. See ELECTRON; NUCLEAR REACTION. [D.G.K.]

**Nuclear radiation (biology)** Nuclear radiations are used in biology because of their common property of ionizing matter. This makes their detection relatively simple, or makes possible the production of biological effects in any living cell.

Ionizing radiation is any electromagnetic or particulate radiation capable of producing ions, directly or indirectly, in its passage through matter.

All ionizing radiations produce biological changes, directly by ionization or excitation of the atoms in the molecules of biological entities, such as in chromosomes, or indirectly by the formation of active radicals or deleterious agents, through ionization and excitation, in the medium surrounding the biological entities. Ionizing radiation, having high penetrating power, can reach the most vulnerable part of a cell, an organ, or a whole organism, and is thus very effective. In terms of the energy absorbed per unit mass of a biological entity in which an effect is produced, some ionizing radiations are more effective than others. The relative biological effectiveness (RBE) depends in fact on the density of ionization (also termed the specific ionization or linear energy transfer, LET) along the path of the ionizing particle rather than on the nature of the particle itself. Relative biological effectiveness depends also on many other factors. See LINEAR ENERGY TRANSFER (BIOLOGY); RADIATION BIOLOGY.

The medical uses of nuclear radiations may be divided into three distinct classes:

1. The radiations, which are principally x-rays, are used to study the anatomical configuration of body organs, usually for the purpose of detecting abnormalities as an aid in diagnosis.
2. The radiations are used for therapeutic purposes to produce biological changes in such tissues as tumors.
3. The radiations are used as a simple means of tracing a suitable radioactive substance through different steps in its course through the body, in the study of some particular physiological process. See RADIOLOGY. [G.F.; E.H.Q.]

The radiations emitted by radioactive isotopes of the various elements are used in biological research. The most useful ones in biological research are the isotopes of the elements which are important in metabolism and in the structural materials of cells. These include carbon, hydrogen, sulfur, and phosphorus. In addition, the radioactive metals like cobalt-60, radium, and others can be used to produce radiations for external application to cells and tissues. Most of the isotopes mentioned emit beta particles when they decay, and a few emit gamma rays. Therefore, they can be easily detected by various means. These procedures are sometimes used in the study of the movement of elements or their compounds in plants and animals. They are frequently used for tracing the sequence of reactions in metabolism. See BETA PARTICLES; GAMMA RAYS; RADIOISOTOPE (BIOLOGY).

In addition to the radiations emitted, some of the elements change to a different element when they decay. Phosphorus-32 changes to sulfur, sulfur-35 changes to chlorine, and tritium (hydrogen-3) changes to helium when they decay by the emission of an electron, a beta particle. Therefore, in addition to the radiation produced, the transmutation of the element affects the molecule and the cell of which it is a part. In other experiments, the decay of phosphorus-32 has been used to give information on the nature and importance of the phosphorus-containing molecules to the survival or reproduction of a cell or virus particle. Nuclear radiations have also proved useful in many studies of the nature and the mechanisms of the effects of radiations on cells and cell constituents. [J.H.T.]

**Nuclear reaction** A process that occurs as a result of interactions between atomic nuclei when the interacting particles approach each other to within distances of the order of nuclear dimensions ( $\approx 10^{-12}$  cm). While nuclear reactions occur in nature, understanding of them and use of them as tools have taken place primarily in the controlled laboratory environment. In the usual experimental situation, nuclear reactions are initiated by bombarding one of the interacting particles, the stationary target nucleus, with nuclear projectiles of some type, and the reaction products and their behaviors are studied.

**Types of nuclear interaction.** As a generalized nuclear process, consider a collision in which an incident particle strikes a previously stationary particle, to produce an unspecified number of final products. If the final products are the same as the two initial particles, the process is called scattering. The scattering is said to be elastic or inelastic, depending on whether some of the kinetic energy of the incident particle is used to raise either of the particles to an excited state. If the product particles are different from the initial pair, the process is referred to as a reaction.

The most common type of nuclear reaction, and the one which has been most extensively studied, involves the production of two final products. Such reactions can be observed, for example, when deuterons with a kinetic energy of a few megaelectronvolts are allowed to strike a carbon nucleus of mass 12. Protons, neutrons, deuterons, and alpha particles are observed to be emitted, and reactions (1)–(4) are responsible. In these equations the nu-

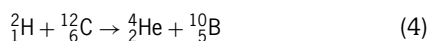
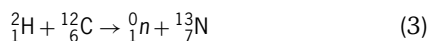
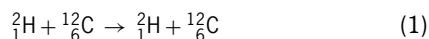

clei are indicated by the usual chemical symbols; the subscripts indicate the atomic number (nuclear charge) of the nucleus, and the superscripts the mass number of the particular isotope. These reactions are conventionally written in the compact notation  ${}^{12}\text{C}(d,d){}^{12}\text{C}$ ,  ${}^{12}\text{C}(d,p){}^{13}\text{C}$ ,  ${}^{12}\text{C}(d,n){}^{13}\text{N}$ , and  ${}^{12}\text{C}(d,\alpha){}^{10}\text{B}$ , where *d* represents deuteron, *p* proton, *n* neutron, and  $\alpha$  alpha particle. In each of these cases the reaction results in the production of an emitted light particle and a heavy residual nucleus. If the residual nucleus is formed in an excited state, it will subsequently emit this excitation energy in the form of gamma rays or, in special cases, electrons. The residual nucleus may also be a radioactive species, in which case it will undergo further transformation in accordance with its characteristic radioactive decay scheme. See RADIOACTIVITY.

**Nuclear cross section.** In general one is interested in the probability of occurrence of the various reactions as a function of the bombarding energy of the incident particle. The measure of probability for a nuclear reaction is its cross section. Consider a reaction initiated by a beam of particles incident on a region which contains *N* atoms per unit area (uniformly distributed), and where *I* particles per second striking the area result in *R* reactions of a particular type per second. The fraction of the area bombarded which is effective in producing the reaction products is *R/I*. If this is divided by the number of nuclei per unit area, the effective area or cross section  $\sigma = R/IN$ . This is referred to as the total cross section for the specific reaction, since it involves all the occurrences of the reaction. The dimensions are those of an area, and total cross sections are expressed in either square centimeters or barns (1 barn =  $10^{-24}$  cm<sup>2</sup>). The differential cross section refers to the probability that a particular reaction product will be observed at a given angle with respect to the beam direction. Its dimensions are those of an area per unit solid angle (for example, barns per steradian).

**Reaction mechanism.** Various reaction models have been extremely successful in describing certain classes or types of nuclear reaction processes. In general, all reactions can be classified

according to the time scale on which they occur, and the degree to which the kinetic energy of the incident particle is converted into internal excitation of the final products. A large fraction of the reactions observed has properties consistent with those predicted by two reaction mechanisms which represent the extremes in this general classification. These are the mechanisms of compound nucleus formation and direct interaction.

Compound nucleus formation is envisioned to take place in two distinct steps. In the first step the incident particle is captured by (or fuses with) the target nucleus, forming an intermediate or compound nucleus which lives a long time ( $\approx 10^{-16}$  s) compared to the approximately  $10^{-22}$  s it takes the incident particle to travel past the target. During this time the kinetic energy of the incident particle is shared among all the nucleons, and all memory of the incident particle and target is lost. The compound nucleus is always formed in a highly excited unstable state, is assumed to approach thermodynamic equilibrium involving all or most of the available degrees of freedom, and will decay, as the second step, into different reaction products, or through so-called exit channels. The essential feature of the compound nucleus formation or fusion reaction is that the probability for a specific reaction depends on two independent probabilities: the probability for forming the compound nucleus, and the probability for decaying into that specific exit channel.

Some reactions have properties which are in striking conflict with the predictions of the compound nucleus hypothesis. Many of these are consistent with the picture of a mechanism where no long-lived intermediate system is formed, but rather a fast mechanism where the incident particle, or some portion of it, interacts with the surface, or some nucleons on the surface, of the target nucleus. These direct reactions are assumed to involve only a very small number of the available degrees of freedom. Most direct reactions are of the transfer type, where one or more nucleons are transferred to or from the incident particle as it passes the target, leaving the two final partners either in their ground states or in one of their many excited states. Such transfer reactions are generally referred to as stripping or pickup reactions, depending on whether the incident particle has lost or acquired nucleons in the reaction.

Inelastic scattering is also a direct reaction. Whereas the states preferentially populated in transfer reactions are those of specific single-particle or shell-model structure, the states preferentially excited in inelastic scattering are collective in nature. See NUCLEAR STRUCTURE; SCATTERING EXPERIMENTS (NUCLEI). [D.G.K.]

**Nuclear reactor** A system utilizing nuclear fission in a controlled and self-sustaining manner. Neutrons are used to fission the nuclear fuel, and the fission reaction produces not only energy and radiation but also additional neutrons. Thus a neutron chain reaction ensues. A nuclear reactor provides the assembly of materials to sustain and control the neutron chain reaction, to appropriately transport the heat produced from the fission reactions, and to provide the necessary safety features to cope with the radiation and radioactive materials produced by its operation. See CHAIN REACTION (PHYSICS); NUCLEAR FISSION.

Nuclear reactors are used in a variety of ways as sources for energy, for nuclear irradiations, and to produce special materials by transmutation reactions. The generation of electrical energy by a nuclear power plant makes use of heat to produce steam or to heat gases to drive turbogenerators. Direct conversion of the fission energy into useful work is possible, but an efficient process has not yet been realized to accomplish this. Thus, in its operation the nuclear power plant is similar to the conventional coal-fired plant, except that the nuclear reactor is substituted for the conventional boiler as the source of heat.

The rating of a reactor is usually given in kilowatts (kW) or megawatts-thermal [MW(th)], representing the heat generation rate. The net output of electricity of a nuclear plant is about one-third of the thermal output. Significant economic gains have been achieved by building improved nuclear reactors with

outputs of about 3300 MW(th) and about 1000 MW-electrical [MW(e)]. See ELECTRIC POWER GENERATION; NUCLEAR POWER.

**Fuel and moderator.** The fission neutrons are released at high energies and are called fast neutrons. The average kinetic energy is 2 MeV, with a corresponding neutron speed of 1/15 the speed of light. Neutrons slow down through collisions with nuclei of the surrounding material. This slowing-down process is made more effective by the introduction of materials of low atomic weight, called moderators, such as heavy water (deuterium oxide), ordinary (light) water, graphite, beryllium, beryllium oxide, hydrides, and organic materials (hydrocarbons). Neutrons that have slowed down to an energy state in equilibrium with the surrounding materials are called thermal neutrons, moving at 0.0006% of the speed of light. The probability that a neutron will cause the fuel material to fission is greatly enhanced at thermal energies, and thus most reactors utilize a moderator for the conversion of fast neutrons to thermal neutrons. See NEUTRON; THERMAL NEUTRONS.

With suitable concentrations of the fuel material, neutron chain reactions also can be sustained at higher neutron energy levels. The energy range between fast and thermal is designated as intermediate. Fast reactors do not have moderators and are relatively small.

Only three isotopes—uranium-235, uranium-233, and plutonium-239—are feasible as fission fuels, but a wide selection of materials incorporating these isotopes is available.

**Heat removal.** The major portion of the energy released by the fissioning of the fuel is in the form of kinetic energy of the fission fragments, which in turn is converted into heat through the slowing down and stopping of the fragments. For the heterogeneous reactors this heating occurs within the fuel elements. Heating also arises through the release and absorption of the radiation from the fission process and from the radioactive materials formed. The heat generated in a reactor is removed by a primary coolant flowing through it.

**Reactor coolants.** Coolants are selected for specific applications on the basis of their heat-transfer capability, physical properties, and nuclear properties.

Water has many desirable characteristics. It was employed as the coolant in many of the first production reactors, and most power reactors still utilize water as the coolant. In a boiling-water reactor (BWR; see illustration), the water boils directly in the reactor core to make steam that is piped to the turbine. In a pressurized-water reactor (PWR), the coolant water is kept under increased pressure to prevent boiling. It transfers heat to a separate stream of feed water in a steam generator, changing that water to steam.

For both boiling-water and pressurized-water reactors, the water serves as the moderator as well as the coolant. Both light

water and heavy water are excellent neutron moderators, although heavy water (deuterium oxide) has a neutron-absorption cross section approximately 1/500 that for light water that makes it possible to operate reactors using heavy water with natural uranium fuel. The high pressure necessary for water-cooled power reactors determines much of the plant design. See NUCLEAR REACTION.

Gases are inherently poor heat-transfer fluids as compared with liquids because of their low density. This situation can be improved by increasing the gas pressure; however, this introduces other problems and costs. Helium is the most attractive gas (it is chemically inert and has good thermodynamic and nuclear properties) and has been selected as the coolant for the development of high-temperature gas-cooled reactor (HTGR) systems, in which the gas transfers heat from the reactor core to a steam generator. The British advanced gas reactor (AGR), however, uses carbon dioxide (CO<sub>2</sub>). Gases are capable of operation at extremely high temperature, and they are being considered for special process applications and direct-cycle gas-turbine applications.

The alkali metals, in particular, have excellent heat-transfer properties and extremely low vapor pressures at temperatures of interest for power generation. Sodium is attractive because of its relatively low melting point (208°F or 98°C) and high heat-transfer coefficient. It is also abundant, commercially available in acceptable purity, and relatively inexpensive. It is not particularly corrosive, provided low oxygen concentration is maintained. Its nuclear properties are excellent for fast reactors. In the liquid-metal fast breeder reactor (LMFBR), sodium in the primary loop collects the heat generated in the core and transfers it to a secondary sodium loop in the heat exchanger, from which it is carried to the steam generator in which water is boiled to make steam.

**Plant balance.** The nuclear chain reaction in the reactor core produces energy in the form of heat, as the fission fragments slow down and dissipate their kinetic energy in the fuel. This heat must be removed efficiently and at the same rate it is being generated in order to prevent overheating of the core and to transport the energy outside the core, where it can be converted to a convenient form for further utilization. The energy transferred to the coolant, as it flows past the fuel element, is stored in it in the form of sensible heat and pressure and is called the enthalpy of the fluid. In an electric power plant, the energy stored in the fuel is further converted to kinetic energy through a device called a prime mover which, in the case of nuclear reactors, is predominantly a steam turbine. Another conversion takes place in the electric generator, where kinetic energy is converted into electric power as the final energy form to be distributed to the consumers through the power grid and distribution system. See ENTHALPY; GENERATOR; PRIME MOVER; STEAM TURBINE.

**Fluid flow and hydrodynamics.** Because heat removal must be accomplished as efficiently as possible, considerable attention must be given to fluid-flow and hydrodynamic characteristics of the system. See FLUID FLOW; HYDRODYNAMICS.

The heat capacity and thermal conductivity of the fluid at the temperature of operation have a fundamental effect upon the design of the reactor system. The heat capacity determines the mass flow of the coolant required. The fluid properties (thermal conductivity, viscosity, density, and specific heat) are important in determining the surface area required for the fuel—in particular, the number and arrangement of the fuel elements. These factors combine to establish the pumping characteristics of the system because the pressure drop and coolant temperature rise in the core are directly related. See CONDUCTION (HEAT); HEAT CAPACITY; VISCOSITY.

**Thermal stress.** The temperature of the reactor coolant increases as it circulates through the reactor core. Fluctuations in power level or in coolant flow rate result in variations in the temperature rise. A reactor is capable of very rapid changes in power level, particularly reduction in power level, which is a safety

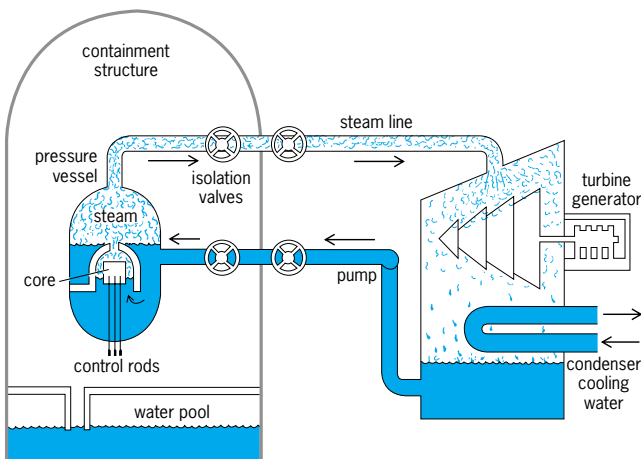

Boiling-water reactor. (Atomic Industrial Forum, Inc.)

feature of the plant. Reactors are equipped with mechanisms (reactor scram systems) to ensure rapid shutdown of the system in the event of leaks, failure of power conversion systems, or other operational abnormalities. Therefore, reactor coolant systems must be designed to accommodate the temperature transients that may occur because of rapid power changes. In addition, they must be designed to accommodate temperature transients that might occur as a result of a coolant system malfunction, such as pump stoppage.

**Coolant system components.** The development of reactor systems has led to the development of special components for reactor component systems. Because of the hazard of radioactivity, leak-tight systems and components are a prerequisite to safe, reliable operation, and maintenance. Special problems are introduced by many of the fluids employed as reactor coolants.

More extensive component developments have been required for sodium, which is chemically active and is an extremely poor lubricant. Centrifugal pumps employing unique bearings and seals have been specially designed. Sodium is an excellent electrical conductor and, in some special cases, electromagnetic-type pumps have been used. These pumps are completely sealed, contain no moving parts, and derive their pumping action from electromagnetic forces imposed directly on the fluid. *See* CENTRIFUGAL PUMP; ELECTROMAGNETIC PUMP.

**Core design.** A typical reactor core for a power reactor consists of the fuel element rods supported by a grid-type structure inside a vessel.

Structural materials employed in reactor systems must possess suitable nuclear and physical properties and must be compatible with the reactor coolant under the conditions of operation. The most common structural materials employed in reactor systems are stainless steel and zirconium alloys. Zirconium alloys have favorable nuclear and physical properties, whereas stainless steel has favorable physical properties. Aluminum is widely used in low-temperature test and research reactors; zirconium and stainless steel are used in high-temperature power reactors. Zirconium is relatively expensive, and its use is therefore confined to applications in the reactor core where neutron absorption is important. *See* ALUMINUM; STAINLESS STEEL; ZIRCONIUM.

Reactors maintain a separation of fuel and coolant by cladding the fuel. The cladding is designed to prevent the release of radioactivity from the fuel. The cladding material must be compatible with both the fuel and the coolant.

The cladding materials must also have favorable nuclear properties. The neutron-capture cross section is most significant because the unwanted absorption of neutrons by these materials reduces the efficiency of the nuclear fission process. Aluminum is a very desirable material in this respect; however, its physical strength and corrosion resistance in water decrease very rapidly above about 300°F (149°C).

Zirconium has favorable neutron properties, and in addition is corrosion-resistant in high-temperature water. It has found extensive use in water-cooled power reactors. Stainless steel is used for the fuel cladding in fast reactors, in some light-water reactors for which neutron captures are less important.

**Control.** A reactor is critical when the rate of production of neutrons equals the rate of absorption in the system. The control of reactors requires the continuing measurement and adjustment of the critical condition. The neutrons are produced by the fission process and are consumed in a variety of ways, including absorption to cause fission, nonfission capture in fissionable materials, capture in fertile materials, capture in structure or coolant, and leakage from the reactor to the shielding. A reactor is subcritical (power level decreasing) if the number of neutrons produced is less than the number consumed. The reactor is supercritical (power level increasing) if the number of neutrons produced exceeds the number consumed. *See* REACTOR PHYSICS.

Reactors are controlled by adjusting the balance between neutron production and neutron consumption. Normally, neutron consumption is controlled by varying the absorption or leakage

of neutrons; however, the neutron generation rate also can be controlled by varying the amount of fissionable material in the system.

The reactor control system requires the movement of neutron-absorbing rods (control rods) in the reactor under carefully controlled conditions. They must be arranged to increase reactivity (increase neutron population) slowly and under good control. They must be capable of reducing reactivity, both rapidly and slowly.

The control drives can be operated by the reactor operator or by automatic control systems. Reactor scram (rapid reactor shutdown) can be initiated automatically by a wide variety of system scram-safety signals, or it can be started by the operator depressing a scram button in the control room.

Control drives are electromechanical or hydraulic devices that impart in-and-out motion to the control rods. They are usually equipped with a relatively slow-speed reversible drive system for normal operational control. Scram is usually effected by a high-speed overriding drive accompanied by disconnecting the main drive system.

**Applications.** Reactor applications include mobile, stationary, and packaged power plants; production of fissionable fuels (plutonium and uranium-233) for military and commercial applications; research, testing, teaching-demonstration, and experimental facilities; space and process heat; dual-purpose design; and special applications. The potential use of reactor radiation or radioisotopes produced for sterilization of food and other products, steam for chemical processes, and gas for high-temperature applications has been recognized. *See* NUCLEAR FUEL CYCLE; NUCLEAR FUELS REPROCESSING; RADIOACTIVITY AND RADIATION APPLICATIONS; SHIP NUCLEAR PROPULSION. [F.J.Ra.]

**Nuclear spectra** The distribution of the intensity of particles (or radiation) emitted in a nuclear process as a function of energy. The nuclear spectrum is a unique signature of the process.

For example, when very slow neutrons (with speeds less than 0.5% of the speed of light) hit nitrogen nuclei, there is a high probability that they will be captured and that the nuclear system which is formed will emit a set of gamma rays (electromagnetic radiation) of very precise energies. The 24 gamma rays have energies ranging from 1.68 to 10.83 MeV, and their relative intensities are well known. A spectrum of these gamma rays, that is, the number of gamma rays having a particular energy, versus that energy can provide a unique signature of the presence of nitrogen. An application is the passing of a beam of slow neutrons through luggage at an airport: the presence of unusual amounts of nitrogen indicates that a plastic explosive may be present. This testing is nondestructive: relatively few neutrons are needed to produce the characteristic spectrum, and the luggage and its contents are not harmed. *See* GAMMA RAYS; NONDESTRUCTIVE EVALUATION.

**Measurements.** The methods used to measure nuclear spectra depend on the nature of the particles (radiation) involved. The most accurate energy measurements are those of gamma rays. Gamma-ray spectra can be measured by determining the energy deposited by the gamma rays in a crystal, often made of sodium iodide, containing thallium impurities [NaI(Tl)], or of germanium, containing lithium impurities [Ge(Li)]. In a NaI(Tl) detector, the gamma-ray energy is transferred to electrons within the crystal, and these charged particles in turn produce electromagnetic radiation with frequencies in the visible range. The crystal is surrounded by detectors (photomultipliers) that are sensitive to the visible light. The intensity of the signal in the photomultipliers is proportional to the energy of the gamma rays that entered the NaI(Tl) crystal. The signal pulse is amplified electronically, and the pulse heights (pulse sizes) are displayed in a pulse-height multichannel analyzer in a histogram. Usually the number of pulses having a certain height (strength) is plotted

versus the height. What results is a plot showing the number of gamma rays having a certain energy versus the energy of the gamma rays, a spectrum. See GAMMA-RAY DETECTORS; PHOTO-MULTIPLIER.

Neutron spectra are often determined by measuring their velocities. This is done by a time-of-flight technique in which an electronic timer measures the time interval between the emission of the neutron from a nucleus and its arrival at a detector a known distance away. This measurement uniquely determines the velocity, and thus the kinetic energy, of the neutrons. See NEUTRON SPECTROMETRY; TIME-OF-FLIGHT SPECTROMETERS.

Measurements of nuclear spectra involving charged particles, such as pions, protons and alpha particles, are often made by determining their momenta ( $\text{mass} \times \text{velocity}$ ) and then calculating the corresponding kinetic energy. Momentum measurements are made by passing the beam of charged particles through a region in which a magnetic field exists. A magnetic field that is constant in time will not cause a change in a charged particle's speed, but it will cause a charged particle to deviate in its path. See PARTICLE ACCELERATOR.

Modern magnetic spectrometers use sophisticated counter telescopes and multiwire proportional counters, which permit not only the registering of the particles characterized by a certain value of the radius of curvature (and therefore of momentum) but enable the particular particle (proton, alpha particle, or whatever) that caused the signal to be identified. Contemporary magnetic spectrometer systems not only utilize complex arrangements of magnetic fields, detectors, and electronics but also generally require powerful computers to monitor and analyze the results. See PARTICLE DETECTOR. [F.A.S.]

**Nuclear structure** At the center of every atom lies a small, dense nucleus, which carries more than 99.97% of the atomic mass in less than  $10^{-12}$  of its volume. The nucleus is a tightly bound system of protons and neutrons which is held together by strong forces that are not normally perceptible in nature because of their extremely short range. The small size, strong forces, and many particles in the nucleus result in a highly complex and unique quantal system that at present defies exact analysis. The study of the nucleus and the forces that hold it together constitute the field of nuclear structure physics. See ATOMIC STRUCTURE AND SPECTRA; NEUTRON; PROTON; QUANTUM MECHANICS; STRONG NUCLEAR INTERACTIONS.

The protons of the nucleus, being positively charged, generate a spherically symmetric electric field in which the atomic electrons orbit. The cloud of negatively charged atomic electrons normally balances the positive nuclear charge, making the atom electrically neutral. The atomic number of protons is usually denoted by  $Z$  and the number of neutrons, which are electrically neutral, by  $N$ . The total number of protons and neutrons (or nucleons) is the mass number  $A = Z + N$ . Isotopes have the same atomic number,  $Z$ , and hence are forms of the same chemical element, having the same chemical properties, but they differ in neutron number; isotones have a common number of neutrons,  $N$ , and isobars have the same mass number,  $A$ . See ISOBAR (NUCLEAR PHYSICS); ISOTONE; ISOTOPE.

Nuclei have masses less than the sum of the constituents, the missing mass  $\Delta M$  being accounted for by the binding energy  $\Delta Mc^2$  (where  $c$  is the speed of light), which holds the nuclear system together. The characteristic energy scale is in megaelectronvolts ( $1 \text{ MeV} = 1.6 \times 10^{-13}$  joule). The internuclear forces generate an attractive potential field which holds the nucleus together and in which the nucleons orbit in highly correlated patterns. The volume of nuclei increases approximately linearly with mass number  $A$ , and the radius is roughly  $R = 1.2 \times 10^{-15} \cdot A^{1/3}$  m. See NUCLEAR BINDING ENERGY.

**Size, shape, and density distributions.** A variety of sophisticated techniques have been developed for precise estimates of the nuclear charge distribution, including electron scat-

tering, the study of muonic atoms, and the laser spectroscopy of hyperfine atomic structure. An overall picture of the nuclear charge distributions emerges. The nuclear charge density saturates in the interior and has a roughly constant value in all but the lightest nuclei. The nucleus has a diffuse skin which is of nearly constant thickness.

Many nuclei are found to have nonspherical shapes. Unlike the atom, which has a spherically symmetric Coulomb field generated by the nucleus, the nuclear field is composed of a complicated superposition of short-range interactions between nucleons, and the most stable nuclear shape is the one that minimizes the energy of the system. In general, it is not spherical, and the nuclear shape is most simply described by a multipole power series, the most important term of which is the nuclear quadrupole moment. A positive quadrupole moment reflects the elongation of nuclei into a prolate or football-like shape, while a negative value reflects an oblate shape like that of Earth. See NUCLEAR MOMENTS.

An accurate determination of nuclear matter distributions, that is, the distribution of both protons and neutrons in nuclei, is harder to precisely ascertain.

**Nuclear masses and binding energies.** The variation of average binding energy with mass number is approximated by the Bethe-Weizsacker mass formula, which is noteworthy for its simplicity in reproducing the overall binding energy systematics. The formula is developed by modeling the nucleus on a liquid drop. By analogy with a drop of liquid, there is an attractive volume term, which depends on the number of particles; a repulsive surface-tension term; and a term due to the mutual Coulomb repulsion of protons, which is responsible for the decrease in binding energy for heavy nuclei. The model is spectacularly successful in reproducing the overall trends in nuclear binding energies, masses, and the energetics of nuclear fission, and in predicting the limits of stability where neutrons and protons become unbound. As in the case of predicting a mean nuclear shape, a comparison of the prediction of the Bethe-Weizsacker mass formula to measured masses shows periodic fluctuations with both  $N$  and  $Z$ , which are due to the quantum shell effects. See NUCLEAR FISSION.

**Nuclear excited states.** The small nuclear size and tightly bound nature impose very restrictive constraints on the orbits that protons and neutrons can undergo inside the system. Thus, each nucleus has a series of quantum states that particles can occupy. The Pauli principle requires that each particle have a unique set of quantum labels. Each nuclear state can then be filled with four particles: protons with internal angular momentum "up" and "down," and likewise two neutrons. See ANGULAR MOMENTUM; ENERGY LEVEL (QUANTUM MECHANICS); EXCLUSION PRINCIPLE; PARITY (QUANTUM MECHANICS); QUANTUM NUMBERS; QUARKS; SPIN (QUANTUM MECHANICS).

A nucleus is most stable when all of its nucleons occupy the lowest possible states without violating this occupancy rule. This is called the nuclear ground state. During nuclear collisions the protons and neutrons can be excited from their most bound states and promoted to higher-lying unoccupied states. The process is usually very short-lived and the particles deexcite to their most stable configuration on a time scale of the order of  $10^{-12}$  s. The energy is usually released in the form of gamma rays of well-defined energy corresponding to the difference in energy of the initial and final nuclear states. Occasionally, gamma decay is not favored because of angular momentum selection rules, and long-lived nuclear isomers result. See GAMMA RAYS; NUCLEAR ISOMERISM; NUCLEAR SPECTRA; SELECTION RULES (PHYSICS).

**Nuclear models.** The detailed categorization of the excitation of protons and neutrons allows a mapping of the excited states of each nucleus and determination of its quantum numbers. These data are the essential information required for development of detailed models that can describe the motion of nucleons inside nuclei. Unlike atomic molecules, where rotational, vibrational, and single-particle degrees of freedom involve

different time scales and energies, the nucleus is highly complex, with rotation, vibration, and single-particle degrees of freedom being excited at similar energies and often strongly mixed. See MOLECULAR STRUCTURE AND SPECTRA.

The measurement of static electric and magnetic moments of nuclear states and of dynamic transition moments has provided a great deal of information. Electric moments have revealed a variety of enhanced collective modes of excitation, including elongated, flattened, and pear-shaped nuclear shapes. Magnetic moments have provided detailed information on the differences between excitations involving neutrons (negative moments) and protons (positive moments).

For atoms, the solutions of the Schrödinger equation with a Coulomb potential lead to a reasonable prediction of the energies of quantized atomic states, as well as their spins, parities, and moments. Attempts to make the same progress for nuclei, using a variety of spherically symmetric geometric potentials of nuclear dimensions, failed to reproduce known properties until it was realized by M. G. Meyer and independently by J. H. Jensen in 1949 that an additional spin-orbit potential was required to reproduce the known sequence of nuclear states. A potential of this form binds states having the internal spin of the nucleons parallel to its orbital angular momentum more tightly than when they are antiparallel. The ensuing sequence of quantum shell gaps and subgaps was then correctly reproduced. The shell model has evolved rapidly, and its domain of applicability has widened from the limited regions of sphericity near doubly magic nuclei to encompass most light nuclei with  $A < 60$  as well as enlarged regions around shell closures.

As valence particles are added to a closed core of nucleons, the mutual residual interactions can act coherently and polarize the nuclear system away from sphericity. The polarization effects are strongest when both valence protons and neutrons are involved. The deformed nuclear potential can then undergo collective rotation, which generally involves less energy than other degrees of freedom and thus dominates the spectrum of strongly deformed nuclei.

Nuclei undergo collective vibrations about both spherical and deformed shapes. The degree of softness of these vibrations is characterized by the excitation energy required to populate states. The distinguishing feature of vibrational excited states is that they are grouped in nearly degenerate angular momentum multiplets, each group being separated by a characteristic phonon energy.

It has been a goal of nuclear structure studies to develop models that incorporate all of the features described above in order to produce a unified nuclear picture. The development of generalized nuclear models has relevance to other fields of physics. There are many isotopes that will never be accessible in the laboratory but may exist in stars or may have existed earlier in cosmological time. The evolution of generalized models greatly increases the power to predict nuclear behavior and provides information that is required for cosmological calculations. See COSMOLOGY; NUCLEOSYNTHESIS.

**Nuclei at high excitation energies.** As nuclei are excited to ever higher excitation energies, it is anticipated that shell effects will be slowly replaced by statistical, or chaotic, behavior. The number of states per mega-electronvolt of excitation energy with each spin and parity rise exponentially with increasing excitation energy until the levels become sufficiently close that they overlap and mix strongly and so become a continuum of states.

Toward the top of this energy regime, new modes of nuclear collectivity become accessible. Giant resonance states can be excited that involve compression and oscillation of the nuclear medium with vibrations of the protons and neutrons in phase (isoscalar) or beating against each other (isovector). The excitation and decay of these giant resonances can provide information about shapes of nuclei at high excitation and about the compressibility of nuclear matter. Results from giant resonance studies indicate that the shell effect persists high into the region

previously thought to be statistical. See GIANT NUCLEAR RESONANCES.

The semiclassical statistical and hydrodynamic behavior of hot nuclear matter and its experimental, theoretical, and astrophysical aspects are of great interest at the highest nuclear energies. The influence of compression and heat on the density of nuclear matter is being investigated in order to measure a nuclear equation of state in analogy with the properties of a classical fluid. It has been suggested that the nuclear matter may undergo phase changes under compression, with high-density condensates possibly providing a new metastable state. At the highest densities and temperatures, the nucleons themselves are forced to overlap and merge, leading to a plasma of quarks and gluons that are the nucleonic constituents. See QUARK-GLUON PLASMA; RELATIVISTIC HEAVY-ION COLLISIONS. [C.J.Li.]

**Nucleation** The formation within an unstable, supersaturated solution of the first particles of precipitate capable of spontaneous growth into large crystals of a more stable solid phase. These first viable particles, called nuclei, may either be formed from solid particles already present in the system (heterogeneous nucleation) or be generated spontaneously by the supersaturated solution itself (homogeneous nucleation). See SUPERSATURATION.

Nucleation is significant in analytical chemistry because of its influence on the physical characteristics of precipitates. Processes occurring during the nucleation period establish the rate of precipitation, and the number and size of the final crystalline particles. See COLLOID; PRECIPITATION (CHEMISTRY). [D.H.K.; L.Go.]

**Nucleic acid** An acidic, chainlike biological macromolecule consisting of multiply repeated units of phosphoric acid, sugar, and purine and pyrimidine bases. Nucleic acids as a class are involved in the preservation, replication, and expression of hereditary information in every living cell. There are two types of nucleic acid; deoxyribonucleic acid (DNA) and ribonucleic acid (RNA). See DEOXYRIBONUCLEIC ACID (DNA); RIBONUCLEIC ACID (RNA). [E.Jo.]

**Nucleon** The collective name for a proton or a neutron. These subatomic particles are the principal constituents of atomic nuclei and therefore of most matter in the universe. The proton and neutron share many characteristics. They have the same intrinsic spin, nearly the same mass, and similar interactions with other subatomic particles, and they can transform into one another by means of the weak interactions. Hence it is often useful to view them as two different states or configurations of the same particle, the nucleon. Nucleons are small compared to atomic dimensions and relatively heavy. Their characteristic size is of order  $1/10,000$  the size of a typical atom, and their mass is of order 2000 times the mass of the electron.

The proton and neutron differ chiefly in their electromagnetic properties. The proton has electric charge  $+1$ , the opposite of the electron, while the neutron is electrically neutral. They have significantly different intrinsic magnetic moments. Because the neutron is slightly heavier than the proton, roughly 1 part in 1000, the neutron is unstable, decaying into a proton, an electron, and an antineutrino with a characteristic lifetime of approximately 900 s. Although some unified field theories predict that the proton is unstable, no experiment has detected proton decay.

The complex forces between nucleons and the discovery during the 1950s of many similar subatomic particles led physicists to suggest that nucleons might not be fundamental particles. During the late 1960s and 1970s, inelastic electron and neutrino scattering experiments indicated that nucleons are composed of pointlike particles with spin  $1/2$  and electric charges that are fractions of the charge on the electron. Particles with similar properties, named quarks, had been hypothesized in the early 1960s to explain other regularities among the properties of hadrons. In the early 1970s, it became clear that nucleons and other hadrons



are indeed bound states of quarks. See HADRON; NUCLEAR STRUCTURE.

Quarks are believed to be fundamental particles without internal structure. The proton consists of two up-type quarks and one down-type quark (*uud*), while the neutron consists of *ddu*. Quarks are bound into nucleons by strong forces carried by gluons. The nucleon contains ambient gluon fields in somewhat the same way that the atom contains ambient electromagnetic fields. Because quarks and gluons are much less massive than the nucleon itself, their motion inside the nucleon is relativistic, making quark-antiquark pair creation a significant factor. Thus the nucleon contains fluctuating quark-antiquark pairs in addition to quarks and gluons. The theory of quark-gluon interactions is known as quantum chromodynamics (QCD), in analogy to the quantum theory of electrodynamics (QED). See ELEMENTARY PARTICLE; GLUONS; NEUTRON; PROTON; QUANTUM CHROMODYNAMICS; QUANTUM ELECTRODYNAMICS; QUARKS. [R.L.Ja.]

**Nucleoprotein** A generic term for any member of a large class of proteins associated with nucleic acid molecules. Nucleoprotein complexes occur in all living cells and in viruses, where they play vital roles in reproduction and protein synthesis.

Classification of the nucleoproteins depends primarily upon the type of nucleic acid involved—deoxyribonucleic acid (DNA) or ribonucleic acid (RNA)—and on the biological function of the complex. Deoxyribonucleoproteins (complexes of DNA and proteins) constitute the genetic material of all organisms and of many viruses. They function as the chemical basis of heredity and are the primary means of its expression and control. Most of the mass of chromosomes is made up of DNA and proteins whose structural and enzymatic activities are required for the proper assembly and expression of the genetic information encoded in the molecular structure of the nucleic acid. See DEOXYRIBONUCLEIC ACID (DNA).

Ribonucleoproteins (complexes of RNA and proteins) occur in all cells as part of the machinery for protein synthesis. This complex operation requires the participation of messenger RNAs (mRNAs), amino acyl transfer RNAs (tRNAs), and ribosomal RNAs (rRNAs), each of which interacts with specific proteins to form functional complexes called polysomes, on which the synthesis of new proteins occurs. See RIBONUCLEIC ACID (RNA).

In simpler life forms, such as viruses which infect animal and plant cells and bacteriophages which infect bacteria, most of the mass of the viral particle is due to its nucleoprotein content. The material responsible for the hereditary continuity of the virus may be DNA or RNA, depending on the type of virus, and it is usually enveloped by one or more proteins which protect the nucleic acid and facilitate infections. See BACTERIOPHAGE; CHROMOSOME; NUCLEIC ACID; VIRUS.

A typical human diploid nucleus contains  $5.6 \times 10^{-12}$  g of DNA. This DNA is arranged in 23 pairs of chromosomes differing in size and DNA content. The large number 1 chromosome, for example, contains  $0.235 \times 10^{-12}$  g of DNA, while the much smaller chromosome number 22 contains only  $0.046 \times 10^{-12}$  g. The DNA double-helix of chromosome 1 is actually 7.3 cm long, but this thin filamentous molecule is packaged to form a chromosome less than 10 micrometers long. The enormity of the packing problem can be appreciated from the fact that the average human contains about 100 g of DNA, and 0.5 g would reach from the Earth to the Sun! The reduction in size is largely due to interactions between the DNA and sets of small basic proteins called histones. All somatic cells of higher organisms contain five major histone classes, all of which are characterized by a high content of basic (positively charged) amino acids. [V.G.A.]

**Nucleosome** The fundamental histone-containing structural subunit of eukaryotic chromosomes. In most eukaryotic organisms, nuclear deoxyribonucleic acid (DNA) is complexed with an approximately equal mass of histone protein. The nucleosome is organized so that the DNA is exterior and the histones

interior. The DNA makes two turns around a core of eight histone molecules, thus forming a squat cylinder 11 nanometers in diameter and 5.5 nm in height. A short length of linker or spacer DNA connects one nucleosome to the next, forming a nucleosomal chain that has been likened to a beaded string. This basic structure is found in all forms of chromatin. Nucleosomes have been found in all eukaryotic organisms examined, the only exceptions being some sperm nuclei and the dinoflagellate algae.

A chain of adjacent nucleosomes is approximately sixfold shorter than the DNA it contains. Moreover, chains of nucleosomes have the property of self-assembling into thicker fibers in which the DNA packing ratio approaches 35:1. These observations, and the lack of any obvious catalytic activity, have led to the assumption that the primary function of the nucleosome consists of organizing and packing DNA. See CHROMOSOME; DEOXYRIBONUCLEIC ACID (DNA); GENE. [C.L.F.W.]

**Nucleosynthesis** Theories of the origin of the elements involve synthesis with charged and neutral elementary particles (neutrons, protons, neutrinos, photons) and other nuclear building blocks of matter, such as alpha particles. The theory of nucleosynthesis comprises a dozen distinct processes, including big bang nucleosynthesis, cosmic-ray spallation in the interstellar medium, and static or explosive burning in various stellar environments (hydrogen-, helium-, carbon-, oxygen-, and silicon-burning, and the *s*-, *r*-, *p*-,  $\gamma$ -, and *v*-processes). Acceptable theories must lead to an understanding of the cosmic abundances observed in the solar system, stars, and the interstellar medium. Hydrogen and helium constitute about 98% of the total element content by number of atoms, and there is a rapid decrease with increasing nuclear mass number *A*. See ELEMENTS, COSMIC ABUNDANCE OF.

Observations of the expanding universe and of the 3-K background radiation indicate that the universe originated in a primordial event known as the big bang about  $15 \times 10^9$  years ago. Absence of stable mass 5 and mass 8 nuclei preclude the possibility of synthesizing the major portion of the nuclei of masses greater than 4 in those first few minutes of the universe, when density and temperature were sufficiently high to support the necessary nuclear reactions to synthesize elements. See BIG BANG THEORY; COSMIC BACKGROUND RADIATION; COSMOLOGY.

The principal source of energy in stars is certainly nuclear reactions which release energy by fusion of lighter nuclei to form more massive nuclei. There is considerable evidence that nucleosynthesis has been going on in stars for billions of years. Observations show that the abundance ratio of iron and heavier elements to hydrogen decreases with increasing stellar age. The oldest known stars in the disk of the Milky Way Galaxy exhibit a ratio 10,000 times smaller than in the Sun. This low ratio is understood on the basis of element synthesis occurring in previous-generation stars that evolved to the point of exploding as supernovae, thus enriching the interstellar medium with the nuclei that were synthesized during their lifetimes and by the explosive synthesis that accompanies the ejection of the stellar envelope. Later-generation stars were then formed from enriched gas and dust. See MILKY WAY GALAXY; STELLAR EVOLUTION; STELLAR POPULATION; SUPERNOVA.

Hydrogen burning, the first process of nucleosynthesis, converts hydrogen to helium. In stars of 1.2 or less solar masses, this process occurs via the proton-proton chain. This chain was also responsible for much of the element synthesis during the big bang, producing the bulk of deuterium and helium, and some of the  ${}^7\text{Li}$ , observed today. In more massive stars where the central temperatures exceed  $2 \times 10^7$  K, hydrogen burning is accomplished through proton captures by carbon, nitrogen, and oxygen nuclei, in the carbon-nitrogen-oxygen (CNO) cycles, to form  ${}^4\text{He}$ . The product (ash) of hydrogen burning is helium, but much of the helium produced is consumed in later stages of stellar evolution or is locked up forever in stars of lower mass that never reach the temperatures required to ignite helium burning. The

observed abundances of some carbon, nitrogen, oxygen, and fluorine nuclei are attributed to hydrogen burning in the CNO cycles. See CARBON-NITROGEN-OXYGEN CYCLES; NUCLEAR FUSION; PROTON-PROTON CHAIN.

When the hydrogen fuel is exhausted in the central region of the star, the core contracts and its temperature and density increase. Helium, the ash of hydrogen burning, cannot be burned immediately due to the larger nuclear charge of helium ( $Z = 2$ ) producing a much higher Coulomb barrier against fusion. When the temperature eventually exceeds about  $10^8$  K, helium becomes the fuel for further energy generation and nucleosynthesis. The basic reaction in this thermonuclear phase is the triple-alpha process in which three  $^4\text{He}$  nuclei (three alpha particles) fuse to form  $^{12}\text{C}$ , a carbon nucleus of mass 12 (atomic mass units). Capture of an alpha particle by  $^{12}\text{C}$  then forms  $^{16}\text{O}$ , symbolically written as  $^{12}\text{C} + ^4\text{He} \rightarrow ^{16}\text{O} + \gamma$ , or simply  $^{12}\text{C}(\alpha, \gamma)^{16}\text{O}$ , where  $\gamma$  represents energy released in the form of electromagnetic radiation. Other reactions that are included in helium burning are  $^{16}\text{O}(\alpha, \gamma)^{20}\text{Ne}$ ,  $^{20}\text{Ne}(\alpha, \gamma)^{24}\text{Mg}$ ,  $^{14}\text{N}(\alpha, \gamma)^{18}\text{F}$ , and  $^{18}\text{O}(\alpha, \gamma)^{22}\text{Ne}$ . Fluorine-18, produced when  $^{14}\text{N}$  captures an alpha particle, is unstable and decays by emitting a positron ( $e^+$ ) and a neutrino ( $\nu$ ) to form  $^{18}\text{O}$  [in short,  $^{14}\text{N}(\alpha, \gamma)^{18}\text{F}(e^+, \nu)^{18}\text{O}$ ]. Because there is likely to be  $^{13}\text{C}$  in the stellar core if hydrogen burning proceeded by the carbon-nitrogen-oxygen cycles, the neutron-producing reaction  $^{13}\text{C}(\alpha, n)^{16}\text{O}$  should also be included with the helium-burning reactions. Helium burning is probably responsible for much of the  $^{12}\text{C}$  observed in the cosmic abundances, although in more massive stars the later burning stages will consume the  $^{12}\text{C}$  produced earlier by helium burning. See NUCLEAR REACTION.

Upon exhaustion of the helium supply, if the star has an initial mass of at least 8 solar masses, gravitational contraction of the stellar core can lead to a temperature exceeding  $5 \times 10^8$  K, where it becomes possible for two  $^{12}\text{C}$  nuclei to overcome their high mutual Coulomb-repulsion barrier and fuse to form  $^{20}\text{Ne}$ ,  $^{23}\text{Na}$ , and  $^{24}\text{Mg}$  through reactions such as  $^{12}\text{C}(^{12}\text{C}, \alpha)^{20}\text{Ne}$ ,  $^{12}\text{C}(^{12}\text{C}, p)^{23}\text{Na}$ , and  $^{12}\text{C}(^{12}\text{C}, \gamma)^{24}\text{Mg}$ . Carbon burning can produce a number of nuclei with masses less than or equal to 28 through further proton and alpha-particle captures.

Carbon burning is followed by a short-duration stage, sometimes referred to as neon burning, in which  $^{20}\text{Ne}$  disintegrates by the reaction  $^{20}\text{Ne}(\gamma, \alpha)^{16}\text{O}$ . The eventual result is that most of the carbon from helium burning becomes oxygen, which supplements the original oxygen formed in helium burning. This stage is followed by the fusion of oxygen nuclei at much higher temperatures. (Temperatures greater than  $10^9$  K are required for  $^{16}\text{O}$  nuclei to overcome their mutual Coulomb barrier.) Some relevant reactions for oxygen burning are  $^{16}\text{O}(^{16}\text{O}, \alpha)^{28}\text{Si}$ ,  $^{16}\text{O}(^{16}\text{O}, p)^{31}\text{P}$ , and  $^{16}\text{O}(^{16}\text{O}, \gamma)^{32}\text{S}$ . Nuclei of masses up to  $A = 40$  may be produced in this phase through proton, neutron, and alpha-particle captures.

Silicon burning commences when the temperature exceeds about  $3 \times 10^9$  K. In this phase, photodisintegration of  $^{28}\text{Si}$  and other intermediate-mass nuclei around  $A = 28$  produces copious supplies of protons, neutrons, and alpha particles. These particles capture on the seed nuclei left from previous burning stages and thus produce new isotopes up to mass 60, resulting in the buildup of the abundance peak near  $A = 56$ .

Because neutrons are neutral particles, their capture is not affected by the Coulomb barrier that inhibits charged-particle reactions. If the number of neutrons per seed nucleus is small, so that time intervals between neutron captures are long compared to the beta-decay lifetimes of unstable nuclei that are formed, the *s*-process (slow process) takes place. The seed nuclei are predominantly in the iron peak, but the abundances of low-mass nuclei are also affected by neutron-capture processing. In the *s*-process, if neutron capture produces a nucleus that is unstable (due to an excess number of neutrons), the newly formed nucleus undergoes beta decay to a stable isobar by emitting an electron and an antineutrino. The resulting nucleus eventually captures

another neutron, and the capture-decay step repeats. The presence of free neutrons leads to a chain of capture-decay events that drives the abundances along a unique *s*-process path that zigzags along a single line in the nuclear *Z-N* diagram near the low of beta-stable nuclei (valley of beta stability). Given enough neutrons, the *s*-process synthesizes nuclei of masses up to 209, when alpha decay becomes a deterrent to further buildup by neutron capture. See RADIOACTIVITY.

The *r*-process occurs when a large neutron flux allows rapid neutron capture, so that seed nuclei capture many neutrons before undergoing beta decay. The rapid neutron capture takes the nuclei far away from the valley of beta stability, into the regime of extremely neutron-rich nuclei. The time scale for the *r*-process is very short, 1–100 s, and the abundance of free neutrons is very large. These conditions are found deep inside the interiors of exploding massive stars, supernovae. The *r*-process can synthesize nuclei all the way into the transuranic elements.

The *p*-process produces heavier elements on the proton-rich side of the beta valley. The *p*-nuclei (about 35 are known) are blocked from formation by stable nuclei produced by either the *r*- or *s*-process. The major task for *p*-process theory is thus to find ways, other than beta decay, to process the more abundant *r*- and *s*-nuclei into the less abundant *p*-nuclei. Two possible mechanisms are: radiative proton capture, and gamma-induced neutron, proton, or alpha-particle removal reactions. In both cases the temperature should be in excess of  $2\text{--}3 \times 10^9$  K.

The neutrino ( $\nu$ ) flux emitted from a cooling proto neutron star alters the yields of explosive nucleosynthesis from type II supernovae. Inelastic scattering of neutrinos (all flavors) off abundant nuclei excites states that can decay via single or multiple nucleon emission. The  $\nu$ -process is probably responsible for significant contributions to the synthesis in nature of about a dozen isotopes. While the neutrino interaction cross section with matter is extremely small (about  $10^{-44}$  cm<sup>2</sup>), the high neutrino energies and the large number flux close to the collapsing iron core of a massive star lead to significant synthesis of nuclei, either directly or indirectly. See NEUTRINO.

The bulk of the light elements lithium, beryllium, and boron found in the cosmic abundance curve cannot have survived processing in stellar interiors because they are readily destroyed by proton capture. Although some  $^7\text{Li}$  originated in the big bang, primordial nucleosynthesis cannot be responsible for the bulk of the  $^7\text{Li}$  in existence. Spallation of more abundant nuclei such as carbon, nitrogen, and oxygen by high-energy protons and alpha particles can account for the low-abundance nuclides  $^6\text{Li}$ ,  $^9\text{Be}$ ,  $^{10}\text{B}$ ,  $^{11}\text{B}$ , and for some  $^7\text{Li}$ . The canonical process is spallation of carbon, nitrogen, and oxygen nuclei in the interstellar medium by fast light particles, such as alpha particles and protons, which are abundant in the gas between the stars. These high-energy particles are referred to as cosmic rays, leading to the term "cosmic-ray spallation (CRS) process." See COSMIC RAYS.

[D.H.H.]

**Nucleotide** A cellular constituent that is one of the building blocks of ribonucleic acids (RNA) and deoxyribonucleic acid (DNA). In biological systems, nucleotides are linked by enzymes in order to make long, chainlike polynucleotides of defined sequence. The order or sequence of the nucleotide units along a polynucleotide chain plays an important role in the storage and transfer of genetic information. Many nucleotides also perform other important functions in biological systems. Some, such as adenosine triphosphate (ATP), serve as energy sources that are used to fuel important biological reactions. Others, such as nicotinamide adenine dinucleotide (NAD) and coenzyme A (CoA), are important cofactors that are needed to complete a variety of enzymatic reactions. Cyclic nucleotides such as cyclic adenosine monophosphate (cAMP) are often used to regulate complex metabolic systems. Chemically modified nucleotides such as fluoro-deoxyridine monophosphate (Fl-dUMP) contain special chemical groups that are useful for inactivating the normal

function of important enzymes. These and other such compounds are widely used as drugs and therapeutic agents to treat cancer and a variety of other serious illnesses. See COENZYME; CYCLIC NUCLEOTIDES; NICOTINAMIDE ADENINE DINUCLEOTIDE (NAD).

Nucleotides are generally classified as either ribonucleotides or deoxyribonucleotides. Both classes consist of a phosphorylated pentose sugar that is linked via an *N*-glycosidic bond to a purine or pyrimidine base. The combination of the pentose sugar and the purine or pyrimidine base without the phosphate moiety is called a nucleoside. See PURINE; PYRIMIDINE.

Ribonucleosides contain the sugar *D*-ribose, whereas deoxyribonucleosides contain the sugar 2-deoxyribose. The four most common ribonucleosides are adenosine, guanosine, cytidine, and uridine. The purine ribonucleosides, adenosine and guanosine, contain the nitrogenous bases adenine and guanine, respectively. The pyrimidine ribonucleosides, cytidine and uridine, contain the bases cytosine and uracil, respectively. Similarly, the most common deoxyribonucleosides include deoxyadenosine, deoxyguanosine, deoxycytidine, and thymidine, which contains the pyrimidine base thymine. Phosphorylation of the ribonucleosides or deoxyribonucleosides yields the corresponding ribonucleotide or deoxyribonucleotide. See DEOXYRIBONUCLEIC ACID (DNA); ENZYME; NUCLEIC ACID; RIBONUCLEIC ACID (RNA). [E.P.G.]

**Nuclide** A species of atom that is characterized by the constitution of its nucleus, in particular by its atomic number *Z* and its neutron number *A* - *Z*, where *A* is the mass number. The total number of stable nuclides is approximately 275. About a dozen radioactive nuclides are found in nature, and hundreds of others have been created artificially. [H.E.D.]

**Nudibranchia** An order of the gastropod subclass Opisthobranchia containing about 2500 living species of carnivorous sea slugs. They occur in all the oceans, at all depths, but reach their greatest size and diversity in warm shallow seas.

In this, the largest order of the Opisthobranchia, there is much evidence indicating polyphyletic descent from a number of long-extinct opisthobranch stocks. In all those lines which persist to the present day, the shell and operculum have been discarded in the adult form. In many of them the body has quite independently become dorsally papillate. In at least two suborders these dorsal papillae have acquired the power to nurture nematocysts derived from their coelenterate prey so as to use them for the nudibranch's own defense. In other cases such papillae (usually called cerata) have independently become penetrated by lobules of the adult digestive gland, or they may contain virulent defensive glands or prickly bundles of dagger-like calcareous spicules. See OPISTHOBANCHIA. [T.E.T.]

**Number theory** The study of the properties and relations of the integers. There are many sets of positive integers of particular interest, such as the primes and the perfect numbers. Number theory, of ancient and continuing interest for its intrinsic beauty, also plays a crucial role in computer science, particularly in the area of cryptography.

**Elementary number theory.** This part of number theory does not rely on advanced mathematics, such as complex analysis and ring theory. The basic notion of elementary number theory is divisibility. An integer *d* is a divisor of *n*, written  $d \mid n$ , if there is an integer *t* such that  $n = dt$ . A prime number is a positive integer that has exactly two positive divisors, 1 and itself. The ten smallest primes are 2, 3, 5, 7, 11, 13, 17, 19, 23, and 29. Euclid (around 300 B.C.) proved that there are infinitely many primes by showing that if the only primes were 2, 3, 5, . . . *p*, a prime not in this list could be found by taking a prime factor of the number shown in Eq. (1). Primes are the building blocks

$$N = 2 \cdot 3 \cdot 5 \cdots p + 1 \tag{1}$$

of the positive integers. The fundamental theorem of arithmetic,

established by K. F. Gauss in 1801, states that every positive integer can be written as the product of prime factors in exactly one way when the order of the primes is disregarded.

A perfect number is a positive integer equal to the sum of its positive divisors other than itself. L. Euler showed that  $2^{n-1}(2^n - 1)$  is perfect if and only if  $2^n - 1$  is prime. If  $2^n - 1$  is prime, then *n* itself must be prime. Primes of the form  $2^p - 1$  are known as Mersenne primes after M. Mersenne, who studied them in the seventeenth century. As of 15 May 2004, there were 41 known Mersenne primes, the largest being  $2^{24,036,583} - 1$ , a number with 7,235,733 decimal digits.

If *a* - *b* is divisible by *m*, then *a* is called congruent to *b* modulo *m*, and this relation is written  $a \equiv b \pmod{m}$ . This relation between integers is an equivalence relation and defines equivalence classes of numbers congruent to each other, called residue classes. Congruences to the same modulus can be added, subtracted, and multiplied in the same manner as equations. However, when both sides of a congruence are divided by the same integer *d*, the modulus *m* must be divided by  $\text{gcd}(d, m)$ . There are *m* residue classes modulo *m*. The number of classes containing only numbers coprime to *m* is denoted by  $\phi(m)$ , where  $\phi(m)$  is called the Euler phi function.

In the third century B.C., Eratosthenes showed how all primes up to an integer *n* can be found when only the primes *p* up to *n* are known. It is sufficient to delete from the list of integers, starting with 2, the multiples of all primes up to *n*. The remaining integers are all the primes not exceeding *n*.

Single equations or systems of equations in more unknowns than equations, with restrictions on solutions such as that they must all be integral, are called diophantine equations, after Diophantus who studied such equations in ancient times. A wide range of diophantine equations have been studied. For example, the diophantine equation (2) has infinitely many solutions

$$x^2 + y^2 = z^2 \tag{2}$$

in integers. These solutions are known as pythagorean triples, since they correspond to the lengths of the sides of right triangles where these sides have integral lengths. All solutions of this equation are given by  $x = t(u^2 - v^2)$ ,  $y = 2tuv$ , and  $z(u^2 + v^2)$ , where *t*, *u*, and *v* are positive integers.

Perhaps the most notorious diophantine equation is Eq. (3).

$$x^n + y^n = z^n \tag{3}$$

Fermat's last theorem states that this equation has no solutions in integers when *n* is an integer greater than 2 where  $xyz \neq 0$ . Establishing Fermat's last theorem was the quest of many mathematicians over 200 years. In the 1980s, connections were made between the solutions of this equations and points on certain elliptic curves. Using the theory of elliptic curves, A. Wiles completed a proof of Fermat's last theorem based on these connections in 1995.

**Algebraic number theory.** Attempts to prove Fermat's last theorem led to the development of algebraic number theory, a part of number theory based on techniques from such areas as group theory, ring theory, and field theory. Gauss extended the concepts of number theory to the ring  $R[i]$  of complex numbers of the form  $a + bi$ , where *a* and *b* are integers. Ordinary primes  $p \equiv 3 \pmod{4}$  are also prime in  $R[i]$ , but  $2 = -i(1 + i)^2$  is not prime, nor are primes  $p \equiv 1 \pmod{4}$  since such primes split as  $p = (a + bi)(a - bi)$ . More generally, an algebraic number field  $R(\theta)$  of degree *n* is generated by the root  $\theta$  of a polynomial equation  $f(x) = 0$  of degree *n* with rational coefficients. A number  $\alpha$  in this field is called an algebraic integer if it satisfies an algebraic equation with integer coefficients with initial coefficient 1. The algebraic integers in an algebraic number field form an integral domain. But, prime factorization may not be unique; for example, in  $R[-5]$ ,  $21 = 3 \cdot 7 = (1 + 2 - 5) \cdot (1 - 2 - 5)$  where each of the four factors in the two products is prime. To restore unique factorization, the concept of ideals is needed, as shown by E. E. Kummer and J. W. R. Dedekind. See RING THEORY.

**Analytic number theory.** There are many important results in number theory that can be established by using methods from analysis. For example, analytic methods developed by G. F. B. Riemann in 1859 were used by J. Hadamard and C. J. de la Vallée Poussin in 1896 to prove the famous prime number theorem. This theorem, first conjectured by Gauss about 1793, states that  $\pi(x)$ , the number of primes not exceeding  $x$ , behaves as shown in Eq. (4). These methods of Riemann are based on  $\zeta(s)$ , the function defined by Eq. (5), where  $s = \sigma + it$  is a complex

$$\lim_{x \rightarrow \infty} \frac{\pi(x)}{(x/\log x)} = 1 \tag{4}$$

$$\zeta(s) = \sum_{n=1}^{\infty} \frac{1}{n^s} \tag{5}$$

variable; the series in this equation is convergent for  $\sigma > 1$ . Via an analytic continuation, this function can be defined in the whole complex plane. It is a meromorphic function with only a simple pole of residue 1 at  $s = 1$ . It can be shown that  $\zeta(s)$  has no zeros for  $\sigma = 1$ ; this result and the existence of a pole at  $s = 1$  suffice to prove the prime number theorem. Riemann's work contains the still unproved so-called Riemann hypothesis: all zeros of  $\zeta(s)$  have a real part not exceeding  $1/2$ . See COMPLEX NUMBERS AND COMPLEX VARIABLES.

**Diophantine approximation.** A real number  $x$  is called rational if there are integers  $p$  and  $q$  such that  $x = p/q$ ; otherwise  $x$  is called irrational. The number  $b^{1/m}$  is irrational if  $b$  is an integer which is not the  $m$ th power of an integer (for example, 2 is irrational). A real number  $x$  is called algebraic if it is the root of a monic polynomial with integer coefficients; otherwise  $x$  is called transcendental. The numbers  $e$  and  $\pi$  are transcendental. That  $\pi$  is transcendental implies that it is impossible to square the circle. See CIRCLE; E (MATHEMATICS).

The part of number theory called diophantine approximation is devoted to approximating numbers of a particular kind by numbers from a particular set, such as approximating irrational numbers by rational numbers with small denominators. A basic result is that, given an irrational number  $x$ , there exist infinitely many fractions  $h/k$  that satisfy the inequality (6), where  $c$  is any

$$\left| x - \frac{h}{k} \right| < \frac{1}{ck^2} \tag{6}$$

positive number not exceeding 5. However, when  $c$  is greater than 5, there are irrational numbers  $x$  for which there are only finitely many such  $h/k$ .

In 1851, J. Liouville showed that transcendental numbers exist; he did so by demonstrating that the number  $x$  given by Eq. (7) has the property that, given any positive real number  $m$ , there is a rational number  $h/k$  that satisfies Eq. (8).

$$x = \sum_{j=1}^{\infty} 10^{-j!} \tag{7}$$

$$\left| x - \frac{h}{k} \right| < \frac{1}{k^m} \tag{8}$$

See ALGEBRA; NUMBERING SYSTEMS; ZERO. [K.H.R.]

**Numbering systems** A numbering system is a systematic method for representing numbers using a particular set of symbols. The most commonly used numbering system is the decimal system, based on the number 10, which is called the basis or radix of the system. The basis tells how many different individual symbols there are in the system to represent numbers. In the decimal system these symbols are the digits 0, 1, 2, 3, 4, 5, 6, 7, 8, 9. The range of these numbers varies from 0 to  $(10 - 1)$ . This is a particular case of a more general rule: Given any positive basis or radix  $N$ , there are  $N$  different individual symbols that can be used to write numbers in that system. The range of these numbers varies from 0 to  $N - 1$ .

In the computer and telecommunication fields, three of the most frequently used numbering systems are the binary (base 2), the octal (base 8), and the hexadecimal (base 16). The binary system has only two symbols: 0 and 1. Either of these symbols can be called a binary digit or a bit. The octal system has eight symbols: 0, 1, 2, 3, 4, 5, 6, 7. The hexadecimal system has 16 symbols: 0, 1, 2, 3, 4, 5, 6, 7, 8, 9, A, B, C, D, E, F. A stands for 10, B for 11, C for 12, D for 13, E for 14, and F for 15. The reason for choosing single letters to represent numbers higher than 9 is to keep all individual symbols single characters. See BIT.

All the numbering systems mentioned so far are positional systems. That is, the value of any symbol depends on its position in the number. For example, the value of 2 in the decimal number 132 is that of two units, whereas its value in decimal 245 is that of two hundreds. In the decimal system, the rightmost position of a number is called the ones ( $10^0$ ) place, the next position from the right is called the tens ( $10^1$ ) place, the next position the hundreds ( $10^2$ ) place, and so on. Observe that the powers increase from the right. The power of the rightmost digit is zero, the power of the next digit is one, the power of the next digit is two, and so on. These powers are sometimes called the weight of the digit.

**Conversion to decimal numbers.** In any positional system, the decimal equivalent of a digit in the representation of the number is the digit's own value, in decimal, multiplied by a power of the basis in which the number is represented. The sum of all these powers is the decimal equivalent of the number. The corresponding powers of each of the digits can be better visualized by writing superscripts beginning with 0 at the rightmost digit, and increasing the powers by 1 in moving toward the left digits of the number.

**Decimal numbers to other bases.** The conversion of a given decimal number to another basis  $r$  ( $r > 0$ ) is carried out by initially dividing the given decimal number by  $r$ , and then successively dividing the resulting quotients by  $r$  until a zero quotient is obtained. The decimal equivalent is obtained by writing the remainders of the successive divisions in the opposite order in which they were obtained.

**Binary to hexadecimal or octal and vice versa.** The table shows the decimal numbers 1 through 15 written in binary, octal, and hexadecimal. Since each four-bit binary number corresponds to one and only one hexadecimal digit and vice versa, the hexadecimal system can be viewed as a shorthand notation of the binary system. Similar reasoning can be applied to the octal system. This one-to-one correspondence between the symbols of the binary system and the symbols of the octal and hexadecimal system provides a method for converting numbers between these bases.

To convert binary numbers to hexadecimal, the following procedure may be used: (1) Form four-bit groups beginning from the rightmost bit of the number. If the last group (at the leftmost

The first 15 integers in binary, octal, hexadecimal, and decimal notation			
Binary	Octal	Hexadecimal	Decimal
0001	1	1	1
0010	2	2	2
0011	3	3	3
0100	4	4	4
0101	5	5	5
0110	6	6	6
0111	7	7	7
1000	10	8	8
1001	11	9	9
1010	13	A	10
1011	14	B	11
1100	14	C	12
1101	15	D	13
1110	16	E	14
1111	17	F	15

position) has fewer than four bits, add extra zeros to the left of the bits in this group to make it a four-bit group. (2) Replace each four-bit group by its hexadecimal equivalent. A process that is almost the reverse of the previous procedure can be used to convert from hexadecimal to binary. However, there is no need to add extra zeros to any group since each hexadecimal number will always convert to a group with four binary bits.

A similar process can be followed to convert a binary number to octal, except that in this case three-bit groups must be formed. Individual octal numbers will always convert to groups with three binary bits. [R.A.M.T.]

**Numerical analysis** The development and analysis of computational methods (and ultimately of program packages) for the minimization and the approximation of functions, and for the approximate solution of equations, such as linear or nonlinear (systems of) equations and differential or integral equations. Originally part of every mathematician's work, the subject is now often taught in computer science departments because of the tremendous impact which computers have had on its development. Research focuses mainly on the numerical solution of (nonlinear) partial differential equations and the minimization of functions.

Numerical analysis is needed because answers provided by mathematical analysis are usually symbolic and not numeric; they are often given implicitly only, as the solution of some equation, or they are given by some limit process. A further complication is provided by the rounding error which usually contaminates every step in a calculation (because of the fixed finite number of digits carried).

Even in the absence of rounding error, few numerical answers can be obtained exactly. Among these are (1) the value of a piece-wise rational function at a point and (2) the solution of a (solvable) linear system of equations, both of which can be produced in a finite number of arithmetic steps. Approximate answers to all other problems are obtained by solving the first few in a sequence of such finitely solvable problems. A typical example is provided by Newton's method: A solution  $c$  to a nonlinear equation  $f(c) = 0$  is found as the

$$\text{limit } c = \lim_{n \rightarrow \infty} x_n,$$

with  $X_{n+1}$  being a solution to the linear equation

$$f(x_n) f'(x_m)(x_{n+1} - x_n) = 0,$$

that is,  $x_{n+1} = x_n - f(x_n)/f'(x_n)$ ,  $n = 0, 1, 2, \dots$ . Of course, only the first few terms in this sequence  $x_0, x_1, x_2, \dots$  can ever be calculated, and thus one must consider when to break off such a solution process and how to gauge the accuracy of the current approximation.

An otherwise satisfactory computational process may become useless, because of the amplification of rounding errors. A computational process is called stable to the extent that its results are not spoiled by rounding errors. The extended calculations involving millions of arithmetic steps now possible on computers have made the stability of a computational process a prime consideration.

**Interpolation and approximation.** Polynomial interpolation provides a polynomial  $p$  of degree  $n$  or less which uniquely matches given function values  $f(x_0), \dots, f(x_n)$  at corresponding distinct points  $x_0, \dots, x_n$ . The interpolating polynomial  $p$  is used in place of  $f$ , for example in evaluation, integration, differentiation, and zero finding. Accuracy of the interpolating polynomial depends strongly on the placement of the interpolation points, and usually degrades drastically as one moves away from the interval containing these points (that is, in case of extrapolation). See EXTRAPOLATION.

When many interpolation points (more than 5 or 10) are to be used, it is often much more efficient to use instead a piece-wise polynomial interpolant or spline. Suppose the interpolation points above are ordered,  $x_0 < x_1 < \dots < x_n$ . Then the cubic spline

interpolant to the above data, for example, consists of cubic polynomial pieces, with the  $i$ th piece defining the interpolant on the interval  $[x_{i-1}, x_i]$  and so matched with its neighboring piece or pieces that the resulting function not only matches the given function values (hence is continuous) but also has a continuous first and second derivative.

Interpolation is but one way to determine an approximant. In full generality, approximation involves several choices: (1) a set  $P$  of possible approximants, (2) a criterion for selecting from  $P$  a particular approximant, and (3) a way to measure the approximation error, that is, the difference between the function  $f$  to be approximated and the approximant  $p$ , in order to judge the quality of approximation.

**Solution of linear systems.** Solving a linear system of equations is probably the most frequently confronted computational task. It is handled either by a direct method, that is, a method which obtains the exact answer in a finite number of steps, or by an iterative method, or by a judicious combination of both. Analysis of the effectiveness of possible methods has led to a workable basis for selecting the one which best fits a particular situation.

Direct methods require a number of operations which increases with the cube of the number of unknowns. Some types of problems arise wherein the matrix of coefficients is sparse, but the unknowns may number several thousand; for these, direct methods are prohibitive in computer time required. One frequent source of such problems is the finite difference treatment of partial differential equations. A significant literature of iterative methods exploiting the special properties of such equations is available. For certain restricted classes of difference equations, the error in an initial iterate can be guaranteed to be reduced by a fixed factor, using a number of computations that is proportional to  $n \log n$ , where  $n$  is the number of unknowns. Since direct methods require work proportional to  $n^3$ , it is not surprising that as  $n$  becomes large, iterative methods are studied rather closely as practical alternatives.

**Differential equations.** Classical methods yield practical results only for a moderately restricted class of ordinary differential equations, a somewhat more restricted class of systems of ordinary differential equations, and a very small number of partial differential equations. The power of numerical methods is enormous here, for in quite broad classes of practical problems relatively straightforward procedures are guaranteed to yield numerical results, whose quality is predictable. See DIFFERENTIAL EQUATION. [C.DeB.]

**Numerical representation (computers)** Numerical data in a computer are written in basic units of storage made up of a fixed number of consecutive bits. The most commonly used units in the computer and communication industries are the byte (8 consecutive bits), the word (16 consecutive bits), and the double word (32 consecutive bits). A number is represented in each of these units by setting the bits according to the binary representation of the number. By convention the bits in a byte are numbered, from right to left, beginning with zero. Thus, the rightmost bit is bit number 0 and the leftmost bit is number 7. The rightmost bit is called the least significant bit, and the leftmost bit is called the most significant bit. Higher units are numbered also from right to left. In general, the rightmost bit is labeled 0 and the leftmost bit is labeled  $(n - 1)$ , where  $n$  is the number of bits available. See BIT.

Since each bit may have one of two values, 0 or 1,  $n$  bits can represent  $2^n$  different unsigned numbers. The range of these nonnegative integers varies from 0 to  $2^n - 1$ . To represent positive or negative numbers, one of the bits is chosen as the sign bit. By convention, the leftmost bit (or most significant bit) is considered the sign bit. A value of 0 in the sign bit indicates a positive number, whereas a value of 1 indicates a negative one. A similar convention is followed for higher storage units, including words

and double words. Various conventions exist for representing integers and real numbers. [R.A.M.T.]

**Numerical taxonomy** The grouping by numerical methods of taxonomic units based on their character states. The application of numerical methods to taxonomy, dating back to the rise of biometrics in the late nineteenth century, has received a great deal of attention with the development of the computer and computer technology. Numerical taxonomy provides methods that are objective, explicit, and repeatable, and is based on the ideas first put forward by M. Adanson in 1963. These ideas, or principles, are that the ideal taxonomy is composed of information-rich taxa based on as many features as possible, that *a priori* every character is of equal weight, that overall similarity between any two entities is a function of the similarity of the many characters on which the comparison is based, and that taxa are constructed on the basis of diverse character correlations in the groups studied. See TAXON.

In the early stages of development of numerical taxonomy, phylogenetic relationships were not considered. However, numerical methods have made possible exact measurement of evolutionary rates and phylogenetic analysis. Furthermore, rapid developments in the techniques of direct measurement of the homologies of deoxyribonucleic acid (DNA), and ribonucleic acid (RNA) between different organisms now provide an estimation of "hybridization" between the DNAs of different taxa and, therefore, possible evolutionary relationships. Thus, research in numerical taxonomy often includes analyses of the chemical and physical properties of the nucleic acids of the organisms the data from which are correlated with phenetic groupings established by numerical techniques. See PHYLOGENY; TAXONOMIC CATEGORIES. [R.R.C.]

**Nummulites** A genus of unicellular shelled protozoa of the order Foraminiferida (superfamily Nummulitacea, family Nummulitidae). Members are of characteristically rock-forming abundance in early Tertiary strata of the circum-Mediterranean region, and are useful as stratigraphic indicators (Paleocene to Holocene). The pyramids of Egypt were constructed of blocks of nummulitic limestone of Eocene age. See LIMESTONE.

The discoidal, lenticular, or globular test or shell can reach a diameter of about 5 in. (12 cm) and is composed of finely perforate calcium carbonate. It consists of planispirally enroled whorls of many tiny undivided chambers. Reproduction may be either sexual or asexual. The alternation of these methods within a species results in successive diploid and haploid generations of marked size disparity. See FORAMINIFERIDA. [A.R.L.]

**Nursing** The application of principles from the basic sciences, social sciences, and humanities to assist healthy and sick individuals and their families or other caring persons in performing those activities that contribute to the individuals' physical and mental well-being and that they would perform unaided if able to do so. Nursing includes providing physical and emotional care, promoting comfort, serving as patient advocates, assisting in rehabilitative efforts, teaching self-care and health promotion activities, and administering treatments prescribed by a licensed physician or dentist. Patient-care activities are conceived and coordinated so as to help individuals gain independence as rapidly as possible or maintain an optimal level of function. When multiple health-care providers are involved, nursing coordinates patient-care efforts to improve the quality of care.

Nursing practice is conducted in a variety of settings, including hospitals, community facilities, private homes, nursing homes, schools, industry, physician's offices, the military, and civil service arenas. Standards for nursing practice and licensure are governed by state nurse practice acts and are directed by professional nursing organizations.

Two types of nurses are legally recognized in the United States: the registered professional nurse and the licensed practical nurse.

Licensed practical or vocational nurses (LPNs or LVNs) are trained to perform uncomplicated patient-care tasks in hospitals or other health-care facilities under the aegis of registered nurses or physicians. See MEDICINE. [J.A.Ve.]

**Nut (engineering)** In mechanical structures, an internally threaded fastener. Plain square and hexagon nuts for bolts and screws are available in three degrees of finish: unfinished, semi-finished, and finished. There are two standard weights: regular and heavy. For specific applications, there are other standard forms such as jam nut, castellated nut, slotted nut, cap nut, wing nut, and knurled nut.

Wing and knurled nuts are designed for applications where a nut is to be tightened or loosened by using finger pressure only. See SCREW FASTENER. [W.J.L.]

**Nutation (astronomy and mechanics)** In mechanics, a bobbing motion that accompanies the precession of a spinning rigid body, such as a top. In simple precession, the axis of a top with a fixed point of contact sweeps out a cone, whose axis is the vertical direction. In the general motion, the angle between the axis of the top and the vertical varies with time. This motion of the top's axis, bobbing up and down as it precesses, is known as nutation. See RIGID-BODY DYNAMICS.

Astronomical nutation refers to irregularities in the precessional motion of the equinoxes caused by the varying torque applied to the Earth by the Sun and Moon. Astronomical nutation should not be confused with nutation as defined in mechanics; the latter is present even if the source of the torques is unvarying. See CELESTIAL MECHANICS; PRECESSION OF EQUINOX. [V.D.B.]

**Nutmeg** A delicately flavored spice obtained from the nutmeg tree (*Myristica fragrans*), a native of the Moluccas, or Spice Islands. The tree is a dark-leaved evergreen, and is a member of the nutmeg family (Myristicaceae). The golden-yellow, mature fruits resemble apricots (see illustration). They gradually lose moisture and when completely ripe, the husk (pericarp) splits open, exposing the shiny brown seed which is the nutmeg of



Mature nutmeg (*Myristica fragrans*) fruits. (USDA)

commerce. Nutmeg oil is used in medicine, perfumery, and dentifrices, and in the tobacco industry. [P.D.St./E.L.C.]

**Nutrition** The science of nourishment, including the study of the nutrients that each organism must obtain from its environment to maintain life and health and to reproduce. Although each kind of organism has its distinctive needs, which can be studied separately, a far-reaching biochemical unity in nature has been discovered which gives vastly more coherence to the whole subject. Many nutrients, such as amino acids, minerals, and vitamins, needed by higher organisms may also be needed by the lowest forms of life—single-celled bacteria and protozoa. The recognition of this fact has made possible highly important developments in biochemistry.

Mammals need for their nutrition (aside from water and oxygen) a highly complex mixture of more than 40 chemical substances, including amino acids; carbohydrates; certain lipids; fibers; a great variety of minerals, including several which are required only in minute amounts, commonly referred to as trace minerals; and vitamins. See AMINO ACIDS; CARBOHYDRATE METABOLISM; LIPID METABOLISM; PROTEIN METABOLISM; VITAMIN.

Early workers in human nutrition focused on the minimum amounts needed to prevent or cure acute deficiency diseases, such as scurvy and beriberi. Since that time, the Recommended Dietary Allowances (RDAs) in the United States and similar recommendations in other countries include consideration of biochemical criteria of adequacy. They also include approximate adjustments for age, sex, and pregnancy and lactation, along with a rough estimate for some other sources of individual variation. However, statistical data needed to adequately assess individual variations are not yet available for any nutrient.

Interests have shifted toward what may be more nearly optimal nutritional intakes, based on the amounts needed to promote health (not merely to avoid disease or biochemical deficiency), longevity, and resistance to chronic disorders, including cardiovascular disease, cancer, hypertension, and diabetes.

For modern humans, the problems of suboptimal nutrition have increased with the advent and extensive consumption of

technologically derived, refined foods. These nonwhole “foods” have lost most or all of the nutrients present in the whole foods from which they derive. Modern dietary guidelines and nutrition education focus substantially on partially replacing nonwhole foods with whole grains, legumes, low-fat meats and dairy products, fish, vegetables, fruits, and nuts that retain their natural biochemical unity.

One of the bases for interest in nutrition is the fact that individuals who have differing genetic backgrounds have differing nutritional needs; for this reason, various human ills may arise because the individuals concerned do not get all of the nutrients in amounts compatible with their own distinctive requirements.

It is clear that improper nutrition may produce or contribute to almost every conceivable type of illness. Nutritional and medical research is yielding important advances in using improved nutrition to prevent, cure, and ameliorate disease and illness. See DISEASE; MALNUTRITION; METABOLIC DISORDERS. [R.J.Wi.; D.R.Da.]

**Nymphaeales** An order of flowering plants that have previously been included in the same larger grouping as Magnoliales, the Magnoliidae. Deoxyribonucleic acid (DNA) sequence studies have demonstrated that Nymphaeales as previously defined contain two families, Ceratophyllaceae (water hornwort) and Nelumbonaceae (lotus), that are not closely related to the others. Remaining in the order is the family Nymphaeaceae, the waterlilies, from which a small group of tropical plants, Cabombaceae, are split by some scientists. Nymphaeaceae contain nearly 100 species of fresh-water aquatics that are typically found in river and lake systems throughout the world. The ovaries of these plants are filled with mucilage, which mediates pollen tube growth from the stigmas to the ovules, and they have either inappertuate or monosulcate pollen. A spectacular plant is the Amazonian water lily (*Victoria*), which has leaves up to 15 ft (5 m) in diameter. The water lily family has been shown by DNA analyses to be one of the oldest lineages of flowering plants and distantly related to all others as well. The family members are relics of the early diversification of the flowering plants. See EU-MAGNOLIIDS; PLANT KINGDOM; POLLEN. [M.W.C.]







**Oak** A genus (*Quercus*) of trees, some of which are shrubby, with about 200 species, mainly in the Northern Hemisphere. About 50 species are native in the United States. All oaks have scaly winter buds, usually clustered at the ends of the twigs, and single at the nodes. The fruit is a nut (acorn). The leaves are simple and usually lobed.

Oaks furnish the most important hardwood lumber in the United States. Principal uses are for charcoal, barrels, building construction, flooring, railroad ties, mine timbers, boxes, crates, vehicle parts, ships, agricultural implements, caskets, woodenware, fence posts, piling, and veneer. Oak is also used for pulp and paper products. See FAGALES. [A.H.G./K.P.D.]

**Oasis** An isolated fertile area, usually limited in extent and surrounded by desert. The term was initially applied to small areas in Africa and Asia typically supporting trees and cultivated crops with a water supply from springs and from seepage of water originating at some distance. However, the term has been expanded to include areas receiving moisture from intermittent streams or artificial irrigation systems. Thus the floodplains of the Nile and Colorado rivers can be considered vast oases, as can arid areas irrigated by humans. See DESERT.

Oases are restricted to climatic regions where precipitation is insufficient to support crop production. Such regions may be classified as extremely arid (annual rainfall less than 2 in. or 50 mm), arid (annual rainfall less than 10 in. or 250 mm), and semiarid (rainfall less than 20 in. or 500 mm). Many African and Asian oases are in extremely arid areas. Most oases are found in warm climates. Oasis soils are weakly developed, high in organic matter but often saline, and have been strongly affected by human occupation. [W.G.McG.]

**Oats** An agricultural crop grown for its grain and straw in most countries of the temperate zones of the world. In the major oat-growing states of the midwestern United States (Iowa, North Dakota, South Dakota, Minnesota, and Wisconsin) the crop is raised for grain, whereas in the Southern states (Texas, Oklahoma, and Georgia) it is used for pasture or a combination of pasture and grain. About 90% of the annual oat grain production is used for animal feeds, and about 10% is processed into food for humans, for example, oatmeal and other cereal products. In general, oats are a cool-season crop which requires a moist climate. They grow well on both light and heavy soils if sufficient moisture and fertility nutrients are available. See ANIMAL FEEDS; CEREAL.

The fifteen species of oats in the genus *Avena* are divided into three groups on the basis of chromosome number: 14, 28, or 42. Within the 42-chromosome cultivated species there is wide variation among varieties for all plant traits. Oats belong to the Graminae (grass) family; thus the oat plant forms a crown at the soil surface from which a fibrous root system penetrates the soil. Culms usually grow 2–5 ft (0.6–1.5 m) tall, and they are terminated with inflorescences called panicles. Each panicle usually bears 10–75 spikelets on its numerous branches. A spikelet is enclosed by two papery glumes and bears two or three florets, each with an ovary, two stigmas, and three anthers enclosed in a lemma and palea (see illustration). In most varieties the lemma and palea adhere to the oat seed after threshing. A trait used to

determine market grade of oats is the color of the lemma, which may be white, yellow, gray, brown, red, or black. The major trait that distinguishes wild from cultivated oats is seed shattering. In cultivated species the seed attachment is persistent, and it can be separated from the panicle only by threshing. See CYPERALES; FLOWER; GRASS CROPS; INFLORESCENCE.

The world collection of oats, maintained by the U.S. Department of Agriculture, contains more than 14,000 lines of 42-chromosome types. These represent lines from wild species and from varieties produced at breeding stations. The collection represents a vast range of genetic types that can be used for varietal improvement. [K.J.F.]

The milling of oats is less complex than wheat milling and has many similarities to rice or barley milling operations because there is limited fractionation of the kernel. The oat grain is covered with a coarse, adhering hull which must be removed prior to production of ingredients or consumer foods. Oats as received at the mill house are termed green oats and must be cleaned to remove foreign seeds and trash. Clean, sound oats are heated slowly prior to hull removal. The green oats have active lipolytic enzymes (lipases) which will catalyze hydrolysis of triglycerides and yield free fatty acids. The heating, drying, or roasting procedures inactivate lipases, facilitate hull removal, and impart a distinctive roasted flavor to the oat product. Roasted oats are air-cooled and size-graded prior to dehulling. The products of the dehuller are primarily the whole kernel or groat and the fiber hull which are readily separated by air aspiration. The low-density oat hulls possess particularly

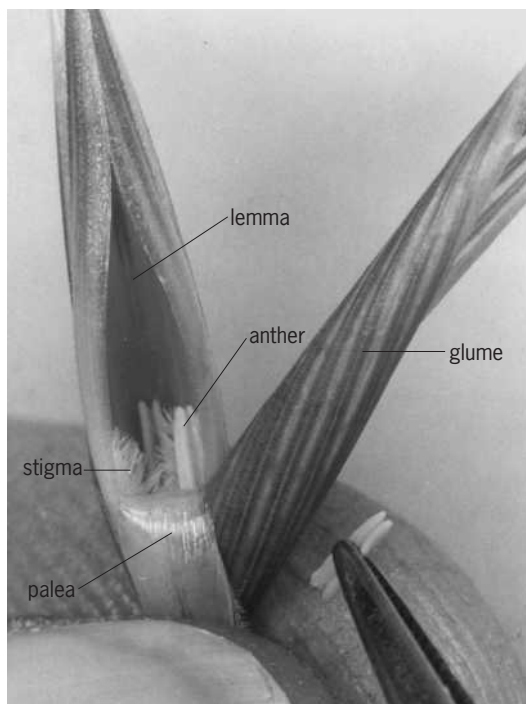

An oat flower; two oat grains are shown at the lower right.

high levels of fiber and pentosans which are suitable feedstock for industrial production of furfural (an important chemical nylon manufacturing) through high-temperature acid hydrolysis and dehydration. Whole, cleaned oat groats are not frequently available in the commercial food market. Selected large-sized groats are excellent for puffing into ready-to-eat cereals.

Oat cutting and flaking procedures provide more extensive utilization of groats in the form of rolled oats. Oat flour is obtained from further reduction and sieving or hammer milling of the whole groat or flaked product. This high-protein flour is frequently used in the formulations of ready-to-eat cereals and many prepared baby foods. Composite flours blended from oat flour and other cereals providing high protein content and extended shelf life have been proposed as suitable for world feeding programs. See FOOD MANUFACTURING. [M.A.U.]

**Obesity** The presence of excess body fat. The great prevalence of this condition, its severe consequences for physical and mental health, and the difficulty of treating it make the prevention of obesity a major public health priority.

Obesity is most often defined in terms of body weight relative to height, since both height and weight are easily measured. Obesity is considered to begin at a weight-for-height that is 20–30% above desirable weight, with this desirable weight taken as the midpoint of ranges of weight associated with the greatest longevity in studies of life-insured individuals. In population surveys, obesity is defined as a body weight that meets or exceeds the 85th percentile of the Body Mass Index (BMI), an index of weight-for-height that correlates well with body fat content. See ADIPOSE TISSUE.

The prevalence of obesity increases with age, is higher in women than men, and is highest among the poor and minority groups. Obesity increases the likelihood of high blood cholesterol, high blood pressure, and diabetes, and therefore of the diseases for which such conditions are risk factors—coronary heart disease, stroke, and kidney disease. It also increases the likelihood of gallbladder disease and cancers of the breast and uterus. Thus, obesity increases overall mortality rates, and it does so in proportion to the degree and duration of overweight. Individuals who become obese at the earliest ages are at highest risk of premature mortality. Distribution of excess fat to the upper body rather than the lower body may also increase risk.

The causes of most cases of obesity are poorly understood. At the simplest level, obesity results from an excess of energy (caloric) intake over expenditure, but this statement does not explain why some individuals can eat as much as they like without gaining weight while others remain overweight despite constant dieting. Studies of genetically obese animals and those with damage to the part of the brain called the hypothalamus suggest that individuals may balance body weight around a “setpoint” that is maintained—without conscious control—by variations in metabolic rate in response to caloric intake. Variations in the prevalence of obesity among population groups suggest a genetic basis for the condition. The complexity of body-weight regulatory mechanisms suggests that obesity is not due to a single cause but, like other chronic diseases, is multifactorial in origin. Specific inherited differences that might influence setpoints include differences in nearly every anatomic, neurologic, and biochemical factor known to affect food intake and utilization, energy metabolism, and energy expenditure. See ENDOCRINE MECHANISMS; ENERGY METABOLISM; METABOLIC DISORDERS.

Because the causes of obesity are incompletely understood, it is difficult to formulate effective treatment strategies. Studies suggest that programs combining diet and exercise help obese individuals lose more weight and maintain losses longer than either program does separately. See FOOD; NUTRITION. [M.N.]

**Object-oriented programming** A computer-programming methodology that focuses on data items rather than processes. Traditional software development models as-

sume a top-down approach. A functional description of a system is produced and then refined until a running implementation is achieved. Data structures (and file structures) are proposed and evaluated based on how well they support the functional models.

The object-oriented approach focuses first on the data items (entities, objects) that are being manipulated. The emphasis is on characterizing the data items as active entities which can perform operations on and for themselves. It then describes how system behavior is implemented through the interaction of the data items.

The essence of the object-oriented approach is the use of abstract data types, polymorphism, and reuse through inheritance.

Abstract data types define the active data items described above. A traditional data type in a programming language describes only the structure of a data item. An abstract data type also describes operations that may be requested of the data item. It is the ability to associate operations with data items that makes them active. The abstract data type makes operations available without revealing the details of how the operations are implemented, preventing programmers from becoming dependent on implementation details. The definition of an operation is considered a contract between the implementor of the abstract data type and the user of the abstract data type. The implementor is free to perform the operation in any appropriate manner as long as the operation fulfills its contract. Object-oriented programming languages give abstract data types the name class.

Polymorphism in the object-oriented approach refers to the ability of a programmer to treat many different types of objects in a uniform manner by invoking the same operation on each object. Because the objects are instances of abstract data types, they may implement the operation differently as long as they fulfill the agreement in their common contract.

A new abstract data type (class) can be created in object-oriented programming simply by stating how the new type differs from some existing type. A feature that is not described as different will be shared by the two types, constituting reuse through inheritance. Inheritance is useful because it replaces the practice of copying an entire abstract data type in order to change a single feature.

In the object-oriented approach, a class is used to define an abstract data type, and the operations of the type are referred to as methods. An instance of a class is termed an object instance or simply an object. To invoke an operation on an object instance, the programmer sends a message to the object. [J.J.Sc.]

**Obolellida** A small extinct order of inarticulate brachiopods that ranges in age from Early to Middle Cambrian. The shell, composed of calcite, is usually elongated oval in outline and biconvex. The ventral (pedicle) valve has a well-defined flat shelf (pseudointerarea) at the posterior. The pedicle opening is unusually variable in position for an order. It can be located between the valves or at the apex of the ventral (pedicle) valve or anterior to the apex of the ventral valve. Members of this group were presumably epifaunal and sessile. See BRACHIOPODA; INARTICULATA. [M.W.F.]

**Obsessive-compulsive disorder** A type of anxiety disorder (commonly referred to as OCD) characterized by recurrent, persistent, unwanted, and unpleasant thoughts (obsessions) or repetitive, purposeful ritualistic behaviors that the person feels driven to perform (compulsions). A cardinal feature of this disorder is an awareness of the irrationality or excess of the obsessions and compulsions accompanied by an inability to control them.

Typical compulsions include an irresistible urge to wash (particularly the hands) or clean, to check doors to confirm that they are locked, to return repeatedly to appliances to make sure they are turned off, to touch, to repeat, to count, to arrange, or to save. Typical obsessions include overconcern about dirt and

contamination, fear of acting on violent or aggressive impulses, feeling overly responsible for the safety of others, abhorrent religious (blasphemous) and sexual intrusions, and inordinate concern with arrangement or symmetry. Obsessions may accompany compulsions, or compulsions may occur alone.

The difference between obsessive-compulsive disorder and milder forms of obsession or compulsion seen in otherwise healthy people is that for the sufferer the obsessions or compulsions cause marked distress, are time-consuming, and significantly interfere with the person's normal routine, occupational functioning, usual social activities, and relationships with others.

Onset in adolescence occurs in about a third of cases. In another third symptoms appear in early adulthood, and in the last third they start later in life. If not treated appropriately, the disorder is often chronic, with waxing and waning of symptoms.

Obsessive-compulsive disorder is generally resistant to traditional psychotherapy, which has tried to trace the condition to conflicts of early childhood. An effective mode of psychotherapy is behavioral therapy, in which the patients are gradually exposed to their feared or triggering situation but are prevented from performing accompanying compulsions. This approach, which focuses on treating the symptoms rather than trying to understand their origin, seems to be more effective in treating the ritualistic behavior (compulsions) than the pervasive thoughts (obsessions). Obsessive-compulsive disorder is also refractory to most drugs used to treat anxiety, depression, and psychosis. However, it often eases with medications that affect the brain's serotonergic system, such as clorimipramine, fluvoxamine, and fluoxetine.

The specific response of patients with obsessive-compulsive disorder to serotonergic drugs, their hypersensitivity to activation of the serotonergic system, and the distinct functional anatomy differences found in those patients suggest a biological cause for this disorder. In this regard, obsessive-compulsive disorder represents a shift from a psychological to a neurobiological approach in the study of anxiety disorders. See ANXIETY DISORDERS; NEUROTIC DISORDERS; SEROTONIN. [J.Z.]

**Obsidian** A volcanic glass, usually of rhyolitic composition, formed by rapid cooling of viscous lava. The color is jet-black because of abundant microscopic, embryonic crystal growths (crystallites) which make the glass opaque except on thin edges. Iron oxide dust may produce red or brown obsidian.

Obsidian usually forms the upper parts of lava flows. Well-known occurrences are Obsidian Cliffs in Yellowstone Park, Wyoming; Mount Hekla, Iceland; and the Lipari Islands off the coast of Italy. See IGNEOUS ROCKS; VOLCANIC GLASS. [C.A.C.]

**Occultation** The temporary apparent disappearance from view of a celestial body as another body passes across the line of sight. Usually, it refers to stars occulted by the Moon, but it also applies to stars occulted by major or minor planets, minor planets occulting each other, Jupiter occulting its Galilean satellites, and so forth. Some occultations are called eclipses for historical reasons, for example, solar eclipses. An occultation refers strictly to a blockage in the line of sight, and not to disappearance in a shadow. See ECLIPSE.

The study of lunar occultations of stars over several centuries was used to improve the theory of the Moon's motion, and also contributed to detecting irregularities of the Earth's rotation. With that knowledge as a basis, lunar occultations are of more importance now in studying the figure of the Moon. See EARTH ROTATION AND ORBITAL MOTION; MOON.

Occultations are used to study the size and shape of bodies whose disk cannot be seen. In such cases, if a planet is predicted to pass within its provisional radius of a star, and no occultation occurs, an upper limit is set. It was in this way that Pluto's small size was established. See PLUTO.

Application of observational techniques has given very accurate profiles of minor planets. Successful observations are still

quite rare, however. The method is also being used to seek suspected binary minor planets. See ASTEROID.

During the occultation of a star by a planet with an atmosphere high-speed photoelectric observations of the light in several distinct wavelengths will yield information on the composition, structure, and dynamics of the atmosphere. The very thin, faint rings of Uranus were discovered accidentally in 1977 when they occulted a star during calibration observations made in preparation for observing an occultation of the star by Uranus. Now such observations are routinely made, from ground and space, both to search for more rings and to determine the fine structure of known ones. See JUPITER; NEPTUNE; SOLAR SYSTEM; URANUS. [A.D.F.]

**Ocean** One of the major subdivisions of the interconnected body of salt water that occupies almost three-quarters of the Earth's surface. Earth is the only planet in the solar system whose surface is covered with significant quantities of water. Of the nearly 1.4 billion cubic kilometers of water found either on the surface or in relatively accessible underground supplies, more than 97% is in the oceans. See OCEANOGRAPHY.

Oceans and the seas that connect them cover some 73% of the surface of the Earth, with a mean depth of 3729 m (12,234 ft) (table). More than 70% of the oceans have a depth between 3000 and 6000 m (10,000 and 20,000 ft). Less than 0.2% of the oceans have depths as great as 7000 m (23,000 ft).

**Ocean basin characteristics**

	Area, km <sup>2</sup>	Volume, km <sup>3</sup>	Mean depth, m
Pacific	181,344,000	714,410,000	3940
Atlantic	94,314,000	337,210,000	3575
Indian	74,118,000	284,608,000	3840
Arctic	12,257,000	13,702,000	1117
Total	362,033,000	1,349,929,000	3729

The oceans are cold and salty. Some 50% have a temperature between 0 and 2°C (32 and 36°F) and a salinity between 34.0 and 35.0. To a high degree of approximation, a salinity of 34 is the equivalent of 34 grams of salt in a kilogram of seawater. Water with a temperature above a few degrees Celsius is confined to a relatively thin surface layer of the ocean. See SEAWATER.

Ocean salinity is primarily controlled by the balance of precipitation, river runoff, and evaporation of water at the sea surface. The highest salinities are found in major evaporation basins with little rainfall or river runoff, such as the Red Sea. The lowest salinities are found near the mouths of major rivers such as the Amazon. See RED SEA.

Nearly all elements known to humankind have been found dissolved in seawater, and those that have not are assumed to be present. However, all but a few are found in very small amounts. Sodium chloride accounts for some 85% of the dissolved salts, and an additional four ions (sulfate, magnesium, calcium, and potassium) bring the total to more than 99.3%. The ratio of ions is remarkably constant from one ocean to another and from top to bottom of each.

The oceans are continually transporting excess heat (warm water) from the tropics toward the Poles and returning colder water toward the tropics. This process of moving excess heat from lower (south of 40°) to higher (north of 40°) latitudes is shared approximately equally by the oceans and the atmosphere. A significant part of the ocean heat exchange process is carried out by the major ocean currents, the "named" currents such as the Gulf Stream, Brazil Current, California Current, and Kuroshio. These currents are primarily driven by the winds, and there is considerable similarity in their pattern from one ocean basin to another. See GULF STREAM; KUROSHIO.

The average winds over the North and South Atlantic as well as the North and South Pacific oceans come out of the west (westerlies) at the middle latitudes and from the east at the lower

latitudes (trade winds). The frictional drag of these winds on the surface of the water imparts a spin or torque to the surface of the ocean, clockwise in the Northern Hemisphere and counterclockwise in the Southern Hemisphere. The major exception is the Indian Ocean north of the Equator, where the circulation is strongly influenced by the winds of the seasonal monsoon. See ATLANTIC OCEAN; CORIOLIS ACCELERATION; EQUATORIAL CURRENTS; INDIAN OCEAN; OCEAN CIRCULATION; PACIFIC OCEAN. [J.A.K.]

**Ocean circulation** The general circulation of the ocean. The term is usually understood to include large-scale, nearly steady features, such as the Gulf Stream, as well as current systems that change seasonally but are persistent from one year to the next, such as the Davidson Current, off the northwestern United States coast and the equatorial currents in the Indian Ocean. A great number of energetic motions have periods of a month or two and horizontal scales of a few hundred kilometers—a very low-frequency turbulence, collectively called eddies. Energetic motions are also concentrated near the local inertial period (24 h, at 30° latitude) and at the periods associated with tides (primarily diurnal and semidiurnal). See TIDE.

The greatest single driving force for currents, as for waves, is the wind. Furthermore, the ocean absorbs heat at low latitudes and loses it at high latitudes. The resultant effect on the density distribution is coupled into the large-scale wind-driven circulation. Some subsurface flows are caused by the sinking of surface waters made dense by cooling or high evaporation. See OCEAN WAVES.

Except in western boundary currents, and in the Antarctic Circumpolar Current, the system of strong surface currents is restricted mainly to the upper 330–660 ft (100–200 m) of the sea. The mid-latitude anticyclonic gyres, however, are coherent in the mean well below 3300 ft (1000 m). The average speeds of the open-ocean surface currents remain mostly below 0.4 knot (20 cm/s). Exceptions to this are found in the western boundary currents, such as the Gulf Stream, and in the Equatorial Currents of the three oceans, all of which have velocities of 2–4 knots (1–2 m/s).

The deep circulation results in part from the wind stress and in part from the internal pressure forces which are maintained by the budgets of heat, salt, and water. Both groups of forces are dependent upon atmospheric influences. Apart from Coriolis and frictional forces, the topography of the sea bottom exercises a decisive influence on the course of deep circulation.

The deep circulation in marginal seas depends largely on the climate of the region, whether arid or humid. Under the influence of an arid climate, evaporation is greater than precipitation. The marginal sea is therefore filled with relatively salty water of a high density. Its surface lies at a lower level than that of the neighboring ocean. Examples of this type are the Mediterranean Sea, Red Sea, and Persian Gulf. The deep circulation of marginal seas in humid climates shows a different pattern. The level of the sea is higher than in the neighboring ocean. Therefore, the surface water with its lower density and accordingly its lower salinity flows outward, and the relatively salty ocean water of higher density flows over the sill into the marginal sea. Examples of this circulation are the Baltic Sea with the shallow Darsser and Drogden rises, the Norwegian and Greenland fiords, and the Black Sea with its entrance through the Bosphorus. See BLACK SEA; FIORD; MEDITERRANEAN SEA.

The deep circulation in the oceans is more difficult to perceive than the circulation in the marginal seas. In addition to the internal pressure forces, determined by the distribution of density and the piling up of water by the wind, there are also the influences of Coriolis forces and large-scale turbulence. There are areas in tropical latitudes in which the surface water, as a result of strong evaporation, has a relatively high density. In thermohaline convection, the water sinks while flowing horizontally until it reaches a density corresponding to its own, and then spreads out horizontally. In this way the colder and deeper levels of the oceans

take on a layered structure consisting of the so-called bottom water, deep water, and intermediate water. See ATLANTIC OCEAN; PACIFIC OCEAN. [W.Stu.]

Wherever oceanographers have made long-term current and temperature measurements, they have found energetic fluctuations with periods of several weeks to several months. These low-frequency fluctuations (compared to tides) are caused by oceanic mesoscale eddies which are in many respects analogous to the atmospheric mesoscale pressure systems that form weather. Like the weather, mesoscale eddies often dominate the instantaneous current, and are thought to be an integral part of the ocean's general circulation.

Eddies occur in virtually all oceans and seas, but their amplitude varies greatly from place to place. The largest amplitudes are found on the western sides of the oceans in conjunction with the strongest ocean currents (the Gulf Stream in the North Atlantic, the Kuroshio in the North Pacific) and near the Equator. Much weaker eddies are found in the ocean interior, distant from major currents. This consistent pattern of eddy amplitude suggests that instabilities of western boundary currents are an important source of eddy energy. Atmospheric forcing by variable winds can also generate eddies, and is probably most important at low latitudes where the horizontal scales of the oceanic eddies best match the scales of the atmospheric forcing. [J.F.P.]

**Ocean waves** The irregular moving bumps and hollows on the ocean surface. Winds blowing over the ocean, in addition to producing currents, create surface water undulations called waves or a sea. The characteristics of these waves (or the state of the sea) depend on the speed of the wind, the length of time that it has blown, the distance over which it has blown, and the depth of the water. If the wind dies down, the waves that remain are called a dead sea.

**Surface waves.** Ocean surface waves are propagating disturbances at the atmosphere-ocean interface. They are the most familiar ocean waves. Surface waves are also seen on other bodies of water, including lakes and rivers. See WAVE MOTION IN LIQUIDS.

A simple sinusoidal wave train is characterized by three attributes: wave height ( $H$ ), the vertical distance from trough to crest; wavelength ( $L$ ), the horizontal crest-to-crest distance; and wave period ( $T$ ), the time between passage of successive crests past a fixed point. The phase velocity ( $C = L/T$ ) is the speed of propagation of a crest. For a given ocean depth ( $h$ ), wavelength increases with increasing period. The restoring force for these surface waves is predominantly gravitational. Therefore, they are known as surface gravity waves, unless their wavelength is shorter than 1.8 cm (0.7 in.), in which case surface tension provides the dominant restoring force.

Surface gravity waves may be classified according to the nature of the forces producing them. Tides are ocean waves induced by the varying gravitational influence of the Moon and Sun. They have long periods, usually 12.42 h for the strongest constituent. Storm surges are individual waves produced by the wind and dropping barometric pressure associated with storms; they characteristically last several hours. Earthquakes or other large, sudden movements of the Earth's crust can cause waves, called tsunamis, which typically have periods of less than an hour. Wakes are waves resulting from relative motion of the water and a solid body, such as the motion of a ship through the sea or the rapid flow of water around a rock. Wind-generated waves, having periods from a fraction of a second to tens of seconds, are called wind waves. Like tides, they are ubiquitous in the ocean, and continue to travel well beyond their area of generation. The ocean is never completely calm. See STORM SURGE; TIDE; TSUNAMI.

The growth of wind waves by the transfer of energy from the wind is not fully understood. At wind speeds less than 1.1 m/s (2.5 mi/h), a flat water surface remains unruffled by waves. Once generated, waves gain energy from the wind by wave-coupling of

pressure fluctuations in the air just above the waves. For waves traveling slower than the wind, secondary, wave-induced airflows shift the wave-induced pressure disturbance downwind so the lowest pressure is ahead of the crests. This results in energy transfer from the wind to the wave, and hence growth of the wave.

If a constant wind blows over a sufficient length of ocean, called the fetch, for a sufficient length of time, a wave field develops whose statistical characteristics depend only on wind velocity.

$$S(f) = A \frac{g^2}{f^5} e^{-1.25(f_m/f)^4}$$

Because of viscosity, surface waves lose energy as they propagate, short-period waves being dampened more rapidly than long-period waves. Waves with long periods (typically 10 s or more) can travel thousands of kilometers with little energy loss. Such waves, generated by distant storms, are called swell.

When waves propagate into an opposing current, they grow in height. For example, when swell from a Weddell Sea storm propagates northeastward into the southwestward-flowing Agulhas Current off South Africa, high steep waves are formed. Many large ships in this region have been severely damaged by such waves.

Because actual ocean waves consist of many components with different periods, heights, and directions, occasionally a large number of these components can, by chance, come in phase with one another, creating a freak wave with a height several times the significant wave height of the surrounding sea. According to linear theory, waves with different periods propagate with different speeds in deep water, and hence the wave components remain in phase only briefly. But nonlinear effects are bound to be significant in a large wave. In such a wave, the effects of nonlinearity can compensate for those of dispersion, allowing a solitary wave to propagate almost unchanged. Consequently, a freak wave can have a lifetime of a minute or two. See SOLITON.

[M.Wi.]

**Internal waves.** Internal waves are wave motions of stably stratified fluids in which the maximum vertical motion takes place below the surface of the fluid. The restoring force is mainly due to gravity; when light fluid from upper layers is depressed into the heavy lower layers, buoyancy forces tend to return the layers to their equilibrium positions. In the oceans, internal oscillations have been observed wherever suitable measurements have been made. The observed oscillations can be analyzed into a spectrum with periods ranging from a few minutes to days. At a number of locations in the oceans, internal tides, or internal waves having the same periodicity as oceanic tides, are prominent.

Internal waves are important to the economy of the sea because they provide one of the few processes that can redistribute kinetic energy from near the surface to abyssal depths. When they break, they can cause turbulent mixing despite the normally stable density gradient in the ocean. Internal waves are known to cause time-varying refraction of acoustic waves because the sound velocity profile in the ocean is distorted by the vertical motions of internal waves. Internal waves have been found by recording fluctuating currents in middepths by moored current meters, by acoustic backscatter Doppler methods, and by studies of the fluctuations of the depths of isotherms as recorded by instruments repeatedly lowered from shipboard or by autonomous instruments floating deep in the water.

Internal waves are thought to be generated in the sea by variations of the wind pressure and stress at the sea surface, by the interaction of surface waves with each other, and by the interaction of tidal motions with the rough sea floor. [C.S.C.]

**Oceanic islands** Islands rising from the deep sea floor. Oceanic islands range in size from mere specks of rock or sand above the reach of tides to large masses such as Iceland

(39,800 mi<sup>2</sup> or 103,000 km<sup>2</sup>). Excluded are islands that have continental crust, such as the Seychelles, Norfolk, or Sardinia, even though surrounded by ocean; all oceanic islands surmount volcanic foundations. A few of these have active volcanoes, such as on Hawaii, the Galápagos islands, Iceland, and the Azores, but most islands are on extinct volcanoes. On some islands, the volcanic foundations have subsided beneath sea level, while coral reefs growing very close to sea level have kept pace with the subsidence, accumulating thicknesses of as much as 5000 ft (1500 m) of limestone deposits between the underlying volcanic rocks and the present-day coral islands. See REEF; VOLCANO.

Oceanic islands owe their existence to volcanism that began on the deep sea floor and built the volcanic edifices, flow on flow, up to sea level and above. The highest of the oceanic islands is Hawaii, where the peak of Mauna Kea volcano reaches 14,000 ft (4200 m). Most volcanic islands are probably built from scratch in less than 10<sup>6</sup> years, but minor recurrent volcanism may continue for millions of years after the main construction stage. See VOLCANOLOGY.

Islands in regions of high oceanic fertility are commonly host to colonies of sea birds, and the deposits of guano have been an important source of phosphate for fertilizer. On some islands, for example, Nauru in the western equatorial Pacific, the original guano has been dissolved and phosphate minerals reprecipitated in porous host limestone rocks. The principal crop on most tropical oceanic islands is coconuts, exploited for their oil content, but some larger volcanic islands, with rich soils and abundant water supplies, are sites of plantations of sugarcane and pineapple. Atoll and barrier-reef islands have very limited water supplies, depending on small lenses of ground water, augmented by collection of rainwater. See ATOLL; ISLAND BIOGEOGRAPHY; REEF.

[E.L.Wi.]

**Oceanographic vessels** Research vessels designed to collect quantitative data from the sea's surface, its depths, the sea floor, and the overlying atmosphere. Their primary purpose is to carry scientists and increasingly sophisticated equipment to and from study sites on the ocean's surface, and in some cases below the surface. The ships must have the ability to lower and retrieve instruments by using winches and wires. The ship's equipment and instrumentation must determine precisely the location on the sea surface, and provide suitable communication, data gathering, archiving, and computational facilities for the scientific party.

The requirements list includes seakeeping (sea-kindliness, a measure of a ship's response to severe seas; and station-keeping, the ability of a ship to maintain its fixed location on the sea surface); work environment; endurance (range, days at sea); scientific complement (number of researchers accommodated); operating economy and scientific effectiveness; subdued acoustical characteristics; payload (scientific storage, weight handling); speed; and ship control. These requirements often conflict, necessitating compromise.

Ships typically can be considered in three major groups based on use: general purpose (classical biological, physical, chemical, geological, and ocean engineering research, or a combination); dedicated special purpose (hydrographic survey, mapping, geophysical, or fisheries); or unique (deep-sea drilling, crewed spar buoy, or support of submersible operations). They can be used simply as delivery and support systems for exploratory devices, such as floats and bottom landers, as well as crewless remote operating vehicles (ROVs—tethered, powered, surface-controlled robots), or autonomous underwater vehicles (AUVs—freely operating robots, using computer programmed guidances). See MARINE ENGINEERING; NAVAL ARCHITECTURE; OCEANOGRAPHY.

[J.J.Gr.; J.F.Ba.]

**Oceanography** The science of the sea; including physical oceanography, marine chemistry, marine geology, and marine

biology. The need to know more about the impact of marine pollution and possible effects of the exploitation of marine resources, together with the role of the ocean in possible global warming and climate change, means that oceanography is an important scientific discipline. Improved understanding of the sea has been essential in such diverse fields as fisheries conservation, the exploitation of underwater oil and gas reserves, and coastal protection policy, as well as in national defense strategies. The scientific benefits include not only improved understanding of the oceans and their inhabitants, but important information about the evolution of the Earth and its tectonic processes, and about the global environment and climate, past and present, as well as possible future changes. See CLIMATE HISTORY; COASTAL ENGINEERING; MARINE MINING; MARINE SEDIMENTS; MARITIME METEOROLOGY; OIL AND GAS, OFFSHORE.

The traditional basis of modern oceanography is the hydrographic station. Hydrographic studies are still carried out at regular intervals, with the research vessel in a specific position. Seawater temperature, depth, and salinity can be measured continuously by a probe towed behind the ship. The revolution in electronics has provided not only a new generation of instruments for studying the sea but also new ways of collecting and analyzing the data they produce. Computers are employed in gathering and processing data in all fields, and are also used in the creation of mathematical models to aid in understanding. Much information can also be gained by remote sensing using satellites, which are also a valuable navigational aid. These provide data on sea surface temperature and currents, and on marine productivity. Satellite altimetry gives information on wave height and winds and even bottom topography (because this affects sea level). Deep-sea cameras and submersibles now permit visual evidence of creatures in remote depths. See HYDROGRAPHY; OCEANOGRAPHIC VESSELS; MARINE ECOLOGY; REMOTE SENSING; SATELLITE NAVIGATION SYSTEMS; SEAWATER.

Since the early 1900s, all recorded ocean depths have been incorporated in the General Bathymetric Chart of the Ocean. The amount of data available increased greatly with the introduction of continuous echo sounders; subsequently, side-scan sonar permitted very detailed topographical surveys to be made of the ocean floor. The features thus revealed, in particular the midocean ridges (spreading centers) and deep trenches (subduction zones), are integral to the theory of plate tectonics. An important discovery made toward the end of the twentieth century was the existence of hydrothermal vents, where hot mineral-rich water gushes from the Earth's interior. The deposition of minerals at these sites and the discovery of associated ecosystems make them of potential economic as well as great scientific interest. See ECHO SOUNDER; HYDROTHERMAL VENT; MARINE GEOLOGY; MID-OCEANIC RIDGE; PLATE TECTONICS; SONAR; SUBDUCTION ZONES.

[M.De.]

**Octane number** A standard laboratory measure of a fuel's ability to resist knock during combustion in a spark-ignition engine. A single-cylinder four-stroke engine of standardized design is used to determine the knock resistance of a given fuel by comparing it with that of primary reference fuels composed of varying proportions of two pure hydrocarbons, one very high in knock resistance and the other very low. A highly knock-resistant isooctane (2,2,4-trimethylpentane,  $C_8H_{18}$ ) is assigned a rating of 100 on the octane scale, and normal heptane ( $C_7H_{16}$ ), with very poor knock resistance, represents zero on the scale. Octane number is defined as the percentage of isooctane required in a blend with normal heptane to match the knocking behavior of the gasoline being tested. See SPARK KNOCK; OCTANE.

For fuels with a rating higher than 100 octane, the rating is usually obtained by determining the amount of tetraethyllead compound that needs to be added to pure isooctane to match the knock resistance of the test fuel.

[J.C.L.]

**Octopoda** An order of the class Cephalopoda (subclass Coleoidea), characterized by eight appendages that encircle the mouth, a saclike body, and an internal shell that is much modified or reduced from that of its ancestors. One or two rows of suckers without chitinous rings occur along the eight highly flexible contractile arms. The approximately 200 species of octopods include shallow-water forms like the common octopus, *Octopus vulgaris*; open-ocean species like the paper argonaut, *Argonauta argo*; and deep-sea forms with fins like the flapjack devilfish, *Opisthoteuthis californica*. Two suborders divide the Octopoda into those with paddle-shaped fins on the body and tendrillike cirri on the arms (Cirrata) and those without fins or cirri (Incirrata). See CEPHALOPODA; COLEOIDEA. [C.FE.R.]

**Oculosida** An order of Radiolaria. Pores of these protozoans are restricted to certain areas in the central capsule, which may be a single or double membrane in different groups. The order is subdivided on the basis of arrangement of the pores. In the Monopylina (Nassellarina) pores lie at one pole of the single-layered capsule. In the Tripylina (Phaeodorina) the major opening (astropyle) usually contains a perforated plate. A common feature is the presence, near the astropyle, of olive-colored material (possibly it is partially digested food) sometimes known as phaeodium. See RADIOLARIA. [R.P.H.]

**Odonata** An order of the class Insecta known as dragonflies. The Odonata are a relatively small order of insects. There are probably less than 3000 species known throughout the world. The order is divided into the Anisoptera, or true dragonflies, and the Zygoptera, or damselflies (see illustration).

The young inhabit ponds, streams, and marshes; the adults fly over these localities or adjacent land. The adult structure is unique, characterized by a head with large compound eyes and wings with clear or transparent membranes traversed by networks of veins; the male has accessory genital organs possessed by no other insects.

There are three general stages in the life history: the egg, the nymph (illus. a), sometimes called naiad, and the adult. Development is usually slow, often requiring 3–5 years. Rarely is there more than one generation a year in the northern range. Adults may live for an extended period in summer. Eggs are laid by insertion into plant stems, either beneath the water or just above the surface. Others are dropped directly into the water and sink to the bottom, where they hatch and the nymphs develop.

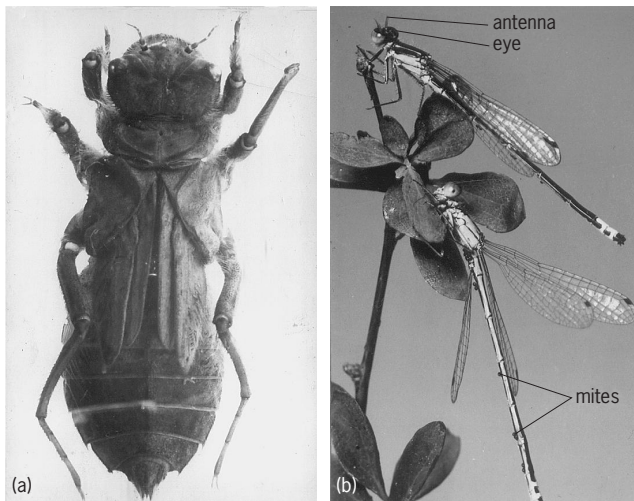

Typical Odonata. (a) Dragonfly nymph. (b) Adult damselflies; note mites attached.

Enemies include birds and fishes, with frogs and insects being of lesser importance. Mites sometimes attach themselves to dragonflies (illus. *b*) but do little harm.

Dragonflies constitute one of the oldest insect orders; they can be traced back through fossil records to the Carboniferous and Permian. Surprisingly few changes have occurred since then, although the order has diversified and specialized to counter competition and to avoid enemies. [P.G.]

**Odontognathae** One of the two superorders making up the subclass Neornithes, or true birds. It was originally erected to include fossil birds that could fly or that were secondarily flightless but still possessed teeth; it was regarded therefore as an evolutionary step between *Archaeopteryx* and fully evolved modern birds. It is now considered to contain only a simple order, Hesperornithiformes, of which the best-known family is the Hesperornithidae containing several species from the Upper Cretaceous of North America. See ARCHAEORNITHES; AVES; HESPERORNITHIFORMES; NEORNITHES. [W.J.B.]

**Odontostomatida** An order of the Spirotrichia which represents a minor group of small, bizarre-looking protozoan species. The odontostomes are compressed laterally and possess very little ciliature. Even the adoral zone of membranelles is reduced in prominence. These ciliates are found in sewage disposal environs and other fresh- or salt-water habitats which have a very low oxygen content. See CILIOPHORA; SPIROTRICHIA. [J.O.C.]

**Oedogoniales** An order of filamentous fresh-water green algae (Chlorophyceae) with unique morphological features including (1) an elaborate method of cell division that results in the accumulation of apical caps, (2) zoospores and antherozoids with a subapical crown of flagella, and (3) a highly specialized type of oogamy. There is a single family, Oedogoniaceae, comprising three genera. See CHLOROPHYCEAE.

*Oedogonium* has the largest number of species (several hundred) and is the most common of the three genera. Its unbranched filaments are initially attached by a holdfast cell to submerged vegetation, stones, or wood, usually in permanent ponds or pools, but at maturity they may form free-floating masses. The cells are cylindrical, each containing a reticulate chloroplast with numerous pyrenoids.

Vegetative multiplication by fragmentation is common. In asexual reproduction, zoospores with a subapical crown of up to 120 flagella are formed singly within a cell. In sexual reproduction, there is a highly specialized interplay between female and male elements. The egg is a metamorphosed protoplast of an enlarged spherical cell (oogonium). Antherozoids, with a subapical crown of about 30 flagella, are produced in pairs or tetrads in very small discoid antheridia. The two types of sex organs may occur on the same filament (homothallic species), or on different filaments (heterothallic species), but in either case certain species have an indirect development of antherozoids. These species, termed nanandrous in distinction to those with direct development (macrandrous), form short cylindrical cells which initially appear like antheridia, but in which the protoplast metamorphoses into a single swimmer bearing a subapical crown of flagella. [P.C.Si.; R.L.Moe]

**Oegophiurida** An extinct order of Ophiuroidea comprising four families. Oegophiurids appeared in the Ordovician and became extinct in the latest Carboniferous. They were apparently the first ophiuroids in which the ambulacral ossicles fused to form the typical ophiuroid arm vertebrae. Dorsal and ventral arm plates are lacking, and the ambulacral groove remains as in their somasteroid ancestors. The gastric ceca extend into the arms, and the gonads are located there too, arranged in series. In the more advanced ophiuroids the gonads and stomach are confined to the disk, and the ambulacra are closed by a ventral

plate. See ASTEROIDEA; ECHINODERMATA; OPHIURIDA; OPHIUROIDEA; PHRYNOPHIURIDA; STENURIDA. [A.C.C.]

**Ohmmeter** A portable instrument for measuring relatively low values of electrical resistance. The range of resistance measured is typically from 0.1 microhm to 1999 ohms ( $\Omega$ ).

The ohmmeter solves quickly and easily a variety of measurement problems, including measuring the resistance of cladding and tracks on printed circuit boards, electrical connectors, and switch and relay contacts, as well as determining the quality of ground-conductor continuity and bonding, cables, bus-bar joints, and welded connector tags. See RESISTANCE MEASUREMENT. [A.D.Sk.]

**Ohm's law** The direct current flowing in an electrical circuit is directly proportional to the voltage applied to the circuit. The constant of proportionality  $R$ , called the electrical resistance, is given by the equation below, in which  $V$  is the applied voltage

$$V = RI$$

and  $I$  is the current. Numerous deviations from this simple, linear relationship have been discovered. See ELECTRICAL RESISTANCE. [C.E.A.]

**Oil analysis** Analysis of petroleum, or crude oil, to determine its value in modern refinery operations. In addition, procedures have been developed for analysis of lubricating oil.

For refinery operations, oil analysis, or assay, must provide the refinery planner with the data needed to predict yields, qualities, and operating costs for a wide variety of refinery operating conditions and product demands. In a refinery, crude oil is distilled and separated into products according to the boiling points of the crude oil components (see table). See PETROLEUM; PETROLEUM PRODUCTS.

Typical products derived from crude oil

Product	Carbon atom range	Boiling point range, °F (°C)
Gas	C <sub>1</sub> and C <sub>2</sub>	
Liquefied petroleum gas	C <sub>3</sub> and C <sub>4</sub>	
Gasolines	C <sub>4</sub> to C <sub>10</sub>	59–370 (15–190)
Kerosines	C <sub>9</sub> to C <sub>15</sub>	300–540 (150–280)
Middle distillates	C <sub>12</sub> to C <sub>20</sub>	390–640 (200–340)
Gas oils	C <sub>20</sub> to C <sub>45</sub>	640–1040 (340–560)
Bottoms	Unvaporized residua	

A crude assay follows much the same procedure. The oil is distilled and separated into up to 40 narrow-boiling-range cuts. Each cut is then subjected to a variety of tests sufficient to characterize it for the products the cut could be included in. The refinery planners may then calculate yield and qualities of any product by blending the yields and qualities of the cuts that are included in the product.

Petroleum consists primarily of compounds of carbon and hydrogen containing from 1 to about 60 carbon atoms. Carbon atoms in natural petroleum occur in straight and branched chains (paraffins), in single or multiple saturated rings (cycloparaffins or naphthenes), and in cyclic structures of the aromatic type such as benzene, naphthalene, and phenanthrene. Cyclic structures may have attached to them side chains of paraffinic carbons. In lubricating oil it is usual to have naphthene rings built onto the aromatic rings and side chains attached. In products produced by cracking in the refinery, olefins or compounds with carbon-carbon double bonds not in aromatic rings are also found. The high-boiling fractions of petroleum contain increasing amounts of oxygen, nitrogen, and sulfur compounds, as well as traces of organic compounds of metals such as vanadium, nickel, and iron.

Three types of tests are used to characterize a crude oil and its narrow-boiling-range cuts: (1) tests for physical properties such as specific gravity, refractive index, freeze temperature, vapor pressure, octane number, and viscosity; (2) tests for specific chemical species such as sulfur, nitrogen, metals, and total paraffins, naphthenes, and aromatics; (3) tests for determining actual chemical composition. [J.Ree.]

Analysis of used lubricating oils is part of the maintenance program for many types of engines and industrial equipment. To analyze a lubricating oil, a representative sample of the lubricating oil flowing in the system at normal operating temperature is collected in a clear container and labeled with pertinent data. The sample is then delivered to the testing laboratory as soon as possible. Tests applied to used engine oils include viscosity, fuel dilution, water, insolubles, and spectrochemical or spectrographic analysis. Wear-metal concentrations are determined in parts per million (ppm); these metals may include silver, aluminum, chromium, copper, iron, nickel, lead, and tin, in addition to silicon. An increase in any of these concentrations may indicate abnormal engine wear. See ENGINE; INTERNAL COMBUSTION ENGINE; SPECTROSCOPY. [D.L.An.]

**Oil and gas, offshore** For many years, petroleum companies stopped at the water's edge or sought and developed oil and gas accumulations only in inland waters or shallow seas bordering onshore producing areas. Exploration deeper under the sea, and production from the continental shelves beyond territorial limits, did not begin in earnest until the world's increasing demand for petroleum energy sources, coupled with a lessening return from land drilling, provided the incentives for the huge investments needed for drilling in the open sea. See CONTINENTAL MARGIN; OIL AND GAS WELL DRILLING; PETROLEUM RESERVES.

Today offshore oil exploration and production is a worldwide industry. By the early 1990s, offshore sources accounted for 30% of worldwide crude oil production and 14% of worldwide natural gas. Until now, most offshore production came from reservoirs located under the continental shelf, in water depths up to 600 ft (180 m). Spurred by technology and a need to find additional secure sources of energy, exploration and production are now moving even farther from shore and into the deeper waters of the continental slopes. Exploration wells have been drilled in water deeper than 9000 ft (2750 m), and hydrocarbons are being produced from offshore fields in waters deeper than 5000 ft (1500 m).

There is a sound geologic basis for the petroleum industry turning to the continental shelves and slopes. Favorable sediments and structures exist beneath the present seas of the world in geologic settings that have proven highly productive onshore. In fact, the subsea geologic similarity, or in some cases superiority, to geologic conditions on land has been a vital factor in the expansion of the world's investment in offshore exploration and production. See MARINE GEOLOGY.

Significant exploration is taking place in water depths up to 10,000 ft (3050 m) in the Gulf of Mexico, offshore Brazil, offshore West Africa, and in the northern Atlantic off the coasts of Norway, Ireland, and the United Kingdom. Oil and natural gas fields in waters as deep as 5500 ft (1675 m) are already on-stream in the Gulf of Mexico and offshore Brazil. In the North Atlantic west of the Shetland Islands, where weather conditions are particularly severe, production has started from reservoirs in water depths up to 1500 ft (450 m). See PETROLEUM GEOLOGY.

The underwater search has been made possible only by vast improvements in offshore technology. Drillers first took to sea with land rigs mounted on barges towed to location and anchored, or with fixed platforms accompanied by a tender ship. As the search for oil and natural gas advanced worldwide and farther away from shore, types of exploration rigs evolved which could move easily between locations and operate in a wide range of water depths.

The move into the open and often hostile sea has required not only the development of drilling vessels but also a host of auxiliary equipment and techniques. An entire industrial complex has developed to serve the offshore industry, including construction of fixed platform structures from which the majority of the world's offshore oil and gas production is presently drilled and produced.

The United States Gulf coast, where a large percentage of the world's offshore drilling has taken place, is regularly hit by hurricanes that damage structures in their path, and a number of platforms were lost early on due to high wind and waves. However, improved understanding of the environment, as well as more advanced materials and structural analysis techniques, has significantly reduced failures due to environmental forces. The major causes of accident are now due to human error, process hazards, and transportation to and from offshore facilities by helicopter. See HURRICANE.

Improved reservoir management and further discoveries have increased production from onshore fields, where costs are less than for offshore. However, the world's increasing demand for petroleum energy continues to force the search for new reserves into even deeper waters and more remote corners of the world. [G.R.S.; J.A.T.; C.Ar.]

**Oil and gas field exploitation** In the petroleum industry, a field is an area underlain without substantial interruption by one or more reservoirs of commercially valuable oil or gas, or both. A single reservoir (or group of reservoirs which cannot be separately produced) is a pool. Several pools separated from one another by barren, impermeable rock may be superimposed one above another within the same field. Pools have variable areal extent. Any sufficiently deep well located within the field should produce from one or more pools. However, each well cannot produce from every pool, because different pools have different areal limits.

Development of a field includes the location, drilling, completion, and equipment of wells necessary to produce the commercially recoverable oil and gas in the field.

**General considerations.** Oil and gas production necessarily are intimately related, since approximately one-third of the gross gas production in the United States is produced from wells that are classified as oil wells. However, the naturally occurring hydrocarbons of petroleum are not only liquid and gaseous but may even be found in a solid state, such as asphaltite and some asphalts.

Where gas is produced without oil, the production problems are simplified because the product flows naturally throughout the life of the well and does not have to be lifted to the surface. However, there are sometimes problems of water accumulations in gas wells, and it is necessary to pump the water from the wells to maintain maximum, or economical, gas production. The line of demarcation between oil wells and gas wells is not definitely established. Most gas wells produce quantities of condensable vapors, such as propane and butane, that may be liquefied and marketed for fuel, and the more stable liquids produced with gas can be utilized as natural gasoline.

**Production methods in producing wells.** The common methods of producing oil wells are (1) natural flow; (2) pumping with sucker rods; (3) gas lift; (4) hydraulic subsurface pumps; (5) electrically driven centrifugal well pumps; and (6) swabbing.

However, most wells are not self-flowing and various lifting methods must be employed. Approximately 90% of the wells made to produce by some artificial lift method in the United States are equipped with sucker-rod-type pumps. In these the pump is installed at the lower end of the tubing string and is actuated by a string of sucker rods extending from the surface to the subsurface pump. The two common variations are mechanical and hydraulic long-stroke pumping. Other lifting mechanisms are the gas lift, hydraulic subsurface pumps, swabs, bailers, jet pumps, and sonic pumps. See OIL AND GAS WELL COMPLETION.



**Production instruments.** The commoner and more important instruments required in petroleum production operations are the following:

1. Gas meters, which are generally of the orifice type, are designed to record the differential pressure across the orifice, and the static pressure.
2. Recording subsurface pressure gages small enough to run down 2-in. (3-cm) ID (inside diameter) tubing are used extensively for measuring pressure gradients down the tubing of flowing wells, recording pressure buildup when the well is closed in, and measuring equilibrium bottom-hole pressures.
3. Subsurface samplers designed to sample well fluids at various levels in the tubing are used to determine physical properties.
4. Oil meters of various types are utilized to meter crude oil flowing to or from storage.
5. Dynamometers are used to measure polished-rod loads.
6. Liquid-level gages and controllers are used. They are similar to those used in other industries, but with special designs for closed lease tanks. [R.L.Ch.]

**Oil and gas storage** Storage, usually in great quantities, of crude oil and natural gas after production from natural reservoirs. Large amounts of refined products are stored as well. Storage is necessary to meet seasonal and other fluctuations in demand; for efficient operation of producing equipment, pipelines, tankers, and refineries; and for emergency use.

**Crude oil and refined products.** Oil from producing wells is first collected in welded-steel, bolted-steel, or wooden tanks of 100 bbl (16 m<sup>3</sup>) or greater capacity. These tanks, upright cylinders with low-pitched conical roofs, provide temporary storage while the oil is awaiting shipment. Several tanks grouped together are a tank battery. Assemblages of large steel tanks, known as tank farms, are used for more permanent storage at pipeline pump stations, points where tankers load and unload, and refineries.

For offshore producing fields a number of unique storage systems have been designed. In several instances old tankers have been adapted for storage, and barges have been constructed especially for offshore storage use.

To minimize vaporization losses, lease tanks are sometimes equipped to hold several ounces pressure. At large-capacity storage sites, special tanks are generally used. Tanks with lifter or floating roofs are used to store crude oil, motor gasoline, and less volatile natural gasoline. Motor and natural gasolines are also stored in spheroid containers. Spherical containers are used for more volatile liquids, such as butane. Horizontal cylindrical containers are used for propane and butane storage. Refrigerated insulated tank systems enabling propane to be stored at a lower pressure are also in use.

Large quantities of volatile liquid-petroleum products, including propane and butane, are stored in underground caverns dissolved in salt formations and in mined caverns, gas reservoirs, and water sands. Refrigerated propane is also being stored in excavations in frozen earth and in underground concrete tanks.

**Natural gas.** Natural gas is stored in low-pressure surface holders, buried high-pressure pipe batteries and bottles, depleted or partially depleted oil and gas reservoirs, water sands, and several types of containers at extremely low temperature (−258°F or −161°C) after liquefaction. Low-pressure holders, which store relatively small volumes of gas, basically use either a water or a dry seal, and variations of each type exist.

In the United States gas pipeline and utility companies store large quantities of natural gas in underground reservoirs. In most cases these reservoirs are located near market areas. Underground storage permits greatly increased pipeline utilization, resulting in lower transportation costs and reduced gas cost to the consumer. Underground storage is the only economical method

of storing large enough quantities of gas to meet the seasonal fluctuations in pipeline loads.

In operating storage reservoirs only a portion of the stored gas, called working gas, is normally withdrawn. The remaining gas, called cushion gas, stays in the reservoir to provide the necessary pressure to produce the storage wells at desired rates. In aquifer storages some water returns to help maintain the reservoir pressure. In aquifer storages the original hydrostatic pressure must be exceeded in order to push the water back.

Storage of liquefied natural gas throughout the world is in connection with shipment of liquefied natural gas by tanker, and is located at the loading and unloading ends of the tanker runs as well as at peak sharing facilities operated by gas pipeline and local utility companies. Storage is in insulated metal tanks, buried concrete tanks, or frozen earth excavations. In two projects using frozen earth excavations, excessive boil-off of the liquefied gas led to replacement with insulated metal tanks. See LIQUEFIED NATURAL GAS (LNG); OIL AND GAS FIELD EXPLOITATION; PETROLEUM; PIPELINE. [P.G.Bu.]

**Oil and gas well completion** The operations that prepare a well bore for producing oil or gas from the reservoir. The goal of these operations is to optimize the flow of the reservoir fluids into the well bore, up through the producing string, and into the surface collection system. See OIL AND GAS FIELD EXPLOITATION; OIL AND GAS WELL DRILLING.

The well bore is lined (cased) with steel pipe, and the annulus between well bore and casing is filled with cement. Properly designed and cemented casing prevents collapse of the well bore and protects fresh-water aquifers above the oil and gas reservoirs from becoming contaminated with oil and gas and the oil reservoir brine. Similarly, the oil and gas reservoir is prevented from becoming invaded by extraneous water from aquifers that were penetrated above or below the productive reservoir. See AQUIFER.

The nature of the reservoir, evaluated from a core analysis, cuttings, or logs, or from experience with like productive formations, determines the type of completion to be used. In a barefoot completion, the casing is set just above the producing formation, and the latter is drilled out and produced with no pipe set across it. Such a completion can be used for hard rock formations which are not friable and will not slough, and when there are no opportunities for producing from another, lower reservoir. Set-through and perforated completions are also employed for relatively well-consolidated formations from which the potential for sand production is small. However, the perforated completion is used when a long producing interval must be prevented from collapse, when multiple intervals are to be completed in the one borehole, or when intervening water sands within the oil-producing interval are to be shut off and the oil-saturated intervals selectively perforated. See WELL LOGGING.

A string of steel tubing is lowered into the casing string and serves as the conduit for the produced fluids. The tubing may be hung from the well-head or supported by a packer set above the producing zone. The packer is used when it is desirable to isolate the casing string from the produced fluids because of the latter's pressure, temperature, or corrosivity, or when such isolation may improve production characteristics.

The tops of wells from which fluids flow as a result of the indigenous reservoir energy are equipped with a manifold known as the Christmas tree. However, only some reservoirs have sufficient pressure and sufficient gas in solution (which is released at the lower pressure existing in the well bore and therefore lowers the effective density of the fluid in the tubing) to permit natural flow to the surface. The reservoir fluids from other reservoirs and, after pressure depletion, even from those which initially flowed must be brought to the surface by one of several methods of artificial lift.

Excessive water production increases the cost of oil production since energy must be expended in lifting the water to the

surface. Water production may also jeopardize the production of oil and gas by saturating the oil-productive interval with water. Such damage is more likely to occur in low-pressure formations or formations which contain water-sensitive clays that swell in an excess of water. Water exclusion may be effected by the application of cements of various types. If it is determined that water is entering from the lower portion of a producing sand in a relatively shallow, low-pressure well, a cement plug may be placed in the bottom of the hole so that it will cover the oil-water interface of the reservoir. This technique is called laying in a plug and may be accomplished by placing the cement with a dump-bottom bailer on a wire line or by pumping cement down the drill pipe or tubing. For deeper, higher-pressure, or more troublesome wells, a squeeze method is used. Squeeze cementing is the process of applying hydraulic pressure to force a cement into an exposed formation or through openings in the casing or liner. It is also used for repairing casing leaks.

Production may be impaired from a well bore as a result of drilling-mud invasion or of accumulation of clays and fine silts carried by the producing fluids to the borehole, or the lithology of the formation itself may have a naturally low permeability to reservoir fluids. Since the permeability to fluids of the formation within the first few feet of the well bore has an exponential effect on limiting the influx of fluid, the productivity of a well can frequently be increased manifold by increasing the permeability of this element of the reservoir or removing the skin just at the face of the producing interval. This is accomplished by acidization and fracturing, and in some instances by the use of surfactants, solvents, and explosives. [T.M.D.; R.E.Wy.]

**Oil and gas well drilling** The drilling of holes for exploration and extraction of crude oil and natural gas. Deep holes and high pressures are characteristics of petroleum drilling not commonly associated with other types of drilling. In general, it becomes more difficult to control the direction of the drilled hole as the depth increases, and additionally, the cost per foot of hole drilled increases rapidly with the depth of the hole. Drilling-fluid pressure must be sufficiently high to prevent blowouts but not high enough to cause fracturing of the borehole. Formation-fluid pressures are commonly controlled by the use of a high-density clay-water slurry, called drilling mud. The chemicals used in drilling mud can be expensive, but the primary disadvantage in the use of drilling muds is the relatively low drilling rate which normally accompanies high bottom-hole pressure. Drilling rates can often be increased by using water to circulate the cuttings from the hole; when feasible, the use of gas as a drilling fluid can lead to drilling rates as much as 10 times those attained with mud. Drilling research has the objectives of improving the utilization of current drilling technology and the development of improved drilling techniques and tools.

The hole direction must be controlled within permissible limits in order to reach a desired target at depths as great as 25,000 ft (7600 m). Inclined layers of rocks with different hardnesses tend to cause the direction of drilling to deviate; consequently, deep holes are rarely truly straight and vertical. The drilling rate generally increases as additional drill-collar weight is applied to the bit by adjusting the pipe tension at the surface. However, crooked-hole tendency also increases with higher weight-on-bit. A so-called packed-hole technique has been used to reduce the tendency to hole deviation. One version of this technique makes use of square drill collars that nearly fill the hole on the diagonals but permit fluid and cuttings to circulate around the sides. This procedure reduces the rate at which the hole direction can change.

In mountainous terrain, it is difficult to construct well locations over each subsurface drilling target, and from offshore drilling platforms it is necessary to drill many wells from a single surface location. For these situations, technology has been developed that permits wells to be drilled directionally from the single surface location to the desired subsurface point.

Advances in technology and the need to accomplish special objectives have led to drilling horizontal wells in deep oil or gas reservoirs. The angle of the well is successively built up in order to reach the ultimate horizontal course of the well. The program for drilling the well is developed before hand, based on the technology for actually increasing the angle and then continuing the drilling at the desired angle.

Novel drilling methods include studies of rock failure by mechanical, thermal, hydraulic, fusion and vaporization, and chemical means. Jet piercing is widely used for drilling very hard, spallable rocks, such as taconite. Other methods include the use of electric arc, laser, plasma, spark, and ultrasonic drills. See OIL AND GAS WELL COMPLETION; PETROLEUM GEOLOGY; ROCK MECHANICS; TURBODRILL; WELL LOGGING. [T.M.D.]

**Oil burner** A device for converting fuel oil from a liquid state into a combustible mixture. A number of different types of oil burners are in use for domestic heating. These include sleeve burners, natural-draft pot burners, forced-draft pot burners, rotary wall flame burners, and air-atomizing and pressure-atomizing gun burners. The most common and modern type that handles 80% of the burners used to heat United States homes is the pressure-atomizing-gun-type burner shown in the illustration.

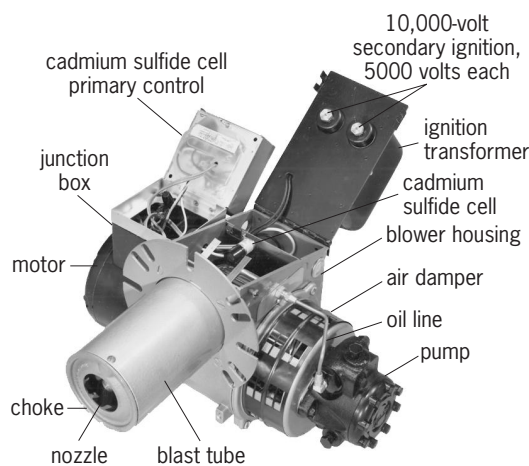

An oil burner of the pressure-atomizing type. (*Automatic Burner Corp.*)

The sleeve burner, commonly known as a range burner because of its use in kitchen ranges, is the simplest form of vaporizing burner. The natural-draft pot burner relies on the draft developed by the chimney to support combustion. A modification of this burner is the forced-draft pot burner which supplies its own air for combustion and does not rely totally on the chimney. The rotary wall flame burners have mechanically assisted vaporization. The gun-type burner uses a nozzle to atomize the fuel so that it becomes a vapor, and burns easily when mixed with air.

The oil burner is used for a wide assortment of heating, air conditioning, and processing applications. Oil burners heat commercial buildings such as hospitals, schools, and factories. Air conditioners using the absorption refrigeration system have been developed and fired with oil burners. Oil burners are used to produce CO<sub>2</sub> in greenhouses to accelerate plant growth. They also produce hot water for many commercial and industrial applications. See AIR COOLING; COMFORT HEATING; HOT-WATER HEATING SYSTEM. [R.A.K.]

**Oil field waters** Waters of varying mineral content which are found associated with petroleum and natural gas or have been encountered in the search for oil and gas. They are also called oil field brines, or brines. They include a variety of

underground waters, usually deeply buried, and have a relatively high content of dissolved mineral matter. These waters may be (1) present in the pore space of the reservoir rock with the oil or gas, (2) separated by gravity from the oil or gas and thus lying below it, (3) at the edge of the oil or gas accumulation, or (4) in rock formations which are barren of oil and gas. Brines are commonly defined as water containing high concentrations of dissolved salts. Potable or fresh waters usually are not considered oil field waters but may be encountered, generally at shallow depths, in areas where oil and gas are produced.

Probably the most important geological use of oil field water analyses is their application to the quantitative interpretation of electrical and neutron well logs, particularly micrologs. See PETROLEUM GEOLOGY; WELL LOGGING. [PMcG.]

**Oil furnace** A combustion chamber in which oil is the heat-producing fuel. Fuel oils, having from 18,000 to 20,000 Btu/lb (42–47 megajoules/kg), which is equivalent to 140,000 to 155,000 Btu/gal (39–43 megajoules/liter), are supplied commercially. The lower flash-point grades are used primarily in domestic and other furnaces without preheating. Grades having higher flash points are fired in burners equipped with preheaters. See FUEL OIL.

Domestic oil furnaces with automatic thermostat control usually operate intermittently, being either off or operating at maximum capacity. See OIL BURNER. [F.H.R.]

**Oil sand** A loose to consolidated sandstone or a porous carbonate rock, impregnated with a heavy asphaltic crude oil, too viscous to be produced by conventional methods; also known as tar sand or bituminous sand.

Oil sands are distributed throughout the world but the largest proven accumulation occurs in Alberta, Canada (the Athabasca deposit). A large accumulation appears to be present in the Orinoco Basin in Venezuela, and far smaller deposits occur in Russia, the United States, Madagascar, Albania, Trinidad, and Romania. [G.R.G.]

**Oil shale** A sedimentary rock containing solid, combustible organic matter in a mineral matrix. The organic matter, often called kerogen, is largely insoluble in petroleum solvents, but decomposes to yield oil when heated. Although "oil shale" is used as a lithologic term, it is actually an economic term referring to the rock's ability to yield oil; oil shale appears to be the cheapest source after natural petroleum for large amounts of liquid fuels. No real minimum oil yield or content of organic matter can be established to distinguish oil shale from sedimentary rocks. Additional names given to oil shales include black shale, bituminous shale, carbonaceous shale, coaly shale, cannel shale, cannel coal, lignitic shale, torbanite, tasmanite, gas shale, organic shale, kerosine shale, coorongite, maharahu, kukersite, kerogen shale, algal shale, and "the rock that burns." See KEROGEN.

The world's oil shale deposits represent a tremendous store of fossil energy. It has been estimated that the organic matter in sedimentary rocks contains  $1.2 \times 10^{16}$  tons ( $1.1 \times 10^{16}$  metric tons) of organic carbon, nearly 1000 times that found in coals. Although part of that organic carbon has matured to produce oil and gas, most of it is still oil shale. Unfortunately, most of this tremendous resource is not well known. Oil shales occur on every continent in sediments ranging in age from Cambrian to Tertiary. Estimates for the total oil resource in shales of all grades reached  $1.75 \times 10^{15}$  barrels. Just 1% of that total shale oil represents more oil than the world is expected to produce as natural petroleum ( $2 \times 10^{12}$  bbl). Oil shale represents a tremendous supply of liquid fuels.

Although the oil potential of the world's oil shales is great, commercial production of this oil has been considered uneconomic. Oil shales are lean ores, producing only limited amounts of oil which historically has been low in price. Mining and heating

1 ton of relatively rich oil shale yielding 25 gal/ton produces only 0.6 bbl of oil.

Shale oil is produced from the organic matter in oil shale when the rock is heated in the absence of oxygen (destructive distillation). This heating process is called retorting, and the equipment that is used to do the heating is known as a retort. The rate at which the oil is produced depends upon the temperature at which the shale is retorted. Most references report retorting temperatures as being about 500°C (930°F). [J.W.S.; H.B.J.]

**Okra** A warm-season annual, *Hibiscus esculentus*, of Ethiopian origin. Okra, also called gumbo, is grown for its immature pods (see illustration), which are generally used for preparing

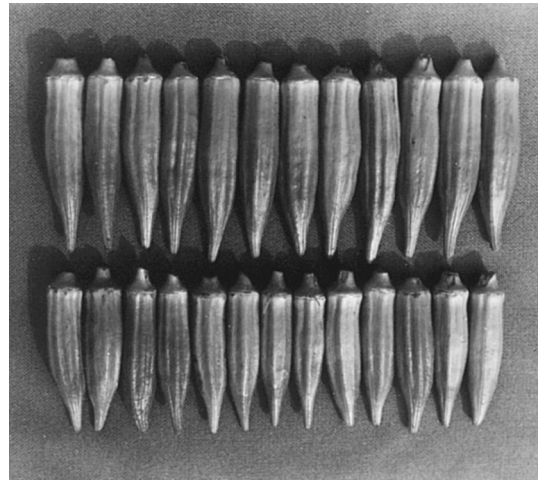

Okra pods. (Asgrow Seed Co., subsidiary of The Upjohn Co.)

soups but are also eaten as a freshly cooked vegetable. It is a member of the order Malvales and is related to cotton. Georgia, Florida, and Louisiana are important producing states. See MALVALES. [H.J.C.]

**Olbers' paradox** The riddle of cosmic darkness. The obvious explanation for the darkness of the night sky, that the Sun is on the other side of the Earth, does not account for the fact that, in space far from any star, the universe is full of darkness and not of light.

In a boundless universe of stars, with no interstellar absorption, every line of sight from the eye must eventually intercept the surface of a star. If most stars are similar to the Sun, the sky at every point should shine as bright as the Sun's disk. The sky (or celestial sphere) is 180,000 times larger than the Sun's disk, and the starlight incident on the Earth should therefore be 180,000 times more intense than sunlight, which obviously is not the case. Hermann Bondi resurrected the riddle of cosmic darkness in 1952 and attributed it to the nineteenth-century astronomer Wilhelm Olbers, although, as is now known, it had previously been discussed by Edmund Halley and other astronomers.

Edgar Allan Poe suggested in 1848 that the universe is not old enough for the light from very distant stars to have reached the Earth; this was investigated by Lord Kelvin in 1901. Modern calculations confirm Kelvin's results: light travels at approximately 186,000 mi/s (300,000 km/s) and, in a static universe  $10\text{--}20 \times 10^9$  years old, stars cannot shine long enough for their light to reach the Earth from regions sufficiently distant for the visible stars to cover the entire sky. This means that stars cannot shine long enough to fill the universe with radiation in equilibrium with their surfaces. Clearly, if the sky at night is dark in a static universe of finite age, then in an expanding universe of similar age the night sky is even darker because of the redshift. See BIG BANG THEORY; COSMOLOGY; UNIVERSE. [E.H.]

**Olfaction** One of the chemical senses, specifically the sense of smell. Olfaction registers chemical information in organisms ranging from insects to humans, including marine organisms. For terrestrial animals, its stimuli comprise airborne molecules. The typical stimulus is an organic chemical with molecular weight below 300 daltons. A few inorganic chemicals can also stimulate olfaction, notably hydrogen sulfide, ozone, ammonia, and the halogens.

The anatomy of olfactory structures and the neurophysiology of olfaction differ significantly among different animal groups. For examples, insect olfactory receptors exist within sensory hairs on the antennae. The olfactory organ of fishes resides typically in tubular chambers on either side of the mouth. In terrestrial vertebrates, the olfactory receptors reside within a sac or cavity more or less similar to the human nasal cavity. The olfactory mucosa patch in the cavity characteristically contains millions of receptor cells, though in some olfactory-dominated mammals, such as the dog and rabbit, it contains tens of millions. The location of the olfactory mucosa relative to air currents in the cavity plays some role in the ongoing olfactory vigilance of the organism. In the human the mucosa sits out of the main airstream. During quiet breathing eddy currents may carry just enough stimulus to evoke a sensation, whereupon sniffing will occur. Sniffing amplifies the amount of stimulus reaching the receptors by as much as tenfold.

Reception of the chemical stimulus and transduction into a neural signal apparently occur on the olfactory receptor cilia. The ciliary membrane contains receptor protein molecules that interact with stimulating molecules through reversible binding. Vertebrate receptor cells show broad tuning, that is, they respond to many odorants.

Adjacent points in the mucosa generally project to adjacent points in the olfactory bulb of the brain (see illustration). The synapses between the incoming olfactory nerve fibers and the second-order cells, mitral cells, occur in basketlike structures called glomeruli. On average, a glomerulus receives about 1000 receptor cell fibers for each mitral cell. The location of cells within the bulb seems to play a role in encoding odor quality: each odorant stimulates a more or less unique spatial array.

The central neural pathways of the olfactory system have a complexity unmatched among the sensory systems. One pathway carries information to the pyriform cortex (paleocortex of the temporal lobe), to a sensory relay in the thalamus (dorsomedial nucleus), and to the frontal cortex (orbitofrontal region). This

pathway seems rather strictly sensory. Another pathway carries information to the pyriform cortex, the hypothalamus, and other structures of the limbic system. The latter have much to do with the control of emotions, feeding, and sex. The strong affective and motivational consequences of olfactory stimulation seem compatible with projections to the limbic system and with the role of olfaction in certain types of physiological regulation. In many vertebrate species, reception of pheromones occurs via an important accessory olfactory organ, known as the vomeronasal organ, which characteristically resides in the hard palate of the mouth or floor of the nasal cavity. See PHEROMONE.

Human olfactory sensitivity varies from odorant to odorant over several orders of magnitude. A common range of thresholds for materials used in fragrances and flavors is 1 to 100 parts per  $10^9$  parts of air. Thresholds gathered from various groups of human subjects permit certain generalities about how the state of the organism affects olfaction. For instance, persons aged 70 and above are about tenfold less sensitive than young adults. Males and females have about equal sensitivity, except perhaps in old age, where females are more sensitive. Persons with certain medical disorders, such as multiple sclerosis, Parkinson's disease, paranasal sinus disease, Kallmann's syndrome, and olfactory tumors, exhibit decreased sensitivity (hyposmia) or complete absence of sensitivity (anosmia).

Above its threshold, the perceived magnitude of an odor changes by relatively small amounts as concentration increases. A tenfold increment in concentration will cause, on average, about a twofold change in perceived magnitude. The perceived magnitude of an odor is often greatly influenced by olfactory adaptation, a process whereby during continuous short-term exposure to a stimulus its perceived magnitude falls to about one-third of its initial value.

The stimuli for olfaction are commonly complex, that is, they are mixtures. Such products as coffee, wine, cigarettes, and perfumes contain at least hundreds of odor-relevant constituents. Only rarely does the distinctive quality of a natural product, such as a vegetable, arise from only a single constituent. A chemical analysis of most products will not usually allow a simple prediction of odor intensity or quality. One general rule, however, is that the perceived intensity of the mixture falls well below the sum of the intensities of the unmixed components.

General notions about the properties that endow a molecule with its quality have spawned more than two dozen theories of olfaction, including various chemical and vibrational theories.

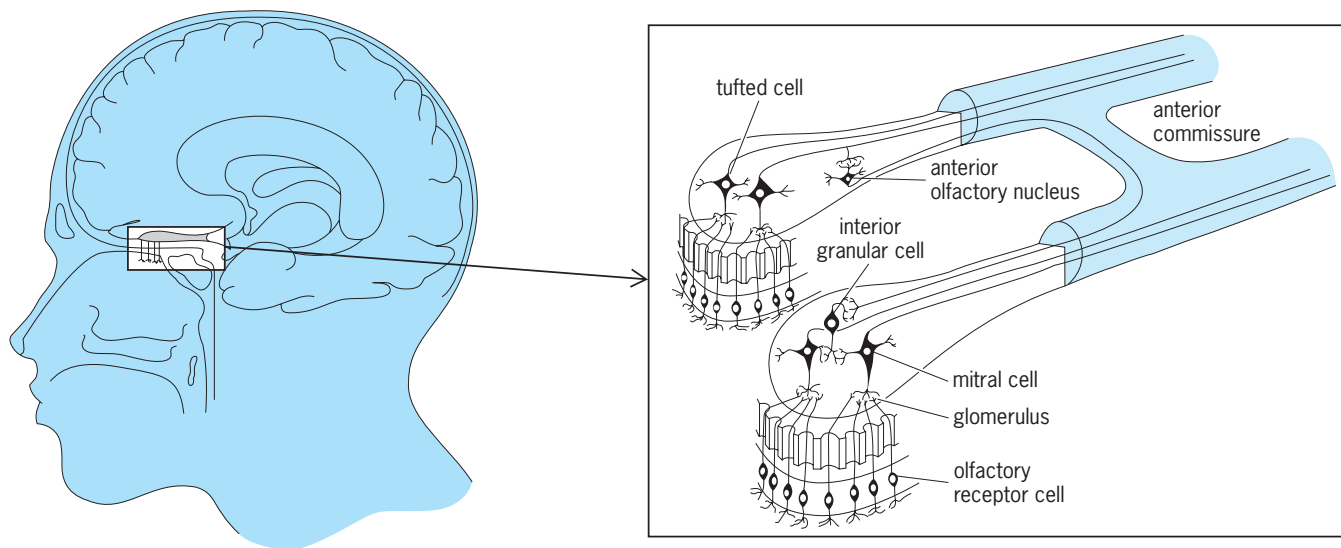

Location of the olfactory bulbs at the interior surface of the human brain and their connections via the anterior commissure. (After D. Ottoson, *Physiology of the Nervous System*, Oxford University Press, 1983)

Most modern theories hold that the key to quality lies in the size and shape of molecules, with some influence of chemical functionality. For molecules below about 100 daltons, functional group has obvious importance: for example, thiols smell skunky, esters fruity, amines fishy-uriny, and carboxylic acids rancid. For larger molecules, the size and shape of the molecule seem more important. Shape detection is subtle enough to enable easy discrimination of some optical isomers. Progressive changes in molecular architecture along one or another dimension often lead to large changes in odor quality. No current theory makes testable predictions about such changes. See CHEMICAL SENSES; CHEMORECEPTION. [W.Ca.]

**Oligocene** The third oldest of the seven geological epochs of the Cenozoic Era. It corresponds to an interval of geological time (and rocks deposited during that time) from the close of the Eocene Epoch to the beginning of the Miocene Epoch. The most recent geological time scales assign an age of 34 to 24 million years before present (m.y. B.P.) to the Oligocene Epoch. See CENOZOIC; EOCENE; MIOCENE.

An important event that characterizes the Oligocene Epoch was the development of extensive glaciation on the continent of Antarctica. Prior to that time, the world was largely ice-free through much of the Mesozoic and early Tertiary. A significant amount of ice is now known to have existed on the Antarctic continent since at least the beginning of the Oligocene, when the Earth was ushered into its most recent phase of ice-house conditions. This in turn created revolutions in the global climatic and hydrographic systems, with important repercussions for the marine and terrestrial biota. The changes include steepened latitudinal and vertical thermal gradients affecting major fluctuations in global climates, and the shift in the route of global dispersal of marine biota from an ancestral equatorial Tethys seaway, which had become severely restricted by Oligocene time, to the newly initiated circum-Antarctic circulation. See GLACIAL EPOCH.

Worldwide, the epoch represents an overall regressive sequence when there was a drawdown of global sea level, with relatively deeper, marine facies in the Early Oligocene and shallower-water to nonmarine facies in the late Oligocene. See FACIES (GEOLOGY).

Due to accentuated thermal gradients and seasonality in the Oligocene, marine biotic provinces became more fragmented. Extreme climates, with greater diurnal and seasonal temperature contrasts, are held responsible for reduced diversities in marine plankton. The Oligocene was characterized by transitional faunal features between the Paleogene and the Neogene.

Rhinocerids, tapirs, and wild boarlike hog species with strong incisors and large canines appeared. *Hyaenodon* was an Oligocene carnivore with strong canines and sharp molars, much like those of the modern cat species. The horses that had first appeared in the Eocene continued to increase in size and became three-toed, typified by *Mesohippus*. Elephants made their first appearance near the Eocene-Oligocene boundary and developed a short trunk and two pairs of tusks. An early simian, *Propliopithecus*, made its first appearance in Oligocene, and is considered ancestral to the modern family of gibbons. The general uniformity of mammalian fauna in the Oligocene suggests that the widespread regressions of the sea most likely resulted in land bridges that reconnected some of the Northern Hemispheric landmasses, which may have led to transigrations of some families of mammals between North America, Asia, and Africa. Birds had achieved some of their modern characteristics, and at least 10 modern genera had already made their appearance by the close of Oligocene time. See AVES; GEOLOGIC TIME SCALE; MAMMALIA; PALEOECOLOGY; PERISSODACTYLA. [B.U.H.]

**Oligochaeta** A class of the phylum Annelida including worms such as the earthworms. There are 21 families with over 3000 species. These animals exhibit both external and internal segmentation. They usually possess setae which are not borne

on parapodia. Oligochaetes are hermaphroditic. The gonads are few in number and situated in the anterior part of the body, the male gonads being anterior to the female gonads. The gametes are discharged through special ducts, the oviducts and sperm ducts. A clitellum is present at maturity. There is no larval stage during development.

The oligochaetes are primarily fresh-water and burrowing terrestrial animals. A few are marine and several species occur in the intertidal zone.

Oligochaetes are cylindrical, elongated animals with the anterior mouth usually overhung by a fleshy lobe, the prostomium, and the anus terminal. The body plan is that of a tube within a tube. Externally, the segments are marked by furrows. The setae or bristles are borne on most segments. Other external features are the pores of the reproductive systems opening on certain segments, the openings of the nephridia, and in many earthworms dorsal pores which open externally from the coelom. Some aquatic species have extensions of the posterior part of the body which function as gills.

The oligochaetes have been used in studies of physiology, regeneration, and metabolic gradients. Some aquatic forms are important in studies of stream pollution as indicators of organic contamination. Earthworms are important in turning over the soil and reducing vegetable material into humus. It is likely that fertile soil furnishes a suitable habitat for earthworms, rather than being a result of their activity. See ANNELIDA. [R.C.H.]

**Oligoclase** A plagioclase feldspar with composition in the range  $Ab_{90}An_{10}$  to  $Ab_{70}An_{30}$ , where Ab represents the composition of albite,  $NaAlSi_3O_8$ , and An represents the composition of anorthite,  $CaAl_2Si_2O_8$ . The diagnostic properties are hardness on Mohs scale, 6–6.5; density, 2.65 g/cm<sup>3</sup>; and color usually white or colorless, transparent to translucent. The presence of minute, mutually parallel inclusions of hematite ( $Fe_2O_3$ ) causes a golden play of color in the variety of oligoclase called aventurine or sunstone. Oligoclase is triclinic. The mineral is common in igneous rocks and metamorphic rocks. See ALBITE; ANORTHITE; FELDSPAR; HARDNESS SCALE; IGNEOUS ROCKS; METAMORPHIC ROCKS. [D.T.G.]

**Oligonucleotide** A deoxyribonucleic acid (DNA) or ribonucleic acid (RNA) sequence composed of two or more covalently linked nucleotides. Oligonucleotides are classified as deoxyribooligonucleotides or ribooligonucleotides. Fragments containing up to 50 nucleotides are generally termed oligonucleotides, and longer fragments are called polynucleotides. See DEOXYRIBONUCLEIC ACID (DNA); RIBONUCLEIC ACID (RNA).

A deoxyribooligonucleotide consists of a 5-carbon sugar called deoxyribose joined covalently to phosphate at the 5' and 3' carbons of this sugar to form an alternating, unbranched polymer. A ribooligonucleotide consists of a similar repeating structure where the 5-carbon sugar is ribose. Chemically synthesized oligonucleotides of predetermined sequence have proven to be very useful for studying a large number of biochemical processes. In the 1960s, these compounds were used to decipher the genetic code. Later, chemically prepared deoxyoligonucleotides were joined to form genes for transfer RNAs. Gene synthesis from synthetic deoxyoligonucleotides is now routinely used to prepare genes and modified genes for proteins having potential clinical applications. Oligonucleotides have also been used to diagnose genetic disorders and bacterial or viral infections. See GENE; GENETIC CODE; GENETIC ENGINEERING; NUCLEIC ACID. [M.H.C.]

**Oligopygoida** An order of irregular echinoids in the superorder Neognathostomata resembling clypeasteroids but lacking the accessory ambulacral pores characteristic of that group. Oligopygoids have well-developed petals, and there are characteristic small demiplates present below the petals. The apical disk is monobasal and the mouth oval and usually deeply sunken. Oligopygoids have a lantern, which closely resembles that of

clypeasteroids, and their lantern muscle-attachment structures are a mixture of ambulacral and interambulacral processes.

There are two genera, *Oligopygus* and *Haimea*, containing about 25 species, all from the middle and upper Eocene of the Caribbean and Gulf of Mexico regions. They were probably infaunal deposit feeders like present-day laganiids. See ECHINODERMATA; NEOGNATHOSTOMATA. [A.B.S.]

**Oligosaccharide** A carbohydrate molecule composed of 3–20 monosaccharides (simple sugars). Generally, free oligosaccharides do not constitute a significant proportion of naturally occurring carbohydrates. Most carbohydrates that occur in nature are in the form of monosaccharides (such as blood sugar, or glucose), disaccharides (such as table sugar, or sucrose, and milk sugar, or lactose), and polysaccharides (such as starch and glycogen, polyglucose molecules, or chitin). See GLUCOSE; LACTOSE; MONOSACCHARIDE; POLYSACCHARIDE.

The monosaccharides of multiple sugar units such as oligosaccharides are connected with each other through bonds called glycosidic linkages. They are linked primarily to other sugars and to other molecules through aldehyde or ketone reducing groups.

Most naturally occurring oligosaccharides are linked either to proteins (glycoproteins) or to lipids (glycolipids). Glycoconjugates are present in essentially all life forms and particularly in cell membranes and cell secretions. Many hormones are glycoproteins, and an increasing number of enzymes have been shown to have sugars attached. Antigenic properties of the human red blood cell ABO blood group system are determined by glycolipid oligosaccharides. In fact, all the major protein components of blood serum, with the exception of serum albumin, are glycoproteins. See BLOOD GROUPS; CELL MEMBRANES; GLYCOLIPID; GLYCOPROTEIN.

Many changes in the structures of oligosaccharides of glycoconjugates have been detected in cancer cells. Changes or differences in oligosaccharide structures are generally the result of differences in biosynthetic pathways or of degradative pathways. An understanding of glycoconjugates in normal biological systems and in certain disease states is currently of great importance. [D.M.Ca.]

**Oligotrichida** A minor order of the Spirotrichia. If somatic ciliature is present, it is sparse. The bodies are round in cross section, and the adoral zone of membranelles is often highly developed at the anterior, or oral, end of the organism. Species are found in fresh- and salt-water habitats, and none occurs as

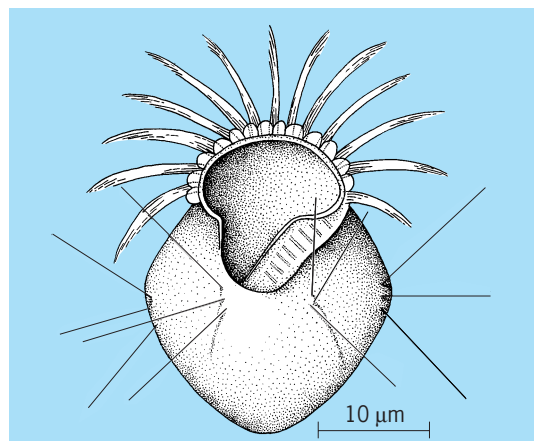

*Halteria*, an example of an oligotrichid.

a parasite. *Halteria* (see illustration) has long bristles which are used in a kind of jumping movement. See SPIROTRICHIA. [J.O.C.]

**Olive** Olive fruits, which are produced by a small to medium-sized evergreen tree (*Olea europaea*), can be eaten, after processing, as table olives, or can be extracted for oil that is used on salads, for cooking, for body lotions, or for medicinal purposes. The olive tree is a historically ancient cultivated plant, having been domesticated by early civilizations in the eastern Mediterranean regions. Olive culture later spread to all the Mediterranean countries and subsequently to South America, California, South Africa, and Australia.

Olive fruits are harvested for table olives in the autumn, when the fruits change from green to straw or to a slightly red color. Raw fruits contain a bitter glucoside which makes them inedible, but treatment with an alkali such as sodium hydroxide (lye) neutralizes the bitterness. The lye must subsequently be leached out of the fruits with water. In another method most of the bitterness can be removed by leaching with salt water. A lactic acid fermentation process is widely used in the Mediterranean countries to preserve the olives.

For oil production, the fruits are harvested in midwinter when they have become black and have reached their maximum oil content—15 to 25% of the fresh weight, depending on the variety. In producing olive oil, the freshly harvested fruits including pits are ground, after which this material is placed in burlap or cloth bags and placed under high pressure. Oil and water are extracted and transferred to tanks, where the oil rises to the top and is removed. See FAT AND OIL (FOOD). [H.T.Ha.]

**Olivine** It is generally accepted that the Earth's upper mantle consists mainly of olivine, an orthorhombic silicate with the composition  $(Mg_{1.8}, Fe_{0.2})SiO_4$ , together with some pyroxene and garnet. The natural occurrence of two high-pressure forms (polymorphs) of olivine—orthorhombic wadsleyite, and cubic ringwoodite (with a spinel structure)—was predicted from high-pressure experiments and was later confirmed by meteorite investigations. The names olivine, wadsleyite, and ringwoodite refer only to naturally occurring compositions  $[(Mg, Fe)_2SiO_4]$ .

Because of their abundance in the Earth's mantle, knowledge of physical and chemical properties of olivine, wadsleyite, and ringwoodite is of great geophysical importance. Until recently, many of these properties had to be inferred from theoretical considerations and from experiments on chemical analogs, which transform at lower pressures. With the development of new experimental apparatus capable of generating very high pressures and temperatures (multianvil press and diamond anvil cell), a growing number of experimental studies are being performed on phases of natural composition.

Experimentally determined thermodynamic phase equilibria data indicate that in the Earth's mantle olivine transforms to wadsleyite, then to ringwoodite, and finally to compositions of magnesiowüstite plus perovskite. Estimated transformation pressures correspond closely to the discontinuities of seismic velocities at, respectively, 246, 322, and 417 mi (410, 520, and 670 km) depth in the mantle. [L.Ke.]

**Omphacite** The pale to bright green monoclinic pyroxene found in eclogites and related rocks. Omphacites are essentially members of the solid solution series between jadeite ( $NaAlSi_2O_6$ ) and diopside ( $CaMgSi_2O_6$ ). The density ranges from 3.16 to 3.43  $g/cm^3$ ; hardness is 5–6.

Omphacite is stable only at the relatively high pressures of the blueschist and eclogite facies of metamorphism, where it is associated with minerals such as glaucophane and lawsonite or pyrope garnet, respectively. In such environments it also occurs in veins, either on its own or with quartz. See GLAUCOPHANE; PYROXENE. [T.J.B.H.]

**Oncholaimida** An order of nematodes comprising the single superfamily Oncholaimoidea. These nematodes are principally marine and brackish-water forms with alleged predaceous and carnivorous feeding habits. The external amphidial aperture

is an oval or a widened ellipse. Generally, the stoma is armed with one dorsal tooth and two subventral teeth, and its wall may be further fortified with transverse rows of small denticles. The stoma is divisible into the cheilostome (secondary blastocoel invagination) and the esophastome (primary blastocoel invagination). In some species the stoma of the adult male is collapsed or indistinct. The cephalic sensilla are in two whorls: one is circumoral and composed of six papilliform sensilla; the second combines the ancestral two whorls of six and four into a single whorl of ten setiform sensory organs. In some forms these sensilla are papilliform. The cylindrical-to-conoid esophagus may exhibit a series of muscular bulbs posteriorly. The cuticle is generally smooth, and over the length of the body there are scattered sensory setae or papillae. *See* NEMATODA. [A.R.M.]

**Oncofetal antigens** Antigens that are commonly present both in fetal tissue during early development of life and in adult tissue when cancer occurs. These antigens, primarily glycoprotein in nature, are the products of one or more genes that normally are expressed only during fetal development and then are repressed in adult life. Their production in adults is a result of activation of the controlled genes by a yet unknown mechanism in association with cancer. Minute but significant changes of these fetal antigens in body fluids can serve in detecting the early oncogenic process and in monitoring the efficacy of, and in developing new modalities of, cancer treatment. *See* ANTIGEN; ONCOLOGY.

Several oncofetal antigens have been investigated extensively, including alpha fetoprotein, carcinoembryonic antigen, and prostate specific antigen.

Alpha fetoprotein is a normal embryonic product during fetal development. After birth the serum alpha fetoprotein decreases to only trace amounts by 2–5 weeks, and to normal adult levels (less than 20 nanograms per milliliter) within 1 year. Alpha fetoprotein in the serum is elevated in individuals with primary hepatocellular carcinoma and with teratocarcinomas of the ovary or testes. Nonhepatic primary cancer generally exhibits an elevation of serum alpha fetoprotein only after spread to the liver.

The carcinoembryonic antigen of human digestive cancer has been the most studied oncofetal antigen. Although it is generally accepted that the carcinoembryonic antigen assay should not be used as a screening test for cancer in the general population, it does have an adjunctive role in diagnostic procedures. One of the more significant results in clinical applications of carcinoembryonic antigen is the use of radioactive-labeled antibodies for localization of carcinoembryonic antigen-producing tumors. Although carcinoembryonic antigen is not specific for malignant disease, it is found in association with a variety of epithelially derived cancers.

Prostate specific antigen is expressed exclusively by human prostate epithelial cells. An elevated level of this antigen in the blood is detected in individuals with prostate cancer, although a slightly elevated antigen also can be detected in individuals with benign prostatic hypertrophy, that is, older men with an enlarged prostate. Prostate specific antigen is the most effective parameter for monitoring the treatment response and detecting the early disease recurrence in individuals with an established diagnosis of prostate cancer. Moreover, prostate specific antigen is of clinical value as a reliable aid in the screening of the high-risk or older population for early detection of prostate cancer. *See* PROSTATE GLAND DISORDERS. [T.M.Ch.]

**Oncogenes** Genes that contribute to the conversion of a normal cell into a cancerous cell. Oncogenes can derive from cellular genes that undergo mutations that alter their expression or activity, or from viruses that carry oncogenes within their genome and that are transferred into the cell by infection. *See* ANIMAL VIRUS; GENE.

Most, if not all, neoplasms (cancers) arise when individual cells within the body suffer irreversible genetic damage that leads

to unrestrained cell growth. Since genes consist of segments of deoxyribonucleic acid (DNA) that are linked in a specific order along each chromosome, any agent or process that breaks the DNA or alters the individual chemical subunits of the DNA can cause genetic damage.

Genetic lesions in neoplastic cells can affect two classes of genes. The first genes identified were called oncogenes, and the mutations that alter these genes occur on only one of the two similar chromosomes in a cell. The unaffected chromosome retains the normal cellular gene, while the mutant form of the gene on the affected chromosome overrides the normal gene function and promotes neoplastic growth. In contrast to the oncogenes, mutations in cancer cells can also inactivate or even delete genes whose function is required for normal cell growth. This second class of genes, called tumor suppressors, appears to restrain cell growth or prevent the accumulation of mutations, and a cell remains normal as long as at least one copy of the tumor suppressor gene is functional. *See* DEOXYRIBONUCLEIC ACID (DNA); MUTAGENS AND CARCINOGENS; MUTATION; TUMOR.

Cellular genes have highly specific functions and patterns of expression, and the mutations that convert a normal gene into an oncogene can alter either of these properties. Four major types of oncogene-forming lesions are commonly found in tumor cells: (1) Point mutations can change individual bases within the segment of the gene that encodes a protein. (2) Chromosomes can break near specific genes and rejoin (chromosomal translocations). (3) Oncogenes can be created by the localized amplification of small chromosomal domains. (4) Viruses can be inserted into the chromosome near a specific gene and alter the expression (insertional mutagenesis). *See* CHROMOSOME ABBERRATION.

Some viruses contain oncogenes that are part of the viral genetic material and not derived from the cell. Although most human cancer is not associated with infectious agents such as viruses, some cancers have been shown to be caused at least in part by viruses. The most common is cervical carcinoma, where the causative agent is human papilloma virus (HPV). *See* ANIMAL VIRUS; TUMOR VIRUSES.

Normal cells divide or remain quiescent as the result of diverse extracellular signals (such as growth factors and cell-cell interactions). These signals are interpreted by receptors and cytoplasmic factors, and eventually lead to reprogramming of gene expression in the nucleus. Thus, it is logical that the majority of oncogenes encode proteins that are components of this signal transduction pathway and then they inappropriately activate the normal growth signals. Many oncogene-encoded proteins localize to the plasma membrane and are enzymes that phosphorylate other proteins, altering the activity of these substrate proteins. Other oncogenic proteins function as regulatory subunits of enzymes, and the mutations signal the enzymes to be active continuously rather than in a regulated manner. The oncogene-encoded proteins that localize to the nucleus are largely DNA-binding proteins that regulate specific sets of cellular genes involved in growth control. Finally, oncogenes can function not by promoting cell growth but by blocking cell death (apoptosis). *See* CANCER (MEDICINE); CELL SENESCENCE AND DEATH; GENE ACTION; GENETIC ENGINEERING; ONCOLOGY. [M.C.]

**Oncology** The study of cancer. There are five major areas of oncology: etiology, prevention, biology, diagnosis, and treatment. As a clinical discipline, it draws upon a wide variety of medical specialties; as a research discipline, oncology also involves specialists in many areas of biology and in a variety of other scientific areas. Oncology has led to major progress in the understanding not only of cancer but also of normal biology.

Cancer defies simple definition. It is a disease that develops when the orderly relationship of cell division and cell differentiation becomes disordered. In cancer, dividing cells seem to lose the capacity to differentiate, and they acquire the ability to invade through basement membranes and spread (metastasize) to

many areas of the body through the bloodstream or lymphatics. Cancer is usually clonal, that is, it develops initially in a single cell. That abnormal cell then produces progeny that may behave rather heterogeneously. Some progeny continue to divide, some develop the capacity to metastasize, and some develop resistance to therapeutic agents. This single cell and its progeny, if unchecked, typically lead to the death of the host. *See* CANCER (MEDICINE).

**Causes of cancer.** Cancer is generally thought to result from one or more permanent genetic changes in a cell. In some cells a single mutational event can lead to neoplastic transformation, but for most tumors it appears that carcinogenesis is a multistep process. Although some rare congenital conditions lead to cancer in infancy, the vast majority of human cancers arise as a result of the complex interplay between genetic and environmental factors. Without question, there are forms of cancer clearly related to particular environmental exposures; it is equally clear, however, that these factors act on a genetic substrate that may be either susceptible or resistant to the development of cancer.

The emergence of cancer appears to involve the accumulation of genetic damage in a target tissue. Such complex genetic changes specific to tissues appear to underlie the progression to cancer. Such multistep progression is quite complicated to study in experimental systems. Much work has focused on the identification, isolation, and characterization of oncogenes, which have the ability to transform normal cells into cancer cells. More than 50 bona fide or putative oncogenes have been characterized and mapped throughout the human genome. *See* HUMAN GENETICS; ONCOGENES.

Environmental factors involved in the development of cancers can be chemical, physical, or biological carcinogenic agents. At least three stages occur in the natural history of cancer development from environmental factors. The first stage is initiation, which is a specific alteration in the deoxyribonucleic acid (DNA) of a target cell; environmental agents may act by inducing expression of oncogenes. The second phase, promotion, involves the reversible stimulation of expansion of the initiated cell or the reversible alteration of gene expression in that cell or its progeny. Because promotion is thought to be reversible, it is a target for prevention. The final phase of carcinogenesis is progression. It is characterized by the development of aneuploidy and clonal variation in the tumor; these in turn result in invasiveness and metastasis. *See* MUTAGENS AND CARCINOGENS.

**Cancer prevention.** An obvious starting point for cancer prevention is avoidance of environmental agents that contribute to carcinogenesis.

The role of diet in cancer prevention is controversial. Epidemiologic evidence suggests a particularly strong link between a high-fat, high-calorie, low-fiber diet and an increased risk of colon cancer. But a change to a low-fat, low-calorie, high-fiber diet may not alter the risk. The addition to the diet of carotenoids, selenium, vitamins A, D, and E, and some short-chain fatty acids may prevent cancers in high-risk populations, but there is no evidence that any dietary supplement will prevent cancer. *See* NUTRITION.

There are a variety of clinical settings in which surgery may prevent cancer. For example, surgical removal of the thyroid will prevent medullary carcinoma in individuals with certain types of multiple endocrine neoplasia, breast removal can be preventive in familial breast cancer, and removal of the ovaries can prevent cancer in familial ovarian cancer.

**Cancer biology.** The study of cancer biology picks up where cancer etiology leaves off, namely, at the point where the tumor has developed into a clonal cluster of autonomously proliferating cells. The pathological correlate of this stage of tumor development is carcinoma *in situ*; a condition in which no tissue destruction is evident, but atypical-appearing cancer cells are present at their site of origin. The transition from carcinoma *in situ* to locally invasive cancer is accompanied by dissolution of the basement membrane, penetration of tumor cells through the membrane

and into the supportive tissues, and disruption of the supportive tissues. Expansion of the primary tumor in locally invasive cancer is always accompanied by the development of blood vessels. The tumor cells can also invade regional blood vessels and lymphatics and circulate throughout the body, attaching to endothelium in a distant organ site, inducing retraction of the endothelium, and becoming attached to the endothelial basement membrane. Once attached to the basement membrane, the tumor cells are covered over by the endothelial cells and effectively separated from the flow of blood. Local dissolution of the basement membrane then occurs, allowing the tumor to completely spread into the tissue and reestablish a blood flow in the breached vessel. As it grows, more blood vessel development nourishes the enlarging tumor.

During metastasis, tumor cells must overcome host defenses. They have various mechanisms to do so. For example, they produce new cell surface receptors to facilitate basement membrane and matrix binding; make new enzymes such as collagenases, serine proteases, metalloproteinases, cysteine proteinases, and endoglycosidases to facilitate their invasiveness; and secrete motility factors to enable them to move through the holes and pathways created by their enzymes. They avoid detection by the immune system through a variety of techniques. Unlike animal tumors, most human tumors are poorly immunogenic. Tumor cells often produce factors that are immunosuppressive. *See* CELLULAR IMMUNOLOGY; TUMOR.

An unexplained feature of metastasis is the propensity of certain tumor types to spread to specific organs.

**Tumor detection.** There are two major strategies to detect tumors at the earliest possible stage in their history: responding to the seven warning signals of cancer and screening populations at high risk. The seven danger signals of cancer are (1) unusual bleeding or discharge, (2) a lump or thickening in the breast or elsewhere, (3) a sore that does not heal, (4) change in bowel or bladder habits, (5) persistent hoarseness or cough, (6) persistent indigestion or difficulty in swallowing, and (7) change in a wart or mole.

**Diagnosis.** The diagnosis of cancer depends on the careful examination of biopsy material. Cancers arising in tissues having ectodermal or endodermal origins are generally called carcinomas; those derived from glands are called adenocarcinomas. Cancers arising in tissues derived from mesoderm are called sarcomas; those of lymphohematopoietic origin are lymphomas and leukemias. The cardinal microscopic features of malignancy are anaplasia, invasion, and metastasis.

Once a diagnosis of cancer is made, it is critical to determine the extent to which the disease has spread. This is called staging. It is distinct from grading, which is an assessment of histologic atypia performed with a microscope. Staging entails performing a careful physical examination, various radiographic studies, and perhaps surgical procedures (biopsies, endoscopies) to examine those sites to which a particular tumor type is most likely to spread. For example, patients with breast cancer often undergo evaluation of the liver, brain, and bones to search for metastatic disease, whereas patients with lymphoma generally require assessment of lymph node groups, bone marrow, and liver. Often the results of such staging tests determine the nature and extent of therapy.

**Treatment.** There are four major approaches to cancer treatment: surgery, radiation therapy, chemotherapy, and biological therapy. These modalities are often used together with additive or synergistic effects. Surgery and radiation therapy are most effective in curing localized tumors and together result in the cure of about 40% of all newly diagnosed cases. Once the cancer has spread to regional nodes or distant sites, it is generally incurable with the use of local therapies alone. Systemic administration of a combination of chemotherapeutic agents may cure another 10–15% of all patients. *See* CHEMOTHERAPY; RADIOLOGY.

Relieving the symptoms of cancer and alleviating the side effects of agents used to treat it is another important aspect of



treatment. Many agents and interventions are available for these purposes. Pharmacologic agents can control nausea and vomiting. Various strategies are available to control pain, improve appetite, and combat insomnia and mood changes. Surgical procedures and radiological techniques can palliate many of the complications of cancer that formerly were incapacitating. Even when the hope for a cure has dwindled, the oncologist can relieve much suffering. [D.L.L.]

**Onion** A cool-season biennial, *Allium cepa*, of Asiatic origin and belonging to the plant order Liliales. The onion is grown for its edible bulbs.

Related species are leek (*A. porrum*), garlic (*A. sativum*), Welsh onion (*A. fistulosum*), shallot (*A. ascalonicum*), and chive (*A. schoenoprasum*).

Onion varieties (cultivars) are classified mainly according to pungency (mild or pungent) and use (dry bulbs or green bunching). Bulbs may be white, red, or yellow. Varieties differ markedly in their keeping quality and in their response to length of day. Hybrid varieties, with increased disease resistance, longer storage life, and improved quality, are rapidly displacing older varieties. Texas, New York, and California are important producing states. See LILIALES. [H.J.C.]

**Oniscoidea** A suborder of the Isopoda which contains the terrestrial members of these crustaceans. They are popularly known as sow bugs, slaters, wood lice, or, in the case of those that roll themselves into a ball, pill bugs. Land isopods commonly occur under rocks, loose bark, leaf mold, and similar moist places. They abound in humid tropical and warm-temperate regions, particularly in the Old World. A few are practically cosmopolitan and have probably been accidentally transported by humans with plants, soil, or building materials. When abundant in gardens or greenhouses, they sometimes do considerable damage by gnawing on plants.

The body is either flattened dorsoventrally or in pill bugs is highly vaulted like an armadillo. Its three subdivisions, the head, thorax, and abdomen, are broadly joined (see illustration). The lateral margins generally form a continuous oval outline, except in types with the abdomen abruptly narrower than the thorax. The surface may be smooth or variously sculptured with tubercles, ridges, or spines. Sexual dimorphism is rare.

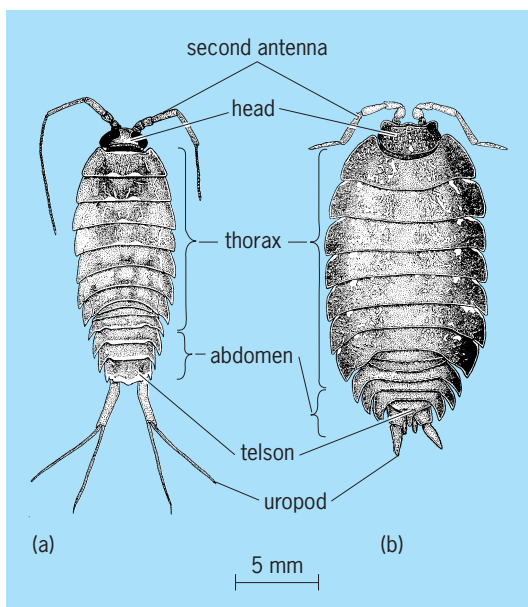

Genera of oniscoideans. (a) *Ligia*. (b) *Porcellio*.

Six fused segments, including the first thoracic somite, make up the head. It bears two pairs of antennae (the first being vestigial), two sessile compound eyes, and four pairs of mouthparts. The thorax has seven free segments, each bearing a pair of similar seven-jointed walking legs. The abdomen has five segments plus a terminal telson. Its appendages are biramous and include five pairs of platelike pleopods and one pair of uropods. See ISOPODA. [M.A.M.]

**Ontogeny** The developmental history of an organism from its origin to maturity. It starts with fertilization and ends with the attainment of an adult state, usually expressed in terms of both maximal body size and sexual maturity. Fertilization is the joining of haploid gametes (a spermatozoon and an ovum, each bearing half the number of chromosomes typical for the species) to form a diploid zygote (with a full chromosome number), a new unicellular living being which will grow through a series of asexual reproductions. The gametes are the link between one generation and the next: the fusion of male and female gametes is the onset of a new ontogenetic cycle. Many organisms die shortly after sexual reproduction, whereas others live longer and generations are overlapped. Species are usually conceived as adults, but in most cases the majority of their representation in the environment is as intermediate ontogenetic stages. See FERTILIZATION; REPRODUCTION (ANIMAL).

In unicellular organisms, each asexual reproduction leads to the formation of new individuals, the cells deriving from a first sexually derived individual forming a clone of genetically identical individuals. In multicellular organisms, the products of the asexual reproductions starting with the first division of the zygote remain connected, and the clone they form is a single individual. Clonation of individuals occurs even in humans, when the first results of asexual reproduction of the zygote separate from each other, leading to twin formation.

The ontogeny of a multicellular organism involves segmentation (or cleavage): the zygote divides into two, four, etc., cells which continue to divide. These cells are initially similar to the zygote, although smaller in size. They soon start to differentiate from their ancestors, acquiring special features, and forming specific tissue layers and, eventually, organs. These processes lead to the formation and growth of an embryo. Embryos can develop freely, within egg shells, or within the body of one parent; they can grow directly into juveniles (as in humans) or into larvae (with an indirect development, as in insects).

Juveniles are similar to adults but are smaller in size and not sexually mature. Their ontogeny continues until they reach a maximal size and reproductive ability. Larvae have different morphology, physiology, and ecology from adults; they become juveniles through a metamorphosis (that is, an abrupt change). Usually ontogeny is interrupted at adulthood, but some organisms can grow throughout their life, so that ontogeny ends with their death. See ECOLOGY. [F.V.B.]

**Onychophora** The only living animal phylum with true lobopods (annulate, saclike legs with internal musculature). There are about 70 known living species in two families, Peripatopsidae and Peripatidae. These terrestrial animals are frequently referred to as Peripatus. Onychophora comprise a single class or order of the same name. They were once considered a missing link between annelid worms and arthropods, but are best considered to be aligned with the arthropods.

They have a cylindrical body, 0.5–6 in. (1.4–15 cm) long, with one antennal pair, an anterior ventral mouth, and 14–43 pairs of stubby, unsegmented legs ending in walking pads and paired claws. Mandibles are present as modified tips of the first appendage pair. The body surface has a flexible chitinous cuticle. The body wall has three layers of smooth muscle, as in annelids, but the coelom is reduced to gonadal and nephridial cavities; the body cavity has an arthropodlike partitioned hemocoel; the heart is tubular with metameric ostia; and the nephridia

are segmental. Gas exchange takes place by means of tracheae; spiracles are minute and numerous, located between skin folds. Slow locomotion is effected by legs and body contractions; the animals can squeeze into very tight spaces. The eyes, located at the antennal base, are the direct type with a chitinous lens and retinal layer. The sexes are separate; the testes and ovaries are paired; and the genital tracts open through the posterior ventral pore. Onychophora are oviparous, ovoviviparous, or viviparous.

The Onychophora are predatory, feeding on small invertebrates. They are largely nocturnal, occurring in humid habitats in forests. [S.B.P.]

**Onychopoda** A specialized order of brachiopod crustaceans formerly included in the order Cladocera. The body is up to about 12 mm (0.5 in.) in length, but much of the length of the longest species is made up by a caudal process.

The head and thorax are short, as is the abdomen in some species, but in others it is drawn out into a long caudal process. A carapace is present but is reduced to a dorsal brood pouch, leaving the body naked. A large median compound eye occupies much of the head.

Onychopods swim actively by means of their antennae—the antennules are small and sensory—and seize their food with their four pairs of grasping trunk limbs. Most are predators, but detritus is also eaten by some species. The mandibles are stoutly denticulate.

Reproduction is mostly by parthenogenesis (males are unknown in some species from the Caspian Sea); eggs and young are carried in the brood pouch. Sexual reproduction gives rise to freely shed resistant eggs that overwinter in temperate zone species. Onychopods occur in the sea and fresh water and are worldwide in distribution, but fresh-water species occur only in the Holarctic temperate zone. There is a remarkable group of endemic species in the Ponto-Caspian region. See BRACHIOPODA. [G.Fr.]

**Onyx** Banded chalcedonic quartz, in which the bands are straight and parallel, rather than curved, as in agate. Unfortunately, in the colored-stone trade, gray chalcedony dyed in various solid colors such as black, blue, and green is called onyx, with the color used as a prefix. Because the color is permanent, the fact that it is the result of dyeing is seldom mentioned.

The natural colors of true onyx are usually red or brown with white, although black is occasionally encountered as one of the colors. When the colors are red-brown with white or black, the material is known as sardonyx; this is the only kind commonly used as a gemstone. Its most familiar gem use is in cameos and intaglios. See CAMEO; CHALCEDONY. [R.T.L.]

**Oogenesis** The generation of ova or eggs, the female gametes. Primordial germ cells, once they have populated the gonads, proliferate and differentiate into sperm (in the testis) or ova (in the ovary). The decision to produce either spermatocytes or oocytes is based primarily on the genotype of the embryo. In rare cases, this decision can be reversed by the hormonal environment of the embryo, so that the sexual phenotype may differ from the genotype. Formation of the ovum most often involves substantial increases in cell volume as well as the acquisition of organellar structures that adapt the egg for reception of the sperm nucleus, and support of the early embryo. In histological sections, the structure of the oocyte often appears random but as the understanding of its chemical and structural organization increases, an order begins to emerge. See OVUM; SPERMATOGENESIS.

Among lower vertebrates and invertebrates, mitotic divisions of the precursor cells, the oogonia, continue throughout the reproductive life of the adult; thus extremely large numbers of ova are produced. In the fetal ovary of mammals, the oogonia undergo mitotic divisions until the birth of the fetus, but a process involving the destruction of the majority of the developing ova by

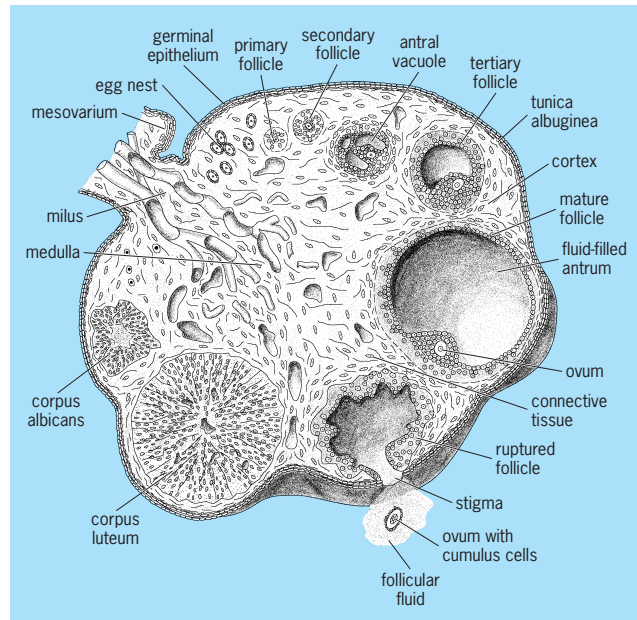

Three-dimensional view of the cyclic changes in the mammalian ovary.

the seventh month of gestation reduces the number of oocytes from millions to a few hundred. Around the time of birth, the mitotic divisions cease altogether, and the infant female ovary contains its full complement of potential ova. At puberty, the pituitary hormones, follicle stimulating hormone (FSH), and luteinizing hormone (LH) stimulate the growth and differentiation of the ova and surrounding cells (see illustration). See MITOSIS.

One important feature of oocyte differentiation is the reduction of the chromosome complement from the diploid state of the somatic cells to the haploid state of gametes. Fusion with the haploid genome of the sperm will restore the normal diploid number of chromosomes to the zygote. The meiotic divisions which reduce the chromosome content of the oocyte occur after the structural differentiation of the oocyte is complete, often only after fertilization. Unlike the formation of sperm, in which the two divisions of meiosis produce four equivalent daughter cells, the cytoplasm of the oocyte is divided unequally, so that three polar bodies with reduced cytoplasm and one oocyte are the final products. Generally, each fertilized oocyte produces a single embryo, but there are exceptions. Identical twins, for example, arise from the same fertilized egg. See FERTILIZATION; MEIOSIS.

The provision of nutrients for the embryo is a major function of the egg, and this is accomplished by the storage of yolk in the cytoplasm. Yolk consists of complex mixtures of proteins (vitellins), lipids, and carbohydrates in platelets, which are membrane-surrounded packets dispersed throughout the egg cytoplasm (ooplasm). The amount of yolk in an egg correlates with the nutritional needs of the embryo. Although the eggs of mammals are extremely small as compared to the fetus, the bulk of the nutrition is supplied by the placenta; yolk is required only until implantation in the uterine wall.

Egg cytoplasm also contains large stores of ribonucleic acid (RNA) in the form of ribosomal, messenger, and transfer RNA. These RNAs direct the synthesis of proteins in the early embryo, and may have a decisive influence on the course of development. The mechanism by which the RNA is supplied to the egg is the basis for a major classification of ovary types. Panoistic ovaries, in which the egg nucleus is responsible for the production of all the stored RNA in the ooplasm, are typical of vertebrates, primitive insects, and a number of invertebrates. The amounts of RNA produced during the meiotic prophase in such ovaries are much larger than those produced by a somatic cell, and

thus special mechanisms seem to be involved in the synthetic process. See DEOXYRIBONUCLEIC ACID (DNA); RIBONUCLEIC ACID (RNA). [S.J.B.]

**Oolite** A deposit containing spheroidal grains with a mineral cortex, most commonly calcite or aragonite, accreted around a nucleus formed primarily of shell fragments or quartz grains. The term ooid is applied to grains less than 0.08 in. (2 mm) in diameter, and the term pisoid to those greater than 0.08 in. (2 mm). Accretionary layering (growth banding) is usually developed clearly. A flattened or elongate shape may occur if the nucleus shows that form. Ooids formed on nuclei of shells and shell fragments and composed of fine, radial calcite are cemented by coarse, clear calcite. Growth banding is visible in most ooids. The pisoids are composed of many thin layers of very small, tangential (lighter layers) and radial (darker layers) aragonite crystals. These pisoids are cemented with fibrous aragonite.

Ooids are primarily marine, forming in agitated shallow, warm waters. Under those conditions, the ooids are kept intermittently moving, so accretion occurs on all sides. Some ooids and most pisoids form in nonmarine environments, such as hypersaline and fresh-water lakes, hot springs, caves, caliche soils, and some rivers. See ARAGONITE; CALCITE. [P.A.Sa.]

**Oomycetes** A class of fungi in the subdivision Mastigomycotina. They comprise a group of heterotrophic, funguslike organisms that are classified with the zoosporic fungi (Mastigomycotina) but in reality are related to the heterokont algae. They are distinguished from other zoosporic fungi by the presence of biflagellate zoospores. Some taxa are nonzoosporic. Asexual reproduction involves the release of zoospores from sporangia; in some taxa the sporangium germinates with outgrowth of a germ tube. Sexual reproduction occurs when an oogonial cell is fertilized by contact with an antheridium, resulting in one or more oospores.

Oomycetes are cosmopolitan, occurring in fresh and salt water, in soil, and as terrestrial parasites of plants. Many species can be grown in pure culture on defined media. There are four orders: The Saprolegniales and Leptomitales are popularly known as water molds. Some species are destructive fish parasites. Many Lagenidiales are parasites of invertebrates and algae. The Peronosporales are primarily plant parasites attacking the root, stem, or leaf, and include some of the more destructive plant pathogens. See EUMYCOTA; FUNGI; MASTIGOMYCOTINA. [D.J.S.B.]

**Opal** A natural hydrated form of silica. Opal is a relatively common mineral in its nongem form, which is known as common opal and lacks the play of color for which gem, or precious, opal is known. All opal is of relatively simple chemical composition,  $\text{SiO}_2 \cdot n\text{H}_2\text{O}$ . The hardness of opal on the Mohs hardness scale ranges from 5 to 6, the specific gravity from 2.25 to 1.99, and the refractive index from 1.455 to 1.435. See HARDNESS SCALES; SILICATE MINERALS.

The color of common opal ranges from transparent, glassy, and colorless to white and bluish white. Common pigmenting agents, such as iron, produce yellow, brown, red, and green colors, and frequently several colors in a single specimen. Precious opal has a play of color that is the result of white light being diffracted by the relatively regular internal array of silica spheres. Because opal is a hydrous mineral, certain opals from specific geologic occurrences may crack because of water loss. Therefore, considerable care is required in the polishing and handling of opal.

Several trade terms are used to describe the appearance of precious opal based on transparency, body color, and the type of play of color. Some of these terms are black opal, which is translucent to almost opaque, with dark gray to black body color, with play of color; fire opal, which is transparent to semitransparent, with yellow, orange, red, or brown body color and with or without play of color; harlequin or mosaic opal, in which

the play of color occurs in distinct, broad, angular patches; and matrix opal, which consists of thin seams of high-quality gem opal in a matrix. See GEM. [P.J.Da.; C.K.]

**Opalescence** The milky iridescent appearance of a dense transparent medium when the system (or medium) is illuminated by polychromatic radiation in the visible range, such as sunlight. Slight changes in the rainbowlike color of the system can occur, depending on the scattering angle, that is, the angle between the directions of incident radiation and of observation.

Opalescence is a general term which applies to the optical phenomenon of intense scattering in the visible range of the electromagnetic radiation by a system with strong local optical inhomogeneities. The iridescence, or rainbowlike display of interference of colors, arises because the intensity of scattered light is approximately proportional to the reciprocal fourth power of the wavelength of incident light (Rayleigh's law). See SCATTERING OF ELECTROMAGNETIC RADIATION. [B.C.]

**Open channel** A covered or uncovered conduit in which liquid (usually water) flows with its top surface bounded by the atmosphere. Typical open channels are rivers, streams, canals, flumes, reclamation or drainage ditches, sewers, and water-supply or hydropower aqueducts.

Open-channel flow is classified according to steadiness, a condition in relation to time, and to uniformity, a condition in relation to distance. Flow is steady when the velocity at any point of observation does not change with time; if it changes from instant to instant, flow is unsteady. At every instant, if the velocity is the same at all points along the channel, flow is uniform; if it is not the same, flow is nonuniform. Nonuniform flow which is steady is called varied; nonuniform flow which is unsteady is called variable.

Flow occurs from a higher to a lower elevation by action of gravity. If the phenomenon is short, wall friction is small or negligible, and gravity shapes the flow behavior. Gravity phenomena are local; they include the hydraulic jump, flow over weirs, spillways, or sills, flow under sluices, and flow into culvert entrances.

If the phenomenon is long, friction shapes the flow behavior. Friction phenomena include flows in rivers, streams, canals, flumes, and sewers. [W.A.]

**Open circuit** A condition in an electric circuit in which there is no path for current between two points; examples are a broken wire and a switch in the open, or off, position. See CIRCUIT (ELECTRICITY).

Open-circuit voltage is the potential difference between two points in a circuit when a branch (current path) between the points is open-circuited. Open-circuit voltage is measured by a voltmeter which has a very high resistance (theoretically infinite). [C.F.G.]

**Open pit mining** The process of extracting beneficial minerals by surface excavations. Open pit mining is a type of surface excavation which often takes the shape of an inverted cone; the shape of the mine opening varies with the shape of the mineral deposit. Other types of surface mining are specific to the type and shape of the mineral deposit. See COAL MINING; PLACER MINING; SURFACE MINING.

The open pit mine, like any other mining operation, must extract the product minerals at a positive economic benefit. All costs of producing the product, including excavation, beneficiation, processing, reclamation, environmental, and social costs, must be paid for by the sales of the mineral product. A mineral that is in sufficient concentration to meet or exceed these economic constraints is called ore. The terms ore body and ore deposit are used to refer to the natural occurrence of an economic mineral deposit. See ORE AND MINERAL DEPOSITS.

Ore bodies occur as the result of natural geologic occurrences. The geologic events that lead to the concentration of a mineral

into an ore deposit are generally complex and rare. If those events placed the deposit sufficiently near the surface, open pit mining may be viable.

Material encountered during the mining process that has little or no economic value is called waste or overburden. One important economic criterion for open pit mining is the amount of overlying waste which must be removed to extract the ore. The ratio of the amount of waste to the amount of ore is referred to as the strip ratio. In general, the lower the strip ratio, the more likely an ore body is to be mined by open pit methods.

Modern open pit mining utilizes large mechanical equipment to remove the ore and waste from the open pit excavation. The amount of equipment and its type and size depend on the characteristics of the ore and waste and the required production capacity. In general, there are four basic unit operations common to most open pit mining operations. These are drilling, blasting, loading, and hauling.

Waste material that is generated during the course of mining at most mines must be discarded as economically as possible without jeopardizing future mining activities but while respecting environmental regulations. Two types of waste material are generated at most mining operations: waste rock and overburden from the mine, and tailings—the waste material from the processing plant after treatment of the ore. *See* LAND RECLAMATION.

Computer software is available to assist the mining engineer in ore reserve estimation with the application of geostatistics, mine planning and design, and production and maintenance monitoring and reporting. With the help of high-speed computers the engineering and production staff can evaluate aspects of the mining activities, which allows a more efficient and economical extraction of the mineral commodity. *See* MINING; OPERATIONS RESEARCH; OPTIMIZATION. [H.We.; J.M.M.]

**Operating system** The software component of a computer system that is responsible for the management and coordination of activities and the sharing of the resources of the computer. The operating system (OS) acts as a host for application programs that are run on the machine. As a host, one of the purposes of an operating system is to handle the details of the operation of the hardware. This relieves application programs from having to manage these details and makes it easier to write applications. Almost all computers, including hand-held computers, desktop computers, supercomputers, and even modern video game consoles, use an operating system of some type. *See* COMPUTER SYSTEMS ARCHITECTURE.

Operating systems offer a number of services to application programs and users. Applications access these services through application programming interfaces (APIs) or system calls. By invoking these interfaces, the application can request a service from the operating system, pass parameters, and receive the results of the operation. Users may also interact with the operating system by typing commands or using a graphical user interface (GUI, commonly pronounced “gooey”). For hand-held and desktop computers, the GUI is generally considered part of the operating system. For large multiuser systems, the GUI is generally implemented as an application program that runs outside the operating system. *See* COMPUTER PROGRAMMING; HUMAN-COMPUTER INTERACTION.

Modern operating systems provide the capability of running multiple application programs simultaneously, which is referred to as multiprogramming. Each program running is represented by a process in the operating system. The operating system provides an execution environment for each process by sharing the hardware resources so that each application does not need to be aware of the execution of other processes. The central processing unit (CPU) of the computer can be used by only one program at a time. The operating system can share the CPU among the processes by using a technique known as time slicing. In this manner, the processes take turns using the CPU. Single-user

desktop personal computers (PCs) may simplify this further by granting the CPU to whichever application the user has currently selected and allowing the user to switch between applications at will.

The main memory of a computer (referred to as random access memory, or RAM) is a finite resource. The operating system is responsible for sharing the memory among the currently running processes. When a user initiates an application, the operating system decides where to place it in memory and may allocate additional memory to the application if it requests it. The operating system may use capabilities in the hardware to prevent one application from overwriting the memory of another. This provides security and prevents applications from interfering with one another. *See* COMPUTER STORAGE TECHNOLOGY.

The details of device management are left to the operating system. The operating system provides a set of APIs to the applications for accessing input/output (I/O) devices in a consistent and relatively simple manner regardless of the specifics of the underlying hardware. The operating system itself will generally use a software component called a device driver to control an I/O device. This allows the operating system to be upgraded to support new devices as they become available. In addition to a device driver for the network I/O device, the operating system includes software known as a network protocol and makes various network utilities available to the user. *See* COMPUTER PERIPHERAL DEVICES; LOCAL-AREA NETWORKS; WIDE-AREA NETWORKS.

Operating systems provide security by preventing unauthorized access to the computer's resources. Many operating systems also prevent users of a computer from accidentally or intentionally interfering with each other. The security policies that an operating system enforces range from none in the case of a video game console, to simple password protection for hand-held and desktop computers, to very elaborate schemes for use in high-security environments. *See* COMPUTER SECURITY. [C.Sch.]

**Operational amplifier** A voltage amplifier that amplifies the differential voltage between a pair of input nodes. For an ideal operational amplifier (also called an op amp), the amplification or gain is infinite.

Most existing operational amplifiers are produced on a single semiconductor substrate as an integrated circuit. These integrated circuits are used as building blocks in a wide variety of applications. *See* INTEGRATED CIRCUITS.

Although an operational amplifier is actually a differential-input voltage amplifier with a very high gain, it is almost never used directly as an open-loop voltage amplifier in linear applications for several reasons. First, the gain variation from one operational amplifier to another is quite high and may vary by  $\pm 50\%$  or more from the value specified by the manufacturer. Second, other nonidealities such as the offset voltage make it impractical to stabilize the dc operating point. Finally, performance characteristics such as linearity and bandwidth of the open-loop operational amplifier are poor. In linear applications, the operational amplifier is almost always used in a feedback mode.

A block diagram of a classical feedback circuit is shown in illus. a. The transfer characteristic, often termed the feedback gain  $A_f$  of this circuit, is given by Eq. (1). In the limiting case, as

$$\frac{X_o}{X_i} = A_f = \frac{A}{1 + A\beta} \quad (1)$$

$A$  becomes very large, the feedback gain is approximated by Eq. (2).

$$A_f \simeq \frac{1}{\beta} \quad (2)$$

*See* FEEDBACK CIRCUIT.

An operational amplifier is often used for the amplifier designated  $A$  in this block diagram. Since  $A_f$  in the limiting case is independent of  $A$ , the exact gain characteristics of the operational amplifier become unimportant provided the gain is large.

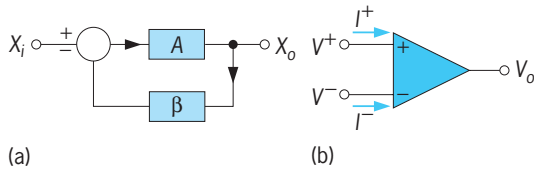

Basic circuits. (a) Classical feedback circuit. (b) Operational amplifier symbol typically used in circuit diagrams.

Although linear applications of the operational amplifier extend well beyond the simple feedback block diagram of illus. a, the applications invariably involve circuit structures with feedback that make the characteristics of the circuit nearly independent of the exact characteristics of the operational amplifier. Such circuits are often termed active circuits.

The commonly used operational amplifier symbol is shown in illus. b. In this circuit, the output voltage is related to the gain  $A$  of the operational amplifier by Eq. (3), where  $A$  is very large

$$V_o = A(V^+ - V^-) \quad (3)$$

and the input currents  $I^+$  and  $I^-$  are nearly zero. See AMPLIFIER; CIRCUIT (ELECTRONICS). [P.M.VanP.]

**Operations research** The application of scientific methods and techniques to decision-making problems. A decision-making problem occurs where there are two or more alternative courses of action, each of which leads to a different and sometimes unknown end result. Operations research is also used to maximize the utility of limited resources. The objective is to select the best alternative, that is, the one leading to the best result.

To put these definitions into perspective, the following analogy might be used. In mathematics, when solving a set of simultaneous linear equations, one states that if there are seven unknowns, there must be seven equations. If they are independent and consistent and if it exists, a unique solution to the problem is found. In operations research there are figuratively "seven unknowns and four equations." There may exist a solution space with many feasible solutions which satisfy the equations. Operations research is concerned with establishing the best solution. To do so, some measure of merit, some objective function, must be prescribed.

In the current lexicon there are several terms associated with the subject matter of this program: operations research, management science, systems analysis, operations analysis, and so forth. While there are subtle differences and distinctions, the terms can be considered nearly synonymous. See SYSTEMS ENGINEERING.

**Methodology.** The success of operations research, where there has been success, has been the result of the following six simply stated rules: (1) formulate the problem; (2) construct a model of the system; (3) select a solution technique; (4) obtain a solution to the problem; (5) establish controls over the system; and (6) implement the solution.

The first statement of the problem is usually vague and inaccurate. It may be a cataloging of observable effects. It is necessary to identify the decision maker, the alternatives, goals, and constraints, and the parameters of the system. A statement of the problem properly contains four basic elements that, if correctly identified and articulated, greatly eases the model formulation. These elements can be combined in the following general form: "Given (the system description), the problem is to optimize (the objective function), by choice of the (decision variable), subject to a set of (constraints and restrictions)."

In modeling the system, one usually relies on mathematics, although graphical and analog models are also useful. It is important, however, that the model suggest the solution technique, and not the other way around.

With the first solution obtained, it is often evident that the model and the problem statement must be modified, and the

sequence of problem-model-technique-solution-problem may have to be repeated several times. The controls are established by performing sensitivity analysis on the parameters. This also indicates the areas in which the data-collecting effort should be made.

Implementation is perhaps of least interest to the theorists, but in reality it is the most important step. If direct action is not taken to implement the solution, the whole effort may end as a dust-collecting report on a shelf.

**Mathematical programming.** Probably the one technique most associated with operations research is linear programming. The basic problem that can be modeled by linear programming is the use of limited resources to meet demands for the output of these resources. This type of problem is found mainly in production systems, but is not limited to this area. See LINEAR PROGRAMMING.

**Stochastic processes.** A large class of operations research methods and applications deals with stochastic processes. These can be defined as processes in which one or more of the variables take on values according to some, perhaps unknown, probability distribution. These are referred to as random variables, and it takes only one to make the process stochastic.

In contrast to the mathematical programming methods and applications, there are not many optimization techniques. The techniques used tend to be more diagnostic than prognostic; that is, they can be used to describe the "health" of a system, but not necessarily how to "cure" it. See PROBABILITY; QUEUEING THEORY; STOCHASTIC PROCESS.

**Scope of application.** There are numerous areas where operations research has been applied. The following list is not intended to be all-inclusive, but is mainly to illustrate the scope of applications: optimal depreciation strategies; communication network design; computer network design; simulation of computer time-sharing systems; water resource project selection; demand forecasting; bidding models for offshore oil leases; production planning; classroom size mix to meet student demand; optimizing waste treatment plants; risk analysis in capital budgeting; electric utility fuel management; optimal staffing of medical facilities; feedlot optimization; minimizing waste in the steel industry; optimal design of natural-gas pipelines; economic inventory levels; optimal marketing-price strategies; project management with CPM/PERT/GERT; air-traffic-control simulations; optimal strategies in sports; optimal testing plans for reliability; optimal space trajectories. See DECISION THEORY; GERT; INVENTORY CONTROL; PERT. [W.G.L.]

**Operator theory** At one level of abstraction an operator is simply a function whose arguments and values are real- (or complex-) valued functions of one or more real variables; in more naive terms an operator is a rule for converting such real- (or complex-) valued functions into others. The following are simple examples: (i) the operator which takes each differentiable real-valued function of one variable into its derivative; (ii) the operator which takes each twice-differentiable function  $f$  of one variable into expression (1); (iii) the operator which takes each twice-differentiable function  $f$  of three variables into expression (2); and (iv) the operator which takes the continuous function  $f$  of one real variable into the function  $g$  where relation (3) holds.

$$\left(\frac{df}{dx}\right)^2 + x^2 \frac{d^2f}{dx^2} \quad (1)$$

$$\frac{\partial^2 f}{\partial x^2} + \frac{\partial^2 f}{\partial y^2} + \frac{\partial^2 f}{\partial z^2} \quad (2)$$

$$g(x) \equiv \int_0^1 \sqrt{x+y} f(y) dy \quad (3)$$

Since an operator is a function, the usual functional notation is applicable.  $L(f)$  may be used to denote the result of operating

on  $f$  with the operator  $L$ . The set of all functions  $f$  for which  $L(f)$  is defined is called the domain of  $L$ , and the set of all functions  $g$  such that  $L(f) = g$  for some  $f$  in the domain of  $L$  is called the range of  $L$ . It is obvious that solving a differential or integral equation is equivalent (in many ways) to solving an operator equation  $L(f) = g$ , where  $g$  and  $L$  are given and it is required to find  $f$ . Moreover, the operator concept can be very useful both in theory and practice, producing a great variety of illuminating insights. See DIFFERENTIAL EQUATION; INTEGRAL EQUATION.

In large part the fruitfulness of the operator concept can be traced to two sources. One of these is the possibility of adding and multiplying operators in such a way that many, though not all, of the laws of ordinary algebra hold. The other is the fact that the ranges and domains of operators behave in many respects like ordinary space and, indeed, may be regarded as contained in infinite dimensional generalizations of the familiar three-dimensional space of solid geometry. This makes it possible to think of an operator as a geometrical transformation and to exploit one's spatial intuition. [G.W.M.]

**Operator training** The specialized education of an organization's employees in the general knowledge and specific skills required to do their jobs effectively. Important to the continued soundness of an enterprise, it is considered an essential function. As science advances and technology becomes more complex, competent and continuous training increases in importance.

The objective of the training is to enable the operator to perform the job in a manner that is satisfactory to the employer and satisfying to the employee. It should contribute to increased output, productivity, quality, pride in quality, and morale and to decreased errors, customer complaints, rejects, rework, waste, accidents, injuries, equipment downtime, unit costs, frustration, absenteeism, and labor turnover.

An operator has been defined in the past as one who controls a machine or process but, with the advent of automated machines and processes, actual control has become less important. In the modern production environment, operators' tasks involve, in addition to controlling the machinery, monitoring the machine so that it performs its functions correctly; diagnosing any faults that may occur; understanding and predicting when problems can occur; and troubleshooting the machinery once a problem occurs. An operator can also be involved in programming the machine so it operates properly. The training should emphasize these cognitive aspects of performing the task. See AUTOMATION.

Operator training can be performed on several kinds of devices—actual equipment, simulators, mock-ups—and through written instructions. Ideally, operators are trained on the actual equipment; but since this is not always possible, other devices must be considered. Simulators, usually computer-controlled, offer a cost-effective alternative to training operators on the actual equipment. Mock-ups are inexpensive, but can only be used to train the worker in some aspects of the task.

Written instructions can include manuals, books, or pamphlets. These are inexpensive to reproduce. Training effectiveness is limited, however, especially when learning to control or monitor a machine. Troubleshooting procedures can be communicated through effective written instructions. [R.Eb.]

**Operon** A group of distinct genes that are expressed and regulated as a unit. Each operon is a deoxyribonucleic acid (DNA) sequence that contains at least two regulatory sites, the promoter and the operator, and the structural genes that code for specific proteins (see illustration). The promoter ( $p$ ) site is the location at which ribonucleic acid (RNA) polymerase binds to the operon. RNA polymerase moves down the operon catalyzing the synthesis of a messenger RNA (mRNA) molecule with a sequence that is complementary to DNA. This process is called transcription. The mRNA is used as a template by ribosomes to synthesize the proteins coded for by the structural genes (in the original DNA)

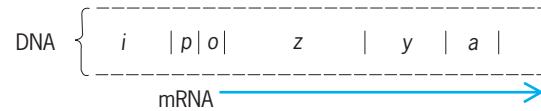

The lactose (*lac*) operon from *Escherichia coli*:  $z$ ,  $y$ , and  $a$  are structural genes;  $i$  is the *lac* repressor gene;  $p$  is the promoter site; and  $o$  is the operator site. The arrow indicates length and direction of mRNA synthesis.

in a process called translation. This mRNA is referred to as polycistronic because its sequence directs the synthesis of more than one protein. The operator ( $o$ ) site is located between the  $p$  site and the beginning of the coding region for the first structural gene. It is at this site that molecules called repressors can bind to the DNA and block RNA polymerase from transcribing the DNA, thus shutting off the operon. Some systems can be derepressed by the addition of small molecules called effectors, which bind to the repressor protein and cause a conformational (shape) change that makes it no longer able to bind to the DNA at the operator site. See DEOXYRIBONUCLEIC ACID (DNA); RIBONUCLEIC ACID (RNA).

Activation is believed to arise from the binding of a protein immediately adjacent to the promoter. The protein provides additional locations with which RNA polymerase can interact; the extra interactions result in an increased amount of polymerase binding to the promoter. Activators are more frequently involved in the regulation of genes in eukaryotes than in prokaryotes.

Once RNA polymerase begins transcribing a gene, it continues making RNA until a termination site is reached. Antiterminators are proteins that prevent termination at certain sites. In the presence of these antiterminators, RNA polymerase continues along the genome and transcribes the genes following the termination site until a different class of termination site is encountered.

Attenuation is the premature termination of the mRNA translation. Although the exact mechanism of attenuation has not been determined, it is thought that attenuation is due to the formation of a translation termination site in mRNA. See GENE; GENE ACTION. [D.H.O.]

**Ophioglossales** An order of the class Polypodiopsida known as the adder's-tongue ferns. It is a small group with only 3 genera and about 80 species. Two genera, *Ophioglossum* and *Botrychium*, are widely distributed in tropical and temperate regions and have about the same number of species; the third genus, *Helminthostachys*, is represented by a single species confined to southeastern Asia and Polynesia. These are considered the most primitive of the present-day ferns. No fossils have been reported for this group.

The chromosome number is high in the species of *Ophioglossum*. *Ophioglossum petiolatum*, a tropical species, has a chromosome count of over 1000, the largest number observed in a naturally occurring species of vascular plants. This group is distinguished from other ferns by the arrangement of the sporogenous tissue in the characteristic fertile spike of the sporophyte. The leaves are erect or merely bent over in bud and not circinate. The gametophyte is a small, nongreen, fleshy, subterranean saprophyte, associated with an endophytic fungus. The group appears to be an evolutionary dead end. See FUNGI; LEAF; POLYPODIALES; POLYPODIOPSIDA; PTEROPSIDA. [PA.V]

**Ophiolite** A distinctive assemblage of mafic plus ultramafic rocks generally considered to be fragments of the oceanic lithosphere that have been tectonically emplaced onto continental margins and island arcs. An ophiolite is a formation made up of an association of typical rocks in a clearly defined sequence. A complete idealized ophiolite sequence from bottom to top includes (1) an ultramafic tectonite complex composed mostly of multilayered, deformed harzburgite, dunite, and minor

chromitite; (2) a plutonic complex of layered mafic-ultramafic cumulates at the base, grading upward to massive gabbro, diorite, and possibly plagiogranite; (3) a mafic sheeted-dike complex; (4) an extrusive section of massive and pillow lavas, pillow breccias, and intercalated pelagic sediments; and (5) a top layer of abyssal or bathyal sediments, which may include ribbon chert, red pelagic limestone, metalliferous sediments, volcanic breccias, or pyroclastic deposits. Most ophiolites lack complete sections, and are dismembered and fragmented. Their estimated original thickness is variable, ranging from about 2 km (1.2 mi) to more than 8 km (5 mi). See EARTH CRUST; LITHOSPHERE.

Ophiolites typically occur in collisional mountain belts or island arcs and define a suture zone marking the boundary where two plates have welded together. The ophiolite complex is interpreted as evidence for a closed marginal ocean or back-arc basin. Throughout the world, ophiolites occur as long narrow belts, up to 10 km (6 mi) wide, that can extend more than 1000 km (600 mi) in length, in two distinct geographic settings. (1) Those in the Alpine-Mediterranean region, Tethyan ophiolite, were formed in small ocean basins that were surrounded by older, attenuated continental crust. (2) Those in western North America and the Circum-Pacific (Cordilleran) region seem to have formed in inter-arc basins. The Cordilleran ophiolites, such as the Trinity ophiolite and the Coast Range ophiolite of California, are generally incomplete, metamorphosed, or dismembered, but they commonly form the basement rocks for many North American continental margin terranes. See BASIN; CONTINENTAL MARGIN; STRUCTURAL GEOLOGY; GEODYNAMICS.

Ophiolites represent new oceanic crust formed in a variety of spreading environments, including oceanic ridge, back-arc basin, and island arcs above a subduction zone, and subsequently emplaced onto the continents. Their occurrence along plate sutures marks the sites of ancient tectonic interaction between oceanic and continental crust. Ophiolites provide the best opportunity for geologists to study the ocean floor on land; they also offer vertical sections in addition to horizontal distributions. Moreover, ophiolite formations record the ages of oceanic fragments that escaped, disappearing into subduction zones. [J.Li.; S.Mar.; Y.O.]

**Ophiurida** An order of Ophiuroidea in which the vertebrae articulate by means of ball-and-socket joints, and the arms, which do not branch, move mainly from side to side and do not coil in the vertical plane. The disk and arms are usually sheathed in regularly arranged plates. These are disposed in four series on the arms, namely, one dorsal, one ventral, and two lateral. There is a single madreporite. The order embraces most of the known genera of brittle stars and includes 13 families. See OPHIUROIDEA. [H.B.F.]

**Ophiuroidea** A subclass of the Asterozoa, known as the brittle stars, in which the arms are usually clearly demarcated from a central disk and perform whiplike locomotor movements, and the tube feet are nonsuctorial sensory tentacles. In all existing ophiuroids the ambulacral plates fuse together in pairs to form articulating joints termed vertebrae, and the ambulacral groove is converted into an internal epineural canal.

There are about 1900 extant species referred to 230 genera, arranged to form 3 orders: Oegophiurida, Phrynophiurida, and Ophiurida. There is also one Paleozoic order, the Stenurida. See OEGOPHIURIDA; OPHIURIDA; PHRYNOPHIURIDA; STENURIDA.

Ophiuroids are usually five-armed, with a few species being regularly six- or seven-armed. In some Euryalae the arms may branch repeatedly; these are the so-called basket fishes. Tropical species are often patterned in contrasting colors, but most ophiuroids tend to match their environment. Some species are luminescent, although not constantly so.

Ophiuroids occur in all the oceans from low-tide level downward, often in dense populations which number millions to the hectare. Six families range below a depth of 2 mi (3.2 km); the

genera *Ophiura*, *Amphiophiura*, and *Ophiacantha* range below 4 mi (6.4 km). The shallow-water forms hide among algae, under stones, or within sponges or bury the disk in sand or mud, leaving only the arms protruding. Deep-water forms lie in or on the bottom material or adhere to corals or cidarids. [H.B.F.]

**Opiates** Drugs derived from opium, the dried juice of the oriental poppy seed. The pharmacologically active substances, which constitute approximately 25% of the extract, are the alkaloids morphine, codeine, and papaverine. The newer synthetic compounds which resemble morphine in their action are called opioids.

The principal effect of opium and opioids is to relieve pain. Even today morphine remains the best analgesic. It also assuages anxiety and causes slight drowsiness, relaxation, and a euphoric state of mind. These psychic effects are so agreeable that many troubled individuals seek solace by ingesting, smoking, or injecting opiates. See MORPHINE.

Codeine has an action similar to morphine, but its analgesic effects are less. Papaverine has almost no analgesic action, and is used as an antispasmodic to relieve vascular spasm and undesirable contraction of smooth muscle. See ANALGESIC; NARCOTIC. [R.D.A.]

**Opilioacariformes** The smallest and most primitive of the three orders of Acari, comprising only one suborder, the Noto-stigmata, and one family, the Opilioacaridae. These mites are characterized by the possession of a pretarsus, or apotele, on the pedipalp, with prominent claws, which are usually relatively unmodified and paired like those on the legs. There are two pairs of eyes on the propodosoma, above the second pair of legs. See ACARI. [J.H.C.]

**Opiliones** The harvestmen or daddy longlegs, an order of the class Arachnida; sometimes known as Phalangida. About 4500 species are known. They are common in temperate and tropical climates. Most are red, brown, or black and 5–20 mm (0.2–0.8 in.) long, although a few are only 1–2 mm (0.04–0.08 in.). Some large tropical species have bright iridescent colors and elaborate spines.

The cephalothorax (prosoma) is broadly attached to the segmented abdomen (opisthosoma). The center of the cephalothoracic shield (carapace) bears a tubercle with a simple eye on each side. Many have scent glands opening on the sides which produce repellent fluids with strong odors, possibly phenols or quinones. The six pairs of appendages include relatively small chelate chelicerae (jaws), leglike (usually) pedipalps, and four pairs of legs. The legs may be very long and slender, the distal ends being able to wrap around plant stalks.

Harvestmen are predators of small invertebrates or may scavenge or eat decaying vegetation. Respiration is by means of tracheae (thin tubes), which open through spiracles on the abdomen; there may be additional spiracles on the legs.

The group is divided into three suborders: the mitelike Cyphophthalmi; the tropical Laniatores with strong pedipalps, and some species adapted for cave life; and the long-legged Palpatores, the most common opiliones in temperate areas. See ARACHNIDA. [H.W.L.]

**Opisthobranchia** A subclass in the class Gastropoda containing about 4000 living species, arranged in nine orders, including the herbivorous Aplysiomorpha (sea hares) and Sacoglossa and the carnivorous Thecosomata (sea butterflies) and Nudibranchia (sea slugs). Primitive members of many of the orders show adaptations for burrowing beneath sand or mud; more advanced members are always active surface-living or pelagic forms. This trend is accompanied by a decrease in the importance of the shell and operculum for passive defense. These are replaced by more dynamic chemical (some species secrete decinormal sulfuric acid through the skin if annoyed),

physical (daggerlike calcareous epidermal spicules), or biological (redirected nematocysts derived from coelenterate prey) defensive mechanisms.

The adult shells of the primitive opisthobranchs living today are often strongly developed and sometimes colorful; a more typical opisthobranch shell is fragile, inflated, and egg-shaped. In rather more advanced forms, the external shell has a very wide gape, and in animals like *Berthella* the widely gaping shell is wholly internal, covered by the mantle. The most varied shells are found in the Sacoglossa. In the highest sacoglossans, some bullomorphs and aplysiomorphs, and in all the nudibranchs, the true shell is completely lost after larval metamorphosis. See GASTROPODA; MOLLUSCA; NUDIBRANCHIA; SACOGLOSSA. [T.E.T.]

**Opisthocomiformes** A small order of birds that contains the single family Opisthocomidae. Its one species, the hoatzin, is restricted to South America and has frequently been included in the Galliformes as a suborder. One group of scientists claims that it is simply a cuckoo, Cuculidae, and not a very aberrant one. In the absence of definite evidence of its relationship, it will be treated here as a distinct order.

The hoatzin is a unique bird, often considered rather reptilian because of the habits of the nearly unfeathered young, which leave the nest soon after birth to crawl about trees by using the clawed wings as well as the feet. The hoatzins are also adept swimmers, capable of surviving a fall into water. They are medium-sized birds of dark brown plumage streaked with white; a distinct crest of reddish-brown feathers tops the head, which is small and has a short, stout bill. The wings are long and rounded, the legs short with strong toes; the long hallux is on the same level as the anterior toes. Hoatzins are weak fliers, but they are arboreal, clambering about in trees to feed on leaves and fruit. Hoatzins are found in the forests of northern South America, especially along rivers and streams.

The hoatzins are known in the fossil record only by the Miocene *Hoazinoides* from Colombia, a typical form that reveals nothing about the evolutionary history of the order. See AVES. [W.J.B.]

**Opossum** Any member of the family Didelphidae in the order Marsupialia which includes about 65 species found in the New World. These mammals are arboreal and are mainly omnivorous.

The common opossum (*Didelphis marsupialis*) is an extremely adaptable mammal that ranges from Argentina through Central America into the United States. The uterine gestation period is quite short, about 12 days, and the young are born no larger than a bee. They then make their way through the mother's fur to the pouch (marsupium), where they remain and continue to develop for as long as 100 days. There may be two litters of 9–12 each year. The opossum is a sedentary animal and the adults, living in solitary pairs, rarely leave their territory. See MARSUPIALIA. [C.B.C.]

**Opportunistic infections** Infections that cause a disease only when the host's immune system is impaired. The classic opportunistic infection never leads to disease in the normal host. The protozoan *Pneumocystis carinii* infects nearly everyone at some point in life but never causes disease unless the immune system is severely depressed. The most common immunologic defect associated with pneumocystosis is acquired immune deficiency syndrome (AIDS). See ACQUIRED IMMUNE DEFICIENCY SYNDROME (AIDS).

A compromised host is an individual with an abnormality or defect in any of the host defense mechanisms that predisposes that person to an infection. The altered defense mechanisms or immunity can be either congenital, that is, occurring at birth and genetically determined, or acquired. Congenital immune deficiencies are relatively rare. Acquired immunodeficiencies are associated with a wide variety of conditions such as

(1) the concomitant presence of certain underlying diseases such as cancer, diabetes, cystic fibrosis, sickle cell anemia, chronic obstructive lung disease, severe burns, and cirrhosis of the liver; (2) side effects of certain medical therapies and drugs such as corticosteroids, prolonged antibiotic usage, anticancer agents, alcohol, and nonprescribed recreational drugs; (3) infection with immunity-destroying microorganisms such as the human immunodeficiency virus that leads to AIDS; (4) age, both old and young; and (5) foreign-body exposure, such as occurs in individuals with prosthetic heart valves, intravenous catheters, and other indwelling prosthetic devices.

Virtually any microorganism can become an opportunist. The typical ones fall into a number of categories and may be more likely to be associated with a specific immunologic defect. Examples include (1) gram-positive bacteria: both *Staphylococcus aureus* and the coagulase-negative *S. epidermidis* have a propensity for invading the skin and as well as catheters and other foreign implanted devices; (2) gram-negative bacteria: the most common is *Escherichia coli* and the most lethal is *Pseudomonas aeruginosa*; these pathogens are more likely to occur in cases of granulocytopenia (granulocyte deficiency, as occurs in leukemia or chemotherapy); (3) acid-fast bacteria: *Mycobacterium tuberculosis* is more likely to reactivate in the elderly and in those individuals with underlying malignancies and AIDS; (4) protozoa: defects in cell-mediated immunity, such as AIDS, are associated with reactivated infection with *Toxoplasma gondii* and *Cryptosporidium*; (5) fungi: *Cryptococcus neoformans* is a fungus that causes meningitis in individuals with impaired cell-mediated immunity such as AIDS, cancer, and diabetes; *Candida albicans* typically causes blood and organ infection in individuals with granulocytopenia. See CELLULAR IMMUNOLOGY; ESCHERICHIA; MEDICAL MYCOLOGY; STAPHYLOCOCCUS; TUBERCULOSIS.

The first step in treatment of opportunistic infections involves making the correct diagnosis, which is often difficult as many of the pathogens can mistakenly be thought of as benign. The second step involves administration of appropriate antimicrobial agents. As a third step, if possible, the underlying immune defect needs to be corrected. See IMMUNOLOGICAL DEFICIENCY; INFECTION; MEDICAL BACTERIOLOGY. [R.Mur.]

**Opsonin** A term used in serology and immunology to refer to a substance that enhances the phagocytosis of bacteria by leukocytes. Opsonin is generally synonymous with the bacteriotropin of F. Neufeld and coworkers (1904–1905), a relatively thermostable antibody, increased in amount during specific immunization, that renders the corresponding bacterium more susceptible to phagocytosis. There is evidence that this action can be promoted to some extent by antibody alone, but that it is substantially increased by the further addition of the thermolabile complement system. See AGGLUTINATION REACTION; ANTIBODY; LYTIC REACTION; NEUTRALIZATION REACTION (IMMUNOLOGY); PHAGOCYTOSIS; PRECIPITIN; SERUM. [H.P.T.]

**Optical activity** The effect of asymmetric compounds on polarized light. To exhibit this effect, a molecule must be non-superimposable on its mirror image, that is, must be related to its mirror image as the right hand is to the left hand. An optically active compound and its mirror image are called enantiomers or optical isomers (see illustration). Enantiomers differ only in their geometric arrangements; they have identical chemical and physical properties. The right-handed and left-handed forms of a molecule can be distinguished only by their optical activity or by their interactions with other asymmetric molecules. Optical activity can be used to probe other aspects of molecular geometry, as well as to identify which enantiomer is present and its purity.

The physical basis of optical activity is the differential interaction of asymmetric substances with left versus right circularly polarized light. If solids and substances in strong magnetic fields are excluded, optical activity is an intrinsic property of the



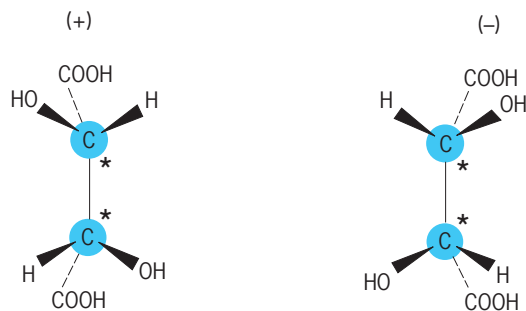

Enantiomers of tartaric acid.

molecular structure and is one of the best methods of obtaining structural information from a sample in which the molecules are randomly oriented. The relationship between optical activity and molecular structure results from the interaction of polarized light with electrons in the molecule. Thus the molecular groups that contribute most directly to optical activity are those that have mobile electrons which can interact with light. Such groups are called chromophores, since their absorption of light is responsible for the color of objects. For example, the chlorophyll chromophore makes plants green. See FARADAY EFFECT; POLARIZED LIGHT; STEREOCHEMISTRY.

Optical activity is measured by two methods, optical rotation and circular dichroism. The optical rotation method depends on the different velocities of left and right circularly polarized light beams in the sample. The velocities are not measured directly, but both beams are passed through the sample simultaneously. This is equivalent to using plane-polarized light. The differing velocities of the left and right circularly polarized components yield a rotation of the plane of polarization. Circular dichroism is the difference in absorption of left and right circularly polarized light. Since this difference is about a millionth of the absorption of either polarization, special techniques are needed to determine it accurately. Circular dichroism is reported as a difference in absorption, or as an ellipticity (a measure of the elliptical polarization of the emergent beam). [V.M.]

**Optical bistability** A phenomenon exhibited by certain resonant optical structures whereby it is possible to have two stable steady transmission states for the device, depending upon the history of the input. Such a bistable device may be useful for optical computing elements because of its memory characteristics. The bistability can result from the intrinsic properties of the optical device or from some external feedback such as an electrical voltage supplied by another device. This second type, extrinsic or hybrid optical bistability, is not true optical bistability.

Optical bistability is an inherently steady-state phenomenon, and typically any cycling of the device through its hysteresis cycle must be done adiabatically; that is, changes in the propagating light amplitude, envelope phase, and profile must occur sufficiently slowly that their impact on the evolution of the system may be neglected. This requirement imposes some rather severe frequency-response limitations on the use of intrinsically bistable devices in optical circuits. The two primary types of intrinsic optical bistability, each arising from a distinct physical mechanism, are absorptive bistability and refractive bistability. See ADIABATIC PROCESS; HYSTERESIS.

Absorptive optical bistability is based upon coupling the feedback mechanism inherent in an optical cavity with an absorbing nonlinear optical medium in which the absorption coefficient decreases with increasing light intensity (a saturable absorber). The basic theory of operation is: the saturable absorber is placed in the cavity, and the cavity is resonantly pumped. For low light intensities, the transmission coefficient for the cavity is small because of the presence of the highly absorbing medium inside the cavity. As the pump intensity is increased, the absorption of the

nonlinear medium decreases. Finally, for some threshold pump intensity, the cavity switches into a high transmission state, because the absorption coefficient is reduced sufficiently that the intrinsic cavity feedback mechanism dominates. The threshold is very sharp because, when the cavity is in a highly transmissive state, the built-up intensity inside the cavity becomes very large compared to the pump intensity (due to the feedback) and effectively bleaches virtually all of the absorption in the nonlinear medium. The intense pump is then largely transmitted, although some energy is stored in the cavity to bleach the absorber. See ABSORPTION OF ELECTROMAGNETIC RADIATION; LASER; OPTICAL PUMPING.

This device exhibits two characteristics that constrain its usefulness in particular applications. (1) The device is based on an absorption mechanism, so the energy absorbed from the pump light must be dissipated in the bistable element or heat-sinked elsewhere. (2) It is highly frequency-sensitive because its operation is based on the switching characteristics of a resonant cavity.

Refractive optical bistability is based on coupling the feedback mechanism inherent in an optical cavity with a nonlinear optical medium that exhibits a change in the refractive index as a function of light intensity. The nonlinear refractive medium is placed inside the optical cavity, and the cavity is pumped slightly off-resonance so that the transmission coefficient is small compared to unity. However, a small amount of light intensity does exist inside the cavity, and changes the effective optical path length inside the cavity by inducing change in the refractive index of the nonlinear medium. As the pump intensity is increased, this change in the effective path length becomes larger, until at some point the cavity switches into, and possibly past, resonance. The transmission coefficient switches abruptly to a value close to unity, and the built-up intensity inside the cavity increases abruptly. If the pump intensity is increased further, it is possible to switch the cavity through a second resonance, with an additional threshold in the transmission coefficient. See REFRACTION OF WAVES.

The most common implementation scheme for a bistable optical device is the nonlinear Fabry-Perot etalon. The device is typically fabricated from a semiconductor, and consists of a slab of material of approximately 1 micrometer thickness. On each surface of the semiconductor, a highly reflective coating may be deposited to increase the bandwidth of the Fabry-Perot cavity. The choice of a proper nonlinear material is based upon the operating wavelength and the temporal response time desired, and possibly other considerations. Typically for applications in the far-infrared, near-infrared, and visible wavelengths, the proper materials are indium antimonide (InSb), gallium arsenide (GaAs), and zinc selenide (ZnSe), respectively. See INTERFEROMETRY. [D.R.A.]

**Optical coherence tomography** Optical coherence tomography (OCT) is a recently developed, noninvasive technique for imaging subsurface tissue structure with micrometer-scale resolution. The principles of time gating, optical sectioning, and optical heterodyning are combined to allow cross-sectional imaging. Depths of 1–2 mm (0.04–0.08 in.) can be imaged in turbid tissues such as skin or arteries; greater depths are possible in transparent tissues such as the eye. Optical coherence tomography complements other imaging modalities commonly used to image subsurface tissue structure, including ultrasound and confocal microscopy.

**Principles of operation.** In a typical optical coherence tomography system (see illustration), light from a broadband, near-infrared source and a visible aiming beam is combined and coupled into one branch of a fiber-optic Michelson interferometer. Broadband sources include superluminescent diodes, fiber amplifiers, and femtosecond pulse lasers in the wavelength range of 800–1550 nanometers. The light is split into two fibers using a 2 × 2 coupler, one leading to a reference mirror and the second focused into the tissue. Light reflects off the reference mirror and

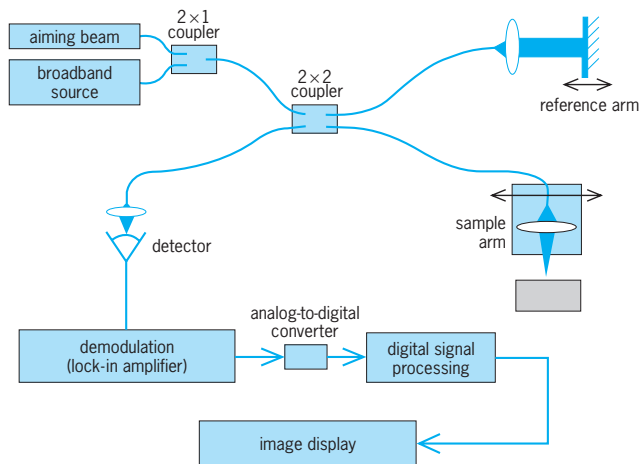

Typical optical coherence tomography system, based on a broadband source and fiber-optic Michelson interferometer.

is recoupled into the fiber leading to the mirror. Concurrently, light is reflected from index-of-refraction mismatches in the tissue and recoupled into the fiber leading to the tissue. Reflections result from changes in the index of refraction within the structure of the tissue, for instance between intercellular fluid and collagen fibers. Light that has been back-reflected from the tissue and light from the reference arm recombine within the  $2 \times 2$  coupler.

Because the broadband source has a short coherence length, only light which has traveled very close to the same time (or optical path length) in the reference and tissue arms will interfere constructively and destructively. By changing the length of the reference arm, reflection sites at various depths in the tissue can be sampled. The depth resolution of the optical coherence tomography system is determined by the effectiveness of this time gating and hence is inversely proportional to the bandwidth of the source. An optical detector in the final arm of the Michelson interferometer detects the interference between the reference and tissue signals. During optical coherence tomography imaging, the reference-arm mirror is scanned at a constant velocity, allowing depth scans (analogous to ultrasound A-scans) to be made. Either the tissue or the interferometer optics is mounted on a stage so that the beam can be scanned laterally across the tissue to build up two- and three-dimensional images, pixel by pixel.

**Variations.** Several instruments have been built based on variations of the basic optical coherence tomography system. For instance, polarization-sensitive optical coherence tomography uses polarization-altering optics in the arms of the interferometer to determine the sample birefringence from the magnitude of the back-reflected light. Optical coherence microscopy uses a system of high numerical aperture to achieve resolutions comparable to confocal microscopy but with increased depth of penetration. Color Doppler optical coherence tomography (CDOCT) is an augmentation capable of simultaneous blood flow mapping and spatially resolved imaging.

**Applications.** Optical coherence tomography can be used to probe the structure of any accessible tissue. Noninvasive studies of the eye and skin are being performed, and a commercial device has been developed for retinal imaging. Using optical coherence tomography, parameters such as eye length can be accurately measured, and the cross-section images of the retina give a clear and quantifiable assessment of retinal separation and macular degeneration, among other pathologies. In skin, the morphology of normal skin layers and components, and disorders such as psoriasis, can be imaged. See COHERENCE; COMPUTERIZED TOMOGRAPHY; CONFOCAL MICROSCOPY; DOPPLER EFFECT; FIBER-OPTICS IMAGING; HETERODYNE PRINCIPLE; INTERFEROMETRY; MEDICAL ULTRASONIC TOMOGRAPHY; ULTRASONICS. [J.K.Ba.]

**Optical communications** The transmission of speech, data, video, and other information by means of the visible and the infrared portion of the electromagnetic spectrum.

Optical communication is one of the newest and most advanced forms of communication by electromagnetic waves. In one sense, it differs from radio and microwave communication only in that the wavelengths employed are shorter (or equivalently, the frequencies employed are higher). However, in another very real sense it differs markedly from these older technologies because, for the first time, the wavelengths involved are much shorter than the dimensions of the devices which are used to transmit, receive, and otherwise handle the signals.

The advantages of optical communication are threefold. First, the high frequency of the optical carrier (typically of the order of 300,000 GHz) permits much more information to be transmitted over a single channel than is possible with a conventional radio or microwave system. Second, the very short wavelength of the optical carrier (typically of the order of 1 micrometer) permits the realization of very small, compact components. Third, the highest transparency for electromagnetic radiation yet achieved in any solid material is that of silica glass in the wavelength region 1–1.5  $\mu\text{m}$ . This transparency is orders of magnitude higher than that of any other solid material in any other part of the spectrum. See ELECTROMAGNETIC RADIATION; LIGHT.

Optical communication in the modern sense of the term dates from about 1960, when the advent of lasers and light-emitting diodes (LEDs) made practical the exploitation of the wide-bandwidth capabilities of the light wave. See LASER; LIGHT-EMITTING DIODE; OPTICAL FIBERS.

**Optical fiber communications.** With the development of extremely low-loss optical fibers during the 1970s, optical fiber communication became a very important form of telecommunication almost instantaneously. For fibers to become useful as light waveguides (or light guides) for communications applications, transparency and control of signal distortion had to be improved dramatically and a method had to be found to connect separate lengths of fiber together.

The transparency objective was achieved by making glass rods almost entirely of silica. These rods could be pulled into fibers at temperatures approaching 3600°F (2000°C).

Reducing distortion over long distances required modification of the method of guidance employed in early fibers. These early fibers (called step-index fibers) consisted of two coaxial cylinders (called core and cladding) which were made of two slightly different glasses so that the core glass had a slightly higher index of refraction than the cladding glass. By reducing the core size and the index difference in a step-index fiber, it is possible to reach a point at which only axial propagation is possible. In this condition, only one mode of propagation exists. These single-mode fibers can transmit in excess of  $10^{11}$  pulses per second over distances of several hundred miles. See WAVEGUIDE.

The problem of joining fibers together was solved in two ways. For permanent connections, fibers can be spliced together by carefully aligning the individual fibers and then epoxying or fusing them together. For temporary connections, or for applications in which it is not desirable to make splices, fiber connectors have been developed.

Almost every major metropolitan area in the United States has a light-wave transmission system in service connecting telephone central offices. These systems typically operate at a wavelength of either 1.3 or 1.55  $\mu\text{m}$  (where silicon fibers have a minimum loss). It is anticipated that light-wave systems will gradually be installed in the telephone loop plant—that is, the portion of the telephone plant which connects the individual subscriber to the telephone central office. See DATA COMMUNICATIONS; FACSIMILE.

**Optical transmitters.** In principle, any light source could be used as an optical transmitter. In modern optical communication systems, however, only lasers and light-emitting diodes are generally considered for use. The most simple device is the light-emitting diode which emits in all directions from a fluorescent

area located in the diode junction. Since optical communication systems usually require well-collimated beams of light, light-emitting diodes are relatively inefficient. On the other hand, they are less expensive than lasers and, at least until recently, have exhibited longer lifetimes.

Another device, the semiconductor laser, provides comparatively well-collimated light. In this device, two ends of the junction plane are furnished with partially reflecting mirror surfaces which form an optical resonator. As a result of cavity resonances, the light emitted through the partially reflecting mirrors is well collimated within a narrow solid angle, and a large fraction of it can be captured and transmitted by an optical fiber.

Both light-emitting diodes and laser diodes can be modulated by varying the forward diode current.

**Optical receivers.** Semiconductor photodiodes are used for the receivers in virtually all optical communication systems. There are two basic types of photodiodes in use. The most simple comprises a reverse-biased junction in which the received light creates electron-hole pairs. These carriers are swept out by the electric field and induce a photocurrent in the external circuit. The minimum amount of light needed for correct reconstruction of the received signal is limited by noise superimposed on the signal by the following circuits. See PHOTODIODE.

Avalanche photodiodes provide some increase in the level of the received signal before it reaches the external circuits. They achieve greater sensitivity by multiplying the photogenerated carriers in the diode junction. This is done by creating an internal electric field sufficiently strong to cause avalanche multiplication of the free carriers. See MICROWAVE SOLID-STATE DEVICES; OPTICAL DETECTORS.

**Coherent communication.** The transmission systems described above are all incoherent systems. That is, the signal is transmitted and detected without making use of the phase of the emitted light. Many lasers are capable of transmitting light with the phase sufficiently stable that coherent techniques such as homodyne and heterodyne detection can be used exactly as they are used for radio detection. Coherent systems offer the potential for a tremendous increase in bandwidth along with a modest increase in sensitivity. See HETERODYNE PRINCIPLE; RADIO RECEIVER.

**Photonic interconnects.** Advances in technology have opened a new application for optical communication; transmission of very large amounts of data over relatively short distances. Devices for this purpose are known as photonic interconnects. These devices are only a few centimeters in length but they are massively parallel; that is, they carry a very large number (millions or even billions) of individual channels from one chip on an integrated circuit board to another chip on the same or near-by board. See OPTICAL INFORMATION SYSTEMS. [W.M.Hu.]

**Optical detectors** Devices that respond to incident ultraviolet, visible, or infrared electromagnetic radiation by giving rise to an output signal, usually electrical. Based upon the manner of their interaction with radiation, they fall into three categories. Photon detectors are those in which incident photons change the number of free carriers (electrons or holes) in a semiconductor (internal photoeffect) or cause the emission of free electrons from the surface of a metal or semiconductor (external photoeffect, photoemission). Thermal detectors respond to the temperature rise of the detecting material due to the absorption of radiation, by changing some property of the material such as its electrical resistance. Detectors based upon wave-interaction effects exploit the wavelike nature of electromagnetic radiation, for example by mixing the electric-field vectors of two coherent sources of radiation to generate sum and difference optical frequencies. See NONLINEAR OPTICAL DEVICES.

The most widely used photon effects are photoconductivity, the photovoltaic effect, and the photoemissive effect. Photoconductivity, an internal photon effect, is the decrease in electrical resistance of a semiconductor caused by the increased numbers

of free carriers produced by the absorbed radiation. See PHOTOCONDUCTIVE CELL.

The photovoltaic effect, also an internal photoeffect, occurs at a *pn* junction in a semiconductor or at a metal-semiconductor interface (Schottky barrier). Absorbed radiation produces free hole-electron pairs which are separated by the potential barrier at the *pn* junction or Schottky barrier, thereby giving rise to a photovoltage. This is the principle employed in a solar cell. See PHOTODIODE; PHOTOVOLTAIC CELL; PHOTOVOLTAIC EFFECT; SEMICONDUCTOR DIODE; SOLAR CELL.

The photoemissive effect, also known as the external photoeffect, is the emission of an electron from the surface of a metal or semiconductor (cathode) into a vacuum or gas due to the absorption of a photon by the cathode. The photocurrent is collected by a positively biased anode. Internal amplification of the photoexcited electron current can be achieved by means of secondary electron emission at internal structures (dynodes). Such a vacuum tube is known as a photomultiplier. Internal amplification by means of an avalanche effect in a gas is employed in a Geiger tube. See GEIGER-MÜLLER COUNTER; LIGHT AMPLIFIER; PHOTOELECTRIC DEVICES; PHOTOEMISSION; PHOTOMULTIPLIER; PHOTOTUBE.

Semiconductors are key to the development of most photon detectors. These materials are characterized by a forbidden energy gap which determines the minimum energy that a photon must have to produce a free hole-electron pair in an intrinsic photoeffect. Since the energy of a photon is inversely proportional to its wavelength, the minimum energy requirement establishes a long-wavelength limit of an intrinsic photoeffect. It is also possible to produce free electrons or free holes by photoexcitation at donor or acceptor sites in the semiconductor; this is known as an extrinsic photoeffect. Here the long-wavelength limit of the photoeffect is determined by the minimum energy (ionization energy) required to photoexcite a free electron from a donor site or a free hole from an acceptor site. See SEMICONDUCTOR.

The choice of materials also plays a role in thermal detectors. The most widely used thermal detector is a bolometer, that is, a temperature-sensitive resistor in the form of a thin metallic or semiconductor film (although superconducting films are also used). Incident electromagnetic radiation absorbed by the film causes its temperature to rise, thereby changing its electrical resistance. The change in resistance is measured by passing a current through the film and measuring the change in voltage. Materials with a high temperature coefficient of resistance are desired for bolometers, a criterion which usually favors semiconductors over metals. See BOLOMETER. [P.W.K.]

**Optical fibers** Flexible transparent fiber devices, sometimes called lightguides, used for either image or information transmission, in which light is propagated by total internal reflection. In simplest form, the optical fiber or lightguide consists of a core of material with a refractive index higher than the surrounding cladding. The optical fiber properties and requirements for image transfer, in which information is continuously transmitted over relatively short distances, are quite different than those for information transmission, where typically digital encoding of information into on-off pulses of light (on = 1, off = 0) is used to transmit audio, video, or data over much longer distances at high bit rates. Another application for optical fibers is in sensors, where a change in light transmission properties is used to sense or detect a change in some property, such as temperature, pressure, or magnetic field. See FIBER-OPTIC SENSOR; FIBER-OPTICS IMAGING; OPTICAL COMMUNICATIONS; REFLECTION OF ELECTROMAGNETIC RADIATION; REFRACTION OF WAVES.

There are three basic types of optical fibers. Propagation in these lightguides is most easily understood by ray optics, although the wave or modal description must be used for an exact description. In a multimode, stepped-refractive-index-profile fiber (illus. a), the number of rays or modes of light which are guided, and thus the amount of light power coupled into the

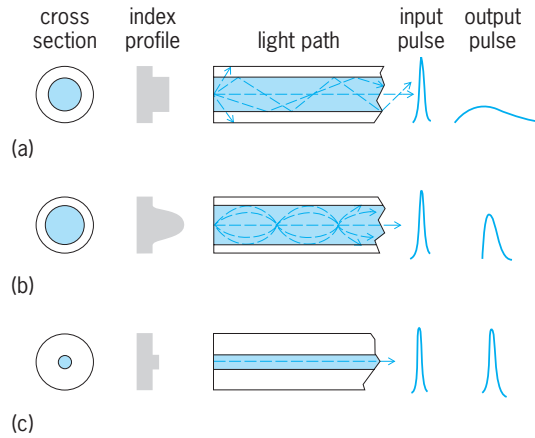

**Types of optical fiber designs. (a) Multimode, stepped-refractive-index-profile. (b) Multimode, graded-index-profile. (c) Single-mode, stepped-index. Graded-index is possible.**

lightguide, is determined by the core size and the core-cladding refractive index difference. Such fibers, used for conventional image transfer, are limited to short distances for information transmission due to pulse broadening. An initially sharp pulse made up of many modes broadens as it travels long distances in the fiber, since high-angle modes have a longer distance to travel relative to the low-angle modes. This limits the bit rate and distance because it determines how closely input pulses can be spaced without overlap at the output end.

A graded-index multimode fiber (illus. *b*), where the core refractive index varies across the core diameter, is used to minimize pulse broadening due to intermodal dispersion. Since light travels more slowly in the high-index region of the fiber relative to the low-index region, significant equalization of the transit time for the various modes can be achieved to reduce pulse broadening. This type of fiber is suitable for intermediate-distance, intermediate-bit-rate transmission systems. For both fiber types, light from a laser or light-emitting diode can be effectively coupled into the fiber. See LASER; LIGHT-EMITTING DIODE.

A single-mode fiber (illus. *c*) is designed with a core diameter and refractive index distribution such that only one fundamental mode is guided, thus eliminating intermodal pulse-broadening effects. Material and waveguide dispersion effects cause some pulse broadening, which increases with the spectral width of the light source. These fibers are best suited for use with a laser source in order to efficiently couple light into the small core of the lightguide and to enable information transmission over long distances at very high bit rates. See WAVEGUIDE.

A special class of single-mode fibers comprises polarization-preserving fibers. In an ideal, perfectly circular single-mode fiber core, the polarization state of the propagating light is preserved, but in a real fiber various imperfections can cause birefringence; that is, the two orthogonally polarized modes of the fundamental mode travel at different speeds. For applications such as sensors, where controlling the polarization is important, polarization-maintaining fibers can be designed that deliberately introduce a polarization. This is typically accomplished by using noncircular cores (shape birefringence) or by introducing asymmetric stresses (stress-induced birefringence) on the core. See BIREFRINGENCE; PHOTOELASTICITY; POLARIZED LIGHT.

The attenuation or loss of light intensity is an important property of the lightguide since it limits the achievable transmission distance, and is caused by light absorption and scattering. Optical fibers based on silica glass have an intrinsic transmission window at near-infrared wavelengths with extremely low losses. Glass fibers, intrinsically brittle, are coated with a protective plastic to preserve their strength. See OPTICAL MATERIALS. [S.R.N.]

**Optical flat** A disk of high-grade quartz glass approximately  $\frac{3}{4}$  in. (2 cm) thick, having at least one side ground

and polished with a deviation in flatness usually not exceeding 50 nanometers all over, and a surface quality of 5 microfinish or less. When two surfaces of this quality are placed lightly together so that the air is not wrung out from between them, they are separated by a film of air and actually touch at only one point. This point is the vertex of a wedge of air separating the two pieces.

If parallel beams of light pass through the flat, part will be reflected against the surface being inspected, while part will be reflected directly back through the flat. Because the distance between the surfaces is constantly increasing along the angle, the beams reflected from the flat and the beams reflected from the workpiece will alternately reinforce and interfere with each other, producing a pattern of alternate light and dark bands (see illustration). Each succeeding full band from a point of



**Optical flat being used to determine flatness of seal ring. Interference bands on seal ring face show lines of constant depth. (Van Keuren Co.)**

contact means the distance between surfaces is one wavelength thicker. If the light is relatively monochromatic, the wavelength is known. Red with a wavelength of 295 nm is commonly used. Thus a definite relationship is established between lineal measurement and light waves. Optical flats are used for two general purposes, determination of surface contour and comparison of lineal measurement. [R.A.B.]

**Optical guided waves** Optical-frequency electromagnetic waves confined within an optical waveguide, a structure designed to carry such waves from one place to another somewhat as a pipe carries water. Optical waveguides confine light by the method of total internal reflection. (The terms optical and light are used here in the broadest sense to include visible and near-infrared electromagnetic radiation.) The demonstrations of the first semiconductor laser and the first low-loss glass optical fiber initiated a technological revolution. See REFLECTION OF ELECTROMAGNETIC RADIATION.

Because of the high data rates that can be achieved, the transmission of information in the form of optical guided waves confined within an optical-fiber waveguide has become the preferred method for the telecommunications industry. The optical fiber consists of two concentric glass cylinders. The inner core region is made of a glass that has a slightly higher index of refraction than the outer cladding region, as required for total internal reflection to occur. Core diameters in the range of 4–50 micrometers are used routinely to carry near-infrared optical radiation. Pulses of light with wavelengths between 0.8 and 1.55  $\mu\text{m}$  are injected into the fiber on the near end. The presence or absence of a pulse is interpreted as a one or a zero by a receiver on

the far end, typically many miles (kilometers) away. See OPTICAL COMMUNICATIONS; OPTICAL FIBERS.

Devices such as semiconductor lasers make use of optical guided waves over distances much shorter than those spanned by optical fibers. In a semiconductor laser, a planar waveguide also serves as an electrically driven amplifying medium. Gallium arsenide (GaAs), aluminum gallium arsenide (AlGaAs), or indium gallium arsenide phosphide (InGaAsP) are common examples of semiconductor laser materials. When mirrors are formed on the ends of the semiconductor waveguide, typically a few hundred micrometers apart, light travels back and forth between those mirrors just as with any laser, but in the form of optical guided waves. See LASER.

Optical waveguides are the basic constituents of an emerging technology known variously as integrated optics, integrated optoelectronics, or photonic integrated circuits. This technology integrates optical and electronic components into or on an optical waveguide. The aim is to process and manipulate light while it is trapped as optical guided waves within the confines of the optical waveguide. See INTEGRATED OPTICS; WAVEGUIDE. [D.G.H.]

**Optical image** The image formed by the light rays from a self-luminous or an illuminated object that traverse an optical system. The image is said to be real if the light rays converge to a focus on the image side and virtual if the rays seem to come from a point within the instrument (see illustration).

The optical image of an object is given by the light distribution coming from each point of the object at the image plane of an optical system. The ideal image of a point according to geometrical optics is obtained when all rays from an object point unite in a single image point. However, diffraction theory teaches that even in this case the image is not a point but a minute disk. See DIFFRACTION.

From the standpoint of geometrical optics, if this most desirable type of image formation cannot be achieved, the next best objective is to have the image free from all but aperture errors (spherical aberration). In this case the light distribution in the image plane is still circular, resembling the point image; there is a true coordination of object point and image, although the image may be slightly unsharp. If the aperture errors are small, or if the image is viewed from a distance, such an image formation may be very satisfactory. See ABERRATION (OPTICS).

Asymmetry and deformation errors may be very disturbing if not held in check, because the light distribution of the

image of a point in this case has a decidedly undesirable shape.

[M.J.H.]

**Optical information systems** Systems that use light to process information. Optical information systems or processors consist of one or several light sources; one- or two-dimensional planes of data such as film transparencies, various lenses, and other optical components; and detectors. These elements can be arranged in various configurations to achieve different data-processing functions. As light passes through various data planes, the light distribution is spatially modulated proportional to the information present in each plane. This modulation occurs in parallel in one or two dimensions, and the processing is performed at the speed of light. Optical processors offer various advantages compared to other technologies: data travels at the speed of light; all data in one-dimensional and two-dimensional arrays are operated on in parallel; multiple planes of data can be processed in parallel by various multiplexing schemes; it is possible to have large numbers of interconnections with no interaction (which is not possible with electrical connections); and power dissipation is less and size and weight can be less for optical processors than for their electronic counterparts. See CONCURRENT PROCESSING; MULTIPLEXING AND MULTIPLE ACCESS.

In practice, the processing speed is limited by the rate at which data can be introduced into the system and the rate at which processed data (produced on output detector arrays) can be analyzed. The reusable real-time spatial light modulators used to produce new input data, filters, interconnections, and so forth, are the major components required for these optical information-processing systems to realize their full potential. Spatial light modulators convert electrical input data into a form suitable for spatially modulating input light, or react to an optical input and generate a different optical output. The manipulation of the light passing through the system is controlled by spatial light modulators, lenses, holographic optical elements, computer-generated holograms, or fiber optics. Four major application areas are image processing, signal processing, computing and interconnections, and neural networks. See HOLOGRAPHY; IMAGE PROCESSING; NEURAL NETWORK; OPTICAL FIBERS; OPTICAL MODULATORS. [D.Ca.]

**Optical isolator** A device that is interposed between two systems to prevent one of them from having undesired effects on the other, while transmitting desired signals between the systems by optical means. Optical isolators are used for both electrical systems and optical systems such as lasers.

An optical isolator for electrical systems is a very small four-terminal electronic circuit element that includes in an integral package a light emitter, a light detector, and, in some devices, solid-state electronic circuits. The emitting and detecting devices are so positioned that the majority of the emission from the emitter is optically coupled to the light-sensitive area of the detector. The device is also known as an optoisolator, optical-coupled isolator, and optocoupler. The device is housed in an integral opaque package so that the only optical emission impinging on the detector is that produced by the emitter. This configuration of components can perform as a solid-state electronic transformer or relay, since an electronic input signal causes an electronic output signal without any electrical connection between the input and the output terminals.

Optical isolators are used in electrical systems to protect humans or machines when high-voltage or high-power equipment is being controlled. In addition, optical isolators are used in electronic circuit design in situations where two circuits have large voltage differences between them and yet it is necessary to transfer small electrical signals between them without changing the basic voltage level of either. [R.D.Co.]

The need for optical isolation has broadened considerably since the advent of lasers. It is often necessary to prevent light from reentering the laser, irrespective of any electrical consideration. One example is a small laser followed by high-power laser amplifiers. If the powerful amplified light reenters the small

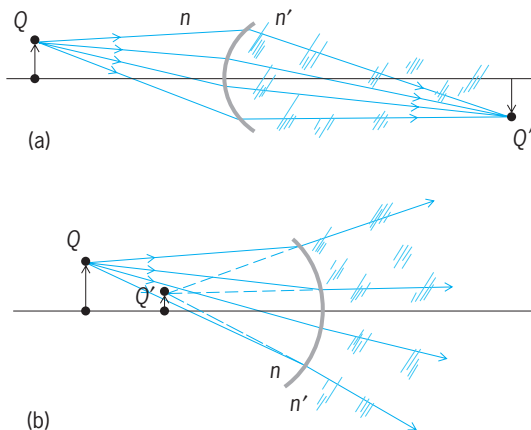

**Optical images.** (a) Real image. Rays leaving object point  $Q$  and passing through the refracting surface separating media  $n$  and  $n'$  are brought to a focus at the image point  $Q'$ . (b) Virtual image. Rays leaving  $A$  and refracted by the concave surface separating  $n$  and  $n'$  appear to be coming from the virtual image point  $Q'$ . As the rays are diverging, they cannot be focused at any point. (Modified from F. A. Jenkins and H. E. White, *Fundamentals of Optics*, 4th ed., McGraw-Hill, 1976)

(master oscillator) laser, it can destroy it. Another example is a frequency-stabilized laser, whose oscillation frequency is perturbed by reentering (injected signal) light.

A polarizer-plus-quarterwave-plate isolator prevents laser light from reentering the laser when the light is scattered back by specular reflectors. This device cannot ensure isolation if there is diffuse reflection or if polarization-altering (birefringent) optics are encountered. Another limitation of this isolator is that the transmitted light is circularly polarized. See BIREFRINGENCE; POLARIZED LIGHT.

In contrast to the quarter-wave polarizer isolator, the Faraday isolator can provide truly one-way transmission irrespective of polarization changes from the exit side if an exit polarizer (which passes light that has undergone the Faraday rotation after passing through the entrance polarizer) is used in addition to the entrance polarizer. For example, it isolates against diffuse reflections and any light source on the exit side. See FARADAY EFFECT.

The isolation properties of an acoustooptic deflector are based on the fact that light deflected by it is shifted in frequency by an amount equal to the acoustic frequency. The reflected beam, passing through the deflector a second time, is again shifted in frequency by the same amount and in the same sense if the deflector is operated in the Bragg mode. Hence, the reflected light that is returned to the laser is shifted in frequency by an amount  $2f$ , where  $f$  is the frequency of the acoustic wave. Provided the frequency of the light returned to the laser is not close to any resonant frequency of the laser cavity, it will not perturb the laser and will simply be reflected from the output mirror. See ACOUSTOOPTICS. [S.F.J.]

**Optical materials** All substances used in the construction of devices or instruments whose function is to alter or control electromagnetic radiation in the ultraviolet, visible, or infrared spectral regions. Optical materials are fabricated into optical elements such as lenses, mirrors, windows, prisms, polarizers, detectors, and modulators. These materials serve to refract, reflect, transmit, disperse, polarize, detect, and transform light. The term "light" refers here not only to visible light but also to radiation in the adjoining ultraviolet and infrared spectral regions. At the microscopic level, atoms and their electronic configurations in the material interact with the electromagnetic radiation (photons) to determine the material's macroscopic optical properties such as transmission and refraction. These optical properties are functions of the wavelength of the incident light, the temperature of the material, the applied pressure on the material, and in certain instances the external electric and magnetic fields applied to the material. See ATOMIC STRUCTURE AND SPECTRA; DISPERSION (RADIATION); ELECTROMAGNETIC RADIATION; ELECTROOPTICS; INFRARED RADIATION; LENS (OPTICS); LIGHT; MAGNETOOPTICS; MIRROR OPTICS; OPTICAL DETECTORS; OPTICAL MODULATORS; OPTICAL PRISM; POLARIZED LIGHT; REFLECTION OF ELECTROMAGNETIC RADIATION; REFRACTION OF WAVES; ULTRAVIOLET RADIATION.

There is a wide range of substances that are useful as optical materials. Most optical elements are fabricated from glass, crystalline materials, polymers, or plastic materials. In the choice of a material, the most important properties are often the degree of transparency and the refractive index, along with each property's spectral dependency. The uniformity of the material, the strength and hardness, temperature limits, hygroscopicity, chemical resistivity, and availability of suitable coatings may also need to be considered. See HARDNESS SCALES; STRENGTH OF MATERIALS.

Glass technology provided the foundation for classical optical elements, such as lenses, prisms, and filters. Glasses developed for use in the visible region have internal transmittances of over 99% throughout the wavelength range of 380–780 nanometers. However, the silicate structure in glasses limits their transmission to about 2.5 micrometers in the infrared. Chalcogenide glasses, heavy-metal fluoride glasses, and heavy-metal oxide glasses extend this transmission to 8–12  $\mu\text{m}$ . See COLOR FILTER.

Advances in the process for manufacturing optical fibers led to the present fiber-optic communication systems that operate

in the near-infrared region with windows at wavelengths of 850, 1310, 1550, and 1625 nm. An advanced fiber-optic system, LEAF (Large Effective Area Fiber), was designed to minimize nonlinearities by spreading the optical power over large areas. See OPTICAL COMMUNICATIONS; OPTICAL FIBERS; VAPOR DEPOSITION.

The use of photolithography for printing integrated circuits has necessitated the improvement in the transmission of glasses for the ultraviolet region. Fused silica, which transmits to about 180 nm, is well suited for the lithography in the ultraviolet region. However, the crystalline material calcium fluoride, which transmits into the ultraviolet region to about 140 nm, outperforms any glass in printing microchips using fluorine excimer lasers. Deep-ultraviolet applications of fused-silica glasses include high-energy lasers, spacecraft windows, blanks for large astronomical mirrors, optical imaging, and cancer detection using ultraviolet-laser-induced autofluorescence. See FLUORESCENCE; INTEGRATED CIRCUITS; TELESCOPE.

The need for an inexpensive, unbreakable lens that could be easily mass-produced precipitated the introduction of plastic optics in the mid-1930s. Although the variety of plastics suitable for precision optics is limited compared to glass or crystalline materials, plastics are often preferred when difficult or unusual shapes, lightweight elements, or economical mass-production techniques are required.

The softness, inhomogeneity, and susceptibility to abrasion intrinsic to plastics often restrict their application. Haze (which is the light scattering due to microscopic defects) and birefringence (resulting from stresses) are inherent to plastics. Plastics also exhibit large variations in the refractive index with changes in temperature. Shrinkage resulting during the processing must be considered. See BIREFRINGENCE; PHOTOELASTICITY.

Organic synthetic polymers are emerging as key materials for information technologies. Polymers often have an advantage over inorganic materials because they can be designed and synthesized into compositions and architectures not possible with crystals, glasses, or plastics. They are manufactured to be durable, optically efficient, reliable, and inexpensive. Many uses of polymers in photonic and optoelectronic devices have emerged, including light-emitting diodes, liquid-crystal-polymer photodetectors, polymer-dispersed liquid-crystal devices (for projection television), optical-fiber amplifiers doped with organic dyes (rhodamine), organic thin-film optics, and electrooptic modulators. See LIGHT-EMITTING DIODE; LIQUID CRYSTALS.

Although most of the early improvements in optical devices were due to advancements in the production of glasses, the crystalline state has taken on increasing importance. Historically, the naturally occurring crystals such as rock salt, quartz, and fluorite plus suitable detectors permitted the first extension of visible optical techniques to harness the invisible ultraviolet and infrared rays. Synthetic crystal-growing techniques have made available single crystals such as lithium fluoride (of special value in the ultraviolet region, since it transmits at wavelengths down to about 120 nm), calcium fluoride, and potassium bromide (useful as a prism at wavelengths up to about 25  $\mu\text{m}$  in the infrared). Many alkali-halide crystals are important because they transmit into the far-infrared. See CRYSTAL GROWTH; CRYSTAL STRUCTURE; SINGLE CRYSTAL.

Following the invention of the transistor, germanium and silicon ushered in the use of semiconductors as infrared optical elements or detectors. Polycrystalline forms of these semiconductors could be fabricated into windows, prisms, lenses, and domes by casting, grinding, and polishing. Compound semiconductors such as gallium arsenide (GaAs), ternary compounds such as gallium aluminum arsenide ( $\text{Ga}_{1-x}\text{Al}_x\text{As}$ ), and quaternary compounds such as indium gallium arsenide phosphide (InGaAsP) now serve as lasers, light-emitting diodes, and photodetectors. See SEMICONDUCTOR.

Single crystals are indispensable for transforming, amplifying, and modulating light. Birefringent crystals serve as retarders, or wave plates, which are used to convert the polarization state of the light. In many cases, it is desirable that the crystals not only

be birefringent, but also behave nonlinearly when exposed to very large fields such as those generated by intense laser beams. A few examples of such nonlinear crystals are ammonium dihydrogen phosphate (ADP), potassium dihydrogen phosphate (KDP), beta barium borate (BBO), lithium borate (LBO), and potassium titanyl phosphate (KTP). See CRYSTAL OPTICS; NON-LINEAR OPTICS.

Other optical materials are the liquid crystals used in displays as light valves, materials used in erasable optical disks for computers and in liquid cells (Kerr cells), laser dyes, dielectric multilayer films, filter materials, and the many metals (aluminum, gold, beryllium, and so forth) and alloys that are important as coating materials. See COMPUTER STORAGE TECHNOLOGY; KERR EFFECT; OPTICAL RECORDING. [J.S.Brø.]

**Optical microscope** An instrument used to obtain an enlarged image of a small object. In general, a compound microscope consists of a light source, a condenser, an objective, and an ocular or eyepiece, which can be replaced by a recording device such as a photoelectric tube or a photographic plate. The optical microscope is limited by the wavelengths of the light used and by the materials available for manufacturing the lenses.

**Magnifying power.** The quality and design of the lens system determines the magnifying power, details of image formation, and color correcting capabilities of a light microscope. The magnifying power of a compound microscope is the product of the magnification of the objective and the magnifying power of the eyepiece. The latter is computed like that of any magnifier. The magnification of the objective is equal to the distance from the second focal point to the image formed by the objective, divided by the focal length. An objective of 18-mm (0.7-in.) focal length thus has a power of  $10\times$ . It is customary to specify objectives in terms of magnifying power instead of focal length. The distance mentioned is called the optical tube length (generally 180 mm or 7 in.), and is to be distinguished from the mechanical tube length, which is the length of the mechanical tube itself. See MAGNIFICATION.

**Catadioptric systems.** Catadioptric systems have been developed for microscopes. Their great advantage is their comparatively small chromatic aberration. Pure mirror systems have no color aberrations. In catadioptric systems, therefore, it is customary to assign all the power to the mirror or mirrors, keeping the refracting system nearly afocal (Fig. 1a). The chromatic errors of the entire system remain small, and the refracting part can be used to correct the remaining monochromatic errors. All microscopic work in the ultraviolet region is done with catadioptric systems (Fig. 1b).

**Condensers.** An external auxiliary lens is used to condense the light from a light source so that the object is brightly and uniformly illuminated. The usual purpose of a condenser system is to make sure that as much light as possible coming from the object goes through an optical system. Condensers are used in macroscopic projection, in which an illuminated film or slide is imaged with the help of a projection objective or magnifier. In microscope systems, they are used to direct the light from a light source so that the rays from any object point fill most of the entrance pupil. A condenser system is usually arranged to image the light source onto the entrance pupil of the optical system (Köhler illumination). The condenser is generally corrected for spherical aberration, color, and sine condition, although the requirements are slightly different than in an image-forming system. [M.Her.]

**Light microscope.** The mirror, condenser, oculars, and body tube of the light microscope are frequently known as the optical train. The stand, stage, and adjustments comprise the mechanical part of the microscope.

A mirror is usually attached to the substage of the microscope to reflect light along the optic axis of the microscope. When no condenser is used, the concave mirror is used because it concentrates more light on the specimen; a plane mirror is used with a condenser.

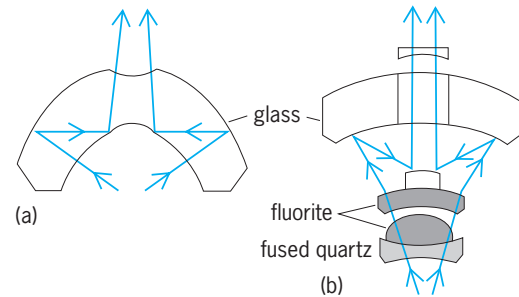

Fig. 1. Two types of catadioptric objective. (a) Maksutov type. (b) 53X, NA 0.72, ultraviolet objective, designed by Gray. Glass elements in the latter serve purely as reflectors. (Photographic Service Department, Kodak Research Laboratory)

Objectives vary from a simple doublet lens to complex corrected lens systems. Achromatic objectives are corrected for spherical aberration in one color and for chromatic aberrations in two colors. Apochromatic objectives are corrected to focus three colors together and the spherical aberration is minimized for two colors. The resolving power of an objective, the least distance at which two objects can be seen to be separate, is equal to the wavelength of light  $\lambda$  divided by the sum of the numerical apertures of the condenser and objective used. The larger the numerical aperture, the greater is the resolving power. Objectives are described also by the equivalent focal length. Objectives of shorter focal length have less depth of field, less working distance, and greater magnification.

Photomicrographic objectives are designed to produce a flat image with little distortion. For convenience, two to five objectives can be mounted on a revolving nosepiece to be parfocal and parcentric, so that the specimen remains almost in focus at the center of the field as the objectives are changed.

The commonly used Huygenian ocular has a fairly flat field with marked pincushion distortion. Compensating oculars complete the color correction for apochromatic objectives and have less distortion, but they do have curvature of field. See EYEPIECE.

The monocular body tube may be of adjustable length. American microscopes are designed for a mechanical tube length of 160 mm (6.3 in.) and a cover-glass thickness of 0.18 mm (0.007 in.). The draw tube is lengthened for thinner and shortened for thicker cover glasses to correct for the spherical aberrations from cover glasses of incorrect thickness.

Binocular bodies are designed for the use of both eyes. Most binocular bodies use prisms to reflect one-half of the light to each eye. Because each eye sees the same field, these binocular bodies do not give stereoscopic vision. The binocular is often longer than the monocular body and the proper tube length is maintained with a compensating lens.

**Inverted microscope.** The inverted microscope has the body of the microscope, including the objective and the ocular, below the stage and the illumination above the stage for transmitted light. The inverted microscope is especially useful for the examination of surfaces. Large and awkward specimens can be moved over the stage more readily than with the usual microscope. The inverted microscope is also useful for microdissection and the observation of hanging-drop preparations and is convenient for observing chemical reactions, melting-point determinations, and photomicrography.

**Comparison microscope.** The comparison microscope is an arrangement of two microscopes connected by a special viewing ocular so that the field of one microscope is seen at one side of a vertical dividing line and the field of the other microscope on the opposite side of the dividing line; or it may be a projection type of microscope in which the image is compared with a template or known pattern.

**Dissecting microscope.** Dissecting microscopes are of two types. The simplest is a magnifying glass mounted on a support above a glass plate, used for the dissection of materials.

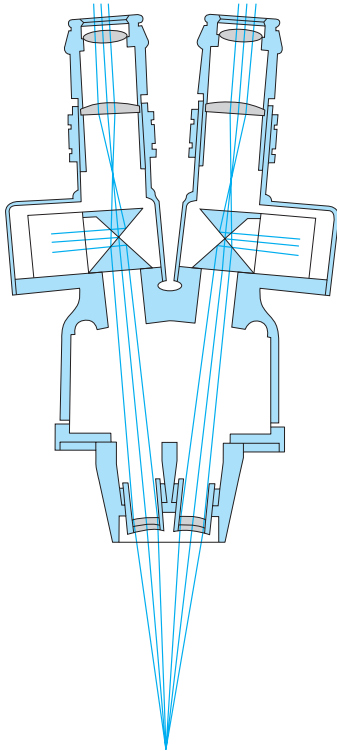

Fig. 2. Diagram of light rays as they pass through a binocular biobjective microscope.

The more usual dissecting microscope, often called a Greenough microscope, is a stereoscopic microscope composed of two separate microscopes fastened together and used as a single unit on one stand (Fig. 2). This is a truly stereoscopic instrument because the right eye sees the specimen from the right side and the left eye from the left side. Prisms are usually included in the body tube to erect the image; thus movements of the specimen are direct and are not reversed as with the monobjective microscope.

**Metallurgical microscope.** The metallurgical microscope is a laboratory microscope with a focusing stage and a vertical illuminator, used primarily for the examination of metal surfaces.

**Near-infrared microscopy.** Near-infrared microscopy is an optical method that can be used for studying a variety of materials that are opaque in transmitted visible light (400–700 nm) yet translucent in the near infrared (700–1200 nm). The method utilizes the near-infrared optical microscope, a device for the conversion of the near-infrared image to a visible image. [L.A.H.]

**Near-field optical microscopy.** A fundamental law of optics, the so-called diffraction limit, states that two objects can be imaged as separate entities only if their distance is larger by about one-half the wavelength of visible light, which ranges from 400 to 700 nm. As a consequence, conventional optical microscopy is restricted to a resolution of about 200 nm, and this is not enough for many important observations. The scanning near-field optical microscope (NSOM or SNOM) circumvents the diffraction limit. In contrast to nonoptical methods of surpassing this limit, such as electron microscopy, it can provide information on such qualities as color, luster, transmissivity, and birefringence, which are sensitive indicators of material composition and status. Furthermore, it operates at ambient conditions, a prerequisite for observations of living organisms. See MICROSCOPE. [D.W.Po.]

**Optical modulators** Devices that serve to vary some property of a light beam. The direction of the beam may be scanned as in an optical deflector, or the phase or frequency of

an optical wave may be modulated. Most often, however, the intensity of the light is modulated.

Rotating or oscillating mirrors and mechanical shutters can be used at relatively low frequencies (less than  $10^5$  Hz). However, these devices have too much inertia to operate at much higher frequencies. At higher frequencies it is necessary to take advantage of the motions of the low-mass electrons and atoms in liquids or solids. These motions are controlled by modulating the applied electric fields, magnetic fields, or acoustic waves in phenomena known as the electrooptic, magneto-optic, or acousto-optic effect, respectively. See ACOUSTOOPTICS; ELECTROOPTICS; KERR EFFECT; MAGNETOOPTICS. [I.PK.]

**Optical phase conjugation** A process that involves the use of nonlinear optical effects to precisely reverse the direction of propagation of each plane wave in an arbitrary beam of light, thereby causing the return beam to exactly retrace the path of the incident beam. The process is also known as wavefront reversal or time-reversal reflection. The unique features of this phenomenon suggest widespread application to the problems of optical beam transport through distorting or inhomogeneous media. Although closely related, the field of adaptive optics will not be discussed here. See ADAPTIVE OPTICS.

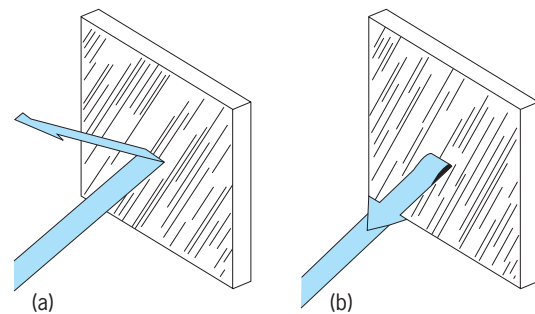

Comparison of reflections (a) from a conventional mirror and (b) from an optical phase conjugator. (After V. J. Corcoran, ed., *Proceedings for the International Conference on Laser '78 for Optical and Quantum Electronics*, STS Press, McLean, Virginia, 1979)

Optical phase conjugation is a process by which a light beam interacting in a nonlinear material is reflected in such a manner as to retrace its optical path. As the illustration shows, the image-transformation properties of this reflection are radically different from those of a conventional mirror. The incoming rays and those reflected by a conventional mirror (illus. a) are related by reversal of the component of the wave vector  $\vec{k}$  which is normal to the mirror surface. Thus a light beam can be arbitrarily redirected by adjusting the orientation of a conventional mirror. In contrast, a phase-conjugate reflector (illus. b) inverts the vector quantity  $\vec{k}$  so that, regardless of the orientation of the device, the reflected conjugate light beam exactly retraces the path of the incident beam. This retracing occurs even though an aberrator (such as a piece of broken glass) may be in the path of the incident beam. Looking into a conventional mirror, one would see one's own face, whereas looking into a phase-conjugate mirror, one would see only the pupil of the eye.

These new and remarkable image-transformation properties (even in the presence of a distorting optical element) open the door to many potential applications in areas such as laser fusion, atmospheric propagation, fiber-optic propagation, image restoration, real-time holography, optical data processing, nonlinear microscopy, laser resonator design, and high-resolution nonlinear spectroscopy. See HOLOGRAPHY; LASER; MIRROR OPTICS; NONLINEAR OPTICS; OPTICAL COMMUNICATIONS; OPTICAL FIBERS.

[R.A.F.; B.J.F.]



**Optical prism** A simple component, made of a light-refracting and transparent material such as glass and bounded by two or more plane surfaces at an angle, that is used in optical devices, especially to change the direction of light travel, to accomplish image rotation or inversion, and to disperse light into its constituent colors. Once light enters a prism, it can be reflected one or more times before it exits the prism.

A variety of prisms can be classified according to their function. Some prisms, such as the dove prism, can be used to rotate an image and to change its parity. Image inversion by prisms in traditional binoculars is a typical application. Some prisms take advantage of the phenomenon of total internal reflection to deviate light, such as the right-angle prism and the pentaprism used in single lens reflex cameras. A thin prism is known as an optical wedge; it can be used to change slightly the direction of light travel, and therefore it can be used in pairs as an alignment device. Optical wedges are also used in stereoscopic instruments to allow the viewer to observe the three-dimensional effect without forcing the eyes to point in different directions. A variable wedge can be integrated into a commercial pair of binoculars to stabilize the line of sight in the presence of the user's slight hand movements. Other prisms such as corner-cubes can be used to reflect light backward, and are fabricated in arrays for car and bicycle retroreflectors. See BINOCULARS; MIRROR OPTICS; PERISCOPE; RANGEFINDER (OPTICS); REFLECTION OF ELECTROMAGNETIC RADIATION.

An important application of a prism is to disperse light. When light enters at an angle to the face of a prism, it is refracted. Since the index of refraction depends on the wavelength, the light is refracted at different angles and therefore it is dispersed into a spectrum of colors. The blue color is refracted more than the red. When light reaches the second face of the prism, it is refracted again and the initial dispersion can be added to or canceled, depending on the prism angle. A combination of prisms in tandem can increase the amount of light dispersion. Dispensing prisms have been used in monochromators and spectroscopic instruments. With two prisms of different materials, it is possible to obtain light deviation without dispersion (an achromatic prism) or dispersion without deviation. See DISPERSION (RADIATION); REFRACTION OF WAVES; SPECTROSCOPY. [J.M.Sa.]

**Optical projection systems** Optical projection is the process whereby a real image of a suitably illuminated object is formed by an optical system in such a manner that it can be viewed, photographed, or otherwise observed. Essential equipment in an optical projection system consists of a light source, a condenser, an object holder, a projection lens, and (usually) a screen on which the image is formed (Fig. 1). For some important applications of optical projection see CINEMATOGRAPHY.

The luminance of the image in the direction of observation will depend upon (1) the average luminance of the image of the light source as seen through the projection lens from the image point under consideration, (2) the solid angle subtended by the exit pupil of the projection lens at this image point, and (3) the reflective or transmissive characteristics of the screen. Usually it is desirable to have this luminance as high as possible. Therefore, with a given screen, lens, and projection distance,

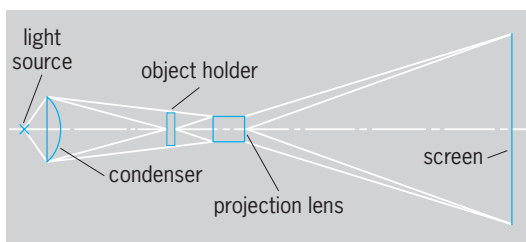

Fig. 1. A simple optical projection system.

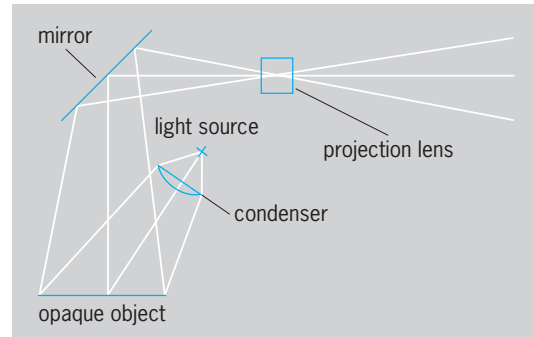

Fig. 2. An epidiascope, or system for projecting an image of an opaque object.

the best arrangement is to have the light source imaged in the projection lens, with its image filling the exit pupil as completely and as uniformly as possible.

The object is placed between the condenser and the projection lens. If transparent, it can be inserted directly in the light beam; however, it should be positioned, and the optical system should be so designed that it does not vignette (cut off) any of the image of the light source in the projection lens. If the object is opaque, an arrangement known as an epidiascope (Fig. 2) is used. [A.J.H.]

**Optical pulses** Bursts of electromagnetic radiation of finite duration. Optical pulses are used to transmit information or to record the chronology of physical events. The simplest example is the photographic flash. This was probably first developed by early photographers who used flash powder that, when ignited, produced a short burst of intense light. This was followed by the flash lamp, in which a tube filled with an inert gas such as xenon is excited by a brief electrical pulse. A great advance in the creation of short optical pulses came with the invention of the laser. Lasers are now the most common and effective way of generating a variety of short optical pulses, of different durations, energies, and wavelengths. See LASER; STROBOSCOPIC PHOTOGRAPHY.

Pulses of millisecond ( $10^{-3}$  s) duration are very simply generated by mechanically modulating a constant light source such as a lamp or a continuous-wave laser. This can be done, for example, by placing a rotating disk with holes in it in front of the light source. Shorter laser pulses, of microsecond ( $10^{-6}$  s) or nanosecond ( $10^{-9}$  s) duration, are generated by using a technique known as Q-switching. A modulating device is incorporated inside the laser cavity that allows the buildup of the laser radiation inside the cavity and then switches it out in an instant. The modulating device is usually controlled by external electrical pulses. Semiconductor diode lasers, which are used to transmit information (voice or data) over a fiber-optic cable, are pumped by electricity and can be directly pulsed by applying to them a pulsed electrical signal. See OPTICAL COMMUNICATIONS; OPTICAL FIBERS.

Ultrashort laser pulses, with durations of the order of picoseconds ( $1 \text{ ps} = 10^{-12}$  s) or femtoseconds ( $1 \text{ fs} = 10^{-15}$  s), are generated by using a general principle known as mode locking, whereby several frequency modes of the laser structure are made to resonate simultaneously and with a well-orchestrated relationship so as to form a short-duration pulse at the laser output.

Pulses as short as 11 fs have been produced directly by a passively mode-locked titanium:sapphire laser. The titanium:sapphire laser has also allowed the extension of ultrashort optical pulses to other wavelength ranges, such as the near-infrared ( $2\text{--}10 \mu\text{m}$ ). Dye lasers, based on organic dyes in solution, have achieved durations as short as 27 fs. Ultrashort diode laser pulses have been obtained by active and passive mode locking and produce pulses as short as a few hundred femtoseconds. They are more commonly operated so as to give rise to

pulses in the picosecond range, appropriate for optical communication systems.

The generation of ultrashort laser pulses has been motivated by the quest for ever better resolution in the study of the temporal evolution and dynamics of physical systems, events, and processes. Such laser pulses are capable of creating snapshots in time of many events that occur on the atomic or molecular scale, a technique known as time-resolved spectroscopy. This stroboscopic aspect of ultrashort laser pulses is their most important scientific application and is used in physics, engineering, chemistry, and biology. For example, ultrashort pulses can excite and take snapshots of molecular vibrations and deformations. They can track the passage of charge carriers through a microscopic semiconductor device. This ability to understand the dynamics of the more elemental building blocks of nature can in turn make it possible to build ever faster devices for use in information processing and information transmission, in addition to providing a better understanding of the physical world. See LASER PHOTO-CHEMISTRY; LASER SPECTROSCOPY; OPTICAL INFORMATION SYSTEMS; ULTRAFast MOLECULAR PROCESSES. [P.C.Be.]

**Optical pumping** The process of causing strong deviations from thermal equilibrium populations of selected quantized states of different energy in atomic or molecular systems by the use of optical radiation (that is, light of wavelengths in or near the visible spectrum), called the pumping radiation.

Optical pumping is vital for light amplification by stimulated emission in an important class of lasers. For example, the action of the ruby laser involves the fluorescent emission of red light by a transition from an excited level  $E_2$  to the ground level  $E_1$ . In this case  $E_2$  is relatively high above  $E_1$  and the equilibrium population of  $E_2$  is practically zero. Amplification of the red light by laser action requires that number of atoms  $N_2$  exceed  $N_1$  (population inversion). The inversion is accomplished by intense green and violet light from an external source which excites the chromium ion in the ruby to a band of levels,  $E_3$  above  $E_2$ . From  $E_3$  the ion rapidly drops without radiation to  $E_2$ , in which its lifetime is relatively long for an excited state. Sufficiently intense pumping forces more luminescent ions into  $E_2$  by way of the  $E_3$  levels than remain in the ground state  $E_1$ , and amplification of the red emission of the ruby by stimulated emission can then occur. See LASER. [W.W.]

**Optical recording** The process of recording signals on a medium through the use of light, so that the signals may be reproduced at a subsequent time. Photographic film has been widely used as the medium, but in the late 1970s development of another medium, the so-called optical disk, was undertaken. The introduction of the laser as a light source greatly improves the quality of reproduced signals. The pulse-code modulation (PCM) techniques make it possible to obtain extremely high-fidelity reproduction of sound signals in optical disk recording systems.

**Optical film recording.** Optical film recording is also termed motion picture recording or photographic recording. A sound motion picture recording system consists basically of a modulator for producing a modulated light beam and a mechanism for moving a light-sensitive photographic film relative to the light beam and thereby recording signals on the film corresponding to the electrical signals. A sound motion picture reproducing system is basically a combination of a light source, an optical system, a photoelectric cell, and a mechanism for moving a film carrying an optical record by means of which the recorded photographic variations are converted into electrical signals of approximately similar form.

In laser-beam film recording, an optical film system utilizes a laser as a light source, a combination of an acoustooptical modulator (AOM) and an acoustooptical deflector (AOD) instead of a galvanometer. A 100-kHz pulse-width modulation (PWM) circuit converts the audio input signal into a PWM signal. The

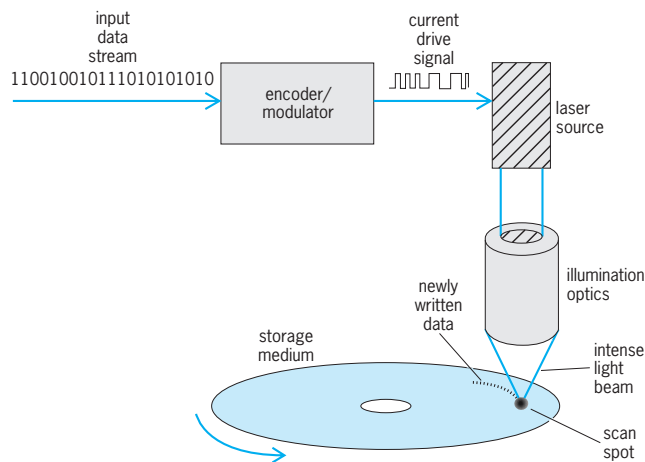
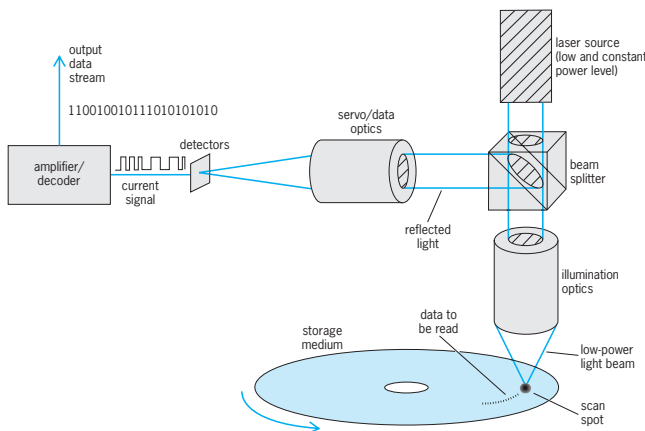

**Fig. 1. Recording process for a simple optical medium. Writing data into the recording layers involves modulating an intense laser beam as the layers move under the scan spot.**

laser beam is made to continuously scan the sound track area at right angles to the direction of the film transport. This is done by means of the acoustooptical deflector, which in turn is driven by a 100-kHz sawtooth signal. Simultaneously, the laser beam is pulse-width-modulated by means of the acoustooptical modulator, which is driven by a 100-kHz PWM signal. The scanning signal and the pulse-width-modulated signal combine and generate the variable-area sound track exposure on the film. The traces of successive scans are fused into a pattern of variable-area recording. [H.D.]

**Optical data storage.** Optical data storage involves placing information in a medium so that, when a light beam scans the medium, the reflected light can be used to recover the information. There are many forms of storage media, and many types of systems are used to scan data.

In the recording process (Fig. 1), an input stream of digital information is converted with an encoder and modulator into a drive signal for a laser source. The laser source emits an intense light beam that is directed and focused into the storage medium with illumination optics. As the medium moves under the scanning spot, energy from the intense scan spot is absorbed, and a small localized region heats up. The storage medium, under the influence of the heat, changes its reflective properties. Since the light beam is modulated in correspondence to the input data stream, a circular track of data marks is formed as the medium



**Fig. 2. Readout of an optical medium. Low-power laser beam illuminates the recording layers, and modulation of the reflected light is observed with the detectors. Beam splitter serves to direct a portion of the reflected light to detectors.**

rotates. After every revolution, the path of the scan spot is changed slightly in radius to allow another track to be written.

In readout of the medium (Fig. 2), the laser is used at a constant output power level that will not heat the medium beyond its thermal writing threshold. The laser beam is directed through a beam splitter into the illumination optics, where the beam is focused into the medium. As the data to be read pass under the scan spot, the reflected light is modulated. The modulated light is collected by the illumination optics and directed by the beam splitter to the servo and data optics, which converge the light onto detectors. The detectors change the light modulation into current modulation that is amplified and decoded to produce the output data stream.

Optical media can be produced in several different configurations. The most common configuration is the single-layer disk, such as the compact disk (CD), where data are recorded in a single storage layer. A substrate provides mechanical support for the storage layer. The substrate also provides a measure of contamination protection, because light is focused through the substrate and into the recording layer. Dust particles on the surface of the substrate only partially obscure the focused beam, so enough light can penetrate for adequate signal recovery. See COMPACT DISK.

In order to increase data capacity of the disk, several layers can be used. Each layer is partially transmitting, which allows a portion of the light to penetrate throughout the thickness of the layers. The scan spot is adjusted by refocusing the illumination optics so that only one layer is read out at a time.

Data can also be recorded in volumetric configurations. As with the multiple-layer disk, the scan spot can be refocused throughout the volume of material to access information. Volumetric configurations offer the highest efficiency for data capacity, but they are not easily paired with simple illumination optics.

The final configuration is to place the information on a flexible surface, such as ribbon or tape. As with magnetic tape, the ribbon is pulled under the scan spot and data are recorded or retrieved. Flexible media have about the same capacity efficiency as volumetric storage. The advantage of a flexible medium over a volumetric medium is that no refocusing is necessary. The disadvantage is that a moderately complicated mechanical system must be used to move the ribbon.

There are several types of optical storage media. The most popular media are based on pit-type, magneto-optic, phase-change, and dye-polymer technologies. CD and digital versatile disc (DVD) products use pit-type technology. Erasable disks using magneto-optic (MO) technology are popular for workstation environments. Compact-disk-rewritable (CD-RW) products [also known as compact-disk-erasable (CD-E)] use phase-change technology, and compact-disk-recordable (CD-R) products use dye-polymer technology. CD and DVD products are read-only memories (ROMs); that is, they are used for software distribution and cannot be used for recording information. CD-R products can be used for recording information, but once the information is recorded, they cannot be erased and reused. Both CD-RW and MO products can be erased and reused. [T.D.M.; G.T.Si.]

**Optical rotatory dispersion** The change in rotation as a function of wavelength experienced by linearly polarized light as it passes through an optically active substance. See OPTICAL ACTIVITY.

In all materials the rotation varies with wavelength. The variation is caused by two quite different phenomena. The first accounts in most cases for the majority of the variation in rotation and should not strictly be termed rotatory dispersion. It depends on the fact that optical activity is actually circular birefringence. In other words, a substance which is optically active transmits right circularly polarized light with a different velocity from left circularly polarized light.

In addition to this pseudodispersion which depends on the material thickness, there is a true rotatory dispersion which depends on the variation with wavelength of the indices of refraction for right and left circularly polarized light. See POLARIZED LIGHT. [B.H.Bi.]

For wavelengths that are absorbed by the optically active sample, the two circularly polarized components will be absorbed to differing extents. This unequal absorption is known as circular dichroism. Circular dichroism causes incident linearly polarized light to become elliptically polarized. See ABSORPTION.

Optical rotatory dispersion and circular dichroism are closely related, just as are ordinary absorption and dispersion. If the entire optical rotatory dispersion spectrum is known, the circular dichroism spectrum can be calculated, and vice versa.

In order for a molecule (or crystal) to exhibit circular birefringence and circular dichroism, it must be distinguishable from its mirror image. An object that cannot be superimposed on its mirror image is said to be chiral, and optical rotatory dispersion and circular dichroism are known as chiroptical properties.

Most biological molecules have one or more chiral centers and undergo enzyme-catalyzed transformations that either maintain or reverse the chirality at one or more of these centers. Still other enzymes produce new chiral centers, always with a high specificity. These properties account for the fact that optical rotatory dispersion and circular dichroism are widely used in organic and inorganic chemistry and in biochemistry. See ENZYME; STEREO-CHEMISTRY.

In the absence of magnetic fields, only chiral substances exhibit optical rotatory dispersion and circular dichroism. In a magnetic field, even substances that lack chirality rotate the plane of polarized light, as shown by M. Faraday. Magnetic optical rotation is known as the Faraday effect, and its wavelength dependence is known as magnetic optical rotatory dispersion. In regions of absorption, magnetic circular dichroism is observable. See FARADAY EFFECT. [R.W.Wo.]

**Optical surfaces** Interfaces between different optical media at which light is refracted or reflected. From a physical point of view, the basic elements of an optical system are such things as lenses and mirrors. However, from a conceptual point of view, the basic elements of an optical system are the refracting or reflecting surfaces of such components. Surfaces are the basic elements of an optical system because they are the elements that affect the light passing through the system. Every wavefront has its curvature changed on passing through each surface so that the final set of wavefronts in the image space may converge on the appropriate image points. Also, the aberrations of the system depend on each surface, the total aberrations of the system being the sum of the aberrations generated at the individual surfaces. See ABERRATION (OPTICS); REFLECTION OF ELECTROMAGNETIC RADIATION; REFRACTION OF WAVES.

Optical systems are designed by ray tracing, and refraction at an optical surface separating two media of different refractive index is the fundamental operation in the process. The transfer between two surfaces is along a straight line if, as is usually the case, the optical media are homogeneous. The refraction of the ray at a surface results in a change in the direction of the ray. This change is governed by Snell's law.

The vast majority of optical surfaces are spherical in form. This is so primarily because spherical surfaces are much easier to generate than nonspherical, or aspheric, surfaces. Moreover, lens systems seldom need aspherics because the aberrations can be controlled by changing the shape of the component lenses without changing their function in the system, apart from modifying the aberrations. Also, many lens components can be included in a lens system in order to control the aberrations. See LENS (OPTICS).

On the other hand, mirror systems usually require aspheric surfaces. Unlike lenses, where the shape can be changed to modify the aberrations, mirrors cannot be changed except by

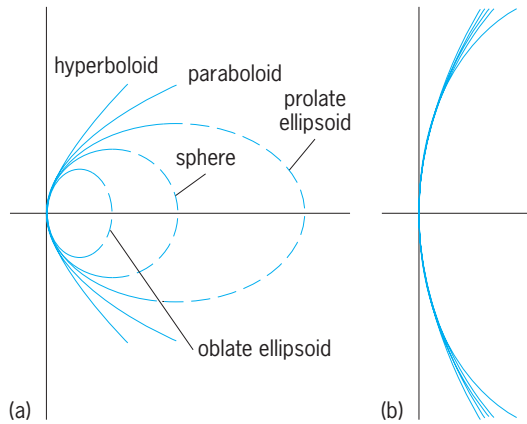

**Conics of revolution. (a) Cross sections of entire surfaces. (b) Cross sections of portions near the optical axis.**

introducing aspheric surfaces. Mirror systems are further constrained by the fact that only a few mirrors, usually two, are used in a system because each successive mirror occludes part of the beam going to the mirror preceding it. See MIRROR OPTICS.

The most common form of rotationally symmetric surface is the conic of revolution. The departure of conic surfaces from spherical form is shown in the illustration. The classical virtue of the conics of revolution for mirrors is the fact that light from a point located at one focus of the conic is perfectly imaged at the other focus. If these conic foci are located on the axis of revolution, the mirror is free of spherical aberration for such conjugate points. See CONIC SECTION. [R.V.S.]

**Optical tracking instruments** A family of optical instruments used for precise time-correlated observation of distant airplanes, missiles, and artificial satellites, all of which travel at apparent velocities much greater than those of most astronomical objects. The instruments supply permanent engineering records for the determination of spatial position, missile attitude, structural behavior, and performance of specific mechanisms. These observations enable engineers to correct design, improve performance, and collect scientific data from missiles and satellites at extreme distances and altitudes.

Optical tracking instruments were used initially for photographic recording of distant engineering events and for the determination of their spatial position. Tracking telescopes were the basic engineering event-recording systems, while cinetheodolites and ballistic cameras were used for precise spatial position. Electrooptical sensors and computer developments have expanded the family of optical tracking instruments to include television and laser detection and tracking of objects out to geosynchronous orbits. The proliferation of sensors has led to the development of flexible optical tracking instruments (see illustration) capable of accommodating a variety of photographic and electrooptical sensors. These sensors have been combined with computer controllers to develop automatic tracking instruments offering both event and position functions in one instrument. The further addition of laser ranging capability permits single-station position solutions along with tracking telescope engineering event recording.

Spatial position determination can be considered the determination of the position of a moving target using dynamic adaptations of the methods of civil surveying. The classical techniques utilize a minimum of four instruments on precisely measured baselines to locate a moving target. Each instrument records the data for computing the direction of the line of sight to the target for each instant of time. This information, in the form of analog or digital elevation and azimuth angles, the times of observation, and the known location of each instrument, is used to triangulate

for the location of the missile as a function of time. See SURVEYING.

**Cinetheodolites.** Most of the spatial position work is performed by cinetheodolites, which are surveying theodolites having 35-mm motion picture cameras with 45–120-in. focal-length (1.2–3-m) lenses substituted for the surveyor's eye and telescope. The system of cameras is synchronized up to a maximum of 30 frames per second from a master control station for simultaneous exposure as the cinetheodolites follow the moving missile. Each photograph records the elevation angle, the azimuth angle, the missile image, and the reticle lines which define the instrumental axis.

**Ballistic cameras.** These are fixed-axis, wide-angle, photographic-plate cameras capable of more precise spatial position determination by recording on one plate multiple exposures of the missile against a stellar background. Use of a static system and precisely cataloged star positions decreases the necessity for long-term mechanical stability and accuracy, allowing ballistic cameras to achieve 2–5 seconds' angular accuracy. Pyrotechnic flares of electronic stroboscopic lamps at the missile are used to indicate the missile positions against the night sky.

**Tracking telescopes.** These are long-focal-length telescopes mounted to track missiles in flight precisely while collecting missile performance data. The first systems were crude attempts to track manually with 35-mm cameras of 12–24-in. (30–60-cm) focal length. Increased focal length led to the use of geared, manually driven naval gun mounts and variable-speed, belt-driven machine gun mounts with the telescopes substituted for the armament. In all such systems, the tracking operator observes the missile through an optical sight while controlling the orientation of the telescope to ensure that the missile remains within its field. The advent of computer control and electrooptical automatic tracking systems has resulted in the adaption of direct-drive torque motor systems to replace the electrohydraulic systems.



**KINETO Model 433 Tracking Mount** shown with 100- and 200-in. focal-length (2.5- and 5.1-m) motion picture cameras, both with 12-in. (30-cm) aperture, and a 40–240-in. focal-length (1.0–6.1-m), 6-in.-aperture (15-cm) television camera. The fourth platform is reserved for either a laser ranger or a thermal imaging system. (Contraves Goerz Corp.)

**Satellite optical tracking.** Satellites equipped with retroreflectors have been placed in orbits at altitudes which minimize gravitational and atmospheric anomalies. Satellites, such as Lageos with a 3700-mi (6000-km) orbit, are the basis of laser ranging measurements which require precise optical tracking to be effective.

The orbit of the satellite becomes the basis of measurements because of its regularity. Operation requires that the optical tracking systems must direct a 10-arc-second laser beam along the predicated laser path. Hundreds of laser ranging measurements are then made from two locations. The satellite ephemeris then becomes the yardstick for measuring the location relative to other measured points. This technique is used for geodetic and geophysical studies of polar motion, Earth rotation, gravimetric and tide models, and precise geoid determination. See ASTRONOMICAL PHOTOGRAPHY; CAMERA; GEODESY; LASER; LENS (OPTICS); SATELLITE (SPACECRAFT); TELESCOPE. [G.A.E.]

**Optics** Narrowly, the science of light and vision; broadly, the study of the phenomena associated with the generation, transmission, and detection of electromagnetic radiation in the spectral range extending from the long-wave edge of the x-ray region to the short-wave edge of the radio region. This range, often called the optical region or the optical spectrum, extends in wavelength from about 1 nanometer to about 1 millimeter. See GEOMETRICAL OPTICS; METEOROLOGICAL OPTICS; PHYSICAL OPTICS; VISION.

The discoveries of the experimentalists of the early 17th century formed the basis of the science of optics. The statement of the law of refraction, the development of the astronomical telescope, observations of diffraction, and the principles of the propagation of light all came in this relatively short period. The publication of Isaac Newton's *Opticks* in 1704, with its comprehensive and original studies of refraction, dispersion, interference, diffraction, and polarization, established the science.

In the early nineteenth century many productive investigators established the transverse-wave nature of light. The relationship between optical and magnetic phenomena led to the crowning achievement of classical optics—the electromagnetic theory of J. C. Maxwell. Maxwell's theory, which holds that light consists of electric and magnetic fields propagated together through space as transverse waves, provided a general basis for the treatment of optical phenomena. In particular, it served as the basis for understanding the interaction of light with matter and, hence, as the basis for treatment of the phenomena of physical optics. See ELECTROMAGNETIC RADIATION; LIGHT; MAXWELL'S EQUATIONS.

In the twentieth century optics has been in the forefront of the revolution in physical thinking caused by the theory of relativity and especially by the quantum theory.

The science of optics finds itself in a position that is satisfactory for practical purposes but less so from a theoretical standpoint. The theory of Maxwell is sufficiently valid for treating the interaction of high-intensity radiation with systems considerably larger than those of atomic dimensions. The modern quantum theory is adequate for an understanding of the spectra of atoms and molecules and for the interpretation of phenomena involving low-intensity radiation, provided one does not insist on a very detailed description of the process of emission or absorption of radiation. However, a general theory of relativistic quantum electrodynamics valid for all conditions and systems has not been worked out.

The development of the laser has been an outstanding event in the history of optics. The theory of electromagnetic radiation from its beginnings was able to comprehend and treat the properties of coherent radiation, but the controlled generation of coherent monochromatic radiation of high power was not achieved in the optical region until the work of C. H. Townes and A. L. Schawlow in 1958 pointed the way. Many achievements in optics, such as holography and interferometry over long paths,

have resulted from the laser. See HOLOGRAPHY; INTERFEROMETRY; LASER. [R.C.L.]

**Optimal control (linear systems)** A branch of modern control theory that deals with designing controls for linear systems by minimizing a performance index that depends on the system variables. Under some mild assumptions, making the performance index small also guarantees that the system variables will be small, thus ensuring closed-loop stability. See CONTROL SYSTEM STABILITY.

Classical control theory applies directly in the design of controls for systems that have one input and one output. Complex modern systems, however, have multiple inputs and outputs. Examples include aircraft, satellites, and robot manipulators, which, though nonlinear, can be linearized about a desired operating point. Modern control theory was developed, beginning about 1960, for these multivariable systems. It is characterized by a state-space description of systems, which involves the use of matrices and linear algebra, and by the use of optimization techniques to determine the control policies. These techniques facilitate the use of modern digital computers, which lead to an interactive approach to design of controls for complex systems. See DIGITAL COMPUTER; LINEAR ALGEBRA; MATRIX THEORY; MULTIVARIABLE CONTROL; OPTIMIZATION.

The multivariable state-variable description is of the form of Eqs. (1), where  $u(t)$  is an  $m$ -dimensional control input vector and

$$\dot{x} = Ax + Bu \quad z = Hx \quad (1)$$

$z(t)$  is a performance output vector for which there are specified performance requirements. The state  $x(t)$  is an internal variable of dimension  $n$  that describes the energy storage properties of the system. Matrices  $A$  and  $B$  describe the system dynamics and are determined by a physical analysis using, for example, Newton's laws of motion. They may in general be time-varying. Matrix  $H$  is chosen to select the variables of importance as the performance outputs. In the case of nonlinear systems, the description of Eq. (1) results when the system is linearized about a desired operating point. See LINEAR SYSTEM ANALYSIS; NONLINEAR CONTROL THEORY.

Traditionally, modern control-system design assumes that all the states  $x(t)$  are available for feedback so that the control input is of the form of Eq. (2), where  $K(t)$  is an  $m \times n$  feedback gain

$$u = -Kx \quad (2)$$

matrix, generally time-varying. Substituting the control of Eq. (2) into the system of Eq. (1) yields the closed-loop system given in Eqs. (3). The control design problem is to choose the  $mn$  entries

$$\dot{x} = (A - BK)x \quad z = Hx \quad (3)$$

of the feedback matrix  $K$  to yield a desired closed-loop behavior of the performance output  $z(t)$ .

To obtain satisfactory performance of the system of Eq. (1), a quadratic performance index of the form of Eq. (4) may be

$$J = \frac{1}{2}x^T(T)S(T)x(T) + \frac{1}{2} \int_0^T (x^T Qx + u^T R u) dt \quad (4)$$

chosen, where  $[0, T]$  is the time interval of interest and the symmetric weighting matrices  $S(T)$ ,  $Q$ , and  $R$  are design parameters that are selected to obtain the required performance. They must be chosen so that  $x^T(T)S(T)x(T) \geq 0$  and  $x^T Qx \geq 0$  for all  $x(t)$ , and  $u^T R u > 0$  for all  $u(t)$ . That is,  $Q$  and  $S(T)$  should be positive semidefinite while  $R$  should be positive definite. [F.L.L.]

**Optimal control theory** An extension of the calculus of variations for dynamic systems with one independent variable, usually time, in which control (input) variables are determined to maximize (or minimize) some measure of the performance (output) of a system while satisfying specified constraints. Theory is conveniently divided into two parts: optimal programming, where the control variables are determined as functions of time

for a specified initial state of the system, and optimal feedback control, where the control variables are determined as functions of the current state of the system.

Examples of optimal control problems are: (1) determining paths of vehicles between two points to minimize fuel or time, and (2) determining feedback control logic for vehicles or industrial processes to keep them near a desired operating point in the presence of disturbances with acceptable control magnitudes.

Dynamic systems are conveniently divided into two categories: continuous dynamic systems, where the control and state variables are functions of a continuous independent variable, such as time or distance, and discrete dynamic systems, where the independent variable changes in discrete increments. Many discrete systems are discretized versions of continuous systems; the discretization is often made so that (1) the system can be analyzed or controlled by digital computers (or both), or (2) measurements of continuous outputs are made at discrete intervals of time (sampled-data systems) in order to share data transmission channels.

A large class of interesting optimal control problems can be described as follows: the dynamic system is described by a set of coupled first-order ordinary differential equations of the form of Eq. (1), where  $x$  (the state vector) represents the state variables

$$\dot{x} = f(x, u, t) \quad (1)$$

of the system (such as position, velocity, temperature, voltage, and so on);  $u$  (the control vector) represents the control variables of the system (such as motor torque, control-surface deflection angle, valve opening, and so on);  $t$  is time; and  $f$  represents a set of functions of  $x$ ,  $u$ , and  $t$ . The performance index  $J$ , which one desires to minimize, is a scalar function of the final time  $t_f$  and the final state  $x(t_f)$  plus an integral from the initial time  $t_0$  to the final time  $t_f$  of a scalar function of the state and control vectors and time, as given in Eq. (2). Possible constraints include: (a)

$$J = \varphi[x(t_f), t_f] = \int_{t_0}^{t_f} L[x(t), u(t), t] dt \quad (2)$$

specified vector functions constraining the initial time  $t_0$  and the initial state  $x(t_0)$ , as in Eq. (3); (b) specified vector functions con-

$$\alpha[x(t_0), t_0] = 0 \quad (3)$$

straining the final time and final state, as in Eq. (4); (c) specified vector functions constraining the control variables [inequality

$$\psi[x(t_f), t_f] = 0 \quad (4)$$

(5)]; (d) specified vector functions constraining both control and

$$C[u(t), t] \leq 0 \quad (5)$$

state variables [inequality (6)]; and (e) specified vector functions

$$CS[x(t), u(t), t] \leq 0 \quad (6)$$

constraining only the state variables [inequality (7)]. Constraints  $a$  and  $b$  are equality constraints, whereas constraints  $c$ ,  $d$ , and  $e$

$$S[x(t), t] \leq 0 \quad (7)$$

are inequality constraints. See LINEAR SYSTEM ANALYSIS.

**Classes of problems.** There are several important classes of optimal control problems.

**Bang-bang control** is a type of control in which the control variables are either at their maximum or at their minimum values, never in between. This type of control is optimal, for example, in certain minimum-fuel problems where the control variables enter linearly into system equations (1), the performance index in Eq. (2), and the constraints in Eq. (5). See NONLINEAR CONTROL THEORY.

**Bang-zero-bang control** is a type of control in which the control values are at their maximum values, zero, or their minimum values. This type of control is optimal, for example, in certain

minimum-fuel problems where the control variables enter linearly into system equations (1) and the constraints in Eq. (5), and the performance index depends on the magnitude (but not the sign) of the control variables.

Linear-quadratic problems are problems in which system equations (1) are linear and the performance index in Eq. (2) is quadratic in the states  $x$  and the control  $u$ .

Neighboring optimum feedback control (NOFC) about a nominal optimal path is a viable alternative to a "complete" optimal feedback control solution. NOFC constitutes an approximation to the optimal feedback control solution in a region neighboring the nominal optimal path.

**Stochastic optimal control theory.** This takes into consideration, in an ensemble average sense, random disturbances on the dynamic system, random initial conditions, and random errors in measurements. A control design is sought that maximizes (or minimizes) the performance criterion on the average and satisfies the constraints within certain tolerances, also on the average. See ESTIMATION THEORY; STOCHASTIC CONTROL THEORY; STOCHASTIC PROCESS.

**Differential games.** These are two-sided optimal control problems. Typically, control system A tries to minimize the performance criterion, while control system B tries to maximize it. This may lead to a minimax feedback strategy in which both systems do their best, taking into account the other controller's intelligence in seeking the opposite goal. See CONTROL SYSTEMS; DECISION THEORY; GAME THEORY. [A.E.Br.]

**Optimization** The design and operation of systems or processes to make them as good as possible in some defined sense. The approaches to optimizing systems are varied and depend on the type of system involved, but the goal of all optimization procedures is to obtain the best results possible (again, in some defined sense) subject to restrictions or constraints that are imposed. While a system may be optimized by treating the system itself, by adjusting various parameters of the process in an effort to obtain better results, it generally is more economical to develop a model of the process and to analyze performance changes that result from adjustments in the model. In many applications, the process to be optimized can be formulated as a mathematical model; with the advent of high-speed computers, very large and complex systems can be modeled, and optimization can yield substantially improved benefits.

Optimization is applied in virtually all areas of human endeavor, including engineering system design, optical system design, economics, power systems, water and land use, transportation systems, scheduling systems, resource allocation, personnel planning, portfolio selection, mining operations, blending of raw materials, structural design, and control systems. Optimizers or decision makers use optimization in the design of systems and processes, in the production of products, and in the operation of systems.

The first step in modern optimization is to obtain a mathematical description of the process or the system to be optimized. A mathematical model of the process or system is then formed on the basis of this description. Depending on the application, the model complexity can range from very simple to extremely complex. An example of a simple model is one that depends on only a single nonlinear algebraic function of one variable to be selected by the optimizer (the decision maker). Complex models may contain thousands of linear and nonlinear functions of many variables. As part of the procedure, the optimizer may select specific values for some of the variables, assign variables that are functions of time or other independent variables, satisfy constraints that are imposed on the variables, satisfy certain goals, and account for uncertainties or random aspects of the system.

System models used in optimization are classified in various ways, such as linear versus nonlinear, static versus dynamic, deterministic versus stochastic, or time-invariant versus time-varying. In forming a model for use with optimization, all of

the important aspects of the problem should be included, so that they will be taken into account in the solution. The model can improve visualization of many interconnected aspects of the problem that cannot be grasped on the basis of the individual parts alone. A given system can have many different models that differ in detail and complexity. Certain models (for example, linear programming models) lend themselves to rapid and well-developed solution algorithms, whereas other models may not. When choosing between equally valid models, therefore, those that are cast in standard optimization forms are to be preferred. See MODEL THEORY.

The model of a system must account for constraints that are imposed on the system. Constraints restrict the values that can be assumed by variables of a system. Constraints often are classified as being either equality or inequality constraints. The types of constraints involved in any given problem are determined by the physical nature of the problem and by the level of complexity used in forming the mathematical model.

Constraints that must be satisfied are called rigid constraints. Physical variables often are restricted to be nonnegative; for example, the amount of a given material used in a system is required to be greater than or equal to zero. Rigid constraints also may be imposed by government regulations or by customer-mandated requirements. Such constraints may be viewed as absolute goals.

In contrast to rigid constraints, soft constraints are those constraints that are negotiable to some degree. These constraints can be viewed as goals that are associated with target values. The amount that the goal deviates from its target value could be considered in evaluating trade-offs between alternative solutions to the given problem.

When constraints have been established, it is important to determine if there are any solutions to the problem that simultaneously satisfy all of the constraints. Any such solution is called a feasible solution, or a feasible point in the case of algebraic problems. The set of all feasible points constitutes the feasible region.

If no feasible solution exists for a given optimization problem, the decision maker may relax some of the soft constraints in an attempt to create one or more feasible solutions; a class of approaches to optimization under the general heading of goal programming may be employed to relax soft constraints in a systematic way to minimize some measure of maximum deviations from goals.

A key step in the formulation of any optimization problem is the assignment of performance measures (also called performance indices, cost functions, return functions, criterion functions, and performance objectives) that are to be optimized. The success of any optimization result is critically dependent on the selection of meaningful performance measures. In many cases, the actual computational solution approach is secondary. Ways in which multiple performance measures can be incorporated in the optimization process are varied. [D.A.Pi.]

**Oral glands** Glands located in the mouth that secrete fluids to moisten and lubricate the mouth and food and may initiate digestive activity, and that may perform other specialized functions. Fishes and aquatic amphibians have only solitary mucus-secreting cells in the epithelium of the mouth cavity. Multicellular glands first appeared in land animals to keep the mouth moist and make food easier to swallow. Some glands of terrestrial amphibians have a lubricative secretion; others serve to make the tongue sticky for use in catching insects. Some frogs secrete a serous fluid that contains ptyalin, a digestive enzyme. The oral glands of reptiles are much the same, but are more distinctly grouped. In poisonous snakes and the single poisonous lizard, the Gila monster, certain oral glands of the serous type are modified to form venom. Also many of the lizards have glands that are mixed in character, containing both mucous and serous cells. Oral glands are poorly developed in crocodilians and sea turtles.

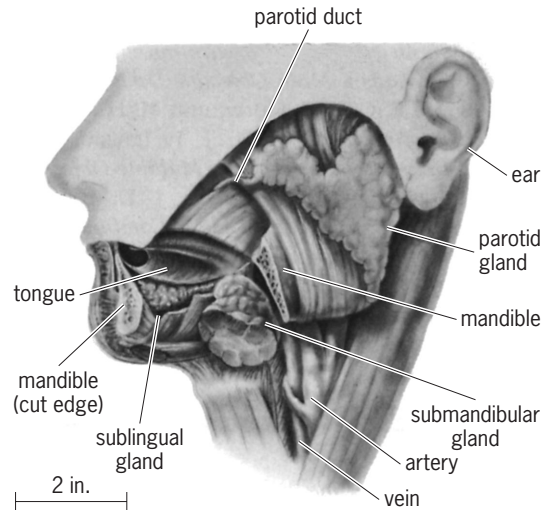

The salivary glands, shown by a partial dissection of the head. (After J. C. Brash, ed., *Cunningham's Textbook of Anatomy, 9th ed., Oxford, 1951*)

Birds bolt their food, yet grain eaters have numerous glands, some of which secrete ptyalin.

All mammals except aquatic forms are well supplied with oral glands. There are numerous small glands, such as the labial glands of the lips, buccal glands of the cheeks, lingual glands of the tongue, and palatine glands of the palate. Besides these, there are larger paired sets in mammals that are quite constant from species to species and are commonly designated as salivary glands (see illustration). The parotid gland, near each ear, discharges into the vestibule. The submaxillary or submandibular gland lies along the posterior part of the lower jaw; its duct opens well forward under the tongue. The sublingual gland lies in the floor of the mouth. It is really a group of glands, each with its duct. See GLAND. [L.B.A.]

**Orange** The sweet orange (*Citrus sinensis*) is the most widely used species of citrus fruit and commercially is the most important. The sour or bitter oranges, of lesser importance, are distinct from sweet oranges and are classified as a separate species, *C. aurantium*. The United States is the largest producer of oranges, followed by Spain, Italy, and Brazil. The orange is also a major crop in several other countries.

Sweet orange fruit is consumed fresh or as frozen or canned juice. A large portion of the crop, particularly in the United States, is used as frozen concentrate. After the juice is extracted, the peel and pulp are used for cattle feed. Peel oil is used in perfumes and flavoring, and citrus molasses is used as a livestock feed.

The sweet orange tree is a moderately vigorous evergreen with a rounded, densely foliated top. The fruits are round or somewhat elongate and usually orange-colored when ripe. They can be placed in four groups: the common oranges, acid-less oranges, pigmented oranges, and navel oranges. They may also be distinguished on the basis of early midseason, and late maturity. See FRUIT; FRUIT, TREE. [R.K.So.]

**Orbital motion** In astronomy the motion of a material body through space under the influence of its own inertia, a central force, and other forces. Johann Kepler found empirically that the orbital motions of the planets about the Sun are ellipses. Sir Isaac Newton, starting from his laws of motion, proved that an inverse-square gravitational field of force requires a body to move in an orbit that is a circle, ellipse, parabola, or hyperbola.

Two bodies revolving under their mutual gravitational attraction, but otherwise undisturbed, describe orbits of the same shape about a common center of mass. The less massive body

has the larger orbit. In the solar system, the Sun and Jupiter have a center of mass just outside the visible disk of the Sun. For each of the other planets, the center of mass of Sun and planet lies within the Sun.

For this reason, it is convenient to consider only the relative motion of a planet of mass  $m$  about the Sun of mass  $M$  as though the planet had no mass and moved about a center of mass  $M + m$ . The orbit so determined is exactly the same shape as the true orbits of planet and Sun about their common center of mass, but it is enlarged in the ratio  $(M + m)/M$ . See CENTER OF MASS; PLANET.

Orbital velocity  $v$  of a planet moving in a relative orbit about the Sun may be expressed by Eq. (1) where  $a$  is the semimajor

$$v^2 = G(M + m) \left( \frac{2}{r} - \frac{1}{a} \right) \quad (1)$$

axis, and  $r$  is the distance from the planet to the Sun. In the special case of a circular orbit,  $r = a$ , and the expression becomes Eq. (2). When the eccentricity of an orbit is exactly unity, the

$$v^2 = \frac{G(M + m)}{a} \quad (2)$$

length of the major axis becomes infinite and the ellipse degenerates into a parabola. The expression for the velocity then becomes Eq. (3). This parabolic velocity is referred to as the ve-

$$v^2 = G(M + m) \left( \frac{2}{r} \right) \quad (3)$$

locity of escape, since it is the minimum velocity required for a particle to escape from the gravitational attraction of its parent body. See ESCAPE VELOCITY.

Eccentricities greater than unity occur with hyperbolic orbits. Because in a hyperbola the semimajor axis  $a$  is negative, hyperbolic velocities are greater than the escape velocity.

Parabolic and hyperbolic velocities seem to be observed in the motions of some comets and meteors. Aside from the periodic ones, most comets appear to be visitors from cosmic distances, as do about two-thirds of the fainter meteors. It is possible that many of the "parabolic" comets are actually moving in elliptical orbits of extremely long period. The close approach of one of these visitors to a massive planet, such as Jupiter, could change the velocity from parabolic to elliptical if retarded, or from parabolic to hyperbolic if accelerated. It is possible that many of the periodic comets, especially those with periods under 9 years, have been captured in this way. See COMET; GRAVITATION; PERTURBATION (ASTRONOMY). [R.L.Du.]

**Orchid** Any member of the orchid family (Orchidaceae), among the largest families of plants, estimated to contain up to 35,000 species. Orchids are monocots; their flowers have inferior ovaries, three sepals, and three petals. They are distinguished by the differentiation of one petal into a labellum, and the fusion of pistil and stamens into the column. Pollen is usually contained in pollinia, that is, bundles that are removed intact by pollinators, usually insects or sometimes birds. Self-pollination and asexual reproduction without fertilization also occur. The combination of lip and column structure, flower color, fragrance, and other factors may limit the range of pollinators. Differing pollination mechanisms often provide barriers to cross-pollination between related species. Each flower can produce large quantities of seeds, with numbers in the millions in some tropical species. Seeds are minute, with undifferentiated embryo and no endosperm. Germination and establishment depends on symbiotic mycorrhizae that provide nutrients and water.

Orchids occur on all continents except Antarctica; they range from arctic tundra and temperate forest and grassland to tropical rainforest, where as epiphytes they reach their greatest abundance and diversity. Vanilla is obtained from seed pods of some species of *Vanilla*, and the beauty and mystique of many orchids

make them important horticultural subjects. See MYCORRHIZAE; ORCHIDALES; VANILLA. [C.J.S.]

**Orchidales** An order of flowering plants, division Magnoliophyta (Angiospermae), in the subclass Liliidae of the class Liliopsida (monocotyledons). The order consists of four families:



Eastern American species of moccasin flower (*Cypripedium acaule*). (U.S. Forest Service photograph by R. Dale Sanders)

the Orchidaceae (see illustration), with perhaps 15,000–20,000 species; the Burmanniaceae, with about 130 species; the Coriariaceae, with 9 species; and the Geosiridaceae, with 1 species. The Orchidales are mycotrophic, sometimes nongreen Liliidae with very numerous tiny seeds that have an undifferentiated embryo and little or no endosperm. The ovary is always inferior and apparently lacks the septal nectaries found in many Liliopsida although other kinds of nectaries are present. See FLOWER; LILIIDAE; LILIOPSIDA; MAGNOLIOPHYTA; ORCHID. [A.Cr.; T.M.Ba.]

**Ordovician** The second-oldest period in the Paleozoic Era. The Ordovician is remarkable because not only did one of the most significant Phanerozoic radiations of marine life take place (early Middle Ordovician), but also one of the two or three most severe extinctions of marine life occurred (Late Ordovician). The early Middle Ordovician radiation of life included the initial colonization of land. These first terrestrial organisms were nonvascular plants. Vascular plants appeared in terrestrial settings shortly afterward. See GEOLOGIC TIME SCALE.

The rocks deposited during this time interval (these are termed the Ordovician System) overlie those of the Cambrian and underlie those of the Silurian. The Ordovician Period was about  $7 \times 10^7$  years in duration, and it lasted from about  $5.05 \times 10^8$  to about  $4.35 \times 10^8$  years ago.

The Ordovician System is recognized in nearly all parts of the world, including the peak of Mount Everest, because the groups of fossils used to characterize the system are so broadly delineated. Biogeographic provinces limited the distribution of organisms in the past to patterns similar to those of modern biogeographic provinces. Three broadly defined areas of latitude—the tropics, the midlatitudes (approximately 30–60°S), and the Southern Hemisphere high latitudes—constitute the biogeographic regions. Provinces may be distinguished within these



three regions based upon organismal associations unique to each province.

Early Ordovician environmental conditions in most areas were similar to those of the Late Cambrian. Accordingly, Early Ordovician life was similar to that of the latter part of the Cambrian. Trilobites were the prominent animal in most shelf sea environments. Long straight-shelled nautiloids, certain snails, a few orthoid brachiopods, sponges, small echinoderms, algae, and bacteria flourished in tropical marine environments. Linguloid brachiopods and certain bivalved mollusks inhabited cool-water, nearshore environments.

Middle Ordovician plate motions were accompanied by significant changes in life. On land, nonvascular, mosslike plants appeared in wetland habitats. Vascular plants appeared slightly later in riverine habitats. The first nonvascular plants occurred in the Middle East on Gondwanan shores. The Middle Ordovician radiation of marine invertebrates is one of the most extensive in the record of Phanerozoic marine life. Corals, bryozoans, several types of brachiopods, a number of crinozoan echniderms, conodonts, bivalved mollusks, new kinds of ostracodes, new types of trilobites, and new kinds of nautiloids suddenly developed in tropical marine environments. As upwelling conditions formed along the plate margins, oxygen minimum zones—habitats preferred by many graptolites—expanded at numerous new sites. Organic walled microfossils (chitinozoans and acritarchs) radiated in mid- to high-latitude environments. Ostracoderms (jawless, armored fish) radiated in tropical marine shallow-shelf environments. These fish were probably bottom detritus feeders. See PALEOECOLOGY.

The latest Ordovician stratigraphic record suggests that glacial ice melted relatively quickly, accompanied by a relatively rapid sea-level rise in many areas. Some organisms—certain conodonts, for example—did not endure significant extinctions until sea levels began to rise and shelf sea environments began to expand. See PALEOCEANOGRAPHY; STRATIGRAPHY. [W.B.N.B.]

**Ore and mineral deposits** Ore deposits are naturally occurring geologic bodies that may be worked for one or more metals. The metals may be present as native elements, or, more commonly, as oxides, sulfides, sulfates, silicates, or other compounds. The term ore is often used loosely to include such nonmetallic minerals as fluorite and gypsum. The broader term, mineral deposits, includes, in addition to metalliferous minerals, any other useful minerals or rocks. Minerals of little or no value which occur with ore minerals are called gangue. Some gangue minerals may not be worthless in that they are used as by-products; for instance, limestone for fertilizer or flux, pyrite for making sulfuric acid, and rock for road material.

Mineral deposits that are essentially as originally formed are called primary or hypogene. The term hypogene also indicates formation by upward movement of material. Deposits that have been altered by weathering or other superficial processes are secondary or supergene deposits. Mineral deposits that formed at the same time as the enclosing rock are called syngenetic, and those that were introduced into preexisting rocks are called epigenetic.

The distinction between metallic and nonmetallic deposits is at times an arbitrary one since some substances classified as nonmetals, such as lepidolite, spodumene, beryl, and rhodochrosite, are the source of metals. The principal reasons for distinguishing nonmetallic from metallic deposits are practical ones, and include such economic factors as recovery methods and uses.

Most mineral deposits are natural enrichments and concentrations of original material produced by different geologic processes. Economic considerations, such as the amount and concentration of metal, the cost of mining and refining, and the market value of the metal, determine whether the ore is of commercial grade. To be of commercial grade, for example, the following metals must be concentrated in the amounts indicated: aluminum, about 30%; copper, 0.7–10%; lead, 2–4%;

zinc, 3–8%; and gold, silver, and uranium, only a small fraction of a percent of metal. See GEOCHEMICAL PROSPECTING; MINERAL. [A.F.H.]

**Ore dressing** Treatment of ores to concentrate their valuable constituents (minerals) into products (concentrate) of smaller bulk, and simultaneously to collect the worthless material (gangue) into discardable waste (tailing). The fundamental operations of ore-dressing processes are the breaking apart of the associated constituents of the ore by mechanical means (severance) and the separation of the severed components (beneficiation) into concentrate and tailing, using mechanical or physical methods which do not effect substantial chemical changes.

Comminution is a single- or multistage process whereby ore is reduced from run-of-mine size to that size needed by the beneficiation process. The process is intended to produce individual particles which are either wholly mineral or wholly gangue, that is, to produce liberation. Since the mechanical forces producing fracture are not susceptible to detailed control, a class of particles containing both mineral and gangue (middling particles) are also produced. Comminution is divided into crushing (down to 6- to 14-mesh) and grinding (down to micrometer sizes).

Screening is a method of sizing whereby graded products are produced, the individual particles in each grade being of nearly the same size. In beneficiation, screening is practiced for two reasons: as an integral part of the separation process, for example, in jigging; and to produce a feed of such size and size range as is compatible with the applicability of the separation process. See SCREENING.

Beneficiation consists of two fundamental operations: the determination that an individual particle is either a mineral or a gangue particle (selection); and the movement of selected particles via different paths (separation) into the concentrate and tailing products. When middling particles occur, they will either be selected according to their mineral content and then caused to report as concentrate or tailing, or be separated as a third product (middling), which is reground to achieve further liberation. See FLOTATION; LEACHING; MECHANICAL SEPARATION TECHNIQUES.

Separation is achieved by subjecting each particle of the mixture to a set of forces which is usually the same irrespective of the nature of the particles excepting for the force based upon the discriminating property. This force may be present for both mineral and gangue particles but differing in magnitude, or it may be present for one type of particle and absent for the other. As a result of this difference, separation is possible, and the particles are collected in the form of concentrate or tailing.

Magnetic separation utilizes the force exerted by a magnetic field upon magnetic materials to counteract partially or wholly the effect of gravity. Thus under the action of these two forces, different paths are produced for the magnetic and nonmagnetic particles. See MAGNETIC SEPARATION METHODS. [M.D.Ha.]

**Oregano** A herb, also known as wild marjoram. The dried leaves of several species of aromatic plants are known as oregano; thus oregano is a common name for a general flavor and aroma rather than the name of a specific plant.

European (*Origanum vulgare*) and Greek (*O. heracleoticum*) oregano are both in the mint family (Lamiaceae). Mexican oregano is obtained primarily from plants of *Lippia graveolens*. These small aromatic shrubs in the verbena family grow wild in Mexico. Origanum oil used in perfumery is steam-distilled primarily from Spanish oregano, *Thymus capitatus*. See LAMIALES.

European oregano can be distinguished by its strong piquant character and tall growth with dark, broad leaves; it is a perennial erect herb 2–3 ft tall (0.6–1 m) with pubescent stems, ovate dark green leaves, and white or purple flowers. Native to southern Europe, southwest Asia, and the Mediterranean countries, European oregano is usually found growing in the dry, rocky, calcareous soils of the mountain regions. Greece, Italy, Spain,

Turkey, and the United States are the primary sources of European oregano.

Dried oregano leaves are used as a culinary herb in meat and sausage products, salads, soups, Mexican foods, and barbecue sauces. The essential oil of oregano is used in food products, cosmetics, and liqueurs. See MARJORAM; SPICE AND FLAVORING.

[S.Kir.]

**Organic chemistry** The study of the structure, preparation, properties, and reactions of carbon compounds. The term organic was early applied to compounds derived from plant and animal sources. These substances from living systems were usually distillable liquids or low-melting solids and were flammable, in contrast to metals, salts, and oxides from mineral sources. Until about 1830 it was held by some that organic compounds contained some special quality, or vital force. This notion was dispelled, but the term organic remained and became broadened to include carbon compounds in general. See CARBON.

**Structure.** The structures of organic compounds are described by a molecular framework of carbon atoms on which substituents may be located at various points.

Structures can be represented in several ways, as illustrated for the three-carbon alcohol 2-propanol (**1**) and the cyclic ketone 2-methyl-3-cyclohexenone (**2**). The expanded structure of

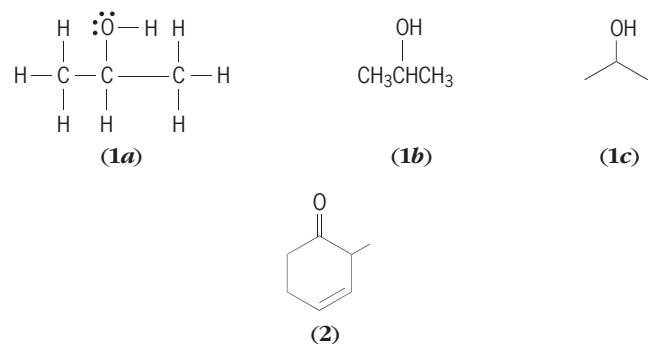

2-propanol (**1a**) shows all bonds and electron pairs, including unshared electrons on oxygen. More compact and convenient is the condensed structure (**1b**) in which the C—C and C—H bonds are implied. In the bond-line convention (**1c**), all C—C bonds are indicated by a line, as shown for 2-propanol. Carbon atoms are not shown explicitly, but rather are implied at the ends of each line segment, together with enough hydrogen atoms to complete the tetravalency at each carbon. The bond-line convention is particularly convenient for cyclic structures such as 2-methyl-3-cyclohexenone; each vertex and the end of each line segment represents a carbon and appropriate number of hydrogens. See STRUCTURAL CHEMISTRY; VALENCE.

A functional group is an atom other than carbon or a multiple bond, such as the hydroxyl group (OH) of 2-propanol, the double bond (C=C), or the carbonyl group (C=O) of 2-methyl-3-cyclohexenone. The group defines a class of compounds and is the point at which characteristic reactions occur, for example, oxidation, reduction, or addition of an electrophilic or nucleophilic reagent. Some of the principal functional groups are shown in the table. See ELECTROPHILIC AND NUCLEOPHILIC REAGENTS.

The fact that there can be two or more compounds, known as isomers, with the same molecular composition was one of the key points in development of a structural theory. One type of isomerism, structural or constitutional, is illustrated by the two isomers that have the formula C<sub>4</sub>H<sub>10</sub>, butane (**3a**) and isobutane (2-methylpropane; **3b**). The number of possible structural isomers becomes enormous in larger molecules.

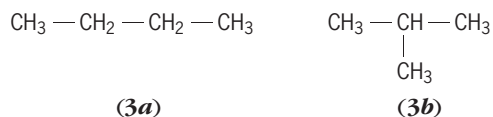

See MOLECULAR ISOMERISM.

### Principal organic functional groups

Composed class	Group	Structure
Alkene	Double bond	$\text{>C=C<}$
Alkyne	Triple bond	$\text{—C}\equiv\text{C—}$
Alcohol	Hydroxyl	$\text{—OH}$
Amine	Amino	$\text{—NH}_2(\text{—NR}_2)^*$
Aldehyde	Carbonyl	$\begin{array}{c} \text{O} \\    \\ \text{—CH} \end{array}$
Ketone	Carbonyl	$\begin{array}{c} \text{O} \\    \\ \text{—CR} \end{array}$
Acid	Carboxyl	$\begin{array}{c} \text{O} \\    \\ \text{—COH} \end{array}$
Ester	Alkoxy carbonyl	$\begin{array}{c} \text{O} \\    \\ \text{—COR} \end{array}$
Amide	Carbamoyl	$\begin{array}{c} \text{O} \\    \\ \text{CN<} \end{array}$
Nitrile	Cyano	$\text{—C}\equiv\text{N}$
Azide	Azido	$\text{—N=N=N}$
Nitro		$\text{—NO}_2$
Sulfide		$\text{—S—}$
Sulfoxide		$\begin{array}{c} \text{O} \\    \\ \text{—S—} \end{array}$
Sulfonic acid		$\text{—SO}_3\text{H}$

\*R = any carbon group, for example, CH<sub>3</sub>.

Several three-dimensional representations of butane, showing the tetrahedral geometry of the carbon atoms, are given in structures (**4**). As indicated in these structures, butane can exist in

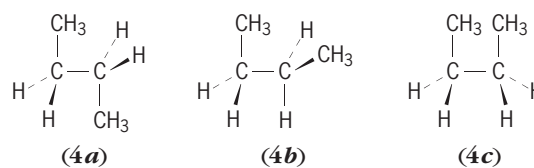

several forms, called conformations, which differ in the relative positions of the carbon atoms, and thus the overall shape of the molecule. However, the barrier to rotation around the central C—C bond is so low that these individual conformational isomers are not separable, and butane is thus a single compound. See CONFORMATIONAL ANALYSIS.

In an alkene, rotation around the C=C bond does not occur, and 2-butene, for example, exists as two isomeric compounds, cis (Z) and trans (E) (**5a** and **5b**, respectively).

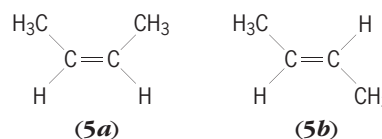

Stereoisomers are compounds that have the same bond sequence but differ in the spatial array of the bonds. When a carbon atom is bonded to four unlike atoms or groups, the tetrahedral geometry of carbon causes the atom to be dissymmetric or

chiral. A compound with a chiral atom can exist in two isomeric forms, known as enantiomers. The relative positions of all atoms is identical in the two enantiomers, but they differ in handedness, a characteristic of an asymmetric object and its nonsuperposable mirror image, as in structures (6) of 1-chlorobutane.

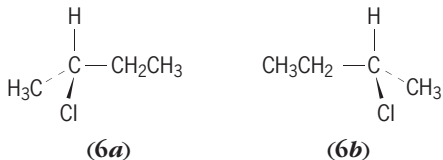

See STEREOCHEMISTRY.

When two chiral centers are present, two stereoisomers can arise from each enantiomer. Thus enantiomer (7a) of chlorobutane can lead to isomeric structures (7b) and (7c), in which the

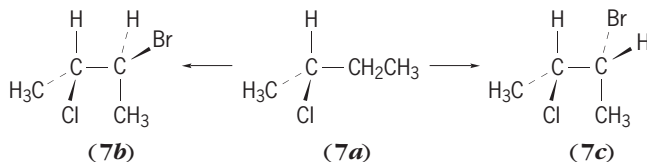

relative positions of the atoms is not identical. In this case, the isomers are known as diastereoisomers. With  $n$  chiral centers, there can be  $2^n$  stereoisomers.

**Acyclic compounds.** The simplest organic compound is methane ( $\text{CH}_4$ ). It is the first member of the homologous series of alkanes, in which successive compounds differ by an additional  $-\text{CH}_2-$  group ( $\text{CH}_3\text{CH}_3$ ,  $\text{CH}_3\text{CH}_2\text{CH}_3$ , and so forth). See ALKANE; METHANE.

Higher alkanes,  $\text{CH}_3(\text{CH}_2)_n\text{CH}_3$  ( $n = 3-20$ ), and also branched isomers and cyclic hydrocarbons are the principal components of petroleum. These compounds have no reactive functional groups.

Both acyclic and cyclic carbon frameworks can contain multiple bonds; oxygen, nitrogen, and sulfur atoms; and other functional groups listed in the table.

**Carbocyclic compounds.** The two large groups of compounds with rings containing only carbon are alicyclic and aromatic. The parent hydrocarbons in the former series are cycloalkanes and in the latter, benzene. The structure of benzene is a planar six-membered ring with six electrons in a delocalized array. See AROMATIC HYDROCARBON; BENZENE.

**Heterocyclic compounds.** A nitrogen, oxygen, or sulfur atom can take the place of carbon in either alicyclic or aromatic rings. The most numerous and important heterocyclic compounds are those with nitrogen in a five- or six-membered aromatic system.

**Synthesis reactions.** The preparation of compounds occupies much of the effort of organic chemistry, and is the principal business of the chemical industry. The manufacture of drugs, pigments, and polymers entails the preparation of organic compounds on a scale of thousands to billions of kilograms per year, and there is constant research to develop new products and processes. Synthesis of new substances is carried out for many purposes beyond the goal of a commercial product. A compound of a specified structure may be needed to test a mechanistic proposal or to evaluate a biochemical response such as inhibition of an enzyme. Synthesis may provide a more dependable and less expensive source of a naturally occurring compound; moreover, a synthetic approach permits variations in the structure that may lead to enhanced biological activity.

The term synthesis usually implies a planned sequence of steps leading from simple starting compounds to a desired end product. Each of these steps involves a reaction that may lead to formation of a C—C bond or to the introduction, alteration, or removal of a functional group. Progress in synthesis depends on the availability of a wide range of reactions that bring about these changes in good yield, with a minimum of interfering by-products. An integral part of synthesis is the development of

new methods and reagents that are selective for a desired transformation, and, very importantly, proceed with control of the stereochemistry. See ASYMMETRIC SYNTHESIS; ORGANIC SYNTHESIS.

[J.A.Mo.]

**Organic conductor** An organic substance with low electrical resistance. Two major classes of organic conductors are charge-transfer compounds and conducting polymers.

**Charge-transfer compounds.** The search for organic conductors in the early 1970s led to the observation of metallic-like electrical conduction in well-ordered molecular crystals and the discovery of many new phenomena such as the stabilization of charge-density waves and spin-density waves, new mechanisms for electronic transport, organic superconductivity, and new states of matter produced under strong magnetic fields. Most of these phenomena are due to the low dimensionality (one or two dimensions) of the electron gas in the charge-transfer compounds where they were observed. Among these properties, superconductivity has created much interest since the zero-resistance state is now observed at temperatures as high as 10 K ( $-442^\circ\text{F}$ ) in certain organic superconductors. See SUPERCONDUCTIVITY.

Charge-transfer compounds are two-component materials containing anionic and cationic species originating by charge transfer between donor and acceptor entities; these may be two organic molecules or an organic molecule with an inorganic ion. Tetrathiafulvalene-tetracyanoquinodimethane (TTF-TCNQ) is the prototype of charge-transfer organic crystals. Its crystal structure exhibits piled-up segregated columns of donor TTF and acceptor TCNQ molecules (illus. a). In the solid state, the amount of charge transferred from donor to acceptor is determined by the overall crystal stability.

Another class of organic conductors is exemplified by radical cation salts such as  $(\text{TMTSF})_2\text{X}$  where the organic molecule is tetramethyltetraselenafulvalene and X is an inorganic anion. In this class of materials (Bechgaard salts) the molecules display a zigzag packing along the stacking axis (illus. b), where one positive charge (hole) is shared between two organic molecules.

The strong overlap between electron clouds of neighboring molecules along the stacks spreads the partially filled molecular electronic states into an energy band 0.5–1 eV wide. This bandwidth is large enough to allow electron delocalization among all molecules on a given stack and to promote electrical conduction similar to that in metal crystals. See BAND THEORY OF SOLIDS; CONDUCTION (ELECTRICITY); DELOCALIZATION; MOLECULAR ORBITAL THEORY.

**Conducting polymers.** Polymeric materials are typically considered as insulators. However, research since the late 1970s has led to the discovery of polymeric materials with extremely high conductivity, approaching that of copper. The prospect of materials combining the properties of plastics and metals or semiconductors has led to a search for applications, made attractive because improved polymers no longer suffer from such drawbacks as low stability, processing difficulties, and brittleness. Most conducting polymers can be switched reversibly between conductive and nonconductive states, with the result that their conductivities can span an enormous range. This switching is accomplished through oxidation-reduction (redox) chemistry, the

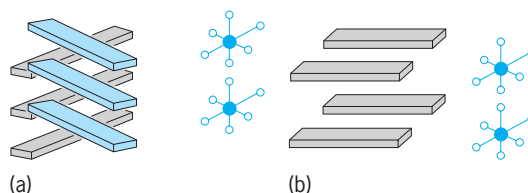

Stacking of charge-transfer compounds. (a) Segregated stacking of TTF-TCNQ-like materials. (b) Typical zigzag stacking of the  $(\text{TMTSF})_2\text{X}$  series.

conductivity being sensitive to the degree of oxidation of the polymer backbone. This property distinguishes conducting polymers from metals and semiconductors and is the basis of many existing and potential applications. In addition, certain polymers become conducting upon oxidation or reduction and thus can exhibit *p*- or *n*-type conduction. See OXIDATION-REDUCTION; POLYMER.

In a conducting polymer an oxidant removes electrons from the  $\pi$ -electron system of the polymer, creating radical cations that, at high concentrations, dimerize to form cation pairs known as bipolarons. Charge-balancing counterions are concomitantly incorporated between polymer chains. The overall process is referred to as doping, and the counteranion (or counteranion in the case of reduction) is the dopant.

Considerable progress has been made on the theory of important parameters such as oxidation potentials, band gaps, and band widths, often with good agreement with experiment. Such work is important for the design of new conductive polymers with specific properties. See SOLID-STATE CHEMISTRY. [G.E.W.]

**Organic evolution** The modification of living organisms during their descent, generation by generation, from common ancestors. Organic, or biological, evolution is to be distinguished from other phenomena to which the term evolution is often applied, such as chemical evolution, cultural evolution, or the origin of life from nonliving matter. Organic evolution includes two major processes: anagenesis, the alteration of the genetic properties of a single lineage over time; and cladogenesis, or branching, whereby a single lineage splits into two or more distinct lineages that continue to change anagenetically.

Anagenesis consists of change in the genetic basis of the features of the organisms that constitute a single species. Populations in different geographic localities are considered members of the same species if they can exchange members at some rate and hence interbreed with each other, but unless the level of interchange (gene flow) is very high, some degree of genetic difference among different populations is likely to develop. The changes that transpire in a single population may be spread to other populations of the species by gene flow. See SPECIES CONCEPT.

Almost every population harbors several different alleles at each of a great many of the gene loci; hence many characteristics of a species are genetically variable. All genetic variations ultimately arise by mutation of the genetic material. Broadly defined, mutations include changes in the number or structure of the chromosomes and changes in individual genes, including substitutions of individual nucleotide pairs, insertion and deletion of nucleotides, and duplication of genes. Many such mutations alter the properties of the gene products (ribonucleic acid and proteins) or the timing or tissue localization of gene action, and consequently affect various aspects of the phenotype (that is, the morphological and physiological characteristics of an organism). Whether and how a mutation is phenotypically expressed often depends on developmental (epigenetic) events. See GENE; GENETIC CODE; MUTATION; RIBONUCLEIC ACID (RNA).

Natural selection is a consistent difference in the average rate at which genetically different entities leave descendants to subsequent generations; such a difference arises from differences in fitness (that is, in the rate of survival, reproduction, or both). In fact, a good approximate measure of the strength of natural selection is the difference between two such entities in their rate of increase. The entities referred to are usually different alleles at a locus, or phenotypically different classes of individuals in the population that differ in genotype. Thus selection may occur at the level of the gene, as in the phenomenon of meiotic drive, whereby one allele predominates among the gametes produced by a heterozygote. Selection at the level of the individual organism, the more usual case, entails a difference in the survival and reproductive success of phenotypes that may differ at one locus or at more than one locus. As a consequence of the difference in

fitness, the proportion of one or the other allele increases in subsequent generations. The relative fitness of different genotypes usually depends on environmental conditions.

Different alleles of a gene that provides an important function do not necessarily differ in their effect on survival and reproduction; such alleles are said to be neutral. The proportion of two neutral alleles in a population fluctuates randomly from generation to generation by chance, because not all individuals in the population have the same number of surviving offspring. Random fluctuations of this kind are termed random genetic drift. If different alleles do indeed differ in their effects on fitness, both genetic drift and natural selection operate simultaneously. The deterministic force of natural selection drives allele frequencies toward an equilibrium, while the stochastic (random) force of genetic drift brings them away from that equilibrium. The outcome for any given population depends on the relative strength of natural selection (the magnitude of differences in fitness) and of genetic drift (which depends on population size).

The great diversity of organisms has come about because individual lineages (species) branch into separate species, which continue to diverge. This splitting process, speciation, occurs when genetic differences develop between two populations that prevent them from interbreeding and forming a common gene pool. The genetically based characteristics that cause such reproductive isolation are usually termed isolating mechanisms. Reproductive isolation seems to develop usually as a fortuitous by-product of genetic divergence that occurs for other reasons (either by natural selection or by genetic drift). See SPECIATION.

A frequent consequence of natural selection is that a species comes to be dominated by individuals whose features equip them better for the environment or way of life of the species. Such features are termed adaptations. Although many features of organisms are adaptive, not all are, and it is a serious error to suppose that species are capable of attaining ideal states of adaptation. Some characteristics are likely to have developed by genetic drift rather than natural selection, and so are not adaptations; others are side effects of adaptive features, which exist because of pleiotropy or developmental correlations.

Higher taxa are those above the species level, such as genera and families. A taxon such as a genus is typically a group of species, derived from a common ancestor, that share one or more features so distinctive that they merit recognition as a separate taxon. The degree of difference necessary for such recognition, however, is entirely arbitrary: there are often no sharp limits between related genera, families, or other higher taxa, and very often the diagnostic character exists in graded steps among a group of species that may be arbitrarily divided into different higher taxa. Moreover, a character that in some groups is used to distinguish higher taxa sometimes varies among closely related species or even within species. In addition, the fossil record of many groups shows that a trait that takes on very different forms in two living taxa has developed by intermediate steps along divergent lines from their common ancestor; thus the inner ear bones of mammals may be traced to jaw elements in reptiles that in turn are homologous to gill arch elements in Paleozoic fishes.

The characteristics of a species evolve individually or in concert with certain other traits that are developmentally or functionally correlated. Because of this mosaic pattern of evolution, it is meaningful to speak of the rate of evolution of characters, but not of species or lineages as total entities. Thus in some lineages, such as the so-called living fossils, many aspects of morphology have evolved slowly since the groups first came into existence, but evolution of their deoxyribonucleic acid and amino acid sequences has proceeded at much the same rate as in other lineages. Every species, including the living fossils, is a mixture of traits that have changed little since the species' remote ancestors, and traits that have undergone some evolutionary change in the recent past. The history of life is not one of progress in any one direction, but of adaptive radiation on a grand scale: the descendants of any one lineage diverge as they adapt to

different resources, habitats, or ways of life, acquiring their own specialized features as they do so. There is no evidence that evolution has any goal, nor does the mechanistic theory of evolutionary processes admit of any way in which genetic change can have a goal or be directed toward the future. However, for life taken as a whole, the only clearly discernible trend is toward ever-increasing diversity.

[D.J.Fu.]

**Organic geochemistry** The study of the abundance and composition of naturally occurring organic substances, their origins and fate, and the processes that affect their distributions on Earth and in extraterrestrial materials. These activities share the common need for identification, measurement, and assessment of organic matter in its myriad forms.

Organic geochemistry was born from a curiosity about the organic pigments extractable from petroleum and black shales. It developed with extensive investigations of the chemical characteristics of petroleum and petroleum source rocks as clues to their occurrence and formation, and now encompasses a broad scope of activities within interdisciplinary areas of earth and environmental science. This range of studies recognizes the potential of geological records of organic matter to help characterize sedimentary depositional environments and to provide evidence of ancient life and indications of evolutionary developments through the Earth's history. Organic geochemistry includes determinations of anthropogenic contaminants amid the natural background of organic molecules and the assessment of their environmental impact and fate. Marine organic geochemistry addresses and interprets aquatic processes involving carbon species. It involves investigations of the chemical character of particulate and dissolved organic matter, evaluation of oceanic primary production including the factors (light, temperature, nutrient availability) that influence the uptake of carbon dioxide (CO<sub>2</sub>), the composition of marine organisms, and the subsequent processing of organic constituents through the food web. Organic geochemistry extends to broader biogeochemical issues, such as the carbon cycle, and the effects of changing carbon dioxide levels, especially efforts to use geochemical data and proxies to help constrain global climate models. Examination of the organic chemistry of meteorites and lunar materials also falls within its compass, and as a critical part of the quest for remnants of life on Mars, such extraterrestrial studies are now regaining the prominence they held in the 1970s during lunar exploration. See COSMOCHEMISTRY; GEOCHEMISTRY.

**Global inventories of carbon.** Carbon naturally exists as oxidized and reduced forms in carbonate carbon and organic matter. The major reservoir of both forms of carbon on Earth is the geosphere. It contains carbonate minerals deposited as sediments and organic matter accumulated from the remains of dead organisms. Estimates of the size of the geological reservoir of carbon vary within the range of 5 to 7 × 10<sup>22</sup> g, of which 75% is carbonate carbon and 25% is organic carbon. The amounts of carbon contained in living biota (5 × 10<sup>17</sup> g), dissolved in the ocean (4 × 10<sup>19</sup> g), and present in atmospheric gases (7 × 10<sup>17</sup> g) are minuscule compared to the quantity of organic carbon buried in the rock record. The importance of buried organic matter extends beyond its sheer magnitude; it includes the fossil fuels—coal, natural gas, and petroleum—that supply 85% of the world's energy. See BIOGEOCHEMISTRY; CARBON; CARBON DIOXIDE; CARBONATE MINERALS; COAL; FOSSIL FUEL; NATURAL GAS; PETROLEUM; SEDIMENTARY ROCKS.

**Sedimentary organic matter.** The vast amounts of organic matter contained in geological materials represent the accumulated vestiges of organisms amassed over the expanse of geological time. Yet, survival of organic cellular constituents of biota into the rock record is the exception rather than the norm. Only a small portion of the carbon fixed by organisms during primary production, especially by photosynthesis, escapes degradation as it settles through the water column and eludes microbial

alteration during subsequent incorporation and assimilation into sedimentary detritus. See BIODEGRADATION.

Sedimentary organic matter can be divided operationally into solvent-extractable bitumen and insoluble kerogen. Bitumens contain a myriad of structurally distinct molecules, especially hydrocarbons, which can be individually identified (such as by gas chromatography-mass spectrometry) although they may be present in only minute quantities (nanograms or picograms). The range of components includes many biomarkers that retain structural remnants inherited from their source organisms, which attest to their biological origins and subsequent geological fate. See BITUMEN; KEROGEN.

Biomarkers are individual compounds whose chemical structures carry evidence of their origins and history. Recognition of the specificity of biomarker structures initially helped confirm that petroleum was derived from organic matter produced by biological processes. Of the thousands of individual petroleum components, hundreds reflect precise biological sources of organic matter, which distinguish and differentiate their disparate origins. The diagnostic suites of components may derive from individual families of organisms, but contributions at a species level can occasionally be recognized. Biomarker abundances and distributions help to elucidate sedimentary environments, providing evidence of depositional settings and conditions. They also reflect sediment maturity, attesting to the progress of the successive, sequential transformations that convert biological precursors into geologically occurring products. Thus, specific biomarker characteristics permit assessment of the thermal history of individual rocks or entire sedimentary basins. See BASIN.

**Carbon isotopes.** Carbon naturally occurs as three isotopes: carbon-12 (<sup>12</sup>C), carbon-13 (<sup>13</sup>C), and radiocarbon (<sup>14</sup>C). Temporal excursions in the <sup>13</sup>C values of sediment sequences can reflect perturbations of the global carbon cycle. Radiocarbon is widely employed to date archeological artifacts, but the sensitivity of its measurement also permits its use in exploration of the rates of biogeochemical cycling in the oceans. This approach permits assessment of the ages of components in sediments, demonstrating that bacterial organic matter is of greater antiquity than components derived from phytoplankton sources. See ISOTOPE; MARINE SEDIMENTS; PALEOCEANOGRAPHY; RADIOCARBON DATING. [S.C.B.]

**Organic nomenclature** A system by which a unique and unambiguous name or other designation is assigned to a given organic molecular structure. A set of rules adopted by the International Union of Pure and Applied Chemistry (IUPAC) is the basis for a standardized name for any organic compound. Common or nonsystematic names are used for many compounds that have been known for a long time. The latter names have the advantage of being short and easily recognized, as in the examples below. However, in contrast to systematic names, common or trivial names do not convey information from which the structure can be written by reference to prescribed rules.

In the IUPAC system, a name is formed by combination of a parent alkyl chain or ring with prefixes and suffixes to denote substituents. For aliphatic compounds, the parent name is a stem that denotes the longest straight chain in the structure with the ending-ane. The first four members of the alkane series are methane, ethane, propane, and butane. From five carbons on, the names follow the Greek numerical roots, for example, pentane and hexane. Changing the ending-ane to -yl gives the name of the corresponding radical or group; for example, CH<sub>3</sub>CH<sub>2</sub>— is the ethyl radical or ethyl group. Branches on an alkyl chain are indicated by the name of a radical or group as a prefix. The location of a branch or other substituent is indicated by number; the chain is numbered from whichever end results in the lowest numbering. See ALKANE.

Double or triple bonds are indicated by the endings-ene or -yne, respectively. The configuration of the chain at a double bond is denoted by *E*- when two similar groups are on opposite

sides of the plane bisecting the bond, and *Z*- when they are on the same side. See ALKENE; ALKYNE.

A compound containing a functional group is named by adding to the parent name a suffix characteristic of the group. If there are two or more groups, a principal group is designated by suffix and the other(s) by prefix.

The same general principles apply to cyclic compounds. For alicyclic rings, the prefix *cyclo-* is followed by a stem indicating the number of carbon atoms in the ring, as is illustrated in the structure below. In bicyclic compounds, the total number of

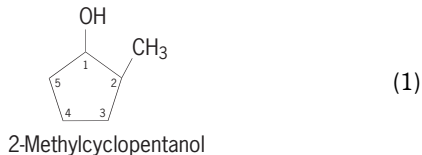

carbons in the ring system is prefixed by *bicyclo-* and numbers in brackets which indicate the number of atoms in each connecting chain.

The names of aromatic hydrocarbons have the ending *-ene*, which denotes a ring system with the maximum number of non-cumulative double bonds. Each of the simpler polycyclic hydrocarbons has a different parent name. To number the positions in a polycyclic aromatic ring system, the structure must first be oriented with the maximum number of rings arranged horizontally and to the right. The system is then numbered in clockwise sequence starting with the atom in the most counterclockwise position of the upper right-hand ring, omitting atoms that are part of a ring fusion. See AROMATIC HYDROCARBON.

#### Basis of nomenclature of heterocyclic compounds

Heteroatom	Prefix	Ring size	Suffix
O	ox(a)-	4	-ete
S	thi(a)-	5	-ole
N	az(a)-	6	-ine
		7	-epine

Systematic names for rings containing a heteroatom (O, S, N) are based on a combination of a prefix denoting the heteroatom(s) and a suffix denoting the ring size, as indicated in the table. See CHEMICAL SYMBOLS AND FORMULAS; HETEROCYCLIC COMPOUNDS; ORGANIC CHEMISTRY. [J.A.Mo.]

**Organic photochemistry** A branch of chemistry that deals with light-induced changes of organic material. Because it studies the interaction of electromagnetic radiation and matter, photochemistry is concerned with both chemistry and physics. In considering photochemical processes, therefore, it is also necessary to consider physical phenomena that do not involve strictly chemical changes, for example, absorption and emission of light, and electronic energy transfer.

Because several natural photochemical processes were known to play important roles (namely, photosynthesis in plants, process of vision, and phototropism), the study of organic photochemistry started very early in the twentieth century. However, the breakthrough occurred only after 1950 with the availability of commercial ultraviolet radiation sources and modern analytical instruments for nuclear magnetic resonance (NMR) spectroscopy and (gas) chromatography.

In general, most organic compounds consist of rapidly interconvertible, nonseparable conformers, because of the free rotation about single bonds. Each conformer has a certain energy associated with it, and its own electronic absorption spectrum. This is one cause of the broad absorption bands produced by organic compounds in solution. The equilibrium of the conformers may be influenced by the solvent and the temperature. According to the Franck-Condon principle, which states that promotion of an electron by the absorption of a photon is much faster than

a single vibration, each conformer will have its own excited-state configuration. See CONFORMATIONAL ANALYSIS; MOLECULAR STRUCTURE AND SPECTRA.

Because of the change in the pi-bond order upon excitation of the substrate and the short lifetime of the first excited state, the excited conformers are not in equilibrium and each yields its own specific photoproduct. Though different conformers may lead to the same photoproduct and one excited conformer may lead to several photoproducts, a change in solvent, temperature, or wavelength of excitation influences the photoproduct composition. This is especially true with small molecules; larger molecules with aromatic groups are less sensitive for small wavelength differences.

The influence of wavelength is also important when the primary photoproduct also absorbs light and then gives rise to another photoreaction. Excitation with selected wavelengths or monochromatic light by use of light filters or a monochromator, respectively, may then be profitable for the selective production of the primary product. Similarly, irradiation at a low temperature is helpful in detecting a primary photoproduct that is unstable when heated (thermolabile). See COLOR FILTER. [W.H.L.]

**Organic reaction mechanism** A complete, step-by-step account of how a reaction of organic compounds takes place. A fully detailed mechanism would correlate the original structure of the reactants with the final structure of the products and account for changes in structure and energy throughout the progress of the reaction. It would also account for the formation of any intermediates and the rates of interconversions of all of the various species. Because it is not possible to detect directly all of these details, evidence for a reaction mechanism is always indirect. Experiments are designed to produce results that provide logical evidence for (but can never unequivocally prove) a mechanism. For most organic reactions, there are mechanisms that are considered to be well established based on bodies of experimental evidence. Nevertheless, new data often become available that provide further insight into new details of a mechanism or that occasionally require a complete revision of an accepted mechanism.

**Classification of organic reactions.** The description of an organic reaction mechanism typically includes designation of the overall reaction (for example, substitution, addition, elimination, oxidation, reduction, or rearrangement), the presence of any reactive intermediates (that is, carbocations, carbanions, free radicals, radical ions, carbenes, or excited states), the nature of the reagent that initiates the reaction (such as electrophilic or nucleophilic), the presence of any catalysis (such as acid or base), and any specific stereochemistry. For example, reaction (1) would be

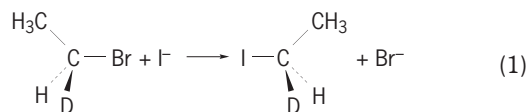

described as a concerted nucleophilic substitution of an alkyl halide that proceeds with inversion of stereochemistry. A reaction that proceeds in a single step, without intermediates, is described as concerted or synchronous. Reaction (1) is an example of the  $S_N2$  mechanism (substitution, nucleophilic, bimolecular).

**Potential energy diagrams.** A common method for illustrating the progress of a reaction is the potential energy diagram, in which the free energy of the system is plotted as a function of the completion of the reaction (see illustration).

The reaction coordinate is intended to represent the progress of the reaction, and it may or may not correlate with an easily observed or measurable feature. In reaction (1), the reaction coordinate could be considered to be the increasing bond length of the carbon-bromine (C-Br) bond as it is broken, or the decreasing separation of C and iodine (I) as they come together to form a bond. In fact, a complete potential energy diagram should illustrate the variation in energy as a function of both of these

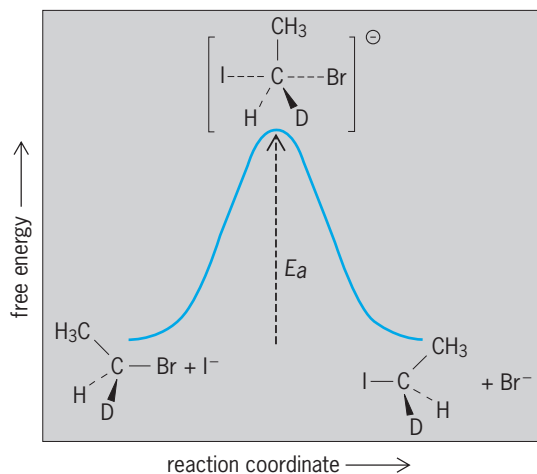

Potential energy–reaction coordinate diagram for a typical nucleophilic substitution reaction that proceeds by the  $S_N2$  mechanism.  $E_a$  = activation energy.

(and perhaps several other relevant structural features), but this would require a three-dimensional (or higher) plot.

Besides identifying the energy levels of the original reactants and the final products, the potential energy diagram indicates the energy level of the highest point along the reaction pathway, called the transition state. Because the transition state represents the highest energy that the molecules must attain as they proceed along the reaction pathway, the energy level of the transition state is a key indication of how easily the reaction can occur. Features that tend to make the transition state more stable (lower in energy) make the reaction more favorable. Such stabilizing features could be intramolecular, such as electron donation or withdrawal by substituents, or intermolecular, such as stabilization by solvent. See CHEMICAL BONDING; ENERGY.

**Kinetics.** Another way to illustrate the various steps involved in a reaction mechanism is as a kinetic scheme that shows all of the individual steps and their rate constants. The  $S_N2$  mechanism is a single step, so the kinetics must represent that step; the rate is observed to depend on the concentrations of both the organic substrate and the nucleophile. However, for multistep mechanisms the kinetics can be a powerful tool for distinguishing the presence of alternative pathways. For example, when more highly substituted alkyl halides undergo nucleophilic substitution, the rate is independent of the concentration of the nucleophile. This evidence suggests a two-step mechanism, called the  $S_N1$  mechanism, as shown in reaction scheme (2), where the  $k$  terms represent rate constants.

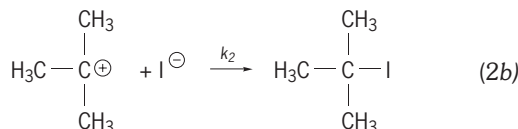
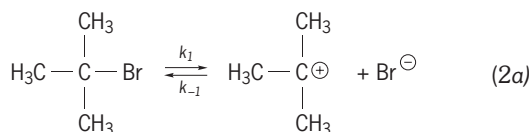

The  $S_N1$  mechanism accomplishes the same overall nucleophilic substitution of an alkyl halide, but does so by initial dissociation of the leaving group ( $\text{Br}^-$ ) to form a carbocation, step (2a). The nucleophile then attaches to the carbocation to form the final product, step (2b). Alkyl halides that have bulky groups around the carbon to be substituted are less likely to be substituted by the direct  $S_N2$  mechanism, because the nucleophile encounters difficulty in making the bond to the inaccessible site (called steric hindrance). If those alkyl groups have substituents

that can support a carbocation structure, generally by electron donation, then the  $S_N1$  mechanism becomes preferable.

A crucial feature of a multistep reaction mechanism is the identification of the rate-determining step. The overall rate of reaction can be no faster than its slowest step. In the  $S_N1$  mechanism, the bond-breaking reaction (2a) is typically much slower than the bond-forming reaction (2b). Hence, the observed rate is the rate of the first step only. Thus, kinetics can distinguish the  $S_N1$  and  $S_N2$  mechanisms, as shown in Eqs. (3) and (4), where  $R$  is an

$$\text{Rate} = k [\text{RX}] [\text{Nu}] \quad \text{for an } S_N2 \text{ mechanism} \quad (3)$$

$$\text{Rate} = k [\text{RX}] \quad \text{for an } S_N1 \text{ mechanism} \quad (4)$$

alkyl group,  $X$  is a halogen or other leaving group,  $\text{Nu}$  is a nucleophile, and the terms in the brackets represent concentrations.

A more complete description of the  $S_N1$  mechanism was recognized when it was observed that the presence of excess leaving group [for example,  $\text{Br}^-$  in reaction (2)] can affect the rate (called the common ion rate depression). This indicated that the mechanism should include a reverse step [ $k_{-1}$  in reaction step (2a)] in which the leaving group returns to the cation, regenerating starting material. In this case, the rate depends in a complex manner on the competition of nucleophile and leaving group for reaction with the carbocation. See CHEMICAL DYNAMICS; REACTIVE INTERMEDIATES; STERIC EFFECT (CHEMISTRY).

**Activation parameters.** The temperature dependence of the rate constant provides significant information about the transition state of the rate-determining step. The Arrhenius equation (5) expresses that dependence in terms of an exponential func-

$$k = A e^{-E_a/RT} \quad (5)$$

tion of temperature and an activation energy,  $E_a$ ;  $A$  is called the Arrhenius or preexponential factor, and  $R$  is the gas constant. See GAS; LOGARITHM.

The activation energy represents the energy difference between the reactants and the transition state, that is, the amount of energy that must be provided in order to proceed along the reaction pathway successfully from reactant to product.

**Stereochemistry.** Careful attention to the stereochemistry of a reaction often provides crucial insight into the specific orientation of the molecules as they proceed through the reaction mechanism. The complete inversion of stereochemistry observed in the  $S_N2$  mechanism provides evidence for the backside attack of the nucleophile. Alkyl halides that undergo substitution by the  $S_N1$  mechanism do not show specific stereochemistry, since the loss of the leaving group is completely uncorrelated with the bonding of the nucleophile.

In addition reactions, possible stereochemical outcomes are addition of the new bonds to the same or opposite sides of the original pi bond, called syn and anti addition, respectively. The anti addition of bromine to double bonds provides evidence

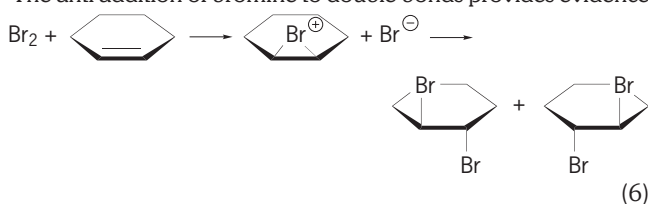

for the intermediacy of a bridged bromonium ion, as shown in reaction (6). [C.C.W.]

**Organic synthesis** The making of an organic compound from simpler starting materials. Organic synthesis plays an important role by allowing for the creation of specific molecules for scientific and technological investigations.

The heart of organic synthesis is designing synthetic routes to a molecule. The simplest synthesis of a molecule is one in which the target molecule can be obtained by submitting a readily available starting material to a single reaction that converts it to the desired target molecule. However, in most cases the

synthesis is not that straightforward; in order to convert a chosen starting material to the target molecule, numerous steps that add, change, or remove functional groups, and steps that build up the carbon atom framework of the target molecule may need to be done.

A systematic approach for designing a synthetic route to a molecule is to subject the target molecule to an intellectual exercise called a retrosynthetic analysis. This involves an assessment of each functional group in the target molecule and the overall carbon atom framework in it; a determination of what known reactions form each of those functional groups or that build up the necessary carbon framework as a product; and a determination of what starting materials for each such reaction are required. The resulting starting materials are then subjected to the same retrosynthetic analysis, thus working backward from the target molecule until starting materials are derived.

The retrosynthetic analysis of a target molecule usually results in more than one possible synthetic route. It is therefore necessary to critically assess each derived route in order to choose the single route that is most feasible and most economical. The safety of each possible synthetic route (the toxicity and reactivity hazards associated with the reactions involved) is also considered when assessing alternative synthetic routes to a molecule.

Selectivity is an important consideration in the determination of a synthetic route to a target molecule. Stereoselectivity refers to the selectivity of a reaction for forming one stereoisomer of a product in preference to another. Stereoselectivity cannot be achieved for all organic reactions; the nature of the mecha-

General equation for the reaction*	Net transformation (name)
$\begin{array}{c} R_1 \\   \\ R_3-C-X \\   \\ R_2 \end{array} + Nu^- \longrightarrow Nu-C \begin{array}{c} R_1 \\   \\ R_2 \\   \\ R_3 \end{array} + X^-$ <p>(X = Cl, Br, I, or OSO<sub>2</sub>R; Nu = OH, OR, CN, NR<sub>2</sub>, others)</p>	Alkyl halide to various functional groups (alcohols, ethers, nitriles, amines, others)
$\begin{array}{c} R_1 \\   \\ R_2-C-X \\   \\ R_3 \\   \\ H \end{array} + \text{base (such as CH}_3\text{O}^-) \longrightarrow \begin{array}{c} R_1 \\   \\ R_2=C \\   \\ R_3 \end{array}$	Alkyl halide to alkene (elimination)
$ROH + HX \longrightarrow RX$ <p>(X = Cl, Br, I)</p>	Alcohol to alkyl halide
$\begin{array}{c} R_1 \\   \\ R_2-C-OH \\   \\ R_3 \\   \\ H \end{array} + H_2SO_4 \longrightarrow \begin{array}{c} R_1 \\   \\ R_2=C \\   \\ R_3 \end{array}$	Alcohol to alkene (dehydration)
$\begin{array}{c} OH \\   \\ R_1-CH \\   \\ R_2 \end{array} \xrightarrow{CrO_2, \text{pyridine}} \begin{array}{c} O \\    \\ R_1-C \\   \\ R_2 \end{array}$	Oxidation of alcohol to ketone or aldehyde
$R_1YH + \begin{array}{c} O \\    \\ R_2-C \\   \\ X \end{array} \longrightarrow \begin{array}{c} O \\    \\ R_2-C \\   \\ OR_1 \end{array}$ <p>(Y = O or N; X = OH, Cl, others)</p>	Alcohol and carboxylic acid derivative to ester (esterification); amine and carboxylic acid derivative to amide
$\begin{array}{c} R_2 \\   \\ R_1-C=C \\   \\ R_3 \end{array} + RCO_3H \longrightarrow \begin{array}{c} R_2 \\   \\ R_1-C-O \\   \\ R_3 \end{array}$	Alkene to epoxide (epoxidation)
$\begin{array}{c} R_2 \\   \\ R_1-C=C \\   \\ R_3 \end{array} + H_2 \xrightarrow[\text{(or other catalyst)}]{Pd} \begin{array}{c} R_2 \\   \\ R_1-CH_2-CH \\   \\ R_3 \end{array}$	Alkene to alkane (hydrogenation)
$\begin{array}{c} O \\    \\ R_1-C \\   \\ R_2 \end{array} + NaBH_4 \longrightarrow \begin{array}{c} OH \\   \\ R_1-CH \\   \\ R_2 \end{array}$	Reduction of ketone or aldehyde to alcohol
$R_1COOR_2 \xrightarrow[2. H_2O \text{ workup}]{1. LiAlH_4} R_1CH_2OH + R_2OH$	Reduction of ester to two alcohols
$R_1COOR_2 \xrightarrow{H_2O, \text{ acid or base}} R_1COOH + R_2OH$	Ester to carboxylic acid and alcohol (ester hydrolysis)
$R-CN \xrightarrow[2. H_2O \text{ workup}]{1. LiAlH_4} RCH_2NH_2$	Reduction of nitrile to amine
$\text{Benzene} + E^+ \longrightarrow \text{Benzene-E}$ <p>(E = Br, NO<sub>2</sub>, R, CO, others)</p>	Benzene to substituted benzene (electrophilic aromatic substitution)

\*R = any organic group (alkyl, aryl, alkenyl) or a hydrogen atom. Nu = nucleophile.

TABLE 2. Examples of some carbon-carbon bond-forming reactions

General equation for the reaction	Name of reaction
$R_1X + Mg \longrightarrow R_1MgX \xrightarrow[2. H^+]{1. R_2COR_3} \begin{array}{c} OH \\   \\ R_1-C-R_3 \\   \\ R_2 \end{array}$ <p>(X = Cl, Br, I)</p>	Grignard
$R_1X \xrightarrow[2. CuI]{1. Li} (R_1)_2CuLi \xrightarrow{R_2X} R_1-R_2$ <p>(X = Cl, Br, I)</p>	Gilman
$X-C(=O)-CH_2R_1 \xrightarrow[3. H^+]{1. (C_2H_5)_2NLi, 2. R_2CHO} \begin{array}{c} O \\    \\ X-C-CH_2R_1 \\   \\ OH \\   \\ R_2 \\   \\ R_1 \end{array}$ <p>(X = R, RO, NR<sub>2</sub>, others)</p>	Aldol addition
$XCH_2CO-Y + RCHO \xrightarrow[2. H_2O \text{ workup}]{1. Zn} \begin{array}{c} OH \\   \\ RCH-CH_2CO-Y \end{array}$ <p>(X = Cl, Br, or I; Y = R, RO, NR<sub>2</sub>, others)</p>	Reformatsky
$\begin{array}{c} O \\    \\ X-C \\   \\ R_1 \end{array} + \begin{array}{c} R_3 \\   \\ C=C \\   \\ R_2 \end{array} + H_2C(COOR)_2 \xrightarrow{NaOR} \begin{array}{c} O \\    \\ X-C-CH(COOR)_2 \\   \\ R_1 \end{array}$ <p>(X = R, RO, NR<sub>2</sub>, others)</p>	Michael addition
$X-C(=O)-CH_2R_1 + R_2CHO \xrightarrow[2. H_2O^+, \text{ heat}]{1. NaOCH_3} \begin{array}{c} O \\    \\ X-C-CH=C \\   \\ R_1 \end{array} \begin{array}{c} O \\    \\ R_2-CH \\   \\ R_2 \end{array}$ <p>(X = R, RO, NR<sub>2</sub>, others)</p>	Aldol condensation
$R_1COOR_2 + R_3CH_2COOR_2 \xrightarrow{NaOR} \begin{array}{c} O \\    \\ R_1-C-CH_2-C \\   \\ R_1 \end{array} \begin{array}{c} O \\    \\ R_3-CH \\   \\ OR_2 \end{array}$	Claisen condensation
$R_1CH_2Br \xrightarrow[2. BuLi]{1. PPh_3} R_1-CH=PPh_3 \xrightarrow{3. R_2CHO} R_1CH=CHR_2$	Wittig
$2RCHO \xrightarrow[2. H_2O \text{ workup}]{1. TiCl_4} \begin{array}{c} HO \\   \\ R-CH-CH-R \\   \\ OH \end{array}$	Pinacol coupling
$\begin{array}{c} Br \\   \\ \text{Cyclopentene} \end{array} \xrightarrow[\text{Bu}_3SnH]{\text{free-radical initiator}} \begin{array}{c} \text{Cyclopentane} \\   \\ CH_3 \end{array}$	Free-radical cyclization
$\begin{array}{c} R \\   \\ \text{Diene} \end{array} + \begin{array}{c} Y \\   \\ \text{Dienophile} \end{array} \xrightarrow{\text{heat}} \begin{array}{c} R \\   \\ \text{Cyclohexene} \\   \\ Y \end{array}$ <p>(Y = COOR, COR, CN, others)</p>	Diels-Alder
$\begin{array}{c} R_2 \\   \\ \text{Cyclohexene} \\   \\ H_2C \end{array} \xrightarrow{\text{heat}} \begin{array}{c} R_2 \\   \\ \text{Cyclohexene} \\   \\ CH_2 \end{array}$	Cope rearrangement

nism of some reactions may not allow for the formation of one particular configuration of a chiral (stereogenic) carbon center or one particular geometry (cis versus trans) for a double bond or ring. When stereoselectivity can be achieved, it requires that the reaction proceed via a geometrically defined transition state and that one or both of the reactants possess a particular geometrical shape during the reaction. For example, if one or both of the reactants is chiral, the absolute configuration of the newly formed stereogenic carbon center can be selected for in many reactions. See ASYMMETRIC SYNTHESIS; ORGANIC REACTION MECHANISM; STEREOCHEMISTRY.

Chemoselectivity is the ability of a reagent to react selectively with one functional group in the presence of another similar functional group. An example of a chemoselective reagent is a reducing agent that can reduce an aldehyde and not a ketone. In cases where chemoselectivity cannot be achieved, the functional group that should be prevented from participating in the reaction can be protected by converting it to a derivative that is unreactive to the reagent involved. The usual strategy employed to allow for such selective differentiation of the same or similar groups is to convert each group to a masked (protected) form which is not reactive but which can be unmasked (deprotected) to yield the group when necessary.

A large variety of organic reactions that can be used in syntheses are known. They can be categorized according to whether they feature a functional group interconversion or a carbon-carbon bond formation.



Functional group interconversions (Table 1) are reactions that change one functional group into another functional group. A functional group is a nonhydrogen, non-all-singly-bonded carbon atom or group of atoms. Included in functional group interconversions are nucleophilic substitution reactions, electrophilic additions, oxidations, and reductions. See COMPUTATIONAL CHEMISTRY; ELECTROPHILIC AND NUCLEOPHILIC REAGENTS; OXIDATION-REDUCTION; OXIDIZING AGENT; SUBSTITUTION REACTION.

Carbon-carbon bond-forming reactions (Table 2) feature the formation of a single bond or double bond between two carbon atoms. This is a particularly important class of reactions, as the basic strategy of synthesis—to assemble the target molecule from simpler, hence usually smaller, starting materials—implies that most complex molecules must be synthesized by a process that builds up the carbon skeleton of the target by using one or more carbon-carbon bond-forming reactions. [R.D.Wa.]

**Organoactinides** Organometallic compounds of the actinides—elements 90 and beyond in the periodic table. Both the large sizes of actinide ions and the presence of 5f valence orbitals are unique features which differ distinctly from most, if not all, other metal ions.

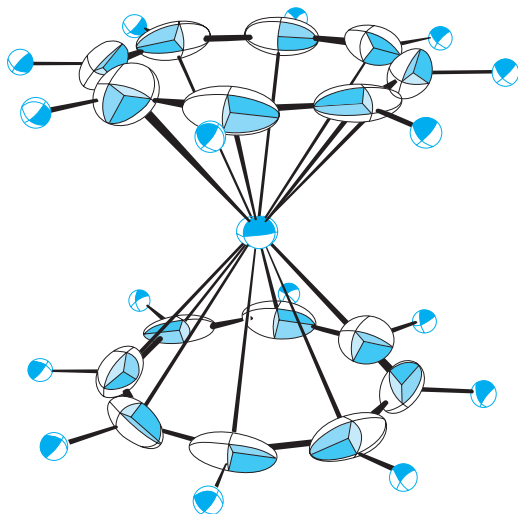

Molecular structure of  $U(C_8H_8)_2$  determined by single-crystal x-ray diffraction. (After K. O. Hodgson and K. N. Raymond, *Inorg. Chem.*, 12:458, 1973)

Organometallic compounds have been prepared for all actinides through curium (element 96), although most investigations have been conducted with readily available and more easily handled natural isotopes of thorium (Th) and uranium (U). Organic groups (ligands) which bind to actinide ions include both  $\pi$ - and  $\sigma$ -bonding functionalities. The importance of this type of compound reflects the ubiquitous character of metal-carbon two-electron sigma bonds in both synthesis and catalysis. See CATALYSIS.

The molecular structures of a number of organoactinides have been determined by single-crystal x-ray and neutron-diffraction techniques. In almost all cases the large size of the metal ion gives rise to unusually high (as compared to a transition-metal compound) coordination numbers. That is, a greater number of ligands or ligands with greater spatial requirements can be accommodated within the actinide coordination sphere. The sandwich complex bis(cyclooctatetraenyl)-uranium (ura-nocene), an example of this latter type, is shown in the illustration. See ACTINIDE ELEMENTS; COORDINATION CHEMISTRY; METALLOCENES; NEUTRON DIFFRACTION; ORGANOMETALLIC COMPOUND; X-RAY DIFFRACTION. [T.J.M.]

**Organometallic compound** A member of a broad class of compounds whose structures contain both carbon (C) and a metal (M). Although not a required characteristic of organometallic compounds, the nature of the formal carbon-metal bond can be of the covalent, ionic, or  $\pi$ -bond type.

The term organometallic chemistry is essentially synonymous with organotransition-metal chemistry; it is associated with a specific portion of the periodic table ranging from groups 3 through 11, and also includes the lanthanides. See CHEMICAL BONDING; LIGAND; PERIODIC TABLE; TRANSITION ELEMENTS.

From the perspective of inorganic chemistry, organometallics afford seemingly endless opportunities for structural variations due to changes in the metal coordination number, alterations in ligand-metal attachments, mixed-metal cluster formation, and so forth. From the viewpoint of organic chemistry, organometallics allow for manipulations in the functional groups that in unique ways often result in rapid and efficient elaborations of carbon frameworks for which no comparable direct pathway using non-transition organometallic compounds exists.

In moving across the periodic table, the early transition metals have seen relatively limited use in synthesis, with two exceptions: titanium (Ti) and zirconium (Zr).

Titanium has an important role in a reaction known as the Sharpless asymmetric epoxidation, where an allylic alcohol is converted into a chiral, nonracemic epoxy alcohol with excellent and predictable control of the stereochemistry [reaction (1)]. The

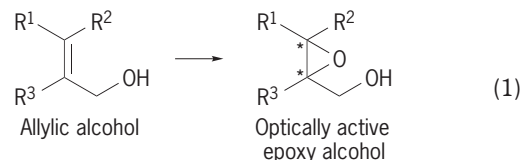

significance of the nonracemic product is that the reaction yields a single enantiomer of high purity.

There are many applications utilizing the Sharpless asymmetric synthesis. Examples of synthetic targets that have relied on this chemistry include riboflavin (vitamin B<sub>2</sub>) and a potent inhibitor of cellular signal transduction known as FK-506. See ASYMMETRIC SYNTHESIS; TITANIUM.

Below titanium in group 4 in the periodic table lies zirconium. Most modern organozirconium chemistry concerns zirconium's ready formation of the carbenelike complex  $[Cp_2Zr:]$ , which because of its mode of preparation is more accurately thought of as a  $\pi$  complex (2). Also important are reactions of the zirconium chloride hydride,  $Cp_2Zr(H)Cl$ , commonly referred to as Schwartz's reagent, with alkenes and alkynes, and the subsequent chemistry of the intermediate zirconocenes. See METALLOGENES.

When the complex  $Cp_2ZrCl_2$  is exposed to two equivalents of ethyl magnesium bromide  $EtMgBr$ , the initially formed  $Cp_2ZrEt_2$  loses a molecule of ethane ( $C_2H_6$ ) to produce the complexed zirconocene  $[Cp_2Zr:]$  (1), as shown in reaction (2). Upon intro-

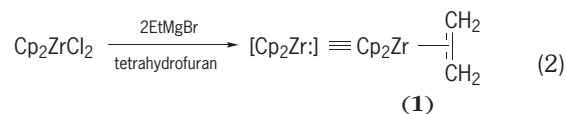

duction of another alkene or alkyne, a zirconacyclopentane or zirconacyclopentene is formed, respectively [reaction (3)], where

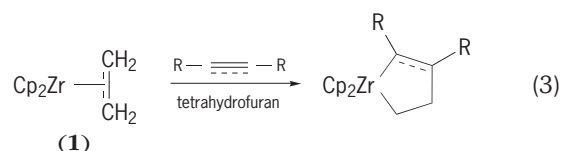

the structure above the arrow indicates that the chemistry applies to either alkenes (no third bond) or alkynes (with third bond)]. These are reactive species that can be converted to many useful

derivatives resulting from reactions such as insertions, halogenations, and transmetalation/quenching. When the preformed complex (**1**) is treated with a substrate containing both an alkene and alkyne, a bicyclic zirconocene results that can ultimately yield polycyclic products (for example, pentalenic acid, a likely intermediate in the biosynthesis of the antibiotic pentalenolactone). See REACTIVE INTERMEDIATES.

Among the group 6–8 metals, chromium (Cr), molybdenum (Mo), and tungsten (W) have been extensively utilized in the synthesis of complex organic molecules in the form of their electrophilic Fischer carbene complexes, which are species having, formally, a double bond between carbon and a metal. They are normally generated as heteroatom-stabilized species bearing a "wall" of carbon monoxide ligands (**2**).

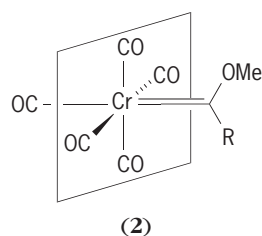

Most of the synthetic chemistry has been performed with chromium derivatives, which are highly electrophilic at the carbene center because of the strongly electron-withdrawing carbonyl (CO) ligands on the metal. Many different types of reactions are characteristic of these complexes, such as  $\alpha$  alkylation, Diels-Alder cycloadditions of  $\alpha,\beta$ -unsaturated systems, cyclopropanation with electron-deficient olefins, and photochemical extrusions/cycloadditions. The most heavily studied and applied in synthesis, however, is the Dötz reaction, which has been applied in the production of antitumor antibiotics in the anthracycline and aureolic acid families. See DIELS-ALDER REACTION; METAL CARBYNYL.

Groups 9–11 contain transition metals that have been the most widely used not only in terms of their abilities to effect C—C bond formations but also organometallic catalysts for some of the most important industrial processes. These include cobalt (Co), rhodium (Rh), palladium (Pd), and copper (Cu). [B.H.L.]

**Organophosphorus compound** One of a series of derivatives of phosphorus that have at least one organic (alkyl or aryl) group attached to the phosphorus atom linked either directly to a carbon atom or indirectly by means of another element (for example, oxygen). The mono-, di-, and trialkylphosphines (and their aryl counterparts) can be regarded formally as the parent compounds of all organophosphorus compounds.

Considering the large number of organic groups that may be joined to phosphorus as well as the incorporation of other elements in these materials, the number of combinations is practically unlimited. A vast family in itself is composed of the heterocyclic phosphorus molecules, in which phosphorus is one of a group of atoms in a ring system.

Some organophosphorus compounds have been used as polymerization catalysts, lubricant additives, flameproofing agents, plant growth regulators, and insecticides. Organophosphorus compounds were made during World War II for use as chemical warfare agents in the form of nerve gases (Sarin, Trilon 46, Soman, and Tabun). See PHOSPHORUS. [S.E.Cr.]

**Organoselenium compound** One of a group of compounds that contain both selenium (Se) and carbon (C) and frequently other elements as well, for example, halogen, oxygen (O), sulfur (S), or nitrogen (N). Organoselenium compounds have become common in organic chemistry laboratories, where they have numerous applications, particularly in the area of or-

ganic synthesis. Organoselenium compounds formally resemble their sulfur analogs and may be classified similarly. For instance, selenols, selenides, and selenoxides are clearly related to thiols, sulfides, and sulfoxides. Despite structural similarities, however, sulfur and selenium compounds are often strikingly different with respect to their stability, properties, and ease of formation. See ORGANOSULFUR COMPOUND; SELENIUM.

Selenols have the general formula RSeH, where R represents either an aryl or alkyl group. They are prepared by the alkylation of hydrogen selenide ( $H_2Se$ ) or selenide salts, as well as by the reaction of Grignard reagents or organolithium compounds with selenium, as in reactions (1).

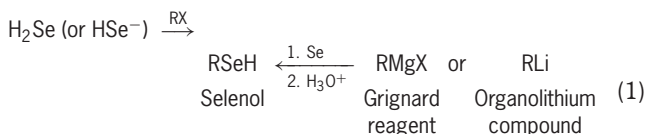

Selenols are stronger acids than thiols. They and their conjugate bases are powerful nucleophiles that react with alkyl halides ( $R'X$ ;  $R'$  = alkyl group) or similar electrophiles to produce selenides ( $RSeR'$ ); further alkylation yields selenonium salts, as shown in reactions (2), where  $R''$  represents an alkyl group that

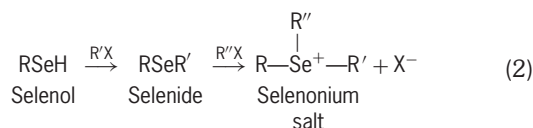

may be different from the alkyl group  $R'$ . Both acyclic and cyclic selenides are known. See ALKYLATION; ELECTROPHILIC AND NUCLEOPHILIC REAGENTS; GRIGNARD REACTION; REACTIVE INTERMEDIATES.

Diselenides ( $RSeSeR$ ) are usually produced by the aerial oxidation of selenols; they react in turn with chlorine or bromine, yielding selenenyl halides or selenium trihalides. Diselenides are easily oxidized to seleninic acids or anhydrides by reagents such as hydrogen peroxide or nitric acid.

Selenoxides are readily obtained from the oxidation of selenides with hydrogen peroxide ( $H_2O_2$ ) or similar oxidants. Selenoxides undergo facile elimination to produce olefins and selenenic acids, a process known as syn-elimination.

Selenocarbonyl compounds tend to be considerably less stable than their thiocarbonyl or carbonyl counterparts because of the weaker double bond between the carbon and selenium atoms. Selenoamides, selenoesters and related compounds can be isolated, but selenoketones (selones) and selenoaldehydes are highly unstable. See ALDEHYDE; AMIDE; ESTER; KETONE.

The charge-transfer complexes formed between certain Organoselenium donor molecules and appropriate acceptors such as tetracyanoquinodimethane are capable of conducting electric current. Selenium-containing polymers are also of interest as organic conductors. See COORDINATION COMPLEXES; ORGANIC CONDUCTOR.

Selenium is an essential trace element, and its complete absence in the diet is severely detrimental to human and animal health. The element is incorporated into selenoproteins such as glutathione peroxidase, which acts as a natural antioxidant. See BIOINORGANIC CHEMISTRY; COORDINATION CHEMISTRY; PROTEIN. [T.G.B.]

**Organosilicon compound** One of a group of compounds in which silicon (Si) is bonded to an organic functional group (R) either directly or indirectly via another atom. Formally, all organosilanes can be viewed as derivatives of silane ( $SiH_4$ ) by the substitution of hydrogen (H) atoms. The most common substituents are methyl ( $CH_3$ ; Me) and phenyl ( $C_6H_5$ ; Ph) groups. However, tremendous diversity results with cyclic structures and the introduction of heteroatoms. See SILICON.

Organosilicon compounds are not found in nature and must be prepared in the laboratory. The ultimate starting material is sand (silicon dioxide, SiO<sub>2</sub>) or other inorganic silicates, which make up over 75% of the Earth's crust. The useful properties of silicone polymers were identified in the 1940s; widespread interest in Organosilicon chemistry followed.

The chemistry of organosilanes can be explained in terms of the fundamental electronic structure of silicon and the polar nature of its bonds to other elements. Silicon appears in the third row of the periodic table, immediately below carbon (C) in group IV, and has many similarities with carbon. However, it is the fundamental differences between carbon and silicon that make silicon so useful in organic synthesis and of such great theoretical interest. See CARBON.

In the majority of organosilicon compounds, silicon follows the octet rule and is 4-coordinate. This trend can be explained by the electronic configuration of atomic silicon (3s<sup>2</sup>3p<sup>2</sup>3d<sup>0</sup>) and the formation of sp<sup>3</sup>-hybrid orbitals for bonding. Unlike carbon (2s<sup>2</sup>2p<sup>2</sup>), however, silicon is capable of expanding its octet and can form 5- and 6-coordinate species with electronegative substituents, such as the 6-coordinate octahedral dianion, [Me<sub>2</sub>SiF<sub>4</sub>]<sup>2-</sup>. See COORDINATION CHEMISTRY; ELECTRON CONFIGURATION; VALENCE.

Silicon is a relatively electropositive element that forms polar covalent bonds (Si<sup>δ+</sup>—X<sup>δ-</sup>) with carbon and other elements, including the halogens, nitrogen, and oxygen. The strength and reactivity of silicon bonds depend on the relative electronegativities of the two elements. For example, the strongly electronegative elements fluorine (F) and oxygen (O) form bonds that have tremendous thermodynamic stabilities. See CHEMICAL THERMODYNAMICS; ELECTRONEGATIVITY.

Before 1981, multiply bonded silicon compounds were identified only as transient species both in solution and in the gas phase. However, when tetramesityldisilene (Ar<sub>2</sub>Si=SiAr<sub>2</sub>, where Ar = 2,4,6-trimethylphenyl) was isolated, it was found to be a crystalline, high-melting-point solid having excellent stability in the absence of oxygen and moisture.

Numerous reactive species have been generated and characterized in organosilicon chemistry. Silylenes are divalent silicon species (SiR<sub>2</sub>, where R = alkyl, aryl, or hydrogen), analogous to carbenes in carbon chemistry. The dimerization of two silylene units gives a disilene. Silicon-based anions, cations, and radicals are important intermediates in the reactions of silicon. See FREE RADICAL.

The direct process for the large-scale preparation of organosilanes has provided a convenient source of raw materials for the development of the silicone industry. The process produces a mixture of chloromethylsilanes from elemental silicon and methyl chloride in the presence of a copper (Cu) catalyst, as in the reaction below.



In spite of concentrated research efforts in this area, the synthetic methods available for the controlled formation of silicon-carbon bonds remain limited to only a few general reaction types. These include the reaction of organometallic reagents with silanes, catalytic hydrosilylation of multiple bonds, and reductive silylation.

The role of silicon in organic synthesis is quite extensive, and chemists exploit the unique reactivity of organosilanes to accomplish a wide variety of transformations. Silicon is usually introduced into a molecule to perform a specific function and is then removed under controlled conditions.

Polysilanes are organosilicon compounds that contain either cyclic arrays or linear chains of silicon atoms. The isolation and characterization of both cyclosilanes (with up to 35 silane units) and high-molecular-weight linear polysilanes (with up to 3000 silane units) have demonstrated that silicon is capable of extended chain formation (catenation). Polysilanes contain only silicon-silicon bonds in their backbone, which differentiates them

from polysiloxanes (silicones), which contain alternating silicon and oxygen repeat units. See SILICONE RESINS.

Polysilanes have found applications as photoresists in microlithography, charge carriers in electrophotography, and photoinitiators for vinyl polymerization. Polysilanes also function as preceramic polymers for the manufacture of silicon carbide fibers. [H.Y.]

**Organosulfur compound** A member of a class of organic compounds with any of several dozen functional groups containing sulfur (S).

Sulfur is an element of the third row of the periodic table; it is larger and less electronegative than oxygen, which lies above it in the second row. Compounds with an expanded valence shell, that is, compounds bonding to as many as six ligands around sulfur, are therefore possible, and a broad range of compounds can be formed. Moreover, sulfur has a much greater tendency than oxygen to undergo catenation to give chains with several atoms linked together through S—S bonds. See CHEMICAL BONDING; PERIODIC TABLE; STRUCTURAL CHEMISTRY; VALENCE.

The structures and names of representative types of organosulfur compounds are shown in the table. Some compounds and groups are named by using the prefix thio to denote replacement of oxygen by sulfur. The prefix thia can be used to indicate that one or more —CH<sub>2</sub>— groups have been replaced by sulfur, as in 2,7-dithianonane [CH<sub>3</sub>S(CH<sub>2</sub>)<sub>4</sub>SCH<sub>2</sub>CH<sub>3</sub>].

Thiols and sulfides are sulfur counterparts of alcohols and ethers, respectively, and can be prepared by substitution reactions analogous to those used for the oxygen compounds. Sulfonium salts are obtained by further alkylation of sulfides.

Although thiols and alcohols are structurally analogous, there are significant differences in the properties of these two groups. Hydrogen bonding of the type —S—H—S— is very weak

Some types of organosulfur compounds and groups

Structure	Name
RSH	Thiol (mercaptan)
RSR	Sulfide (thioether)
RSSR	Disulfide
RSSSR	Trisulfide (trisulfane)
$\begin{array}{c} + \\ \text{RSR} \text{ X}^- \\   \\ \text{R} \end{array}$	Sulfonium salt
$\begin{array}{c} \text{R}_2\text{C}=\text{S} \\ \text{RN}=\text{C}=\text{S} \end{array}$	Thio ketone Isothiocyanate
$\begin{array}{c} \text{O} \\    \\ \text{RCSR} \end{array}$	Thiolate ester (thio acid S-ester)
$\begin{array}{c} \text{S} \\    \\ \text{RCOR} \end{array}$	Thionoate ester
RCS <sub>2</sub> R	Dithioate ester
RSOH	Sulfenic acid
RSCI	Sulfonyl chloride
RSOR	Sulfoxide
NR	Sulfimide
$\begin{array}{c}    \\ \text{RSR} \end{array}$	
RSO <sub>2</sub> H	Sulfonic acid
RSO <sub>2</sub> R	Sulfinate ester
R <sub>2</sub> S=R <sub>2</sub>	Sulfonium ylide (sulfurane)
RSO <sub>2</sub> R	Sulfone
RSO <sub>3</sub> H	Sulfonic acid
RSO <sub>2</sub> NH <sub>2</sub>	Sulfonamide
RSO <sub>2</sub> Cl	Sulfonyl chloride
ROSO <sub>3</sub> R	Sulfate ester

compared to  $\text{—O—H—O—}$ , and thiols are thus more volatile and have lower boiling points than the corresponding alcohols; for example, methanethiol ( $\text{CH}_3\text{SH}$ ) has a boiling point of  $5.8^\circ\text{C}$  ( $42.4^\circ\text{F}$ ) compared to  $65.7^\circ\text{C}$  ( $150.3^\circ\text{F}$ ) for methanol ( $\text{CH}_3\text{OH}$ ).

Thiols form insoluble precipitates with heavy-metal ions such as lead or mercury. Both thiols and sulfides are extremely malodorous compounds, recalling the stench of rotten eggs (hydrogen sulfide). However, traces of these sulfur compounds are an essential component of the distinctive flavors and aromas of many vegetables, coffee, and roast meat. See MAILLARD REACTION; MERCAPTAN; SPICE AND FLAVORING.

Thiocarbonyl compounds contain a carbon-sulfur double bond ( $\text{C=S}$ ). Thiocarbonyl compounds (thiones) are much less common than carbonyl compounds ( $\text{C=O}$  bond). Simple thioaldehydes or thioketones have a strong tendency to form cyclic trimers, polymers, or other products.

Sulfides can be oxidized sequentially to sulfoxides and sulfones, containing the sulfinyl ( $\text{—SO—}$ ) and sulfonyl ( $\text{—SO}_2\text{—}$ ) groups, respectively, as in the reaction below.

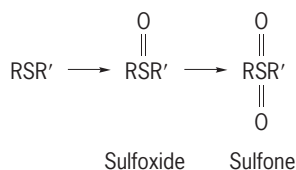

Dimethyl sulfoxide (DMSO) is available in large quantities as a by-product of the Kraft sulfite paper process. It is useful as a polar solvent with a high boiling point and as a selective oxidant and reagent in organic synthesis. See DIMETHYL SULFOXIDE.

Compounds containing the sulfonyl group include sulfones, sulfonyl chlorides, sulfonic acids, and sulfonamides. The sulfonyl group resembles a carbonyl in the acidifying effect on an  $\alpha$ -hydrogen. The diaryl sulfone unit is the central feature of polysulfone resins, used in some high-performance plastics. Sulfonic acids are obtained by oxidation of thiols or by sulfonation. Sulfonamides, prepared from the chlorides, were the mainstay therapeutic agents in infections until the advent of antibiotics; they are still used for some conditions. See POLYSULFONE RESINS; SULFONAMIDE; SULFONIC ACID.

A number of proteins and metabolic pathways in systems of living organisms depend on the amino acid cysteine and other sulfur compounds. In many proteins, for example, in the enzyme insulin, disulfide bonds formed from the  $\text{—SH}$  groups of cysteine units are an essential part of the structure. The  $\text{—SH}$  groups of cysteine also play a role in the metal-sulfur proteins that mediate electron-transport reactions in respiration and photosynthesis. See INSULIN; PHOTOSYNTHESIS.

The coenzyme lipoic acid is a cyclic disulfide that functions together with the coenzyme thiamine diphosphate to accept electrons and undergo reduction of the  $\text{—S—S—}$  bond in the oxidative decarboxylation of pyruvic acid. Two other major pathways in metabolism, the transfer of acetyl groups and of methyl groups, are mediated by organosulfur compounds. Acetyl transfer, a key step in lipid and carbohydrate metabolism, occurs by way of thioesters. See CARBOHYDRATE METABOLISM; COENZYME; LIPID METABOLISM; THIAMINE.

Sulfur is present in numerous other compounds found in natural sources. Petroleum contains variable amounts of sulfur, both as simple thiols and sulfides, and also heterocyclic compounds such as benzothiophene. Removal of these is an important step in petroleum refining. See PETROLEUM; PETROLEUM PROCESSING AND REFINING.

Several sulfur-containing compounds from natural sources have important pharmacological properties. Examples are the  $\beta$ -lactam antibiotics penicillin, cephalosporin, and thienamycin, and the platelet anticoagulating factor ajoene from garlic, produced by a series of complex enzymatic reactions from alliin.

See ANTIBIOTIC; HETEROCYCLIC COMPOUNDS; ORGANIC CHEMISTRY; SULFUR. [J.A.Mo.]

**Oriental vegetables** Oriental vegetables are very important in Asian countries, but are considered as minor crops in the United States and Europe. However, in recent years there has been an increased interest in these crops because of their unusual flavors and textures and in some cases their high nutritional values. Some of the more common ones are described below.

Chinese cabbage, celery cabbage, napa, or pe-tsai (*Brassica campestris*, *pekinensis* group; *B. rapa*, *pekinensis* group; *B. pekinensis*) belongs to the mustard (Cruciferae) family, and is a biennial leafy plant but is grown as an annual. The harvested part is a head which is composed of broad crinkled leaves with a very wide, indistinct, white midrib. The outer leaves are pale green, and the inner leaves of the head are blanched. It is a good salad vegetable because of the mild flavor and crisp texture.

There are many varieties of pak choy, bok choy, Chinese mustard, or celery mustard (*Brassica campestris*, *chinensis* group; *B. rapa*, *chinensis* group; *B. chinensis*). The crop is grown as an annual. Pak choy does not form a head like most varieties of Chinese cabbage, but forms a celerylike stalk of tall, dark green leaves, with prominent white veins and long white petioles (see illustration). The base of the petiole may be expanded and spoon-shaped; the blade of the leaf is smooth, and not crinkled like that of Chinese cabbage.

The large, long, white radish (*Raphanus sativus*, *longipinnatus* group) is often called oriental winter radish, daikon, Chinese winter radish, lobok, and lob paak. Radish is a dicotyledonous herbaceous plant grown for its long, enlarged roots.

Edible podded peas, China peas, sugar peas, or snow peas (*Pisum sativum*, *macrocarpon* group) belong to the Leguminosae family. The primitive forms of pea are slightly bitter and have a tough seed coat, which allows for long dormant periods. In the garden pea the pod swells first as the seeds enlarge, but in the edible podded pea the immature seeds bulge the pod, which demarks the developing seeds. Unlike the regular garden peas which have tough fibery seed pods, the edible podded peas were selected for the tender pods and not for the seeds.



Pak choy or Chinese mustard (*Brassica campestris*). (University of California Agricultural Experiment Station)

Yard-long bean or asparagus bean (*Vigna sinensis*, sesquipedalis group) belongs to the Leguminosae family. It is an annual climbing plant. It is a relative of the cow pea (*V. unguiculata*).

Mung bean or green gram (*Phaseolus aureus*) sprouts have been used by the Chinese for their remarkable healing qualities for thousands of years. Only recently has the Western world recognized the value of sprouted leguminous seeds (mung, soy, and alfalfa sprouts). The unsprouted mung bean seeds contain negligible amounts of vitamin C (ascorbic acid), whereas the sprouted seeds contain 20 mg per 100 g of sprouts, which is as high as tomato juice.

Jicama (*Pachyrhizus erosus*), also called the yam bean, is indigenous to Mexico and Central America. It belongs to the pea (Leguminosae) family. The crop is grown for its enlarged turnip-shaped root, which is eaten raw or cooked, has a crisp texture, and is sweetish in taste.

Chinese winter melon, wax gourd, winter gourd, white gourd, ash gourd, Chinese preserving melon, ash pumpkin, or tung kwa (*Benincasa hispida*; *B. cerifera*) is a viny annual cucurbit. The flesh of mature fruits is used in making Chinese soups. It can be eaten raw or made into sweet preserves similar to citron or watermelon rind preserves.

Balsam pear, alligator pear, bitter melon, bitter melon, bitter cucumber, or fu kwa (*Momordica charantia*) is an annual herbaceous vine. The heart-shaped to cylindrical fruits are extremely bitter; some of the bitterness is removed before cooking by peeling and steeping in salt water. Immature fruits are less bitter than mature ones.

Chinese okra or angled loofa (*Luffa acutangula*) is called zit kwa by the Chinese; it is a close relative of *L. cylindrica*, known as loofa, sponge gourd, or dishcloth gourd. Chinese okra is an annual climbing vine grown for the immature fruits. The thoroughly mature fruits can be made into vegetable sponge.

Water spinach, water convolvulus, swamp cabbage, kang kong, or shui ung tsoi (*Ipomoea aquatica*) is a perennial semi-aquatic plant grown for its long, tender shoots. It is a relative of the sweet potato (*I. batatas*), but does not produce an enlarged root. [M.Y.]

**Orion** The Warrior, in astronomy, and undoubtedly the finest of all constellations in the sky. Orion is a winter group near the celestial equator. Four of the most prominent stars,  $\alpha$ ,  $\gamma$ ,  $\beta$ , and  $\kappa$ , form a huge crude rectangle (see illustration). The group is

pictured as the figure of a warrior, holding a shield with his left hand and swinging a club with his raised right arm ready to strike the charging Bull. Betelgeuse (meaning armpit), one of the largest stars known, is the red star at the right shoulder, Bellatrix is at the left shoulder, and Rigel, the blue-white star, is at the left leg. Three bright stars in a straight line in the middle of the rectangle represent the warrior's belt. The center star is Alnilam. See CONSTELLATION; ORION NEBULA; TAURUS. [C.S.Y.]

**Orion Nebula** The brightest emission nebula in the sky, designated M42 in Messier's catalog. The Great Nebula in Orion consists of ionized hydrogen and other trace elements (see illustration). The nebula belongs to a category of objects known as H II regions (the Roman numeral II indicates that hydrogen is in the ionized state), which mark sites of recent massive star formation. Located in Orion's Sword at a distance of 460 parsecs or 1500 light-years ( $8.8 \times 10^{15}$  mi or  $1.4 \times 10^{16}$  km), the Orion Nebula consists of dense plasma, ionized by the ultraviolet radiation of a group of hot stars less than 100,000 years old known as the Trapezium cluster. The nebula covers an area slightly smaller than the full moon and is visible with the aid of binoculars or a small telescope. See ORION.



Visual-wavelength view of the Orion Nebula obtained by taking a time exposure on a photographic plate with the 4-m-diameter (158-in.) telescope on Kitt Peak, Arizona (National Optical Astronomy Observatories).

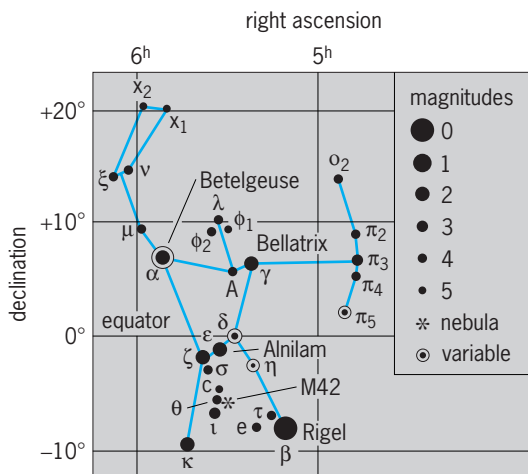

Line pattern of the constellation Orion. M42 designates the Orion Nebula. The grid lines represent the coordinates of the sky. The apparent brightness, or magnitude, of the stars is shown by the size of the dots, graded by appropriate numbers.

In addition to the Trapezium cluster of high-mass stars, the Orion Nebula contains about 700 low-mass stars packed into an unusually small volume of space. As the Orion Nebula evolves, the cluster is expected to expand and possibly dissolve into the smooth background of stars in the Milky Way.

Observations with the Hubble Space Telescope have shown that many low-mass stars in the Orion Nebula are surrounded by disks of dense gas and dust. These so-called proplyds (derived from the term "proto planetary disks") appear to be rapidly losing

their mass as they are irradiated by intense ultraviolet radiation produced by high-mass stars in the nebula. However, the protoplanets may eventually evolve into planetary systems if most of the solids in these disks have already coagulated into centimeter-sized objects which are resistant to ablation by the radiation field.

A star-forming molecular cloud core (known as OMC1 for Orion Molecular Cloud 1) is hidden behind the Orion Nebula by a shroud of dust. This cloud core is only a small part of a giant molecular cloud (the Orion A cloud), 100,000 times more massive than the Sun. See INTERSTELLAR MATTER; MOLECULAR CLOUD; NEBULA. [J.Ba.]

**Ornithischia** One of two orders of extinct reptiles popularly known as dinosaurs, the other being the Saurischia. The two orders are distinguished by various anatomical differences, but the shape of the pelvis is the primary distinction, tetraradiate or superficially "birdlike" in the Ornithischia and triradiate in the Saurischia. The ordinal names refer to these distinctive conditions: "bird-hipped" and "reptile-hipped." Like the saurischians, ornithischians probably originated from the Thecodontia in Early or Middle Triassic times. Ornithischian remains are known from rock strata ranging from Middle Triassic to latest Cretaceous in age and have been found on all continents except Antarctica. On the basis of tooth shape, all ornithischians are judged to have been herbivores. Most kinds had peculiar beaks or bills, featuring a unique premaxillary bone at the front of the lower jaw, for plucking vegetation. Many possessed highly specialized batteries of teeth for crushing, grinding, or slicing plant tissues. See SAURISCHIA.

Traditional classifications recognize four suborders: Ornithomiridae, Stegosauria, Ankylosauria, and Ceratopsia. A fifth suborder, Pachycephalosauria, was suggested as a result of new discoveries in Mongolia. See DINOSAUR. [J.H.O.]

**Orogeny** The process of mountain building. As traditionally used, the term orogeny refers to the development of long, mountainous belts on the continents that are called orogenic belts or orogens. These include the Appalachian and Cordilleran orogens of North America, the Andean orogen of western South America, the Caledonian orogen of northern Europe and eastern Greenland, and the Alpine-Himalayan orogen that stretches from western Europe to eastern China. It is important to recognize that these systems represent only the most recent orogenic belts that retain the high relief characteristic of mountainous regions. In fact, the continents can be viewed as a collage of ancient orogenic belts, most of which are so deeply eroded that no trace of their original mountainous topography remains. By comparing characteristic rock assemblages from more recent orogens with their deeply eroded counterparts, geologists surmise that the processes responsible for mountain building today extended back through most (if not all) of geologic time and played a major role in the growth of the continents. See CONTINENTS, EVOLUTION OF.

The construction of mountain belts is best understood in the context of plate tectonics theory. Orogenic belts form at convergent boundaries, where lithosphere plates collide. See LITHOSPHERE; PLATE TECTONICS.

There are two basic kinds of convergent plate boundaries, leading to the development of two end-member classes of orogenic belts. Oceanic subduction boundaries are those at which oceanic lithosphere is thrust (subducted) beneath either continental or oceanic lithosphere. The process of subduction leads to partial melting near the plate boundary at depth, which is manifested by volcanic and intrusive igneous activity in the overriding plate. Where the overriding plate consists of oceanic lithosphere, the result is an intraoceanic island arc, such as the Japanese islands. Where the overriding plate is continental, a continental arc is formed. The Andes of western South America is an example. See MARINE GEOLOGY; OCEANIC ISLANDS; SUBDUCTION ZONES.

The second kind of convergent plate boundary forms when an ocean basin between two continental masses has been completely consumed at an oceanic subduction boundary and the continents collide. Continental collisional orogeny has resulted in some of the most dramatic mountain ranges on Earth; a good example is the Himalayan orogen, which began forming roughly 50 million years ago when India collided with the Asian continent. Because the destruction of oceanic lithosphere at subduction boundaries is a prerequisite for continental collision, continental collisional orogens contain deformational features and rock associations developed during arc formation as well as those produced by continental collision. [K.Ho.]

**Orpiment** A mineral having composition  $As_2S_3$ . Crystals are small, tabular, and rarely distinct; the mineral occurs more commonly in foliated or columnar masses. The hardness is 1.5–2 (Mohs scale) and the specific gravity is 3.49. The luster is resinous and pearly on the cleavage surface; the color is lemon yellow. Orpiment is found in Romania, Peru, Japan, and Russia. In the United States it occurs at Mercer, Utah; Manhattan, Nevada; and in deposits from geyser waters in Yellowstone National Park. See ARSENIC. [C.S.Hu.]

**Orthida** An order of articulate brachiopods which includes the oldest known representatives of the class. They first appeared in Early Cambrian times and became especially prolific and diverse in the Ordovician. Subsequently, the group diminished in relative abundance during Silurian and Late Paleozoic time, finally becoming extinct during the Permian. The majority of the order belong to the suborder Orthidina. Characteristically, these are biconvex, finely ribbed shells with a straight hinge line and well developed interareas on both valves. See BRACHIOPODA. [A.J.R.]

**Orthoclase** Potassium feldspar ( $Or = KAlSi_3O_8$ ) that usually contains up to 30 mole % albite ( $Ab = NaAlSi_3O_8$ ) in solid solution. Its hardness is 6; specific gravity, 2.57–2.5, depending on Ab content; mean refractive index, 1.52; color, white to dull pink or orange-brown. Some orthoclases may be intergrown with relatively pure albite which exsolved during cooling from a high temperature in pegmatites, granites, or granodiorites. This usually is ordered low albite, but in rare cases it may show some degree of Al,Si disorder, requiring it to be classified as analbite or high albite. If exsolution is detectable by eye, the Or-Ab composite mineral is called perthite; if microscopic examination is required to distinguish the phases, it is called microperthite; and if exsolution is detectable only by x-ray diffraction or electron optical methods, it is called cryptoperthite. Orthoclase is optically monoclinic. Its structure averaged over hundreds of nanometers may be monoclinic, but its true symmetry is triclinic. See ALBITE; CRYSTAL STRUCTURE; PERTHITE. [P.H.R.]

**Orthogonal polynomials** A special case of orthogonal functions that arise in many physical problems (often as the solutions of differential equations), in the study of distribution functions, and in certain other situations where one approximates fairly general functions by polynomials. See PROBABILITY.

Each set of orthogonal polynomials is defined with respect to a particular averaging procedure. The average value of a suitable function  $f$  is denoted by  $E(f)$ . An example is shown in Eq. (1). In general an averaging procedure has the form shown in Eq. (2),

$$E\{f\} = \frac{1}{2} \int_{-1}^1 f(x) dx \quad (1)$$

$$E\{f\} = \int_{-\infty}^{\infty} f(x) d\sigma(x) \quad (2)$$

a Stieltjes integral, where  $\sigma$  is a distribution function, that is, an increasing function with  $\sigma(-\infty) = 0$  and  $\sigma(+\infty) = 1$ .

Two functions  $f$  and  $g$  are said to be orthogonal with respect to a given averaging procedure if  $E\{f\bar{b}a|g\} = 0$  where the bar denotes complex conjugation. By the system of orthogonal polynomials associated with the averaging procedure is meant a sequence  $P_0, P_1, P_2 \dots$  of polynomials  $P_n$  having exact degree  $n$ , which are mutually orthogonal, that is,  $E\{P_m P_n\} = 0$  for  $m \neq n$ . This last condition is equivalent to the statement that each  $P_n$  is orthogonal to all polynomials of degree less than  $n$ . Thus  $P_n$  has the form  $P_n(x) = a_0 + a_1x + a_2x^2 + \dots + a_nx^n$  where  $a_n \neq 0$  and is subject to the  $n$  conditions  $E\{x^k P_n\} = 0$  for  $k = 0, 1, \dots, n-1$ . This gives  $n$  linear equations in the  $n+1$  coefficients of  $P_n$ , leaving one more condition, called a normalization, to be imposed. The method of normalization differs in different references. See POLYNOMIAL SYSTEMS OF EQUATIONS.

[C.S.He.]

**Orthonectida** An order of Mesozoa. The orthonectids parasitize various marine invertebrates as multinucleate plasmodia. The plasmodia multiply by fragmentation. Eventually they give rise asexually, by polyembryony, to sexual males and females. Commonly only one sex arises from a given plasmodium.

These sexually mature forms escape as minute ciliated organisms. Structurally they are composed of a single layer of ciliated epithelial cells surrounding an inner mass of sex cells. The ciliated cells are disposed in rings around the body.

After insemination the eggs develop in the female and form ciliated larvae. When liberated, these larvae invade new individuals of their host and then disaggregate, liberating germinal cells which give rise to new plasmodia. See MESOZOA. [B.H.McC.]

**Orthoptera** A related group of generalized insect orders (also known as Orthopteroidea). The group is characterized by gradual metamorphosis, chewing mouthparts, and two pairs of wings, the anterior pair of which is usually thickened and leathery and covers the fanwise folded second pair. Wings are reduced or absent in many species. Common representatives include cockroaches, stick insects, praying mantids, grasshoppers, locusts, and crickets. Food habits range from omnivorous to strictly carnivorous or herbivorous. Habitats are nearly all terrestrial, including arctic-alpine tundra and floating aquatic plants in the tropics. There are no parasitic orthopteroids, but a few species live as "guests" in ant nests. Although most orthopteroids are silent, many of the order Orthoptera Saltatoria (grasshoppers, crickets, and katydids) are outstandingly noisy or musical. The orthopteroids include orders of great economic importance and of considerable research potential. See ANIMAL COMMUNICATION.

The order Blattodea includes the cockroaches, of which only a few species (illus. a) are important pests of stored products and homes.

Mantodea, the order of praying mantises (illus. b), is characterized by raptorial (grasping) forelegs on the elongated prothorax. Most are cryptically colored and some closely mimic sticks, leaves, and even flower petals, from which they ambush moving insects.

Phasmatodea, the order of stick and leaf insects (illus. c), are slow-moving, sometimes even mimicking the breeze-induced flutterings of their models. Most temperate species are wingless, but many tropical forms have weakly powered wings that may resemble leaves or corrugated bark. All walkingsticks are herbivorous. Many species of phasmids occur only as females.

The order Orthoptera Saltatoria has enlarged hind femora adapted for jumping. There are many families, most of which are grouped as acridoids (short-horned grasshoppers), tettigonioids (long-horned grasshoppers), or grylloids (crickets). Most are herbivorous, but omnivores and carnivores are known.

1. Acridoids. Most temperate species of short-horned grasshoppers belong to the family Acrididae. Antennae are less than half the length of the body. The ovipositor has outwardly pointing hooks. Most species are diurnal and cryptic, some mim-

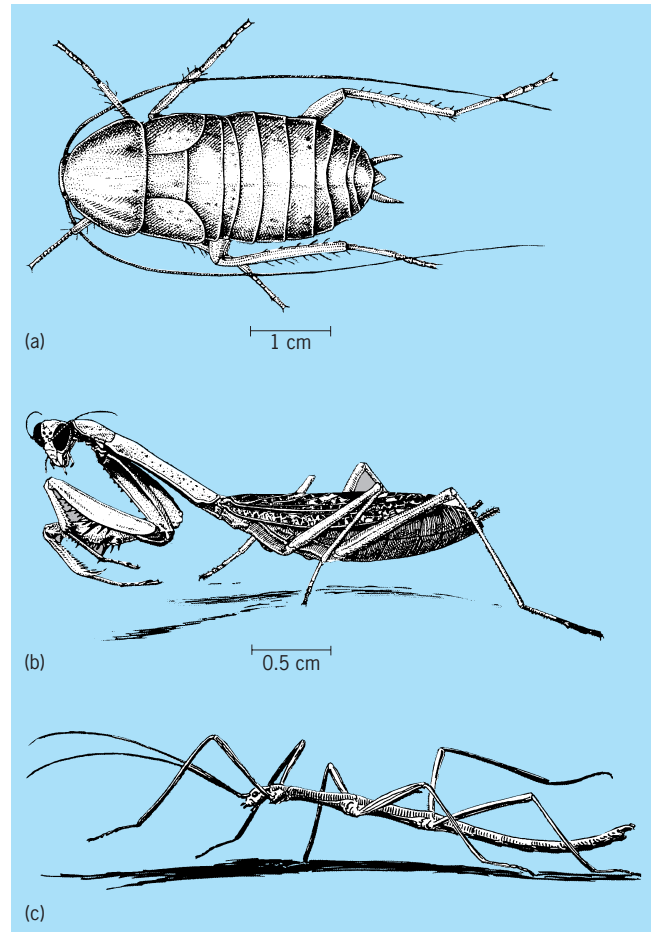

Orthoptera. (a) Cockroach (*Blatta orientalis*). (b) Praying mantis (*Stagomantis carolina*). (c) Walkingstick (*Diaperomera femorata*). (From Illinois Natural History Survey)

icking stones, debris, and grass stems. The plague locusts, *Locusta migratoria*, several species of *Schistocerca*, and others migrate hundreds of miles from the outbreak center in some years to devastate thousands of acres of crops in the tropics and subtropics.

2. Tettigonioids. Antennae are usually longer than the body in the family Tettigoniidae. Most species are nocturnal and the males' stridulation can be very loud, especially when chorusing. The ovipositor is long and sword-shaped. Meadow grasshoppers and katydids are usually cryptically shaped and colored. A major western North American pest is the flightless Mormon cricket.

3. Grylloids. True crickets (Gryllidae) are ground-, tree-, or bush-dwelling, relatively chunky insects with antennae longer than the body and a needle-shaped ovipositor. The mole crickets (Gryllotalpidae) are serious pests of tropical crops.

Several features of the rock crawlers, order Grylloblattodea, including roachlike legs and asymmetrical male genitalia, indicate that they are a relict order of some ancient orthopteroid group (illus. i), but the ovipositor is katydidlike. The rock crawlers are wingless, and there is probably only a single genus, *Grylloblatta*, although the Japanese and Siberian species are sometimes given separate status. They prefer temperatures close to freezing. See INSECTA.

[R.B.W.]

**Orthorhombic pyroxene** A group of minerals having the general chemical formula  $XYSi_2O_6$ , in which the Y site contains Fe or Mg and the X site contains Fe, Mg, Mn, or a small amount of Ca (up to about 3%). The end members of this solid solution series are enstatite ( $Mg_2Si_2O_6$ ) and ferrosilite ( $Fe_2Si_2O_6$ ).

Names used for intermediate members of the series are enstatite, bronzite, hypersthene, and orthoferrosilite.

Many of the physical and optical properties of orthopyroxene are strongly dependent upon composition, and especially upon the Fe-Mg ratio. In hand specimens, orthopyroxene can be distinguished from amphibole by its characteristic  $88^\circ$  cleavage angles, and from augite by color—augite is typically green to black, while orthopyroxene is more commonly brown, especially on slightly weathered surfaces.

Orthopyroxene is a widespread mineral in metamorphic rocks. It is characteristic of granulite facies metamorphism, in both mafic and feldspathic gneisses. Orthopyroxene occurs in many basalts and gabbros, particularly those of tholeiitic composition, and many meteorites, but is notably absent from most alkaline igneous rocks. The greatest abundance of orthopyroxene is in ultramafic rocks, especially those in large layered intrusions. See PYROXENE. [R.J.Tr.]

**Orthotrichales** An order of the true mosses (subclass Bryidae) consisting of five families and 23 genera. The plants grow in mats or tufts in relatively exposed places, on trunks of trees and on rock. They are rather freely branched and prostrate, or may be sparsely forked and erect-ascending; the habit is more or less pleurocarpous, but sporophytes may be produced at the ends of leading shoots or branches. The leaves are generally oblong and broadly pointed, with a strong midrib. The capsules are often ribbed, and the peristome, if present, has a poor development of endostome. The calyptrae are often hairy. See BRYIDAE; BRYOPHYTA; BRYOPSIDA. [H.Cr.]

**Oscillation** Any effect that varies in a back-and-forth or reciprocating manner. Examples of oscillation include the variations of pressure in a sound wave and the fluctuations in a mathematical function whose value repeatedly alternates above and below some mean value.

The term oscillation is for most purposes synonymous with vibration, although the latter sometimes implies primarily a mechanical motion. The alternating current and the associated electric and magnetic fields are referred to as electric (or electromagnetic) oscillations.

If a system is set into oscillation by some initial disturbance and then left alone, the effect is called a free oscillation. A forced oscillation is one in which the oscillation is in response to a steadily applied periodic disturbance.

Any oscillation that continually decreases in amplitude, usually because the oscillating system is sending out energy, is spoken of as a damped oscillation. An oscillation that maintains a steady amplitude, usually because of an outside source of energy, is undamped. See ANHARMONIC OSCILLATOR; DAMPING; FORCED OSCILLATION; HARMONIC OSCILLATOR; MECHANICAL VIBRATION; OSCILLATOR; VIBRATION. [J.M.Ke.]

**Oscillator** An electronic circuit that generates a periodic output, often a sinusoid or a square wave. Oscillators have a wide range of applications in electronic circuits: they are used, for example, to produce the so-called clock signals that synchronize the internal operations of all computers; they produce and decode radio signals; they produce the scanning signals for television tubes; they keep time in electronic wristwatches; and they can be used to convert signals from transducers into a readily transmitted form.

Oscillators may be constructed in many ways, but they always contain certain types of elements. They need a power supply, a frequency-determining element or circuit, a positive-feedback circuit or device (to prevent a zero output), and a nonlinearity (to define the output-signal amplitude). Different choices for these elements give different oscillator circuits with different properties and applications.

Oscillators are broadly divided into relaxation and quasilinear classes. Relaxation oscillators use strong nonlinearities, such

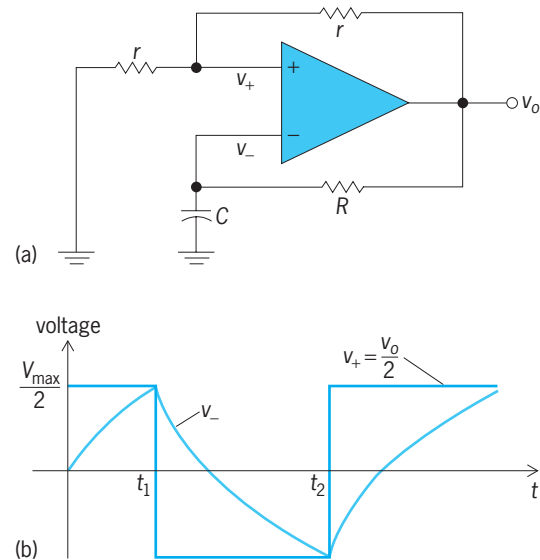

Simple operational-amplifier relaxation oscillator. (a) Circuit diagram. (b) Waveforms.

as switching elements, and their internal signals tend to have sharp edges and sudden changes in slope; often these signals are square waves, trapezoids, or triangle waves. The quasilinear oscillators, on the other hand, tend to contain smooth sinusoidal signals because they regulate amplitude with weak nonlinearities. The type of signal appearing internally does not always determine the application, since it is possible to convert between sine and square waves. Relaxation oscillators are often simpler to design and more flexible, while the nearly linear types dominate when precise control of frequency is important.

**Relaxation oscillators.** Illustration *a* shows a simple operational-amplifier based relaxation oscillator. This circuit can be understood in a number of ways (for example, as a negative-resistance circuit), but its operation can be followed by studying the signals at its nodes (illus. *b*). The two resistors, labeled *r*, provide a positive-feedback path that forces the amplifier output to saturate at the largest possible (either positive or negative) output voltage. If  $v_+$ , for example, is initially slightly greater than  $v_-$ , then the amplifier action increases  $v_o$ , which in turn further increases  $v_+$  through the two resistors labelled *r*. This loop continues to operate, increasing  $v_o$  until the operational amplifier saturates at some value  $V_{\max}$ . [An operational amplifier ideally follows Eq. (1), where  $A_v$  is very large, but is restricted to output

$$v_o = A_v(v_+ - v_-) \quad (1)$$

levels  $|v_o| \leq V_{\max}$ .] For the purposes of analyzing the circuit, the waveforms in the illustration have been drawn with the assumption that this mechanism has already operated at time 0 and that the initial charge on the capacitor is zero. See AMPLIFIER; OPERATIONAL AMPLIFIER.

Capacitor *C* will now slowly change from  $v_o$  through resistor *R*, toward  $V_{\max}$ , according to Eq. (2).

$$v_- = V_{\max}(1 - e^{-t/RC}) \quad (2)$$

Up until time  $t_1$ , this process continues without any change in the amplifier's output because  $v_+ > v_-$ , and so  $v_o = V_{\max}$ . At  $t_1$ , however,  $v_+ = v_-$  and  $v_o$  will start to decrease. This causes  $v_+$  to drop, and the positive-feedback action now drives the amplifier output negative until  $v_o = -V_{\max}$ . Capacitor *C* now discharges exponentially toward the new output voltage until once again, at time  $t_2$ ,  $v_+ = v_-$ , and the process starts again. The period of oscillation for this circuit is  $2RC \ln 3$ .

The basic elements of an oscillator that were mentioned above are all clearly visible in this circuit. Two direct-current power supplies are implicit in the diagram (the operational amplifier



will not work without them), the RC circuit sets frequency, there is a resistive positive-feedback path that makes the mathematical possibility  $v_o(t) = 0$  unstable, and the saturation behavior of the amplifier sets the amplitude of oscillation at the output to  $\pm V_{\max}$ .

Relaxation oscillators that have a low duty cycle—that is, produce output pulses whose durations are a small fraction of the overall period—are sometimes called blocking oscillators because their operation is characterized by an “on” transient that “blocks” itself, followed by a recovery period.

Inverters (digital circuits that invert a logic signal, so that a 0 at the input produces a 1 at the output, and vice versa) are essentially voltage amplifiers and can be used to make relaxation oscillators in a number of ways. A circuit related to that of the illustration uses a loop of two inverters and a capacitor  $C$  to provide positive feedback, with a resistor  $R$  in parallel with one of the inverters to provide an RC charging time to set frequency. This circuit is commonly given as a simple example, but there are a number of problems with using it, such as that the input voltage to the first gate sometimes exceeds the specified limits for practical gates. A more practical digital relaxation oscillator, called a ring oscillator, consists simply of a ring containing an odd number  $N$  (greater than 1) of inverters. See LOGIC CIRCUITS.

**Sine-wave oscillators.** Oscillators in the second major class have their oscillation frequency set by a linear circuit, and their amplitudes set by a weak nonlinearity.

A simple example of a suitable linear circuit is a two-component loop consisting of an ideal inductor [whose voltage is given by Eq. (3), where  $i$  is its current] and a capacitor [whose

$$v = L \frac{di}{dt} \quad (3)$$

current is given by Eq. (4)], connected in parallel. These are said

$$i = C \frac{dv}{dt} \quad (4)$$

to be linear elements because, in a sense, output is directly proportional to input, for example, doubling the voltage  $v$  across a capacitor also doubles  $dv/dt$  and therefore doubles  $i$ . The overall differential equation for a capacitor-inductor loop can be written as Eq. (5).

$$i + LC \frac{d^2i}{dt^2} = 0 \quad (5)$$

Mathematically this has solutions of the form of Eq. (6), where

$$i = A \sin(\omega t + \phi) \quad (6)$$

$\omega = 1/LC$  [which means that the circuit oscillates at a frequency  $1/(2\pi LC)$ ] and  $A$  and  $\phi$  are undefined. They are undefined precisely because the elements in the circuit are linear and do not vary with time: any solution (possible behavior) to the equation can be scaled arbitrarily or time-shifted arbitrarily to give another. Practically,  $A$  and  $\phi$  are determined by weak nonlinearities in a circuit. See DIFFERENTIAL EQUATION; LINEARITY.

Equation (5) is a good first approximation to the equation describing a pendulum, and so has a long history as an accurate timekeeper. Its value as an oscillator comes from Galileo's original observation that the frequency of oscillation ( $\omega/2\pi$ ) is independent of the amplitude  $A$ . This contrasts sharply with the case of the relaxation oscillator, where any drift in the amplitude (resulting from a threshold shift in a comparator, for instance) can translate directly into a change of frequency. Equation (5) also fundamentally describes the operation of the quartz crystal that has replaced the pendulum as a timekeeper; the physical resonance of the crystal occurs at a time constant defined by its spring constant and its mass. See HARMONIC MOTION; HARMONIC OSCILLATOR; PENDULUM.

**Frequency locking.** If an external signal is injected into an oscillator, the natural frequency of oscillation may be affected. If the external signal is periodic, oscillation may lock to the external

frequency, a multiple of it, or a submultiple of it, or exhibit an irregular behavior known as chaos. See CHAOS.

This locking behavior occurs in all oscillators, sometimes corrupting intended behavior (as when an oscillator locks unintentionally to a harmonic of the power-line frequency) and sometimes by design. An important example of an oscillator that exploits this locking principle is the human heart. Small portions of heart muscle act as relaxation oscillators. They contract, incidentally producing an output voltage that is coupled to their neighbors. For a short time the muscle then recovers from the contraction. As it recovers, it begins to become sensitive to externally applied voltages that can trigger it to contract again (although it will eventually contract anyway). Each small section of heart muscle is thus an independent oscillator, electrically coupled to its neighbors, but the whole heart is synchronized by the frequency-locking mechanism. See CARDIAC ELECTROPHYSIOLOGY. [M.Sn.]

**Oscillatory reaction** A chemical reaction in which some composition variable of a chemical system exhibits regular periodic variations in time or space. It is a basic tenet of chemistry that a closed system moves inexorably toward an unchanging state called chemical equilibrium. That motion can be described by the monotonic increase of entropy if the system is isolated, and by the monotonic decrease of Gibbs free energy if the system is constrained to constant temperature and pressure. See CHEMICAL EQUILIBRIUM; ENTROPY.

The species taking part in a chemical reaction can be classified as reactants, products, or intermediates. The concentrations of reactants decrease. Intermediates are formed by some steps and destroyed by others. If there is only one intermediate, and if its concentration is always much less than the initial concentrations of reactants, this intermediate attains a stable steady state in which the rates of formation and destruction are virtually equal. Some oscillations require at least two intermediates which interact in such a way that the steady state of the total system is unstable to the minor fluctuations present in any collection of molecules. The concentrations of the intermediates may then oscillate regularly, although the oscillations must disappear before the inevitable monotonic approach to equilibrium.

The systems whose chemistries are best understood all involve an element that can exist in several different oxidation states. An example is the so-called Belousov-Zhabotinsky reaction. A strong oxidizing agent (bromate) attacks an organic substrate (such as malonic acid), and the reaction is catalyzed by a metal ion (such as cerium) that can exist in two different oxidation states.

As long as bromide ion (Br) is present, it is oxidized by bromate ( $\text{BrO}_3^-$ ), as in reaction (1).

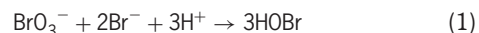

When bromide ion is almost entirely consumed, the cerous ion ( $\text{Ce}^{3+}$ ) is oxidized, as in reaction (2). Reaction (2) is inhibited by



$\text{Br}^-$ , but when the concentration of bromide has been reduced to a critical level, reaction (2) accelerates autocatalytically until bromate is being reduced by  $\text{Ce}^{3+}$  many times as rapidly as it is by  $\text{Br}^-$  when reaction (3) is dominant.

The hypobromous acid (HOBr) brominates the organic substrate to form bromomalonic acid (BrMA), as in reaction (3).

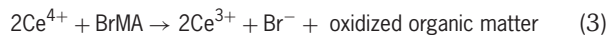

Reaction (3) creates the bromide ion necessary to shut off fast reaction (2) and throw the system back to dominance by slow reaction (1).

As other redox oscillators become understood, they fit the same pattern of a slow reaction destroying a species that inhibits a fast reaction that can be switched on autocatalytically;

the fast reaction then generates conditions to produce the inhibitor again. See OXIDATION-REDUCTION. [R.M.No.]

**Oscilloscope** An electronic measuring instrument which produces a display showing the relationship of two or more variables. In most cases it is an orthogonal (x,y) plot with the horizontal axis being a linear function of time. The vertical axis is normally a linear function of voltage at the signal input terminal of the instrument. Because transducers of many types are available to convert almost any physical phenomenon into a corresponding voltage, the oscilloscope is a very versatile tool that is useful for many forms of physical investigation. See TRANSDUCER.

The oscillograph is an instrument that performs a similar function but provides a permanent record. The light-beam oscillograph used a beam of light reflected from a mirror galvanometer which was focused onto a moving light-sensitive paper. These instruments are obsolete. The mechanical version, in which the galvanometer drives a pen which writes on a moving paper chart, is still in use, particularly for process control. See GALVANOMETER; GRAPHIC RECORDING INSTRUMENTS.

Oscilloscopes are one of the most widely used electronic instruments because they provide easily understood displays of electrical waveforms and are capable of making measurements over an extremely wide range of voltage and time. Although a very large number of analog oscilloscopes are in use, digitizing oscilloscopes (also known as digital oscilloscopes or digital storage oscilloscopes) are preferred, and analog instruments are likely to be superseded. See ELECTRONIC DISPLAY.

An analog oscilloscope, in its simplest form, uses a linear vertical amplifier and a time base to display a replica of the input signal waveform on the screen of a cathode-ray tube (CRT). The screen is typically divided into 8 vertical divisions and 10 horizontal divisions. Analog oscilloscopes may be classified into non-storage oscilloscopes, storage oscilloscopes, and sampling oscilloscopes.

Analog nonstorage oscilloscopes are the oldest and most widely used type. Except for the cathode-ray tube, the circuit descriptions also apply to analog storage oscilloscopes. A typical oscilloscope might have a bandwidth of 150 MHz, two main vertical channels plus two auxiliary channels, two time bases (one usable for delay), and a cathode-ray-tube display area; and it might include on-screen readout of some control settings and measurement results. A typical oscilloscope is composed of five basic elements: (1) the cathode-ray tube and associated controls; (2) the vertical or signal amplifier system with input terminal and controls; (3) the time base, which includes sweep generator, triggering circuit, horizontal or x-amplifier, and unblanking circuit; (4) auxiliary facilities such as a calibrator and on-screen readout; and (5) power supplies.

Digital techniques are applied to both timing and voltage measurement in digitizing oscilloscopes. A digital clock determines sampling instants at which analog-to-digital converters obtain digital values for the input signals. The resulting data can be stored indefinitely or transferred to other equipment for analysis or plotting. See VOLTAGE MEASUREMENT; WAVEFORM DETERMINATION.

In its simplest form a digitizing oscilloscope comprises six basic elements: (1) analog vertical input amplifier; (2) high-speed analog-to-digital converter and digital waveform memory; (3) time base, including triggering and clock drive for the analog-to-digital converter and waveform memory; (4) waveform reconstruction and display circuits; (5) display, generally, but not restricted to, a cathode-ray tube; (6) power supplies and ancillary functions. In addition, most digitizing oscilloscopes provide facilities for further manipulation of waveforms prior to display, for direct measurements of waveform parameters, and for connection to external devices such as computers and hard-copy units.

Higher measurement accuracy is available from digitizing oscilloscopes. The first decision to be made in choosing an oscilloscope is whether this or any of the other properties exclusive to the digitizing type are essential. If not, the option of an analog design remains. The selected instrument must be appropriate for the signal under examination. It must have enough sensitivity to give an adequate deflection from the applied signal, sufficient bandwidth, adequately short rise time, and time-base facilities capable of providing a steady display of the waveform. An analog oscilloscope needs to be able to produce a visible trace at the sweep speed and repetition rate likely. A digitizing oscilloscope must have an adequate maximum digitizing rate and a sufficiently long waveform memory. [R.B.D.K.]

**Osmium** A chemical element, Os, atomic number 76, atomic weight 190.2. The element is a hard white metal of rare natural occurrence, usually found in nature alloyed with other platinum metals. See METAL; PERIODIC TABLE; PLATINUM.

Physical properties of the element, which is found as seven naturally occurring isotopes, are given in the table. The metal is exceeded in density only by iridium. Osmium is a very hard metal and unworkable, and so it must be used in cast form or fabricated by powder metallurgy. Osmium is a third-row transition element and has the electronic configuration  $[Xe](4f)^{14}(5d)^6(6s)^2$ ; in the periodic table it lies below iron (Fe) and ruthenium (Ru). In powder form the metal may be attacked by the oxygen in air at room temperature, and finely divided osmium has a faint odor of the tetroxide. In bulk form it does not oxidize in air below 500°C (750°F), but at higher temperatures it yields  $OsO_4$ . It is attacked by fluorine or chlorine at 100°C (212°F). It dissolves in alkaline oxidizing fluxes to give osmates ( $OsO_4^{2-}$ ). See ELECTRON CONFIGURATION; IRIDIUM; IRON; RUTHENIUM.

The chemistry of osmium more closely resembles that of ruthenium than that of iron. The high oxidation states VI and VIII ( $OsO_4^{2-}$  and  $OsO_4$ ) are much more accessible than for iron. See OXIDATION-REDUCTION.

Osmium forms many complexes. In water, osmium complexes with oxidation states ranging from II to VIII may be obtained. Oxo compounds, which contain  $Os=O$ , are very common and occur for oxidation states IV to VIII. Although  $OsO_4$  is tetrahedral in the gas phase and in noncomplexing solvents such as

Principal properties of osmium

Property	Value
Density, g/cm <sup>3</sup>	22.6
Naturally occurring isotopes (% abundance)	184 (0.018) 186 (1.59) 187 (1.64) 188 (13.3) 189 (16.1) 190 (26.4) 192 (41.0)
Ionization enthalpy, kJ/mol: 1st 2d	840 1640
Oxidation states	-1 to VIII
Most common	IV, VI, VIII
Ionic radius, Os <sup>4+</sup> , nm	0.078
Melting point, °C (°F)	3050 (5522)
Boiling point, °C (°F)	5500 (9932)
Specific heat, cal/g·°C	0.032
Crystal structure	Hexagonal close-packed
Lattice constant a at 25°C, nm c/a at 25°C	0.27341 0.15799
Thermal neutron capture cross section, barns	15.3
Thermal conductivity, 0-100°C, (cal·cm)/(cm <sup>2</sup> ·s·°C)	0.21
Linear coefficient of thermal expansion at 20-100°C, (μin./in.°C)	6.1
Electrical resistivity at 0°C, μΩ-cm	8.12
Temperature coefficient of electrical resistance, 0-100°C/°C	0.0042
Young's modulus at 20°C, lb/in. <sup>2</sup> , static	81 × 10 <sup>6</sup>

dichloromethane ( $\text{CH}_2\text{Cl}_2$ ), it tends to be six-coordinate when appropriate ligands are available; thus, in sodium hydroxide ( $\text{NaOH}$ ) solution, dark purple  $\text{OsO}_4(\text{OH})_2^{2-}$  is formed from  $\text{OsO}_4$ . Similarly,  $\text{OsO}_2(\text{OH})_4^{2-}$  is formed by addition of hydroxide to osmate anion. Analogous reactions with ligands such as halides, cyanide, and amines give osmyl derivatives like the cyanide-duct  $\text{OsO}_2(\text{CN})_4^{2-}$ , in which the trans dioxo group ( $\text{O}=\text{Os}=\text{O}$ ) is retained.

Osmium tetroxide, a commercially available yellow solid (melting point  $40^\circ\text{C}$  or  $104^\circ\text{F}$ ), is used commercially in the important *cis*-hydroxylation of alkenes and as a stain for tissue in microscopy. It is poisonous and attacks the eyes. Osmium metal is catalytically active, but it is not commonly used for this purpose because of its high price. Osmium and its alloys are hard and resistant to corrosion and wear (particularly to rubbing wear). Alloyed with other platinum metals, osmium has been used in needles for record players, fountain-pen tips, and mechanical parts. See ALLOY; STAIN (MICROBIOLOGY); TRANSITION ELEMENTS.

[C.Cr.]

**Osmoregulatory mechanisms** Physiological mechanisms for the maintenance of an optimal and constant level of osmotic activity of the fluid within and around the cells, considered to be most favorable for the initiation and maintenance of vital reactions in the cell and for maximal survival and efficient functioning of the entire organism.

The actions of osmoregulatory mechanisms are, first, to impose constraints upon the passage of water and solute between the organism and its surroundings and, second, to accelerate passage of water and solute between organism and surroundings. The first effect requires a change of architecture of membranes in that they become selectively permeable and achieve their purpose without expenditure of energy. The accelerating effect, apart from requiring a change of architecture of cell membranes, requires expenditure of energy and performance of useful osmotic work. Thus substances may be moved from a region of low to a region of higher chemical activity. Such movement can occur in opposition to the forces of diffusion of an electric field and of a pressure gradient, all of which may act across the cell membrane. It follows that there must be an energy source which is derived from the chemical reactions of cellular metabolism and that part of the free energy so generated must be stored in molecules which are driven across the membrane barrier. Active transport is the modern term for such processes. See CELL MEMBRANES; OSMOSIS.

[W.A.B.; T.P.S.]

**Osmosis** The transport of solvent through a semipermeable membrane separating two solutions of different solute concentration. The solvent diffuses from the solution that is dilute in solute to the solution that is concentrated.

The flow of liquid through such a barrier may be stopped by applying pressure to the liquid on the side of higher solute concentration. The applied pressure required to prevent the flow of solvent across a perfectly semipermeable membrane is called the osmotic pressure and is a characteristic of the solution. The walls of cells in living organisms permit the passage of water and certain solutes, while preventing the passage of other solutes, usually of relatively high molecular weight. These walls act as selectively permeable membranes, and allow osmosis to occur between the interior of the cell and the surrounding media. See EDEMA; OSMOREGULATORY MECHANISMS; SOLUTION.

[E.J.J.]

**Osteichthyes** The bony fishes, one of the three classes (most recently considered a subclass of the class Teleostomi) of Recent fishlike vertebrates. It includes most of the familiar fishes. The Osteichthyes are similar to the Chondrichthyes, or cartilaginous fishes, and contrast with the living Agnatha in having jaws, paired nostrils, true teeth, paired pelvic and pectoral fins and girdles (unless lost secondarily), three semicircular canals,

and bony scales (unless lost or modified). Many fossil agnath fishes possess bony scales but differ from the higher fishes in the above-mentioned features. Separation of the Osteichthyes from the Paleozoic Placodermi and Acanthodii is more difficult because these three groups agree in most basic vertebrate features. The Osteichthyes contrast with the Chondrichthyes in having a bony skeleton (some Recent bony fishes possess a largely cartilaginous skeleton), a swim bladder (at least primitively), a true gill cover, and mesodermal ganoid, cycloid, or ctenoid scales (sharks possess dermal denticles, or placoid scales) which are sometimes modified or lost. Fertilization is usually external, but if it is internal, the intromittent organ is not derived from pelvic-fin claspers. Most often a modified anal fin or a fleshy tube or sheath functions in sperm transfer. See COPULATORY ORGAN; SCALE (ZOOLOGY); SWIM BLADDER.

The Osteichthyes evolved from some group among the primitive, bony gnathostome fishes. Plated agnaths and primitive acanthodians are known from the Silurian, but the oldest osteichthyans, or typical bony fishes, do not appear until the Lower Devonian, when lobefins and lungfishes enter the paleontological record. The class became well represented in the Middle Devonian, at which time the three subclasses (rayfin fishes, lobefin fishes, and lungfishes) were well differentiated. The ancestral stock of the Osteichthyes may be sought from among the other major groups of gnathostomes, the Placodermi, Acanthodii (spiny sharks), and Chondrichthyes, but the still fragmentary character of the early fossil record prevents clear elucidation of the origin and initial history of the group. Although the beginnings of the Osteichthyes are shrouded in uncertainty, advancements in paleontology have laid to rest the belief that the osteichthyans evolved from that other great class of modern fishes, the Chondrichthyes. See ACANTHODII; CHONDRICHTHYES; PLACODERMI.

The Recent fauna of the class Osteichthyes includes 3 subclasses, 32 orders, about 357 families, roughly 3570 genera, and probably about 17,600 species. A classification of the Osteichthyes follows. Equivalent names are given in parentheses; orders known only as fossils are preceded by asterisks. For more detailed information see separate articles on each group.

#### Class Osteichthyes

##### Subclass Actinopterygii

##### Infraclass Chondrostei

##### Order: \*Palaeonisciformes

##### Polypteriformes (Cladistia)

##### Order: Acipenseriformes

##### Infraclass Holostei

##### Order: Semionotiformes (Protospondyli, Ginglymodi, and Lepisosteii)

##### \*Pycnodontiformes

##### Amiiformes (Halecomorphi)

##### \*Aspidorhynchiformes

##### \*Pholidophoriformes (Halecostomi)

##### Infraclass Teleostei

##### Order: \*Leptolepiformes

##### Order: Elopiformes (Isospondyli in part)

##### Anguilliformes (Apodes and

##### Saccopharyngiformes or

##### Lyopomi)

##### Notacanthiformes (Lyopomi and

##### Heteromi)

##### Clupeiformes

##### Osteoglossiformes (Isospondyli in

##### part and Mormyriiformes)

##### Salmoniformes (Myctophiformes,

##### or Iniomi and Haplomi)

##### Order: Cetomimiformes (Cetunculi)

##### Ctenothrissiformes

##### Gonorynchiformes

- Cypriniformes (Heterognathi, Eventognathi, and Gymnonoti)
- Siluriformes (Nematognathi)
- Percopsiformes (Salmopercae and Amblyopsiformes)
- Batrachoidiformes (Haplodoci)
- Gobiesociformes (Xenopterygii)
- Lophiiformes (Pediculati)
- Gadiformes (Anacanthini)
- Atheriniformes (Beloniformes or Synentognathi, Cyprinodontiformes or Microcyprini, and Phallostethiformes)
- Beryciformes (Berycomorphi)
- Zeiformes (Zeomorphi)
- Lampridiformes (Allotriognathi)
- Gasterosteiformes (Thoracostei and Solenichthyes)
- Pegasiformes (Hypostomides)
- Synbranchiformes (Synbranchii)
- Perciformes (Acanthopterygii or Percomorphi)
- Pleuronectiformes (Heterostomata)
- Tetraodontiformes (Plectognathi)
- Subclass Crossopterygii
- Order: \*Osteolepiformes (Rhipidistia)
- Coelacanthiformes (Coelacanthini)
- Subclass Dipnoi [R.M.B.]

**Osteoglossiformes** An order of soft-rayed, actinopterygian fishes that includes the mooneyes, featherbacks, mormyrids or elephantfishes, and bonytongues.

Osteoglossiforms have the primary bite between the well-toothed tongue and the roof of the mouth, usually the strongly toothed parasphenoid but occasionally the endopterygoids. The mouth is bordered by the premaxilla, which in some forms is fused to its mate from the opposite side, and the maxilla. A unique feature is the presence of paired, usually bony rods at the base of the second gill arch.

Osteoglossiforms represent one of the basal stocks among the teleosts. The Ichthyodectidae and two related families are well represented in Cretaceous marine deposits, and *Allothrissops* and *Pachythrissops* of the Jurassic and Cretaceous probably belong here. Recent members may be classified in 2 suborders, 6 families, 22 genera, and about 135 species. All inhabit fresh water, and all are tropical except for the two species of Hiodontidae or mooneyes of North America, where they have a history to the Eocene.

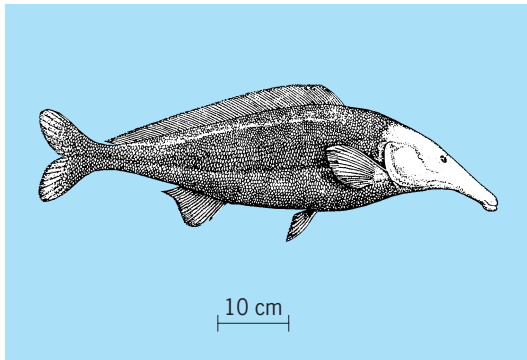

African elephantnose (*Mormyrus proboscetroris*). (After G. A. Boulenger, *Catalogue of Fresh Water Fishes of Africa in the British Museum, Natural History*, vol. 1, 1909)

Numerically the Osteoglossiformes are dominated by the Mormyridae, African river and lake fishes of varied size and form. In some the snout is very blunt and rounded, in others it is elongated (see illustration), the source of the vernacular name elephantfish. The related family Gymnarchidae consists of a single species. Scientifically, mormyrids and gymnarchids are of especial interest in that all are electrogenic. Modified muscles in the caudal peduncle generate and emit a continuous electric pulse. The discharge frequency varies, being low at rest and high when the fish is under stress. The mechanism operates like a radar device, since the fish is alerted whenever an electrical conductor enters the electromagnetic field surrounding it. See ACTINOPTERYGII; ELECTRIC ORGAN (BIOLOGY). [R.M.B.]

**Osteoporosis** A metabolic bone disease in which the amount of bone tissue is reduced sufficiently to increase the likelihood of fracture. Fractures of the vertebrae, femur (hip), and wrist are the most common osteoporotic fractures, but other bones such as the ribs, upper arm, and pelvis may also fracture.

Although low bone mass is the major factor in osteoporotic fractures, there may also be qualitative and architectural changes in bone with aging that lead to increased fragility. Osteoporosis can be primary or secondary. Primary osteoporosis occurs independently of other causes. The secondary osteoporoses result from identifiable causes, such as exogenous cortisone administration, Cushing's disease, hyperparathyroidism, hyperthyroidism, hypogonadism, multiple myeloma, prolonged immobilization, alcoholism, anorexia nervosa, and various gastrointestinal disorders. Primary osteoporosis occurring in children is called juvenile osteoporosis; that occurring in premenopausal women and middle-aged or young men is known as idiopathic osteoporosis. Osteoporosis, which is found in older persons, can be classified as postmenopausal (type I) or involutional (type II) osteoporosis. See ALCOHOLISM; ANOREXIA NERVOSA; GASTROINTESTINAL TRACT DISORDERS; METABOLIC DISORDERS.

Goals should include prevention of both the underlying disorder (the disease) and its effects (osteoporotic fractures). Secondary osteoporoses are managed by eliminating the underlying disorder. To prevent primary osteoporosis, good health-related behavior during childhood and young adulthood has been suggested as the most important factor. Such behavior includes avoiding cigarette smoking and excess alcohol intake, maintaining a normal body weight, and maintaining optimal dietary intake of calcium. It has been suggested that the recommended daily allowance (RDA) for calcium in the postmenopausal period and the recommended intake of vitamin D in the aged should be increased. At menopause, the possibility of estrogen replacement therapy should be considered for women who are at high risk for osteoporosis. Fracture prevention should be a lifelong effort. During childhood and the premenopausal years, a maximal peak bone mass should be developed through weight-bearing exercise. Exercise to improve coordination and flexibility and to maintain good posture is also useful. See ESTROGEN; NUTRITION; VITAMIN D.

The diagnosis of primary osteoporosis is made in the presence of either low bone mass or a characteristic fracture that cannot be attributed to some other cause.

The goals of treatment are rehabilitation and minimization of the risk of future fractures. Goals for rehabilitation include restoring a positive outlook on life, treating depression if it exists, increase of physical activity, restoring independence, relieving pain, restoring muscle mass, and improving posture. Various medications, including estrogen and calcitonin, can maintain bone mass. See AGING; BONE; SKELETAL SYSTEM DISORDERS.

[J.F.A.]

**Osteostraci** An order of extinct jawless vertebrate fishes, also called Cephalaspida, of the class Agnatha, known from the Middle Silurian to Upper Devonian of Europe, Asia, and North America. They were mostly small, about 2 in. to 2 ft (5 to 60 cm)

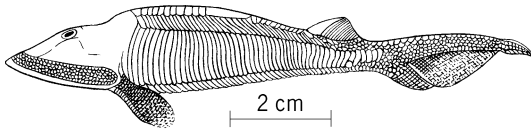

The ostracoderm *Hemicyclaspis*, a cephalaspid, a Lower Devonian jawless vertebrate. (After E. H. Colbert, *Evolution of the Vertebrates*, Wiley, 1955)

in length. The head and part of the body were encased in a solid armor of bone, and the posterior part of the body and the tail were covered with thick scales. Some early forms lacked paired fins, though most possessed flaplike pectoral fins. One or two dorsal fins were present. Their depressed shape and the position of the eyes on the top of the head suggest that Osteostraci were bottom dwellers (see illustration). The underside of the throat region was covered by small plates and there was a small mouth in front. [R.H.DE.]

**Ostracoda** A major taxon of the Crustacea containing small bivalved animals 0.004–1.4 in. (0.1–33 mm) long, with most between 0.04 and 0.08 in. (1 and 2 mm). They inhabit aquatic environments in nearly all parts of the world. Semiterrestrial species have been described from moss and leaf-litter habitats in Africa, Madagascar, Australia, and New Zealand, and from vegetable debris of marine origin in the Kuril Archipelago. Of the more than 2000 species extant, none is truly parasitic and most are free-living. However, a few fresh-water and marine forms live commensally on other animals. Most ostracodes are scavengers, some are herbivorous, and a few are predacious carnivores. Exceptional biological features are known; there are myodocopine ostracodes that produce bioluminescence, and some species of podocopines form a secretion from spinning glands to enable them to climb polished surfaces.

Researchers disagree on the hierarchical classification of the Ostracoda. It is recognized as a distinct class by some and a subclass within the Maxillopoda by others. Consequently, the subdivisions within the Ostracoda may be ranked as subclasses, superorders, or orders. Six major subdivisions are currently recognized: Bradoriida, Phosphatocopida, Leperditicopida, Paleocopa, Myodocopa, and Podocopa. The first four taxa are extinct. The Myodocopa are further subdivided into the Myodocopida and Halocyprida, and the Podocopa into Platycopida and Podocopida. All fresh-water Ostracoda belong to the Podocopida. See MAXILLOPODA; PODOCOPA.

Knowledge of the morphology of the Ostracoda is based primarily on extensive study of many species. The two valves, sufficient to enclose the rest of the animal, are joined dorsally along a hinge, that may vary from a simple juncture to a complex series of teeth and sockets. From the dorsal part of the carapace, the elongate body is suspended as a pliable sac, with lateral flaps of hypodermis extending between the lamellae of the valves. It is unsegmented, but reinforced by chitinous processes for rigidity in the vicinity of the appendages. There is no true abdominal region.

Ostracodes of the Podocopida and Myodocopida possess seven pairs of segmented appendages: antennules, antennae, mandibles, maxillules, and three pairs of thoracic legs. The body terminates posteroventrally in a pair of furcae or caudal processes. The Platycopida have two pairs of thoracic legs, and the Halocyprida frequently only one pair. Appendages have muscles within them and are connected by musculature to the valves and to a centrally located chitinous structure, the endoskeleton. They are usually specialized for particular functions, such as swimming, walking, food gathering, mastication, and cleaning the interior of the carapace.

Ostracodes have separate sexes, although many species are parthenogenetic and lack males. Most ostracodes lay their eggs

on the substrate or on vegetation, but some transfer them to the posterior space within the carapace, where they hatch and the young brood is retained for a time. [P.A.McL.]

**Otter** Members of the family Mustelidae, a large group of carnivores which also includes the martens, weasels, badgers, and skunks. Otters are more completely adapted to aquatic life than other members of the family, having a long thin body, short legs, and somewhat flattened head. The small ears possess a membrane which closes the ear canal when the animal dives. The feet have five webbed toes with nonretractile claws. The tail is broad and flattened, being used along with body movements for swimming. The short thick fur is impervious to water. Like other members of the family all have well-developed perianal scent glands. See CARNIVORA; MAMMALIA. [C.B.C.]

**Otto cycle** The basic thermodynamic cycle for the prevalent automotive type of internal combustion engine. The engine uses a volatile liquid fuel (gasoline) or a gaseous fuel to carry out the theoretic cycle shown in the illustration. The cycle consists of two isentropic (reversible adiabatic) phases interspersed between two constant-volume phases. The theoretic cycle should not be confused with the actual engine built for such service as automobiles, motor boats, aircraft, lawn mowers, and other small self-contained power plants.

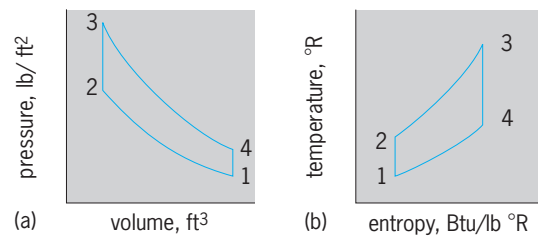

Diagrams of (a) pressure-volume and (b) temperature-entropy for Otto cycle.

The thermodynamic working fluid in the cycle is subjected to isentropic compression, phase 1–2; constant-volume heat addition, phase 2–3; isentropic expansion, phase 3–4; and constant-volume heat rejection (cooling), phase 4–1.

The Otto cycle is represented in many millions of engines utilizing either the four-stroke principle or the two-stroke principle. Evidence indicates that actual Otto engines offer peak efficiencies (25±%) at compression ratios of 15±. Above this ratio, efficiency falls. The most probable explanation is that the extreme pressures associated with high compression cause increasing amounts of dissociation of the combustion products. This dissociation, near the beginning of the expansion stroke, exerts a more deleterious effect on efficiency than the corresponding gain from increasing compression ratio. See BRAYTON CYCLE; CARNOT CYCLE; DIESEL CYCLE; INTERNAL COMBUSTION ENGINE; THERMODYNAMIC CYCLE. [T.Ba.]

**Ovarian disorders** A variety of neoplastic and nonneoplastic disorders that occur in the ovary. Ovarian neoplasms are of greater diversity in histologic appearance and biologic behavior than for any other organ. The nonneoplastic disorders include physiologic cysts, pregnancy luteomas, and polycystic ovarian disease (Stein-Leventhal syndrome). The ovary can also be a site of metastasis from malignant tumors originating in the genital tract, breast, and gastrointestinal tract. See CANCER (MEDICINE).

As ovarian enlargement due to tumors occurs, compression of pelvic and abdominal structures produces vague symptoms such as constipation, pelvic discomfort, a feeling of heaviness, and frequent urination. Pain can be an initial symptom of both benign

and malignant ovarian disorders. The symptoms of malignant ovarian disorders include abdominal pain and swelling, bloating, heartburn, nausea, and anorexia.

An examination of the pelvis is the most crucial component in the diagnosis and evaluation of ovarian disorders. This often allows the physician to differentiate between disorders of the ovary and other pelvic structures such as the uterus, rectum, and bladder.

**Benign disorders.** Physiologic cysts occur in response to cyclic stimulation of the ovary by hormones. Simple cysts in women of reproductive age which are greater than about 1.2 in. (3 cm) can often be treated with oral contraceptives. Persistence of the cyst for 2 months warrants surgical exploration with removal of the cyst, leaving the ovary intact.

Polycystic ovarian syndrome is caused by abnormal regulation of the hypothalamic-pituitary-ovarian axis. In this condition, the ovaries are bilaterally enlarged with multiple follicular cysts. Therapy consists of administering oral contraceptives, progesterone preparations, or clomiphene.

Endometriosis is characterized by ectopic endometrial glandular and stromal tissue that often involves the ovary as well as other pelvic structures. Ovarian endometriosis often produces a cystic mass filled with old blood termed a chocolate cyst. The two most common symptoms of endometriosis are pelvic pain and infertility. This can be treated medically with agents that suppress ovulation, or surgically by removing the ovary.

Neoplasms of the ovary can originate from epithelial, stromal, or germ cells, and produce a variety of symptoms. In a reproductive-age woman who has not completed childbearing or desires conservative therapy, removal of the cyst or one ovary is adequate treatment. In the individual who has completed childbearing or is peri- or postmenopausal, removal of both ovaries is acceptable.

**Malignant disorders.** As with benign tumors, malignant ovarian neoplasms can arise from epithelial, stromal, or germ cells. The primary treatment is surgery; procedures include removal of the ovaries, fallopian tubes, uterus, omentum, and other tumor masses within the abdominal cavity. See ONCOLOGY; OVARY; TUMOR. [D.L.Ta.]

**Ovary** A part of the reproductive system of all female vertebrates. Although not vital to individual survival, the ovary is vital to perpetuation of the species. The function of the ovary is to produce the female germ cells or ova, and in some species to elaborate hormones that assist in regulating the reproductive cycle.

The ovaries develop as bilateral structures in all vertebrates, but adult asymmetry is found in certain species of all vertebrates on the elasmobranchs to the mammals.

The ovary of all vertebrates functions in essentially the same manner. However, ovarian histology of the various groups differs considerably. Even such a fundamental element as the ovum exhibits differences in various groups. See OVUM.

The mammalian ovary is attached to the dorsal body wall. The free surface of the ovary is covered by a modified peritoneum called the germinal epithelium. Just beneath the germinal epithelium is a layer of fibrous connective tissue. Most of the rest of the ovary is made up of a more cellular and more loosely arranged connective tissue (stroma) in which are embedded the germinal, endocrine, vascular, and nervous elements.

The most obvious ovarian structures are the follicles and the corpora lutea. The smallest, or primary, follicle consists of an oocyte surrounded by a layer of follicle (nurse) cells. Follicular growth results from an increase in oocyte size, multiplication of the follicle cells, and differentiation of the perifollicular stroma to form a fibrocellular envelope called the theca interna. Finally, a fluid-filled antrum develops in the granulosa layer, resulting in a vesicular follicle.

The cells of the theca interna hypertrophy during follicular growth and many capillaries invade the layer, thus forming the

endocrine element that is thought to secrete estrogen. The other known endocrine structure is the corpus luteum, which is primarily the product of hypertrophy of the granulosa cells remaining after the follicular wall ruptures to release the ovum. Ingrowths of connective tissue from the theca interna deliver capillaries to vascularize the hypertrophied follicle cells of this new corpus luteum; progesterone is secreted here. See ESTROGEN; ESTRUS; MENSTRUATION; PROGESTERONE. [K.L.D.]

**Overvoltage** The difference between the electrical potential of an electrode or cell under the passage of current and the thermodynamic value of the electrode or cell potential under identical experimental conditions in the absence of electrolysis; it is also known as overpotential. Overvoltage is expressed in volts, often in absolute value; it is a measure of the rates of the different processes associated with an electrode reaction.

An understanding of the factors that contribute to the overvoltage is important in the operation of practical electrochemical systems. In batteries, the overvoltage plays a significant role in the available voltage and power. In large-scale industrial electrolysis, overvoltage is a major factor in determining the energy efficiency of a process, and hence, the cost of electricity. See DECOMPOSITION POTENTIAL; ELECTROCHEMICAL PROCESS; ELECTRODE POTENTIAL; ELECTROLYSIS.

Since the overvoltage is governed by kinetic considerations, all of the experimental conditions that can affect the rate of an electrolytic reaction are of importance. These include concentration of electrolyzed substance, temperature, composition of solvent and electrolyte, nature of the electrode surface, mode of mass transfer, and the current density (current per unit area of electrode). A rapid reaction occurs with a small overvoltage (a few millivolts). A slow reaction requires a large overvoltage (a few volts).

The rates of electrode reactions are frequently determined from current density-potential curves (see illustration). Since the departure of the electrode or cell potential from the thermodynamic value upon passage of current is sometimes termed polarization, such curves are also known as polarization curves. These curves are obtained by measurements with three-electrode electrolytic cells. The current density that flows through the electrode of interest (the working electrode) is adjusted with an external direct-current power supply, and the potential of this electrode is measured with respect to a reference electrode whose potential is known and fixed. The measured potential contains a contribution, known as the ohmic drop, that results from the flow of current through the solution resistance between the working electrode and the reference electrode. This drop is minimized by placing these electrodes close together and using various experimental approaches. The thermodynamic potential is obtained from available data for the electrode reaction of interest, corrected for the concentration of the reaction species in the

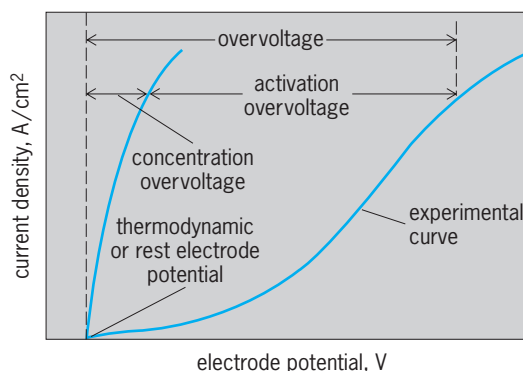

Current density-potential curve.

solution under the experimental conditions. It is also sometimes given by the working electrode potential in the electrolysis cell when no current flows (the rest potential). The overvoltage can be read directly from the current-potential curve, as shown in the illustration. See ELECTRODE; REFERENCE ELECTRODE.

The total overvoltage can be decomposed into different components, which are assigned to different sources of rate limitations, for example, concentration overvoltage, activation overvoltage, reaction overvoltage, and crystallization overvoltage.

Concentration overvoltage occurs when the concentration of the reactants or products at the electrode surface are different from those in the bulk solution. These differences arise because the electroactive reactant is consumed, and products are produced by the passage of current.

Activation overvoltage arises from slowness in the rate of the electron transfer reaction at the electrode surface. To drive an electrode reaction at a given rate (current density), it is necessary to overcome an energy barrier, the energy of activation for the reaction. The additional energy (that is, beyond the thermodynamic requirements) needed to overcome this barrier is provided by the electrical energy supplied to the cell in the form of an increase in the applied potential. The magnitude of this activation overvoltage often depends upon the nature of the electrode material.

Reaction overvoltage arises when a chemical reaction is associated with the overall electrode reaction. For example, if the electroactive substance is generated from the major reactant by a chemical reaction that precedes the electron transfer, its concentration at the electrode surface will be governed by the rate of this reaction. This preceding reaction will thus affect the potential at which the electrode reaction occurs. Slow steps in the formation of nuclei and the crystal lattice, for example, in the electroplating of a metal, can lead to nucleation and crystallization overvoltages, respectively. [A.J.Ba.]

**Ovum** The egg or female sex cell. Strictly speaking, the term refers to this cell when it is ready for fertilization, but it is often applied to earlier or later stages. Confusion is avoided by using qualifying adjectives such as immature, ripe, mature, fertilized, or developing ova. The mature ova are generally spheroidal and large. The number of ova produced at one time varies in different animals, from millions in many marine animals that spawn into the surrounding sea water to about a dozen or less in mammals in which adaptations for internal nourishment of the developing embryo and care of the young are highly developed.

In the ovary the immature ovum is associated with follicle cells through which it receives material for growth. In mammals, as the egg matures, these cells arrange themselves into a structure known as the Graafian, or vesicular, follicle, consisting of a large fluid-filled cavity into which the ovum, surrounded by several

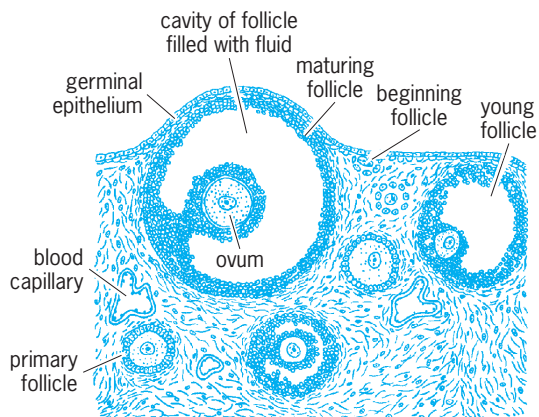

Section of a mammalian ovary.

layers of cells, projects from the layer of follicle cells that constitutes the inner wall (see illustration). The fluid contains estrogenic female sex hormone secreted by cells in an intermediate layer of the follicular wall.

Yolk, or deutoplasm, is essentially a food reserve in the form of small spherules, present to a greater or lesser extent in all eggs. It accounts largely for the differences in size of eggs. Eggs are classified according to the distribution of yolk. In the isolecithal type there is a nearly uniform distribution through the cytoplasm, as in most small eggs. The yolk in teleolecithal eggs is increasingly concentrated toward one pole, as in the large eggs of fish, amphibians, reptiles, and birds. Centrolecithal, or centrally located, yolk occurs in eggs of insects and cephalopod mollusks. See GAMETOGENESIS; OOGENESIS. [A.T./H.L.H.]

**Oxalidales** An order of flowering plants (angiosperms) in the eurousid I group of the rosid dicots. The order is previously unrecognized in classifications of the angiosperms but is indicated by numerous studies of DNA sequences. Oxalidales consist of five small families: Cephalotaceae (one species), Connaraceae (300 species of tropical trees and vines), Cunoniaceae (250 species of trees and shrubs mostly from the Southern Hemisphere), Elaeocarpaceae (350 species of trees and shrubs from the Southern Hemisphere and Asian tropics), and Oxalidaceae (350 species, mostly in *Oxalis*, mostly herbs that are found throughout the world). Oxalidales are heterogeneous in their morphological traits. Many species of the order are locally economically important, producing timbers and fruits, including zebra wood (*Connarus*, Connaraceae), star fruit (*Averrhoa*, Oxalidaceae), and lightwood (*Ceratopetalum* and *Eucryphia*, Cunoniaceae). *Oxalis* (Oxalidaceae) has some species that are grown as ornamentals and several that are noxious introduced weeds. See MAGNOLIOPHYTA; MAGNOLIOPSIDA; ORNAMENTAL PLANTS; PITCHER PLANT; ROSIDAE; WEEDS. [M.W.C.]

**Oxidation process** A process in which oxygen is caused to combine with other molecules. The oxygen may be used as elemental oxygen, as in air, or in the form of an oxygen-containing molecule which is capable of giving up all or part of its oxygen. Oxidation in its broadest sense, that is, an increase in positive valence or removal of electrons, is not considered here if oxygen itself is not involved. See OXIDATION-REDUCTION.

Most oxidations occur with the liberation of large amounts of energy in the form of either heat, light, or electricity. The stable ultimate products of oxidation are oxides of the elements involved. These oxidations occur in nature as corrosion, decay, and respiration and in the deliberate burning of matter such as wood, petroleum, sulfur, or phosphorus to oxides of the constituent elements.

The principal variables to be considered and controlled in any partial oxidation are temperature, pressure, reaction time (or contact time), nature of catalyst, if any, mole ratio of oxidizing agent, and whether the substance to be oxidized is to be kept in the liquid or vapor phase. Only a narrow range of conditions unique to each substance being oxidized and each product desired will give satisfactory yields. It is also essential to maintain conditions outside the range of spontaneous ignition, to avoid explosive mixtures or the accidental accumulation of unstable peroxides, and to choose materials which not only can resist the environmental conditions but also which do not have adverse catalytic effects or otherwise interfere with the desired reaction. See COMBUSTION. [I.E.L.]

**Oxidation-reduction** An important concept of chemical reactions which is useful in systematizing the chemistry of many substances. Oxidation can be represented as involving a loss of electrons by one molecule and reduction as involving an absorption of electrons by another. Both oxidation and reduction

occur simultaneously and in equivalent amounts during any reaction involving either process.

**Oxidation number.** The oxidation state is a concept which describes some important aspects of the state of combination of the elements. An element in a given substance is characterized by a number, the oxidation number, which specifies whether the element in question is combined with elements which are more electropositive or more electronegative than it is. It further specifies the combining capacity which the element exhibits in a particular combination. A scale of oxidation numbers is defined by assigning to an oxygen atom in an ion such as  $\text{SO}_4^{2-}$  the value of 2-. That for sulfur as 6+ then follows from the requirement that the sum of the oxidation numbers of all the atoms add up to the net charge on the species. The value of 2- for oxygen is not chosen arbitrarily. It recognizes that oxygen is more electronegative than sulfur, and that when it reacts with other elements it seeks to acquire two more electrons, by sharing or outright transfer from the electropositive partner, so as to complete a stable valence shell of eight electrons.

Although oxidation number is in some respects similar to valence, the two concepts have distinct meanings. In the substance  $\text{H}_2$ , the valence of hydrogen is 1 because each H makes a single bond to another H, but the oxidation number is 0, because the hydrogen is not combined with a different element. See VALENCE.

When the oxidation number of an atom in a species is increased, the process is described as oxidation, no matter what reagent produces it; when a decrease in oxidation number takes place, the process is described as reduction, again without regard to the identity of the reducing agent. The term oxidation has been generalized to imply combination of an element with an element more electronegative than itself.

**Reactions.** In an oxidation-reduction reaction, some element decreases in oxidation state and some element increases in oxidation state. The substances containing these elements are defined as the oxidizing agents and reducing agents, and they are said to be reduced and oxidized, respectively. The processes in question can always be represented formally as involving electron absorption by the oxidizing agent and electron donation by the reducing agent. For example, reaction (1) can be regarded as the sum of the two partial processes, or half-reactions, (2) and (3). Similarly, reaction (4) consists of the two half-reactions (5) and (6), with half-reaction (5) being taken five times to balance the electron flow from reducing agent to oxidizing agent.

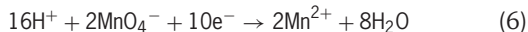
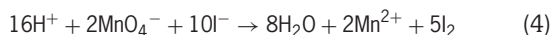
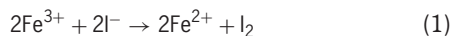

Each half-reaction consists of an oxidation-reduction couple; thus, in half-reaction (6) the reducing agent and oxidizing agent making up the couple are manganous ion,  $\text{Mn}^{2+}$ , and permanganate ion,  $\text{MnO}_4^-$ , respectively; in half-reaction (5) the reducing agent is  $\text{I}^-$  and the oxidizing agent is  $\text{I}_2$ . The fact that  $\text{MnO}_4^-$  reacts with  $\text{I}^-$  to produce  $\text{I}_2$  means that  $\text{MnO}_4^-$  in acid solution is a stronger oxidizing agent than is  $\text{I}_2$ . Because of the reciprocal relation between the oxidizing agent and reducing agent comprising a couple, this statement is equivalent to saying that  $\text{I}^-$  is a stronger reducing agent than  $\text{Mn}^{2+}$  in acid solution. Reducing agents may be ranked in order of tendency to react, and this ranking immediately implies an opposite order of tendency to react for the oxidizing agents which complete the couples. In the list below some

common oxidation-reduction couples are ranked in this fashion:

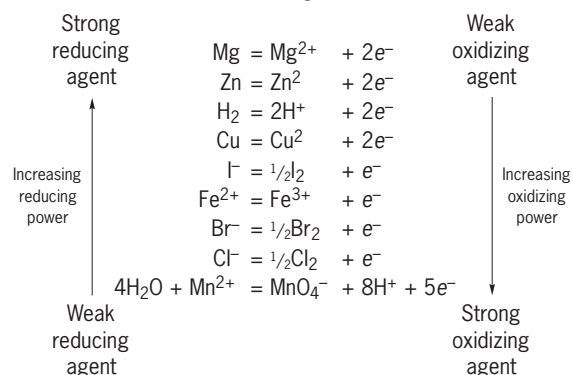

See ELECTROCHEMICAL SERIES; ELECTRONEGATIVITY; OXIDIZING AGENT. [H.Ta.]

**Oxide** A binary compound of oxygen with another element. Oxides have been prepared for essentially all the elements except the noble gases. Often, several different oxides of a given element can be prepared; a number exist naturally in the Earth's crust and atmosphere: silicon dioxide ( $\text{SiO}_2$ ) in quartz; aluminum oxide ( $\text{Al}_2\text{O}_3$ ) in corundum; iron oxide ( $\text{Fe}_2\text{O}_3$ ) in hematite; carbon dioxide ( $\text{CO}_2$ ) gas; and water ( $\text{H}_2\text{O}$ ).

Most elements will react with oxygen at appropriate temperature and oxygen pressure conditions, and many oxides may thus be directly prepared. Most metals in massive form react with oxygen only slowly at room temperatures because the first thin oxide coat formed protects the metal. The oxides of the alkali and alkaline-earth metals, except for beryllium and magnesium, are porous when formed on the metal surface, and they provide only limited protection to the continuation of oxidation, even at room temperatures. Gold is exceptional in its resistance to oxygen, and its oxide ( $\text{Au}_2\text{O}_3$ ) must be prepared by indirect means. The other noble metals, although ordinarily resistant to oxygen, will react at high temperatures to form gaseous oxides.

Oxides may be classified as acidic or basic according to the character of the solution resulting from their reactions with water. The nonmetal oxides generally form acid solutions and the metal oxides generally form alkaline solutions. See ACID AND BASE; EQUIVALENT WEIGHT; OXYGEN. [R.K.E.]

**Oxidizing agent** A participant in a chemical reaction that absorbs electrons from another reactant. In the process a component atom of this substance undergoes a decrease in oxidation number. In this action as an oxidizing agent, the substance undergoes reduction.

A measure of the effectiveness of a reagent as an oxidizing agent is its reduction potential. This is, in electrochemical terms, the equivalent of the free-energy change for the reduction process. The element with the highest reduction potential (and, therefore, the strongest oxidizing agent) is fluorine,  $\text{F}_2$ . The practical effectiveness of a given oxidizing (or reducing) agent will depend upon both the thermodynamics and the available kinetic pathway for the reaction process. See CHEMICAL THERMODYNAMICS.

Substances that are widely used as oxidizing agents in chemistry include ozone ( $\text{O}_3$ ), permanganate ion ( $\text{MnO}_4^-$ ), nitric acid ( $\text{HNO}_3$ ), as well as oxygen itself. Organic chemists have empirically developed combinations of reagents to carry out specific oxidation steps in synthetic processes. The action of molecular oxygen as an oxidizing agent may be made more specific by photochemical excitation to an excited singlet electronic state. [F.J.J.]

**Oxime** One of a group of chemical substances with the general formula  $\text{RR}'\text{C}=\text{N}-\text{OH}$ , where R and R' represent any carbon group or hydrogen. Oximes are derived from aldehydes



(RHC=NOH, aldoximes) and ketones (RR'C=NOH, where R and R' are not hydrogen; ketoximes), and they are used to isolate and characterize these carbonyl compounds. Oximes are also useful as intermediates in organic syntheses. See ALDEHYDE; KETONE.

Hydroxylamine (H<sub>2</sub>NOH) reacts readily with aldehydes or ketones to give oximes. The rate of the reaction of hydroxylamine with acetone is greatest at pH 4.5. Oximes are formed by nucleophilic attack of hydroxylamine at the carbonyl carbon (C=O) of an aldehyde or ketone to give an unstable carbinolamine intermediate, as in the reaction below. Since the breakdown of

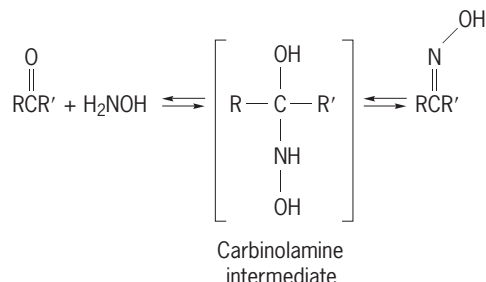

the carbinolamine intermediate to an oxime is acid-catalyzed, the rate of this step is enhanced at low pH. If the pH is too low, however, most of the hydroxylamine will be in the nonnucleophilic protonated form (NH<sub>3</sub>OH<sup>+</sup>), and the rate of the first step will decrease. Thus, in oxime formation the pH has to be such that there is sufficient free hydroxylamine for the first step and enough acid so that dehydration of the carbinolamine is facile. See REACTIVE INTERMEDIATES.

One of the best-known reactions of oximes is their rearrangement to amides. This reaction, the Beckmann rearrangement, can be carried out with a variety of reagents [such as phosphorus pentachloride (PCl<sub>5</sub>), concentrated sulfuric acid (H<sub>2</sub>SO<sub>4</sub>), and perchloric acid (HClO<sub>4</sub>)] that induce the rearrangement by converting the oxime hydroxyl group into a group of atoms that easily departs in a displacement reaction by either protonation or formation of a derivative. The industrial synthesis of  $\epsilon$ -caprolactam is carried out by a Beckmann rearrangement on cyclohexanone oxime.  $\epsilon$ -Caprolactam is polymerized to the polyamide known as nylon 6, which is used in tire cords. See ORGANIC SYNTHESIS. [J.E.Jo.]

**Oximetry** A technique that employs an oximeter, a photoelectric photometer, to measure the oxygenated fraction of the hemoglobin. This fraction is usually expressed in percent, which is referred to as the "oxygen saturation of blood."

One type of oximeter is designed to measure the oxygen saturation of blood circulating in a particular tissue of an intact animal or human. The tissue most commonly studied is the cartilaginous pinna of the ear, and the instrument used for this purpose is called an ear oximeter.

Another type of oximeter is designed to measure the oxygen saturation of blood during, or shortly after, its withdrawal from various sites in the vascular system. Such a device usually is designated a cuvette oximeter. [E.H.W.]

**Oxygen** A gaseous chemical element, O, atomic number 8, and atomic weight 15.9994. Oxygen is of great interest because it is the essential element both in the respiration process in most living cells and in combustion processes. It is the most abundant element in the Earth's crust. About one-fifth (by volume) of the air is oxygen. See PERIODIC TABLE.

Oxygen is separated from air by liquefaction and fractional distillation. The chief uses of oxygen in order of their importance are (1) smelting, refining, and fabrication of steel and other metals; (2) manufacture of chemical products by controlled oxidation; (3) rocket propulsion; (4) biological life support and medicine;

#### Properties of oxygen

Property	Value
Atomic number	8
Atomic weight	15.9994
Triple point (solid, liquid, and gas in equilibrium)	-218.80°C (-139.33°F)
Boiling point at 1 atm pressure	-182.97°C (-119.4°F)
Gas density at °C and 10 <sup>5</sup> Pa pressure, g/liter	1.4290
Liquid density at the boiling point, g/ml	1.142
Solubility in water at 20°C, oxygen (STP) per 1000 g water at 10 <sup>5</sup> Pa partial pressure of oxygen	30

and (5) mining, production, and fabrication of stone and glass products.

Uncombined gaseous oxygen usually exists in the form of diatomic molecules, O<sub>2</sub>, but oxygen also exists in a unique triatomic form, O<sub>3</sub>, called ozone. See OZONE.

Under ordinary conditions oxygen is a colorless, odorless, and tasteless gas. It condenses to a pale blue liquid, in contrast to nitrogen, which is colorless in the liquid state. Oxygen is one of a small group of slightly paramagnetic gases, and it is the most paramagnetic of the group. Liquid oxygen is also slightly paramagnetic. Some data on oxygen and some properties of its ordinary form, O<sub>2</sub>, are listed in the table. See PARAMAGNETISM.

Practically all chemical elements except the inert gases form compounds with oxygen. Most elements form oxides when heated in an atmosphere containing oxygen gas. Many elements form more than one oxide; for example, sulfur forms sulfur dioxide (SO<sub>2</sub>) and sulfur trioxide (SO<sub>3</sub>). Among the most abundant binary oxygen compounds are water, H<sub>2</sub>O, and silica, SiO<sub>2</sub>, the latter being the chief ingredient of sand. Among compounds containing more than two elements, the most abundant are the silicates, which constitute most of the rocks and soil. Other widely occurring compounds are calcium carbonate (limestone and marble), calcium sulfate (gypsum), aluminum oxide (bauxite), and the various oxides of iron which are mined as a source of iron. Several other metals are also mined in the form of their oxides. Hydrogen peroxide, H<sub>2</sub>O<sub>2</sub>, is an interesting compound used extensively for bleaching. See HYDROGEN PEROXIDE; OXIDATION-REDUCTION; OXIDE; PEROXIDE; WATER. [A.W.F.; L.M.Sa.]

**Oxygen toxicity** A toxic effect in a living organism caused by a species of oxygen. Oxygen has two aspects, one benign and the other malignant. Those organisms that avail themselves of the enormous metabolic advantages provided by dioxygen (O<sub>2</sub>) must defend themselves against its toxicity. The complete reduction of one molecule of O<sub>2</sub> to two of water (H<sub>2</sub>O) requires four electrons; therefore, intermediates must be encountered during the reduction of O<sub>2</sub> by the univalent pathway. The intermediates of O<sub>2</sub> reduction, in the order of their production, are the superoxide radical (O<sub>2</sub><sup>-</sup>), hydrogen peroxide (H<sub>2</sub>O<sub>2</sub>), and the hydroxyl radical (HO·). See OXYGEN; SUPEROXIDE CHEMISTRY.

The intermediates of oxygen reduction, rather than O<sub>2</sub>, itself, are probably the primary cause of oxygen toxicity. It follows that defensive measures must deal with these intermediates. The superoxide radical is eliminated by enzymes that catalyze the following reaction.

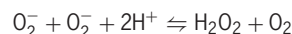

These enzymes, known as superoxide dismutases, have been isolated from a wide variety of living things.

Hydrogen peroxide (H<sub>2</sub>O<sub>2</sub>) must also be eliminated, and this is achieved by two enzymatic mechanisms. The first of these is the dismutation of H<sub>2</sub>O<sub>2</sub> into water and oxygen, a process catalyzed by catalases. The second is the reduction of H<sub>2</sub>O<sub>2</sub> into two molecules of water at the expense of a variety of reductants, a process catalyzed by peroxidases. See ENZYME.

The multiplicity of superoxide dismutases, catalases, and peroxidases, and the great catalytic efficiency of these enzymes, provides a formidable defense against  $O_2^-$  and  $H_2O_2$ . If these first two intermediates of  $O_2$  reduction are eliminated, the third ( $HO\cdot$ ) will not be produced. No defense is perfect, however, and some  $HO\cdot$  is produced; therefore its deleterious effects must be minimized. This is achieved to a large extent by antioxidants, which prevent free-radical chain reactions from propagating. See ANTIOXIDANT; CHAIN REACTION (CHEMISTRY); FREE RADICAL; PEPTIDE.

The apparent comfort in which aerobic organisms live in the presence of an atmosphere that is 20%  $O_2$  is due to a complex and effective system of defenses against this peculiar gas. Indeed, these defenses are easily overwhelmed, and overt symptoms of oxygen toxicity become apparent when organisms are exposed to 100%  $O_2$ . For example, a rat maintained in 100%  $O_2$  will die in 2 to 3 days. [I.Fr.]

**Oxymonadida** An order of class Zoomastigophorea in the phylum Protozoa. These are colorless flagellate symbionts in the digestive tract of the roach *Cryptocercus* and of certain termites. They are xylophagous; that is, they ingest wood particles taken in by the host. Seven or more genera of medium or large size have been identified, the organisms varying from pyriform to ovoid in shape. At the anterior end a pliable neck-like rostrum attaches the organism to the host intestinal wall, but they are sometimes free. They can be either uni- or multinucleate. See ZOOMASTIGOPHOREA. [J.B.L.]

**Ozone** A powerfully oxidizing allotropic form of the element oxygen. The ozone molecule contains three atoms ( $O_3$ ). Ozone gas is decidedly blue, and both liquid and solid ozone are an opaque blue-black color, similar to that of ink. See OXYGEN.

Some properties of ozone are given in the table. Ozone has a characteristic, pungent odor familiar to most persons because ozone is formed when electrical apparatus produces sparks in air. Ozone is irritating to mucous membranes and toxic to human beings and lower animals.

Ozone is a more powerful oxidizing agent than oxygen, and oxidation with ozone takes place with evolution of more heat and usually starts at a lower temperature than when oxygen is used. In the presence of water, ozone is a powerful bleaching

Some properties of ozone

Property	Value
Density of the gas at 0°C, 1 atm pressure	2.154 g/liter
Density of the liquid	
-111.9°C	1.354 g/ml
-183°C	1.573 g/ml
Boiling point at 1 atm pressure	-111.9°C
Melting point of the solid	-192.5°C

agent, acting more rapidly than hydrogen peroxide, chlorine, or sulfur dioxide. See OXIDIZING AGENT.

Ozone is utilized in the treatment of drinking-water supplies. Odor- and taste-producing hydrocarbons are effectively eliminated by ozone oxidation. Iron and manganese compounds which discolor water are diminished by ozone treatment. Compared to chlorine, bacterial and viral disinfection with ozone is up to 5000 times more rapid.

Ozone occurs to a variable extent in the Earth's atmosphere. Near the Earth's surface the concentration is usually 0.02–0.03 ppm in country air, and less in cities except when there is smog. At vertical elevations above 13 mi (20 km), ozone is formed by photochemical action on atmospheric oxygen. Maximum concentration of  $5 \times 10^{12}$  molecules/cm<sup>3</sup> (more than 1000 times the normal peak concentration at Earth's surface) occurs at an elevation of 19 mi (30 km). [A.W.F.]

**Ozonolysis** A process which uses ozone to cleave unsaturated organic bonds. Generally, ozonolysis is conducted by bubbling ozone-rich oxygen or air into a solution of the reactant. The reaction is fast at moderate temperatures. Intermediates are usually not isolated but are subjected to further oxidizing conditions to produce acids or to reducing conditions to form alcohols or aldehydes. An unsymmetrical olefin is capable of yielding two different products whose structures are related to the groups substituted on the olefin and the position of the double bond.

Before World War I, ozonolysis was applied commercially to the preparation of vanillin from isoeugenol. The only modern application of the technique in the United States is in the manufacture of azelaic and pelargonic acids from oleic acid. See ALKENE; OZONE. [R.K.Ba.]

# P

**Pacific islands** A geographic designation that includes thousands of mainly small coral and volcanic islands scattered across the Pacific Ocean from Palau in the west to Easter Island in the east. Island archipelagos off the coast of the Asian mainland, such as Japan, Philippines, and Indonesia, are not included even though they are located within the Pacific Basin. The large island constituting the mainland of Papua New Guinea and Irian Jaya is also excluded, along with the continent of Australia and the islands that make up Aotearoa or New Zealand. The latter, together with the Asian Pacific archipelagos, contain much larger landmasses, with a greater diversity of resources and ecosystems, than the oceanic islands, commonly labelled Melanesia, Micronesia, and Polynesia. See AUSTRALIA; NEW ZEALAND; OCEANIC ISLANDS.

The great majority of these islands are between 4 and 4000 mi<sup>2</sup> (10 and 10,000 km<sup>2</sup>) in land surface area. The three largest islands include the main island of New Caledonia (6220 mi<sup>2</sup> or 16,100 km<sup>2</sup>), Viti Levu (4053 mi<sup>2</sup> or 10,497 km<sup>2</sup>) in Fiji, and Hawaii (4031 mi<sup>2</sup> or 10,440 km<sup>2</sup>) the big island in the Hawaiian chain. When the 80-mi (200-km) Exclusive Economic Zones are included in the calculation of surface area, some Pacific island states have very large territories. These land and sea domains, far more than the small, fragmented land areas per se, capture the essence of the island world that has meaning for Pacific peoples. See EAST INDIES.

Oceanic islands are often classified on the basis of the nature of their surface lithologies. A distinction is commonly made between the larger continental islands of the western Pacific, the volcanic basalt island chains and clusters of the eastern Pacific, and the scattered coral limestone atolls and reef islands of the central and northern Pacific.

It has been suggested that a more useful distinction can be drawn between plate boundary islands and intraplate islands. The former are associated with movements along the boundaries of the great tectonic plates that make up the Earth's surface. Islands of the plate boundary type form along the convergent, divergent, or tranverse plate boundaries, and they characterize most of the larger island groups in the western Pacific. These islands are often volcanically and tectonically active and form part of the Pacific so-called Ring of Fire, which extends from Antarctica in a sweeping arc through New Zealand, Vanuatu, Bougainville, and the Philippines to Japan.

The intraplate islands comprise the linear groups and clusters of islands that are thought to be associated with volcanism, either at a fixed point or along a linear fissure. Volcanic island chains such as the Hawaii, Marquesas, and Tuamotu groups are classic examples. Others, which have their volcanic origins covered by great thickness of coral, include the atoll territories of Kiribati, Tuvalu, and the Marshall Islands. Another type of intraplate island is isolated Easter Island, possibly a detached piece of a mid-ocean ridge. The various types of small islands in the Pacific are all linked geologically to much larger structures that lie below the surface of the sea. These structures contain the answers to some puzzles about island origins and locations, especially when considered in terms of the plate tectonic theory of crustal evolution. See MARINE GEOLOGY; MID-OCEANIC RIDGE; PLATE TECTONICS; SEAMOUNT AND GUYOT; VOLCANO.

The climate of most islands in the Pacific is dominated by two main forces: ocean circulation and atmospheric circulation. Oceanic island climates are fundamentally distinct from those of continents and islands close to continents, because of the small size of the island relative to the vastness of the ocean surrounding it. Because of oceanic influences, the climates of most small, tropical Pacific islands are characterized by little variation through the year compared with climates in continental areas.

The major natural hazards in the Pacific are associated either with seasonal climatic variability (especially cyclones and droughts) or with volcanic and tectonic activity. See CLIMATE HISTORY. [R.D.Be.]

**Pacific Ocean** The Pacific Ocean has an area of  $6.37 \times 10^7$  mi<sup>2</sup> ( $1.65 \times 10^8$  km<sup>2</sup>) and a mean depth of 14,000 ft (4280 m). It covers 32% of the Earth's surface and 46% of the surface of all oceans and seas, and its area is greater than that of all land areas combined. Its mean depth is the greatest of the three oceans and its volume is 53% of the total of all oceans. Its greatest depths in the Marianas and Japan trenches are the world's deepest, more than 6 mi (10 km).

The two major wind systems driving the waters of the ocean are the westerlies which lie about 40–50° lat in both hemispheres (the “roaring forties”) and the trade winds from the east which dominate in the region between 20°N and 20°S. These give momentum directly to the west wind drift (flow to the east) in high latitudes and to the equatorial currents which flow to the west. At the continents there is flow of water from one system to the other and huge circulatory systems result. See OCEAN CIRCULATION; SOUTHEAST ASIAN WATERS.

The swiftest flow (greater than 2 knots) is found in the Kuroshio Current near Japan. It forms the northwestern part of a huge clockwise gyre whose north edge lies in the west wind drift centered at about 40°N, whose eastern part is the south-flowing California Current, and whose southern part is the North Equatorial Current.

Equatorward of 30° lat heat received from the Sun exceeds that lost by reflection and back radiation, and surface waters flowing into these latitudes from higher latitudes (California and Peru currents) increase in temperature as they flow equatorward and turn west with the Equatorial Current System. They carry heat poleward and transfer part of it to the high-latitude cyclones along the west wind drift. The temperature of the equatorward currents along the eastern boundaries of the subtropical anticyclones is thus much lower than that of the currents of their western boundaries at the same latitudes. The highest temperatures (more than 82°F or 28°C) are found at the western end of the equatorial region. Along the Equator itself somewhat lower temperatures are found. The cold Peru Current contributes to its eastern end, and there is apparent upwelling of deeper, colder water at the Equator.

Upwelling also occurs at the edge of the eastern boundary currents of the subtropical anticyclones. When the winds blow strongly equatorward (in summer) the surface waters are driven offshore, and the deeper colder waters rise to the surface and further reduce the low temperatures of these equatorward-flowing currents. See UPWELLING.

The limiting temperature in high latitudes is that of freezing. Ice is formed at the surface at temperatures slightly less than 30°F (−1°C) depending upon the salinity; further loss of heat is retarded by its insulating effect. The ice field covers the northern and eastern parts of the Bering Sea in winter, and most of the Sea of Okhotsk, including that part adjacent to Hokkaido (the north island of Japan). Summer temperatures, however, reach as high as 43°F (6°C) in the northern Bering Sea and as high as 50°F (10°C) in the northern part of the Sea of Okhotsk. See **BERING SEA**.

Pack ice reaches to about 62°S from Antarctica in October and to about 70°S in March, with icebergs reaching as far as 50°S. See **ICEBERG**; **SEA ICE**.

Surface waters in high latitudes are colder and heavier than those in low latitudes. As a result, some of the high-latitude waters sink below the surface and spread equatorward, mixing mostly with water of their own density as they move, and eventually become the dominant water type in terms of salinity and temperature of that density over vast regions.

The most conspicuous water masses formed in the Pacific are the Intermediate Waters of the North and of the South Pacific, which on the vertical sections include the two huge tongues of low salinity extending equatorward beneath the surface from about 55°S and from about 45°N. The southern tongue is higher in salinity and density and lies at a greater depth. [J.L.Re.]

**Packet switching** A software-controlled means of directing digitally encoded information in a communication network from a source to a destination, in which information messages may be divided into smaller entities called packets. Switching and transmission are the two basic functions that effect communication on demand from one point to another in a communication network, an interconnection of nodes by transmission facilities. Each node functions as a switch in addition to having potentially other nodal functions such as storage or processing.

Switched (or demand) communication can be classified under two main categories: circuit-switched communication and store-and-forward communication. Store-and-forward communication, in turn, has two principal categories: message-switched communication (message switching) and packet-switched communication (packet switching).

In circuit switching, an end-to-end path of a fixed bandwidth (or speed) is set up for the entire duration of a communication or call. The bandwidth in circuit switching may remain unused if no information is being transmitted during a call. In store-and-forward switching, the message, either as a whole or in parts, transits through the nodes of the network one node at a time. The entire message, or a part of it, is stored at each node and then forwarded to the next.

In message switching, the switched message retains its integrity as a whole message at each node during its passage through the network. For very long messages, this requires large buffers (or storage capacity) at each node. Also, the constraint of receiving the very last bit of the entire message before forwarding its first bit to the next node may result in unacceptable delays. Packet switching breaks a large message into fixed-size, small packets and then switches these packets through the network as if they were individual messages. This approach reduces the need for large nodal buffers and “pipelines” the resources of the network so that a number of nodes can be active at the same time in switching a long message, reducing significantly the transit delay. One important characteristic of packet switching is that network resources are consumed only when data are actually sent.

All public packet networks require that terminals and computers connecting to the network use a standard access protocol. Interconnection of one public packet network to others is carried out by using another standardized protocol.

Packet-switched networks using satellite or terrestrial radio as the transmission medium are known as packet satellite or packet

radio networks, respectively. Such networks are especially suited for covering large areas for mobile stations, or for applications that benefit from the availability of information at several locations simultaneously.

Asynchronous transfer mode (ATM) is a type of packet switching that uses short, fixed-size packets (called cells) to transfer information. The ATM cell is 53 bytes long, containing a 5-byte header for the address of the destination, followed by a fixed 48-byte information field. The rather short packet size of ATM, compared to conventional packet switching, represents a compromise between the needs of data communication and those of voice and video communication, where small delays and low jitter are critical for most applications.

Data communication (or computer communication) has been the primary application for packet networks. Computer communication traffic characteristics are fundamentally different from those of voice traffic. Data traffic is usually bursty, lasting from several milliseconds to several minutes or hours. The holding time for data traffic is also widely different from one application to another. These characteristics of data communication make packet switching an ideal choice for most applications. The principal motivation for ATM is to devise a unified transport mechanism for voice, still image, video, and data communication. See **DATA COMMUNICATIONS**. [PK.V.]

**Packing** A seal usually used for high pressure as in steam and hydraulic applications. The motion between parts may be infrequent as in valve stems, or continual as in pump or engine piston rods. There is no sharp dividing line between seals and packing; both are dynamic pressure resistors under motion. Diverse materials are used for packing such as impregnated fiber, rubber, cork, or asbestos compounds. In packings, it is necessary that the surface finish of the contacting metal part be smooth for long life of the material. See **PRESSURE SEAL**. [P.H.B.]

**Pain** Pain, especially in its acute form, is usually a reflection of a tissue-damaging or potentially tissue-damaging stimulus. There is a transmission system that conveys this information to the central nervous system. This phenomenon is called nociception. Pain is more complex than other sensory systems such as vision or hearing because it not only involves the transfer of sensory information to the nervous system, but produces suffering which then leads to aversive corrective behavior. In certain disease states, defects in the transmission system can of themselves generate false information to the nervous system, as though tissue damage were occurring in the periphery. An example of this is phantom limb pain, in which the individual often has a crushing type of pain in a foot that has been amputated.

Acute pain such as occurs with broken bones and other significant injuries is almost inevitably accounted for by the phenomenon of nociception and is probably a purely neurophysiological event. However, the more pain becomes a chronic phenomenon, the more such influences as psychological factors and behavior become part of the expression of pain.

Acute pain is a useful warning system. There are specific nerve paths for conducting this sensation (see illustration). Pain receptors in the skin and other tissues are nerve terminals which lack any special characteristics, and they are probably triggered by a chemical stimulus when potential tissue damage occurs. There appear to be two types of terminals: one responds to many types of painful stimuli, whereas the other specifically responds to either mechanical or thermal energy. When the terminals are stimulated, the pain (that is, nociception message) is carried along specific small sensory fibers called A-delta and C fibers. The A-delta fibers are larger and transmit the “first pain” or “fast pain” The smaller C fibers transmit a secondary dull continuous pain. These nerve fibers were traditionally believed to enter the spinal cord through the dorsal root, but it now seems that many also enter through the ventral root into the spinal cord.

Having entered the spinal cord, these fibers relay in the dorsal

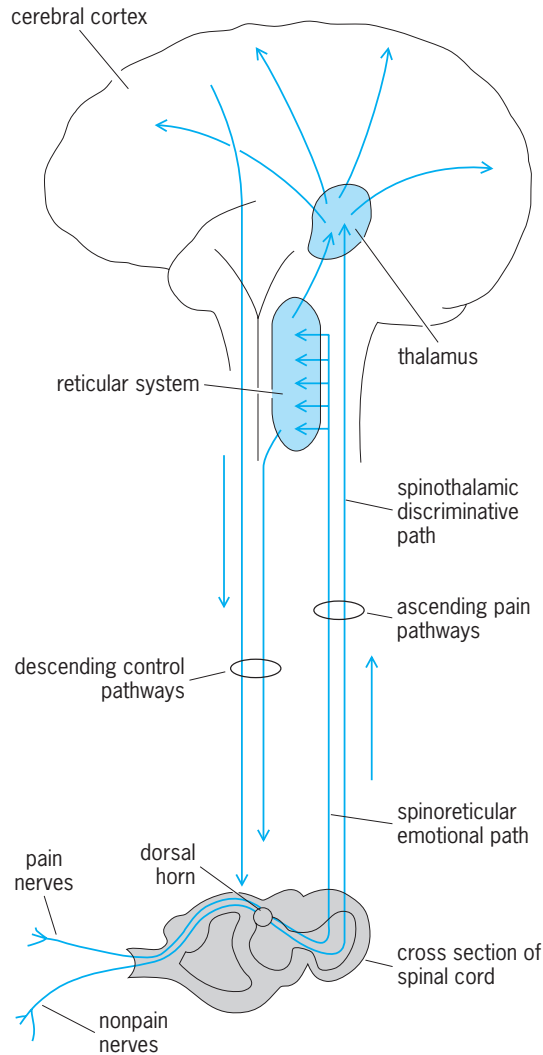

**Neurophysiology of incoming pain.** Sensation from peripheral receptors travels along specific pain nerves, and is modulated throughout the spinal cord and brain.

horn of the spinal gray matter, an area of considerable regulation and modulation of the incoming pain stimulus which is influenced by other incoming sensory stimuli; that is, touch or pressure sensations can suppress the transmission of signals in the small pain fibers. This helps to explain why when a person is hurting, the pain can be reduced by rubbing the affected part, and this phenomenon forms the basis of some of the treatment strategies of stimulation-produced analgesia. In addition, the incoming pain signal in the spinal cord is also modulated by descending signals from the brain. At times of anxiety, these pain signals may be augmented. From these relay stations in the dorsal horn, the pain signal is carried by two nerve paths up to the brain. The classical pathway is the spinothalamic tract, on the side of the spinal cord opposite to the incoming stimulus, and this leads to the posterior part of the thalamus in the brainstem, and from there nerve paths radiate the pain sensation to many parts of the cerebral cortex, where the pain is appreciated. In addition to this direct path, there is also a diffuse ascending path known as the spinoreticular tract which relays to many of the basal ganglia in the brain, and from there to areas of the brain connected with motivational and affective behavior such as the hippocampus and the cingulate gyrus. It is possible that narcotic analgesics exert some of their action on this ascending spinoreticular tract because these drugs tend to reduce the suffering aspects of pain, but still preserve many of the discriminative qualities so that individuals can still feel

the pain, but it does not bother them so much. See ANALGESIC; NARCOTIC.

Certain parts of the brainstem around the central canal appear to exert a strong inhibitory effect on incoming pain signals. Stimulation of these areas probably releases endorphins, which are morphinelike substances produced by the body and liberated at various sites on the incoming pain path to suppress these signals. See ENDORPHINS. [T.M.M.]

**Paint** A fluid, with viscosity, drying time, and flowing properties dictated by formulation, normally consisting of a vehicle or binder, a pigment, a solvent or thinner, and a drier, which may be applied in relatively thin layers and which changes to a solid in time. The change to a solid may or may not be reversible, and may occur by evaporation of the solvent, by chemical reaction, or by a combination of the two.

In modern technology, paint is classified in three major categories because of differing performance requirements: architectural paints, commercial finishes, and industrial coatings. A fourth category is artistic media.

Architectural paints are air-drying materials applied by brush or spray to architectural and structural surfaces and forms for decorative and protective purposes. Materials are classified by formulation type as solvent-thinned and water-thinned. The drying mechanism of solvent-thinned paints predominantly may be by solvent evaporation, oxidation, or a combination of the two. Solvent-thinned paints which dry essentially by solvent evaporation rely on a fairly hard resin as the vehicle. Resins include shellac, cellulose derivatives, acrylic resins, vinyl resins, and bitumens. In paints that dry by oxidation, the vehicle is usually an oil or an oil-based varnish. Water-thinned paints may be subdivided into those in which the vehicle is dissolved in water and those in which it is dispersed in emulsion form. Paints with water-soluble vehicles include the calcimines, in which the vehicle is glue, and casein paints, in which the vehicle is casein or soybean protein. Materials formed by emulsion polymerization are described as a latex, and products are called latex paints. See DRIER (PAINT); DRYING OIL; POLYMER.

Commercial finishes include air-drying or baking-cured materials applied by brush, spray, or magnetic agglomeration to kitchen and laundry appliances, automobiles, machinery, and furniture and used as highway marking materials. Industrial coatings are subdivided by their intended service: corrosion-resistant coatings, high-temperature coatings, and coatings for immersion service. See PIGMENT; SURFACE COATING. [C.R.Ma.; C.W.Si.]

**Palaeacanthocephala** An order of Acanthocephala, the adults of which are parasitic worms found in fishes, aquatic

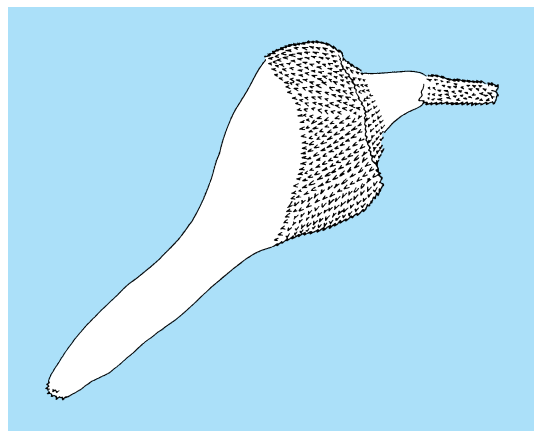

*Corynosoma reductum*. (After H. J. Van Cleave, *Acanthocephala of North American Mammals*, University of Illinois Press, 1953)

birds, and mammals. They have the following characteristics. The nuclei of the hypodermis are fragmented and the chief lacunar vessels are lateral. The males have usually 2–7 cement glands. The ligament sac in the female breaks down so that the eggs develop in the body cavity. Proboscis hooks occur in long rows and spines are present on the body of some species. Species which commonly occur in vertebrates are *Leptorhynchoides thecatus* and *Corynosoma* (see illustration). See ACANTHOCEPHALA.

[D.V.Mo.]

**Palaeonemertini** A rarer order of the class Anopla in the phylum Rhynchocoela, characterized by an unarmed proboscis, a thin gelatinous dermis, and either a two-layered or three-layered body musculature. Many members show primitive features, such as a peripherally located nervous system and the absence of ocelli, ciliated grooves, and intestinal diverticula. Cerebral organs, if present, are generally simple. See ANOPLA; RHYNCHOCOELA.

[J.B.J.]

**Palaeonisciformes** A large order of chondrosteian fish which includes the earliest known and most primitive ray-finned fishes and has a long history from the Lower Devonian, or earlier, to the Cretaceous. Many genera and species, both marine and fresh-water, have been described, but the majority are poorly understood. There are two principal Paleozoic suborders: the fusiform Palaeoniscoidei and their deep-bodied derivatives, the Platsysomoidei.

Palaeoniscoids are small to medium-sized fishes with a heavily ossified exoskeleton. The body is usually covered with thick rhombic scales surfaced with enamel and articulated in oblique rows by a peg and socket mechanism. Posteriorly the body is tapered to a graceful point. This slender tapered portion is turned upward in heterocercal fashion to form the dorsal or axial lobe of the caudal fin.

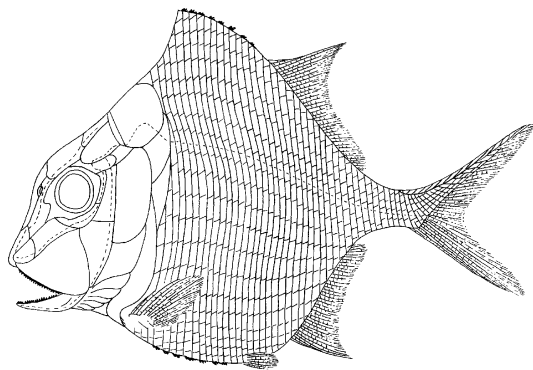

*Platysomus parvulus*, an Upper Carboniferous platysomid from Britain which attained a length of 5 in. (13 cm). (Modified from R. H. Traquair, *On the structure and affinities of the Platsysomidae*, *Trans. Roy. Soc. Edinburgh*, vol. 29, 1879)

Typical platysomids have a laterally compressed, rhombic-shaped body with an angle at the front of the long dorsal and anal fins, small pelvic fins or none, a short lower jaw, and an upright jaw suspension. The flank scales are much deeper than long; the tail is heterocercal and forked; the facial profile is very steep (see illustration). See ACANTHODII; CHONDROSTEI; CROSSOPTERYGII; OSTEICHTHYES.

[T.M.C.]

**Palaeospondyloidea** An ordinal name assigned to the single, tiny, problematic fish *Palaeospondylus*, which is known only from Middle Devonian shales of restricted extent in Caithness, Scotland. This animal seldom exceeded 2 in. (5 cm) in length. The skeleton consists of a well-calcified skull, vertebral column, caudal fin, and occasional traces of paired pelvic fins. The relationships of *Palaeospondylus* are uncertain. [R.H.De.]

**Palate** The roof of the mouth in those vertebrates whose mouth cavity and nasal passages are wholly or partially separate.

The palate of mammals consists of two portions. The hard palate, more anterior in position, underlies the nasal cavity, whereas the soft palate hangs like a curtain between the mouth and nasal pharynx. The hard palate has an intermediate layer of bone. The oral surface of the hard palate is a mucous membrane, covered with a stratified squamous epithelium.

The soft palate is a backward continuation from the hard palate. Its free margin connects on each side with two folds of mucous membrane, the palatine arches, enclosing a palatine tonsil. In the midline the margin extends into a fingerlike projection named the uvula. The oral side of the soft palate continues as the covering of the hard palate, and the submucosa contains pure mucous glands.

Besides separating the nasal passages from the mouth, the hard palate is a firm plate, against which the tongue crushes and manipulates food. The soft palate, at rest, is pendant. In sucking, swallowing, or vomiting it is raised to separate the oral from the nasal portion of the pharynx. The closing action also occurs in speech, except for certain consonants requiring nasal resonance. See SPEECH.

[L.B.A.]

**Paleobiochemistry** The study of chemical processes used by organisms that lived in the geological past. Most information on the nature of life in the geological past comes from the study of fossils; a record of biochemical processes that occurred can be found in the organic molecules of sedimentary rocks and fossils. The organic matter in fossil fuel deposits and finely dispersed in shales and limestones represents the debris of cells which have been chemically altered to a more stable form. A comparison of the molecular structure of these preserved organic compounds with that of components of living cells enables the researcher to identify similarities and dissimilarities between past and present biochemistry.

Paleobiochemical studies have shown that a number of the common chemical processes used by living organisms today have been in use for a very great length of time. Paleobiochemical techniques are also used on materials returned from extraterrestrial sources to determine whether life exists outside of Earth. See PALEOECOLOGY; PALEONTOLOGY.

[T.C.H.]

**Paleobotany** The study of fossil plants of the geologic past. A paleobotanist is a plant historian who attempts to carefully piece together the geologic history of the plant kingdom. Other organisms, including fungi and various types of microscopic plankton, are also studied by paleobotanists. Paleobotany is a branch of paleontology that requires a knowledge of both plant biology (botany) and the geological sciences. See BOTANY; FOSSIL; PLANT KINGDOM.

The materials used by the paleobotanist to reconstruct plants and the vegetation they represent through geologic time include fossilized remains preserved in the rock layers of the Earth. Such materials as fossil leaves, seeds, fragments of wood, fruits, and flowers are used to interpret the biology and evolution of prehistoric plants. In addition, the activities and distribution of plants are recorded in the rock record in the form of coal, resins, chemicals, and various other substances produced by plants. Some plant fossils, such as pollen grains and spores, are studied by palynologists, who work in a discipline (palynology) that has been especially important in mineral and petroleum exploration and in correlating rock layers that are widely separated geographically. See FOSSIL SEEDS AND FRUITS; PALYNOLOGY.

Paleobotany not only involves the collection, description, reconstruction, and naming of fossil plants but is also concerned with the evolution of major groups, relationships that exist between fossil and living forms, how ancient plants functioned and reproduced, what type of environment they lived in, how they were fossilized, and many other biological and geological questions.

Plants are preserved in a variety of ways, and various combinations of physical and chemical processes are involved at the time of preservation. To become a fossil, several unique processes must take place concomitantly to preserve the leaf of a plant. The first process involves proximity to a site where sediments are accumulating, and rapid burial of the leaf. Short-distance transport ensures that tissues of the leaf are not torn, abraded, or otherwise destroyed. Rapid burial is necessary to ensure that the biological activities of microbes do not destroy the tissues of the leaf. See BIODEGRADATION.

Plant parts are best preserved in very fine grained silts and shales that represent the lithified muds of ancient deposits. These sediments generally yield excellent fossils because the small grain size preserves minute details of the leaf. The location of where the fossil is deposited is critical as to whether fossil remains will ever be discovered. For example, sediments deposited in certain types of lakes, rivers, and swamps may be easily lost as the depositional system changes over time, or the sediments are eroded away as river systems cut into older fossil-bearing rocks.

Fossil plants are extensively used in two principal areas: plant biology (botany) and biostratigraphy. In botany the geological record of past floras is traced to the present. Fossil plants have provided an enormous body of knowledge about the evolution of plants from the earliest Precambrian unicellular forms to the complex multicellular flowering plants used for food and shelter. In biostratigraphy, fossils such as some plant megafossils as well as pollen grains and spores are used to date rock layers. Fossil plants can also be valuable in reconstructing climates of the past. See PALEOCLIMATOLOGY; PALEONTOLOGY; STRATIGRAPHY. [T.N.T.]

**Paleoceanography** The study of the history of the ocean with regard to circulation, chemistry, biology, and patterns of sedimentation. The source of information is largely the biogenous deep-ocean sediments, so the field may be considered a branch of sedimentology or paleontology. However, there are also strong links to geophysics, marine geochemistry, and mathematical modeling. Geophysical sciences are called upon for reconstruction of geography (position of continents, horizontal motion of the ocean floor), topography (changing depth patterns in the ocean, general subsidence of any given piece of sea floor), and dating (radioisotopes, magnetic patterns on the sea floor and in sediments). Geochemical analyses deliver information on sediment composition (stable and unstable isotopes; major and minor components such as carbonate, opal, and trace elements). Such information is useful in correlating sedimentary sequences and, when combined with geochemical arguments, yields insights about the dynamics of carbon and nutrient cycles. Mathematical modeling introduces a strong quantitative element. It draws upon the knowledge reservoir of modern oceanography and climatology. See CLIMATOLOGY; GEOCHEMISTRY; GEOPHYSICS; PALEONTOLOGY; SEDIMENTOLOGY.

The study of marine sediments on land is as old as geology itself. Modern paleoceanography is set apart by the study of sediments recovered from the ocean, especially the deep ocean, and by the use of concepts developed by oceanographers (controls on ocean currents and upwelling, vertical stratification, heat budget, nutrient and carbon cycles, pelagic biogeography, and water masses). Important early studies were on cores raised by the United States cable ship *Lord Kelvin* (1936) in the North Atlantic. The glacial debris zones noted in the *Kelvin* cores are now commonly referred to as Heinrich layers; they are witness to sporadic input of iceberg armadas during the last glacial epoch. See GLACIAL EPOCH.

Comparisons of climate-related changes between major ocean basins became possible through the systematic recovery of long cores by the circumglobal Swedish Deep Sea Expedition (1947–1949) on the research vessel *Albatross*. The expedition retrieved cores up to 15 m (45 ft) long, with records reaching back 500,000–1,000,000 years. Many fundamental paleoceanographic concepts were established by the geologists who

analyzed these cores, including the role of trade winds in promoting glacial-age upwelling, the changing supply of North Atlantic Deep Water, the cyclicity of climatic change in the late Quaternary, and large-scale shifts in biogeographic boundaries. See CLIMATE MODELING; PALEOCLIMATOLOGY; QUATERNARY.

A quantum jump in paleoceanographic research resulted from the initiation of deep-sea drilling using the research vessel *Glo-Mar Challenger* (1968). Enormous blank regions on the world's map suddenly became accessible for detailed exploration far back into geologic time, that is, into the Early Cretaceous. Highlights of the first decade of drilling results include the documentation of cooling steps as the planet moved into the present ice age; the reconstruction of long-term fluctuations in the carbonate compensation depth; the documentation of large-scale salt deposition in an isolated Mediterranean basin; and the discovery of temporary anoxic conditions in the Cretaceous deep sea. See CRETACEOUS. [W.H.B.; G.We.]

**Paleocene** The oldest of the seven geological epochs of the Cenozoic Era, and the oldest of the five epochs that make up the Tertiary Period. The Paleocene Epoch represents an interval of geological time (and rocks deposited during that time) from the end of the Cretaceous Period to the beginning of the Eocene Epoch. Recent revisions of the geological time scales place the Paleocene Epoch between 65 to 55 million years before present. See CENOZOIC; EOCENE; GEOLOGIC TIME SCALE; TERTIARY.

The close of the Cretaceous Period was characterized by the disappearance of many terrestrial and marine animals and plants. The dawn of the Cenozoic in the Paleocene Epoch saw the establishment of new fauna and flora that have evolved into modern biota.

Modern schemes of the Paleocene subdivide it into Lower and Upper series, and their formal equivalents, the Danian and Selandian stages. Some authors prefer to use a threefold subdivision of the Paleocene, adding the Thanetian at the top. The older, Danian lithofacies generally tend to be calcium carbonate-rich (pure chalk in the Danian type area), whereas the younger, Selandian and Thanetian facies have greater land-derived components and are more siliciclastic (sand, sandstone, marl). See CHALK; FACIES (GEOLOGY); MARL; SAND; SANDSTONE.

Several major tectonic events that began in the Mesozoic continued into the Paleocene. For example, the Laramide Orogeny that influenced deformation and uplift in the North American Rocky Mountains in the Mesozoic continued into the Paleocene. See OROGENY.

The establishment of deeper connections between the North and South Atlantic in the Paleocene facilitated enhanced deep-water flow from the northern to the southern basin. In the south, the Drake Passage between South America and Antarctica was still closed, although Australia had already separated from Antarctica by Paleocene time. The lack of circum-Antarctic flow precluded the geographic isolation of Antarctica and the development of cold deep water from a southern source. See PALEOCEANOGRAPHY; PALEO GEOGRAPHY.

Terrestrial floras and faunas corroborate the peak warming in the latest Paleocene and early Eocene and suggest that the warm tropical-temperate belt may have been twice its modern latitudinal extent. The temperate floral and faunal elements extended to 60°N, which has been used as an argument to invoke a very low angle of inclination of the Earth's rotational axis in the Paleocene-Eocene. Alternatively, the mild, equable polar climates and well-adapted physiological responses of plants and animals of those times to local conditions may be enough to explain the presence of a rich vertebrate fauna on Ellesmere Island in arctic Canada. See CLIMATE HISTORY; PALEOBOTANY; PALEOCLIMATOLOGY.

The Paleocene Epoch began after a meteorite struck the Earth, causing massive extinctions at the end of Cretaceous and decimating a large percentage of the terrestrial and marine biota. In the oceans, all ammonites, genuine belemnites, rudistids, most

species of planktonic foraminifera and nannoplankton, and marine reptiles disappeared at the close of the Cretaceous Period. Even though some groups, such as squids, octopus, nautilus, and a few species of marine plankton, survived, the genetic pool was relatively small at the dawn of the Tertiary Period. The recovery of the marine biota was, however, fairly rapid after the mid-Paleocene due to overall transgressing seas and ameliorating climates. By the late Paleocene, the biota was well on its way to the high diversification of the Eocene. The end of the Paleocene Epoch saw marked changes in deep-water circulation of the world ocean that resulted in a massive extinction of the benthic marine species. See EXTINCTION (BIOLOGY).

On land the large dinosaurs, which had been on the decline for over 20 million years, died out at the close of the Cretaceous Period. However, smaller reptiles, including alligators and crocodiles, and some of the land flora escaped extinction and continued into the Paleocene. The Paleocene saw the first true radiation of mammals. The mammals of this epoch were characteristically primitive and small in size (50 cm or 20 in. or less). As the continent of Australia became more isolated geographically, its mammalian fauna, such as the marsupials, became sequestered and more specialized. See DINOSAUR; MAMMALIA; PALEONTOLOGY. [B.U.H.]

**Paleoclimatology** The study of ancient climates. Climate is the long-term expression of weather; in the modern world, climate is most noticeably expressed in vegetation and soil types and characteristics of the land surface. To study ancient climates, paleoclimatologists must be familiar with various disciplines of geology, such as sedimentology and paleontology, and with climate dynamics, which includes aspects of geography and atmospheric and oceanic physics. Understanding the history of the Earth's climate system greatly enhances the ability to predict how it might behave in the future. See CLIMATOLOGY.

Information about ancient climates comes principally from three sources: sedimentary deposits, including ancient soils; the past distribution of plants and animals; and the chemical composition of certain marine fossils. These are all known as proxy indicators of climate (as opposed to direct indicators, such as temperature, which cannot be measured in the past). In addition, paleoclimatologists use computer models of climate that have been modified for application to ancient conditions. See GEOLOGY; PALEONTOLOGY.

Like modern climatologists, paleoclimatologists are concerned with boundary conditions, forcing, and response. Boundary conditions are the limits within which the climate system operates. The boundary conditions considered by paleoclimatologists depend on the part of Earth history that is being studied. For the recent past, that is, the last few million years, boundary conditions that can change on short time scales are considered, for example, atmospheric chemistry. For the more distant past, paleoclimatologists must also consider boundary conditions that change on long time scales. Geographic features—that is, the positions of the continents, the location and orientation of major mountain ranges, the positions of shorelines, and the presence or absence of epicontinental seaways—are important for understanding paleoclimatic patterns. Forcing is a change in boundary conditions, such as continental drift, and response is how forcing changes the climate system. Forcing and response are cause and effect in paleoclimatic change. See CONTINENTAL DRIFT; CONTINENTS, EVOLUTION OF; PALEOGEOGRAPHY; PLATE TECTONICS.

Proxy indicators of paleoclimate are abundant in the geologic record. Important sedimentary indicators forming on land are coal, eolian sandstone (ancient sand dunes), evaporites (salt), tillites (ancient glacial deposits), and various types of paleosols (ancient soils), such as bauxite (aluminum ore) and laterite (some iron ores). Coals may form where conditions are favorable for growth of plants and accumulation and preservation of peat, conditions that are partly controlled by climate, especially seasonality of rainfall. See BAUXITE; COAL; PALEOSOL.

Fossil indicators provide information about climate mostly by their distribution (paleobiogeography), although a few specific types of fossils may be indicative of certain climatic conditions. The latter are usually fossils from the younger part of the geologic record and are closely related to modern species that have narrow environmental tolerances. Another type of information available for documenting paleoclimatic patterns and change is stable isotope geochemistry of fossils and certain types of sedimentary rock. Many elements that are used by organisms to make shells, teeth, and stems occur naturally in several different forms, known as isotopes. The most climatically useful isotopes are those of oxygen (O). Although the effects of temperature change and ice volume change can be difficult to distinguish, the analysis of oxygen isotopes has provided a powerful quantitative tool for the study of both long-term temperature change and the history of the polar ice caps. See FOSSIL; ISOTOPE.

A great deal of research in paleoclimatology has been devoted to understanding the causes of climatic change, and the overriding conclusion is that any given shift in the paleoclimatic history of the Earth was brought about by multiple factors operating in concert. The most important forcing factors for paleoclimatic variation are changes in paleogeography and atmospheric chemistry and variations in the Earth's orbital parameters. See ATMOSPHERIC CHEMISTRY; BIOGEOCHEMISTRY; EARTH ROTATION AND ORBITAL MOTION; PRECESSION OF EQUINOXES. [J.T.P.; E.J.Ba.]

**Paleocopa** An extinct order of the crustacean class Ostracoda; also called Palaeocopida. The order is divided into nine superfamilies, one of which, Barychilinae, is only tentatively assigned to the order. A principal feature of the species in the order is their long, straight hinge that extends along the dorsal margin of the carapace and joins the two valves together. As is true of most benthic ostracodes, the palaeocopes lack a frontal opening through which to extend their walking legs. Unlike modern ostracodes, however, they have no calcified inner lamella, and their muscle-scar patterns, which are quite useful in the taxonomy of many other groups of ostracodes, are very poorly known. See OSTRACODA.

The carapaces of many palaeocopes are marked by ornamentation in the form of lobes and sulci. Appendages of the palaeocopes are largely unknown except for a few rather poorly preserved specimens.

One of the most remarkable morphological features of many species of palaeocope ostracodes is that their sexual dimorphism is quite pronounced and is carried far beyond the rather simple sexual dimorphism that characterizes Ostracoda. In typical instances, the males resemble the instars (immature forms), and the females have developed strongly modified morphology that is associated with reproduction—especially the development of pouches for carrying eggs and brooding the young.

The study of the ontogeny of the palaeocopes presents paleontologists with a unique opportunity to learn about the pathways and mechanisms of evolution. The palaeocopes lend themselves to this sort of study because they molt, have a predetermined number of growth stages, and have pronounced sexual dimorphism that allows one to determine the sex of individuals and the sex ratios of populations. Thus, research on the palaeocopes can reveal the pathways their evolution has followed in a way that is possible for few other kinds of fossil organisms.

As is true of other benthic ostracodes, the palaeocopes do not have a planktonic larval stage. As a result, they are quite limited in their means of dispersal, and few species are biogeographically widespread. [R.L.Ka.]

**Paleoecology** Ecology of prehistoric times, extending from about 10,000 to about  $3.5 \times 10^9$  years ago. Although the principles of paleoecology are the same as those underlying modern ecology, the two fields differ greatly. Paleoecology is a historical science that must rely on empirical data from fossils and their enclosing sedimentary rocks to make inferences about past



conditions. Experimental approaches and direct measurement of environmental parameters, which are critical components of modern ecology, are generally impossible in paleoecology. Furthermore, distortion and loss of information during fossilization means that fossil assemblages and distributions are rarely congruent with living communities. Hence, the resolution of ancient ecosystems must remain relatively imprecise. The lack of precision is compensated for by the fact that paleoecology deals with processes occurring over vast spans of time that are unavailable to modern ecology. Long-term changes in communities (replacement) may be discerned and related to patterns of environmental change. More significantly, overall patterns of ecological change in the global biosphere may be documented; evolutionary paleoecology focuses on recognition and interpretation of long-term ecological trends that have been critical in shaping evolution.

Among the goals of paleoecology are the reconstruction of ancient environments (primarily depositional environments), the inference of modes of life for ancient organisms from fossils, the recognition of recurring groupings of ancient organisms that define relicts of communities (paleocommunities), the reconstruction of the interactions of organisms with their environments and with each other, and the documentation of large-scale and long-term patterns of stasis or change in ecosystems. *See* ECOSYSTEM.

To reconstruct ancient marine environments, many different parameters must be inferred, such as temperature, water salinity, oxygen levels, nutrient concentrations, and water movements and depth. In this regard, paleoecology interfaces directly with the fields of sedimentology and stratigraphy, including study of modern depositional environments. *See* DEPOSITIONAL SYSTEMS AND ENVIRONMENTS; STRATIGRAPHY.

Paleoautecology, the interpretation of modes of life (broadly, niches) of ancient organisms, involves a multidisciplinary approach. Although ancient modes of life cannot be determined completely, paleoecologists can often assign fossils to generalized guilds in terms of types of feeding, substrate preference, and degree of activity. A thorough understanding of the biology of closest modern analogs is particularly important in any attempt to reconstruct paleoautecology. *See* LIVING FOSSILS.

The fossil record contains highly biased remnants of past communities or paleocommunities. Paleocommunities are generally recognized as recurring associations of fossil species. Multivariate statistical techniques such as cluster analysis and ordination analysis are commonly employed to aid in discerning the recurrent groupings of fossil species.

Communities and paleocommunities are not static entities in time, but undergo important structural changes on at least three different time scales: succession, replacement, and evolution. Because it operates on a very short time scale, from decades to centuries, ecological succession can be resolved only in a few fossil samples. Longer-term changes in community composition, encompassing thousands of years, are not truly succession. These changes are properly termed community replacement, involving wholesale migration or restructuring of communities at particular locations due to changing environments. On a scale of millions of years, communities show evolutionary changes because their component species have evolved. *See* ECOLOGICAL COMMUNITIES; ECOLOGICAL SUCCESSION.

Organisms evolve within the context of other organisms, not in a vacuum. There is substantial fossil evidence to indicate increasing complexity of organism interactions through time. This escalation in the intensity of predatory interactions, for example, may have important implications for evolutionary change.

One of the most interesting aspects of paleoecology is the possibility of long-term shifts in organism habitats. Evolutionary innovations appear to arise preferentially in shallow-water areas, but through time these new faunas may migrate offshore. Evidence from the fossil record suggests that many paleocommunities were relatively resistant to major changes over long spans of time. These periods of relative stasis in community structure may be punctuated by minor or major crises, during which com-

munities are restructured, with new species added while others become extinct. In many cases, shoreline biotas display very little change. Similarly, deep-oceanic benthic organisms may be little changed through time. In contrast, shallow-water, shelf-dwelling, and especially pelagic organisms may be strongly affected by environmental crises such as the lowering of average temperatures. *See* ECOLOGY; PALEOCLIMATOLOGY; PALEOGEOGRAPHY; PALEONTOLOGY. [C.E.Br.]

**Paleogeography** The geography of the ancient past. Paleogeographers study the changing positions of the continents and the ancient extent of land, mountains, and shallow-sea and deep-ocean basins. The Earth's geography changes because its surface is in constant motion due to plate tectonics. The continents move at rates of 2–10 cm/yr (0.75–4 in./yr). Though this may seem slow, over millions of years continents can travel across the globe. As the continents move, new ocean basins form, mountains rise and erode, and sea level rises and falls. Paleogeographic maps are necessary in order to understand global climatic change, migration routes, oceanic circulation, mountain building, and the formation of many of the Earth's natural resources, including oil and gas. *See* BASIN; CONTINENTS, EVOLUTION OF; GEOGRAPHY; MID-OCEANIC RIDGE; PALEOCLIMATOLOGY; PLATE TECTONICS; SUBDUCTION ZONES.

In the late Precambrian the continents were colliding to form supercontinents, and the Earth was locked in a major ice age. About 1100 million years ago (Ma), the supercontinent of Rodinia was assembled. Rodinia split into halves approximately 750 Ma, opening the Panthalassic Ocean. By the end of the Precambrian three continents came together to form the supercontinent of Gondwana(land). This major continent-continent collision is known as the Pan-African orogeny. *See* OROGENY; PRECAMBRIAN; PROTEROZOIC; SUPERCONTINENT.

The supercontinent that formed at the end of the Precambrian Era, approximately 600 Ma, had already begun to break apart by the beginning of the Paleozoic Era. Gondwana, which was considerably larger than any of the other continents, stretched from the Equator to the south. *See* ORDOVICIAN; PALEOZOIC.

By the end of the Paleozoic Era, the continents had collided to form the supercontinent of Pangea. Centered on the Equator, Pangea stretched from the South Pole to the North Pole. Though the supercontinent that formed at the end of the Paleozoic Era is called Pangea (literally, "all land,"), this supercontinent probably did not include all the landmasses that existed at that time.

The supercontinent of Pangea did not rift apart all at once, but in three main episodes. The first episode of rifting began in the Middle Jurassic, about 180 Ma when North America rifted away from northwest Africa, opening the Central Atlantic. *See* JURASSIC.

The second phase in the breakup of Pangea began in the Early Cretaceous, about 140 Ma. Gondwana continued to fragment as South America separated from Africa, opening the South Atlantic, and India together with Madagascar rifted away from Antarctica and the western margin of Australia, opening the Eastern Indian Ocean. *See* CRETACEOUS.

The third and final phase in the breakup of Pangea took place during the early Cenozoic. North America and Greenland split away from Europe, and Antarctica released Australia. Australia, like India some 50 million years earlier, moved rapidly northward on a collision course with Southeast Asia. *See* CENOZOIC.

About 18,000 years ago, all of Antarctica and much of North America, northern Europe, and the mountainous regions of the world were covered by glaciers and great sheets of ice. These ice sheets melted approximately 10,000 years ago, giving rise to familiar geographic features such as Hudson's Bay, the Great Lakes, the English Channel, and the fiords of Norway. [C.R.Sc.]

**Paleoindian** The oldest archeological cultures of the New World, the ancestors of modern Native Americans, are termed Paleoindian. These colonizing populations of the Americas were

*Homo sapiens sapiens* who arrived during the late Pleistocene (Ice Age) from Asia, though precisely when, and whether in a single or multiple pulses of migration, are not yet known.

The presumed entryway was the Bering Straits, which emerged as dry land during glacial periods. The Bering Land Bridge (or Beringia) existed most recently between 25,000 and 11,000 years before present (B.P.), during the last major episode of the Pleistocene. The conditions that linked Siberia to Alaska may have simultaneously hindered migration south from Alaska. Groups headed in that direction had two potential routes (broadly defined): down the Pacific coast, or via the continental interior along the eastern flank of the Rocky Mountains. There is no evidence yet as to which routes might have been taken.

So far, the earliest archeologically confirmed dates put human groups in the Lena Basin and Lake Baikal region of northeast Asia at about 39,000 years B.P., in subarctic Siberia by 25,000 years B.P., but not in western Beringia (such as Kamchatka) until 14,000 years B.P. Humans were in eastern Beringia (Alaska) soon after 12,000 years B.P., and present south of the ice sheets in North America by at least 11,500 years B.P.—the latter represented by the Clovis culture. Yet, the earliest accepted archeological evidence puts human groups in South America earlier still, by at least 12,500 years B.P. at the site of Monte Verde, Chile.

There are no obvious historical or technological affinities between Clovis and the Monte Verde materials, suggesting that the two may represent populations with distinct archeological traditions and separate migratory pulses: a later one (Clovis) that came south through the ice-free corridor soon after it became viable for travel, and an earlier population that perhaps moved along the Pacific coast and reached South America without, so far at least, any traces being found in North America.

Clovis is a widespread entity that first appears on the western Plains and southwest at 11,500 years B.P. and in eastern North America at 10,600 years B.P. That Clovis and related groups apparently expanded across the continent in what may have been less than 1000 years is all the more remarkable given that they spread at a time of geologically rapid environmental and climatic change. Yet Clovis groups seemingly coped with such adaptive challenges with ease: their stylistically distinctive projectile points and tool kits—often including bifacial knives, a variety of unifacial scrapers, occasional blades and flake tools, and (more rarely) bone and ivory implements—are surprisingly similar across the continent. These were highly mobile groups who relied on high-quality stone often obtained from geological sources hundreds of kilometers from the sites where the stone was used and discarded. Their rapid radiation, broadly similar tool kits, and long-distance movement bespeak a cultural “founders effect,” suggesting their access to large areas of North America was largely unrestricted. Clovis subsistence, it appears, more often involved less risky and smaller prey—and presumably plants, though remains of such are rarely preserved in the archeological record of this period.

Although the timing varies by area, by 10,500 years B.P. the Clovis tradition was replaced by regional Paleoindian variants, which generally have reduced settlement mobility (relative to Clovis), and include new technologies, prey-specific strategies for hunting and processing, increasing use of local resources, and distinctive stylistic elements and functional artifact forms.

The South American Paleoindian record, by contrast, does not evince any artifact forms that dominate the archeological landscape as Clovis does. Instead, this period is marked by more diverse unifacial and bifacial stone tool technologies, often made of stone acquired locally (and not necessarily of superior quality), and includes forms such as bolas—modified spherical stones used in slings or as hand missiles. Projectile points tend to be less common in assemblages here than in North America, and show considerable stylistic variety. South American Paleoindians utilized a wide range of animals, and early on even made occasionally heavy use of plants.

Once the founding population dispersed across South America (over an unknown length of time), subgroups became geographically isolated relatively quickly. From the earliest known site at 12,500 years B.P. (Monte Verde) until the end of the Pleistocene (10,000 years B.P.), there is a continuing diversification in tool forms and technology, evidently reflecting less mobility, increasing heterogeneity and regional mosaics in culture and adaptations, and less expansive social networks and territories. All told, it is a different trajectory from the one that unfolded in North America—testimony that the earliest colonization of the two continents, though ultimately derived from the same northeast Asian source, may have taken place at different times under very different circumstances. See ARCHEOLOGY; PLEISTOCENE; PREHISTORIC TECHNOLOGY. [D.J.Me.]

**Paleolithic** The prehistoric period when people made stone tools exclusively by chipping or flaking. John Lubbock proposed and defined the term Paleolithic, or Old Stone Age, in 1865, and also defined a subsequent Neolithic, or New Stone Age, during which some stone tools were formed by polishing or grinding. Later archeologists altered these definitions; to many today the Paleolithic is the period during which human beings lived entirely by hunting and gathering, while the Neolithic is the following interval during which plant and animal domestication was introduced. To other archeologists, the Paleolithic is simply a time interval, roughly equivalent to the Pleistocene Epoch, while the Neolithic comprises the early part of the succeeding Holocene (or Recent) Epoch.

It is impossible to devise a rigorous, global definition of the Paleolithic or any other cultural stage, because artifact technology and economic practices have changed independently at different times in different parts of the world. Hence, Paleolithic will be used here informally to refer to the time interval between the earliest appearance of stone tools, more than 2 million years before present (m.y. B.P.), and the end of the last glacial period, 12,000–10,000 years B.P. See GEOLOGIC TIME SCALE; NEOLITHIC; PREHISTORIC TECHNOLOGY.

The oldest artifacts found so far come from sites in Ethiopia, Kenya, and Tanzania where they are dated to between 2.5 and 1.6 m.y. B.P. They comprise crude flakes and the modified pebbles and stone chunks from which the flakes were struck. Approximately 1.6–1.5 m.y. B.P., at least some people in East Africa began to manufacture the bifacially flaked tools known to archeologists as hand axes. The flaking of the first hand axes was crude. As time passed, however, their flaking tended to become more refined. By 1 m.y. B.P. hand-ax makers had spread through most of Africa and the Near East, and by 900,000–600,000 years B.P. they had reached Europe.

The Early Stone Age/Lower Paleolithic apparently persisted until sometime between 200,000 and 130,000 years B.P., the exact time perhaps depending on the place. In sub-Saharan Africa the Early Stone Age was succeeded by the Middle Stone Age, while in North Africa and Eurasia the Lower Paleolithic was followed by the Middle Paleolithic. Most Middle Stone Age/Middle Paleolithic assemblages lack hand axes. The principal Middle Stone Age/Middle Paleolithic tools are well-made stone flakes, often modified by edge flaking (“retouch”) into types called sidescrapers, knives, denticulates (serrate-edged pieces), and so forth. In Europe, Middle Paleolithic people were the Neanderthals, *H. (sapiens) neanderthalensis*. Neanderthals also lived in the Near East during the early Middle Paleolithic, but were apparently supplanted by anatomically modern people (*H. sapiens sapiens*) during the latter part (after ?70,000–60,000 years B.P.). Outside of Europe and the Near East, bones representing Middle Paleolithic/Middle Stone Age people are rare, very fragmentary, or both. See NEANDERTHALS.

In Europe, the Near East, and North Africa, the Middle Paleolithic was followed by the Upper Paleolithic, perhaps 50,000 years B.P. in the Near East, adjacent North Africa, and eastern Europe, and beginning around 40,000 years B.P. in

western Europe. The time difference within Europe may reflect the movement of technology, people, or both from east to west. The Upper Paleolithic and Later Stone Age are difficult to characterize artifactually, because wherever they are well known, they exhibit great variability in time and space. The amount of artifactual change through time and space during the Upper Paleolithic/Later Stone Age far exceeds that in earlier periods and suggests an ability to innovate that earlier people did not exhibit. Conventionally, the Upper Paleolithic is said to end with the end of the Last Ice Age, 12,000–10,000 years B.P., although Upper Paleolithic/Later Stone Age artifact types and economic practices continued on for many millennia throughout much of Eurasia and sub-Saharan Africa.

Throughout the long Paleolithic time span, all human beings lived by hunting and gathering wild resources. Only from the very end of the Paleolithic, about 12,000–10,000 years B.P., is there evidence that some people domesticated animals, plants, or both.

The oldest reasonably secure evidence for human use of fire comes from the famous Peking man (*H. erectus*) site of Zhoukoudian in north China, tentatively dated to 500,000–240,000 years ago. More equivocal evidence for older or equally old controlled use of fire has been found in Kenya, South Africa, and Europe. Unequivocal fireplaces are found in many sites occupied by European Neanderthals and their near-modern African contemporaries after 127,000 years B.P.

Concentrations of rocks or other debris that may mark the positions of ancient structures such as wind breaks and flimsy tent-like shelters have been uncovered at several Lower Paleolithic sites in Africa and across Eurasia, but the oldest widely accepted “ruins” date from the Middle Paleolithic. However, it is not until 50,000–40,000 years ago that evidence for housing becomes compelling, with such features as fireplaces and substantial wall supports being commonplace.

The oldest undeniable evidence for burial of the dead comes from the Middle Paleolithic of Europe and the Near East. The deceased were Neanderthals. Upper Paleolithic people also buried their dead. In addition, unlike Middle Paleolithic graves, Upper Paleolithic ones often contain special objects, such as hundreds of ivory beads, carved pendants, or other body ornaments. Upper Paleolithic graves, together with Upper Paleolithic art, provide the oldest available evidence for the intangible part of culture called ideology or religion. [R.G.K.; A.P.T.]

**Paleomagnetism** The study of the direction and intensity of the Earth’s magnetic field through geologic time. Paleomagnetism has been, and continues to be, an important tool in unraveling the past movements of the Earth’s tectonic plates. By studying the records of the ancient magnetic field left in rocks, earth scientists are able to learn how the continental and oceanic plates have moved relative to the Earth’s spin axis and relative to one another. In addition, the global reference frame of the Earth’s magnetic field provides a very useful basis for temporal correlation of rocks on a local or global geographic scale (magnetostratigraphy). See GEOMAGNETISM; PLATE TECTONICS.

Many rocks acquire remanent magnetizations at or about the time they are formed. These magnetizations are nearly always parallel to the direction of the Earth’s magnetic field at the locality where the rock formed. See ROCK MAGNETISM.

In paleomagnetic studies a suite of carefully oriented samples spanning a time interval long enough to average magnetic secular variations is collected. For magnetostratigraphy, an ordered suite of samples spanning the stratigraphic section of interest are collected. The samples are taken to the laboratory, where they are cut into small upright cylinders and their magnetization is measured by using a sensitive magnetometer.

The end product of the laboratory experiments is a suite of magnetization vector directions from the collected samples. These directions are specified by the inclination *I*, the angle that the magnetization vector makes with the horizontal, and the dec-

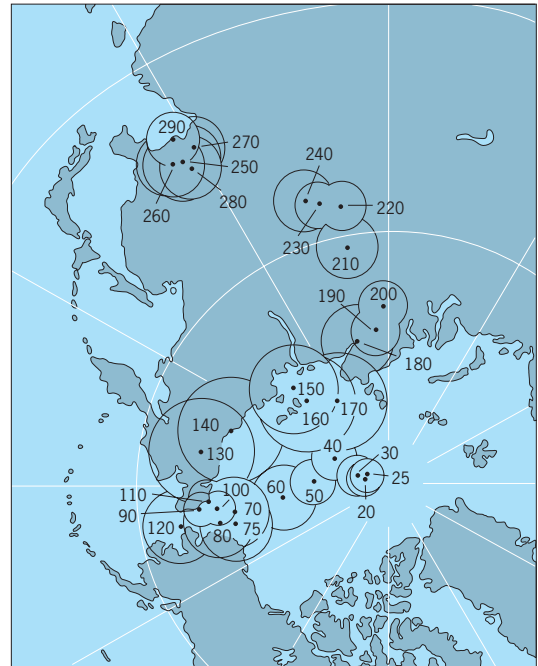

**Apparent polar wander path for North America for Late Carboniferous time to the present. The numbers represent time in millions of years before present. Circles encompass standard error. (After E. Irving, *Paleopoles and paleolatitudes of North America and speculations about displaced terranes*, *Can. J. Earth Sci.*, 16:669–694, 1979)**

lination *D*, the angle that the projection of the magnetization vector upon a horizontal plane makes with true north, reckoned positive clockwise from north. Provided that the sample collection represents a sufficiently long time span to average out secular variation, representative mean *D* and *I* values and an associated uncertainty in direction may be calculated by using statistical techniques. The mean declination and inclination, together with the inclination-latitude relationship mentioned earlier and some elementary spherical trigonometry, allow the calculation of a representative paleomagnetic pole from the rock unit. By connecting paleomagnetic poles of different ages in an ordered time sequence, an apparent polar wander path (APWP) may be constructed for a particular tectonic plate (see illustration). The APWP specifies the displacement history of a plate or continent with respect to the spin axis, and can be directly compared with APWPs from other plates or continents to determine whether relative movements have occurred.

The end product of a magnetostratigraphic study is a set of normal (N) and reversed (R) magnetizations from the stratigraphic section under investigation. The positioning and frequency of occurrence of these N-to-R and R-to-N transitions is highly diagnostic in many cases, and by using these data together with other local geologic information, such as the position of major unconformities, one stratigraphic section can be correlated with another over considerable distances. The method can also be used over intracontinental and intercontinental distances. However, because the field has only two possible states (N or R), correlation over longer distances where tectonics and sedimentation rates may vary is correspondingly less accurate. [M.O.McW.]

**Paleontology** The study of animal history as recorded by fossil remains. The fossil record includes a very diverse class of objects ranging from molds of microscopic bacteria in rocks more than  $3 \times 10^9$  years old to unaltered bones of fossil humans in ice-age gravel beds formed only a few thousand years ago. Quality of preservation ranges from the occasional occurrence of soft parts (skin and feathers, for example) to barely decipherable

impressions made by shells in soft mud that later hardened to rock. See FOSSIL; MICROPALAEONTOLOGY.

The most common fossils are hard parts of various animal groups. Thus the fossil record is not an accurate account of the complete spectrum of ancient life but is biased in overrepresenting those forms with shells or skeletons. Fossilized worms are extremely rare, but it is not valid to make the supposition that worms were any less common in the geologic past than they are now. See EDIACARAN BIOTA.

The data of paleontology consist not only of the parts of organisms but also of records of their activities: tracks, trails, and burrows. Even chemical compounds formed only by organisms can, if extracted from ancient rocks, be considered as part of the fossil record. Artifacts made by people, however, are not termed fossils, for these constitute the data of the related science of archeology, the study of human civilizations. See ARCHEOLOGY; PALEOBIOCHEMISTRY.

Paleontology lies on the boundary between two disciplines, biology and geology. See BIOLOGY; GEOLOGY.

**Geological aspects.** A major task of any historical science, such as geology, is to arrange events in a time sequence and to describe them as fully as possible.

Fossils only tell that a rock is older or younger than another; they do not give absolute age. The decay of radioactive minerals may provide an age in years, but this method is expensive and time-consuming, and cannot always be applied since most rocks lack suitable radioactive minerals. Correlation by fossils remains the standard method for comparing ages of events in different areas. See INDEX FOSSIL; STRATIGRAPHY.

The physical appearance and climate of the Earth during a given period of the geologic past can be described from compilation and analysis of the data which is obtained through studies of the habitats of extant fauna, the geographic distribution of fossils, and the climatic preferences of ancient forms of life. See PALEOCLIMATOLOGY; PALEOECOLOGY; PALEOGEOGRAPHY.

**Biological aspects.** The most fundamental fact of paleontology is that organisms have changed throughout earth history and that each geological period has had its characteristic forms of life. An evolutionist has two major interests: first, to know how the process of evolution works; this is accomplished by studying the genetics and population structure of modern organisms; second, to reconstruct the events produced by this process, that is, to trace the history of life. Any modern animal group is merely a stage, frozen at one moment in time, of a dynamic, evolving lineage. Fossils give the only direct evidence of previous stages in these lineages. Horses and rhinoceroses, for example, are very different animals today, but the fossil history of both groups is traced to a single ancestral species that lived early in the Cenozoic Era. From such evidence, a tree of life can be constructed whereby the relationships among organisms can be understood. See ANIMAL EVOLUTION. [S.J.G.]

**Paleopathology** The study of ancient diseases and their origins. Paleopathology is especially important in the understanding of the origins, prevalence, and spread of infectious diseases, including how humans have contributed to the spread of disease and how they can overcome it. See EPIDEMIOLOGY; INFECTIOUS DISEASE; PATHOLOGY.

Hypothesis testing of populations has contributed to the field of paleopathology, as has application of macroscopic (visual) examination, routine x-ray, computerized tomography (CAT) scans, magnetic resonance imaging (MRI), electron microscopy, and immunologic, chemical, and mass spectrophotometry techniques to skeletons, soft tissue, and even scat (animal droppings). See COMPUTERIZED TOMOGRAPHY; MAGNETIC RESONANCE; X-RAY DIFFRACTION.

The scientific method in paleopathology is based upon comparison of archeologic or paleontologic findings with individuals documented to have the disease. To this end the following basic tenets are observed: (1) Tissue must be adequately preserved

to allow recognition of disease and distinguish possible pseudopathology or postdeath artifact. (2) The manifestations of a disease must be sufficiently stable across generations to allow comparison of ancient with modern disease. (3) Analysis of entire skeletons is more accurate than analysis of isolated bones. (4) Analysis of afflicted populations (paleoepidemiology) is more accurate than analysis of isolated skeletons.

The range of diagnostic methods used in paleopathology is extensive. Skeletal remains are visually examined to identify occurrence and nature of alterations, mapping their skeletal distribution. Internal structure can then be assessed, preferably by a nondestructive technique. Even fossils are not simply casts of external surfaces, but have a visualizable internal structure.

Mummies provide an additional source of information. Rehydration of mummy tissue allows standard soft tissue histology, providing information often transcending that available through study of bones. Anthropologic study of artifacts such as daggers that sometimes accompany mummies and skeletons has also contributed to the understanding of ancient lifestyles and the diseases which impacted them. See HISTOLOGY.

Some of the diseases recognized in living individuals for which evidence has also been found in ancient life forms include tuberculosis, leprosy, arthritis, cancer, and various parasitic diseases. See ARTHRITIS; CANCER (MEDICINE); LEPROSY; PARASITOLOGY; TUBERCULOSIS. [B.M.R.]

**Paleoseismology** The study of geological evidence for past earthquakes. This scientific discipline has contributed greatly to modern understanding of the nature of earthquakes. The patterns of earthquakes, in both space and time, evolve over centuries and millennia and cannot be discovered by modern instruments. Knowledge of these patterns is important for understanding the physics of earthquakes and for forecasting future destructive earthquakes.

In certain natural environments, the features related to ancient earthquakes are preserved in the landforms and superficial layers of the Earth's surface. Geologists use this paleoseismological evidence to extend the short historical and instrumental record of earthquakes into ancient centuries and millennia. Such paleoseismological studies have clarified the earthquake record of many parts of the world, including the midcontinent and east coast of the United States, northern Africa, southern Europe, China, Japan, Indonesia, and New Zealand.

The geological preservation of ancient earthquakes has enabled scientists to compare modern earthquakes with those of the past. In 1983, for example, a sparsely populated region of Idaho was struck by a magnitude-7.3 earthquake. Subsequent investigations revealed a fresh, 30-km-long (18-mi) fault scarp running along the western base of the lofty Lost River Range. Inspection of the fresh escarpment revealed that it is surmounted by a more subdued, vegetated escarpment of nearly identical length and height. Excavations across this ancient fault scarp showed that it had formed about 5000 years earlier during an event very similar to the 1983 earthquake. This is one of several examples of what paleoseismologists call a characteristic earthquake: apparently, some earthquakes are nearly identical repetitions of their predecessors. See EARTHQUAKE; SEISMOLOGY. [K.Si.]

**Paleosol** A soil of the past, that is, a fossil soil. Paleosols are most easily recognized when they are buried by sediments. They also include surface profiles that are thought to have formed under very different conditions from those now prevailing, such as the deeply weathered tropical soils of Tertiary geological age that are widely exposed in desert regions of Africa and Australia. Such profiles are generally known as relict paleosols. Those that can be shown to have been buried and then uncovered by erosion are known as exhumed paleosols. The main problem in defining the term paleosol comes from defining what is meant by soil, a term that has very different meanings for agronomists, engineers, geologists, and soil scientists. Soil can be considered

distinct from sediment in that it forms in place, but soil need not necessarily include traces of life. At its most general level, soil is material forming the surface of a planet or similar body and altered in place from its parent material by physical, chemical, or biological processes. See SOIL.

Paleosols are especially abundant in volcanic, alluvial, and eolian sedimentary sequences. Along with the fossils, sedimentary structures, and volcanic rocks found in such deposits, paleosols provide an additional line of evidence for ancient environments during times between eruptions and depositional events. See PALEOCLIMATOLOGY; SEDIMENTOLOGY. [G.J.R.]

**Paleozoic** A major division of time in geologic history, extending from about 540 to 250 million years ago (Ma). It is the earliest era in which significant numbers of shelly fossils are found, and Paleozoic strata were among the first to be studied in detail for their biostratigraphic significance.

The Paleozoic Era is divided into six systems; from oldest to youngest they are Cambrian, Ordovician, Silurian, Devonian, Carboniferous, and Permian. The Carboniferous is subdivided into two subsystems, the Mississippian and the Pennsylvanian which, in North America, are considered systems by many geologists. The Silurian and Devonian systems are closer to international standardization than others; all the series and stage names and lower boundaries have been agreed upon, and most have been accepted. See CAMBRIAN; CARBONIFEROUS; DEVONIAN; ORDOVICIAN; PERMIAN; SILURIAN.

Because Alpine and Appalachian mountain chains were among the first studied in detail, orogenies were first named there. In eastern North America, mountain-building effects during the early Paleozoic were ascribed to the Taconic orogeny (Middle and Late Ordovician); middle Paleozoic events were assigned to the Acadian orogeny (Middle and Late Devonian); and late Paleozoic movements were called Appalachian (more accurately Alleghenian) for Permian and, perhaps, Triassic events. See DATING METHODS; ISOTOPE; OROGENY; PLATE TECTONICS; UNCONFORMITY.

The major changes in lithofacies during the Paleozoic were also effected by biotic evolution through the era. Limestone facies became more abundant and more diversified in the shallow warm seas as calcium-fixing organisms became more diverse and more widespread. Sediment input from the land was modified as plants moved from the seas to the low coastal plains and, eventually, to the higher ground during the Devonian. Primitive vertebrates evolved during the Cambro-Ordovician, but true fishes and sharks did not flourish until the Devonian. Amphibians invaded the land during the Late Devonian and early Carboniferous at about the same time that major forests began to populate the terrestrial realm. These changes produced an entirely new suite of nonmarine facies related to coal formation, and the Carboniferous was a time of formation of major coal basins on all continental plates.

Major cycles of cold and warm climates were overlaid on depositional and evolutionary patterns, producing periods of continental glaciation when large amounts of the Earth's water were tied up in ice during the Late Ordovician, the Late Devonian, and the late Permian. During the earliest and latest of these periods, icesheets were concentrated in the Southern Hemisphere on a single large Paleozoic continental mass—Gondwana. See DEPOSITIONAL SYSTEMS AND ENVIRONMENTS; FACIES (GEOLOGY); PALEOCLIMATOLOGY.

The Paleozoic featured a single southern landmass (Gondwana) for most of the era. This megaplate moved relatively sedately northward during this entire time interval (540–250 Ma) and always contained the magnetic and geographic south poles. Consequently, many of the facies and biologic provinces in the Gondwanan region were influenced by the cooler marine realms and continental and mountain glaciers in nearly every Paleozoic period. Most of the tectonic action that produced major periods of collision, mountain building, carbonate platform building,

back-arc fringing troughs with their distinctive faunas and lithofacies, and formation of coal basins and evaporites took place in the Northern Hemisphere. These pulsations produced combinations of Laurentian (North American), Euro-Baltic, Uralian, Siberian, and Chinese plates a various times during the Paleozoic; and these combined units, in turn, moved slowly across the latitudes, producing climatic change; lithofacies changed in response to both the climate and the plate tectonics. See PALEO-GEOGRAPHY.

There were fewer and simpler life forms in the Cambrian—often termed the Age of Trilobites. All groups of invertebrates and plants became more numerous through geologic time. For example, 7 major invertebrate animal groups at the beginning of the Cambrian doubled to 14 by the end of the period, 20 by the end of the Ordovician, 23 at the end of the Devonian, and 25 at the end of the Paleozoic. The pattern for plant diversification, although starting later, is similar. Three simple plant groups became 5 by the end of the Silurian, 7 at the end of the Devonian, and 13 at the end of the Paleozoic. The vertebrates also diversified very slowly. From one or two groups in the Cambro-Ordovician (conodonts are now considered primitive vertebrates), the number of major kinds rose to 6 at the end of the Devonian and 8 at the end of the Paleozoic. See BIOGEOGRAPHY; GEOLOGIC TIME SCALE; INDEX FOSSIL; PALEOECOLOGY; STRATIGRAPHY; TRILOBITA. [J.T.D.]

**Palladium** A chemical element, Pd, atomic number 46, and atomic weight 106.4. A transition metal, palladium occurs in combination with platinum (Pt) and is the second most abundant platinum-group metal, accounting for 38% of the reserves of these metals. See PERIODIC TABLE; PLATINUM.

Palladium is soft and ductile and can be fabricated into wire and sheet. The metal forms ductile alloys with a broad range of elements. Palladium is not tarnished by dry or moist air at ordinary temperatures. At temperatures from 350 to 790°C (660 to 1450°F) a thin protective oxide forms in air, but at temperatures from 790°C (1450°F) this film decomposes by oxygen loss, leaving the bright metal. In the presence of industrial sulfur-containing gases a slight brownish tarnish develops; however, alloying palladium with small amounts of iridium or rhodium prevents this action. Important physical properties of palladium are given in the table. See ALLOY; METAL.

At room temperature, palladium is resistant to nonoxidizing acids such as sulfuric acid, hydrochloric acid, hydrofluoric acid, and acetic acid. The metal is attacked by nitric acid, and a mixture of nitric acid and hydrochloric acid is a solvent for the metal.

Physical properties of palladium

Property	Value
Atomic weight	106.4
Naturally occurring isotopes (percent abundance)	102 (0.96) 104 (10.97) 105 (22.23) 106 (27.33) 108 (26.71) 110 (11.81)
Crystal structure	Face-centered cubic
Thermal neutron capture cross section, barns	8.0
Density at 25°C (77°F), g/cm <sup>3</sup>	12.01
Melting point, °C (°F)	1554 (2829)
Boiling point, °C (°F)	2900 (5300)
Specific heat at 0°C (32°F), cal/g	0.0584
Thermal conductivity, (cal-cm)/(cm <sup>2</sup> -s-°C)	0.18
Linear coefficient of thermal expansion, (μin./in.)/°C	11.6
Electrical resistivity at 0°C (32°F), μΩ-cm	9.93
Young's modulus, lb/in. <sup>2</sup> , static, at 20°C (68°F)	16.7 × 10 <sup>6</sup>
Atomic radius in metal, nm	0.1375
Ionization potential, eV	8.33
Binding energy, eV	3.91
Pauling electronegativity	2.2
Oxidation potential, V	-0.92

Palladium is also attacked by moist chlorine (Cl) and bromine (Br). See ELECTROPLATING OF METALS; NONSTOICHIOMETRIC COMPOUNDS.

The major applications of palladium are in the electronics industry, where it is used as an alloy with silver for electrical contacts or in pastes in miniature solid-state devices and in integrated circuits. Palladium is widely used in dentistry as a substitute for gold. Other consumer applications are in automobile exhaust catalysts and jewelry. See INTEGRATED CIRCUITS.

Palladium supported on carbon or alumina is used as a catalyst for hydrogenation and dehydrogenation in both liquid- and gas-phase reactions. Palladium finds widespread use in catalysis because it is frequently very active under ambient conditions, and it can yield very high selectivities. Palladium catalyzes the reaction of hydrogen with oxygen to give water. Palladium also catalyzes isomerization and fragmentation reactions. See CATALYSIS.

Halides of divalent palladium can be used as homogeneous catalysts for the oxidation of olefins (Wacker process). This requires water for the oxygen transfer step, and a copper salt to reoxidize the palladium back to its divalent state to complete the catalytic cycle. See HOMOGENEOUS CATALYSIS; TRANSITION ELEMENTS. [D.M.Ro.]

**Palpigradi** An order of rare arachnids comprising 21 known species from tropical and warm temperate regions. American species occur in Texas and California. All are minute, whitish, eyeless animals, varying from 0.027 to 0.112 in. (0.68 to 2.8 mm) in length, that live under stones, in caves, and in other moist, dark places. The elongate body terminates in a slender, multisegmented flagellum set with setae. In a curious reversal of function, the pedipalps, the second pair of head appendages, serve as walking legs. The first pair of true legs, longer than the others and set with sensory setae, has been converted to tactile appendages which are vibrated constantly to test the substratum. See ARACHNIDA. [W.J.Ger.]

**Palynology** The study of pollen grains and spores, both extant and extinct, as well as other organic microfossils. Although the origin of the discipline dates back to the seventeenth century, when modern pollen was first examined microscopically, the term palynology was not coined until 1944.

Palynologists study microscopic bodies generally known as palynomorphs. These include an array of organic entities, each consisting of a highly resistant wall component. Examples include acritarchs and chitinozoans (microfossils with unknown affinities), foraminiferans (protists), scolecodonts (tooth and mouth parts of marine annelid worms), fungal spores, dinoflagellates, algal spores, and spores and pollen grains of land plants. Spores and pollen grains are reproductive propagules and play a paramount role in the life history of land plants. See MICROPALAEONTOLOGY; POLLEN; REPRODUCTION (PLANT).

Palynology can be classified into two broad fields, paleopalynology and neopalynology. Although a range of methodologies and instruments are employed in both subdisciplines, the utilization of contemporary microscopy is fundamental.

The subdisciplines of neopalynology include taxonomy, genetics, and evolution; development, functional morphology, and pollination; aeropalynology; and melissopalynology. Aeropalynology is the study of pollen grains and spores that are dispersed into the atmosphere. Melissopalynologists analyze bee pollen loads and the pollen component within honeys. See PLANT EVOLUTION; PLANT TAXONOMY; POLLINATION.

The main fields of study within paleopalynology are paleobotany, past vegetation and climate reconstruction, geochronology and biostratigraphy, and petroleum and natural gas exploration. See FOSSIL; PALEOBOTANY; PALEOGEOGRAPHY; POSTGLACIAL VEGETATION AND CLIMATE; STRATIGRAPHY. [J.M.Os.]

**Pancreas** A composite gland in most vertebrates, containing both exocrine cells—which produce and secrete enzymes involved in digestion—and endocrine cells, arranged in separate islets which elaborate at least two distinct hormones, insulin and glucagon, both of which play a role in the regulation of metabolism, and particularly of carbohydrate metabolism. See CARBOHYDRATE METABOLISM.

**Anatomy.** The pancreas of mammals shows large variations. The extremes are the unique, massive pancreas of humans, and the richly branched organ of the rabbit. Usually, the main duct, the duct of Wirsung, opens into the duodenum very close to the hepatic duct. In humans, the pancreas weighs about 2.5 oz (70 g). It can be divided into head, body, and tail. Accessory pancreases are frequently found anywhere along the small intestine, in the wall of the stomach, and in Meckel's diverticulum.

The exocrine portion of the pancreas shows tubuloalveolar glands. Each terminal alveolus is called an acinus. The various acini have central cavities, which open into intralobular ducts through narrow intercalated tubes. The interlobular ducts anastomose and ultimately form the main duct of Wirsung. The activity of the acini is stimulated by secretin as well as by pilocarpine.

The endocrine portion shows cellular masses called islands or islets of Langerhans, in which the cellular cords or masses are more or less isolated by irregular spaces filled with connective tissue and blood capillaries. The two main types of cells are the alpha and the beta cells.

Between the grapelike exocrine portion with its ducts and the islands of Langerhans, it is possible to observe connective tissue septa, numerous blood vessels, and nerves.

**Physiology.** The pancreatic juice carried to the duodenum is a slightly alkaline liquid containing trypsinogen, which, when activated, causes the hydrolysis of the proteins into amino acids, amylase, and maltase, which act on the glucides, and lipase, which causes the hydrolysis of fatty substances. The intense stimulation of the pancreatic secretion after ingestion of food is considered to be the result of a nervous reflex originating in the mouth, and also of direct introduction of acids and fats into the duodenum, causing the liberation of a hormone called secretin into the bloodstream to stimulate the exocrine secretion.

F. Banting and C. Best (1922) prepared pancreatic extracts which were able to prevent the lethal effects of pancreatectomy. The same effect was obtained with extracts from pancreas in which, after ligation of the duct of Wirsung, the exocrine portion of the gland had disappeared. See DIABETES.

The alpha cells and beta cells in the islets are the sources of two hormones, insulin from the beta, and glucagon, also known as the hyperglycemic factor, from the alpha. The former is a hormone which influences carbohydrate metabolism, enabling the organism to utilize sugar. The latter accelerates the conversion of liver glycogen into glucose. Glucagon elevates the blood sugar level, and its effects are the opposite of those of insulin, so that the two hormones together maintain the sugar metabolism of the body in balance. When the level of sugar in the blood becomes too low, the secretion of glucagon is stimulated. See GLUCAGON; INSULIN. [E.L.V.C.]

**Pancreas disorders** The pancreas is affected by a variety of congenital and acquired diseases. Because of the dual functional role, the diseases of the exocrine portion of the pancreas will be separated from the endocrine lesions in this discussion.

The most frequent congenital lesion of the pancreas is more appropriately designated as a developmental abnormality—ectopic or aberrant pancreas. Ectopic pancreas can be found anywhere within the gastrointestinal tract, but is more frequent in the stomach and duodenum.

Cystic fibrosis (mucoviscidosis) is a systemic disease in which mucus secretion is altered so that a viscid mucus is produced. The disease is inherited as a mendelian recessive. Cystic fibrosis affects all exocrine glands, including the acinar portion of

the pancreas. Production of altered mucus leads to dilation of the exocrine ducts (cystic), destruction of acinar tissue, and replacement of the destroyed tissue by fibrous connective tissue (fibrosis). The islets are not affected by this disease. Elevation in secretion of sodium and chloride in sweat is also common.

Acute hemorrhagic pancreatitis is a serious disease of unknown etiology which causes sudden liberation of activated pancreatic enzymes that digest the pancreatic parenchyma. The digestive process leads to dissolution of fat and production of calcium soaps. In addition, rupture of pancreatic vessels occurs with resultant hemorrhage and shock. This disease is associated with biliary tract disease, especially gallstones (cholelithiasis), alcoholism, hyperlipidemia, and hypercalcemia. See ALCOHOLISM; GALLBLADDER DISORDERS.

Chronic pancreatitis, perhaps better designated chronic relapsing pancreatitis, is a condition in which recurrent episodes of pancreatitis occur without the production of symptoms or with the production of mild symptoms. Destruction of the pancreatic tissue, with repair by fibrosis, calcification, and cyst formation, is frequent.

Diabetes mellitus is the principal disease associated with the endocrine portion of the pancreas. Two clinical forms of the disease are recognized—insulin-dependent diabetes mellitus and non-insulin-dependent diabetes mellitus. While many factors are involved in the causation of this disease, basically the disease is a result of the failure of the beta cells of the pancreas to produce appropriate kinds and amounts of insulin to meet metabolic needs. See DIABETES.

Tumors of the pancreas can be either benign or malignant. They affect both the endocrine and exocrine portions of the pancreas. Benign tumors of the exocrine pancreas are extremely rare. Malignant tumors of the exocrine pancreas arise most frequently from the pancreatic ducts. Acinar carcinomas also exist but are very rare. Exocrine pancreatic carcinomas are very malignant tumors. Islet cell lesions are quite rare but may be associated with increased hormone production. The tumors can be single or multiple, benign or malignant, and they can form anywhere in the pancreas. Hyperfunction of the islets of Langerhans can result in three distinct clinical syndromes: hyperinsulinism and hypoglycemia, the Zollinger-Ellison syndrome (gastrinoma), and multiple endocrine neoplasia. See ONCOLOGY; PANCREAS. [H.T.N.]

**Panda** The name for two species of carnivores in the raccoon family, Procyonidae, both of which are found in Asia. The red panda (*Ailurus fulgens*) inhabits the forested regions of the Himalayas and western China. It has thick fur which gives it a heavy stocky appearance. Actually, it weighs an average of 10–12 lb (4.5–5.5 kg). The fur is black on the lower parts and red on the back. The face is white with a dark stripe from each eye to the corner of the mouth. The red panda is primarily a vegetarian, feeding on lichens, roots, and bamboo shoots. It is arboreal, nesting in a hollow tree or in the fork of a tree. The giant panda (*Ailuropoda melanoleuca*) superficially resembles a bear and may be a true member of the Ursidae. Little is known about the natural history of this animal; its diet of bamboo restricts it to the bamboo forests located in cold, damp mountainous areas of central China. The adults weigh 200–300 lb (90–135 kg) and are somewhat smaller than the brown bear. See CARNIVORA. [C.B.C.]

**Pandanales** An order of monocotyledons, the composition of which only recently has been revealed by deoxyribonucleic acid (DNA) sequence studies of four genes. Included are four families. Pandanaceae (800 species; the screw pine family), Cyclanthaceae (230 species; the Panama hat family), Stemonaceae (35 species), and Velloziaceae (200 species). Pandanaceae are often lianas or large herbs from the Old World; Cyclanthaceae are herbs or lianas from the New World tropics; Stemonaceae are herbs or lianas of the Old World (but with one species in the southeastern United States); and Velloziaceae are

herbs or small shrubs of Africa and particularly South America (with one genus in southwest China). Cyclanthaceae, Pandanaceae, and Stemonaceae have flower parts in twos or fours, which is unusual among monocotyledons, in which threes are most common.

Several species in Pandanales are economically important. The leaves of Pandanaceae are fibrous and used for making rope and roofing, and the fruits are eaten in many areas. Cyclanthaceae leaves are fibrous and have similar uses, including the manufacture of Panama hats. See ARECIDAE; LILIOPSIDA; MAGNOLIOPHYTA; PLANT KINGDOM. [M.W.C.]

**Panel heating and cooling** A system in which the heat-emitting and heat-absorbing means is the surface of the ceiling, floor, or wall panels of the space which is to be environmentally conditioned. The heating or cooling medium may be air, water, or other fluid circulated in air spaces, conduits, or pipes within or attached to the panel structure. For heating only, electric current may flow through resistors in or on the panels. See ELECTRIC HEATING.

Heat energy is transmitted from a warmer to a cooler mass by conduction, convection, and radiation. The output from heating surfaces comprises both radiation and convection components in varying proportions. In panel heating systems, especially the ceiling type, the radiation component predominates. See RADIANT HEATING.

When a panel system is used for cooling, the dew-point temperature of the ambient air must remain below the surface temperature of the heat-absorbing panels to avoid condensation of moisture on the panels. Panel cooling effectively prevents the disagreeable feeling of cold air blown against the body and minimizes the occurrence of summer colds. See COMFORT HEATING; HOT-WATER HEATING SYSTEM. [E.L.W./R.Ko.]

**Pantodonta** An extinct order of relatively large placental mammals represented by Paleocene-Eocene fossils from western Europe, North America, and eastern Asia. Pantodonts were an early evolutionary experiment in large-bodied herbivory by primitive placental mammals. They first appeared in Asia during the early Paleocene and disappeared during the middle Eocene, leaving no descendants. With the possible exception of the most primitive pantodonts, all were herbivores, and pantodonts were either the largest or among the largest mammals of their time. The adaptive radiation of pantodonts was diverse and encompassed mammals as different as small [1 kg (2 lb) or less in body mass], arboreal herbivores, and large [650 kg (1430 lb)], ground-sloth-like, terrestrial herbivores. See EOCENE; PALEOCENE.

Pantodonts are unique among placental mammals in having upper third and fourth premolar tooth crowns in which there are V-shaped crests. All pantodonts were obligate quadrupeds, with four nearly equal-sized limbs. Most pantodonts had large tusks and long, heavy tails. When compared to living mammals, many pantodonts would have looked somewhat like bears, pigs, or small hippos. See DENTITION; MAMMALIA.

The most primitive pantodonts are assigned to the family Bemalambdidae. All other pantodonts belong to the suborder Eupantodonta, which diverged early into the superfamilies Pantolambdodontoidea and Pantolambdoidea. The pantolambdodontoids include the Asian family Pantolambdodontidae, the North American family Titanoideidae, and the South American genus *Alcidedorbignya*. The pantolambdoids include the North American families Pantolambdidae and Barylambdidae and the more cosmopolitan (known from North America and Eurasia) family Coryphodontidae. [S.G.L.]

**Pantograph** A four-bar parallel linkage, with no links fixed, used as a copying device for generating geometrically similar figures, larger or smaller in size, within the limits of the mechanism. In the illustration the curve traced by point *T* will be similar to that generated by point *S*. This similarity results because points

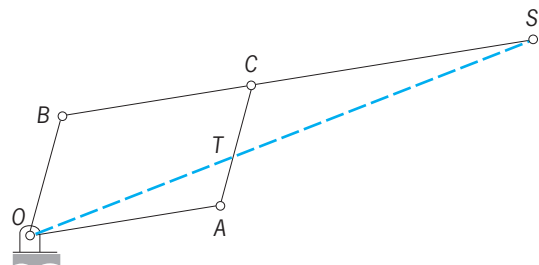

Similar triangles of a pantograph.

$T$  and  $S$  will always lie on the straight line  $\overline{OTS}$ ; triangles  $\overline{OBS}$  and  $\overline{TCS}$  are always similar because lengths  $\overline{OB}$ ,  $\overline{BS}$ ,  $\overline{CT}$ , and  $\overline{CS}$  are constant and  $\overline{OB}$  is always parallel to  $\overline{CT}$ . Distance  $\overline{OT}$  always maintains a constant proportion to distance  $\overline{OS}$  because of the similarity of the above triangles. Numerous modifications of the pantograph as a copying device have been made. See FOUR-BAR LINKAGE.

A second use of the pantograph geometry is seen in the collapsible parallel linkage used on electric locomotives and rail cars to keep a current-collector bar or wheel in contact with an overhead wire. Two such congruent linkages in planes parallel to the train's motion are affixed securely on the top of the locomotive with joining horizontal members perpendicular to each other. The uppermost member collects the current, and powerful springs thrust the configuration upward with sufficient pressure normally to make low-resistance contact from wire to collector.

[D.P.Ad.]

**Pantothenic acid** A member of the B vitamin group with the structural formula

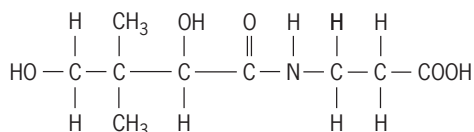

It is a light-yellow, viscous oil which is readily soluble in  $\text{H}_2\text{O}$ . Pantothenic acid is widely distributed, and liver, kidneys, fresh green vegetables, and egg yolks are among its best sources. Losses of the vitamin during cooking are minimal, as it is present in stable conjugated form in food.

No definite pathologic lesions due to a specific pantothenic acid deficiency have been reported in humans. The factors affecting the requirement for pantothenic acid are probably similar to those altering the needs for the other B vitamins. Pantothenic acid has been reported to improve the reactions of young men to stress. The widespread occurrence of pantothenic acid assures protection against the deficiency state under most conditions. Most Americans eat 10 mg of pantothenic acid per 2500 cal of good diet. The daily requirement is probably about 3–5 mg.

[S.N.G.]

**Papaverales** An order of flowering plants, division Magnoliophyta (Angiospermae), subclass Magnoliidae of the class Magnoliopsida (dicotyledons). The order consists of only two families: Papaveraceae with some 200 species, and Fumariaceae with about 400 species. Within its subclass, the order is marked by its syncarpous gynoecium, parietal placentation, and only two (seldom three) sepals. Most of the species are herbaceous, and many of them contain isoquinoline alkaloids similar to those in the order Ranunculales. The Papaveraceae, with regular flowers, numerous stamens, and a well-developed latex system, include the poppies (*Papaver* and related genera; see illustration), bloodroot (*Sanguinaria*), and celandine (*Chelidonium*). *Papaver somniferum* is the source of opium. The Fumariaceae, with four or six stamens, irregular flowers that usually have some of the petals



Oriental poppy (*Papaver orientale*) of the family Papaveraceae and the order Papaverales. (John H. Gerard, National Audubon Society)

spurred or saccate, and no latex system, include the bleeding heart (*Dicentra spectabilis*) and some other common ornamentals. See MAGNOLIIDAE; MAGNOLIOPHYTA; MAGNOLIOPSIDA; POPPY; RANUNCULALES.

[A.Cr.; T.M.Ba.]

**Paper** A flexible web or mat of fibers isolated from wood or other plants materials by the operation of pulping. Nonwovens are webs or mats made from synthetic polymers, such as high-strength polyethylene fibers, that substitute for paper in large envelopes and tote bags.

Paper is made with additives to control the process and modify the properties of the final product. The fibers may be whitened by bleaching, and the fibers are prepared for papermaking by the process of refining. Stock preparation involves removal of dirt from the fiber slurry and mixing of various additives to the pulp prior to papermaking. Papermaking is accomplished by applying a dilute slurry of fibers in water to a continuous wire or screen; the rest of the machine removes water from the fiber mat. The steps can be demonstrated by laboratory handsheet making, which is used for process control.

Although paper has numerous specialized uses in products as diverse as cigarettes, capacitors, and counter tops (resin-impregnated laminates), it is principally used in packaging (~50%), printing (~40%), and sanitary (~7%) applications.

Material of basis weight greater than 200 g/m<sup>2</sup> is classified as paperboard, while lighter material is called paper. Production by weight is about equal for these two classes. Paperboard is used in corrugated boxes; corrugated material consists of top and bottom layers of paperboard called linerboard, separated by fluted corrugating paper. Paperboard also includes chipboard (a solid material used in many cold-cereal boxes, shoe boxes, and the backs of paper tablets) and food containers.

Mechanical pulp is used in newsprint, catalog, and other short-lived papers; they are only moderately white, and yellow quickly with age because the lignin is not removed. A mild bleaching treatment (called brightening) with hydrogen peroxide or sodium dithionite (or both) masks some of the color of the lignin without lignin removal. Paper made with mechanical pulp and coated with clay to improve brightness and gloss is used in 70% of magazines and catalogs, and in some enamel grades. Bleached chemical pulps are used in higher grades of printing papers used for xerography, typing paper, tablets, and envelopes; these papers are termed uncoated wood-free (meaning free of mechanical pulp). Coated wood-free papers are of high to very high grade and are used in applications such as high-quality magazines and annual reports; they are coated with calcium carbonate, clay, or titanium dioxide.

Like wood, paper is a hygroscopic material; that is, it absorbs water from, and also releases water into, the air. It has an equilibrium moisture content of about 7–9% at room temperature



and 50% relative humidity. In low humidities, paper is brittle; in high humidities, it has poor strength properties.

The heaviest grades of papers, such as chipboard, are made on multiformer (cylinder) machines that form three to eight layers of fiber mats. These fiber mats are combined prior to pressing and drying. The lightest grades of paper, tissues, cannot withstand numerous felt transfers and are dried on very large Yankee dryers.

Paper may be smoothed against a series of rolls made from metal or rubbery material to impart smoothness or gloss. Paper may also be coated with a paintlike material to give it high brightness and gloss. In addition, numerous other converting operations may be performed on paper. [C.J.Bi.]

**Paprika** A type of pepper, *Capsicum annuum* (order Polemoniales), with nonpungent flesh, grown for its long red fruit. It is of American origin, but is most popular in Hungary and adjacent countries. Seeds are removed from the mature fruit, and the flesh is dried and ground to prepare the dry condiment commonly referred to as paprika. California is the only important producing state in the United States. See PEPPER; SOLANALES. [H.J.C.]

**Parablastoidea** A small class of primitive blastozoan echinoderms containing three genera found in the early Middle Ordovician in eastern Canada; northeastern, eastern, southcentral, and western United States; and near Leningrad, Russia. Parablastoids have a bud-shaped theca or body with well-developed pentamerous symmetry. A stem with one-piece columnals attached the theca to the sea floor, suggesting that parablastoids were attached, medium- to high-level suspension feeders. Although they converged on blastoids in thecal design and way of life, parablastoids had differences in their plating, ambulacra, and respiratory structures to indicate a separate origin and history. That is the justification for assigning parablastoids and blastoids to different classes. See CRINOZOA; ECHINODERMATA. [J.Sp.]

**Parabola** A member of the class of curves that are intersections of a plane with a cone of revolution. It is obtained (see illustration) when the cutting plane is parallel to an element of the cone. See CONIC SECTION.

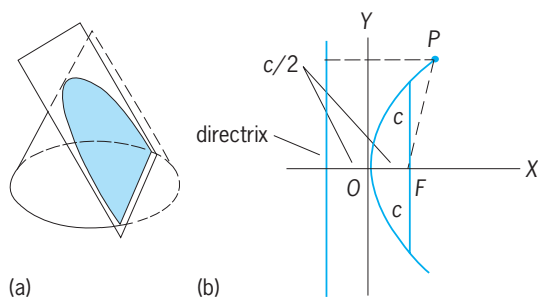

Parabola as (a) conic section and (b) locus of points.

In analytic geometry the parabola is defined as the locus of points (in a plane) equally distant from the fixed point  $F$  (focus) and a fixed line (directrix) not through the point. It is symmetric about the line through  $F$  perpendicular to the directrix.

The curve has numerous other properties of interest in both pure and applied mathematics. For example, the trajectory of an artillery shell, assumed to be acted upon only by the force of gravity, is a parabola.

Archimedes found the area bounded by an arc of a parabola and its chord; for example, the area bounded by the parabola  $y^2 = 2cx$  and its latus rectum (the chord through  $F$  perpendicular to the axis) is  $\frac{2}{3}c^2$ . [L.M.Bl.]

**Parachute** A flexible, lightweight structure, generally intended to retard the passage of an object within or through atmo-

sphere by materially increasing the resistive surface. A parachute is a decelerator or air-braking device in the general form of an oblate hemisphere. The parachute is the only suitably demonstrated device for emergency descent from aircraft. It comprises a canopy and cords, which form the suspension and attachment between canopy and object. A parachute canopy is a membrane which relies upon pressure differential across it to maintain its inflated shape. The differential is created by entrapment of an air mass on the inside and movement of the air on the outside. [S.E.W.]

**Paraffin** A term used variously to describe either a waxlike substance or a group of compounds. The former use pertains to the high-boiling residue obtained from certain petroleum crudes. It is recovered by freezing out on a cold drum and is purified by crystallization from methyl ethyl ketone. Paraffin wax is a mixture of 26- to 30-carbon alkane hydrocarbons; it melts at 52–57°C (126–135°F). Microcrystalline wax contains compounds of higher molecular weight and has a melting point as high as 90°C (190°F). The name paraffin was formerly used to designate a group of hydrocarbons—now known as alkanes. See ALKANE. [A.L.H.]

**Parainfluenza virus** A member of the genus *Paramyxovirus* of the family Paramyxoviridae which is associated with a variety of respiratory illnesses. The virus particles range in size from 90 to 200 nanometers, agglutinate red blood cells, and (like the influenza viruses) contain a receptor-destroying enzyme. They differ from the influenza viruses in their large size, their possession of the larger ribonucleoprotein helix characteristic of the paramyxoviruses, their tendency to lyse as well as agglutinate erythrocytes, and their generally poor growth in eggs. See COMPLEMENT-FIXATION TEST; EMBRYONATED EGG CULTURE; PARAMYXOVIRUS; TISSUE CULTURE.

Four subgroups are known, designated parainfluenza 1, 2, 3, and 4. Types 1, 2, and 3 are distributed throughout the world, but type 4 has been found only in the United States. Parainfluenza 1 and 3 are ubiquitous endemic agents producing infections all through the year. Types 2 and 4 occur more sporadically. With all of the parainfluenza viruses, most primary infections take place early in life. About half of the first infections with parainfluenza 1, about two-thirds of those with parainfluenza 2, and three-fourths of those with parainfluenza 3 produce febrile illnesses. The target organ of type 3 is the lower respiratory tract, with first infections frequently resulting in bronchial pneumonia, bronchiolitis, or bronchitis. Type 1 is the chief cause of croup, but the other types have also been incriminated, to the extent that one-half of all cases of croup can be shown to be caused by parainfluenza viruses. See ANIMAL VIRUS; INFLUENZA; VIRUS CLASSIFICATION. [J.L.Me.; M.E.Re.]

**Parainsecta** A class of hexapod (six-legged) arthropods consisting of the orders Collembola and Protura. Class Parainsecta (also known as Ellipura) is one of several classifications of those hexapods, which, while similar to insects, are sufficiently different that most researchers believe they deserve separate class status.

Collembola and Protura have frequently been lumped with the Diplura (Entotrophi) into one class (Entognatha) on the basis of their mouthparts, which are inside the head capsule rather than exposed as in the Insecta. However, some recent morphological and paleontological studies support a closer link between insects and Diplura. In addition, there are a number of features found in Protura and Collembola that are not found in Diplura. These include the developmental process: Both Collembola and Protura have epimorphic development (that is, development of the young is completed in the egg). Two unique features of the Parainsecta are the presence of a ventral midline or groove and coxal vesicles (fluid-filled sacs, generally associated with leg bases) that are limited to the first abdominal segment.

In the Collembola these vesicles are fused into a single ventral tube. The digestive tract lacks anterior or posterior enlargements, which are often present in Diplura and primitive insects. Other distinguishing features of the Parainsecta are the absence of styli and unpaired pretarsal claws.

Both Collembola and Protura contain very small animals, generally less than 4 mm long. Protura are exclusively, and Collembola primarily, soil and litter inhabitants. Genetic evidence concerning relationships is at present confusing. In addition, differences of interpretation concerning the phylogenetic importance of various morphological features leave the status of the Parainsecta ambiguous. See ARTHROPODA; DIPLURA; INSECT PHYSIOLOGY; INSECTA; PROTURA. [K.C.]

**Parallax (astronomy)** The apparent angular displacement of a celestial object due to a change in the position of the observer. With a baseline of known length between two observations, the distance to the object can be determined directly.

The rotation of the Earth or the linear separation of two points on its surface can be used to establish distances within the solar system. The parallax determined is scaled to the equatorial radius of the Earth, which is equal to 6378 km (3963 mi). At the mean distance of the Moon, this baseline subtends an angle of  $57'02.61''$ , and at the mean distance to the Sun it amounts to  $8.794148''$ . This latter distance is defined as the astronomical unit and serves as a measure of distances within the solar system. One astronomical unit is  $149,597,870.66 \pm 0.02$  km ( $92,955,807.25 \pm 0.01$  mi) in length, and its high precision results from tracking interplanetary space probes. See ASTRONOMICAL UNIT; EARTH ROTATION AND ORBITAL MOTION.

The astronomical unit is the baseline for the measure of stellar parallaxes or distances and ultimately every other distance in the universe outside the solar system. Observations made from the Earth in its orbit on opposite sides of the Sun are scaled to the astronomical unit. The stellar parallax is given in units of arc-seconds and is by definition the reciprocal of the distance in parsecs. One parsec is the distance at which one astronomical unit subtends an angle of one second of arc and equals 206,264.8 astronomical units or 3.2616 light-years. See LIGHT-YEAR; PARSEC.

In 1989 the European Space Agency launched the first space satellite entirely devoted to astrometry, named *HIPPARCOS* (from *High Precision Parallax Collecting Satellite*, and also honoring the ancient astronomer Hipparchus). In 1993 it completed its mission by obtaining positions, parallaxes, and proper motions for 118,322 stars listed in its final catalog. Its precision averages about  $\pm 0.0015''$  for stars brighter than its completeness limit of about the 8th magnitude, and rises to perhaps twice that amount at its ultimate limiting magnitude of 12. This precision is about equal to that of the best of current ground-based work for the brighter stars and less for faint stars. The advantage of *HIPPARCOS* lies in the much greater numbers of stars, including all the bright ones, with quality parallaxes. The contributions to stellar knowledge from this satellite are enormous. See BINARY STAR; HERTZSPRUNG-RUSSELL DIAGRAM; SATELLITE (ASTRONOMY).

Distance estimates are possible based on the assumption that the apparent mean space motion of a large number of stars with similar characteristics is a reflection of the peculiar motion of the Sun, derived from previous observations. Two related methods apply; the first equates the mean drift of the stars to the Sun's motion vector. The second requires measurements of radial velocities as well as proper motions, and assumes that the radial velocity distribution at the solar apex and antapex (the directions toward and away from which the Sun is moving, respectively) matches that in the transverse velocities along the direction normal to that of the assumed solar motion. These methods are referred to as secular and statistical parallax, respectively, although the terms are sometimes confused.

Several methods for the establishment of distance are frequently and incorrectly labeled parallax. These methods, such

as spectroscopic or photometric parallax, involve a comparison of an object to another of known distance and like luminosity, and scaling the distance as necessary. See ASTROMETRY. [A.R.U.]

**Parallel circuit** An electric circuit in which the elements, branches (elements in series), or components are connected between two points with one of the two ends of each component connected to each point. The illustration shows a simple parallel circuit. In more complicated electric networks one or more branches of the network may be made up of various combinations of series or series-parallel elements. See CIRCUIT (ELECTRICITY).

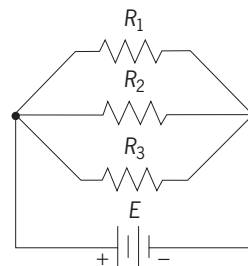

Schematic of a parallel circuit. *E* is a battery; *R*<sub>1</sub>, *R*<sub>2</sub>, and *R*<sub>3</sub> are resistors.

In a parallel circuit the potential difference (voltage) across each component is the same. However, the current through each branch of the parallel circuit may be different. For example, the lights and outlets in a house are connected in parallel so that each load will have the same voltage (120 volts) but each load may draw a different current (0.5 ampere in a 60-watt lamp and 10 amperes in a toaster). [C.F.G.]

**Paramagnetism** A property exhibited by substances which, when placed in a magnetic field, are magnetized parallel to the field to an extent proportional to the field (except at very low temperatures or in extremely large magnetic fields). Paramagnetic materials always have permeabilities greater than 1, but the values are in general not nearly so great as those of ferromagnetic materials. Paramagnetism is of two types, electronic and nuclear.

The following types of substances are paramagnetic:

1. All atoms and molecules which have an odd number of electrons. According to quantum mechanics, such a system cannot have a total spin equal to zero; therefore, each atom or molecule has a net magnetic moment which arises from the electron spin angular momentum. Examples are organic free radicals and gaseous nitric oxide.
2. All free atoms and ions with unfilled inner electron shells and many of these ions when in solids or in solution. Examples are transition, rare-earth, and actinide elements and many of their salts. This includes ferromagnetic and antiferromagnetic materials above their transition temperatures. For a discussion of these materials See ANTIFERROMAGNETISM; FERRIMAGNETISM; FERROMAGNETISM.
3. Several miscellaneous compounds including molecular oxygen and organic biradicals.
4. Metals. In this case, the paramagnetism arises from the magnetic moments associated with the spins of the conduction electrons and is called Pauli paramagnetism.

Relatively few substances are paramagnetic. Aside from the Pauli paramagnetism found in metals, the most important paramagnetic effects are found in the compounds of the transition and rare-earth elements which have partially filled 3*d* and 4*f* electron shells respectively.

Electronic paramagnetism arises in a substance if its atoms or molecules possess a net electronic magnetic moment. The

magnetization arises because of the tendency of a magnetic field to orient the electronic magnetic moments parallel to itself.

Nuclear paramagnetism arises when there is a net magnetic moment due to the magnetic moments of the nuclei in a substance. Nuclear magnetic moments are about  $10^3$  times smaller than electron magnetic moments. As a result, nuclear paramagnetism produces effects  $10^6$  times smaller than electron paramagnetic or diamagnetic effects. See DIAMAGNETISM; MAGNETIC RESONANCE; NUCLEAR MOMENTS. [E.Ad.; FKe.]

**Parameter** An auxiliary variable, functions of which give the coordinates of a curve or surface. The coordinates of a curve are functions of one parameter. A curve in 3-space has parametric equations (1).

$$x = f(t) \quad y = g(t) \quad z = h(t) \quad (1)$$

The coordinates of a surface are functions of two parameters, shown in Eqs. (2).

$$x = f(u, v) \quad y = g(u, v) \quad z = h(u, v) \quad (2)$$

An arbitrary constant in an equation is also called a parameter. Variations in the values of the parameter generate a system of equations which may represent a family of curves or surfaces. Such families are called one-parameter, two-parameter, and so on, according to the number of independent parameters. See PARAMETRIC EQUATION. [L.Br.]

**Parametric amplifier** A highly sensitive low-noise amplifier for ultrahigh-frequency and microwave radio signals, utilizing as the active element an inductor or capacitor whose reactance is varied periodically at another microwave or ultra-high frequency. A varactor diode is most commonly used as the variable reactor. Amplification of weak signal waves occurs through a nonlinear modulation or signal-mixing process which produces additional signal waves at other frequencies. This process may provide negative-resistance amplification for the applied signal wave and increased power in one or more of the new frequencies which are generated. See VARACTOR.

There are several possible circuit arrangements for obtaining useful parametric amplification. The two most common are the up-converter and the negative-resistance amplifier. In both types, the pump frequency is normally much higher than the input-signal frequency. In the up-converter, a new signal wave is generated at a higher power than the input wave. In the negative-resistance device, negative resistance is obtained for the input-signal frequency, causing an enhancement of signal power at the same frequency. See NEGATIVE-RESISTANCE CIRCUITS.

The most important advantage of the parametric amplifier is its low level of noise generation. The parametric amplifier finds its greatest use as the first stage at the input of microwave receivers where the utmost sensitivity is required. Its noise performance has been exceeded only by the maser. Maser amplifiers are normally operated under extreme refrigeration using liquid helium at about 4 K above absolute zero ( $-452^\circ\text{F}$ ). The parametric amplifier does not require such refrigeration but in some cases cooling to very low temperatures has been used to give improved noise performance that is only slightly poorer than the maser. See AMPLIFIER; MASER. [M.E.Hi.]

**Parametric arrays** Arrays of sources (or receivers) of sound formed by variation of appropriate parameters of the propagation medium. Normally, these parameters are the local sound speed and the particle velocity which vary because of the presence of large-amplitude pump, or primary, sound waves.

The usual parametric source configuration simply consists of a directional transducer (often a plane piston or planar array) driven at two frequencies near the transducer resonance, forming a dual-frequency sound beam called the primary beam. Because sound-wave propagation is not a completely linear process, signals at new frequencies are formed effectively through

the interaction of sound with sound as the beam progresses and are generated along the length of the primary beam. The lowest of these new frequencies is the difference of the two primary frequencies, and so the primary beam acts as an end-fire array of sources at the difference frequency. The effective length of the array will be determined by the attenuation of the primary beam, which occurs either as a result of small-signal absorption or, for sufficiently high primary amplitudes, as a result of nonlinear losses due to the generation of harmonics of the primary frequencies and other intermodulation components, such as the sum-frequency component.

Most applications of parametric sources have been to underwater acoustics, but their use in air, as well as in other media, may be expected. Because the effective length of a parametric source can be made quite long in practice, it is possible to generate highly directional difference-frequency beams, and because the primary amplitude is shaded very gradually along the length of the array, these beams can be made practically side-lobe-free, in contrast to the beams from conventional acoustic sources. As a result, echoes from a parametric source exhibit practically no reverberation, whereas conventional echoes may be obscured by reverberation from reflection of the side lobes. Thus, the parametric source may be expected to be useful in reverberation-limited situations where one desires a narrow beam from a small projector. Such applications include precision fathometry, sub-bottom profiling, echo ranging, communications, and Doppler navigation logs. In order to obtain the advantages of a parametric source, however, one must be willing to tolerate low efficiency and low search rate. See DIRECTIVITY; ECHO SOUNDER; SONAR; SOUND; UNDERWATER SOUND. [M.B.M.]

**Parametric equation** A type of mathematical equation used, typically, to represent curves in a plane or in space of three dimensions. In principle, however, there is no limitation to any particular number of dimensions. A parameter is actually an independent variable. In elementary analytic geometry a curve in the  $xy$  plane is often studied, in the first instance, as the locus of an equation  $y = F(x)$  or  $G(x, y) = 0$ . The form  $y = F(x)$  is not adequate for the complete representation of certain curves, whereas the form  $G(x, y) = 0$  may be adequate. The circle  $x^2 + y^2 - 16 = 0$  affords an example. But the form  $G(x, y) = 0$  is not always convenient. The parametric form  $x = f(t)$ ,  $y = g(t)$  is often the most convenient; moreover, it is often the naturally occurring form of representation of the curve. For the circle  $x^2 + y^2 - 16 = 0$ , one possible parametric representation is  $x = 4 \cos t$  and  $y = 4 \sin t$ .

A pair of equations  $x = f(t)$ ,  $y = g(t)$ , where  $f$  and  $g$  are continuous functions defined for some interval of values of  $t$ , for example,  $a \leq t \leq b$ , is said to define a parametric curve. If one thinks of  $t$  as time, the equations define the motion of the point  $(x, y)$  as  $t$  increases from  $a$  to  $b$ . Clearly the path can cross itself, double back on itself, or the point may even remain motionless.

A parametric surface in space of three dimensions is defined by  $x = f(u, v)$ ,  $y = g(u, v)$ ,  $z = h(u, v)$ , where  $f$ ,  $g$ ,  $h$  are continuous functions of the two parameters,  $u, v$ . See ANALYTIC GEOMETRY; CALCULUS; PARTIAL DIFFERENTIATION. [A.E.Ta.]

**Paramo** A biological community, essentially a grassland, covering extensive high areas in equatorial mountains of the Western Hemisphere. Geographically, paramos are limited to the Northern Andes and adjacent mountains. Paramos occur in alpine regions above timberline and are controlled by a complex of climatic and soil factors peculiar to mountains near the Equator. The richly diverse flora and the fauna of the paramos are adapted to severely cold, mostly wet conditions. Humans have found some paramos suitable for living and use. [H.G.B.]

**Paramyxovirus** A subgroup of myxoviruses that includes the viruses of mumps, measles, parainfluenza, respiratory syncytial (RS) disease, and Newcastle disease. Like influenza viruses,

the paramyxoviruses are ribonucleic acid (RNA)-containing viruses and possess an ether-sensitive lipoprotein envelope. See ANIMAL VIRUS; MEASLES; MUMPS; NEWCASTLE DISEASE; PARAINFLUENZA VIRUS. [J.L.Me.]

**Paranoia** A mode of thought, feeling, and behavior characterized centrally by false persecutory beliefs, more specifically referred to as paranoidness. Commonly associated with these core persecutory beliefs are properties of suspiciousness, fearfulness, hostility, hypersensitivity, rigidity of conviction, and an exaggerated sense of self-reference. These properties are evident with varying degrees of intensity and duration.

The paranoid mode can be triggered at either biological or psychological levels. Common precipitating biological causes are brain trauma or tumor, thyroid disorder, cerebral arteriosclerosis, and intoxication with certain drugs, including alcohol, amphetamines, cocaine, other psychostimulants, and hallucinogens such as mescaline or lysergic acid diethylamide (LSD). They can produce disordered activity of central dopaminergic and noradrenergic pathways. At the psychological level, triggering causes include false arrest, birth of a deformed child, social isolation, deafness, and intensely humiliating experiences. See NORADRENERGIC SYSTEM.

The paranoid mode is resistant to modification by psychotherapeutic or pharmacological methods. Acute psychotic states of paranoidness accompanied by high levels of anxiety are usually responsive to neuroleptic medication. See PSYCHOPHARMACOLOGY. [K.M.C.]

**Parasitology** The scientific study of parasites and of parasitism. Parasitism is a subdivision of symbiosis and is defined as an intimate association between an organism (parasite) and another, larger species of organism (host) upon which the parasite is metabolically dependent. Implicit in this definition is the concept that the host is harmed, while the parasite benefits from the association. Although technically parasites, pathogenic bacteria and viruses and nematode, fungal, and insect parasites of plants are traditionally outside the field of parasitology.

Parasites often cause important diseases of humans and animals. For this reason, parasitology is an active field of study; advances in biotechnology have raised expectations for the development of new drugs, vaccines, and other control measures. However, these expectations are dampened by the inherent complexity of parasites and host-parasite relationships, the entrenchment of parasites and vectors in their environments, and the vast socioeconomic problems in the geographical areas where parasites are most prevalent.

The ecological and physiological relationships between parasites and their hosts constitute some of the most impressive examples of biological adaptation known. Much of classical parasitology has been devoted to the elucidation of one of the most important aspects of host-parasite ecological relationships, namely, the dispersion and the transmission of parasites to new hosts.

Parasite life cycles range from simple to highly complex. Simple life cycles (transmission from animal to animal) are direct and horizontal with adaptations that include high reproduction rates, and the production of relatively inactive stages (cysts or eggs) that are resistant to environmental factors such as desiccation, ultraviolet radiation, and extreme temperatures. The infective stages are passively consumed when food or water is contaminated with feces that contain cysts. The cysts are then activated in the gut by cues such as acidity to continue their development. Other direct-transmission parasites, such as hookworms, actively invade new hosts by penetrating the skin. Physiologically more complicated are those life cycles that are direct and vertical, with transmission being from mother to offspring. The main adaptation of the parasite for this type of life cycle is the ability to gain access to the fetus or young animal through the ovaries, placenta, or mammary glands of the mother.

Many parasites have taken advantage of the food chain of free-living animals for transmission to new hosts. During their life cycle, these parasites have intermediate hosts that are the normal prey of their final hosts. Parasites may ascend the food chain by utilizing a succession of progressively larger hosts, a process called paratenesis. See FOOD WEB.

Vectors are intermediate hosts that are not eaten by the final host, but rather serve as factories for the production of more parasites and may even carry them to new hosts or to new environments frequented by potential hosts. Blood-sucking arthropods such as mosquitoes and tsetse flies are well-known examples. After acquiring the parasite from an infected host, they move to another host, which they bite and infect. Snails are important vectors for two-host trematodes (flukes), which increase their numbers greatly in the snail by asexual reproduction. The stages that leave the snail may either infect second intermediate hosts that are eaten by carnivorous final hosts, may encyst on vegetation that is eaten by herbivorous hosts, or in the case of the blood flukes (schistosomes) may swim to and directly penetrate the final host.

Metabolic dependency is the key to parasitism, and parasites employ many ways to feed off their hosts. The simplest is exhibited by the common intestinal roundworm, *Ascaris*, which consumes the host's intestinal contents. Parasites require from their hosts not only energy-yielding molecules but also basic monomers for macromolecular synthesis and essential cofactors for these synthetic processes. Many examples of the specific absence of key parts of energy-yielding or biosynthetic pathways in parasites are known, and these missing enzymes, cofactors, or intermediates are supplied by the host. Tapeworms are more complex than *Ascaris* in nutritional requirements from the host. They lack a gut, but their surface actively takes up, by facilitated diffusion or active transport, small molecules such as amino acids and simple sugars.

Parasites, by coevolving with their hosts, have the ability to evade the immune response. The best-known evasive tactic is antigenic variation, as found in African trypanosomes, which have a complicated genetic mechanism for producing alternative forms of a glycoprotein that virtually cover the entire parasite. By going through a genetically programmed sequence of variant surface glycoproteins, the trypanosome population in a host stays one step ahead of immunity and is not eliminated. Other possible immune escape mechanisms in parasites have been discovered and probably cooperate to prolong parasite survival.

Parasites are not altogether exempt from the effects of immunity. Rather than completely eliminating parasites, the immune system more often functions to control their populations in the host. Thus a balance is achieved between hosts and parasites that have lived in long evolutionary association, with both surviving through compromise. Enhancing these particular antiparasite mechanisms and neutralizing the parasite's evasion mechanisms would tip the balance in favor of the host. See MEDICAL PARASITOLOGY; POPULATION ECOLOGY. [R.T.D.]

**Parasympathetic nervous system** A portion of the autonomic system. It consists of two neuron chains, but differs from the sympathetic nervous system in that the first neuron has a long axon and synapses with the second neuron near or in the organ innervated. In general, its action is in opposition to that of the sympathetic nervous system, which is the other part of the autonomic system. It cannot be said that one system, the sympathetic, always has an excitatory role and the other, the parasympathetic, an inhibitory role; the situation depends on the organ in question. However, it may be said that the sympathetic system, by altering the level at which various organs function, enables the body to rise to emergency demands encountered in flight, combat, pursuit, and pain. The parasympathetic system appears to be in control during such pleasant periods as digestion and rest. The alkaloid pilocarpine excites parasympa-

thetic activity while atropine inhibits it. See AUTONOMIC NERVOUS SYSTEM; SYMPATHETIC NERVOUS SYSTEM. [D.B.W.]

**Parathyroid gland** An endocrine organ usually associated with the thyroid gland and possessed by all vertebrates except the fishes. In response to lowered serum calcium concentration, a hormone is produced which promotes bone destruction and inhibits the phosphorus-conserving activity of the kidneys. See THYROID GLAND.

In humans, there are typically four glands situated as shown in the illustration; however, the number varies between three and six, with four appearing about 80% of the time. Variations in the positioning of the glands along the craniocaudal axis occur but, excepting parathyroid III which may occasionally be found upon the anterior surface of the trachea, the relation to the posterior surface of the thyroid is rarely lost. [W.E.D.]

The parathyroid glands are essential for the regulation of calcium and phosphate concentrations in the extracellular fluids of amphibians and higher vertebrates. Parathyroid hormone has two major target organs, bone and kidney. It acts on bone in several ways. Short-term changes include a rapid uptake of bone fluid calcium into osteoblast cells, which in turn pump the calcium into the extracellular fluids. Long-term effects include increased activity and number of osteoclasts, bone cells which act to break down bone matrix and release calcium from bone. All of these effects result in increased blood calcium values. See BONE; CALCIUM METABOLISM.

Parathyroid hormone inhibits the renal reabsorption of phosphate, thus increasing the urinary output of phosphate. Phosphate reabsorption across the renal tubule is dependent upon sodium transport, and parathyroid hormone interferes with this sodium-dependent phosphate transport in the proximal tubule. Another important effect of parathyroid hormone on the kidney is to increase the renal reabsorption of calcium, thus reducing the loss of calcium in the urine and conserving calcium in the body. See KIDNEY.

Finally, there are reports that parathyroid hormone indirectly stimulates calcium uptake into the body across the intestine. Parathyroid hormone stimulates the production of the most ac-

tive metabolite of vitamin D, 1,25-dihydroxycholecalciferol, during vitamin D synthesis. This metabolite of vitamin D directly stimulates the intestinal absorption of calcium. See ENDOCRINE SYSTEM (VERTEBRATE); PARATHYROID HORMONE; VITAMIN D. [N.B.C.]

**Parathyroid gland disorders** Disorders involving excessive or deficient blood levels of parathyroid hormone caused by abnormal functioning of the parathyroid gland. Parathyroid hormone is responsible for keeping the concentration of calcium in blood within a narrow normal range. If the blood calcium concentration falls, the parathyroid glands respond by secreting hormone which tends to increase the concentration of calcium. Parathyroid hormone acts directly on bone and kidney, and indirectly on the intestine, to increase the concentration of calcium in blood. It also acts on the kidney to increase excretion of phosphate in the urine, causing a lowering of the concentration of phosphorus in blood. See PARATHYROID GLAND.

Hyperparathyroidism is a group of disorders characterized by excessive parathyroid hormone secretion. Primary hyperparathyroidism is defined as increased parathyroid hormone secretion despite elevated blood calcium. Symptoms and signs range from overt loss of calcium from bone and formation of calcium stones in the kidney to nonspecific manifestations such as weakness and fatigue. The disorder occurs most frequently in women after menopause. There are also inherited forms of the disease. Treatment of primary hyperparathyroidism involves surgical removal of the abnormal gland(s). Secondary hyperparathyroidism is defined as excessive secretion of parathyroid hormone in response to reduction in blood calcium caused by kidney or intestinal disorders or vitamin D deficiency. Treatment is directed at the underlying disorder (for example, kidney transplantation for kidney failure). See CALCIUM METABOLISM; VITAMIN D.

Hypoparathyroidism is a group of disorders that involves a deficiency in parathyroid hormone secretion or metabolism. Manifestations include involuntary muscle contractions, or generalized seizures in the most extreme cases. In most forms of hypoparathyroidism, parathyroid hormone is low or undetectable in blood despite reduced blood calcium because the parathyroid glands are unable to respond appropriately by secreting parathyroid hormone. Hypoparathyroidism can be caused by parathyroid gland destruction, for example, by inadvertent surgical removal. Certain rare forms of hypoparathyroidism are due to resistance to parathyroid hormone action rather than hormone deficiency, and are termed pseudohypoparathyroidism. Treatment of all forms of hypoparathyroidism involves administration of calcium and large amounts of vitamin D to restore a normal blood calcium and phosphorus. [A.M.Sp.]

**Parathyroid hormone** The secretory product of the parathyroid glands. Parathyroid hormone (PTH) is a single-chain polypeptide composed of 84 amino acids. The sequences of human, bovine, and porcine parathyroid hormone are known, and the gene for human parathyroid hormone has been cloned and sequenced.

The major regulator of parathyroid hormone secretion is the serum concentration of calcium ions, to which the parathyroid cells are exquisitely sensitive. Only a limited amount of parathyroid hormone is stored in secretory granules, so that a hypocalcemic stimulus must ultimately influence biosynthesis as well as secretion of the hormone. Parathyroid secretory protein is a large, acidic glycoprotein which is stored and cosecreted with parathyroid hormone in roughly equimolar amounts; the biological function of parathyroid secretory protein is unknown.

Parathyroid hormone is responsible for the fine regulation of serum calcium concentration on a minute-to-minute basis. This is achieved by the acute effects of the hormone on calcium resorption in bone and calcium reabsorption in the kidney. The phosphate mobilized from bone is excreted into the

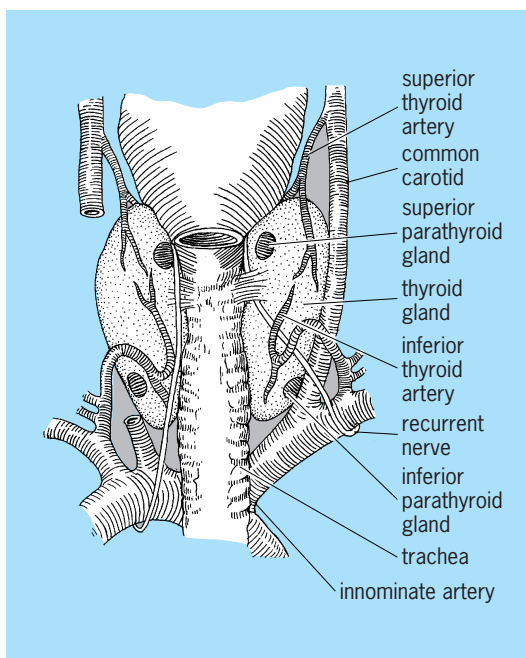

Common positions of human parathyroid glands on the posterior aspect of the thyroid. (After W. H. Hollinshead, *Anatomy of the endocrine glands, Surg. Clin, N. Amer.*, 21(4):1115-1140, 1952)

urine by means of the hormone's influence on renal phosphate handling. Parathyroid hormone also stimulates calcium absorption in the intestine, this being mediated indirectly by 1,25-dihydroxyvitamin D. Thus, a hypocalcemic stimulus of parathyroid hormone secretion results in an increased influx of calcium from three sources (bone, kidney, and intestine), resulting in a normalization of the serum calcium concentration without change in the serum phosphate concentration. See CALCIUM METABOLISM; PARATHYROID GLAND; PARATHYROID GLAND DISORDERS; THYROCALCITONIN; VITAMIN D. [A.E.Bro.]

**Parazoa** A name proposed for a subkingdom of animals which includes the sponges. Erection of a separate subkingdom for the sponges implies that they originated from protozoan ancestors independently of all other Metazoa. This theory is supported by the uniqueness of the sponge body plan and by peculiarities of fertilization and development. Much importance is given to the fact that during the development of sponges with parenchymella larvae, the flagellated external cells of the larva take up an internal position as choanocytes after metamorphosis, whereas the epidermal and mesenchymal cells arise from what was an internal mass of cells in the larva. These facts suggest that either the germ layers of sponges are reversed in comparison with those of other Metazoa or the choanocytes cannot be homologized with the endoderm of other animals. Either interpretation supports the wide separation of sponges from all other Metazoa to form the subkingdom Parazoa or Enantiozoa. On the other hand, there are cogent arguments in favor of the basic similarity of the development of sponges and other Metazoa. See CALCAREA; DEMOSPONGIAE; METAZOA; PORIFERA. [W.D.H.]

**Parenchyma** A ground tissue chiefly concerned with the manufacture and storage of food. The primary functions of plants, such as photosynthesis, assimilation, respiration, storage, secretion, and excretion—those associated with living protoplasm—proceed mainly in parenchymal cells. Parenchyma is frequently found as a homogeneous tissue in stems, roots, leaves, and flower parts. Other tissues, such as sclerenchyma, xylem, and phloem, seem to be embedded in a matrix of parenchyma; hence the use of the term ground tissue with regard to parenchyma is derived. The parenchymal cell is one of the most frequently occurring cell types in the plant kingdom. See PLANT ANATOMY; PLANT PHYSIOLOGY.

Typical parenchyma occurs in pith and cortex of roots and stems as a relatively undifferentiated tissue composed of polyhedral cells that may be more or less compactly arranged and show little variation in size or shape. The mesophyll, that is, the tissue located between the upper and lower epidermis of leaves, is a specially differentiated parenchyma called chlorenchyma because its cells contain chlorophyll in distinct chloroplasts.

This chlorenchymatous tissue is the major locus of photosynthetic activity and consequently is one of the more important variants of parenchyma. Specialized secretory parenchymal cells are found lining resin ducts and other secretory structures. See PHOTOSYNTHESIS; SECRETORY STRUCTURES (PLANT). [R.L.Hu.]

**Pareto's law** A law (sometimes called the 20–80 rule) describing the frequency distribution of an empirical relationship fitting the skewed concentration of the variate-values pattern. The phenomenon wherein a small percentage of a population accounts for a large percentage of a particular characteristic of that population is an example of Pareto's law. When the data are plotted graphically, the result is called a maldistribution curve. To take a specific case, an analysis of a manufacturer's inventory might reveal that less than 15% of the component part items account for over 90% of the total annual usage value.

The mathematics required to calculate and graph the curve of Pareto's law is simple arithmetic. It should be noted, however, that the calculations need not be done in all cases. It may suffice to merely make a rough approximation of a situation in order to

determine whether or not Pareto's law is present and whether benefits may subsequently accrue. [V.M.A.]

**Parity (quantum mechanics)** A physical property of a wave function which specifies its behavior under simultaneous reflection of all spatial coordinates through the origin, that is, when  $x$  is replaced by  $-x$ ,  $y$  by  $-y$ , and  $z$  by  $-z$ . If the single-particle wave function  $\psi$  satisfies Eq. (1), it is said to have even parity. If, on the other hand, Eq. (2) holds, the wave function is said to have odd parity. These two expressions can be combined in Eq. (3), where  $P = \pm 1$  is a quantum number, parity, having

$$\psi(x, y, z) = \psi(-x, -y, -z) \quad (1)$$

$$\psi(x, y, z) = -\psi(-x, -y, -z) \quad (2)$$

$$\psi(x, y, z) = P\psi(-x, -y, -z) \quad (3)$$

only the two values  $+1$  (designated as even parity) and  $-1$  (odd parity). More precisely, parity is defined as the eigenvalue of the operation of space inversion. Parity is a concept that has meaning only for fields or waves and therefore has meaning only in classical field theory or in quantum mechanics. See QUANTUM MECHANICS.

The conservation of parity follows from the inversion symmetry of space, that is, the invariance of the Schrödinger equation  $H\psi = E\psi$  (the wave equation satisfied by the wave function  $\psi$ ) to the inversion of space coordinates,  $\mathbf{r} \rightarrow -\mathbf{r}$ . The parity (or inversion) operator, which changes  $\mathbf{r}$  to  $-\mathbf{r}$ , has the alternative interpretation that the coordinate values remain unchanged but the coordinate axes are inverted; that is, the positive  $x$  axis of the new frame points along the old negative  $x$  axis, and similarly for  $y$  and  $z$ . If the original frame was right-handed, then the new frame is left-handed. [A cartesian coordinate system (frame, for short) is called right-handed if it is possible to place the right hand at the origin and point the thumb and first and second fingers along the positive  $x$ ,  $y$ , and  $z$  axes, respectively.] Thus, parity would be conserved if the statement of physical laws were independent of the handedness of the coordinate system that was being used. Of course, the fact that most people are right-handed is not a physical law but an accident of evolution; there is nothing in the relevant laws of physics which favors a right-handed over a left-handed human. The same holds for optically active organic compounds, such as the amino acids. However, the statement that the neutrino is left-handed is a physical law. See NEUTRINO.

All the strong interactions between hadrons (for example, nuclear forces) and the electromagnetic interactions are symmetrical to inversion, so that parity is conserved by these interactions. As far as is known, only the weak interactions fail to conserve parity. Thus parity is not conserved in the weak decays of elementary particles (including beta decay of nuclei); in all other processes the weak interactions play a small role, and parity is very nearly conserved. Likewise, in energy eigenstates, weak interactions can be neglected to a very good approximation, and parity is very nearly a good quantum number, so that each atomic, nuclear, or hadronic state is characterized by a definite value of parity, and its conservation in reactions is an important principle. See FUNDAMENTAL INTERACTIONS; WEAK NUCLEAR INTERACTIONS.

One of the selection rules which follows from parity conservation is the following: A spin zero boson cannot decay sometimes into two  $\pi$  mesons and sometimes into three  $\pi$  mesons, because these final states have different parities, even and odd respectively. But the positive  $K$  meson is observed to have both these decay modes, originally called the  $\theta$  and the  $\tau$  mesons, respectively, but later shown by the identity of masses and lifetimes to be decay modes of the same particle. This  $\tau$ - $\theta$  puzzle was the first observation of parity nonconservation. In 1956, T. D. Lee and C. N. Yang made the bold hypothesis that parity also is not conserved in beta decay. They reasoned that the magnitude of the beta-decay coupling is about the same as the coupling which

leads to decay of the *K* meson, and so these decay processes may be manifestations of a single kind of coupling. Also, there is a very natural way to introduce parity nonconservation in beta decay, namely, by assuming a restriction on the possible states of the neutrino (two-component theory). They pointed out that no beta-decay experiment had ever looked for the spin-momentum correlations that would indicate parity nonconservation; they urged that these correlations be sought.

In the first experiment to show parity nonconservation in beta decay, the spins of the beta-active nuclei cobalt-60 were polarized with a magnetic field at low temperature; the decay electrons were observed to be emitted preferentially in directions opposite to the direction of the <sup>60</sup>Co spin. The magnitude of this correlation shows that the parity-nonconserving and parity-conserving parts of the beta interaction are of equal size, substantiating the two-component neutrino theory.

It was at first somewhat disconcerting to find parity not conserved, for that seemed to imply a handedness of space. But this is not really the situation; the saving thing is that anti-<sup>60</sup>Co decays in the opposite direction. Thus, after all, there is nothing intrinsically left-handed about the world, just as there is nothing intrinsically positively charged about nuclei. What really exists here is a correlation between handedness and sign of charge.

[C.J.G.]

**Parkinson's disease** A progressive disorder of the nervous system that mainly affects elderly people, with peak onset in the 60s and 70s. Males and females are equally affected. The basic mechanism of the disease is not known. The disease usually occurs sporadically. However, 10–15% of the time it runs in families.

Parkinson's disease is characterized by abnormalities of motor function, several of which predominate, but all do not necessarily occur in all individuals. Slowness of movement and an inability to start a movement are hallmarks of the disease. The motor disturbance also results in diminished facial expression and a decreased rate of blinking. The second important manifestation is stiffness and rigidity so that the person encounters increased resistance when attempting to move a limb and a joint. The third manifestation, in some individuals, is a tremor that may be quite asymmetrical, occurring in just one hand, or may involve both hands and the trunk.

As the disease progresses, problems with balance become quite limiting, and falls may occur frequently. Alternatively, with disease progression, episodes of "freezing" may occur, during which voluntary movement becomes impossible. Finally, some individuals have an associated dementia, which appears to be an integral part of the Parkinson's disease process, although in others it may be a manifestation of Alzheimer's disease. See ALZHEIMER'S DISEASE.

The basic pathologic change is degeneration of a group of nerve cells deep within the center of the brain in an area called the substantia nigra. These cells use dopamine as their neurotransmitter to signal other nerve cells. As these cells degenerate and stop functioning, dopamine fails to reach the areas of the brain that affect motor functions. The possible role of toxins in the disease process has aroused considerable interest. See DOPAMINE.

Therapy for Parkinson's disease is aimed at replacing dopamine. Since the blood-brain barrier prevents dopamine from entering the brain from the bloodstream, a precursor of dopamine (L-dopa) that will enter the brain is given. L-Dopa is usually administered as part of a compound that inhibits the enzymes that break down L-dopa in the liver, thus making a greater part of it available to the brain. See MOTOR SYSTEMS; NERVOUS SYSTEM (VERTEBRATE); SENSATION.

[G.M.McK.]

**Parsec** A unit of measure of astronomical distances. One parsec is equivalent to  $3.084 \times 10^{13}$  kilometers, or  $1.916 \times 10^{13}$  miles. There are 3.26 light-years in 1 parsec. The parsec is

defined as the distance at which the semimajor axis of Earth's orbit around the Sun (1 astronomical unit) subtends 1 second of arc. Thus, because the angle is small, the equation below holds.

$$\frac{1 \text{ astronomical unit}}{1 \text{ parsec}} = 1 \text{ second} = \frac{1}{206,265}$$

A parsec is then 206,265 astronomical units. At a distance of 1 parsec, the parallax is 1 second of arc. The nearest star is about 1.3 parsecs distant; the farthest known galaxy is several billion parsecs. See PARALLAX (ASTRONOMY).

[J.L.Gr.]

**Parsley** A biennial, *Petroselinum crispum*, of European origin belonging to the plant order Umbellales. Parsley is grown for its foliage and is used to garnish and flavor foods. It contains large quantities of vitamins A and C. Two types, plain-leafed and curled, are grown for their foliage; Hamburg parsley (*P. crispum* var. *tuberosum*), also called turnip-rooted parsley, is grown for its edible parsniplike root. See APIALES.

[H.J.C.]

**Parsnip** A hardy biennial, *Pastinaca sativa*, of Mediterranean origin belonging to the plant order Umbellales. The parsnip is grown for its thickened taproot and is used primarily as a cooked vegetable. Exposure of mature roots to low temperatures, not necessarily freezing, improves the quality of the root by favoring the conversion of starch to sugar. See APIALES.

[H.J.C.]

**Partial differentiation** A mathematical operation performed on functions of more than one variable. In this article only two or three variables are considered; however, the principles apply to functions of *n* variables, for any positive integer *n* > 1. If *z* = *f*(*x*, *y*), the partial derivative  $\partial z/\partial x$  is defined as the derivative of *f*(*x*, *y*) with respect to *x*, *y* being regarded as fixed; that is,

$$\frac{\partial z}{\partial x} = \lim_{h \rightarrow 0} \frac{f(x+h, y) - f(x, y)}{h}$$

Another notation for  $\partial z/\partial x$  is  $f_1(x, y)$ . The other first partial derivative is  $\partial z/\partial y$ , also written  $f_2(x, y)$ . For values at particular points the notation is

$$\left(\frac{\partial z}{\partial x}\right)_{(a,b)} = f_1(a, b)$$

In the case of a function of three variables, *f*(*x*, *y*, *z*), the expression is

$$\frac{\partial f}{\partial z} = f_3(x, y, z)$$

The second derivatives of *f*(*x*, *y*) are given by

$$f_{11}(x, y) = \frac{\partial}{\partial x} \left(\frac{\partial f}{\partial x}\right) \quad f_{12}(x, y) = \frac{\partial}{\partial y} \left(\frac{\partial f}{\partial x}\right)$$

$$f_{21}(x, y) = \frac{\partial}{\partial y} \left(\frac{\partial f}{\partial y}\right) \quad f_{22}(x, y) = \frac{\partial}{\partial y} \left(\frac{\partial f}{\partial y}\right)$$

It can happen that  $f_{12}(x, y) \neq f_{21}(x, y)$ , but this will not happen in common practice, especially with elementary functions. If  $f_1, f_2, f_{12}, f_{21}$  are defined in neighborhood of (*a*, *b*), and if  $f_{12}, f_{21}$  are continuous at (*a*, *b*), then  $f_{12}(a, b) = f_{21}(a, b)$ . In addition, there are more delicate theorems relating to this matter.

The notion of the differentiability of a function is fundamental in the theory of partial differentiation. The requirement that *f*(*x*, *y*) be differentiable is not the same as the requirement that  $f_1(x, y)$  and  $f_2(x, y)$  both exist; it is a more inclusive requirement. The geometric meaning of *f* being differentiable at (*a*, *b*) is that the surface defined by *z* = *f*(*x*, *y*) has a tangent plane not parallel to the *z* axis when *x* = *a*, *y* = *b*. In analytic terms the condition is that if

$$\epsilon = f(a+h, b+k) - f(a, b) - f_1(a, b)h - f_2(a, b)k$$

then

$$\lim_{(h,k) \rightarrow (0,0)} \frac{\epsilon}{|h| + |k|} = 0$$

A sufficient condition that  $f$  be differentiable at  $(a, b)$  is that the partial derivatives  $f_1, f_2$  be defined at all points near  $(a, b)$ , and continuous at  $(a, b)$ .

The prime importance of the differentiability concept is that the differentiability property is needed in proving the chain rule for functions of several variables. This rule asserts that a differentiable function of a differentiable function is differentiable, and the rule tells how to compute partial derivatives of the composite function. For example, if  $x = f(s, t)$ ,  $y = g(s, t)$ , where  $f$  and  $g$  are differentiable, and if  $z = F(x, y)$ , where  $F$  is differentiable, then the composite function is  $G(s, t) = F[f(s, t), g(s, t)]$ . Then  $z = G(s, t)$  is differentiable as a function of  $s$  and  $t$ , and

$$\frac{\partial G}{\partial s} = \frac{\partial F}{\partial x} \frac{\partial f}{\partial s} + \frac{\partial F}{\partial y} \frac{\partial g}{\partial s}$$

$$\frac{\partial G}{\partial t} = \frac{\partial F}{\partial x} \frac{\partial f}{\partial t} + \frac{\partial F}{\partial y} \frac{\partial g}{\partial t}$$

These equations, expressing the formal part of the chain rule, are often written in the form

$$\frac{\partial z}{\partial s} = \frac{\partial z}{\partial x} \frac{\partial x}{\partial s} + \frac{\partial z}{\partial y} \frac{\partial y}{\partial s}$$

$$\frac{\partial z}{\partial t} = \frac{\partial z}{\partial x} \frac{\partial x}{\partial t} + \frac{\partial z}{\partial y} \frac{\partial y}{\partial t}$$

See CALCULUS; DIFFERENTIATION; PARAMETRIC EQUATION. [A.E.Ta.]

**Particle accelerator** An electrical device which accelerates charged atomic or subatomic particles to high energies. The particles may be charged either positively or negatively. If subatomic, the particles are usually electrons or protons and, if atomic, they are charged ions of various elements and their isotopes throughout the entire periodic table of the elements.

Accelerators that produce various subatomic particles at high intensity have many practical applications in industry and medicine as well as in basic research. Electrostatic generators, pulse transformer sets, cyclotrons, and electron linear accelerators are used to produce high levels of various kinds of radiation that in turn can be used to polymerize plastics, provide bacterial sterilization without heating, and manufacture radioisotopes which are utilized in industry and medicine for direct treatment of some illnesses as well as research. They can also be used to provide high-intensity beams of protons, neutrons, heavy ions, pi mesons, or x-rays that are used for cancer therapy and research. The x-rays used in industry are usually produced by arranging for accelerated electrons to strike a solid target. However, with the advent of electron synchrotron storage rings that produce x-rays in the form of synchrotron radiation, many new industrial applications of these x-rays have been realized, especially in the field of solid-state microchip fabrication and medical diagnostics. See ISOTOPIC IRRADIATION; RADIATION BIOLOGY; RADIATION CHEMISTRY; RADIOACTIVITY AND RADIATION APPLICATIONS; RADIOGRAPHY; RADIOISOTOPE; RADIOLOGY; SYNCHROTRON RADIATION.

Particle accelerators fall into two general classes—electrostatic accelerators that provide a steady dc potential, and varieties of accelerators that employ various combinations of time-varying electric and magnetic fields.

**Electrostatic accelerators.** Electrostatic accelerators in the simplest form accelerate the charged particle either from the source of high voltage to ground potential or from ground potential to the source of high voltage. All particle accelerations are carried out inside an evacuated tube so that the accelerated particles do not collide with air molecules or atoms and may follow trajectories characterized specifically by the electric fields utilized for the acceleration. The maximum energy available from this

kind of accelerator is limited by the ability of the evacuated tube to withstand some maximum high voltage.

**Time-varying field accelerators.** In contrast to the high-voltage-type accelerator which accelerates particles in a continuous stream through a continuously maintained increasing potential, the time-varying accelerators must necessarily accelerate particles in small discrete groups or bunches.

An accelerator that varies only in electric field and does not use any magnetic guide or turning field is customarily referred to as a linear accelerator or linac. In the simplest version of this kind of accelerator, the electrodes that are used to attract and accelerate the particles are connected to a radio-frequency (rf) power supply or oscillator so that alternate electrodes are of opposite polarity. In this way, each successive gap between adjacent electrodes is alternately accelerating and decelerating. If these acceleration gaps are appropriately spaced to accommodate the increasing velocity of the accelerated particle, the frequency can be adjusted so that the particle bunches are always experiencing an accelerating electric field as they cross each successive gap. In this way, modest voltages can be used to accelerate bunches of particles indefinitely, limited only by the physical length of the accelerator construction.

All conventional (but not superconducting) research linacs usually are operated in a pulsed mode because of the extremely high rf power necessary for their operation. The pulsed operation can then be adjusted so that the duty cycle or amount of time actually on at full power averages to a value that is reasonable in cost and practical for cooling. This necessarily limited duty cycle in turn limits the kinds of research that are possible with linacs; however, they are extremely useful (and universally used) as pulsed high-current injectors for all electron and proton synchrotron ring accelerators. Superconducting linear accelerators have been constructed that are used to accelerate electrons and also to boost the energy of heavy ions injected from electrostatic machines. These linacs can easily operate in the continuous-wave (cw) rather than pulsed mode, because the rf power losses are only a few watts.

The Continuous Electron Beam Accelerator Facility (CEBAF) uses two 400-MeV superconducting linacs to repeatedly accelerate electrons around a racetrack-like arrangement where the two linacs are on the opposite straight sides of the racetrack and the circular ends are a series of recirculation bending magnets, a different set for each of five passes through the two linacs in succession. The continuous electron beam then receives a 400-MeV acceleration on each straight side or 0.8 GeV per turn, and is accelerated to a final energy of 4 GeV in five turns and extracted for use in experiments. The superconducting linacs allow for continuous acceleration and hence a continuous beam rather than a pulsed beam. This makes possible many fundamental nuclear and quark structure measurements that are impossible with the pulsed electron beams from conventional electron linacs. See SUPERCONDUCTING DEVICES.

As accelerators are carried to higher energy, a linac eventually reaches some practical construction limit because of length. This problem of extreme length can be circumvented conveniently by accelerating the particles in a circular path maintained by either static or time-varying magnetic fields. Accelerators utilizing steady magnetic fields as guide paths are usually referred to as cyclotrons or synchrocyclotrons, and are arranged to provide a steady magnetic field over relatively large areas that allow the particles to travel in an increasing spiral orbit of gradually increasing size as they increase in energy.

Practical limitations of magnet construction and cost have kept the size of circular proton accelerators with static magnetic fields to the vicinity of 100 to 1000 MeV. For even higher energies, up to 400 GeV per nucleon in the largest conventional (not superconducting) proton synchrotron in operation, it is necessary to vary the magnetic field as well as the electric field in time. In this way the magnetic field can be of a minimal practical size, which is still quite extensive for a 980-GeV accelerator (6500 ft or



2000 m in diameter). This circular magnetic containment region, or "racetrack," is injected with relatively low-energy particles that can coast around the magnetic ring when it is at minimum field strength. The magnetic field is then gradually increased to stay in step with the higher magnetic rigidity of the particles as they are gradually accelerated with a time-varying electric field.

**Superconducting magnets.** The study of the fundamental structure of nature and all associated basic research require an ever increasing energy in order to allow finer and finer measurements on the basic structure of matter. Since the voltage-varying and magnetic-field-varying accelerators also have limits to their maximum size in terms of cost and practical construction problems, the only way to increase particle energies even further is to provide higher-varying magnetic fields through superconducting magnet technology, which can extend electromagnetic capability by a factor of 4 to 5. Large superconducting cyclotrons and superconducting synchrotrons are in operation. See MAGNET.

**Storage rings.** Beyond the limit just described, the only other possibility is to accelerate particles in opposite directions and arrange for them to collide at certain selected intersection regions around the accelerator. The main technical problem is to provide adequate numbers of particles in the two colliding beams so that the probability of a collision is moderately high. Such storage ring facilities are in operation for both electrons and protons. Besides storing the particles in circular orbits, the rings can operate initially as synchrotrons and accelerate lower-energy injected particles to much higher energies and then store them for interaction studies at the beam interaction points.

Large proton synchrotrons have been used as storage-ring colliders by accelerating and storing protons in one direction around the ring while accelerating and storing antiprotons (negative charge) in the opposite direction. The proton and antiproton beams are carefully programmed to be in different orbits as they circulate in opposite directions and to collide only when their orbits cross at selected points around the ring where experiments are located. The antiprotons are produced by high-energy proton collisions with a target, collected, stored, cooled, and eventually injected back into the synchrotron as an antiproton beam.

Electron-positron synchrotron accelerator storage rings have been in operation for many years in the basic study of particle physics, with energies ranging from 2 GeV + 2 GeV to 104 GeV + 104 GeV. The by-product synchrotron radiation from many of these machines is used in numerous applications. However, the synchrotron radiation loss forces the machine design to larger and larger diameters, characterized by the Large Electron Positron Storage Ring (LEP) at CERN, near Geneva, Switzerland (closed down in 2000), which was 17 mi (27 km) in circumference. Conventional rf cavities enable electron-positron acceleration only up to 50–70 GeV (limited by synchrotron radiation loss) while higher energies of 100–150 GeV require superconducting cavities. See SYNCHROTRON RADIATION.

**Advanced linacs.** Although circular machines with varying magnetic fields have been developed because linacs of comparable performance would be too long (many miles), developments in linac design and utilization of powerful laser properties may result in a return to linacs that will outperform present ring machines at much lower cost. As a first example, the 20-GeV electron linac at Stanford University, Palo Alto, California, has been modified to provide simultaneous acceleration of positrons and electrons to energies as high as 50 GeV, while operating in what is called the SLED mode. After acceleration the electrons and positrons are separated by a magnet, and the two beams are magnetically directed around the opposite sides of a circle so that they collide at one intersection point approximately along a diameter extending from the end of the linac across the circle. This collider arrangement is much less expensive than the 17-mi (27-km) ring at CERN and provides electron-positron collisions of comparable energies but at lower intensities. [H.E.W.]

**Particle detector** A device used to detect and measure radiation characteristically emitted in nuclear processes, including gamma rays or x-rays, lightweight charged particles (electrons or positrons), nuclear constituents (neutrons, protons, and heavier ions), and subnuclear constituents such as mesons. The device is also known as a radiation detector. Since human senses do not respond to these types of radiation, detectors are essential tools for the discovery of radioactive minerals, for all studies of the structure of matter at the atomic, nuclear, and subnuclear levels, and for protection from the effects of radiation. They have also become important practical tools in the analysis of materials using the techniques of neutron activation and x-ray fluorescence analysis. See ACTIVATION ANALYSIS; ELEMENTARY PARTICLE; NUCLEAR REACTION; NUCLEAR SPECTRA; PARTICLE ACCELERATOR; PROSPECTING; RADIOACTIVITY; X-RAY FLUORESCENCE ANALYSIS.

A convenient way to classify radiation detectors is according to their mode of use: (1) For detailed observation of individual photons or particles, a pulse detector is used to convert each such event (that is, photon or particle) into an electrical signal. (2) To measure the average rate of events, a mean-current detector, such as an ion chamber, is often used. Radiation monitoring and neutron flux measurements in reactors generally fall in this category. Sometimes, when the total number of events in a known time is to be determined, an integrating version of this detector is used. (3) Position-sensitive detectors are used to provide information on the location of particles or photons in the plane of the detector. (4) Track-imaging detectors image the whole three-dimensional structure of a particle's track. The output may be recorded by immediate electrical readout or by photographing tracks as in the bubble chamber. (5) The time when a particle passes through a detector or a photon interacts in it is measured by a timing detector. Such information is used to determine the velocity of particles and when observing the time relationship between events in more than one detector. See TIME-OF-FLIGHT SPECTROMETERS.

The ionization produced by a charged particle is the effect commonly employed in a particle detector. In the basic type of gas ionization detector, an electric field applied between two electrodes separates and collects the electrons and positive ions produced in the gas by the radiation to be measured. Multiwire proportional chambers and spark chambers are position-sensitive adaptations of gas detectors. The signal division or time delay that occurs between the ends of an electrode made of resistive material is sometimes used to provide position sensitivity in gas and semiconductor detectors. Track-imaging detectors rely on a secondary effect of the ionization along a particle's track to reveal its structure. See IONIZATION CHAMBER.

In a semiconductor detector, a solid replaces the gas. The "insulating" region (depletion layer) of a reverse-biased *pn* junction in a semiconductor is employed. Since solids are approximately 1000 times denser than gases, absorption of radiation can be accomplished in relatively small volumes. A less obvious but fundamental advantage of semiconductor detectors is the fact that much less energy is required (~3 eV) to produce a hole-electron pair than that required (~30 eV) to produce an ion electron pair in gases. See CRYSTAL COUNTER; JUNCTION DETECTOR.

In addition to producing free electrons and ions, the passage of a charged particle through matter temporarily raises electrons in the material into excited states. When these electrons fall back into their normal state, light may be emitted and detected as in the scintillation detector. See SCINTILLATION COUNTER.

Neutral particles, such as neutrons, cannot be detected directly by ionization. Consequently, they must be converted into charged particles by a suitable process and then observed by detecting the ionization caused by these particles.

Although ionization detectors dominate the field, a number of detector types based on other radiation-induced effects are used. Examples are (1) transition radiation detectors, which depend on the x-rays and light emitted when a particle passes through the interface between two media of different refractive indices;

(2) track detectors, in which the damage caused by charged particles in plastic films and in minerals is revealed by etching procedures; (3) thermoluminescent and radiophotoluminescent detectors, which rely on the latent effects of radiation in creating traps in a material or in creating trapped charge; and (4) Cerenkov detectors, which depend on measurement of the light produced by passage of a particle whose velocity is greater than the velocity of light in the detector medium. See CERENKOV RADIATION; PARTICLE TRACK ETCHING; TRANSITION RADIATION DETECTORS.

The very large detector systems used in relativistic heavy-ion experiments and in the detection of the products of collisions of charged particles at very high energies, typically at the intersection region of storage rings, deserve special consideration. These detectors are frequently composites of several of the basic types of detectors discussed above and are designed to provide a detailed picture of the multiple products of collisions at high energies. The complete detector system may occupy a space tens of feet in extent and involve tens or hundreds of thousands of individual signal processing channels, together with large computer recording and analysis facilities. [F.S.G.]

**Particle flow** Particle flow is important to many industrial processes, including the pneumatic conveying of solids, transport of solids in liquids (slurries), removal of particulates from gas streams for pollution control, combustion of pulverized coal, and drying of particulates in the food and pharmaceutical industries. The vast majority of flow problems in industrial design involve the flow of gas or liquids with suspended solids. See DRYING; FLUIDIZED-BED COMBUSTION; PIPELINE.

A key parameter in fluid-particle flows is the Stokes number, which is the ratio of the response time of a particle to a time characteristic of a flow system. Particle response time is the time that a particle takes to respond to a change in carrier flow velocity. If the Stokes number is small (say, less than 0.1), the particles have sufficient time to respond to the change in fluid velocity, so the particle velocity approaches the fluid velocity. However, if the Stokes number is large (say, greater than 10), the particles have little time to respond to the varying fluid velocity and the particle velocity shows little change.

The relative concentration of the particles in the fluid is referred to as loading. The loading may be defined in several ways, such as the ratio of particle mass flow to fluid mass flow. Many industrial applications involve highly loaded particle flows.

If the particle loading is small, the fluid will affect the particle properties (velocity, temperature, and so forth), but the particles will not influence the fluid properties. This is referred to as one-way coupling. If the conditions are such that there is a mutual interaction between the particles and fluid, the flow is two-way-coupled. Two-way coupling effects are reduced with increasing Stokes number because the particles undergo less acceleration.

If the particle motion is controlled by the action of the fluid on the particle, the flow is termed dilute. But if the particle concentration is sufficiently high, the particles will collide with each other and their motion will be dependent on particle-particle collisions; the flow is then regarded as dense. See FLUID FLOW; PARTICULATES. [C.T.Cr.]

**Particle track etching** A technique of selective chemical etching to reveal tracks of heavy nuclear particles in a wide variety of solid substances. Developed in order to see fossil particle tracks in extraterrestrial materials, the technique finds application in many fields of science and technology.

An etchable track is produced if the charged particle has a sufficiently high radiation-damage rate and if the damaged region in the solid is permanently localized. Thus only highly ionizing particles are detectable; only nonconductors record tracks; and radiation-sensitive plastics can detect lighter particles than can radiation-insensitive minerals and glasses. The conical shape of the etched track depends on the ratio of the rate of etching along the track to the bulk etching rate of the solid.

The lunar surface, meteorites, and other objects exposed in space have been irradiated by charged particles from a variety of sources in the Sun and the Galaxy. Comparison of fossil particle tracks in lunar rocks and meteorites with spacecraft measurements of present-day radiations has established that solar flares and galactic cosmic rays have not changed over the last  $2 \times 10^7$  years—the typical time a lunar rock exists before being shattered by impacting interplanetary debris.

Studies of tracks in a piece of glass from the *Surveyor 3* spacecraft after a 2.6-year exposure on the lunar surface, and of tracks in plastic detectors exposed briefly above the Earth's atmosphere in rockets, have led to the surprising discovery that the Sun preferentially ejects heavy elements in its flares rather than an unbiased sample of its atmosphere. The existence of galactic cosmic rays with atomic number greater than 30 was discovered in 1966 when fossil particle tracks were first studied in meteorites. Several particles heavier than uranium have been detected, indicating that cosmic rays originate in sources where synthesis has proceeded explosively beyond uranium. See COSMIC RAYS.

Unique advantages of etched-track detectors in nuclear and elementary particle physics are their ability to distinguish heavy-particle events in a large background of lightly ionizing radiation and their ability to detect individual rare events by a specialized technique such as electric-spark scanning or ammonia penetration through etched holes. These advantages have permitted such advances as the measurement of very long fission half-lives and the discovery of ternary fission. See NUCLEAR FISSION; TRANSURANIUM ELEMENTS.

The spontaneous fission of  $^{238}\text{U}$ , present as a trace-element purity, gives tracks that can be used to date terrestrial samples ranging from rocks to human artifacts. Because fission tracks are erased in a particular mineral at a well-defined temperature, one can use the apparent fission-track ages as a function of distance from the heat source to measure the thermal (tectonic) history of regions. See FISSION TRACK DATING.

Filters are produced by irradiating thin plastic sheets with fission fragments and then etching holes to the desired size. Uses include biological research, wine filtration, and virus sizing. A uranium exploration method relies on a survey of radon emanation, as measured by alpha-particle tracks in plastic detectors, to locate promising locations in which to drill. Plastic detectors are also used in conjunction with a beam of high-energy heavy ions to take radiographs of cancer patients that reveal details not detectable in x-rays. [P.B.P.]

**Particle trap** A device used to confine charged or neutral particles where their interaction with the wall of a container must be avoided. Electrons or protons accelerated to energies as high as 1 teraelectronvolt ( $10^{12}$  electronvolts) are trapped in magnetic storage rings in high-energy collision studies. Other forms of magnetic bottles are designed to hold dense hot plasmas of hydrogen isotopes for nuclear fusion. At the other end of the energy spectrum, ion and atom traps can store isolated atomic systems at temperatures below 1 millikelvin. Other applications of particle traps include the storage of antimatter such as antiprotons and positrons (antielectrons) for high-energy collision studies or low-energy experiments. See ANTIMATTER; NUCLEAR FUSION; PARTICLE ACCELERATOR; PLASMA (PHYSICS); POSITRON.

**Charged-particle traps.** Charged particles can be trapped in a variety of ways. An electrostatic (Kingdon) trap is formed from a thin charged wire. The ion is attracted to the wire, but its angular momentum causes it to spiral around the wire in a path with a low probability of hitting the wire.

A magnetostatic trap (magnetic bottle) is based on the fact that a charged particle with velocity perpendicular to the magnetic field lines travels in a circle, whereas a particle moving parallel to the field is unaffected by it. In general, the particle has velocity components both parallel and perpendicular to the field lines and moves in a helical spiral. In high-energy physics, accelerators and storage rings also use magnetic forces to guide and confine

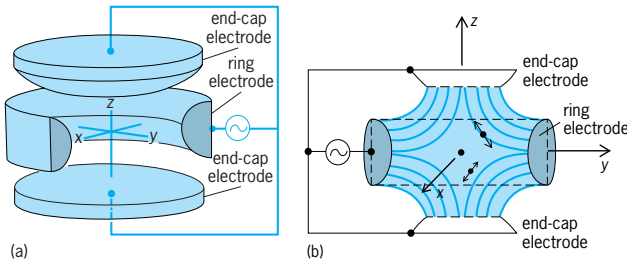

**Radio-frequency Paul trap consisting of two end caps and a ring electrode. (a) Cutaway view (after G. Kamas, ed., *Time and Frequency Users's Manual, National Bureau of Standards Technical Note 695, 1977*). (b) Cross section, showing the amplitude of the instantaneous oscillations for several locations in the trap.**

charged particles. A tokamak has magnetic field lines configured in the shape of a torus, confining particles in spiral orbits. This type of bottle is used to contain hot plasmas in nuclear fusion studies. Another type of bottle uses a magnetic mirror.

The radio-frequency Paul trap uses inhomogeneous radio-frequency electric fields to confine particles, forcing them to oscillate rapidly in the alternating field (see illustration). If the amplitude of oscillation (micromotion) is small compared to the trap dimensions, the trap may be thought of as increasing the (kinetic) energy of the particle in a manner that is a function of the particle position. The particle moves to the position of minimal energy and is therefore attracted to the center of the trap where the oscillating electric fields are weakest. At the center of the trap, the fields are exactly zero, and a single, cold ion or electron trapped there is essentially at rest with almost no micromotion.

The Penning trap, with the same electrode configuration as the Paul trap, uses a combination of static electric and magnetic fields instead of oscillating electric fields.

**Neutral-particle traps.** Uncharged particles such as neutrons or atoms are manipulated by higher-order moments of the charge distribution such as the magnetic or electric dipole moments.

Magnetic traps of neutral particles use the fact that atoms usually have a magnetic dipole moment on which the gradient of a magnetic field exerts a force. The atom can be in a state whose magnetic energy increases or decreases with the field strength, depending on whether the moment is antiparallel or parallel to the field. A magnetic field cannot be constructed with a local maximum in a current-free region, but a local minimum is possible, allowing particles seeking a weak field to be trapped.

Laser traps use the strong electric fields of the laser beam to induce an electric dipole moment on the atom. A laser field tuned below the atomic resonance polarizes the atom in phase with the driving field; the instantaneous dipole moment points in the same direction as the field. Thus the energy of the atom is lowered if it is in a region of high laser intensity. The high-intensity trapping region is formed simply by focusing the beam of a laser. See LASER.

Magneto-optic hybrid traps use, instead of the dipole forces induced by the laser field, the scattering force that arises when an atom absorbs photons. An inhomogeneous magnetic field separates the magnetic substates of an atom in a position-dependent manner. These states interact differently with circularly polarized light. It is possible to arrange a combination of laser beams with proper polarizations to create net scattering forces that drive the atom into the region of zero magnetic field. Such a trap requires much lower laser intensities and weaker magnetic fields. See LASER COOLING. [S.Ch.]

**Particulates** Solids or liquids in a subdivided state. Because of this subdivision, particulates exhibit special characteristics which are negligible in the bulk material. Normally, par-

ticulates will exist only in the presence of another continuous phase, which may influence the properties of the particulates. A particulate may comprise several phases. The table categorizes particulate systems and relates them to commonly recognized designations. See ALLOY; EMULSION; FOAM; GEL.

Fine-particle technology deals with particulate systems in which the particulate phase is subject to change or motion, and is concerned with those particles which are tangible to human senses, yet small compared to the human environment—particles that are larger than molecules but smaller than gravel. Fine particles are in abundance in nature (as in rain, soil, sand, minerals, dust, pollen, bacteria, and viruses) and in industry (as in paint pigments, insecticides, powdered milk, soap, powder, cosmetics, and inks). Particulates are involved in such undesirable forms as fumes, fly ash, dust, and smog and in military strategy in the form of signal flares, biological and chemical warfare, explosives, and rocket fuels.

Many of the characteristics of particulates are influenced to a major extent by the particle size. For this reason, particle size has been accepted as a primary basis for characterizing particulates. However, with anything but homogeneous spherical particles, the measured “particle size” is not necessarily a unique property of the particulate but may be influenced by the technique used. Consequently, it is important that the techniques used for size analysis be closely allied to the utilization phenomenon for which the analysis is desired.

Size is generally expressed in terms of some representative, average, or effective dimension of the particle. The most widely used unit of particle size is the micrometer ( $\mu\text{m}$ ). Another common method is to designate the screen mesh that has an aperture corresponding to the particle size. The screen mesh normally refers to the number of screen openings per unit length or area; several screen standards are in general use.

Particulate systems are often complex. Primary particulates may exist as loosely adhering (as by van der Waals forces) particles called flocs or as strongly adhering (as by chemical bonds) particulates called agglomerates. Primary particles are those whose size can only be reduced by the forceful shearing of crystalline or molecular bonds. See CHEMICAL BONDING; INTERMOLECULAR FORCES.

Mechanical dispersoids are formed by comminution, decrepitation, or disintegration of larger masses of material, as by grinding of solids or spraying of liquids, and usually involve a wide distribution of particle sizes. Condensed dispersoids are formed by condensation of the vapor phase (or crystallization of a solution) or as the product of a liquid- or vapor-phase reaction; these

Types of particulate systems				
System		Hydrosol	Aerosol	Powder
Continuous phase	Solid	Liquid	Gas	None (or gas)
Dispersed or particulate phase	Gas	Sponge	Foam	—
	Liquid	Gel	Emulsion	Mist Spray Fog Rain
	Solid	Alloy	Slurry Suspension	Fume Dust Snow Hail
				Single phase
				Multi-phase (ores, flour)

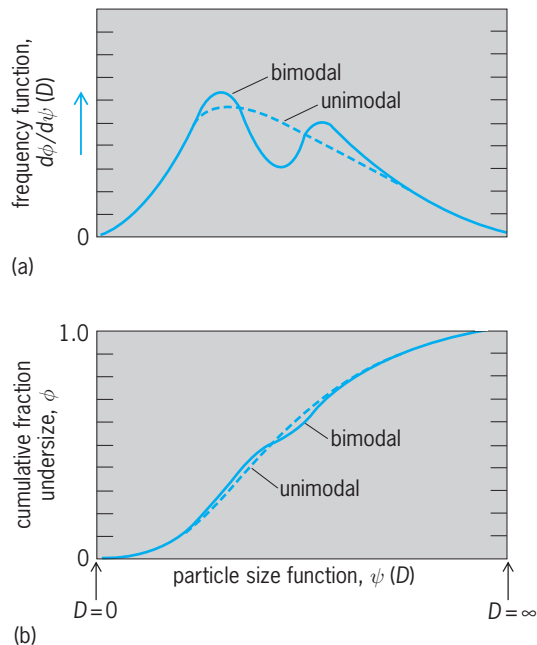

Methods for representing size distribution. (a) Frequency distribution. (b) Cumulative distribution.

are usually very fine and often relatively uniform in size. Condensed dispersoids and very fine mechanical dispersoids generally tend to flocculate or agglomerate to form loose clusters of larger particle size.

Most real systems are composed of a range of particle sizes. The two common general methods for representing size distribution graphically are shown in the illustration. The frequency distribution (illus. a) gives the fraction of particles  $d\phi$  (on whatever basis desired) that lie in a given narrow size range  $dD$  as a function of the average size of the range (or of some function of the average size). A cumulative distribution (illus. b) is the integral of the frequency curve. It gives the fraction  $\phi$  of the particles that are smaller or larger than a given size  $D$ . See INTEGRATION; STATISTICS.

If a particle suspended in a fluid is acted upon by a force, it will accelerate to a terminal velocity at which the resisting force due to fluid friction just balances the applied force. If a particle falls under the action of gravity, this velocity is known as the terminal gravitational settling velocity.

Particles suspended in a fluid partake of the molecular motion of the suspending fluid and hence acquire diffusional characteristics analogous to those of the fluid molecules. This random zigzag motion of the particles, commonly known as brownian motion, is obvious under the microscope for particles smaller than  $1\ \mu\text{m}$ . See BROWNIAN MOVEMENT. [C.E.La.]

**Pascal's law** A law of physics which states that a confined fluid transmits externally applied pressure uniformly in all directions. More exactly, in a static fluid, force is transmitted at the velocity of sound throughout the fluid. The force acts normal to any surface. This natural phenomenon is the basis of the pneumatic fire, balloon, hydraulic jack, and related devices. See HYDROSTATICS. [K.Am.; R.S.R.]

**Paschen-Back effect** An effect on spectral lines obtained when the light source is placed in a very strong magnetic field, first explained by F. Paschen and E. Back in 1921. In such a field the anomalous Zeeman effect, which is obtained with weaker fields, changes over to what is, in a first approximation, the normal Zeeman effect. The term "very strong field" is a relative one, since the field strength required depends on the

particular lines being investigated. It must be strong enough to produce a magnetic splitting that is large compared to the separation of the components of the spin-orbit multiplet. See ATOMIC STRUCTURE AND SPECTRA; ZEEMAN EFFECT. [F.A.J./W.W.W.]

**Passeriformes** The largest and most diverse order of birds, which is found worldwide, including most oceanic islands but excluding Antarctica, in all terrestrial habitats. The most closely related species may be other land birds such as the Coraciiformes and the Piciformes. The Passeriformes is divided into the suborders: Eurylaimi, Furnarii, Tyranni, and Oscines. The affinities of most families within those suborders is still much disputed. See CORACIIFORMES; PICIFORMES.

The perching birds are small to medium-sized birds, ravens (*Corvus corax*) being the largest. The wings are short to medium in length and vary from rounded to pointed. A few species, including lyrebirds, scrubbirds, and New Zealand wrens, are almost flightless. The tail varies from nearly absent to long. The bill is widely variable in shape. Passeriforms have legs of short to medium length that are usually strong. The four toes show the usual avian arrangement, three in front and a well-developed hallux behind. Most forms can walk or climb well, or both. Plumage varies widely, from all black to mostly white and from bright colors and bold patterns to cryptic coloration.

Feeding habits and food choices show wide variation. Most species eat insects or small animals. Song is important to most perching birds for species recognition and courtship. The pair bond is usually strong, with both sexes incubating and caring for the young, which remain in the nest until they are able to fly. Many arctic and cold temperature passerine species migrate to warmer areas for the cold months. Some of the migratory flights measure several thousand miles. See AVES. [W.J.B.]

**Passive radar** A receive-only radar used for search, tracking, surveillance, identification, guidance, and mapping. The operation of passive radars depends upon the detection of microwave or infrared radiation from warm bodies. See INFRARED RADIATION; MICROWAVE; RADIOMETRY.

Many potential military targets radiate high noise power, such as ships at sea, exhaust from trucks, tanks, missiles, and airplanes, and factory chimneys. Unlike an active radar, a passive radar cannot determine the range to a target. However, using the high antenna directivity obtainable at microwave and infrared wavelengths, a passive radar can locate a source of radiation accurately in direction and discriminate between nearby targets.

A passive radar can track a target closely and be used to direct weapon fire toward it. A passive radar, mounted on a missile, can be used to home the missile in on a target by using just the pointing information provided by the radar. The power required to operate such a radar is quite small because there is no transmitter. Ground surveillance and mapping can be accomplished with an airborne ground scanner. This type of radar provides an infrared picture of the terrain and any targets which may be present. Radars of this type can often see through visual camouflage.

The absence of transmitted power makes the location, and even the existence, of a passive radar difficult to determine. Even if the position of a passive radar is known, its frequency cannot be determined; for this reason and because of the high angular resolution, it is difficult to jam. See RADAR. [C.L.Ru.]

**Pasteurella** A genus of gram-negative, nonmotile, nonsporulating, facultatively anaerobic coccobacillary to rod-shaped bacteria which are parasitic and often pathogens in many species of mammals, birds, and reptiles. It was named to honor Louis Pasteur in 1887. Genetic studies have shown that *Pasteurella*, together with *Haemophilus* and *Actinobacillus*, constitute a family, Pasteurellaceae.

The genus contains at least 10 species. *Pasteurella multocida* causes hemorrhagic septicemia in various mammals and fowl

cholera, and is occasionally transmitted to humans, mainly in rural areas. Human pasteurellosis may include inflammation in bite and scratch lesions, infections of the lower respiratory tract and of the small intestine, and generalized infections with septicemia and meningitis. *Pasteurella canis* and *P. stomatis* may cause similar, though generally less severe, infections in humans after contact with domestic or wild animals. Although drug-resistant *Pasteurella* strains have been encountered, human *Pasteurella* infections are as a rule readily sensitive to the penicillins and a variety of other chemotherapeutic agents. See ANTIBIOTIC; DRUG RESISTANCE. [W.Ma.]

**Pasteurellosis** A variety of infectious diseases caused by the coccobacilli *Pasteurella multocida* and *P. haemolytica*; the term also applies to diseases caused by any *Pasteurella* species. All *Pasteurella* species occur as commensals in the upper respiratory and alimentary tracts of their various hosts. Although varieties of some species cause primary disease, many of the infections are secondary to other infections or result from various environmental stresses. *Pasteurella* species are generally extracellular parasites that elicit mainly a humoral immune response. Several virulence factors have been identified. See VIRULENCE.

*Pasteurella multocida* is the most prevalent species of the genus causing a wide variety of infections in many domestic and wild animals, and humans. It is a primary or, more frequently, a secondary pathogen of cattle, swine, sheep, goats, and other animals. As a secondary invader, it is often involved in pneumonic pasteurellosis of cattle (shipping fever) and in enzootic or mycoplasmal pneumonia of swine. It is responsible for a variety of sporadic infections in many animals, including abortion, encephalitis, and meningitis. It produces severe mastitis in cattle and sheep, and toxin-producing strains are involved in atrophic rhinitis, an economically important disease of swine. Hemorrhagic septicemia, caused by capsular type B strains, has been reported in elk and deer in the United States.

All strains of *P. haemolytica* produce a soluble cytotoxin (leukotoxin) that kills various leukocytes of ruminants, thus lowering the primary pulmonary defense. It is the principal cause of the widespread pneumonic pasteurellosis of cattle. Other important diseases caused by certain serotypes of *P. haemolytica* are mastitis of ewes and septicemia of lambs.

All of the *Pasteurella* species can be isolated by culturing appropriate clinical specimens on blood agar. Multiple drug resistance is frequently encountered. Treatment is effective if initiated early. Among the drugs used are penicillin and streptomycin, tetracyclines, chloramphenicol, sulphonamides, and some cephalosporins. Sound sanitary practices and segregation of affected animals may help limit the spread of the major pasteurelloses. Live vaccines and bacterins (killed bacteria) are used for the prevention of some. See PASTEURILLA. [G.R.Ca.]

**Pasteurization** The treatment of foods or beverages with mild heat, irradiation, or chemical agents to improve keeping quality or to inactivate disease-causing microorganisms. Originally, Louis Pasteur observed that spoilage of wine and beer could be prevented by heating them a few minutes at 122–140°F (50–60°C). Today pasteurization as a thermal treatment is applied to many foods. In foods consumed directly, destruction of pathogens to protect consumer health is paramount, while in products without public health hazards, control of spoilage microorganisms is primary. In fermentation processes, the raw material may be pasteurized to eliminate microorganisms that produce abnormal end products, or the final product may be heated to stop the fermentation at the desired level.

Milk and dairy products probably represent the most widespread use of pasteurization. Several time-temperature combinations have been approved as equivalent: 145°F (63°C) for 30 min; 161°F (72°C) for 15 s; 191°F (89°C) for 1 s; 194°F (90°C) for 0.5 s; 201°F (94°C) for 0.1 s; 204°F (96°C) for 0.05 s;

or 212°F (100°C) for 0.01 s. These precise heat treatments are based on the destruction of the rickettsia *Coxiella burnetii*, which is considered the most heat-resistant nonsporeforming pathogen found in milk. Absolute control of the thermal treatment is essential for safety. Pasteurization of milk has successfully eliminated the spread of diseases such as diphtheria, tuberculosis, and brucellosis through contaminated milk. See DAIRY MACHINERY; FOOD MANUFACTURING; MALT BEVERAGE; MILK; WINE. [F.F.B.]

**Patent** Common designation for letters patent, which is a certificate of grant by a government of an exclusive right with respect to an invention for a limited period of time. A United States patent confers the right to exclude others from making, using, or selling the patented subject matter in the United States and its territories. Portions of those rights deriving naturally from it may be licensed separately, as the rights to use, to make, to have made, and to lease. Any violation of this right is an infringement.

An essential substantive condition which must be satisfied before a patent will be granted is the presence of patentable invention or discovery. To be patentable, an invention or discovery must relate to a prescribed category of contribution, such as process, machine, manufacture, composition of matter, plant, or design. In the United States there are different classes of patents for different members of these categories. [D.W.B.]

**Paterinida** A small extinct order of inarticulate brachiopods that ranges in age from Early Cambrian to Middle Ordovician. The shell is chitinophosphatic in composition, and its outline is circular or elliptical. The ventral (pedicle) valve is more convex than the dorsal (brachial) valve. The pedicle was absent or emerged between the valves. The muscle scars are unusual compared to other inarticulates, and form narrow triangular tracks radiating from the posterior extremity of each valve. Except for their shell composition and lack of articulation, the Paterinida resemble articulate brachiopods. Members were presumably epifaunal and sessile. See BRACHIOPODA; INARTICULATA. [M.W.F.]

**Pathogen** Any agent capable of causing disease. The term pathogen is usually restricted to living agents, which include viruses, rickettsia, bacteria, fungi, yeasts, protozoa, helminths, and certain insect larval stages. See DISEASE.

Pathogenicity is the ability of an organism to enter a host and cause disease. The degree of pathogenicity, that is, the comparative ability to cause disease, is known as virulence. The terms pathogenic and nonpathogenic refer to the relative virulence of the organism or its ability to cause disease under certain conditions. This ability depends not only upon the properties of the organism but also upon the ability of the host to defend itself (its immunity) and prevent injury. The concept of pathogenicity and virulence has no meaning without reference to a specific host. For example, gonococcus is capable of causing gonorrhea in humans but not in lower animals. See MEDICAL MYCOLOGY; MEDICAL PARASITOLOGY; PLANT PATHOLOGY; PLANT VIRUSES AND VIROIDS; VIRULENCE. [D.N.La.]

**Pathology** The study of the etiologies, mechanisms, and manifestations of disease. Techniques and knowledge gained from other disciplines, including anatomy, physiology, microbiology, biochemistry, and histology, are utilized. The information obtained from the study of pathology is necessary prior to developing methods with which to control and prevent disease.

With the light microscope it became possible to correlate the observed signs and symptoms in an individual with cellular changes. In its early stages pathology was very descriptive. Diseases were understood and categorized in part, by how gross and microscopic anatomy was altered. In the last half of the 19th century, by using this approach to pathology, coupled with

microbiological techniques, it was learned that the major causes of human death were biotic agents: protozoans, bacteria, viruses, and fungi. Infectious diseases took a heavy toll in human lives. Better sanitation and public health measures were instrumental in controlling these diseases, and the production of antibiotics and immunization procedures further reduced their importance. It is now apparent that all diseases reflect changes at the molecular level. Scientists are beginning to understand what these biochemical alterations are in some diseases.

There are many branches of pathology. Divisions are made depending upon focus of interest. Clinical pathology is concerned with diagnosis of disease. As medicine has expanded, subspecialties such as surgical pathology and neuropathology have developed. Experimental pathology attempts to study disease mechanisms under controlled conditions. General pathology covers all areas, but in less detail, and serves in medical education.

A relatively new area of pathology is environmental pathology, which deals with disease processes resulting from physical and chemical agents. At present, the leading causes of death have environmental agents as the known or suspected major etiologic factors; these diseases include heart disease, atherosclerosis, and cancer. It is believed that with understanding, many such diseases, like those produced in response to biotic agents, can be brought under control. See DISEASE. [N.K.M.; C.Qu.]

**Pathotoxin** A chemical of biological origin, other than an enzyme, that plays an important causal role in a plant disease. Most pathotoxins are produced by plant pathogenic fungi or bacteria, but some are produced by higher plants, and one has been reported to be the product of an interaction between a plant and a bacterial pathogen. Some pathogen-produced pathotoxins are highly selective in that they cause severe damage and typical disease symptoms only on plants susceptible to the pathogens that produce them. Others are nonselective and are equally toxic to plants susceptible or resistant to the pathogen involved. A few pathotoxins are species-selective, and are damaging to many but not all plant species. In these instances, some plants resistant to the pathogen are sensitive to its toxic product. See PLANT PATHOLOGY. [H.Wh.]

**Pattern formation (biology)** The mechanisms that ensure that particular cell types differentiate in the correct location within the embryo and that the layers of cells bend and grow in the correct relative positions. Pattern formation is one of four processes that underlie development, the others being growth, cell diversification, and morphogenesis. See ANIMAL GROWTH; ANIMAL MORPHOGENESIS; CELL DIFFERENTIATION; PLANT GROWTH.

Pattern formation is the creation of a predictable arrangement of cell types in space during embryonic development. The types of patterns of cell types found in animals and plants can be conveniently described as simple or complex. Simple patterns involve the spatial arrangement of identical or equivalent structures such as bristles on the leg of a fly, hairs on a person's head, or leaves on a plant. Such equivalent patterns are thought to be produced by mechanisms that are the same or very similar in the fly and the plant. Complex patterns are those that are made up of parts that are not equivalent to one another. In the vertebrate limb, for example, the structure of the arm is different at each level, with one bone (humerus) in the upper arm, two bones (radius and ulna) in the lower arm, and a complex set of bones making up the wrist and the hand. How are such nonequivalent parts patterned during development? The theoretical framework that allows a basis for understanding how such patterns arise is called positional information. Two stages exist in the positional information framework. First, a cell must become aware of its position within a developing group, or field, of cells. This specification of cellular position requires a mechanism by which each cell within a field can obtain a unique value or address. The second component is the interpretation of the positional address

by a cell to manifest a particular cell type by the expression of a particular set of genes. See DEVELOPMENTAL BIOLOGY; EMBRYONIC DIFFERENTIATION. [N.Ho.]

**Paupropoda** A class, and perhaps the most obscure group, of the Myriapoda. They are pale creatures, no more than 0.04–0.08 in. (1–2 mm) in length, inhabiting damp situations in leaf litter, under bark, stones and debris, and in humus and similar detritus. Apparently very widely distributed as a class, they have been undiscovered only in deserts and in the arctic and antarctic regions.

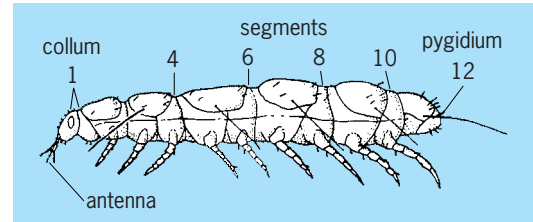

*Paupropus silvaticus*. (After R. E. Snodgrass, *A Textbook of Arthropod Anatomy*, Cornell University Press, 1952)

Like millipedes, they are progoneate and have one pair of maxillae, and their trunk segments display a certain degree of amalgamation. Their peculiar bifurcate antennae and adult complement of 12 trunk segments with 9 pairs of functional legs are distinctive within the myriapod complex (see illustration). All paupropods lack eyes, spiracles, tracheae, and a circulatory system.

The class currently consists of 2 families with less than 10 genera; there are probably fewer than 60 species known. [R.E.Cr.]

**Pavement** An artificial surface laid over the ground to facilitate travel. A pavement's ability to support loads depends primarily upon the magnitude of the load, how often it is applied, the supporting power of the soil underneath, and the type and thickness of the pavement structure. Before the necessary thickness of a pavement can be calculated, the volume, type, and weight of the traffic (the traffic load) and the physical characteristics of the underlying soil must be determined.

Once the grading operation has been completed and the subgrade compacted, construction of the pavement can begin. Pavements are either flexible or rigid. Flexible pavements, which are composed of aggregate (sand, gravel, or crushed stone) and

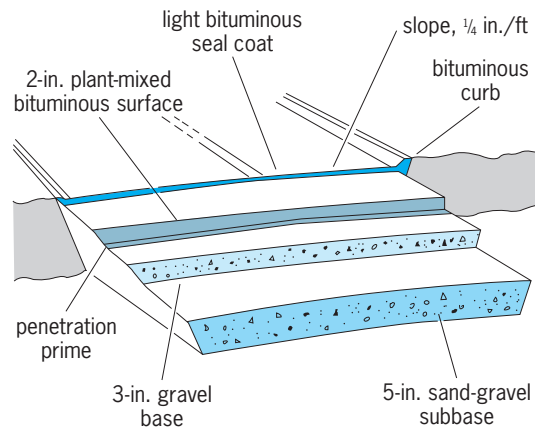

Flexible pavement design for a city collector street with maximum traffic load of 5 tons (4.5 metric tons) per axle. Right-of-way is 60 ft (18 m) wide and the pavement width is 38 ft (11.6 m). Berms or boulevards at the sides are sloped in order to drain toward the street. 1 in. = 2.5 cm.

bituminous material (see illustration), have less resistance to bending than do rigid pavements, which are made of concrete. Both types can be designed to withstand heavy traffic. Selection of the type of pavement depends, among other things, upon (1) estimated construction costs; (2) experience of the highway agency doing the work with each of the two types; (3) availability of contractors experienced in building each type; (4) anticipated yearly maintenance costs; and (5) experience of the owner in maintenance of each type. See CONCRETE; HIGHWAY ENGINEERING. [A.N.C.]

**Pawl** The driving link or holding link of a ratchet mechanism, also called a click or detent. In the illustration the driving pawl at A, forced upward by lever B, engages the teeth of the ratchet wheel and rotates it counterclockwise. Holding pawl C prevents clockwise rotation of the wheel when the pawl at A is making its return stroke. Pawl and ratchet are an open, upper pair.

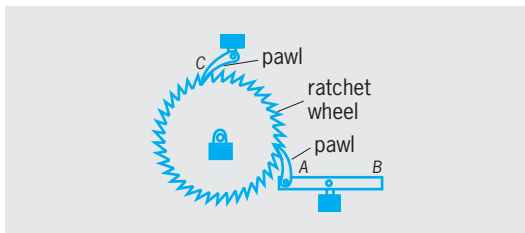

Holding and driving pawls with a ratchet wheel.

Driving and holding pawls likewise engage rack teeth on the plunger of a ratchet lifting jack, such as those supplied with automobiles. A ratchet wheel with a holding pawl only, acting as a safety brake, is fastened to the drum of a capstan, winch, or other powered hoisting device.

A double pawl can drive in either direction or be easily reversed in holding. A cam pawl prevents the wheel from turning clockwise by a wedging action while permitting free counterclockwise rotation. This technique is used in the automobile hill-holder to prevent the vehicle's rolling backward. See ESCAPEMENT. [D.P.Ad.]

**Paxillosida** An order of sea stars and members of the class Asteroidea. The name is derived from the club-shaped plates, or paxillae, that form the sea star's upper skeletal surface and that have tiny spinelets or granules covering their tips. Paxillosida encompasses six families, the largest being the Astropectinidae, Luidiidae, and Porcellanasteridae. The Ctenodiscidae, Gonioplectinidae, and Radiasteridae are represented by comparatively few members. Astropectinids and luidiids are primarily predators of mollusks and other echinoderms. The former are found over a wide range of depths, whereas the latter live in relatively shallow water. Porcellanasterids are deep-water asteroids that swallow sediment in bulk as they bury themselves to a level just below the surface.

In addition to the presence of paxillae, paxillosidans are characterized by a number of unusual features that have been thought to indicate a primitive phylogenetic position among living asteroids. Although the tube feet of most asteroids have suckered disks, those of most paxillosidans are pointed. The digestive system of most asteroids is relatively complex and complete, terminating in an anus, whereas that of the paxillosidans is simple, saclike, and lacking an anus in some members. Most asteroids can extrude their stomach during feeding, but that ability is limited in paxillosidans. A brachiolarian larval stage has been recognized in the development of most asteroids, yet that stage is thought to be absent from paxillosidans. See ASTEROIDEA; ECHINODERMATA. [D.B.B.]

**Pea** The pea is one of the oldest cultivated crops. It is a native to western Asia from the Mediterranean Sea to the Himalaya Mountains. It appears to have been carried to Europe as early as the time of the lake dwellers of prehistoric times. Peas were introduced into China from Persia about A.D. 400; they were introduced into the United States in very early Colonial days.

Garden peas (*Pisum sativum*) have wrinkled seed coats at maturity when dry; field peas (*P. arvense*) have a smooth seed coat. Both types are annual leafy plants. Each leaf bears three pairs of leaflets and ends in a slender tendrils. Five to nine round seeds are enclosed in a pod about 3 in. (7.5 cm) long. Seed color varies from white to cream, green, yellow, or brown. Smooth-seeded varieties may be harvested fresh for freezing or canning, or harvested dry as edible peas. Dry peas may be split or ground and prepared in various ways, such as for split-pea soup.

Wisconsin, Washington, Minnesota, Oregon, Illinois, New York, Pennsylvania, Utah, and Idaho lead in the production of peas harvested green. [K.J.M.]

**Peach** A deciduous fruit tree species (*Prunus persica*) that originated and was first cultivated in western China. It is adapted to relatively moderate climates in the temperate zone. Although most peach cultivars require a substantial amount of winter chilling (temperatures between 32 and 45°F, or 0–7°C) to ensure adequate breaking of winter dormancy and uniform budbreak, peach wood is susceptible to winter injury at temperatures below –15°F (–25°C) and dormant fruit buds are injured by temperatures below 0°F (–18°C). Consequently, commercial cultivation is limited to lower latitudes in the temperate zone or to higher latitudes where large bodies of water have a moderating influence on climate. The principal peach-growing regions in North America, ranked in order of commercial production, are central California, Georgia and the Carolinas, the mid-Atlantic region, the Great Lakes region, and the Pacific northwestern region. Other important peach-growing regions in the world include Italy, southern France, Spain, Japan, China, Argentina, southern Brazil, Chile, South Africa, and southeastern Australia. See FRUIT; FRUIT, TREE; ROSALES.

Peach cultivars can vary greatly and are usually distinguished by their fruit types. Peach fruits are covered with short epidermal trichomes called fuzz (smooth-skinned peaches are called nectarines) and at maturity are usually yellow or white with a red blush. The internal flesh is also yellow or white. Clingstone cultivars have a relatively firm flesh that adheres to the pit at maturity, and are primarily used for canning. Freestones usually have a softer flesh that separates from the pit at fruit maturity, and are primarily used for the fresh market, freezing, and drying. [T.M.DeJ.]

**Peanut** A self-pollinated, one- to six-seeded legume which is cultivated throughout the tropical and temperate climates of the world. The oil, expressed from the seed, is of high quality, and a large percentage of the annual world production is used for this purpose. In the United States some 65% goes into the cleaned and shelled trade, the end products of which are roasted or salted peanuts, peanut butter, and confections. See ROSALES.

Botanically, peanuts may be divided into three main types, Virginia, Spanish, and Valencia, based on branching order and pattern and the number of seeds per pod. The USDA Marketing Standards includes an additional type, Runner, which refers to the small-seeded Virginia type produced in Georgia and Alabama. See SEED.

The peanut's most distinguishing characteristic is the yellow flower, which resembles a butterfly (papilionaceous) and is borne above ground. The pod, a one-loculed legume, splits under pressure along a longitudinal ventral suture. Pod size varies, and seed weight varies from 0.08 to 0.2 oz (0.2 to 5 g). The number of seeds per pod usually is two in the Virginia type, two or three in the Spanish, and three to six in the Valencia. See LEGUME. [A.Pe.]

**Pear** Any of approximately 20 species of deciduous tree fruits in the genus *Pyrus*. About half of the species are native to Europe, North Africa, and the Middle East around the Mediterranean Sea; the others are native to Asia. Pear culture is documented to have started as early as 1100 B.C. Pears are best adapted to temperate climates with warm, dry summers and cold winters. They require winter cold to break the dormant period but are injured by temperatures below  $-10$  to  $-15^{\circ}\text{F}$  ( $-23$  to  $-26^{\circ}\text{C}$ ). Commercial pear production in the United States is concentrated in the interior valleys of California, Oregon, and Washington.

Nearly all United States pear production is of the European pear, *P. communis*. The Bartlett variety comprises over 75% of the United States pear crop. Other European pear varieties include d'Anjou, Bosc, Comice, Seckel, and Winter Nelis. The European pear is noted for its soft, juicy flesh. The skin color is medium green to yellow, depending on fruit maturity and the variety. Skin texture can be smooth or rough. Fruit shape ranges from the classic pear shape (round base with narrow neck) to a rounded oblong shape with no clearly defined neck area.

The crisp-fleshed Asian pear, *P. pyrifolia*, is the second most popular type of pear grown worldwide. The Asian pear is characterized by a crisp, juicy flesh that has a gritty texture, and has been referred to as the sand pear. The fruit shape is round, the skin color is generally yellow to amber at maturity, and the skin texture is smooth or corky. *Pyrus communis* and *P. pyrifolia* hybrids, such as Kieffer and Leconte, have been developed for limited commercial use in the southeastern United States. *Pyrus ussuriensis* has also been selected for Asian pear varieties. The snow pear, *P. nivalis*, is produced in Europe for cider and perry (a fermented liquor). See FRUIT; FRUIT, TREE. [K.M.W.]

**Pearl** Any mollusk-formed calcareous concretion that displays an orient and is lustrous. There are two major groups of bivalved mollusks in which gem pearls may form: the saltwater pearl oyster (*Pinctada*), and a number of genera of freshwater clams. Usually, jewelers refer to salt-water pearls as Oriental pearls, regardless of their place of discovery, and to those from fresh-water bivalves as fresh-water pearls.

Between the body mass and the valves of the mollusk extends a curtainlike tissue called the mantle. In order for a pearl to form, a tiny object such as a parasite or a grain of sand must work through the mantle. When this happens, secretion of nacre around the invading object builds a pearl within the body of the mollusk. Whole pearls form within the body mass of the mollusk, in contrast to blister pearls, which form as protrusions on the inner surface of the shell. Edible oysters produce lusterless concretions, but never pearls.

The substitute for natural pearls, to which the name cultured pearl has been given, is usually made by inserting a large bead into a mollusk to be coated with nacre. [R.T.L.]

**Peat** A dark-brown or black residuum produced by the partial decomposition and disintegration of mosses, sedges, trees, and other plants that grow in marshes and other wet places. Forest-type peat, when buried and subjected to geological influences of pressure and heat, is the natural forerunner of most coal. Moor peat is formed in relatively elevated, poorly drained moss-covered areas, as in parts of Northern Europe. See COAL; HUMUS. [G.H.C.]

**Pebble mill** A tumbling mill that grinds or pulverizes materials without contaminating them with iron. Because the pebbles have lower specific gravity than steel balls, the capacity of a given size shell with pebbles is considerably lower than with steel balls. The lower capacity results in lower power consumption. The shell has a nonmetallic lining to further prevent iron contamination,

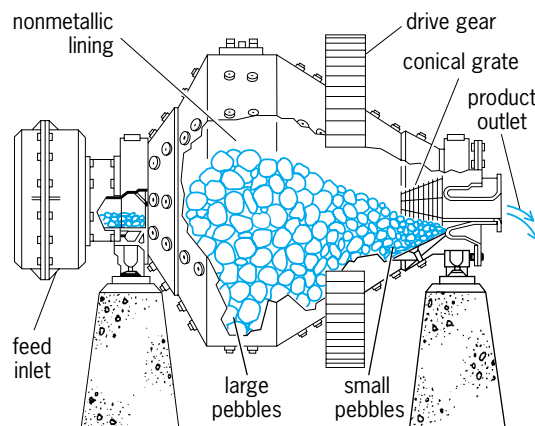

Diagrammatic sketch of a conical pebble mill.

as in pulverizing ceramics or pigments (see illustration). Selected hard pieces of the material being ground can be used as pebbles to further prevent contamination. See TUMBLING MILL. [R.M.H.]

**Pecan** A large tree (*Carya illinoensis*) of the family Juglandaceae, and the nut from this tree. Native to valleys of the Mississippi River and tributaries as far north as Iowa, to other streams of Texas, Oklahoma, and northern and central Mexico, this nut tree has become commercially important throughout the southern and southwestern United States and northern Mexico. [R.H.S.]

**Pectin** A group of polysaccharides occurring in the cell walls and intercellular layers of all land plants. They are extractable with hot water, dilute acid, or ammonium oxalate solutions. Pectins are precipitated from aqueous solution by alcohol and are commercially used for their excellent gel-forming ability.

Commercially, the primary source of pectin is the peel of citrus fruits such as lemon and lime, although orange and grapefruit may be used. A secondary source is apple pomace and sunflower heads.

Pectin is widely used in the food industry, principally in the preparation of gels. It is used as a base for jelly and as a stabilizer in some dairy products and frozen desserts, such as sherbet, and also as edible protective coatings for sausages, almonds, candied dried fruit, and soft dates. See GEL; POLYSACCHARIDE. [R.L.Wh.; J.R.D.]

**Pectolite** A mineral inosilicate with composition  $\text{Ca}_2\text{Na-Si}_3\text{O}_8(\text{OH})$ . The hardness is 5 on Mohs scale, and the specific gravity is 2.75. The mineral is colorless, white, or gray with a vitreous to silky luster. Pectolite is found in the United States at Paterson, Bergen Hill, and Great Notch, New Jersey. See SILICATE MINERALS. [C.S.Hu.]

**Pediculosis** Human infestation with lice. There are two biological varieties of the human louse, *Pediculus humanus*, var. *capitis* and var. *corporis*, each showing a strong preference for a specific location on the human body. *Pediculus humanus capitis* colonizes the head and *P. h. corporis* lives in the body-trunk region.

These lice are wingless insects which are ectoparasites. Their mouthparts are modified for piercing skin and sucking blood. The terminal segments of their legs are modified into clawlike structures which are utilized to grasp hairs and clothing fibers.

Lice are important vectors of human diseases. Their habit of sucking blood and their ability to crawl rapidly from one human to another transmit such diseases as typhus (rickettsial) and epidemic relapsing fever (spirochetal). The body fluids and feces of infected lice transmit these diseases. [R.Su.]



**Pedinoida** An order of Diadematacea, making up those genera which possess solid spines and a rigid test. The ambulacra show typical diadematooid structure, and the tubercles are noncrenulate. The single known family, Pedinidae, includes 15 genera, ranging from the Late Triassic onward, though only one genus, *Caenopedina*, survives today. See DIADEMATACTEA.

[H.B.F.]

**Pedology** Defined narrowly, a science that is concerned with the nature and arrangement of horizons in soil profiles; the physical constitution and chemical composition of soils; the occurrence of soils in relation to one another and to other elements of the environment such as climate, natural vegetation, topography, and rocks; and the modes of origin of soils. Pedology so defined does not include soil technology, which is concerned with uses of soils.

Broadly, pedology is the science of the nature, properties, formation, distribution, and function of soils, and of their response to use, management, and manipulation. The first definition is widely used in the United States and less so in other countries. The second definition is worldwide. See SOIL; SOIL MECHANICS.

[R.W.S.]

**Pegasiformes** The sea moths or sea dragons, a small order of peculiar actinopterygian fishes also known as the Hypostomides. The body is encased in a broad, bony framework anteriorly and has bony rings posteriorly, simulating the seahorses and pipefishes (see illustration). Unlike those fishes, which have the mouth at the tip of the produced snout, sea moths have enlarged nasal bones which form a rostrum that projects well forward of the small, toothless mouth. The greatly expanded horizontal pectoral fin belies its appearance and does not function in aerial gliding. The pelvic fin is abdominal and consists of a slender spine and one or two long rays. The short, opposed dorsal and anal fins have no spines. There is no swim bladder. See GASTEROSTEIFORMES.

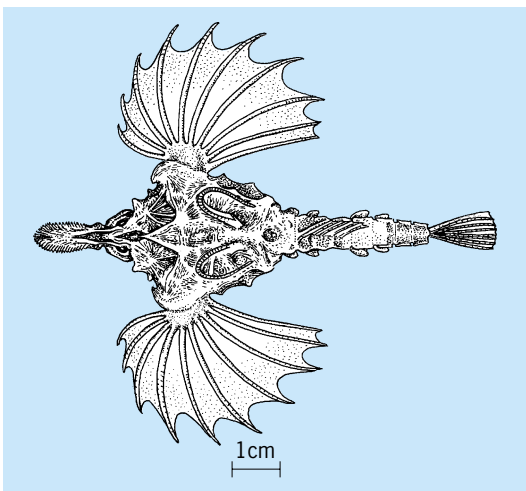

Sea moth (*Pegasus draconis*). (After D. S. Jordan and J. O. Snyder, vol. 24, *Leland Stanford University Contributions to Biology*, 1901)

There is a single family, Pegasidae, with one genus, *Pegasus*, and four or five species. They live amidst vegetation on Indo-Pacific shores from East Africa to Japan, Australia, and Hawaii. There is no fossil record. See ACTINOPTERYGII.

[R.M.B.]

**Pegasus** The Winged Horse, in astronomy, an autumnal constellation. Pegasus is usually identified by the four bright stars  $\alpha$ ,  $\beta$ ,  $\gamma$ , and  $\alpha$  (Alpha Andromedae) situated on the corners of a large square known as the Great Square in Pegasus (see

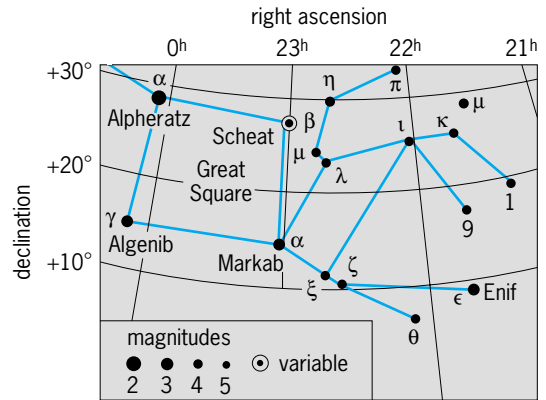

Line pattern of the constellation Pegasus. The grid lines represent the coordinates of the sky. The apparent brightness, or magnitude, of the stars is shown by the sizes of the dots, graded by appropriate numbers.

illustration). The star Alpheratz at the northeastern corner of the square is really in the constellation Andromeda. See CONSTELLATION.

[C.-S.Y.]

**Pegmatite** Exceptionally coarse-grained and relatively light-colored crystalline rock composed chiefly of minerals found in ordinary igneous rocks. Extreme variations in grain size also are characteristic, and close associations with dominantly fine-grained aplites are common. Pegmatites are widespread and very abundant where they occur, especially in host rocks of Precambrian age, but their aggregate volume in the Earth's crust is small. Many pegmatites have been economically valuable as sources of clays, feldspars, gem materials, industrial crystals, micas, silica, and special fluxes, as well as beryllium, bismuth, lithium, molybdenum, rare-earth, tantalumniohium, thorium, tin, tungsten, and uranium minerals. See APLITE; IGNEOUS ROCKS.

Essential minerals (1) in granitic pegmatities are quartz, potash feldspar, and sodic plagioclase; (2) in syenitic pegmatites, alkali feldspars with or without feldspathoids; and (3) in diorite and gabbro pegmatities, soda-lime or lime-soda plagioclase. Varietal minerals such as micas, amphiboles, pyroxenes, black tourmaline, fluorite, and calcite further characterize the pegmatites of specific districts. Accessory minerals include allanite, apatite, beryl, garnet, magnetite, monazite, tantalite-columbite, lithium tourmaline, zircon, and a host of rarer species.

[R.H.J.]

**Pelecaniformes** A small order of diverse aquatic, mainly marine, fish-eating birds that includes the pelicans, boobies, and cormorants. The members of the order, which is found worldwide, are very different, and some researchers believe that it is an artificial group; however, all members are characterized by several unique features. There are nine families (six living and three fossil) of the order Pelecaniformes. The living families include Phaethontidae (tropic birds; 3 species), Pelecanidae (pelicans; 8 species), Sulidae (boobies, gannets; 9 species), Phalacrocoracidae (cormorants; 33 species), Anhingidae (anhingas; 4 species), and Fregatidae (frigate birds; 5 species).

The pelecaniforms are medium-sized to large marine birds that were characterized by a foot with four toes united in a common web (totipalmate). The legs are short and stout or weak, and they are used for swimming and perching. The birds are poor walkers, but all living forms—with the exception of the flightless Galápagos cormorant—are excellent fliers, particularly the frigate birds. The bill varies widely in size and shape, from the short, stout bill of tropical birds to the long, hooked bill of frigate birds and the long, flat, flexible bill of pelicans. All species

have a bare throat pouch; the largest such pouch is found in the pelicans, which use it as a fishing net. The plumage is black, gray, or white. All pelecaniforms feed on fish, crustaceans, and squid that are caught by diving from the air or the water surface, taken from the water surface, or stolen from other birds. See AVES. [W.J.B.]

**Pelmatozoa** A division of the Echinodermata made up of those forms which are anchored to the substrate during at least a part of the life history. Formerly treated as a formal unit of classification with the rank of subphylum, pelmatozoans are now realized to be a heterogeneous assemblage of forms with similar habits but dissimilar ancestry, their common features having arisen by convergent evolution. Most pelmatozoan echinoderms are members of the subphylum Crinozoa, but some echinozoans also exhibit a sedentary, anchored life, with modifications for such existence. See CRINOZOA; ECHINODERMATA; ECHINOZOA; ELEUTHEROZOA. [H.B.F.]

**Peltier effect** A phenomenon discovered in 1834 by J. C. A. Peltier, who found that at the junction of two dissimilar metals carrying a small current the temperature rises or falls, depending upon the direction of the current. In view of experiments, which establish that the rate of intake or output of heat is proportional to the magnitude of the current, it can be shown that an electromotive force resides at a junction. Electromotive forces of this type are called Peltier emf's. See SEEBECK EFFECT; THERMOELECTRICITY; THOMSON EFFECT. [J.W.St.]

**Pelycosauria** An extinct order of primitive, mammallike reptiles of the subclass Synapsida. They are characterized by a temporal fossa that lies low on the side of the skull. The group is known from rocks of the Upper Carboniferous and lower and middle Permian. Three suborders are included: Ophiacodontia, Edaphosauria, and Sphenacodontia. Late in the early Permian the sphenacodonts gave rise to more advanced mammallike reptiles, the therapsids. See SYNAPSIDA; THERAPSIDA. [E.C.O.]

**Pendulum** A rigid body mounted on a fixed horizontal axis, about which it is free to rotate under the influence of gravity. The period of the motion of a pendulum is virtually independent of its amplitude and depends primarily on the geometry of the pendulum and on the local value of  $g$ , the acceleration of gravity. Pendulums have therefore been used as the control elements in clocks, or inversely as instruments to measure  $g$ .

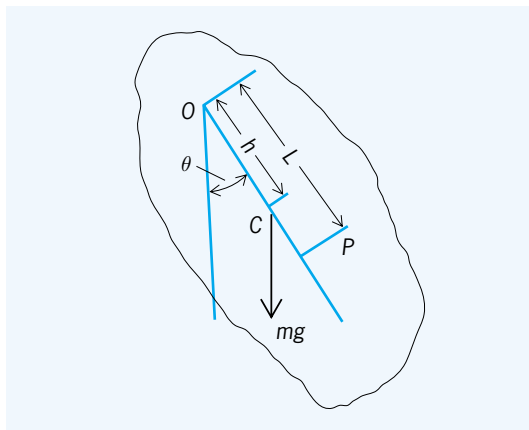

Schematic diagram of a pendulum.  $O$  represents the axis,  $C$  is the center of mass, and  $P$  the center of oscillation.

**Motion.** In the schematic representation of a pendulum shown in the illustration,  $O$  represents the axis and  $C$  the center of mass. The line  $OC$  makes an instantaneous angle  $\theta$  with the vertical. In rotary motion of any rigid body about a fixed axis, the angular acceleration is equal to the torque about the axis divided by the moment of inertia  $I$  about the axis. If  $m$  represents the mass of the pendulum, the force of gravity can be considered as the weight  $mg$  acting at the center of mass  $C$ .

If the amplitude of motion is small, the motion is simple harmonic. The period  $T$ , time for a complete vibration (for example, from the extreme displacement right to the next extreme displacement right), is given by Eq. (1). See HARMONIC MOTION.

$$T = 2\pi\sqrt{I/mgh} \quad (1)$$

The actual form of a pendulum often consists of a long, light bar or a cord that serves as a support for a small, massive bob. The idealization of this form into a point mass on the end of a weightless rod of length  $L$  is known as a simple pendulum. An actual pendulum is sometimes called a physical or compound pendulum. In a simple pendulum the lengths  $h$  and  $L$  become identical, and the moment of inertia  $I$  equals  $mL^2$ . Equation (1) for the period becomes Eq. (2).

$$T = 2\pi\sqrt{L/g} \quad (2)$$

**Center of oscillation.** Equation (2) can be used to define the equivalent length of a physical pendulum. Comparison with Eq. (1) shows that Eq. (3) holds. The point  $P$  on line  $OC$  of the

$$L = I/mh \quad (3)$$

illustration, whose distance from the axis  $O$  equals  $L$ , is called the center of oscillation. Points  $O$  and  $P$  are reciprocally related to each other in the sense that if the pendulum were suspended at  $P$ ,  $O$  would be the center of oscillation.

**Types.** Kater's reversible pendulum is designed to measure  $g$ , the acceleration of gravity. It consists of a body with two knife-edge supports on opposite sides of the center of mass as at  $O$  and  $P$  (and with at least one adjustable knife-edge). If the pendulum has the same period when suspended from either knife-edge, then each is located at the center of oscillation of the other, and the distance between them must be  $L$ , the length of the equivalent simple pendulum. The value for  $g$  follows from Eq. (2).

The ballistic pendulum is a device to measure the momentum of a bullet. The pendulum bob is a block of wood into which the bullet is fired. The bullet is stopped within the block and its momentum transferred to the pendulum. This momentum is determined from the amplitude of the pendulum swing. See BALLISTICS.

The spherical pendulum is a simple pendulum mounted on a pivot so that its motion is not confined to a plane. The bob then moves over a spherical surface. A Foucault pendulum is a spherical pendulum suspended so that its plane of oscillation is free to rotate. Its purpose is to demonstrate the rotation of the Earth. See FOUCAULT PENDULUM; SCHULER PENDULUM. [J.M.Ke.]

**Penicillin** One of the beta-lactam antibiotics, all of which possess a four-ring beta-lactam structure fused with a five-membered thiazolidine ring. These antibiotics are nontoxic and kill sensitive bacteria during their growth stage by the inhibition of biosynthesis of their cell wall mucopeptide. See PLANT CELL.

The antibiotic properties of penicillin were first recognized by A. Fleming in 1928 from the serendipitous observation of a mold, *Penicillium notatum*, growing on a petri dish agar plate of a staphylococcal culture. The mold produced a diffuse zone which lysed the bacterial cells. Commercial production of penicillin came from the pioneer work of E. Chain and H. W. Florey

in 1938. Penicillin (as penicillin G) was made available to the allied troops in Europe in the latter part of World War II.

Penicillin is produced from the fungal culture *P. chrysogenum* that was isolated from a moldy cantaloupe. The biosynthesis of penicillin is known in detail, and all the enzymes involved in the formation of this secondary metabolite have been isolated and purified.

The fermented penicillin G and penicillin V are susceptible to destruction by an enzyme (beta-lactamase) produced by certain bacteria which makes them resistant. The penicillins methicillin, oxacillin, nafcillin, cloxacillin and dicloxacillin are resistant to hydrolysis by beta-lactamases and are used to treat staphylococcal infections. Cloxacillin and dicloxacillin are used orally. Ampicillin and amoxicillin are penicillins with extended spectra, and they are effective against many gram-negative bacteria. They are used mainly orally against streptococci and other respiratory-tract pathogens, including *Haemophilus influenzae*, in the treatment of sinusitis, bronchitis, and pneumonia. They are used extensively in pediatrics and against *Listeria monocytogenes* and *Salmonella* spp. See ANTIBIOTIC; DRUG RESISTANCE; SALMONELLOSES; STREPTOCOCCUS.

Penicillin G, the most commonly fermented penicillin, is produced by the addition of a precursor, phenylacetic acid, to the growing culture. Use of phenoxyacetic acid as a precursor produces penicillin V. Both penicillins are recovered by extraction into organic solvents at acid pH, and precipitation as their potassium or sodium salt. Penicillin G is generally given by injection against penicillin-sensitive streptococci such as pneumococci (meningitis), and in treatment of endocarditis and gonorrhea. Penicillin V is acid stable and is usually given orally. It is effective in the treatment of upper respiratory infections and periodontal work. See GONORRHEA; MENINGITIS. [D.A.Lo.]

**Penis** The male organ of copulation, or phallus. In mammals the penis consists basically of three elongated masses of erectile tissue. The central corpus spongiosum (corpus urethrae) lies ventral to the paired corpora cavernosa. The urethra runs along the underside of the spongiosum and then normally rises to open at the expanded, cone-shaped tip, the glans penis, which fits like a cap over the end of the penis. Loose skin encloses the penis and also forms the retractable foreskin, or prepuce.

Erection of the penis is caused by nervous stimulation resulting in engorgement of the spiral helicine arteries and the plentiful venous sinuses of the organ. In most mammals other than Primates the penis is retracted into a sheath when not in use.

In submammalian forms the penis is not as well developed. Crocodylians, turtles, and some birds have a penis basically like that of mammals, lying in the floor of the cloaca. When erected, it protrudes from the cloaca and functions in copulation. Other vertebrates lack a penis, although various functionally comparable organs may be developed such as the claspers on the pelvic fins of sharks and the gonopodia on the anal fins of certain teleost fishes. See COPULATORY ORGAN. [T.S.P.]

**Pennatulacea** An order of the subclass Alcyonaria, commonly called the sea pens. These animals lack stolons and live with their bases embedded in the soft substratum of the sea. The colony consists of a distal rachis bearing many polyps and a polypless proximal peduncle, whose terminal end sometimes expands to form a bladder. The colony of *Pennatula* looks like a feather being formed of numerous secondary polyps which arise from leaf-shaped lateral expansions of the very elongated primary axial or terminal polyp. In the other form of colony the polyps arise directly from the primary one, as in *Veretillum* (see illustration) and *Renilla* and *Cavenularia*. The colony has a horny unbranched axial skeleton composed of pennatulin and some

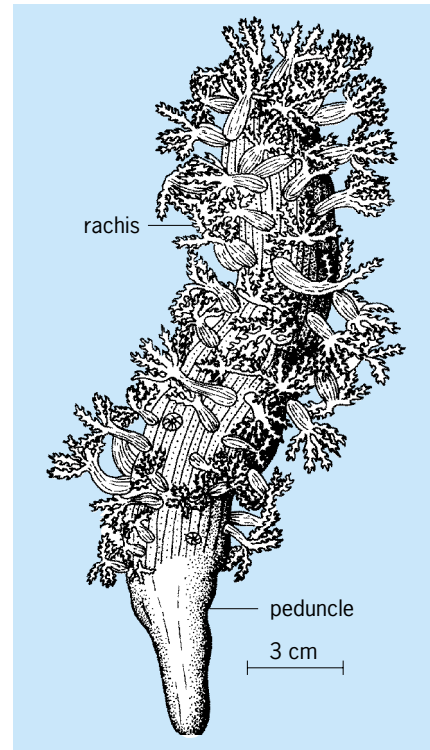

*Veretillum cynomorium*.

calcium carbonate and phosphate, but *Cavenularia*, including the luminous species, has a rudimentary one and *Renilla* lacks a skeleton. See ALCYONARIA. [K.At.]

**Pennsylvanian** A major division of late Paleozoic time, considered either as an independent period or as the younger subperiod of the Carboniferous. In North America, the Pennsylvanian has been widely recognized as a geologic period and derives its name from a thick succession of mostly nonmarine, coal-bearing strata in Pennsylvania. Radiometric ages place the beginning of the period at approximately 320 million years ago and its end at about 290 million years ago. In northwestern Europe, strata of nearly equivalent age are commonly designated as Upper Carboniferous and in eastern Europe as Middle and Upper Carboniferous. See CARBONIFEROUS.

In North America, the Pennsylvanian Period was characterized by the progressive growth and enlargement of the Alleghenian-Ouachita-Marathon orogenic belt, which formed as the northwestern parts of the large continent Gondwana (mainly northwestern Africa, the area that is now Florida, and northern South America) collided against and deformed the eastern and southern parts of the North American continent. See OROGENY.

Much of North America remained a stable, low-lying cratonic platform during the Pennsylvanian and was covered by a relatively thin veneer of shallow-water marine carbonates and marine and nonmarine clastic sediments. These were deposited as sea level repeatedly rose and fell as the polar glaciers of southern Gondwana contracted and expanded. In Pennsylvania and along the western part of the present Allegheny Plateau, Pennsylvanian strata are predominantly nonmarine deposits made up of channel sandstones, floodplain shales, siltstones, sandstones, and coals. See CARBONATE MINERALS; COAL; CRATON; MARINE SEDIMENTS.

During Pennsylvanian time, the paleoequator extended across North America from southern California to Newfoundland, through northwestern Europe into the Ukrainian region of eastern Europe, and across parts of northern China. This was a time

of extensive coal deposition in a tropical belt that appears to have included areas from 15 to 20° north and south of the paleo-equator. Coal of this age is abundant and relatively widespread and has great economic importance.

Petroleum is commonly trapped in nearshore marine deposits of Pennsylvanian age, particularly in carbonate banks near the edge of shelves, in longshore bars and beaches, in reefs and mounds, and at unconformities associated with transgressive-regressive shore lines. Many of these traps contribute significantly to petroleum production. See PETROLEUM.

Pennsylvanian paleogeography changed significantly during the period as the supercontinent Pangaea gradually was formed by the joining together of Gondwana and Laurasia. North America and northern Europe, which had been combined into the continent Laurasia since the late Silurian, and South America and northwestern Africa, which formed the northern part of the continent of Gondwana, came together along the Ouachita-Southern Appalachian-Hercynian geosyncline. The result was an extensive orogeny, or mountain-building episode, which supplied the vast amounts of sediments that make up most of the Pennsylvanian strata in the eastern and midwestern parts of the United States. See PALEOGEOGRAPHY.

Evidence in the form of well-developed tree rings, less diverse fossil floras and faunas, and glacial deposits indicates that temperate and glacial conditions were common in nonequatorial climatic belts during Pennsylvanian time. Climatic fluctuations during the period caused significant increases and decreases in the amount of water that was temporarily stored in the glaciers in Gondwana and contributed to eustatic changes of sea level. See PALEOCLIMATOLOGY. [C.A.R.; J.R.P.R.]

**Pentamerida** An extinct order of brachiopods that lived from Middle Cambrian to Late Devonian (520 to 390 million years ago) with a peak during the Silurian Period. Pentamerides are among the largest brachiopods, with adults ranging 1–15 cm (0.4–6 in.) in length. The two valves, always composed of calcite (CaCO<sub>3</sub>), are both convex, with a larger ventral (pedicle) valve and a smaller dorsal (brachial) valve. Externally, most pentamerides are smooth except for concentric growth-line increments, but a proportion have radial ribs (costae) which may be sinuous or sharp-crested in cross section. Internally, the valve space is divided by variably developed walls (septa), with one median septum in the ventral valve dividing it into two, and two septa in the dorsal valve, dividing it into three, for a total of five divisions. The septa in the dorsal valve unite to form a platform termed the spondylium, which was used as an attachment area for the muscles which opened and closed the valves. The form and disposition of the soft parts are not well known.

Within the order Pentamerida there are currently 215 genera, which have been described from Paleozoic rocks in all continents. The order is subdivided into the rather smaller suborder Syntrophidina, with 90 genera ranging in age from the Middle Cambrian to the Early Devonian, and the suborder Pentameridina, which ranged from the Middle Ordovician to the Late Devonian. See BRACHIOPODA. [L.R.M.C.]

**Pentastomida** A class of bloodsucking arthropods, parasitic in the respiratory organs of vertebrates, that frequently are referred to as the Linguatulida or tongue worms. The adults are vermiform, with a short cephalothorax and an elongate, annulate abdomen that may be cylindrical or flattened.

The class is divided into two orders: the Cephalobaenida, a more primitive group, and the Porocephalida, a more specialized one. The first has six-legged larvae and the other, four-legged larvae. The mitelike form of the larvae, with short stumpy legs, demonstrates relationship to the arthropods. Characteristic arthropod features include the presence of (1) jointed appendages in the larvae; (2) stigmata or breathing pores in the body wall; (3) specialized reproductive organs, especially those

of the male; and (4) ecdysis or molting of larvae and nymphs. More than 50 species have been described.

Human infection occurs frequently in Africa and the Orient, where humans are an accidental intermediate host of the nymphal form. The liver is a common site of infection, and large numbers of larvae may produce serious and even fatal effects. See ARTHROPODA; CEPHALOBAENIDA; POROCEPHALIDA. [H.W.S.]

**Pentlandite** A mineral having composition (Fe,Ni)<sub>9</sub>S<sub>8</sub>. Pentlandite is the major ore of nickel. It is usually massive, showing a well-defined octahedral parting. The hardness is 3.5–4 (Mohs scale) and the specific gravity varies from 4.6 to 5.0, depending on the ratio of iron to nickel; greater amounts of iron cause an increase in the specific gravity. The luster is metallic and the color yellowish bronze. Pentlandite is found at many localities in small amounts, but its chief occurrence is at Sudbury, Ontario, where it is mined on a large scale. See NICKEL. [C.S.Hu.]

**Pepper** The garden pepper, *Capsicum annuum* (family Solanaceae), is a warm-season crop originally domesticated in Mexico. It is usually grown as an annual, although in warm climates it may be perennial. This species includes all peppers grown in the United States except for the "Tabasco" pepper (*C. frutescens*), grown in Louisiana. Other cultivated species, *C. chinense*, *C. baccatum*, and *C. pubescens*, are grown primarily in South America. Some 10–12 strictly wild species also occur in South America. Peppers are grown worldwide, especially in the more tropical areas, where the pepper is an important condiment.

Sweet (nonpungent) peppers, harvested fully developed but still green, are widely used in salads or cooked with other foods. Perfection pimento, harvested red ripe, is used for canning. Paprika is made from ripe red pods of several distinct varieties; the pods are dried and ground. See PAPRIKA; PIMENTO.

The ripe color of most varieties is red, a few varieties are orange-yellow, and in Latin America brown-fruited varieties are common. Nutritionally, the mature pepper fruit has three to four times the vitamin C content of an orange, and is an excellent source of vitamin A. See ASCORBIC ACID; VITAMIN A. [P.G.S.]

**Peppermint** The mint species *Mentha piperita* (family Lamiaceae), a sterile interspecific hybrid believed to have occurred in nature from the hybridization of fertile *M. spicata*. Peppermint oil is obtained by steam distillation from the partially dried hay. The main uses of peppermint oil are to flavor chewing gum, confectionery products, toothpaste, mouthwashes, medicines, and as a carminative in certain medical preparations for the alleviation of digestive disturbances. [M.J.M.]

**Pepsin** A proteolytic enzyme found in the gastric juice of mammals, birds, reptiles, and fish. It is formed from a precursor, pepsinogen, which is found in the stomach mucosa. Pepsinogen is converted to pepsin either by hydrochloric acid, naturally present in the stomach, or by pepsin itself. See ENZYME.

Pepsin is prepared commercially from the glandular layer of fresh hog stomachs. It is a part of the crude preparation known as rennet, which is used to curdle milk in preparation for cheese manufacture. Pepsin is also used for a variety of other applications in food manufacturing; to modify soy protein and gelatin, thereby providing whipping qualities; to modify vegetable proteins for use in nondairy snack items; to make precooked cereals into instant hot cereals; and to prepare animal and vegetable protein hydrolysates for use in flavoring foods and beverages. [M.So.]

**Peptide** A compound that is made up of two or more amino acids joined by covalent bonds which are formed by the elimination of a molecule of H<sub>2</sub>O from the amino group of one amino acid and the carboxyl group of the next amino acid. Peptides larger than about 50 amino acid residues are usually classified

as proteins. Glutathione is the most abundant peptide in mammalian tissue. Hormones such as oxytocin (8), vasopressin (8), glucagon (29), and adrenocorticotrophic hormone (39) are peptides whose structures have been deduced; in parentheses are the numbers of amino acid residues for each peptide.

For each step in the biological synthesis of a peptide or protein there is a specific enzyme or enzyme complex that catalyzes each reaction in an ordered fashion along the biosynthetic route. However, it is noteworthy that, although the biological synthesis of proteins is directed by messenger RNA on cellular structures called ribosomes, the biological synthesis of peptides does not require either messenger RNA or ribosomes. See AMINO ACIDS; PROTEIN; RIBONUCLEIC ACID (RNA); RIBOSOMES. [J.M.M.]

**Peracarida** A superorder of the superclass Crustacea, subclass Eumalacostraca. The Peracarida includes the orders Amphipoda, Cumacea, Isopoda, Mictacea, Mysidacea, Spelaeogriphacea, Thermosbaenacea, and Tanaidacea. In these orders the young develop within the mother's ventral thoracic marsupium, which they leave at an advanced stage of development. The marsupium is formed by one to seven pairs of membranous oostegites that extend inward from the coxae of the thoracic legs. The eggs or developing young lie free in the space between the ventral surface of the thorax and the overlapping oostegites. The other basic feature of the Peracarida is an accessory incisor process (*lacinia mobilis*) in the adult that is known elsewhere only in the primitive class Remipedia. The *lacinia mobilis*, on the left mandible or both mandibles, is formed from modification of the anterior spine of the spine-row. Besides aiding in cutting, the *lacinia mobilis* helps align the incisor processes for occlusion.

As with other Malacostraca, the thorax consists of eight somites, the first of which is fused with the head. A carapace is present except in the Amphipoda, Isopoda, and Mictacea; in the last, small carapace folds cover the bases of the mouthparts posterior to the mandibles. When present, the carapace does not coalesce with more than four thoracic somites. The thorax is followed by an abdomen of six segments bearing up to five pairs of biramous swimming legs or pleopods. The sixth segment has a pair of uropods, which, together with the telson, forms a tail fan. Pleopods are absent in all female and some male Cumacea, may be reduced or absent in female Tanaidacea, and may be rudimentary in female Mysidacea. The embryo in the Amphipoda is ventrally concave and lies with the dorsal side toward the outside of the egg. The position is reversed in the other orders. Mysidacea and Amphipoda leave the egg with a full complement of appendages; hatchlings in the other orders lack the eighth thoracic leg. See CRUSTACEA; EUMALACOSTRACA. [T.E.B.]

**Percent** A ratio comparison of two quantities expressed by using 100 equal parts, or hundredths; symbolized %. There are three major uses of percent: part of a whole, rate, and comparison of any two quantities.

**Part of a whole.** The basic idea of percent is as a ratio that shows a part of a whole. The technical name for the whole is base.

If 89 out of 100 problems are correct, the part-whole comparison shows 89/100 or 89% correct. If the whole is not already divided into equal parts, an equivalent ratio to 100 is found.

Certain ratios are easy to express as hundredths. When 3 baskets are made in basketball out of 10 attempts, an equivalent ratio using 100 is found from which the percent is obvious:  $3/10 = 30/100 = 30\%$ .

For 35 hits out of 126 times at bat, the ratio 35/126 is not easily expressed as a ratio using 100. Hundredths will be more obvious by dividing 35 by 126, and then reading the number of hundredths to find the percent:  $35 \div 126 \approx 0.278$  or 27.8%. The percent is obtained by moving the decimal point two places to the right.

**Rate.** While percent always means a comparison to 100, percent can show a rate of so many per 100, not so many out of 100. A sales tax of 6% means a rate of 6 cents for each dollar, and this 6 cents is in addition to the dollar. The tax amount can often be calculated mentally by multiplying the 6% rate by the number of dollars.

Interest paid or interest received is done by using rates. Simple interest at a rate of 6% means \$6 per \$100 for a full year. If interest is calculated monthly on the unpaid balance and the yearly rate is 18%, the monthly rate is approximately  $18\% \div 12$  or about 1.5%.

With compound interest, the amount of interest is added each compounding period, and this total amount is subject to compounding for the next period. For example, \$1.00 invested at 8% will be worth 108% of \$1.00 at the end of one year, or \$1.08. The worth at the end of the second year is 108% of \$1.08, or  $(1.08)^2$ . At this same rate, after 10 years the compounded value is  $(1.08)^{10} = 2.1589247$ , or \$2.15, using 1.08 as a factor for 10 times.

**Comparing any two quantities.** Percent is used to compare any two quantities, but special care must be given to the base for the comparison. Comparison of city A with a population of 42,000 people and city B with 67,000 people will depend on the base. A compared to B is  $42,000/67,000$ , 62.7%; A is 62.7% of B. B compared to A is  $67,000/42,000$ , 1.595, or 159.5%; B is 159.5% of A. See ARITHMETIC. [J.N.P.]

**Perception** Those subjective experiences of objects or events that ordinarily result from stimulation of the receptor organs of the body. This stimulation is transformed or encoded into neural activity (by specialized receptor mechanisms) and is relayed to more central regions of the nervous system where further neural processing occurs. Most likely, it is the final neural processing in the brain that underlies or causes perceptual experience, and so perceptionlike experiences can sometimes occur without external stimulation of the receptor organs, as in dreams.

In contemporary psychology, interest generally focuses on perception or the apprehension of objects or events, rather than simply on sensation or sensory process. While no sharp line of demarcation between these topics exists, it is fair to say that sensory qualities are generally explicable on the basis of mechanisms within the receptor organ, whereas object and event perception entails higher-level activity of the brain. See HEARING (HUMAN); SENSATION; VISION.

Since objects or events are not experienced only through vision, the term perception obviously applies to other sense modalities as well. Certainly things and their movement may be experienced through the sense of touch. Such experiences derive from receptors in the skin (tactile perception), but more importantly, from the positioning of the fingers with respect to one another when an object is grasped, the latter information arising from receptors in the muscles and joints (haptic or tactual perception). The position of the parts of the body are also perceived with respect to one another whether they are stationary (proprioception) or in motion (kinesthesia), and the position of the body is experienced with respect to the environment through receptors sensitive to gravity such as those in the vestibular apparatus in the inner ear. Auditory perception yields recognition of the location of sound sources and of structures such as melodies and speech. Other sense modalities such as taste (gustation), smell (olfaction), pain, and temperature provide sensory qualities but not perceptual structures as do vision, audition, and touch, and thus are usually dealt with as sensory processes. See OLFACTION; PAIN; PROPRICEPTION.

**Constancy.** By and large, these perceptual properties of objects remain remarkably constant despite variations in distance, slant, and retinal locus caused by movements of the observer. This fact, referred to as perceptual constancy, is perhaps the hallmark of perception and more than any other, serves to characterize the field of perception.

Examples of perceptual constancy are: size (except at very great distances, an object appears the same size whether seen nearby or far away, although the size of its image on the retina can be very different); shape (a circle seen from the side is perceived as a circle, although it appears as an ellipse on the retina); orientation (objects appear to keep the same orientation in space, independently of the orientation of the observer's head); and position (a fixed object remains perceived as stationary even when its image on the retina moves because of eye or head movements).

**Motion perception.** Perceived movement cannot simply be explained by the motion of an object's retinal image since image motion caused by observer or eye movement does not lead to perceived object movement. Moreover, an object tracked by smooth-pursuit eye movements will appear to move, although in that case there is essentially no motion of the object's image over the retina. Similarly, an afterimage will appear to move during eye movement even in a completely darkened room. Where ordinarily the movement of the retinal image caused by the moving eye is computed to signify "no object motion," thus yielding position constancy (since the image motion and eye motion are equal in magnitude), the same computational rule must signify "object motion" in the case of the afterimage.

**Form perception.** Form perception means the experience of a shaped region in the field. Recognition means the experience that the shape is familiar. Identification means that the function or meaning or category of the shape is known. For those who have never seen the shape before, it will be perceived but not recognized or identified. For those who have, it will be perceived as a certain familiar shape and also identified. Recognition and identification obviously must be based on past experience, which means that through certain unknown processes, memory contributes to the immediate experience that one has, giving the qualities of familiarity and meaning.

The figure of a 4 in Fig. 1a is seen as one unit, separate from other units in the field, even if these units overlap. This means that the parts of the figure are grouped together by the perceptual system into a whole, and these parts are not grouped with the parts of other objects. This effect is called perceptual organization. There are other problems about form perception that remain to be unraveled. For example, the size of a figure can vary, as can its locus on the retina or even its color or type of contour, without affecting its perceived shape (Fig. 2).

A further fact about form perception is that it is dependent upon orientation. It is a commonplace observation that printed or written words are difficult to read when inverted, and faces look very odd or become unrecognizable when upside down. Simple figures also look different when their orientation is changed: a square looks like a diamond when tilted by 45°.

**Geometrical illusions.** Related to the topic of form perception is the misperception of the size or direction of parts of figures

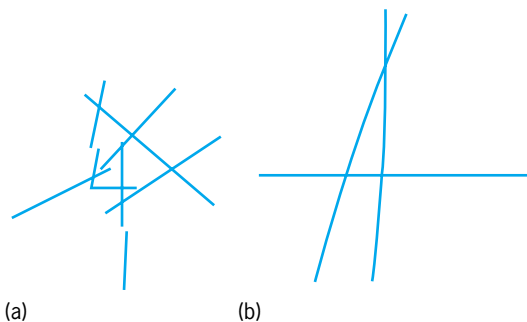

**Fig. 1. Perceptual organization, (a) The figure of a four is immediately and spontaneously perceived despite the presence of other overlapping and adjacent lines, (b) The four, although physically present, is not spontaneously perceived and is even difficult to see when one knows it is there.**

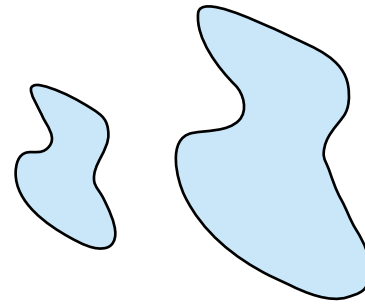

**Fig. 2. Transposition of form; the two shapes clearly look the same despite the difference in size.**

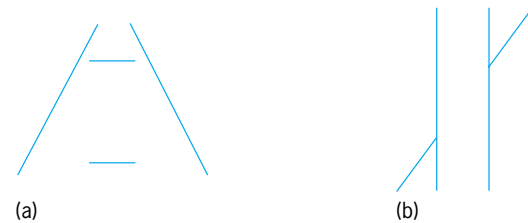

**Fig. 3. Geometrical illusions, (a) The Ponzo illusion in which the two horizontal lines of equal length appear unequal, (b) The Poggendorff illusion in which the two oblique line segments are aligned with one another (that is, are collinear) but appear to be misaligned.**

that constitutes many of the geometric illusions. In an illusion figure, one particular part is perceived to be either longer or shorter than another part, although they are objectively equal (Fig. 3a); or the direction of a contour is perceived to be different from that of another contour although they are the same (Fig. 3b). For reasons still not understood, the background or context of the rest of the figure affects these parts.

**Innate or learned?** A central problem is whether the perception of properties such as form and depth or the achievement of veridical perception as in the constancies is innately determined or is based on past experience. By "innate" it is meant that the perception is the result of evolutionary adaptation and thus is present at birth or when the necessary neural maturation has occurred. By "past experience" it is meant that the perception in question is the end result of prior exposure to certain relevant patterns or conditions, a kind of learning process. Despite centuries of discussion of this problem, and considerable experimental work, there is still no final answer to the question. It now seems clear that certain kinds of perception are innate, but equally clear that past experience also is a determining factor. See INTELLIGENCE. [I.R.]

**Perciformes** The typical spiny-rayed fishes, also known by the ordinal names Acanthopteri and Percomorphi. This is the largest order of vertebrates; the approximately 7500 species include 41% of all fishes. Perciformes include a diversity of structural types and sizes. The characters of the Perciformes include fin spines, usually present; a pelvic fin which, if present, is usually thoracic or jugular in position; the pelvic girdle usually attached to the cleithra, sometimes connected by ligaments; the pelvic fin usually with a spine and 5 soft rays, the latter occasionally reduced; the pectoral fin base more or less vertical, usually placed well up on the side; a swim bladder without a duct; scales usually ctenoid, sometimes secondarily cycloid, absent, or variously modified; and the caudal fin with 17 principal rays (15 branched) or fewer.

Perciform fishes dominate the modern vertebrate life of the oceans and have done so throughout the Cenozoic. The group first appeared in the Upper Cretaceous, after which it underwent a rapid adaptive radiation; many of the basic structural

types, as well as most major perciform derivatives such as the Pleuronectiformes and Tetraodontiformes, were present in the Eocene. A few families of perciforms have been notably successful in fresh water. Other families have effectively adapted to life in the deep seas, and still others have become specialized for pelagic existence. It is in the shore areas, the offshore banks, the coral reefs, the coastal beaches and lagoons, and the intertidal zone, however, that the perciforms have attained their ultimate achievement. Here the enormous variety attests to the adaptive effectiveness of the group. See ACTINOPTERYGII; OSTEICHTHYES.

[R.M.B.]

**Percopsiformes** A small order of actinopterygian fishes that is also known as the Salmopercae and Amblyopsiformes. The order is thought to be remotely related to the codfishes (Gadiformes) and toadfishes (Batrachoidiformes). The characters (see illustration) include single, ray-supported dorsal and anal fins, each usually with one to four anterior spines; pelvic fin, if present, subabdominal in position, with three to eight soft rays; pelvic girdle, if present, attached to the postcleithra; swim bladder without a duct; and body covered with cycloid or ctenoid scales. See BATRACHOIDIFORMES; GADIFORMES.

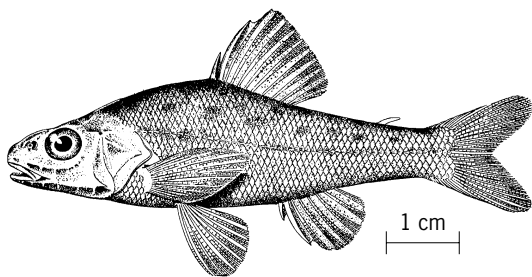

Sand roller (*Percopsis transmontana*). (After D. S. Jordan and B. W. Evermann, *The Fishes of North and Middle America*, U.S. Nat. Mos. Bull. 47, 1900)

The order comprises three families, five genera, and eight Recent species of North American fresh-water fishes. See ACTINOPTERYGII; TELEOSTEI.

[R.M.B.]

**Performance rating** A procedure for determining the value for a factor which will adjust the measured time for an observed task performance to a task time that one would expect of a trained operator performing the task, utilizing the approved method and performing at normal pace under specified workplace conditions. Normal time (ultimately subjectively based) is the time that a trained worker requires to perform the specified task under defined workplace conditions, employing the assumed philosophy of "a fair day's work for a fair day's pay."

The performance rating process is concerned with determining normal pace during the work portion of an average day and must, therefore, consider the fatigue recovery aspects of allowance (nonwork) times occurring during the day. The following two equations relate factors in determining how much time a worker will be allowed per unit of output:

$$\begin{aligned} \text{Standard time} &= \text{normal time} \times \text{allowances} \\ \text{Normal time} &= \text{observed time} \times \text{rating factor} \end{aligned}$$

If the observed time for a task is adjusted by the performance rating factor to determine normal time, and allowance time is added for nonwork time, the standard time will represent the allowed time per unit of production.

The most commonly employed rating technique throughout the history of stopwatch time study, including the present, is referred to as pace rating. A properly trained employee of average skill is time-studied while performing the approved task method under specified work conditions. Rating consists only of deter-

mining the relative pace (speed) of the operator in relation to the observer's concept of what normal pace should be for the observed task, including consideration of expected allowances to be applied to the standard. See HUMAN-FACTORS ENGINEERING; METHODS ENGINEERING; WORK MEASUREMENT.

[P.E.H.]

**Pericycle** As commonly defined, the outer boundary of the stele of plants. Originally it was interpreted as a band of cells between the phloem and the innermost layer (endodermis) of the cortex. Such pericycle is commonly found in roots and, in lower vascular plants, also in stems. In higher vascular plants, however, a distinct layer of cells may not be present between the phloem and the cortex. The pericycle, if present, may be composed of parenchyma or sclerenchyma cells with relatively thin or heavily thickened walls. It may be one to several layers in radial dimensions.

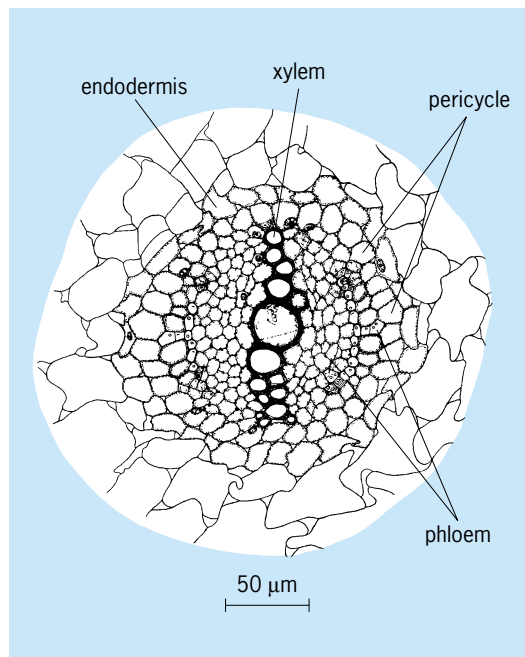

Transsection of central part of sugarbeet. (From K. Esau, *Hilgardia*, 9(8), 1935)

Primordia of branch roots commonly arise in the pericycle in seed plants, most frequently outside the xylem ridges (see illustration). The first cork cambium may also arise in the pericycle of those roots that have secondary vascular tissues. In roots, a part of the vascular cambium itself (that outside the primary xylem ridges) originates from pericycle cells. See CORTEX (PLANT); ENDODERMIS; LATERAL MERISTEM; PARENCHYMA; PHLOEM; ROOT (BOTANY); SCLERENCHYMA; STEM; XYLEM.

[V.I.C.]

**Pericyclic reaction** Concerted (single-step) processes in which bond making and bond breaking occur simultaneously (but not necessarily synchronously) via a cyclic (closed-curve) transition state. Although a given reaction may appear formally to be pericyclic, it cannot be assumed to be a concerted process. In each case, the detailed mechanism of the reaction must be established experimentally. Pericyclic reactions can be promoted either by heat or by light; the stereochemistry of the reaction is determined by the mode of activation employed and the number of electrons that are delocalized in the transition state. See CHEMICAL BONDING; PHYSICAL ORGANIC CHEMISTRY; STEREOCHEMISTRY.

Four types of pericyclic reactions that are frequently encountered in organic chemistry are electrocyclic processes, cycloadditions, sigmatropic shifts, and chelotropic reactions.

Electrocyclic processes are reactions that involve their cyclization across the termini of a conjugated  $\pi$ -system with concomitant formation of a new  $\sigma$ -bond or the microscopic reverse. The sequence of steps involved in the forward reaction must be the same, in the reverse order, as that in the reverse direction when the forward and reverse reactions are carried out under identical conditions. This statement is known as the principle of microscopic reversibility.

The effect of the mode of activation upon the stereochemistry of an electrocyclic process is shown in the reaction (1), where

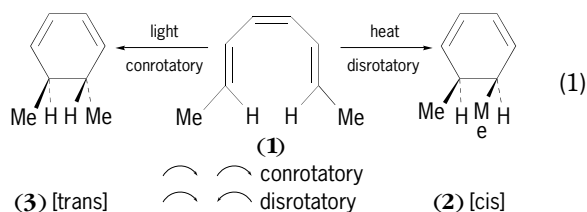

Me = methyl, for the hexatrienecyclohexadiene interconversion (a six-electron electrocyclic process). Thus, when *trans,cis,trans*-2,4,6-octatriene [structure (1)] is heated, disrotatory motion of the two terminal  $2p$  orbitals occurs; that is, they rotate in opposite directions thereby resulting in exclusive formation of *cis*-5,6-dimethylcyclohexa-1,3-diene (2). The corresponding photochemical process results in conrotatory motion of the termini in structure (1); that is, the two terminal  $2p$  orbitals rotate in the same direction thereby yielding *trans*-5,6-dimethylcyclohexa-1,3-diene (3) exclusively.

Cycloadditions occur when two (or more)  $\pi$ -electron systems react under the influence of heat or light to form a cyclic compound with concomitant formation of two new  $\sigma$ -bonds that join the termini of the original  $\pi$ -systems. The stereochemistry of this reaction is classified with respect to the two molecular planes of the reactants. Thus, if  $\sigma$ -bond formation occurs from the same face of the molecular plane across the termini of one of the component  $\pi$ -systems, the reaction is said to be suprafacial on that component. If instead  $\sigma$ -bond formation occurs from opposite faces of the molecular plane, the reaction is said to be antarafacial on that component. This distinction is illustrated in reaction (2) for two thermal processes, where the symbol  $\neq$  indicates the structure of the transition state. Reaction (2a) shows the Diels-Alder [4 + 2] cycloaddition of butadiene (4) to ethylene (5), a six-electron pericyclic reaction in which additions across the termini of the diene (four-electron component) and dienophile (two-electron component) both occur suprafacially. Reaction (2b) shows a [14 + 2] cycloaddition in which  $\sigma$ -bond formation occurs suprafacially on the two-electron component [tetracyanoethylene (6)] and antarafacially on the fourteen-electron component [heptafulvalene (7)].

Sigmatropic shifts involve migration of a  $\sigma$ -bond that is flanked at either (or both) ends by conjugated  $\pi$ -systems. Either one or both ends of the  $\sigma$ -bond may migrate to a new location within the one or more flanking  $\pi$ -systems.

Cheletropic reactions involve extrusion of a fragment via concerted cleavage of two  $\sigma$ -bonds that terminate at a single atom or the reverse process. Cheletropic fragmentations may be either linear or nonlinear [reaction 3].

R. B. Woodward and R. Hoffmann introduced an application of molecular orbital theory that permits prediction of rates and products of pericyclic reactions. They utilized symmetry properties of molecular orbitals to estimate relative energies of diastereoisomeric transition states for structurally similar pericyclic reactions.

In an alternative theoretical approach to understanding pericyclic reactions, the transition state is examined directly, and

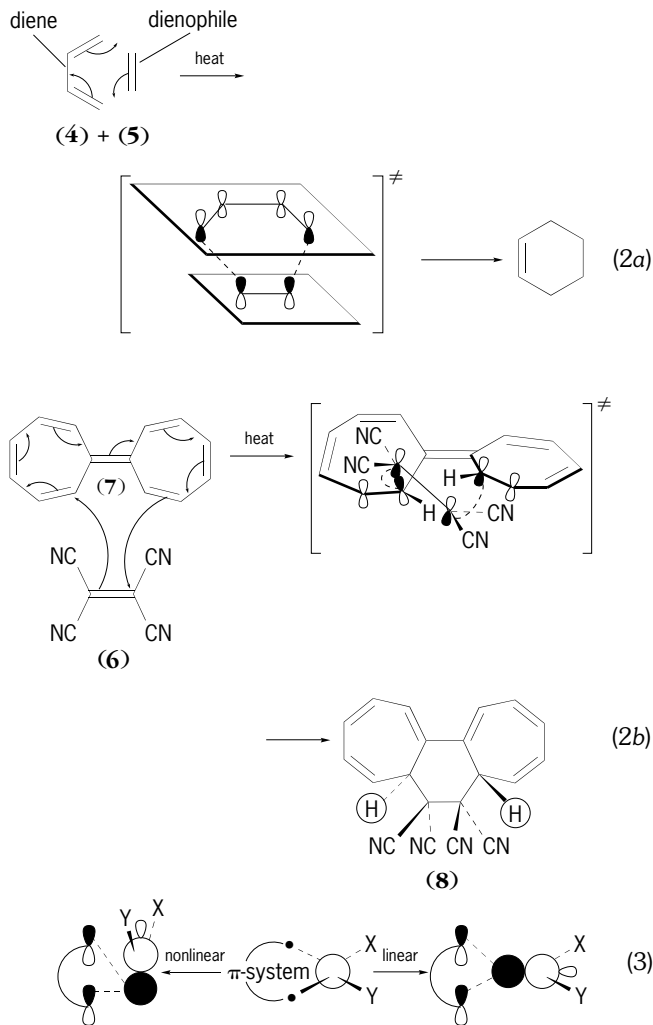

attempts to estimate the degree of electronic stabilization (allowedness) or destabilization (forbiddenness) inherent in that transition state are made. One such approach emphasizes the importance of frontier orbitals (highest-occupied-lowest-unoccupied molecular orbitals) in determining the course of a pericyclic reaction. See DELOCALIZATION; DIELS-ALDER REACTION; ELECTRON CONFIGURATION; MOLECULAR ORBITAL THEORY; ORGANIC REACTION MECHANISM; WOODWARD-HOFFMANN RULE. [A.P.M.]

**Periderm** A group of tissues which replaces the epidermis in the plant body. Its main function is to protect the underlying tissues from desiccation, freezing, heat injury, mechanical destruction, and disease. Although periderm may develop in leaves and fruits, its main function is to protect stems and roots. The fundamental tissues which compose the periderm are the phellogen, phelloderm, and phellem.

The phellogen is the meristematic portion of the periderm and consists of one layer of initials. These exhibit little variation in form, appearing rectangular and somewhat flat in cross and radial sections, and polygonal in tangential sections.

The phelloderm cells are phellogen derivatives formed inward. The number of phelloderm layers varies with species, season, and age of the periderm. In some species, the periderm lacks the phelloderm altogether. The phelloderm consists of living cells with photosynthesizing chloroplasts and cellulosic walls.

The phellem, or cork, cells are phellogen derivatives formed outward. These cells are arranged in tiers with almost no intercellular spaces except in the lenticel regions. After completion of their differentiation, the phellem cells die and their protoplasts disintegrate. The cell lumens remain empty, excluding a few



species in which various crystals can be found. The remarkable impermeability of the suberized cell walls is largely due to their impregnation with waxes, tannins, cerin, friedelin, and phelliconic and phellogenic acids.

Lenticels are loose-structured openings that develop usually beneath the stomata and that facilitate gas transport through the otherwise impermeable layers of phellem. See BARK; SCLERENCHYMA. [Y.W.; H.Wi.]

**Peridotite** A rock consisting of more than 90% of millimeter-to-centimeter-sized crystals of olivine, pyroxene, and hornblende, with more than 40% olivine. Other minerals are mainly plagioclase, chromite, and garnet. Much of the volume of the Earth's mantle probably is peridotite.

Peridotites have three principal modes of occurrence corresponding approximately to their textures: (1) Peridotites with well-formed olivine crystals occur mainly as layers in gabbroic complexes. (2) Peridotite nodules in alkaline basalts and diamond pipes generally have equigranular textures, but some have irregular grains. (3) Peridotite also occurs on the walls of rifts in the deep sea floor and as hills on the sea floor, some of which reach the surface. See GABBRO.

Peridotites are rich in magnesium, reflecting the high proportions of magnesium-rich olivine. The compositions of peridotites from layered igneous complexes vary widely, reflecting the relative proportions of pyroxenes, chromite, plagioclase, and amphibole.

Peridotite is an important rock economically. Where granites have intruded peridotite, asbestos and talc are common. Pure olivine rock (dunite) is quarried for use as refractory foundry sand and refractory bricks used in steelmaking. Serpentinized peridotite is locally quarried for ornamental stone. Tropical soils developed on peridotite are locally ores of nickel. The sulfides associated with peridotites are common ores of nickel and platinum metals. The chromite bands commonly associated with peridotites are the world's major ores of chromium. See IGNEOUS ROCKS. [A.T.A.]

**Period doubling** A scenario for the transition of a natural process from regular motion to chaos. Various natural processes develop in time in a way that depends upon prevailing environmental details. A quantity that specifies the particular state of the environment of a process is called a parameter, and is taken as a fixed value over the course of development of the process.

It is a frequent natural occurrence for a process to have a regular and easily describable motion for some range of parameters, but to have complex, irregular, and difficult-to-describe motions for other ranges of parameters. In the context of fluid flow, the latter circumstance is termed turbulence. In a more general context it is called chaos (which includes fluid turbulence but presages an underlying generality). See FLUID FLOW; TURBULENT FLOW.

Sometimes, as the environmental parameters are varied, a process may systematically exhibit more irregular motions, turning over into chaotic motion beyond some parameter value. In analogy to the phenomenology of phase transitions, this circumstance is termed a transition to chaos. There are a variety of qualitatively different transitions to chaos, each termed a scenario. Period doubling is one frequently encountered scenario leading to chaos for which a full theoretical account exists. Since it occurs in a wide variety of processes of significantly divergent physical characters (for example, fluid-flow, chemical reactions, and electronic devices), it is sensible to consider it as a phenomenon in its own right. See PHASE TRANSITIONS.

In order to observe this scenario, it is sufficient that all but one parameter is held fixed. Over some range of this varied parameter (it shall be defined to increase over the range of investigation) the motion is observed to be periodic. Above a certain value of the parameter the motion grows more complicated (a bifurcation has occurred): after the amount of time  $T$  for which the

motion exactly repeated itself just prior to the bifurcation, the motion now slightly fails to do so, exactly repeating, however, after another  $T$  seconds. That is, the period has doubled from  $T$  to  $2T$ . As the parameter is further increased, the error to repeat after the first half of the new period systematically increases. A still further increase of parameter produces another bifurcation resulting in a new doubling of the period: the motion slightly fails to repeat after two roughly periodic cycles, exactly doing so after four. As the parameter is further increased, there are successive period-doubling bifurcations, more and more closely spaced in parameter value until at a critical value the doubling has occurred an infinite number of times, so that the motion is now no longer periodic and hence of a more complex character than had yet been encountered. Unpredictably complex motions occur for values of the parameter above its critical value, although ranges of parameter still exist for which the system exhibits new periodic motions. Indeed any period-doubling system exhibits the same sequence of truly chaotic motion and interspersed periodicities as its parameter increases. Thus there is a strong degree of qualitatively universal behavior for all systems experiencing this scenario.

However, there is also a precise quantitative universality. That is, without knowing the system (or its equations) essentially all measurable quantities can be predicted: By looking at the data alone, it would not be possible to guess the physical system responsible for that data. Thus, reminiscent of thermodynamics, questions can be posed and answered in a general manner that bypasses the specific mechanisms governing any particular system. [M.J.F.]

**Periodic motion** Any motion that repeats itself identically at regular intervals. If  $x(t)$  represents the displacement of any coordinate of the system at time  $t$ , a periodic motion has the property defined by the following equation for every value of the

$$x(t + T) = x(t)$$

variable time  $t$ . The fixed time interval  $T$  between repetitions, or the duration of a cycle, is known as the period of the motion.

The motion of the escapement mechanism of a watch, the motion of the Earth about the Sun, and the more complicated motion of the crankshaft, piston rods, and pistons in an engine running at uniform speed are all examples of periodic motion.

The vibration of a piano string after it is struck is a damped periodic motion, not strictly periodic according to the definition. Although the motion very nearly repeats itself, and with a fixed repetition time, each successive cycle has a slightly smaller amplitude. See DAMPING; HARMONIC MOTION; VIBRATION; WAVE MOTION. [J.M.Ke.]

**Periodic table** A list of elements (atoms) ordered along horizontal rows according to atomic number (the number of electrons in an atom and also the charge on its nucleus). In the periodic table (see illustration), the rows are arranged so that elements with nearly the same chemical properties occur in the same column (group), and each row ends with a noble gas (closed-shell element that is generally inert). For chemists, the position of atoms in the periodic table provides the most powerful guide for classifying the expected properties of molecules and solids made from these particular atoms. See INERT GASES.

The origin of the periodic table was explained in the 1920s in terms of the basic physical laws (quantum mechanics) obeyed by the electrons of an atom. Thus, the rows in the periodic table correspond to the shell number,  $n$ , and groups correspond to a particular electronic configuration designated by the number and type of electrons in the outermost shell. These electrons govern chemical properties and are known as valence electrons. See ELECTRON CONFIGURATION; QUANTUM MECHANICS; VALENCE.

Additional information from the physical laws of atoms can be incorporated into the periodic table and can greatly enhance its organizing capability. For example, configuration energy adds a



Although bacteria are essential for induction of the disease, predisposing factors are also important, though their elucidation is not complete. Individuals who manifest functionally abnormal neutrophilic granulocytes or monocytes are unusually susceptible to the severe early onset forms of periodontitis. The leukocyte abnormality appears to be genetically transmitted. The early-onset forms have been designated as prepubertal, juvenile, and rapidly progressive periodontitis; adult periodontitis has a later onset and does not seem to be related to leukocyte abnormalities. Some persons with acquired immune deficiency syndrome (AIDS) manifest a highly destructive, unique form of periodontitis. Other predisposing conditions include unusually stressful situations and periods of hormone imbalance occurring at puberty, during pregnancy, and in some women taking birth control drugs.

Good daily oral hygiene practices, including vigorous brushing of the exposed surfaces of the teeth and use of dental floss, interproximal brushes, and other devices to clean between the teeth, constitute the most effective measures to prevent periodontal disease. Basic ingredients of treatment of existing disease include bringing the infection under control and establishing conditions which preclude reinfection. All of the microbial deposits must be removed from the crown and root surfaces. In individuals with severe forms of periodontitis, these procedures may be supplemented by use of antibiotics either systematically or directly into the pocket. These procedures usually lead to reduction of the inflammation and to some shrinkage in the gums, but the periodontal pockets remain. Based on the traditional view that treated pockets may become reinfected and the disease may continue to spread, surgical treatment may be performed with the aim of reducing pocket depth and restoring normal tissue contours. Alternatively, regenerative procedures use various grafting materials, including freeze-dried decalcified bone or bone substitutes and guided tissue regeneration. To perform guided tissue regeneration, flaps are opened in the gingival tissue and the root surfaces are thoroughly cleaned; a porous membrane is placed around the tooth, covering the bone defect with or without placing grafts, and flaps covering the membranes are sutured into place. The membrane permits the wound site to become populated with cells having the capacity to generate new bone, cementum, and periodontal attachment. See TOOTH DISORDERS. [R.C.P.]

**Perischoechinoidea** A subclass of Echinoidea lacking stability in the number of columns of plates that make up the ambulacra and interambulacra. The ambulacral columns vary from 2 to 20, the interambulacral from 1 to 14. Of the four included orders, three are exclusively Paleozoic; the other, Cidaroida, includes both Paleozoic and extant members and is probably ancestral to all other surviving echinoids. See ECHINOIDEA. [H.B.F.]

**Periscope** An optical instrument that permits viewing along a displaced or deflected axis, providing an observer with the view from a position which may be inaccessible or dangerous. Periscopes range in complexity from the simple unit-power tank periscope to the complex multielement submarine periscope.

The tank periscope, intended to protect the user from bullets, employs a pair of plane, parallel, reflecting surfaces (either mirrors or prisms), so arranged in a mount that the path of light through the instalment forms a crude letter Z. If powers greater than unity are desired or if the periscope is to be used for sighting, a terrestrial telescope can be added to the periscope. See TELESCOPE.

In the submarine periscope, it is necessary to employ a telescope system having a wide field of view and uniform illumination across a field which can be fitted into a long, narrow tube whose length-to-diameter ratio may be 50 or greater. This is achieved by utilizing a plurality of lenses so spaced along the length of the tube as to cause the incoming principal rays from

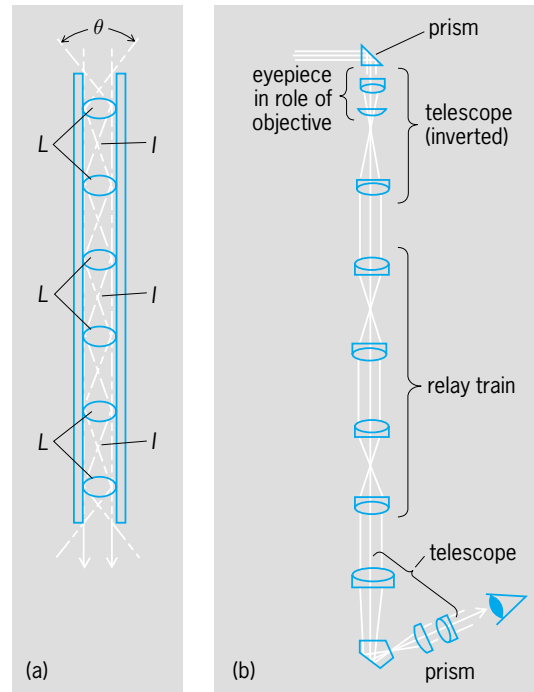

**Periscopic relay train, (a) Showing lenses *L*, inversions *i*, and angle of view  $\theta$ . (b) Between a pair of facing telescopes in a submarine periscope.**

the edge of the field to be deviated from side to side within the tube (see illustration). In general, the greater the number of lenses, the wider the field of view.

Various modifications of the basic optical systems described here are employed as viewing periscopes in military aircraft and as viewing devices in particle accelerators and nuclear reactors. The cystoscope and endoscope are slender, sometimes mechanically flexible periscopes used for visual examination and photography of body cavities inaccessible to direct observation; an entirely different basis for the design of such instruments is in the use of bundles of optical fibers. See OPTICAL FIBERS. [E.K.K.]

**Perissodactyla** An order of herbivorous, odd-toed, hoofed mammals, including the living horses, zebras, asses, tapirs, rhinoceroses, and their extinct relatives. They are defined by a number of unique specializations, but the most diagnostic feature is their feet. Most perissodactyls have either one or three toes on each foot, and the axis of symmetry of the foot runs through the middle digit.

The perissodactyls are divided into three groups: the Hippomorpha (horses and their extinct relatives); the Titanotheriomorpha (the extinct brontotheres); and the Moropomorpha (tapirs, rhinoceroses, and their extinct relatives). See RHINOCEROS; TAPIR.

Perissodactyls originated in Asia some time before 57 million years ago (Ma). By 55 Ma, the major groups of perissodactyls had differentiated, and migrated to Europe and North America. Before 34 Ma, the brontotheres and the archaic tapirs were the largest and most abundant hoofed mammals in Eurasia and North America. After these groups became extinct, horses and rhinoceroses were the most common perissodactyls, with a great diversity of species and body forms. Both groups were decimated during another mass extinction about 5 Ma, and today only five species of rhinoceros, four species of tapir, and a few species of horses, zebras, and asses cling to survival in the wild. The niches of large hoofed herbivores have been taken over by the ruminant artiodactyls, such as cattle, antelopes, deer, and their relatives.

Most extinct horses were browsers and ate soft, leafy vegetation, but all living horses are grazers, using their sharp incisors

and mobile lips to crop low-growing grasses. The only common wild horse, the plains zebra, lives in large herds (up to 100 individuals) and migrates over large areas of grasslands in search of food. However, desert-dwelling asses and Grevy's zebra live in small herds, with a stallion guarding a small harem of mares. Most species of wild horses, including the Grevy's and mountain zebras, all species of onagers and asses, and Przewalski's horse (an ancestor of domesticated horses), are nearly extinct in the wild.

The earliest moropomorphs, such as *Homogalax*, from strata about 55 million years old, are virtually indistinguishable from the earliest horses. From this unspecialized ancestry, a variety of archaic tapirlike animals diverged. Most retained the simple leaf-cutting teeth characteristic of tapirs and, like brontotheres, died out about Ma when their forest habitats shrank. Only the modern tapirs, with their distinctive long proboscis, survive in the jungles of Central and South America (three species), and southeast Asia (one species). All are stocky, piglike beasts with short stout legs, oval hooves, and a short tail. They have no natural defenses against large predators (such as jaguars or tigers), so they are expert at fleeing through dense brush and swimming to make their escape.

Rhinoceroses have been highly diverse and successful throughout the past 50 million years. They have occupied nearly every niche available to a large herbivore, from dog-sized running animals, to several hippolike forms, to the largest land mammal that ever lived—the 18-ft-tall (6-m), 44,000-lb (20,000-kg) *Paraceratherium*. Between 20 and 5 Ma, rhinos diversified into several browsing (leaf-eating) lineages, and hippolike grazing lineages, and browser-grazer pairs of rhinos were found all over the grasslands of Eurasia, Africa, and North America. The mass extinction event that occurred about 5 Ma wiped out North American rhinos and decimated most of the archaic rhino lineages in the Old World. During the ice ages, woolly rhinos and their relatives were common all over Eurasia. Their only surviving descendant is the endangered Sumatran rhinoceros. Only a few hundred individuals still live in the mountainous jungles of Sumatra. Four other species of rhino survive in Asia and Africa, but all are on the brink of extinction because of heavy poaching for their horns. See MAMMALIA. [D.R.Pr.]

**Peritoneum** The membranous lining of the coelomic, especially the abdominal, cavity, which surrounds most of the organs. It is composed mainly of flattened epithelial cells that produce a small amount of watery, or serous, fluid. In the embryo the coelomic wall is lined by this membrane, which continues over the developing viscera so that they are suspended and supported by the reflected peritoneum, principally from the dorsal body wall, but also from the ventral body wall in the region of the liver. See EPITHELIUM; FETAL MEMBRANE. [T.S.P.]

**Peritonitis** Inflammation of the peritoneum. The condition may be caused by infectious organisms or foreign substances introduced into the abdominal cavity. The small amount of serous fluid normally present as a lubricant acts as an excellent culture medium for bacterial growth and also as a means of spreading invading materials. The source of such substances or organisms is commonly a gastrointestinal inflammation, especially if perforation has occurred. Appendicitis, peptic ulcer, cancer of the bowel, gallbladder disease, and dysentery are common sources of infection that may produce peritonitis, as well as blood-borne forms of tuberculosis and pneumonia. See PERITONEUM. [E.G.St./N.K.M.]

**Peritrichia** A specialized subclass of the class Ciliata composed of a large group of unusual-looking ciliate protozoans. Many are sessile and stalked, while some form colonies which may reach a large size. A number are attached as ectocommensals to a variety of animals and plants. A free-swimming stage in the life cycle, indispensable for distribution, is known as

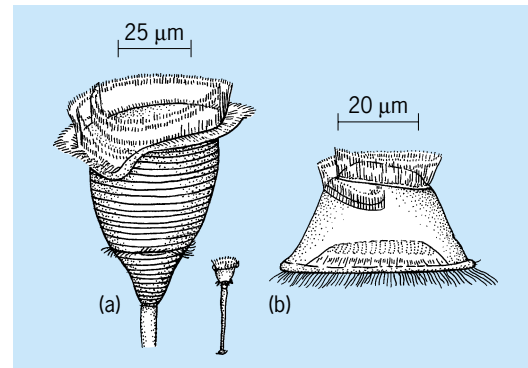

**Peritrichida.** (a) *Vorticella*, a stalked peritrich, (b) a mobile peritrich.

the telotroch. It is a small, mouthless form equipped with a single girdle of posteriorly located locomotor cilia. This is quite unlike the morphology of the mature, sedentary form, which is an inverted bell form atop a long stalk.

*Vorticella* (illustration a) and *Epistylis* are probably the best-known stalked forms. The former is a solitary ciliate, the latter a colony builder. *Trichodina* (illustration b) belongs to the group of mobile peritrichs. See CILIATEA; HYMENOSTOMATIDA; THIGMOTRICHIDA. [J.O.C.]

**Permafrost** Perennially frozen ground, occurring wherever the temperature remains below 32°F (0°C) for several years, whether the ground is actually consolidated by ice or not and regardless of the nature of the rock and soil particles of which the earth is composed. Perhaps 25% of the total land area of the Earth contains permafrost; it is continuous in the polar regions and becomes discontinuous and sporadic toward the Equator. During glacial times permafrost extended hundreds of miles south of its present limits in the Northern Hemisphere.

Temperature of permafrost at the depth of no annual change, about 30–100 ft (10–30 m), crudely approximates mean annual air temperature. It is below 23°F (–5°C) in the continuous zone, between 23–30°F (–5 and –1°C) in the discontinuous zone, and above 30°F (–1°C) in the sporadic zone. Temperature gradients vary horizontally and vertically from place to place and from time to time.

Ice is one of the most important components of permafrost, being especially important where it exceeds pore space. Physical properties of permafrost vary widely from those of ice to those of normal rock types and soil. The cold reserve, that is, the number of calories required to bring the material to the melting point and melt the contained ice, is determined largely by moisture content.

Permafrost develops today where the net heat balance of the surface of the Earth is negative for several years. Much permafrost was formed thousands of years ago but remains in equilibrium with present climates. Permafrost eliminates most groundwater movement, preserves organic remains, restricts or inhibits plant growth, and aids frost action. It is one of the primary factors in engineering and transportation in the polar regions. [R.F.B.]

**Permeance** The reciprocal of reluctance in a magnetic circuit. It is the analog of conductance (the reciprocal of resistance) in an electric circuit, and is given by Eq. (1), where **B** is the

$$P_m = \frac{\text{magnetic flux}}{\text{magnetomotive force}} = \frac{\iint \mathbf{B} \cdot d\mathbf{S}}{\oint \mathbf{H} \cdot d\mathbf{l}} \quad (1)$$

magnetic flux density, **H** is the magnetic field strength, and the integrals are respectively over a cross section of the circuit and around a path within it. See CONDUCTANCE.

From Eq. (1), it can be shown that Eq. (2) is valid, where  $A$  is

$$P_m = \mu A/l \quad (2)$$

the cross-sectional area of the magnetic circuit,  $l$  its length, and  $\mu$  the permeability. If the material is ferromagnetic, as is often the case, then  $\mu$  is not constant but varies with the flux density and the complete magnetization curve of  $B$  against  $H$  may have to be used to determine the permeance. See MAGNETIC MATERIALS; RELUCTANCE. [A.E.Ba.]

**Permian** The name applied to the last period of geologic time in the Paleozoic Era and to the corresponding system of rock formations that originated during that period. The Permian Period commenced approximately 290 million years ago and ceased about 250 million years ago. The system of rocks that originated during this interval of time is widely distributed on all the continents of the world. The Permian Period was a time of variable and changing climates, and during much of this time latitudinal climatic belts were well developed. During the latter half of Permian time, many long-established lineages of marine invertebrates became extinct and were not immediately replaced by new fossil-forming lineages. Rocks of Permian age contain many resources, including petroleum, coal, salts, and metallic ores. See LIVING FOSSILS.

During the Permian Period, several important changes took place in the paleogeography of the world. The joining of Gondwana to western Laurasia, which had started during the Carboniferous, was completed during Wolfcampian time (earliest Permian). The addition of eastern Laurasia (Angara) to the eastern edge of western Laurasia finished during Artinskian time (middle to latest early Permian) and completed the assembly of the supercontinent Pangaea. The climatic effects of these changes were dramatic. Instead of having a circumequatorial tropical ocean, such as during the middle Paleozoic, a large landmass with several high chains of mountains extended from the South Pole across the southern temperate, the tropical, and into the north temperate climatic belts. One very large world ocean, Panthalassa and its western tropical branch, the Tethys, occupied the remaining 75% of the Earth's surface, with a few much smaller cratonic blocks, island arcs, and atolls. See CONTINENTAL DRIFT; CONTINENTS, EVOLUTION OF; PALEOGEOGRAPHY.

Most marine invertebrates of the Early Permian were continuations of well-established phylogenetic lines of middle and late Carboniferous ancestry. During early Permian time, these faunas were dominated by brachiopods, bryozoans, conodonts, corals, fusulinaceans, and ammonoids. The Siberian traps, an extensive outflow of very late Permian basalts and other basic igneous rocks (dated at about 250 million years ago), are considered by many geologists as contributing to climatic stress that resulted in major extinctions of many animal groups, particularly the shallow-water marine invertebrates. The end of the Permian is also associated with unusually sharp excursions in values of the carbon-12 isotope ( $^{12}\text{C}$ ) in organic material trapped in marine sediments, suggesting major disruption of the ocean chemistry system.

Terrestrial faunas included insects which showed great advances over those of the Carboniferous Coal Measures. Several modern orders emerged, among them the Mecoptera, Odonata, Hemiptera, Trichoptera, Hymenoptera, and Coleoptera. See INSECTA.

Of the vertebrates, labyrinthodont amphibians were common and varied; however, reptiles showed the greatest evolutionary radiation and the most significant advances. Reptiles are found in abundance in the lower half of the system in Texas and throughout most of the upper part of the system in Russia and also are common in Gondwana sediments. Of the several Permian reptilian orders, the most significant was the Theriodonta. These reptiles carried their bodies off the ground and walked or ran like mammals. Unlike most reptiles, their teeth were varied—incisors, canines, and jaw teeth as in the mammals—and all the elements

of the lower jaw except the mandibles showed progressive reduction. Most of the known theriodonts are from South Africa and Russia. See PALEOZOIC; REPTILIA; THERAPSIDA. [C.A.R.; J.R.P.R.]

**Permittivity** A property of a dielectric medium that determines the forces that electric charges placed in the medium exert on each other. If two charges of  $q_1$  and  $q_2$  coulombs in free space are separated by a distance  $r$  meters, the electrostatic force  $F$  newtons acting upon each of them is proportional to the product of the charges and inversely proportional to the square of the distance between them. Thus,  $F$  is given by Eq. (1), where

$$F = \frac{q_1 q_2}{4\pi \epsilon_0 r^2} \quad \text{newtons} \quad (1)$$

$1/(4\pi \epsilon_0)$  is the constant of proportionality, having the magnitude and dimensions necessary to satisfy Eq. (1). This condition leads to a value for  $\epsilon_0$ , termed the permittivity of free space, given by Eq. (2), where  $c$  is the velocity of light in vacuum.

$$\epsilon_0 = \frac{1}{4\pi 10^{-7} c^2} \simeq 8.8542 \times 10^{-12} \quad \text{farads/meter} \quad (2)$$

If now the charges are placed in a dielectric medium that is homogeneous and isotropic, the force on each of them is reduced by a factor  $\epsilon_r$ , where  $\epsilon_r$  is greater than 1. This dimensionless scalar quantity is termed the relative permittivity of the medium, and the product  $\epsilon_0 \epsilon_r$  is termed the absolute permittivity  $\epsilon$  of the medium.

A consequence is that if two equal charges of opposite sign are placed on two separate conductors, then the potential difference between the conductors will be reduced by a factor  $\epsilon_r$  when the conductors are immersed in a dielectric medium compared to the potential difference when they are in vacuum. Hence a capacitor filled with a dielectric material has a capacitance  $\epsilon_r$  times greater than a capacitor with the same electrodes in vacuum would have. Except for exceedingly high applied fields, unlikely normally to be reached,  $\epsilon_r$  is independent of the magnitude of the applied electric field for all dielectric materials used in practice, excluding ferroelectrics. See CAPACITANCE; CAPACITOR; FERROELECTRICS. [J.H.Ca.]

**Perovskite** A minor accessory mineral, formula  $\text{CaTiO}_3$ , occurring in basic rocks. Perovskite has given its name to a large family of materials, synthetic and natural, crystallizing in similar structures. The crystal structure is ideally cubic, with a framework of corner-sharing octahedra, containing titanium (Ti) or other relatively small cations surrounded by six oxygen (O) or fluorine (F) anions. Within this framework are placed calcium (Ca) or other large cations, surrounded by twelve anions. Tilting of the octahedra and other distortions often lower the symmetry from cubic, giving the materials important ferroelectric properties and decreasing the coordination of the central cation. This flexibility gives the structure the ability to incorporate ions of different sizes and charges. Substitution of niobium (Nb), cerium (Ce), and other rare-earth elements in natural calcium titanate ( $\text{CaTiO}_3$ ) is common and can make perovskite an ore for these elements. See COORDINATION CHEMISTRY; CRYSTAL STRUCTURE; RARE-EARTH ELEMENTS.

A number of synthetic perovskites are of major technological importance. Barium titanate ( $\text{BaTiO}_3$ ) and lead zirconate-titanate (PZT) ceramics form the basis of a sizable industry in ferroelectric and piezoelectric materials crucial to transducers, capacitors, and electronics. Lanthanum chromate ( $\text{LaCrO}_3$ ) and related materials find applications in fuel cells and high-temperature electric heaters. See CERAMICS; FUEL CELL; SOLID-STATE CHEMISTRY. [A.Na.]

**Peroxide** A chemical compound which contains the peroxy ( $-\text{O}-\text{O}-$ ) group, which may be considered to be a derivative of hydrogen peroxide ( $\text{HOOH}$ ). An organic (or inorganic) peroxide is one in which some organic (or inorganic) substituent

has replaced one or both hydrogens. Peroxides are used in such diverse reactions as oxidation, synthesis, polymerization, and oxygen generation. Inorganic peroxides include persulfates, hydrogen peroxide ( $\text{H}_2\text{O}_2$ ), sodium peroxide, bivalent metal peroxides, and  $\text{H}_2\text{O}_2$  addition compounds. Organic peroxides include peroxyacetic acid, dibenzoyl peroxide, and cumene peroxide. See HYDROGEN PEROXIDE; OXIDIZING AGENT; OXYGEN. [S.S.N.]

**Peroxisome** An intracellular organelle found in all eukaryotes except the archezoa (original lifeforms). In electron micrographs, peroxisomes appear round with a diameter of 0.1–1.0 micrometer, although there is evidence that in some mammalian tissues peroxisomes form an extensive reticulum (network). They contain more than 50 characterized enzymes and perform many biochemical functions, including detoxification. See CELL ORGANIZATION; ENZYME.

Peroxisomes are important for lipid metabolism. In humans, the  $\beta$ -oxidation of fatty acids greater than 18 carbons in length occurs in peroxisomes. In yeast, all fatty acid  $\beta$ -oxidation occurs in peroxisomes. Peroxisomes contain the first two enzymes required for the synthesis of plasmalogens. Peroxisomes also play important roles in cholesterol and bile acid synthesis, purine and polyamine catabolism, and prostaglandin metabolism. In plants, peroxisomes are required for photorespiration. See LIPID METABOLISM; PHOTORESPIRATION.

A number of recessively inherited peroxisomal disorders have been described and grouped into three categories. Group I is the most severe and is characterized by a general loss of peroxisomal function. Many of the enzymes normally localized to the peroxisome are instead found in the cytosol. Among the diseases found in group I are Zellweger syndrome, neonatal adrenoleukodystrophy, and infantile Refsum disease. Patients with these disorders usually die within the first years after birth and exhibit neurological and hepatic (liver) dysfunction, along with craniofacial dysmorphism (malformation of the cranium and the face). Groups II and III peroxisomal disorders are characterized by a loss of peroxisomal function less severe than in group I. [R.A.Ra.]

**Peroxynitrite** A nitrogen oxyanion containing an O—O peroxy bond that is a structural isomer of the nitrate ion. These species are generally distinguished as  $\text{ONOO}^-$  and  $\text{NO}_3^-$ , respectively. Other names for peroxynitrite include pernitrite and peroxonitrite; the systematic name recommended by the International Union of Pure and Applied Chemistry (IUPAC) is oxoperoxonitrate (1-). Energy calculations indicate that there are two stable conformations of  $\text{ONOO}^-$ , for which all of the atoms lie in a plane with the peroxy O—O and N=O bonds forming dihedral angles of approximately  $0^\circ$  (cis isomer) or  $180^\circ$  (trans isomer) [notation (1)].

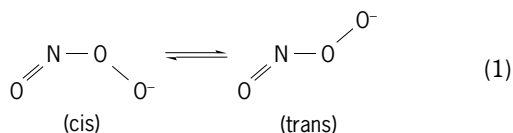

See CHEMICAL BONDING.

Peroxynitrite is formed in nitrate salts or nitrate-containing solutions when exposed to ionizing radiation or ultraviolet light. Solutions can also be prepared by a variety of chemical reactions, including the reaction of hydrogen peroxide with nitrous acid (2); reaction of the hydroperoxide anion with organic and inorganic nitrosating agents (3); reaction of ozone with the azide ion (4); or, apparently, reaction of  $\text{O}_2$  with compounds capable of generating the nitroxyl anion ( $\text{NO}^-$ ) [5]. These preparations

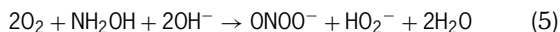
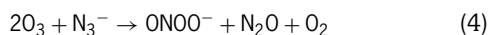
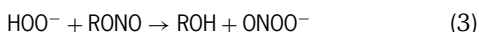
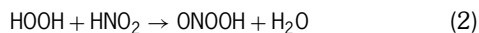

invariably contain unreacted materials or decomposition products, particularly nitrite ion, which can significantly modulate the peroxynitrite chemical reactivity. Peroxynitrite is also formed in radical-radical coupling reactions, notably superoxide ( $\cdot\text{O}_2^-$ ) with nitric oxide ( $\cdot\text{NO}$ ) [reaction (6)], and hydroxyl radical with nitrogen dioxide [reaction (7)].

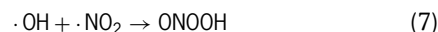
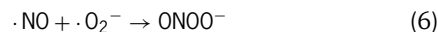

See SUPEROXIDE CHEMISTRY.

Peroxynitrite has been isolated as the tetramethylammonium salt by carrying out reaction (6) in liquid ammonia. Formation of peroxynitrite in both solids and solutions is indicated by the appearance of yellow coloration, which is due to tailing of intense near-ultraviolet absorption bands into the visible region.

Peroxynitrite is a powerful oxidant that has been shown to react with a wide variety of inorganic and organic reductants. Interest in these reactions has been greatly stimulated by recognition that  $\cdot\text{NO}$  and  $\cdot\text{O}_2^-$  radicals are generated in the bloodstream, neuronal tissues, and phagocytic cells of animals in sufficient quantities to form peroxynitrite [reaction (6)]. Correspondingly, major roles for this powerful oxidant have been proposed both in diseases and tissue damage associated with oxidative stress, and in natural cellular defense mechanisms against microbial infection. See BIOINORGANIC CHEMISTRY. [J.K.Hu.]

**Perpetual motion** The expression perpetual motion, or perpetuum mobile, arose historically in connection with the quest for a mechanism which, once set in motion, would continue to do useful work without an external source of energy or which would produce more energy than it absorbed in a cycle of operation. This type of motion, now called perpetual motion of the first kind, involves only one of the three distinct concepts presently associated with the idea of perpetual motion.

Perpetual motion of the first kind refers to a mechanism whose efficiency exceeds 100%. Clearly such a mechanism violates the now firmly established principle of conservation of energy, in particular that statement of the principle of conservation of energy embodied in the first law of thermodynamics. (Indeed, the first law of thermodynamics is sometimes stated as "A perpetuum mobile of the first kind cannot exist.") See CONSERVATION OF ENERGY.

Perpetual motion of the second kind refers to a device that extracts heat from a source and then converts this heat completely into other forms of energy, a process which satisfies the principle of conservation of energy. A dramatic scheme of this type would be an ocean liner, which extracts heat from the nearly limitless oceanic source and then uses this heat for propulsion. This type of perpetual motion is, however, precluded by the second law of thermodynamics which is sometimes stated as "A perpetuum mobile of the second kind cannot exist."

The third type of perpetual motion is, in contrast to the two types described above wherein useful output was the goal, merely a device which can continue moving forever. It could result in actual systems if all mechanisms by which energy is dissipated could be eliminated. Since experience indicates that dissipative effects in mechanical systems can be reduced, by lubrication in the case of friction, for example, but not eliminated, mechanical perpetual motion of the third kind can be approximated but never achieved. An example of a genuine case of this kind occurs in a superconductor. If a direct current is caused to flow in a superconducting ring, this current will continue to flow undiminished in time without application of any external force. See SUPERCONDUCTIVITY; THERMODYNAMIC PRINCIPLES. [K.L.K.]

**Perseus** A compact circumpolar constellation of the northern sky, like its neighbor, Cassiopeia, on the east. Both constellations lie in a brilliant part of the Milky Way. The prominent stars

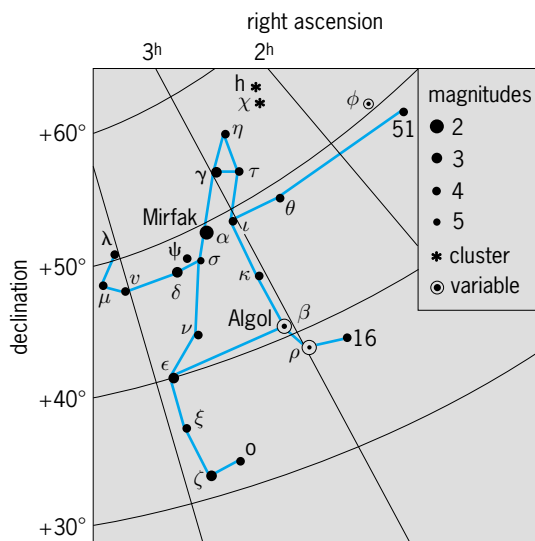

**Line pattern of the constellation Perseus.** The grid lines in the chart represent the coordinates of the sky. The apparent brightness, or magnitude, of the stars is shown by the size of the dots, which are graded by appropriate numbers as indicated.

in Perseus form the capital script letter A (see illustration). This group is represented by the figure of the hero Perseus. Mirfak, a navigational star, lies in the right shoulder. The constellation is noted for its clusters of stars. Just above the head are the famous double clusters *h* and *x* in Perseus. Algol, the Demon Star, which is an eclipsing variable, is located in this constellation. See CASSIOPEIA; CONSTELLATION. [C.-S.Y.]

**Persian melon** A long-season cultivar of muskmelon, *Cucumis melo*, of the gourd family, Cucurbitaceae. The fruit is round and without sutures; it has dark-green skin and thin, abundant netting. The flesh is deep orange, very thick and firm, and distinctly sweet in flavor. The flesh is very rich in potassium, vitamin A, and vitamin C. See MUSKMELON; VIOLALES. [O.A.L.]

**Persimmon** A deciduous fruit tree species, *Diospyros kaki*. Persimmons originated in the subtropical regions of China but were cultivated more extensively in Japan, the current leader in world production. Persimmons have been introduced to a number of temperate zone countries; however, they have not attained substantial popularity, and only small commercial plantings exist in the United States (primarily in California), Italy, Brazil, and Israel. Persimmon cultivars adapt to a wide climatic range. Although they have a low chilling requirement, they can tolerate temperatures as low as 5°F (−15°C) if they are dormant. However, areas with late spring and early fall temperatures below 27°F (−3°C) should be avoided, as young growth and maturing fruit will be damaged. Mean annual temperatures averaging 57–59°F (14–15°C) are required for good growth and quality. Multiple, selective harvests are done in late fall to ensure that the fruits achieve the desirable deep orange-red color.

Persimmons are clonally propagated by budding onto seedling rootstocks. Seed extracted from mature fruits of *D. lotus*, *D. kaki*, and *D. virginiana* are germinated in the greenhouse in the fall. Seedlings are transplanted in outdoor nursery rows when temperatures are over 55°F (13°C). For horticultural purposes, persimmons are classified as astringent or nonastringent. Astringent persimmons have water-soluble tannins in the flesh that decrease as the fruit softens to ripeness. They are conical in shape. Nonastringent persimmons are firm when ripe, as their soluble tannins decrease with pollination. They have an oblate shape. Astringent

cultivars produce best in cool climates, whereas nonastringent types require hot, dry climates for good quality. See FRUIT, TREE.

[L.Fe.]

**Personality theory** A branch of psychology concerned with developing a scientifically defensible model or view of human nature—in the modern parlance, a general theory of behavior.

Most personality theories can be classified in terms of two broad categories, depending on their underlying assumptions about human nature. On the one hand, there are a group of theories that see human nature as fixed, unchanging, deeply perverse, and self-defeating. These theories emphasize self-understanding and resignation; in the cases of Freudian psychoanalysis and existentialism, they also reflect a distinctly tragic view of life—the sources of human misery are so various that the best that can be hoped for is to control some of the causes of suffering. On the other hand, there are a group of theories that see human nature as plastic, flexible, and always capable of growth, change, and development. Human nature is basically benevolent; therefore bad societies are the source of personal misery. Social reform will produce human happiness if not actual perfection. These theories emphasize self-expression and self-actualization—in the cases of Carl Rogers and Abraham Maslow, they reflect a distinctly optimistic and romantic view of life. [R.Hog.]

**PERT** An acronym for program evaluation and review technique; a planning, scheduling, and control procedure based upon the use of time-oriented networks which reflect the interrelationships and dependencies among the project tasks (activities). The major objectives of PERT are to give management improved ability to develop a project plan and to properly allocate resources within overall program time and cost limitations, to control the time and cost performance of the project, and to replan when significant departures from budget occur.

The basic requirements of PERT, in its time or schedule form of application, are:

1. All individual tasks required to complete a given program must be visualized in a clear enough manner to be put down in a network composed of events and activities. An event denotes a specified program accomplishment at a particular instant in time. An activity represents the time and resources that are necessary to progress from one event to the next.

2. Events and activities must be sequenced on the network under a logical set of ground rules.

3. Time estimates can be made for each activity of the network on a three-way basis. Optimistic (minimum), most likely (modal), and pessimistic (maximum) performance time figures are estimated by the person or persons most familiar with the activity involved. The three-time estimates are used as a measure of uncertainty of the eventual activity duration.

4. Finally, critical path and slack times are computed. The critical path is that sequence of activities and events on the network that will require the greatest expected time to accomplish. Slack time is the difference between the earliest time that an activity may start (or finish) and its latest allowable start (or finish) time, as required to complete the project on schedule.

5. The difference between the pessimistic (*b*) and optimistic (*a*) activity performance times is used to compute the standard deviation ( $\hat{\sigma}$ ) of the hypothetical distribution of activity performance times [ $\hat{\sigma} = (b - a)/6$ ]. The PERT procedure employs these expected times and standard deviations ( $\sigma^2$  is called variance) to compute the probability that an event will be on schedule, that is, will occur on or before its scheduled occurrence time.

In the actual utilization of PERT, review and action by responsible managers is required, generally on a biweekly basis, concentrating on important critical path activities. A major advantage of PERT is the kind of planning required to create an

initial network. Network development and critical path analysis reveal interdependencies and problem areas before the program begins that are often not obvious or well defined by conventional planning methods. [J.J.M.]

**Perthite** Any of the oriented intergrowths of potassium- and sodium-rich feldspars,  $(K,Na)AlSi_3O_8$ , whose proportions are determined in part by the initial composition of the alkali feldspar from which they exsolved and whose physical properties are thus somewhat variable. The early stages of perthite formation from homogeneous, usually monoclinic  $(K,Na)AlSi_3O_8$  may be observed experimentally by high-magnification electron microscopy.

If the final K- and Na-rich lamellae or particles are submicroscopic, the composite feldspar is called cryptoperthite. If the particles are small enough and the feldspar relatively clear, Rayleigh-type scattering of light may occur, giving rise to the beautiful blue-to-whitish luster of the semiprecious gem called moonstone. If coarsening has progressed to the micrometer scale and can be seen on a polarizing microscope, the composite is called micropertthite; and if the two feldspars are visible to the eye in hand specimen, it is called perthite or macropertthite. Often the albite phase will appear as white veins or blotchy patches against a colored K-rich phase, which may be green to blue microcline (amazonite) or dull pink to orange-brown orthoclase. See ALBITE; ANORTHITE; ANORTHOCLASE; FELDSPAR; MICROCLINE; ORTHOCLASE. [P.H.R.]

**Perturbation (astronomy)** Departure of a celestial body from the trajectory it would follow if moving only under the action of a single central force. Perturbations may be caused by either gravitational or nongravitational forces.

Planetary orbits are subject to two classes of disturbances: secular, or long-term, perturbations; and periodic, or relatively short-term, perturbations. Secular perturbations, so called because they are either progressive or have excessively long periods, arise because of the relative orientation of the orbits in space. They cause slow oscillatory changes of eccentricities and inclinations about their mean values with accompanying changes in the motions of the nodes and perihelia. Periodic perturbations arise from the relative positions of the planets in their orbits. When the disturbed and disturbing planets are aligned on the same side of the Sun, the perturbation reaches a maximum, and reduces to minimum when alignment is reached on opposite sides of the Sun.

The motions of planetary satellites, natural and artificial, reflect both gravitational and nongravitational perturbations. The centrifugal force arising from the rotation of a planet causes a deformation or oblateness of figure. In such a case the central mass does not attract as if it were concentrated at its center. For a close satellite the principal perturbation arises from the attraction of this equatorial bulge. [R.L.Du.]

**Perturbation (mathematics)** A modification in the mathematical structure of a problem changing the problem from one that can be solved exactly, the unperturbed problem, to one, the perturbed problem, for which it is usually possible to obtain only an approximate solution. The methods employed for this purpose form perturbation theory. These methods attempt to express the solution of the perturbed problem in terms of the properties of the solutions of the unperturbed problem.

Examples of perturbation problems can be found in nearly every branch of mathematics and physics, and in astronomy. The simplest case occurs in ordinary algebra. Suppose that the roots of the equation  $f(x) = 0$  are known (the unperturbed problem), and that the roots of the equation  $f(x) + \epsilon g(x) = 0$  are to be found (the perturbed problem). The parameter  $\epsilon$  measures the size of the perturbation. Another set of examples occurs in linear differ-

ential equations and in particle dynamics. Possible perturbations include changes in the forces considered to be acting on the particle as well as changes in initial conditions. See PERTURBATION (ASTRONOMY).

Several examples occur in partial differential equations. One physical realization occurs in the theory of wave propagation where the perturbations can be changes in the index of refraction, changes in initial conditions, or changes in the nature or shape of the surfaces encountered by the waves. All of these changes can occur separately or concurrently. The first of these changes is called a volume perturbation, the second a perturbation of initial conditions, and the third a perturbation of boundary conditions. Similar examples can be taken from quantum mechanics, where the volume perturbation corresponds to a change in the hamiltonian, and perturbation of initial conditions to quantum mechanical time-dependent perturbation theory. Other partial differential equations of physics, such as the Laplace equation, the diffusion equation, and the equations of hydrodynamics, furnish further examples. See PERTURBATION (QUANTUM MECHANICS).

All of these problems are linear and can therefore be cast into an equation of the form  $A\psi = \lambda\psi$ , where  $\psi$  is the unknown quantity,  $\lambda$  is a constant, and  $A$  is an operator involving among other possibilities differentiation and integration. The quantity  $\sigma$  may be a scalar, a vector, or more generally a matrix quantity. When solutions can be obtained for only special values of  $\lambda$ , the eigenvalues, the equation is called the eigenvalue equation, and the associated problem is called the eigenvalue problem. The operator  $A$  contains the perturbation: that is,  $A$  equals  $A_0 + \epsilon A_1$ , where  $A_0$  is the unperturbed operator and  $\epsilon A_1$ , the perturbing term. [H.F.]

**Perturbation (quantum mechanics)** An expansion technique useful for solving complicated quantum-mechanical problems in terms of solutions for simple problems. Perturbation theory in quantum mechanics provides an approximation scheme whereby the physical properties of a system, modeled mathematically by a quantum-mechanical description, can be estimated to a required degree of accuracy. Such a scheme is useful because very few problems occurring in quantum mechanics can be solved analytically. Consequently an approximation technique must be employed in order to give an approximate analytic solution or to provide suitable algorithms for a numerical solution. Even for problems which admit an exact analytic solution, the exact solution may be of such mathematical complexity that its physical interpretation is not apparent. For these situations, perturbation techniques are also desirable.

Here the discussion of the application of perturbation techniques to quantum mechanics is limited to the domain of non-relativistic quantum theory. Applications of a similar but mathematically more intricate nature have also been made in quantum electrodynamics and quantum field theory. See QUANTUM ELECTRODYNAMICS; QUANTUM FIELD THEORY; QUANTUM MECHANICS.

Perturbation theory is applied to the Schrödinger equation,  $H\Psi = (H_0 + \lambda V)\Psi = i\hbar(\partial/\partial t)\Psi$  [where  $\hbar$  is Planck's constant  $h$  divided by  $2\pi$ , and  $(\partial/\partial t)$  represents partial differentiation with respect to the time variable  $t$ ], for which the exact hamiltonian  $H$  is split into two parts: the approximate (unperturbed) time-independent hamiltonian  $H_0$  whose solutions of the corresponding Schrödinger equation are known analytically, and the perturbing potential  $\lambda V$ . The basic idea is to expand the exact solution  $\Psi$  in terms of the solution set of the unperturbed hamiltonian  $H_0$  by means of a power series in the coupling constant  $\lambda$ . Such a procedure is expected to be successful if the system characterized by the unperturbed hamiltonian closely resembles that characterized by the exact hamiltonian. Supposedly the differences are not singular in character, but change as a continuous function of the parameter  $\lambda$ .

Perturbation theory is used in two contexts to provide information about the state of the system, which in quantum mechanics is determined by the wave function  $\Psi$ . If  $\lambda V$  is time-independent,



an objective may be to find the stationary states of the system  $\Psi_n$  whose time dependence is given by  $\exp(-iE_n t/\hbar)$ , where  $i = \sqrt{-1}$  and  $E_n$  represents the energy of the stationary state labeled by  $n$ . If  $\lambda V$  is either time-independent or time-dependent, an objective may be to find the time evolution of a state which at some specified time was a stationary state of the unperturbed hamiltonian. The perturbing potential is then considered as causing transitions from the original state to other states of the unperturbed hamiltonian, and application of time-dependent perturbation theory provides the probability of such transitions. See PERTURBATION (MATHEMATICS). [D.M.Fr.]

**Pesticide** A material useful for the mitigation, control, or elimination of plants or animals detrimental to human health or economy. Algicides, defoliant, desiccants, herbicides, plant growth regulators, and fungicides are used to regulate populations of undesirable plants which compete with or parasitize crop or ornamental plants. Attractants, insecticides, miticides, acaricides, molluscicides, nematocides, repellants, and rodenticides are used principally to reduce parasitism and disease transmission in domestic animals, the loss of crop plants, the destruction of processed food, textile, and wood products, and parasitism and disease transmission in humans.

Some pesticides are obtained from plants and minerals. Examples include the insecticides cryolite, a mineral, and nicotine, rotenone, and the pyrethrins which are extracted from plants. A few pesticides are obtained by the mass culture of microorganisms. Two examples are the toxin produced by *Bacillus thuringiensis*, which is active against moth and butterfly larvae, and the so-called milky disease of the Japanese beetle produced by the spores of *B. popilliae*. Most pesticides, however, are products which are chemically manufactured. Two outstanding examples are the insecticide DDT and the herbicide 2,4-D.

Concern over the undesirable effects of pesticides on non-pest organisms culminated in laws to prevent exposure of either humans or the environment to unreasonable hazard from pesticides through rigorous registration procedures. The purpose of regulations are to classify pesticides for general or restricted use as a function of acute toxicity, to certify the qualifications of users of restricted pesticides, to identify accurately and label pesticide products, and to ensure proper and safe use of pesticides. Recommendations as to the product and method of choice for control of any pest problem—weed, insect, or varmint—are best obtained from county or state agricultural extension specialists. [G.F.L.]

Sophisticated methods of pest control are continually being developed. Highly specific synthetic insect hormones are being developed. In an increasing number of pest situations, a natural predator of an insect has been introduced, or conditions are maintained that favor the propagation of the predator. The numbers of the potential pest species are thereby maintained below a critical threshold. An insect control program in which use of insecticides is only one aspect of a strategy based on ecologically sound measures is known as integrated pest management. See AGRICULTURAL CHEMISTRY; CHEMICAL ECOLOGY; FUNGICIDE AND FUNGICIDE; HERBICIDE; INSECT CONTROL, BIOLOGICAL; INSECTICIDE. [R.W.Ri.]

**Petalite** A rare pegmatitic mineral with composition  $\text{LiAlSi}_4\text{O}_{10}$ . Its economic significance is markedly disproportionate to the number of its occurrences. It is the only basic raw material suitable for production of a group of materials known as crystallized glass ceramics (melt-formed ceramics). These extremely fine-grained substances are based on a keatite-type structure (stuffed silica derivative). Among the desirable properties of such submicroscopic aggregates are their exceedingly low thermal expansion and high strength, making them suitable for use in cooking utensils and telescopic mirror blanks.

The color is white, pink, pale green, or gray to black. Hardness is  $6\frac{1}{2}$  on Mohs scale. Petalite is mined from a large lithium-rich pegmatite at Bikita, Zimbabwe, the only major world source.

[E.W.H.]

**Petrifaction** A mechanism by which the remains of extinct organisms are preserved in the fossil record. In petrifications (though chiefly in plants rather than animals) the original shape and topography of the tissues, and occasionally even minute cytological details, are retained relatively undeformed.

The term petrifaction was adopted as a scientific term before knowledge existed of the geochemical mechanism or processes involved. It was formerly widely believed that in the formation of a petrifaction the organic matter of the organism or tissue was replaced molecule by molecule with mineral material entering in solution in percolating groundwater. It is now evident that what actually happens is that the mineral fills cell lumina and the intercellular interstices of cell walls with insoluble salts depositing from solution. Petrifaction is hence a form of mineral emplacement or embedding, by which the organic residues are filled with solid substance which infiltrates in solution. The most common substances involved in petrifications are silica,  $\text{SiO}_2$ , and calcium carbonate,  $\text{CaCO}_3$  (calcite). Occasionally phosphate minerals, pyrite, hematite, and other less common minerals make up all or part of the petrifaction matrix. See FOSSIL; PALEOBOTANY; PETRIFIED FORESTS. [E.S.B.]

**Petrified forests** Exposures containing appreciable numbers of petrified tree trunks, either standing upright or lying prostrate in the enclosing sedimentary rocks; sometimes called fossil forests. The best-known examples are the Petrified Forest of Arizona, and the fossil forests near Cairo, Egypt; near Calistoga, California; near Vantage Bridge, Washington; and in Yellowstone National Park, Wyoming. See PALEOBOTANY; PETRIFICATION. [E.Do.]

**Petrochemical** Any of the chemicals derived from petroleum or natural gas. The definition of petrochemicals has been broadened to include the whole range of aliphatic, aromatic, and naphthenic organic chemicals, as well as carbon black and such inorganic materials as sulfur and ammonia.

Petrochemicals are made or recovered from the entire range of petroleum fractions, but the bulk of petrochemical products are formed from the lighter ( $\text{C}_1$ – $\text{C}_4$ ) hydrocarbon gases as raw materials. These materials generally occur in natural gas, but they are also recovered from the gas streams produced during refinery operations, especially cracking. Refinery gases are particularly valuable because they contain substantial amounts of olefins that, because of their double bonds, are much more reactive than the saturated (paraffin) hydrocarbons. Also important as raw materials are the aromatic hydrocarbons (benzene, toluene, and xylene) that are obtained from various refinery product streams. For example, catalytic reforming processes convert nonaromatic hydrocarbons to aromatic hydrocarbons by dehydrogenation and cyclization. See PETROLEUM; PETROLEUM PRODUCTS.

Thermal cracking processes (such as coking) are focused primarily on increasing the quantity and quality of gasoline and other liquid fuels, but also produce gases, including lower-molecular-weight olefins such as ethylene ( $\text{CH}_2=\text{CH}_2$ ), propylene ( $\text{CH}_3\text{CH}=\text{CH}_2$ ), and butylenes (butenes,  $\text{CH}_3\text{CH}=\text{CHCH}_3$  and  $\text{CH}_3\text{CH}_2\text{CH}=\text{CH}_2$ ). Catalytic cracking is a valuable source of propylene and butylene, but it is not a major source of ethylene, the most important of the petrochemical building blocks. See CRACKING; ETHYLENE.

The starting materials for the petrochemical industry are obtained from crude petroleum in one of two ways. They may be present in the raw crude oil and are isolated by physical methods, such as distillation or solvent extraction; or they are synthesized during the refining operations. Unsaturated (olefin) hydrocarbons, which are not usually present in natural petroleum, are

nearly always manufactured as intermediates during the refining sequences. See DISTILLATION; PETROLEUM PROCESSING AND REFINING; SOLVENT EXTRACTION.

The main objective in producing chemicals from petroleum is the formation of a variety of well-defined chemical compounds, including (1) chemicals from aliphatic compounds; (2) chemicals from olefins; (3) chemicals from aromatic compounds; (4) chemicals from natural gas; (5) chemicals from synthesis gas (carbon monoxide and hydrogen); and (6) inorganic petrochemicals.

A significant proportion of the basic petrochemicals are converted into plastics, synthetic rubbers, and synthetic fibers. These materials, known as polymers, are high-molecular-weight compounds made up of repeated structural units. The major polymer products are polyethylene, polyvinyl chloride, and polystyrene, all derived from ethylene, and polypropylene, derived from propylene. Major raw material sources for synthetic rubbers include butadiene, ethylene, benzene, and propylene. Among synthetic fibers the polyesters, which are a combination of ethylene glycol and terephthalic acid (made from xylene), are the most widely used. They account for about one-half of all synthetic fibers. The second major synthetic fiber is nylon, its most important raw material being benzene. Acrylic fibers, in which the major raw material is the propylene derivative acrylonitrile, make up most of the remainder of the synthetic fibers. See MANUFACTURED FIBER; POLYACRYLATE RESIN; POLYAMIDE RESINS; POLYESTER RESINS; POLYMER; POLYMERIZATION; POLYOLEFIN RESINS; POLYURETHANE RESINS; POLYVINYL RESINS; RUBBER.

An inorganic petrochemical is one that does not contain carbon atoms; typical examples are sulfur (S), ammonium sulfate  $[(\text{NH}_4)_2\text{SO}_4]$ , ammonium nitrate  $(\text{NH}_4\text{NO}_3)$ , and nitric acid  $(\text{HNO}_3)$ . Of the inorganic petrochemicals, ammonia is by far the most common. Ammonia is produced by the direct reaction of hydrogen with nitrogen, with air being the source of nitrogen. Refinery gases, steam reforming of natural gas (methane) and naphtha streams, and partial oxidation of hydrocarbons or higher-molecular-weight refinery residual materials (residua, asphalt) are the sources of hydrogen. The ammonia is used predominantly for the production of ammonium nitrate  $(\text{NH}_4\text{NO}_3)$  as well as other ammonium salts and urea  $(\text{H}_2\text{HCONH}_2)$  that are major constituents of fertilizers. See AMMONIA; AMMONIUM SALT; FERTILIZER; UREA. [J.G.S.]

**Petrofabric analysis** The systematic study of the fabrics of rocks, generally involving statistical study of the orientations and distribution of large numbers of fabric elements. The term fabric denotes collectively all the structural or spatial characteristics of a rock mass. The fabric elements are classified into two groups: (1) megascopic features, including bedding, schistosity, foliation, cleavage, faults, joints, folds, and mineral lineations; and (2) microscopic features, including the shapes, orientations, and mutual arrangement of the constituent mineral crystals (texture) and of internal structures (twin lamellae, deformation bands, and so on) inside the crystals.

The aim of fabric analysis is to obtain as complete and accurate a description as possible of the structural makeup of the rock mass with a view to elucidating its kinematic history. The fabric of a sedimentary rock, for example, may retain evidence of the mode of transport, deposition, and compaction of the sediment in the size, shape, and disposition of the particles; similarly, that of an igneous rock may reflect the nature of the flow or of gravitational segregation of crystals and melt during crystallization. The fabrics of deformed metamorphic rocks (tectonites) have been most extensively studied by petrofabric techniques with the objective of determining the details of the history of deformation and recrystallization. See STRUCTURAL GEOLOGY; STRUCTURAL PETROLOGY. [J.M.Ch.]

**Petrography** The description of rocks with goals of classification and interpretation of origin. Most schemes for the

classification of rocks are based on the size of grains and the proportions of various minerals. Interpretations of origin rely on field relations, structure, texture, and chemical composition as well as sizes and proportions of different kinds of grains. The names of rocks are based on the sizes and relative proportions of different minerals; boundaries between the names are arbitrary. The conditions of formation of a rock can be estimated from the types and textures of its constituent minerals.

The description of rocks begins in the field with observation of the shape and structure of bodies of rock at the scale of centimeters to kilometers. The geometrical relations between and structures within mappable rock units are generally the domain of field geology, but are simply rock descriptions at a reduced scale.

A petrographer can correctly name most rocks in which most crystals are larger than about 0.04 in. (1 mm) simply by examining the rock with a 10-power magnifying lens. Rocks with smaller grains require either microscopical examination or chemical analysis for proper classification.

Sizes, shapes, and orientations of grains and voids are the most important features of a rock relevant to its origin. The same features also affect density, porosity, permeability, strength, and magnetic behavior. It is also essential to know the identity, abundance, and compositions of minerals constituting the grains in order to name a rock and infer its conditions of formation.

Petrographers study organic as well as inorganic objects, and petrographic analyses are useful to both paleontologists and petroleum geologists. The quality of coal is revealed with polarizing and reflecting light microscopes. Inclusions of petroleum and brine in crystals of silicates and salt in rocks help scientists infer how petroleum formation is connected with cementation and other modifications of buried sediments. See PALEONTOLOGY; PETROLEUM GEOLOGY.

Petrographers also study synthetic objects. The textures of metals and alloys are scrutinized by petrographers in order to understand what makes these materials strong and resistant to corrosion. Flaws in glasses and ceramics are revealed by microscopical and polarizing techniques. Fragments of minerals and rocks in some pottery can help point to its source and help trace prehistoric routes of trade. The industrial, agricultural, and natural sources of particles in the air and water may be established from petrographic study. See MINERALOGY; PETROLOGY. [A.T.A.]

**Petrolatum** A smooth, semisolid blend of mineral oil with waxes crystallized from the residual type of petroleum lubricating oil. The wax molecules are microneedles and hold a large amount of oil in a gel. Petrolatums are useful because they cling, lubricate, and resist both moisture and oxidation. They serve as lubricants in baking and candymaking; as carriers in polishes, cosmetics, and ointments; as rust preventives; as waterproofing agents for paper; and in other uses calling for an inert greaselike material. [J.K.R.]

**Petroleum** Unrefined, or crude, oil is found underground and under the sea floor, in the interstices between grains of sandstone and limestone or dolomite (not in caves). Petroleum is a mixture of liquids varying in color from nearly colorless to jet black, in viscosity from thinner than water to thicker than molasses, and in density from light gases to asphalts heavier than water. It can be separated by distillation into fractions that range from light color, low density, and low viscosity to the opposite extreme. In places where it has oozed from the ground, its volatile fractions have vaporized, leaving the dense, black parts of the oil as a pool of tar or asphalt (such as the Brea Tar Pits in California). Much of the world's crude oil is today produced from drilled wells. See PETROLEUM ENGINEERING.

Petroleum consists mostly of hydrocarbon molecules. The four main classes of hydrocarbons are paraffins (also called alkanes), olefins (alkenes), cycloparaffins (cycloalkanes), and aromatics. Olefins are absent in crude oil but can be formed in certain

refining processes. The simplest hydrocarbon is one carbon atom bonded to four hydrogen atoms (chemical formula  $\text{CH}_4$ ), and is called methane. See ALKANE; PARAFFIN.

Petroleum usually contains all of the possible hydrocarbon structures except alkenes, with the number of carbon atoms per molecule going up to a hundred or more. These fractions include compounds that contain sulfur, nitrogen, oxygen, and metal atoms. The proportion of compounds containing these atoms increases with increasing size of the molecule.

Asphaltic molecules contain many cyclic compounds in which the rings contain sulfur, nitrogen, or oxygen atoms; these are called heterocyclic compounds. An example is pyridine. See ASPHALT AND ASPHALTITE.

It is generally agreed that petroleum formed by processes similar to those which yielded coal, but was derived from small animals rather than from plants. Dead organisms have been buried in mud over millions of years. Further layers deposited over these mud layers have in some cases reached a thickness of thousands of feet, and compacted the layers beneath them, until the mud has become shale rock. The mud layers were heated and compressed by the layers above. The bodies of the organisms in the mud were decomposed and converted into fatty liquids and solids. Heating these fatty materials over a very long time caused their molecules to break into smaller fragments and combine into larger ones, so the original range of molecular size was spread greatly into the range found in crude oil. Bacteria were usually present, and helped remove oxygen from the molecules and turned them into hydrocarbon compounds. The great pressure of the overlying rock layers helped to force the oil out of the compacted mud (shale) layers into less compacted limestone, dolomite, or sandstone layers next to the shale layers. See DOLOMITE; LIMESTONE; ORGANIC GEOCHEMISTRY; PETROLEUM GEOLOGY; SANDSTONE; SEDIMENTOLOGY; SHALE.

At depths greater than about 25,000 ft (7620 m), the temperature is so high that the oil conversion processes go all the way to natural gas and soot. Natural gas formed by the conversion processes is now also found over a variety of depths which do not indicate the depth and temperature of their origin. See NATURAL GAS.

The oil formed by the natural thermal and bacterial processes was squeezed out of the compacting mud layers into sandstone or limestone layers and migrated upward in tilted layers. Tectonic processes caused such uptilting and bulging of layers to form ridges and domes. When the ridges and domes were covered by shale already formed, the pores of the shale were too tiny to let the oil through, so the shale acted as a sealing cap. When the oil could not rise farther, it was trapped. Porous rock in such a structure that contains oil or gas is called an oil or gas reservoir.

The recovery from typical reservoirs is not as high as might be thought. Multiple-layer reservoirs will typically contain oil-bearing layers with a wide range of permeability. When recovery from the highest-permeability layers is as complete as it can be, the low-permeability layers will usually have been only slightly depleted, despite all efforts to improve the recovery. Despite recovery efforts, half or more of the oil originally present in oil reservoirs is still in them. See PETROLEUM ENHANCED RECOVERY; PETROLEUM RESERVES; PETROLEUM RESERVOIR ENGINEERING. [E.L.C.]

Heavy oil and tar sand oil (bitumen) are petroleum hydrocarbons found in sedimentary rocks. They are formed by the oxidation and biodegradation of crude oil, and occur in the liquid or semiliquid state in limestones, sandstones, or sands. See BITUMEN.

These oils are characterized by their viscosity; however, density (or API gravity) is also used when viscosity measurements are not available. Heavy oils contain 3 wt % or more sulfur and as much as 200 ppm vanadium. Titanium, zinc, zirconium, magnesium, manganese, copper, iron, and aluminum are other trace elements that can be found in these deposits. Their high

naphthenic acid content makes refinery processing equipment vulnerable to corrosion. See OIL AND GAS FIELD EXPLOITATION. [E.Ok.]

**Petroleum engineering** The technologies used for the exploitation of crude oil and natural gas reservoirs. It is usually subdivided into the branches of petrophysical, geological, reservoir drilling, production, and construction engineering. After an oil or gas accumulation is discovered, technical supervision of the reservoir is transferred to the petroleum engineering group, although in the exploration phase the drilling and petrophysical engineers have played a role in the completion and evaluation of the discovery.

By the use of down-hole logging tools and of laboratory analysis of cores made during the drilling operation, the petrophysical engineer estimates the porosity, permeability, and oil content of the reservoir rock that has been sampled at the drill site. See WELL LOGGING.

The geological engineer, using the petrophysical data, the seismic surveys conducted during the exploration operations, and an analysis of the regional and environmental geology, develops inferences concerning the lateral continuity and extent of the reservoir. See PETROLEUM GEOLOGY.

The reservoir engineer, using the initial studies of the petrophysicist and geological engineers together with the early performance of the wells drilled into the reservoir, attempts to assess the producing rates (barrels of oil or millions of cubic feet of gas per day) that individual wells and the entire reservoir are capable of sustaining. One of the major assignments of the reservoir engineer is to estimate the ultimate production that can be anticipated from both primary and enhanced recovery from the reservoir. See PETROLEUM ENHANCED RECOVERY; PETROLEUM RESERVES; PETROLEUM RESERVOIR ENGINEERING.

The drilling engineer has the responsibility for the efficient penetration of the earth by a well bore, and for cementing of the steel casing from the surface to a depth usually just above the target reservoir. The drilling engineer or another specialist, the mud engineer, is in charge of the fluid that is continuously circulated through the drill pipe and back up to surface in the annulus between the drill pipe and the bore hole.

The production engineer, upon consultation with the petrophysical and reservoir engineers, plans the completion procedure for the well. This involves a choice of setting a liner across the formation or perforating a casing that has been extended and cemented across the reservoir, selecting appropriate pumping techniques, and choosing the surface collection, dehydration, and storage facilities. See OIL AND GAS WELL COMPLETION.

Major construction projects, such as the design and erection of offshore platforms, require the addition of civil engineers to the staff of petroleum engineering departments, and the design and implementation of natural gasoline and gas processing plants require the addition of chemical engineers. See OIL AND GAS, OFFSHORE; PETROLEUM. [T.M.D.]

Relational databases and advanced computer graphics are used in petroleum exploration. There is a heavy emphasis on facile gathering of data and extraction of selected items to provide effective displays and interpretations. In general, petroleum computing can be viewed on three levels: geological computing, geophysical computing, and engineering applications. Geological computing trends have focused on database and spatial system configurations, with specialty applications such as cross-section balancing or geochemical modeling. Geophysical computing tends to be computer-intensive; interpretive installations are, like all interactive workstation environments, driven by graphics. Engineering applications are also computer-intensive; they are generally classified as either simulation or process types. [B.R.S.]

**Petroleum enhanced recovery** Technology to increase oil recovery from a porous formation beyond that

obtained by conventional means. Conventional oil recovery technologies produce an average of about one-third of the original oil in place in a formation. Conventional technologies are primary or secondary. Primary technologies rely on native energy, in the form of fluid and rock compressibility and natural aquifers, to produce oil from the formation to wells. Secondary technologies supplement the native energy to drive oil to producing wells by injecting water or low-pressure gas at injection wells. The target of enhanced recovery technologies is that large portion of oil that is not recovered by primary and secondary means. See PETROLEUM ENGINEERING.

Many of the challenges encountered by secondary technologies are identical to those encountered by enhanced recovery technologies. Those challenges include reducing residual oil saturation, improving sweep efficiency, fitting the technology to the reservoir heterogeneities, and minimizing up-front and operating costs.

Residual oil remains trapped in a porous rock after the rock has been swept with water, gas, or any other recovery fluid. The residual oil saturation is the percentage of the pore space occupied by the residual oil. The residual oil saturation depends on the pore size distribution and connectivity, the interfacial tension between a recovery agent and the oil, the relative wettability of the rock surfaces with respect to the recovery agent and the oil, the viscosity of the fluids, and the rate at which the fluids are moving through the rock.

The sweep efficiency specifies that portion of a reservoir that is contacted by a recovery fluid. Sweep efficiency increases with volume of injected fluid. It also depends on the pattern of injection and production wells in a formation, on the mobility of the oil and the recovery fluid, and on heterogeneities in the formation.

A wide variety of processes have been considered for enhancing oil recovery: thermal processes, high-pressure gas processes, and chemical processes. Specifically, low residual oil saturation can be obtained by selecting a recovery fluid that provides a very low interfacial tension between the oil and the fluid. With very low interfacial tension, the capillary number is large. And high sweep efficiency can be obtained by selecting a recovery agent with low mobility or by increasing the mobility of the oil.

[R.L.Chr.]

**Petroleum geology** The practice of utilizing geological principles and applying geological concepts to the discovery and recovery of petroleum. Related fields in petroleum discovery include geochemistry and geophysics. The related areas in petroleum recovery are petroleum and chemical engineering. See CHEMICAL ENGINEERING; GEOCHEMISTRY; GEOPHYSICS.

Petroleum occurs in a liquid phase as crude oil and condensate, and in a gaseous phase as natural gas. The phase is dependent on the kind of source rock from which the petroleum was formed and the physical and thermal environment in which it exists. Most petroleum occurs at varying depths below the ground surface, but generally petroleum existing as a liquid (crude oil) is found at depths of less than 20,000 ft (6100 m) while natural gas is found both at shallow depths and at depths exceeding 30,000 ft (9200 m). In some cases, oil may seep to the surface, forming massive deposits of oil or tar sands. Natural gas also seeps to the surface but escapes into the atmosphere, leaving little or no surface trace. See NATURAL GAS; OIL SAND; PETROLEUM.

Most petroleum is found in sedimentary basins in sedimentary rocks, although many of the 700 or so sedimentary basins of the world contain no known significant accumulations. Several conditions must exist for the accumulation of petroleum: (1) There must be a source rock, usually high in organic matter, from which petroleum can be generated. (2) There must be a mechanism for the petroleum to move, or migrate. (3) A reservoir rock with voids to hold petroleum fluids must exist. (4) The reservoir must be in a configuration to constitute a trap and be covered by a seal—any kind of low-permeability or dense rock

formation that prevents further migration. If any of these conditions do not exist, petroleum either will not form or will not accumulate in commercially extractable form. See BASIN; SEDIMENTARY ROCKS.

The aim of petroleum geologists is to find traps or accumulations of petroleum. The trap not only must be defined but must exist where other conditions such as source and reservoir rocks occur.

To locate these traps, the geologist must rely on subsurface information and data gathered by drilling exploratory wells and data obtained by geophysical surveying. These data, once interpreted, are used to construct maps, cross sections, and models that are used to infer or to actually depict subsurface configurations that might contain petroleum. Such depictions are prospects for drilling. See GEOPHYSICAL EXPLORATION; OIL AND GAS WELL DRILLING.

Oil and gas must be trapped in an individual reservoir in sufficient quantities to be commercially producible. Worldwide, 25% of all oil discovered so far is contained in only ten fields, seven of which are in the Middle East. Fifty percent of all oil discovered to date is found in only 50 fields.

Most of the large and fairly obvious fields in the United States have been discovered, except those possibly existing in frontier or lightly explored areas such as Alaska and the deep waters offshore. Few areas of the world remain entirely untested, but many areas outside the United States are only partly explored, and advanced techniques have yet to be deployed in the recovery of oil and gas found so far. See PETROLEUM RESERVES.

Greater efforts in petroleum geology along with petroleum engineering are being made to increase recovery from existing fields. Of all oil discovered so far, it is estimated that there will be recovery of only 35% on the average. Recovering some part of this huge oil resource will require geological reconstruction of reservoirs, a kind of very detailed and small-scale exploration. These reconstructions and models have allowed additional recovery of oil that is naturally movable in the reservoir. If the remaining oil is immobile because it is too viscous or because it is locked in very small pores or is held by capillary forces, techniques must be used by the petroleum geologist and the petroleum engineer to render the oil movable. [W.L.Fi.]

**Petroleum microbiology** Those aspects of microbiology in which crude oil, refined petroleum products, or pure hydrocarbons serve as nutrients for the growth of microorganisms or are altered as a result of their activities. Applications of petroleum microbiology include oil pollution control, enhanced oil recovery, microbial contamination of petroleum fuels and oil emulsions, and conversion of petroleum hydrocarbons into microbial products.

Many species of bacteria, fungi, and algae have the enzymatic capability to use petroleum hydrocarbons as food. Biodegradation of petroleum requires an appropriate mixture of microorganisms, contact with oxygen gas, and large quantities of utilizable nitrogen and phosphorus compounds and smaller amounts of other elements essential for the growth of all microorganisms. Part of the hydrocarbons are converted into carbon dioxide and water and part into cellular materials, such as proteins and nucleic acids. The requirement for a mixture of different microorganisms arises from the fact that petroleum is composed of a wide variety of different groups of hydrocarbons, whereas any specific microorganism is highly specialized with regard to the type of hydrocarbon it can digest. The bacterial genera that contain the most frequently isolated hydrocarbon degraders are *Pseudomonas*, *Acinetobacter*, *Flavobacterium*, *Brevibacterium*, *Corynebacterium*, *Arthrobacter*, *Mycobacterium*, and *Nocardia*. The fungal genera that contain oil utilizers include *Candida*, *Cladosporium*, *Rhodotorula*, *Torulopsis*, and *Trichosporium*. See BIODEGRADATION.

Oil pollution results from natural hydrocarbon seeps, accidental spills, and intentional discharge of oily materials into the

environment. Once the oil is released and comes into contact with water, air, and the necessary salts, microorganisms present in the environment begin the natural process of petroleum biodegradation. If this process did not occur, the world's oceans would soon become completely covered with a layer of oil. The reason that oil spills become a pollution problem is that the natural microbial systems for degrading the oil become temporarily overwhelmed. See WATER POLLUTION.

The largest potential application of petroleum microbiology is in the field of enhanced oil recovery. Microbial products, as well as viable microorganisms, have been used as stimulation agents to enhance oil recovery from petroleum reservoirs. Xanthan, a polysaccharide produced by *Xanthomonas campestris*, is used as a waterflood thickening agent in oil recovery. Emulsan, a lipopolysaccharide produced by a strain of *Acinetobacter calcoaceticus*, stabilizes oil-in-water emulsions. A number of other microbial products are being tested for potential application in enhanced oil recovery processes. Field tests have indicated that injection of viable microorganisms with their nutrients into petroleum reservoirs can lead to enhanced oil recovery, presumably due to production of carbon dioxide gas, acids, and surfactants. See PETROLEUM ENHANCED RECOVERY.

A variety of valuable materials, such as amino acids, carbohydrates, nucleotides, vitamins, enzymes, antibiotics, citric acid, long-chain dicarboxylic acids, and biomass, can be produced by microbial processes using petroleum hydrocarbons as substrates. The main advantage of using hydrocarbons as substrates is their lower cost. Also, certain products, such as tetradecane-1,14-dicarboxylic acid, a raw material for preparing perfumes, are synthesized in higher yields on hydrocarbon than on carbohydrate substrates.

The most active area of research and development in petroleum microbiology since the mid-1960s has been in the large-scale production and concentration of microorganisms for animal feed and human food. Dried microbial cells are collectively referred to as single-cell protein. In spite of its advantages, single-cell protein has not yet played a significant role in providing protein for animal feed or human consumption. However, many scientists are optimistic about its potential. The ability of microorganisms to utilize petroleum also has its detrimental aspects, particularly with respect to the deterioration of petroleum fuels, asphalt coatings, and oil emulsions used with cutting machinery. All hydrocarbons become contaminated if they come into contact with water during storage. See BACTERIAL PHYSIOLOGY AND METABOLISM; CORROSION; INDUSTRIAL MICROBIOLOGY.

[E.Ros.]

**Petroleum processing and refining** The separation of petroleum into fractions and the treating of these fractions to yield marketable products. Petroleum is a mixture of gaseous, liquid, and solid hydrocarbon compounds that occurs in sedimentary rock deposits throughout the world. In the crude state, petroleum has little value but, when refined, it provides liquid fuels (gasoline, diesel fuel, aviation fuel), solvents, heating oil, lubricants, and the distillation residuum asphalt, which is used for highway surfaces and roofing materials. See PETROLEUM; PETROLEUM PRODUCTS.

Crude petroleum (oil) is a mixture of compounds with different boiling temperatures that can be separated into a variety of fractions (see table). Since there is a wide variation in the composition of crude petroleum, the proportions in which the different fractions occur vary with origin. Some crude oils have higher proportions of lower-boiling components, while others have higher proportions of residuum (asphaltic components).

Petroleum processing and refining involves a series of steps by which the original crude oil is converted into products with desired qualities in the amounts dictated by the market. In fact, a refinery is essentially a group of manufacturing plants that vary in number with the variety of products in the mix. Refinery processes must be selected and products manufactured to

**Petroleum fractions and their uses\***

Fraction	Boiling range		Uses
	°C	°F	
Fuel gas	-160 to -40	-260 to -40	Refinery fuel
Propane	-40	-40	Liquefied petroleum gas (LPG)
Butane(s)	-12 to -1	11-30	Increases volatility of gasoline, advantageous in cold climates
Light naphtha	-1 to 150	30-300	Gasoline components, may be (with heavy naphtha) reformer feedstock
Heavy naphtha	150-205	300-400	Reformer feedstock, with light gas oil, jet fuels
Gasoline	-1 to 180	30-355	Motor fuel
Kerosine	205-260	400-500	Fuel oil
Stove oil	205-290	400-550	Fuel oil
Light gas oil	260-315	500-600	Furnace and diesel fuel components
Heavy gas oil	315-425	600-800	Feedstock for catalytic cracker
Lubricating oil	>400	>750	Lubrication
Vacuum gas oil	425-600	800-1100	Feedstock for catalytic cracker
Residuum	>600	>1100	Heavy fuel oil, asphalts

\*From J. G. Speight (ed.), *The Chemistry and Technology of Petroleum*, 3d ed., Marcel Dekker, New York, 1999.

give a balanced operation; that is, crude oil must be converted into products according to the demand for each. For example, the manufacture of products from the lower-boiling portion of petroleum automatically produces a certain amount of higher-boiling components. If the latter cannot be sold as, say, heavy fuel oil, these products will accumulate until refinery storage facilities are full. To prevent such a situation, the refinery must be flexible and able to change operations as needed. This usually means more processes, such as thermal processes to change excess heavy fuel oil into gasoline with coke as the residual product, or vacuum distillation processes to separate heavy oil into lubricating oil stocks and asphalt.

**Distillation.** In a petroleum distillation unit, a tower is used for fractionation. The feedstock of crude oil flows through one or more pipes arranged within a large furnace where it is heated to a temperature at which a predetermined portion of the feed changes into vapor. The heated feed is introduced into a fractional distillation tower where the nonvolatiles or liquid portions pass downward to the bottom of the tower and are pumped away, while the vapors pass upward through the tower and are fractionated into gas oils, kerosine, and naphthas.

Vacuum distillation is used in petroleum refining to separate the less volatile products, such as lubricating oils, from petroleum without subjecting the high-boiling products to cracking conditions. Operating pressure for vacuum distillation is usually 50-100 mm of mercury (6.7-13.3 kilopascals) [atmospheric pressure = 760 mm of mercury]. By this means, a heavy gas oil that has a boiling range in excess of 315°C (600°F) at atmospheric pressure may be obtained at temperatures of around 150°C (300°F); and lubricating oil, having a boiling range in excess of 370°C (700°F) at atmospheric pressure may be obtained at temperatures of 250-350°C (480-660°F). Atmospheric and vacuum distillation are major parts of refinery operations, and no doubt will continue to be used as the primary refining operation.

**Thermal processes.** One of the earliest conversion processes used in the petroleum industry was the thermal decomposition of higher-boiling materials into lower-boiling products. This process is known as thermal cracking. The majority of the thermal cracking processes use temperatures of 455-540°C (850-1005°F) and pressures of 100-1000 psi (690-6895 kPa). For example, the feedstock (reduced crude) is preheated by direct exchange with the cracking products in the fractionating columns. Cracked gasoline and heating oil are removed from the upper section of the column. Light and heavy distillate fractions are

removed from the lower section and are pumped to separate heaters. Higher temperatures are used to crack the more stable light distillate fraction. The streams from the heaters are combined and sent to a soaking chamber where additional time is provided to complete the cracking reactions. The cracked products are then separated in a low-pressure flash chamber where a heavy fuel oil is removed as bottoms. The remaining cracked products are sent to fractionating columns. The thermal cracking of higher-boiling petroleum fractions to produce gasoline is now virtually obsolete. The antiknock requirements of modern automobile engines together with the different nature of crude oils (compared to those of 50 years ago) has reduced the ability of the thermal cracking process to produce gasoline on an economic basis. See DISTILLATION COLUMN.

Visbreaking (viscosity breaking) is a mild thermal cracking operation that can be used to reduce the viscosity of residua to allow the products to meet fuel oil specifications. Alternatively, the visbroken residua can be blended with lighter product oils to produce fuel oils of acceptable viscosity. By reducing the viscosity of the residuum, visbreaking reduces the amount of light heating oil that is required for blending to meet fuel oil specifications.

Delayed coking is a thermal process for converting residua into lower-boiling products, such as gases, naphtha, fuel oil, gas oil, and coke. It is a semicontinuous process in which the heated charge is transferred to large soaking (or coking) drums, which provide the long residence time needed to allow the cracking reactions to proceed to completion. The feedstock is introduced into a product fractionator where it is heated and the lighter fractions are removed as side streams. Gas oil, often the major product of a coking operation, serves primarily as a feedstock for catalytic cracking units. The coke obtained is typically used as fuel; but specialty uses, such as electrode manufacture, and production of chemicals and metallurgical coke are also possible, increasing the value of the coke. For these uses, the coke may require treatment to remove sulfur and metal impurities. See COKE; CRACKING; FUEL OIL; NAPHTHA.

Catalytic cracking is basically the same as thermal cracking, but differs by the use of a catalyst, which directs the course of the cracking reactions to produce more of the desired higher-octane hydrocarbon products. Catalytic cracking is regarded as the modern method for converting high-boiling petroleum fractions, such as gas oil, into gasoline and other low-boiling fractions. The usual commercial process involves contacting a gas oil fraction with an active catalyst at a suitable temperature, pressure, and residence time so that a substantial part (>50%) of the gas oil is converted into gasoline and lower-boiling products, usually in a single-pass operation. See GASOLINE; OCTANE NUMBER.

**Hydroprocesses.** The use of hydrogen in thermal processes was perhaps the single most significant advance in refining technology during the twentieth century. The process uses the principle that the presence of hydrogen during a thermal reaction of a petroleum feedstock will terminate many of the coke-forming reactions and enhance the yields of the lower-boiling components, such as gasoline, kerosine, and jet fuel. See HYDROGENATION.

Destructive hydrogenation (hydrogenolysis or hydrocracking) is characterized by the conversion of the higher-molecular-weight constituents in a feedstock to lower-boiling products. Such treatment requires severe processing conditions and the use of high hydrogen pressures to minimize the polymerization and condensation reactions that lead to coke formation. See HYDROCRACKING.

Nondestructive hydrogenation is used for improving product quality without appreciable alteration of the boiling range. Nitrogen, sulfur, and oxygen compounds undergo reaction with the hydrogen, forming ammonia, hydrogen sulfide, and water, respectively. Unstable compounds that might lead to the formation of gums or insoluble materials are converted to more stable compounds.

[J.G.S.]

**Petroleum products** Petroleum products are those fractions derived from petroleum that have commercial value as a bulk product. Petrochemicals, in contrast, are individual chemicals, derived from bulk fractions, that are used as the basic building blocks of the chemical industry. Gases and liquid fuels are currently the main products of the petroleum industry (see table). However, other products, such as lubricating oils, waxes, and asphalt, have also added to the value of petroleum resources. See PETROCHEMICAL; PETROLEUM.

Petroleum products are hydrocarbon compounds, containing combinations of hydrogen and carbon with various molecular forms. Many compounds occur naturally. Other compounds are created by commercial processes for altering one combination to form another. Each combination has its unique set of chemical and physical properties. Specifications for petroleum products are based on properties such as density and boiling range to assure that a petroleum product can perform its intended task. See PETROLEUM PROCESSING AND REFINING.

Natural gas is predominantly methane (CH<sub>4</sub>), which has the lowest boiling point and least complex structure of all hydrocarbons. Natural gas from an underground reservoir, when brought to the surface, may contain other, higher-boiling-point hydrocarbons, and is often referred to as wet gas. Wet gas is processed to remove the entrained hydrocarbons that are higher-boiling than methane. The high-boiling hydrocarbons that are isolated and liquefied are called natural gas condensates. See METHANE; NATURAL GAS.

Gasoline (motor fuel) is a complex mixture of hydrocarbons that boils below 200°C (390°F) and is intended for most spark-ignition engines (such as those used in passenger cars, light-duty trucks, motorcycles, and motorboats). The properties of gasoline are intended to satisfy the requirements of smooth and clean burning, easy ignition in cold weather, minimal evaporation in hot weather, and stability during long storage periods. See GASOLINE; INTERNAL COMBUSTION ENGINE.

Petroleum naphtha is a generic term applied to refined, partly refined, or unrefined petroleum products. Naphthas are prepared by several methods, including (1) fractionation of distillates or crude petroleum, (2) solvent extraction, (3) hydrogenation of distillates, (4) polymerization of unsaturated (olefinic) compounds, and (5) alkylation processes. The naphtha may also be a combination of product streams from more than one process. The main uses of petroleum naphthas fall into the general areas of (1) solvents (diluent) for paints, (2) dry-cleaning solvents, (3) solvents for cutback asphalts, (4) solvents in rubber industry, and (5) solvents for industrial extraction processes. Turpentine, the traditional solvent for paints, has been almost completely replaced by the cheaper and more abundant petroleum naphthas. See NAPHTHA; SOLVENT.

Kerosine is essentially a distillation fraction of petroleum. The quantity and quality of the kerosine vary with the type of crude

**Commercial names and uses for major petroleum products**

Crude oil cuts	Refinery blends	Consumer products
Gases	Still gases	Fuel gas
	Propane/butane	Liquefied petroleum gas (LPG)
Light/heavy naphtha	Motor fuel	Gasoline
Kerosine	Aviation turbine, Jet-B	Jet fuel (naphtha type)
	Aviation turbine, Jet-A No. 1 fuel oil	Jet fuel (kerosine type) Kerosine (range oil)
Light gas oil	Diesel	Auto and tractor diesel
	No. 2 fuel oil	Home heating oil
Heavy gas oil	No. 4 fuel oil	Commercial heating oil
	No. 5 fuel oil	Industrial heating oil
	Bright stock	Lubricants
Residuals	No. 6 fuel oil	Bunker C oil
	Heavy residual	Asphalt
	Coke	Coke

oil; some crude oils yield excellent kerosine, while others produce kerosine that requires substantial refining. Kerosine is a very stable product, and additives are not required to improve the quality. Apart from the removal of excessive quantities of aromatics, kerosine fractions may need only a lye (alkali) wash if hydrogen sulfide is present. Kerosine is used as a fuel for heating and cooking, jet engines, and lamps, for weed burning, and as a base for insecticides. See Kerosine.

Diesel fuel is a distillate product that has a higher boiling point than gasoline (or naphtha) but that also must self-ignite easily. This is determined through the cetane rating, derived from the reference fuel *n*-cetane. Cetane number is a measure of the tendency of a diesel fuel to knock in a diesel engine. The scale is based upon the ignition characteristics of two hydrocarbons, *n*-hexadecane (cetane) and 2,3,4,5,6,7,8-heptamethylnonane. Diesel fuel oil is essentially the same as furnace fuel oil, but the proportion of cracked gas oil is usually less since the high aromatic content of the cracked gas oil reduces the cetane value of the diesel fuel. See CETANE NUMBER; DIESEL ENGINE; DIESEL FUEL.

Domestic fuel oil is used primarily in the home, and includes kerosine, stove oil, and furnace fuel oil. Stove oil is a straight-run (distilled) fraction from crude oil, whereas other fuel oils are usually blends of two or more fractions. The straight-run fractions available for blending into fuel oils are heavy naphtha, light and heavy gas oil, and residua. Cracked fractions such as light and heavy gas oil from catalytic cracking, cracking coal tar, and fractionator bottoms from catalytic cracking may also be used as blends to meet the specifications of the different fuel oils.

Heavy fuel oil includes a variety of oils, ranging from distillates to residual oils that must be heated to 260°C (500°F) or higher before they can be used. In general, heavy fuel oil consists of residual oil blended to suit specific needs and to meet designed specifications.

Heavy fuel oil usually contains residuum that is mixed (cut back) to a specified viscosity with gas oils and fractionator bottoms. For some industrial purposes where flames or flue gases contact the product (ceramics, glass, heat treating, open hearth furnaces), the fuel oil must be blended to have a minimum specified sulfur content. See FUEL OIL.

Asphalt is a residuum that cannot be distilled even under the highest vacuum since the temperatures required to volatilize the residuum promote the formation of coke. Asphalts have complex chemical and physical compositions that usually vary with the source of the crude oil. See ASPHALT AND ASPHALTITE.

Petroleum coke is the residue left by the noncatalytic destructive distillation (thermal decomposition with simultaneous removal of distillate) of petroleum residua. The coke formed in catalytic cracking operations is usually nonrecoverable because it adheres to the catalyst employed as fuel for the process. The composition of the coke varies with the source of the crude oil, but in general, large amounts of high-molecular-weight complex hydrocarbons (rich in carbon but correspondingly poor in hydrogen) make up a high proportion. Petroleum coke is employed for a number of purposes, but the major use is in the manufacture of carbon electrodes for aluminum refining, which requires a high-purity carbon (that is, low in ash and sulfur-free). In addition, petroleum coke is employed in the manufacture of carbon brushes, silicon carbide abrasives, and structural carbon (such as pipes and Rashig rings), as well as in the manufacture of calcium carbide (CaC<sub>2</sub>) from which acetylene is produced. See COKE. [J.G.S.]

**Petroleum reserves** Proved reserves are the estimated quantities of crude oil liquids which with reasonable certainty can be recovered in future years from delineated reservoirs under existing economic and operating conditions. Thus, estimates of crude oil reserves do not include synthetic liquids which at some time in the future may be produced by converting coal or oil shale, nor do reserves include fluids which may be recovered

following the future implementation of a supplementary or enhanced recovery scheme.

Indicated reserves are those quantities of petroleum which are believed to be recoverable by already implemented but unproved enhanced oil recovery processes or by the application of enhanced recovery processes to reservoirs similar to those in which such recovery processes have been proved to increase recovery.

Thus, crude oil reserves can be called upon in the future with a high degree of certainty, subject of course to the limitations placed on production rate by fluid flow within the reservoir and the capacity of the individual producing wells and surface facilities to handle the produced fluids. It is important to bear in mind the distinction between resources and reserves. The former term refers to the total amount of oil that has been discovered in the subsurface, whereas the latter refers to the amount of oil that can be economically recovered in the future. The ratio of the ultimate recovery (the sum of currently proved reserves and past production) to the resource or original oil in place is the anticipated recovery efficiency. See NATURAL GAS; PETROLEUM; PETROLEUM ENHANCED RECOVERY. [T.M.D.]

**Petroleum reservoir engineering** The technology concerned with the prediction of the optimum economic recovery of oil or gas from hydrocarbon-bearing reservoirs. It is an eclectic technology requiring coordinated application of many disciplines: physics, chemistry, mathematics, geology, and chemical engineering. Originally, the role of reservoir engineering was exclusively that of counting oil and natural gas reserves. The reserves—the amount of oil or gas that can be economically recovered from the reservoir—are a measure of the wealth available to the owner and operator. It is also necessary to know the reserves in order to make proper decisions concerning the viability of downstream pipeline, refining, and marketing facilities that will rely on the production as feedstocks.

The scope of reservoir engineering has broadened to include the analysis of optimum ways for recovering oil and natural gas, and the study and implementation of enhanced recovery techniques for increasing the recovery above that which can be expected from the use of conventional technology.

The amount of oil in a reservoir can be estimated volumetrically or by material balance techniques. A reservoir is sampled only at the points at which wells penetrate it. By using logging techniques and core analysis, the porosity and net feet of pay (oil-saturated interval) and the average oil saturation for the interval can be estimated in the immediate vicinity of the well. The oil-saturated interval observed at one location is not identical to that at another because of the inherent heterogeneity of a sedimentary layer. It is therefore necessary to use statistical averaging techniques in order to define the average oil content of the reservoir (usually expressed in barrels per net acre-foot) and the average net pay. The areal extent of the reservoir is inferred from the extrapolation of geology and fluid content as well as the drilling of dry holes beyond the productive limits of the reservoir. The definition of reservoir boundaries can be heightened by study of seismic surveys, particularly 3-D surveys, and analysis of pressure buildups in wells after they have been brought on production. See PETROLEUM GEOLOGY; WELL LOGGING.

The overall recovery of crude oil from a reservoir is a function of the production mechanism, the reservoir and fluid parameters, and the implementation of supplementary recovery techniques. In general, recovery efficiency is not dependent upon the rate of production except for those reservoirs where gravity segregation is sufficient to permit segregation of the gas, oil, and water. Where gravity drainage is the producing mechanism, which occurs when the oil column in the reservoir is quite thick and the vertical permeability is high and a gas cap is initially present or is developed on producing, the reservoir will also show a significant effect of rate on the production efficiency. Reservoir engineering expertise, together with geological and petrophysical

engineering expertise, is being used to make very detailed studies of the production performance of crude oil reservoirs in an effort to delineate the distribution of residual oil and gas in the reservoir, and to develop the necessary technology to enhance the recovery. See PETROLEUM ENHANCED RECOVERY. [T.M.D.]

Well testing broadly refers to the diagnostic tests run on wells in petroleum reservoirs to determine well and reservoir properties. The most important well tests are called pressure transient tests and are conducted by changing the rate of a well in a prescribed way and recording the resulting change in pressure with time.

The information obtained from pressure transient tests includes estimates of (1) unaltered formation permeability to the fluid(s) produced in the well; (2) altered (usually reduced) permeability near the well caused by drilling and completion practices; (3) altered (increased) permeability near the well created by deliberately stimulating the well by injecting either an acid that dissolves some of the formation or a high-pressure fluid that creates fractures in the formation; (4) distances to flow barriers located in the area drained by the well; and (5) average pressure in the area drained by the well. In addition, some testing programs may confirm hypothesized models of the reservoir, including important variations of formation properties with distance or location of gas/oil, oil/water, or other fluid/fluid contacts.

Pressure transient tests are usually interpreted by comparing the observed pressure-time response to the predicted response by a mathematical model of the well/reservoir system. Graphical techniques are used to calculate permeability. More sophisticated graphical techniques involve matching changes in pressure to preplotted analytical solutions (type-curve matching). Regression analysis is used to match observed pressure-time data to mathematical models. Although analytical solutions are being found for more and more complex reservoir models each year, many reservoirs are still so complex that their behavior cannot be described accurately by analytical solutions. In such cases, finite-difference approximations to the governing flow equations can be used in commercial reservoir simulators, the reservoir properties treated as unknowns, and properties found that fit the observed data well. [W.J.Le.]

Reservoir behavior can be simulated using models that have been constructed to have properties similar either to an ideal geometric shape of constant properties or to the shape and varying properties of a real (nonideal) oil or gas reservoir. See MODEL THEORY; SIMULATION.

For application to petroleum reservoirs, it is necessary to predict the simultaneous flow behavior of more than one fluid phase having different properties (water, gas, and crude oil). The permeability, the relative permeability, and the density and viscosity of each phase constitute its transport properties for calculating its flow. The relative permeability is a factor for each phase (oil, water, gas) which, when multiplied by the permeability for a single phase such as water, will give the permeability for the given phase. It varies with the volume fraction of the pore space occupied by the phase, called the saturation of the given phase. Generally, the relative permeability of the water phase depends only on its own saturation, and likewise for the gas phase. The relative permeability of the oil phase is a function of the saturations of both gas and water phases. See FLUID FLOW; FLUID-FLOW PRINCIPLES; FLUID MECHANICS. [E.L.Cl.]

**Petrology** The study of rocks, their occurrence, composition, and origin. Petrography is concerned primarily with the detailed description and classification of rocks, whereas petrology deals primarily with rock formation, or petrogenesis. A petrological description includes definition of the unit in which the rock occurs, its attitude and structure, its mineralogy and chemical composition, and conclusions regarding its origin. See MINERALOGY; PETROGRAPHY; ROCK. [W.I.R.]

One aim of mineralogy and petrology is to decipher the history of igneous and metamorphic rocks. Detailed study of the field geology, the structures, the petrography, the mineralogy, and the

geochemistry of the rocks is used as a basis for hypotheses of origin. The conditions at depth within the Earth's crust and mantle, the processes occurring at depth, and the whole history of rocks once deeply buried are deduced from the study of rocks now exposed at the Earth's surface. One approach used to test hypotheses so developed is experimental petrology; the term experimental minerals refers to similar studies involving minerals rather than rocks (mineral aggregates). See IGNEOUS ROCKS; METAMORPHIC ROCKS.

The experimental petrologist reproduces in the laboratory the conditions of high pressure and high temperature encountered at various depths within the Earth's crust and mantle where the minerals and rocks were formed. By suitable selection of materials the petrologist studies the chemical reactions that actually occur under these conditions and attempts to relate these to the processes involved in petrogenesis. [P.J.Wy.]

**Petromyzontida** The order comprising the lampreys, sometimes called Petromyzontiformes, which are eellike, jawless vertebrates (class Agnatha). Lampreys differ from Myxiniiformes as follows: the single nasal opening is on the dorsal side of the head and ends internally as a blind sac; the mouth is surrounded by a circular oral disk and provided with a rasping tongue (both disk and tongue are set with horny teeth); seven pairs of gill pouches open separately to the exterior; two pairs of semicircular canals are present; adults have well-developed eyes; dorsal and caudal fins are separate, and both are supported by fin rays; there are separate sexes and a distinct larval stage; and they either live in fresh water or enter fresh water to breed if they live in the sea. See MYXINIFORMES.

After they have metamorphosed to adults, most lampreys aggressively attack other fish to which they attach themselves by suction, using their oral disks; then they rasp through skin and scales with their tongues and suck the blood and flesh of the host. This parasitic habit has resulted in serious damage to commercial fisheries. Lampreys are rarely used as food.

The Petromyzontida have a worldwide distribution and are divided into eight Recent genera, of which *Petromyzon* and *Lampetra* are well known. Two genera of fossil lampreys are currently known. Details of the structure of the four genera indicate a relationship to the Osteostraci and Anaspida, extinct ostracoderms of the Silurian and Devonian periods, from which they may be descended. See ANASPIDA; OSTEOSTRACI. [R.H.De.; E.C.O.]

**Pewter** A tarnish-resistant alloy of lead and tin always containing appreciably more than 63% tin. Other metals are sometimes used with or in place of the lead; among them are copper, antimony, and zinc. Pewter is commonly worked by spinning and it polishes to a characteristic luster. Because pewter work hardens only slightly, pewter products can be finished without intermediate annealing. Early pewter, with high lead content, darkened with age. With less than 35% lead, pewter was used for decanters, mugs, tankards, bowls, dishes, candlesticks, and canisters. The lead remained in solid solution with the tin so that the alloy was resistant to the weak acids in foods. [F.H.R.]

**pH** An expression for the effective concentration of hydrogen ions in solution. The activity of hydrogen ions or, more correctly, hydronium ions, which are hydrated hydrogen ions  $H(H_2O)_n^+$ , affects the equilibria and kinetics of a wide variety of chemical and biochemical reactions. Because these effects are activity-dependent, it is extremely important to distinguish between the hydrogen-ion concentration and activity. The concentration, or total acidity, is obtained by titration and corresponds to the total concentration of hydrogen ions available in a solution, that is, free, unbound hydrogen ions as well as hydrogen ions associated with weak acids. The hydrogen-ion activity refers to the effective concentration of unassociated hydrogen ions, the form that directly affects physicochemical reaction rates and equilibria. This activity is therefore of fundamental importance in many areas of



science and technology. The relationship between hydrogen-ion activity ( $a_{\text{H}^+}$ ) and concentration ( $C$ ) is given by Eq. (1), where

$$a_{\text{H}^+} = \gamma C \quad (1)$$

the activity coefficient  $\gamma$  is a function of the total ionic strength (concentration) of the solution and approaches unity as the ionic strength approaches zero; that is, the difference between the activity and the concentration of hydrogen ion diminishes as the solution becomes more dilute. See ACTIVITY (THERMODYNAMICS); CHEMICAL EQUILIBRIUM; HYDROGEN ION.

The effective concentration of hydrogen ions in solution is expressed in terms of pH, which is the negative logarithm of the hydrogen-ion activity [Eq. (2)]. Because of the negative

$$\text{pH} = -\log_{10} a_{\text{H}^+} \quad (2)$$

logarithmic (exponential) relationship, the more acidic a solution, the smaller the pH value. The pH of a solution may have little relationship to the titratable acidity of a solution that contains weak acids or buffering substances; the pH of a solution indicates only the free hydrogen-ion activity. If total acid concentration is to be determined, an acid-base titration must be performed. See ACID AND BASE; BUFFERS (CHEMISTRY); TITRATION.

Two methods, electrometric and chemical indicator (optical), are used for measuring pH. The more commonly used electrometric method is based on measurement of the difference between the pH of a test solution and that of a standard solution. The pH scale is defined by a series of reference buffer solutions that are used to calibrate the pH measurement system. The instrument measures the potential difference developed between the pH electrode and a reference electrode of constant potential. The difference in potential obtained when the electrode pair is removed from the standard solution and placed in the test solution is converted to the pH value. In the indicator method, the pH value is obtained by simple visual comparison of the color of pH-sensitive dyes to standards (for example, color charts) or by use of calibrated optical readout devices (photometers), often in combination with fiber-optic sensors. See ELECTRODE; REFERENCE ELECTRODE. [R.A.D.]

**pH regulation (biology)** The processes operating in living organisms to preserve a viable acid-base state. In higher animals, much of the body substance (60–70%) consists of complex solutions of inorganic and organic solutes. For convenience, these body fluids can be subdivided into the cellular fluid (some two-thirds of the total) and the extracellular fluid. The latter includes blood plasma and interstitial fluid, the film of fluid that bathes all the cells of the body. For normal function, the distinctive compositions of these various fluids are maintained within narrow limits by a process called homeostasis. A crucial characteristic of these solutions is pH, an expression representing the concentration (or preferably the activity) of hydrogen ions,  $[\text{H}^+]$ , in solution. The pH is defined as  $-\log [\text{H}^+]$ , so that in the usual physiological pH range of 7 to 8,  $[\text{H}^+]$  is exceedingly low, between  $10^{-7}$  and  $10^{-8}$  M. Organisms use a variety of means to keep pH under careful control, because even small deviations from normal pH can disrupt living processes. See HOMEOSTASIS; pH.

The most accessible and commonly studied body fluid is blood, and it, therefore, provides the most information on pH regulation. Blood pH in humans, and in mammals generally, is about 7.4. This value indicates that blood is slightly alkaline, because neutrality, the condition in which the concentration of hydrogen ions  $[\text{H}^+]$  equals the concentration of hydroxyl ions  $[\text{OH}^-]$ , is pH 6.8 at mammalian body temperature of 98°F (37°C). The pH within cells, including the red blood cells, is typically lower by 0.2–0.6 unit, and is thus close to neutrality. In most animals other than warm-blooded mammals, blood pH deviates from the familiar value of 7.4. The major reason is that body temperature has an important influence on pH regulation. Consequently, animals that experience significant changes in body

temperature have no single normal pH at which they regulate, but rather a series of values depending on body temperature.

Blood pH regulation is necessary because metabolic and ingestive processes add acidic or basic substances to the body and can displace pH from its proper value. For true regulation, active physiological mechanisms are required that can alter the acid-base composition of the blood in a controlled fashion. It is conventional to identify these control mechanisms with their effects on the principal buffer of the extracellular fluid, carbon dioxide ( $\text{CO}_2$ ). Carbon dioxide is produced by cellular metabolism and distributes readily throughout the body because of its high solubility and rapid diffusion. In solution,  $\text{CO}_2$  is hydrated to carbonic acid ( $\text{H}_2\text{CO}_3$ ) which dissociates almost completely to  $\text{H}^+$  and bicarbonate ions  $[\text{HCO}_3^-]$ . Dissolved  $\text{CO}_2$  can be identified with a particular partial pressure of  $\text{CO}_2$  ( $\text{PCO}_2$ ). To regulate blood pH, organisms have mechanisms to independently control  $\text{PCO}_2$  and  $[\text{HCO}_3^-]$ .

The cells, while benefitting from the stability afforded by whole body mechanisms (respiratory and ionic), also have local means for their own pH regulations. An acute acid load on a cell, whether from its intrinsic metabolism or from an external source, is dealt with first by the cell's chemical buffering capacity, a capacity that exceeds that of the blood by severalfold. Other cellular mechanisms include the conversion of organic acids to neutral compounds through metabolic transformations, and the transfer of acid equivalents from the primary cell fluid, the cytoplasm, into cellular organelles. See BIOPOTENTIALS AND IONIC CURRENTS; CHEMOSMOSIS; ENZYME. [D.C.J.]

**Phaeophyceae** A class of plants, commonly called brown algae, in the chlorophyll *a-c* phyletic line (Chromophycota). Brown algae occur almost exclusively in marine or brackish water, where they are attached to rocks, wood, sea grasses, or other algae. Approximately 265 genera and 1500 species are recognized, arranged in about 15 orders. See ALGAE; CHROMOPHYCOTA.

Phaeophyceae are characterized primarily by biochemical and ultrastructural features. The cells are typically uninucleate and contain one or more chloroplasts with or without pyrenoids. Photosynthetic pigments include chlorophyll *a* and *c*,  $\beta$ -carotene, and several xanthophylls, principally fucoxanthin. The simplest thallus exhibited by Phaeophyceae is generally considered to be an erect, unbranched or branched, uniseriate filament arising from a prostrate filamentous base. Many Phaeophyceae are crustose or bladelike. Complex thalli differentiated into macroscopic organs are produced by kelps and rockweeds.

The geographic distribution of Phaeophyceae is bimodal. Kelps are most abundant and diverse on surf-swept rocky shores of the North Pacific, but they form an ecologically important vegetation belt in the lower intertidal and upper sub-tidal zones on all cold-water shores except Antarctica. Rockweeds are similarly abundant on cold-water shores, forming conspicuous belts in the upper intertidal zone. They also form extensive stands in salt marshes in the Northern Hemisphere. Tropical waters support a diverse array of Dictyotales and members of the fucalean family Sargassaceae. [P.C.Si.; R.L.Moe]

**Phagocytosis** A mechanism by which single cells of the animal kingdom, such as smaller protozoa, engulf and carry particles into the cytoplasm. It differs from endocytosis primarily in the size of the particle rather than in the mechanism; as particles approach the dimensions and solubility of macromolecules, cells take them up by the process of endocytosis.

Cells such as the free-living amoebas or the wandering cells of the metazoa often can "sense" the direction of a potential food source and move toward it (chemotaxis). If, when the cell contacts the particle, the particle has the appropriate chemical composition, or surface charge, it adheres to the cell. The cell responds by forming a hollow, conelike cytoplasmic process around the particle, eventually surrounding it completely.

Although the particle is internalized by this sequence of events, it is still enclosed in a portion of the cell's surface membrane and thus isolated from the cell's cytoplasm. The combined particle and membrane package is referred to as a food or phagocytic vacuole. See VACUOLE.

Ameboid cells of the metazoa also selectively remove foreign particles, bacteria, and other pathogens by phagocytosis. After the foreign particle or microorganism is trapped in a vacuole inside the macrophage, it is usually digested. To accomplish this, small packets (lysosomes) of lytic proenzymes are introduced into the phagocytic vacuole, where the enzymes are then dissolved and activated. See LYSOSOME. [P.W.B.]

**Pharetronidia** A subclass of sponges of the class Calcarea in which the skeleton is formed of quadriradite spicules cemented together into a compact network, or includes an aspiculous massive basal skeleton formed of irregular calcitic spherulites. Spicules shaped like tuning forks are characteristically present, and free triradiates, quadriradiates, and diactinal spicules may occur. See CALCAREA. [W.D.H.]

**Pharmaceutical chemistry** The chemistry of drugs and of medicinal and pharmaceutical products. The important aspects of pharmaceutical chemistry are as follows:

1. Isolation, purification, and characterization of medicinally active agents and materials from natural sources used in treatment of disease and in compounding prescriptions.
2. Synthesis of medicinal agents not known from natural sources, or the synthetic duplication, for reasons of economy, purity, or adequate supply, of substances first known from natural sources.
3. Semisynthesis of drugs, whereby natural substances are transformed by means of comparatively simple steps into products which possess more favorable therapeutic or pharmaceutical properties.
4. Determination of the derivative or form of a medicinal agent which exhibits optimum medicinal activity and at the same time lends itself to stable formulation and elegant dispensing.
5. Determination of incompatibilities, chemical and biological, between the various ingredients of a prescription.
6. Establishment of safe and practical standards, with respect to both dosage and quality, to assure uniform and therapeutically reliable forms for all medication.
7. Improvement and promotion of the use of chemical agents for prevention of illness, alleviation of pain, cure of disease, and search for new therapeutic agents, particularly where no satisfactory remedy now exists. [W.H.H.]

**Pharmaceuticals testing** Techniques used to determine that pharmaceuticals conform to specified standards of identity, strength, quality, and purity. Conformance to these standards assures pharmaceuticals which are safe and efficacious, of uniform potency and purity, and of acceptable color, flavor, and physical appearance. Pharmaceuticals are medicinal products which are prescribed by medical doctors and dispensed through pharmacies and hospitals. They are usually taken orally or by parenteral injection.

Standards or specifications and their attendant procedures are designed to provide desired characteristics and acceptable tolerances for all raw materials, intermediates, and finished products. These standards thus provide an objective determination of whether pharmaceuticals are properly constituted. Two components are vital to the makeup of such standards: appropriate analytical procedures to permit a comprehensive examination, and a list of specifications to define the acceptable limits for each property tested. Standards are established by the pharmaceutical manufacturer, official compendiums (*U.S. Pharmacopeia* and the *National Formulary*), and regulations promulgated by the U.S. Food and Drug Administration (FDA).

The steps in the production cycle for pharmaceuticals must be rigidly and uniformly controlled so that each phase is completely accurate. The four control phases are generally designated as raw materials, manufacturing procedures, finished product testing, and control of identity.

Raw materials are usually referred to as components and are purchased on specifications. Physical specifications include such characteristics as bulk density, mesh size, color, odor, extraneous contamination such as fibers, and homogeneity. Chemical specifications usually include such characteristics as chemical or physiological potency, melting point, boiling range, optical rotation, moisture, heavy-metals content, chemical identity, solubility, and presence of chemical contaminants. Samples are taken upon receipt of a specific batch of raw material. The samples are tested to ensure conformance to each specification. Only after the raw material has been checked against each of the specifications can it be approved for use in pharmaceuticals.

Pharmaceutical manufacturers must make products in conformance with the Good Manufacturing Practices as prescribed by the FDA. These regulations provide criteria on the following: buildings, equipment, personnel, components, master-formula and batch-production records, production and control procedures, product containers, packaging and labeling, laboratory controls, distribution records, stability, and complaint files. The quality-control system must provide regular and continuous use of all reasonable procedures, methods, and operations that are necessary to ensure uniform safety and effectiveness of the pharmaceutical.

Finished pharmaceuticals must conform to appropriate standards of identity, strength, quality, and purity. Accordingly each batch of a pharmaceutical must satisfy five requirements: conformance with (1) the label claim for potency, (2) homogeneity standards, (3) standards of pharmaceutical elegance (the physical appearance of the dosage units), (4) identity specifications, and (5) regulatory standards if they are applicable to the specific pharmaceutical.

Identity is the final requirement in pharmaceutical testing. Identity techniques guarantee proper labeling, that is, that the right product is in the right bottle with the right label. To maintain the identity of the product, extensive checks are made throughout the manufacturing operation, including the use of duplicate label tags on all bulk goods, and very rigid controls are applied to printing, storage, and application of labels on finished pharmaceuticals. See BIOASSAY; QUALITY CONTROL. [W.B.Fo.]

**Pharmacognosy** The general biology, biochemistry, and economics of nonfood natural products of value in medicine, pharmacy, and other health professions. The products studied are of biologic origin, either plant or animal. Pharmacognosy literally means knowledge of drugs, as do pharmacology and pharmacy. The center of interest in pharmacology, however, is on the mode of action of drugs. In pharmacy major attention is directed toward provision of suitable dosage forms, their production and distribution. Pharmacognosy is restricted to natural products with attention centered on sources of drugs, plant and animal, and on the biosynthesis and identity of their pharmacodynamic constituents.

Organs, or occasionally entire plants or animals, are dried or frozen for preservation and are termed crude drugs. They may be used medicinally in essentially this form or as sources of mixtures or of chemicals obtained by processes of extraction. Mixtures obtained by exudation from living plants include such drugs as opium, turpentine, and acacia. Processes of extraction are required to obtain such mixtures as peppermint oil (steam distillation), podophyllum resin (percolation), and parathyroid extract (solution).

Pure chemicals may be extracted from a crude drug (for example, the glycoside digitoxin from digitalis or the hormone insulin from pancreas), from a mixture obtained by exudation (for example, the alkaloid morphine from opium), or from an

extracted mixture (for example, the terpene menthol from peppermint oil).

Vitamins as a class of natural products are within the scope of pharmacognosy, although many are obtained commercially by laboratory synthesis. Included also are antibiotics and biologicals (serums, vaccines, and diagnostic biological products).

Development of synthetic drugs related chemically to the active constituent of a natural product has frequently followed investigation of native use of the natural product as drug or poison. The objective of such development is usually to produce a drug having fewer undesirable side effects while retaining the useful therapeutic action. See PHARMACEUTICAL CHEMISTRY; PHARMACOLOGY; PHARMACY. [R.A.De.]

**Pharmacology** The science of detection and measurement of the effects of drugs or other chemicals on biological systems. The effect of chemicals may be beneficial (therapeutic) or harmful (toxic). The pure chemicals or mixtures may be of natural origin (plant, animal, or mineral) or may be synthetic compounds.

The broad area covered may be conveniently divided into a number of categories: chemotherapy, the use of chemicals to destroy invading organisms such as bacteria and molds in or on the host; pharmacotherapy, the use of drugs to restore or replace normal function in various tissue cells, organs, or integrated units; pharmacodynamics, studies on the mechanism of action of drugs which may utilize physiological, biochemical, or electrical techniques; toxicology, the study of the poisonous effects of chemicals; psychopharmacology, the study of the effects of chemicals on the behavior of humans or animals; biochemical pharmacology, the effects of chemicals on biochemical reactions in living systems, and the effects of these systems on the chemicals, that is, their metabolism; structure-activity relationship, relationship of biological activity to chemical structure and molecular properties; and clinical pharmacology, the study and evaluation of the effects of drugs in humans. See CHEMOTHERAPY; PATHOLOGY; TOXICOLOGY. [C.J.K.]

**Pharmacy** The health profession concerned with the discovery, development, production, and distribution of drugs. Drugs are substances (other than devices) used to diagnose, prevent, cure, or relieve the symptoms of disease. For relations to closely allied fields. See MEDICINE; PHARMACEUTICAL CHEMISTRY; PHARMACOGNOSY; PHARMACOLOGY.

General practice is carried on in exclusive prescription pharmacies, semiprofessional pharmacies, and drug stores. It consists of compounding and dispensing drugs on order of the physician, dentist, or veterinarian; serving as consultant on drugs to the health professions and to the public; and selling other health supplies such as antiseptics, bandages, and home remedies.

A hospital pharmacy includes special administrative features, provision of drugs for nursing stations, manufacturing of pharmaceutical preparations, teaching of nurses and medical and pharmacy interns, service to the hospital committee on pharmacy and therapeutics, preparation and revision of a hospital formulary, and monitoring the drug regimen of the individual patient (clinical pharmacy). The pharmacist may have charge of investigational drugs, radioactive pharmaceuticals, medical and surgical sterile supplies, and gaseous drugs for inhalation therapy. [R.A.De.]

**Pharynx** A chamber at the oral end of the vertebrate alimentary canal, leading to the esophagus. In adult humans it is divided anteriorly by the soft palate into a nasopharynx and an oropharynx, lying behind the tongue but anterior to the epiglottis; there is also a retropharyngeal compartment, posterior to both epiglottis and soft palate. The nasopharynx receives the

nasal passages and communicates with the two middle ears through auditory tubes. The retropharynx leads to the esophagus and to the larynx, and the paths of breathing and swallowing cross within it. See ESOPHAGUS; LARYNX; PALATE. [W.W.B.]

**Phase (astronomy)** The changing fraction of the disk of an astronomical object that is illuminated, as seen from some particular location. The monthly phases of the Moon are a familiar example (see illustration). When the Sun is approximately on the far side of the Moon as seen from Earth (conjunction), the dark side of the Moon faces the Earth and there is a new moon. The phase waxes, beginning with crescent phases, as an increasing fraction of the illuminated face of the Moon is seen. At quadrature, when half the visible face of the Moon is illuminated, the phase is called the first-quarter moon, since the Moon is now one-quarter of the way through its cycle of phases. The waxing moon continues through its gibbous phases until it is in opposition; the entire visible face of the Moon is illuminated, the full moon. During the full moon, the Moon and the Sun are on opposite sides of the Earth, a configuration known as a syzygy. Then the Moon wanes, going through waning gibbous, third-quarter, and waning crescent phases until it is new again. The cycle of moon phases takes approximately 29.53 days and explains the origin of the word month. See MOON.

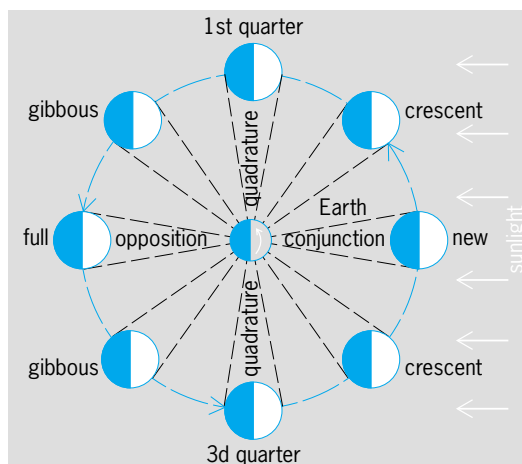

From Earth, different fractions of the illuminated half of the Moon are seen at different times as the Moon goes through a 29.53-day cycle of phases.

Galileo discovered the phases of the planet Venus when he observed the sky with his telescope in 1610. Giovanni Zupus discovered the phases of the planet Mercury in 1639. Because of the angle at which the outer planets are seen from Earth, and because of their great distance, they do not appear to go through phases as seen from Earth. [J.M.P.]

**Phase (periodic phenomena)** The fractional part of a period through which the time variable of a periodic quantity (alternating electric current, vibration) has moved, as measured at any point in time from an arbitrary time origin. In the case of a sinusoidally varying quantity, the time origin is usually assumed to be the last point at which the quantity passed through a zero position from a negative to a positive direction.

In comparing the phase relationships at a given instant between two time-varying quantities, the phase of one is usually assumed to be zero, and the phase of the other is described, with respect to the first, as the fractional part of a period through which the second quantity must vary to achieve a zero of its own (see illustration). In this case, the fractional part of the period is

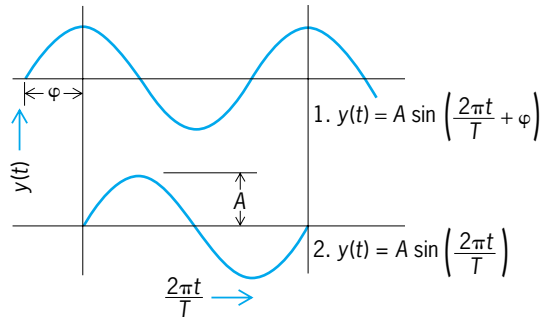

An illustration of the meaning of phase for a sinusoidal wave. The difference in phase between waves 1 and 2 is  $\varphi$  and is called the phase angle. For each wave,  $A$  is the amplitude and  $T$  is the period.

usually expressed in terms of angular measure, with one period being equal to  $360^\circ$  or  $2\pi$  radians. See PHASE-ANGLE MEASUREMENT; SINE WAVE. [W.J.G.]

**Phase-angle measurement** Measurement of the time delay between two periodic signals. The phase difference between two sinusoidal waveforms that have the same frequency

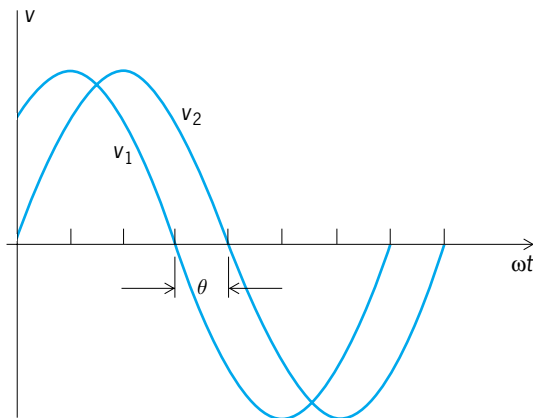

Phase angle  $\theta$  between voltages  $v_1$  and  $v_2$ .

and are free of a dc component can be conveniently described as shown in the illustration. It can be seen that the phase angle can be considered as a measure of the time delay between two periodic signals expressed as a fraction of the wave period. This

fraction is normally expressed in units of angle, with a full cycle corresponding to  $360^\circ$ . For example, in the illustration, where the voltage  $v_1$  passes through zero  $\frac{1}{8}$  cycle before a second voltage  $v_2$ , it leads by  $360^\circ/8$  or  $45^\circ$ . Phase angle is usually defined from the fundamental component of each waveform; therefore distortion of either or both signals can give rise to errors, the extent of which depends on the nature of the distortion and the method of measurement. See DISTORTION (ELECTRONIC CIRCUITS).

The majority of modern phase-measuring devices are based on the use of zero-crossing detectors. The time at which each signal crosses the zero-voltage axis is determined, usually by means of a squaring-up circuit (for example, an overdriven amplifier) followed by a high-speed comparator. This produces, in each channel, a trigger pulse that is used to drive a bistable flip-flop. The output from the bistable is a rectangular wave, the duty cycle of which is proportional to the phase difference between the input signals. If this signal is integrated by means of a suitable filter, a dc voltage is produced that is an analog representation of the phase angle. This voltage is then displayed on a panel meter (analog or digital) suitably scaled in degrees or radians. Instrumentation using this principle is capable of measuring phase differences to approximately  $\pm 0.05^\circ$  over a wide range of amplitudes and frequencies. See AMPLIFIER; COMPARATOR; ELECTRIC FILTER; MULTIVIBRATOR; SWITCHING CIRCUIT; WAVE-SHAPING CIRCUITS.

Conventional phase meters have an upper frequency limit of a few hundred kilohertz. This limit is imposed mainly by the ability of the arrangement consisting of a comparator and a flip-flop to maintain a clean and precise rectangular waveform under conditions of high-speed operation. In order to measure phase angle at frequencies between about 100 kHz and several gigahertz, it is necessary to down-convert the radio-frequency signals to a frequency that can be handled correctly by the phase meter. At microwave frequencies, instruments such as slotted lines, air lines, and vector network analyzers are also used for phase-angle measurements. See MICROWAVE MEASUREMENTS. [J.Hur.]

**Phase-contrast microscope** A microscope used for making visible differences in phase or optical path in transparent or reflecting specimens. It is one of the most important instruments available for studying living cells and is widely used in biological and medical research.

The essential features of a phase-contrast microscope are shown in the illustration. The practical problem is to find some way of separating the incident or direct light from that diffracted by the object. This is done by placing a diaphragm  $D$  of easily recognizable shape, such as an annulus, at the front focal plane of the substage condenser  $C$ . Light from each point of

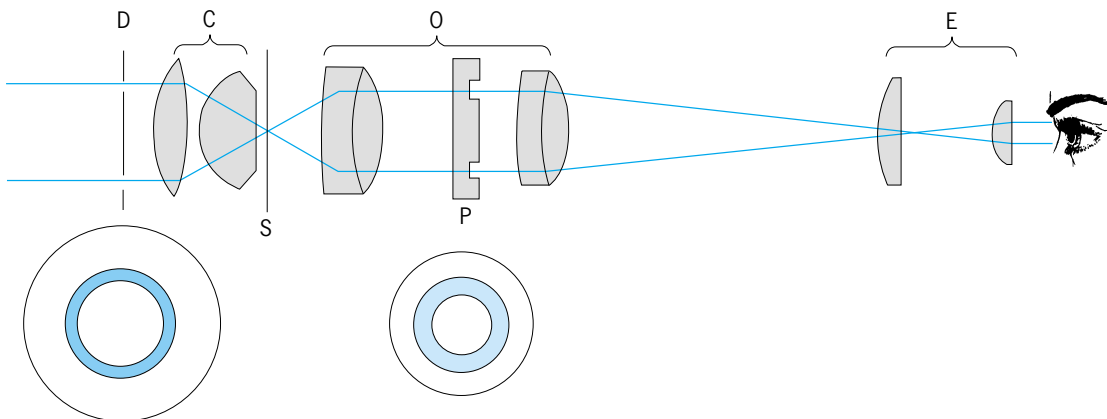

Diagram of a phase-contrast microscope.

the focal plane passes as a parallel pencil of rays through the specimen S and is brought to a focus at the rear focal plane P of the objective O. Thus, on removing the eyepiece, an image of the annulus will be seen at the back of the objective lens. This image corresponds to the incident light. In addition, when a specimen is present, some light is diffracted by it and spreads out to fill the whole of the back lens of the objective. Thus, apart from the small area of overlap over the image of the annulus, the direct and diffracted waves are essentially separated at the plane P. A phase plate is now inserted at this level. This can be a transparent disk with an annular groove of such dimensions that it coincides exactly with the image of the diaphragm D. All the direct light now passes through the groove in the phase plate, whereas the diffracted light passes mainly outside the groove. Since the diffracted light has to pass through a greater thickness of transparent material than the direct light, a phase difference, depending on the refractive index of the phase-plate material and on the thickness of the groove, is introduced between them. If this phase difference is about one-quarter of a wavelength, the basic conditions for phase contrast will have been achieved. If the phase plate is made to retard the incident wave by a quarter of a wavelength, the crests and troughs of the two waves will coincide, giving a resultant of greater amplitude. Refractile details will appear bright (negative contrast) instead of dark (positive contrast).

The phase-contrast microscope is the routine instrument for the examination of living cells because it is possible to study the cell structure under excellent optical conditions and with no loss in resolving power. The method is also useful for the study of unstained tissue sections and has found considerable use for the comparison of material in the electron and optical microscopes. See ELECTRON MICROSCOPE; MICROSCOPE; OPTICAL MICROSCOPE.

[R.Ba.]

**Phase equilibrium** A general field of physical chemistry dealing with the various situations in which two or more phases (or states of aggregation) can coexist in thermodynamic equilibrium with each other, with the nature of the transitions between phases, and with the effects of temperature and pressure upon these equilibria. Many superficial aspects of the subject are largely qualitative, for example, the empirical classification of types of phase diagrams; but the basic problems always are susceptible to quantitative thermodynamic treatment, and in many cases, statistical thermodynamic methods can be applied to simple molecular models.

Thermodynamics requires that when two phases,  $\alpha$  and  $\beta$ , are free to exchange heat, mechanical work, and matter (chemical species), the temperature  $T$ , the pressure  $P$ , and the chemical potential (partial molar free energy)  $\mu_i$  of each particular component  $i$  must be equal in both phases at equilibrium. Algebraically, equilibrium exists when  $T_\alpha = T_\beta$ ,  $P_\alpha = P_\beta$ ,  $\mu_{i,\alpha} = \mu_{i,\beta}$ , and  $\mu_{j,\alpha} = \mu_{j,\beta}$ .

These conditions of thermal, mechanical, and material equilibrium need not all be present if the equilibrium between phases is subject to inhibiting restrictions. Thus, for a solution of a nonvolatile solute in equilibrium with the solvent vapor, the condition of equality of solute chemical potentials  $\mu_{2,\alpha} = \mu_{2,\beta}$  need not apply, since there can be no solute molecules in the vapor phase. Similarly, in osmotic equilibria, in which solvent molecules can pass through a semipermeable membrane, whereas solute molecules cannot,  $\mu_{1,\alpha} = \mu_{1,\beta}$  and  $T_{1,\alpha} = T_{2,\beta}$ , but the solute chemical potentials  $\mu_2$  are unequal, as are the pressures on opposite sides of the membrane. See OSMOSIS; SOLUTION.

If a system consists of  $P$  phases and  $C$  distinguishable components, there are  $C + 2$  thermodynamic variables ( $C$  chemical potentials  $\mu_i$ , plus the temperature and pressure) which are interrelated by an equation for each phase. Since there are  $P$  independent equations relating the  $C + 2$  variables, only  $F =$

$C + 2 - P$  variables need be fixed to define completely the state of the system at equilibrium; the other variables are then beyond control. This relation for the number of degrees of freedom  $F$ , or variance, is called the phase rule. It has proved to be a powerful tool in interpreting and classifying types of phase equilibria.

When chemical changes may occur in the system, the number of components  $C$  is the number of independent components whose amounts can be varied by the experimenter; this is equal to the total number of chemical species present less the number of independent chemical equilibria between them.

An invariant system has no degrees of freedom ( $F = 0$ ), for which the number of phases  $P = C + 2$ . For a one-component system, such an invariant point is a triple point at which three phases coexist at a single temperature and pressure only; for a two-component system, a quadruple point (four phases) would be invariant. See TRIPLE POINT. [R.L.S.]

**Phase inverter** A circuit having the primary function of changing the phase of a signal by  $180^\circ$ . The phase inverter is most commonly employed as the input stage for a push-pull amplifier. Therefore, the phase inverter must supply two voltages of equal magnitude and  $180^\circ$  phase difference. A variety of circuits are available for the phase inversion. See PUSH-PULL AMPLIFIER.

Overall fidelity of a phase inverter and push-pull amplifier can be adversely affected by improper design of the phase inverter. The principal design requirement is that frequency response of one input channel to the push-pull amplifier be identical to the frequency response of the other channel.

The simplest form of phase-inverter circuit is a transformer with a center-tapped secondary. Careful design of the transformer assures that the secondary voltages are equal. The transformer forms a good inverter when the inverter must supply power to the input of the push-pull amplifier. The transformer inverter has several disadvantages. It usually costs more, occupies more space, and weighs more than a transistor circuit. Furthermore, some means must be found to compensate for the frequency response of the transformer, which may not be as uniform as that which can be obtained from solid-state circuits. See TRANSFORMER.

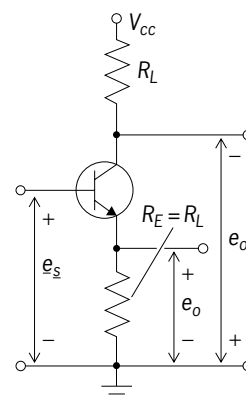

Single-transistor inverter,  $e_s$  = signal voltage;  $e_o$  = output voltage;  $V_{cc}$  = collector supply voltage;  $R_L$  = load resistance;  $R_E$  = emitter resistance.

An amplifier that provides two equal output signals  $180^\circ$  out of phase is called a paraphase amplifier. If coupling capacitors can be omitted, the simplest paraphase amplifier is shown in the illustration. Approximately the same current flows through  $R_L$  and  $R_E$ , and therefore if  $R_L$  and  $R_E$  are equal, the ac output voltages from the collector and from the emitter are equal in magnitude and  $180^\circ$  out of phase. See PHASE (PERIODIC PHENOMENA); PHASE-ANGLE MEASUREMENT. [H.F.K.]

**Phase-locked loops** Electronic circuits for locking an oscillator in phase with an arbitrary input signal. A phase-locked loop (PLL) is used in two fundamentally different ways: (1) as a demodulator, where it is employed to follow (and demodulate) frequency or phase modulation, and (2) to track a carrier or synchronizing signal which may vary in frequency with time. When operating as a demodulator, the PLL may be thought of as a matched filter operating as a coherent detector. When used to track a carrier, it may be thought of as a narrowband filter for removing noise from the signal and regenerating a clean replica of the signal. See DEMODULATOR; ELECTRIC FILTER.

The basic components of a phase-locked loop are shown in the illustration. The input signal is a sine or square wave of arbitrary frequency. The voltage-controlled oscillator (VCO) output signal is a sine or square wave of the same frequency as the input, but the phase angle between the two is arbitrary. The output of the phase detector consists of a direct-current (dc) term, and components of the input frequency and its harmonics. The low-pass filter removes all alternating-current (ac) components, leaving the dc component, the magnitude of which is a function of the phase angle between the VCO signal and the input signal. If the frequency of the input signal changes, a change in phase angle between these signals will produce a change in the dc control voltage in such a manner as to vary the frequency of the VCO to track the frequency of the input signal.

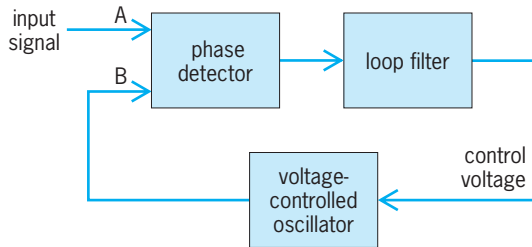

**Phase-locked loop.**  $R_1$  and  $R_2$  are resistors;  $C_1$  and  $C_2$  are capacitors.

The most widespread use of phase-locked loops is undoubtedly in television receivers. Synchronization of the horizontal oscillator to the transmitted sync pulses is universally accomplished with a PLL. The color reference oscillator is often synchronized with a phase-locked loop. Phase-locked loops are also used as frequency demodulators. They have been applied to stereo decoders made on silicon monolithic integrated circuits. High-performance amplitude demodulators may be built using phase-lock techniques. See AMPLITUDE-MODULATION DETECTOR. [T.B.M.]

**Phase modulation** A technique used in telecommunications transmission systems whereby the phase of a periodic carrier signal is changed in accordance with the characteristics of an information signal, called the modulating signal. Phase modulation (PM) is a form of angle modulation. For systems in which the modulating signal is digital, the term "phase-shift keying" (PSK) is usually employed. See ANGLE MODULATION.

In typical applications of phase modulation or phase-shift keying, the carrier signal is a pure sine wave of constant amplitude, represented mathematically as Eq. (1), where the constant  $A$  is

$$c(t) = A \sin \theta(t) \quad (1)$$

its amplitude,  $\theta(t) = \omega t$  is its phase, which increases linearly with time, and  $\omega = 2\pi f$  and  $f$  are constants that represent the carrier signal's radian and linear frequency, respectively.

Phase modulation varies the phase of the carrier signal in direct relation to the modulating signal  $m(t)$ , resulting in Eq. (2),

$$\theta(t) = \omega t + km(t) \quad (2)$$

where  $k$  is a constant of proportionality. The resulting transmitted

signal  $s(t)$  is therefore given by Eq. (3).

$$s(t) = A \sin[\omega t + km(t)] \quad (3)$$

At the receiver,  $m(t)$  is reconstructed by measuring the variations in the phase of the received modulated carrier.

Phase modulation is intimately related to frequency modulation (FM) in that changing the phase of  $c(t)$  in accordance with  $m(t)$  is equivalent to changing the instantaneous frequency of  $c(t)$  in accordance with the time derivative of  $m(t)$ . See FREQUENCY MODULATION.

Among the advantages of phase modulation are superior noise and interference rejection, enhanced immunity to signal fading, and reduced susceptibility to nonlinearities in the transmission and receiving systems. See DISTORTION (ELECTRONIC CIRCUITS); ELECTRICAL INTERFERENCE; ELECTRICAL NOISE.

When the modulating signal  $m(t)$  is digital, so that its amplitude assumes a discrete set of values, the phase of the carrier signal is "shifted" by  $m(t)$  at the points in time where  $m(t)$  changes its amplitude. The amount of the shift in phase is usually determined by the number of different possible amplitudes of  $m(t)$ . In binary phase-shift keying (BPSK), where  $m(t)$  assumes only two amplitudes, the phase of the carrier differs by  $180^\circ$ . An example of a higher-order system is quadrature phase-shift keying (QPSK), in which four amplitudes of  $m(t)$  are represented by four different phases of the carrier signal, usually at  $90^\circ$  intervals. See MODULATION. [H.J.He.]

**Phase-modulation detector** A device which recovers or detects the modulating signal from a phase-modulated carrier. Any frequency-modulation (FM) detector with minor modifications will detect phase-modulated waves. See FREQUENCY-MODULATION DETECTOR; PHASE MODULATION.

The only difference between FM and phase modulation (PM) is the manner in which the modulation index varies with the modulating frequency. The modulation index is independent of the modulating frequency in PM but is inversely proportional to the modulating frequency in FM. Therefore an FM detector, when used to detect a phase-modulated wave, produces an output voltage which is proportional to the modulating frequency, assuming the original modulating signal to be of constant amplitude. Consequently, a low-pass filter with a single reactive element, such as an RC (resistance-capacitance) filter, is needed in the output of the FM detector which is used to detect a phase-modulated wave. [C.L.A.]

**Phase modulator** An electronic circuit that causes the phase angle of the modulated wave to vary (with respect to the unmodulated carrier) in accordance with the modulating signal. Since frequency is the rate of change of phase, a phase modulator will produce the characteristics of frequency modulation (FM) if the frequency characteristics of the modulating signal are so altered that the modulating voltage is inversely proportional to frequency. Commercial FM transmitters normally employ a phase modulator because a crystal-controlled oscillator can then be used to meet the strict carrier-frequency control requirements of the Federal Communications Commission. The chief disadvantage of phase modulators is that they generally produce insufficient frequency-deviation ratios, or modulation index, for satisfactory noise suppression. Frequency multiplication can be used, however, to increase the modulation index to the desired value, since the frequency deviation is multiplied along with the carrier frequency. See FREQUENCY MODULATION; PHASE MODULATION; PHASE-MODULATION DETECTOR.

Many types of phase modulators have been devised. A simple modulator is shown in the illustration. In this circuit the modulating voltage changes the capacitance of the varactor diode. The phase shift depends upon the relative magnitudes of the capacitive reactance of the varactor diode and the load resistance  $R$ . Therefore the phase shift varies with the modulating voltage and phase modulation (PM) is accomplished. However, the phase

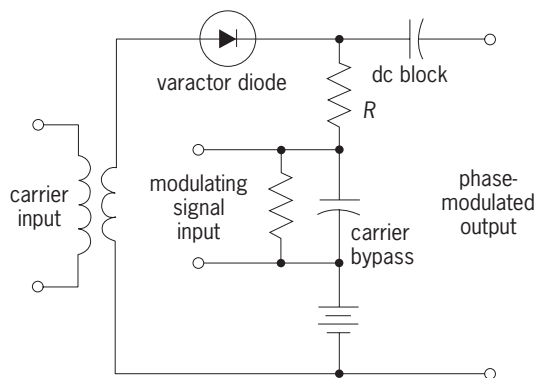

A simple phase modulator.

shift is not linearly related to the modulating voltage if the PM exceeds a few degrees, because the phase shift is not linearly related to the capacitance and the capacitance of the varactor diode is not linearly related to the modulating voltage. See VARACTOR. [C.L.A.]

**Phase rule** A relationship used to determine the number of state variables  $F$ , usually chosen from among temperature, pressure, and species compositions in each phase, which must be specified to fix the thermodynamic state of a system in equilibrium. It was derived by J. Willard Gibbs. The phase rule (in the absence of electric, magnetic, and gravitational phenomena) is given by the equation below, where  $C$  is the number of chemical

$$F = C - P - M + 2$$

species present at equilibrium,  $P$  is the number of phases, and  $M$  is the number of independent chemical reactions. Here phase is used to indicate a homogeneous, mechanically separable portion of the system, and the term independent reactions refers to the smallest number of chemical reactions which, upon forming various linear combinations, includes all reactions which occur among the species present. The number of independent state variables  $F$  is referred to as the degrees of freedom or variance of the system. See CHEMICAL EQUILIBRIUM; CHEMICAL THERMODYNAMICS; PHASE EQUILIBRIUM; THERMODYNAMIC PROCESSES. [S.I.S.]

**Phase-transfer catalysis** A process in which the rate of a reaction occurring in a two-phase organic-water system is enhanced by addition of a compound that helps transfer the water soluble reactant across the interface to the organic phase.

An important factor, which contributes to the slowness of many organic reactions, is the lack of homogeneity of the reaction mixture. This is particularly the case with nucleophilic substitution reactions such as the reaction below, where  $RX$  is an organic

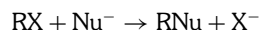

reagent and  $Nu^+$  is the nucleophilic reagent. The nucleophilic reagent is frequently an inorganic anion, which is soluble in water in which the organic substrate is insoluble, but is insoluble in the organic phase. The encounter rate between  $Nu^-$  and  $RX$  is consequently low, as they can only meet at the interface of the heterogeneous system. The water-soluble anion is also frequently highly solvated by water molecules, which stabilize the anion and thus reduce its nucleophilic reactivity. These problems have been overcome in the past by the use of polar aprotic solvents, which will dissolve both the organic and inorganic reagents, or by the use of homogeneous mixed-solvent systems, such as water:ethanol or water:dioxan. See ELECTROPHILIC AND NUCLEOPHILIC REAGENTS.

Phase-transfer catalysis involves the transportation of the inorganic anion,  $Nu^-$ , from the aqueous phase into the organic phase by the formation of a nonsolvated ion-pair with a cationic phase-transfer catalyst,  $Q^+$ . With highly lipophilic catalysts, the

reactive ion pair  $[Q^+Nu^-]$  is formed at the interface between the aqueous and organic phases, followed by rapid transportation into the bulk of the organic phase. The rate of the reaction is enhanced, as the encounter rate of the nucleophile,  $Nu^-$ , with the organic reagent,  $RX$ , in the single phase will be significantly higher than at the interface. Moreover, as the anion is transferred without water of solvation, its nucleophilic reactivity can be considerably higher in the organic phase than in the aqueous phase. Rate enhancements of greater than  $10^7$  have thus been observed. See CATALYSIS; HETEROGENEOUS CATALYSIS; HOMOGENEOUS CATALYSIS; QUATERNARY AMMONIUM SALTS; STEREO-CHEMISTRY. [R.A.J.]

**Phase transitions** Changes of state brought about by a change in an intensive variable (for example, temperature or pressure) of a system. Some familiar examples of phase transitions are the gas-liquid transition (condensation), the liquid-solid transition (freezing), the normal-to-superconducting transition in electrical conductors, the paramagnet-to-ferromagnet transition in magnetic materials, and the superfluid transition in liquid helium. Further examples include transitions involving amorphous or glassy structures, spin glasses, charge-density waves, and spin-density waves. See AMORPHOUS SOLID; CHARGE-DENSITY WAVE; METALLIC GLASSES; SPIN-DENSITY WAVE; SPIN GLASS; SUPERCONDUCTIVITY; SUPERFLUIDITY.

Typically the phase transition is brought about by a change in the temperature of the system. The temperature at which the change of state occurs is called transition temperature (usually denoted by  $T_c$ ). For example, the liquid-solid transition occurs at the freezing point.

The two phases above and below the phase transition can be distinguished from each other in terms of some ordering that takes place in the phase below the transition temperature. For example, in the liquid-solid transition, the molecules of the liquid get "ordered" in space when they form the solid phase. In a paramagnet, the magnetic moments on the individual atoms can point in any direction (in the absence of an internal magnetic field), but in the ferromagnetic phase the moments are lined up along a particular direction, which is then the direction of ordering. Thus in the phase above the transition, the degree of ordering is smaller than in the phase below the transition. One measure of the amount of disorder in a system is its entropy, which is the negative of the first derivative of the thermodynamic free energy with respect to temperature. When a system possesses more order, the entropy is lower. Thus at the transition temperature the entropy of the system changes from a higher value above the transition to some lower value below the transition. See ENTROPY; FERROMAGNETISM; PARAMAGNETISM.

This change in entropy can be continuous or discontinuous at the transition temperature. In other words, the development of order in the system at the transition temperature can be gradual or abrupt. This leads to a convenient classification of phase transitions into two types, namely, discontinuous and continuous.

Discontinuous transitions involve a discontinuous change in the entropy at the transition temperature. A familiar example of this type of transition is the freezing of water into ice. As water reaches the freezing point, order develops without any change in temperature. Thus there is a discontinuous decrease in the entropy at the freezing point. This is characterized by the amount of latent heat that must be extracted from the water for it to be "ordered" into the solid phase (ice). Discontinuous transitions are also called first-order transitions.

In a continuous transition, entropy changes continuously, and hence the growth of order below  $T_c$  is also continuous. There is no latent heat involved in a continuous transition. Continuous transitions are also called second-order transitions. The paramagnet-to-ferromagnet transition in magnetic materials is an example of such a transition.

The degree of ordering in a system undergoing a phase transition can be made quantitative in terms of an order parameter.

At temperatures above the transition temperature the order parameter has a value zero, and below the transition it acquires some nonzero value. For example, in a ferromagnet the order parameter is the magnetic moment per unit volume (in the absence of an externally applied magnetic field). It is zero in the paramagnetic state since the individual magnetic moments in the solid may point in any random direction. Below the transition temperature, however, there exists a preferred direction of ordering, and as the temperature is lowered below  $T_c$ , more and more individual magnetic moments start to align along the preferred direction of ordering, leading to a continuous growth of the magnetization or the macroscopic magnetic moment per unit volume in the ferromagnetic state. Thus the order parameter changes continuously from zero above to some nonzero value below the transition temperature. In a first-order transition, the order parameter would change discontinuously at the transition temperature. [D.J.S.; S.J.]

**Phase velocity** The velocity of propagation of a pure sine wave of infinite extent. In one dimension, for example, the form of the disturbance for such a wave is given by  $y(x, t) = A \sin [2\pi(x/\lambda - t/T)]$ . Here  $x$  is the position at which the disturbance  $y(x, t)$  exists at time  $t$ ,  $\lambda$  is the wavelength,  $T$  is the period which is related to the wave frequency by  $T = 1/f$ , and  $A$  is the disturbance amplitude. The argument of the sine function is called the phase. The phase velocity is the speed with which a point of constant phase can be said to move. Thus  $x/\lambda - ft = \text{constant}$ , so the phase velocity  $v_p$  is given by  $dx/dt = v_p = \lambda f$ . This is the basic relationship connecting phase velocity, wavelength, and frequency. See PHASE (PERIODIC PHENOMENA); SINE WAVE; WAVE MOTION.

The phase velocity for waves in a medium is determined in part by intrinsic properties of the medium. For all mechanical waves in elastic media, the square of the phase velocity is proportional to the ratio of the appropriate elastic property of the medium to the appropriate inertia property. The phase velocity of electromagnetic waves depends upon the medium as well. In vacuum, the phase velocity  $c$  is given by  $c^2 = 1/\epsilon_0\mu_0 \approx 9 \times 10^{16} \text{ m}^2/\text{s}^2$ , where  $\epsilon_0$  and  $\mu_0$  are respectively the permittivity and permeability of the vacuum. Phase velocity may also depend upon the mode of wave propagation—in general, upon the frequency of the wave. Waves of different frequencies will travel at different speeds, resulting in a phenomenon called dispersion. See ELECTROMAGNETIC RADIATION; LIGHT; WAVE EQUATION; YOUNG'S MODULUS. [S.A.Wi.]

**Phenocryst** A relatively large crystal embedded in a finer-grained or glassy igneous rock. The presence of phenocrysts gives the rock a porphyritic texture. Phenocrysts are represented most commonly by feldspar, quartz, biotite, hornblende, pyroxene, and olivine. Strictly speaking, phenocrysts crystallize from molten rock material (lava or magma). They commonly represent an earlier and slower stage of crystallization than does the matrix in which they are embedded. See IGNEOUS ROCKS; PORPHYROBLAST. [C.A.C.]

**Phenol** The simplest member of a class of organic compounds possessing a hydroxyl group attached to a benzene ring or to a more complex aromatic ring system. Phenol itself,  $\text{C}_6\text{H}_5\text{OH}$ , may also be called hydroxybenzene or carboic acid. Pure phenol is a colorless solid melting at  $42^\circ\text{C}$  ( $108^\circ\text{F}$ ), moderately soluble in water, and weakly acidic ( $\text{pK}$  9.9).

Phenol has broad biocidal properties, and dilute aqueous solutions have long been used as an antiseptic. At higher concentrations phenol causes severe skin burns; it is a violent systemic poison. See ANTISEPTIC.

Phenol has the structure shown. Simple substituted phenols, such as the three isomeric chlorophenols, are named as indicated, using the ortho (*o*), meta (*m*), and para (*p*) prefixes. In more highly substituted phenols the positions of substitution are

indicated by numbers (as in 2,4-dichlorophenol). Compounds with more than one hydroxyl group per aromatic ring are known as polyhydric phenols, and include catechol, resorcinol, hydroquinone, phloroglucinol, and pyrogallol.

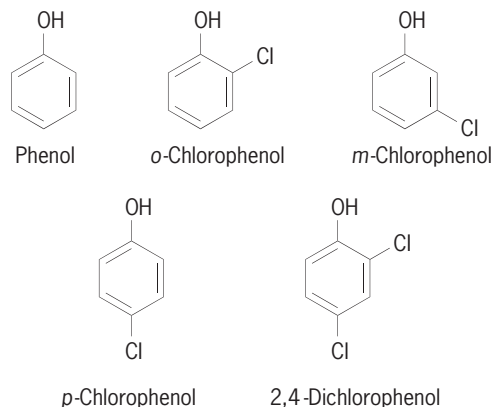

Until World War I phenol was essentially a natural coal tar product. However, synthetic methods have replaced extraction from natural sources. There are many possible syntheses.

Phenol is one of the most versatile and important industrial organic chemicals. It is the starting point for many diverse products used in the home and industry. A partial list includes: nylon, epoxy resins, surface active agents, synthetic detergents, plasticizers, antioxidants, lube oil additives, phenolic resins (with formaldehyde, furfural, and so on), polyurethanes, aspirin, dyes, wood preservatives, herbicides, drugs, fungicides, gasoline additives, inhibitors, explosives, and pesticides. See PHENOLIC RESIN. [R.I.S.; M.St.]

**Phenolic resin** One of the condensation products of phenols or phenolic derivatives with aldehydes such as formaldehyde and furfural. The phenol-formaldehyde resins, developed commercially between 1905 and 1910, were the first truly synthetic polymers and have found wide usage. They are characterized by low cost, dimensional stability, high strength, and resistance to aging.

Phenolic resins can be cast from syrupy intermediates or molded from B-stage solid resins. Laminated products can be produced by impregnating fiber, cloth, wood, and other materials with the resin. An important type of phenolic resin product is rigid foam. Cured phenolic plastics are rigid, hard, and resistant to chemicals (except strong alkali) and to heat.

Some of the uses for phenolic resins are for making precisely molded articles, such as telephone parts, for manufacturing strong and durable laminated boards, or for impregnating fabrics, wood, or paper. Phenolic resins are also widely used as adhesives, as the binder for grinding wheels, as thermal insulation panels, as ion-exchange resins, and in paints and varnishes. See ADHESIVE; ION EXCHANGE; PHENOL; PLASTICS PROCESSING; POLYMERIZATION. [J.A.M.]

**Phenylketonuria** An inborn error of metabolism in which affected individuals lack the liver enzyme needed to metabolize phenylalanine, an amino acid essential for normal growth and development. If untreated, affected individuals may become severely mentally retarded, become microcephalic, have behavioral problems, develop epilepsy, or show other signs of neurological impairment. Phenylketonuria (PKU) is inherited as an autosomal recessive trait and is found in all ethnic groups but most frequently in individuals of northern European descent. Its incidence is about 1 per 14,000 births in the United States.

Newborn screening programs for phenylketonuria have been successful in identifying most cases within a few weeks of birth. A low phenylalanine diet with restriction of proteins, if initiated early in infancy, can prevent the development of severe



intellectual and neurological handicaps that would otherwise occur in virtually all untreated cases. See PROTEIN METABOLISM. [F.deLaC.]

**Pheromone** A substance that acts as a molecular messenger, transmitting information from one member of a species to another member of the same species. A distinction is made between releaser pheromones, which elicit a rapid, behavioral response, and primer pheromones, which elicit a slower, developmental response and may pave the way for a future behavior.

Communication via pheromones is common throughout nature, including some eukaryotic microorganisms such as fungi that exchange vital chemical signals. The cellular slime molds form large aggregations of amoebas which unite to form a sorocarp made up of a long, slender stalk that supports a spore-containing fruiting body. A pheromone is responsible for the aggregation. In several species of algae, relatively simple hydrocarbons act as sperm attractants.

By far the largest number of characterized pheromones come from insect species. In social insects, such as termites and ants, there may be as many as a dozen different types of messages that are used to coordinate the complex activities which must be carried out to maintain a healthy colony. These activities might require specialized pheromones such as trail pheromones (to lead to a food source), alarm pheromones (recruiting soldiers to the site of an enemy attack), or pheromones connected with reproductive behavior. Much less is known about mammalian pheromones because mammalian behavior is more difficult to study. There are, however, a small number of well-characterized mammalian pheromones from pigs, dogs, hamsters, mice, and marmosets.

There is great potential for controlling the behavior of a given species by manipulating its natural chemical signals. For example, pheromones have been used to disrupt the reproduction of certain insect pests. This approach can lead to reduced use of pesticides as well as advances in the control of both agricultural pests and disease vectors. See CHEMICAL ECOLOGY; CHEMORECEPTION; INSECT CONTROL, BIOLOGICAL; SOCIAL INSECTS. [J.Mein.]

**Phlebitis** An inflammation of a vein. Individuals with phlebitis typically experience tenderness, redness, and hardness along the course of the vein. The cause of the inflammation may be related to injury of the vein or infection. The presence of varicose veins and the long-term use of indwelling intravenous catheters or irritating intravenous solutions place individuals at risk of developing phlebitis. In addition, those with certain diseases, including systemic lupus erythematosus, vasculitis, or malignancy, are at increased risk. Two varieties of phlebitis are recognized: phlebothrombosis and thrombophlebitis.

Phlebothrombosis is a condition in which a blood clot develops within an inflamed vein. As the clot enlarges, it may detach and travel to the lung, becoming a pulmonary embolism. Thrombophlebitis begins with an inflammatory reaction in the vein wall. When the lining of the vein is damaged, three reactions influence the development of thrombosis. Initially, damage to the lining results in adherence of white blood cells, coagulation, and a loss of the lining's nonthrombogenic characteristics. Subsequently, the deep lining of the vein is exposed, bringing it into contact with blood and allowing platelets to adhere and aggregate. Finally, the exposed lining and activated platelets result in changes in coagulation, causing more platelets to interact with deep-lining structures. These factors are influenced by the velocity of blood flow in the affected area. See EMBOLISM; THROMBOSIS.

Symptomatic thrombophlebitis usually results in a clot which is firmly adherent to the vein wall with a decreased risk of embolizing. Some individuals may develop symptoms suggestive of deep venous thrombosis such as pain and swelling, and should undergo noninvasive ultrasound examination of the deep veins of the leg. In the absence of deep venous thrombosis, the goal of treatment of superficial phlebitis is symptomatic relief. Anal-

gesics, warm compresses and elevation of the affected limb may be beneficial. Late effects of phlebitis include damage to the vein wall and destruction of the venous valves or obliteration of the vein. When the deep veins of the lower extremity are involved, many individuals develop chronic venous insufficiency and its associated morbidity. See CIRCULATION; INFLAMMATION. [L.J.Gr.; M.C.P.]

**Phloem** The principal food-conducting tissue in vascular plants. Its conducting cells are known as sieve elements, but phloem may also include companion cells, parenchyma cells, fibers, sclereids, rays, and certain other cells. As a vascular tissue, phloem is spatially associated with xylem, and the two together form the vascular system. See XYLEM.

Sieve elements differ from phloem parenchyma cells in the structure of their walls and to some extent in the character of their protoplasts. Sieve areas, distinctive structures in sieve element walls, are specialized primary pit fields in which there may be numerous modified plasmodesmata. Plasmodesmata are strands of cytoplasm connecting the protoplasts of two contiguous cells. These strands are often surrounded by callose, a carbohydrate material, that appears to form rapidly in plants when they are placed under stress.

Typical sieve cells are long elements in which all the sieve areas are of equal specialization, though sieve areas may be more numerous in some walls than in others. In contrast, a sieve-tube member has some sieve areas more specialized than others; that is, the pores, or modified plasmodesmata, are larger in some sieve areas. Parts of the walls containing such sieve areas are called sieve plates.

Companion cells are specialized parenchyma cells that occur in close ontogenetic and physiologic association with sieve tube members. Some sieve-tube members lack companion cells. The precise functional relationship between these two kinds of cells is unknown.

Parenchyma cells in the phloem occur singly or in strands of two or more cells. They store starch, frequently contain tannins or crystals, commonly enlarge as the sieve elements become obliterated, or may be transformed into sclereids or cork cambium cells.

Phloem fibers vary greatly in length (from less than 0.04 in. or 1 mm in some plants to 20 in. or 50 cm in the ramie plant). The secondary walls are commonly thick and typically have simple pits, but may or may not be lignified. [M.A.W.]

**Phlogopite** A mineral with an ideal composition of  $\text{KMg}_3(\text{AlSi}_3\text{O}_{10}(\text{OH})_2)$ . Phlogopite belongs to the mica mineral group. It has been occasionally called bronze mica. Phlogopite is a trioctahedral mica, where all three possible octahedral cation sites are occupied by magnesium (Mg). The magnesium octahedra,  $\text{Mg}(\text{O},\text{OH})_6$ , form a sheet by sharing edges. As in all micas, tetrahedra are located on either side of the octahedral sheet, which may be occupied by aluminum (Al) or silicon (Si). Adjacent tetrahedra share corners to form a two-dimensional network of sixfold rings, thus producing a tetrahedral sheet. Two opposing tetrahedral sheets and the included octahedral sheet form a 2:1 layer. Potassium (K) ions are located between adjacent tetrahedral sheets in the interlayer region.

Specific gravity is 2.86, hardness on the Mohs scale is 2.5–3.0, and luster is vitreous to pearly. Thin sheets are flexible. Color is yellow brown, reddish brown, or green, and thin sheets are transparent. Thermal stability varies greatly with composition, with iron or fluorine substitutions reducing or increasing stability, respectively. Weathering of phlogopite may produce vermiculite. See HARDNESS SCALES; VERMICULITE; WEATHERING PROCESSES.

Phlogopite occurs in marbles produced by the metamorphism of siliceous magnesium-rich limestones or dolomites and in ultrabasic rocks, such as peridotites and kimberlites. See DOLOMITE; LIMESTONE; PERIDOTITE.

Phlogopite is used chiefly as an insulating material and for fireproofing. It has high dielectric properties and high thermal stability. See MICA; SILICATE MINERALS. [S.Gu.]

**Phobia** An intense irrational fear that often leads to avoidance of an object or situation. Phobias (or phobic disorders) are common (for example, fear of spiders, or arachnophobia; fear of heights, or acrophobia) and usually begin in childhood or adolescence. Psychiatric nomenclature refers to phobias of specific places, objects, or situations as specific phobias. Fear of public speaking, in very severe cases, is considered a form of social phobia. Social phobias also include other kinds of performance fears (such as playing a musical instrument in front of others; signing a check while observed) and social interactional fears (for example, talking to people in authority; asking someone out for a date; returning items to a store). Individuals who suffer from social phobia often fear a number of social situations. Although loosely regarded as a fear of open spaces, agoraphobia is actually a phobia that results when people experience panic attacks (unexpected, paroxysmal episodes of anxiety and accompanying physical sensations such as racing heart, shortness of breath).

The origin of phobias is varied and incompletely understood. Most individuals with specific phobias have never had anything bad happen to them in the past in relation to the phobia. In a minority of cases, however, some traumatic event occurred that likely led to the phobia. It is probable that some common phobias, such as a fear of snakes or a fear of heights, may actually be instinctual, or inborn. Both social phobia and agoraphobia run in families, suggesting that heredity plays a role. However, it is also possible that some phobias are passed on through learning and modeling.

Phobias occur in over 10% of the general population. Social phobia may be the most common kind, affecting approximately 7% of individuals. When persons encounter the phobic situation or phobic object, they typically experience a phobic reaction consisting of extreme fearfulness, physical symptoms (such as racing heart, shaking, hot or cold flashes, or nausea), and cognitive symptoms (particularly thoughts such as "I'm going to die" or "I'm going to make a fool of myself"). These usually subside quickly when the individual is removed from the situation. The tremendous relief that escape from the phobic situation provides is believed to reinforce the phobia and to fortify the individual's tendency to avoid the situation in the future.

Many phobias can be treated by exposure therapy: the individual is gradually encouraged to approach the feared object and to successively spend longer periods of time in proximity to it. Cognitive therapy is also used (often in conjunction with exposure therapy) to treat phobias. It involves helping individuals to recognize that their beliefs and thoughts can have a profound effect on their anxiety, that the outcome they fear will not necessarily occur, and that they have more control over the situation than they realize.

Medications are sometimes used to augment cognitive and exposure therapies. For example, beta-adrenergic blocking agents, such as propranolol, lower heart rate and reduce tremulousness, and lead to reduced anxiety. Certain kinds of antidepressants and anxiolytic medications are often helpful. It is not entirely clear how these medications exert their antiphobic effects, although it is believed that they affect levels of neurotransmitters in regions of the brain that are thought to be important in mediating emotions such as fear. See NEUROTIC DISORDERS. [M.B.St.]

**Phoenicopteriformes** The flamingos, a small monotypic order of wading birds that includes the family Phoenicopteridae, which has six species found worldwide in tropical marine and fresh waters; one species lives in the high Andes. The flamingos were formally included in the Ciconiiformes and are still placed there by many researchers; others have advocated a close relationship with either the Anseriformes or the Charadriiformes. None of these classifications, however, are strongly sup-

ported by available evidence, and so it is best to place these bizarre birds in a unique order. See ANSERIFORMES; CHARADRIIFORMES; CICONIIFORMES.

The earliest definite flamingo fossil is *Juncitarsus*, from the middle Eocene of Wyoming; it possesses several primitive traits for the family. Beginning in the late Oligocene, modern flamingos are found in the fossil records from all areas of the world.

Flamingos are long-legged, long-necked wading birds with a thick bill which is sharply bent downward at the midpoint. The three anterior toes are webbed, possibly for walking on soft substrates. The long and broad wings enable the bird to fly well. The adult plumage is pink to light red, with black flight feathers. Flamingos are gregarious, often congregative in flocks in excess of 1 million. They breed monogamously in large colonies, and both parents incubate the one or two eggs in a nest formed of a stout pillar of mud 1 ft (0.3 m) high on a mud flat. See AVES.

[W.J.B.]

**Pholidophoriformes** An extinct actinopterygian group composed of mostly small fusiform fishes of an advanced holostean level that are found in both marine and fresh-water deposits and range from the Middle Triassic to the Lower Cretaceous. The best-known representative is *Pholidophorus bechei*

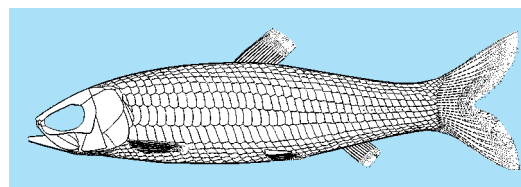

*Pholidophorus bechei* Lower Jurassic of England; length to 8 in. (20 cm). (After D. Rayner, *The structure of certain Jurassic holostean fishes with special reference to their neurocrania*, *Phil. Trans. Roy. Soc. London, Ser. B, no. 601, Cambridge University Press, 1948*)

(see illustration), which exhibits holostean features in its enamel-covered ganoid scales, fin rays, and head bones; in the fulcrum bordering all the fins with a strong series on the upper caudal lobe; and in the structure of its caudal skeleton. See ACTINOPTERYGII; HOLOSTEI; TELEOSTEI. [T.M.C.]

**Pholidota** An order of mammals comprising the living pangolins, or scaly anteaters, and their poorly known fossil predecessors. All living pangolins are assigned to the genus *Manis*. They are found in Africa south of the Sahara and in southeastern Asia, including certain islands of the East Indies.

Pangolins feed principally on termites and ants. The elongate tubular skull without teeth, long protrusive tongue, small eyes with heavy eyelids, thick skin, strong legs, five-toed feet with large claws, and large tail enable these unique animals to rip open ant nests and termite dens and devour the animals therein. The greatest peculiarity of animals in the genus *Manis* is a covering of all but the undersides of the body by an armor of large imbricating dermal horny scales. Living pangolins are frequently characterized as being animated pine cones. The position and number of hairs in relation to the scales are peculiar to each modern species. See MAMMALIA. [D.E.S.]

**Phonetics** The science that deals with the production, transmission, and perception of spoken language. At each level, phonetics overlaps with some other sciences, such as anatomy, physiology, acoustics, psychology, and linguistics. In each case, phonetics focuses on phenomena relevant to the study of spoken language.

Speech is normally produced by exhaling air from the lungs through the vocal tract. The vocal tract extends from the larynx through the pharynx and the oral cavity to the lips. If the velum

(soft palate) is not raised, the air also passes through the nasal cavities. The shape and size of the oral cavity can be varied by the movement of active articulators: tongue, lips, and velum. See PALATE.

Phoneticists usually describe speech sounds with reference to their point (or place) of articulation and their manner of articulation. The point of articulation of a sound is the place of maximum constriction within the vocal tract. The great majority of sounds are produced by moving some part of the tongue toward some region on the roof of the mouth. Exceptions are articulations involving lips and those sounds in which the vocal folds serve as articulators.

At most of these points of articulation, sounds can be produced with several manners of articulation. One way to classify manners of articulation refers to the degree of stricture employed in producing the sound. Sounds produced with complete constriction of the vocal tract are stops, or plosives. If the closure is incomplete, but the articulators are brought close enough so that the air passing between them is set into turbulent motion, the resultant sounds are fricatives or spirants. If the articulators are approximated, but the constriction remains large enough so that air can pass through without friction, the sounds are called approximants—vowel-like sounds functioning as consonants. Most of these consonant sounds can be voiced or voiceless; vowels are normally voiced. The terms “voiced” and “voiceless” refer to the presence and the absence of vocal fold vibration.

Acoustic phonetics deals with the manner in which the spoken message is encoded in the sound waves. According to the generally accepted source-filter theory of speech acoustics, sound is generated at a source (which for phonated speech is constituted by the vibrating vocal folds) and passed through the vocal tract. The opening and closing of the vocal folds create a succession of condensations and rarefactions of air molecules—variations in air pressure—and transform kinetic energy into acoustic energy. The sound wave generated at the glottis can be considered, for practical purposes, a complex periodic wave, and as such it contains energy at frequencies that are multiples of the fundamental frequency (harmonics).

The vocal tract acts as a filter, transmitting more energy at those frequencies that correspond to the resonances of the vocal tract than at other frequencies. Energy concentrations at the resonance frequencies of the vocal tract are referred to as formants.

In principle, the source and filter are independent of each other; consider the fact that the same vowel can be sung at different fundamental frequencies (pitches), and different vowels can be produced at the same pitch. The sound wave can be described by specifying its fundamental frequency, amplitude, and spectrum.

The subject matter of phonetics is not limited to the production and perception of vowels and consonants; of equal importance are such prosodic and suprasegmental aspects of spoken language as duration, fundamental frequency, and intensity, as they determine such linguistically relevant phenomena as tone and intonation, stress and emphasis, and the signaling of various boundaries—boundaries of morphemes and words, phrases, clauses, and sentences. See SPEECH. [I.Le.]

**Phonolite** A light-colored, aphanitic (not visibly crystalline) rock of volcanic origin, composed largely of alkali feldspar, feldspathoids (nepheline, leucite, sodalite), and smaller amounts of dark-colored (mafic) minerals (biotite, soda amphibole, and soda pyroxene). Phonolite is chemically the effusive equivalent of nepheline syenite and similar rocks. Rocks in which plagioclase (oligoclase or andesine) exceeds alkali feldspar are rare and may be called feldspathoidal latite. See FELDSPATHOID; MAGMA.

Phonolites are rare and highly variable rocks. They occur as volcanic flows and tuffs and as small intrusive bodies (dikes and sills). They are associated with trachytes and a wide variety of feldspathoidal rocks. See IGNEOUS ROCKS; TRACHYTE. [C.A.C.]

**Phonon** A quantum of vibrational energy in a solid or other elastic medium. This vibrational energy can be transported by elastic waves. The energy content of each wave is quantized. For a wave of frequency  $f$ , the energy is  $(N + \frac{1}{2})hf$ , where  $N$  is an integer and  $h$  is Planck's constant. Apart from the zero-point energy,  $\frac{1}{2}hf$ , there are  $N$  quanta of energy  $hf$ . In elastic or lattice waves, these quanta are called phonons. Quantization of energy is not related to the discreteness of the lattice, and also applies to waves in a continuum. See QUANTUM MECHANICS; WAVE MOTION.

The concept of phonons closely parallels that of photons, quanta of electromagnetic wave energy. The indirect consequences of quantization were established for phonons just as for photons in the early days of quantum mechanics—for example, the decrease of the specific heat of solids at low temperatures. Direct evidence that the energy of vibrational modes is changed one phonon at a time came much later than that for photons—for example, the photoelectric effect—because phonons exist only within a solid, are subject to strong attenuation and scattering, and have much lower quantum energy than optical or x-ray photons. See PHOTOEMISSION; SPECIFIC HEAT OF SOLIDS.

Like photons, phonons can be regarded as particles, each of energy  $hf$  and momentum proportional to the wave vector of the elastic or lattice wave. Such a particle can be said to transport energy, thus moving with a velocity equal to the group velocity of the underlying wave. See LATTICE VIBRATIONS; PHOTON. [P.G.KI.]

**Phonoreception** The perception of sound by animals through specialized sense organs. A sense of hearing is possessed by animals belonging to two divisions of the animal kingdom: the vertebrates and the insects. The sense is mediated by the ear, a specialized organ for the reception of vibratory stimuli. Such an organ is found in all except the most primitive vertebrates, but only in some of the many species of insects. The vertebrate and insect types of ear differ in evolutionary origin and in their modes of operation, but both have attained high levels of performance in the reception and discrimination of sounds. See SOUND.

The vertebrate ear is a part of the labyrinth, located deep in the bone or cartilage of the head, one ear on either side of the brain. A complex assembly of tubes and chambers contains a membranous structure which bears within it a number of sensory endings of different kinds. Beginning with the amphibians, which are the earliest vertebrates to spend a considerable portion of their lives on land, there appears a special mechanism, the middle ear, whose function is the transmission of aerial vibrations to the sensory endings of the inner ear. All the vertebrates above the fishes, and certain of the fishes as well, have some type of sound-facilitative mechanism. See EAR (VERTEBRATE); HEARING (VERTEBRATE).

The group of invertebrates which has received the most attention has been the insects. Other arthropods, such as certain crustaceans and spiders, have also been found to be sensitive to sound waves. The insect ear consists of a superficial membrane of thin chitin with an associated group of sensilla called scolophores. These ears are found in most species of katydids, crickets, grasshoppers, cicadas, waterboatmen, mosquitoes, and nocturnal and spinner moths. They occur in different places in the body: on the antennae of mosquitoes, on the forelegs of katydids and crickets, on the metathorax of cicadas and waterboatmen, and on the abdomen of grasshoppers. Probably these differently situated organs represent separate evolutionary developments, through the association of a thinned-out region of the body wall with sensilla that are found extensively in the bodies of insects and that by themselves seem to serve for movement perception.

The insects mentioned above are noted for their production of stridulatory sounds made by rubbing the edges of the wings together, or a leg against a wing, or by other means. These sounds are produced by the males and serve for enticing the females in mating. A striking adaptation is that shown by mosquitoes: The ear of the male mosquito is sensitive only to a narrow range of

frequencies around 380 Hz, and this frequency is the one which is produced by the wings of the female in flight. If the ear of the male mosquito is made nonfunctional, the mosquito fails to find a mate. [E.G.W.]

**Phoresy** A relationship between two different species of organisms in which the larger, or host, organism transports a smaller organism, the guest. It is regarded as a type of commensalism in which the relationship is limited to transportation of the guest. [C.B.C.]

**Phoronida** A small, relatively homogeneous group of animals now generally considered to constitute a separate animal phylum. Two genera, *Phoronis* and *Phoronopsis*, and about 16 species are recognized.

Phoronids may occur in vertical tubes placed just below the surface in intertidal or subtidal mud flats, or as feltlike masses of intertwined tubes attached to rocks, pilings, or old logs in shallow water. In both cases the tubes, composed basically of a secreted, parchmentlike material, are encrusted with small particles of sand or shell. A third living habit concerns those phoronids found inside channels, probably self-made, in limestone rock or the shells of dead pelecypod mollusks.

The geographical distribution of phoronids appears to be worldwide in temperate and tropical seas. There are no records of phoronids from the polar regions.

The body is more or less elongate, ranging in length from about 1.6 to 8 in. (4 to 20 cm), and bears a crown of tentacles arranged in a double row surrounding the mouth which is usually crescent-shaped (see illustration). The anus occurs at the level of the mouth and is borne on a papilla immediately outside the double row of tentacles. The digestive tract is therefore U-shaped, the mouth and anus opening close together at one end of the animal. The tentacles rest on a connective tissue base known as the lophophore. Associated with the mouth is a ciliated flap of tissue known as the epistome. See LOPHOPHORE.

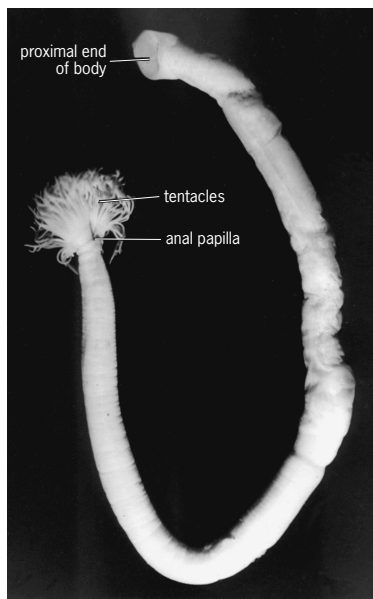

*Phoronopsis harmeri* removed from its tube.

The phylum includes both dioecious animals and hermaphrodites. All phoronids may reproduce sexually, and in most cases the life history includes the pelagic actinotroch larva. Some species reproduce asexually by transverse fission. [J.R.M.]

**Phosphate metabolism** Organic phosphate compounds are present in the structural units of every animal cell, and inorganic phosphate is associated with calcium in bone and teeth. The total phosphorus in the adult human body is about 12 g/kg, with only 1.4 g/kg present in the soft tissues and the remainder in mineralized tissue in the form of apatite crystals. Blood phosphate plays an important role in regulating neutrality, and it is in equilibrium with both bone and cellular organic phosphates. The blood level is held relatively constant by regulating phosphate excretion by the kidney. This control is primarily mediated by action of parathyroid hormone. Vitamin D enhances the entry of phosphate into bone. Phosphate plays an important role in absorption of sugars from the intestine and reabsorption of glucose from the kidney. See PARATHYROID HORMONE; VITAMIN D.

The central role of phosphates in life processes is indicated by their occurrence in ribonucleic acid (RNA) and deoxyribonucleic acid (DNA). Through the formation of lecithins, phosphates are involved in fat metabolism. Phosphates play a major role in the conservation and transfer of energy, particularly of the energy produced in the tricarboxylic acid cycle (Krebs cycle), in glycolysis, and in the pentose shunt. They do so by participating in many phosphorylation and transphosphorylation reactions involving sugars and other organic compounds. See CARBOHYDRATE METABOLISM; CHROMOSOME; CITRIC ACID CYCLE; LIPID METABOLISM; NUCLEIC ACID.

In phosphorylation reactions, compounds such as phosphocreatine (PC) and adenosine triphosphate (ATP) are formed which are capable of yielding relatively large amounts of free energy (5000–11,000 cal or 21–46 kilojoules per mole) when the phosphate bonds are broken by hydrolysis. ATP and PC have a central role in energy storage and transfer in all tissues.

Phosphorus-containing coenzyme systems include the pyridine (nicotinamide) and the riboflavin nucleotide systems concerned with oxidation-reduction reactions; coenzyme A, the functional form of pantothenic acid, concerned with transacetylation, acylation, and condensation reactions; the diphosphothiamine system concerned with decarboxylation; and pyridoxal phosphate concerned with transamination. See BIOCHEMISTRY; BIOLOGICAL OXIDATION; COENZYME; ENERGY METABOLISM. [M.K.S.]

**Phosphate minerals** Any naturally occurring inorganic salts of phosphoric acid,  $H_3[PO_4]$ . All known phosphate minerals are orthophosphates. There are over 150 species of phosphate minerals, and their crystal chemistry is often very complicated. Phosphate mineral paragenesis can be divided into three categories: primary phosphates (crystallized directly from a melt or fluid), secondary phosphates (derived from the primary phosphates by hydrothermal activity), and rock phosphates (derived from the action of water upon buried bone material, skeletons of small organisms, and so forth). See MINERAL; PHOSPHATE. [P.B.M.]

**Phospholipid** A lipid that contains one or more phosphate groups. Phospholipids are amphipathic in nature; that is, each molecule consists of a hydrophilic (water-loving) portion and a hydrophobic (water-hating) portion. Due to the amphipathic nature and insolubility in water, phospholipids are ideal compounds for forming the biological membrane. See LIPID.

There are two classes of phospholipids: those that have a glycerol backbone and those that contain sphingosine. Both classes are present in the biological membrane. Phospholipids that contain a glycerol backbone are called phosphoglycerides (or glycerophospholipids), which are the most abundant class of phospholipid found in nature. The most abundant types of naturally occurring phosphoglyceride are phosphatidylcholine (lecithin), phosphatidylethanolamine, phosphatidylserine, phosphatidylinositol, phosphatidylglycerol, and cardiolipin. The structural diversity within each type of phosphoglyceride is due to the variability of the chain length and degree of saturation of the fatty acid ester groups.

Sphingomyelin is the major sphingosine-containing phospholipid. Its general structure consists of a fatty acid attached to sphingosine by an amide linkage.

A bilayer membrane is formed spontaneously when phospholipids are dispersed in an aqueous solution. In this bilayer structure, phospholipids are arranged in two leaflets with the hydrophobic tails facing each other, and the hydrophilic ends exposed to the aqueous medium. Differences in the head group, the chain length, and the degree of saturation of fatty acids in the hydrophobic end are important factors in determining the shape of the bilayer. Individual phospholipid molecules are able to move freely in the lateral plane of the bilayer but not in the transverse plane (flip-flop). Small uncharged molecules are able to diffuse through the bilayer structure, but the permeability of larger or charged molecules is restricted. The arrangement of phospholipid molecules into a bilayer in an aqueous medium follows the laws of thermodynamics and represents the structural basis for the formation of all biological membranes. See CELL MEMBRANES.

For a long time, phospholipids were regarded as merely building blocks for the biological membrane. It was discovered in the mid-1970s, however, that phospholipids participate in the transduction of biological signals across the membrane. For example, when the hormone vasopressin is bound to its receptor on the plasma membrane of a liver cell, the binding sets off a cascade of reactions which result in enhanced breakdown of glycogen in the liver cell, thus producing more glucose. See SECOND MESSENGERS.

A special form of phosphoglyceride, 1-alkyl-2-acetyl-glycero-3-phosphocholine, acts as a very powerful biological mediator. It causes the aggregation and degranulation of blood platelets, and is known as platelet-activating factor (PAF).

Phospholipases are responsible for the degradation of phosphoglycerides. These enzymes are found in all tissues and in the pancreatic juice. A number of toxins and venoms have very high phospholipase activity, and several pathogenic bacteria produce phospholipases that dissolve cell membrane and allow the spread of infection. There are very few inherited diseases associated with the metabolism of phosphoglycerides; presumably, such genetic defects would be lethal during the early stage of cellular development.

Sphingomyelinase, a lysosomal enzyme, hydrolytically degrades sphingomyelin. A genetic disorder caused by a defect in the production of sphingomyelinase, called Niemann-Pick disease, leaves the cell with no or limited ability to degrade sphingomyelin. In a severe form (type A) of this disease, the liver and spleen are sites of lipid deposits and are therefore tremendously enlarged. The lipid deposits consist primarily of the sphingomyelin that cannot be degraded. See LIPID METABOLISM. [PCh.]

**Phosphorescence** A delayed luminescence, that is, a luminescence that persists after removal of the exciting source. It is sometimes called afterglow.

This original definition is rather imprecise, because the properties of the detector used will determine whether or not there is an observable persistence. There is no generally accepted rigorous definition or uniform usage of the term phosphorescence. In the literature of inorganic luminescent systems, some authors define phosphorescence as delayed luminescence whose persistence time decreases with increasing temperature. According to this usage, luminescence whose persistence time is independent of temperature is called fluorescence regardless of the length of the afterglow; a temperature-independent afterglow of long duration is called simply a slow fluorescence, which implies that the atomic or molecular transition involved is forbidden to a greater or lesser degree by the spectroscopic selection rules. The most common mechanism of phosphorescence in photoconductive inorganic systems, however, occurs when electrons or holes, set free by the excitation process and trapped at lattice defects, are expelled from their traps by the thermal energy in the sys-

tem and recombine with oppositely charged carriers with the emission of light. See HOLE STATES IN SOLIDS; SELECTION RULES (PHYSICS).

In the organic literature the term phosphorescence is reserved for the forbidden luminescent transition from a metastable energy state M to the ground state G, while the afterglow corresponding to the M→E→G process (where E is a higher energy state) is called delayed fluorescence. See FLUORESCENCE; LIGHT; LUMINESCENCE. [C.C.K.; J.H.S.]

**Phosphorus** A chemical element, P, atomic number 15, atomic weight 30.9738. Phosphorus forms the basis of a very large number of compounds, the most important class of which are the phosphates. For every form of life, phosphates play an essential role in all energy-transfer processes such as metabolism, photosynthesis, nerve function, and muscle action. The nucleic acids which among other things make up the hereditary material (the chromosomes) are phosphates, as are a number of coenzymes. Animal skeletons consist of a calcium phosphate. See PERIODIC TABLE; PHOSPHATE.

About three-quarters of the total phosphorus (in all of its chemical forms) used in the United States goes into fertilizers. Other important uses are as builders for detergents, nutrient supplements for animal feeds, water softeners, additives for foods and Pharmaceuticals, coating agents for metal-surface treatment, additives in metallurgy, plasticizers, insecticides, and additives for petroleum products. See DETERGENT; WATER SOFTENING.

Of the nearly 200 different phosphate minerals, only one, fluorapatite,  $\text{Ca}_5\text{F}(\text{PO}_4)_3$ , is mined chiefly from large secondary deposits originating from the bones of dead creatures deposited on the bottom of prehistoric seas and from bird droppings on ancient rookeries. See PHOSPHATE MINERALS.

Research in phosphorus chemistry indicates that there may be as many compounds based on phosphorus as on carbon. In organic chemistry it has been customary to group the various chemical compounds based on carbon into families which are called homologous series. This can also be done in the chemistry of phosphorus compounds, even though many phosphorus-based families are incomplete. The best known of the families of compounds based on phosphorus is the group of chain phosphates. Phosphate salts consist of cations, such as sodium, along with chain anions, such as  $(\text{P}_n\text{O}_{3n+1})^{(n+2)-}$ , which may have 1–1,000,000 phosphorus atoms per anion.

The phosphates are based on phosphorus atoms tetrahedrally surrounded by oxygen atoms, with the lowest member of the series being the simple  $\text{PO}_4^{3-}$  anion (the orthophosphate ion). The family of chain phosphates is based on a row of alternating phosphorus and oxygen atoms in which each phosphorus atom remains in the center of a tetrahedron of four oxygen atoms. There is also a closely related family of ring phosphates, a member of which, the trimetaphosphate, is shown in Fig. 1.

An interesting structural characteristic of many known phosphorus compounds is the formation of cage-like structures. Such cage-like molecules are exemplified by white phosphorus,  $\text{P}_4$ , and one of the phosphorus pentoxides,  $\text{P}_4\text{O}_{10}$  (Fig. 2). Network structures are also common; for example, black phosphorus crystals in which the atoms are bonded together in the form of vast, corrugated planes (Fig. 3).

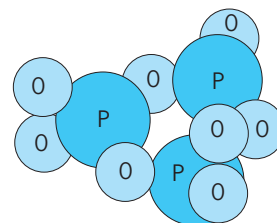

Fig. 1. Ring phosphate anion,  $(\text{P}_3\text{O}_9)^{3-}$ .

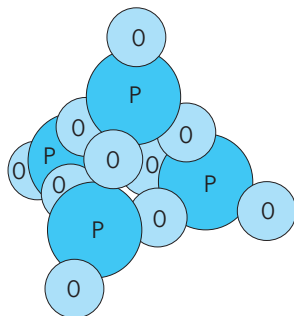

Fig. 2. Phosphorus pentoxide,  $P_4O_{10}$ , in vapor state.

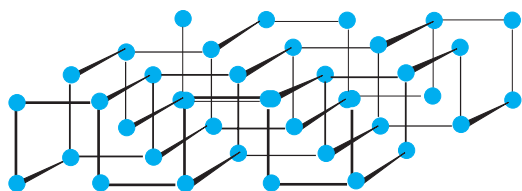

Fig. 3. Black phosphorus,  $P_n$ .

In the majority of its compounds, phosphorus is chemically bonded to four neighboring atoms. There is a large number of compounds in which one of the four neighboring atoms is absent, and in which its place is taken by an unshared pair of electrons. There are also a few compounds in which there are five or six neighboring atoms bonded to the phosphorus. These compounds are very reactive and tend to be unstable.

During the 1960s and 1970s a large number of organic-phosphorus compounds were prepared. Most of these chemical structures involve three or four neighboring atoms bonded to the phosphorus, but stable structures having two, five, or six neighboring atoms per phosphorus are also known. See ORGANOPHOSPHORUS COMPOUND; PHOSPHATE.

Essentially all of the phosphorus used in commerce is in the form of phosphates. The majority of phosphatic fertilizers consist of highly impure monocalcium or dicalcium orthophosphate,  $Ca(H_2PO_4)_2$  and  $CaHPO_4$ . These phosphates are salts of orthophosphoric acid. See FERTILIZER.

The phosphorus compound of major biological importance is adenosine triphosphate (ATP), which is an ester of sodium tripolyphosphate, widely employed in detergents and water-softening compounds. Practically every reaction in metabolism and photosynthesis involves the hydrolysis of this tripolyphosphate to its pyrophosphate derivative, called adenosine diphosphate (ADP). [J.R.V.W.]

**Photoacoustic spectroscopy** A technique for measuring small absorption coefficients in gaseous and condensed media, involving the sensing of optical absorption by detection of sound. It is frequently called optoacoustic spectroscopy.

During the transmission of optical radiation through a sample (gas, liquid, or solid), the absorption of radiation by the sample can be measured by several techniques. The straightforward detection technique requires a measurement of the optical radiation level with and without the sample in the optical path. The transmitted power  $P_{out}$  and the incident power  $P_{in}$  are related through the equation below, where  $\alpha$  is the absorption coefficient and  $l$  is the length of the absorber. With this technique, the minimum measurable value of  $\alpha l$  is of the order of  $10^{-4}$  unless

$$P_{out} = P_{in}e^{-\alpha l}$$

special precautions have been taken to stabilize the source of radiation.

Optoacoustic detection is a calorimetric method where no direct detection of optical radiation is carried out but, instead, a measurement is made of the power absorbed by the medium from the incident radiation. The optoacoustic signal is proportional to the incident power and the absorption-length product  $\alpha l$ . Thus, for given sources of noise from the detection transducers, the signal-to-noise ratio improves as the incident energy is increased.

If optical radiation is amplitude-modulated at an audio frequency, the absorption of such radiation by a gaseous medium that has been confined in a cell with appropriate optical windows for the entrance and exit of the radiation, and nonradiative relaxation of the medium, will cause a periodic variation in the temperature of the column of the irradiated gas. Such a periodic rise and fall in temperature gives rise to a corresponding periodic variation in the gas pressure at the audio frequency. The audio-frequency pressure fluctuations (that is, sound) are efficiently detected using a sensitive gas-phase microphone.

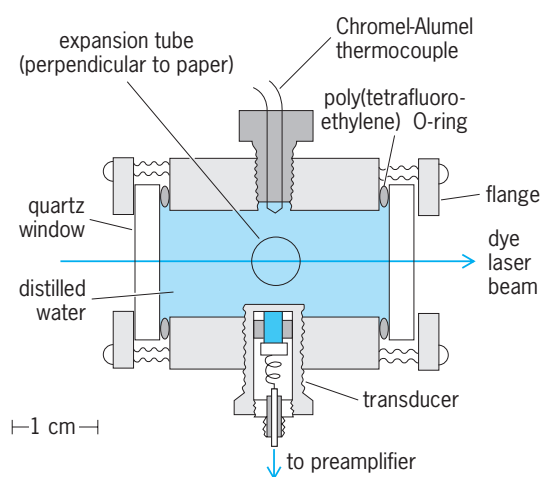

Key:

- poly(tetrafluoroethylene)
- stainless steel
- PZT cylinder

(a)

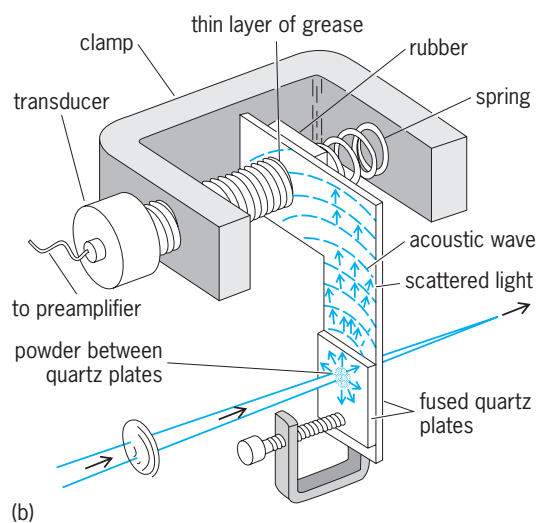

(b)

Arrangement for pulsed-laser (a) immersed and (b) contacted piezoelectric transducer optoacoustic spectroscopy.

The capability of measuring extremely small absorption coefficients and correspondingly small concentrations of the absorption gases has many applications, including high-resolution spectroscopy of isotopically substituted gases, excited states of molecules and forbidden transitions, and pollution detection. The pollution measurements have demonstrated that the optoacoustic spectroscopy technique in conjunction with tunable lasers can be routinely used for on-line real-time in-place detection of undesirable gaseous constituents at sub-parts-per-billion levels. See LASER; LASER SPECTROSCOPY.

A very sensitive calorimetric spectroscopic technique has been developed for the study of weak absorption in liquids and solids. This technique uses a pulsed tunable laser for excitation and a submerged piezoelectric transducer, in the case of a liquid, or a contacted piezoelectric transducer, in the case of a solid, for the detection of the ultrasonic signal generated due to the absorption of the radiation and its subsequent conversion into a transient ultrasonic signal (see illustration). Because of the capability of measuring very small fractional absorptions, the technique is clearly applicable to the area of monitoring water pollution, impurity detection in thin semiconductor wafers, transmission studies of ultrapure glasses (used in optical fibers for optical communications), and so forth. See ABSORPTION. [C.K.N.P.]

**Photoaffinity labeling** A process by which a macromolecule can be labeled at or near its binding or active site. The method can be applied to proteins, nucleic acids, and lipids by chemists who need to identify the parts of these molecules that are significant for particular biological functions. X-ray crystallography can frequently determine the complete structure of proteins and sometimes of nucleic acids, although the method does not necessarily highlight the reactive groups in a biomolecule. Nuclear magnetic resonance spectroscopy is increasingly useful in illuminating such structures. See NUCLEAR QUADRUPOLE RESONANCE; X-RAY CRYSTALLOGRAPHY.

Many important biological processes involve the formation of a complex between a biopolymer and a chemical reagent; for example, enzymes form complexes with their substrates on the way to catalysis, and antibodies form tight complexes with their antigens. Many biochemical receptors (such as hormone receptors) are complexed with lipid membranes. These complexes cannot usually be crystallized, but information about them can often be obtained by photoaffinity labeling. The idea behind photoaffinity labeling is to place in the binding site a compound that is essentially inert but can be photoactivated at will to yield a highly reactive intermediate. Preferably, this intermediate will react with almost any chemical structure.

The successful photoaffinity labeling reagents include diazirines that yield carbenes on photolysis, arylazides that are photochemically decomposed to nitrenes (highly reactive compounds that contain univalent nitrogen), and ketones that yield free radicals on irradiation. Special structural features (such as trifluoromethyl substituents) can enhance the activity of the reagents.

In order to identify the products of reactions, many of which occur only in low yield, the reagent must be made radioactive. This is usually accomplished with carbon-14 ( $^{14}\text{C}$ ) or tritium ( $^3\text{H}$ ), radioactive isotopes of relatively low energy that nevertheless can easily be traced. [F.H.W.]

**Photochemistry** The study of chemical reactions of molecules in electronically excited states produced by the absorption of infrared (700–1000 nanometers), visible (400–700 nm), ultraviolet (200–400 nm), or vacuum ultraviolet (100–200 nm) light. Bond making and bond breaking as well as electron transfer and ionization are often observed in both organic and inorganic compounds as a consequence of such excitation. See ELECTROMAGNETIC RADIATION.

**Electronic absorption.** An important generalization sometimes called the first law of photochemistry is that only light that is absorbed can induce chemical change. The absorption of a photon induces an electronic transition in which an electron originally present in a molecular orbital, usually a bonding or nonbonding molecular orbital of the ground state of the absorbing molecule, is promoted to a higher-lying orbital. The excited state produced by absorption of light has a different electronic structure than its ground-state precursor and can reasonably be regarded as an isomeric species with distinct and characteristic chemical and physical properties. See PHOTON.

Most organic molecules exist as ground-state singlets in which all electrons are paired. Because photoexcitation causes the promotion of only a single electron, two singly occupied orbitals are produced upon excitation. If the electronic transition takes place without a spin inversion, these two electrons have opposite spins, and a singlet excited state is produced. The number of unpaired electrons in a molecule determines its multiplicity: a molecule with no unpaired spins is a singlet; one with one unpaired spin is a doublet; one with two unpaired spins is a triplet; one with three unpaired spins is a quartet, and so forth. If an electronic transition were to take place with a spin inversion, the two singly occupied orbitals would be populated by electrons with parallel spins, producing a triplet excited state. Spin restrictions forbid spin inversion during excitation, and only singlet-singlet electronic transitions are easily observed spectroscopically. After excitation, however, a change in state multiplicity can take place by a process called intersystem crossing. The facility of intersystem crossing is influenced by the magnitude of spin-orbital coupling, which can be enhanced by the presence of a heavy atom (an atom in the third row or below of the periodic table), either bound to the absorbing molecule or present externally as solvent. See PERIODIC TABLE; TRIPLET STATE.

**Transitions.** A chromophore is that part of the molecule that accounts for its absorption of light and its photochemical activity. The absorption corresponding to a particular chromophore depends on the type of transition involved in that particular excitation. The promotion of an electron from a  $\pi$ -bonding molecular orbital to a  $\pi$ -antibonding orbital is referred to as a  $\pi, \pi^*$  (read pi to pi star) transition. Such transitions are frequently encountered in alkenes, alkynes, aromatic molecules, and other unsaturated compounds. Because the spatial overlap of  $\pi$  and  $\pi^*$  orbitals is substantial, such a transition typically has high oscillator strength and a large extinction coefficient (absorptivity). Promotion of an electron from a nonbonding molecular orbital to a  $\pi$ -antibonding orbital, referred to as an  $n, \pi^*$  transition, involves orbitals that are nearly orthogonal; and it takes place only inefficiently; that is, it has a low oscillator strength and a small extinction coefficient. Such transitions are often encountered in compounds containing carbon-heteroatom or heteroatom-heteroatom double bonds. Because nonbonding molecular orbitals lie at higher energy than bonding ones,  $n, \pi^*$  transitions are of lower energy than the corresponding  $\pi, \pi^*$  transitions. Both  $n, \pi^*$  and  $\pi, \pi^*$  transitions are usually found in the ultraviolet region of the electromagnetic spectrum. Transitions involving sigma ( $\sigma$ ) bonds (for example  $n\sigma^*$  transitions in amines, alcohols, ethers, and alkyl halides and  $\sigma, \sigma^*$  transitions in alkanes) are usually encountered at the high-energy end of the ultraviolet spectrum or in the vacuum ultraviolet region. See CHEMICAL BONDING; ULTRAVIOLET RADIATION.

Each allowed transition of a compound registers as a band in the absorption spectrum, with the intensity of the transition (measured by its extinction coefficient) being governed by the operative selection rules. The transition intensity of a given absorption is measured by integrating over the whole absorption band. The resulting integrated absorption coefficient is directly proportional to the oscillator strength of the transition. The oscillator strength, a measure of the allowedness of an electric dipole transition compared to that of a free electron oscillating in the

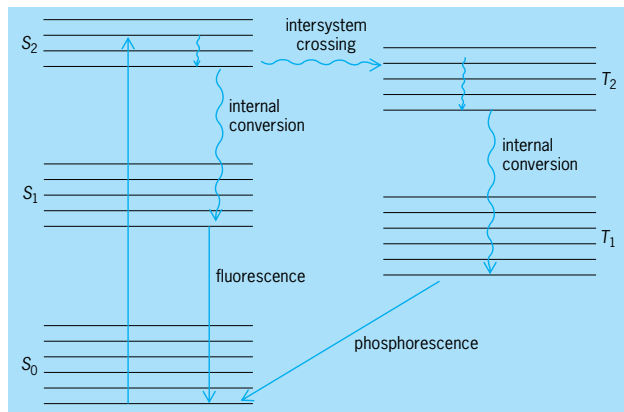

**Jablonski diagram.** Solid arrows represent radiative processes; and wavy arrows nonradiative processes. S terms = singlet states; T terms = triplet states.

three dimensions, is directly related to an experimentally measured value, the extinction coefficient ( $\epsilon$ ). Beer's law is given by Eq. (1), where  $A$  is the observed absorbance,  $\epsilon$  is the extinction

$$A = \epsilon bc \quad (1)$$

coefficient,  $b$  is the path length (in centimeters) of the cell used for the measurement, and  $c$  is the molar concentration of the absorbing species. This law is used to correlate the observed absorbance with the extinction coefficient and concentration of the absorbing species. See ABSORPTION OF ELECTROMAGNETIC RADIATION.

**Photophysics.** The excited state produced by absorption of a photon is not generally a stable species. After a characteristic lifetime that can vary from femtoseconds ( $10^{-15}$  s) to hours, the excited molecule will either relax to its ground-state precursor or undergo a chemical transformation. The term photophysics is used to describe nonreactive relaxation processes, which include radiative (taking place with the emission of light) and nonradiative (taking place without the emission of light) pathways.

The energies of the lowest singlet and triplet excited states (relative to the ground state) can be obtained from the longest wavelength band of the fluorescence and phosphorescence spectra, respectively. This band is called a 0,0 band to indicate a transition between the lowest vibrational levels of the lowest-lying states. Singlet and triplet energies can also be determined indirectly by measuring quenching efficiencies. The shift between the 0,0 bands for absorption and emission in a single molecule is called its Stokes shift. A small Stokes shift is usually observed when the excited state has a geometry similar to the ground state. A Jablonski diagram (see illustration) is often used to graphically depict the relationship between competing photophysical processes.

Quantum yield, or quantum efficiency, is defined as the number of molecules participating in a given photophysical process or reaction divided by the number of photons absorbed. The quantum yield ranges between zero and one for photoreactions induced by a single photon; values larger than one are indicative of a chain process in which product is formed in a repeating, dark cycle initiated by the photoexcitation. For a photochemical reaction, the number of molecules participating in the reaction is determined spectroscopically or chromatographically as a chemical yield per volume unit per time. The number of photons absorbed is obtained by measuring with a radiometer the light flux per volume unit per time or by employing a chemical actinometer, a known chemical reaction for which the quantum yield is known and accepted as a standard. See QUANTUM CHEMISTRY.

**Energy transfer.** The process by which an excited state molecule,  $M^*$ , in an excited singlet or triplet state transfers all

or part of its excitation energy to a reaction partner or quencher,  $Q$ , is called energy transfer or quenching when the molecule of interest is  $M$  [reaction (2)]. This same process is called sensitiza-



tion when the molecule of interest is  $Q$ . In the latter case,  $M$  is called the sensitizer. Energy transfer permits an exception to the first law of photochemistry in that  $Q^*$  is produced without having absorbed the incident light.

For energy transfer to take place, an incident wavelength must be chosen so that  $M$  is primarily excited, producing an excited state  $M^*$  whose energy lies above that of  $Q^*$ . Symmetry selection rules require that all energy transfer events preserve spin multiplicity. Thus, if  $M^*$  is an excited singlet and  $Q$  is a ground-state singlet,  $M$  will be produced as a ground-state singlet and  $Q^*$  as an excited singlet. If  $M^*$  is an excited triplet and  $Q$  is a ground-state singlet,  $M$  will be produced as a ground-state singlet and  $Q^*$  as an excited triplet.

**Photochemical mechanisms.** As in all studies of mechanisms of chemical reactions, determining the structure of all products is the first step in the specification of a photochemical reaction. Spectroscopic (nuclear magnetic resonance spectroscopy, electron spin resonance spectroscopy, infrared spectroscopy, mass spectroscopy, x-ray analysis, absorption spectroscopy) and chromatographic (gas, liquid, or thin-layer chromatography) techniques are used to establish product structure and to determine product yields. Monitoring the effect of solvent polarity on reaction rate, the retention or loss of optical activity during the reaction, the positions of isotopic labels, and the success of intermediate trapping experiments can distinguish step-wise chemical reactions (those that proceed through one or more intermediates) from concerted reactions (those that proceed without intermediates). In addition to these mechanistic approaches, the identity and lifetime of the reactive excited state (singlet, triplet, and so forth) and the quantum yields for both product formation and for other competing photophysical processes are required for a full photochemical mechanistic characterization. Time-resolved flash photolysis and pulse radiolysis measurements can, in addition, be used sometimes for direct spectroscopic detection of absorptive or emissive intermediates encountered in a photochemical mechanism, as well as for their kinetic characterization. The addition of specific reactive quenchers or traps, conducting a photoreaction in a low-temperature matrix in which diffusion processes are stopped, and sensitization experiments are effective means for assigning the observed transient absorptions or emissions. The energetics of a well-defined photochemical reaction can be obtained by photoacoustic calorimetry measurements. See CHROMATOGRAPHY; MATRIX ISOLATION; PHOTOLYSIS; SPECTROSCOPY. [M.A.F.]

**Photoclinometer** A term applied to directional surveying instruments which record photographically the direction and magnitude of well deviations from the vertical. Two instruments of this type are in wide use, the Schlumberger photoclinometer and the Surwell clinograph. Both instruments record a series of deviation measurements on one trip into and out of the well. From this series of data it is possible to plot quite accurately the course of the well.

In the Schlumberger photoclinometer (see illustration) the deviation from the vertical is indicated by a small metal ball which rolls in a transparent glass bowl graduated in circular degrees. The direction of the deviation in azimuth is indicated by a magnetic compass. With the instrument suspended by an electrical cable, the positions of the compass and steel ball are photographed on a 35-mm film by operation of electrical controls at the surface. Correlation of the pictures with the depths at which they are taken yields a measure of the magnitude and direction of deviation of the hole as a function of depth.



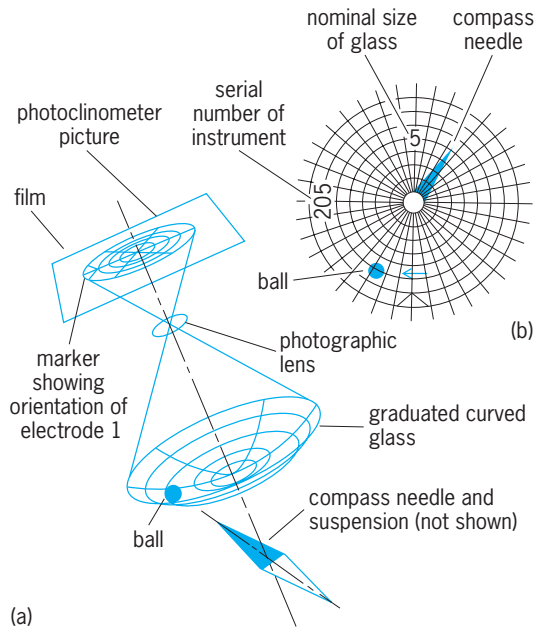

Diagram of a Schlumberger photoclinoimeter. (a) Principal features. (b) Type of record obtained. (Schlumberger Well Surveying Corp.)

The Surwell clinograph also operates electrically but is powered by batteries contained in the instrument. The deviation from the vertical is indicated by a box level gage and the direction in azimuth by a gyroscopic compass, permitting its use inside steel pipe. See SURVEYING. [H.G.Bo.]

**Photoconductive cell** A device for detecting electromagnetic radiation (photons) by variation of the electrical conductivity of a substance (a photoconductor) upon absorption of the radiation by this substance. During operation the cell is connected in series with an electrical source and current-sensitive meter, or in series with an electrical source and resistor. Current in the cell, as indicated by the meter, is a measure of the photon intensity, as is the voltage drop across the series resistor. Photoconductive cells are made from a variety of semiconducting materials in the single-crystal or polycrystalline form. See PHOTOCONDUCTIVITY; PHOTOELECTRIC DEVICES. [S.R.B.]

**Photoconductivity** The increase in electrical conductivity caused by the excitation of additional free charge carriers by light of sufficiently high energy in semiconductors and insulators. Effectively a radiation-controlled electrical resistance, a photoconductor can be used for a variety of light- and particle-detection applications, as well as a light-controlled switch. Other major applications in which photoconductivity plays a central role are television cameras (vidicons), normal silver halide emulsion photography, and the very large field of electrophotographic reproduction. See OPTICAL DETECTORS; OPTICAL MODULATORS; PARTICLE DETECTOR; PHOTOGRAPHY; TELEVISION CAMERA TUBE.

Although all insulators and semiconductors may be said to be photoconductive, that is, they show some increase in electrical conductivity when illuminated by light of sufficiently high energy to create free carriers, only a few materials show a large enough change, that is, show a large enough photosensitivity, to be practically useful in applications of photoconductors.

Since the electrical conductivity  $\sigma$  of a material is given by the product of the carrier density, its charge, and its mobility, an increase in the conductivity can be formally due to either an increase in carrier density or an increase in mobility. Although cases are found in which both types of effects are observable,

photoconductivity in single-crystal materials is due primarily to an increase in carrier density. In polycrystalline materials, on the other hand, where transport may be limited by potential barriers between the crystalline grains, an increase in mobility due to photoexcitation effects on these intergrain barriers may dominate the photoconductivity.

The variation of photoconductivity with photon energy is called the spectral response of the photoconductor. Spectral response curves typically show a fairly well-defined maximum at a photon energy close to that of the bandgap of the material, that is, the minimum energy required to excite an electron from a bond in the material into a higher-lying conduction band where it is free to contribute to the conductivity. This energy ranges from 3.7 eV, in the ultraviolet, for zinc sulfide (ZnS) to 0.2 eV, in the infrared, for cooled lead selenide (PbSe).

Another major characteristic of a photoconductor of practical concern is the rate at which the conductivity changes with changes in photoexcitation intensity. If a steady photoexcitation is turned off at some time, for example, the length of time required for the current to decrease to  $1/e$  of its initial value is called the decay time of photoconductivity,  $t_d$ . The magnitude of the decay time is determined by the lifetime  $\pi$  and by the density of carriers trapped in imperfections as a result of the previous photoexcitation, which must now also be released in order to return to the thermal equilibrium situation. See PHOTOCONDUCTIVE CELL. [R.H.Bu.]

**Photocopying processes** Processes that use light to generate copies directly from original paper documents. Light is employed to examine an original document and to detect the presence or absence of an image. In most cases, light reflected from the original subject directly exposes the medium used to produce an image on a copy. However, in an increasing number of cases, the light is converted into an electrical signal, which is later converted back to light to expose the copying medium.

Xerography, the most popular of the photocopying processes, relies on photoconductors and toner powders to create copies. The toner is fused to copy paper by heat or pressure. Microfilming employs silver halide films which must normally be developed and fixed by using wet chemicals. Electrofax, diazo, thermography, and nonmicrofilm forms of silver halide photocopying, although not used as widely as in the past, also have continuing applications. See PHOTOGRAPHIC MATERIALS.

The emergence of dual-imaging systems that accept both optical and digital input is making it increasingly difficult to characterize a given piece of equipment as a photocopier (optical input) or electronic printer (digital input). A number of electronic printers equipped with scanner attachments can function as either, and some employ both photocopying and digital imaging processes in generating an individual copy. See PRINTING. [R.I.E.; J.G.Ja.; T.De.]

**Photodegradation** Reduction in the useful properties of materials because of chemical changes resulting from the absorption of light. The chemical changes can include bond scission (especially of the molecular backbone), color formation, cross-linking, and chemical rearrangements. All organic materials can photodegrade, but the process has greatest practical relevance for polymers where scission of the polymer backbone is particularly important. Photodegradations of polymers in the absence of oxygen (photolysis) or using wavelengths shorter (more energetic) than those at the Earth's surface ( $<280$  nanometers) have been studied extensively, but only the more practical situation of polymers exposed to terrestrial sunlight (or its equivalent) in air is discussed in this article.

Although all organic polymers can be degraded by light, the rate of degradation varies enormously from polymer to polymer, and is also dependent on the incident wavelengths. Light containing ultraviolet (uv; shorter-wavelength) components is much more destructive than visible light, so that polymers exposed

indoors, behind window glass (transmitting  $>330$  nm), will degrade much more slowly than samples exposed outdoors.

For many aromatic polymers, such as polyester and the aramids, in which the polymer itself is the chromophore (light-absorbing group), backbone scission results predominantly from this direct absorption of light energy. For many other polymers, including polyolefins, and polyvinyl chloride where only impurities absorb energy from sunlight, scission of a chemical bond by light to give free radicals is followed by reaction of these highly reactive free radicals with atmospheric oxygen. See FREE RADICAL.

Although numerous organic materials will undergo photodegradation, hydrocarbon polymers are particularly vulnerable because their useful properties depend entirely on their high molecular weights, in the tens or hundreds of thousands. Anything that reduces the molecular weight of polymeric systems will alter the characteristics of these systems and limit their service life. In fact, the scission of as few as one carbon-carbon bond in a thousand in a polymer molecule can completely destroy its useful physical properties. This sensitivity is not observed in lower-molecular-weight substances such as liquid hydrocarbons.

A general approach to reducing the rates of photodegradation for all types of polymers is the use of low levels of additives. These additives, known as photostabilizers or uv stabilizers, are effective at fractions of a weight percent. See PHOTOCHEMISTRY; POLYMER; STABILIZER (CHEMISTRY). [D.M.W.; D.J.Ca.]

**Photodiode** A semiconductor two-terminal component with electrical characteristics that are light-sensitive. All semiconductor diodes are light-sensitive to some degree, unless enclosed in opaque packages, but only those designed specifically to enhance the light sensitivity are called photodiodes.

Most photodiodes consist of semiconductor *pn* junctions housed in a container designed to collect and focus the ambient light close to the junction. They are normally biased in the reverse, or blocking, direction; the current therefore is quite small in the dark. When they are illuminated, the current is proportional to the amount of light falling on the photodiode. See JUNCTION DIODE.

Photodiodes are used both to detect the presence of light and to measure light intensity. See PHOTOELECTRIC DEVICES. [W.R.Si.]

**Photoelasticity** An experimental technique for the measurement of stresses and strains in material objects by means of the phenomenon of mechanical birefringence. Photoelasticity is especially useful for the study of objects with irregular boundaries and stress concentrations, such as pieces of machinery with notches or curves, structural components with slits or holes, and materials with cracks. The method provides a visual means of observing overall stress characteristics of an object by means of light patterns projected on a screen or photographic film. Photoelasticity is generally used to study objects stressed in two planar directions (biaxial), but with refinements it can be used for objects stressed in three spatial directions (triaxial). See BIREFRINGENCE.

When a stressed model is subjected to monochromatic polarized light in a polariscope the birefringence of the model causes the light to emerge refracted into two orthogonal planes. Because the velocities of light propagation are different in each direction, there occurs a phase shifting of the light waves.

When the waves are recombined with the polariscope, regions of stress where the wave phases cancel appear black, and regions of stress where the wave phases combine appear light. Therefore, in models of complex stress distribution, light and dark fringe patterns (isochromatic fringes) are projected from the model (see illustration). These fringes are related to the stresses. See POLARIZED LIGHT.

When white light is used in place of monochromatic light, the relative retardation of the model causes the fringes to appear in

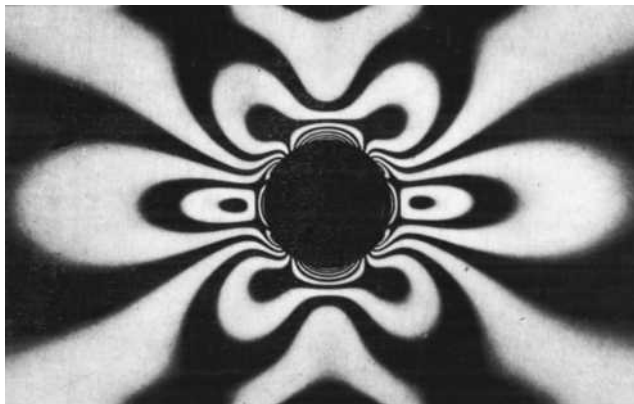

Isochromatic fringe pattern for plate with hole. (From M. M. Frocht, *Photoelasticity*, vol. 2, copyright © 1948 by John Wiley and Sons, Inc.; used with permission)

colors of the spectrum. White light is often used for demonstration, and monochromatic light is used for precise measurements. See STRESS AND STRAIN. [W.Z.]

**Photoelectric devices** Devices which give an electrical signal in response to visible, infrared, or ultraviolet radiation. They are often used in systems which sense objects or encoded data by a change in transmitted or reflected light. Photoelectric devices which generate a voltage can be used as solar cells to produce useful electric power. The operation of photoelectric devices is based on any of the several photoelectric effects in which the absorption of light quanta liberates electrons in or from the absorbing material. See PHOTOVOLTAIC EFFECT; SOLAR CELL.

Photoconductive devices are photoelectric devices which utilize the photo-induced change in electrical conductivity to provide an electrical signal. Photoemissive systems have also been used in photoelectric applications. These vacuum-tube devices utilize the photoemission of electrons from a photocathode and collection at an anode. See PHOTOCONDUCTIVE CELL; PHOTOEMISSION.

Many photoelectric systems now utilize silicon photodiodes or phototransistors. These devices utilize the photovoltaic effect, which generates a voltage due to the photoabsorption of light quanta near a *pn* junction. Modern solid-state integrated-circuit fabrication techniques can be used to create arrays of photodiodes which can be used to read printed information. See PHOTODIODE; PHOTOTRANSISTOR. [R.A.C.]

**Photoemission** The ejection of electrons from a solid (or less commonly, a liquid) by incident electromagnetic radiation. Photoemission is also called the external photoelectric effect. The visible and ultraviolet regions of the electromagnetic spectrum are most often involved, although the infrared and x-ray regions are also of interest. For important practical applications of photoemission see PHOTOTUBE; TELEVISION CAMERA TUBE.

The salient experimental features of photoemission are the following: (1) There is no detectable time lag between irradiation of an emitter and the ejection of photoelectrons. (2) At a given frequency the number of photoelectrons ejected per second is proportional to the intensity of the incident radiation. (3) The photoelectrons have kinetic energies ranging from zero up to a well-defined maximum, which is proportional to the frequency of the incident radiation and independent of the intensity.

In 1905 Albert Einstein made the clarifying assumption that electromagnetic radiation had characteristics like those of particles when it delivered energy to electrons in the emitter. In Einstein's approach the light beam behaves like a stream of photons, each of energy  $h\nu$ , where  $h$  is Planck's constant, and  $\nu$  is the frequency of the photon. The energy required to eject an electron from the emitter has a well-defined minimum value  $\phi$

called the photoelectric threshold energy. When a photon interacts with an electron, the latter absorbs the entire photon energy. See PHOTON.

For  $h\nu$  values below the threshold, photoelectrons are not ejected. Even though the electrons absorb photon energy, they do not receive enough to surmount the potential barrier at the surface, which normally holds the electrons in the solid. For photon energies above  $\phi$ , the kinetic energies of photo-electrons range from zero up to a maximum value,  $E = h\nu - \phi$ . This is the Einstein photoelectric law, and  $E$  is commonly termed the Einstein maximum energy. See HEAT RADIATION; SCHOTTKY EFFECT. [L.Ap.]

**Photoferroelectric imaging** The process of storing an image in a ferroelectric material by utilizing either the intrinsic or extrinsic photosensitivity in conjunction with the ferroelectric properties of the material. Specifically, photoferroelectric (PFE) imaging is a process of storing photographic images or other optical information in transparent lead lanthanum zirconate titanate (PLZT) ceramics. The photoferroelectric imaging device consists simply of a thin flat plate (about 0.01 in. or 0.2–0.3 mm thick) of optically polished PLZT ceramic with transparent conductive indium-tin oxide (ITO) electrodes sputter-deposited on the two major surfaces. The image to be stored is exposed onto one of the ITO electroded surfaces by using near-ultraviolet illumination in the intrinsic photosensitivity region (corresponding to a bandgap energy of approximately 3.35 eV) of the PLZT. Simultaneously, a voltage pulse is applied across the electrodes to switch the ferroelectric polarization from one stable remanent state to another. Images are stored both as spatial distributions of light-scattering centers in the bulk of the PLZT and as surface deformation strains which form a relief pattern of the image on the exposed surface. Both the light scattering and surface strains are related to spatial distributions of ferroelectric domain orientations introduced during the image-storage process. These spatial distributions correspond to brightness variations in the image to which the PLZT is exposed. The stored image may be viewed directly or it may be projected onto a screen by using either transmitted or reflected light.

Important potential applications of photoferroelectric imaging are temporary image storage and display. Various types of image processing, including image contrast enhancement, are also offered by the capability of switching from a positive to a negative stored image in discrete steps. See ELECTRONIC DISPLAY; FERROELECTRICS; PHOTOCONDUCTIVITY. [C.E.L.]

**Photogrammetry** The practice of obtaining surveys by means of photography. The camera commonly is airborne with its axis vertical, but oblique and horizontal (ground-based) pho-

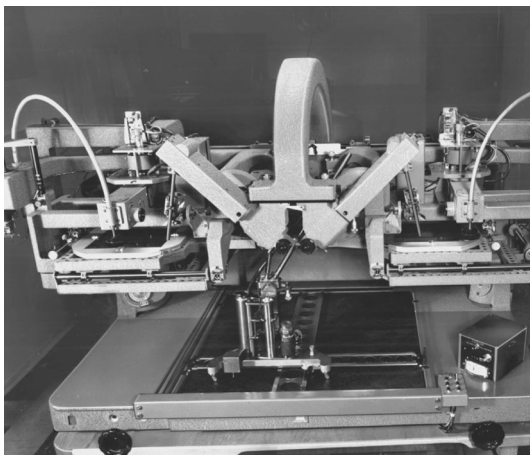

Typical automated stereoplotting system. (Lockwood, Hill Kessler, and Bartlett, Inc.)

tographs also are applicable. Data reduction is accomplished by stereoscopic line-of-sight geometry with use of both analytical and analog methods. See AERIAL PHOTOGRAPH; REMOTE SENSING; SURVEYING.

In vertical aerial surveys adjacent photos are overlapped. The two images of the same terrain are then superimposed for three-dimensional viewing by human operators or automated sensors.

In a widely used analog procedure the two photos are placed in the projectors of a stereoplotting instrument. With the aid of visible ground-control points the photos are oriented to the relative positions they had at the instants of exposure. In a typical automated stereoplotting system (see illustration) scanning devices substitute for human eyes to sense model-surface slope and thus to control servomechanisms that raise and lower the plotting table and translate it along a succession of closely spaced parallel horizontal dimensions, or ground profiles. [R.H.D.]

**Photographic materials** The light-sensitive recording materials of photography, that is, photographic films, plates, and papers. They consist primarily of a support of plastic sheeting, glass, or paper, respectively, and a thin, light-sensitive layer, commonly called the emulsion, in which the image will be formed and stored. The material will usually embody additional layers to enhance its photographic or physical properties.

Film support, for many years made mostly of flammable cellulose nitrate, is now exclusively made of slow-burning "safety" materials, usually cellulose triacetate or polyester terephthalate, which are manufactured to provide thin, flexible, transparent, colorless, optically uniform, tear-resistant sheeting. Film supports usually range in thickness from 0.0025 to 0.009 in. (0.06 to 0.23 mm) and are made in rolls up to 60 in. (1.5 m) wide and 6000 ft (1800 m) long. See ESTER; POLYESTER RESINS.

Glass is the predominant substrate for photographic plates, though methacrylate sheet, fused quartz, and other rigid materials are sometimes used. Plate supports are selected for optical clarity and flatness. Thickness, ranging usually from 0.04 to 0.25 in. (1 to 6 mm), is increased with plate size as needed to resist breakage and retain flatness. See GLASS.

Photographic paper is made from bleached wood pulp of high  $\alpha$ -cellulose content, free from ground wood and chemical impurities. It is often coated with a suspension of baryta (barium sulfate) in gelatin for improved reflectance and may be calendered for high smoothness. Fluorescent brighteners may be added to increase the appearance of whiteness. See PAPER.

Most emulsions are basically a suspension of silver halide crystals in gelatin. The crystals, ranging in size from 2.0 to less than 0.05 micrometers, are formed by precipitation by mixing a solution of silver nitrate with a solution containing one or more soluble halides in the presence of a protective colloid. During manufacture, the emulsion is ripened to control crystal size and structure. Chemicals are added in small but significant amounts to control speed, image tone, contrast, spectral sensitivity, keeping qualities, fog, and hardness; to facilitate uniform coating; and, in the case of color films and papers, to participate in the eventual formation of dye instead of metallic silver images upon development. The gelatin, sometimes modified by the addition of synthetic polymers, is more than a simple vehicle for the silver halide crystals. It interacts with the silver halide crystals during manufacture, exposure, and processing and contributes to the stability of the latent image. See EMULSION; GELATIN; SILVER.

The silver halides (and silver behenates) are normally sensitive only to x-radiation and to ultraviolet, violet, and blue wavelengths, but they can be made sensitive to longer wavelengths by adding special dyes, predominantly polymethines, to the emulsion. The process is known as spectral sensitizing to distinguish it from the chemical sensitizing used to raise the overall or inherent sensitivity of the grains. See PHOTOGRAPHY. [R.D.Anw.]

**Photography** The process of forming stable or permanent visible images directly or indirectly by the action of light or other forms of radiation on sensitive surfaces. Traditional photography

uses the action of light to cause changes in a film of silver halide crystals in which development converts exposed silver halide to (nonsensitive) metallic silver. Following exposure in a camera or other device, the film or plate is developed, fixed in a solution that dissolves the undeveloped silver halide, washed to remove the soluble salts, and dried. Printing from the original, if required, is done by contact or optical projection onto a second emulsion-coated material, and a similar sequence of processing steps is followed. Digital photography captures images directly with an electronic photosensor. *See* PHOTOGRAPHIC MATERIALS.

Photography is practiced on a professional level for portraiture and for various commercial and industrial applications, including the preparation of photographs for advertising, illustration, display, and record-keeping. Press photography is for newspaper and magazine illustrations of topical events and objects. Photography is used at several levels in the graphic arts to convert original photographs or other illustrations into printing plates for high-quality reproduction in quantity. Industrial photography includes the generation and reproduction of engineering drawings, high-speed photography, schlieren photography, metallography, and many other forms of technical photography which can aid in the development, design, and manufacture of various products. Aerial photography is used for military reconnaissance and mapping, civilian mapping, urban and highway planning, and surveys of material resources. Biomedical photography is used to reveal or record biological structures, often of significance in medical research, diagnosis, or treatment. Photography is widely applied to preparing projection slides and other displays for teaching through visual education. *See* PRINTING; SCHLIEREN PHOTOGRAPHY.

Photography is one of the most important tools in scientific and technical fields. It extends the range of vision, allowing records to be made of things or events which are difficult or impossible to see because they are too faint, too brief, too small, or too distant, or associated with radiation to which the eye is insensitive. Technical photographs can be studied at leisure, measured, and stored for reference or security. The acquisition and interpretation of images in scientific and technical photography usually requires direct participation by the scientist or skilled technicians.

**Infrared photography.** Emulsions made with special sensitizing dyes can respond to radiation at wavelengths up to 1200 nanometers, though the most common infrared films exhibit little sensitivity beyond 900 nm. One specialized color film incorporates a layer sensitive in the 700–900-nm region and is developed to false colors to show infrared-reflecting subjects as bright red. *See* INFRARED RADIATION.

Photographs can thus be made of subjects which radiate in the near-infrared, such as stars, certain lasers and light-emitting diodes, and hot objects with surface temperatures greater than 500°F (260°C). Infrared films are more commonly used to photograph subjects which selectively transmit or reflect near-infrared radiation, especially in a manner different from visible radiation. Infrared photographs taken from long distances or high altitudes usually show improved clarity of detail because atmospheric scatter (haze) is diminished with increasing wavelength and because the contrast of ground objects may be higher as a result of their different reflectances in the near-infrared. Grass and foliage appear white because chlorophyll is transparent in the near-infrared, while water is rendered black because it is an efficient absorber of infrared radiation. *See* INFRARED IMAGING DEVICES.

**Ultraviolet photography.** Two distinct classes of photography rely on ultraviolet radiation. In the first, the recording material is exposed directly with ultraviolet radiation emitted, reflected, or transmitted by the subject; in the other, exposure is made solely with visible radiation resulting from the fluorescence of certain materials when irradiated in the ultraviolet. In the direct case, the wavelength region is usually restricted by the camera lens and filtration to 350–400 nm, which is readily detected with

conventional black-and-white films. Ultraviolet photography is accomplished at shorter wavelengths in spectrographs and cameras fitted with ultraviolet-transmitting or reflecting optics, usually with specialized films. In ultraviolet-fluorescence photography, ultraviolet radiation is blocked from the film by filtration over the camera lens and the fluorescing subject is recorded readily with conventional color or panchromatic films. Both forms of ultraviolet photography are used in close-up photography and photomicrography by mineralogists, museums, art galleries, and forensic photographers. *See* ULTRAVIOLET RADIATION.

**High-speed photography.** Photography at exposure durations shorter than those possible with conventional shutters or at frequencies (frame rates) greater than those achievable with motion picture cameras with intermittent film movements is useful in a wide range of technical applications.

The best conventional between-the-lens shutters rarely yield exposures shorter than 1/500 s. Some focal plane shutters are rated at 1/2000 or 1/4000 s but may take 1/100 s to traverse the film format. Substantially shorter exposures are possible with magneto-optical shutters (using the Faraday effect), with electro-optical shutters (using the Kerr effect), or with pulsed electron image tubes. Alternatively, a capping shutter may be used in combination with various pulsed light sources which provide intense illumination for very short durations, including pulsed xenon arcs (electronic flash), electric arcs, exploding wires, pulsed lasers, and argon flash bombs. Flash durations ranging from 1 millisecond to less than 1 nanosecond are possible. Similarly, high-speed radiographs have been made by discharging a short-duration high-potential electrical pulse through the x-ray tube. *See* FARADAY EFFECT; KERR EFFECT; LASER; STROBOSCOPIC PHOTOGRAPHY.

The classical foundation for serial frame separation is the motion picture camera. Intermittent movement of the film in such cameras is usually limited to 128 frames/s (standard rates are 16 and 24). For higher rates (up to 10,000 frames/s or more) continuous film movement is combined with optical compensation, as with a rotating plane-parallel glass block, to avoid image smear. Pictures made at these frequencies but projected at normal rates slow down (stretch) the motion according to the ratio of taking and projection rates. Higher rates, up to 10<sup>7</sup> frames/s, have been achieved with a variety of ingenious special-purpose cameras. In some, the sequence of photographs is obtained with a rapidly rotating mirror at the center of an arcuate array of lenses, and a stationary strip of film. In others, the optics are stationary and the film strip is moved at high speed by mounting it around the outside or inside of a rapidly rotating cylinder. To overcome mechanical limitations on the rotation of mirrors or cylindrical film holders at high speeds, image dissection methods have been employed, that is, an image is split into slender sections and rearranged to fill a narrow slit at the film. The image is unscrambled by printing back through the dissecting optics. *See* CINEMATOGRAPHY.

**Remote sensing.** The art of aerial photography, in which photographs of the Earth's surface are made with specialized roll-film cameras carried aloft on balloons, airplanes, and spacecraft, is an important segment of a broader generic technology, remote sensing. The film is often replaced with an electronic sensor, the sensor system may be mounted on an aircraft or spacecraft, and the subject may be the surface of a distant planet instead of Earth. Remote sensing is used to gather military intelligence; to provide most of the information for plotting maps; for evaluating natural resources (minerals, petroleum, soils, crops, water) and natural disasters; and for planning cities, highways, dams, pipelines, and airfields. Aerial photography normally provides higher ground resolution and geometric accuracy than the imagery obtained with electronic sensors, especially when covering small areas, so it continues as the foundation for mapmaking, urban planning, and some other applications. Films designed for aerial photography, both black-and-white and color, have somewhat higher contrast than conventional products because the

luminance range of the Earth's surface as seen from altitudes of 5000 ft (1500 m) or more is roughly 100 times lower than that of landscapes photographed horizontally. See AERIAL PHOTOGRAPH; PHOTOGRAMMETRY; TOPOGRAPHIC SURVEYING AND MAPPING.

The acquisition of image information with scanning sensors mounted on spacecraft provides an inexpensive means for gathering photographs of large areas of the Earth or the whole Earth at regular intervals (minutes or hours for meteorological satellites, days for Earth resources satellites) or for photographing subjects which cannot be reached with aircraft or approached with spacecraft. Some sensors operate at wavelengths beyond those detected by infrared films. The image information is transmitted to receiving stations on Earth, usually processed electronically to correct for geometric and atmospheric factors, and recorded on a variety of image recorders. Scanning sensors, as well as film cameras, are employed in aerial reconnaissance because they can transmit tactical information to ground stations for evaluation before the aircraft returns to base or is shot down. Synthetic aperture radar, which maps the reflectance of microwaves from the surface of the Earth and other planets, represents another form of remote sensing for both military and commercial purposes in which the information is returned to Earth and reconstructed in photographic form for study. See AERIAL PHOTOGRAPH; METEOROLOGICAL SATELLITES; MILITARY SATELLITES; REMOTE SENSING. [R.D.Anw.]

**Digital photography.** The process of electronic acquisition, the equivalent of taking a photograph, is often referred to as image capture.

Light intensity is detected in digital camera by a photosensor. This is normally a charge-coupled device (CCD), although complementary metal oxide silicon (CMOS) devices are beginning to appear in some systems. See CHARGE-COUPLED DEVICES.

When photons strike the sensor, they give up energy. This causes electrons to be emitted, turning the energy of the photons into electrical energy. The number of electrons that are emitted can be measured to determine how many photons struck the capture element, and from this the scanner can generate a value for the intensity of light arriving from the point on the original being analyzed.

The aim of the digitization stage is to capture all the information from an original that will be needed in the reproduction and convert it into an array of binary numbers that a computer can process. The human visual system actively seeks cues that will give it information about the objects within the visual field, and a reproduction of an image that contains a large amount of detail is almost always preferred to one in which some of the detail has been lost. The more information that the reproduction contains about the original scene—the objects in it, their colors, textures—the more realistic the reproduction appears. See IMAGE PROCESSING.

Like conventional cameras, digital cameras come in compact, single-lens reflex, and large-format varieties. Low-resolution compacts are useful for producing classified advertisements and tend to have relatively simple optics, image-sensing electronics, and controlling software. Digital cameras are often based on existing single-lens reflex camera designs with the addition of CCD backs and storage subsystems. The capture resolution of these cameras is ideal for news photography and other applications with similar quality requirements. See CAMERA. [T.De.]

**Photoionization** The ejection of one or more electrons from an atom, molecule, or positive ion following the absorption of one or more photons. The process of electron ejection from matter following the absorption of electromagnetic radiation has been under investigation for over a century. The earliest measurements involved the ultraviolet irradiation of metal surfaces. The theoretical interpretation of this phenomenon, known as the photoelectric effect, played an important role in establishing quantum mechanics. It was shown that, contrary to classical ideas, energy exchanges between radiation and matter are me-

diated by integral numbers of photons. In the gas phase the photoeffect is called either photoionization (atoms, molecules, and their positive ions) or photodetachment (atomic and molecular negative ions). See PHOTOEMISSION.

Photoionization involves a radiative bound-free transition from an initial state consisting of  $n$  photons and an atom, molecule, or ion in a bound state to a final continuum state consisting of a residual ion (or an atom in the case of photodetachment) and  $m$  free electrons: that is,

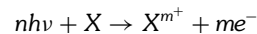

In the simplest atomic photoionization process a single electron is ejected from an atom following the absorption of a single photon. Each mode of fragmentation defines a final-state channel that is characterized by the energy and angular momentum of the outgoing electron as well as the excitation state of the residual ion. Since the photoionization process is endoergic, each channel has a well-defined threshold energy below which the channel is energetically closed. The threshold photon energy for a particular channel is equal to the binding energy of the electron that is to be ejected plus the excitation energy, if any, of the residual ion.

Above threshold, the energy carried off by the outgoing electron represents the balance between the energy supplied by the photon and the binding energy of the electron plus the excitation energy of the residual ion (neglecting the small recoil of the heavy ion). A photoelectron spectrum is characterized by a discrete set of peaks, each peak being associated with a particular state of the residual ion. Information on the excitation state of the ion following photoionization can also be obtained by monitoring the fluorescence emitted in the subsequent radiative decay of the state. One of the earliest applications of photoionization measurements was the investigation of the structure of atoms by determining the binding energies of both outer- and inner-shell electrons by means of photoelectron spectroscopy. See ATOMIC STRUCTURE AND SPECTRA; ELECTRON SPECTROSCOPY. [D.J.Pe.]

**Photoluminescence** A luminescence excited in a body by some form of electromagnetic radiation incident on the body. The term photoluminescence is generally limited to cases in which the incident radiation is in the ultraviolet, visible, or infrared regions of the electromagnetic spectrum.

Photoluminescence may be either a fluorescence or a phosphorescence, or both. Energy can be stored in certain luminescent materials by subjecting them to light or some other exciting agent, and can be released by subsequent illumination of the material with light of certain wavelengths. This type of photoluminescence is called stimulated photoluminescence. See FLUORESCENCE; LUMINESCENCE; PHOSPHORESCENCE. [C.C.K.; J.H.S.]

**Photolysis** The chemical decomposition of matter due to absorption of incident light. For example, illumination of microcrystals of silver bromide embedded in gelatin results in formation of metallic silver, and is the basis of the photographic process. See PHOTOGRAPHIC MATERIALS.

Numerous metal complexes, azides, nitrides, and sulfides, and most organometallic compounds undergo decomposition upon illumination, often with concomitant evolution of a gaseous product. In the presence of water and oxygen, illumination of many semiconductors results in their corrosion; for example, an aqueous suspension of cadmium sulfide (CdS) undergoes rapid decomposition upon irradiation with sunlight. The outcome of these photochemical processes can often be controlled by addition of adventitious materials. For example, illumination of cadmium sulfide in aqueous solution containing hydrogen sulfide (H<sub>2</sub>S) and colloidal platinum results in evolution of hydrogen gas. Here, the semiconductor photosensitizes (or photocatalyzes) decomposition of hydrogen sulfide into its elements, and the reaction can be used to remove sulfides from industrial waste. See COORDINATION COMPLEXES; SEMICONDUCTOR.

Many ketones, for example, acetone, abstract hydrogen atoms from adjacent organic matter under illumination. According to the circumstances, the resultant free radicals may be used to initiate polymerization of a monomer or cause decomposition of a plastic film. Both reactions have important commercial applications, and photoinitiators are commonly used for emulsion paints, inks, polymers, explosives, fillings for teeth and for development of photodegradable plastics. Photolysis of carbonyl compounds, released into the atmosphere by combustion of fossil fuels, is responsible for the onset of photochemical smog. Many other types of photochemical transformation of organic molecules are known, including isomerization of unsaturated bonds, cleavage of carbon-halogen bonds, olefin addition reactions, halogenation of aromatic species, hydroxylation, and oxygenation processes. Indeed, photochemistry is often used to produce novel pharmaceutical products that are difficult to synthesize by conventional methods. See FREE RADICAL; PHOTODEGRADATION; SMOG.

The most important photochemical reaction is green plant photosynthesis. Here, chlorophyll that is present in the leaves absorbs incident sunlight and catalyzes reduction of carbon dioxide to carbohydrate. See PHOTOSYNTHESIS.

Excitation of an organic molecule results in spontaneous generation of the singlet excited state. In most molecules, this highly unstable excited singlet state may undergo an intersystem-crossing process that results in population of the corresponding (less energetic) excited triplet state, in competition to fluorescence. The excited triplet state, because of spin restriction rules, retains a significantly longer lifetime than is found for the corresponding excited singlet state, and may be formed in high yield.

Almost without exception, these triplet states react quantitatively with molecular oxygen ( $O_2$ ) present in the system via a triplet energy-transfer process. The resulting product is singlet molecular oxygen. This species is a potent and promiscuous reactant, and it is responsible for widespread damage to both synthetic and natural environments. Indeed, plants and photosynthetic bacteria contain carotenoids to protect the organism against attack by singlet oxygen. The same species is known to be responsible, at least in part, for photodegradation of paint, plastic, fabric, colored paper, and dyed wool. Secondary reactions follow from attack on a substrate by singlet oxygen, resulting in initiation of chain reactions involving free radicals. However, modern technological processes have evolved in which singlet molecular oxygen is used to destroy unwanted organic matter, such as tumors, viruses, and bacteria, in a controlled and specific manner. In photodynamic therapy a dye is injected into a tumor and selectively illuminated with laser light. The resultant singlet oxygen destroys the tumor. Similar methodology can be used to produce photoactive soap powders, bleaches, bactericides, and pest-control reagents. See CHAIN REACTION (CHEMISTRY); FLUORESCENCE; TRIPLET STATE. [A.Ha.]

**Photometer** An instrument used for making measurements of light, or electromagnetic radiation, in the visible range. In general, photometers may be divided into two classifications: laboratory photometers, which are usually fixed in position and yield results of high accuracy; and portable photometers, which are used in the field or outside the laboratory and yield results of lower accuracy. Each class may be subdivided into visual (subjective) photometers and photoelectric (objective or physical) photometers. These in turn may be grouped according to function, such as photometers to measure luminous intensity (candelas or candlepower), luminous flux, illumination (illuminance), luminance (photometric brightness), light distribution, light reflectance and transmittance, color, spectral distribution, and visibility. Visual photometric methods have largely been supplanted commercially by physical methods, but because of their simplicity, visual methods are still used in educational laboratories to demonstrate photometric principles. See ILLUMINANCE; LUMINANCE; LUMINOUS FLUX; LUMINOUS INTENSITY. [G.A.Ho.]

**Photometry** That branch of science which deals with measurements of light (visible electromagnetic radiation) according to its ability to produce visual sensation. Specifically, photometry deals with the attribute of light that is perceived as intensity, while the related attribute of light that is perceived as color is treated in colorimetry. See COLOR; COLORIMETRY.

The purely physical attributes of light such as energy content and spectral distribution are treated in radiometry. Sometimes the word photometry is used to denote measurements that have nothing to do with human vision, but this is a mistake according to modern usage. Such measurements are properly referred to as radiometry, even if they are performed in the visible spectral region. See RADIOMETRY.

The relative visibility of a fixed power level of monochromatic electromagnetic radiation varies with wavelength over the visible spectral region (400–700 nanometers). The relative visibility of radiation also depends upon the illumination level that is being observed. The cone cells in the retina determine the visual response at high levels of illumination, while the rod cells dominate in the dark-adapted eye at very low levels (such as starlight). Cone-controlled vision is called photopic, and rod-controlled vision is called scotopic, while the intermediate region where both rods and cones play a role is called mesopic. See VISION.

Originally, photometry was carried out by using the human visual sense as the detector of light. As a result, photometric measurements were subjective. In order to put photometric measurements on an objective basis, and to allow convenient electronic detectors to replace the eye in photometric measurements, the Commission Internationale de l'Éclairage (CIE; International Commission on Illumination) has adopted two relative visibility functions as standards. These internationally accepted functions are called the spectral luminous efficiency functions for photopic and scotopic vision, and are denoted by  $V(\lambda)$  and  $V'(\lambda)$ , respectively. See LUMINOUS EFFICIENCY.

Thus photopic and scotopic (but not mesopic) photometric quantities have objective definitions, just as do the purely physical quantities. However, there is a difference. The purely physical quantities are defined in terms of physical laws, whereas the photometric quantities are defined by convention. In recognition of this difference the photometric quantities are called psychophysical quantities.

According to the International System of Units, SI, the photometric units are related to the purely physical units through a defined constant called the maximum spectral luminous efficacy. This quantity, which is denoted by  $K_m$ , is the number of lumens per watt at the maximum of the  $V(\lambda)$  function.  $K_m$  is defined in SI to be 683 lm/W for monochromatic radiation whose wavelength is 555 nanometers, and this defines the photometric units with which the photometric quantities are to be measured.

At various times, the photometric units have been defined in terms of the light from different standard sources, such as candles made according to specified procedures, and blackbodies at the freezing point of platinum. According to these definitions,  $K_m$  was a derived, rather than defined, quantity. See ILLUMINATION; LIGHT; PHYSICAL MEASUREMENT; UNITS OF MEASUREMENT. [J.Gei.]

**Photomorphogenesis** The regulatory effect of light on plant form, involving growth, development, and differentiation of cells, tissues, and organs. Morphogenic influences of light on plant form are quite different from light effects that nourish the plant through photosynthesis, since the former usually occur at much lower energy levels than are necessary for photosynthesis. Light serves as a trigger in photomorphogenesis, frequently resulting in energy expenditure orders of magnitude larger than the amount required to induce a given response. Photomorphogenic processes determine the nature and direction of a plant's growth and thus play a key role in its ecological adaptations to various environmental changes. See PHOTOSYNTHESIS.

Morphogenically active radiation is known to control seed and spore germination, growth and development of stems and

leaves, lateral root initiation, opening of the hypocotyl or epicotyl hook in seedlings, differentiation of the epidermis, formation of epidermal hairs, onset of flowering, formation of tracheary elements in the stem, and form changes in the gametophytic phase of ferns, to mention but a few of such known phenomena. Many nonmorphogenic processes in plants are also basically controlled by light independent of photosynthesis. Among these are chloroplast movement, biochemical reactions involved in the synthesis of flavonoids, anthocyanins, chlorophyll, and carotenoids, and leaf movements in certain legumes. [W.R.Br.]

**Photomultiplier** A very sensitive vacuum-tube detector of light or radiant flux containing a photocathode which converts the light to photoelectrons; one or more secondary-electron-emitting electrodes or dynodes which amplify the number of photoelectrons; and an output electrode or anode which collects the secondary electrons and provides the electrical output signal. It is also known as a multiplier phototube. Because of the very large amplification provided by the secondary-emission mechanism, and the very short time variation associated with the passage of the electrons within the device, the photomultiplier is applied to the detection and measurement of very low light levels, especially if very high speed of response is required.

The illustration is a schematic of a typical photomultiplier and shows its operation. Light incident on a semitransparent photocathode located inside an evacuated envelope causes photoelectron emission from the opposite side of the photocathode. The efficiency of the photoemission process is called the quantum efficiency, and is the ratio of emitted photoelectrons to incident photons (light particles). Photoelectrons are directed by an accelerating electric field to the first dynode, where from 3 to 30 secondary electrons are emitted for each incident electron, depending upon the dynode material and the applied voltage. These secondaries are directed to the second dynode, where the process is repeated and so on until the multiplied electrons from the last dynode are collected by the anode.

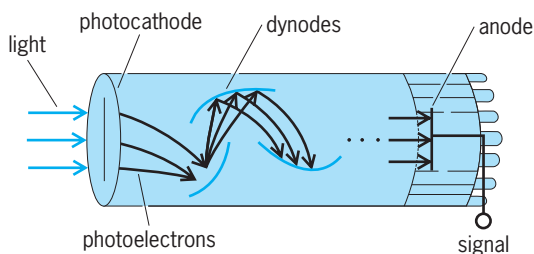

Schematic of a photomultiplier. (After P. W. Engstrom, *Photomultipliers—then and now*, *RCA Eng.*, 24(1):18–26, June–July 1978)

A typical photomultiplier may have 10 stages of secondary emission and may be operated with an overall applied voltage of 2000 V. In most photomultipliers the focusing of the electron streams is done by electrostatic fields shaped by the design of the electrodes. Some special photomultipliers designed for very high speed utilize crossed electrostatic and magnetic fields which direct the electrons in approximate cycloidal paths between electrodes.

Ever since their invention, photomultipliers have been found useful in low-level photometry and spectrometry. The most important applications of photomultipliers are related to scintillation counting, and these form the basis of a whole science of tracer chemistry that has been applied to agriculture, medicine, and industrial problems. In medicine, photomultiplier-scintillator combinations are used in the gamma-ray camera, computerized tomography, and the positron scanner. See COMPUTERIZED TOMOGRAPHY; GAMMA-RAY DETECTORS; NUCLEAR MEDICINE; RADIOLOGY; SCINTILLATION COUNTER. [R.W.E.]

**Photon** An entity that can be loosely described as a quantum of energy of electromagnetic radiation. According to classical electromagnetic theory, an electromagnetic wave can transfer arbitrarily small amounts of energy to matter. According to the quantum theory of radiation, however, the energy is transferred in discrete amounts. The energy of a photon is the product of Planck's constant and the frequency of the electromagnetic field. In addition to energy, the photon possesses momentum and also possesses angular momentum corresponding to a spin of unity. The interaction of radiation with matter involves the absorption, scattering, and emission of photons. Consequently, the energy interchange is inherently quantized. See ANGULAR MOMENTUM; ENERGY; MOMENTUM; SPIN (QUANTUM MECHANICS).

For many purposes, the photon behaves like a particle of zero rest mass moving at the speed of light. The particlelike nature of the photon is vividly exhibited by the photoelectric effect, predicted by A. Einstein, in which light is absorbed in a metal, causing electrons to be ejected. An electron absorbs a photon, gaining its energy. In leaving the metal, it loses energy because of interactions with the surface; the energy loss equals the product of the so-called work function of the surface and the charge of the electron. The final kinetic energy of the electron therefore equals the energy of the incident photon minus this energy loss. See PHOTOEMISSION.

A second demonstration of the particlelike behavior of photons is provided by the scattering of an x-ray photon from an electron bound in an atom. The electron recoils because of the momentum of the photon, thereby gaining energy. As a result, the frequency, and hence the wavelength of the scattered x-ray, is altered. If the x-ray is scattered through a certain angle, the wavelength is shifted by an amount determined by this scattering angle and the mass of an electron, according to the laws of conservation of energy and momentum. See COMPTON EFFECT.

From a more fundamental view, the photon is the quantum of excitation of a single mode of a radiation field. The dynamical equations for the electric and magnetic energy in such a field are identical to those of a harmonic oscillator. According to quantum theory, the allowed energies of a harmonic oscillator are given by  $E = (j + \frac{1}{2})hf$ , where  $h$  is Planck's constant,  $f$  is the frequency of the oscillator, and the quantum number  $j = 0, 1, 2, \dots$ , describes the state of excitation of the oscillator. This quantum relation was first postulated by M. Planck for the material oscillators in the walls of a thermal enclosure in order to obtain the correct form for the density of radiation in a thermal field, but it was quickly applied by Einstein to describe the state of the radiation field itself. In this picture,  $j$  describes the number of photons in the field. See HARMONIC OSCILLATOR; NONRELATIVISTIC QUANTUM THEORY; QUANTUM ELECTRODYNAMICS; QUANTUM MECHANICS. [D.K.I.]

**Photoperiodism** The growth, development, or other responses of organisms to the length of night or day or both. Photoperiodism has been observed in plants and animals, but not in bacteria (prokaryotic organisms), other single-celled organisms, or fungi.

A true photoperiodism response is a response to the changing day or night. Some species respond to increasing day lengths and decreasing night lengths (for example, by forming flowers or developing larger gonads); this is called a long-day response. Other species may exhibit the same response, or the same species may respond in some different way, to decreasing days and increasing nights; this is a short-day response. Sometimes a response is independent or nearly independent of day length, and is said to be day-neutral. There are many plant responses to photoperiod. These include development of reproductive structures in lower plants (mosses) and in flowering plants; rate of flower and fruit development; stem elongation in many herbaceous species as well as coniferous and deciduous trees (usually a long-day response and possibly the most widespread photoperiodism

response in higher plants); autumn leaf drop and formation of winter dormant buds (short days); development of frost hardiness (short days); formation of roots on cuttings; formation of many underground storage organs such as bulbs (onions, long days), tubers (potato, short days), and storage roots (radish, short days); runner development (strawberry, short day); balance of male to female flowers or flower parts (especially in cucumbers); aging of leaves and other plant parts; and even such obscure responses as the formation of foliar plantlets (such as the minute plants formed on edges of *Bryophyllum* leaves), and the quality and quantity of essential oils (such as those produced by jasmine plants). Note that a single plant, for example, the strawberry, might be a short-day plant for one response and a long-day plant for another response.

**Animal responses.** There are also many responses to photoperiod in animals, including control of several stages in the life cycle of insects (for example, diapause) and the long-day promotion in birds of molting, development of gonads, deposition of body fat, and migratory behavior. Even feather color may be influenced by photoperiod (as in the ptarmigan). In several mammals the induction of estrus and spermatogenic activity is controlled by photoperiod (sheep, goat, snowshoe hare), as is fur color in certain species (snowshoe hare). Growth of antlers in American elk and deer can be controlled by controlling day length. Increasing day length causes antlers to grow, whereas decreasing day length causes them to fall off. By changing day lengths rapidly, a cycle of antler growth can be completed in as little as 4 months; slow changes can extend the cycle to as long as 2 years. When attempts are made to shorten or extend these limits even more, the cycle slips out of photoperiodic control and reverts to a 10–12-month cycle, apparently controlled by an internal annual “clock.”

**Seasonal responses.** Response to photoperiod means that a given manifestation will occur at some specific time during the year. Response to long days (shortening nights) normally occurs during the spring, and response to short days (lengthening nights) usually occurs in late summer or autumn. Since day length is accurately determined by the Earth’s rotation on its tilted axis as it revolves in its orbit around the Sun, detection of day length provides an extremely accurate means of determining the season at a given latitude. Such other environmental factors as temperature and light levels also vary with the seasons but are clearly much less dependable from year to year.

**Mechanisms.** It has long been the goal of researchers on photoperiodism to understand the plant or animal mechanisms that account for the responses. Light must be detected, the duration of light or darkness must be measured, and this time measurement must be metabolically translated into the observed response: flowering, stem elongation, gonad development, fur color, and so forth. Basic mechanisms differ not only between plants and animals but among different species as well. The roles (synchronization, anticipation, and so on) are similar in all organisms that exhibit photoperiodism, but the mechanisms through which these roles are achieved are apparently quite varied.

Strongest inhibition of flowering in short-day plants comes when the light interruption occurs around the time of the critical night (about 7–9 h for cocklebur plants), but actual effectiveness also depends on the length of the dark period. With short-day cockleburs, the shorter the night, the less the flowering and the longer the time that light inhibits flowering.

Orange-red wavelengths used as a night interruption are by far the most effective part of the spectrum in inhibition of short-day responses and promotion of long-day responses (flowering in most studies), and effects of orange-red light can be completely reversed by subsequent exposure of plants to light of somewhat longer wavelengths, called far-red light. These observations led in the early 1950s to discovery of the phytochrome pigment system, which is apparently the molecular machinery that detects the light effective in photoperiodism of higher plants. See PHYTOCHROME.

In photoperiodism of short-day plants, an optimum response is usually obtained when phytochrome is in the far-red receptive form during the day and the red-receptive form during the night. Although normal daylight contains a balance of red and far-red wavelengths, the red-receptive form is most sensitive, so the pigment under normal daylight conditions is driven mostly to the far-red receptive form. At dusk this form is changed metabolically, and the red-receptive form builds up. It is apparently this shift in the form of phytochrome that initiates measurement of the dark period. This is how a plant “sees”: when the far-red-sensitive form of the pigment is abundant, the plant “knows” it is in the light; the red-sensitive form (or lack of far-red form) indicates to the plant’s biochemistry that it is in the dark.

The measurement of time—the durations of the day or night—is the very essence of photoperiodism. The discovery of a biological clock in living organisms was made in the late 1920s. It was shown that the movement of leaves on a bean plant (from horizontal at noon to vertical at midnight) continued uninterrupted for several days, even when plants were placed in total darkness and at a constant temperature, and that the time between given points in the cycle (such as the most vertical leaf position) was almost but not exactly 24 h. In the case of bean leaves, it was about 25.4 h. Many other cycles have now been found with similar characteristics in virtually all groups of plants and animals. There is strong evidence that the clocks are internal and not driven by some daily change in the environment. Such rhythms are called circadian.

Circadian rhythms usually have period lengths that are remarkably temperature-insensitive, which is also true of time measurement in photoperiodism. Furthermore, the rhythms are normally highly sensitive to light, which may shift the cycle to some extent. Thus, daily rhythms in nature are normally synchronized with the daily cycle as the Sun rises and sets each day. Their circadian nature appears only when they are allowed to manifest themselves under constant conditions of light (or darkness) and temperature, so that their free-running periods can appear.

[F.B.S.]

**Photophore gland** A highly modified integumentary gland which arises from an epithelial invagination into the dermis. It becomes cut off from its site of origin and develops into a luminous organ composed of a lens and a light-emitting gland, at the back of which is a pigmented reflector of probably dermal-cell origin. These luminous bodies occur in deep-sea teleosts and elasmobranchs which live in areas of total darkness. See EPITHELIUM; GLAND. [O.E.N.]

**Photoreception** The process of absorption of light energy by plants and animals and its utilization for biologically important purposes. In plants photoreception plays an essential role in photosynthesis and an important role in orientation. Photoreception in animals is the initial process in vision. See PHOTOSYNTHESIS; TAXIS; VISION.

The photoreceptors of animals are highly specialized cells or cell groups which are light-sensitive because they contain pigments which are unstable in the presence of light of appropriate wavelengths. These light-sensitive receptor pigments absorb radiant energy and then undergo physicochemical changes, which lead to the initiation of nerve impulses that are conducted to the central nervous system. See EYE (INVERTEBRATE); EYE (VERTEBRATE). [V.J.W.]

**Photorespiration** Light-dependent carbon dioxide release and oxygen uptake in photosynthetic organisms caused by the fixation of oxygen instead of carbon dioxide during photosynthesis. This oxygenation reaction forms phosphoglycolate, which represents carbon lost from the photosynthetic pathway. Phosphoglycolate also inhibits photosynthesis if it is allowed to accumulate in the plant. The reactions of photorespiration break down phosphoglycolate and recover 75% of the carbon to the



photosynthetic reaction sequence. The remaining 25% of the carbon is released as carbon dioxide. Photorespiration reduces the rate of photosynthesis in plants in three ways: carbon dioxide is released; energy is diverted from photosynthetic reactions to photorespiratory reactions; and competition between oxygen and carbon dioxide reduces the efficiency of the important photosynthetic enzyme ribulose-bisphosphate (RuBP) carboxylase. There is no known function of the oxygenation reaction; most scientists believe it is an unavoidable side reaction of photosynthesis. See PHOTOSYNTHESIS.

The rate of photosynthesis can be stimulated as much as 50% by reducing photorespiration. Since photosynthesis provides the material necessary for plant growth, photorespiration inhibits plant growth by reducing the net rate of carbon dioxide assimilation (photosynthesis). Plants grow faster and larger under nonphotorespiratory conditions, in either low oxygen or high carbon dioxide atmospheres. Most of the beneficial effects on plant growth achieved by increasing CO<sub>2</sub> may result from the reduced rate of photorespiration. See PLANT GROWTH.

There are some plants that avoid photorespiration under certain conditions by actively accumulating carbon dioxide inside the cells that have ribulose-bisphosphate carboxylase/oxygenase. Many cacti do this by taking up carbon dioxide at night and then releasing it during the day to allow normal photosynthesis. These plants are said to have crassulacean acid metabolism (CAM). Another group of plants, including corn (*Zea mays*), take up carbon dioxide by a special accumulating mechanism in one part of the leaf, then transport it to another part of the leaf for release and fixation by normal photosynthesis. The compound used to transport the carbon dioxide has four carbon atoms, and so these plants are called C<sub>4</sub> plants. Plants that have no mechanism for accumulating carbon dioxide produce the three-carbon compound phosphoglycerate directly and are therefore called C<sub>3</sub> plants. Most species of plants are C<sub>3</sub> plants. See PLANT RESPIRATION. [I.D.S.]

**Photosphere** The apparent, visible surface of the Sun. The photosphere is a gaseous atmospheric layer a few hundred miles deep with a diameter of 864,000 mi (1,391,000 km; usually considered the diameter of the Sun) and an average temperature of approximately 5800 K (10,500°F). Radiation emitted from the photosphere accounts for most of the solar energy flux at the Earth.

Convective cells give the photosphere a granular appearance with bright cells (hot rising gas) surrounded by dark intergranular lanes (cool descending gas). A typical granule is approximately 600 mi (1000 km) in diameter. Measurements of horizontal velocity reveal a larger convective pattern, the supergranulation; the horizontal motion of individual granules reveals intermediate-scale convective flows. See SUN. [S.L.K.]

**Photosynthesis** The manufacture in light of organic compounds (primarily certain carbohydrates) from inorganic materials by chlorophyll- or bacteriochlorophyll-containing cells. This process requires a supply of energy in the form of light. In chlorophyll-containing plant cells and in cyanobacteria, photosynthesis involves oxidation of water (H<sub>2</sub>O) to oxygen molecules, which are released into the environment. In contrast, bacterial photosynthesis does not involve O<sub>2</sub> evolution—instead of H<sub>2</sub>O, other electron donors, such as H<sub>2</sub>S, are used. This article will focus on photosynthesis in plants. See BACTERIAL PHYSIOLOGY AND METABOLISM; CHLOROPHYLL; PLANT RESPIRATION.

The light energy absorbed by the pigments of photosynthesizing cells, especially by the pigment chlorophyll or bacteriochlorophyll, is efficiently converted into stored chemical energy. Together, the two aspects of photosynthesis—the conversion of inorganic into organic matter, and the conversion of light energy into chemical energy—make it the fundamental process of life on Earth: it is the ultimate source of all living matter and of all life energy.

The net overall chemical reaction of plant photosynthesis is shown in the equation below, where {CH<sub>2</sub>O} stands for a carbohydrate (sugar).

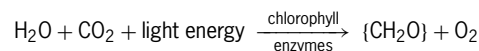

The photochemical reaction in photosynthesis belongs to the type known as oxidation-reduction, with CO<sub>2</sub> acting as the oxidant (hydrogen or electron acceptor) and water as the reductant (hydrogen or electron donor). The unique characteristic of this particular oxidation-reduction is that it goes “in the wrong direction” energetically; that is, it converts chemically stable materials into chemically unstable products. Light energy is used to make this “uphill” reaction possible.

Photosynthesis is a complex, multistage process. Its main parts are (1) the primary photochemical process in which light energy absorbed by chlorophyll is converted into chemical energy, in the form of some energy-rich intermediate products; and (2) the enzyme-catalyzed “dark” (that is, not photochemical) reactions by which these intermediates are converted into the final products—carbohydrates and free oxygen.

Experiments suggest that plants contain two pigment systems. One (called photosystem I, or PS I, sensitizing reaction I) contains the major part of chlorophyll *a*; the other (called photosystem II, or PS II, sensitizing reaction II) contains some chlorophyll *a* and the major part of chlorophyll *b* or other auxiliary pigments (for example, the red and blue pigments, called phycobilins, in red and blue-green algae, and the brown pigment fucoxanthol in brown algae and diatoms). It appears that efficient photosynthesis requires the absorption of an equal number of light quanta in PS I and in PS II; and that within both systems excitation energy undergoes resonance migration from one pigment to another until it ends in special molecules of chlorophyll *a* called the reaction centers. The latter molecules then enter into a series of chemical reactions that result in the oxidation of water to produce O<sub>2</sub> and the reduction of nicotinamide adenine dinucleotide phosphate (NADP<sup>+</sup>). Chromatophores from photosynthetic bacteria and chloroplasts from green plants, when illuminated in the presence of adenosine diphosphate (ADP) and inorganic phosphate, also use light energy to synthesize adenosine triphosphate (ATP); this photophosphorylation could be associated with some energy-releasing step in photosynthesis. [G.; R.Gov.]

The light-dependent conversion of radiant energy into chemical energy as ATP and reduced nicotinamide adenine

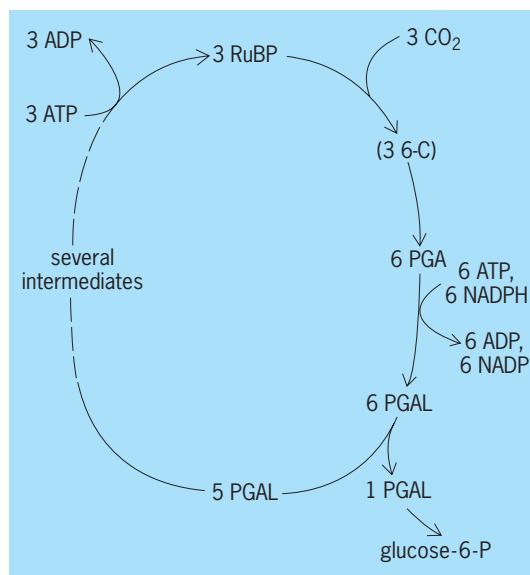

Fig. 1. Schematic outline of the Calvin (C<sub>3</sub>) carbon dioxide assimilation cycle.

dinucleotide phosphate (NADPH) serves as a prelude to the utilization of these compounds for the reductive fixation of  $\text{CO}_2$  into organic molecules. Such molecules, broadly designated as photosynthates, are usually but not invariably in the form of carbohydrates such as glucose polymers or sucrose, and form the base for the nutrition of all living things. Collectively, the biochemical processes by which  $\text{CO}_2$  is assimilated into organic molecules are known as the photosynthetic dark reactions, not because they must occur in darkness, but because light—in contrast to the photosynthetic light reactions—is not required.

**$\text{C}_3$  photosynthesis.** The essential details of  $\text{C}_3$  photosynthesis can be seen in Fig. 1. Three molecules of  $\text{CO}_2$  combine with three molecules of the five-carbon compound ribulose biphosphate (RuBP) in a reaction catalyzed by RuBP carboxylase to form three molecules of an enzyme-bound six-carbon compound. These are hydrolyzed into six molecules of the three-carbon compound phosphoglyceric acid (PGA), which are phosphorylated by the conversion of six molecules of ATP (releasing ADP for photophosphorylation via the light reactions). The resulting compounds are reduced by the NADPH formed in photosynthetic light reactions to form six molecules of the three-carbon compound phosphoglyceraldehyde (PGAL). One molecule of PGAL is made available for combination with another three-carbon compound, dihydroxyacetone phosphate,

which is isomerized from a second PGAL (requiring a second “turn” of the Calvin-cycle wheel) to form a six-carbon sugar. The other five PGAL molecules, through a complex series of enzymatic reactions, are rearranged into three molecules of RuBP, which can again be carboxylated with  $\text{CO}_2$  to start the cycle turning again. The net product of two “turns” of the cycle, a six-carbon sugar (glucose-6-phosphate) is formed either within the chloroplast in a pathway leading to starch (a polymer of many glucose molecules), or externally in the cytoplasm in a pathway leading to sucrose (condensed from two six-carbon sugars, glucose and fructose).

**$\text{C}_4$  photosynthesis.** Initially, the  $\text{C}_3$  cycle was thought to be the only route for  $\text{CO}_2$  assimilation, although it was recognized by plant anatomists that some rapidly growing plants (such as maize, sugarcane, and sorghum) possessed an unusual organization of the photosynthetic tissues in their leaves (Kranz morphology). It was then demonstrated that plants having the Kranz anatomy utilized an additional  $\text{CO}_2$  assimilation route now known as the  $\text{C}_4$ -dicarboxylic acid pathway (Fig. 2). Carbon dioxide enters a mesophyll cell, where it combines with the three-carbon compound phosphoenolpyruvate (PEP) to form a four-carbon acid, oxaloacetic acid, which is reduced to malic acid or transaminated to aspartic acid. The four-carbon acid moves into bundle sheath cells, where the acid is decarboxylated, the  $\text{CO}_2$  assimilated via the  $\text{C}_3$  cycle, and the resulting three-carbon compound, pyruvic acid, moves back into the mesophyll cell and is transformed into PEP, which can be carboxylated again. The two cell types, mesophyll and bundle sheath, are not necessarily adjacent, but in all documented cases of  $\text{C}_4$  photosynthesis the organism had two distinct types of green cells.  $\text{C}_4$  metabolism is classified into three types, depending on the decarboxylation reaction used with the four-carbon acid in the bundle sheath cells:

1. NADP-ME type (sorghum):

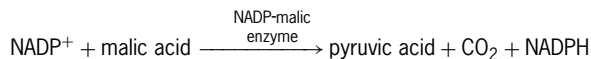

2. NAD-ME type (*Atriplex* species):

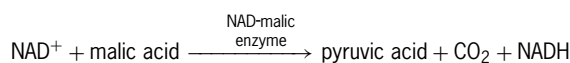

3. PCK type (*Panicum* species):

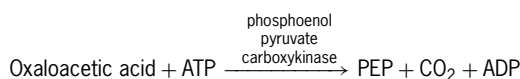

**CAM photosynthesis.** Under arid and desert conditions, where soil water is in short supply, transpiration during the day when temperatures are high and humidity is low may rapidly deplete the plant of water, leading to desiccation and death. By keeping stomata closed during the day, water can be conserved, but the uptake of  $\text{CO}_2$ , which occurs entirely through the stomata, is prevented. Desert plants in the Crassulaceae, Cactaceae, Euphorbiaceae, and 15 other families evolved, apparently independently of  $\text{C}_4$  plants, an almost identical strategy of assimilating  $\text{CO}_2$  by which the  $\text{CO}_2$  is taken in at night when the stomata open; water loss is low because of the reduced temperatures and correspondingly higher humidities. First studied in plants of the Crassulaceae, the process has been called crassulacean acid metabolism (CAM).

In contrast to  $\text{C}_4$ , where two cell types cooperate, the entire process occurs within an individual cell; the separation of  $\text{C}_4$  and  $\text{C}_3$  is thus temporal rather than spatial. At night,  $\text{CO}_2$  combines with PEP through the action of PEP carboxylase, resulting in the formation of oxaloacetic acid and its conversion into malic acid. The PEP is formed from starch or sugar via the glycolytic

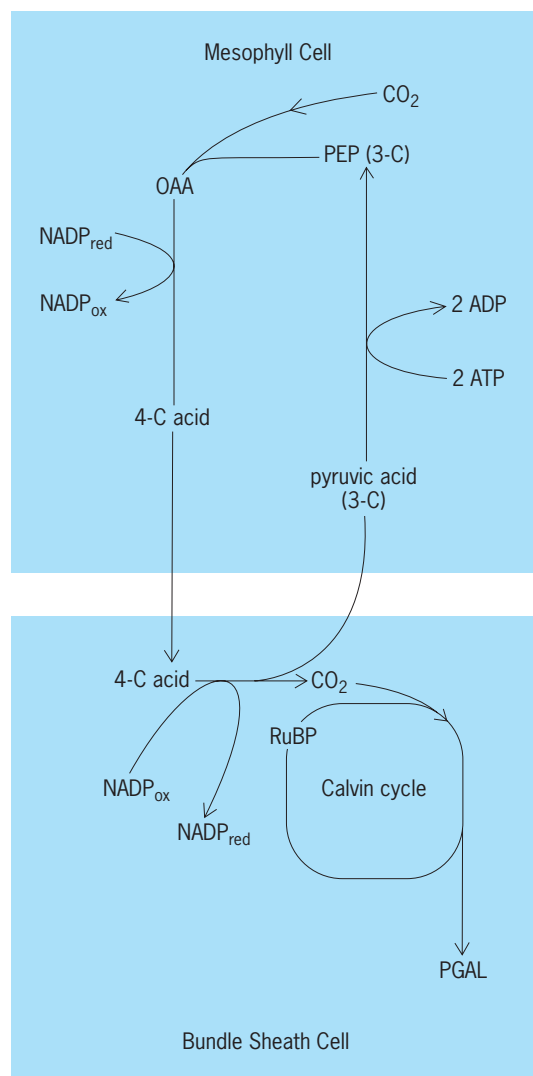

Fig. 2. Schematic outline of the Hatch-Slack ( $\text{C}_4$ ) carbon dioxide assimilation route in two cell types of a NADP-ME-type plant.

route of respiration. Thus, there is a daily reciprocal relationship between starch (a storage product of  $C_3$  photosynthesis) and the accumulation of malic acid (the terminal product of nighttime  $CO_2$  assimilation). [M.G.; G.A.B.]

**Phototransistor** A semiconductor device with electrical characteristics that are light-sensitive. Phototransistors differ from photodiodes in that the primary photoelectric current is multiplied internally in the device, thus increasing the sensitivity to light. See PHOTODIODE; TRANSISTOR.

Some types of phototransistors are supplied with a third, or base, lead. This lead enables the phototransistor to be used as a switching, or bistable, device. The application of a small amount of light causes the device to switch from a low current to a high current condition. See PHOTOELECTRIC DEVICES. [W.R.Si.]

**Phototube** An electron tube comprising a photocathode and an anode mounted within an evacuated glass envelope through which radiant energy is transmitted to the photocathode. A gas phototube contains, in addition, argon or other inert gas which provides amplification of the photoelectric current by partial ionization of the gas. The photocathode emits electrons when it is exposed to ultraviolet, visible, or near-infrared radiation. The anode is operated at a positive potential with respect to the photocathode. See ELECTRICAL CONDUCTION IN GASES; ELECTRON TUBE.

A phototube responds to radiation over a limited range of the spectrum that is determined by the photocathode material. Radiant sensitivity is the photoelectric current emitted per unit of incident monochromatic radiant power. See PHOTOEMISSION.

Quantum efficiency, or photoelectron yield, is the number of electrons emitted per incident photon. For photometric applications a useful parameter is luminous sensitivity: the photoelectric current per lumen incident from a specified source of light. A source commonly used is a tungsten-filament lamp operated at a color temperature of  $4700^\circ F$  ( $2870 K$ ). See INCANDESCENCE; LUMINOUS FLUX; PHOTON.

Photocathodes are semiconductors which contain one or more of the alkali metals sodium, potassium, rubidium, or cesium chemically combined with bismuth, antimony, or silver oxide. The cathode surface contains a critical excess of the alkali metal which enhances photoelectric emission by decreasing the affinity of the surface for electrons. Negative affinity for electrons is achieved with the gallium arsenide:cesium (GaAs:Cs) and indium gallium arsenide:cesium (InGaAs:Cs) photocathodes used in photomultipliers. Phototubes also emit electrons thermionically at ambient temperatures. This "dark current," observed in the absence of all irradiance, increases almost exponentially with temperature. Thermionic emission from the cesium antimonide (CsSb) photocathode is about  $10^{-15} A/cm^2$  at  $68^\circ F$  ( $20^\circ C$ ). See PHOTOMULTIPLIER; SEMICONDUCTOR.

Vacuum phototubes are used as detectors of radiant energy in the spectral range from 200 to 1100 nanometers. Since the photoelectric current is directly proportional to the intensity of the radiation, these tubes are used in radiometers, photometers, and colorimeters. By virtue of their narrow pulse response, vacuum phototubes are also used to measure the intensity of very short pulses of light generated by lasers and visible nuclear radiation. Gas phototubes can be used in light-operated relays and for the reproduction of sound from motion picture film, although their response to intensity-modulated light is limited to frequencies below 15 kHz. Vacuum as well as phototubes have been replaced in many applications by semiconductor photodiodes and photovoltaic cells. See COLORIMETRY; LASER; PHOTODIODE; PHOTOMETER; PHOTOVOLTAIC CELL; RADIOMETRY. [J.L.We.]

**Photovoltaic cell** A device that detects or measures electromagnetic radiation by generating a current or a voltage, or both, upon absorption of radiant energy. Specially designed photovoltaic cells are used for power generation, as in solar bat-

teries or solar cells, and for sensitive detection of electromagnetic radiation in radiometry, optical communications, spectroscopy, and other applications. An important advantage of the photovoltaic cell in these particular applications is that no separate bias supply is needed—the device generates a signal (voltage or current) simply by the absorption of radiation.

Most photovoltaic cells consist of a semiconductor  $pn$  junction or Schottky barrier in which electron-hole pairs produced by absorbed radiation are separated by the internal electric field in the junction to generate a current, a voltage, or both, at the device terminals. Under open-circuit conditions (current  $I = 0$ ) the terminal voltage increases with increasing light intensity, and under short-circuit conditions (voltage  $V = 0$ ) the magnitude of the current increases with increasing light intensity. When the current is negative and the voltage is positive, the photovoltaic cell delivers power to the external circuit. In this case, if the source of radiation is the Sun, the photovoltaic cell is referred to as a solar battery or solar cell. When a photovoltaic cell is used as a photographic exposure meter, it produces a current proportional to the light intensity, which is indicated by a low-impedance galvanometer or microammeter. For use as sensitive detectors of infrared radiation, specially designed photovoltaic cells can be operated with either low-impedance (current) or high-impedance (voltage) amplifiers, although the lowest noise and highest sensitivity are achieved in the current or short-circuit mode. Another mode of operation of a  $pn$  junction diode as a photodetector involves the application of a reverse bias voltage to the diode. In this case, the photogenerated current is directly proportional to the incident power, and the diode is said to be operated in the photodiode mode rather than the photovoltaic mode. See EXPOSURE METER; JUNCTION DIODE; OPTICAL DETECTORS; PHOTODIODE; PHOTOELECTRIC DEVICES; PHOTOVOLTAIC EFFECT; RADIOMETRY; SEMICONDUCTOR; SEMICONDUCTOR DIODE; SOLAR CELL. [G.E.Sti.]

**Photovoltaic effect** The conversion of electromagnetic radiation into electric power through absorption by a semiconducting material. Devices based on this effect serve as power sources in remote terrestrial locations and for satellites and other space applications. Photovoltaic powered calculators and other consumer electronic products are widely available, and solar photovoltaic automobiles and aircraft have been demonstrated.

The basic requirements for the photovoltaic effect are (1) the absorption of photons through the creation of electron-hole pairs in a semiconductor; (2) the separation of the electron and hole so that their recombination is inhibited and the electric field within the semiconductor is altered; and (3) the collection of the electrons and holes, separately, by each of two current-collecting electrodes so that current can be induced to flow in a circuit external to the semiconductor itself.

There are many approaches to achieving these three requirements simultaneously. A very common approach for separating the electrons from the holes is to use a single-crystal semiconductor, for example, silicon, into which a  $pn$  junction has been diffused. Silicon is often chosen because its optical band gap permits the absorption of a substantial portion of solar photons via the generation of electron-hole pairs. The fabrication of such a device structure causes a local transfer of negative charges from the  $n$  layer into the  $p$  layer, bending the conduction and valence bands in the vicinity of the  $p$ - $n$  boundary, and thereby creating a rectifying junction. Electrons generated in the  $p$  region can lower their energy by migrating into the  $n$  region, which they will do by a random walk process in the electric-field-free region far from the junction, or by drift induced by the electric field in the junction region. Holes created in the  $n$  region, conversely, lose energy by migrating into the  $p$  region. Thus the presence of such a junction leads to the spontaneous spatial separation of the photogenerated carriers, thereby inducing a voltage difference between current-carrying electrodes connected to the  $p$  and  $n$  regions. This process will continue until the difference in

potential between the two electrodes is large enough to flatten the bands in the vicinity of the junction, canceling out the internal electric field existing there and so eliminating the source of carrier separation. The resulting voltage is termed the open-circuit voltage, and approximates the built-in voltage associated with the *pn* junction in the dark, a value which cannot exceed the band gap of the semiconductor. See HOLE STATES IN SOLIDS; SEMICONDUCTOR; SEMICONDUCTOR DIODE.

In the limit when the device is short-circuited by the external circuit, no such buildup of potential can occur. In this case, one electron flows in the external circuit for each electron or hole which crosses the junction, that is, for each optically generated electron-hole pair which is successfully separated by the junction. The resulting current is termed the short-circuit current and, in most practical photovoltaic devices, approaches numerically the rate at which photons are being absorbed within the device. Losses can arise from the recombination of minority carriers (for example, electrons in the *p*-type region, holes in the *n*-type region) with majority carriers. See ELECTRON-HOLE RECOMBINATION.

For a photovoltaic device to generate power, it is necessary to provide a load in the external circuit which is sufficiently resistive to avoid short-circuiting the device. In this case, the voltage will be reduced compared to the open-circuit voltage because a continuing requirement exists for carrier separation at the junction; thus some band bending and its associated internal field must be retained.

Various multiple-layered device configurations based on doped and undoped alloys of amorphous silicon have been developed for photovoltaic devices used in applications ranging from solar watches and calculators to remote power generators. The photovoltaic effect in these devices is particularly intriguing since it is possible to build up so-called tandem devices by stacking one device electrically and optically in series above another. In addition to the increased voltage and concomitant reduction in the required current-carrying capability of electrode grid structures, such devices permit, in principle, an increased efficiency of solar photovoltaic energy conversion. See SOLAR CELL. [J.P.deN.]

**Phreatoicoidea** A suborder of the Isopoda and class Crustacea. The body is subcylindrical, appearing laterally compressed, mainly because of the downward development of the pleura of the pleon (see illustration). The first and occasionally the second thoracic segment is fused with the head. Antennules are shorter than the antennae. The eyes may be large, small, or absent. Mouthparts are primitive.

The suborder is divided into two families, the Amphisopidae, and the Phreatoicidae. The suborder is an ancient one and includes a fossil, *Protamphisopus wianamattensis*, from the Triassic beds of New South Wales. Three extant species are recorded from Australia, Tasmania, New Zealand, and South Africa and one that is subterranean from India. Most species occur in fresh

water. Several are blind, subterranean forms and one occurs in hot water from deep artesian bores. A few are semiterrestrial, burrowing forms. [E.M.S.]

**Phrynophiurida** An order of Ophiuroidea in which the vertebrae usually articulate by means of hourglass-shaped surfaces and the arms are able to coil upward or downward in the vertical plane. There is usually a leathery integument, in which calcareous granules or platelets are embedded. Most species are found in deep water. Of the families, the Gorgonocephalidae often have branched arms, the Asteronychidae have a large disk and slender arms, and the Asteroschematidae have a small disk and stout arms.

These families share a number of characteristics and are grouped in one suborder, Euryalina. One remaining family, the Ophiomyxidae, differs in having a soft, unprotected integument. See OPHIUROIDEA. [H.B.F.]

**Phycobilin** Any member of a class of intensely colored pigments found in some algae that absorb light for photosynthesis. Phycobilins are structurally related to mammalian bile pigments, and they are unique among photosynthetic pigments in being covalently bound to proteins (phycobiliproteins). In at least two groups of algae, phycobiliproteins are aggregated in a highly ordered protein complex called a phycobilisome.

Phycobilins occur only in three groups of algae: cyanobacteria (blue-green algae), Rhodophyta (red algae), and Cryptophyceae (cryptophytes), and are largely responsible for their distinctive colors, including blue-green, yellow, and red. Five different phycobilins have been identified to date, but the two most common are phycocyanobilin, a blue pigment, and phycoerythrobilin, a red pigment. In the cell, these pigments absorb light maximally in the orange (620-nanometers) and green (550-nm) portion of the visible light spectrum, respectively. A blue-green light (495-nm) absorbing pigment, phycourobilin, is found in some cyanobacteria and red algae. A yellow light (575-nm) absorbing pigment, phycobiliviolin (also called cryptoviolin) is apparently found in all cryptophytes but in only a few cyanobacteria. A fifth phycobilin, which absorbs deep-red light (697 nm), has been identified spectrally in some cryptophytes, but its chemical properties are unknown. See CRYPTOPHYCEAE; CYANOPHYCEAE; RHODOPHYCEAE.

Phycobilins are associated with the photosynthetic light-harvesting system in chloroplasts of red algae and cryptophytes and with the photosynthetic membranes of cyanobacteria, which lack chloroplasts. Phycobilins are covalently bound to a water-soluble protein that aggregates on the surface of the photosynthetic membrane. All other photosynthetic pigments (for example, chlorophylls and carotenoids) are bound to photosynthetic membrane proteins by hydrophobic attraction. Phycobiliprotein can constitute a major fraction of an alga. In some cyanobacteria, phycobiliproteins can account for more than 50% of the soluble protein and one-quarter of the dry weight of the cell. See CELL PLASTIDS.

Phycobilins are photosynthetic accessory pigments that absorb light efficiently in the yellow, green, orange, or red portion of the light spectrum, where chlorophyll *a* only weakly absorbs. Light energy absorbed by phycobilins is transferred with greater than 90% efficiency to chlorophyll *a*, where it is used for photosynthesis. See CHLOROPHYLL; PHOTOSYNTHESIS. [T.M.K.]

**Phylactolaemata** A class of ectoproct bryozoans. Phylactolaemates have lophophores which usually are markedly U-shaped (or rarely nearly circular but still kidney-shaped) in basal outline, and relatively short, wide zoecia; these animals dwell only in fresh waters. See BRYOZOA; LOPHOPHORE.

Phylactolaemate colonies are either encrusting threadlike networks of relatively isolated zoecia with solid chitinous uncalcified walls, or small to large masses of gelatinous material in which the individual zooids are embedded side-by-side without definite separating zoecial walls. Stolons are not present.

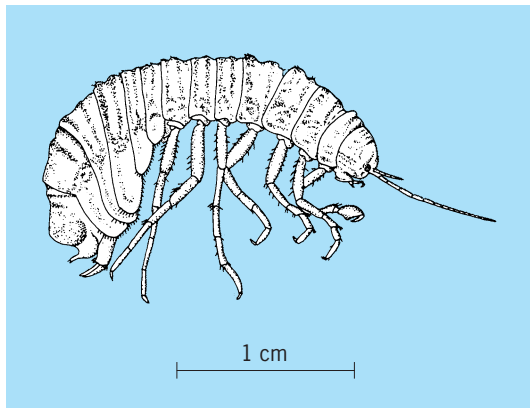

*Onchotelson brevicaudatus*, adult male.

Only a few (about 50) phylactolaemate species exist, all classified in a single order, the Plumatellida (or Plumatellina). Exclusively fresh-water, the phylactolaemates may have evolved relatively recently from ctenostomes, although some workers have suggested that phylactolaemates might be very primitive ectoprocts surviving as evolutionary relics. See CTENOSTOMATA.

[R.J.Cu.]

**Phyllite** A type of metamorphic rock formed during low-grade metamorphism of clay-rich sediments called pelites. Phyllites are very fine grained rocks with a grain size barely visible in a hand specimen. They have a well-developed planar element called cleavage defined by alignment of mica grains and interlayering of quartz-rich and mica-rich domains. Typically, mica grains show the greater alignment, although other mineral components (quartz, carbonate, and feldspars) may show a preferred shape orientation. Where all minerals of a particular type show the same degree of alignment and the fabric is well developed throughout the rock, the fabric is termed a penetrative fabric. Cleavage surfaces in phyllites have a glittery, lustrous sheen due to light reflecting off grains of chlorite and muscovite. The mineralogy of phyllites is dependent on chemical composition; typical minerals in phyllites are chlorite, muscovite, and quartz. Other minerals that may be present in phyllites formed during low-grade metamorphism include chloritoid, garnet (rarely), sodium-mica, and sulfide minerals. See CHLORITE; MUSCOVITE; QUARTZ.

Phyllite is found in most regionally metamorphosed terranes in the world, including the Appalachians of eastern North America, the Scottish Highlands, and the Alps. See METAMORPHIC ROCKS.

[M.W.N.]

**Phyllocarida** A subclass of the crustacean class Malacostraca containing the extant order Leptostraca and the fossil order Archiostraca. The Phyllocarida has a long fossil record, and many early fossil taxa were referred to this subclass. However, studies of presumed phyllocarids from the Burgess Shale have shown that only the archiostracans agree with the definition of the Phyllocarida.

Phyllocarids are distinct from other malacostracan crustaceans because of two other characteristics considered to reflect the primitive condition, which strengthen the hypothesis of early separation from the main evolutionary line. The first is the presence of a bivalve carapace. The second is an abdomen consisting of seven fully formed somites and terminating in a telson that bears caudal rami. See CRUSTACEA; LEPTOSTRACA; MALACOSTRACA.

[P.A.McL.]

**Phylogeny** The genealogical history of organisms, both living and extinct. Phylogeny represents the historical pattern of relationships among organisms which has resulted from the actions of many different evolutionary processes. Phylogenetic relationships are depicted by branching diagrams called cladograms, or phylogenetic trees. Cladograms show relative affinities of groups of organisms called taxa. Such groups of organisms have some genealogical unity, and are given a taxonomic rank such as species, genera, families, or orders. For example, two species of cats—say, the lion (*Panthera leo*) and the tiger (*Panthera tigris*)—are more closely related to each other than either is to the gray wolf (*Canis latrans*). The family including all cats, Felidae, is more closely related to the family including all dogs, Canidae, than either is to the family that includes giraffes, Giraffidae. The lion and tiger, and the Felidae and Canidae, are called sister taxa because of their close relationship relative to the gray wolf, or to the Giraffidae, respectively.

Cladograms thus depict a hierarchy of relationships among a group of taxa (illus. a). Branch points, or nodes, of a cladogram represent hypothetical common ancestors (not specific real ancestors), and the branches connect descendant sister taxa. If the taxa being considered are species, nodes are taken to sig-

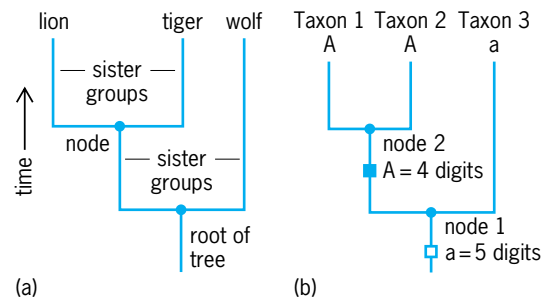

**Phylogenetic trees.** (a) A tree representing a hierarchical pattern of sister-group relationships (those taxa descended from a common ancestor). (b) Relationships are determined by identifying derived characters; in this case the condition of five digits is primitive, whereas the loss of a digit is derived and unites taxa 1 and 2.

nify speciation events. The goal of the science of cladistics, or phylogenetic analysis, is to discover these sister-group (cladistic) relationships and to identify what are termed monophyletic groups—two or more taxa postulated to have a single, common origin.

The acceptance of a cladogram depends on the empirical evidence that supports it relative to alternative hypotheses of relationship for those same taxa. Evidence for or against alternative phylogenetic hypotheses comes from the comparative study of the characteristics of those taxa. Similarities and differences are determined by comparison of the anatomical, behavioral, physiological, or molecular [such as deoxyribonucleic acid (DNA) sequences] attributes among the taxa. A statement that two features in two or more taxa are similar and thus constitute a shared character is, in essence, a preliminary hypothesis that they are homologous; that is, the taxa inherited the specific form of the feature from their common ancestor. However, not all similarities are homologs; some are developed independently through convergent or parallel evolution, and although they may be similar in appearance, they had different histories and thus are not really the same feature. In cladistic theory, shared homologous similarities are either primitive (plesiomorphic condition) or derived (apomorphic condition), whereas nonhomologous similarities are termed homoplasies (or sometimes, parallelisms or convergences). This distinction over concepts and terminology is important because only derived characters constitute evidence that groups are actually related.

As evolutionary lineages diversify, some characters will become modified. Examples include the enlargement of forelimbs or the loss of digits on the hand. Thus, during evolution the foot of a mammal might transform from a primitive condition of having five digits to a derived form with only four digits (illus. b). Following branching at node 1, the foot in one lineage undergoes an evolutionary modification involving the loss of a digit (expressed as character state A). A subsequent branching event then produced taxa 1 and 2, which inherited that derived character. The lineage leading to taxon 3, however, retained the primitive condition of five digits (character state a). The presence of the shared derived character, A, is called a synapomorphy, and identifies taxa 1 and 2 as being more closely related to each other than either is to taxon 3. Distinguishing between the primitive and derived conditions of a character within a group of taxa (the ingroup) is usually accomplished by comparisons to groups postulated to have more distant relationships (outgroups). Character states that are present in ingroups but not outgroups are postulated to be derived. Systematists have developed computer programs that attempt to identify shared derived characters (synapomorphies) and, at the same time, use them to construct the best phylogenetic trees for the available data.

Knowledge of phylogenetic relationships provides the basis for classifying organisms. A major task of the science of systematics

is to search for monophyletic groups. Some groups, such as birds and mammals, are monophyletic; that is, phylogenetic analysis suggests they are all more closely related to each other than to other vertebrates. However, other traditional groups, such as reptiles, have been demonstrated to be nonmonophyletic (some so-called reptiles, such as dinosaurs and their relatives, are more closely related to birds than they are to other reptiles such as snakes). Classifications based on monophyletic groups are termed natural classifications. Phylogenies are also essential for understanding the distributional history, or biogeography, of organisms. Knowing how organisms are related to one another helps the biogeographer to decipher relationships among areas and to reconstruct the spatial histories of groups and their biotas. See ANIMAL EVOLUTION; ANIMAL SYSTEMATICS; BIOGEOGRAPHY; TAXONOMIC CATEGORIES. [J.Cr.]

**Phymosomatoida** An order of regular sea urchins, class Echinoidea, characterized by imperforate tubercles, complex ambulacral compounding in which one or more elements are occluded from the perradial suture, and a stirodont lantern with unfused epiphyses. They comprise two families. They first appeared in the Lower Jurassic and are probably paraphyletic, since they include the ancestors of camarodonts. The two extant genera are each known from a single species: *Glyptocidaris*, from a depth of 30–490 ft (10–150 m) around northern Japan, and *Stomechinus*, a common inhabitant of rocky shores around the Indo-West Pacific. They are epifaunal grazers. See ECHINODERMATA; ECHINOIDEA. [A.Sm.]

**Physical anthropology** The subfield of anthropology that deals with human and nonhuman primate evolution, the biological bases of human behavior, and human biological variability and its significance. Some refer to the field as biological anthropology in order to signal the close links with other biological sciences. The term physical anthropology is largely an American and British invention; in most European and many other countries physical anthropologists are the only anthropologists, while persons who study behavioral aspects of the human condition are known as archeologists, ethnologists, linguists, or prehistorians.

**Paleoanthropology.** Paleoanthropology is the multidisciplinary study of human evolution as evidenced by fossils, artifacts, and their geological and burial site contexts. Physical anthropologists organize expeditions and direct excavations that lead to discoveries of fossil Hominidae, and then engage in the painstaking repair and reconstruction of specimens, their anatomical description, comparison with other specimens, and placement in hominid phylogeny. See FOSSIL HUMANS.

Morphological paleoanthropologists must have detailed knowledge of human and other primate anatomy and the principles of taxonomy in order to restore and interpret their discoveries. In addition to traditional anatomical descriptions and measurements, it is requisite that the variations in samples be presented and, when possible, be tested for statistical significance. Because of the fragmentary nature of many fossils, one of the most difficult problems is to decide whether the new discoveries belong with previously described species or represent new undescribed ones.

**Paleoprimatology.** Physical anthropologists also look to nonhuman primates for clues to human physical history and status as mammals, and for analogies to the behavior and cognitive abilities of human ancestors. Like paleoanthropologists, paleoprimatologists employ methods of other paleobiologists to collect, describe, and interpret fossil specimens phylogenetically and functionally. Contextual information, including the manner in which specimens were deposited and their possible alteration over time, is vital. See FOSSIL PRIMATES.

**Comparative primate morphology.** Recent primates, including humans, are the current end products of evolution. Anatomical studies of modern primates are essential for re-

constructing the morphologies of fossil forms and for revealing their singularity. Carefully controlled comparative studies on extant primates hold the greatest promise for modeling the functional morphology, physiology, and habitat preferences of extinct forms. Since 1970, advanced techniques and concepts from rehabilitation medicine, orthopedics, orthodontics, radiology, and neurology have been used to establish a truly functional morphology of the primates.

**Molecular anthropology.** The explosion of molecular biology that followed the cracking of the genetic code attracted physical anthropologists who wished to test hypotheses about the propinquity of humans with the apes, and the relationships of other primates to one another and to other creatures. Some have endeavored to find “molecular clocks” that could tell when species diverged from one another. Assuming that genetic changes occur at fairly steady rates and given a few well-dated fossils, the time when the living species may have branched from one another can be calculated. See MOLECULAR ANTHROPOLOGY.

**Primate behavior and ecology.** Although firmly rooted in comparative psychology, behavioral primatology has also become a major section of physical anthropology; anthropologists have contributed mainly through field studies. An original goal of primate field studies by anthropologists was to find predictable relationships between specific habitats and the patterns of sociality of the primates that inhabit them. Because of their close genetic relationships to humans, chimpanzees have emerged as the most popular model for early hominid sociality. But theorists emphasizing different aspects of their behavior arrive at markedly different models for early hominid behavior.

**Human variation.** The term human variation is rapidly replacing its historical predecessor “race” in anthropology because the latter carries so much negative connotation. Many scientists believe that the concept of race should be abandoned. Instead, researchers should simply record the gene frequencies and biological traits of human populations that are otherwise identified only by their geographic localities. This genotypic and phenotypic information would be interpreted in terms of historical and proximate selective forces in each environment. See HUMAN GENETICS; HUMAN VARIATION.

**Skeletal biology.** Some skeletal biologists have adopted functional approaches from primatological anthropology, and have been discerning the genetic determinants of nonmetric (discrete) and measurable (continuous) traits that would allow them to document the local history of burial populations in an area.

**Paleopathology.** Human bones and teeth sometimes reflect diseases and mechanical trauma during the lifetime of an individual. Rehydrated soft tissues of mummies may show evidence of parasitic infestations and lesions, such as those from cancer and tuberculosis. Such studies allow reasonable correlations of disease features with demography, ecology, diet, and social factors. See PALEOPATHOLOGY.

**Growth, physique, and aging.** The field of growth studies has developed robustly as part of physical anthropology since the 1940s. Standards for the appearance and ossification of bones and for sexual maturation have been established so that congenital, nutritional, and other environmental effects can be detected and often corrected clinically in children and adolescents. It has been established from global nutritional surveys that small adult size is correlated with dietary insufficiency. Since 1975, physical anthropologists have begun to apply anthropometric and microscopic techniques to the study of aging in an effort to understand why some people have greater longevity. See AGING; NUTRITION.

**Nutritional anthropology.** Refined chemical assays promise to reveal past diets from hominid skeletal remains. Hence paleonutrition has emerged as a special focus for technical research. Trace elements, such as strontium (Sr), sodium (Na), zinc (Zn), and calcium (Ca), may indicate the nutrients that were incorporated in bones, so that classes of food items can be inferred. The kind of carbon ( $C^{12}$ – $C^{13}$  ratios) in bones may indicate the types of plants that were eaten. This is an important tool for following

the spread of maize agriculture in the New World. Protein and vitamin D deficiencies are indicated by flatness of the skull base relative to the skulls of better-nourished people.

**Blood group genetics and disease.** Many human features such as stature, head shape, epidermal pigmentation, and fingerprints are caused by undetermined multifactorial genetic systems whose phenotypic expression is commonly affected by environmental factors. In contrast, the genetics of blood group systems (such as ABO, MNS, and Rh) are based on single gene loci and are well understood. See BLOOD GROUPS; FINGERPRINT; POPULATION GENETICS.

**Human adaptability and ecology.** *Homo sapiens* is one of the most versatile species on Earth. The invention and ramification of culture has permitted people to survive on impoverished islands and in climatic extremes of high altitude, deserts, and polar regions. In addition to many clever technological and social conventions, people show physiological and ontogenetic characteristics that enhance their survival and ability to work in harsh environments. The extent to which these features are genetically determined is still largely unknown. See HUMAN ECOLOGY.

**Forensic anthropology.** Forensic anthropology is growing quickly, as anthropologists are called as expert witnesses regarding not only classic sorts of criminal evidence (fingerprints, blood types, and skeletal remains) but also grisly exhibits such as bloody footprints and bite marks on murder victims. In criminal cases, forensic anthropologists operate best if contextual evidence is preserved, particularly when the victims were hidden in graves. Here the techniques of field archeology can be as important as those of physical anthropology. See ANTHROPOLOGY; ARCHEOLOGY; FORENSIC ANTHROPOLOGY. [R.H.Tu.]

**Physical chemistry** The branch of chemistry that deals with the interpretation of chemical phenomena and properties in terms of the underlying physical processes, and with the development of techniques for their investigation. The term chemical physics is often employed to denote a branch of physical chemistry where the emphasis is on the interpretation and analysis of the physical properties of individual molecules and bulk systems, instead of their reactions. Theoretical chemistry is another major branch, where the emphasis is on the calculation of the properties of molecules and systems, and which used the techniques of quantum mechanics and statistical thermodynamics. It is convenient to regard physical chemistry as dealing with three aspects of matter: its equilibrium properties, structure, and ability to change.

**Equilibrium properties.** The study of matter in a state of equilibrium constitutes the field of chemical thermodynamics. In particular, chemical thermodynamics provides a technique for discussing the response of a system to a change in the external conditions (such as the shift in the boiling and freezing point of either a pure substance or a mixture when the applied pressure is changed, or when the composition of the mixture is modified), and for rationalizing the energy changes that occur in the course of a chemical reaction. The branch of thermodynamics dealing with the latter is called thermochemistry. Chemical thermodynamics also provides a framework for the determination of the maximum amount of work that may be generated by a system undergoing a specified change, and it therefore provides a way of establishing bounds for the efficiencies of a variety of devices, including engines, refrigerators, and electrochemical cells. Thermodynamics is used in chemistry to assess the position of equilibrium of a chemical reaction (that is, how far it will proceed), and to determine what conditions are necessary in order to optimize the yield of a particular product. The branch of chemical thermodynamics dealing with ionic reactions occurring in the presence of electrodes constitutes the field of equilibrium electrochemistry. See CHEMICAL EQUILIBRIUM; CHEMICAL THERMODYNAMICS; ELECTROCHEMISTRY; ENTHALPY; ENTROPY; FREE ENERGY; THERMOCHEMISTRY.

**Structure.** The principal role of quantum mechanics in chemistry is in the discussion of atomic and molecular structure, and in the interpretation of spectroscopic data. In the branch of physical chemistry known as computational quantum chemistry, interest centers on the numerical solution of the Schrödinger equation in order to obtain wave functions and geometries of molecules. Computational quantum chemistry is so developed that it is capable of being used to map the changes in the structures of molecules while they are in the course of reaction, when atoms and groups of atoms are being transferred from one molecule to another. See QUANTUM CHEMISTRY; SCHRÖDINGER'S WAVE EQUATION.

Spectroscopic techniques are used not only to identify molecules present in a sample, but also to determine their shape, size, and electron distribution. The techniques fall into four categories: absorption spectroscopy, emission spectroscopy, Raman spectroscopy, and resonance techniques. See ELECTRON PARAMAGNETIC RESONANCE (EPR) SPECTROSCOPY; ELECTRON SPECTROSCOPY; MOLECULAR STRUCTURE AND SPECTRA; MÖSSBAUER EFFECT; NUCLEAR MAGNETIC RESONANCE (NMR); PHOTOCHEMISTRY; RAMAN EFFECT; SPECTROSCOPY.

Techniques for the investigation of molecular structure based on diffraction depend on the observation of the direction through which radiation and particles are scattered when they impinge on a sample. Other techniques for investigating structure include the electric and magnetic properties of molecules, in particular, the determination of electric polarizabilities and dipole moments, magnetic properties, and the properties based on optical birefringence, such as optical activity and the Faraday effect. See X-RAY DIFFRACTION.

Structural properties and thermodynamic properties are brought together by statistical thermodynamics. This major theoretical procedure gives a way of predicting the thermodynamic properties of assemblies of molecules in terms of their individual energy levels.

**Physical and chemical change.** The third major branch of physical chemistry is concerned with change: physical change and chemical change. In particular, it is concerned with the rate of change. Physical change includes the diffusion of one substance into another, or the migration of ions in an electrode solution. The application of thermodynamics to change in general constitutes the field of nonequilibrium thermodynamics. See GAS; TRANSPORT PROCESSES.

Chemical change may be studied at a variety of levels. Empirical chemical kinetics is the study of reactions in order to determine how their rates depend on the concentrations of the participants in the reaction and on the conditions, mainly the temperature. Investigation of the time dependence of reactions yields a detailed picture of the sequence of molecular transformations involved in a complex chemical reaction. See CHEMICAL DYNAMICS; SHOCK TUBE; ULTRAFAST MOLECULAR PROCESSES.

An important extension of chemical kinetics is to the reactions that occur on surfaces; these are the processes involved in heterogeneous catalysis. A special application of surface chemistry is to the stability of colloidal suspensions of species in fluids, and another is to the processes that occur at the interface between an electrode and the solution in which it is immersed. See ADSORPTION; COLLOID; HETEROGENEOUS CATALYSIS; SURFACE PHYSICS. [P.W.A.]

**Physical geography** The study of the Earth's surface features and associated processes. Physical geography aims to explain the geographic patterns of climate, vegetation, soils, hydrology, and landforms, and the physical environments that result from their interactions. Physical geography merges with human geography to provide a synthesis of the complex interactions between nature and society.

The basic content of physical geography comprises a number of areas of specialization. Climatology, the scientific

study of climates, concerns the total complex of weather conditions at a given location over an extended time period; it deals not only with average conditions but with extremes and variations. Geomorphology is the interpretive description and explanation of landforms and the fluvial, glacial, coastal, and eolian process that operate on them. The forms, processes, and patterns within the biosphere, including vegetation and animal distributions, are studied as biogeography. With strong ties to fluvial geomorphology, geographic hydrology concerns the scientific study of water from the aspects of distribution, movement, and utilization. Soil geography, with emphasis on the origin, characteristics, classification, and utilization potential of soils, provides an area of specialization with links to land use. Ultimately, the physical geography of a region is understood through an integration of the multiple aspects. [J.E.O.]

**Physical law** A term that designates four different concepts: (1) objective pattern (or natural regularity), (2) formula purporting to represent an objective pattern, (3) law-based rule (or uniform procedure), and (4) principle concerning any of the preceding.

For example, Newton's second law of motion,  $ma = F$ , is a law of type 2. It represents, to a good approximation, the actual behavior (law of type 1) of medium-size particles moving slowly relative to the speed of light. Alternative laws of motion, such as the relativistic and quantum-mechanical ones, are different laws of type 2 representing the same objective pattern or law of type 1 to even better approximations. One of the rules (laws of type 3) associated with Newton's second law of motion is: In order to set in motion a stationary particle, exert a force on it. Another is: In order to stop a moving particle, exert on it a force in the opposite direction. An example of a law of type 4 is: Newton's laws of motion are invariant under a Galileo transformation. See NEWTON'S LAWS OF MOTION.

A physical law of type 1, or objective pattern, is a constant relation among two or more properties of a physical entity. In principle, any such pattern can be conceptualized in different ways, that is, as alternative laws of type 2. The history of theoretical physics is to a large extent a sequence of laws of type 2. Every one of these is hoped to constitute a more accurate representation of the corresponding objective pattern or law of type 1, which is assumed to be constant and, in particular, untouched by human efforts to grasp it. Likewise, the history of engineering is to some extent a sequence of laws of type 3, or law-based rules of action, of which there are least two for every law of type 2. As for the laws of type 4, or laws of laws, they are of two kinds: scientific and philosophical. The general covariance principle is of the first kind, whereas the hypothesis that all events are lawful is a philosophical thesis. Unlike the former, whose truth can be checked, the principle of lawfulness is irrefutable. See ENGINEERING; THEORETICAL PHYSICS.

Not all formulas are called physical laws. For example, the regularities found by curve fitting are called empirical formulas. In physics a formula is called a law if and only if it meets the following conditions: it is part of a theory, and it has been satisfactorily confirmed by measurement or experiment at least within a certain domain (for example, for small mass densities or high field intensities). Thus, the basic assumptions of all the standard physical theories are laws, and so are their logical consequences. In particular, the usual variational principles, such as Hamilton's, are basic laws. However, the equations of motion and field equations entailed by such principles are derived laws (theorems); so are the conservation laws entailed by the equations of motion and field equations. However, the distinction between basic and derived laws is contextual: what is a principle in one theory may be a theorem in another. For example, Newton's second law of motion is a theorem in analytical dynamics, and the first principle of thermodynamics is a theorem of statistical mechanics. See CONSERVATION LAWS (PHYSICS); CURVE FITTING; HAMILTON'S PRINCIPLE; PHYSICAL THEORY; SCIENTIFIC METHODS; STATISTICAL

MECHANICS; THERMODYNAMIC PRINCIPLES; VARIATIONAL METHODS (PHYSICS). [M.Bun.]

**Physical measurement** Quantitative information on physical conditions, properties, or relations essential for coordination of activities, efficiency of communication, and understanding of the nature of things in science and engineering and in much of everyday life. Time, distance, mass, temperature, force, power, and all other physical quantities (or parameters or variables), as well as the properties of matter, materials, and devices, must be described and measured in terms which have the same meaning for everyone. The measuring device or instrument is calibrated (that is, the functional relationship between its indication and the magnitude of the measured quantity is determined) by direct or indirect comparison with a standard which embodies, possesses, or generates a fixed or reproducible magnitude of the physical quantity which is taken as the unit or some multiple or fraction of the unit. Any measured quantity may thus be expressed by a number (the magnitude ratio) and the name of the unit, for example, a length of 1.54 meters. The general area of scientific activity relating to standards and units and the accuracy of measurement is called metrology. See UNITS OF MEASUREMENT.

**Metric system.** The basic unit of length in the decimal metric system was defined as one ten-millionth of the Earth's polar quadrant (as determined from latitude surveys), and is termed the meter. The basic unit for mass was defined as the mass of a cubic decimeter of water, to be called the kilogram.

The United States has adopted the Metric Conversion Act, declaring that "the policy of the U.S. shall be to coordinate and plan the increasing use of the metric system in the United States," and established the U.S. Metric Board "to coordinate the voluntary conversion to the metric system." However, English units have become almost universal in some worldwide industries—for example, dimensions of oil-drilling equipment, or altitude measurement in aviation. Thus it is likely that there will always be exceptions to uniformity, requiring special knowledge of special units for at least some people even as the whole world "goes metric" in principle.

**International System of Units (SI).** At present the International System of Units (abbreviated SI, from the French *Système International d'Unités*) is constructed from seven base units for independent quantities (Table 1). Units for all other quantities are derived from these seven units. In Table 2 are listed 22 SI derived units with special names. These units are derived from the base units in a coherent manner, which means they are expressed as products and quotients of the seven base units without numerical factors. All other SI derived units are similarly derived in a coherent manner from the 29 base and special-name SI units. For use with the SI units, there is a set of 20 prefixes (Table 3) to form multiples and submultiples of these units. For mass, the prefixes are to be applied to the gram instead of to the SI unit, the kilogram. See DIMENSIONAL ANALYSIS.

The SI units together with the SI prefixes provide a logical and interconnected framework for measurements in science, industry, and commerce.

In some cases, quantities are commonly expressed in terms of

**Table 1. SI base units**

Quantity*	Unit name	Symbol
Length	meter	m
Mass	kilogram	kg
Time	second	s
Electric current	ampere	A
Thermodynamic temperature	kelvin	K
Amount of substance	mole	mol
Luminous intensity	candela	cd

\*Quantity here and in Table 2 means a measurable attribute.



Table 2. SI derived units with special names

Quantity	Unit name	Symbol	Expression in terms of other units	Expression in terms of SI base units
Plane angle	radian	rad		$m \cdot m^{-1} = 1$
Solid angle	steradian	sr		$m^2 \cdot m^{-2} = 1$
Frequency	hertz	Hz		$s^{-1}$
Force	newton	N		$m \cdot kg \cdot s^{-2}$
Pressure, stress	pascal	Pa	$N/m^2$	$m^{-1} \cdot kg \cdot s^{-2}$
Energy, work, quantity of heat	joule	J	$N \cdot m$	$m^2 \cdot kg \cdot s^{-2}$
Power, radiant flux	watt	W	$J/s$	$m^2 \cdot kg \cdot s^{-3}$
Quantity of electricity, electric charge	coulomb	C	$A \cdot s$	$s \cdot A$
Electric potential difference, electromotive force, voltage	volt	V	$W/A$	$m^2 \cdot kg \cdot s^{-3} \cdot A^{-1}$
Capacitance	farad	F	$C/V$	$m^{-2} \cdot kg^{-1} \cdot s^4 \cdot A^2$
Electric resistance	ohm	$\Omega$	$V/A$	$m^2 \cdot kg \cdot s^{-3} \cdot A^{-2}$
Electric conductance	siemens	S	$A/V$	$m^{-2} \cdot kg^{-1} \cdot s^3 \cdot A^2$
Magnetic flux	weber	Wb	$V \cdot s$	$m^2 \cdot kg \cdot s^{-2} \cdot A^{-1}$
Magnetic flux density	tesla	T	$Wb/m^2$	$kg \cdot s^{-2} \cdot A^{-1}$
Inductance	henry	H	$Wb/A$	$m^2 \cdot kg \cdot s^{-2} \cdot A^{-2}$
Celsius temperature	degree Celsius	$^{\circ}C$		K
Luminous flux	lumen	lm	$cd \cdot sr$	$m^2 \cdot m^{-2} \cdot cd = cd$
Illuminance	lux	lx	$lm/m^2$	$m^2 \cdot m^{-4} \cdot cd = m^{-2} \cdot cd$
Activity (of a radionuclide)	becquerel	Bq		$s^{-1}$
Absorbed dose, specific energy imparted, kerma	gray	Gy	$J/kg$	$m^2 \cdot s^{-2}$
Dose equivalent	sievert	Sv	$J/kg$	$m^2 \cdot s^{-2}$
Catalytic activity	katal	kat		$s^{-1} \cdot mol$

fundamental constants of nature, and use of these constants or "natural units" is acceptable. See FUNDAMENTAL CONSTANTS.

Typical examples of natural units, with their symbols, are:

elementary charge	$e$
electron mass	$m_e$
proton mass	$m_p$
Bohr radius	$a_0$
electron radius	$r_e$
Compton wavelength of electron	$\lambda_c$
Bohr magneton	$\mu_B$
nuclear magneton	$\mu_N$
speed of light	$c$
Planck constant	$h$

Certain units which are not part of the SI are used so widely that it is impractical to abandon them. The units that are accepted for continued use with the International System are listed in Table 4. It is likewise necessary to recognize, outside the International System, the following units which are used in specialized fields:

electronvolt	eV
unified atomic mass unit	u
astronomical unit	AU
parsec	pc

Logarithmic measures such as pH, dB (decibel), and Np (neper)

Table 3. SI prefixes

Factor	Prefix	Symbol	Factor	Prefix	Symbol
$10^{24}$	yotta	Y	$10^{-1}$	deci	d
$10^{21}$	zetta	Z	$10^{-2}$	centi	c
$10^{18}$	exa	E	$10^{-3}$	milli	m
$10^{15}$	peta	P	$10^{-6}$	micro	$\mu$
$10^{12}$	tera	T	$10^{-9}$	nano	n
$10^9$	giga	G	$10^{-12}$	pico	p
$10^6$	mega	M	$10^{-15}$	femto	f
$10^3$	kilo	k	$10^{-18}$	atto	a
$10^2$	hecto	h	$10^{-21}$	zepto	z
$10^1$	deka	da	$10^{-24}$	yocto	y

are acceptable. See ASTRONOMICAL UNIT; ATOMIC MASS UNIT; DECIBEL; ELECTRONVOLT; NEPER; PARSEC; pH.

The internationally accepted definitions for the seven base units follow:

**Mass.** The kilogram (kg) is equal to the mass of the International Prototype Kilogram. The International Prototype is a platinum-iridium cylinder preserved at the International Bureau of Weights and Measures at Sèvres, France.

Mass is the only one of the base quantities for which the standard is an arbitrarily defined object. No basic property of matter involving mass can be measured with more precision than is possible in comparing kilogram masses by weighing, about 1 part in  $10^8$ . See BALANCE; MASS; WEIGHT MEASUREMENT. [W.A.Wi.]

**Length.** The meter is defined in terms of time and the speed of light: "The meter is the length of the path traveled by light in a vacuum during a time interval of  $1/299\,792\,458$  of a second." This definition defines the speed of light to be exactly  $299\,792\,458$  m/s and defines the meter in terms of the most accurately known quantity, the second. See LIGHT.

The most accurate method of realizing the meter is by means of an interferometrically measured distance by fringe counting in which each vacuum fringe is a half wavelength from the next one. This wavelength,  $\lambda$ , is obtained from the measured frequency,  $f$ ,

Table 4. Units in use with the International System

Name	Symbol	Value in SI unit
Minute	min	1 min = 60 s
Hour	h	1 h = 60 min = 3600 s
Day	d	1 d = 24 h = 86,400 s
Degree	$^{\circ}$	$1^{\circ} = (\pi/180)$ rad
Minute	'	$1' = (1/60)^{\circ} = (\pi/10,800)$ rad
Second	"	$1'' = (1/60)' = (\pi/648,000)$ rad
Liter	L*	1 L = 1 dm <sup>3</sup> = $10^{-3}$ m <sup>3</sup>
Metric ton	t	1 t = $10^3$ kg
Neper <sup>d</sup>	Np	1 Np = 1
Bel <sup>b</sup>	B	1 B = (1/2) ln 10 (Np)

\*An alternate symbol for liter is "l." Since "l" can be easily confused with the numeral 1, the symbol "L" is recommended for United States use.

<sup>d</sup>The neper is used to express values of various logarithmic quantities. Natural logarithms are used to obtain the numerical values of quantities expressed in nepers. The neper is coherent with the SI, but is not yet adopted as an SI unit.

<sup>b</sup>The bel is used to express values of various logarithmic quantities. Logarithms to base ten are used to obtain the numerical values of quantities expressed in bels.

using the relation  $\lambda = c/f$ , where  $c$  is the value of the speed of light in vacuum. To this end, major standards laboratories have measured the frequencies of several lasers stabilized to narrow molecular absorptions in the visible and near-infrared spectral regions. These stabilized lasers now serve as standards of length. See INTERFEROMETRY; WAVELENGTH STANDARDS. [D.A.J.]

**Time interval.** The second (s) is the duration of 9 192 631 770 periods of the radiation corresponding to the transition between the two hyperfine levels of the ground state of the cesium-133 atom. In the best equipments the stability and accuracy of the cesium frequency generator correspond to an uncertainty of a few parts in  $10^{15}$ .

The second was long defined, for physical measurements as well as for civil affairs, as 1/86,400 of the time required for an average complete rotation of the Earth on its axis with respect to the Sun. Because of the slight slowing of the Earth's rotation rate, now averaging about 1 second per year (that is, 3 parts in  $10^8$ ) but with erratic and unexplained fluctuations, the universal second thus defined is not a constant. A time scale called Coordinated Universal Time (UTC) recommended by the General Conference of Weights and Measures (CGPM) in 1975 is defined in such a manner that it differs from international atomic time (TAI) by an exact whole number of seconds. This difference is adjusted occasionally by the use of a positive or negative leap second at the end of certain months to keep UTC in agreement with the time defined by the rotation of the Earth with an approximation better than 9/10 second. See ATOMIC CLOCK; ATOMIC TIME; DYNAMICAL TIME; EARTH ROTATION AND ORBITAL MOTION; FREQUENCY MEASUREMENT; TIME. [W.A.Wi.]

**Temperature.** The kelvin (K), the unit of thermodynamic temperature, is the fraction 1/273.16 of the thermodynamic temperature of the triple point of water. The unit kelvin and its symbol K should also be used to express an interval or differences of temperature.

To provide convenient and adequately accurate means for practical realization and measurement of temperature, the International Temperature Scale is used, based on the assigned values of the temperatures of a number of reproducible equilibrium states (defining fixed points), on standard instruments calibrated at those temperatures, and on vapor-pressure temperature relationships. Interpolation between the fixed-point temperatures is provided by formulas used to establish the relation between indications of the standard instruments and values of International Temperature. An extensive revision, which came into effect in 1990, is called the ITS-90. See TEMPERATURE; TEMPERATURE MEASUREMENT. [B.W.M.]

**Electric current.** The ampere (A) is that constant current which, if maintained in two straight parallel conductors of infinite length and of negligible circular sections, and placed 1 meter apart in a vacuum, would produce between these conductors a force equal to  $2 \times 10^{-7}$  newton per meter of length. See ELECTRICAL UNITS AND STANDARDS.

**Luminous intensity.** The CGPM, in 1979, redefined the base SI unit candela as the luminous intensity, in a given direction, of a source that emits monochromatic radiation of frequency  $540 \times 10^{12}$  hertz and of which the radiant intensity in that direction is 1/683 watt per steradian. See ILLUMINATION; LIGHT; LUMINOUS EFFICACY; LUMINOUS EFFICIENCY; LUMINOUS INTENSITY; PHOTOMETRY; RADIOMETRY.

**Amount of substance.** The mole is the amount of substance of a system which contains as many elementary entities as there are atoms in 0.012 kilogram of carbon-12. When the mole is used, the elementary entities must be specified, and may be atoms, molecules, ions, electrons, other particles, or specified groups of such particles. See GRAM-MOLECULAR WEIGHT; MOLE (CHEMISTRY). [W.A.Wi.]

**Physical optics** The study of the interaction of electromagnetic waves in the optical range with material systems. The optical range of wavelengths may be taken as the range from about 1 nanometer to about 1 millimeter.

The explanation of the absorption, reflection, scattering, polarization, and dispersion of light by a material medium in terms of the properties of the atoms and molecules making up the medium is the objective of physical optics. In the course of seeking this objective, physicists have found that optical investigations are powerful methods of determining the structures of atoms and molecules and of large systems composed thereof. See ABSORPTION; ATOMIC STRUCTURE AND SPECTRA; CRYSTAL OPTICS; DIFFRACTION; DISPERSION (RADIATION); ELECTROMAGNETIC RADIATION; ELECTROOPTICS; FARADAY EFFECT; FLUORESCENCE; INTERFERENCE OF WAVES; LASER; LIGHT; MAGNETOOPTICS; MOLECULAR STRUCTURE AND SPECTRA; POLARIZED LIGHT; REFLECTION OF ELECTROMAGNETIC RADIATION; REFRACTION OF WAVES; SCATTERING OF ELECTROMAGNETIC RADIATION; SPECTROSCOPY. [R.C.L.]

**Physical organic chemistry** A branch of science concerned with the scope and limitations of the various rules, effects, and generalizations in use in organic chemistry by means of physical and mathematical methods. It includes, but is not limited to, the dynamics and energetics of organic chemical transformations, transient intermediates in these reactions, rate comparisons between families of reactions, dynamic stereochemistry, conservation of orbital symmetry, the least-motion principle, the isomer number for a given elemental composition, conformational analysis, nonexistent compounds, aromaticity, tautomerism, strain and steric hindrance, and the double-bond rule. Spectroscopy is the main tool employed, with nuclear magnetic resonance being the most widely used spectroscopic technique. With the advent of modern fast computers, computational chemistry has also become an important tool. See NUCLEAR MAGNETIC RESONANCE (NMR); SPECTROSCOPY.

Physical organic chemistry is traditionally distinguished from, yet totally intertwined with, synthetic organic chemistry, which deals with the question of how to obtain desired products from available compounds. This distinction can be illustrated with a diagram (see illustration) showing how the energy might vary during a chemical reaction in which the reactant R yields a product P ( $R \rightarrow P$ ). Whereas the synthetic organic chemist will be interested primarily in the practical problem of how to convert R into P, the physical organic chemist studies the curve or curves connecting R and P as well as the structure and physical properties at all extrema, including R and P. However, the demarcation between synthetic organic chemistry and physical organic chemistry is not sharp. Physical organic chemists have contributed greatly to the understanding of the chemistry of hydrocarbons and their derivatives and have enhanced the repertoire of the synthetic organic chemists. In turn, synthetic organic chemists have made possible the construction of the custom-made, often intricate molecules that physical organic chemists use for their studies. The efforts of both groups, moreover, have made possible the birth of such new fields as molecular biochemistry and computational chemistry. See COMPUTATIONAL CHEMISTRY; MOLECULAR BIOLOGY.

**Chemical reaction mechanisms.** The diagram shown in the illustration is also useful in discussions of the dynamics of chemical reactions. It is an attempt to portray how the atoms in the reactant molecule R may move in space to their final positions in the product molecule P, and how the potential energy of the system would vary as a function of these positions. A complete correlation would be multidimensional; what is normally shown is a cross section in which the maximum potential energy is in fact a minimum (saddle point). While an essentially infinite number of pathways between R and P can be imagined and followed, the vast majority of the molecules will in practice use the one that makes the least demand on energy to reach the next maximum; this pathway is known as the reaction mechanism. The maxima (T terms in the illustration) are known as transition states, and the minima (I terms in the illustration) as intermediates.

If a reaction has a single transition state (and, hence, no intermediate), it is known as concerted; alternatively, it is step-wise. A stepwise reaction is simply a succession of concerted steps

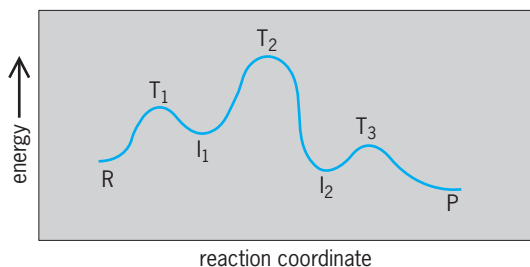

Energy profile of an organic reaction  $R \rightarrow P$ . T terms indicate transition states and I terms indicate intermediates.

in which the intermediates are not isolated. See FREE RADICAL; ORGANIC REACTION MECHANISM; REACTIVE INTERMEDIATES; PHOTOCHEMISTRY.

**Chemical kinetics.** The most important route to quantitative information about a reaction is the study of its kinetics. This must begin with an experimental determination of the rate law: the expression that shows how the rate of formation of product  $d[P]/dt$  (or loss of reactant:  $-d[R]/dt$ ) depends on the concentration of all species involved in the reaction other than the solvent. The differential might be found to equal  $k[R_1]$ ,  $k[R_1][R_2]$ ,  $k[R_1]^2$ , and so on;  $k$  is known as the rate constant, and the reaction is described as first-order, second-order, and so forth, depending on the total number of concentration terms. One important feature is that the reaction order equals the sum of all molecules that have participated in the formation of the transition state ( $T_2$  in the illustration). Thus, for a reaction to be concerted, it is necessary that the order equal the sum of all reactant molecules involved in the stoichiometry. See CATALYSIS; CHEMICAL DYNAMICS; PERICYCLIC REACTION.

**Stereochemistry.** This is also a powerful tool in physical organic chemistry. Experimental work has demonstrated that when a chiral compound such as  $(-)\text{HCR}_1\text{R}_2\text{X}$  is converted into optically active  $\text{HCR}_1\text{R}_2\text{Y}$  by direct displacement with Y, the product obtained has an optical rotation that is opposite to that exhibited by the same material if it is produced in two steps, via initial displacement by A to give intermediate  $\text{HCR}_1\text{R}_2\text{A}$  as shown in the following reaction scheme. This result demonstrates that

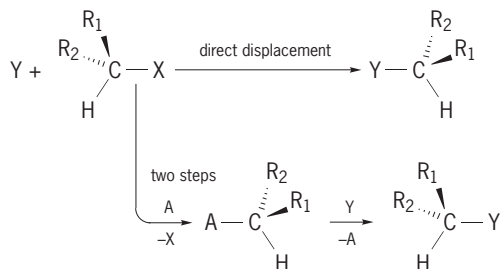

displacement reactions occur with inversion; the reagent approaches in front, and the leaving group departs in the back. See OPTICAL ACTIVITY; STEREOCHEMISTRY.

**Isomers.** The isomer number has perhaps been the most important organizing principle in organic chemistry since its inception. Simply put, it means that for every elemental composition and molecular mass the isomer number can be predicted by writing all possible sequences of the atoms present, obeying the valence numbers of the atoms: four for carbon, three for nitrogen, two for oxygen, one for hydrogen and the halogens, and so forth. Once reliable atomic weights became available so that elemental compositions could be reported with confidence, this simple rule proved remarkably successful. See CHEMICAL BONDING; ORGANIC CHEMISTRY; VALENCE.

The need to specify molecular mass has proved more troublesome: it requires a definition of the concept of a molecule. Such definitions usually refer to covalent bonds as the entities that hold the atoms together, to rule out ionic species such as sodium chloride as candidates.

Among the extra compounds, none have affected organic chemistry more drastically than the stereoisomers. It turns out that for all but the simplest compounds a given sequence of the atoms may represent two, more than two, or even many more isomers. See CONFORMATIONAL ANALYSIS; MOLECULAR ISOMERISM.

Many compounds that are considered to be nonexistent, even though they are allowed by the simple rules of isomer numbers, in fact are transient intermediates in various reactions. Sometimes they can be detected spectroscopically, but cannot be isolated. There are instances in which neither of two isomers can be isolated, but mixtures of the two can. In other words, the barrier between the two is low, and the equilibrium constant is close to unity. An example is acetoacetic ester, which normally contains about 15% of the enol isomer. Such isomers are known as tautomers. See TAUTOMERISM. [W.J.LeN.]

**Physical science** The fields of inquiry to which the general designation science may be appropriately applied are broadly divided into social science and natural science. The latter is further subdivided into biology and physical science. Physical science is generally considered to include astronomy, chemistry, geology, mineralogy, meteorology, and physics. These overlap more or less, as illustrated by astrophysics, chemical physics, physical chemistry, and geophysics. There is overlap, likewise, between the physical and biological sciences, as seen in biochemistry, biophysics, virology, and the close relation between geology and paleontology. The boundaries implied in all such classifications are artificial and consist of regions where one field shades into another. See ASTRONOMY; BIOLOGY; CHEMISTRY; GEOLOGY; METEOROLOGY; MINERALOGY; PHYSICS; SCIENCE. [J.H.Hi.]

**Physical theory** A physical theory usually involves the attempt to explain a certain class of physical phenomena by deducing them as necessary consequences of other phenomena regarded as more primitive and less in need of explanation. The value of a theory depends on both the success with which it coordinates a wide range of presently known facts and its fertility in suggesting places to look for presently unknown phenomena. [P.W.Br./G.Ho.]

**Physics** Formerly called natural philosophy, physics is concerned with those aspects of nature which can be understood in a fundamental way in terms of elementary principles and laws. In the course of time, various specialized sciences broke away from physics to form autonomous fields of investigation. In this process physics retained its original aim of understanding the structure of the natural world and explaining natural phenomena.

The most basic parts of physics are mechanics and field theory. Mechanics is concerned with the motion of particles or bodies under the action of given forces. The physics of fields is concerned with the origin, nature, and properties of gravitational, electromagnetic, nuclear, and other force fields. Taken together, mechanics and field theory constitute the most fundamental approach to an understanding of natural phenomena which science offers. The ultimate aim is to understand all natural phenomena in these terms. See CLASSICAL FIELD THEORY; MECHANICS; QUANTUM FIELD THEORY.

The older, or classical, divisions of physics were based on certain general classes of natural phenomena to which the methods of physics had been found particularly applicable. The divisions are all still current, but many of them tend more and more to designate branches of applied physics or technology, and less and less inherent divisions in physics itself. The divisions or branches, of modern physics are made in accordance with particular types of structures in nature with which each branch is concerned.

In every area physics is characterized not so much by its subject-matter content as by the precision and depth of understanding which it seeks. The aim of physics is the construction of

a unified theoretical scheme in mathematical terms whose structure and behavior duplicates that of the whole natural world in the most comprehensive manner possible. Where other sciences are content to describe and relate phenomena in terms of restricted concepts peculiar to their own disciplines, physics always seeks to understand the same phenomena as a special manifestation of the underlying uniform structure of nature as a whole. In line with this objective, physics is characterized by accurate instrumentation, precision of measurement, and the expression of its results in mathematical terms.

For the major areas of physics and for additional listings of articles in physics see ACOUSTICS; ASTROPHYSICS; ATOMIC PHYSICS; BIOPHYSICS; CLASSICAL MECHANICS; ELECTRICITY; ELECTROMAGNETISM; ELEMENTARY PARTICLE; FLUID MECHANICS; HEAT; LOW-TEMPERATURE PHYSICS; MOLECULAR PHYSICS; NUCLEAR PHYSICS; OPTICS; SOLID-STATE PHYSICS; STATISTICAL MECHANICS; THEORETICAL PHYSICS. [W.G.P.]

**Physiological acoustics** The study of specific responses that may occur in the ear or elsewhere along the central auditory pathways, following presentation of an appropriate stimulus at any level of the auditory system. Such responses may be recorded with the aid of various techniques which may be mechanical, electrical, optical, and so forth. The specific stimulus for the ear is acoustic energy. Experimentally, signals with well-defined parameters are used. The approach employed by physiological acoustics thus is purely analytical. This is in contrast to the holistic approach employed by psychoacoustics, which lends itself well to experiments on human subjects. Systematic physiological experiments can be performed only in animals, but differences between humans and other mammals are mainly in degree, not in principle. See EAR; HEARING (HUMAN); PSYCHOACOUSTICS. [J.T.]

**Physiological action spectra** Representations of the comparative effects of different wavelengths of light on living systems or on the components of living systems. A knowledge of the effects of different wavelengths on living systems helps lead to an understanding of the detailed mechanisms of energy transfer and utilization and to a determination of the essential compounds involved in light action of living systems. The work of action spectroscopy is founded on the firm bases that energy must be absorbed before it is utilized and that each chemical compound has a characteristic absorption spectrum. Therefore, the shape of the action spectrum may lead to the identification of the absorbing molecules. Action spectroscopy has been used extensively to study three classes of compounds: porphyrin-containing proteins, nucleic acid polymers, and plant pigments. See ABSORPTION OF ELECTROMAGNETIC RADIATION. [R.B.Se.]

**Physiological ecology (animal)** A discipline that combines the study of physiological processes, the functions of living organisms and their parts, with ecological processes that connect the individual organism with population dynamics and community structure. See POPULATION ECOLOGY.

Physiological ecologists focus on whole-animal function and adjustments to ever-changing environments, in both laboratory and field. Short-term behavioral adjustments and longer-term physiological adjustments tend to maximize the fitness of animals, that is, their capacity to survive and reproduce successfully. Among the processes that physiological ecologists study are temperature regulation, energy metabolism and energetics, nutrition, respiratory gas exchange, water and osmotic balance, and responses to environmental stresses. These environmental stresses may include climate variation, nutrition, disease, and toxic exposure. For instance, climate affects animal heat and mass balances, and such changes affect body temperature regulation. Behavioral temperature regulation (typically, avoidance of temperature extremes) modifies mass and energy intake and expenditure, and the difference between intake and expendi-

ture provides the discretionary mass for growth and reproduction. Mortality risk (survivorship) also depends on temperature-dependent behavior, which determines daily activity. Activity time constrains the time for foraging and habitat selection, which in turn influence not only mortality risk but also community composition. Animals are similarly constrained in their discretionary mass and energy by reduction in nutrition, which decreases absorbed food, and by disease and toxins, which may elevate the costs to maintain a higher body temperature (fever). See BEHAVIORAL ECOLOGY; HOMEOSTASIS. [W.Pb.]

**Physiological ecology (plant)** The branch of plant science that seeks physiological (mechanistic) explanations for ecological observations. Emphasis is placed on understanding how plants cope with environmental variation at the physiological level, and on the influence of resource limitations on growth, metabolism, and reproduction of individuals within and among plant populations, along environmental gradients, and across different communities and ecosystems. The responses of plants to natural, controlled, or manipulated conditions above and below ground provide a basis for understanding how the features of plants enable their survival, persistence, and spread. Information gathered is often used to identify the physiological and morphological features of a plant that permit adaptation to different sets of environmental conditions.

The environments that plants occupy are often subject to variation or change. The ecophysiological characteristics of these plants must be able to accommodate this or the plants face extinction. Given the right conditions, ample time, and genetic variation among a group of interbreeding individuals, plant populations and species can evolve to accommodate marked ecological change or habitat heterogeneity. If evolutionary changes in physiology or morphology occur on a local or regional scale, populations within a single species may diverge in their characteristics. Separate ecological races (ecotypes) arise in response to an identifiable, set of environmental conditions. Ecotypes are genetically distinct and are particularly well suited to the local or regional environment they occupy. Such ecotypes can often increase the geographical range and amplitude of environmental conditions that the species occupies or tolerates. Ecotypes may also occur as a series of populations arrayed over a well-defined environmental gradient called an ecocline. In contrast, if ecotypes are not present, some plant species may still be able to accommodate a wide range of growth conditions through morphological and physiological adjustments, by acclimation to a single factor (such as light) or acclimatization to a complex suite of factors which define the entire habitat. Acclimatization can occur when individuals from several different regions or populations are grown in a common location and adjust, physiologically or morphologically, to this location. Acclimation and acclimatization can therefore be defined as the ability of a single genotype (individual) to express multiple phenotypes (outward appearances) in response to variable growing conditions. Neither requires underlying genetic changes, though some genetic change might occur which could mean that the response seen may itself evolve. Acclimation and acclimatization may also be called phenotypic plasticity. See PLANT EVOLUTION.

Studies of metabolic rates in relation to environmental conditions within populations, ecotypes, or species provide a way to measure the tolerance limits expressed at different scales. These data in turn help identify the scales at which different adaptations are expressed, and enhance an understanding of the evolution of physiological processes. Combining observations and measurements from the field with those obtained in laboratory and controlled environment experiments can help identify which conditions may be most influential on plant processes and therefore what may have shaped the physiological responses seen. Laboratory and controlled environment (common garden) experiments also assist in helping identify how much of the variation expressed in a particular metabolic process can be assigned to

a particular environmental factor and how much to the plants themselves and the genetic and developmental plasticity they possess. See ECOLOGY; ECOSYSTEM; PLANT PHYSIOLOGY. [T.E.D.]

**Phytomastigophorea** A class of the subphylum Sarcostomastigophora, also known as the Phytomastigina. These are the plant flagellates which contain chlorophyll and other pigments, but colorless forms are also included. Encystment is frequent among phytomastigophores, cyst composition being one method of determining relationships for some colorless species.

The Phytomastigophorea include 10 orders: Chrysoomonadida, Silicoflagellida, Coccolithophora, Heterochlorida, Cryptomonadida, Dinoflagellida, Ebriida, Euglenida, Chloromonadida, and Volvocida. See articles on these groups. See SARCOMASTIGOPHORA. [J.B.L.]

**Phytoalexin** Any antibiotic produced by plants in response to microorganisms. Plants use physical and chemical barriers as a first line of defense. When these barriers are breached, however, the plant must actively protect itself by employing a variety of strategies. Plant cell walls are strengthened, and special cell layers are produced to block further penetration of the pathogen. These defenses can permanently stop a pathogen when fully implemented, but the pathogen must be slowed to gain time.

The rapid defenses available to plants include phytoalexin accumulation, which takes a few hours, and the hypersensitive reaction, which can occur in minutes. The hypersensitive reaction is the rapid death of plant cells in the immediate vicinity of the pathogen. Death of these cells is thought to create a toxic environment of released plant components that may in themselves interfere with pathogen growth, but more importantly, damaged cells probably release signals to surrounding cells and trigger a more comprehensive defense effort. Thus, phytoalexin accumulation is just one part of an integrated series of plant responses leading from early detection to eventual neutralization of a potentially lethal invading microorganism.

The tremendous capacity of plants to produce complex chemical compounds is reflected in the structural diversity of phytoalexins. Each plant species produces one or several phytoalexins, and the types of phytoalexins produced are similar in related species. The diversity, complexity, and toxicity of phytoalexins may provide clues about their function. The diversity of phytoalexins may reflect a plant survival strategy. That is, if a plant produces different phytoalexins from its neighbors, it is less likely to be successfully attacked by pathogens adapted to its neighbor's phytoalexins. Diversity and complexity, therefore, may reflect the benefits of using different deterrents from those found in other plants. See PLANT PATHOLOGY. [A.R.A.]

**Phytochrome** A pigment that controls most photomorphogenic responses in higher plants. Mechanisms have evolved in plants that allow them to adapt their growth and development to more efficiently seek and capture light and to tailor their life cycle to the climatic seasons. These mechanisms enable the plant to sense not only the presence of light but also its intensity, direction, duration, and spectral quality. Plants thus regulate important developmental processes such as seed germination, growth direction, growth rate, chloroplast development, pigmentation, flowering, and senescence, collectively termed photomorphogenesis.

To perceive light signals, plants use several receptor systems that convert light absorbed by specific pigments into chemical or electrical signals to which the plants respond. This signal conversion is called photosensory transduction. Pigments used include cryptochrome, a blue light-absorbing pigment; an ultraviolet light-absorbing pigment; and phytochrome, a red/far-red light-absorbing pigment.

Phytochrome consists of a compound that absorbs visible light (chromophore) bound to a protein. The chromophore is an open-chain tetrapyrrole closely related to the photosynthetic pigments found in the cyanobacteria and similar in structure to the circular tetrapyrroles of chlorophyll and hemoglobin. Phytochrome is one of the most intensely colored pigments found in nature, enabling phytochrome in seeds to sense even the dim light present well beneath the surface of the soil and allowing leaves to perceive moonlight. See CHLOROPHYLL; HEMOGLOBIN.

Phytochrome can exist in two stable photointerconvertible forms,  $P_r$  or  $P_{fr}$ , with only  $P_{fr}$  being biologically active. Absorption of red light (near 666 nanometers) by inactive  $P_r$  converts it to active  $P_{fr}$ , while absorption of far-red light (near 730 nm) by active  $P_{fr}$  converts phytochrome back to inactive  $P_r$ . Plants frequently respond quantitatively to light by detecting the amount of  $P_{fr}$  produced. As a result, the amount of  $P_{fr}$  must be strictly regulated nonphotochemically by precisely controlling both the synthesis and degradation of the pigment. See ABSORPTION OF ELECTROMAGNETIC RADIATION.

Phytochrome has a variety of functions in plants. Initially, production of  $P_{fr}$  is required for many seeds to begin germination. This requirement prevents germination of seeds that are buried too deep in the soil to successfully reach the surface. In etiolated (dark-grown) seedlings, phytochrome can measure an increase in light intensity and duration through the increased formation of  $P_{fr}$ . Light direction also can be deduced from the asymmetry of  $P_{fr}$  levels from one side of the plant to the other. Different phytochrome responses vary in their sensitivity to  $P_{fr}$ ; some require very low levels of  $P_{fr}$  (less than 1% of total phytochrome) to elicit a maximal response, while others require almost all of the pigment to be converted to  $P_{fr}$ . Thus, as the seedling grows toward the soil surface, a cascade of photomorphogenic responses are induced, with the more sensitive responses occurring first. This chain of events produces a plant that is mature and photosynthetically competent by the time it finally reaches the surface. Production of  $P_{fr}$  also makes the plant aware of gravity, inducing shoots to grow up and roots to grow down into the soil. See PLANT MOVEMENTS; SEED.

In light-grown plants, phytochrome allows for the perception of daylight intensity, day length, and spectral quality. Intensity is detected through a measurement of phytochrome shuttling between  $P_r$  and  $P_{fr}$ ; the more intense the light, the more interconversion. This signal initiates changes in chloroplast morphology to allow shaded leaves to capture light more efficiently. If the light is too intense, phytochrome will also elicit the production of pigments to protect plants from photodamage.

Temperate plants use day length to tailor their development, a process called photoperiodism. How the plant measures day length is unknown, but it involves phytochrome and actually measures the length of night. See PHOTOPERIODISM.

Finally, phytochrome allows plants to detect the spectral quality of light, a form of color vision, by measuring the ratio of  $P_r$  to  $P_{fr}$ . When a plant is grown under direct sun, the amounts of red and far-red light are approximately equal, and the ratio of  $P_r$  to  $P_{fr}$  in the plant is about 1:1. Should the plant become shaded by another plant, the  $P_r/P_{fr}$  ratio changes dramatically to 5:1 or greater. This is because the shading plant's chlorophyll absorbs much of the red light needed to produce  $P_{fr}$  and absorbs almost none of the far-red light used to produce  $P_r$ . For a shade-intolerant plant, this change in  $P_r/P_{fr}$  ratio induces the plant to grow taller, allowing it to grow above the canopy.

It is not known how phytochrome elicits the diverse array of photomorphogenic responses, but the regulatory action must result from discrete changes in the molecule following photoconversion of  $P_r$  to  $P_{fr}$ . These changes must then start a chain of events in the photosensory transduction chain leading to the photomorphogenic response. Many photosensory transduction chains probably begin by responding to  $P_{fr}$  or the  $P_r/P_{fr}$  ratio and branch off toward discrete end points. See PHOTOMORPHOGENESIS. [R.D.V.]

**Phytoplankton** Mostly autotrophic microscopic algae which inhabit the illuminated surface waters of the sea, estuaries, lakes, and ponds. Many are motile. Some perform diel (diurnal) vertical migrations, others do not. Some nonmotile forms regulate their buoyancy. However, their locomotor abilities are limited, and they are largely transported by horizontal and vertical water motions.

A great variety of algae make up the phytoplankton. Diatoms (class Bacillariophyceae) are often conspicuous members of marine, estuarine, and fresh-water plankton. Dinoflagellates (class Dinophyceae) occur in both marine and fresh-water environments and are important primary producers in marine and estuarine environments. Coccolithophorids (class Haptophyceae) are also marine primary producers of some importance. They do not occur in fresh water.

Even though marine and fresh-water phytoplankton communities contain a number of algal classes in common, phytoplankton samples from these two environments will appear quite different. These habitats support different genera and species and groups of higher rank in these classes. Furthermore, fresh-water plankton contains algae belonging to additional algal classes either absent or rarely common in open ocean environments. These include the green algae (class Chlorophyceae), the euglenoid flagellates (class Euglenophyceae), and members of the Prasinophyceae.

The phytoplankton in aquatic environments which have not been too drastically affected by human activity exhibit rather regular and predictable seasonal cycles. Coastal upwelling and divergences, zones where deeper water rises to the surface, are examples of naturally occurring phenomena which enrich the mixed layer with needed nutrients and greatly increase phytoplankton production. In the ocean these are the sites of the world's most productive fisheries. See EUTROPHICATION. [R.W.H.]

**Phytotronics** Research using whole plants and conducted under controlled environmental conditions to determine responses to a single or known combination of environmental elements. Originally, the term phytotronics was used to identify research conducted specifically in phytotrons where controlled plant growth units are available for simultaneous use. The name phytotronics is also often applied to any research conducted with whole plants in a controlled environment plant growth chamber or room. [H.H.]

**Piciformes** A large order of land birds, second in size only to the Passeriformes, that is found throughout the world, except for the Australian region, and is concentrated in tropical areas. The Piciformes is divided into the following eight families: Primobucconidae (fossil), Galbulidae (jacamars), Bucconidae (puffbirds), Zygodactylidae (fossil), Capitonidae (barbets), Ramphastidae (toucans), Indicatoridae (honeyguides), and Picidae (woodpeckers). The family Picidae is the largest, with 204 species of woodpeckers.

The piciforms are small to medium-sized, hole-nesting land birds. The bill is short to medium-long, straight, and strong, and the wings are of medium length and rounded. The legs are short and strong, with the strong toes arranged in a zygodactylous (yoke) pattern, with two toes forward and two toes back. The tail may have stiffened feathers. The plumage, which varies greatly in hue, is frequently brightly colored and boldly patterned. Piciforms are good fliers and can easily perch and climb, but they walk poorly. Most species feed on insects. The eggs are incubated by both sexes, and both parents care for the unfeathered young, which remain in the nests. Except for a few species of woodpeckers, the piciforms are nonmigratory. See AVES; PASSERIFORMES. [W.J.B.]

**Picornaviridae** A viral family made up of the small (18–30 nanometer) ether-sensitive viruses that lack an envelope and have a ribonucleic acid (RNA) genome. The name is de-

rived from “pico” meaning very small, and RNA for the nucleic acid type. Picornaviruses of human origin include the following subgroups: enteroviruses (polioviruses, coxsackieviruses, and echoviruses) and rhinoviruses. There are also picornaviruses of lower animals (for example, bovine foot-and-mouth disease, a rhinovirus). See ANIMAL VIRUS; COXSACKIEVIRUS; ECHOVIRUS; ENTEROVIRUS; FOOT-AND-MOUTH DISEASE; POLIOMYELITIS; RHINOVIRUS. [J.L.Me.]

**Picrite** The term picrite has been used with several different meanings. It is generally considered to include certain medium- to fine-grained igneous rocks composed chiefly of olivine with smaller amounts of pyroxene, hornblende, and plagioclase feldspar (labradorite). Its feldspar content is slightly higher than that of peridotite and lower than that of gabbro. Certain analcite-bearing types, associated with teschenite, have also been included under the term picrite. Picrite is rare and is found in small intrusives (sills and dikes). See GABBRO; IGNEOUS ROCKS; PERIDOTITE. [C.A.C.]

**Pictorial drawing** A view of an object (actual or imagined) as it would be seen by an observer who looks at the object either in a chosen direction or from a selected point of view. Pictorial sketches often are more readily made and more clearly understood than are front, top, and side views of an object. Pictorial drawings, either sketched freehand or made with drawing instruments, are frequently used by engineers and architects to convey ideas to their assistants and clients. See DESCRIPTIVE; GEOMETRY; ENGINEERING DRAWING.

In making a pictorial drawing, the viewing direction that shows the object and its details to the best advantage is chosen. The resultant drawing is orthographic if the viewing rays are considered as parallel, or perspective if the rays are considered as meeting at the eye of the observer. Perspective drawings provide the most realistic, and usually the most pleasing, likeness when compared with other types of pictorial views.

Several types of nonperspective pictorial views can be sketched, or drawn with instruments. In the isometric pictorial, the direction of its axes and all measurements along these axes are made with one scale (Fig. 1). Oblique pictorial drawings, while not true orthographic views, offer a convenient method for drawing circles and other curves in their true shape (Fig. 2).

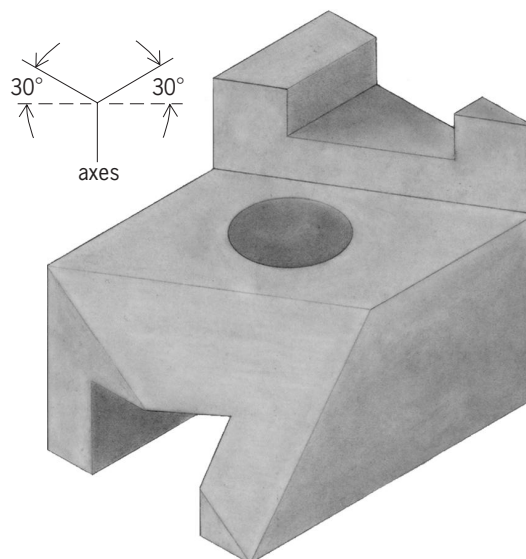

Fig. 1. Isometric drawing; measurements along each axis are made with the same scale.

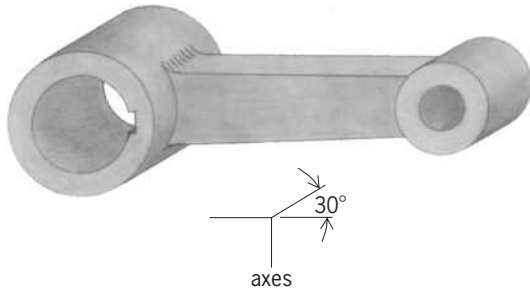

Fig. 2. Oblique pictorial drawing.

In order to reduce the distortion in an oblique drawing, measurements along the receding axis may be foreshortened. When they are halved, the method is called cabinet drawing. [C.J.B.]

**Picture tube** A cathode-ray tube used as a television picture tube. Television picture tubes use large glass envelopes that have a light-emitting layer of luminescent material deposited on the inner face. A modulated stream of high-velocity electrons scans this luminescent layer in a series of horizontal lines so that the picture elements (light and dark areas) are recreated.

In a color picture tube (see illustration), the glass bulb is made in two pieces, the face panel and the funnel-neck region. The separate face panel allows the fabrication of the segmented phosphor screen and the mounting of the shadow mask. The two glass pieces are sealed together by a special frit to provide a strong vacuum-tight seal.

The light-emitting colored phosphors on the segmented screen can be either in dot arrays or, now more commonly, in line arrays. Typically, the trios of vertical phosphor lines are spaced 0.6–0.8 mm apart. Most tubes use a black matrix screen in which the phosphor lines are separated by opaque black lines. This black matrix reduces reflected light, thereby giving better contrast, and also provides a tolerance for the registration of the electron beam with the phosphor lines.

The shadow mask is made of a thin (0.10–0.17 mm) steel sheet in which elongated slits (one row of slits for each phosphor-line trio) have been photoetched. It is formed to a contour similar

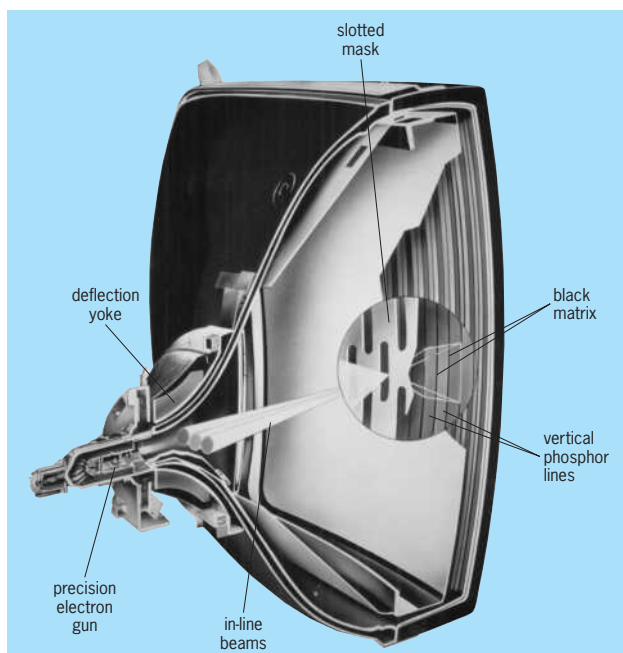

Color picture tube.

to that of the glass panel and is mounted at a precise distance from the glass. The width of the slits and their relative position to the phosphor lines are such that the electron beam from one of the three electron guns can strike only one of the sets of color phosphor lines. The shadow mask “shadows” the beam from the other two sets of phosphor lines.

The electron gun for color is similar to that for monochrome except that there are three guns, usually arranged side by side, or in-line. This triple gun has common structural elements, but uses three independent cathodes with separate beam forming and focusing for each beam.

The electromagnetic deflection yoke deflects or bends the beams, as in a monochrome tube, to scan the screen in a television raster. In addition, the yoke’s magnetic field is shaped so that the three beams will be deflected in such a way that they land at the same phosphor trio on the screen at the same time. This convergence of the beams produces three images, one in red, one in green, and one in blue, that are superimposed to give a full-color picture. See CATHODE-RAY TUBE; TELEVISION. [A.M.Mo.]

**Piezoelectricity** Electricity, or electric polarity, resulting from the application of mechanical pressure on a dielectric crystal. The application of a mechanical stress produces in certain dielectric (electrically nonconducting) crystals an electric polarization (electric dipole moment per cubic meter) which is proportional to this stress. If the crystal is isolated, this polarization manifests itself as a voltage across the crystal, and if the crystal is short-circuited, a flow of charge can be observed during loading. Conversely, application of a voltage between certain faces of the crystal produces a mechanical distortion of the material. This reciprocal relationship is referred to as the piezoelectric effect. The phenomenon of generation of a voltage under mechanical stress is referred to as the direct piezoelectric effect, and the mechanical strain produced in the crystal under electric stress is called the converse piezoelectric effect. See POLARIZATION OF DIELECTRICS.

The necessary condition for the piezoelectric effect is the absence of a center of symmetry in the crystal structure. Of the 32 crystal classes, 21 lack a center of symmetry, and with the exception of one class, all of these are piezoelectric. Hydrostatic pressure produces a piezoelectric polarization in the crystals of those 10 classes that show pyroelectricity in addition to piezoelectricity. See CRYSTALLOGRAPHY; PYROELECTRICITY.

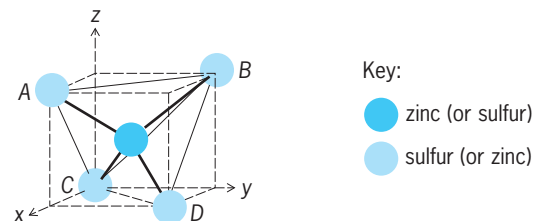

Tetrahedral structure of zincblende, ZnS. Only part of unit cell is shown. Size of circles has no relation to size of ions.

**Molecular theory.** Quantitative theories based on the detailed crystal structure are very involved. Qualitatively, however, the piezoelectric effect is readily understood for simple crystal structures. The illustration shows this for a particular cubic crystal, zincblende (ZnS). Every Zn ion is positively charged and is located in the center of a regular tetrahedron  $ABCD$ , the corners of which are the centers of sulfur ions, which are negatively charged. When this system is subjected to a shear stress in the  $xy$  plane, the edge  $AB$ , for example, is elongated, and the edge  $CD$  of the tetrahedron becomes shorter. Consequently, these edges are no longer equivalent, and the Zn ion will be displaced along the  $z$  axis, thus giving rise to an electric dipole moment. The dipole moments arising from different octahedrons sum up because they all have the same orientation with respect to the axes  $x$ ,  $y$ , and  $z$ .

**Applications.** The sharp resonance curve of a piezoelectric resonator makes it useful in the stabilization of the frequency of radio oscillators. Quartz crystals are used almost exclusively in this application. In vacuum-tube oscillators, the crystal generally is part of the feedback circuit. Selective band-pass filters with low losses can be built by using piezoelectric resonators as circuit elements. A synthetic piezoelectric crystal which is often substituted for quartz in this application is ethylene diamine tartrate. See QUARTZ CLOCK.

Piezoelectric materials are used extensively in transducers for converting a mechanical strain into an electrical signal. Such devices include microphones, phonograph pickups, vibration-sensing elements, and the like. The converse effect, in which a mechanical output is derived from an electrical signal input, is also widely used in such devices as sonic and ultrasonic transducers, headphones, loudspeakers, and cutting heads for disk recording. See MICROPHONE; ULTRASONICS. [H.G.]

**Piezoelectric materials.** The principal piezoelectric materials used commercially are crystalline quartz and rochelle salt, although the latter is being superseded by other materials, such as barium titanate. Quartz has the important qualities of being a completely oxidized compound (silicon dioxide), and is almost insoluble in water. Therefore, it is chemically stable against changes occurring with time. It also has low internal losses when used as a vibrator. Rochelle salt has a large piezoelectric effect, and is thus useful in acoustical and vibrational devices where sensitivity is necessary, but it decomposes at high temperatures (131°F or 55°C) and requires protection against moisture. Barium titanate provides lower sensitivity, but greater immunity to temperature and humidity effects. Other crystals that have been used for piezoelectric devices include tourmaline, ammonium dihydrogen phosphate (ADP), and ethylenediamine tartrate (EDT). See QUARTZ. [FD.L.]

**Pigeonite** Monoclinic pyroxenes of the general formula (Mg,Fe)SiO<sub>3</sub> having some augite in solid solution. Pigeonite bears the same relation to the orthorhombic pyroxenes as augite does to the diopside-hedenbergite series. Pigeonite is the orthorhombic pyroxene equivalent in the volcanic rocks. See AUGITE; DIOPSIDE; ORTHORHOMBIC PYROXENE; PYROXENE. [G.W.DeV.]

**Pigment** A finely divided material which contributes to optical and other properties of paint, finishes, and coatings. Pigments are insoluble in the coating material, whereas dyes dissolve in and color the coating. Pigments are mechanically mixed with the coating and are deposited when the coating dries. Their physical properties generally are not changed by incorporation in and deposition from the vehicle. Pigments may be classified according to composition (inorganic or organic) or by source (natural or synthetic). However, the most useful classification is by color (white, transparent, or colored) and by function. Special pigments include anticorrosive, metallic, and luminous pigments. See DYE; LUMINOUS PAINT; PAINT. [C.R.Ma.; C.W.Si.]

**Pigmentation** A property of biological materials that imparts coloration. Hence, pigmentation determines the quantity and quality of reflected visible light. The characteristics of light returning from living matter are a function of its chemical and physical properties and, therefore, are not only due to pigments proper but can be of structural origin (for example, due to reflection, scattering, or interference) as well.

Pigments are essential constituents of the living world. Their contribution to the evolution and maintenance of life, and its manifold expressions, is most evident in the role of chlorophylls and the associated carotenoids of certain bacteria and most plants. These pigments harvest solar light energy for utilization in the photosynthesis of organic material from inorganic precursors. See CAROTENOID; CHLOROPHYLL; PHOTOSYNTHESIS.

The outermost structures on the animal skin are pigmented for many reasons, for example, to reduce the animal's visibility against a colored background or to provide optical signals to the other sex or to other species. Conspicuously pigmented flowers attract pollinators, and colored fruits are easily found by animals, which eat them and then disperse the undigested seeds.

The role of pigments in communication depends on the ability of organisms to discriminate between different regions of the solar spectrum. In animals with eyes, this is accomplished by differently colored visual pigments contained in specialized receptor cells. Microorganisms, fungi, and plants also have special pigment systems that permit these organisms to move or grow toward, or away from, light (positive and negative phototaxis and phototropism, respectively). See PLANT MOVEMENTS.

Since most organisms are totally dependent on light—at least indirectly—elaborate pigment systems have evolved which tune metabolic and activity patterns to the daily pattern of light and dark, and to the changes in the relative lengths of day and night in the course of a year. The phytochrome of plants and the pigments of the eye or of extraretinal photoreceptor organs of many vertebrates and invertebrates are typical representatives of pigments that correlate biological activity with light-dark cycles (photo-periodism). See COLOR VISION; PHOTOPERIODISM; PHOTORECEPTION.

In the examples listed above, pigments mediate, in various ways, the beneficial actions of light. Absorbed solar light energy may, however, also have detrimental effects by causing undesirable or even destructive reactions. Pigmentations can provide a light-absorbing shield that protects the tissue below from such potentially damaging radiation of the Sun. See INTEGUMENT; SKIN. [PH.Ho.]

**Pike** Any of about five species of fish which compose the family Esocidae in the order Clupeiformes, known by a variety of names such as pickerel and muskellunge. These fish are voracious predators with an elongated beaklike snout and sharp teeth. The head is partly scaled and the body is covered with cycloid scales that have deeply scalloped edges. The body is cylindrical and compressed; thus, these fish are well adapted for rapid movements as they dart after prey. They prey upon each other, as well as other fish, amphibians, small aquatic birds and mammals, and rats. All species are edible but are considered second-rate game fish. See CLUPEIFORMES. [C.B.C.]

**Pile foundation** A special type of foundation that enables a structure to be supported by a layer of soil found at any depth below the ground surface. A pile foundation comprises two basic structural elements, the pile and the pile cap. A pile cap is a structural base, similar to a spread footing, that supports a structural column, wall, or slab, except that it bears on a single pile or group of piles. A pile can be described as a structural stilt hammered into the ground. Each pile carries a portion of the pile cap load and transfers it to the soil in the vicinity of the pile tip, located at the bottom of the pile (see illustration).

The pile and pile cap configuration has provided the basic design solution to the difficult problem of obtaining deep foundation support below areas where poor soil conditions prevail. Poor soil conditions may be difficult to excavate through, and are incapable of supporting structural loads. They are typically characterized by the presence of a soft, compressible layer of clay, high ground-water levels, loosely filled soils, uncontrolled landfills, boulders, abandoned underground structures, and natural bodies of water. By supporting a structure on piles in lieu of spread footings, any adverse soil condition may be virtually bypassed, and adequate foundation support can be obtained at any depth, without the need to perform deep excavation, dewater, and install temporary sheeting and bracing.

Piles are available in a variety of sizes, shapes, and materials that enable a particular type of pile foundation to be viable both economically and structurally. Principal materials are timber, concrete, and steel.



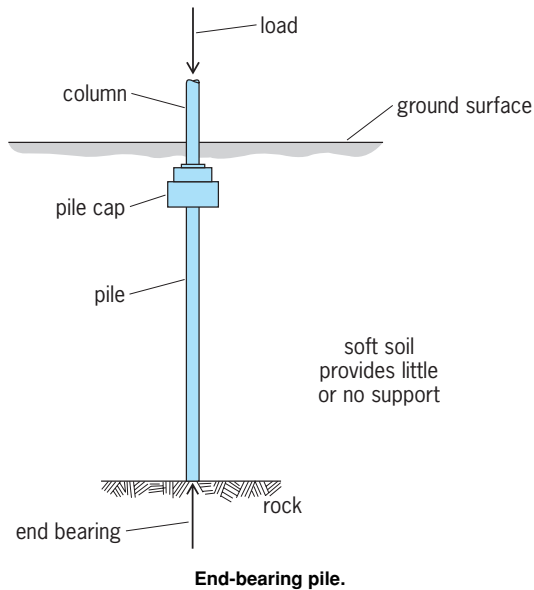

Pile foundations are used to support marine structures and offshore platforms, since they are located over bodies of water. On land, pile foundations are used primarily in locations where poor soil conditions exist. [A.J.M.]

**Pilot production** The production of a product, process, or piece of equipment on a simulated factory basis. In mass-production industries where complicated products, processes, or equipment are being developed, a pilot plan often leads to the presentation of a better product to the customer, lower development and manufacturing costs, more efficient factory operations, and earlier introduction of the product. Following the engineering development of a product, process, or complicated piece of equipment and its one-of-a-kind fabrication in the model shop, it becomes desirable and necessary to “prove out” the development on a simulated factory basis. See PRODUCT DESIGN; PRODUCTION ENGINEERING; QUALITY CONTROL. [J.E.Wo.]

**Pilotage** One of four procedures used in navigating an aircraft. The other three are position fixing, homing, and dead reckoning. Pilotage is the procedure of using landmarks, such as cities, towns, rivers, railroads, and prominent highways, to guide an aircraft to a destination. The installation of lights at airports and prominent spots across the country enhanced the ability of the pilot to direct the aircraft. See DEAD RECKONING.

The introduction of radar brought a new dimension to pilotage. Airborne radar operating at microwaves produces very sharp maps of the terrain over which the aircraft is flying. Radar pilotage has also been adapted to missile guidance. [P.C.S.]

**Piloting** The form of navigation in which position is determined relative to external reference points, usually fixed points on the Earth. It is the oldest form of navigation. With the development of electronic aids, piloting techniques were extended far from shore. However, the term “piloting” is generally associated with nearness of land, where tidal and other currents may be strong, shoals and other underwater obstructions may be in near proximity, and maneuvering room is limited when other vessels are encountered. Thus it is not unusual for ships to employ the services of a local expert, called a pilot, to assist in the navigation of the vessel while it enters or leaves port.

A conspicuous object, structure, or light that serves as an indicator for establishing the position of a craft or otherwise assisting in its safe navigation is called a mark. To be useful, not only must a mark be identified, but its position must be known accurately. Artificial marks designed and erected specifically to assist

the navigator are called aids to navigation and include beacons, both lighted and unlighted, lighthouses, buoys, both lighted and unlighted, and lightships. Unlighted aids are called daymarks. See BUOY; LIGHTHOUSE.

In addition to visible aids to navigation, bottom topography can be of assistance in locating the position of a vessel. Sound signals transmitted through water or air may be used for navigation. Electronic beacons and positioning systems have been established at a number of places to assist in navigation. See ELECTRONIC NAVIGATION SYSTEMS.

The measurements made for piloting purposes are of direction, distance, differential distance between two points, and distance to bottom.

Bearings are usually measured (1) by noting when two objects are in range (directly in line); (2) by means of a suitable attachment to a compass or compass repeater; (3) by pelorus, a compasslike instrument without directive properties; or (4) electronically, by radio direction finder, by radar, or by the indication of the receiver-indicator of an electronic system of navigation. Distance is generally measured by radar. The difference in distance from the ship to two points is usually measured electronically by means of the receiver-indicator of a hyperbolic navigation system. Depth measurement is usually made by an echo sounder. See DIRECTION-FINDING EQUIPMENT; ECHO SOUNDER; HYPERBOLIC NAVIGATION SYSTEM; RADAR.

Traditionally, position by piloting has been determined by means of lines of positions, each indicating a series of possible positions of the craft at the time of measurement. A measured bearing provides a straight line of position (actually part of a great circle) passing through the object sighted. A measured distance provides a circular line of position with the object as the center and the distance as the radius. A measured differential distance provides a hyperbolic line of position. A position, called a fix, is usually determined by crossing two or more lines of position taken simultaneously or nearly so.

Digitization of a nautical chart provides the information needed for display of an electronic facsimile of a published chart. Selective determination of features to be shown makes possible the tailoring of the facsimile to individual requirements. If a radar image is added to the display, the position of the vessel relative to its surroundings is immediately apparent. A suitable electronic positioning system such as the Global Positioning System (GPS) or differential GPS (DGPS) can be used to display a symbol indicating the position of the vessel, thus providing a check on accuracy of the radar data. Other information can be added as desired. The combined display is called an electronic chart display information system (ECDIS). See CELESTIAL NAVIGATION; DEAD RECKONING; MARINE NAVIGATION; NAVIGATION; POLAR NAVIGATION; SATELLITE NAVIGATION SYSTEMS. [A.B.M.]

**Pitldown man** The scientifically most successful fraud in the history of anthropology. Between 1908 and 1914 in the English village of Pitldown, parts of a thick human braincase, half of an apelike chinless lower jaw containing two molar teeth, a relatively large lower canine tooth, animal fossils, stone implements, and a 16-in. (41-cm) pointed tool made from a fossilized elephant bone were recovered. Within arguable limits the braincase could be restored as of modern size and shape, with a well-developed forehead; the uniform thickness was the primitive character. The jaw was decidedly apelike, but the surviving teeth showed the flat wear characteristic of premodern humans. The canine tooth was larger than in moderns but smaller than in apes. The glenoid fossa of the jaw joint on the skull had the normal form for human chewing motions, but no corresponding condyle on the lower jaw was found. All parts had the dark color of local fossilized material, as did the tools and other bones. The fauna as well as the tools could be placed as early as the Pliocene or as late as the mid-Pleistocene.

The material was presented in 1912 as a new form of early human, *Coanthropus dawsoni*. In spite of the incongruity of brain

size and jaw form, scientists generally accepted the find at face value. In 1953, when the broader picture of fossil humans had made Piltdown incongruous, logic led to the hypothesis of a deliberate hoax. Chemical tests, such as nitrogen loss or fluorine uptake, then showed that none of the human bones could be more than a few centuries old. Also, on reexamination at the same time, signs of forging were evident. The jaw was identified as that of an orangutan. The thickened skull was apparently that of someone with Paget's disease. The most important result of the Piltdown find was to cast doubt on a model for early hominids having a small brain and large, more human teeth. Thus when *Australopithecus* was reported in 1925, it was initially pronounced to be an ape. See FOSSIL HUMANS. [W.W.Ho.]

**Pimento** A type of pepper, *Capsicum annuum*, grown for its thick, sweet-fleshed red fruit. A member of the plant order Polemoniales, pimento is of American origin, and gets its name from the Spanish word designating all sweet peppers. In the United States, however, the term pimento generally refers to the heart-shaped varieties (cultivars) grown for canning and used for stuffing olives and flavoring foods. Georgia is the only important pimento-producing state. See PEPPER; SOLANALES. [H.J.C.]

**Piña** A fiber, also known as pineapple fiber, obtained from the large leaves of the pineapple plant grown in tropical countries. This natural fiber is white and especially soft and lustrous. In the Philippine Islands, it is woven into piña cloth, which is soft, durable, and resistant to moisture. Piña is also used in making coarse grass cloth and for mats, bags, and clothing. See NATURAL FIBER; PINEAPPLE. [M.D.P.]

**Pinales** An order of the class Pinopsida (=Coniferopsida), of the division Pinophyta (Gymnospermae), with about 50 genera and 600 species still living. All are woody plants, as shrubs or trees, and are often the principal trees of the forests worldwide. Pine, spruce, fir, hemlock, cedar, larch, juniper, cypress, yew, redwood, big tree, kauri, podocarpus, araucaria, and others are all part of this order. The big tree (*Sequoia gigantea*) of California is the largest plant, reaching a height of 330 ft (100 m) and a diameter of 33 ft (10 m), and being over 3500 years old. Leaves are usually needlelike or scalelike, with a few exceptions such as *Agathis* (kauri), *Podocarpus*, *Phyllocladus*, and *Araucaria*. Most species are evergreen, bearing their leaves year-round. Modern conifers form some of the most extensive forests in recent times, mainly occurring in the temperate regions or mountainous regions of the subtropics. The families of extant conifers are Araucariaceae, Pinaceae, Taxodiaceae, Cupressaceae, Podocarpaceae, Taxaceae, and Cephalotaxaceae. The phylogenetic relations among these families are practically unknown. See PINOPHYTA; PINOPSIDA.

The cones are unisexual. In some species, both male and female cones are borne on the same plant (monoecious); in others, on separate plants (dioecious). Usually, a year intervenes between pollination and fertilization, and another year between fertilization and embryo formation. See REPRODUCTION (PLANT).

The conifers are a principal source of lumber and pulp for paper and wood products. Turpentine, tar, resin, and essential oils are some by-products. The group yields little food for humans; some seeds are edible (pine, pinyon, or piñon nuts). See PINE NUT; PINE TERPENE. [T.A.Z.]

**Pinch effect** A name given to manifestations of the magnetic self-attraction of parallel electric currents having the same direction. The effect at modest current levels of a few amperes can usually be neglected, but when current levels approach a million amperes such as occur in electrochemistry, the effect can be damaging and must be taken into account by electrical engineers. The pinch effect in a gas discharge has been the subject of intensive study, since it presents a possible way of achieving the magnetic confinement of a hot plasma (a highly ionized

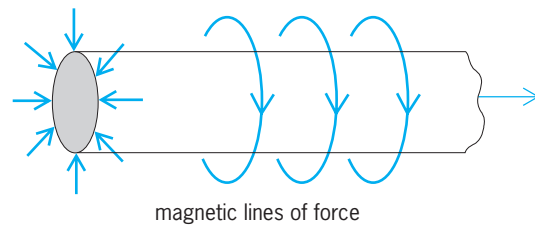

Fig. 1. Pinch pressure on a current-carrying conductor. Arrows at left show direction of pinch pressure.

gas) necessary for the successful operation of a thermonuclear or fusion reactor.

The law of attraction which describes the interaction between parallel electric currents was discovered by A. M. Ampère in 1820. For a cylindrical wire of radius  $r$  meters carrying a total surface current of  $I$  amperes, it manifests itself as an inward pressure on the surface (Fig. 1) given by  $I^2/2 \times 10^7\pi r^2$  pascals. For the electric currents of normal experience, this force is small and passes unnoticed, but it is significant that the pressure increases with the square of the current,  $I^2$ . For example, at 25,000 amperes the pressure amounts to about 1 atm (100 kilopascals) for a wire of 1-cm radius, but at  $10^6$  amperes the pressure is about 1600 atm or about 12 tons in.<sup>-2</sup> (160 megapascals).

There are a number of ways in which the magnetic field of a fusion reactor can be arranged around the plasma to hold it together, and one of these methods is the pinch effect. A fusion reactor using this type of confinement would ideally be a toroidal tube in which the confined plasma would carry a large electric current induced in it by magnetic induction from a transformer core passing through the major axis of the torus. The current would have the double function of ohmically heating the plasma and compressing the plasma toward the center of the tube.

Characteristically, as can be shown by high-speed photography, the pinch forms at the inner surface of a discharge tube wall and contracts radially inward, forming an intense line, the pinch, on the axis; the pinch rebounds slightly; the contracted discharge rapidly develops necks and kinks; and in a few microseconds all structure is lost in an apparently turbulent glowing gas which fills the tube. Thus, the pinch turns out to be unstable, and plasma confinement is soon lost by contact with the wall. The cause of the instability is easily seen qualitatively: The pinch confinement can be described as being caused by the magnetic field lines encircling the pinch which are stretched longitudinally but which are in compression transversely (Fig. 2). For a uniform cylindrical pinch, the magnetic pinch pressure is everywhere equal to the

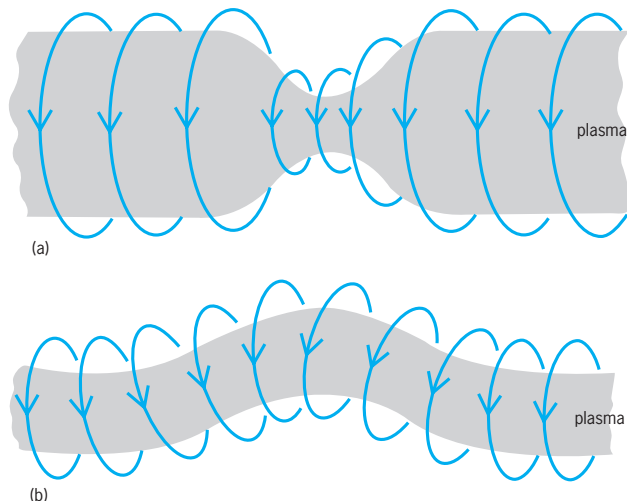

Fig. 2. Instability. (a) Sausage type. (b) Kink type.

outward plasma pressure, but at a neck or on the inward side of a kink, the magnetic field lines crowd together, creating a higher magnetic pressure than the outward gas pressure. Consequently, the neck contracts still further, the kink cuts in on the concave side and bulges out on the convex side, and both perturbations grow. The instability has a disastrous effect on the confinement time.

The term theta pinch has come into wide usage to denote an important plasma confinement system which relies on the repulsion of oppositely directed currents and which is thus not in accord with the original definition of the pinch effect (self-attraction of currents in the same direction). Plasma confinement systems based on the original pinch effect are known as Z pinches.

Tokamak is essentially a low-density, slow Z pinch in a torus with a very strong longitudinal field. The helical magnetic field lines, resultant from the externally applied field and that of the pinch, do not close, that is, do not complete one revolution of the minor axis in going around the major axis of the torus once. This is known theoretically to prevent the growth of certain helical distortions of the plasma. The performance of tokamak experiments has raised the possibility of achieving a net power balance. See NUCLEAR FUSION. [J.A.Ph.]

**Pine** The genus *Pinus*, of the pine family, characterized by evergreen leaves, usually in tight clusters (fascicles) of two to five, rarely single. There are about 80 known species distributed throughout the Northern Hemisphere. Botanically the leaves are of two kinds: (1) a scalelike form, the primary leaf, which subtends a much shortened and eventually deciduous shoot bearing (2) the secondary leaves or needles. The wood of pines is easily recognized by the numerous resin ducts and by the characteristic resinous odor. See PINALES; PINE NUT. [A.H.G./K.P.D.]

**Pine nut** The edible seed of more than a dozen species of evergreen cone-bearing trees in the genus *Pinus*, native to the temperate zone of the Northern Hemisphere. The important nut-producing species are the stone pine (*P. pinea*) of southern Europe; the Swiss stone pine (*P. cembra*), native to the Swiss Alps and eastward through Siberia to Mongolia; and the pinon pine (*P. cembroides* var. *edulis*) of the arid regions of the southwestern United States. The seeds or nuts, variable in size according to species, are borne in cones which take 3–4 years to develop. See PINE. [L.H.MacD.]

**Pine terpene** A major component of the essential oils obtained from various *Pinus* species. The principal terpenes of the oil of southern pines [longleaf pine (*P. palustris*) and slash pine (*P. caribaea*)] are  $\alpha$ - and  $\beta$ -pinene, whose structures are shown below. See ESSENTIAL OIL; PINE.

 $\alpha$ -Pinene $\beta$ -Pinene

Gum turpentine (gum spirits) is the volatile fraction of the oleoresin that exudes from cuts made in the trunks of live trees. The resin is collected and distilled by a process that yields about 20% turpentine, mainly  $\alpha$ - and  $\beta$ -pinene, and 70% rosin; it was the basis of the original naval stores industry.

Wood turpentine is obtained by steam distillation from stumps and other logging residues. The volatile material in this case consists of about 50% turpentine and 30–40% of higher-boiling-point alcohols; the latter fraction is known as pine oil. The bulk of the wood turpentine and pine oil produced by modern industrial processes is a by-product of the sulfate wood-pulping process (sulfate turpentine).

Important uses of turpentine or the purified pinenes derived from turpentine are in terpene resins, as a thinner in paints and

varnishes, and as a starting material in the synthesis of other commercially valuable terpenes.

Pine oil is a mixture of monoterpene alcohols, mainly  $\alpha$ -terpineol, obtained in large amounts mixed with wood turpentine or sulfate turpentine. The term pine oil is also used to designate the essential oil of various species of pine.

Much of the pine oil of commerce is prepared synthetically by acid-catalyzed hydration of  $\alpha$ -pinene. This process involves a complex series of reactions that occur via cationic intermediates.

The composition of industrial-grade pine oil is approximately 65%  $\alpha$ -terpineol, 20–25% of other monoterpene alcohols, and 10–15% hydrocarbons. Pine oil has surfactant and emulsifying properties and is also a disinfectant. Most of the pine oil manufactured is used in the manufacture of cleansers and textile penetrants. See SURFACTANT; TERPENE; WOOD CHEMICALS. [J.A.Mo.]

**Pineal gland** An endocrine gland located in the brain which secretes melatonin, is strongly regulated by light stimuli, and is an important component of the circadian timing system. The pineal gland is virtually ubiquitous throughout the vertebrate animal kingdom. In nonmammalian vertebrates, it functions as a photoreceptive third eye and an endocrine organ. In mammals, it serves as an endocrine organ that is regulated by light entering the body via the eyes. Despite extensive species variation in anatomy and physiology, the pineal gland generally serves as an essential component of the circadian system which allows animals to internally measure time and coordinate physiological time-keeping with the external environment. See BIOLOGICAL CLOCKS; BRAIN.

The pineal gland is an unpaired organ attached by a stalk to the roof of the diencephalon. In frogs and lizards, one component of the pineal complex (the frontal organ or parietal eye) projects upward through the skull to lie under the skin; in all other vertebrates the pineal is located beneath the roof of the skull. Across evolution, cells within the pineal gland have progressed from classic photoreceptor cells in the earliest vertebrates, to rudimentary photoreceptors in birds, to classic endocrine cells in mammals. See PHOTORECEPTION; SENSE ORGAN.

In mammals, nerve fibers extend from a variety of sources in the brain to the pineal gland. The best studied of these neural inputs is through the retinohypothalamic tract, which extends from the eyes to the pineal gland in mammals. Originating in the retina, the majority of the retinohypothalamic fibers project to or around the bilateral suprachiasmatic nuclei in the hypothalamus. These nuclei serve as endogenous oscillators with period lengths close to 24 h. Thus, the suprachiasmatic nuclei function as pacemakers for the circadian system, which regulates daily physiological and behavioral rhythms. From the suprachiasmatic nuclei there are short projections to the paired paraventricular hypothalamic nuclei, and then long descending axons project from these nuclei to synapse on preganglionic sympathetic neurons in the upper thoracic spinal cord. These sympathetic neurons then extend out of the central nervous system to the superior cervical ganglia in the neck region. From there, postganglionic sympathetic axons reenter the cranium and ultimately innervate the pineal gland.

In mammals, information about environmental light and darkness is relayed from the eye to entrain circadian neural activity of the suprachiasmatic nuclei. In turn, the suprachiasmatic nuclei synchronize circadian rhythms in the pineal gland through its sympathetic innervation. One of the best-studied rhythms in the pineal gland is the biosynthesis of the hormone melatonin. Pinealocytes also have the necessary enzymes for converting tryptophan into a larger family of indole compounds, and numerous polypeptides have been localized in the pineal gland. The biological functions of these other pineal indole and peptide constituents are currently unknown.

In all vertebrate species studied, high levels of melatonin are produced and secreted during the night, while low levels are released during the day. The melatonin circadian rhythm is

produced by the endogenous pacemaking activity of the suprachiasmatic nuclei, while the entrainment of this rhythm is coordinated by signals of light and darkness relayed from the eyes. Day length or photoperiod can influence the duration that melatonin production is elevated during the night. This represents a seasonal effect of light on the pineal gland. Specifically, in the summer when days are longer and nights are shorter, the duration of increased nocturnal melatonin secretion is shorter than during the winter when nights are longer. This effect of photoperiod length influencing the duration of nighttime melatonin rise has been documented in many species, including humans.

There is extensive species diversity in the capacity of melatonin to regulate physiology. Numerous species, ranging from insects to mammals, have yearly cycles of activity, morphology, reproduction, or development which are responsive to seasonal changes in day length (photoperiodism). Among many species that breed seasonally, melatonin has been shown to be a potent regulator of the reproductive axis in both males and females. The effects of melatonin on the regulation of circadian physiology has been elucidated in many vertebrate species, including humans. In addition, melatonin has been studied in different species for its influence on retinal physiology, sleep, body temperature regulation, immune function, and cardiovascular regulation. [G.C.B.]

**Pineapple** A low-growing perennial plant, indigenous to the Americas. The cultivated varieties (cultivars) belong to the species *Ananas sativus* of the plant order Bromeliales.

The edible portion of the pineapple develops from a mass of ovaries on a fleshy flower stock having persistent bracts (see illustration). On the cultivated types, the flowers are usually abortive. The leaves are long and swordlike and usually roughedged. Commercial plantings bear fruit at the age of 12–20 months, and may continue to be productive for as much as 8–10 years. See BROMELIALES.

The major producing area is Hawaii, where special methods of culture and harvesting have been developed. Pineapples are also grown in the West Indies and other tropical areas, and to a limited extent in southern Florida.

Pineapples are consumed fresh in considerable quantity, but because of distance from markets and the problems of transport-



Pineapple (*Ananas sativus*), fruit and leaves. (USDA)

ing fresh fruit, most of the crop is canned as sliced pineapple or as juice. See FRUIT. [J.H.C.]

**Pinnipeds** Carnivorous mammals of the suborder Pinnipedia, which includes 32 species of seals, sea lions, and walrus in 3 families. All species of the order are found along coastal areas, from the Antarctic to the Arctic regions. Although many species have restricted distribution, the group as a whole has worldwide distribution.

Pinnipeds are less modified both anatomically and behaviorally for marine life than are other marine mammals: Each year they return to land to breed, and they have retained their hindlimbs. They are primarily carnivorous mammals, with fish supplying the basic diet. They also eat crustaceans, mollusks, and, in some instances, sea birds. Their body is covered with a heavy coat of fur, the limbs are modified as flippers, the eyes are large, the external ear is small or lacking, and the tail is absent or very short.

The single species of the family Odobenidae is the walrus (*Odobenus rosmarus*); it grows to 10 ft (3 m) and weighs 3000 lb (1350 kg). It has no external ears but does have a distinct neck region. The upper canines of both sexes are prolonged as tusks which can be used defensively (illus. a). The walrus feeds on marine invertebrates and fish.

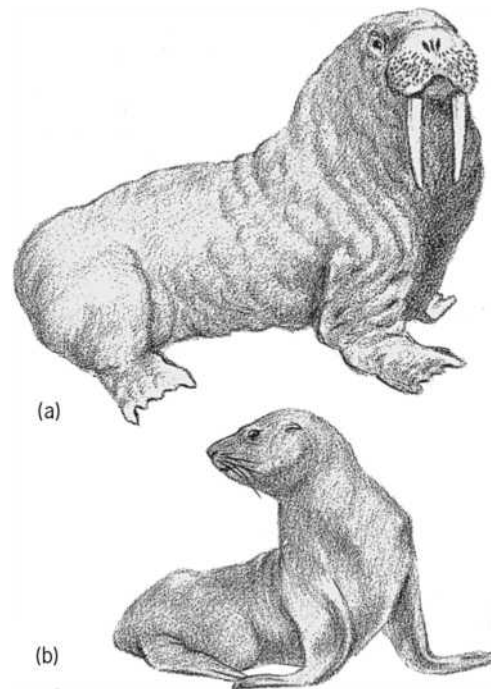

Pinnipeds. (a) Walrus (*Odobenus rosmarus*). (b) Alaska fur seal (*Callorhinus ursinus*).

The family Otariidae, the eared seals, includes the sea lions and fur seals (illus. b), which are characterized by an external ear. The neck is longer and more clearly defined than that of true seals, and the digits lack nails. The California sea lion (*Zalophus californianus*) occurs along the Pacific coast, and is commonly seen in zoos and performing in circuses. The southern sea lion (*Otaria byronia*) is found around the Galapagos Islands and along the South American coast. Stellar's sea lion (*Eumetopias jubatus*) is a large species found along the Pacific coast. Minor species are the Australian sea lion (*Neophoca cinerea*) and the New Zealand species (*Phocarctos hookeri*).

Phocidae is the largest family of pinnipeds, the true seals. It includes the monk seals, elephant seals, common seals, and other less well-known forms. The family is unique in that the digits have nails, the soles and palms are covered with hair, and the

necks are very short. Most species live in marine habitats; however, the Caspian seal (*Pusa caspica*) lives in brackish water. The only fresh-water seal is the Baikal seal (*P. sibirica*). It is estimated that there are between 40,000 and 100,000 Baikal seals in Lake Baikal. One of the best-known species is the Atlantic gray seal (*Halichoerus grypus*), a species found in the North Atlantic along the coasts of Europe, Iceland, and Greenland. See CARNIVORA; MAMMALIA. [C.B.C.]

**Pinophyta** One of the two divisions of the seed plants, comprising about 600 to 700 species extant on all continents except Antarctica. The most familiar and common representatives are the evergreen, cone-bearing trees of the Pinales. Because the ovules (young seeds) are exposed directly to the air at the time of pollination, the Pinophyta are commonly known as the gymnosperms, in contrast to the other division of flowering plants, the angiosperms (division Magnoliophyta), which have the ovules enclosed in an ovary. The division Pinophyta consists of three classes: Ginkgoopsida, Cycadopsida, and Pinopsida. See CYCADOPSIDA; GINKGOOPSIDA; MAGNOLIOPHYTA; PINOPSIDA; PLANT KINGDOM. [T.A.Z.]

**Pinopsida** The largest and most important class of the division Pinophyta (Gymnospermae), the other classes being Ginkgoopsida and Cycadopsida. There are two orders: the Cordaitanthales, with three extinct families, and the Pinales (Coniferales), with six extinct families and seven families with some extant genera.

The living Pinopsida are woody plants; most are trees with a central axis and excurrent branches. Leaves are simple, alternate, or opposite or in whorls, scalelike or needlelike or rarely planar. The wood lacks vessels and usually has resin canals. Male reproductive structures are aggregated on microsporophylls directly attached to the cone axis. The ovules are borne in compound cones or singly or paired at the end of a stalk (Taxaceae). The main seed plane is tangential to the cone axis (if the seed scale is regarded as a modified dwarf shoot). The embryo has two or more cotyledons. See CYCADOPSIDA; GINKGOOPSIDA; PINALES. [T.A.Z.]

**Pionium** An exotic atom, also called the pi-mu atom, which is similar in structure to the hydrogen atom but with the proton replaced by a pion and the electron replaced by a muon. Pionium is unique among atoms that have been observed in the laboratory in that all of its constituents are unstable particles not found in ordinary matter. Pionium is formed during the decay of a certain heavier particle called the neutral kaon. A kaon has many modes of decay, one of which results in the formation of a pion, a muon, and a neutrino. See ELEMENTARY PARTICLE.

The nomenclature of exotic atoms is not well established, and the name pionium may also refer to the pion-electron atom. [P.A.S.]

**Pipe flow** Conveyance of fluids in closed circular ducts. Flow in closed conduits is probably the most common way of transporting fluids. Crude oil and its components are moved through pipes in a refinery. Water in the home is transported through tubing. Heated and conditioned air is distributed to all parts of a dwelling in circular or rectangular ducts. See PIPELINE.

Flow in a closed conduit (circular or otherwise) can be either laminar or turbulent. In laminar flow, the fluid particles move smoothly through the duct in layers called laminae. A fluid particle in one layer stays in that layer. In turbulent flow, flowing fluid particles move tortuously about the cross section, resulting in an effective mixing action. Eddies and vortices are responsible for the mixing, which does not occur in laminar flow. Turbulent flow exists at much higher flow rates than laminar flow.

The criterion for distinguishing between laminar and turbulent flow is this observed mixing action. When injected into a laminar flow in a duct, a dye moves downstream in a threadlike

line. When injected into a turbulent flow, a dye disperses quickly. Experiments have shown that laminar flow exists when the dimensionless Reynolds number,  $Re = VD/\nu$ , is less than 2100; here  $V$  is the average velocity,  $D$  is the inside diameter of the pipe or tube, and  $\nu$  is the kinematic viscosity (a property of the fluid). See FLUID FLOW; LAMINAR FLOW; REYNOLDS NUMBER; TURBULENT FLOW.

The energy loss experienced by the fluid is manifested as a pressure drop  $\Delta p$ , which is found in terms of a dimensionless friction factor  $f$  as shown in Eq. (1). Here, the density  $\rho$  is a

$$\Delta p = \frac{fL}{D} \frac{\rho V^2}{2} \quad (1)$$

property of the fluid,  $L$  is the length over which the pressure drop occurs,  $D$  is the inside diameter of the pipe or tube,  $V$  is the average velocity, and the quantity  $\rho V^2/2$  is the kinetic energy of the flow per unit volume. For laminar flow through a circular duct, the friction factor is found in terms of the Reynolds number, as indicated in Eq. (2). For turbulent flow, the friction factor is

$$f = \frac{64}{Re} \quad \left( \begin{array}{l} \text{laminar flow,} \\ \text{circular duct} \end{array} \right) \quad (2)$$

dependent upon the wall roughness, the fluid properties, the average velocity, and the pipe diameter; that is,  $f = f(V, D, \rho, \mu, \varepsilon)$ , in which  $\varepsilon$  is a measure of the absolute roughness of the conduit wall, having the dimension of length. Values of the roughness  $\varepsilon$  have been measured for many commercial pipe materials. The friction factor for turbulent flow may be obtained from a Moody diagram in which the friction factor  $f$  is graphed as a function of the Reynolds number  $Re$ , with the relative roughness  $\varepsilon/D$  as an independent parameter. The Moody diagram is a result of many flow rate and pressure drop measurements made on commercial pipe and tube materials. [W.S.J.]

**Pipeline** A line of piping and the associated pumps, valves, and equipment necessary for the transportation of a fluid. Major uses of pipelines are for the transportation of petroleum, water (including sewage), chemicals, foodstuffs, pulverized coal, and gases such as natural gas, steam, and compressed air. Pipelines must be leakproof and must permit the application of whatever pressure is required to force conveyed substances through the lines. Pipe is made of a variety of materials and in diameters from a fraction of an inch up to 30 ft (9 m). Principal materials are steel, wrought and cast iron, concrete, clay products, aluminum, copper, brass, cement and asbestos (called cement-asbestos), plastics, and wood.

Pipe is described as pressure and nonpressure pipe. In many pressure lines, such as long oil and gas lines, pumps force substances through the pipelines at required velocities. Pressure may be developed also by gravity head, as for example in city water mains fed from elevated tanks or reservoirs.

Nonpressure pipe is used for gravity flow where the gradient is nominal and without major irregularities, as in sewer lines, culverts, and certain types of irrigation distribution systems.

Design of pipelines considers such factors as required capacity, internal and external pressures, water- or airtightness, expansion characteristics of the pipe material, chemical activity of the liquid or gas being conveyed, and corrosion. [L.N.McC.]

**Piperales** A small order of flowering plants (3600 species) in the eumagnoliid group, which is composed of three anomalously woody vines (shrubs) or herbaceous families—the pipeworts (Aristolochiaceae), the black pepper family (Piperaceae), and the lizard's tail family (Saururaceae). The last two families have reduced flowers in dense spikelike flower stems, and the first has medium-sized to enormous flowers that often trap insects for a period before releasing them, covered with pollen.

Black pepper comes from *Piper nigrum* and betel nuts from *P. betle*. Several species of *Aristolochia* have medicinal properties, and some genera in each of these families are commonly grown ornamentals in the temperate zones or house plants, such as *Asarum* (wild ginger), *Peperomia* (pepper elders), and *Houttuynia*. See EUMAGNOLIIDS; LAURALES; MAGNOLIALES; MONOCOTYLEDONS. [M.W.C.]

**Pirani gage** A type of instrument used to measure vacuum by utilizing a resistance change due to a temperature change in a filament. This fine-wire filament, one of the four electrical resistances forming a Wheatstone bridge circuit, is exposed to the vacuum to be measured. Electric current heats the wire; the surrounding gas (in the vacuum) conducts heat away from the wire. At a stable vacuum, the wire quickly reaches equilibrium temperature. If the pressure rises, the gas carries away more heat, and the temperature of the wire decreases. Since the resistance of the filament is a function of temperature, the electrical balance of the Wheatstone bridge is changed. Pressure measurement range of this type of gage is usually 1 to  $10^{-4}$  torr ( $10^2$  to  $10^{-2}$  pascals). See VACUUM MEASUREMENT. [R.C.]

**Pisces (constellation)** The Fishes, in astronomy, a zodiacal constellation appearing in the autumn evening sky. Pisces is the twelfth and last sign of the zodiac. It is inconspicuous, having no star brighter than the fourth magnitude. But it is an important constellation because the vernal equinox, which

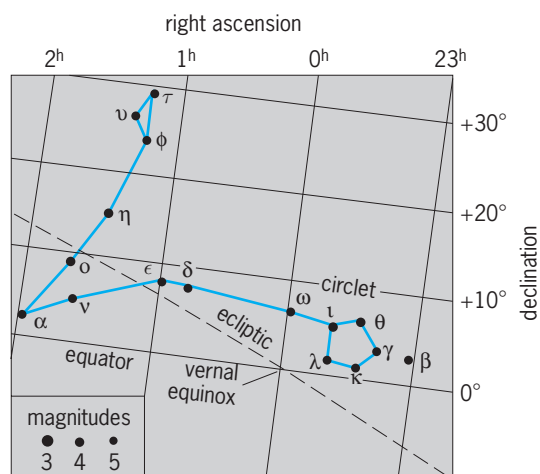

Line pattern in the constellation Pisces. The grid lines represent the coordinates of the sky. The apparent brightness, or magnitude, of the various stars is shown by the sizes of the dots, which are graded by appropriate numbers as indicated.

marks the beginning of the astronomical year, is now located in it (see illustration). See CONSTELLATION. [C.-S.Y.]

**Pisces (zoology)** A term that embraces all fishes and fishlike vertebrates. The Pisces include four well-defined groups that merit recognition as classes: the Agnatha or jawless fishes, the most primitive; the Placodermi or armored fishes, known only as Paleozoic fossils; the Chondrichthyes or cartilaginous fishes; and the Osteichthyes or bony fishes. See CHONDRICTHYES; JAWLESS VERTEBRATES; OSTEICHTHYES; PLACODERM. [R.M.B.]

**Pistachio** A tree, *Pistacia vera*, of the Anacardiaceae family. It is native to central Asia and has been grown for its edible nuts throughout recorded history in various countries of the Mediterranean region. Extensive areas in California were planted with pistachios in the 1970s, and the first commercial nut crop was harvested in 1977. See SAPINDALES.

The pistachio tree, relatively slow-growing, reaches a height and spread of 20–25 ft (6–8 m). It thrives under long, hot summers with low humidity, but needs moderately cold winters to satisfy its chilling requirement. Pistachio is deciduous and has imparipinnate leaves, most often 2-paired. It is dioecious, and both staminate and pistillate inflorescences are panicles that may have 150 or more individual flowers. They lack petals and nectaries and, consequently, are wind-pollinated. The fruit, a semidry drupe, is borne on 1-year-old wood in clusters similar to grapes and matures in September. The hull (exocarp and mesocarp) at that time slips easily from the shell (endocarp) which has already dehisced, exposing the kernel. Pistachio kernels contain only 5–10% sugars, but their protein and oil content of about 20 and 40%, respectively, make them high in food value. See NUT CROP CULTURE. [J.C.Cr.]

**Pitch** The psychological property of sound characterized by highness or lowness. Pitch is one of the two major auditory attributes of simple sounds, the other being loudness.

A simple sound source, such as a tuning fork, produces an acoustic wave that approximates a perfect sinusoid, and the pitch of a sinusoid wave is almost completely determined by its frequency. Many sounds, however, are complex and contain a number of sinusoidal components. Complex sounds often appear to have a strong pitch, which is the frequency of a sinusoid that appears to match the complex sound. Hence, a tuning fork that vibrates at about 440 Hz will have a pitch very nearly equal to the note A above middle C on the piano. Loudness is determined by the amplitude of the sound vibrations. See LOUDNESS; TUNING FORK; WAVE (PHYSICS).

A sequence of different sounds having definite pitches produces a musical tune, making pitch extremely important in music. Practically all musical conventions recognize that doubling the frequency of vibration produces a particular pitch interval, known as an octave. See MUSICAL ACOUSTICS; SCALE (MUSIC).

The human auditory system can hear frequencies in the range of 20–20,000 Hz. For frequencies between 100 and 4000 Hz, sinusoidal sounds have a clear pitch. Beyond these limits, the pitch of sound is not distinct. Sounds below 100 Hz may be described as rumbles, while those above 4000 Hz may be described as shrill and squeaky. The ability to detect changes in pitch is remarkably acute. The just-detectable change in frequency is about 0.3% for the midfrequency range. Frequency changes are best detected when the sound is loud. Weaker sounds require greater changes in frequency to be detectable. See AUDIOMETRY; HEARING (HUMAN). [D.M.Gree.]

**Pitcher plant** Any member of the families Sarraceniaceae and Nepenthaceae. In these insectivorous plants the leaves form deep cups or pitchers in which water collects. Visiting insects, falling into this water, are drowned and digested by the action of enzymes secreted by cells located in the walls of the pitcherlike structures of these plants. Often these plants climb by tendrils. The end of a tendril may develop into a pitcher, which captures and digests insects. See INSECTIVOROUS PLANTS; NEPENTHALES. [P.D.St./E.L.C.]

**Pitchstone** A natural glass with dull or pitchy luster and generally brown, green or gray color. It is extremely rich in microscopic, embryonic crystal growths (crystallites) which may cause its dull appearance. The water content of pitchstone is high and generally ranges from 4 to 10% by weight. Pitchstone is formed by rapid cooling of molten rock material (lava or magma) and occurs most commonly as small dikes or as marginal portions of larger dikes. See IGNEOUS ROCKS; VOLCANIC GLASS. [C.A.C.]

**Pith** The central zone of tissue of an axis in which the vascular tissue is arranged as a hollow cylinder. Pith is present in most stems and in some roots. Stems without pith rarely occur in angiosperms but are characteristic of psilopsids, lycopsids,

*Sphenophyllum*, and some ferns. Roots of some ferns, many monocotyledons, and some dicotyledons include a pith, although most roots have xylem tissue in the center.

Pith is composed usually of parenchyma cells often arranged in longitudinal files. This arrangement results from predominantly transverse division of pith mother cells near the apical meristem. See PARENCHYMA; ROOT (BOTANY); STEM. [H.W.Bi.]

**Pitot tube** A device to measure the stagnation pressure due to isentropic deceleration of a flowing fluid. In its original form it was a glass tube bent at  $90^\circ$  and inserted in a stream flow, with its opening pointed upstream. Water rises in the tube a distance,  $h$ , above the surface, and if friction losses are negligible, the velocity of the stream,  $V$ , is approximately  $2gh$ , where  $g$  is the acceleration of gravity. However, there is a significant measurement error if the probe is misaligned at an angle  $\alpha$  with respect to the stream. For an open tube, the error is about 5% at  $\alpha \approx 10^\circ$ .

The misalignment error of a pitot tube is greatly reduced if the probe is shielded, as in the Kiel-type probe. The Kiel probe is accurate up to  $\alpha \approx 45^\circ$ .

The modern application is a pitot-static probe, which measures both the stagnation pressure, with a hole in the front, and the static pressure in the moving stream, with holes on the sides. A pressure transducer or manometer records the difference between these two pressures. Pitot-static tubes are generally unshielded and must be carefully aligned with the flow to carry out accurate measurements. See BERNOULLI'S THEOREM.

When used with gases, estimate of the stream velocity is only valid for a low-speed or nearly incompressible flow, where the stream velocity is less than about 30% of the speed of sound of the fluid. At higher velocities, estimate of the stream velocity must be replaced with a Bernoulli-type theory, which accounts for gas density and temperature changes. If the gas stream flow is supersonic, or the stream velocity is greater than the speed of sound of the gas, a shock wave forms in front of the probe and the theory must be further corrected by complicated supersonic-flow algebraic relations. See COMPRESSIBLE FLOW; GAS DYNAMICS; SHOCK WAVE.

A disadvantage of pitot and pitot-static tubes is that they have substantial dynamic resistance to changing conditions and thus cannot accurately measure unsteady, accelerating, or fluctuating flows. See ANEMOMETER; FLOW MEASUREMENT. [F.M.Wh.]

**Pituitary gland** The most structurally and functionally complex organ of the endocrine system. Through its hormones, the pituitary, also known as the hypophysis, affects every physiological process of the body. All vertebrates have a pituitary gland with a common basic structure and function. In addition to its endocrine functions, the pituitary may play a role in the immune response.

The hypophysis of all vertebrates has two major segments—the neurohypophysis (a neural component) and the adenohypophysis (an epithelial component)—each with a different embryological origin. The neurohypophysis develops from a downward process of the diencephalon (the base of the brain), whereas the adenohypophysis originates as an outpocketing of the primitive buccal epithelium, known as Rathke's pouch. The adenohypophysis has three distinct subdivisions: the pars tuberalis, the pars distalis, and the pars intermedia. The neurohypophysis comprises the pars nervosa and the infundibulum. The latter consists of the infundibular stalk and the median eminence of the tuber cinereum.

The structural intimacy of neurohypophysis and adenohypophysis that is established early during embryogenesis reflects the direct functional interaction between the central nervous system and endocrine system. The extent of this anatomical intimacy varies considerably among the vertebrate classes, from limited contact to intimate interdigitation. Vascular or neuronal pathways, or both, provide the means of exchanging chemical

signals, thus enabling centers in the brain to exert control over the synthesis and release of adenohypophysial hormones.

Neurohormones, which are synthesized in specific regions of the brain, are conveyed to the neurohypophysis by way of axonal tracts, where they may be stored in distended axonal endings. Axons may also contact blood vessels and discharge their neurosecretory products into the systemic circulation or into a portal system leading to the adenohypophysis, or they may directly innervate pituitary gland cells. See NEUROSECRETION.

In most animals, the vascular link is the prime route of information transfer between brain and pituitary gland. This link begins in the tuber cinereum, the portion of the third ventricle floor that extends toward the infundibulum. The lower tuber cinereum, which is known as the median eminence, is well endowed with blood vessels that drain down into the pituitary stalk and ultimately empty into the anterior pituitary. The vascular link between the median eminence and the pituitary gland is known as the hypothalamo-hypophysial portal system. The median eminence in humans is vascularized by the paired superior hypophysial arteries. The pituitary gland is believed to have the highest blood flow rate of any organ in the body. However, its blood is received indirectly via the median eminence and the hypothalamo-hypophysial portal system. Most of the blood flow is from the brain to the pituitary gland, with retrograde flow from the adenohypophysis to the hypothalamus, suggesting a two-way communication between nervous and endocrine systems. Although the brain is protected from the chemical substances in the circulatory system by the blood-brain barrier, the median eminence lies outside that protective mechanism and is therefore permeable to intravascular substances. See BRAIN.

The hormones of the adenohypophysis may be grouped into three categories based on chemical and functional similarities. The first category consists of growth hormone (also known as somatotropin) and prolactin, both of which are large, single, polypeptide chains; the second category consists of the glycoprotein hormones; this family of hormones contains the gonadotropins and thyrotropin. The gonadotropins in many species, including humans, can be segregated into two distinct hormones, follicle-stimulating hormone and luteinizing hormone. The third group comprises adrenocorticotrophic hormone and melanotropin (MSH; melanocyte-stimulating hormone). See ADENOHYPOPHYSIS HORMONE.

The regulation of the release of pituitary hormones is determined by precise monitoring of circulating hormone levels in the blood and by genetic and environmental factors that manifest their effect through the releasing and release-inhibiting factors of the hypothalamus. The hypothalamus is located at the base of the brain (the diencephalon) below the thalamus and above the pituitary gland, forming the walls and the lower portion of the third ventricle. It receives major neuronal inputs from the sense organs, hippocampus, thalamus, and lower brainstem structures, including the reticular formation and the spinal cord. Thus, the hypothalamus is designed and anatomically positioned to receive a diversity of messages from external and internal sources that can be transmitted by way of hypothalamic releasing factors to the pituitary gland, where they are translated into endocrine action. See NERVOUS SYSTEM (VERTEBRATE).

The neurohypophysis hormones, oxytocin and vasopressin, are synthesized in different neurons of the paraventricular and supraoptic nuclei of the hypothalamus and travel by axonal flow to the terminals in the neurohypophysis for storage and ultimate release into the vascular system. Oxytocin is important in stimulating milk release through its contractile action on muscle elements in the mammary gland. It also stimulates uterine smooth muscle contraction at parturition. Vasopressin affects water retention by its action on certain kidney tubules. Thus, it also affects blood pressure. See LACTATION; NEUROHYPOPHYSIS HORMONE.

The better-known neurotransmitters of the central nervous system include the catecholamines (dopamine, epinephrine, and norepinephrine), serotonin, acetylcholine, gamma-amino

butyric acid (GABA), histamine, and the opioid peptides (enkephalins, endorphins, dynorphin, neendorphin, rimorphin, and leuromorphin). These substances are distributed widely in the central nervous system and, for most, also in the pituitary gland. If a particular amine or neurotransmitter is present in nerve fibers leading to the median eminence, it probably will influence pituitary gland activity via the portal system. Dopamine, serotonin, gamma-amino butyric acid, and acetylcholine are best known for such activity. These neurotransmitters play an important, but poorly understood, role in regulating pituitary function, either directly or by their action on neuropeptide-producing neurons. Understanding the pharmacology of neurotransmitters holds promise for the treatment of basic disorders of the hypothalamic-pituitary axis. See ACETYLCHOLINE; ENDOCRINE MECHANISMS; ENDOCRINE SYSTEM (VERTEBRATE); ENDORPHINS; HISTAMINE; HORMONE; NEUROBIOLOGY; NEUROIMMUNOLOGY; PITUITARY GLAND DISORDERS; SEROTONIN. [M.P.S.]

**Pituitary gland disorders** Inborn or acquired abnormalities in the structure or function of the human pituitary gland. Pituitary disorders can stem from any of five disease processes: tumors and other growths, intrinsic lesions of the anterior lobe, diseases affecting gland function, hypothalamic malfunction, and systemic disease that affects the adenohypophysis.

Tumors and other growths in and near the pituitary may cause failure of hormone secretion or impinge on nearby brain structures. The latter effect can give rise to neurological malfunctions, the most common of which is visual impairment such as narrowing of the visual fields. Intrinsic lesions of the anterior pituitary, usually benign, secrete excessive amounts of a single (rarely multiple) hormone, producing characteristic endocrine syndromes, the most dramatic of which are acromegaly and Cushing's disease. Infections, congenital anomalies, granulomas, vascular disorders, and, rarely, metastatic cancers may induce partial or total failure of one or more pituitary secretions, in which case growth hormone, follicle-stimulating hormone, and luteinizing hormone are the first to fail.

Diseases of the hypothalamus affect pituitary function through the mechanical effects of a mass or through disrupted secretion of the hypophysiotropic peptides. Typical manifestations include precocious or delayed puberty; diabetes insipidus; and derangements of sleep, eating, and temperature regulation. The dysfunction may be of congenital, traumatic, inflammatory, or neoplastic origin. However, the most important hypothalamic-pituitary diseases are tertiary hypothyroidism, precocious or delayed puberty, diabetes insipidus, and Kallmann's syndrome, which consists of a deficient sense of smell and lack of sexual development due to inborn failure of the hypothalamus to secrete gonadotropin-releasing hormone. Hypothalamic disorders can cause abnormalities of growth hormone secretion. Whereas most individuals with acromegaly (an excess of growth hormone) have intrinsic pituitary tumors that secrete growth hormone, some have excessive secretion of hypothalamic growth hormone-releasing hormone or insufficient secretion of somatostatin. Pituitary dwarfism, caused by the failure to secrete growth hormone in childhood, is usually due to primary disease of the adenohypophysis, but in some individuals the fundamental dysfunction (opposite to that in acromegaly) lies in the hypothalamus. See DIABETES; DWARFISM AND GIGANTISM; SOMATOSTATIN; THYROID GLAND DISORDERS.

The adenohypophysis can be affected subtly by systemic diseases, or more obviously by metastases from breast cancer. Prolonged treatment with large doses of adrenal corticosteroids, as in cases of lupus, asthma, or acute leukemia, can result in the failure of the adenohypophysis to secrete adrenocorticotropic hormone in times of physical stress. A deficiency in adrenocorticotropic hormone is a potentially fatal condition. See ADENOHYPOPHYSIS HORMONE; ADRENAL GLAND DISORDERS; ENDOCRINE MECHANISMS; PITUITARY GLAND. [N.Ch.]

**pK** The logarithm (to the base 10) of the reciprocal of the equilibrium constant for a specified reaction under specified conditions (for example, solvent and temperature). The pK values are often more convenient to tabulate and use than the equilibrium constants themselves. The value of  $K$  for the dissociation of the  $\text{HSO}_4^-$  ion in aqueous solution at  $25^\circ\text{C}$  ( $77^\circ\text{F}$ ) is 0.0102 mole/liter. The logarithm is  $0.008_6 - 2 = -1.991_4$ . The pK is therefore  $+1.991_4$ . The choice of algebraic sign, although arbitrary, results in positive values for most dissociation constants applicable to aqueous solutions. The concept of pK is especially valuable in the study of solutions. See CHEMICAL EQUILIBRIUM; IONIC EQUILIBRIUM; pH. [T.F.Y.]

**Placentation** The intimate association or fusion of a tissue or organ of the embryonic stage of an animal to its parent for physiological exchange to promote the growth and development of the young. It enables the young, retained within the body or tissues of the mother, to respire, acquire nourishment, and eliminate wastes by bringing the bloodstreams of mother and young into close association but never into direct connection. Placentation characterizes the early development of all mammals except the egg-laying duckbill platypus and spiny anteater. It occurs in some species of all other orders of vertebrates except the birds. In fact, in certain sharks and reptiles it is almost as well developed as in mammals. A few examples are also known among invertebrates (*Peripatus*, certain tunicates, and insects). See FETAL MEMBRANE.

Efficient interchange depends on close proximity of large areas of fetal tissues to maternal blood and glandular areas. This is provided in mammals by a remarkable regulatory cooperation between the developing outer layer (trophoblast) of the chorion, together with the vascular yolk sac or allantois or both, and the mother's uterine lining (endometrium). In the typical mammalian placenta, which is always formed by the chorion and the allantoic vessels, the fetal and maternal bloodstreams are as close as a few thousandths of a millimeter from each other (see illustration). The surface area of the fetal villi which contain the functional fetal capillaries is probably several times larger than the

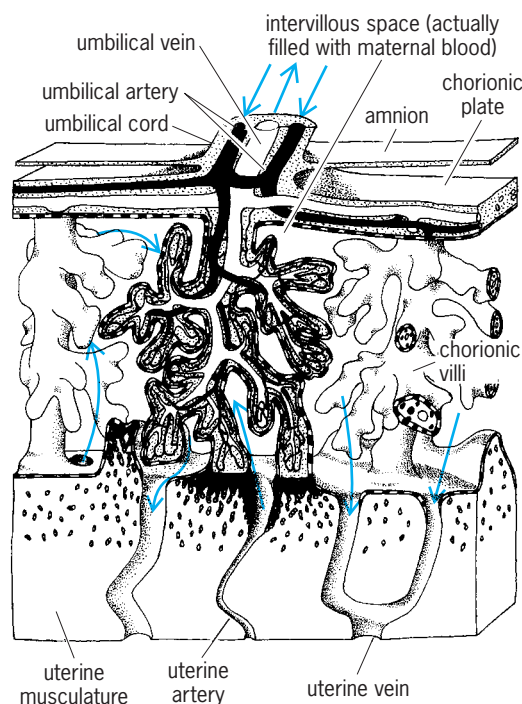

Block removed from center of human placenta.



body surface of the female. In humans this ratio is known to be about 8:1. [H.W.Mo.]

**Placer mining** The exploitation of placer mineral deposits for their valuable heavy minerals. Placer mineral deposits consist of detrital natural material containing discrete mineral particles. They are formed by chemical and physical weathering of in-place heavy minerals, which are then concentrated through the action of wind or moving water. This concentration can be done through wave and current action in the ocean (beach and offshore placers), glacial action (moraine placers), wind action removing the lighter material (eolian placers), or the action of running water (stream placers). Stream placers are the most important of these deposits because of their common occurrence and their highly efficient concentration mechanisms. Marine placers, primarily beach placers, are the next most economically important, with the potential of offshore placers being the most recent to be recognized and developed. See MARINE MINING; ORE AND MINERAL DEPOSITS.

Minerals that are concentrated in placer deposits are a result of differences in specific gravity and, therefore, the economically important deposits are for minerals with high specific gravities [for example, gold (specific gravity 15–19), and platinum (14–19)].

Precious metals, primarily gold and platinum group metals, have been the most important product from placer mines. Their extremely high specific gravity coupled with their low chemical reactivity means that these minerals are efficiently concentrated in a placer environment and can be effectively recovered in a readily usable form. Although most modern gold is produced from lode, or “hard rock,” deposits, the placer deposits of northern Canada, Alaska, and Siberia represent a virtually untapped source of the metal. See GOLD; PLATINUM.

Of more importance than gold are placer diamond deposits. Another important placer mineral is cassiterite, an ore of tin. Additionally, rutile and ilmenite, the principal ores of titanium, are found in commercial quantities only in beach placers. These same types of placers also yield monazite, a source of the rare earths yttrium, lanthanum, cerium, and thorium. See CASSITERITE; DIAMOND; ILMENITE; RUTILE.

Most placer mining operations involve surface mining methods, although underground methods are sometimes used. See SURFACE MINING; UNDERGROUND MINING.

The two major environmental problems associated with placer mining are water pollution and land disturbance. Both the mining and the processing of placer minerals require a great deal of water, and, once used, this water contains large amounts of suspended solids. If the water is allowed to run off into the rivers, these solids can have an adverse impact on the downstream environment. In suspension they can harm aquatic habitats, and when settled out can clog waterways and choke off irrigated crops. Since most placer mining is surface mining, surface disturbance is necessary, especially where dredging operations create vast piles of cobbles as mining progresses. One method of land reclamation is a mining plan which stockpiles top soil (where possible), recontours the spoil (waste) piles, and then returns the land to useful status. See ENVIRONMENTAL ENGINEERING; LAND RECLAMATION; WATER POLLUTION. [D.L.Tay.]

**Placodermi** A class of fishes known from the Devonian Period, and a few that survived into the base of the Carboniferous. They were true fishes or gnathostomes, and can be distinguished from other fishes by the following characters: the gill chamber extends far under the cranium and is covered laterally by opercula; there is a neck joint between the cranium and the fused anterior vertebrae; often there is also a coaxial joint developed between the dermal bones of the cranial roof and shoulder girdle; the head and shoulder girdle are covered with dermal bones composed typically of cellular bone and superficially of semidentine instead of true dentine; the bones are commonly ornamented

with tubercles or ridges; the endoskeleton is cartilage and may be calcified in a globular fashion or perichondrally ossified; the notochord is persistent, and the vertebrae consist only of neural and hemal arches; the tail is diphyccercal or slightly heterocercal, and an anal fin is lacking.

Most placoderms were bottom-dwelling fishes, with the head and trunk dorsoventrally depressed; only the Stensioellida and some specialized arthrodires had laterally compressed and deepened bodies, suggesting a more nectic manner of life. Most of them were small or moderate-sized, but a few were, for their time, gigantic, reaching a length of as much as 20 ft (6 m). They were the dominant fishes of the Devonian, and are found in both marine and fresh-water deposits.

The Placodermi are subdivided into nine orders, each with its own distinct specializations: Stensioellida, Pseudopetalichthyida, Rhenanida, Ptyctodontida, Anthracothoraci, Petalichthyida, Phyllolepidia, Arthrodira, and Antiachi. The evolution and interrelations of these orders are matters of disagreement. [R.H.De.; E.C.O.]

**Placodontia** A small but interesting order of marine reptiles of the subclass Euryapsida that are known only from deposits of Triassic age of Europe and the Near East (Israel). As the name implies, they are reptiles with grossly specialized dentitions—flat-crowned teeth are located in both the upper and lower jaws and on the palate—that probably functioned as crushing devices for hard-shelled prey.

The modification of the dentition had its effect on the entire skull, which became massive in relation to the body; and the coronoid region of the mandible, to which most of the masticatory muscles were attached, became greatly extended upward, giving it a superficial similarity to a mammalian jaw. The postcranial skeleton shows a number of aquatic adaptations. The thorax was box-shaped and the digits of hand and foot were probably webbed; the joint surfaces of the limb bones suggest that the animals did little if any walking on land. The advanced placodonts resemble sea turtles in overall appearance and in the fact that their body is encased in an armor of dermal bones similar to that of the dermochelyid sea turtle *Psephophorus*. The more generalized genera lack such an armor and possess a long tail. See REPTILIA. [R.Z.]

**Plague** An infectious disease of humans and rodents caused by the bacterium *Yersinia pestis*. The sylvatic (wild-animal) form persists today in more than 200 species of rodents throughout the world. The explosive urban epidemics of the Middle Ages, known as the Black Death, resulted when the infection of dense populations of city rats living closely with humans introduced disease from the Near East. The disease then was spread both by rat fleas and by transmission between humans. During these outbreaks, as much as 50% of the European population died. At present, contact with wild rodents and their fleas, sometimes via domestic cats and dogs, leads to sporadic human disease. See INFECTIOUS DISEASE.

After infection by *Y. pestis*, fleas develop obstruction of the foregut, causing regurgitation of plague bacilli during the next blood meal. The rat flea, *Xenopsylla cheopsis*, is an especially efficient plague vector, both between rats and from rats to humans. Human (bubonic) plague is transmitted by the bite of an infected flea; after several days, a painful swelling (the bubo) of local lymph nodes occurs. Bacteria can then spread to other organ systems, especially the lung; fever, chills, prostration, and death may occur. Plague pneumonia develops in 10–20% of all bubonic infections. In some individuals, the skin may develop hemorrhages and necrosis (tissue death), probably the origin of the ancient name, the Black Death. The last primary pneumonic plague outbreak in the United States occurred in 1919, when 13 cases resulting in 12 deaths developed before the disease was recognized and halted by isolation of cases.

Bubonic plague is suspected when the characteristic painful, swollen glands develop in the groin, armpit, or neck of an individual who has possibly been exposed to wild-animal fleas in an area where the disease is endemic. Immediate identification is possible by microscopic evaluation of bubo aspirate stained with fluorescent-tagged antibody. Antibiotics should be given if plague is suspected or confirmed. Such treatment is very effective if started early. The current overall death rate, approximately 15%, is reduced to less than 5% among patients treated at the onset of symptoms. See IMMUNOFLUORESCENCE; MEDICAL BACTERIOLOGY.

[D.L.Pa.]

**Plains** The relatively smooth sections of the continental surfaces, occupied largely by gentle rather than steep slopes and exhibiting only small local differences in elevation. Because of their smoothness, plains lands, if other conditions are favorable, are especially amenable to many human activities. Thus it is not surprising that the majority of the world's principal agricultural regions, close-meshed transportation networks, and concentrations of population are found on plains. Large parts of the Earth's plains, however, are hindered for human use by dryness, shortness of frost-free season, infertile soils, or poor drainage. Because of the absence of major differences in elevation or exposure or of obstacles to the free movement of air masses, extensive plains usually exhibit broad uniformity or gradual transition of climatic characteristics.

Somewhat more than one-third of the Earth's land area is occupied by plains. With the exception of ice-sheathed Antarctica, each continent contains at least one major expanse of smooth land in addition to numerous smaller areas. The largest plains of North America, South America, and Eurasia lie in the continental interiors, with broad extensions reaching to the Atlantic (and Arctic) Coast. The most extensive plains of Africa occupy much of the Sahara and reach south into the Congo and Kalahari basins. Much of Australia is smooth, with only the eastern margin lacking extensive plains. See TERRAIN AREAS.

Surfaces that approach true flatness, while not rare, constitute a minor portion of the world's plains. Most commonly they occur along low-lying coastal margins, the lower sections of major river systems, or the floors of inland basins. Nearly all are the products of extensive deposition by streams or in lakes or shallow seas. The majority of plains, however, are distinctly irregular in surface form, as a result of valley-cutting by streams or of irregular erosion and deposition by continental glaciers.

[E.H.Ha.]

**Planck's constant** A fundamental physical constant which represents the elementary quantum of action, action being defined as energy multiplied by time. Introduced by Max Planck in 1900, it has the value  $h = 6.6261 \times 10^{-27}$  erg-second or  $6.6261 \times 10^{-34}$  joule-second. The symbol  $\hbar$  sometimes called the Dirac  $h$ , is often used for convenience in physics to denote the quantity  $h/2\pi$ , where  $\pi = 3.1416\dots$

As used by Planck in deriving his radiation law,  $h$  multiplied by the frequency of radiation represented a bundle of energy, that is, a quantum of energy. Radiant energy at any wavelength can occur only as multiples of this energy; thus energy is quantized. See COMPTON EFFECT; FUNDAMENTAL CONSTANTS; HEAT RADIATION; QUANTUM MECHANICS.

[H.G.S./P.J.W.]

**Planck's radiation law** A law of physics which gives the spectral energy distribution of the heat radiation emitted from a so-called blackbody at any temperature. Discovered by Max Planck, this law laid the foundation for the advent of the quantum theory because it was the first physical law to postulate that electromagnetic energy exists in discrete bundles, or quanta. See HEAT RADIATION; QUANTUM MECHANICS.

[H.G.S./P.J.W.]

**Plane curve** The locus of points in the euclidean plane that satisfy some geometric or algebraic definition. Not all sets of points deserve to be called a curve, but the distinction is some-

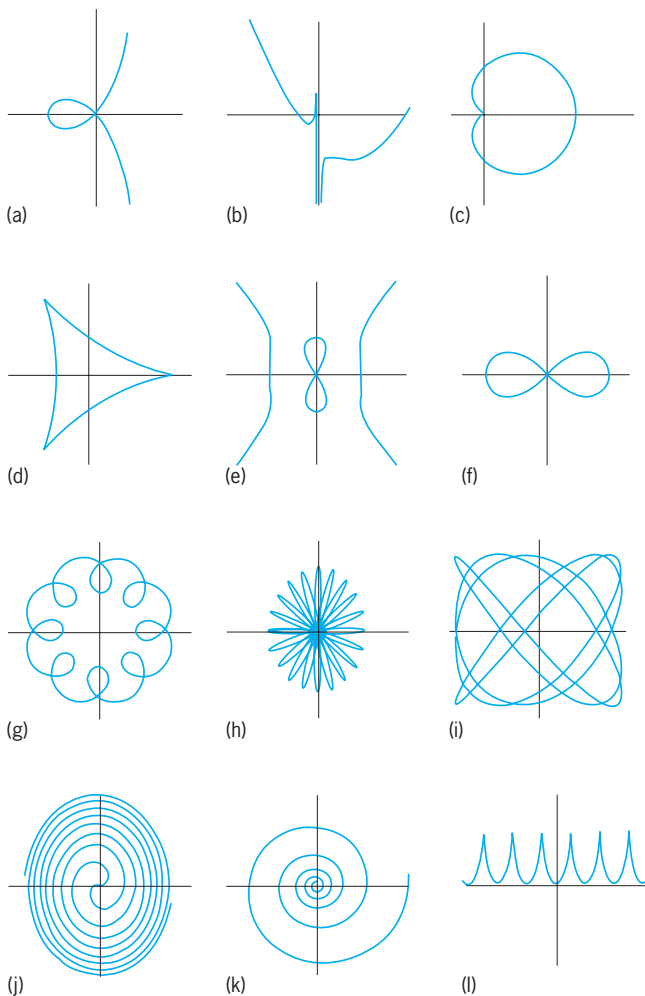

Plane curves. (a) Right strophoid. (b) Trident of Newton. (c) Cardioid. (d) Deltoid. (e) Devil on two sticks. (f) Lemniscate of Bernoulli. (g) Epitrochoid. (h) Rhodona. (i) Bowditch curve. (j) Fermat's spiral. (k) Logarithmic spiral. (l) Cycloid.

what arbitrary. For most of this article, a curve is considered to be the locus of a set of points that satisfy an algebraic or transcendental equation in two variables.

The most interesting geometric properties are those preserved by linear transformations, especially translations, rotations, reflections, and magnifications. Useful geometric properties include the number of branches into which the curve is divided; the number and degree of nodes, cusps, isolated points, and flex points; the number of loops; symmetries; branches that go to infinity; and asymptotes.

These terms can be defined informally as follows. A branch is a maximal smooth continuous portion of the curve. A multiple point is a point in the plane that lies on two or more branches; its degree is the number of branches involved. A node is a multiple point where the branches cross. A cusp is a multiple point where the branches meet but do not pass; that is, each of the branches ends at that point. An isolated point is a point of the curve through which no branches pass. Multiple and isolated points are collectively termed singular points. Any point that is not singular is termed ordinary. A flex (or point of inflection) is a point on the curve whose tangent cuts the curve. A smooth closed branch forms a loop. A curve is symmetric about a line  $L$  if every line perpendicular to  $L$  intersects the curve at equal distances from  $L$  on opposite sides of  $L$ ; that is, portions of the curve form mirror images about  $L$ . The curve is symmetric about a point  $P$  if every line through  $P$  intersects the curve at equal distances from  $P$  in opposite directions. An asymptote is a line

toward which a branch approaches as it moves to infinity from the origin; the curve and line are said to intersect at infinity.

In addition to these geometric properties, the form of the defining equation is of interest. This can be an algebraic (polynomial in  $x$  and  $y$ ) or transcendental equation. In the former case, quadratic, cubic, and quartic equations are of special interest.

Once a coordinate system has been chosen, and the defining equation is known (in any of the forms, though the parametric form is usually the most useful), various properties of the curve can be defined in terms of the equation. These include the locations of  $x$ - and  $y$ -intercepts, local maxima and minima, flexes, nodes, and cusps. See ANALYTIC GEOMETRY.

The illustration shows some of the many plane curves of sufficient historical interest to have received names. See CARDIROID; CYCLOID; LEMNISCATE OF BERNOULLI; ROSE CURVE. [J.D.L.]

**Plane geometry** The branch of mathematics that deals with geometric figures, that is, collections of points that all lie in the same plane (coplanar). Although the words "point" and "plane" are undefined concepts, for elementary applications the intuitive meanings will serve: a point is a location, and a plane is a flat surface. For similar definitions, together with a discussion of the postulates and axioms (assumed truths) used in plane geometry, See EUCLIDEAN GEOMETRY.

**Dimensions and measures.** There are three spatial dimensions; geometric figures are classified as being zero, one, two, or three dimensional. Plane geometry deals only with geometric figures having fewer than three dimensions. Three-dimensional geometric figures, called solids, are dealt with in another branch of euclidean geometry. See SOLID (GEOMETRY).

A dimension is any measurement associated with a geometric figure that has units of length. The measure of a geometric figure is a number multiplied by a power of a length, with the result giving information about the size of the figure. The power of the length will be 1, 2, or 3, depending on whether the figure is one, two, or three dimensional. See UNITS OF MEASUREMENT.

**Lines, line segments, and rays.** Exactly one line passes through two given points. The part of a line between (and including) two points is called a line segment, with the two defining points being the end points of the segment. That part of a line that lies on one side of a point (together with that point) is called a ray.

**Angles.** An angle is the geometric figure formed by joining two rays having a common end point. Each ray is a side of the angle; the common end point is the vertex of the angle.

The concept of the measure of an angle may be understood by imagining that one ray of an angle is held fixed but the other ray is hinged at the vertex and allowed to rotate in the plane. A measure of the angle is a number, together with some unit of angular measure, that tells how much the hinged ray would need to be rotated so that it would overlie the fixed ray. If a ray were to be rotated exactly one revolution, it would return to its original position. The measure of an angle can be what fraction of one revolution would enable one side of the angle to become coincident with the other.

The revolution is a convenient unit of angular measure for many applications. However, a more commonly used unit is the degree, which is defined by  $360^\circ = 1$  revolution. In the modern-day use of calculators and computers, fractions of degrees are most conveniently expressed by using decimal fractions; however, another subdivision of degrees is firmly entrenched in many applications: 1 degree = 60 minutes ( $1^\circ = 60'$ ), and 1 minute = 60 seconds ( $1' = 60''$ ).

An angle of measure  $1/4$  revolution, or  $90^\circ$ , is called a right angle. Two lines (or rays or segments) that intersect so as to form a right angle are said to be perpendicular. Two angles are complementary if their measures have a sum of  $90^\circ$ . An angle of measure  $1/2$  revolution, or  $180^\circ$ , is called a straight angle. Two angles are supplementary if their measures have a sum of  $180^\circ$ .

**Polygons.** A polygon is the geometric figure formed when line segments are joined end to end so as to enclose a region of the plane. The polygon having the least number of sides (three) is the triangle. An angle whose sides are two of those segments and whose arc lies inside the triangle is an interior angle of the triangle; an exterior angle of the triangle is any angle that is adjacent and supplementary to an interior angle. The interior angles of any triangle have measures that sum to  $180^\circ$ . This fact allows the determination of the measures of all angles formed by the intersections of three lines if the measures of only two angles with different vertices are known. See POLYGON.

**Congruent and similar geometric figures.** Two geometric figures are congruent ( $\cong$ ) if they have exactly the same shape and size. If two geometric figures are congruent, one figure could be made to overlie the other by a combination of these types of motion: translation (sliding), rotation (twisting), and reflection about a line (flipping over). The parts of the geometric figures that would then coincide are called corresponding parts, where a part of a geometric figure is any set of points associated with that figure.

Two geometric figures are similar ( $\sim$ ) if they have the same shape but (perhaps) have different sizes. If two geometric figures are similar, one figure could be made to overlie the other by a combination of translation, rotation, reflection, and either expanding or shrinking. The parts that would then coincide are corresponding.

**Circles.** A circle is a collection of points in the plane, all of which are the same distance from another point, called the center. The region bounded by a circle sometimes is called a disk. Circumference means either the circle that is the boundary curve of a disk or the distance around that circle. A radius of a circle is any line segment that joins the center and a point of a circle. A chord is any line segment whose end points lie on the circle. A diameter is any chord that contains the center. A secant is a line that intersects a circle in two points. A tangent is a line that intersects a circle in only one point, called the point of tangency.

Associated with a circle are several important dimensions, including the lengths of a radius and a diameter, usually denoted, respectively, by  $r$  and  $d$ . These symbols appear in almost all formulas involving the length of the circumference  $C$  or the area  $A$  enclosed by a circle. Relationships between these variables for any circle are given by the equations

$$d = 2r \quad C = \pi d \quad A = \pi r^2$$

In these formulas,  $\pi$  (the lowercase Greek letter pi) represents the irrational number (value 3.141592 . . .) that is usually defined as the ratio of the circumference to the diameter of any circle. See CIRCLE. [H.L.Ba.]

**Planer** A machine for the shaping of long, flat, or flat contoured surfaces by reciprocating the workpiece under a stationary single-point tool or tools. Usually the workpiece is too large to be handled on a shaper.

Planers are built in two general types, open-side or double-housing. The former is constructed with one upright or housing to support the crossrail and tools. The double-housing type has an upright on either side of the reciprocating table connected by an arch at the top. See WOODWORKING. [A.H.T.]

**Planet** A relatively small, solid celestial body moving in orbit around a star, in particular the Sun.

**Planets of the solar system.** The nine known planets of the solar system are Mercury, Venus, Earth, Mars, Jupiter, Saturn, Uranus, Neptune, and Pluto; in addition, over 20,000 minor planets, or asteroids, mostly located between the orbits of Mars and Jupiter, are known (see illustration). See ASTEROID; JUPITER; MARS; MERCURY (PLANET); NEPTUNE; PLUTO; SATURN; URANUS; VENUS.

There are two basic groups of planets in the solar system: the small, dense, terrestrial planets—Mercury, Venus, Earth, Mars,

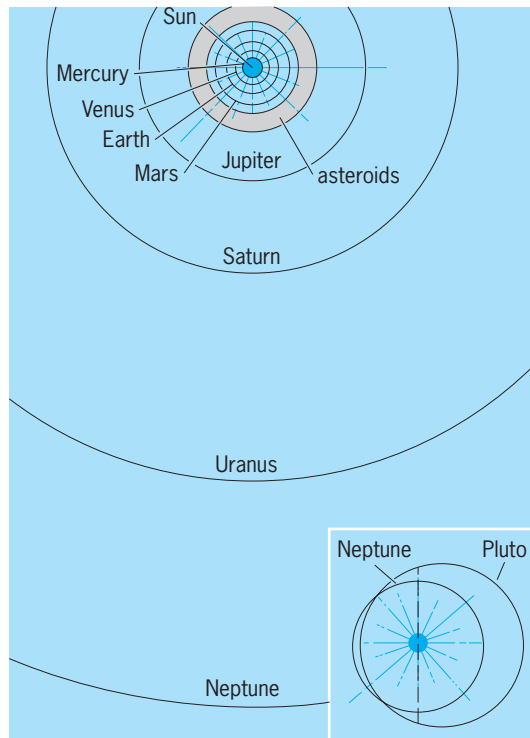

Plan of the solar system. (After L. Rudaux and G. de Vaucouleurs, *Larousse Encyclopedia of Astronomy*, Prometheus Press, 1959)

and Pluto—and the giant or Jovian planets—Jupiter, Saturn, Uranus, and Neptune. With the exception of Pluto, the terrestrial planets are all located within the inner solar system. The low-density Jovian planets extend outward from Jupiter to the remote reaches of the solar system. This distribution is not accidental, but is related to the fractionation of rocky, icy, and gaseous materials during the early stages of formation of the solar system. See PLANETARY PHYSICS; SOLAR SYSTEM.

The planets may also be divided into inferior planets, Mercury and Venus, located inside Earth's orbit, and superior planets, from Mars to Pluto, circulating outside Earth's orbit.

The motions of the planets in their orbits around the Sun are governed by three laws discovered by Johannes Kepler at the beginning of the seventeenth century.

First law: The orbit of a planet is an ellipse, with the Sun at one of its foci.

Second law (the law of areas): As a planet revolves in its orbit, the radius vector (the line from the Sun to the planet) sweeps out equal areas in equal intervals of time.

Third law (the harmonic law): The square of the period of revolution is proportional to the cube of the orbit's semimajor axis.

Kepler's laws are true only when the mutual perturbations of the motions of the planets by the others are neglected. Table 1 gives the mean distances of the planets from the Sun and the sidereal periods of revolution. See CELESTIAL MECHANICS; KEPLER'S LAWS.

In the course of their motions around the Sun, Earth and other planets occupy a variety of relative positions or configurations. The inferior planets are in conjunction with the Sun when closest to the Earth-Sun line, either between Earth and the Sun (inferior conjunction) or beyond the Sun (superior conjunction). On rare occasions when the planet is very close to the plane of Earth's orbit at the time of an inferior conjunction, a transit in front of the Sun is observed. Between conjunctions, the geocentric angular distance from the planet to the Sun, or the elongation, varies up

Table 1. Planetary orbits

Planet	Mean distance from Sun (semimajor axis of orbit)			Sidereal period of revolution	
	AU	10 <sup>6</sup> mi	10 <sup>6</sup> km	Years	Days
Mercury	0.387	36.0	57.9	0.241	87.97
Venus	0.723	67.2	108.2	0.615	224.70
Earth	1.000	93.0	149.6	1.000	365.24
Mars	1.524	141.6	227.9	1.881	686.93
Jupiter	5.203	483.6	778.3	11.857	4,330.60
Saturn	9.555	888.2	1,429.4	29.424	10,746.9
Uranus	19.22	1,786.	2,875.	83.75	30,588.7
Neptune	30.11	2,799.	4,504.	164.72	59,799.9
Pluto	39.54	3,676.	5,916.	248.0	90,589.

to a maximum value. The superior planets are not so limited, and their elongations can reach up to 180° when they are in opposition with the Sun. See TRANSIT (ASTRONOMY).

The combinations of the orbital motions of Earth and of any other planet give rise to complicated apparent motions of the planets as seen from Earth. Because the orbits of the main planets are, except for Pluto, only slightly inclined to the plane of the orbit of Earth, the apparent paths of the planets (except Pluto) are restricted to the zodiac, a belt 16° wide centered on the ecliptic. The ecliptic is the path in the sky traced out by the Sun in its apparent annual journey as the Earth revolves around it. See ASTRONOMICAL COORDINATE SYSTEMS; ECLIPTIC.

The apparent motions with respect to the celestial sphere, that is, to the fixed stars, appear for the inferior planets as oscillations back and forth about the position of the Sun steadily moving eastward among the stars. For the superior planet the apparent motion is generally eastward or direct, but for short periods near the time of opposition it is westward or retrograde.

The size, mass, density, and rotation period of each of the planets is given in Table 2. [J.K.B.]

**Extrasolar planets.** It is technically very challenging to detect planets orbiting Sun-like stars. Planets do not generate light; they shine only by the reflected light of the host star. The largest (and easiest to detect) planet in the solar system, Jupiter, is 10<sup>9</sup> times fainter than the Sun. Although a photograph of a Jupiter-like planet orbiting another star is beyond current technology, a number of strategies have been suggested that might be capable of taking direct images of Jupiter-like, or even Earth-like, planets within a few decades.

In the meantime, the presence of extrasolar planets must be deduced by indirect means. The two most developed techniques, astrometry and Doppler spectroscopy, rely on the gravitational perturbations that giant planets impose on their host stars. For example, the Sun and Jupiter jointly orbit a common center of mass, which lies on the line connecting the Sun and Jupiter, just outside the surface of the Sun. A hypothetical alien astronomer

Table 2. Physical characteristics of the Sun's planets

Planet	Equatorial radius (Earth = 1)	Mass (Earth = 1)	Density, g/cm <sup>3</sup>	Rotation period
Mercury	0.38	0.055	5.43	58 d 15.5 h
Venus	0.95	0.815	5.20	243 d 0.5 h
Earth	1.00	1.000	5.52	23 h 56 m 23 s
Mars	0.53	0.107	3.34	24 h 37 m 23 s
Jupiter	11.21	317.710	1.33	9 h 55 m 30 s*
Saturn	9.45	95.162	0.69	10 h 39 m 22 s*
Uranus	4.01	14.535	1.32	17 h 22.2 m*
Neptune	3.88	17.141	1.64	16 h 6.6 m*
Pluto	0.18	0.002	2.0	6 d 9 h 17.6 m

\*Internal (System III) rotation period, the rotation period of the planet's core, as deduced from its magnetic field.

could detect the presence of Jupiter either by noting that the position of the Sun is periodically wobbling about against the background stars (astrometry), or by measuring the periodic velocity variation of the Sun (Doppler spectroscopy) as Jupiter pulls the Sun about their common center of mass. Such measurements would reveal the orbital period and the magnitude of the wobble. From these data, the orbital radius and mass of the unseen Jupiter could be calculated from Kepler's third law of planetary motion and the principle of momentum conservation. See ASTROMETRY; DOPPLER EFFECT.

The Doppler spectroscopy method provided the first definitive detections of extrasolar planets orbiting normal stars. Any wave (sound or light) emitted by a moving object will be shifted as observed by a stationary observer. The velocity of the emitting object can be directly deduced from the magnitude of this frequency (or wavelength) shift. Doppler velocities are calculated based on the measured wavelength shift of absorption lines in stellar spectra. See ASTRONOMICAL SPECTROSCOPY; FRAUNHOFER LINES.

The first confirmed discovery of an extrasolar planet orbiting a normal star was announced in 1995 by Michel Mayor and Didier Queloz. They discovered that the Sun-like star 51 Pegasi periodically changes in its velocity by 187 ft/s (57 m/s) every 4.2 days (Fig. 7). This implies that a planet with about one-half of a Jupiter mass orbits the star at a distance of only  $5 \times 10^6$  mi ( $8 \times 10^6$  km), 20 times closer than the Earth is to the Sun. This result was completely unexpected. Virtually all theoretical predictions of planet formation suggested that giant Jupiter-like planets should form more than 3 astronomical units away from their host stars. [R.PBu.]

Doppler surveys for extrasolar planets have been expanded to include about 2000 stars, providing a nearly complete sample of Sun-like stars within 30 parsecs (100 light-years). By March 2004, 111 extrasolar planets had been discovered orbiting normal stars. Of these, 24 orbit at distances less than 0.15 AU from their parent stars (with periods ranging from 3 to 30 days), indicating that at least several percent of all stars have extremely close planetary companions. These 51 Pegasi-like planets are thought to have formed considerably farther from their host stars and then migrated inward when their orbits were destabilized by gravitational interactions with other planets or with material in the circumstellar disk. See PROTOSTAR.

Most of the remaining 87 planets that have been discovered orbiting at distances of 0.15 AU or more travel in elliptical orbits. Indeed, all but 15 of these orbits have eccentricities greater than 0.1, whereas Jupiter and the other giant solar system planets have eccentricities of around 0.05 or less. This result, like the discovery of the 51 Pegasi-like planets, was unexpected. The nearly circular orbits of solar system planets had led to the expectation that extrasolar planets would travel in circular orbits as well. Planets probably form from disks of gas and dust following circular orbits, and friction within these disks can be expected to circularize the planetary orbits. Several explanations have been proposed for the elliptical orbits: gravitational scattering among giant planets; gravitational perturbations exerted by a companion or passing star, or by the protoplanetary disk; or instabilities in the disk.

Because many of the extrasolar planets orbit extremely close to their host stars, astronomers realized that if one of them were in an approximately edge-on orbit it would periodically pass in front of the parent star, reducing its brightness. In 1999, the transit of a planet orbiting the star HD 209458 at a distance 0.045 AU was observed as a 2% reduction in the star's brightness at the predicted time. This was the first direct observation of an extrasolar planet. See TRANSIT (ASTRONOMY).

Before extrasolar planets were discovered around normal stars, the discovery of planets orbiting a pulsar was announced in 1992. The discovery was based on precise measurements of arrival times of radio pulses from the 6.2-millisecond pulsar PSR B1257+12. See PULSAR. [J.FWe.]

**Planetarium** An instrument that projects the stars, Sun, Moon, planets, and other celestial objects upon a large hemispherical dome, showing their motions as viewed from the Earth or space near the Earth. Days and years may be compressed into minutes. There are over 100 major planetariums around the world with domes 50 ft (15 m) or more in diameter; and there are also over 1000 smaller planetariums in communities, schools, and colleges.

The term planetarium originally applied to a mechanical model (also known as an orrery) that depicted the motions of the planets. Today the term refers to an optical projector. Most planetariums now have mechanical movements, but planetariums projecting computer-generated displays have also been developed. Additional optical devices and computer controls are common. The term planetarium also refers to the theater or building that houses the projector.

Many projectors are patterned after the basic design of the Carl Zeiss Company. Star spheres at each end of the projector show 8900 stars down to magnitude 6.5; 32 lenses (16 located in each globe) are used to project the stars. Cages between the two star spheres contain projectors for the Sun, Moon, and planets. The center part of the machine houses the driving motors. Additional projectors show such effects as variable stars, solar and lunar eclipses, the Milky Way, comets, and various circles and coordinates. Depending on the manufacturer, there may be constellation outlines, clouds, and built-in zoom effects for the planets.

Another design philosophy, begun in the late 1940s when A. Spitz designed a small planetarium for school classrooms and museums, was to manufacture a small and relatively inexpensive projector that would do for schools and small communities what the larger machines had done for the cities.

Some planetariums have tipped domes with all-sky 70mm motion picture projection systems. Another innovation in planetarium design, based on computer-graphics television projection, is the Evans & Sutherland Digistar II. The projector utilizes a high-resolution cathode-ray tube with a special  $160^\circ$  wide-angle lens for projection onto domes ranging in diameter 20–80 ft (6–24 m). Software and documentation include stellar, planetary, and constellation data files. The star and planet positions are fed into the high-intensity cathode-ray tube projector by a computer and thence onto the dome via the wide-angle lens. See CATHODE-RAY TUBE; COMPUTER GRAPHICS. [C.F.H.]

**Planetary gear train** An assembly of meshed gears consisting of a central or sun gear, a coaxial internal or ring gear, and one or more intermediate pinions supported on a revolving carrier. Sometimes the term planetary gear train is used broadly as a synonym for epicyclic gear train, or narrowly to indicate that the ring gear is the fixed member. In a simple planetary gear train the pinions mesh simultaneously with the two coaxial gears. With the central gear fixed, a pinion rotates about it as a planet rotates about its sun, and the gears are named accordingly: the central gear is the sun, and the pinions are the planets.

In operation, input power drives one member of a planetary gear train, the second member is driven to provide the output, and the third member is fixed. If the third member is not fixed, no power is delivered. This characteristic provides a convenient clutch action. A clutch or brake band positioned about the intermediate member and fixed to the gearbox housing serves to lock or free the third member. The holding device itself does not enter into the power path.

Any one of these three elements can be fixed: the sun gear, the carrier, or the ring gear. Either of the two remaining elements can be driven and the other one used to deliver the output. There are six possible combinations, although three of these provide velocity ratios that are reciprocals of the other three. The ratios are entirely independent of the number of teeth on each planet.

## 1700 Planetary nebula

Two simple planetary gear sets running on a common sun gear are known as a Simpson gear train. It is widely used in automotive automatic transmissions. In a compound planetary train, two planet gears are attached together on a common shaft. One planet meshes only with the central sun gear, the other only with the ring gear. As in simple planetary trains, there can be several of these planet pairs around the train to distribute the load and achieve balance. See AUTOMOTIVE TRANSMISSION; GEAR TRAIN; RECIPROCATING AIRCRAFT ENGINE. [J.R.Z.; D.L.An.]

**Planetary nebula** A gaseous shell thrown off by a dying star just before the star settles down to become a degenerate white dwarf. Planetary nebulae are among the brightest and best studied nebular objects in the sky, although they are generally a few thousand light-years from Earth. The many shapes of planetary nebulae reflect the processes that occur inside most stars late in their lives. The Sun is likely to eject a planetary nebula in about 5 billion years. See SUN; WHITE DWARF STAR.

Planetary nebulae appear small, round, and greenish in color, like the planet Uranus, when seen through small telescopes—hence the origin of the name. However, planetary nebulae are not planets but large (0.1–10 light-years), expanding (10–100 km/s; 6–60 mi/s), highly symmetrical gaseous clouds of stellar ejecta. The shapes of planetary nebulae vary, and are denoted as round, elliptical, or bipolar depending on their outlines. Delicate filaments, knots, and bubbles of material characterize their interiors. These features evolve as stellar winds of increasing speed (from 100 to 1000 km/s; 60 to 600 mi/s) plow into the older, much slower gas ahead of them.

About 2000 planetary nebulae have been cataloged. Ten to twenty times as many are believed to exist in the Milky Way Galaxy. Planetary nebulae last for several thousand years before they expand and become too diffuse to be seen as discrete objects.

Complex patterns appear when the spectrum of light from a given nebula is analyzed. Such studies have shown that the gas ejected from the parent stars of planetary nebulae is enriched in carbon and nitrogen. Their masses, lifetimes, and large numbers suggest that planetary nebulae are the most prolific source enriching the interstellar medium with carbon and, to a lesser degree, nitrogen. See INTERSTELLAR MATTER. [B.Bal.]

**Planetary physics** The study of the structure, composition, and physical and chemical properties of the planets of the solar system, including their atmospheres and their immediate cosmic environment.

Planetary scientists attempt to synthesize their information about the structure and properties of each of the planets by constructing models of them. The most obvious gross properties of the planet are its mass and its radius. In constructing a model, it is required that the model be in hydrostatic equilibrium. This means that at any interior point in the model, the pressure must be great enough to sustain the weight of the overlying mass of material. Thus, given the mass and the radius, estimating the interior pressures through the principles of hydrostatic equilibrium, and knowing something about the compressibilities of materials, it is generally possible to place constraints upon the interior composition of the planets. Knowledge of the equatorial bulge and the rate of spin provides additional information about the distribution of mass in the interior of the planet.

**Classes of chemical composition.** The planets in the solar system have an extremely wide range of properties. This distribution of characteristics can be understood in part from a knowledge of the more abundant elements in nature and their volatility properties. Approximately 98% of matter in the Sun, and therefore also presumably in the matter from which the Sun and the solar system were formed, consists of the gases hydrogen and helium. Most of the remaining material consists of carbon, nitrogen, and oxygen, which in the presence of very large amounts of

hydrogen tends to form methane, ammonia, and water. These substances are collectively called ices, and they evaporate at relatively low temperatures. Both the light gases hydrogen and helium and the ices are of quite low abundance on the Earth and the other inner planets in the solar system. What constitutes the bulk of the material in these planets is the rocky material, constituting only about 3 parts in 1000 of the solar mix of elements.

The differences in the volatilities of these materials, which correlate with the properties of the planetary bodies in the solar system, give information about the properties of the environment in which the planets formed in the solar system. The inner planets, composed predominantly of rocks, evidently formed in a rather hot environment, so that the volatile gases and ices were not condensed and did not collect along with the rocky material, which presumably was condensed. The comets, residing at very large distances from the Sun in the solar system, appear to be mixtures of rocky materials and of the ices. The outer giant planets, Uranus and Neptune, appear to be primarily composed of materials heavier than hydrogen and helium, probably mixtures of rocky and icy materials. The two largest planets in the solar system, Jupiter and Saturn, are much closer in composition to that of the Sun itself, although studies of their interior structures tend to indicate that there is some degree of enrichment in the heavier elements. These differences in composition thus indicate that the tendency to collect hydrogen and helium depends upon the size of the body which has formed, the larger bodies being more successful in gravitationally capturing the elusive hydrogen and helium. See COMET.

These compositional classes provide a natural means for dividing the planetary objects within the solar system into separate groups, as follow.

**Giant planets.** The giant planets are Jupiter, Saturn, Uranus, and Neptune. Nowhere in the interiors of the giant planets can anything resembling a solid surface be expected. The temperatures in the interiors tend to be thousands to tens of thousands of degrees Celsius. The pressures range up to the order of  $10^7$  atmospheres ( $10^{12}$  pascals) and higher. Under these circumstances all materials behave like fluids. There may be a certain amount of compositional stratification, with denser fluids underlying lighter ones.

**Terrestrial planets.** The terrestrial planets include Mercury, Venus, Earth, and Mars. The Earth's Moon may also be considered a terrestrial planet. The Earth consists of a thin upper crust composed of rocks of relatively low density and low melting points, overlying a much thicker mantle composed predominantly of metallic silicates and oxides, which in turn overlies a substantial core, which is composed of much denser materials, believed predominantly to be iron with other elements, either alloyed or in solution.

It is conjectured that the interior of Venus is probably much like that of the Earth, with a core, a mantle, and a crust. Major structural features on the surface of the planet suggest extensive tectonic activity. The extent to which the crust of Venus is subject to extensive continental drift motions is quite unknown. See VENUS.

The mass of Mars is approximately one-tenth that of the Earth, and hence significant differences in the internal structure are to be expected. There appears to be less of a density contrast between the core of Mars and that of its mantle. Because the planet is smaller, the temperature increases less rapidly with depth than in the case of the Earth, and hence Mars should have a somewhat more rigid outer mantle and crust than the Earth. There is no indication that large amounts of continental drift have taken place on Mars. On the other hand, tectonic activity has clearly played a large role in the history of Mars. See MARS.

Mercury has only about half the mass of Mars. The mean density of Mercury is very high, indicating that Mercury probably has an abnormally large core predominantly composed of metallic iron. There is much evidence of extensive tectonic activity,

although, like Mars, the increase of temperature below the surface of Mercury probably occurs sufficiently slowly that the crust and upper mantle are relatively rigid, and nothing resembling continental drift has probably taken place. See MERCURY (PLANET).

The Moon has a history which includes extensive episodes of melting and differentiation. The upper layers of the Moon, which is only just over 1% of the mass of the Earth, are quite rigid, and there is no evidence for extensive horizontal motions of the structural units. The Moon is unique in the solar system in having a relatively low density among the inner planets, and at best a very small core, indicating that the planet is practically devoid of metallic iron. See MOON.

**Major satellites.** The four Galilean satellites of Jupiter—Io, Europa, Ganymede, and Callisto—have masses which are all roughly comparable to the mass of the Earth's Moon. The Galilean satellites appear to represent a composition class which is slightly more volatile-rich than the pure rocky materials characteristic of the inner solar system. See JUPITER.

The Saturnian satellite system contains only one satellite comparable in mass to the Galilean satellites, Titan. Titan has a significantly higher volatile content than the Galilean satellites. It has an extensive atmosphere (virtually unique in the solar system) largely composed of methane. It is not known what lies at the bottom of this atmosphere, but it has been reasonably speculated that there is a transition layer of heavier hydrocarbons. The satellite has a relatively low density, characteristic of an extensive content of ices, quite likely more than just water ice as in the Galilean satellites. The atmosphere is completely opaque, and hence it is not known whether Titan has surface relief.

**Atmospheres.** The temperature at the surface of a planetary body depends in a complex manner on the properties of the overlying atmosphere, as well as upon the distance of the planet from the Sun. The atmosphere of Venus is very much hotter relative to the Earth than would be expected purely on the basis of the relative distances from the Sun. The difference appears to arise from the extensive operation of the greenhouse effect within the very thick atmosphere of Venus.

The only terrestrial planets with atmospheres are Venus, Earth, and Mars. Both Mars and Venus have atmospheres composed predominantly of carbon dioxide. The element of next greatest abundance in the atmospheres of Mars and Venus is nitrogen, which is also the predominant element in the atmosphere of the Earth. The next most abundant element in the terrestrial atmosphere is oxygen, which is maintained there predominantly as the result of the operation of life.

**Magnetospheres.** Some of the planets contain substantial magnetic fields; others do not. Within the inner solar system, the Earth possesses a relatively strong field, Mercury a relatively weak one, and if Venus and Mars contain significant intrinsic fields, they are sufficiently weak that they have not been confirmed. On the other hand, Jupiter and Saturn have very strong magnetic fields. The generation of planetary magnetic fields appears to depend upon a combination of planetary rotation with an inner convecting layer having significant electrical conductivity. See MAGNETOSPHERE; PLANET; VAN ALLEN RADIATION.

[A.G.W.C.]

**Plant** An organism that belongs to the Kingdom Plantae (plant kingdom) in biological classification. The study of plants is called botany. See BOTANY; CLASSIFICATION, BIOLOGICAL.

The Plantae share the characteristics of multicellularity, cellulose cell walls, and photosynthesis using chlorophylls *a* and *b* (except for a few plants that are secondarily heterotrophic). Most plants are also structurally differentiated, usually having organs specialized for anchorage, support, and photosynthesis. Tissue specialization for photosynthetic, conducting, and covering functions is also characteristic. Plants have a sporic (rather than gametic or zygotic) life cycle that involves both sporophytic and gametophytic phases, although the latter is evolu-

tionarily reduced in the majority of species. Reproduction is sexual, but diversification of breeding systems is a prominent feature of many plant groups. See PHOTOSYNTHESIS; REPRODUCTION (PLANT).

A conservative estimate of the number of described species of plants is 250,000. There are possibly two or three times that many species as yet undiscovered, primarily in the Southern Hemisphere. Plants are categorized into nonvascular and vascular groups, and the latter into seedless vascular plants and seed plants. The nonvascular plants include the liverworts, hornworts, and mosses. The vascular plants without seeds are the ground pines, horsetails, ferns, and whisk ferns; seed plants include cycads, ginkgos, conifers, gnetophytes, and flowering plants. Each of these groups constitutes a division in botanical nomenclature, which is equivalent to a phylum in the zoological system. See PLANT TAXONOMY.

[M.La.]

**Plant anatomy** The area of plant science concerned with the internal structure of plants. It deals both with mature structures and with their origin and development.

The plant anatomist dissects the plant and studies it from different planes and at various levels of magnification. At the level of the cell, anatomy overlaps plant cytology, which deals exclusively with the cell and its contents. Sometimes the name plant histology is applied to the area of plant anatomy directed toward the study of cellular details of tissues. See PLANT CELL; PLANT ORGANS.

[K.E.]

**Plant-animal interactions** The examination of the ecology of interacting plants and animals by using an evolutionary, holistic perspective. For example, the chemistry of defensive compounds of a plant species may have been altered by natural-selection pressures resulting from the long-term impacts of herbivores. Also, the physiology of modern herbivores may be modified from that of thousands of years ago as adaptations for the detoxification or avoidance of plant defensive chemicals have arisen.

The application of the theories based on an understanding of plant-animal interactions provides an understanding of problems in modern agricultural ecosystems. In addition, plant-animal interactions have practical applications in medicine. For example, a number of plant chemicals, such as digitalin from the foxglove plant, that evolved as herbivore-defensive compounds have useful therapeutic effects on humans.

Effects of interaction types for each species\*

Interaction	Effect on species A	Effect on species B
Mutualism	+	+
Commensalism	+	0
Antagonism	+	-
Competition	-	-
Amensalism	0	-
Neutralism	0	0

\*+ = beneficial, - = harmful, 0 = neutral.

The evolutionary consequences of plant-animal interactions vary, depending on the effects on each participant. Interaction types range from mutualisms, that is, relationships which are beneficial to both participating species, to antagonisms, in which the interaction benefits only one of the participating species and negatively impacts the other. Interaction types are defined on the basis of whether the impacts of the interaction are beneficial, harmful, or neutral for each interacting species (see table).

[W.G.A.]

**Fossil record.** Plants and animals interact in a variety of ways within modern ecosystems. These interactions may range from simple examples of herbivory (animals eating plants) to more complex interactions such as pollination or seed and fruit

dispersal. Animals also rely on plants for food and shelter. The complex interactions between these organisms over geologic time not only have resulted in an abundance and diversity of organisms in time and space but also have contributed to many of the evolutionary adaptations found in the biological world.

Paleobiologists have attempted to decipher some of the interrelationships that existed between plants and animals throughout geologic time. The ecological setting in which the organisms lived in the geologic past is being analyzed in association with the fossils. Thus, as paleobiologists have increased their understanding of certain fossil organisms, it has become possible to consider some aspects of the ecosystems in which they lived, and in turn, how various types of organisms interacted.

**Herbivory.** Perhaps the most widespread interaction between plants and animals is herbivory, in which plants are utilized as food. One method of determining the extent of herbivory in the fossil record is by analyzing the plant material that has passed through the digestive gut of the herbivore.

The stems of some fossil plants show tissue disruption similar to various types of wounds occurring in plant parts that have been pierced by animal feeding structures. As plants developed defense systems in the form of fibrous layers covering inner, succulent tissues, some animals evolved piercing mouthparts that allowed them to penetrate these thick-walled layers. In some fossil plants, it is also possible to see evidence of wound tissue that has grown over these penetration sites. See COAL BALLS; HERBIVORY.

**Mimicry.** Another example of the interactions between plants and animals that can be determined from the fossil record is mimicry. Certain fossil insects have wings that are morphologically identical to plant leaves, thus providing camouflage from predators as the insect rested on a seed fern frond.

**Pollination.** The transfer of pollen from the pollen sacs to the receptive stigma in angiosperms or to the seed in gymnosperms is an example of an ancient interaction between plants and animals. It has been suggested that pollination in some groups initially occurred as a result of indiscriminate foraging behavior by certain animals, and later evolved specifically as a method to effect pollination. The size, shape, and organization of fossil pollen grains provide insight into potential pollination vectors. See FOSSIL; PALEOBOTANY; POLLINATION. [T.N.T.]

**Plant cell** The basic unit of structure and function in nearly all plants. Although plant cells are variously modified in structure and function, they have many common features. The most distinctive feature of all plant cells is the rigid cell wall, which is absent in animal cells. The range of specialization and the character of association of plant cells is very wide. In the simplest plant forms a single cell constitutes a whole organism and carries out all the life functions. In just slightly more complex forms, cells are associated structurally, but each cell appears to carry out the fundamental life functions, although certain ones may be specialized for participation in reproductive processes. In the most advanced plants, cells are associated in functionally specialized tissues, and associated tissues make up organs such as the leaves, stem, and root. See CELL WALLS (PLANT).

Plant and animal cells are composed of the same fundamental constituents—nucleic acids, proteins, carbohydrates, lipids, and various inorganic substances—and are organized in the same fundamental manner. A characteristic of their organization is the presence of unit membranes composed of phospholipids and associated proteins and in some instances nucleic acids.

Perhaps the most conspicuous and certainly the most studied of the features peculiar to plant cells is the presence of plastids. The plastids are membrane-bound organelles with an inner membrane system. Chlorophylls and other pigments are associated with the inner membrane system. See CELL (BIOLOGY); CELL PLASTIDS; CHLOROPHYLL. [W.G.W.]

**Plant communication** Movement of signals or cues, presumably chemical, among individual plants or plant parts. These chemical cues are a consequence of damage to plant tissues and stimulate physiological changes in the undamaged “receiving” plant or tissue. There are very few studies of this phenomenon, and so theories of its action and significance are fairly speculative.

Plants produce a wealth of secondary metabolites that do not function in the main, or primary, metabolism of the plant, which includes photosynthesis, nutrient acquisition, and growth. Since many of these chemicals have very specific negative effects on animals or pathogens, ecologists speculate that they may be produced by plants as defenses. Plant chemical defenses either may be present all of the time (constitutive) or may be stimulated in response to attack (induced). Those produced in response to attack by pathogens are called phytoalexins. In order to demonstrate the presence of an induced defense, the chemistry of plant tissues or their suitability to some “enemy” (via a bioassay) must be compared before and after real or simulated attack. Changes found in the chemistry and suitability of control or unattacked plants when nearby experimental plants are damaged imply that some signal or cue has passed from damaged to undamaged plants. Controlled studies have shown that responses in undamaged plants are related to the proximity of a damaged neighbor. See ALLELOPATHY; PHYTOALEXIN; PLANT METABOLISM. [J.C.Sc.]

**Plant evolution** The process of biological and organic change within the plant kingdom by which the characteristics of plants differ from generation to generation. The main levels (grades) of evolution have long been clear from comparisons among living plants, but the fossil record has been critical in dating evolutionary events and revealing extinct intermediates between modern groups, which are separated from each other by great morphological gaps. Plant evolution has been clarified by cladistic methods for estimating relationships among both living and fossil groups. These methods attempt to reconstruct the branching of evolutionary lines (phylogeny) by using shared evolutionary innovations (for example, presence of a structure not found in other groups) as evidence that particular organisms are descendants of the same ancestral lineage (a monophyletic group, or clade). Many traditional groups are actually grades rather than clades; these are indicated below by names in quotes.

Most botanists restrict the term plants to land plants, which invaded the land after 90% of Earth history. There is abundant evidence of photosynthetic life extending back 3.5 billion years to the early Precambrian, in the form of microfossils resembling cyanobacteria (prokaryotic blue-green algae) and limestone reefs (stromatolites) made by these organisms. Larger cells representing eukaryotic “algae” appear in the late Precambrian, followed by macroscopic “algae” and animals just before the Cambrian. See ALGAE; EUKARYOTAE; FOSSIL; PROKARYOTAE.

**Origin of land plants.** Cellular, biochemical, and molecular data place the land plants among the “green algae,” specifically the “charophytes,” which resemble land plants in their mode of cell division and differentiated male and female gametes (oogamy). Land plants themselves are united by a series of innovations not seen in “charophytes,” many of them key adaptations required for life on land. They have an alternation of generations, with a haploid, gamete-forming (gametophyte) and diploid, spore-forming (sporophyte) phase. Their reproductive organs (egg-producing archegonia, sperm-producing antheridia, and spore-producing sporangia) have a protective layer of sterile cells. The sporophyte, which develops from the zygote, begins its life inside the archegonium. The spores, produced in fours by meiosis, are air-dispersed, with a resistant outer wall that prevents desiccation. See CHAROPHYCEAE; REPRODUCTION (PLANT).

Land plants have been traditionally divided into “bryophytes” and vascular plants (tracheophytes). These differ in the relative role of the sporophyte, which is subordinate and permanently attached to the gametophyte in “bryophytes” but dominant and



independent in vascular plants. In vascular plants, tissues are differentiated into an epidermis with a waxy cuticle that retards water loss and stomates for gas exchange, parenchyma for photosynthesis and storage, and water- and nutrient-conducting cells (xylem, phloem). However, cladistic analyses imply that some "bryophytes" are closer to vascular plants than others. This implies that the land-plant life cycle originated before the full suite of vegetative adaptations to land life, and that the sporophyte began small and underwent a trend toward elaboration and tissue specialization. See EPIDERMIS (PLANT); PHOTOSYNTHESIS; PRIMARY VASCULAR SYSTEM (PLANT).

In the fossil record, the first recognizable macroscopic remains of land plants are Middle Silurian vascular forms with a branched sporophyte, known as "rhyniophytes." These differed from modern plants in having no leaves or roots, only dichotomously branching stems with terminal sporangia. However, spore tetrads formed by meiosis are known from older beds (Middle Ordovician); these may represent more primitive, bryophytic plants. See BRYOPHYTA; RHYNIOPHYTA.

In one of the most spectacular adaptive radiations in the history of life, vascular plants diversified through the Devonian. At the beginning of this period, vegetation was low and probably confined to wet areas, but by the Late Devonian, size had increased in many lines, resulting in large trees and forests with shaded understory habitats. Of the living groups of primitive vascular plants, the lycopsids (club mosses) branched off first, along with the extinct "zosterophylloids." A second line, the "trimerophytes," gave rise to sphenopsids (horsetails) and ferns (filicopsids). This radiation culminated in the coal swamp forests of the Late Carboniferous, with tree lycopsids (*Lepidodendrales*), sphenopsids (*Calamites*), and ferns (*Marattiales*). Remains of these plants make up much of the coal of Europe and eastern North America, which were then located on the Equator. See LYCOPODIALES; MARATTIALES; SPHENOPHYTA.

**Seed plants.** Perhaps the most significant event after the origin of land plants was evolution of the seed. Primitive seed plants ("gymnosperms") differ from earlier groups in their reproduction, which is heterosporous (producing two sizes of spores), with separate male and female gametophytes packaged inside the pollen grain (microspore), and the ovule (a sporangium with one functional megaspore, surrounded by an integument, which develops into the seed). The transfer of sperm (two per pollen grain) from one sporophyte to another through the air, rather than by swimming, represents a step toward independence from water for reproduction. This step must have helped plants invade drier areas than they had previously occupied. In addition, seed plants have new vegetative features, particularly secondary growth, which allows production of a thick trunk made up of secondary xylem (wood) surrounded by secondary phloem and periderm (bark). Together, these innovations have made seed plants the dominant organisms in most terrestrial ecosystems ever since the disappearance of the Carboniferous coal swamps. See ECOSYSTEM; PTERIDOSPERMS; SEED.

A major breakthrough in understanding the origin of seed plants was recognition of the "progymnosperms" in the Middle and Late Devonian. These plants, which were the first forest-forming trees, had secondary xylem, phloem, and periderm, but they still reproduced by spores, implying that the anatomical advances of seed plants arose before the seed. Like sphenopsids and ferns, they were apparently derived from "trimerophytes." The earliest seed plants of the Late Devonian and Carboniferous, called "seed ferns" because of their frondlike leaves, show steps in origin of the seed. Origin of the typical mode of branching in seed plants, from buds in the axils of the leaves, occurred at about the same time. See PTERIDOSPERMS.

Seed plants became dominant in the Permian during a shift to drier climate and extinction of the coal swamp flora in the European-American tropical belt, and glaciation in the Southern Hemisphere Gondwana continents. Early conifers predominated in the tropics; extinct glossopterids inhabited Gondwana.

Moderation of climate in the Triassic coincided with the appearance of new seed plant groups as well as more modern ferns. Many Mesozoic groups show adaptations for protection of seeds against animal predation, while flowers of the Bennettitales constitute the first evidence for attraction of insects for cross-pollination, rather than transport of pollen by wind.

**Angiosperms.** The last major event in plant evolution was the origin of angiosperms (flowering plants), the seed plant group that dominates the modern flora. The flower, typically made up of protective sepals, attractive petals, pollen-producing stamens, and ovule-producing carpels (all considered modified leaves), favors more efficient pollen transfer by insects. The ovules are enclosed in the carpel, so that pollen germinates on the sticky stigma of the carpel rather than in the pollen chamber of the ovule. The carpels (separate or fused) develop into fruits, which often show special adaptations for seed dispersal. Other advances include an extreme reduction of the gametophytes, and double fertilization whereby one sperm fuses with the egg, and the second sperm with two other gametophyte nuclei to produce a triploid, nourishing tissue called the endosperm. Angiosperms also developed improved vegetative features, such as more efficient water-conducting vessels in the wood and leaves with several orders of reticulate venation. These features may have contributed to their present dominance in tropical forests, previously occupied by conifers with scale leaves. See RAINFOREST.

Most botanists believed that the most primitive living angiosperms are "magnoliid dicots," based on their "gymnosperm"-like pollen, wood anatomy, and flower structure. Studies of Cretaceous fossil pollen, leaves, and flowers confirm this view by showing a rapid but orderly radiation beginning with "magnoliid"-like and monocotlike types, followed by primitive eudicots (with three pollen apertures), some related to sycamores and lotuses. See MAGNOLIOPHYTA.

Both morphological and molecular data imply that angiosperms are monophyletic and most closely related to Bennettitales and Gnetales, a seed plant group that also radiated in the Early Cretaceous but later declined to three living genera. Since all three groups have flowerlike structures, suggesting that the flower and insect pollination arose before the closed carpel, they have been called anthophytes. These relationships, plus problematical Triassic pollen grains and macrofossils with a mixture of angiospermlike and more primitive features, suggest that the angiosperm line goes back to the Triassic, although perhaps not as fully developed angiosperms. Within angiosperms, it is believed that "magnoliids" are relatively primitive, monocots and eudicots are derived clades, and wind-pollinated temperate trees such as oaks, birches, and walnuts (*Amentiferae*) are advanced eudicots. However, "magnoliids" include both woody plants and herbs, and their flowers range from large, complex, and insect-pollinated to minute, simple, and wind-pollinated. These extremes are present among the earliest Cretaceous angiosperms, and cladistic analyses disagree on which is most primitive.

Although plant extinctions at the end of the Cretaceous have been linked with radiation of deciduous trees and proliferation of fruits dispersed by mammals and birds, they were less dramatic than extinctions in the animal kingdom. Mid-Tertiary cooling led to contraction of the tropical belt and expansion of seasonal temperate and arid zones. These changes led to the diversification of herbaceous angiosperms and the origin of open grassland vegetation, which stimulated the radiation of hoofed mammals, and ultimately the invention of human agriculture. See AGRICULTURE; FLOWER; PALEOBOTANY; PLANT KINGDOM. [J.A.Do.]

**Plant geography** The study of the spatial distributions of plants and vegetation and of the environmental relationships which may influence these distributions. Plant geography (or certain aspects of it) is also known as phytogeography, phytochorology, geobotany, geographical botany, or vegetation science.

A flora is the collection of all plant species in an area, or in a period of time, independent of their relative abundances and relationships to one another. The species can be grouped and regrouped into various kinds of floral elements based on some common feature. For example, a genetic element is a group of species with a common evolutionary origin; a migration element has a common route of entry into the territory; a historical element is distinct in terms of some past event; and an ecological element is related to an environmental preference. An endemic species is restricted to a particular area, which is usually small and of some special interest. The collection of all interacting individuals of a given species, in an area, is called a population.

An area is the entire region of distribution or occurrence of any species, element, or even an entire flora. The description of areas is the subject of areography, while chorology studies their development. The local distribution within the area as a whole, as that of a swamp shrub, is the topography of that area. Areas are of interest in regard to their general size and shape, the nature of their margin, whether they are continuous or disjunct, and their relationships to other areas. Closely related plants that are mutually exclusive are said to be vicarious (areas containing such plants are also called vicarious). A relict area is one surviving from an earlier and more extensive occurrence. On the basis of areas and their floristic relationships, the Earth's surface is divided into floristic regions, each with a distinctive flora.

Floras and their distribution have been interpreted mainly in terms of their history and ecology. Historical factors, in addition to the evolution of the species themselves, include consideration of theories of shifting continental masses, changing sea levels, and orographic and climatic variations in geologic time, as well as theories of island biogeography, all of which have affected migration and perpetuation of floras. The main ecological factors include the immediate and contemporary roles played by climate, soil, animals, and humans. *See* ISLAND BIOGEOGRAPHY; PALEOBOTANY; PALEOECOLOGY.

Vegetation refers to the mosaic of plant life found on the landscape. The vegetation of a region has developed from the numerous elements of the local flora but is shaped also by nonfloristic physiological and environmental influences. Vegetation is an organized whole, at a higher level of integration than the separate species, composed of those species and their populations. Vegetation may possess emergent properties not necessarily found in the species themselves. Sometimes vegetation is very weakly integrated, as pioneer plants of an abandoned field. Sometimes it is highly integrated, as in an undisturbed tropical rainforest. Vegetation provides the main structural and functional framework of ecosystems. *See* ECOSYSTEM.

Plant communities are an important part of vegetation. No definition has gained universal acceptance, in part because of the high degree of independence of the species themselves. Thus, the community is often only a relative social continuity in nature, bounded by a relative discontinuity, as judged by competent botanists. *See* ECOLOGICAL COMMUNITIES.

In looking at vegetation patterns over larger areas, it is the basic physiognomic distinctions between grassland, forest, and desert, with such variants as woodland (open forest), savanna (scattered trees in grassland), and scrubland (dominantly shrubs), which are most often emphasized. These general classes of vegetation structure can be broken down further by reference to leaf types and seasonal habits (such as evergreen or deciduous). Geographic considerations may complete the names of the main vegetation formation types, also called biomes (such as tropical rainforest, boreal coniferous forest, or temperate grasslands). Such natural vegetation regions are most closely related to climatic patterns and secondarily to soil or other environmental factors. *See* ALTITUDINAL VEGETATION ZONES.

Vegetational plant geography has emphasized the mapping of such vegetation regions and the interpretation of these in terms of environmental (ecological) influences. Distinction has been made between potential and actual vegetation, the latter becom-

ing more important due to human influence. *See* VEGETATION AND ECOSYSTEM MAPPING.

Some plant geographers point to the effects of ancient human populations, natural disturbances, and the large-herbivore extinctions and climatic shifts of the Pleistocene on the species composition and dynamics of so-called virgin vegetation. On the other hand, it has been shown that the site occurrence and geographic distributions of plant and vegetation types can be predicted surprisingly well from general climatic and other environmental patterns. Unlike floristic botany, where evolution provides a single unifying principle for taxonomic classification, vegetation structure and dynamics have no single dominant influence.

Basic plant growth forms (such as broad-leaved trees, stem-succulents, or forbs) have long represented convenient groups of species based on obvious similarities. When these forms are interpreted as ecologically significant adaptations to environmental factors, they are generally called life forms and may be interpreted as basic ecological types.

In general, basic plant types may be seen as groups of plant taxa with similar form and ecological requirements, resulting from similar morphological responses to similar environmental conditions. When similar morphological or physiognomic responses occur in unrelated taxa in similar but widely separated environments, they may be called convergent characteristics. *See* PLANTS, LIFE FORMS OF.

As human populations alter or destroy more and more of the world's natural vegetation, problems of species preservation, substitute vegetation, and succession have increased in importance. This is especially true in the tropics, where deforestation is proceeding rapidly. Probably over half the species in tropical rainforests have not yet even been identified. Because nutrients are quickly washed out of tropical rainforest soils, cleared areas can be used for only a few years before they must be abandoned to erosion and much degraded substitute vegetation. Perhaps the greatest current challenge in plant geography is to understand tropical vegetation and succession sufficiently well to design self-sustaining preserves of the great diversity of tropical vegetation. *See* BIOGEOGRAPHY; ECOLOGY; RAINFOREST. [E.O.B.]

**Plant growth** An irreversible increase in the size of the plant. As plants, like other organisms, are made up of cells, growth involves an increase in cell numbers by cell division and an increase in cell size. Cell division itself is not growth, as each new cell is exactly half the size of the cell from which it was formed. Only when it grows to the same size as its progenitor has growth been realized. Nonetheless, as each cell has a maximum size, cell division is considered as providing the potential for growth. *See* CELL (BIOLOGY); CELL DIVISION.

While growth in plants consists of an increase in both cell number and cell size, animal growth is almost wholly the result of an increase in cell numbers. Another important difference in growth between plants and animals is that animals are determinate in growth and reach a final size before they are mature and start to reproduce. Plants have indeterminate growth and, as long as they live, continue to add new organs and tissues. In a plant new cells are produced all the time, and some parts such as leaves and flowers may die, while the main body of the plant persists and continues to grow. The basic processes of cell division are similar in plants and animals, though the presence of a cell wall and vacuole in plant cells means that there are certain important differences. This is particularly true in plant cell enlargement, as plant cells, being restrained in size by a cellulose cell wall, cannot grow without an increase in the wall. Plant cell growth is thus largely a property of the cell wall. *See* CELL WALLS (PLANT).

**Sites of cell division.** Cell division in plants takes place in discrete zones called meristems. The stem and root apical meristems produce all the primary (or initial) tissues of the stem and root. The cylindrical vascular cambium produces more conducting cells at the time when secondary thickening (the acquisition of

a woody nature) begins. The vascular cambium is a sheet of elongated cells which divide to produce xylem or water-conducting cells on the inside, and phloem or sugar-conducting cells on the outside. Unlike the apical meristems whose cell division eventually leads to an increase in length of the stem and root, divisions of the vascular cambium occur when that part of the plant has reached a fixed length, and lead only to an increase in girth, not in length. The final meristematic zone, the cork cambium, is another cylindrical sheet of cells on the outer edge of older stems and roots of woody plants. It produces new outer cells only, and these cells differentiate into the corky layers of the bark so that new protective layers are produced as the tree increases in circumference. See APICAL MERISTEM; BUD; LATERAL MERISTEM; PERIDERM; ROOT (BOTANY); STEM.

**Controls.** Plant growth is affected by internal and external factors. The internal controls are all the product of the genetic instructions carried in the plant. These influence the extent and timing of growth and are mediated by signals of various types transmitted within the cell, between cells, or all around the plant. Intercellular communication in plants may take place via hormones (or chemical messengers) or by other forms of communication not well understood. There are several hormones (or groups of hormones), each of which may be produced in a different location, that have a different target tissue and act in a different manner. See ABSCISIC ACID; AUXIN; CYTOKININS; GIBBERELLIN; PLANT HORMONES.

The external environments of the root and shoot place constraints on the extent to which the internal controls can permit the plant to grow and develop. Prime among these are the water and nutrient supplies available in the soil. Because cell expansion is controlled by cell turgor, which depends on water, any deficit in the water supply of the plant reduces cell turgor and limits cell elongation, resulting in a smaller plant. See PLANT-WATER RELATIONS.

Mineral nutrients are needed for the biochemical processes of the plant. When these are in insufficient supply, growth will be less vigorous, or in extreme cases it will cease altogether. See PLANT MINERAL NUTRITION.

An optimal temperature is needed for plant growth. The actual temperature range depends on the species. In general, metabolic reactions and growth increase with temperature, though high temperature becomes damaging. Most plants grow slowly at low temperatures, 32–50°F (0–10°C), and some tropical plants are damaged or even killed at low but above-freezing temperatures.

Light is important in the control of plant growth. It drives the process of photosynthesis which produces the carbohydrates that are needed to osmotically retain water in the cell for growth. See PHOTOSYNTHESIS.

**Fruits and seeds.** Fruits and seeds are rich sources of hormones. Initial hormone production starts upon pollination and is further promoted by ovule fertilization. These hormones promote the growth of both seed and fruit tissue. Fruits grow initially by cell division, then by cell enlargement, and finally sometimes by an increase in air spaces.

The growth of a seed starts at fertilization. A small undifferentiated cell mass is produced from the single-celled zygote. This proceeds to form a small embryo consisting of a stem tip bearing two or more leaf primordia at one end and a root primordium at the other. Either the endosperm or the cotyledons enlarge as a food store. See FRUIT; SEED.

**Flowering.** At a certain time a vegetative plant ceases producing leaves and instead produces flowers. This often occurs at a particular season of the year. The determining factor for this event is day length (or photoperiod). Different species of plants respond to different photoperiods. See FLOWER; PHOTOPERIODISM.

The light signal for flowering is received by the leaves, but it is the stem apex that responds. Exposing even a single leaf to the correct photoperiod can induce flowering. Clearly, then, a signal must travel from the leaf to the apex. Grafting a plant

that has been photoinduced to flower to one not so induced can cause the noninduced plant to flower. It has been proposed that a flower-inducing hormone travels from the leaf to the stem apex and there induces changes in the development of the cells such that the floral morphology results.

**Dormancy.** At certain stages of the life cycle, most perennial plants cease growth and become dormant. Plants may cease growth at any time if the environmental conditions are unfavorable. When dormant, however, a plant will not grow even if the conditions are favorable. See DORMANCY.

**Leaf abscission.** As a perennial plant grows, new leaves are continuously or seasonally produced. At the same time the older leaves are shed because newer leaves are metabolically more efficient in the production of photosynthates. A total shedding of tender leaves may enable the plant to withstand a cold period or drought. In temperate deciduous trees, leaf abscission is brought about by declining photoperiods and temperatures. See ABSCISSION; PLANT MORPHOGENESIS. [P.J.D.]

**Plant hormones** Organic compounds other than nutrients that regulate plant development and growth. Plant hormones, which are active in very low concentrations, are produced in certain parts of the plants and are usually transported to other parts where they elicit specific biochemical, physiological, or morphological responses. They are also active in tissues where they are produced. Each plant hormone evokes many different responses. Also, the effects of different hormones overlap and may be stimulatory or inhibitory. The commonly recognized classes of plant hormones are the auxins, gibberellins, cytokinins, abscisic acid, and ethylene. Circumstantial evidence suggests that flower initiation is controlled by hypothetical hormones called florigens, but these substances remain to be identified. A number of natural or synthetic substances such as brassin, morphactin, and other growth regulators not considered to be hormones nevertheless influence plant growth and development. Each hormone performs its specific functions; however, nearly all of the measurable responses of plants to heredity or environment are controlled by interaction between two or more hormones. Such interactions may occur at various levels, including the synthesis of hormones, hormone receptors, and second messengers, as well as at the level of ultimate hormone action. Furthermore, hormonal interactions may be cooperative, antagonistic, or in balance.

The term plant growth regulator is usually used to denote a synthetic plant hormone, but most of the synthetic compounds with structures similar to those of the natural hormones have also been called hormones. For instance, the synthetic cytokinin kinetin is considered a hormone. See ABSCISIC ACID; ABSCISSION; AUXIN; CYTOKININS; ETHYLENE; GIBBERELLIN.

There are a number of applications of plant hormones in agriculture, horticulture, and biotechnology. Synthetic auxins are used as weed killers. Auxins are also used to counteract the effects of hormones that promote the dropping of fruit from trees. Gibberellins are used extensively to increase the size of seedless grapes: when applied at the appropriate time and with the proper concentration, gibberellins cause fruits to elongate so that they are less tightly packed and less susceptible to fungal infections. Gibberellins are also used by some breweries to increase the rate of malting because they enhance starch digestion. They have also been sprayed on fruits and leaves of navel orange trees to prevent several rind disorders that appear during storage. They are used commercially to increase sugarcane growth and sugar yields. Cytokinins and auxins are used in plant cell culture, particularly in cultivating genetically engineered plants. The ability of cytokinins to retard senescence also applies to certain cut flowers and fresh vegetables. Ethylene has been used widely in promoting pineapple flowering; flowering occurs more rapidly and mature fruits appear uniformly, so that a one-harvest mechanical operation is possible. Because carbon dioxide in high concentrations inhibits ethylene production, it is often used to

prevent overripening of picked fruits. Ethylene is also used for accelerating fruit ripening. See HORMONE; PLANT GROWTH; PLANT PHYSIOLOGY. [Cm.C.]

**Plant keys** Artificial analytical constructs for identifying plants. The identification, nomenclature, and classification of plants are the domain of plant taxonomy, and one basic responsibility of taxonomists is determining if the plant at hand is identical to a known plant. The dichotomous key provides a shortcut for identifying plants that eliminates searching through numerous descriptions to find one that fits the unknown plant.

A key consists of series of pairs (couplets) of contradictory statements (leads). Each statement of a couplet must "lead" to another couplet or to a plant name. Each couplet provides an either-or proposition wherein the user must accept one lead as including the unknown plant in question and must simultaneously reject the opposing lead. The user then proceeds from acceptable lead to acceptable lead of successive couplets until a name for the unknown plant is obtained. For confirmation, the newly identified plant should then be compared with other known specimens or with detailed descriptions of that species.

Keys are included in monographic or revisionary treatments of groups of plants, most often for a genus or family. Books containing extended keys, coupled with detailed descriptions of each kind of plant (taxon), for a given geographic region are called manuals or floras, though the latter technically refers to a simple listing of names of plants for a given region. See PLANT KINGDOM; PLANT TAXONOMY. [D.J.Pi.]

**Plant kingdom** The worldwide array of plant life, including plants that have roots in the soil, plants that live on or within other plants and animals, plants that float on or swim in water, and plants that are carried in the air. Fungi used to be included in the plant kingdom because they looked more like plants than animals and did not move about. It is now known that fungi are probably closer to animals in terms of their evolutionary relationships. Also once included in plants were the "blue-green algae," which are now clearly seen to be bacteria, although they are photosynthetic (and presumably the group of organisms from which the chloroplasts present in true plants were derived). The advent of modern methods of phylogenetic DNA analysis has allowed such distinctions, but even so, what remains of the plantlike organisms is still remarkably divergent and difficult to classify.

Plants range in size from unicellular algae to giant redwoods. Some plants complete their life cycles in a matter of hours, whereas the bristlecone pines are known to be over 4000 years old. Plants collectively are among the most poorly understood of all forms of life, with even their most basic functions still inadequately known, including how they sense gravity and protect themselves from infection by bacteria, viruses, and fungi. Furthermore, new species are being recorded every year.

Within the land plants, a great deal of progress has been made in sorting out phylogenetic (evolutionary) relationships of extant taxa based on DNA studies, and the system of classification listed below includes these changes. The angiosperms or flowering plants (Division Magnoliophyta) have recently been reclassified based on phylogenetic studies of DNA sequences. Within the angiosperms, several informal names are indicated in parentheses; these names may at some future point be formalized, but for the present they are indicated in lowercase letters because they have not been formally recognized under the Code of Botanical Nomenclature.

It is known that the bryophytes (Division Bryophyta) are not closely related to each other, but which of the three major groups is closest to the other land plants is not yet clear. Among the extant vascular plants, Lycophyta are the sister group to all the rest, with all of the fernlike groups forming a single monophyletic (natural) group, which is reflected here in the classification by putting them all under Polypodiophyta. This group is the sister to the extant seed plants, within which all gymnosperms form a group

that is sister to the angiosperms. Therefore, if Division is taken as the highest category within Embryobionta (the embryo-forming plants), then the following scheme would reflect the present state of knowledge of relationships (an asterisk indicates that a group is known only from fossils). See separate articles on names marked by daggers.

- Subkingdom Thallobionta (thallophytes)<sup>†</sup>
  - Division Rhodophycota (red algae)
    - Class Rhodophyceae<sup>†</sup>
  - Division Chromophycota<sup>†</sup>
    - Class: Chrysophyceae (golden or golden-brown algae)<sup>†</sup>
      - Prymnesiophyceae<sup>†</sup>
      - Xanthophyceae (yellow-green algae)<sup>†</sup>
      - Eustigmatophyceae<sup>†</sup>
      - Bacillariophyceae (diatoms)<sup>†</sup>
      - Dinophyceae (dinoflagellates)<sup>†</sup>
      - Phaeophyceae (brown algae)<sup>†</sup>
      - Raphidophyceae (chloromonads)<sup>†</sup>
      - Cryptophyceae (cryptomonads)<sup>†</sup>
  - Division Euglenophycota (euglenoids)
    - Class Euglenophyceae<sup>†</sup>
  - Division Chlorophycota (green algae)<sup>†</sup>
    - Class: Chlorophyceae<sup>†</sup>
      - Charophyceae<sup>†</sup>
      - Prasinophyceae
- Subkingdom Embryobionta (embryophytes)<sup>†</sup>
  - Division Rhyniophyta<sup>\*†</sup>
    - Class Rhyniopsida<sup>†</sup>
  - Division Bryophyta<sup>†</sup>
    - Class Hepaticopsida (liverworts)<sup>†</sup>
      - Subclass Jungermanniiidae<sup>†</sup>
        - Order: Takakiales<sup>†</sup>
          - Calobryales<sup>†</sup>
          - Jungermanniales<sup>†</sup>
          - Metzgeriales<sup>†</sup>
        - Subclass Marchantiidae<sup>†</sup>
          - Order: Sphaerocarpaceales<sup>†</sup>
            - Monocleales<sup>†</sup>
            - Marchantiales<sup>†</sup>
      - Class: Anthocerotopsida (hornworts)<sup>†</sup>
        - Sphagnopsida (peatmosses)<sup>†</sup>
        - Andreaeopsida (granite mosses)<sup>†</sup>
      - Bryopsida (mosses)<sup>†</sup>
        - Subclass: Archidiidae<sup>†</sup>
          - Bryidae<sup>†</sup>
            - Order: Fissidentales<sup>†</sup>
              - Bryoxiphales<sup>†</sup>
              - Schistostegales<sup>†</sup>
              - Dicranales<sup>†</sup>
              - Pottiales<sup>†</sup>
              - Grimmiales<sup>†</sup>
              - Seligeriales<sup>†</sup>
              - Encalyptales<sup>†</sup>
              - Funariales<sup>†</sup>
              - Splachnales<sup>†</sup>
            - Order: Bryales<sup>†</sup>
              - Mitteniales<sup>†</sup>
              - Orthotrichales<sup>†</sup>
              - Isobryales<sup>†</sup>
              - Hookeriales<sup>†</sup>
              - Hypnales<sup>†</sup>
          - Subclass: Buxbaumiidae<sup>†</sup>
            - Tetraphididae<sup>†</sup>
            - Dawsoniidae<sup>†</sup>
            - Polytrichidae<sup>†</sup>
      - Division Lycophyta<sup>†</sup>
        - Class Lycopsidea<sup>†</sup>
          - Order: Lycopodiales<sup>†</sup>
            - Asteroxylales<sup>\*†</sup>

Protolpidodendrales\*†  
 Selaginellales\*  
 Lepidodendrales\*†  
 Isoetales†  
 Class Zosterophyllopsida\*†  
 Division Polypodiophyta†  
 Class Polypodopsida†  
 Order: Equisetales†  
   Marattiales†  
   Sphenophyllales\*  
   Pseudoborniales\*  
   Psilotales  
   Ophioglossales†  
   Noeggerathiales\*  
   Protopteridales\*  
   Polypodiales†  
 Class Progymnospermopsida\*  
 Division Pinopsida†  
 Class Ginkgoopsida†  
 Order: Calamopityales\*  
   Callistophytales\*  
   Peltaspermales\*  
   Ginkgoales†  
   Leptostrobales\*  
   Caytoniales†  
   Arberiales\*  
   Pentoxylales\*  
 Class Cycadopsida†  
 Order: Lagenostomales\*  
   Trigonocarpales\*  
   Cycadales†  
   Bennettiales\*  
 Class Pinopsida†  
 Order: Cordaitales\*†  
   Pinales†  
   Podocarpaceae  
   Gnetales†  
 Division Magnoliophyta (angiosperms, flowering plants)†  
 Class Magnoliopsida†  
 unplaced groups: Amborellaceae, Ceratophyllaceae,  
   Chloranthaceae, Nymphaeaceae, etc.  
 eumagnoliids†  
 Order: Magnoliales†  
   Laurales†  
   Piperales†  
   Winterales  
 monocotyledons†  
 Order: Acorales†  
   Alismatales†  
   Asparagales†  
   Dioscoreales†  
   Liliales†  
   Pandanales†  
 commelinids  
   Arecales†  
   Commelinales†  
   Poales†  
   Zingiberales†  
 eudicotyledons†  
 (basal eudicots)  
 Order: Ranunculales†  
   Proteales†  
   Buxales  
   Trochodendrales†  
 (core eudicots)  
 Order: Berberidopsidales  
   Gunnerales  
   Dilleniales†  
   Santalales†  
   Caryophyllales†

Saxifragales†  
 Rosidae†  
 Order: Vitales  
   Myrtales†  
   Geraniales†  
   Crossosomatales  
 (eurosoid I)  
 Order: Celastrales†  
   Cucurbitales  
   Fabales†  
   Fagales†  
   Malpighiales†  
   Oxalidales†  
   Rosales†  
   Zygophyllales†  
 (eurosoid II)  
 Order: Brassicales†  
   Malvales†  
   Sapindales†  
 Asteridae†  
 Order: Cornales†  
   Ericales†  
 (euasterid I)  
 Order: Garryales  
   Gentianales†  
   Lamiales†  
   Solanales†  
 (euasterid II)  
 Order: Apiales†  
   Aquifoliales  
   Asterales†  
   Dipsacales†

See DEOXYRIBONUCLEIC ACID (DNA); PLANT EVOLUTION; PLANT PHYLOGENY; PLANT TAXONOMY. [M.W.C.; M.F.F.]

**Plant metabolism** The complex of physical and chemical events of photosynthesis, respiration, and the synthesis and degradation of organic compounds. Photosynthesis produces the substrates for respiration and the starting organic compounds used as building blocks for subsequent biosyntheses of nucleic acids, amino acids, and proteins, carbohydrates and organic acids, lipids, and natural products. See PHOTORESPIRATION; PHOTOSYNTHESIS; PLANT RESPIRATION. [I.P.T.]

**Plant mineral nutrition** The relationship between plants and all chemical elements other than carbon, hydrogen, and oxygen in the environment. Plants obtain most of their mineral nutrients by extracting them from solution in the soil or the aquatic environment. Mineral nutrients are so called because most have been derived from the weathering of minerals of the Earth's crust. Nitrogen is exceptional in that little occurs in minerals: the primary source is gaseous nitrogen of the atmosphere.

Some of the mineral nutrients are essential for plant growth; others are toxic, and some absorbed by plants may play no role in metabolism. Many are also essential or toxic for the health and growth of animals using plants as food. Six basic facts have been established: (1) plants do not need any of the solid materials in the soil—they cannot even take them up; (2) plants do not need soil microorganisms; (3) plant roots must have a supply of oxygen; (4) all plants require at least 14 mineral nutrients; (5) all of the essential mineral nutrients may be supplied to plants as simple ions of inorganic salts in solution; and (6) all of the essential nutrients must be supplied in adequate but nontoxic quantities. These facts provide a conceptually simple definition of and test for an essential mineral nutrient. A mineral nutrient is regarded as essential if, in its absence, a plant cannot complete its life cycle.

Nutrients which plants require in relatively large amounts, that is, the essential macronutrients, are nitrogen, sulfur, phosphorus, calcium, potassium, and magnesium. Iron is not required in large amounts and hence is regarded as an essential micronutrient or trace element. With the progressive development of better techniques for purifying water and salts, the list of essential nutrients for all plants has expanded to include boron, manganese, zinc, copper, molybdenum, and chlorine. Evidence has accumulated in support of nickel being essential. In addition, sodium and silicon have been shown to be essential for some plants, beneficial to some, and possibly of no benefit to others. Cobalt has also been shown to be essential for the growth of legumes when relying upon atmospheric nitrogen. Claims that two other chemical elements (vanadium and selenium) may be essential micronutrients have still to be firmly established.

Mineral nutrients may be toxic to plants either because the specific nutrient interferes with plant metabolism or because its concentration in combination with others in solution is excessive and interferes with the plant's water relations. Other chemical elements in the environment may also be toxic. High concentrations of salts in soil solutions or aquatic environments may depress their water potential to such an extent that plants cannot obtain sufficient water to germinate or grow. Some desert plants growing in saline soils can accumulate salt concentrations of 20–50% dry weight in their leaves without damage, but salt concentrations of only 1–2% can damage the leaves of many species. See PLANT-WATER RELATIONS; PLANTS, SALINE ENVIRONMENTS OF.

A number of elements interfere directly with other aspects of plant metabolism. Sodium is thought to become toxic when it reaches concentrations in the cytoplasm that depress enzyme activity or damage the structure of organelles, while the toxicity of selenium is probably due to its interference in metabolism of amino acids and proteins. The ions of the heavy metals, cobalt, nickel, chromium, manganese, copper, and zinc are particularly toxic in low concentrations, especially when the concentration of calcium in solution is low; increasing calcium increases the plant's tolerance. Aluminum is toxic only in acid soils. Boron may be toxic in soils over a wide pH range, and is a serious problem for sensitive crops in regions where irrigation waters contain excessive boron or where the soils contain unusually high levels of boron.

All plants grow poorly on very acid soils (pH  $\leq$  3.5); some plants may grow reasonably well on somewhat less acid soils. Several factors may be involved, and their interactions with plant species are complex. The harmful effects of soil acidity in some areas have been exacerbated by industrial emissions resulting in acid rain and in deposition of substances which increase the acidity on further reaction in the soil, with consequent damage to plants and animals in these ecosystems. See ACID RAIN.

The elemental composition of plants is important to the health and productivity of animals which graze them. With the exception of boron, all elements which are essential for plant growth are also essential for herbivorous mammals. Animals also require sodium, iodine, and selenium and, in the case of ruminant herbivores, cobalt. As a result, animals may suffer deficiencies of any one of this latter group of elements when ingesting plants which are quite healthy but contain low concentrations of these elements. In addition, nutrients in forage may be rendered unavailable to animals through a variety of factors that prevent their absorption from the gut. Plants and animals differ also in their tolerance of high levels of nutrients, sometimes with deleterious results for grazing animals. For example, the toxicity of high concentrations of selenium in plants to animals grazing them, known as selenosis, was recognized when the puzzling and long-known "alkali disease" and "blind staggers" in grazing livestock in parts of the Great Plains of North America were shown to be symptoms of chronic and acute selenium toxicity. See ABSORPTION (BIOLOGY); NITROGEN CYCLE; PLANT TRANSPORT OF SOLUTES; RHIZOSPHERE; ROOT (BOTANY); SOIL CHEMISTRY. [J.F.L.]

**Plant morphogenesis** The origin and development of plant form and structure. Morphogenesis may be concerned with the whole plant, with a plant part, or with the subcomponents of a structure.

The establishment of differences at the two ends of a structure is called polarity. In plants, polar differences can be recognized very early in development. In the zygote, cytological differences at the two ends of the cell establish the position of the first cell division, and thus the fate of structures produced from the two newly formed cells. During the development of a plant, polarity is also exhibited in the plant axis (in the shoot and root tips). If a portion of a shoot or root is excised and allowed to regenerate, the end toward the shoot tip always regenerates shoots whereas the opposite end forms roots. Polarity is also evident on the two sides of a plant organ, such as the upper and lower surface of a leaf, sepal, or petal.

The diversity in plant form is produced mainly because different parts of the plant grow at different rates. Furthermore, the growth of an individual structure is different in various dimensions. Thus the rate of cell division and cell elongation as well as the orientation of the plane of division and of the axis of cell elongation ultimately establish the form of a structure. Such differential growth rates are very well orchestrated by genetic factors. Although the absolute growth rates of various parts of a plant may be different, their relative growth rates, or the ratio of their growth rates, are always constant. This phenomenon is called allometry (or heterogony), and it supports the concept that there is an interrelationship between the growth of various organs of a plant body. See PLANT GROWTH.

During development, either the removal of or changes in one part of the plant may drastically affect the morphogenesis of one or more other parts of the plant. This phenomenon is called correlation and is mediated primarily through chemical substances, such as nutrients and hormones. See APICAL DOMINANCE.

The ultimate factors controlling the form of a plant and its various organs are the genes. In general, several genes interact during the development of a structure, although each gene plays a significant role. Thus, a mutation in a single gene may affect the shape or size of a leaf, flower, or fruit, or the color of flower petals, or the type of hairs produced on stems and leaves. There are at least two classes of genes involved in plant morphogenesis: regulatory genes that control the activity of other genes, and effector genes that are directly involved in a developmental process. The effector genes may affect morphogenesis through a network of processes, including the synthesis and activity of proteins and enzymes, the metabolism of plant growth substances, changes in the cytoskeleton and the rates and planes of cell division, and cell enlargement. See GENE ACTION; PLANT HORMONES.

Plant form is also known to be affected by nutritional factors, such as sugars or nitrogen levels. For example, leaf shape can be affected by different concentrations of sucrose, and the sexuality of flowers is related to the nitrogen levels in the soil in some species. Inorganic ions (such as silver and cobalt) have also been known to affect the type of flower produced. See PLANT MINERAL NUTRITION.

Although genes are the ultimate controlling factors, they do not act alone, but interact with the existing environmental factors during plant development. Environmental factors, including light, temperature, moisture, and pressure, affect plant form. See PHYSIOLOGICAL ECOLOGY (PLANT); PLANT-WATER RELATIONS.

[V.K.S.]

**Plant movements** The wide range of movements that allow plants to reorient themselves in relation to changed surroundings, to facilitate spore or seed dispersal, or, in the case of small free-floating aquatic plants, to migrate to regions optimal for their activities. There are two types of plant movement: abio-genic movements, which arise purely from the physical properties of the cells and therefore take place in nonliving tissues or

organs; and biogenic movements, which occur in living cells or organs and require an energy input from metabolism.

**Abiogenic movements.** Drying or moistening of certain structures causes differential contractions or expansions on the two sides of cells and hence causes movements of curvature. Such movements are called hygroscopic and are usually associated with seed and spore liberation and dispersal. Examples of such movement occur in the "parachute" hairs of the fruit of dandelion (*Taraxacum officinale*), which are closed when damp but open when the air is dry to induce release from the heads and give buoyancy for wind dispersal.

Another type of abiogenic movement is due to changes in volume of dead water-containing cells. In the absence of a gas phase, water will adhere to lignocellulose cell walls. As water is lost by evaporation from the surface of these cells, considerable tensions can build up inside, causing them to decrease in volume while remaining full of water. The effect is most commonly seen in some grasses of dry habitats, such as sand dunes, where longitudinal rows of cells on one side of the leaf act as spring hinges, contracting in a dry atmosphere and causing the leaf to roll up into a tight cylinder, thus minimizing water loss by transpiration.

**Biogenic movements.** There are two types of biogenic movement. One of these is locomotion of the whole organism and is thus confined to small, simply organized units in an aqueous environment. The other involves the change in shape and orientation of whole organs of complex plants, usually in response to specific stimuli.

**Locomotion.** In most live plant cells the cytoplasm can move by a streaming process known as cyclosis. Energy for cyclosis is derived from the respiratory metabolism of the cell. The mechanism probably involves contractile proteins very similar to the actomyosin of animal muscles.

Cell locomotion is a characteristic of many simple plants and of the gametes of more highly organized ones. Motility in such cells is produced by cilia anchored in the peripheral layers of the cell and projecting into the surrounding medium. See CILIA AND FLAGELLA.

Cell locomotion is usually not random but is directed by some environmental gradient. Thus locomotion may be in response to specific chemicals, in which case it is called chemotaxis. Light gradients induce phototaxis; temperature gradients induce thermotaxis; and gravity induces geotaxis. One or more of these environmental factors may operate to control movement to optimal living conditions.

**Movement of organs.** In higher plants, organs may change shape and position in relation to the plant body. When bending or twisting of the organ is evoked spontaneously by some internal stimulus, it is termed autonomous movement. The most common movements, however, are those initiated by external stimuli such as light and the force of gravity. Of these there are two kinds. In nastic movements (nasties), the stimulus usually has no directional qualities (such as a change in temperature), and the movement is therefore not related to the direction from which the stimulus comes. In tropisms, the stimulus has a direction (for instance, gravitational pull), and the plant movement direction is related to it.

The most common autonomous movement is circumnutation, a slow, circular, sometimes waving movement of the tips of shoots, roots, and tendrils as they grow; one complete cycle usually takes from 1 to 3 h. These movements are due to differential growth, but some may be caused by turgor changes in the cells of special hinge organs and are thus reversible.

1. **Nastic movements.** There are two kinds of nastic movements, due either to differential growth or to differential changes in the turgidity of cells. They can be triggered by a wide variety of external stimuli.

Photonastic (light/dark trigger) movements are characteristic of many flowers and inflorescences, which usually open in the light and close in the dark. Thermonasty (temperature-change trigger) is seen in the tulip and crocus flowers, which open in a

warm room and close again when cooled. The most striking nastic movements are seen in the sensitive plant (*Mimosa pudica*). Its multipinnate leaves are very sensitive to touch or slight injury. Leaflets fold together, pinnae collapse downward, and the whole leaf sinks to hang limply.

Epinasty and hyponasty occur in leaves as upward and downward curvatures respectively. They arise either spontaneously or as the result of an external stimulus, such as exposure to the gas ethylene in the case of epinasty; they are not induced by gravity.

2. **Tropisms.** Of these the most universal and important are geotropism (or more properly gravitropism) and phototropism; others include thigmotropism and chemotropism.

In geotropism, the stimulus is gravity. The main axes of most plants grow in the direction of the plumb line with shoots upward (negative geotropism) and roots downward (positive geotropism).

In phototropism the stimulus is a light gradient, and unilateral light induces similar curvatures; those toward the source are positively phototropic; those away from the source are negatively phototropic. Main axes of shoots are usually positively phototropic, while the vast majority of roots are insensitive.

In thigmotropism (sometimes called haptotropism), the stimulus is touch; it occurs in climbing organs and is responsible for tendrils curling around a support. In many tendrils the response may spread from the contact area, causing the tight coiling of the basal part of the tendril into an elaborate and elastic spring.

Chemotropism is induced by a chemical substance. Examples are the incurling of the stalked digestive glands of the insectivorous plant *Drosera* and incurling of the whole leaf of *Pinguicula* in response to the nitrogenous compounds in the insect prey. A special case of chemotropism concerns response to moisture gradients; for example, under artificial conditions in air, the primary roots of some plants will curve toward and grow along a moist surface. This is called hydrotropism and may be of importance under natural soil conditions in directing roots toward water sources. See PLANT HORMONES; PLANT PHYSIOLOGY. [L.J.A.]

**Plant organs** Plant parts having rather distinct form, structure, and function. Organs, however, are interrelated through both evolution and development and are similar in many ways.

Roots, stems, and leaves are vegetative, or asexual, plant organs. They do not produce sex cells or play a direct role in sexual reproduction. In many species, nevertheless, these organs or parts of them (cuttings), may produce new plants asexually (vegetative reproduction). Sex organs are formed during the reproductive stage of plant development. In flowering plants, sex cells are produced in certain floral organs. The flower as a whole is sometimes called an organ, although it is more appropriate to consider it an assemblage of organs. See FLOWER; FRUIT; LEAF; REPRODUCTION (PLANT); ROOT (BOTANY); STEM. [K.E.]

**Plant pathology** The study of disease in plants; it is an integration of many biological disciplines and bridges the basic and applied sciences. As a science, plant pathology encompasses the theory and general concepts of the nature and cause of disease, and yet it also involves disease control strategies, with the ultimate goal being reduction of damage to the quantity and quality of food and fiber essential for human existence.

**Kinds of plant diseases.** Diseases were first classified on the basis of symptoms. Three major categories of symptoms were recognized long before the causes of disease were known; necroses, destruction of cell protoplasts (rots, spots, wilts); hypoplasies, failure in plant development (chlorosis, stunting); and hyperplasies, overdevelopment in cell number and size (witches' brooms, galls). This scheme remains useful for recognition and diagnosis.

When fungi, and then bacteria, nematodes, and viruses, were recognized as causes of disease, it became convenient to classify diseases according to the responsible agent. If the agents were

infectious (biotic), the diseases were classified as being "caused by bacteria," "caused by nematodes," or "caused by viruses." To this list were added phanerogams and protozoans, and later mollicutes (mycoplasmas, spiroplasmas), rickettsias, and viroids. In a second group were those diseases caused by such noninfectious (abiotic) agents as air pollutants, inadequate oxygen, and nutrient excesses and deficiencies.

Other classifications of disease have been proposed, such as diseases of specific plant organs, diseases involving physiological processes, and diseases of specific crops or crop groups (for example, field crops, fruit crops, vegetable crops).

**Symptoms of plant diseases.** Symptoms are expressions of pathological activity in plants. They are visible manifestations of changes in color, form, and structure: leaves may become spotted, turn yellow, and die; fruits may rot on the plants or in storage; cankers may form on stems; and plants may blight and wilt. Diagnosticians learn how to associate certain symptoms with specific diseases, and they use this knowledge in the identification and control of pathogens responsible for the diseases.

Those symptoms that are external and readily visible are considered morphological. Others are internal and primarily histological, for example, vascular discoloration of the xylem of wilting plants. Microscopic examination of diseased plants may reveal additional symptoms at the cytological level, such as the formation of tyloses (extrusion of living parenchyma cells of the xylem of wilted tissues into vessel elements).

It is important to make a distinction between the visible expression of the diseased condition in the plant, the symptom, and the visible manifestation of the agent which is responsible for that condition, the sign. The sign is the structure of the pathogen, and when present it is most helpful in diagnosis of the disease.

All symptoms may be conveniently classified into three major types because of the manner in which pathogens affect plants. Most pathogens produce dead and dying tissues, and the symptoms expressed are categorized as necroses. Early stages of necrosis are evident in such conditions as hydrosis, wilting, and yellowing. As cells and tissues die, the appearance of the plant or plant part is changed, and is recognizable in such common conditions as blight, canker, rot, and spot.

Many pathogens do not cause necrosis, but interfere with cell growth or development. Plants thus affected may eventually become necrotic, but the activity of the pathogen is primarily inhibitory or stimulatory. If there is a decrease in cell number or size, the expressions of pathological activity are classified as hypoplasies; if cell number or size is increased, the symptoms are grouped as hyperplasies. These activities are very specific and most helpful in diagnosis. In the former group are such symptoms as mosaic, rosetting, and stunting, with obvious reduction in plant color, structure, and size. In the latter group are gall, scab, and witches'-broom, all visible evidence of stimulation of growth and development of plant tissues. See CROWN GALL.

[C.W.B.]

The primary agents of plant disease are fungi, bacteria, viruses and viroids, nematodes, parasitic seed plants, and a variety of noninfectious agents.

**Fungi.** More plant diseases are caused by fungi than by any other agent. The fungi that cause plant disease derive their food from the plant (host) and are called parasites. Those that can live and grow only in association with living plant tissues are obligate parasites. Some fungi obtain their food from dead organic matter and are known as saprobes or saprophytes. Still others can utilize food from either dead organic matter or from living plant cells, and are referred to as either facultative parasites or facultative saprophytes. The classes with plant disease-causing fungi are Plasmodiophoromycetes, Chytridiomycetes, Zygomycetes, Oomycetes, Ascomycetes, Basidiomycetes, and Deuteromycetes. See FUNGI.

[C.W.E.]

**Bacteria.** Over 100 species of bacteria mainly in five genera cause disease in hundreds of different species of flowering plants.

Destructive bacterial diseases affect the major cereal, vegetable, and fruit crops. None of the bacterial pathogens of plants causes serious diseases of humans or animals, and certain groups of green plants (mosses, ferns, conifers, and hardwood trees) have few or no major bacterial diseases. See BACTERIA.

Each species of bacteria produces a distinctive pattern of symptoms on those hosts that it attacks.

With a few exceptions, most of the bacteria that cause disease in plants are non-spore-forming, rod-shaped, gram-negative cells. It is not possible to separate plant pathogenic bacteria into species on the basis of colony characteristics, cell morphology, or staining characteristics. Therefore, biochemical and physical tests used to differentiate bacteria in general are also used in studies on plant pathogens. Helpful techniques include serological tests, DNA hybridization, sensitivity to phages, and gel electrophoresis of proteins. However, one of the most important of the tests for identification is the demonstration of pathogenicity to a specific plant.

Many foliage pathogens are dependent upon wind-driven splashing rain as the primary means of spread from plant to plant. Bacteria also may be spread from plant to plant by insects, in irrigation water, and by various cultural operations during the growing season. Bacteria can also survive the winter in insects such as flea beetles. Most bacterial plant pathogens survive adverse conditions in host plants. Only a small number of species survive for long periods of time in the soil in the absence of host plants. Bacterial plant pathogens are not capable of forcing their way through the cuticle of a leaf or bark of a stem. They must enter through wounds or natural openings.

The exact manner by which bacteria induce disease in plants is not fully understood. The surface area of hundreds of thousands of cells in intimate contact with the surrounding plant cells is very large, and enzymes, as well as toxic materials, can be released readily into the host tissue.

Certain vascular parasites produce gumlike substances or polysaccharides. Masses of bacterial cells embedded in the polysaccharide material and host responses to hormone imbalances reduce the rate of flow of water when such bacteria as the one causing bacterial wilt of tomato invade water-conducting tissue. The genetic control for tumor induction in the crown gall bacterium has been shown to reside in a plasmid, a nonchromosomal DNA element. The presence of the tumor-inducing plasmid ensures that genetic information in the bacterial cell is transferred and maintained in the transformed cells of the plant cancer resulting from infection.

Since primary sources of inoculum for new infections are often in undecomposed plant debris or seed, crop rotation and the use of pathogen-free seed or seed treatments are, in general, effective in reducing losses from a large number of bacterial diseases affecting foliage. Resistant varieties have been developed for a number of foliage diseases because spraying or dusting, in general, has been relatively ineffective. Certain antibiotics are effective, but not widely used because of the concern for the development of resistant strains. An insect-transmitted bacterium can be controlled if populations of the insect vector are reduced.

[A.K.]

**Viruses and viroids.** Viruses and viroids are the simplest of the various causative agents of plant disease. The essential element of each of these two pathogens is an infective nucleic acid. The nucleic acid of viruses is covered by an exterior shell (coat) of protein, but that of viroids is not. See PLANT VIRUSES AND VIROIDS.

Approximately 400 plant viruses and about 10 viroids are known. The nucleic acid of most plant viruses is a single-stranded RNA; a number of isometric viruses have a double-stranded RNA. A few viruses contain double-stranded DNA, and several containing single-stranded DNA have been reported. The nucleic acid of viroids is a single-stranded RNA, but its molecular weight is much lower than that of viruses.



Some viruses, such as tobacco mosaic virus (TMV) and cucumber mosaic virus, are found in many plant species; others, such as wheat streak mosaic virus, occur only in a few grasses. Viruses are transmitted from plant to plant in several ways. The majority are transmitted by vectors such as insects, mites, nematodes, and fungi which acquire viruses during feeding upon infected plants. Some viruses are transmitted to succeeding generations by infected seed. Viroids are spread mainly by contact between healthy and diseased plants or by the use of contaminated cutting tools.

The control or prevention of virus diseases involves breeding for resistance, propagation of virus-free plants, use of virus-free seed, practices designed to reduce the spread by vectors, and, in some cases, the deliberate inoculation of plants with mild strains of a virus to protect them from the deleterious effects of severe strains. See PLANT VIRUSES AND VIROIDS. [R.I.H.]

**Nematodes.** All soils that support plant life contain nematodes living in the water films that surround soil particles. Most nematodes feed primarily on microscopic plants, animals, and bacteria, but a few are parasites of animals; another relatively small group of nematodes parasitize plants. See NEMATODA.

Plant-parasitic nematodes are distinguished by their small size, about 1 mm average length, and mouthparts that are modified to form a hollow stylet which is inserted into plant cells. All of the plant parasites are placed into two orders, Tylenchida and Dorylaimida.

Plant injury is of three general types and is related to feeding habits. Migratory endoparasites destroy tissues as they feed, producing necrotic lesions in the root cortex. Other migratory endoparasites invade leaf tissues and produce extensive brown spots. Sedentary endoparasites do not kill host cells, but induce changes in host tissues, which lead to an elaborate feeding site or gall. The third general type of symptom is produced by certain migratory ectoparasites, where root tips are devitalized and cease to grow without any associated swelling or necrosis.

In addition to the plant injury that they cause directly, nematodes are important factors in disease complexes. Lesions and galls provide entrance courts for soil fungi and bacteria, and many diseases caused by soil-borne pathogens are more severe when nematodes are present. Important viruses are transmitted by nematodes of the order Dorylaimida.

Control of plant-parasitic nematodes often is based on selection of nonhosts for crop rotations or nematode-resistant varieties. Some plant species release compounds into the soil that are toxic to nematodes. Animal manures, compost, and other organic amendments enhance the buildup of natural enemies of nematodes. [R.A.R.]

Many parasitic seed plants (estimated at nearly 3000) attack other higher plants. In some families (for example, the mistletoes Loranthaceae and Viscaceae) all members are parasitic; in others, only a single genus is parasitic in an otherwise autotrophic family.

Most parasitic plants are terrestrial; that is, the parasitic connection with the host plant is through the roots. Other parasitic plants grow on the above-ground parts of the host. Some plants are classed as semiparasites because they can live in the soil as independent plants for a time, but are not vigorous or may not flower if they do not become attached to a suitable host. The nutritional status of parasitic plants ranges from total parasites with no chlorophyll (for example, the broomrapes, Orobanchaceae) to plants that are well supplied with chlorophyll and obtain primarily water and minerals from their hosts (many mistletoes; see illustration). [F.G.H.]

**Noninfectious agents of disease.** Plants with symptoms caused by noninfectious agents cannot serve as sources of further spread of the same disorder. Such noninfectious agents may be deficiencies or excesses of nutrients, anthropogenic pollutants, or biological effects by organisms external to the affected plants. On the farm, plant-damaging pollution may be caused by care-



Many small plants of a dwarf mistletoe (*Arceuthobium vaginatum*) parasitizing a ponderosa pine branch. This is the most damaging disease of ponderosa pine in many parts of the West.

less use of pesticides. Mishandled herbicides are by far the most damaging to plants. Off the farm, anthropogenic air pollutants are generated by industrial processes, and by any heating or transportation method that uses fossil fuels. The most common air pollutants that damage plants are sulfur oxides and ozone. Sulfur oxides are produced when sulfur-containing fossil fuels are burned or metallic sulfides are refined. Human-generated ozone is produced by sunlight acting on clouds of nitrogen oxides and hydrocarbons that come primarily from automobile exhausts. See AIR POLLUTION; WATER POLLUTION. [G.N.A.]

**Epidemiology of plant disease.** Epidemiology is the study of the intensification of disease over time and the spread of disease in space. The botanical epidemiologist is concerned with the interrelationships of the host plant (suscept), the pathogen, and the environment, which are the components of the disease triangle. With a thorough knowledge of these components, the outbreak of disease may be forecast in advance, the speed at which the epidemic will intensify may be determined, control measures can be applied at critical periods, and any yield loss to disease can be projected. The maximum amount of disease occurs when the host plant is susceptible, the pathogen is aggressive, and the environment is favorable.

Epidemiologically, there are two main types of diseases: monocyclic, those that have but a single infection cycle (with the rare possibility of a second or even third cycle) per crop season; and polycyclic, those that have many, overlapping, concatenated cycles of infection per crop season. For both epidemiological types, the increase of disease slows as the proportion of disease approaches saturation or 100%. [R.D.Ber.]

Control of plant disease is defined as the maintenance of disease severity below a certain threshold, which is determined by economic losses. Diseases may be high in incidence but low in severity, or low in incidence but high in severity, and are kept in check by preventing the development of epidemics. The principles of plant disease control form the basis for preventing epidemics. However, the practicing agriculturist uses three approaches to the control of plant disease: cultural practices affecting the environmental requirement of the suscept-pathogen-environment triangle necessary for disease development, disease resistance, and chemical pesticides. [R.E.St.]

**Plant phylogeny** The evolutionary chronicle of plant life on the Earth. Understanding of this history is largely based on knowledge of extant plants, but the fossil record is playing an increasingly important role in refining and illuminating this picture. Study of deoxyribonucleic acid (DNA) sequences has also been revolutionizing this process in recent years. The molecular data (largely in the form of DNA sequences from several genes) have been demonstrated to be highly correlated with other information. See PHYLOGENY.

“Algae” was once a taxonomic designation uniting the lower photosynthetic organisms, but ultrastructural and molecular data have uncovered a bewildering diversity of species. Algae are now recognized as 10 divergent lineages on the tree of life that join organisms as distinct as bacteria and eukaryotic protozoans, ciliates, fungi, and embryophytes (including the land plants). In a biochemical context, the term “algae” defines species characterized by chlorophyll *a* photosynthesis (except Embryophyta); some of their descendants are heterotrophic (secondary chloroplast loss). Despite the variety of species it encompasses, the term “algae” also retains phylogenetic relevance. See ALGAE; CHLOROPHYLL; PHOTOSYNTHESIS. [G.W.Sa.]

Embryobionta, or embryophytes, are largely composed of the land plants that appear to have emerged 475 million years ago. The evidence indicates that land plants have not evolved from different groups of green algae (Chlorophyta) as suggested in the past, but instead share a common ancestor, which was a green alga. Land plants all have adaptations to the terrestrial environment, including an alternation of generations (sporophyte or diploid and gametophyte or haploid) with the sporophyte generation producing haploid spores that are capable of resisting desiccation and dispersing widely, a cuticle covering their outside surfaces, and separate male and female reproductive organs in the gametophyte stage. The life history strategies of land plants fall into two categories that do not reflect their phylogenetic relationships. The mosses, hornworts, and liverworts represent the first type, and they have expanded the haploid generation, upon which the sporophyte is dependent. Several recent analyses of DNA data as well as evidence from mitochondrial DNA structure have demonstrated that the liverworts alone are the remnants of the earliest land plants and that the mosses and hornworts are closer to the vascular plants (tracheophytes). The tracheophytes include a large number of extinct and relatively simple taxa, such as the rhinophytes and hornophytes known only as Silurian and Devonian fossils. All tracheophytes are of the second category, and they have expanded the sporophyte generation. Among extant tracheophytes, the earliest branching are the lycopods or club mosses (*Lycopodium* and *Selaginella*), and there are still a diversity of other forms, including sphenophytes (horsetails, *Equisetum*) and ferns (a large and diverse group in which the positions of several families still are not clear). See EMBRYOBIONTA.

All seeds plants take the reduction of the gametophyte generation a step further and make it dependent on the sporophyte, typically hiding it within reproductive structures, which are either cones or flowers. The first seed plants originated at least by the Devonian, and they are known to have a great diversity of extinct forms, including the seed ferns. There are two groups of extant seed-bearing plants, gymnosperms and angiosperms. In the gymnosperms, the seeds are not enclosed within tissue derived from the parent plant. There are four distinct groups of extant gymnosperms, often recognized as classes: Cycadopsida, Gnetopsida, Ginkgoopsida, and Pinopsida.

The angiosperms (also flowering plants or Magnoliopsida) are the dominant terrestrial plants, although the algae collectively must still be acknowledged as the most important in the maintenance of the Earth's ecological balance (fixation of carbon dioxide and production of oxygen). In angiosperms the seeds are covered by protective tissues derived from the parental plant. There are no generally accepted angiospermous fossils older than 120 million years, but the lineage is clearly much older

based on DNA clocks and other circumstantial lines of evidence such as their current geographic distributions.

Traditionally the angiosperms have been divided into two groups, monocotyledons (monocots) and dicotyledons (dicots), based on the number of seed leaves. However, DNA sequence data have demonstrated that, although there are two groups, these are characterized by fundamentally different pollen organization, such that the monocots share with a group of dicots pollen with one pore whereas the rest of the dicots have pollen with three (or more) pores. [M.W.C.]

**Plant physiology** That branch of plant sciences that aims to understand how plants live and function. Its ultimate objective is to explain all life processes of plants by a minimal number of comprehensive principles founded in chemistry, physics, and mathematics.

Plant physiology seeks to understand all the aspects and manifestations of plant life. In agreement with the major characteristics of organisms, it is usually divided into three major parts: (1) the physiology of nutrition and metabolism, which deals with the uptake, transformations, and release of materials, and also their movement within and between the cells and organs of the plant; (2) the physiology of growth, development, and reproduction, which is concerned with these aspects of plant function; and (3) environmental physiology, which seeks to understand the manifold responses of plants to the environment. The part of environmental physiology which deals with effects of and adaptations to adverse conditions—and which is receiving increasing attention—is called stress physiology.

Plant physiological research is carried out at various levels of organization and by using various methods. The main organizational levels are the molecular or subcellular, the cellular, the organismal or whole-plant, and the population level. Work at the molecular level is aimed at understanding metabolic processes and their regulation, and also the localization of molecules in particular structures of the cell but with little if any consideration of other processes and other structures of the same cell. Work at the cellular level often deals with the same processes but is concerned with their integration in the cell as a whole. Research at the organismal level is concerned with the function of the plant as a whole and its different organs, and with the relationships between the latter.

Research at the population level, which merges with experimental ecology, deals with physiological phenomena in plant associations which may consist either of one dominant species (like a field of corn) or of numerous diverse species (like a forest). Work at the organismal and to some extent the population level is carried out in facilities permitting maintenance of controlled environmental conditions (light, temperature, water and nutrient supply, and so on). See PLANT METABOLISM; PLANT RESPIRATION; PHYSIOLOGICAL ECOLOGY (PLANT); PHYTOTRONICS. [A.L.]

**Plant pigment** A substance in a plant that imparts coloration. The photosynthetic pigments are involved in light harvesting and energy transfer in photosynthesis. This group of pigments comprises the tetrapyrroles, which include chlorophylls (chl) and phycobilins, and the carotenoids. The light-absorbing groups of these molecules, the chromophores, contain conjugated double bonds (alternating single and double bonds), which make them effective photoreceptors. The sum of the absorption spectra of the chlorophylls and the carotenoids, evident in the absorption spectrum of a green leaf, is equivalent to the action spectrum of photosynthesis. See CAROTENOID; CHLOROPHYLL; PHOTOSYNTHESIS; PHYCOBILIN; PIGMENTATION.

The second major group comprises the anthocyanins, intensely colored plant pigments responsible for most scarlet, crimson, purple, mauve, and blue colors in higher plants. About 100 different anthocyanins are known. Unlike the chlorophylls and carotenoids, which are lipid-soluble chloroplast pigments, the anthocyanins are water-soluble and are located in the cell

vacuole. Chemically, they are a class of flavonoids and are particularly closely related, both structurally and biosynthetically, to the flavonols. Their value to the plant lies in the contrasting colors they provide in flower and fruit, against the green background of the leaf, to attract insects and animals for purposes of pollination and seed dispersal. See FLAVONOID. [S.Ra.]

**Plant propagation** The deliberate, directed reproduction of plants using plant cells, tissues, or organs. Asexual propagation, also called vegetative propagation, is accomplished by taking cuttings, by grafting or budding, by layering, by division of plants, or by separation of specialized structures such as tubers, rhizomes, or bulbs. This method of propagation is used in agriculture, in scientific research, and in professional and recreational gardening. It has a number of advantages over seed propagation: it retains the genetic constitution of the plant type almost completely; it is faster than seed propagation; it may allow elimination of the nonfruiting, juvenile phase of the plant's life; it preserves unique, especially productive, or esthetically desirable plant forms; and it allows plants with roots well adapted for growth on poor soils to be combined with tops that produce superior fruits, nuts, or other products. See BREEDING (PLANT); REPRODUCTION (PLANT). [C.E.LaM.]

Tissue cultures and protoplast cultures are among the techniques that have been investigated for plant propagation; the success of a specific technique depends on a number of factors. Practical applications of such methods include the clonal propagation of desirable phenotypes and the commercial production of virus-free plants.

Plant tissue cultures are initiated by excising tissue containing nucleated cells and placing it on an enriched sterile culture medium. The response of a plant tissue to a culture medium depends on a number of factors: plant species, source of tissue, chronological age and physiological state of the tissue, ingredients of the culture medium, and physical culturing conditions, such as temperature, photoperiod, and aeration.

Though technically more demanding, successful culture of plant protoplasts involves the same basic principles as plant tissue culture. Empirical methods are used to determine detailed techniques for individual species; such factors as plant species, tissue source, age, culture medium, and physical culture conditions have to be considered. See PLANT CELL; TISSUE CULTURE. [K.G.F.]

**Plant respiration** A biochemical process whereby specific substrates are oxidized with a subsequent release of carbon dioxide, CO<sub>2</sub>. There is usually conservation of energy accompanying the oxidation which is coupled to the synthesis of energy-rich compounds, such as adenosine triphosphate (ATP), whose free energy is then used to drive otherwise unfavorable reactions that are essential for physiological processes such as growth. Respiration is carried out by specific proteins, called enzymes, and it is necessary for the synthesis of essential metabolites, including carbohydrates, amino acids, and fatty acids, and for the transport of minerals and other solutes between cells. Thus respiration is an essential characteristic of life itself in plants as well as in other organisms.

Overall aerobic respiration is the end result of a sequence of many biochemical reactions that ultimately lead to O<sub>2</sub> uptake and CO<sub>2</sub> evolution. In the absence of O<sub>2</sub>, as may occur in bulky plant tissues such as the potato tuber and carrot root and in submerged plants such as germinating rice seedlings, the breakdown of hexose does not go to completion. The end products are either lactic acid or ethanol, which are produced by anaerobic glycolysis or fermentation.

The sequence of reactions of anaerobic glycolysis or fermentation is shown in the illustration. The enzymes associated with anaerobic glycolysis have been isolated from many plant tissues, but more often ethanol and not lactic acid is the final product.

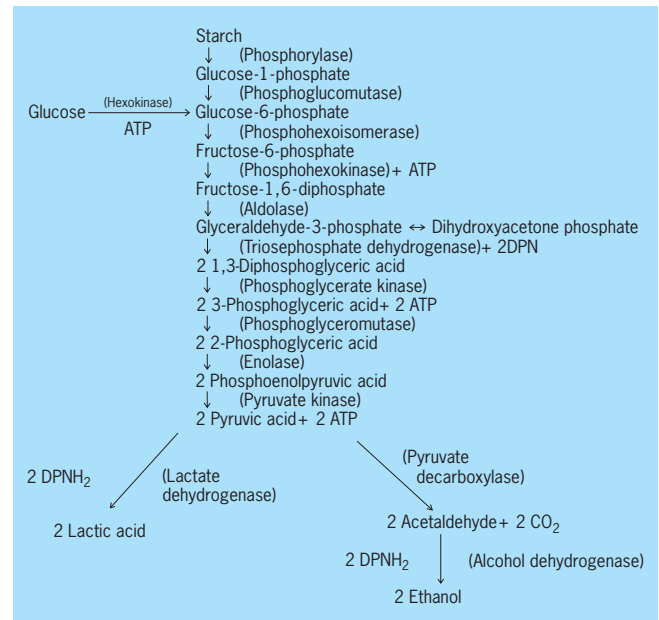

**Reaction sequence for anaerobic glycolysis. The soluble enzymes are shown in parentheses.**

In aerobic tissues, pyruvic acid produced during glycolysis is completely oxidized with the accompanying synthesis of much more ATP than in anaerobic glycolysis. Pyruvic acid oxidation takes place in the mitochondria by means of a cyclic sequence of reactions, the Krebs cycle (also known as the citric acid cycle) which begins when the first product of pyruvate oxidation, acetyl coenzyme A, reacts with oxaloacetic acid to produce citric acid. Oxaloacetic acid is eventually regenerated. Thus the cycle can be repeated. In terms of conservation of chemical energy, the Krebs cycle is about 12 times more efficient than anaerobic glycolysis per mole of glucose oxidized. See CITRIC ACID CYCLE.

In addition to anaerobic glycolysis and the Krebs cycle, there are two other sequences of biochemical reactions related to respiration that are important in plant tissues: (1) The pentose phosphate pathway permits an alternate mechanism for converting hexose phosphate to pyruvate, and (2) in germinating fatty seeds the reactions of the Krebs cycle are modified so that acetyl coenzyme A is converted to succinic acid and then to hexose by a pathway called the glyoxylate cycle. See PHOTORESPIRATION; PHOTOSYNTHESIS; PLANT GROWTH; PLANT METABOLISM. [I.Z.]

**Plant taxonomy** The area of study focusing on the development of a classification system, or taxonomy, for plants based on their evolutionary relationships (phylogeny). The assumption is that if classification reflects phylogeny, reference to the classification will help researchers focus their work in a more accurate manner. The task is to make phylogeny reconstruction as accurate as possible. The basic unit of classification is generally accepted to be the species, but how a species should be recognized has been intensely debated. See PLANT KINGDOM; PLANT PHYLOGENY.

The earliest classifications of plants were those of the Greek philosophers such as Aristotle (384–322 B.C.) and Theophrastus (372–287 B.C.). The latter is often called the father of botany largely because he listed the names of over 500 species, some of which are still used as scientific names today. In the next 1600 years little progress occurred in plant taxonomy. It was not until the fifteenth century that there was renewed interest in botany, much of which was propelled by the medical use of plants. In 1753 Carolus Linnaeus, a Swedish botanist, published his *Species Plantarum*, a classification of all plants known to Europeans at that time. Linnaeus's system was based on the

arrangement and numbers of parts in flowers, and was intended to be used strictly for identification (a system now referred to as an artificial classification as opposed to a natural classification, based on how closely related the species are).

In *Species Plantarum*, Linnaeus made popular a system of binomial nomenclature developed by the French botanist Gaspard Bauhin (1560–1624), which is still in use. Each species has a two-part name, the first being the genus and the second being the species epithet. For example, *Rosa alba* (italicized because it is Latin) is the scientific name of one species of rose; the genus is *Rosa* and the species epithet is *alba*, meaning white (it is not a requirement that scientific names be similar to common names or have real meaning, although such relevance is often the case). The genus name *Rosa* is shared by all species of roses, reflecting that they are thought to be more closely related to each other than to species in any other group.

Today, we understand that the best classification system is one that reflects the patterns of the evolutionary processes that produced these plants. The rules of botanical nomenclature (and those of zoology as well, although they are not identical) are part of an internationally accepted Code that is revised (minimally) at an international congress every 5 years. See PLANT EVOLUTION.

Use of common names in science and horticulture is not practical. Scientific names are internationally agreed upon so that a consistent taxonomic name is used everywhere for a given organism. In addition to genus and species, plants are classified by belonging to a family; related families are grouped into orders, and these are typically grouped into a number of yet higher and more encompassing categories. In general, higher categories are composed of many members of lower types—for example, a family may contain 350 genera, but some may be composed of a single genus with perhaps a single species if that species is distantly related to all others.

Many botanists use a number of intermediate categories between the level of genus and family, such as subfamilies, tribes, and subtribes, as well as some between species and genus, such as subgenera and sections, but none of these categories is formally mandated. They are useful nonetheless to reflect intermediate levels of relatedness, particularly in large families (composed of several hundreds or even thousands of species). Below the level of species, some botanists use the concept of subspecies (which is generally taken to mean a geographically distinct form of a species) and variety (which is often a genetic form or genotype, for example a white-flowered form of a typically blue-flowered species, or a form that is ecologically distinct).

The basic idea that plant classification should reflect evolutionary (genetic) relationships has been well accepted for some time, but the degree to which this could be assessed by the various means available differed. It has only recently become possible to assess genetic patterns of relatedness directly by analyzing DNA sequences. In the 1990s, DNA technology became much more efficient and less costly, resulting in a dramatic upsurge in the availability of DNA sequence data for various genes from each of the three genetic compartments present in plants (nuclear, mitochondrial, and plastid or chloroplast). In 1998 a number of botanists collectively proposed the first DNA-based classification of a major group of organisms, the angiosperms or flowering plants. For the first time, a classification was directly founded on assessments of the degree of relatedness made with objective, computerized methods of phylogeny reconstruction. Other data, such as chemistry and morphology, were also incorporated into these analyses, but by far the largest percentage of information came from DNA sequences—that is, relatedness was determined mostly on the basis of similarities in plants' genetic codes. The advantages of such a classification were immediately obvious: (1) it was not based on intuition about which category of information best reflected natural relationships; (2) it ended competition between systems based on differing emphases; (3) the analysis could be repeated by other researchers using either the same or different data (other genes or categories of information); and

(4) it could be updated as new data emerged, particularly from studies of how chromosomes are organized and how morphology and other traits are determined by the genes that code for them. See DEOXYRIBONUCLEIC ACID (DNA); GENETIC MAPPING.

At the same time that DNA data became more widely available as the basis for establishing a classification, a more explicit methodology for turning the results of a phylogenetic analysis into a formal classification became popular. This methodology, called cladistics, allowed a large number of botanists to share ideas of how the various taxonomic categories could be better defined. Although there remain a number of dissenting opinions about some minor matters of classification, it is now impossible for scientists to propose alternative ideas based solely on opinion. See PHYLOGENY; TAXONOMY. [M.W.C.; M.F.F.]

**Plant tissue systems** Most plants are composed of coherent masses of cells called tissues. Large units of tissues having some features in common are called tissue systems. In actual usage, however, the terms tissue and tissue system are not strictly separated. A given tissue or a combination of tissues may be continuous throughout the plant or large parts of it.

Plant tissues are primary or secondary in origin. The primary arise from apical meristems, the perennially embryonic tissues at the tips of roots and shoots. The primary tissues include the surface layer, or epidermis; the primary vascular tissues, xylem and phloem, which conduct water and food, respectively; and the ground tissues. The ground tissues are parenchyma (chiefly concerned with manufacture and storage of food) and collenchyma and sclerenchyma (the two supporting tissues). In the stem and root, the vascular tissues and some associated ground tissue are often treated as a unit, the stele. Ground tissue may be present in the center of the stele (pith) and on its periphery (pericycle). The ground tissue system enclosing the stele on the outside is the cortex. It may have a hypodermis peripherally and an endodermis next to the stele.

The secondary tissues arise from lateral meristems, and their formation is mainly responsible for the growth in thickness of stems and roots. They comprise secondary vascular tissues and the protective tissue called periderm. Secondary growth may build up a massive core of wood, but the outer tissue system, the bark, remains relatively thin because its outer or older part becomes compressed and, in many species, is continuously sloughed off.

The production of flowers instead of vegetative shoots results from physiological and morphological changes in the apical meristem, which then becomes the flower meristem. The latter, however, produces tissue systems fundamentally similar to those in the vegetative body of the plant. [K.E.]

**Plant transport of solutes** The movement of organic and inorganic compounds through plant vascular tissues. Transport can take place over considerable distances; in tree species transport distances are often 100–300 ft (30–100 m).

This long-distance transport is necessary for survival in higher land plants in which specialized organs of uptake or synthesis are separated by a considerable distance from the organs of utilization. Diffusion is not rapid enough to account for the amount of material moved over such long distances. Rather, transport depends on a flowing stream of liquid in vascular tissues (phloem and xylem) that are highly developed structurally.

The movement of organic solutes occurs mainly in the phloem, where it is also known as translocation and where the direction of transport is from places of production, such as mature leaves, to places of utilization or storage, such as the shoot apex or developing storage roots. Organic materials translocated in the phloem include the direct products of photosynthesis (sugars) as well as compounds derived from them (nitrogenous compounds and plant hormones, for example). Some movement of organic solutes does occur in the xylem of certain species. Inorganic solutes or mineral elements, however, generally move with water

in the xylem from sites of uptake in the roots to sites where water is lost from the plant, primarily the leaves. Some redistribution of the ions throughout the plant may then occur in the phloem.

The mechanism of phloem translocation is not known with certainty. Proposed mechanisms fall into two classes: one stresses the role of the conducting tissues in generating the moving force, and the other views the regions of supply and utilization as the source of this force. In the former group are mechanisms that depend on cytoplasmic streaming, electroosmosis, and activated diffusion in the sieve elements. The second group of theories, which has received more general acceptance in spite of a number of admitted limitations, includes a variety of mass-flow mechanisms. Theories of translocation must account for the important observations: polarity, bidirectional movement, velocity, energy requirement, turgor pressure, and phloem structure.

The model for the ascent of sap in the xylem which is correct according to all present evidence is called the cohesion hypothesis. According to this hypothesis, water is lost in the leaves by evaporation from cell-wall surfaces; water vapor then diffuses into the atmosphere by way of small pores between two specialized cells (guard cells). The guard cells and the pore are collectively called a stomate. This loss of water from the leaf causes movement of water out of the xylem in the leaf to the surfaces where evaporation is occurring. Water has a high internal cohesive force, especially in small tubes with wettable walls. In addition, the xylem elements and the cell walls provide a continuous water-filled system in the plant. Thus the loss of water from the xylem elements in the leaves causes a tension or negative pressure in the xylem sap. This tension is transmitted all the way down the stem to the roots, so that a flow of water occurs up the plant from the roots and eventually from the soil. The velocity of this sap flow in tree species ranges from 3 to approximately 165 ft/h (1 to 50 m/h), depending on the diameter of the xylem vessels. [S.S.D.]

**Plant viruses and viroids** Plant viruses are pathogens which are composed mainly of a nucleic acid (genome) normally surrounded by a protein shell (coat); they replicate only in compatible cells, usually with the induction of symptoms in the affected plant. Viroids are among the smallest infections agents known. Their circular, single-stranded ribonucleic acid (RNA) molecule is less than one-tenth the size of the smallest viruses.

**Viruses.** Viruses can be seen only with an electron microscope (see illustration). Isometric (spherical) viruses range from 25 to 50 nanometers in diameter, whereas most anisometric (tubular) viruses are 12 to 25 nm in diameter and of various lengths (200–2000 nm), depending on the virus. The coat of a few viruses is covered by a membrane which is derived from its host.

Over 800 plant viruses have been recognized and characterized. The genomes of most of them, such as the tobacco mosaic virus (TMV), are infective single-stranded RNAs; some RNA viruses have double-stranded RNA genomes. Cauliflower mosaic virus and bean golden mosaic virus are examples of viruses having double-stranded and single-stranded deoxyribonucleic acid (DNA), respectively. The genome of many plant viruses is a single polynucleotide and is contained in a single particle, whereas the genomes of brome mosaic and some other viruses are segmented and distributed between several particles. There are also several low-molecular-weight RNAs (satellite RNAs) which depend on helper viruses for their replication. See DEOXYRIBONUCLEIC ACID (DNA); RIBONUCLEIC ACID (RNA).

The natural hosts of plant viruses are widely distributed throughout the higher-plant kingdom. Some viruses (TMV and cucumber mosaic virus) are capable of infecting over a hundred species in many families, whereas others, such as wheat streak mosaic virus, are restricted to a few species in the grass family. The replication of single-stranded RNA viruses involves release of the virus genome from the coat protein; the association of the

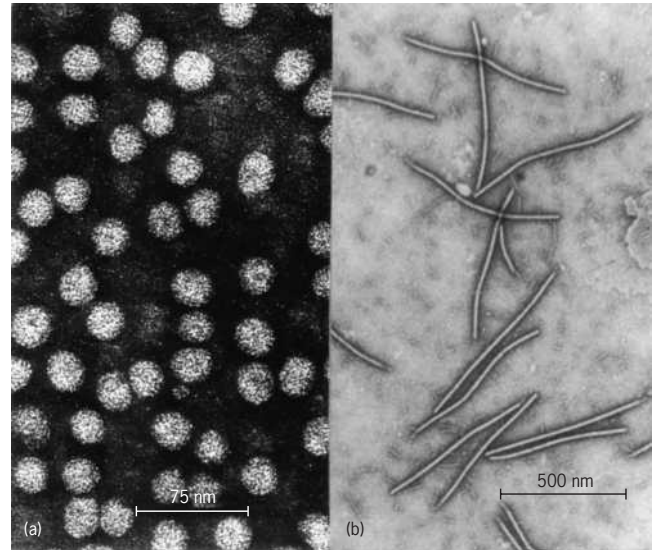

Representative plant viruses in purified virus preparation obtained from infected leaves. (a) Tobacco streak virus (isometric). (b) Pea seed-borne mosaic virus (anisometric).

RNA with the ribosomes of the cell; translation of the genetic information of the RNA into specific proteins, including subunits of the coat protein and possibly viral RNA-synthesizing enzymes (replicases); transmission by vectors and diseases induction; synthesis of noninfective RNA using parental RNA as the template; and assembly of the protein subunits and viral RNA to form complete virus particles.

In other RNA viruses, such as lettuce necrotic yellows virus, an enzyme which is contained in the virus must first make a complementary (infective) copy of the RNA; this is then translated into enzymes and coat protein subunits. The replication of double-stranded RNA viruses is similar to that of lettuce necrotic yellows virus.

With double-stranded DNA viruses, viral DNA is uncoated in a newly infected cell and transported to the nucleus, where it associates with histones to form a closed circular minichromosome. Two major RNA species (35S and 19S) are transcribed from the minichromosome by a host-encoded enzyme and are translated in the cytoplasm to produce virus-associated proteins. The 35S RNA serves as the template for a viral enzyme which transcribes it to viral DNA, which is then encapsidated to form virus particles.

Symptoms are the result of an alteration in cellular metabolism and are most obvious in newly developing tissues. In some plants, depending on the virus, the initial infection does not spread because cells surrounding the infected cells die, resulting in the formation of necrotic lesions. Such plants are termed hypersensitive. The size and shape of leaves and fruit may be adversely affected, and in some instances plants may be killed. Not all virus infections produce distinctive symptoms.

The most common mode of transmission for many viruses is by means of vectors, mainly insects (predominantly aphids and leafhoppers), and to a lesser extent mites, soil-inhabiting fungi, and nematodes which acquire viruses by feeding on infected plants. Viruses transmitted by one class of vector are rarely transmitted by another, and there is often considerable specificity between strains of a virus and their vectors.

Some viruses are transmitted to succeeding generations mainly by embryos in seeds produced by infected plants; over 200 viruses are transmitted in this way.

**Viroids.** Only about 30 viroids are known, but they cause very serious diseases in such diverse plants as chrysanthemum, citrus, coconut, and potato. They can also be isolated from plants that do not exhibit symptoms. Viroids are mainly transmitted by

vegetative propagation, but some, such as potato spindle tuber viroid, are transmitted by seed or by contact between infected and healthy plants. Tomato planta macho viroid is efficiently transmitted by aphids. See PLANT PATHOLOGY; VIROIDS; VIRUS. [R.I.H.]

**Plant-water relations** Water is the most abundant constituent of all physiologically active plant cells. Leaves, for example, have water contents which lie mostly within a range of 55–85% of their fresh weight. Other relatively succulent parts of plants contain approximately the same proportion of water, and even such largely nonliving tissues as wood may be 30–60% water on a fresh-weight basis. The smallest water contents in living parts of plants occur mostly in dormant structures, such as mature seeds and spores. The great bulk of the water in any plant constitutes a unit system. This water is not in a static condition. Rather it is part of a hydrodynamic system, which in terrestrial plants involves absorption of water from the soil, its translocation throughout the plant, and its loss to the environment, principally in the process known as transpiration.

**Cellular water relations.** The typical mature, vacuolate plant cell constitutes a tiny osmotic system, and this idea is central to any concept of cellular water dynamics. Although the cell walls of most living plant cells are quite freely permeable to water and solutes, the cytoplasmic layer that lines the cell wall is more permeable to some substances than to others.

If a plant cell in a flaccid condition—one in which the cell sap exerts no pressure against the encompassing cytoplasm and cell wall—is immersed in pure water, inward osmosis of water into the cell sap ensues. This gain of water results in the exertion of a turgor pressure against the protoplasm, which in turn is transmitted to the cell wall. This pressure also prevails throughout the mass of solution within the cell. If the cell wall is elastic, some expansion in the volume of the cell occurs as a result of this pressure, although in many kinds of cells this is relatively small.

If a turgid or partially turgid plant cell is immersed in a solution with a greater osmotic pressure than the cell sap, a gradual shrinkage in the volume of the cell ensues; the amount of shrinkage depends upon the kind of cell and its initial degree of turgidity. When the lower limit of cell wall elasticity is reached and there is continued loss of water from the cell sap, the protoplasmic layer begins to recede from the inner surface of the cell wall. Retreat of the protoplasm from the cell wall often continues until it has shrunk toward the center of the cell, the space between the protoplasm and the cell wall becoming occupied by the bathing solution. This phenomenon is called plasmolysis. See OSMOREGULATORY MECHANISMS.

In some kinds of plant cells movement of water occurs principally by the process of imbibition rather than osmosis. The swelling of dry seeds when immersed in water is a familiar example of this process.

**Stomatal mechanism.** Various gases diffuse into and out of physiologically active plants. Those gases of greatest physiological significance are carbon dioxide, oxygen, and water vapor. The great bulk of the gaseous exchanges between a plant and its environment occurs through tiny pores in the epidermis that are called stomates. Although stomates occur on many aerial parts of plants, they are most characteristic of, and occur in greatest abundance in, leaves. See EPIDERMIS (PLANT); LEAF.

**Transpiration process.** The term transpiration is used to designate the process whereby water vapor is lost from plants. Although basically an evaporation process, transpiration is complicated by other physical and physiological conditions prevailing in the plant. Whereas loss of water vapor can occur from any part of the plant which is exposed to the atmosphere, the great bulk of all transpiration occurs from the leaves. There are two kinds of foliar transpiration: (1) stomatal transpiration, in which water vapor loss occurs through the stomates, and (2) cuticular transpiration, which occurs directly from the outside surface of

epidermal walls through the cuticle. In most species 90% or more of all foliar transpiration is of the stomatal type.

Transpiration is a necessary consequence of the relation of water to the anatomy of the plant, and especially to the anatomy of the leaves. Terrestrial green plants are dependent upon atmospheric carbon dioxide for their survival. In terrestrial vascular plants the principal carbon dioxide-absorbing surfaces are the moist mesophyll cells walls which bound the intercellular spaces in leaves. Ingress of carbon dioxide into these spaces occurs mostly by diffusion through open stomates. When the stomates are open, outward diffusion of water vapor unavoidably occurs, and such stomatal transpiration accounts for most of the water vapor loss from plants. Although transpiration is thus, in effect, an incidental phenomenon, it frequently has marked indirect effects on other physiological processes which occur in the plant because of its effects on the internal water relations of the plant.

**Water translocation.** In terrestrial rooted plants practically all of the water which enters a plant is absorbed from the soil by the roots. The water thus absorbed is translocated to all parts of the plant. The mechanism of the “ascent of sap” (all translocated water contains at least traces of solutes) in plants, especially tall trees, was one of the first processes to excite the interest of plant physiologists.

The upward movement of water in plants occurs in the xylem, which, in the larger roots, trunks, and branches of trees and shrubs, is identical with the wood. In the trunks or larger branches of most kinds of trees, however, sap movement is restricted to a few of the outermost annual layers of wood. See XYLEM.

Root pressure is generally considered to be one of the mechanisms of upward transport of water in plants. While it is undoubtedly true that root pressure does account for some upward movement of water in certain species of plants at some seasons, various considerations indicate that it can be only a secondary mechanism of water transport.

Upward translocation of water (actually a very dilute sap) is engendered by an increase in the negativity of water potential in the cells of apical organs of plants. Such increases in the negativity of water potentials occur most commonly in the mesophyll cells of leaves as a result of transpiration.

**Water absorption.** The successively smaller branches of the root system of any plant terminate ultimately in the root tips, of which there may be thousands and often millions on a single plant. Most absorption of water occurs in the root tip regions, and especially in the root hair zone. Older portions of most roots become covered with cutinized or suberized layers through which only very limited quantities of water can pass. See ROOT (BOTANY).

Whenever the water potential in the peripheral root cells is less than that of the soil water, movement of water from the soil into the root cells occurs. There is some evidence that, under conditions of marked internal water stress, the tension generated in the xylem ducts will be propagated across the root to the peripheral cells. If this occurs, water potentials of greater negativity could develop in peripheral root cells than would otherwise be possible. The absorption mechanism would operate in fundamentally the same way whether or not the water in the root cells passed into a state of tension. The process just described, often called passive absorption, accounts for most of the absorption of water by terrestrial plants.

The phenomenon of root pressure represents another mechanism of the absorption of water. This mechanism is localized in the roots and is often called active absorption. Water absorption of this type only occurs when the rate of transpiration is low and the soil is relatively moist. Although the xylem sap is a relatively dilute solution, its osmotic pressure is usually great enough to engender a more negative water potential than usually exists in the soil water when the soil is relatively moist. A gradient of water potentials can thus be established, increasing in negativity across the epidermis, cortex, and other root tissues, along which

the water can move laterally from the soil to the xylem. See PLANT MINERAL NUTRITION. [B.S.M.]

**Plantaginales** An order of flowering plants, division Magnoliophyta (Angiospermae), in the subclass Asteridae of the class Magnoliopsida (dicotyledons). The order consists of only the family Plantaginaceae, with about 250 species. Within its subclass the order is marked by its small, chiefly wind-pollinated flowers that have a persistent regular corolla. The perianth and stamens of the flowers are attached directly to the receptacle (hypogynous) and there are typically four petals. The plants are herbs or seldom half-shrubs with mostly basal, alternate leaves. The common plantain (*Plantago major*) is a lawn weed of this order. See ASTERIDAE; MAGNOLIOPSIDA. [A.Cr.]

**Plants, life forms of** A term for the vegetative (morphological) form of the plant body. Life-form systems are based on differences in gross morphological features, and the categories bear no necessary relationship to reproductive structures, which form the basis for taxonomic classification. Features used in establishing life-form classes include deciduous versus evergreen leaves, broad versus needle leaves, size of leaves, degree of protection afforded the perennating tissue, succulence, and duration of life cycle (annual, biennial, or perennial).

There is a clear correlation between life forms and climates. For example, broad-leaved evergreen trees clearly dominate in the hot humid tropics, whereas broad-leaved deciduous trees prevail in temperate climates with cold winters and warm summers, and succulent cacti dominate American deserts. Although cacti are virtually absent from African deserts, members of the family Euphorbiaceae have evolved similar succulent life forms. Such adaptations are genetic, having arisen by natural selection.

Many life-form systems have been developed. The most successful and widely used system is that of C. Raunkiaer, proposed in 1905. Reasoning that it was the perennating buds (the tips of shoots which renew growth after a dormant season, either of cold or drought) which permit a plant to survive in a specific climate, Raunkiaer's classes were based on the degree of protection afforded the bud and the position of the bud relative to the soil surface. They applied to autotrophic, vascular, self-supporting plants. Raunkiaer's classificatory system is:

Phanerophytes: bud-bearing shoots in the air, predominantly woody trees and shrubs; subclasses based on height and on presence or absence of bud scales

Chamaephytes: bud within 10 in. (25 cm) of the surface, mostly prostrate or creeping shrubs

Hemicryptophytes: buds at the soil surface, protected by scales, snow, and litter

Cryptophytes: buds underneath the soil surface or under water

Therophytes: annuals, the seed representing the only perennating tissue

By determining the life forms of a sample of 1000 species from the world's floras, Raunkiaer showed a correlation between the percentage of species in each life-form class present in an area and the climate of the area. Raunkiaer concluded that there were four main phytoclimates: phanerophyte-dominated flora of the hot humid tropics, hemicryptophyte-dominated flora in moist to humid temperate areas, therophyte-dominated flora in arid areas, and a chamaephyte-dominated flora of high latitudes and altitudes.

Subsequent studies modified Raunkiaer's views. (1) Phanerophytes dominate, to the virtual exclusion of other life forms, in true tropical rainforest floras, whereas other life forms become proportionately more important in tropical climates with a dry season. (2) Therophytes are most abundant in arid climates and are prominent in temperate areas with an extended dry season, such as regions with Mediterranean climate. (3) Other

temperate floras have a predominance of hemicryptophytes with the percentage of phanerophytes decreasing from summer-green deciduous forest to grassland. (4) Arctic and alpine tundra are characterized by a flora which is often more than three-quarters chamaephytes and hemicryptophytes, the percentage of chamaephytes increasing with latitude and altitude. See PLANT GEOGRAPHY.

There has been interest in developing systems which describe important morphologic features of plants and which permit mapping and diagramming vegetation. Descriptive systems incorporate essential structural features of plants, such as stem architecture and height; deciduousness; leaf texture, shape, and size; and mechanisms for dispersal. These systems are important in mapping vegetation because structural features generally provide the best criteria for recognition of major vegetation units. See ALTITUDINAL VEGETATION ZONES; VEGETATION AND ECOSYSTEM MAPPING. [A.W.C.]

**Plasma (physics)** The field of physics that studies highly ionized gases. Plasma is a gas of charged and neutral particles which exhibits collective behavior. All gases become ionized at sufficiently high temperatures, creating what has been called a fourth state of matter, together with solids, liquids, and gases. It has been estimated that more than 99% of the universe is in the plasma state. On the Earth, plasmas are much less common. Lightning is a familiar natural manifestation, and fluorescent lights are a practical application. Plasma applications and studies make use of an enormous range of plasma temperatures, densities, and neutral pressures. They extend from plasma processing applications at relatively low temperatures (such as plasma etching of semiconductor chips at low pressure, or plasma cutting torches at atmospheric pressure) to studies of controlled fusion at very high temperatures. See FLUORESCENT LAMP.

Plasma physics is a many-body problem that can be described by a combination of Newton's laws and Maxwell's equations. The charged particles in plasmas are usually ions, both positive and negative, and electrons. Plasmas are normally quasineutral; that is, the net positive ion charge density approximately equals the net negative charge density everywhere in the bulk of the plasma. Quasineutrality refers to charge density and does not imply equal densities of electrons and ions since ions can be multiply charged and can also have negative charge. In space and fusion plasmas, plasmas are normally magnetized, while in application plasmas on Earth, such as plasma processing, both magnetized and unmagnetized plasmas are employed. See MAXWELL'S EQUATIONS; NEWTON'S LAWS OF MOTION.

It is convenient to keep track of plasma properties in terms of characteristic lengths, frequencies, and velocities. Among these are the Debye length, the electron and ion plasma frequencies, the electron and ion gyrofrequencies and gyroradii, the electron and ion thermal velocities, the ion sound velocity, the Alfvén velocity, and various collision lengths. The definition of a plasma depends on several of these characteristic parameters, and the magnitude of ratios of these parameters to system size or applied frequencies determines most plasma behavior.

The simplest plasma is a collisionless, unmagnetized collection of ions and electrons with no significant currents. Such plasmas have quasineutral regions and nonneutral regions. The nonneutral regions are highly localized. They are usually located near boundaries (where they are known as sheaths), but are sometimes located within the plasma (where they are known as double layers).

Collective behavior refers to the plasma properties not present in single-particle motion. Collective behavior is a distinguishing characteristic of a plasma. It consists of flows, waves, instabilities, and so forth. Common examples are fluctuations in the aurora, generation of microwaves in devices such as magnetrons and klystrons, and reflection of electromagnetic waves from the ionosphere. See AURORA; KLYSTRON; MAGNETRON; RADIO-WAVE PROPAGATION.

Curiously, very high density collections of equal numbers of ions and electrons are not plasmas. Such systems are referred to as strongly coupled plasmas (even though, strictly speaking, they are not plasmas at all).

A collection of either electrons or ions can exhibit properties similar to those of an electrically neutral plasma if the charged-particle density is sufficiently large. For such so-called plasmas, the Debye length and the characteristic frequency of electrons or ions can still be defined, and collective behavior is still exhibited when the Debye length is less than the system's characteristic dimension. So-called pure electron plasmas or pure ion plasmas are unconfined in an unmagnetized system. However, particle traps consisting of a combination of electric and magnetic fields can be used to confine the charges. See PARTICLE TRAP.

The visual appearance of a plasma depends on the kind of ion present, the electron temperature, and the plasma density. Some plasmas are invisible. Curiously, if a plasma is present and not glowing, it is either very hot or very cold. For example, an  $H^+$  plasma, or any other relatively hot plasma with fully stripped ions, contains atomic nuclei with no electrons, so there is no atomic physics and no optical emission or absorption. If plasma electrons and ions are very cold, there is insufficient energy to excite optical transitions. The glow often associated with plasmas indicates only where visible energy transitions are excited by energetic electrons or perhaps absorption of ultraviolet radiation, and may have little to do with the presence of bulk plasma. In fusion plasmas, the edges are often copious sources of emission associated with the dissociation and ionization of hydrogen and edge-generated impurities, while much of the hotter core plasma is fully ionized and invisible.

Direct-current glow-discharge plasmas originate from electrons created by secondary electron emission due to ion bombardment of a negatively biased cathode. The secondary electrons are accelerated through the cathode sheath potential (called the cathode fall) to energies the order of 1 keV, and partially ionize the neutral gas, releasing additional energetic electrons in a multiplicative process. The energetic electrons also undergo inelastic collisions with neutrals which result in optical emission that contributes to the so-called glow. See GLOW DISCHARGE; SECONDARY EMISSION.

The understanding of plasma physics begins with an understanding of the motion of single charged particles in a combination of electric and magnetic fields ( $E$  and  $B$ ), produced by a combination of external fields and the motion of the charged particles themselves. The motion of a single particle, with mass  $m$ , charge  $q$ , and velocity  $\mathbf{v}$ , is governed by the Lorentz force, as given in Eq. (1). From the perpendicular component of Eq. (1),

$$m \frac{d\mathbf{v}}{dt} = q(\mathbf{E} + \mathbf{v} \times \mathbf{B}) \quad (1)$$

it can be shown that the charged particles gyrate about magnetic field lines with a characteristic frequency (the cyclotron frequency). Ions rotate about the magnetic field in the clockwise direction, while electrons rotate counterclockwise with the magnetic field pointing outward. See ELECTRIC FIELD; PARTICLE ACCELERATOR.

In addition to the motion parallel to the magnetic field and the gyromotion about the magnetic field, there are drifts perpendicular to the magnetic field. For a general force,  $\mathbf{F}$ , in the presence of a magnetic field, the perpendicular drift velocity is given by Eq. (2).

$$\mathbf{v}_D = \frac{\mathbf{F} \times \mathbf{B}}{qB^2} \quad (2)$$

Given a perpendicular electric field, particles can walk across a magnetic field. Forces associated with magnetic-field curvature give rise to a curvature drift in the direction orthogonal to the magnetic field, and to the radius of curvature of the magnetic field lines.

For gyro motion in a slowly changing magnetic field, which is approximately periodic, it can be shown that the ratio of the perpendicular energy to the magnetic field is approximately constant. This means that a charged particle moving parallel to a magnetic field and gyrating about the field will gyrate faster as the magnetic field increases. If the magnetic field changes in space and is constant in time, the total energy is conserved. For a sufficiently large magnetic field, a point is reached where the total energy equals the perpendicular energy, so that the parallel energy goes to zero and the particle reflects. This is known as magnetic mirroring.

Magnetic mirroring is the chief natural mechanism of charged-particle confinement. For example, this process confines charged particles in the ionosphere and magnetosphere. The magnetic field lines that connect the north and south magnetic poles of the Earth provide a mirror magnetic field which increases as either pole is approached. In the absence of collisions, a particle moving along and gyrating about such a magnetic field is magnetically confined, if it has a sufficiently large velocity perpendicular to the magnetic field. The Van Allen belts are composed of such mirror-trapped charged particles. The source of these particles is the solar wind, a stream of charged particles continuously emitted by the Sun.

For fully ionized plasmas, it is convenient to describe the plasma as a single fluid together with Maxwell's equations. This gives the magnetohydrodynamic (MHD) equations, which are used to describe plasma equilibria and plasma waves and instabilities. Their relative simplicity has made them ideal for solutions of fusion problems in complicated geometries, and they have been widely used to describe astrophysical plasmas and magnetohydrodynamic energy conversion. See MAGNETOHYDRODYNAMIC POWER GENERATOR; MAGNETOHYDRODYNAMICS.

Plasmas can support an impressive variety of electrostatic and electromagnetic waves not present in the absence of plasma. The waves are distinguished by their frequency, the presence or absence of dc magnetic fields, and the plasma temperature and density.

Ionization is the key to plasma production and can be accomplished in many different ways. The most common approach is to employ energetic electrons with energies greater than the ionization potential of the gas being ionized. In dc glow discharges, electrons produced by ion secondary electron emission are accelerated by the cathode sheath potential, as are electrons created by thermionic emission in hot-cathode plasmas. Electrons can also pick up energy by reflecting from oscillating radio-frequency sheath electric fields, or by cyclotron resonance in magnetic fields, or from collisions with other energetic electrons. See ELECTRICAL CONDUCTION IN GASES; GAS DISCHARGE; IONIZATION POTENTIAL; THERMIONIC EMISSION.

Several other approaches involving collisions, which do not require energetic electrons, also exist. These techniques include photoionization, ion-neutral charge exchange, surface ionization, and Penning ionization. Ions can also be produced in the dissociation of molecules. Yet another mechanism, called critical ionization velocity, is instability driven, and occurs when the kinetic energy of the neutral gas atoms streaming perpendicular to a magnetic field exceeds their ionization potential. See ION SOURCES; IONIZATION; PHOTOIONIZATION.

A vacuum chamber provides the simplest approach to confinement. In an unmagnetized plasma, electrons are lost more rapidly than ions, and the plasma acquires a net positive charge. The excess positive charge appears in a sheath at the plasma boundary with the bulk plasma potential more positive than the boundary potential. The decrease in potential at the boundary provides plasma electron confinement, reducing their loss rate to balance the ion loss rate.

Addition of a uniform magnetic field reduces the loss rate of ions and electrons transverse to the magnetic field, but has no effect on losses parallel to the magnetic field because the Lorentz force has no components along this field. Effective confinement



by magnetic fields requires that the ion and electron gyroradii be small compared to device dimensions. Plasma transport across the magnetic field can still occur as a result of collisions or of perpendicular drifts.

In the absence of magnetic fields (both inside and outside the plasma), an equilibrium can be achieved by establishing a pressure balance between plasma and edge walls or edge gas. The existence of an equilibrium does not guarantee that a particular configuration is stable.

Plasma processing can be defined as the collection of techniques which make use of plasmas to create new materials or to modify properties of existing materials. It is used in a large variety of applications including semiconductor etching, preparing plastic surfaces to accept ink, depositing polymers, depositing diamond films, and hardening artificial hip joints. The technique has its foundations in plasma physics, chemistry, electrical and chemical engineering, and materials science.

Controlled fusion aims at taking advantage of nuclear fusion reactions to generate net power. Advances in fusion studies have been tied to the techniques developed for plasma confinement and heating. Fusion experiments employ either magnetic confinement or inertial confinement, in which fusion reactions take place before the plasma has a chance to expand to chamber boundaries. Magnetic mirrors are an example of open systems, while tokamaks, stellarators, and reversed-field pinches are examples of closed toroidal systems. Most magnetic confinement research experiments are done on tokamaks. See NUCLEAR FUSION. [N.He.]

Naturally occurring plasmas exist throughout the solar system and beyond. Above the atmosphere, most matter is ionized. The lower-density ionized materials are considered to be plasmas, and they behave in manners very different from the behavior of nonplasmas. Some dense materials, such as stellar matter or electrolytic solutions, are often not considered to be plasmas even though they are ionized; they behave, for the most part, as do ordinary fluids.

Some of the major plasma-physics issues that are under study with naturally occurring plasmas are the energization of charged particles, the reconnection of magnetic fields (temporal changes in magnetic-field topology), the production of magnetic fields by dynamos, the production of electromagnetic waves, the interaction between waves and particles, and the transport of mass, momentum, and energy across magnetic fields.

Naturally occurring plasmas are in general difficult to measure. The solar-wind, ionospheric, and magnetospheric plasmas are diagnosed by single-point measurements by rockets and satellites; the solar atmosphere and all astrophysical plasmas are unreachable and must be diagnosed by the light and radio waves that they emit; and lightning is unpredictable and inhospitable to instruments and must be diagnosed primarily by the light that it emits. As a consequence of limited diagnostics, theoretical analysis and laboratory-plasma experiments play supporting roles in the investigations of naturally occurring plasmas. [J.E.Bo.]

**Plasma diagnostics** Techniques to measure the properties and parameters of ionized gases. Plasmas are gases in which a sufficient proportion of the atoms are ionized that the resulting mixture of free electrons and positively charged ions exhibits collective behavior resulting from electromagnetic interactions. See PLASMA (PHYSICS).

The simplest properties of a plasma that one might wish to measure are the density ( $n$ ) of particles per unit volume, the fluid velocity ( $\langle \mathbf{v} \rangle$ ), and the temperature ( $T$ ). These gaseous parameters may be different for the different particle species in the plasma. There are normally at least two such species, electrons (subscript  $e$ ) and ions (subscript  $i$ ); but often multiple ion species and neutral particles are present. (The brackets around  $\mathbf{v}$  indicate that it is the average value of the particle velocities of all the particles, or of the particles of a particular species.) Because plasma temperatures are generally high, from a few thousand

degrees Celsius upward, they are usually expressed in energy units such as electronvolts ( $1 \text{ eV} = 1.6 \times 10^{19} \text{ J} \simeq 11,600^\circ\text{C}$ ).

Plasmas often possess nonthermal particle distributions. That is, the velocity distribution function of electrons or ions,  $f_s$  ( $s = e, i$ ), which measures the numbers of electrons or ions that have various velocities, has not simply the Maxwell-Boltzmann form corresponding to thermal equilibrium at some temperature but has some more complicated form  $f_s(\mathbf{v}_s)$ . In that case an ideal that may sometimes be approached is to measure the entire velocity distribution  $f_s(\mathbf{v}_s)$  and not just the parameters  $n$ ,  $\langle \mathbf{v} \rangle$ , and  $T$ , which are moments of this distribution. See BOLTZMANN STATISTICS; KINETIC THEORY OF MATTER.

The electromagnetic fields  $\mathbf{E}$  and  $\mathbf{B}$  are also essential parameters that affect the plasma. They are affected in turn by the charge and current densities,  $\rho$  and  $\mathbf{j}$ , which are simple sums of the densities and velocities of the plasma species weighted by their charge per particle.

Techniques to measure the plasma parameters, and their space- and time-variation, are based on a wide variety of physical principles. Direct invasion of the plasma using solid probes is possible only for relatively cold and tenuous plasmas; otherwise the probe will be damaged by excessive heat flux. However, powerful noncontact diagnostics are based on measurements external to the plasma of electromagnetic fields, waves propagated through or scattered by the plasma, photons emitted by plasma electrons or atoms, and particle emission, transmission, or scattering.

By far the majority of probe measurements are based on measuring the electric current carried to the probe by the plasma particles. The simplest and most direct such measurement, called the Langmuir probe, consists of an electrode of some well-defined geometry (plane, cylinder, and sphere are all used). The potential of this probe is varied and the resulting probe current is measured.

The Langmuir probe cannot provide an independent measurement of the ion temperature because the ions are usually the attracted species and their current is almost independent of probe potential. More elaborate plasma flux measurements can be performed with devices called gridded energy analyzers, which can obtain energy distribution functions of both electrons and ions at the expense of far greater complexity, greater probe size and hence plasma perturbation, and often loss of absolute density calibration.

Langmuir probes can provide measurement of the electrostatic potential in the plasma, and hence the electric field, although not quite directly. The magnetic field can be measured by sensors based either on simple induction in a coil for pulsed fields, or typically on the Hall effect in a semiconductor for static fields. The former approach dominates fusion plasma research because of its linearity, noise insensitivity, and robustness, while the latter dominates space measurements in which sensitivity and dc response are essential. See ELECTRIC FIELD; HALL EFFECT; MAGNETIC INSTRUMENTS; MAGNETISM.

Propagating an electromagnetic wave through the plasma and measuring the plasma's effect on it is a powerful nonperturbing diagnostic technique. The plasma's presence modifies the refractive index. The index measurement is performed by measuring the phase difference caused by the plasma along an optical path, using some form of interferometer; the Michelson or Mach-Zehnder configurations are most popular. The phase shift is approximately proportional to the average plasma density along the optical path. See INTERFEROMETRY.

Electromagnetic wave emission from the free electrons in the plasma occurs predominantly from acceleration either by the ambient magnetic field (cyclotron or synchrotron emission) or by collisions with other plasma particles (bremsstrahlung). Bremsstrahlung from optically thin (hot and tenuous) plasmas has a photon energy spectrum that resembles the electron energy distribution; so, for example, its logarithmic slope gives the electron temperature. The spectrum for kiloelectronvolt-temperature

plasmas is measured by x-ray techniques such as pulse-height analysis or approximately using foil filters. Large, dense, or cold plasmas are often optically thick to bremsstrahlung, in which case their spectrum is blackbody and provides electron temperature. Alternatively, by backlighting the plasma (for example with x-rays), their bremsstrahlung (collisional) absorption provides a measure of line-averaged density. This last technique is particularly important for laser-produced plasmas and inertial fusion research. See BREMSSTRAHLUNG.

Line radiation arises from electronic transitions between bound levels of atomic species in the plasma. The characteristic wavelengths serve to identify the species, and the intensities are proportional to the excited-state densities. Therefore line radiation is the primary method for determining the atomic and molecular composition of plasmas. Excitation of the atom from the ground state usually occurs by electron impact, requiring an electron energy greater than the excitation energy. Therefore the ratio of the intensities of lines from different excited states whose excitation energies differ by an amount comparable to the electron temperature, is a measure of electron temperature. The rate of excitation is proportional to electron density; however, in order to eliminate from the measured intensity its dependence on the atomic density, a line ratio is generally chosen for measurement. If the population of one excited level of the line pair chosen is substantially affected by collisional deexcitation, because it is a metastable level for example, or is populated by recombination, then the ratio is sensitive to electron density. See ATOMIC STRUCTURE AND SPECTRA; SCATTERING EXPERIMENTS (ATOMS AND MOLECULES).

Neutral atoms are continually formed from plasma ions by charge exchange with other neutrals or recombination with electrons. The neutrals formed may escape promptly from the plasma, providing a means for detection of the ion distribution using a neutral-particle spectrometer. In fusion research plasmas, fusion reactions give rise to megaelectronvolt-energy neutrons and charged products. These too provide information on the ion temperature and density via the reaction rate and the emitted spectrum.

Energetic neutral or ion beams, generated specifically for the purpose, can be used for active plasma probing. Their attenuation is generally proportional to plasma density; but more important special-purpose applications include the internal measurement of potential (by local beam ionization in the plasma) and the provision of localized atomic species for other spectroscopic diagnostics. [I.H.H.]

**Plasma propulsion** The imparting of thrust to a spacecraft through the acceleration of a plasma (ionized gas). A plasma can be accelerated by electrical means to exhaust velocities considerably higher than those attained by chemical rockets. The higher exhaust velocities (specific impulses) of plasma thrusters usually imply that for a particular mission the spacecraft would use less propellant than the amount required by conventional chemical rockets. This means that for the same amount of propellant a spacecraft propelled by a plasma rocket can increase in velocity over a set distance by an increment larger than that possible with a chemical propulsion system. Plasma propulsion is one of three major classes of electric propulsion, the others being electrothermal propulsion and ion (or electrostatic) propulsion. See ELECTROTHERMAL PROPULSION; ION PROPULSION; SPACECRAFT PROPULSION; SPECIFIC IMPULSE.

**Pure electromagnetic acceleration.** The most promising and thoroughly studied electromagnetic plasma accelerator is the magnetoplasmadynamic (MPD) thruster. In this device the plasma is both created and accelerated by a high-current discharge. The discharge is due to the breakdown of the gas as it is injected in the interelectrode region. The acceleration process can be described as being due to a body force acting on the plasma. This body force is the Lorentz force created by the interaction between the current conducted through the plasma and the magnetic field.

The latter could either be externally applied by a magnet or self-induced by the discharge, if the current is sufficiently high. See MAGNETOHYDRODYNAMICS.

Microscopically, the acceleration process can be described as the momentum transfer from the electrons, which carry the current, to the heavy particles through collisions. Such collisions are responsible for the creation of the plasma (ionization) and its acceleration and heating (Joule heating).

**Hybrid acceleration.** The collision processes invariably heat the plasma. If the gas particles are exhausted hot, they are dissipating energy in kinetic modes useless to propulsion since their thermal motion is random. Moreover, if the exhausted atoms are in an excited or ionized state, the fraction of the internal energy tied in these internal modes is also not available for propulsion. If a fraction of these translational and internal modes is somehow recovered, the plasma acceleration is called hybrid (electromagnetic-electrothermal). Hybrid acceleration is an active area of research and is the most promising alternative for surpassing the 40% efficiency level of magnetoplasmadynamic thrusters.

**Flight tests.** Few tests of plasma thrusters in space are known publicly outside Russia. Most of the flown plasma propulsion systems are of the pulsed solid-fed (Teflon-ablative) type launched in the 1970s for satellite attitude control. [E.Y.C.]

**Plasmal** Those aldehydic components of lipids which give positive color tests with reagents used for detecting aldehydes in tissues. The Feulgen test for plasmalogens depends on the liberation of plasmal, principally derivatives of palmitaldehyde and stearaldehyde, from these lipids by the action of mercuric chloride and acetic acid. [R.H.G.; H.E.Ca.]

**Plasmid** A circular extrachromosomal genetic element that is ubiquitous in prokaryotes and has also been identified in a number of eukaryotes. In general, bacterial plasmids can be classified into two groups on the basis of the number of genes and functions they carry. The larger plasmids are deoxyribonucleic acid (DNA) molecules of around 100 kilobase (kb) pairs, which is sufficient to code for approximately 100 genes. There is usually a small number of copies of these plasmids per host chromosome, so that their replication must be precisely coordinated with the cell division cycle. The plasmids in the second group are smaller in size, about 6–10 kb. These plasmids may harbor 6–10 genes and are usually present in multiple copies (10–20 per chromosome). See GENE.

Plasmids have been identified in a large number of bacterial genera. Some bacterial species harbor plasmids with no known functions (cryptic plasmids) which have been identified as small circular molecules present in the bacterial DNA. The host range of a particular plasmid is usually limited to closely related genera. Some plasmids, however, are much more promiscuous and have a much broader host range.

The functions specified by different bacterial plasmids are usually quite specialized in nature. Moreover, they are not essential for cell growth since the host bacteria are viable without a plasmid when the cells are cultured under conditions that do not select for plasmid-specified gene products. Plasmids thus introduce specialized functions to host cells which provide versatility and adaptability for growth and survival. Plasmids which confer antibiotic resistance (R plasmids) have been extensively characterized because of their medical importance. Plasmids have played a seminal role in the spectacular advances in the area of genetic engineering. Individual genes can be inserted into specific sites on plasmids in cell cultures and the recombinant plasmid thus formed introduced into a living cell by the process of bacterial transformation. See GENETIC ENGINEERING. [R.H.R.]

**Plasmin** A proteolytic enzyme which can digest many proteins through the process of hydrolysis. Plasmin (fibrinolysin) is found in plasma in the form of the inert precursor, or zymogen,

plasminogen (profibrinolysin); its site of synthesis in the body is unknown. Plasma also contains several inhibitors which limit the action of plasmin.

Plasma itself has the potentiality of activating plasminogen, perhaps because it contains intrinsic activators. Plasmin activator is produced in blood vessel walls, from which it is released following vascular injury. Further, the process of blood coagulation may foster the activation of plasminogen. Moreover, the presence of a fibrin clot enhances activation of plasminogen by many agents, perhaps because plasminogen is adsorbed to the fibrin and thus separated from its inhibitors in the plasma.

Plasmin can act on many protein substrates. It liquefies coagulated blood by digesting fibrin (fibrinolysis), the insoluble meshwork of the clot; it also digests fibrinogen, the precursor of fibrin, rendering it incoagulable. The digestion products of fibrinogen and fibrin are anticoagulant substances which further interfere with the clotting process. Plasmin also inactivates several other protein procoagulant factors, particularly proaccelerin (factor V) and antihemophilic factor (factor VIII). Other substrates attacked by plasmin include gamma globulin and several protein or polypeptide hormones found in plasma.

The action of plasmin may be related to certain body defenses. It can convert the first component of complement to a proteolytic enzyme. It can also liberate polypeptide kinins (for example, bradykinin) from plasma precursors. The kinins can reproduce such elements of the inflammatory process as pain, dilatation and increased permeability of small blood vessels, and the migration of leukocytes. Besides these physiological actions, plasmin also hydrolyzes casein, gelatin, denatured hemoglobin, and certain synthetic esters of arginine and lysine, for example, *p*-toluenesulfonylarginine methyl ester (TAME). See BLOOD; COMPLEMENT; FIBRINOGEN; IMMUNOLOGY; INFLAMMATION. [O.D.R.]

**Plasmodiophorida** Protozoa composing an order of Mycetozoa. They are endoparasitic in plants, primarily causing, for example, club root of cabbage, powdery scab of potatoes, and galls in *Ruppia*. Underground portions of host plants are invaded by young parasites, often a flagellate which sometimes arises from a freshly excysted ameba. Becoming intracellular, the young parasite grows and develops into a plasmodium. At maturity, the plasmodium produces uninucleate cysts (spores) which are released upon degeneration of the damaged cell. Under favorable conditions, the released spores hatch into uninucleate stages which become the infective forms. In the invaded area, the host's tissue commonly undergoes hypertrophy to form a gall. [R.P.H.]

**Plasmon** The quanta of waves produced by collective effects of large numbers of electrons in matter when the electrons are disturbed from equilibrium. Metals provide the best evidence of plasmons, because they have a high density of electrons free to move. The results of plasmon stimulation are seen in the illustration. The graph shows the probability of energy losses by fast electrons transmitted through a thin aluminum foil. The number of detected electrons in a beam is plotted against their energy loss during transit through the foil. Each energy-loss peak corresponds to excitation of one or more plasmons. Within experimental error, the peaks occur at integral multiples of a fundamental loss. Further evidence is the fact that the areas under the peaks (a measure of the energy-loss probability) follow a Poisson distribution. See DISTRIBUTION (PROBABILITY).

The name plasmon derives from the physical plasma as a state of matter in which the atoms are ionized. At the lowest densities this means an ionized gas, or classical plasma; but densities are much higher in a metal, or quantum plasma, the atoms of a solid metal being in the form of ions. In both types of physical plasma, the frequency of plasma-wave oscillation is determined by the electronic density. In a quantum plasma the energy of the plasmon is its frequency multiplied by Planck's constant, a basic

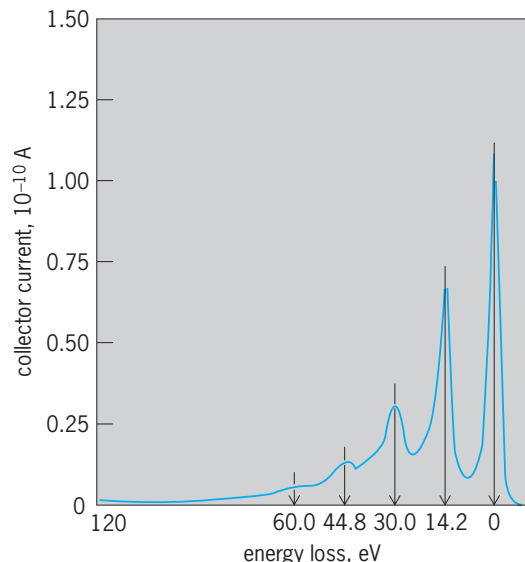

Number of detected electrons in a beam versus their energy loss during transit through a thin aluminum foil. (Number of electrons is expressed as a current;  $10^{-14}$  A =  $6.7 \times 10^6$  electrons per second.) Peaks at approximate multiples of 14.2 eV correspond to energy donated to plasmons in the aluminum. (After T. L. Ferrell, T. A. Calicott, and R. J. Warmack *Plasmons and surfaces*, *Amer. Sci.*, 73:344-353, 1985)

relationship of quantum mechanics. See FREE-ELECTRON THEORY OF METALS; QUANTUM MECHANICS.

The plasmon energy for most metals corresponds to that of an ultraviolet photon. However, for silver, gold, the alkali metals, and a few other materials, the plasmon energy is sufficiently low to correspond to that of a visible or near-ultraviolet photon. This means there is a possibility of exciting plasmons by light. If plasmons are confined upon a surface, optical effects can be easily observed. In this case, the quanta are called surface plasmons, and they have the bulk plasmon energy as an upper energy limit.

Surface plasmons were first proposed to explain energy losses by electrons reflected from metal surfaces. Since then, numerous experiments have involved coupling photons to surface plasmons. Potential applications extend to new light sources, solar cells, holography, Raman spectroscopy, and microscopy. [T.L.F.]

**Plaster** A plastic mixture of solids and water which sets to a hard, coherent solid and which is used to line the interiors of buildings. A similar material of different composition, used to line the exteriors of buildings, is known as stucco. The term plaster is also used in the industry to designate plaster of paris.

Plaster is usually applied in one or more base (rough or scratch) coats up to  $\frac{3}{4}$  in. (1.9 cm) thick, and also in a smooth, white, finish coat about  $\frac{1}{16}$  in. (0.16 cm) thick. The solids in the base coats are hydrated (or slaked) lime, sand, fiber or hair (for bonding), and portland cement (the last may be omitted in some plasters). The finish coat consists of hydrated lime and gypsum plaster (in addition to the water). See LIME (INDUSTRY); MORTAR; PLASTER OF PARIS. [J.F.McM.]

**Plaster of paris** The hemihydrate of calcium sulfate, composition  $\text{CaSO}_4 \cdot \frac{1}{2}\text{H}_2\text{O}$ , made by calcining the mineral gypsum, composition  $\text{CaSO}_4 \cdot 2\text{H}_2\text{O}$ , at temperatures up to  $480^\circ\text{F}$  ( $250^\circ\text{C}$ ). It is used for making plasters, molds, and models.

When the powdered hemihydrate is mixed with water to form a paste or slurry, the calcining reaction is reversed and a solid mass of interlocking gypsum crystals with moderate strength is formed. Upon setting there is very little (a slight contraction) dimensional change, making the material suitable for accurate molds and models.

Diverse types of plaster, varying in the time taken to set, the amount of water needed to make a pourable slip, and the final hardness, are made for different applications. These characteristics are controlled by the calcination conditions (temperature and pressure) and by additions to the plaster. See GYPSUM; PLASTER.

[J.F.McM.]

**Plastic deformation of metal** The permanent change in shape of a metallic body as the result of forces acting on its surface. The plasticity of a metal permits it to be shaped into various useful forms that are retained after the forming pressures have been removed. Complete comprehension of plastic deformation of metals requires an understanding of three areas: (1) the mechanisms by which plastic deformation occurs in metals; (2) the way in which different metals respond to a variety of imposed external or environmental conditions; and (3) the relation between the internal structure of a metal and its ability to plastically deform under a given set of conditions.

Pure metals are crystalline solids, or mixtures of crystalline solids in the case of some alloys. Most metals and alloys that can undergo significant amounts of plastic deformation have their atoms orderly packed in one of three types of crystal structure: hexagonal close-packed, face-centered cubic, or body-centered cubic, or slight variations thereof. See ALLOY; CRYSTAL STRUCTURE.

For any type of atomic packing, as the crystal is viewed from different directions, the atoms can be visualized as lying on differently oriented planes in space. Within each plane the atoms are in a regular array, and certain directions are equivalent with respect to the distance between atoms and the location of their neighbors. The primary step in the plastic deformation of a metal crystal is the translation, or slip, of one part of the crystal with respect to the other across one of a set of crystallographically equivalent planes and in one of several possible crystallographically equivalent directions. These are known as the slip plane and slip direction, respectively. The particular direction and plane orientation differ from one metal to another, depending principally on the type of atom packing and the temperature of plastic deformation. Metals with equivalent crystal structures tend to exhibit a similar plastic response to stresses even though the actual strength and temperature range of such a like response will differ from metal to metal.

When a metal consists of a single crystal, it deforms anisotropically when stressed, depending on the orientation of the operative slip system. These translations leave linear traces on the surface called slip lines which are observable under a light microscope. As normally produced, however, metals are polycrystalline; that is, they are composed of a multitude of tiny crystals or grains, all with identical packing but with each crystal having its principal slip planes or directions oriented differently from its neighbors. On a gross scale this permits a metal when stressed to act as an isotropic body even though each grain, if isolated, would behave in an anisotropic manner that would depend on both its orientation with respect to the stress imposed on it and the particular crystal structure of the metal of which it is a part. One structural factor that the metallurgist can control to alter the properties of a metal is grain size and shape.

Most substances are weak relative to the strength that is theoretically calculated for them on the basis of the strength of the bonds between atoms in the crystal and the interatomic spacing. This strength is estimated to be in the neighborhood of one-tenth of the elastic modulus of the particular metal. The observed maximum strengths of metals, moreover, are more like one-tenth of this calculated strength, and the stress under which plastic deformation begins is often several times lower than the observed maximum strength. The reason for this discrepancy between the predicted and observed strengths of metal has been explained to be caused by submicroscopic defects called dislocations. These defects permit metals to be plastically deformed even though their presence also reduces the maximum attainable strength

of the metals to the observed value. Understanding the nature and behavior of individual dislocations and their interactions forms the modern basis for understanding the various phenomena associated with plastic deformation in metals. See CRYSTAL DEFECTS.

The phenomenology of metal behavior has been explored and documented by metalworkers and metallurgical engineers for centuries. This information has been vital to the design and manufacture or construction of metal objects from tin cans to complex gas turbines. The properties of metals that are associated with plastic deformation are ductility (the ability of a metal to be deformed considerably before breaking), behavior in creep (the time-dependent deformation of metal under stress), and the response to fatigue (conditions where the stresses are applied in a cyclic fashion rather than steadily). See CREEP (MATERIALS); METAL; METAL, MECHANICAL PROPERTIES OF; METAL FORMING; METALLOGRAPHY.

[H.C.Rc.]

**Plasticity** The ability of a solid body to permanently change shape (deform) in response to mechanical loads or forces. Deformation characteristics are dependent on the material from which a body is made, as well as the magnitude and type of the imposed forces. In addition to plastic, other types of deformation are possible for solid materials.

One common test for measuring the plastic deformation characteristics of materials is the tensile test, in which a tensile (stretching) load is applied along the axis of a cylindrical specimen, with deformation corresponding to specimen elongation. The load is converted into stress; its units are megapascals (1 MPa =  $10^6$  newtons per square meter) or pounds per square inch (psi). Likewise, the amount of deformation is converted into strain, which is unitless. The test results are expressed as a plot of stress versus strain. See STRESS AND STRAIN.

Typical tensile stress-strain curves have been calculated for metal alloys and polymeric materials. For both materials, the initial regions of the curves are linear and relatively steep. Deformation that occurs within these regions is nonpermanent (non-plastic) or elastic. This means that the body springs back to its original dimensions once the stress is released, or that all of the deformation is recovered. In addition, stress is proportional to strain (Hooke's law), and the slope of this linear segment corresponds to the elastic (Young's) modulus. See ELASTICITY; HOOKE'S LAW; YOUNG'S MODULUS.

Plastic (permanent) deformation begins at the point where linearity ceases such that, upon removal of the load, not all deformation is recovered (the body does not assume its original or stress-free dimensions). The onset of plastic deformation is called yielding, and the corresponding stress value is called the yield strength. After yielding, all deformation is plastic and, until fracture, the curves are nonlinear. This behavior is characteristic of many metal alloys and polymeric materials. The concept of plasticity does not normally relate to ceramic materials such as glasses and metal oxides (for example, aluminum oxide). See PLASTIC DEFORMATION OF METAL.

[W.D.C.]

**Plastics processing** Those methods used to convert plastics materials in the form of pellets, granules, powders, sheets, fluids, or preforms into formed shapes or parts. The plastics materials may contain a variety of additives which influence the properties as well as the processability of the plastics. After forming, the part may be subjected to a variety of ancillary operations such as welding, adhesive bonding, machining, and surface decorating (painting, metallizing).

**Injection molding.** This process consists of heating and homogenizing plastics granules in a cylinder until they are sufficiently fluid to allow for pressure injection into a relatively cold mold where they solidify and take the shape of the mold cavity. Solid particles, in the form of pellets or granules, constitute the main feed for injection moldable plastics. The major advantages of the injection-molding process are the speed of production,

minimal requirements for postmolding operations, and simultaneous multipart molding. The development of reaction injection molding (RIM) allowed the rapid molding of liquid materials. This process has proven particularly effective for high-speed molding of such materials as polyurethanes, epoxies, polyesters, and nylons.

**Extrusion.** In this process, plastic pellets or granules are fluidized, homogenized, and continuously formed. Products made this way include tubing, pipe, sheet, wire and substrate coatings, and profile shapes. The process is used to form very long shapes or a large number of small shapes which can be cut from the long shapes. Extrusion can result in the highest output rate of any plastics processes; for example, pipe has been formed at rates of 2000 lb/h (900 kg/h). The extrusion process produces pipe and tubing by forcing the melt through a cylindrical die. See EXTRUSION.

**Blow molding.** This process consists of forming a tube (called a parison) and introducing air or other gas to cause the tube to expand into a free-blown hollow object or against a mold for forming into a hollow object with a definite size and shape. The parison is traditionally made by extrusion, although injection-molded tubes have increased in use.

**Thermoforming.** Thermoforming is the forming of plastics sheets into parts through the application of heat and pressure. Tooling for this process is the most inexpensive compared to other plastics processes, accounting for the method's popularity. It can also accommodate very large parts as well as small parts.

**Rotational molding.** In this process, finely ground powders are heated in a rotating mold until melting or fusion occurs. If liquid materials are used, the process is often called slush molding. The melted or fused resin uniformly coats the inner surface of the mold. When cooled, a hollow finished part is removed.

**Compression and transfer molding.** Compression molding consists of charging a plastics powder or preformed plug into a mold cavity, closing a mating mold half, and applying pressure to compress, heat, and cause flow of the plastic to conform to the cavity shape. The process is primarily used for thermosets, and consequently the mold is heated to accelerate the chemical cross-linking. Transfer molding is an adaptation of compression molding in that the molding powder or preform is charged to a separate preheating chamber and, when appropriately fluidized, injected into a closed mold. It is most used for thermosets, and is somewhat faster than compression molding.

**Foam processes.** Foamed plastics materials have achieved a high degree of importance in the plastics industry. Foams can be made in a range from soft and flexible to hard and rigid. There are three types of cellular plastics: blown (expanded matrix, such as a natural sponge), syntactic (the encapsulation of hollow organic or inorganic microspheres in the matrix), and structural (dense outer skin surrounding a foamed core). There are seven basic processes used to generate plastics foams. They include the incorporation of a chemical blowing agent that generates gas (through thermal decomposition) in the polymer liquid or melt; gas injection into the melt which expands during pressure relief; generation of gas as a by-product of a chemical condensation reaction during cross-linking; volatilization of a low-boiling liquid (for example, Freon) through the exothermic heat of reaction; mechanical dispersion of air by mechanical means (whipped cream); incorporation of nonchemical gas-liberating agents (adsorbed gas on finely divided carbon) into the resin mix which is released by heating; and expansion of small beads of thermoplastic resin containing a blowing agent through the external application of heat. See FOAM.

**Reinforced plastics/composites.** These are plastics whose mechanical properties are significantly improved because of the inclusion of fibrous reinforcements. The wide variety of resins and reinforcements that constitute this group of materials led to the more generalized description "composites." Composites consist of two main components, the fibrous material in various physical forms and the fluidized resin which will convert to

a solid. There are fiber-reinforced thermoplastic materials, and these are typically processed in standard thermoplastic processing equipment. The first step in any composite fabrication procedure is the impregnation of the reinforcement with the resin. The impregnated reinforcement can be subjected to heat to remove impregnating solvents or advance the resin cure to a slightly tacky or dry state. The composite in this form is called a prepreg. Premixes, often called bulk molding compounds, are mixtures of resin, inert fillers, reinforcements, and other formulation additives which form a puttylike rope, sheet, or preformed shape. See COMPOSITE MATERIAL; POLYMERIC COMPOSITE.

**Casting and encapsulation.** Casting is a low-pressure process requiring nothing more than a container in the shape of the desired part. For thermoplastics, liquid monomer is poured into the mold and, with heat, allowed to polymerize in place to a solid mass. For vinyl plastisols, the liquid is fused with heat. Thermosets are poured into a heated mold wherein the cross-linking reaction completes the conversion to a solid. Encapsulation and potting are terms for casting processes in which a unit or assembly is encased or impregnated, respectively, with a liquid plastic which is subsequently hardened by fusion or chemical reaction. These processes are predominant in the electrical and electronic industries for the insulation and protection of components.

**Calendering.** In the calendering process, a plastic is masticated between two rolls that squeeze it out into a film which then passes around one or more additional rolls before being stripped off as a continuous film. Fabric or paper may be fed through the latter rolls, so that they become impregnated with the plastic. See POLYMER. [S.H.G.]

**Plate girder** A beam built up of steel plates and shapes which may be welded or bolted together to form a deep beam larger than can be produced by a rolling mill (see illustration). As such, it is capable of supporting greater loads on longer spans. The typical welded plate girder consists of flange plates welded to a deep web plate. A bolted configuration consists of flanges built of angles and cover plates bolted to the web plate. Both types may have vertical stiffeners connected to the web plate, and both may have additional cover plates on the flanges to increase the load capacity of the member. Box girders consist of

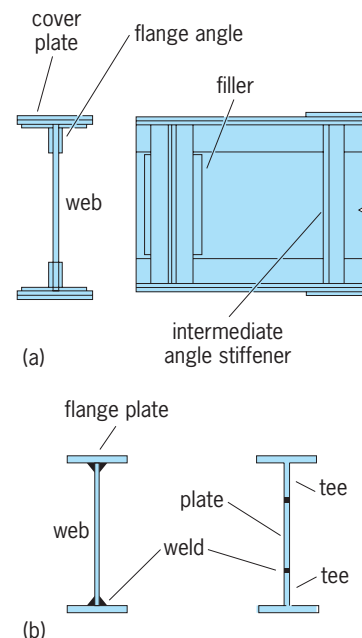

Plate girder configurations: (a) bolted type and (b) welded type.

common flanges connected to two web plates, forming a closed section.

In general, the depth of plate girders is one-tenth to one-twelfth of the span length, varying slightly for heavier or lighter loads. On occasion, the depth may be controlled by architectural considerations.

Stiffeners, plates or angles, may be attached to the girder web by welding or bolting to increase the buckling resistance of the web. Stiffeners are also required to transfer the concentrated forces of applied loads and reactions to the web without producing local buckling.

Splices are required for webs and flanges when full lengths of plates are not available from the mills or when shorter lengths are more readily fabricated. Splices provide the necessary continuity required in the web and flanges. [J.B.S.]

**Plate tectonics** The theory that provides an explanation for the behavior of the Earth's crust, particularly the global distribution of mountain building, earthquake activity, and volcanism in a series of linear belts. Numerous other geological phenomena such as lateral variations in surface heat flow, the physiography and geology of ocean basins, and various associations of igneous, metamorphic, and sedimentary rocks can also be logically related by plate tectonics theory.

The theory is based on a simple model of the Earth in which a rigid outer shell 30–90 mi (50–150 km) thick, the lithosphere, consisting of both oceanic and continental crust as well as the upper mantle, is considered to lie above a hotter, weaker semi-plastic asthenosphere. The asthenosphere, or low-velocity zone, extends from the base of the lithosphere to a depth of about 400 mi (700 km). The brittle lithosphere is broken into a mosaic of internally rigid plates which move horizontally across the Earth's surface relative to one another. Only a small number of major lithospheric plates exist, which grind and scrape against each other as they move independently like rafts of ice on water. Most dynamic activity such as seismicity, deformation, and the generation of magma occur only along plate boundaries, and it is on the basis of the global distribution of such tectonic phenomena that plates are delineated. See ASTHENOSPHERE; EARTHQUAKE; LITHOSPHERE.

The plate tectonics model for the Earth is consistent with the occurrence of sea-floor spreading and continental drift. Convincing evidence exists that both these processes have been occurring for at least the last  $6 \times 10^8$  years. This evidence includes the magnetic anomaly patterns of the sea floor, the paucity and youthful age of marine sediment in the ocean basins, the topographic features of the sea floor, and the indications of shifts in the position of continental blocks which can be inferred from paleomagnetic data on paleopole positions, paleontological and paleoclimatological observations, the match-up of continental margins and geological provinces across present-day oceans, and the structural style and rock types found in ancient mountain belts. See PALEOCLIMATOLOGY; PALEOMAGNETISM.

Geological observations, geophysical data, and theoretical considerations support the existence of three fundamentally distinct types of plate boundaries, named and classified on the basis of whether immediately adjacent plates move apart from one another (divergent plate margins), toward one another (convergent plate margins), or slip past one another in a direction parallel to their common boundary (transform plate margins). The boundaries of plates can, but need not, coincide with the contact between continental and oceanic crust. The velocity at which plates move varies from plate to plate and within portions of the same plate, ranging between 0.8 and 8 in. (2 and 20 cm) per year. See CONTINENTS, EVOLUTION OF; MID-OCEANIC RIDGE.

Not only does plate tectonics theory explain the present-day distribution of seismic and volcanic activity around the globe and physiographic features of the ocean basins such as trenches and mid-oceanic rises, but most Mesozoic and Cenozoic mountain belts appear to be related to the convergence of lithospheric

plates. Two different varieties of modern mobile belts have been recognized, cordilleran type and collision type. The Cordilleran range, which forms the western rim of North and South America (the Rocky Mountains, Pacific Coast ranges, and the Andes) have for the most part been created by the underthrusting of an ocean lithospheric plate beneath a continental plate. Underthrusting along the Pacific margin of South America is causing the continued formation of the Andes. The Alpine-Himalayan belt, formed where the collision of continental blocks buckled intervening volcanic belts and sedimentary strata into tight folds and faults, is an analog of the present tectonic situation in the Mediterranean, where the collision of Africa and Europe has begun. See CORDILLERAN BELT; OROGENY.

Plate tectonics is considered to have been operative as far back as  $2.5 \times 10^9$  years. Prior to that interval, evidence suggests that plate tectonics may have occurred, although in a markedly different manner, with higher rates of global heat flow producing smaller convective cells or more densely distributed mantle plumes which fragmented the Earth's surface into numerous small, rapidly moving plates. See CONTINENTAL DRIFT; GEODYNAMICS. [W.C.P.]

**Plateau** Any elevated area of relatively smooth land. Usually the term is used more specifically to denote an upland of subdued relief that on at least one side drops off abruptly to adjacent lower lands. In most instances the upland is cut by deep but widely separated valleys or canyons. Small plateaus that stand above their surroundings on all sides are often called tables, tablelands, or mesas. The abrupt edge of a plateau is an escarpment or, especially in the western United States, a rim. [E.H.Ha.]

**Platinum** A chemical element, Pt, atomic number 78, and atomic weight 195.09. Platinum is a soft, ductile, white noble metal. The platinum-group metals—platinum, palladium, iridium, rhodium, osmium, and ruthenium—are found widely distributed over the Earth. Their extreme dilution, however, precludes their recovery, except in special circumstances. For example, small amounts of the platinum metals, palladium in particular, are recovered during the electrolytic refining of copper. See IRIDIUM; OSMIUM; PALLADIUM; PERIODIC TABLE; RHODIUM; RUTHENIUM.

The platinum-group metals have wide chemical use because of their catalytic activity and chemical inertness. As a catalyst, platinum is used in hydrogenation, dehydrogenation, isomerization, cyclization, dehydration, dehalogenation, and oxidation reactions. See CATALYSIS; ELECTROCHEMICAL PROCESS.

Platinum is not affected by atmospheric exposure, even in sulfur-bearing industrial atmospheres. Platinum remains bright and does not visually exhibit an oxide film when heated, although a thin, adherent film forms below 450°C (840°F). Platinum may be worked to fine wire and thin sheet, and by special processes, to extremely fine wire. Important physical properties are given in the table.

Platinum can be made into a spongy form by thermally decomposing ammonium chloroplatinate or by reducing it from an aqueous solution. In this form it exhibits a high absorptive power for gases, especially oxygen, hydrogen, and carbon monoxide. The high catalytic activity of platinum is related directly to this property. See CRACKING; HYDROGENATION.

Platinum strongly tends to form coordination compounds. Platinum dioxide, PtO<sub>2</sub>, is a dark-brown insoluble compound, commonly known as Adams catalyst. Platinum(II) chloride, PtCl<sub>2</sub>, is an olive-green water-insoluble solid. Chloroplatinic acid, H<sub>2</sub>PtCl<sub>6</sub>, is the most important platinum compound. See COORDINATION CHEMISTRY.

In the glass industry, platinum is used at high temperatures to contain, stir, and convey molten glass. In the electrical industry, platinum is used in contacts and resistance wires because of its low contact resistance and high reliability in contaminated

## Physical properties of platinum

Properties	Value
Atomic weight ( $^{12}\text{C} = 12.00000$ )	195.09
Naturally occurring isotopes and % abundance	190, 0.0127% 192, 0.78% 194, 32.9% 195, 33.8% 196, 25.3% 198, 7.21%
Crystal structure	Face-centered cubic
Lattice constant $a$ at $25^\circ\text{C}$ , nm	0.39231
Thermal neutron capture cross section, barns	8.8
Common chemical valence	2, 4
Density at $25^\circ\text{C}$ , $\text{g}/\text{cm}^3$	21.46
Melting point	$1772^\circ\text{C}$ ( $3222^\circ\text{F}$ )
Boiling point	$3800^\circ\text{C}$ ( $6900^\circ\text{F}$ )
Specific heat at $0^\circ\text{C}$ , cal/g	0.0314
Thermal conductivity, $0\text{--}100^\circ\text{C}$ , cal/cm $^2$ s $^\circ\text{C}$	0.17
Linear coefficient of thermal expansion, $20\text{--}100^\circ\text{C}$ , $\mu\text{in.}/\text{in.}^\circ\text{C}$	9.1
Electrical resistivity at $0^\circ\text{C}$ , microhm-cm	9.85
Temperature coefficient of electrical resistance, $0\text{--}100^\circ\text{C}/^\circ\text{C}$	0.003927
Tensile strength, 1000 lb/in. $^2$	
Soft	18–24
Hard	30–35
Young's modulus at $20^\circ\text{C}$	
lb/in. $^2$ , static	$24.8 \times 10^6$
lb/in. $^2$ , dynamic	$24.5 \times 10^6$
Hardness, Diamond Pyramid Number (DPN)	
Soft	37–42
Hard	90–95

atmospheres. Platinum is clad over tungsten for use in electron tube grid wires. In the medical field, the simple coordination compounds cisplatin and carboplatin are two of the most active clinical anticancer agents. In combination with other agents, cisplatin is potentially curative for all stages of testicular cancer. Both agents are used for advanced gynecologic malignancies, especially ovarian tumors, and for head and neck and lung cancers. Carboplatin was developed in attempts to alleviate the severe toxic side effects of the parent cisplatin, with which it shares a very similar spectrum of anticancer efficacy. See CANCER (MEDICINE); CHEMOTHERAPY. [H.J.A.; N.F.]

**Platyasterida** A Paleozoic (Ordovician and Devonian) order of sea stars of the class Asterozoa; only two genera have been recognized. Platyasteridans have relatively elongate flat arms; broad, transversely aligned ventral arm plates; and paxilliform aboral plates. Fundamental differences in ambulacral system construction have been found between modern asteroids and all of the well-known early Paleozoic asteroids, including the platyasteridans. Similarities between platyasteridans and modern asteroids are attributable to evolutionary convergence. See ASTEROIDEA; ECHINODERMATA. [D.B.B.]

**Platycopida** An order of the Podocopa (Ostracoda) containing a single family, Cytherellidae, and two extinct superorders. Platycopids are small marine or brackish-water ostracods with an asymmetrical shell that is oblong, nearly rectangular, and laterally compressed; their six pairs of appendages are adapted for burrowing and filter feeding.

Species are dimorphic. The female carapace is wider near the rear and longer than that of the male, providing a brood chamber behind the body. All living species are benthic, and fossil forms probably were also. Some species live at great depths in the Atlantic Ocean, but others have been found in the Arabian, Caribbean, and Mediterranean seas in shallower water. See CRUSTACEA; OSTRACODA; PODOCOPA. [P.A.McL.]

**Platyctenida** An order of the phylum Ctenophora comprising four families (Ctenoplanidae, Coeloplanidae, Tjalfiellidae, Savangiidae) and six genera. All species are highly modified

from the planktonic ctenophores. The platyctenes are fairly small (1–6 cm or 0.4–2.4 in.) and brightly colored. They have adopted a variety of swimming, creeping, and sessile habits, with concomitant morphological changes and loss of typical ctenophoran characteristics. The body is compressed in the oral-aboral axis, and the oral part of the stomodeum is everted to form a creeping sole. Sexual reproduction involves internal fertilization in many species, with retention of the developing cydippid larvae in brood pouches. Some species also reproduce asexually by fission. Most platyctenids are found in tropical coastal waters, where many are ectocommensals on benthic organisms. See CTENOPHORA. [L.P.M.]

**Platyhelminthes** A phylum of the invertebrates, commonly called the flatworms. They are bilaterally symmetrical, nonsegmented, dorsoventrally flattened worms characterized by lack of coelom, anus, circulatory and respiratory systems, and exo- or endoskeleton. They possess a protonephridial excretory system, a complicated hermaphroditic reproductive system, and a solid mesenchyme which fills the interior of the body (see illustration). Three classes occur in the phylum: (1) the Turbellaria, mainly free-living, predacious worms; (2) the Trematoda, or flukes, holozoic ecto- or endoparasites; and (3) the Cestoda, or tapeworms, saprozoic endoparasites in the enteron of vertebrates, whose larvae are found in the tissues of invertebrates or vertebrates.

Turbellaria are widespread in fresh water and the littoral zones of the sea, while one group of triclads occurs on land in moist habitats. Adult trematodes occur on, or in, practically all tissues and cavities of the vertebrates on which they feed. They are responsible for troublesome diseases in humans and animals. Larval flukes are frequent in mollusks, mainly gastropods, and occasionally occur in pelecypods. Vector hosts, such as insects and fish, are often interpolated between mollusk and vertebrate. Adult tapeworms, living in the enteron or the biliary ducts, compete with the host for food and accessory food factors such as

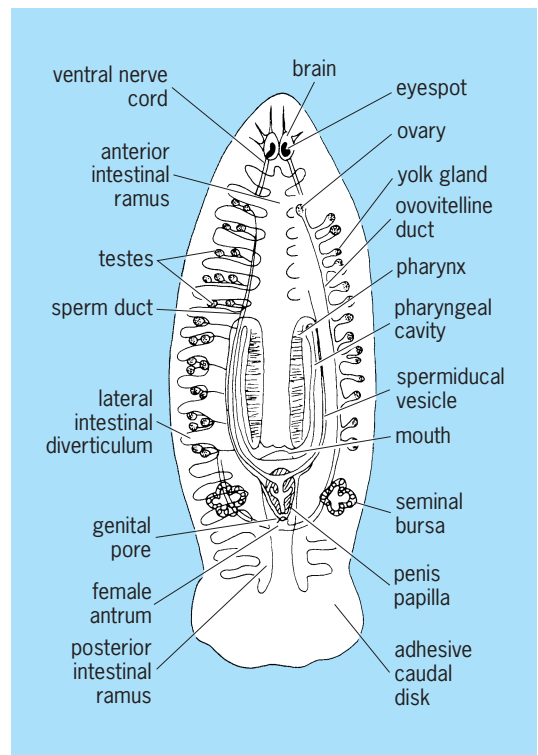

*Bdelloura candida* (Tricladida), ectocommensal on the king crab, *Limulus*. Complete digestive and male systems are shown on left, female systems on right.

## 1726 Platypus

vitamins. Larval tapeworms reside chiefly in arthropods, but larvae of one group, the Cyclophyllidea, develop in mammals, which may be severely impaired, or even killed, by the infection. See CESTODA; TREMATODA; TURBELLARIA. [C.G.G.]

**Platypus** The single species *Ornithorhynchus anatinus* of the family Ornithorhynchidae in the order Monotremata, which occurs in eastern Australia and Tasmania. This mammal is a monotreme, which lays eggs and incubates them in a manner similar to birds. The platypus is also known as the duckbill, duckmole, and water mole. One of the most primitive mammals, it retains some reptilian characteristics. The female lacks a marsupium; however, marsupial or epipubic bones are well developed.



The platypus, a primitive aquatic mammal, showing the webbed digits which aid in swimming.

*Ornithorhynchus* is well adapted to aquatic life. It ranges from the tropical, sea-level streams to cold lakes at altitudes of 6000 ft (1800 m). It is covered with short dense fur, typical of many aquatic mammals; the external ears are lacking; and the tail is broad and flattened, resembling that of the beaver (see illustration). The rubbery bill is covered with a highly sensitive skin. There are no teeth, but horny ridges are used for crushing food and grubbing on the bottom of rivers. See MONOTREMATA. [C.B.C.]

**Playa** A nearly level, generally dry surface in the lowest part of a desert basin with internal drainage (see illustration). When its surface is covered by a shallow sheet of water, it is a playa lake. Playas and playa lakes are also called dry lakes, alkali flats, mud flats, saline lakes, salt pans, inland sabkhas, ephemeral lakes, salinas, and sinks.



Light-colored playa in lowest part of Sarcobatus Flat in southern Nevada.

A playa surface is built up by sandy mud that settles from flood-water when a playa is inundated by downslope runoff during a rainstorm. A smooth, hard playa occurs where ground-water discharge is small or lacking and the surface is flooded frequently. These mud surfaces are cut by extensive desiccation polygons caused by shrinkage of the drying clay. Puffy-ground playas form by crystallization of minerals as ground water evaporates in muds near the surface.

Subsurface brine is present beneath many playas. The type of brine depends on the original composition of the surface water and reflects the lithology of the rocks weathered in the surrounding mountains. See GROUND-WATER HYDROLOGY.

Numerous playas in the southwestern United States yield commercial quantities of evaporite minerals, commonly at shallow depths. Important are salt (NaCl) and the borates, particularly borax ( $\text{Na}_2\text{B}_4\text{O}_7 \cdot 10\text{H}_2\text{O}$ ), kernite ( $\text{Na}_2\text{B}_4\text{O}_7 \cdot 4\text{H}_2\text{O}$ ), ulexite ( $\text{NaCaB}_5\text{O}_9 \cdot 8\text{H}_2\text{O}$ ), probertite ( $\text{NaCaB}_5\text{O}_9 \cdot 5\text{H}_2\text{O}$ ), and colemanite ( $\text{Ca}_2\text{B}_6\text{O}_{11} \cdot 5\text{H}_2\text{O}$ ). Soda ash (sodium carbonate;  $\text{Na}_2\text{CO}_3$ ) is obtained from trona ( $\text{Na}_3\text{H}(\text{CO}_3)_2 \cdot 2\text{H}_2\text{O}$ ) and gaylussite ( $\text{Na}_2\text{Ca}(\text{CO}_3)_2 \cdot 5\text{H}_2\text{O}$ ). Lithium and bromine are produced from brine waters. See DESERT EROSION FEATURES; SALINE EVAPORITES. [J.F.Hu.]

**Plecoptera** An order of primitive insects known as the stoneflies. Except for wings and tracheal gills, there are relatively slight differences between aquatic immature stages and adult mature ones. The soft and somewhat flattened body, strong legs, paired tarsal claws, chewing mouthparts, and rusty blacks, dull yellows, and browns are characteristic of both immature and adult stages (see illustration).

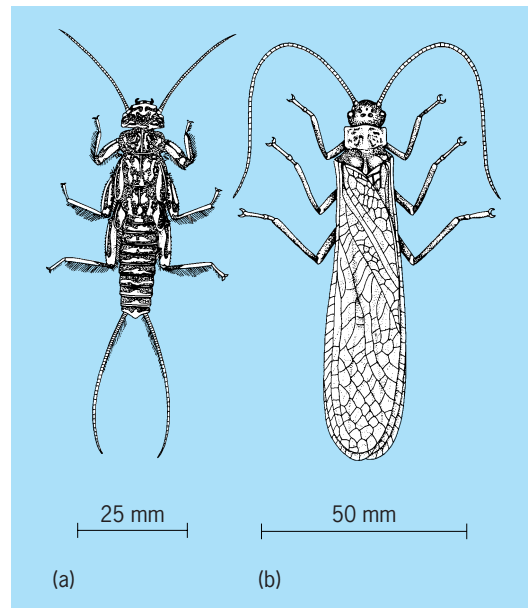

Plecoptera. (a) Nymph of *Perla*, (b) Adult of *Pteronarcys*. (After A. H. Morgan, *Field Book of Ponds and Streams*, Putnam, 1930)

Immature stoneflies live in the rapid, stony parts of clean, swift streams, although a few species occur along the rocky shores of large temperate lakes.

Adult stoneflies hold the wings close to the backs when at rest or walking. The hindwings are pleated and hidden. The name Plecoptera means pleated wings.

In various parts of North America stonefly adults emerge in every month of the year. Successions of species reach their peaks of abundance from November to March, with some extending to August. Nymphs and adults of some species are plant feeders; others are carnivorous. See INSECTA. [L.Ber.]



**Plectomycetes** A class of the phylum Ascomycota. The Plectomycetes produce a well-developed mycelium on which both sexual (asci) and asexual (conidia) states occur. The asci form in association with small ascomata of varying complexity. These arise from special coiled or intertwined hyphal branches that are sometimes differentiated into male (antheridium) and female (ascogonium) structures. The ascomata may consist of a loose grouping of hyphae around the asci forming a gymnothecium, or may be spherical, with a definite wall or peridium that lacks an opening, forming a cleistothecium. The asci are usually spherical, are scattered throughout the ascoma, and have thin walls that dissolve at maturity. The ascospores are small, colorless or sometimes pigmented, round in face view, somewhat flattened in side view, and may be ornamented or flanged.

The two recognized orders, Onygenales and Eurotiales, are differentiated by the structure of the ascoma and the type of asexual conidia produced. In the Onygenales, the ascoma usually is not well developed (gymnothecium), but many species form characteristic peridial hyphae. These fungi occur in soil, on dung, and on plant debris. The most serious fungal pathogens of humans belong in the Onygenales. *Arthroderma simii*. In the Eurotiales, the ascomata have a definite wall (peridium) enclosing the asci, and they are often brightly colored. They are common in soil and on plant materials. The most important species is *Penicillium chrysogenum*, the original source of penicillin. See ASCOMYCOTA; EUMYCOTA; FUNGI. [R.T.Ha.]

**Pleiades** A beautiful group of stars resembling a little dipper, in the constellation of Taurus, known since earliest records. The Pleiades is a typical open cluster (see illustration). Its distance is 410 light-years ( $2.4 \times 10^{15}$  mi or  $3.9 \times 10^{15}$  km), its linear diameter about 15 light-years ( $9 \times 10^{13}$  mi or  $1.4 \times 10^{14}$  km). The cluster is permeated with diffuse nebulosity. Though early accounts refer to the Pleiades in terms of seven stars, only six are now conspicuous to the unaided eye, which raises a the-

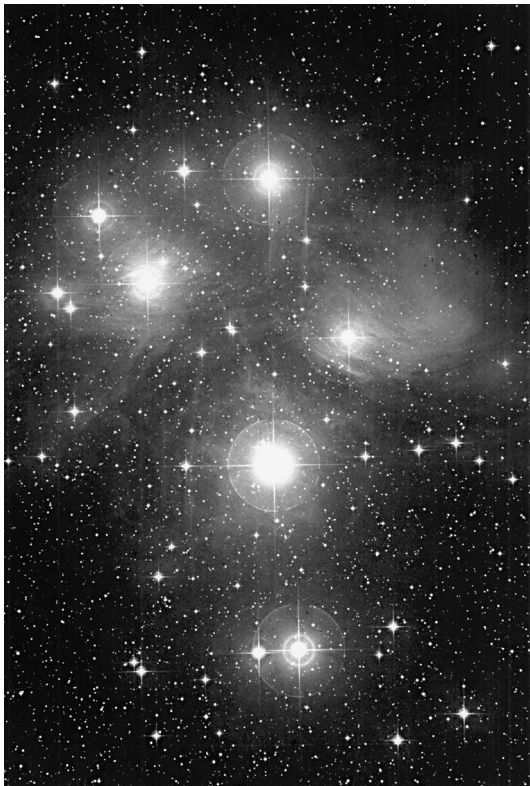

The Pleiades. (Lick Observatory photograph)

ory that one, the lost Pleiad, has faded. The observation of flare stars and x-ray emission has increased interest in this cluster. See CONSTELLATION; STAR CLUSTERS. [H.S.H.]

**Pleistocene** The older of the two epochs of the Quaternary Period. The Pleistocene Epoch represents the interval of geological time (and rocks accumulated during that time) extending from the end of the Pliocene Epoch (and the end of the Tertiary Period) to the start of the Holocene Epoch. Most recent time scales show the Pleistocene Epoch spanning the interval from 1.8 million years before present (m.y. B.P.) to 10,000 years B.P. The Pleistocene is commonly characterized as an epoch when the Earth entered its most recent phase of widespread glaciation. See HOLOCENE; PLIOCENE; QUATERNARY; TERTIARY.

In modern geological time scales, the Pleistocene is subdivided into a lower and an upper series. In Europe the lower series is considered equivalent to the Calabrian Stage, while the upper series is equated with the Sicilian and Tyrrethian stages.

The onset of the Pleistocene brought glaciations that were more widespread than those in the Pliocene. Mountain glaciers expanded and continental ice fields covered large areas of the temperate latitudes. Sea ice also became more widespread. As evidence has accumulated in recent decades from both the land and the sea, it clearly shows at least 17 glacial events occurred during the Pleistocene. See CLIMATE HISTORY; GLACIAL EPOCH.

The expansion and decay of the ice sheets had a direct effect on the global sea level. Global sea-level fluctuations of 50–150 m (170–500 ft) have been estimated for various glacial-interglacial episodes during the Pleistocene. Since the last deglaciation, which began some 17,000 years ago, the sea level has risen by about 110 m (360 ft) worldwide, drowning all of the ancient low-stand shorelines. One important product of the sea-level drops was the migration of large river deltas to the edges of the continental shelves and to the deeper parts of the basins. Conversely, the last marine transgression that started in the late Pleistocene after rapid deglaciation and ended in the Holocene (6000 to 7000 years ago) resulted in new deltas that formed at the mouths of modern rivers. See DELTA; PALEOCEANOGRAPHY.

The onset of cooler climate and Pleistocene glaciation is also approximated with a wave of mammalian migration from the east to the west. A relatively modern-looking fauna that included the first true oxen, elephants, and the first one-toed horse appeared at the beginning of Pleistocene. The modern horse, *E. caballus*, made its first appearance some 250,000 years ago in the late Pleistocene in North America. From North America it migrated to Asia and then west to Europe. However, during the last glacial maximum, some 18,000 years ago, it became extinct in North America when it was unable to cross the deserts to migrate to South America. Oxen, deer and reindeer, large cats, mammoth, great elk, wolf, hyena, and woolly rhinos proliferated during the middle and late Pleistocene. Mammoths, which have been found preserved nearly intact in frozen soils in Siberia, ranged over much of Europe during the glacial times. See GEOLOGIC TIME SCALE; MAMMALIA.

The unique Pleistocene mammalian faunas of some of the isolated islands, such as Madagascar, the Philippines, Taiwan, and the Japanese Archipelago, indicate restriction in the dispersal of species during the Pleistocene. The Pliocene Epoch had given rise to the human precursor, *Homo habilis*, around 2 m.y. B.P. The appearance of *H. erectus* came on the scene almost at the Plio-Pleistocene boundary around 1.8 m.y. B.P. The first archaic *H. sapiens* are now considered to have arrived on the scene around about a million years ago. The appearance of *H. neanderthalensis* or the Neanderthal Man, is now dated at least as far back as 250,000 years B.P. Recent datings have the appearance of the first true modern *H. sapiens* (the Cro-Magnon Man) to around 100,000 years B.P. See FOSSIL HUMANS; GEOLOGIC TIME SCALE. [B.U.H.]

**Pleochroic halos** Spherical or elliptical regions up to 40 micrometers in diameter in which there is a change in color from the surrounding mineral when viewed with a petrographic microscope. Pleochroic halos are found around small inclusions of radioactive minerals—for example, zircon, monazite, allanite, xenotime, and apatite—and in rock-forming minerals, principally quartz, micas, amphiboles, and pyroxenes. Halos have also been identified in coalified wood preserved in deposits on the Colorado Plateau. See CORDIERITE; PETROFABRIC ANALYSIS; RADIOACTIVE MINERALS.

The change in color is a result of radiation damage caused by alpha particles emitted during the radioactive decay of nuclides in the decay chains of uranium-238, uranium-235, and thorium-232. The range of the alpha particle and ionization effects account for the size and color of the halos. The halos have a distinctive ring structure with varying degrees of discoloration between the rings: the coloration in the halos increases, saturates, and finally diminishes with increasing ion dose. See ALPHA PARTICLES; METAMICT STATE.

The early interest in pleochroic halos was in their use for geologic age dating. Careful attempts were made to correlate the halo color with the alpha-irradiation dose in order to estimate the age of the enclosing mineral. Additionally, the constant size of the rings of the uranium and thorium halos for minerals of different ages was taken as evidence that the decay constants for radionuclides used in age dating had remained constant throughout geologic time. Thermal annealing of the halos has been used to model the thermal histories of rock units. See FISSION TRACK DATING; GEOCHRONOMETRY. [R.Ew.]

**Pleochroism** In some colored transparent crystals, the effect wherein the color is quite different in different directions through the crystals. In such a crystal the absorption of light is different for different polarization directions. In colored transparent tourmaline the effect may be so strong that one polarized component of a light beam is wholly absorbed, and the crystal can be used as a polarizer. See DICHROISM; TRICHOISM. [B.H.Bi.]

**Plesiosauria** An order of extinct aquatic diapsid reptiles within the infraclass Sauropterygia, common throughout the world during the Jurassic and Cretaceous periods. These large carnivores are characterized by long, paddle-shaped limbs and short, dorsoventrally compressed bodies. Unlike the nothosaurs (more primitive members of the Sauropterygia), plesiosaurs have greatly expanded ventral portions of both pectoral and pelvic girdles to provide large areas for the attachment of muscles to move the limbs anteriorly and posteriorly. Lateral undulation of the trunk was severely restricted by elaboration of the ventral scales.

Approximately 40 genera of plesiosaurs are recognized, divided into two large groups: The plesiosauroids include the most primitive genera and others that have small heads and very long necks. Among the plesiosauroids, the elasmosaurids had as many as 76 cervical vertebrae. The pliosauroids had shorter necks but larger skulls. Both elasmosaurs and pliosaurs persisted until the end of the Mesozoic. See DIAPSIDA; NOTHOSAURIA; REPTILIA; SAUROPTERYGIA. [R.L.C.]

**Pleuronectiformes** One of the most distinctive orders of actinopterygian fishes, also called Heterosomata, composed of the flatfishes: halibut, plaice, flounders, soles, tonguesoles, and their allies. The striking feature of the group is the loss of bilateral symmetry (see illustration), a characteristic of almost all vertebrates. Like the ancestors of pleuronectiforms, young flatfishes are symmetrical and swim upright; early in life, however, one eye migrates across the top of the skull to lie on the same side as the other eye. This transformation is associated with deformation of the skull bones and nerves, a change in position so that the fish lies on one (the blind) side, partial or complete depigmentation of the blind surface, and sometimes modification and develop-

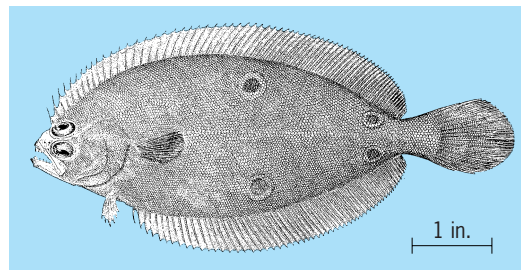

Fourspot flounder (*Paralichthys oblongus*), of the Pleuronectiformes. 1 in. = 2.5 cm. (After G. B. Goode, *Fishery Industries of the United States*, sect. 1, 1884)

ment of asymmetry in paired fins, dentition, squamation, visceral anatomy, and other structures. See ACTINOPTERYGII. [R.M.B.]

**Pliocene** The youngest of the five geological epochs of the Tertiary Period. The Pliocene represents the interval of geological time (and rocks deposited during that time) extending from the end of the Miocene Epoch to the beginning of the Pleistocene Epoch of the Quaternary Period. Modern time scales assign the duration of 5.0 to 1.8 million years ago (Ma) to the Pliocene Epoch. See MIOCENE; PLEISTOCENE; QUATERNARY; TERTIARY.

Pliocene marine sediments are commonly distributed along relatively restricted areas of the continental margins and in the deep-sea basins. Continental margin sediments are most often terrigenous and range from coarser-grained sandstone to finer-grained mudstone and clay. Major rivers of the world, such as the Amazon, Indus, and Ganges, contain thick piles of Pliocene terrigenous sediments in their offshore fans. The Pliocene deep-sea sediments are carbonate-rich (commonly biogenic oozes) and are often very thick (up to 5000 m or 16,400 ft). See BASIN; CONTINENTAL MARGIN.

Modern stratigraphic usage subdivides the Pliocene Epoch into two standard stages, the lower, Zanclean stage and the upper, Piacenzian stage.

The most notable tectonic events in the Pliocene include the beginning of the third and last phase of the Himalayan uplift, the Attican orogeny that began in the late Miocene and continued into the Pliocene, and the Rhodanian and Walachian orogenies that occurred during the later Pliocene. See OROGENY.

The latest Miocene is marked by a global cooling period that continued into the earliest Pliocene, and there is evidence that the East Antarctic ice sheet had reached the continental margins at this time. The global sea level had been falling through the late Miocene, and with the exception of a marked rise in the mid-Zanclean, the trend toward lowered sea levels continued through the Pliocene and Pleistocene. The mid-Zanclean sea-level rise (3.5–3 Ma) was also accompanied by a significant global warming event. The oxygen isotopic data, which record the prevailing sea surface temperatures and total ice volume on the ice caps, show little variations in the Equatorial Pacific during the middle Pliocene. By early Pliocene time, the major surface circulation patterns of the world ocean and the sources of supply of bottom waters were essentially similar to their modern counterparts. See GEOLOGIC THERMOMETRY.

By Pliocene time, much of the marine and terrestrial biota had essentially evolved its modern characteristics. The late Pliocene cooling led to the expansion of cooler-water marine assemblages of the higher latitudes into lower latitudes, particularly the foraminifers, bivalves, and gastropods. At the onset of cooling, the warm-water-preferring calcareous nannoplankton group of discoasters began waning in the late Pliocene and became extinct at the close of the epoch. See BIVALVIA; COCCOLITHOPHORIDA; FORAMINIFERIDA; GASTROPODA.

The widespread grasslands of the Pliocene were conducive to the proliferation of mammals and increase in their average size.

The mid-Zanclean sea-level rise led to the geographic isolation of many groups of mammals and the increase in endemism. But the late Pliocene-Pleistocene lowering of sea level facilitated land connections and allowed extensive mammalian migration between continents with interchanges between North and South America. The arrival of the North American mammals led to increased competitive pressure and extinction of many typically South American groups. Horses evolved and spread widely in the Pliocene. See MAMMALIA.

The Pliocene Epoch also saw the appearance of several hominid species that are considered to be directly related to modern human ancestry. The earliest hominid bones have been discovered from Baringo, Kenya, in sediments that are dated to be of earliest Pliocene age. After this first occurrence, a whole suite of australopithecine species made their appearance in the Pliocene. See AUSTRALOPITHECINE; FOSSIL HUMANS; PALEONTOLOGY. [B.U.H.]

**Plum** Any of the smooth-skinned stone fruits grown on shrubs or small trees. Plums are widely distributed in all land areas of the North Temperate Zone, where many species and varieties are adapted to different climatic and soil conditions.

There are four principal groups: (1) *Domestica* (*Prunus domestica*) of European or Southwest Asian origin, (2) Japanese or *Salicina* (*P. salicina*) of Chinese origin, (3) *Insititia* or Damson (*P. insititia*) of Eurasian origin, and (4) American (*P. americana* and *P. hortulana*). The *Domesticas* are large, meaty, prune-type plums. A prune is a plum which dries without spoiling. [R.P.L.]

**Plumbaginales** An order of flowering plants, division Magnoliophyta (Angiospermae), in the subclass Caryophyllidae of the class Magnoliopsida (dicotyledons). The order consists of only the family Plumbaginaceae, with about 400 species. The plants are herbs or less often shrubs. The flowers are strictly pentamerous (that is, each floral whorl has five members); the petals are fused (sympetalous condition) and all alike in shape and size; the pollen is trinucleate; and there is a single basal ovule located in a compound ovary that has a single locule or cell. The Plumbaginaceae differ from most families of their subclass in their straight embryo, copious endosperm, absence of perisperm, and the presence of anthocyanin pigments instead of betalains. The family contains a few garden ornamentals, such as species of *Armeria*, known as thrift or sea-pink. See CARYOPHYLLIDAE; MAGNOLIOPHYTA; MAGNOLIOPSIDA. [A.Cr.; T.M.Ba.]

**Pluto** Commonly considered the outermost planet, Pluto is actually the largest member of a disk of icy planetesimals that surround the solar system beyond the orbit of Neptune. Pluto was discovered in 1930.

Pluto is visible only through fairly large telescopes. Periodic variations in its brightness demonstrate that the surface of Pluto is covered with bright and dark markings and indicate a period of rotation of 6.4 days.

Pluto has a small satellite named Charon. The radius of Pluto was found to be  $730 \pm 20$  mi ( $1170 \pm 30$  km), so Pluto is significantly smaller than the Earth's Moon (whose radius is 1080 mi or 1738 km), while Charon's radius is  $390 \pm 15$  mi ( $625 \pm 25$  km). Charon is thus about half the size of Pluto itself, making this the most closely matched pair in the solar system. The combined mass of Pluto and Charon is 0.0025 times the mass of the Earth. Their densities are close to  $2.0 \text{ g/cm}^3$ , indicating a composition of ice and rock, similar to that of the large icy satellites of Jupiter and Saturn, but surprisingly dense for bodies this small.

The near-infrared spectrum of Pluto reveals absorption features of solid nitrogen ( $\text{N}_2$ ), carbon monoxide (CO), and methane ( $\text{CH}_4$ ) ice. From these absorptions it is possible to conclude that nitrogen is the dominant ice on Pluto's surface, which means it must also be the major constituent of the planet's atmosphere. The nitrogen absorption in the spectrum indicates

a surface temperature near 38 K ( $-391^\circ\text{F}$ ), consistent with an atmospheric surface pressure roughly  $10^{-5}$  times that on Earth.

Demonstrating a striking difference with Pluto, Charon apparently has little if any frozen methane on its surface, which instead exhibits the spectral signature of water ice. The orbit of Charon is unique in the solar system in that the satellite's period of revolution is identical to the rotational period of the planet. Thus an inhabitant of Pluto who lived on the appropriate hemisphere would see Charon hanging motionless in the sky. [T.C.O.]

**Pluton** A solid rock body that formed by cooling and crystallization of molten rock (magma) within the Earth. Most plutons, or plutonic bodies, are regarded as the product of crystallization of magma intruded into surrounding "country rocks" within the Earth (principally within the crust). Igneous rock bodies are referred to generally as either extrusive or volcanic on one hand, or as intrusive or plutonic on the other, although the term volcanic is sometimes also used to refer to small, shallow intrusive bodies associated with volcanoes. See IGNEOUS ROCKS; MAGMA.

Plutons occur in a nearly infinite variety of shapes and sizes, so that definition of types is arbitrary in many cases. In general, two modes of emplacement can be recognized with regard to the country rock. Concordant plutons are intruded between layers of stratified rock, whereas the more common discordant plutons are characterized by boundaries that cut across preexisting structures or layers in the country rock. The principal types of concordant plutons are sills, laccoliths, and lopoliths; the principal types of discordant plutons are dikes, volcanic necks or plugs, stocks, and batholiths.

Several mechanisms of magma intrusion are known or proposed. The most simple ones, pertaining to smaller plutonic bodies, are forceful injection or passive migration into fractures. Larger plutons may form by several processes. For example, less dense magma may migrate upward along a myriad of channels to accumulate as a large molten body within the upper crust. Further migration could occur by forceful injection, by stoping (a process where the magma rises as blocks of the roof of the magma chamber break off and sink), and by diapiric rise, where country rocks flow around the upward-moving magma body. See PETROLOGY. [W.R.V.S.]

**Plutonium** A chemical element, Pu, atomic number 94. Plutonium is a reactive, silvery metal in the actinide series of element elements. The principal isotope of chemical interest is  $^{239}\text{Pu}$ , with a half-life of 24,131 years. It is formed in nuclear reactors by the process shown in the following reaction. Plutonium-

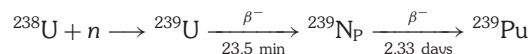

239 is fissionable, but may also capture neutrons to form higher plutonium isotopes. See PERIODIC TABLE.

Plutonium-238, with a half-life of 87.7 years, is utilized in heat sources for space application, and has been used for heart pacemakers. Plutonium-239 is used as a nuclear fuel, in the production of radioactive isotopes for research, and as the fissile agent in nuclear weapons.

Plutonium exhibits a variety of valence states in solution and in the solid state. Plutonium metal is highly electropositive. Numerous alloys of plutonium have been prepared, and a large number of intermetallic compounds have been characterized.

Reaction of the metal with hydrogen yields two hydrides. The hydrides are formed at temperatures as low as  $150^\circ\text{C}$  ( $300^\circ\text{F}$ ). Their decomposition above  $750^\circ\text{C}$  ( $1400^\circ\text{F}$ ) may be used to prepare reactive plutonium powder. The most common oxide is  $\text{PuO}_2$ , which is formed by ignition of hydroxides, oxalates, peroxides, and nitrates of any oxidation state in air of  $870$ – $1200^\circ\text{C}$  ( $1600$ – $2200^\circ\text{F}$ ). A very important class of plutonium compounds are the halides and oxyhalides. Plutonium hexafluoride, the most volatile plutonium compound known, is a strong fluorinating agent. A number of other binary compounds are

known. Among these are the carbides, silicides, sulfides, and selenides, which are of particular interest because of their refractory nature.

Because of its radiotoxicity, plutonium and its compounds require special handling techniques to prevent ingestion or inhalation. Therefore, all work with plutonium and its compounds must be carried out inside glove boxes. For work with plutonium and its alloys, which are attacked by moisture and by atmospheric gases, these boxes may be filled with helium or argon. See ACTINIDE ELEMENTS; NEPTUNIUM; NUCLEAR CHEMISTRY; TRANSURANIUM ELEMENTS; URANIUM. [FWe.]

**Plywood** A wood product in which thin sheets of wood are glued together, grains of adjacent sheets being at right angles to each other in the principal plane. Because of this cross-grained orientation, mechanical properties are less directional than those of natural lumber and more dimensionally stable. Tree farms are now cultivated specifically to yield logs suitable for processing into sheets for plywood.

The American Plywood Association identifies several grades of product. Plywood is designated group 1 when made from northern-grown Douglas-fir, western larch, and such southern pines as loblolly and longleaf, or other woods noted for their strength. Plywoods in groups 2, 3, and 4 are made from woods of successively lower strengths. Consequently, group 1 plywood offers the greatest stiffness, group 4 the least.

Plywood with waterproof glue is designated exterior type; it is also used interiorly where moisture is present. Plywood with nonmoisture-resistant glue is designated interior type; it can withstand an occasional soaking but neither repeated soakings nor continuous high humidity.

Veneer grades A through D extend from a smooth surface to a surface with occasional knotholes and limited splits. If the outer face of the plywood is cut from only heartwood or sapwood, free from open defects, the plywood is assigned veneer grade N, indicating that it will take a natural finish. See STEM; VENEER.

Most commonly used plywoods are  $\frac{1}{4}$ -in. (0.6-cm) sanded interior paneling or  $\frac{1}{2}$ -in. (1.3-cm) exterior grade plywood sheeting. Other standard thicknesses extend to 1 in. (2.5 cm) for interior types and to  $1\frac{1}{8}$  in. (2.8 cm) for exterior types. The most common panel size is 4 × 8 ft (1.2 × 2.4 m); larger sizes are manufactured for such special purposes as boat hulls.

Finished plywood may be unsanded, sanded, or overlaid with several types of coatings for decorative and specialty uses. Plywood in appropriate grades is used in many different applications, such as furniture, wall facings, shelving, containers, crates, fences, forms, subflooring, and roof decking. See WOOD PRODUCTS. [F.H.R.; R.M.Ro.]

**Pneumatolysis** The alteration of rocks or crystallization of minerals by gases or supercritical fluids (generically termed magmatic fluids) derived from solidifying magma. At surface conditions, magmatic fluids contain steam with lesser amounts of carbon dioxide, sulfur dioxide, hydrogen sulfide, hydrogen chloride, and hydrogen fluoride, and trace amounts of many other volatile constituents. Magmatic fluids may contain relatively high concentrations of light and heavy elements, particularly metals, that do not crystallize readily in common rock-forming silicates constituting most of the solidifying magma; thus, valuable rare minerals and ores are sometimes deposited in rocks subjected to pneumatolysis. Magmatic fluids are acidic and may react extensively with rocks in the volcanic edifice or with wall rocks surrounding intrusions. Penetration of magmatic fluids into adjacent rocks is greatly aided by faults, fractures, and cracks developed during intrusion and eruption or created by earlier geologic events. See MAGMA; METAMORPHISM; METASOMATISM; ORE AND MINERAL DEPOSITS; VOLCANO.

Pneumatolysis describes specific mechanisms of mineral deposition, hydrothermal alteration, or metasomatism in which magmatic fluids play an extremely significant role. For example,

lavas and ejecta at volcanoes may contain blocks (xenoliths) of wall rock that react with magmatic fluids to form pneumatolytic minerals such as vesuvianite (idocrase). Gases streaming from volcanic fumaroles deposit sublimates of sulfur, sulfates, chlorides, fluorides, and oxides of many metals. Wall rocks surrounding volcanic conduits may be thoroughly altered to mixtures of quartz, alunite, anhydrite, pyrite, diaspore, kaolin, as well as other minerals by acidic fluids degassed from magma. Rarely, gold, silver, base-metal sulfides, arsenides, and tellurides are deposited by the fluids, making valuable ores. See LAVA; METASOMATISM; PYROCLASTIC ROCKS; SUBLIMATION; VESUVIANITE; XENOLITH. [F.Go.]

**Pneumococcus** The major causative microorganism (*Streptococcus pneumoniae*) of lobar pneumonia. Pneumococci occur singly or as pairs or short chains of oval or lancet-shaped cocci, 0.05–1.25 micrometers each, flattened at proximal sides and pointed at distal ends. A capsule of polysaccharide envelops each cell or pair of cells. The organism is nonmotile and stains gram-positive unless degenerating.

Pneumococci have been isolated from the upper respiratory tract of healthy humans, monkeys, calves, horses, and dogs. Epizootics of pneumococcal infection have been described in monkeys, guinea pigs, and rats but are not the source of human infection. In humans, pneumococci may be found in the upper respiratory tract of nearly all individuals at one time or another. Following damage to the epithelium lining the respiratory tract, pneumococci may invade the lungs. They are the principal cause of lobar pneumonia in humans and may cause also pleural empyema, pericarditis, endocarditis, meningitis, arthritis, peritonitis, and infection of the middle ear. Approximately one of four cases of pneumococcal pneumonia is accompanied by invasion of the bloodstream by pneumococci, producing bacteremia. Although the high mortality of untreated pneumococcal infection has been reduced significantly by treatment with antibiotics, one of every six patients with bacteremic lobar pneumonia still succumbs despite optimal therapy. In addition, the number of isolates of pneumococci resistant to one or more antimicrobial drugs has been gradually but steadily increasing. For these reasons, prophylactic vaccination is recommended, especially for those segments of the population that are at high risk for fatal infection. The polyvalent vaccine contains the purified capsular polysaccharides of the 23 types that are responsible for 85% of bacteremic pneumococcal infection and has an aggregate efficacy of 65–70% in preventing infection with any of the types represented in it. [R.Au.]

**Pneumonia** An acute or chronic inflammatory disease of the lungs. More specifically when inflammation is caused by an infectious agent, the condition is called pneumonia; when the inflammatory process in the lung is not related to an infectious organism, it is called pneumonitis.

An estimated 45 million cases of infectious pneumonia occur annually in the United States, with up to 50,000 deaths directly attributable to it. Pneumonia is a common immediate cause of death in persons with a variety of underlying diseases. With the use of immunosuppressive and chemotherapeutic agents for treating transplant and cancer patients, pneumonia caused by infectious agents that usually do not cause infections in healthy persons (that is, pneumonia as an opportunistic infection) has become commonplace. Moreover, individuals with acquired immune deficiency syndrome (AIDS) usually die from an opportunistic infection, such as pneumocystis pneumonia or cytomegalovirus pneumonia. Concurrent with the variable and expanding etiology of pneumonia and the more frequent occurrence of opportunistic infections is the development of new antibiotics and other drugs used in the treatment of pneumonia. See ACQUIRED IMMUNE DEFICIENCY SYNDROME (AIDS); OPPORTUNISTIC INFECTIONS.

Bacteria, as a group, are the most common cause of infectious pneumonia, although influenza virus has replaced *Streptococcus pneumoniae* (*Diplococcus pneumoniae*) as the most common single agent. Some of the bacteria are normal inhabitants of the body and proliferate to cause disease only under certain conditions. Other bacteria are contaminants of food or water.

Most bacteria cause one of two main morphologic forms of inflammation in the lung. *Streptococcus pneumoniae* causes lobar pneumonia, in which an entire lobe of a lung or a large portion of a lobe becomes consolidated (firm, dense) and nonfunctional secondary to an influx of fluid and acute inflammatory cells that represent a reaction to the bacteria. This type of pneumonia is uncommon today, usually occurring in people who have poor hygiene and are debilitated. If lobar pneumonia is treated adequately, the inflammatory process may entirely disappear, although in some instances it undergoes a process called organization, in which the inflammatory tissue changes into fibrous tissue, usually rendering that portion of the lung nonfunctional.

The other morphologic form of pneumonia, which is caused by the majority of bacteria, is called bronchopneumonia. In this form there is patchy consolidation of lung tissue, usually around the small bronchi and bronchioles, again most frequently in the lower lobes. This type of pneumonia may also undergo complete resolution if there is adequate treatment, although rarely it organizes.

Viral pneumonia is usually a diffuse process throughout the lung and produces a different type of inflammatory reaction than is seen in bronchopneumonia or lobar pneumonia. Mycoplasma pneumonia, caused by *Mycoplasma pneumoniae*, is referred to as primary atypical pneumonia and causes an inflammatory reaction similar to that of viral pneumonia.

Pneumonia can be caused by a variety of other fungal organisms, especially in debilitated persons such as those with cancer or AIDS. *Mycobacterium tuberculosis*, the causative agent of pulmonary tuberculosis, produces an inflammatory reaction similar to fungal organisms. See MYCOBACTERIAL DISEASES; TUBERCULOSIS.

*Legionella pneumoniae*, initially called Legionnaire's disease, is caused by bacteria of the genus *Legionella*. The condition is frequently referred to under the broader name of legionellosis. See LEGIONNAIRES' DISEASE.

The signs and symptoms of pneumonia and pneumonitis are usually nonspecific, consisting of fever, chills, shortness of breath, and chest pain. Fever and chills are more frequently associated with infectious pneumonias but may also be seen in pneumonitis. The physical examination of a person with pneumonia or pneumonitis may reveal abnormal lung sounds indicative of regions of consolidation of lung tissue. A chest x-ray also shows the consolidation, which appears as an area of increased opacity (white area). Cultures of sputum or bronchial secretions may identify an infectious organism capable of causing the pneumonia.

The treatment of pneumonia and pneumonitis depends on the cause. Bacterial pneumonias are treated with antimicrobial agents. If the organisms can be cultured, the sensitivity of the organism to a specific antibiotic can be determined. Viral pneumonia is difficult to treat, as most drugs only help control the symptoms. The treatment of pneumonitis depends on identifying its cause; many cases are treated with cortisone-type medicines.

[S.P.H.]

**Poales** An order of flowering plants (angiosperms) that includes the bromeliads, grasses, restios, rushes, and sedges. It comprises approximately 18 families and more than 18,000 species, over half of which are grasses (Poaceae). These families in general include plants without showy flowers (except for Bromeliaceae, Xyridaceae, and Rapateaceae) and with a grasslike form. These plants dominate vast areas of the Earth's surface and include some important grain crops, such as corn (*Zea mays*), rice (*Oryza sativa*), and wheat (*Triticum aestivum*), as well as rushes, sedges, grasses used for thatch, and bamboos

used for construction. See DUNE VEGETATION; GRAIN CROPS; GRASS CROPS.

[M.W.C.; M.F.F.]

**Podicipediformes** A small order of aquatic birds that contains only a single living family, the Podicipedidae (grebes), with 20 species found throughout the world. They are small to medium-sized birds that are specialized for aquatic life and can swim and dive skillfully. Their legs are placed far posteriorly with lobed—not webbed—toes that are used to propel the bird through the water, but their terrestrial locomotion is awkward. Their wings are small, and they rarely fly; yet they migrate over long distances and have colonized many remote islands. The body is compact with a dense, waterproof plumage. The neck is medium to long, the head is large, and the bill is short to medium and pointed. Grebes feed on fish and other aquatic animals they pursue under water. Grebes are monogamous, with an elaborate courtship and strong pair bond. Grebes are found throughout the world except on some remote oceanic islands. See AVES.

[W.J.B.]

**Podocopa** One of two Recent subclasses of Ostracoda. The two may share many characteristics but differ significantly in others. Shared characteristics include a carapace (shell) with a straight-to-concave ventral margin and somewhat convex dorsal margin; adductor muscle-scar patterns varying from numerous to few; the absence of an anterior notch in the bivalve shell; and the absence of lateral eyes, heart, and frontal organ (Bellonci organ). Podocopid ostracods are small, rarely exceeding 0.25 in. (7 mm). The carapace valves are unequal, weakly or strongly calcified, and may be heavily ornamented. The hinge varies from simple to complex. Six or seven pairs of appendages are present; the seventh is adapted for walking, for cleaning, or as a clasping leg in males. The subclass is represented by the two extant orders, Platycopida and Podocopida.

Podocopid ostracods are found in fresh-water, marine, and brackish-water environments, and a few are terrestrial. The majority are burrowing or crawling inhabitants of the benthos and are filter or detritus feeders or herbivores. Some are capable of swimming, but none appear to ever lead a planktonic existence. See OSTRACODA.

[P.A.McL.]

**Podocopida** An order of the subclass Podocopa, class Ostracoda, that consists of the extant suborder Podocopina and the extinct Metacopina. There is agreement on the assignment of the superfamilies Cypridoidea, Bairdioidea, Cytheroidea, and Darwinuloidea to the Podocopida; however, some researchers also include the Sigillioidea, and others consider the Terrestriotheroidea a podocopid taxon of equivalent rank. In all podocopids the two valves fit firmly, hermetically sealing the animal inside when closed.

Appendages include antennules, antennae, mandibles, maxillules, and three pairs of thoracic legs. Antennules and antennae are both used in locomotion; swimming forms are provided with long, feathered setae, whereas crawling forms have only short, stout setae. Mandibles are strongly constructed and, with rare exceptions, used for mastication. The maxilla has setiferous endites and bears a large branchial plate to circulate water alongside the body. The furca is variously developed but never lamelliform. If eyes are present, the two lateral eyes and the median eye are joined into one central structure. No heart is developed. See CRUSTACEA; PODOCOPA.

[P.A.McL.]

**Podostemales** An order of flowering plants, division Magnoliophyta (Angiospermae), in the subclass Rosidae of the class Magnoliopsida (dicotyledons). The order consists of only the family Podostemaceae, with about 200 species, the greatest number occurring in tropical America. They are submerged aquatics with modified, branching, often thalluslike shoots, and small, perfect flowers with a much reduced perianth. See MAGNOLIOPSIDA; ROSIDAE.

[A.Cr.]

**Poecilosclerida** An order of sponges of the class Demospongiae in which the skeleton includes two or more types of megascleres, each localized in a particular part of the sponge colony. Frequently one type of megasclere is restricted to the dermis and another type occurs in the interior of the sponge. Sometimes one category is embedded in spongin fibers while a second category, usually spinose, protrudes from the fibers at right angles. Spongin is always present but varies in amount from species to species. Microscleres are usually present; often several types occur in one species. A wide variety of microsclere categories is found in the order but asters are never present. See DEMOSPONGIAE. [W.D.H.]

**Poecilostomatoida** One of two major orders of parasitic Copepoda that were previously included in the Cyclopoidea. The classification of parasitic copepods has been established on the basis of the structure of the mouth. In poecilostomatoids the mouth is represented by a transverse slit, partially covered by the overhanging labrum, which resembles an upper lip. Although there is variability in the form of the mandible among poecilostomatoids, it can be generalized as being falcate. Body segmentation is typically podoplean, having prosome-urosome articulation between the fifth and sixth thoracic somites; however, this segmentation is often lost with the molt to adulthood. The antennules frequently are reduced in size and the antennae modified to terminate in small hooks or claws that are used in attachment to host organisms.

Most poecilostomatoid copepods are ectoparasites of marine fishes or invertebrates, usually attaching to the external surface of the host or in the branchial cavity on the walls or gill surfaces. Representatives of one family, however, have successfully made the transition to fresh-water habitats, and a second family has evolved an endoparasitic mode of life. See COPEPODA; CRUSTACEA; CYCLOPOIDA. [P.A.McL.]

**Pogonophora** The beard worms—a phylum of sedentary marine worms living in cool waters of all the world's oceans, generally at depths between 330 and 13,200 ft (100 and 4000 m), shallower at higher latitudes and deeper in trenches. They were first dredged late in the nineteenth century but first investigated in the 1950s. Pogonophorans construct a tube, and are the only nonparasitic metazoans to have no mouth, gut, or anus in their postembryonic anatomy. These are long, slender worms, the diameter in most being less than 1 mm and the length being over 100 times the diameter. Superficially the tubes remind one of corn silk or coarse thread, but most have a characteristic banding pattern with annuli of brown or yellow pigments. The larger tubes are sometimes rigid, thicker, and darkcolored.

The evidence now suggests that these worms absorb their nutrients, such as amino acids, glucose, and fatty acids, through the pinnules and microvilli of the tentacles without the aid of digestive enzymes. This is accomplished against concentration gradients and may be supplemented by limited pinocytosis and phagocytosis by tentacular surfaces in a few species. The presence of internal symbiotic bacteria was demonstrated in several genera. These chemosynthetic organisms also play an important role in providing nutrients to these worms.

The sexes are separate, with the gonopore location being the only sexual dimorphism. Spermatophores with long tail filaments are released by the male. Fertilization has not been observed but must occur within the maternal tube, as fertilized eggs and developing larvae have been found there.

The Pogonophora consist of two orders: Athecanephria and Thecanephria. See ATHECANEPHRIA; THECANEPHRIA. [E.B.Cu.]

**Poison** A substance which by chemical action and at low dosage can kill or injure living organisms. Broadly defined, poisons include chemicals toxic for any living form: microbes, plants, or animals. In common usage the word is limited to substances toxic for humans and mammals, particularly where toxicity is a

substance's major property of medical interest. Because of their diversity in origin, chemistry, and toxic action, poisons defy any simple classification. Almost all chemicals with recognized physiological effects are toxic at sufficient dosage.

**Origin and chemistry.** Many poisons are of natural origin. Some bacteria secrete toxic proteins (for example, botulinus, diphtheria, and tetanus toxins) that are among the most poisonous compounds known. Lower plants notorious for poisonous properties are ergot (*Claviceps purpurea*) and a variety of toxic mushrooms. See ERGOT AND ERGOTISM; MUSHROOM; TOXIN.

Higher plants, which constitute the major natural source of drugs, contain a great variety of poisonous substances. Many of the plant alkaloids double as drugs or poisons, depending on dose. These include curare, quinine, atropine, mescaline, morphine, nicotine, cocaine, picrotoxin, strychnine, lysergic acid, and many others. See ATROPINE; COCAINE; MORPHINE ALKALOIDS; QUININE.

Poisons of animal origin (venoms) are similarly diverse. Toxic marine animals alone include examples of every phylum. Insects and snakes represent the best-known venomous land animals, but on land, too, all phyla include poison-producing species. Among mammalian examples are certain shrews with poison-producing salivary glands. See POISON GLAND.

Poisons of nonliving origin vary in chemical complexity from the toxic elements, for example, the heavy metals, to complex synthetic organic molecules. Most of the heavy metals (gold, silver, mercury, arsenic, and lead) are poisons of high potency in the form of their soluble salts. Strong acids or bases are toxic largely because of corrosive local tissue injury.

The chemically reactive gases hydrogen sulfide, hydrocyanic acid, chlorine, bromine, and ammonia are also toxic, even at low concentration, both because of their corrosiveness and because of more subtle chemical interaction with enzymes or other cell constituents.

Many organic substances of synthetic origin are highly toxic and represent a major source of industrial hazard. Most organic solvents are more or less toxic on ingestion or inhalation. Many alcohols, such as methanol, are much more toxic. Many solvents (for example, carbon tetrachloride, tetrachloroethane, dioxane, and ethylene glycol) produce severe chemical injury to the liver and other viscera, sometimes from rather low dosage.

**Physiological actions.** The action of poisons is generally described by the physiological or biochemical changes which they produce. For most poisons, a descriptive account can be given which indicates what organic system (for example, heart, kidney, liver, brain, and bone marrow) appears to be most critically involved and contributes most to seriously disordered body function or death. In many cases, however, organ effects are multiple, or functional derangements so generalized that a cause of death cannot be localized.

More precise understanding of the mechanism of poisons requires detailed knowledge of their action in chemical terms. Information of this kind is available for only a few compounds, and then in only fragmentary detail. Poisons that inhibit acetylcholinesterase have toxic actions traceable to a single blocked enzyme reaction, hydrolysis of normally secreted acetylcholine. Detailed understanding of the mechanism of chemical inhibition of cholinesterase is not complete, but allows some prediction of chemical structures likely to act as inhibitors. See ACETYLCHOLINE.

Carbon monoxide toxicity is also partly understood in chemical terms, since formation of carboxyhemoglobin, a form incapable of oxygen transport, is sufficient to explain the anoxic features of toxicity.

Heavy metal poisoning in many cases is thought to involve inhibition of enzymes by formation of metal mercaptides with enzyme sulfhydryl groups, the unsubstituted form of which is necessary for enzyme action. This is a general reaction that may occur with a variety of sulfhydryl-containing enzymes in

the body. Specific susceptible enzymes whose inhibition explains toxicity have not yet been well documented.

Metabolic antagonists active as poisons function by competitive blocking of normal metabolic reactions. Some antagonists may act directly as enzyme inhibitors, others may be enzymatically altered to form derivatives which are even more potent inhibitors at a later metabolic step. See ENZYME INHIBITION.

Where poison mechanisms are relatively well understood, it has sometimes been possible to employ rationally selected antidotes.

**Potency.** The strength or potency of poisons is most frequently measured by the lethal dose, potency being inversely proportional to lethal dose. From statistically treated dose-response data, the dose killing 50% of the sample population can be determined, and is usually designated the MLD (median lethal dose) or LD<sub>50</sub>. This is the commonest measure of toxic potency. See LETHAL DOSE 50; TOXICOLOGY. [E.A.]

**Poison gland** The specialized gland of certain fishes, as well as the granular glands and some mucous glands of many aquatic and terrestrial Amphibia. The poison glands of fishes are simple or slightly branched acinous structures which use the holocrine method of secreting a mucuslike substance. The poison glands of snakes are modified oral or salivary glands. Amphibian glands are simple, acinous, holocrine, with granular secretion. In some cases these amphibian poison glands produce mucus by a merocrine method of secretion. These glands function as protective devices. See GLAND. [O.E.N.]

**Poison ivy** A general name applied to certain species of the genus *Toxicodendron*, previously known as *Rhus*, in the sumac family (Anacardiaceae). *Toxicodendron radicans* is the poison ivy of eastern North America; *T. diversiloba* is the poison oak of California. These plants are natives of North America. Both cause ivy poisoning, an annoying and often painful dermatitis. *Toxicodendron radicans*, the most widespread species, is extremely variable. It has a bushy or climbing habit and three-lobed leaves which are smooth and glossy or hairy and are entire, toothed, or lobed. Poison ivy bears white fruits whereas the nonpoisonous sumacs bear red fruits. See HYPERSENSITIVITY; SAPINDALES. [P.D.St.; E.L.C.]

**Poison sumac** The plant *Toxicodendron vernix* (previously in the genus *Rhus*), a member of the sumac family (Anacardiaceae). It is an inhabitant of swamps ranging from Quebec to Minnesota, and southward to Florida, Louisiana, and Texas. It is a tall bush or small tree bearing pinnately compound leaves with 7–13 entire (without marginal teeth) leaflets, and drooping, axillary clusters of persisting white fruits (see illustration). Like



Poison sumac fruits and leaf (*Toxicodendron vernix*).

poison ivy, this plant is poisonous to touch, causing in many persons a severe inflammation of the skin, or dermatitis. The presence of white fruit separates this species from the nonpoisonous sumacs with their red fruits. See HYPERSENSITIVITY; SAPINDALES. [P.D.St.; E.L.C.]

**Poisonous plants** More than 700 species of seed plants, ferns, horsetails, and fungi that cause toxic, though rarely fatal, reactions in humans and animals. Human allergic responses, including hay fever, asthma, and dermatitis, are widespread. Allergic responses are produced by many different plant species, but most common are poison ivy, poison sumac, and Pacific poison oak (all are species of *Toxicodendron*). Internal injury by toxic plants is less common but can be detrimental or lethal. See ASTHMA; POISON IVY; POISON SUMAC.

**Glycoside-containing plants.** Glycosides are common compounds in plants. They decompose to form one or more sugars, but sometimes the remaining compounds, aglycones, can be quite poisonous. Cyanogenic glycosides, which produce hydrocyanic acid, are found worldwide in many plant families; the best known are in the rose family (Rosaceae) and in the pea family (Fabaceae). Leaves, bark, and seeds of stone fruits such as cultivated and wild cherries, plums, peaches, bitter almonds, and apricots contain the glycoside amygdalin, which hydrolyzes to form hydrocyanic acid that can be fatally toxic to humans or animals. The same toxic substance is found in apple and pear seeds. Cardiac glycosides are found in many unrelated species of plants. Those of the foxglove (*Digitalis purpurea*) contain a number of these glycosides used medicinally to slow and strengthen the heartbeat. Oleander (*Nerium oleander*), which is cultivated in the warmer parts of the United States, contains a toxic glycoside that has an action similar to that of digitalis. See CYANIDE; DIGITALIS; GLYCOSIDE.

**Alkaloid-containing plants.** Alkaloids, compounds containing a nitrogen atom, have specific pharmacological effects on both humans and animals. Found in many different plant families, they have been used in drug therapy since ancient times, but misuse of these plants can produce poisonings. The potato family (Solanaceae) has many species that contain a number of alkaloids. Hyoscyamine and atropine are the alkaloids occurring in belladonna or deadly nightshade (*Atropa belladonna*), black henbane (*Hyoscyamus niger*), thornapples and jimsonweed (*Datura*), and tree daturas or angel's-trumpets (*Brugmansia*). The black nightshades (*Solanum*) contain glycoalkaloids. Plants of tobacco, *Nicotiana*, contain numerous alkaloids, principally the very toxic nicotine or its isomer anabasine. Plants of poison hemlock (*Conium maculatum*) have several alkaloids similar to nicotine, which affect the central nervous system. Plants of rattlesnake (*Crotalaria*), groundsel (*Senecio*), and fiddleneck (*Amsinckia*) have alkaloids of similar molecular structure. Anagyrine is a toxic alkaloid found in several species of lupine (*Lupinus*) in the western United States. Alkaloids present in species of monkshood (*Aconitum*) are extremely toxic. Larkspur plants (*Delphinium*) have similar toxic alkaloids affecting the central nervous system, causing excitability and muscular spasms. Plants of false hellebores (*Veratrum*) and death camas (*Zigadenus*) have complex alkaloids of similar structure and cause livestock deaths in the western United States. See ALKALOID; ATROPINE.

**Heath plants.** Toxic resins, andromedotoxins, formed by members of the heath family (Ericaceae) are derived from diterpenes. The most toxic species are mountain laurel, sheep laurel, and bog laurel, all in the genus *Kalmia*.

**Pokeweed.** Pokeweed (*Phytolacca americana*) is a garden weed throughout the United States, but it is native to the eastern and central areas. The entire plant, especially the seeds and the large root, is poisonous. Human poisonings have resulted from inadvertently including parts of the root along with the shoots.

**Waterhemlock.** The waterhemlocks (*Cicuta*) are widespread in North America. The large underground tubers, mistakenly considered edible, have caused human poisonings and death.

Livestock usually do not eat waterhemlock, but have been fatally poisoned. The highly toxic principle is an unsaturated aliphatic alcohol which acts directly on the central nervous system.

**Oxalate poisoning.** Oxalic acid, as oxalate salts, accumulates in large amounts in some species of plants such as those of the genera *Halogeton*, *Bassia*, *Rumex*, and *Oxalis*.

**Nitrate poisoning.** Nitrate poisoning is widespread and results in many cattle deaths yearly. Any disruption of the normal synthesis of nitrates into amino acids and proteins causes large accumulations of nitrates in various species of plants, particularly in the goosefoot family (*Chenopodiaceae*).

**Allelopathic toxins.** Allelopathic phytotoxins are chemical compounds produced by vascular plants that inhibit the growth of other vascular plants. Residues of grain sorghum (*Sorghum bicolor*) can markedly reduce the following year's growth of wheat and some weedy grass seedlings. Locoweeds, belonging to the genera *Oxytropis* and *Astragalus*, produce an unknown toxin that causes loss of livestock that become addicted to eating these unpalatable plants. Other species of *Astragalus* produce toxic aliphatic nitro compounds. Still other species of *Astragalus* accumulate toxic quantities of selenium which usually causes chronic poisoning of livestock. See ALLELOPATHY.

**Fungi.** Every year human fatalities occur from ingestion of wild poisonous mushrooms. Those gathered in the wild require individual identification since toxic species may grow alongside edible ones. Ergot fungus, infecting many species of grasses, causes widespread poisoning of livestock. See ERGOT AND ERGOTISM; TOXICOLOGY. [T.C.F.]

**Polar meteorology** The science of weather and climate in the high latitudes of the Earth. In the polar regions the Sun never rises far above the horizon and remains below it continuously for part of the year, so that snow and ice can persist for long periods even at low elevations. The meteorological processes that result have distinctive local and large-scale characteristics in both polar regions. [U.R.]

**Polar molecule** A molecule possessing a permanent electric dipole moment. Molecules containing atoms of more than one element are polar except where forbidden by symmetry; molecules formed from atoms of a single element are nonpolar (except ozone). The dipole moments of polar molecules result in stronger intermolecular attraction, increased viscosities, higher melting and boiling points, and greater solubility in polar solvents than in nonpolar molecules. [R.D.W.]

**Polar navigation** The complex of navigational techniques modified from those used in other areas to suit the distinctive regional character of polar areas. Although polar navigation has become routine to a rising number of navigators operating in and through such high-latitude parts of the world, their success continues to be based on a sound grasp of the regional differences and the developing adaptations of navigational principles and aids to suit these peculiar area needs. For example, in polar regions the meridians radiate outward from the poles, and parallels are concentric circles. Thus the rectangular coordinates familiar to the navigator accustomed to using the Mercator projection are replaced by polar coordinates.

**Limitations.** Piloting in polar regions is strongly affected by the absence of any great number of aids to navigation. Also, natural landmarks may not be shown on the chart, or may be difficult to identify. The appearance of some landmarks changes markedly under different ice conditions. When snow covers both the land and a wide ice foot attached to the shore and extending for miles seaward, even the shoreline is difficult to locate. See PILOTING.

Charts of polar regions are less reliable than those of other regions, because relatively little surveying has been done in the polar areas. Because relatively few soundings are shown on charts, ships entering harbors often send small boats ahead to determine

the depth of water available. However, the reliability of charts of polar regions has steadily improved as additional information has become available.

Coverage of electronic navigation systems has also improved, but is still somewhat limited. Loran C sky waves are available throughout the Arctic, and ground waves extend to some parts of this area, but neither ground waves nor sky waves are available in the Antarctic. Radar is useful, but experience in interpretation of the scope in polar regions is essential for reliable results. This is particularly true in aircraft, where the relative appearance of water and land areas often reverse in winter and summer. A radio direction finder is useful, when radio signals are available. The use of electronics in polar regions is further restricted by magnetic storms, which are particularly severe in the auroral zones. See ELECTRONIC NAVIGATION SYSTEMS; RADAR.

Reliable dead reckoning depends upon the availability of accurate measurement of direction and distance (or speed and time). There are difficulties in meeting these requirements in polar regions. Direction is measured largely by a compass. The magnetic compass becomes unreliable in the vicinity of the magnetic poles of the Earth, and the north-seeking gyrocompass becomes unreliable in the vicinity of the geographical poles of the Earth. One solution to the directional problem in high latitudes is to use a directional gyro, a gyroscopic device that maintains its axis in a set direction but must be reset at frequent intervals, as every 15 min, because of gyroscopic drift. One of the devices discussed below for celestial direction determination can provide the directional data needed for setting or resetting a directional gyro. Directional gyros are not generally used aboard ship, and in aircraft they have been largely replaced by inertial navigators, which are also used by submarines and to a limited extent by surface ships. However, because inertial systems are self-contained, without reference to external signals, the insertion of incorrect data is always a possibility. See AIRCRAFT COMPASS SYSTEM; DEAD RECKONING; GYROSCOPE; INERTIAL GUIDANCE SYSTEM.

Several types of devices have been developed to facilitate the use of celestial bodies for determination of direction. The oldest is the sun compass, which utilizes the shadow of a shadow pin, or gnomon, and a suitable dial. A sky compass indicates direction of the Sun by means of polarized light in the sky when the Sun is near the horizon, even though it may be below the horizon or otherwise obscured. This device may offer the only means of determining direction during the brighter part of the long polar twilight. An astrocompass can be set for the coordinates of any celestial body and the latitude of the observer, and then gives an indication of azimuth, true north, and heading.

Distance or speed measurement in polar regions presents no problems in aircraft. When ships operate in ice, however, the sensing element in the water may be adversely affected or damaged by the ice. At best, dead reckoning is difficult aboard a ship operating in the ice, not only because of the difficulty encountered in measuring course and speed, but also because neither of these may be constant for very long.

Celestial navigation is of great importance in polar regions, sometimes providing the only means of determining position accurately, or establishing a directional reference. When operating in lower latitudes, navigators generally avoid observation of bodies near the horizon because of the uncertainty of the refraction correction there. In polar regions, even though refraction is more uncertain, navigators often have no choice. Near the equinoxes the Sun may be the only body available for several weeks, and it remains close to the horizon. During the polar summer the Sun is often the only celestial body available. When only one body is available, it is observed at frequent intervals, perhaps hourly, and a series of running fixes is plotted. See CELESTIAL NAVIGATION.

**Modern technology.** Advances in technology have contributed significantly to the safety and reliability of navigation in polar regions. The availability of modern echo sounders has made possible a continuous plot of the bottom profile beneath a



vessel while under way. Sonar indicates the presence of an underwater obstruction. Reliable inertial navigators are available to make aircraft navigation in polar regions almost routine, providing both positional and directional data. Ship inertial navigation systems are available and have made practicable submarine operations under sea ice. See ECHO SOUNDER; SONAR.

The NAVSTAR Global Positioning System (GPS) of the U.S. Department of Defense has eliminated the limitations of the now defunct Navy Navigation Satellite System. Although all GPS satellites operate on the same frequencies (1227 and 1575 MHz), signals are modulated with two codes, one of which provides for identification of and lock-on to the desired signal. See NAVIGATION; SATELLITE NAVIGATION SYSTEMS. [A.B.M.]

**Polarimetric analysis** A method of chemical analysis based on the optical activity of the substance being determined. Optically active materials are asymmetric; that is, their molecules or crystals have no plane or center of symmetry. These asymmetric molecules can occur in either of two forms, *d*- and *l*-, called optical isomers. Asymmetric substances possess the power of rotating the plane of polarization of plane-polarized light. Measurement of the extent of this rotation, polarimetry, is performed by an instrument known as a polarimeter. Polarimetry is applied to both organic and inorganic materials. See OPTICAL ACTIVITY.

The extent of the rotation depends on the character of the substance, the length of the light path, the temperature of the solution, the wavelength of the light which is being used, the solvent (if there is one), and the concentration of the substance. In most work, the yellow light of the D line of the sodium spectrum (589.3 nanometers) is used to determine the specific rotation, according to the equation below. Here  $\alpha$  is the measured angle

$$\text{Specific rotation} = [\alpha]_D^{20} = \frac{\alpha}{l\rho}$$

of rotation,  $l$  is the length of the column of liquid in decimeters, and  $\rho$  the density of the solution. In other words, the specific rotation is the rotation in degrees which this plane-polarized light of the sodium D line undergoes in passing through a 10-cm-long (4-in.) sample tube containing a solution of 1 g/ml concentration at 20°C (68°F).

In the illustration, light from the sodium lamp is polarized by the polarizer (prism). It then passes through the cell containing the material being analyzed. After that, it passes through the analyzer (another prism) and then is detected (by eye or photocell). A comparison of the angular orientation of the analyzer as measured on the scale with the cell empty and with the cell filled with solution serves to measure the rotation of the polarized light by the sample. This rotation may be either clockwise (+) or counterclockwise (−).

Polarimetry may be used for either qualitative or quantitative analytical work. In qualitative applications, the presence of an optically active material is shown, and then a calculation of specific rotation often leads to the identification of the unknown. In quantitative work, the concentration of a given optically active material is determined.

Polarimetry is used in carbohydrate chemistry, especially in the analysis of sugar solutions. Since there is great difference between the biological activities of the different optical forms of organic compounds, polarimetry is used in biochemical research to identify the molecular configurations.

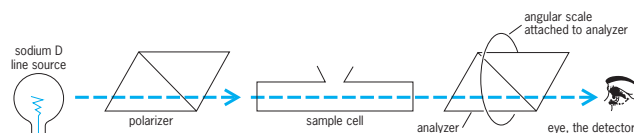

Simplified diagram of a polarimeter.

Optical rotatory dispersion is the measurement of the specific rotation as a function of wavelength. The information obtained by this method has shown that minor changes in configuration of a molecule have a marked effect on its dispersion properties. By using the properties of compounds of known configuration, it has been possible to determine the absolute configurations of many other molecules and to identify various isomers. Most of the applications have been to steroids, sugars, and other natural products, including amino acids, proteins, and polypeptides. See COTTON EFFECT; OPTICAL ROTATORY DISPERSION; POLARIZED LIGHT.

[R.F.G.; J.N.L.]

**Polarimetry** The science of determining the polarization state of electromagnetic radiation (x-rays, light or radio waves). Radiation is said to be linearly polarized when the electric vector oscillates in only one plane. It is circularly polarized when the x-plane component of the electric vector oscillates 90° out of phase with the y-plane component.

To completely specify the polarization state, it is necessary to make six intensity measurements of the light passed by a quarter-wave retarder and a rotatable linear polarizer, such as a Polaroid or a Nicol prism. The retarder converts circular light into linear light.

Most starlight is unpolarized. However, atoms in the presence of a magnetic field align themselves at fixed, quantized angles to the field direction. Then the spectral lines they emit are circularly polarized when the magnetic field is parallel to the line of sight, and linearly polarized when the field is perpendicular. The light from sunspots is polarized because the magnetic fields impose some direction in the emitting gas. Other phenomena also remove isotropy and produce polarization. See SOLAR MAGNETIC FIELD; ZEEMAN EFFECT.

Electrooptical devices are rapidly replacing rotating polarizers and fixed retarders. The magnetograph consists of a spectrograph to isolate the atomic spectral line for study; a Pockels cell, an electrooptic crystal whose retardance depends on an applied voltage; a polarizing prism to isolate the polarization state passed by the retarder; a pair of photocells to detect the transmitted light; and a scanning mechanism to sweep the solar image across the spectrograph entrance slit. Two photocells are needed to simultaneously measure left- and right-circular polarization. See SPECTROGRAPH.

A magnetograph can be made sensitive to linear polarization, but the signal levels are about 100 times weaker for the inferred transverse fields than for longitudinal fields of comparable strength. To improve signal-to-noise levels, the spectrograph can be replaced with an optical filter having a narrow passband, and the photocells can be replaced with an array of photosensitive picture elements (pixels). [D.M.R.]

**Polaris** The star  $\alpha$  Ursae Minoris, also known as the North Star or Pole Star. It is perhaps the best-known star in the northern sky. Its location only 1 degree of arc from the north celestial pole, the point where the Earth's rotation axis intersects the celestial sphere, has made it a very useful reference point for navigation. It may easily be found by following the line joining the two bright stars at the end of the bowl of the Big Dipper. See URSA MAJOR; URSA MINOR.

Polaris (apparent magnitude 1.99) is a supergiant with an intrinsic brightness about 1500 times that of the Sun. It is accompanied by a 9th-magnitude main-sequence star, and its spectrum shows evidence of another, much closer companion in an eccentric orbit with a period of 30 years. See SUPERGIANT STAR.

Polaris is a variable star, displaying slight changes in brightness with a period close to 4 days. Polaris is a member of an important group of stars known as the Cepheid variables. However, it is atypical in that the amplitude of the variations is very small compared to other Cepheids and has decreased steadily over 100 years to the point where the pulsation of the star has virtually stopped. See CEPHEIDS; STAR; VARIABLE STAR. [D.W.L.]

**Polarization of dielectrics** A vector quantity representing the electric dipole moment per unit volume of a dielectric material. See DIELECTRIC MATERIALS.

Dielectric polarization arises from the electrical response of individual molecules of a medium and may be classified as electronic, atomic, orientation, and space-charge or interfacial polarization, according to the mechanism involved.

Electronic polarization represents the distortion of the electron distribution or motion about the nuclei in an electric field.

Atomic polarization arises from the change in dipole moment accompanying the stretching of chemical bonds between unlike atoms in molecules. See MOLECULAR STRUCTURE AND SPECTRA.

Orientation polarization is caused by the partial alignment of polar molecules, that is, molecules possessing permanent dipole moments, in an electric field. This mechanism leads to a temperature-dependent component of polarization at lower frequencies.

Space-charge or interfacial polarization occurs when charge carriers are present which can migrate an appreciable distance through a dielectric but which become trapped or cannot discharge at an electrode. This process always results in a distortion of the macroscopic field and is important only at low frequencies. See ELECTRIC FIELD; ELECTRIC SUSCEPTIBILITY. [R.D.W.]

**Polarization of waves** The directional dependence of certain wave phenomena, at right angles to the propagation direction of the wave. In particular, ordinary light may be regarded as composed of two such asymmetrical components, referred to as its two states of linear polarization.

These two components are refracted differently by doubly refracting crystals, such as calcite, or Iceland spar. Each state of linear polarization is refracted according to its own separate refractive index. On a subsequent refraction by the same crystal, but now rotated through an angle  $\theta$  about the direction of the beam, each component appears as a mixture of the original two polarization components, according to the proportions  $\cos^2 \theta : \sin^2 \theta$ . See BIREFRINGENCE; CRYSTAL OPTICS; REFRACTION OF WAVES.

In the early nineteenth century, T. Young suggested that light polarization arises from transverse oscillations. In J. C. Maxwell's theory of light as electromagnetic waves, visible light—and also other types of electromagnetic radiation such as radio waves, microwaves, and x-rays (distinguished from visible light only by wavelength)—consists of electric and magnetic fields, each oscillating in directions perpendicular to the propagation direction, the electric and magnetic field vectors being perpendicular to each other. The plane of polarization of the wave contains the electric vector (or magnetic vector; there is no general agreement which) and the propagation direction. See ELECTROMAGNETIC RADIATION; LIGHT; MAXWELL'S EQUATIONS.

If the plane of polarization remains constant along the wave (as in the case of each light component in a doubly refracting medium), the wave has linear (or plane) polarization. However, the plane of polarization can also rotate. If the rotation rate is constant, the intensity of the wave being also constant, a circularly polarized wave results. These are of two types: right-handed and left-handed.

Any electromagnetic wave can be considered to be composed of monochromatic components, and each monochromatic component can be decomposed into a left-handed and a right-handed circularly polarized part. The states of linear polarization are each made up of equal magnitudes of the two circularly polarized parts, with differing phase relations to provide the different possible directions of plane polarization. Monochromatic waves composed of unequal magnitudes of the two circularly polarized parts are called elliptically polarized. This refers to the fact that the electric and magnetic vectors trace out ellipses in the plane perpendicular to the direction of motion.

Photons have quantum-mechanical spin, which refers to the angular momentum of the photon, necessarily about its direction of motion. A photon's spin has magnitude 1, in fundamental

units. This spin can point along the direction of motion (positive helicity, right-handed spin) or opposite to it (negative helicity, left-handed spin), and this corresponds (depending on conventions used) to a classical electromagnetic wave of right- or left-handed circular polarization. See HELICITY (QUANTUM MECHANICS); PHOTON.

Electromagnetic and gravitational waves both have the specific property that they are entirely transverse in character, which is a consequence of their speed of propagation being the absolute speed of relativity theory (the speed of light). This corresponds to the fact that their respective quanta, namely photons and gravitons, are massless particles. In the case of waves that travel at a smaller speed, as with fields whose quanta are massive rather than massless, there can be (unpolarized) longitudinal as well as transverse effects. Seismic waves traveling through the Earth's material, for example, can be transverse (polarized sideways oscillations) or longitudinal (unpolarized pressure waves). See SEISMOLOGY; SOUND; WAVE MOTION IN FLUIDS.

In most situations encountered in practice, light (or gravitational waves) consists of an incoherent mixture of different polarization states, and is referred to as unpolarized. However, light reflected off a refracting surface (for example, glass or water) is polarized to some extent; that is, there is a certain preponderance of one state of linear polarization over the orthogonal possibility. Complete polarization occurs for a particular angle of incidence, known as the Brewster angle. See POLARIZED LIGHT; REFLECTION OF ELECTROMAGNETIC RADIATION; WAVE MOTION. [R.Pe.]

**Polarized light** Light which has its electric vector oriented in a predictable fashion with respect to the propagation direction. In unpolarized light, the vector is oriented in a random, unpredictable fashion. Even in short time intervals, it appears to be oriented in all directions with equal probability. Most light sources seem to be partially polarized so that some fraction of the light is polarized and the remainder unpolarized.

According to all available theoretical and experimental evidence, it is the electric vector rather than the magnetic vector of a light wave that is responsible for all the effects of polarization and other observed phenomena associated with light. Therefore, the electric vector of a light wave, for all practical purposes, can be identified as the light vector. See CRYSTAL OPTICS; ELECTROMAGNETIC RADIATION; LIGHT; POLARIZATION OF WAVES.

One of the simplest ways of producing linearly polarized light is by reflection from a dielectric surface. At a particular angle of incidence, known as Brewster's angle, the reflectivity for light whose electric vector is in the plane of incidence becomes zero. The reflected light is thus linearly polarized at right angles to the plane of incidence.

**Linear polarizing devices.** The first polarizers were glass plates inclined so that the incident light was at Brewster's angle. Such polarizers are quite inefficient since only a small percentage of the incident light is reflected as polarized light.

Certain natural materials absorb linearly polarized light of one vibration direction much more strongly than light vibrating at right angles. Such materials are termed dichroic. Tourmaline is one of the best-known dichroic crystals, and tourmaline plates were used as polarizers for many years. See DICHOISM.

Other natural materials exist in which the velocity of light depends on the vibration direction. These materials are called birefringent. One of the best-known of these birefringent crystals is transparent calcite (Iceland spar). The Nicol prism is made of two pieces of calcite cemented together (Fig. 1). The cement is Canada balsam, in which the wave velocity is intermediate between the velocity in calcite for the fast and the slow ray. The angle at which the light strikes the boundary is such that for one ray the angle of incidence is greater than the critical angle for total reflection. Thus the rhomb is transparent for only one polarization direction. See BIREFRINGENCE; CRYSTAL; OPTICS.

A different type of polarizer, made of quartz, is shown in Fig. 2. Here the vibration directions are different in the two pieces so

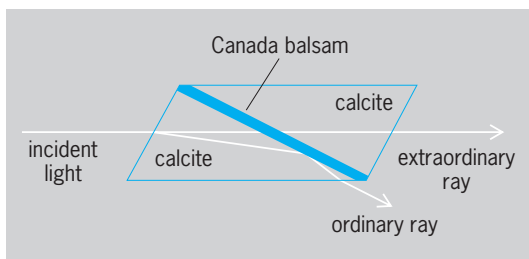

Fig. 1. Nicol prism. The ray for which Snell's law holds is called the ordinary ray.

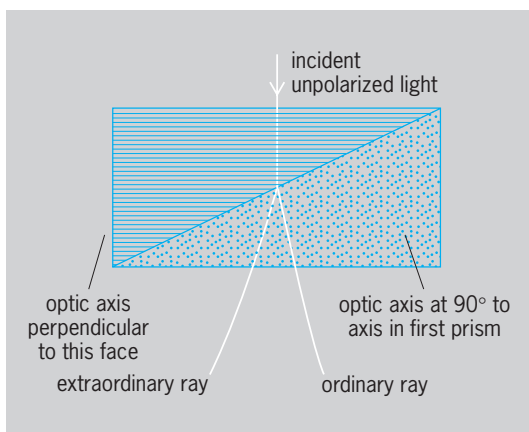

Fig. 2. Wollaston prism.

that the two rays are deviated as they pass through the material. The incoming light beam is thus separated into two oppositely linearly polarized beams which have an angular separation between them, and it is possible to select either beam.

A third mechanism for obtaining polarized light is the Polaroid sheet polarizer, of which there are three types. The first is a microcrystalline polarizer in which small crystals of a dichroic material are oriented parallel to each other in a plastic medium. The second type depends for its dichroism on a property of an iodine-in-water solution. The iodine appears to form a linear high polymer. If the iodine is put on a transparent oriented sheet of material such as polyvinyl alcohol (PVA), the iodine chains apparently line themselves parallel to the PVA molecules and the resulting dyed sheet is strongly dichroic. A third type of sheet polarizer depends for its dichroism directly on the molecules of the plastic itself. This plastic consists of oriented polyvinylene.

**Polarization by scattering.** When an unpolarized light beam is scattered by molecules or small particles, the light observed at right angles to the original beam is polarized. The best-known example of polarization by scattering is the light of the north sky. See SCATTERING OF ELECTROMAGNETIC RADIATION.

**Types.** Polarized light is classified according to the orientation of the electric vector. In linearly polarized light, the electric vector remains in a plane containing the propagation direction. For monochromatic light, the amplitude of the vector changes sinusoidally with time. In circularly polarized light, the tip of the electric vector describes a circular helix about the propagation direction. The amplitude of the vector is constant. The frequency of rotation is equal to the frequency of the light. In elliptically polarized light, the vector also rotates about the propagation direction, but the amplitude of the vector changes so that the projection of the vector on a plane at right angles to the propagation direction describes an ellipse.

**Circular and elliptical polarizing devices.** Circularly and elliptically polarized light are normally produced by combining a linear polarizer with a wave plate. A Fresnel rhomb can be used to produce circularly polarized light.

A plate of material (quartz, calcite, or other birefringent crystals) which is linearly birefringent is called a wave plate or retardation sheet. Wave plates have a pair of orthogonal axes which are designated fast and slow. Polarized light with its electric vector parallel to the fast axis travels faster than light polarized parallel to the slow axis. The thickness of the material can be chosen so that for light traversing the plate, there is a definite phase shift between the fast component and the slow component. A plate with a  $90^\circ$  phase shift is termed a quarter-wave plate.

If linearly polarized light is incident normally on a quarter-wave plate and oriented at  $45^\circ$  to the fast axis, the transmitted light will be circularly polarized. If the linearly polarized light is at an angle other than  $45^\circ$  to the fast axis, the transmitted radiation will be elliptically polarized.

**Analyzing devices.** Polarized light is one of the most useful tools for studying the characteristics of materials. The absorption constant and refractive index of a metal can be calculated by measuring the effect of the metal on polarized light reflected from its surface. See REFLECTION OF ELECTROMAGNETIC RADIATION.

The analysis of polarized light can be performed with a variety of different devices. If the light is linearly polarized, it can be extinguished by a linear polarizer and the direction of polarization of the light determined directly from the orientation of the polarizer. If the light is elliptically polarized, it can be analyzed with the combination of a quarter-wave plate and a linear polarizer. Any such combination of polarizer and analyzer is called a polariscope. [B.H.Bi.]

**Polarized light microscope** A microscope that utilizes polarized light to form a highly magnified image of an object. Polarizing microscopes play an important role in crystallography, petrography, microchemistry, and biology. Although all light microscopes compare poorly with electron microscopes with respect to image resolution, polarized light microscopes have the unique ability to deliver information about the submicroscopic structure of the objects being examined. They also have the advantage of being relatively nondestructive, and may be used safely with living cells. Polarized light interactions with electromagnetically anisotropic structures, down to atomic dimensions, can be measured by polarized light microscopy. The sensitivity of polarized light microscopy as well as its importance to biology have been enhanced by the use of video technology. See POLARIZED LIGHT.

A polarizing microscope differs from a conventional light microscope in a number of ways. A polarizing microscope has a pair of polars (polarizing devices) in the optical train. The first polar (polarizer) defines the initial plane of polarization for light entering the microscope and is located between the illuminator and the condenser. The other polar (analyzer) is usually placed between the objective and the ocular tube and defines the plane of polarization of the light reaching the ocular. One or both must be accurately rotatable about the optical axis of the instrument. Usually the analyzer is also removable from the optical path.

The most frequently used type of polar is a dichroic sheet polarizing filter. For petrographic, crystallographic, and most microchemical applications, dichroic filter polars are the better choice. For critical biological applications, such as investigating the weak birefringence of cytoskeletal structures in living cells, the expense and complication attendant to the use of prism polars can be justified by the attainment of sensitivity unobtainable by other means.

In addition to the polars, all polarizing microscopes need rotatable specimen stages and one or more removable birefringence compensators. The compensators are birefringent devices used to measure magnitude and sign of retardation due to specimen birefringence, to enhance specimen image contrast, and to manipulate the state of polarization of light passing through any point in the specimen. See BIREFRINGENCE.

Polarizing microscopes for different applications have some differences in construction. For petrography and crystallography,

the microscope should be able to accept a universal specimen stage capable of rotating the specimen about three axes. A polarizing microscope for biological use has less rigid requirements for angular orientation but needs rectified optics (to eliminate or greatly reduce depolarization at high numerical apertures), prism polars, and a sensitive elliptic compensator because the birefringence of the typical biological specimen is much smaller. An ocular telescope or a Bertrand lens (a built-in lens that optionally converts the ocular into a telescope) is essential for some applications and useful for all.

There are two traditional modes of use for the polarizing microscope, the orthoscopic mode and the conoscopic mode. In the orthoscopic mode, the ocular projects an image of the specimen, as in conventional microscopy. Rotation of the specimen stage reveals the location and orientation of any anisotropic features in the specimen. The conoscopic mode is used to characterize crystalline specimens. Here the ocular is not used to project an image of the specimen, but rather—with the aid of a special lens—the image of the objective exit pupil is examined to reveal the relative retardation experienced by polarized light as a function of its angle of incidence on the specimen. See CRYSTAL OPTICS; MICROSCOPE. [G.W.E.]

**Polarographic analysis** An electrochemical technique used in analytical chemistry. Polarography involves measurements of current-voltage curves obtained when voltage is applied to electrodes (usually two) immersed in the solution being investigated. One of these electrodes is a reference electrode: its potential remains constant during the measurement. The second electrode is an indicator electrode. Its potential varies in the course of measurement of the current-voltage curve, because of the change of the applied voltage. In the simplest version, so-called dc polarography, the indicator electrode is a dropping-mercury electrode, consisting of a mercury drop hanging at the orifice of a fine-bore glass capillary. The capillary is connected to a mercury reservoir so that mercury flows through it at the rate of a few milligrams per second. The outflowing mercury forms a drop at the orifice, which grows until it falls off. The lifetime of each drop is several seconds (usually 2 to 5). Each drop forms a new electrode; its surface is practically unaffected by processes taking place on the previous drop. Hence each drop represents a well-reproducible electrode with a fresh, clean surface. See ELECTRODE; ELECTROCHEMICAL TECHNIQUES.

The dropping-mercury electrode is immersed in the solution to be investigated and placed in a cell containing the reference electrode. Polarographic current-voltage curves can be recorded with a simple instrument consisting of a potentiometer or another source of voltage and a current-measuring device. The voltage can be varied by manually changing the applied voltage in finite increments, measuring current at each, and plotting current as a function of the voltage. Alternatively, commercial instruments are available in which voltage is increased linearly with time (a voltage ramp), and current variations are recorded automatically.

Another polarographic technique is called pulse or differential pulse polarography. This technique is more sensitive by two orders of magnitude than dc polarography, and in inorganic trace analysis competes with atomic absorption and neutron activation analysis. The sensitivity of differential pulse polarography has found application in drug analysis. There is also a polarographic technique called ac polarography that is particularly useful for obtaining information on adsorption-desorption processes at the surface of the dropping-mercury electrode.

Polarographic studies can be applied to investigation of electrochemical problems, to elucidation of some fundamental problems of inorganic and organic chemistry, and to solution of practical problems. In electrochemistry, polarography allows measurement of potentials, and yields information about the rate of the electrode process, adsorption-desorption phenomena, and fast chemical reactions accompanying the electron transfer. In fundamental applications, polarography makes

it possible to distinguish the form and charge of the species (for example, inorganic complex or organic ion) in the solution. Polarography also permits the study of equilibria (complex formation, acid-base, tautomeric), rates, and mechanisms.

Polarography can be used for investigation of the relationship between electrochemical data and structure. In inorganic analysis, polarography is used predominantly for trace-metal analysis (with increased sensitivity of differential pulse polarography and stripping analysis). In organic analysis, it is possible in principle to use polarography in elemental analysis and functional group analysis. The most important fields of application of inorganic determinations are in metallurgy, environmental analysis (air, water, and seawater contaminants), food analysis, toxicology, and clinical analysis. The possibility of being able to determine vitamins, alkaloids, hormones, terpenoid substances, and natural coloring substances has made polarography useful in analysis of biological systems, analysis of drugs and pharmaceutical preparations, and determination of pesticide or herbicide residues in foods. [P.Z.]

**Polaron** The object that results when an electron in the conduction band of a crystalline insulator or semiconductor polarizes or otherwise deforms the lattice in its vicinity. The polaron comprises the electron plus its surrounding lattice deformation. (Polarons can also be formed from holes in the valence band.) If the deformation extends over many lattice sites, the polaron is "large," and the lattice can be treated as a continuum. Charge carriers inducing strongly localized lattice distortions form "small" polarons. See BAND THEORY OF SOLIDS; HOLE STATES IN SOLIDS; SEMICONDUCTOR. [D.M.L.]

**Poliomyelitis** An acute infectious viral disease which in its serious form affects the central nervous system and, by destruction of motor neurons in the spinal cord, produces flaccid paralysis. However, about 99% of infections are either inapparent or very mild. See ANIMAL VIRUS; CENTRAL NERVOUS SYSTEM.

The virus probably enters the body through the mouth; primary multiplication occurs in the throat and intestine. Transitory viremia occurs; the blood seems to be the most likely route to the central nervous system. The severity of the infection may range from a completely inapparent through minor influenzalike illness, or an aseptic meningitis syndrome (nonparalytic poliomyelitis) with stiff and painful back and neck, to the severe forms of paralytic and bulbar poliomyelitis. In all clinical types, virus is regularly present in the enteric tract. In paralytic poliomyelitis the usual course begins as a minor illness but progresses, sometimes with an intervening recession of symptoms (hence biphasic), to flaccid paralysis of varying degree and persistence. When the motor neurons affected are those of the diaphragm or of the intercostal muscles, respiratory paralysis occurs. Bulbar poliomyelitis results from viral attack on the medulla (bulb of the brain) or higher brain centers, with respiratory, vasomotor, facial, palatal, or pharyngeal disturbances.

Poliomyelitis occurs throughout the world. In temperate zones it appears chiefly in summer and fall, although winter outbreaks have been known. It occurs in all age groups, but less frequently in adults because of their acquired immunity. The virus is spread by human contact; the nature of the contact is not clear, but it appears to be associated with familial contact and with interfamily contact among young children. The virus may be present in flies.

Inactivated poliovirus vaccine (Salk; IPV), prepared from virus grown in monkey kidney cultures, was developed and first used in the United States, but oral poliovirus vaccine (Sabin; OPV) is now generally used throughout the world. The oral vaccine is a living, attenuated virus. [J.L.Me.]

**Pollen** The small male reproductive bodies produced in the pollen sacs of seed plants (gymnosperms and angiosperms).

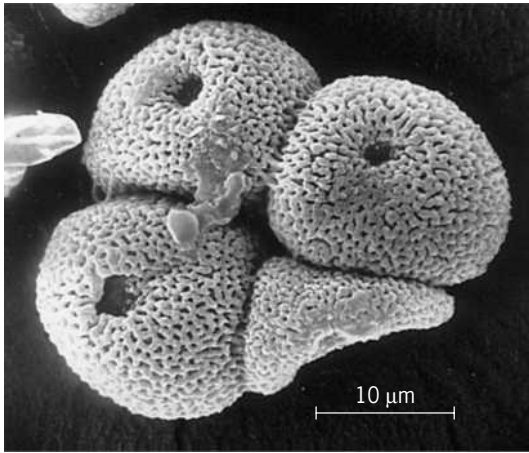

Fig. 1. Tetrad of cattail (*Typha latifolia*), with grains cohering, one-pored, exine reticulate. (Scanning electron micrograph by C. M. Drew, U.S. Naval Weapons Center, Cina Lake, California).

On maturation in the pollen sac, a pollen grain may reach 0.00007 mg as in spruce, or less than 1/20 of this weight. A grain usually has two waxy, durable outer walls, the exine, and an inner fragile wall, the intine. These walls surround the contents with their nuclei and reserves of starch and oil.

Pollen identification depends on interpretation of morphological features. Exine and aperture patterns are especially varied in the more highly evolved dicots, so that recognition at family, genus, or even species level may be possible despite the small surface area available on a grain (Figs. 1 and 2). Since the morphological characters are conservative in the extreme, usually changing very slowly through geologic time, studies of fine detail serve to establish the lineal descent of many plants living today. See PALYNOLOGY.

Extreme variations in size may occur within a family, but pollen grains range mainly from 24 to 50 micrometers, with the dicot range being from 2  $\mu\text{m}$  in *Myosotis* to 250  $\mu\text{m}$  in *Mirabilis*; the monocots range from about 15 to 150  $\mu\text{m}$  or more in the ginger family, with eelgrass (*Zostera*) having pollen measuring 2550  $\times$  3.7  $\mu\text{m}$  in a class of its own; living gymnosperms range from 15  $\mu\text{m}$  in *Gnetum* to about 180  $\mu\text{m}$  in *Abies* (including sacs), while fossil types range from about 11  $\mu\text{m}$  (one-furrowed) to 300  $\mu\text{m}$ .

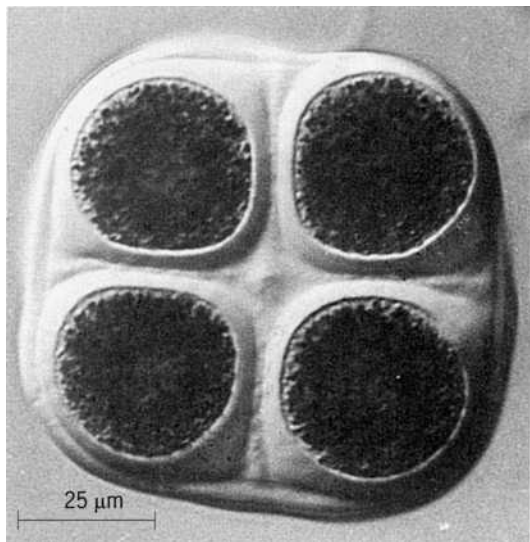

Fig. 2. Young tetrad of *Lavatera* (mallow family), with grains free in callose of pollen mother cell. (Photomicrograph by Luc Waterkeyn)

Most grains are free (monads) though often loosely grouped because of the spines or sticky oils and viscin threads. Compound grains (polyads) are richly developed in some angiosperm families, commonly occurring in four (tetrads), or in multiples of four up to 64 or more.

In most microspores (pollen and spore) the polar axis runs from the inner (proximal) face to the outer (distal) face, as oriented during tetrad formation. The equator crosses it at right angles. Bilateral grains dominate in the gymnosperms and monocots, the polar axis usually being the shorter one, with the single aperture on the distal side. On the other hand, almost all dicot pollen is symmetrical around the polar axis (usually the long axis), with shapes ranging mainly from spheroidal to ellipsoidal, with rounded equatorial outlines, and sometimes "waisted" as in the Umbelliferae. Three-pored grains often have strikingly triangular outlines in polar view.

Rarely lacking, the flexible membranes of apertures are sometimes covered only by endexine. They allow for sudden volume changes, as for the emergence of the germ tube. They are classified as furrows, with elongate outlines, and pores usually more or less circular in shape. Short slitlike intermediate forms occur. A few families have no apertures, some as a result of reduction of exine as an adaptation to wind- or water-pollination. Gymnosperms may also lack openings, or have one small papilla; most have one furrow, or a long weak area.

Few pollen grains are completely smooth (psilate) at ordinary magnifications; most have sculpture both on the surface and the structure below it. See FLOWER; POLLINATION; REPRODUCTION (PLANT). [L.M.C.]

**Pollination** The transport of pollen grains from the plant parts that produce them to the ovule-bearing organs, or to the ovules (seed precursors) themselves. In gymnosperms, the pollen, usually dispersed by the wind, is simply caught by a drop of fluid excreted by each freely exposed ovule. In angiosperms, where the ovules are contained in the pistil, the pollen is deposited on the pistil's receptive end (the stigma), where it germinates. See FLOWER.

Without pollination, there would be no fertilization; it is thus of crucial importance for the production of fruit crops and seed crops. Pollination also plays an important part in plant breeding experiments aimed at increasing crop production through the creation of genetically superior types. See BREEDING (PLANT); REPRODUCTION (PLANT).

**Self- and cross-pollination.** In most plants, self-pollination is difficult or impossible, and there are various mechanisms which are responsible. For example, in dichogamous flowers, the pistils and stamens reach maturity at different times; in protogyny, the pistils mature first, and in protandry, the stamens mature before the pistils. Selfing is also impossible in dioecious species, where some plants bear flowers that have only pistils (pistillate or female flowers), while other individuals have flowers that produce only pollen (staminate or male flowers). In monoecious species, where pistillate and staminate flowers are found in the same plant, self-breeding is at least reduced. Heterostyly is another device that promotes outbreeding. Here some flowers (pins) possess a long pistil and short stamens, while others (thrums) exhibit the reverse condition; each plant individual bears only pins or only thrums.

**Flower attractants.** As immobile organisms, plants normally need external agents for pollen transport. These can be insects, wind, birds, mammals, or water, roughly in that order of importance. In some plants the pollinators are simply trapped; in the large majority of cases, however, the flowers offer one or more rewards, such as sugary nectar, oil, solid food bodies, perfume, sex, an opportunity to breed, a place to sleep, or some of the pollen itself. For the attraction of pollinators, flowers provide either visual or olfactory signals. Color includes ultraviolet, which is perceived as a color by most insects and at least some hummingbird species. Fragrance is characteristic of flowers pollinated

by bees, butterflies, or hawkmoths, while carrion or dung odors are produced by flowers catering to certain beetles and flies. A few orchids, using a combination of olfactory and visual signals, mimic the females of certain bees or wasps so successfully that the corresponding male insects will try to mate with them, thus achieving pollination (pseudocopulation).

While some flowers are "generalists," catering to a whole array of different animals, others are highly specialized, being pollinated by a single species of insect only. Extreme pollinator specificity is an important factor in maintaining the purity of plant species in the field, even in those cases where hybridization can easily be achieved artificially in a greenhouse or laboratory, as in most orchids. The almost incredible mutual adaptation between pollinating animal and flower which can frequently be observed exemplifies the idea of coevolution. See POLLEN. [B.J.D.M.]

**Polonium** A chemical element, Po, atomic number 84. Marie Curie discovered the radioisotope  $^{210}\text{Po}$  in pitchblende. This isotope is the penultimate member of the radium decay series. All polonium isotopes are radioactive, and all are short-lived except the three  $\alpha$ -emitters, artificially produced  $^{208}\text{Po}$  (2.9 years) and  $^{209}\text{Po}$  (100 years), and natural  $^{210}\text{Po}$  (138.4 days). See PERIODIC TABLE.

Polonium ( $^{210}\text{Po}$ ) is used mainly for the production of neutron sources. It can also be used in static eliminators and, when incorporated in the electrode alloy of spark plugs, is said to improve the cold-starting properties of internal combustion engines.

Most of the chemistry of polonium has been determined using  $^{210}\text{Po}$ , 1 curie of which weighs 222.2 micrograms; work with weighable amounts is hazardous, requiring special techniques. Polonium is more metallic than its lower homolog, tellurium. The metal is chemically similar to tellurium, forming the bright red compounds  $\text{SPoO}_3$  and  $\text{SePoO}_3$ . The metal is soft, and its physical properties resemble those of thallium, lead, and bismuth. Valences of 2 and 4 are well established; there is some evidence of hexavalency. Polonium is positioned between silver and tellurium in the electrochemical series.

Two forms of the dioxide are known: low-temperature, yellow, face-centered cubic ( $\text{UO}_2$  type), and high-temperature, red, tetragonal. The halides are covalent, volatile compounds, resembling their tellurium analogs. See RADIOACTIVITY; TELLURIUM. [K.W.B.]

**Poly(ethylene glycol)** Any of a series of water-soluble polymers with the general formula  $\text{HO}-(\text{CH}_2-\text{CH}_2-\text{O})_n-\text{H}$ . These colorless, odorless compounds range in appearance from viscous liquids to waxy solids. The low-molecular-weight members, diethylene glycol ( $n = 2$ ) through tetraethylene glycol ( $n = 4$ ), are produced as pure compounds and find use as humectants, dehydrating solvents for natural gas, textile lubricants, heat-transfer fluids, solvents for aromatic hydrocarbon extractions, and intermediates for polyester resins and plasticizers.

The intermediate members of the series with average molecular weights of 200 to 20,000 are used commercially in ceramic, metal-forming, and rubber-processing operations; as drug suppository bases and in cosmetic creams, lotions, and deodorants; as lubricants; as dispersants for casein, gelatins, and inks; and as antistatic agents. The highest members of the series have molecular weights from 100,000 to 10,000,000. They are of interest because of their ability at very low concentrations to reduce friction of flowing water. See ETHYLENE OXIDE; GLYCOLIPID; POLYMERIZATION. [R.K.B.]

Poly(ethylene glycol) has a range of properties making it suitable for medical and biotechnical applications. Since poly(ethylene glycol) is soluble both in water and in most organic solvents, many applications are derived from this amphiphilicity. Other properties include lack of toxicity and immunogenicity, and a tendency to avoid other polymers and particles also present in aqueous solution.

Poly(ethylene glycol) is attached to drugs to enhance water

and blood solubility. Similarly, poly(ethylene glycol) is attached to enzymes to impart solubility in organic solvents. These poly(ethylene glycol) enzymes are used as catalysts for industrial reactions in organic solvents. See CATALYSIS.

The tendency of poly(ethylene glycol) to avoid interaction with cellular and molecular components of the immune system results in the material being nonimmunogenic. This property leads to a greatly enhanced blood circulation lifetime of poly(ethylene glycol) proteins and to application as pharmaceuticals. Similarly, adsorption of proteins and cells to surfaces is greatly reduced by attaching poly(ethylene glycol) to the surface, and such coated materials find wide application as biomaterials. See BIOMEDICAL CHEMICAL ENGINEERING. [J.M.Ha.]

**Polyacetal** A polyether derived from aldehydes ( $\text{RCHO}$ ) or ketones ( $\text{RR}'\text{CO}$ ) and containing  $-\text{O}-\text{R}-\text{O}-$  groups in the main chain. Of the many possible polyacetals, the most common is a polymer or copolymer of formaldehyde, polyoxymethylene ( $-\text{O}-\text{CH}_2-$ ) $_n$ . While the substance paraformaldehyde contains oligomers or low-molecular-weight polyoxymethylenes ( $n$  very small), high-molecular-weight, crystalline polyoxymethylenes constitute an important class of engineering plastics that, in commerce, is often simply referred to as polyacetal. Cellulose and its derivatives also have a polyacetal structure. See ACETAL; CELLULOSE; FORMALDEHYDE; POLYETHER RESINS; POLYMER.

As shown below, formaldehyde can be readily polymerized

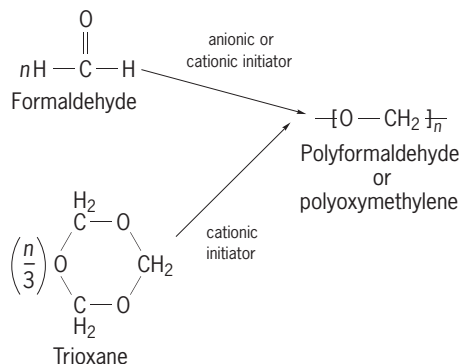

by using anionic initiators such as triphenylphosphine and, somewhat less readily, by using cationic initiators such as protonic acids. Alternatively, a similar polymer can be obtained by the ring-opening polymerization of trioxane using, for example, a boron trifluoride complex as initiator. See POLYMERIZATION.

At temperatures above  $\sim 110^\circ\text{C}$  ( $230^\circ\text{F}$ ; the ceiling temperature, above which depolymerization becomes favored over polymerization), the polymers degrade by an unzipping reaction to monomer. To prevent this, one of two approaches is commonly used: esterification of the hydroxyl end groups, or copolymerization with a small amount of a monomer such as ethylene oxide or 1,3-dioxolane.

Polyacetals are typically strong and tough, resistant to fatigue, creep, organic chemicals (but not strong acids or bases), and have low coefficients of friction. Electrical properties are also good. Improved properties for particular applications may be attained by reinforcement with fibers of glass or polytetrafluoroethylene, and by incorporation of an elastomeric toughening phase. The combination of properties has led to many uses such as plumbing fittings, pump and valve components, bearings and gears, computer hardware, automobile body parts, and appliance housings. [J.A.M.]

**Polyacrylate resins** Polymers obtained from a variety of acrylic monomers, such as acrylic and methacrylic acids, their salts, esters, and amides, and the corresponding nitriles. The most important monomers with corresponding repeat units are shown here.

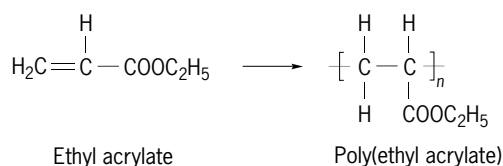
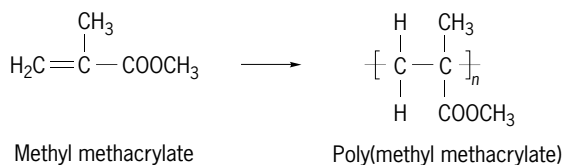

Poly(methyl methacrylate) is a hard, transparent polymer with high optical clarity, high refractive index, and good resistance to the effects of light and aging. It and its copolymers are useful for lenses, signs, indirect lighting fixtures, transparent domes and skylights, dentures, and protective coatings.

Solutions of poly(methyl methacrylate) and its copolymers are useful as lacquers. Aqueous latexes formed by the emulsion polymerization of methyl methacrylate with other monomers are useful as water-based paints and in the treating of textiles and leather.

Poly(ethyl acrylate) is a tough, somewhat rubbery product. The monomer is used mainly as a plasticizing or softening component of copolymers.

Methyl methacrylate is of interest as a polymerizable binder for sand or other aggregates, and as a polymerizable impregnant for concrete; usually a cross-linking acrylic monomer is also incorporated. The binder systems (polymer concrete) are used as overlays for bridge decks as well as for castings, while impregnation is used to restore concrete structures and protect bridge decks against corrosion by deicing salts. See PLASTICS PROCESSING; POLYMERIZATION. [J.A.M.]

**Polyacrylonitrile resins** Hard, relatively insoluble, and high-melting materials produced by the polymerization of acrylonitrile, as shown in the reaction below. Polyacrylonitrile

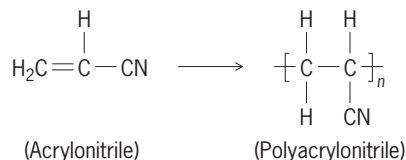

is used almost entirely in copolymers. The copolymers fall into three groups: fibers, plastics, and rubbers. The presence of acrylonitrile in a polymeric composition tends to increase its resistance to temperature, chemicals, impact, and flexing. The polymerization of acrylonitrile can be readily initiated by means of the conventional free-radical catalysts such as peroxides, by irradiation, or by the use of alkali metal catalysts. Although polymerization in bulk proceeds too rapidly to be commercially feasible, satisfactory control of a polymerization or copolymerization may be achieved in suspension and in emulsion, and in aqueous solutions from which the polymer precipitates. Copolymers containing acrylonitrile may be fabricated in the manner of thermoplastic resins.

The major use of acrylonitrile is in the form of fibers. By definition, an acrylic fiber must contain at least 85% acrylonitrile. The high strength; high softening temperature; resistance to aging, chemicals, water, and cleaning solvents; and the soft woollike feel or fabrics have made the product popular for many uses such as sails, cordage, blankets, and various types of clothing. See MANUFACTURED FIBER.

Copolymers of vinylidene chloride with small proportions of acrylonitrile are useful as tough, impermeable, and heat-sealable packaging films. Extensive use is made of copolymers of acry-

lonitrile with butadiene, often called NBR (formerly Buna N) rubbers, which contain 15–40% acrylonitrile. The NBR rubbers resist hydrocarbon solvents such as gasoline, abrasion, and in some cases show high flexibility at low temperatures. See RUBBER.

The development of blends and interpolymers of acrylonitrile-containing resins and rubbers represented a significant advance in polymer technology. The products, usually called ABS resins, typically are made by blending acrylonitrile-styrene copolymers with a butadiene-acrylonitrile rubber, or by interpolymerizing polybutadiene with styrene and acrylonitrile. The combination of low cost, good mechanical properties, and ease of fabrication by a variety of methods led to the rapid development of new uses for ABS resins. Applications include products requiring high impact strength, such as pipe, and sheets for structural uses, such as industrial duct work and components of automobile bodies. See ACRYLONITRILE; PLASTICS PROCESSING; STYRENE. [J.A.M.]

**Polyamide resins** Products of polymerization of an amino acid or the condensation of a diamine with a dicarboxylic acid. They are used for fibers, bristles, bearings, gears, molded objects, coatings, and adhesives. The term nylon formerly referred specifically to synthetic polyamides as a class. Because of many applications in mechanical engineering, nylons are considered engineering plastics.

The most common commercial aliphatic polyamides are nylons-6,6; -6; -6,10; -11; and -12. Nylon-6,6, nylon-6,10, nylon-6,12, and nylon-6 are the most commonly used polyamides for general applications as molded or extruded parts; nylon-6,6 and nylon-6 find general application as fibers.

As a group, nylons are strong and tough. Mechanical properties depend in detail on the degree and distribution of crystallinity, and may be varied by appropriate thermal treatment or by nucleation techniques. Because of their generally good mechanical properties and adaptability to both molding and extrusion, certain nylons are often used for gears, bearings, and electrical mountings. Nylon bearings and gears perform quietly and need little or no lubrication. Nylon resins are also used extensively as filaments, bristles, wire insulation, appliance parts, and film. Properties can also be modified by copolymerization. Reinforcement of nylons with glass fibers results in increased stiffness, lower creep and improved resistance to elevated temperatures. See HETEROCYCLIC POLYMER; PLASTICS PROCESSING; POLYETHER RESINS; POLYMERIZATION. [J.A.M.]

**Polychaeta** The largest class of the phylum Annelida, containing 68–70 families. About 1600 genera and 10,000 species have been named from worldwide areas; about one-fourth of this number may be synonymous. Polychaeta (meaning “many setae”) is conveniently though not clearly divisible into the Errantia, or free-moving annelids, and Sedentaria, or tubicolous families. See ERRANTIA; SEDENTARIA.

The body may be long, cylindrical, and multisegmented, or short and compact, with a limited number of segments. It consists of prostomium (Fig. 1), or head; peristomium, or first segment around the mouth; trunk, or body proper; and tail region, or pygidium. Most segments have highly diagnostic paired, lateral fleshy appendages called parapodia. These are provided with secreted supporting rods and spreading fascicles of setae, or hooks, which display remarkable specificity.

The anterior end, or prostomium, may be a simple lobe derived from the larval trochophore, modified as a pseudoannulated cone, or covered by peristomial structures so as to be invisible. Oral tentacles for food gathering may be eversible from the buccal cavity; they may be long, slender, or thick and their surface smooth or papillated.

The anterior, preoral end may be developed as a thick, fleshy papillated, nonretractile proboscis (Fig. 2), or the prostomium may be completely retractile into the first several segments and protected by a cage formed of setae directed forward, or

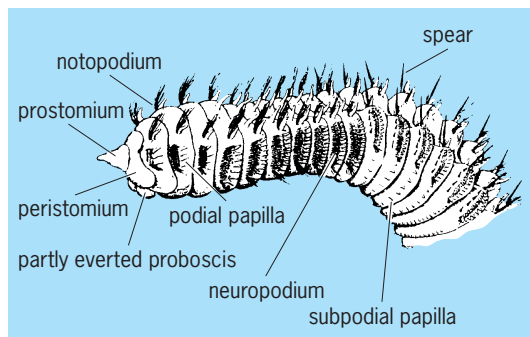

Fig. 1. Terminology of the anterior parts of the body, based on *Phylo* (Orbiniidae).

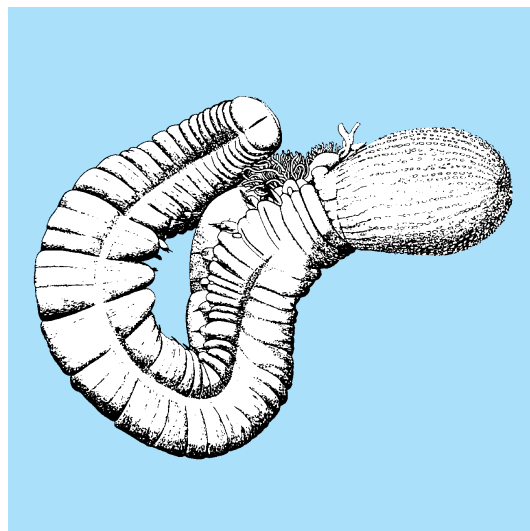

Fig. 2. Nonretractile proboscis organ preceding prostomium in *Artacama* (Terebellidae).

concealed by a compact operculum formed of setae of the first several segments. The anterior end of the alimentary tract is muscular or epithelial; it may be covered with soft papillae or hard structures. These structures function for secretion, food gathering, and maintaining traction; they are named for their form or function.

The trunk is the main body region and is composed of metameres numbering few to many. They may be similar to one another (homonomous) as in Errantia, or different (heteronomous) resulting in anterior thoracic and posterior abdominal regions.

Reproduction is highly evolved and diversified; it can be sexual or asexual. Sexual reproduction is usually dioecious, with the two sexes similar. In rare cases it is dimorphic.

Polychaetes range in length from a fraction of 0.04 in. (1 mm) to more than 144 in. (360 cm). Colors and patterns are varied and specific, due to pigment and refraction of light. Littoral, warm-water species may be brilliant and multicolored, whereas polar and deep-water species tend to be drab or sometimes melanistic to almost black.

Most polychaetes are free-living; some of the remaining members are commensal with another animal for attachment surface, for food, or for protection. Polychaetes are distributed in all marine habitats and show remarkable specificity according to latitude, depth, and kinds of substrata. Most of the families tend to be represented in any major geographic area, although taxa may differ with place. See ANNELIDA. [O.H.]

**Polychlorinated biphenyls** A generic term for a family of 209 chlorinated isomers of biphenyl. The biphenyl molecule is composed of two six-sided carbon rings connected at one carbon site on each ring. Ten sites remain for chlorine atoms to join the biphenyl molecule. The term polychlorinated biphenyl (PCB) has been used to refer to the biphenyl molecule with one to ten chlorine substitutions, as shown below.

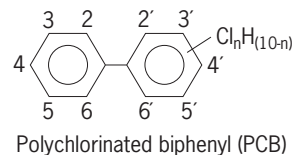

PCBs were introduced into United States industry on a large scale in 1929. The qualities that made PCBs attractive were chemical stability, resistance to heat, low flammability, and high dielectric constant. The PCB mixture is a colorless, viscous fluid, is relatively insoluble in water, and can withstand high temperatures without degradation (higher-chlorinated isomers are not readily degraded in the environment).

The major use of PCBs has been as dielectric fluid in electrical equipment, particularly transformers capacitors, electromagnets, circuit breakers, voltage regulators, and switches. PCBs have also been used in heat transfer systems and hydraulic systems, and as plasticizers and additives in lubricating and cutting oils. See DIELECTRIC MATERIALS.

PCBs have been reported in animals, plants, soil, and water all over the world, even in animals living under 11,000 ft (3400 m) of water. These phenomena are the result of bioaccumulation and biomagnification in the food chain. In a few instances, poultry products, cattle, and hogs have been found to contain high concentrations of PCBs after the animals have eaten feed contaminated with PCBs. It is not known what quantities of PCBs have been released to the environment, but major sources are industrial and municipal waste disposal, spills and leaks from PCB-containing equipment, and manufacture and handling of PCB mixtures. See ATMOSPHERIC GENERAL CIRCULATION; BIOSPHERE; FOOD WEB; HUMAN ECOLOGY.

PCBs can enter the body through the lungs, gastrointestinal tract, and skin, circulate throughout the body, and be stored in adipose tissue. PCBs have been detected in human adipose tissues and in the milk of cows and humans. Some PCBs have the ability to alter reproductive processes in mammals. There is concern that PCBs may be carcinogenic in humans. [G.Ku.]

**Polycladida** A class of marine Turbellaria which are several millimeters to several centimeters in length and whose leaflike bodies have a central intestine with radiating branches. Most species live in the littoral zone on the bottom, on seaweed or on other objects, or as commensals in the shells of mollusks and hermit crabs. None are parasitic. Except in warm waters, they are seldom brightly colored. See TURBELLARIA. [E.R.J.]

**Polyester resins** Synthetic polymers made by esterification of dicarboxylic acids with diols. The aliphatic polyesters tend to be relatively soft, and the aromatic derivatives are usually hard and brittle, or tough. The properties of either group may be modified by cross linking, crystallization, plasticizers, or fillers. See ESTER.

The commercial products are alkyds which are used in paints, enamels, and molding compounds; unsaturated polyesters or unsaturated alkyds which are used extensively with fiber glass for boat hulls and panels; aliphatic saturated polyesters; aromatic polyesters, such as polyethylene terephthalate which is used in the form of fibers and films; and the aromatic polycarbonates. The polydiallyl esters, while frequently listed with the polyesters, are not true polyesters as defined above. See POLYVINYL RESINS.



The alkyds are commonly used as coatings. Combinations of conventional vegetable drying oils and alkyd resins represent the basis of most of the oil-soluble paints. The drying oil-alkyd may be further modified by the inclusion of a vinyl monomer, such as styrene. Some of the styrene polymerizes, probably as a graft polymer, and the remainder polymerizes and copolymerizes in the final drying or curing of the paint. See DRYING OIL; PAINT; POLYMERIZATION.

The unsaturated polyesters, in combination with glass fiber, have found applications as panels, roofing, radar domes, boat hulls, and protective armor for soldiers. The compositions are distinguished by ease of fabrication and high impact resistance. See POLYMERIC COMPOSITE.

Saturated aliphatic polyesters have long been frequently used as intermediates in the preparation of prepolymers for making segmented polyurethanes. Lactone rings can also be opened to yield linear polyesters.

The aromatic polyesters which have achieved general importance are the polyethylene terephthalates, which yield very strong and chemically resistant fibers and films. Polyethylene terephthalate is the principal ingredient of polyester fibers. Polyethylene terephthalate may be molded or extruded to yield materials that can replace metals or thermoset resins in some automotive, electrical, and specialty applications, especially when reinforced with glass fibers or mineral fillers.

Aromatic polycarbonates are a strong, tough group of thermoplastic polymers formed most frequently from bisphenol A and phosgene. The products, polycarbonates, are noted for high softening temperatures, and high impact resistance, clarity, and resistance to creep. Polycarbonate is usually available as a molding compound. Because of its high strength, toughness, and softening point, the resin, both by itself and as a glass-reinforced material, has found many electrical domestic and engineering applications. It is often used to replace glass and metals. Examples include bottles, unbreakable windows, appliance parts, electrical housings, marine propellers, and shotgun shells. Flame-retardant grades are of interest because of low toxicity and smoke emission on burning.

Polydiallyl esters are polymers of diallyl esters. Thermosetting molding compounds may be produced by careful limitation of the initial polymerization to yield a product which is fusible. Major applications are in electronic components, sealants, coatings, and glass-fiber composites. See PLASTICS PROCESSING. [J.A.M.]

**Polyether resins** Thermoplastic or thermosetting materials which contain ether-oxygen linkages,  $\text{—C—O—C—}$ , in the polymer chain. Depending upon the nature of the reactants and reaction conditions, a large number of polyethers with a wide range of properties may be prepared. The main groups of polyethers in use are epoxy resins, phenoxy resins, polyethylene oxide and polypropylene oxide resins, polyoxymethylene, and polyphenylene oxides.

The epoxy resins form an important and versatile class of cross-linked polyethers characterized by excellent chemical resistance, adhesion to glass and metals, electrical insulating properties, and ease and precision of fabrication. Various fillers such as calcium carbonate, metal fibers and powders, and glass fibers are commonly used in epoxy formulations in order to improve such properties as the strength and resistance to abrasion and high temperatures. Some reactive plasticizers act as curing agents, become permanently bound to the epoxy groups, and are usually called flexibilizers. Rubbery polymers are added to improve toughness and impact strength. Epoxies are commonly used in protective coatings. They are used as potting or encapsulating compositions for the protection of delicate electronic assemblies from the thermal and mechanical shock of rocket flight, and as dies for stamping metal forms.

Polyethylene oxide and polypropylene oxide are thermoplastic products whose properties are greatly influenced by molecular weight. Low-to-moderate-molecular-weight polyethylene oxides

vary in form from oils to waxlike solids. They are relatively non-volatile, are soluble in a variety of solvents, and have found many uses as thickening agents, plasticizers, lubricants for textile fibers, and components of various sizing, coating, and cosmetic preparations. The polypropylene oxides of similar molecular weight have somewhat similar properties, but tend to be more oil-soluble (hydrophobic) and less water-soluble (hydrophilic). While polyalkylene oxides are not of interest as such in structural materials, polypropylene oxides are used extensively in the preparation of polyurethane foams.

Phenoxy resins are transparent, strong, ductile, and resistant to creep, and, in general, resemble polycarbonates in their behavior. The major application is as a component in protective coatings, especially in metal primers. See POLYESTER RESINS.

Polyphenylene oxide (PPO) is the basis for an engineering plastic characterized by chemical, thermal, and dimensional stability. Polyphenylene oxide is outstanding in its resistance to water. Uses include medical instruments, pump parts, and insulation.

Polyoxymethylene, or polyacetal, resins are polymers of formaldehyde. Having high molecular weights and high degrees of crystallinity, they are strong and tough and are established in the general class of engineering thermoplastics. Polyacetals are typically resistant to fatigue, creep, organic chemicals (but not strong acids or bases), and have low coefficients of friction. Electrical properties are also good. The combination of properties has led to many uses such as plumbing fittings, pump and valve components, bearings and gears, computer hardware, automobile body parts, and appliance housings. See PLASTICS PROCESSING; POLYMERIZATION. [J.A.M.]

**Polyfluoroolefin resins** Resins distinguished by their resistance to heat and chemicals and by the ability to crystallize to a high degree. Several main products are based on tetrafluoroethylene,  $\text{F}_2\text{C}=\text{CF}_2$  (TFE); hexafluoropropylene,  $\text{F}_2\text{C}=\text{CFCF}_3$  (HFP); and monochlorotrifluoroethylene,  $\text{FCIC}=\text{CF}_2$  (CTFE).

Poly(tetrafluoroethylene) is the polymer of tetrafluoroethylene and is commonly known by the trade name Teflon<sup>®</sup>. It is insoluble, resistant to heat (up to 275°C or 527°F) and chemical attack, and has the lowest coefficient of friction of any solid. However, special surface treatments are required to ensure adhesion because poly(tetrafluoroethylene) does not adhere well to anything. Poly(tetrafluoroethylene) (TFE resin) is used for bearings, valve seats, packings, gaskets, coatings and tubing, and can withstand relatively severe conditions. Because of its excellent electrical properties, poly(tetrafluoroethylene) is useful when a dielectric material is required for service at a high temperature. The nonadhesive quality is often used to coat articles such as rolls and cookware to which materials might otherwise adhere.

The properties of poly(chlorotrifluoroethylene) (CTFE resin) are generally similar to those of poly(tetrafluoroethylene); however, the presence of the chlorine atoms in the former causes the polymer to be a little less resistant to heat and to chemicals. The applications of poly(chlorotrifluoroethylene) are in general similar to those for poly(tetrafluoroethylene). Because of its stability and inertness, the polymer is useful in the manufacture of gaskets, linings, and valve seats that must withstand hot and corrosive conditions. It is also used as a dielectric material, as a vapor and liquid barrier, and for microporous filters.

Poly(vinylidene fluoride) properties has generally similar to those of the other fluorinated resins: relative inertness, low dielectric constant, and thermal stability (up to about 150 or 300°F). The resins (PVF<sub>2</sub> resins) are, however, stronger and less susceptible to creep and abrasion than TFE and CTFE resins. Applications of poly(vinylidene fluoride) are mainly as electrical insulation, piping, process equipment, and as a protective coating in the form of a liquid dispersion.

Several types of fluorinated, noncrystallizing elastomers were developed in order to meet needs (usually military) for rubbers which possess good low-temperature behavior with a high degree of resistance to oils and to heat, radiation, and weathering. See HALOGENATED HYDROCARBON; PLASTICS PROCESSING; POLYMERIZATION. [J.A.M.]

**Polygalales** An order of flowering plants, division Magnoliophyta (Angiospermae), in the subclass Rosidae of the class Magnoliopsida (dicotyledons). The order consists of 7 families and nearly 2300 species, mostly of tropical and subtropical regions. The vast majority of the species belong to only 3 families, the Malpighiaceae (about 1200 species), Polygalaceae (about 750 species), and Vochysiaceae (about 200 species). Within its subclass the order is distinguished by its simple leaves and usually irregular flowers, which have the perianth and stamens attached directly to the receptacle (hypogynous), and often have the anthers opening by terminal pores instead of longitudinal slits. The Barbados cherry (*Malpighia glabra*), noted for the high vitamin-C content of its fruits, is a well-known member of the Polygalales. See MAGNOLIOPSIDA; PLANT KINGDOM; ROSIDAE. [A.Cr.; T.M.Ba.]

**Polygon** A geometric figure consisting of an ordered set of three or more (but a finite number of) points called vertices, each vertex connected by line segments called sides or edges to two other vertices. These two sides are said to be adjacent, and so are any two vertices that are end points of a side. The perimeter of the polygon is the sum of the lengths of the sides. The line segments that join two nonadjacent vertices of a polygon are called diagonals. A polygon is said to be directed, or oriented, if a preferred direction is assigned to each side so that at each vertex one of the adjacent sides is directed toward the vertex and the other away from it.

The angle between the two sides of a polygon at a vertex is called an angle of the polygon. Thus an  $n$ -sided polygon, called an  $n$ -gon, has  $n$  vertices and  $n$  angles. In particular, if  $n$  is 3, 4, 5, 6, 7, 8, 10, or 12, the polygon is called a triangle (3), quadrangle (4) [or quadrilateral, meaning four sides], pentagon (5), hexagon (6), heptagon (7), octagon (8), decagon (10), or dodecagon (12).

A plane polygon is one whose vertices all lie in the same plane. Other polygons are called skew polygons, except for the spherical polygons described below. Skew polygons can be constructed in any number of dimensions.

A plane polygon is called ordinary if no point belongs to more than two edges; it is proper if no two adjacent sides are collinear; it is simple if no two edges intersect each other except at vertices. A simple polygon divides the plane into two regions: an unbounded outside region and an inside region whose area is called the area of the polygon.

A simple polygon is called convex if its interior lies entirely on one side of each (infinite) line through any two adjacent vertices. A nonconvex polygon has at least one interior angle that exceeds  $180^\circ$ . The sum of the interior angles in a convex  $n$ -gon is  $(n - 2)180^\circ$ . A plane polygon is called regular if all its sides are equal and all its angles are equal; it is semiregular if all its angles are equal. See REGULAR POLYTOPES.

A spherical polygon consists of points on a spherical surface called vertices, each connected to two adjacent vertices by great-circle arcs, called sides, that are measured by their central angles. The  $n$  angles of a convex spherical  $n$ -gon are the angles at each vertex between the tangent lines to the two sides that meet there, and their sum exceeds  $(n - 2)180^\circ$  by an amount, called the spherical excess, that is proportional to the spherical area enclosed by the polygon. [J.S.Fra.]

**Polygonales** An order of flowering plants, division Magnoliophyta (Angiospermae), in the subclass Caryophyllidae of the class Magnoliopsida (dicotyledons). The order consists only of the family Polygonaceae, with about 800 species, most abun-

dant in north temperate regions. Within its subclass the order is characterized by its well-developed endosperm; an ovary with but one chamber (unilocular), mostly tricarpetate with a single basal ovule which is usually straight and has the micropyle at the opposite end from the stalk (orthotropous); the flowers are often trimerous, that is, with floral parts in sets of three, and usually two or three sets of stamens. Rhubarb (*Rheum rhaponticum*) and buckwheat (*Fagopyrum esculentum*) are familiar members of the Polygonales. See BUCKWHEAT; CARYOPHYLLIDAE; MAGNOLIOPSIDA; RHUBARB. [A.Cr.]

**Polyhedron** A solid whose boundary consists of a finite number of polygonal faces, that is, planar regions that are bounded by polygons. The sides of the faces are edges of the polyhedron; the vertices of the faces also are vertices of the polyhedron. See PLANE GEOMETRY; POLYGON.

Most polyhedra met in applied geometry are convex and simply connected. A polyhedron is convex if it passes this test: if any face is placed coincident with a plane, then all other points of the polyhedron lie on the same side of that plane. A more informal test is to imagine enclosing the polyhedron within a stretched elastic membrane; the polyhedron is convex if all points on the boundary are in contact with the membrane. A simply connected polyhedron has a boundary that is topologically equivalent to a sphere: if the boundary were made of some perfectly elastic material, then the boundary could be distorted into a sphere without tearing or piercing the surface. A simply connected polyhedron is said to be eulerian, because the number of faces  $F$ , the number of edges  $E$ , and the number of vertices  $V$  satisfy Euler's formula:

$$F + V = E + 2$$

Polyhedra exist having any number of faces greater than three. Some polyhedra have names that convey the number of faces (but not the shape) of the polyhedron: tetrahedron, 4 faces; pentahedron, 5 faces; hexahedron, 6 faces; octahedron, 8 faces; dodecahedron, 12 faces; and icosahedron, 20 faces.

A polyhedron is regular (or platonic) if all faces are congruent and all dihedral angles (the angles between adjacent faces) are equal. There are only five regular polyhedra: the tetrahedron, cube, octahedron, dodecahedron, and icosahedron. [H.L.Ba.]

**Polymer** Polymers, macromolecules, high polymers, and giant molecules are high-molecular-weight materials composed of repeating subunits. These materials may be organic, inorganic, or organometallic, and synthetic or natural in origin. Polymers are essential materials for almost every industry as adhesives, building materials, paper, cloths, fibers, coatings, plastics, ceramics, concretes, liquid crystals, photoresists, and coatings. They are also major components in soils and plant and animal life. They are important in nutrition, engineering, biology, medicine, computers, space exploration, health, and the environment. See CERAMICS; MANUFACTURED FIBER; NATURAL FIBER; SURFACE COATING.

Natural inorganic polymers include diamonds, graphite, sand, asbestos, agates, chert, feldspars, mica, quartz, and talc. Natural organic polymers include polysaccharides (or polycarbohydrates) such as starch and cellulose, nucleic acids, and proteins. Synthetic inorganic polymers include boron nitride, concrete, many high-temperature superconductors, and a number of glasses. Siloxanes or polysiloxanes represent synthetic organometallic polymers. See SILICONE RESINS.

Synthetic polymers used for structural components weigh considerably less than metals, helping to reduce the consumption of fuel in vehicles and aircraft. They even outperform most metals when measured on a strength-per-weight basis. Polymers have been developed which can also be used for engineering purposes such as gears, bearings, and structural members.

**Nomenclature.** Many polymers have both a common name and a structure-based name specified by the International Union of Pure and Applied Chemistry (IUPAC). Some polymers are commonly known by their acronyms. Some companies use trade

names to identify the specific polymeric products they manufacture. For example, Fortrel<sup>®</sup> polyester is a poly(ethylene terephthalate) (PET) fiber. Polymers are often generically named, such as rayon, polyester, and nylon. See ORGANIC NOMENCLATURE; POLYACRYLATE RESIN; POLYAMIDE RESINS; POLYESTER RESINS.

**Composition.** Polymer structures can be represented by similar or identical repeat units. These are derived from smaller molecules, called monomers, which react to form the polymer. Propylene monomer and the repeat unit it forms in polypropylene are shown below. With the exception of its end groups,

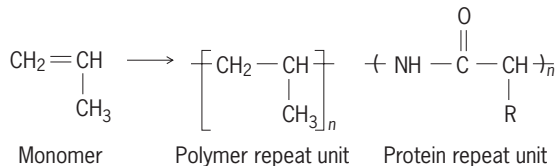

polypropylene is composed entirely of this repeat unit. The number of units ( $n$ ) in a polymer chain is called the degree of polymerization (DP). Other polymers, such as proteins, can be described in terms of the approximate repeat unit where the nature of R (a substituted atom or group of atoms) varies. See POLYVINYL RESINS; PROTEIN.

**Primary structure.** The sequence of repeat units within a polymer is called its primary structure. Unsymmetrical reactants, such as substituted vinyl monomers, react almost exclusively to give a “head-to-tail” product, in which the R substituents occur on alternate carbon atoms. A variety of head-to-head structures are also possible.

Each R-substituted carbon atom is a chiral center (an atom in a molecule attached to four different groups) with different geometries possible. Arrangements where the substituents on the chiral carbon are random are referred to as atactic structures. Arrangements where the geometry about the chiral carbon alternates are said to be syndiotactic. Structures where the geometry about the chiral atom has the same geometry are said to be isotactic or stereoregular.

Stereoregular polymers are produced using special stereoregulating catalyst systems. A series of soluble catalysts have been developed that yield products with high stereoregularity and low chain-size disparity. As expected, polymers with regular structures—that is, isotactic and syndiotactic structures—tend to be more crystalline and stronger.

Polymers can be linear or branched with varying amounts and lengths of branching. Most polymers contain some branching.

Copolymers are derived from two different monomers, which may be represented as A and B. There exists a large variety of possible structures and, with each structure, specific properties. These varieties include alternating, random, block, and graft (see illustration). See COPOLYMER.

**Secondary structure.** This refers to the localized shape of the polymer, which is often the consequence of hydrogen bonding. Most flexible to semiflexible linear polymer chains tend toward two structures—helical and pleated sheet/skirtlike. The pleated skirt arrangement is most prevalent for polar materials where hydrogen bonding can occur. In nature, protein tissue is often of a pleated skirt arrangement. For both polar and nonpolar polymer chains, there is a tendency toward helical formation with the inner core having “like” secondary bonding forces. See HYDROGEN BOND.

**Tertiary structure.** This refers to the overall shape of a polymer, such as in polypeptide folding. Globular proteins approximate rough spheres because of a complex combination of environmental and molecular constraints, and bonding opportunities. Many natural and synthetic polymers have “superstructures,” such as the globular proteins and aggregates of polymer chains, forming bundles and groupings.

**Quaternary structure.** This refers to the arrangement in space of two or more polymer subunits, often a grouping of tertiary structures. For example, hemoglobin (quaternary structure)

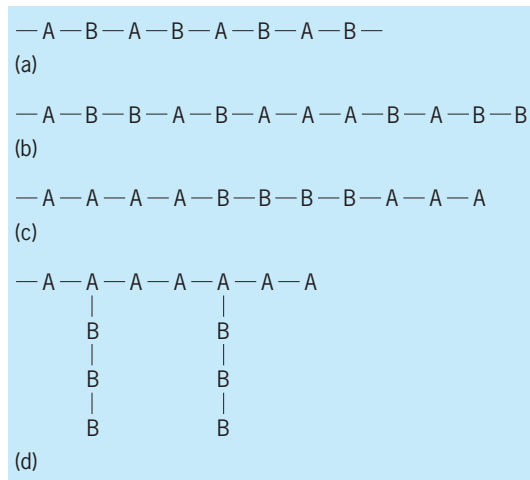

**Copolymer structures: (a) alternating, (b) random, (c) block, (d) graft.**

is essentially the combination of four myoglobin (tertiary structure) units. Many crystalline synthetic polymers form spherulites. See HEMOGLOBIN.

**Synthesis.** For polymerization to occur, monomers must have at least two reaction points or functional groups. There are two main reaction routes to synthetic polymer formation—addition and condensation. In chain-type kinetics, initiation starts a series of monomer additions that result in the reaction mixture consisting mostly of unreacted monomer and polymer. Vinyl polymers, derived from vinyl monomers and containing only carbon in their backbone, are formed in this way. Examples of vinyl polymers include polystyrene, polyethylene, polybutadiene, polypropylene, and poly(vinyl chloride).

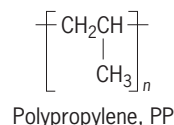

The second main route is a step-wise polymerization. Polymerization occurs in a step-wise fashion so that the average chain size within the reaction mixture may have an overall degree of polymerization of 2, then 5, then 10, and so on, until the entire mixture contains largely polymer with little or no monomer left. Polymers typically produced using the step-wise process are called condensation polymers, and include polyamides, polycarbonates, polyesters, and polyurethanes. Condensation polymer

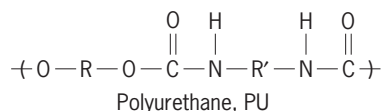
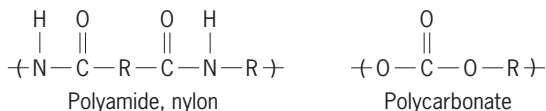

chains are characterized as having a noncarbon atom in their backbone. For polyamides the noncarbon is nitrogen (N), while for polycarbonates it is oxygen (O). Condensation polymers are synthesized using melt (the reactants are heated causing them to melt), solution (the reactants are dissolved), and interfacial (the reactants are dissolved in immiscible solvents) techniques. See POLYMERIZATION; POLYOLEFIN RESINS; POLYURETHANE RESINS.

**Molecular properties.** These are used to help determine the structure and behavior of the polymer. The molecular weight of a particular polymer chain is the product of the number of units

times the molecular weight of the repeating unit. Two statistical averages describe polymers, the number-average molecular weight and the weight-average molecular weight. See MOLECULAR WEIGHT.

Size is the most important property of polymers allowing for storage of information (nucleic acids and proteins). Polymeric materials remember any action that distorts or moves polymer chains or segments (such as bending, stretching, and melting). Size also accounts for an accumulation of the interchain and intrachain secondary attractive forces called van der Waals forces. For nonpolar polymers, such as polyethylene, the attractive forces for each repeating unit are less than that for polar polymers. Polyvinyl chloride, a polar polymer, has attractive forces that include both dispersion and dipole-dipole forces so that the total attractive forces are proportionally larger than those for polyethylene. Polymers with hydrogen bonding (such as proteins, polysaccharides, nucleic acids, and nylons) have attractive forces that are even greater. Hydrogen bonding is so strong in cellulose that cellulose is not soluble in water until the inter- and intrachain hydrogen bonds are broken. See CELLULOSE.

Polymers often have a combination of ordered regions, called crystalline regions, and disordered or amorphous regions. Crystalline regions are more rigid, contributing to strength and resistance to external forces. The amorphous regions contribute to polymers' flexibility. Most commercial polymers have a balance between amorphous and crystalline regions, allowing a balance between flexibility and strength.

Polymers are viscoelastic materials. Ductile polymers, such as polyethylene and polypropylene, "give" or "yield," and at high elongations some strengthening and orientation occur. A brittle polymer, such as polystyrene, does not give much and breaks at a low elongation. A fiber, a polymer material that is much longer than it is wide, exhibits high strength, high stiffness, and little elongation.

**Materials.** Fibers are polymer materials that are strong in one direction, and they are much longer (>100 times) than they are wide. Elastomers (or rubbers) are polymeric materials that can be distorted through the application of force, and when the force is removed, the material returns to its original shape. Plastics are materials that have properties between fibers and elastomers—they are hard and flexible. Coatings and adhesives are generally derived from polymers that are members of other groupings (for example, polysiloxanes are elastomers, but also are used as adhesives). Industrially important adhesives and coatings include laminates, sealants and caulks, composites, films, polyblends, liquid crystals, ceramics, cements, and smart materials. See ADHESIVE; CEMENT; COMPOSITE LAMINATES; LIQUID CRYSTALS; POLYMERIC COMPOSITE; RUBBER.

**Additives.** Processed polymeric materials are generally a combination of the polymer and the materials that are added to modify its properties, assist in processing, and introduce new properties. Additives can be solids, liquids, or gases. Typical additives are plasticizers, antioxidants, colorants, fillers, and reinforcements. See ANTIOXIDANT; INHIBITOR (CHEMISTRY).

**Recycling.** Many polymers are thermoplastics, that is, they can be reshaped through application of heat and pressure and used in the production of other thermoplastic materials. The recycling of thermosets, polymers that do not melt but degrade prior to softening, is more difficult. These materials are often ground into a fine powder, are blended with additives (often adhesives or binders), and then are reformed. See RECYCLING TECHNOLOGY. [C.E.Ca.]

**Polymer-supported reaction** An organic chemical reaction where one of the species, such as the substrate, the reagent, or a catalyst, is bound to a cross-linked, and therefore insoluble, polymer support. A major attraction of polymer-supported reactions is that at the end of the reaction period the polymer-supported species can be separated cleanly and easily, usually by filtration, from the soluble species. This easy separa-

tion can greatly simplify product isolation procedures, and it may even allow the polymer-supported reactions to be automated. Because it is possible to reuse or recycle polymer-supported reactants and because they are insoluble, involatile, easily handled, and easily recovered, polymer-supported reactants are also attractive from an environmental point of view. See ASYMMETRIC SYNTHESIS; CATALYSIS.

Polymer-supported reactants are usually prepared in the form of beads of about 50–100 micrometers' diameter. Such beads can have a practically useful loading only when their interiors are functionalized, that is, carry functional groups. With a typical polymer-supported reactant, more than 99% of the reactive groups are inside the beads. An important consequence is that for soluble species to react with polymer-supported species the former must be able to diffuse freely into the polymer beads. See POLYMER.

In a typical application of reactions involving polymer-supported substrates, a substrate is first attached to an appropriately functionalized polymer support. The synthetic reactions of interest are then carried out on the supported species. Finally, the product is detached from the polymer and recovered. Often the polymer-supported species has served as a protecting group that is also a physical "handle" to facilitate separation. Combinatorial synthesis is carried out on polymer-supported substrates. This approach is used in the pharmaceutical industry to identify lead compounds, which can thus be identified in weeks rather than years.

Reactions involving polymer-supported reagents are generally more useful than those involving polymer-supported substrates, because no attachment or detachment reactions are needed, and it is not necessary for all the polymer-supported species to react in high yield. Indeed, polymer-supported reagents are often used in excess to drive reactions to high conversions. Polymer-supported catalysts are the most attractive type of polymer-supported reactants; in such reactions, the loadings of catalytic sites need not be high, not all sites need be active and, in most cases, the polymer-supported catalyst is recovered in a suitable form for reuse. [P.H.]

**Polymeric composite** Any of the combinations or compositions that comprise two or more materials as separate phases, at least one of which is a polymer. By combining a polymer with another material, such as glass, carbon, or another polymer, it is often possible to obtain unique combinations or levels of properties. Typical examples of synthetic polymeric composites include glass-, carbon-, or polymer-fiber-reinforced thermoplastic or thermosetting resins, carbon-reinforced rubber, polymer blends, silica- or mica-reinforced resins, and polymer-bonded or -impregnated concrete or wood. It is also often useful to consider as composites such materials as coatings (pigment-binder combinations) and crystalline polymers (crystallites in a polymer matrix). Typical naturally occurring composites include wood (cellulosic fibers bonded with lignin) and bone (minerals bonded with collagen). On the other hand, polymeric compositions compounded with a plasticizer or very low proportions of pigments or processing aids are not ordinarily considered as composites.

Typically, the goal is to improve strength, stiffness, or toughness, or dimensional stability by embedding particles or fibers in a matrix or binding phase. A second goal is to use inexpensive, readily available fillers to extend a more expensive or scarce resin; this goal is increasingly important as petroleum supplies become costlier and less reliable. Still other applications include the use of some fillers such as glass spheres to improve processability, the incorporation of dry-lubricant particles such as molybdenum sulfide to make a self-lubricating bearing, and the use of fillers to reduce permeability.

The most common fiber-reinforced polymer composites are based on glass fibers, cloth, mat, or roving embedded in a matrix of an epoxy or polyester resin. Reinforced thermosetting

resins containing boron, polyaramids, and especially carbon fibers confer especially high levels of strength and stiffness. Carbon-fiber composites have a relative stiffness five times that of steel. Because of these excellent properties, many applications are uniquely suited for epoxy and polyester composites, such as components in new jet aircraft, parts for automobiles, boat hulls, rocket motor cases, and chemical reaction vessels.

Although the most dramatic properties are found with reinforced thermosetting resins such as epoxy and polyester resins, significant improvements can be obtained with many reinforced thermoplastic resins as well. Polycarbonates, polyethylene, and polyesters are among the resins available as glass-reinforced composition. The combination of inexpensive, one-step fabrication by injection molding, with improved properties has made it possible for reinforced thermoplastics to replace metals in many applications in appliances, instruments, automobiles, and tools.

In the development of other composite systems, various matrices are possible; for example, polyimide resins are excellent matrices for glass fibers, and give a high-performance composite. Different fibers are of potential interest, including polymers [such as poly(vinyl alcohol)], single-crystal ceramic whiskers (such as sapphire), and various metallic fibers. See COMPOSITE MATERIAL; GLASS; GRAPHITE; POLYACRYLATE RESIN; POLYAMIDE RESINS; POLYESTER RESINS; POLYETHER RESINS; POLYMER; POLYSTYRENE RESIN; POLYVINYL RESINS; RUBBER. [J.A.M.]

**Polymerization** The linking of small molecules (monomers) to make larger molecules. Polymerization requires that each small molecule have at least two reaction points or functional groups. There are two distinct major types of polymerization processes, condensation polymerization, in which the chain growth is accompanied by elimination of small molecules such as H<sub>2</sub>O or CH<sub>3</sub>OH, and addition polymerization, in which the polymer is formed without the loss of other materials. There are many variants and subclasses of polymerization reactions.

An example of the condensation process is the reaction (1)

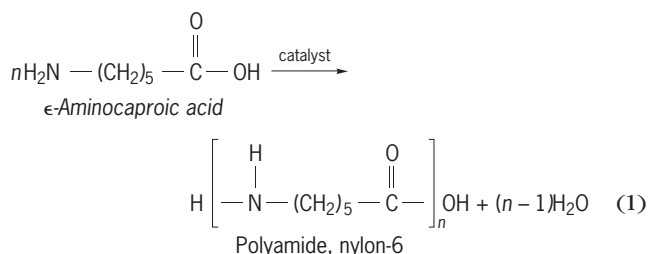

of  $\epsilon$ -aminocaproic acid in the presence of a catalyst to form the polyamide, nylon-6. The repeating structural unit is equivalent to the starting material minus H and OH, the elements of water. The molecules formed are linear because the total functionality of the reaction system (functional groups per molecule) is always two. However, if a trifunctional material, such as a tricarboxylic acid, were added to the nylon-6,6 polymerizing mixture, a branched polymeric structure would result, because two of the carboxylic groups would participate in one polymer chain, and the third carboxylic group would start the growth of another. Under appropriate conditions, these chains can become bridges between linear chains and the polymer becomes cross-linked. The arrangements of the chains are shown in Fig. 1.



Fig. 1. Polymer chains. (a) Linear polymer chain. (b) Branched polymer chain. (c) Cross-linked polymer chain.

An example of addition polymerization is reaction (2). The

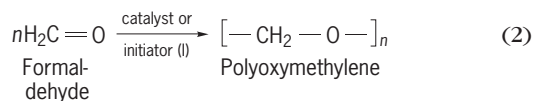

structure of the repeating unit is the difunctional monomeric unit, or "mer." In the presence of catalysts or initiators, the monomer yields a polymer by the joining together of  $n$  mers. If  $n$  is a small number, 2–10, the products are dimers, trimers, tetramers, or oligomers, and the materials are usually gases, liquids, oils, or brittle solids. In most solid polymers,  $n$  has values ranging from a few score to several hundred thousand, and the corresponding molecular weights range from a few thousand to several million. The end groups of this example of addition polymers are shown to be fragments of the initiator.

If only one monomer is polymerized, the product is called a homopolymer. The polymerization of a mixture of two monomers of suitable reactivity leads to the formation of a copolymer, a polymer in which the two types of mer units have entered the chain in a more or less random fashion. If chains of one homopolymer are chemically joined to chains of another, the product is called a block or graft copolymer:

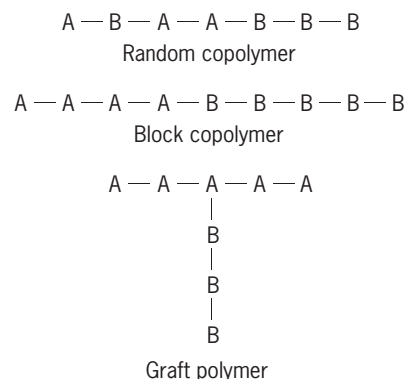

Isotactic and syndiotactic (stereoregular) polymers are formed in the presence of complex catalysts, or by changing polymerization conditions, for example, by lowering the temperature. The groups attached to the chain in a stereoregular polymer are in a spatially ordered arrangement. The configuration of these ordered polymers and the disordered, atactic form is shown in Fig. 2. The regular structures of the isotactic and syndiotactic forms make them often capable of crystallization. The crystalline melting points of isotactic polymers are often substantially higher than the softening points of the atactic product.

In Fig. 2 each carbon atom to which a phenyl group is attached is asymmetrically substituted. For illustration, the heavily marked bonds are assumed to project up from the paper, and the dotted bonds down. Thus in a fully syndiotactic polymer, asymmetric carbons alternate in their left- or right-handedness (alternating  $d$ ,  $l$  configurations), while in an isotactic polymer, successive carbons have the same steric configuration ( $d$  or  $l$ ).

Among the several kinds of polymerization catalysis, free-radical initiation has been most thoroughly studied and is most widely employed. Atactic polymers are readily formed by free-radical polymerization, at moderate temperatures, of vinyl and diene monomers and some of their derivatives. See CATALYSIS; FREE RADICAL.

Some polymerizations can be initiated by materials, often called ionic catalysts, that contain highly polar reactive sites or complexes. The term heterogeneous catalyst is often applicable to these materials because many of the catalyst systems are insoluble in monomers and other solvents. These polymerizations are usually carried out in solution from which the polymer can be obtained by evaporation of the solvent or by precipitation on

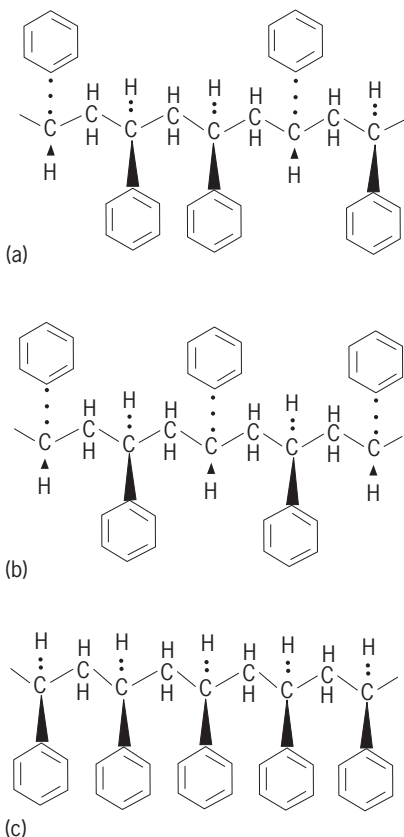

Fig. 2. Spatially oriented polymers. (a) Atactic (random; *dldl* or *ldld*, and so on). (b) Syndiotactic (alternating; *dldl*, and so on). (c) Isotactic (right- or left-handed; *dddd*, or *llll*, and so on).

the addition of a nonsolvent. A distinguishing feature of complex catalysts is the ability of some representatives of each type to initiate stereoregular polymerization at ordinary temperatures or to cause the formation of polymers which can be crystallized. See CHAIN REACTION (CHEMISTRY); CHEMICAL DYNAMICS; HETEROGENEOUS CATALYSIS; INHIBITOR (CHEMISTRY); INORGANIC POLYMER; ORGANIC REACTION MECHANISM; PLASTICS PROCESSING; POLYMER.

[J.A.M.]

**Polymorphism (crystallography)** The existence of different crystal structures with the same chemical composition. If only one chemical element is present, the forms are called allotropes. Graphite and diamond are allotropes of carbon, whereas quartz and cristobalite are polymorphs of silica (silicon dioxide,  $\text{SiO}_2$ ). Although properties are different in these forms, reversible transformations, which involve small shifts in atom positions and no bulk transport of material, are common. The quartz transformation at  $1063^\circ\text{F}$  ( $573^\circ\text{C}$ ) is a reversible, atom-displacement transformation. See SILICA MINERALS.

In metals and ceramics, similar transformations are called martensitic. Advantage is taken of the localized nature of reversible transformation in steel by controlling the melting atmosphere, temperature, composition, mechanical working (alloying), and tempering and quenching operations. See HEAT TREATMENT (METALLURGY).

Control over transformations to achieve desirable properties as either devices or structural materials in extreme environments is a frequent objective. In the case of tin, reversibility on the atomic scale can have devastating consequences for bulk properties. Similar transformations may be beneficial in the right place and in the desired degree. Such transformation is attempted with metals and ceramics. See CERAMICS; CRYSTAL STRUCTURE.

[D.Ev.]

**Polymorphism (genetics)** A form of genetic variation, specifically a discontinuous variation, occurring within plant and animal species in which distinct forms exist together in the same population, even the rarest of them being too common to be maintained solely by mutation. Thus the human blood groups are examples of polymorphism, while geographical races are not; nor is the diversity of height among humans, because height is "continuous" and does not fall into distinct tall, medium, and short types. See MUTATION.

Distinct forms must be controlled by some switch which can produce one form or the other without intermediates such as those arising from environmental differences. This clear-cut control is provided by the recombination of the genes. Each gene may have numerous effects and, in consequence, all genes are nearly always of importance to the organism by possessing an overall advantage or disadvantage. They are very seldom of neutral survival value, as minor individual variations in appearance often are. Thus a minute extra spot on the hindwings of a tiger moth is in itself unlikely to be of importance to the survival of the insect, but the gene controlling this spot is far from negligible since it also affects fertility. See RECOMBINATION (GENETICS).

Genes having considerable and discontinuous effects tend to be eliminated if harmful, and each gene of this kind is therefore rare. On the other hand, those that are advantageous and retain their advantage spread through the population so that the population becomes uniform with respect to these genes. Evidently, neither of these types of genes can provide the switch mechanism necessary to maintain a polymorphism. That can be achieved only by a gene which has an advantage when rare, yet loses that advantage as it becomes commoner.

Occasionally there is an environmental need for diversity within a species, as in butterfly mimicry. Mimicry is the resemblance of different species to one another for protective purposes, chiefly to avoid predation by birds. Sexual dimorphism falls within the definition of genetic polymorphism. In any species, males and females are balanced at optimum proportions which are generally near equality. Any tendency for one sex to increase relative to the other would be opposed by selection.

In general, a gene having both advantageous and disadvantageous effects may gain some overall advantage and begin to spread because one of the features it controls becomes useful in a new environment. A balance is then struck between the advantages and disadvantages of such a gene, ensuring that a proportion of the species carry it, thus giving rise to permanent discontinuous variation, that is, to polymorphism. See PROTECTIVE COLORATION.

Polymorphism is increasingly known to be a very common situation. Its existence is apparent whenever a single gene having a distinct recognizable effect occurs in a population too frequently to be due merely to mutation. Even if recognized by some trivial effect on the phenotype, it must in addition have important other effects. About 30% of the people in western Europe cannot taste as bitter the substance phenylthiourea. This is truly an insignificant matter; indeed, no one even had the opportunity of tasting it until the twentieth century. Yet this variation is important since it is already known that it can affect disease of the thyroid gland. See GENETICS; POPULATION GENETICS. [E.B.F.; J.R.Po.]

**Polynomial systems of equations** Systems of mathematical equations which have the form of system (1).

$$\begin{aligned} f_1(x_1, x_2, \dots, x_n) &= 0 \\ f_2(x_1, x_2, \dots, x_n) &= 0 \\ &\dots\dots\dots \\ f_m(x_1, x_2, \dots, x_n) &= 0 \end{aligned} \quad (1)$$

Each  $f_i(x_1, x_2, \dots, x_n)$ ,  $i = 1, 2, \dots, m$ , is a sum of terms of the form shown as expression (2), where the coefficient  $a_{i_1 i_2 \dots i_n}$  is a

$$a_{i_1 i_2 \dots i_n} x_1^{i_1} x_2^{i_2} \dots x_n^{i_n} \quad (2)$$

constant, or fixed number, and the exponent  $i_j$  of the variable  $x_j$  is a nonnegative whole number. An example of such a system in two variables is system (3). The expressions  $f_i(x_1, x_2, \dots, x_n)$  are

$$\begin{aligned}x^2 - xy + y^2 - 1 &= 0 \\x^2 + xy - 3y^2 - 2x + 2y + 1 &= 0\end{aligned}\quad (3)$$

called polynomials in several variables. The problem posed by system (1) is to find necessary and sufficient conditions that there exist values of the variables  $x_1 = a_1, x_2 = a_2, \dots, x_n = a_n$  which simultaneously satisfy each equation of the system, and to find all such sets of values, which are called solutions of the system. In example (3), a complete set of solutions is given by  $x = 1, y = 0; x = 0, y = 1; x = 1, y = 1; \text{ and } x = -1, y = -1$ . See EQUATIONS, THEORY OF; LINEAR SYSTEMS OF EQUATIONS. [R.A.BE.]

**Polynuclear hydrocarbon** One of a class of hydrocarbons possessing more than one ring. The aromatic polynuclear hydrocarbons may be divided into two groups. In the first, the rings are fused, which means that at least two carbon atoms are shared between adjacent rings. Examples are naphthalene (1), which has two six-membered rings, and acenaphthene (2), which has two six-membered rings and one five-membered ring.

In the second group of polynuclear hydrocarbons, the aromatic rings are joined either directly, as in the case of biphenyl (3), or through a chain of one or more carbon atoms, as in 1,2-diphenylethane (4).

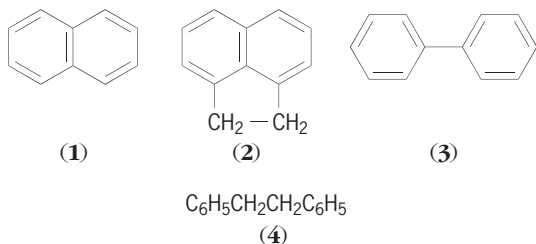

The higher-boiling polynuclear hydrocarbons found in coal tar or in tars produced by the pyrolysis or incomplete combustion of carbon compounds are frequently fused-ring hydrocarbons, some of which may be carcinogenic. See AROMATIC HYDROCARBON; STEROID. [C.K.B.]

**Polyol** A compound containing more than one hydroxyl group ( $-\text{OH}$ ). Each hydroxyl is attached to separate carbon atoms of an aliphatic skeleton. This group includes glycols, glycerol, and pentaerythritol and also such products as trimethylolpropane, trimethylolpropane, 1,2,6-hexanetriol, sorbitol, inositol, and poly(vinyl alcohol). Polyols are obtained from many plant and animal sources and are synthesized by a variety of methods.

Polyols such as glycerol, pentaerythritol, trimethylolpropane, and trimethylolpropane are used in making alkyd resins for decorative and protective coatings. Glycols, glycerol, 1,2,6-hexanetriol, and sorbitol find application as humectants and plasticizers for gelatin, glue, and cork.

The polymeric polyols used in manufacture of the urethane foams represent a series of synthetic polyols. These polyols are generally poly(oxyethylene) or poly(oxypropylene) adducts of di- to octahydric alcohols. See GLYCEROL; GLYCOL. [P.C.J.]

**Polyolefin resins** Polymers derived from hydrocarbon molecules that possess one or more alkenyl (or olefinic) groups. The term polyolefin typically is applied to polymers derived from ethylene, propylene, and other alpha-olefins, isobutylene, cyclic olefins, and butadiene, and other diolefins. See ALKENE.

**Polyethylene.** Polyethylene is any homopolymer or copolymer in which ethylene is the major component monomer. It is a semicrystalline polymer of low to moderate strength and high toughness; its stiffness, yield strength, and thermal and mechanical properties increase with crystallinity. Toughness and ultimate

tensile strength increase with molecular weight. Polyethylene shows excellent toughness at low temperatures. Polyethylene is relatively inexpensive, extremely versatile, and adaptable to a large array of fabrication techniques. It is chemically inert; resistant to solvents, acids, and alkalis; and has good dielectric and barrier properties. It is used in many housewares, films, molded articles, and coatings.

Low-density polyethylene has densities ranging from 0.905 to 0.936  $\text{g/cm}^3$ . High-pressure low-density polyethylene is referred to simply as LDPE; linear low-density polyethylene (LLDPE) is a copolymer of polyethylene that is produced by a low-pressure polymerization process. High-density polyethylene (HDPE) covers the density range from 0.941 to 0.967  $\text{g/cm}^3$ . HDPE generally consists of a polymethylene  $(\text{CH}_2)_n$  chain with no, or very few, side chains to disrupt crystallization, while LLDPE contains side chains whose length depends on the comonomer used. See COPOLYMER.

LLDPE finds wide application in plastic films such as garbage bags and stretch cling films. Sheathing and flexible pipe are applications that take advantage of the flexibility and low-temperature toughness of LLDPE. HDPE is used in food packaging, grocery bags, pickup truck bedliners, and large containers. Fibers have been produced that approach the strength of spider silk, and is used in fishing lines and in medical applications.

Rubbery ethylene copolymers are used in compounded mixtures and range in comonomer content from 25 to 60% by weight, with propylene being the most widely used comonomer to form ethylene-propylene rubber. In addition to propylene, small amounts of a diene are sometimes included, forming a terpolymer. Products containing ethylene-propylene rubber and terpolymer have many automotive uses such as in bumpers, fascia, dashboard panels, steering wheels, and assorted interior trim. See RUBBER.

Ethylene copolymers are used to produce the polymer poly(ethylene-co-vinyl acetate) [EVA]. Applications include specialty film for heat sealing, adhesives, flexible hose and tubing, footwear components, bumper components, and gaskets. Foamed and cross-linked poly(ethylene-co-vinyl acetate) is used in energy-absorbing applications. Ionomers are ethylene copolymers that are produced from the copolymerization of ethylene with a comonomer containing a carboxylic group ( $\text{COOH}$ ) such as methyl acrylic acid. Because of their toughness, ionomers are widely used in the covers for golf balls. [B.Be.]

**Polypropylene.** Commercial polypropylene (PP) homopolymers are isotactic, high-molecular-weight, semicrystalline solids having melting points around 160–165°C (320–329°F), low density (0.90–0.91  $\text{g/cm}^3$ ), and excellent stiffness and tensile strength. They have moderate impact strength (toughness), low density over a wide temperature range, excellent mechanical properties, and low electrical conductivity. Propylene, like ethylene, is produced in large quantities at low cost from the cracking of oil and other hydrocarbon feedstocks. Low-molecular-weight resins are used for melt spun and melt blown fibers and for injection-molding applications. Polypropylene resins are used in extrusion and blow-molding processes and to make cast, slit, and oriented films. Stabilizers are added to polypropylene to protect it from attack by oxygen, ultraviolet light, and thermal degradation; other additives improve resin clarity, flame retardancy, or radiation resistance.

Polypropylene homopolymers, random copolymers, and impact copolymers are used in such products as automotive parts, appliances, battery cases, carpeting, electrical insulation, fiber and fabrics, food packaging, and medical equipment. See PETROLEUM PRODUCTS.

**Other poly(alpha-olefins).** Poly(1-butene) is a tough and flexible resin that has been used in the manufacture of film and pipe. Poly(4-methyl-1-pentene) is used in the manufacture of chemical and medical equipment. High-molecular-weight polyisobutylenes are rubbery solids that are used as sealants, inner tubes, and tubeless tire liners. Low-molecular-weight

polyisobutylenes are used in formulations for caulking, sealants, and lubricants. Butadiene and isoprene can be polymerized to give a number of polymer structures. The commercially important forms of polybutadiene and polyisoprene are similar in structure to natural rubber. See POLYACRYLONITRILE RESINS; POLYMER; POLYSTYRENE RESIN. [S.A.Co.]

**Polyoma virus** A papovavirus that infects rodents. The name derives from the capability of this virus to induce a wide variety of tumors when inoculated into newborn animals. The icosahedral viral particle consists of deoxyribonucleic acid (DNA) and protein only. The genome is a small, double-stranded, closed circular DNA molecule approximately 5300 base pairs in length. It encodes the T antigens expressed early in the productive cycle and in transformed cells, and the viral capsid proteins, expressed late in the productive cycle.

Polyoma virus is endemic in most wild populations of mice, but causes no disease. Tumors produced by this virus are unknown in the wild. Inoculation of large quantities of virus into newborn rodents, however, induces a number of tumor types, particularly many sarcomas and carcinomas. These tumors contain the viral genome but produce few infectious viral particles. Infected animals produce neutralizing antibodies directed against structural components of the virus; tumor-bearing animals produce antibodies to antigens (T antigens) which are present in tumor cells but not in the virus particle.

The virus is easily propagated to high titer in mouse embryo tissue culture, resulting in the lysis of the cells and the production of a hemagglutinin. This "productive infection" occurs only in mouse cells. Small numbers of "abortively infected" cells retain the viral genome and become transformed. Transformed cells are tumorigenic when injected into syngeneic animals, and contain the T antigens but produce no virus. The expression of the T antigens has been shown to be necessary and sufficient to induce cell transformation. See IMMUNOLOGY; ONCOLOGY; TUMOR VIRUSES; VIRUS. [S.M.D.]

**Polyplacophora** A class within the phylum Mollusca whose members are popularly called chitons, coat-of-mail shells, or sea cradles. All chitons are marine, and they typically live in the intertidal zone, although some live in deeper waters. They are found from subarctic to tropical latitudes but are most abundant in warmer waters. There are roughly 750 chiton species living today.

Polyplacophorans exhibit bilateral symmetry and are oval or elongate in outline. Chitons vary in length from a few millimeters ( $\frac{1}{16}$  in.) to over 30 cm (12 in.), though most are a few centimeters (about 1 in.) long. They are flattened dorsoventrally and bear eight shell plates on their back. The plates, termed valves, are formed from crystals of the mineral aragonite, and the upper layer of the valves contains canals filled with sensory organs called esthetes. The larger of these structures serve as photoreceptors and hence act as eyes. See CHITON.

Chitons possess three valve types—head, intermediate, and tail. The valves are laterally embedded in the fleshy but tough girdle, which typically bears small aragonite spicules or scales of varying shapes. Ventrally, polyplacophorans possess a large foot which they use for moving about and for attaching to rocks in a manner similar to a limpet gastropod. The gills hang along both sides of the animal, in a deep groove between the foot and the shell. The anus is located near the posterior end of the foot. At the front of the foot is the head which bears the mouth with its associated rasping structure (the radula, which is characteristic of most mollusks). A unique feature of the chiton radula is that the largest teeth are hardened with magnetite, an iron mineral. Characters of the valves, the gills, and the radula typically have been used to differentiate major groups within the Polyplacophora. See LIMPET; MOLLUSCA. [M.V.]

**Polyploidy** The occurrence of related forms possessing chromosome numbers which are multiples of a basic number ( $n$ ), the haploid number. Forms having  $3n$  chromosomes are triploids;  $4n$ , tetraploids;  $5n$ , pentaploids, and so on. Autopolyploids are forms derived by the multiplication of chromosomes from a single diploid organism. As a result the homologous chromosomes come from the same source. These are distinguished from allopolyploids, which are forms derived from a hybrid between two diploid organisms. As a result, the homologous chromosomes come from different sources. About one-third of the species of vascular plants have originated at least partly by polyploidy, and as many more appear to have ancestries which involve ancient occurrences of polyploidy. The condition can be induced artificially with the drug colchicine and the production of polyploid individuals has become a valuable tool for plant breeding.

In animals, most examples of polyploidy occur in groups which are parthenogenetic, or in species which reproduce asexually by fission. See BREEDING (PLANT); CHROMOSOME ABERRATION; GENE; GENETICS; PLANT EVOLUTION; SPECIATION. [G.L.St.]

In addition to polyploid organisms in which all of the body cells contain multiples of the basic chromosome number, most plants and animals contain particular tissues that are polyploid or polytene. Both polyploid and polytene cells contain extra copies of DNA, but they differ in the physical appearance of the chromosomes. In polytene cells the replicated copies of the DNA remain physically associated to produce giant chromosomes that are continuously visible and have a banded pattern. The term polyploid has been applied to several types of cells: multinucleate cells; cells in which the chromosomes cyclically condense but do not undergo nuclear or cellular division (this process is termed endomitosis); and cells in which the chromosomes appear to be continually in interphase, yet the replicated chromosomes are not associated in visible polytene chromosomes. See CHROMOSOME; CHROMOSOME ABERRATION; GENETICS; MITOSIS. [T.L.O.W.]

**Polypodiales** The largest order of modern ferns, commonly called the true ferns, with approximately 250 genera and 9000 species; also known as Filicales. Although well represented in the temperate regions, they reach their greatest development in the moist tropics. They vary in habit from small filmy structures to large tree-like plants. Many are epiphytic (live perched on other plants) and a number are climbing species. A few are aquatic. Perhaps the most striking species are the tropical tree ferns with their upright, unbranched stems and terminal clusters of large graceful leaves.

The Polypodiales differ from the other fern orders in being leptosporangiate—that is, their sporangium, or spore sac, arises from a single surface cell—and in having small sporangia with a definite number of spores. The wall of the sporangium is almost encircled with a ring of cells having unevenly thickened walls. This ring is called the annulus. When the sporangium is mature, the annulus, acting as a spring, causes the sporangium wall to rupture, thus discharging the spores. These plants are valued for their beauty and for the clues they give to the evolutionary history of the Polypodiales which extends back through the coal measures of the Paleozoic. See PALEOBOTANY.

The sporophyte is the conspicuous phase of the true ferns, and like other vascular plants it has true roots, stems, and leaves (Fig. 1). In most ferns, especially those of the temperate regions, the mature stem is usually a creeping rhizome (underground stem) without aerial branches. However, in several species the stems are branched, and in some they are erect. Whereas in the tropics the leaves are usually persistent and evergreen, in temperate regions the leaves of most species die back each year and are replaced by new ones the next growing season. Characteristic of this order is the apparent uncoiling of the leaves from the base toward the apex.

The internal structure of the blade of the leaf and of the root is very similar to that of these organs in the seed plants. The main



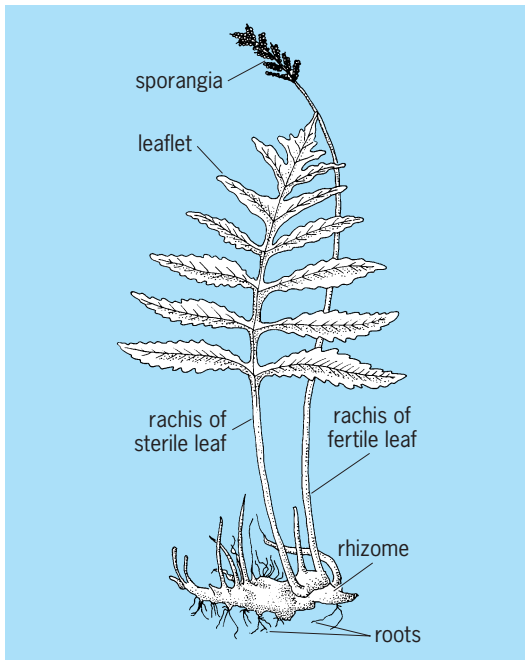

Fig. 1. The sensitive fern (*Onoclea sensibilis*), a representative of the Polypodiopsida. (After W. W. Robbins, T. E. Weier, and C. R. Stocking, *Botany: An Introduction to Plant Science*, 3d ed., John Wiley and Sons, Inc., 1964)

difference is the presence of large intercellular spaces in the fern leaf and the frequent lack of apparent distinction between the spongy and palisade cells of the mesophyll, possibly because most ferns grow in the shade.

The life cycle of the fern consists of two independent (self-sustaining) alternating generations. The common leafy fern plant is the sporophytic (spore-producing) generation. When the mature spores are discharged and reach a suitable substrate, they germinate and produce a small, flat, green, heart-shaped structure known as the prothallium or gametophytic (gamete-producing) generation. The gametophyte produces the sex organs antheridia (male) and archegonia (female). The gametes (sperm and egg) unite in fertilization and the resultant cell, or zygote, develops into the spore-bearing (sporophytic) fern plant.

In all ferns, the spores are produced in special multicellular organs known as sporangia. Except for a few genera, the sporangia are arranged in groups or clusters called sori (Fig. 2). These are on the lower surface of the leaves or fertile fronds,

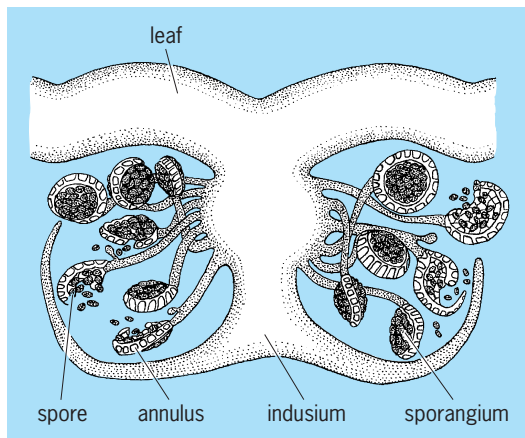

Fig. 2. Diagram of section through a fern leaf, showing details of a sorus. (After W. W. Robbins, T. E. Weier, and C. B. Stocking, *Botany: An Introduction to Plant Science*, 3d ed., John Wiley and Sons, Inc., 1964)

either along the midrib of the pinnae, near the leaf margins, or scattered. Usually each sorus is covered by a flaplike structure called the indusium, which may be of various shapes and sizes. However, a few ferns have naked sori, and others have a false indusium formed by the folding or inrolling of the leaf margin. See POLYPODIOPHYTA; PSILOTOPHYTA. [P.A.V.]

**Polypodiophyta** A division of the plant kingdom, commonly called the ferns, which is widely distributed throughout the world but is most abundant and varied in moist, tropical regions. The Polypodiophyta are sometimes treated as a class Polypodiopsida of a broadly defined division Tracheophyta (vascular plants). The group consists of five living orders (Ophioglossales, Marattiales, Polypodiales, Marsileales, and Salviniales), plus several orders represented only by Paleozoic fossils. The vast majority of the nearly 10,000 species belong to the single order Polypodiales, sometimes also called Filicales. See POLYPODIOPHYTA.

The Polypodiophyta ordinarily have well-developed roots, stems, and leaves that contain xylem and phloem as conducting tissues. The central cylinder of vascular tissue in the stem usually has well-defined parenchymatous leaf gaps where the leaf traces depart from it. The leaves are spirally arranged on the stem and are usually relatively large, with an evidently branching vascular system. In most kinds of ferns the leaves, called fronds, are compound or dissected. See LEAF; PHLOEM; ROOT (BOTANY); STEM; XYLEM.

The Polypodiophyta show a well-developed alternation of generations, both the sporophyte and the gametophyte generation being detached and physiologically independent of each other at maturity. The sporophyte is much the more conspicuous, and is the generally recognized fern plant. On some or all of its leaves it produces tiny sporangia which in turn contain spores. See COENOPTERIDALES; MARATTIALES; POLYPODIALES; REPRODUCTION (PLANT). [A.Cr.]

**Polypodiopsida** A class (also known as Filicineae) of the plant division Polypodiophyta containing a large group of plants commonly called ferns. They are widely distributed throughout the world with their greatest development in the moist tropics. Polypodiopsida is an old class with a good representation in the Paleozoic flora. Some of the plant fossils resemble contemporary living species. See COENOPTERIDALES; MARATTIALES; POLYPODIALES; POLYPODIOPHYTA. [P.A.V.]

**Polypteriformes** A distinctive and apparently ancient order of actinopterygian fishes, also called the Cladistia or the bichirs. Their characters include thick, rhombic, ganoid scales with an enamellike covering; a slitlike spiracle behind the eye; a well-ossified internal skeleton; a symmetrical caudal fin, basally heterocercal, with the upper part continuous with the dorsal fin (see illustration); a dorsal series of free, spinelike finlets, each supported by a radial bone; a distinctive pectoral fin base with three enlarged radial bones; and paired ventral lungs.

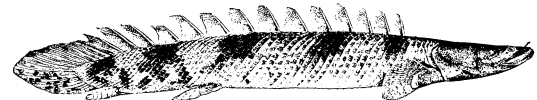

Bichir (*Polypterus endlicheri*), length to 3 ft (90 cm). (After G. A. Boulenger, *Catalogue of the Fresh Water Fishes of Africa in the British Museum*, vol. 1, 1909)

This order consists of a single family, the Polypteridae, that is known from the Eocene. The two Recent genera, *Polypterus*, with about 10 species, and *Erpetoichthys*, with 1 species, are confined to fresh waters of tropical Africa. See ACTINOPTERYGII; CHONDROSTEI. [R.M.B.]

**Poly(*p*-xylylene) resins** Linear, crystallizable resins based on an unusual polymerization of *p*-xylene and derivatives. The polymers are tough and chemically resistant, and may be deposited as adherent coatings by a vacuum process. The vapor deposition process makes it possible to coat small micro-electronic parts with a thin layer of the polymer. [J.A.M.]

**Polysaccharide** A class of high-molecular-weight carbohydrates, colloidal complexes, which break down on hydrolysis to monosaccharides containing five or six carbon atoms. The polysaccharides are considered to be polymers in which monosaccharides have been glycosidically joined with the elimination of water. A polysaccharide consisting of hexose monosaccharide units may be represented by the reaction below.

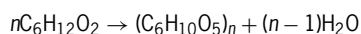

The term polysaccharide is limited to those polymers which contain 10 or more monosaccharide residues. Polysaccharides such as starch, glycogen, and dextran consist of several thousand D-glucose units. Polymers of relatively low molecular weight, consisting of two to nine monosaccharide residues, are referred to as oligosaccharides. See DEXTRAN; GLUCOSE; GLYCOGEN; MONOSACCHARIDE; STARCH.

Polysaccharides are often classified on the basis of the number of monosaccharide types present in the molecule. Polysaccharides, such as cellulose or starch, that produce only one monosaccharide type (D-glucose) on complete hydrolysis are termed homopolysaccharides. On the other hand, polysaccharides, such as hyaluronic acid, which produce on hydrolysis more than one monosaccharide type (*N*-acetylglucosamine and D-glucuronic acid) are named heteropolysaccharides. See CARBOHYDRATE. [W.Z.H.]

**Polystyrene resin** A hard, transparent, glasslike thermoplastic resin. Polystyrene is characterized by excellent electrical insulation properties, relatively high resistance to water, high refractive index, clarity, and low softening temperature.

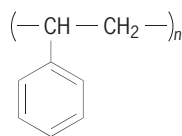

Polystyrene

High-molecular-weight homopolymers, copolymers, and polyblends are used as extrusion and molding compounds for packaging, appliance and furniture components, toys, and insulating panels. Styrene-butadiene copolymers are still used for automobile tires and in various rubber articles. The effects of blending small amounts of a rubbery polymer, such as butadiene-styrene rubber, with a hard, brittle polymer are most dramatic when the latter is polystyrene. The polyblend may have impact strength greater than ten times that of polystyrene. Various combinations of complex polyblends and interpolymers of acrylonitrile, styrene, and butadiene (ABS) resins are important as molding resins. ABS resins are also used as toughening agents for polymers such as polyvinyl chloride. Polystyrene is also used in combination with paints. The homopolymer and polyblends are used for panels or liners for refrigerator doors. Polystyrene may also be fabricated in the form of a rigid foam, which is used in packaging, food-service articles, and insulating panels. See ACRYLONITRILE; COPOLYMER; PLASTICS PROCESSING; POLYACRYLONITRILE RESINS; POLYMER; POLYMERIZATION; RUBBER; STYRENE. [J.A.M.]

**Polysulfide resins** Resins that vary in properties from viscous liquids to rubberlike solids. Organic polysulfide resins are prepared by the condensation of organic dihalides with a polysulfide.

Compounding and fabrication of the rubbery polymers can be handled on conventional rubber machinery. The polysulfide rubbers are distinguished by their resistance to solvents such as gasoline, and to oxygen and ozone. The polymers are relatively impermeable to gases. The products are used to form coatings which are chemically resistant and special rubber articles, such as gasoline bags. The polysulfide rubbers were among the first polymers to be used in solid-fuel compositions for rockets. See ORGANOSULFUR COMPOUND; POLYMERIZATION; RUBBER. [J.A.M.]

**Polysulfone resins** Polymers containing sulfone groups ( $\text{—SO}_2\text{—}$ ) in the main chain, along with a variety of aromatic or aliphatic constituents. Polysulfones based on aromatic backbones constitute a useful class of engineering plastics, owing to their high strength, stiffness, and toughness together with high thermal and oxidative stability, low creep, transparency, and the ability to be processed by standard techniques for thermoplastics. The aromatic structural elements and the presence of sulfone groups are responsible for the resistance to heat and oxidation; ether and isopropylidene groups contribute some chain flexibility. Aromatic polysulfones can be used over wide temperature ranges. The high-temperature performance of poly(ethersulfones) to 200°C (390°F) is surpassed by few other polymers.

Because of the combination of properties discussed, aromatic polysulfone resins find many applications in electronic and automotive parts, medical instrumentation subject to sterilization, chemical and food processing equipment, and various plumbing and home appliance items. Coating formulations are also available, as well as grades reinforced with glass beads or fibers. Aliphatic polysulfones are less stable, for example, to hydrolysis. However, they have potential use in biomedical applications such as artificial membranes to remove carbon dioxide and perfuse with oxygen. See COPOLYMER; HETEROCYCLIC POLYMER; ORGANOSULFUR COMPOUND. [J.A.M.]

**Polytrichidae** A subclass of the mosses (class Bryopsida), consisting of one family and 19 genera. The plants are acrocarpous and perennial, grow on soil, often in dry habitats, and are usually unbranched; annual increments often grow up through the male inflorescences, but do not give the appearance of forked stems. The plants are nearly always dioecious, with both male and female inflorescences terminal. The stems generally have well-developed vascular tissues. The long, narrow leaves are sheathed at the base; above the base the midrib often occupies most of the leaf. Stomata are usually present at or near the base of the capsule. See BRYOPHYTA; BRYOPSIDA; DAWSONIIDAE. [H.Cr.]

**Polytropic process** A process which occurs with an interchange of both heat and work between the system and its surroundings. The nonadiabatic expansion or compression of a fluid is an example of a polytropic process. The interrelationships between the pressure ( $P$ ) and volume ( $V$ ) and pressure and temperature ( $T$ ) for a gas undergoing a polytropic process are given by Eqs. (1) and (2), where  $a$  and  $b$  are the polytropic

$$PV^a = \text{constant} \quad (1)$$

$$P^b/T = \text{constant} \quad (2)$$

constants for the process of interest. These constants, which are usually determined from experiment, depend upon the equation of state of the gas, the amount of heat transferred, and the extent of irreversibility in the process. See GAS; ISENTROPIC PROCESS; ISOTHERMAL PROCESS; THERMODYNAMIC PROCESSES. [S.I.S.]

**Polyurethane resins** Polyurethane (or polyisocyanate) resins are produced by the reaction of a diisocyanate with a compound containing at least two active hydrogen atoms, such as a diol or diamine. Linear, fiber-forming polymers are formed by

the addition of diisocyanates to diols, while cross-linking is made possible by the use of polyols or isocyanates having more than two functional groups. Unique elastomeric or stretch fibers can be made from polyester prepolymers, in which rubbery polyester blocks alternate with rigid urethane units and terminal isocyanate groups provide sites for further chain extension and cross-linking.

There are three major types of polyurethane elastomers. One type is based on ether- or ester-type prepolymers that are chain-extended and cross-linked using polyhydroxyl compounds or amines; alternately, unsaturated groups may be introduced to permit vulcanization with common curing agents such as peroxides. A second type is obtained by first casting a mixture of prepolymer with chain-extending and cross-linking agents, and then cross-linking further by heating. The third type is prepared by reacting a dihydroxy ester- or ether-type prepolymer, or a diacid, with a diisocyanate such as diphenylmethane diisocyanate and a diol.

Polyurethane resins can be produced in forms varying from hard, glossy, solvent-resistant coatings, to abrasion- and solvent-resistant rubbers, fibers, and flexible-to-rigid foams. The foams have found the widest use. The more flexible foams are employed as upholstery material for furniture, as rug backing, insulation, and crash pads. The more rigid foams are employed as the core in structural and insulating laminates and as insulation in refrigerated appliances and vehicles. Polyurethanes are also used as adhesives, for example, in the bonding of rubber and of nylon. The flexible polyurethanes may be used for coating rubber articles to give them additional resistance to abrasion and solvents. Wire insulated with polyurethane resin can be soldered directly without previously removing the coating because the polymer decomposes at the soldering temperature to yield a clean wire surface. See PLASTICS PROCESSING; POLYESTER RESINS; POLYETHER RESINS; POLYMERIZATION. [J.A.M.]

**Polyvinyl resins** Polymeric materials generally considered to include polymers derived from monomers having the structure

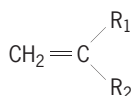

in which  $\text{R}_1$  and  $\text{R}_2$  represent hydrogen, alkyl, halogen, or other groups. This article refers to polymers whose names include the term vinyl. For discussions of other vinyl-type polymers see POLYACRYLATE RESIN; POLYACRYLONITRILE RESINS; POLYFLUOROLEFIN RESINS; POLYOLEFIN RESINS; POLYSTYRENE RESIN.

Many of the monomers can be prepared by addition of the appropriate compound to acetylene. For example, vinyl chloride, vinyl fluoride, vinyl acetate, and vinyl methyl ether may be formed by the reactions of acetylene with  $\text{HCl}$ ,  $\text{HF}$ ,  $\text{CH}_3\text{OOH}$ , and  $\text{CH}_3\text{OH}$ , respectively. Processes based on ethylene as a raw material have also become common for the preparation of vinyl chloride and vinyl acetate.

The polyvinyl resins may be characterized as a group of thermoplastics which, in many cases, are inexpensive and capable of being handled by solution, dispersion, injection molding, and extrusion techniques. The properties vary with chemical structure, crystallinity, and molecular weight.

Poly(vinyl acetals) are relatively soft, water-insoluble thermoplastic products obtained by the reaction of poly(vinyl alcohol) with aldehydes. Properties depend on the extent to which alcohol groups are reacted. Poly(vinyl butyral) is rubbery and tough and is used primarily in plasticized form as the inner layer and binder for safety glass. Poly(vinyl formal) is the hardest of the group; it is used mainly in adhesive, primer, and wire-coating formulations, especially when blended with a phenolic resin.

Poly(vinyl acetate) is a leathery, colorless thermoplastic material which softens at relatively low temperatures and which is relatively stable to light and oxygen. The polymers are clear

and noncrystalline. The chief applications are as adhesives and binders for water-based or emulsion paints. See PAINT.

Poly(vinyl alcohol) is a tough, whitish polymer which can be formed into strong films, tubes and fibers that are highly resistant to hydrocarbon solvents. Although poly(vinyl alcohol) is one of the few water-soluble polymers, it can be rendered insoluble in water by drawing or by the use of cross-linking agents. Two groups of products are available, those formed by the essentially complete hydrolysis of poly(vinyl acetate), and those formed by incomplete hydrolysis.

The former may be plasticized with water or glycols and molded or extruded into films, tubes, and filaments which are resistant to hydrocarbons. These products are used for liners in gasoline hoses, for grease-resistant coating and paper adhesives, for treating paper and textiles, and as emulsifiers and thickeners.

Poly(vinyl carbazole) is a tough, glassy thermoplastic with excellent electrical properties and a relatively high softening temperature. Uses of the product has been limited to small-scale electrical applications requiring resistance to high temperatures.

Poly(vinyl chloride) [PVC] is a tough, strong thermoplastic material which has an excellent combination of physical and electrical properties. The products are usually characterized as plasticized or rigid types. Poly(vinyl chloride)[and copolymers] is the second most commonly used polyvinyl resin and one of the most versatile plastics. The plasticized types are somewhat elastic materials which are familiar in the form of shower curtains, floor coverings, raincoats, dishpans, dolls, bottle-top sealers, prosthetic forms, wire insulation, and films. Rigid products, which may consist of the homopolymer, copolymer, or polyblends, are commonly used in the manufacture of phonograph records, pipe, chemically resistant liners for chemical reaction vessels, and siding and window sashes.

Poly(vinylidene chloride) is a tough, hornlike thermoplastic with properties generally similar to those of poly(vinyl chloride). Because of its relatively low solubility and decomposition temperature, the material is most widely used in the form of copolymers with other vinyl monomers, such as vinyl chloride. The copolymers are employed as packaging film, rigid pipe, and as filaments for upholstery and window screens.

Poly(vinyl ethers) exist in several forms varying from soft, balsamlike semisolids to tough, rubbery masses, all of which are readily soluble in organic solvents. Polymers of the alkyl vinyl ethers are used in adhesive formulations and as softening or flexibilizing agents for other polymers.

Poly(vinyl fluoride) is a tough, partially crystalline thermoplastic material which has a higher softening temperature than poly(vinyl chloride). Films and sheets are characterized by high resistance to impact and cracking caused by flexing and temperature and by resistance to weathering.

Poly(vinyl pyrrolidone) is a water-soluble polymer of basic nature which has film-forming properties, strong absorptive or complexing qualities for various reagents, and the ability to form water-soluble salts which are polyelectrolytes. The main uses are as a water-solubilizing agent for medicinal agents such as iodine, and as a semipermanent setting agent in hair sprays. Certain synthetic textile fibers containing small amounts of vinylpyrrolidone as a copolymer have improved affinity for dyes. See PLASTICS PROCESSING; POLYMER; POLYMERIZATION. [J.A.M.]

**Pomegranate** A small deciduous tree, *Punica granatum*, belonging to the plant order Myrtales. Pomegranate is grown as an ornamental as well as for its fruit. The pomegranate is a native of Asia. It was originally known for its medicinal qualities, and cures for various ills were attributed to the fruit juice, the rind, and the bark of the roots. The fruit is a reddish, pomelike berry, containing numerous seeds imbedded in crimson pulp, from which an acid, reddish juice may be obtained. Limited quantities are grown in California and the Gulf states. See FRUIT, TREE; MYRTALES. [J.H.Cl.]

**Poplar** Any tree of the genus *Populus*, family Salicaceae, marked by simple, alternate leaves which are usually broader than those of the willow, the other American representative of this family. Poplars have scaly buds, bitter bark, flowers and fruit in catkins, and a five-angled pith. See SALICALES; WILLOW.

Some species are commonly called cottonwood because of the cottony hairs attached to the seeds. Other species, called aspens, have weak, flattened leaf stalks which cause the leaves to flutter in the slightest breeze. One of the important species in the United States is the quaking, or trembling, aspen (*P. tremuloides*). The soft wood of this species is used for paper pulp. The European aspen (*P. nigra*), which is similar to the quaking aspen, is sometimes planted, and its variety, *italica*, the Lombardy poplar of erect columnar habit, is used in landscape planting. The black cottonwood (*P. trichocarpa*) is the largest American poplar and is also the largest broad-leaved tree in the forests of the Pacific Northwest. The cottonwood or necklace poplar (*P. deltoides*) is native in the eastern half of the United States. In the balsam or tacamahac poplar (*P. balsamifera*), the resin is used in medicine as an expectorant. The wood is used for veneer, boxes, crates, furniture, paper pulp, and excelsior. [A.H.G./K.P.D.]

**Poppy** A plant, *Papaver somniferum* (Papaveraceae), which is probably a native of Asia Minor. It is cultivated extensively in China, India, and elsewhere. This plant is the source of opium, obtained by cutting into the fruits (capsules) soon after the petals have fallen. The white latex (juice) flows from the cuts and hardens when exposed to the air. This solidified latex is collected, shaped into balls or wafers, and often wrapped in the flower petals. This is the crude opium, which contains at least 20 alkaloids, including morphine and codeine. See MORPHINE; PAPAVERALES. [P.D.St./E.L.C.]

**Population dispersal** The process by which groups of living organisms expand the space or range within which they live. Dispersal operates when individual organisms leave the space that they have occupied previously, or in which they were born, and settle in new areas. Natal dispersal is the first movement of an organism from its birth site to the site in which it first attempts to breed. Adult dispersal is a subsequent movement when an adult organism changes its location in space. As individuals move across space and settle into new locations, the population to which they belong expands or contracts its overall distribution. Thus, dispersal is the process by which populations change the area they occupy.

Migration is the regular movement of organisms during different seasons. Many species migrate between wintering and breeding ranges. Such migratory movement is marked by a regular return in future seasons to previously occupied regions, and so usually does not involve an expansion of population range. Some migratory species show astounding abilities to return to the exact locations used in previous seasons. Other species show no regular movements, but wander aimlessly without settling permanently into a new space. Wandering (called nomadism) is typical of species in regions where the availability of food resources are unpredictable from year to year. Neither migration nor nomadism is considered an example of true dispersal. See MIGRATORY BEHAVIOR.

Virtually all forms of animals and plants disperse. In most higher vertebrates, the dispersal unit is an entire organism, often a juvenile or a member of another young age class. In other vertebrates and many plants, especially those that are sessile (permanently attached to a surface), the dispersal unit is a specialized structure (disseminule). Seeds, spores, and fruits are disseminules of plants and fungi; trochophores and planula larvae are disseminules of sea worms and corals, respectively. Many disseminules are highly evolved structures specialized for movement by specific dispersal agents such as wind, water, or other animals.

A special case of zoochory (dispersal using animal agents) involves transport by humans. The movement of people and cargo by cart, car, train, plane, and boat has increased the potential dispersal of weedy species worldwide. Many foreign aquatic species have been introduced to coastal areas by accidental dispersal of disseminules in ship ballast water. The zebra mussel is one exotic species that arrive in this manner and is now a major economic problem throughout the Great Lakes region of North America. Some organisms have been deliberately introduced by humans into new areas. Domestic animals and plants have been released throughout the world by farmers. A few pest species were deliberately released by humans; European starlings, for example.

Some of the most highly coevolved dispersal systems are those in which the disseminule must be eaten by an animal. Such systems have often evolved a complex series of signals and investments by both the plant and the animal to ensure that the seeds are dispersed at an appropriate time and that the animal is a dependable dispersal agent. Such highly evolved systems are common in fruiting plants and their dispersal agents, which are animals called frugivores. Fruiting plants cover their seeds with an attractive, edible package (the fruit) to get the frugivore to eat the seed. To ensure that fruits are not eaten until the seeds are mature, plants change the color of their fruits as a signal to show that the fruits are ready for eating.

Many plants in the tropical rainforests are coevolved to have their seeds dispersed by specific animal vectors, including birds, mammals, and ants. Many tropical trees, shrubs, and herbaceous plants are specialized to have their seeds dispersed by a single animal species. Temperate forest trees, in contrast, often depend on wind dispersal of both pollen and seeds.

Dispersal barriers are physical structures that prevent organisms from crossing into new space. Oceans, rivers, roads, and mountains are examples of barriers for species whose disseminules cannot cross such features. It is believed that the creation of physical barriers is the primary factor responsible for the evolution of new species. A widespread species can be broken into isolated fragments by the creation of a new physical barrier. With no dispersal linking the newly isolated populations, genetic differences that evolve in each population cannot be shared between populations. Eventually, the populations may become so different that no interbreeding occurs even if dispersal pathways are reconnected. The populations are then considered separate species. See SPECIATION.

Dispersal is of major concern for scientists who work with rare and endangered animals. Extinction is known to be more prevalent in small, isolated populations. Conservation biologists believe that many species exist as a metapopulation, that is, a group of populations interconnected by the dispersal of individuals or disseminules between subpopulations. The interruption of dispersal in this system of isolated populations can increase the possibility of extinction of the whole metapopulation. Conservation plans sometimes propose the creation of corridors to link isolated patches of habitat as a way of increasing the probability of successful dispersal. See EXTINCTION (BIOLOGY); POPULATION DISPERSION. [J.B.D.]

**Population dispersion** The spatial distribution at any particular moment of the individuals of a species of plant or animal. Under natural conditions organisms are distributed either by active movements, or migrations, or by passive transport by wind, water, or other organisms. The act or process of dissemination is usually termed dispersal, while the resulting pattern of distribution is best referred to as dispersion. Dispersion is a basic characteristic of populations, controlling various features of their structure and organization. It determines population density, that is, the number of individuals per unit of area, or volume, and its reciprocal relationship, mean area, or the average area per individual. It also determines the frequency, or chance of encountering one or more individuals of the population in a particular sample unit of area, or volume. The ecologist

therefore studies not only the fluctuations in numbers of individuals in a population but also the changes in their distribution in space. See POPULATION DISPERSAL.

**Principal types of dispersion.** The dispersion pattern of individuals in a population may conform to any one of several broad types, such as random, uniform, or contagious (clumped). Any pattern is relative to the space being examined; a population may appear clumped when a large area is considered, but may prove to be distributed at random with respect to a much smaller area.

Random or haphazard implies that the individuals have been distributed by chance. In such a distribution, the probability of finding an individual at any point in the area is the same for all points. Hence a truly random pattern will develop only if each individual has had an equal and independent opportunity to establish itself at any given point. Examples of approximately random dispersions can be found in the patterns of settlement by free-floating marine larvae and of colonization of bare ground by airborne disseminules of plants. Nevertheless, true randomness appears to be relatively rare in nature.

Uniform distribution implies a regularity of distance between and among the individuals of a population. Perfect uniformity exists when the distance from one individual to its nearest neighbor is the same for all individuals. Patterns approaching uniformity are most obvious in the dispersion of orchard trees and in other artificial plantings, but the tendency to a regular distribution is also found in nature, as for example in the relatively even spacing of trees in forest canopies, the arrangement of shrubs in deserts, and the distribution of territorial animals.

The most frequent type of distribution encountered is contagious or clumped, indicating the existence of aggregations or groups in the population. Clusters and clones of plants, and families, flocks, and herds of animals are common phenomena. The formation of groups introduces a higher order of complexity in the dispersion pattern, since the several aggregations may themselves be distributed at random, evenly, or in clumps. An adequate description of dispersion, therefore, must include not only the determination of the type of distribution, but also an assessment of the extent of aggregation if the latter is present.

**Factors affecting dispersion.** The principal factors that determine patterns of population dispersion include (1) the action of environmental agencies of transport, (2) the distribution of soil types and other physical features of the habitat, (3) the influence of temporal changes in weather and climate, (4) the behavior pattern of the population in regard to reproductive processes and dispersal of the young, (5) the intensity of intra- and interspecific competition, and (6) the various social and antisocial forces that may develop among the members of the population. Although in certain cases the dispersion pattern may be due to the overriding effects of one factor, in general populations are subject to the collective and simultaneous action of numerous distributional forces and the dispersion pattern reflects their combined influence. When many small factors act together on the population, a more or less random distribution is to be expected, whereas the domination of a few major factors tends to produce departure from randomness.

**Optimal population density.** The degree of aggregation which promotes optimum population growth and survival varies according to the species and the circumstances. Groups or organisms often flourish best if neither too few nor too many individuals are present; they have an optimal population density at some intermediate level. The concept of an intermediate optimal population density is sometimes known as Allee's principle. See ECOLOGICAL COMMUNITIES; POPULATION ECOLOGY; POPULATION GENETICS. [F.C.E.]

**Population ecology** The study of spatial and temporal patterns in the abundance and distribution of organisms and of the mechanisms that produce those patterns. Species differ dramatically in their average abundance and geographical dis-

tributions, and they display a remarkable range of dynamical patterns of abundance over time, including relative constancy, cycles, irregular fluctuations, violent outbreaks, and extinctions. The aims of population ecology are threefold: (1) to elucidate general principles explaining these dynamic patterns; (2) to integrate these principles with mechanistic models and evolutionary interpretations of individual life-history tactics, physiology, and behavior as well as with theories of community and ecosystem dynamics; and (3) to apply these principles to the management and conservation of natural populations.

In addition to its intrinsic conceptual appeal, population ecology has great practical utility. Control programs for agricultural pests or human diseases ideally attempt to reduce the intrinsic rate of increase of those organisms to very low values. Analyses of the population dynamics of infectious diseases have successfully guided the development of vaccination programs. In the exploitation of renewable resources, such as in forestry or fisheries biology, population models are required in order to devise sensible harvesting strategies that maximize the sustainable yield extracted from exploited populations. Conservation biology is increasingly concerned with the consequences of habitat fragmentation for species preservation. Population models can help characterize minimum viable population sizes below which a species is vulnerable to rapid extinction, and can help guide the development of interventionist policies to save endangered species. Finally, population ecology must be an integral part of any attempt to bring the world's burgeoning human population into harmonious balance with the environment. See ECOLOGY; MATHEMATICAL ECOLOGY; THEORETICAL ECOLOGY. [R.Hol.]

**Population genetics** The study of both experimental and theoretical consequences of mendelian heredity on the population level, in contradistinction to classical genetics which deals with the offspring of specified parents on the familial level. The genetics of populations studies the frequencies of genes, genotypes, and phenotypes, and the mating systems. It also studies the forces that may alter the genetic composition of a population in time, such as recurrent mutation, migration, and intermixture between groups, selection resulting from genotypic differential fertility, and the random changes incurred by the sampling process in reproduction from generation to generation. This type of study contributes to an understanding of the elementary step in biological evolution. The principles of population genetics may be applied to plants and to other animals as well as humans. See GENETICS; MENDELISM. [C.C.L.]

**Population viability** The ability of a population to persist and to avoid extinction. The viability of a population will increase or decrease in response to changes in the rates of birth, death, and growth of individuals. In natural populations, these rates are not stable, but undergo fluctuations due to external forces such as hurricanes and introduced species, and internal forces such as competition and genetic composition. Such factors can drive populations to extinction if they are severe or if several detrimental events occur before the population can recover. See ECOLOGY; POPULATION ECOLOGY.

One of the most important uses of population viability models comes from modern conservation biology, which uses these models to determine whether a population is in danger of extinction. This is called population viability analysis (PVA) and consists of demographic and genetic models that are used to make decisions on how to manage populations of threatened or endangered species. The National Research Council has called population viability analysis "the cornerstone, the obligatory tool by which recovery objectives and criteria [for endangered species] are identified." See ECOLOGICAL MODELING. [G.LeB.; T.E.M.]

**Porcelain** A high-grade ceramic ware characterized by high strength, a white color (under the glaze), very low absorption, good translucency, and a hard glaze. Equivalent terms are

## 1756 Porcupine

European porcelain, hard porcelain, true porcelain, and hard paste porcelain. See GLAZING; POTTERY.

Porcelain is distinguished from other fine ceramic ware, such as china, by the fact that the firing of the unglazed ware (the bisque firing) is done at a lower temperature (1800–2200°F or 1000–1200°C) than the final or glaze firing, which may be as high as 2700°F (1500°C). In other words, the ware reaches its final state of maturity at the maturing temperatures of the glaze.

The white color is obtained by using very pure white-firing kaolin or china clay and other pure materials, the low absorption results from the high firing temperature, and the translucency results from the glass phase. See CERAMICS. [J.F.McM.]

**Porcupine** Any of about 26 species of rodents which have spines or quills in addition to regular hair. These mammals are included in two families, the Hystricidae, or Old World porcupines, and the Erethizontidae, or New World porcupines. The spines are sharply pointed, erectile hairs which serve the animal as defensive structures and are controlled by powerful skin muscles. These animals have short limbs which terminate in five functional digits in the Old World species and four in the New World species. See MAMMALIA; RODENTIA. [C.B.C.]

**Porifera** The sponges, a phylum of the animal kingdom which includes about 5000 described species. The body plan of sponges is unique among animals. Currents of water are drawn through small pores, or ostia, in the sponge body and leave by way of larger openings called oscula. The beating of flagella on collar cells or choanocytes, localized in chambers on the interior of the sponge, maintains the water current. Support for the sponge tissues is provided by calcareous or siliceous spicules, or by organic fibers, or by a combination of organic fibers and siliceous spicules. Some species have a compound skeleton of organic fibers, siliceous spicules, and a basal mass of aragonite or calcite. The skeletons of species with supporting networks of organic fibers have long been used for bathing and cleaning purposes. Because of their primitive organization, sponges are of interest to zoologists as an aid in understanding the origin of multicellular animals. See ANIMAL KINGDOM; PARAZOA.

The Porifera have a fossil record extending from the Precambrian to Recent times. More than 1000 genera of fossil sponges have been described from the Paleozoic, Mesozoic, and Cenozoic eras.

The living Porifera are divided into four classes on the basis of their skeletal structures. A taxonomic scheme of the Porifera follows.

- Class Hexactinellida
  - Subclass Amphidiscophora
    - Order: Amphidiscosa
      - Hemidiscosa
      - Reticulosa
  - Subclass Hexasterophora
    - Order: Hexactinosa
      - Lynchniscosa
      - Lyssacinosa
- Class Calcarea
  - Subclass Calcinea
    - Order: Clathrinida
      - Leucettida
    - Subclass Calcaronea
      - Order: Leucosoleniida
        - Sycettida
    - Subclass Pharetronida
  - Class Demospongiae
    - Subclass Tetractinomorpha
      - Order: Homosclerophorida
        - Choristida

- Spirophorida
- Hadromerida
- Axinellida
- Subclass Ceractinomorpha
  - Order: Dendroceratida
    - Dictyoceratida
    - Halichondrida
    - Haplosclerida
    - Poecilosclerida
    - (Permosphincta, extinct)
- Class Sclerospongiae

[J.K.Ri.]

**Porocephalida** One of two orders in the class Pentastomida of the phylum Arthropoda. In this order the larvae have four legs. The hooks on the adult articulate on a chitinous base or fulcrum and are arranged in a flattened trapezoidal pattern, or in a curved line or straight line. There are no podial or parapodial lobes. The two suborders are Porocephaloidea and Linguatuloidea.

The Porocephaloidea comprise five families—Porocephalidae, Sebekidae, Armilliferidae, Sambonidae, and Subtriquetridae—and include most of the pentastomid species. These animals are cylindrical, with rounded ends. The hooks are sessile; the mouth is anterior between the hooks. Adults occur in the respiratory passages of snakes, lizards, turtles, and crocodiles; the larvae are encysted in fishes, snakes, lizards, crocodiles, and mammals.

Linguatuloidea contains a single family, with a single genus, *Linguatula*. Adults live in the nasal cavities of carnivorous mammals; the larvae are encysted in herbivorous mammals. The body is elongate, flattened ventrally, annulate, and attenuated posteriorly. See PENTASTOMIDA. [H.W.S.]

**Porphyrim** One of a class of cyclic compounds in which the parent macrocycle consists of four pyrrole-type units linked together by single carbon bridges. Several porphyrins with selected peripheral substitution and metal coordination carry out vital biochemical processes in living organisms. Chlorins, bacteriochlorins, and corrins are related tetrapyrrolic macrocycles that are also observed in biologically important compounds.

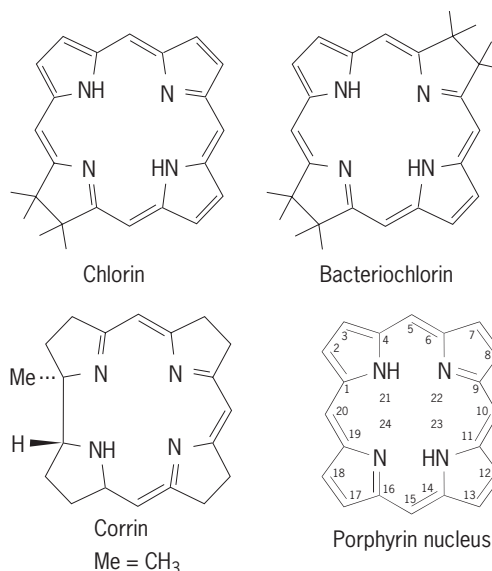

The complexity of porphyrin nomenclature parallels the complex structures of the naturally occurring derivatives. Hans Fischer used a simple numbering system for the porphyrin nucleus and a set of common names to identify the different

porphyrins and their isomers. A systematic naming based on the 1–24 numbering system for the porphyrin nucleus was later developed by the International Union of Pure and Applied Chemistry (IUPAC) and the International Union of Biochemistry (IUB), and this system has gained general acceptance. The need for common names is clear after examination of the systematic names; for example, protoporphyrin IX has the systematic name 2,7,12,18-tetramethyl-3,8-divinyl-13,17-dipropanoic acid.

The aromatic character (hence stability) of porphyrins has been confirmed by measurements of their heats of combustion. In addition, x-ray crystallographic studies have established planarity of the porphyrin macrocycle which is a basic requirement for aromatic character. See DELOCALIZATION; X-RAY CRYSTALLOGRAPHY.

Most metals and metalloids have been inserted into the central hole of the porphyrin macrocycle. The resulting metalloporphyrins are usually very stable and can bind a variety of small molecules (known as ligands) to the central metal atom. Heme, the iron complex of protoporphyrin IX, is the prosthetic group of a number of major proteins and enzymes that carry out diverse biological functions. These include binding, transport, and storage of oxygen (hemoglobin and myoglobin), electron-transfer processes (cytochromes), activation and transfer of oxygen to substrates (cytochromes P450), and managing and using hydrogen peroxide (peroxidases and catalases). See COORDINATION COMPLEXES; CYTOCHROME; HEMOGLOBIN.

Chlorophylls and bacteriochlorophylls are magnesium complexes of porphyrin derivatives known as chlorins and bacteriochlorins, respectively. They are the pigments responsible for photosynthesis. Several chlorophylls have been identified, the most common being chlorophyll *a*, which is found in all oxygen-evolving photosynthetic plants. Bacteriochlorophyll *a* is found in many photosynthetic bacteria. See CHLOROPHYLL; PHOTOSYNTHESIS.

Porphyrins and metalloporphyrins exhibit many potentially important medicinal and industrial properties. Metalloporphyrins are being examined as potential catalysts for a variety of processes, including catalytic oxidations. They are also being examined as possible blood substitutes and as electrocatalysts for fuel cells and for the electrochemical generation of hydrogen peroxide. The unique optical properties of porphyrins make them likely candidates for photovoltaic devices and in photocopying and other optical devices. A major area where porphyrins are showing significant potential is in the treatment of a wide range of diseases, including cancer, using photodynamic therapy. See CATALYSIS. [T.W.D.]

**Porphyroblast** A relatively large crystal formed in a metamorphic rock. The presence of abundant porphyroblasts gives the rock a porphyroblastic texture. Minerals found commonly as porphyroblasts include biotite, garnet, chloritoid, staurolite, kyanite, sillimanite, andalusite, cordierite, and feldspar. Porphyroblasts are generally a few millimeters or centimeters across, but some attain a diameter of over 1 ft (30 cm). They may be bounded by well-defined crystal faces, or their outlines may be highly irregular or ragged. Very commonly they are crowded with tiny grains of other minerals that occur in the rock.

Most commonly, porphyroblasts develop in schist and gneiss during the late stages of recrystallization. As the rock becomes reconstituted, certain components migrate to favored sites and combine there to develop the large crystals. See GNEISS; METAMORPHIC ROCKS; SCHIST. [C.A.C.]

**Porphyry** An igneous rock characterized by porphyritic texture, in which large crystals (phenocrysts) are enclosed in a matrix of very fine-grained to aphanitic (not visibly crystalline) material. Porphyries are generally distinguished from other porphyritic rocks by their abundance of phenocrysts and by their occurrence in small intrusive bodies (dikes and sills) formed at shallow depth

within the earth. In this sense porphyries are hypabyssal rocks. See IGNEOUS ROCKS; PHENOCRYST.

Porphyries occur as marginal phases of medium-sized igneous bodies (stocks, laccoliths) or as apophyses (offshoots) projecting from such bodies into the surrounding rocks. They are also abundant as dikes cutting compositionally equivalent plutonic rock, or as dikes, sills, and laccoliths injected into the adjacent older rocks. [W.I.R.]

**Porulosida** An order of Radiolaria. The central capsule shows many pores, more or less uniformly distributed over the surface of the thick and usually globular layer. The development of skeletal structures ranges from none at all through scattered spines to well-developed latticework shells. Colonial aggregates, in which the capsules of a number of organisms are embedded in a matrix, occur in several genera. See RADIOLARIA. [R.P.H.]

**Positron** An elementary particle with mass equal to that of the electron, and positive charge equal in magnitude to the electron's negative charge. The positron is thus the antiparticle (charge-conjugate particle) to the electron. The positron has the same spin and statistics as the electron. Positrons, like electrons, appear as decay products of many heavier particles; electron-positron pairs are produced by high-energy photons in matter. See ANTIMATTER; ELECTRON; ELECTRON-POSITRON PAIR PRODUCTION; ELEMENTARY PARTICLE.

A positron is, in itself, stable, but cannot exist indefinitely in the presence of matter, for it will ultimately collide with an electron. The two particles will be annihilated as a result of this collision, and photons will be created. However, a positron can first become bound to an electron to form a short-lived "atom" termed positronium. See POSITRONIUM.

Quantum field theory predicts the occurrence of a fundamental positron creation process in the presence of strong, static electric fields. For a bare nucleus with atomic number  $Z > 173$ , it becomes energetically favorable to transform the electron binding energy of larger than  $2m_0c^2$ , where  $m_0$  is the electron rest mass and  $c$  is the speed of light, into simultaneously creating an electron bound to the nucleus and a positron that escapes from the nucleus. This process of spontaneous positron emission has not been observed since atoms with  $Z > 173$  are not available in nature. However, with the introduction of heavy-ion accelerators, it has become possible to simulate such an atom for a short period in a high-energy collision between two stable heavy atoms such as uranium. Experiments have utilized a variety of such collision systems with total  $Z$  ranging from 180 to 188 to search for spontaneous positron emission. A number of these experiments reproduce the salient features expected for this process. However, some inconsistencies with the predictions of the theory have yet to be resolved before spontaneous positron emission is established experimentally. See NUCLEAR MOLECULE; QUASIAMO; SUPERCRITICAL FIELDS. [C.G.; J.Gre.]

**Positronium** An atomic-like system consisting of an electron and positron. Just as in the hydrogen atom, the energy levels of positronium are quantized, with the deepest levels bound by about 6.8 eV. The electron and positron spins can be aligned in the same direction (singlet states) or in opposite directions (triplet states). Annihilation of the positron and electron destroys the lowest-energy singlet state (parapositronium) in about  $10^{-10}$  s, but the lowest triplet state (orthopositronium) survives longer, about  $10^{-7}$  s. This allows sufficient time for precise measurement of the energy levels of triplet states. Because of the absence of nuclei in positronium, these measurements provide an accurate test of theories of the electromagnetic force (quantum electrodynamics) without interference from the strong force. See ATOMIC STRUCTURE AND SPECTRA; ELECTRON; FUNDAMENTAL INTERACTIONS; POSITRON.

Since the formation of positronium requires the close approach of a positron and an electron, beams of slow positrons

can be used as probes of the electron density in gases, in insulating solids, or near surfaces. Since the singlet and triplet forms of positronium have very different lifetimes, and transitions between the two states can be induced by neighboring electrons, study of the decay of positronium can also provide information about electron densities on a microscopic scale. This is especially useful in the study of density fluctuations in gases near the critical point for condensation into liquids or solids. See CRITICAL PHENOMENA.

Annihilation radiation from positronium forms a component of the gamma-ray spectrum observed by astronomers, in particular from the galactic center. See GAMMA-RAY ASTRONOMY. [J.N.Ba.]

**Posttraumatic stress disorder** An anxiety disorder in some individuals who have experienced an event that poses a direct threat to the individual's or another person's life. The characteristic features of anxiety disorders are fear, particularly in the absence of a real-life threat to safety, and avoidance behavior.

A diagnosis of posttraumatic stress disorder requires that four criteria be met. First, the individual must have been exposed to an extremely stressful and traumatic event beyond the range of normal human experience. Second, the individual must periodically and persistently reexperience the event. This reexperiencing can take different forms, such as recurrent dreams and nightmares, an inability to stop thinking about the event, flashbacks during which the individual relives the trauma, and auditory hallucinations. Third, there is persistent avoidance of events related to the trauma, and psychological numbing that was not present prior to the trauma. Fourth, enduring symptoms of anxiety and arousal are present. These symptoms can be manifested in different forms, including anger, irritability, a very sensitive startle response, an inability to sleep well, and physiological evidence of fear when the individual is reexposed to a traumatic event.

Posttraumatic stress disorder symptoms appear to range over a continuum of severity, and it is unlikely that the disorder is an all-or-nothing phenomenon. The degree of the posttraumatic stress response is likely to be influenced by a complex interaction of personality, nature of the trauma, and posttraumatic events.

Physiological arousal responses in individuals with posttraumatic stress disorder include increases in heart rate, respiration rate, and skin conductivity upon reexposure to traumatic stimuli. Posttraumatic stress disorder may also be associated with structural and physiological changes in the brain. Stressful events also affect the activity level of the pituitary and adrenal glands. All these physiological changes are probably complexly related to the persistence and waxing and waning of symptoms in posttraumatic stress disorder. In addition, extreme and prolonged stress is associated with a variety of physical ailments, including heart attacks, ulcers, colitis, and decreases in immunological functioning. See NEUROBIOLOGY.

When an individual is diagnosed as having this disorder, particularly after it has been present for a number of years, it is common to also find significant depression, generalized anxiety, substance abuse and dependence, marital problems, and intense, almost debilitating anger. Although the primary symptoms of posttraumatic stress disorder are quite amenable to psychological treatment efforts, these secondary problems commonly associated with the chronic disorder are more difficult to treat.

Posttraumatic stress disorder can be treated by pharmacological means and with psychotherapy. Most psychological treatments for the disorder involve reexposure to the traumatic event. This reexposure is typically imaginal and can range from simply talking about the trauma to having the person vividly imagine reliving the traumatic event. This latter behavioral procedure is called implosion therapy or flooding. While flooding is not appropriate for all posttraumatic stress disorder cases, the procedure can dramatically decrease anxiety and arousal, intrusive thoughts, avoidance behavior, and emotional numbing. Along with specific behavior interventions, individuals with posttrau-

matic stress disorder should become involved in psychotherapeutic treatment for secondary problems. See NORADRENERGIC SYSTEM; PSYCHOPHARMACOLOGY; STRESS (PSYCHOLOGY). [R.W.But.]

**Postulate** In a formal deductive system, a proposition accepted without proof, from which other propositions are deduced by the conventional methods of formal logic. There is a certain arbitrariness as to which propositions are to be treated as postulates, because when certain proved propositions are treated as such, other propositions which were originally postulates often become proved propositions. In strict usage, the term postulate is nearly equivalent to axiom, although axiom is often loosely used to denote a truth supposed to be self-evident. See LOGIC.

[P.W.Br./H.Ma.]

**Postural equilibrium** A lifeless object is said to be in equilibrium, or in a state of balance, when all forces acting upon it cancel. The result is a state of rest. In an actively moving animal, internal as well as external forces have to be considered, and the maintenance of a balanced attitude in a body consisting of a number of parts that are loosely connected by movable joints is complex.

The maintenance of equilibrium is relatively easy in limbless animals. When the animal is turned on its back, the lack of contact pressure on the creeping surface and the tactile stimulation of the back initiate movements which return the animal to its normal position. This is known as the righting reflex. Free-swimming and flying animals are often in a precariously poised state of equilibrium, so that the normal attitude can be maintained only by the continuous operation of corrective equilibrating mechanisms. The same applies to a lesser degree to long-legged quadrupeds, such as many mammals, and to bipeds, such as birds and some primates (including humans).

For most species, there is a specific orientation of the whole body or of body segments (such as the head) with respect to gravity. This orientation is based on multisensory inputs and on a set of inborn reflexes acting on the musculature. These postural reflexes also stabilize the genetically defined body orientation against external disturbances. The sensory information relies on a number of sources: (1) static and dynamic information from the eyes; (2) static and dynamic mechanoreceptors incorporated in the various types of statocysts in invertebrate animals and in the vestibular organ or labyrinth of vertebrates; (3) proprioceptor organs such as muscle spindles, Golgi endings in tendons, Pacinian corpuscles and similar encapsulated endings associated with tendons and joints, and other pressure receptors in supporting surfaces (for example, the soles of feet); and (4) sensory endings in the viscera, capable of being differentially stimulated by changes in the direction of visceral pull on mesenteries, and on other structures. See SENSATION; SENSE ORGAN.

In higher terrestrial vertebrates, during stance the center of mass is usually situated high above the ground due to the support of the body by the limbs. A critical aspect of posture in quadrupedal and bipedal stance is equilibrium maintenance which is preserved only when under static conditions the projection of the center of mass remains inside the support base. This positioning of the center of mass is based on two main controls. A "bottom up" control is based on the afferent nerve impulses, cutaneous and proprioceptive, from the feet and the ankle joint muscles. These nerve impulses serve in building up posture from the feet to the head. A "top down" control starts from the head, and is predominant during dynamic activities such as locomotion. Due to labyrinthine afferent nerve impulses, the head axis orientation remains stable with respect to space. The movement-related visual afferents recorded by the retina monitor the head displacements with respect to space and adjust the body posture as a function of these inputs.

Two levels of control are involved in maintaining balance. A first level includes the spinal cord and the brainstem, where a set of inborn reflexes are organized for stance regulation and head



orientation. Most postural reflexes rely on networks at that level. The cerebellum is involved in the adaptation of these reflexes to the external constraints. See REFLEX.

A second level of control includes cortical areas involved in multisensory integration and control as well as the basal ganglia. The postural body schema and the body orientation with respect to the external world are organized mainly at that level, with a predominant role in the right hemisphere. Coordination between balance control and locomotion or movements also depends on these higher levels. [J.Mas.]

**Potassium** A chemical element, K, atomic number 19, and atomic weight 39.102. It stands in the middle of the alkali metal family, below sodium and above rubidium. This lightweight, soft, low-melting, reactive metal (see table) is very similar to sodium in its behavior in metallic forms. See ALKALI METALS; PERIODIC TABLE; RUBIDIUM; SODIUM.

Potassium chloride, KCl, finds its main use in fertilizer mixtures. It also serves as the raw material for the manufacture of other potassium compounds. Potassium hydroxide, KOH, is used in the manufacture of liquid soaps, and potassium carbonate in making soft soaps. Potassium carbonate,  $K_2CO_3$ , is also an important raw material for the glass industry. Potassium nitrate,  $KNO_3$ , is used in matches, in pyrotechnics, and in similar items which require an oxidizing agent. [M.Si.]

Potassium is a very abundant element, ranking seventh among all the elements in the Earth's crust, 2.59% of which is potassium in combined form. Seawater contains 380 parts per million, making potassium the sixth most plentiful element in solution.

Potassium is even more reactive than sodium. It reacts vigorously with the oxygen in air to form the monoxide,  $K_2O$ , and the peroxide,  $K_2O_2$ . In the presence of excess oxygen, it readily forms the superoxide,  $KO_2$ .

Potassium does not react with nitrogen to form a nitride, even at elevated temperatures. With hydrogen, potassium reacts slowly at  $200^\circ C$  ( $392^\circ F$ ) and rapidly at  $350$ – $400^\circ C$  ( $662$ – $752^\circ F$ ). It forms the least stable hydride of all the alkali metals.

The reaction between potassium and water or ice is violent, even at temperatures as low as  $-100^\circ C$  ( $-148^\circ F$ ). The hydrogen evolved is usually ignited in reaction at room temperature. Reactions with aqueous acids are even more violent and verge on being explosive.

The potassium ion ( $K^+$ ) is the most common intracellular cation and is essential for maintaining osmotic pressure and electrodynamic cellular properties in organisms. The intracellular potassium ion concentrations are typically high for most cells, whereas the potassium ion concentrations present in extracellu-

lar fluids are significantly lower. The hydrolysis of the coenzyme adenosine triphosphate (ATP) is mediated by the membrane-bound enzyme  $Na^+$ ,  $K^+$ -ATPase. This enzyme is called the sodium pump and it is activated by both potassium and sodium ions; however, many enzymes are activated by potassium ions alone (for example, pyruvate kinase, aldehyde dehydrogenase, and phosphofructokinase).

Potassium deficiency may occur in several conditions, including malnutrition and excessive vomiting or diarrhea, and in patients undergoing dialysis; supplementation with potassium salts is sometimes required. See OSMOREGULATORY MECHANISMS. [D.M.DeF.]

**Potato, Irish** A plant of the genus *Solanum* in the nightshade family, Solanaceae; it is related to tomatoes and peppers. There are more than 2000 species of *Solanum*, of which about 150 bear tubers. The potato of commerce, *S. tuberosum*, originated in South America, probably in the highlands of Peru and Bolivia, where it has been cultivated for several thousand years. Potatoes were introduced into Europe by Spanish explorers in the late sixteenth century and into the United States from Ireland in 1719. The crop became a staple in Europe, was a primary source of food in Ireland, and is known even today as the Irish potato. See SOLANALES.

The potato plant is an annual, herbaceous dicotyledon that is grown primarily for its edible tubers, which are short, thick underground stems that form on the ends of stolons (lateral stems). Lateral buds (eyes) on the mature tuber are the growing points for a new crop, provided that whole tubers or pieces with at least one eye are planted.

There are 95–100 varieties certified for seed production in the United States and Canada. In the United States, seven varieties account for more than 70% of the commercial acreage planted. These are Russet Burbank, Norchip, Atlantic, Russet Norkotah, Superior, Centennial Russet, and Kennebec.

Potatoes are grown in more countries than any crop except for corn (maize), and they are the fourth-most important food crop in supplying energy in the human diet, following rice, wheat, and corn. The leading potato producers are Russia, China, Poland, and the United States, in descending order.

Chemical constituents can be affected by variety, production area, cultural practices, maturity at harvest, and storage conditions. The average composition of potatoes is 78–80% water, 14–18% starch, 2% protein, 1% minerals, 0.4% fiber, and 0.1% fat, with some sugars, organic acids, amino acids, and vitamins. The potato is very nutritious, serving as a nearly complete food itself, and it produces more food per acre than any other crop.

Physical properties of potassium metal

Property	Temperature		SI units	Customary (engineering) units
	$^\circ C$	$^\circ F$		
Density	100	212	0.819 g/cm <sup>3</sup>	51.1 lb/ft <sup>3</sup>
	400	752	0.747 g/cm <sup>3</sup>	46.7 lb/ft <sup>3</sup>
	700	1292	0.676 g/cm <sup>3</sup>	42.2 lb/ft <sup>3</sup>
Melting point	63.7	147		
Boiling point	760	1400		
Heat of fusion	63.7	147	14.6 cal/g	26.3 Btu/lb
Heat of vaporization	760	1400	496 cal/g	893 Btu/lb
Viscosity	70	158	5.15 millipoises	6.5 kinetic units
	400	752	2.58 millipoises	3.5 kinetic units
	800	1472	1.36 millipoises	2 kinetic units
Vapor pressure	342	648	1 mm	0.019 lb/in. <sup>2</sup>
	696	1285	400 mm	7.75 lb/in. <sup>2</sup>
Thermal conductivity	200	392	0.017 cal/(s)(cm <sup>2</sup> )(cm)( $^\circ C$ )	26.0 Btu/(h)(ft <sup>2</sup> )( $^\circ F$ )
	400	752	0.09 cal/(s)(cm <sup>2</sup> )(cm)( $^\circ C$ )	21.7 Btu/(h)(ft <sup>2</sup> )( $^\circ F$ )
Heat capacity	200	392	0.19 cal/(g)( $^\circ C$ )	0.19 Btu/(lb)( $^\circ F$ )
	800	1472	0.19 cal/(g)( $^\circ C$ )	0.19 Btu/(lb)( $^\circ F$ )
Electrical resistivity	150	302	18.7 microhm-cm	
	300	572	28.2 microhm-cm	
Surface tension	100–150	212–302	About 80 dynes/cm	

Starch constitutes about 65–80% of the dry weight of the potato and, calorically, is the most important component. Potatoes contain appreciable amounts of the B vitamins, and they are an excellent source of vitamin D. Potatoes contribute more vitamin C to the United States food supply than any other single food source. Inorganic constituents or minerals of potatoes are predominantly potassium, phosphorus, sulfur, chlorine, magnesium, and calcium. Potatoes contain sufficient quantities of iron to be a good nutritional source of this mineral as well. [J.C.Mi.]

**Potato, sweet** The fleshy root of the plant *Ipomoea batatas*. The sweet potato was mentioned as being grown in Virginia as early as 1648. In 1930 the selection of outstanding strains of the Porto Rico variety, which was introduced into Florida in 1908, was begun in Louisiana, and the best strain, Unit I Porto Rico, was released in 1934. The Unit I Porto Rico is now being replaced by the Centennial, a yam type which has three times its vitamin A content. More than 70% of the commercial crop in the United States is of the Centennial variety. Louisiana is the leading state for commercial production of both the canned and fresh products.

There are two principal types of sweet potato, the kind erroneously called yam and the Jersey type. The chief difference between the two is that in cooking or baking the yam, much of the starch is broken down into simple sugars (glucose and fructose) and an intermediate product, dextrin. This gives it a moist, syrupy consistency somewhat sweeter than that of the dry (Jersey) type. On cooking, the sugar in the dry type remains as sucrose.

The yam is produced largely in the Southern states; however, because of the breeding of more widely adapted varieties, it is now being grown farther north. The Jersey sweet potato is grown largely along the eastern shore of Virginia. Maryland, Delaware, and New Jersey, and also in Iowa and Kansas. [J.C.M.]

Technically, the sweet potato is a perennial plant, but in commercial production the growth is terminated by harvest due to impending change of seasons (cold or rainy) or by achievement of optimum storage root size. Plantings are established from sprouts obtained from stored roots or from vine cuttings. Production of storage roots does not require pollination, so that adverse conditions only delay or reduce harvests; crop failures are rare. A variety of soil types may be used; however, light sandy soils are preferred for ease of harvest.

A number of factors contribute to the worldwide importance of sweet potatoes. Perhaps foremost is the high energy yield, which exceeds that of Irish potatoes and grains. Sweet potato roots are also high in nutritional quality.

The sweet potato is a versatile crop that is used as a food, an ingredient in other foods, an animal feed, and a feedstock for the production of starch and ethanol. See ANIMAL FEEDS; POTATO, IRISH; STARCH. [J.C.Bo.]

**Potential flow** A fluid flow that is isentropic and that, if incompressible, can be mathematically described by Laplace's equation. For an ideal fluid, or a flow in which viscous effects are ignored, vorticity (defined as the curl of the velocity) cannot be produced, and any initial vorticity existing in the flow simply moves unchanged with the fluid. Ideal fluids, of course, do not exist since any actual fluid has some viscosity, and the effects of this viscosity will be important near a solid wall, in the region known as the boundary layer. Nevertheless, the study of potential flow is important in hydrodynamics, where the fluid is considered incompressible, and even in aerodynamics, where the fluid is considered compressible, as long as shock waves are not present. See BOUNDARY-LAYER FLOW; COMPRESSIBLE FLOW; ISENTROPIC FLOW.

In the absence of viscous effects, a flow starting from rest will be irrotational for all subsequent time. For an irrotational flow, the curl of the velocity is zero ( $\nabla \times V = 0$ ). The curl of the gradient of any scalar function is zero ( $\nabla \times \nabla\phi = 0$ ). It then

follows mathematically that the condition of irrotationality can be satisfied identically by choosing the scalar function,  $\phi$ , such that the velocity is the gradient of  $\phi$  ( $V = \nabla\phi$ ). For this reason, this scalar function  $\phi$  has been traditionally referred to as the velocity potential, and the flow as a potential flow. See CALCULUS OF VECTORS; POTENTIALS.

By applying the continuity equation to the definition of the potential function, it becomes possible to represent the flow by the well-known Laplace equation ( $\nabla^2\phi = 0$ ), instead of the coupled system of the continuity and nonlinear Euler equations. The linearity of the Laplace equation, which also governs other important physical phenomena such as electricity and magnetism, makes it possible to use the principle of superposition to combine elementary solutions in solving more complex problems. See EQUATION OF CONTINUITY; FLUID FLOW; LAPLACE'S DIFFERENTIAL EQUATION; LAPLACE'S IRROTATIONAL MOTION. [P.E.R.]

**Potentials** Functions or sets of functions from whose first derivatives a vector can be formed. A vector is a quantity which has a magnitude and a direction, such as force.

A single function, the scalar potential, is used in gravitation theory, electricity and magnetism, fluid mechanics, and other areas. The vectors obtained from it by partial differentiation are in these cases the gravitational, electric and magnetic field strengths, and the velocity, respectively. The vector potential is a set of three functions whose first derivatives give the magnetic induction. See ELECTRIC FIELD; GRAVITATION; LAPLACE'S IRROTATIONAL MOTION.

[F.Ro.]

**Potentiometer** An instrument that precisely measures an electromotive force (emf) or a voltage by opposing to it a known potential drop established by passing a definite current through a resistor of known characteristics. (A three-terminal resistive voltage divider is sometimes also called a potentiometer.) There are two ways of accomplishing this balance: (1) the current  $I$  may be held at a fixed value and the resistance  $R$  across which the  $IR$  drop is opposed to the unknown may be varied; (2) current may be varied across a fixed resistance to achieve the needed  $IR$  drop. See ELECTROMOTIVE FORCE (EMF); RESISTOR.

The essential features of a general-purpose constant-current instrument are shown in the illustration. The value of the current is first fixed to match an  $IR$  drop to the emf of a reference standard cell. With the standard-cell dial set to read the emf of the reference cell, and the galvanometer (balance detector) in position  $G_1$ , the resistance of the supply branch of the circuit is adjusted until the  $IR$  drop in 10 steps of the coarse dial plus the set portion of the standard-cell dial balances the known reference emf, indicated by a null reading of the galvanometer. This adjustment permits the potentiometer to be read directly in volts. Then, with the galvanometer in position  $G_2$ , the coarse, intermediate, and slide-wire dials are adjusted until the galvanometer again reads null. If the potentiometer current has not changed, the emf of the unknown can be read directly from the dial settings. There is usually a switching arrangement so that the galvanometer can be quickly shifted between positions 1 and 2 to check that the current has not drifted from its set value. See ELECTROMOTIVE FORCE (CELLS); GALVANOMETER.

Potentiometer techniques may also be used for current measurement, the unknown current being sent through a known resistance and the  $IR$  drop opposed by balancing it at the voltage terminals of the potentiometer. Here, of course, internal heating and consequent resistance change of the current-carrying resistor (shunt) may be a critical factor in measurement accuracy; and the shunt design may require attention to dissipation of heat resulting from its  $I^2R$  power consumption. See CURRENT MEASUREMENT; JOULE'S LAW.

Potentiometer techniques have been extended to alternating-voltage measurements, but generally at a reduced accuracy level (usually 0.1% or so). Current is set on an ammeter which must have the same response on ac as on dc, where it may be

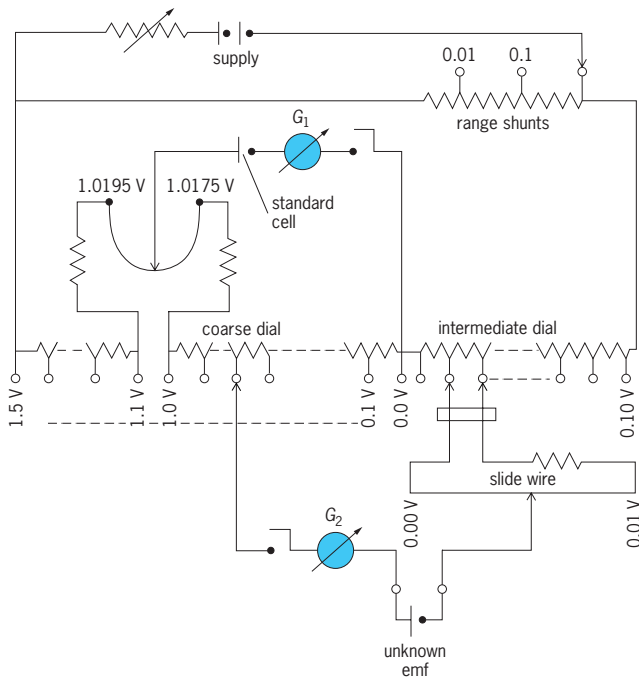

Circuit diagram of a general-purpose constant-current potentiometer, showing essential features.

calibrated with a potentiometer and shunt combination. Balance in opposing an unknown voltage is achieved in one of two ways: (1) a slide-wire and phase-adjustable supply; (2) separate in-phase and quadrature adjustments on slide wires supplied from sources that have a 90° phase difference. Such potentiometers have limited use in magnetic testing. See ALTERNATING CURRENT; ELECTRICAL MEASUREMENTS; VOLTAGE MEASUREMENT.

[F.K.H.; R.F.Dz.]

**Pottery** Vessels made entirely or partly of clay, and fired to a strong, hard product; occasionally, the term refers to just the lower grades of such ware. Pottery may be glazed or unglazed. See CERAMICS; GLAZING.

Grades of pottery (such as china, stoneware, earthenware, and other special types) are distinguished by their color, strength, absorption (the weight of water soaked up when the piece is submerged, expressed as a percentage of the original weight), and translucency (ability to transmit light). All these properties refer to the material or "body" under any glaze present. See PORCELAIN.

Absorption is due to the presence of open pores or voids in the fired material into which water can penetrate; in general, the higher the firing temperature, the lower the absorption. Body color is determined mainly by raw-material purity. Strength depends on the porosity and also on the amount and type of glass and crystals developed in the body on firing. Translucency is obtained in products in which there is low porosity and little differences in index of refraction between the glass and crystals in the body. See CLAY.

[J.F.McM.]

**Pottiales** An order of the true mosses (subclass Bryidae), consisting of three families and about 91 genera. The order is characterized by short, papillose leaf cells and deeply divided, commonly twisted peristome teeth. Members of the Pottiales typically grow erect, with stems simple or forked by subfloral innovation, and they often produce gemmae (asexual reproductive bodies) on leaves, stems, or rhizoids. The leaves have revolute margins, and are arranged in many rows. The single costa often ends in a hyaline hairpoint. See BRYIDAE; BRYOPHYTA; BRYOPSIDA.

[H.Cr.]

**Poultry production** Poultry production comprises two major categories, meat production and egg production. Most poultry produced in North America is grown under close control on highly specialized farms. The evolution from small flocks to large commercial units after World War II was facilitated by rapid advances in the knowledge of nutrition, breeding, housing, disease control, and processing of poultry and eggs, and by improvements in transportation and refrigeration which made possible distant marketing of fresh products.

**Incubation.** Artificial incubation was a major advance in poultry production because it became possible to hatch large numbers of chicks of the same age for farmers to raise for meat or egg production. Modern incubators are constructed of materials that can be effectively cleaned and disinfected and that provide good insulation of the chamber. Eggs are set in specially designed plastic flats which fit into channels in egg racks that move on wheels. The egg racks are equipped with mechanical systems to tilt the eggs 45°; turning is usually done hourly. Eggs are transferred from the setting trays into hatching trays 3 days before expected hatch. After the hatch is completed, the chicks are transferred to a conveyer belt for processing or directly into plastic boxes with absorbent paper pads or into disposable paper boxes with wood fiber pads. Chick servicing often involves sexing, vaccination, and beak trimming. Usually, chicks are held at the hatchery prior to shipment to farms, starting early on the day after hatching. Specially designed delivery trucks or buses are used to provide adequate ventilation for chicks during shipment.

**Breeding.** The genetic stock used for modern poultry production is produced by highly specialized breeding companies. Meat poultry is selected for good meat type, fast growth, disease resistance, and efficient conversion of feed to meat. Different strains of chickens are used for table egg production. These are selected for high egg production, large egg size, and small body weight for better conversion of feed to eggs and good livability. The body weights of meat and egg production strains are dramatically different. See BREEDING (ANIMAL).

**Brooding and rearing.** Day-old chicks require an ambient temperature of 85–87°F (29–30°C) for normal growth and health during the first week of life. As the chicks grow and feather, they can tolerate lower temperatures. Brooding heat is often provided by a radiant gas brooder stove. Most chicks are started on floors that are covered with 2–4 in. (5–10 cm) of a litter material such as pine shavings, rice hulls, or peanut hulls. Feeding is usually done in small troughs or on plastic trays until the chicks learn to eat and drink. Chicks are quickly trained to eat from mechanical feeders and drink from closed water delivery systems to reduce labor.

**Feeding and nutrition.** Poultry diets consist of common grains and protein sources with mineral and vitamin supplements. Animal or vegetable fats may be added to increase energy and reduce dustiness. Corn, grain sorghum, wheat, oats, and barley are often used for poultry feeding in the United States. Soybean meal is widely used as a protein supplement. Other important protein supplements are meat meal, fish meal, safflower meal, feather meal, and canola meal. See ANIMAL FEEDS.

**Housing.** The purpose of a poultry house is to confine the birds; to protect them from predators and environmental extremes which would cause mortality or reduce growth, feed efficiency, immunocompetence, fertility or egg production; to facilitate light control; and to facilitate bird management. Poultry houses can be constructed from locally available building materials. Smooth interior surfaces are preferred for effective sanitation. Houses are usually a maximum of 40 ft (12 m) wide to facilitate more uniform ventilation. House length is approximately 500 ft (152 m); most houses are constructed with a gable roof.

**Production systems.** Chickens for table egg production are often housed in cages to provide cleaner eggs and protect the birds from disease agents which are recycled to birds from the manure. Meat chickens and turkeys are usually grown in

litter-floor houses because heavier poultry experience more lameness, breast blisters, and weaker bones and joints when grown in cages.

**Ducks and geese.** With some modification of husbandry, ducks and geese can be successfully raised in confinement. They do not require water for swimming and can be grown in litter-floor houses similar to meat chickens or turkeys.

**Health maintenance.** The production of commercial poultry in large flocks requires well-designed disease-control programs. The first requirement is for maintenance of biosecurity in production units. This means that entrance of contaminated workers and visitors, birds, feed, and equipment must be prevented. Some poultry diseases are more effectively or economically controlled by vaccination. Examples are Marek's disease, Newcastle disease, infectious bronchitis, avian pox, infectious bursal disease, and often several others, depending on the disease history of the farm and the area where the poultry are raised. See NEWCASTLE DISEASE.

**Processing and marketing.** Shell eggs are often processed in plants located on the farm. A mechanical system can detect and separate cracked eggs. Egg processing machines can process up to 300 cases of eggs (360 eggs per case) per hour. Machines are also available to separate the yolk and albumen from the egg shell. Poultry are usually processed at large central plants under inspection by the U.S. Department of Agriculture. The meat birds are loaded on trucks at farms during the night, and processing typically begins at midnight, and is followed by extensive cleaning and disinfection of the plant. Poultry are removed from transport racks or coops and hung on shackles. After stunning, bleeding, scalding, and feather removal, the carcasses must be transferred to a second line or table in a different room for evisceration, chilling, cutting, and packaging. Many poultry processing plants cut up poultry before packaging, and they may also separate meat from bone or skin. See AGRICULTURAL SCIENCE (ANIMAL); EGG (FOWL). [R.A.E.]

**Powder metallurgy** A metalworking process used to fabricate parts of simple or complex shape from a wide variety of metals and alloys in the form of powders. The process involves shaping of the powder and subsequent bonding of its individual particles by heating or mechanical working. Powder metallurgy is a highly flexible and automated process that is environmentally friendly, with a low relative energy consumption and a high level of materials utilization. Thus it is possible to fabricate high-quality parts to close tolerance at low cost. Powder metallurgy processing encompasses an extensive range of ferrous and nonferrous alloy powders, ceramic powders, and mixes of metallic and ceramic powders (composite powders). See METALLURGY.

Regardless of the processing route, all powder metallurgy methods of part fabrication start with the raw material in the form of a powder. A powder is a finely divided solid, smaller than about 1 mm (0.04 in.) in its maximum dimension. There are four major methods used to produce metal powders, involving mechanical comminution, chemical reactions, electrolytic deposition, and liquid-metal atomization. Metal powders exhibit a diversity of shapes ranging from spherical to acicular. Particle shape is an important property, since it influences the surface area of the powder, its permeability and flow, and its density after compaction. Chemical composition and purity also affect the compaction behavior of powders.

Powder metallurgy processes include pressing and sintering, powder injection molding, and full-density processing. See SINTERING.

Normally, parts made by pressing and sintering require no further treatment. However, properties, tolerances, and surface finish can be enhanced by secondary operations such as repressing, resintering, machining, heat treatment, and various surface treatments.

Powder injection molding is a process that builds on established injection molding technology used to fabricate plastics

into complex shapes at low cost. It produces parts which have the shape and precision of injection-molded plastics but which exhibit superior mechanical properties such as strength, toughness, and ductility.

Parts fabricated by pressing and sintering are used in many applications. However, their performance is limited because of the presence of porosity. In order to increase properties and performance and to better compete with products manufactured by other metalworking methods (such as casting and forging), several powder metallurgy techniques have been developed that result in fully dense materials; that is, all porosity is eliminated. Examples of full-density processing are hot isostatic pressing, powder forging, and spray forming.

Powder metallurgy competes with several more conventional metalworking methods in the fabrication of parts, including casting, machining, and stamping. Characteristic advantages of powder metallurgy are close tolerances, low cost, net shaping, high production rates, and controlled properties. Other attractive features include compositional flexibility, low tooling costs, available shape complexity, and a relatively small number of steps in most powder metallurgy production operations.

Metal powders can be thermally unstable in the presence of oxygen. Very fine metal powders can burn in air (pyrophoricity) and are potentially explosive. Some respirable fine powders pose a health concern and can cause disease or lung dysfunction. Control is exercised by the use of protective equipment and safe handling systems such as glove boxes. See INDUSTRIAL HEALTH AND SAFETY. [A.La.]

**Power** The time rate of doing work. Like work, power is a scalar quantity, that is, a quantity which has magnitude but no direction. Some units often used for the measurement of power are the watt (1 joule of work per second) and the horsepower (550 foot-pounds of work per second). See WORK.

Power is a concept which can be used to describe the operation of any system or device in which a flow of energy occurs. In many problems of apparatus design, the power, rather than the total work to be done, determines the size of the component used. Any device can do a large amount of work by performing for a long time at a low rate of power, that is, by doing work slowly. However, if a large amount of work must be done rapidly, a high-power device is needed. High-power machines are usually larger, more complicated, and more expensive than equipment which need operate only at low power. A motor which must lift a certain weight will have to be larger and more powerful if it lifts the weight rapidly than if it raises it slowly. An electrical resistor must be large in size if it is to convert electrical energy into heat at a high rate without being damaged. [P.W.S.]

**Power amplifier** The final stage in multistage amplifiers, such as audio amplifiers and radio transmitters, designed to deliver appreciable power to the load. Power amplifiers may be called upon to supply power ranging from a few watts in an audio amplifier to many thousands of watts in a radio transmitter. In audio amplifiers the load is usually the dynamic impedance presented to the amplifier by a loudspeaker, and the problem is to maximize the power delivered to the load over a wide range of frequencies. The power amplifier in a radio transmitter operates over a relatively narrow band of frequencies with the load essentially a constant impedance. See AMPLIFIER. [H.F.K.]

**Power factor** The ratio of watts average power (the average power measured in watts) to the apparent power of an alternating-current circuit. By definition, the equation below holds, which is the ratio of instrument readings.

$$\text{pf} = \frac{\text{watts average power}}{\text{rms volts} \times \text{rms amperes}}$$

A watt-meter indicates average power, and electrodynamicometer or iron-vane instruments show rms voltage and current. For

the steady-state ac circuit under sinusoidal voltage and current,  $\text{pf} = \cos \theta$ , where  $\theta$  is the phase angle between the voltage and current. This definition is restricted to sine waves of the same frequency. See ALTERNATING-CURRENT CIRCUIT THEORY. [B.L.R.]

**Power-factor meter** An instrument used to indicate whether load currents and voltages are in time-phase with one another. See POWER FACTOR.

The single-phase meter contains a fixed coil that carries the load current, and crossed coils that are connected to the load voltage. There is no spring to restrain the moving system, which takes a position to indicate the angle between the current and voltage. The scale can be marked in degrees or in power factor.

The angle between the currents in the crossed coils is a function of frequency, and consequently each power-factor meter is designed for a single frequency and will be in error at all other frequencies. [H.So./E.C.St.]

**Power integrated circuits** Integrated circuits that are capable of driving a power load. The key feature of a power integrated circuit that differentiates it from other semiconductor technologies is its ability to handle high voltage, high current, or a combination of both.

In its simplest form, a power integrated circuit may consist of a level-shifting and drive circuit that translates logic-level input signals from a microprocessor to a voltage and current level sufficient to energize a load. For example, such a chip may be used to operate electronic display, where the load is usually capacitive in nature but requires drive voltages above 100 V, which is much greater than the operating voltage of digital logic circuits (typically 5 V). At the other extreme, the power integrated circuit may be required to perform load monitoring, diagnostic functions, self-protection, and information feedback to the microprocessor, in addition to handling large amounts of power to actuate the load. An example of this is an automotive multiplexed bus system with distributed power integrated circuits for control of lights, motors, air conditioning, and so forth. See AUTOMOTIVE ELECTRICAL SYSTEM; ELECTRONIC DISPLAY; MICROPROCESSOR.

Power integrated circuits are expected to have an impact on all areas in which power semiconductor devices are presently being used. In addition, they are expected to open up new applications based upon their added features. The wide spectrum of voltages and currents over which power semiconductor devices are utilized are summarized in the table. See INTEGRATED CIRCUITS. [B.J.Ba.]

**Power plant** A means for converting stored energy into work. Stationary power plants such as electric generating stations are located near sources of stored energy, such as coal fields or river dams, or are located near the places where the work is to be performed, as in cities or industrial sites. Mobile power plants for transportation service are located in vehicles, as the gasoline engines in automobiles and diesel locomotives for railroads. Power plants range in capacity from a fraction of a horsepower (hp) to over  $10^6$  kW in a single unit. Large power plants are assembled, erected, and constructed on location from equipment and systems made by different manufacturers. Smaller units are produced in manufacturing facilities.

Most power plants convert part of the stored raw energy of fossil fuels into kinetic energy of a spinning shaft. Some power plants harness nuclear energy. Elevated water supply or run-of-the-river energy is used in hydroelectric power plants. For transportation, the plant may produce a propulsive jet, as in some aircraft, instead of the rotary motion of a shaft. Other sources of energy, such as fuel cells, winds, tides, waves, geothermal, ocean thermal, nuclear fusion, photovoltaics, and solar thermal, have been of negligible commercial significance in the generation of power despite their magnitudes. See ENERGY SOURCES.

There is no practical way of storing the mechanical or electrical output of a power plant in the magnitudes encountered in

power plant applications, although several small-scale concepts have been researched. As of now, however, the output must be generated at the instant of its use. This results in wide variations in the loads imposed upon a plant. The capacity, measured in kilowatts or horsepower, must be available when the load is imposed. Much of the capacity may be idle during extended periods when there is no demand for output. Hence much of the potential output, measured as kilowatt-hours or horsepower-hours, cannot be generated because there is no demand for output. Kilowatts cannot be traded for kilowatt-hours, and vice versa. See ENERGY STORAGE.

The efficiency of energy conversion is vital in most power plant installations. With thermal power plants the basic limitations of thermodynamics fix the efficiency of converting heat into work. The cyclic standards of Carnot, Rankine, Otto, Diesel, and Brayton are the usual criteria on which heat-power operations are variously judged. Performance of an assembled power plant, from fuel to net salable or usable output, may be expressed as thermal efficiency (%); fuel consumption (lb, pt, or gal per hp-h or per kWh); or heat rate (Btu supplied in fuel per hp-h or per kWh). American practice uses high or gross calorific value of the fuel for measuring heat rate or thermal efficiency and differs in this respect from European practice, which prefers the low or net calorific value.

In scrutinizing data on thermal performance, it should be recalled that the mechanical equivalent of heat (100% thermal efficiency) is 2545 Btu/hp-h and 3413 Btu/kWh (3.6 megajoules/kWh). Modern steam plants in large sizes (75,000–1,300,000 kW units) and internal combustion plants in modest sizes (1000–20,000 kW) have little difficulty in delivering a kilowatt-hour for less than 10,000 Btu (10.55 MJ) in fuel (34% thermal efficiency). For condensing steam plants, the lowest fuel consumptions per unit output (8200–9000 Btu/kWh or 8.7–9.5 MJ/kWh) are obtained in plants with the best vacuums, regenerative-reheat cycles using eight stages of extraction feed heating, two stages of reheat, primary pressures of 4500 lb/in.<sup>2</sup> gage or 31 megapascals gage (supercritical), and temperatures of 1150°F (620°C). An industrial plant cogenerating electric power with process steam is capable of having a thermal efficiency of 5000 Btu/kWh (5.3 MJ/kWh).

Combustion turbines used in combined cycle configurations have taken a dominant role in new power generation capacity. The reason is the higher efficiency and lower emissions of the power plant in this arrangement. The rapid pace in advances in combustion turbine technology (such as higher firing temperatures that improve the Brayton cycle efficiency) has driven combined cycle efficiency to nearly 60% when using natural gas as fuel, while attaining low emission rates. Low fuel consumption (5700–6000 Btu/kWh or 6.0–6.3 MJ/kWh) is obtained by using higher firing temperatures, steam cooling on the combustor and gas turbine blades, a reheat steam cycle with a three-pressure heat recovery steam generator, and higher pressure and temperature of the steam cycle. These conditions are balanced with the need to keep the exhaust flue gas temperature as low as practical to achieve low emissions.

Gas turbines in simple cycle configuration are used mostly for peaking service due to their fast startup capabilities. The advances in the gas turbines have also increased the efficiency of simple cycle operations. Recuperation of the classic Brayton cycle gas turbine (simple cycle) is an accepted method of improving cycle efficiency that involves the addition of a heat exchanger to recover some portion of the exhaust heat that otherwise would be lost. See GAS TURBINE.

The nuclear power plant substitutes the heat of fission for the heat of combustion, and the consequent plant differs only in the method of preparing the thermodynamic fluid. It is otherwise similar to the usual thermal power plant. The pressure of a light-water reactor core is limited by material and safety considerations, while the temperature at which the steam is produced is determined by the core pressure. Because a nuclear reactor

does not have the capability to superheat the steam above the core temperature, the steam temperature in a nuclear cycle is less than in a fossil cycle. See ELECTRIC POWER GENERATION; NUCLEAR REACTOR. [K.K.R.; R.S.G.]

**Power shovel** A power-operated digging machine consisting of a lower frame and crawlers, a machinery frame, and a gantry supporting a boom which in turn supports a dipper handle and dipper. The machines are powered by on-board diesel engines or by electric motors. Diesel-powered machines utilize a series of clutches and brakes that allow the operator to control various motions. Electric motor machines generally have individual motors for each motion, but occasionally clutches and brakes are used allowing one motor to drive two motions. See BULK-HANDLING MACHINES; CONSTRUCTION EQUIPMENT; HOISTING MACHINES. [E.W.S.]

**Poynting's vector** A vector, the outward normal component of which, when integrated over a closed surface in an electromagnetic field, represents the outward flow of energy through that surface. It is given by the equation below, where  $\mathbf{E}$  is the electric field strength,  $\mathbf{H}$  the magnetic field strength,  $\mathbf{B}$

$$\mathbf{\Pi} = \mathbf{E} \times \mathbf{H} = \mu^{-1} \mathbf{E} \times \mathbf{B}$$

the magnetic flux density, and  $\mu$  the permeability.

When an electromagnetic wave is incident on a conducting or absorbing surface, theory predicts that it should exert a force on the surface in the direction of the difference between the incident and the reflected Poynting's vector. See ELECTRIC FIELD; ELECTROMAGNETIC RADIATION; MAXWELL'S EQUATIONS; RADIATION PRESSURE. [W.R.Sm.]

**Prairie dog** A stout, fossorial rodent belonging to the family Sciuridae. Three species are recognized; the black-tailed prairie dog (*Cynomys ludovicianus*), once abundant on the prairies of the western United States, but now reduced in numbers; the white-tailed prairie dog (*C. gunnisoni*), discontinuously distributed in mountainous and high plains areas of Colorado, New Mexico, Utah, and Montana; and *C. mexicanus*, found in northern Mexico. All species have the same general features. The tail is short and flat, the ears are small, and the limbs are short and terminate in long claws which are used for burrowing. Prairie dogs are social animals and live in colonies. Their burrows are constructed with the main entrance surrounded by a mound of hard-packed dirt to protect against flooding. See RODENTIA. [C.B.C.]

**Praseodymium** A chemical element, Pr, atomic number 59, and atomic weight 140.91. Praseodymium is a metallic element of the rare-earth group. The stable isotope 140.907 makes up 100% of the naturally occurring element. The oxide is a black powder, the composition of which varies according to the method of preparation. If oxidized under a high pressure of oxygen it can approach the composition  $\text{PrO}_2$ . The black oxide dissolves in acid with the liberation of oxygen to give green solutions or green salts which have found application in the ceramic industry for coloring glass and for glazes. See PERIODIC TABLE; RARE-EARTH ELEMENTS. [F.H.Sp.]

**Prasinophyceae** A small class of mostly motile, photosynthetic, unicellular algae in the chlorophyll *a-b* phyletic line (Chlorophycota). It is segregated from the Chlorophyceae primarily on the basis of ultrastructural characters, especially the possession of one or more layers of polysaccharide scales outside the plasmalemma. Prasinophytes are mainly members of the marine plankton, but they are also found in brackish- and freshwater habitats. A few are benthic, with both coccoid and colonial forms known, while others live symbiotically within dinoflagellates, radiolarians, and turbellarian worms. Approximately 180 species are known in 13 genera. See ALGAE; CHLOROPHYCOTA; PHYTOPLANKTON. [P.C.Si.; R.L.Moe]

**Preamplifier** A voltage amplifier suitable for operation with a low-level input signal. It is intended to be connected to another amplifier with a higher input level. Preamplifiers are necessary when an audio amplifier is to be used with low-output transducers such as magnetic phonograph pickups. A preamplifier may incorporate frequency-correcting networks to compensate for the frequency characteristics of a given input transducer and to make the frequency response of the preamplifier-amplifier combination uniform. See AMPLIFIER; VOLTAGE AMPLIFIER. [H.F.K.]

**Prebiotic organic synthesis** The plausible pathways by which the molecular precursors of life may have formed on the primitive Earth. Amino acids, the nitrogenous bases, and ribose phosphates can be prepared under conditions that might have prevailed on the primitive Earth. The linking together of amino acids to form polypeptides, and of nucleotides to form polynucleotides, has in principle been established.

Harold C. Urey's model of the primordial Earth postulates an atmosphere rich in methane, ammonia, water, and hydrogen. When this gas mixture is subjected to an electrical spark, analogous to the way that lightning may have initiated such syntheses 4 billion years ago, the identified products included several amino acids (glycine, alanine, and aspartic acid), the building blocks of proteins. This novel result lent credibility to a theory in which the origin of life was viewed as a cumulative, stepwise process, beginning with the gaseous synthesis of small molecules, which rained down into oceans, lagoons, and lakes. With water as a ubiquitous solvent, organic molecules could then react with one another to form larger molecules (biopolymers) and finally to assemble into primitive cells. This general scenario has guided the design of prebiotic simulations.

However, an accumulation of geophysical data and computational models has cast doubt on the relevance of the synthesis of amino acids to the primordial Earth. Hydrogen probably escaped rapidly as the Earth cooled, leaving an atmosphere in which methane and ammonia were virtually absent. As the input of hydrogen is diminished, the formation of biomolecules is inhibited. This problem has led some scientists to look for extraterrestrial sources of organic matter. For example, meteorites are known to contain a rich source of amino acids and other small biomolecules, and perhaps the infall of such cosmic bodies onto the young Earth gave life its start. Alternatively, there may have been localized environments on the Earth where methane and other hydrogen-rich precursors were abundant, such as deep-ocean hydrothermal vents, which would have been favorable for the formation of life. See AMINO ACIDS; HYDROTHERMAL VENT. [W.J.Hag.]

**Precambrian** A major interval of geologic time between about 540 million years (Ma) and 3.8 billion years (Ga) ago, comprising the Archean and Proterozoic eons and encompassing most of Earth history. The Earth probably formed around 4.6 Ga and was then subjected to a period of intense bombardment by meteorites so that there are few surviving rocks older than about 3.8 billion years. Ancient rocks are preserved exclusively in continental areas. All existing oceanic crust is younger than about 200 million years, for it is constantly being recycled by the processes of sea-floor spreading and subduction. Development of techniques for accurate determination of the ages of rocks and minerals that are billions of years old has revolutionized the understanding of the early history of the Earth. See DATING METHODS; GEOCHRONOMETRY; GEOLOGIC TIME SCALE; ROCK AGE DETERMINATION.

Detailed sedimentological and geochemical investigations of Precambrian sedimentary rocks and the study of organic remains have facilitated understanding of conditions on the ancient Earth. Microorganisms are known to have been abundant in the early part of Earth history. The metabolic activities of such organisms played a critical role in the evolution of the atmosphere and oceans. There have been attempts to apply the concepts of plate tectonics to Precambrian rocks. These diverse

lines of investigation have led to a great leap in understanding the early history of the planet. See PLATE TECTONICS.

Rocks of the Archean Eon (2.5–3.8 Ga) are preserved as scattered small “nuclei” in shield areas on various continents. The Canadian shield contains perhaps the biggest region of Archean rocks in the world, comprising the Superior province. Much of the Archean crust is typified by greenstone belts, which are elongate masses of volcanic and sedimentary rocks that are separated and intruded by greater areas of granitic rocks. The greenstones are generally slightly metamorphosed volcanic rocks, commonly extruded under water, as indicated by their characteristic pillow structures. These structures develop when lava is extruded under water and small sac-like bodies form as the lava surface cools and they are expanded by pressure from lava within. Such structures are common in Archean greenstone assemblages in many parts of the world. See ARCHEAN; METAMORPHIC ROCKS.

The Proterozoic Eon extends from 2.5 Ga until 540 Ma, the beginning of the Cambrian Period and Phanerozoic Eon. Proterozoic successions include new kinds of sedimentary rocks, display proliferation of primitive life forms such as stromatolites, and contain the first remains of complex organisms, including metazoans (the Ediacaran fauna). Sedimentary rocks of the Proterozoic Eon contain evidence of gradual oxidation of the atmosphere. Abundant and widespread chemical deposits known as banded iron formations (BIF) make their appearance in Paleoproterozoic sedimentary basins. See BANDED IRON FORMATION; PROTEROZOIC. [G.M.Y.]

**Precast concrete** Concrete that has been cast into a form which is later incorporated into a structure. A concrete structure may be constructed by casting the concrete in place on the site, by building it of components cast elsewhere, or by a combination of the two. Concrete cast in other than its final position is called precast.

In contrast with cast-in-place concrete construction, in which columns, beams, girders, and slabs are cast integrally or bonded together by successive pours, precast concrete requires field connections to tie the structure together. These connections can be a major design problem.

Precast units can be standardized. Savings can then result from repeated reuse of forms and assembly-line production. Furthermore, high quality can be maintained because of the controls that can be kept on production under plant conditions. However, there is always the possibility that transportation, handling, and erection costs for the precast units will offset the savings. See CONCRETE; PRESTRESSED CONCRETE. [F.S.M.]

**Precession** The motion of an axis fixed in a body around a direction fixed in space. If the angle between the two is constant so that the axis sweeps out a circular cone, the motion is pure precession; oscillation of the angle is called nutation. An example of precession is the motion of the Earth’s polar axis around the normal to the plane of the ecliptic; this is the precession of the equinoxes. A fast-spinning top, with nonvertical axis, which precesses slowly around the vertical direction, is another example. In both examples the precession is due to torque acting on the body. Another kind of precession, called free or fast precession, with a rate which is comparable to the rotation rate of the body, is seen, for instance, in a coin spun into the air. See NUTATION (ASTRONOMY AND MECHANICS); PRECESSION OF EQUINOXES.

As a simple example of gyroscopic motion, consider a rapidly spinning wheel with a horizontal axis supported at a distance  $d$  from the plane of the wheel (see illustration).

The angular momentum  $\vec{L}$  is along the wheel symmetry axis and is approximately given by the angular momentum of the wheel about this axis; in the simple precession approximation to the motion, the angular momentum associated with precessional motion is neglected. The external torque  $\vec{N}$  due to the gravitational force is perpendicular to the wheel axis in the horizontal plane. The change in the angular momentum  $\vec{L}$  in an infinitesimal

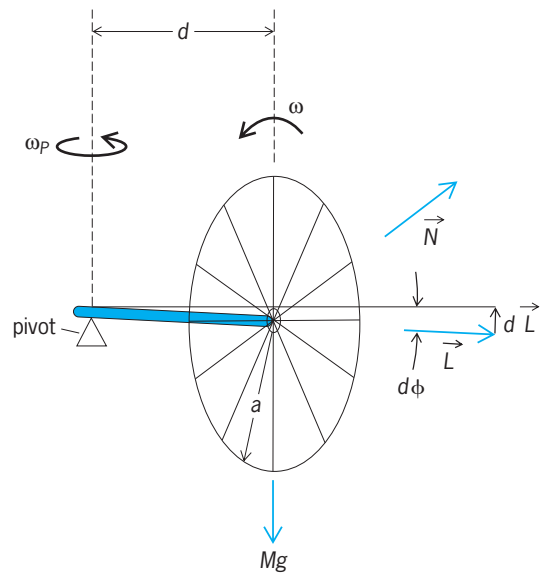

Simple precession of a rapidly spinning wheel with a horizontal axis supported by a pivot.

time interval  $dt$  is given by the rotational equation of motion in Eq. (1).

$$d\vec{L} = \vec{N} dt \tag{1}$$

See RIGID-BODY DYNAMICS.

Since  $d\vec{L}$  and  $\vec{L}$  are perpendicular, the length  $\vec{L}$  is unchanged to first order in  $dt$ . The direction of  $\vec{L}$  is rotated counterclockwise in the horizontal plane. The angular velocity of precession  $\omega_p$  about the vertical axis is then given by Eq. (2), where  $g$  is the

$$\omega_p = \frac{gd}{\omega a^2} \tag{2}$$

gravitational acceleration,  $\omega$  is the spin angular velocity, and  $a$  is the radius of the wheel. Thus  $\omega_p$  is independent of the mass of the wheel and inversely proportional to  $\omega$ . For  $\omega$  very large, the precession rate  $\omega_p$  is quite slow. See GYROSCOPE. [V.D.B.]

**Precession of equinoxes** A slow change in the direction of orientation of Earth’s axis of rotation which results in a gradual westward motion of the equinoxes. There are two types, known as lunisolar precession and planetary precession.

The lunisolar precession of the equinoxes is caused by the gravitational attraction of the Sun and the Moon which, as a result of the polar flattening of Earth and the inclination of Earth’s axis, gives rise to a small turning moment, or torque, on the Earth in its orbit. As a result of this torque, Earth’s axis describes

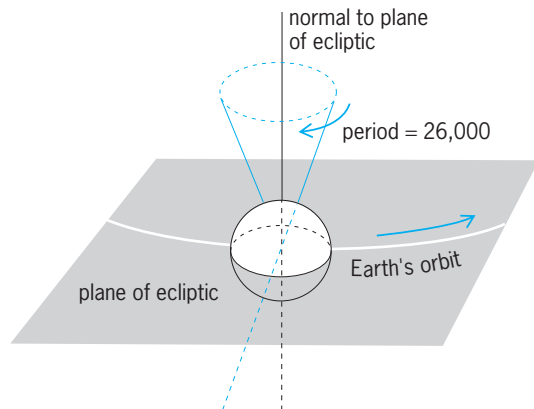

Conical motion of Earth’s axis. One complete cycle of precession requires 26,000 years.

a cone about the normal to the plane of its orbit (see illustration); the period of this precession is approximately 26,000 years in a direction opposite to that of Earth's rotation.

The planetary precession is a comparatively small eastward motion of the equinoxes caused by the action of the other planets in altering the plane of Earth's orbit.

As a result of precession, Polaris will not always be the pole star. Vega will be nearer to the north celestial pole in about 12,000 years;  $\alpha$  Draconis was the pole star about 4600 years ago. Another effect of precession is that the signs of the zodiac no longer correspond to their respective constellations. See PRECESSION. [J.A.Hy.]

**Precious stones** The materials found in nature that are used frequently as gemstones, including amber, beryl (emerald and aquamarine), chrysoberyl (cat's-eye and alexandrite), coral, corundum (ruby and sapphire), diamond, feldspar (moonstone and amazonite), garnet (almandite, demantoid, and pyrope), jade (jadeite and nephrite), jet, lapis lazuli, malachite, opal, pearl, peridot, quartz (amethyst, citrine, and agate), spinel, spodumene (kunzite), topaz, tourmaline, turquoise and zircon. See GEM.

The terms precious and semiprecious have been used to differentiate between gemstones on a basis of relative value. Because there is a continuous gradation of values from materials sold by the pound to those valued at many thousands of dollars per carat, and because the same mineral may furnish both, a division is essentially meaningless. [R.T.L.]

**Precipitation (chemistry)** The process of producing a separable solid phase within a liquid medium. In analytical chemistry, precipitation is widely used to effect the separation of a solid phase in an aqueous solution. For example, the addition of a water solution of silver nitrate to a water solution of sodium chloride results in the formation of insoluble silver chloride. Quite often, one of the components in the solution is thus virtually completely separated in a relatively pure form. It can then be isolated from the solution phase by filtration or centrifugation, and the substance determined by weighing. This procedure is known as gravimetric analysis. Precipitation may also be used merely to effect partial or complete separation of a substance for purposes other than that of gravimetric analysis. Such purposes might involve either the isolation of a relatively pure substance or the removal of undesirable components of the solution. See GRAVIMETRIC ANALYSIS.

The extent to which a component can be separated from solution can be determined from the solubility-product constant obtained by determining the quantity of dissolved substance present in a known amount of saturated solution. This value is known as the solubility. The solubility can be drastically altered merely by adding to the solution any of the ions that make up the precipitate, for example, by adding varying quantities of either silver nitrate or sodium chloride to a saturated solution of silver chloride. Although solubility can be altered over a wide range, the solubility product itself remains practically constant over this same range. See SOLUBILITY PRODUCT CONSTANT.

Various techniques may be employed in order to reduce contamination by foreign ions. Precipitation from dilute solution is often effective. Heating the reaction mixture speeds recrystallization processes by which incorporated foreign ions may be returned to the solution phase. Precipitation from homogeneous solution results in the slow formation of large crystals of small surface area and hence lessens coprecipitation. If all these methods fail to reduce adequately the quantity of foreign ions incorporated in the solid phase, the precipitate is dissolved and reprecipitated by the previous procedure. See CHEMICAL SEPARATION TECHNIQUES; CRYSTALLIZATION; NUCLEATION. [L.Go./R.W.Mu.]

**Precipitation (meteorology)** The fallout of water drops or frozen particles from the atmosphere. Liquid types are rain or drizzle, and frozen types are snow, hail, small hail, ice

pellets (also called ice grains; in the United States, sleet), snow pellets (graupel, soft hail), snow grains, ice needles, and ice crystals. In England sleet is defined as a mixture of rain and snow, or melting snow. Deposits of dew, frost, or rime, and moisture collected from fog are occasionally also classed as precipitation. See HAIL; SNOW.

All precipitation types are called hydrometeors, of which additional forms are clouds, fog, wet haze, mist, blowing snow, and spray. Whenever rain or drizzle freezes on contact with the ground to form a solid coating of ice, it is called freezing rain, freezing drizzle, or glazed frost; it is also called an ice storm or a glaze storm, and sometimes is popularly known as silver thaw or erroneously as a sleet storm. See CLOUD; FOG.

Rain, snow, or ice pellets may fall steadily or in showers. Steady precipitation may be intermittent though lacking sudden bursts of intensity. Hail, small hail, and snow pellets occur only in showers; drizzle, snow grains, and ice crystals occur as steady precipitation. Showers originate from instability clouds of the cumulus family, whereas steady precipitation originates from stratiform clouds.

The amount of precipitation, often referred to as precipitation or simply as rainfall, is measured in a collection gage. It is the actual depth of liquid water which has fallen on the ground, after frozen forms have been melted, and is recorded in millimeters or inches and hundredths. A separate measurement is made of the depth of unmelted snow, hail, or other frozen forms. See SNOW GAGE. For discussions of other topics related to precipitation; CLOUD PHYSICS; DEW; DEW POINT; HUMIDITY; HYDROLOGY; HYDROMETEOROLOGY; RAIN SHADOW; VAPOR PRESSURE; WEATHER MODIFICATION. [J.R.F.]

**Precipitation measurement** Instruments used to measure the amount of rain or snow that falls on a level surface. Such measurements are made with instruments known as precipitation gages. A precipitation gage can be as simple as an open container on the ground to collect rain, snow, and hail; it is usually more complex, however, because of the need to avoid wind effects, enhance accuracy and resolution, and make a measurement representative of a large area. Precipitation is measured as the depth to which a flat horizontal surface would have been covered per unit time if no water were lost by runoff, evaporation, or percolation. Depth is expressed in inches or millimeters, typically per day. The unit of time is often understood and not stated explicitly. Snow and hail are converted to equivalent depth of liquid water. See METEOROLOGICAL INSTRUMENTATION; PRECIPITATION (METEOROLOGY); SNOW SURVEYING. [F.V.B.]

Accurate quantitative precipitation measurement is probably the most important weather radar application. It is extremely valuable for hydrological applications such as watershed management and flash flood warnings. Radar can make rapid and spatially contiguous measurements over vast areas of a watershed at relatively low cost. See METEOROLOGICAL RADAR; PRECIPITATION (METEOROLOGY); RADAR METEOROLOGY. [R.J.Do.]

**Precipitin** The visible result of the chemical interaction of antigen and antibody. Not all antibodies will result in precipitation, yet they may participate in agglutination reactions or add onto particulate antigens, and evidence for their occurrence together with precipitating antibody can be obtained for most sera. Precipitins may be noted qualitatively or be quantified by noting the end-point dilution (titer) of serum required to give a precipitate at the threshold of visibility, or the amount of antibody may be determined in milligrams or micrograms by analysis of the precipitate with correction for the antigen contained therein. See ANTIBODY; ANTIGEN. [D.R.]

**Precision agriculture** The application of technologies and agronomic principles to manage spatial and temporal variability associated with all aspects of agricultural production for the purpose of improving crop performance and environmental



quality. The intent of precision agriculture is to match agricultural inputs and practices to localized conditions within a field (site-specific management) and to improve the accuracy of their application. The finer-scale management of precision agriculture is in contrast to whole-field or whole-farm management strategies, where management decisions and practices are uniformly applied throughout a field or farmstead.

Successful implementation of precision agriculture requires three basic steps. First, farmers must obtain accurate maps of the spatial variability of factors (soils, plants, and pests) that determine crop yield and quality and/or factors that cause environmental degradation. Second, once known, variability can be managed using site-specific management recommendations and accurate input control technologies. Third, precision agriculture requires an evaluation component to understand the economic, environmental, and social impacts on the farm and adjacent ecosystems and to provide feedback on cropping system performance.

Precision agriculture is technology-enabled, information-based, and decision-focused, because it relies on an increasing level of detail in information acquired with technology to improve decision making in crop production. Consequently, precision agriculture will evolve as technology, information management, and decision tools emerge in this era of rapid technological advancement. See AGRICULTURAL SOIL AND CROP PRACTICES; AGRICULTURE; AGRONOMY; DECISION SUPPORT SYSTEM; INFORMATION SYSTEMS ENGINEERING. [E.J.P.; P.N.]

**Precision approach radar (PAR)** A tracking system that provides a ground control approach (GCA) air-traffic controller with a precise display of an aircraft's position relative to a runway final-approach course. To ensure absolute safety, precise information is displayed on a plan position indicator (PPI). This display provides the controller with aircraft position information for control of heading and rate of descent. To accomplish this and maintain the required precision for a final-approach aid, the display shows the aircraft position in relation to range, azimuth, and elevation. The information presented on the precision approach radar display allows an air-traffic controller to direct a pilot down along a runway approach course to a precision landing. Precision radar approaches are accomplished in most weather conditions and do not require any on-board avionics equipment, such as an instrument landing system (ILS).

There are two ways to provide the required range, azimuth, and elevation information on the plan position indicator: use of two antennas, one scanning elevation and the other azimuth; and a single computer-controlled phased-array antenna that can provide pencil-beam tracking for both elevation and azimuth positions. See ANTENNA (ELECTROMAGNETISM); RADAR. [M.A.DeP.]

**Predator-prey interactions** Predation occurs when one animal (the predator) eats another living animal (the prey) to utilize the energy and nutrients from the body of the prey for growth, maintenance, or reproduction. In the special case in which both predator and prey are from the same species, predation is called cannibalism. Sometimes the prey is actually consumed by the predator's offspring. This is particularly prevalent in the insect world. Insect predators that follow this type of lifestyle are called parasitoids, since the offspring grow parasitically on the prey provided by their mother.

Predation is often distinguished from herbivory by requiring that the prey be an animal rather than a plant or other type of organism (bacteria). To distinguish predation from decomposition, the prey animal must be killed by the predator. Some organisms occupy a gray area between predator and parasite. Finally, the requirement that both energy and nutrients be assimilated by the predator excludes carnivorous plants from being predators, since they assimilate only nutrients from the animals they consume. See FOOD WEB.

Population dynamics refers to changes in the sizes of populations of organisms through time, and predator-prey interactions may play an important role in explaining the population dynamics of many species. They are a type of antagonistic interaction, in which the population of one species (predators) has a negative effect on the population of a second (prey), while the second has a positive effect on the first. For population dynamics, predator-prey interactions are similar to other types of antagonistic interactions, such as pathogen-host and herbivore-plant interactions.

Community structure refers generally to how species within an ecological community interact. The simplest conception of a community is as a food chain, with plants or other photosynthetic organisms at the bottom, followed by herbivores, predators that eat herbivores, and predators that eat other predators. This simple conception works well for some communities. Nonetheless, the role of predator species in communities is often not clear. Many predators change their ecological roles over their lifetime. Many insect predators that share the same prey species are also quite likely to kill and devour each other. This is called intraguild predation, since it is predation within the guild of predators. Furthermore, many species are omnivores, feeding at different times as either predators or herbivores. Therefore, the role of particular predator species in a community is often complex.

Predator-prey interactions may have a large impact on the overall properties of a community. For example, most terrestrial communities are green, suggesting that predation on herbivores is great enough to stop them from consuming the majority of plant material. In contrast, the biomass of herbivorous zooplankton in many aquatic communities is greater than the biomass of the photosynthetic phytoplankton, suggesting that predation on zooplankton is not enough to keep these communities green. See POPULATION ECOLOGY. [A.R.I.]

**Pregnancy** The period during which a developing fetus is carried within the uterus. In humans, pregnancy averages 266 days (38 weeks) from conception to childbirth. Traditionally, pregnancy duration is counted from the woman's last menstrual period, which adds roughly 2 weeks to gestational age. This is how physicians arrive at a pregnancy length of 40 weeks (280 days).

The 9 months of pregnancy are typically divided into three periods (trimesters) of 3 months. The first sign of pregnancy is often the absence of an expected menstrual period. Common symptoms include nausea, breast tenderness, fatigue, and frequent urination. The diagnosis of pregnancy can be made as early as 10 days after fertilization by means of blood tests. By 6 weeks (from the last menstrual period), the uterus feels soft and is palpably enlarged. Pregnancy can be positively confirmed by observing cardiac motion of the fetus by ultrasound scanning (8 weeks) or by hearing fetal heart "tones" by using a Doppler detection instrument (10–12 weeks).

Early in the first trimester, the embryo's germ layers differentiate into organs and systems, a process that is nearly completed by the twelfth week. It is during this critical period of development that the fetus is most vulnerable to the adverse effects of drugs and other teratogenic influences. The second and third trimesters of pregnancy are characterized by increased fetal growth and gradual physiologic maturation of fetal organ systems. During this time, the maternal changes of pregnancy are greatest. The enlarging uterus encroaches on the abdominal region by the fourth month and at term nearly reaches the diaphragm. The breasts gradually enlarge in preparation for lactation. Striking cardiovascular changes, including nearly a 50% increase in cardiac output, provide the increased blood flow to accommodate the growing fetoplacental unit. Other changes in the renal, digestive, pulmonary, and endocrine systems reflect the numerous maternal adaptations that eventually must occur in a healthy pregnancy. See EMBRYOLOGY.

Early, regular prenatal care is associated with improved pregnancy outcome and seeks to identify risk factors in the pregnancy that may apply to mother or fetus. At 6–8 weeks, a complete physical examination, along with blood and urine analyses, should be performed. In addition to undergoing traditional tests, patients are now routinely screened for hepatitis B at the beginning of pregnancy, for fetal neural-tube defects such as open spine at 16 weeks, and for gestational diabetes at about 28 weeks. In addition to these blood tests, many physicians offer a sonogram at 16–18 weeks to establish gestational age, check for a multiple pregnancy, and screen for birth defects. During prenatal visits, a physician can evaluate nutrition, blood pressure, and fetal growth. See **PRENATAL DIAGNOSIS**.

Ideally, at the end of the third trimester, the process of labor begins. The muscles of the uterus contract, dilating the cervix and allowing the baby to begin moving into the vagina or birth canal. Continued contractions push the baby out of the mother's body. In the final stage of labor, the placenta detaches from the uterine walls and is expelled as the afterbirth. An alternative to vaginal delivery is the cesarean section, in which the baby is removed surgically through an abdominal incision.

The legal status of pregnancy termination (therapeutic abortion) varies from country to country, but about two-thirds of women in the world have access to legal abortion. Over 90% of abortions in the United States are performed in the first trimester by suction curettage, a technique that uses suctioning and removal of the uterine contents through the vagina with surgical instruments. Later pregnancies are terminated by a procedure called dilatation and evacuation (D&E) or by administration of drugs to stimulate uterine contractions. Medical and psychological sequelae to abortion are few, and are fewest for terminations in the first trimester. See **PREGNANCY DISORDERS**. [B.D.Sh.]

**Pregnancy disorders** Physical disorders that can arise as a consequence of pregnancy, ranging from mild to life-threatening. Extreme conditions can result in termination of the pregnancy or death of the mother.

The most common disorder of early pregnancy, persistent vomiting, is without known cause and usually subsides spontaneously within a few weeks. A more serious threat to pregnancy, vaginal bleeding (within the first 20 weeks), may be a sign of miscarriage (spontaneous abortion) or much less often, ectopic pregnancy (embryonic development outside the uterus, usually within the Fallopian tube). Over 50% of miscarriages are due to a spontaneous chromosomal abnormality in the sperm, egg, or developing embryo. Ectopics are nearly always removed surgically; the involved Fallopian tube usually can be preserved.

Some abnormal conditions in pregnancy are identified as a result of routine blood tests. Examples include rubella (German measles) and syphilis, both of which occur relatively infrequently and can cause birth defects. Rh disease is also uncommon because of prevention by prenatal blood tests and treatment with immunoglobulins in Rh-negative mothers. Routine screening is also recommended for hepatitis B. See **HEPATITIS**; **PRENATAL DIAGNOSIS**; **RH INCOMPATIBILITY**; **RUBELLA**; **SYPHILIS**.

Maternal conditions that may worsen during pregnancy include some forms of heart disease, seizure disorders, hypertensive disease, and acquired immune deficiency syndrome (AIDS). See **ACQUIRED IMMUNE DEFICIENCY SYNDROME (AIDS)**.

Among the most important disorders during the second half of pregnancy are those associated with low birth weight due to either premature labor or fetal growth problems. Low birth weight is associated with twins, hypertensive disorders, smoking, and inadequate nutrition. The hypertensive disorders include pregnancy-induced hypertension (formerly known as toxemia) as well as chronic hypertension that exists before the pregnancy. Signs and symptoms of pregnancy-induced hypertension can include swelling of the hands and face, headaches, and a sudden weight gain of 5 lb (2 kg) or more in 1 week. Vaginal bleeding in late pregnancy, which is a potential emergency condition, often results from a placental problem; either the placenta is abnor-

mally located near or over the cervix (placenta previa), or the placenta separates prematurely from the uterus (abruptio placenta). See **HYPERTENSION**.

Far less dramatic than these conditions, but equally important as a cause of fetal distress, is the "post dates" pregnancy, which occurs once pregnancy has extended 2 weeks beyond the date of expected delivery. When a pregnancy reaches 42 weeks, delivery is attempted as soon as possible as the aging placenta may lose its ability to provide adequate oxygen and nutrition.

Increased rest and proper nutrition are especially important in pregnancies complicated by high blood pressure, fetal growth problems, and twins. More immediate management often centers on the timing of delivery. See **PREGNANCY**. [B.D.Sh.]

**Prehistoric technology** The set of ideas that prescribe the manufacture and use of implements before written history. Technology is the principal means through which the human species has succeeded in occupying most of the world. Archeologists tend to use the term "artifact" for any material that was modified by ancient humans, whether this material was used or not, and the term "tool" for any material that was used by ancient humans, whether it was modified or not.

Archeological evidence has demonstrated that the human lineage has been making and using identifiable tools for at least 2.5–2.6 million years, beginning with stone implements and associated prehistoric remains. The advent of metalworking technologies, especially in the Old World, gradually brought about a decline in stone artifacts. By 2000 B.C., stone tools had been replaced by metal implements in much of Eurasia. Subsequent migrations of peoples and diffusion of ideas accelerated this replacement. See **NEOLITHIC**; **PALEOLITHIC**.

The archeological evidence for prehistoric technologies may be biased because of the nature of the raw materials that were used and the conditions of burial and preservation of these materials. In general, artifacts of stone, bone, pottery, and metal preserve fairly well in many areas, whereas artifacts of wood and other vegetable materials, skin, and horn tend to decay fairly rapidly and are normally found only in exceptional prehistoric contexts.

In 1816, C. Thompsen, director of the Danish National Museum, began to chronologically order the museum's prehistoric collections into three major groups, based upon technology, and now called the Three Age System. The earliest was a Stone Age, followed by a Bronze Age, and finally an Iron Age. As time went on, the prehistory of Europe was further divided, based on regional sequences that could be documented through excavation. In other places, such as the Americas, Australia, Oceania, and sub-Saharan Africa, different nomenclature was often used, since the regional technological sequences differed from that of western Europe.

New technological traits can be introduced into a society in a number of ways: (1) innovation or invention, which is the development of new ideas, including new technological characteristics; (2) diffusion, which involves the spread of ideas, including technological knowledge, from one group to another; and (3) migration, which is the spread of peoples, often with new technologies, into new areas. One of the goals of a prehistorian is to try to ascertain, based on archeological evidence, which factors best explain the technological changes seen in the archeological record. [N.To.; B.Bl.]

**Prehnite** A mineral with the formula  $\text{Ca}_2(\text{Al,Fe}^{3+})(\text{OH})_2 - [\text{Si}_3\text{AlO}_{10}]$ , with Al in parentheses in octahedral and Al in brackets in tetrahedral coordination by oxygens. The mineral usually occurs as stalactitic aggregates or as curved crystals, has a vitreous luster, and is yellowish green to pale green in color. Hardness is 6–6½ on Mohs scale; specific gravity 2.8–2.9. Common occurrences include vesicular basalts such as the Keweenaw basalts in the Upper Peninsula of Michigan, and the Watchung basalts in New Jersey. See **SILICATE MINERALS**. [P.B.M.]

**Prenatal diagnosis** The identification of disease before the birth of a fetus. It often implies genetic diagnosis, but identification of anatomical defects as well as assessment of fetal functions and maturity are also considered. Some of the relatively common diseases that can be diagnosed prenatally are Tay-Sachs disease, cystic fibrosis, Duchenne's muscular dystrophy, hemophilia A, congenital adrenal hyperplasia, thalassemia, and sickle cell anemia.

Ultrasonic data have vastly improved the understanding of normal growth and development, thus permitting earlier and more accurate diagnosis of fetal disease. Fetal movements can also be observed, allowing assessment of functional well-being. See MEDICAL IMAGING; MEDICAL ULTRASONIC TOMOGRAPHY.

Obstetricians typically review the health history of the pregnant woman, the father-to-be, and their families in order to identify any possible heritable disorders in the families. Certain risks related to the patient's age, race, and geographic origin may be noted. Based on these assessments, genetic testing of the unborn child may be discussed or recommended. Using cells from the fetus, a prenatal genetic diagnosis can be made for at least 10% of those disorders that are known or assumed to result from a gene mutation. Such diagnosis is based on deoxyribonucleic acid (DNA) analysis or on detection of an abnormal enzyme or other protein produced by the defective gene. See HUMAN GENETICS. [D.McN.]

**Press fit** A force fit that has negative allowance; that is, the bore in the fitted member is smaller than the shaft which is pressed into the bore. Tight fits have slight negative allowance so that light pressure is required to assemble the parts; they are used for gears, pulleys, cranks, and rocker arms. Medium force fits have somewhat greater negative allowance and require considerable pressure for assembly; they are used for fastening locomotive wheels, car wheels, and motor armatures. See ALLOWANCE; FORCE FIT; SHRINK FIT. [P.H.B.]

**Pressure** The ratio of force to area. Atmospheric pressure at the surface of Earth is in the vicinity of  $15 \text{ lbf/in.}^2$  ( $1.0 \times 10^5 \text{ Pa}$ ). Pressures in enclosed containers less than this value are spoken of as vacuum pressures; for example, the vacuum pressure inside a cathode-ray tube is  $10^{-8} \text{ mmHg}$ , meaning that the pressure is equal to the pressure that would be produced by a column of mercury, with no force acting above it, that is  $10^{-8} \text{ mm}$  high. This is absolute pressure measured above zero pressure as a reference level. Inside a steam boiler, the pressure may be  $800 \text{ lbf/in.}^2$  ( $5.5 \times 10^6 \text{ Pa}$ ) or higher. Such pressure, measured above atmospheric pressure as a reference level, is gage pressure, designated psig. See PRESSURE MEASUREMENT. [F.H.R.]

**Pressure measurement** The determination of the magnitude of a fluid force applied to a unit area. Pressure measurements are generally classified as gage pressure, absolute pressure, or differential pressure. See PRESSURE.

Pressure gages generally fall in one of three categories, based on the principle of operation: liquid columns, expansible-element gages, and electrical pressure transducers.

Liquid-column gages include barometers and manometers. They consist of a U-shaped tube partly filled with a nonvolatile liquid. Water and mercury are the two most common liquids used in this type of gage. See BAROMETER; MANOMETER.

There are three classes of expansible metallic-element gages: bourdon, diaphragm, and bellows. Bourdon-spring gages, in which pressure acts on a shaped, flattened, elastic tube, are by far the most widely used type of instrument. These gages are simple, rugged, and inexpensive. In diaphragm-element gages, pressure applied to one or more contoured diaphragm disks acts against a spring or against the spring rate of the diaphragms, producing a measurable motion. In bellows-element gages, pressure in or around the bellows moves the end plate of the bellows against a calibrated spring, producing a measurable motion.

Electrical pressure transducers convert a pressure to an electrical signal which may be used to indicate a pressure or to control a process. Such devices as strain gages and resistive, magnetic, crystal, and capacitive pressure transducers are commonly used to convert the measured pressure to an electrical signal. See PRESSURE TRANSDUCER; STRAIN GAGE. [J.H.Z.]

**Pressure seal** A seal used to make pressure-proof the interface (contacting surfaces) between two parts that have frequent or continual relative rotational or translational motion; such seals are known as dynamic seals, as compared with static seals. While the pressure in seals is lower than that in gaskets, the motion hinders their effectiveness so that there are more types of seals than gaskets, each type attempting to serve its environment. The materials are leather, rubber, cotton, and flax, and for piston rings, cast iron. The forms of nonmetallic seals are rectangular, V-ring, and O-ring. Cartridge seals are available for rolling-contact bearings. Special seals include carbon ring and labyrinth seals for turbines and mechanical seals for pumps. See GASKET. [P.H.B.]

**Pressure transducer** An instrument component which detects a fluid pressure and produces an electrical, mechanical, or pneumatic signal related to the pressure. See TRANSDUCER.

In general, the complete instrument system comprises a pressure-sensing element such as a bourdon tube, bellows, or diaphragm element; a device which converts motion or force produced by the sensing element to a change of an electrical, mechanical, or pneumatic parameter; and an indicating or recording instrument. Frequently the instrument is used in an autocontrol loop to maintain a desired pressure. See PROCESS CONTROL.

Although pneumatic and mechanical transducers are commonly used, electrical measurement of pressure is often preferred because of a need for long-distance transmission, higher accuracy requirements, more favorable economics, or quicker response. Electrical pressure transducers may be classified by the operating principle as resistive transducers, strain gages, magnetic transducers, crystal transducers, capacitive transducers, and resonant transducers.

In resistive pressure transducers, pressure is measured by an element that changes its electrical resistance as a function of pressure. Many types of resistive pressure transducers use a movable contact, positioned by the pressure-sensing element. One form is a contact sliding along a continuous resistor, which may be straight-wire, wire-wound, or nonmetallic such as carbon.

Strain-gage pressure transducers might be considered to be resistive transducers, but are usually classified separately. They convert a physical displacement into an electrical signal. When a wire is placed in tension, its electrical resistance increases. The change in resistance is a measure of the displacement, hence of the pressure. Another variety of strain gage transducer uses integrated circuit technology. Resistors are diffused onto the surface of a silicon crystal within the boundaries of an area which is etched to form a thin diaphragm. See INTEGRATED CIRCUITS; STRAIN GAGE.

In magnetic pressure transducers, a change of pressure is converted into change of magnetic reluctance or inductance when one part of a magnetic circuit is moved by a pressure-sensing element—bourdon tube, bellows, or diaphragm.

Piezoelectric crystals produce an electric potential when placed under stress by a pressure-sensing element. Crystal transducers offer a high speed of response and are widely used for dynamic pressure measurements in such applications as ballistics and engine pressures. See PIEZOELECTRICITY.

Capacitive pressure transducers almost invariably sense pressure by means of a metallic diaphragm, which is also used as one plate of a capacitor.

The resonant transducer consists of a wire or tube fixed at one end and attached at the other (under tension) to a

pressure-sensing element. The wire is placed in a magnetic field and allowed to oscillate. As the pressure is increased, the element increases the tension in the wire or tube, thus raising its resonant frequency. See PRESSURE MEASUREMENT. [J.H.Z.]

**Pressure vessel** A cylindrical or spherical metal container capable of withstanding pressures exerted by the material enclosed. Pressure vessels are important because many liquids and gases must be stored under high pressure. Special emphasis is placed upon the strength of the vessel to prevent explosions as a result of rupture. Codes for the safety of such vessels have been developed that specify the design of the container for specified conditions.

Most pressure vessels are required to carry only low pressures and thus are constructed of tubes and sheets rolled to form cylinders. Some pressure vessels must carry high pressures, however, and the thickness of the vessel walls must increase in order to provide adequate strength. Hydraulic and pneumatic cylinders are machine elements that are forms of pressure vessels. [J.J.R.]

**Pressurized blast furnace** A blast furnace operated under higher than normal pressure. The pressure is obtained by throttling the off-gas line, which permits a greater volume of air to be passed through the furnace at lower velocity and results in an increasing smelting rate. The process permits large increases in the weight of high-temperature air blown into the bottom of the furnace at lower gas velocities, thus increasing the rate of smelting and decreasing the rate of coke consumption, and also permitting smoother operation with less flue dust production through decreased pressure drop between bottom and top pressures. See FURNACE. [B.S.O.]

**Prestressed concrete** Concrete with stresses induced in it before use so as to counteract stresses that will be produced by loads. Prestress is most effective with concrete, which is weak in tension, when the stresses induced are compressive. One way to produce compressive prestress is to place a concrete member between two abutments, with jacks between its ends and the abutments, and to apply pressure with the jacks. The most common way is to stretch steel bars or wires, called tendons, and to anchor them to the concrete; when they try to regain their initial length, the concrete resists and is prestressed. The tendons may be stretched with jacks or by electrical heating.

Prestressed concrete is particularly advantageous for beams. It permits steel to be used at stresses several times larger than those permitted for reinforcing bars. It permits high-strength concrete to be used economically, for in designing a member with reinforced concrete, all concrete below the neutral axis is considered to be in tension and cracked, and therefore ineffective, whereas the full cross section of a prestressed concrete beam is effective in bending. See REINFORCED CONCRETE; STRESS AND STRAIN. [F.S.M.]

**Priapulida** One of the minor groups of wormlike marine animals, now regarded as a separate phylum of the animal kingdom with uncertain zoological affinities. The phylum is a small one with only two genera, *Priapulus* and *Halicryptus*.

Priapulida inhabit the colder waters of both hemispheres. They burrow in mud and sand of the sea floor, from the intertidal region to depths of 14,850 ft (4500 m).

Priapulids are small to medium-sized animals, the largest specimen attaining 6 in. (15 cm) in length. The body of *Priapulus* is made up of three distinct portions: proboscis, trunk, and caudal appendage (see illustration). Separated by a constriction from the trunk, the bulbous, introversible proboscis usually constitutes the anterior third of the body and is marked by 25 longitudinal ridges of papillae or spines. The mouth is located at the anterior end of the proboscis and is surrounded by concentric rows

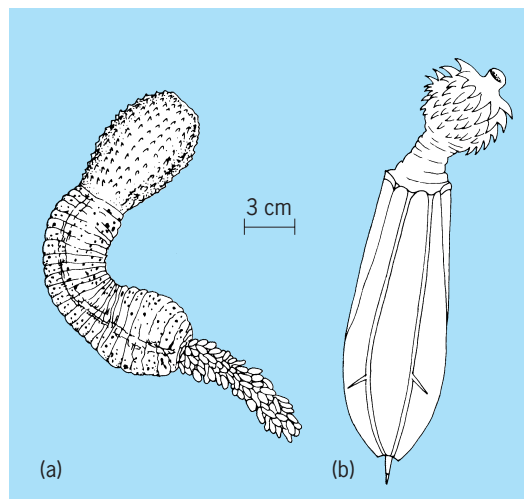

Priapulida. (a) *Priapulus* adult and (b) larva.

of teeth. The cylindrical trunk is annulated, but not segmented, and is often covered with irregularly dispersed spines and tubercles. At the posterior end of the trunk there are three openings: the anus and two urogenital apertures. [M.E.Ri.]

**Prilling** Solidification of droplets of molten material free-falling against an upward stream of air in a tower. It is a process used extensively in nitrogen fertilizer manufacturing. Melt is dispersed in the top of the tower at a temperature just above the solidification point of the material being processed. The dispersion arrangement, air flow, tower dimensions, and feed material are selected so the droplets approach a spherical shape and solidify before reaching the bottom of the tower. Prilling has long been a major way of agglomerating ammonium nitrate and urea because of its relative simplicity and economy. Prills of ammonium nitrate and urea are smooth, spherical, dust-free, and moderately rugged, but usually are smaller and more fragile than granulated fertilizers. See DRYING; FERTILIZER. [E.O.H.]

**Primary vascular system (plant)** The arrangement of conducting elements which serves for two-way transportation of substances between different parts of a plant. The conducting elements are of two principal kinds: xylem, which is mainly responsible for the conduction of water together with dissolved inorganic substances upward from the root to other plant organs; and phloem, which is mainly responsible for the conduction of food materials (assimilates), a flow which may take place in either direction. In the shoot region of the plant, xylem and phloem are usually associated into vascular bundles. In the root, however, they usually alternate with one another on different radii. See PHLOEM; XYLEM. [W.R.P.]

**Primates** The mammalian order to which humans belong. Primates are generally arboreal mammals with a geographic distribution largely restricted to the Tropics. Unlike most other mammalian orders, the primates cannot be defined by a diagnostic suite of specializations, but are characterized by a combination of primitive features and progressive trends. These include:

1. Increased dominance of vision over olfaction, with eyes more frontally directed, development of stereoscopic vision, and reduction in the length of the snout.
2. Eye sockets of the skull completely encircled by bone.
3. Loss of an incisor and premolar from each half of the upper and lower jaws with respect to primitive placental mammals.
4. Increased size and complexity of the brain, especially those centers involving vision, memory, and learning.

5. Development of grasping hands and feet, with a tendency to use the hands rather than the snout as the primary exploratory and manipulative organ.

6. Progressive elaboration of the placenta in conjunction with longer gestation period, small litter size (only one or two infants), and precocial young.

7. Increased period of infant dependency and more intensive parenting.

8. A tendency to live in complex, long-lasting social groups.

It has been recognized for a long time that many of these features are adaptations for living in trees. However, it has been proposed more recently that primates may have developed their specializations as a consequence of being visually directed predators, living among the smaller branches of the forest canopy or undergrowth, that captured insects with their hands.

Classification of the primates is as follows:

- Order Primates
  - Suborder Strepsirhini
    - Infraorder Lorisiformes
      - Superfamily Lorioidea
        - Family: Lorisidae (lorises)
          - Galagidae (bushbabies)
    - Infraorder Lemuriformes
      - Superfamily Lemuroidea
        - Family: Cheirogaleidae (dwarf lemurs)
          - Lepilemuridae (sportive lemur)
          - Lemuridae (true lemurs)
          - Indriidae (sifakas, indri, woolly lemur)
          - Daubentonidae (aye-aye)
  - Suborder Haplorhini
    - Hyporder Tarsiiformes
      - Superfamily Tarsiioidea
        - Family Tarsiidae (tarsiers)
    - Hyporder Anthropeoidea
      - Infraorder Platyrrhini
        - Superfamily Ceboidea
          - Family: Callitrichidae (marmosets, tamarins)
            - Cebidae (capuchins, squirrel monkeys, douroucoulis, titis)
            - Atelidae (sakis, uakaris, howler monkeys, spider monkeys, woolly monkeys)
      - Infraorder Catarrhini
        - Superfamily Cercopithecoidea
          - Family Cercopithecidae (Old World monkeys)
        - Superfamily Hominoidea
          - Family: Hylobatidae (gibbons, siamang)
            - Hominidae (orangutan, gorilla, chimpanzees, humans)

There are two major groups of primates: the strepsirhines or “lower” primates, and the haplorhines or “higher” primates. Strepsirhines have elongated and forwardly projecting lower front teeth that form a toothcomb, used for grooming the fur and for obtaining resins and gums from trees as a source of food. The digits of the hands and feet bear flattened nails, rather than claws, except for the second toe, which retains a sharp toilet claw for grooming. They also have a moist, naked rhinarium and cleft upper lip (similar to the wet noses of dogs). Most strepsirhines are nocturnal, with large eyes and a special reflective layer (the tapetum lucidum) behind the retina that intensifies images in low light. Compared with haplorhines, the brain size is relatively small and the snout tends to be longer.

The strepsirhines are subdivided into two major groups: the lorisooids, which are found throughout tropical Africa and Asia, and the lemuroids, which are restricted to Madagascar.

The lorisooids include the galagids or bushbabies (*Galago*, *Otolemur*, *Euoticus*, and *Galagoides*) and the lorisooids or lorises (*Loris*, *Nycticebus*, *Perodicticus*, *Pseudopotto*, and *Arctocebus*).

They are small nocturnal primates, in which the largest species, the greater bushbaby, weighs only about 1 kg (2 lb). Their diet consists mainly of a combination of insects, fruits, and gums. Lorisooids are semisolitary, living in small, dispersed social groups.

The greatest diversity of strepsirhines is found on Madagascar, where more than 30 species are represented, belonging to five different families.

Tarsiers, tiny primates (weighing only about 120 g) from the islands of Southeast Asia, all belong to a single genus, *Tarsius*. They are nocturnal with the largest eyes of any primate, and other adaptations for a specialized lifestyle as vertical clingers and leapers. In the past, tarsiers have been grouped together with the strepsirhines as prosimians, because they retain many primitive features lost in higher primates. However, tarsiers share a number of distinctive specializations with anthropoids that suggest that they are more closely related to each other than either is to the strepsirhines. For this reason, tarsiers and anthropoids are classified together as haplorhines.

The anthropoids include the platyrrhines or New World monkeys and the catarrhines or Old World monkeys, apes, and humans. Anthropoids are distinguished from strepsirhines and tarsiers in having a larger brain, relatively small eyes (all anthropoids are diurnal, active by day, except for the nocturnal douroucoulis from South America), eye sockets almost completely enclosed by a bony septum, the two halves of the lower jaw fused in the midline rather than separated by a cartilage, small and immobile ears, the hands and feet bearing nails with no toilet claws (except for the callitrichids that have secondarily evolved claws on all fingers and toes), a single-chambered uterus rather than two-horned, and a more advanced placenta.

The platyrrhines from South and Central America are a diverse group of primates comprising more than 50 species and 16 genera. Primatologists have had a difficult time establishing a classification of platyrrhines that reflects their evolutionary interrelationships, and no consensus has been reached. There is agreement, however, that three distinct clusters can be defined: the callitrichids, the pitheciines, and the atelines. The last two groups appear to be closely related and are commonly included together in the family Atelidae. The relationships of the remaining platyrrhines are uncertain, and they are often placed together for convenience in the Cebidae.

All platyrrhines are arboreal, and they are widely distributed throughout tropical forests extending from Mexico to northern Argentina. They are small to medium-sized primates ranging from 100 g to 15 kg (0.2 to 33 lb). Platyrrhines exhibit a variety of quadrupedal locomotor types ranging from squirrellike scrambling, to leaping and forelimb suspension. Atelines and capuchin monkeys are unique among primates in having a specialized prehensile tail that can grasp around branches for extra support.

The catarrhines include all anthropoid primates from Africa, Asia, and Europe. There are two main groups: the cercopithecids or Old World monkeys, and the hominoids or apes and humans. Catarrhines are distinguished from platyrrhines by a reduction in the number of premolars from three to two in each half of the upper and lower jaw, and the development of a tubelike (rather than ringlike) tympanic bone to support the eardrum.

Old World monkeys are widely distributed throughout sub-Saharan Africa and tropical Asia, and also occur in the extreme southwestern tip of the Arabian Peninsula, northwest Africa, Gibraltar (their only European record), and East Asia. They are a highly successful group comprising more than 80 species. They are distinguished from other anthropoids in having bilophodont molar teeth that bear a pair of transverse crests. They also have naked, roughened sitting pads on their rumps, called ischial callosities—a feature that they share with hylobatids. In addition, most Old World monkeys are highly sexually dimorphic, with males considerably larger than females.

Hominoidea is the superfamily to which apes and humans belong. Hominoids are distinguished from cercopithecoids in

having primitive nonbilophodont molars, larger brains, longer arms than legs (except in humans), a broader chest, a shorter and less flexible lower back, and no tail. Many of these specializations relate to a more upright posture in apes, associated with a greater emphasis on vertical climbing and forelimb suspension.

Hominoids can be classified into two families: the Hylobatidae, which includes the gibbons and siamang, and the Hominidae, which includes the great apes and humans. The gibbons and siamang (*Hylobates*) are the smallest of the hominoids (4–11 kg or 9–24 lb), and for this reason they are sometimes referred to as the lesser apes. The nine or so species are common throughout the tropical forests of Asia. They are remarkable in having the longest arms of any primates, which are 30–50% longer than their legs. This is related to their highly specialized mode of locomotion, called brachiation, in which they swing below branches using only their forelimbs. Gibbons are fruit eaters, while the larger siamang incorporates a higher proportion of leaves in its diet. Hylobatids live in monogamous family groups in which males and females are similar in size.

The great apes include the orangutan (*Pongo*) from Asia and the gorilla (*Gorilla*) and chimpanzees (*Pan*) from Africa. These were formerly included together in their own family, the Pongidae, to distinguish them from humans, who were placed in the Hominidae. However, recent anatomical, molecular, and behavioral evidence has confirmed that humans are closely related to the great apes, especially to the African apes, and for this reason most scientists now classify them together in a single family, the Hominidae. The orangutan is restricted to the tropical rainforests of Borneo and northern Sumatra. They are large, arboreal primates that climb cautiously through the trees using all four limbs for support. Orangutans subsist mainly on fruits.

The gorilla, the largest of the hominoids, has a disjunct distribution in tropical Africa. Because of their great size, gorillas are almost entirely terrestrial, although females and young individuals frequently climb trees. Nests are often built on the ground. Gorillas move quadrupedally, and like chimpanzees, the hands are specialized for knuckle walking in which the weight of the animal is borne on the upper surface of the middle joints of the fingers. Mountain gorillas eat a variety of leaves, stems, and roots, while lowland gorillas eat a greater proportion of fruits. Groups consist of a dominant male, called a silverback, as well as several adult females, subadults, and infants.

There are two species of chimpanzees, the common chimpanzee (*Pan troglodytes*) and the bonobo or pygmy chimpanzee (*Pan paniscus*). The common chimpanzee is widely distributed in the forests and woodlands stretching across equatorial Africa, while the pygmy chimpanzee is restricted to the tropical rainforests of the Congo. Both species nest and feed in trees, but they mostly travel on the ground. Common chimpanzees have eclectic diets, including meat, which they obtain by hunting small to medium-sized mammals. Tool-using behaviors are common, and more than a dozen simple tool types have been identified. Chimpanzees are gregarious and sociable, and they live in large multimale communities that divide into smaller subgroups for foraging. See APES; FOSSIL APES; FOSSIL HUMANS; FOSSIL PRIMATES; MAMMALIA; MONKEY. [T.Ha.]

**Prime mover** The component of a power plant that transforms energy from the thermal or the pressure form to the mechanical form. Mechanical energy may be in the form of a rotating or a reciprocating shaft, or a jet for thrust or propulsion. The prime mover is frequently called an engine or turbine and is represented by such machines as waterwheels, hydraulic turbines, steam engines, steam turbines, windmills, gas turbines, internal combustion engines, and jet engines. These prime movers operate by either of two principles: (1) balanced expansion, positive displacement, intermittent flow of a working fluid into and out of a piston and cylinder mechanism so that by pressure difference on the opposite sides of the piston, or its equivalent, there is relative motion of the machine parts; or (2) free continuous flow

through a nozzle where fluid acceleration in a jet (and vane) mechanism gives relative motion to the machine parts by impulse, reaction, or both. See GAS TURBINE; HYDRAULIC TURBINE; IMPULSE TURBINE; INTERNAL COMBUSTION ENGINE; POWER PLANT; REACTION TURBINE; STEAM ENGINE; STEAM TURBINE; TURBINE. [T.Ba.]

**Primer (surface coating)** A material used for the first coat of paint or as the prime coat in a protective coating system. Primers are designed to promote adhesion of the coating system to the substrate, to furnish a good base for further coatings, and to prevent attack on the substrate by air, water, or other materials.

Wood primers are formulated to give maximum adhesion and to provide adequate flexibility for adjustment to dimensional changes that occur when wood swells or shrinks because of changes in moisture content. Primers used as the undercoat for enamels must provide a smooth film and permit easy sanding.

Metal primers must provide excellent adhesion by mechanical anchorage or chemical bonding. Modern corrosion-resistant coating systems applied over steel contain inorganic or organic zinc dispersed in a suitable vehicle. Zinc is attacked by the electrochemical corrosion process preferentially before steel, and protects the steel substrate by this sacrificial property. Prime coat materials for nonferrous metallic substrates usually are generically related to materials used in subsequent coats.

Primers for porous surfaces such as concrete must seal the surface adequately to provide a uniform base for future coatings.

Primers are always pigmented. In clear finishes the coat which performs this function is described as a sealer, an under-coater, or a wash coat. See CORROSION; PAINT; PIGMENT; SURFACE COATING.

[C.R.Ma.; C.W.Si.]

**Primitive gut** The tubular structure in embryos which differentiates into the alimentary canal. The method by which the primitive gut arises depends chiefly on the yolk content of the egg.

Eggs with small or moderate amounts of yolk usually develop into spherical blastulae which invaginate at the vegetative pole to form double-walled gastrulae. The invaginated sac extends in length to become the primitive gut.

Animals such as fish, reptiles, and birds, having more yolk than can be cleaved, form flattened gastrulae consisting of three-layered blastoderms surmounting the yolk. Mammals also belong in this group, although the yolk has been lost secondarily in all except the monotremes. The head is formed by a folding of the blastoderm upon itself. The entodermal layer within the head fold becomes the pharynx. This foregut is extended by an anterior growth of the whole head and by the union of lateral entodermal folds at its posterior boundary. In most forms, the hindgut arises by a similar folding in the opposite direction, the tail fold, at the posterior end of the blastoderm. See CLEAVAGE (EMBRYOLOGY); GASTRULATION; OVUM. [H.L.Ha.]

**Primulales** An order of flowering plants, division Magnoliophyta (Angiospermae), in the subclass Dilleniidae of the class Magnoliopsida (dicotyledons). The order consists of three families: the Myrsinaceae, with about 1000 species; the Primulaceae, with about 1000 species; and the Theophrastaceae, with a little more than 100 species. These are plants with sympetalous flowers; that is, the petals are fused by their margins to form a corolla with a basal tube and terminal lobes. The functional stamens are opposite the corolla lobes, and there is a compound ovary that has a single style and two to numerous ovules which usually have two integuments and are on a free-central or basal placenta. The Myrsinaceae and Theophrastaceae are chiefly tropical and subtropical woody plants, but the Primulaceae are mostly herbaceous and are best developed in north temperate regions. Primrose (*Primula*) and cyclamen are familiar members of the Primulaceae. See DILLENIIDAE; MAGNOLIOPSIDA; PLANT KINGDOM.

[A.Cr.; T.M.Ha.]

**Printed circuit** A conductive pattern that may or may not include printed components, formed in a predetermined design on the surface of an insulating base in an accurately repeatable manner. Printed circuits are fabricated by any of several graphic art processes. They greatly simplify mass production and increase equipment reliability. Their most important contribution, however, is the tremendous reduction achieved in size and weight of electronic devices and equipment. Printed circuits are used in practically all types of electronic equipment: toys, radio and television sets, telephone systems units, electrical wiring behind automobile dashboards, computers, and industrial control equipment.

**Technology.** The configuration in which electronic circuit elements are located and the routing of conductor paths between the circuit elements establish the precise circuit pattern. Location of the circuit elements can depend on a number of factors, including the form factor (outline of a printed wiring board in a piece of electronic equipment), signal criticality, and the power dissipation of the circuit elements. Conductor path routing is a function of the circuit element location, signal criticality, width and spacing of interconnection conductors, number of wiring channels per layer of interconnect structure, and number of interconnect layers allowed.

As a result of increased circuit complexity, sophisticated computer-aided engineering (CAE) programs have been developed to automate the design of printed circuits. Output from the computer-aided engineering database includes a circuit element parts list and schematic diagrams of the circuit interconnections. This computer-aided engineering database can be used as input to a computer-aided design (CAD) program that optimizes the location of circuit elements within the given form factor and automatically performs the conductor routing between circuit elements. See COMPUTER-AIDED DESIGN AND MANUFACTURING; COMPUTER-AIDED ENGINEERING.

Artwork masters are used to fabricate the screens and masks for the application of photoresistive materials in the actual formation of the required patterns on the finished parts. The computer-aided design database is also used in the preparation of numerous types of tooling, for example, drill templates, tapes for operation of numerical-tape-controlled drilling equipment, routing templates and dicing fixtures for trimming printed circuits or integrated-circuit dies to final configuration, laminating and holding fixtures, and string lists to drive automated test equipment. Numerous processes, including etching, screening, plating, laminating, vacuum deposition, diffusion, and application of protective coatings, are used in combination to produce various types of printed circuits. Completed printed circuits are inspected visually and dimensionally by using such techniques as microsectioning and infrared photospectrometer measurements in determining thicknesses of critical materials; in addition, they may be x-rayed and electrically tested to assure conformance to requirements. See PRINTING.

**Printed wiring.** Printed wiring is undoubtedly the most common type of printed circuit. The printed wiring board (PWB) is a copper-clad dielectric material with conductors etched on the external or internal layers. Printed wiring boards can be subdivided into single-sided, double-sided, and multilayer boards.

Single-sided boards contain all the interconnect structure on one of the external layers and are the least expensive to manufacture. Double-sided boards contain circuitry on both external layers. Plated through-holes and occasionally eyelets are used to provide electrical continuity between the sides. Double-sided boards are used in those applications in which the maximum number of interconnections (conductors) in a given area are required for minimum cost. Both single- and double-sided boards are commonly used in such commercial applications as automotive equipment, radio and television sets, and toys.

Multilayer boards contain circuitry on internal layers throughout the cross section of the board as well as on the external layers. Because of the reduced size of miniaturized microelectronic

parts, these boards accommodate the increasing complexity and density of circuitry used in applications such as high-speed computers and signal processors. Multilayer printed wiring boards are manufactured by using two different methods: subtractive (print and etch) technology and additive (plate-up) technology.

**Thick-film circuits.** Thick-film circuits consist of such passive elements as resistors, capacitors, and inductors deposited on wafers or substrates of such dielectric materials as ceramic, glass, quartz, sapphire, and porcelain-coated metal. They are used for mass fabrication of passive networks for inclusion in linear microcircuits and large-signal digital and analog modules. Thick-film design and manufacture are usually based on film thicknesses of approximately 0.0005–0.0015 in. (12–38  $\mu\text{m}$ ).

**Thin-film circuits.** The deposition of thin films was the first application of printed circuit technology to microelectronics. The most important advantages to thin-film circuits are the following: (1) films with a uniform thickness in the range from  $5 \times 10^{-6}$  mm to  $5 \times 10^{-3}$  mm can be vacuum-deposited and controlled by measuring the resistance across a test pattern during deposition to ensure that final thicknesses are within design limits; (2) patterns formed during deposition or by selective etching afterward are much more precisely controlled than those which are printed, as in thick-film circuits; (3) more stable resistive materials can be used; and (4) thin films have less porous surface metallization, enabling faster rise times. Because of this precision and stability, thin-film circuits are frequently used in radio-frequency applications in avionics and industrial electronics.

**Multichip devices.** A multichip device, often referred to as a hybrid, is a combination of two or more electronic components mounted and interconnected via a substrate. The multichip device serves a customized electronic function and is packaged as a single device.

A multichip device serves the same function as a circuit card assembly; however, all the components are packaged together in a single hermetic case. Unlike printed wiring boards where all components are individually packaged and then mounted to the board, multichip devices may use bare, unpackaged dies. The advantages of multichip devices are the vast reduction in volume, area, and weight; improved thermal management; and increased functional densities, frequencies, and electrical performance. The disadvantage is the increased cost over that of equivalent printed wiring board assemblies. Multichip devices can be digital, analog, or a combination of both. [L.K.L.; V.J.B.; D.B.Ha.]

**Printing** A process in which an image is reproduced on a surface, such as paper. There are five general classes of printing processes: relief printing, which includes letterpress and flexography; planographic printing, which includes offset lithography, screenless lithography, collotype, and waterless printing; intaglio, which includes gravure, steel-die, and copper-plate engraving; stencil and screen printing; and electronic printing, which includes electrostatic, magnetographic, ion or electron deposition, and ink-jet printing.

In relief printing, the printing element consists of a raised surface of type, lines, and dots that are inked. Printing is done by transferring the ink directly from the image surface to the paper. The nonprinting areas are below the printing surface.

In planographic printing, the printing areas of the plate are on the same plane as the nonprinting areas. Lithographic printing is accomplished by using the principle that grease and water do not mix. Early lithography was done by using a greasy crayon or greasy ink to draw letters, symbols, and pictures in reverse on a porous stone. The surface of the stone was then sponged with a solution of gum arabic in water to render the nonprinting portions receptive to moisture but repellent to greasy ink, and the printing portions receptive to grease and repellent to moisture. This process is still used as a fine-arts medium for making lithographic prints from drawings or lettering done manually on the stone and printed on a handpress.

Commercial lithography uses thin metal plates made photochemically or digitally and mounted on a press that has means for inking and dampening the plates and prints indirectly by a method commonly known as offset. The inked image on the plate is first transferred to an intermediate rubber-covered blanket cylinder, which then transfers the image to the paper. Relief and intaglio printing can also be printed by the offset principle. Because almost all lithography is printed by the offset principle, the term offset has become synonymous with lithography. Another planographic process is waterless printing, which uses temperature-controlled offset lithographic presses and special silicone-coated plates that can be printed without dampening. Collotype and screenless printing are planographic processes that print illustrations without the need of halftone images.

Intaglio printing, also known as gravure printing, is accomplished by cutting or engraving and etching various sizes or depths of minute cells (or wells) below the surface of a plate or cylinder to form the images. The cells are flooded and loaded with ink, the excess ink is scraped off the surface of the plate by a doctor blade, and the ink left in the cells is transferred to the substrate. The depth and size of each cell determine the amount of ink that is transferred to the printed surface. The nature of the process permits a heavy laydown of ink, which accounts for the rich, saturated colors typical of the gravure process.

In stencil and screen printing, also known as porous printing, ink is brushed or squeezed through a stencil image on a fine screen onto paper or other surface such as metal, glass, or textile. The screen holds the image area, which may carry either pictorial or typographic material. Although this process accounts for a comparatively small part of the total volume of printing, mechanization has made it more useful commercially. Because of the heavy laydown of ink, strong colors can be obtained by this process, making it suitable for posters and signs as well as fine art.

Conventional printing processes use printing plates and presses to produce quantities of the same image. Electronic printing processes use digital imaging systems that produce an image in each cycle of the imaging device. The images can be the same or can be changed from cycle to cycle. Electronic printing is especially suited to printed products requiring variable information such as utility bills, personalized mail, insurance policies, and customized books.

Electrostatic or electrophotographic printing is similar to photocopying. The processes use a photoconductor that is charged, exposed by lasers, and imaged with dry powder or liquid toners. They are used extensively for on-demand printing. Color electrophotographic printing systems are used for short-run variable and on-demand printing. Magnetographic printing is similar to electrophotographic printing except that magnetic toners are used. It is used for single- and spot-color short-run and on-demand printing.

In ion or electron deposition printing, a latent image is formed by ions or electrons on a heated dielectric coated cylinder, toned with a magnetic toner, and transferred and fixed to paper under pressure. The system is used for on-demand variable short-run single- or spot-color printing.

Ink-jet printing uses jets of ink droplets controlled by computer signals to print variable information. It is used extensively in packaging, and in mailing and distribution of magazines and catalogs. Color ink-jet is used for color proofing and short-run printed displays and billboards.

All the individual printing processes use a sequence of procedures. There are two types of processes in use: plate and plateless. The plate processes are the conventional printing processes—letterpress, flexography, lithography, gravure, screen printing, and others—which use a plate or other type of image carrier such as a cylinder or screen, and a printing press on which the image carrier is mounted, ink is applied, and the image is transferred to paper or other substrate. The plateless processes are the electronic or digital printing processes—

electrophotographic, magnetographic, ion or electron deposition, and ink-jet—in which the images are produced digitally by lasers or other devices using special toners or inks.

The sequence of steps in both processes is prepress, press or print, and postpress. The prepress and postpress operations are similar for both processes: that is, the design, preparation, and assembly of images for reproduction, the finishing operations to give the final product such as a leaflet, book, or package, and their distribution, are essentially the same. The two differ in the means used to convert the imaging information into the imaged page, sheet, or board that must be converted to the final printed product for distribution.

The prepress operations for the conventional plate processes have consisted of typesetting, layout and design, process photography, image assembly, and platemaking. These were traditionally manual, labor-intensive operations, but electronics and computers have gradually replaced many manual operations. Phototypesetting and electronic scanning were the first computerized systems to replace manual operations. These were followed by other digital systems. The phototypesetter became the imagesetter. Page layout was accomplished by computer software programs. The scanner was enhanced by color electronic prepress systems. Personal computers developed into desktop publishing systems that emulated color electronic prepress systems, and imagesetters produced films for platemaking.

The conventional printing systems require plates. These plates are traditionally made from photographic negatives or positives. The availability of imagesetters that could produce the films for plates spurred the development of high-speed printing plates that could be exposed by lasers directly in the imagesetter. Also, the introduction of high-speed imagesetters with large memory capacity encouraged the development of digital printing systems that give printed products directly without the use of printing plates or presses.

Each conventional printing process has specific requirements for its printing plates or image carriers. The printing press unit has a cylinder for mounting the plate; an inking system to feed ink to the plate; and on an offset lithographic press, a cylinder covered with a rubber blanket to which the image is transferred from the plate and which transfers the image to the paper feeding over an impression cylinder. The press has a means for feeding paper or other substrate into the printing units, and a delivery device for collecting the printed sheets. The press has as many printing units as the number of colors that it can print (a four-color press has four printing units).

Digital printing uses different printing engines, depending on the process. Electrophotographic printing systems are like high-speed copiers, with a photoconductor-coated cylinder, means for charging the photoconductor, a device for laser exposure of the image on the photoconductor, and means for toning and fixing the image on the substrate. Ink-jet printing systems use an engine for ejecting selected droplets of dyed inks through small orifices in glass or stainless steel nozzles onto paper or other substrate.

After the sheets are printed, most must be put through some finishing operations to make a functional product. Sheets for books or booklets must be folded, collated, bound into covers, and stacked. They must also be prepared for distribution to the customer.

[M.H.B.]

**Prion disease** Transmissible spongiform encephalopathies in both humans and animals. Scrapie is the most common form in animals, while in humans the most prevalent form is Creutzfeldt-Jakob disease. This group of disorders is characterized at a neuropathological level by vacuolation of the brain's gray matter (spongiform change). They were initially considered to be examples of slow virus infections. Experimental work has consistently failed to demonstrate detectable nucleic acids—both ribonucleic acid (RNA) and deoxyribonucleic acid (DNA)—as constituting part of the infectious agent. Contemporary understanding suggests that the infectious particles are composed



predominantly, or perhaps even solely, of protein, and from this concept was derived the acronym prion (proteinaceous infectious particles). Also of interest is the apparent paradox of how these disorders can be simultaneously infectious and yet inherited in an autosomal dominant fashion (from a gene on a chromosome other than a sex chromosome).

**Disorders.** Scrapie, which occurs naturally in sheep and goats, was the first of the spongiform encephalopathies to be described. An increasing range of animal species have been recognized as occasional natural hosts of this type of disease. Bovine spongiform encephalopathy, commonly known as mad cow disease, has been epidemic in British cattle. The first confirmed cases were reported in late 1986. By early 1995 it had been identified in almost 150,000 cattle and more than half of all British herds. Its exact origin is not known, but claims that it came from sheep are now discredited.

So far, animal models have indicated that only central nervous system tissue has been shown to transmit the disease after oral ingestion—a diverse range of other organs, including udder, skeletal muscle, lymph nodes, liver, and buffy coat of blood (white blood cells) proving noninfectious.

The currently recognized spectrum of human disorders encompasses kuru, Creutzfeldt-Jakob disease, Gerstmann-Straussler-Scheinker disease, and fatal familial insomnia. All, including familial cases, have been shown to be transmissible to animals and hence potentially infectious; all are invariably fatal with no effective treatments currently available.

**Human-to-human transmission.** A variety of mechanisms of human-to-human transmission have been described. Transmission is due in part to the ineffectiveness of conventional sterilization and disinfection procedures to control the infectivity of transmissible spongiform encephalopathies. Numerically, pituitary hormone-related Creutzfeldt-Jakob disease is the most important form of human-to-human transmission of disease. However, epidemiological evidence suggests that there is no increased risk of contracting Creutzfeldt-Jakob disease from exposure in the form of close personal contact during domestic and occupational activities. Incubation periods in cases involving human-to-human transmission appear to vary enormously, depending upon the mechanism of inoculation. Current evidence suggests that transmission of Creutzfeldt-Jakob disease from mother to child does not occur. Two important factors pertaining to transmissibility are the method of inoculation and the dose of infectious material administered. A high dose of infectious material administered by direct intracerebral inoculation is clearly the most effective method of transmissibility and generally provides the shortest incubation time. See BRAIN; MUTATION; NERVOUS SYSTEM DISORDERS; SCRAPIE; VIRUS INFECTION, LATENT, PERSISTENT, SLOW. [C.L.Mas.; S.J.Co.]

**Prism** A polyhedron of which two faces are congruent polygons in parallel planes, and the other faces are parallelograms (see illustration). The bases  $B$  are the congruent polygons; the lateral faces are the parallelograms; the lateral edges are the edges not lying in the bases; and the perpendicular distance between the bases is the altitude  $h$ . Sections parallel to the bases are congruent to the bases. A prism is a right prism if its lateral edges are

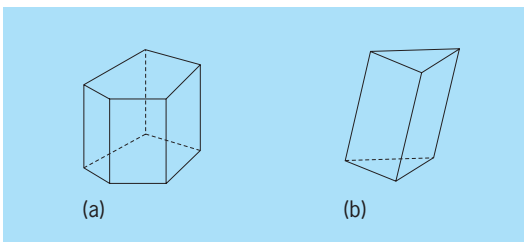

Prism configurations. (a) Right. (b) Oblique.

perpendicular to the bases; an oblique prism otherwise. A prism is called a triangular prism if its bases are triangles; a pentagonal prism if its bases are pentagons; and a parallelepiped if its bases are parallelograms. The volume of any prism is equal to the area of its base times its altitude ( $V = Bh$ ). See POLYHEDRON. [J.S.F.]

**Prismatic astrolabe** A surveying instrument used to make the celestial observations needed in establishing an astronomical position. The instrument (see illustration) consists of an accurate prism, a small pan of mercury to serve as an artificial horizon, an observing telescope with two eyepieces of different power, level bubbles and leveling screws, a magnetic compass and azimuth circle, adjusting screws, flashlight-battery power source, light, and a rheostat to control the intensity of illumination.

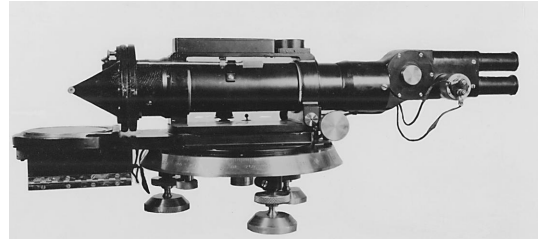

A prismatic astrolabe, used to make celestial observations. (U.S. Naval Oceanographic Office)

By using a fixed prism, the instrument measures a fixed altitude, usually  $45^\circ$ . As a rising star increases altitude past that for which the instrument was constructed, the direct image appears to move upward from the bottom of the field of vision to the top. The image reflected by the mercury horizon appears to move downward from top to bottom. At the established altitude the rays produce images at the center of the field of view. A fixed altitude is used to minimize error due to variations from standard atmospheric refraction. Each accurately timed observation provides one line of position. [A.B.M.]

**Private branch exchange** A telecommunications switching system physically located at a customer's place of business. The private branch exchange (PBX) provides internal station-to-station communications for a well-defined set of users. It also provides access to outside telephone lines, called trunks, which connect the private branch exchange to the telephone company's central office. A typical private branch exchange has more stations than trunks (often as many as 10 stations for each trunk) because the stations share the use of the trunks. See TELEPHONE SERVICE.

CENTREX service, a leased business telephone service provided by the local telephone operating company, provides many of the same station features and functions as a private branch exchange. However, the main switching vehicle for CENTREX is located at the telephone company central office rather than the customer's premises. Conceptually, however, it is similar to a private branch exchange because station users must access the public switched network (PSN) on a contention basis, whereby stations share trunks.

Three distinct generations of private branch exchanges have appeared. In the first generation (1900–1930), a human operator manually set up calls. Second-generation private branch exchanges (mid-1930s to mid-1970s) used mechanical relays to establish the call path. The third generation of private branch exchanges is the stored-program microprocessor-controlled system. Introduced in the mid-1970s, these systems use computer instructions to perform the call set-up and tear-down. Because the private branch exchange is software-based, features and upgrades can often be added without disturbing its operation and

the system can be expanded modularly as necessary. The third-generation private branch exchange is physically much smaller than electromechanical models, uses less power, and generates less heat. See DIGITAL COMPUTER; MICROPROCESSOR.

One significant development of this generation is the rise of digital transmission as the predominant method of signal transmission within the private branch exchange. The analog voice signal can be encoded into a string of digital pulses by a coder/decoder (codec). After it is switched through the private branch exchange, the signal is reconverted to analog format. See ANALOG-TO-DIGITAL CONVERTER; DIGITAL-TO-ANALOG CONVERTER; ELECTRICAL COMMUNICATIONS; PULSE MODULATION.

Telephone instruments have also evolved, becoming more intelligent and versatile. The trend is toward proprietary electronic digital multibutton telephone sets with their own microprocessors, which support enhanced features and functions. Many private branch exchanges permit transmission of data as well as voice conversations. Integrated voice-data terminals, data adapters mounted within the telephone, and stand-alone data units allow the user to conduct voice and data calls simultaneously. See TELEPHONE.

Data transmissions switched through the private branch exchange can communicate with another data device or computer connected to the system or, via the public switched network, with a wide variety of remote data devices and computers. Communications between two data devices attached to the same private branch exchange is usually end-to-end digital. Completely digital transmission between two private branch exchanges is also possible by using public switched network digital trunk facilities, called T1 or DS1 trunks. However, in most cases when transmission through the public switched network is required, the originating location must convert the digital signal to analog format by using a modem. See DATA COMMUNICATIONS; MODEM.

Modern private branch exchanges have extensive and virtually identical feature complements, which include several types of call forwarding, least-cost routing, station message detail recording (SMDR), conferencing, hunting, and calling restrictions. In addition to these features, many private branch exchanges interface with outboard applications processors, which enhance the call-processing function of the private branch exchange.

[B.W.Ba.; V.F.R.]

**Probability** Although probability theory derives its notion and terminology from intuition, a vague statement such as "John will probably come" is as remote from it as the statement "John is forceful and energetic" is remote from mechanics. Probability theory constructs abstract models, mostly of a qualitative nature, and only experience can show whether these reasonably describe laws of nature or life. As always in mathematics, only logical relations and implications enter the theory, and the notion of probability is just as undefinable (and as intuitive) as are the notions of point, line, or mass.

**The sample space.** One speaks of probabilities only in connection with conceptual (not necessarily performable) experiments and must first define the possible outcomes. It is necessary to distinguish between elementary (indivisible) and compound outcomes or events. Each elementary outcome is called sample point; their aggregate is the sample space. The conceptual experiment is defined by the sample space, and it must be introduced and established at the outset.

**Events.** In examining a bridge hand, one may ask whether it contains an ace or satisfies some other condition. In principle each such event may be described by specifying the sample points which do satisfy the stipulated condition. Thus every compound event is represented by an aggregate of sample points, and in probability theory these terms are synonymous. The standard notations of set theory are used to describe relations among events. See SET THEORY.

Given an event  $A$  one may consider the case that  $A$  does not occur. This is the negation or complement of  $A$ , denoted by  $A'$ ; it consists of those sample points that do not belong to  $A$ . Given

two events  $A$  and  $B$ , the event  $C$  that either  $A$  or  $B$  or both occur is the union of  $A$  and  $B$  and denoted by  $C = A \cup B$ . In particular  $A \cup A'$  is the whole sample space  $\mathfrak{S}$  which therefore represents certainty. The event  $D$ , both  $A$  and  $B$  occur, is the intersection of  $A$  and  $B$  and written  $D = A \cap B$ . It consists of the points common to  $A$  and  $B$ .

**Probabilities in finite spaces.** If the sample space  $\mathfrak{S}$  contains only  $N$  points  $E_1, \dots, E_N$  their probabilities may be any numbers such that  $P\{E_j\} \geq 0$  and  $P\{E_1\} + \dots + P\{E_N\} = 1$ .

The probability  $P\{A\}$  of an event  $A$  is the sum of the probabilities of all points contained in  $A$ ; thus  $P\{\mathfrak{S}\} = 1$ .

Frequently considerations of symmetry lead one to consider all  $E_j$  as equally likely; that is, to set  $P\{E_j\} = 1/N$ . In this case  $P(A) = n/N$  where  $n$  is the number of points in  $A$ ; for a gambler betting on  $A$ , these represent the "favorable cases." For example, in throwing a pair of "perfect" dice, one naturally assumes that the 36 possible outcomes are equally likely. This model does not lose its justification or usefulness by the fact that actual dice do not live up to it. The assumption of perfect randomness in games, card shuffling, industrial quality control, or sampling is rarely realized, and the true usefulness of the model stems from the experience that noticeable departures from the ideal scheme lead to the detection of assignable causes and thus to theoretical or experimental improvements.

**Conditional probability-independence.** Suppose that a population of  $N$  people includes  $N_A$  color-blind persons and  $N_H$  females. To the event  $A$  "a randomly chosen person is color-blind" can be ascribed probability  $P\{A\} = N_A/N$ , and similarly for the event  $H$  that a person be female one has  $P\{B\} = N_H/N$ . If  $N_{AH}$  is the number of color-blind females, the ratio  $N_{AH}/N_H$  may be interpreted as probability that a randomly chosen female is color-blind; here the experiment "random choice in the population" is replaced by a selection from the female subpopulation. In the original experiment,  $N_{AH}/N$  is the probability of the simultaneous occurrence of both  $A$  and  $H$ , so that  $N_{AH}/N_H = P\{A \cap H\}/P\{H\}$ . Similar situations occur so frequently that it is convenient to define the conditional probability of the event  $A$  relative to  $H$  by Eq. (1).

$$P\{A | H\} = \frac{P\{A \cap H\}}{P\{H\}} \quad (1)$$

This concept is useful whenever it is desired to restrict the consideration to those cases where the event  $H$  occurs (or where the hypothesis  $H$  is fulfilled). Thus, in betting on an event  $A$  the knowledge that  $H$  occurred would induce one to replace  $P\{A\}$  by  $P\{A | H\}$ .

**Independent trials.** The intuitive frequency interpretation of probability is based on the concept of experiments repeated under identical conditions; a theoretical model for this concept can be developed.

Consider an experiment described by a sample space  $\mathfrak{S}$ ; for simplicity of language it can be assumed that  $\mathfrak{S}$  consists of finitely many sample points  $E_1, \dots, E_N$ . When the same experiment is performed twice in succession, the thinkable outcomes are the  $N^2$  pairs of sample points  $(E_1, E_1), (E_1, E_2), \dots, (E_N, E_N)$ , and these now constitute the new sample space. It is called the combinatorial product of  $\mathfrak{S}$  by itself and denoted by  $\mathfrak{S} \times \mathfrak{S}$ .

Probabilities must be assigned to the events in  $\mathfrak{S} \times \mathfrak{S}$ . If the second trial is independent of the first, the probabilities in  $\mathfrak{S} \times \mathfrak{S}$  follow the productive rule  $P\{E_i, E_j\} = P\{E_i\}P\{E_j\}$ .

In the case of  $n$  tossings of a coin, this rule leads to the probability  $2^{-n}$  for each sample point in agreement with the requirement of equally likely cases. In the more general case of Bernoulli trials, each trial results in success  $S$  or failure  $F$ , and  $P\{S\} = p$ ,  $P\{F\} = q$  where  $p + q = 1$ . (This may be considered as the model of a skew coin.) A succession of  $n$  independent trials of this kind leads to the sample space of  $n$ -tuples ( $SFFS \dots FS$ ), and the probability of such a point is the product ( $pqqp \dots qp$ ) obtained on replacing each  $S$  by  $p$  and each  $F$  by  $q$ .

**Markov chains.** Markov chains represent an important scheme for dependent trials. Suppose that at each trial the

possible outcomes are  $E_1, \dots, E_N$  and that whenever  $E_i$  occurs the conditional probability of  $E_j$  at the next trial is  $p_{ij}$ , independently of what happened at the preceding trials. Here, of course,  $p_{ij} \geq 0$  and  $p_{i1} + p_{i2} + \dots + p_{iN} = 1$  for each  $i$ . The  $p_{ij}$  are called transition probabilities. The whole process is now determined if the initial probabilities,  $\pi_i$ , at the first trial are known. For example,  $P\{E_a E_b E_c\} = \pi_a p_{ab} p_{bc}$ . The probability of the event " $E_c$  at the third trial" is obtained by summation over all  $a$  and  $b$ , and so on. Markov chains, and their analog with continuous time, represent the simplest type of stochastic process. See STOCHASTIC PROCESS.

**Random variables and their distributions.** The theory of probability traces its origin to gambling, and the gambler's gain may still serve as the simplest example of a random variable. With every possible outcome (sample point) there is associated a number, namely, the corresponding gain. In other words, the gain is a function on the sample space, and such functions are called random variables. With the same experiment, one may associate many random variables.

Every random variable  $X$  has a distribution function  $F(t) = P\{X \leq t\}$ . If  $X$  assumes only finitely many values, then  $F(t)$  is a step function. The notion of independence carries over: Two random variables  $X$  and  $Y$  are independent if  $P\{X \leq x, Y \leq t\} = P\{X \leq x\} \cdot P\{Y \leq t\}$ .

**Expectations.** Given a random variable  $X$  one may interpret its distribution function  $F(t)$  as describing the distribution of a unit mass along the real axis such that the interval  $a < x \leq b$  carries mass  $F(b) - F(a)$ . In the case of a discrete variable assuming the values  $x_1, x_2, \dots$  with probabilities  $p_1, p_2, \dots$  the entire mass is concentrated at the points  $x_i$ ; if  $F(x) = f(x)$  exists, it represents the ordinary mass density as defined in mechanics. The center of gravity of this mass distribution is called the expectation of  $X$ ; the usual symbol for it is  $E(X)$ , but physicists and engineers use notations such as  $\langle X \rangle$ ,  $\langle X \rangle_{Av}$ , or  $\bar{X}$ . In the cases mentioned,  $E(X)$  is given by Eqs. (2) and (3).

$$E(X) = \sum P_i x_i \tag{2}$$

$$E(X) = \int_{-\infty}^{+\infty} x f(x) dx \tag{3}$$

Before discussing the significance of the new concept, a few frequently used definitions are appropriate. Put  $m = E(X)$ . Then  $(X - m)^2$  is, of course, a random variable. In mechanics, its expectation represents the moment of inertia of the mass distribution. In probability, it is called variance of  $X$ , given by Eq. (4). Its positive root is the standard deviation.

$$\text{Var}(X) = E(X - m)^2 = E(X^2) - m^2 \tag{4}$$

The variance is a measure of spread: It is zero only if the entire mass is concentrated at the point  $m$ , and it increases as the mass is moved away from  $m$ . In the case of two variables  $X_1$  and  $X_2$  with expectations  $m_1$  and  $m_2$  it is necessary to consider not only the two variances  $s_i^2 = E[(X_i - m_i)^2]$  but also the covariance  $\text{Cov}(X_1, X_2) = E[(X_1 - m_1)(X_2 - m_2)] = E(X_1 X_2) - m_1 m_2$ . The covariance divided by  $s_1 s_2$  is called the correlation coefficient of  $X_1$ , and  $X_2$ . If it vanishes,  $X_1$  and  $X_2$  are called uncorrelated. Every pair of independent variables is uncorrelated, but the converse is not true.

**Laws of large numbers.** To explain the meaning of the expectation and, at the same time, to justify the intuitive frequency interpretation of probability, consider a gambler who at each trial may gain the amounts  $x_1, x_2, \dots, x_n$  with probabilities  $p_1, p_2, \dots, p_n$ . The gains at the first and second trials are independent random variables  $X_1, X_2$  with the indicated distribution and the common expectation  $m = \sum p_i x_i$ . The event that an individual gain equals  $x$ , as probability  $p_i$ , and the frequency interpretation of probability leads one to expect that in a large number  $n$  of trials this event should happen approximately  $np_i$  times. If this is true, the total gain  $S_n = X_1 + X_2 + \dots + X_n$  should be approximately  $nm$ ; that is, the average gain  $(1/n)S_n$  should be close to

$m$ . The law of large numbers in its simplest form asserts this to be true. See GAME THEORY; STATISTICS. [W.F.]

**Proboscidea** An order of placental mammals derived from conservative (that is, primitive or ancient) hooved mammal stock (sometimes informally referred to as condylarths), the oldest members known from Paleocene sediments of North Africa. At one point, proboscideans had a wide distribution, having reached every continent except Australia and Antarctica. They included an astonishing variety of forms. However, currently this order consists of only two forms, belonging to the family Elephantidae: the African elephant (*Loxodonta africana*) and the Asian elephant (*Elephas maximus*). Features commonly associated with the proboscideans include large body size, enlarged incisors that form paired tusks (relatively small lower tusks were present in the jaws in the majority of extinct forms in addition), and a proboscis (often referred to informally as a trunk). It is important to realize that the very early forms lacked both significant tusks and a proboscis, though they are still formally considered proboscideans. Unlike most modern hooved mammals which have reduced the toe number to four or more often fewer, proboscideans have retained five toes. Throughout their known history, proboscideans have been strictly herbivorous.

Early elephant evolution mostly occurred in Africa during the Eocene and Oligocene. Near the beginning of the Miocene, proboscideans exited Africa and spread all over Europe and Asia, and by the middle Miocene they reached North America. The proboscideans were highly successful in North America, and between 2 and 1.5 million years ago they entered South America across the Panamanian landbridge. Between 12,000 and 10,000 years ago, most of the world's proboscideans became extinct, with only the African and Asian elephants surviving.

There has been considerable debate by paleontologists as to which animals are actually proboscideans, in part because some members of the order bear little or no superficial resemblance to modern forms. Two suborders in the classification below, Deinotherioidea and Barytherioidea, represent such sometimes disputed groups.

- Order Proboscidea
  - Suborder: Deinotherioidea
    - Barytherioidea
    - Moeritherioidea
    - Elephantoidea
  - Infraorder Mammutoidea
    - Family Mammutidae
  - Infraorder Gomphotherioidea
    - Family: Gomphotheriidae
    - Elephantidae

The conservative proboscideans consist of the members of the suborders Deinotherioidea, Barytherioidea, and Moeritherioidea. Though these animals are considered to be proboscideans, they mostly bear little or no resemblance to elephants. In fact, such typically elephantine characters as tusks and a proboscis do not strictly define the order Proboscidea. Instead, proboscideans are characterized by relatively obscure features in the teeth, shoulder, and ankle. The relationship of these suborders to the advanced suborder Elephantoidea (which includes the living elephants) is not well understood. See ELEPHANT; MAMMALIA. [W.D.L.]

**Procellariiformes** A large order of strictly marine birds found far offshore except when breeding. The procellariiforms, or tube-nosed swimmers, are most closely related to their descendant group, the penguins. The Procellariiformes comprise four families: Diomededidae (albatrosses; 13 species); Procellariidae (shearwaters, petrels, and fulmars; 66 species); Hydrobatidae (storm petrels; 21 species); and Pelecanoididae (diving petrels; 4 species).

The tube-nosed swimmers are characterized by having their nostrils enclosed in a tube, which is paired in albatrosses; dense plumage; webbed feet; and long wings. They range in size from the sparrow-sized storm petrels to large albatrosses, which have the greatest wingspan of all living birds, up to 12 ft (3.7 m). The procellariiforms are excellent fliers, as evidenced by the migratory—actually nomadic wandering—flights of many thousands of miles. Procellariiforms swim well, but only the pelicanoidids dive under water, using their wings for propulsion. They are highly pelagic and feed on fish, squids, and crustaceans. Procellariiforms have a well-developed olfactory sense to locate food and apparently to locate their nesting burrows at night. The larger species mature slowly; some albatrosses begin breeding only after reaching 6 to 8 years of age. Tight pair bonds are formed during courtship, which can take elaborate forms, as is seen in albatrosses. See AVES. [W.J.B.]

**Process control** A field of engineering dealing with ways and means by which conditions of processes are brought to and maintained at desired values, and undesirable conditions are avoided as much as possible. In general, a process is understood to mean any system where material and energy streams are made to interact and to transform each other. Examples are the generation of steam in a boiler; the separation of crude oil by fractional distillation into gas, gasoline, kerosine, gas-oil and residue; the sintering of iron ore particles into pellets; and the polymerization of propylene molecules for the manufacture of polypropylene. In the wide sense, process control also encompasses determining the desired values.

Process control includes a number of functions, which can be arranged in a hierarchy, as follows:

Scheduling  
Mode setting  
Quality control  
Regulatory control/Sequence control  
Coping with faults

Computerized instrumentation has revolutionized the interaction with plant personnel, in particular the process operators. Traditionally, the central control room was provided with long panels or consoles, on which alarm lights, indicators, and recorders were mounted. Costs were rather high, and surveyability was poor. In computerized instrumentation, visual display units can provide information in a concise and flexible way, adapted to human needs and capabilities. See AUTOMATION; CONTROL SYSTEMS. [J.E.R.]

**Process engineering** A branch of engineering in which a process effects chemical and mechanical transformations of matter, conducted continuously or repeatedly on a substantial scale. Process engineering constitutes the specification, optimization, realization, and adjustment of the process applied to manufacture of bulk products or discrete products. Bulk products are those which are homogeneous throughout and uniform in properties, are in gaseous, liquid, or solid form, and are made in separate batches or continuously. Examples of bulk product processes include petroleum refining, municipal water purification, the manufacture of penicillin by fermentation or synthesis, the forming of paper from wood pulp, the separation and crystallization of various salts from brine, the production of liquid oxygen and nitrogen from air, the electrolytic beneficiation of aluminum, and the manufacture of paint, whiskey, plastic resin, and so on. Discrete products are those which are separate and individual, although they may be identical or very nearly so. Examples of discrete product processes include the casting, molding, forging, shaping, forming, joining, and surface finishing of the component piece parts of end products or of the end products themselves. Processes are chemical when one or more essential steps involve chemical reaction. Almost no chemical process

occurs without many accompanying mechanical steps such as pumping and conveying, size reduction of particles, classification of particles and their separation from fluid streams, evaporation and distillation with attendant boiling and condensation, absorption, extraction, membrane separations, and mixing. See DIALYSIS; DISTILLATION; EVAPORATION; EXTRACTION; ION-SELECTIVE MEMBRANES AND ELECTRODES; MECHANICAL CLASSIFICATION; MECHANICAL SEPARATION TECHNIQUES; MIXING; OPTIMIZATION; PRODUCTION ENGINEERING. [E.F.L.]

**Prochirality** The property displayed by a prochiral molecule or a prochiral atom (prostereoisomerism). A molecule or atom is prochiral if it contains, or is bonded to, two constitutionally identical ligands (atoms or groups), replacement of one of which by a different ligand makes the molecule or atom chiral. Examples are shown below.

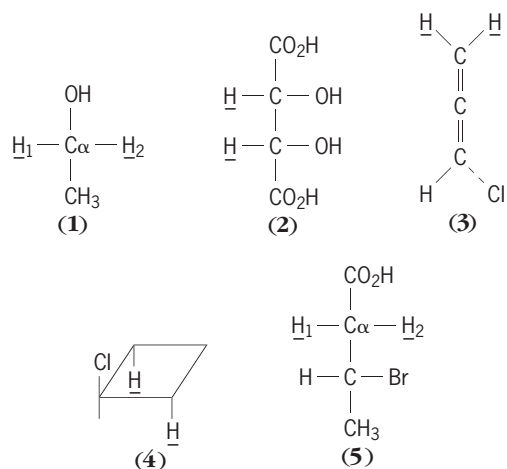

None of molecules **1–4** is chiral, but if one of the underlined pair of hydrogens is replaced, say, by deuterium, chirality results in all four cases. In compound **1**, ethanol, a prochiral atom or center can be discerned ( $C\alpha:CH_2$ ); upon replacement of H by D, a chiral atom or center is generated, whose configuration depends on which of the two pertinent atoms ( $H_1$  or  $H_2$ ) is replaced. Molecule **5** is chiral to begin with, but separate replacement of  $H_1$  and  $H_2$  (say, by bromine) creates a new chiral atom at  $C\alpha$  and thus gives rise to a pair of chiral diastereomers. No specific prochiral atom can be discerned in molecules **2–4**, which are nevertheless prochiral (**3** has a prochiral axis).

Faces of double bonds may also be prochiral (and give rise to prochiral molecules), namely, when addition to one or other of the two faces of a double bond gives chiral products.

Although the term prochirality is widely used, especially by biochemists, a preferred term is prostereoisomerism. This is because replacement of one or other of the two corresponding ligands (called heterotopic ligands) or addition to the two heterotopic faces often gives rise to achiral diastereomers without generation of chirality. Thus not all compounds which display prostereoisomerism also display prochirality. See MOLECULAR ISOMERISM; STEREOCHEMISTRY. [E.L.E.]

**Prochlorophyceae** A class of prokaryotic organisms co-extensive with the division Prochlorophycota in the kingdom Monera. Because prochlorophytes carry out oxygen-evolving photosynthesis, they may be considered algae. They are distinguished from Cyanophyceae, the only other prokaryotic algae, by the presence in their photosynthetic lamellae of chlorophyll *b* in addition to chlorophyll *a* and the absence of phycobilin pigments. Otherwise, they resemble Cyanophyceae biochemically and ultrastructurally. The class comprises a single genus, *Prochloron*, with one species. See ALGAE; CYANOPHYCEAE. [P.C.Si.; R.L.Moe]

**Procyon** The brightest star in the constellation Canis Minor, apparent magnitude +0.36. Procyon ( $\alpha$  Canis Minoris) is among the stars nearest to the Earth, at a distance of only 3.5 parsecs ( $1.08 \times 10^{14}$  km or  $6.7 \times 10^{13}$  mi). Its spectral type is F5, but Procyon is slightly overluminous compared to a main-sequence star of the same spectral type, which indicates that Procyon has already begun to evolve off the main sequence. Its intrinsic luminosity is about seven times that of the Sun. See SPECTRAL TYPE; STELLAR EVOLUTION.

Procyon has a faint 11th-magnitude companion, Procyon B, a white dwarf in the final stages of its evolution, with a luminosity only 1/2000 that of the Sun. From the astrometric orbit the masses of the primary and its companion have been computed as 1.75 and 0.62 solar masses, respectively. The progenitor of the white dwarf was originally the more massive of the two stars and underwent the final stages of its stellar evolution sooner than the original secondary, which is now seen as Procyon A. See BINARY STAR; STAR; WHITE DWARF STAR. [D.W.L.]

**Product design** The determination and specification of the parts of a product and their interrelationship so that they become a unified whole. The design must satisfy a broad array of requirements in a condition of balanced effectiveness. A product is designed to perform a particular function or set of functions effectively and reliably, to be economically manufacturable, to be profitably salable, to suit the purposes and the attitudes of the consumer, and to be durable, safe, and economical to operate. For instance, the design must take into consideration the particular manufacturing facilities, available materials, know-how, and economic resources of the manufacturer. The product may need to be packaged; usually it will also need to be shipped so that it should be light in weight and sturdy of construction. The product should appear significant, effective, compatible with the culture, and appear to be worth more than the price. See PRODUCTION ENGINEERING; PRODUCTION PLANNING. [R.I.F.]

**Product of inertia** The product of inertia of area  $A$  relative to the indicated  $XY$  rectangular axes is  $I_{XY} = \int xy \, dA$  (see illustration). The product of inertia of the mass contained in volume  $V$  relative to the  $XY$  axes is  $I_{XY} = \int xy\rho \, dV$ —similarly for  $I_{YZ}$  and  $I_{ZX}$ .

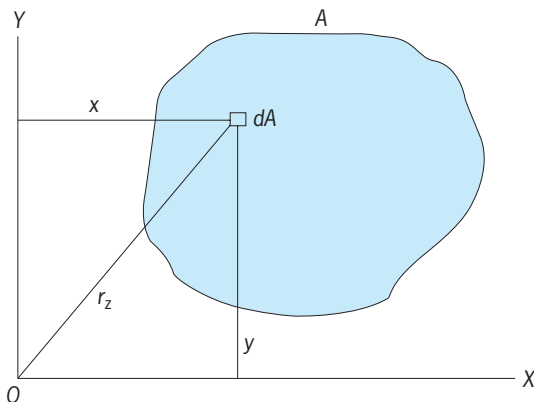

Product of inertia of an area.

Relative to principal axes of inertia, the product of inertia of a figure is zero. If a figure is mirror symmetrical about a  $YZ$  plane,  $I_{ZX} = I_{XY} = 0$ . See MOMENT OF INERTIA. [N.S.F.]

**Product quality** The collection of features and characteristics of a product that contribute to its ability to meet given requirements. Early work in controlling product quality was on creating standards for producing acceptable products. By the mid-1950s, mature methods had evolved for controlling quality, including statistical quality control and statistical process control, utilizing sequential sampling techniques for tracking the mean

and variance in process performance. During the 1960s, these methods and techniques were extended to the service industry. During 1960–1980, there was a major shift in world markets, with the position of the United States declining while Japan and Europe experienced substantial growth in international markets. Consumers became more conscious of the cost and quality of products and services. Firms began to focus on total production systems for achieving quality at minimum cost. This trend has continued, and today the goals of quality control are largely driven by consumer concerns and preferences.

There are three views for describing the overall quality of a product. First is the view of the manufacturer, who is primarily concerned with the design, engineering, and manufacturing processes involved in fabricating the product. Quality is measured by the degree of conformance to predetermined specifications and standards, and deviations from these standards can lead to poor quality and low reliability. Efforts for quality improvement are aimed at eliminating defects (components and subsystems that are out of conformance), the need for scrap and rework, and hence overall reductions in production costs. Second is the view of the consumer or user. To consumers, a high-quality product is one that well satisfies their preferences and expectations. This consideration can include a number of characteristics, some of which contribute little or nothing to the functionality of the product but are significant in providing customer satisfaction. A third view relating to quality is to consider the product itself as a system and to incorporate those characteristics that pertain directly to the operation and functionality of the product. This approach should include overlap of the manufacturer and customer views. See MANUFACTURING ENGINEERING.

Quality control (QC) is the collection of methods and techniques for ensuring that a product or service is produced and delivered according to given requirements. This includes the development of specifications and standards, performance measures, and tracking procedures, and corrective actions to maintain control. The data collection and analysis functions for quality control involve statistical sampling, estimation of parameters, and construction of various control charts for monitoring the processes in making products. This area of quality control is formally known as statistical process control (SPC) and, along with acceptance sampling, represents the traditional perception of quality management. Statistical process control focuses primarily on the conformance element of quality, and to somewhat less extent on operating performance and durability. See PROCESS CONTROL; QUALITY CONTROL.

Concurrent engineering, quality function deployment, and total quality management (TQM) are modern management approaches for improving quality through effective planning and integration of design, manufacturing, and materials management functions throughout an organization. Quality improvement programs typically include goals for reducing warranty claims and associated costs because warranty data directly or indirectly impact most of the product quality dimensions. See ENGINEERING DESIGN. [M.U.T.]

**Product usability** A concept in product design, sometimes referred to as ease of use or user-friendliness, that is related directly to the quality of the product and indirectly to the productivity of the work force. Customer surveys show that product quality is broken down into six components (in descending order of importance): reliability, durability, ease of maintenance, usability, trusted or brand name, and price. Ease of maintenance and usability both relate to product usability. Reliability also has a component of usability to it. If a product is too difficult to use and thus appears not to work properly, the customer may think that it has malfunctioned. Consequently, the customer may return the product to the store not because it is unreliable but because it does not work the way the customer thinks it should. See HUMAN-COMPUTER INTERACTION.

There are five criteria by which a product's usability can be measured, including time to perform a task, or the execution

time; learnability; mental workload, or the mental effort required to perform a task; consistency in the design; and errors. The usability of a product usually cannot be optimized for all five criteria at the same time. Trade-offs will occur. As an example, a product that is highly usable in terms of fast execution times will often have poor usability in terms of the time needed to learn how to use the product. A product designer must be aware that it may not be possible for a product to be highly usable by all usability criteria, and so design according to the criteria that are most important to potential customers. Casual users of a product will have different demands on a product compared to expert users. See CONTROL SYSTEMS; HUMAN-FACTORS ENGINEERING; HUMAN-MACHINE SYSTEMS.

Many companies, especially computer or consumer electronics companies, have laboratories in which to test the usability of their products. The methods of usability testing are formal experimentation, informal experimentation, and task analyses. Although laboratory methods for improving usability can increase the cost of the product design, the benefits (market share, productivity) will outweigh the costs. See METHODS ENGINEERING; OPTIMIZATION. [R.Eb.]

**Production engineering** A branch of engineering that involves the design, control, and continuous improvement of integrated systems in order to provide customers with high-quality goods and services in a timely, cost-effective manner. It is an interdisciplinary area requiring the collaboration of individuals trained in industrial engineering, manufacturing engineering, product design, marketing, finance, and corporate planning. In many organizations, production engineering activities are carried out by teams of individuals with different skills rather than by a formal production engineering department.

In product design, the production engineering team works with the designers, helping them to develop a product that can be manufactured economically while preserving its functionality. Features of the product that will significantly increase its cost are identified, and alternative, cheaper means of obtaining the desired functionality are investigated and suggested to the designers. The process of concurrently developing the product design and the production process is referred to by several names such as design for manufacturability, design for assembly, and concurrent engineering. See ACTIVITY-BASED COSTING; DESIGN STANDARDS; PROCESS ENGINEERING; PRODUCT DESIGN; PRODUCTION PLANNING.

The specification of the production process should proceed concurrently with the development of the product design. This involves selecting the manufacturing processes and technology required to achieve the most economical and effective production. The technologies chosen will depend on many factors, such as the required production volume, the skills of the available work force, market trends, and economic considerations. In manufacturing industries, this requires activities such as the design of tools, dies, and fixtures; the specification of speeds and feeds for machine tools; and the specification of process recipes for chemical processes.

Actual production of physical products usually begins with a few prototype units being manufactured in research and development or design laboratories for evaluation by designers, the production engineering team, and sales and marketing personnel. The goal of this pilot phase is to give the production engineering team hands-on experience making the product, allowing problems to be identified and remedied before investing in additional production equipment or shipping defective products to the customer. The pilot production process involves changes to the product design and fine-tuning of unit manufacturing processes, work methods, production equipment, and materials to achieve an optimal trade-off between cost, functionality, and product quality and reliability. See PILOT PRODUCTION; PROTOTYPE.

The production facility itself can be designed around the se-

quence of operations required by the product, referred to as a product layout. General-purpose production machinery is used, and often must be set up for each individual job, incurring significant changeover times while this takes place. This type of production facility is usually organized in a process layout, where equipment with similar functions is grouped together. See HUMAN-MACHINE SYSTEMS; PRODUCTION METHODS.

The production engineering process does not stop once the product has been put into production. A major function of production engineering is continuous improvement—continually striving to eliminate inefficiencies in the system and to incorporate and advance the frontier of the best existing practice. The task of production engineering is to identify potential areas for improving the performance of the production system as a whole, and to develop the necessary solutions in these areas. See PRODUCT QUALITY. [R.M.U.]

**Production methods** Processes and techniques that are used to manufacture a product. Production methods can vary greatly, depending on the specifications of the product and the quantity required. Determining the production methods is typically part of the process-planning phase of design, that is, the steps related to converting the design into a final product. Production methods must be considered carefully and planned properly because the production cycle generally represents a large investment of time and money. See PROCESS ENGINEERING; PRODUCT DESIGN; PRODUCTION PLANNING.

The two basic forms of production systems are job-shop production (for applications where the products are made either in single units or in limited production runs) and mass production. A third production form, specific process production, is normally restricted to industries such as the chemical process industry where the processing is the product, such as distilling and refining. See DISTILLATION; PETROLEUM PROCESSING AND REFINING; UNIT PROCESSES.

In spite of the many advances that have been made in the methods and equipment used in manufacturing, the basic categories of manufacturing processes have remained relatively unchanged. These can be divided into seven general categories: casting and molding, shearing and forming, machining/material removal, heat treating, finishing, assembly, and inspection. However, none of these processes is totally exclusive. See HEAT TREATMENT (METALLURGY); METAL CASTING; METAL FORMING; PLASTICS PROCESSING. [E.G.Ho.]

**Production planning** The function of a manufacturing enterprise responsible for the efficient planning, scheduling, and

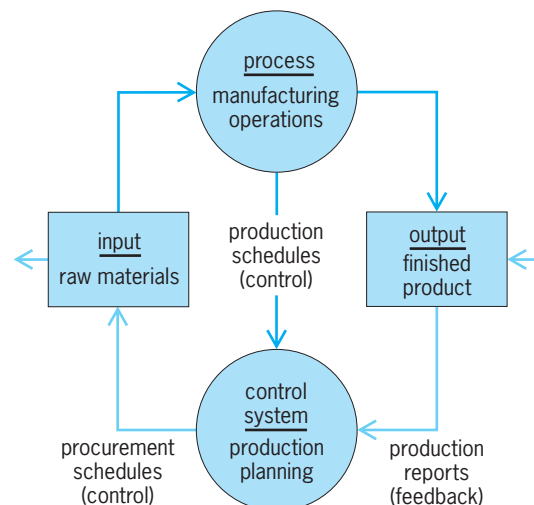

The production process as an input-output process.

coordination of all production activities. The planning phase involves forecasting demand and translating the demand forecast into a production plan that optimizes the company's objective, which is usually to maximize profit while in some way optimizing customer satisfaction. These twin objectives are not always synonymous. During the scheduling phase the production plan is translated into a detailed, usually day-by-day, schedule of products to be made. During the coordination phase actual product output is compared with scheduled product output, and this information is used to adjust production plans and production schedules. *See* OPTIMIZATION.

If the production or manufacturing process is viewed as an input-output process, then the production planning function can be viewed as a control process with feedback (see illustration). The control is in the form of schedules and plans, while the feedback results from the comparison of the production reports with the production schedules. *See* CONTROL SYSTEMS; INVENTORY CONTROL; PRODUCTION ENGINEERING; PRODUCTION METHODS.

[J.E.Bi.]

**Productivity** In a business or industrial context, the ratio of output production to input effort. The productivity ratio is an indicator of the efficiency with which an enterprise converts its resources (inputs) into finished goods or services (outputs). If the goal is to increase productivity, this can be done by producing more output with the same level of input. Productivity can also be increased by producing the same output with fewer inputs. One problem with trying to measure productivity is that a decision must be made in terms of identifying the inputs and outputs and how they will be measured. This is relatively easy when productivity of an individual is considered, but it becomes difficult when productivity involves a whole company or a nation.

Industry and government officials have adopted three common types of productivity measures. Partial productivity is the simplest type of productivity measure; a single type of input is selected for the productivity ratio. The company or organization selects an input factor that it monitors in daily activity. Direct labor hours is a factor that most companies monitor because they pay their employees based on hours worked.

Total factor productivity is a productivity measure combines that labor and capital, two of the most common input factors used in the partial productivity measure. This measure is often used at the national level, because many governments collect statistics on both labor and capital. In calculating at the national level, the gross national product (GNP) is used as the output.

Total productivity is a productivity measure that incorporates all the inputs required to make a product or provide a service. The inputs could be grouped in various categories as long as they determine the total inputs required to produce an output.

Many factors affect productivity. Some general categories for these factors are product, process, labor force, capacity, external influences, and quality.

There are many different plans that companies develop in an attempt to improve productivity. Wage incentive plans and changes in management structure are two ways that companies focus on the labor force. Investment in research and development allows companies to develop new products and processes that are more productive. Quality improvement programs can reduce waste and provide more competitive products at a lower cost. *See* METHODS ENGINEERING; OPERATIONS RESEARCH; PRODUCTION PLANNING.

[G.L.To.]

**Progesterone** A steroid hormone produced in the corpus luteum and placenta. The hormone has an important physiological role in the luteal phase of the menstrual cycle and in the maintenance of pregnancy. In addition, progesterone produced in the testis and adrenals has a key role as an intermediate in the biosynthesis of androgens, estrogens, and the corticoids (adrenal cortex steroids). *See* ANDROGEN; CHOLESTEROL; ESTROGEN; MENSTRUATION; PREGNANCY; STEROID; STEROL.

[R.I.D.]

**Programmable controllers** Electronic computers that are used for the control of machines and manufacturing processes through the implementation of specific functions such as logic, sequencing, timing, counting, and arithmetic. They are also known as programmable logic controllers (PLCs). Historically, process control of a single or a few related devices has been implemented through the use of banks of relays and relay logic for both the control of actuators and their sequencing. The advent of small, inexpensive microprocessors and single-chip computers, or microcontroller units, brought process control from the age of simple relay control to one of electronic digital control while neither losing traditional design methods such as relay ladder diagrams nor restricting their programming to that single paradigm. The computational power of programmable controllers and their integration into networks has led to capabilities approaching those of distributed control systems, and plantwide control is now a mixture of distributed control systems and programmable controllers. Applications for programmable controllers range from small-scale, local process applications in which as few as 10 simple feedback control loops are implemented, up to large-scale, remote supervisory process applications in which 50 or more process control loops spread across the facility are implemented. Typical applications include batch process control and materials handling in the chemical industry, machining and test-stand control and data acquisition in the manufacturing industry, wood cutting and chip handling in the lumber industry, filling and packaging in food industries, and furnace and rolling-mill controls in the metal industry. *See* DIGITAL COMPUTER; DISTRIBUTED SYSTEMS (CONTROL SYSTEMS); MICROPROCESSOR.

Although programmable controllers have been available since the mid-1970s, developments—such as the ready availability of local area networks (LANs) in the industrial environment, standardized hardware interfaces for manufacturer interchangeability, and computer software to allow specification of the control process in both traditional (ladder logic) and more modern notations such as that of finite-state machines—have made them even more desirable for industrial process control. *See* LOCAL-AREA NETWORKS.

Programmable logic controllers are typically implemented by using commonly available microprocessors combined with standard and custom interface boards which provide level conversion, isolation, and signal conditioning and amplification. Microprocessors used in programmable controllers are similar or the same as those used in personal computers. The software of a programmable controller must respond to interrupts and be a real-time operating system, characteristics which the typical operating system of a personal computer does not possess. *See* MICROCOMPUTER; OPERATING SYSTEM; REAL-TIME SYSTEMS; SOFTWARE.

Perhaps the biggest benefit of programmable controllers is their small size, which allows computational power to be placed immediately adjacent to the machinery to be controlled, as well as their durability, which allows them to operate in harsh environments. This proximity of programmable controllers to the equipment that they control allows them to effect the sensing of the process and control of the machinery through a reduced number of wires, which reduces installation and maintenance costs. The proximity of programmable controllers to processes also improves the quality of the sensor data since it reduces line lengths, which can introduce noise and affect sensor calibration.

[K.J.Hi.]

**Programming languages** The different notations used to communicate algorithms to a computer. A computer executes a sequence of instructions (a program) in order to perform some task. In spite of much written about computers being electronic brains or having artificial intelligence, it is still necessary for humans to convey this sequence of instructions to the computer before the computer can perform the task. The set of

instructions and the order in which they have to be performed is known as an algorithm. The result of expressing the algorithm in a programming language is called a program. The process of writing the algorithm using a programming language is called programming, and the person doing this is the programmer. See ALGORITHM.

In order for a computer to execute the instructions indicated by a program, the program needs to be stored in the primary memory of the computer. Each instruction of the program may occupy one or more memory locations. Instructions are stored as a sequence of binary numbers (sequences of zeros and ones), where each number may indicate the instruction to be executed (the operator) or the pieces of data (operands) on which the instruction is carried out. Instructions that the computer can understand directly are said to be written in machine language. Programmers who design computer algorithms have difficulty in expressing the individual instructions of the algorithm as a sequence of binary numbers. To alleviate this problem, people who develop algorithms may choose a programming language. Since the language used by the programmer and the language understood by the computer are different, another computer program called a compiler translates the program written in a programming language into an equivalent sequence of instructions that the computer is able to understand and carry out. See COMPUTER STORAGE TECHNOLOGY.

**Machine language.** For the first machines in the 1940s, programmers had no choice but to write in the sequences of digits that the computer executed. For example, assume we want to compute the absolute value of  $A + B - C$ , where  $A$  is the value at machine address 3012,  $B$  is the value at address 3013, and  $C$  is the value at address 3014, and then store this value at address 3015.

It should be clear that programming in this manner is difficult and fraught with errors. Explicit memory locations must be written, and it is not always obvious if simple errors are present. For example, at location 02347, writing 101... instead of 111... would compute  $|A + B + C|$  rather than what was desired. This is not easy to detect.

**Assembly language.** Since each component of a program stands for an object that the programmer understands, using its name rather than numbers should make it easier to program. By naming all locations with easy-to-remember names, and by using symbolic names for machine instructions, some of the difficulties of machine programming can be eliminated. A relatively simple program called an assembler converts this symbolic notation into an equivalent machine language program.

The symbolic nature of assembly language greatly eased the programmer's burden, but programs were still very hard to write. Mistakes were still common. Programmers were forced to think in terms of the computer's architecture rather than in the domain of the problem being solved.

**High-level language.** The first programming languages were developed in the late 1950s. The concept was that if we want to compute  $|A + B - C|$ , and store the result in a memory location called  $D$ , all we had to do was write  $D = |A + B - C|$  and let a computer program, the compiler, convert that into the sequences of numbers that the computer could execute. FORTRAN (an acronym for Formula Translation) was the first major language in this period.

FORTRAN statements were patterned after mathematical notation. In mathematics the  $=$  symbol implies that both sides of the equation have the same value. However, in FORTRAN and some other languages, the equal sign is known as the assignment operator. The action carried out by the computer when it encounters this operator is, "Make the variable named on the left of the equal sign have the same value as the expression on the right." Because of this, in some early languages the statement would have been written as  $-D \rightarrow D$  to imply movement or change, but the use of  $\rightarrow$  as an assignment operator has all but disappeared.

The compiler for FORTRAN converts that arithmetic statement into an equivalent machine language sequence. In this case, we did not care what addresses the compiler used for the instructions or data, as long as we could associate the names  $A$ ,  $B$ ,  $C$ , and  $D$  with the data values we were interested in.

**Structure of programming languages.** Programs written in a programming language contain three basic components: (1) a mechanism for declaring data objects to contain the information used by the program; (2) data operations that provide for transforming one data object into another; (3) an execution sequence that determines how execution proceeds from start to finish.

**Data declarations.** Data objects can be constants or variables. A constant always has a specific value. Thus the constant 42 always has the integer value of forty-two and can never have another value. On the other hand, we can define variables with symbolic names. The declaration of variable  $A$  as an integer informs the compiler that  $A$  should be given a memory location much like the way the variable  $A$  in example (2) was given the machine address 03012. The program is given the option of changing the value stored at this memory location as the program executes.

Each data object is defined to be of a specific type. The type of a data object is the set of values the object may have. Types can generally be scalar or aggregate. An object declared to be a scalar object is not divisible into smaller components, and generally it represents the basic data types executable on the physical computer. In a data declaration, each data object is given a name and a type. The compiler will choose what machine location to assign for the declared name.

**Data operations.** Data operations provide for setting the values into the locations allocated for each declared data variable. In general this is accomplished by a three-step process: a set of operators is defined for transforming the value of each data object, an expression is written for performing several such operations, and an assignment is made to change the value of some data object.

For each data type, languages define a set of operations on objects of that type. For the arithmetic types, there are the usual operations of addition, subtraction, multiplication, and division. Other operations may include exponentiation (raising to a power), as well as various simple functions such as modula or remainder (when dividing one integer by another). There may be other binary operations involving the internal format of the data, such as binary *and*, *or*, *exclusive or*, and *not* functions. Usually there are relational operations (for example, equal, not equal, greater than, less than) whose result is a boolean value of *true* or *false*. There is no limit to the number of operations allowed, except that the programming language designer has to decide between the simplicity and smallness of the language definition versus the ease of using the language.

**Execution sequence.** The purpose of a program is to manipulate some data in order to produce an answer. While the data operations provide for this manipulation, there must be a mechanism for deciding which expressions to execute in order to generate the desired answer. That is, an algorithm must trace a path through a series of expressions in order to arrive at an answer. Programming languages have developed three forms of execution sequencing: (1) control structures for determining execution sequencing within a procedure; (2) interprocedural communication between procedures; and (3) inheritance, or the automatic passing of information between two procedures.

Corrado Böhm and Giuseppe Jacopini showed in 1966 that a programming language needs only three basic statements for control structures: an assignment statement, an IF statement, and a looping construct. Anything else can simplify programming a solution, but is not necessary. If we add an input and an output statement, we have all that we need for a programming language. Languages execute statements sequentially with the following variations to this rule.



*IF statement.* Most languages include the IF statement. In the IF-THEN statement, the expression is evaluated, and if the value is *true*, then Statement<sub>1</sub> is executed next. If the value is *false*, then the statement after the IF statement is the next one to execute. The IF-THEN-ELSE statement is similar, except that specific true and false options are given to execute next. After executing either the THEN or ELSE part, the statement following the IF statement is the next one to execute.

The usual looping constructs are the WHILE statement and the REPEAT statement. Although only one is necessary, languages usually have both.

Inheritance is the third major form of execution sequencing. In this case, information is passed automatically between program segments. This is the basis for the models used in the object-oriented languages C++ and Java.

Inheritance involves the concept of a class object. There are integer class objects, string class objects, file class objects, and so forth. Data objects are instances of these class objects. Objects inherit the properties of the objects from which they were created. Thus, if an integer object were designed with the methods (that is, functions) of addition and subtraction, each instance of an integer object would inherit those same functions. One would only need to develop these operations once and then the functionality would pass on to the derived object.

All objects are derived from one master object called an Object. An Object is the parent class of objects such as magnitude, collection, and stream. Magnitude now is the parent of objects that have values, such as numbers, characters, and dates. Collections can be ordered collections such as an array or an unordered collection such as a set. Streams are the parent objects of files. From this structure an entire class hierarchy can be developed.

If we develop a method for one object (for example, *print* method for *object*), then this method gets inherited to all objects derived from that object. Therefore, there is not the necessity to always define new functionality. If we create a new class of integer that, for example, represents the number of days in a year (from 1 to 366), then this new integerlike object will inherit all of the properties of integers, including the methods to add, subtract, and print values. It is this concept that has been built into C++, Java, and current object-oriented languages.

Once we build concepts around a class definition, we have a separate package of functions that are self-contained. We are able to sell that package as a new functionality that users may be willing to pay for rather than develop themselves. This leads to an economic model where companies can build add-ons for existing software, each add-on consisting of a set of class definitions that becomes inherited by the parent class. See OBJECT-ORIENTED PROGRAMMING.

**Current programming language models.** C was developed by AT&T Bell Laboratories during the early 1970s. At the time, Ken Thompson was developing the UNIX operating system. Rather than using machine or assembly language as in (2) or (3) to write the system, he wanted a high-level language. See OPERATING SYSTEM.

C has a structure like FORTRAN. A C program consists of several procedures, each consisting of several statements, that include the IF, WHILE, and FOR statements. However, since the goal was to develop operating systems, a primary focus of C was to include operations that allow the programmer access to the underlying hardware of the computer. C includes a large number of operators to manipulate machine language data in the computer, and includes a strong dependence on reference variables so that C programs are able to manipulate the addressing hardware of the machine.

C++ was developed in the early 1980s as an extension to C by Bjarne Stroustrup at AT&T Bell Labs. Each C++ class would include a record declaration as well as a set of associated functions. In addition, an inheritance mechanism was included in order to provide for a class hierarchy for any program.

By the early 1990s, the World Wide Web was becoming a significant force in the computing community, and web browsers were becoming ubiquitous. However, for security reasons, the browser was designed with the limitation that it could not affect the disk storage of the machine it was running on. All computations that a web page performed were carried out on the web server accessed by web address (its Uniform Resource Locator, or URL). That was to prevent web pages from installing viruses on user machines or inadvertently (or intentionally) destroying the disk storage of the user.

Java bears a strong similarity to C++, but has eliminated many of the problems of C++. The three major features addressed by Java are:

1. There are no reference variables, thus no way to explicitly reference specific memory locations. Storage is still allocated by creating new class objects, but this is implicit in the language, not explicit.

2. There is no procedure call statement; however, one can invoke a procedure using the member of class operation. A call to *CreateAddress* for class *address* would be encoded as *address.CreateAddress( )*.

3. A large class library exists for creating web-based objects.

The Java bytecodes (called applets) are transmitted from the web server to the client web site and then execute. This saves transmission time as the executing applet is on the user's machine once it is downloaded, and it frees machine time on the server so it can process more web "hits" effectively. See CLIENT-SERVER SYSTEM.

Visual Basic, first released in 1991, grew out of Microsoft's GW Basic product of the 1980s. The language was organized around a series of events. Each time an event happened (for example, mouse click, pulling down a menu), the program would respond with a procedure associated with that event. Execution happens in an asynchronous manner.

Although Prolog development began in 1970, its use did not spread until the 1980s. Prolog represents a very different model of program execution, and depends on the resolution principle and satisfaction of Horn clauses of Robert A. Kowalski at the University of Edinburgh. That is, a Prolog statement is of the form  $p:-q, r$  which means  $p$  is true if both  $q$  is true or  $r$  is true.

A Prolog program consists of a series Horn clauses, each being a sequence of relations concerning data in a database. Execution proceeds sequentially through these clauses. Each relation can invoke another Horn clause to be satisfied. Evaluation of a relation is similar to returning a procedure value in imperative languages such as C or C++.

Unlike the other languages mentioned, Prolog is not a complete language. That means there are algorithms that cannot be programmed in Prolog. However, for problems that are amenable for searching large databases, Prolog is an efficient mechanism for describing those algorithms. See SOFTWARE; SOFTWARE ENGINEERING. [M.V.Z.]

**Progression (mathematics)** Ordered, countable sets of numbers,  $x_1, x_2, x_3, \dots$ , not necessarily all different. In general such sets are called sequences, whereas the term progression is usually confined to the special types: the arithmetic, in which the difference  $x_k - x_{k-1}$  between successive terms is constant; the geometric, in which the ratio  $x_k/x_{k-1}$  is constant; and the harmonic, in which the reciprocals of the terms are in arithmetic progression.

If the first term of an arithmetic progression is  $a$  and the common difference  $b$ , then the terms of the progression are given by Eqs. (1). The sum of the first  $n$  terms  $S_n$  is given by Eq. (2).

$$x_1 = a, x_2 = a + b, x_3 = a + 2b, \dots, x_n = a + (n - 1)b, \dots \quad (1)$$

$$S_n = n \frac{x_1 + x_n}{2} = n \left( a + \frac{n - 1}{2} b \right) \quad (2)$$

If the first term of a geometric progression is  $a$  and the common ratio  $r$ , then the terms of the progression are given by Eqs. (3). Excluding the case  $r = 1$  (when all terms are the same), the sum  $S_n$  of the first  $n$  terms is given by Eq. (4).

$$x_1 = a, x_2 = ar, x_3 = ar^2, \dots, x_n = ar^{n-1}, \dots \quad (3)$$

$$S_n = a \frac{1 - r^n}{1 - r} \quad (4)$$

The arithmetic mean  $A$  and the geometric mean  $G$  of  $n$  positive numbers are defined by Eqs. (5) and (6).

$$A = \frac{x_1 + x_2 + \dots + x_n}{n} \quad (5)$$

$$G = \sqrt{x_1 x_2 \dots x_n} \quad (6)$$

The reciprocals of sequence (1) form a harmonic progression. There is no compact expression for the sum of  $n$  terms.

If  $x_1, x_2, x_3$  are in harmonic progression, then Eq. (7) is called

$$x_2 = \frac{2x_1x_3}{x_1 + x_3} \quad (7)$$

their harmonic mean.

[L.B.]

**Projective geometry** A geometry that investigates those properties of figures that are unchanged (invariant) when the figures are projected from a point to a line or plane.

Two features of plane projective geometry are (1) introduction of an ideal line that each ordinary line  $g$  intersects (the intersection being common to all lines parallel to  $g$ ), and (2) the principle of duality, according to which any statement that is obtained from a valid one (theorem) by substituting for each concept involved, its dual, is also valid. ("Line" and "point" are dual, "connecting two points by a line" is dual to "intersecting two lines," and so on.) The subject has been developed both synthetically (as a logical consequence of a set of postulates) and analytically (by the introduction of coordinates and the application of algebraic processes). See CONFORMAL MAPPING; EUCLIDEAN GEOMETRY.

[L.M.B.]

**Prokaryotae** A group of predominantly unicellular microorganisms or infectious agents of cells (the viruses), lacking nuclei, and having asexual and chromosomal reproduction and unidirectional recombination. The Prokaryotae may be considered to include a kingdom for viruses, although such "organisms" are considered acellular or noncellular (even nonliving) by many authorities, and one for the typical moneran forms, the many kinds of bacteria plus the cyanobacteria (the blue-green algae) and the Prochlorophycota. See VIRUS.

Bacteria, viruses, and blue-green algae possess little in common, besides such superficial characters as microscopic (or ultra-microscopic) size and frequent involvement in causing diseases in other organisms, including human beings, and such negative characters as not being eukaryotic, not possessing any mouth opening, and not being multicellular (or, in the case of viruses, even cellular) in their organization. In the smallest dimension, prokaryotes measure from 0.2 to 10 micrometers; viruses show a diameter of 10 to 300 nanometers, the largest, therefore, just barely overlapping in width with the smallest bacterium.

Monerans (above the virus level) are generally solitary, unicellular forms; but some species are filamentous, colonial, or mycelial. Some are also motile, either by gliding or by the action of bacterial flagella containing the protein flagellin. Modes of nutrition are diverse: absorptive, chemosynthetic, photoheterotrophic, and photoautotrophic. Respiration is anaerobic or aerobic, or facultatively either one. Respiratory and photosynthetic functions are both generally associated with the plasma membrane system: there are no specialized organelles such as mitochondria or plastids, although thylakoids are present in cyanobacteria and in Prochlorophycota.

Virus particles can survive in a dried, crystalline, metabolically inert state. Bacteria may produce endospores of great resistance to a variety of environmental stresses; the trophic forms occur ubiquitously in aquatic or moist habitats, including cells and tissues of hosts belonging to all other groups of organisms. Complex viruses have an envelope surrounding the nucleocapsid; many bacteria possess rigid cell walls, and some produce outer sheaths. See ALGAE; BACTERIA; CYANOBACTERIA; EUKARYOTAE; PROCHLOROPHYCEAE.

[J.O.C.]

**Promethium** A chemical element, Pm, atomic number 61. Promethium is the "missing" element of the lanthanide rare-earth series. The atomic weight of the most abundant separated radioisotope is 147. See PERIODIC TABLE.

Although a number of scientists have claimed to have discovered this element in nature as a result of observing certain spectral lines, no one has succeeded in isolating element 61 from naturally occurring materials. It is produced artificially in nuclear reactors, since it is one of the products that results from the fission of uranium, thorium, and plutonium.

All the known isotopes are radioactive. Its principal uses are for research involving tracers. Its main application is in the phosphor industry. It has also been used to manufacture thickness gages and as a nuclear-powered battery in space applications. See RARE-EARTH ELEMENTS.

[F.H.Sp.]

**Pronghorn** An antelopelike animal, *Antilocapra americana*, the sole representative of the family Antilocapridae, and of uncertain taxonomic affinities. This animal is reputed to be the fastest ungulate in North America and is the only hollow-horned ungulate with branched horns present in both sexes. Like the deer, the pronghorn sheds its horns each fall; the new growth is complete by midsummer.

The pronghorn live in small herds in rather wild, rocky desert country. They feed on cactus, sagebrush, and other vegetation. In late summer, a buck begins to accumulate a harem of about 10–15 does. Two young are usually born in the spring after a gestation period of 35 weeks. Average life-span for a pronghorn is about 8 years. See ARTIODACTYLA.

[C.B.C.]

**Propagator (field theory)** The probability amplitude for a particle to move or propagate to some new point of space and time when its amplitude at some point of origination is known. The propagator occurs as an important part of the probability in reactions and interactions in all branches of modern physics. Its properties are best described in the framework of quantum field theory for relativistic particles, where it is written in terms of energy and momentum. Concrete examples for electron-proton and proton-proton scattering are provided in the illustration. The amplitude for these processes contains the propagators for the exchanged proton and meson, which actually specify the dominant part of the probability of each process when the scattering occurs at small angles. In similar fashion, for any electromagnetic process, a propagator for each internal line of the Feynman diagram (each line not connected directly to the outside world) enters the probability amplitude.

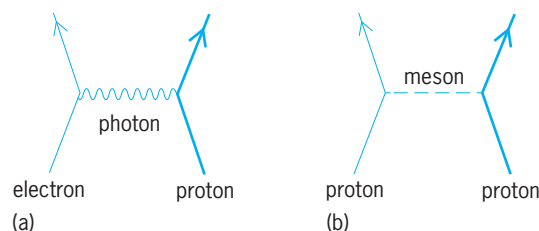

Feynman diagrams for scattering processes. (a) Electron-proton scattering via photon exchange. (b) Proton-proton scattering via meson exchange.

See FEYNMAN DIAGRAM; QUANTUM ELECTRODYNAMICS; QUANTUM FIELD THEORY; QUANTUM MECHANICS. [K.E.L.]

**Propellant** Usually, a combustible substance that produces heat and supplies ejection particles, as in a rocket engine. A propellant is both a source of energy and a working substance; a fuel is chiefly a source of energy, and a working substance is chiefly a means for expending energy. Because the distinction is more decisive in rocket engines, the term propellant is used primarily to describe chemicals carried by rockets for propulsive purposes. See AIRCRAFT FUEL; ROCKET PROPULSION; THERMODYNAMIC CYCLE.

Propellants are classified as liquid or as solid. Even if a propellant is burned as a gas, it may be carried under pressure as a cryogenic liquid to save space. For example, liquid oxygen and liquid hydrogen are important high-energy liquid bipropellants.

**Liquid propellants.** A liquid propellant releases energy by chemical action to supply motive power for jet propulsion. The three principal types of propellants are monopropellant, bipropellant, and hybrid propellant. Monopropellants are single liquids, either compounds or solutions. Bipropellants consist of fuel and oxidizer carried separately in the vehicle and brought together in the engine. Hybrid propellants use a combination of liquid and solid materials to provide propulsion energy and working substance. Typical liquid propellants are listed in the table. See METAL-BASE FUEL.

The availability of large quantities and their high performance led to selection of liquefied gases such as oxygen for early liquid-propellant rocket vehicles. Liquids of higher density with low vapor pressure (see table) are advantageous for the practical requirements of rocket operation under ordinary handling conditions. Such liquids can be retained in rockets for long periods ready for use and are convenient for vehicles that are to be used several times. The high impulse of the cryogenic systems is desirable for rocket flights demanding maximum capabilities, however, such as space exploration or transportation of great weights for long distances. [S.Si.]

**Solid propellants.** A solid propellant is a mixture of oxidizing and reducing materials that can coexist in the solid state at ordinary temperatures. When ignited, a propellant burns and generates hot gas. Although gun powders are sometimes called propellants, the term solid propellant ordinarily refers to materials used to furnish energy for rocket propulsion.

A solid propellant normally contains three essential components: oxidizer, fuel, and additives. Oxidizers commonly used in solid propellants are ammonium and potassium perchlorates, ammonium and potassium nitrates, and various organic nitrates, such as glyceryl trinitrate (nitroglycerin). Common fuels are hydrocarbons or hydrocarbon derivatives, such as synthetic rub-

bers, synthetic resins, and cellulose or cellulose derivatives. The additives, usually present in small amounts, are chosen from a wide variety of materials and serve a variety of purposes. Catalysts or suppressors are used to increase or decrease the rate of burning; ballistic modifiers may be used for a variety of reasons, as to provide less change in burning rate with pressure (platinizing agent); stabilizers may be used to slow down undesirable changes that may occur in long-term storage.

Solid propellants are classified as composite or double base. The composite types consist of an oxidizer of inorganic salt in a matrix of organic fuels, such as ammonium perchlorate suspended in a synthetic rubber. The double-base types are usually high-strength, high-modulus gels of cellulose nitrate (guncotton) in glyceryl trinitrate or a similar solvent. [H.W.R.]

**Propeller (aircraft)** A hub-and-multiblade device for changing rotational power of an aircraft engine into thrust power for the purpose of propelling an aircraft through the air (see illustration). An air propeller operates in a relatively thin medium compared to a marine propeller, and is therefore characterized by a relatively large diameter and a fairly high rotational speed. It is usually mounted directly on the engine drive shaft in front of or behind the engine housing. See PROPELLER (MARINE CRAFT).

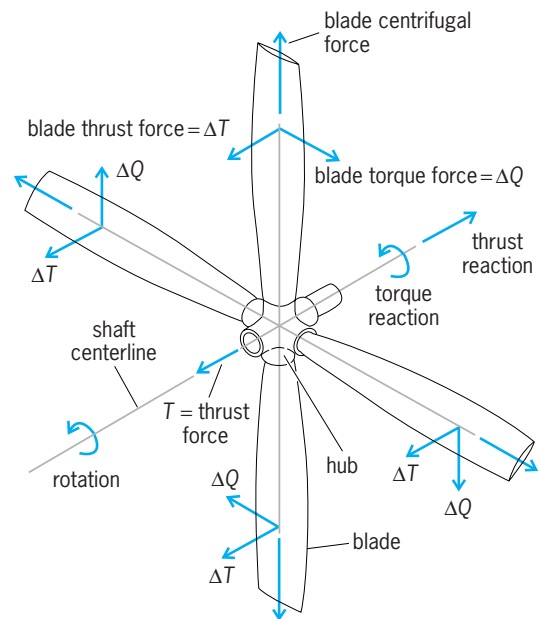

Typical four-bladed propeller system.

Usually propellers have two, three, or four blades; for high-speed or high-powered airplanes, six or more blades are used. In some cases these propellers have an equal number of opposite rotating blades on the same shaft, and are known as dual-rotation propellers.

A propeller blade advances through the air along an approximate helical path which is the result of its forward and rotational velocity components. This action is similar to a screw being turned in a solid surface, except that in the case of the propeller a slippage occurs because air is a fluid. Because of the similarity to the action of a screw, a propeller is also known as an airscrew. To rotate the propeller blade, the engine exerts a torque force. This force is reacted on by the blade in terms of lift and drag force components produced by the blade sections in the opposite direction. As a result of the rational forces reacting on the air, a rotational velocity remains in the propeller wake with the same rotational direction as the propeller. This rotational velocity times the mass of the air is proportional to the power input. The sum of all the lift and drag components of the blade sections in the

Physical properties of liquid propellants				
Propellant	Boiling point, °F (°C)	Freezing point, °F (°C)	Density g/ml	Specific impulse,* s
<i>Monopropellants</i>				
Acetylene	-119 (-84)	-115 (-82)	0.62	265
Hydrazine	236 (113)	35 (2)	1.01	194
Ethylene oxide	52 (11)	-168 (-111)	0.88	192
Hydrogen peroxide	288 (142)	13 (-11)	1.39	170
<i>Bipropellants</i>				
Hydrogen	-423 (-253)	-433 (-259)	0.07	
Hydrogen-fluorine	-306 (-188)	-360 (-218)	1.54	410
Hydrogen-oxygen	-297 (-183)	-362 (-219)	1.14	390
Nitrogen tetroxide	70 (21)	12 (-11)	1.49	—
Nitrogen-tetroxide-hydrazine	236 (113)	35 (2)	1.01	290
Red nitric acid	104 (40)	-80 (-62)	1.58	
Red fuming nitric acid-uns-dimethyl hydrazine	146 (63)	-71 (-57)	0.78	275

\*Maximum theoretical specific impulse at 1000 psi (6.895 megapascals) chamber pressure expanded to atmospheric pressure.

## 1786 Propeller (marine craft)

direction of flight are equal to the thrust produced. These forces react on the air, giving an axial velocity component opposite to the direction of flight. By the momentum theory, this velocity times the mass of the air going through the propeller is equal to the thrust.

A propeller blade must be designed to withstand very high centrifugal forces. The blade also must withstand the thrust force produced plus any vibratory forces generated, such as those due to uneven flow fields. To withstand the high stresses due to rotation, propeller blades have been made from a number of materials, including wood, aluminum, hollow steel, and plastic composites. The most common material used has been solid aluminum. However, the composite blade constructions are being used for new turboprop installations because of their very light weight and high strength characteristics.

For a small, low-power airplane, very simple, fixed-pitch, single-piece, two-blade propellers are used. The rotational speed of these propellers depends directly on the power input and forward speed of the airplane. Because of the fixed-blade angle of this type of propeller, it operates near peak efficiency only at one condition. To overcome the limitations of the simple fixed-pitch propeller, configurations that provide for variable blade angles are used. The blades of these propellers are retained in their hub so that they can be rotated about their centerline while the propeller rotates. For the normal range of operation, the blade angle varies from the low blade angle needed for takeoff to the high blade angle needed for the maximum speed of the airplane. See AIRCRAFT PROPULSION; AIRPLANE; HELICOPTER. [H.V.B.]

**Propeller (marine craft)** A component of a ship-propulsion power plant which converts engine torque into propulsive force or thrust, thus overcoming a ship's resistance to forward motion by creating a sternward accelerated column of water. Since 1860 the screw propeller has been the only propeller type used in ocean transport, mainly because of the evolution of the marine engine toward higher rotative speed.

The advantages of a screw propeller include light weight, flexibility of application, good efficiency at high rotative speed, and relative insensitivity to ship motion. The fundamental theory of screw propellers is applicable to all forms of marine propellers. In its present form a screw propeller consists of a streamlined hub attached outboard to a rotating engine shaft, on which are mounted two to seven blades. The blades are either solid with the hub, detachable, or movable. The screw propeller has the characteristic motion of a screw; it revolves about the axis along which it advances. The screw blades are approximately elliptical in outline.

One or more screw propellers are usually fitted as low as possible at the ship's stern to act as thrust-producing devices (see illustration). The low position of the propellers affords good protection and sufficient immersion during the pitching movements of the ship. The choice of the number of propellers to incorporate into a vessel design is based upon several factors. In general, a single-screw arrangement yields a higher propulsive efficiency than multiple screws, particularly when most of the propeller is operating in the boundary layer of the ship and can recover some of the energy loss. In addition, single-screw propulsion systems generally result in savings in machinery cost and weight in comparison to multiple-screw arrangements.

The formation and collapse of vapor-filled bubbles, or cavities, causes noise, vibration, and often rapid erosion of the propeller material, especially in fast, high-powered vessels. This phenomenon is known as cavitation. As long as the rotational and translational speeds of the propeller are not too high, the onset of cavitation can be delayed or limited to an acceptable amount by clever design of blade sections. See CAVITATION.

Supercavitating and superventilated propellers are designed to have fully developed blade cavities which spring from the leading edge of the blade, cover the entire back of the blade, and collapse well downstream of the blade trailing edge. The

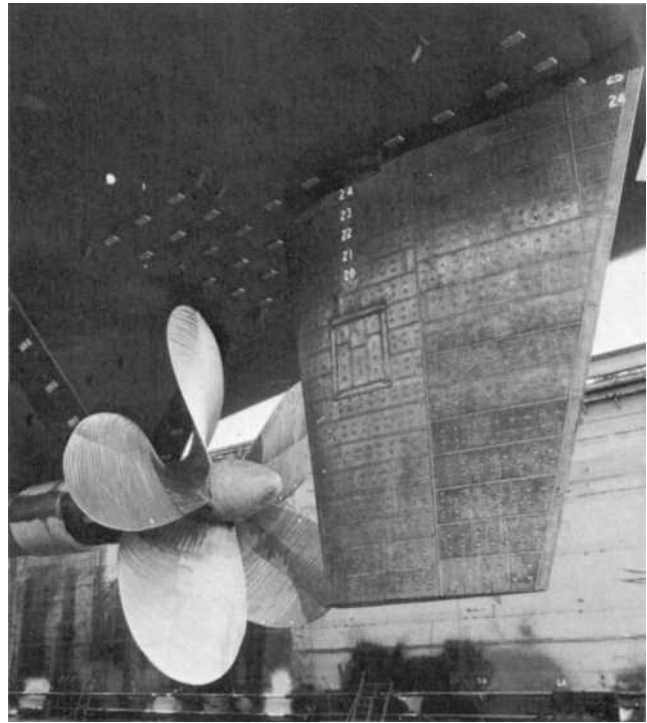

**Stern view of Great Land in drydock, showing screw propeller.** (From E. Schorsch, R. T. Bicicchi, and J. W. Fu, *Hull experiments on 24-knot RO/RO vessels directed toward fuel-saving application of copper-nickel*, Soc. Nav. Archit. Mar. Eng. Trans., 86:254-276, 1978)

blade of such propellers has unique sections which usually are wedge-shaped with a sharp leading edge, blunt trailing edge, and concave face. Supercavitating propellers have cavities filled with water vapor and small amounts of gases dissolved in the fluid media. Superventilated propellers have cavities filled primarily with air from the water surface or gases other than water vapor from a gas supply system through the propeller shaft.

For ships which normally operate at widely varying speeds and propeller loadings (towboats, rescue vessels, trawlers, and ferryboats), the application of controllable-pitch (rotatable-blade) propellers permits the use of full engine power at rated rpm under all operational conditions, ensuring maximum thrust production, utmost flexibility, and maneuverability. Since these propellers are also reversible, they permit the use of nonreversible machinery (gas turbines). See MARINE ENGINE; MARINE MACHINERY. [J.B.H.]

**Proprioception** The sense of position and movement of the limbs and the sense of muscular tension. The awareness of the orientation of the body in space and the direction, extent, and rate of movement of the limbs depend in part upon information derived from sensory receptors in the joints, tendons, and muscles. Information from these receptors, called proprioceptors, is normally integrated with that arising from vestibular receptors (which signal gravitational acceleration and changes in velocity of movements of the head), as well as from visual, auditory, and tactile receptors. Sensory information from certain proprioceptors, particularly those in muscles and tendons, need not reach consciousness, but can be used by the motor system as feedback to guide postural adjustments and control of well-practiced or semiautomatic movements such as those involved in walking.

Receptors for proprioception are the endings of peripheral nerve fibers within the capsule or ligaments of the joints or within muscle. These endings are associated with specialized end organs such as Pacinian corpuscles, Ruffini's cylinders, and Golgi

organs (the latter resembling histologic Golgi structures in the skin), and muscle spindles. *See* CUTANEOUS SENSATION; SENSATION; SOMESTHESIS. [R.LaM.]

**Propulsion** The process of causing a body to move by exerting a force against it. Propulsion is based on the reaction principle, stated qualitatively in Newton's third law, that for every action there is an equal and opposite reaction. A quantitative description of the propulsive force exerted on a body is given by Newton's second law, which states that the force applied to any body is equal to the rate of change of momentum of that body, and is exerted in the same direction as the momentum change. *See* NEWTON'S LAWS OF MOTION.

In the case of a vehicle moving in a fluid medium, such as an airplane or a ship, the required change in momentum is generally produced by changing the velocity of the fluid (air or water) passing through the propulsive device or engine. In other cases, such as that of a rocket-propelled vehicle, the propulsion system must be capable of operating without the presence of a fluid medium; that is, it must be able to operate in the vacuum of space. The required momentum change is then produced by using up some of the propulsive device's own mass, which is called the propellant. *See* AERODYNAMIC FORCE; AIRFOIL; FLUID FLOW; FLUID MECHANICS; PROPELLANT.

The two terms most generally used to describe propulsion efficiency are thrust specific fuel consumption for engines using the ambient fluid (air or water), and specific impulse for engines which carry all propulsive media on board. *See* SPECIFIC FUEL CONSUMPTION; SPECIFIC IMPULSE.

The energy source for most propulsion devices is the heat generated by the combustion of exothermic chemical mixtures composed of a fuel and an oxidizer. An air-breathing chemical propulsion system generally uses a hydrocarbon such as coal, oil, gasoline, or kerosene as the fuel, and atmospheric air as the oxidizer. A non-air-breathing engine, such as a rocket, almost always utilizes propellants that also provide the energy source by their own combustion.

Where nuclear energy is the source of propulsive power, the heat developed by nuclear fission in a reactor is transferred to a working fluid, which either passes through a turbine to drive the propulsive element such as a propeller, or serves as the propellant itself. Nuclear-powered ships and submarines are accepted forms of transportation. *See* TURBINE PROPULSION. [J.Gr.]

**Prosobranchia** The largest and most diverse subclass of the molluscan class Gastropoda. The group includes mostly marine snails but with a few fresh-water and land genera, all retaining an anterior mantle cavity and internal evidence of torsion. Adult prosobranchs always retain the streptoneurous (twisted-commisured) condition of the central nervous system, with the commissures to the visceral ganglia in the characteristic figure-eight pattern. This pattern reflects the torsion through 180° during larval (or embryonic) development which has brought the mantle cavity to a position above the head and facing forward. This contrasts with conditions in the other two gastropod subclasses, Opisthobranchia and Pulmonata, in which the effects of torsion are reduced or obscured in adults by secondary processes of development and growth. *See* GASTROPODA; OPISTHOBRANCHIA; PULMONATA.

The diversity of functional morphology exhibited by the prosobranchs is not equaled by any comparable subclass in the entire animal kingdom. From two-gilled forms with symmetrical cardiac and renal structures (the "Diotocardia") which can be numbered among the most primitive of all living mollusks, evolution within prosobranch stocks has involved increasing asymmetry of pallial, cardiac, and renal systems and greater hydrodynamic efficiencies. Torsion and the anterior mantle cavity create locomotory, circulatory, sanitary, and hydraulic problems which have been solved in a variety of ways in different prosobranchs. Four orders are commonly recognized in subclass Prosobranchia:

Archaeogastropoda, Neritacea, Mesogastropoda, and Neogastropoda. *See* NEOGASTROPODA. [W.D.R.H.]

**Prospecting** Exploration for mineral deposits. The result of prospecting is the discovery of potentially economic mineralization, that is, the prospect. Mineral exploration continues beyond prospecting to include the delineation and evaluation of the prospect to determine its minability as an orebody or economic mineral deposit. A successful prospect is developed into a mine. *See* MINING.

Prospecting generally pertains to the search for deposits of metallic ore minerals, but it also includes the search for non-metallic or industrial minerals and rocks such as sulfur, potash, and limestone, and mineral fuels such as petroleum, coal, and oil shale.

With much of the Earth's readily accessible surface having been investigated for minerals, prospecting is increasingly directed toward the discovery of deeper mineralization in recognized mining districts; mineralization hidden beneath overlying rocks, sediments, and soils; and mineralization in the less-known jungle, arctic, and offshore parts of the world. *See* MARINE MINING; OIL AND GAS, OFFSHORE.

Prospecting is done on the basis of the guides to ore associated with a conceptual image of the anticipated orebody. The image is referred to as an exploration model, and it is drawn from the characteristics of known orebodies in similar terrain. The exploration model and its guides to ore are expressed in terms of the regional and local geologic pattern; it has a certain diagnostic mineralogical character, it will commonly have a halo or envelope of associated guide minerals, and it will be expected to have a recognizable geochemical and geophysical expression. *See* ORE AND MINERAL DEPOSITS.

The topography itself may give evidence of abrupt depressions related to the leaching and collapse of sulfide ore minerals, or it may show boldly exposed silicified zones associated with ore. Some of the latter expressions of ore mineralization represent outcrops of siliceous iron formation host rocks, quartz-filled breccia pipes, and the prospector's classic quartz reefs that indicate vein deposits. Aerial photography and satellite imagery are valuable in searching for the topographic expression of potential ore mineralization.

Outcrops of gossan (the residue of red, brown, and yellow iron oxides and silica that remains from the weathering and near-surface leaching of sulfide ore minerals) are examined in the field for evidence of underlying ore mineralization, and trains of float (fragments of ore and gossan) are traced toward their apparent topographic origin. In glaciated terrain, trains of ore boulders are mapped and traced systematically toward their apparent sources.

Placer gold and placer accumulations of other minerals such as platinum, cassiterite, rutile, and diamonds are sought as economic deposits in themselves and are used as guides to upstream deposits of associated minerals. In addition, resistant and relatively dense minerals in stream gravels and residual heavy minerals in soil are collected by the long-established prospector's method of panning the loose material, and these are traced to a source area.

Geochemical prospecting is based on two characteristics of orebodies: an association with anomalous concentrations of chemical elements within primary halos in the surrounding rock, and an association with secondary dispersal patterns of chemical elements in the surficial products of their weathering and erosion. Geochemical methods involve the field and laboratory analysis of sampled rock, soil, vegetation, and other natural materials for trace amounts (in parts per million or billion) of the principal indicator elements of an orebody and of the related pathfinder elements that provide more recognizable or farther-reaching anomalies. *See* GEOCHEMICAL PROSPECTING.

Imagery provided by remote sensing from aircraft and orbiting satellites is of fundamental importance in prospecting and

in the patterns of exploration data associated with geographical information systems. Aerial photography in spectral bands of the near-infrared and near-ultraviolet frequencies is also used in photogeology for discriminating between types of exposed rock and soil and for emphasizing the appearance of bleached and stained areas as well as geobotanical anomalies. Airborne remote-sensing systems have provided radar imagery of terrain in the prospecting of cloud-covered jungle regions, and they have furnished thermal-band infrared surveys for recognizing anomalously warm areas that may be associated with mineralization. Airborne multispectral sensors with the capability of identifying some of the specific kinds of minerals in altered zones have been tested for use in prospecting. See AERIAL PHOTOGRAPHY; GEOGRAPHIC INFORMATION SYSTEMS; REMOTE SENSING.

Geophysical exploration is based on the measurement of physical properties associated with geologic features. As a means of both airborne and ground prospecting for mineral deposits, it involves the recognition of contrasts in properties between the deposit and the adjacent rock, generally to depths on the order of 330–660 ft (100–200 m), and the definition of deeper structural and lithologic features to be used as guides to ore mineralization. Magnetic, electrical, electromagnetic, and radioactive methods are the most widely used in prospecting for ore and industrial minerals deposits. Geophysical surveys are often made by several methods, so that more than one physical property can be taken into account. See GEOMAGNETISM; GEOPHYSICAL EXPLORATION; ROCK, ELECTRICAL PROPERTIES OF.

Drilling is the principal method of subsurface prospecting where evidence of ore mineralization and geophysical or geochemical anomalies indicates a target for prospecting at a depth of more than a few feet. Geophysical information is obtained by the probing or logging of drill holes. Electrical and electromagnetic logging is done in holes drilled in search of metallic orebodies; with these methods, the radius of search is extended considerably beyond that of the small-diameter cylinder of sampled rock. Gamma-ray methods of geophysical drill-hole logging have become standard practice in prospecting for uranium ore. See ENGINEERING GEOLOGY; WELL LOGGING. [W.C.Pe.]

**Prostate gland** A triangular body in men, the size and shape of a chestnut, that lies immediately in front of the bladder with its apex directed down and forward. It is found only in the male, having no female counterpart. The prostatic portion

of the urethra extends through it, passing from the bladder to the penis. This organ contains 15–20 branched, tubular glands which form lobules. The gland ducts open into the urethra. Between the gland clusters, or alveoli, there is a dense, fibrous, connecting tissue, the stroma, which also forms a tough capsule around the gland, continuous with the bladder wall. Penetrating the prostate to empty into the urethra are the ejaculatory ducts from the seminal vesicles which are located above and behind the organ (see illustration). The prostatic gland secretes a viscid, alkaline fluid which aids in sperm motility and in neutralizing the acidity of the vagina, thus enhancing fertilization. After middle age, the prostate is sometimes subject to new tissue growth, usually benign, that may result in interference with urine flow through the compressed urethra. [W.J.B.]

**Prosthesis** An artificial replacement of a body part. It may be an internal replacement such as an artificial joint or an external replacement such as an artificial limb. Prostheses of all types are lighter and more functional than their predecessors; the broad field of prosthetics has benefited from advances in materials, miniaturization, and computer-generated fabrication.

**Limb prosthetics.** A standard nomenclature is used to refer to level of amputation and related prostheses. The term *trans* is used when an amputation goes across the axis of a long bone, such as *trans*tibial (across the tibia of the leg) or *trans*humeral (across the humerus of the arm). When there are two bones together such as the tibia and fibula, the primary bone is identified. Amputations between long bones or through a joint are referred to as *disarticulations* and identified by the major body part, such as *knee disarticulation*. The term *partial* is used to refer to a part of the foot or hand distal to the ankle or wrist that may be amputated.

Socket design varies with the level of amputation and the configurations of the individual residual limb. The prosthetic socket must support body weight and hold the residual limb firmly and comfortably during all activities. Additionally, the socket needs to grip the residual limb firmly to reduce movement between the socket and the skin. Sockets are individually constructed for each client from a cast made of the residual limb. Sockets may be hard and rigid, or flexible and supported by a rigid frame.

There are several methods of suspending each type of prosthesis. Suction sockets allow suspension without belts, sleeves, or cuffs. In the *trans*tibial prosthesis a rubber sleeve or a cuff that fits on the thigh may be used. In the *trans*femoral prosthesis a belt around the pelvis provides suspension.

Foot and ankle function is complex, and a variety of prosthetic feet are designed to respond dynamically to the pressure of walking and running. They store energy at the moment of heel contact, then return it at toe-off.

Of paramount importance is the prosthetic component, called a *terminal device*, that will substitute for the missing hand. There is no device that completely replaces the appearance or function of the anatomic hand. The two types of terminal device are the *hand* and the *hook*. Either is secured to a plastic socket encasing the forearm.

The hand may be active or passive: passive hands have no moving parts; active hands have a mechanism that permits the client to control finger position by appropriate action in the proximal part of the amputated limb. The most popular active hand is operated myoelectrically. The individual wears a socket with one or more skin electrodes that contact appropriate muscle groups.

A hook is made either of aluminum or steel, hooks have two fingers that the client can open and close. Myoelectrically controlled hooks are available; however, most individuals who wear hooks have cable-operated ones that are either voluntary-opening or voluntary-closing.

**Joint replacements.** Artificial replacements of joints, such as hip, knee, or shoulder, are another type of prosthesis. The knee and hip joints are the most frequently replaced. Lower limb joint replacements must have load-bearing capabilities and are

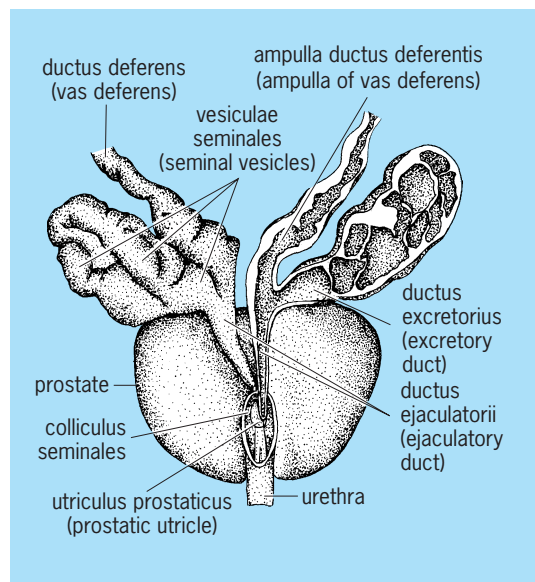

Prostate gland and seminal vesicles. (After Eycleshymer and Jones, in W. A. N. Darland, ed., *American Illustrated Medical Dictionary*, 19th ed., Saunders, 1942)

fabricated in different sizes of metal. Joint replacements may sometimes be secured by polymer adhesive. A high degree of restoration of function is usually obtained with hip and knee joint replacements.

In the upper extremity, shoulder and metacarpal phalangeal joints are most frequently replaced. The joint replacement in the upper limb needs to be light and to allow a great range of movement.

**Other prostheses.** There are a great variety of other types of replacements of body parts. Women who lose a breast to cancer are fitted with a prosthesis that can be fabricated of a number of lightweight materials and molded to resemble in shape and texture the remaining breast. Prosthodontics are devices used to replace teeth. The cardiac pacemaker is a form of a prosthesis replacing the natural electrical stimulation of the heart with a battery-operated device inserted within the body. Damaged heart valves are replaced with artificial valves attached directly to the heart muscle and to the major blood vessels. Prosthetic eyes, fabricated to resemble the remaining eye in color and configuration, serve a cosmetic function only. [B.J.Ma.]

**Biologic-prosthetic systems.** Although mechanical or electromechanical prosthetic devices represent the main option in many situations, regeneration of destroyed or resected tissue is the preferred goal. The use of inert materials to provide a basis for regenerated tissue growth offers intermediate options for reconstruction. See BIOMEDICAL ENGINEERING; SURGERY. [W.R.]

**Protactinium** A chemical element, Pa, atomic number 91. Isotopes of mass numbers 216, 217, and 222–238 are known, all of them radioactive. Only  $^{231}\text{Pa}$ , the parent of actinium,  $^{234}\text{Pa}$ , and  $^{233}\text{Pa}$  occur in nature. The most important of these is  $^{231}\text{Pa}$ , an  $\alpha$ -emitter with a half-life of 32,500 years. The artificial isotope,  $^{233}\text{Pa}$ , is important as an intermediary in the production of fissile  $^{233}\text{U}$ . Both  $^{231}\text{Pa}$  and  $^{233}\text{Pa}$  can be synthesized by neutron irradiation of thorium. See ACTINIUM; PERIODIC TABLE; RADIOACTIVITY; URANIUM.

Protactinium is, formally, the third member of the actinide series of elements and the first in which a 5f electron appears, but its chemical behavior in aqueous solution resembles that of tantalum and niobium more closely than that of the other actinides. See NIOBIUM; TANTALUM.

Metallic protactinium is silver in color, malleable, and ductile. The crystal structure is body-centered tetragonal. Samples exposed to air at room temperature show little or no tarnishing over a period of several months. The numerous compounds of protactinium that have been prepared and characterized include binary and polynary oxides, halides, oxyhalides, sulfates, oxysulfates, double sulfates, oxynitrates, selenates, carbides, organometallic compounds, and noble metal alloys. See ACTINIDE ELEMENTS. [H.W.Ki.]

**Protandry** That condition in which an animal is first a male and then becomes a female. It occurs in many groups, including oysters and cyclostomes. The reverse condition is protogyny. See PROTOGYNY. [T.I.S.]

**Proteales** An order of flowering plants, division Magnoliophyta, in the eudicots. Consisting of three families, the order is one of the most controversial in current classifications, with a lack of obvious morphological characters linking the family Nelumbonaceae (two species) to the other two families, Platanaceae (seven species) and Proteaceae (about 1350 species). However, DNA sequences indicate that the three families form a natural group. See MAGNOLIOPHYTA; MAGNOLIOPSIDA; WOOD ANATOMY.

Nelumbonaceae are aquatic, rhizomatous herbs with peltate leaves held above the water on long petioles, and have often been thought to be related to the true waterlilies (Nymphaeales). *Nelumbo* (sacred lotus and American lotus) is used as a source of food, as an ornamental, and as a sacred plant in several Asian countries.

Platanaceae, from the Northern Hemisphere, are deciduous, monoecious trees with simple, palmately lobed leaves, flaking bark, and branched hairs. Plane trees (*Platanus*) are common street trees, due to the regular loss of bark (which gives some resistance to pollution), and they also provide timber. See BARK; DECIDUOUS PLANTS; FRUIT; LEAF; NYMPHAEALES.

Proteaceae (predominantly tropical and subtropical, in the Southern Hemisphere) are evergreen shrubs and trees that often accumulate aluminum. Several genera (including *Banksia*, *Protea*, and *Leucospermum*) are widely cultivated for cut flowers; *Grevillea* and other genera are used for timber; and *Macadamia* yields edible nuts. See EVERGREEN PLANTS; ROOT (BOTANY). [M.F.F.]

**Protective coloration** A strategy that organisms use to avoid or deflect the attacks of predators by misleading the latter's visual senses.

Protective coloration can be classified according to whether the functioning or malfunctioning of the vertebrate visual system is exploited. Exploiting the malfunction of the system means simply "not being seen": the prey fails to attract the attention of the predator, usually because it is the same color as the general background or because it fails to cast a shadow. The organism avoids producing shadow by flattening itself against the substrate, or by countershading, in which the lower parts of a cylindrical prey such as a caterpillar are more lightly colored than the upper parts. As shadows normally form on the underside of cylinders, the shading cancels the shadow and makes the caterpillar optically flat. Animals that match their background often have an ability to select the appropriate background to rest on, or much less frequently can change their own color to match (as in the case of the chameleon).

Exploiting the functioning of the vertebrate perceptual system takes many forms. The vertebrate visual cortex decodes the image on the retina in a hierarchical process starting with the detection of edges. A moth may counter this by possessing strikingly contrasted patches of color on its wings, arranged in a random way. The outline of the moth is thus broken up, and the predator cannot decode it as a significant shape. The prey may also exploit the learning capacity of the predator. For example, insectivorous birds see leaves but do not attack them because they have learned (or perhaps know innately) that these are not edible. Resemblances to leaves, twigs, thorns, flowers, parts of flowers, and more bizarre objects like fresh turds (usually bird droppings) are very widespread. This type of camouflage is termed mimetic camouflage. Camouflage in general is often termed cryptic coloration.

Coloration may be considered mimetic if protection is achieved by a resemblance to some other existing object, which is recognized by the predator but not associated in its mind with feeding. Usually this negative or neutral association is learned, but in a minority of instances it is almost certainly innate. Small birds have an innate flight response to large eyes in close-up (which normally indicate that a cat or a predatory bird is dangerously close). This reaction is exploited by many moths and other insects, which have eyelike markings, sometimes very convincing in their shading and highlighting, on concealed parts of the wings. Attack by a bird causes such a moth to change its posture rapidly to reveal the fake eyes, thus frightening away the attacker. Motmots (birds which habitually prey on snakes) have a similar innate fear of the red, black, and yellow striping patterns of the deadly coral snakes. These patterns are mimicked by various nonvenomous snakes, and even some caterpillars.

Flash coloration describes the phenomenon in which the prey is cryptic when at rest, but reveals brilliantly colored parts while escaping. This behavior seems to function simply by startling the predator. Very small eye marks at the tips of the wings, or a false head at the wrong end of the body (shown by some coral reef fish, for example) may cause the predator to misdirect its attack.

Protection through the possession of a chemical or physical defense that is dangerous to one's potential predator, accompanied by a strikingly conspicuous pattern known as warning coloration (often black, red, yellow, and white), is widespread—the ensemble of defense and color is termed aposematic. The actual defense ranges from toxic venoms through stings (in wasps, for example), to the oozing of noxious foams or hemolymph (as in ladybirds), to the possession of toxic chemicals (cyanides, cardiac glycosides, alkaloids) that will poison the predator or simply produce a revolting taste. The function of the warning color is to remind the predator of its previous unpleasant experience.

Sometimes the term mimicry is restricted to resemblances between edible species and actively defended and warningly colored models (as opposed to inedible objects such as thorns). Much is known about the evolution of this kind of mimicry in butterflies (and to a lesser extent, in bees and flies). If the mimic is entirely edible, the relationship is parasitic; the mimic benefits from the resemblance, but as every encounter with a mimic reduces the predator's aversion, the model suffers some increase in the rate of attack. Such mimicry has traditionally been termed Batesian mimicry. Alternatively, the mimic may be almost or fully as defended as the model, leading to a mutualistic relationship known as Müllerian mimicry, in which both the model and the mimic species suffer a decreased rate of predation. [J.R.G.T.]

**Protein** A biological macromolecule made up of various  $\alpha$ -amino acids that are joined by peptide bonds. A peptide bond is an amide bond formed by the reaction of an  $\alpha$ -amino group ( $-\text{NH}_2$ ) of one amino acid with the carboxyl group ( $-\text{COOH}$ ) of another, as shown below. Proteins generally contain from 50 to 1000 amino acid residues per polypeptide chain.

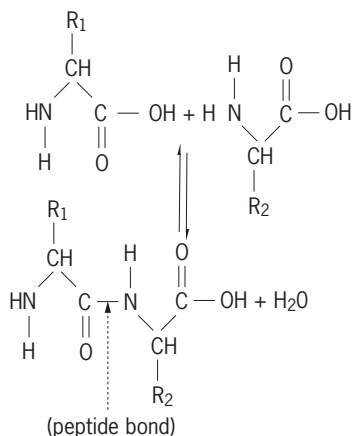

See PEPTIDE.

**Occurrence.** Proteins are of importance in all biological systems, playing a wide variety of structural and functional roles. They form the primary organic basis of structures such as hair, tendons, muscle, skin, and cartilage. All of the enzymes, the catalysts in biochemical transformations, are protein in nature. Many hormones, such as insulin and growth hormone, are proteins. The substances responsible for oxygen and electron transport (hemoglobin and the cytochromes, respectively) are conjugated proteins that contain a metalloporphyrin as the prosthetic group. Chromosomes are highly complex nucleoproteins, that is, proteins conjugated with nucleic acid. Viruses are also nucleoprotein in nature. Of the more than 200 amino acids that have been discovered either in the free state or in small peptides, only 20 amino acids are present in mammalian proteins. Thus, proteins play a fundamental role in the processes of life. See AMINO ACIDS.

**Specificity.** The linear arrangement of the amino acid residues in a protein is termed its sequence (primary structure). The sequence in which the different amino acids are linked in any given protein is highly specific and characteristic for that particular protein.

This specificity of sequence is one of the most remarkable aspects of protein chemistry. The number of possible permutations of sequence in even so small a protein as insulin, of molecular weight 5732 and with 51 amino acid residues, is astronomic: 1051 permutations. Yet it has been established that the pancreatic cell of a given species has only one of these possible sequences. The elucidation of the mechanism conferring such a high degree of specificity on the biosynthetic reactions by which proteins are built up from free amino acids has been one of the key problems of modern biochemistry. See MOLECULAR BIOLOGY.

Proteins are not stretched polymers; rather, the polypeptide backbone of the molecule can fold in several ways by means of hydrogen bonds between the carbonyl oxygen and the amide nitrogen. The folding of each protein is determined by its particular sequence of amino acids. The long polypeptide chains of proteins, particularly those of the fibrous proteins, are held together in a rather well-defined configuration. The backbone is coiled in a regular fashion, forming an extended helix. As a result of this coiling, peptide bonds separated from one another by several amino acid residues are brought into close spatial approximation. The stability of the helical configuration can be attributed to hydrogen bonds between these peptide bonds. See FIBROUS PROTEIN.

In addition to hydrogen bonds, there are electrostatic interactions, such as those between  $\text{COO}^-$  and  $\text{NH}_3^+$  groups of the side chains, and van der Waals forces, that is, hydrophobic interactions, which help to determine the configuration of the polypeptide chain. The term secondary structure is used to refer to all those structural features of the polypeptide chain determined by noncovalent bonding interactions.

In addition to the  $\alpha$ -helical sections of proteins, there are segments that contain  $\beta$ -structures in which there are hydrogen bonds between two polypeptide chains that run in parallel or antiparallel fashion.

The tertiary structure (third level of folding) of a protein comes about through various interactions between different parts of the molecule. Disulfide bridges formed between cysteine residues at different locations in the molecule can stabilize parts of a three-dimensional structure by introducing a primary valence bond as a cross-link. Hydrogen bonds between different segments of the protein, hydrophobic bonds between nonpolar side chains of amino acids such as phenylalanine and leucine, and salt bridges such as those between positively charged lysyl side chains and negatively charged aspartyl side chains all contribute to the individual tertiary structure of a protein.

Finally, for those proteins that contain more than one polypeptide chain per molecule, there is usually a high degree of interaction between each subunit, for example, between the  $\alpha$ - and  $\beta$ -polypeptide chains of hemoglobin. This feature of the protein structure is termed its quaternary structure.

**Properties.** The properties of proteins are determined in part by their amino acid composition. As macromolecules that contain many side chains that can be protonated and unprotonated depending upon the pH of the medium, proteins are excellent buffers. The fact that the pH of blood varies only very slightly in spite of the numerous metabolic processes in which it participates is due to the very large buffering capacity of the blood proteins.

**Biosynthesis.** The processes by which proteins are synthesized biologically have become one of the central themes of molecular biology. The sequence of amino acid residues in a protein is controlled by the sequence of the DNA as expressed in messenger RNA at ribosomes. See DEOXYRIBONUCLEIC ACID (DNA); RIBONUCLEIC ACID (RNA); RIBOSOMES. [G.E.Pe.; J.M.Ma.]

**Degradation.** As with many other macromolecular components of the organism, most body proteins are in a dynamic state of synthesis and degradation (proteolysis). During proteolysis, the peptide bond that links the amino acids to each other is hydrolyzed, and free amino acids are released. The process is carried out by a diverse group of enzymes called proteases.



During proteolysis, the energy invested in generation of the proteins is released. See ENZYME.

Distinct proteolytic mechanisms serve different physiological requirements. Proteins can be divided into extracellular and intracellular, and the two groups are degraded by two distinct mechanisms. Extracellular proteins such as the plasma immunoglobulins and albumin are degraded in a process known as receptor-mediated endocytosis. Ubiquitin-mediated proteolysis of a variety of cellular proteins plays an important role in many basic cellular processes such as the regulation of cell cycle and division, differentiation, and development; DNA repair; regulation of the immune and inflammatory responses; and biogenesis of organelles. [A.J.Ci.]

**Molecular chaperones.** Molecular chaperones are specialized cellular proteins that bind nonnative forms of other proteins and assist them to reach a functional conformation. The role of chaperone proteins under conditions of stress, such as heat shock, is to protect proteins by binding to misfolded conformations when they are just starting to form, preventing aggregation; then, following return of normal conditions, they allow refolding to occur. Chaperones also play essential roles in folding under normal conditions, providing kinetic assistance to the folding process, and thus improving the overall rate and extent of productive folding. [A.Ho.]

**Protein engineering.** The amino acid sequences, sizes, and three-dimensional conformations of protein molecules can be manipulated by protein engineering, in which the basic techniques of genetic engineering are used to alter the genes that encode proteins. These manipulations are used to generate proteins with novel activities or properties for specific applications, to discover structure-function relationships, and to generate biologically active minimalist proteins (containing only those sequences necessary for biological activity) that are smaller than their naturally occurring counterparts.

Many subtle variations in a particular protein can be generated by making amino acid replacements at specific positions in the polypeptide sequence. For example, at any specific position an amino acid can be replaced by another to generate a mutant protein that may have different characteristics by virtue of the single replaced amino acid. Amino acids can also be deleted from a protein sequence, either individually or in groups. These proteins are referred to as deletion mutants. Deletion mutants may or may not be missing one or more functions or properties of the full, naturally occurring protein. Moreover, part or all of a protein sequence can be joined or fused to that of another protein. The resulting protein is called a hybrid or fusion protein, which generally has characteristics that combine those of each of the joined partners. [P.Sc.]

**Protein metabolism** The transformation and fate of food proteins from their ingestion to the elimination of their excretion products. Proteins are of exceptional importance to organisms because they are the chief constituents, aside from water, of all the soft tissue of the body. Special proteins have unique roles as structural and functional elements of cells and tissues. Examples are keratin of skin, collagen of tendons, actin and myosin of muscle, the blood proteins, enzymes in all tissues, and protein hormones of the hypophysis. See BLOOD; ENZYME; HORMONE; MUSCLE.

Isotopic labeling experiments have established that body proteins are in a dynamic state, constantly being broken down and replaced. This is a rapid process in organs active in metabolism, such as liver, kidney, intestinal mucosa, and pancreas, much slower in skeletal muscle, and extremely slow in connective tissue elements and skin.

Protein is digested to amino acids in the gastrointestinal tract. These are absorbed and distributed among the different tissues, where they form a series of amino acid pools that are kept equilibrated with each other through the medium of the circulating blood. The needs for protein synthesis of the different organs

are supplied from these pools. Excess amino acids in the tissue pools lose their nitrogen by a combination of transamination and deamination. The nitrogen is largely converted to urea and excreted in the urine. The residual carbon products are then further metabolized by pathways common to the other major foodstuffs—carbohydrates and fats. See CARBOHYDRATE; LIPID.

Ingestion of protein is needed primarily to supply amino acids for the formation of new and depleted body protein and as a source of various other body constituents derived from the amino acids. The amino acids of proteins fall into two nutritional categories: essential or indispensable, and nonessential or dispensable. For a number of amino acids, the category to which they belong changes between the periods of body growth and adulthood and changes also in different animal species. Eight essential amino acids are needed for maintenance of nitrogen equilibrium in healthy young men. The remaining amino acids can be formed in the body from other materials. See AMINO ACIDS.

Protein digestion occurs to a limited extent in the stomach and is completed in the duodenum of the small intestine. The main proteolytic enzyme of the stomach is pepsin, which is secreted in an inactive form, pepsinogen. Its transformation to the active pepsin, initiated by the acidity of the gastric juice, involves liberation of a portion of the pepsinogen molecule as a peptide. Pepsin preferentially hydrolyzes peptide bonds containing an aromatic amino acid, and it requires an acid medium to function. See DIGESTIVE SYSTEM; PEPSIN.

The acid chyme is discharged from the stomach, containing partially degraded proteins, into a slightly alkaline fluid in the small intestine. This fluid is composed of pancreatic juice and succus entericus, the intestinal secretion. The pancreas secretes three known proteinases, trypsin, chymotrypsin, and carboxypeptidase. All three are secreted as inactive zymogens. Activation starts with the transformation of the inactive trypsinogen into the active trypsin. Trypsin, in turn, activates chymotrypsin and carboxypeptidase. See PEPTIDE.

Trypsin and chymotrypsin are endopeptidases; that is, they cleave internal peptide bonds. The so-called peptidases are exopeptidases; they cleave terminal peptide bonds. Trypsin has a predilection for those containing the basic amino acid residues of lysine and arginine. These two proteinases perform the major share in hydrolyzing proteins to small peptides. Digestion to amino acids is completed by the exopeptidases. Carboxypeptidase acts on peptides from the free carboxyl end; aminopeptidases from the free amino end. Other peptidases act on di- or tripeptides, or peptides containing such special amino acids as proline.

The amino acid digestion products of the proteins are absorbed by the small intestine as rapidly as they are liberated. The absorbed amino acids are carried by the portal blood system to the liver, from which they are distributed to the rest of the body. Small amounts of the peptides formed during digestion escape further hydrolysis and may also enter the circulation from the intestine. This is shown by a rise in the peptide nitrogen in the blood.

The unabsorbed food residue in the small intestine is passed into the cecum, then the colon, and finally is eliminated as feces.

The absorbed amino acids that escape decomposition become part of the amino acid pools of the body. From these amino acids, new tissue proteins are synthesized to meet body needs. The rate of tissue replacement varies greatly for different tissues. In humans, it has been estimated that the average half-life of the total body protein is 80 days; that of lung, brain, bone, skin, and most muscle combined is 158 days; while that of liver and serum proteins combined is only 10 days.

The major organ of plasma protein synthesis is the liver. It forms all of the plasma albumin and fibrinogen and a considerable proportion of the globulins. (A portion of the total plasma globulin is synthesized in other tissues containing reticuloendothelial cells. The hormones and enzymes present in blood

plasma are derived in the main from nonhepatic sources.) See ALBUMIN; FIBRINOGEN; LIVER.

The plasma proteins have numerous important physiological functions. The albumin is the major factor in the regulation of the blood volume through its osmotic action, which counteracts the fluid expulsion effect of the hydrostatic pressure resulting from the contractions of the heart. Fibrinogen is one component of a sequential process essential for coagulation of the blood. Other plasma components include the blood platelets and prothrombin. The globulins include fractions that are carriers of phospholipids and sterols and certain essential metal ions, iron, and copper. Other fractions, chiefly  $\gamma$ -globulin, contain the antibodies that are the defenses against numerous diseases.

Synthesis and utilization of the plasma proteins is a rapid process. There is a complete turnover of the major plasma proteins in a period of a few days. The difference from normal in the turnover times in a variety of diseases provides an insight into the nature of the disease processes. [D.M.G.]

**Proteins, evolution of** Proteins are large organic molecules that are involved in all aspects of cell structure and function. They are made up of polypeptide chains, each constructed from a basic set of 20 amino acids, covalently linked in specific sequences. Each amino acid is coded by three successive nucleotide residues in deoxyribonucleic acid (DNA); the sequence of amino acids in a polypeptide chain, which determines the structure and function of the protein molecule, is thus specified by a sequence of nucleotide residues in DNA. See GENE; PROTEIN.

Sequence analyses of polypeptides which are shared by diverse taxonomic groups have provided considerable information regarding the genetic events that have accompanied speciation. Interspecies comparison of the amino acid sequences of functionally similar proteins has been used to estimate the amount of genetic similarity between species; species that are genetically more similar to each other are considered to be evolutionarily more closely related than those that are genetically less similar.

The study of functionally related proteins from different animal species has suggested that single amino acid substitutions are the predominant type of change during evolution of such proteins. Insertions or deletions of one or more amino acids have also been reported. In proteins that serve the same function in dissimilar species small differences in the amino acid sequence will often not affect overall functioning of the protein molecule.

In taxonomic protein sequence analysis, the amino acid sequence of a protein from one species is compared with the amino acid sequence of the protein from another species, and the minimum number of nucleotide replacements (in DNA) required to shift from one amino acid to another is calculated. Peptide "genealogies" can be constructed from many such comparisons in a related group of organisms.

**Classical versus protein-derived phylogenies.** It has been recognized for a long time that the amino acid sequences of a protein are species-specific. Protein sequencing has been used widely since the mid-1960s to examine taxonomic relationships. Results indicate that, in general, genealogical relationships (phylogenies) based on sequence analyses correspond fairly well with the phylogeny of organisms as deduced from more classical methods involving morphological and paleontological data.

Evolutionary biologists are turning increasingly to the new nucleic acid sequencing technology as an alternative to determining the amino acid sequence of proteins. Knowing the actual nucleotide sequences of genes rather than having to infer them from protein sequence data allows more accurate data to be used in determining genealogical relationships of organisms. For example, silent nucleotide substitutions (that is, base changes in DNA codons that do not result in amino acid changes) can be detected.

**Orthologous and paralogous sequences.** The reconstruction of phylogenies from analysis of protein sequences is

based on the assumption that the genes coding for the proteins are homologous, that is, descendants of a common ancestor. Those sequences whose evolutionary history reflects that of the species in which they are found are referred to as orthologous. The cytochrome *c* molecules (present in all eukaryotes) are an example of an orthologous gene family. Organisms as diverse as humans and yeast have a large proportion of the amino acids in these molecules in common; they derive from a single ancestral gene present in a species ancestral to both these organisms and to numerous others.

Sequences which are descendants of an ancestral gene that has duplicated are referred to as paralogous. Paralogous genes evolve independently within each species. The genes coding for the human  $\alpha$ ,  $\beta$ ,  $\gamma$ ,  $\delta$ ,  $\epsilon$ , and  $\zeta$  hemoglobin chains are paralogous. Their evolution reflects the changes that have accumulated since these genes duplicated. Analysis of paralogous genes in a species serves to construct gene phylogenies, that is, the evolutionary history of duplicated genes within a given lineage.

**Rate of evolution.** Sequence data from numerous proteins have shown that different proteins evolve at different rates. Some proteins show fewer amino acid substitutions, or more conservation, than others. Proteins such as immunoglobulins, snake venom toxins, and albumins have changed extensively. Their function apparently requires relatively less specificity of structure and therefore has relatively greater tolerance for variance. By contrast, certain proteins, such as various histones, have changed relatively little over long periods of time. Histone H4 shows extreme conservation; it has essentially the same sequence in all eukaryotes examined. Such extensive sequence conservation is generally interpreted to indicate that the functions of H4 are extremely dependent on its entire structure; thus little or no change is tolerated in its structure. The rates at which different proteins evolve are therefore thought to be due to different functional constraints on the structure of the proteins—the more stringent the conditions that determine the function of a protein molecule, the smaller the chance that a random change will be tolerated in its structure.

Each protein generally has a nearly constant evolutionary rate (the rate of acceptance of mutations) in each line of descent. Exceptions to this rule have been reported, however, and much effort has been spent on determining whether these anomalies are genuine. Some anomalies have been shown to be due to comparison of nonhomologous proteins, and others due to sequencing errors. Other deviations from constant rate of sequence evolution remain to be explained; once uncovered, these may provide useful information about the mechanisms of evolution at the molecular level. [P.K.M.]

**Proteocephaloidea** An order of tapeworms of the subclass Cestoda. With one exception, these worms are intestinal parasites of fresh-water fishes, amphibians, and reptiles. The holdfast organ bears four suckers and, frequently, an apical organ which may be suckerlike. The segmental anatomy is very similar to that of the Tetraphyllidea. Most authorities recognize two families, the Proteocephalidae and the Monticellidae. See CESTODA. [C.PR.]

**Proteomyxidia** A subclass of Actinopodea including protozoan organisms without protective coverings (tests) or skeletal elements. Pseudopodia are fine, branched, and interconnected (reticulopodia), or filamentous (filopodia). Many are invaders of algae and other plants. There is one order, Proteomyxida, which contains two families, Pseudosporidae and Vampyrellidae. See ACTINOPODEA. [R.P.H.]

**Proterozoic** A major division of geologic time spanning from 2500 to 543 million years before present (Ma). The beginning of Proterozoic time is an arbitrary boundary that roughly coincides with the transition from a tectonic style dominated by extensive recycling of the Earth's continental crust to a style

characterized by preservation of the crust as stable continental platforms. The end of the Proterozoic coincides with the Precambrian-Cambrian boundary, which is formally defined on the basis of the first appearance of diverse coelomate invertebrate animals. Proterozoic Earth history testifies to several remarkable biogeochemical events, including the formation and dispersal of the first supercontinent, the maturation of life and evolution of animals, the rise of atmospheric oxygen, and the decline of oceanic carbonate saturation. Tremendous iron and lead-zinc mineral deposits occur in Proterozoic rocks, as do the first preserved accumulations of oil and gas. See CAMBRIAN; PRE-CAMBRIAN.

Many of the Earth's Archean cratons are blanketed by little-deformed sequences of Proterozoic sedimentary rocks, which indicate that vigorous recycling of the Earth's crust, characteristic of Archean time, had slowed markedly by the beginning of Proterozoic time. This decrease in crustal recycling is attributed to the development of thick continental roots, which stabilized the cratons, and the decrease in heat that was escaping from the Earth's interior, believed to drive thermal convection in the Earth's mantle and recycling of the crust. Most of the Earth's Archean cratons appear to have participated in the formation of a supercontinent in Mesoproterozoic time, about 1200 Ma. This supercontinent, called Rodinia, seems to have assembled with the North American craton (Laurentia) at its center. Rodinia persisted until the latest part of the Neoproterozoic, about 600 Ma. See ARCHEAN; CONTINENTS, EVOLUTION OF; EARTH, CONVECTION IN; EARTH, HEAT FLOW IN; EARTH CRUST; EARTH INTERIOR; PLATE TECTONICS.

Giant iron oxide deposits were formed by precipitation from seawater about 2000 Ma, whereupon oxygen was free to accumulate in the atmosphere and shallow ocean. During most of Paleoproterozoic time the oceans and atmosphere were reducing and ferrous iron was abundant in seawater. See ATMOSPHERE, EVOLUTION OF.

The partial pressure of carbon dioxide on the early Earth was very high. During Proterozoic time, much of the mass of carbon shifted from the ocean and atmosphere to the solid Earth. Enormous volumes of limestone [ $\text{CaCO}_3$ ] and dolomite [ $\text{CaMg}(\text{CO}_3)_2$ ] were deposited and testify to this shift. See DOLOMITE ROCK; LIMESTONE; SEDIMENTARY ROCKS.

Glaciers covered significant parts of the Earth during two widely separated times in Proterozoic history. The first episode occurred about 2200 Ma, and glacial deposits of that age cover various parts of North America and Scandinavia. The second episode consisted of at least two different pulses spanning from 750 to 600 Ma during Neoproterozoic time. Glaciers formed at that time were of almost global extent, and were thought to have extended from the poles to the Equator, according to the snowball Earth hypothesis. See GLACIAL EPOCH.

A number of significant events in the evolution of life occurred during Proterozoic time. The record of biological activity is rich, consisting of actual body fossils, in addition to organism traces and impressions, and complex chemical biomarkers. Eukaryotic microbes appear to have evolved by about 1900 Ma, when they became major players in ecosystems present at that time. By the beginning of Neoproterozoic time, about 1000 Ma, multicellular eukaryotic algae are present in numerous sedimentary basins around the world. See EUKARYOTAE; RIBONUCLEIC ACID (RNA).

The evolution of animals did not take place until the close of Neoproterozoic time. Why these organisms evolved at this particular time in Earth history remains unanswered. General opinion proposes that it was likely the result of the confluence of a number of environmental factors, such as the rise in oxygen. Whatever the cause of their origin, these existed until at least 543 Ma, when another major evolutionary adaptive radiation began which marks the onset of Cambrian time and the end of the Proterozoic Eon. See ANIMAL EVOLUTION; EXTINCTION (BIOLOGY); GEOLOGIC TIME SCALE. [J.P.Gr.]

**Protista** The kingdom comprising all single-celled forms of living organisms in both the five-kingdom and six-kingdom systems of classification. Kingdom Protista encompasses both Protozoa and Protophyta, allowing considerable integration in the classification of both these animallike and plantlike organisms, all of whose living functions as individuals are carried out within a single cell membrane. Among the kingdoms of cellular organisms, this definition can be used to distinguish the Protista from the Metazoa (sometimes named Animalia) for many-celled animals, or from the Fungi and from the Metaphyta (or Plantae) for many-celled green plants. See METAZOA.

The most significant biological distinction is that which separates the bacteria and certain other simply organized organisms, including blue-green algae (collectively, often designated Kingdom Monera), from both Protista and all many-celled organisms. The bacteria are described as prokaryotic; both the Protista and the cells of higher plants and animals are eukaryotic. Structurally, a distinguishing feature is the presence of a membrane, closely similar to the bounding cell membrane, surrounding the nuclear material in eukaryotic cells, but not in prokaryotic ones. See EUKARYOTAE; PROKARYOTAE; PROTOZOA.

The definition that can separate the Protista from many-celled animals is that the protistan body never has any specialized parts of the cytoplasm under the sole control of a nucleus. In some protozoa, there can be two, a few, or even many nuclei, rather than one, but no single nucleus ever has separate control over any part of the protistan cytoplasm which is specialized for a particular function. In contrast, in metazoans there are always many cases of nuclei, each in control of cells of specialized function.

Most authorities would agree that the higher plants, the Metazoa, and the Parazoa (or sponges) almost certainly evolved (each independently) from certain flagellate stocks of protists. [W.D.R.H.]

**Protobranchia** A subclass of bivalve mollusks characterized by a foot with a sole that is divided sagittally and longitudinally and has papillate margins. The Protobranchia are divided into two orders, Solemyoidea and Nuculoidea. The Solemyoidea have an edentulous shell, and if teeth are present, they are not chevron-shaped. The palps are small, triangular, and without palp proboscides. This is in contrast to the Nuculoidea, which have well-developed, chevron-shaped hinge teeth and large palps with palp proboscides. The Nuculoidea are subdivided into two superfamilies, Nuculacea and Nuculanacea.

The Protobranchia are found throughout the seas of the world, and they are particularly common in the deep sea, where they may form up to 10% of the invertebrate infauna. The subclass has one of the longest geological records within the animal kingdom, dating from the Early Ordovician if not the Late Cambrian. See BIVALVIA; MOLLUSCA. [J.A.A.]

**Protococcida** An order of the protozoan subclass Coccidia in the class Telosporea, subphylum Sporozoa. This is a very small group containing perhaps six species in perhaps three genera. All are parasites of marine invertebrates. Only sexual reproduction is known. See COCCIDIA. [N.D.L.]

**Protogyny** A condition in hermaphroditic or dioecious animals in which the female reproductive structures mature before the male structures. It is of rare occurrence. Botanically, protogyny occurs in some plant species in which the stigma develops, withers, and dies before the anthers mature. See PROTANDRY. [T.I.S.]

**Protolepidodendrales** An extinct order of the class Lycopodiopsida (clubmosses) of the Devonian Period. Most of these clubmosses are poorly preserved and not well understood; the notable exception is the widespread *Leclercqia complexa*, which has been largely reconstructed from fragmentary fossils.

*Leclercqia* (Early to Middle Devonian) was a medium-sized herb; its horizontal rhizomes generated vertical axes up to 0.4 in. (1 cm) in diameter. The vascular tissue formed a star-shaped actinostele, with inward maturation of the metaxylem tracheids. Additional structural support was provided in the cortical cylinder by thickened hypodermal fibers. The micro-phyllous leaves were not routinely shed. Most branched into five unequal, needlelike lobes, each supplied by a lateral branch of the median vascular trace, and arranged three-dimensionally. Zones of sterile leaves alternated with zones of fertile sporophylls; both sterile and fertile leaves bore a small ligule on the upper surface. The stomata-bearing sporangia were located on the same surface of the sporophyll, somewhat closer to the stem than the ligule. The sporangia were elliptical and released spores of the same size; thus, *Leclercqia* is primitively homosporous.

Complex leaf morphologies are important characteristics in assigning genera to the Protolpidodendrales, even though it may be that they represent multiple independent evolutionary events. The presence of a ligule has been demonstrated only in *Leclercqia*; yet it is the combination of homosporous reproduction and the presence of a ligule that delimits the order and testifies to its evolutionary intermediacy between the eligulate homosporous Lycopodiales and the ligulate heterosporous Selaginellales. See LYCOPODIALES; SELAGINELLALES. [R.M.Ba.; W.A.DiM.]

**Proton** A positively charged particle that is the nucleus of the lightest chemical element, hydrogen. The hydrogen atom consists of a proton as the nucleus, to which a single negatively charged electron is bound by an attractive electrical force (since opposite charges attract). The proton is about 1836 times heavier than the electron, so that the proton constitutes almost the entire mass of the hydrogen atom. Most of the interior of the atom is empty space, since the sizes of the proton and the electron are very small compared to the size of the atom. See ATOMIC STRUCTURE AND SPECTRA; ELECTRIC CHARGE; HYDROGEN.

For chemical elements heavier than hydrogen, the nucleus can be thought of as a tightly bound system of  $Z$  protons and  $N$  neutrons. An electrically neutral atom will then have  $Z$  electrons bound comparatively loosely in orbits outside the nucleus. See NEUTRON; NUCLEAR STRUCTURE.

The numerical values of some overall properties of the proton can be summarized as follows: charge,  $1.602 \times 10^{-19}$  coulomb; mass,  $1.673 \times 10^{-27}$  kg; spin,  $(1/2)\hbar$  (where  $\hbar$  is Planck's constant  $h$  divided by  $2\pi$ ); magnetic dipole moment,  $1.411 \times 10^{-26}$  joule/tesla; radius, about  $10^{-15}$  m. See FUNDAMENTAL CONSTANTS; NUCLEAR MOMENTS; SPIN (QUANTUM MECHANICS).

It is instructive to contrast the proton's properties with those of the electron. All of the electron's properties have been found to be those expected of a spin- $1/2$  particle which is described by the Dirac equation of quantum mechanics. Such a Dirac particle has no internal size or structure. See ELECTRON; RELATIVISTIC QUANTUM THEORY.

By contrast, although it also has a spin of  $1/2$ , the proton's magnetic moment, which is different from that for a Dirac particle, and its binding with neutrons into nuclei strongly suggest that it has some kind of internal structure, rather than being a point particle. Two different kinds of high-energy physics experiments have been used to study the internal structure of the proton. An example of the first type of experiment is the scattering of high-energy electrons, above say 1 GeV, from a target of protons. The angular pattern and energy distribution of the scattered electrons give direct information about the size and structure of the proton. The second type of high-energy experiment involves the production and study of excited states of the proton, often called baryonic resonances. It has been found that the spectrum of higher-mass states which are produced in high-energy collisions follows a definite pattern. See BARYON.

In 1963, M. Gell-Mann and, independently, G. Zweig pointed out that this pattern is what would be expected if the proton

were composed of three spin- $1/2$  particles, quarks, with two of the quarks (labeled  $u$ ) each having a positive electric charge of magnitude equal to  $2/3$  of the electron's charge ( $e$ ), and the other quark (labeled  $d$ ) having a negative charge of magnitude of  $1/3e$ . Subsequently, the fractionally charged quark concept was developed much further, and has become central to understanding every aspect of the behavior and structure of the proton. See QUARKS.

An important class of fundamental theories, called grand unification theories (GUTs), makes the prediction that the proton will decay. The predicted lifetime of the proton is very long, about  $10^{30}$  years or more—which is some  $10^{20}$  times longer than the age of the universe—but this predicted rate of proton decay may be detectable in practical experiments. See GRAND UNIFICATION THEORIES.

If the proton is observed to decay, this new interaction will also have profound consequences for understanding of cosmology. The very early times of the big bang (about  $10^{-30}$  s) are characterized by energies so high that the same grand unified interaction which would allow proton decay would also completely determine the subsequent evolution of the universe. This could then explain the remarkable astrophysical observation that the universe appears to contain only matter and not an equal amount of antimatter. See COSMOLOGY; ELEMENTARY PARTICLE. [T.H.F.]

**Proton-induced x-ray emission (PIXE)** A highly sensitive analytic technique for determining the composition of elements in small samples. Proton-induced x-ray emission (PIXE) is a nondestructive method capable of analyzing many elements simultaneously at concentrations of parts per million in samples as small as nanograms. PIXE is the preferred technique for surveying the environment for trace quantities of such toxic elements as lead and arsenic. There has also been a rapid development in the use of focused proton beams for PIXE studies in order to produce two-dimensional maps of the elements at spatial resolutions of micrometers.

The typical PIXE apparatus uses a small Van de Graaff machine to accelerate the protons which are then guided to the sample. Nominal proton energies are between 1 and 4 MeV; too low an energy gives too little signal while too high an energy produces too high a background. The energetic protons ionize some of the atoms in the sample, and the subsequent filling of empty inner orbits results in the characteristic x-rays. These monoenergetic x-rays emitted by the sample are then efficiently counted in a high-resolution silicon (lithium) detector which is sensitive to the x-rays of all elements heavier than sodium. See JUNCTION DETECTOR; X-RAYS.

The advantages of PIXE over electron-induced x-ray techniques derive from the heaviness of the proton which permits it to move through matter with little deflection. The absence of scattering results in negligible continuous radiation (bremsstrahlung). As a result, proton-induced x-ray techniques are two to three orders of magnitude more sensitive to trace elements than are techniques based on electron beams. See BREMSSTRAHLUNG. [L.Gro.]

**Proton-proton chain** A group of nuclear reactions involving fusion of light nuclei that converts hydrogen into helium. It is believed to be the principal source of energy in main sequence stars of a little more than a solar mass and of less massive stars. Completion of a chain results in the consumption of four protons (hydrogen-1 nuclei, designated  $^1\text{H}$ ), and the production of a helium ( $^4\text{He}$ ) nucleus plus two positrons ( $e^+$ ) and two neutrinos ( $\nu$ ). The two positrons are annihilated along with two electrons ( $e^-$ ), and the total energy release is 26.73 MeV. Approximately 0.58 MeV is released as neutrino energy and is not available as thermal energy in a star. The chain can be thought of as the conversion of four hydrogen atoms into a helium atom plus energy in the form of photons or neutrinos, or the kinetic

energy of particles. The energy  $E = 26.73$  MeV arises from the mass difference between four hydrogen atoms and the helium atom, and is calculated from the Einstein mass-energy equation  $E = \Delta mc^2$ , where  $\Delta m$  is the mass difference and  $c^2$  is the square of the velocity of light. Because hydrogen is the fuel consumed in the process, it is referred to as hydrogen burning by means of the proton-proton chain. See NUCLEAR FUSION; NUCLEAR REACTION; STELLAR EVOLUTION. [G.R.C.; D.H.H.]

**Protosauria** An order of primitive diapsid reptiles in the infraclass Archosauria, known from the upper Permian to the end of the Triassic Series. Protosaurs (also known as prolacertiforms) are the earliest and most primitive known reptiles that show modifications of the rear limb for a more upright posture and a fore-and-aft movement that culminated in bipedal dinosaurs and birds. Protosaurs are characterized by elongate neck vertebrae, reduction of the lower temporal bar, and emargination of the quadrate to support a tympanum.

*Protosaurus*, from the upper Permian of Europe, was up to 6 ft (2 m) in length. Both the neck and the limbs were long. *Protosaurus* may have resembled a large varanid lizard in life, although the ankle bones were specialized in a much different way than those of lizards. The most distinctive protosaurus was *Tanystropheus* from the Middle Triassic Series of Europe. It reached 9 ft (3 m) in length, most of which consisted of a bizarrely elongated neck, at least three times the length of the trunk region. *Tanystropheus* was apparently an aquatic animal, as was the related North American genus *Tanytrachelus*. See ARCHOSAURIA; DIAPSIDA; REPTILIA. [R.L.C.]

**Protostar** A dense condensation of material that is still in the process of accreting matter to form a star. Protostars are expected in dense interstellar complexes of gas and dust. Since the gas is mostly in the form of molecules, especially molecular hydrogen ( $H_2$ ), these complexes are called molecular clouds. See INTERSTELLAR MATTER; MOLECULAR CLOUD.

Molecular clouds contain clumps of material with relatively low temperatures, typically 10 to 50 K ( $-442$  to  $-370^\circ F$ ), and den-

sities significantly higher than in the surrounding medium, between 10,000 and 100,000 atoms per cubic centimeter (illus. a). Such condensations will collapse under the effect of gravity if they are more massive than a certain value, now called the Jeans mass. The protostar is the central core that forms as a cloud condensation contracts.

Because the collapsing core is also rotating, its outer parts are flattened into a disk (illus. b). At this stage, the protostar's mass is very small, perhaps only 1/1000 of the mass of the present Sun. Over a period of  $10^4$ – $10^6$  years it continues to accrete material from the infalling envelope and eventually attains a stellarlike mass. Core collapse is checked, leaving a central protostar, when the gravitational heating produced by the contraction can no longer be radiated away as quickly as it is generated. Eventually, the core becomes sufficiently hot that the nuclear reactions that sustain stars can begin.

Much of this description of protostellar evolution is based on theoretical considerations. Although the velocity patterns of the gas around many objects have been measured, infalling material has not been detected. By contrast, in many cases (illus. c), gas is seen emanating from an embedded source in two well-collimated and oppositely directed outflows. The objects at the cores of these bipolar outflows are loosely referred to as protostars. See STELLAR EVOLUTION; T TAURI STAR. [A.I.S.]

**Prototheria** One of the four subclasses of the class Mammalia. Prototheria contains a single order, the Monotremata. No ancestral genera of fossil monotremes are known, and the structure of the living monotremes is so specialized that the affinities of the Prototheria are largely conjectural. Most mammalogists believe that the prototheres arose from a different stock of therapsid reptiles than the one that gave rise to the Theria.

No fossils earlier than the Pleistocene are known, and these come from Australia. The duckbilled platypus and several species of the echidnas are living representatives of this group. Everything indicates that the Prototheria represent a very small and relatively unsuccessful group that has miraculously survived in an isolated corner of the Earth. See MAMMALIA; MONOTREMATA; THERAPSIDA. [D.D.D.; F.S.S.]

**Prototype** A first or original model of hardware or software. Prototyping involves the production of functionally useful and trustworthy systems through experimentation with evolving systems. Generally, this experimentation is conducted with much user involvement in the evaluation of the prototype.

A primary use for prototyping is the acquisition of information that affects early product development. For example, if requirements for human-computer interfaces are ambiguous or inadequate, prototyping is frequently used to define an acceptable functional solution. It is a method for increasing the utility of user knowledge for purposes of continuing development to a final product. Information obtained through prototyping is important to designers, managers, and users in identifying issues and problems. Prototyping conserves time and resources prior to the commitment of effort to construct a final product.

In many hardware and software development projects, the first prototype product built is barely usable. It is usually too slow, too big, too awkward in use. Hence, the term throwaway prototype is generally applied to describe this early use of prototyping. Usually this is due to lack of understanding of user requirements. There is no alternative but to start again and build a redesigned version in which these problems are solved.

A developmental prototyping approach for incremental design of subsystems is often used to reduce the risk involved in building a system-level prototype. In this prototyping environment an incremental approach to rapid prototyping of subsystems development is used. This provides for management oversight of the entire process to assure that resource usage is effective and efficient. Product assurance is implemented throughout the

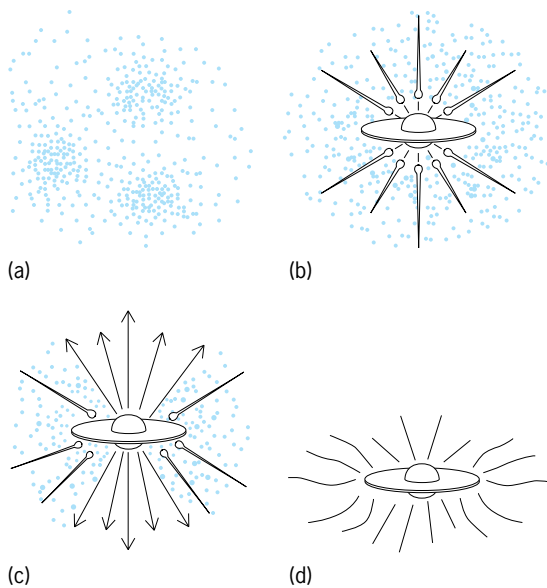

Stages of protostellar evolution. (a) Dense cores occur in a large molecular cloud. (b) A protostar surrounded by a disk has formed in a collapsing core. (c) A well-collimated wind has broken through at the opposite poles of the system. (d) A visible star with a circumstellar disk is revealed. (After F. H. Shu, F. C. Adams, and S. Lizano, *Star formation in molecular clouds: Observations and theory, Annu. Rev. Astron. Astrophys.*, 25:23–84, 1987)

process to make certain that the prototype operation contains the necessary components to satisfy subsystem requirements. Requirements analysis is performed and reviewed, then incremental specifications are developed and reviewed, followed by design of the approved specifications, and completed by implementation of the product. See MODEL THEORY; SOFTWARE ENGINEERING; SYSTEMS ENGINEERING. [J.D.P.]

**Protozoa** A group of eukaryotic microorganisms traditionally classified in the animal kingdom. Although the name signifies primitive animals, some Protozoa (phytoflagellates and slime molds) show enough plantlike characteristics to justify claims that they are plants.

Protozoa are almost as widely distributed as bacteria. Free-living types occur in soil, wet sand, and in fresh, brackish, and salt waters. Protozoa of the soil and sand live in films of moisture on the particles. Habitats of endoparasites vary. Some are intracellular, such as malarial parasites in vertebrates, which are typical Coccidia in most of the cycle. Other parasites, such as *Entamoeba histolytica*, invade tissues but not individual cells. Most trypanosomes live in the blood plasma of vertebrate hosts. Many other parasites live in the lumen of the digestive tract or sometimes in coelomic cavities of invertebrates, as do certain gregarines. See COCCIDIA; GREGARINIA; TRYPANOSOMATIDAE.

Many Protozoa are uninucleate, others are binucleate or multinucleate, and the number of nuclei also may vary at different stages in a life cycle. Protozoa range in size from 1 to  $10^6$  micrometers. Colonies are known in flagellates, ciliates, and Sarcodina.

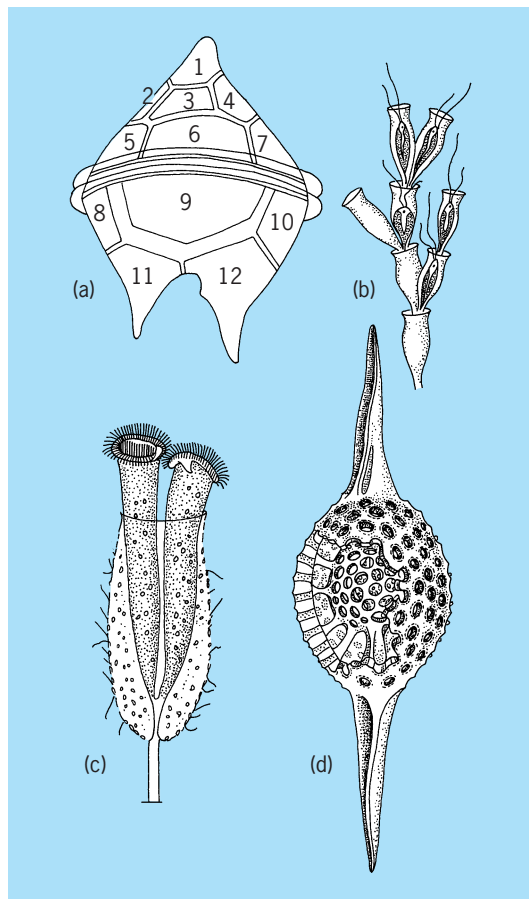

Fig. 1. External coverings of Protozoa. (a) Theca of dinoflagellate (*Peridinium*), showing separate plates. (b) Lorica of a colonial chrysomonad, *Dinobryon*. (c) Two zooids within a lorica of a peritrich, *Cothurnia*. (d) A radiolarian skeleton, siliceous type. (After L. H. Hyman, *The Invertebrates*, vol. 1, McGraw-Hill, 1940)

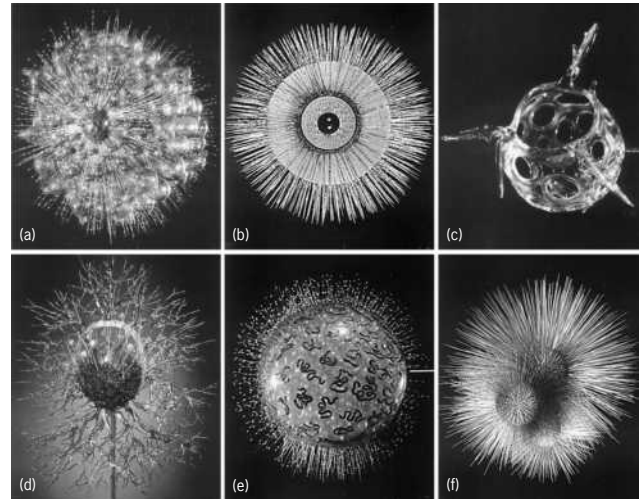

Fig. 2. Glass models of marine Protozoa. Radiolarian types: (a) *Trypanosphaera transformata* Haeckel (Indian Ocean); (b) *Actissa princeps* Haeckel (Indian and Pacific oceans); (c) *Peridium spinipes* Haeckel (Pacific Ocean); (d) *Lithocircus magnificus* Haeckel (Atlantic Ocean); (e) *Collozoum serpentinum* Haeckel (Atlantic Ocean). (f) Foraminiferan type: the pelagic *Globigerina bulloides* d'Orbigny (which is found in all seas). (American Museum of Natural History)

Although marked differentiation of the reproductive and somatic zooids characterizes certain colonies, such as *Volvox*, Protozoa have not developed tissues and organs.

**Morphology.** A protozoan may be a plastic organism (ameboid type), but changes in form are often restricted by the pellicle. A protective layer is often secreted outside the pellicle, although the pellicle itself may be strengthened by incorporation of minerals. Secreted coverings may fit closely, for example, the cellulose-containing theca of Phytomonadida and Dinoflagellida, analogous to the cell wall in higher plants. The dinoflagellate theca (Fig. 1a) may be composed of plates arranged in a specific pattern. Tests, as seen in Rhizopodea (Arcellinida, Gromiida, Foraminiferida), may be composed mostly of inorganic material, although organic (chitinous) tests occur in certain species. Siliceous skeletons, often elaborate, characterize the Radiolaria (Figs. 1d and 2c). A vase-shaped lorica, from which the anterior part of the organism or its appendages may be extended, occurs in certain flagellates (Fig. 1b) and ciliates (Fig. 1c). Certain marine ciliates (Tintinnida) are actively swimming loricate forms.

Flagella occur in active stages of Mastigophora and flagellated stages of certain Sarcodina and Sporozoa. A flagellum consists of a sheath enclosing a matrix in which an axoneme extends from the cytoplasm to the flagellar tip. In certain groups the sheath shows lateral fibrils (mastigonemes) which increase the surface area and also may modify direction of the thrust effecting locomotion. Although typically shorter than flagella, cilia are similar in structure. See CILIA AND FLAGELLA.

Two major types of pseudopodia have been described, the contraction-hydraulic and the two-way flow types. The first are lobopodia with rounded tips and ectoplasm denser than endoplasm. The larger ones commonly contain granular endoplasm and clear ectoplasm. Two-way flow pseudopodia include reticulopodia of Foraminiferida and related types, filoreticulopodia of Radiolaria, and axopodia of certain Heliozoia.

In addition to nuclei, food vacuoles (gastroles) in phagotrophs, chromatophores and stigma in many phytoflagellates, water-elimination vesicles in many Protozoa, and sometimes other organelles, the cytoplasm may contain mitochondria, Golgi material, pinocytotic vacuoles, stored food materials, endoplasmic reticulum, and sometimes pigments of various kinds.

**Nutrition.** In protozoan feeding, either phagotrophic (holozoic) or saprozoic (osmotrophic) methods predominate in particular species. In addition, chlorophyll-bearing flagellates profit from photosynthesis; in fact, certain species have not been grown in darkness and may be obligate phototrophs.

Phagotrophic ingestion of food, followed by digestion in vacuoles, is characteristic of Sarcodina, ciliates, and many flagellates. Digestion follows synthesis of appropriate enzymes and their transportation to the food vacuole. Details of ingestion vary. Formation of food cups, or gulletlike invaginations to enclose prey, is common in more or less ameboid organisms, such as various Sarcodina, many flagellates, and at least a few Sporozoa. Entrapment in a sticky reticulopodial net occurs in Foraminiferida and certain other Sarcodina. A persistent cytostome and gullet are involved in phagotrophic ciliates and a few flagellates. Many ciliates have buccal organelles (membranes, membranelles, and closely set rows of cilia) arranged to drive particles to the cytostome. Particles pass through the cytostome into the cytopharynx (gullet), at the base of which food vacuoles (gastrioles) are formed. Digestion occurs in such vacuoles.

By definition saprozoic feeding involves passage of dissolved foods through the cortex. It is uncertain to what extent diffusion is responsible, but enzymatic activities presumably are involved in uptake of various simple sugars, acetate and butyrate. In addition, external factors, for example, the pH of the medium, may strongly influence uptake of fatty acids and phosphates.

**Reproduction.** Reproduction occurs after a period of growth which ranges, in different species, from less than half a day to several months (certain Foraminiferida). General methods include binary fission, budding, plasmotomy, and schizogony. Fission, involving nuclear division and replication of organelles, yields two organisms similar in size. Budding produces two organisms, one smaller than the other. In plasmotomy, a multinucleate organism divides into several, each containing a number of nuclei. Schizogony, characteristic of Sporozoa, follows repeated nuclear division, yielding many uninucleate buds.

Simple life cycles include a cyst and an active (trophic) stage undergoing growth and reproduction. In certain free-living and parasitic species, no cyst is developed. Dimorphic cycles show two active stages; polymorphic show several. The former include adult and larva (Suctorina); flagellate and ameba (certain Mastigophora and Sarcodina); flagellate and palmella (nonflagellated; certain Phytomonadida); and ameba and plasmodium (Mycetozoa especially).

**Parasitic protozoa.** Parasites occur in all major groups. Sporozoa are exclusively parasitic, as are some flagellate orders (Trichomonadida, Hypermastigida, and Oxymonadida), the Opalinata, Piroplasma, and several ciliate orders (Apostomatida, Astomatida, and Entodiniomorphida). Various other groups contain both parasitic and free-living types. Protozoa also serve as hosts of other protozoa, certain bacteria, fungi, and algae.

Relatively few parasites are distinctly pathogenic, causing amebiasis, visceral leishmaniasis (kala azar), sleeping sickness, Chagas' disease, malaria, tick fever of cattle, dourine of horses, and other diseases. See CILIOPHORA; CNIDOSPORA; MALARIA; SARCOMASTIGOPHORA; SPOROZOA. [R.P.H.]

**Protura** An order of ancestrally wingless insects (subclass Apterygota). The order is usually classified into four families in two suborders (Eosentomoidea and Acerentomoidea), and about 500 species are recognized.

The insects are under 0.08 in. (2 mm) in length and have an elongated body with a small head, relatively large abdomen, and three pairs of functional legs. The first pair of legs is normally held out in front of the head, antennalike. They serve to replace the sensory role of true antennae, which are absent. Paired pseudoculi (probably chemosensory) occupy eyelike po-

sitions on the head. The mouthparts include an elongate and styliform mandible, a maxilla, and a two-part labium. All parts are enclosed within a pocket in the head, so that only their tips are exposed. The thorax bears five-segmented legs, each with an apical claw. In the adult, the abdomen has 12 segments; the anus is terminal, and cerci (segmented sensory appendages on the last abdominal segment) are lacking. The sterna of the first, second, and third segments bear short styli, probably representing vestigial limbs. A large gland opens at the rear of the eighth dorsal plate, which sometimes has a comblike lid. The genitalia are enclosed within a ventral pouch between the eleventh and twelfth segments, and have paired protrusible stylets (slender, elongated appendages).

Protura live in forest soil, leaf litter, and similar places, and are thought to feed on mycorrhizal fungi. They are distributed globally but unevenly in temperate and tropical climates, and they sometimes occur in enormous numbers, as in some Oregon fir forests in the United States. See APTERYGOTA; INSECTA. [W.L.Brø.]

**Proustite** A mineral having composition  $Ag_3AsS_3$ . It occurs in prismatic crystals terminated by steep ditrigonal pyramids, but is more commonly massive or in disseminated grains. Hardness is 2–2.5 (Mohs scale) and specific gravity is 5.55. The luster is adamantine and the color ruby red. It is called light ruby silver in contrast to pyrargyrite, dark ruby silver. Proustite and pyrargyrite are found together in silver veins. Noted localities are at Chañarcillo, Chile; Freiberg, Germany; Guanajuato, Mexico; and Cobalt, Ontario, Canada. See PYRARGYRITE. [C.S.Hu.]

**Provenance (geology)** In sedimentary geology, all characteristics of the source area from which clastic (detrital) sediments and sedimentary rocks are derived, including relief, weathering, and source rocks. See WEATHERING PROCESSES.

The goal of most provenance studies of sedimentary rocks is the determination of source characteristics of the mountains or hills from which the constituent sediment was derived. Such determinations are difficult to make because sediment composition and texture are continually modified during erosion, transport, deposition, and diagenesis (postdepositional modification). It is most straightforward to determine provenance in situations in which these modifying effects are minimal; provenance may be indeterminate or ambiguous in situations involving extensive modification of sediment composition and texture. The former situation is most common in tectonically active areas, resulting in rapid uplift and erosion of mountains, rapid transport and deposition, and slight diagenetic modification after deposition. In contrast, stable continental areas (for example, cratons) provide ample opportunity for intense weathering so that chemical, mineralogical, and textural characteristics of sediment are intensely modified. See DIAGENESIS; EROSION; SEDIMENTARY ROCKS.

Clastic sediment is commonly recycled during multiple episodes of mountain building, erosion, sedimentation, lithification, and renewed mountain building. This process constitutes the rock cycle, within which igneous, sedimentary, and metamorphic rocks are created and modified. During this process, it is common for older sedimentary rocks to be uplifted and eroded, so that individual sedimentary particles (clasts) are recycled to form new sediment, which may be lithified to form new sedimentary rock. Provenance studies must determine the proportion of a sedimentary rock derived directly from indicated source rocks versus the proportion derived directly from another sedimentary rock (that is, rocks exposed during previous cycles of sedimentation). This determination is essential, but commonly difficult to accomplish because the multicyclic nature of sediment may be difficult to recognize. See METAMORPHIC ROCKS.

Fundamentally different methods of study are utilized, depending on what aspect of provenance is emphasized, what type

of sediment is studied, and what scale of sampling and study is attempted. Grain size of detrital sediment is a dominant control over what methods may be employed.

Methods of determining provenance include direct determination of rock types (primarily used for coarse to medium grains); direct determination of mineralogy (used for all grain sizes); whole-rock geochemistry (used for medium to fine grains); geochemistry of individual mineral species (used for all grain sizes, but especially for medium grains); and radiometric dating of individual mineral species (primarily for medium grains). See GEOCHEMISTRY; MINERALOGY; ROCK AGE DETERMINATION. [R.V.I.]

**Pymnesiophyceae** A class of algae (also known as Haptophyceae) in the chlorophyll *a-c* phyletic line (Chromophycota). In protozoological classification these organisms constitute an order, Pymnesiida or Haptomonadida, in the class Phytamastigophora. Most of the approximately 300 species of pymnesiophytes are biflagellate monads. See CHROMOPHYCOTA.

This class has been segregated from the Chrysophyceae, with which it shares many biochemical and ultrastructural characters. Pymnesiophytes differ from chrysophytes, however, in several significant characters: (1) the typical monad bears a filiform organelle, the haptonema, between the two flagella; (2) except in the order Pavloales, the flagella are of equal length and smooth; (3) organic scales, which may be calcified, cover most mottle cells.

Calcified scales (cellulosic scales impregnated with calcite) are characteristic of many pymnesiophytes. These scales, which are given the general term coccoliths, were discovered in marine sediment before they were observed on living cells. Coccoliths are classified into several morphological types (such as rhabdoliths, discoliths, zycoliths, and ceratoliths), which are of great diagnostic value in the taxonomy of the pymnesiophytes that bear them (coccolithophorids).

In most pymnesiophytes a nonmotile phase alternates with a motile phase. The nonmotile phase is a free-living unicell or a palmelloid or pseudofilamentous colony. In some cases the alternation is mediated by sexual reproduction. Usually, however, reproduction is effected by binary fission or the production of zoospores.

Pymnesiophytes are primary marine, with coccolithophorids constituting one of the three major components of phytoplankton (the others being diatoms and dinoflagellates). See ALGAE; COCCOLITHOPHORIDA; PHYTOPLANKTON; PROTOZOA. [P.C.Si; R.L.Møe]

**Pseudoborniales** An order of fossil plants found in Middle and Upper Devonian rocks. The group is related to Sphenophyllales and includes a single family and two monotypic genera. *Pseudobornia ursina* is known from Bear Island (north of Norway), Alaska, and Germany. *Prosseria grandis* is found in New York State. Sphenopsid characters are more firmly established in this order than in Hyeniales. See HYENIALES; SPHENOPHYLLALES. [H.P.B.]

**Pseudomonas** A genus of gram-negative, nonsporeforming, rod-shaped bacteria. Motile species possess polar flagella. They are strictly aerobic, but some members do respire anaerobically in the presence of nitrate. Some species produce acids oxidatively from carbohydrates; none is fermentative and none photosynthetic.

Members of the genus *Pseudomonas* cause a variety of infective diseases; some species cause disease of plants. One species, *P. mallei*, is a mammalian parasite, and is the causative agent of glanders, an infectious disease of horses that occasionally is transmitted to humans by direct contact. *Pseudomonas aeruginosa* is the most significant cause of hospital-acquired infections, particularly in predisposed patients with metabolic, hematologic, and malignant diseases. The spectrum of clinical disease ranges from urinary tract infections to septicemia, pneu-

monia, meningitis, and infections of postsurgical and posttraumatic wounds. See GLANDERS; HOSPITAL INFECTIONS; MENINGITIS; PNEUMONIA. [G.L.Gi.]

**Pseudophyllidea** An order of tapeworms of the subclass Cestoda, parasitic in the intestine of all classes of vertebrates. Typically, the head is simple in structure with two groove-like attachment organs, the bothria. Most pseudophyllideans are segmented and polyzoic with replication of the reproductive systems, although there are a number which do not show such replication and are monozoic.

*Dibothriocephalus latus*, the broad or fish tapeworm of humans and certain piscivorous mammals, is a pseudophyllidean. In humans, this worm sometimes precipitates a pernicious anemia by competing with the host for vitamin B<sub>12</sub>. Larval pseudophyllideans are occasionally found as parasites in the extraintestinal tissues of humans, producing a condition known as sparganosis. See CESTODA. [C.P.R.]

**Pseudoscorpionida** An order of terrestrial Arachnida having the general appearance of miniature scorpions without the postabdomen and sting. The body length is seldom greater than 0.2 in. (5.0 mm). Typically, each finger of the anterior appendages, or chelicerae, has a serrula composed of a row of ligulate plates. Ducts of silk glands open near the end of the movable finger, often in connection with a simple or branched spinneret. The second pair of appendages, or palpi, are large and conspicuous, usually with glands that discharge venom through a terminal tooth on one or both of the chelal fingers. The four pairs of legs are ambulatory.

Pseudoscorpions feed chiefly on small arthropods and, although frequently found on birds, mammals, and insects, are considered nonparasitic. Pseudoscorpions are common in the nests of mammals, birds, and social insects, in woody debris and forest litter, under stones, and in crevices in the bark of trees. About 2000 species have been described. See ARACHNIDA. [C.C.Ho.]

**Pseudosphaeriales (lichenized)** An order of the class Ascolichenes. The order is also called the Pleosporales. They resemble the typical pyrenomycetous lichens except for the structure of the ascocarp, which is not a true perithecium. It is flask-shaped and lined with a layer of interwoven, branched pseudoparaphyses. The asci, with bitunicate walls, are located in scattered locules.

There are two major families: the larger one, Arthophyreniaceae, is a widespread family with at least five genera; the Mycoporaceae is a small family with two well-known genera, *Dermatina* and *Mycoporellum*. All of the species in this order are crustose and many lack a well-defined thallus. [M.E.H.]

**Pseudotuberculosis** A disease of rodents and birds caused by the bacterium *Pasteurella pseudotuberculosis*. The disease is occasionally transmitted to humans.

This sporadic, or epizootic, plague-like disease in rodents and animals causes small abscesses in the liver, spleen, and intestinal wall. In humans, the infection has been reported as an acute fatal septicemia in some cases. The organisms may localize in mesenteric lymph nodes of the ileocecal region and cause acute appendicitis and gastrointestinal symptoms. [K.F.M.]

**Psilophytales** A group long recognized as an order of fossil plants (subdivision Psilopsida) collected in rocks of Late Silurian and Devonian age. It has been subdivided into three categories whose descriptions include the chief kinds of plants formerly included in Psilophytales. They are given in this Encyclopedia as three classes of the division Rhyniophyta: Rhyniopsida, Zosterophylloids, and Trimerophytosida. See EMBRYOBIONTA; PALEOBOTANY; RHYNIOPHYTA; RHYNIOPSIDA; TRIMEROPHYTOPSIDA; ZOSTEROPHYLLOPSIDA. [H.P.B.]



**Psilotophyta** A division of the plant kingdom consisting of only two genera with three living species, *Psilotum nudum*, *P. complanatum*, and *Tmesipteris tannensis*. *Psilotum* is widespread in tropical and subtropical regions of both hemispheres, but *Tmesipteris* is confined to Australia and some of the Pacific islands. The Psilotophyta have the typical life cycle of vascular cryptogams, with an alteration of sporophyte and gametophyte generations, the sporophyte being much the larger and more complex. The Psilotophyta have no economic importance, but they are interesting as possible remnants of an ancient (Silurian and Devonian) group of plants, the Rhyniophyta, which is regarded as ancestral to all other vascular plants. See POLYPODIOPHYTA; PSILOPHYTALES; RHYNIOPHYTA. [A.Cr.]

**Psittaciformes** The parrots, a large order of land birds found worldwide but with most species concentrated in the landmasses of the Southern Hemisphere, particularly Australasia, the Neotropics, Africa, and southern Asia. Only a few species are found in the northern temperate regions. The parrots are most closely allied to pigeons, from which they have probably evolved. See COLUMBIFORMES.

Although the parrots are generally placed in a single family, the Psittacidae, they are divided into a number of distinct subfamilies, which are listed below; the largest subfamily is the Psittacinae, with 247 species of parrots.

- Order Psittaciformes
- Family Psittacidae
- Subfamily: Psittacinae (parrots)
- Cacatuinae (cockatoos)
- Micropsittinae (pygmy parrots)
- Strigopinae (owl parrot)
- Nestorinae (keas)
- Loriinae (lories)
- Psittichadinae (Pesquet's parrot)
- Loriculinae (hanging parrots)

Parrots have a characteristic strong hooked bill. The tongue is large and fleshy. A short neck connects the large head to the stocky body. The wings are of medium length, varying from pointed to rounded. The legs are short and stout with strong, clawed toes arranged in a zygodactyl pattern, two pointing forward and two backward. The tail varies from short to long. Parrots fly well and can attain high speeds, but even those few parrots that are migratory journey only short distances. One species, the owl parrot, is flightless. Parrots can walk well but not rapidly. The parrot's plumage is variable; most often it is green, but red, orange, yellow, blue, black, and white in bold, bright patterns are also common. Parrots are mainly vegetarians, eating seeds, nuts, fruit, nectar, or pollen; a few consume animal food.

Parrots are social birds and usually live in flocks. Almost all species have a strong pair bond, remaining together year-round for life. Parrots are found mainly in the tropics and in the southern continents, and the center of parrot radiation is the Australia-New Zealand region. Many parrots in captivity have an excellent ability to mimic words, and some can be taught a large vocabulary. However, parrots are not known to mimic the calls of other birds in the wild. Their vocalizing ability is probably important for the constant communication between mates.

Parrots are the most important birds in the avicultural and pet trade, with most species kept in captivity. Because the demand for parrots is so great, many countries have imposed exportation bans on native birds or importation restrictions on wild-trapped parrots. See AVES. [W.J.B.]

**Psocoptera** An order of insects frequently referred to as the Corrodentia, or Copeognatha. Common names for members of this order are book lice, bark lice, and psocids, the latter a general term for all members of the order. They are usually less than 0.25 in. (0.6 cm) long, though rarely some may reach

about 0.5 in. (1.2 cm). Wings may be absent, and when present are of differing distinctive venational types. Tarsi are two- or three-segmented, cerci are absent and metamorphosis is gradual. Chewing mouthparts usually have a much enlarged clypeus; the lacinia of the maxilla is usually elongate and chisel-like, and the antennae have 13 or more segments.

Book lice are most common among old papers on dusty shelves, in cereals, or other domestic situations. They are usually pale, wingless types of insects. Many bark lice, the majority winged, occur on the bark or foliage of trees, and some are found under dead bark or beneath stones. Nymphs of a few species occur on tree trunks as clusters of gregarious individuals, but disperse when mature.

Psocoptera are worldwide, especially in warm countries, and some 1300 species are known. Current classification now lists about 27 families for this group. About 150 species, in 11 families, have been found in the United States. See INSECTA. [A.B.Gu.]

**Psychoacoustics** All of the psychological interactions between humans (and animals) and the world of sound. It encompasses all studies of the perception of sound, as well as the production of speech. See HEARING (HUMAN); SPEECH. [L.E.M.]

**Psychoanalysis** Psychoanalysis may be defined as (1) a psychological theory; (2) a form of psychotherapy, especially for the treatment of neurotic and character or personality disorders; and (3) a method for investigating psychological phenomena. Psychoanalysis was created and developed by Sigmund Freud, who presented his method, clinical observations, and theory in *Interpretation of Dreams* and other major works, including *The Psychopathology of Everyday Life* and *Three Essays on the Theory of Sexuality*, as well as in many of his case studies.

**Psychoanalytic theory.** Generally, psychoanalysis is concerned with the causal role of wishes and beliefs in human life. More specifically, it attempts to explain mental or behavioral phenomena that do not appear to make sense as the effects of unconscious wishes and beliefs. Such phenomena include dreams, disturbances in functioning such as slips of the tongue or pen and transient forgetting, and neurotic symptoms. Typically, unconscious wishes and beliefs are constituents of conflicts.

The term unconscious in psychoanalysis does not mean simply that mental contents are out of awareness. Its psychodynamic meaning is that the person does not want to be aware of these contents, and takes active steps to avoid being aware of them. A fundamental hypothesis of psychoanalysis is that because a mental entity is dynamically unconscious it has the causal power to produce the phenomena that are of interest to psychoanalysis.

At first, the dynamic unconscious was thought to consist of traumatic memories. Later, it was believed to consist of impulses or wishes—especially sexual (and aggressive) impulses or wishes. Psychoanalysis now emphasizes that the dynamic unconscious consists of fantasies, which have a history reaching back to childhood. These fantasies are internal scenarios in which sexual (and aggressive) wishes are imagined as fulfilled.

Psychoanalysis is distinct in attributing causal powers to unconscious sexual wishes. Such attribution depends on extending the meaning of sexual to encompass the quest for sensual pleasure in childhood (so-called infantile sexuality) and choices of objects and aims. One theme that is thought to have particular importance is the Oedipus complex, in which the child rivals one parent in seeking sensual gratifications of various kinds from the other parent.

When an unconscious fantasy is activated, it manifests itself in conscious mental states or in actions—importantly, in emotions; in interpretations of the significance of events or states of affairs; in attributions of motives to others; and in daydreams, dreams, and neurotic symptoms.

Unconscious fantasies, as distinct from both conscious reality-oriented imagining and conscious day-dreaming, are

constructed when imagination functions under very special conditions.

This emphasis on fantasy underscores the fact that psychoanalysis gives priority to the relation between wishes (including wishes a person knows could not conceivably be gratified in reality) and imagination (functioning under very special conditions).

**Psychotherapy.** Free association is the method of psychoanalysis. Patients are encouraged not to talk about some particular problem or aspect of their lives but rather to suspend any conscious purposive organization of what they say, speaking freely. Both psychoanalyst and patient follow the patient's productions: conscious purposes are replaced by unconscious purposes, which, under these conditions, can determine the direction of the patient's mental processes with less interference.

Interventions are predominantly interpretative; psychoanalysts do not seek primarily to tell their patients what to do, to educate them about the world, to influence their values, or to reassure them in one way or another that everything is or will be all right. Psychoanalysts look for patterns in what each patient says and for signs of feelings of which the patient is more or less unaware. They then engage their patients (who are increasingly aware of these patterns and able to experience and articulate these feelings) in an inquiry about the reasons for them or motives behind them. The focus is on what the patients do not know—and do not want to know—about themselves and their inner life, including strategies for avoiding such knowledge and the consequences of these strategies.

The goal of psychoanalytic psychotherapy is to extend the realm of what patients permit themselves to experience. It tries to mitigate the misery that patients with a neurotic, character, or personality disorder inflict on themselves.

The case-study method is characteristic of psychoanalytic research. The arguments that can be used in case studies are analogy (the use of familiar or homely models in which postulated causes and mechanisms can be shown to exist); consilience (the convergence of inferences from different kinds of information on a common cause); and abduction (inference to the best explanation). See PSYCHOTHERAPY. [M.Ed.]

**Psycholinguistics** An area of study which draws from linguistics and psychology and focuses upon the comprehension and production of language. Although psychologists have long been interested in language, and the field of linguistics is an older science than psychology, scientists in the two fields have had little contact until the work of Noam Chomsky was published in the late 1950s. Chomsky's writing had the effect of making psychologists acutely aware of their lack of knowledge about the structure of language, and the futility of focusing attention exclusively upon the surface structure of language. As a result, psycholinguists, who have a background of training in both linguistics and psychology, have been attempting since the early 1960s to gain a better understanding of how the abstract rules which determine human language are acquired and used to communicate appropriately created meaningful messages from one person to another via the vocal-auditory medium. Research has been directed to the evolutionary development of language, the biological bases of language, the nature of the sound system, the rules of syntax, the nature of meaning, and the process of language acquisition. [D.S.P.]

**Psychology** The study of human behavior and mental processes. Psychology is sharply divided into applied and experimental areas. However, many fields are represented in both research and applied psychology.

Researchers in psychology study a wide range of areas. Cognitive research is often included as part of subdiscipline called cognitive science. This area examines central issues such as how mental process work, the relation between mind and brain, and the way in which biological transducing systems can convert physical regularities into perceptions of the world. Cognitive

science is carved from the common ground shared by computer science, cognitive psychology, philosophy of mind, linguistics, neuropsychology, and cognitive anthropology. The study of human attention is a cognitive area that is central in the field. See COGNITION.

The study of consciousness involves such basic questions as the physiological basis of mental activity, the freedom of will, and the conscious and unconscious uses of memory. The latter topic can be classified under the rubric of implicit memory. See INSTINCTIVE BEHAVIOR; MEMORY; PSYCHOLINGUISTICS; SENSATION.

Social psychology includes the study of interactions between individuals and groups, as well as the effects of groups on the attitudes, opinions, and behavior of individuals. The field covers such topics as persuasion, conformity, obedience to authority, stereotyping, prejudice, and decision making in social contexts. See MOTIVATION; PERSONALITY THEORY.

Developmental psychology has three subfields: life-span development, child development, and aging. Most research in the area concentrates on child development, which examines the development of abilities, personality, social relations, and, essentially, every attribute and ability seen in adults. See AGING; INTELLIGENCE.

A clinical psychologist is usually known by the term psychologist, which in some states is a term that can be used only by a registered practitioner. A psychiatrist is a physician with a specialty in psychiatric treatment and, in most states, with certification as a psychiatrist by a board of medical examiners. A psychoanalyst is typically trained by a psychoanalytic institute in a version of the Freudian method of psychoanalysis. A large number of practitioners qualify both as psychoanalysts and psychiatrists. See PSYCHOANALYSIS.

Neuropsychologists are usually psychologists, who may come from an experimental or a clinical background but who must go through certification as psychologists. They treat individuals who have psychological disorders with a clear neurological etiology, such as stroke.

Clinical practice includes individual consultation with clients, group therapy, and work in clinics or with teams of health professionals. Psychological therapists work in many settings and on problems ranging from short-term crises and substance abuse, to psychosis and major disorders. While there are definite biases within each field, it is possible for a practitioner with any background to prefer behavior therapy, a humanistic approach, a Freudian (dynamic) approach, or an eclectic approach derived from these and other areas.

Nonclinical professional work in psychology includes the human-factors element, which traditionally is applied to the design of the interface between a machine and its human operator. Cognitive engineering is a branch of applied psychology that deals mainly with software and hardware computer design. Industrial psychology also includes personnel selection and management and organizational planning and consulting.

The use of psychology in forensic matters is a natural result of the fact that much of law is based on psychology. Psychologists have been involved in jury selection, organization of evidence, evaluation of eyewitness testimony, and presentation of material in court cases. Psychiatrists and psychologists are also called on to diagnose potential defendants for mental disorders and the ability to stand trial. [W.P.B.]

**Psychoneuroimmunology** The study of the interactions among behavioral, neural and endocrine, and immune functions. This convergence of disciplines has evolved to achieve a more complete understanding of adaptive processes. At one time, the immune system was considered an independent agency of defense that protected the organism against foreign material (that is, proteins that were not part of one's "self"). Indeed, the immune system is capable of considerable self-regulation. However, converging data from the behavioral and brain sciences indicate that the brain plays a critical role in the

regulation or modulation of immunity. Thus, psychoneuroimmunology emphasizes the study of the functional significance of the relationship between these systems—not in place of, but in addition to, the more traditional analysis of the mechanisms governing the functions within a single system—and the significance of these interactions for health and disease. See NEUROIMMUNOLOGY.

**Brain-immune system interactions.** Evidence for nervous system-immune system interactions exists at several biological levels. Primary and secondary lymphoid organs are innervated by the sympathetic nervous system, and lymphoid cells bear receptors for many hormones and neurotransmitters. These substances, secreted by the pituitary gland, are thus able to influence lymphocyte function. Moreover, lymphocytes themselves can produce neuropeptide substances. Thus, there are anatomical and neurochemical channels of communication that provide a structural foundation for the several observations of functional relationships between the nervous and immune systems.

**Stress and immunity.** The link between behavior and immune function is suggested by experimental and clinical observations of a relationship between psychosocial factors, including stress, and susceptibility to or progression of disease processes that involve immunologic mechanisms. Abundant data document an association between stressful life experiences and changes in immunologic reactivity. The death of a family member and other, less severe, stressful experiences (such as taking examinations) result in transient impairments in several parameters of immune function. See DISEASE; STRESS (PSYCHOLOGY).

In animals, a variety of stressors can influence a variety of immune responses. Since immune responses are themselves capable of altering levels of circulating hormones and neurotransmitters, these interactions probably include complex feedback and feedforward mechanisms. See ENDOCRINOLOGY.

The direction, magnitude, and duration of stress-induced alterations of immunity are influenced by (1) the quality and quantity of stressful stimulation; (2) the capacity of the individual to cope effectively with stressful events; (3) the quality and quantity of immunogenic stimulation; (4) the temporal relationship between stressful stimulation and immunogenic stimulation; (5) the sampling times and the particular aspect of immune function chosen for measurement; (6) the experiential history of the individual and the existing social and environmental conditions upon which stressful and immunogenic stimulation are superimposed; (7) a variety of host factors such as species, strain, age, sex, and nutritional state; and (8) interactions among these variables.

**Conditioning.** Central nervous system involvement in the modulation of immunity is dramatically illustrated by the classical (Pavlovian) conditioning of the acquisition and extinction of suppressed and enhanced antibody- and cell-mediated immune responses. In a one-trial taste-aversion conditioning situation, a distinctively flavored drinking solution (the conditioned stimulus) was paired with an injection of the immunosuppressive drug cyclophosphamide (the unconditioned stimulus). When subsequently immunized with sheep red blood cells, conditioned animals reexposed to the conditioned stimulus showed a reduced antibody response compared to nonconditioned animals and conditioned animals that were not reexposed to the conditioned stimulus. See CONDITIONED REFLEX.

The acquisition and the extinction (elimination of the conditioned response by exposures to the conditioned stimulus without the unconditioned stimulus) of the conditioned enhancement and suppression of both antibody- and cell-mediated immune responses—and nonimmunologically specific host defense responses as well—have been demonstrated under a variety of experimental conditions.

**Prospects.** An elaboration of the integrative nature of neural, endocrine, and immune processes and the mechanisms

underlying behaviorally induced alterations of immune function is likely to have clinical and therapeutic implications that will not be fully appreciated until more is known about the extent of these interrelationships in normal and pathophysiological states. See ENDOCRINE SYSTEM (VERTEBRATE); IMMUNOLOGY; NERVOUS SYSTEM (VERTEBRATE). [R.Ad.]

**Psychopharmacology** A discipline that merges the subject matter of psychology, which studies cognition, emotion, and behavior, and pharmacology, which characterizes different drugs. Thus, psychopharmacology focuses on characterizing drugs that affect thinking, feeling, and action. In addition, psychopharmacology places particular emphasis on those drugs that affect abnormalities in thought, affect, and behavior, and thus has a relationship to psychiatry. Psychopharmacology is predominantly, but not exclusively, concerned with four major classes of drugs that are of clinical significance in controlling four major categories of psychiatric disorder: anxiety, depression, mania, and schizophrenia.

Anxiety is an emotional state that can range in intensity from mild apprehension and nervousness to intense fear and even terror. It has been estimated that 2–4% of the general population suffer from an anxiety disorder at some time. Although anxiety in some form is a common experience, it can become so intense and pervasive as to be debilitating; it may therefore require psychiatric attention and treatment with an anxiolytic drug. There are three major groups of anxiolytics. Members of the first group are called propanediols; meprobamate is the most widely used. The second group is the barbiturates, of which phenobarbital is the most generally prescribed. The third group, most frequently prescribed, is the benzodiazepines, the best known of which is diazepam.

A major advance in understanding the benzodiazepines was the identification of the cellular sites at which these drugs act (so-called benzodiazepine receptors). The distribution of these receptors in the brain has also been found to have a striking parallel to the distribution of the receptors for a naturally occurring substance called gamma-amino butyric acid (GABA). Furthermore, it is known that GABA has a ubiquitous inhibitory role in modulating brain function. Most importantly, it is now clear that benzodiazepines share a biochemical property in that all augment the activity of GABA. See ANXIETY DISORDERS; SEROTONIN; TRANQUILIZER.

The symptoms of depression can include a sense of sadness, hopelessness, despair, and irritability, as well as suicidal thoughts and attempts, which are sometimes successful. In addition, physical symptoms such as loss of appetite, sleep disturbances, and psychomotor agitation are often associated with depression. When depression becomes so pervasive and intense that normal functioning is impaired, antidepressant medication may be indicated. It has been estimated that as much as 6% of the population will require antidepressant medication at some time in their lives.

There are two major groups of antidepressant drugs. Members of the first group are called heterocyclics because of their characteristic chemical structures. Members of the second group, which are less often prescribed, are called monoamine oxidase inhibitors. See MONOAMINE OXIDASE.

The antidepressants typically require at least several weeks of chronic administration before they become effective in alleviating depression. This contrasts with the anxiolytics, which are effective in reducing anxiety in hours and even minutes. Another difference between these two classes of drugs is that the anxiolytics are more likely to be efficacious: anxiolytics are effective in the vast majority of nonphobic, anxious patients, whereas the antidepressants are effective in only about 65–70% of depressed patients. See AFFECTIVE DISORDERS.

Manic episodes are characterized by hyperactivity, grandiosity, flight of ideas, and belligerence; affected patients appear to be euphoric, have racing thoughts, delusions of grandeur,

and poor if not self-destructive judgment. Periods of depression follow these episodes of mania in the majority of patients. The cycles of this bipolar disorder are typically interspersed among periods of normality that are, in most cases, relatively protracted.

Mania can usually be managed by chronic treatment with lithium salts and can be expected to be effective in 70–80% of the individuals treated. Furthermore, the period of depression that typically follows the manic episode can usually be prevented, or at least attenuated, if lithium treatment is maintained after the manic phase has subsided. Any periods of depression that do occur can be managed by antidepressant drugs. Lithium is no longer the only drug used in the management of mania. Carbamazepine, an anticonvulsant that is used in the treatment of epilepsy, is also useful in the treatment of periods of mania.

Schizophrenia is a form of psychosis; it incorporates a broad range of symptoms that can include bizarre delusions, hallucinations, incoherence of thought processes, inappropriate affect, and grossly disorganized movements. It affects 1–2% of the population. The symptoms of schizophrenia can be controlled, in varying degrees, by a large group of drugs called antipsychotics. Symptom management requires chronic medication and can be expected in about 80% or more of the schizophrenics treated. However, management is only partially successful in that normal functioning is not completely restored in most patients.

The antipsychotics have a broad range of side effects among which are disturbances of movement that fall into two general classes. The first class includes an array of symptoms very like those characteristic of Parkinson's disease. The second class of movement disorder is called tardive dyskinesia. Signs of this disturbance typically include involuntary movements that most often affect the tongue and facial and neck muscles but can also include the digits and trunk.

Although different antipsychotic drugs have different kinds and degrees of side effects, all share a single biochemical action: they all attenuate the activity of dopamine, a naturally occurring substance in the brain. The reduction in dopamine activity produced by the antipsychotics directly accounts for their effects on motor behavior. It is to be expected, therefore, that disrupted dopamine activity in this system would produce disturbances of movement. It is less clear, however, whether reduced dopamine function is also a factor in the process by which these drugs control psychotic (including schizophrenic) symptoms. See SCHIZOPHRENIA. [P.L.C.]

**Psychophysical methods** Methods for the quantitative study of the relations between physical stimulus magnitudes and the corresponding magnitudes of sensation, for example, between the physical intensity of a light and its perceived brightness or the concentration of a sugar solution and its observed sweetness. To establish these relations, measurement scales are needed, not only for physical magnitudes but also for subjective magnitudes. Subjective scales are not obtained directly from observation but are theoretical models which summarize observed relations between stimuli and responses. See SENSATION.

The term psychophysical methods is sometimes extended to include certain scaling techniques which are most often used with subjective dimensions to which there correspond no simple physical dimensions, for example, food preferences. See MULTIDIMENSIONAL SCALING.

In 1860, G. Fechner designed psychophysical methods to measure the absolute threshold, defined as the minimum stimulus energy that an organism can detect, and the differential threshold, defined as the minimum detectable change in a stimulus. Both quantities had to be defined as statistical averages. To obtain reliable measurements for these averages, Fechner devised the method of limits (also called the method of minimal changes) and the method of constant stimuli.

In the method of limits, the experimenter begins with a stimulus which is too weak for the subject to detect. In successive

presentations, the stimulus intensity is increased in small, equal steps, the subject reporting after each presentation whether the stimulus was perceived until it has been detected. The descending series is then begun, the stimulus intensity beginning at an above-threshold value and decreasing in steps until the subject signals the disappearance of the stimulus. Many such series are given.

In measuring the difference threshold, essentially the same procedure is involved, except that the subject now signals the relation of a comparison stimulus to a standard stimulus. After a large number of such trials, the average of each of these four threshold values is computed.

To measure the absolute threshold by the method of constant stimuli, the experimenter selects a small number of stimulus values in the neighborhood of the absolute threshold (previously roughly located by informal use of the method of limits) and presents them to the subject a large number of times each, in an irregular order unknown to the subject. Each time a stimulus is presented, the subject reports the presence or absence of sensation.

The data provide the proportion of times that each stimulus resulted in a report of sensation by the subject. One can then estimate the stimulus value that has a probability of .50 of producing sensation, this value being defined as the absolute threshold. An analogous procedure is followed in obtaining difference thresholds.

Fechner proposed to use the results of threshold measurement in developing a subjective metric or scale. He defined the difference threshold, or just noticeable difference (jnd), as the subjective unit and the absolute threshold as the zero point of the subjective scale. Thus the subjective intensity of a particular brightness of light, for example, would be specified when it was given as 100 jnd's above threshold. The subjective scale so defined is not a linear function of the physical stimulus scale since jnd's, though defined as subjectively equal units, are not of physically equal magnitude throughout the intensity scale. The size of the jnd is approximately proportional to physical stimulus intensity. To the extent that this relation holds, Fechner deduced that subjective intensity should be proportional to the logarithm of the stimulus intensity.

Rather than requiring of the subject merely either yes-no or ordinal judgments, some methods require the subject to make direct-ratio discriminations. For instance, he or she may be presented with a moderately loud tone, and then required, by turning a knob, to adjust the loudness of a comparison tone until it is half as loud, or twice as loud, as the first. The first case illustrates the method of fractionation, the second the method of multiplication. In the method of magnitude estimation, the subject is given a stimulus, such as the brightness of a light, to serve as a modulus with a value assigned to it, for example, 10. The task, as other lights of different intensities are presented, is to assign them numbers which shall stand in the same ratio to 10 as their brightness stands to that of the modulus. One twice as bright is given the designation 20; one half as bright is 5. In these and other similar methods, whether the subject's task is to estimate or to produce the prescribed ratio or the prescribed fraction, there are certain common characteristics. Direct-ratio assessments are obtained from the subject; there can be experimental checks on internal consistency of the results, and since the individual judgments are not of high precision, repetition is required if stable averages are to be obtained.

The empirical results obtained by the various methods are in fairly good agreement. They agree in that, to at least a first approximation, subjective magnitudes on a variety of dimensions are found to be power functions of suprathreshold stimulus intensity; that is to say, subjective magnitude is proportional to the suprathreshold stimulus magnitude raised to a power. The powers have a range from 0.3 for auditory loudness to 3.5 for subjective intensity of alternating current that is applied to the skin.

In direct-matching methods the subject is not required to produce or assess the ratio of one subjective magnitude to another, but only to adjust a comparison stimulus until some attribute appears to match that of a standard stimulus. For example, the subject might be asked to adjust the physical intensities of tones of various frequencies until their loudness matched that of a 1000-Hz tone of fixed intensity. The result would be an equal-loudness contour, showing the intensities to which tones of various frequencies must be set to produce sensations of equal loudness. These data are of use in acoustics. See *LOUDNESS*.

The method of average error, the third of the three methods devised by Fechner, is a special application of direct-matching methods to cases in which the point of interest is in discrepancies between perception and stimulation. The subject adjusts a comparison stimulus to match a standard stimulus; the average of a number of such settings gives the point of subjective equality, and the difference between this point and the standard stimulus is the average error. Two illustrative uses of the method are the measurement of accuracy of distance perception and the measurement of the magnitude of so-called optical illusions. See *HEARING (HUMAN)*; *PSYCHOLOGY*. [J.F.H.]

**Psychosis** Any disorder of higher mental processes of such severity that judgments pertaining to the reality of external events are significantly impaired. A wide range of conditions can bring about a psychotic state. They include schizophrenia, mania, depression, ingestion of drugs, withdrawal from drugs, liver or kidney failure, endocrine disorders, metabolic disorders, and Alzheimer's disease, epilepsy, and other neurologic dysfunctions. The dreams of normal sleep are a form of psychosis.

Psychotic alterations of beliefs are called delusions. Psychotic alterations of perception are referred to as hallucinations. Psychotic states that are due to alcoholism, metabolic diseases, or other medical conditions are frequently accompanied by general mental confusion. On the other hand, psychiatric illnesses and drugs can produce hallucinations and delusions in the absence of general confusion. Few of those symptoms are unique to a particular illness, which can make proper diagnosis difficult and challenging. Correct diagnosis, however, is critical so that appropriate treatment can be provided. See *ADDICTIVE DISORDERS*; *AFFECTIVE DISORDERS*; *ALZHEIMER'S DISEASE*; *NEUROTIC DISORDERS*; *PARANOIA*; *PSYCHOTOMIMETIC DRUG*; *SCHIZOPHRENIA*. [R.E.Ho.]

**Psychosomatic disorders** Disorders characterized by physiological changes that originate, at least in part, from emotional factors. The classical psychosomatic symptoms and their theorized causes are shown in the table.

Psychological states influence body organs through a combination of three interrelated mechanisms: neural, hormonal, and immunologic. Voluntary movements (for example, clenching the teeth) are mediated through the motor neurons by the conscious

**Theorized psychological factors in classical psychosomatic disorders**

Symptom (disease)	Psychological factors	Presumed psychosomatic mechanism
Hyperacidity (peptic ulcer)	Inhibited dependence; general stress	Increased acid secretion
Essential hypertension	Conflict over hostility; general stress	Vasoconstriction
Bronchial asthma	Conflict over wish for protection or separation; anxiety; general stress	Bronchospasm Bronchospasm
Migraine	Conflict over control; general stress	Vasoconstriction and vasodilatation
Thyrotoxicosis (Graves' disease)	Conflict over premature self-sufficiency	Increased thyroid-stimulating hormone secretion
Diarrhea (ulcerative colitis)	Conflict over an obligation	Gastrointestinal cholinergic activation

command of the brain. In stress, clenching of the teeth, mediated by the same motor neurons, may also occur, but the act may not be voluntary and conscious. Stress usually causes an activation of the sympathetic nervous system and the hypothalamo-pituitary-adrenal axis followed by a decrease in immunocompetence. Immune mechanisms may be suppressed in part through corticosteroid activation, but a decrease in T-lymphocyte activity in stress may not be mediated by hormones. Individual specific, but inadvertent, conditioning of specific conflict or stress to specific bodily malfunction may be an important psychosomatic mechanism. See *CONDITIONED REFLEX*; *NEUROIMMUNOLOGY*.

Conversion disorders refer to physical symptoms referable to the somatosensory nervous system or special sensory organs that cannot be explained on the basis of a medical or neurologic disease. Common symptoms include paralysis, blindness, ataxia, aphonia, and numbness of the feet (stocking anesthesia). The symptoms may represent a psychological conflict or may be a form of body-language communication. The treatment of choice is psychotherapy.

In somatization disorder (also known as Briquet's syndrome), the patient recurrently complains of multiple somatic symptoms that are referable to practically every organ system in the body and which, upon medical investigation, turn out not to be a diagnosable physical disease. This disorder is distinguished from conversion disorder by the chronicity and multiplicity of its symptoms. The symptoms do not usually symbolize psychological conflicts but may represent general dysphoria and distorted illness behavior. There is no definitive treatment; patients should be managed by one physician who coordinates all diagnostic and treatment plans and who provides ongoing support and follow-up without unnecessary invasive procedures.

Specific psychological conflicts often characterize patients with classical psychosomatic symptoms or disorders they represent; however, only one aspect of a multifactorial or heterogeneous disorder is not considered to be etiologic. Genetic factors are known to play important roles in the pathogenesis of most of these diseases. Some of the psychological difficulties demonstrated by these patients may in fact be a result of the disease. Psychotherapy is often helpful in resolving the conflicts when they are severe enough to warrant it, but it does not necessarily ameliorate the physical symptoms or the course of disease. See *PSYCHOTHERAPY*. [H.Lei.]

**Psychotherapy** Any treatment or therapy that is primarily psychological in nature. In recent years, counseling also has been included in this categorization.

**Psychodynamic therapies.** Historically, psychoanalysis—created by Sigmund Freud—has played an important role in the growth and development of psychotherapy. Central to Freud's theories was the importance of unconscious conflicts in producing the symptoms and defenses of the patient. The goal of therapy is to help the patient attain insight into the repressed conflicts which are the source of difficulty. Since patients resist these attempts bring to consciousness the painful repressed material, therapy must proceed slowly. Consequently, psychoanalysis is a long-term therapy requiring several years for completion and almost daily visits. Since Freud's time, there have been important modifications associated with former disciples such as Alfred Adler and Carl Jung. Self psychology and ego psychology are among more recent emphases. However, the popularity of psychoanalysis has waned. See *PSYCHOANALYSIS*.

**Experiential therapies.** A number of related therapies are included in this group. Probably best known was the patient-centered therapy of Carl Rogers appearing in the 1940s. In Rogers' therapy, a major emphasis is placed on the ability of the patient to change when the therapist is empathic and genuine and conveys nonpossessive warmth. The therapist is nondirective in the interaction with the patient and attempts to facilitate the growth potential of the patient. Other therapeutic approaches

considered as experiential include Gestalt therapy, existential approaches, and transpersonal approaches. The facilitation of experiencing is emphasized as the basic therapeutic task, and the therapeutic relationship is viewed as a significant potentially curative factor.

**Cognitive, behavioral, and interpersonal therapies.** In behavioral therapies, therapists play a more directive role. The emphasis is on changing the patient's behavior, using positive reinforcement, and increasing self-efficacy. More recently, cognitive therapies such as those of A. T. Beck have tended to be combined with behavioral emphases. The cognitive-behavioral therapies have focused on changing dysfunctional attitudes into more realistic and positive ones and providing new information-processing skills. See COGNITION.

Most of the developments in interpersonal therapy have occurred in work with depressed patients. The goal of interpersonal therapy (a brief form of therapy) is centered on increasing the quality of the patient's interpersonal interactions. Emphasis is placed on enhancing the patient's ability to cope with stresses, improving interpersonal communications, increasing morale, and helping the patient deal with the effects of the depressive disorder. See PERSONALITY THEORY.

**Eclectic and integrative therapies.** The largest number of psychotherapists consider themselves to be eclectics. They do not adhere strictly to one theoretical orientation or school but use any procedures that they believe will be helpful for the individual patient. Eclecticism has been linked with the development of a movement for integration in psychotherapy. The emphasis in this new development is on openness to the views of other approaches, a less doctrinaire approach to psychotherapy, and an attempt to integrate two or more different theoretical views or systems of psychotherapy.

**Group, family, and marital therapy.** Most psychotherapy is conducted on a one-to-one basis—one therapist for one patient—and the confidentiality of these sessions is extremely important. However, there are other instances where more than one patient is involved because of particular goals. These include marital, family, and group therapy. Outpatient groups have been used for smoking cessation, weight loss, binge eating, and similar problems as well as for what were traditionally viewed as psychoneurotic problems. Inpatient group therapy was frequently employed in mental hospital settings.

There has been research on the combined use of medication and psychotherapy. In general, where two highly successful treatments are combined in cases with depressive or anxiety disorders, there appears to be little gain in effectiveness. However, in several studies of hospitalized patients with schizophrenia where individual psychotherapy has been ineffective, a combination of psychotherapy and medication has produced better results than medication alone. See AFFECTIVE DISORDERS; PSYCHOPHARMACOLOGY; SCHIZOPHRENIA. [S.L.G.]

**Psychotomimetic drug** A class of drugs reliably inducing temporary states of altered perception, often with symptoms similar to those of psychosis. The drug experiences are clearly perceived, vivid, and remembered. Sensory input is heightened and subjective experience is intensified, but control is diminished. The subject's feelings and momentary perceptions gain an independence from the normal corrections of logic; whatever stray item occupies the attention (a sensation or an unguarded and unevaluated memory or thought) becomes at the moment compellingly significant. Thinking and perceiving of this order coexist with the capacity for, but not an interest in, normal thought and function.

These drugs have been called psychedelic (or mind-manifesting) because of the convincing clarity with which a normally suppressed, more sensory, plastic, and primitive part of the mind is revealed to the drugged subject, contrasting sharply with the capacity to focus, discriminate, and judge.

The two drugs of chief interest, mescaline and LSD-25 (lysergic acid diethylamide), are of ancient lineage. Mescaline, used in highly structured Amerindian tribal religious rituals, is derived from peyote buttons, which are the dried tops of a cactus found in the southwestern United States. LSD has been synthesized with compounds derived from ergot, which infests such grasses as rye. (Some ergot derivatives are useful in the treatment of migraine and in obstetrics for the postpartum constriction of the uterus and blood vessels.) See ERGOT.

There are a number of other psychotomimetics (less potent than LSD but similar), such as those from mushrooms (psilocybin and psilocin) and those synthesized in the laboratory. Ring-substituted amphetamines resembling mescaline's structure (for example, "STP") have been produced in profusion. There are subtle differences among these newer compounds, some producing more or less euphoria and more or less dyscontrol and anxiety. [D.X.F.]

**Psychrometer** An instrument consisting of two thermometers which is used in the measurement of the moisture content of air or other gases. The bulb or sensing area of one of the thermometers either is covered by a thin piece of clean muslin cloth wetted uniformly with distilled water or is otherwise coated with a film of distilled water. The temperatures of both the bulb and the air contacting the bulb are lowered by the evaporation which takes place when unsaturated air moves past the wetted bulb. An equilibrium temperature, termed the wet-bulb temperature ( $T_w$ ), will be reached; it closely approaches the lowest temperature to which air can be cooled by the evaporation of water into that air. The water-vapor content of the air surrounding the wet bulb can be determined from this wet-bulb temperature and from the air temperature measured by the thermometer with the dry bulb ( $T_D$ ) by using an expression of the form  $e = e_{SW} - aP(T_D - T_w)$ . Here  $e$  is the water-vapor pressure of the air,  $e_{SW}$  is the saturation water-vapor pressure at the wet-bulb temperature,  $P$  is atmospheric pressure, and  $a$  is the psychrometric constant, which depends upon properties of air and water, as well as on speed of ventilation of air passing the wet bulb. See PSYCHROMETRICS. [R.M.Sch.]

**Psychrometrics** A study of the physical and thermodynamic properties of the atmosphere. The properties of primary concern in air conditioning are (1) dry-bulb temperature, (2) wet-bulb temperature, (3) dew-point temperature, (4) absolute humidity, (5) percent humidity, (6) sensible heat, (7) latent heat, (8) total heat, (9) density, and (10) pressure.

The dry-bulb temperature is the ambient temperature of the air and water vapor as measured by a thermometer or other temperature-measuring device in which the thermal element is dry and shielded from radiation. See AIR TEMPERATURE; TEMPERATURE.

If the bulb of a dry-bulb thermometer is covered with a silk or cotton wick saturated with distilled water and the air is drawn over it at a velocity not less than 1000 ft/min (5 m/s), the resultant temperature will be the wet-bulb temperature. Where the dry-bulb and wet-bulb temperatures are the same, the atmosphere is saturated.

The dew-point temperature is the temperature at which the water vapor in the atmosphere begins to condense. This is also the temperature of saturation at which the dry-bulb, wet-bulb, and dew-point temperatures are all the same. See DEW POINT.

The actual quantity of water vapor in the atmosphere is designated as the absolute humidity. Percentage or relative humidity is the ratio of the actual water vapor in the atmosphere to the quantity of water vapor the atmosphere could hold if it were saturated at the same temperature. See HUMIDITY.

Sensible heat, or enthalpy of dry air, is heat which manifests itself as a change in temperature. See ENTHALPY.

Latent heat, or enthalpy of vaporization, is the heat required to change a liquid into a vapor without change in temperature.

Latent heat is sometimes referred to as the latent heat of vaporization and varies inversely as the pressure.

The total heat, or enthalpy, of the atmosphere is the sum of the sensible heat, latent heat, and superheat of the vapor above the saturation or dew-point temperature. Total heat is relatively constant for a constant wet-bulb temperature, deviating only about 1.5–2% low at relative humidities below 30%.

The density of the atmosphere varies with both altitude and percentage humidity. The higher the altitude the lower the density, and the higher the moisture content the lower the density. See DENSITY.

Atmospheric pressure is usually referred to as barometric pressure. Pressure varies inversely as elevation, as temperature, and as percentage saturation. See MOISTURE-CONTENT MEASUREMENT; PSYCHROMETER. [J.Ev.]

**Pteraspidomorpha** The subclass of Agnatha that includes the jawless vertebrates with paired nostrils. Pteraspidomorphi, sometimes called Diplorhina, includes only the extinct ostracoderm order Heterostraci and some or all of the problematical fossil genera now referred to the order Thelodonti. See HETEROSTRACI. [R.H.De.]

**Pteridosperms** A group of extinct seed plants characterized by fernlike leaves that produced naked seeds. The discovery of the seed ferns was a major contribution to the study of plant evolution because it demonstrated the existence of a group of vascular plants that is today extinct. Although the seed ferns probably have their ultimate origin within the progymnosperm order Aneurophytales, the best evidence of the group comes from lower Carboniferous (Mississippian) and younger sediments. Some seed ferns are reconstructed as trees with stout stems, while perhaps the majority were vines or lianas that supported massive fernlike fronds. The seed ferns consist of six Paleozoic orders (Calamopityales, Buteoxylonales, Lyginopteridales, Medullosales, Callistophytales, Glossopteridales) and three orders (Peltaspermales, Corystospermales, Caytoniales) found in Mesozoic rocks. See CAYTONIALES; PALEOBOTANY. [T.N.T.]

**Pterobranchia** A group of small sessile hemichordates that may be colonial (*Rhabdopleura*), pseudocolonial (*Cephalodiscus*), or solitary (*Atubaria*). Each individual, or zooid, lives inside a nonchitinous tube secreted by the protosome, except for *Atubaria*; an aggregation of zooids is called a coenecium and can vary in shape. The protosome, or oral shield, is disciform, closes the mouth ventrally, and secretes the tube. The protocoel has symmetrical pores at the base of the first pair of arms. The mesosome, or collar, has an anteroventral mouth and one to nine pairs of dorsally ciliated tentaculated arms, which are used to collect small organisms for food. The mesocoels extend into both arms and tentacles.

The metasome is divided into a sacciform trunk and a slender ventral stalk that may be free at its end. The trunk contains the U-shaped digestive tract, with the pharynx having a single pair of gills, except in *Rhabdopleura*. The stomach is a sacciform expansion of the gut, and the tubular intestine curves dorsally and opens behind the arms by a middorsal anus.

The nervous system is very simple and lacks a neurochord. The buccal diverticulum is hollow, with an anteroventral heart vesicle and central sinus. The glomerulus is poorly developed, and the circulatory system is simpler than in enteropneusts. See HEMICHORDATA. [J.Ben.]

**Pteropsida** A large group of vascular plants characterized by having parenchymatous leaf gaps in the stele and by having leaves which are thought to have originated in the distant past as branched stem systems. Some botanists regard the Pteropsida as a natural group which they recognize as a class, subdivision, or division. Others regard it as an artificial assemblage of plants that have undergone certain similar changes from a rhyniophyte

ancestry. The various components of the Pteropsida are here treated as three separate divisions under the names Magnoliophyta, Pinophyta, and Polypodiophyta. See MAGNOLIOPHYTA; PINOPHYTA; POLYPODIOPHYTA. [A.Cr.]

**Pterosauria** The “winged reptiles” of the Mesozoic Era, constituting the closest major group to Dinosauria and sharing many features with them. Their common ancestor was a small, bipedal, agile archosaur similar to *Scleromochlus* with a large, lightly built skull, short body, long hindlimbs, and digitigrade feet with four long metatarsals. Pterosaurs inherited all these features, and further evolved the power of flight. Pterosaurs had a wing of skin that was internally supported by long, fine, possibly collagenous stiffening fibers and braced by the forelimb, including a greatly elongated fourth finger (the first three remained small). Their brains were large and birdlike. Their bone walls were the thinnest of all tetrapods; See ORNITHISCHIA; SAURISCHIA.

The earliest pterosaurs are known from the Late Triassic, about the time that the first dinosaurs appeared: they include *Eudimorphodon*, *Peteinosaurus*, and *Preondactylus*, all from marine rocks of Italy. Pterodactyloids (“wing-fingers”) were a subgroup of Late Jurassic and Cretaceous pterosaurs that replaced the early pterosaurs. The best-known members of this group include the small *Pterodactylus* and the *Pteranodon* with 7-m (23-ft) wing span (see illustration).

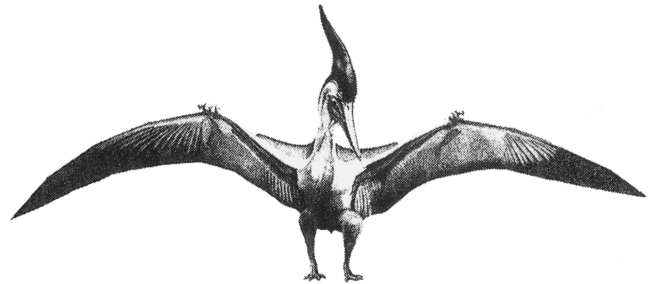

*Pteranodon* (reconstruction).

Most pterosaurs are known from shallow marine sediments, and ecologically resemble shorebirds and seabirds. See ARCHOSAURIA; DINOSAUR; REPTILIA. [K.Pa.]

**Pterygota** The larger of two subclasses of Insecta. All have wings in the adult stage or have been derived from winged ancestors; that is, if wingless, they are secondarily so. The primitive pterygotes make up the section Paleoptera; the mayflies, dragonflies, and damselflies are in this category. All other pterygotes constitute the section Neoptera. The more primitive Neoptera have exopterygote development, as in the grasshoppers, true bugs, and others, whereas the more specialized Neoptera have endopterygote development, as in the butterflies, moths, beetles, wasps, and so on. See APTERYGOTA; ENDOPTERYGOTA; EXOPTERYGOTA; INSECTA. [F.M.C.]

**Ptychodactiaria** An order of the zoantharian anthozoans of the phylum Coelenterata. This group of solitary sea anemones is known only from two genera, *Ptychodactis* and *Dactylanthus* from the Arctic and Antarctic. See ANTHOZOA; COELENTERATA. [C.H.]

**Public health** An effort organized by society to protect, promote, and restore the people's health. It is the combination of sciences, skills, and beliefs that is directed to the maintenance and improvement of health through collective or social actions. The programs, services, and institutions of public health emphasize the prevention of disease and the health needs of the population as a whole. Additional goals include the reduction of the

amount of disease, premature death, disability, and discomfort in the population.

The basic sciences of public health include epidemiology and vital statistics, which measure health status and assess health trends in the population. Epidemiology is also a powerful research method, used to identify causes and calculate risks of acquiring or dying of many conditions. Many sciences, including toxicology and microbiology, are applied to detect, monitor, and correct physical, chemical, and biological hazards in the environment. Such applications are being used to address concerns about a deteriorating global environment. The social and behavioral sciences have become more prominent in public health since the recognition that such factors as indolence, loneliness, personality type, and addiction to tobacco contribute to the risk of premature death and chronic disabling diseases. See EPIDEMIOLOGY.

In most industrial nations, public health services are organized nationally, regionally, and locally. National public health services are usually responsible for setting, monitoring, and maintaining health standards, for promoting good health, for collecting and compiling national health statistics, and for supporting and performing research on diseases important to public health. Regional (for example, state) public health services deal mainly with major health protection activities such as ensuring safe water and food supplies; they may also operate screening programs for early detection of disease and are responsible for health care of certain groups such as chronic mentally ill persons. Local public health services (in cities, large towns, and some rural communities) conduct a variety of personal public health services, such as immunization programs, health education, health surveillance and advice for mothers and newborn babies, and personal care of vulnerable groups such as the elderly and housebound long-term sick. Local health services also investigate and control epidemics and other communicable conditions such as sexually transmitted diseases.

National public health services communicate with each other in efforts to control diseases of international importance, and they collaborate worldwide under the auspices of the World Health Organization (WHO). While much of the work of WHO has been concentrated in the developing nations, it has also been involved in global efforts to control major epidemic diseases and to set standards for hazardous environmental and occupational exposures. [J.M.La.]

**Pulley** A wheel with a flat, crowned, or grooved rim used with a flat belt, V-belt, or a rope to transmit motion and energy. Pulleys for use with V-belt and rope drives have grooved surfaces and are usually called sheaves. A combination of ropes, pulleys, and pulley blocks arranged to gain a mechanical advantage, as for hoisting a load, is referred to as block and tackle. See BELT DRIVE; BLOCK AND TACKLE.

Pulleys for flat belts are made of cast iron, fabricated steel, wood, and paper. A particular pulley design must be based on such considerations as the ability to resist shock, to conduct heat, and to resist corrosive environments. The face must be smooth enough to minimize belt wear; yet there must be adequate friction between belt and pulley face to carry the load.

The two common types of V-belt pulley are pressed-steel and cast-iron. The pressed-steel pulleys are suitable for single-belt drives. For multiple-belt drives, or in single-belt drives where pulley mass should be high to get a flywheel effect, cast-iron pulleys are used. [J.R.Z.]

**Pulmonata** A subclass of the molluscan class Gastropoda, containing about 23,500 species of snails that are grouped into three superorders: Systellommatophora, Basommatophora, and Stylommatophora. Pulmonates include most of the common snails found on land or in freshwaters, although a few proso-branches have invaded both habitats. Certain pulmonates are intertidal to subtidal on rocky shores of tropical and temperate

regions. See BASOMMATOPHORA; STYLOMMATOPHORA; SYSTELLOMMATOPHORA.

Fresh-water pulmonates belong to the superorder Basommatophora and are adapted to make use of accidental transport on birds or insects from one isolated body of water to another. Mostly they have short life-spans, and their numbers vary dramatically with the seasons.

Land pulmonates belong to the superorder Stylommatophora and are marginally terrestrial in that they can be active only when the humidity in their microhabitat is 90% or above. Thus many are cryptic or nocturnal in both feeding and reproduction. They can survive in deserts by estivating for up to 6 years. See GASTROPODA. [G.A.S.]

**Pulsar** A celestial radio source producing intense short bursts of radio emission. Since the discovery of pulsars in 1968, about 1300 pulsars have been found (as of May 2001), and it has become clear that 100,000 pulsars must exist in the Milky Way Galaxy—most of them too distant to be detected with existing radio telescopes. See RADIO ASTRONOMY.

Pulsars are distinguished from most other types of celestial radio sources in that their emission, instead of being constant over time scales of years or longer, consists of periodic sequences of brief pulses. The interval between pulses, or pulse period, is nearly constant for a given pulsar, but for different sources ranges from 0.0016 to 8.5 s. The bursts of emission are generally confined to a window whose width is a few percent of the interpulse period. Individual pulses can vary widely in intensity.

The association of pulsars with neutron stars, the collapsed cores left behind when moderate- to high-mass stars become unstable and collapse, is supported by many arguments. The standard model for pulsars is a spinning neutron star with an intense dipole magnetic field (surface field of  $10^{12}$  gauss or  $10^8$  teslas) misaligned with the rotation axis. The off-axis rotating dipole field develops a huge voltage difference between the neutron star surface and the surrounding matter. Charges accelerate in this voltage and generate an avalanche of electrons and positrons, a relativistic current leaving the polar zones of the star. Highly directive radio emission is formed in this current, which is observed as pulses, one per rotation, just like a rotating searchlight. See ELECTRON; POSITRON.

A fundamental observation that supports the rotating neutron star model is the remarkable stability of the basic pulsation periods, which typically remain constant to a few tens of nanoseconds over a year. This stability is natural to the free rotation of a compact, rigid object like a neutron star, but is extremely difficult to produce by any other known physical process.

Pulsars have provided a unique set of probes for the investigation of the diffuse gas and magnetic fields in interstellar space. Measurement of absorption at 1420 MHz, the frequency of the hyperfine transition in ground-state neutral hydrogen atoms, gives information on the structure of gas clouds, and in many cases provides an estimate of the pulsar distance. The index of refraction for radio waves in the ionized interstellar gas is strongly frequency-dependent, and low-frequency signals propagate more slowly than those at high frequencies. The broadband, pulsed nature of pulsar signals makes them ideal for measurements of this dispersion.

The first pulsar in a binary, PSR B1913+167, was found in 1975. About 50 binary pulsars are now known. The binary pulsar PSR B1913+167 has an orbital speed near one-thousandth the speed of light. This large speed and the intense gravitational field of the nearby companion neutron star, when combined with the accurate clock mechanism provided by the pulsations, make this system an ideal testing ground for relativistic gravitation theories. One especially important prediction of the general theory of relativity is that a close binary star system should gradually lose energy by the radiation of gravitational waves, and consequently the two stars should slowly spiral closer together. Observations of Doppler shifts of the pulsar signals have



established that the two masses in the PSR B1913+167 system are each approximately 1.4 times the mass of the Sun. The quantitative prediction of general relativity is, then, that the orbital period should diminish by about  $10^{-7}$  s per orbit, amounting to a cumulative orbital phase shift of 8 s after 14 years. Just such an effect has been found, and the observations provide the first (and only) experimental evidence in support of the existence of gravitational waves. See GRAVITATION; GRAVITATIONAL RADIATION; RELATIVITY. [D.C.Ba.]

**Pulse demodulator** A device that recovers the modulating signal from a pulse-modulated wave. This recovery may or may not require a two-stage demodulation. Pulse-duration-modulated (PDM) or pulse-amplitude-modulated (PAM) signals may be completely recovered by a conventional detector in amplitude-modulation (AM) radio or a phase-quadrature-type demodulator in frequency-modulation (FM) radio. The reason is that the pulse area is proportional to the modulating-signal amplitude at the time of each pulse, and the low-pass demodulator output filter removes the pulse-frequency components as well as the carrier-frequency components and leaves only the original modulating-frequency components in the filter output. See AMPLITUDE-MODULATION DETECTOR; FREQUENCY-MODULATION DETECTOR.

Pulse-position-modulated (PPM) and pulse-code-modulated (PCM) signals require a two-stage demodulation because the pulse train must be processed before the original modulation can be recovered. The pulse-train modulation may be recovered from a radio-frequency (rf) carrier by any appropriate AM or FM detector, provided that the low-pass filter in the detector output passes the significant frequency components of the pulse. See PULSE MODULATION. [C.L.A.]

**Pulse generator** An electronic circuit capable of producing a waveform that rises abruptly, maintains a relatively flat top for an extremely short interval, and then rapidly falls to zero. A relaxation oscillator, such as a multivibrator, may be adjusted to generate a rectangular waveform having an extremely short duration, and as such it is referred to as a pulse generator. However, there is a class of circuits whose exclusive function is generating short-duration, rectangular waveforms. These circuits are usually specifically identified as pulse generators. An example of such a pulse generator is the triggered blocking oscillator, which is a single relaxation oscillator having transformer-coupled feedback from output to input. See MULTIVIBRATOR.

Pulse generators sometimes include, but are usually distinguished from, trigger circuits. Trigger circuits generate a short-duration, fast-rising waveform for initiating or triggering an event or a series of events in other circuits. In the pulse generator, the pulse duration and shape are of equal importance to the rise and fall times. See TRIGGER CIRCUIT.

The term pulse generator is often applied not only to an electronic circuit generating prescribed pulse sequences but to an electronic instrument designed to generate sequences of pulses with variable delays, pulse widths, and pulse train combinations, programmable in a predetermined manner, often microprocessor-controlled.

A network, formed in such a way as to simulate the delay characteristics of a lossless transmission line, and appropriate switching elements to control the duration of a pulse form the basis for a variety of types of pulse generators. Some delay-line-controlled pulse generators are capable of generating pulses containing considerable amounts of power for such applications as modulators in radar transmitters. See DELAY LINE; WAVE-SHAPING CIRCUITS. [G.M.G.]

**Pulse jet** A type of jet engine characterized by periodic surges of thrust. The pulse jet engine was widely known for its use during World War II on the German V-1 missile (see illustration). The basic engine cycle was invented in 1908. The inlet end of the

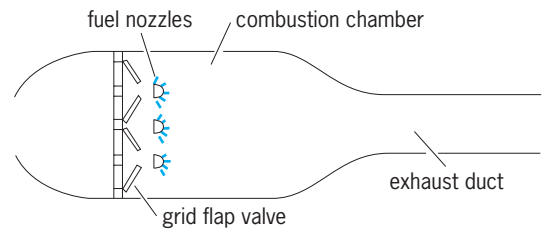

Diagram of a pulse jet.

engine is provided with a grid to which are attached flap valves. These valves are normally held by spring tension against the grid face and block the flow of air back out of the front of the engine. They can be sucked inward by a negative differential pressure to allow air to flow into the engine. Downstream from the flap valves is the combustion chamber. A fuel injection system is located at the entrance to the combustion chamber. The chamber is also fitted with a spark plug. Following the combustion chamber is a long exhaust duct which provides an inertial gas column.

Pulse jets have also been used to propel radio-controlled target drones and experimental helicopters. In the latter case, they were mounted on the blade tips for directly driving the rotor. The high fuel consumption, noise, and vibrations generated by the pulse jet limit its scope of applications. See PROPULSION. [B.Pi.]

**Pulse modulation** A set of techniques whereby a sequence of information-carrying quantities occurring at discrete instances of time is encoded into a corresponding regular sequence of electromagnetic carrier pulses. Varying the amplitude, polarity, presence or absence, duration, or occurrence in time of the pulses gives rise to the four basic forms of pulse modulation: pulse-amplitude modulation (PAM), pulse-code modulation (PCM), pulse-width modulation (PWM, also known as pulse-duration modulation, PDM), and pulse-position modulation (PPM).

**Analog-to-digital conversion.** An important concept in pulse modulation is analog-to-digital (A/D) conversion, in which an original analog (time- and amplitude-continuous) information signal  $s(t)$  is changed at the transmitter into a series of regularly occurring discrete pulses whose amplitudes are restricted to a fixed and finite number of values. An inverse digital-to-analog (D/A) process is used at the receiver to reconstruct an approximation of the original form of  $s(t)$ . Conceptually, analog-to-digital conversion involves two steps. First, the range of amplitudes of  $s(t)$  is divided or quantized into a finite number of predetermined levels, and each such level is represented by a pulse of fixed amplitude. Second, the amplitude of  $s(t)$  is periodically measured or sampled and replaced by the pulse representing the level that corresponds to the measurement. See ANALOG-TO-DIGITAL CONVERTER; DIGITAL-TO-ANALOG CONVERTER.

According to the Nyquist sampling theorem, if sampling occurs at a rate at least twice that of the bandwidth of  $s(t)$ , the latter can be unambiguously reconstructed from its amplitude values at the sampling instants by applying them to an ideal low-pass filter whose bandwidth matches that of  $s(t)$ .

Quantization, however, introduces an irreversible error, the so-called quantization error, since the pulse representing a sample measurement determines only the quantization level in which the measurement falls and not its exact value. Consequently, the process of reconstructing  $s(t)$  from the sequence of pulses yields only an approximate version of  $s(t)$ .

**Pulse-amplitude modulation.** In PAM the successive sample values of the analog signal  $s(t)$  are used to effect the amplitudes of a corresponding sequence of pulses of constant duration occurring at the sampling rate. No quantization of the samples normally occurs (Fig. 1a, b). In principle the pulses may occupy the entire time between samples, but in most practical systems the pulse duration, known as the duty cycle, is limited to a

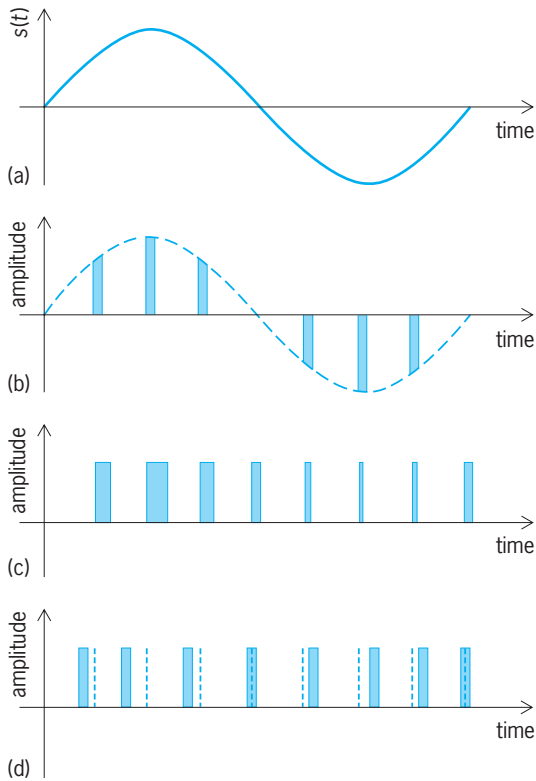

Fig. 1. Forms of pulse modulation for the case where the analog signal,  $s(t)$ , is a sine wave. (a) Analog signal,  $s(t)$ . (b) Pulse-amplitude modulation. (c) Pulse-width modulation. (d) Pulse-position modulation.

fraction of the sampling interval. Such a restriction creates the possibility of interleaving during one sample interval one or more pulses derived from other PAM systems in a process known as time-division multiplexing (TDM). See MULTIPLEXING AND MULTIPLE ACCESS.

**Pulse-width modulation.** In PWM the pulses representing successive sample values of  $s(t)$  have constant amplitudes but vary in time duration in direct proportion to the sample value. The pulse duration can be changed relative to fixed leading or trailing time edges or a fixed pulse center. To allow for time-division multiplexing, the maximum pulse duration may be limited to a fraction of the time between samples (Fig. 1c).

**Pulse-position modulation.** PPM encodes the sample values of  $s(t)$  by varying the position of a pulse of constant duration relative to its nominal time of occurrence. As in PAM and PWM, the duration of the pulses is typically a fraction of the sampling interval. In addition, the maximum time excursion of the pulses may be limited (Fig. 1d).

**Pulse-code modulation.** Many modern communication systems are designed to transmit and receive only pulses of two distinct amplitudes. In these so-called binary digital systems, the analog-to-digital conversion process is extended by the additional step of coding, in which the amplitude of each pulse representing a quantized sample of  $s(t)$  is converted into a unique sequence of one or more pulses with just two possible amplitudes. The complete conversion process is known as pulse-code modulation.

Figure 2a shows the example of three successive quantized samples of an analog signal  $s(t)$ , in which sampling occurs every  $T$  seconds and the pulse representing the sample is limited to  $T/2$  seconds. Assuming that the number of quantization levels is limited to 8, each level can be represented by a unique sequence of three two-valued pulses. In Fig. 2b these pulses are of amplitude  $V$  or 0, whereas in Fig. 2c the amplitudes are  $V$  and  $-V$ .

PCM enjoys many important advantages over other forms of pulse modulation due to the fact that information is represented by a two-state variable. First, the design parameters of a PCM transmission system depend critically on the bandwidth of the original signal  $s(t)$  and the degree of fidelity required at the point of reconstruction, but are otherwise largely independent of the information content of  $s(t)$ . This fact creates the possibility of deploying generic transmission systems suitable for many types of information. Second, the detection of the state of a two-state variable in a noisy environment is inherently simpler than the precise measurement of the amplitude, duration, or position of a pulse in which these quantities are not constrained. Third, the binary pulses propagating along a medium can be intercepted and decoded at a point where the accumulated distortion and attenuation are sufficiently low to assure high detection accuracy. New pulses can then be generated and transmitted to the next such decoding point. This so-called process of repeating significantly reduces the propagation of distortion and leads to a quality of transmission that is largely independent of distance.

**Time-division multiplexing.** An advantage inherent in all pulse modulation systems is their ability to transmit signals from multiple sources over a common transmission system through the process of time-division multiplexing. By restricting the time duration of a pulse representing a sample value from a particular analog signal to a fraction of the time between successive samples, pulses derived from other sampled analog signals can be accommodated on the transmission system.

One important application of this principle occurs in the transmission of PCM telephone voice signals over a digital transmission system known as a T1 carrier. In standard T1 coding, an original analog voice signal is band-limited to 4000 hertz by passing it through a low-pass filter, and is then sampled at the Nyquist rate of 8000 samples per second, so that the time between successive samples is 125 microseconds. The samples are quantized to 256 levels, with each of them being represented by a sequence of 8 binary pulses. By limiting the duration of a single pulse to 0.65 microsecond, a total of 193 pulses can be accommodated in the time span of 125 microseconds between

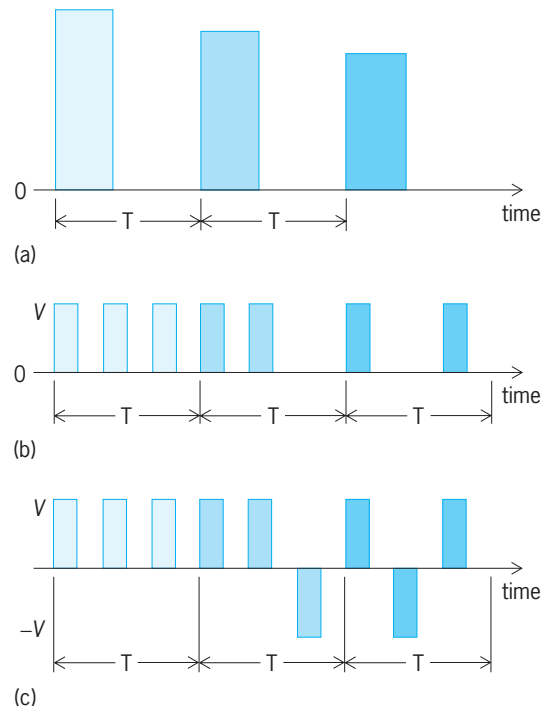

Fig. 2. Pulse-code modulation. (a) Three successive quantized samples of an analog signal. (b) With pulses of amplitude  $V$  or 0. (c) With pulses of amplitude  $V$  or  $-V$ .

samples. One of these serves as a synchronization marker that indicates the beginning of such a sequence of 193 pulses, while the other 192 pulses are the composite of 8 pulses from each of 24 voice signals, with each 8-pulse sequence occupying a specified position. T1 carriers and similar types of digital carrier systems are in widespread use in the world's telephone networks.

**Bandwidth requirements.** Pulse modulation systems may incur a significant bandwidth penalty compared to the transmission of a signal in its analog form. An example is the standard PCM transmission of an analog voice signal band-limited to 4000 hertz over a T1 carrier. Since the sampling, quantizing, and coding process produces 8 binary pulses 8000 times per second for a total of 64,000 binary pulses per second, the pulses occur every 15.625 microseconds. Depending on the shape of the pulses and the amount of intersymbol interference, the required transmission bandwidth will fall in the range of 32,000 to 64,000 hertz. This compares to a bandwidth of only 4000 hertz for the transmission of the signal in analog mode.

**Applications.** PAM, PWM, and PPM found significant application early in the development of digital communications, largely in the domain of radio telemetry for remote monitoring and sensing. They have since fallen into disuse in favor of PCM.

Since the early 1960s, many of the world's telephone network providers have gradually, and by now almost completely, converted their transmission facilities to PCM technology. The bulk of these transmission systems use some form of time-division multiplexing, as exemplified by the 24-voice channel T1 carrier structure. These carrier systems are implemented over many types of transmission media, including twisted pairs of telephone wiring, coaxial cables, fiber-optic cables, and microwave. See COAXIAL CABLE; COMMUNICATIONS CABLE; MICROWAVE; OPTICAL COMMUNICATIONS; OPTICAL FIBERS; SWITCHING SYSTEMS (COMMUNICATIONS); TELEPHONE SERVICE.

The deployment of high-speed networks such as the Integrated Service Digital Network (ISDN) in many parts of the world has also relied heavily on PCM technology. PCM and various modified forms such as delta modulation (DM) and adaptive differential pulse-code modulation (ADPCM) have also found significant application in satellite transmission systems. See COMMUNICATIONS SATELLITE; DATA COMMUNICATIONS; ELECTRICAL COMMUNICATIONS; INTEGRATED SERVICES DIGITAL NETWORK (ISDN); MODULATION. [H.J.He.]

**Pulse modulator** A device for the pulse modulation of a radio-frequency carrier signal. In pulse modulation, information is transmitted by generating a train of discrete pulses whose amplitude, duration, position, or mere presence is controlled in accordance with the signal. See PULSE MODULATION.

**Pulse-amplitude modulation.** In pulse-amplitude modulation (PAM) the desired signal to be transmitted is sampled periodically (Fig. 1). PAM may be accomplished by the use of a multiplier circuit. The signal that contains the intelligence to be transmitted is applied to one of the multiplier inputs, and the train of pulses known as the sampling signal is applied to the other multiplier input. If this train of pulses has an amplitude of one during the pulse and zero elsewhere, the multiplier output will consist of a train of pulses, each having an amplitude equal to the signal amplitude at the time of sampling (Fig. 1). The main reason for using PAM is that several signals may be transmitted over a single communication channel by a technique known as multiplexing. See MULTIPLEXING AND MULTIPLE ACCESS.

The most simple technique for multiplexing several signals onto a single channel is to use a rotating multipole switch known as a commutator. The commutator may serve as the sampler, or modulator, as well as the multiplexer. A commutator must be used on the receiving end as well as the transmitting end of the multiplexed channel in order to unscramble the signals. These commutators must be synchronized so that each message is sent to its proper destination at the receiving end. For example, several telephone conversations might be sampled and multiplexed



Fig. 1. Pulse-amplitude modulation by means of a multiplier circuit.

onto a single telephone line. An easily identifiable synchronizing signal must also be sent to synchronize the commutators at the two ends of the system. A low-pass filter is used in each message line at the receiving end to pass only the desired message frequencies and remove the higher frequencies of the pulses. See ELECTRICAL FILTER.

**Pulse-width and pulse-position modulation.** PAM is a satisfactory method of communication when transmission distances are short enough to maintain high signal-to-noise ratios. However, when transmission distances become long, such as many miles, the atmospheric noise from lightning and other electrical sources that is induced into either a hard-wire line or a radio antenna may degrade the signal-to-noise ratio sufficiently to at least cause annoyance and at worst render the message unintelligible. Both pulse-width modulation (PWM) and pulse-position modulation (PPM) have been used in the past with the hope of improving the signal-to-noise ratio. See ELECTRICAL INTERFERENCE; ELECTRICAL NOISE; SIGNAL-TO-NOISE RATIO.

PWM may be obtained from the PAM pulse by charging a small capacitor to the peak voltage of each pulse as it comes along, and then discharging the capacitor through a constant current source before the next pulse arrives. Then the capacitor voltage decreases linearly to zero during a time that is proportional to the pulse amplitude. These triangular pulses may then be passed through a Schmitt trigger circuit to square them up and provide constant amplitude pulses of varying width.

PPM may then be obtained by differentiating the PWM signals to produce narrow pulses at both the leading and trailing edges of the PWM pulses. The leading-edge pulse is used as the reference pulse, and the time difference between it and the trailing-edge pulse represents the modulation amplitude. These sharp PPM pulses may be squared up by the use of either a Schmitt trigger circuit or a one-shot multivibrator. Both the PWM and PPM signals are subject to noise modulation so their use may or may not improve the signal-to-noise ratio in comparison with a PAM system. See MULTIVIBRATOR.

**Pulse-code modulation.** A signal transmission system of any type may become essentially immune to atmospheric and other induced noise when pulse-code modulation (PCM) is used. In this type of modulation, the modulating signal is first sampled (Fig. 2a). The resulting PAM signals are then quantized by a circuit that compares each pulse amplitude with a set of predetermined levels and produces a stepwise-varying replica of the original signal having only the predetermined voltage levels. In Fig. 2b, eight equally spaced levels were chosen to represent signals limited to the range from approximately 0 to 7 V peak amplitude. Thus the quantizing levels are separated by 1 V. Each quantized level is then represented by a sequence of pulses known as a code. Any of many different coding systems may be used, but the binary code is basic and is very commonly used (Fig. 2c). Analog-to-digital converters are available in integrated-circuit form. See ANALOG-TO-DIGITAL CONVERTER; INTEGRATED CIRCUITS.

If the transmission path is very long, one or more repeater stations may be needed at intermediate points. These repeaters receive the signal while it is still larger than the noise, remove the noise, amplify the signal, and retransmit it along the channel.

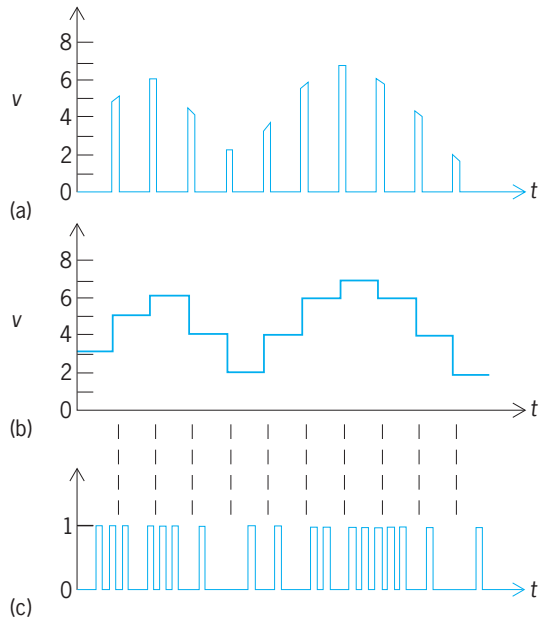

Fig. 2. Pulse-code modulation. (a) Signal sampling. (b) Quantization. (c) Binary pulse coding.

In fact, PCM signals that are weaker than the noise may be received and the noise rejected if a phase-locked loop is used as the demodulator in the receiver. See PHASE-LOCKED LOOPS.

The signal-to-noise ratio of PCM voice communication decreases if the signal level decreases significantly from its maximum permissible value because some of the quantization levels are then not used. In order to overcome this problem, signal compression is used prior to modulation. This compression is accomplished by amplifying the weak signals more than the strong ones so the variation in signal level is greatly reduced. In order to restore the original relative signal levels at the receiving end of the system after demodulation, a circuit known as an expander is used to amplify the stronger signals more than the weak ones. A circuit that will serve as either a compressor or expander is known as a compander. [C.L.A.]

**Pumice** A rock froth, formed by the extreme puffing up of liquid lava by expanding gases liberated from solution in the lava prior to and during solidification. Some varieties will float in water for many weeks before becoming waterlogged. Typical pumice is siliceous (rhyolite or dacite) in composition, but the lightest and most vesicular pumice (known also as reticulite and thread-lace scoria) is of basaltic composition. See LAVA; VOLCANIC GLASS. [G.A.M.]

**Pump** A machine that draws a fluid into itself through an entrance port and forces the fluid out through an exhaust port (see illustration). A pump may serve to move liquid, as in a cross-country pipeline; to lift liquid, as from a well or to the top of a tall building; or to put fluid under pressure, as in a hydraulic brake. These applications depend predominantly upon the discharge

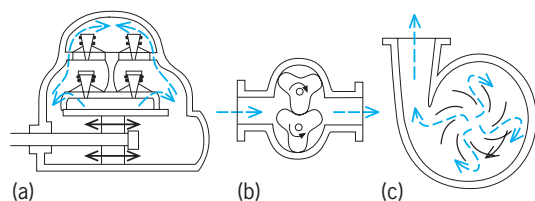

Pumps. (a) Reciprocating. (b) Rotary. (c) Centrifugal.

characteristic of the pump. A pump may also serve to empty a container, as in a vacuum pump or a sump pump, in which case the application depends primarily on its intake characteristic. See CENTRIFUGAL PUMP; COMPRESSOR; DISPLACEMENT PUMP; FAN; FUEL PUMP; PUMPING MACHINERY; VACUUM PUMP. [E.F.W.]

**Pumped storage** A process, also known as hydroelectric storage, for converting large quantities of electrical energy to potential energy by pumping water to a higher elevation, where it can be stored indefinitely and then released to pass through hydraulic turbines and generate electrical energy. An indirect process is necessary because electrical energy cannot be stored effectively in large quantities. Storage is desirable, as the consumption of electricity is highly variable between day and night, between weekday and weekend, as well as among seasons. Consequently, much of the generating equipment needed to meet the greatest daytime load is unused or lightly loaded at night or on weekends. During those times the excess capability can be used to generate energy for pumping, hence the necessity for storage.

A typical pumped-storage development is composed of two reservoirs of essentially equal volume situated to maximize the difference in their levels. These reservoirs are connected by a system of waterways along which a pumping-generating station is located (see illustration). Under favorable geological conditions,

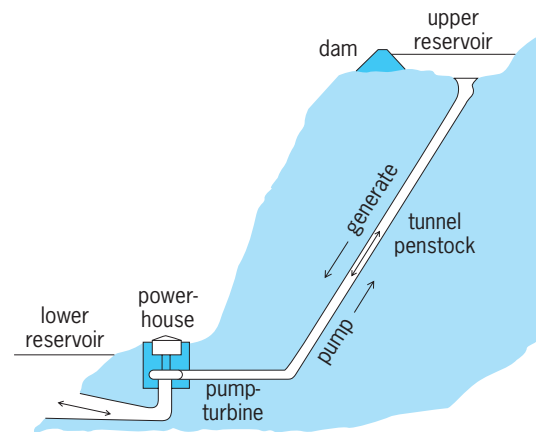

Schematic of a conventional pumped-storage development.

the station will be located underground, otherwise it will be situated on the lower reservoir. The principal equipment of the station is the pumping-generating unit. In United States practice, the machinery is reversible and is used for both pumping and generating; it is designed to function as a motor and pump in one direction of rotation and as a turbine and generator in opposite rotation. See ELECTRIC POWER GENERATION; PUMPING MACHINERY; WATERPOWER. [D.L.G.]

**Pumping machinery** Devices which convey fluids, chiefly liquids, from a lower to a higher elevation or from a region of lower pressure to one of higher pressure. Pumping machinery may be broadly classified as mechanical or as electromagnetic.

In mechanical pumps the fluid is conveyed by direct contact with a moving part of the pumping machinery. The two basic types are (1) velocity machines, centrifugal or turbine pumps, which impart energy to the fluid primarily by increasing its velocity, then converting part of this energy into pressure or head, and (2) displacement machines with plungers, pistons, cams, or other confining forms which act directly on the fluid, forcing it to flow against a higher pressure. See CENTRIFUGAL PUMP; DISPLACEMENT PUMP.

Where direct contact between the fluid and the pumping machinery is undesirable, as in atomic energy power plants for circulating liquid metals used as reactor coolants or as solvents

for reactor fuels, electromagnetic pumps are used. There are no moving parts in these pumps; no shaft seals are required. The liquid metal passing through the pump becomes, in effect, the rotor circuit of an electric motor. [E.F.W.]

**Pumpkin** The term commonly applied to the larger, orange-colored fruit of the *Cucurbita* species, used when ripe as a table vegetable, in pies, or for autumn decoration. Although some taxonomists would restrict the term pumpkin to the species *Cucurbita* pepper and *C. moschata*, it is also used in referring to *C. mixta*. New Jersey, Illinois, and California are important producing states. See VIOLAELES. [H.J.C.]

**Puna** An alpine biological community in the central portion of the Andes Mountains of South America. Sparsely vegetated, treeless stretches cover high plateau country (altiplano) and slopes of central and southern Peru, Bolivia, northern Chile, and northwestern Argentina. The poor vegetative cover and the puna animals are limited by short seasonal precipitation as well as by the low temperatures of high altitudes.

Like the paramos of the Northern Andes, punas occur above timberline, and extend upward, in modified form, to perpetual snow. Due to greater heights of the Central Andean peaks, aolian regions, that is, regions supplied with airborne nutrients above the upper limit of vascular plants, generally the snowline, are more extensive here than above the paramos. See PARAMO. [H.G.B.]

**Purine** A heterocyclic organic compound (1) containing

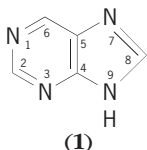

fused pyrimidine and imidazole rings. A number of substituted purine derivatives occur in nature; some, as components of nucleic acids and coenzymes, play vital roles in the genetic and metabolic processes of all living organisms. See COENZYME; NUCLEIC ACID.

Purines are generally white solids of amphoteric character. They can form salts with both acids and bases. Conjugated double bonds in purines results in aromatic chemical properties, that confers considerable stability, and accounts for their strong ultraviolet absorption spectra. With the exception of the parent compound, most substituted purines have low solubilities in water and organic solvents.

The purine bases, adenine (2) and guanine (3), together with pyrimidines, are fundamental components of all nucleic acids. Certain methylated derivatives of adenine and guanine are also present in some nucleic acids in low amounts. In biological systems, hypoxanthine (4), adenine, and guanine occur mainly as

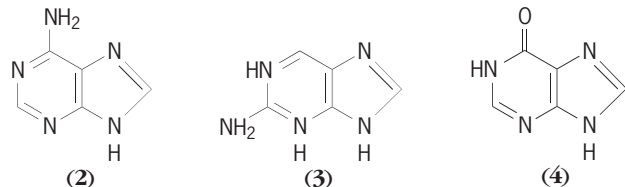

their 9-glycosides, the sugar being either ribose or 2-deoxyribose. Such compounds are termed nucleosides generically, and inosine (hypoxanthine nucleoside), adenosine, or guanosine specifically. The principal nucleotides contain 5'-phosphate groups, as in guanosine 5'-phosphate (GTP) and adenosine 5'-triphosphate (ATP).

Most living organisms are capable of synthesizing purine compounds. The sequence of enzymatic reactions by which the initial purine product, inosine 5'-phosphate, is formed utilizes glycine,

carbon dioxide, formic acid, and amino groups derived from glutamine and aspartic acid. Adenosine 5'-phosphate and guanosine 5'-phosphate are formed from inosine 5'-phosphate.

Metabolic degradation of purine derivatives may also occur by hydrolysis of nucleotides and nucleosides to the related free bases. Deamination of adenine and guanine produces hypoxanthine and xanthine (5), both of which may be oxidized to uric acid (6).

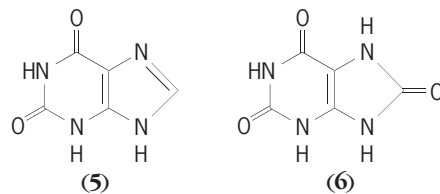

See URIC ACID.

Purine-related compounds have been investigated as potential chemotherapeutic agents. In particular, 6-mercaptopurine, in the form of its nucleoside phosphate, inhibits several enzymes required for synthesis of adenosine and guanosine nucleotides, and thus proves useful in selectively arresting the growth of tumors. The pyrazolopyrimidine has been used in gout therapy. As a purine analog, this agent serves to block the biosynthesis of inosine phosphate, as well as the oxidation of hypoxanthine and xanthine to uric acid. As a result of its use, overproduction of uric acid is prevented and the primary cause of gout is removed. See CHEMOTHERAPY; GOUT; PYRIMIDINE. [S.C.H.]

**Push-pull amplifier** An electronic circuit in which two transistors (or vacuum tubes) are used, one as a source of current and one as a sink, to amplify a signal. One device "pushes" current out into the load, while the other "pulls" current from it when necessary. A common example is the complementary-symmetry push-pull output stage widely used to drive loudspeakers (see illustration), where an *npn* transistor can source (push) current from a positive power supply into the load, or a *pnp* transistor can sink (pull) it into the negative power supply. The circuit functions as an amplifier in that the current levels at the output are larger than those at the input.

A so-called bias network in a complementary-symmetry push-pull output stage (see illustration) functions to maintain a constant voltage difference between the bases of the two transistors. It can be designed either by setting a bias current, and diode sizes or by replacing it with a different network for class B, class A, or the common compromise, class AB mode of operation.

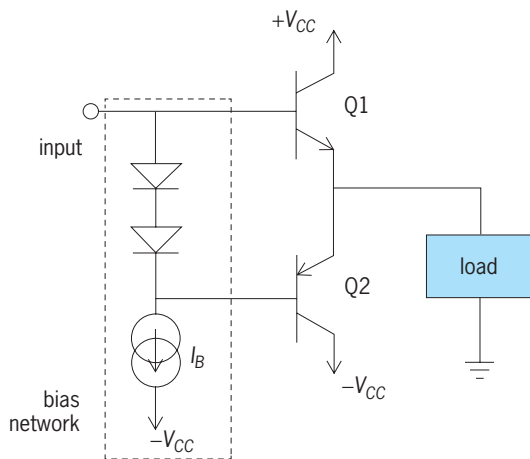

Complementary-symmetry push-pull output stage. Q1 is an *nnp* transistor and Q2 is a *pnp* transistor;  $I_B$  is a bias current; positive (+ $V_{CC}$ ) and negative ( $-V_{CC}$ ) power supplies are shown.

In class B operation, where the bases of the transistors might simply be shorted together, only one transistor is "on" at a time and each is on average "on" for only 50% of the time; when the output current is zero, no current at all flows in the circuit. In class A operation a large voltage is maintained between the bases so that both devices stay "on" at all times, although their currents vary so that the difference flows into the load; and even when the output is zero, a large quiescent current flows from the power supplies. Class B operation is much more efficient than class A, which wastes a large amount of power when the signal is small. However, class B suffers from zero-crossing distortion as the output current passes through zero, because there is generally a delay involved as the input swings far enough to turn one transistor entirely off and then turn the other on. In class AB operation, some intermediate quiescent current is chosen to compromise between power and distortion.

Class AB amplifiers are conventionally used as loudspeaker drivers in audio systems because they are efficient enough to be able to drive the required maximum output power, often on the order of 100 W, without dissipating excessive heat, but can be biased to have acceptable distortion. Audio signals tend to be near zero most of the time, so good performance near zero output current is critical, and that is where class A amplifiers waste power and class B amplifiers suffer zero-crossing distortion. A class AB push-pull amplifier is also conventionally used as the output stage of a commercial operational amplifier. See AUDIO AMPLIFIER; OPERATIONAL AMPLIFIER; POWER AMPLIFIER; TRANSISTOR.

[M.Sn.]

**Pycnodontiformes** An order of very specialized deep-bodied fishes near the holostean level of organization that are known only from the fossil record. They were a widespread group that first appeared in the Upper Triassic of Europe, flourished during the Jurassic and Cretaceous, and persisted to the Upper Eocene. Pycnodontiforms are a closely interrelated group most commonly found preserved in marine limestone and associated with coraliferous facies.

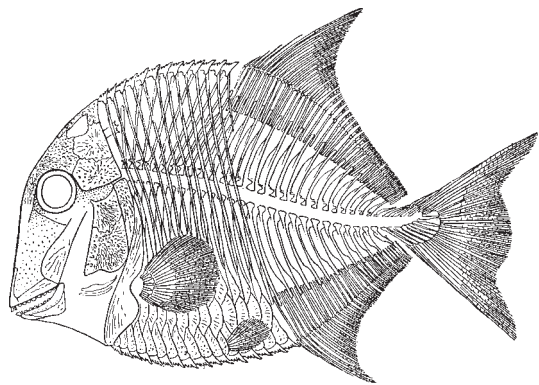

*Coelodus costue*, a pycnodont from Lower Cretaceous of Italy; length to 4 in. (10 cm). (After A. S. Woodward)

They are characterized (see illustration) by a laterally compressed, disk-shaped body; long dorsal and anal fins, with each fin ray supported by its own endoskeletal element; an externally symmetrical tail; and an axial skeleton having greatly extended neural and hemal spines that are expanded in some forms, and neural and hemal arches which are well ossified—sometimes interdigitating around the notochord—but with no vertebral centra.

[T.M.C.]

**Pycnogonida** A subphylum of marine arthropods, consisting of about 600 Recent and 3 Devonian species. The Pycnogonida, or Pantopoda, are commonly called sea spiders.

The pycnogonids are characterized by reduction of the body to a series of cylindrical trunk somites supporting the appendages, a large specialized feeding apparatus called the proboscis, gonopores opening on the second joints of the legs, and a reduced abdomen. In many genera, there are seven pairs of appendages, of which the first four, namely the chelifores, palpi, ovigers, and first walking legs, are on the first or cephalic segment. This segment also bears a dorsal tubercle containing four simple eyes. Each of the remaining three trunk segments bears a single pair of legs.

Pycnogonids are found in all seas except the inner Baltic and Caspian, from intertidal regions to depths of 21,000 ft (6500 m), and one species is bathypelagic at about 3300 ft (1000 m). They are especially common in polar seas. Most of the intertidal species spend their lives in association with coelenterates as encysted, parasitic larval and juvenile stages, or are ectoparasitic as adults, being attached to anemones and hydroids by their claws and proboscides. Most of the deep-sea species are known only as adults, and their mode of life is a mystery.

The Pycnogonida are classified primarily on the presence or absence of various anterior appendages; about 60 genera are recognized, grouped in 8 families: Nymphonidae, Callipallenidae, Phoxichilidiidae, Endeidae, Ammotheidae, Austrodecidae, Colossendeidae, and Pycnogonidae. See ARTHROPODA; PALAEOISOPUS.

[J.W.He.]

**Pygasteroidea** An order of Eognasthostomata which exhibits various stages in the backward migration of the anus out of the apical system. They have four genital pores, nonrenulate tubercles, and simple ambulacral plates. All members are referred to a single family, the Pygasteridae. They apparently arose from Triassic Pedinidae and occur in the Jurassic and Cretaceous of the Northern Hemisphere. They were formerly classified with other bilaterally symmetrical echinoids in the artificial assemblage Irregularia. See ECHINODERMATA; IRREGULARIA.

[H.B.F.]

**Pyrargyrite** A mineral having composition  $Ag_3SbS_3$ . The mineral occurs as prismatic crystals and in massive form and in disseminated grains. The hardness is 2.5 on Mohs scale and specific gravity is 5.85. The luster is adamantine and the color a deep ruby red to black, giving it the name dark ruby silver. Pyrargyrite is an important silver ore when it is found in veins associated with proustite and other silver minerals. It has been mined as silver ore at Chanarcillo, Chile; Freiberg, Germany; Guanajuato, Mexico; and Cobalt, Ontario, Canada. See PROUSTITE.

[C.S.Hu.]

**Pyrenomyces** The largest class in the phylum Ascomycota. The distinguishing feature of these fungi is the ascoma, or perithecium, that gives rise to the common name for the class, perithecial ascomycetes. Most ascomata are brown or black, but some are blue, yellow, or red. Ascomal ontogeny is ascohymental; coiled branches form on the hyphae to initiate ascoma formation, and they are quickly enveloped by layers of hyphae to form a wall around the coil, which subsequently differentiates into ascogenous hyphae that will form the asci. The internal tissues of the ascoma vary between species. In most species, a neck with a canal forms through which the ascospores will be discharged. The asci are formed in a cluster or layer in the base of the ascoma. Most have a single rigid wall (unitunicate), and the eight ascospores are forcibly discharged through a pore in the apex of the ascus, but in some the ascus wall dissolves. The ascospores are variable in color, size, shape, and number of cells. Most pyrenomyces also form abundant asexual conidia.

Pyrenomyces are widespread and occur primarily on living and dead plant materials. They may cause serious disease or act as agents of decomposition, producing a well-developed mycelium that may be superficial or immersed in the host or substrate. See ASCOMYCOTA; EUMYCOTA; FUNGI.

[R.T.Ha.]

**Pyrenulales** An order of the class Ascolichenes, also known as the Pyrenolichenes. The flask-shaped perithecia are uniformly immersed in the medulla of the thalli with a small ostiole opening at the surface. The asci and paraphyses arise from a blackened hypothecium and line the walls of the perithecium. The spores eventually burst the ascial walls and ooze out through the ostiole in a jelly matrix.

There are about 10 families, 50 genera, and more than 1500 species in the Pyrenulales. The major taxonomic criteria for separating genera and species are the septation and color of spores, since vegetative characters are so poorly developed. [M.E.H.]

**Pyridine** An organic heterocyclic compound containing a triunsaturated six-membered ring of five carbon atoms and one nitrogen atom. Pyridine (1) and pyridine homologs are obtained

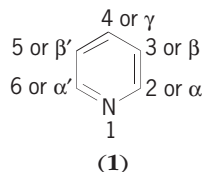

by extraction of coal tar or by synthesis. The pyridine system is found in natural products, for example, in nicotine (2) from tobacco, in ricinine (3) from castor bean, in pyridoxine or vitamin B<sub>6</sub> (4), in nicotinamide or niacinamide or vitamin P (5), and in several groups of alkaloids. See HETEROCYCLIC COMPOUNDS..

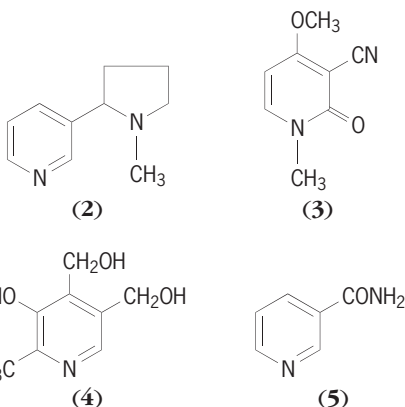

Pyridine (1) is a colorless, hygroscopic liquid with a pungent, unpleasant odor. When anhydrous it boils at 115.2–115.3°C (239.4–239.5°F). Pyridine is miscible with organic solvents as well as with water. The pyridine system is aromatic. It is stable to heat, to acid, and to alkali. Pyridine is used as a solvent for organic and inorganic compounds, as an acid binder, as a basic catalyst, and as a reaction intermediate.

Pyridine is an irritant to skin (eczema) and other tissues (conjunctivitis), and chronic exposure has been known to cause liver and kidney damage. Repeated exposure to atmospheric levels greater than 5 parts per million is considered hazardous.

[W.J.Ge.]

**Pyrimidine** A heterocyclic organic compound (1) containing nitrogen atoms at positions 1 and 3. Naturally occurring

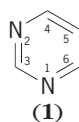

derivatives of the parent compound are of considerable biological importance as components of nucleic acids and coenzymes and, in addition, synthetic members of this group have found use as pharmaceuticals. See COENZYME; NUCLEIC ACID.

Pyrimidine compounds which are found universally in living organisms include uracil (2), cytosine (3), and thymine (4).

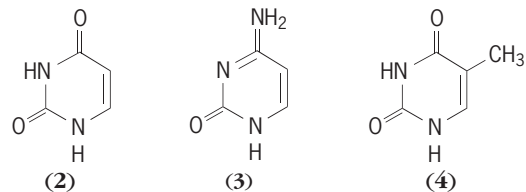

Together with purines these substances make up the “bases” of nucleic acids, uracil and cytosine being found characteristically in ribonucleic acids, with thymine replacing uracil in deoxyribonucleic acids. A number of related pyrimidines also occur in lesser amounts in certain nucleic acids. Other pyrimidines of general natural occurrence are orotic acid and thiamine (vitamin B<sub>1</sub>). See DEOXYRIBONUCLEIC ACID (DNA); PURINE; RIBONUCLEIC ACID (RNA).

Among the sulfa drugs, the pyrimidine derivatives, sulfadiazine, sulfamerazine, and sulfamethazine, have general formula (5). These agents are inhibitors of folic acid biosynthesis in mi-

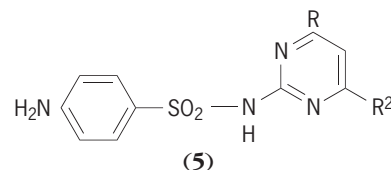

croorganisms. The barbiturates are pyrimidine derivatives which possess potent depressant action on the central nervous system. See BARBITURATES; SULFONAMIDE. [S.C.H.]

**Pyrite** A mineral having composition FeS<sub>2</sub>. Pyrite has a Mohs hardness of 6–6.5 and a density of 5.02. The luster is metallic, the color brass yellow, and the streak greenish black or brownish black.

Pyrite, or iron pyrites, is the most common “fool’s gold,” but it is hard and brittle whereas gold is soft and sectile. Its hardness also distinguishes it from softer chalcopyrite. Marcasite was once thought to be polymorphous with pyrite, but precise analyses show that marcasite contains excess iron, whereas pyrite is stoichiometric FeS<sub>2</sub>. See MARCASITE.

Pyrite is the most common and most widespread sulfide mineral. It forms under almost all known conditions of mineral deposition. Under oxidizing conditions, pyrite readily alters to iron sulfates and eventually to limonite, forming gossan, the surface expression of pyrite-rich mineral deposits. See LIMONITE.

Because of its high sulfur content (53.4%), pyrite has become a source of sulfur for the production of sulfuric acid. In some places, it is mined for sulfur alone. See SULFUR. [L.Gr.]

**Pyroclastic rocks** Rocks of extrusive (volcanic) origin, composed of rock fragments produced directly by explosive eruptions. Pyroclastic fragments may represent shattered and comminuted older rocks (volcanic, plutonic, sedimentary, or metamorphic) or solidified lava droplets formed by violent explosion. See TUFF; VOLCANO. [C.A.C.]

**Pyroelectricity** The property of certain crystals to produce a state of electric polarity by a change of temperature. Certain dielectric (electrically nonconducting) crystals develop an electric polarization (dipole moment per unit volume) when they are subjected to a uniform temperature change. This pyroelectric effect occurs only in crystals which lack a center of symmetry and also have polar directions (that is, a polar axis). These conditions are fulfilled for 10 of the 32 crystal classes. Typical examples of pyroelectric crystals are tourmaline, lithium sulfate monohydrate, cane sugar, and ferroelectric barium titanate.

Pyroelectric crystals can be regarded as having a built-in or permanent electric polarization. When the crystal is held at

constant temperature, this polarization does not manifest itself because it is compensated by free charge carriers that have reached the surface of the crystal by conduction through the crystal and from the surroundings. However, when the temperature of the crystal is raised or lowered, the permanent polarization changes, and this change manifests itself as pyroelectricity.

The magnitude of the pyroelectric effect depends upon whether the thermal expansion of the crystal is prevented by clamping or whether the crystal is mechanically unconstrained. In the clamped crystal, the primary pyroelectric effect is observed, whereas in the free crystal, a secondary pyroelectric effect is superposed upon the primary effect. The secondary effect may be regarded as the piezoelectric polarization arising from thermal expansion, and is generally much larger than the primary effect. See PIEZOELECTRICITY. [H.Gr.]

Pyroelectrics have a broad spectrum of potential scientific and technical applications. The most developed is the detection of infrared radiation. In addition, pyroelectric detectors can be used to measure the power generated by a radiation source (in radiometry), or the temperature of a remote hot body (in pyrometry, with corrections due to deviations from the blackbody emission). See PYROMETER; RADIOMETRY.

An infrared image can be projected on a pyroelectric plate and transformed into a relief of polarization on the surface. Other potential applications of pyroelectricity include solar energy conversion, refrigeration, information storage, and solid-state science. [A.Had.]

**Pyroelectricity (biology)** Electrical polarity in a biological material produced by a change in temperature. Pyroelectricity is probably a basic physical property of all living organisms. First discovered in 1966 in tendon and bone, it has since been shown to exist in most animal and plant tissues and in individual cells. Pyroelectricity appears to play a fundamental part in the growth processes (morphogenesis) and in physiological functions (such as sensory perception) of organisms. See PYROELECTRICITY.

The elementary components (for example, molecules) of biological (as well as of nonbiological) pyroelectric structures have a permanent electric dipole moment, and are arranged so that all positive dipole ends point in one direction and all negative dipole ends in the opposite direction. This parallel alignment of elementary dipoles is termed spontaneous polarization because it occurs spontaneously without the action of external fields or forces. In this state of molecular order, the structure concerned has a permanent electric dipole moment on a microscopic and macroscopic level. See DIPOLE MOMENT.

Spontaneous polarization is temperature-dependent; thus any change in temperature causes a change of the dipole moments, measurable as a change of electric charges at both ends of the polar axis. This is the pyroelectric effect. All pyroelectric structures are also piezoelectric, but the reverse is not true. See FERROELECTRICS; PIEZOELECTRICITY.

Prerequisites for the development of spontaneous polarization and pyroelectric activity in biological structures are (1) the presence of a permanent dipole moment in the molecules or molecular aggregates and (2) a molecular shape that favors a parallel alignment as much as possible (or at least does not impede it). Both these conditions are ideally fulfilled in bar- or board-shaped molecules with a permanent dipole moment along the longitudinal molecular axis. Several important organic substances have these molecular properties, and therefore behave pyroelectrically in biological structures. Examples include the epidermis of animals and plants, sensory receptors in animals, and tissues of the nervous and skeletal systems.

Living organisms are able to detect and discriminate between different stimuli in the environment, such as rapid changes of temperature, of illumination, and of hydrostatic and uniaxial pressure. These stimuli represent different forms of energy and are transduced, or converted, into the nearly uniform type of

electrical signals whose voltage-time course frequently depends on  $dX/dt$  ( $X$  = external stimulus,  $t$  = time). Such electrical signals have been recorded on cutaneous sensory receptors, on external nerve endings, on epidermal structures, and even on the cell wall of single-cell organisms. The mechanisms of detection and transduction in these biological systems, still little understood, may lie in the pyroelectric behavior of the structures. Pyroelectric (and thus piezoelectric) behavior has been proved to exist in most biological systems, which means that these systems should in principle be able to function as pyroelectric detectors and transducers. [H.A.]

**Pyrolusite** A mineral having composition  $MnO_2$ . Well-developed crystals (polianite) are rare; it is usually in radiating fibers or reniform coatings. The hardness is 1–2 on the Mohs scale (often soiling the fingers) and the specific gravity is 4.75. The luster is metallic and the color iron-black. It frequently forms pseudomorphs after other manganese minerals, notably manganite.

Pyrolusite is extensively mined as a manganese ore in many countries, chiefly in Russia, Ghana, India, the Republic of South Africa, Morocco, Brazil, and Cuba. See MANGANESE; MANGANITE. [C.S.Hu.]

**Pyrolysis** A chemical process in which a compound is converted to one or more products by heat. By this definition, reactions that occur by heating in the presence of a catalyst, or in the presence of air when oxidation is usually a simultaneous reaction, are excluded. The terms thermolysis or thermal reaction have been used in essentially the same sense as pyrolysis. A simple example of pyrolysis is the classic experiment in which oxygen was first prepared by heating mercuric oxide [reaction (1)].

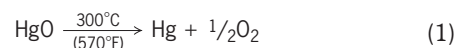

Similar reactions occur with numerous other metallic oxides and salts. Thermal decomposition or calcining of limestone (calcium carbonate) is the basic step in the manufacture of lime [reaction (2)].

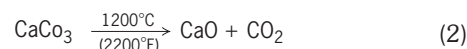

See LIME (INDUSTRY).

The term pyrolysis is most commonly associated with thermal reactions of organic compounds. Pyrolysis of material from plant and animal sources provided some of the first clues about constitution, as in the formation of isoprene from the thermal breakdown of rubber. A range of substances, including benzene, naphthalene, pyridine, and many other aromatic compounds, was obtained from coal tar, a pyrolysis product of coal. All of these pyrolysis processes lead to formation of volatile products characteristic of the source and also residues of char with high carbon content.

Pyrolysis reactions have been used as preparative methods and as means of generating transient intermediates that can be trapped or observed spectroscopically, or quenched by a further reaction. For preparative purposes, pyrolysis can generally be carried out by a flow process in which the reactant is vaporized with a stream of inert gas through a heated tube, sometimes at reduced pressure. In flash vacuum pyrolysis, the apparatus is placed under very low pressure, and the material to be pyrolyzed is vaporized by molecular distillation. See CHEMICAL DYNAMICS.

**Types of reactions.** At temperatures of 600–800°C (1100–1500°F), most organic compounds acquire sufficient vibrational energy to cause breaking of bonds with formation of free radicals. Alkanes undergo rupture of carbon-hydrogen (C-H) and carbon-carbon (C-C) bonds to two radicals that then react to give lower alkanes, alkenes, hydrogen, and also higher-molecular-weight



compounds resulting from their recombination [reactions (3)].

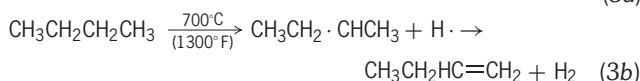
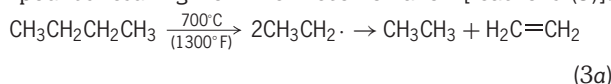

These reactions are the basis of the thermal cracking processes used in petroleum refining. Pyrolysis of simple aromatic hydrocarbons such as benzene or naphthalene produces aryl radicals, which can attack other hydrocarbon molecules to give bi- and polyaryls, as shown in reaction (4) for the formation of biphenyl.

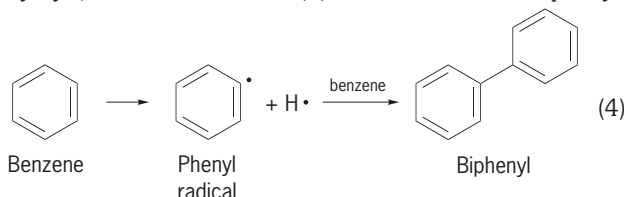

See CRACKING; FREE RADICAL.

Pyrolytic eliminations can result in formation of a multiple bond by loss of HX from a compound H—C—C—X, where X = any leaving group. A typical example is the pyrolysis of an ester, which is one of the general methods for preparing alkenes. Pyrolytic elimination is particularly useful when acid-catalyzed dehydration of the parent alcohol leads to cationic rearrangement. Another useful application of this process is the production of ketenes from acid anhydrides [reaction (5)].

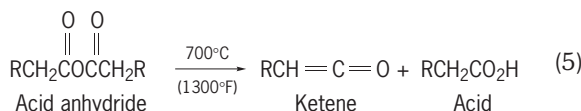

See ACID ANHYDRIDE; ALKENE; ESTER.

Another type of thermal elimination occurs by loss of a small molecule such as nitrogen (N<sub>2</sub>), carbon monoxide (CO), carbon dioxide (CO<sub>2</sub>), or sulfur dioxide (SO<sub>2</sub>), leading to reactive intermediates such as arynes, diradicals, carbenes, or nitrenes. The nitrene generated from aminobenzotriazole breaks down to benzyne at 0°C (32°F). Benzyne can be trapped by addition reaction or can dimerize to biphenylene. See REACTIVE INTERMEDIATES.

A number of pyrolytic reactions involve cleavage of specific C—C bonds in a carbon chain or ring. Fragmentation accompanied by transfer of hydrogen is a general reaction that occurs by a cyclic process. An example is decarboxylation of acids that contain a carbonyl group, which lose CO<sub>2</sub> on relatively mild heating. Acids with a double or triple carbon-to-carbon bond undergo decarboxylation at 300–400°C (570°–750°F). This type of reaction also occurs at higher temperatures with unsaturated alcohols and, by transfer of hydrogen from a C—H bond, with unsaturated ethers. Cleavage of a ring frequently occurs on pyrolysis. With alicyclic or heterocyclic four-membered rings, cleavage into two fragments is the reverse of 2 + 2 cycloaddition, as illustrated by the cracking of diketene [reaction (6)]. Pyrolysis is an important

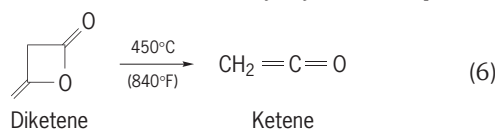

reaction in the chemistry of the pine terpenes, as in the conversion of  $\beta$ -pinene to myrcene. Benzocyclobutenes undergo ring opening to *o*-quinone dimethides. By combining this reaction in tandem with formation of the benzocyclobutene and a final Diels-Alder reaction, a versatile one-step synthetic method for the steroid ring system has been developed. See DIELS-ALDER REACTION; PINE TERPENE.

Many thermal reactions involve isomerization without elimination or fragmentation. These processes can occur by way of intermediates such as diradicals, as in the pyrolysis of pinene, or they may be concerted pericyclic reactions. An example of the latter is the Claisen-Cope rearrangement of phenyl or vinyl ethers and other 1,5-diene systems. These reactions can be carried out by relatively mild heating, and they are very useful in synthesis. See ORGANIC SYNTHESIS; PERICYCLIC REACTION.

**Analytical applications.** Thermal breakdown of complex structures leads to very complex mixtures of products arising from concurrent dissociation, elimination, and bond fission. Separation of these mixtures provides a characteristic pyrogram that is valuable as an analytical method, particularly for polymeric materials of both biological and synthetic origin. In this application, a small sample is heated on a hot filament or by laser. The pyrolysis products are then analyzed by gas chromatography, mass spectrometry, or a combination of both techniques. See GAS CHROMATOGRAPHY; MASS SPECTROMETRY.

Instrumentation with appropriate interfaces and data-handling systems has been developed to permit rapid and sensitive detection of pyrolysis products for a number of applications. One example is the optimization of conditions in petroleum cracking to produce a desired product from varied crude oils. The profile of pyrolysis fragments from a polymer can also be used to detect impurities. [J.A.Mo.]

**Pyrometallurgy** The branch of extractive metallurgy in which processes employing chemical reactions at elevated temperatures are used to extract metals from raw materials, such as ores and concentrates, and to treat recycled scrap metal.

For metal production, the pyrometallurgical operation commences with either a raw material obtained by mining and subsequent mineral and ore processing steps to produce a concentrate, or a recycled material such as separated materials from scrapped automobiles, machinery, or computers.

Pyrometallurgical preparation processes convert raw materials to forms suitable for future processing. Reduction processes reduce metallic oxides and compounds to metal. Oxidizing processes oxidize the feed material to an intermediate or a semifinished metal product. Refining processes remove the last of the impurities from a crude metal. See ELECTROMETALLURGY; IRON METALLURGY; METALLURGY; PYROMETALLURGY, NONFERROUS. [P.J.Ma.]

**Pyrometallurgy, nonferrous** The branch of extractive metallurgy in which processes employing chemical reactions at elevated temperatures are used to extract and refine nonferrous metals from ores, concentrates, and recycled materials. The entire process from feed to finished metal may be pyrometallurgical, or a pyrometallurgical step may be used in conjunction with other technologies. Increasingly, a mix of processes maximizes the efficiency and advantages of an overall operation.

The processes in pyrometallurgy in general can be classified as preparatory, reduction, oxidation, and metal refining. Treatment of a given raw material or metal may involve all these steps, or some of the steps may form a part of the total processing system, which may include nonpyrometallurgical operations.

In preparatory processes, the concentrate or upgraded ore or other feed is converted by chemical reaction to a form suitable for further processing. The most common subprocesses are drying and calcination, pyrolysis and hydrolysis, roasting, sintering, and chlorination. Even though a chemical reaction does not actually take place during drying, this subprocess is included since it is often part of a subsequent high-temperature operation such as smelting. In some cases, the preparatory process is carried out to provide a material that is amenable to treatment by hydrometallurgical processing, such as the roasting of zinc concentrates to produce a zinc calcine (essentially a zinc oxide intermediate product) which is leached with sulfuric acid solution for zinc

production, or it is a step such as calcination in the preparation of alumina for aluminum smelting.

Reduction processes effect the high-temperature reaction of a metal compound to the metal and its separation from the residue, as represented by the reaction below, where MX is the metal



compound, R the reacting or reducing agent, and M the metal. The reducing agent and reaction conditions (for example, temperature and pressure) and the concentration of reactants and products are selected to achieve a rapid or spontaneous reaction. These reactions usually require energy input.

The amount of reducing agent used should be low and inexpensive, relative to the value of the metal produced, while the product RX should be readily separable from the metal. Reducing agents commonly used in nonferrous pyrometallurgy include carbon (usually as coke), carbon monoxide gas (from coke), natural gas, iron and ferrosilicon (for Mg production), aluminum (for Ca production), and magnesium (for Ti, Zr, and Hf production).

For thousands of years, pyrometallurgical smelting of sulfide materials has been the key production method for nonferrous metals, in particular for copper, nickel, tin, lead, and zinc. This still remains the case on account of lower costs associated with new intensive technology and lower overall energy consumption. Formerly, it was common to roast such feed materials prior to the actual smelting operation. Roasting is still a major processing step in zinc and tin production. However, the roasting step for copper and nickel production was gradually eliminated, and during the latter part of the twentieth century continuous smelting processes were developed to directly treat sulfide concentrates, producing (by oxidation of the sulfide material) a high-grade copper matte product (~70% Cu) in a single step. In the case of lead, the metal itself can be readily produced directly. Oxidation processes are normally exothermic, a characteristic that has generally led to the development of autogenous processes, requiring virtually no fossil fuel.

Two basic types of smelting processes are used for copper or nickel production: flash smelting and bath smelting. In flash smelting, a fine concentrate feed is introduced into the furnace chamber, along with oxygen-enriched air, and the reaction principally occurs in a gas-phase system between the oxygen-bearing gas and solid particles. In bath smelting, a concentrate feed is introduced into the furnace melt, which is blown and kept highly agitated by submerged tuyeres (injecting the oxygen-enriched air), such that the feed is enveloped and reacts within the turbulent bath.

The new continuous lead smelting process can produce lead directly, while on account of the thermodynamics of the copper smelting system with the immiscible Cu-Cu<sub>2</sub>S phases being present, copper production is normally carried out in two stages: (1) copper concentrate smelting to produce a high-grade matte (typically 60–75% Cu, 4–12% Fe, ~21% S), a slag (approximately 27–30% FeO, 15–20% Fe<sub>3</sub>O<sub>4</sub>, 25–30% SiO<sub>2</sub>, 1–5% Cu), and a sulfur dioxide-rich gas (9–15% SO<sub>2</sub> at acid plant); and (2) copper matte converting, wherein the matte is oxidized or converted to metallic copper, producing a small amount of slag and sulfur dioxide gas.

A significant amount of copper is produced from recycled materials (such as from used automobiles, motors, old electrical appliances), and the pyrometallurgical processes are well able to handle this feed load on account of the flexibility as to feed type.

In metal refining processes, the starting material is generally an impure metal, usually produced in a primary production process. Impurities are removed to yield a final metal product, meeting a product specification. The processes are classified as (1) volatilization (separation of metal or metal compound as a gas from a liquid or solid); (2) dressing and precipitation (separation of the metal or impurities as a solid from the liquid melt); and (3) slag refining (separation of metal or impurities by their extraction from one liquid into a second immiscible liquid phase). [P.J.Ma.]

**Pyrometer** A temperature-measuring device, originally an instrument that measures temperatures beyond the range of thermometers, but now in addition a device that measures thermal radiation in any temperature range. This article discusses radiation pyrometers; for other temperature-measuring devices See BOLOMETER; THERMISTOR; THERMOCOUPLE.

The illustration shows a very simple type of radiation pyrometer. Part of the thermal radiation emitted by a hot object is intercepted by a lens and focused onto a thermopile. The resultant heating of the thermopile causes it to generate an electrical signal (proportional to the thermal radiation) which can be displayed on a recorder.

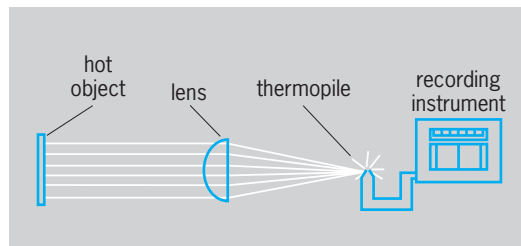

Elementary radiation pyrometer. (After D. M. Considine and S. D. Ross, *Process Instruments and Controls Handbook*, 2d ed., McGraw-Hill, 1974)

Unfortunately, the thermal radiation emitted by the object depends not only on its temperature but also on its surface characteristics. The radiation existing inside hot, opaque objects is so-called blackbody radiation, which is a unique function of temperature and wavelength and is the same for all opaque materials. However, such radiation, when it attempts to escape from the object, is partly reflected at the surface. In order to use the output of the pyrometer as a measure of target temperature, the effect of the surface characteristics must be eliminated. A cavity can be formed in an opaque material and the pyrometer sighted on a small opening extending from the cavity to the surface. The opening has no surface reflection, since the surface has been eliminated. Such a source is called a blackbody source, and is said to have an emittance of 1.00. By attaching thermocouples to the black-body source, a curve of pyrometer output voltage versus blackbody temperature can be constructed. See BLACKBODY; HEAT RADIATION.

Pyrometers can be classified generally into types requiring that the field of view be filled, such as narrow-band and total-radiation pyrometers; and types not requiring that the field of view be filled, such as optical and ratio pyrometers. The latter depend upon making some sort of comparison between two or more signals.

The optical pyrometer should more strictly be called the disappearing-filament pyrometer. In operation, an image of the target is focused in the plane of a wire that can be heated electrically. A rheostat is used to adjust the current through the wire until the wire blends into the image of the target (equal brightness condition), and the temperature is then read from a calibrated dial on the rheostat.

The ratio, or “two-color,” pyrometer makes measurements in two wavelength regions and electronically takes the ratio of these measurements. If the emittance is the same for both wavelengths, the emittance cancels out of the result, and the true temperature of the target is obtained. This so-called gray-body assumption is sufficiently valid in some cases so that the “color temperature” measured by a ratio pyrometer is close to the true temperature. See TEMPERATURE MEASUREMENT; THERMOMETER. [T.P.M.]

**Pyromorphite** A mineral series in the apatite group, or in the larger grouping of phosphate, arsenate, and vanadate-type minerals. In this series lead (Pb) substitutes for calcium (Ca) of

the apatite formula  $\text{Ca}_5(\text{PO}_4)_3(\text{F},\text{OH},\text{Cl})$ , and little fluorine (F) or hydroxide (OH) is present. See APATITE.

The pyromorphite series crystallizes in the hexagonal system. Crystals are prismatic. Other forms are granular, globular, and botryoidal. Pyromorphite colors range through green, yellow, and brown; vanadinite occurs in shades of yellow, brown, and red.

Pyromorphites are widely distributed as secondary minerals in oxidized lead deposits. Pyromorphite is a minor ore of lead; vanadinite is a source of vanadium and minor ore of lead. See LEAD; VANADIUM. [W.R.Lo.]

**Pyrophyllite** A hydrated aluminum silicate with composition  $\text{Al}_2\text{Si}_4\text{O}_{10}(\text{OH})_2$ . The mineral is commonly white, grayish, greenish, or brownish, with a pearly to waxy appearance and greasy feel. It occurs as compact masses, as radiating aggregates (see illustration), and as foliated masses. Pyrophyllite belongs to the layer silicate (phyllosilicate) group of minerals. The mineral is soft (hardness  $1-1\frac{1}{2}$  on the Mohs scale) and has easy cleavage parallel to the structural layers. The mineral is highly stable to acids.

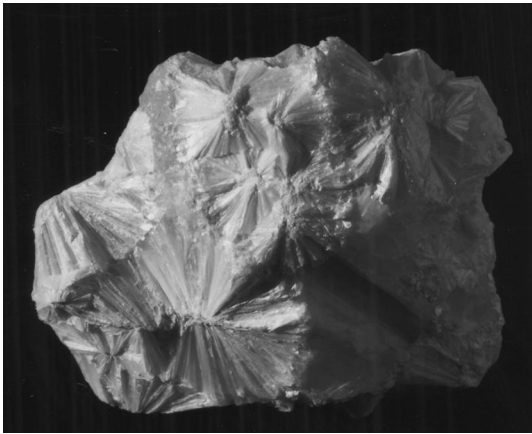

Specimen of pyrophyllite. (Pennsylvania State University)

Pyrophyllite is used principally for refractory materials and in other ceramic applications. The main sources for pyrophyllite in the United States are in North Carolina. An unusual form from the Transvaal is called African wonderstone. See SILICATE MINERALS. [G.W.Br.]

**Pyrotechnics** Mixtures of substances that produce noise, light, heat, smoke, or motion when ignited. They are used in matches, incendiaries, and other igniters; in fireworks and flares; in fuses and other initiators for primary explosives; in delay trains; for powering mechanical devices; and for dispersing materials such as insecticides.

Black powder, an intimate mixture of potassium nitrate, charcoal, and sulfur, was perhaps the earliest pyrotechnic and remains the most important one. It was discovered prior to A.D. 1000 in China during the Sung dynasty, where it was used in rockets and fireworks. Its introduction to Europe prior to 1242 eventually revolutionized warfare. Its use in blasting rock was also revolutionary, enabling rapid fragmentation of ore and other rock with a great reduction in manual labor.

A pyrotechnic mixture contains a fuel and an oxidizer, usually another ingredient to give a special effect, and often a binder. The oxidizer is usually a nitrate, perchlorate, chlorate, or peroxide of potassium, barium, or strontium. Fuels may be sulfur, charcoal, boron, magnesium, aluminum, titanium, or antimony sulfide. Examples of binders that are also fuels are dextrin and natural polysaccharides such as red gum. Salts of strontium, calcium, barium, copper, and sodium and powdered magnesium metal

when combined with a fuel and oxidizer can give the special effects of scarlet, brick red, green, blue-green, yellow, and white flames, respectively.

Many pyrotechnic mixtures are easily ignited by impact, friction, flame, sparks, or static electricity. Even those that burn quietly in small quantities can explode violently when ignited under confinement or in larger quantities. [D.L.C.]

**Pyrotheria** An extinct order of primitive, mastodonlike, herbivorous, hooped mammals restricted to the Eocene and Oligocene deposits of South America. There is only one family (Pyrotheriidae) in the order and four genera in the family.

The characters of this group superficially resembling those in early proboscideans are nasal openings over orbits indicating the presence of a trunk, strong neck musculature, and six upper and four lower bilophodont cheek teeth. Pyrotheres are distantly related to the members of the superorder Paenungulata, including Proboscidea, Xenungulata, and others. See PROBOSCIDEA; XENUNGULATA. [G.T.J.]

**Pyroxene** A large, geologically significant group of dark, rock-forming silicate minerals. Pyroxene is found in abundance in a wide variety of igneous and metamorphic rocks. Because of their structural complexity and their diversity of chemical composition and geologic occurrence, these minerals have been intensively studied by using a wide variety of modern analytical techniques. Knowledge of pyroxene compositions, crystal structures, phase relations, and detailed microstructures provides important information about the origin and thermal history of rocks in which they occur.

The general chemical formula for pyroxenes is  $\text{M}_2\text{M}_1\text{T}_2\text{O}_6$ , where T represents the tetrahedrally coordinated sites, occupied primarily by silicon cations ( $\text{Si}^{4+}$ ). Names of specific end-member pyroxenes are assigned based on composition and structure type. Those pyroxenes containing primarily calcium ( $\text{Ca}^{2+}$ ) or sodium ( $\text{Na}^+$ ) cations in the M2 site are monoclinic. Pyroxenes containing primarily  $\text{Mg}^{2+}$  or iron(II) ( $\text{Fe}^{2+}$ ) cations in the M2 site are orthorhombic at low temperatures, but they may transform to monoclinic at higher temperature. See CRYSTAL STRUCTURE; CRYSTALLOGRAPHY.

Common pyroxenes have specific gravity ranging from about 3.2 (enstatite, diopside) to 4.0 (ferrosilite). Hardnesses on the Mohs scale range from 5 to 6. Iron-free pyroxenes may be colorless (enstatite, diopside, jadeite); as iron content increases, colors range from light green or yellow through dark green or greenish brown, to brown, greenish black, or black (orthopyroxene, pigeonite, augite, hedenbergite, aegirine). Spodumene may be colorless, yellowish emerald green (hiddenite), or lilac pink (kunzite). See HARDNESS SCALES; SPODUMENE.

Pyroxenes in the rock-forming quadrilateral are essential constituents of ferromagnesian igneous rocks such as gabbros and their extrusive equivalents, basalts, as well as most peridotites. Pyroxenes may also be present as the dark constituents of more silicic diorites and andesites. See ANDESITE; BASALT; DIORITE; GABBRO; IGNEOUS ROCKS; PERIDOTITE.

Pyroxenes, especially those of the diopside-hedenbergite series, are found in medium- to high-grade metamorphic rocks of the amphibolite and granulite facies. See METAMORPHISM.

The peridotites found in the Earth's upper mantle contain Mg-rich, Ca-poor pyroxenes, in addition to olivine and other minor minerals. At successively greater depths in the mantle, these Mg-rich pyroxenes will transform sequentially to spinel ( $\text{Mg}_2\text{SiO}_4$ ) plus stishovite ( $\text{SiO}_2$ ), an ilmenite structure, or a garnet structure, depending on temperature; and finally at depths of around 360–420 mi (600–700 km) to an  $\text{MgSiO}_3$  perovskite structure. See ASTHENOSPHERE; EARTH INTERIOR; GARNET; ILMENITE; OLIVINE; PEROVSKITE; SILICATE MINERALS; SPINEL; STISHOVITE. [C.W.Bu.]

**Pyroxenite** A heavy, dark-colored, phaneritic (visibly crystalline) igneous rock composed largely of pyroxene with smaller

amounts of olivine or hornblende. Pyroxenite composed largely of orthopyroxene occurs with anorthosite and peridotite in large, banded gabbro bodies. Some of these pyroxenite masses are rich sources of chromium. Certain pyroxenites composed largely of clinopyroxene are also of magmatic origin, but many probably represent products of reaction between magma and limestone. Other pyroxene-rich rocks have formed through the processes of metamorphism and metasomatism. See GABBRO; IGNEOUS ROCKS; PERIDOTITE; PYROXENE. [C.A.C.]

**Pyroxenoid** A group of silicate minerals whose physical properties resemble those of pyroxenes. In contrast with the two-tetrahedra periodicity of pyroxene single silicate chains, the pyroxenoid crystal structures contain single chains of  $(\text{SiO}_4)^{4-}$  silicate tetrahedra having repeat periodicities ranging from three to nine (see illustration). The tetrahedron is a widely used geometric representation for the basic building block of most silicate minerals, in which all silicon cations ( $\text{Si}^{4+}$ ) are bonded to four oxygen anions arranged as if they were at the corners of a tetrahedron. In pyroxenoids, as in other single-chain silicates, two of the four oxygen anions in each tetrahedron are shared between two  $\text{Si}^{4+}$  cations to form the single chains, and the other two oxygen anions of each tetrahedron are bonded to divalent cations, such as calcium ( $\text{Ca}^{2+}$ ), iron ( $\text{Fe}^{2+}$ ), or manganese ( $\text{Mn}^{2+}$ ). These divalent cations bond to six (or sometimes seven or eight) oxygen anions, forming octahedral (or irregular seven- or eight-cornered) coordination polyhedra. See PYROXENE; SILICATE MINERALS.

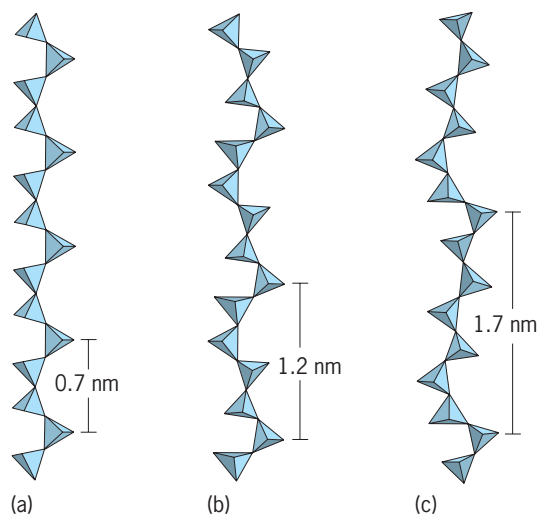

**Tetrahedral silicate chains in three pyroxenoid structures: (a) wollastonite with three-tetrahedra periodicity, (b) rhodonite with five-tetrahedra periodicity, and (c) pyroxmangite-pyroxferroite with seven-tetrahedra periodicity.**

The pyroxenoid structures have composite structural units consisting of strips of octahedra (or larger polyhedra) two or more units wide formed by sharing of polyhedral edges, to which the silicate tetrahedral chains are attached on both top and bottom. The repeat periodicity of the octahedral strips is the same as that of the silicate chains to which they are attached. These composite units are cross-linked to form the three-dimensional crystal structures. The pyroxenoid minerals are triclinic, with either  $\text{C}\bar{1}$  or  $\text{I}\bar{1}$  space-group symmetry depending on the stacking of the composite units, and *c*-axis lengths ranging from about 0.71 nanometer for three-repeat silicate tetrahedral chains to about 2.3 nm for nine-repeat chains. See CRYSTAL STRUCTURE.

There are two series of pyroxenoid minerals, one anhydrous

and one hydrous. The anhydrous pyroxenoids are significantly more abundant. A general formula for anhydrous pyroxenoids is  $(\text{Ca}, \text{Mn}, \text{Fe}^{2+})\text{SiO}_3$ . Silicate-chain repeat length is inversely proportional to mean divalent cation size. The hydrogen in hydrous pyroxenoids is hydrogen-bonded between two oxygen atoms; additional hydrogen in santaclaraite is bound as hydroxyl (OH) and as a water molecule ( $\text{H}_2\text{O}$ ). [C.W.Bu.]

**Pyrrhotite** A mineral with composition  $\text{Fe}_{1-x}\text{S}$  ( $x = 0$  to 0.2). Eskebornite,  $\text{Fe}_{1-x}\text{Se}$ , is the selenium analog. The iron-deficient pyrrhotites are ferrimagnetic at room temperature, but at some higher temperature they become paramagnetic, presumably because of vacancy disorder.

The mineral occurs as rounded grains to large masses, more rarely as tabular pseudo-hexagonal crystals and rosettes. Color is brownish bronze-yellow with dark grayish-black streaks. Hardness is 4 on Mohs scale and specific gravity 4.6 (for the composition  $\text{Fe}_7\text{S}_8$ ).

Pyrrhotite occurs in basic igneous rocks as a late-stage fractional differentiate, particularly in norites and gabbros, and sufficient quantities may constitute an ore of iron. Pyrrhotite also occurs with magnetite and chondrodite in contact metamorphic marbles, and in low-temperature veins with calcite and other sulfides and sulfosalts. [P.B.M.]

**Pyrrrole** One of a group of organic compounds containing a doubly unsaturated five-membered ring in which nitrogen occupies one of the ring positions. Pyrrole (**1**) is a representative compound. The pyrrole system is found in the green leaf pigment, chlorophyll, in the red blood pigment, hemoglobin, and in the blue dye, indigo. Interest in these colored bodies has been largely responsible for the intensive study of pyrroles. Tetrahydropyrrole, or pyrrolidine (**2**), is part of the structures of two



protein amino acids, proline and hydroxyproline. See HETEROCYCLIC COMPOUNDS; INDOLE; PORPHYRIN.

Pyrrole is a liquid that darkens and resinifies on standing in air, and that polymerizes quickly when treated with mineral acid. Familiar substitution processes, such as halogenation, nitration, sulfonation, and acylation, can be realized. Pyrrole, by virtue of its heterocyclic nitrogen, is very weakly basic. The hydrogen at the 1 position is removable as a proton, and accordingly, pyrrole is also an acid, although a weak one.

Pyrrolidine can be prepared by catalytic hydrogenation of pyrrole or by ring-closure reactions. Another derivative of pyrrole, 2-ketopyrrolidine, or pyrrolidone, is of considerable interest in connection with the preparation of polyvinylpyrrolidone. Pyrrolidone is combined with acetylene to form vinylpyrrolidone; polymerization of this material furnishes polyvinylpyrrolidone, which is suitable for maintaining osmotic pressure in blood and so acting as an extender for plasma or whole blood. See PYRIDINE. [W.J.Ge.]

**Pythagorean theorem** This theorem states that in any right triangle the square on the hypotenuse is equal to the sum of the squares on the other two sides:  $r^2 = x^2 + y^2$ . More than 100 different proofs have been given for this extremely important theorem of euclidean plane geometry.

The three-dimensional Pythagorean theorem may be phrased "the square of the diagonal of a rectangular box is equal to the sum of the squares of three adjacent edges that meet at a vertex:  $r^2 = x^2 + y^2 + z^2$ ." [J.S.F.]



**Q (electricity)** Often called the quality factor of a circuit,  $Q$  is defined in various ways, depending upon the particular application. In the simple  $RL$  and  $RC$  series circuits,  $Q$  is the ratio of reactance to resistance, as in Eqs. (1), where  $X_L$  is the inductive

$$Q = \frac{X_L}{R} \quad Q = \frac{X_C}{R} \quad (\text{a numerical value}) \quad (1)$$

reactance,  $X_C$  is the capacitive reactance, and  $R$  is the resistance. An important application lies in the dissipation factor or loss angle when the constants of a coil or capacitor are measured by means of the alternating-current bridge.

$Q$  has greater practical significance with respect to the resonant circuit, and a basic definition is given by Eq. (2), where

$$Q_0 = 2\pi \frac{\text{max stored energy per cycle}}{\text{energy lost per cycle}} \quad (2)$$

$Q_0$  means evaluation at resonance. For certain circuits, such as cavity resonators, this is the only meaning  $Q$  can have.

For the  $RLC$  series resonant circuit with resonant frequency  $f_0$ , Eq. (3) holds, where  $R$  is the total circuit resistance,  $L$  is the

$$Q_0 = \frac{2\pi f_0 L}{R} = \frac{1}{2\pi f_0 C R} \quad (3)$$

inductance, and  $C$  is the capacitance.  $Q_0$  is the  $Q$  of the coil if it contains practically the total resistance  $R$ . The greater the value of  $Q_0$ , the sharper will be the resonance peak.

The practical case of a coil of high  $Q_0$  in parallel with a capacitor also leads to  $Q_0 = 2\pi f_0 L/R$ .  $R$  is the total series resistance of the loop, although the capacitor branch usually has negligible resistance.

In terms of the resonance curve, Eq. (4) holds, where  $f_0$  is

$$Q_0 = \frac{f_0}{f_2 - f_1} \quad (4)$$

the frequency at resonance, and  $f_1$  and  $f_2$  are the frequencies at the half-power points. See RESONANCE (ALTERNATING-CURRENT CIRCUITS). [B.L.R.]

**Q meter** A direct-reading instrument widely used for measuring the  $Q$  of an electric circuit at radio frequencies. Originally designed to measure the  $Q$  of coils, the  $Q$  meter has been developed into a flexible, general-purpose instrument for determining many other quantities such as (1) the distributed capacity, effective inductance, and self-resonant frequency of coils; (2) the capacitance,  $Q$  or power factor, and self-resonant frequency of capacitors; (3) the effective resistance, inductance or capacitance, and the  $Q$  of resistors; (4) characteristics of intermediate- and radio-frequency transformers; and (5) the dielectric constant, dissipation factor, and power factor of insulating materials. See ELECTRICAL MEASUREMENTS; Q (ELECTRICITY). [I.F.K./E.C.St.]

**Quadrature** The condition in which the phase angle between two alternating quantities is  $90^\circ$ , corresponding to one-quarter of an electrical cycle. The electric and magnetic fields of electromagnetic radiation are in space quadrature, which means that they are at right angles in space. See ELECTROMAGNETIC RADIATION.

The current and voltage of a perfect coil are in quadrature because the coil current lags behind the coil voltage by exactly  $90^\circ$ . The current and voltage of a perfect capacitor are also in quadrature, but here the current leads the voltage by  $90^\circ$ . In these last two cases the current and voltage are in time quadrature.

[J. Mar.]

**Quadric surface** A surface defined analytically by an equation of the second degree in three variables. If these variables are  $x$ ,  $y$ ,  $z$ , such an equation has the form:

$$ax^2 + by^2 + cz^2 + 2exy + 2fxz + 2gyz + 2px + 2qy + 2rz + d = 0$$

Every plane section of such a surface is a conic. See CYLINDER; ELLIPSOID AND SPHEROID; HYPERBOLOID; PARABOLOID; SURFACE AND SOLID OF REVOLUTION. [J.S.F.]

**Qualitative chemical analysis** The branch of chemistry concerned with identifying the elements and compounds present in a sample of matter. Inorganic qualitative analysis traditionally used classical "wet" methods to detect elements or groups of chemically similar elements, but instrumental methods have largely superseded the test-tube methods. Methods for the detection of organic compounds or classes of compounds have become increasingly available and important in organic, forensic, and clinical chemistry. Once it is known which elements and compounds are present, the role of quantitative analysis is to determine the composition of the sample. See ANALYTICAL CHEMISTRY; QUANTITATIVE CHEMICAL ANALYSIS.

**Inorganic analysis.** The operating principles of all systematic inorganic qualitative analysis schemes for the elements are similar: separation into groups by reagents producing a phase change; isolation of individual elements within a group by selective reactions; and confirmation of the presence of individual elements by specific tests.

Through usage and tradition, descriptive terms for sample sizes have been:

macro	0.1 gram or more
semimicro	0.01 to 0.1 gram
micro	1 milligram (1 mg or $10^{-3}$ g)
ultramicro	1 microgram (1 $\mu$ g or $10^{-6}$ g)
submicrogram	less than 1 microgram

For defining the smallest amount of a substance that can be detected by a given method, the term "limit of identification" is used. Under favorable conditions, an extremely sensitive method can detect as little as  $10^{-15}$  g.

Spot tests are selective or specific single qualitative chemical tests carried out on a spot plate (a glass or porcelain plate with small depressions in which drop-size reactions can be carried out), on paper, or on a microscope slide. On paper or specially prepared adsorbent surfaces, spot tests become one- or two-dimensional through the use of solvent migration and differential adsorption (thin-layer chromatography). Containing selected indicator dyes, pH indicator paper strips are widely used for pH estimation. Solid reagent monitoring devices and indicator tubes

are used for the detection and estimation of pollutant gases in air. See CHROMATOGRAPHY; PH.

By use of the microscope, crystal size and habit can be used for qualitative identification. With the addition of polarized light, chemical microscopy becomes a versatile method. See CHEMICAL MICROSCOPY.

Any instrumental method of quantitative analysis can be adapted to qualitative analysis. Some, such as electrochemical methods, are not often used in qualitative analysis (an exception would be the ubiquitous pH meter). Others, such as column chromatography (gas and liquid) and mass spectrometry, are costly and uncomplicated but capable of providing unique results. Emission spectroscopy is important in establishing the presence or absence of a suspected element in forensic analysis. The simple qualitative flame test developed into flame photometry and subsequently into atomic absorption spectrometry. See ATOMIC SPECTROMETRY; FLAME PHOTOMETRY; SPECTROCHEMICAL ANALYSIS.

Bombardment of surfaces by x-rays, electrons, and positive ions has given rise to a number of methods useful in analytical chemistry. X-ray diffraction is used to determine crystal structure and to identify crystalline substances by means of their diffraction patterns. X-ray fluorescence analysis employs x-rays to excite emission of characteristic x-rays by elements. The electron microprobe uses electron bombardment in a similar manner to excite x-ray emission. See SECONDARY ION MASS SPECTROMETRY (SIMS); X-RAY DIFFRACTION; X-RAY FLUORESCENCE ANALYSIS.

Neutron activation analysis, wherein neutron bombardment induces radioactivity in isotopes of elements not naturally radioactive, involves measurement of the characteristic gamma radiation and modes of decay produced in the target atoms. See ACTIVATION ANALYSIS. [J.L.L.]

**Organic analysis.** Qualitative analysis of an organic compound is the process by which the characterization of its class and structure is determined. Due to the numerous classes of organic compounds and the complexity of their molecular structures, a systematic analytical procedure is often required.

A typical procedure entails an initial assignment of compound classification, followed by a complete identification of the molecular structure.

The initial step is an examination of the physical characteristics. Color, odor, and physical state can be valuable clues. The physical constants of an unknown compound provide pertinent data for the analyst. Constants such as melting point, boiling point, specific gravity, and refractive index are commonly measured.

The preliminary chemical tests which are applied are elemental analysis procedures. The elements generally associated with carbon, hydrogen, and oxygen are sulfur, nitrogen, and the halogens. The analyst is usually interested in the latter group. These elements are converted to water-soluble ionic compounds via sodium fusion. The resulting products are then detected with wet chemical tests. The solubility of a compound in various liquids provides information concerning the molecular weight and functional groups present in the compound. In order to indicate the presence or absence of a functional group, specific classification reactions are tested. The reactions are simple, are rapid, and require a small quantity of sample. No single test is conclusive evidence. A judicious choice of reactions can confirm or negate the presence of a functional group.

Instrumental methods are commonly applied for functional group determination and structure identification. Absorption spectroscopy and infrared absorption spectroscopy are among the most important techniques. Whenever a molecule is exposed to electromagnetic radiation, certain wavelengths cause vibrational, rotational, or electronic effects within the molecule. The radiation required to cause these effects is absorbed. The nature and configuration of the atoms determine which specific wavelengths are absorbed. Raman spectroscopy is slightly different from the other spectroscopic techniques. A sample is irradiated

by a monochromatic source. Depending upon the vibrational and rotational energies of the functional groups in the sample, light is scattered from the sample in a way which is characteristic of the functional groups. Instrumental techniques are also valuable for structure identification. In addition to infrared spectroscopy, nuclear magnetic resonance and mass spectrometry are widely used. Other, less common techniques are electron spin resonance, x-ray diffraction, and nuclear quadrupole spectroscopy. See INFRARED SPECTROSCOPY; MASS SPECTROMETRY; NUCLEAR MAGNETIC RESONANCE (NMR); RAMAN EFFECT.

In addition to chemical structure, the physical structure of a sample can be important. Thermal analysis is a useful procedure for examining structural characteristics. Among the most popular methods are thermogravimetry, differential thermal analysis, differential scanning calorimetry, and thermal mechanical analysis. See CALORIMETRY.

Although the implementation of instrumental methods has greatly simplified qualitative analytical procedures, no individual instrument is capable of complete identification for all samples. A complement of instrumental and wet chemical techniques is generally required for adequate proof of identification. See SPECTROSCOPY. [S.S.; K.Lo.]

**Quality control** The operational techniques and the activities that sustain the quality of a product or service in order to satisfy given requirements. Quality control is a major component of total quality management and is applicable to all phases of the product life cycle: design, development, manufacturing, delivery and installation, and operation and maintenance.

The quality-control cycle consists of four steps: quality planning, data collection, data analysis, and implementation. Quality planning consists of defining measurable quality objectives. Quality objectives are specific to the product or service and to the phase in their life cycle, and they should reflect the customer's requirements.

The collection of data about product characteristics that are relevant to the quality objectives is a key element of quality control. These data include quantitative measurements (measurement by variables), as well as determination of compliance with given standards, specifications, and required product features (measurement by attributes). Measurements may be objective, that is, of physical characteristics, which are often used in the control of the quality of services. Since quality control was originally developed for mass manufacturing, which relied on division of labor, measurements were often done by a separate department. However, in the culture of Total Quality Management, inspection is often done by the same individual or team producing the item.

The data are analyzed in order to identify situations that may have an adverse effect on quality and may require corrective or preventive action. The implementation of those actions as indicated by the analysis of the data is undertaken, including modifications of the product design or the production process, to achieve continuous and sustainable improvement in the product and in customer satisfaction.

The methods and techniques for data analysis in quality control are generic and can be applied to a variety of situations. The techniques are divided into three main categories: diagnostic techniques; process control, which includes process capability assessment and control charts; and acceptance sampling.

Diagnostic techniques serve to identify and pinpoint problems or potential problems that affect the quality of processes and products, and include the use of flowcharts, cause-and-effect diagrams, histograms, Pareto diagrams, location diagrams, scatter plots, and boxplots.

Process-control methods are applicable to systems that produce a stream of product units, either goods or services. They serve to control the processes that affect those product characteristics that are relevant to quality as defined in the quality objectives. For example, in a system that produces metal parts, some of the processes that might need to be controlled are

cutting, machining, deburring, bending, and coating. The relevant product characteristics are typically spelled out in the specifications in terms of physical dimensions, position of features, surface smoothness, material hardness, paint thickness, and so on. In a system that produces a service, such as a telephone help line, the relevant processes could be answering the call, identifying the problem, and solving the problem. The characteristics that are relevant to quality as perceived by the customer might include response time, number of referrals, frequency of repeat calls for the same problem, and elapsed time to closure.

Process control focuses on keeping the process operating at a level that can meet quality objectives, while accounting for random variations over which there is no control. There are two main aspects to process control: control charts and capability analysis. Control charts are designed to ascertain the statistical stability of the process and to detect changes in its level or variability that are due to assignable causes and can be corrected. Capability analysis considers the ability of the process to meet quality objectives as implied by the product specifications.

Process-control techniques were originally developed for manufactured goods, but they can be applied to a variety of situations as long as the statistical distribution of the characteristics of interest can be approximated by the normal distribution. In other cases, the principles still apply, but the formula may need to be modified to reflect the specific mathematical expression of the probability distribution functions. See PROCESS CONTROL.

Acceptance sampling refers to the procedures used to decide whether or not to accept product lots or batches based on the results of the inspection of samples drawn from the lots. Acceptance sampling techniques were originally developed for use by customers of manufactured products while inspecting lots delivered by their suppliers. These techniques are particularly well suited to situations where a decision on the quality level of product lots and their subsequent disposition needs to be made but it is not economic or feasible to inspect the entire production output. [T.Ra.]

**Quantitative chemical analysis** The determination of the amount of an element or compound in a sample. Selection of a technique is based in part on the size of sample available, the quantity of analyte expected to be in the sample, the precision and accuracy of the technique, and the speed of analysis required. All techniques require calibration with respect to some standard of known composition. Caution is necessary to prevent other substances from giving signals falsely attributable to the sought-for substance, called the analyte. See CALIBRATION.

Direct measurement of a signal related to concentration or activity of the chemical species of interest is the most intuitive approach. Generally, a linear relationship between signal (or its logarithm) and concentration (or its logarithm) is sought. The relationship between signal and concentration is called a working curve. The slope of the line describing the relationship is known as sensitivity. The smallest quantity which is measurably different from the absence of analyte is the detection limit. Although a linear working curve is the simplest form to use, nonlinear curves may still be employed (either graphically or with the use of computers).

Titration is the process by which an unknown quantity of analyte (generally in solution) is determined by adding to it a standard reagent with which it reacts in a definite and known proportion. A chemical or instrumental means is provided to indicate when the standard reagent has consumed exactly the amount of analyte initially present. Each determination is performed with a reagent whose concentration is directly traceable to a primary standard, so that accuracy is frequently superior to that of other methods. See STOICHIOMETRY; TITRATION.

The sensitivity of a method is related to the method and analyte of interest, as well as to the presence of other species in the sample. The materials other than the analyte constitute a sample matrix. For example, seawater is a matrix quite different

from distilled water because of the large amount of dissolved electrolyte present. If a signal can be derived from the analyte which is proportional to the amount of the analyte, but the sensitivity of the signal to concentration varies as a function of the sample matrix, the method of standard additions may be useful. The signal from the analyte is measured, after which small, known quantities of analyte are successively added to the sample, and the signal remeasured. The sensitivity of the method can thus be obtained, and the initial, preaddition signal interpreted to give the amount of analyte ( $C_1$ ) initially present by using the relationship shown in the equation below, where  $S_1$  is the initial

$$C_1 = \frac{\Delta C}{\Delta S} \cdot S_1$$

signal,  $C_1$  the initial quantity of analyte,  $\Delta C$  the standard addition of analyte, and  $\Delta S$  the change in the signal caused by the addition. The sensitivity is  $\Delta C/\Delta S$ .

This approach is applicable only in the absence of reagent blanks, that is, signals caused by the presence of analyte in the reagent used for the determination.

In many methods, aliquots of samples are introduced into the measurement instrument. The signal from the analyte may vary with sample uptake rate or volume. To compensate for such effects, an internal standard, or species other than the analyte, may be added to the analyte in a known concentration prior to determination. The signal due to the internal standard is measured simultaneously with the analyte signal. Variation of the signal of the internal standard is interpreted to indicate the variation in sample uptake, which should be the same for both analyte and internal standard. The ratio of analyte signal to internal standard signal is independent of sample uptake. Thus the ratio of analyte to internal standard signal is used to establish the working curve, rather than using analyte signal alone.

If the relationship between signal and analyte concentration is nonlinear, quantitation may require the use of null comparison. A signal is observed from the analyte and from a standard whose concentration can be adjusted in a known way. When the signal from the adjustable standard equals the signal from the analyte, the two have identical concentrations. This condition is called a null, as there is no detectable difference between the sample and reference signals.

It is good laboratory practice to check every quantitative measurement for the influence of species other than the one being sought. For example, a glass electrode designed to sense hydrogen ion will also respond to high concentrations of sodium ion. The degree to which a given sensor responds to one species in preference to another is called the selectivity coefficient. If a general detector is desired, this coefficient ideally should be 1.0. If a species-specific detector is desired, the coefficient should be infinite. A signal of unknown or general origin which appears to underlie the analyte signal is known as background. This quantity, together with that for the reagent blank, may be subtracted from the raw signal and thus be compensated. However, variations in their level may prevent reliable compensation, particularly when small quantities of analyte are to be determined.

For further information on common quantitative techniques see ACTIVATION ANALYSIS; CALORIMETRY; CHEMICAL MICROSCOPY; CHROMATOGRAPHY; COMBUSTION; ELECTRON SPECTROSCOPY; ELECTROPHORESIS; GAS CHROMATOGRAPHY; GEL PERMEATION CHROMATOGRAPHY; IMMUNOASSAY; IMMUNOELECTROPHORESIS; ION EXCHANGE; ISOTOPE DILUTION TECHNIQUES; KINETIC METHODS OF ANALYSIS; MASS SPECTROMETRY; NUCLEAR MAGNETIC RESONANCE (NMR); POLARIMETRIC ANALYSIS; SPECTROSCOPY; X-RAY SPECTROMETRY. [A.Sche.]

**Quantized electronic structure (QUEST)** A material that confines electrons in such a small space that their wavelike behavior becomes important and their properties are strongly modified by quantum-mechanical effects. Such structures occur in nature, as in the case of atoms, but can be

synthesized artificially with great flexibility of design and applications. They have been fabricated most frequently with layered semiconductor materials. Generally, the confinement regions for electrons in these structures are 1–100 nanometers in size. The allowable energy levels, motion, and optical properties of the electrons are strongly affected by the quantum-mechanical effects. The structures are referred to as quantum wells, wires, and dots, depending on whether electrons are confined with respect to motion in one, two, or three dimensions. Multiple closely spaced wells between which electrons can move by quantum-mechanical tunneling through intervening thin barrier-material layers are referred to as superlattices. See QUANTUM MECHANICS.

The most frequently used fabrication technique for quantized electronic structures is epitaxial growth of thin single-crystal semiconductor layers by molecular-beam epitaxy or by chemical vapor growth techniques. These artificially synthesized quantum structures find major application in high-performance transistors such as the microwave high-electron-mobility transistor (HEMT), and in high-performance solid-state lasers such as the semiconductor quantum-well laser. They also have important scientific applications for the study of fundamental two-dimensional, one-dimensional, and zero-dimensional physics problems in which particles are confined so that they have free motion in only two, one, or zero directions. Chemically formed nanocrystals, carbon nanotubes, zeolite cage compounds, and carbon buckyball  $C_{60}$  molecules are also important quantized electronic structures.

The optical applications are based on the interactions between light and electrons in the quantum structures. The absorption of a photon by an electron in a quantum well raises the electron from occupied quantum states to unoccupied quantum states. Electrons and holes in quantum wells may also recombine, with the resultant emission of photons from the quantized electronic structure as the electron drops from a higher state to a lower state. See ELECTRON-HOLE RECOMBINATION.

The photon emission is the basis for quantum-well semiconductor lasers, which have widespread applications in optical fiber communications and compact disk and laser disk optical recording. Quantum-well lasers operate by electrically injecting or pumping electrons into the lowest-conduction-band ( $n = 1$ ) quantum-well state, where they recombine with holes in the highest-valence-band ( $n = 1$ ) quantum-well state (that is, the electrons drop to an empty  $n = 1$  valence-band state; illus. a), producing the emission of photons. These photons stimulate further photon emission and produce high-efficiency lasing. See COMPACT DISK; LASER; OPTICAL COMMUNICATIONS; OPTICAL RECORDING.

The photon absorption is the basis for quantum-well photodetectors and light modulators. In the quantum-well infrared photodetector an electron is promoted from lower (say,  $n = 1$ ) to higher (say,  $n = 2$ ) conduction band quantum-well states (illus. b) by absorption of an infrared photon. An electron in the higher state can travel more freely across the barriers, enabling it to escape from the well and be collected in a detector circuit. Changes in quantum-well shapes produced by externally applied electric fields can change the absorption wavelengths for light in a quantized electronic structure. The shift in optical absorption wavelength with electric field is known as the quantum-confined Stark effect. It forms the basis for semiconductor light modulators and semiconductor optical logic devices. See OPTICAL DETECTORS; OPTICAL MODULATORS; STARK EFFECT.

Modulation doping is a special way of introducing electrons into quantum wells for electrical applications. The electrons come from donor atoms lying in adjacent barrier layers (illus. c). Modulation doping is distinguished from conventional uniform doping in that it produces carriers in the quantum well without introducing impurity dopant atoms into the well. Since there are no impurity atoms to collide with in the well, electrons there are free to move with high mobility along the quantum-well layer. Resistance to electric current flow is thus much reduced relative to electrical resistance in conventional semiconductors. This enhances

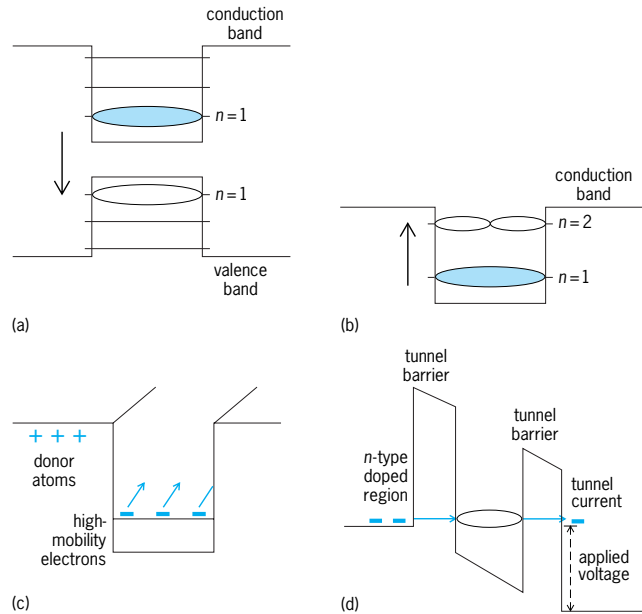

**Principles of operation of quantum-well devices. (a) Quantum-well laser. (b) Quantum-well infrared detector. (c) High-electron-mobility transistor (HEMT or MODFET). Electrons in the quantum well that came from donor atoms in the barrier are free to move with high mobility in the direction perpendicular to the page. (d) Resonant tunneling device.**

the low-noise and high-speed applications of quantum wells and is the basis of the high-electron-mobility transistor (HEMT), which is also known as the modulation-doped field-effect transistor (MODFET). HEMTs are widely used in microwave receivers for direct reception of satellite television broadcasts. See TRANSDUCER.

Electrical conductivity in carbon nanotubes occurs without doping and results from the absence of any energy gap in the electronic energy band structure of the nanotubes and the presence of allowed states at the Fermi energy. Individual nanotubes can be electrically contacted. Simple quantum wire transistors displaying quantized electron motion have been formed from single nanotubes.

Quantum-mechanical tunneling is another important property of quantized electronic structures. Tunneling of electrons through thin barrier layers between quantum wells is a purely quantum-mechanical effect without any real analog in classical physics or classical mechanics. It results from the fact that electrons have wavelike properties and that the particle waves can penetrate into the barrier layers. This produces a substantial probability that the particle wave can penetrate entirely through a barrier layer and emerge as a propagating particle on the opposite side of the barrier. The penetration probability has an exponential drop-off with barrier thickness. The tunneling is greatest for low barriers and thin barriers.

This effect finds application in resonant tunnel devices, which can show strong negative resistance in their electrical properties. In such a device (illus. d), electrons from an  $n$ -type doped region penetrate the barrier layers of a quantum well by tunneling. The tunneling current is greatest when the tunneling electrons are at the same energy as the quantum-well energy. The tunneling current actually drops at higher applied voltages, where the incident electrons are no longer at the same energy as the quantum-state energy, thus producing the negative resistance characteristic of the resonant tunneling diode. See ARTIFICIALLY LAYERED STRUCTURES; NANOSTRUCTURE; NEGATIVE-RESISTANCE CIRCUITS; RESONANCE (QUANTUM MECHANICS); TUNNELING IN SOLIDS.

[A.C.Go.]



**Quantized vortices** A type of flow pattern exhibited by superfluids, such as liquid  $^4\text{He}$  below 2.17 K ( $-455.76^\circ\text{F}$ ). The term vortex designates the familiar whirlpool pattern where the fluid moves circularly around a central line and the velocity diminishes inversely proportionally to the distance from the center. The strength of a vortex is determined by the circulation, which is the line integral of the velocity around any path enclosing the central line. See VORTEX.

A superfluid is believed to be characterized by a macroscopic (that is, large-scale) quantum-mechanical wave function  $\psi$ . This wave function locks the superfluid into a coherent state. Since the velocity around the vortex increases without limit as the center is approached, the superfluid density and thus  $\psi$  must vanish at the center in order to avoid an infinite energy. Thus the central core of the vortex marks the zeros, or nodal lines, in the macroscopic wave function. See QUANTUM MECHANICS.

Quantized vortex lines are usually produced by rotating a vessel containing superfluid helium. At very low rotation speeds, no vortices exist: the superfluid remains at rest while the vessel rotates. At a certain speed the first vortex appears and corresponds to the first excited rotational state of the system. If the container continues to accelerate, additional quantized vortices will appear. At any given speed the vortices form a regular array which rotates with the vessel.

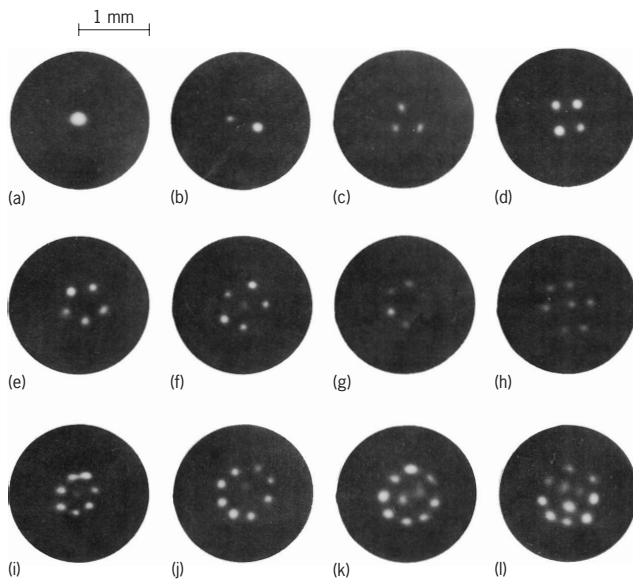

Stationary configurations of vortices which appear when a cylindrical container of superfluid  $^4\text{He}$  is rotated about its axis. As the rotation speed increases from  $a$  to  $l$ , more vortices appear and the patterns become more complex. (From E. J. Yarmchuk, M. J. V. Gordon, and R. E. Packard, *Observation of stationary vortex arrays in rotating superfluid helium*, *Phys. Rev. Lett.*, 43:214–217, 1979)

Quantized vortex lines were first detected in the mid-1950s by their influences on superfluid thermal waves traveling across the lines. In the late 1950s it was discovered that electrons in liquid helium form tiny charged bubbles which can become trapped on the vortex core but can move quite freely along the line. These electron bubbles (often referred to as ions) have been one of the most useful probes of quantized vortices. Researchers have been able to use ions to detect single quantized vortex lines. In one experiment the trapped ions are pulled out at the top of the vortex lines, accelerated, and focused onto a phosphor screen. The pattern of light thus produced on the phosphor is a map of the position of the vortices where they contact the liquid meniscus (see illustration). See LIQUID HELIUM; SUPERFLUIDITY. [R.E.P.]

**Quantum (physics)** A term characterizing an excitation in a wave or field, connoting fundamental particlelike properties

such as energy or mass, momentum, and angular momentum for this excitation. In general, any field or wave equation that is quantized, including systems already treated in quantum mechanics that are second-quantized, leads to a particle interpretation for the excitations which are called quanta of the field. This term historically was first applied to indivisible amounts of electromagnetic, or light, energy usually referred to as photons. The photon, or quantum of the electromagnetic field, is a massless particle, best interpreted as such by quantizing Maxwell's equations. Analogously, the electron can be said to be the quantum of the Dirac field through second quantization of the Dirac equation, which also leads to the prediction of the existence of the positron as another quantum of this field with the same mass but with a charge opposite to that of the electron. In similar fashion, quantization of the gravitational field equations suggests the existence of the graviton. The pi meson or pion was theoretically predicted as the quantum of the nuclear force field. Another quantum is the quantized lattice vibration, or phonon, which can be interpreted as a quantized sound wave since it travels through a quantum solid or fluid, or through nuclear matter, in the same manner as sound goes through air.

The use of quantum as an adjective (quantum mechanics, quantum electrodynamics) implies that the particular subject is to be treated according to the modern rules that have evolved for quantized systems. See ELEMENTARY PARTICLE; GRAVITATION; GRAVITON; MAXWELL'S EQUATIONS; MESON; PHONON; PHOTON; QUANTUM ELECTRODYNAMICS; QUANTUM FIELD THEORY; QUANTUM MECHANICS. [K.E.L.]

**Quantum acoustics** The investigation of the effects of the laws of quantum mechanics on the propagation and absorption of sound. At the present stage of development of physical science, quantum mechanics is the most fundamental theory of physical phenomena. However, for many applications in the everyday world, a sufficiently accurate description of nature is provided by classical mechanics. Quantum acoustics refers to acoustic experiments that are carried out under conditions such that the results can be understood only in terms of quantum theory. As a general tendency, quantum effects become more important in acoustic experiments that are performed with higher-frequency sound waves or that are carried out at lower temperatures. See NONRELATIVISTIC QUANTUM THEORY; QUANTUM MECHANICS.

**Sound and phonons.** To understand the quantum nature of sound, it is valuable to consider the origins of the quantum theory of light. Experiments in the latter part of the nineteenth century showed that the classical theory of electromagnetism combined with the laws of statistical mechanics could not explain the spectrum of light emitted by a heated surface. To reconcile theory and experiment, Max Planck in 1900 proposed that the energy of a light wave is quantized. This means that only certain values of the energy of the wave are allowed. These allowed values are given by the equation

$$E = n\hbar\omega$$

where  $\hbar$  is Planck's constant divided by  $2\pi$ ,  $\omega$  is the angular frequency of the light wave, and  $n$  is an integer. The modern interpretation of this formula describes this energy in terms of elementary quanta called photons. Each photon has an energy  $\hbar\omega$ , and the wave is made up of  $n$  photons. It was later realized that this same quantization of energy should apply to sound waves. These fundamental units of sound energy were given the name phonons. See HEAT RADIATION; LIGHT; PHONON; PHOTON.

**Phonoatomic effect.** One of the earliest experiments that confirmed the idea that light consists of photons was the photoelectric effect. In this effect the energy of light quanta is used to eject electrons from the surface of a metal. Only if the frequency of the light is sufficiently high do the photons have enough energy to knock the electrons out of the metal. The detection of this threshold frequency is thus strong evidence for quantization of energy. An analogous experiment has been performed with

sound. In the experiment, sound is generated by a source in a vessel of liquid helium maintained at very low temperature, less than 0.1 K above absolute zero. In liquid helium, each atom is bound to the other atoms in the liquid by an energy that is unusually small compared to that of other liquids. For sound of sufficiently high frequency, the sound quanta when they arrive at the surface of the liquid have sufficient energy to knock helium atoms out of the liquid. These atoms can be detected by a suitable receiver placed above the surface of the liquid. The energy of an ejected atom, which determines its velocity, is equal to the energy of a phonon minus the binding energy. The time of arrival of the ejected atoms at the receiver is, in turn, determined by this velocity and hence is dependent on the frequency of the sound wave. Experiments have confirmed that the helium atoms arrive at the time expected based on this theory. See PHOTOEMISSION.

**Phonon-phonon interactions.** Sound waves in solids are attenuated during their propagation by a wide variety of physical processes. In many materials the most important mechanisms are related to impurities or defects in the solid, such as cracks, grain boundaries, or dislocations. Even when sound travels through a perfect crystal containing no defects, it is found that a measurable attenuation still occurs. In insulating crystals, where there are no free electrons, this attenuation is due to an interaction between the sound wave and the random thermal vibrations of the atoms in the solid. These random vibrations, which constitute the heat energy of the solid, are also quantized and are called thermal phonons. The attenuation of the sound wave can be attributed to collisions with the thermal phonons in which some of the sound quanta are scattered out of the sound beam. This mechanism is referred to as phonon-phonon scattering. See CRYSTAL DEFECTS; LATTICE VIBRATIONS; SOUND ABSORPTION.

In a linear elastic solid the elastic stress is exactly proportional to the strain, a phenomenon that is called Hooke's law. If Hooke's law holds, the presence of one wave does not affect the propagation of another, and so there are no interactions between phonons. Phonon-phonon scattering occurs because real solids always exhibit some deviations from linear elastic behavior. This nonlinearity is called anharmonicity. See HOOKE'S LAW; NONLINEAR ACOUSTICS.

Even when the temperature is very low and there are very few thermal phonons, anharmonicity can still give rise to an attenuation of a sound wave. This is because the sound phonons can spontaneously decay into phonons of lower frequencies. The rate at which this decay occurs is proportional to the frequency of the sound wave to the fifth power, and so the attenuation is important only for sound waves of very high frequency. If the number of phonons is sufficiently large, it is possible under some circumstances for there to be a large buildup in the population of some of the decay phonons. This process is called parametric amplification. See PARAMETRIC AMPLIFIER. [H.J.Ma.]

**Quantum anomalies** Phenomena that arise when a quantity that vanishes according to the dynamical rules of classical physics acquires a finite value when quantum rules are used. For example, the classical Poisson bracket for some entities may vanish; yet the corresponding quantum commutator may be nonzero—this is a commutator anomaly. Alternatively, the flow of some material current may satisfy a continuity equation by virtue of the classical equations of motion, indicating conservative flow; but upon quantization the continuity equation may fail and the flow may no longer be conservative in the quantum theory—this is an anomalous divergence (of the current in question). Since the forms of Poisson brackets and quantum commutators as well as the occurrence of continuity equations for currents are related to symmetries and conservation laws of the theory, quantum anomalies serve to break some symmetries and destroy some conservation laws of classical models. This violation of symmetry is not driven by explicit symmetry-breaking terms in the dynamical equations—rather the quantization procedure itself violates the classical symmetry. The mathematical

reason for this phenomenon is that classical dynamics, involving a finite number of degrees of freedom, usually leads to a quantum theory on an infinite-dimensional vector space (Hilbert space), and this "infinity" gives rise to novel effects. See CANONICAL TRANSFORMATIONS; CONSERVATION LAWS (PHYSICS); EQUATION OF CONTINUITY; HILBERT SPACE; NONRELATIVISTIC QUANTUM THEORY; SYMMETRY LAWS (PHYSICS).

The physically interesting setting for these phenomena is in quantum field theory, especially as applied to elementary particle physics, where the mechanism serves as an important source for symmetry breaking. Quantum anomalies also play a role in various other branches of physics, in which quantum field theory finds application, including condensed matter, supersymmetry, string theory, and motion in curved space-time. See ELEMENTARY PARTICLE; QUANTUM FIELD THEORY; SPACE-TIME; SUPERSTRING THEORY; SUPERSYMMETRY; SYMMETRY BREAKING. [R.J.]

**Quantum chemistry** A branch of chemistry concerned with the application of quantum mechanics to chemical problems. More specifically, it is concerned with the electronic structure of molecules. Methods developed since 1960 permit the quantum chemist to obtain reliable approximate solutions to the nonrelativistic Schrödinger equation. The method which dominates the field of quantum chemistry is the Hartree-Fock or self-consistent-field approximation. See HAMILTON'S EQUATIONS OF MOTION; QUANTUM MECHANICS.

For closed-shell molecules, the form of the Hartree-Fock wave function is given by Eq. (1), in which  $A(n)$ , the antisymmetrizer

$$\Psi_{HF} = A(n)\phi_1(1)\phi_2(2) \dots \phi_n(n) \quad (1)$$

for  $n$  electrons, has the effect of making a Slater determinant out of the orbital product on which it operates. The  $\phi$ 's are spin orbitals, products of a spatial orbital  $\chi$  and a one-electron spin function  $\alpha$  or  $\beta$ . For any given molecular system, there are an infinite number of wave functions of form (1), but the Hartree-Fock wave function is the one for which the orbitals  $\phi$  have been varied to yield the lowest possible energy [Eq. (2)].

$$E = \int \Psi \times {}_{HF}H\Psi_{HF} d\tau \quad (2)$$

The resulting Hartree-Fock equations are relatively tractable due to the simple form of the energy  $E$  for single determinant wave functions [Eq. (3)].

$$E_{HF} = \sum_i I(i|i) + \sum_i \sum_{j>i} [(ij|ij) - (ij|ji)] \quad (3)$$

To solve the Hartree-Fock equations exactly, either the orbitals  $\phi$  must be expanded in a complete set of analytic basis functions or strictly numerical (that is, tabulated) orbitals must be obtained. The former approach is impossible from a practical point of view for systems with more than two electrons, and the latter has been accomplished only for atoms and for a few diatomic molecules. Therefore, the exact solution of the Hartree-Fock equations is abandoned for polyatomic molecules. Instead an incomplete (but reasonable) set of analytic basis functions is adopted and solved for the best variational [that is, lowest energy given by Eq. (2)] wave function of form (1). Such a wave function is referred to as being of self-consistent-field (SCF) quality. For very-large-basis sets, then, it is reasonable to refer to the resulting SCF wave function as near-Hartree-Fock.

For large chemical systems, only minimum basis sets (MBS) can be used in ab initio theoretical studies. The term "large" includes molecular systems, with 100 or more electrons.

Ab initio theoretical methods have had the greatest impact on chemistry in the area of structural predictions. The most encouraging aspect of ab initio geometry predictions is their reliability. Essentially all molecular structures appear to be reliably predicted at the Hartree-Fock level of theory. Even more encouraging, many structures are accurately reproduced by using only

minimum-basis-set self-consistent-field methods. A fairly typical example is methylenecyclopropane (see structure), with its

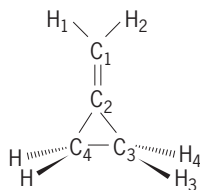

minimum-basis-set self-consistent-field structure compared with experiment in the table. Carbon-carbon bond distances differ typically by 0.002 nm from experiment, and angles are rarely in error by more than a few degrees. Thus, for many purposes, theory may be considered complementary to experiment in the area of structure prediction.

**Minimum-basis-set self-consistent-field geometry prediction compared with experiment for methylenecyclopropane**

Parameter*	Theory	Experiment
$r(C_1=C_2)$	0.1298 nm	0.1332 nm
$r(C_2=C_3)$	0.1474 nm	0.1457 nm
$r(C_3=C_4)$	0.1522 nm	0.1542 nm
$r(C_1-H_1)$	0.1083 nm	0.1088 nm
$r(C_3H_3)$	0.1083 nm	0.109
$\theta(H_1C_1H_2)$	116.0°	114.3°
$\theta(H_3C_3H_4)$	113.6°	113.5°
$\theta(H_{34}C_3C_4)$	149.4°	150.8°

\*Here  $r$  represents the carbon-carbon bond distance;  $\theta$  represents the bond angle in degrees of H-C-H bonds; the numbers on C and H correspond to the numbered atoms in the displayed structure.

The most important post-Hartree-Fock methods for quantum chemistry are perturbation theory and the configuration interaction (CI) and coupled cluster (CC) methods. These three rigorous approaches may be labeled “convergent” quantum-mechanical methods, as each is ultimately capable of yielding exact solutions to Schrödinger’s equation. The coupled cluster method treats excitations based on the number of electrons by which they differ from the Hartree-Fock reference function. Thus the CCSD method incorporates amplitudes differing by single (S) and double (D) excitations from Hartree-Fock. The CCSDT method adds all triple excitations to the CCSD treatment. As one goes to higher and higher excitations (for example, CCSDTQ includes all configurations differing by one, two, three, or four electrons from the Hartree-Fock reference configuration), one approaches the exact quantum-mechanical result.

In fact, coupled cluster theory beyond CCSD becomes impractical for large molecular systems. Thus, although the coupled cluster path to exact results is clear, it becomes a difficult road to follow. Triple excitations are sufficiently important that effective coupled cluster methods have been developed in which the effects of triples are approximated. The best of these methods, CCSD(T), is the closest thing to a panacea that exists today in quantum chemistry for very difficult problems involving smaller molecules. However, the range of applicability of the theoretically superior CCSD(T) method is much narrower than that of the popular hybrid Hartree-Fock/density functional methods. Thus, for most chemists the Hartree-Fock and density functional methods are likely to play central roles in molecular electronic structure theory for many years to come. See CHEMICAL BONDING; MOLECULAR ORBITAL THEORY; MOLECULAR STRUCTURE AND SPECTRA; RESONANCE (MOLECULAR STRUCTURE). [H.F.S.]

**Quantum chromodynamics** A theory of the strong (“nuclear”) interactions among quarks, which are regarded as fundamental constituents of matter. Quantum chromodynamics (QCD) seeks to explain why quarks combine in certain configurations to form the observed patterns of subnuclear particles, such as the proton and pi meson. According to this picture, the strong

interactions among quarks are mediated by a set of force particles known as gluons. Strong interactions among gluons may lead to new structures that correspond to as-yet-undiscovered particles. The long-studied nuclear force that binds protons and neutrons together in atomic nuclei is regarded as a collective effect of the elementary interactions among constituents of the composite protons and neutrons. See NUCLEAR STRUCTURE.

Quantum chromodynamics has not yet been subjected to precise experimental tests. Several qualitative predictions of quantum chromodynamics do seem to have been borne out. Part of the esthetic appeal of the theory is due to the fact that quantum chromodynamics is nearly identical in mathematical structure to quantum electrodynamics (QED) and to the unified theory of weak and electromagnetic interactions. This resemblance encourages the hope that a unified description of the strong, weak, and electromagnetic interactions may be at hand. See ELECTROWEAK INTERACTION; QUANTUM ELECTRODYNAMICS; WEAK NUCLEAR INTERACTIONS.

**Gauge theories.** At the heart of current theories of the fundamental interactions is the idea of gauge invariance. It is widely believed that gauge theories constructed to embody various symmetry principles represent the correct quantum-mechanical descriptions of the strong, weak, and electromagnetic interactions. See GAUGE THEORY; SYMMETRY LAWS (PHYSICS).

**Color.** Although the idea that the strongly interacting particles are built up of quarks brought new order to hadron spectroscopy and suggested new relations among mesons and baryons, the constituent description brought with it a number of puzzles. According to the Pauli exclusion principle, identical spin- $1/2$  particles cannot occupy the same quantum state. As a consequence, the observed baryons such as  $\Delta^{++}$  ( $uuu$ ) and  $\Omega^-$  ( $sss$ ), which would be composed of three identical quarks in the same state, would seem to be forbidden configurations. To comply with the Pauli principle, it is necessary to make the three otherwise identical quarks distinguishable by supposing that every flavor of quark exists in three varieties, fancifully labeled by the colors red, green, and blue. Color may be regarded as the strong-interaction analog of electric charge. Color cannot be created or destroyed by any of the known interactions. Like electric charge, it is said to be conserved. See COLOR (QUANTUM MECHANICS); EXCLUSION PRINCIPLE.

In the face of evidence that color could be regarded as the conserved charge of the strong interactions, it was natural to seek a gauge symmetry that would have color conservation as its consequence. An obvious candidate for the gauge symmetry group is the unitary group SU(3), now to be applied to color rather than flavor. The theory of strong interactions among quarks that is prescribed by local color gauge symmetry is known as quantum chromodynamics. The mediators of the strong interactions are eight massless spin-1 bosons, one for each generator of the symmetry group. These strong-force particles are named gluons because they make up the “glue” that binds quarks together into hadrons. Gluons also carry color and hence have strong interactions among themselves.

**Asymptotic freedom.** The theoretical description of the strong interactions has historically been inhibited by the very strength of the interaction, which renders low-order perturbative calculations untrustworthy. However, in 1973 it was found that in many circumstances the effective strength of the interaction in Yang-Mills theories becomes increasingly feeble at short distances, a property known as asymptotic freedom. For quantum chromodynamics, this remarkable observation implies that the interaction between quarks becomes weak at small separations. This discovery raises the hope that some aspects of the strong interactions might be treated by using familiar computational techniques that are predicated upon the smallness of the interaction strength.

**Quarkonium.** It was suggested in 1974 that the bound system of an extremely massive quark with its antiquark would be so small that the strong force would be extremely feeble. In this case,

the binding between quark and antiquark is mediated by the exchange of a single massless gluon, and the spectrum of bound states resembles that of an exotic atom composed of an electron and an antielectron (positron) bound electromagnetically in a Coulomb potential generated by the exchange of a massless photon. Since the electron-positron atom is known as positronium, the heavy quark-antiquark atom has been called quarkonium. Two families of heavy quark-antiquark bound states, the  $\psi/J$  system composed of charmed quarks and the  $\Upsilon$  system made up of  $b$  quarks, have been discovered. Both have level schemes characteristic of atomic spectra, which have been analyzed by using tools of nonrelativistic quantum mechanics developed for ordinary atoms. The atomic analogy has proved extremely fruitful for studying the strong interaction. See CHARM; J/PSI PARTICLE; POSITRONIUM.

**Lattice models.** To deal with the existence and properties of the hadrons themselves, it is necessary to devise a new computational approach that does not break down when the interaction becomes strong. The most promising method has been the crystal lattice formulation of the theory. By considering the values of the color field only on individual lattice sites, it is possible to use many of the techniques developed in statistical physics for the study of spin systems such as magnetic substances. See ELEMENTARY PARTICLE; FUNDAMENTAL INTERACTIONS; GLUONS; ISING MODEL; QUANTUM FIELD THEORY; QUARKS; STANDARD MODEL; STATISTICAL MECHANICS; STRONG NUCLEAR INTERACTIONS. [C.Q.]

**Quantum electrodynamics** The field of physics that studies the interaction of electromagnetic radiation with electrically charged matter within the framework of relativity and quantum mechanics. It is the fundamental theory underlying all disciplines of science concerned with electromagnetism, such as atomic physics, chemistry, biology, the theory of bulk matter, and electromagnetic radiation.

Efforts to formulate quantum electrodynamics (QED) were initiated by P. A. M. Dirac, W. Heisenberg, and W. Pauli soon after quantum mechanics was established. The first step was to remedy the obvious shortcoming of quantum mechanics: that it applies only to the case where particle speeds are small compared with that of light,  $c$ . This led to Dirac's discovery of a relativistic wave equation, in which the wave function has four components and is multiplied by certain  $4 \times 4$  matrices. His equation incorporates in a natural manner the observed electron-spin angular momentum, which implies that the electron is a tiny magnet. The strength of this magnet (magnetic moment) was predicted by Dirac and agreed with observation. A detailed prediction of the hydrogen spectrum was also in good agreement with experiment. See ATOMIC STRUCTURE AND SPECTRA; ELECTRON SPIN; MATRIX THEORY.

In order to go beyond this initial success and calculate higher-order effects, however, the interaction of charge and electromagnetic field had to be treated dynamically. To begin with, a good theoretical framework had to be found for describing the wave-particle duality of light, that is, the experimentally well-established fact that light behaves like a particle (photon) in some cases but like a wave in others. Similarly, the electron manifests wave-particle duality, another observed fact. Once this problem was settled, the next question was how to deal with the interaction of charge and electromagnetic field. It is here that the theory ran into severe difficulties. Its predictions often diverged when attempts were made to calculate beyond lowest-order approximations. This inhibited the further development of the theory for nearly 20 years. Stimulated by spectroscopic experiments vastly refined by microwave technology developed during World War II, however, S. Tomonaga, R. P. Feynman, and J. Schwinger discovered that the difficulties disappear if all observable quantities are expressed in terms of the experimentally measured charge and mass of the electron. With the discovery of this procedure, called renormalization, quantum electrodynamics became a theory in which all higher-order corrections are finite and well

defined. See NONRELATIVISTIC QUANTUM THEORY; PHOTON; QUANTUM MECHANICS; RELATIVISTIC QUANTUM THEORY; RELATIVITY; WAVE MECHANICS.

Quantum electrodynamics is the first physical theory ever developed that has no obvious intrinsic limitation and describes physical quantities from first principles. Nature accommodates forces other than the electromagnetic force, such as those responsible for radioactive disintegration of heavy nuclei (called the weak force) and the force that binds the nucleus together (called the strong force). A theory called the standard model, has been developed which unifies the three forces and accounts for all experimental data from very low to extremely high energies. This does not mean, however, that quantum electrodynamics fails at high energies. It simply means that the real world has forces other than electromagnetism.

High-precision tests have provided excellent confirmation for the validity of the renormalization theory of quantum electrodynamics. In the high-energy regime, tests using electron-positron colliding-beam facilities at various high-energy physics laboratories have confirmed the predictions of quantum electrodynamics at center-of-mass energies up to  $1.8 \times 10^{11}$  electronvolts (180 GeV). The uncertainty principle implies that this is equivalent to saying that quantum electrodynamics is valid down to about  $10^{-17}$  meter, a distance 100 times shorter than the radius of the proton.

High-precision tests of quantum electrodynamics have also been carried out at low energies by using various simple atomic systems. The most accurate is that of the measurement of the magnetic moment of the electron, or the gyromagnetic ratio  $g$ , the ratio of spin and rotation frequencies, which is correctly predicted by quantum electrodynamics to 12 significant figures. This is the most precise confirmation of any theory ever carried out. See QUANTUM FIELD THEORY. [T.K.]

**Quantum electronics** A loosely defined field concerned with the interaction of radiation and matter, particularly those interactions involving quantum energy levels and resonance phenomena, and especially those involving lasers and masers. Quantum electronics encompasses useful devices such as lasers and masers and their practical applications; related phenomena and techniques, such as nonlinear optics and light modulation and detection; and related scientific problems and applications, such as quantum noise processes, laser spectroscopy, picosecond spectroscopy, and laser-induced optical breakdown.

In one sense any electronic device, even one as thoroughly classical in nature as a vacuum tube, may be considered a quantum electronic device, since quantum theory is accepted to be the basic theory underlying all physical devices. In practice, however, quantum electronics is usually understood to refer to only those devices such as lasers and atomic clocks in which stimulated transitions between discrete quantum energy levels are important, together with related devices and physical phenomena which are excited or explored using lasers. Other devices such as transistors or superconducting devices which may be equally quantum-mechanical in nature are not usually included in the domain of quantum electronics. See ATOMIC CLOCK; LASER; LASER SPECTROSCOPY; MASER; NONLINEAR OPTICS; OPTICAL DETECTORS; OPTICAL MODULATORS; OPTICAL PULSES; QUANTUM MECHANICS. [A.E.S.]

**Quantum field theory** The quantum-mechanical theory of physical systems whose dynamical variables are local functions of space and time. As distinguished from the quantum mechanics of atoms, quantum field theories describe systems with an infinite number of degrees of freedom. Such theories provide the natural language for describing the interactions and properties of elementary particles, and have proved to be successful in providing the basis for the fundamental theories of the interactions of matter. The present understanding of the basic forces of nature is based on quantum field theories of the strong, weak,

electromagnetic, and gravitational interactions. Quantum field theory is also useful in the study of many-body systems, especially in situations where the characteristic length of a system is large compared to its microscopic scale. See NONRELATIVISTIC QUANTUM THEORY; QUANTUM MECHANICS.

Quantum field theory originated in the attempt, in the late 1920s, to unify P. A. M. Dirac's relativistic electron theory and J. C. Maxwell's classical electrodynamics in a quantum theory of interacting photon and electron fields. This effort was completed in the 1950s and was extremely successful. At present the quantitative predictions of the theory are largely limited to perturbative expansions (believed to be asymptotic) in powers of the fine-structure constant. However, because of the extremely small value of this parameter,  $\alpha = e^2/\hbar c \approx 1/137$  (where  $e$  is the electron charge,  $\hbar$  is Planck's constant divided by  $2\pi$ , and  $c$  is the speed of light), such an expansion is quite adequate for most purposes. The remarkable agreement of the predictions of quantum electrodynamics with high-precision experiments (sometimes to an accuracy of 1 part in  $10^{12}$ ) provides strong evidence for the validity of the basic tenets of relativistic quantum field theory. See CLASSICAL FIELD THEORY; ELECTROMAGNETIC RADIATION; MAXWELL'S EQUATIONS; PERTURBATION (QUANTUM MECHANICS); PHOTON; QUANTUM ELECTRODYNAMICS; RELATIVISTIC ELECTRODYNAMICS; RELATIVISTIC QUANTUM THEORY.

Quantum field theory also provides the natural framework for the treatment of the weak, strong, and gravitational interactions.

The first of such applications was Fermi's theory of the weak interactions, responsible for radioactivity, in which a hamiltonian was constructed to describe beta decay as a product of four fermion fields, one for each lepton or nucleon. This theory has been superseded by the modern electroweak theory that unifies the weak and the electromagnetic interactions into a common framework. This theory is a generalization of Maxwell's electrodynamics which was the first example of a gauge theory, based on a continuous local symmetry. In the case of electromagnetism the local gauge symmetry is the space-time-dependent change of the phase of a charged field. The existence of massless spin-1 particles, photons, is one of the consequences of the gauge symmetry. The electroweak theory is based on generalizing this symmetry to space-time-dependent transformations of the labels of the fields, based on the group  $SU(2) \times U(1)$ . However, unlike electromagnetism, part of this extended symmetry is not shared by the ground state of the system. This phenomenon of spontaneous symmetry breaking produces masses for all the elementary fermions and for the gauge bosons that are the carriers of the weak interactions, the  $W^\pm$  and  $Z$  bosons. (This is known as the Higgs mechanism.) The electroweak theory has been confirmed by many precision tests, and almost all of its essential ingredients have been verified. See ELECTROWEAK INTERACTION; GAUGE THEORY; INTERMEDIATE VECTOR BOSON; SYMMETRY BREAKING; SYMMETRY LAWS (PHYSICS); WEAK NUCLEAR INTERACTIONS.

The application of quantum field theory to the strong or nuclear interactions dates from H. Yukawa's hypothesis that the short-range nuclear forces arise from the exchange of massive particles that are the quanta of local fields coupled to the nucleons, much as the electromagnetic interactions arise from the exchange of massless photons that are the quanta of the electromagnetic field. The modern theory of the strong interactions, quantum chromodynamics, completed in the early 1970s, is also based on a local gauge theory. This is a theory of spin- $1/2$  quarks invariant under an internal local  $SU(3)$  (color) gauge group. The observed hadrons (such as the proton and neutron) are  $SU(3)$  color-neutral bound states of the quarks whose interactions are dictated by the gauge fields (gluons). This theory exhibits almost-free-field behavior of quarks and gluons over distances and times short compared to the size of a hadron (asymptotic freedom), and a strong binding of quarks at large separations that results in the absence of colored states (confinement). See ELEMENTARY PARTICLE; GLUONS; MESON; QUANTUM CHROMODYNAMICS; QUARKS.

Quantum field theory has been tested down to distances of  $10^{-20}$  m. There appears to be no reason why it should not continue to work down to Planck's length,  $(G\hbar/c^3)^{1/2} \approx 10^{-35}$  m (where  $G$  is the gravitational constant), where the quantum effects of gravity become important. In the case of gravity, A. Einstein's theory of general relativity already provides a very successful classical field theory. However, the union of quantum mechanics and general relativity raises conceptual problems that seem to call for a radical reexamination of the foundations of quantum field theory. See FUNDAMENTAL INTERACTIONS; GRAVITATION; QUANTUM GRAVITATION; RELATIVITY. [D.Gr.]

**Quantum gravitation** The quantum theory of the gravitational field; also, the study of quantum fields in a curved space-time. In classical general relativity, the gravitational field is represented by the metric tensor  $g_{\mu\nu}$  of space-time. This tensor satisfies Einstein's field equation, with the energy-momentum tensor of matter and radiation as a source. However, the equations of motion for the matter and radiation fields also depend on the metric.

Classical field theories such as Maxwell's electromagnetism or the classical description of particle dynamics are approximations valid only at the level of large-scale macroscopic observations. At a fundamental level, elementary interactions of particles and fields must be described by relativistic quantum mechanics, in terms of quantum fields. Because the geometry of space-time in general relativity is inextricably connected to the dynamics of matter and radiation, a consistent theory of the metric in interaction with quantum fields is possible only if the metric itself is quantized. See MAXWELL'S EQUATIONS; QUANTUM FIELD THEORY; RELATIVISTIC QUANTUM THEORY; RELATIVITY.

Under ordinary laboratory conditions the curvature of space-time is so extremely small that in most quantum experiments gravitational effects are completely negligible. Quantization in Minkowski space is then justified. Gravity is expected to play a significant role in quantum physics only at rather extreme conditions of strongly time-dependent fields, near or inside very dense matter. The scale of energies at which quantization of the metric itself becomes essential is given by  $(\hbar c^5/G)^{1/2} \approx 10^{19}$  GeV, where  $G$  is the gravitational constant,  $\hbar$  is Planck's constant divided by  $2\pi$ , and  $c$  is the velocity of light. Energies that can be reached in the laboratory or found in cosmic radiation are far below this order of magnitude. Only in the very early stages of the universe, within a proper time of the order of  $(G\hbar/c^5)^{1/2} \approx 10^{-43}$  s after the big bang, would such energies have been produced. See BIG BANG THEORY.

In most physical systems the metric is quasistationary over macroscopic distances so that its fluctuations can be ignored. A quantum description of fields in a curved space-time can then be given by treating the metric as a classical external field in interaction with the quantum fields.

**Quantum effects of black holes.** The most striking quantum effect in curved space-time is the emission of radiation by black holes. A black hole is an object that has undergone gravitational collapse. Classically this means that it becomes confined to a space-time region in which the metric has a singularity (the curvature becomes infinite). This region is bounded by a surface, called the horizon, such that any matter or radiation falling inside becomes trapped. Therefore, classically the mass of a black hole can only increase. However, this is no longer the case if quantum effects are taken into account. When, because of fluctuations of the quantum field, particle-antiparticle or photon pairs are created near the horizon of a black hole, one of the particles carrying negative energy may move toward the hole, being absorbed by it, while the other moves out with positive energy. See BLACK HOLE; GRAVITATIONAL COLLAPSE.

It is found that the total rate of emission is inversely proportional to the square of the mass. For stellar black holes whose masses are of the order of a solar mass, the emission rate is negligibly small and unobservable. Only primordial black holes, of

mass less than  $10^{13}$  kg, formed very early in the quantum era of the universe, would have been small enough to produce quantum effects that could play any significant role in astrophysics or in cosmology. See ASTROPHYSICS.

**Quantization of the metric.** There are basically two approaches to the quantization of the metric, the canonical and the covariant quantization. A third method, which can be derived from the first and is now most widely used, is based on the Feynman path integral representation for the vacuum-to-vacuum amplitude, which is the generator of Green's functions for the quantum theory. One important feature of this method is that since the topology of the manifold is not specified at the outset it is possible to include a sum over paths in different topologies. The outcome of this idea is that the vacuum would, at the level of the Planck length,  $(G\hbar/c^3)^{1/2} \approx 10^{-35}$  m, acquire a foamlike structure. See FEYNMAN INTEGRAL; GREEN'S FUNCTION.

At present a complete, consistent theory of quantum gravity is still lacking. The formal theory fails to satisfy the power-counting criterion for renormalizability. In every order of the perturbation expansion, new divergences appear which could only be canceled by counterterms that do not exist in the original lagrangian. This may not be just a technical problem but the reflection of a conceptual difficulty stemming from the dual role, geometric and dynamic, played by the metric. See RENORMALIZATION.

**Supergravity and superstrings.** Supergravity is a geometric extension of general relativity which incorporates the principle of supersymmetry. Supersymmetry is a kind of symmetry, discovered in the 1970s, that allows for the transformation of fermions and bosons into each other. (Fermions carry half-integer spin while bosons carry integer spin; they also obey different statistics.) Supergravity can be formulated in space-time manifolds with a total of  $D = d + 1$  dimensions, where  $d$ , the number of space dimensions, can be as large as 10. They constitute truly unified theories of all interactions including gravity.

In the early 1980s, some encouraging results were found with a theory based on the idea that the basic objects of nature are not pointlike but actually one-dimensional objects like strings, which can be open or closed. Incorporating supersymmetry into the theory leads to a critical dimension  $D = 10$ .

In the approximation of neglecting string excitations, certain superstring models may be described in terms of local fields as a  $D = 10$  supergravity theory. At present, these are the only theories that both include gravity and can be consistently quantized. Although a superstring theory may eventually become the ultimate theory of all the interactions, there is still a very long way to go in making the connection between its fundamental fields and the fields representing the particles and their interactions as observed at low energies. See FUNDAMENTAL INTERACTIONS; GRAVITATION; SUPERGRAVITY; SUPERSTRING THEORY; SUPERSYMMETRY. [S.W.MacD.]

**Quantum mechanics** The modern theory of matter, of electromagnetic radiation, and of the interaction between matter and radiation; also, the mechanics of phenomena to which this theory may be applied. Quantum mechanics, also termed wave mechanics, generalizes and supersedes the older classical mechanics and Maxwell's electromagnetic theory. Atomic and subatomic phenomena provide the most striking evidence for the correctness of quantum mechanics and best illustrate the differences between quantum mechanics and the older classical physical theories. Quantum mechanics is needed to explain many properties of bulk matter, for instance, the temperature dependence of the specific heats of solids.

The formalism of quantum mechanics is not the same in all domains of applicability. In approximate order of increasing conceptual difficulty, mathematical complexity, and likelihood of future fundamental revision, these domains are the following: (i) Nonrelativistic quantum mechanics, applicable to systems in

which particles are neither created nor destroyed, and in which the particles are moving slowly compared to the velocity of light. Here a particle is defined as a material entity having mass, whose internal structure either does not change or is irrelevant to the description of the system, (ii) Relativistic quantum mechanics, applicable in practice to a single relativistic particle (one whose speed equals or nearly equals  $c$ ); here the particle may have zero rest mass, in which event, its speed must equal  $c$ . (iii) Quantum field theory, applicable to systems in which particle creation and destruction can occur; the particles may have zero or nonzero rest mass. This article is concerned mainly with non-relativistic quantum mechanics, which apparently applies to all atomic and molecular phenomena, with the exception of the finer details of atomic spectra. Nonrelativistic quantum mechanics also is well established in the realm of low-energy nuclear physics. See ATOMIC STRUCTURE AND SPECTRA; NUCLEAR PHYSICS; QUANTUM FIELD THEORY; RELATIVISTIC QUANTUM THEORY.

**Planck's constant.** The quantity  $6.626 \times 10^{-34}$  joule-second, first introduced into physical theory by Max Planck in 1901, is a basic ingredient of the formalism of quantum mechanics. Planck's constant commonly is denoted by the letter  $h$ ; the notation  $\hbar = h/2\pi$  also is standard.

**Uncertainty principle.** In classical physics the observables characterizing a given system are assumed to be simultaneously measurable (in principle) with arbitrarily small error. For instance, it is thought possible to observe the initial position and velocity of a particle and therewith, using Newton's laws, to predict exactly its future path in any assigned force field. According to the uncertainty principle, accurate measurement of an observable quantity necessarily produces uncertainties in one's knowledge of the values of other observables. In particular, for a single particle relation (1a) holds, where  $\Delta x$  represents the uncertainty

$$\Delta x \Delta p_x > \hbar \quad (1a)$$

$$\Delta t \Delta E \gtrsim \hbar \quad (1b)$$

(error) in the location of the  $x$  coordinate of the particle at any instant, and  $\Delta p_x$  is the simultaneous uncertainty in the  $x$  component of the particle momentum. Relation (1a) asserts that under the best circumstances, the product  $\Delta x \Delta p_x$  of the uncertainties cannot be less than about  $10^{-34}$  joule second.

The uncertainty relation (1b) is derived and interpreted somewhat differently than relation (1a); it asserts that for any system, an energy measurement with error  $\Delta E$  must be performed in a time not less than  $\Delta t \sim \hbar/\Delta E$ . If a system endures for only  $\Delta t$  seconds, any measurement of its energy must be uncertain by at least  $\Delta E \sim \hbar/\Delta t$ . See UNCERTAINTY PRINCIPLE.

**Wave-particle duality.** It is natural to identify such fundamental constituents of matter as protons and electrons with the mass points or particles of classical mechanics. According to quantum mechanics, however, these particles, in fact all material systems, necessarily have wavelike properties. Conversely, the propagation of light, which, by Maxwell's electromagnetic theory, is understood to be a wave phenomenon, is associated in quantum mechanics with massless energetic and momentum-transporting particles called photons. The quantum-mechanical synthesis of wave and particle concepts is embodied in the de Broglie relations, given by Eqs. (2a) and (2b). These give the

$$\lambda = h/p \quad (2a)$$

$$f = E/h \quad (2b)$$

wavelength  $\lambda$  and wave frequency  $f$  associated with a free particle (a particle moving freely under no forces) whose momentum is  $p$  and energy is  $E$ ; the same relations give the photon momentum  $p$  and energy  $E$  associated with an electromagnetic wave in free space (that is, in a vacuum) whose wavelength is  $\lambda$  and frequency is  $f$ . See PHOTON.

The wave properties of matter have been demonstrated conclusively for beams of electrons, neutrons, atoms (hydrogen, H, and helium, He), and molecules ( $H_2$ ). When incident upon

crystals, these beams are reflected into certain directions, forming diffraction patterns. Diffraction patterns are difficult to explain on a particle picture; they are readily understood on a wave picture, in which wavelets scattered from regularly spaced atoms in the crystal lattice interfere constructively along certain directions only. See ELECTRON DIFFRACTION; NEUTRON DIFFRACTION.

The particle properties of light waves are observed in the photoelectric effect and the Compton effect. See COMPTON EFFECT; PHOTOEMISSION.

**Complementarity.** Wave-particle duality and the uncertainty principle are thought to be examples of the more profound principle of complementarity, first enunciated by Niels Bohr (1928). According to the principle of complementarity, nature has "complementary" aspects; an experiment which illuminates one of these aspects necessarily simultaneously obscures the complementary aspect. To put it differently, each experiment or sequence of experiments yields only a limited amount of information about the system under investigation; as this information is gained, other equally interesting information (which could have been obtained from another sequence of experiments) is lost. Of course, the experimenter does not forget the results of previous experiments, but at any instant, only a limited amount of information is usable for predicting the future course of the system.

**Quantization.** In classical physics the possible numerical values of each observable, meaning the possible results of exact measurement of the observable, generally form a continuous set. For example, the  $x$  coordinate of the position of a particle may have any value between  $-\infty$  and  $+\infty$ . In quantum mechanics the possible numerical values of an observable need not form a continuous set, however. For some observables, the possible results of exact measurement form a discrete set; for other observables, the possible numerical values are partly discrete, partly continuous; for example, the total energy of an electron in the field of a proton may have any positive value between 0 and  $+\infty$ , but may have only a discrete set of negative values, namely,  $-13.6$ ,  $-13.6/4$ ,  $-13.6/9$ ,  $-13.6/16$  eV, . . . Such observables are said to be quantized; often there are simple quantization rules determining the quantum numbers which specify the allowable discrete values. Spectroscopy, especially the study of atomic spectra, probably provides the most detailed quantitative confirmation of quantization.

**Probability considerations.** The uncertainty and complementarity principles, which limit the experimenter's ability to describe a physical system, must limit equally the experimenter's ability to predict the results of measurement on that system. Suppose, for instance, that a very careful measurement determines that the  $x$  coordinate of a particle is precisely  $x = x_0$ . This is permissible in nonrelativistic quantum mechanics. Then formally, the particle is known to be in the eigenstate corresponding to the eigenvalue  $x = x_0$  of the  $x$  operator. Under these circumstances, an immediate repetition of the position measurement again will indicate that the particle lies at  $x = x_0$ . Knowing that the particle lies at  $x = x_0$  makes the momentum  $p_x$  of the particle completely uncertain, however, according to relation (1a). A measurement of  $p_x$  immediately after the particle is located at  $x = x_0$  could yield any value of  $p_x$  from  $-\infty$  to  $+\infty$ .

More generally, suppose the system is known to be in the eigenstate corresponding to the eigenvalue  $\alpha$  of the observable  $A$ . Then for any observable  $B$ , which is to some extent complementary to  $A$ , that is, for which an uncertainty relation of the form of relations (1) limits the accuracy with which  $A$  and  $B$  can simultaneously be measured, it is not possible to predict which of the many possible values  $B = \beta$  will be observed. However, it is possible to predict the relative probabilities  $P_\alpha(\beta)$  of immediately thereafter finding the observable  $B$  equal to  $\beta$ , that is, of finding the system in the eigenstate corresponding to the eigenvalue  $B = \beta$ .

To the eigenvalues correspond eigenfunctions, in terms of which  $P_\alpha \lesssim \beta$  can be computed. In particular, when  $\alpha$  is a discrete eigenvalue of  $A$ , and the operators depend only on  $x$  and

$p_x$ , the probability  $P_\alpha(\beta)$  is postulated as in Eq. (3), where  $u(x, \alpha)$

$$P_\alpha(\beta) = \left| \int_{-\infty}^{\infty} dx v^*(x, \beta) u(x, \alpha) \right|^2 \quad (3)$$

is the eigenfunction corresponding to  $A = \alpha$ ;  $v(x, \beta)$  is the eigenfunction corresponding to  $B = \beta$ ; and the  $*$  denotes the complex conjugate. The integral in Eq. (3) is called the projection of  $u(x, \alpha)$  on  $v(x, \beta)$ . The quantity  $|u(x, \alpha)|^2 dx$  is the probability that the system, known to be in the eigenstate  $A = \alpha$ , will be found in the interval  $x$  to  $x + dx$ . See EIGENVALUE (QUANTUM MECHANICS).

**Wave function.** When the system is known to be in the eigenstate corresponding to  $A = \alpha$ , the eigenfunction  $u(x, \alpha)$  is the wave function; that is, it is the function whose projection on an eigenfunction  $v(x, \beta)$  of any observable  $B$  gives the probability of measuring  $B = \beta$ . The wave function  $\psi(x)$  may be known exactly; in other words, the state of the system may be known as exactly as possible (within the limitations of uncertainty and complementarity), even though  $\psi(x)$  is not the eigenfunction of a known operator. This circumstance arises because the wave function obeys Schrödinger's wave equation. Knowing the value of  $\psi(x)$  at time  $t = 0$ , the wave equation completely determines  $\psi(x)$  at all future times. In general, however, if  $\psi(x, 0) = u(x, \alpha)$ , that is, if  $\psi(x, t)$  is an eigenfunction of  $A$  at  $t = 0$ , then  $\psi(x, t)$  will not be an eigenfunction of  $A$  at later times  $t > 0$ .

A system described by a wave function is said to be in a pure state. Not all systems are described by wave functions, however. For example, a beam of hydrogen atoms streaming out of a small hole in a hydrogen discharge tube can be regarded as a statistical ensemble or mixture of pure states oriented with equal probability in all directions.

**Schrödinger equation.** Equation (4) describes a plane wave of frequency  $f$ , wavelength  $\lambda$ , and amplitude  $A(\lambda)$ , propagating

$$\psi(x, t) = A(\lambda) \exp \left[ 2\pi i \left( \frac{x}{\lambda} - ft \right) \right] \quad (4)$$

in the positive  $x$  direction. The previous discussion concerning wave-particle duality suggests that this is the form of the wave function for a beam of free particles moving in the  $x$  direction with momentum  $p = p_x$ , with Eq. (2) specifying the connections between  $f$ ,  $\lambda$ , and  $E$ ,  $p$ . Differentiating Eq. (4), it is seen that Eqs. (5) hold. Since for a free particle  $E = p^2/2m$ , it follows also that Eq. (6) is valid.

$$p_x \psi = \frac{h}{\lambda} \psi = \frac{\hbar}{i} \frac{\partial \psi}{\partial x} \quad (5a)$$

$$E \psi = hf \psi = -\frac{\hbar}{i} \frac{\partial \psi}{\partial t} \quad (5b)$$

$$\frac{-\hbar^2}{2m} \frac{\partial^2 \psi}{\partial x^2} = -\frac{\hbar}{i} \frac{\partial \psi}{\partial t} \quad (6)$$

See WAVE MOTION.

Equation (6) holds for a plane wave of arbitrary  $\lambda$ , and therefore for any superposition of waves of arbitrary  $\lambda$ , that is, arbitrary  $p_x$ . Consequently, Eq. (6) should be the wave equation obeyed by the wave function of any particle moving under no forces, whatever the projections of the wave function on the eigenfunctions of  $p_x$ . Equations (5) and (6) further suggest that for a particle whose potential energy  $V(x)$  changes, in other words, for a particle in a conservative force field,  $\psi(x, t)$  obeys Eq. (7).

$$\frac{-\hbar^2}{2m} \frac{\partial^2 \psi}{\partial x^2} + V(x) \psi = -\frac{\hbar}{i} \frac{\partial \psi}{\partial t} \quad (7)$$

Equation 7 is the time-dependent Schrödinger equation for a one-dimensional (along  $x$ ), spinless particle. Noting Eq. (5b), and observing that Eq. (7) has a solution for the form of Eq. (8), it is inferred that  $\psi(x)$  of Eq. (8) obeys the time-dependent Schrödinger equation, Eq. (9).

$$\psi(x, t) = \psi(x) \exp(-iEt/\hbar) \quad (8)$$

$$\frac{-\hbar^2}{2m} \frac{\partial^2 \psi}{\partial x^2} + V(x) \psi = E \psi \quad (9)$$

See FORCE.

Equation (9) is solved subject to reasonable boundary conditions, for example, that  $\psi$  must be continuous and must not become infinite as  $x$  approaches  $\pm\infty$ . These boundary conditions restrict the values of  $E$  for which there exist acceptable solutions  $\psi(x)$  to Eq. (9), the allowed values of  $E$  depending on  $V(x)$ . In this manner, the allowed energies of atomic hydrogen listed in the earlier discussion of quantization are obtained.

The forms of Eqs. (5a), (7), and (9) suggest that the classical observable  $p_x$  must be replaced by the operator  $(\hbar/i)(\partial/\partial x)$ . With this replacement, Eq. (10) holds. In other words, whereas

$$(xp_x - p_x x)\psi = i\hbar\psi \quad (10)$$

the classical canonically conjugate variables  $x$  and  $p_x$  are numbers, obeying the commutative law in Eq. (11a), the quantum-mechanical quantities  $x$  and  $p_x$  are noncommuting operators, obeying Eq. (11b).

$$xp_x - p_x x = 0 \quad (11a)$$

$$xp_x - p_x x = i\hbar \quad (11b)$$

**Correspondence principle.** Since classical mechanics and Maxwell's electromagnetic theory accurately describe macroscopic phenomena, quantum mechanics must have a classical limit in which it is equivalent to the older classical theories. Although there is no rigorous proof of this principle for arbitrarily complicated quantum-mechanical systems, its validity is well established by numerous illustrations. [E.G.]

**Quantum mineralogy** Quantum mechanics applied to mineralogical systems. A theoretical understanding of chemical bonding and the electronic structure of minerals is fundamental to understanding the behavior of minerals. The principal goal of quantum mineralogy is to calculate from first principles the properties and transformations of solid earth materials. One of the advantages of this theoretical tool is the ability to predict the behavior of materials at conditions which are not readily accessible to experiment. More importantly, though, experimental observations may be interpreted in terms of quantum-mechanical theory. See CHEMICAL BONDING; QUANTUM CHEMISTRY; QUANTUM MECHANICS.

The methods used in quantum mineralogy are no different from those used for other chemical systems. They range from simple conceptions of the chemical bond in terms of quantum-mechanical expressions to rigorous calculation of wave functions for model systems. Too often, the more exact the quantum-mechanical calculation, the less understandable are the results for the nonspecialist. Despite such limitations, quantum mineralogy is a powerful theoretical probe into the nature, of structure, bonding, and properties of mineral systems. The size and complexity of model systems that can be considered in rigorous calculations continue to grow rapidly with increasing efficiency of computer hardware and program algorithms. See CHEMICAL STRUCTURES; MINERALOGY; SOLID-STATE CHEMISTRY; SOLID-STATE PHYSICS. [B.C.C.]

**Quantum numbers** The quantities, usually discrete with integer or half-integer values, which are needed to characterize a physical system of one or more atomic or subatomic particles. Specification of the set of quantum numbers serves to define such a system or, in other words, to label the possible states the system may have. In general, quantum numbers are obtained from conserved quantities determinable by performing symmetry transformations consisting of arbitrary variations of the system which leave the system unchanged. For example, since the behavior of a set of particles should be independent of the location of the origin in space and time (that is, the symmetry operation is translation in space-time), it follows that momentum and energy are rigorously conserved. See SYMMETRY LAWS (PHYSICS).

In general, each physical system must be studied individually to find the symmetry transformations, and thus the conserved

quantities and possible quantum numbers. The quantum numbers themselves, that is, the actual state labels, are usually the eigenvalues of the physical operators corresponding to the conserved quantities for the system in question. See EIGENVALUE (QUANTUM MECHANICS); ELEMENTARY PARTICLE; PARITY (QUANTUM MECHANICS).

It is not necessary that the conserved quantity be "quantized" in order to be regarded as a quantum number; for example, a free particle possesses energy and momentum, both of which can have values from a continuum but which are used to specify the state of the particle. [K.E.L.]

**Quantum solids** A class of solids whose atoms or molecules undergo large zero-point motion even in the quantum ground state (at temperature  $T = 0 \text{ K} = -459.67^\circ\text{F}$ ) as a result of their small mass and the weak attractive part of their interaction potential. The most striking examples are the isotopes of helium,  $^3\text{He}$  and  $^4\text{He}$ , which have a root-mean-square displacement from their lattice sites of approximately 25%. Further examples are the molecular hydrogens,  $\text{H}_2$ ,  $\text{D}_2$ , and  $\text{HD}$ , as well as some heavier molecular solids. See INTERMOLECULAR FORCES; QUANTUM MECHANICS.

These materials display quantum effects in their bulk properties when cooled to temperatures near absolute zero so that the chaotic thermal motion is reduced. Both of the helium isotopes remain liquid all the way to absolute zero, unless external pressure ( $\sim 3$  megapascals  $\approx 30$  atm) is applied. This is because the atoms are not at rest at 0 K; the zero-point motion acts as an internal pressure which must be overcome in order to bring the atoms close enough together for solidification. All other substances, including the hydrogens, freeze under their own vapor pressure above 10 K.

The two melting curves are quite different in detail because of the different types of quantum statistics which the particles obey. There is a pronounced minimum in the  $^3\text{He}$  melting pressure which is unique, and can be understood by considering the entropies of the liquid and the solid. The pressure minimum leads to the bizarre situation of the addition of heat causing freezing. The inverse of this process, the adiabatic formation of the solid by compression, is an important process which has been used extensively to cool liquid and solid  $^3\text{He}$  to temperatures of approximately 1 mK. See CRYOGENICS; LIQUID HELIUM. [E.D.A.]

**Quantum statistics** The statistical description of particles or systems of particles whose behavior must be described by quantum mechanics rather than by classical mechanics. As in classical, that is, Boltzmann statistics, the interest centers on the construction of appropriate distribution functions. However, whereas these distribution functions in classical statistical mechanics describe the number of particles in given (in fact, finite) momentum and positional ranges, in quantum statistics the distribution functions give the number of particles in a group of discrete energy levels. In an individual energy level there may be, according to quantum mechanics, either a single particle or any number of particles. This is determined by the symmetry character of the wave functions. For antisymmetric wave functions only one particle (without spin) may occupy a state; for symmetric wave functions, any number is possible. Based on this distinction, there are two separate distributions, the Fermi-Dirac distribution for systems described by antisymmetric wave functions and the Bose-Einstein distribution for systems described by symmetric wave functions. See BOLTZMANN STATISTICS; BOSE-EINSTEIN STATISTICS; EXCLUSION PRINCIPLE; FERMI-DIRAC STATISTICS; KINETIC THEORY OF MATTER; QUANTUM MECHANICS; STATISTICAL MECHANICS. [M.Dr.]

**Quantum theory of matter** The microscopic explanation of the properties of condensed matter, that is, solids and liquids, based on the fundamental laws of quantum mechanics. Without the quantum theory, some properties of matter such



as magnetism and superconductivity have no explanation at all, while for others only a phenomenological description can be obtained. With the theory, it is at least possible to comprehend what is needed to approach a complete understanding.

The theoretical problem of condensed matter—large aggregates of elementary particles with mutual interactions—is the quantum-mechanical many-body problem: an enormous number, of order  $10^{23}$ , of constituent particles in the presence of a heat bath and interacting with each other according to quantum-mechanical laws. What makes the quantum physics of matter different from the traditional quantum theory of elementary particles is that the fundamental constituents (electrons and ions) and their interactions (Coulomb interactions) are known but the solutions of the appropriate quantum-mechanical equations are not. This situation is not due to the lack of a sufficiently large computer, but is caused by the fact that totally new structures, such as crystals, magnets, ferroelectrics, superconductors, liquid crystals, and glasses, appear out of the complexity of the interactions among the many constituents. The consequence is that entirely new conceptual approaches are required to construct predictive theories of matter. The usual technique for approaching the quantum many-body problem for a condensed-matter system is to try to reduce the huge number of variables (degrees of freedom) to a number which is more manageable but still can describe the essential physics of the phenomena being studied. See CRYSTAL; FERROELECTRICS; GLASS; LIQUID CRYSTALS; MAGNETIC MATERIALS; QUANTUM MECHANICS; SOLID-STATE PHYSICS; SUPERCONDUCTIVITY. [E.A.]

**Quantum theory of measurement** The attempt to reconcile the counterintuitive features of quantum mechanics with the hypothesis that quantum mechanics is in principle a complete description of the physical world, even at the level of everyday objects. A paradox arises because, at the atomic level where the quantum formalism has been directly tested, the most natural interpretation implies that where two or more different outcomes are possible it is not necessarily true that one or the other is actually realized, whereas at the everyday level such a state of affairs seems to conflict with direct experience.

The resolution of this paradox that is probably most favored by practicing physicists proceeds in two stages. At stage 1, it is pointed out that, quite generically, whenever the quantum formalism appears to generate a superposition of macroscopically distinct states it is impossible to demonstrate the effects of interference between them. The reasons for this claim include the facts that the initial state of a macroscopic system is likely to be unknown in detail; the initial state has extreme sensitivity to random external noise; and most important, merely by virtue of its macroscopic nature any such system will rapidly have its quantum-mechanical state correlated (entangled) with that of its environment in such a way that no measurement on the system alone (without a simultaneous measurement of the complete state of the environment) can demonstrate any interference between the two states in question—a result often known as decoherence. Thus, it is argued, the outcome of any possible experiment on the ensemble of macroscopic systems prepared in this way will be indistinguishable from that expected if each system had actually realized one or the other of the two macroscopically distinct states in question. Stage 2 of the argument (often not stated explicitly) is to conclude that if this is indeed true, then it may be legitimately asserted that such realization of a definite macroscopic outcome has indeed taken place by this stage.

Most physicists agree with stage 1 of the argument. However, not all agree that the radical reinterpretation of the meaning of the quantum formalism which is implicit at stage 2 is legitimate; that is, an interpretation in terms of realization, by each individual system, of one alternative or the other, forbidden at the atomic level by the observed phenomenon of interference, is allowed once, on going to the macroscopic level, the phenomenon dis-

appears. Consequently, various alternative interpretations have been developed. See QUANTUM MECHANICS. [A.J.L.]

**Quark-gluon plasma** A predicted state of matter containing deconfined quarks and gluons. According to the theory of strong interactions, called quantum chromodynamics, hadrons such as mesons and nucleons (the generic name for protons and neutrons) are bound states of more fundamental objects called quarks. The quarks are confined within the individual hadrons by the exchange of particles called gluons. However, calculations indicate that at sufficiently high temperatures or densities, hadronic matter should evolve into a new phase of matter containing deconfined quarks and gluons, called a quark-gluon plasma or quark matter. Such a state of matter is thought to have existed briefly in the period about 1–10 microseconds after the big bang, and might also exist inside the cores of dense neutron stars. See BIG BANG THEORY; HADRON; NEUTRON STAR; QUANTUM CHROMODYNAMICS.

The study of such a new state of matter requires a means for producing it under controlled laboratory conditions. Experimentally the transition from the hadronic to the quark-gluon phase requires collisions of beams of heavy ions such as nuclei of gold or uranium (although lighter nuclei can be used) with other heavy nuclei at high enough energies to produce the necessary extreme conditions of heat and compression. Quantum chromodynamics calculations using the lattice gauge model indicate that energy densities of at least  $1\text{--}2 \text{ GeV}/\text{fm}^3$  (1 femtometer =  $10^{-15} \text{ m}$ ), about 10 times that found in ordinary nuclear matter, must be produced in the collision for plasma formation to occur. See NUCLEAR REACTION; RELATIVISTIC HEAVY-ION COLLISIONS.

Accelerator experiments using beams of nuclei with energies of  $10\text{--}200 \text{ GeV}/\text{nucleon}$  bombarding stationary nuclear targets have found interesting phenomena such as nuclear stopping. In such cases, the colliding nucleons of the target and projectile are observed to pile up on each other, achieving large nuclear matter densities (two to four times normal nuclear density, or higher) corresponding to energy densities near the threshold for quark matter production. Other results of these experiments suggest that conditions favorable to thermal and chemical equilibrium may be present in some of these collisions. Such experiments can provide critical tests of the theory of the strong interaction and illuminate the earliest moments of the universe. See ELEMENTARY PARTICLE; GLUONS; QUARKS. [L.S.S.]

**Quarks** The basic constituent particles of which elementary particles are understood to be composed. Theoretical models built on the quark concept have been very successful in understanding and predicting many phenomena in the physics of elementary particles.

The study of the elastic scattering of electrons on protons demonstrated that the proton has a finite form factor, that is, a finite radial extent of its electric charge and magnetic moment distributions. It was plausible that the charge cloud which constitutes the proton is a probability distribution of some smaller, perhaps pointlike constituents, just as the charge cloud of an atom was learned to be the probability distribution of electrons. Subsequent high-energy, deep inelastic scattering experiments of electrons on protons, leading to meson production, revealed form factors corresponding to pointlike constituents of the proton. These proton constituents, first referred to as partons, are now understood to include the constituent quarks of the proton.

These high-energy collisions also produced an abundance of resonance states, equivalent to short-lived particles. The spectroscopy of these hadronic states revealed an order and symmetry among the observed hadrons that could be interpreted in terms of representations of the  $SU(3)$  symmetry group. This in turn is interpreted as a consequence of the grouping of elementary constituents of fractional electric charge in pairs and triplets to form the observed particles. The general features of the quark model of hadrons have withstood the tests of time,

## Properties of quarks

Flavor	Mass <sup>†</sup> , GeV/c <sup>2</sup>	Electric charge <sup>‡</sup>	Baryon number	Spin <sup>§</sup>	Isotopic spin	Strangeness	Charm
<i>u</i>	0.0015–0.004	+2/3	+1/3	1/2	1/2	0	0
<i>d</i>	0.004–0.008	−1/3	+1/3	1/2	1/2	0	0
<i>c</i>	1.15–1.35	+2/3	+1/3	1/2	0	0	+1
<i>s</i>	0.080–0.130	−1/3	+1/3	1/2	0	−1	0
<i>t</i>	174.3±5.1 <sup>¶</sup>	+2/3	+1/3	1/2	0	0	0
<i>b</i>	4.1–4.4	−1/3	+1/3	1/2	0	0	0

<sup>†</sup>As the mass of baryons composed of quarks is strongly influenced by the gluons binding the quarks, and as free quarks are not observed, the masses are theoretical estimates.

<sup>‡</sup>Charge is in units of the magnitude of the charge of an electron,  $1.6 \times 10^{-19}$  coulomb.

<sup>§</sup>Spin is in units of Planck's constant divided by  $2\pi$ , written as  $\hbar$ .

<sup>¶</sup>The top quark mass is deduced from experimental measurements of its decay dynamics.

and the static properties of hadrons are consistent with predictions of this model. See SYMMETRY LAWS (PHYSICS); UNITARY SYMMETRY.

Thus, the proton and neutron are not fundamental constituents of matter, but each is composed of three quarks, very much as the nuclei of <sup>3</sup>H and <sup>3</sup>He are made of protons and neutrons, and the molecules of NO<sub>2</sub> and N<sub>2</sub>O are made of oxygen and nitrogen atoms.

There are two kinds (or “flavors”) of quarks of very low mass of which the proton, neutron, and pions are composed, and a third, more massive quark which is a constituent of “strange” particles, including the *K* mesons and hyperons such as the  $\Lambda^0$ . These are known as the up quark (*u*), the down quark (*d*), and the strange quark (*s*). Baryons are composed of three quarks, for example the proton (*uud*), neutron (*udd*),  $\Lambda^0$  (*uds*), and  $\Xi^-$  (*dss*). Antiparticles such as antiprotons are formed by the antiquarks of those forming the particle, for example, the antiproton  $\bar{p}$  ( $\bar{u}\bar{u}\bar{d}$ ). Mesons are composed of a quark-antiquark pair, such as the  $\pi^+$  (*u* $\bar{d}$ ),  $\pi^-$  ( $\bar{u}$ *d*), *K*<sup>+</sup> (*u* $\bar{s}$ ), and *K*<sup>−</sup> ( $\bar{u}$ *s*). See BARYON; HYPERON; MESON; STRANGE PARTICLES.

The quantum numbers of quarks are added to give the quantum numbers of the elementary particle which they form on combination. The unit of electrical charge of a quark is +2/3 or −1/3 of the charge on a proton ( $1.6 \times 10^{-19}$  coulomb), and the baryon number of each quark is +1/3 (see table). The charge, baryon number, and so forth, of each antiquark are just the negative of that for each quark.

During the 1970s, experiments at electron-positron colliders and proton accelerators detected a relatively long-lived (that is, very narrow, in energy) resonant state of about 3.1 GeV total energy. This was interpreted as evidence for a new quark, the charm (*c*) quark, produced as a quark-antiquark resonance analogous to the  $\phi$ . The discovery of this *J/ψ* resonance was followed by the observation and study of meson systems, now labeled *D* mesons, containing a single *c* or quark (paired with an antiquark of another flavor), as well as baryon states containing these quarks. See CHARM; *J/ψ* PARTICLE; PARTICLE ACCELERATOR.

A few years later, experiments with higher-energy proton beams, studying the spectra of muon-antimuon pairs at the Fermi National Accelerator Laboratory, discovered a more massive, narrow resonant state at about 9.4 GeV, which was labeled the  $\Upsilon$  (upsilon). This was interpreted as evidence for a more massive quark, the *b* (bottom) quark. Subsequent experiments at proton and electron accelerators confirmed the existence of the *b* quark and also observed a corresponding family of meson resonant states, now referred to as *B* mesons.

During the 1990s, experiments observing collisions of protons and antiprotons at an energy of 1.8 TeV in the center of mass established the existence of the *t* (top) quark, primarily through analysis of its decay to a *B* meson and a *W* intermediate vector boson. The *t* mass of  $174.3 \pm 5.1$  GeV/c<sup>2</sup> (about the mass of a tungsten atom) is so great that its weak decay through this channel is very fast, and mesonic states of the *t* and  $\bar{t}$

quark (analogous to the  $\Upsilon$ , the *J/ψ*, and the  $\phi$ ) are not observed, although the observed *t*'s are from the production of pairs. See INTERMEDIATE VECTOR BOSON.

Quarks are understood to have a spin of 1/2; that is, their intrinsic angular momentum is  $\hbar/2$  (where  $\hbar$  is Planck's constant *h* divided by  $2\pi$ ), just as for the electron and muon. A problem arose when the structure of observed baryons required two or, in some cases, three quarks of the same flavor in the same quantum state, a situation forbidden for spin-1/2 particles by the Pauli exclusion principle. In order to accommodate this contradiction, a new quantum variable, arbitrarily labeled color, was introduced; the idea is that each quark is red, green, or blue (and the antiquarks, antired, and so forth). The color quantum number then breaks the degeneracy and allows up to three quarks of the same flavor to occupy a single quantum state. Confirmation of the color concept has been obtained from experiments with electron-positron storage rings, and the theory of quantum chromodynamics (QCD), based on this concept, has been developed. According to quantum chromodynamics, hadrons must be colorless; for example, baryons must consist of a red, a green, and a blue quark, and mesons of a quark-antiquark pair of the same color (for example, a red quark and an anti-red antiquark). See COLOR (QUANTUM MECHANICS); EXCLUSION PRINCIPLE; SPIN (QUANTUM MECHANICS).

The field quanta of quantum chromodynamics are gluons, massless, spin-1 quanta which interact with quarks. This is very analogous to the manner in which photons, the quanta of electromagnetic interaction, interact with particles containing electric charge and are responsible for electromagnetic forces. The QCD theory is part of the now widely accepted standard model of elementary particle interactions, together with the electroweak theory. Experiments have increasingly confirmed details of the standard model to the extent that most physicists are confident that it is fundamentally correct. See ELECTROWEAK INTERACTION; GLUONS; QUANTUM CHROMODYNAMICS; STANDARD MODEL.

There are three sets, or “generations,” of quarks and leptons. Each generation contains a charged lepton (electron, muon, or tau lepton); a corresponding neutrino; a charge −1/3 quark color triad; and a charge +2/3 quark triad. See LEPTON; NEUTRINO.

Quarks and the theory of quantum chromodynamics are now firmly established as cornerstones of the standard model of elementary particles (together with the electroweak theory, charged leptons, neutrinos, and so forth). However, unanswered questions remain.

The advanced string and M theories have the property of supersymmetry, which demands that every spin-1/2 quark and lepton must have a partner with integral spin. As of 2004, no experimental evidence for any of these supersymmetric (SUSY) particles had been found. See SUPERSTRING THEORY; SUPERSYMMETRY.

Contemporary theories also predict that there exists one or more massive particles of integral spin, the Higgs particles, responsible for the rest masses of the quarks and charged leptons. Again, the lack of evidence suggests that the Higgs particles must

also have a rest mass of over  $100 \text{ GeV}/c^2$ , if they exist. See HIGGS BOSON.

Quarks may be permanently stable against decay via the weak interaction; however, it is also possible that quarks spontaneously decay to leptons. Intensive searches for the decay of the proton (into a neutral pion and a positron, for example) have been negative, setting a lower limit of over  $10^{32}$  years for the proton lifetime. However, the apparent asymmetry of the universe between matter and antimatter (there is, at present, no evidence for primordial antimatter) suggests that antiprotons, for example, may spontaneously decay (or transform) more readily. See ANTIMATTER; PROTON.

Some theories have postulated that quarks are composed of smaller constituents, just as other objects that were originally believed to be fundamental subsequently were found to have internal structure. So far, all observations are compatible with the quarks as point objects, like the electron. [L.W.J.]

**Quarrying** The process of extracting stone for commercial use from natural rock deposits. The industry has two major branches: a dimension-stone branch, involving preparation of blocks of various sizes and shapes for use as building stone, monumental stone, paving stone, curbing, and flagging; and a crushed-stone branch, involving preparation of crushed and broken stone for use as a basic construction, chemical, and metallurgical raw material. [S.H.Bo.]

**Quartz** The most common oxide on the Earth's surface, constituting 12% of the crust by volume. Quartz is a crystalline form of silicon dioxide ( $\text{SiO}_2$ ). Among the igneous rocks, quartz is especially common within granites, granodiorites, pegmatites, and rhyolites. In addition, quartz can be observed in low- to high-grade metamorphic rocks, including phyllites, quartzites, schists, granulites, and eclogites. Because hydrothermal fluids are enriched in dissolved silica, the passage of fluids through rock fractures results in the emplacement of quartz veins. See GRANITE; GRANODIORITE; IGNEOUS ROCKS; METAMORPHIC ROCKS; PEGMATITE; RHYOLITE.

Once quartz has formed, it persists through erosional reworking because of its low solubility in water (parts per million) and its high mechanical hardness (7 on Mohs scale). Consequently, quartz becomes increasingly concentrated in beach sands as they mature, and it is a major component of sandstone. In sedimentary environments, quartz also forms as the final crystallization product during silica diagenesis; amorphous silica on the sea floor that derives from the skeletons of diatoms, radiolarians, and sponges will transform to quartz upon prolonged exposure to increased temperatures ( $\leq 300^\circ\text{C}$  or  $572^\circ\text{F}$ ) and pressures ( $\leq 2$  kilobars or 200 pascals) after burial. See DIAGENESIS; HARDNESS SCALES; SANDSTONE.

As with virtually all silicates, the atomic framework of the quartz structure consists of  $\text{Si}^{4+}$  cations that are tetrahedrally coordinated by oxygen anions ( $\text{O}^{2-}$ ). Every oxygen anion is bonded to two silicon cations, so that the tetrahedral units are corner-linked to form continuous chains. In low-temperature quartz (or  $\alpha$ -quartz), two distinct tetrahedral chains spiral about the crystallographic  $c$  axis.

Although the silica tetrahedra can be depicted as spirals about the  $c$  axis in a left-handed sense, right-handed quartz crystals are found in nature as abundantly as are left-handed crystals. These enantiomorphic varieties are known as the Brazil twins of quartz, and they may be distinguished by crystal shape (corresponding crystal faces occur in different orientations) and by opposite optical activities. See CRYSTAL OPTICS.

Impurity concentrations in natural  $\alpha$ -quartz crystals usually fall below 1000 parts per million. The violet and yellow hues observed in amethyst and citrine are associated with Fe, and black smoky quartz contains Al. The white coloration of milky quartz reflects light scattering off minute fluid inclusions, and

the pink tint in rose quartz is believed to arise from fine-scale intergrowths of a pegmatitic mineral called dumortierite [ $\text{Al}_{27}\text{B}_4\text{Si}_{12}\text{O}_{69}(\text{OH})_3$ ]. See AMETHYST; DUMORTIERITE.

Quartz is used predominantly by the construction industry as gravel and as aggregate in concrete. In addition, quartz is important in advanced technologies. Quartz is piezoelectric and has an extremely high quality factor. The high quality factor means that a bell made of quartz would resonate (ring) for a very long time. This property, combined with its piezoelectric behavior, makes quartz the perfect crystal for oscillators in watches.

Compression of  $\alpha$ -quartz perpendicular to the  $c$  axis creates an electrostatic charge, and this property is exploited in oscillator plates in electronic components. Large flawless crystals of quartz are routinely synthesized for oscillators and for prisms in laser optic systems. Quartz also is employed in abrasives, fluxes, porcelains, and paints. See CONCRETE; OSCILLATOR; PIEZOELECTRICITY. [P.J.H.]

**Quartz clock** A clock that makes use of the piezoelectric property of a quartz crystal. When a quartz crystal vibrates, a difference of electric potential is produced between two of its faces. The crystal has a natural frequency of vibration that depends on its size and shape. If it is placed in an oscillating electric circuit having nearly the same frequency as the crystal, it is caused to vibrate at its natural frequency, and the frequency of the entire circuit becomes the same as the natural frequency of the crystal. See OSCILLATOR; PIEZOELECTRICITY.

In the quartz oscillator, this natural frequency may be used to produce such other frequencies as 1 or 5 MHz. A clock displaying the time of day can also be driven by using one of these frequencies.

The natural frequency of a quartz crystal is nearly constant if precautions are taken when it is cut and polished and it is maintained at nearly constant temperature and pressure. After a crystal has been placed in operation, its frequency usually varies slowly as a result of physical changes. If allowance is made for changes, laboratory quartz-crystal clocks may run for a year with accumulated errors of less than a few thousandths of a second. However, quartz crystals typically used in watches may accumulate errors of several tens of seconds in one year. See WATCH.

The advantage of quartz clocks is that they are relatively inexpensive and easy to use in various applications such as computers and microprocessors. Thus, despite their inaccuracy relative to some other types of clocks, they enjoy wide popularity, particularly in applications requiring accurate timekeeping over a relatively short time span. In these applications, the rates and epochs of the quartz clocks may be readjusted periodically to account for possible accumulated errors. See CLOCK; COMPUTER; HOROLOGY; MICROPROCESSOR; TIME. [D.D.McC.]

**Quartzite** A metamorphic rock consisting largely or entirely of quartz. Most quartzites are formed by metamorphism of sandstone; but some have developed by metasomatic introduction of quartz,  $\text{SiO}_2$ , often accompanied by other chemical elements, for example, metals and sulfur (ore quartzites). See METAMORPHIC ROCKS; METASOMATISM; SANDSTONE.

Pure sandstones yield pure quartzites. Impure sandstones yield a variety of quartzite types. The cement of the original sandstone is in quartzite recrystallized into characteristic silicate minerals, whose composition often reflects the mode of development. Even the Precambrian quartzites correspond to types that are parallel to present-day deposits. See QUARTZ. [T.F.W.B.]

**Quasar** An astronomical object that appears starlike on a photographic plate but possesses many other characteristics, such as a large redshift, that prove that it is not a star. The name quasar is a contraction of the term quasistellar object (QSO), which was originally applied to these objects for their photographic appearance. The objects appear starlike because their

angular diameters are less than about 1 second of arc, which is the resolution limit of ground-based optical telescopes imposed by atmospheric effects.

Quasars were discovered in 1961 when it was noticed that very strong radio emission was coming from a localized direction in the sky that coincided with the position of a starlike object. When the positions of small-angular-diameter radio sources were accurately determined, the coincidence with starlike objects on optical photographs led to the discovery of a new, hitherto-unsuspected class of objects, the quasars. The full significance of the discovery was not appreciated until 1963, when it was noted that the hydrogen emission lines seen in the optical spectrum of the quasar 3C 273 were shifted by about 16% to the red from their normal laboratory wavelength. This redshift of the spectral lines is characteristic of galaxies whose spectra are redshifted because of the expansion of the universe and is not characteristic of stars in the Milky Way Galaxy.

The color of quasars is generally much bluer than that of most stars with the exception of white dwarf stars. The blueness of quasars as an identifying characteristic led to the discovery that many blue starlike objects have a large redshift and are therefore quasars. The quasistellar objects discovered this way turned out to emit little or no radio radiation and to be about 20 times more numerous than the radio-emitting quasistellar radio sources (QSSs). Why some should be strong radio emitters and most others not is unknown. Several orbiting x-ray satellites have found that most quasars also emit strongly at x-ray frequencies. Gamma rays have also been observed in many quasars. See GAMMA-RAY ASTRONOMY; X-RAY ASTRONOMY.

The emission from quasars varies with time. The shortest time scale of variability ranges from years to months at short radio wavelengths, to days at optical wavelengths, to hours at x-ray wavelengths. These different time scales suggest that the emissions from the different bands originate from different regions in the quasar. The rapid fluctuations indicate that there are some components in quasars that have diameters less than a light-hour or of the order of  $10^9$  km ( $10^9$  mi), the size of the solar system. Very highly active quasars are sometimes referred to as optically violent variables (OVVs), blazars, or BL Lac's, after the prototype BL Lacertae, a well-known variable "star" that turned out to be a quasar. The optically violent variables have no or very weak emission lines in their optical spectrum.

The many similarities of the observed characteristics of quasars with radio galaxies, Seyfert galaxies, and BL Lacertae objects strongly suggest that quasars are active nuclei of galaxies. Quasars with large redshifts are spatially much more numerous than those with small redshifts. Because high-redshift objects are very distant and emitted their radiation at an earlier epoch, quasars must have been much more common in the universe about  $10^{10}$  years ago. Observations with the Hubble Space Telescope have shown that this is the same epoch when galaxies are observed to be forming. Thus it is likely that quasars are associated with the birth of some galaxies.

More than  $10^{53}$  J of energy are released in quasars over their approximately  $10^6$ -year lifetime. Of the known energy sources, only gravitational potential energy associated with a mass about  $10^9$  times the mass of the Sun can provide this energy, but it is unknown how this gravitational energy produces jets of particles that are accelerated to very near the speed of light.

Several theories have been proposed for quasars. However, the most favored interpretation is that quasars are massive black holes surrounded by rapidly spinning disks of gas in the nuclei of some galaxies. The hot gas in the disk emits the x-ray and optical continuum, a heated halo around the disk produces the emission lines, and the relativistic radio jets are ejected along the rotation axis of the spinning disk. See ASTRONOMICAL SPECTROSCOPY; ASTROPHYSICS, HIGH-ENERGY; BLACK HOLE; INFRARED ASTRONOMY; NEUTRON STAR; RADIO ASTRONOMY. [W.D.]

**Quasiatom** A structure in which the nuclei of two atoms approach each other closely and their electrons are arranged in atomic orbitals characteristic of a single atom of atomic number equal to the sum of the nuclear charges. Quasiatoms can be formed for short times in atom-atom and ion-atom collisions when the nuclei are much closer than the mean orbital radius of the innermost K-shell electrons. The electrons are then bound in the electric field of both nuclear charges  $Z_1$  and  $Z_2$ , which resembles the spherically symmetric  $1/r^2$  Coulomb field of a single united atom having charge  $Z_{ua} = Z_1 + Z_2$ . See ATOMIC STRUCTURE AND SPECTRA.

An interesting effect is associated with quasiatoms with  $Z > 173$ , in which the 1s binding energy is more than twice the electron rest mass,  $E_{1s} > 2mc^2$ . If a vacancy exists in this orbital, it is energetically favorable to create an electron-positron pair with the electron bound in this state. The positron would be repelled from the nucleus with kinetic energy equal to  $E_{e^+} = |E_{1s}| - 2mc^2$ . In the Dirac hole picture, in which the vacuum consists of a negative energy continuum ( $E < -mc^2$ ) filled with electrons, the 1s level is said to fall into the negative-energy Dirac sea as  $Z$  increases above the critical value,  $Z_{cr} = 173$ . A 1s hole (vacancy) becomes embedded in the negative continuum as an unstable resonance state that decays in a time of  $\sim 10^{-19}$  s to a bound electron and a spontaneously emitted monoenergetic positron.

The quantum electrodynamic vacuum in the presence of a bare supercritical nuclear charge is therefore unstable and decays to a fundamentally new charged vacuum, which consists of the nucleus with two 1s electrons (from the two spin orientations). At higher values of  $Z_{ua}$ , as additional quasiatomic levels enter the negative continuum, the charge of the quantum electrodynamic vacuum increases accordingly. If detected, spontaneous positron emission would represent the first observation of a phase transition in a gauge field theory. See ANTIMATTER; ELECTRON-POSITRON PAIR PRODUCTION; GAUGE THEORY; PHASE TRANSITIONS; POSITRON; QUANTUM ELECTRODYNAMICS; SUPERCRITICAL FIELDS. [T.E.C.]

**Quasicrystal** A solid with conventional crystalline properties but exhibiting a point-group symmetry inconsistent with translational periodicity. Like crystals, quasicrystals display discrete diffraction patterns, crystallize into polyhedral forms, and have long-range orientational order, all of which indicate that their structure is not random. But the unusual symmetry and the finding that the discrete diffraction pattern does not fall on a reciprocal periodic lattice suggest a solid that is quasiperiodic. Their discovery in 1982 contradicted a long-held belief that all crystals would be periodic arrangements of atoms or molecules.

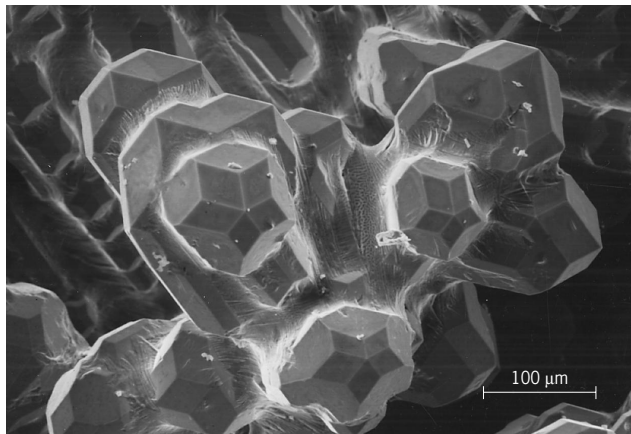

Quasicrystals of an alloy of aluminum, copper, and iron, displaying an external form consistent with their icosahedral symmetry.

It is easily shown that in two and three dimensions the possible rotations that superimpose an infinitely repeating periodic structure on itself are limited to angles that are  $360^\circ/n$ , where  $n$  can be only 1, 2, 3, 4, or 6. Various combinations of these rotations lead to only 32 point groups in three dimensions, and 230 space groups which are combinations of the 14 Bravais lattices that describe the periodic translations with the allowed rotations. Until the 1980s, all known crystals could be classified according to this limited set of symmetries allowed by periodicity. Periodic structures diffract only at discrete angles (Bragg's law) that can be described by a reciprocal lattice, in which the diffraction intensities fall on lattice points that, like all lattices, are by definition periodic, and which has a symmetry closely related to that of the structure. See CRYSTAL; CRYSTALLOGRAPHY; X-RAY CRYSTALLOGRAPHY; X-RAY DIFFRACTION.

Icosahedral quasicrystals were discovered in 1982 during a study of rapid solidification of molten alloys of aluminum with one or more transition elements, such as manganese, iron, and chromium. Since then, many different alloys of two or more metallic elements have led to quasicrystals with a variety of symmetries and structures. The illustration shows the external polyhedral form of an icosahedral aluminum-copper-iron alloy.

The diffraction patterns of quasicrystals violate several predictions resulting from periodicity. Quasicrystals have been found in which the quantity  $n$  is 5, 8, 10, and 12. In addition, most quasicrystals exhibit icosahedral symmetry in which there are six intersecting fivefold rotation axes. Furthermore, in the electron diffraction pattern the diffraction spots do not fall on a (periodic) lattice but on what has been called a quasilattice. See ELECTRON DIFFRACTION. [J.W.C.; D.S.]

**Quasielastic light scattering** Small frequency shifts or broadening from the frequency of the incident radiation in the light scattered from a liquid, gas, or solid. The term quasielastic arises from the fact that the frequency changes are usually so small that, without instrumentation specifically designed for their detection, they would not be observed and the scattering process would appear to occur with no frequency changes at all, that is, elastically. The technique is used by chemists, biologists, and physicists to study the dynamics of molecules in fluids, mainly liquids and liquid solutions. It is often identified by a variety of other names, the most common of which is dynamic light scattering (DLS).

Several distinct experimental techniques are grouped under the heading of quasielastic light scattering (QELS). Photon correlation spectroscopy (PCS) is the technique most often used to study such systems as macromolecules in solution, colloids, and critical phenomena where the molecular motions to be studied are rather slow. This technique, also known as intensity fluctuation spectroscopy and, less frequently, optical mixing spectroscopy, is used to measure the dynamical constants of processes with relaxation time scales slower than about  $10^{-6}$  s. For faster processes, dynamical constants are obtained by utilizing techniques known as filter methods, which obtain direct measurements of the frequency changes of the scattered light by utilizing a monochromator or filter much as in Raman spectroscopy. See RAMAN EFFECT; SCATTERING OF ELECTROMAGNETIC RADIATION. [R.P.]

**Quaternary** A period that encompasses at least the last 3,000,000 years of the Cenozoic Era, and is concerned with major worldwide glaciations and their effect on land and sea, on worldwide climate, and on the plants and animals that lived then. The Quaternary is divided into the Pleistocene Epoch and Holocene. The universal term Pleistocene is gradually re-placing Quaternary; Holocene involves the last 7000 years since the

CENOZOIC	QUATERNARY	
	TERTIARY	
MESOZOIC	CRETACEOUS	
	JURASSIC	
	TRIASSIC	
PALEOZOIC	PERMIAN	
	CARBONIFEROUS	Pennsylvanian
		Mississippian
	DEVONIAN	
	SILURIAN	
	ORDOVICIAN	
CAMBRIAN		
PRECAMBRIAN		

Pleistocene. See CENOZOIC; GLACIAL EPOCH; HOLOCENE; PLEISTOCENE. [S.E.Wh.]

**Quaternary ammonium salts** Analogs of ammonium salts in which organic radicals have been substituted for all four hydrogens of the original ammonium cation. Substituents may be alkyl, aryl, or aralkyl, or the nitrogen may be part of a ring system. Such compounds are usually prepared by treatment of an amine with an alkylating reagent under suitable conditions. They are typically crystalline solids which are soluble in water and are strong electrolytes. Treatment of the salts with silver oxide, potassium hydroxide, or an ion-exchange resin converts them to quaternary ammonium hydroxides, which are very strong bases, as shown in the reaction below.

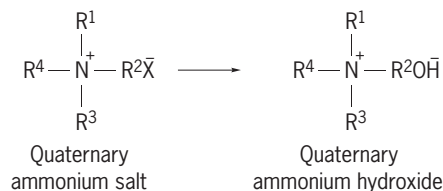

Some quaternary ammonium salts have found use as water repellents, fungicides, emulsifiers, paper softeners, antistatic agents, and corrosion inhibitors. See AMINE; AMMONIUM SALT; SURFACTANT. [P.E.F.]

**Quaternions** An associative, noncommutative algebra based on four linearly independent units or basal elements. Quaternions were originated in 1843, by W. R. Hamilton.

The four linearly independent units in quaternion algebra are commonly denoted by 1,  $i$ ,  $j$ ,  $k$ , where 1 commutes with  $i$ ,  $j$ ,  $k$

and is called the principal unit or modulus. These four units are assumed to have the following multiplication table:

$$1^2 = 1i^2 = j^2 = k^2 = ij k = -1$$

$$i(jk) = (ij)k = ijk$$

$$1i = i1 \quad 1j = j1 \quad 1k = k1$$

The  $i$ ,  $j$ ,  $k$  do not commute with each other in multiplication, that is,  $ij \neq ji$ ,  $jk \neq kj$ ,  $ik \neq ki$ , etc. But all real and complex numbers do commute with  $i$ ,  $j$ ,  $k$ , thus if  $c$  is a real number, then  $ic = ci$ ,  $jc = cj$ , and  $kc = ck$ . On multiplying  $ijk = -1$  on the left by  $i$ , so that  $ij k = i(-1) = -i$ , it is found, since  $i^2 = -1$ , that  $jk = i$ . Similarly  $j k = ji = -k$ ; when exhausted, this process leads to all the simple noncommutative relations for  $i$ ,  $j$ ,  $k$ , namely,

$$ij = -ji = k \quad jk = -kj = i \quad ki = -ik = j$$

More complicated products, for example,  $jikjk = -kki = i$ , are evaluated by substituting for any adjoined pair the value given in the preceding series of relations and then proceeding similarly to any other adjoined pair in the new product, and so on until the product is reduced to  $\pm 1$ ,  $\pm i$ ,  $\pm j$ , or  $\pm k$ . Multiplication on the right is also permissible; thus from  $ij = k$ , one has  $ijj = kj$ , or  $-i = kj$ . Products such as  $jj$  and  $jjj$  may be written  $j^2$  and  $j^3$ .

All the laws and operations of ordinary algebra are assumed to be valid in the definition of quaternion algebra, except the commutative law of multiplication for the units  $i$ ,  $j$ ,  $k$ . Thus the associative and distributive laws of addition and multiplication apply without restriction throughout. Addition is also commutative, for example,  $i + j = j + i$ . [D.M.Y.]

**Quebracho** Any of a number of trees belonging to different genera but having similar qualities, all indigenous to South America and valuable for both wood and bark. The heartwood of one South American tree, *Schinopsis lorentzii* (family Anacardiaceae), is called quebracho (meaning ax-breaker) in reference to the exceedingly hard wood, one of the hardest known. Quebracho is the world's most important source of tannin. See SAPINDALES; TANNIN. [PD.St./E.L.C.]

**Queueing theory** The mathematical theory of the formation and behavior of queues or waiting lines. The name is also applied loosely to the mathematical study of a wide variety of problems connected with traffic congestion and storage systems. Uneven flow through a service point, with fluctuating arrivals and service times, constitutes a major topic of operations research. For the mathematician, queueing theory is particularly interesting because it is concerned with relatively simple stochastic processes, which are in general non-Markovian and possibly stationary. See OPERATIONS RESEARCH; STOCHASTIC PROCESS.

The principal pioneer of queueing theory, A. K. Erlang, began in 1908 to study problems of telephone congestion. It is of interest to study the waiting times of subscribers in a manually operated system—for example, the average waiting time and the chance that a subscriber will obtain service immediately without waiting—and to examine how much the waiting times will be affected if the number of operators is altered, or conditions are changed in any other way. If there are more operators or if service can be speeded up, subscribers will be pleased because waiting will be reduced, but the improved facility will be more expensive to maintain; therefore, a reasonable balance must be struck.

Related problems in the use of automatic telephone exchanges and of long-distance lines able to carry only a limited number of messages simultaneously have resulted in much mathematical study of telephone traffic problems. Similar problems arise in other contexts. In a factory a number of machines, such as looms, may be under the care of one or more repairer. If a machine breaks down, it must stand idle until a repairer is free from repairing other machines. Machines here correspond to telephone subscribers, breakdown corresponds to attempts to make a call,

and repair corresponds to connection. Other examples of congestion situations are aircraft flying around in circles waiting to use an airport landing strip, automobiles lining up at a turnpike toll booth, and customers lining up at the counter of a retail shop, waiting for service.

What is most interesting to investigate varies with the circumstances. Sometimes it is the mean waiting time of customers, sometimes the frequency with which the queue length exceeds a given limit, sometimes the proportion of the servers' time that is idle, and sometimes the average duration of a period during which a server is continuously occupied. In the study of stocking a warehouse or retail shop, known generally as the theory of inventories, the frequency with which the stock will be exhausted is considered under various reordering policies. Similar considerations apply in the theory of dams and water storage. See LINEAR PROGRAMMING; SYSTEMS ENGINEERING. [F.J.An.]

**Quince** The deciduous tree *Cydonia oblonga*, originally from Asia, grown for its edible fruit. The fruit is a pear-shaped or apple-shaped pome, characteristically tomentose, aromatic, sour, astringent, and green, turning clear yellow at maturity. Used mostly for jam and jelly or as a stewed fruit, the fruit of the quince develops a pink color in cooking. See DECIDUOUS PLANTS; FRUIT; FRUIT, TREE; ROSALES. [H.B.T.]

**Quinine** The chief alkaloid of the bark of the cinchona tree, which is indigenous to certain regions of South America. The structure of quinine is shown below.

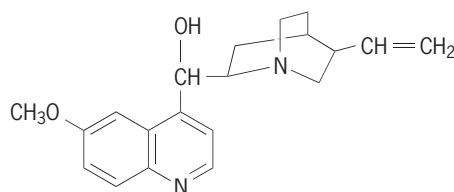

Until the 1920s quinine was the best chemotherapeutic agent for the treatment of malaria. However, clinical studies definitely established the superiority of the newer synthetic antimalarials such as primaquine, chloroquine, and chloroguanide. See ALKALOID; MALARIA. [S.M.K.]

**Quinoa** An annual herb, *Chenopodium quinoa* (family Chenopodiaceae), a native of Peru, and the staple food of many people in South America. These plants, grown at high altitudes, produce large quantities of highly nutritious seeds used whole in soups or ground into flour, which is made into bread or cakes. The seeds are also used as poultry feed, in medicine, and in making beer. In the United States the leaves are sometimes used as a substitute for spinach. See CARYOPHYLLALES. [PD.St./E.L.C.]

**Quinone** One of a class of aromatic diketones in which the carbon atoms of the carbonyl groups are part of the ring structure. The name quinone is applied to the whole group, but it is often used specifically to refer to *p*-benzoquinone (**1**), *o*-Benzoquinone (**2**) is also known but the meta isomer does not exist.

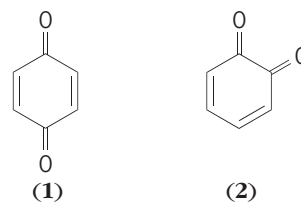

Quinones are prepared by oxidation of the corresponding aromatic ring systems containing amino ( $[bd]NH_2$ ) or hydroxyl ( $[bd]OH$ ) groups on one or both of the carbon atoms being converted to the carbonyl group.

Three of the several possible quinones derived from naphthalene are known: 1,4-naphthoquinone (**2**), 1,2-naphtho-quinone, and 2,6-naphthoquinone (**4**).

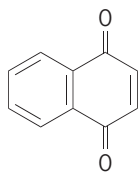

(3)

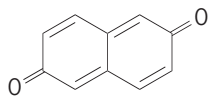

(4)

Important naturally occurring naphthoquinones are vitamins K<sub>1</sub> and K<sub>2</sub> which are found in blood and are responsible for proper blood clotting reaction. A number of quinone pigments have been isolated from plants and animals. Illustrative of these are juglone found in unripe walnut shells and spinulosin from the mold *Penicillium spinulosum*. 9,10-Anthraquinone derivatives form an important class of dyes of which alizarin is the parent type. *p*-Benzoquinone is manufactured for use as a photographic developer. See ANTHRAQUINONE PIGMENTS; AROMATIC HYDROCARBON; DYE; HYDROQUINONE; KETONE; OXIDATION-REDUCTION; VITAMIN K. [D.A.S.]





# R

**Rabies** An acute, encephalitic viral infection. Human beings are infected from the bite of a rabid animal, usually a dog. Canine rabies can infect all warm-blooded animals, and death usually results. See ANIMAL VIRUS.

The virus is believed to move from the saliva-infected wound through sensory nerves to the central nervous system, multiply there with destruction of brain cells, and thus produce encephalitis, with severe excitement, throat spasm upon swallowing (hence hydrophobia, or fear of water), convulsions, and death—with paralysis sometimes intervening before death.

All bites should immediately be cleaned thoroughly with soap and water, and a tetanus shot should be considered. The decision to administer rabies antibody, rabies vaccine, or both depends on four factors: the nature of the biting animal; the existence of rabies in the area; the manner of attack (provoked or unprovoked) and the severity of the bite and contamination by saliva of the animal; and recommendations by local public health officials. See PUBLIC HEALTH; TETANUS.

Diagnosis in the human is made by observation of Negri bodies (cytoplasmic inclusion bodies) in brains of animals inoculated with the person's saliva, or in the person's brain after death. A dog which has bitten a person is isolated and watched for 10 days for signs of rabies; if none occur, rabies was absent. If signs do appear, the animal is killed and the brain examined for Negri bodies, or for rabies antigen by testing with fluorescent antibodies. See FLUORESCENCE MICROSCOPE; VIRAL INCLUSION BODIES.

Individuals at high risk, such as veterinarians, must receive preventive immunization. If exposure is believed to have been dangerous, postexposure prophylaxis should be undertaken. If antibody or immunogenic vaccine is administered promptly, the virus can be prevented from invading the central nervous system. An inactivated rabies virus vaccine is available in the United States. It is made from virus grown in human or monkey cell cultures and is free from brain proteins that were present in earlier Pasteur-type vaccines. This material is sufficiently antigenic that only four to six doses of virus need be given to obtain a substantial antibody response. See VACCINATION. [J.L.Me.]

**Raccoon** Any of the carnivorous mammals which belong to the family Procyonidae, of which there are 16 species, found only in the New World. The robust body is covered with long gray-brown hair, the face is marked by a black mask across the eyes, and the bushy tail has five to seven black rings. The raccoon is plantigrade when standing but walks with its heels off the ground. The digits are long and terminate in nonretractile claws. This animal is found in woodland areas near forest edges, and is a good climber. Primarily terrestrial, it is also a good swimmer, although it cannot pursue prey underwater. A litter of five or six is born each year, and the animals live and travel in family groups. See CARNIVORA; MAMMALIA. [C.B.C.]

**Racemization** The formation of a racemate from a pure enantiomer. Alternatively stated, racemization is the conversion of one enantiomer in a 50:50 mixture of the two enantiomers (+ and –, or R and S) of a substance. Racemization is normally associated with the loss of optical activity over a period of time since 50:50 mixtures of enantiomers are optically inactive. See OPTICAL ACTIVITY.

Racemization is an energetically favored process since it reflects a change from a more ordered to a more random state. But the rate at which enantiomers racemize is typically quite slow unless a suitable mechanistic pathway is available, since racemization usually, but not always, requires that a chemical bond at the chiral center of an enantiomer be broken. Racemization of enantiomers possessing more than one chiral center requires that all chiral centers of half of the molecules invert their configurations. See ENTROPY.

The observation and study of racemization have important implications for the understanding of the mechanisms of chemical reactions and for the synthesis and analysis of chiral natural products such as peptides. Moreover, racemization is of economic importance since it provides a way of converting an unwanted enantiomer into a useful one. Synthetic medicinal agents are often produced industrially as racemates. After resolution and isolation of the desired enantiomer, half of the product would have to be discarded were it not for the possibility of racemizing the unwanted isomer and of recycling the resultant racemate. [S.H.W.]

**Radar** An acronym for radio detection and ranging, the original and still principal application of radar. The name is applied to both the technique and the equipment used.

Radar is a sensor; its purpose is to provide estimates of certain characteristics of its surroundings of interest to a user, most commonly the presence, position, and motion of such objects as aircraft, ships, or other vehicles in its vicinity. In other uses, radars provide information about the Earth's surface (or that of other astronomical bodies) or about meteorological conditions. To provide the user with a full range of sensor capability, radars are often used in combinations or with other elements of more complete systems.

Radar operates by transmitting electromagnetic energy into the surroundings and detecting energy reflected by objects. If a narrow beam of this energy is transmitted by the directive antenna, the direction from which reflections come and hence the bearing of the object may be estimated. The distance to the reflecting object is estimated by measuring the period between the transmission of the radar pulse and reception of the echo. In most radar applications this period will be very short since electromagnetic energy travels with the velocity of light.

**Kinds of radar.** The physical nature of radars varies greatly. Several radars are available for use on small boats as a safety and navigation aid, some so small as to be carried by an operator. Another radar seen in a hand-held form is that used by police to measure the speed of automobiles. See MARINE NAVIGATION.

Perhaps the largest radars are those covering acres of land, long arrays of antennas all operating together to monitor the flight of space vehicles or astronomical bodies. Other very large radars are designed to monitor flight activity at substantial distances. These are large mainly because they must use longer-than-usual radio wavelengths associated with ionospheric containment of the signal for over-the-horizon operations.

More common in size are those radars seen at airports, with rotating antennas 20–40 ft (6–12 m) wide. Radars intended for mobile use, particularly airborne radars, are quite compact. See AIRBORNE RADAR.

Airborne and spaceborne radars have been developed to perform ground mapping with extraordinary resolution by special Doppler-sensitive processing while the radar is moved over a substantial distance. Such radars are called synthetic-aperture radars (SARS) because of the very large virtual antenna formed by the path covered while the processing is performed. Interferometry can provide topological information (3D SAR), and polarimetry and other signal analysis can provide more information on the nature of the surface (type of vegetation, for example). See REMOTE SENSING; SYNTHETIC APERTURE RADAR (SAR).

Radars intended principally to determine the presence and position of reflecting targets in a region around the radar are called search radars. Other radars examine further the targets detected: examples are height finders with antennas that scan vertically in the direction of an assigned target, and tracking radars that are aimed continuously at an assigned target to obtain great accuracy in estimating target motion. In some modern radars, these search and track functions are combined, usually with some computer control. Surveillance radar connotes operation of this sort, somewhat more than just search alone. There are also very complex and versatile radars with considerable computer control, with which many functions are performed and which are therefore called multifunction radars. Very accurate tracking radars intended for use at missile test sites or similar test ranges are called instrumentation radars. Radars designed to detect clouds and precipitation are called meteorological or weather radars. See RADAR METEOROLOGY; SURVEILLANCE RADAR.

Some radars have separate transmit and receive antennas sometimes located miles apart. These are called bistatic radars, the more conventional single-antenna radar being monostatic. Some useful systems have no transmitter at all and are equipped to measure, for radarlike purposes, signals from the targets themselves. Such systems are often called passive radars, but the terms radiometers or signal intercept systems are generally more appropriate. See PASSIVE RADAR.

The terms primary and secondary are used to describe, respectively, radars in which the signal received is reflected by the target and radars in which the transmission causes a transponder (transmitter-responder) carried aboard the target to transmit a signal back to the radar. See AIR-TRAFFIC CONTROL; ELECTRONIC NAVIGATION SYSTEMS.

**Operation.** It is convenient to consider radars composed of four principal parts: the transmitter, antenna, receiver, and display (see illustration).

The transmitter provides the rf signal in sufficient strength (power) for the radar sensitivity desired and sends it to the antenna, which causes the signal to be radiated into space in a desired direction. The signal propagates (radiates) in space, and some of it is intercepted by reflecting bodies. These reflections, in part at least, are radiated back to the antenna. The antenna collects them and routes all such received signals to the receiver, where they are amplified and detected. The presence of an echo of the transmitted signal in the received signal reveals the presence of a target. The echo is indicated by a sudden rise in the output of the detector, which produces a voltage (video) proportional to the sum of the rf signals being received and the rf noise inherent in the receiver itself. The time between the transmission and the receipt of the echo discloses the range to the target. The direction or bearing of the target is disclosed by the direction the antenna is pointing when an echo is received.

A duplexer permits the same antenna to be used on both transmit and receive, and is equipped with protective devices to block the very strong transmit signal from going to the sensitive receiver and damaging it. The antenna forms a beam, usually quite directive, and, in the search example, rotates throughout the region to be searched. See ANTENNA (ELECTROMAGNETISM).

The radar reflections are among the signals received by the antenna in the period between transmissions. Most search radars have a pulse repetition frequency (prf), antenna beam-width, and rotation rate such that several pulses are transmitted (per-

Key:

--- rf signals  
 — i-f signals  
 — video, timing, bias voltages, control, and data

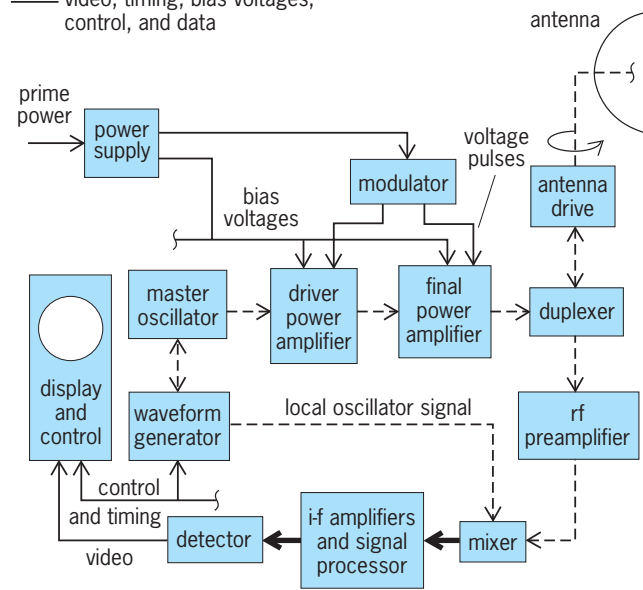

Block diagram of a pulse radar.

haps 20 to 40) while the antenna scans past a target. This allows a buildup of the echo being received. Most radars are equipped with low-noise rf preamplifiers to improve sensitivity. The signal is then "mixed" with (multiplied by) a local oscillator signal to produce a convenient intermediate-frequency (i-f) signal, commonly at 30 or 60 MHz; the same principle is used in all heterodyne radio receivers. The local oscillator signal, kept offset from the transmit frequency by precisely this intermediate frequency, is supplied by the transmitter oscillators during reception. After other significant signal processing in the i-f circuitry (of a digital nature in many newer radars), a detector produces a video signal, a voltage proportional to the strength of the processed i-f signal. This video can be applied to a cathode-ray-tube (CRT) display so as to form a proportionately bright spot (a blip), which could be judged to originate from a target echo. However, increasingly radars use artificial computerlike displays based on computer analysis of the video. Automatic detection and automatic tracking (based on a sequence of dwells) are typical of such data processing, reports being displayed for radar operator management and also made instantly available to the user system. See CATHODE-RAY TUBE; ELECTRONIC DISPLAY; HETERODYNE PRINCIPLE; MIXER; PREAMPLIFIER; RADIO RECEIVER.

Radar carrier frequencies are broadly identified by a nomenclature that originated in wartime secrecy and has since been found very convenient and widely accepted. The spectrum is divided into bands, the frequencies and wavelengths of which are given in the table. The charged layers of the ionosphere present a highly refractive shell at radio frequencies well below the microwave frequencies of most radars. Consequently, over-the-horizon radars have been built in the 10-MHz area to exploit this skip path. See CONTINUOUS-WAVE RADAR; MONOPULSE RADAR; RADIO SPECTRUM ALLOCATIONS. [R.T.H.]

**Radar-absorbing materials** Materials that are designed to reduce the reflection of electromagnetic radiation from a conducting surface in the frequency range from approximately 100 MHz to 100 GHz. The level of reduction that is achieved varies from a few decibels to greater than 50 dB, reducing the reflected energy by as much as 99.999%.

Two methods have been widely adopted in order to produce such absorbers. The first is to avoid a discrete change of impedance at the material surface by gradually varying the impedance. The removal of the discontinuity at the surface allows the microwave energy to be transmitted into the absorbing medium without reflection. This transition from the impedance of free space to that of the bulk material is commonly achieved by a geometric profile. The carbon-loaded foam pyramids used as the lining of anechoic chambers are typical of this type of absorber. To produce such absorbers, it is necessary in practice to taper the material over distances which are large compared with the wavelength of the frequencies to be absorbed. Therefore, practical absorbers of this type giving greater than 20 dB absorption vary in thickness from about 0.8 in. (2 cm) at 10 GHz and above to 6 ft (2 m) at 100 MHz and above. The absorber performance improves with increasing thickness until the point is reached where all of the energy that enters the material is absorbed and only the front-face reflection is left. While this type of absorber is capable of producing a very high degree of absorption over a broad bandwidth, it is at the same time a relatively thick material. See ANECHOIC CHAMBER.

The second method of absorber design produces much thinner absorbing layers which are capable of producing good absorption ( $\geq 25$  dB) with restricted bandwidths. These materials achieve the absorption by a combination of attenuation within the material and destructive interference at the interface. The electromagnetic properties and the thickness of the layer are such that the initial reflected wave and the sum of the emergent rays resulting from the multiple reflections within the material are equal in magnitude and opposite in phase. The thickness of the layer is close to a quarter-wavelength at the frequency of operation, giving a  $180^\circ$  phase difference between the interface reflection and the emergent waves. See INTERFERENCE OF WAVES.

Microwave-absorbing materials are widely used both within the electronics industry and for defense purposes. Their uses can be classified into three major areas: (1) for test purposes so that accurate measurements can be made on microwave equipment unaffected by spurious reflected signals; (2) to improve the performance of any practical microwave system by removing unwanted reflections which can occur if there is any conducting material in the radiation path; and (3) to camouflage a military target by reducing the reflected radar signal. See ELECTRONIC WARFARE; MICROWAVE; MICROWAVE MEASUREMENTS; REFLECTION OF ELECTROMAGNETIC RADIATION. [S.B.M.]

**Radar astronomy** A powerful astronomical technique that uses radar echoes to furnish otherwise-unavailable information about bodies in the solar system. By comparing a radar echo to the transmitted signal, information can be obtained about the target's size, shape, topography, surface bulk density, spin vector, and orbital elements. While other astronomical techniques rely on passive measurement of reflected sunlight or naturally emitted radiation, the illumination used in radar astronomy is a coherent signal whose polarization and time modulation or frequency modulation are tailored to meet specific scientific objectives. Through measurements of the distribution of echo power in time delay or Doppler frequency, radar achieves spatial resolution of a planetary target despite the fact that the radar beam is typically much larger than the angular extent of the target. This capability is particularly valuable for asteroids and planetary satellites, which appear as unresolved point sources through optical telescopes. Moreover, the centimeter-to-meter wavelengths used in radar astronomy readily penetrate cometary comas and the optically opaque clouds that conceal Venus and Titan, and also permit determination of near-surface roughness (abundance of wavelength-scale rocks), bulk density, and metal concentration in planetary regoliths. See ASTEROID; SATELLITE (ASTRONOMY); SATURN; VENUS.

A radar telescope is essentially a radio telescope equipped with a high-power transmitter (a klystron vacuum-tube amplifier)

and specialized instrumentation that links the transmitter, low-noise maser receiver, high-speed data-acquisition computer, and antenna together in an integrated radar system. Planetary radars, which must detect echoes from targets at distances from about  $10^6$  km for closely approaching asteroids and comets to more than  $10^9$  km for Saturn's rings and satellites, are the largest and most sensitive radars on Earth. See KLYSTRON; MASER; RADAR; RADIO TELESCOPE. [S.J.O.]

**Radar meteorology** The application of radar to the study of the atmosphere and to the observation and forecasting of weather. Meteorological radars transmit electromagnetic waves at microwave and radio-wave frequencies. Water and ice particles, inhomogeneities in the radio refractive index associated with atmospheric turbulence and humidity variations, insects, and birds scatter radar waves. The backscattered energy received at the radar constitutes the returned signal. Meteorologists use the amplitude, phase, and polarization state of the backscattered energy to deduce the location and intensity of precipitation, the wind speed along the direction of the radar beam, and precipitation type (for example, rain or hail). See METEOROLOGICAL RADAR; RADAR; WEATHER FORECASTING AND PREDICTION.

Much of the understanding of the structure of storms derives from measurements made with networks of Doppler radars. They are used to investigate the complete three-dimensional wind fields associated with storms, fronts, and other meteorological phenomena. See DOPPLER; PRECIPITATION (METEOROLOGY); STORM; STORM DETECTION; THUNDERSTORM. [R.M.Ra.]

**Radian measure** A radian is the angle subtended at the center of a circle by an arc of the circle equal in length to its radius. It is proved in geometry that equal central angles of two circles subtend arcs proportional to their radii; and the converse is true. Hence the radian is independent of the length of the radius. The illustration represents two circles of radius  $r$ . Arc  $AB$  of length  $r$

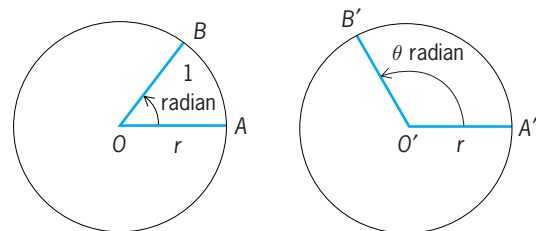

Diagrams showing radian measurement.

subtends 1 radian (rad) at the center  $O$  of the circle, and arc  $A'B'$  of length  $s$  subtends  $\theta$  rad at its center. Since arcs on equal circles are proportional to their subtended central angles,  $s/r = \theta/1$ , or the formula  $s = r\theta$  holds. If  $\theta = 2\pi$ ,  $s = 2\pi r$ , the circumference of the circle. Therefore  $2\pi$  rad is the complete angle about a point or  $360^\circ$ , and  $2\pi$  rad =  $360^\circ$ ,  $1$  rad =  $360^\circ/2\pi = 57.2958\pi$ .

The degree as a unit of angle has come down from antiquity. However, its use in various theories involves clumsy constants. The use of the radian avoids these constants. The radian is employed generally as a measure of angle in theoretical discussions; when no unit of angle is mentioned, the radian is understood. [L.M.K.]

**Radiance** The physical quantity that corresponds closely to the visual brightness of a surface. A simple radiometer for measuring the (average) radiance of an incident beam of optical radiation (light, including invisible infrared and ultraviolet radiation) consists of a cylindrical tube, with a hole in each end cap to define the beam cross section there, and with a photocell against one end to measure the total radiated power in the beam of all rays that reach it through both holes (see illustration).

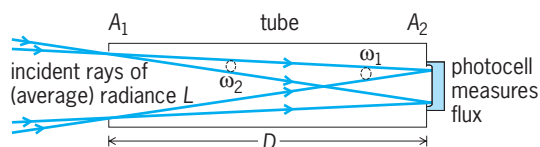

A simple radiometer.

If  $A_1$  and  $A_2$  are the respective areas of the two holes,  $D$  is the length of the tube (distance between holes), and  $\Phi$  is the radiant flux or power measured by the photocell, then the (average) radiance is approximately given by the equation  $L = \Phi / (A_1 \cdot A_2 / D^2) \text{ W} \cdot \text{m}^{-2} \cdot \text{sr}^{-1}$ . [E.E.N.]

**Radiant heating** Any system of space heating in which the heat-producing means is a surface that emits heat to the surroundings by radiation rather than by conduction or convection. The surfaces may be radiators such as baseboard radiators or convectors, or they may be the panel surfaces of the space to be heated. See PANEL HEATING AND COOLING.

The heat derived from the Sun is radiant energy. Radiant rays pass through gases without warming them appreciably, but they increase the sensible temperature of liquid or solid objects upon which they impinge. The same principle applies to all forms of radiant-heating systems, except that convection currents are established in enclosed spaces and a portion of the space heating is produced by convection. Any radiant-heating system using a fluid heat conveyor may be employed as a cooling system by substituting cold water or other cold fluid. However, the technique is not practical on the scale required for comfort control of an occupied space. [E.L.W./R.Ko.]

**Radiation** The emission and propagation of energy; also, the emitted energy itself. The etymology of the word implies that the energy propagates rectilinearly, and in a limited sense, this holds for the many different types of radiation encountered.

The major types of radiation may be described as electromagnetic, acoustic, and particle, and within these major divisions there are many subdivisions. Electromagnetic radiation is classified roughly in order of decreasing wavelength as radio, microwave, visible, ultraviolet, x-rays, and  $\gamma$ -rays. Acoustic or sound radiation may be classified by frequency as infrasonic, sonic, or ultrasonic in order of increasing frequency, with sonic being between about 16 and 20,000 Hz. The traditional examples of particle radiation are the  $\alpha$ - and  $\beta$ -rays of radioactivity. See ELECTROMAGNETIC RADIATION; RADIOACTIVITY; SOUND. [McA.H.H.]

**Radiation biology** The study of the action of ionizing and nonionizing radiation on biological systems. Ionizing radiation includes highly energetic electromagnetic radiation (x-rays, gamma rays, or cosmic rays) and particulate radiation (alpha particles, beta particles, neutrons, or heavy charged ions). Nonionizing radiation includes ultraviolet radiation, microwaves, and extralow-frequency (ELF) electromagnetic radiation. These two types of radiation have different modes of action on biological material: ionizing radiation is sufficiently energetic to cause ionizations, whereas nonionizing radiation causes molecular excitations. In both cases, the result is that chemical bonds of molecules may be altered, causing mutations, cell death, or other biological changes. See ELECTROMAGNETIC RADIATION; RADIATION.

Ionizing radiation originates from external sources (medical x-ray equipment, cathode-ray tubes in television sets or computer video displays) or from internal sources (ingested or inhaled radioisotopes, such as radon-222, strontium-90, and iodine-131), and is either anthropogenic or natural.

Nonionizing radiation originates from natural sources (sunlight, Earth's magnetic field, lightning, static electricity, endogenous body currents) and technological sources (computer video

displays and television sets, microwave ovens, communications equipment, electric equipment and appliances, and high-voltage transmission lines).

**Ionizing radiation.** The action of ionizing radiation is best described by the three stages (physical, chemical, and biological) that occur as a result of energy release in the biological target material.

*Physical stage.* All ionizing radiation causes ionizations of atoms in the biological target material. The Compton effect, which predominates at the energies of electromagnetic radiation that are commonly encountered (for example, x-rays or gamma rays), strips orbital electrons from the atoms. These electrons (Compton electrons) travel through the target material, colliding with atoms and thereby releasing packets of energy. For low-energy x-rays, the photoelectric effect predominates, producing photoelectrons that transfer their energy in the same manner as Compton electrons. See COMPTON EFFECT; ELECTRON; GAMMA RAYS; X-RAYS.

The absorbed dose of ionizing radiation is measured as the gray (Gy, 1 joule of energy absorbed by 1 kilogram of material). Because of the very localized absorption of ionizing radiation, an amount of ionizing radiation energy equivalent to 1/100 the heat energy in a cup of coffee will result in a 50% chance that the person absorbing the radiation will die in 30 days.

Neutrons with energies between 10 keV and 10 MeV transfer energy mainly by elastic scattering, that is, billiard-ball-type collisions, of atomic nuclei in the target material. In this process the nucleus is torn free of some or all of the orbital electrons because its velocity is greater than that of the orbital electrons. The recoiling atomic nucleus behaves as a positively charged particle. Because the mass of the neutron is nearly the same as that of the hydrogen atom, hydrogenous materials are most effective for energy transfer. See NEUTRON.

*Chemical stage.* Chemical changes in biological molecules are caused by the direct transfer of radiation energy (direct radiation action) or by the production of chemically reactive products from radiolysis of water that diffuses to the biological molecule (indirect radiation action). More than half the biological action of low linear-energy-transfer (LET) ionizing radiation (for example, x-rays and gamma rays) results from indirect radiation action, about 90% of which is due to the action of the hydroxyl radical ( $\text{OH}\cdot$ ). For high linear-energy-transfer radiation, direct radiation action predominates. Chemicals that react with hydroxyl radicals, rendering them unreactive, provide protection against indirect radiation damage. See LINEAR ENERGY TRANSFER (BIOLOGY); RADIATION CHEMISTRY.

The most important biological targets for damage from ionizing radiation are probably the plasma membrane and DNA, because there is only one copy, or a few copies, in the cell; because they serve critical roles for the survival and propagation of cells; and because they are large. The last factor is important because ionizing radiation releases its energy in a random manner; thus the larger the target, the more likely that it will be damaged by radiation. Consequences of radiation damage in membranes are changes in ion permeability, with leakage of potassium ions; changes in active transport; and cell lysis. Lesions in DNA include single-strand breaks, double-strand breaks, base damage, interstrand cross-links, and DNA-protein cross-links. See CELL MEMBRANES; DEOXYRIBONUCLEIC ACID (DNA).

*Biological stage.* Various biological effects can result from the actions of ionizing radiation. Reproductive death is most pronounced in mammalian cells that are actively dividing and in nondifferentiated tissue. Thus, dividing tissues (bone marrow and the germinal cells of the ovary and testis) are radiosensitive, and nondividing tissues (liver, kidney, brain, muscle, cartilage, and connective tissue) are radioresistant. Developing embryos are quite radiosensitive. The radiosensitivity of organisms varies greatly, being related to their intrinsic sensitivity to radiobiological damage and to their ability to repair the damage. Radiation doses resulting in 10% survival range from 3 Gy (mouse and

human cells), to greater than 1000 Gy (the bacterium *Deinococcus radiodurans*).

The three organ systems that generally contribute to the death of mammals following a single dose of whole-body irradiation are, in decreasing order of radiosensitivity, the hematopoietic system, the gastrointestinal system, and the cerebrovascular system. Late somatic effects may take years or decades to appear and include genetic mutations transmitted to subsequent generations, tumor development and carcinogenesis, and shortening of life span. See MUTAGENS AND CARCINOGENS; MUTATION; TUMOR.

**Nonionizing radiation.** Of all the nonionizing radiations, only ultraviolet radiation, microwaves, and high-voltage electromagnetic radiation are considered in the study of radiation biology.

**Ultraviolet radiation.** Since it can penetrate only several layers of cells, the effects of ultraviolet (UV) radiation on humans are restricted to the skin and the eyes. Ultraviolet radiation is divided into UV-C (wavelength of 200–280 nanometers), UV-B (280–320 nm), and UV-A (320–400 nm). The most biologically damaging is UV-C, and the least damaging is UV-A. The solar spectrum at the Earth's surface contains only the UV-B and UV-A radiations.

Biological effects can arise only when absorption of ultraviolet radiation occurs. Absorption is dependent on the chemical bonds of the material, and it is highly specific. Sunburn is a form of erythema produced by overexposure to the UV-B portion of the solar spectrum. A rare but deadly form of skin cancer in humans, malignant melanoma, is induced by exposure to sunlight, with occurrences localized on those regions of the body that are most frequently exposed. Ultraviolet light can also cause photochemical damage. Cyclobutane pyrimidine dimers are the main photoproduct following exposure to UV-C and UV-B, and they can lead to cell death and precarcinogenic lesions. Other types of dimers are considered to be especially mutagenic. DNA-protein cross-links that are observed after ultraviolet radiation can be lethal. See PHOTOCHEMISTRY.

Survival from ultraviolet irradiation is reduced as the dose of radiation is increased. The shapes of survival curves are similar to those for lethality from ionizing radiation, they are dependent on the presence or absence of repair systems. The four repair systems that enhance biological survival include photoreactivation (splitting of cyclobutane dimers in the DNA of cells that have been irradiated by ultraviolet light); DNA excision repair; DNA recombination repair; and an inducible repair system of bacteria known as SOS repair. See ULTRAVIOLET RADIATION; ULTRAVIOLET RADIATION (BIOLOGY).

**Microwaves.** Microwaves are electromagnetic radiation in the region from 30 MHz to 300 GHz. They originate from devices such as telecommunications equipment and microwave ovens. Thermal effects of microwaves occur at exposure rates greater than 10 mW/cm<sup>2</sup> (70 mW/in.<sup>2</sup>), while nonthermal effects are associated with exposure rates less than 10 mW/cm<sup>2</sup>. Material with a high water content will have a higher absorption coefficient for microwaves, and thus a greater thermal response to microwave action. Microwave absorption is high in skin, muscle, and internal organs, and lower in bone and fat tissue. See MICROWAVE.

Cultured mammalian cells exposed to microwaves at a high power density show chromosome abnormalities after 15 min of exposure. Progression through the cell cycle is also temporarily interrupted, which interrupts DNA synthesis. Chromosome aberrations in peripheral blood lymphocytes are significantly greater for persons who are occupationally exposed to microwaves. Microwaves can be lethal when the power intensity and exposure time are sufficient to cause a rise in temperature that exceeds an organism's homeostatic capabilities.

There are also some nonthermal effects associated with microwaves. A list of clinical symptoms includes increased fatigue, periodic or constant headaches, extreme irritability, decreased hearing acuity, and drowsiness during work. Laboratory stud-

ies involving exposure of animals to microwaves have produced changes in the electroencephalogram, blood-brain barrier, central nervous system, hematology, and behavior. Cell membrane permeability is also altered.

**Extremely low frequency electromagnetic fields.** This type of radiation is generated by the electric and magnetic fields associated with high-voltage current in power transmission lines, and also some household and industrial electrical equipment. Biological effects from ELF radiation are the least understood, and the potential consequences are the most controversial. The issue of potential biological damage from this type of radiation has arisen only since the introduction of very high voltage electric power transmission lines (440 kV and above) and the occurrence of widespread use of various electrical and electronic equipment. See ELECTROMAGNETIC PULSE (EMP).

Biological studies on ELF electromagnetic fields have been performed on cells and whole animals; and epidemiological studies have been carried out on populations exposed occupationally. The results share some common features: (1) There is not always a clear dose response; that is, increasing the exposure does not necessarily give rise to an increased biological effect. (2) Some biological effects are seen only at certain frequencies and dose rates. Some of the reported effects are subjective, and may be related to normal physiological adaptation to environmental changes. In humans, qualitative biological effects of low-frequency radiation (0 to 300 Hz) include headaches, lethargy, and decreased sex drive. Humans have been noted to perceive the presence of a 60-Hz electric field when the intensity is in the range of 2 to 12 kV/m (0.6 to 3.6 kV/ft), and animals were observed to avoid entering an area where the electric field was greater than 4 kV/m (1.2 kV/ft). See RADIATION INJURY (BIOLOGY).

[P.M.Ac.]

**Radiation chemistry** The study of chemical changes resulting from the absorption of high-energy, ionizing radiation, including alpha particles, electrons, gamma rays, fission fragments, protons, deuterons, helium nuclei, and heavier charged projectiles. In absorbing materials of low and intermediate atomic weight such as aqueous systems and most biological systems, such radiation deposits energy in a largely indiscriminate manner, leaving behind a complex mixture of short-lived ions, free radicals, and electronically excited molecules. Radiation-induced chemical changes result from reaction with these intermediates. See PHOTOCHEMISTRY.

Sources of high-energy radiation include radioactive nuclides [for example, cobalt-60 (<sup>60</sup>Co), strontium-90 (<sup>90</sup>Sr), and hydrogen-3 (<sup>3</sup>H)] and instruments such as x-ray tubes, Van de Graaff generators, the betatron, the cyclotron, and the synchrotron. An electron accelerator known as the Linac (linear electron accelerator) has proved particularly valuable for the study of transient species that have lifetimes as short as 16 picoseconds; and another electron accelerator, known as the Febetron, has been used for the study of the effects of single pulses of electrons with widths of several nanoseconds at very high currents.

The primary absorption processes for high-energy radiation are ionization and molecular excitation. The distribution of the absorbed energy, however, depends significantly upon the nature of the radiation and absorbing medium.

Evaluation of the yields of radiation-induced reactions requires knowledge of the energy imparted to the reacting system. The energy deposited in the system is termed the dose, and the measurement process is called dosimetry. Absorbed energy from ionizing radiation is described in terms of grays (Gy; joule/kg), in rads (100 ergs/g), or in electronvolts per gram or per cubic centimeter.

Because of its importance in both chemical and biological systems, the radiation chemistry of water has been extensively studied and serves as an example of radiation-induced chemical change. A primary radiation interaction process may be

represented by the reaction below, where  $\text{H}_2\text{O}^*$  represents an

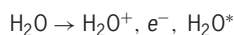

electronically excited water molecule. The secondary electron ( $e^-$ ), if formed with sufficient energy, will form its own trail of ionization and excitation. Within  $10^{-10}$  to  $10^{-8}$  s, reactions within spurs form hydrogen (H) atoms, hydroxyl (OH) radicals, hydrated electrons and molecular products, molecular hydrogen ( $\text{H}_2$ ), and hydrogen peroxide ( $\text{H}_2\text{O}_2$ ). In pure water, radicals escaping the spurs undergo further radical-radical reactions and reactions with molecular products. Upon continuous irradiation, steady-state concentrations of  $\text{H}_2$ ,  $\text{H}_2\text{O}_2$ , and smaller amounts of dioxygen ( $\text{O}_2$ ) result and no further decomposition occurs.

In addition to basic kinetics and mechanistic studies, the principles of radiation chemistry find application in any process in which ionizing radiation is used to study, treat, or modify a biological or chemical system.

In radiation therapy, tumors are destroyed by the application of ionizing radiation from external or internally administered sources. Gamma rays are used for treatment of internal tumors; electron or charged-particle beams are applied to external or invasively accessible lesions.

The physiological concentration of iodine in the thyroid is the basis for the treatment of hyperthyroidism with  $^{131}\text{I}$ . The beta radiation from this isotope is effective in localized tissue destruction.

A goal of any radiation therapy is maximum tumor cell destruction with minimum damage to healthy cells. See RADIATION THERAPY.

Radiation chemistry is used in food preservation by using ionizing radiation in doses that are lethal to microorganisms. The use of ionizing radiation for pathogen control has been approved by most governments for a wide range of foods. In general, limitations on dose have been specified for all products. Radiation is used to control pathogens in meat and meat products.

Processing of commercial quantities of food supplies requires a source of stable intensity and a radiation of sufficient penetrating power to deposit energy throughout the product in an economic, brief time period. [F.J.J.]

**Radiation damage to materials** Harmful changes in the properties of liquids, gases, and solids, caused by interaction with nuclear radiations. For a discussion of radiation damage in minerals see METAMICT STATE. For a description of damage caused to biological systems by radiation. See RADIATION BIOLOGY.

Radiation damage is usually associated with materials of construction that must function in an environment of intense high-energy radiation from a nuclear reactor. Materials that are an integral part of the fuel element or cladding and nearby structural components are subject to such intense nuclear radiation that a decrease in the useful lifetime of these components can result. Radiation damage will also be a factor in thermonuclear reactors. See NUCLEAR FUSION; NUCLEAR REACTOR.

Electronic components are extremely sensitive to even moderate radiation fields. Transistors malfunction because of defect trapping of charge carriers. Ferroelectrics such as  $\text{BaTiO}_3$  fail because of induced isotropy; quartz oscillators change frequency and ultimately become amorphous. High-permeability magnetic materials deteriorate because of hardening. Plastics used for electrical insulation rapidly deteriorate.

There are several mechanisms that function on an atomic and nuclear scale to produce radiation damage in a material if the radiation is sufficiently energetic, whether it be electrons, protons, neutrons, x-rays, fission fragments, or other charged particles.

Electronic excitation and ionization is most severe in liquids and organic compounds and appears in a variety of forms such as gassing, decomposition, viscosity changes, and polymerization in liquids. Rapid deterioration of the mechanical properties of plastics takes place either by softening or by embrittlement,

while rubber suffers severe elasticity changes at low fluxes. Cross-linking, scission, free-radical formation, and polymerization are the most important reactions. See RADIATION CHEMISTRY.

In an environment of neutrons, transmutation effects may be important. Even materials that have a low cross section such as aluminum can show an appreciable accumulation of impurity atoms from transmutations. The elements boron and europium have very large cross sections and are used in control rods. Damage to the rods is severe in boron-containing materials. See TRANSMUTATION.

Displaced atoms are the most important source of radiation damage in nuclear reactors outside the fuel element. It is a consequence of the ability of the energetic neutrons to knock atoms from their equilibrium position in their crystal lattice, displacing them many atomic distances away into interstitial positions and leaving behind vacant lattice sites.

Nuclear irradiations performed at low temperatures (4 K) result in the maximum retention of radiation-produced defects. As the temperature of irradiation is raised, many of the defects are mobile and some annihilation may take place. The increased mobility, particularly of vacancies and vacancy agglomerates, may lead to acceleration of solid-state reactions, such as precipitation, short- and long-range ordering, and phase changes. These reactions may lead to undesirable property changes.

The presence of small amounts of impurities may profoundly affect the behavior of engineering alloys in a radiation field. It has been observed that helium concentrations as low as  $10^{-9}$  seriously reduce the high-temperature ductility of a stainless steel. Small amounts of copper, phosphorus, and nitrogen have a strong influence on the increase in the ductile-brittle transition temperature of pressure vessel steels under irradiation. Heat treatment prior to irradiation determines the retention of both major alloying components and impurities in solid solution in metastable alloys. It also affects the number and disposition of dislocations. Thus heat treatment is an important variable in determining subsequent radiation behavior. [D.S.B.]

**Radiation hardening** The protection of semiconductor electronic devices and electronic systems from the effects of high-energy radiation. Applications for such devices are in three major areas: (1) satellites, which are exposed to natural space radiation from the Van Allen belts, solar flares, and cosmic rays; (2) electronics, especially sensor and control electronics for commercial nuclear power-generating plants; and (3) equipment designed to survive the radiation from nuclear explosions.

Although most radiation effects have been explained and are well understood, much remains to be done. Among the better-understood phenomena are displacement damage from neutrons and photocurrent transients produced by ionizing-radiation pulses. Basic electromagnetic-pulse interactions are also well understood, although their effects on complex electronic systems are extremely difficult to predict. See ELECTROMAGNETIC PULSE (EMP).

The quasipermanent effects of exposure to ionizing radiation are least understood, and understanding the response of semiconductor devices to this radiation is probably the single most important remaining radiation-hardening problem. Hardening of metal-oxide-semiconductor (MOS) devices has been accomplished by lower-temperature processing, which probably reduces physical or crystalline defects, and by developing extremely clean processes, which probably reduce chemical defects. The most important electrical manifestations of ionizing dose damage in MOS devices are an increase in leakage current; a shift in threshold voltage; and a decrease in speed, transconductance, and channel conductance. See CRYSTAL.

Dose-rate effects are well understood. The generation of electron-hole pairs in semiconductors is proportional to the dose. Carriers generated in or near a  $pn$  junction result in a transient photocurrent proportional to dose rate and the effective volume of the junction. High dose rates can damage semiconductor

devices through logic upset, latch-up, and burnout. See PHOTO-VOLTAIC EFFECT.

Displacement damage effects are caused by neutrons, protons, electrons, and other high-energy particles. The production of lattice defects is proportional to the nonionizing energy absorbed by the lattice. The dominant effect in bipolar silicon devices is a reduction in common-emitter current gain.

Single-event upsets are caused at a very low rate in logic and memory circuits by cosmic rays. Rates are low enough (less than  $10^{-3}$  upset per bit per day) that error-detection-and-correction (EDAC) software can be effectively used. Single-event phenomena have led to the development of fault-tolerant architectures to mitigate the effects of random digital upsets, and to the design modification of integrated circuits to prevent an upset even when the active volume is struck by a cosmic ray. See FAULT-TOLERANT SYSTEMS.

Hardening of electronic systems is accomplished by a combination of selecting hardened components, designing circuits more tolerant to radiation-induced degradations, and shielding. Shielding is effective against x-rays and electrons, which have short ranges in materials, and relatively ineffective against gamma radiation, neutrons, and cosmic rays, which have long ranges in materials. See INTEGRATED CIRCUITS; RADIATION DAMAGE TO MATERIALS; RADIATION SHIELDING; SEMICONDUCTOR. [G.C.M.]

**Radiation pressure** Pressure exerted by electromagnetic radiation on objects on which it impinges. This pressure is caused by the fact that electromagnetic radiation transmits energy and possesses momentum. These pressures are very small. The effect is conspicuous in the case of a comet near the Sun, where the radiation pressure from the Sun forces the lighter cometary constituents away from the Sun. See ELECTROMAGNETIC RADIATION. [W.R.Sm.]

**Radiation shielding** Physical barriers designed to provide protection from the effects of ionizing radiation; also, the technology of providing such protection. Major sources of radiation are nuclear reactors and associated facilities, medical and industrial x-ray and radioisotope facilities, charged-particle accelerators, and cosmic rays. Types of radiation are directly ionizing (charged particles) and indirectly ionizing (neutrons, gamma rays, and x-rays). In most instances, protection of human life is the goal of radiation shielding. In other instances, protection may be required for structural materials which would otherwise be exposed to high-intensity radiation, or for radiation-sensitive materials such as photographic film and certain electronic components.

Charged particles lose energy and are thus attenuated and stopped primarily as a result of coulombic interactions with electrons of the stopping medium. Gamma-ray and x-ray photons lose energy principally by three types of interactions: photoemission, Compton scattering, and pair production. Neutrons lose energy in shields by elastic or inelastic scattering. Elastic scattering is more effective with shield materials of low atomic mass, notably hydrogenous materials, but both processes are important, and an efficient neutron shield is made of materials of both high and low atomic mass. See COMPTON EFFECT; ELECTRON-POSITRON PAIR PRODUCTION; PHOTOEMISSION.

The most common criteria for selecting shielding materials are radiation attenuation, ease of heat removal, resistance to radiation damage, economy, and structural strength.

For neutron attenuation, the lightest shields are usually hydrogenous, and the thinnest shields contain a high proportion of iron or other dense material. For gamma-ray attenuation, the high-atomic-number elements are generally the best. For heat removal, particularly from the inner layers of a shield, there may be a requirement for external cooling with the attendant requirement for shielding the coolant to provide protection from induced radioactivity.

Metals are resistant to radiation damage, although there is some change in their mechanical properties. Concretes, frequently used because of their relatively low cost, hold up well; however, if heated they lose water of crystallization, becoming somewhat weaker and less effective in neutron attenuation.

If shielding cost is important, cost of materials must be balanced against the effect of shield size on other parts of the facility, for example, building size and support structure. If conditions warrant, concrete can be loaded with locally available material such as natural minerals (magnetite or barytes), scrap steel, water, or even earth.

Radiation shields vary with application. The overall thickness of material is chosen to reduce radiation intensities outside the shield to levels well within prescribed limits for occupational exposure or for exposure of the general public. The reactor shield is usually considered to consist of two regions, the biological shield and the thermal shield. The thermal shield, located next to the reactor core, is designed to absorb most of the energy of the escaping radiation and thus to protect the steel reactor vessel from radiation damage. It is often made of steel and is cooled by the primary coolant. The biological shield is added outside to reduce the external dose rate to a tolerable level. See RADIATION BIOLOGY; RADIATION DAMAGE TO MATERIALS. [R.E.F.]

**Radiation therapy** The use of ionizing radiation to treat disease; the method is also known as radiotherapy and therapeutic radiology. Radiotherapy was widely used in the past to treat diseases of the skin, lymph nodes, and other organs. However, because radiation can cause cancer and because alternative treatments for these diseases have been discovered, radiation therapy is now mainly limited to treating malignant tumors: the medical specialty is called radiation oncology. See ONCOLOGY.

The exact mechanisms by which radiation kills cells remain uncertain. Most likely, electrons dislodged from water or biological molecules disrupt the bonds between atoms of the nuclear deoxyribonucleic acid (DNA), resulting in double-strand breaks. Although usually not immediately fatal, such damage may cause the death of cells when they attempt to divide. Complex enzymatic mechanisms can repair some of the damage if given sufficient time.

The fraction of cells surviving after irradiation depends on many factors. Radiation affects both normal and cancerous cells in a similar manner qualitatively, but different cell lines vary greatly in their quantitative sensitivity. Rapidly dividing tissues—such as the skin, bone marrow, and gastrointestinal mucosa—usually display the greatest sensitivity experimentally and the most immediate side effects clinically.

The goal of radiation therapy is either to cure the disease permanently (radical treatment) or to reduce or eliminate symptoms (palliative treatment) by destroying tumors without causing unacceptable injuries to normal tissues. For many cancers—such as cancers of the reproductive organs, lymphomas, and small head and neck tumors—a cure usually is possible, and the chance of functionally significant complications is small. Some tumors, however, contain too many cells to be entirely destroyed by tolerable doses. Also, some neoplasms, such as sarcomas and glioblastomas, are relatively resistant to irradiation and are difficult to eradicate even when only small numbers of cells are present. Such situations are best handled by using surgery to remove all visible tumor. See CANCER (MEDICINE); RADIATION BIOLOGY. [A.R.]

**Radiative transfer** The study of the propagation of energy by radiative processes; it is also called radiation transport. Radiation is one of the three mechanisms by which energy moves from one place to another, the other two being conduction and convection. See ELECTROMAGNETIC RADIATION; HEAT TRANSFER.

The kinds of problems requiring an understanding of radiative transfer can be characterized by looking at meteorology, astronomy, and nuclear reactor design. In meteorology, the energy

budget of the atmosphere is determined in large part by energy gained and lost by radiation. In astronomy, almost all that is known about the abundance of elements in space and the structure of stars comes from modeling radiative transfer processes. Since neutrons moving in a reactor obey the same laws as radiation being scattered by atmospheric particles, radiative transfer plays an important part in nuclear reactor design.

Each of these three fields—meteorology, astronomy, and nuclear engineering—concentrates on a different aspect of radiative transfer. In meteorology, situations are studied in which scattering dominates the interaction between radiation and matter; in astronomy, there is more interest in the ways in which radiation and the distribution of electrons in atoms affect each other; and in nuclear engineering, problems relate to complicated, three-dimensional geometry.

Radiative transfer is a complicated process because matter interacts with the radiation. This interaction occurs when the photons that make up radiation exchange energy with matter. These processes can be understood by considering the transfer of visible light through a gas made up of atoms. Similar processes occur when radiation interacts with solid dust particles or when it is transmitted through solids or liquids. *See* PHOTON.

If a gas is hot, collisions between atoms can convert the kinetic energy of motion to potential energy by raising atoms to an excited state. Emission is the process which releases this energy in the form of photons and cools the gas by converting the kinetic energy of atoms to energy in the form of radiation. The reverse process, absorption, occurs when a photon raises an atom to an excited state, and the energy is converted to kinetic energy in a collision with another atom. Absorption heats the gas by converting energy from radiation to kinetic energy. Occasionally an atom will absorb a photon and reemit another photon of the same energy in a random direction. If the photon is reradiated before the atom undergoes a collision, the photon is said to be scattered. Scattering has no net effect on the temperature of the gas. *See* ABSORPTION; ATOMIC STRUCTURE AND SPECTRA; SCATTERING OF ELECTROMAGNETIC RADIATION. [A.H.K.]

**Radiator** Any of numerous devices, units, or surfaces that emit heat, mainly by radiation, to objects in the space in which they are installed. Because their heating is usually radiant, radiators are of necessity exposed to view. They often also heat by conduction to the adjacent thermally circulated air.

Radiators are usually classified as cast-iron (or steel) or nonferrous. They may be directly fired by wood, coal, charcoal, oil, or gas (such as stoves, ranges, and unit space heaters). The heating medium may be steam, derived from a steam boiler, or hot water, derived from a water heater, circulated through the heat-emitting units.

Electric heating elements may be substituted for fluid heating elements in all types of radiators, convectors, and unit ventilators. *See* HOT-WATER HEATING SYSTEM; RADIANT HEATING; STEAM HEATING. [E.L.W./R.Ko.]

**Radio** Communication between two or more points, employing electromagnetic waves as the transmission medium.

Radio waves transmitted continuously, with each cycle an exact duplicate of all others, indicate only that a carrier is present. The message must cause changes in the carrier which can be detected at a distant receiver. The method used for the transmission of the information is determined by the nature of the information which is to be transmitted as well as by the purpose of the communication system.

In code telegraphy the carrier is keyed on and off to form dots and dashes. The technique, often used in ship-to-shore and amateur communications, has been largely superseded in many other point-to-point services by more efficient methods.

In frequency-shift transmission the carrier frequency is shifted a fixed amount to correspond with telegraphic dots and dashes or

with combinations of pulse signals identified with the characters on a typewriter. This technique is widely used in handling the large volume of public message traffic on long circuits, principally by the use of teletypewriters. *See* TELETYPEWRITER.

In amplitude modulation the amplitude of the carrier is made to fluctuate, to conform to the fluctuations of a sound wave. This technique is used in AM broadcasting, television picture transmission, and many other services. *See* AMPLITUDE-MODULATION RADIO.

In frequency modulation the frequency of the carrier is made to fluctuate around an average axis, to correspond to the fluctuations of the modulating wave. This technique is used in FM broadcasting, television sound transmission, and microwave relaying. *See* FREQUENCY-MODULATION RADIO.

In pulse transmission the carrier is transmitted in short pulses, which change in repetition rate, width, or amplitude, or in complex groups of pulses which vary from group to succeeding group in accordance with the message information. These forms of pulse transmission are identified as pulse-code, pulse-time, pulse-position, pulse-amplitude, pulse-width, or pulse-frequency modulation. Such techniques are complex and are employed principally in microwave relay systems. *See* PULSE MODULATION.

In radar the carrier is normally transmitted as short pulses in a narrow beam, similar to that of a searchlight. When a wave pulse strikes an object, such as an aircraft, energy is reflected back to the station, which measures the round-trip time and converts it to distance. A radar can display varying reflections in a maplike presentation on a cathode-ray tube. *See* RADAR.

Hundreds of thousands of radio transmitters exist, each requiring a carrier at some radio frequency. To prevent interference, different carrier frequencies are used for stations whose service areas overlap and receivers are built to select only the carrier signal of the desired station. Resonant electric circuits in the receiver are adjusted, or tuned, to accept one frequency and reject others.

All nations have a sovereign right to use freely any or all parts of the radio spectrum. But a growing list of international agreements and treaties divides the spectrum and specifies sharing among nations for their mutual benefit and protection. Each nation designates its own regulatory agency. In the United States all nongovernmental radio communications are regulated by the Federal Communications Commission (FCC). *See* AMATEUR RADIO; RADIO BROADCASTING; RADIO SPECTRUM ALLOCATIONS.

[J.D.Si.]

**Radio astronomy** The study of celestial objects by measurement and analysis of the electromagnetic radiation they emit in the wavelength range from 1 mm to 30 m (0.04 in. to 100 ft). Radio astronomers study an entire range of celestial objects, including the normal stars, planets, galaxies, and the exotic quasars, pulsars, and x-ray sources.

**Radio universe.** Since the late 1940s, radio telescopes have been used to map the skies and determine the positions and intensities, or fluxes, of individual sources of radio emission. Such maps have been made with increasing sensitivity and angular resolution; the latter property enables astronomers to determine the position of the radio sources accurately. Knowing the position, astronomers can refer to optical photographs of the sky and establish precisely which object is emitting radio waves. This procedure has led to the identification of radio sources with many bright galaxies and even with the most distant objects in the universe, the quasistellar objects (or quasars). However, nearly one-fifth of all radio sources are unidentified, that is, excellent photographs taken at the radio source positions show no object at all from which the radiation could arise. One concludes from this that these unidentified sources are "normal" galaxies and quasars at such great distances that they cannot be seen optically. *See* RADIO TELESCOPE.



It appears that there are more sources at great distances per unit volume of space than there are nearby, a result that means the universe is expanding, and that those distant sources are, in general, stronger than ones nearby. These two conclusions are fundamentally linked, and together they mean that further work on cosmological problems must await a clearer understanding of the nature and evolution of individual radio sources. See COSMOLOGY.

**Galaxies and radio galaxies.** Spiral galaxies, such as the Milky Way Galaxy, are often radio sources, although most are quite weak. Elliptical galaxies are usually not radio sources. However, the few elliptical galaxies that are radio sources are very spectacular ones, being among the most energetic radio objects in the sky. These are known as the radio galaxies.

The radio emission from spiral galaxies is typically confined to a small nuclear region supplemented by much weaker extended emission from the disk of the galaxy. In elliptical radio galaxies, on the other hand, the radio emission emanates from a small region at the center of the galaxy. Radio-emitting material is expelled from the nuclear region in two oppositely directed collimated streams, or jets, that extend out to distances many times the size of the visible galaxy. The enormous radio energy involved,  $10^{10}$ – $10^{12}$  times the solar luminosity, together with the very small size of the nuclear region from which this energy arises, less than  $10^{14}$  km, leads to the conclusion that the source of energy is a black hole at the center of the radio galaxy. Such a black hole would be  $10^7$ – $10^9$  times as massive as the Sun. See BLACK HOLE.

The radio emission from galaxies and radio galaxies is generated by the electron synchrotron process, in which relativistic electrons spiral around magnetic field lines and emit a continuous radiation spectrum throughout the band accessible to radio astronomers. See GALAXY, EXTERNAL.

**Solar system astronomy.** The Sun is an intense radio source, but only because it is so close to Earth. If it were at the distance of the nearest stars, its radio emission could not be detected. Solar radio emission tends to be intermittent: solar flares that produce cosmic rays and plasma streams that interact with Earth are visible as radio bursts; these are most frequent during the peak of the 11-year solar cycle. See COSMIC RAYS; SUN.

Jupiter is a much stronger radio source than had been expected from estimates of its surface temperature by optical astronomers. Most of its radio emission is caused by electron synchrotron emission in its very strong magnetic field. The very-long-wavelength emission of Jupiter is impulsive, and its strength depends upon the position of Io, one of Jupiter's moons. Similar impulsive long-wavelength bursts have also been discovered from Saturn. See JUPITER; SATURN.

**Radio stars.** Several nearby, apparently normal stars are detectable at radio wavelengths. Such stars as Algol,  $\beta$  Persei, and AR Lacerta are multiple star systems that have been found to be radio sources. The radio emission from these stars is dominated by radio bursts in which the radio fluxes may increase by a factor of 100 or more. It is clear that the radio bursts are initiated by or are a product of mass exchange processes going on between (at least) two closely bound stars.

An extreme example of radio emission from stars comes from stars that are also x-ray sources. Again, these objects are usually binary systems in which mass exchange plays a deciding role in their continuing evolution, but with x-ray sources one of the component stars appears to be a star that has exhausted its reservoir of nuclear fuel and is collapsing to its final state. See BINARY STAR; X-RAY ASTRONOMY.

**Supernova remnants.** During the formation of a supernova, the atmospheric envelope of a star is ejected and in this process becomes a rapidly expanding cloud of relativistic particles, magnetic field, and filaments of ionized gas. These conditions are precisely those necessary for the generation of radio emission through electron synchrotron radiation, and very intense radio

sources indeed exist at the positions of old supernovae chronicled by ancient astronomers. One of the most interesting of the radio sources associated with a supernova remnant is the Crab Nebula. See CRAB NEBULA; SUPERNOVA.

**HII regions.** An HII region (a region of ionized hydrogen) is a large cloud of interstellar gas that has been ionized and heated by one or more bright, hot stars located within. These nebulae are sources of both continuum and line energy at radio and optical wavelengths. Since cosmic matter consists mostly of hydrogen, the ionized gas consists mainly of protons and electrons that emit continuum energy by bremsstrahlung. See NEBULA.

**Hydrogen line.** Study of the 21-cm line of neutral atomic hydrogen has been exceptionally rewarding in its contribution to the knowledge of galactic structure and of the physical characteristics of interstellar gas. Line intensity normally reflects the amount of gas in the line of sight; line wavelength and width indicate the line-of-sight velocity of the gas and the state of internal motion, just as with recombination lines in HII regions. If the gas overlies a strong radio source, the gas temperature can be inferred by observing the 21-cm line in absorption.

The structure of the Galaxy has been elucidated by the study of the amount and velocity of the hydrogen within it. A prime advantage of this method is that the very distant gas is just as visible as nearby gas, whereas optical studies of the whole Galaxy are impossible because the very distant stars are made invisible by intervening clouds of dust. The results of these radio studies indicate that the Milky Way Galaxy is a spiral. See MILKY WAY GALAXY.

**Molecular lines.** It has long been believed that simple molecules could not exist in the tenuous gas between stars, because the starlight radiation field would be sufficiently intense to break apart even the simplest molecular species. In spite of these arguments, by 1968 radio astronomers had found rotational transitions of three simple molecules, OH, H<sub>2</sub>O, and NH<sub>3</sub>. These molecules were found in dark clouds of gas and dust in the interstellar medium. Such dark clouds are believed to be the sites of recent and continuing star formation. Since 1968, more than 87 molecular species have been detected in interstellar space principally by observations of millimeter rotational lines or lines arising from the interaction of the rotation of the molecule's nuclei with the spin of its electrons. More complicated organic molecules containing as many as 12 atoms have been discovered. Observations of these molecular species may make it possible to establish the chemistry and thermodynamics in the interstellar clouds from which, ultimately, stars, planets, and life itself must form. See MOLECULAR STRUCTURE AND SPECTRA; RADIO TELESCOPE.

[R.L.Bro.]

**Radio broadcasting** The transmission, via radio-frequency electromagnetic waves, of audible program material for direct reception by the general public. Electromagnetic waves can be made to travel or propagate from a transmitting antenna to a receiving antenna. By modifying the amplitude, frequency, or relative phase of the wave in response to some message signal (a process known as modulation), it is possible to convey information from the transmitter to the receiver. In radio broadcasting, this information usually takes the form of voice or music. See ELECTRICAL COMMUNICATIONS; ELECTROMAGNETIC WAVE TRANSMISSION; MODULATION; RADIO.

Radio broadcasting occurs in seven frequency bands. Long-wave broadcasting is permitted by international agreement in a portion of the low-frequency band from 150 to 290 kHz in Europe. The most widely used broadcast band is in the medium-frequency (mf) range between 525 and 1700 kHz. It is commonly known as AM after amplitude modulation, the technique employed. Shortwave broadcasting is permitted worldwide in eight frequency bands between 5950 and 26,100 kHz. The very high frequency (VHF) band of 88 to 108 MHz is used for what is commonly called FM broadcasting, after frequency modulation that is

used for transmissions. During the 1990s, a digital audio broadcasting (DAB) service in the 1452–1492- and 174–240-MHz frequency bands was put in place in Europe, Canada, and other countries. This band is unavailable in the United States for this service, so an alternate DAB system is being devised for use there. Radio broadcasting from satellites to listeners has been authorized in the 2310–2360-MHz frequency band. See AMPLITUDE MODULATION; AMPLITUDE-MODULATION RADIO; FREQUENCY MODULATION; FREQUENCY-MODULATION RADIO.

**AM medium-frequency band.** Broadcast stations in the medium-frequency band use amplitude modulation of a carrier wave to transmit information. The amplitude of the wave is modified in response to the changing amplitude of an audible voice or music signal. The AM receiver detects these amplitude changes and converts them back into audible signals, which can then be amplified and reproduced on acoustical transducers or speakers. See RADIO RECEIVER; RADIO TRANSMITTER.

The audible frequency range is generally considered to extend from 20 to 20,000 Hz. As a practical matter, AM broadcasting transmissions are limited to a range of 50 to 10,000 Hz. Because of transmission components and directional antennas, the fidelity of many stations is more severely restricted, resulting in voice transmission that is still acceptable but music transmission that is of relatively low fidelity.

An AM station may use a single tower for an antenna, resulting in an omnidirectional radiation pattern; or two or more transmitting towers to augment the radiation in certain directions while suppressing it in others, in order to comply with station allocation criteria. Since the allocation restrictions may be different during the daytime and nighttime hours, many stations employ two different directional antennas. The radiation from the antenna is expressed in millivolts per meter at 1 km (0.62 mi) from the antenna. See ANTENNA (ELECTROMAGNETISM).

AM broadcast signals propagate from the transmitter by three mechanisms: ground-wave, space-wave, and skywave. Ground waves travel along the ground surface (the boundary between the Earth and the atmosphere). Because they are surface waves, they penetrate into the ground, resulting in the energy being diminished because of losses in the ground. The current flowing in the antenna also produces space waves, which travel through the atmosphere from transmitter to receiver. Space-wave propagation is usually limited by intervening terrain obstacles or the curvature of the Earth. Sky-wave propagation occurs when space waves directed toward the ionosphere are reflected toward the Earth. This phenomenon can result in substantial signal strengths at distances of several hundred miles from the antenna. AM sky-wave propagation occurs primarily during nighttime hours by reflections from the E and F layers of the ionosphere at about 60 and 130 mi (100 and 220 km) altitude above the Earth's surface, respectively. See IONOSPHERE; RADIO-WAVE PROPAGATION.

The daytime ground-wave signal level protected by allocation criteria is usually 0.5 mV/m, although much higher signal strengths may be necessary to overcome noise from atmospheric and artificial sources, especially in highly urbanized areas. During nighttime hours, the service area for most AM stations (other than class A stations) is usually limited by interference from other cochannel stations. For low-power stations, this may be only 10 mi (16 km) or less from the transmitter. For the highest class of stations (class A), nighttime service is protected by the allocation criteria to the 0.5-mV/m, 50%-time sky-wave contour. Because such service is subject to the time variations and fading of sky-wave propagation, the 0.5-mV/m, 50%-time contour is considered to be a secondary service area.

**FM VHF band.** FM broadcasting has become the dominant broadcast service in the United States primarily because of its better fidelity and its superior reception, which is less subject to noise and interference than that of AM. Information is conveyed by frequency modulation or deviation of a carrier wave. In the United States, the carrier frequency may be deviated  $\pm 75$  kHz

around the assigned carrier frequency. The carrier frequencies, or channels, are spaced at 200-kHz intervals in the United States; a few other countries use slightly different channel spacings. Nearly all FM stations transmit in stereo.

The service area of an FM station depends on the propagation of space waves from the transmitter to the receiver. Space waves propagate through the atmosphere and are diffracted around, and reflected off, mountains, buildings, and other objects. Propagation within areas that have an unobstructed line-of-sight from transmitter to receiver is most reliable and predictable.

**Shortwave broadcasting.** For reaching audiences in foreign countries or other distant places, shortwave broadcasting is most often used. Nearly 600 million shortwave radio receivers are in use worldwide. Shortwave broadcasting is permitted worldwide in eight frequency bands from 5950 to 26,100 kHz. The assigned transmitting frequencies are spaced at 5-kHz intervals, resulting in a limited usable audio bandwidth. Voice transmissions are most effective, while music transmissions have limited fidelity.

Shortwave signals propagate via sky waves that are reflected one or more times from the E and F layers of the ionosphere. Multiple reflections are possible because a signal can also bounce off the Earth's surface after reflecting off the ionosphere in a "Ping-Pong" effect.

**Digital audio broadcasting.** To enhance audio quality, a digital audio broadcasting service has been put in place in Europe and elsewhere, operating primarily in the 1452–1492-MHz band. As in VHF FM broadcasting, DAB uses transmitters located at elevated locations (mountaintops, building roofs) that provide the best line-of-sight paths to the intended service area. Digital broadcasting differs from VHF FM broadcasting in that the audio signal (voice or music) is first converted to a stream of binary digits (data bits) that represent the audio signal. These data bits are then used to modulate the radio-frequency carrier signal using one of several techniques. After transmission via the radio waves, the radio-frequency carrier is demodulated at the receiver to recover the stream of data bits, and the bits are then converted back to the audio signal. DAB offers improved reception quality and fidelity because error-correcting codes in the digital signal can be used to eliminate many flaws that may occur during transmission. See INFORMATION THEORY; MODULATION.

**Satellite broadcasting.** Satellite broadcasting also uses digital modulation techniques. However, in this case the transmitters are located on satellites high above the Earth. From this position, satellite broadcasting can achieve essentially universal coverage of an entire nation or most of a continent from one or two transmitters. Both geostationary and low-Earth-orbit satellites are used for these systems. Specialized receiving antennas placed in locations visible to the sky are usually needed, along with a special radio receiver specifically designed for satellite service. To extend coverage into areas that are not visible to the sky, some satellite broadcasting networks employ a network of ground-based transmitters (repeaters) to supplement the coverage of the satellite signal. Satellite broadcasting is capable of providing 100 or more channels of audio programming, usually on a subscription or fee basis. See DIRECT BROADCASTING SATELLITE SYSTEMS. [H.R.A.]

**Radio broadcasting network** A group of broadcast stations interconnected by leased channels on wire, microwave, or satellite to one or more central feed points for the purpose of receiving and rebroadcasting program material of a timely nature. Networks make it possible to broadcast live programs simultaneously to the public through affiliated radio stations; they make national and regional markets available to advertisers and offer stations quality entertainment and public service programs.

Radio networking is now carried out almost exclusively through Earth-orbiting satellites which are geosynchronous with the Earth's rotation; that is, they remain essentially stationary

with respect to terrestrial locations, approximately 22,250 mi (35,800 km) above the surface of the Earth. Basically the transmit-receive technology is microwave, using uplink (ground station to satellite) frequencies in the 6-GHz frequency range, and 4-GHz downlink frequencies. Typically, each satellite contains 24 transponders. Each transponder is in effect a receiver-transmitter unit, which receives the uplink signal and then modulates a downlink transmitter, which returns the signal to Earth station receivers. See COMMUNICATIONS SATELLITE.

The "fixed-position" satellites, operated and maintained in their orbiting positions by the common carriers, repeat the signal on assigned transponder frequencies, beaming a broad pattern of signal which can cover an entire continent. The signal may be received in any location by the affiliated radio station utilizing low-noise receiving amplifiers centered in the focus of microwave receiving antennas aimed toward the satellite. See FREQUENCY-MODULATION RADIO; RADIO; RADIO BROADCASTING. [O.R.]

**Radio compass** A popular term for an automatic radio direction finder used for navigation purposes on ships and aircraft. It is not strictly a compass, because it indicates direction with respect to the radio station to which it is tuned, rather than to the north magnetic pole. The modern radio compass uses a nondirectional antenna in combination with a bidirectional loop antenna to provide a unidirectional bearing indication. Navigators thus know at all times whether they are traveling toward or away from the radio station used as a reference. The antennas are used with a special radio receiver that provides a visual indication of direction on a meter or cathode-ray indicator. See DIRECTION-FINDING EQUIPMENT. [J.Mar.]

**Radio-frequency amplifier** A tuned amplifier that amplifies the high-frequency signals commonly used in radio communications. The frequency at which maximum gain occurs

in a radio-frequency (rf) amplifier is made variable by changing either the capacitance or the inductance of the tuned circuit. A typical application is the amplification of the signal received from an antenna before it is mixed with a local oscillator signal in the first detector of a radio receiver. The amplifier that follows the first detector is a special type of rf amplifier known as an intermediate-frequency (i-f) amplifier. See AMPLIFIER; INTERMEDIATE-FREQUENCY AMPLIFIER.

An rf amplifier is distinguished by its ability to tune over the desired range of input frequencies. The shunt capacitance, which adversely affects the gain of a resistance-capacitance coupled amplifier, becomes a part of the tuning capacitance in the rf amplifier, thus permitting high gain at radio frequencies. The power gain of an rf amplifier is always limited at high radio frequencies, however.

Two typical rf amplifier circuits are shown in the illustration. The conventional bipolar transistor amplifier of illus. a uses tapped coils in the tuned circuits to provide optimum gain-bandwidth characteristics consistent with the desirable value of tuning capacitance. Inductive coupling provides the desired impedance transformation in the input and output circuits. The tuning capacitors are usually ganged so as to rotate on a single shaft, providing tuning by a single knob. Sometimes varactor diodes are used to tune the circuits, in which case the tuning control is a potentiometer that controls the diode voltage. Automatic gain control (AGC) is frequently used on the rf amplifier, as shown. AGC voltage controls the bias and hence the transconductance of the amplifier. In the field-effect transistor (FET) circuit (illus. b), tapped coils are not required because of the very high input and output resistances of the FET. See AUTOMATIC GAIN CONTROL (AGC); SEMICONDUCTOR; TRANSISTOR. [C.L.A.]

### Radio-frequency impedance measurements

Measurements of electrical impedance at frequencies ranging from a few tens of kilohertz to about 1 gigahertz. In the electrical context, impedance is defined as the ratio of voltage to current (or electrical field strength to magnetic field strength), and it is measured in units of ohms ( $\Omega$ ). See ELECTRICAL IMPEDANCE.

At zero frequency, that is, when the current involved is a direct current, both voltage and current are expressible as real numbers. Their ratio, the resistance, is a scalar (real) number. However, at nonzero frequencies, the voltage is not necessarily in phase with the current, and both are represented by vectors, and therefore are conveniently described by using complex numbers. To distinguish between the scalar quantity of resistance at zero frequency and the vectorial quantity at nonzero frequencies, the word impedance is used for the complex ratio of voltage to current. See ALTERNATING CURRENT; DIRECT CURRENT; ELECTRICAL RESISTANCE.

The measurement of impedance at radio frequencies cannot always be performed directly by measuring an rf voltage and dividing it by the corresponding rf current, for the following reasons: (1) it may be difficult to measure rf voltages and currents without loading the circuit by the sensing probes; (2) the distributed parasitic reactances (stray capacitances to neighboring objects, and lead inductances) may be altered by the sensing probes; and (3) the spatial voltage and current distributions may prevent unambiguous measurements (in waveguides, for instance).

At low frequencies, impedance measurements are often carried out by measuring separately the resistive and reactive parts, using either Q-meter instruments (for resonance methods), or reconfigurable bridges, which are sometimes called universal LCR (inductance-capacitance-resistance) bridges. In one such bridge the resistive part of the impedance is measured at dc with a Wheatstone bridge. Capacitive reactance is measured with a series-resistance-capacitance bridge, and inductive reactance is measured with a Maxwell bridge, using alternating-current (ac) excitation and a standard capacitance. See WHEATSTONE BRIDGE.

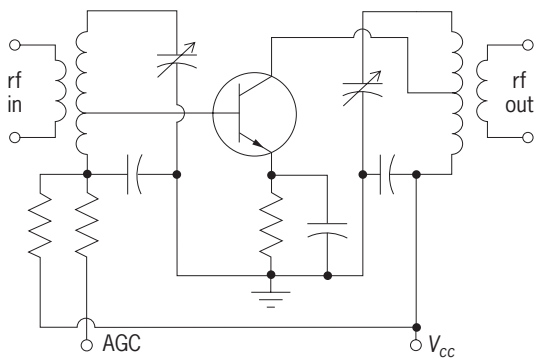

(a)

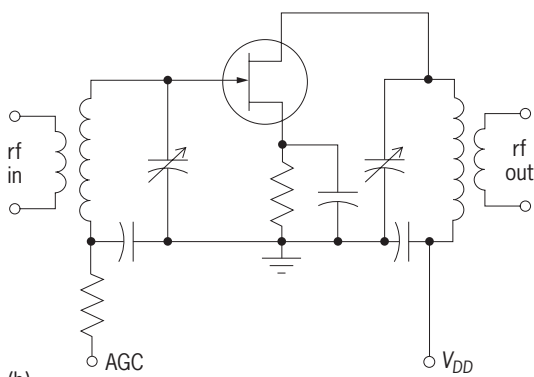

(b)

**Typical rf amplifiers.** Circuits with (a) bipolar transistor and (b) field-effect transistor.  $V_{CC}$  = collector supply voltage;  $V_{DD}$  = drain supply voltage.

Transformer bridges are capable of operating up to 100 MHz. The use of transformers offers the following advantages: (1) only two bridge arms are needed, the standard, and the unknown arms, and (2) both the detector and the source may be grounded at one of their terminals, minimizing ground-loop problems and leakage. See TRANSFORMER.

A coaxial line admittance bridge is usable from 20 MHz to 1.5 GHz. The currents flowing in three coaxial branch lines are driven from a common junction, and are sampled by three independently rotatable, electrostatically shielded loops, whose outputs are connected in parallel.

A quantity related to impedance is the complex (voltage) reflection coefficient, defined as the ratio of the reflected voltage to the incident voltage, when waves propagate along a uniform transmission line in both directions. Usually, uppercase gamma ( $\Gamma$ ) or lowercase rho ( $\rho$ ) is used to represent the reflection coefficient. When a transmission line of characteristic impedance  $Z_0$  is terminated in impedance  $Z_T$ , the reflection coefficient at the load is given by Eq. (1), and the voltage standing-wave ratio (VSWR) is related to the magnitude of  $\Gamma$  by Eq. (2).

$$\Gamma = \frac{Z_T - Z_0}{Z_T + Z_0} \quad (1)$$

$$\text{VSWR} = \frac{1 + |\Gamma|}{1 - |\Gamma|} \quad (2)$$

See TRANSMISSION LINES.

When it is sufficient to measure only the voltage standing-wave ratio, resistive bridges may be used. Resistive bridges employed as reflectometers use a matched source and detector, and therefore differ from the Wheatstone bridge, which aims to use a zero-impedance voltage source and an infinite-impedance detector.

Some specialized electronic instruments make use of the basic definition of impedance, and effectively measure voltage and current. One such instrument is called an rf vector impedance meter. Instead of measuring both the voltage and the current, it drives a constant current into the unknown impedance, and the resultant voltage is measured.

Vector voltmeters (VVM) are instruments with two (high-impedance) voltmeter probes, which display the voltages at either probe (relative to ground) as well as the phase difference between them. One type operates from 1 MHz to 1 GHz, and linearly converts to a 20-kHz intermediate frequency by sampling.

When the magnitude of the reactive part of the impedance is much greater than the resistive part at a given frequency, resonance methods may be employed to measure impedance. The most commonly used instrument for this purpose is the Q meter. See Q METER.

At the upper end of the rf range, microwave methods of impedance measurement may also be used, employing slotted lines and six-port junctions. See MICROWAVE MEASUREMENTS.

[P.S.]

**Radio paging systems** Systems, consisting of three basic elements—a personal paging receiver, radio transmitter, and an encoding device—whose primary purpose is to alert an individual, or group of individuals, and deliver a short message of a temporary or perishable nature. Characteristics that are used to define a specific paging system include distance covered, radio frequency, modulation type, paging code format, and message type.

On-site systems cover a single building or a small complex of buildings typically utilizing one low-power transmitter. Wide-area systems can cover an entire city or country and usually use multiple transmitters which simulcast the paging signals. Most paging systems now utilize the very high-frequency (VHF) or ultrahigh-frequency (UHF) radio spectrum using frequency mod-

ulation (FM). See FREQUENCY MODULATION; RADIO SPECTRUM ALLOCATIONS.

Paging receivers fall into four basic categories: tone alert, tone and voice, numeric, and alphanumeric. Tone pagers emit a “beep” when they are signaled. Some models silently alert the user with a vibration in place of a beep; other models use differing staccato beeps to provide the user with several alert messages. Tone and voice pagers allow the initiator of the page to transmit a simple voice message which will follow a pager’s beep alert. Numeric pagers, sometimes called digital pagers, allow the initiator to convey numerical information. These messages are typically composed by using a tone telephone key pad. Alphanumeric pagers allow the initiator to send a complete textual message to the pager user. These messages are composed on word processors, personal computers, or dedicated terminals which can connect to a paging terminal. See MICROCOMPUTER; WORD PROCESSING.

[J.A.Wr.]

**Radio receiver** The part of the radio communications system that extracts information from radio-frequency (rf) energy intercepted by the antenna. Radio receivers are the most common electronic equipment worldwide and a vital part of all radio, television, and radar systems. Since the 1960s, radio receiver performance has improved greatly, while size, weight, and cost have fallen dramatically. In the past, radio receivers were built from analog circuits, but increasingly they are realized by digital signal processing. See RADIO.

The antenna intercepts a band of energy in the radio frequencies containing many transmissions. These may have different modes of modulation; the two most common are amplitude modulation (AM) and frequency modulation (FM). Signals have a large size range, from a large fraction of a volt down to a small fraction of a microvolt. The receiver must be selective, responding to only one signal, must demodulate the signal, extracting the impressed information from the radio-frequency wave, and must raise it to an acceptable power level by amplification.

Single-sideband (SSB) transmissions are similar to amplitude modulation, but with one of the symmetrical pair of sidebands eliminated and the carrier suppressed. Single-sideband is significant because it conserves electromagnetic spectrum, introducing less spectrum pollution than any other modulation. Because of the growing prevalence of digital signals, digital modulation systems are increasingly important. See AMPLITUDE MODULATION; FREQUENCY MODULATION; MODULATION; SINGLE SIDEBAND.

**Amplitude modulation.** Figure 1 shows a simple receiver for amplitude-modulated signals. A band-pass filter selects the required signal, which, after optional amplification, is passed to the demodulator (obsolete term: detector), which in this version consists of a limiting amplifier and a multiplier. The high-gain limiting amplifier has an output of the same sign as the input but constant magnitude (a square wave). When multiplied by the amplitude-modulated waveform, this inverts negative half-cycles. After low-pass filtering to remove residual radio-frequency ripple, the modulating waveform is obtained, shown as an audio waveform, which passes to the loudspeaker. There are other amplitude demodulator circuits, all of which either suppress or invert alternate half-cycles of the amplitude-modulated waveform. See AMPLIFIER; AMPLITUDE-MODULATION DETECTOR; ELECTRIC FILTER.

Since the input signal may be on the order of microvolts whereas volts are required to operate a loudspeaker, the total receiver gain may range up to the order of a million or more. In this simple tuned-radio-frequency (TRF) receiver it is difficult to adjust the center frequency of a high-performance band-pass radio-frequency filter in order to receive other stations; also, the radio frequency may be too high for effective amplification. For this reason the superheterodyne (superhet) receiver (Fig. 2) superseded it.

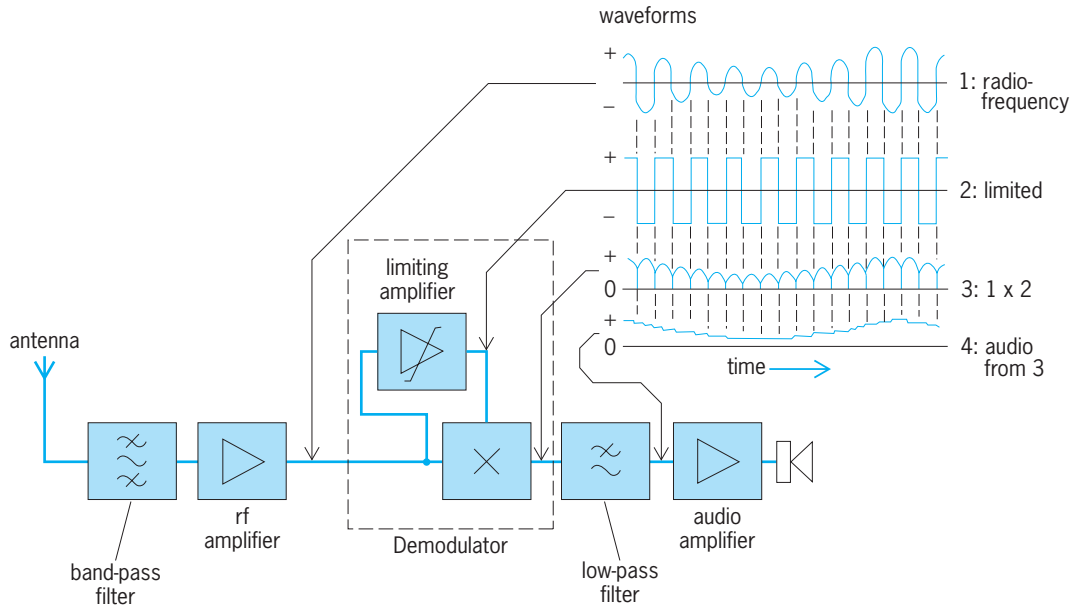

Fig. 1. Simple tuned-radio-frequency (TRF) receiver for amplitude-modulated (AM) signals.

In superheterodyne receivers, after a radio-frequency filter and amplifier, the signal passes to a mixer, from which the output is formed by the product of the signal and a locally generated wave. If the signal carrier is at  $f_c$  and the local oscillator is at  $f_o$ , the result is a wave at a frequency  $\pm(f_o - f_c) = f_{i-f}$ , known as the intermediate frequency (i-f), and this difference frequency can be kept constant, whatever the value of  $f_c$ , by a suitable choice of  $f_o$ . Subsequent to the mixer, the superheterodyne receiver becomes similar to the tuned-radio-frequency receiver except that it is now operating at a fixed frequency, so that, provided a low intermediate frequency is chosen, amplification is easy and high-performance filters can be used. Fixed-frequency intermediate-frequency filters, based on mechanical resonance in piezoelectric ceramics and crystals or on surface-acoustic waves, give extreme attenuation outside the passband. See HETERODYNE PRINCIPLE; MIXER; OSCILLATOR; PIEZOELECTRICITY; SURFACE-ACOUSTIC-WAVE DEVICES.

In amplitude-modulation systems, the amplitude of the signal carries the information, and so to keep the audio output from wide level changes it is desirable to adjust the strength of the signal at the demodulator to be roughly constant, despite variations at the antenna due to transmitter power or range. Thus, automatic gain control (AGC) is used in most amplitude-modulation receivers. See AUTOMATIC GAIN CONTROL (AGC).

**Frequency-modulation.** For frequency modulation, the signal is of constant amplitude but varies in frequency, and so it is usual for the intermediate-frequency amplifier to be a limiter, giving a constant output. In other respects the receiver may be iden-

tical with one of those in Fig. 2. Automatic gain control is often omitted, but may be combined with limiting for the highest performance. The frequency demodulator is quite different, often utilizing a phase-sensitive detector. See FREQUENCY-MODULATION DETECTOR; LIMITER CIRCUIT. [W.Go.]

**Radio spectrum allocations** The specification of the frequency bands of the radio spectrum which are made available for use by the various radio services. The radio spectrum is the part of the natural spectrum of electromagnetic radiation lying between the frequency limits of  $10^4$  and  $3 \times 10^{11}$  hertz. Since the characteristics of the radiation do not change abruptly, these limits are not sharply defined and may change, depending upon the demands for changes in service and upon changes in technology.

For purposes of identification the radio spectrum is divided into bands differing from adjacent bands by frequency ratios of 10. These bands are identified by the metric wavelength of the shortest waves in each band (kilometric band, and so forth) or by adjective or numerical designators (for example, very-low-frequency band or band 4). The wavelength  $\lambda$  in meters is related to the frequency  $f$  in hertz by the relationship  $c = f\lambda$ , where  $c$ , the velocity of propagation of radio waves in space, is about  $3 \times 10^8$  m/s.

The major classes of radio services are provided with international allocations within the various frequency bands. Within the United States there is a national allocation which conforms in general to the international allocation. The Radio Regulations divide the Earth into three regions and contain a detailed table of allocations, with some differences between regions, together with exceptions to the listed allocations and conditions for frequency use. Regional and national allocations can be made within the worldwide framework, but any departures by signatories of the Regulations must be accomplished on the basis of noninterference with services operating in accordance with the agreed allocations.

The characteristics of radio waves, due to natural phenomena such as atmospherics, vary greatly with frequency. Attempts are made to take advantage of propagation characteristics when making allocations, and normally the frequencies allocated have characteristics satisfying the operational requirements of the service with regard to distance, bandwidth, and other technique factors. Allocations are sometimes made for a new service which

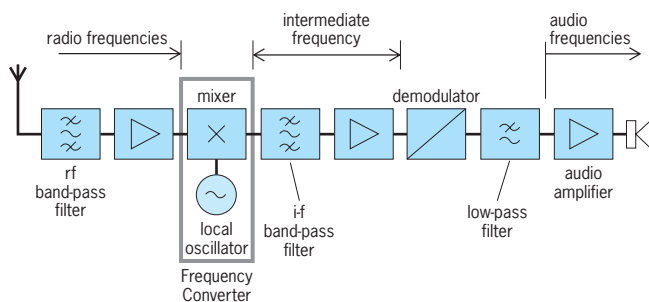

Fig. 2. Superheterodyne (superhet) receiver.

has already begun to use a particular band. Since many services have varied and continually growing requirements, allocations to them will be found in several frequency bands. In making specific frequency assignments to individual radio stations, the separation between assignable frequencies must be such as to avoid harmful interference in view of the bandwidth requirements, the frequency stability of the transmitters, the frequency selectivity of the receivers, the transmitter power and its distance separation from receivers operating on adjacent channels, and other factors. Thus the separation between adjacent assigned frequencies varies widely between services and between different locations in the frequency spectrum.

In most of the frequency bands it has been found practical to make block allocations of frequencies to given services in each region. Individual frequency assignments can then be made to radio stations operating in that service without the need for coordination with frequency assignments to stations in other services. Interference problems are more easily resolved, as they occur between compatible users. Some of these allocations are exclusive to a particular service, and some are shared between specified services to varying degrees. Similarly, in some services the stations have individual frequency assignments which are protected from interference from other stations, whereas the stations in other services may share time or geographic coverage on frequencies common to several stations. These arrangements are based upon the nature and the needs of the particular services being provided.

[L.M.P.; J.M.L.]

**Radio telescope** An instrument used in astronomical research to detect and measure the radio-frequency power coming from various directions in the sky. It consists of three complementary parts: the large reflecting surface that collects and focuses the incident radiation; the electronic receiver that amplifies and detects cosmic radio signals; and a data display device. From the ground, observations with radio telescopes must be made at wavelengths shorter than 100 ft (30 m), because of ionospheric attenuation, and longer than 0.04 in. (1 mm), because the very-short-wavelength radio radiation is absorbed by atmospheric  $H_2O$ ,  $CO_2$ , and  $O_3$ .

The fundamental principle of a radio telescope is identical to that of a reflecting telescope used at visual wavelengths. The incoming waves (radio or optical) are intercepted by a precise mirror and reflected to a common focal point. The shape of the reflecting surface or "dish" is important: the radio waves must arrive "in phase" at the focal point following their reflection from the dish; that is, the path length from the point of reflection to the focus must be exactly the same for all points on the dish. This restriction can be most simply satisfied if the shape of the reflecting surface is made paraboloidal; consequently, most modern radio telescopes have this shape (see illustration). See TELESCOPE.

Once the radio waves are collected and brought together at the focal point of the telescope, they are in general still extremely weak. The incoming radio-frequency (rf) signals are first amplified at the focus 10 to 1000 times and then converted to a lower frequency, the intermediate frequency (i-f), that can be easily transmitted by cables from the focal point to the telescope-control building. There the i-f is further amplified, and the signal is detected and displayed in the manner the astronomer finds most suited to the particular investigation.

The types of astronomical objects that emit radio-frequency radiation and hence can be studied by radio astronomers are of such a diverse nature that a variety of radio telescopes and receiving equipment are necessary for a modern radio observatory. Two general astronomical considerations dictate what instruments are needed: first, radio telescopes should have the highest possible angular resolution so that the small-scale details of radio sources can be studied; second, the radio receivers should be extremely sensitive to the very weak signals emitted by cosmic radio sources.



The 328-ft-diameter (100-m) radio telescope operated by the Max Planck Institut für Radioastronomie at Effelsberg, Germany. (Max Planck Insitut für Radioastronomie)

The ultimate in angular resolution is achieved by the technique of very-long-baseline interferometry (VLBI), in which one simultaneously utilizes radio telescopes separated by thousands of miles. Data are acquired independently at each telescope and recorded on video tape. Precise time markings are made on the tape using hydrogen maser clocks. After the data are recorded, the video tapes from the separate telescopes are brought together; the time markings on the individual tapes are aligned, and data taken at precisely the same times can be compared and analyzed. Such VLBI techniques have achieved angular resolutions of about 0.0003 second of arc. See ASTRONOMY. [R.L.Bro.]

**Radio transmitter** A generator of radio-frequency (rf) signals for wireless communication over some distance, which can vary from the short ranges within a building to intercontinental distances. Most applications utilize signals from very low frequencies (VLF) to extremely high frequencies (EHF); some applications require frequencies as low as 45 Hz or as high as 100 GHz. The radio-frequency output power varies from a fraction of a watt in emergency beacons and portable equipment to several megawatts in long-range, low-frequency transmitters. See RADIO SPECTRUM ALLOCATIONS.

The architecture (organization) of a radio transmitter is determined by the type of signal it is intended to produce. The four basic architectures are those used for continuous-wave, frequency-modulation, amplitude-modulation, and single-sideband signals. Transmitters for some applications (for example, television) use a combination of these architectures (for example, frequency modulation for sound and single sideband for video), while others (for example, Loran C) use unique architectures. Alternative architectures such as envelope elimination and restoration or outphasing can be used to improve efficiency. See ELECTRICAL COMMUNICATIONS; MODULATION.

**Continuous-wave (CW) transmitter.** The most basic type of radio transmitter produces only a continuous-wave signal. Such transmitters are often switched on and off (keyed) to produce telegraph signals. The block diagram of a simple continuous-wave transmitter is shown in Fig. 1. The oscillator G1 produces a low-power signal, which is boosted to the final

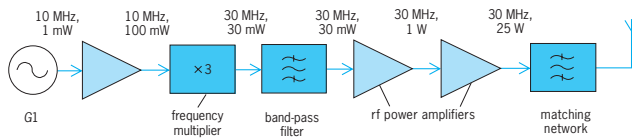

Fig. 1. Basic continuous-wave (CW) transmitter.

output power by a series of progressively larger power amplifiers. The optional inclusion of a frequency multiplier improves stability by allowing the frequencies of the oscillator and high-power amplifiers to be different. See FREQUENCY MULTIPLIER; OSCILLATOR; POWER AMPLIFIER.

The architecture includes both frequency translation and power splitting, which makes it more suitable for generating high-power signals at various frequencies. While at a relatively low level, the signal is translated by a mixer to the desired output frequency. After amplification by a chain of power amplifiers, it is split into two parts to drive two final power amplifiers whose outputs are combined to produce the transmitter output. See MIXER; TELEGRAPHY.

**Frequency-modulation (FM) transmitter.** Analog frequency modulation is widely used for voice communication, high-quality audio broadcasting, and television audio. Frequency-shift keying (FSK) and phase-shift keying (PSK) are widely used for transmission of digital data via radio-frequency signals. See FREQUENCY MODULATION; FREQUENCY-MODULATION RADIO; MOBILE RADIO; RADIO BROADCASTING; TELEVISION.

Frequency-modulated and phase-modulated (PM) signals have constant amplitudes and are therefore produced by transmitters with architectures similar to those of the continuous-wave transmitter (Fig. 1). The principal change is the replacement of oscillator G1 by a frequency or phase modulator. In frequency-modulation transmitters, the frequency multiplier increases the frequency deviation as well as the carrier frequency of the frequency-modulated signal. See PHASE MODULATION.

In communication applications, the frequency modulator is typically a voltage-controlled crystal oscillator (VCXO) in which the capacitance of a varactor diode is used to vary slightly the frequency of a crystal oscillator. Other applications employ various types of modulators, including phase-shift, phase-locked-loop, comparator, and Armstrong. See FREQUENCY MODULATOR.

**Amplitude-modulation transmitter.** Full-carrier amplitude modulation is used in medium-frequency (MF) broadcasting, high-frequency (HF) international broadcasting, citizen-band communication, aircraft communication, and nondirectional navigation beacons. See AMPLITUDE MODULATION; ELECTRONIC NAVIGATION SYSTEMS.

Most modern full-carrier amplitude-modulation transmitters produce the output signal by amplitude modulation of the final radio-frequency power amplifier. Generally, the modulation is accomplished by varying the supply voltage of the radio-frequency power amplifier with a high-power radio-frequency amplifier. Since the radio-frequency carrier has constant amplitude until the final power amplifier, the architecture of the radio-

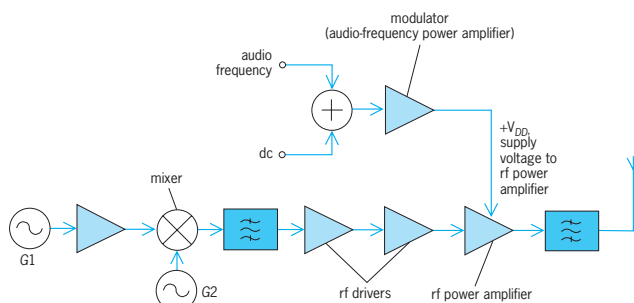

Fig. 2. Amplitude-modulation (AM) transmitter.

frequency chain (Fig. 2) is similar to that of a continuous-wave or frequency-modulation transmitter. See AUDIO AMPLIFIER.

**Single-sideband (SSB) transmitter.** Single-sideband amplitude modulation is widely used for high-frequency voice communications, including military, marine, aeronautical, diplomatic, and amateur. It also finds use (as amplitude-companded single-sideband, or ACSB) at very high frequencies (VHF) and ultrahigh frequencies (UHF).

Although single sideband is technically a form of amplitude modulation, the single-sideband signal itself has variations of both amplitude and phase. Signals such as multitone, independent sideband (ISB), and vestigial sideband (VSB), used for video, also possess such characteristics. Consequently, these signals are traditionally amplified by a chain of linear radio-frequency power amplifiers operating in class B. See SINGLE SIDE-BAND.

The low-level output of the single-sideband modulator is first shifted by the local oscillator G2 to an intermediate frequency (i-f) that is at least twice the highest output frequency. The intermediate-frequency signal is then shifted downward to the desired output frequency by the variable-frequency oscillator (VFO) G3. The mixer output is low-pass-filtered and then amplified to the desired power. See ELECTRIC FILTER. [F.H.Ra.]

**Radio-wave propagation** The means by which radio signals are transported through space from a transmitting antenna to a receiving antenna. See RADIO.

The frequencies around 20 kHz can be received reliably at distances of thousands of miles but are limited to telegraph-type signals and require very large transmitting antennas. Higher frequencies are needed for voice, and still higher frequencies for television transmission. As the frequency increases, the transmission range tends to decrease. Frequencies above 100 MHz can transmit wide-band signals, but they are limited to approximately line-of-sight distances with the usual type of equipment. However, distances of 200 mi (320 km) or more are possible by the use of high power and large antennas to provide narrow "searchlight" beams.

Reflections from the ionosphere (ionized layers 50–250 mi or 80–400 km above the Earth's surface) provide a useful but variable long-distance service at frequencies less than about 30 MHz. These reflections account for the long-range broadcast coverage at night and for the shortwave intercontinental communication. See RADIO BROADCASTING.

The principal components of the received radio signal are shown symbolically in the illustration. The vector sum of the direct, reflected, and surface waves has been called the space wave, ground wave, or tropospheric transmission to differentiate it from the ionospheric reflections. The ionospheric and surface waves are the principal components at frequencies below 10–30 MHz. The direct and reflected rays are the principal factors at frequencies above 30–50 MHz. Although the ionospheric, direct, and ground-reflected waves can be easily visualized as rays, the surface wave is more difficult to understand; it originates at the air-Earth boundary because the Earth is not a perfect reflector.

Variations in signal level with time are caused by changing atmospheric conditions. The severity of the fading usually increases as either the frequency or path length increases. Most fading is temporary diversion of energy to some direction other than the intended location, associated with refraction or interference, but absorption effects are important in the microwave region.

The dielectric constant of the atmosphere normally decreases gradually with increasing altitude. The result is that on the average the radio ray is bent or refracted toward the Earth so that the distance to the radio horizon is slightly greater than to the optical horizon. The amount of refraction is variable, and exceptionally long-range transmission may occur occasionally. Conversely, when the radio energy is bent away from the Earth (upward

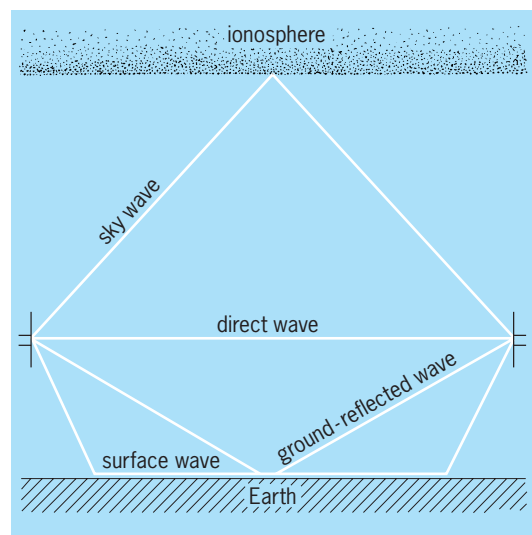

Possible transmission paths between antennas.

bending), the transmission loss is increased. See REFRACTION OF WAVES. [K.B.]

**Radioactive beams** Beams of radioactive (unstable) nuclei. In several nuclear physics laboratories, a capability exists to produce such beams and, before these nuclei spontaneously decay, use them to gain insight into the reactions on and structure of nuclei never before accessible. Radioactive beams are particularly useful to study stellar explosions such as novae, supernovae, and x-ray bursts. These explosions are some of the most catastrophic events in the universe, generating enormous amounts of energy while synthesizing the elements that make up lifeforms and the world. These spectacular explosions involve, and in some cases are driven by, reactions where the atomic nuclei of hydrogen (protons) and helium (alpha particles) fuse with (are captured by) radioactive isotopes of heavier elements to form new elements. The capability to produce beams of radioactive nuclei allows direct measurements of these reactions, providing crucial information needed to theoretically model cataclysmic stellar events and to understand the origin of many chemical elements.

One approach to radioactive beam production is the isotope separator on-line (ISOL) technique. One accelerator bombards a target with a beam of stable nuclei, and a small number of the radioactive atoms of interest are produced through nuclear reactions. These atoms are transported, by various techniques, including thermal diffusion, to an ion source where they are ionized (removing or adding electrons to give atoms an electrical charge) and extracted. The radioactive ions are then mass-separated from other ions and accelerated to energies needed for nuclear physics experiments by a second accelerator. The ISOL technique can produce very high beam qualities, purities, and intensities; the disadvantages are that only a few radioactive beam species can be generated from each combination of production target and primary beam, and that beams with short lifetimes (less than 1 s) are difficult to produce. See ION SOURCES; MASS SPECTROSCOPE.

A complementary radioactive beam production technique is projectile fragmentation. When a high-energy beam of stable heavy ions passes through a thin target, the beam particles (projectiles) can break up into fragments—some of which are the radioactive isotope of interest. The desired fragments are then mass-separated from other ions and steered toward a target to undergo the reaction of interest. The projectile fragmentation technique can produce beams of very short lifetimes ( $10^{-6}$  s or less), and the same setup can be used to produce many differ-

ent beam species; the disadvantages are that high beam quality, purity, and intensity are difficult to obtain. See NUCLEAR FUSION; NUCLEAR REACTION; PARTICLE ACCELERATOR. [M.S.S.]

**Radioactive fallout** Whenever radioactive materials become airborne, either from a nuclear device detonation or from a nuclear release accident, the resultant contaminated atmospheric plume will ultimately return radioactivity to the Earth's surface. Material settling from the radioactive plume and its subsequent surface deposition is known as radioactive fallout.

Radioactive materials consist of unstable atoms which emit gamma rays, beta particles, or alpha particles. These emissions—rays and particles—are unique in that they cause ionizations in neighboring atoms. The energy of the emitted radiation and subsequent ionizations can be a cause of concern if absorbed by living systems. See ALPHA PARTICLES; BETA PARTICLES; GAMMA RAYS; RADIOACTIVITY.

Fissioning of uranium and plutonium produces isotopes of about 70 different atoms; each atom may have several different isotopic forms. Examples of daughter products are the isotopes of elemental strontium, which are efficiently produced in nuclear fission. The isotope strontium-90 ( $^{90}\text{Sr}$ ) has a 28-year half-life, while  $^{89}\text{Sr}$  is produced in slightly higher concentrations but has a half-life of only 50 days. In addition to the differing half-lives, each isotope emits a unique radiation spectrum. The two strontium isotopes emit beta particles of different energies. Other isotopes such as cesium-137 ( $^{137}\text{Cs}$ , half-life 30 years) and iodine-131 ( $^{131}\text{I}$ , half-life 8 days) emit both beta particles and gamma rays. See CESIUM; IODINE; ISOTOPE; STRONTIUM.

Atmospheric fallout can be scavenged by rainfall. Wet deposition, involving washing out of atmospheric fallout, can increase local deposition patterns. This was the case following the Chernobyl accident, where local rainfall in Belarus, Ukraine, and Russia washed high concentrations of radioactive iodine and cesium out of the plume and onto the spring pasture. Radioactive iodine and cesium are relatively volatile and were more easily "boiled" out of Chernobyl's burning core. Cesium is a congener of potassium and therefore is fairly uniformly distributed throughout the body once inhaled or ingested. The result is a whole-body radiation dose. Furthermore, the energetic gamma-ray emission from  $^{137}\text{Cs}$  adds a source of external radiation from surface deposits on the ground. These factors, in addition to its long half-life and relatively high concentration, make  $^{137}\text{Cs}$  the major long-term contamination concern from fallout. For example, although the Chernobyl accident occurred in 1986, precautions must still be taken against potential intake doses of  $^{137}\text{Cs}$ : inhalation doses can occur when burning wood from contaminated trees, and consuming mushrooms grown in contaminated forests delivers an ingestion dose.

Levels of  $^{131}\text{I}$  in the plumes of radioactive fallout are of particular concern. With an 8 day half-life and a strong beta- and gamma-ray emission, this radionuclide concentrates almost exclusively in the thyroid gland. Recent dose reconstructions in the United States show that the 1950s and 1960s fallout radiation doses from  $^{131}\text{I}$  were large enough to have increased the risk for thyroid cancer, especially in children. See THYROID GLAND.

In 1955, the United Nations established the Scientific Committee on the Effects of Atomic Radiation, due to concern over possible risks from fallout. It issues comprehensive reports about every 5 years and has collected and documented the world's literature on radioactive fallout and, more recently, on possible radiation consequences. See ATOMIC BOMB; NUCLEAR EXPLOSION; NUCLEAR FISSION; NUCLEAR FUELS; NUCLEAR REACTOR; RADIATION INJURY (BIOLOGY). [M.Gol.]

**Radioactive minerals** Minerals that contain uranium (U) or thorium (Th) as an essential component of their chemical



composition. Examples are uraninite ( $\text{UO}_2$ ) or thorite ( $\text{ThSiO}_4$ ). There are radioactive minerals in which uranium and thorium substitute for ions of similar size and charge. There are approximately 200 minerals in which uranium or thorium are essential elements, although many of these phases are rare and poorly described. These minerals are important, as they are found in ores mined for uranium and thorium, most commonly uraninite and its fine-grained variety, pitchblende, for uranium. Thorite and thorumite are the principal ore minerals of thorium. Minerals in which uranium and thorium occur in trace amounts, such as zircon ( $\text{ZrSiO}_4$ ), are important because of their use in geologic age dating. The isotope uranium-238 ( $^{238}\text{U}$ ) decays to lead-206 ( $^{206}\text{Pb}$ );  $^{235}\text{U}$  decays to  $^{207}\text{Pb}$ ;  $^{232}\text{Th}$  decays to  $^{208}\text{Pb}$ ; thus, the ratios of the isotopes of uranium, thorium, and lead can be used to determine the ages of minerals that contain these elements. See DATING METHODS; GEOCHRONOMETRY; LEAD ISOTOPES (GEOCHEMISTRY); THORITE; THORIUM; URANINITE; URANIUM.

[R.Ew.]

**Radioactive tracer** A radioactive isotope which, when injected into a chemically similar substance or artificially attached to a biological or physical system, can be traced by radiation detection devices. Many problems in biology and medicine not amenable to other approaches can be solved by the use of these tracers. See RADIOACTIVITY; RADIOACTIVITY AND RADIATION APPLICATIONS; RADIOISOTOPE; RADIOISOTOPE (BIOLOGY).

The simplest radioactive tracer studies consist of the tagging of a biological entity with a radioactive isotope (radioisotope). The entity is then tracked by following the radiation from the isotope. The operation becomes more complex when a large number of biological particles are labeled, for example, in the tagging of red blood cells or bacteria. When the labeled substance is injected into an animal, it is impossible to follow the individual labeled particles, but their average movement can be tracked by observations of the radiation. Finally, a radioisotope of a particular element can be used to tag that element. Phosphorus-32 can be introduced into the soil where a plant is growing, and the amount of phosphorus absorbed and its distribution throughout the plant can be studied.

In most biological tracer experiments, the radio-isotope is introduced into the system and its radiation subsequently measured with Geiger-Müller counters or scintillation detectors. Extremely soft (low-intensity) radiations can be detected by the use of photographic film. See GEIGER-MÜLLER COUNTER; SCINTILLATION COUNTER.

[G.L.B.]

In medical applications, a radioactive atom can be attached to a molecule or more complex substance, which can then be used to examine a chemical reaction in a test tube, or it can be administered to a patient by ingestion or injection and subsequently be incorporated into a biochemical process. The radioactive emissions from the radioactive atom can be used to track (trace) the behavior of the labeled molecule or substance in biological processes by means of medical imaging, utilizing techniques such as positron emission tomography (PET) or single-photon-emission computed tomography (SPECT). See MEDICAL IMAGING.

The branch of medicine that uses radioactive tracers in the care of patients is called nuclear medicine. Radiotracers of practically every element can be produced in nuclear reactors or cyclotrons. Radioactive tracers are used as part of the diagnostic process. Three radionuclides—carbon-14, tritium (hydrogen-3), and phosphorus-32—remain the backbone of modern biomedical sciences. See NUCLEAR MEDICINE.

[H.N.W.]

**Radioactive waste management** The treatment and containment of radioactive wastes. These wastes originate almost exclusively in the nuclear fuel cycle and in the nuclear weapons program. Their toxicity requires careful isolation from the biosphere. Their radioactivity is commonly measured in curies (Ci). Considering its toxicity, the curie is a rather

large unit of activity. A more appropriate unit is the microcurie ( $1 \mu\text{Ci} = 10^{-6} \text{ Ci}$ ), but the nanocurie ( $1 \text{ nCi} = 10^{-9} \text{ Ci}$ ) and picocurie ( $1 \text{ pCi} = 10^{-12} \text{ Ci}$ ) are also frequently used. See UNITS OF MEASUREMENT.

Radioactive wastes are classified in four major categories: spent fuel elements and high-level waste (HLW), transuranic (TRU) waste, low-level waste (LLW), and uranium mill tailings. Examples of minor waste categories include radioactive gases produced during reactor operation, radioactive emissions resulting from the burning of uranium-containing coal, or contaminated uranium mine water.

Spent fuel elements arise when uranium is fissioned in a reactor to generate energy. Most of the existing radioactivity is contained in spent nuclear fuel and high-level waste. For the first 100 years, the toxicity is dominated by the beta- and gamma-emitting fission products [such as strontium-90 ( $^{90}\text{Sr}$ ) and cesium-137 ( $^{137}\text{Cs}$ ), with half-lives of approximately 30 years]; thereafter, the long-lived, alpha-emitting transuranium elements [for example, plutonium-239 ( $^{239}\text{Pu}$ ), with a half-life of 24,000 years] and their radioactive decay daughters [for example, americium-241 ( $^{241}\text{Am}$ ), with a half-life of 432 years, a daughter of plutonium-241 ( $^{241}\text{Pu}$ ), with a half-life of 13 years] are important. Burial in geologic formations at a depth of 500–1000 m (1600–3200 ft) appears at present the most practical and attractive disposal method. See NUCLEAR FISSION; NUCLEAR FUEL CYCLE; NUCLEAR FUELS REPROCESSING; TRANSURANIUM ELEMENTS.

However, geology as a predictive science is still in its infancy, and many of the parameters entering into model calculations of the long-term retention of the waste in geologic media are questionable. The major single problem is the heating of the waste and its surrounding rock by the radioactive decay heat. This heating can accelerate the penetration of groundwater into the repository, the dissolution of the waste, and its transport to the biosphere. Much effort has been devoted to the development of canisters to encapsulate the spent fuel elements or the glass blocks containing high-level waste, and of improved waste forms and overpacks that promise better resistance to attack by groundwater.

Although the radioactivity of the transuranic wastes is considerably smaller than that of high-level waste or spent fuel, the high radiotoxicity and long lifetime of these wastes also require disposal in a geologic repository. Waste with less than 100 nCi/g (3.78 Bq/kg) of transuranic elements will be treated as low-level waste.

Uranium is naturally radioactive, decaying in a series of steps to stable lead. It is currently a rare element, averaging between 0.1 and 0.2% in the mined ore. At the mill, the rock is crushed to fine sand, and the uranium is chemically extracted. The residues are discharged to the tailings pile. The tailings contain the radioactive daughters of the uranium. The long-lived isotope thorium-230 ( $^{230}\text{Th}$ , half-life 80,000 years) decays into radium-226 ( $^{226}\text{Ra}$ , half-life 1600 years), which in turn decays to radon-222 ( $^{222}\text{Rn}$ , half-life 3.8 days). Radium and radon are known to cause cancer, the former by ingestion, the latter by inhalation. Radon is an inert gas and thus can diffuse out of the mill tailings pile and into the air. Ground-water pollution by radium that has leached from the pile has also been observed around tailings piles, but its health effects are more difficult to estimate, since the migration in the ground water is difficult to assess and also highly site-specific. See RADIOACTIVITY; RADIUM; RADON; URANIUM.

Although the radioactivity contained in the mill tailings is very small relative to that of the high-level waste and spent fuel, it is comparable to that of the transuranic waste. It is mainly the dilution of the thorium and its daughters in the large volume of the mill tailings that reduces the health risks to individuals relative to those posed by the transuranium elements in the transuranic wastes. However, this advantage is offset by the great mobility of the chemically inert radon gas, which emanates into the atmosphere from the unprotected tailings. New mill tailings piles

will be built with liners to protect the ground water, and will be covered with earth and rock to reduce atmospheric release of the radon gas.

By definition, practically everything that does not belong to one of the three categories discussed above is considered low-level waste. This name is misleading because some wastes, though low in transuranic content, may contain very high beta and gamma activity. The current method of low-level waste disposal is shallow-land burial, which is relatively inexpensive but provides less protection than a geologic repository.

At the end of their lifetime, nuclear facilities have to be dismantled (decommissioned) and the accumulated radioactivity disposed of. Nuclear power plants represent the most important category of nuclear facilities, containing the largest amounts of radioactive wastes, which can be grouped in three classes: neutron-activated wastes, surface-contaminated wastes, and miscellaneous wastes. See NUCLEAR POWER; NUCLEAR REACTOR.

The neutron-activated wastes are mainly confined to the reactor pressure vessel and its internal components, which have been exposed to large neutron fluences during reactor operation. These components contain significant amounts of long-lived nontransuranic radioactive isotopes such as niobium-94 ( $^{94}\text{Nb}$ , an impurity in the stainless steel), which emits highly penetrating gamma rays and has a half-life of 20,000 years. These wastes are unacceptable for shallow-land disposal as low-level wastes. Disposal in a geologic repository is envisioned. See DECONTAMINATION OF RADIOACTIVE MATERIALS. [R.O.P.]

**Radioactivity** A phenomenon resulting from an instability of the atomic nucleus in certain atoms whereby the nucleus experiences a spontaneous but measurably delayed nuclear transition or transformation with the resulting emission of radiation. The discovery of radioactivity by H. Becquerel in 1896 marked the birth of nuclear physics.

All chemical elements may be rendered radioactive by adding or by subtracting (except for hydrogen and helium) neutrons from the nucleus of the stable ones. Studies of the radioactive decays of new isotopes far from the stable ones in nature continue as a major frontier in nuclear research. The availability of this wide variety of radioactive isotopes has stimulated their use in a wide variety of fields, including chemistry, biology, medicine, industry, artifact dating, agriculture, and space exploration. See ALPHA PARTICLES; BETA PARTICLES; GAMMA RAYS; ISOTOPE; RADIOACTIVITY AND RADIATION APPLICATIONS.

A particular radioactive transition may be delayed by less than a microsecond or by more than a billion years, but the existence of a measurable delay or lifetime distinguishes a radioactive nuclear transition from a so-called prompt nuclear transition, such as is involved in the emission of most gamma rays. The delay is expressed quantitatively by the radioactive decay constant, or by the mean life, or by the half-period for each type of radioactive atom, discussed below.

The most commonly found types of radioactivity are alpha, beta negatron, beta positron, electron capture, and isomeric transition. Each is characterized by the particular type of nuclear radiation which is emitted by the transforming parent nucleus. In addition, there are several other decay modes that are observed more rarely in specific regions of the periodic table.

**Transition rates and decay laws.** The rate of radioactive transformation, or the activity, of a source equals the number  $A$  of identical radioactive atoms present in the source, multiplied by their characteristic radioactive decay constant  $\lambda$ . Thus Eq. (1)

$$\text{Activity} = A\lambda \text{ disintegrations per second} \quad (1)$$

holds, where the decay constant  $\lambda$  has dimensions of  $\text{s}^{-1}$ . The numerical value of  $\lambda$  expresses the statistical probability of decay of each radioactive atom in a group of identical atoms, per unit time. For example, if  $\lambda = 0.01 \text{ s}^{-1}$  for a particular radioactive species, then each atom has a chance of 0.01 (1%) of decaying in 1 s, and a chance of 0.99 (99%) of not decaying in any given 1-s

interval. The constant  $\lambda$  is one of the most important characteristics of each radioactive nuclide:  $\lambda$  is essentially independent of all physical and chemical conditions such as temperature, pressure, concentration, chemical combination, or age of the radioactive atoms.

Many radioactive nuclides have two or more independent and alternative modes of decay. For example,  $^{238}\text{U}$  can decay either by alpha-particle emission or by spontaneous fission. When two or more independent modes of decay are possible, the nuclide is said to exhibit dual decay. The competing modes of decay of any nuclide have independent partial decay constants given by the probabilities  $\lambda_1, \lambda_2, \lambda_3, \dots$ , per second, and the total probability of decay is represented by the total decay constant  $\lambda$ , defined by Eq. (2).

$$\lambda = \lambda_1 + \lambda_2 + \lambda_3 + \dots \quad (2)$$

The actual life of any particular atom can have any value between zero and infinity. The average or mean life of a large number of identical radioactive atoms is, however, a definite and important quantity. The total  $L$  of the life-spans of all the  $A_0$  atoms initially present is given by Eq. (3). Then the average lifetime  $L/A_0$ , which is called the mean life  $\tau$ , is given by Eq. (4).

$$L = \frac{A_0}{\lambda} \quad (3)$$

$$\tau = 1/\lambda \quad (4)$$

The time interval over which the chance of survival of a particular radioactive atom is exactly one-half is called half-period  $T$  (also called the half-life, written  $T_{1/2}$ ). The half-period  $T$  is related to the total radioactive decay constant  $\lambda$ , and to the mean life  $\tau$ , by Eq. (5). For mnemonic reasons, the half-period  $T$  is much

$$T = 0.693/\lambda = 0.693\tau \quad (5)$$

more frequently employed than the total decay constant  $\lambda$  or the mean life  $\tau$ .

**Radioactive series decay.** In a number of cases a radioactive nuclide  $A$  decays into a nuclide  $B$  which is also radioactive; the nuclide  $B$  decays into  $C$  which is also radioactive, and so on. For example,  $^{232}\text{Th}$  decays into a series of 10 successive radioactive nuclides. Substantially all the primary products of nuclear fission are negatron beta-particle emitters which decay through a chain or series of two to six successive beta-particle emitters before a stable nuclide is reached as an end product.

**Alpha-particle decay.** Alpha-particle decay is that type of radioactivity in which the parent nucleus expels an alpha particle (a helium nucleus), which contains two protons and two neutrons. Thus, the atomic number, or nuclear charge, of the decay product is 2 units less than that of the parent, and the nuclear mass of the product is 4 atomic mass units less than that of the parent, because the emitted alpha particle carries away this amount of nuclear charge and mass. This decrease of 2 units of atomic number or nuclear charge between parent and product means that the decay product will be a different chemical element, displaced by 2 units to the left in a periodic table of the elements.

In the simplest case of alpha decay, every alpha particle would be emitted with exactly the same velocity and hence the same kinetic energy. However, in most cases there are two or more discrete energy groups called lines. For example, in the alpha decay of a large group of  $^{238}\text{U}$  atoms, 77% of the alpha decays will be by emission of alpha particles whose kinetic energy is 4.20 MeV, while 23% will be by emission of 4.15-MeV alpha particles. When the 4.20-MeV alpha particle is emitted, the decay product nucleus is formed in its ground (lowest energy) level. When a 4.15-MeV alpha particle is emitted, the decay product is produced in an excited level, 0.05 MeV above the ground level. This nucleus promptly transforms to its ground level by the emission of a 0.05-MeV gamma ray or alternatively by the emission

of the same amount of energy in the form of a conversion electron and the associated spectrum of characteristic x-rays. Thus in all alpha-particle spectra, the alpha particles are emitted in one or more discrete and homogeneous energy groups, and alpha-particle spectra are accompanied by gamma-ray and conversion electron spectra whenever there are two or more alpha-particle groups in the spectrum.

Among all the known alpha-particle emitters, most alpha-particle energy spectra lie in the domain of 4–6 MeV, although a few extend as low as 2 MeV and as high as 10 MeV. There is a systematic relationship between the kinetic energy of the emitted alpha particles and the half-period of the alpha emitter. The highest-energy alpha particles are emitted by short-lived nuclides, and the lowest-energy alpha particles are emitted by the very-long-lived alpha-particle emitters. H. Geiger and J. M. Nuttall showed that there is a linear relationship between  $\log \lambda$  and the energy of the alpha particle.

The Geiger-Nuttall rule is inexplicable by classical physics, but emerges clearly from quantum, or wave, mechanics. In 1928 the hypothesis of transmission through nuclear potential barriers was shown to give a satisfactory account of the alpha-decay data, and it has been altered subsequently only in details.

**Beta-particle decay.** Beta-particle decay is a type of radioactivity in which the parent nucleus emits a beta particle. There are two types of beta decay established: in negatron beta decay ( $\beta^-$ ) the emitted beta particle is a negatively charged electron (negatron); in positron beta decay ( $\beta^+$ ) the emitted beta particle is a positively charged electron (positron). In beta decay the atomic number shifts by one unit of charge, while the mass number remains unchanged. In contrast to alpha decay, when beta decay takes place between two nuclei which have a definite energy difference, the beta particles from a large number of atoms will have a continuous distribution of energy.

For each beta-particle emitter, there is a definite maximum or upper limit to the energy spectrum of beta particles. This maximum energy,  $E_{\max}$ , corresponds to the change in nuclear energy in the beta decay. As in the case of alpha decay, most beta-particle spectra include additional continuous spectra which have less maximum energy and which leave the product nucleus in an excited level from which gamma rays are then emitted.

For nuclei very far from stability, the energies of these excited states populated in beta decay are so large that the excited states may decay by proton, two-proton, neutron, two-neutron, three-neutron, or alpha emission, or spontaneous fission.

The continuous spectrum of beta-particle energies implies the simultaneous emission of a second particle besides the beta particle, in order to conserve energy and angular momentum for each decaying nucleus. This particle is the neutrino. The neutrino has zero charge and extremely small rest mass, travels at nearly the same speed as light ( $3 \times 10^{10}$  cm/s), and is emitted as a companion particle with each beta ray. By postulating the simultaneous emission of a beta particle and a neutrino, E. Fermi developed in 1934 a quantum-mechanical theory which satisfactorily gives the shape of beta-particle spectra, and the relative half-periods of beta-particle emitters for allowed beta decays. See NEUTRINO.

When the ground state of a nucleus differing by two units of charge from nucleus  $A$  has lower energy than  $A$ , then it is theoretically possible for  $A$  to emit two beta particles, either  $\beta^+\beta^+$  or  $\beta^-\beta^-$  as the case may be, and two neutrinos or antineutrinos, and go from  $Z$  to  $Z \pm 2$ . Here two protons decay into two neutrons, or vice versa. This is a second-order process and so should go much slower than beta decay. There are a number of cases where such decays should occur, but their half-lives are of the order of  $10^{20}$  years or greater. Such decay processes are obviously very difficult to detect. The first direct evidence for two-neutrino double-beta-minus decay of selenium-82, was found only in 1987.

Whenever it is energetically allowed by the mass difference between neighboring isobars, a nucleus  $Z$  may capture one of

its own atomic electrons and transform to the isobar of atomic number  $Z - 1$ . Usually the electron-capture (EC) transition involves an electron from the  $K$  shell of atomic electrons, because these innermost electrons have the greatest probability density of being in or near the nucleus. See ELECTRON CAPTURE.

**Gamma-ray decay.** Gamma-ray decay involves a transition between two excited levels of a nucleus, or between an excited level and the ground level. A nucleus in its ground level cannot emit any gamma radiation. Therefore gamma-ray decay occurs only as a sequel of another radioactive decay process or of some other process whereby the product nucleus is left in an excited state. Such additional processes include the fusion of two nuclei, Coulomb excitation, and induced nuclear fission. See COULOMB EXCITATION; NUCLEAR FISSION; NUCLEAR FUSION.

A gamma ray is high-frequency electromagnetic radiation (a photon) in the same family with radio waves, visible light, and x-rays. The energy of a gamma ray is given by  $h\nu$ , where  $h$  is Planck's constant and  $\nu$  is the frequency of oscillation of the wave in hertz. The gamma-ray or photon energy  $h\nu$  lies between 0.05 and 3 MeV for the majority of known nuclear transitions. Higher-energy gamma rays are seen in neutron capture and some reactions. See ELECTROMAGNETIC RADIATION.

Gamma rays carry away energy, linear momentum, and angular momentum, and account for changes of angular momentum, parity, and energy between excited levels in a given nucleus. This leads to a set of gamma-ray selection rules for nuclear decay and a classification of gamma-ray transitions as "electric" or as "magnetic" multipole radiation of multipole order  $2^l$ , where  $l = 1$  is called dipole radiation,  $l = 2$  is quadrupole radiation, and  $l = 3$  is octupole,  $l$  being the vector change in nuclear angular momentum. The most common type of gamma-ray transition in nuclei is the electric quadrupole (E2). There are cases where several hundred gamma rays with different energies are emitted in the decays of atoms of only one isotope. See MULTIPOLE RADIATION.

An alternative type of deexcitation which always competes with gamma-ray emission is known as internal conversion. Instead of the emission of a gamma ray, the nuclear excitation energy can be transferred directly to a bound electron of the same atom. Then the nuclear energy difference is converted to energy of an atomic electron, which is ejected from the atom.

When the energy between two states in the same nucleus exceeds 1.022 MeV, twice the rest mass energy of an electron, it is also possible for the nucleus to give up its excess energy to an electron-positron pair—a pair creation process. See ELECTRON-POSITRON PAIR PRODUCTION.

**Spontaneous fission.** This involves the spontaneous breakup of a nucleus into two heavy fragments and neutrons. Spontaneous fission can occur when the sum of the masses of the two heavy fragments and the neutrons is less than the mass of the parent undergoing decay. After the discovery of fission in 1939, it was subsequently discovered that isotopes like  $^{238}\text{U}$  had very weak decay branches for spontaneous fission, with branching ratios on the order of  $10^{-6}$ . Some isotopes with relatively long half-lives such as  $^{252}\text{Cf}$  have large (3.1%) spontaneous fission branching. [J.H.H.]

**Heavy cluster decays.** Alpha-particle decay and spontaneous fission are two natural phenomena in which an atomic nucleus spontaneously breaks into two fragments, but the fragments are of very different size in one case and almost equal size in the other. On the basis of fragmentation theory and the two-center shell model, new kinds of radioactivities that are intermediate between alpha particle decay and fission were predicted in 1980. Subsequently, it was shown theoretically that the new processes should occur throughout a very broad region of the nuclear chart, including elements with atomic numbers higher than 40. However, experimentally observable emission rates could be expected only for nuclei heavier than lead, in a breakup leading to a very stable heavy fragment with proton and neutron numbers equal or very close to  $Z = 82$ ,  $N = 126$  ( $^{208}_{82}\text{Pb}$  or its neighborhood). The main competitor is always

alpha-particle decay. In 1984, a series of experimental confirmations began with the discovery of  $^{14}\text{C}$  radioactivity of  $^{223}\text{Ra}$ . A very promising technique uses solid-state track-recording detectors with special plastic films and glasses that are sensitive to heavier clusters but not to alpha particles. [W.Gr.; J.H.H.]

**Proton radioactivity.** Proton radioactivity is a mode of radioactive decay that is generally expected to arise in proton-rich nuclei far from the stable isotopes, in which the parent nucleus changes its chemical identity by emission of a proton in a single-step process. Its physical interpretation parallels almost exactly the quantum-mechanical treatment of alpha-particle decay. For many years only a few examples of this decay mode were observed, because of the narrow range of half-lives and decay energies where this mode can compete with other modes. However, in the late 1990s, experimental techniques using new recoil mass spectrometers, which can separate rare reaction products, and new double-sided silicon strip detectors became available and opened up the discovery of many new proton radioactivities. Two-proton radioactivity (the simultaneous emission of two protons) was first observed in 2001 in an excited state of neon-18 and in 2002 in the ground state of iron-45.

**Delayed particle emissions.** Twelve types of beta-delayed particle emissions have been observed. Beta-delayed deuteron ( $^2\text{H}$ ) emission, which is not shown there, also can be expected. Over 100 beta-delayed particle radioactivities are now known. Theoretically, the number of isotopes which can undergo beta-delayed particle emission could exceed 1000. Thus, this mode, which was observed in only a few cases prior to 1965, is among the important ones in nuclei very far from the stable ones in nature. Studies of these decays can provide insights into the nucleus which can be gained in no other way. [J.H.H.]

**Radioactivity and radiation applications** The field in which the subatomic fragments emitted in radioactive decay (alpha-, beta-, gamma-rays) or produced by high-voltage accelerators (electrons, protons, x-rays) are applied to the problems of science, engineering, industry, and medicine. The techniques are extraordinarily versatile and sensitive and are basically inexpensive. A disadvantage that limits the range and extent of these applications is the health hazard that may be involved. See RADIOACTIVITY; RADIOISOTOPE.

Tracer applications are based on two principles. First is the chemical similarity of radioactive atoms and other atoms of the same element. Periodically a few of the radioactive atoms decay, emitting some penetrating subatomic fragments that can be detected one by one, usually through their ability to cause ionization. Thus the movement of a particular element can be followed through various chemical, physical, and biological steps. The second principle involves the characteristic half-life and nature of the emitted fragments. This makes a radioactive species unique and thereby detectable above a background of radioactive emitters associated with elements. For discussions of radioisotope techniques relating to tracer methodology see ACTIVATION ANALYSIS; ISOTOPE DILUTION TECHNIQUES; RADIOACTIVE TRACER; RADIOECOLOGY.

Penetration and scattering applications arise from the fact that subatomic fragments can penetrate a thick section of a material, and yet a small fraction of the incident particles can be backscattered by a relatively thin section. The oldest application of the penetrating properties of energetic ionizing photons is radiography. An extension of this technique is autoradiography. Since World War II the penetration and scattering properties of beta- and gamma-rays have been applied in industry in the form of thickness gages. See AUTORADIOGRAPHY; RADIOGRAPHY.

The absorption of small amounts of energy from ionizing particles and ionizing photons has chemical effects that have been the basis of several practical applications. The oldest application of this principle is radiation therapy. For example, in cancer therapy the local affected areas are irradiated by external beams of gammas from cobalt-60 or of radiation from accelera-

tors. Radioactive sources have also been administered internally to induce beneficial biochemical reactions in patients afflicted with various ailments. See ISOTOPIC IRRADIATION; RADIOLOGY.

A related area is the radiation sterilization of biomedical supplies. The advantages to this method of biochemical destruction of microscopic life are that (1) unlike steam sterilization, it can be performed at low temperatures on plastics and other thermally unstable materials, and (2) unlike germicidal gases, ionizing radiation can reach every point in the treated product. Radiation-sterilized objects are not radioactive.

The radiation preservation of food is an area of considerable promise. Small doses can inhibit sprouting in potatoes, kill insects in wheat, and sterilize pork products but practical applications have been sharply limited due to a cautious role by regulatory authorities in approving such procedures.

Kinetic energy of emissions in radioactive decay can be converted to useful forms of light, heat, and electricity. See LUMINOUS PAINT; NUCLEAR BATTERY. [J.Sil.]

**Radioactivity standards** Calibrated standard sources of radioactive substances used to determine, by comparison, the strength or activity of samples of the same substances in terms of the number of radioactive atoms they contain or in terms of some figure proportional to this number. The calibration of the standard source in terms of the number of radioactive atoms is usually an elaborate procedure but need only be carried out once, and the calibration may be made at a standardizing laboratory, such as the National Institute of Standards and Technology, having special equipment for the work. Comparison between a sample and the standard is usually made by finding the ratio of the response of an ionization chamber, or other detector of radiation, to the radiation from a sample and from the standard. In each case the intensity of the radiation, and therefore the response of the detector under identical conditions, is proportional to the number of radioactive atoms in the source, because this number is also proportional to the activity or disintegration rate of a source. See HALF-LIFE; RADIOACTIVITY. [L.F.Cu.; K.Z.M.]

**Radiocarbon dating** A method of obtaining age estimates on organic materials which has been used to date samples as old as 75,000 years. The method has provided age determinations in archeology, geology, geophysics, and other branches of science.

Radiocarbon ( $^{14}\text{C}$ ) determinations can be obtained on wood; charcoal; marine and fresh-water shell; bone and antler; peat and organic-bearing sediments; carbonate deposits such as tufa, caliche, and marl; and dissolved carbon dioxide ( $\text{CO}_2$ ) and carbonates in ocean, lake, and ground-water sources. Each sample type has specific problems associated with its use for dating purposes, including contamination and special environmental effects. While the impact of  $^{14}\text{C}$  dating has been most profound in archeological research and particularly in prehistoric studies, extremely significant contributions have also been made in hydrology and oceanography. In addition, beginning in the 1950s the testing of thermonuclear weapons injected large amounts of artificial  $^{14}\text{C}$  ("bomb  $^{14}\text{C}$ ") into the atmosphere, permitting it to be used as a geochemical tracer.

Carbon (C) has three naturally occurring isotopes. Both  $^{12}\text{C}$  and  $^{13}\text{C}$  are stable, but  $^{14}\text{C}$  decays by very weak beta decay (electron emission) to nitrogen-14 ( $^{14}\text{N}$ ) with a half-life of approximately 5700 years. Naturally occurring  $^{14}\text{C}$  is produced as a secondary effect of cosmic-ray bombardment of the upper atmosphere. As  $^{14}\text{CO}_2$ , it is distributed on a worldwide basis into various atmospheric, biospheric, and hydrospheric reservoirs on a time scale much shorter than its half-life. Metabolic processes in living organisms and relatively rapid turnover of carbonates in surface ocean waters maintain  $^{14}\text{C}$  levels at approximately constant levels in most of the biosphere. The natural  $^{14}\text{C}$  activity in the geologically recent contemporary "prebomb" biosphere

was approximately 13.5 disintegrations per minute per gram of carbon. See COSMOGENIC NUCLIDE; ISOTOPE.

To the degree that  $^{14}\text{C}$  production has proceeded long enough without significant variation to produce an equilibrium or steady-state condition,  $^{14}\text{C}$  levels observed in contemporary materials may be used to characterize the original  $^{14}\text{C}$  activity in the corresponding carbon reservoirs. Once a sample has been removed from exchange with its reservoir, as at the death of an organism, the amount of  $^{14}\text{C}$  begins to decrease as a function of its half-life. A  $^{14}\text{C}$  age determination is based on a measurement of the residual  $^{14}\text{C}$  activity in a sample compared to the activity of a sample of assumed zero age (a contemporary standard) from the same reservoir. The relationship between the  $^{14}\text{C}$  age and the  $^{14}\text{C}$  activity of a sample is given by the equation below, where  $t$

$$t = \frac{1}{\lambda} \ln \frac{A_o}{A_s}$$

is radiocarbon years B.P. (before the present),  $\lambda$  is the decay constant of  $^{14}\text{C}$  (related to the half-life  $t_{1/2}$  by the expression  $t_{1/2} = 0.693/\lambda$ ),  $A_o$  is the activity of the contemporary standards, and  $A_s$  is the activity of the unknown age samples. Conventional radiocarbon dates are calculated by using this formula, an internationally agreed half-life value of  $5568 \pm 30$  years, and a specific contemporary standard.

The naturally occurring isotopes of carbon occur in the proportion of approximately 98.9%  $^{12}\text{C}$ , 1.1%  $^{13}\text{C}$ , and  $10^{-10}\%$   $^{14}\text{C}$ . The extremely small amount of radiocarbon in natural materials was one reason why  $^{14}\text{C}$  was one of the isotopes which had been produced artificially in the laboratory before being detected in natural concentrations. A measurement of the  $^{14}\text{C}$  content of an organic sample will provide an accurate determination of the sample's age if it is assumed that (1) the production of  $^{14}\text{C}$  by cosmic rays has remained essentially constant long enough to establish a steady state in the  $^{14}\text{C}/^{12}\text{C}$  ratio in the atmosphere, (2) there has been a complete and rapid mixing of  $^{14}\text{C}$  throughout the various carbon reservoirs, (3) the carbon isotope ratio in the sample has not been altered except by  $^{14}\text{C}$  decay, and (4) the total amount of carbon in any reservoir has not been altered. In addition, the half-life of  $^{14}\text{C}$  must be known with sufficient accuracy, and it must be possible to measure natural levels of  $^{14}\text{C}$  to appropriate levels of accuracy and precision. [R.E.T.]

**Radiochemical laboratory** A laboratory or facility used for investigation and handling of radioactive chemicals that provides a safe environment for the worker and the public. Features vary depending on the type of radioactive emissions to be handled, the quantity, the half-life, and the physical form (solid, liquid, gas, or powder). Special measures to minimize spread of contaminated material and to dispose of radioactive waste are required. Working surfaces should be smooth and easily washable to permit effective decontamination if necessary. Good ventilation and detectors for monitoring radiation and contamination on surfaces or people are also typical features. See VENTILATION.

Investigations utilizing only very small amounts (a few microcuries) of beta or gamma emitters which are not readily dispersed (no powders or volatile liquids) may sometimes be performed without special facilities on the bench top. In this case, precautions such as working on plastic-backed absorbent paper and wearing protective gloves and lab coat may be sufficient. A special bag or can for disposing of the paper and gloves as radioactive waste is required. If the radioactive isotopes are solely alpha-particle emitters, containment and isolation from direct contact are more serious concerns. Due to the limited penetration but high biological toxicity of alpha particles, it is essential to avoid ingestion or inhalation. For very small quantities, work may take place with double rubber gloves in a fume hood with appropriate filter. Generally, an enclosed glove box is used, situated inside a hood and maintained at negative pressure with respect to the face of the hood and the room. Sensors to monitor proper differential pressure and adequate airflow are usually

used to assure containment and to generate an alarm if conditions degrade.

For work with pure beta-emitting isotopes, long-handled tongs or other tools are used for higher levels of radioactivity in order to shield the hands. Generally, since most beta emission is also accompanied by penetrating gamma emission, the entire work area must be enclosed in heavily shielded enclosures. See ALPHA PARTICLES; BETA PARTICLES; RADIATION CHEMISTRY; RADIOACTIVITY; RADIOCHEMISTRY; RADIOISOTOPE.

Hot laboratories contain walled enclosures for remotely handling larger quantities of gamma-emitting isotopes. A small enclosure is usually referred to as a cave, while large ones are called hot cells. Hot cells are usually equipped with remote manipulators and thick windows made from high-density lead glass. [L.F.M.]

**Radiochemistry** A subject which embraces all applications of radioactive isotopes to chemistry. It is not precisely defined and is closely linked to nuclear chemistry. The widespread use of isotopes in chemistry is based on two fundamental properties exhibited by all radioactive substances. The first property is that the disintegration rate of an isotopic sample is directly proportional to the number of radioactive atoms in the sample. Thus, measurement of its disintegration rate (with a Geiger counter, for example) serves to analyze a radioactive compound. With nearly all chemical elements (notable exceptions being nitrogen and oxygen, which have no suitable radioactive isotopes), an isotope may be incorporated in a chemical compound, and thereafter, masses of this compound as small as  $10^{-6}$  to  $10^{-10}$  g may be measured with a high precision. The second property is that the disintegration rate is completely unaffected by the chemical form of the isotope, and conversely, the property of radioactivity does not affect the chemical properties of the isotope. By substituting or labeling a particular atom within a molecule, isotopes can be used to trace the fate of that atom during a chemical reaction. Radiochemistry has been used to study the efficiency of chemical separations, rates of chemical reaction and diffusion, isotopic exchange reactions, and chemical reaction mechanisms. See NUCLEAR CHEMISTRY; RADIATION CHEMISTRY; RADIOACTIVITY; RADIOCHEMICAL LABORATORY. [D.R.S.]

**Radioecology** The study of the fate and effects of radioactive materials in the environment. It derives its principles from basic ecology and radiation biology.

Responses to radiation stress have consequences for both the individual organism and for the population, community, or ecosystem of which it is a part. When populations or individuals of different species differ in their sensitivities to radiation stress, for example, the species composition of the entire biotic community may be altered as the more radiation-sensitive species are removed or reduced in abundance and are replaced in turn by more resistant species. Such changes have been documented by studies in which natural ecological systems, including grasslands, deserts, and forests, were exposed to varying levels of controlled gamma radiation stress. See POPULATION ECOLOGY.

Techniques of laboratory toxicology are also available for assessing the responses of free-living animals to exposure to low levels of radioactive contamination in natural environments. This approach uses sentinel animals, which are either tamed, imprinted on the investigator, or equipped with miniature radio transmitters, to permit their periodic relocation and recapture as they forage freely in the food chains of contaminated habitats. When the animals are brought back to the laboratory, their level of radioisotope uptake can be determined and blood or tissue samples taken for analysis. In this way, even subtle changes in deoxyribonucleic acid (DNA) structure can be evaluated over time. These changes may be suggestive of genetic damage by radiation exposure. In some cases, damage caused by a radioactive contaminant may be worsened by the synergistic effects



amount of specific antibody with the inhibitory effect of known standards.

A typical radioimmunoassay is performed by the simultaneous preparation of a series of standard and unknown mixtures in test tubes, each containing identical concentrations of labeled antigen and specific antibody. After an appropriate reaction time the antibody-bound (B) and free (F) fractions of the labeled antigen are separated by one of a variety of techniques. The B/F ratios in the standards are plotted as a function of the concentration of unlabeled antigen (standard curve), and the unknown concentration of antigen is determined by comparing the observed B/F ratio with the standard curve.

The radioimmunoassay principle has found wide application in the measurement of a large and diverse group of substances in a variety of problems of clinical and biological interest. It is therefore not unexpected that there are differences in the specific methods employed for the assay of a particular substance. The full potential of the method has yet to be exploited. It seems that virtually any substance of biologic interest can be measured, the method being modified according to the characteristics of the particular substance. See ANTIBODY; ANTIGEN; IMMUNOLOGY.

[R.S.Y.]

**Radioisotope** A radioactive isotope (as distinguished from a stable isotope) of an element. Atomic nuclei are of two types, unstable and stable. Those in the former category are said to be radioactive and eventually are transformed, by radioactive decay, into the latter. One of the three types of particles or radiation (alpha particles, beta particles, and gamma rays) is emitted during each stage of the decay. See ISOTOPE; RADIOACTIVITY.

The term radioisotope is also loosely used to refer to any radioactive atomic species. Whereas approximately a dozen radioisotopes are found in nature in appreciable amounts, hundreds of different radioisotopes have been artificially produced by bombarding stable nuclei with various atomic projectiles.

A very wide variety of radioisotopes are produced in particle accelerators, such as the cyclotron. Charged particles, such as deuterons ( $D^+$ ) and protons ( $H^+$ ), are accelerated to great speeds by high-voltage electrical fields and allowed to strike targets in which nuclear reactions take place; for example, proton in, neutron out ( $p,n$ ), increasing the target-atom atomic number by one without changing the atomic mass; and deuteron in, proton out ( $d,p$ ), increasing the atomic mass by one without changing the atomic number. The target elements become radioactive because the nuclei of the atoms are unbalanced, having an excess or deficit of neutrons or protons. Although the particle-accelerating machines are most versatile in producing radioisotopes, the amount of radioactive material that can be produced is relatively smaller than that made in a nuclear reactor [less than curie amounts; a curie (abbreviated Ci) is that quantity of a radioisotope required to supply  $3.7 \times 10^{10}$  disintegrations per second or  $3.7 \times 10^{10}$  becquerels (Bq)]. For large-scale production, nuclear reactors with neutron fluxes of  $1 \times 10^{10}$  to  $5 \times 10^{15}$  neutrons per square centimeter per second are required. See NUCLEAR REACTION; NUCLEAR REACTOR; PARTICLE ACCELERATOR; REACTOR PHYSICS; UNITS OF MEASUREMENT.

[A.F.Ru.]

**Radioisotope (biology)** A radioactive isotope used in studying living systems, such as in the investigation of metabolic processes. The usefulness of radioisotopes as tracers arises chiefly from three properties: (1) At the molecular level the physical and chemical behavior of a radioisotope is practically identical with that of the stable isotopes of the same element. (2) Radioisotopes are detectable in extremely minute concentrations. (3) Analysis for radioisotopic content often can be achieved without alteration of the sample or system. In some applications, principally those in which reaction rates and transfer rates are studied, isotopes, particularly radioisotopes, have unique advantages as tracers. See ISOTOPE; RADIOISOTOPE.

The amount of isotope to be used and the path by which it is introduced into the system are governed by many factors. Sufficient tracer to be detectable must be used, but the amounts of material which are introduced must be small enough not to disturb the system by their mass, pharmacological effects, or the effects of radiation. The mass of 1 curie, the unit of disintegration rate, depends inversely upon the half-life and directly upon the atomic weight of the particular radioisotope; it is 1 gram for  $^{226}\text{Ra}$  (half-life 1620 years), but only 8 micrograms for  $^{131}\text{I}$  (half-life 8.0 days). In tracer experiments with small animals, microcurie quantities are usually adequate.

There are many methods for detecting the presence of radioactive material. The Geiger counter has largely been displaced by thallium-activated sodium iodide scintillation crystals for counting gamma rays, but Geiger counters and proportional counters are still useful for counting alpha and beta particles. In histological and cytological studies the method of autoradiography, in which photographic film is exposed through contact with the specimen, is very useful. The autoradiographic method is also used extensively in conjunction with paper or column chromatography, particularly in studies of metabolic pathways. See AUTORADIOGRAPHY; CHROMATOGRAPHY; GEIGER-MÜLLER COUNTER; PARTICLE DETECTOR; SPECTROSCOPY.

One of the outstanding achievements in which radioisotopes have played a role has been the use of carbon-14 in the elucidation of the metabolic path of carbon in photosynthesis. The products produced in the first few seconds following exposure to light have been identified by combinations of paper chromatography and autoradiography. The extrathyroidal metabolism of iodine, the path of iodine in the thyroid gland, and other problems of intermediary metabolism have been studied intensively. The concept of the dynamic state of cell constituents is largely attributable to discoveries made with isotopic tracers. At one time it was thought that concentration gradients across cell membranes depended upon their being impermeable, but the use of isotopes has refuted this hypothesis by proving that in many such cases the substances involved are normally transported in both directions across the membrane. In physiology, radioisotopes have been used in a wide variety of permeability, absorption, and distribution studies. See ABSORPTION (BIOLOGY); CELL MEMBRANE; PHOTOSYNTHESIS.

The kinetics of cellular proliferation has provided a rich vein for application of radioisotopic methods. For example, the lifetime of human red blood cells (about 120 days) was established with the use of  $^{59}\text{Fe}$ -labeled cells. Some applications, such as the intake of  $^{131}\text{I}$  by the thyroid, the measurement of the red-cell mass with  $^{51}\text{Cr}$ -labeled red cells, and the absorption of  $^{60}\text{Co}$ -labeled vitamin  $B_{12}$ , are of practical clinical importance in the diagnosis and treatment of disease, and knowledge of the rates of distribution and disposal of a wide variety of radioactive substances is basic to the problem of evaluating the hazard from fallout radiation.

[J.S.Ro.]

**Radioisotope geochemistry** A branch of environmental geochemistry and isotope geology concerned with the occurrence of radioactive nuclides in sediment, water, air, biological tissues, and rocks. The nuclides have relatively short half-lives ranging from a few days to about  $10^6$  years, and occur only because they are being produced by natural or anthropogenic nuclear reactions or because they are the intermediate unstable daughters of long-lived naturally occurring radioactive isotopes of uranium and thorium. The nuclear radiation, consisting of alpha particles, beta particles, and gamma rays, emitted by these nuclides constitutes a potential health hazard to humans. However, their presence also provides opportunities for measurements of the rates of natural processes in the atmosphere and on the surface of the Earth. See ALPHA PARTICLES; BETA PARTICLES; GAMMA RAYS.

The unstable daughters of uranium and thorium consist of a group of 43 radioactive isotopes of 13 chemical elements, including all of the naturally occurring isotopes of the chemical elements radium, radon, polonium, and several others. A second group of radionuclides is produced by the interaction of cosmic rays with the chemical elements of the Earth's surface and atmosphere. This group includes hydrogen-3 (tritium), beryllium-10, carbon-14, aluminum-26, silicon-32, chlorine-36, iron-55, and others. A third group of radionuclides is produced artificially by the explosion of nuclear devices, by the operation of nuclear reactors, and by various particle accelerators used for research in nuclear physics. Some of the radionuclides produced in nuclear reactors decay sufficiently slowly to be useful for geochemical research, including strontium-90, cesium-137, iodine-129, and isotopes of plutonium. The explosion of nuclear devices in the atmosphere has also contributed to the abundances of certain radionuclides that are produced by cosmic rays such as tritium and carbon-14. See COSMOGENIC NUCLIDE; DATING METHODS; ENVIRONMENTAL RADIOACTIVITY; RADIOACTIVE FALLOUT; RADIOISOTOPE; TRANSURANIUM ELEMENTS. [G.Fau.]

**Radiolaria** A group of marine protozoa, regarded as a subclass of Actinopodea in older classifications, but not recognized as a natural group in some modern systems owing to its heterogeneity. In certain modern systems, the Radiolaria are subdivided into two classes, Polycystinea and Phaeodarea. Radiolarians occur almost exclusively in the open ocean as part of the plankton community, and are widely recognized for their ornate siliceous skeletons produced by most of the groups (illus. a-c). Their skeletons occur abundantly in ocean sediments and are used in analyzing the layers of the sedimentary record (biostratigraphy).

A characteristic feature of the group is the capsule, a central mass of cytoplasm bearing one or more nuclei, food reserves, and metabolic organelles. This is surrounded by a perforated wall and a frothy layer of cytoplasm known as the extracapsulum, where food digestion generally occurs and where numerous axopodia (stiffened strands of cytoplasm) and rhizopodia radiate toward the surrounding environment. Algal symbionts including dinoflagellates, green algae, and golden-brown pigmented algae occur profusely in the extracapsulum. The algal symbionts living within the protection of the extracapsulum provide photosynthetically derived food for the radiolarian host.

In the order Spumellarida (class Polycystinea) the central capsule is perforated by numerous pores distributed evenly on the surface of the capsular wall. These pores, containing strands of cytoplasm, provide continuity between the cytoplasm in the central capsule and the surrounding extracapsulum. The skeletons of the Spumellarida are characteristically developed on a spherical organizational plan, but some are spiral-shaped (resembling snail shells) or produce elongate skeletons composed of numerous chambers built one upon another. In some genera, such as *Thalassicolla* (illus. e), there is no skeleton; in others there are rods or spicules, or often a single or multiple concentric lattice-work skeleton (illus. c).

Multicellular aggregates (colonies of spumellaridans), measuring several centimeters in diameter (or even several meters in some rare elongate forms), consist of numerous radiolarian central capsules enclosed within a gelatinous envelope and interconnected by a web of rhizopodia that bears abundant algal symbionts. A thin halo of feeding rhizopodia protrudes from the surface of the colony and is used to capture prey. Reproduction is poorly understood. In some colonial forms, daughter colonies are produced by asexual reproduction (fission). Flagellated swimmers (illus. f) released from mature central capsules of some species are possibly gametes and contain a large crystal inclusion of strontium sulfate.

In the Nassellarida (Polycystinea), the central capsule is often ovate and the pores are localized at one pole (illus. d). The axopodia and rhizopodia emerge from this pore field and are

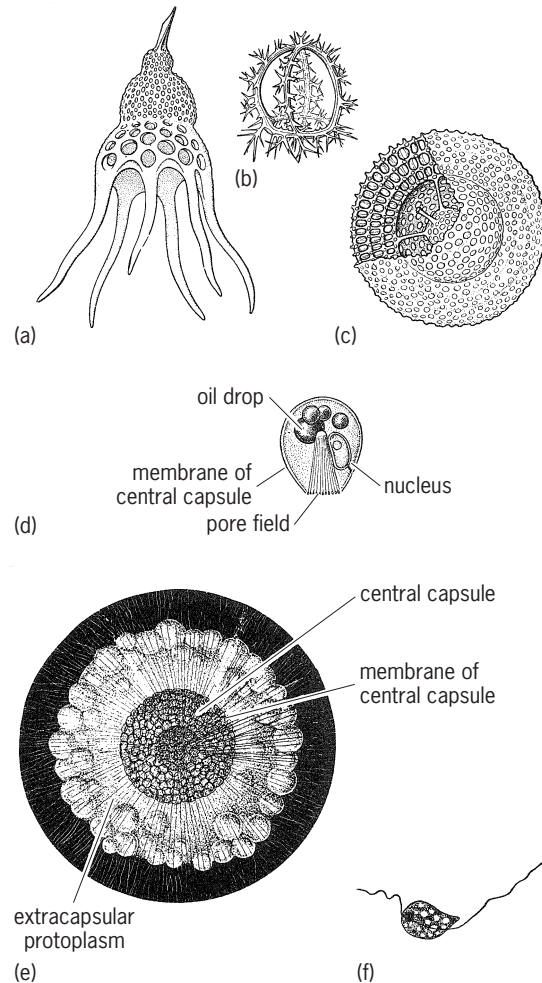

**Radiolaria.** Skeletons representing (a, b) certain Nassellarida (or Monopylina) and (c) certain Spumellarida (or Periphyllina). (d) Central capsule, one of the Nassellarida showing one group of pores. (e) *Thalassicolla*, one of the Spumellarida without skeletal elements. (f) Biflagellate gametes. (After L. H. Hyman, *The Invertebrates*, vol. 1, McGraw-Hill, 1940)

supplied by a conelike array of microtubules within the central capsule. The skeleton, when present, is often shaped like a dome or helmet.

Radiolarians in the class Phaeodarea possess a central capsule with two types of pore areas, a larger one (astropyle) that serves as a kind of cytopharynx where food is carried into the central capsule, and two accessory openings (parapylae) where smaller strands of cytoplasm emerge. The skeleton exhibits a wide range of shapes, including geodesic-like lattice spheres and small porous clam-shaped shells.

Radiolarians have a fossil record that extends back to early Paleozoic time, about a half billion years ago. Compared to other groups of shell-bearing marine microplankton, they are highly diverse, several hundred species having inhabited the oceans at any given time. Because they are planktonic and have undergone continuous evolutionary change, radiolarians are particularly useful for determining time equivalence (and geological ages) of marine sedimentary deposits at widely separated localities. The Cenozoic record of radiolarians in sediments, particularly on the deep-sea floor, is sufficiently complete to show the course of evolutionary change in considerable detail.

Assemblages of fossil radiolarians also provide clues to oceanic conditions during the geological past. Each of the major oceanic water masses has its characteristic radiolarian fauna, and so changes in the distribution or composition of these assemblages



can be interpreted in terms of changes in the pattern of water masses, or in their oceanographic properties. See OCULOSIDA; PROTOZOA. [O.R.A.; W.R.R.]

**Radiology** The medical science concerned with x-rays, radioactive materials, and other ionizing radiations, and the application of the principles of this science to diagnosis and treatment of disease. Nonionizing radiations of infrared and ultrasound are also used for diagnosis.

Diagnostic radiology uses radiation, usually x-rays, to study the configuration of anatomical structures or the function of body organ systems. See RADIOGRAPHY.

Radioactive isotopes are used to obtain images of organ systems and functions. The accumulation of isotope in a tumor or an organ such as the thyroid is recorded by a suitable  $\gamma$ -ray detector attached to an electronic amplifier and recording equipment. The image of the radioactivity concentrated in an organ is viewed on a television-type screen and recorded on a photographic print. See RADIOACTIVE TRACER.

Sound waves of 1–10 MHz are transmitted from a crystal transducer, and after amplification are displayed on an oscilloscope and recorded on a photographic print. The ultrasound pulses demonstrate organ structures such as the heart, liver, and spleen. Although the resolution is less fine than that obtained with x-ray, there is an advantage in that the ultrasound is nonionizing radiation. Ultrasound is particularly useful, therefore, in determining the size and degree of development of the human fetus. See ULTRASONICS.

Infrared radiation from the human body is used to detect tumors such as breast tumors, which are near the body surface. The technique, thermography, is based on the idea that tumors are warmer than the surrounding normal tissue. This increase in temperature is detected by an infrared device, and the “hot spot” scan is displayed on a television-type screen, with permanent records kept on photographic prints.

Radiation therapy deals with the treatment of disease with ionizing radiation. The diseases most commonly treated are cancer and allied diseases. Radiation therapy has been found useful in the management of some diseases such as ringworm of the scalp and bursitis, but because of possible serious complications occurring many years later, the use of ionizing radiation is generally avoided if alternative methods of treatment are available.

In cancer therapy the objective is to destroy a tumor without causing irreparable radiation damage in normal body tissues that must of necessity be irradiated in the process of delivering a lethal dose to the tumor. This applies particularly to important normal structures in the vicinity of the tumor. The relative radiosensitivity of the tumor with respect to these normal structures is the chief factor determining the success of the treatment. [L.B.Lu.]

**Radiometry** A branch of science that deals with the measurement or detection of radiant electromagnetic energy. Radiometry is divided according to regions of the spectrum in which the same experimental techniques can be used. Thus, vacuum ultraviolet radiometry, intermediate-infrared radiometry, far-infrared radiometry, and microwave radiometry are considered separate fields, and all of these are to be distinguished from radiometry in the visible spectral region. Curiously, radiometry in the visible is called radiometry, optical radiation measurement science, or photometry, but it is not called visible radiometry. See ELECTROMAGNETIC RADIATION; INFRARED RADIATION; LIGHT; MICROWAVE; ULTRAVIOLET RADIATION.

Any radiation detector (such as a thermometer) that responds to an increase in temperature caused by the absorption of radiant energy is known as a thermal detector. Similarly, any detector (such as a photochemical reaction) that responds to the excitation of a bound electron is called a photon or quantum detector.

Liquid-in-glass thermometers are sluggish and relatively insensitive. The key to developing thermal detectors with better performance than liquid-in-glass thermometers has been to

secure a large and rapid rise in temperature associated with a high sensitivity to temperature changes.

Thermal detectors have been based upon a number of different principles. Radiation thermocouples produce a voltage, bolometers undergo a change in resistance, pyroelectric detectors undergo a change in spontaneous electric polarization, and the gas in pneumatic detectors (Golay cells) and photoacoustic detectors expands in response to incident radiation. The periodic expansion and contraction of the gas in response to high-frequency modulated radiation is detected by a sensitive microphone in the case of the photoacoustic detector. The Golay cell, on the other hand, uses a sensitive photomultiplier and a reference beam of light to detect distortion of a flexible membrane mirror caused by the expansion and contraction of the gas. See BOLOMETER; PYROELECTRICITY; THERMOCOUPLE.

The main problem with thermal detectors is that they respond not only to electromagnetic radiation but to any source of heat. This makes their design, construction, and use rather difficult, because they must be made sensitive to the radiation of interest while remaining insensitive to all other sources of heat, such as conduction, convection, and background radiation, that are of no interest in the particular measurement.

Photon detectors respond only to photons of electromagnetic radiation that have energies greater than some minimum value determined by the quantum-mechanical properties of the detector material. Since heat radiation from the environment at room temperature consists of infrared photons, photon detectors for use in the visible can be built so that they do not respond to any source of heat except the radiation of interest.

Following the introduction of planar silicon technology for microelectronics, the same technology was quickly exploited to make planar photodiodes based on the internal photoelectric effect in silicon. In these devices, the separation of a photogenerated electron-hole pair by the built-in field surrounding the  $p^+n$  junction induces the flow of one electron in an external short circuit (such as the inputs to an operational amplifier) across the electrodes. The number of electrons flowing in an external short circuit per absorbed photon is called the quantum efficiency. The use of these diodes has grown to the point where they are the most widely used detector for the visible and nearby spectral regions. Their behavior as a radiation detector in the visible is so nearly ideal that they can be used as a standard, their cost is so low that they can be used for the most mundane of applications, and their sensitivity is so high that they can be used to measure all but the weakest radiation (which requires the most sensitive photomultipliers). See JUNCTION DIODE; PHOTODIODE; SEMICONDUCTOR DIODE.

Research efforts have been directed at producing photon detectors based on more exotic semiconductors, and more complicated structures to extend the sensitivity, time response, and spectral coverage. See OPTICAL DETECTORS. [J.Ge.]

**Radish** A cool-season annual or biennial crucifer, *Raphanus sativus*, of Chinese origin belonging to the plant order Capparales. The radish is grown for its thickened hypocotyl, which is eaten uncooked as a salad vegetable. Colors include red, yellow, white, black, pink, and red-white combinations. See CAPPARALES. [H.J.C.]

**Radium** A chemical element, Ra, with atomic number 88. The atomic weight of the most abundant naturally occurring isotope is 226. Radium is a rare radioactive element found in uranium minerals to the extent of 1 part for about every  $3 \times 10^6$  parts of uranium. Chemically, radium is an alkaline-earth metal having properties quite similar to those of barium. Radium is important because of its radioactive properties and is used primarily in medicine for the treatment of cancer, in atomic energy technology for the preparation of standard sources of radiation, as a source for actinium and protactinium by neutron

bombardment, and in certain metallurgical and mining industries for preparing gamma-ray radiographs. See PERIODIC TABLE.

Thirteen isotopes of radium are known; all are radioactive; four occur naturally; the rest are produced synthetically. Only  $^{226}\text{Ra}$  is technologically important. It is distributed widely in nature, usually in exceedingly small quantities. The most concentrated source is pitchblende, a uranium mineral containing about 0.014 oz (0.4 g) of radium per ton of uranium.

Biologically, radium behaves as a typical alkaline-earth element, concentrates in bones by replacing calcium and, as a result of prolonged irradiation, causes anemia and cancerous growths. The tolerance dose for the average human being has been estimated at a total of 1  $\mu\text{g}$  of radium fixed within the body. However, because radiations from radium and its decay products preferentially destroy malignant tissue, radium and radon, the gaseous decay product of radium, have been used to check the growth of cancer.

When first prepared, nearly all radium compounds are white, but they discolor on standing because of intense radiation. Radiation causes a purple or brown coloration in glass on long contact with radium compounds. Eventually the glass crystallizes and becomes crazed. Radium salts ionize the surrounding atmosphere, thereby appearing to emit a blue glow, the spectrum of which consists of the band spectrum of nitrogen. Radium compounds will discharge an electroscope, fog a light-shielded photographic plate, and produce phosphorescence and fluorescence in certain inorganic compounds such as zinc sulfide. The emission spectrum of radium compounds is similar to those of the other alkaline earths; radium halide imparts a carmine color to a flame.

#### Physical properties of radium

Property	Value
Atomic number	88
Atomic weight	226.05
Valence states	0, 2+
Specific gravity	6.0 at 20°C
Melting point	700°C (1290°F)
Boiling point	~1140°C (2080°F)
Ionic radius, $\text{Ra}^{2+}$	0.245 nm (estimated)
Atomic parachor	~140
Decomposition potential	1.718 volt
Heat of formation of oxide	130 kcal/mole
Magnetic susceptibility	Feebly paramagnetic

When freshly prepared, radium metal has a brilliant white metallic luster. Some of its physical properties are shown in the table. Chemically, the metal is highly reactive. It blackens rapidly on exposure to air because of the formation of a nitride. Radium reacts readily with water, evolving hydrogen and forming a soluble hydroxide. See ALKALINE-EARTH METALS; NUCLEAR REACTION; RADIOACTIVE MINERALS; RADIOACTIVITY; RADON. [M.L.S.]

**Radius of gyration** A relation of the area or mass of a figure to its moment of inertia. If  $I$  is the moment of inertia about a line of a figure whose area is  $A$ , the figure's radius of gyration with respect to that line is  $k = +\sqrt{I/A}$ . Accordingly,  $I = k^2A$ . For a figure of mass  $M$ ,  $k = +\sqrt{I/M}$ ;  $I = k^2M$ . In these equations,  $k$  is measured in length units such as feet. Geometrically similar figures have equal radii of gyration about corresponding centroidal axes. See MOMENT OF INERTIA. [N.S.F.]

**Radome** A strong, but electrically transparent, thin shell used to house a radar antenna, or a space-communications antenna of similar structure. The shell must be large enough not to interfere with the scanning motion of the antenna. In airborne radar the radome prevents the antenna from upsetting the aerodynamic characteristics of the airplane or missile and protects

the antenna against aerodynamic forces. Shipboard radars frequently require radomes to protect them against wind and water damage and blast pressures from nearby guns. Large land-based radars are usually shielded by radomes, especially in severe climatic conditions. See ANTENNA (ELECTROMAGNETISM); RADAR. [R.I.B.]

**Radon** A chemical element, Rn, atomic number 86. Radon is produced as a gaseous emanation from the radioactive decay of radium. The element is highly radioactive and decays by the emission of energetic alpha particles. Radon is the heaviest of the noble, or inert, gas group and thus is characterized by chemical inertness. More than 25 isotopes of radon have been identified. All isotopes are radioactive with short half-lives. See PERIODIC TABLE.

Radon is found in natural sources only because of its continuous replenishment from the radioactive decay of longer-lived precursors in minerals containing uranium, thorium, or actinium.  $^{222}\text{Rn}$  (half-life 3.82 days),  $^{220}\text{Rn}$  (thoron; half-life 55 s), and  $^{219}\text{Rn}$  (actinon; half-life 4.0 s), occur in nature as members of the uranium (U), thorium (Th), and actinium (Ac) series, respectively. All three decay by the emission of energetic alpha particles. See ACTINIUM; ALPHA PARTICLES; RADIOACTIVITY; RADIUM; THORIUM; URANIUM.

Any surface exposed to  $^{222}\text{Rn}$  becomes coated with an active deposit which consists of a group of short-lived daughter products. The radiations of this active deposit include energetic alpha particles, beta particles, and gamma rays. The ultimate decay products of radon following the rapid decay of the active deposit to lead-210 include bismuth-210, polonium-210, and finally, stable lead-206. Radon possesses a particularly stable electronic configuration, which gives it the chemical properties characteristic of noble gas elements. It has a boiling point of  $-62^\circ\text{C}$  ( $-80^\circ\text{F}$ ) and a melting point of  $-71^\circ\text{C}$  ( $-96^\circ\text{F}$ ). The spectrum of radon has been extensively studied, and resembles that of the other inert gases. Radon is readily adsorbed on charcoal, silica gel, and other adsorbents, and this property can be used to separate the element from gaseous impurities. [E.K.H.]

The rocks and soils of the Earth's crust contain approximately 3 parts per million of  $^{238}\text{U}$ , the long-lived head of the uranium series; 11 ppm of  $^{232}\text{Th}$ , the head of the thorium series; but only about 0.02 ppm of  $^{235}\text{U}$ , the long-lived member of the actinium group. The radon isotopes  $^{222}\text{Rn}$  and  $^{220}\text{Rn}$  are produced in proportion to the amount of the parent present. Some of the newly formed radon atoms which originate in or on the surface of mineral grains escape into the soil gas, where they are free to diffuse within the soil capillaries. Some of the radon atoms eventually find their way to the surface, where they become a part of the atmosphere. Even though thorium ( $^{232}\text{Th}$ ) is generally more abundant than uranium in the Earth's crust, the probability for decay is smaller; hence, the production rate of  $^{222}\text{Rn}$  and  $^{220}\text{Rn}$  in the soil is roughly the same. Much of the  $^{220}\text{Rn}$  decays before reaching the Earth's surface due to its short half-life.

When radon ( $^{222}\text{Rn}$  or  $^{220}\text{Rn}$ ) passes from soil to air, it is mixed throughout the lower atmosphere by eddy diffusion and the prevailing winds. Mean radon levels are found to be higher during those times of year when atmospheric stability is the greatest such as may occur during the fall months. Radon and its daughters play an important role in atmospheric electricity. Near the Earth's surface almost half of the ionization of the air is due to  $^{220}\text{Rn}$  and  $^{222}\text{Rn}$  and their daughter products. The alpha emitters from these chains typically produce about  $10^7$  ion pairs per second per cubic meter. See ATMOSPHERIC CHEMISTRY; ATMOSPHERIC ELECTRICITY.

Radon is readily soluble in water. Since ground and surface waters are in close contact with soil and rocks containing small quantities of radium, it is not surprising to find radon in public water supplies.

The radon isotopes  $^{220}\text{Rn}$  and  $^{222}\text{Rn}$  are used widely in the study of gaseous transport processes both in the underground

environment and in the atmosphere. Radon accumulates to high levels of the order of 4000 becquerels/m<sup>3</sup> or more in caves unless natural or artificial ventilation occurs. Changes in <sup>222</sup>Rn concentrations in spring and well water and in soil and rocks have been suggested as a means of predicting earthquakes.

The tendency of the decay products of radon to attach to aerosols means that these nuclides will be inhaled and deposited in the bronchial epithelium and lungs. The daughter products, therefore, make up the major part of the internal radiation dose from radon. Ways of reducing radon levels within homes or workplaces include increased ventilation and sealing of major sources of entry from soil and building materials. Workers in uranium mines may encounter radon and decay product levels of the order of 50,000 Bq/m<sup>3</sup> or more. Ventilation procedures and special filters for the miners must be used. See BIOSPHERE; RADIATION INJURY (BIOLOGY); RADIOECOLOGY; RADIOISOTOPE (GEOCHEMISTRY).

[M.Wi.]

**Raffinose** The best-known trisaccharide (oligosaccharide), widely distributed in higher plants. The best-known sources are cottonseed meal and the manna of *Eucalyptus*. It is also known as melitose, melitriose, gossypose, and *O*- $\alpha$ -D-galactopyranosyl-(1 $\rightarrow$ 6)-*O*- $\alpha$ -D-glucopyranosyl-(1 $\rightarrow$ 2)- $\beta$ -D-fructofuranoside. See OLIGOSACCHARIDE.

Complete acid hydrolysis gives 1 mole each of D-galactose, D-glucose, and D-fructose. In structure, it comprises melibiose and sucrose with the central D-glucose in common. See FRUCTOSE; GALACTOSE; GLUCOSE.

Raffinose can be hydrolyzed by enzymes in two ways. Invertase ( $\beta$ -D-fructofuranoside) hydrolyzes the sucrose part of the molecule to give melibiose and D-fructose. Almond emulsin, which contains an  $\alpha$ -D-galactosidase, hydrolyzes the melibiose residue to yield D-galactose and sucrose.

Raffinose was found to be enzymically synthesized in plants from uridine diphosphate D-galactose and sucrose by an enzyme which transfers the D-galactose moiety of this sugar nucleotide to sucrose, resulting in the formation of raffinose. [W.Z.H.]

**Rafflesiales** An order of flowering plants, division Magnoliophyta (Angiospermae), in the subclass Rosidae of the class Magnoliopsida (dicotyledons). The order consists of three families and fewer than a hundred species, all tropical or subtropical. The plants are highly specialized, nongreen, rootless parasites which grow from the roots of the host. They have few or solitary, rather large to very large flowers with numerous ovules and a single set of tepals that are commonly united into a conspicuous, corolloid calyx. See MAGNOLIOPSIDA; ROSIDAE. [A.Cr.]

**Railroad control systems** Those devices and systems used to direct or restrain the movement of trains, cars, or locomotives on railroads, rapid-transit lines, and similar guided ground-transportation networks. Such control varies from the use of simple solenoid valves to fully automatic electronic-electromechanical systems.

A primary function of railroad control systems is to ensure the safe movement of trains. This is generally accomplished by providing train operators and track-side operators with visual indications of equipment status. The simplest form of control consists of track-switch-position indicators combined with track-side manually operated "stop" or "proceed" signals, which the train operator follows. Advanced systems incorporate fully automated train control, subject to human supervisory control and potential intervention when faults occur in automated systems. See CONTROL SYSTEMS; RAILROAD ENGINEERING; TRAFFIC-CONTROL SYSTEMS.

Block signaling significantly improves the safety of railroad operations. Automatic block signaling is accomplished by sectioning the track into electrical circuits to detect the presence of other trains, engines, or cars. Logic circuits in the control system detect the locations of the trains and the positions of switches,

and then set the necessary signals to inform the train operators when to stop, run slowly, or proceed at posted speeds. The control system automatically detects the presence of a leading train, selects the signal to be given, and then sets the signal indications for the following train operators to read so that they may perform accordingly. In conjunction with automatic block signals, many subway rapid-transit lines incorporate automatic trip stops along the tracks to ensure that train operators obey the stop signals.

Automatic cab signaling systems display signaling information (traditionally, permitted speeds) on board the train. Coded information is transmitted to the train, generally via the running rails. Antennas and receivers aboard the train pick up, amplify, decode, and distribute the intelligence, which then causes the proper signal aspects to be displayed in the cab. Automatic cab signaling reduces or eliminates the need for wayside signals and improves the all-weather capability of trains and the train-handling capacity of the track.

Automatic train control (ATC) subsystems, located wholly on board the train, sense whether or not the train is operating within safe speed limits. If it is not, automatic train control sets the brake to bring the train to a stop or to a speed below the allowed speed. Automatic cab signaling with automatic train control is used on many railroads and several rapid-transit lines in the United States and on systems in Europe and Japan. Automatic train operation (ATO) subsystems perform nonvital operating functions such as starting, running at the prescribed speeds, slowing down, and stopping, and on some rapid-transit installations include passenger-door controls. Automatic train operation builds upon the information transmitted to the train as part of automatic cab signaling, and is a logical next step in automating train operations.

Station stopping presents a special set of requirements for rapid transit, commuter railroads, and mainline railroad passenger operations. Accurate positioning of car doors at the station platform and smooth deceleration at relatively high rates are desirable for passenger comfort and efficient operating performance. A special subsystem of control referred to as programmed train-stop systems (or station-stop systems) are a combination of on-board and wayside electronic and electromechanical equipment that can bring a train to rest within inches of its stopping-point target.

Car identification systems is an example of central line supervision. This system scans and decodes a series of colored and patterned lines placed on the side of each car to identify an individual car. This information is transmitted to the operations area, where a computer system is used to establish routing, determine maintenance schedules, and so on. Dispatchers and central operators can also use computer workstations to obtain information on system status.

Railroad terminals (points of origin and destination of trains) are critical to the efficient, cost-effective operation of railroads, so they represent a major focus for automation. A terminal generally contains three types of yards: a receiving yard, where incoming trains from the main line are temporarily stored; the hump yard, where cars are classified and resorted into new trains; and a departure yard, where trains are assembled and stored for dispatch onto the main line. [J.Cos.; D.C.N.]

**Railroad engineering** A branch of engineering concerned with the design, construction, maintenance, and operation of railways. Railway engineering includes elements of civil, mechanical, industrial, and electrical engineering. It is unique in being concerned with the interaction between moving vehicles (mechanical engineering) and infrastructure (civil engineering). The employment of both a load-supporting guideway and groups or strings of connected vehicles on flanged wheels for the transport of goods and people sets railways apart from other modes of transport. See CIVIL ENGINEERING; MECHANICAL ENGINEERING.

The plan view of a railroad track is known as the horizontal alignment. It is made up of a series of curves (arcs of simple circles), tangents (straight tracks), and spirals joining the curves and tangents. Deviations from any of the three are flaws. These imperfections are corrected periodically by a technique known as lining the track.

The side or elevation view of track, composed of a series of straight portions and the vertical curves joining them, is known as the vertical alignment. The vertical change in elevation, in feet, over a horizontal distance of 100 ft is the percent grade. Because the friction coefficient of steel wheels on steel rails is low, railroad grades must also be low, with values from zero to 1.5% fairly common. Two-percent grades are severe, usually requiring helper locomotives. Grades that are more severe, up to about 4%, can be surmounted only with considerable extra operating care and at significant additional expense.

Track gage is the distance between rails. The standard gage throughout the world is 4 ft 8.5 in. Narrow gages of 3 ft and broad gages of 5 and 6 ft have all been tried at various times and in different places.

The function of rail is to guide wheels and distribute their vertical and lateral loads over a wider area. Neither cast nor wrought iron was ideally suited to this task. The development of steel that was three times harder than wrought iron at reasonable cost made it possible for the weight of vehicles and therefore the productivity of railways to increase. Rails are joined end to end by butt welding, whereby continuous rails of over 1000 ft (300 m) in length can be produced. When laid in track, the rails are heavily anchored to restrain movement due to temperature changes. See CAST IRON; STEEL; STEEL MANUFACTURE; WROUGHT IRON.

Crossties play important roles in the distribution of wheel loads vertically, longitudinally, and laterally. Each tie must withstand loads up to one-half that imposed on the rail by a wheel. The crosstie must then distribute that load to the ballast surrounding it. Timber crossties vary in section from 6 in.  $\times$  6 in. (15 cm  $\times$  15 cm) for the lightest applications to 7 in.  $\times$  9 in. (18 cm  $\times$  23 cm) for heavy-duty track and in length from 8 ft 6 in. (2.6 m) to 9 ft (2.7 m) in length. Well-treated hardwood ties in well-maintained track may be expected to last 30 years or more. Timber crossties become unserviceable after time because of splitting, decay, insect attack, center cracking, mechanical wear, and crushing. Prestressed concrete monoblock crossties are standard in the United Kingdom and parts of continental Europe.

The granular material that supports crossties vertically and restrains them laterally is known as ballast. Ideal ballast is made up of hard, sharp, angular interlocking pieces that drain well and yet permit adjustments to vertical and horizontal alignment. Materials that crush and abrade, creating fines that block drainage or that cement, should not be used. Soft limestones and gravel, including rounded stones, are examples of poor ballast, while crushed granite, trap rock, and hard slags are superior.

The earliest diesel-electric switching locomotives developed about 600 horsepower and road freight units 1350 hp. Single locomotive units of 4000 hp are common. Common practice since dieselization began has been to employ a number of locomotive units coupled together to form a single, more powerful power source.

Locomotive development includes designs using liquefied natural gas as a fuel to reduce environmental pollutants. Locomotives equipped with the necessary power conditioning equipment and squirrel-cage asynchronous motors, made possible by the advent of high-capacity solid-state electronics, exhibit superior adhesion and have no troublesome commutators. They are adept at hauling heavy-tonnage mineral freight, fast passenger trains, or high-speed merchandise trains (freight trains that haul primarily high-value merchandise, as opposed to low-cost raw materials such as coal or grain). See LOCOMOTIVE.

Rail passenger systems such as the Shinkansen in Japan (1964); TGV (Très Grande Vitesse; 1981) in France; ICE (Inter

City Eisenbahn; 1991) in Germany; X-2000 in Sweden (1990); or Britain's several High-Speed Intercity Trains are notable for speed and convenience. These systems have developed in context of an awareness of deteriorating highway infrastructures, serious concern with the air pollution generated by automobiles and trucks, increasing traffic congestion in urban areas, and worries over petroleum usage and supply. See AIR POLLUTION; MAGNETIC LEVITATION.

High-speed passenger trains require significantly different track configurations (for example, curve superelevation and turnout designs) than do slower freight trains, even those high-valued merchandise or intermodal highway trailers and containers, which frequently travel at speeds of 70 mi/h (110 km/h). These engineering differences are impractical on lines primarily moving heavy mineral freight, where axle loadings and speeds differ even more radically from high-speed passenger trains. [G.H.W.]

**Rain shadow** An area of diminished precipitation on the lee side of mountains. There are marked rain shadows, for example, east of the coastal ranges of Washington, Oregon, and California, and over a larger region, much of it arid, east of the Cascade Range and Sierra Nevadas. All mountains decrease precipitation on their lee; but rain shadows are sometimes not marked if moist air often comes from different directions, as in the Appalachian region.

The causes of rain shadow are (1) precipitation of much of the moisture when air is forced upward on the windward side of the mountains, (2) deflection or damming of moist air flow, and (3) downward flow on the lee slopes, which warms the air and lowers its relative humidity. [J.R.F.]

**Rainbow** An optical effect of the sky formed by sunlight falling on the spherical droplets of water associated with a rain shower. The circular arc of colors in the rainbow is seen on the side of the sky away from the Sun. The bright, primary rainbow shows the spectrum of colors running from red, on the outside of the bow, to blue on the inside. Sometimes a fainter, secondary bow is seen outside the primary bow with the colors reversed from their order in the primary bow. The shape of each bow is that of a circle, centered on the antisolar point, a point in the direction exactly opposite to that of the Sun, which is marked by the shadow of the observer's head.

As a light ray from the Sun strikes the surface of a water drop, some light is reflected and some passes through the surface into the drop. The primary bow results from light that enters the drop, reflects once inside the drop, and then leaves the drop headed toward the observer's eye. Light that is reflected twice inside the drop produces the secondary bow. The change of direction that occurs when a light ray enters or leaves the waterdrop (refraction) is different for the different colors that make up white sunlight. As a result, the size of the circle is different for each color, thereby separating the colors into the rainbow sequence. See METEOROLOGICAL OPTICS. [R.Gr.]

**Rainforest** Forests that occur in continually wet climates with no dry season. There are relatively small areas of temperate rainforests in the Americas and Australasia, but most occur in the tropics and subtropics.

The most extensive tropical rainforests are in the Americas. These were originally  $1.54 \times 10^6$  mi<sup>2</sup> ( $4 \times 10^6$  km<sup>2</sup>) in extent, about half the global total, and mainly in the Amazon basin. A narrow belt also occurs along the Atlantic coast of Brazil, and a third block lies on the Pacific coast of South America, extending from northern Peru to southern Mexico.

Tropical rainforests have a continuous canopy (commonly 100–120 ft or 30–36 m tall) above which stand huge emergent trees, reaching 200 ft (60 m) or taller. Within the rainforest canopy are trees of many different sizes, including pygmies, that reach only a few feet. Trees are the main life form and

are often, for purposes of description and analysis, divided into strata or layers. Trees form the framework of the forest and support an abundance of climbers, orchids, and other epiphytes, adapted to the microclimatic conditions of the different zones of the canopy, from shade lovers in the gloomy, humid lower levels, to sun lovers in the brightly lit, hotter, and drier upper levels. Most trees have evergreen leaves, many of which are pinnate or palmate. These features of forest structure and appearance are found throughout the world's lowland tropical rainforests. There are other equally distinctive kinds of rainforest in the lower and upper parts of perhumid tropical mountains, and additional types on wetlands.

Rainforests occur where the monthly rainfall exceeds 4 in. (100 mm) for 9–12 months. They merge into other seasonal or monsoon forests where there is a stronger dry season (3 months or more with 2.5 in. or 60 mm of rainfall). The annual mean temperature in the lowlands is approximately 64°F (18°C). There is no season unfavorable for growth.

Primary rainforests are exceedingly rich in species of both plants and animals. There are usually over 100 species of trees 2.5 in. (10 cm) in diameter or bigger per 2.4 acres (1 ha). There are also numerous species of climbers and epiphytes. Flowering and fruiting occur year-round, but commonly there is a peak season; animal breeding may be linked to this. Secondary rainforests are much simpler. There are fewer tree species, less variety from location to location, and fewer epiphytes and climbers; the animals are also somewhat different. See ECOLOGICAL SUCCESSION.

Tropical rainforests are a source of resins, dyes, drugs, latex, wild meat, honey, rattan canes, and innumerable other products essential to rural life and trade. Modern technology for extraction and for processing has given timber of numerous species monetary value, and timber has come to eclipse other forest products in importance. The industrial nations use much tropical hardwood for furniture, construction, and plywood. Rainforest timbers, however, represent only 11% of world annual industrial wood usage, a proportion that has doubled since 1950. West Africa was the first main modern source, but by the 1960s was eclipsed by Asia, where Indonesia and Malaysia are the main producers of internationally traded tropical hardwoods. Substantial logging has also developed in the neotropics. See FOREST ECOSYSTEM; FOREST TIMBER RESOURCES. [T.C.Wh.]

**Raman effect** A phenomenon observed in the scattering of light as it passes through a material medium, whereby the light suffers a change in frequency and a random alteration in phase. Raman scattering differs in both these respects from Rayleigh and Tyndall scattering, in which the scattered light has the same frequency as the unscattered and bears a definite phase relation to it. The intensity of normal Raman scattering is roughly one-thousandth that of Rayleigh scattering in liquids and smaller still in gases. See SCATTERING OF ELECTROMAGNETIC RADIATION; TYNDALL EFFECT.

Because of its low intensity, the Raman effect was not discovered until 1928, although the scattering of light by transparent solids, liquids, and gases had been investigated for many years before. The development of the laser has led to a resurgence of interest in the Raman effect and to the discovery of a number of related phenomena. See LASER.

When the exciting radiation falls within the frequency range of a molecule's absorption band in the visible or ultraviolet spectrum, the radiation may be scattered by two different processes, resonance fluorescence or the resonance Raman effect. Both these processes give much more intense scattering than the normal nonresonant Raman effect. The absolute frequencies of the resonance Raman effect shift by exactly the amount of any shift in the exciting frequency, just as do those of the normal Raman effect. Thus the main characteristic of the resonance as compared to the normal Raman effect is its intensity, which may be greater by two or three orders of magnitude. See FLUORESCENCE.

Raman scattering is analyzed by spectroscopic means. The collection of new frequencies in the spectrum of monochromatic radiation scattered by a substance is characteristic of the substance and is called its Raman spectrum. Although the Raman effect can be made to occur in the scattering of radiation by atoms, it is of greatest interest in the spectroscopy of molecules and crystals. In a typical experiment monochromatic radiation from a laser impinges on the sample in an appropriate transparent cell. Raman scattering is approximately uniform in all directions and is usually studied at right angles. In this way the intense radiation of the laser beam interferes least with the observation of the weak scattered light.

Raman spectroscopy is of considerable value in determining molecular structure and in chemical analysis. Molecular rotational and vibrational frequencies can be determined directly, and from these frequencies it is sometimes possible to evaluate the molecular geometry, or at least to find the molecular symmetry. Even when a precise determination of structure is not possible, much can often be said about the arrangement of atoms in a molecule from empirical information about the characteristic Raman frequencies of groups of atoms. This kind of information is closely similar to that provided by infrared spectroscopy; in fact, Raman and infrared spectra often provide complementary data about molecular structure. Raman spectra also provide information for solid-state physicists, particularly with respect to lattice dynamics but also concerning the electronic structures of solids. See INFRARED SPECTROSCOPY; LATTICE VIBRATIONS; MOLECULAR STRUCTURE AND SPECTRA. [R.C.L.]

**Ramie** The plant *Boehmeria nivea*, a stingless member of the nettle family; the only member of the family used commercially for fiber. This herbaceous perennial is erect, usually non-branching, and 3 to 9 ft (1 to 2 m) tall at maturity. The fiber, which comes from the inner bark, is exceptionally strong and has uses similar to those for fiber flax. Ramie is grown mostly in the tropics and subtropics of the Far East and Brazil. See NATURAL FIBER. [E.G.N.]

**Ramjet** A member of a class of high-speed air-breathing propulsion systems. These include subsonic combustion ramjets (RAM), supersonic combustion ramjets (SCRAM), dual-mode ram-scrumjets (RAM-SCRAM), dual-combustor ramjets (DCR or DCRJ), and air-ducted rockets (ADR). In each case, air collected from the atmosphere is ducted into the engine to serve as the oxidizer for the burning of fuel that is stored on board. All the engines operate on a modified form of the basic Joule or Brayton cycle; that is, the air is compressed in the inlet, burned at near-constant pressure, and accelerated in an expansion nozzle. In accordance with Newton's second law, thrust is produced by the increase in momentum as the gas passes from the inlet to the nozzle exit. Compression is produced by one or a multiplicity of compression waves generated on the inlet surfaces. The level of pressure that can be reached in these waves is insufficient to produce net thrust unless the air speed is greater than about Mach 0.9 (that is, the velocity is 0.9 times the local speed of sound). Thus the ramjet must be launched from a high-speed aircraft or brought up to speed by a booster rocket or another adjunct engine. The latter type are known as combined-cycle engines. A classic example is the combination of a turbojet and a ramjet, which is called a turboramjet. See BRAYTON CYCLE; MACH NUMBER; NEWTON'S LAWS OF MOTION; ROCKET PROPULSION; TURBOJET; TURBORAMJET.

A subsonic combustion ramjet may be boosted to its operating speed by a solid-fueled rocket (see illustration). After the booster separates, the air entering the inlet is compressed through oblique shocks and a terminal normal shock. The flow aft of the normal shock and in the combustor is subsonic, but the velocity is high and flameholders are needed to anchor the flame and thereby produce high combustion efficiency. Passing from the combustor, the exhaust gases are reaccelerated in a

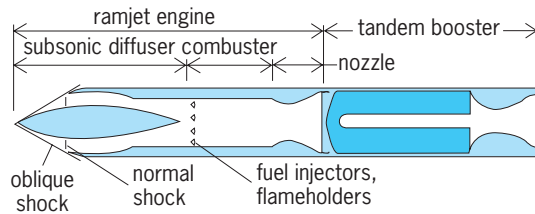

Diagram of a ramjet engine.

converging-diverging nozzle to supersonic speed at the engine exit. See DIFFUSER; NOZZLE.

There are several characteristics that lead to the choice of one of the ramjet cycles for a variety of missions. Foremost are the engine performance as measured by specific impulse, light weight, and low cost. For applications up to about Mach 3, the turbojet has the highest specific impulse among hydrocarbon-fueled engines, which leads to its choice as the power plant for subsonic and supersonic aircraft. Most missile applications demand higher thrust which requires afterburning. For flight speeds between Mach 3 and 5, the subsonic combustion ramjet is optimal, and above Mach 5 the choice is among the supersonic combustion ramjet, the dual-mode ram-scrumjet, and the dual-combustor ramjet. The solid rocket has much lower engine performance and is used only when high specific impulse is not the governing factor. Rocket-powered vehicles are used for relatively short-range missions or for near-to-vertical flight. See AFTERBURNER; AIRCRAFT ENGINE PERFORMANCE; AIRCRAFT FUEL. [F.S.Bi.]

**Random matrices** Collections of large matrices, chosen at random from some ensemble. Random-matrix theory is a branch of mathematics which emerged from the study of complex physical problems, for which a statistical analysis is often more enlightening than a hopeless attempt to control every degree of freedom, or every detail of the dynamics. Although the connections to various parts of mathematics are very rich, the relevance of this approach to physics is also significant.

Random matrices were introduced by Eugene Wigner in nuclear physics in 1950. In quantum mechanics the discrete energy levels of a system of particles, bound together, are given by the eigenvalues of a hamiltonian operator, which embodies the interactions between the constituents. This leads to the Schrödinger equation which, in most cases of interest in the physics of nuclei, cannot be solved exactly, even with the most advanced computers. For a complex nucleus, instead of finding the location of the nuclear energy levels through untrustworthy approximate solutions, Wigner proposed to study the statistics of eigenvalues of large matrices, drawn at random from some ensemble. The only constraint is to choose an ensemble which respects the symmetries that are present in the forces between the nucleons in the original problem, and to select a sequence of levels corresponding to the quantum numbers that are conserved as a consequence of these symmetries, such as angular momentum and parity. The statistical theory does not attempt to predict the detailed sequence of energy levels of a given nucleus, but only the general properties of those sequences and, for instance, the presence of hidden symmetries. In many cases this is more important than knowing the exact location of a particular energy level. This program became the starting point of a new field, which is now widely used in mathematics and physics for the understanding of quantum chaos, disordered systems, fluctuations in mesoscopic systems, random surfaces, zeros of analytic functions, and so forth. See CONSERVATION LAWS (PHYSICS); EIGENVALUE (QUANTUM MECHANICS); MATRIX THEORY; NONRELATIVISTIC QUANTUM THEORY; QUANTUM MECHANICS.

The mathematical theory underlying the properties of random matrices overlaps with several active fields of contempo-

rary mathematics, such as the asymptotic behavior of orthogonal polynomials at large-order, integrable hierarchies, tau functions, semiclassical expansions, combinatorics, and group theory; and it is the subject of active research and collaboration between physics and mathematics. [E.B.]

**Rangefinder (optics)** An optical instrument for measuring distance, usually from its position to a target point. Light from the target enters the optical system through two windows spaced apart, the distance between the windows being termed the base length of the rangefinder. The rangefinder operates as an angle-measuring device for solving the triangle comprising the rangefinder base length and the line from each window to the target point. Rangefinders can be classified in general as being of either the coincidence or the stereoscopic type.

In coincidence rangefinders, one-eyed viewing through a single eyepiece provides the basis for manipulation of the rangefinder adjustment to cause two images or parts of each to match or coincide. This type of device is used, in its simpler forms, in photographic cameras. The basic optical arrangement is shown in the illustration, where  $M_1$  and  $M_2$  are a semitrans-

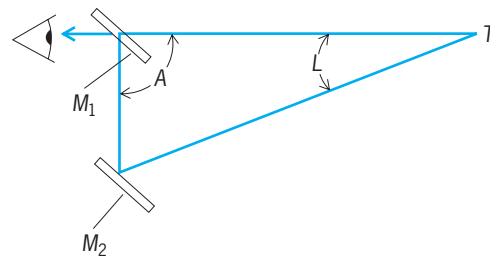
Simple coincidence rangefinder.  $A$  is a right angle;  $L$  = convergence angle at target  $T$ .

parent mirror and a reflecting mirror, respectively. When coincidence is obtained, that is, when the target  $T$  is seen in the same apparent position along either path, the rangefinder equation for the range  $D$  is satisfied:

$$D = B \cot L$$

Stereoscopic rangefinders are entirely different, although externally they resemble coincidence rangefinders except for the fact that they possess two eyepieces. It is essentially a large stereobinocular fitted with special reticles which allow a skilled user to superimpose the stereo image formed by the pair of reticles over the images of the target seen in the eyepieces, so that the reticle marks appear to be suspended over the target and at the same apparent distance. [E.E.K.]

**Rankine cycle** A thermodynamic cycle used as an ideal standard for the comparative performance of heat-engine and heat-pump installations operating with a condensable vapor as the working fluid. Applied typically to a steam power plant, as shown in the illustration, the cycle has four phases: (1) heat addition  $bcd$  in a boiler at constant pressure  $p_1$  changing water at  $b$  to superheated steam at  $e$ , (2) isentropic expansion  $ef$  in a prime mover from initial pressure  $P_1$  to backpressure  $P_2$ , (3) heat rejection  $fa$  in a condenser at constant pressure  $p_2$  with wet steam at  $f$  converted to saturated liquid at  $a$ , and (4) isentropic compression  $ab$  of water in a feed pump from pressure  $p_2$  to pressure  $p_1$ .

This cycle more closely approximates the operations in a real steam power plant than does the Carnot cycle. Between given temperature limits it offers a lower ideal thermal efficiency for the conversion of heat into work than does the Carnot standard. Losses from irreversibility, in turn, make the conversion

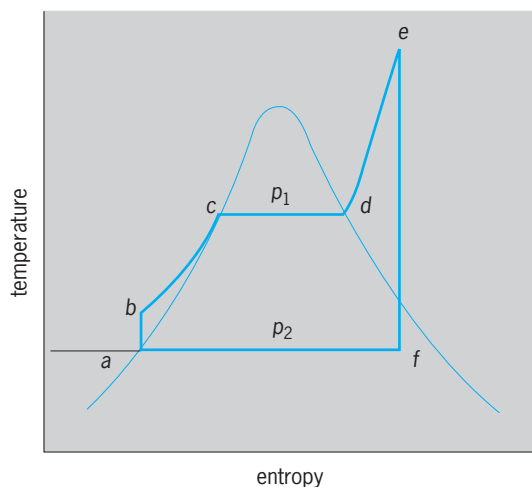
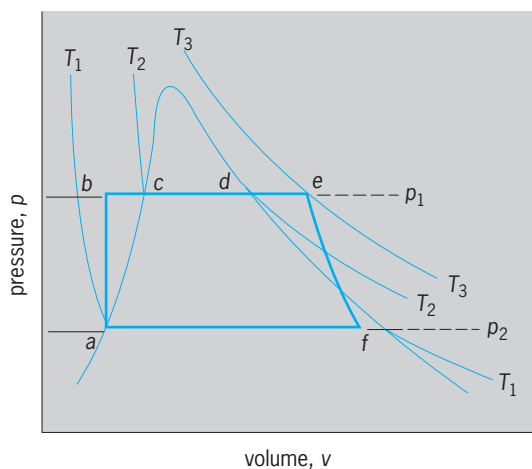

**Rankine-cycle diagrams (pressure-volume and temperature-entropy) for a steam power plant using superheated steam. Pressure-volume diagrams shows curves for constant temperatures  $T_1$ ,  $T_2$ , and  $T_3$  (isothermals).**

efficiency in an actual plant less than the Rankine cycle standard. See CARNOT CYCLE; REFRIGERATION CYCLE; THERMODYNAMIC CYCLE; VAPOR CYCLE. [T.Ba.]

**Ranunculales** An order of flowering plants, division Magnoliophyta (Angiospermae), in the subclass Magnoliidae of the class Magnoliopsida (dicotyledons). The order consists of 8 families and about 3200 species. The vast majority of the species belong to only 3 families, the Ranunculaceae (2000), Berberidaceae (650), and Menispermaceae (425). Within its subclass, the order is characterized by its mostly separate carpels, triparturate pollen, herbaceous or only secondarily woody habit, frequently numerous stamens, generally more than two sepals, and lack of ethereal oil cells. Many members of the order contain isoquinoline alkaloids, most notably berberin. The barberry (*Berberis*), in the family Berberidaceae, and the buttercup (*Ranunculus*), columbine (*Aquilegia*), larkspur (*Delphinium*), and wind flower (*Anemone*), in the family Ranunculaceae, are familiar genera of the Ranunculales. See MAGNOLIIDAE; MAGNOLIOPSIDA. [A.Cr.]

**Rape** Rape (*Brassica napus*) and turnip rape (*B. campestris*) plants are members of the Cruciferae family. The name is derived from the Latin *rapum*, meaning "turnip," to which these plants are closely related. The aerial portions of rape plants have been bred to produce oilseeds, fodder, and vegetable crops. Rapeseed

is small, round, and usually black, although varieties with yellow seed coats are also grown.

The seeds contain over 40% oil. Rapeseed contributes approximately 10–12% of the world's total edible vegetable oil supply and is one of the few edible oilseed crops that can be produced in northern Canada, Europe, and Asia, or, as a cool season crop, in subtropical areas. Rapeseed meal, the by-product of oilseed extraction, is high-quality protein feed supplement for livestock and poultry. In some Asian countries it is also used as a fertilizer and soil conditioner for specialty crops such as tobacco and citrus fruits. Rape is widely used for forage. In some countries the whole plant is cut and fed to cattle. See CAPPARALES; TURNIP. [R.K.D.]

**Raphidophyceae** A small class of poorly known biflagellate unicellular algae (raphidomonads) in the chlorophyll *a-c* phyletic line (Chromophycota). It is sometimes called Chloromonadophyceae, and its members called chloromonads, but this nomenclature is confusing because it calls to mind *Chloromonas*, a totally unrelated genus of green algae (*Chlorophyceae*). The alternative nomenclature used here is derived from Raphidomonas, a generic name within the class. See CHROMOPHYCOTA.

Two families are recognized. All photosynthetic raphidomonads are placed in the Vacuolariaceae. The Thaumatomastigaceae comprises a few colorless forms that bear pseudopodia. They are osmotrophic or phagotrophic or both.

Most genera in both families occur in fresh water (acidic to neutral), but there are brackish-water and marine forms that produce conspicuous blooms. *Heterosigma*, for example, is a frequent cause of red tide in the inland seas of Japan. See ALGAE. [P.C.Si.; R.L.Moe]

**Rare-earth elements** The group of 17 chemical elements with atomic numbers 21, 39, and 57–71; the name lanthanides is reserved for the elements 58–71. The name rare earths is a misnomer, because they are neither rare nor earths. See ACTINIDE ELEMENTS; LANTHANIDE CONTRACTION; PERIODIC TABLE.

Most of the early uses of the rare earths took advantage of their common properties and were centered principally in the glass, ceramic, lighting, and metallurgical industries. Today these applications use a very substantial amount of the mixed rare earths just as they are obtained from the minerals, although sometimes these mixtures are supplemented by the addition of extra cerium or have some of their lanthanum and cerium fractions removed.

The elements exhibit very complex spectra, and the mixed oxides, when heated, give off an intense white light which resembles sunlight, a property finding application in cored carbon arcs, such as those employed in the movie industry.

The rare-earth metals have a great affinity for the nonmetallic elements, as, for example, hydrogen, carbon, nitrogen, oxygen, sulfur, phosphorus, and the halides. Considerable amounts of the mixed rare earths are reduced to metals, such as misch metal, and these alloys are used in the metallurgical industry. Alloys made of cerium and the mixed rare earths are used in the manufacture of lighter flints. Rare earths are also used in the petroleum industry as catalysts. Yttrium aluminum garnets (YAG) are used in the jewelry trade as artificial diamonds.

Although the rare earths are widely distributed in nature, they generally occur in low concentrations. They are found in high concentrations as mixtures in a number of minerals. The relative abundance of the different rare earths in various rocks, geological formations, and the stars is of great interest to the geophysicist, astrophysicist, and cosmologist.

The rare-earth elements are metals possessing distinct individual properties. Many of the properties of the rare-earth metals and alloys are quite sensitive to temperature and pressure. They are also different when measured along different crystal axes of

the metal; for example, electrical conductivity, elastic constants, and so on. The rare earths form organic salts with certain organic chelate compounds. These chelates, which have replaced some of the water around the ions, enhance the differences in properties among the individual rare earths. Advantage is taken of this technique in the modern ion-exchange methods of separation. See CHELATION; ION EXCHANGE; TRANSITION ELEMENTS. [F.H.Sp.]

**Rare-earth minerals** Naturally occurring solids, formed by geological processes, that contain the rare-earth elements—the lanthanides (atomic numbers 57–71) and yttrium (atomic number 39)—as essential constituents. In a rare-earth mineral, at least one crystallographic site contains a total atomic ratio of lanthanides and yttrium that is greater than that of any other element. The mineral name generally has a suffix, called a Levinson modifier, indicating the dominant rare-earth element; for example, monazite-(La)  $[\text{LaPO}_4]$  contains predominantly lanthanum, and monazite-(Ce)  $[\text{CePO}_4]$  contains predominantly cerium. See MINERAL; MONAZITE; PERIODIC TABLE; RARE-EARTH ELEMENTS.

So far, about 170 distinct species of rare-earth minerals have been described. A large number of carbonates, phosphates, silicates, niobates, and fluorides are known as rare-earth minerals. It is necessary to obtain structural as well as chemical information about a mineral to judge the essentiality of its rare-earth elements (that is, whether the rare-earth element is part of the mineral's ideal formula or is an impurity). Sometimes, minerals with significant rare-earth content are treated as rare-earth minerals, even if the rare-earth element content appears unessential to the mineral. More than 60 mineral species, including the apatite group minerals, garnet group minerals, and fluorite, are in this category. See APATITE; FLUORITE; GARNET.

Rare-earth minerals can be observed as accessory minerals in igneous rocks, such as monazite-(Ce) in granite. Carbonatite is the typical host rock of rare-earth minerals such as bastnäsite-(Ce)  $[\text{CeCO}_3\text{F}]$  and monazite-(Ce). Rare-earth minerals also often occur in pegmatite. In both carbonatite and pegmatite, rare-earth elements are concentrated by primary crystallization from melt and by hydrothermal reactions. Carbonatite deposits containing rare-earth elements are found throughout the world. Chemically stable, rare-earth minerals are not weathered easily. As a result, they have been deposited as heavy minerals in beach sand. Such deposits are found in Southeast Asia and Western Australia. See CARBONATITE; PEGMATITE.

Among the rare-earth minerals, bastnäsite-(Ce) is the most important source of rare-earth elements. Monazite-(Ce), synchysite-(Ce)  $[\text{CaCe}(\text{CO}_3)_2\text{F}]$ , xenotime-(Y), britholite-(Ce)  $[(\text{Ce}_3\text{Ca}_2)(\text{SiO}_4)_3(\text{OH})]$ , and allanite-(Ce)  $[\text{CaCeAl}_2\text{Fe}(\text{Si}_2\text{O}_7)(\text{SiO}_4)\text{O}(\text{OH})]$  are also sources. Rare-earth elements have been leached with acid from the surface of clay minerals. Rare-earth minerals containing radioactive nuclear species, such as thorium and uranium, are not used as source materials. See CLAY MINERALS. [R.Miy.]

**Rarefied gas flow** Flow of gases below standard atmospheric pressure, sometimes called low-pressure gas flow. The flow may be confined to pipes between a chamber or vessel to be evacuated and a pump, or it may be the beam of molecules issuing from an orifice into a large evacuated chamber or the plume of exhaust gases from a rocket launched into the upper atmosphere, for example. The flow velocity is measured with respect to a fixed boundary such as the wall of a pipe, the surface of a rocket or jet plane, or a model in a wind tunnel. See FLUID FLOW; GAS; MOLECULAR BEAMS; PIPE FLOW; VACUUM PUMP; WIND TUNNEL.

For flow through ducts, the gases concerned are initially those of the original atmosphere inside a chamber that must be evacuated. However, even after the bulk of the original gas has been removed, the pumps must continue to remove gas evolved from surfaces and leaking in through imperfections in the walls. In

some cases, gas is introduced through valves at a controlled rate as part of the process being carried out at a low pressure.

Since the flow through pipes involves an interaction or drag at the walls, a pressure drop is generated across the entrance and exit of the pipe. Also, gaseous impurities from the pump may flow toward the chamber when the pressure is very low. Proper design of the duct system therefore involves selecting pipes and valves of adequate internal diameter to ensure a minimal pressure drop and the insertion of baffles or traps to prevent impurities from the pumps from entering the process chamber.

The resistance due to the walls depends on the mass flow velocity, and may depend on the gas viscosity and the pressure or density of the gas. The mean free path of molecules is the distance between collisions with other molecules in the gas. See KINETIC THEORY OF MATTER; MEAN FREE PATH; VISCOSITY.

The analysis of low-pressure flow is divided into three or four flow regimes depending on the value of the Knudsen number  $Kn$  defined as the ratio of the mean free path to a characteristic length, and the dimensionless Reynolds number. The characteristic length may be chosen as the mean pipe diameter in the case of confined flow or as some length associated with a test model suspended in a wind tunnel, for example. See GAS DYNAMICS; KNUDSEN NUMBER; REYNOLDS NUMBER.

Another dimensionless number used in gas flow dynamics is the Mach number ( $Ma$ ), defined as the ratio of the mass flow velocity to the local velocity of sound in the gas. See MACH NUMBER.

When the mean free path is much smaller than the pipe diameter ( $Kn < 0.01$ ), the gas flows as a continuous viscous fluid with velocity near the axis of the pipe at locations well beyond the pipe entrance much higher than the velocity in gas layers near the wall. The velocity profile as a function of radial distance from the axis depends on the distance from the entrance and the viscosity of the gas. When the Reynolds number is less than 2000, the profile is a simple curved surface so that the flow is laminar (laminar flow regime). When the mean free path becomes greater than about 0.01 times the diameter, the profile is distorted by boundary-layer effects, and the velocity near the wall does not approach zero (sometimes referred to as slip flow). See LAMINAR FLOW.

For Reynolds numbers above the critical value (approximately 2100), the flow is subject to instabilities depending on the geometry of the boundary and at high Reynolds numbers becomes turbulent (turbulent flow regime). See TURBULENT FLOW.

When the mean free path is about equal to or greater than the pipe diameter ( $Kn \geq 1$ ), the gas molecules seldom collide with each other, but can either pass through the pipe without striking the wall or scatter randomly back and forth between various points on the wall and eventually escape through the exit or pass back through the entrance. This type of gas flow is known as free-molecule flow (molecular flow regime). The transition region ( $0.01 < Kn < 1$ ) between the laminar flow regime and the molecular flow regime is referred to as the Knudsen or transition flow regime.

The flow may also be classified by the boundary conditions or by the Mach number. For example, Couette flow involves the flow of rarefied gas between two surfaces that are moving with respect to each other with different parallel tangential velocities. For hypersonic flow,  $Ma \geq 5$ . [B.B.Da.]

**Raspberry** The horticultural name for certain species of the genus *Rubus*, plant order Rosales. In these species the fruit, when ripe (unlike the blackberry), separates thimblelike from the receptacle. Raspberry plants are upright shrubs with perennial roots and prickly, biennial canes (stems). There are several species, both American and European, from which the cultivated raspberries have been developed. Varieties are grouped as to color of fruit—black, red, and purple, the last being hybrids between the red and black types. Leading states in commercial production are Michigan, Oregon, New York, Washington, Ohio,



Pennsylvania, New Jersey, and Minnesota. The fruit is sold fresh for dessert purposes, is canned, and is made into jelly or jam, but quick freezing is the most important processing method. See FRUIT; ROSALES. [J.H.C.I.]

**Rat** The name for over 650 species of mammals in a number of different families of the order Rodentia. These animals are of great economic importance to humans. In addition to harboring many diseases transmissible to humans, such as bubonic plague, endemic typhus, rat-bite fever, and infectious jaundice, ingested rats can transmit trichinosis to swine. See PLAGUE.

Rats are usually active at night, feeding on nearly every type of food. The teeth are modified for gnawing, with sharp and chisel-like incisors that grow continually and have heavily enameled fronts. There is a large space between the one pair of incisors and the molars into which the flesh of the cheeks is drawn during gnawing. This prevents the cheek teeth from meeting and wearing down and also prevents the swallowing of dirt and debris. See RODENTIA. [C.B.C.]

**Ratchet** A wheel, usually toothed, operating with a catch or a paw] so as to rotate in a single direction (see illustration).

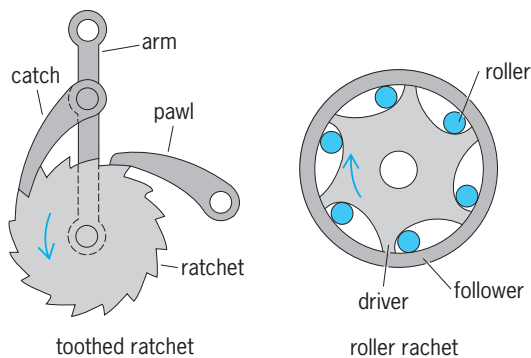

**Ratchets.** Toothed ratchet is driven by catch when arm moves to left; pawl holds ratchet during return stroke of catch. In roller ratchet, rollers become wedged between driver and follower when driver turns faster than follower in direction of arrow.

A ratchet and pawl mechanism locks a machine such as a hoisting winch so that it does not slip. The locking action may serve to produce rotation in a desired direction and to disengage in the undesired direction as in a drill brace. The catch or pawl may be of various shapes such as an eccentrically mounted disk or ball bearing. Gravity, a spring, or centrifugal force (with the catch mounted internal to the ratchet) are commonly used to hold the pawl against the ratchet. A ratchet and pawl provides an arresting action. See BRAKE; ESCAPEMENT; PAWL. [F.H.R.]

**Rate-of-climb indicator** An aircraft instrument that provides an indication of the vertical change of the aircraft position within the air mass. It is more commonly known as the vertical-velocity or vertical-speed indicator. Contained within a sealed case, it is connected to the aircraft static pressure source, the so-called at-rest air pressure outside the aircraft, through a calibrated leak. Although the instrument operates from a static pressure source, it is a differential pressure indicator. The differential pressure is established between the static pressure in the diaphragm or pressure capsule and the trapped static pressure within the case. When the aircraft changes vertical position, the static pressure in the diaphragm changes immediately but, because of the metering action of the calibrated leak, the case pressure will remain at its prior value and cause the needle to show a change in vertical speed. The needle is usually calibrated in feet per minute but may be calibrated in any appropriate unit of length over time.

In many modern aircraft with flight computers, the rate of climb or descent is electronically calculated by differentiating the altitude from the pitot-static source. See AIRCRAFT INSTRUMENTATION; PITOT TUBE. [G.W.W.]

**Ratites** A group of flightless (except for tinamous), mostly large, running birds formerly segregated as a superorder of birds, the Palaeognathae, but whose interrelationships have been a long-standing controversy. The ratites represent two or three phyletic lines (the emus, cassowaries, moos and kiwis, ostriches and elephant birds, and rheas and tinamous—the last two groups may be very closely related) which evolved from a common ancestral stock, possibly much like the still volant tinamous of Central and South America. See AVES; NEOGNATHAE; STRUTHIONIFORMES. [W.J.B.]

**Rauwolfia** A genus of mostly poisonous, tropical trees and shrubs of the dogbane family (Apocynaceae). Certain species are the source of valuable emetics and cathartics. The species *Rauwolfia serpentina* has received special attention as the source of tranquilizing drugs. Among the purified alkaloids obtained from *R. serpentina*, reserpine is perhaps the one most used as a tranquilizing agent. See GENTIANALES; TRANQUILIZER. [P.D.St./E.L.C.]

**Raw water** Water obtained from natural sources such as streams, reservoirs, and wells. Natural water always contains impurities in the form of suspended or dissolved mineral or organic matter and as dissolved gases acquired from contact with earth and atmosphere. Industrial or municipal wastes may also contaminate raw water. See WATER POLLUTION.

If admitted to a steam-generating unit, such contaminations may corrode metals or form insulating deposits of sediments or scale on heat-transfer surfaces, with resultant overheating and possible failure of pressure parts.

Raw water can be treated to remove objectionable impurities or to convert them to forms that can be tolerated. For steam generation, suspended solids are removed by settling or filtration. Scale-forming hardness is diminished by chemical treatment to produce insoluble precipitates that are removable by filtration, or soluble compounds that do not form scale. Essentially complete purification is achieved by demineralizing treatment or evaporation. See WATER SOFTENING; WATER TREATMENT. [F.G.E.]

**Reactance** The imaginary part of the impedance of an alternating-current circuit.

The impedance  $Z$  of an alternating current circuit is a complex number given by Eq. (1). The imaginary part  $X$  is the reactance.

$$Z = R + jX \quad (1)$$

$$Z = jL\omega = jX \quad (2)$$

$$Z = -\frac{j}{C\omega} = jX \quad (3)$$

The units of reactance, like those of impedance, are ohms. Reactance may be positive or negative. For example, the impedance of an inductor  $L$  at frequency  $\omega$  is given by Eq. (2), so  $X$  is positive. The impedance of a capacitor  $C$  is given by Eq. (3), so  $X$  is negative.

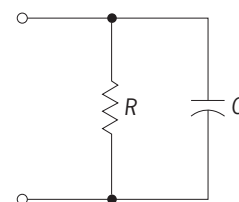

Circuit with a resistor and capacitor in parallel.

The reactance of a circuit may depend on both the resistors and the inductors or capacitors in the circuit. For example, the circuit in the illustration has admittance [Eq. (4)] and impedance

$$Y = \frac{1}{R} + jC\omega \quad (4)$$

[Eq. (5)], so that the reactance [Eq. (6)], depends on both the capacitor  $C$  and the resistor  $R$ .

$$Z = \frac{R}{1 + jRC\omega} \quad (5)$$

$$X = -\frac{R^2C\omega}{1 + R^2C^2\omega^2} \quad (6)$$

See ADMITTANCE; ALTERNATING-CURRENT CIRCUIT THEORY; ELECTRICAL IMPEDANCE. [J.O.S.]

**Reaction turbine** A power-generation prime mover utilizing the steady-flow principle of fluid acceleration, where nozzles are mounted on the moving element. The rotor is turned by the reaction of the issuing fluid jet and is utilized in varying degrees in steam, gas, and hydraulic turbines. All turbines contain nozzles; the distinction between the impulse and reaction principles rests in the fact that impulse turbines use only stationary nozzles, while reaction turbines must incorporate moving nozzles. See IMPULSE TURBINE; PRIME MOVER. [T.Ba.]

**Reactive intermediates** Unstable compounds which are formed as necessary intermediate stages during a chemical reaction. Thus, if a reaction in which A is converted to B requires that A first be converted to C, then C is an intermediate in the reaction ( $A \rightarrow C \rightarrow B$ ). The term reactive further implies a certain degree of instability of the intermediate; reactive intermediates are typically isolable only under special conditions, and most of the information regarding the structure and properties of reactive intermediates comes from indirect experimental evidence.

In organic reactions the most common types of reactive intermediates are those arising from dissociative reactions, in which carbon has a decreased valence. Associative reactions can also give rise to some of the same intermediates, and to others in which carbon has an increased valence. See VALENCE.

Carbocations are compounds in which carbon bears a positive charge. Classical carbocations (also called carbenium ions) are trivalent, and have only six valence electrons. Nonclassical carbocations (also called carbonium ions) are tetra- or pentavalent, and have eight valence electrons. Examples are the methyl cation (classical)  $\text{CH}_3^+$ , and the methonium ion (nonclassical)  $\text{CH}_5^+$ .

Carbanions are compounds in which carbon bears a negative charge. A carbanion will always have a positive counterion in association with it; depending upon the particular cation and the stability of the carbanion, the association may be ionic, covalent, or some intermediate combination of ionic and covalent bonding, as shown below ( $M = \text{metal}$ ). Carbanions are trivalent, with eight valence electrons.

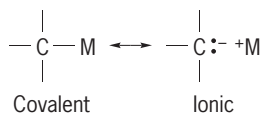

Free radicals are neutral compounds having an odd number of electrons and therefore one unpaired electron. Carbon free radicals are trivalent, with seven valence electrons, and typically assume a planar structure. Free radicals are primarily electron-deficient species and are stabilized by structural features which donate electron density or delocalize the odd electron by resonance. See FREE RADICAL; RESONANCE (MOLECULAR STRUCTURE).

Radical ions are charged compounds with an unpaired electron, and are either radical cations (positively charged) or radical

anions (negatively charged). In many cases a radical ion is derived from a stable neutral molecule by addition of one electron (radical anion) or removal of one electron (radical cation).

Carbenes are compounds which have a divalent carbon. The divalent carbon also has two nonbonded electrons, for a total of six valence electrons. The two nonbonded electrons may have either the same spin quantum number, which is a triplet state, or an opposite spin quantum number, which is a singlet state. Generation of carbenes is most commonly by photolysis or thermolysis of diazo compounds or ketenes, or by alpha-elimination reactions.

There are many other kinds of reactive intermediates which do not fit into the previous classifications. Some are simply compounds which are unstable for a variety of possible reasons, such as structural strain or an unusual oxidation state. See CHEMICAL DYNAMICS; ELECTROPHILIC AND NUCLEOPHILIC REAGENTS; MOLECULAR ORBITAL THEORY. [C.C.W.]

**Reactor (electricity)** A device for introducing an inductive reactance into a circuit. Inductive reactance  $x$  is a function of the product of frequency  $f$  and inductance  $L$ ; thus,  $x = 2\pi fL$ . For this reason, a reactor is also called an inductor. Since a voltage drop across a reactor increases with frequency of applied currents, a reactor is sometimes called a choke. All three terms describe a coil of insulated wire. See CHOKE (ELECTRICITY); INDUCTOR.

According to their construction, reactors can be divided into those that employ iron cores and those where no magnetic material is used within the windings. The first type consists of a coil encircling a circuit of iron which usually contains an air gap or a series of air gaps. The air gaps are used to attenuate the effects of saturation of the iron core. The second type, called an air-core reactor, is a simple circular coil, wound around a cylinder constructed of nonmagnetic material for greater mechanical strength. This strength is necessary for the coil to withstand the electromagnetic forces acting on each conductor. These forces become very large with heavy current flow, and their direction tends to compress the coil into less space: radial forces tend to elongate internal conductors in the coil and to compress the external ones while the axial forces press the end sections toward the center of the coil.

Both iron-core and air-core reactors may be of the air-cooled dry type or immersed in oil or a similar cooling fluid. Both types of reactors are normally wound with stranded wire in order to reduce losses due to eddy currents and skin effect. In addition, it is important to avoid formation of short-circuited metal loops when building supporting structures for air-core reactors since these reactors usually produce large magnetic fields external to the coil. If these fields penetrate through closed-loop metal structures, induced currents will flow, causing both losses and heating of the structures. Which of these two reactor types should be used depends on the particular application. See EDDY CURRENT; SKIN EFFECT (ELECTRICITY). [V.R.S.]

**Reactor physics** The science of the interaction of the elementary particles and radiations characteristic of nuclear reactors with matter in bulk. These particles and radiations include neutrons, beta rays, and gamma rays of energies between zero and about  $10^7$  electronvolts. See BETA PARTICLES; GAMMA RAYS.

The study of the interaction beta and gamma radiations with matter is, within the field of reactor physics, undertaken primarily to understand the absorption and penetration of energy through reactor structures and shields. See RADIATION SHIELDING.

With this exception, reactor physics is the study of those processes pertinent to the chain reaction involving neutron-induced nuclear fission with consequent neutron generation. Reactor physics is differentiated from nuclear physics, which is concerned primarily with nuclear structure. Reactor physics makes direct use of the phenomenology of nuclear reactions. Neutron physics is concerned primarily with interactions between neutrons and

individual nuclei or with the use of neutron beams as analytical devices, whereas reactor physics considers neutrons primarily as fission-producing agents. In the hierarchy of professional classification, neutron physics and reactor physics are both ranked as subfields of the more generalized area of nuclear physics. See CHAIN REACTION (PHYSICS); NEUTRON; NUCLEAR FISSION; NUCLEAR PHYSICS.

**Concepts.** Reactor physics borrows most of its basic concepts from other fields. From nuclear physics comes the concept of the nuclear cross section for neutron interaction, defined as the effective target area of a nucleus for interaction with a neutron beam. The total interaction is the sum of interactions by a number of potential processes, and the probability of each of them multiplied by the total cross section is designated as a partial cross section. An outgrowth of this is the definition of macroscopic cross section, which is the product of cross section (termed microscopic, for specificity) with atomic density of the nuclear species involved.

Cross sections vary with energy according to the laws of nuclear structure. In reactor physics this variation is accepted as input data to be assimilated into a description of neutron behavior. Common aspects of cross section dependence, such as variation of absorption cross section inversely as the square root of neutron energy, or the approximate regularity of resonance structure, form the basis of most simplified descriptions of reactor processes in terms of mathematical or logical models.

The concept of neutron flux is related to that of macroscopic cross section. This may be defined as the product of neutron density and neutron speed, or as the rate at which neutrons will traverse the outer surface of a sphere embedded in the medium, per unit of spherical cross-sectional area. The product of flux and macroscopic cross section yields the reaction rate per unit volume and time.

**Criticality.** The critical condition is what occurs when the arrangement of materials in a reactor allows, on the average, exactly one neutron of those liberated in one nuclear fission to cause one additional nuclear fission. If a reactor is critical, it will have fissions occurring in it at a steady rate. This desirable condition is achieved by balancing the probability of occurrence of three competing events: fission, neutron capture which does not cause fission, and leakage of neutrons from the system. If  $\nu$  is the average number of neutrons liberated per fission, then criticality is the condition under which the probability of a neutron causing fission is  $1/\nu$ . Generally, the degree of approach to criticality is evaluated by computing  $k_{\text{eff}}$ , the ratio of fissions in successive links of the chain, as a product of probabilities of successive processes.

**Reactivity.** Reactivity is a measure of the deviation of a reactor from the critical state at any frozen instant of time. The term reactivity is qualitative, because several sets of units are in current use to describe it.

**Reflectors.** Reflectors are bodies of material placed beyond the chain-reacting zone of a reactor, whose function is to return to the active zone (or core) neutrons which might otherwise leak. Reflector worth can be crudely measured in terms of the albedo, or probability that a neutron passing from core to reflector will return again to the core.

Good reflectors are materials with high scattering cross sections and low absorption cross sections. The first requirement ensures that neutrons will not easily diffuse through the reflector, and the second, that they will not easily be captured in diffusing back to the core.

Beryllium is the outstanding reflector material in terms of neutronic performance. Water, graphite,  $D_2O$ , iron, lead, and  $^{283}U$  are also good reflectors.

**Reactor dynamics.** Reactor dynamics is concerned with the temporal sequence of events when neutron flux, power, or reactivity varies. The inclusive term takes into account sequential events, not necessarily concerned with nuclear processes, which may affect these parameters. There are basically three ways in

which a reactor may be affected so as to change reactivity. A control element, absorbing rod, or piece of fuel may be externally actuated to start up, shut down, or change reactivity or power level; depletion of fuel and poison, buildup of neutron-absorbing fission fragments, and production of new fissionable material from the fertile isotopes  $^{232}Th$ ,  $^{234}U$ ,  $^{238}U$ , and  $^{240}Pu$  make reactivity depend upon the irradiation history of the system; and changes in power level may produce temperature changes in the system, leading to thermal expansion, changes in neutron cross sections, and mechanical changes with consequent change of reactivity.

**Reactor control physics.** Reactor control physics is the study of the effect of control devices on reactivity and power level. As such, it includes a number of problems in reactor statics, because the primary question is to determine the absorption of the control elements in competition with the other neutronic processes. It is, however, a problem in dynamics, given the above information, to determine what motions of the control devices will lead to stable changes in reactor output.

**Reactivity changes.** Long-term reactivity changes may represent a limiting factor in the burning of nuclear fuel without costly reprocessing and refabrication. As the chain reaction proceeds, the original fissionable material is depleted, and the system would become subcritical if some form of slow addition of reactivity were not available. This is the function of shim rods in a typical reactor. The reactor is originally loaded with enough fuel to be critical with the rods completely inserted. As the fuel burns out, the rods are withdrawn to compensate. See NUCLEAR FUELS.

**Reactor kinetics.** This is the study of the short-term aspects of reactor dynamics with respect to stability, safety against power excursion, and design of the control system. Control is possible because increases in reactor power often reduce reactivity to zero (the critical value) and also because there is a time lapse between successive fissions in a chain resulting from the finite velocity of the neutrons and the number of scattering and moderating events intervening, and because a fraction of the neutrons is delayed. See DELAYED NEUTRON; NUCLEAR REACTOR. [B.I.S.]

**Reagent chemicals** High-purity chemicals used for analytical reactions, for the testing of new reactions where the effects of impurities are unknown, and in general for chemical work where impurities must either be absent or at known concentrations.

Chemicals are purified by a variety of methods, the most common being recrystallization from solution. If the desired chemical is volatile and the impurities are not volatile, sublimation is an effective method of purification. For liquid chemicals, distillation is an effective procedure. Finally, the simplest procedure may be to synthesize the desired reagent from pure materials. See CHEMICAL SEPARATION TECHNIQUES; CRYSTALLIZATION; DISTILLATION.

Commercial chemicals are available at several levels of purity. Chemicals labeled "technical" or "commercial" are usually quite impure. The grade "USP" indicates only that the chemical meets the requirements of the United States Pharmacopeia. The term "CP" means only that the chemical is purer than "technical." Chemicals designated "reagent grade" or "analyzed reagent" are specially purified materials which usually have been analyzed to establish the levels of impurities. The American Chemical Society has established specifications and tests for purity for some chemicals. Materials which meet these specifications are labeled "Meets ACS Specifications." [K.G.S./C.Ru.]

**Real-time systems** Computer systems in which the computer is required to perform its tasks within the time restraints of some process or simultaneously with the system it is assisting. Usually the computer must operate faster than the system assisted in order to be ready to intervene appropriately.

Real-time computer systems and applications span a number of different types.

In real-time control and real-time process control the computer is required to process systems data (inputs) from sensors for the purpose of monitoring and computing system control parameters (outputs) required for the correct operation of a system or process. The type of monitoring and control functions provided by the computer for subsystem units ranges over a wide variety of tasks, such as turn-on and turn-off signals to switches; feedback signals to controllers (such as motors, servos, and potentiometers) to provide adjustments or corrections; steering signals; alarms; monitoring, evaluation, supervision, and management calculations; error detection, and out-of-tolerance and critical parameter detection operations; and processing of displays and outputs.

In real-time assistance the computer is required to do its work fast enough to keep up with a person interacting with it (usually at a computer terminal device of some sort, for example, a screen and keyboard). The computer supports the person or persons interacting with it and provides access, retrieval, and storage functions, usually through some sort of database management system, as well as data processing and computational power. System access allows the individual to intervene in the system's operation. The real-time computer also often provides monitoring or display information, or both. See MULTIAccess COMPUTER.

In real-time robotics the computer is a part of a robotic or self-contained machine. Often the computer is embedded in the machine, which then becomes a smart machine. If the smart machine also has access to, or has embedded within it, artificial intelligence functions (for example, a knowledge base and knowledge processing in an expert system fashion), it becomes an intelligent machine. See COMPUTER; DIGITAL COMPUTER; EMBEDDED SYSTEMS; EXPERT SYSTEMS; ROBOTICS. [E.C.J.]

**Real variable** A variable whose range is a subset of the real numbers. By extension the term is also used to refer to the theory of functions of one or more real variables. This theory has to do with properties of broad classes of functions, such as continuity, types of discontinuities, differentiability of functions, oscillation and variation of functions, and the various kinds of integrals. See CALCULUS; INTEGRATION.

Real numbers are those commonly used in the geometric theory of measurement. The integers and fractions, also called rational numbers, are included among the real numbers. In practice an irrational number  $x$  is specified by telling which rational numbers are less than  $x$  and which are greater than  $x$ . Such a division of the rational numbers into two classes was used by J. W. R. Dedekind as the formal definition of a real number and is called a Dedekind cut. [L.M.G.]

**Realgar** A mineral having composition AsS and crystallizing in the monoclinic system. Realgar can occur in short, vertically striated crystals, but more frequently is granular and in crusts. The hardness is 1.5–2 (Mohs scale) and the specific gravity is 3.48. The luster is resinous and the color red to orange. Realgar is found in ores of lead, silver, and gold associated with orpiment and stibnite. It occurs with the silver and lead ores in Hungary, Czechoslovakia, and Germany. Good crystals have come from Binnenthal, Switzerland, and Allchar, Macedonia. In the United States it is found at Manhattan, Nevada; Mercer, Utah; and as deposits from geyser waters in Yellowstone National Park. See ARSENIC; ORPIMENT; STIBNITE. [C.S.Hu.]

**Rearrangement reaction** A reaction in which an atom or bond moves or migrates, having been initially located at one site in a reactant molecule and ultimately located at a different site in a product molecule. A rearrangement reaction may involve several steps, but the key feature defining it as a rearrangement is that a bond shifts from one site of attachment to another.

The simplest examples of rearrangement reactions are intramolecular, that is, reactions in which the product is simply a structural isomer of the reactant [reaction (1)].

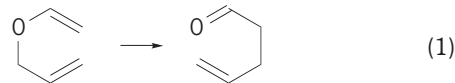

See MOLECULAR ISOMERISM.

More complex rearrangement reactions occur when the rearrangement is accompanied by another reaction, for example, a substitution reaction (2).

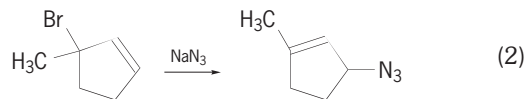

Rearrangement reactions are classified and named on the basis of the group that migrates and the initial and final location of the migrating bond. The initial bond location is designated as position 1, and the final location as position  $i$ , where the number of atoms is simply counted along the connection from 1 to  $i$ . Such a migration is called a  $[1,i]$  rearrangement or  $[1,i]$  shift. If the migrating group also reattaches itself at a different site from the one to which it had originally been attached, then both shifts are indicated, as in  $[i,j]$  shift. Reaction (1) is an example of a  $[3,3]$  rearrangement, because the initial carbon-oxygen (C-O) bond that breaks designates the 1 position for each component, and both components then rearrange and form a new C-C bond by reattaching at position 3 for each component. Reaction (2) is an example of a  $[1,3]$  rearrangement with substitution, commonly called an  $S_N2'$  reaction.

In addition, classification can be based on how many electrons move with the migrating group. Of the two electrons in the initial bond that breaks, the migrating group may bring with it both electrons (nucleophilic or anionotropic), one electron (radical), or no electrons (electrophilic or cationotropic). If the rearrangement is a concerted reaction in which there is a cyclic delocalized transition state that results in shifts of pi bonds as well as sigma bonds, the reaction is called a sigmatropic rearrangement [for example, reaction (1)]. See DELOCALIZATION; PERICYCLIC REACTION.

The great majority of rearrangement reactions occur when a molecule develops a severely electron-deficient site. Shift of a nearby atom or group, with its pair of electrons, can serve to satisfy the electron deficiency at the original site, although it typically leaves behind another site with electron deficiency. As long as the final site can bear the electron deficiency better than the original site, the rearrangement will be favorable. See CHEMICAL BONDING. [C.C.Wa.]

**Reciprocating aircraft engine** A fuel-burning internal combustion piston engine specially designed and built for minimum fuel consumption and light weight in proportion to developed shaft power. The rotating output shaft of the engine may be connected to a propeller, ducted fan, or helicopter rotor.

Reciprocating aircraft engines are used in about 86% of all powered aircraft flying in the United States. Most of the aircraft powered by these engines belong to the general aviation segment of the domestic aviation fleet. The reciprocating aircraft engine is used to power single-engine and multiengine airplanes, helicopters, and airships. It is the principal engine used in aircraft for air taxi, pilot training, business, personal, and sport flying as well as aerial application of seed, fertilizer, herbicides, and pesticides for farming. See AGRICULTURAL AIRCRAFT; GENERAL AVIATION.

Predominantly, reciprocating aircraft engines operate on a four-stroke cycle, where each piston travels from one end of its stroke to the other four times in two crankshaft revolutions to complete one cycle. The cycle is composed of four distinguishable events called intake, compression, expansion (or power),

and exhaust, with ignition taking place late in the compression stroke and combustion of the fuel-air charge occurring early in the expansion stroke. These spark-ignition engines burn specially formulated aviation gasolines. See INTERNAL COMBUSTION ENGINE.

Most modern aircraft using engines with up to 336 kW (450 hp) output are powered by air-cooled, horizontally opposed, reciprocating engines. The trend in modern reciprocating engine development is toward lower engine weight and improved fuel economy rather than increased power. [K.J.S.]

**Reciprocity principle** In the scientific sense, a theory that expresses various reciprocal relations for the behavior of some physical systems. Reciprocity applies to a physical system whose input and output can be interchanged without altering the response of the system to a given excitation. Optical, acoustical, electrical, and mechanical devices that operate equally well in either direction are reciprocal systems, whereas unidirectional devices violate reciprocity. The theory of reciprocity facilitates the evaluation of the performance of a physical system. If a system must operate equally well in two directions, there is no need to consider any nonreciprocal components when designing it.

Some systems that obey the reciprocity principle are any electrical network composed of resistances, inductances, capacitances, and ideal transformers; systems of antennas, which obey certain restrictions; mechanical gear systems; and light sources, lenses, and reflectors.

Devices that violate the theory of reciprocity are transistors, vacuum tubes, gyrators, and gyroscopic couplers. Any system that contains the above devices as components must also violate the reciprocity theory. The gyrator differs from the transistor and vacuum tube in that it is linear and passive, as opposed to the active and nonlinear character of the other two devices. See GYRATOR; TRANSISTOR. [H.S.La.]

**Recombination (genetics)** The formation of new genetic sequences by piecing together segments of previously existing ones. Recombination often follows deoxyribonucleic acid (DNA) transfer in bacteria and, in higher organisms, is a regular feature of sexual reproduction. See DEOXYRIBONUCLEIC ACID (DNA); REPRODUCTION (ANIMAL); REPRODUCTION (PLANT).

The fact that recombinants occur in sexual reproduction is due to reciprocal exchanges between chromosomes (crossing over) that take place in the first meiotic division. See CROSSING-OVER (GENETICS).

Crossing-over between homologous chromosome pairs can also occur during the prophase of mitotic nuclear division. The frequency is very much lower than in meiosis, presumably because the mitotic cell does not form the synaptic apparatus for efficient pairing of homologs. See MITOSIS.

Recombination was once thought to occur only between genes, never within them. Indeed, the supposed indivisibility of the gene was regarded as one of its defining features, the other being that it was a single unit of function. However, examination of very large progenies shows that, in all organisms studied, nearly all functionally allelic mutations of independent origin can recombine with each other to give nonmutant products, generally at frequencies ranging from a few percent (the exceptionally high frequency found in *Saccharomyces*) down to 0.001% or less. Recombination within genes is most frequently nonreciprocal.

Bacteria have no sexual reproduction in the true sense, but many or most of them are capable of transferring fragments of DNA from cell to cell by one of three mechanisms. (1) Fragments of the bacterial genome can become joined to plasmid DNA and transferred by cell conjugation. (2) Genomic fragments can be carried from cell to cell in the infective coats of bacterial viruses (phages), a process called transduction. (3) Many bacteria have the capacity to assimilate fragments of DNA from solution and so may acquire genes from disrupted cells. Fragments of DNA ac-

quired by any of these methods can be integrated into the DNA of the genome in place of homologous sequences previously present. Homologous integration in bacteria is similar in its nonreciprocal nature to recombination within genes of eukaryotic organisms. See BACTERIAL GENETICS; BACTERIOPHAGE; TRANSDUCTION (BACTERIA).

Bacteriophages, plasmids, bacteria, and unicellular eukaryotes provide many examples of differentiation through controlled and site-specific recombination of DNA segments. In vertebrates, a controlled series of deletions leads to the generation of the great diversity of gene sequences encoding the antibodies and T-cell receptors necessary for immune defense against pathogens. All these processes depend upon interaction and recombination between specific DNA sequences, catalyzed by site-specific recombinase enzymes. The molecular mechanisms may have some similarities with those responsible for general meiotic recombination, except that the latter does not depend on any specific sequence, only on similarity (homology) of the sequence recombined.

Techniques have been devised for the artificial transfer of DNA fragments from any source into cells of many different species, thus conferring new properties upon them (transformation). In bacteria and the yeast *S. cerevisiae*, integration of such DNA into the genome requires substantial sequence similarity between incoming DNA and the recipient site. However, cells of other fungi, higher plants, and animals are able to integrate foreign DNA into their chromosomes with little or no sequence similarity. These organisms appear to have some system that recombines the free ends of DNA fragments into chromosomes regardless of their sequences. It may have something in common with the mechanism, equally obscure, whereby broken ends of chromosomes can heal by nonspecific mutual joining. See TRANSFORMATION (BACTERIA).

The science of genetics has been revolutionized by the development of techniques using isolated cells for specific cleaving and rejoining of DNA segments and the introduction of the reconstructed molecules into living cells. This artificial recombination depends on the use of site-specific endonucleases (restriction enzymes) and DNA ligase. See GENE; GENE ACTION; GENETIC ENGINEERING; GENETICS; RESTRICTION ENZYME. [J.R.S.F.]

**Rectifier** A nonlinear circuit component that allows more current to flow in one direction than in the other. An ideal rectifier is one that allows current to flow in one (forward) direction unimpeded but allows no current to flow in the other (reverse) direction. Thus, ideal rectification might be thought of as a switching action, with the switch closed for current in one direction and open for current in the other direction. Rectifiers are used primarily for the conversion of alternating current (ac) to direct current (dc). See ELECTRONIC POWER SUPPLY.

A variety of rectifier elements are in use. The vacuum-tube rectifier can efficiently provide moderate power. Its resistance to current flow in the reverse direction is essentially infinite because the tube does not conduct when its plate is negative with respect to its cathode. In the forward direction, its resistance is small and almost constant. Gas tubes, used primarily for higher power requirements, also have a high resistance in the reverse direction. The semiconductor rectifier has the advantage of not requiring a filament or heater supply. This type of rectifier has approximately constant forward and reverse resistances, with the forward resistance being much smaller. Mechanical rectifiers can also be used. The most common is the vibrator, but other devices are also used. See GAS TUBE; MECHANICAL RECTIFIER; SEMICONDUCTOR RECTIFIER.

If the average current is subtracted from the current flowing in the rectifier, an alternating current results. This ripple current flowing through a load produces a ripple voltage which is often undesirable. Filter and regulator circuits are used to reduce it to as low a value as is required. See ELECTRIC FILTER; VOLTAGE REGULATOR.

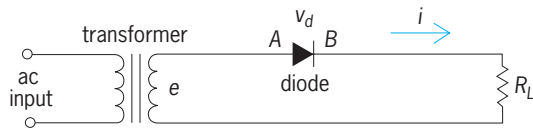

Fig. 1. Half-wave diode rectifier.  $V_d =$  voltage across diode. Ideal diode allows current  $i$  to flow only in forward direction from A to B.

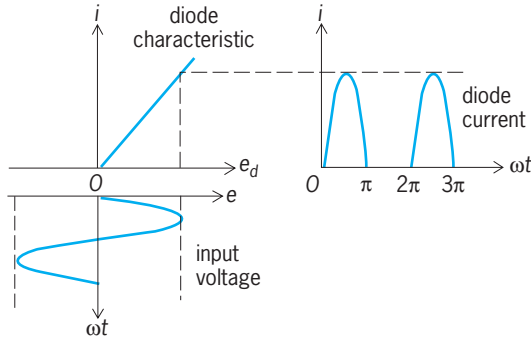

Fig. 2. Rectifying action of half-wave diode rectifier.  $t =$  time;  $\omega =$  angular frequency of input voltage.

A half-wave rectifier circuit is shown in Fig. 1. The rectifier, a diode, is practically ideal. The ac input is applied to the primary of the transformer; secondary voltage  $e$  supplies the rectifier and load resistor  $R_L$ . The rectifying action of the diode is shown in Fig. 2, in which the current  $i$  of the rectifier is plotted against the voltage  $e_d$  across the diode. The applied sinusoidal voltage from the transformer secondary is shown under the voltage axis; the resulting current  $i$  flowing through the diode is shown at the right to be half-sine loops.

A full-wave rectifier circuit uses two separate diodes. The resulting current wave shape is shown in Fig. 3. A more continuous flow of direct current is produced because the first diode conducts for the positive half-cycle and the second diode conducts for the negative half-cycle.

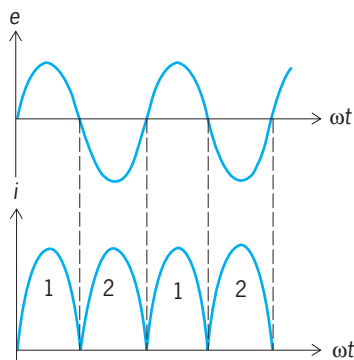
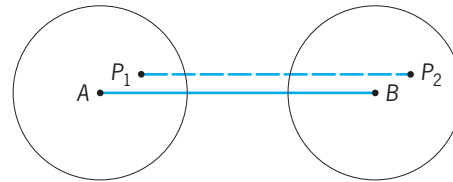

Fig. 3. Applied voltage and output current of full-wave rectifier.

When high dc power is required by an electronic circuit, a polyphase rectifier circuit may be used. It is also desirable when expensive filters must be used. This is particularly true of power supplies for the final radio-frequency and audiofrequency stages of large radio and television transmitters. [D.L.W.]

**Rectilinear motion** Motion is defined as continuous change of position of a body. If the body moves so that every



Rectilinear motion. All points move parallel to the center of mass.

particle of the body follows a straight-line path, then the motion of the body is said to be rectilinear. See MOTION.

When a body moves from one position to another, the effect may be described in terms of motion of the center of mass of the body from a point A to a point B (see illustration). If the center of mass of the body moves along a straight line connecting the points A and B, then the motion of the center of mass of the body is rectilinear. If the body as a whole does not rotate while it is moving, then the path of every particle of which the body is composed is a straight line parallel to or coinciding with the path of the center of mass, and the body as a whole executes rectilinear motion. This is shown by the straight line connecting points  $P_1$  and  $P_2$  in the illustration. See CENTER OF MASS.

Rectilinear motion is an idealized form of motion which rarely, if ever, occurs in actual experience, but it is the simplest imaginable type of motion and thus forms the basis for the analysis of more complicated motions. However, many actual motions are approximately rectilinear and may be treated as such without appreciable error. For example, a ball thrown directly upward may follow, for all practical purposes, a straight-line path. The motion of a high-speed rifle bullet fired horizontally may be essentially rectilinear for a short length of path, even though in its larger aspects the ideal path is a parabola. The motion of an automobile traveling over a straight section of roadway is essentially rectilinear if minor variations of path are neglected. The motion of a single wheel of the car is not rectilinear, although the motion of the center of mass of the wheel may be essentially so. See BALLISTICS. [R.D.Ru.]

**Recursive function** A function that maps natural numbers to natural numbers and is special in that it must be calculable by using a precisely specified algorithm. The mathematical definitions of partial recursive functions and recursive functions were developed to give a precise mathematical characterization of those functions or operations on the natural numbers which are computable by using effective procedures.

An effective procedure is a procedure or process determined by a finite list of precise instructions. There is no upper bound on the number of instructions in this list. These instructions can be carried out in a discrete one-step-at-a-time fashion. The only equipment needed is pencil and paper, and an unlimited supply is assumed to be available. No creativity is involved in applying these instructions, and no random devices such as flipping a coin are allowed in carrying them out.

An effective procedure may be used to calculate a function as follows: The calculator inputs to the effective procedure a natural number (0, 1, 2, 3, ...) and allows the procedure to be carried out on this input. If an output is obtained, the function is said to be defined at this input and its value at this input is the output so obtained. Any function which can be computed in this way is called effectively computable. For example, addition and multiplication of natural numbers are effectively computable functions.

The notion of effective procedure is intuitive and vague. In the setting of an idealized computing device called a Turing machine, a more precise definition of certain effectively computable functions can be given. See AUTOMATA THEORY; GÖDEL'S THEOREM; LOGIC. [G.C.N.]

**Recycling technology** Methods for reducing solid waste by reusing discarded materials to make new products. The three integral phases of recycling are the collection of recyclable materials, manufacture or reprocessing of these materials into new products, and purchase of these products. Various techniques have been developed to recycle plastics, glass, metals, paper, and wood.

**Plastics.** Plastic discards represent an estimated 10% by weight and up to 26% by volume of the municipal solid waste in the United States discarded after materials recovery. About 2% by weight of discarded plastics is recovered. Approximately half of plastic waste consists of single-use convenience packaging and containers. Many manufacturers prefer plastic for packaging because it is lightweight, resists breakage and environmental deterioration, and can be processed to suit specific needs. Once plastics are discarded, these attractive physical properties become detriments.

The collected plastic waste is usually separated manually from the waste stream, and often it is cleaned to remove adhesives or other contaminants. It is sorted further, based on different resins. Mechanical separation techniques can be used to sort plastics based on unique physical or chemical properties.

A significant problem is the presence of contaminants such as dirt, glass, metals, chemicals from previous usage, toxicants from metallic-based pigments, and other materials that are part of or have adhered to the plastic products. Other constraints involve inconsistencies in the amount of different plastic resins in commingled plastic wastes used for recycling, and engineering aspects of recycled plastic products, such as lessened chemical and impact resistance, strength, and stiffness, and the need for additional chemicals to counteract other types of degradation for reprocessing. There may be limitations to the number of times that a particular plastic product can be effectively recycled as compared to steel, glass, or aluminum, which can be recycled many times with no loss of their properties and virtually no contamination. [R.L.Sw.; V.T.B.; M.L.Bo.]

**Glass.** Glass containers are a usual ingredient in community recycling programs; they are 100% recyclable and can be recycled indefinitely. In 1993 in the United States, glass containers, which constitute 6% of the solid-waste stream by weight, were recycled at a rate of 35%. Nearly one-third of the glass containers available for consumption in the United States were cycled back into glass containers and other useful items such as glassphalt, or were returned as refillable bottles.

The process of recycling glass is straightforward. Cullet (scrap glass) in the form of used glass bottles and jars is mixed with silica sand, soda ash, and limestone in a melting furnace at temperatures up to 2800°F (1540°C). The molten glass is poured into a forming machine, where it is blown or pressed into shape. The new containers are gradually cooled, inspected, and shipped to the customer. Before glass can be recycled, however, it must be furnace ready, that is, sorted by color and free of contaminants.

Cullet must meet a standard of quality similar to that of the raw material it replaces. Contamination from foreign material will result in the cullet being rejected by the plants, as it poses a serious threat to the integrity and purity of the glass packaging being produced. Contaminants include metal caps, lids, stones, dirt, and ceramics. Paper labels do not need to be removed for recycling, as they burn off at high furnace temperatures. [N.T.; N.U.R.]

**Metals.** Metals must be recycled to alleviate the need to mine more ore, to reduce energy consumption, to limit the dissemination of metals into the environment, and to reduce the cost of metals. In the United States a substantial portion of these needs are met by recycling metals.

The extensive recycling is important for three reasons. (1) The energy required to recycle a metal is considerably less in comparison to producing it from ore. (2) Extracting the metal from ore produces a tremendous amount of waste material. (3) Metals that are not recycled become dissipated throughout the environ-

ment; since many metals are toxic, this can result in the pollution of water and soil. See HAZARDOUS WASTE.

While it is beneficial to recycle, two important problems hinder recycling: collection and impurity buildup. When a metal becomes scrap and is a candidate for recycling, it must be collected at a cost that makes it attractive to recyclers. It is useful to divide scrap into three categories—home scrap, new or prompt scrap, and old or obsolete scrap—whose methods for collection differ significantly. Home scrap is waste produced during fabrication, and includes casting waste (for example, risers), shearings and trimmings, and rejected material. This scrap is usually recycled within the plant, and therefore it is not recognized as recycled material in recycling statistics. New or prompt scrap is waste generated by the user of semifinished material, that is, scrap from machining operations (such as turnings or borings), trimmings, and rejected material. This material is collected and sold to recyclers and, if properly labeled and segregated, it is easy to recycle and is valuable. Old or obsolete scrap is waste derived from products that have completed their life cycle, such as used beverage cans, old automobiles, and defunct batteries. The collection and the impurity buildup problems are most severe when considering old or obsolete scrap. [D.F.S.]

**Paper.** Paper and paperboard for recycling come from a variety of sources, including offices, retail businesses, converters, printers, and households. Paper products that have been distributed, have been purchased, and have served their intended purposes are considered postconsumer waste. Other sources, such as scrap paper generated in the papermaking process (mill broke) or converting operations (such as trimmings from envelopes and boxes), are considered preconsumer waste.

Recycled paper fibers are used in the manufacture of many recycled-content paper products such as paperboard, corrugated containers, tissue products, newspapers, and printing and writing paper. They can also be used in other products such as insulation, packing materials, and molded egg cartons and flowerpots. See PRINTING.

Collection is the crucial first step in recycling. It occurs in curbside programs, in drop-off centers, in paper drives, and increasingly in commercial collection systems run side by side with waste collection for landfill or incineration.

Reprocessing begins by sorting waste papers by grade and level of cleanliness. Next, the waste paper (usually in bales) is mixed with water in a slusher or pulper to produce a fiber-and-water slurry. In this pulping stage the paper is agitated until broken down into fibers, and large-size contaminants (greater than about 5 mm or 0.2 in.) are removed when the pulper is emptied through the screen plate. Depending on the intended product, chemicals such as surfactants are added to the pulper to help remove undesirable materials from the fibers for separation in later operations.

The pulp is then pumped through several different-size slotted or perforated screens to separate medium-size contaminants (usually 5–0.2 mm or 0.2–0.05 in.) from the pulp. Screening is generally followed by centrifugal cleaning, where the pulp is subjected to a vortex in a tapered cone. Using specific designs, cleaners separate high-specific-gravity materials, such as dirt and sand, and low-specific-gravity materials, such as styrofoam and some plastics, from the pulp. See PAPER. [J.S.S.]

**Wood.** Waste is generated at every stage of the process by which a forest tree is turned into consumer and industrial products. Additional waste is generated in the disposal of those products. Wood waste is also produced by the homeowner and by large and small businesses and is generated from landscaping and agricultural operations such as pruning and tree removal. While these processes do not strictly return wood to the economy in its original form, they have the effect of diverting wood residues from the landfill, and thus they may be included under a broadly interpreted definition of recycling.

Wood recycling begins with wood separation from the waste stream. Recovered materials can be processed into various

products, including fuel, raw material for particleboard or other wood-composite panel products, compost, landscaping mulch, animal bedding, landfill cover, amendments for municipal solid waste and sludge compost, artificial firewood, wood-plastic composite lumber and other composite products, charcoal, industrial oil absorbents, insulation, and specialty concrete.

Most of these products require that the wood be ground into small particles. A typical grinder is a hammermill, although a variety of grinders are used. The size of the particles is determined by the end use of the wood; sizes smaller than about 20 mesh are called wood flour (the particles passing the 20-mesh screen are usually less than 0.8 mm in size). Wood may then be passed over an electromagnet which removes items made of ferrous metals such as nails or staples. If additional processing is performed, it is typically to separate wood particles by size. This is accomplished in two ways: the particles can be passed through a series of screens of different mesh size and the various-sized particles can be collected from the screens; or the particles may be separated in a tower with air blown in the bottom and out the top; the particles distribute themselves in the tower, with the small, light particles on top and the large, dense ones at the bottom. See WOOD PRODUCTS. [J. Simo.]

**Red dwarf star** A low-mass main-sequence star of spectral classes M and L. Red dwarf stars range from about 0.6 solar mass at class M0 down to 0.08 solar mass in cool M and warm L, below which the proton-proton chain cannot run. Lower-mass bodies are termed brown dwarfs. Effective temperatures range from 3800 K (6400°F) at class M0 down to 2000 K (3100°F) at class L0, and absolute visual magnitudes from +9 to +20. Downward along the main sequence, red dwarfs produce progressively more radiation in the infrared. Luminosities range from about 0.05 down to  $2 \times 10^{-4}$  the solar luminosity. Radii range from about 0.5 to down 0.1 solar. Spectra become increasingly complex. See BROWN DWARF; MAGNITUDE (ASTRONOMY); PROTON-PROTON CHAIN.

Red dwarfs constitute over 70% of all stars, and as a result constitute about half the visible mass of the Milky Way Galaxy. Yet their intrinsic faintness renders them all invisible to the unaided eye. Their lifetimes are so long that none has ever evolved in the Milky Way Galaxy's lifetime. See DWARF STAR; MILKY WAY GALAXY; SPECTRAL TYPE; STAR; STELLAR EVOLUTION. [J.B.Ka.]

**Red Sea** A body of water that separates northeastern Africa from the Arabian Peninsula. The Red Sea forms part of the African Rift System, which also includes the Gulf of Aden and a complex series of continental rifts in East Africa extending as far south as Malawi. The Red Sea extends for 1920 km (1190 mi) from Ras (Cape) Muhammed at the southern tip of the Sinai Peninsula to the Straits of Bab el Mandab at the entrance to the Gulf of Aden. At Sinai the Red Sea splits into the Gulf of Suez, which extends for an additional 300 km (180 mi) along the northwest trend of the Red Sea and the nearly northward-trending Gulf of Aqaba. The 175-km-long (109-mi) Gulf of Aqaba forms the southern end of the Levant transform, a primarily strike-slip fault system extending north into southern Turkey. The Levant transform also includes the Dead Sea and Sea of Galilee and forms the northwestern boundary of the Arabian plate. See ESCARPMENT; FAULT AND FAULT STRUCTURES.

The Red Sea consists of narrow marginal shelves and coastal plains and a broad main trough with depths ranging from about 400 to 1200 m (1300 to 3900 ft). The main trough is bisected by a narrow (<60 km or 37 mi wide) axial trough with a very rough bottom morphology and depths of greater than 2000 m (6600 ft). The maximum recorded depth is 2920 m (9580 ft). See REEF.

Water circulation in the Red Sea is driven by monsoonal wind patterns and changes in water density due to evaporation. Evaporation in the Red Sea is sufficient to lower the sea level by over 2 m (6.6 ft) per year. No permanent rivers flow into the sea, and

there is very little rainfall. As a result, there must be a net inflow of water from the Gulf of Aden to compensate for evaporative losses. During the winter monsoon, prevailing winds in the Red Sea are from the south, and there is a surface current from the Gulf of Aden into the Red Sea. During the summer monsoon, the wind in the Red Sea blows strongly from the north, causing a surface current out of the Red Sea. See MONSOON METEOROLOGY; SEAWATER. [J.R.Co.]

**Redbeds** Clastic sediments and sedimentary rocks that are pigmented by red ferric oxide which coats grains, fills pores as cement, or is dispersed as a muddy matrix. These conspicuously colored rocks commonly constitute thick sequences of nonmarine, paralic (marginal marine), and less commonly shallow marine deposits. Clastic redbeds accumulated in many parts of the globe during the past  $10^9$  years of Earth history. Ferric oxides also pigment marine chert, limestone, and cherty iron formations and ooidal ironstones, but these chemical deposits are not usually included among redbeds.

Some redbeds contain abundant grains of sedimentary and low-grade metamorphic rocks and relatively few grains of iron-bearing minerals. Most of them, however, contain feldspar and relatively abundant grains of opaque black oxides derived from igneous and high-grade metamorphic source rocks. Clay minerals in older redbeds, as in most other ancient clastic deposits, are predominantly illite and chlorite, thus providing no specific clue to the climate in the source area or at the place of deposition.

In many of the younger redbeds the pigmenting ferric oxide mineral cannot be identified specifically because of its poor crystallinity. In most of the older ones, however, hematite is the pigment. As seen under the scanning electron microscope, the hematite is in the form of hexagonal crystals scattered over the surface of grains and clay mineral platelets. In red mudstones most of the pigment is associated with the clay fraction.

Redbeds do not contain significantly more total iron than nonred sedimentary rocks. Normally, iron increases with decreasing grain size of redbeds. Moreover, the amount of iron in the grain-coating pigments is small compared with that in opaque oxides, dark silicates, and clay minerals.

On a global scale, paleomagnetic evidence of the distribution of redbeds relative to their pole position corroborates paleogeographic data, suggesting that most redbeds, evaporites, and eolian sandstones accumulated less than  $30^\circ$  north and south of a paleo equator where hot, dry climate generally prevailed. But diagenetic development of red hematite may be acquired long after deposition. Moreover, continental drift reconstructions reveal that the most widespread redbeds in the geologic record developed near the Equator in late Paleozoic and early Mesozoic time when the continents were assembled in a great landmass, Pangaea. See CONTINENTS, EVOLUTION OF; PALEOGEOGRAPHY; PALEOMAGNETISM. [F.B.V.H.]

**Redshift** A systematic displacement toward longer wavelengths of lines in the spectra of distant galaxies, and also of the continuous part of the spectrum. First studied systematically by E. Hubble, redshift is central to observational cosmology, in which it provides the basis for the modern picture of an expanding universe.

There are two fundamental properties of redshifts. First, the fractional redshift  $\Delta\lambda/\lambda$  is independent of wavelength. This rule has been verified from 21 cm (radio radiation from neutral hydrogen atoms) to about  $6 \times 10^{-5}$  cm (the visible region of the electromagnetic spectrum) and leads to the interpretation of redshift as resulting from a recession of distant galaxies. Though this interpretation has been questioned, no other mechanism is known that would explain the observed effect.

Second, redshift is correlated with apparent magnitude in such a way that when redshift is translated into recession speed and apparent magnitude into distance, the recession speed is found to be nearly proportional to the distance. This rule was



formulated by Hubble in 1929, and the constant of proportionality bears his name. See HUBBLE CONSTANT; MAGNITUDE (ASTRONOMY). [D.La.]

**Redtop grass** One of the bent grasses, *Agrostis alba* and its relatives, which occur in cooler, more humid regions of the United States on a wide variety of soils. Redtop tolerates both wet and dry lands and acid and infertile soils, and it is used where other species of grasses do not thrive. Redtop is a perennial and makes a coarse, loose turf. The inflorescence is a reddish open panicle. Redtop is used for pasture and hay and is fairly nutritious if harvested promptly when heading occurs. It is effective in preventing erosion by holding banks of drainage ditches, waterways, and terrace channels. See CYPERALES. [H.B.S.]

**Redwood** A member of the pine family, *Sequoia sempervirens*, is the tallest tree in the Americas, attaining a height of 350 ft (107 m) and a diameter of 27 ft (8.2 m). Its present range is limited to a strip along the Pacific Coast, extending from southwest Oregon to south of San Francisco. The leaves are evergreen, sharply pointed, small, disposed in two vertical rows on short branches, and scalelike on the main stem. The cones are egg-shaped. The bark is a dull red-brown, on old trees sometimes 1 ft (0.3 m) thick, densely fibrous, and highly resistant to fire. The tree gets its common name from the color of the bark as well as that of the heartwood.

The wood holds paint well and is used for bridge timbers, tanks, flumes, silos, posts, shingles, paneling, doors, caskets, furniture, siding, and many other building purposes. See PINALES; PINE. [A.H.G./K.P.D.]

**Reef** A mass or ridge of rock or rock-forming organisms in a water body, a rock trend on land or in a mine, or a rocky trend in soil. Usually the term reef means a rocky menace to navigation, within 6 fathoms (11 m) of the water surface. Various kinds of calcium carbonate-secreting animals and plants create biogenic, or organic, reefs throughout the warmer seas. Most biogenic reefs are made of corals and associated organisms, but some entire reefs and important parts of others consist mainly of lime-secreting algae, hydrozoans, annelids, oysters, or sponges. See ALGAE; SCLERACTINIA.

The term fringing reef refers to a coral or other biogenic reef that fringes the edge of the land. A barrier reef ordinarily made of corals or other organisms parallels the shore at the seaward side of a natural lagoon. An atoll is an annular coral reef that surrounds a lagoon. See ATOLL. [P.C.I.]

**Reengineering** The application of technology and management science to the modification of existing systems, organizations, processes, and products in order to make them more effective, efficient, and responsive. Responsiveness is a critical need for organizations in industry and elsewhere. It involves providing products and services of demonstrable value to customers, and thereby to those individuals who have a stake in the success of the organization. Reengineering can be carried out at the level of the organization, at the level of organizational processes, or at the level of the products and services that support an organization's activities. The entity to be reengineered can be systems management, process, product, or some combination. In each case, reengineering involves a basic three-phase systems-engineering life cycle comprising definition, development, and deployment of the entity to be reengineered.

**Systems-management reengineering.** At the level of systems management, reengineering is directed at potential change in all business or organizational processes, including the systems acquisition process life cycle itself. Systems-management reengineering may be defined as the examination, study, capture, and modification of the internal mechanisms or functionality of existing system-management processes and practices in an organization in order to reconstitute them in a new form and with

new features, often to take advantage of newly emerged organizational competitiveness requirements, but without changing the inherent purpose of the organization itself.

**Process reengineering.** Reengineering can also be considered at the levels of an organizational process. Process reengineering is the examination, study, capture, and modification of the internal mechanisms or functionality of an existing process or systems-engineering life cycle, in order to reconstitute it in a new form and with new functional and nonfunctional features, often to take advantage of newly emerged or desired organizational or technological capabilities, but without changing the inherent purpose of the process that is being reengineered.

**Product reengineering.** The term "reengineering" could mean some sort of reworking or retrofit of an already engineered product, and could be interpreted as maintenance or refurbishment. Reengineering could also be interpreted as reverse engineering, in which the characteristics of an already engineered product are identified, such that the product can perhaps be modified or reused. Inherent in these notions are two major facets of reengineering: it improves the product or system delivered to the user for enhanced reliability or maintainability, or to meet a newly evolving need of the system users; and it increases understanding of the system or product itself. This interpretation of reengineering is almost totally product-focused.

Thus, product reengineering may be redefined as the examination, study, capture, and modification of the internal mechanisms or functionality of an existing system or product in order to reconstitute it in a new form and with new features, often to take advantage of newly emerged technologies, but without major change to the inherent functionality and purpose of the system. This definition indicates that product reengineering is basically structural reengineering with, at most, minor changes in purpose and functionality of the product. This reengineered product could be integrated with other products having rather different functionality than was the case in the initial deployment. Thus, reengineered products could be used, together with this augmentation, to provide new functionality and serve new purposes. There are a number of synonyms for product reengineering, including renewal, refurbishing, rework, repair, maintenance, modernization, reuse, redevelopment, and retrofit.

Much of product reengineering is very closely associated with reverse engineering to recover either design specifications or user requirements. Then follows refinement of these requirements or specifications and forward engineering to achieve an improved product. Forward engineering is the original process of defining, developing, and deploying a product, or realizing a system concept as a product; whereas reverse engineering, sometimes called inverse engineering, is the process through which a given system or product is examined in order to identify or specify the definition of the product either at the level of technological design specifications or at system- or user-level requirements.

[A.P.S.]

**Reference electrode** An electrode with an invariant potential. In electrochemical methods, where it is necessary to observe, measure, or control the potential of another electrode (denoted indicator, test, or working electrode), it is necessary to use a reference electrode, which maintains a potential that remains practically unchanged during the course of an electrochemical measurement. Potentials of indicator or working electrodes are measured or expressed relative to reference electrodes. See POTENTIALS.

One such electrode, the normal hydrogen electrode, has been chosen as a reference standard, relative to which potentials of other electrodes and those of oxidation-reduction couples are often expressed. By maintaining a constant pressure of hydrogen gas the potential of a hydrogen electrode can be used for determination of the activity of hydrogen ions in the tested solution. However, in practice the determination of the hydrogen-ion activity (pH) is performed by using a glass electrode. The

hydrogen electrode itself is used only in fundamental studies and some nonaqueous solutions. The hydrogen electrode, however, remains important for providing a reference standard. See ACTIVITY (THERMODYNAMICS); pH.

In practice, potentials are measured against reference electrodes that are easier to work with than the normal hydrogen electrode. Such electrodes are known as secondary reference electrodes; the most common are the calomel and silver-silver chloride electrodes. See ELECTRODE; SOLVENT. [P.Z.]

**Reflecting microscope** A microscope whose objective is composed of two mirrors, one convex and the other concave (see illustration). The imaging properties are independent

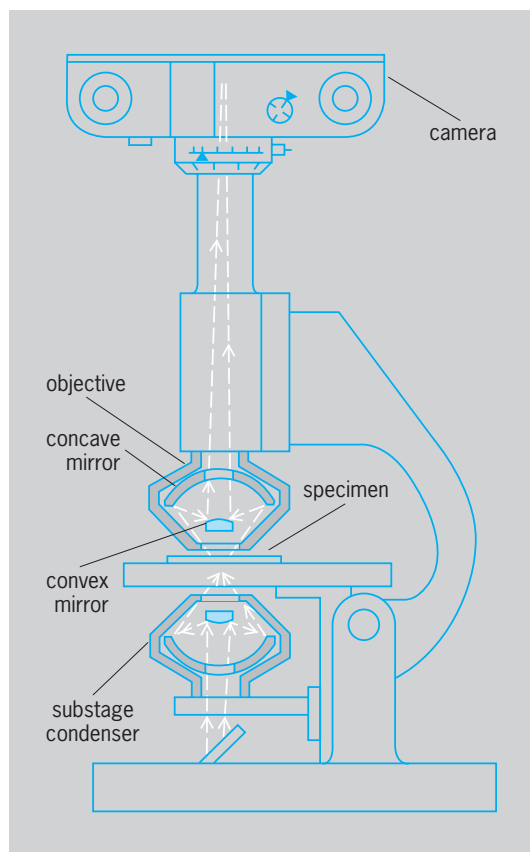

Reflecting microscope arranged for photomicrography.

of the wavelength of light, and this freedom from chromatic aberration allows the objective to be used even for infrared and ultraviolet radiation. Although the reflecting microscope is simple in appearance, the construction tolerances are so small and so difficult to achieve that the system is used only when refracting objectives are unsuitable. The distance from the objective to the specimen can be made very large; this large working distance is useful in special applications, such as examining objects situated within metallurgical furnaces. Reflecting microscopes have been mainly used for microspectrometry in the infrared and the ultraviolet, and for ultraviolet microphotography. See MICROSCOPE; OPTICAL MICROSCOPE. [D.S.G.]

### Reflection and transmission coefficients

When an electromagnetic wave passes from a medium of permeability  $\mu_1$  and dielectric constant  $\epsilon_1$  to one with values  $\mu_2$  and  $\epsilon_2$ , part of the wave is reflected at the boundary and part transmitted. The ratios of the amplitudes in the reflected wave and the transmitted wave to that in the incident wave are called the reflection and transmission coefficients, respectively. For oblique

incidence, the reflection and refraction formulas of optics are most convenient, but for normal incidence of plane waves on plane boundaries, such as occur with transmission lines, waveguides, and some free waves, the concept of wave impedance and characteristic impedance is useful. See ELECTROMAGNETIC RADIATION; TRANSMISSION LINES; WAVEGUIDE. [W.R.Sm.]

**Reflection of electromagnetic radiation** The returning or throwing back of electromagnetic radiation such as light, ultraviolet rays, radio waves, or microwaves by a surface upon which the radiation is incident. In general, a reflecting surface is the boundary between two materials of different electromagnetic properties, such as the boundary between air and glass, air and water, or air and metal. Devices designed to reflect radiation are called reflectors or mirrors.

The simplest reflection laws are those that govern plane waves of radiation. The law of reflection concerns the incident and reflected rays (as in the case of a beam from a flashlight striking a mirror) or, more precisely, the wave normals of the incident and reflected waves. The law states that the incident and reflected rays and the normal to the reflecting surface all lie in one plane, called the plane of incidence, and that the reflection angle equals the angle of incidence as in Eq. (1) [see illustration]. The

$$\theta_{\text{refl}} = \theta_{\text{inc}} \quad (1)$$

angles  $\theta_{\text{inc}}$  and  $\theta_{\text{refl}}$  are measured between the surface normal and the incident and reflected rays, respectively. The surface (in the above example, that of the mirror) is assumed to be smooth, with surface irregularities small compared to the wavelength of the radiation. This results in so-called specular reflection. In contrast, when the surface is rough, the reflection is diffuse. An example of this is the diffuse scattering of light from a screen or from a white wall where light is returned through a whole range of different angles.

The reflectivity of a surface is a measure of the amount of reflected radiation. It is defined as the ratio of the intensities of the reflected and incident radiation. The reflectivity depends on the angle of incidence, the polarization of the radiation, and the electromagnetic properties of the materials forming the boundary surface. These properties usually change with the wavelength of the radiation. Reflecting materials are divided into two groups: transparent materials also called dielectrics, and opaque conducting materials, usually metals.

The reflectivity of polished metal surfaces is usually quite high. Silver and aluminum, for example, reflect more than 90% of visible light. In ordinary mirrors the reflecting surface is the interface between metal and glass, which is thus protected from oxidation, dirt, and other forms of deterioration. When it is not

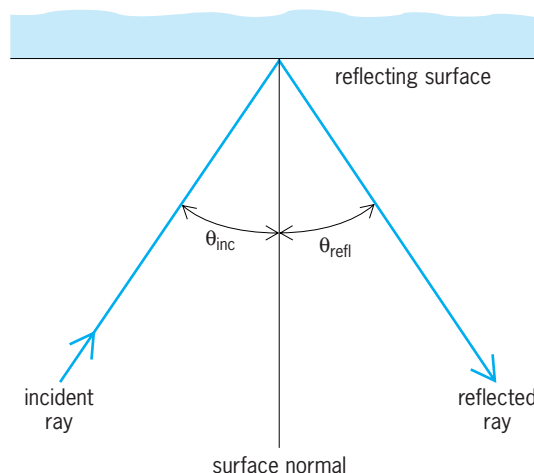

Reflection of electromagnetic radiation from smooth surface.

permissible to use this protection for technical reasons, one uses "front-surface" mirrors, which are usually coated with evaporated aluminum.

The material property that determines the amount of radiation reflected from an interface between two dielectric media is the phase velocity  $v$  of the electromagnetic radiation in the two materials. In optics one uses as a measure for this velocity the refractive index  $n$  of the material, which is defined by Eq. (2) as

$$n = c/v \quad (2)$$

the ratio of the velocity of light  $c$  in vacuum and the phase velocity in the material. For visible light, for example, the refractive index of air is about  $n = 1$ , the index of water is about  $n = 1.33$ , and the index of glass is about  $n = 1.5$ . See PHASE VELOCITY; REFRACTION OF WAVES.

For normal incidence ( $\theta_{\text{inc}} = 0$ ) the reflectivity  $R$  of the interface is given by Eq. (3), in which the material constants are

$$R = \left( \frac{v_1 - v_2}{v_1 + v_2} \right)^2 = \left( \frac{n_2 - n_1}{n_2 + n_1} \right)^2 \quad (3)$$

labeled 1 and 2, where the radiation is incident in material 1. The reflectivity of an air-water interface is about 2% ( $R = 0.02$ ) and that of an air-glass interface about 4% ( $R = 0.04$ ); the other 98% or 96% are transmitted through the water or glass, respectively. See ALBEDO; GEOMETRICAL OPTICS; MIRROR OPTICS; REFLECTION OF SOUND. [H.K.]

**Reflection of sound** The return of sound waves from surfaces on which they are incident. The geometrical laws for reflection of sound waves are the same as those for light waves. The apparent differences involve only questions of scale, because the average wavelength of sound is about 100,000 times that of light. For example, a mirror or lens used to produce a beam of sound waves must be enormously large compared to mirrors and lenses used in optical systems. See REFLECTION OF ELECTROMAGNETIC RADIATION.

A concave surface tends to concentrate the reflected sound waves. Convex reflectors tend to spread the reflected waves. Therefore, when placed at the boundaries of a room, they tend to diffuse the sound throughout the room. For this reason, some radio-broadcasting studios employ cylindrical convex panels as part of their wall construction to promote diffusion. See ARCHITECTURAL ACOUSTICS; ECHO; SOUND. [C.M.H.]

**Reflex** A simple, unlearned, yet specific behavioral response to a specific stimulus. Reflexes are exhibited by virtually all animals from protozoa to primates. Along with other, more complex stimulus-bound responses such as fixed action patterns, they constitute much of the behavioral repertoire of invertebrates. In higher animals, such as primates, where learned behavior dominates, reflexes nevertheless persist as an important component of total behavior.

The simplest known reflexes require only one neuron or, in the strictest sense, none. For example, ciliated protozoa, which are single cells and have no neurons, nevertheless exhibit apparently reflexive behaviors. However, most reflexes require activity in a large sequence of neurons. The neurons involved in most reflexes are connected by specific synapses to form functional units in the nervous system. Such a sequence begins with sensory neurons and ends with effector cells such as skeletal muscles, smooth muscles, and glands, which are controlled by motor neurons. The central neurons which are often interposed between the sensory and motor neurons are called interneurons. The sensory side of the reflex arc conveys specificity as to which reflex will be activated. The remainder of the reflex response is governed by the specific synaptic connections that lead to the effector neurons. A familiar reflex is the knee-jerk or stretch reflex. It involves the patellar (kneecap) tendon and a group of upper leg muscles. Other muscle groups show similar reflexes. [J.L.La.]

**Reforestation** The reestablishment of forest cover either naturally or artificially. Given enough time, natural regeneration will usually occur in areas where temperatures and rainfall are adequate and when grazing and wildfires are not too frequent.

Reforestation occurs on land where trees have been recently removed due to harvesting or to natural disasters such as a fire, landslide, flooding, or volcanic eruption. When abandoned cropland, pastureland, or grasslands are converted to tree cover, the practice is termed afforestation (where no forest has existed in recent memory). Afforestation is common in countries such as Australia, South Africa, Brazil, India, and New Zealand. Although natural regeneration can occur on abandoned cropland, planting trees will decrease the length of time required until the first harvest of wood. Planting also has an advantage in that both tree spacing and tree species can be prescribed. The selection of tree species can be very important since it affects both wood quality and growth rates. Direct seeding is also used for both afforestation and reforestation, although it often is less successful and requires more seed than tree planting. Unprotected seed are often eaten by birds and rodents, and weeds can suppress growth of newly germinated seed. For these reasons, direct seeding accounts for only about 5% and 1% of artificial reforestation in Canada and the United States, respectively. [D.B.So.]

**Reforming processes** Those processes used to convert, with limited cracking, petroleum liquids into higher-octane gasoline. Due to the demand for higher-octane gasoline, thermal reforming was developed (from thermal cracking processes) to improve the octane number of fractions within the boiling range of gasoline. See CRACKING; GASOLINE; OCTANE NUMBER; PETROLEUM.

Upgrading by reforming may be accomplished, in part, by an increase in volatility (reduction of molecular size) or by the conversion of  $n$ -paraffins to isoparaffins, olefins, and aromatics, and of naphthenes (cycloalkanes) to aromatics. The nature of the final product is influenced by the structure and composition of the straight-run (virgin) naphtha (hydrocarbon mixture) feedstock. In thermal reforming, the reactions resemble those in the cracking of gas oils. The molecular size is reduced, while olefins and some aromatics are synthesized. For example, hydrocracking of high-molecular-weight paraffins yields lower-molecular-weight paraffins and an olefin; dehydrocyclization of paraffin compounds yields aromatic compounds; isomerization of  $n$ -paraffins yields isoparaffins; and isomerization of methylcyclopentane yields cyclohexane.

In the presence of catalysts and in the presence of the hydrogen available from dehydrogenation reactions, hydrocracking of paraffins to yield two lower-molecular-weight paraffins takes place, and olefins that do not undergo dehydrocyclization are dehydrogenated so that the end product contains only traces of olefins. See DEHYDROGENATION; HYDROCRACKING; ISOMERIZATION; PARAFFIN.

Thermal reforming was a natural development from thermal cracking, since reforming is also a thermal decomposition reaction. Cracking converts heavier oils into gasoline constituents, whereas reforming converts these gasoline constituents into higher-octane molecules. The equipment for thermal reforming is essentially the same as for thermal cracking, but higher temperatures are used. The higher octane number of the product (reformate) is due primarily to the cracking of longer-chain paraffins into higher-octane olefins. See DISTILLATION.

The products of thermal reforming are gases, gasoline, and residual oil. The amount and quality of the reformate are very dependent on the temperature. As a rule, the higher the reforming temperature, the higher the octane number of the product but the lower the reformate yield. Adding catalysts increases the yield for higher-octane gasolines at a given temperature.

Thermal reforming is less effective and less economical than catalytic processes and has been largely supplanted. The octane number was changed by the severity of the cracking, and the

product had increased volatility, compared to the volatility of the feedstock.

Modifications of the thermal reforming process due to the inclusion of hydrocarbon gases with the feedstock are known as gas reversion and polyforming. These are essentially the same but differ in the manner in which the gases and naphtha are passed through the heating furnace. In gas reversion, the naphtha and gases flow through separate lines in the furnace and are heated independently of one another. In naphtha reforming, the  $C_3$  and  $C_4$  gases are premixed with the naphtha and pass together through the furnace.

Like thermal reforming, catalytic reforming converts low-octane gasoline into high-octane gasoline (reformate). Although thermal reforming can produce reformate with a research octane number of 65–80 depending on the yield, catalytic reforming produces reformate with octane numbers on the order of 90–95. Catalytic reforming is conducted in the presence of hydrogen over hydrogenation-dehydrogenation catalysts. Depending on the catalyst, a definite sequence of reactions takes place, involving structural changes in the feedstock. See CATALYSIS; PETROLEUM PROCESSING AND REFINING. [J.G.S.]

**Refraction of waves** The change of direction of propagation of any wave phenomenon which occurs when the wave velocity changes. The term is most frequently applied to visible light, but it also applies to all other electromagnetic waves, as well as to sound and water waves.

The physical basis for refraction can be readily understood with the aid of the illustration. Consider a succession of equally spaced wavefronts approaching a boundary surface obliquely. The direction of propagation is in ordinary cases perpendicular to the wavefronts. In the case shown, the velocity of propagation is less in medium 2 than in medium 1, so that the waves are slowed down as they enter the second medium. Thus, the direction of travel is bent toward the perpendicular to the boundary surface (that is,  $\theta_2 < \theta_1$ ). If the waves enter a medium in which the velocity of propagation is faster than in their original medium, they are refracted away from the normal.

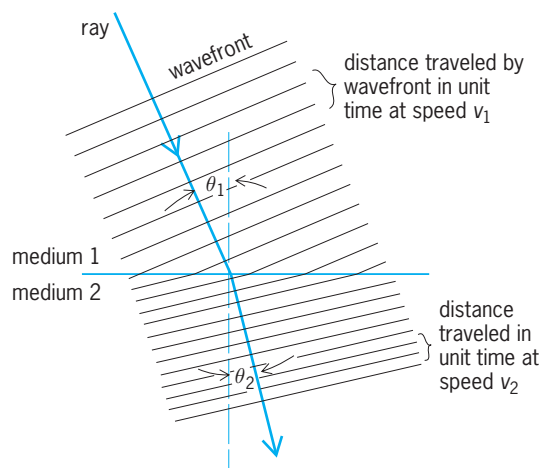

Physical basis for Snell's law.

**Snell's law.** The simple mathematical relation governing refraction is known as Snell's law. If waves traveling through a medium at speed  $v_1$  are incident on a boundary surface at angle  $\theta_1$  (with respect to the normal), and after refraction enter the second medium at angle  $\theta_2$  (with the normal) while traveling at speed  $v_2$ , then Eq. (1) holds. The index of refraction  $n$  of a

$$\frac{v_1}{v_2} = \frac{\sin \theta_1}{\sin \theta_2} \quad (1)$$

medium is defined as the ratio of the speed of waves in vacuum  $c$  to their speed in the medium. Thus  $c = n_1 v_1 = n_2 v_2$ , and therefore Eq. (2) holds. The refracted ray, the normal to the surface,

$$n_1 \sin \theta_1 = n_2 \sin \theta_2 \quad (2)$$

and the incident ray always lie in the same plane.

The relative index of refraction of medium 2 with respect to that of medium 1 may be defined as  $n = n_1/n_2$ . Snell's law then becomes Eq. (3). For sound and other elastic waves which

$$\sin \theta_1 = n \sin \theta_2 \quad (3)$$

require a medium in which to propagate, only this last form has meaning. Equation (3) is frequently used for light when one medium is air, whose index of refraction is very nearly unity.

When the wave travels from a region of low velocity (high index) to one of high velocity (low index), refraction occurs only if  $(n_1/n_2) \sin \theta_1 \leq 1$ . If  $\theta_1$  is too large for this relation to hold, then  $\sin \theta_2 > 1$ , which is meaningless. In this case the waves are totally reflected from the surface back into the first medium. The largest value that  $\theta_1$  can have without total internal reflection taking place is known as the critical angle  $\theta_c$ . Thus  $\sin \theta_c = n_2/n_1$ .

**Atmospheric refraction.** The index of refraction of the Earth's atmosphere increases continuously from 1.000000 at the edge of space to 1.000293 (yellow light) at 0°C and 760 mmHg (101.3 kilopascals) pressure. Thus celestial bodies as seen in the sky are actually nearer to the horizon than they appear to be. The effect decreases from a maximum of about 35 minutes of arc for an object on the horizon to zero at the zenith, where the light enters the atmosphere at perpendicular incidence.

Other manifestations of atmospheric refraction are the mirages and "looming" of distant objects which occur over oceans or deserts, where the vertical density gradient of the air is quite uniform over a large area. See MIRAGE.

**Sound waves.** The velocity of sound in a gas is proportional to the square root of the absolute temperature. Because of the vertical temperature gradients in the atmosphere, refraction of sound can be quite pronounced. As in mirage formation, to allow large-scale refraction the temperature at a given height must be uniform over a rather large horizontal area. See ATMOSPHERIC ACOUSTICS; SOUND.

**Seismic waves.** The velocity of elastic waves in a solid depends upon the modulus of elasticity and upon the density of the material. Waves propagating through solid earth are refracted by changes of material or changes of density. Worldwide observations of earthquake waves enable scientists to draw conclusions on the distribution of density within the Earth. See SEISMOLOGY.

**Water waves.** As the waves enter shallower water they travel more slowly. As a train of waves approaches a coastline obliquely, its direction of travel becomes more nearly perpendicular to the shore because of refraction. See WAVE MOTION.

[J.W.St.]

**Refractometric analysis** A method of chemical analysis based on the measurement of the index of refraction of a substance. The most common type of refractometer is the Abbe refractometer. It is simple to use, requiring but a drop or two of sample and allowing a measurement of refractive index to be made in 1–2 min, with a precision of 0.0001. More precise measurements of refractive indices may be made by using a dipping or immersion refractometer, the prism of which is completely immersed in the sample. The most precise measurements of the refractive indices of gases or solutions containing small traces of impurities are made with an interferometer. For measurements in flowing systems, differential refractometers are used.

The measurement of refractive index is used to identify compounds whose other physical constants are quite similar. Because minute amounts of impurities often cause a measurable change in the refractive index of a pure material, refractive index is often used as a criterion for purity. A measurement of refractive index

gives information as to the gross amount of impurity; it does not serve to identify the impurity. See REFRACTION OF WAVES.

[R.F.G.; J.N.L.]

**Refractory** One of a number of ceramic materials for use in high-temperature structures or equipment. The term high-temperatures is somewhat indefinite but usually means above about 1830°F (1000°C), or temperatures at which, because of melting or oxidation, the common metals cannot be used. In some special high-temperature applications, the so-called refractory metals such as tungsten, molybdenum, and tantalum are used. See CERAMICS.

The greatest use of refractories is in the steel industry, where they are used for construction of linings of equipment such as blast furnaces, hot stoves, and open-hearth furnaces. Other important uses of refractories are for cement kilns, glass tanks, non-ferrous metallurgical furnaces, ceramic kilns, steam boilers, and paper plants. Special types of refractories are used in rockets, jets, and nuclear power plants. Many refractory materials, such as aluminum oxide and silicon carbide, are also very hard and are used as abrasives; some applications, for example, aircraft brake linings, make use of both characteristics.

Refractory materials are commonly grouped into (1) those containing mainly aluminosilicates; (2) those made predominantly of silica; (3) those made of magnesite, dolomite, or chrome ore, termed basic refractories (because of their chemical behavior); and (4) a miscellaneous category usually referred to as special refractories.

[J.F.McM.]

**Refrigeration** The cooling of a space or substance below the environmental temperature. Mechanical refrigeration is primarily an application of thermodynamics wherein the cooling medium, or refrigerant, goes through a cycle so that it can be recovered for reuse. The commonly used basic cycles, in order of importance, are vapor-compression, absorption, steam-jet or steam-ejector, and air. Each cycle operates between two pressure levels, and all except the air cycle use a two-phase working medium which alternates cyclically between the liquid and vapor phases.

The term "refrigeration" is used to signify cooling below the environmental temperature to lower than about 150 K (−190°F; −123°C). The term "cryogenics" is used to signify cooling to temperatures lower than 150 K. See CRYOGENICS.

**Vapor-compression cycle.** The vapor-compression cycle consists of an evaporator in which the liquid refrigerant boils at low temperature to produce cooling, a compressor to raise the pressure and temperature of the gaseous refrigerant, a condenser in which the refrigerant discharges its heat to the environment, usually a receiver for storing the liquid condensed in the condenser, and an expansion valve through which the liquid expands from the high-pressure level in the condenser to the low-pressure level in the evaporator. This cycle may also be used for heating if the useful energy is taken off at the condenser level instead of at the evaporator level. See HEAT PUMP.

**Absorption cycle.** The absorption cycle accomplishes compression by using a secondary fluid to absorb the refrigerant gas, which leaves the evaporator at low temperature and pressure. Heat is applied, by means such as steam or gas flame, to distill the refrigerant at high temperature and pressure. The most-used refrigerant in the basic cycle is ammonia; the secondary fluid is then water. This system is used for the lower temperatures. Another system is lithium bromide-water, where the water is used as the refrigerant. This is used for higher temperatures. Due to corrosion, special inhibitors must be used in the lithium bromide-water system. The condenser, receiver, expansion valve, and evaporator are essentially the same as in any vapor-compression cycle. The compressor is replaced by an absorber, generator, pump, heat exchanger, and controlling-pressure reducing valve.

**Steam-jet cycle.** The steam-jet cycle uses water as the refrigerant. High-velocity steam jets provide a high vacuum in the

evaporator, causing the water to boil at low temperature and at the same time compressing the flashed vapor up to the condenser pressure level. Its use is limited to air conditioning and other applications for temperatures above 32°F (0°C).

**Air cycle.** The air cycle, used primarily in airplane air conditioning, differs from the other cycles in that the working fluid, air, remains as a gas throughout the cycle. Air coolers replace the condenser, and the useful cooling effect is obtained by a refrigerator instead of by an evaporator. A compressor is used, but the expansion valve is replaced by an expansion engine or turbine which recovers the work of expansion. Systems may be open or closed. In the closed system, the refrigerant air is completely contained within the piping and components, and is continuously reused. In the open system, the refrigerant is replaced by the space to be cooled, the refrigerant air being expanded directly into the space rather than through a cooling coil.

**Refrigerants.** The working fluid in a two-phase refrigeration cycle is called a refrigerant. A useful way to classify refrigerants is to divide them into primary and secondary. Primary refrigerants are those fluids (pure substances, azeotropic mixtures which behave physically as a single pure compound, and zeotropes which have temperature glides in the condenser and evaporator) used to directly achieve the cooling effect in cycles where they alternately absorb and reject heat. Secondary refrigerants are heat transfer or heat carrier fluids. See AIR CONDITIONING; AIR COOLING; AUTOMOTIVE CLIMATE CONTROL; COLD STORAGE; COOLING TOWER; MARINE REFRIGERATION; REFRIGERATOR.

[P.E.Li.; C.F.K.]

**Refrigeration cycle** A sequence of thermodynamic processes whereby heat is withdrawn from a cold body and expelled to a hot body. Theoretical thermodynamic cycles consist of nondissipative and frictionless processes. For this reason, a thermodynamic cycle can be operated in the forward direction to produce mechanical power from heat energy, or it can be operated in the reverse direction to produce heat energy from mechanical power. The reversed cycle is used primarily for the cooling effect that it produces during a portion of the cycle and so is called a refrigeration cycle. It may also be used for the heating effect, as in the comfort warming of space during the cold season of the year. See HEAT PUMP; THERMODYNAMIC PROCESSES.

In the refrigeration cycle a substance, called the refrigerant, is compressed, cooled, and then expanded. In expanding, the refrigerant absorbs heat from its surroundings to provide refrigeration. After the refrigerant absorbs heat from such a source, the cycle is repeated. Compression raises the temperature of the refrigerant above that of its natural surroundings so that it can give up its heat in a heat exchanger to a heat sink such as air or water. Expansion lowers the refrigerant temperature below the temperature that is to be produced inside the cold compartment or refrigerator. The sequence of processes performed by the refrigerant constitutes the refrigeration cycle. When the refrigerant is compressed mechanically, the refrigerative action is called mechanical refrigeration.

There are many methods by which cooling can be produced. The methods include the noncyclic melting of ice, or the evaporation of volatile liquids, as in local anesthetics; the Joule-Thomson effect, which is used to liquefy gases; the reverse Peltier effect, which produces heat flow from the cold to the hot junction of a bimetallic thermocouple when an external emf is imposed; and the paramagnetic effect, which is used to reach extremely low temperatures. However, large-scale refrigeration or cooling, in general, calls for mechanical refrigeration acting in a closed system. See PARAMAGNETISM; REFRIGERATION.

The purpose of a refrigerator is to extract as much heat from the cold body as possible with the expenditure of as little work as possible. The yardstick in measuring the performance of a refrigeration cycle is the coefficient of performance, defined as the ratio of the heat removed to the work expended. The coefficient of performance of the reverse Carnot cycle is the maximum

obtainable for stated temperatures of source and sink. See CARNOT CYCLE.

The reverse Brayton cycle it was one of the first cycles used for mechanical refrigeration. Before Freon and other condensable fluids were developed for the vapor-compression cycle, refrigerators operated on the Brayton cycle, using air as their working substance. Air undergoes isentropic compression, followed by reversible constant-pressure cooling. The high-pressure air next expands reversibly in the engine and exhausts at low temperature. The cooled air passes through the cold storage chamber, picks up heat at constant pressure, and finally returns to the suction side of the compressor. See BRAYTON CYCLE. [T.Ba.; P.E.Li.]

**Refrigerator** An insulated, cooled compartment. If it is large enough for the entry of a person, it is termed a walk-in box; otherwise it is called a reach-in refrigerator. Cooling may be by mechanical or gas refrigeration, by water or dry ice, or by brine circulation. Temperatures maintained depend upon the requirements of the product stored, generally varying from 55°F (13°C) down to 0°F (−18°C), and sometimes lower.

A household or domestic refrigerator is a factory-built, self-contained cabinet. The range of storage capacities is wide and varies among manufacturers. Modern designs have a main compartment for holding food above freezing, a second compartment for storage below freezing, and trays for the freezing of ice cubes. Low-temperature household refrigerators, or home freezers, for the storage of frozen foods are manufactured in both the chest and the upright, or vertical, types.

A commercial refrigerator is any factory-built refrigerated fixture, cabinet, or room that can be assembled and disassembled readily. Commercial or built-in refrigerators are used in restaurants, markets, hospitals, hotels, and schools for the storage of food and other perishables. See REFRIGERATION. [C.F.K.]

**Regeneration (biology)** The process by which an animal restores a lost part of its body. Broadly defined, the term can include wound healing, tissue repair, and many kinds of restorative activities. Within the field of developmental biology, however, most research in regeneration involves systems in which removing a complex structure or major part of an organism initiates a chain of events that produces a structure that duplicates the missing part both functionally and anatomically.

The best-known and most widely studied examples of regeneration are those involving epimorphosis, in which the lost structure is reproduced directly by a combination of cell proliferation and redifferentiation of new tissue. Examples can be found throughout the animal kingdom. Research on regenerating systems yields information regarding basic mechanisms of animal development. Noteworthy has been the progress in understanding the factors that control pattern formation in the development of complex structures, such as vertebrate limbs.

Mammals, birds, and reptiles have a much more poorly developed ability than amphibians and fish to regenerate complete organs, but nevertheless can reform missing tissue and restore function after partial removal of certain organs. For example, if part of the liver is cut away, the remaining portions increase in size to compensate for the missing tissue and to restore the normal functional capacity of the organ. The process of liver regeneration involves the triggering of active growth in the remaining liver cells, in cells of bile ductules, and in unspecialized cells called stem cells, all of which are usually quiescent in the normal liver. Proliferation of these cells and their subsequent differentiation are key events in the process by which the missing liver mass is replaced and adequate hepatic function restored. In the musculoskeletal system, different populations of quiescent stem cells allow efficient replacement of damaged or partially removed bones and muscles. See BONE; LIVER; MUSCLE.

Of all vertebrates, amphibians have the most highly developed capacity for regeneration. Certain species have the ability to regenerate not only limbs and tails but also parts of the eye, lower

jaw, intestine, and heart. Complete regeneration of amputated limbs can occur throughout the lifetime of most salamanders and newts. In frogs and toads, the ability to regenerate limbs is lost during metamorphosis to the adult form.

Protozoa and simple multicellular animals, including sponges, coelenterates, and flatworms, display remarkable capacities for regeneration following various experimental manipulations. Regenerative ability in such organisms correlates closely with their capacity to reproduce asexually, most commonly by fission or by budding, and the mechanisms of growth involved in regeneration are often very similar to those of asexual propagation. For example, just as complete ciliated protozoa will develop after fission, which divides the nucleus and organelles between daughter cells, intact individuals will also be reconstituted from fragments of a single organism if the fragment contains a complete set of the genetic material and a portion of the original cell's cortical cytoplasm. Similar rules regarding the importance of the nucleus apply to regenerative processes in all protozoa.

Most annelids, such as the earthworm, can readily regenerate segments after their removal: some species can regenerate whole organisms from any fragment. Like more primitive invertebrates, certain annelids can reproduce asexually by transverse fission. The capacities for fission and for reconstitution from fragments in annelids are remarkable, considering the anatomical complexity of animals in this phylum. When an earthworm is cut transversely into two parts, the anterior part can regenerate several posterior segments. The ability of the posterior half to regenerate anterior segments is, however, more limited and is absent altogether in some species. Experiments in which components of the nervous system are removed surgically have revealed the importance of a neural influence for segment regeneration, presumably mediated by a growth-stimulating hormone secreted from neural cells. See ANNELIDA.

The ability of certain echinoderms, such as starfish, to regenerate missing arms is well known. Cutting such an animal into several pieces results in each piece forming a new organism, a phenomenon that usually requires the presence of at least some of the central portion of the body. Equally remarkable is a regenerative response shown by another echinoderm, the sea cucumber. When this animal is strongly irritated, it eviscerates itself through its anus or through a rupture of its body wall. This phenomenon produces a nearly empty sack of skin and muscle, which then proceeds to regenerate all the internal organs, beginning with the digestive tract. See ECHINODERMATA.

The capacity for appendage regeneration is widespread among the many diverse members of the phylum *Arthropoda*. In these complex animals with well-developed exoskeletons and no asexual mode of reproduction, regeneration shows a close correlation with the molting process. See ARTHROPODA; DEVELOPMENTAL BIOLOGY. [A.Me.]

**Regeneration (engineering)** The process of feeding back a portion of the output signal of an amplifier to its input in such a way that the input signal is reinforced. The result is greatly increased amplification. The feedback must be positive; that is, the two signals must be in phase, and it must be limited in magnitude to prevent the circuit from going into oscillation. See FEEDBACK CIRCUIT. [J.Mar.]

**Regolith** The mantle or blanket of unconsolidated or loose rock material that overlies the intact bedrock and nearly everywhere forms the land surface. The regolith may be residual (weathered in place), or it may have been transported to its present site. The undisturbed residual regolith may grade from agricultural soil at the surface, through fresher and coarser weathering products, to solid bedrock several feet or more beneath the surface. The transported regolith includes the alluvium of rivers, sand dunes, glacial deposits, volcanic ash, coastal deposits, and the various mass-wasting deposits that occur on hillslopes. The lunar surface also has a regolith. This layer of

fragmental debris is believed to derive from prolonged meteoritic and secondary fragment impact. See SOIL; WEATHERING PROCESSES. [V.R.B.]

**Regular polytopes** The  $n$ -dimensional analogs of the regular polygons ( $n = 2$ ) and platonic solids ( $n = 3$ ). They are conveniently denoted by their Schläfli symbols  $\{p, q, \dots\}$ ; for instance, the pentagon, hexagon, octagon, tetrahedron, octahedron are denoted by  $\{5\}$ ,  $\{6\}$ ,  $\{8\}$ ,  $\{3, 3\}$ ,  $\{3, 4\}$ . The cube is  $\{4, 3\}$  because its faces are squares  $\{4\}$  and there are three of them at each vertex. The five platonic solids  $\{p, q\}$ , are determined by the inequality below. The numbers of vertices, edges,

$$(p - 2)(q - 2) < 4$$

faces ( $V, E, F$ ) can be deduced from the obvious relations  $pF = 2E = qV$  with the help of Euler's formula  $V - E + F = 2$ .

The general polytope (sometimes loosely called a "polyhedron" [see illustration] regardless of the number of dimensions)

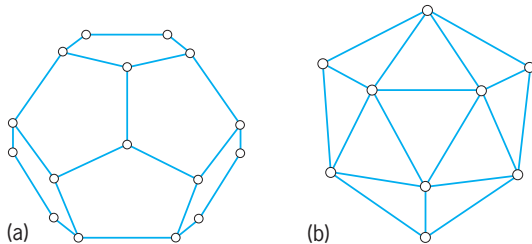

Two regular polyhedrons. (a) Dodecahedron  $\{5, 3\}$ . (b) Icosahedron  $\{3, 5\}$ .

is a finite region of  $n$ -dimensional space enclosed by a finite number of hyperplanes. When any redundant hyperplanes have been discarded, those that remain contain  $(n - 1)$ -dimensional polytopes called cells or "facets." For instance, the cells of a polygon are its sides, those of a polyhedron are its faces, and those of a four-dimensional polytope are solids. See ANALYTIC GEOMETRY; EUCLIDEAN GEOMETRY. [H.S.M.C.]

**Regularia** The name given by G. Cuvier in 1817 to an assemblage of echinoids in which the anus and periproct lie within the apical system. The test is globular and preponderantly radially symmetrical, and the ambulacral plates are commonly compound. The group included, in effect, all those echinoids which did not fall in the Irregularia. See ECHINOIDEA; IRREGULARIA. [H.B.F.]

**Regulator** A control device designed to maintain the value of some quantity substantially constant. The value to be maintained can usually be established at any value within the range of the regulator by making an appropriate setting. A regulated system is a feedback control system employing a regulator to maintain some quantity of the system at a constant value. See CONTROL SYSTEMS. [J.A.Hr.]

**Reheating** The addition of heat to steam of reduced pressure after the steam has given up some of its energy by expansion through the high-pressure stages of a turbine. The reheater tube banks are arranged within the setting of the steam-generating unit in such relation to the gas flow that the steam is restored to a high temperature. Under suitable conditions of initially high steam pressure and superheat, one or two stages of reheat can be advantageously employed to improve thermodynamic efficiency of the cycle. See STEAM-GENERATING UNIT; STEAM TURBINE; SUPERHEATER; VAPOR CYCLE. [R.A.M.]

**Reindeer** A ruminant, *Rangifer tarandus*, of the deer family, Cervidae. Reindeer inhabit the Arctic region and have a circumpolar distribution. They have been domesticated for cen-

turies and are economically important to the Laplanders, who use them as draft animals as well as for their skins, flesh, and milk.

Both sexes have antlers, a characteristic peculiar to this deer species. Although their senses of sight and hearing are not sharp, their sense of smell is quite keen. The hooves are round and broad, giving the animal stable footing in snow and on ice. In the wild, they are the most migratory of all deer, traveling in large herds in search of food during the winter months. The rutting season begins during the autumn migrations; fawns are born during the spring. See ARTIODACTYLA; DEER. [C.B.C.]

**Reinforced concrete** Portland cement concrete containing higher-strength, solid materials to improve its structural properties. Generally, steel wires or bars are used for such reinforcement, but for some purposes glass fibers or chopped wires have provided desired results.

Unreinforced concrete cracks under relatively small loads or temperature changes because of low tensile strength. The cracks are unsightly and can cause structural failures. To prevent cracking or to control the size of crack openings, reinforcement is incorporated in the concrete. Reinforcement may also be used to help resist compressive forces or to improve dynamic properties.

Steel usually is used in concrete. It is elastic, yet has considerable reserve strength beyond its elastic limit. Under a specific axial load, it changes in length only about one-tenth as much as concrete. In compression, steel is more than 10 times stronger than concrete, and in tension, more than 100 times stronger. See STEEL.

During construction, the bars are placed in a form and then concrete from a mixer is cast to embed them. After the concrete has hardened, deformation is resisted and stresses are transferred from concrete to reinforcement by friction and adhesion along the surface of the reinforcement. Individual wires or bars resist stretching and tensile stress in the concrete only in the direction in which such reinforcement extends. Tensile stresses and deformations, however, may occur simultaneously in other directions. Therefore reinforcement must usually be placed in more than one direction. For this purpose, reinforcement sometimes is assembled as a rectangular grid. Bars, grids, and fabric have the disadvantage that the principal effect of reinforcement occurs primarily in the plane of the layer in which they are placed. Consequently, the reinforcement often must be set in several layers or formed into cages. Under some conditions, fiber-reinforced concrete is an alternative to such arrangements. See COMPOSITE BEAM; CONCRETE; CONCRETE BEAM; CONCRETE COLUMN; CONCRETE SLAB; PRESTRESSED CONCRETE. [F.S.M.]

**Relapsing fever** An acute infectious disease characterized by recurring fever. It is caused by spirochetes of the genus *Borrelia* and transmitted by the body louse (*Pediculus humanus humanus*) and by ticks of the genus *Ornithodoros*.

Louse-borne relapsing fever, caused by *Borrelia recurrentis*, is typically epidemic. Epidemics, once widespread on all continents, are rare but still occur in certain parts of South America, Africa, and Asia. Tick-borne relapsing fevers are endemic. They are more widely distributed throughout the Eastern and Western hemispheres. At least 15 species of *Borrelia* have been recognized as causative agents.

After incubation of 2–10 days, the initial attack begins abruptly with chills, high fever, headache, and pains in muscles and joints, and lasts 2–8 days, ending by crisis. A remission period of 3–10 days is followed by a relapse similar to the initial attack but milder. There may be 4–5 relapses, although occasionally 10 or more have been recorded. Mortality varies from 2 to 5% but may be considerably higher during epidemics.

Chlortetracycline is the most effective antibiotic drug, but penicillin, oxytetracycline, and streptomycin also have therapeutic value. See ANTIBIOTIC.

The best way to prevent relapsing fever is to control louse and tick populations with effective insecticides and acaricides. See MEDICAL BACTERIOLOGY; PEDICULOSIS. [W.Bu.]

**Relative atomic mass** The ratio of the average mass per atom of the natural nuclidic composition of an element to  $1/12$  of the mass of an atom of nuclide  $^{12}\text{C}$ . For example,  $\mu(\text{Cl}) = 35.453$ . Relative atomic mass replaces the concept of atomic weight. It is also known as relative nuclidic mass. See NUCLIDE. [T.C.W.]

**Relative molecular mass** The ratio of the average mass per formula unit of the natural nuclidic composition of a substance to  $1/12$  of the mass of an atom of nuclide  $^{12}\text{C}$ . For example,  $\mu(\text{KCl}) = 74.555$ . Relative molecular mass replaces the concept of molecular weight. See NUCLIDE. [T.C.W.]

**Relative motion** All motion is relative to some frame of reference. The simplest laboratory frame of reference is three mutually perpendicular axes at rest with respect to an observer. In terms of the frame of reference of an observer some distance from Earth, the laboratory frame of reference would be moving with Earth as it rotates on its axis and as it revolves about the Sun. What would be a simple form of motion in the laboratory frame of reference would appear to be a much more complicated motion in the frame of reference of the distant observer. See FRAME OF REFERENCE.

Motion means continuous change of position of an object with respect to an observer. To another observer in a different frame of reference the object may not be moving at all, or it may be moving in an entirely different manner. The motions of the planets were found in ancient times to appear quite complicated in the laboratory frame of reference of an observer on Earth. By transferring to the frame of reference of an imaginary observer on the Sun, Johannes Kepler showed that the relative motion of the planets could be simply described in terms of elliptical orbits. The validity of one description is no greater than the other, but the latter description is far more convenient. [R.D.Ru.]

**Relativistic electrodynamics** The study of the interaction between electrically charged particles and electromagnetic fields when the velocities involved are comparable to that of light.

A group of charged particles in motion can be represented by a distribution in charge and distribution in current. During the latter part of the eighteenth century and the early part of the nineteenth century, experiments by C. A. Coulomb, M. Faraday, A. M. Ampère, and others showed that electric and magnetic fields are produced by charge and current distributions. These fields, in turn, act on other charges and currents. The interaction between charges and currents on the one hand and electric and magnetic fields on the other is the topic of study of electrodynamics. This field of study was established as a quantitative and self-contained subject in 1864 when J. C. Maxwell formulated his equations for the electromagnetic field. Maxwell conjectured that a time-varying electric field is equivalent to an electric current in its effect of producing a magnetic field, and named it the displacement current. The inclusion of this displacement current enabled Maxwell to combine all the previously established laws of electromagnetism into a coherent whole in his equations. See CLASSICAL FIELD THEORY; DISPLACEMENT CURRENT; MAXWELL'S EQUATIONS.

With the inclusion of the displacement current, the Maxwell equations are relativistically covariant, meaning that they are valid for all velocities, even those approaching the velocity of light. However, the implications of the covariance of the equations were not fully appreciated until A. Einstein formulated the special theory of relativity in 1905. Relativistic electrodynamics was then rapidly developed into a powerful and precise field of physics. It describes and predicts all macroscopic electrodynamic phenomena to the minutest detail and with perfect accuracy, and

now forms the foundation on which the entire electrical industry is based. However, its limitations soon became evident when attempts were made to apply it to atomic phenomena: Straightforwardly applied, relativistic electrodynamics failed to explain many of these phenomena, and its predictions frequently disagreed with experimental observations. For these microscopic phenomena, quantum electrodynamics (QED) was developed in the 1930s to replace classical relativistic electrodynamics. In 1967 quantum electrodynamics was further unified by S. Weinberg and A. Salam with the theory of weak interactions to form the electroweak theory. See QUANTUM ELECTRODYNAMICS; RELATIVISTIC MECHANICS; RELATIVITY; WEAK NUCLEAR INTERACTIONS.

Electrodynamic problems generally fall into one of two categories:

1. Finding the electromagnetic field produced by prescribed charge and current distributions. For example, one may want to determine the electromagnetic field produced or radiated by a given oscillatory electric current in a transmitting antenna, or the field radiated by an accelerating electron.

2. Finding the effect of a predetermined electromagnetic field on the motion of charges and currents. This is the inverse problem corresponding to that of the receiving antenna or of the motion of charged particles in an accelerator.

All other electrodynamic problems are combinations or iterations of these two basic types. For instance, the scattering of light (electromagnetic radiation) by a charged particle is composed of, first, the incident light shaking the charge and, second, the subsequent emission of the scattered light by the shaken charge. See SCATTERING OF ELECTROMAGNETIC RADIATION. [L.C.T.]

**Relativistic heavy-ion collisions** Collisions between heavy atomic nuclei at relative velocities close to the speed of light. These high-energy nuclear collisions are usually divided into two different domains, relativistic and ultrarelativistic collisions, depending on whether the kinetic energy per nucleon (the generic name for protons and neutrons) is either close to the rest mass of the nucleon (relativistic collisions) or much larger than the nucleon rest mass (ultrarelativistic collisions).

By utilizing high-energy nuclear collisions, it is possible to study nuclear matter under conditions of very high temperatures and densities. The most common form of nuclear matter, at least under terrestrial conditions, is found in the atomic nucleus, which consists of protons and neutrons bound together by the strong nuclear force. If nuclear matter is heated up to temperatures comparable to the rest mass of the pion, it becomes a mixture of nucleons, pions, and various other particles, collectively denoted hadrons. Under these circumstances, nuclear matter is referred to as hadronic matter. See HADRON; NEUTRON; NEUTRON STAR; NUCLEAR STRUCTURE; PROTON.

According to the quantum chromodynamics (QCD) theory, all hadrons are bound states of a set of more fundamental entities called quarks. The quarks are confined within the hadrons by the exchange of gluons. Quantum chromodynamics calculations using the most powerful computers available show that if hadronic matter is further heated or compressed to very high densities it will undergo a phase transition into a new phase of matter, called the quark-gluon plasma. In this phase the hadrons will lose their identity, and the quarks and gluons will be deconfined within volumes much larger than the typical hadron volume of 0.1–0.5 cubic femtometer. Quantum chromodynamics calculations indicate that the phase transition will occur at a critical density around 5–10 times the normal nuclear matter density of approximately  $0.2 \text{ nucleon}/\text{fm}^3$ , or at a critical temperature around 150 MeV. See GLUONS; QUANTUM CHROMODYNAMICS; QUARK-GLUON PLASMA; QUARKS.

When two nuclei collide at high energies, some of the nucleons in each nucleus, called spectators, will continue their motion unaffected, while other nucleons, called participants, will strike one or several nucleons in the other nucleus. In the overlap volume a hot and dense fireball will develop. If the temperature or density of the fireball becomes larger than the critical values, a



quark-gluon plasma will be created with an estimated lifetime of  $1-5 \times 10^{-23}$  s. The fireball will start to expand and cool, and the quarks in the plasma will eventually be reconfined into a large number of hadrons (hadronization). After further expansion the hadrons will cease interacting with each other (freeze out) and leave the collision zone without further mutual interactions.

In the search for the quark-gluon plasma, a fundamental problem is that even if the plasma is created in the early phases of the collisions, the subsequent hadronization and scattering of the hadrons before freeze-out might mask any traces of the plasma. In order to circumvent this problem, many plasma signatures have been proposed. [S.P.S.]

**Relativistic quantum theory** The quantum theory of particles which is consistent with the special theory of relativity, and thus can describe particles moving arbitrarily close to the speed of light. It is now realized that the only satisfactory relativistic quantum theory is quantum field theory; the attempt to relativize the Schrödinger equation for the wave function of a single particle fails [Eq. (1)]. However, with a change of interpretation, relativistic wave equations do correctly describe some aspects of the motions of particles in an electromagnetic field. See QUANTUM FIELD THEORY; QUANTUM MECHANICS; RELATIVITY.

The Schrödinger equation for the wave function  $\psi(\mathbf{r}, t)$  of a particle is Eq. (1), where  $E$  is the energy operator  $i\hbar(\partial/\partial t)$ ,  $\mathbf{p}$  is the

$$E\psi = H(\mathbf{p}, \mathbf{r})\psi \quad (1)$$

momentum operator  $-i\hbar\Delta$ ,  $H(\mathbf{p}, \mathbf{r})$  is the classical hamiltonian, and  $\hbar$  is Planck's constant divided by  $2\pi$ . For a nonrelativistic free particle,  $H = \mathbf{p}^2/2m$ . The naive way to relativize Eq. (1) would be to use the relativistic hamiltonian, Eq. (2). However, this equation is not relativistically invariant.

$$H = \sqrt{(mc^2)^2 + \mathbf{p}^2 c^2} \quad (2)$$

The so-called Klein-Gordon equation, Eq. (3), is relativistically

$$E^2\varphi = [(mc^2)^2 + \mathbf{p}^2 c^2]\varphi \quad (3)$$

invariant. However, the only possible density of a conserved quantity formed from  $|\varphi|$  is of the form shown in (4). But this

$$\rho \propto \varphi^* E\varphi - \varphi E\varphi^* \quad (4)$$

cannot be a probability density, because it is not positive definite (it changes sign when  $\varphi$  is replaced by  $\varphi^*$ ).

But  $\rho$ , in relation (4), can be interpreted as a charge density (when multiplied by a unit charge  $e$ );  $\varphi$  is then to be interpreted as a matrix element of a field operator  $\Phi$  of a quantized field whose quanta are particles with mass  $m$  and charge  $e$  or  $-e$  and zero spin.

P. A. M. Dirac found a relativized form of Eq. (1), Eq. (5), which is both linear in  $E$  and has a positive definite density form  $\rho$ , where  $\beta$  and  $\alpha$  are constants which obey Eqs. (6). Obviously

$$E\psi = [\beta mc^2 + \alpha \cdot pc]\psi (\rho \propto \psi^* \psi) \quad (5)$$

$$\alpha_i \alpha_j + \alpha_j \alpha_i = 0, \quad i \neq j \quad (6)$$

$$\alpha\beta + \beta\alpha = 0 \quad \alpha_i^2 = 1 \quad \beta^2 = 1 \quad i, j = 1, 2, 3$$

the four constants  $\beta$  and  $\alpha_i$  cannot be numbers; however, they can be  $4 \times 4$  matrices, and  $\Psi$  is then a four-component object called a Dirac spinor.

If plane wave solutions of Dirac's equation (5) are considered, then  $\mathbf{P}$  is now a number. Taking Eq. (5) as an eigenequation for  $E$ , four eigenstates are found (because  $H$  is a  $4 \times 4$  matrix), two with

$$E = +\sqrt{(mc^2)^2 + p^2 c^2}$$

and two with

$$E = -\sqrt{(mc^2)^2 + p^2 c^2}$$

The interpretation of the two positive energy states is that they

are the two spin states of a particle with spin  $1/2[\hbar]$ . But the two negative energy states are an embarrassment; even a particle that was initially in a positive energy state would quickly make radiative transitions down through the negative energy states. Dirac's solution was to observe that if the particle described by  $\psi$  obeyed the Pauli principle, then one can suppose that all the negative energy states are already filled with particles, thus excluding any more. There are still four single-particle states for a given momentum  $\mathbf{p}$ : the two spin states of a particle with positive energy, and the two states obtained by removing a negative energy particle (of momentum  $-\mathbf{p}$ ). These last states ("hole states") have positive energy and a charge opposite the charge of the particle. The hole is in fact the antiparticle; if the particle is an electron, the hole is a positron. See ANTIMATTER; POSITRON.

With the filling up of the negative energy states, one no longer has a single-particle system, and  $\psi$ , just as in the Klein-Gordon case, no longer can be interpreted as a wave function but must be interpreted as a matrix element of a field operator  $\Psi$ . [C.J.G.]

**Relativity** A general theory of physics, primarily conceived by Albert Einstein, which involves a profound analysis of time and space, leading to a generalization of physical laws, with far-reaching implications in important branches of physics and in cosmology. Historically, the theory developed in two stages. Einstein's initial formulation in 1905 (now known as the special, or restricted, theory of relativity) does not treat gravitation; and one of the two principles on which it is based, the principle of relativity (the other being the principle of the constancy of the speed of light), stipulates the form invariance of physical laws only for inertial reference systems. Both restrictions were removed by Einstein in his general theory of relativity developed in 1915, which exploits a deep-seated equivalence between inertial and gravitational effects, and leads to a successful "relativistic" generalization of Isaac Newton's theory of gravitation.

**Special theory.** The key feature of the theory of special relativity is the elimination of an absolute notion of simultaneity in favor of the notion that all observers always measure light to have the same velocity, in vacuum,  $c$ , independently of their own motion. The impetus for the development of the theory arose from the theory of electricity and magnetism developed by J. C. Maxwell. This theory accounted for all observed phenomena involving electric and magnetic fields and also predicted that disturbances in these fields would propagate as waves with a definite speed,  $c$ , in vacuum. These electromagnetic waves predicted in Maxwell's theory successfully accounted for the existence of light and other forms of electromagnetic radiation. However, the presence of a definite speed,  $c$ , posed a difficulty, since if one inertial observer measures light to have velocity  $c$ , it would be expected that another inertial observer, moving toward the light ray with velocity  $v$  with respect to the first, would measure the light to have velocity  $c + v$ . Hence, it initially was taken for granted that there must be a preferred rest frame (often referred to as the ether) in which Maxwell's equations would be valid, and only in that frame would light be seen to travel with velocity  $c$ . However, this viewpoint was greatly shaken by the 1887 experiment of A. A. Michelson and E. W. Morley, which failed to detect any motion of the Earth through the ether. By radically altering some previously held beliefs concerning the structure of space and time, the theory of special relativity allows Maxwell's equations to hold, and light to propagate with velocity  $c$ , in all frames of reference, thereby making Maxwell's theory consistent with the null result of Michelson and Morley. See ELECTROMAGNETIC RADIATION; LIGHT; MAXWELL'S EQUATIONS.

**Simultaneity in prerelativity physics.** The most dramatic aspect of the theory of special relativity is its overthrowing of the notion that there is a well-defined, observer-independent meaning to the notion of simultaneity. The following terminology will be introduced: An event is a point of space at an instant of time. Since it takes four numbers to specify an event—one for the time at which the event occurred and three for its spatial

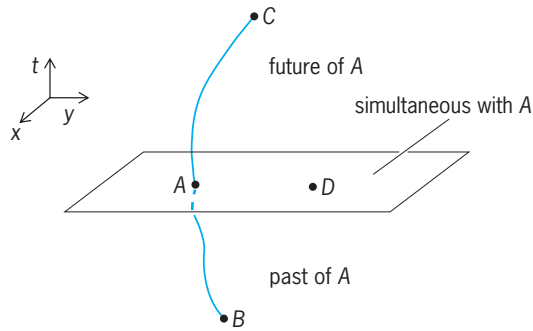

**Fig. 1. Space-time diagram illustrating the causal relationships with respect to an event,  $A$ , in prerelativity physics. Event  $B$  lies to the past of  $A$ , event  $C$  lies to the future of  $A$ , and event  $D$  is simultaneous with  $A$ .**

position—it follows that the set of all events constitutes a four-dimensional continuum, which is referred to as space-time.

A space-time diagram (Fig. 1) is a plot of events in space-time, with time,  $t$ , represented by the vertical axis and two spatial directions ( $x, y$ ) represented by the horizontal axes. (The  $z$  direction is not shown.) For any event  $A$  shown in the diagram, there are many other events in this diagram—say, an event  $B$ —having the property that an observer or material body starting at event  $B$  can, in principle, be present at event  $A$ . The collection of all such events constitutes the past of event  $A$ . Similarly, there are many events—say, an event  $C$ —having the property that an observer or material body starting at event  $A$  can, in principle, be present at event  $C$ . These events constitute the future of  $A$ . Finally, there remain some events in space-time which lie neither to past nor future of  $A$ . In prerelativity physics, these events are assumed to make a three-dimensional set, and they are referred to as the events which are simultaneous with event  $A$ .

In both prerelativity physics and special relativity, an inertial observer is one who is not acted upon by any external forces. In both theories it is assumed that any inertial observer,  $\mathcal{O}$  can build a rigid cartesian grid of meter sticks, all of which intersect each other at right angles. Observer  $\mathcal{O}$  may then label the points on this cartesian grid by the coordinates ( $x, y, z$ ) representing the distance of the point from  $\mathcal{O}$  along the three orthogonal directions of the grid. A clock may then be placed at each grid point. In prerelativity physics, these clocks may be synchronized by requiring that they start simultaneously with each other. Any event in space-time may then be labeled by the four numbers  $t, x, y, z$ , where  $t$  is the time of the event as determined by the synchronized clock situated at that grid point. See FRAME OF REFERENCE.

It is of interest to compare the coordinate labelings given to events in space-time by two inertial observers,  $\mathcal{O}$  and  $\mathcal{O}'$ , who are in relative motion. The relationship occurring in prerelativity physics is called a galilean transformation. In the simple case where  $\mathcal{O}'$  moves with velocity  $v$  in the  $x$  direction with respect to  $\mathcal{O}$ , and these observers meet at the event  $A$  labeled by  $(t, x, y, z) = (t', x', y', z') = (0, 0, 0, 0)$ , with the axes of the grid of meter sticks carried by  $\mathcal{O}'$  aligned (that is, not rotated) with respect to those of  $\mathcal{O}$ , the transformation is given by Eqs. (1). The galilean

$$t' = t \tag{1a}$$

$$x' = x - vt \tag{1b}$$

$$y' = y \tag{1c}$$

$$z' = z \tag{1d}$$

transformation displays in an explicit manner that the two inertial observers,  $\mathcal{O}$  and  $\mathcal{O}'$ , agree upon the time labeling of events and, in particular, agree upon which events are simultaneous with a given event.

**Causal structure in special relativity.** In special relativity there is a different causal relationship between an arbitrary event  $A$  and other events in space-time (Fig. 2). As in prerelativity physics, there are many events,  $B$ , which lie to the past of  $A$ . There also are many events which lie to the future of  $A$ . However, there is now a much larger class of events which lie neither to the past nor to the future of  $A$ . These events are referred to as being spacelike-related to  $A$ .

The most striking feature of this causal structure (Fig. 2) is the absence of any three-dimensional surface of simultaneity. Indeed, the closest analog to the surface of simultaneity in prerelativity physics is the double-cone-shaped surface that marks the boundaries of the past and future of event  $A$ . This surface comprises the paths in space-time of all light rays which pass through event  $A$ , and for this reason it is referred to as the light cone of  $A$ . Thus, the statement that the events lying to the future of  $A$  are contained within the light cone of  $A$  is equivalent to the statement that a material body present at event  $A$  can never overtake a light ray emitted at event  $A$ . In special relativity, the light cone of an event  $A$  replaces the surface of simultaneity with event  $A$  as the absolute, observer-independent structure of space-time related to causality.

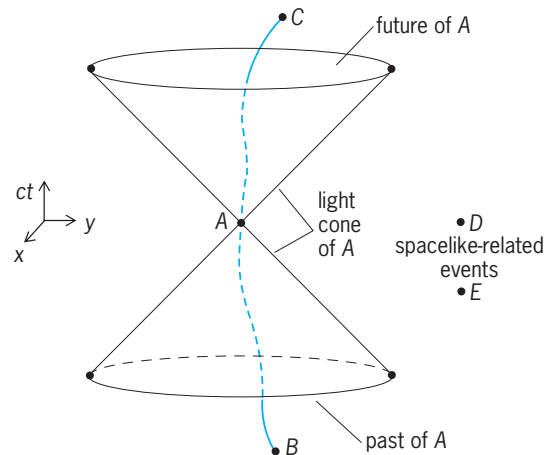

**Fig. 2. Space-time diagram illustrating the causal relationships with respect to an event,  $A$ , in special relativity. Event  $B$  lies to the past of  $A$ , event  $C$  lies to the future of  $A$ , and events  $D$  and  $E$  are spacelike-related to  $A$ .**

As in prerelativity physics, it is assumed in special relativity that an inertial observer,  $\mathcal{O}$ , can build a rigid grid of meter sticks, place clocks at the grid points, and label events in space-time by global inertial coordinates ( $t, x, y, z$ ). The only difference from the procedure used for the construction of the similar coordinates in prerelativity physics is that the synchronization of clocks is now nontrivial, since the causal structure of space-time no longer defines an absolute notion of simultaneity. Nevertheless, any pair of clocks in  $\mathcal{O}$ 's system can be synchronized—and thereby all of  $\mathcal{O}$ 's clocks can be synchronized—by having an assistant stationed half-way between the clocks send a signal to the two clocks in a symmetrical manner. This synchronization of clocks allows  $\mathcal{O}$  to define a notion of simultaneity; that is,  $\mathcal{O}$  may declare events  $A_1$  and  $A_2$  to be simultaneous if time readings,  $t_1$  and  $t_2$ , of the synchronized clocks at events  $A_1$  and  $A_2$  satisfy  $t_1 = t_2$ . However, events judged by  $\mathcal{O}$  to be simultaneous will, in general, be judged by  $\mathcal{O}'$  to be nonsimultaneous. See LORENTZ TRANSFORMATIONS.

The key assumptions of special relativity are encapsulated by the following two postulates.

**Postulate 1:** The laws of physics do not distinguish between inertial observers; in particular, no inertial observer can be said to be at rest in an absolute sense. Thus, if observer  $\mathcal{O}$  writes down equations describing laws of physics obeyed by physically measurable quantities in her global inertial coordinate system

$(t, x, y, z)$ , then the form of these equations must be identical when written down by observer  $\mathcal{O}'$  in his global inertial coordinates  $(t', x', y', z')$ .

Postulate 2: All inertial observers (independent of their relative motion) must always obtain the same value,  $c$ , when they measure the velocity of light in vacuum. In particular, the path of a light ray in space-time must be independent of the motion of the emitter of the light ray. Furthermore, no material body can have a velocity greater than  $c$ .

The precise relationship between the labeling of events in space-time by the coordinate systems of two inertial observers,  $\mathcal{O}$  and  $\mathcal{O}'$ , in special relativity is given by the Lorentz transformation formulas. In the simple case where  $\mathcal{O}'$  moves with velocity  $v$  in the  $x$  direction with respect to  $\mathcal{O}$  and crosses  $\mathcal{O}$ 's world line at the event labeled by  $(t, x, y, z) = (t', x', y', z') = (0, 0, 0, 0)$  with spatial axes aligned, the Lorentz transformation is given by Eqs. (2a)–(2d). Equation (2a) shows explicitly that  $\mathcal{O}$  and  $\mathcal{O}'$  disagree over simultaneity.

$$t' = \frac{t - \frac{xv}{c^2}}{\sqrt{1 - \frac{v^2}{c^2}}} \quad (2a)$$

$$x' = \frac{x - vt}{\sqrt{1 - \frac{v^2}{c^2}}} \quad (2b)$$

$$y' = y \quad (2c)$$

$$z' = z \quad (2d)$$

**Space-time geometry.** A key question both in prerelativity physics and in special relativity is what quantities, describing the space-time relationships between events, are observer independent. Such quantities having observer-independent status may be viewed as describing the fundamental, intrinsic structure of space-time.

It has already been seen that in special relativity the time interval,  $\Delta t$ , between two events is no longer observer independent. Furthermore, since different inertial observers disagree over simultaneity, the spatial interval between two simultaneous events is not even a well-defined concept, and cannot be observer independent. Remarkably, however, in special relativity, all inertial observers agree upon the value of the space-time interval,  $I$ , between any two events, where  $I$  is defined by Eq. (3). What is most

$$I = (\Delta x)^2 + (\Delta y)^2 + (\Delta z)^2 - c^2(\Delta t)^2 \quad (3)$$

remarkable about this formula for  $I$  is that it is very closely analogous to the formula for squared distance in euclidean geometry. The minus sign occurring in the last term in Eq. (3) is of considerable importance, since it distinguishes between the notions of time and space in special relativity. Nevertheless, this minus sign turns out not to be a serious obstacle to the mathematical development of the theory of lorentzian geometry based upon the space-time interval,  $I$ , in a manner which parallels closely the development of euclidean geometry. In particular, notions such as geodesics (straightest possible lines) can be introduced in lorentzian geometry in complete analogy with euclidean geometry. The Lorentz transformation between the two inertial observers is seen from this perspective to be the mathematical analog of a rotation between two cartesian frames in euclidean geometry.

The formulation of special relativity as a theory of the lorentzian geometry of space-time is of great importance for the further development of the theory, since it makes possible the generalization which describes gravitation. The lorentzian geometry defined by Eq. (3) is a flat geometry, wherein initially parallel geodesics remain parallel forever. The theory of general

relativity accounts for the effects of gravitation by allowing the lorentzian geometry of space-time to be curved. See SPACE-TIME.

**Consequences.** The theory of special relativity makes many important predictions, the most striking of which concern properties of time. One such effect, known as time dilation, is predicted directly by the Lorentz transformation formula (2a). If observer  $\mathcal{O}$  carries a clock, then the event at which  $\mathcal{O}$ 's clock reads time  $\tau$  would be labeled by her as  $(\tau, 0, 0, 0)$ . According to Eq. (2a), the observer  $\mathcal{O}'$  would label the event as  $(t', x', 0, 0)$  where  $t'$  is given by Eq. (4). Thus,  $\mathcal{O}'$  could say that a clock carried by  $\mathcal{O}$

$$t' = \frac{\tau}{\sqrt{1 - \frac{v^2}{c^2}}} > \tau \quad (4)$$

slows down on account of  $\mathcal{O}'$ 's motion relative to  $\mathcal{O}$ '. Similarly,  $\mathcal{O}$  would find that a clock carried by  $\mathcal{O}'$  slows down with respect to hers. This apparent disagreement between  $\mathcal{O}$  and  $\mathcal{O}'$  as to whose clock runs slower is resolved by noting that  $\mathcal{O}$  and  $\mathcal{O}'$  use different notions of simultaneity in comparing the readings of their clocks.

The decay of unstable elementary particles provides an important direct application of the time dilation effect. If a particle is observed to have a decay lifetime  $T$  when it is at rest, special relativity predicts that its observed lifetime will increase according to Eq. (6) when it is moving. Exactly such an increase is routinely observed in experiments using particle accelerators, where particle velocities can be made to be extremely close to  $c$ . See PARTICLE ACCELERATOR.

An even more striking prediction of special relativity is the clock paradox: Two identical clocks which start together at an event  $A$ , undergo different motions, and then rejoin at event  $B$  will, in general, register different total elapsed time in going from  $A$  to  $B$ . This effect is the lorentzian geometry analog of the mundane fact in euclidean geometry that different paths between two points can have different total lengths. See CLOCK PARADOX. [R.H.Wa.]

**General theory.** One of the basic tenets of special relativity is that no physical effect can propagate with a velocity greater than the speed of light,  $c$ , which represents a universal speed limit. On the other hand, classical gravitational theory describes the gravitational field of a body throughout space as a function of its instantaneous position, which is equivalent to the assumption that gravitational effects propagate with an infinite velocity. Thus, special relativity and classical gravitational theory are inconsistent, and a modified theory of gravity is necessary.

**Principle of equivalence.** It had long been considered a fundamental question why bodies of different mass fall with the same acceleration in a gravitational field. This situation was explained by Newton with the statement that both the gravitational force on a body and its inertial resistance to acceleration are proportional to its mass.

Newton's explanation is more in the nature of an ad hoc description. A deeper and more natural explanation occurred to Einstein. There are numerous forces other than gravity which are mass-proportional. These generally arise due to the use of accelerated coordinate systems to describe the motion, for example, the centrifugal force encountered in a rotating coordinate system. If an observer in the gravitational field of the Earth and another in an accelerating elevator or rocket in free space both drop a test body, they will both observe it to accelerate relative to the floor. According to classical theory, the Earth-based observer would attribute this to a gravitational force and the elevator-based observer would attribute it to the accelerated floor overtaking the uniformly moving body. In both cases the motion is identical, and in particular the acceleration is independent of the mass of the test body. Einstein elevated this fact to a general principle, the principle of equivalence; the principle states that on a local scale all physical effects of a gravitational field are indistinguishable from the physical effects of an accelerated coordinate system. This profound principle is the physical

cornerstone of the theory of general relativity. From the point of view of the principle of equivalence, it is obvious why the motion of a test body in a gravitational field is independent of its mass. But the principle applies not only to mechanics but to all physical phenomena and thereby has profound consequences for electromagnetic and other nonmechanical phenomena. See CENTRIFUGAL FORCE.

**Tensor field equations.** The close connection between gravity and accelerating coordinate systems convinced Einstein that gravity is fundamentally a geometric phenomenon. Because of this, it is naturally described by the mathematics of higher-dimensional abstract geometry. This geometry involves systems of equations, called tensor equations, that are manifestly independent of the coordinate system. Tensors are a simple generalization of vectors. See TENSOR ANALYSIS.

The space-time of relativity contains one covariant second-rank tensor of particularly great importance, called the metric tensor  $g_{\mu\nu}$ , which is a generalization of the Lorentz metric of special relativity, introduced in Eq. (3). Nearby points in space-time, called events, which are separated by coordinate distances  $dx^\mu$  have an invariant physical separation whose square, called the line element, is defined by Eq. (5). This quantity is a generaliza-

$$ds^2 = g_{\mu\nu} dx^\mu dx^\nu \quad (5)$$

tion of the space-time interval,  $I$ , in special relativity.

Tensor equations are equations in which one tensor of a given type is set equal to another of the same type. The field equations of general relativity are tensor equations for the metric tensor, which completely describes the geometry of the space. The Riemann tensor (or curvature tensor),  $R_{\mu\beta\nu\alpha}$ , plays a central role in the geometric structure of a space; if it is zero, the space is termed flat and has no gravitational field; if nonzero, the space is termed curved, and a gravitational field is present. In terms of the contracted Riemann tensor, that is, a Riemann tensor summed over  $\alpha = \beta$ , the Einstein field equations for empty space are given by Eq. (6).

$$\sum_{\alpha} R_{\mu\alpha\nu}^{\alpha} \equiv R_{\mu\nu} = 0 \quad (\text{empty space}) \quad (6)$$

The field equations are a set of 10 second-order partial differential equations since the four-by-four symmetric tensor  $R^{\mu\nu}$  has 10 independent components; they are to be solved for the metric tensor. A solution in a given coordinate system defines an Einstein space-time. The curvature of this space corresponds to the intrinsic presence of a gravitational field. Thus the concept of a field of mechanical force in classical gravitational theory is replaced by the geometric concept of curved space in relativity theory. See DIFFERENTIAL EQUATION.

In a nonempty region of space the field equations (6) must be modified to include a tensor representing the matter or energy content of space, the energy-momentum tensor  $T_{\mu\nu}$ . The modified equations are Eq. (7), where  $G$  is the gravitational constant,

$$\begin{aligned} G_{\mu\nu} &\equiv R_{\mu\nu} - \frac{1}{2}g_{\mu\nu} \sum_{\alpha} R_{\alpha}^{\alpha} \\ &= -\frac{8\pi G}{c^4} T_{\mu\nu} \quad (\text{nonempty space}) \quad (7) \end{aligned}$$

equal to  $6.67 \times 10^{-11} \text{ N} \cdot \text{m}^2 \cdot \text{kg}^{-2}$ . On the left is the tensor  $G_{\mu\nu}$  representing the geometry of space, and on the right is the tensor  $T_{\mu\nu}$  representing the mass or energy content of space. The tensor  $G_{\mu\nu}$  defined in Eq. (7) is called the Einstein tensor. These equations automatically imply the conservation of energy and momentum, which is an extremely important result. Moreover, in the limiting case when the mass densities of all the gravitating bodies are small and their velocities are small compared to  $c$ , the equations reduce to the classical newtonian equations of gravity.

**Cosmological term.** The field equations were given in the form of Eq. (7) by Einstein in 1916. However, they can be consistently generalized by the addition of another term on the left

side, which he called the cosmological term,  $\Lambda g_{\mu\nu}$ . The more general equations are (8). The constant  $\Lambda$  is called the cosmological constant.

$$G_{\mu\nu} + \Lambda g_{\mu\nu} = -\frac{8\pi G}{c^4} T_{\mu\nu} \quad (8)$$

Einstein introduced the cosmological term in 1917 in order to obtain mathematical models of the universe that were independent of time, since it was then believed that the universe was static. When it was discovered in 1929 that the universe is expanding, as evidenced by the Doppler shifts of distant galaxies, Einstein abandoned the cosmological term. However, interest in the cosmological constant has revived in connection with a serious inconsistency between relativity and quantum theory involving the quantum energy of the vacuum, and with observations since 1998 of type Ia supernovae which suggest that the expansion of the universe is accelerating.

**Motion of test bodies.** The path of a test body is a generalization of a straight line in euclidean space; it is the shortest "distance" (in terms of intervals  $ds$ ) between points in space-time, known as a geodesic. General relativity theory possesses an extraordinary property: because the field equations are nonlinear, unlike those of newtonian theory, the motion of a test body in a gravitational field is not arbitrary since the body itself has mass and contributes to the field. Indeed, the field equations are so restrictive that the geodesic equation of motion is a necessary consequence and need not be treated as a separate postulate.

**Schwarzschild solution.** A very important solution of the field equations was obtained by K. Schwarzschild in 1916, surprisingly soon after the inception of general relativity. This solution represents the field in free space around a spherically symmetric body such as the Sun. It is the basis for a relativistic description of the solar system and most of the experimental tests of general relativity which have been carried out.

**Gravitational redshift.** Electromagnetic radiation of a given frequency emitted in a gravitational field will appear to an outside observer to have a lower frequency; that is, it will be redshifted. The redshift can be derived from the principle of equivalence. The most accurate test of the redshift to date was performed using a hydrogen maser on a rocket. Comparison of the maser frequency with Earth-based masers gave a measured redshift in agreement with theory to about 1 part in  $10^4$ . See REDSHIFT.

**Perihelion shift.** The equations of motion can be solved for a planet considered as a test body in the Schwarzschild field of the Sun. As should be expected, the orbits obtained are very similar to the ellipses of classical theory. However, the ellipse rotates very slowly in the plane of the orbit so that the perihelion, the point of closest approach of the planet to the Sun, is at a slightly different angular position for each orbit. This shift is extremely small. It is greatest in the case of the planet Mercury, whose perihelion advance is predicted to be 43 seconds of arc in a century. This agrees with the discrepancy between classical theory and observation, which was well known for many years before the discovery of general relativity. See CELESTIAL MECHANICS.

**Deflection of light.** The principle of equivalence suggests an extraordinary phenomenon of gravity. Light or other electromagnetic radiation crossing the Einstein elevator horizontally will appear to be deflected downward in a parabolic arc because of the upward acceleration of the elevator. The same phenomenon must occur for light in the gravitational field of the Sun; it must be deflected toward the Sun. A calculation of this deflection gives 1.75 seconds for the net deflection of starlight grazing the edge of the Sun. Modern measurements, made by tracking quasars as they pass near or behind the Sun, find the deflection to be within 1% of the value predicted by general relativity.

In 1936 Einstein observed that if two stars were exactly lined up with the Earth, the more distant star would appear as a ring of light, distorted from its point appearance by the lens effect of the gravitational field of the nearer star. It was soon pointed

out that a very similar phenomenon was much more likely to occur for entire galaxies instead of individual stars. Many candidates for such gravitational lens systems have been found. See GRAVITATIONAL LENS.

**Radio time delay.** In the curved space around the Sun the distance between points in space, for example between two planets, is not the same as it would be in flat space. In particular, the round-trip travel time of a radar signal sent between the Earth and the planet will be measurably increased by the curvature effect when the Earth, the Sun, and the planet are approximately lined up. Using a transponder on the Viking spacecraft, the time delay was found to agree with the predictions of general relativity to an accuracy of about one-half of 1%.

For applications of general relativity certain studies see BLACK HOLE; COSMOLOGY; GRAVITATIONAL RADIATION; PULSAR. [R.J.A.]

**Relaxation time of electrons** The characteristic time for a distribution of electrons in a solid to approach or “relax” to equilibrium after a disturbance is removed. A familiar example is the property of electrical conductivity, in which an applied electric field generates an electron current which relaxes to an equilibrium zero current after the field is turned off. The conductivity of a material is directly proportional to this relaxation time; highly conductive materials have relatively long relaxation times. The closely related concept of a lifetime is the mean time that an electron will reside in a given quantum state before changing state as a result of collision with another particle or intrinsic excitation. This lifetime is related to equilibrium properties of the material, whereas the relaxation time relates to the thermal and electrical transport properties. The average distance that an electron travels before a collision is called the mean free path. Although typical collision times in metals are quite short (on the order of  $10^{-14}$  s at room temperature), mean free paths range from about 100 atomic distances at room temperature to  $10^6$  atomic distances in pure metals near absolute zero temperature. Considering the very dense packing of atoms in a solid, these surprisingly long electron path lengths are analogous to the unlikely event that a rifle bullet might travel for miles through a dense forest without hitting a tree. The detailed explanation of the electron mean free path in metals is a major success of the modern theory of solids.

A relaxation time appears in the simplest expression for the transport property of electrical conductivity, which states that the electrical conductivity equals the product of the relaxation time, the density of conduction electrons, and the square of the electron charge, divided by the electron effective mass in the solid. See BAND THEORY OF SOLIDS; ELECTRICAL CONDUCTIVITY OF METALS.

The conduction process is a steady-state balance between the accelerating force of an electric field and the decelerating friction of electron collisions which occur on the time scale of the relaxation time. This process may be described in terms of the probability distribution function for the electrons, which depends on the electron momentum (proportional to the wave vector,  $\mathbf{k}$ , which labels the quantum state of the electrons), the position, and the time. Viewed in  $\mathbf{k}$ -space, the entire distribution will shift from an equilibrium state under the influence of a perturbation such as an electric field (see illustration). For example, in the ground state, the collection of occupied electron states in  $\mathbf{k}$ -space is bounded by the Fermi surface centered at the origin, while in an electric field this region is shifted. Because of electron collisions with impurities, lattice imperfections, and vibrations (also called phonons), the displaced surface may be maintained in a steady state in an electric field. These collisions also restore the equilibrium distribution after the field is turned off, and the relaxation time is determined by the rate at which the shifted distribution returns to equilibrium. Specifically, the contribution of collisions to the rate of change of the shifted distribution after the field is turned off equals the difference between the shifted and equilibrium distributions divided by the relaxation time. This

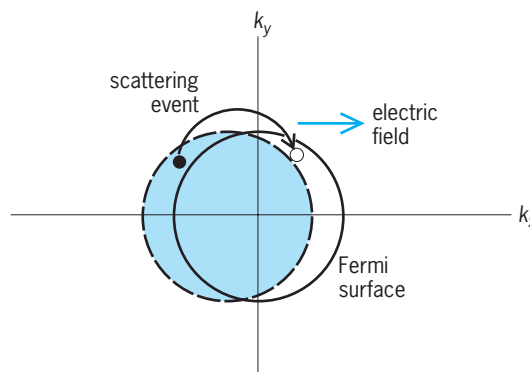

**Effect of the electric field on electron distribution in a solid, viewed in  $\mathbf{k}$ -space, where  $\mathbf{k}$  is the electron wave vector. The shaded area indicates occupied states in distribution which result when the field is applied.**

statement is referred to as the relaxation-time approximation, and is a simple way of expressing the role of collisions in the maintenance of thermodynamic equilibrium. The details of the various collision mechanisms are lumped into the parameter of the relaxation time. For example, in the case of mixed scattering by impurities and phonons, the inverse of the relaxation time can be determined from the sum of collision rates as the sum of the inverses of the electron-impurity and electron-phonon scattering times. See CRYSTAL DEFECTS; FERMI SURFACE; LATTICE VIBRATIONS; PHONON.

In pure metals at low temperatures, the long mean free path of conduction electrons results from their large velocity (on the order of  $10^6$  m/s near the Fermi surface) and relatively long relaxation time, on the order of  $10^{-9}$  s. From a practical standpoint, this is what makes metals useful as electrical conductors even at room temperature, where a relaxation time on the order of  $10^{-14}$  s and a mean free path (equal to the product of the velocity and the relaxation time) on the order of  $10^{-8}$  m (or about 100 atomic distances) is typical.

As compared to poorly conducting solids or insulators, an excess of so-called free electrons in a metal contributes to the long mean free paths. From a quantum mechanical standpoint, the free-electron wave function readjusts in a perfectly periodic atomic lattice to avoid the atomic ion cores and spend most of the time in the spaces between. In the analogy of the rifle fired into a forest, the bullet will not travel far, but the sound of the gunshot can, because the sound waves bend around the trees in a constructive manner. In a perfectly periodic lattice, the electron waves scatter constructively from the atomic ion cores, resulting in screening of the cores and coherent transmission of the waves over large distances. Any disturbance to the lattice periodicity tends to destroy this wave phenomenon, resulting in lower transmission or energy loss. At room temperature, the conductivity is usually limited by scattering from lattice vibrations (phonons). At lower temperatures, vibrations are greatly reduced, but the conductivity is still limited by scattering from impurities and imperfections. See ELECTRICAL RESISTIVITY; FREE-ELECTRON THEORY OF METALS; QUANTUM MECHANICS.

In the superconductive state, observed in many metals and certain complex compounds at sufficiently low temperatures, impurities, imperfections, and lattice vibrations become completely ineffective in retarding current flow, leading to persistent electric currents even after the driving electric field is removed. This state of resistanceless conduction is described as an ordered quantum state of pairs of electrons resulting from lattice vibrations which deform the ion core potential in such a way as to provide an attractive electron-electron interaction. The relaxation time thus becomes infinite (as nearly as can be measured), a rare macroscopic manifestation of a quantum effect. See SUPERCONDUCTIVITY. [G.L.Ee.]

**Relay** An electromechanical or solid-state device operated by variations in the input which, in turn, operate or control other devices connected to the output. They are used in a wide variety of applications throughout industry, such as in telephone exchanges, digital computers, motor and sequencing controls, and automation systems. Highly sophisticated relays are utilized to protect electric power systems against trouble and power blackouts as well as to regulate and control the generation and distribution of power. In the home, relays are used in refrigerators, automatic washers and dishwashers, and heat and air-conditioning controls. Although relays are generally associated with electrical circuitry, there are many other types, such as pneumatic and hydraulic. Input may be electrical and output directly mechanical, or vice-versa.

Relays using discrete solid-state components, operational amplifiers, or microprocessors can provide more sophisticated designs. Their use is increasing, particularly in applications where the relay and associated equipment are packaged together. See AMPLIFIER; MICROPROCESSOR. [J.L.B.]

### Reliability, availability, and maintainability

Reliability is the probability that an engineering system will perform its intended function satisfactorily (from the viewpoint of the customer) for its intended life under specified environmental and operating conditions. Maintainability is the probability that maintenance of the system will retain the system in, or restore it to, a specified condition within a given time period. Availability is the probability that the system is operating satisfactorily at any time, and it depends on the reliability and the maintainability. Hence the study of probability theory is essential for understanding the reliability, maintainability, and availability of the system. See PROBABILITY.

Reliability is basically a design parameter and must be incorporated into the system at the design stage. It is an inherent characteristic of the system, just as is capacity, power rating, or performance. A great deal of emphasis is placed on quality of products and services, and reliability is a time-oriented quality characteristic. There is a relationship between quality or customer satisfaction and measures of system effectiveness, including reliability and maintainability. Customers are concerned with the performance of the product over time.

To analyze and measure the reliability and maintainability characteristics of a system, there must be a mathematical model of the system that shows the functional relationships among all the components, the subsystems, and the overall system. The reliability of the system is a function of the reliabilities of its components. A system reliability model consists of some combination of a reliability block diagram or a cause-consequence chart, a definition of all equipment failure and repair distributions, and a statement of spare and repair strategies. All reliability analyses and optimizations are made on these conceptual mathematical models of the system.

Maintainability is a measure of the ease and rapidity with which a system or equipment can be restored to operational status following a failure. It is a characteristic of equipment design and installation, personnel availability in the required skill levels, adequacy of maintenance procedures and test equipment, and the physical environment under which maintenance is performed. Maintainability is expressed as the probability that an item will be retained in or restored to a specific condition within a given period of time, when the maintenance is performed in accordance with prescribed procedures and resources. [K.C.K.]

**Reluctance** A property of a magnetic circuit analogous to resistance in an electric circuit.

Every line of magnetic flux is a closed path. Whenever the flux is largely confined to a well-defined closed path, there is a magnetic circuit. That part of the flux that departs from the path is called flux leakage.

For any closed path of length  $l$  in a magnetic field  $H$ , the line integral of  $H \cos \alpha \, dl$  around the path is the magnetomotive force (mmf) of the path, as in Eq. (1), where  $\alpha$  is the angle between

$$\text{mmf} = \oint H \cos \alpha \, dl \quad (1)$$

$H$  and the path. If the path encloses  $N$  conductors, each with current  $I$ , Eq. (2) holds.

$$\text{mmf} = \oint H \cos \alpha \, dl = NI \quad (2)$$

Consider the closely wound toroid shown in the illustration. For this arrangement of currents, the magnetic field is almost

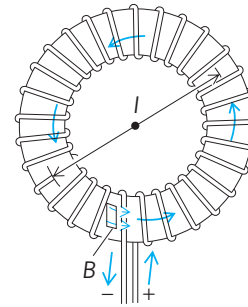

A toroidal coil.

entirely within the toroidal coil, and there the flux density or magnetic induction  $B$  is given by Eq. (3), where  $l$  is the mean

$$B = \mu \frac{NI}{l} \quad (3)$$

circumference of the toroid and  $\mu$  is the permeability. The flux  $\Phi$  within the toroid of cross-sectional area  $A$  is given by either form of Eqs. (4), which is similar in form to the equation for the

$$\begin{aligned} \Phi &= BA = \frac{\mu A}{l} NI \\ \Phi &= \frac{NI}{l/\mu A} = \frac{\text{mmf}}{l/\mu A} = \frac{\text{mmf}}{\mathcal{R}} \end{aligned} \quad (4)$$

electric circuit, although nothing actually flows in the magnetic circuit. The factor  $l/\mu A$  is called the reluctance  $\mathcal{R}$  of the magnetic circuit. The reluctance is not constant because the permeability  $\mu$  varies with changing flux density. [K.V.M.]

**Reluctance motor** An alternating current motor with a stator winding like that of an induction motor, and a rotor that has projecting or salient poles of ferromagnetic material. When connected to an alternating-current source, the stator winding produces a rotating magnetic field, with a speed of  $4\pi f/p$  radians per second ( $120f/p$  revolutions per minute), where  $f$  is the frequency of the source and  $p$  the number of magnetic poles produced by the winding. When the rotor is running at the same speed as the stator field, its iron poles tend to align themselves with the poles of that field, producing torque. If a mechanical load is applied to the shaft of the motor, the rotor poles lag farther behind the stator-field poles, and increased torque is developed to match that of the mechanical load. This torque is given by the equation below, where  $\phi$  is the flux per pole, determined largely

$$\tau = \frac{p}{2} \phi^2 \frac{dR}{d\delta}$$

by the applied voltage. The quantity  $dR/d\delta$  is the rate of change of magnetic reluctance per pole with respect to  $\delta$ , the angle of lag in mechanical radians. This quantity typically varies as  $\sin p\delta$ . Here,  $p\delta = 2\delta_e$ , where  $\delta_e$  is the lag angle in electrical radians. Therefore, at constant torque load the rotor runs in synchronism with the stator field, with the rotor poles lagging the field poles by a constant angle. See ELECTRICAL DEGREE.

This phenomenon develops torque only at synchronous speed, and thus no starting torque is produced. For that reason, induction-motor rotor bars are usually built into the pole faces, and the motor starts as an induction motor. When the rotor speed approaches that of the magnetic field, the pole pieces lock in step with the magnetic poles of the field, and the rotor runs at synchronous speed.

Single-phase reluctance motors may be started by the methods used for single-phase induction motors, such as capacitor, split-phase, or shaded-pole starting. See ALTERNATING-CURRENT MOTOR; ELECTRIC ROTATING MACHINERY; INDUCTION MOTOR; MOTOR; SYNCHRONOUS MOTOR. [G.McP.]

**Remipedia** A unique class of the Crustacea whose members, at first glance, resemble polychaete worms in overall body form. This impression comes from their multiple serial segments and lack of obvious body divisions. The lack of body organization suggests that remipeds are the most primitive crustaceans yet recognized. When compared with the other presumably primitive crustacean class, the Cephalocarida, remipeds are relatively large, with mature individuals ranging from 0.6 to 1.7 in. (15 to 42 mm) in body length. Although the trunk appendages are biramous and paddle-shaped in both classes, endites and epipods that are present in cephalocarids are lacking in remipeds. See CEPHALOCARIDA; CRUSTACEA.

As now constituted, the Remipedia comprise two orders, three families, and four genera; however, as more marine caves are explored additional species will be discovered. [P.A.McL.]

**Remote-control system** A control system in which the issuing of the control command and its execution are separated by a relatively significant distance. The system normally includes a command device where the control command is entered, and an actuator that executes it. These are connected by a transmission medium that transmits the command, usually in a coded format.

The transmission medium may be a mechanical link, where the command is transmitted as force; a pneumatic or hydraulic line, where pressure represents the command; an electrical line with a voltage or current signal; or radio or infrared waves that are modulated according to the command. See MODULATION.

The simplest remote-control systems are limited to switching-type functions. These systems operate basically in an open loop, that is, without relying on feedback. Some typical examples are a ceiling lamp turned on and off by a light switch via an electrical wire; the on/off function of a television receiver with an infrared remote controller; and railway switches operated from a remote-control room.

The most characteristic remote-control systems involve feedback that is provided by the human operator. The person issuing the control command senses the result of the control action and guides the system accordingly. This kind of operation can be found, for example, in remote control of toy cars and airplanes by wire or radio, remote operation of large construction cranes, and cockpit control of an airplane's engines and control surfaces. See FLIGHT CONTROLS.

Teleoperation represents an important class within remote-control systems with human feedback. Teleoperators (or remote manipulators) act as extensions of the human hand. They are employed in situations where access is difficult or impossible or where the environment is hazardous for humans, such as in underwater and space operations, or in the presence of radiation, chemical, or biological contamination. See REMOTE MANIPULATORS.

Many automatic control systems may also be considered as remote controllers. This is the case whenever the sensing of the controlled variable and the automatic formation of the control command are removed from the actuator. A typical example is the heating and air-conditioning system of a building, where

room thermostats operate remotely located furnaces, compressors, and fans. See CONTROL SYSTEMS. [J.Ger.]

**Remote manipulators** Mechanical, electromechanical, or hydromechanical devices which enable a person to perform manual operations while separated from the site of the work. Remote manipulators are designed for situations where direct contact would be dangerous to the human (working with radioactive material), where direct human contact is ill-advised or impossible (certain medical procedures), and where human force-producing capabilities are absent (the disabled) or need to be amplified to complete some task (industrial assembly or construction).

Basic defining elements are common to almost all remote manipulators. An input device or control handle allows the operator to command the remote manipulator. The movement of the input device is received by a control station that translates the inputs into a form that can be transmitted over the distance separating the human and remote manipulator. This translation can be mechanical, using cables and linkages, or electrical/electromagnetic, using the movement of the input device to generate an electrical or electromagnetic signal that is easily transmitted to the remote manipulator. Since vision is an important cue that humans use in direct manipulation, visual feedback of a remote manipulator's actions typically must be provided. In some remote manipulation systems, tactile feedback to the human operator is provided; that is, forces proportional to those being exerted by the remote manipulator on the object are fed back to the human through the input device. Such force feedback is important in certain tasks where the possibility of damage to the manipulator or object can occur.

The growth in the number and variety of remote manipulator applications has been aided by enabling technologies such as digital computers, lightweight materials, and video communication links. Space applications include the space shuttle remote manipulator arm, which has been used to retrieve and launch large satellites. The arm is operated by astronauts in the shuttle orbiter cabin, and employs graphic displays of the forces and torques being applied by the manipulator arm to the satellite. Other applications include use in crewless underwater vehicles and surgical procedures. See SPACE SHUTTLE; UNDERWATER VEHICLE.

Aiding the disabled is an important use of remote manipulators. One example is devices that allow individuals with little or no control of their upper extremities to feed themselves. Such devices have been referred to as teletheses (alluding to the extrasensory perception of distant objects).

Devices that augment the strength of the human have been proposed for industrial applications. For example, a load-sharing manipulator has been envisioned in which human arm-manipulator coordination effectively allows the human to work with a "partner" that has considerably more strength. See CONTROL SYSTEMS; HUMAN-MACHINE SYSTEMS; ROBOTICS. [R.A.He.]

**Remote sensing** The gathering and recording of information about terrain and ocean surfaces without actual contact with the object or area being investigated. Remote sensing uses the visual, infrared, and microwave portions of the electromagnetic spectrum. Remote sensing is generally conducted by means of remote sensors installed in aircraft and satellites.

**Photography.** Photography is probably the most useful remote sensing system. Much of the experience gained over the years from photographs of the terrain taken from aircraft is being drawn upon for use in space.

Multispectral photography isolates the reflected energy from a surface in a number of given wavelength bands and records each spectral band separately on film. This technique allows selection of the significant bandwidths in which a given area of terrain displays maximum tonal contrast and, hence, increases the effective spectral resolution of the system over conventional

black-and-white or color systems. Because of its spectral selectivity capabilities, the multispectral approach provides a means of collecting a great amount of specific information.

**Multispectral imagery.** Multispectral scanning systems record the spectral reflectance by photoelectric means (rather than by photochemical means as in multispectral photography) simultaneously in several individual wavelengths within the visual and near-infrared portions of the electromagnetic spectrum.

In satellite applications, optical energy is sensed by an array of detectors simultaneously in four spectral bands from 0.47 to 1.1 micrometers. As the optical sensors for the various frequency bands sweep across the underlying terrain in a plane perpendicular to the flight direction of the satellite, they record energy from individual areas on the ground. The smallest individual area distinguished by the scanner is called a picture element or pixel, and a separate spectral reflectance is recorded in analog or digital form for each pixel. The spectral reflectance values for each pixel can be transmitted electronically to ground receiving stations in near-real time, or stored on magnetic tape in the satellite until it is over a receiving station. When the signal intensities are received on the ground, they can be reconstructed almost instantaneously into the virtual equivalent of conventional aerial photographs.

**Infrared.** Thermal infrared radiation is mapped by means of infrared scanners similar to multispectral scanners, but in this case radiated energy is recorded generally in the 8–14- $\mu\text{m}$  portion of the electromagnetic spectrum. The imagery provided by an infrared scanning system gives information that is not available from ordinary photography or from multispectral scanners operating in the visual portion of the electromagnetic spectrum. See EMISSIVITY; INFRARED RADIATION.

In the past, thermal infrared images were generally recorded on photographic film. Videotape records are replacing film as the primary recording medium and permit better imagery to be produced and greater versatility in interpretation of data.

Thermal infrared mapping (thermography) from satellite altitudes is proving to be useful for a number of purposes, one of which is the mapping of thermal currents in the ocean. Thermal infrared mapping from aircraft and satellite altitudes has many other uses also, including the mapping of volcanic activity and geothermal sites, location of groundwater discharge into surface and marine waters, and regional pollution monitoring.

**Microwave radar.** This type of remote sensing utilizes both active and passive sensors. The active sensors such as radar supply their own illumination and record the reflected energy. The passive microwave sensors record the natural radiation. A variety of sensor types are involved. These include imaging radars, radar scatterometers and altimeters, and over-the-horizon radars using large ground-based antenna arrays, as well as passive microwave radiometers and imagers. One of the most significant advantages of these instruments is their all-weather capability, both day and night. See MICROWAVE; RADAR.

**High-frequency (hf) radar.** Such radars utilize frequencies in the 3–30-MHz portion of the electromagnetic spectrum (median wavelength of about 20 m) and are thus not within the microwave part of the spectrum. The energy is transmitted by ground-based antennas in either a sky-wave or surface-wave mode. In the sky-wave mode, the energy is refracted by the various ionospheric layers back down to the Earth's surface some 480–1800 mi or 800–3000 km (on a single-hop basis) away from the hf radar antenna site. The incident waves are reflected from such surface features as sea waves. [P.C.B.]

**Renewable resources** Agricultural materials used as feedstocks for industrial processes. For many centuries agricultural products were the main sources of raw material for the manufacturing of soap, paint, ink, lubricants, grease, paper, cloth, drugs, and a host of other nonfood products. During the early 1900s, the advances in organic synthesis in western Europe and the United States led to the use of coal as an alternative resource;

in the 1940s, oil and natural gas were added as starting materials as a result of great advances in catalysis and polymer sciences. Since then the petrochemical industry has grown rapidly as the result of the abundance and low price of the starting materials as well as the development of new products. However, with the rapidly increasing economies of the nations of the world, these developments did not ever result in reduction in the utilization of agricultural products as industrial materials.

Animal fats, marine and vegetable oils, and their fatty acid derivatives have always played a major role in the manufacturing of many industrial products. Some of these commodities are produced solely for industrial end uses; examples are linseed, tung, castor (not counting minor amounts used for medicinal purposes), and sperm whale oils. Others, such as tallow and soybean oil, are used for both edible and industrial products. See DETERGENT; FAT AND OIL; LUBRICANT; SOAP.

Starch, cellulose, and gums also have been used for many centuries as industrial materials, whereas sugar crops, such as sugarcane and sugarbeet, have mainly satisfied world food requirements. See CELLULOSE; GUM; STARCH.

Natural rubber and turpentine are excellent examples of plant-derived hydrocarbons. The development of synthetic rubbers during and after World War II has never threatened the demand for natural rubber; there is generally a world shortage. Turpentine is a product of the wood and paper pulp industry and is used as a solvent and thinner in paints and varnishes. See RUBBER.

The threat that industrial nations might be separated from part or all of their traditional sources of raw materials through political and economic upheavals or natural calamities has resulted in a renewed effort to develop additional crops for local agriculture. In the United States, research has provided a number of candidate species that either are now in commercial development or are ready for the time when circumstances warrant such development. Examples are jojoba (liquid wax ester to replace sperm whale oil), guayule (alternate source of natural rubber), kenaf (paper fiber with annual yields much higher than available from trees), and crambe and meadow-foam (long-chain fatty acids, since erucic acid is no longer available from rapeseed oil). There is also active research involving *Cuphea* species (alternate source of lauric and other medium-chain fatty acids, to augment coconut oil), *Vernonia* (source of epoxy oil), and several other promising plants. For example, the Chinese tallow tree has the potential of producing 2.2 tons per acre (5 metric tons per hectare) of seed oil that could be used for manufacturing fuel and other chemicals. [L.H.P.]

**Renner-Teller effect** The splitting, into two, of the potential function along the bending coordinate in degenerate electronic states of linear triatomic or polyatomic molecules. Most of the areas and methods of molecular physics and spectroscopy assume the validity of the Born-Oppenheimer approximation. The nuclei generally move much more slowly than the electrons, the frequencies associated with electronic transitions are much higher than vibrational frequencies, and one can consider separately the three types of molecular motion: electronic, vibrational, and rotational. These statements are no longer necessarily valid for electronic states which are degenerate or at least close to degeneracy, and the Born-Oppenheimer approximation breaks down.

Degenerate electronic states usually occur in molecules having a high degree of symmetry. The symmetric equilibrium geometry which causes the electronic degeneracy is, in general, lowered in the course of molecular vibrations, and this may lead to splitting of the potential. The molecular potential is usually expressed in terms of a polynomial expansion in displacements  $r$ , and, in nonlinear molecules, the linear terms may lead to coupling of the electronic and vibrational degrees of freedom. The resulting breakdown of the Born-Oppenheimer approximation is in this case known as the Jahn-Teller effect. In linear molecules the symmetry is lowered during bending vibrations. In the bending



potential the linear (and other odd) terms are zero by symmetry. The first nonvanishing terms which can couple the degenerate electronic states are quadratic in the bending coordinate. The results of this coupling in linear molecules are referred to as the Renner-Teller effect, or simply the Renner effect. See JAHN-TELLER EFFECT; MOLECULAR STRUCTURE AND SPECTRA. [V.E.B.; T.A.M.]

**Rennin** The common name for chymosin, a proteolytic enzyme that is used to coagulate milk in cheese making. Rennin participates in the cheese-ripening process through its proteolytic activity.

The traditional source of rennin is the fourth stomach (abomasum) of calves that have been fed only milk. The stomachs are dried or salted, cut into small pieces, and soaked in 10% salt brine to extract enzyme components from the stomach lining. Rennin also is produced commercially by using genetically engineered microorganisms.

Approximately 6% of the rennin used to coagulate milk is retained in active form in cheese curd. During cheese ripening, rennin modifies the curd protein structure through its proteolytic action on  $\alpha$ -casein, leading to textural changes described as a loss of curdiness. Casein peptides resulting from rennin action become precursors for flavor compounds in some cheeses such as Cheddar. See CASEIN; CHEESE; ENZYME; MILK. [PKi.]

**Renormalization** A program in quantum field theory consisting of a set of rules for calculating S-matrix amplitudes which are free of ultraviolet (or short-distance) divergences, order by order in perturbative calculations in an expansion with respect to coupling constants. See SCATTERING MATRIX.

So far the only field theories known to be renormalizable in four dimensions are those which include spin-0, spin- $1/2$ , and spin-1 fields such that no term in the lagrangian exceeds operator dimension 4. The operator dimension of any term is calculated by assigning dimension 1 to bosons and derivatives  $\partial_\mu$ , and dimension  $3/2$  to fermions. Spin-1 fields are allowed only if they correspond to the massless gauge potentials of a locally gauge-invariant Yang-Mills-type theory associated with any compact Lie group. The gauge invariance can remain exact or can be allowed to break via spontaneous breakdown without spoiling the renormalizability of the theory. In the latter case the spin-1 field develops a mass. The successful quantum chromodynamics theory describing the strong forces and the  $SU(2) \times U(1)$  Weinberg-Salam-Glashow gauge model of unified electroweak particle interactions are such renormalizable gauge models containing spin 0,  $1/2$ , and 1 fields. See ELECTROWEAK INTERACTION; FUNDAMENTAL INTERACTIONS; GAUGE THEORY; LIE GROUP; QUANTUM CHROMODYNAMICS; QUANTUM ELECTRODYNAMICS; WEAK NUCLEAR INTERACTIONS. [I.Ba.]

Effective field theory is a general and powerful method for analyzing quantum field theories over a wide range of length scales. Together with a closely related idea, the Wilson renormalization group, it places renormalization theory on a more general, physical, and rigorous basis. This method is most naturally developed in the Feynman path integral formulation of quantum field theory, where amplitudes are given by an integral over all histories. Each history is weighted by a phase equal to the classical action divided by Planck's constant. See ACTION. [J.Pol.]

**Reproduction (animal)** The formation of new individuals, which may occur by asexual or sexual methods. In the asexual methods, which occur mainly among the lower animals, the offspring are derived from a single individual. Sexual methods are general throughout the animal kingdom, with offspring ordinarily derived from the paired union of special cells, the gametes, from two individuals. Basic to all processes of reproduction is the origin of the new individual from one or more living cells of the parent or parents.

**Asexual reproduction.** Asexual processes of reproduction include binary fission, multiple fission, fragmentation, budding, and polyembryony. Among the protozoa and lower metazoa, these are common methods of reproduction. However, the last-mentioned process can occur in mammals, including humans.

Binary fission involves an equal, or nearly equal, longitudinal or transverse splitting of the body of the parent into two parts, each of which grows to parental size and form. This method of reproduction occurs regularly among protozoans.

Multiple fission, schizogony, or sporulation produces several new individuals from a single parent. It is common among the Sporozoa, such as the malarial parasite, which form cystlike structures containing many cells, each of which gives rise to a new individual.

Fragmentation is a form of fission occurring in some metazoans, especially the Platyhelminthes, or flatworms; the Nematinea, or ribbon worms; and the Annelida, or segmented worms. The parent worm breaks up into a number of parts, each of which regenerates missing structures to form a whole organism.

Budding is a form of asexual reproduction in which the new individual arises from a relatively small mass of cells that initially forms a growth or bud on the parental body. The bud may assume parental form either before separation from the body of the parent as in external budding, or afterward, as in internal budding. External budding is common among sponges, coelenterates, bryozoans, flatworms, and tunicates. Internal budding occurs among fresh-water sponges and bryozoans. In the sponges the internal buds, termed gemmules, consist of groups of primitive cells surrounded by a dense capsule formed by the body wall. If the parent animal dies as a result of desiccation or low temperature, the cells of the gemmules can later be released and form new sponges. In the bryozoans the similarly functioning buds are known as statoblasts.

Polyembryony is a form of asexual reproduction, occurring at an early developmental stage of a sexually produced embryo, in which two or more offspring are derived from a single egg. Examples are found scattered throughout the animal kingdom, including humans; in humans it is represented by identical twins, triplets, or quadruplets.

**Sexual reproduction.** Sexual reproduction in animals assumes various forms which may be classified under conjugation, autogamy, fertilization (syngamy), and parthenogenesis. Basically, the various processes all involve the occurrence of certain special nuclear changes, termed meiotic divisions, preliminary to the production of the new individual. See GAMETOGENESIS; MEIOSIS.

Conjugation occurs principally among the ciliate protozoans, such as *Paramecium*, and involves a temporary union of two individuals during which each is "fertilized" by a micronucleus from the other.

In autogamy the nuclear changes described for conjugation take place, but since there is no mating, there is no transfer of micronuclei. Instead, the prospective migratory micronucleus reunites with the stationary one. The process may be considered related to parthenogenesis.

Fertilization, or syngamy, comprises a series of events in which two cells, the gametes, fuse and their nuclei, which had previously undergone meiotic divisions, fuse. In metazoans, the gametes are of two morphologically distinct types: spermatozoa, or microgametes, and eggs, also called ova or macrogametes. These types are produced by male and female animals, respectively, but in some cases both may be produced by a single, hermaphroditic individual. The nucleus of the spermatozoon has half the number of chromosomes characteristic of the ordinary (somatic) cells of the animal. The nucleus of the ripe egg in some animals, for instance, coelenterates and echinoderms, also has attained this haploid condition, but in most species of animals it is at an early stage of the meiotic divisions when ready for fertilization. In the latter situation, the meiotic divisions of the egg,

characterized by formation of small, nonfunctional cells termed polar bodies, are completed after the sperm enters, whereupon the haploid egg nucleus fuses with the haploid sperm nucleus. Fertilization thus produces a zygote with the diploid chromosome number typical of the somatic cells of the species (23 pairs in humans), and this is maintained during the ensuing cell divisions.

Parthenogenesis is the development of the egg without fertilization by a spermatozoon. It is listed as a form of sexual reproduction because it involves development from a gamete. Rotifers, crustaceans, and insects are the principal groups in which it occurs naturally. It has also been induced (artificial parthenogenesis) in species from all the major phyla by various kinds of chemical or physical treatment of the unfertilized egg. Even in mammals, several adult rabbits have reportedly been thus produced. See ESTRUS; OOGENESIS; OVUM; SPERM CELL; SPERMATOGENESIS. [A.T.; H.L.H.]

**Reproduction (plant)** The formation by a plant of offspring that are either exact copies or reasonable likenesses. When the process is accomplished by a single individual without fusion of cells, it is referred to as asexual; when fusion of cells is involved, whether from an individual or from different donors, the process is sexual.

**Asexual reproduction.** Using the technique of tissue culture, higher green plants can be regenerated from a single cell and can usually flower and set seed normally when removed and placed in soil. This experiment shows that each cell of the plant body carries all the information required for formation of the entire organism. The culture of isolated cells or bits of tissue thus constitutes a means of vegetative propagation of the plant and can provide unlimited copies identical to the organism from which the cells were derived. See TISSUE CULTURE.

All other vegetative reproductive devices of higher plants are elaborations of this basic ability and tendency of plant cells to produce tissue masses that can organize into growing points (meristems) to yield the typical patterns of differentiated plant organs. For example, a stem severed at ground level may produce adventitious roots. Similarly, the lateral buds formed along stems can, if excised, give rise to entire plants. The "eyes" of the potato tuber, a specialized fleshy stem, are simply buds used in vegetative propagation of the crop. In many plants, cuttings made from fleshy roots can similarly form organized buds and reconstitute the plant by vegetative propagation. Thus, each of the vegetative organs of the plant (leaf, stem, and root) can give rise to new plants by asexual reproduction. See PLANT PROPAGATION.

**Sexual reproduction.** While in asexual reproduction, the genetic makeup of the progeny rarely differs greatly from that of the parent, the fusion of cells in sexual reproduction can give rise to new genetic combinations, resulting in new types of plants. The life cycle of higher green plants consists of two distinct generations, based on the chromosomal complement of their cells. The sporophyte generation is independent and dominant in the flowering plants and ferns, but small, nongreen, and dependent in the mosses, and contains the  $2n$  number of chromosomes. The diploidy results in each case from the fusion of sperm and egg to form the zygote, which then develops into an embryo and finally into the mature sporophyte. The sporophyte generation ends with the formation of  $1n$  spores by reduction division, or meiosis, in a spore mother cell. The spore then develops into the gametophyte generation, which in turn produces the sex cells, or gametes. The gametophyte generation ends when gametes fuse to form the zygote, restoring the  $2n$  situation typical of sporophytes. See MEIOSIS.

In flowering plants, the gametophyte or  $1n$  generation is reduced to just a few cells (generally three for the male and eight for the female). The male gametophyte is formed after meiosis occurs in the microspore mother cells of the anther, yielding a tetrad of  $1n$  microspores. Each of these microspores then divides mitotically at least twice. The first division produces the tube nu-

cleus and the generative nucleus. The generative nucleus then divides again to produce two sperms. These nuclei are generally not separated by cell walls, but at this stage the outer wall of the spore becomes thickened and distinctively patterned—a stage typical of the mature male gametophyte, the pollen grain. See FLOWER; MITOSIS; POLLEN; POLLINATION.

Each pollen grain has a weak pore in its wall, through which the pollen tube emerges at the time of germination. Pollen germinates preferentially in the viscous secretion on the surface of the stigma, and its progress down the style to the ovary is guided through specific cell-to-cell recognition processes. Throughout its growth, which occurs through the deposition of new cell wall material at the advancing tip, the pollen tube is controlled by the tube nucleus, usually found at or near the tip. When the pollen tube, responding to chemical signals, enters the micropyle of the ovule, its growth ceases and the tip bursts, discharging the two sperms into the embryo sac, the female gametophyte of the ovary.

The female gametophyte generation, like the male, arises through meiotic division of a  $2n$  megaspore mother cell. This division forms four  $1n$  megaspores, of which three usually disintegrate, the fourth developing into an eight-nucleate embryo sac by means of three successive mitotic divisions. The eight nuclei arrange themselves into two groups of four, one at each pole of the embryo sac. Then one nucleus from each pole moves to the center of the embryo sac. One of the three nuclei at the micropylar end of the embryo sac is the female gamete, the egg, which fuses with one of the sperm nuclei to form the zygote, the first cell of the sporophyte generation, which produces the embryo. The second sperm fuses with the two polar nuclei at the center of the embryo sac to form a  $3n$  cell that gives rise to the endosperm of the seed, the tissue in which food is stored. The entire ovule ripens into the seed, with the integuments forming the protective seed coat. The entire ovary ripens into a fruit, whose color, odor, and taste are attractive to animals, leading to dispersal of the seeds. The life cycle is completed when the seed germinates and grows into a mature sporophyte with flowers, in which meiotic divisions will once again produce  $1n$  microspores and megaspores.

Nonflowering higher plants such as the ferns and mosses also show a distinct alternation of generations. The familiar fern plant of the field is the sporophyte generation. Meiosis occurs in sporangia located in special places on the leaves, generally the undersides or margins. A spore mother cell produces a tetrad of  $1n$  spores, each of which can germinate to produce a free-living, green gametophyte called a prothallus. On the prothallus are produced male and female sex organs called antheridia and archegonia, which give rise to sperms and eggs, respectively. Sperms, motile because of their whiplike flagella, swim to the archegonium, where they fertilize the egg to produce the zygote that gives rise to the sporophyte generation again.

In mosses, by contrast, the dominant green generation is the gametophyte. Antheridia or archegonia are borne at the tips of these gametophytes, where they produce sperms and eggs, respectively. When suitably wetted, sperms leave the antheridium, swim to a nearby archegonium, and fertilize the egg to produce a  $2n$  zygote that gives rise to a nongreen, simple, dependent sporophyte. The moss sporophyte consists mainly of a sporangium at the end of a long stalk, at the base of which is a mass of tissue called the foot, which absorbs nutrients from the green, photosynthetic gametophyte. Meiosis occurs in the sporangium when a spore mother cell gives rise to four reduced spores. Each spore can germinate, giving rise to a filamentous structure from which leafy gametophytic branches arise, completing the life cycle.

Various members of the algae that reproduce sexually also display alternation of generations, producing sperms and eggs in antheridia and oogonia. Sporophyte and gametophyte generations may each be free-living and independent, or one may be partially or totally dependent on the other. See FRUIT; PLANT PHYSIOLOGY; POPULATION DISPERSAL; SEED. [A.W.G.]

**Reproductive behavior** Behavior related to the production of offspring; it includes such patterns as the establishment of mating systems, courtship, sexual behavior, parturition, and the care of young. Successful reproductive efforts require the establishment of a situation favorable for reproduction, often require behavior leading to the union of male and female gametes, and often require behavior that facilitates or ensures the survival and development of the young; the mere union of gametes is not generally sufficient for successful reproduction. For each species, there is a complex set of behavioral adaptations that coordinate the timing and patterning of reproductive activity. Typically, this entails integration of both overt behavioral and internal physiological events in both male and female, all of which are intricately enmeshed in manners adapted to the environment in which the animals live. The behavioral patterns related to reproduction tend to be relatively stereotyped within a species, but diverse among different species—especially distantly related species. The end products of cycles of reproductive activity are viable, fertile offspring which, in turn, will reproduce and thus perpetuate the species.

The relationships between individual males and females and the degree of exclusivity in mating are part of the mating system of a species or population. There are three basic mating system types: monogamy, polygamy, and promiscuity. In monogamy the reproductive unit is generally a single male and a single female, the partners copulate only with each other, there may be shared parental care, and there is some kind of prolonged pair bond. In polygamous mating systems, there is again a prolonged association, but more than two individuals are involved in the relationship. In the promiscuous mating system, there is no prolonged bond formed, and there are multiple matings by members of at least one of the sexes.

Territoriality or dominance occurs in many kinds of mating systems. A territory is an area that is defended against conspecific animals (those of the same species). It may be occupied by a single individual, a bonded male-female pair, or a larger group. The resident of a territory generally has privileged access to the resources on that territory. Where the territory is relatively large, as in many diurnal songbirds, it may include sufficient resources to support a bonded pair and their offspring. By contrast, in many colonially nesting marine birds the territories may encompass little more than a nest site, while food and other resources are collected at a distance. In a special form of territoriality, a lek, males of some species, such as sage grouse, defend small territories that are used only for breeding. See TERRITORIALITY.

Whereas in a territorial system the outcome of a contest for resources is generally predictable given only the location of the encounter, in a dominance relationship an individual wins regardless of location. In troops of various species of primates, for example, there may be a single dominant male and a hierarchy of males ranking below him. There are many varieties of dominance relationships, with male hierarchies, female hierarchies, mixed-sex hierarchies, and triangular relationships that are departures from linearity. Dominance-related contests may occur seasonally, generally peaking in intensity during the breeding season, and can be of great importance in determining which individuals reproduce.

Mate choice and then courtship are both essential to successful reproduction in animals. The importance of female choice remains controversial. Ultimately, females can benefit by mating with males that are exceptional either in their ability to accrue resources or in the possession of “good genes,” or both. Males forming prolonged pair bonds invest much, and it is not surprising that they may exercise mate choice as well. In a variety of species of invertebrates, for example, males prefer large females to small ones.

Courtship entails a sequence of behavioral patterns that eventually may lead to the completed mating. Patterns of courtship are quite diverse among different species but generally entail

reciprocal signaling between male and female. Mate choice is an important function of courtship. Many bouts of courtship break off without going to completed matings, often as a result of choice on the part of one or both partners. Another function of courtship relates to synchronization. The gametes must be shed at a time when sperm are viable, eggs are ripe, male and female are in the appropriate state of readiness, and the environment is supportive of reproductive effort. The progressive interactive sequence of the courtship episode allows for coordinated events to occur at times appropriate for successful reproduction.

Prior to birth or hatching of offspring, parents may engage in behavioral patterns that will aid the young when they arrive. This may entail preparation of a burrow or nest, provision of stored food, or acquisition of other resources. In some species the parent's aid ends with such preparations, but in others parental care may be extensive and prolonged. Parental care, especially maternal care, is highly developed in all species of mammals. By definition, the females of all mammalian species possess mammary glands for the nourishment of young. It is probably for this physiological reason that role reversal is less common among mammals than in other taxa.

Parental investment entails any investment by the parent that increases the ability of the young to survive and reproduce at some cost to the parent. Much parental investment, like milk, cannot be shared; that which is given to one offspring cannot be given to another. Other kinds of parental investment, like defense against predators, is shareable. In addition, the parent making any investment is prevented from engaging in other activities, such as searching for his or her own food or seeking additional mates.

Because they contribute larger gametes and often engage in more extensive parental behavior, the females of most species display a higher level of parental investment than males. Members of the sex investing more (typically females) thus become a limiting resource for the sex investing less (typically males). It is generally agreed that this gives rise to the disparity between female and male reproductive strategies—with males more often competing for access to females and females more choosy than males. See ANIMAL COMMUNICATION; BEHAVIORAL ECOLOGY; ETHOLOGY; REPRODUCTION (ANIMAL). [D.A.D.]

**Reproductive system** The structures concerned with the production of sex cells (gametes) and perpetuation of the species. The reproductive function constitutes the only vertebrate physiological function that necessitates the existence of two morphologically different kinds of individuals in each animal species, the males and the females (sexual dimorphism). The purpose of the reproductive function is fertilization, that is, the fusion of a male and a female sex cell produced by two distinct individuals.

**Anatomy.** Egg cells, or ova, and sperm cells, or spermatozoa, are formed in the primary reproductive organs, which are collectively known as gonads. Those of the male are called testes; those of the female are ovaries. The gonads are paired structures, although in some forms what appears to be an unpaired gonad is the result either of fusion of paired structures or of unilateral degeneration.

The reproductive elements formed in the gonads must be transported to the outside of the body. In most vertebrates, ducts are utilized for this purpose. These ducts, together with the structures that serve to bring the gametes of both sexes together, are known as accessory sex organs. The structures used to transport the reproductive cells in the male are known as deferent ducts and those of the female as oviducts. In a few forms no ducts are present in either sex, and eggs and sperm escape from the body cavity through genital or abdominal pores.

Oviducts, except in teleosts and a few other fishes, are modifications of Möllerian ducts formed during early embryonic

development. In all mammals, each differentiates into an anterior, nondistensible Fallopian tube and a posterior, expanded uterus. In all mammals except monotremes the uterus leads to a terminal vagina which serves for the reception of the penis of the male during copulation. The lower part, or neck, of the uterus is usually telescoped into the vagina to a slight degree. This portion is referred to as the cervix.

In most vertebrates the reproductive ducts in both sexes open posteriorly into the cloaca. In some, modifications of the cloacal region occur and the ducts open separately to the outside or, in the male, join the excretory ducts to emerge by a common orifice. See COPULATORY ORGAN; OVARY; PENIS; REPRODUCTION (ANIMAL); TESTIS. [C.K.W.]

**Physiology.** The physiological process by which a living being gives rise to another of its kind is considered one of the outstanding characteristics of plants and animals. It is one of the two great drives of all animals; self-preservation and racial perpetuation.

**Estrous and menstrual cycles.** The cyclic changes of reproductive activities in mammalian females are known as estrous or menstrual cycles.

Most mammalian females accept males only at estrus (heat). Estrus in mammals can occur several times in one breeding season; the mare, ewe, and rat come to estrus every 21, 16, and 5 days respectively if breeding does not take place. This condition is called poly estrus. The bitch is monestrous; she has only one heat, or estrus, to the breeding season and if not served then, she does not come into heat again for a prolonged interval, 4–6 months according to different breeds. In monestrous and seasonally polyestrous species the period of sexual quiescence between seasons is called anestrus. See ESTRUS.

The reproductive cycle of the female in the primate and human is well marked by menstruation, the period of vaginal blood flow. Menstruation does not correspond to estrus but occurs between the periods of ovulation at the time the corpus luteum declines precipitously. See MENSTRUATION.

**Mating.** Mating, also called copulation or coitus, is the synchronized bodily activity of the two sexes which enables them to deposit their gametes in close contact. It is essential for successful fertilization because sperm and ovum have a very limited life span.

The logistics of sperm transport to the site of fertilization in the oviduct present many interesting features in mammals, but it is important to distinguish between passive transport of sperm cells in the female genital tract, and sperm migration, which clearly attributes significance to the intrinsic motility of the cell. Viable spermatozoa are actively motile, and although myometrial contractions play a major role in sperm transport through the uterus, progressive motility does contribute to migration into and within the oviducts. Even though a specific attractant substance for spermatozoa has not yet been demonstrated to be released from mammalian eggs or their investments, some form of chemotaxis may contribute to the final phase of sperm transport and orientation toward the egg surface.

Although in most mammalian species the oocyte is shed from the Graafian follicle in a condition suitable for fertilization, ejaculated spermatozoa must undergo some form of physiological change in the female reproductive tract before they can penetrate the egg membranes. The interval required for this change varies according to species, and the process is referred to as capacitation. The precise changes that constitute capacitation remain unknown, although there is strong evidence that they are—at least in part—membrane-associated phenomena, particularly in the region of the sperm head, that permit release of the lytic acrosomal enzymes with which the spermatozoon gains access to the vitelline surface of the egg.

Fertilization takes place in the oviducts of mammals and the fertilized eggs or embryos do not descend to the uterus for some 3 to 4 days in most species. During this interval, the embryo

undergoes a series of mitotic divisions until it comprises a sphere of 8 or 16 cells and is termed a morula. Formation of a blastocyst occurs when the cells of the morula rearrange themselves around a central, fluid-filled cavity, the blastocoele. As the blastocyst develops within the uterine environment, it sheds its protective coat and undergoes further differentiation before developing an intimate association with the endometrium, which represents the commencement of implantation or nidation.

Association of the embryo with the uterine epithelium, either by superficial attachment or specific embedding in or beneath the endometrium, leads in due course to the formation of a placenta and complete dependence of the differentiating embryo upon metabolic support from the mother. Implantation and placental development exhibit a variety of forms, but in all instances the hormonal status of the mother is of great importance in determining whether or not implantation can proceed. See PREGNANCY.

**Endocrine function.** The endocrine glands secrete certain substances (hormones) which are necessary for growth, metabolism, reproduction, response to stress, and various other physiological processes. The endocrine glands most concerned with the process of reproduction are the pituitary and the gonads.

The posterior lobe of the pituitary gland secretes two neurohumoral agents, vasopressin and oxytocin. These are involved in reproduction only indirectly, through their effect on uterine contractility in labor and on the release of milk from the mammary gland when a suckling stimulus is applied. The anterior lobe secretes a variety of trophic hormones, including two gonadotrophic hormones, the follicle-stimulating hormone (FSH) and the luteinizing or interstitial-cell stimulating hormone (LH or ICSH). These hormones act directly on both ovaries and testes. See PITUITARY GLAND.

The gonadal (steroidal) hormones control the secretion of gonadotrophins by acting on the hypothalamus. It has been suggested that steroids act by means of a "negative feedback"; that is, high levels of circulating gonadal hormones stop further release of gonadotropins. However, although this is true for experiments involving pharmacological doses of such hormones, it may not be the case with endogenous physiological levels. It is certainly true that less steroid is required to inhibit pituitary function in the female than in the male. Under certain circumstances small doses of gonadal hormones can stimulate release of gonadotropic hormones from the pituitary. Estrogen can simulate the release of LH; hence the occurrence of ovulation in rats, rabbits, sheep, and women. Progesterone can also facilitate ovulation in persistently estrous rats, in chickens, and in estrous sheep and monkeys. See ESTROGEN; PROGESTERONE.

The formation of gametes (spermatogenesis and oogenesis) is controlled by anterior pituitary hormones. The differentiation of male and female reproductive tracts is influenced, and mating behavior and estrous cycles are controlled, by male or female hormones. The occurrence of the breeding season is mainly dependent upon the activity of the anterior lobe of the pituitary, which is influenced through the nervous system by external factors, such as light and temperature. The transportation of ova from the ovary to the Fallopian tube and their subsequent transportation, development, and implantation in the uterus are controlled by a balanced ratio between estrogen and progesterone. Furthermore, it is known that estrogens, androgens, and progesterone can all have the effect of inhibiting the production or the secretion, or both, of gonadotrophic hormones, permitting the cyclic changes of reproductive activity among different animals.

Mammary glands are essential for the nursing of young. Their growth, differentiation, and secretion of milk, and in fact the whole process of lactation, are controlled by pituitary hormones as well as by estrogen and progesterone. Other glands and physiological activities also influence lactation, although this is largely via the trophic support of other pituitary hormones.

[M.C.C.; M.J.K.H.; R.H.F.H.]

**Reproductive system disorders** Those disorders which involve the structures of the human female and male reproductive systems.

**Female system.** Disorders of the female reproductive system may involve the ovaries, Fallopian tubes, uterus, cervix, vagina, or vulva.

Failure of the ovaries to form normally results in short stature, sterility, and lack of development of female secondary sex characteristics, such as breast growth, fat deposition in buttocks and thighs and mons pubis, and female escutcheon. Destruction of the ovaries after puberty results in loss of fertility, cessation of menses, loss of secondary sex characteristics, and osteoporosis. See OSTEOPOROSIS.

Neoplastic enlargement of the ovary can be cystic or solid, benign or malignant. Malignant ovarian tumors are commonly asymptomatic in their early stages, and may be quite widely spread in the pelvic and abdominal cavity before they are discovered. See OVARIAN DISORDERS; OVARY.

Endometriosis, which is a condition involving the presence of ectopic endometrial tissue, can affect the ovaries. Endometriosis can be found as large "chocolate" cysts of the ovary, called endometriomas, or small "blue domed" cysts; both are filled with old, dark brown blood. Tiny implants of endometriosis commonly called powder burns also occur on the surface of the ovaries, on other pelvic peritoneum, and over the Fallopian tubes and uterus as well. Endometriomas of the ovary may be painful, or may rupture and cause diffuse pelvic pain, while the smaller endometrial implants may cause severe pain with menstrual periods, generalized pelvic pain, pain with intercourse, and infertility.

Inflammation is the most common disorder of the Fallopian tubes, and if it is repeated or severe, destruction of the tubal lining with closure of the outer ends of the tubes can occur. This inflammation can be caused by several organisms. Sterility commonly results because the tube is permanently closed to passage of egg and sperm. The second most common problem involving the tube is pregnancy. The egg is fertilized in the outer portion of the tube and descends to implant in the uterus, but in some cases the passage is delayed and the conceptus attaches to the wall of the tube. The tube has a small lumen and thin wall, and the growing pregnancy quickly enlarges and grows through the tube, leading usually to rupture and hemorrhage into the peritoneal cavity. See PREGNANCY DISORDERS.

Developmental abnormalities can occur during formation of the uterus. The Fallopian tubes might not join at all, or might join partially from the cervical end upward. Septae or walls in the vagina and uterus can also occur. These abnormalities are more common in females who are exposed to diethylstilbesterol (DES) during the mother's pregnancy. The muscle (myometrium) and lining (endometrium) of the uterus are susceptible to various problems, including tumors, infections, and hormonal derangements. Benign tumors of the myometrium (fibroids) are a common disorder, producing irregular enlargement of the uterus and sometimes causing pain, obstruction of the urinary tract, and heavy vaginal bleeding. The uterus can be one site of a significant infection which produces fever and pain and usually involves other organs, such as ovaries and tubes. Hormonal abnormalities resulting in anovul can lead to overgrowth and irregular shedding of the endometrium. Pregnancy usually proceeds uneventfully, but certain accidents of pregnancy, such as threatened, incomplete, or missed abortion, can produce irregular bleeding and some uterine discomfort. See PREGNANCY; UTERINE DISORDERS; UTERUS.

Infection of the endocervical glands with gonococcus or chlamydia trachomatis agent can occur. This may be asymptomatic, except for producing a mucopurulent discharge, or it may cause pain when the cervix is manipulated, particularly during intercourse. The infection can ascend from this area into the internal genital organs and adjacent structures. The cervix can be

affected by malignant tumors which can be adenocarcinomas, or tumors of the glandular cells, or more commonly squamous tumors. Cervical cancer is associated with several factors, including early age at first coitus, multiple sex partners, especially at an early age, smoking, and infection with certain subtypes of human papilloma virus. There is no single factor that "causes" this cancer, but rather a combination of these factors is critical. Papanicolaou smears are used to detect early changes suggestive of this cancer. Further evaluation is by low-power magnification, called colposcopy, and biopsy. See GONORRHEA.

Developmental abnormalities of the vagina may include imperforate hymen, septae, both vertical and horizontal, and complete failure of development. Inflammation of the lining of the vagina can be due to several common organisms. Specific chemical treatment is available for each of these entities. Postmenopausal women can experience atrophy or shrinkage of the vagina and mucosa secondary to estrogen deprivation. This produces itching, bleeding, and pain with intercourse. Estrogen therapy can relieve these symptoms. The vaginal support can be weakened through childbirth, or may simply be naturally poor, allowing the bladder and rectum to bulge inward, and the cervix and uterus to protrude from the introitus. This condition can cause a variety of symptoms, including involuntary loss of urine with a cough or laugh, inability to move the bowels without mechanically pushing the stool out, and a sensation of pelvic heaviness. Intravaginal devices called pessaries may improve support, but surgical correction may be necessary. Vaginal cancer can occur, but it is rare, and cervical cancer can also involve the vagina. Treatment is usually surgical. Vaginal trauma can lead to significant bleeding. Penetrating straddle injuries can occur, and trauma with intercourse or childbirth can produce lacerations. Surgical repair is usually undertaken. Vaginismus, or painful spasm of the muscular sidewalls of the vagina, can occur, making intercourse painful. See VAGINAL DISORDERS.

Infection of the female external genitalia can be diffuse or localized, involving bacteria, viruses, or fungal agents. Inflammation can be caused by allergic reactions to soap, powders, semen, lubricant, or even clothing.

**Male system.** The principal organs of the male reproductive system are the testicles, epididymis, vas deferens and seminal vesicles, prostate gland, urethra, and penis.

During fetal life the testicles form in the abdominal cavity near the kidneys and migrate down into the scrotum. Failure of descent permanently damages the sperm-producing cells, but allows the interstitial cells which produce hormones to survive. Other causes of male infertility are organic problems which block passage of seminal fluid or interfere with sperm production. The testes are sites of malignant tumors which carry a high mortality rate. Undescended testicles are more susceptible to malignant transformation, and for that reason should be removed when discovered, and appropriate hormonal replacement instituted. The membranes covering the testicle can become filled with fluid, a condition known as hydrocele. See TESTIS.

The major disorder of the epididymis is infection and inflammation, which can lead to scarring and permanent blockage of the ducts.

The vas deferens and seminal vesicles are rarely afflicted by disease, although the network of veins surrounding the vas deferens can become engorged and tortuous, and is called a varicocele.

Inflammation and development of small calculi are relatively minor ailments of the prostate. Benign overgrowth of this gland is the most common and troublesome complaint. This enlargement results in constriction of the urethra, which obstructs urinary outflow and leads to an increasing residual of urine in the bladder. Cancer of the prostate is another relatively frequent problem in older males. This tumor spreads primarily to bones, where it is markedly painful. See PROSTATE GLAND DISORDERS.

## 1900 Reproductive technology

Inflammation is the chief disorder of the urethra, causing dysuria and a discharge.

Inflammation (balanitis) or narrowing (phimosis) of the foreskin, which covers the glans penis, can occur and may interfere with urination. Viral infections can produce warty growths (condyloma acuminata) or painful ulcers (herpetic lesions) of the glans or shaft of the penis, and a syphilitic infection can result in the firm, painless ulcer known as a chancre. See HERPES; SYPHILIS.

Disorders of erectile capability range from tumescence unaccompanied by sexual desire (Peyronie's disease, priapism) to impotence, both psychologic and secondary to old age. Carcinoma can arise from the surface epithelium of the penis and spread both locally and via the lymphatic system to the nodes of the groin. This disease is virtually unknown in populations where males are circumcised at birth. See INFERTILITY; ONCOLOGY; REPRODUCTIVE SYSTEM; REPRODUCTIVE TECHNOLOGY. [G.M.Gu.]

**Reproductive technology** Any procedure undertaken to aid in conception, intrauterine development, and birth when natural processes do not function normally. The most common are in vitro fertilization and gamete intrafallopian transfer.

Infertility, which is the inability to conceive during at least 12 months of unprotected intercourse, is an increasingly common problem. Hormonal therapy and microsurgery are used to overcome many hormonal and mechanical forms of infertility, but many types of infertility do not respond to such treatment. See INFERTILITY.

In vitro fertilization bypasses the Fallopian tubes. Immediately prior to ovulation the mature oocyte is removed from the ovary and placed, together with prepared sperm, in a petri dish for 2-3 days. Fertilization takes place during this time and the fertilized oocyte develops into a two- to eight-cell embryo, which is then transferred into the uterus. In vitro fertilization is useful for females with absent or severely damaged Fallopian tubes; couples in which the female has endometriosis; when the male has severely reduced sperm counts; or when the couple has immunologic or unexplained infertility for a period of 2 or more years. The four principal steps of in vitro fertilization are induction and timing of ovulation, oocyte retrieval, fertilization, and embryo transfer.

Gamete intrafallopian transfer, or GIFT, is similar to in vitro fertilization with a few important distinctions. In gamete intrafallopian tube transfer, the spermatozoa and oocytes are placed into the fimbriated end of the Fallopian tube during the laparoscopy. It is unusual for more than two oocytes to be placed into either Fallopian tube. Indications for gamete intrafallopian transfer include unexplained infertility of two or more years' duration, cervical stenosis, immunologic infertility, oligospermia, and endometriosis. At least one Fallopian tube must appear normal; where there has been severe pelvic adhesions or distorted tubal anatomy from any cause, gamete intrafallopian transfer should not be considered. See PREGNANCY; REPRODUCTIVE SYSTEM DISORDERS. [M.M.S.]

**Reptilia** A class of vertebrates composed of four living orders, the turtles or Chelonia, the tuatara or Sphenodonta, the lizards and snakes or Squamata, and the crocodylians or Crocodylia. Numerous extinct orders are also known. The group first appeared in the Carboniferous and underwent a culminating evolutionary radiation in the Mesozoic, often called the age of reptiles. Although the major portion of the class is now extinct, several Recent groups, particularly the Squamata, are very successful, and there are approximately 5000 living species of reptiles as compared to about 4000 living mammals. A classification is given below; see separate articles on each of the groups listed.

### Class Reptilia

#### Subclass Anapsida

Order: Captorhinida

Mesosauria

Chelonia

#### Subclass Diapsida

Infraclass Sauropterygia

Order: Nothosauria

Plesiosauria

Placodontia

Infraclass Lepidosauria

Order: Araucoscelida

Eosuchia

Sphenodonta

Squamata

#### Infraclass Archosauria

Order: Protosauria

Rhynchosauria

Thecodontia

Crocodylia

Pterosauria

Saurisachia

Ornithischia

Subclass Ichthyopterygia

Subclass Synapsida

Order: Pelycosauria

Therapsida

The reptiles are the most primitive of the completely terrestrial vertebrates and are consequently the first to exhibit amniote features. Reptile eggs are covered by a complex series of protective layers, including a leathery or calcareous shell. A rich supply of food material in the form of yolk is deposited inside the ovum to furnish food for the developing embryo. A series of protective extraembryonic membranes, the serosa and amnion, appears later in embryogenesis to protect the embryo from water loss and shock. A third such membrane, the allantois, functions as a storage sac for nitrogenous wastes. The serosa and allantois usually fuse to form a respiratory structure. Gaseous exchanges take place across the shell and seroallantoic membrane between the outside air and the blood vessels of the allantois. These adaptations allowed the reptile egg to be deposited on land, undergo its development there, and hatch into a fully developed form without a gilled larval stage. Most reptilian eggs are buried in the soil or in rotting vegetation out of direct sunlight. See AMNIOTA.

Paleoherpetology, the study of fossil reptiles, is especially important for two reasons. First, the class Reptilia lies at the center of vertebrate history; the reptiles evolved from the amphibians (which themselves had originated from the fishes), and both birds and mammals evolved from the reptiles. Thus reptiles are concerned in three of the four major "jumps" (the class-to-class transitions) in vertebrate evolution. The distinction between the living representatives of two successive classes is always very clear, being based on a number of features of their anatomy, physiology, and embryology; the distinction between their fossil members, however, is inevitably less clear, not only because the distinction must be based almost entirely upon characters of the skeleton but also because there must have been animals with a mixture of the characters of both classes during the transitional period. These help elucidate the reasons for the jumps and the precise mechanism by which each occurred. See AMPHIBIA; ANIMAL EVOLUTION.

Second, the Reptilia were the dominant class of land vertebrates (and were also important in the sea and in the air) during a very long period of the Earth's history. Knowledge of the extinct reptiles, their morphology and their habits, is vital to an understanding of the life of those times, of how the animals and plants and the physical environment reacted upon each other (paleoecology). See PALEOECOLOGY; PALEONTOLOGY. [A.J.C.]

**Repulsion motor** An alternating-current (ac) commutator motor designed for single-phase operation. The chief distinction between the repulsion motor and the single-phase series motors is the way in which the armature receives its power. In the series motor the armature power is supplied by conduction from the line power supply. In the repulsion motor, however, armature power is supplied by induction (transformer action) from the field of the stator winding. For discussion of the ac series motor see UNIVERSAL MOTOR; ALTERNATING-CURRENT MOTOR.

The repulsion motor primary or stationary field winding is connected to the power supply. The secondary or armature winding is mounted on the motor shaft and rotates with it. The

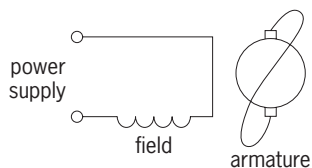

Schematic of a repulsion motor.

terminals of the armature winding are short-circuited through a commutator and brushes. There is no electrical contact between the stationary field and rotating armature (see illustration). See WINDINGS IN ELECTRIC MACHINERY. [I.L.K.]

**Reservoir** A place or containment area where water is stored. Where large volumes of water are to be stored, reservoirs usually are created by the construction of a dam across a flowing stream. When water occurs naturally in streams, it is sometimes not available when needed. Reservoirs solve this problem by capturing water and making it available at later times. See DAM.

In addition to large reservoirs, many small reservoirs are in service. These include varieties of farm ponds, regulating lakes, and small industrial or recreational facilities. In some regions, small ponds are called tanks. Small reservoirs can have important cumulative effects in rural regions

Reservoirs can be developed for single or multiple purposes, such as to supply water for people and cities, to provide irrigation water, to lift water levels to make navigation possible on streams, and to generate electricity.

Another purpose of reservoirs is to control floods by providing empty spaces for flood waters to fill, thereby diminishing the rate of flow and water depth downstream of the reservoir.

Reservoirs also provide for environmental uses of water by providing water to sustain fisheries and meet other fish and wildlife needs, or to improve water quality by providing dilution water when it is needed in downstream sections of rivers. Reservoirs may also have esthetic and recreational value, providing boating, swimming, fishing, rafting, hiking, viewing, photography, and general enjoyment of nature. See PUMPED STORAGE; RIVER ENGINEERING; WATER SUPPLY ENGINEERING. [N.S.Gr.]

**Resin** Originally a category of vegetable substances soluble in ethanol but insoluble in water, but generally in modern technology an organic polymer of indeterminate molecular weight. The class of flammable, amorphous secretions of conifers or legumes are considered true resins. Water-swellable secretions of various plants, especially the Burseraceae, are called gum resins. The natural vegetable resins are largely polyterpenes and their acid derivatives, which find application in the manufacture of lacquers, adhesives, varnishes, and inks.

The synthetic resins, originally viewed as substitutes for certain natural resins, have a large place of their own in industry and commerce. Phenol-formaldehyde, phenol-urea, and phenol-melamine resins are important commercially. Any unplasticized organic polymer is considered a resin, thus nearly any of the common plastics may be viewed as a synthetic resin. Water-soluble resins are marketed chiefly as substitutes for vegetable gums and in their own right for highly specialized applications. Carboxymethylcellulose, hydroxyalkylated cellulose derivatives, modified starches, polyvinyl alcohol, polyvinylpyrrolidone, and polyacrylamides are widely used as thickening agents for foods, paints, and drilling muds, as fiber sizings, in various kinds of protective coatings, and as encapsulating substances. See POLYMER. [F.W.]

**Resistance heating** The generation of heat by electric conductors carrying current. The degree of heating for a given current is proportional to the electrical resistance of the conductor. If the resistance is high, a large amount of heat is generated, and the material is used as a resistor rather than as a conductor.

In addition to having high resistivity, heating elements must be able to withstand high temperatures without deteriorating or sagging. Other desirable characteristics are low temperature coefficient of resistance, low cost, formability, and availability of materials. Most commercial resistance alloys contain chromium or aluminum or both, since a protective coating of chrome oxide or aluminum oxide forms on the surface upon heating and inhibits or retards further oxidation.

Since heat is transmitted by radiation, convection, or conduction or combinations of these, the form of element is designed for the major mode of transmission. The simplest form is the helix, using a round wire resistor, with the pitch of the helix approximately three wire diameters. This form is adapted to radiation and convection and is generally used for room or air heating. It is also used in industrial furnaces, utilizing forced convection up to about 1200°F (650°C). Such helixes are stretched over grooved high-alumina refractory insulators and are otherwise open and unrestricted.

The electrical resistance of molten salts between immersed electrodes can be used to generate heat. Limiting temperatures are dependent on decomposition or evaporation temperatures of the salt. Parts to be heated are immersed in the salt. Heating is rapid and, since there is no exposure to air, oxidation is largely prevented. Disadvantages are the personnel hazards and discomfort of working close to molten salts.

A major application of resistance heating is in electric home appliances, including electric ranges, clothes dryers, water heaters, coffee percolators, portable radiant heaters, and hair dryers. Resistance heating also has application in home or space heating.

If the resistor is located in a thermally insulated chamber, most of the heat generated is conserved and can be applied to a wide variety of heating processes. Such insulated chambers are called ovens or furnaces, depending on the temperature range and use. The term oven is generally applied to units which operate up to approximately 800°F (430°C). Typical uses are for baking or roasting foods, drying paints and organic enamels, baking foundry cores, and low-temperature treatments of metals. The term furnace generally applies to units operating above 1200°F (650°C). Typical uses of furnaces are for heat treatment or melting of metals, for vitrification and glazing of ceramic wares, for annealing of glass, and for roasting and calcining of ores. See ELECTRIC HEATING; FURNACE. [W.Ro.]

**Resistance measurement** The quantitative determination of that property of an electrically conductive material, component, or circuit called electrical resistance. The ohm, which is the International System (SI) unit of resistance, is defined through the application of Ohm's law as the electric resistance between two points of a conductor when a constant potential difference of 1 volt applied to these points produces in the conductor a current of 1 ampere. Ohm's law can thus be taken to define resistance  $R$  as the ratio of dc voltage  $V$  to current  $I$ , Eq. (1). For bulk metallic conductors, for example, bars, sheets,

$$R = \frac{V}{I} \quad (1)$$

wires, and foils, this ratio is constant. For most other substances, such as semiconductors, ceramics, and composite materials, it may vary with voltage, and many electronic devices depend on this fact. The resistance of any conductor is given by the integral of expression (2), where  $l$  is the length,  $A$  the cross-sectional

$$\int_0^l \frac{\rho dl}{A} \quad (2)$$

area, and  $\rho$  the resistivity. See ELECTRICAL CONDUCTIVITY OF METALS; ELECTRICAL RESISTANCE; ELECTRICAL RESISTIVITY; OHM'S LAW; SEMICONDUCTOR.

Since January 1, 1990, all resistance measurements worldwide have been referred to the quantized Hall resistance standard, which is used to maintain the ohm in all national standards

laboratories. Conventional wire-wound working standards are measured in terms of the quantized Hall resistance and then used to disseminate the ohm through the normal calibration chain. These working standards can be measured in terms of the quantized Hall resistance with a one-standard-deviation uncertainty of about 1 part in  $10^8$ . See HALL EFFECT.

The value of an unknown resistance is determined by comparison with a standard resistor. The Wheatstone bridge is perhaps the most basic and widely used resistance- or impedance-comparing device. Its principal advantage is that its operation and balance are independent of variations in the supply. The greatest sensitivity is obtained when all resistances are similar in value, and the comparison of standard resistors can then be made with a repeatability of about 3 parts in  $10^8$ , the limit arising from thermal noise in the resistors. In use, the direction of supply is reversed periodically to eliminate effects of thermal or contact emf's.

The bridge is normally arranged for two-terminal measurements, and so is not suitable for the most accurate measurement at values below about 100  $\Omega$ , although still very convenient for lower resistances if the loss of accuracy does not matter. However, a Wheatstone bridge has also been developed for the measurement of four-terminal resistors. This involves the use of auxiliary balances, and resistors of the same value can be compared with uncertainties of a few parts in  $10^8$ .

Typically a bridge will have two decade-ratio arms, for example, of 1, 10, 100, 1000, and 10,000  $\Omega$ , and a variable switched decade arm of 1–100,000  $\Omega$ , although many variations are encountered. For the measurement of resistors of values close to the decade values, a considerable increase in accuracy can be obtained by substitution measurement, in which the bridge is used only as an indicating instrument. The resistors being compared can be brought to the same value by connecting a much higher variable resistance across the larger of them, and the accuracy of this high-resistance shunt can be much less than that of the resistance being compared. See WHEATSTONE BRIDGE.

The Kelvin double bridge is a double bridge for four-terminal measurements, and so can be used for very low resistances. The addition to its use for accurate laboratory measurement of resistances below 100  $\Omega$ , it is very valuable for finding the resistance of conducting rods or bars, or for the calibration in the field of air-cooled resistors used for measurement of large currents. See KELVIN BRIDGE.

Measurements of resistances from 10 megohms to 1 terohm ( $10^{12}$   $\Omega$ ) or even higher with a Wheatstone bridge present additional problems. The resistance to be measured will usually be voltage-dependent, and so the measurement voltage must be specified. The resistors in the ratio arms must be sufficiently high in value that they are not overloaded. If a guard electrode is fitted, it is necessary to eliminate any current flowing to the guard from the measurement circuit. The power dissipated in the 1-M $\Omega$  resistor is then 10 mW, and the bridge ratio is  $10^6$ . The guard is connected to a subsidiary divider of the same ratio, so that any current flowing to it does not pass through the detector. Automated measurements can be made by replacing the ratio arms of the Wheatstone bridge by programmable voltage sources. An alternative method that can also be automated is to measure the RC time constant of the unknown resistor  $R$  combined with a capacitor of known value  $C$ . See INSULATION RESISTANCE TESTING.

An obvious and direct way of measuring resistance is by the simultaneous measurement of voltage and current, and this is usual in very many indicating ohmmeters and multirange meters. In most digital instruments, which are usually also digital voltage meters, the resistor is supplied from a constant-current circuit and the voltage across it is measured by the digital voltage meter. This is a convenient arrangement for a four-terminal measurement, so that long leads can be used from the instrument to the resistor without introducing errors. The simplest systems, used in passive pointer instruments, measure directly the current

through the meter which is adjusted to give full-scale deflection by an additional resistor in series with the battery. This gives a nonlinear scale of limited accuracy, but sufficient for many practical applications. See CURRENT MEASUREMENT; VOLTAGE MEASUREMENT. [C.H.Di.; R.G.Jon.]

**Resistance welding** A process in which the heat for producing the weld is generated by the resistance to the flow of current through the parts to be joined. The application of external force is required; however, no fluxes, filler metals, or external heat sources are necessary. Most metals and their alloys can be successfully joined by resistance welding processes. Several methods are classified as resistance welding processes: spot, roll-spot, seam, projection, upset, flash, and percussion.

In resistance spot welding, coalescence at the faying surfaces is produced in one spot by the heat obtained from the resistance to electric current through the work parts held together under pressure by electrodes. The size and shape of the individually formed welds are limited primarily by the size and contour of the electrodes. See SPOT WELDING.

In roll resistance spot welding, separated resistance spot welds are made with one or more rotating circular electrodes. The rotation of the electrodes may or may not be stopped during the making of a weld.

In resistance seam welding, coalescence at the faying surfaces is produced by the heat obtained from resistance to electric current through the work parts held together under pressure by electrodes. The resulting weld is a series of overlapping resistance spot welds made progressively along a joint by rotating the electrodes.

In projection welding, coalescence is produced by the heat obtained from resistance to electric current through the work parts held together under pressure by electrodes. The resulting welds are localized at predetermined points by projections, embossments, or intersections.

In upset welding, coalescence is produced simultaneously over the entire area of abutting surfaces or progressively along a joint, by the heat obtained from resistance to electric current through the area of contact of those surfaces. Pressure is applied before heating is started and is maintained throughout the heating period.

In flash welding, coalescence is produced simultaneously over the entire area of abutting surfaces by the heat obtained from resistance to electric current between the two surfaces and by the application of pressure after heating is substantially completed. Flash and upsetting are accompanied by expulsion of the metal from the joint. See FLASH WELDING.

In percussion welding, coalescence is produced simultaneously over the entire abutting surfaces by the heat obtained from an arc produced by a rapid discharge of electrical energy with pressure percussively applied during or immediately following the electrical discharge.

Most metals and alloys can be resistance-welded to themselves and to each other. The weld properties are determined by the metal and by the resultant alloys which form during the welding process. Stronger metals and alloys require higher electrode forces, and poor electrical conductors require less current. Copper, silver, and gold, which are excellent electrical conductors, are very difficult to weld because they require high current densities to compensate for their low resistance. Medium- and high-carbon steels, which are hardened and embrittled during the normal welding process, must be tempered by multiple impulses. [E.FN.]

**Resistor** One of the three basic passive components of an electric circuit that displays a voltage drop across its terminals and produces heat when an electric current passes through it. The electrical resistance, measured in ohms, is equal to the ratio of the voltage drop across the resistor terminals measured in volts divided by the current measured in amperes. See OHM'S LAW.



Resistors are described by stating their total resistance in ohms along with their safe power-dissipating ability in watts. The tolerance and temperature coefficient of the resistance value may also be given. See ELECTRICAL RESISTANCE; ELECTRICAL RESISTIVITY.

All resistors possess a finite shunt capacitance across their terminals, leading to a reduced impedance at high frequencies. Resistors also possess inductance, the magnitude of which depends greatly on the construction and is largest for wire-wound types. See CAPACITANCE; ELECTRICAL IMPEDANCE; INDUCTANCE.

Resistors may be classified according to the general field of engineering in which they are used. Power resistors range in size from about 5 W to many kilowatts and may be cooled by air convection, air blast, or water. The smaller sizes, up to several hundred watts, are used in both the power and electronics fields of engineering.

Direct-current (dc) ammeters employ resistors as meter shunts to bypass the major portion of the current around the low-current elements. These high-accuracy, four-terminal resistors are commonly designed to provide a voltage drop of 50–100 mV when a stated current passes through the shunt. See AMMETER.

Voltmeters of both the dc and the ac types employ scale-multiplying resistors designed for accuracy and stability. The over-voltage rating of these resistors is of importance in the case of high-voltage voltmeters. See VOLTMETER.

Standard resistors are used for calibration purposes in resistance measurements and are made to be as stable as possible, in value, with time, temperature, and other influences. Resistors with values from 1 ohm to 10 megohms are wound by using wire made from special alloys. The best performance is obtained from quaternary alloys, which contain four metals. The proportions are chosen to give a shallow parabolic variation of resistance with temperature, with a peak, and therefore the slowest rate of change, near room temperature. See ELECTRICAL UNITS AND STANDARDS.

By far the greatest number of resistors manufactured are intended for use in the electronics field. The major application of these resistors is in transistor analog and digital circuits which operate at voltage levels between 0.1 and 200 V, currents between 1  $\mu$ A and 100 mA, and frequencies from dc to 100 MHz. Their power-dissipating ability is small, as is their physical size.

Since their exact value is rarely important, resistors are supplied in decade values (0.1, 1, 10, 100 ohms, and so forth) with the interval between these divided into a geometric series, thus having a constant percentage increase. For noncritical applications, values from a series with intervals of 20% (12 per decade) are appropriate. A series with 10% intervals (24 per decade) is often used for resistors having a tolerance of 1%. Where the precise value of a resistor is important, a series with 2.5% intervals (96 per decade) may be used.

Resistors are also classified according to their construction, which may be composition, film-type, wire-wound, or integrated circuit.

The composition resistor is in wide use because of its low cost, high reliability, and small size. Basically it is a mixture of resistive materials, usually carbon, and a suitable binder molded into a cylinder. Copper wire leads are attached to the ends of the cylinder, and the entire resistor is molded into a plastic or ceramic jacket. Composition resistors are commonly used in the range from several ohms to 10–20 M $\Omega$ , and are available with tolerances of 20, 10, or 5%.

The film-type resistor is now the preferred type for most electronic applications because its performance has surpassed that of composition resistors and mass-production techniques have reduced the cost to a comparable level. Basically this resistor consists of a thin conducting film of carbon, metal, or metal oxide deposited on a cylindrical ceramic or glass former. The resistance is controlled by cutting a helical groove through the conducting film. This helical groove increases the length and decreases the width of the conducting path, thereby determining its ohmic value. By controlling the conductivity, thickness of the

film, and pitch of the helix, resistors over a wide range of values can be manufactured. Film construction is used for very high value resistors, up to and even beyond 1 T $\Omega$  ( $10^{12}$  ohms).

Wire remains the most stable form of resistance material available; therefore, all high-precision instruments rely upon wire-wound resistors. Wire also will tolerate operation at high temperatures, and so compact high-power resistors use this construction. Power resistors are available in resistance values from a fraction of an ohm to several hundred thousand ohms, at power ratings from one to several thousand watts, and at tolerances from 10 to 0.1%. The usual design of a power resistor is a helical winding of wire on a cylindrical ceramic former. After winding, the entire resistor is coated in vitreous enamel. Alternatively, the wound element may be fitted inside a ceramic or metal package, which will assist in heat dissipation. The helical winding results in the resistor having significant inductance, which may become objectionable at the higher audio frequencies and all radio frequencies. Precision wire-wound resistors are usually wound in several sections on ceramic or plastic bobbins and are available in the range from 0.1  $\Omega$  to 10 M $\Omega$ .

Integrated circuit resistors must be capable of fabrication on a silicon integrated circuit chip along with transistors and capacitors. There are two major types: thin-film resistors and diffused resistors. Thin-film resistors are formed by vacuum deposition or sputtering of nichrome, tantalum, or Cermet (Cr-SiO). Such resistors are stable, and the resistance may be adjusted to close tolerances by trimming the film by using a laser. Typical resistor values lie in the range from 100  $\Omega$  to 10 k $\Omega$  with a matching tolerance of  $\pm 0.2\%$  and a temperature coefficient of resistance of  $\pm 10$  to  $\pm 200$  ppm/ $^{\circ}$ C.

Diffused resistors are based upon the same fabrication geometry and techniques used to produce the active transistors on the silicon chip or die. A diffused base, emitter, or epitaxial layer may be formed as a bar with contacts at its extremities. The resistance of such a semiconductor resistor depends upon the impurity doping and the length and cross section of the resistor region. In the case of the base-diffused resistor, the emitter and collector regions may be formed so as to pinch the base region to a very small cross-sectional area, thereby appreciably increasing the resistance. The relatively large impurity carrier concentration in *n*- and *p*-type regions limits the resistance value. Resistor values between 100  $\Omega$  and 10 k $\Omega$  are common. See INTEGRATED CIRCUITS.

The deposited-film and wire-wound resistors lend themselves to the design of adjustable resistors or rheostats and potentiometers. Adjustable-slider power resistors are constructed in the same manner as any wire-wound resistor on a cylindrical form except that when the vitreous outer coating is applied an uncovered strip is provided. The resistance wire is exposed along this strip, and a suitable slider contact can be used to adjust the overall resistance, or the slider can be used as the tap on a potentiometer. See POTENTIOMETER; RHEOSTAT. [R.B.D.K.]

**Resolving power (optics)** A quantitative measure of the ability of an optical instrument to produce separable images. The images to be resolved may differ in position because they represent (1) different points on the object, as in telescopes and microscopes, or (2) images of the same object in light of two different wavelengths, as in prism and grating spectroscopes. For the former class of instruments, the resolving limit is usually quoted as the smallest angular or linear separation of two object points, and for the latter class, as the smallest difference in wavelength or wave number that will produce separate images. Since these quantities are inversely proportional to the power of the instrument to resolve, the term resolving power has generally fallen into disfavor. It is still commonly applied to spectroscopes, however, for which the term chromatic resolving power is used, signifying the ratio of the wavelength itself to the smallest wavelength interval resolved. The figure quoted as the resolving power or resolving limit of an instrument may be the theoretical

value that would be obtained if all optical parts were perfect, or it may be the actual value found experimentally. Aberrations of lenses or defects in the ruling of gratings usually cause the actual resolution to fall below the theoretical value, which therefore represents the maximum that could be obtained with the given dimensions of the instrument in question. This maximum is fixed by the wave nature of light and may be calculated for given conditions by diffraction theory. See DIFFRACTION; OPTICAL IMAGE. [F.A.J.; G.R.H.]

**Resonance (acoustics and mechanics)** When a mechanical or acoustical system is acted upon by an external periodic driving force whose frequency equals a natural free oscillation frequency of the system, the amplitude of oscillation becomes large and the system is said to be in a state of resonance.

A knowledge of both the resonance frequency and the sharpness of resonance is essential to any discussion of driven vibrating systems. When a vibrating system is sharply resonant, careful tuning is required to obtain the resonance condition. Mechanical standards of frequency must be sharply resonant so that their peak response can easily be determined. In other circumstances, resonance is undesirable. For example, in the faithful recording and reproduction of musical sounds, it is necessary either to have all vibrational resonances of the system outside the band of frequencies being reproduced or to employ heavily damped systems. See ACOUSTIC RESONATOR; SYMPATHETIC VIBRATION; VIBRATION. [L.E.K.]

**Resonance (alternating-current circuits)** A condition in a circuit characterized by relatively unimpeded oscillation of energy from a potential to a kinetic form. In an electrical network there is oscillation between the potential energy of charge on capacitance and the kinetic energy of current in inductance. This is analogous to the mechanical resonance seen in a pendulum.

Three kinds of resonant frequency in circuits are officially defined. Phase resonance is the frequency at which the phase angle between sinusoidal current entering a circuit and sinusoidal voltage applied to the terminals of the circuit is zero. Amplitude resonance is the frequency at which a given sinusoidal excitation (voltage or current) produces the maximum oscillation of electric charge in the resonant circuit. Natural resonance is the natural frequency of oscillation of the resonant circuit in the absence of any forcing excitation. These three frequencies are so nearly equal in low-loss circuits that they do not often have to be distinguished.

Resonance is of great importance in communications, permitting certain frequencies to be passed and others to be rejected. Thus a pair of telephone wires can carry many messages at the same time, each modulating a different carrier frequency, and each being separated from the others at the receiving end of the line by an appropriate arrangement of resonant filters. A radio or television receiver uses much the same principle to accept a desired signal and to reject all the undesired signals that arrive concurrently at its antenna; tuning a receiver means adjusting a circuit to be resonant at a desired frequency. [H.H.Sk.]

**Resonance (molecular structure)** A feature of the valence-bond method, which is a mathematical procedure to obtain approximate solutions to the Schrödinger equation for molecules. The valence-bond method is based on the theorem that if two or more solutions to the Schrödinger equation are available, certain linear combinations of them will also be solutions. It has this basis in common with its rival, the molecular orbital method. The valence-bond and molecular orbital approaches are both approximations and, if carried out to their logical and exact extremes, must yield identical results; nevertheless, both are often described as theories. In the valence-bond theory, combinations of solutions represent hypothetical struc-

tures of the molecule in question. These structures are said to be resonance (or contributing) structures, and the real molecule is said to be the resonance hybrid (or just simply the hybrid) of these structures. See MOLECULAR ORBITAL THEORY; SCHRÖDINGER'S WAVE EQUATION.

The resonance theory provided a solution for a molecule which had baffled and preoccupied chemists for a century—benzene. The principal use of resonance still lies in the qualitative description of molecules whose properties would otherwise be difficult to understand. See BENZENE.

Until the beginning of the 20th century, benzene posed a baffling challenge to organic chemists. In spite of its relatively simple formula,  $C_6H_6$ , they were unable to conceive of a suitable structure for it. While a great many structures were proposed, the properties of benzene corresponded to none of them.

In the early 1870s F. A. Kekulé proposed a revolutionary idea; benzene must be represented by two structures, (1) and (2),

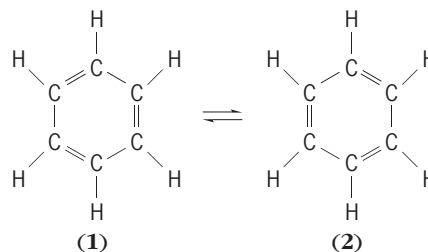

rather than one, and all compounds containing the benzene skeleton must be subject to a rapid equilibration (oscillation) between the two. Kekulé's description of benzene was not completely satisfactory. While it accounted for the number of substituted benzene isomers, it did not explain why the compound failed to exhibit reactivity indicating the presence of multiple bonds. The problem was resolved with the advent of quantum mechanics in the early part of this century. In a sense, this solution is an expansion of Kekulé's oscillating pair; the so-called activation energy (the energy which must be imparted to a molecule in order to make it overcome the barrier that keeps it from being converted into another molecule) is negative in the case of benzene with respect to the oscillation, and this molecule therefore exists neither as (1) nor as (2) at any time, but it is an intermediate form (3) all the time. This intermediate structure of benzene

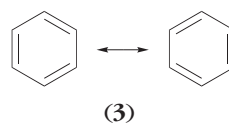

is described in terms of Kekulé's structures with the symbol  $\leftrightarrow$  between them; this is intended to signify that benzene has neither structure, but in fact is a hybrid of the two. The properties of benzene are thereby indicated to be those of neither (1) nor (2), but to be intermediate between the two.

The only property of the hybrid which is not intermediate between those of the hypothetical contributing structures is the energy: the energy of a resonance hybrid is by definition always at a minimum. This fact is responsible for the abnormal reluctance of benzene to undergo addition reactions; such reactions would lead to products that no longer have the resonance energy.

Although benzene is the classical example of resonance, the phenomenon is certainly not limited to it. Furthermore, the properties of all compounds are affected by resonance to some degree.

Although the molecular orbital approach has largely supplanted the valence-bond method, the resonance language remains so convenient that it is still used. See CHEMICAL BONDING; MOLECULAR STRUCTURE AND SPECTRA; QUANTUM CHEMISTRY. [W.J.Ln.]

**Resonance (quantum mechanics)** An enhanced coupling between quantum states with the same energy. The concept of resonance in quantum mechanics is closely related to resonances in classical physics. See RESONANCE (ACOUSTICS AND MECHANICS); RESONANCE (ALTERNATING-CURRENT CIRCUITS).

The matching of frequencies is central to the concept of resonance. An example is provided by waves, acoustic or electromagnetic, of a spectrum of frequencies propagating down a tube or waveguide. If a closed side tube is attached, its characteristic natural frequencies will couple and resonate with waves of those same frequencies propagating down the main tube. This simple illustration provides a description of all resonances, including those in quantum mechanics. The propagation of all quantum entities, whether electrons, nucleons, or other elementary particles, is represented through wave functions and thus is subject to resonant effects. See ACOUSTIC RESONATOR; CAVITY RESONATOR; HARMONIC (PERIODIC PHENOMENA); WAVEGUIDE.

An important allied element of quantum mechanics lies in its correspondence between frequency and energy. Instead of frequencies, differences between allowed energy levels of a system are considered. In the presence of degeneracy, that is, of different states of the system with the same energy, even the slightest influence results in the system resonating back and forth between the degenerate states. These states may differ in their internal motions or in divisions of the system into subsystems. The above example of wave flow suggests the terminology of channels, each channel being a family of energy levels similar in other respects. These energies are discretely distributed for a closed channel, whereas a continuum of energy levels occurs in open channels whose subsystems can separate to infinity. If all channels are closed, that is, within the realm of bound states, resonance between degenerate states leads to a theme of central importance to quantum chemistry, namely, stabilization by resonance and the resulting formation of resonant bonds. See DEGENERACY (QUANTUM MECHANICS); ENERGY LEVEL (QUANTUM MECHANICS); RESONANCE (MOLECULAR STRUCTURE).

Resonances occur in scattering when at least one channel is closed and one open. Typically, a system is divided into two parts: projectile + target, such as electron + atom or nucleon + nucleus. One channel consists of continuum states with their two parts separated to infinity. The other, closed channel consists of bound states. In the atomic example, a bound state of the full system would be a state of the negative ion and, in the nuclear example, a state of the larger nucleus formed by incorporating one extra nucleon in the target nucleus. See QUANTUM MECHANICS; SCATTERING EXPERIMENTS (ATOMS AND MOLECULES); SCATTERING EXPERIMENTS (NUCLEI). [A.R.P.R.]

**Resonance ionization spectroscopy** A form of atomic and molecular spectroscopy in which wavelength-tunable lasers are used to remove electrons from (that is, ionize) a given kind of atom or molecule. Laser-based resonance ionization spectroscopy (RIS) methods have been developed and used with ionization detectors, such as proportional counters, to detect single atoms. Resonance ionization spectroscopy is combined with mass spectrometers to provide analytical systems for a wide range of applications, including physics, chemistry, materials sciences, medicine, and the environmental sciences.

When an atom or molecule is irradiated with a light source of frequency  $\nu$ , photons at this selected frequency are absorbed only when the energy  $h\nu$  ( $h$  is Planck's constant) is almost exactly the same as the difference in energy between some excited state and the ground state of the atom or molecule. If a laser source is tuned to a very narrow bandwidth at a frequency that excites a given kind of atom (see illustration), it is highly unlikely that any other kind of atom will be excited. An atom in an excited state can be ionized by photons of the specified frequency  $\nu$ , provided that  $2h\nu$  is greater than the ionization potential of the atom. While the final ionization step can occur with any energy above a threshold, the entire process of ionization is a resonance

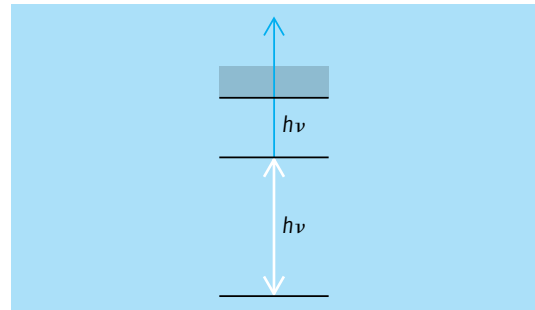

**Basic laser scheme for resonance ionization spectroscopy.** The atom or molecule is irradiated by a light source with frequency  $\nu$  and photons of energy  $h\nu$ , where  $h$  is Planck's constant.

one. Resonance ionization spectroscopy is a selective process in which only those atoms that are in resonance with the light source are ionized. Modern pulsed lasers have made resonance ionization spectroscopy a practical method for the sensitive (and highly selective) detection of nearly every type of atom in the periodic table. See ATOMIC STRUCTURE AND SPECTRA; IONIZATION POTENTIAL; LASER; LASER SPECTROSCOPY; PHOTOIONIZATION; RESONANCE (QUANTUM MECHANICS).

Resonance ionization spectroscopy is used to analyze very low levels of trace elements in extremely pure materials, for example, semiconductors in the electronics industry. A sputter-initiated resonance ionization spectroscopy (SIRIS) apparatus uses an argon ion beam to sputter a tiny cloud of atoms from a sample placed in a high-vacuum system and a pulsed laser tuned to detect the specified impurity atom. See SPUTTERING.

The sputter-initiated resonance ionization spectroscopy method is also used for chemical and materials research, geophysical research and explorations, medical diagnostics, biological research, and environment analysis. Thermal-atomization resonance ionization spectroscopy (TARIS) may be used for the bulk analysis of materials. By simply using resonance ionization spectroscopy with ionization chambers or proportional counters, gas-phase work can be done to study the diffusion of atoms, measure chemical reaction rates, and investigate the statistical behavior of atoms and molecules. See CHEMICAL DYNAMICS; DIFFUSION.

Resonance ionization spectroscopy is used in sophisticated nuclear physics studies involving high-energy accelerators. It is used as an on-line detector to record the hyperfine structure of nuclei with short lifetimes and hence to determine several nuclear properties such as nuclear spin and the shape of nuclei. See FINE STRUCTURE (SPECTRAL LINES); NUCLEAR STRUCTURE.

Resonance ionization spectroscopy is used for measurements of krypton-81 in the natural environment to determine the ages of polar ice caps and old ground-water deposits. Oceanic circulation and the mixing of oceans could also be studied by measuring the concentrations of noble-gas isotopes by resonance ionization spectroscopy. See DATING METHODS; RADIOISOTOPE (GEOCHEMISTRY). [G.S.H.]

**Respiration** The various processes associated with the biochemical transformation of the energy available in the organic substrates derived from foodstuffs, to energy usable for synthetic and transport processes, external work, and, eventually, heat. This transformation, generally identified as metabolism, most commonly requires the presence of oxygen and involves the complete oxidation of organic substrates to carbon dioxide and water (aerobic respiration). If the oxidation is incomplete, resulting in organic compounds as end products, oxygen is typically not involved, and the process is then identified as anaerobic respiration. See METABOLISM.

The term "external respiration" is more appropriate for describing the exchange of O<sub>2</sub> and CO<sub>2</sub> between the organism and its environment. In most multicellular organisms, and nearly all vertebrates (with the exception of a few salamanders lacking both lungs and gills), external respiration takes place in specialized structures termed respiratory organs, such as gills and lungs. See LUNG; RESPIRATORY SYSTEM.

The ultimate physical process causing movement of gases across living tissues is simple passive diffusion. Respiratory gas exchange also depends on two convective fluid movements. The first is the bulk transport of the external medium, air or water, to and across the external respiratory exchange surfaces. The second is the transport of coelomic fluid or blood across the internal surfaces of the respiratory organ. These two convective transports are referred to as ventilation and circulation (or perfusion). They are active processes, powered by ciliary or muscular pumps.

In all vertebrates and many invertebrates, the circulating internal medium (coelomic fluid, hemolymph, or blood) contains a respiratory pigment, for example, hemocyanin or hemoglobin, which binds reversibly with O<sub>2</sub>, CO<sub>2</sub>, and protons. Respiratory pigments augment respiratory gas exchange, both by increasing the capacity for bulk transport of the gases, and by influencing gas partial pressure (concentration) gradients across tissue exchange surfaces. See BLOOD; HEMOGLOBIN; RESPIRATORY PIGMENTS (INVERTEBRATE).

The physiological adjustment of organisms to variations in their need for aerobic energy production involves regulated changes in the exchange and transport of respiratory gases. The adjustments are effected by rapid alterations in the ventilatory and circulatory pumps and by longer-term modifications in the respiratory properties of blood. [K.J.]

**Respirator** A device designed to protect the wearer from noxious gases, vapors, and aerosols or to supply oxygen or doses of medication to the wearer. Respirators are used widely in industry to protect workers against harmful atmospheres, and in the military to protect personnel against chemical, biological, or radioactive warfare agents. Respirators are classified according to whether they are atmosphere-supplying or air-purifying.

Atmosphere-supplying respirators are used in atmospheres deficient in oxygen or extremely hazardous to the health of the wearer. Such atmospheres can occur in unventilated cellars, wells, mines, burning buildings, and enclosures containing inert gas. The self-contained breathing apparatus (SCBA) is a completely self-contained unit with the air supply or the oxygen-generating material being carried by the wearer. Air-supplied respirators are equipped with the same variety of facepieces as the SCBA, however these respirators can have the air supplied to the facepiece by means of a hose and a blower—the hose



Negative-pressure air-purifying respirator.

mask—or from a compressed-air source equipped with proper airflow and pressure-regulating equipment—the air-line mask.

In an air-purifying respirator, ambient air is passed through a purifying medium to remove the contaminants. However, these devices do not provide oxygen or protect against oxygen-deficient atmospheres. A widely used air-purifying respirator is the nonpowered, or negative-pressure, respirator (see illustration). Ambient air is inhaled through the purifying medium in the replaceable cartridges and exhaled through an exhaust valve. In the case of the powered air-purifying respirator, an external blower, usually powered by a belt or helmet-mounted battery pack, forces air through the purifying medium and supplies it to the wearer under positive pressure, thus minimizing the problem of face-seal leakage. [B.Y.H.L.; D.A.Ja.]

**Respiratory pigments (invertebrate)** Colored, metal-containing proteins which combine reversibly with oxygen, and which are found in the body fluids or tissues of invertebrate animals. The role of these pigments is primarily to aid in the transport of molecular oxygen. Thus they are distinguished from respiratory enzymes, which are concerned with the metabolic consumption of oxygen. Four distinctly colored groups of respiratory pigments exist among invertebrates: hemoglobins (purple, become orange-red with oxygen), chlorocruorins (green, become red with oxygen), hemocyanins (colorless, become blue with oxygen), and hemerythrins (colorless, become red with oxygen).

Each of the pigments is composed of two parts, a large protein molecule to which is bound one or more small moieties called prosthetic groups, each of which is or contains a metal. The metal binds the oxygen, and this binding imparts the characteristic color to the pigment. In hemoglobins the prosthetic group is an iron porphyrin compound called heme. Chlorocruorin contains a similar iron porphyrin which differs from heme only in that a vinyl group in the molecule is replaced by formyl. The prosthetic group of hemerythrin consists of two adjacent iron atoms which bind an oxygen molecule between them. The prosthetic group of hemocyanin is analogous and consists of two adjacent copper atoms. Pigments containing vanadium have been found in tunicates, but these substances do not combine reversibly with oxygen and so cannot be considered respiratory pigments.

The protein part of the pigment confers reversibility upon the combination of the metal with oxygen. In the absence of protein, the prosthetic groups lose their capacity to combine with oxygen reversibly. Instead, the metals are irreversibly oxidized: Electrons are transferred from metal to oxygen. The bonds between metal and protein so alter the electronic energy levels of the metal that this transfer, if it occurs, is reversible. For this reason, the combination of hemoglobin with oxygen is described as oxygenation rather than oxidation. The protein is also responsible for certain physiological adaptations of the pigment to the environment. Thus the affinity of the pigment for oxygen is often highest in animals which inhabit environments with the lowest oxygen content. See HEMOGLOBIN. [A.F.R.]

**Respiratory syncytial virus** A virus belonging to the Paramyxoviridae, genus *Pneumovirus*. This virus, although unrelated to any other known respiratory disease agent and differing from the parainfluenza viruses in a number of important characteristics, has been associated with, a large proportion of respiratory illnesses in very young children, particularly bronchiolitis and pneumonia. It appears to be one of the major causes of these serious illnesses of infants. It is the only respiratory virus that occurs with its greatest frequency in infants in their first 6 months of life. In older infants and children, a milder illness is produced.

The clinical disease in young infants may be the result of an antigen-antibody reaction that occurs when the infecting virus meets antibody transmitted from the mother. For this reason respiratory syncytial vaccines that stimulate production of

antibodies in the serum, but not in the nasal secretions, may do more harm than good. See ANIMAL VIRUS; VIRUS CLASSIFICATION.

[J.I.L.; M.E.Re.]

**Respiratory system** The system of organs involved in the acquisition of oxygen and the elimination of carbon dioxide by an organism. The lungs and gills are the two most important structures of vertebrates involved in the phase known as external respiration, or gaseous exchanges, between the blood and environment. Internal respiration refers to the gaseous exchanges which occur between the blood and cells. Certain other structures in some species of vertebrates serve as respiratory organs; among these are the integument or skin of fishes and amphibians. The moist, highly vascular skin of anuran amphibians is important in respiration. Certain species of fish have a vascular rectum which is utilized as a respiratory structure, water being taken in and ejected regularly by the animal. Saclike cloacal structures occur in some aquatic species of turtles. These are vascular and are intermittently filled with, and emptied of, water. It is thought that they may function in respiration. During embryonic life the yolk sac and allantois are important respiratory organs in certain vertebrates. See ALLANTOIS; YOLK SAC.

Structurally, respiratory organs usually present a vascular surface that is sufficiently extensive to provide an adequate area of absorption for gaseous exchange. This surface is moist and thin enough to allow for the passage of gases. [R.S.McE./T.S.P.]

The shape and volume of the lung, because of its pliability, conforms almost completely to that of its cavity. The lungs are conical; each has an apex and a base, two surfaces, two borders, and a hilum. The apex extends into the superior limit of the thoracic cavity. The base is the diaphragmatic surface. The costal surface may show bulgings into the intercostal spaces. The medial surface has a part lying in the space beside the vertebral column and a part imprinted by the form of structures bulging outward beneath the mediastinal pleura. The cardiac impression is deeper on the left lung because of the position of the heart.

For convenience the lung may be divided into anatomical areas. The bronchial tree branches mainly by dichotomy. The ultimate generations, that is, the respiratory bronchioles, alveolar ducts, and alveoli constitute all of the respiratory portion of the lung. The trachea and extrapulmonary bronchi are kept open by C-shaped bars of hyaline cartilage. When in their branching the bronchi and bronchioles are reduced to a diameter of 1 mm or less, they are then free of cartilage and are called terminal bronchioles. One of the terminal bronchioles enters the apex of a secondary lobule of the lung. These secondary lobules are anatomic units of the lung, whose hexagonal bases rest on the pleura or next to a bronchiole or blood vessel. Finer lines divide the bases of the secondary lobules into smaller areas. These are the bases of primary lobules, each served by a respiratory bronchiole. See LUNG; RESPIRATION.

The blood supply to the lung is provided by the pulmonary and the bronchial arteries. The nerves which supply the lung are branches of the vagus and of the thoracic sympathetic ganglia 2, 3, and 4. Efferent vagal fibers are bronchoconstrictor and secretory, whereas the afferents are part of the arc for the breathing reflex. Efferent sympathetic fibers are bronchodilators; hence, the use of adrenalin for relief of bronchial spasm resulting from asthma. See ASTHMA; NERVOUS SYSTEM (VERTEBRATE). [L.P.C.]

**Respiratory system disorders** Dysfunction of the respiratory system, which supplies the body with the oxygen needed for metabolic activities in the cells and removes carbon dioxide, a product of cellular metabolism. The respiratory system includes the nose, mouth, throat, larynx, trachea, bronchi, lungs, and the muscles of respiration such as the intercostal muscles and the diaphragm. See RESPIRATION.

The lung has a great reserve capacity, and therefore a significant amount of disease usually must be present to produce clinical signs and symptoms. Shortness of breath (dyspnea) on

exertion is the most common symptom of a respiratory disorder. Shortness of breath while at rest is indicative of severe respiratory disease and usually implies a severe abnormality of the lung tissue. If the respiratory system is so diseased that normal oxygenation of the blood cannot occur, blood remains dark, and a bluish color can be seen in the lips or under the fingernails; this condition is referred to as cyanosis. Other signs and symptoms of respiratory disorder can include fever, chest pain, coughing, excess sputum production, and hemoptysis (coughing up blood). Most of these signs and symptoms are nonspecific. See HYPOXIA.

Most diseases of the airways increase the resistance against which air is sucked in and pushed out of the lungs. Diseases of the nose usually have little influence since collateral respiration through the mouth compensates easily. Diseases of the throat, larynx, and trachea can significantly inhibit the flow of air into the lungs. Infections in the back of the throat, such as in diphtheria, can cause marked swelling of mucous membranes, resulting in air obstruction. Edema (swelling) of the mucosal lining of the larynx can also cause a reduction in air flow. Likewise, air flow can be inhibited in asthma, in which the smooth muscle in the trachea and bronchi episodically constricts. Chronic bronchitis results in inflammation of and excess mucus production by the bronchi and this also can lead to a reduction in air flow. Bronchiolitis, a condition that usually occurs in children and is often caused by a respiratory virus, results in narrowing and inflammation of small airways and a decrease in air flow.

Pneumonia, cancer, and emphysema are the most common lung diseases and are a major cause of morbidity and mortality in the United States. Of the four major types of lung cancer, approximately 90% can be attributed to the carcinogens present in cigarette smoke. Lung cancer may be detected in asymptomatic persons with a routine chest x-ray, or it may be discovered because of pain, excess coughing, or hemoptysis. See CANCER (MEDICINE); EMPHYSEMA; PNEUMONIA.

Among the diseases of pulmonary circulation, congenital malformations of the heart and pulmonary artery account for many cases of respiratory insufficiency in newborn and younger children. In adults, acquired heart diseases can cause backup of blood into the lung and an increased pressure in the pulmonary circulatory system. Also, blood clots, which usually develop first in the deep veins of the legs, can break free and flow to the heart. There they enter the pulmonary arteries and wedge in their small branches, where the clots are referred to as pulmonary thromboemboli, and can cause areas of death in the lung tissue (pulmonary infarcts). Persons who develop thromboemboli usually have chest pain and shortness of breath, and some have hemoptysis. See CARDIOVASCULAR SYSTEM; CIRCULATION DISORDERS.

Some neuromuscular diseases, such as poliomyelitis and amyotrophic lateral sclerosis (Lou Gehrig's disease), can cause dysfunction of the muscles of respiration. The resulting inability of these muscles to move air into the lungs can cause severe shortness of breath and predispose the patient to pneumonia. See MUSCULAR SYSTEM DISORDERS; POLIOMYELITIS; RESPIRATORY SYSTEM. [S.P.H.]

**Response** A quantitative expression of the manner in which a microphone, amplifier, loudspeaker, or other component or system performs its intended function. A linear response means that the output signal is exactly proportional to the input signal for the entire range of frequencies over which the device is intended to operate. A logarithmic response means that the output signal is a logarithmic function of the input signal. The frequency response of a device, often presented as a curve on a graph, is the deviation over the frequency range from the response at some selected frequency, such as 1000 Hz. See AMPLIFIER; CHARACTERISTIC CURVE; LOUDSPEAKER; MICROPHONE. [J.Mar.]

**Rest mass** A constant intrinsic to a body which determines its inertial and energy-momentum properties. It is a fundamental concept of special relativity, and in particular it determines

the internal energy content of a body. It is the same as the inertial mass of classical mechanics. According to the principle of equivalence, the basic physical principle of general relativity, the inertial mass of a body is also equal to its gravitational mass. See CLASSICAL MECHANICS; GRAVITATION; RELATIVISTIC MECHANICS; RELATIVITY.

The rest mass or inertial mass of a body,  $m$ , is a measure of its resistance to being accelerated at a by  $\mathbf{a}$  force  $\mathbf{F}$ ; in classical mechanics the relation between inertial mass, acceleration, and force is given by Newton's law, Eq. (1). In special relativity

$$\mathbf{F} = m\mathbf{a} \quad (1)$$

Newton's law holds exactly only in the body's rest frame, that is, the frame in which the body is instantaneously at rest. See NEWTON'S LAWS OF MOTION.

Associated with the rest mass of a body, there is an internal or rest energy. In the system where the body is at rest, the energy of the body is given by Eq. (2).

$$E = mc^2 \quad (\text{body at rest}) \quad (2)$$

The experimental realization of the interconversion of mass and energy is accomplished in the reactions of nuclei and elementary particles. In particular, the energy source of nuclear bombs and nuclear fission reactors is a small decrease in the total mass of the interacting nuclei, which gives rise to a large energy release because of the large numerical value of  $c^2$ . See ELEMENTARY PARTICLE; NUCLEAR FISSION. [R.J.A.]

**Restionales** An order of flowering plants, division Magnoliophyta (Angiospermae), in the subclass Commelinidae of the class Liliopsida (monocotyledons). The order consists of 4 families and about 450 species, some 400 of them belonging to the Restionaceae. The vast majority of the species grow in temperate regions of the Southern Hemisphere. The Restionales are wind- or self-pollinated, with reduced flowers and a single, pendulous, orthotropous ovule in each of the 1–3 locules of the ovary. See COMMELINIDAE; CYPERALES; LILIOPSIDA; MAGNOLIOPHYTA. [A.Cr.; T.M.Ba.]

**Restoration ecology** A field in the science of conservation that is concerned with the application of ecological principles to restoring degraded, derelict, or fragmented ecosystems. The primary goal of restoration ecology (also known as ecological restoration) is to return a community or ecosystem to a condition similar in ecological structure, function, or both, to that existing prior to site disturbance or degradation.

A reference framework is needed to guide any restoration attempt—that is, to form the basis of the design (for example, desired species composition and density) and monitoring plan (for example, setting milestones and success criteria for restoration projects). Such a reference system is derived from ecological data collected from a suite of similar ecosystems in similar geomorphic settings within an appropriate biogeographic region. Typically, many sites representing a range of conditions (for example, pristine to highly degraded) are sampled, and statistical analyses of these data reveal what is possible given the initial conditions at the restoration site. See ECOLOGY, APPLIED; ECOSYSTEM. [P.L.Fi.]

**Restriction enzyme** An enzyme, specifically an endode-oxynuclease, that recognizes a short specific sequence within a deoxyribonucleic acid (DNA) molecule and then catalyzes double-strand cleavage of that molecule. Restriction enzymes have been found only in bacteria, where they serve to protect the bacterium from the deleterious effects of foreign DNA. See DEOXYRIBONUCLEIC ACID (DNA).

There are three known types of restriction enzymes. Type I enzymes recognize a specific sequence on DNA, but cleave the DNA chain at random locations with respect to this sequence. They have an absolute requirement for the cofactors adenosine

triphosphate (ATP) and S-adenosylmethionine. Because of the random nature of the cleavage, the products are a heterogeneous array of DNA fragments. Type II enzymes also recognize a specific nucleotide sequence but differ from the type I enzymes in that they do not require cofactors and they cleave specifically within or close to the recognition sequence, thus generating a specific set of fragments. It is this exquisite specificity which has made these enzymes of great importance in DNA research, especially in the production of recombinant DNAs. Type III enzymes have properties intermediate between those of the type I and type II enzymes. They recognize a specific sequence and cleave specifically a short distance away from the recognition sequence. They have an absolute requirement for the ATP cofactor, but they do not hydrolyze it.

A key feature of the fragments produced by restriction enzymes is that when mixed in the presence of the enzyme DNA ligase, the fragments can be rejoined. Should the new fragment carry genetic information that can be interpreted by the bacterial cell containing the recombinant molecule, then the information will be expressed as a protein and the bacterial cell will serve as an ideal source from which to obtain that protein. For instance, if the DNA fragment carries the genetic information encoding the hormone insulin, the bacterial cell carrying that fragment will produce insulin. By using this method, the human gene for insulin has been cloned into bacterial cells and used for the commercial production of human insulin. The potential impact of this technology forms the basis of the genetic engineering industry. See ENZYME; GENETIC ENGINEERING. [R.Ro.]

**Resultant of forces** A system of at most a single force and a single couple whose external effects on a rigid body are identical with the effects of the several actual forces that act on the body. For analytic purposes, forces are grouped and replaced by their resultant. Forces can be added graphically (see illustration) or analytically. The sum of more than two vector forces can be found by extending the method of illustration *c* to a three-dimensional vector polygon in which one force is drawn from the tip of the previous one until all are laid out.

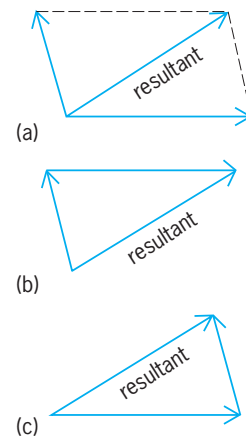

**Resultant of two forces acting through a common center.** (a) Diagonal of parallelogram. (b, c) Hypotenuse of triangle.

The resultant force is the force vector required to close the polygon directed from the tail of the first force vector to the tip of the last. A force system has a zero force resultant if its vector polygon closes. See CALCULUS OF VECTORS.

Two force systems are equivalent if their resultant forces, as described above, are equal and if their total vector moments about the same point are also equal. Vector moments are combined in the same manner as forces, that is, by parallelograms, triangles, or polygons. A resultant is the equivalent force system having the fewest possible forces and couples. See COUPLE; FORCE; STATICS. [N.S.F.]

**Retaining wall** A generic structure that is employed to restrain a vertical-faced or near-vertical-faced mass of earth. The earth behind the wall may be either the natural embankment or the backfill material placed adjacent to the retaining wall. Retaining walls must resist the lateral pressure of the earth, which tends to cause the structure to slide or overturn.

There are several types of retaining walls. A gravity wall is typically made of concrete and relies on its weight for stability (illus. a). The mass of the structure must be sufficient to develop enough frictional resistance to sliding, and the base or footing of the structure must be wide enough to develop sufficient moment to resist overturning earth forces. A cantilever retaining wall (illus. b) gains a larger effective mass by virtue of the soil placed on the horizontal cantilevered section of the wall. Reinforced counterforts are spaced along the wall to increase its strength. A variation of the gravity retaining wall is the crib wall (illus. c) is usually constructed of prefabricated interlocking concrete units. The crib is then filled with soil before the backfill adjacent to the crib is placed. Bulkhead retaining walls (illus. d) consist of vertical sheet piling that extends down into the soil and is stabilized by one or more tiebacks and anchors periodically spaced along the structure. The sheet piling may be made of reinforced concrete, steel, or aluminum. See CANTILEVER.

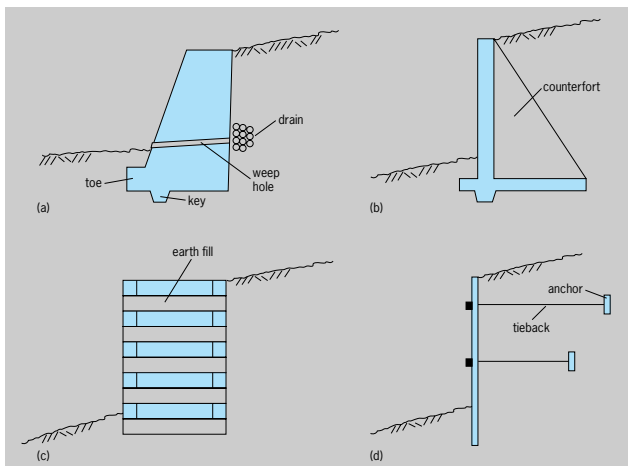

Common types of retaining walls. (a) Gravity wall. (b) Cantilever wall. (c) Crib wall. (d) Bulkhead.

Retaining walls are often used in the marine environment, where they separate the retained soil from the water. Gravity walls (known as seawalls) can be constructed where strong wave and current forces are exerted on the wall. Bulkheads are more commonly found in sheltered areas such as harbors and navigation channels. See HARBORS AND PORTS. [R.M.S.]

**Reticular formation** Characteristic clusters of nerve cell bodies (gray matter) and their meshwork or reticulum, of fibers which are found in the brainstem and the diencephalon. The reticular formation is thought to be a complex, highly integrated mechanism which exerts both inhibition and facilitation on almost every type of activity of the central nervous system. See NERVOUS SYSTEM (VERTEBRATE). [D.B.W.]

**Reticulosa** An order of the subclass Hexasterophora in the class Hexactinellida. This is a group of Paleozoic hexactinellids with a branching form. Each branch is provided with dermal, parenchymal, and gastral spicule reticulations. See HEXACTINOPHORA. [W.D.H.]

**Retortamonadida** An order of parasitic flagellate protozoa belonging to the class Zoomastigophorea. All retorta-

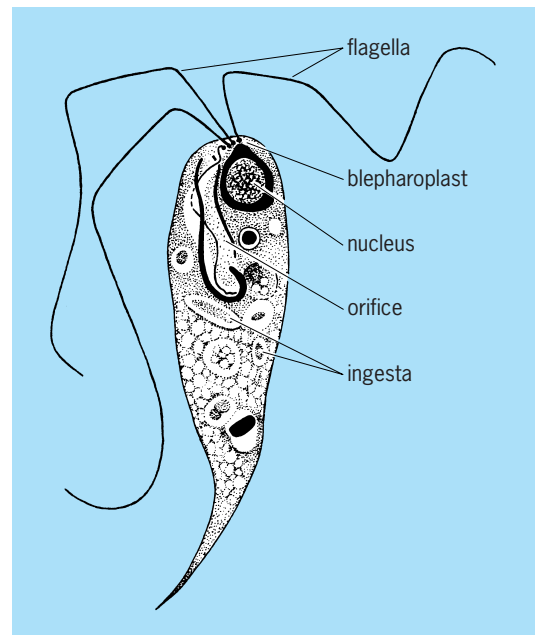

A retortamonad, *Chilomastix aulastomi*.

monads are medium to large in size and have a complicated blepharoplast-centrosome-axo-style apparatus. Retortamonadida have two or four flagella, one turned ventrally into a cytostomal depression. The nucleus, containing a distinct endosome, is located at the anterior tip. The body is twisted. These organisms are actually symbionts, ingesting bacteria in the digestive tracts of their hosts. *Retortamonas* has several species, some of which infest insects and vertebrates. *Chilomastix* also has a number of species, found in vertebrates and invertebrates (see illustration). See PROTOZOA; SARCOMASTIGOPHORA; ZOOMASTIGOPHOREA. [J.B.L.]

**Retrograde motion (astronomy)** In astronomy, either an apparent east-to-west motion of a planet or comet with respect to the background stars or a real east-to-west orbital motion of a comet about the Sun or of a satellite about its primary. The majority of the objects in the solar system revolve from west to east about their primaries. However, near the time of closest approach of Earth and a superior planet, such as Jupiter, because of their relative motion, the superior planet appears to move from east to west with respect to the background stars. The same apparent motion occurs for an inferior planet, such as Venus, near the time of closest approach to Earth.

Actual, rather than apparent, retrograde motion occurs among the satellites and comets; the eighth and ninth satellites of Jupiter and the ninth satellite of Saturn are examples. See ORBITAL MOTION. [R.L.Du.]

**Retrovirus** A family of viruses distinguished by three characteristics: (1) genetic information in ribonucleic acid (RNA); (2) virions possess the enzyme reverse transcriptase; and (3) virion morphology consists of two proteinaceous structures, a dense core and an envelope that surrounds the core. Some viruses outside the retrovirus family have some of these characteristics, but none has all three. Numerous retroviruses have been described; they are found in all families of vertebrates. See ANIMAL VIRUS; REVERSE TRANSCRIPTASE; RIBONUCLEIC ACID (RNA).

The genome is composed of two identical molecules of single-stranded RNA, which are similar in structure and function to cellular messenger RNA. Deoxyribonucleic acid (DNA) is not present in the virions of retroviruses. The reverse transcriptase in each virus makes a DNA copy of the RNA genome shortly after

## 1910 Reverberation

entry of the virus into the host cell. The discovery of this enzyme changed thinking in biology. Previously, the only known direction for the flow of genetic information was from DNA to RNA, yet retroviruses make DNA copies of their genome by using an RNA template. This reversal of genetic information was considered backward and hence the family name retrovirus, meaning backward virus.

Once the DNA copy of the RNA genome is made, it is inserted directly into one of the chromosomes of the host cell. This results in new genetic information being acquired by the host species. The study of reverse transcriptase has led to other discoveries of how retroviruses add a variety of new genetic information into the host. One such class of genes carried by retroviruses is oncogenes, meaning tumor genes. Retroviral oncogenes appear to be responsible for tumors in animals. See ONCOGENES; VIRUS CLASSIFICATION.

Two distinct retroviruses have been discovered in humans. One is human T-cell lymphotropic virus type 1 (HTLV-1), a type C-like virus associated with adult T-cell leukemia. The other is the human acquired immune deficiency syndrome (AIDS) virus, a type E lentivirus. See ACQUIRED IMMUNE DEFICIENCY SYNDROME (AIDS); LEUKEMIA. [P.A.Ma.]

**Reverberation** After sound has been produced in, or enters, an enclosed space, it is reflected repeatedly by the boundaries of the enclosure, even after the source ceases to emit sound. This prolongation of sound after the original source has stopped is called reverberation. A certain amount of reverberation adds a pleasing characteristic to the acoustical qualities of a room. However, excessive reverberation can ruin the acoustical properties of an otherwise well-designed room. A typical record representing the sound-pressure level at a given point in a room plotted against time, after a sound source has been turned off, is given in the decay curve shown in the illustration. The rate of sound decay is not uniform

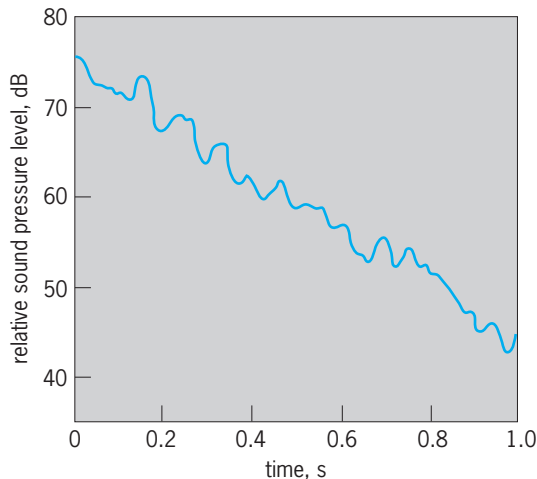

Typical decay curve illustrating reverberation.

but fluctuates about an average slope. See ARCHITECTURAL ACOUSTICS; SOUND. [C.M.H.]

**Reverse transcriptase** Any of the deoxyribonucleic acid (DNA) polymerases present in particles of retroviruses which are able to carry out DNA synthesis using an RNA template. This reaction is called reverse transcription since it is the opposite of the usual transcription reaction, which involves RNA synthesis using a DNA template. See RETROVIRUS.

The transfer of genetic information from RNA to DNA in retrovirus replication was proposed in 1964 by H. M. Temin in the DNA provirus hypothesis for the replication of Rous sarcoma

virus, an avian retrovirus which causes tumors in chickens and transformation of cells in culture, and reverse transcriptase has since been purified from virions of many retroviruses. The avian, murine, and human retrovirus DNA polymerases have been extensively studied.

Studies indicate that reverse transcriptase is widely distributed in living organisms and that all reverse transcriptases are evolutionarily related. For example, the organization of the nucleotide sequence of integrated retroviral DNA has a remarkable resemblance to the structure of bacterial transposable elements, in particular, transposons.

Reverse transcriptase genes are present in the eukaryotic organisms in retrotransposons and in retrotransposons or long interspersed (LINE) elements. Both of these types of elements can transpose in cells. See DEOXYRIBONUCLEIC ACID (DNA); RIBONUCLEIC ACID (RNA); TRANSPOSONS. [H.M.T.]

**Revetment** A facing or veneer of stone, concrete, or other materials constructed on a sloping embankment, dike, or beach face to protect it against erosion caused by waves or currents. The revetment may be a rigid cast-in-place concrete structure; but more commonly it is a flexible structure constructed of stone riprap or interlocking concrete blocks. It is sometimes an articulated block structure where the armor blocks are set in a form known as a flexible carpet; that is, the blocks interlock for stability, but the interlocking makes them flexible enough to respond to settlement of the underlying soil. A flexible revetment provides protection from exterior hydraulic forces, and it also can tolerate some settlement or consolidation of the underlying soil.

A typical revetment might employ stone riprap as the armor material (see illustration). A revetment typically has three major components: (1) the armor layer, which resists the wave or current-induced hydraulic forces; (2) a filter layer under the armor layer to allow water seepage out of the underlying soil without the removal of fine soil particles; and (3) a mechanism to stabilize the structure toe. Toe stabilization is particularly important where waves break on the structure, but may not be necessary if the revetment extends to sufficient depths where hydraulic forces will not erode the toe of the slope. The design water level (see illus.) for the structure may be higher than the normal water level during nonstorm conditions. If the revetment is exposed to waves that will break and run up the face of the revetment, the upper extent of the revetment must be sufficiently high to counter the force exerted by the waves.

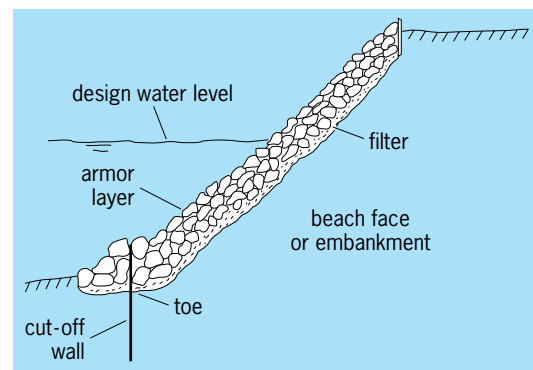

Cross-sectional profile of a typical stone revetment.

Although stone riprap is the most commonly used material for revetment armor layers, a wide variety of other materials have been used, including cast-in-place concrete and poured asphalt, wire bags filled with stone (gabions), interlocking concrete blocks, soil cement, cement-filled bags, interlocked tires, woven wooden mattresses, and vegetation (only used for surfaces exposed to very low waves or slow-moving currents). See RETAINING WALL; RIVER ENGINEERING. [R.M.S.]



**Reynolds number** In fluid mechanics, the ratio  $\rho v d / \mu$ , where  $\rho$  is fluid density,  $v$  is velocity,  $d$  is a characteristic length, and  $\mu$  is fluid viscosity. The Reynolds number is significant in the design of a model of any system in which the effect of viscosity is important in controlling the velocities or the flow pattern. In the evaluation of drag on a body submerged in a fluid and moving with respect to the fluids, the Reynolds number is important.

The Reynolds number also serves as a criterion of type of fluid motion. In a pipe, for example, laminar flow normally exists at Reynolds numbers less than 2000, and turbulent flow at Reynolds numbers above about 3000. See DYNAMIC SIMILARITY; FLUID MECHANICS; LAMINAR FLOW; TURBULENT FLOW. [G.Mu.]

**Rh incompatibility** A condition in which red blood cells of the fetus become coated with an immunoglobulin (IgG) antibody [Rh (rhesus) antibody] of maternal origin which is directed against an antigen (Rh D antigen) of paternal origin that is present on fetal cells. See ANTIBODY; ANTIGEN; BLOOD GROUPS; IMMUNOGLOBULIN.

A pregnant woman may develop an antibody to a red blood cell antigen that the fetus has but that she does not possess. This occurs because the fetus has inherited the antigen from the father; fetal red cells pass into the maternal circulation and are recognized as foreign by the mother. The mother develops antibodies to the foreign protein; the antibodies pass across the placenta and attack the fetal red blood cells, producing a hemolytic anemia. This phenomenon is known as alloimmunization. Alloimmunization of the mother results in hemolytic disease of the newborn (also known as erythroblastosis fetalis). See ANEMIA; AUTOIMMUNITY.

The development of Rh incompatibility is determined by the Rh types of the parents. Some Rh-incompatible pregnancies do not result in sensitization. Factors influencing the occurrence of sensitization include the timing and extent of the transplacental hemorrhage, the degree and strength of antibody development in the mother, and the ABO status of mother and fetus. Most immunizations result from transplacental hemorrhage during placental separation at delivery.

The at-risk mother is monitored for the development and progression of Rh incompatibility with serial serum antibody titers to anti-D. The presence of anti-D and its titer do not necessarily correlate with the status of the fetus. To monitor the status, amniocentesis is performed. This procedure permits measurement of bile pigment concentration and assessment of lung maturity. These tests are done serially to decide when to deliver the fetus or whether to transfuse the fetus until it is mature enough to be delivered safely. See PRENATAL DIAGNOSIS.

Following delivery, the infant may require transfusion immediately or during the postnatal period. This may involve simple replacement or exchange transfusion, in which the infant's blood volume is replaced with compatible blood. The aim of exchange is to remove bilirubin and antibody-coated red blood cells and to correct the anemia while replacing the infant's blood with blood that is antigen negative for the offending antibody. Other medical treatment for jaundice may also be required. See TRANSFUSION.

Rh immune globulin (RhIG) is a concentrated solution of IgG anti-D obtained from pooled human plasma. Its action is to interfere with antigen recognition. Rhlg should be administered to any Rh-negative mother of an Rh-positive infant within 72 h after delivery. Administration of RhIG at the twenty-eighth week of pregnancy followed by a second dose at birth has been very successful in all but eliminating Rh hemolytic disease. See PREGNANCY. [N.L.C.L.]

**Rhabditida** An order of nematodes in which the number of labia varies from a full complement of six to three or two or none. The tubular stoma may be composed of five or more sections called rhabdions. The three-part esophagus always ends in a muscular bulb that is invariably valved. The excretory tube is cuticular lined, and paired lateral collecting tubes generally

run posteriorly from the excretory cell; some taxa have anterior tubules also. Females have one or two ovaries; when only one is present, the vulva shifts posteriorly. The cells of the intestine may be uninucleate, binucleate, or tetranucleate, and the hypodermal cells may also be multinucleate.

There are eight superfamilies in the order: Rhabditoidea, Allionematoidea, Bunonematoidea, Cephaloidea, Panagrolaimoidea, Robertioidea, Chambersiellolidae, and Elaphonematoidea. The Rhabditoidea are one of the largest nematode superfamilies and contain many important parasites of humans and domestic animals. This superfamily is distinguished by the well-developed cylindrical stoma and three-part esophagus that ends in a valved terminal bulb. In parasitic species, adult stages and some larval stages lack the valved terminal bulb. Though most species of Rhabditoidea are free-living feeders on terrestrial bacteria, others are important in the biological control of insects or as parasites of mammals. See MEDICAL PARASITOLOGY. [A.R.M.]

**Rhabdocoela** Formerly considered an order of the Turbellaria, the group Rhabdocoela is now usually divided into three orders, Catenulida, Macrostomida, and Neorhabdocoela. The temocephalids are a group of rhabdocoeloses closely related to the Dalyelloida. They are sometimes considered a distinct order but are usually classified under the Neorhabdocoela. They differ from other rhabdocoeloses chiefly in the possession of tentacles and adhesive organs and in the absence of epidermal cilia in most species.

The rhabdocoeloses have a simple, unbranched intestine, with little if any diverticulations. The pharynx is simple or bulbous, the gonads are usually compact, a cuticular apparatus is associated with the copulatory organ, and there are two main longitudinal nerves. This large group includes most small freshwater Turbellaria as well as many marine and some terrestrial species. See TURBELLARIA. [E.R.J.]

**L-Rhamnose** A methyl pentose, known also as 6-deoxy-L-mannose and L-mannomethyllose. The free sugar, with the structure shown, occurs in leaves and flowers of poison ivy (*Rhus toxicodendron*).

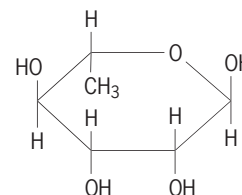

It is a constituent of many of the plant glycosides such as quercitrin and rutin. The type II *Pneumococcus* specific polysaccharides and a wide variety of gums and mucilages contain L-rhamnose, and there is evidence that this sugar is present in a number of bacterial polysaccharides. See MONOSACCHARIDE. [W.Z.H.]

**Rhenium** A chemical element, Re, with atomic number 75 and atomic weight 186.2. Rhenium is a transition element. It is a dense metal (21.04) with the very high melting point of 3440°C (6220°F). See PERIODIC TABLE.

Rhenium is similar to its homolog technetium in that it may be oxidized at elevated temperatures by oxygen to form the volatile heptoxide,  $\text{Re}_2\text{O}_7$ ; this in turn may be reduced to a lower oxide,  $\text{ReO}_2$ . The compounds  $\text{ReO}_3$ ,  $\text{Re}_2\text{O}_3$ , and  $\text{Re}_2\text{O}$ , are well known. Perrhenic acid,  $\text{HReO}_4$ , is a strong monobasic acid and is only a very weak oxidizing agent. Complex perrhenates, such as cobalt hexammine perrhenate,  $[\text{Co}(\text{NH}_3)_6(\text{ReO}_4)_3]$ , are also known.

The halogen compounds of rhenium are very complicated, and a large series of halides and oxyhalides have been reported. Rhenium forms two well-characterized sulfides,  $\text{Re}_2\text{S}_7$  and  $\text{ReS}_2$ , as well as two selenides,  $\text{Re}_2\text{Se}_7$  and  $\text{ReSe}_2$ . The sulfides have their counterparts in the technetium compounds,  $\text{Tc}_2\text{S}_7$  and  $\text{TcS}_2$ . See TECHNETIUM; TRANSITION ELEMENTS. [S.F.]

**Rheology** In the broadest sense of the term, that part of mechanics which deals with the relation between force and deformation in material bodies. The nature of this relation depends on the material of which the body is constituted. It is customary to represent the deformation behavior of metals and other solids by a model called the linear or hookean elastic solid (displaying the property known as elasticity) and that of fluids by the model of the linear viscous or newtonian fluid (displaying the property known as viscosity). These classical models are, however, inadequate to depict certain nonlinear and time-dependent deformation behavior that is sometimes observed. It is these nonclassical behaviors which are the chief interest of rheologists and hence referred to as rheological behavior. See ELASTICITY; STRESS AND STRAIN; VISCOSITY.

Rheological behavior is particularly readily observed in materials containing polymer molecules which typically contain thousands of atoms per molecule, although such properties are also exhibited in some experiments on metals, glasses, and gases. Thus rheology is of interest not only to mathematicians and physicists, who consider it to be a part of continuum mechanics, but also to chemists and engineers who have to deal with these materials. It is of special importance in the plastics, rubber, film, and coatings industries. See FLUID MECHANICS; PAINT; PLASTICS PROCESSING; POLYMER; RUBBER; SURFACE COATING.

**Models and properties.** Consider a block of material of height  $h$  deformed in the manner indicated in Fig. 1; the bottom surface is fixed and the top moves a distance  $w$  parallel to itself. A measure of the deformation is the shear strain  $\gamma$  given by Eq. (1).

$$\gamma = \frac{w}{h} \tag{1}$$

To achieve such a deformation if the block is a linear elastic material, it is necessary to apply uniformly distributed tangential forces on the top and bottom of the block as shown in Fig. 1b. The intensity of these forces, that is, the magnitude of the net force per unit area, is called the shear stress  $S$ . For a linear elastic material,  $\gamma$  is much less than unity and is related to  $S$  by Eq. (2),

$$S = G\gamma \tag{2}$$

where the proportionality constant  $G$  is a property of the material known as the shear modulus.

If the material in the block is a newtonian fluid and a similar set of forces is imposed, the result is a simple shearing flow, a deformation as pictured in Fig. 1b with the top surface moving with a velocity  $dw/dt$ . This type of motion is characterized by a rate of shear  $\dot{\gamma} = (dw/dt)/h$ , which is proportional to the shear stress  $S$  as given by Eq. (3), where  $\eta$  is a property of the material called the viscosity.

$$S = \eta\dot{\gamma} \tag{3}$$

**Linear viscoelasticity.** If the imposed forces are small enough, time-dependent deformation behavior can often be described by the model of linear viscoelasticity. The material properties in this model are most easily specified in terms of simple experiments.

In a creep experiment a stress is suddenly applied and then held constant; the deformation is then followed as a function of time. This stress history is indicated in the solid line of Fig. 2a

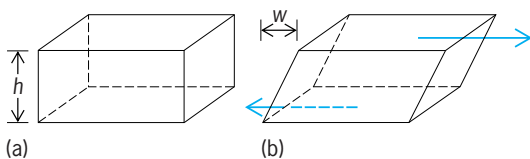

Fig. 1. Simple shear. (a) Undeformed block of height  $h$ . (b) Deformed block after top has moved a distance  $w$  parallel to itself. The arrows indicate the net forces acting on the top and bottom faces. The forces which must be applied to left and right faces to maintain a steady state are not indicated.

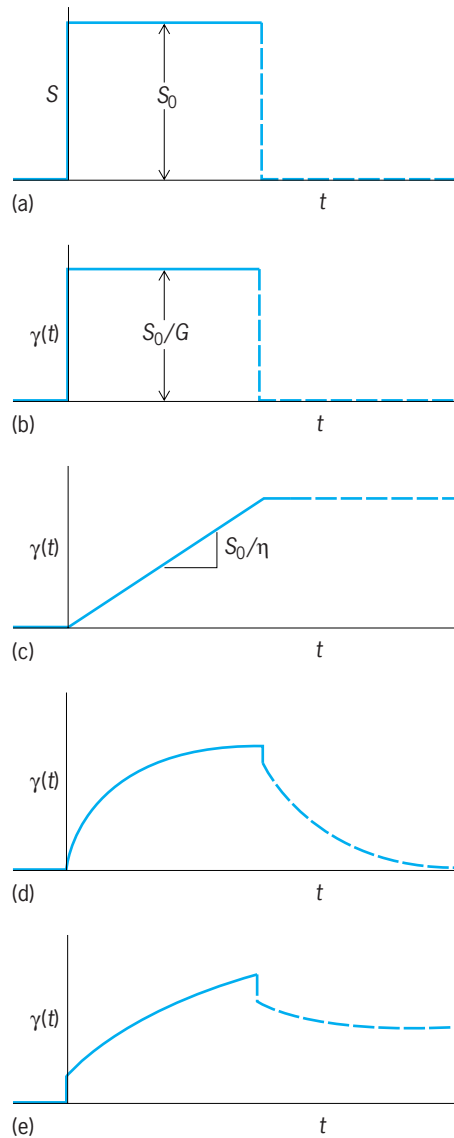

Fig. 2. Creep and recovery; solid lines indicate creep; broken lines indicate recovery. (a) Applied stress history. (b) Corresponding strain history for linear elastic solid, (c) linear viscous fluid, (d) viscoelastic solid, and (e) viscoelastic fluid.

for the case of an applied constant shear stress  $S_0$ . If such an experiment is performed on a linear elastic solid, the resultant deformation is indicated by the full line in Fig. 2b and for the linear viscous fluid in Fig. 2c. In the case of elasticity, the result is an instantly achieved constant strain; in the case of the fluid, an instantly achieved constant rate of strain. In the case of viscoelastic materials, there are some which eventually attain a constant equilibrium strain (Fig. 2d) and hence are called viscoelastic solids. Others eventually achieve constant rate of strain (Fig. 2e) and are called viscoelastic fluids. If the material is linear viscoelastic, the deformation  $\gamma(S_0, t)$  is a function of the time  $t$  since the stress was applied and also a linear function of  $S_0$ ; that is, Eq. (4) is satisfied, where  $J(t)$  is independent of  $S_0$ . The

$$\gamma(S_0, t) = S_0 J(t) \tag{4}$$

function  $J(t)$  is a property of the material known as the shear creep compliance. See CREEP (MATERIALS).

**Nonlinear viscoelasticity.** If stresses become too high, linear viscoelasticity is no longer an adequate model for materials which exhibit time-dependent behavior. In a creep experiment, for example, the ratio of the strain to stress,  $\gamma(t, S_0)/S_0$ , is no

longer independent of  $S_0$ ; this ratio generally decreases with increasing  $S_0$ . Two examples of nonlinear viscoelasticity are shear thinning and thixotropy.

For polymer melts, solutions, and suspensions, generally speaking, the viscosity decreases as the shear rate increases. This type of behavior, called shear thinning, is of considerable industrial significance. For example, paints are formulated to be shear-thinning. A high viscosity at low flow rates keeps the paint from dripping from the brush or roller and prevents sagging of the paint film newly applied to a vertical wall. The lower viscosity at the high deformation rates while brushing or rolling means that less energy is required, and hence the painter's arm does not become overly tired.

Thixotropy is a property of suspensions (for example, bentonite clay in water) which, after remaining at rest for a long time, act as solids; for example, they cannot be poured. However, if it is stirred, such a suspension can be poured quite freely. If the suspension is then allowed to rest, the viscosity increases with time and finally sets again. This whole process is reversible; it can be repeated again and again. See GEL; NON-NEWTONIAN FLUID. [H.Mark.]

**Rheostat** A variable resistor constructed so that its resistance value may be changed without interrupting the circuit to which it is connected. It is used to vary the current in a circuit. The resistive element of a rheostat may be a metal wire or ribbon, carbon disks, or a conducting liquid. See RESISTOR.

The metallic rheostat is the most common. The wire or ribbon is constructed in a coil or a grid, and taps are brought out from different sections of the element to a multicontact switch which can short-circuit any section of the resistor or switch it out of the circuit. For more continuous control, as is needed for laboratory rheostats, a sliding-contact finger bears directly on closely wound coils of resistive wire.

Typical applications of rheostats are for starting or controlling the speed of motors, for adjusting generator characteristics, for controlling storage-battery charging, for dimming lights, and for imposing artificial loads on electrical equipment during tests. [F.H.R.]

**Rheumatic fever** An illness that follows an upper respiratory infection with the group A streptococcus (*Streptococcus pyogenes*) and is characterized by inflammation of the joints (arthritis) and the heart (carditis). Arthritis typically involves multiple joints and may migrate from one joint to another. The carditis may involve the outer lining of the heart, the heart muscle itself, or the inner lining of the heart. A minority of affected individuals also develop a rash (erythema marginatum), nodules under the skin, or Sydenham's chorea (a neurologic disorder characterized by involuntary, uncoordinated movements of the legs, arms, and face). Damage to heart valves may be permanent and progressive, leading to severe disability or death from rheumatic heart disease years after the initial attack. The disease occurs an average of 19 days after the infection and is thought to be the result of an abnormal immunologic reaction to the group A streptococcus. Initial attacks of rheumatic fever generally occur among individuals aged 5 to 15. Those who have had one attack are highly susceptible to recurrences after future streptococcal infections.

Initial attacks of rheumatic fever can be prevented by treatment of strep throat with penicillin for at least 10 days. Patients who have had an episode of rheumatic fever should continue taking antibiotics for many years to prevent group A streptococcal infections that may trigger a recurrence of rheumatic fever. See HEART DISORDERS; STREPTOCOCCUS. [A.L.Bi.; J.B.Da.]

**Rheumatism** Any combination of muscle or joint pain, stiffness, or discomfort arising from nonspecific disorders. It is generally used as a lay expression to indicate a chronic or recurrent condition affecting a certain area and precipitated by cold, dampness, or emotional stress.

Lumbago, wryneck, charleyhorse and shinsplint are commonly used expressions included under the catchall category of rheumatism. [R.Se.]

**Rhinoceros** Odd-toed ungulates (order Perissodactyla) which are members of the family Rhinocerotidae. The bodies and limbs of these mammals are massive and thick-skinned. Also characteristic of the family are the horns (epidermal derivatives), either one or two, which are composed of a solid mass of hairs attached to a bony prominence on the skull. The feet are tridactyl, with three hooves; the middle one is the most developed. There are five species, found in Asia and Africa.

Sight is poorly developed in these animals; however, hearing is quite good and the sense of smell is excellent. Most species are solitary and aggressive and are extremely dangerous since they are unpredictable in behavior. All species are vegetarians. See PERISSODACTYLA. [C.B.C.]

**Rhinovirus** A genus of the family Picornaviridae. Members of the human rhinovirus group include at least 113 antigenically distinct types. Like the enteroviruses, the rhinoviruses are small (17–30 nanometers), contain ribonucleic acid (RNA), and are not inactivated by ether. Unlike the enteroviruses, they are isolated from the nose and throat rather than from the enteric tract, and are unstable if kept under acid conditions (pH 3–5) for 1–3 h. Rhinoviruses have been recovered chiefly from adults with colds and only rarely from patients with more severe respiratory diseases. See COMMON COLD; ENTEROVIRUS.

In a single community, different rhinovirus types predominate during different seasons and during different outbreaks in a single season, but more than one type may be present at the same time.

Although efforts have been made to develop vaccines, none is available. Problems that hinder development of a useful rhinovirus vaccine include the short duration of natural immunity even to the specific infecting type, the large number of different antigenic types of rhinovirus, and the variation of types present in a community from one year to the next. See ANIMAL VIRUS; PICORNAVIRIDAE; VIRUS CLASSIFICATION. [J.L.Me.; M.E.Re.]

**Rhizocephala** An order of crustacean parasites related to the barnacles. Worldwide in distribution, they prey on other crustaceans, principally Decapoda, such as crabs, shrimp, and their allies. Rhizocephala produce modifications affecting the abdomen of the crab, making males resemble females and causing immature females to acquire precociously the adult form. These parasites have become so modified by their mode of life that, as adults, they are no longer recognizable as barnacles, or even as crustaceans.

An adult rhizocephalan is a thin-walled sac enclosing a visceral mass, composed chiefly of ovaries and testes. It shows no trace of segmentation, appendages, or sense organs. Even an alimentary tract is missing. Instead, it possesses a threadlike root system which penetrates the interior of the host in all directions and absorbs nourishment from the body fluids of the crab. [P.G.Re.]

**Rhizomastigida** An order of the class Zoomastigophorea, also known as the Rhizomastigina. All Rhizomastigida species are microscopic and ameoboid, and have one or two flagella. Rhizomastigida are small, colorless, and rarely abundant. They generally occur at the mud–water interface and are holozoic, saprozoic, or parasitic. Life histories are poorly known, except for *Mastigella*. The group is small, but species occur in both fresh and salt water. See ZOOMASTIGOPHOREA. [J.B.L.]

**Rhizophorales** An order of flowering plants, division Magnoliophyta (Angiospermae), in the subclass Rosidae of the class Magnoliopsida (dicotyledons). The order contains a single family, Rhizophoraceae, with about 100 species widely distributed in the tropics. The plants are mostly tanniferous trees and shrubs with the leaves opposite, simple, and entire. The flowers are regular, mostly perfect, and variously perigynous or

epigynous. The sepals are four or five and commonly fleshy or leathery; the petals are the same number as the sepals and likewise small and fleshy. The stamens are twice as many as the petals or sometimes more. The fruit is berrylike or rarely a capsule. Most members of the family are inland species, but the most conspicuous group are some 17 species of shoreline shrubs, the mangroves. See MAGNOLIOPHYTA; MAGNOLIOPSIDA; PLANT KINGDOM. [T.M.Ba.]

**Rhizopodea** A class of Sarcodina including both parasitic and free-living species found in fresh and salt water and the soil. No species forms true axopodia; instead, pseudopodia may be filopodia, lobopodia, or reticulopodia; or there may be no pseudopodia in some cases. Rhizopodea include five subclasses: Lobosia, Filosia, Granuloreticulosa, Mycetozoa, and Labyrinthulia. See FILOSIA; GRANULORETICULOSA; LABYRINTHULIA; LOBOSIA; SARCODINA. [R.P.H.]

**Rhizosphere** The soil region subject to the influence of plant roots. It is characterized by a zone of increased microbiological activity and is an example of the relationship of soil microbes to higher plants.

A sharp boundary cannot be drawn between the rhizosphere and the soil unaffected by the plant (edaphosphere). At the root surface the rhizosphere effect is most intense, falling off sharply with increasing distance.

Growth of a plant markedly changes the microbial population of soil within its influence. In the rhizosphere there are more microorganisms than in soil distant from the plant. This increase is most pronounced with bacteria but is evident with other groups. The rhizosphere effect is seen in seedling plants; it increases with the age of the plant and usually reaches a maximum at the stage of greatest vegetative growth. Upon death of the plant the microbial population reverts to the level of the surrounding soil. Leguminous plants support higher rhizosphere populations than nonlegumes. The stimulation of microorganism growth in the rhizosphere results chiefly from the liberation of readily available organic substances by the growing plant. See SOIL MICROBIOLOGY. [A.G.L.]

**Rhizostomeae** An order of the class Scyphozoa with the most highly organized features of this class. The umbrella is generally higher than it is wide. The margin of the umbrella is divided into many lappets but is not provided with tentacles. Many radial canals, which are connected with each other to form a compli-

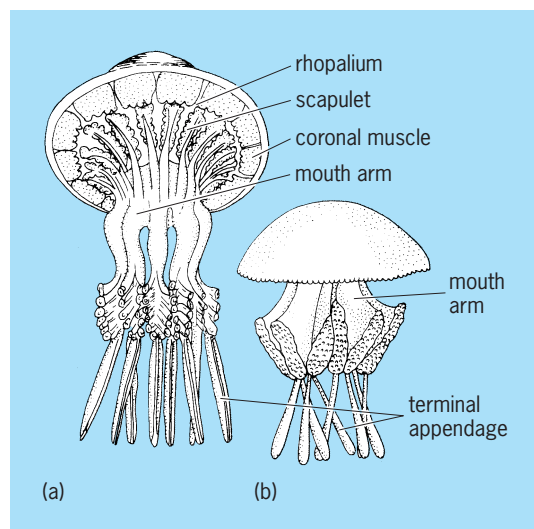

Rhizostomeae. (a) *Rhizostoma*. (b) *Mastigias*. (After L. Hyman, *The Invertebrates*, vol. 1, McGraw-Hill, 1940)

cated network, issue from the cruciform stomach. The oral part is eight-sided, with many suckorial mouths surrounded by numerous small tentacles (see illustration). Usually there is no central mouth. No species of this group is injurious to the human skin. Some large forms, such as *Rhopilema*, are used as food in China and Japan.

A fair number of fossils of this order were found in the strata of the Jurassic Period. See SCYPHOZOA. [T.U.]

**Rho-theta system** A navigation system in which one or more signals are emitted from a facility (or collocated facilities) to produce simultaneous indication of bearing and distance. Since a bearing is a radial line of position and a distance is a circular line of position, the rho-theta system always ensures a position fix produced by the intersection of two lines of position which are at right angles to each other. This produces a minimum geometric dilution of position, a figure of merit for all radio navigation systems, and is one of the chief advantages of a rho-theta system. Another major advantage is that it is a single-site system and can thus be installed on a ship or an island. This has also made it attractive politically, enabling small countries to have their own navigation systems. See DOPPLER VOR; ELECTRONIC NAVIGATION SYSTEMS; TACAN; VOR (VHF OMNIDIRECTIONAL RANGE). [S.V.D.]

**Rhodium** A chemical element, Rh, atomic number 45, relative atomic weight 102.905. Rhodium is a transition metal and one of the group of platinum metals (ruthenium, osmium, rhodium, iridium, palladium, and platinum) that share similar chemical and physical properties. See METAL; PERIODIC TABLE; PLATINUM.

The terrestrial abundance of rhodium is exceedingly low; it is estimated to be 0.0004 part per million in the Earth's crust. It is found as a single isotope,  $^{103}\text{Rh}$ , with a nuclear spin of 12. Since the platinum metals share common reactivities and are mined from a common source, there is an involved chemical process that is used to separate the individual elements, including rhodium. See ISOTOPE.

Metallic rhodium is the whitest of the platinum metals and does not tarnish under atmospheric conditions. Its surface is normally covered by a thin, firmly bound layer of rhodium(IV) oxide ( $\text{RhO}_2$ ). Rhodium is insoluble in all acids, including aqua regia. It

#### Physical properties of rhodium metal

Property	Value
Crystal structure	Face-centered cubic
Lattice constant $a$ , at 25°C (77°F), nm	0.38031
Thermal neutron capture cross section, barns ( $10^{-28} \text{ m}^2$ )	149
Density at 25°C (77°F), $\text{g/cm}^3$	12.43
Melting point	1963°C (3565°F)
Boiling point	3700°C (6700°F)
Specific heat at 0°C, cal/g (J/kg)	0.0589 (246)
Thermal conductivity, 0–100°C, $\text{cal cm/cm}^2 \text{ s } ^\circ\text{C}$ ( $\text{J} \cdot \text{m/m}^2 \cdot \text{s} \cdot ^\circ\text{C}$ )	0.36 (151)
Linear coefficient of thermal expansion, 20–100°C, $\mu\text{in./in.} ^\circ\text{C}$ or $\text{m}/(\text{m} \cdot ^\circ\text{C})$	8.3
Electrical resistivity at 0°C, microhm-cm	4.33
Temperature coefficient of electrical resistance, 0–100°C/°C	0.00463
Tensile strength, $10^3 \text{ lb/in.}^2$ (6.895 MPa)	
Soft	120–130
Hard	200–230
Young's modulus at 20°C (68°F), $\text{lb/in.}^2$ (Gpa)	
Static	$46.2 \times 10^6$ (319)
Dynamic	$54.8 \times 10^6$ (378)
Hardness, diamond pyramid number	
Soft	120–140
Hard	300
$\Delta H_{\text{fusion}}$ , kJ/mol	21.6
$\Delta H_{\text{vaporization}}$ , kJ/mol	494
$\Delta H_f$ monoatomic gas, kJ/mol	556
Electronegativity	2.2

dissolves in molten potassium bisulfate ( $\text{KHSO}_4$ ), a useful property for its extraction from platinum ores, since iridium, ruthenium, and osmium are insoluble in this melt. Important physical properties of metallic rhodium are given in the table. See ACID AND BASE; AQUA REGIA; HALOGEN ELEMENTS.

Metallic rhodium is available as powder, sponge, wire, and sheets. It is ductile when hot and retains its ductility when cold. However, it work-hardens rapidly. Molten rhodium dissolves oxygen. Upon cooling, the oxygen gas is liberated, and this can lead to ruptures in the external surface of the crust of the metal. As a result, molten rhodium is best handled under an inert atmosphere of argon, which does not dissolve in rhodium.

Complexes of Rh(III), including  $\text{RhCl}_3(\text{pyridine})_3$ ,  $\text{Rh}(\text{CO})\text{Cl}_3[\text{P}(\text{C}_6\text{H}_5)_3]_2$ , and  $\text{RhCl}_6^{3-}$ , are diamagnetic six-coordinate with octahedral geometry. The most common chemical form of rhodium is  $\text{RhCl}_3 \cdot 3\text{H}_2\text{O}$ , a red-brown, deliquescent material that is a useful starting material for the preparation of other rhodium compounds. In contrast to the hydrated material, red anhydrous rhodium(III) chloride ( $\text{RhCl}_3$ ) is a polymeric, paramagnetic compound that does not dissolve in water. See DIAMAGNETISM.

The low natural abundance and high cost of rhodium limit its uses to specialty applications. The major use is in catalysis, which accounts for over 60% of its production. Rhodium is a component of catalytic converters used in the control of exhaust emissions from automobiles. See CATALYTIC CONVERTER.

Rhodium is also used in the hydrogenation of olefins to alkanes. For hydrogenation, both heterogeneous catalysis and homogeneous catalysis are used. Heterogeneous conditions are achieved with rhodium metal finely dispersed on an inert support (activated carbon, charcoal, or alumina).

Rhodium complexes have been developed as catalysts for the synthesis of one optical isomer of L-dopa (used in treatment of Parkinson's disease). Greater selectivity makes rhodium catalysts more useful in hydroformylation or oxo reactions than the less expensive cobalt catalysts. A platinum-rhodium alloy is an efficient commercial catalyst for the formation of nitric acid through ammonia oxidation. See CATALYSIS; HETEROGENEOUS CATALYSIS; HOMOGENEOUS CATALYSIS; HYDROFORMYLATION; HYDROGENATION.

Rhodium-platinum alloys are favored for high-temperature applications. The International Temperature Scale over the range  $630.5\text{--}1063^\circ\text{C}$  ( $1134.9\text{--}1945.4^\circ\text{F}$ ) is defined by a thermocouple using a 10% rhodium-platinum alloy. Electroplated rhodium retains its bright surface under atmospheric conditions and finds use as electrical contacts and reflective surfaces. The reflectivity of rhodium surfaces is high (80%) and does not tarnish. About 6% of the rhodium production goes into jewelry manufacturing. See ELECTROPLATING OF METALS; TRANSITION ELEMENTS. [A.L.Ba.]

**Rhodochrosite** The mineral form of manganese carbonate. Calcium, iron, magnesium, and zinc have all been reported to replace some of the manganese. The equilibrium replacement of manganese by calcium increases with the temperature of crystallization.

Rhodochrosite occurs more often in massive or columnar form than in distinct crystals. The color ranges from pale pink to brownish pink. Hardness is 3.5–4 on Mohs scale, and specific gravity is 3.70.

Well-known occurrences of rhodochrosite are in Europe, Asia, and South America. In the United States large quantities occur at Butte, Montana. As a source of manganese, rhodochrosite is also important at Chamberlain, South Dakota, and in Aroostook County, Maine. See CARBONATE MINERALS; MANGANESE. [R.I.Ha.]

**Rhodonite** A mineral inosilicate with composition  $\text{MnSiO}_3$ . Hardness is 5.5–6 on Mohs scale, and specific gravity is 3.4–3.7. The luster is vitreous and the color is rose red, pink, or brown. Rhodonite is similar in color to rhodochrosite, manganese car-

bonate, but it may be distinguished by its greater hardness and insolubility in hydrochloric acid. It has been found at Langban, Sweden; near Sverdlovsk in the Ural Mountains; and at Broken Hill, Australia. Fine crystals of a zinc-bearing variety, fowlerite, are found at Franklin, New Jersey. See SILICATE MINERALS.

[C.S.Hu.]

**Rhodophyceae** A large class of plants, commonly called red algae, coextensive with the division Rhodophycota. Most red algae are found in the ocean, growing on rocks, wood, other plants, or animals in the intertidal zone and to depths limited by the availability of light. A few genera and species occur in fresh water, and these are usually found in rapidly flowing, well-aerated, cold streams. Some, however, grow in quiet warm water, while a few are subaerial. Most red algae are photosynthetic, but some grow on other algae with varying degrees of parasitism. Approximately 675 genera and 4100 species are recognized. See ALGAE.

Rhodophyceae are characterized by a unique combination of biochemical, reproductive, and ultrastructural features. The primary photosynthetic pigment is chlorophyll *a*. Water-soluble tetrapyrrolic compounds called phycobilins serve as accessory photosynthetic pigments. The chief food reserve, floridean starch, is a branched polymer of glucose similar to amylopectin of green plants. It occurs as granules in the cytoplasm. Multinucleate cells are common. Rhodophyceae are distinctive among eukaryotic algae in their lack of flagella, a feature shared among major groups only by the chlorophycean order Zygnematales. Some unicellular forms and many spores and male gametes of multicellular forms are capable of gliding or feeble ameoboid motion. Unicellular red algae, which may form mucilaginous colonies, are considered primitive. Most red algae have multicellular thalli of microscopic or macroscopic size, including individual filaments, blades, and complex plants of distinctive form produced by the interplay of filamentous systems. See CORALLINALES; ZYGNEMATALES.

Two subclasses of Rhodophyceae are traditionally recognized: the Bangiophycidae and the Florideophycidae. Classification within the Bangiophycidae is based largely on vegetative and asexual reproductive features, while that of the Florideophycidae is based primarily on details of the development of the female reproductive system and carposporophyte, secondarily on vegetative features. Rhodophyceae seem most closely related to Cyanophyceae in their use of chlorophyll *a* and phycobilins as photosynthetic pigments and the absence of flagella. They probably did not evolve directly from Cyanophyceae, however, but from a colorless, nonflagellate, eukaryotic ancestor that acquired pigments from an endosymbiotic blue-green alga.

The most salient feature of red algae is their beauty, which has drawn admiration from generations of seaside visitors. Their greatest significance, however, is their role in the formation of coral reefs, the Corallinales being responsible for cementing together various animal and algal components. Of more apparent economic importance is their use as food, a centuries-old tradition of maritime peoples in many parts of the world. See AGAR; CARRAGEENAN; REEF. [P.C.Si.; R.L.Moe]

**Rhombifera** An extinct class of Echinodermata in which the thecal canals crossed the sutures at the edges of the plates, so that one-half of any canal lay in one plate and the other half on an adjoining plate. The canals sometimes occurred in lozenge-shaped clusters, called rhombs (see illustration). The theca was ovoid and sessile in earlier forms and comprised numerous irregular plates. The ambulacral grooves were trimerous and were restricted to the brachioles. In later forms the thecal plates became fewer and larger, and were arranged in five horizontal rows, termed cycles. A stem developed aborally and the ambulacra became pentamerous, traversing part of the theca

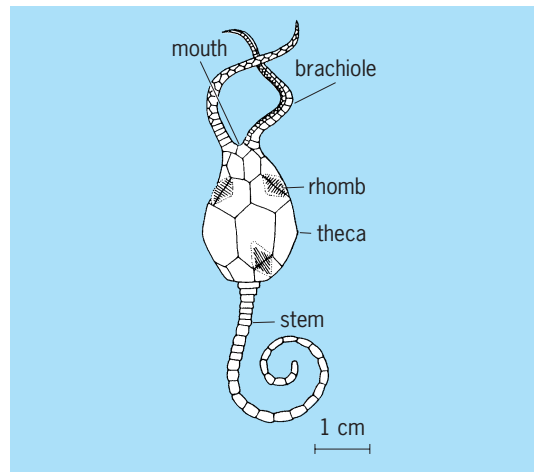

Ordovician *Pleurocystis*. (Simplified after O. Jaekel)

before ascending the brachioles. Rhombifera probably died out in the Devonian. See ECHINODERMATA. [H.B.F.]

**Rhubarb** A herbaceous perennial, *Rheum rhaponticum*, of Mediterranean origin, belonging to the plant order Polygonales. Rhubarb is grown for its thick petioles which are used mainly as a cooked dessert; it is frequently called the pieplant. The leaves, which are high in oxalic acid content, are not commonly considered edible. Outdoor rhubarb is a common garden vegetable in most areas of the United States except the South. Michigan and Washington are important centers for forced or hothouse rhubarb. See POLYGONALES. [H.J.C.]

**Rhynchobdellae** An order of the class Hirudinea. These leeches possess an eversible proboscis and lack hemoglobin in the blood. They may be divided into two families, the Glossiphoniidae and the Ichthyobdellidae. Glossiphoniidae are flattened, mostly small leeches occurring chiefly in fresh water. Ichthyobdellidae typically have cylindrical bodies with conspicuous, powerful suckers used to attach themselves to passing fish. They frequently have lateral appendages which aid in respiration. See HIRUDINEA. [K.H.M.]

**Rhynchocoela** A phylum of bilaterally symmetrical, unsegmented, ribbonlike worms, frequently referred to as the Nemertinea. They have an eversible proboscis and a complete digestive tract with an anus. There is no coelom or body cavity, and the mesenchyme or parenchyma and the muscle fibers fill the area between the ciliated epidermis and the cellular lining of the digestive tract. Many species are brightly colored, sometimes having stripes or transverse bars.

The nemertineans are the simplest animals with a circulatory system. There are two lateral blood vessels and in some a third, unpaired dorsal vessel. The blood consists of a colorless fluid which may contain blood cells of several types. In species in which the blood is colored, the pigment is present in the cells. There is no heart, but the walls of the principal vessels may be contractile.

The nervous system has a pair of cerebral ganglia forming the brain as well as two longitudinal nerve cords and many smaller nerves. The ganglia and lateral cords may contain unusually large neurochord cells. In the epidermis there are scattered sensory nerve cells, probably tactile. A few to many simple eyes, or ocelli, may be present in front of the cerebral ganglia. There are no special respiratory organs; respiration occurs through the body surface. Nemertineans are usually either male or female, but a few individuals have both sex organs. Fertilization occurs outside the body in many species but may be internal in certain forms.

The nemertineans are mostly marine, bottom-dwelling worms, found in greatest numbers along the coasts of northern temperate regions. They live under stones, among the tangled masses of plants, in sand, mud, or gravel, and sometimes form mucus-lined tubes. A few are pelagic, fresh-water, or terrestrial. Certain species are commensal with other animals, but none can be regarded as parasitic in a strict sense.

That the Rhynchocoela represent the most highly organized acoelomate animals is indicated by the circulatory system, the presence of an anus, and the specialization of the epidermis. All groups of animals more complex than the nemertineans have some kind of cavity, a pseudocoel or coelom, between the body wall and the gut, instead of solid mesenchyme. See COELOM.

The phylum Rhynchocoela, containing about 550 known species, is divided into two classes, Anopla and Enopla. See ANOPLA; ENOPLA. [A.G.Hu.; J.B.J.]

**Rhynchonellida** An extant order of brachiopods that has been an important component of marine benthic communities since the Ordovician. Rhynchonellids possess unequally biconvex valves typically with a fold and sulcus; many species contain strong radial ribs that produce deflections in the commissure, the line of junction between the two valves. Their shells are generally impunctate and also typically lack a hinge line parallel to the hinge axis, resulting in a pointed beak or umbo when viewed in lateral profile. Internally, rhynchonellids possess calcareous processes (crura) that in extant species provide support for the lophophore. Rhynchonellids are sessile, attached, epifaunal suspension feeders. They have a functional pedicle that they use to attach to the substrate. Although rhynchonellids were never diverse compared to other brachiopod orders, they were commonly important members of local communities. They achieved a diversity peak in the Devonian and again in the Jurassic.

Rhynchonellids have shifted their habitat preference in the oceans since their origin in the Middle Ordovician when they originated in shallow low-latitude seas; however, presently they are more common in deep-water habitats from middle and high latitudes and are rare members of benthic communities in low-latitude shallow seas. See ARTICULATA (ECHINODERMATA); BRACHIOPODA. [M.E.P.]

**Rhynchonelliformea** One of three subphyla currently recognized in the phylum Brachiopoda. The name is derived from the stratigraphically oldest subclade with extant representatives, the order Rhynchonellida. Rhynchonelliforms constitute over 90% of the more than 4500 named brachiopod genera, most of which (over 95%) are extinct. Rhynchonelliformea includes all taxa formerly referred to the class Articulata, in addition to several groups either newly discovered as fossils, formerly placed in class Inarticulata, or of uncertain taxonomic affiliation.

All rhynchonelliforms have an organic-rich, bivalved calcite shell and can be distinguished from other brachiopods by the following shared, derived characters: the presence of a fibrous secondary shell layer, a pedicle without a coelomic core, a diductor muscle system, and the presence of articulation between the two valves.

Rhynchonelliformea includes 19 orders organized in five classes. Chileata (Chileida and Dictyonellida), Obolellata (Obolellida and Naukatida), Kutorginata (Kutorginida), Strophomenata (Strophomenida, Productida, Orthotetida, and Billingisellida), Rhynchonellata (Protorthida, Orthida, Pentamerida, Rhynchonellida, Atrypida, Spiriferida, Spiriferinida, Thecideida, Athyridida, and Terebratulida).

Living rhynchonelliforms are distributed globally, but enjoy their greatest abundance and diversity in temperate latitudes. They live from deep intertidal to abyssal depths, reaching greatest abundance and diversity in the shallow to relatively deep (few hundred meters) subtidal. See BRACHIOPODA; ORTHIDA; PENTAMERIDA; SPIRIFERIDA; STROPHOMENIDA; TEREBRATULIDA. [S.Ca.]

**Rhynchosauria** An order of herbivorous diapsid reptiles in the infraclass Archosauria, limited to the Triassic System but with a worldwide distribution. Rhynchosaurs were pig- or sheep-sized quadrupedal reptiles that were common in the Middle and Upper Triassic Series of India, South America, Europe, and eastern Africa. Except for the earliest South African genus, *Mesosuchus*, they are characterized by multiple rows of teeth on both the upper and lower jaws that were fused into deep sockets. Teeth were not replaced as they were worn but were added posteriorly as the jaw grew. In most genera, the premaxillae are devoid of teeth and overhang the front of the lower jaw like a beak. The external nostril is median rather than paired.

Rhynchosaurs were elements of the early archosauromorph radiation that included the protosaurs and primitive archosaurs. The structure of the ankle is nearly identical in the early members of these groups, but later rhynchosaurs enlarged the centrals which contributed to a simple hinge joint between the lower leg and the tarsals.

Rhynchosaurs were locally common in the Late Triassic but are unknown in the Jurassic. Their rapid extinction may have resulted from changes in the vegetation on which they fed, or from predation from the expanding community of predaceous archosaurs, including early dinosaurs. See ARCHOSAURIA; DIAPSIDA; PROTOSAURIA; REPTILIA. [R.L.C.]

**Rhyniophyta** A division of the subkingdom Embryobionta. The bryophytes and vascular plants are included in this subkingdom. The category Rhyniophyta was devised for the relatively simple Silurian-Devonian vascular plants long held to be ancestral to other groups of vascular plants and usually referred to as Psilophytales. These plants have leafless stems and lack roots; their general morphological structure is not complex. The three classes of Rhyniophyta currently recognized are Rhyniopsida, Zosterophylloids, and Trimerophytopsida. See EMBRYOBIONTA; PSILOPHYTALES; RHYNIOPSIDA; TRIMEROPHYTOPSIDA; ZOSTEROPHYLLOPSIDA. [H.P.B.]

**Rhyniopsida** The earliest demonstrable vascular land plants, appearing in Silurian (mid-Ludlovian) time. Their small, leafless axes were usually branched dichotomously in three planes; adventitious and perhaps pseudomonopodial branching also occurred. Sporangia were usually terminal on the main axes. Some terminated in lateral branches, and some were subtended by adventitious branches. See RHYNIOPHYTA. [H.P.B.]

**Rhyolite** A very light-colored, aphanitic (not visibly crystalline), volcanic rock that is rich in silica and broadly equivalent to granite in composition. Migration of rhyolitic magma through the Earth's crust, which causes much of the Earth's explosive and hazardous volcanic activity, represents a major process of chemical fractionation by which continental crust grows and evolves. See GRANITE.

Rhyolites are formed by the process of molten silica-rich magma flowing toward the Earth's surface. Small differences in this process, notably those related to the release of gas from the magma at shallow depth, produce extremely diverse structural features. The high silica content gives rhyolitic lava a correspondingly high viscosity; this hinders crystallization and often causes young rhyolite to be a mixture of microcrystalline aggregates and glassy material. Because of the glassy nature of most rhyolites, they are best characterized by chemical analysis. They typically have 70–75 wt % silicon dioxide (SiO<sub>2</sub>) and more potassium oxide (K<sub>2</sub>O) than sodium oxide (Na<sub>2</sub>O). See LAVA; MAGMA; VOLCANIC GLASS; VOLCANO.

Rhyolite is one of the most common volcanic rocks in continental regions; it is virtually absent in the ocean basins. The rock often occurs in large quantities associated with andesite and basalt. It is common in environments ranging from accretionary prisms at continental margins to magmatic arcs related to subduction zones. Rhyolite is also prevalent in extensional

regions and hot spots in continental interiors. See ANDESITE; BASALT. [L.W.Y.]

**Riboflavin** Also known as vitamin B<sub>2</sub>, riboflavin is widely distributed in nature, and is found mostly in milk, egg white, liver, and leafy vegetables. It is a water-soluble yellow-orange fluorescent pigment.

Riboflavin deficiency results in poor growth and other pathologic changes in the skin, eyes, liver, and nerves. Riboflavin deficiency in humans is usually associated with a cracking at the corners of the mouth called cheilosis; inflammation of the tongue, which appears red and glistening (glossitis); corneal vascularization accompanied by itching; and a scaly, greasy dermatitis about the corners of the nose, eyes, and ears. See VITAMIN. [S.N.G.]

**Ribonuclease** A group of enzymes, widely distributed in nature, which catalyze hydrolysis of the internucleotide phosphodiester bonds in ribonucleic acid (RNA). The sites of hydrolysis may vary considerably, depending upon the specificity of the particular enzyme. Differences in specificity for the site of cleavage have led to the use of these various ribonucleases as tools in determining the structure and chemistry of RNA. See ENZYME; NUCLEIC ACID.

Research on ribonuclease has played a prime role in advancing the understanding of protein structure and function; also, it was the first protein to be totally synthesized from its component amino acids. Since the elucidation of the amino acid sequence of ribonuclease, much information has been compiled with regard to the three-dimensional structure of the enzyme and to specific regions of the molecule which are catalytically important. See PROTEIN. [R.L.He.]

**Ribonucleic acid (RNA)** One of the two major classes of nucleic acid, mainly involved in translating into proteins the genetic information that is carried in deoxyribonucleic acid (DNA). Ribonucleic acids serve two functions in protein synthesis: transfer RNAs (tRNAs) and ribosomal RNAs (rRNAs) function in the synthesis of all proteins, while messenger RNAs (mRNAs) are a diverse set, each member of which acts specifically in the synthesis of one protein. Messenger RNA is the intermediate in the usual biological pathway DNA → RNA → protein. Ribonucleic acid is a very versatile molecule, however. In addition to the roles in protein synthesis, other types of RNA serve other important functions for cells and viruses, such as the involvement of small nuclear RNAs (snRNAs) in mRNA splicing. In some cases, RNA performs functions typically considered DNA-like, such as serving as the genetic material for certain viruses, or roles typically carried out by proteins, such as RNA enzymes or ribozymes. See DEOXYRIBONUCLEIC ACID (DNA).

**Structure.** RNA is a linear polymer of four different nucleotides. Each nucleotide is composed of three parts: a five-carbon sugar known as ribose, a phosphate group, and one of four bases attached to each ribose, either adenine (A), cytosine (C), guanine (G), or uracil (U). The structure of RNA is basically a repeating chain of ribose and phosphate moieties, with one of the four bases attached to each ribose. The structure and function of the RNA vary depending on its sequence and length. See NUCLEOTIDE; RIBOSE.

In its basic structure, RNA is quite similar to DNA. It differs by a single change in the sugar group (ribose instead of deoxyribose) and by the substitution of uracil for the base thymine (T). Typically, RNA does not exist as long double-stranded chains as does DNA, but rather as short single chains with higher-order structure due to base pairing and tertiary interactions within the RNA molecule. Within the cell, RNA usually exists in association with specific proteins in a ribonucleoprotein complex.

The nucleotide sequence of RNA is encoded in genes in the DNA, and it is transcribed from the DNA by a complementary templating mechanism that is catalyzed by one of the RNA

polymerase enzymes. In this templating scheme, the DNA base T specifies A in the RNA, A specifies U, C specifies G, and G specifies C.

**Transfer RNA.** These small RNAs (70–90 nucleotides) that act as adapters to translate the nucleotide sequence of mRNA into protein sequence. They do this by carrying the appropriate amino acid to the ribosome during the process of protein synthesis. Each cell contains at least one type of tRNA specific for each of the 20 amino acids, and usually several types. The base sequence in the mRNA directs the appropriate amino acid-carrying tRNAs to the ribosome to ensure that the correct protein sequence is made. See PROTEIN.

**Ribosomal RNA.** Ribosomes are complex ribonucleoprotein particles that are the site of protein synthesis, that is, the process of linking amino acids to form proteins. The RNA components of the ribosome account for more than half of its weight. Like tRNAs, rRNAs are stable molecules and exist in complex folded structures. Each of these rRNAs is essential in determining the exact structure of the ribosome. In addition, the rRNAs, rather than the ribosomal proteins, are likely the basic functional elements of the ribosome. See RIBOSOMES.

**Messenger RNA.** Whereas most types of RNA are the final products of their genes, mRNA is an intermediate in information transfer. It carries information from DNA to the ribosome in a genetic code that the protein-synthesizing machinery translates into protein. Specifically, mRNA sequence is recognized in a sequential fashion as a series of nucleotide triplets by tRNAs via base pairing to the three-nucleotide anticodons in the tRNAs. There are specific triplet codons that specify the beginning and end of the protein-coding sequence. Thus, the function of mRNA involves the reading of its primary nucleotide sequence, rather than the activity of its overall structure. Messenger RNAs are typically shorter-lived than the more stable structural RNAs, such as tRNA and rRNA. See GENETIC CODE.

**Small nuclear RNA.** Small RNAs, generally less than 300 nucleotides long and rich in uridine (U), are localized in the nucleoplasm (snRNAs) and nucleolus (snoRNAs) of eukaryotic cells. They take part in RNA processing, such as intron removal during eukaryotic mRNA splicing and posttranscriptional modification that occurs during production of mature rRNA. See INTRON.

**Catalytic RNA.** RNA enzymes, or ribozymes, are able to catalyze specific cleavage or joining reactions either in themselves or in other molecules of nucleic acid. See CATALYSIS; RIBOZYME.

**Viral RNA.** While most organisms carry their genetic information in the form of DNA, certain viruses, such as polio and influenza viruses, have RNA as their genetic material. The viral RNAs occur in different forms in different viruses. For example, some are single-stranded and some are double-stranded; some occur as a single RNA chromosome while others are multiple. In any case, the RNA is replicated as the genetic material and either its sequence, or a complementary copy of itself, serves as mRNA to encode viral proteins. The RNA viruses known as retroviruses contain an enzyme that promotes synthesis of complementary DNA in the host cell, thus reversing the typical flow of information in biological systems. See ANIMAL VIRUS; RETROVIRUS; VIRUS.

**Other types of RNA.** There are RNAs that serve other important and diverse cellular functions. For example, a ribonucleoprotein enzyme is responsible for replication of chromosome ends. Also, there is an essential RNA component in a ribonucleoprotein complex that ensures that membrane and secreted proteins are synthesized in the appropriate cellular location.

RNA molecules can function both as carriers of genetic information and as enzymes. The discoveries of RNA catalysis and of the central role of rRNA in protein synthesis have led to an enhanced appreciation of RNA as the probable original informational macromolecule, preceding both the more specialized DNA and protein molecules in evolution. See MOLECULAR BIOLOGY; NUCLEIC ACID.

[A.L.Be.; M.W.G.]

**Ribose** A water-soluble pentose, also known as D-ribose (see first structural formula), which, together with 2-deoxy-D-ribose, makes up the carbohydrate constituents of nucleic acids, which are found in all living organisms. The universal occurrence

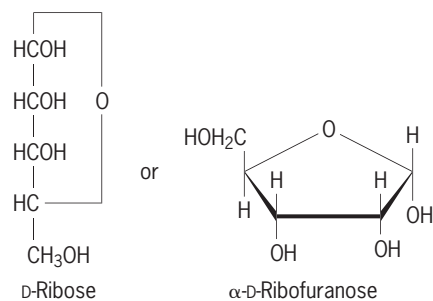

of nucleic acids in all living cells makes this pentose highly interesting to biochemists and biologists. The type of nucleic acid that yields D-ribose is referred to as ribonucleic acid (RNA). D-Ribose is a constituent not only of the nucleic acids, but also of several vitamins and coenzymes. As in the nucleic acids, this sugar occurs in the furanose configuration (see second structural formula) in these natural products. See COENZYME; DEOXYRIBOSE; NUCLEIC ACID; VITAMIN. [W.Z.H.]

**Ribosomes** Small particles, present in large numbers in every living cell, whose function is to convert stored genetic information into protein molecules. In this synthesis process, a molecule of messenger ribonucleic acid (mRNA) is fed through the ribosome, and each successive trinucleotide codon on the messenger is recognized by complementary base-pairing to the anticodon of an appropriate transfer RNA (tRNA) molecule, which is in turn covalently bound to a specific amino acid. The successive amino acids become linked together on the ribosome, forming a polypeptide chain whose amino acid sequence has thus been determined by the nucleic acid sequence of the mRNA. The polypeptide is subsequently folded into an active protein molecule. Ribosomes are themselves complex arrays of protein and RNA molecules, and their fundamental importance in molecular biology has prompted a vast amount of research, with a view to finding out how these particles function at the molecular level. See GENETIC CODE; PROTEIN; RIBONUCLEIC ACID (RNA).

Ribosomes are composed of two subunits, one approximately twice the size of the other. In the bacterium *Escherichia coli*, whose ribosomes have been the most extensively studied, the smaller subunit (30S) contains 21 proteins and a single 16S RNA molecule. The larger (50S) subunit contains 32 proteins, and two RNA molecules (23S and 5S). The overall mass ratio of RNA to protein is about 2:1. Cations, in particular magnesium and polyamines, play an important role in maintaining the integrity of the ribosomal structures. The ribosomes are considerably larger in the cytoplasm of higher organisms (eukaryotes). Nevertheless, all ribosomal RNA molecules have a central core of conserved structure, which presumably reflects the universality of the ribosomal function. See CELL (BIOLOGY); ORGANIC EVOLUTION.

The process of protein biosynthesis is essentially very similar in both prokaryotes and eukaryotes; what follows is a brief summary of what happens in *E. coli*. The first step is that an initiator tRNA molecule attached to the amino acid *N*-formyl methionine recognizes its appropriate codon on a mRNA molecule, and binds with the mRNA to the 30S subunit. A 50S subunit then joins the complex, forming a complete 70S ribosome. A number of proteins (initiation factors, which are not ribosomal proteins) are also involved in the process. At this stage, the initiator aminoacyl tRNA occupies one binding site, the P-site (peptidyl site), on the ribosome, while a second tRNA binding site (the A-site, or aminoacyl site) is free to accept the next aminoacyl



tRNA molecule. In the subsequent steps, the elongation process aminoacyl tRNA molecules are brought to the A-site as ternary complexes together with guanosine triphosphate (GTP) and a protein factor (elongation factor Tu). Once an aminoacyl tRNA is in the A-site, the initiator amino acid (or at later stages the growing polypeptide chain) is transferred from the P-site tRNA to the A-site aminoacyl tRNA. It is not clear whether this peptidyl transferase activity requires the active participation of a ribosomal component. After peptide transfer has taken place, the peptide is attached to the A-site tRNA, and an "empty" tRNA molecule is at the P-site. The peptidyl tRNA complex must now be translocated to the P-site, in order to free the A-site for the next incoming tRNA molecule. Here again protein factors and GTP are involved, and it is probable that the empty tRNA occupies a third ribosomal site (exit or E-site) before finally leaving the complex. Studies show that elongation factor G hydrolyzes GTP to bring about translocation of the tRNA molecules. The protein chain is completed by the appearance of a "stop" codon in the mRNA. This is recognized by yet another set of protein factors, which causes the completed polypeptide chain to be released from the ribosome. At any one time a number of ribosomes are engaged in the reading of a single mRNA molecule, which leads to the appearance of polyribosomes (polysomes). See MOLECULAR BIOLOGY. [R.Bri.; H.G.W.; S.Jo.]

**Ribozyme** A ribonucleic acid (RNA) molecule that, like a protein, can catalyze specific biochemical reactions. Examples include self-splicing rRNA and RNase P, both involved in catalyzing RNA processing reactions (that is, the biochemical reactions that convert a newly synthesized RNA molecule to its mature form). Different ribozyme structures catalyze quite distinct RNA processing reactions, just as protein enzyme families that are composed of different structures catalyze different types of biochemical reactions.

Ribozymes share many similarities with protein enzymes, as assessed by two parameters that are used to describe a biological catalyst. The Michaelis-Menten constant  $K_m$  relates to the affinity that the catalyst has for its substrate, and ribozymes possess  $K_m$  values which are comparable to  $K_m$  values of protein enzymes. The catalytic rate constant describes how efficiently a catalyst converts substrate into product. The values of this constant for ribozymes are markedly lower than those values observed for protein enzymes. Nevertheless, ribozymes accelerate the rate of chemical reaction with specific substrates by  $10^{11}$  compared with the rate observed for the corresponding uncatalyzed, spontaneous reaction. Therefore, ribozymes and protein enzymes are capable of lowering to similar extents the activation energy for chemical reaction. See ENZYME; PROTEIN; RIBONUCLEIC ACID (RNA). [D.W.Ce.]

**Ribulose** A pentose sugar, also known as D-riboketose and D-erythropetulose; it has never been prepared in crystalline form, and exists only as a syrup. The structural formula of ribulose is shown below.

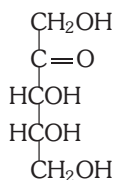

Ribulose-5-phosphate occurs in animal and plant tissues. It can be converted to ribulose-1, 5-diphosphate by a phosphokinase enzyme acting in the presence of adenosine triphosphate (ATP). The ribulose-5-phosphate is also a significant intermediate in the carbohydrate metabolism through the pentose phosphate pathway. See CARBOHYDRATE METABOLISM; MONOSACCHARIDE. [W.Z.H.]

**Rice** The plant *Oryza sativa* is the major source of food for nearly one-half of the world's population. The most important rice-producing countries are mainland China, India, and Indonesia, but in many smaller countries rice is the leading food crop. In the United States, rice production is largely concentrated in selected areas of Arkansas, California, Louisiana, and Texas. See CARBOHYDRATE; CYPERALES; WHEAT.

Over 95% of the world rice crop is used for human food. Although most rice is boiled, a considerable amount is consumed as breakfast cereals. Rice starch also has many uses. Broken rice is used as a livestock feed and for the production of alcoholic beverages. The bran from polished rice is used for livestock feed; the hulls are used for fuel and cellulose. The straw is used for thatching roofs in the Orient and for making paper, mats, hats, and baskets. Rice straw is also woven into rope and used as cordage for bags. This crop serves a multitude of purposes in countries where agriculture is dependent largely upon rice.

Rice is unlike many other cereal grains in that all cultivated varieties belong to the same species and have 12 pairs of chromosomes, as do most wild types. The extent of variation in morphological and physiological characteristics within this single species is greater than for any other cereal crop. See GENETICS.

Rice is an annual grass plant varying in height from 2 to 6 ft (0.6 to 1.8 m). Plants tiller, that is, develop new shoots freely, the number depending upon spacing and soil fertility. The inflorescence is an open panicle. Flowers are perfect and normally self-pollinated, with natural crossing seldom exceeding 3-4%. A distinct characteristic of the flower is the six anthers rather than the customary three of other grasses. Spikelets have a single floret, lemma and palea completely enclosing the caryopsis or fruit, which may be yellow, red, brown, or black. Lemmas may be awnless, partly awned, or fully awned. Threshed rice, which retains its lemma and palea, is called rough rice or paddy. See FLOWER; FRUIT; GRASS CROPS; INFLORESCENCE; REPRODUCTION (PLANT).

In the United States, only about 25 varieties are in commercial production. Cultivated rices are classified as upland and lowland. Upland types, which can be grown in high-rainfall areas without irrigation, produce relatively low yields. The lowland types, which are grown submerged in water for the greater part of the season, produce higher yields. In contrast to most plants, rice can thrive when submerged because oxygen is transported from the leaves to the roots. All rice in the United States is produced under lowland or flooded conditions. Rice varieties are also classified as long- or short-grain. Most long-grain rices have high amylose content and are dry or fluffy when cooked, while most short-grain rices have lower amylose content and are sticky when cooked. In the United States a third grain length is recognized: medium-grain. The medium-grain rices have cooking qualities similar to those of short-grain varieties. See AGRICULTURAL SCIENCE (PLANT); GRAIN CROPS. [J.N.R.]

The rice kernel has four primary components: the hull or husk, the seedcoat or bran, the embryo or germ, and the endosperm. The main objective of milling rice is to remove the indigestible hull and additional portions of bran to yield whole unbroken endosperm. Rice milling involves relatively uncomplicated abrasive and separatory procedures which provide a variety of products dependent on the degree of bran removal or the extent of endosperm breakage.

Instant rice is made from whole grain rice by pretreating under controlled cooking, cooling, and drying conditions to impart the quick-cooking characteristic. Ready-to-eat breakfast rice cereals are prepared from milled rice as flakes or puffs. Rice bran oil was developed as a result of increased extraction of lipids from rice bran. It is utilized as an edible-grade oil in a variety of applications as well as an industrial feedstock for soap and resin manufacture. See CEREAL; FAT AND OIL (FOOD); FOOD MANUFACTURING; SOLVENT EXTRACTION. [M.A.U.]

**Ricinulei** An order of extremely rare arachnids, also known as the Podogona, with a body less than 1 in. (2.5 cm) in length. Superficially, they resemble ticks in general appearance and movement, and are found only in tropical Africa and in the Americas, from the Amazon to Texas. The two anterior pairs of appendages are chelate. Less than 25 modern species are known. The occurrence of several fossils from Carboniferous time suggests that the group was formerly more common. See ARACHNIDA. [C.C.Ho.]

**Rickettsioses** Often severe infectious diseases caused by several diverse and specialized bacteria, the rickettsiae and rickettsia-like organisms. The best-known rickettsial diseases infect humans and are usually transmitted by parasitic arthropod vectors.

Rickettsiae and rickettsia-like organisms are some of the smallest microorganisms visible under a light microscope. Although originally confused with viruses, in part because of their small size and requirements for intracellular replication, rickettsiae and rickettsia-like organisms are characterized by basic bacterial (gram-negative) morphologic features. Their key metabolic enzymes are variations of typical bacterial enzymes. The genetic material of rickettsiae and rickettsia-like organisms likewise seems to conform to basic bacterial patterns. The genome of all rickettsia-like organisms consists of double-stranded deoxyribonucleic acid (DNA).

Rickettsiae enter host cells by phagocytosis and reproduce by simple binary fission. The site of growth and reproduction varies among the various genera.

Clinically, the rickettsial diseases of humans are most commonly characterized by fever, headache, and some form of cutaneous eruption, often including diffuse rash, as in epidemic and murine typhus and Rocky Mountain spotted fever, or a primary ulcer or eschar at the site of vector attachment, as in Mediterranean spotted fever and scrub typhus. Signs of disease may vary significantly between individual cases of rickettsial disease. Q fever is clinically exceptional in several respects, including the frequent absence of skin lesions.

All of the human rickettsial diseases, if diagnosed early enough in the infection, can usually be effectively treated with the appropriate antibiotics. Tetracycline and chloramphenicol are among the most effective antibiotics used; they halt the progression of the disease activity, but do so without actually killing the rickettsial organisms. Presumably, the immune system is ultimately responsible for ridding the body of infectious organisms. Penicillin and related compounds are not considered effective. See ANTIBIOTIC.

Most rickettsial diseases are maintained in nature as diseases of nonhuman vertebrate animals and their parasites. Human infection may usually be regarded as peripheral to the normal natural infection cycles, and human-to-human transmission is not the rule. However, the organism responsible for epidemic typhus (*Rickettsia prowazekii*) and the agent responsible for trench fever (*Rochalimaea quintana*) have the potential to spread rapidly within louse-ridden human populations. See ZOONOSES.

All known spotted fever group organisms are transmitted by ticks. Despite a global distribution in the form of various diseases, nearly all spotted fever group organisms share close genetic, antigenic, and certain pathologic features. Examples of human diseases include Rocky Mountain spotted fever (in North and South America), fièvre boutonneuse or Mediterranean spotted fever (southern Europe), South African tick-bite fever (Africa), Indian tick typhus (Indian subcontinent), and Siberian tick typhus (northeastern Europe and northern Asia). If appropriate antibiotics are not administered, Rocky Mountain spotted fever, for example, is a life-threatening disease. See INFECTIOUS DISEASE.

[R.L.Re.]

**Riemann surface** A generalization of the complex plane that was originally conceived to make sense of mathematical ex-

pressions such as  $\sqrt{z}$  or  $\log z$ . These expressions cannot be made single-valued and analytic in the punctured plane  $\mathbf{C} \setminus \{0\}$  (that is, the complex plane with the point 0 removed). The difficulty is that for some closed paths the value of the expression when reaching the end of the path is not the same as it is at the beginning. For example, the closed path can be chosen to be the unit circle centered at  $z = 0$  and followed counterclockwise from  $z = 1$ . If  $\sqrt{z}$  is assigned the value  $+1$  at  $z = 1$ , its value at the end of the circuit is  $-1$ . Similarly, if  $\log z$  is assigned the value 0 at  $z = 1$ , at the end of the circuit, allowing the values to change continuously, the value is  $2\pi i$ . See COMPLEX NUMBERS.

The construction of an abstract surface for  $\sqrt{z}$  on which  $\sqrt{z}$  has a single value at each point and on which the values of  $\sqrt{z}$  vary continuously around each closed path, always ending with the starting value, proceeds as follows. From the complex plane  $\mathbf{C}$  the nonnegative half of the real axis  $\{z = x + iy : y = 0, 0 \leq x\}$  is removed. This slit is thought of as having two edges: an upper or  $+$  edge and a lower or  $-$  edge ( $z = 0$  is not counted). Another copy of this slit plane is then placed over, and parallel to, the original, as the first and second floors in a building. Next, the two sheets are connected by attaching the  $-$  edge of the bottom sheet to the  $+$  edge of the top sheet, and the  $+$  edge of the bottom sheet to the  $-$  edge of the top sheet. The abstract surface thus constructed is not embedded in euclidean 3-space because the attachments cannot be done in 3-space without creating self-intersections. The expression  $\sqrt{z}$  is defined at the point over  $z$  on the upper sheet to have positive imaginary part and on the lower to have negative part.

The abstract surface constructed is called the Riemann surface for  $\sqrt{z}$ . It is two-sheeted over the  $z$  plane, except that only one point lies over  $z = 0$ , which is therefore called a branch point. The Riemann surface for  $\sqrt[n]{z}$ , which has  $n$  branches instead of 2, is shown in the illustration.

In the early 1920s, H. Weyl defined a Riemann surface in the context of the newly developing field of topology. This definition does not depend on having a particular function in hand, and does not require the use of such seemingly artificial devices as slits. A Riemann surface is a two-dimensional connected

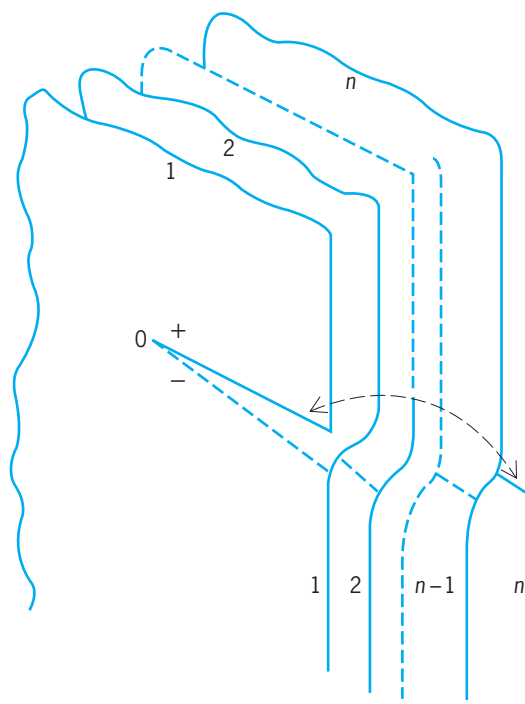

Riemann surface for  $\sqrt[n]{z}$ . (After A. D. Sveshnikov and A. N. Tikhonov, *The Theory of Functions of a Complex Variable*, Mir Publishers, 1973)

topological manifold (surface) with a complex structure. See MANIFOLD (MATHEMATICS); TOPOLOGY. [A.M.]

**Riemannian geometry** The geometry of riemannian manifolds. Riemannian geometry was initiated by B. Riemann in 1854, following the pioneering work of C. F. Gauss on surface theory in 1827. Riemann introduced a coordinate space in which the infinitesimal distance between two neighboring points is specified by a quadratic differential form, given below. Such a space is a natural generalization of euclidean geometry and Gauss's geometry of surfaces in three-dimensional euclidean space, as well as the noneuclidean geometries: hyperbolic geometry (previously discovered by J. Bolyai and N. I. Lobachevsky) and elliptic geometry. A riemannian manifold is a topological space that further generalizes this notion. Riemannian geometry derives great importance from its application in the general theory of relativity, where the universe is considered to be a riemannian manifold. See DIFFERENTIAL GEOMETRY; EUCLIDEAN GEOMETRY; NONEUCLIDEAN GEOMETRY; RELATIVITY.

An  $n$ -dimensional riemannian space is a space whose points can be characterized by  $n$  coordinates  $u^i$  ( $i = 1, 2, \dots, n$ ), and where an infinitesimal distance  $ds$  between two points with coordinate differences  $du^i$  is given by a quadratic differential form, Eq. (1), to be called the metric. In general, the quantities  $g_{ij}$  are functions of the coordinates  $u^i$ .

$$ds^2 = \sum_{i,j} g_{ij} du^i du^j \quad (1)$$

$$g_{ij} = g_{ji} \quad 1 \leq i, j \leq n$$

Riemannian geometry is local in the sense that it is valid in a neighborhood of the  $u^i$  coordinates. It studies properties that are invariant under coordinate transformations of the form of Eq. (2), where the functions are smooth with the functional determinant  $\det(\partial u^i/\partial u^j) \neq 0$ .

$$u^i = u^i(u^1, \dots, u^n) \quad 1 \leq i \leq n \quad (2)$$

At the foundation of riemannian geometry is the notion of a riemannian manifold. A differentiable manifold is a topological space with a covering by coordinate neighborhoods, such that in the domain where the  $u^i$  coordinates and the  $u^i$  coordinates are both valid, they are related by the transformation of Eq. (2) with the conditions mentioned there. The manifold is called riemannian if a riemannian metric is defined in each neighborhood that gives the same value of  $ds^2$  in the intersection of any two neighborhoods. Riemannian geometry is divided between local and global: the former dealing with properties in a neighborhood, the latter with properties of the manifold as a whole. See MANIFOLD (MATHEMATICS); TOPOLOGY. [S.S.C.]

**Rift valley** One of the geomorphological expressions between two tectonic plates that are opening relative to each other or sliding past each other. The term originally was used to describe the central graben structures of such classic continental rift zones as the Rhinegraben and the East African Rift, but the definition now encompasses mid-oceanic ridge systems with central valleys such as the Mid-Atlantic Ridge. See MID-OCEANIC RIDGE; PLATE TECTONICS.

Continental and oceanic rift valleys are end members in what many consider to be an evolutionary continuum. In the case of continental rift valleys, plate separation is incomplete, and the orientation of the stress field relative to the rift valley can range from nearly orthogonal to subparallel. Strongly oblique relationships are probably the norm. In contrast, oceanic rift valleys mark the place where the trailing edges of two distinctly different plates are separating. The separation is complete, and the spreading is organized and focused, resulting in rift valleys that tend to be oriented orthogonal or suborthogonal to the spreading directions.

The basic cross-sectional form of rift valleys consists of a central graben surrounded by elevated flanks. It is almost universally accepted that the central grabens of continental rift valleys

are subsidence features. The crystalline basement floors of some parts of the Tanganyika and Malawi (Nyasa) rift valleys in East Africa lie more than 5 mi (9 km) below elevated flanks. See GRABEN.

In continental rift valleys the true cross-sectional form is typically asymmetric, with the rift floors tilted toward the most elevated flank. Most of the subsidence is controlled by one border fault system, and most of the internal faults parallel the dip of the border faults. See FAULT AND FAULT STRUCTURES.

Oceanic rift valleys are also distinctly separated into segments by structures known as transform faults. The cross-sectional form of oceanic rift valleys can be markedly asymmetric. It is unlikely that the cross-sectional form of oceanic rift valleys is related genetically to that of continental rift valleys, except in the broadest possible terms. See TRANSFORM FAULT. [B.R.R.]

**Rift Valley fever** An arthropod-borne (primarily mosquito), acute, febrile, viral disease of humans and numerous species of animals. Rift Valley fever is caused by a ribonucleic acid (RNA) virus in the genus *Phlebovirus* of the family Bunyaviridae. In sheep and cattle, it is also known as infectious enzootic hepatitis. First described in the Rift Valley of Africa, the disease presently occurs in west, east, and south Africa and has extended as far north as Egypt. Historically, outbreaks of Rift Valley fever have occurred at 10–15-year intervals in normally dry areas of Africa subsequent to a period of heavy rainfall.

In humans, clinical signs of Rift Valley fever are influenzalike, and include fever, headache, muscular pain, weakness, nausea, epigastric pain, and photophobia. Most people recover within 4–7 days, but some individuals may have impaired vision or blindness in one or both eyes; a small percentage of infected individuals develop a hemorrhagic syndrome and die.

Rift Valley fever should be suspected when high abortion rates, high mortality, or extensive liver lesions occur in newborn animals. The diagnosis is confirmed by isolating the virus from tissues of the infected animal or human. Control of the disease is best accomplished by widespread vaccination of susceptible animals to prevent amplification of the virus and, thus, infection of vectors. Any individual that works with infected animals or live virus in a laboratory should be vaccinated. See ANIMAL VIRUS; VACCINATION. [C.A.Me.]

**Rigel** The bright star in the southwest corner of the constellation Orion (apparent magnitude +0.12), also referred to as  $\beta$  Orionis. It is a blue-white supergiant of spectral type B8, one of the most luminous stars known. Its intrinsic brightness is estimated to be more than 50,000 times that of the Sun. Rigel is a very young star by stellar standards, with such an enormous rate of energy output that its life span is only a few million years. By comparison, the Sun is approximately  $5 \times 10^9$  years old, and is still only half way through its main-sequence evolution. Rigel is the brightest member of the Orion OB1 Association, a large molecular cloud complex in which active star formation is currently taking place. In addition to its high luminosity, Rigel has a photosphere which is so large that if the star were placed where the Sun is, it would almost fill the orbit of Mercury. See MOLECULAR CLOUD; ORION; SPECTRAL TYPE; STAR; STELLAR ROTATION; SUPERGIANT STAR. [D.W.L.]

**Rigid body** An idealized extended solid whose size and shape are definitely fixed and remain unaltered when forces are applied. Treatment of the motion of a rigid body in terms of Newton's laws of motion leads to an understanding of certain important aspects of the translational and rotational motion of real bodies without the necessity of considering the complications involved when changes in size and shape occur. Many of the principles used to treat the motion of rigid bodies apply in good approximation to the motion of real elastic solids. See RIGID-BODY DYNAMICS. [D.Wi.]

**Rigid-body dynamics** The study of the motion of a rigid body under the influence of forces. A rigid body is a system of particles whose distances from one another are fixed. The general motion of a rigid body consists of a combination of translations (parallel motion of all particles in the body) and rotations (circular motion of all particles in the body about an axis). Its equations of motion can be derived from the equations of motion of its constituent particles. See RECTILINEAR MOTION; ROTATIONAL MOTION.

The location of a mass point  $m_i$  can be specified relative to a fixed-coordinate system by a position vector  $\vec{r}_i$  with cartesian components  $(x_i, y_i, z_i)$ . The vector force  $\vec{F}_i$  which acts on the mass points has corresponding components  $(F_{ix}, F_{iy}, F_{iz})$ . Newton's second law for the motion of  $m_i$  is stated in Eq. (1). Here

$$\vec{F}_i = m_i \vec{a}_i \quad (1)$$

$\vec{a}_i \equiv d^2\vec{r}_i/dt^2 = \vec{a}$  is the acceleration of  $m_i$ . See ACCELERATION; FORCE; NEWTON'S LAWS OF MOTION.

**Translational motion.** If Eq. (1) is summed over all particles in the rigid body, the left-hand side becomes the total force acting

$$\vec{F} = \sum_i \vec{F}_i$$

on the rigid body. If the internal forces satisfy Newton's third law (to each action there is an equal but opposite reaction), the contributions of the internal forces cancel in pairs and  $\vec{F}$  is the total external force on the rigid body,  $\vec{F}^{\text{ext}}$ . The right-hand side can be expressed in terms of the center-of-mass (CM) position vector defined by Eq. (2), where  $M$  is the total mass of the body. Then the sum of the equations of motion, Eq. (1), takes the form of Eq. (3). This equation of motion for the center of mass

$$\vec{R} = \frac{1}{M} \sum_i m_i \vec{r}_i \quad (2)$$

$$M = \sum_i m_i$$

$$\vec{F}^{\text{ext}} = M \vec{a} \quad (3)$$

of the rigid body has exactly the form of the equation of motion for a particle of mass  $M$  and position  $\vec{R}$ , under the influence of an external force  $\vec{F}^{\text{ext}}$ . Consequently, the second law of motion holds, not just for a particle, but for an arbitrary rigid body, if the position of the body is interpreted to mean the position of its center of mass. See CENTER OF MASS.

The momentum of a mass point is given by the product of the mass and the velocity,  $\vec{p}_i = m_i \dot{\vec{r}}_i$ , where  $\dot{\vec{r}}_i \equiv d\vec{r}_i/dt$ . The total momentum of the center of mass of the rigid body, obtained by summing over the momenta  $\vec{p}_i$  of its constituent masses, is given by Eq. (4). In terms of the center-of-mass momentum  $\vec{P}$ , the equation of motion for the center of mass is expressed by Eq. (5). For an isolated rigid body, the external force is zero and

$$\vec{P} = M \vec{v} \quad (4)$$

$$\dot{\vec{P}} = \vec{F}^{\text{ext}} \quad (5)$$

therefore  $\vec{P}$  is constant. According to Eq. (4), this implies that the center of mass moves with constant velocity  $\vec{v} = \vec{P}/M$ . See CONSERVATION OF MOMENTUM; MOMENTUM.

In fact, the preceding equations for translational motion hold for any body, rigid or nonrigid.

**Rotational motion.** The total angular momentum of a rigid body about a point  $O$  with coordinate  $\vec{r}_O$  is the sum of the angular momenta of its constituent masses, and is given by Eq. (6). Here

$$\vec{L}_O = \sum_i (\vec{r}_i - \vec{r}_O) \times m_i (\dot{\vec{r}}_i - \dot{\vec{r}}_O) \quad (6)$$

$\times$  denotes the cross-product of the coordinate vector  $(\vec{r}_i - \vec{r}_O)$  with the momentum vector  $m_i(\dot{\vec{r}}_i - \dot{\vec{r}}_O)$ . The time derivative of

$\vec{L}$  is given in Eq. (7). Hereafter the point  $O$  is taken to be either a

$$\dot{\vec{L}}_O = \sum_i (\vec{r}_i - \vec{r}_O) \times m_i (\ddot{\vec{r}}_i - \ddot{\vec{r}}_O) \quad (7)$$

fixed point (in which case  $\dot{\vec{r}}_O = \ddot{\vec{r}}_O = 0$ ) or the center-of-mass point. Using the equation of motion (1),  $m_i \ddot{\vec{r}}_i$  can be replaced by  $\vec{F}_i$ . Thus the rotational equation of motion (8) is obtained.

$$\dot{\vec{L}}_O = \sum_i (\vec{r}_i - \vec{r}_O) \times \vec{F}_i \quad (8)$$

The right-hand side of Eq. (9) is known as the torque,  $\vec{N}$ . The contribution of the internal forces to the torque vanishes if the "extended third law" holds; namely, action equals reaction and is directed along a line between the particles. In this circumstance the rotational equation of motion is given by Eqs. (9), where  $\vec{N}^{\text{ext}}$

$$\dot{\vec{L}}_O = \vec{N}_O^{\text{ext}} \quad (9a)$$

$$\vec{N}_O^{\text{ext}} = \sum_i (\vec{r}_i - \vec{r}_O) \times \vec{F}_i^{\text{ext}} \quad (9b)$$

is the total torque associated with external forces that act on the rigid body. See ANGULAR MOMENTUM; TORQUE.

It is straightforward to show from Eq. (6) that the angular momentum about an arbitrary point  $O$  is related to the angular momentum about the center of mass by Eq. (10). The torque about an arbitrary point  $O$  can also be easily related to the torque about the center of mass, by Eq. (11).

$$\vec{L}_O = \vec{L}_{\text{CM}} + (\vec{R} - \vec{r}_O) \times \vec{P} \quad (10)$$

$$\vec{N}_O^{\text{ext}} = \vec{N}_{\text{CM}}^{\text{ext}} + (\vec{R} - \vec{r}_O) \times \vec{F}^{\text{ext}} \quad (11)$$

Six coordinates determine the positions of all particles in a rigid body, and the motion of a rigid body is described by six equations of motion. The translational motion of the center of mass is determined by Eq. (5), and the rotational motion about the center of mass, or a fixed point, is determined by Eq. (9). These six equations, which hold for any system of particles, completely describe the motion of a rigid body.

**Motion of an isolated system.** The equation  $\dot{\vec{L}} = \vec{N}^{\text{ext}}$  has the same form as  $\dot{\vec{P}} = \vec{F}^{\text{ext}}$ . Both  $\vec{L}$  and  $\vec{p}$  are constants for an isolated system since  $\vec{N}^{\text{ext}} = 0$  and  $\vec{F}^{\text{ext}} = 0$ . Even though the two conditions  $\vec{N}^{\text{ext}} = 0$  and  $\vec{F}^{\text{ext}} = 0$  appear similar, there are some important differences for systems in which internal motion is possible. If  $\vec{F}^{\text{ext}} = 0$ , a center of mass which is at rest will remain so, regardless of internal forces or internal motion. If  $\vec{N}^{\text{ext}} = 0$ , the total angular momentum is constant, and if initially zero, will remain zero. However,  $\vec{L} = 0$  does not exclude changes in orientation of the system by the use of merely internal forces. There is no rotational analog to the equation  $\vec{r}(t) = (\vec{P}/M)t + \vec{r}(0)$  for linear motion of the center of mass.

**Static equilibrium.** In the design of permanent structures, the conditions under which a rigid body remains in steady motion under the action of a set of forces are of great importance. The six conditions for complete equilibrium of a rigid body are given in Eqs. (12). However, in many circumstances equilibrium

$$\vec{F}^{\text{ext}} = \sum_i \vec{F}_i^{\text{ext}} = 0 \quad (12)$$

$$\vec{N}_{\text{CM}}^{\text{ext}} = \sum_i (\vec{r}_i - \vec{R}) \times \vec{F}_i^{\text{ext}} = 0$$

is desired only for a subset of the six independent directions of motion. To illustrate, the external force in the direction of motion of an accelerating automobile is nonzero, but equilibrium is maintained in all other directions. See STATICS. [V.D.B.]

**Rinderpest** An acute or subacute, contagious viral disease of ruminants and swine, manifested by high fever, lacrimal discharge, profuse diarrhea, erosion of the epithelium of the mouth and of the digestive tract, and high mortality.

Rinderpest (also known as cattle plague) is caused by a ribonucleic acid (RNA) virus classified in the genus *Morbillivirus* within the Paramyxoviridae family. This virus is closely associated with the viruses of human measles, peste des petits ruminants of sheep and goats, canine distemper, and phocine distemper, and with the dolphin morbillivirus. Although there are significant differences in virulence, only one serotype of rinderpest virus is known. The rinderpest virus is easily inactivated by heat and survives outside the host for a short time. Therefore, transmission of rinderpest is by direct contact between animals.

Although all cloven-hoofed animals are considered susceptible to rinderpest, clinical cases are mostly seen in cattle and water buffalo. Rinderpest is characterized by the development of high fever that lasts for several days until just prior to death. The morbidity in susceptible cattle and buffalo is greater than 90%, with death of almost all clinically affected animals. Rinderpest has been controlled in most African nations, but persists in regions of eastern Africa. See ANIMAL VIRUS; PARAMYXOVIRUS. [A.To.]

**Ring** A tie member or chain link. Tension or compression applied through the center of a ring produces bending moment, shear, and normal force on radial sections. Because shear stress is zero at the boundaries of the section where bending stress is maximum, it is usually neglected. [W.J.K./W.G.B.]

**Ring theory** The mathematical term ring is used to designate a type of algebraic system with two compositions satisfying most but not all the properties of addition and multiplication in the system of integers,  $0, \pm 1, \pm 2, \dots$ . In precise terms a ring is a set  $R$  with two binary compositions called addition and multiplication whose results on an ordered pair  $(a, b)$ ,  $a, b$  in  $R$ , are denoted by  $a + b$  and  $ab$ , respectively.

These compositions must satisfy the following conditions:

- C.  $a + b$  and  $ab$  belong to  $R$  (closure).
- A1.  $a + b = b + a$  (commutative law).
- A2.  $(a + b) + c = a + (b + c)$  (associative law).
- A3. There exists an element  $0$  (called zero) in  $R$  satisfying  $a + 0 = a$  for every  $a$  in  $R$ .
- A4. For each  $a$  in  $R$  there exists an element  $-a$  (called the negative of  $a$ ) in  $R$  such that  $a + (-a) = 0$ .
- M1.  $(ab)c = a(bc)$ .
- D.  $a(b + c) = ab + ac$ ;  $(b + c)a = ba + ca$  (distributive laws).

In the ring  $I$  of integers (addition and multiplication as usual) there are further conditions, for example, the commutative law of multiplication ( $ab = ba$ ) and the cancellation law that if  $a \neq 0$  and  $ab = ac$ , then  $b = c$ . See SET THEORY.

The importance of the concept of a ring stems from the fact that it embraces many special cases which are fundamental in all branches of mathematics. Thus it includes the ring  $I$  of integers, the ring  $R_0$  of rational numbers, the ring  $R^{\neq}$  of real numbers, the ring  $C$  of complex numbers, various rings of functions, rings of matrices, and so on.

The conditions A1–A4 on the addition composition are exactly equivalent to the statement that any ring is a commutative group relative to its addition composition. This group is called the additive group of the ring. The algebraic system consisting of the set of elements of a ring together with its multiplication composition is called the multiplicative semigroup of the ring. See GROUP THEORY.

Various classes of rings are singled out by imposing conditions on the multiplicative semigroup. Thus integral domains are rings in which the product of nonzero elements is nonzero. Division rings are rings whose sets of nonzero elements are groups relative to the multiplication composition, and fields are division rings satisfying the commutative law of multiplication. [N.J.]

**Ripple voltage** The time-varying part of a voltage that is ideally time-invariant. Most electronic systems require a direct-

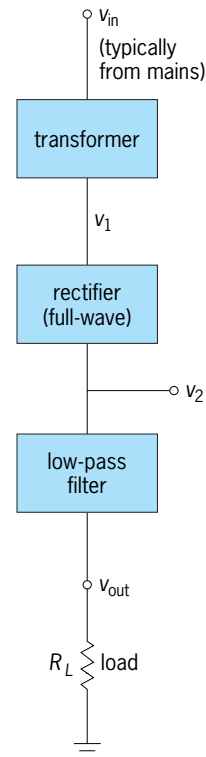

System configuration of a power supply system.

current voltage for at least part of their operation. An ideal direct-current voltage is available from a battery, but batteries are impractical for many applications. To obtain a direct-current voltage from the alternating-current power mains requires using some type of power supply.

A typical linear power supply system configuration (see illustration) consists of a transformer to change the voltage at the mains to the desired level, a rectifier to convert the alternating-current input voltage  $v_1$  to a pulsating direct-current voltage  $v_2$ , followed by a low-pass filter. The output voltage  $v_{out}$  of the filter consists of a large direct-current voltage with a superimposed alternating-current voltage. This remaining superimposed alternating-current voltage is called the ripple voltage.

Practical linear power supplies often include a voltage regulator between the low-pass filter and the load. The voltage regulator is usually an electronic circuit that is specifically designed to provide a very stable dc output voltage even if large variations occur in the input. Nonlinear power supplies, which are often termed switching power supplies or switched-mode power supplies, are becoming increasingly popular as a practical alternative for producing a low-ripple dc output. See ELECTRIC FILTER; ELECTRONIC POWER SUPPLY; RECTIFIER; VOLTAGE REGULATOR. [S.G.Bu.]

**Risk assessment and management** The scientific study of risk, the potential realization of undesirable consequences from hazards arising from a possible event, the assessment of the acceptability of the risks, and the management of unacceptable risks. For example, the probability of contracting lung cancer (unwanted consequence) is a risk caused by carcinogens (hazards) contained in second-hand tobacco smoke (event). The risk is estimated using scientific methods, and then the acceptability of that risk is assessed by public health officials. Risk management is the term for the systematic analysis and control of risk, such as prohibiting smoking in public places. Risks are caused by exposure to hazards. Sudden hazards are referred to as acute (for example, a flash flood caused by heavy

rains); prolonged hazards are referred to as chronic (for example, carcinogens in second-hand tobacco smoke and polluted air).

The definition of risk contains two components: the probability of an undesirable consequence of an event and the seriousness of that consequence. In the example of a flash flood, risk can be defined as the probability of having a flood of a given magnitude. Sometimes the probability is expressed as a return period, which means, for instance, that a flood of a specified magnitude is expected to occur once every 100 years. The scope of a flood can be expressed as the level or stage of a river, or the dollar amount of property damage.

Most human activities involve risk. The risk of driving, for example, can be subdivided according to property damage, human injuries, fatalities, and harm to the environment. Even the stress and lack of exercise due to driving create health risks. Although risk pervades modern society and is widely acknowledged, it continues to cause unending controversy and debate.

Risk estimates are seldom accurate to even two orders of magnitude, and widely varying perceptions of risk by different interest groups can add confusion and conflict to the risk management process. Environmental risk assessment is laden with uncertainty, particularly with respect to the quantification of chemical emissions; the nature of contaminant transport (such as the region over which a chemical may spread and the velocity of movement) in the water, air, and soil; the type of exposure pathway (such as inhalation, ingestion, and dermal contact); the effects on people based on dose-response studies (which are extrapolated from animals); ecological impacts; and so forth.

Thousands of natural and other hazards are subjected to the statistical analysis of mortality and morbidity data. Society selects a small number of risks to manage, but often some high risks (such as radon in houses) may not be managed, while some low risks (such as movement of dangerous goods) may be selected for management. Management alternatives include banning of the hazard (drugs), regulating the hazard (drivers' tests and licensing), controlling the release and exposure of hazardous materials, treatment after exposure, and penalties for damages. Each management alternative may be analyzed to estimate the impact on risk.

Risk estimates are uncertain, are described in technical language, and are outside the general understanding or experience of most people. Perception plays a crucial role, tending to exaggerate the significance, for example, of risks that are involuntary, catastrophic, or newsworthy. Effective risk management therefore requires effective risk communication.

Risk assessment is the evaluation of the relative importance of an estimated risk with respect to other risks faced by the population, the benefits of the activity source of the risk, and the costs of managing the risk. For risks due to long-term exposure to chemicals, the risk assessment activity generally incorporates the estimation of the response of people to the exposure (that is, risk analysis is a part of risk assessment). The methods used include studies on animals, exposure of tissues, and epidemiology. See ENVIRONMENTAL ENGINEERING; ENVIRONMENTAL TOXICOLOGY; HAZARDOUS WASTE. [K.W.H.; J.Sh.]

**Ritz's combination principle** The empirical rule, formulated by W. Ritz in 1905, that sums and differences of the frequencies of spectral lines often equal other observed frequencies. The rule is an immediate consequence of the quantum-mechanical formula  $hf = E_i - E_f$  relating the energy  $hf$  of an emitted photon to the initial energy  $E_i$  and final energy  $E_f$  of the radiating system;  $h$  is Planck's constant and  $f$  is the frequency of the emitted light. See ATOMIC STRUCTURE AND SPECTRA; ENERGY LEVEL (QUANTUM MECHANICS); QUANTUM MECHANICS. [E.G.]

**River** A natural, fresh-water surface stream that has considerable volume compared with its smaller tributaries. The tributaries are known as brooks, creeks, branches, or forks. Rivers are usually the main stems and larger tributaries of the drainage systems

that convey surface runoff from the land. Rivers flow from head-water areas of small tributaries to their mouths, where they may discharge into the ocean, a major lake, or a desert basin.

Rivers flowing to the ocean drain about 68% of the Earth's land surface. Regions draining to the sea are termed exoreic, while those draining to interior closed basins are endoreic. Areic regions are those which lack surface streams because of low rainfall or lithologic conditions.

Sixteen of the largest rivers account for nearly half of the total world river flow of water. The Amazon River alone carries nearly 20% of all the water annually discharged by the world's rivers. Rivers also carry large loads of sediment. The total sediment load for all the world's rivers averages about  $22 \times 10^9$  tons ( $20 \times 10^9$  metric tons) brought to the sea each year. Sediment loads for individual rivers vary considerably. The Yellow River of northern China is the most prolific transporter of sediment. Draining an agricultural region of easily eroded loess, this river averages about  $2 \times 10^9$  tons ( $1.8 \times 10^9$  metric tons) of sediment per year, one-tenth of the world average. See DEPOSITIONAL SYSTEMS AND ENVIRONMENTS; LOESS.

River discharge varies over a broad range, depending on many climatic and geologic factors. The low flows of the river influence water supply and navigation. The high flows are a concern as threats to life and property. However, floods are also beneficial. The ancient Egyptian civilization was dependent upon the Nile River floods to provide new soil and moisture for crops. Floods are but one attribute of rivers that affect human society. Means of counteracting the vagaries of river flow have concerned engineers for centuries. In modern times many of the world's rivers are managed to conserve the natural flow for release at times required by human activity, to confine flood flows to the channel and to planned areas of floodwater storage, and to maintain water quality at optimum levels. See FLOODPLAIN; RIVER ENGINEERING. [V.R.B.]

**River engineering** A branch of civil engineering that involves the control and utilization of rivers for the benefit of humankind. Its scope includes river training, channel design, flood control, water supply, navigation improvement, hydraulic structure design, hazard mitigation, and environmental enhancement. River engineering is also necessary to provide protection against floods and other river disasters. The emphasis is often on river responses, long-term and short-term, to changes in nature, and stabilization and utilization, such as damming, channelization, diversion, bridge construction, and sand or gravel mining. Evaluation of river responses is essential at the conceptual, planning, and design phases of a project and requires the use of fundamental principles of river and sedimentation engineering. See CANAL; DAM; RIVER; STREAM TRANSPORT AND DEPOSITION. [H.H.C.]

**River tides** Tides that occur in rivers emptying directly into tidal seas. These tides show three characteristic modifications of ocean tides. (1) The speed at which the tide travels upstream depends on the depth of the channel. (2) The further upstream, the longer the duration of the falling tide and the shorter the duration of the rising tide. (3) The range of the tide decreases with distance upstream. See TIDE.

In a river the difference between the depths of water at high and low tides may be relatively large, leading to a marked difference between the speeds at which high and low tides move. The difference in depth between various points on the river also partially explains the second modification, or duration of fall and rise. In addition, the river flow, which may fluctuate widely, helps a falling tide but hinders a rising tide, increasing the difference in duration.

The third modification or decrease in tidal range upstream may be accounted for by loss of energy of the water through friction with the sides and bottom of the channel. Although friction always saps energy from the tide, if the channel becomes

constricted within a short distance, the water may be forced into a smaller space, thus producing a larger tidal range. [B.K.]

**Rivet** A short rod with a head formed on one end. A rivet is inserted through aligned holes in two or more parts to be joined; then by pressing the protruding end, a second head is formed to hold the parts together permanently. The first head is called the manufactured head and the second one the point. In forming the point, a hold-on or dolly bar is used to back up the manufactured head and the rivet is driven, preferably by a machine riveter.

Blind rivets are special rivets that can be set without access to the point. They are available in many designs but are of three general types: screw, mandrel, and explosive (see illustration). In

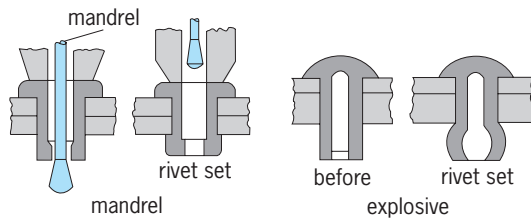

Two types of blind rivet.

the mandrel type the rivet is set as the mandrel is pulled through. In the explosive type an explosive charge in the point is set off by a special hot iron; the explosion expands the point and sets the rivet. [P.H.B.]

**Robotics** A field of engineering concerned with the development and application of robots, and computer systems for their control, sensory feedback, and information processing. The many types of robotic systems include robotic manipulators, robotic hands, mobile robots, walking robots, aids for disabled persons, telerobots, and microelectromechanical systems.

The term "robotics" has been broadly interpreted. It includes research and engineering activities involving the design and development of robotic systems. Planning for the use of industrial robots in manufacturing or evaluation of the economic impact of robotic automation can also be viewed as robotics. This breadth of usage arises from the interdisciplinary nature of robotics, a field involving mechanisms, computers, control systems, actuators, and software. See BIOMECHANICS; COMPUTER; CONTROL SYSTEMS; CYBERNETICS; ELECTRICAL ENGINEERING; INDUSTRIAL ENGINEERING; MECHANICAL ENGINEERING; SOFTWARE ENGINEERING.

Robots produce mechanical motion that, in most cases, results in manipulation or locomotion. Mechanical characteristics for robotic mechanisms include degrees of freedom of movement, size and shape of the operating space, stiffness and strength of the structure, lifting capacity, velocity, and acceleration under load. Performance measures include repeatability and accuracy of positioning, speed, and freedom from vibration.

A robot control system directs the motion and sensory processing of a robot or system of cooperating robots. The controller may consist of only a sequencing device for simple robots, although most multiaxis industrial robots today employ servo-controlled positioning of their joints by a microprocessor-based system.

The robot sensory system gathers specific information needed by the control system and, in more advanced systems, maintains an internal model of the environment to enable prediction and decision making. The joint position transducers on industrial robots provide a minimal sensory system for many industrial applications, but other sensors are needed to gather data about the external environment. Sensors may detect position, velocity, acceleration, visual, proximity, acoustic, force-torque, tactile, thermal, and radiation data.

As information moves up from the sensory device, the amount of information increases and the speed of data acquisition de-

creases. These control architectures form the basis for computer integrated manufacturing (CIM), a hierarchical approach to organizing automated factories. A new paradigm has emerged, based on the interconnection of intelligent system elements that can learn, reason, and modify their configuration to satisfy overall system requirements. One of the most important of these approaches is based on holonic systems. See AUTOMATION; COMPUTER-INTEGRATED MANUFACTURING; INTELLIGENT MACHINE.

A telerobotic system augments humans by allowing them to extend their ability to perform complex tasks in remote locations. It is a technology that couples the human operator's visual, tactile, and other sensory perception functions with a remote manipulator or mobile robot. These systems are useful for performing tasks in environments that are dangerous or not easily accessible for humans. Telerobotic systems are used in nuclear handling, maintenance in space, undersea exploration, and servicing electric transmission lines. Perhaps the most important sensory data needed for telepresence are feedback of visual information, robot position, body motion and forces, as well as tactile information. Master-slave systems have been developed in which, for example, a hand controller provides control inputs to an articulated robotic manipulator. These systems are capable of feeding back forces felt by the robot to actuators on the exoskeletal master controller so that the operator can "feel" the remote environment. See HUMAN-MACHINE SYSTEMS; REMOTE MANIPULATORS.

Graphical simulation is used to design and evaluate a workcell layout before it is built. The robot motion can be programmed on the simulation and downloaded to the robot controller. Companies market software systems that include libraries of commercially available robots and postprocessors for off-line robot programming. [W.A.G.]

**Roche limit** The closest distance which a satellite, revolving around a parent body, can approach the parent without being pulled apart tidally. The simplest formal definition is that the Roche limit is the minimum distance at which a satellite can be in equilibrium under the influence of its own gravitation and that of the central mass about which it is describing a circular orbit. If the satellite is in a circular orbit and has negligible mass, the same density as the primary, and zero tensile strength, the Roche limit is 2.46 times the radius of the primary.

When a star has exhausted the supply of hydrogen in its core, its radius will increase by a factor of 10 to 100. A star in a binary system may then exceed its Roche limit, material will thus escape from that star, and its companion will receive the excess material. See BINARY STAR. [P.K.S.]

**Rock** A relatively common aggregate of mineral grains. Some rocks consist essentially of but one mineral species (monomineralic, such as quartzite, composed of quartz); others consist of two or more minerals (polymineralic, such as granite, composed of quartz, feldspar, and biotite). Rock names are not given for those rare combinations of minerals that constitute ore deposits, such as quartz, pyrite, and gold. In the popular sense rock is considered also to denote a compact substance, one with some coherence; but geologically, friable volcanic ash also is a rock. A genetic classification of rocks is shown below.

- Igneous
  - Intrusive
    - Plutonic (deep)
    - Hypabyssal (shallow)
  - Extrusive
    - Flow
    - Pyroclastic (explosive)
- Sedimentary
  - Clastic (mechanical or detrital)
  - Chemical (crystalline or precipitated)
  - Organic (biogenic)

Metamorphic  
 Cataclastic  
 Contact metamorphic and pyrometasomatic  
 Regional metamorphic (dynamothermal)  
 Hybrid  
 Metasomatic  
 Migmatitic

Exceptions to the requirement that rocks consist of minerals are obsidian, a volcanic rock consisting of glass; and coal, a sedimentary rock which is a mixture of organic compounds. *See* COAL; IGNEOUS ROCKS; METAMORPHIC ROCKS; OBSIDIAN; ROCK MECHANICS; SEDIMENTARY ROCKS; VOLCANIC GLASS. [E.W.H.]

**Rock, electrical properties of** The effect of changes in pressure and temperature on electrical properties of rocks. There has been increasing interest in the electrical properties of rocks at depth within the Earth and the Moon. The reason for this interest has been consideration of the use of electrical properties in studying the interior of the Earth and its satellite, particularly to depths of tens or hundreds of kilometers. At such depths pressures and temperatures are very great, and laboratory studies in which these pressures and temperatures are duplicated have been used to predict what the electrical properties at depth actually are. More direct measurements of the electrical properties deep within the Earth have been made by using surface-based electrical surveys of various sorts. An important side aspect of the study of electrical properties has been the observation that, when pressures near the crushing strength are applied to a rock, marked changes in electrical properties occur, probably caused by the development of incipient fractures. Such changes in resistivity might be used in predicting earthquakes, if they can be measured in the ground. *See* GEOELECTRICITY; GEOPHYSICAL EXPLORATION.

Attempts to measure the electrical properties of rocks to depths of tens or hundreds of kilometers in the Earth indicate that the Earth's crust is zoned electrically. The surface zone, with which scientists are most familiar, consists of a sequence of sedimentary rocks, along with fractured crystalline and metamorphic rocks, all of which are moderately good conductors of electricity because they contain relatively large amounts of water in pore spaces and other voids. This zone, which may range in thickness from a kilometer to several tens of kilometers, has conductivities varying from about  $\frac{1}{2}$  ohm-m in recent sediments to 1000 ohm-m or more in weathered crystalline rock.

The basement rocks beneath this surface zone are crystalline, igneous, or metamorphic rocks which are much more dense, having little pore space in which water may collect. Since most rock-forming minerals are good insulators at normal temperatures, conduction of electricity in such rocks is determined almost entirely by the water in them. As a result, this part of the Earth's crust is electrically resistant (the resistivity lies in the range 10,000–1,000,000 ohm-m).

At rather moderate depths beneath the surface of the second zone, resistivity begins to decrease with depth. This decrease is considered to be the result of higher temperatures, which almost certainly are present at great depths. High temperatures lead to partial ionization of the molecular structure of minerals composing a rock, and the ions render even the insulating minerals conductive. [G.VK.]

**Rock age determination** Finding the age of rocks based on the presence of naturally occurring long-lived radioactive isotopes of several elements in certain minerals and rocks. Measurements of rock ages have enabled geologists to reconstruct the geologic history of the Earth from the time of its formation  $4.6 \times 10^9$  years ago to the present. Age determinations of rocks from the Moon have also contributed to knowledge of the history of the Moon, and may someday be used to study the

Parent-daughter pairs used for dating rocks and minerals

Parent	Daughter	Half-life, 10 <sup>9</sup> years
Potassium-40	Argon-40	11.8
Potassium-40	Calcium-40	1.47
Rubidium-87	Strontium-87	48.8
Samarium-147	Neodymium-143	107
Rhenium-187	Osmium-187	43
Thorium-232	Lead-208	14.008
Uranium-235	Lead-207	0.7038
Uranium-238	Lead-206	4.468

history of Mars and of other bodies within the solar system. *See* EARTH, AGE OF; RADIOACTIVITY.

Many rocks and minerals contain radioactive atoms that decay spontaneously to form stable atoms of other elements. Under certain conditions these radiogenic daughter atoms accumulate within the mineral crystals so that the ratio of the daughter atoms divided by the parent atoms increases with time. This ratio can be measured very accurately with a mass spectrometer, and is then used to calculate the age of the rock by means of an equation based on the law of radioactivity. The radioactive atoms used for dating rocks and minerals have very long half-lives, measured in billions of years. They occur in nature only because they decay very slowly. The pairs of parents and daughters used for dating are listed in the table. *See* DATING METHODS.

The rubidium-strontium method is based on rubidium-87, which decays to stable strontium-87 (<sup>87</sup>Sr) by emitting a beta particle from its nucleus. The abundance of the radiogenic strontium-87 therefore increases with time at a rate that is proportional to the Rb/Sr ratio of the rock or mineral. The method is particularly well suited to the dating of very old rocks such as the ancient gneisses near Godthaab in Greenland, which are almost  $3.8 \times 10^9$  years old. This method has also been used to date rocks from the Moon and to determine the age of the Earth by analyses of stony meteorites.

The potassium-argon method is based on the assumption that all of the atoms of radiogenic argon-40 that form within a potassium-bearing mineral accumulate within it. This assumption is satisfied only by a few kinds of minerals and rocks, because argon is an inert gas that does not readily form bonds with other atoms. The K-Ar method of dating has been used to establish a chronology of mountain building events in North America beginning about  $2.8 \times 10^9$  years ago and continuing to the present. In addition, the method has been used to date reversals of the polarity of the Earth's magnetic field during the past  $1.3 \times 10^7$  years. *See* OROGENY; PALEOMAGNETISM.

The uranium, thorium-lead method is based on uranium and thorium atoms which are radioactive and decay through a series of radioactive daughters to stable atoms of lead (Pb). Minerals that contain both elements can be dated by three separate methods based on the decay of uranium-238 to lead-206, uranium-235 to lead-207, and thorium-232 to lead-208. The three dates agree with each other only when no atoms of uranium, thorium, lead, and of the intermediate daughters have escaped. Only a few minerals satisfy this condition. The most commonly used mineral is zircon (ZrSiO<sub>4</sub>), in which atoms of uranium and thorium occur by replacing zirconium. *See* LEAD ISOTOPES (GEO-CHEMISTRY); RADIOACTIVE MINERALS.

The common-lead method is based on the common ore mineral galena (PbS) which consists of primordial lead that dates from the time of formation of the Earth and varying amounts of radiogenic lead that formed by decay of uranium and thorium in the Earth. The theoretical models required for the interpretation of common lead have provided insight into the early history of the solar system and into the relationship between meteorites and the Earth.

The fission-track method is based on uranium-238 which can



decay both by emitting an alpha particle from its nucleus and by spontaneous fission. The number of spontaneous fission tracks per square centimeter is proportional to the concentration of uranium and to the age of the sample. When the uranium content is known, the age of the sample can be calculated. This method is suitable for dating a variety of minerals and both natural and manufactured glass. Its range extends from less than 100 years to hundreds of millions of years. See FISSION TRACK DATING.

The samarium-neodymium method of dating separated minerals or whole-rock specimens is similar to the Rb-Sr method. The Sm-Nd method is even more reliable than the Rb-Sr method of dating rocks and minerals, because samarium and neodymium are less mobile than rubidium and strontium. The isotopic evolution of neodymium in the Earth is described by comparison with stony meteorites. See METEORITE.

The rhenium-osmium method is based on the beta decay of naturally occurring rhenium-187 to stable osmium-187. It has been used to date iron meteorites and sulfide ore deposits containing molybdenite. [G.Fau.]

**Rock burst** A sudden and violent rock failure around a mining excavation on a sufficiently large scale to be considered a hazard endangering the existence of mine openings, equipment, and personnel. It has been estimated that the energy released in some big bursts was equivalent to that released in exploding 200 tons (180 metric tons) of TNT. Such bursts resemble small earthquakes and may be detected several hundred miles away.

Rock bursts are related to the fracture of rock in place and require two conditions for their occurrence: a stress in the rock mass sufficiently high to exceed its strength, and physical characteristics of the rock which enable it to store energy up to the threshold value for sudden rupture. Rocks which yield gradually in plastic strain when under load usually do not generate rock bursts. See ROCK MECHANICS. [S.H.B.]

**Rock cleavage** A secondary, planar structure of deformed rocks. A cleavage is penetrative and systematic, as opposed to fractures and shear zones which may occur alone or in widely spaced sets. It is generally better developed in fine grained rocks than in coarse ones. Application of the term derives from the ability to split rocks along the structure.

Simple cleavages are generally parallel to the axial surfaces of folds. This is true for folds formed by uniform flow of the rock mass where primary layering behaves as a passive marker. When rock layers are buckled, the primary layering behaving as mechanical discontinuities, cleavage that develops early may be fanned by subsequent growth of the fold. Cleavage is also associated with faults. See FAULT AND FAULT STRUCTURES; FOLD AND FOLD SYSTEMS.

Continuous (microscopically penetrative) cleavages, as in slates, are the earliest tectonic fabric elements that can be recognized in rocks. Cleavage also develops in rocks of lower deformational and metamorphic grade than slates. In these rocks, the cleavage occurs as discrete surfaces or seams, often coated with a film of clay or carbonaceous material; the cleavage surfaces are separated by zones of undeformed sedimentary rock. The surfaces may be smooth, anastomosing, or stylolitic. See METAMORPHISM; ROCK MECHANICS; SLATE. [D.B.Bi.]

**Rock magnetism** The permanent and induced magnetism of rocks and minerals on scales ranging from the atomic to the global, including applications to magnetic field anomalies and paleomagnetism. Natural compasses, concentrations of magnetite ( $\text{Fe}_3\text{O}_4$ ) called lodestones, are one of humankind's oldest devices. W. Gilbert in 1600 discovered that the Earth itself is a giant magnet, and speculated that its magnetism might be due to subterranean lodestone deposits. Observations by B. Brunhes in 1906 that some rocks are magnetized reversely to the present Earth's magnetic field, and by M. Matuyama in 1929 that reversely and normally magnetized rocks correspond to dif-

ferent geological time periods, made it clear that geomagnetism is dynamic, with frequent reversals of north and south poles. Nevertheless, permanent magnetism of rocks remains important because it alone provides a memory of the intensity, direction, and polarity of the Earth's magnetic field in the geological past. From this magnetic record comes much of the evidence for continental drift, sea-floor spreading, and plate tectonics. See CONTINENTAL DRIFT; GEOMAGNETISM; MAGNET; MAGNETISM; PALEOMAGNETISM; PLATE TECTONICS.

The magnetism of rocks arises from the ferromagnetism or ferrimagnetism of a few percent or less of minerals such as magnetite. The magnetic moments of neighboring atoms in such minerals are coupled parallel or antiparallel, creating a spontaneous magnetization  $M_S$ . All magnetic memory, including that of computers, permanent magnets, and rocks, is due to the spontaneous and permanent nature of this magnetism. Spontaneous magnetization requires no magnetic field to create it, and cannot be demagnetized.

The magnetism can be randomized on the scale of magnetic mineral grains because different regions of a crystal tend to have their  $M_S$  vectors in different directions. These regions are called magnetic domains. Grains so small that they contain only one domain (single-domain grains) are the most powerful and stable paleomagnetic recorders. Larger, multidomain grains can also preserve a paleomagnetic memory, through imbalance in the numbers, sizes, or directions of domains, but this memory is more easily altered by time and changing geological conditions. See FERRIMAGNETISM; FERROMAGNETISM; MAGNETISM; MAGNETITE; MAGNETIZATION; MAGNETOMETER. [D.J.Du.]

**Rock mechanics** Application of the principles of mechanics and geology to quantify the response of rock when it is acted upon by environmental forces, particularly when human-induced factors alter the original ambient conditions. Rock mechanics is an interdisciplinary engineering science that requires interaction between physics, mathematics, and geology, and civil, petroleum, and mining engineering. The present state of knowledge permits only limited correlations between theoretical predictions and empirical results. Therefore, the most useful principles are based upon data obtained from laboratory and in-place measurements and from prototype behavior (behavior of the completed engineering works). Increasing emphasis is upon in-place measurements because rock properties are regarded as site-specific; that is, the properties of the rock system at one site probably will be significantly different from those at another site, even if geologic environments are similar. See ENGINEERING GEOLOGY.

Because of the interdisciplinary aspects, there is no standardization of rock mechanics terminology. However, the following terms and definitions are useful.

Environmental factors are the natural factors and human influences that require consideration in engineering problems in rock mechanics. The major natural factors are geology, ambient stresses, and hydrology. The human influences derive from the application of chemical, electrical, mechanical, or thermal energy during construction (or destruction) processes.

The ambient stress field is the distribution and numerical value of the stresses in the environment prior to its disturbance by humans.

The term rock system includes the complete environment that can influence the behavior of that portion of the Earth's crust that will become part of an engineering structure. Generally, all natural environmental factors are included.

A rock element is the coherent, intact piece of rock that is the basic constituent of the rock system and which has physical, mechanical, and petrographic properties that can be described or measured by laboratory tests on each such element. The concepts of rock system and rock element enable the concomitant engineering design to be optimized according to the principles of system engineering. See SYSTEMS ENGINEERING.

“Rock failure” occurs when a rock system or element no longer can perform its intended engineering function. Failure may be evidenced by fractures, distortion of shape, or reduction in strength. “Failure mechanism” includes the causes for the manner of rock failure. See ROCK BURST; SOIL MECHANICS; TUNNEL; UNDERGROUND MINING. [W.R.J.]

**Rock varnish** A dark coating on rock surfaces exposed to the atmosphere. Rock varnish is probably the slowest-accumulating sedimentary deposit, growing at only a few micrometers to tens of micrometers per thousand years. Its thickness ranges from less than 5  $\mu\text{m}$  to over 600  $\mu\text{m}$ , and is typically 100  $\mu\text{m}$  or so. Although found in all terrestrial environments, varnish is mostly developed and well preserved in arid to semiarid deserts; thus, another common name is desert varnish. Rock varnish is composed of about 30% manganese and iron oxides, up to 70% clay minerals, and over a dozen trace and rare-earth elements. The building blocks of rock varnish are mostly blown in as airborne dust. Although the mechanism responsible for the formation of rock varnish remains unclear, two hypotheses have been proposed to explain the great enrichment in manganese within varnish (typically over 50 times compared with the adjacent environment such as soils, underlying rock, or dust). The abiotic hypothesis assumes that small changes in pH can concentrate manganese by geochemical processes. The biotic hypothesis suggests that bacteria, and perhaps other microorganisms, concentrate manganese; this is supported by culturing experiments and direct observations of bacterial enhancement of manganese. See SEDIMENTARY ROCKS.

Since rock varnish records environmental, especially climatic, events that are regionally or even globally synchronous, varnish microstratigraphy can be used as a tool for age dating. Without radiometric calibration, varnish microstratigraphy itself may be used to estimate relative ages of varnished geomorphic or archeological features in deserts. Once calibrated, varnish microstratigraphy can provide numerical age estimates for geomorphic and archeological features. Specifically, for petroglyphs and geoglyphs, the layering patterns of rock varnish hold the greatest potential for assigning ages. See ARCHEOLOGICAL CHRONOLOGY; DATING METHODS; ROCK AGE DETERMINATION. [T.L.]

**Rocket** Either a propulsion system or a complete vehicle driven by such a propulsive engine. A rocket engine provides the means whereby chemical matter is burned to release the energy stored in it and the energy is expended, by ejection at high velocity of the products of combustion (the working fluid). The ejection imparts motion to the vehicle in a direction opposite to that of the ejected matter. A rocket vehicle is propelled by rocket reaction and includes all components necessary for such propulsion, and a payload such as an explosive charge, scientific instruments, or a crew. A rocket vehicle also includes guidance and control equipment mounted in a structural airframe or spaceframe. See ROCKET PROPULSION; ROCKET STAGING; SATELLITE (SPACECRAFT); SPACE FLIGHT; SPACE PROBE. [G.P.S.]

**Rocket astronomy** The discipline that makes use of sounding rockets that fly near-vertical paths carrying scientific instruments to altitudes ranging from 25 to more than 900 mi (40 to 1500 km). Altitudes up to 30 mi (48 km) can be reached by balloons, so sounding rockets are typically used for higher altitudes in order to measure emissions from the Sun or other celestial sources that do not penetrate the Earth's atmosphere. Sounding rockets do not achieve orbital velocity; after completion of the launch phase, the payload follows a ballistic trajectory that permits 5–15 min of data taking before reentry. See ROCKET.

In comparison with experiments launched on satellites, rockets offer the advantages of simplicity, relatively frequent access to launch opportunities, a shorter time scale from conception to reality, lower cost, and recoverability of the payload and the possibility of postflight instrument calibration, refurbishment, and

reflight. Major disadvantages are short observing time, localized coverage, and size and weight restrictions on payloads. See SATELLITE ASTRONOMY.

Scientific rocket programs focus on the disciplines of aeronomy, magnetospheric physics, meteorology, and material sciences, as well as astronomy and astrophysics. The ability to carry out vertical profile measurements of relevant atmospheric parameters at heights of 25–125 mi (40–200 km) is essential in many of these scientific disciplines. To the extent that the Sun influences or controls conditions in the upper atmosphere and magnetosphere of the Earth, there is a strong connection between solar astronomy and the more local research areas. See AERONOMY; IONOSPHERE; MAGNETOSPHERE.

The emission from the solar corona is dominated by ultraviolet and x-ray photons. During the late 1950s and early 1960s, techniques were developed for focusing x-rays and thereby providing direct imaging of the corona. These early studies revealed the highly structured nature of the atmosphere, with approximately semicircular loops of hot plasma outlining the shape of the underlying magnetic field, which confines the hot gas. Among the notable advances in coronal studies from rockets has been the development of a new technique for x-ray imaging: the use of multilayer coatings for enhanced x-ray reflectivity. See SUN; X-RAY ASTRONOMY; X-RAY TELESCOPE.

Observations of nonsolar sources from sounding rockets are hindered by the low intensity of the emission and the problem of pointing the payload at the source during the flight. [L.Gol.]

**Rocket propulsion** The process of imparting a force to a flying vehicle, such as a missile or a spacecraft, by the momentum of ejected matter. This matter, called propellant, is stored in the vehicle and ejected at high velocity. In chemical rockets the propellants are chemical compounds that undergo a chemical combustion reaction, releasing the energy for thermodynamically accelerating and ejecting the gaseous reaction products at high velocities. Chemical rocket propulsion is thus differentiated from other types of rocket propulsion, which use nuclear, solar, or electrical energy as their power source and which may use mechanisms other than the adiabatic expansion of a gas for achieving a high ejection velocity. Propulsion systems using liquid propellants (such as kerosine and liquid oxygen) have traditionally been called rocket engines, and those that use propellants in solid form have been called rocket motors. See ELECTROTHERMAL PROPULSION; INTERPLANETARY PROPULSION; ION PROPULSION; PLASMA PROPULSION; PROPULSION; SPACECRAFT PROPULSION.

**Performance.** The performance of a missile or space vehicle propelled by a rocket propulsion system is usually expressed in terms of such parameters as range, maximum velocity increase of flight, payload, maximum altitude, or time to reach a given target. Propulsion performance parameters (such as rocket exhaust velocity, specific impulse, thrust, or propulsion system weight) are used in computing these vehicle performance

Typical performance values of rocket propulsion systems\*

Propulsion system parameter	Typical range of values
Specific impulse at sea level	180–390 s
Specific impulse at altitude	215–470 s
Exhaust velocity at sea level	5800–15,000 ft/s (1800–4500 m/s)
Combustion temperature	4000–7200 °F (2200–4000 °C)
Chamber pressures	100–3000 lb/in. <sup>2</sup> (0.7–20 MPa)
Ratio of thrust to propulsion system weight	20–150
Thrust	0.01–6.6 × 10 <sup>6</sup> lb (0.05–2.9 × 10 <sup>7</sup> n) <sup>†</sup>
Flight speeds	0–50,000 ft/s (0–15,000 m/s)

\*Exact values depend on application, propulsion system design, and propellant selection.

<sup>†</sup>Maximum value applies to a cluster; for a single rocket motor it is 3.3 × 10<sup>6</sup> lb (14,700 kN).

criteria. The table gives typical performance values. See SPECIFIC IMPULSE; THRUST.

**Applications.** Rocket propulsion is used for different military missiles or space-flight missions. Each requires different thrust levels, operating durations, and other capabilities. In addition, rocket propulsion systems are used for rocket sleds, jet-assisted takeoff, principal power plants for experimental aircraft, or weather sounding rockets. For some space-flight applications, systems other than chemical rockets are used or are being investigated for possible future use. See GUIDED MISSILE; MISSILE; ROCKET-SLED TESTING; SATELLITE (SPACECRAFT); SPACE FLIGHT; SPACE PROBE.

**Liquid-propellant rocket engines.** These use liquid propellants stored in the vehicle for their chemical combustion energy. The principal hardware subsystems are one or more thrust chambers, a propellant feed system, which includes the propellant tanks in the vehicle, and a control system.

Bipropellants have a separate oxidizer liquid (such as liquefied oxygen or nitrogen tetroxide) and a separate fuel liquid (such as liquefied hydrogen or hydrazine). Monopropellants consist of a single liquid that contains both oxidizer and fuel ingredients. A catalyst is required to decompose the monopropellant into gaseous combustion products. Bipropellant combinations allow higher performance (higher specific impulse) than monopropellants. See PROPELLANT.

The three principal components of a thrust chamber are the combustion chamber, where rapid, high-temperature combustion takes place; the converging-diverging nozzle, where the hot reaction-product gases are accelerated to supersonic velocities; and an injector, which meters the flow of propellants in the desired mixture of fuel and oxidizer, introduces the propellants into the combustion chamber, and causes them to be atomized or broken up into small droplets. Some thrust chambers (such as the space shuttle's main engines and orbital maneuvering engines) are gimballed or swiveled to allow a change in the direction of the thrust vector for vehicle flight motion control.

**Solid-propellant rocket motors.** In rocket motors the propellant is a solid material that feels like a soft plastic or soap. The solid propellant cake or body is known as the grain. It can have a complex internal geometry and is fully contained inside the solid motor case, to which a supersonic nozzle is attached.

The propellant contains all the chemicals necessary to maintain combustion. Once ignited, a grain will burn on all exposed surfaces until all the usable propellant is consumed; small unburned residual propellant slivers often remain in the chamber. As the grain surface recedes, a chemical reaction converts the solid propellant into hot gas. The hot gas then flows through internal passages within the grain to the nozzle, where it is accelerated to supersonic velocities. A pyrotechnic igniter provides the energy for starting the combustion.

The nozzle must be protected from excessive heat transfer, from high-velocity hot gases, from erosion by small solid or liquid particles in the gas (such as aluminum oxide), and from chemical reactions with aggressive rocket exhaust products. The highest heat transfer and the most severe erosion occur at the nozzle throat and immediately upstream from there. Special composite materials, called ablative materials, are used for heat protection, such as various types of graphite or reinforced plastics with fibers made of carbon or silica. The development of a new composite material, namely, woven carbon fibers in a carbon matrix, has allowed higher wall temperatures and higher strength at elevated temperatures; it is now used in nozzle throats, nozzle inlets, and exit cones. It is made by carbonizing (heating in a nonoxidizing atmosphere) organic materials, such as rayon or phenolics. Multiple layers of different heat-resistant and heat-insulating materials are often particularly effective. A three-dimensional pattern of fibers created by a process similar to weaving gives the nozzle extra strength. See NOZZLE.

Nozzles can have sophisticated thrust-vector control mechanisms. In one such system the nozzle forces are absorbed by a

doughnut-shaped, confined, liquid-filled bag, in which the liquid moves as the nozzle is canted. The space shuttle solid rocket boosters have gimbaled nozzles for thrust-vector control, with actuators driven by auxiliary power units and hydraulic pumps.

**Hybrid rocket propulsion.** A hybrid uses a liquid propellant together with a solid propellant in the same rocket engine. The arrangement of the solid fuel is similar to that of the grain of a solid-propellant rocket; however, no burning takes place directly on the surface of the grain because it contains little or no oxidizer. Instead, the fuel on the grain surface is heated, decomposed, and vaporized, and the vapors burn with the oxidizer some distance away from the surface. The combustion is therefore inefficient.

**Testing.** Because flights of rocket-propelled vehicles are usually fairly expensive and because it is sometimes difficult to obtain sufficient and accurate data from fast-moving flight vehicles, it is accepted practice to test rocket propulsion systems and components extensively on the ground under simulated flight conditions. Components such as an igniter or a turbine are tested separately. Complete engines are tested in static engine test stands; the complete vehicle stage is also tested statically. In the latter two tests the engine and vehicle are adequately secured by suitable structures. Only in flight tests are they allowed to leave the ground. [G.P.S.]

**Rocket-sled testing** A method of subjecting structures and devices to high accelerations or decelerations and aerodynamic flow phenomena under controlled conditions. The test object is mounted on a sled chassis running on precision steel rails and accelerated by rockets and decelerated by water scoops. This captive track testing of full-scale aircraft and missile components makes possible the recovery of expensive test sections, facilitates the instrumentation of the test and the reception and recording of the data, and provides a degree of repeatability not normally achieved under conditions of free flight. The components tested may be the rocket engines themselves, sections of flight vehicles, or equipment intended to operate under conditions of high acceleration or other specific environments such as structural vibration, acoustic vibration, and related aerodynamic conditions.

The test vehicle takes many diversified forms, ranging from the highly faired, aerodynamically clean type used to explore the transonic and supersonic speed ranges to the relatively simple all-purpose utility type used for testing in the subsonic and low transonic ranges. All sleds are carried on shoes or slippers that grip the railhead in order to prevent derailing. They may be powered by either liquid- or solid-propellant rocket engines.

Tests conducted on the track provide initial design data, developmental evaluation, and performance measurements of completed components and equipments. [E.Co.]

**Rocket staging** The use of successive rocket sections, each having its own engine or engines. One way to minimize the weight of large missiles, or space vehicles, is to use multiple stages. The first or initial stage is usually the heaviest and biggest and often called the booster; the next few stages are successively smaller and are generally called sustainers. Each stage is a complete vehicle in itself and carries its own propellant (either solid or liquid; both fuel and oxidizer), its own propulsion system, and has its own tankage and control system.

Once the propellant of a given stage is expended, the dead weight of that stage including empty tanks, rocket engine, and controls is no longer useful in contributing additional kinetic energy to the succeeding stages. By dropping off this useless weight, the mass that remains to be accelerated is made smaller; therefore it is possible to accelerate the payload to higher velocity than would be attainable if multiple staging were not used.

It is quite possible to employ different types of power plants, different types of propellants, and entirely different configurations in successive stages of any one multistage vehicle (see

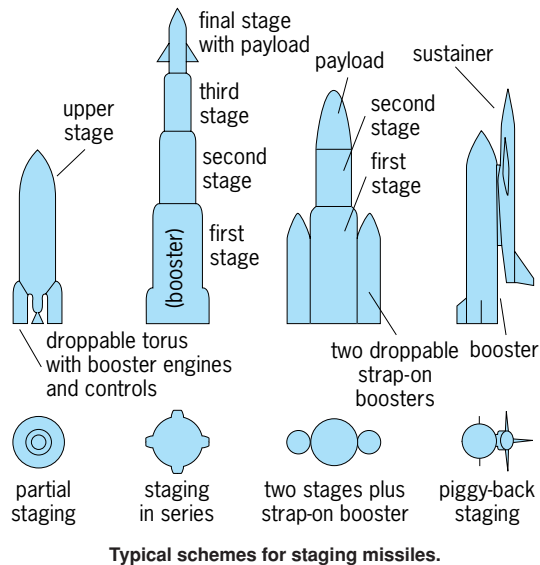

Typical schemes for staging missiles.

illustration). Because staging adds complications, it is impractical to have more than four to seven stages in any one vehicle. See ROCKET PROPULSION. [G.P.S.]

**Rodentia** The mammalian order consisting of the rodents, often known as the gnawing mammals. This is the most diverse group of mammals in the world, consisting of over 2000 species, more than 40% of the known species of mammals on Earth today. Rodents range in size from mice, weighing only a few grams, to the Central American capybara, which is up to 130 cm (4 ft) in length and weighs up to 79 kg (170 lb). Rodents have been found in virtually every habitat and on every continent except Antarctica. Rodents have adapted to nearly every mode of life, including semiaquatic swimming (beavers and muskrats), gliding ("flying" squirrels), burrowing (gophers and African mole rats), arboreal (dormice and tree squirrels), and hopping (kangaroo rats and jerboas). Nearly all rodents are herbivorous, with a few exceptions that are partially insectivorous to totally omnivorous, such as the domestic rat. The great adaptability and rapid evolution and diversity of rodents are mainly due to their short gestation periods (only 3 weeks in some mice) and rapid turnover of generations.

The most diagnostic feature of the Rodentia is the presence of two pair of ever-growing incisors (one pair above and one below) at the front of the jaws. These teeth have enamel only on the front surface, which allows them to wear into a chisel-like shape, giving rodents the ability to gnaw. Associated with these unique teeth are a number of other anatomical features that enhance this ability. Behind the incisors is a gap in the jaws where no teeth grow, called a diastema. The diastema of the upper jaw is longer than that of the lower jaw, which allows rodents to engage their gnawing incisors while their chewing teeth (molars and premolars) are not being used. The reverse is also true; rodents can use their chewing teeth (also called cheek teeth) while their incisors are disengaged.

The entire skull structure of rodents is designed to accommodate this task of separating the use of the different types of teeth. Rodent skulls have long snouts; the articulation of the lower jaw with the skull is oriented front to back rather than sideways as in other mammals; the jaw muscles (masseter complex) are extended well forward into the snout; and the number of cheek teeth is less than in most other mammals—all features unique to rodents.

The classification of rodents has always been difficult because of the great diversity of both Recent and fossil species. Traditionally, there are two ways that rodents have been divided: into three major groups based on the structure of the attachment of

the jaw muscle on the skull (Sciuromorpha, Hystricomorpha, Myomorpha); or into two groups based on the structure of the lower jaw (Sciurognathi, Hystricognathi). The difficulty in using these groups (usually considered suborders or infraorders) is that the distinctive adaptations of one group of rodents are also present in others, derived in completely separate ways. [W.W.K.]

**Rodenticide** A toxic chemical that is used to kill pest rodents and sometimes other pest mammals, including moles, rabbits, and hares. Most rodenticides are used to control rats and house mice.

Rodenticides are generally combined with some rodent-preferred food item such as grain (corn, wheat, oats) or a combination of grains in low yet effective amounts. Bait formulations may be in pellet forms or incorporated in paraffin blocks of varying sizes. As a safeguard against accidental ingestion by nontarget species, baits are placed either where they are inaccessible to children, domestic animals, or wildlife, or within tamper-resistant bait boxes designed to exclude all but rodent-size animals.

As a group, anticoagulant rodenticides dominate the market and are sold under a wide variety of trade names. In order of their development, they are warfarin, pindone (Pival), diphacinone, and chlorofacinone. When small amounts of these anticoagulants are consumed over several days, death results from internal bleeding. The newer, second-generation anticoagulant rodenticides, such as brodifacoum, bromadiolone, and difethialone, were developed to counteract the growing genetic resistance in rats and house mice to the earlier anticoagulants, especially warfarin. The second-generation compounds are more potent and capable of being lethal following a single night's feeding, although death is generally delayed by several days. Rodenticides that do not belong to the anticoagulant group include zinc phosphide, bromethalin, and cholecalciferol (vitamin D<sub>3</sub>). The feeding and lethal characteristics differ among them. Acutely toxic strychnine baits are also available but are restricted to underground application, primarily for pocket gophers and moles. Several lethal fumigants or materials that produce poisonous gases are used to kill rodents in burrows and within other confined areas such as unoccupied railway cars or buildings. Lethal fumigants include aluminum phosphide, carbon dioxide, chloropicrin, and smoke or gas cartridges, which are ignited to produce carbon monoxide and other asphyxiating gases.

Because of their high toxicity, rodenticides are inherently hazardous to people, domestic animals, and wildlife. They are highly regulated, as are certain other types of pesticides. Some rodenticides can be purchased and used only by trained certified or licensed pest control operators, while others with a greater safety margin can be used by the general public. All rodenticides must be used in accordance with the label directions and may be prohibited where they may jeopardize certain endangered species. See PESTICIDE; RODENTIA. [R.E.Ma.]

**Roll mill** A series of rolls operating at different speeds and used to grind paint or to mill flour. In paint grinding, a paste is fed between two low-speed rolls running toward each other at different speeds. Because the next roll in the mill is turning faster, it develops shear in the paste and draws the paste through the mill. The film is scraped from the last high-speed roll. For grinding flour, rolls are operated in pairs, rolls in each pair running toward each other at different speeds. Grooved rolls crush the grain; smooth rolls mill the flour to the desired fineness. See GRINDING MILL. [R.M.H.]

**Rolling contact** Contact between bodies such that the relative velocity of the two contacting surfaces at the point of contact is zero. Common applications of rolling contact are the friction gearing of phonograph turntables, speed changers, and wheels on roadways. Rolling contact mechanisms are, generally speaking, a special variety of cam mechanisms. The concepts of rolling contact are used in the study of antifriction bearings and

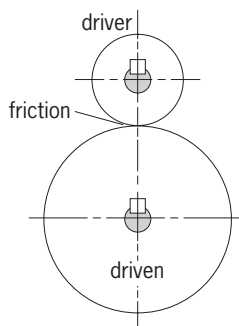

Rolling friction disks.

in the study of the behavior of toothed gearing. See ANTIFRICTION BEARING; CAM MECHANISM; GEAR.

Pure rolling contact can exist between two cylinders rotating about their centers, with either external or internal contact. Two friction disks (see illustration) have external rolling contact if no slipping occurs between them. The rotational speeds of the disks are then inversely proportional to their radii. [J.R.Z.]

**Romanechite** A barium-containing manganese oxide mineral with an ideal composition of  $(\text{Ba}, \text{H}_2\text{O})_2(\text{Mn}^{4+}, \text{Mn}^{3+})_5\text{O}_{10}$ . Romanechite is a basic member of a group of manganese oxide minerals that are similar in physical appearance and have closely related structures. It is an ore of manganese and occurs in a variety of widespread localities. Its name is derived from its occurrence in Romaneche, Soane-et-Loire, France. See MANGANESE; MANGANESE OXIDE MINERALS.

Romanechite is black to steel gray in color, opaque, and fine-grained. It occurs mainly as hard crusts that are botryoidal or reniform, but also as unusual samples that are soft and powdery. Many botryoidal samples have a fine-scale banding or layering parallel to their surfaces. Crystals are rare. The reported specific gravity of romanechite ranges from approximately 4.4 to 4.8, and the Mohs hardness ranges from 5 to 6 (less for powdery varieties). Romanechite is commonly intimately intergrown with other manganese oxide minerals, and is difficult to identify without the use of analytical techniques such as x-ray diffraction or electron microscopy. See HARDNESS SCALES. [S.T.]

**Roof construction** An assemblage to provide cover for homes, buildings, and commercial, industrial, and recreational areas. Roofs are constructed in different forms and shapes with various materials. A properly designed and constructed roof protects the structure beneath it from exterior weather conditions, provides structural support for superimposed loads, provides diaphragm strength to maintain the shape of the structure below, suppresses fire spread, and meets desired esthetic criteria.

Modern roof construction usually consists of an outer roofing assembly that is attached atop a deck or sheathing surface, which in turn is supported by a primary framework such as a series of beams, trusses, or arches. The shape of the roof and type of roof construction are usually determined by, and consistent with, the materials and deck of the primary structure underneath. See ARCH; BEAM; TRUSS.

Roof shapes include flat; hipped, where two sloping deck surfaces intersect in a line, the ridge or hip; pyramidal, which involves three or more sloping planes; domed, or other three-dimensional-surface, such as spherical, parabolic, or hyperbolic, shells; and tentlike, which are suspended fabric or membrane surfaces.

A roof assembly is a series of layers of different materials placed on and attached to the roof deck. Each type of roof assembly—related to protection against water entry from rain, snow, or ice; and insulation for temperature change, fire propagation, wind

uplift, and moisture migration—has its own design requirements and methods of construction and attachment.

A roof is built upward from the structure below. The framework, or primary structural components, rest on the walls and columns of the structure, and these support the roof deck or the sheathing, which in turn carries the roofing assembly. The walls and columns may have girders framing into them. Beams rest on or are connected to girders. The roof deck or sheathing, the components that provide the basic support for the roofing assembly, span between and are anchored to the primary structural framing.

Long-span roofs are use space trusses, usually, of steel; but reinforced-concrete domes or other shell shapes, including folded plates, may be employed. In cable-supported roofs, the primary framework is composed of cables in tension that are slung between separate posts or from the top of the surrounding building perimeter. Tentlike or membrane roofs are a special application of a cable-supported roof. Air-supported roofs utilize a waterproof coated fabric that is inflated to its rigid shape by developing and maintaining a positive air pressure inside the structure, which keeps the roof surface under tension. Tennis-court “bubbles” utilize this design. See BUILDINGS; REINFORCED CONCRETE; STRUCTURAL STEEL. [M.A.]

**Root (botany)** The absorbing and anchoring organ of vascular plants. Roots are simple axial organs that produce lateral roots, and sometimes buds, but bear neither leaves nor flowers. Elongation occurs in the root tip. The older portion of the root, behind the root tip, may thicken through cambial activity. Some roots, grass for example, scarcely thicken, but tree roots can become 4 in. (10 cm) or more in diameter near the stem. Roots may be very long. The longest maple (*Acer*) roots are usually as long as the tree is tall, but the majority of roots are only a few inches long. The longest roots may live for many years, while small roots may live for only a few weeks or months.

Root tips and the root hairs on their surface take up water and minerals from the soil. They also synthesize amino acids and growth regulators (gibberellins and cytokinins). These materials move up through the woody, basal portion of the root to the stem. The thickened, basal portion of the root anchors the plant in the soil. Thickened roots, such as carrots, can store food that is later used in stem growth. See CYTOKININ; GIBBERELLIN.

Roots usually grow in soil where: it is not too dense to stop root tip elongation; there is enough water and oxygen for root growth; and temperatures are high enough (above 39°F or 4°C) to permit root growth, but not so high that the roots are killed (above 104°F or 40°C). In temperate zones most roots are in the uppermost 4 in. (10 cm) of the soil; root numbers decrease so rapidly with increasing depth that few roots are found more than 6 ft (2 m) below the surface. Roots grow deeper in areas where the soil is hot and dry; roots from desert shrubs have been found in mines more than 230 ft (70 m) below the surface. In swamps with high water tables the lack of oxygen restricts roots to the uppermost soil layers. Roots may also grow in the air. Poison ivy vines form many small aerial roots that anchor them to bark or other surfaces.

The primary root originates in the seed as part of the embryo, normally being the first organ to grow. It grows downward into the soil and produces lateral second-order roots that emerge at right angles behind the root tip. Sometimes it persists and thickens to form a taproot. The second-order laterals produce third-order laterals and so on until there are millions of roots in a mature tree root system. In contrast to the primary root, most lateral roots grow horizontally or even upward. In many plants a few horizontal lateral roots thicken more than the primary, so no taproot is present in the mature root system.

Adventitious roots originate from stems or leaves rather than the embryo or other roots. They may form at the base of cut stems, as seen in the horticultural practice of rooting cuttings.

[B.F.W.]

**Root (mathematics)** If a function  $f(x)$  has the value 0 for  $x = a$ ,  $a$  is a root of the equation  $f(x) = 0$ . The fundamental theorem of algebra states that any algebraic equation of the form  $a_0x^n + a_1x^{n-1} + \dots + a_{n-1}x + a_n = 0$ , where the  $a_k$ 's are real numbers, has at least one root. From this it follows readily that such an equation has roots, real or complex, in number equal to the index (here  $n$ ) of the highest power of  $x$ .

Furthermore, if  $a + ib$  (where  $i = \sqrt{-1}$ ) is a complex root of the given equation, so is  $a - ib$ , the conjugate of  $a + ib$ . Equations of degrees up to four may be solved algebraically. This statement means that the roots may be expressed as functions of the coefficients, the functions involving the elementary arithmetical processes of addition, multiplication, raising a number to a power, or extracting the root of a certain order of a given number. It was proved by H. Abel and by E. Galois that it is not possible to solve algebraically the *general* algebraic equation of degree higher than four. However, it is possible to determine the real roots of an algebraic equation to any desired degree of approximation. See CALCULUS; EQUATIONS, THEORY OF; NUMERICAL ANALYSIS. [A.N.L./S.Bo.]

**Root-mean-square** The square root of the arithmetic mean of the squares of a set of numbers is called their root-mean-square. If the numbers are  $x_1, x_2, x_3, \dots, x_n$ , the root-mean-square is equal to

$$\sqrt{\frac{x_1^2 + x_2^2 + x_3^2 + \dots + x_n^2}{n}}$$

It is valuable as an average of the magnitudes of quantities, and it is not affected by the signs of the quantities.

Among applications of root-mean-square the most important is the standard deviation from the arithmetic mean. If the arithmetic mean  $\bar{x}$  is equal to

$$\frac{x_1 + x_2 + x_3 + \dots + x_n}{n}$$

then the standard deviation  $s$  is equal to

$$\sqrt{\frac{(x_1 - \bar{x})^2 + (x_2 - \bar{x})^2 + (x_3 - \bar{x})^2 + \dots + (x_n - \bar{x})^2}{n}}$$

Thus standard deviation from the mean is the root-mean-square of the deviations from the mean. See STATISTICS. [H.R.C.]

**Rope** A long flexible structure consisting of many strands of wire, plastic, or vegetable fiber such as manila. Rope is classified as a flexible connector and is used generally for hoisting, conveying, or transporting loads; transmitting motion; and occasionally transmitting power. For flexibility and to reduce stresses as the rope bends over the sheave (pulley), a rope is made of many small strands. See PULLEY. [P.H.B.]

**Rosales** An order of flowering plants in the eurosoid I group of the rosid eudicots. Recently on the basis of DNA sequence studies the number of families was greatly reduced and changed. The order as now recognized contains only 11 families, many of which are small. Many families in this order are wind-pollinated (the former Urticales) and exhibit the typical syndrome of small petalless flowers with dangling anthers, whereas the other families are insect-pollinated with large, showy flowers in which the carpels are sometimes free. See FLOWER; MAGNOLIOPHYTA; MAGNOLIOPSIDA; POLLINATION.

The largest family is Rosaceae with nearly 3000 species. The great number of economically important trees, shrubs, and herbs in this family include apples (*Malus*), pears (*Pyrus*), almonds, cherries, plums, and prunes (*Prunus*), strawberries (*Fragaria*), blackberries, raspberries, and their relatives (*Rubus*), as well as many minor fruits. Many are grown as ornamental plants, including roses (*Rosa*), avens (*Geum*), cinquefoil (*Potentilla*),

firethorn (*Pyracantha*), redbush (*Photinia*), and spirea (*Spiraea*). See ALMOND; APPLE; BLACKBERRY; CHERRY; PEAR; PLUM; RASPBERRY; STRAWBERRY.

The second-largest family, Rhamnaceae (900 species), includes mostly woody species (shrubs and trees) that differ from Rosaceae in having fused carpels and only five stamens (rather than many) that are placed in the same position as the petals. A number of species in Rhamnaceae are of minor economic importance as timbers, some are of medicinal use or as dyes, and one is a minor fruit crop, the jujube (*Zizyphus*). A few are ornamentals, such as *Ceanothus* and *Colletia*.

Of the families formerly placed in Urticales, the largest are Moraceae (950 species) and Urticaceae (700 species). Many of these are large forest trees, but some are forest herbs and weeds. In Moraceae, many species are sources of timber and fruit, including figs (*Ficus*), mulberries (*Morus*), and breadfruits (*Artocarpus*). In Urticaceae, fiber-producing species are common, including hemp (*Cannabis*), ramie or China grass (*Boehmeria*), and bast-fiber (*Urtica*). Ulmaceae and Celtidaceae are small families of north temperate forest trees, many of which provide useful timbers, including elm (*Ulmus*), hackberries (*Celtis*), and *Zelkova*. See ELM; FIBER CROPS; FIG; HACKBERRY; HEMP; MULBERRY; RAMIE. [M.W.C.]

**Rose curve** A type of plane curve that consists of loops (leaves, petals) emanating from a common point and that has a roselike appearance. Taking the common point  $O$  as the pole of a polar coordinate system (see illustration), these curves have

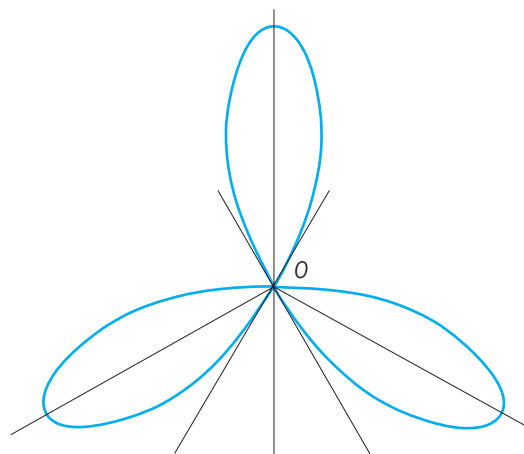

Diagram of rose curve.

equations of the form  $\rho = a \cdot \sin n\theta$ , where  $a > 0$  and  $n$  is a positive integer (also  $\rho = a \cdot \cos n\theta$ , with a different choice of the initial line of the coordinate system). The curve is a circle of diameter  $a$  for  $n = 1$ . It has  $n$  or  $2n$  leaves, according as  $n$  is an odd or even integer, respectively. The lemniscate is sometimes called a two-leaved rose, though its equation  $\rho^2 = a^2 \cos 2\theta$  is not of the form given above. See LEMNISCATE OF BERNOULLI. [L.M.B.]

**Rosemary** *Rosmarinus officinalis*, a member of the mint family, grown for its highly aromatic leaves and as an ornamental. Rosemary is an evergreen and perennial which can live as long as 20 years under favorable conditions. Although many varieties exist, *R. officinalis* is the only species. Most varieties are suitable for culinary use, although some (such as Pine Scented) contain high levels of terpenes and have a turpentine-like scent. See LAMIALES.

Rosemary is native to the Mediterranean area, and much of the world production is harvested from wild plants growing there. Though it is widely cultivated mainly in France, Spain, and

California, it will grow in most temperate areas not subject to hard frosts.

Rosemary oil has been found to contain chemicals such as rosmanol which inhibit oxidation and bacterial growth. Rosemary is used in poultry seasoning and for flavoring soups and vegetables. See SPICE AND FLAVORING. [S.Kir.]

**Rosidae** A former widely recognized subclass of Magnoliophyta (angiosperms or flowering plants). Deoxyribonucleic acid (DNA) and morphological studies have demonstrated that this group includes many more families than previously thought. Approximately 136 families (roughly 30% of the total angiosperms) in 11 orders are included in the rosids. With the asterids (often recognized as Asteridae), the rosids represent the two most advanced lines of dicots.

The primary distinguishing features of rosids are their diplostemonous flowers (anthers in two whorls, each whorl typically numbering the same as the perianth parts, although in some groups the number of stamens has increased) with unfused parts, except for the carpels (asterids have haplostemonous flowers with fused parts, typically with the stamens fused at least to the bases of the petals). Rosids have ovules with two integuments (that is, they are bitegmic, as opposed to the unitegmic asterids) and a several-layered nucellus (that is, they are crassinucellate, as opposed to the tenuinucellate asterids, which have a single-layered nucellus). There is nuclear endosperm formation (cellular in asterids), a reticulate pollen layer, mucilaginous leaf epidermis, and generally simple perforation vessel end-walls in the wood. The largest rosid orders are Malpighiales (16,100 species), Fabales (17,500), and Myrtales (10,600). See APIALES; CELASTRALES; CORNALES; EUPHYRIBIALES; FABALES; GERANIALES; HALORAGALES; LINALES; MAGNOLIOPSIDA; MYRATALES; PODOSTEMALES; POLYGALALES; PROTEALES; RAFFLESIALES; RHIZOPHORALES; ROSALES; SANTALALES; SAPINDALES. [M.W.C.]

**Rosin** A brittle resin ranging in color from dark brown to pale lemon yellow and derived from the oleoresin of pine trees. Rosin is insoluble in water, but soluble in most organic solvents. It softens at about 180–190°F (80–90°C). Rosin consists of about 90% resin acids and about 10% neutral materials such as anhydrides, sterols, and diterpene aldehydes and alcohols.

Rosin is obtained by wounding living trees and collecting the exudate (gum rosin), by extraction of pine stumps (wood rosin), and as a by-product from the kraft pulping process (sulfate or tall oil rosin).

The largest single use of rosin is in sizing paper to control water absorption, an application in which fortified rosin is important. Rosin soaps are used as emulsifying and tackifying agents in synthetic rubber manufacture. Other rosin uses include adhesives, printing inks, and chewing gum. [I.S.G.]

**Rotary engine** Internal combustion engine that duplicates in some fashion the intermittent cycle of the piston engine, consisting of the intake-compression-power-exhaust cycle, wherein the form of the power output is directly rotational.

Four general categories of rotary engines can be considered: (1) cat-and-mouse (or scissor) engines, which are analogs of the reciprocating piston engine, except that the pistons travel in a circular path; (2) eccentric-rotor engines, wherein motion is imparted to a shaft by a principal rotating part, or rotor, that is eccentric to the shaft; (3) multiple-rotor engines, which are based on simple rotary motion of two or more rotors; and (4) revolving-block engines, which combine reciprocating piston and rotary motion. See AUTOMOBILE; COMBUSTION CHAMBER; DIESEL CYCLE; DIESEL ENGINE; GAS TURBINE; INTERNAL COMBUSTION ENGINE; OTTO CYCLE. [W.Ch.]

**Rotational motion** The motion of a rigid body which takes place in such a way that all of its particles move in circles

about an axis with a common angular velocity; also, the rotation of a particle about a fixed point in space. Rotational motion is illustrated by (1) the fixed speed of rotation of the Earth about its axis; (2) the varying speed of rotation of the flywheel of a sewing machine; (3) the rotation of a satellite about a planet; (4) the motion of an ion in a cyclotron; and (5) the motion of a pendulum. Circular motion is a rotational motion in which each particle of the rotating body moves in a circular path about an axis. Such motion is exhibited by the first and second examples. For information concerning the other examples see HARMONIC MOTION; PARTICLE ACCELERATOR; PENDULUM.

The speed of rotation, or angular velocity, remains constant in uniform circular motion. In this case, the angular displacement  $\theta$  experienced by the particle or rotating body in a time  $t$  is  $\theta = \omega t$ , where  $\omega$  is the constant angular velocity.

A special case of circular motion occurs when the rotating body moves with constant angular acceleration. If a body is moving in a circle with an angular acceleration of  $\alpha$  radians/s<sup>2</sup>, and if at a certain instant it has an angular velocity  $\omega_0$ , then at a time  $t$  seconds later, the angular velocity may be expressed as  $\omega = \omega_0 + \alpha t$ , and the angular displacement as  $\theta = \omega_0 t + \frac{1}{2}\alpha t^2$ . See ACCELERATION; VELOCITY.

A rotating body possesses kinetic energy of rotation which may be expressed as  $T_{\text{rot}} = \frac{1}{2}I\omega^2$ , where  $\omega$  is the magnitude of the angular velocity of the rotating body and  $I$  is the moment of inertia, which is a measure of the opposition of the body to angular acceleration. The moment of inertia of a body depends on the mass of a body and the distribution of the mass relative to the axis of rotation. For example, the moment of inertia of a solid cylinder of mass  $M$  and radius  $R$  about its axis of symmetry is  $\frac{1}{2}MR^2$ .

The action of a torque  $L$  is to produce an angular acceleration  $\alpha$  according to the equation below, where  $I\omega$ , the product of

$$L = I\alpha = I \frac{d\omega}{dt} = \frac{d}{dt}(I\omega)$$

moment of inertia and angular velocity, is called the angular momentum of the rotating body. This equation points out that the angular momentum  $I\omega$  of a rotating body, and hence its angular velocity  $\omega$ , remains constant unless the rotating body is acted upon by a torque. Both  $L$  and  $I\omega$  may be represented by vectors.

It is readily shown that the work done by the torque  $L$  acting through an angle  $\theta$  on a rotating body originally at rest is exactly equal to the kinetic energy of rotation. See ANGULAR MOMENTUM; MOMENT OF INERTIA; RIGID-BODY DYNAMICS; TORQUE; WORK. [C.E.H./R.J.S.]

**Rotifera** A phylum of pseudocoelomate, microscopic, mainly free-living aquatic animals, characterized by an anterior ciliary apparatus, the corona, whose cilia when in motion have the appearance of a pair of rapidly rotating wheels. This structure is implicit in the phyletic name (literally “wheel bearers”) and the older popular name wheel animalcules.

The Rotifera show considerable diversity in form and structure, but all are bilaterally symmetrical, pseudocoelomate animals possessing complete digestive, excretory, nervous, and reproductive systems, but lacking separate respiratory and circulatory systems. They possess two features unique to their phylum: the corona, which is a retractile trochal disk, and the mastax, which is a gizzardlike structure derived from the modified pharynx.

Rotifers are dioecious and sexually dimorphic; females are commoner than males, some of which are degenerate organisms lacking a mouth and digestive organs. Males, when produced in the life cycle, are short-lived and survive for only hours or at the most a few days.

The three major subdivisions of the Rotifera, now given class status, are the Seisonacea, Bdelloidea, and Monogononta. See BDELLOIDEA; MONOGONONTA; SEISONACEA. [J.B.J.]

**Rous sarcoma** The first filterable agent (virus) known to cause a solid tumor in chickens. It was discovered in 1911 by P. F. Rous, who won the Nobel prize in 1967 for his discovery. It is a ribonucleic acid virus and belongs to the avian leukosis group. Certain strains of the virus cause tumors in hamsters, rabbits, monkeys, and other species. The Rous virus is known as a "defective" virus in that it is incapable of producing tumors by itself but requires another closely related virus of the avian leukosis group to act as a "helper" for the production of the foci. See ANIMAL VIRUS; TUMOR VIRUSES; VIRUS, DEFECTIVE. [A.E.Mo.]

**Rubber** Originally, a natural or tree rubber, which is a hydrocarbon polymer of isoprene units. With the development of synthetic rubbers having some rubbery characteristics but differing in chemical structure as well as properties, a more general designation was needed to cover both natural and synthetic rubbers. The term elastomer, a contraction of the words elastic and polymer, was introduced, and defined as a substance that can be stretched at room temperature to at least twice its original length and, after having been stretched and the stress removed, returns with force to approximately its original length in a short time.

Three requirements must be met for rubbery properties to be present in both natural and synthetic rubbers: long thread like molecules, flexibility in the molecular chain to allow flexing and coiling, and some mechanical or chemical bonds between molecules.

Natural rubber and most synthetic rubbers are also commercially available in the form of latex, a colloidal suspension of polymers in an aqueous medium. Natural rubber comes from trees in this form; many synthetic rubbers are polymerized in this form; some other solid polymers can be dispersed in water. See POLYMER.

Latexes are the basis for a technology and production methods completely different from the conventional methods used with solid rubbers.

In the crude state, natural and synthetic rubbers possess certain physical properties which must be modified to obtain useful end products. The raw or unmodified forms are weak and adhesive. They lose their elasticity with use, change markedly in physical properties with temperature, and are degraded by air and sunlight. Consequently, it is necessary to transform the crude rubbers by compounding and vulcanization procedures into products which can better fulfill a specific function.

Although natural rubber may be obtained from hundreds of different plant species, the most important source is the rubber tree (*Hevea brasiliensis*). Natural rubber is *cis*-1,4-polyisoprene, containing approximately 5000 isoprene units in the average polymer chain. See RUBBER TREE.

Styrene-butadiene rubber (SBR) is the most important synthetic rubber and the most widely used rubber in the entire world. Formerly designated GR-S, SBRs are obtained by the emulsion polymerization of butadiene and styrene in varying ratios. However, in the most commonly used type, the ratio of butadiene to styrene is approximately 78:22. Unlike natural rubber, SBR does not crystallize on stretching and thus has low tensile strength unless reinforced. The major use for SBR is in tires and tire products. Other uses include belting, hose, wire and cable coatings, flooring, shoe products, sponge, insulation, and molded goods.

Butyl rubber is essentially a polyisobutylene except for the presence of diolefin, usually isoprene, to provide the unsaturation necessary for vulcanization. Butyl rubbers have excellent resistance to oxygen, ozone, and weathering. In addition, these rubbers exhibit good electrical properties and high impermeability to gases. The high impermeability to gases results in use of butyl as an inner liner in tubeless tires. Other widespread uses are for wire and cable products, injection-molded and extruded products, hose, gaskets, and sealants, and where good damping characteristics are needed.

Ethylene-propylene polymers are produced by the copolymerization of ethylene and propylene. These copolymers exhibit out-

standing resistance to heat, oxygen, ozone, and other aging and degrading agents. Abrasion resistance in tire treads is excellent. The mechanical properties of their vulcanizates are generally approximately equivalent to those of SBR.

One of the first synthetic rubbers used commercially in the rubber industry is neoprene, a polymer of chloroprene, 2-chlorobutadiene-1,3. The neoprenes have exceptional resistance to weather, sun, ozone, and abrasion. They are good in resilience, gas impermeability, and resistance to heat, oil, and flame. They are fairly good in low temperature and electrical properties. This versatility makes them useful in many applications requiring oil, weather, abrasion, or electrical resistance or combinations of these properties, such as wire and cable, hose, belts, molded and extruded goods, soles and heels, and adhesives.

Nitrile-type rubbers are copolymers of acrylonitrile and a diene, usually butadiene. The nitrile rubbers can be blended with natural rubber, polysulfide rubbers, and various resins to provide characteristics such as increased tensile strength, better solvent resistance, and improved weathering resistance.

Fluoroelastomers are basically copolymers of vinylidene fluoride and hexafluoropropylene. Because of their fluorine content, they are the most chemically resistant of the elastomers and also have good properties under extremes of temperature conditions. They are useful in the aircraft, automotive, and industrial areas.

Polyurethane elastomers are of interest because of their versatility and variety of properties and uses. They can be used as liquids or solids in a number of manufacturing methods. The largest use has been for making foam for upholstery and bedding. See POLYURETHANE RESINS.

Polysulfide rubbers have a large amount of sulfur in the main polymer chain and are therefore very chemically resistant, particularly to oils and solvents. They are used in such applications as putties, caulks, and hose for paint spray, gasoline, and fuel. Polyacrylate rubbers are useful because of their resistance to oils at high temperatures, including sulfur-bearing extreme-pressure lubricants. See POLYSULFIDE RESINS.

Proper choice of catalyst and order of procedure in polymerization have led to development of thermoplastic elastomers. The leading commercial types are styrene block copolymers having a structure which consists of polystyrene segments or blocks connected by rubbery polymers such as polybutadiene, polyisoprene, or ethylene-butylene polymer. Thermoplastic elastomers are very useful in providing a fast and economical method of producing a variety of products. One of the disadvantages for many applications is the low softening point of the thermoplastic elastomers. [E.G.P.]

**Rubber tree** *Hevea brasiliensis*, a member of the spurge family (Euphorbiaceae) and a native of the Amazon valley. It is the natural source of commercial rubber.

It has been introduced into all the tropical countries supporting the rainforest type of vegetation, and is grown extensively in established plantations, especially in Malaysia. The latex from the trees is collected and coagulated. The coagulated latex is treated in different ways to produce the kind of rubber desired. Rubber is made from the latex of a number of other plants, but *Hevea* is the rubber plant of major importance. See EUPHORBIALES; RUBBER. [P.D.St./E.L.C.]

**Rubella** A benign, infectious virus disease of humans characterized by coldlike symptoms and transient, generalized rash. This disease, also known as German measles, is primarily a disease of childhood. However, maternal infection during early pregnancy may result in infection of the fetus, giving rise to serious abnormalities and malformations. The congenital infection persists in the infant, who harbors and sheds virus for many months after birth.

In rubella infection acquired by ordinary person-to-person contact, the virus is believed to enter the body through



respiratory pathways. Antibodies against the virus develop as the rash fades, increase rapidly over a 2–3-week period, and then fall during the following months to levels that are maintained for life. One attack confers life-long immunity, since only one antigenic type of the virus exists. Immune mothers transfer antibodies to their offspring, who are then protected for approximately 4–6 months after birth. See IMMUNITY.

Live attenuated rubella vaccines have been available since 1969. The vaccine induces high antibody titers and an enduring and solid immunity. It may also induce secretory immunoglobulin (IgA) antibody in the respiratory tract and thus interfere with establishment of infection by wild virus. This vaccine is available as a single antigen or combined with measles and mumps vaccines (MMR vaccine). The vaccine induces immunity in at least 95% of recipients, and that immunity endures for at least 10 years. See BIOLOGICALS; VACCINATION. [J.L.Me.]

**Rubellite** The red to red-violet variety of the gem mineral tourmaline. Perhaps the most sought-for of the many colors in which tourmaline occurs, it was named for its resemblance to ruby. The color is thought to be caused by the presence of lithium. It has a hardness of 7–7.5 on Mohs scale, a specific gravity near 3.04, and refractive indices of 1.624 and 1.644. Fine gem-quality material is found in Brazil, Madagascar, Maine, southern California, the Ural Mountains, and elsewhere. See GEM; TOURMALINE. [R.T.L.]

**Rubiales** An order of flowering plants, division Magnoliophyta (Angiospermae), in the subclass Asteridae of the class Magnoliopsida (dicotyledons). The order consists of the large family Rubiaceae, with about 6500 species and the family Theligoniaceae with only 3 species. The Rubiales are marked by their inferior ovary; regular or nearly regular corolla with the petals grown together by their margins; stamens (equal in number to the petals) which are attached to the corolla tube alternate with the lobes; and opposite leaves with interpetiolar stipules or whorled leaves without stipules. The most familiar species of temperate regions are herbs with whorled leaves, such as madder (*Rubia tinctorum*, the traditional source of red dye), but opposite-leaved tropical shrubs such as *Coffea* (the source of coffee) are more typical of the group. See COFFEE; IPECAC; MAGNOLIOPHYTA; MAGNOLIOPSIDA. [A.Cr.; T.M.Ba.]

**Rubidium** A chemical element, Rb, atomic number 37, and atomic weight 85.47. Rubidium is an alkali metal. It is a light, low-melting, reactive metal. See PERIODIC TABLE.

Most uses of rubidium metal and rubidium compounds are the same as those of cesium and its compounds. The metal is used in the manufacture of electron tubes, and the salts in glass and ceramic production.

Rubidium is a fairly abundant element in the Earth's crust, being present to the extent of 310 parts per million (ppm). This places it just below carbon and chlorine and just above fluorine and strontium in abundance. Sea water contains 0.2 ppm of rubidium, which (although low) is twice the concentration of lithium. Rubidium is like lithium and cesium in that it is tied up in complex minerals; it is not available in nature as simple halide salts as are sodium and potassium.

Rubidium has a density of 1.53 g/cm<sup>3</sup> (95.5 lb/ft<sup>3</sup>, a melting point of 39°C (102°F), and a boiling point of 688°C (1270°F).

Rubidium is so reactive with oxygen that it will ignite spontaneously in pure oxygen. The metal tarnishes very rapidly in air to form an oxide coating, and it may ignite. The oxides formed are a mixture of Rb<sub>2</sub>O, Rb<sub>2</sub>O<sub>2</sub>, and RbO<sub>2</sub>. The molten metal is spontaneously flammable in air.

Rubidium reacts violently with water or ice at temperatures down to –100°C (–148°F). It reacts with hydrogen to form a hydride which is one of the least stable of the alkali hydrides. Rubidium does not react with nitrogen. With bromine or chlorine, rubidium reacts vigorously with flame formation. Organorubidium

compounds can be prepared by techniques similar to those used for sodium and potassium. See ALKALI METALS; CESIUM. [M.Si.]

**Ruby** The red variety of the mineral corundum, in its finest quality the most valuable of gemstones. Only medium to dark tones of red to slightly violet-red or very slightly orange-red are called rubies; light reds, purples, and other colors are properly called sapphires. In its pure form the mineral corundum, with composition Al<sub>2</sub>O<sub>3</sub>, is colorless. The rich red of fine-quality ruby is the result of the presence of a minute amount of chromic oxide. The chromium presence permits rubies to be used for lasers producing red light. See CORUNDUM; LASER; SAPPHIRE.

The finest ruby is the transparent type with a medium tone and a high intensity of slightly violet-red, which has been likened to the color of pigeon's blood. Star rubies do not command comparable prices, but they, too, are in great demand. The ruby was among the first of the gemstones to be duplicated synthetically and the first to be used extensively in jewelry. See GEM. [R.T.L.]

**Rugosa** An order of extinct corals which flourished during the Paleozoic Era. The Rugosa, or Tetracorallia, first appeared in the Ordovician and became extinct in the Permian. Nothing is known of the soft parts. Both simple and compound skeletons are common, the simple ones having typically a curved, horn-shaped appearance, and the compound ones forming groups of cylindrical stems or polygonal columns. The simple form is called a corallite, the compound one a corallum. See COELENTERATA. [E.C.Stu.]

**Runge vector** The Runge vector describes certain unchanging features of a nonrelativistic two-body interaction for which the potential energy is inversely proportional to the distance  $r$  between the bodies or, alternatively, in which each body exerts a force on the other that is directed along the line between them and proportional to  $r^{-2}$ . Two basic interactions in nature are of this type: the gravitational interaction between two masses (called the classical Kepler problem), and the Coulomb interaction between like or unlike charges (as in the hydrogen atom). Both at the classical level and the quantum-mechanical level, the existence of a Runge vector is a reflection of the symmetry inherent in the interaction. See COULOMB'S LAW; QUANTUM MECHANICS; SYMMETRY LAWS (PHYSICS). [D.M.Fr.]

**Running fit** The intentional difference in dimensions of mating mechanical parts that permits them to move relative to each other. A free running fit has liberal allowance; it is used on high-speed rotating journals or shafts. A medium fit has less allowance; it is used on low-speed rotating shafts and for sliding parts. Running fits are affected markedly by their surface finish and the effectiveness of lubrication. See ALLOWANCE. [P.H.B.]

**Rust (microbiology)** Plant diseases caused by fungi of the order Uredinales and characterized by the powdery and usually reddish spores produced. There are more than 4000 species of rust fungi. All are obligate parasites (require a living host) in nature, and each species attacks only plants of particular genera or species. Morphologically identical species that attack different host genera are further classified as special forms (*formae speciales*); for example, *Puccinia graminis* f. sp. *tritici* attacks wheat and *P. graminis* f. sp. *hordei* attacks barley. Each species or special form can have many physiological races that differ in their ability to attack different cultivars (varieties) of a host species. Rusts are among the most destructive plant diseases. Economically important examples include wheat stem rust, white pine blister rust, and coffee rust. See UREDINALES.

Rust fungi have complex life cycles, producing up to five different fruiting structures with distinct spore types that appear in a definite sequence. Macrocytic (long-cycled) rust fungi produce all five spore types, whereas microcytic (short-cycled) rust fungi produce only teliospores and basidiospores. Some

macrocytic rust fungi complete their life cycle on a single host and are called autoecious, whereas others require two different or alternate hosts and are called heteroecious. See FUNGI; PLANT PATHOLOGY. [E.A.M.]

**Rutabaga** The plant *Brassica napobrassica*, a cool-season, hardy biennial crucifer of European origin, belonging to the order Capparales and probably resulting from the natural crossing of cabbage and turnip. The fleshy roots are cooked and usually eaten mashed as a vegetable. Rutabagas have been widely grown as a livestock feed in northern Europe and eastern Canada. Commercial production is limited to Canada and the northern part of the United States. See CAPPARALES; TURNIP. [H.J.C.]

**Ruthenium** A chemical element, Ru, atomic number 44. The element is a brittle gray-white metal of low natural abundance, usually found alloyed with other platinum metals in nature. Ruthenium occurs as seven stable isotopes, and more than ten radioactive (unstable) isotopes are known. Four allotropes of the metal are known. Ruthenium is a hard white metal, workable only at elevated temperatures. It can be melted with an electric arc or an electron beam. See ISOTOPE; METAL; PERIODIC TABLE; RADIOISOTOPE; TRANSITION ELEMENTS.

The metal is not oxidized by air at room temperature, but it does oxidize to give a surface layer of ruthenium dioxide ( $\text{RuO}_2$ ) at about  $900^\circ\text{C}$  ( $1650^\circ\text{F}$ ); at about  $1000^\circ\text{C}$  ( $1830^\circ\text{F}$ ) the volatile compounds ruthenium tetroxide ( $\text{RuO}_4$ ) and ruthenium monoxide ( $\text{RuO}$ ) form, which can result in loss of the metal. Metallic ruthenium is insoluble in common acids and aqua regia up to  $100^\circ\text{C}$  ( $212^\circ\text{F}$ ). The principal properties of ruthenium ore given in the table. See AQUA REGIA.

Ruthenium is relatively rare, having a natural abundance in the Earth's crust of about 0.0004 part per million. It is always found in the presence of other platinum metals. The major commercial sources of the element are the native alloys osmiridium and iridosmium and the sulfide ore laurite. The element is also separated from other platinum metals by an intricate process, involving treatment with aqua regia (in which ruthenium, osmium, rhodium, and iridium are insoluble), to yield the pure metal.

Ruthenium is used commercially to harden alloys of palladium and platinum. The alloys are used in electrical contacts, jewelry, and fountain-pen tips. Application of ruthenium to industrial catalysis (hydrogenation of alkenes and ketones) and to automobile emission control (catalytic reduction of nitric oxide)

and detection have been active areas of research. In medicine, ruthenium complexes have attracted some attention as potential antitumor reagents and imaging reagents. Ruthenium tetroxide is finding increasing use as an oxidant for organic compounds. See CATALYSIS; CATALYTIC CONVERTER; HYDROGENATION; OSMIUM; PALLADIUM; PLATINUM; TECHNETIUM. [C.Cr.]

**Rutherfordium** A chemical element, symbol Rf, atomic number 104. Rutherfordium is the first element beyond the actinide series. In 1964 G. N. Flerov and coworkers at the Dubna Laboratories in Russia claimed the first identification of rutherfordium. A. Ghiorso and coworkers made a definitive identification at the Lawrence Radiation Laboratory, Berkeley, University of California, in 1969. See PERIODIC TABLE.

The Dubna group claimed the preparation of rutherfordium, mass number 260, by irradiating plutonium-242 with neon-22 ions in the heavy-ion cyclotron. The postulated nuclear reaction was  $^{242}\text{Pu} + ^{22}\text{Ne} \rightarrow ^{260}\text{Rf} + 4 \text{ neutrons}$ . By 1969 the Berkeley group had succeeded in discovering two alpha-emitting isotopes of rutherfordium with mass numbers 257 and 259 by bombarding  $^{249}\text{Cf}$  with  $^{12}\text{C}$  and  $^{13}\text{C}$  projectiles from the Berkeley heavy-ion linear accelerator (HILAC).

A number of years after the discovery at Berkeley, a team at Oak Ridge National Laboratory confirmed discovery of the isotope  $^{257}\text{Rf}$  by detecting the characteristic nobelium x-rays following alpha decay. See ACTINIDE ELEMENTS; NOBELIUM; TRANSURANIUM ELEMENTS. [A.Gh.]

**Rutile** The most frequent of the three polymorphs of titania,  $\text{TiO}_2$ ; the two other polymorphs are brookite and anatase.

The mineral occurs as striated tetragonal prisms and needles, commonly repeatedly twinned. The color is deep blood red, reddish brown, to black, rarely violet or yellow. Specific gravity is 4.2, and hardness 6.5 on Mohs scale. Melting point is  $1825^\circ\text{C}$  ( $3317^\circ\text{F}$ ).

Rutile occurs as an accessory in many rock types, ranging from plutonic to metamorphic rocks, and even as detrital material in sediments and placers because of its resistance to weathering. Large crystals have been found in some granite pegmatites; in Brazil it often occurs as inclusions in clear quartz crystals (rutiled quartz). Rutile is commonly associated with apatite in high-temperature veins. In sufficient quantities, it is marketed as an ore of titanium. See TITANIUM. [P.B.M.]

**Rydberg atom** An atom which possesses one valence electron orbiting about an atomic nucleus within an electron shell well outside all the other electrons in the atom. Such an atom approximates the hydrogen atom in that a single electron is interacting with a positively charged core. Early observations of atomic electrons in such Rydberg quantum states involved studies of the Rydberg series in optical spectra. Electrons jumping between Rydberg states with adjacent principal quantum numbers,  $n$  and  $n - 1$ , with  $n$  near 80 produce microwave radiation. Microwave spectral lines due to such electronic transitions in Rydberg atoms have been observed both in laboratory experiments and in the emissions originating from certain low-density partially ionized portions of the universe called HII regions. See ELECTRON CONFIGURATION; INTERSTELLAR MATTER; MICROWAVE.

The advent of the laser has made possible the production of sizable numbers of Rydberg atoms within a bulb containing gas at low pressures,  $10^{-2}$  torr (1.3 pascals) or less. The rapid energy-resonance absorption of several laser light photons by an atom in its normal or ground state results in a Rydberg atom in a state with a selected principal quantum number. Aggregates of Rydberg atoms have been used as sensitive detectors of infrared radiation, including thermal radiation. They have also been observed to collectively participate in spontaneous photon emission, called superradiance. Such aggregates form the active medium for infrared lasers that operate through the usual laser mechanism

#### Principal properties of ruthenium

Property	Value
Atomic number	44
Atomic weight	101.07
Crystal structure	Hexagonal close-packed
Lattice constant $a$ at $25^\circ\text{C}$ ( $77^\circ\text{F}$ ), nm	0.27056
$c/a$ at $25^\circ\text{C}$ ( $77^\circ\text{F}$ )	1.5820
Density at $25^\circ\text{C}$ ( $77^\circ\text{F}$ ), $\text{g/cm}^3$	12.37
Thermal neutron capture cross section, barns ( $10^{-28} \text{m}^2$ )	2.50
Melting point	$2310^\circ\text{C}$ ( $4190^\circ\text{F}$ )
Boiling point	$4080^\circ\text{C}$ ( $7380^\circ\text{F}$ )
Specific heat at $0^\circ\text{C}$ , cal/g (J/kg)	0.0551 (231)
Thermal conductivity, $0-100^\circ\text{C}$ , cal $\text{cm/cm}^2\text{ }^\circ\text{C}$	0.25
Linear coefficient of thermal expansion, $20-100^\circ\text{C}$ , $\mu\text{in.}/(\text{in.})^\circ\text{C}$ or $\mu\text{m}/(\text{m})^\circ\text{C}$	9.1
Electrical resistivity at $0^\circ\text{C}$ , microhm-cm	6.80
Temperature coefficient of electrical resistance, $0-100^\circ\text{C}/^\circ\text{C}$	0.0042
Tensile strength (annealed), $\text{kN} \cdot \text{m}^{-2}$	$4.96 \times 10^5$
Young's modulus at $20^\circ\text{C}$ ( $68^\circ\text{F}$ ), $\text{lb}/\text{in.}^2$ (Pa)	
Static	$60 \times 10^6$ ( $4.1 \times 10^{11}$ )
Dynamic	$69 \times 10^6$ ( $4.75 \times 10^{11}$ )
Vickers hardness number (diamond pyramid hardness)	200-350

of collective stimulated photon emission. All these developments are based upon the great sensitivity of Rydberg atoms to external electromagnetic radiation fields. Atoms with  $n$  near 40 can absorb almost instantaneously over a hundred microwave photons and become ionized at easily achievable microwave power levels. Isotope separation techniques have been developed that combine the selectivity of laser excitation of Rydberg states with the ready ionizability of Rydberg atoms. Such applications have been pursued for atoms ranging from deuterium through uranium. See INFRARED RADIATION; ISOTOPE SEPARATION; LASER. [J.E.B.]

**Rydberg constant** The most accurately measured of the fundamental constants; it is a universal scaling factor for any spectroscopic transition and an important cornerstone in the determination of other constants.

This constant was introduced empirically. J. Balmer's formula described the visible spectral lines of atomic hydrogen, while J. Rydberg's formula applied to the spectra of many elements. Their results may be summarized by Eq. (1), where  $\lambda$  is the wavelength

$$\frac{1}{\lambda} = R \left( \frac{1}{n_1^2} - \frac{1}{n_2^2} \right) \quad (1)$$

of the spectral line and  $R$  is a constant. In Balmer's account of the visible hydrogen spectrum,  $n_1$  was equal to 2, while  $n_2$  took on the integer values 3, 4, 5, and so forth. In Rydberg's more general work,  $n_1$  and  $n_2$  differed slightly from integer values. A remarkable result of Rydberg's work was that the constant  $R$  was the same for all spectral series he studied, regardless of the element. This constant  $R$  has come to be known as the Rydberg constant.

Applied to hydrogen, Niels Bohr's atomic model leads to Balmer's formula with a predicted value for the Rydberg constant given by Eq. (2), where  $m_e$  is the electron mass,  $e$  is the

$$R_\infty = \frac{m_e e^4}{8h^3 \epsilon_0^2 c} \quad (2)$$

electron charge,  $h$  is Planck's constant,  $\epsilon_0$  is the permittivity of vacuum, and  $c$  is the speed of light. The equation expresses the Rydberg constant in SI units. To express it in cgs units, the right-hand side must be multiplied by  $(4\pi\epsilon_0)^2$ . The subscript  $\infty$  means that this is the Rydberg constant corresponding to an infinitely massive nucleus.

E. Schrödinger's wave mechanics predicts the same energy levels as the simple Bohr model, but the relativistic quantum theory of P. A. M. Dirac introduces small corrections or fine-structure splittings. The modern theory of quantum electrodynamics predicts further corrections. Additional small hyperfine-structure corrections account for the interaction of the electron and nuclear magnetic moments. See FINE STRUCTURE (SPECTRAL LINES); HYPERFINE STRUCTURE; NONRELATIVISTIC QUANTUM.

The Rydberg constant is determined by measuring the wavelength or frequency of a spectral line of a hydrogenlike atom or ion. The highest resolution and accuracy has been achieved by the method of Doppler-free two-photon spectroscopy, which permits the observation of very sharp resonance transitions between long-living states. The 2002 adjustment of the fundamental constants, taking into account different measurements, adopted the value  $R_\infty = 10,973,731.568,525 \pm 0.000,073 \text{ m}^{-1}$  for the Rydberg constant. The measurements provide an important cornerstone for fundamental tests of basic laws of physics. See ATOMIC STRUCTURE AND SPECTRA; FUNDAMENTAL CONSTANTS; LASER; LASER SPECTROSCOPY. [T.W.Ha.; M.We.]

**Rye** A winter-hardy and drought-resistant cereal plant, *Secale cereale*, in the grass family (Graminae). It resembles wheat, with which it intercrosses to a limited extent. Rye is propagated almost completely by cross-pollination. The inflorescence is a spike or ear (see illustration). Spikelets are arranged flatwise against a zigzag rachis; they usually have two flowers, enclosed by a lemma and palea with two adjacent glumes. The young florets contain three stamens and a pistil. The fertilized pistil develops into a naked grain, or kernel, that is easily threshed. There are several recognized species of *Secale*, most of which have shattering spikes and small kernels. There are both perennial and winter-annual species of rye, with winter forms being favored over spring types for production. The only commercially cultivated species is the nonshattering *S. cereale*. See CYPERALES; GRASS CROPS; WHEAT.



Rye spikes or ears.

Rye is more important in Europe and Asia than in the Western Hemisphere. Russia is the leading world producer, followed by Poland and Germany. Canada and Argentina produce significant amounts, and Switzerland and northwest Europe have high yields. Rye production in the United States is mostly in South Dakota, North Dakota, Minnesota, and Georgia.

Rye grain is used for animal feed, human food, and production of spirits. Ground rye is mixed with other feeds for livestock. It is often fall-sown to provide soil cover and pasturage for livestock. Egg yolks of chickens and butter from cows fed on rye have a rich yellow color. See DISTILLED SPIRITS.

Compared to other small grains, rye has a fewer number of cultivars (agricultural varieties). Short-strawed types are gaining favor. Plant and kernel characteristics of rye are variable, partly because of cross-pollination. Height may range from 4 to 6 ft (120 to 180 cm) under moderately fertile conditions. Kernel color may be amber, gray, green, blue, brown, or black.

Tetraploid forms, whose chromosome number has been doubled, are available. Tetraploid wheat and rye have been hybridized and chromosomes doubled to form Triticales, which is increasing in usage. See BREEDING (PLANT); GRAIN CROPS. [H.L.S.]

Rye grain is milled into flour in a manner similar to that used for wheat flour. Variations are made based on the compositional and structural differences between these grains. Rye bread production requires blending of rye flours with wheat flours to provide sufficient dough strength. Specialty varieties of rye breads are classified according to ethnic origins or as sweet or sour doughs. Sour rye breads may be developed from natural lactic fermentations or through the incorporation of cultured milk. Swedish rye crisp breads are generally prepared from whole ground meal. See FOOD ENGINEERING. [M.A.U.]



**Sable** A carnivore, *Martes zibellina*, of the family Mustelidae, found in northern Asia from the Urals to Japan; it is a valuable fur-bearing animal and quite similar to the American marten. The sable obtains food by preying upon other arboreal animals, principally birds and small mammals. It is well adapted to these activities, with its slender, supple body and short limbs with five short toes on each foot that terminate in sharp curved claws. The long bushy tail serves as a balancing organ. Mating occurs in summer, and three or four young are born the following spring. See CARNIVORA; MARTEN. [C.B.C.]

**Saccharin** The sodium salt of *o*-sulfobenzimide, manufactured by processes that start with toluene or phthalic anhydride. The free imide, called insoluble saccharin because it is insoluble in water, has limited use as a flavoring agent in pharmaceuticals. The sodium and calcium salts are very soluble in water and are widely used as sweetening agents.

Sodium saccharin is 300–500 times sweeter than cane sugar (sucrose). The saccharin salts are used to improve the taste of pharmaceuticals and toothpaste and other toiletries, and as nonnutritive sweeteners in special dietary foods and beverages. Using noncaloric saccharin in place of sugar permits the formulation of low-calorie products for people on calorie-restricted diets and of low-sugar products for diabetics. See ASPARTAME. [K.M.B.]

**Sacoglossa** An order of the gastropod subclass Opisthobranchia containing a thousand living species of herbivorous sea

slugs; sometimes called Ascoglossa. They occur in all the oceans, at shallow depths, reaching their greatest size and diversity in tropical seas.

Members of this abundant order have two common features: the herbivorous habit (except for *Olea* and a species of *Stiliger* which eat the eggs of other mollusks) and the possession of a uniseriate radula in which the oldest, often broken, teeth are usually retained within the body, not discarded.

Sacoglossans possess varied shells; there may be a single shell, capacious and coiled (*Volvatella*, illus. a; *Cylindrobulla*), a flattened open dorsal shell (*Lobiger*), or two lateral shells (the bivalved gastropods, *Berthelinia*, illus. b). In the highest sacoglossans (*Elysia*, *Limapontia*) the true shell is completely lost after larval metamorphosis. The association between sacoglossan species and the algae of the sea bottom may be extraordinarily precise, as evidenced in the shallow waters of Florida. See OPISTHOBRANCHIA. [T.E.T.]

**Safety glass** A unitary structure formed of two or more sheets of glass between each of which is interposed a sheet of plastic, usually polyvinyl butyral. In usual manufacture, two clean and dry sheets of plate glass and a sheet of plastic are preliminarily assembled as a sandwich under slight pressure to produce a void-free bond. The laminate is then pressed under heat long enough to unite. For use in surface vehicles the finished laminated glass is approximately  $\frac{1}{4}$  in. (6 mm) thick; for aircraft it is thicker. See GLASS. [F.H.R.]

**Safety valve** A relief valve set to open at a pressure safely below the bursting pressure of a container, such as a boiler or compressed air receiver. Typically, a disk is held against a seat

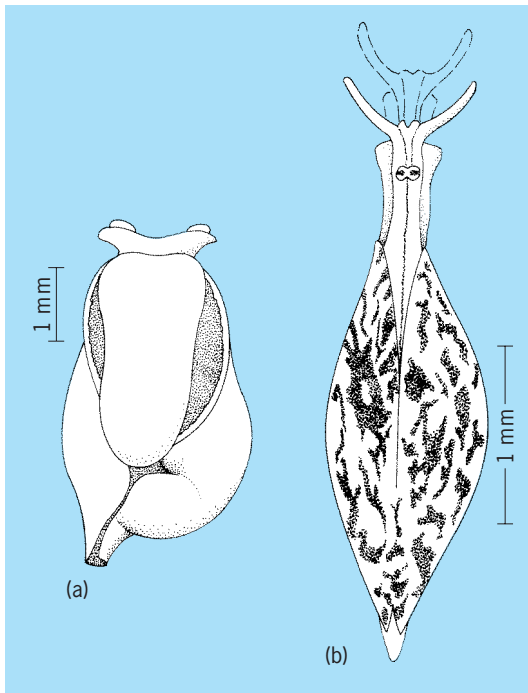

Representative sacoglossans: (a) *Volvatella*; (b) *Berthelinia*.

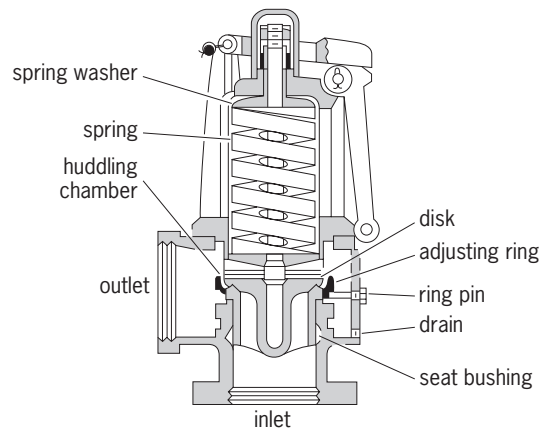

Diagram of a typical safety valve.

by a spring; excessive pressure forces the disk open (see illustration). Construction is such that when the valve opens slightly, the opening force builds up to open it fully and to hold the valve open until the pressure drops a predetermined amount.

## 1940 Safflower

This differential or blow-down pressure and the initial relieving pressure are adjustable. See VALVE. [T.Ba.]

**Safflower** An oilseed crop (*Carthamus tinctorius*) that is a member of the thistle (Compositae) family and produces its seed in heads. Flowers vary in color from white through shades of yellow and orange to red. The seed is shaped like a small sunflower seed, and is covered with a hull that may be white with a smooth surface or off-white to dark gray with a ridged surface. Depending on hull thickness, the oil content varies from 25 to 45%. Safflower is grown commercially in Mexico, Australia, and California. See ASTERALES.

There are two types of safflower oil, both with 6–8% palmitic acid and 1–2% stearic acid. One type, the standard or polyunsaturated type, has 76–79% linoleic acid and 11–17% oleic acid. This high-linoleic type has been used in soft margarines, in salad oils, and in the manufacture of paints and varnishes. It has had limited use for frying foods, because heat causes it to polymerize and form a tough film on the cooking vessel. The second type of oil, called the high-oleic-acid or monounsaturated type, has 76–79% oleic acid and 11–17% linoleic acid. Its fatty-acid composition is similar to that of olive oil, but the flavor is bland. High-oleic safflower oil is a premium frying oil. The meal left after the extraction of the oil may contain 20–45% protein, depending on the amount of hull removed from the seed before processing. The meal is used as a poultry and livestock feed. See FAT AND OIL (FOOD). [P.F.K.]

**Saffron** The plant *Crocus sativus*, a member of the iris family (Iridaceae). A native of Greece and Asia Minor, it is now cultivated in various parts of Europe, India, and China. This crocus is the source of a potent yellow dye used for coloring foods and medicine. The dye is extracted from the styles and stigmas of the flowers, which appear in autumn. It takes 4000 flowers to produce 1 oz (28 g) of the dye. See LILIALES. [P.D.St./E.L.C.]

**Sage** A shrubby perennial plant in the genus *Salvia* of the mint family (Lamiaceae). There are several species, including garden, or true, sage (*S. officinalis*), the sage most commonly used in foods. Many varieties of garden sage are known, but the Dalmatian type possesses the finest aroma. Garden sage is native to southern and eastern Europe, and is still cultivated extensively there and in the United States and Russia. It is a plant of low stature (2 ft or 60 cm), with hairy, oblong grayish-green leaves about 1½–2 in. (4–5 cm) long. Sage does best in warm, dry regions, with full sun.

To preserve the essential oil content and leaf color, sage is dried, as are most other herbs. Once dried, sage is separated from the stems and made available to consumers as whole, rubbed (crushed), or ground leaves. The dried leaves are among the most popular spices in western foods. Sage is highly aromatic and fragrant, with a pungent, slightly bitter and astringent taste. Both the dried leaves and essential oil of sage are used in flavoring and for antioxidant properties in cheeses, pickles, processed foods, vermouth, and bitters. See LAMIALES; SPICE AND FLAVORING. [S.Kr.]

**Sagittarius** The Archer, in astronomy, a zodiacal and summer constellation, the major portion of which lies directly in the Milky Way. Sagittarius is the ninth sign and the southernmost constellation of the zodiac (see illustration). In mythology, it is represented by a centaur, Chiron, drawing his bow to release an arrow. Its most prominent feature is a star group commonly called the Little Milk Dipper. The Milky Way in Sagittarius is very bright, containing rich star fields and clusters,

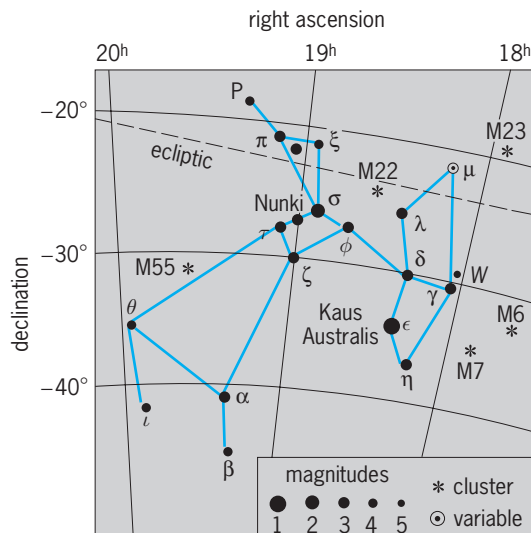

Line pattern of the constellation Sagittarius. The grid lines in the chart represent the coordinates of the sky. The apparent brightness, or magnitude, of the stars is shown by the sizes of the dots, which are graded by appropriate numbers as indicated.

because its direction lies in the center of the Milky Way stellar system. See CONSTELLATION. [C.S.Y.]

**Saint Elmo's fire** A type of corona discharge observed on ships under conditions approaching those of an electrical storm. The charge in the atmosphere induces a charge on the masts and other elevated structures. The result of this is a corona discharge which causes a spectacular glow around these points. See CORONA DISCHARGE. [G.H.M.]

**Salenioida** An order of Echinacea in which the apical system includes one or several large angular plates covering the periproct, with the other characters similar to those of the hemidicardoid urchins. There are two families: the Acrosaleniidae, an extinct group confined to the Jurassic and Cretaceous; and the Saleniidae, which ranged from the Jurassic onward, with two surviving deep-sea genera. See ECHINACEA. [H.B.F.]

**Salicales** An order of flowering plants, division Magnoliophyta (Angiospermae), in the subclass Dilleniidae of the class Magnoliopsida (dicotyledons). The order consists of the single family Salicaceae, with about 350 species. There are only two genera, *Salix* (willow) and *Populus* (poplar and cottonwood), the former by far the larger. The Salicales are dioecious, woody plants, with alternate, simple, stipulate leaves and much reduced flowers that are aggregated into catkins. The mature seeds are plumose-hairy and are distributed by the wind. See DILLENIIDAE; MAGNOLIOPSIDA; POPLAR; WILLOW. [A.Cr.]

**Salicylate** A salt or ester of salicylic acid having the general formula shown below and formed by replacing the carboxylic

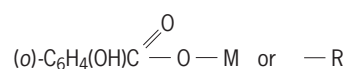

hydrogen of the acid by a metal (M) to give a salt or by an organic radical (R) to give an ester. Alkali-metal salts are water-soluble; the others, insoluble. Sodium salicylate is used in medicines as an antirheumatic and antiseptic, in the manufacture of dyes, and

as a preservative (illegal in foods). Salicylic acid is used in the preparation of aspirin. The methyl ester is the chief component of oil of wintergreen. This ester is used in pharmaceuticals as a component of rubbing liniment. It is also used as a flavoring agent and an odorant. See ASPIRIN. [E.H.H.]

**Saline evaporites** Deposits of bedded sedimentary rocks composed of salts precipitated during solar evaporation of surface or near-surface brines derived from seawater or continental waters. Dominant minerals in ancient evaporite beds are anhydrite (along with varying amounts of gypsum) and halite, which make up more than 85% of the total sedimentary evaporite salts. Many other salts make up the remaining 15%; their varying proportions in particular beds can be diagnostic of the original source of the mother brine. See ANHYDRITE; EVAPORATION; GYPSUM; HALITE; SALT (CHEMISTRY); SEAWATER; SEDIMENTARY ROCKS.

Today, brines deposit their salts within continental playas or coastal salt lakes and lay down beds a few meters thick and tens of kilometers across. In contrast, ancient, now-buried evaporite beds are often much thicker and wider; they can be up to hundreds of meters thick and hundreds of kilometers wide. Most ancient evaporites were formed by the evaporation of saline waters within hyperarid areas of huge seaways typically located within arid continental interiors. The inflow brines in such seaways were combinations of varying proportions of marine and continental ground waters and surface waters. There are few modern depositional counterparts to these ancient evaporites, and none to those beds laid down when whole oceanic basins dried up, for example, the Mediterranean some 5.5 million years ago. See BASIN; DEPOSITIONAL SYSTEMS AND ENVIRONMENTS; MEDITERRANEAN SEA; PLAYA.

Evaporite salts precipitate by the solar concentration of seawater, continental water, or hybrids of the two. The chemical makeup, salinity (35‰), and the proportions of the major ions in modern seawater are near-constant in all the world's oceans, with sodium (Na) and chloride (Cl) as the dominant ions and calcium (Ca) and sulfate (SO<sub>4</sub>) ions present in smaller quantities [Na(Ca)SO<sub>4</sub>Cl brine]. Halite and gypsum anhydrites have been the major products of seawater evaporation for at least the past 2 billion years, but the proportions of the more saline minerals, such as sylvite/magnesium sulfate (MgSO<sub>4</sub>) salts, appear to have been more variable. See CALCIUM; CHLORINE; ION; MAGNESIUM; SODIUM; SULFUR. [J.Wa.]

**Salmonellosis** Diseases caused by *Salmonella*. These include enteritis and septicemia with or without enteritis. *Salmonella typhi*, *S. paratyphi A*, *B*, and *C*, and occasionally *S. cholerae suis* cause particular types of septicemia called typhoid and paratyphoid fever, respectively; while all other types may cause enteritis or septicemia, or both together.

Typhoid fever has an incubation period of 5–14 days. It is typified by a slow onset with initial bronchitis, diarrhea or constipation, a characteristic fever pattern (increase for 1 week, plateau for 2 weeks, and decrease for 2–3 weeks), a slow pulse rate, development of rose spots, swelling of the spleen, and often an altered consciousness; complications include perforation of the bowel and osteomyelitis. Typhoid fever leaves the individual with a high degree of immunity. Vaccination with an oral vaccine gives an individual considerable protection for about 3 years. The only effective antibiotic is chloramphenicol. See ANTIBIOTIC; IMMUNITY; VACCINATION.

Paratyphoid fever has a shorter course and is generally less severe than typhoid fever. Vaccination is an ineffective protective measure.

Enteric fevers, that is, septicemias due to types of *Salmonella* other than those previously mentioned, are more frequent in the United States than typhoid and paratyphoid fever but much less

frequent than *Salmonella* enteritis. In children and in previously healthy adults, enteric fevers are most often combined with enteritis and have a favorable outlook. The organisms involved are the same as those causing *Salmonella* enteritis. Chloramphenicol or ampicillin are used in treatment. However, resistant strains have been observed. See DRUG RESISTANCE.

Inflammation of the small bowel due to *Salmonella* is one of the most important bacterial zoonoses. The most frequent agents are *S. typhimurium*, *S. enteritidis*, *S. newport*, *S. heidelberg*, *S. infantis*, and *S. derby*. The incubation period varies from 6 h to several days. Diarrhea and fever are the main symptoms; the intestinal epithelium is invaded, and early bacteremia is probable. Predisposed are persons with certain preexisting diseases (the same as for enteric fevers), very old and very young individuals, and postoperative patients. Antimicrobial treatment serves only to prolong the carrier state and has no effect on the disease. [A.W.C.V.G.]

**Salmoniformes** An order of soft-rayed fishes comprising salmon and their allies. They make up the stem group from which most higher teleostean fishes have evolved.

Salmoniformes are generalized fishes characterized by soft or articulated fin rays; adipose dorsal fin usually present; cycloid (smooth) scales; pelvic fin in an abdominal position (well back on the trunk), usually with more than six rays, and with pelvic girdle free from pectoral girdle; pectoral fin placed low on the side and more or less horizontal; upper jaw usually bordered by premaxillae and maxillae; premaxillae not protractile; no Weberian apparatus connecting the swim bladder with the inner ear, but a duct joining the bladder with the gut; and branchiostegal rays variable in number and arrangement.

Salmoniform fishes have an imperfect fossil record; they were present in the Cretaceous and likely earlier. The order consists of 8 suborders, 37 families, some 212 genera, and about 950 species. Most are marine fishes, and they are common in all seas. A few are adapted to pelagic or shore waters, most live in the bathypelagic zone, some tolerate arctic seas, and many inhabit warm or cold fresh water, or are anadromous; that is, they enter fresh water to reproduce.

The suborder Salmonoidei includes many of the most important and best known of all fishes, especially in the family Salmonidae, or salmon, trouts, whitefishes, and graylings. The Argentinoidei (argentines, deep-sea smelts, and related fishes), Alepocephaloidei (slickeheads), and Bathylaconoidei are found chiefly in deep marine waters. The Galaxioidei are mostly small, fresh-water fishes of south temperate lands, especially Australia and New Zealand. Esocoidei are a small group, the pikes and mudminnows of northern fresh waters. The Stomiatoidei, lightfishes and allies, inhabit the middle depths of the oceans. They are of small size and often grotesque form, and are equipped with photophores. The Myctophoidei is the largest of the suborders. All species are marine; some, including lizardfishes, inhabit shore waters, but the majority are oceanic. Those that live at moderate to considerable depths, such as the lantern fishes, commonly have photophores on the head and body. See PHOTOPHORE; TELEOSTEI. [R.M.B.]

**Salt (chemistry)** A compound formed when one or more of the hydrogen atoms of an acid are replaced by one or more cations of the base. The common example is sodium chloride in which the hydrogen ions of hydrochloric acid are replaced by the sodium ions (cations) of sodium hydroxide. There is a great variety of salts because of the large number of acids and bases which has become known.

Salts are classified in several ways. One method—normal, acid, and basic salts—depends upon whether all the hydrogen ions of the acid or all the hydroxide ions of the base have been replaced:

## 1942 Salt (food)

Class	Examples
Normal salts	NaCl, NH <sub>4</sub> Cl, Na <sub>2</sub> SO <sub>4</sub> , Na <sub>2</sub> CO <sub>3</sub> , Na <sub>3</sub> PO <sub>4</sub> , Ca <sub>3</sub> (PO <sub>4</sub> ) <sub>2</sub>
Acid salts	NaHCO <sub>3</sub> , NaH <sub>2</sub> PO <sub>4</sub> , Na <sub>2</sub> HPO <sub>4</sub> , NaHSO <sub>4</sub>
Basic salts	Pb(OH)Cl, Sn(OH)Cl

The other method—simple salts, double salts (including alums), and complex salts—depends upon the character of completeness of the ionization:

Class	Examples
Simple salts	NaCl, NaHCO <sub>3</sub> , Pb(OH)Cl
Double salts	KCl·MgCl <sub>2</sub>
Alums	KAl(SO <sub>4</sub> ) <sub>2</sub> , NaFe(SO <sub>4</sub> ) <sub>2</sub> , NH <sub>4</sub> Cr(SO <sub>4</sub> ) <sub>2</sub>
Complex salts	K <sub>3</sub> Fe(CN) <sub>6</sub> , Cu(NH <sub>3</sub> ) <sub>4</sub> Cl <sub>2</sub> , K <sub>2</sub> Cr <sub>2</sub> O <sub>7</sub>

See ACID AND BASE; CHEMICAL BONDING.

[A.B.G.]

**Salt (food)** The chemical compound sodium chloride. It is used extensively in the food industry as a preservative and flavoring, as well as in the chemical industry to make chlorine and sodium. See CHLORINE; FOOD PRESERVATION; SALT (CHEMISTRY); SODIUM.

Salt was originally made by evaporating sea water (solar salt). This method is still in common usage; however, impurities in solar salt make it unsatisfactory for most commercial uses, and these impurities also lead to clumping. Salt, freshly produced from sea-water evaporation ponds, may contain large numbers of halophilic (salt-loving) microorganisms. In the United States refined salt is obtained from underground mines located in Michigan and Louisiana. Salt is usually handled during the refining processes as brine.

Salt is liable to clumping during periods of high humidity, so preventives are added. Materials used include magnesium carbonate and certain silicates. Iodides are added in those areas where iodine deficiencies exist.

[R.E.M.]

**Salt dome** An upwelling of crystalline rock salt and its areole of deformed sediments. A salt pillow is an immature salt dome comprising a broad salt swell draped by concordant strata. A salt stock is a more mature, pluglike diapir of salt that has pierced, or appears to have pierced, overlying strata. Most salt stocks are 0.6–6 mi (1–10 km) wide and high. Salt domes are closely related to other salt upwellings, some of which are much larger. Salt canopies, which form by coalescence of salt domes and tongues, can be more than 200 mi (300 km) wide. See DIAPIR.

Exploration for oil and gas has revealed salt domes in more than 100 sedimentary basins that contain rock salt layers several hundred meters or more thick. The salt was precipitated from evaporating lakes in rift valleys, intermontaine basins, and especially along divergent continental margins. Salt domes are known in every ocean and continent. See BASIN.

Salt domes consist largely of halite (NaCl, common table salt). Other evaporites, such as anhydrite (CaSO<sub>4</sub>) and gypsum (CaSO<sub>4</sub>·2H<sub>2</sub>O), form thinner layers within the rock salt. See HALITE; SALINE EVAPORITES.

Salt domes supply industrial commodities, including fuel, minerals, chemical feedstock, and storage caverns. Giant oil or gas fields are associated with salt domes in many basins around the world, especially in the Middle East, North Sea, and South Atlantic regions. Salt domes are also used to store crude oil, natural gas (methane), liquefied petroleum gas, and radioactive or toxic wastes. See OIL AND GAS STORAGE.

[M.P.A.J.]

**Salt-effect distillation** A process of extractive distillation in which a salt that is soluble in the liquid phase of the system being separated is used in place of the normal liquid ad-

ditive introduced to the extractive distillation column in order to effect the separation.

Extractive distillation is a process used to separate azeotrope-containing systems or systems in which relative volatility is excessively low. An additive, or separating agent, that is capable of raising relative volatility and eliminating azeotropes in the system being distilled is supplied to the column, where it mixes with the feed components and exerts its effect. The agent is subsequently recovered from one or both product streams by a separate process and recycled for reuse. See AZEOTROPIC MIXTURE.

In salt-effect distillation, the process is essentially the same as for a liquid agent, although the subsequent process used to recover the agent for recycling is different; that is, evaporation is used rather than distillation. The salt is added to the system by being dissolved in the reentering reflux stream at the top of the column. Being nonvolatile, it will reside in the liquid phase, flowing down the column and out in the bottom product stream.

The major commercial use of salt-effect distillation is in the concentration of aqueous nitric acid, using the salt magnesium nitrate as the separating agent. Other commercial applications include acetone-methanol separation using calcium chloride and isopropanol-water separation using the same salt. See AZEOTROPIC DISTILLATION; DISTILLATION.

[W.F.F.]

**Salt gland** A specialized gland located around the eyes and nasal passages in marine turtles, snakes, and lizards, and in birds such as the petrels, gulls, and albatrosses, which spend much time at sea. In the marine turtle it is an accessory lacrimal gland which opens into the conjunctival sac. In seagoing birds and in marine lizards it opens into the nasal passageway. Salt glands copiously secrete a watery fluid containing a high percentage of salt, higher than the salt content of urine in these species. As a consequence, these animals are able to drink salt-laden sea water without experiencing the dehydration necessary to eliminate the excess salt via the kidney route. See GLAND.

[O.E.N.]

**Salt marsh** A maritime habitat characterized by grasses, sedges, and other plants that have adapted to continual, periodic flooding. Salt marshes are found primarily throughout the temperate and subarctic regions.

The tide is the dominating characteristic of a salt marsh. The salinity of the tide defines the plants and animals that can survive in the marsh area. The vertical range of the tide determines flooding depths and thus the height of the vegetation, and the tidal cycle controls how often and how long vegetation is submerged. Two areas are delineated by the tide: the low marsh and the high marsh. The low marsh generally floods and drains twice daily with the rise and fall of the tide; the high marsh, which is at a slightly higher elevation, floods less frequently. See MANGROVE.

Salt marshes usually are developed on a sinking coastline, originating as mud flats in the shallow water of sheltered bays, lagoons, and estuaries, or behind sandbars. They are formed where salinity is high, ranging from 20 to 30 parts per thousand of sodium chloride. Proceeding up the estuary, there is a transitional zone where salinity ranges from 20 to less than 5 ppt. In the upper estuary, where river input dominates, the water has only a trace of salt. This varying salinity produces changes in the marsh—in the kinds of species and also in their number. Typically, the fewest species are found in the salt marsh and the greatest number in the fresh-water tidal marsh. See ESTUARINE OCEANOGRAPHY.

The salt marsh is one of the most productive ecosystems in nature. In addition to the solar energy that drives the photosynthetic process of higher rooted plants and the algae growing on the surface muds, tidal energy repeatedly spreads nutrient-enriched waters over the marsh surface. Some of this enormous supply of live plant material may be consumed by marsh animals, but the most significant values are realized when the vegetation dies and is decomposed by microorganisms to form detritus. Dissolved organic materials are released, providing an essential energy source for bacteria that mediate wetland biogeochemical



cycles (carbon, nitrogen, and sulfur cycles). See BIOGEOCHEMISTRY; BIOLOGICAL PRODUCTIVITY.

The salt marsh serves as a sediment sink, a nursery habitat for fishes and crustaceans, a feeding and nesting site for waterfowl and shorebirds, a habitat for numerous unique plants and animals, a nutrient source, a reservoir for storm water, an erosion control mechanism, and a site for esthetic pleasures. Appreciation for the importance of salt marshes has led to federal and state legislation aimed at their protection. [F.C.D.]

**Salviniales** A small order of heterosporous, leptosporangiate ferns (division Polypodiophyta) which float on the surface of the water. The delicate, branching stem is provided with small, simple to bifid or more or less dissected leaves. The sporangia are enclosed in specialized appendages of the leaves, called sporocarps. The order contains only a single family, with two widely distributed genera, *Salvinia* and *Azolla*, with only about 20 species in all. See POLYPODIOPHYTA. [A.Cr.]

**Samarium** A chemical element, Sm, atomic number 62, belonging to the rare-earth group. Its atomic weight is 150.35, and there are 7 naturally occurring isotopes;  $^{147}\text{Sm}$ ,  $^{148}\text{Sm}$ , and  $^{149}\text{Sm}$  are radioactive and emit  $\alpha$  particles. See PERIODIC TABLE.

Samarium oxide is pale yellow, is readily soluble in most acids, and gives topaz-yellow salts in solutions. Samarium has found rather limited use in the ceramic industry, and it is used as a catalyst for certain organic reactions. One of its isotopes has a very high cross section for the capture of neutrons, and therefore there has been some interest in samarium in the atomic industry for use as control rods and nuclear poisons. See LANTHANUM; RARE-EARTH ELEMENTS. [F.H.Sp.]

**Sampled-data control system** A type of digital control system in which one or more of the input or output signals is a continuous, or analog, signal that has been sampled. There are two aspects of a sampled signal: sampling in time and quantization in amplitude. Sampling refers to the process of converting an analog signal from a continuously valued range of amplitude values to one of a finite set of possible numerical values. This sampling typically occurs at a regular sampling rate, but for some applications the sampling may be aperiodic or random.

While the device to be controlled is usually referred to as the plant, sampled-data control systems are also used to control processes. The term plant refers to machines or mechanical devices which can usually be mathematically modeled by an analysis of their kinematics, such as a robotic arm or an engine. A process refers to a system of operations such as a batch reactor for the production of a particular chemical, or the operation of a nation's economy. The output of the plant which is to be controlled is called the controlled variable. A regulator is one type of sampled-data control system, and its purpose is to maintain the controlled variable at a preset value (for example, the robotic arm at a particular position, or an airplane turboprop engine at a constant speed) or the process at a constant value (for example, the concentration of an acid, or the inflation rate of an economy). This input is called the reference or setpoint. The second type of sampled-data control system is a servomechanism, whose purpose is to make the controlled variable follow an input variable. Examples of servomechanisms are a robotic arm used to paint automobiles which may be required to move through a predefined path in three-dimensional space while holding the sprayer at varying angles, an automobile engine which is expected to follow the input commands of the driver, a chemical process that may require the pH of a batch process to change at a specified rate, and an economy's growth rate which is to be changed by altering the money supply. See ANALOG-TO-DIGITAL CONVERTER; PROCESS CONTROL; REGULATOR; SERVOMECHANISM.

The analog-to-digital converter changes the sampled signal into a binary number so that it can be used in calculations by the digital compensator. Since a digital controller computes the

control signal used to drive the plant, a digital-to-analog converter must be used to change this binary number to an analog voltage. The digital compensator in the typical sampled-data control system takes the digitized values of the analog feedback signals and combines them with the setpoint or desired trajectory signals to compute a digital control signal, to actuate the plant through the digital-to-analog converter. A compensator is used to modify the feedback signals in such a way that the dynamic performance of the plant is improved relative to some performance index. See CONTROL SYSTEMS; DIGITAL COMPUTER; DIGITAL CONTROL; DIGITAL-TO-ANALOG CONVERTER. [K.J.Hi.]

**Sand** Unconsolidated granular material consisting of mineral, rock, or biological fragments between 63 micrometers and 2 mm in diameter. Finer material is referred to as silt and clay; coarser material is known as gravel. Sand is usually produced primarily by the chemical or mechanical breakdown of older source rocks, but may also be formed by the direct chemical precipitation of mineral grains or by biological processes. Accumulations of sand result from hydrodynamic sorting of sediment during transport and deposition. See CLAY MINERALS; DEPOSITIONAL SYSTEMS AND ENVIRONMENTS; GRAVEL; MINERAL; ROCK; SEDIMENTARY ROCKS.

Most sand originates from the chemical and mechanical breakdown, or weathering, of bedrock. Since chemical weathering is most efficient in soils, most sand grains originate within soils. Rocks may also be broken into sand-size fragments by mechanical processes, including diurnal temperature changes, freeze-thaw cycles, wedging by salt crystals or plant roots, and ice gouging beneath glaciers. See WEATHERING PROCESSES.

Because sand is largely a residual product left behind by incomplete chemical and mechanical weathering, it is usually enriched in minerals that are resistant to these processes. Quartz not only is extremely resistant to chemical and mechanical weathering but is also one of the most abundant minerals in the Earth's crust. Many sands dominantly consist of quartz. Other common constituents include feldspar, and fragments of igneous or metamorphic rock. Direct chemical precipitation or hydrodynamic processes can result in sand that consists almost entirely of calcite, glauconite, or dense dark-colored minerals such as magnetite and ilmenite. See FELDSPAR; QUARTZ.

Although sand and gravel has one of the lowest average per ton values of all mineral commodities, the vast demand makes it among the most economically important of all mineral resources. Sand and gravel is used primarily for construction purposes, mostly as concrete aggregate. Pure quartz sand is used in the production of glass, and some sand is enriched in rare commodities such as ilmenite (a source of titanium) and in gold. See CONCRETE. [M.J.J.]

**Sand dollar** An echinoderm belonging to the order Clypeasteroidea in the class Echinoidea. Sand dollars have a flat, disk-shaped body, with the mouth in a mid-ventral position and with the anus also on the ventral surface. There are several species.

Sand dollars live in sand, on the surface or partly buried, from the low-tide mark to depths of 4800 ft (1460 m). Burrowing and locomotion are assisted by the short spines which cover the body. Sand dollars ingest sand grains covered with diatoms or other algae. See CLYPEASTEROIDA. [C.B.C.]

**Sandalwood** The name applied to any species of the genus *Santalum* of the sandalwood family (Santalaceae). However, the true sandalwood is the hard, close-grained, aromatic heartwood of a parasitic tree, *S. album*, of the Indo-Malayan region. This fragrant wood is used in ornamental carving, cabinet work, and as a source of certain perfumes. The odor of the wood is an insect repellent, and on this account the wood is much used in making boxes and chests. The fragrant wood of a number of

species in other families bears the same name, but none of these is the real sandalwood. See SANTALALES. [P.D.St./E.L.C.]

**Sandstone** A clastic sedimentary rock comprising an aggregate of sand-sized (0.06–2.0-mm) fragments of minerals, rocks, or fossils held together by a mineral cement. Sandstone forms when sand is buried under successive layers of sediment. During burial the sand is compacted, and a binding agent such as quartz, calcite, or iron oxide is precipitated from ground water which moves through passageways between grains. Sandstones grade upward in grain size into conglomerates and breccias; they grade downward in size into siltstones and shales. When the proportion of fossil fragments or carbonate grains is greater than 50%, sandstones grade into clastic limestones. See BRECCIA; CONGLOMERATE; LIMESTONE; SAND; SHALE.

The basic components of a sandstone are framework grains (sand particles), which supply the rock's strength; matrix or mud-sized particles, which fill some of the space between grains; and crystalline cement. The composition of the framework grains reveals much about the history of the derivation of the sand grains, including the parent rock type and weathering history of the parent rock. Textural attributes of sandstone are the same as those for sand, and they have the same genetic significance. See SAND. [L.J.S.]

Sandstones are classified according to the relative proportion of quartz to other grain types, and according to the ratio of feldspar grains to finely crystalline lithic fragments. Quartz-rich sandstones are commonly called quartz-arenite. Sandstones poor in quartz are commonly called arkose, when feldspar grains are more abundant than lithic fragments, and litharenite (or graywacke) when the reverse is true. Subarkose and sublitharenite (or subgraywacke) refer to analogous sandstones of intermediate quartz content. Sandstones composed dominantly of calcareous grains are called calcarenite, and represent a special variety of limestone. Other sandstones composed exclusively of volcanic debris are called volcanic sandstone, and are gradational, through the interplay of eruptive and erosional processes, to tuff, the fragmental volcanic rocks produced by the disintegration of magma during explosive volcanic eruptions. SeeARENACEOUS ROCKS; ARKOSE; FELDSPAR; GRAYWACKE; QUARTZ; TUFF. [W.R.D.]

Because sandstone can possess up to 35% connected pore space, it is the most important reservoir rock in the Earth's crust. In the future sandstone may serve as a reservoir into which hazardous fluids, such as nuclear wastes, are injected for storage. See HAZARDOUS WASTE.

Sandstone which is easily split (flagstone) and has an attractive color is used as a building stone. Sandstone is also an important source of sand for the glass industry and the construction industry, where it is used as a filler in cement and plaster. Crushed sandstone is used as road fill and railroad ballast. Silica-cemented sandstone is used as firebrick in industrial furnaces. Some of the most extensive deposits of uranium are found in sandstones deposited in ancient stream channels. See GLASS; SEDIMENTARY ROCKS; STONE AND STONE PRODUCTS; URANIUM. [L.J.S.]

**Santalales** An order of flowering plants, division Magnoliophyta (Angiospermae), in the subclass Rosidae of the class Magnoliopsida (dicotyledons). The order consists of 10 families and about 2000 species. The largest families are the Loranthaceae (about 900 species), Santalaceae (about 400 species), Viscaceae (about 350 species), and Olacaceae (about 250 species). A few of the more primitive members of the Santalales are autotrophic, but otherwise the order is characterized by progressive adaptation to parasitism, accompanied by progressive simplification of the ovules. Some members of the Santalales, such as sandalwood (*Santalum album*, a small tree of southern Asia), are rooted in the ground and produce small branch roots which invade and parasitize the roots of

other plants. Others, such as mistletoe (*Viscum* and other genera of the Viscaceae), grow on trees, well above the ground. See FLOWER; MAGNOLIOPHYTA; MAGNOLIOPSIDA; MISTLETOE; SANDALWOOD. [A.Cr.; T.M.Ba.]

**Sapindales** An order of flowering plants, division Magnoliophyta (Angiospermae), in the subclass Rosidae of the class Magnoliopsida (dicotyledons). The order consists of 15 families and about 5400 species. The largest families are the Rutaceae (about 1500 species), Sapindaceae (about 1500 species), Meliaceae (about 550 species), Anacardiaceae (about 600 species), and Burseraceae (about 600 species). Most of the Sapindales are woody plants, with compound or lobed leaves and polypetalous, hypogynous to perigynous flowers with one or two sets of stamens and only one or two ovules in each locule of the ovary. A large proportion of the species have glandular cavities in the leaves, or resin ducts in the bark and wood, or other sorts of secretory structures.



Poison ivy (*Toxicodendron radicans*), a characteristic member of the family Anacardiaceae in the order Sapindales, division Magnoliophyta. (John Gerard, *National Audubon Society*)

Some of the Anacardiaceae, including poison ivy (*Toxicodendron radicans*; see illustration) and the lacquer tree (*T. vernicifluum*) of the Orient, are notoriously allergenic to humans. Some other well-known members of the order are orange, lemon, lime, and grapefruit (all species of *Citrus* in the Rutaceae); the various kinds of maple (*Acer*, in the Aceraceae); and the horse chestnut (*Aesculus hippocastanum*, in the Hippocastanaceae). See BUCKEYE; CASHEW; CITRON; GRAPEFRUIT; KUMQUAT; LEMON; LIGNUMVITAE; LIME (BOTANY); MAGNOLIOPHYTA; MAGNOLIOPSIDA; MAHOGANY; MANDARIN; MAPLE; ORANGE; PISTACHIO; POISON IVY; QUEBRACHO; TANGERINE; VARNISH TREE. [A.Cr.; T.M.Ba.]

**Sapphire** The name given to all gem varieties of the mineral corundum, except those that have medium to dark tones of red that characterize ruby. Although the name sapphire is most commonly associated with the blue variety, there are many other colors of gem corundum to which sapphire is applied correctly; these include yellow, brown, green, pink, orange, purple, colorless, and black. Sapphire has a hardness of 9, a specific gravity near 4.00, and refractive indices of 1.76–1.77. Asterism, the star effect, is the result of reflections from tiny, lustrous, needlelike

inclusions of the mineral rutile, plus a domed form of cutting. See CORUNDUM; GEM; RUBY; RUTILE. [R.T.L.]

**Sapropel** A term originally defined as an aquatic sediment rich in organic matter that formed under reducing conditions (lack of dissolved oxygen in the water column) in a stagnant water body. Such inferences about water-column dissolved-oxygen contents are not always easy to make for ancient environments. Therefore, the term sapropel or sapropelic mud has been used loosely to describe any discrete black or dark-colored sedimentary layers (>1 cm or 0.4 in. thick) that contain greater than 2 wt % organic carbon. Sapropels may be finely laminated (varved) or homogeneous, and may less commonly exhibit structures indicating reworking or deposition of the sediment by currents. Sapropels largely contain amorphous organic matter derived from planktonic organisms (such as planktonic or benthic algae in lakes or plankton in marine settings). Such organic matter possesses a large hydrogen-to-carbon ratio; therefore, sapropelic sequences are potential petroleum-forming deposits. The enhanced preservation of amorphous organic matter in sapropels may indicate conditions of exceptionally great surface-water productivity, extremely low bottom-water dissolved-oxygen contents, or both. Some sapropels may, however, contain substantial amounts of organic matter derived from land plants. See ANOXIC ZONES; MARINE SEDIMENTS; ORGANIC GEOCHEMISTRY; PETROLEUM; VARVE. [M.A.Ar.]

**Sarcodina** A superclass of Protozoa (in the subphylum Sarcomastigophora) in which movement involves protoplasmic flow, often with recognizable pseudopodia. Gametes may be flagellated, as in certain Foraminiferida. Most species are floating or creeping; a few are sessile. The pellicle is relatively thin, and the body is apt to be plastic unless restrained by skeletal structures. Sarcodina live in fresh, brackish, or salt waters; soil or sand; and as endoparasites in animals and plants. A group may be limited to a specific habitat, but many have a rather wide range. Sarcodina include two major classes: Rhizopodea and Actinopodea. See ACTINOPODEA; RHIZOPODEA; SARCOMASTIGOPHORA. [R.P.H.]

**Sarcomastigophora** A subphylum of Protozoa, including those forms that possess flagella or pseudopodia or both. Organisms have a single type of nucleus, except the developmental stages of some Foraminiferida. Sexuality, if present, is syngamy, the fusion of two gametes. Spores typically are not formed. Flagella may be permanent or transient or confined to a certain stage in the life history; this is true also of pseudopodia. Both flagella and pseudopodia may be present at the same time.

Three superclasses are included: (1) Mastigophora, commonly flagellates, contains 19 orders. (2) Opalinata includes 1 order; these organisms were once considered as ciliates, but further research has indicated flagellate kinships. (3) Sarcodina comprises organisms which normally possess pseudopodia and are flagellated only in the developmental stages; 13 orders possess irregularly distributed lobose or filose and branching pseudopodia, while 7 orders have radially distributed axopodia, often with axial filaments. See MASTIGOPHORA; SARCODINA.

Most of the plant flagellates will live in either fresh water or in both fresh and salt water. The zooflagellates are small and are not sufficiently abundant to enter markedly into the food chain. But the parasites and symbionts are of considerable interest economically and theoretically, for example, the trypanosomes and the peculiar xylophagous (wood-eating) symbionts of termites. In the termites these parasites actually digest the wood eaten by the host. Conspicuous in the ecology of marine waters are the dinoflagellates, radiolarians, and acantharians, especially in tropical waters of otherwise low productivity. See PROTOZOA. [J.B.L.]

**Sarcopterygii** A name often employed to unite the lobe-fin, or crossopterygian, fishes and the lungfishes as a subclass of the Osteichthyes. The older names Amphibioidei and Cho-

anichthyes are equivalent to Sarcopterygii. The structural differences between lobe-fin fishes and lungfishes are great, and their common ancestry, if any, lies in the Lower Devonian, long antedating the origin of the earliest tetrapods which have since diverged into four classes. It seems best to rank the Crossopterygii (lobe-fins) and Dipnoi (lungfishes) each equivalent in rank to the subclass Actinopterygii (rayfin fishes), in which the vast majority of fishes are classified. See ACTINOPTERYGII; CROSSOPTERYGII; DIPNOI; OSTEICHTHYES. [R.M.B.]

**Sarcoptiformes** One of the five suborders of the order Acarina. These are minute (0.012–0.06 in. or 0.3–1.5 mm long) globular mites without stigmata, but there may be a tracheal system. The legs may be simple, or enlarged in the male, and may terminate in suckers, claws, or in a modification of both; their coxae form subdermal apodemes on the venter. The chelicerae are normally pincerlike. In normal development these creatures pass through four stages (larva and first, second, and third nymphal stages) before becoming adult. Under certain conditions a dispersal form, the hypopus, may develop between the first and second nymphal stages.

This group can be separated rather easily into the pale, weakly sclerotized Acaridae and the dark, heavily sclerotized Oribatei. The former group includes such economically significant forms as the free-living grain and cheese mites, parasitic itch mites, and feather mites, while the latter group includes the oribatid mites, all of which are free-living, though some act as intermediate hosts of tapeworms. See ACARI. [H.H.J.N.]

**Sarcosporida** An order of Protozoa of the class Haplosporea which comprises parasites in skeletal and cardiac muscle of vertebrates. The organisms have a very wide distribution both geographically and in host species, infecting reptiles, birds, and mammals (including marsupials). Humans are occasionally infected by the parasite referred to as *Sarcocystis lindemanni*. It is doubtful whether Sarcosporida found in different hosts are themselves always different, though this has often been assumed. Host specificity is known not to be strict; however, it is unlikely that there is only one species—*S. miescheriana*—as proposed by some investigators.

The criteria of species are very hard to define for *Sarcocystis*. Species descriptions have usually been based on an assumed host specificity, size of spores, and cyst characteristics. But host specificity has seldom been proved, spore size is variable (degree of variation often in part dependent on the host species), and cyst morphology is frequently inconstant. Nevertheless, cyst morphology is probably more stable than anything else about the parasite.

In general, the cyst wall is said to have one or two layers, the outer one being either smooth or provided with spines or villi. The genesis of the wall is in some dispute; some think it is formed by the host as a reaction to the parasite, but the majority opinion is that the parasite itself forms the cyst. The cyst is divided internally into compartments, and the outer wall is smooth or rough, depending on the species, with numerous, minute villuslike projections on the outer surface. The spores are crescent-shaped and have a minute projection, termed a conoid, at the more pointed or anterior end, from which fibrils pass anteriorly. These fibrils are called toxonemes at the point of origin, and sarconemes (in *Sarcocystis*) farther back. The nucleus and several mitochondria are in the posterior half.

The life cycle of *Sarcocystis* is quite typical of the Sporozoa, since sexual stages are lacking and schizogony (multiple fission), though sometimes claimed, apparently does not occur. Instead, reproduction is by binary fission, with the eventual development of cysts (Miescher's tubules) in the muscles. These cysts are relatively large structures, easily visible with the unaided eye, and contain myriads of the minute crescentic spores. Infection of a new host is believed to be by the ingestion of these spores with food and water contaminated by feces from an infected animal.

Most natural infections appear to be mild and to do the host little harm. See HAPLOSPORA; PROTOZOA; SPOROZOA. [R.D.M.]

**Sassafras** A medium-sized tree, *Sassafras albidum*, of the eastern United States, extending north as far as southern Maine. Sometimes it is only a shrub in the north, but from Pennsylvania southward heights of 90 ft (27 m) or more with diameters of 4–7 ft (1.2–2.1 m) have been reported for this plant. Sassafras is said to live from 700 to 1000 years. It can be recognized by the bright-green color and aromatic odor of the twigs and leaves. The leaves are simple or mitten-shaped (hence a common name “mitten-tree”), or they may have lobes on both sides of the leaf blade. See MAGNOLIALES. [A.H.G./K.P.D.]

**Satellite (astronomy)** A relatively small body orbiting a larger one that in turn orbits a star. In the solar system, all of the planets except Mercury and Venus have satellites. Well over 100 planetary satellites are known to exist, of which a total of 101 were definitely established by July 2004, distributed as follows: Earth 1, Mars 2, Jupiter 38, Saturn 30, Uranus 21, Neptune 8, and Pluto 1. Additional satellites have been observed in all four giant systems; more observations are needed to define their orbits. The close flyby of the *Galileo* spacecraft (en route to Jupiter) of the asteroid 243 Ida in 1993 revealed the presence of a 0.9-mi (1.5-km) diameter satellite, now known as Dactyl. This unexpected discovery was soon followed by the detection of several other asteroid satellites by Earth-based observers. Several Kuiper Belt objects (distant comet nuclei) have also been observed to be binaries. See ASTEROID; KUIPER BELT.

It is customary to distinguish between regular satellites that have nearly circular orbits lying essentially in the plane of a planet's equator and irregular satellites whose orbits are highly inclined, very elliptical, or both. The former almost certainly originated with the parent planet, while the latter must be captured objects. The Earth's Moon is a special case. The most widely favored hypothesis for its origin invokes an impact with Earth by a Mars-sized planetesimal, and ejection of material that first formed a ring around the Earth and then coalesced to form the Moon. Pluto's Charon may have formed through a similar collision. See MOON; PLUTO. [T.C.O.]

**Satellite (spacecraft)** A spacecraft that is in orbit about a planet (usually the Earth). Spacecraft are devices intended for observation, research, or communication in space. Even those spacecraft which are on the way to probe the outer reaches of the solar system usually complete at least a partial revolution around Earth before being accelerated into an interplanetary trajectory. Devices such as sounding rockets follow ballistic (approximately parabolic) paths after fuel exhaustion, but they are not satellites because they do not achieve velocities great enough to avoid falling back to Earth before completing even one revolution. See ROCKET ASTRONOMY; SPACE PROBE.

The space shuttle, the International Space Station (ISS), and many automated (crewless, robotic) satellites travel in low Earth orbits (LEO) about 100 mi (160 km) above Earth's surface. They have typical orbital periods of about 90 min. These satellites have lifetimes of days, weeks, months, or years, depending on their altitudes, their mass-to-drag ratios, and atmospheric drag variations caused by solar activity. The International Space Station would have an orbital lifetime of only a few years without the periodic orbital boosts provided by the space shuttle or other rocket-powered space vehicles such as the Russian *Progress*. Most LEO satellites spend up to nearly half of their time in Earth's shadow. The space shuttle provides its electric power from fuel cells, but almost every other LEO spacecraft depends on solar cells for its power and batteries to operate through the sixteen 35-min “nights” which occur during each 24-h terrestrial day. See SPACE SHUTTLE; SPACE STATION.

Earth is not a perfect sphere. Its rotation causes its equatorial diameter to be 26 mi (42 km) greater than its corresponding

polar dimension. For LEO satellites at altitudes below 3700 mi (6000 km), a retrograde inclination slightly greater than 90° may be selected which will cause the orbital plane to rotate eastward at exactly one revolution per year. This equatorial bulge phenomenon has the desirable result of permitting the plane of such Sun-synchronous orbits, as viewed from the Sun, to remain in the same apparent orientation throughout the year. In more practical terms, if such a Sun-synchronous satellite crosses the Equator in Brazil at 10:00 a.m. on January 1, it will also do so on June 30 or on any other day of the year. Since the orbital plane remains fixed relative to the Earth-Sun axis, the equatorial crossing time also occurs at the same local time at any longitude. This is ideal for weather, Earth resources monitoring, and reconnaissance purposes, because shadows will fall with the same relative length in the same direction and daily weather buildups will be imaged at essentially the same stage from each orbit to the next. See METEOROLOGICAL SATELLITES; MILITARY SATELLITES; REMOTE SENSING.

Earth has a period of rotation relative to the fixed stars of 23 h 56 min 4 s, which is one sidereal day. A satellite orbit of this period is said to be a geosynchronous orbit (GEO). If this orbit is also circular and equatorial, the spacecraft is said to be geostationary, because it remains in a fixed position relative to any observer on the approximately one-third of Earth from which the satellite is visible. Its principal advantage for communications is that, once pointed at the GEO spacecraft, an antenna on Earth never needs to be repointed. See COMMUNICATIONS SATELLITE.

In addition to communications, the GEO arc is used for weather observation spacecraft. Three such spacecraft evenly spaced along the Equator can monitor continuously severe weather around the entire globe, with the exception of regions within about 10° of the North and South poles, where hurricanes and tornadoes are absent.

Many *Explorer*-class spacecraft [special-purpose smaller satellites, typically 150–500 lb (70–230 kg) mass] have been devoted to studying phenomena whose investigation requires direct sampling of the local environment, such as magnetic fields and associated ionized plasma particles in Earth's magnetosphere and radiation (Van Allen) belts. Their orbits have been quite varied. Most have traveled in highly eccentric Earth orbits, characterized by perigees (lowest altitudes) of 100–200 mi (160–320 km) and apogees (highest altitudes) out to lunar distances. See SCIENTIFIC SATELLITES.

During the 1990s, radio navigation satellite systems assumed global importance. The two leading systems are the U.S. Global Positioning Satellite (GPS) constellation and the Russian GLONASS system. See SATELLITE NAVIGATION SYSTEMS.

The size and shape of a spacecraft is almost always dictated primarily by its mission requirements. The principal constraints are usually imposed by the dimensions and shape of the satellite payload provisions of the launch vehicle. An important requirement of virtually all powered automated spacecraft is sufficient solar cell mounting area both to power the payload in sunlight and to charge its batteries to continue payload operations during solar eclipse periods. Another requirement is to provide spacecraft attitude stabilization and control so that sensors and antennas can be pointed in the required directions. See SPACE FLIGHT; SPACECRAFT STRUCTURE. [J.F.C.]

**Satellite astronomy** The study of astronomical objects by using detectors mounted on Earth-orbiting satellites or deep-space probes so that observations unobstructed by the Earth's atmosphere can be made. The Earth's atmosphere allows only a narrow slice of the visible and near-infrared spectrum through, in addition to much of the radio band. Even at visible and near-infrared wavelengths, atmospheric turbulence distorts the light and smears the images of ground-based telescopes, limiting their resolution to about 1 arc-second.

This article discusses orbiting telescopes that observe electromagnetic radiation that is blocked by the Earth's atmosphere

in the microwave, infrared, ultraviolet, x-ray, and gamma-ray regions of the electromagnetic spectrum. For a discussion of the Hubble Space Telescope, which was launched in 1990 to make visible, ultraviolet, and near-infrared observations at a higher resolution than previously possible, see SPACE TELESCOPE, HUBBLE.

**Cosmic background radiation.** The shortest radio wavelengths are blocked so that studies of the high-frequency end of the spectrum of the cosmic microwave background radiation, which is the thermal blackbody radiation at approximately 3-K temperature and is the signature of the big bang, must be made from high-altitude balloons, rockets, or satellites. The *Cosmic Background Explorer (COBE)* satellite carried out such studies from 1989 to 1991 and provided discoveries of historic importance, as did the Wilkinson Microwave Anisotropy Probe (WMAP), launched in 2001. See COSMIC BACKGROUND RADIATION.

**Infrared astronomy.** At infrared wavelengths longer than about 2 micrometers (that is, some four times that of visible light), the atmosphere is largely opaque, and again astronomy must be done from balloons, rockets, and satellites. In 1983 the United States launched the *Infrared Astronomical Satellite (IRAS)* into low Earth orbit, where it carried out the first all-sky survey in four different infrared-wavelength bands over the next 2 years.

The European Space Agency's *Infrared Space Observatory (ISO; 1995–1998)* was designed to do detailed studies of selected regions of the sky with better angular resolution, wider wavelength coverage, enhanced imaging and spectroscopic capabilities, and higher sensitivity than *IRAS*. In 2003, the National Aeronautics and Space Administration (NASA) launched the Spitzer Telescope, the last of its four great observatories, with infrared arrays that were substantially larger and more sensitive than those on *ISO*. See INFRARED ASTRONOMY.

**Ultraviolet astronomy.** Since the Earth's atmosphere is opaque to ultraviolet (UV) light with wavelengths shorter than about 310 nanometers, ultraviolet astronomy had to await the space age. Astrophysical problems were explored with the several ultraviolet detector systems flown on the *OSO (Orbiting Solar Observatory)* and *OAO (Orbiting Astronomical Observatory)* satellite series in the 1960s and early 1970s, as well as with the subsequent *IUE (International Ultraviolet Explorer)* satellite. A much more powerful tool became available in 1990 with the launch of the Hubble Space Telescope. In June 1990 the *ROSAT* satellite was launched by NASA for the Germans, and carried out the first far-ultraviolet sky survey with the Wide Field Camera supplied by United Kingdom investigators. The first dedicated ultraviolet astronomy satellite, the *Extreme Ultraviolet Explorer (EUVE)*, was launched in 1992 and operated until January 2001.

The Wide Field Camera ultraviolet telescope on *ROSAT* and the ultraviolet telescopes on *EUVE* detected some 400 far-ultraviolet objects in several bands in the wavelength range 6–80 nm. *EUVE* also enabled ultraviolet spectra on a great variety of objects to be measured, from coronae of relatively nearby stars (such as alpha Centauri) to measurements of an unexpectedly bright ultraviolet halo around the active galaxy M87 in the Virgo cluster of galaxies.

The major leap forward in ultraviolet observations, both imaging and spectra, of galactic objects came with the Hubble Space Telescope. Even with its initially blurred vision, this instrument made countless discoveries by obtaining much higher spatial resolution in the ultraviolet than ever before. Its images of SN1987A were able to resolve the expanding ring of ejecta from the bright supernova and the presupernova shell of gas expelled by the giant. With the enhanced ultraviolet sensitivity of the repaired Hubble Space Telescope, significant studies of the nature of quasars and distant galaxies became possible. See GALAXY, EXTERNAL; SUPERNOVA.

The *Far Ultraviolet Spectroscopic Explorer (FUSE)*, launched in 1999, studies a wide range of astronomical problems in the 90.5–118.7-nanometer wavelength region through the use of high-resolution spectroscopy. The *FUSE* bandpass complements

the spectral coverage provided by the Hubble Space Telescope, which extends down to about 117 nm.

**X-ray astronomy.** X-ray astronomy can be done only from above the Earth's atmosphere. The first *Small Astronomy Satellite (SAS 1; 1970)*, designated *Uhuru*, carried two proportional-counter x-ray detectors. The *OSO* satellites also carried cosmic x-ray detectors (proportional counters similar to *Uhuru*) and contributed much to the detailed understanding of individual sources. The *Astronomical Netherlands Satellite (ANS; 1974)* was the first x-ray observatory. Both it and the *SAS 3* satellite (1975) contained a variety of x-ray detectors. A major increase in sensitivity for x-ray astronomy was achieved with the *High Energy Astronomical Observatory (HEAO)* satellite (1977).

The *HEAO 2* satellite, or *Einstein Observatory* (1978), provided the first x-ray images of celestial objects and detected thousands of new sources. The European satellite *EXOSAT* (1982) provided follow up x-ray imaging and spectroscopy to *Einstein*. It was particularly sensitive to very low energy x-ray sources, although its total collecting area was much less than that of the *Einstein Observatory*.

*ROSAT* (1990–1999) was a relatively large x-ray telescope with approximately twice the sensitivity of the *Einstein Observatory*. *ROSAT* carried out the first all-sky imaging x-ray survey, discovering more than 60,000 sources, and thus was as revealing as the Palomar survey for optical astronomy. The all-sky survey was followed by pointed observations.

In 1993 the Japanese x-ray program launched *ASCA*, the first x-ray imaging telescope with energy response extending up to 8 keV. This was a major breakthrough since it allowed imaging and spectroscopy of objects in the x-ray light of their iron emission lines.

NASA's *Rossi X-ray Timing Explorer (RXTE)*, launched in 1995, carries three telescopic instruments that cover a wide energy range, 2–200 keV, provide accurate timing and measurement of x-ray sources, and can detect emissions as brief as 10–100 microseconds.

The Italian-Dutch x-ray satellite *BeppoSAX* (1996) is characterized by a very wide spectral coverage (0.1–300 keV) with balanced performances from its low- and high-energy instrumentation. It discovered the x-ray afterglow of gamma-ray bursts, enabling them to be more precisely located and allowing follow-up radio and optical observations that confirmed that the bursts are of cosmological origin.

The *Chandra X-ray Observatory (CXO; 1999)*, the third of NASA's great observatories, has the highest spatial and energy resolution of any x-ray observatory in orbit. At the focus of this 50-foot-long (15-m) telescope are two detectors, the Advanced CCD Imaging Spectrometer (ACIS) and the High-Resolution Camera (HRC). The ACIS uses 10 charge-coupled devices (CCDs) to measure the energy, location, and arrival time of each photon, while the HRC uses a microchannel plate. See CHARGE-COUPLED DEVICES.

The European Space Agency's *X-ray Multimirror Observatory*, renamed *XMM-Newton* (2000), carries three advanced telescopes, each containing 58 concentric mirrors, nested so as to offer the largest possible collecting area. Its highly eccentric orbit enables long, uninterrupted observations. See X-RAY ASTRONOMY.

**Gamma-ray astronomy.** Gamma rays, more energetic than x-rays, still do not penetrate the Earth's atmosphere. *SAS 2*, launched in 1972, first established the existence of gamma-ray point sources (such as the Crab and Vela pulsars) at energies of about 100 MeV. A more sensitive follow-up mission, *COS-B*, was launched by the European Space Agency in 1975.

The *Compton Gamma-Ray Observatory (CGRO; 1991–2000)*, the second of NASA's great observatories, carried four high-sensitivity gamma-ray detectors: EGRET (Energetic Gamma-Ray Experiment Telescope, a much larger and more sensitive spark chamber than on *COS-B*), for the energy range 30 MeV–10 GeV; COMPTEL (Compton Telescope), a Compton-scattering telescope sensitive in the poorly explored 1–30-MeV

band; OSSE (Oriented Scintillation Spectrometer Experiment), a scintillator detector sensitive in the 100-keV–10-MeV band, and thus able to detect hard x-ray sources; and BATSE (Burst and Transient Source Experiment), a detector system specifically designed to study gamma-ray bursts and determine their arrival directions. Each of these instruments obtained numerous significant discoveries. See GAMMA-RAY ASTRONOMY. [J.E.Gr.]

**Satellite meteorology** The branch of meteorological science that uses meteorological sensing elements on satellites to define the past and present state of the atmosphere. Meteorological satellites can measure a wide spectrum of electromagnetic radiation in real time, providing the meteorologist with a supplemental source of data.

Modern satellites are sent aloft with multichannel high-resolution radiometers covering an extensive range of infrared and microwave wavelengths. Radiometers sense cloudy and clear-air atmospheric radiation at various vertical levels, atmospheric moisture content, ground and sea surface temperatures, and ocean winds, and provide visual imagery as well. See METEOROLOGICAL SATELLITES.

There are two satellite platforms used for satellite meteorology: geostationary and polar. Geostationary (geo) satellites orbit the Earth at a distance that allows them to make one orbit every 24 hours. By establishing the orbit over the Equator, the satellite appears to remain stationary in the sky. This is important for continuous scanning of a region on the Earth for mesoscale (approximately 10–1000 km horizontal) forecasting.

Polar satellites orbit the Earth in any range of orbital distances with a high inclination angle that causes part of the orbit to fly over polar regions. The orbital distance of 100–200 mi (160–320 km) is selected for meteorological applications, enabling the satellite to fly over a part of the Earth at about the same time every day. With orbital distances of a few hundred miles, the easiest way to visualize the Earth-satellite relationship is to think of a satellite orbiting the Earth pole-to-pole while the Earth rotates independently beneath the orbiting satellite. The advantage of polar platforms is that they eventually fly over most of the Earth. This is important for climate studies since one set of instruments with known properties will view the entire world.

The enormous aerial coverage by satellite sensors bridges many of the observational gaps over the Earth's surface. Satellite data instantaneously give meteorologists up-to-the minute views of current weather phenomena.

Images derived from the visual channels are presented as black and white photographs. The brightness is solely due to the reflected solar light illuminating the Earth. Visible images are useful for determining general cloud patterns and detailed cloud structure. In addition to clouds, visible imagery shows snowcover, which is useful for diagnosing snow amount by observing how fast the snow melts following a storm. Cloud patterns defined by visual imagery can give the meteorologist detailed information about the strength and location of weather systems, which is important for determining storm motion and provides a first guess or forecast as to when a storm will move into a region. See CLOUD.

More quantitative information is available from infrared sensors, which measure radiation at longer wavelengths (from infrared to microwave). By analyzing the infrared data, the ground surface, cloud top, and even intermediate clear air temperatures can be determined 24 hours a day. By relating the cloud top temperature in the infrared radiation to an atmospheric temperature profile from balloon data, cloud top height can be estimated. This is a very useful indicator of convective storm intensity since more vigorous convection will generally extend higher in the atmosphere and appear colder. See BLACKBODY; MICROWAVE; PLANCK'S RADIATION LAW.

The advent of geosynchronous satellites allowed the position of cloud elements to be traced over time. These cloud movements can be converted to winds, which can provide an addi-

tional source of data in an otherwise unobserved region. These techniques are most valuable for determination of mid- and high-level winds, particularly over tropical ocean areas. Other applications have shown that low-level winds can be determined in more spatially limited environments, such as those near thunderstorms, but those winds become more uncertain when the cloud elements grow vertically into air with a different speed and direction (a sheared environment). See WIND.

By using a wide variety of sensors, satellite data provide measurements of phenomena from the largest-scale global heat and energy budgets down to details of individual thunderstorms. Having both polar orbiting and geosynchronous satellites allows coverage over most Earth locations at time intervals from 3 minutes to 3 hours.

The greatest gain with the introduction of weather satellites was in early detection, positioning, and monitoring of the strength of tropical storms (hurricanes, typhoons). Lack of conventional meteorological data over the tropics (particularly the oceanic areas) makes satellite data indispensable for this task. The hurricane is one of the most spectacular satellite images. The exact position, estimates of winds, and qualitative determination of strength are possible with continuous monitoring of satellite imagery in the visible channels. In addition, infrared sensors provide information on cloud top height, important for locating rain bands. Microwave sensors can penetrate the storm to provide an indication of the interior core's relative warmth, closely related to the strength of the hurricane, and sea surface temperature to assess its development potential. See HURRICANE; TROPICAL METEOROLOGY.

Most significant weather events experienced by society— heavy rain or snow, severe thunderstorms, or high winds—are organized by systems that have horizontal dimensions of about 60 mi (100 km). These weather systems, known as mesoscale convective systems, often fall between stations of conventional observing networks. Hence, meteorologists might miss them were it not for satellite sensing. See HAIL; MESOMETEOROLOGY; METEOROLOGY; PRECIPITATION (METEOROLOGY); STORM; THUNDERSTORM; TORNADO; WEATHER FORECASTING AND PREDICTION. [D.L.B.; J.A.McG.]

**Satellite navigation systems** Electronic navigation systems employing artificial satellites as radio signal sources and position references. Satellites have the advantage that their signals have line-of-sight propagation to almost an entire hemisphere of the Earth. These systems have become the preeminent radio navigation systems and are gradually replacing ground-based systems such as Loran and Omega. Two main types of satellite navigation systems have been developed, Doppler systems and differential-time-of-arrival systems. See ELECTRONIC NAVIGATION SYSTEMS; LORAN; SATELLITE (SPACECRAFT).

The first operational systems were Doppler systems. The Doppler technique uses the Doppler shift of signals received from a low-orbit satellite. The frequency of the signal received from a moving source is shifted by an amount proportional to its velocity toward or away from the receiver. As the satellite passes the receiver, the Doppler shift will decrease from a positive to a negative value. The distance from the satellite track determines the magnitude of the shift. The crossover from a positive to negative shift will occur at the point of closest approach. The Earth's rotation during the satellite pass changes the shape of the curve in a way that indicates which side of the satellite track the receiver is on. These satellites orbit at relatively low altitude, about 900 km (550 mi), in order to produce a large Doppler shift. See DOPPLER EFFECT.

Doppler systems have inherent limitations. They provide only two-dimensional position fixes. Altitude must be determined by some other means. They provide limited accuracy and no velocity information. Because of their low altitude and limited coverage area, they provide at most a few position fixes a day. As a result, these systems have been phased out.

In differential-time-of-arrival systems, the receiver measures the difference of the time of arrival of signals transmitted simultaneously from several satellites. Two such systems have been put into operation. The Global Positioning System (GPS) was developed by the United States. The former Soviet Union developed a similar system called Glonass, which is now operated by Russia and operates with some minor differences, similarly to GPS.

The Global Positioning System provides worldwide coverage with four satellites in each of six planes for a total of 24 satellites. The orbits are nearly circular and have an inclination of  $55^\circ$ . The ascending nodes of the six planes are equally spaced around the Equator. An altitude of 20,200 km (12,500 mi) gives the orbits a subsynchronous period such that they repeat their ground track every second orbit. The satellites are three-axis-stabilized by a combination of reaction wheels and magnetic torque applied against the Earth's magnetic field. The satellite is rotated so that the Earth panel with the antennas always faces the Earth and the solar panels are at right angles to the Sun.

Each satellite broadcasts a ranging signal which is measured by all satellites in view. The satellites then broadcast a data message which contains the satellite ephemeris and all the measurements which it received. In this way, each member of a pair of ranging satellites has access to the pseudorange measurements in both directions (from the first satellite to the second, and vice versa). Each intersatellite range measurement is a combination of the geometric distance between the satellites and the difference of their clock biases. The two pseudoranges can be combined to yield an independent derived clock measurement and a derived true range measurement. The actual implementation of this requires additional terms to compensate for the satellite's motion and to account for the general-relativistic offset between the two satellites.

In a satellite navigation receiver, the antenna converts the radio signal from the satellite to electric current which can be filtered, amplified, and processed by the receiver. The phase center of the antenna is the position which the receiver locates. A preamplifier filters and amplifies the radio-frequency signal. A mixer shifts the L-band frequency to a lower intermediate frequency (IF) by, in effect, subtracting the frequency of a local oscillator from the incoming signal while preserving the signal modulation. Most newer receiver designs convert the intermediate-frequency signal to digital samples at this point. See ANALOG-TO-DIGITAL CONVERTER; MIXER.

In addition to providing navigation service to aircraft, vehicles, and watercraft, many other uses have become practical because of the accuracy, global coverage, and low cost of satellite navigation receivers. Small, inexpensive, handheld receivers are available for use in hiker, boating, and other recreational activities. In other applications, the receiver is combined with a communication system or a geographic database. Surveying has been revolutionized by a very accurate type of differential system. A surveying system can take advantage of the fact that it is not moving for the duration of its measurements. This yields very precise position estimates relative to a local reference point. The tectonic motion of the Earth's crust around fault lines has been measured with an accuracy of 1 cm (0.4 in.) or less. See SURVEYING.

In automobile systems, the navigation receiver is combined with a display and a digitized map which is stored on a CD-ROM. Vehicle tracking systems use satellite navigation to determine a vehicle's position, which is then periodically reported to a central location by using a cellular telephone or some other communications system. Variations of this concept have been employed to track livestock, weather balloons, wildlife migration, and many other things. The ability to easily record the exact location at any point makes satellite navigation receivers ideal for mapping environmental data such as soil conditions, forest growth patterns, and pollution. Such data are used to monitor environmental damage. In aircraft navigation systems, satellite

navigation is often combined with an inertial navigation system. The inertial system improves short-term accuracy, particularly during a maneuver. The satellite navigation maintains accuracy over the long term. See INERTIAL GUIDANCE SYSTEM. [L.J.D.]

**Saturable reactor** An iron-core inductor in which the effective inductance is changed by varying the permeability of the core. Saturable-core reactors are used to control large alternating currents where rheostats are impractical. Theater light dimmers often employ saturable reactors.

In the illustration of two types of saturable-core reactors, illus. a shows two separate cores, while in illus. b a three-legged core is formed by placing two two-legged cores together. The load winding, connected in series with the load, carries the alternating current and acts as an inductive element. The control winding carries a direct current of adjustable magnitude, which can saturate the magnetic core.

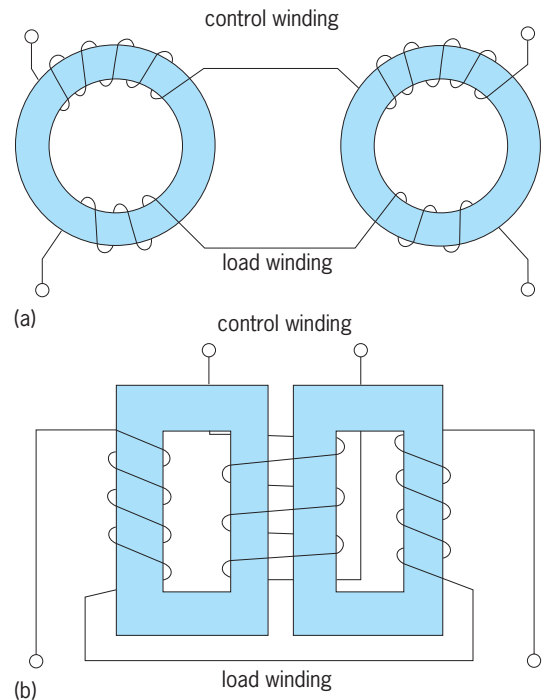

Typical construction of saturable-core reactors. (a) Two separate cores. (b) Three-legged cores.

Reducing the magnitude of the control current reduces the intensity of saturation. This increases the reactance of the load winding. As the reactance increases, the voltage drop in the load winding increases and causes a reduction in the magnitude of the voltage applied to the load. See INDUCTANCE; MAGNETIC PERMEABILITY; MAGNETIZATION. [W.S.P.]

**Saturation** The condition in which, after a sufficient increase in a causal force, further increase in the force produces no additional increase in the resultant effect. Many natural phenomena display saturation. For example, after a magnetizing force becomes sufficiently strong, further increase in the force produces no additional magnetization in a magnetic circuit; all the magnetic domains have been aligned, and the magnetic material is saturated. See MAGNETIC MATERIALS.

After a sponge has absorbed all the liquid it can hold, it is saturated. In thermionic vacuum tubes thermal saturation is reached when further increase in cathode temperature produces no (or negligible) increase in cathode current; anode saturation is reached when further increase in plate voltage produces substantially no increase in anode current. See DISTORTION (ELECTRONIC CIRCUITS); SATURATION CURRENT; VACUUM TUBE.

## 1950 Saturation current

In colorimetry the purer a color is, the higher its saturation. Radiation from a color of low saturation contains frequencies throughout much of the visible spectrum. See COLORIMETRY.

[F.H.R.]

**Saturation current** A term having a variety of specific applications but generally meaning the maximum current which can be obtained under certain conditions.

In a simple two-element vacuum tube, it refers to either the space-charge-limited current on one hand or the temperature-limited current on the other. In the first case, further increase in filament temperature produces no significant increase in anode current, whereas in the latter a further increase in voltage produces only a relatively small increase in current. See VACUUM TUBE.

In a gaseous-discharge device, the saturation current is the maximum current which can be obtained for a given mode of discharge. Attempts to increase the current result in a different type of discharge. See ELECTRICAL CONDUCTION IN GASES.

A third case is that of a semiconductor. Here again the saturation current is that maximum current which just precedes a change in conduction mode. See SEMICONDUCTOR. [G.H.M.]

**Saturn** The second-largest planet in the solar system and the sixth in order of distance to the Sun. The outermost planet known prior to 1781, Saturn is surrounded by a beautiful system of rings. Saturn is also the only planet that has a satellite (Titan) with a dense atmosphere. This distant planetary system has been visited by four NASA spacecraft, including *Cassini*, which went into orbit around the planet in July 2004.

Saturn makes one revolution about the Sun in 29.42 years. The equatorial diameter of Saturn is about 75,000 mi (120,540 km), and the polar diameter about 67,600 mi (108,700 km). The volume is 769 (Earth = 1) with a few percent uncertainty. The mass is about 95.2 (Earth = 1) or 1/3500 (Sun = 1). The mean density is 0.70 g/cm<sup>3</sup>, the lowest mean density of all the planets. The rotation axis of both the planet and the rings is inclined 27° to the perpendicular to the orbital plane. The visible cloud layers of Saturn are much more homogeneous than those of Jupiter. There is no feature comparable to the Great Red Spot, and the contrast of the features that are visible is very low (Fig. 1).

The optical spectrum of Saturn is characterized by strong absorption bands of methane (CH<sub>4</sub>) and by much weaker bands of ammonia (NH<sub>3</sub>). Absorption lines of molecular hydrogen (H<sub>2</sub>) have also been detected.

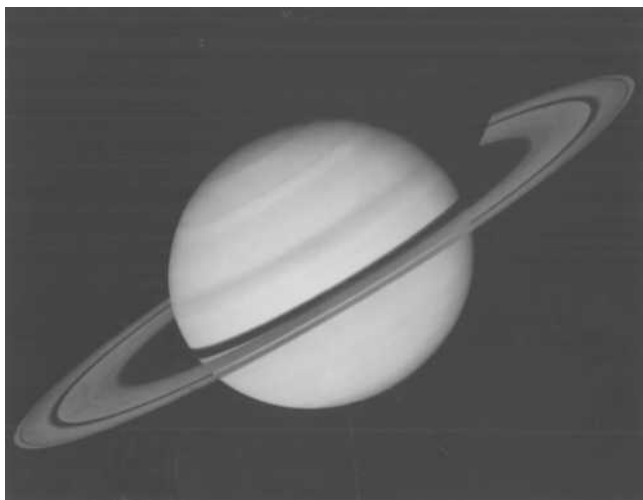

Fig. 1. Saturn, viewed from *Voyager 1*. The soft, velvety appearance of the low-contrast banded structure is due to scattering by a haze layer above the planet's cloud deck. (NASA)

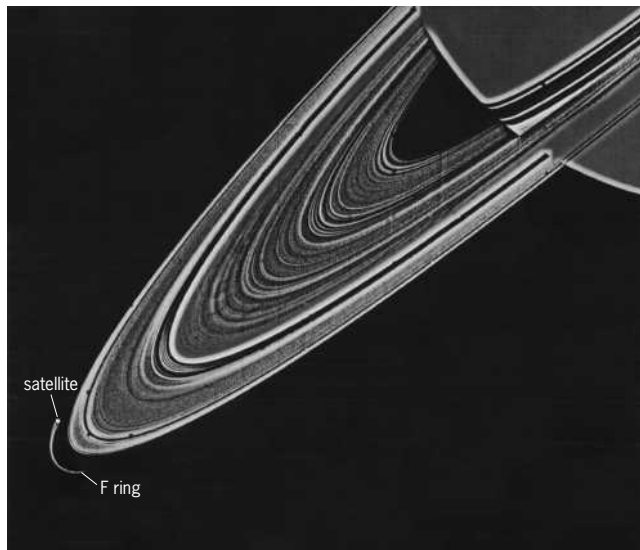

Fig. 2. Saturn's rings, viewed from *Voyager 1*. Approximately 95 individual concentric features are visible. One of the satellites discovered by *Voyager 1* is visible just inside the narrow F ring. (NASA)

The temperature the planet should assume in response to solar heating is calculated to be about 76 K (−323°F), somewhat lower than the measured value of 92 K (−294°F). This suggests that Saturn has an internal heat source of roughly the same magnitude as that on Jupiter. As in the case of Jupiter, a thermal inversion exists in the upper atmosphere. The inversion region is well above the main cloud layer, which is thought to consist primarily of frozen ammonia crystals, with an admixture of some other substances to provide the yellowish color sometimes observed in the equatorial zone.

Theoretical models for the internal structure of Saturn are similar to those for Jupiter, that is, a dense core surrounded by hydrogen compressed to a metallic state which gradually merges into an extremely deep atmosphere. The fact that the two planets radiate comparable amounts of energy despite their difference in size means that smaller Saturn must have some additional energy source besides gravitational contraction. The existence of a magnetic field and belts of trapped electrons has been deduced from observations of nonthermal radiation and mapped out in detail by the Pioneer and Voyager spacecraft.

Jupiter and Saturn are relatively similar bodies. Both seem to have compositions virtually identical with that of the Sun and the other stars—rich in hydrogen and helium. In that sense, they may represent the primitive material from which the entire solar system was formed, whereas the other planets have undergone fractionation processes resulting in the loss of most of the light gases. This conclusion has been strengthened by measurements of the heavy isotope of hydrogen known as deuterium. They demonstrate that the hydrogen that makes up most of the mass of both Jupiter and Saturn was captured directly from the solar nebula when these planets formed 4.5 billion years ago. However, both Jupiter and Saturn show an enhancement of the carbon/hydrogen ratio (as determined from methane and hydrogen) compared with the Sun. This suggests that both of these planets formed in a two-stage process that led initially to formation of a large core with an outgassed, secondary atmosphere, followed by the attraction of an envelope of gases from the surrounding nebula. See PLANETARY PHYSICS.

The most remarkable feature associated with Saturn is the complex ring system that surrounds the planet (Fig. 2). The system is divided into four main regions, designated A through D. The narrow F ring is located just beyond the edge of ring A, and there are G and E rings still farther out. Each of the four main regions is subdivided into many individual “ringlets,” so



that Saturn is actually surrounded by thousands of rings. The ring system is made up of myriad separate particles that move independently in flat, mostly circular orbits in Saturn's equatorial plane. Periodic perturbations by the major satellites are responsible, in part, for the main divisions of Saturn's rings.

As of July 2004, Saturn had 30 confirmed satellites. The largest and brightest, Titan, is visible with small telescopes; the other satellites are much fainter. Titan's mean apparent diameter corresponds to a linear diameter of approximately 3440 mi (5550 km). But this diameter refers to the satellite's atmosphere, which is filled with a dense aerosol produced photochemically by incident sunlight. The solid surface of Titan has a diameter of 3200 mi (5150 km), making this satellite larger than Mercury but smaller than Jupiter's giant Ganymede. This object contains a large fraction of icy material and is thus quite different from the Moon or the inner planets in composition. Furthermore, it is large and cold enough to retain a thick, nitrogen (N<sub>2</sub>)-dominated atmosphere that contains a few percent of methane (CH<sub>4</sub>) and exerts a surface pressure of 1.5 bars (1.5 × 10<sup>5</sup> Pa), or 1.5 times the sea-level pressure on Earth. The main constituent of this atmosphere is molecular nitrogen. The surface of Titan is so cold [94 ± 2K or (-290 ± 4°F)] that lakes of liquid ethane may be present. See PLANET; SATELLITE (ASTRONOMY). [T.C.O.]

**Saurischia** One of two orders of extinct reptiles popularly known as dinosaurs, the other being the Ornithischia. The two orders are distinguished by a number of anatomical differences, but foremost is the triradiate shape of the saurischian pelvis, in contrast to the tetradiate pelvis of ornithischians. Both dinosaurian orders originated from thecodont reptiles by Middle Triassic times and are classified together with the order Thecodontia in the infraclass Archosauria. Saurischian bones have been found on all continents except Antarctica, and in rock strata ranging from Middle Triassic to latest Cretaceous in age.

Most recent classifications recognize two suborders, the Sauropodomorpha and the Theropoda. The latter includes all carnivorous dinosaurs, and the former consists of the *Brontosaurus*-like animals (sauropods), together with their ancestral stock, the prosauropods. The Prosauropoda includes the oldest known saurischians, ranging from Middle Triassic time to the close of the Triassic Period. Like their ancestral thecodont stock, many show pronounced anatomical tendencies toward bipedal posture. Most, like *Plateosaurus*, appear to have been herbivores, but fragmentary evidence indicates that some may have been carnivorous. In general, prosauropods were of moderate size, up to 15–20 ft (4.5–6 m) long, and less than a ton in weight.

The saurischians, like the ornithischians, became extinct at the end of the Cretaceous, due to unknown causes. Most saurischians died out, leaving no descendants, but studies indicate that birds, via *Archaeopteryx*, probably are direct descendants of a small theropod dinosaur. See ARCHAEORNITHES; ARCHOSAURIA; DINOSAUR; ORNITHISCHIA. [J.H.O.]

**Sauropterygia** An infraclass of Mesozoic reptiles that are, without exception, adapted to the marine environment. The infraclass includes the nothosaurs, plesiosaurs, and placodonts. These reptiles, along with the ichthyosaurs, played a significant role as predators within the marine animal community of the Mesozoic Era.

The placodonts are a distinctive but highly varied assemblage of aquatic reptiles. They had short bodies, paddlelike limbs, and flat cheek teeth designed for crushing hard-shelled prey. The genus *Helodus* was covered by a dorsal bony armor and a roofing of dermal scutes, but most other genera lacked armor. Placodonts have come only from rocks of the Middle and Upper Triassic of Europe, North Africa, and the Middle East. See PLACODONTIA.

The Nothosauria are the relatively generalized stem group from which the plesiosaurs evolved. With the exception of a

single New World species and a record from Japan, nothosaurs are known primarily from Europe and the Near East (Israel) in rocks of Triassic age. The nothosaurs are notably diverse in the mode and degree of secondary aquatic modification. The directions of aquatic specialization involve shortening, or more often lengthening, of the neck; enlargement of the orbits or the temporal fenestrae; and reduction, or more commonly increase, in the number of phalanges in manus (hand), pes (foot), or both. A feature of considerable evolutionary significance in the light of plesiosaurian differentiation is the great individual variability in the number of presacral vertebrae (32–42) in *Pachypleurosaurus edwardsi*.

The Plesiosauria are the successful, compact, and highly specialized offshoot of the nothosaurs that attained worldwide distribution. The early steps of aquatic adaptation, initiated by the nothosaurs, have led to extensive anatomical modifications: The region comprising chest and abdomen became short, stout, and inflexible; the ventral bones of shoulder girdle and pelvis increased in area enormously; and the limbs, transformed into large flippers, became the principal organs of propulsion. Two major trends of plesiosaur evolution may be discerned since the Early Jurassic: In the one group there was a tendency toward a shortening of the neck from 27 to 13 vertebrae and an increase in skull size; in the other group the opposite trend led to forms of bizarre body proportions, for example, *Elasmosaurus*, with a neck containing 76 vertebrae. The plesiosaurs were carnivorous.

The precise affinities of placodonts, nothosaurs, and plesiosaurs remain uncertain. No earlier group of reptiles from which they might have come is known, and they left no descendants. See NOTHOSAURIA; PLACODONTIA; PLESIOSAURIA; REPTILIA. [R.Z.; E.C.O.]

**Savanna** The term savanna was originally used to describe a tropical grassland with more or less scattered dense tree areas. This vegetation type is very abundant in tropical and subtropical areas, primarily because of climatic factors. The modern definition of savanna includes a variety of physiognomically or environmentally similar vegetation types in tropical and extratropical regions. The physiognomically savannalike extratropical vegetation types (forest tundra, forest steppe, and everglades) differ greatly in environment and species composition.

In the widest sense savanna includes a range of vegetation zones from tropical savannas with vegetation types such as the savanna woodlands to tropical grassland and thornbush. In the extratropical regions it includes the "temperate" and "cold savanna" vegetation types known under such names as taiga, forest tundra, or glades. See GRASSLAND ECOSYSTEM; TAIGA; TUNDRA. [H.Li.]

**Savory** A herb of the mint family in the genus *Satureja*. There are more than 100 species, but only *S. hortensis* (summer savory) and *S. montana* (winter savory) are grown for flavoring purposes. See LAMIALES.

Summer savory, an annual herb, is characterized by long thin wiry stems with long internodes between small leaves. Winter savory is a perennial in most climates and, unlike summer savory, will tolerate some freezing weather. It can become woody after one or two growing seasons.

Savory is indigenous to areas surrounding the Mediterranean Sea. *Satureja montana* occurs wild from North Africa to as far north as Russia but is little cultivated. *Satureja hortensis*, which is widely cultivated, is native to Europe. Both types of savory are harvested or cut two or three times a year, after which the leaves are dehydrated and separated from the stems to be used as a spice in various foods, including poultry seasoning and beans. See SPICE AND FLAVORING. [S.Kir.]

**Saxifragales** An order of flowering plants near the base of the eudicots. The order's exact relationships to other orders are still under study, but the Saxifragales appear to be related

to the rosid eudicots. They include 13 small to moderately sized families and perhaps around 2300 species. There are two categories: woody species that are sometimes wind-pollinated, and insect-pollinated herbs. The members are difficult to characterize morphologically but fall into several sets of families that have been considered closely related by most authors. See MAGNOLIOPHYTA; MAGNOLIOPSIDA; POLLINATION; ROSIDAE.

None of the families are of particular economic importance except as ornamentals, although *Cercidiphyllum* (Cercidiphyllaceae), *Liquidambar* (sweet gums), *Altingia* (both Altingiaceae), and a few others produce timbers. The largest family is Crassulaceae (1500 species), which are plants of arid zones, including the stonecrops (*Sedum*) and kalanchoes (*Kalanchoe*). A number of species are commonly cultivated ornamentals, including peony (*Paeonia*, Paeoniaceae), saxifrages (*Saxifraga*, Saxifragaceae), and witch hazel (*Hamamelis*, Hamamelidaceae); a few, the currants and gooseberries (*Ribes*, Grossulariaceae), are cultivated as fruits. See HAMAMELIDALES. [M.W.C.]

**Scalar** A term synonymous in mathematics with “real” in real number or real function. The magnitude of a vector two units in length is the real number of scalar 2. The dot or scalar product of two vectors is the product of three real numbers associated with them (the magnitude of the first vector times the magnitude of the second, times the cosine of the angle between them) and is therefore a scalar. If in the functional relationships  $S = S(s, y, z)$ ,  $\mathbf{F} = \mathbf{F}(x, y, z)$ ,  $S$  is a real number and  $\mathbf{F}$  is a vector, then  $S(s, y, z)$  is a scalar function but  $\mathbf{F}(x, y, z)$  is a vector function. See CALCULUS OF VECTORS. [H.V.C.]

**Scale (music)** As a piece of music progresses, it typically outlines a set of pitches by repeatedly sounding a subset of all the possible notes. When these notes are rearranged into ascending or descending order, they are called a musical scale.

There is often a range of pitches that will be heard as the same. Perhaps the trumpet plays middle C a bit flat, while the guitar plays a bit sharp, in accordance with the artistic requirements of the musical context. The mind hears both pitches as the same note, C, and the limits of acceptability are far cruder than the ear's powers of resolution. This suggests a kind of categorical perception, where a continuum of possible stimuli (in this case, pitch) is perceived as consisting of a small number of disjoint classes. Thus scales partition pitch space into disjoint chunks. See MUSICAL INSTRUMENTS; PITCH; SENSATION.

In the modern Western tradition, scales are standardized subsets of the 12-tone equal temperament (abbreviated 12-tet, and also called the chromatic scale) in which each octave is divided into 12 (approximately) equal sounding divisions. These are further classified into major and minor depending on the exact ordering of the intervals, and are classified into modes depending on the starting point. Historically, however, scales based on 12-tet are fairly recent. In addition, other cultures use musical scales that are quite different. See TUNING. [W.A.Se.]

**Scale (zoology)** The fundamental unit of the primary scaled integument of vertebrates, of which the epidermal or dermal component may be the more conspicuous or elaborated. Although there is great diversity in detailed structure among vertebrate groups, scaled integuments may be interpreted as the most effective way of producing a physically strong external body surface, with maximum flexibility necessitated by the fundamental pattern of vertebrate locomotion relying on lateral sinusoidal movements of the body.

In the majority of extant fish the epidermis is extremely thin. The term “scale” when used in an ichthyological context usually refers to the relatively large, prominent, dermal ossification, on the outer surface of which lie so-called dental tissues. The latter—enamel or enamellike mineralizations and dentine—are

therefore present at the dermoepidermal boundary. The scaled integument of fish shows a definite pattern which is governed by the orientation of the underlying myomeres and by changes in body depth and length. The general evolutionary tendency toward thinning, or size reduction, of integumentary sclerifications seen in various fish lineages is probably associated with weight reduction and increased locomotor efficiency.

Scaled integuments are absent from modern amphibians, although nonoverlapping dermal ossifications are seen in some apodans. It seems probable that the absence of scales in other modern species is associated with the secondary utilization of the integument as a respiratory surface. In most reptilian lineages, there is a ubiquity of scaled integuments, with or without dermal ossifications, but always with elaboration of epidermal tissues. The distribution of keratinaceous protein types varies in different groups of reptiles, and in this respect modern crocodilian scales exactly resemble the leg scales of birds. Scaled integuments prompted the subclass name for lepidosaurs—the tuatara, lizards, and snakes, the last two constituting the order Squamata. Lepidosaurian scales may or may not possess dermal ossifications. Among extant reptiles the extraordinary development of the dermal skeleton in turtles forms the characteristic carapace. [P.F.M.]

**Scandium** A chemical element, Sc, atomic number 21, atomic weight 44.956. The only naturally occurring isotope is  $^{45}\text{Sc}$ . The electronic configuration of the ground-state, gaseous atom consists of the argon rare-gas core plus three more electrons in the 3d14s2 levels. It has an unfilled inner shell (only one 3d electron) and is the first transition metal. It is one of the elements of the rare-earth group. See PERIODIC TABLE; RARE-EARTH ELEMENTS; TRANSITION ELEMENTS.

The principal raw materials for the commercial production of scandium are uranium and tungsten tailings and slags from tin smelters or blast furnaces used in cast iron production. Wolframite ( $\text{WO}_3$ ) concentrates contain 500–800 ppm scandium. See WOLFRAMITE.

Scandium is the least understood of the 3d metals. The major reason has been the unavailability of high-purity scandium metal, especially with respect to iron impurities. Many of the

Room-temperature properties of scandium metal (unless otherwise specified)

Property	Value
Atomic number	21
Atomic weight	44.9559 ( $^{12}\text{C} = 12$ )
Lattice constant (hcp, $\alpha\text{-Sc}$ ), $a_0$	0.33088 nm
$c_0$	0.52680 nm
Density	2.989 g/cm <sup>3</sup>
Metallic radius	0.16406 nm
Atomic volume	15.041 cm <sup>3</sup> /mol
Transformation point	1337°C (2439°F)
Melting point	1541°C (2806°F)
Boiling point	2836°C (5137°F)
Heat capacity	25.51 J/mol K
Standard entropy, $S_{298.15}^{\circ}$	34.78 J/mol K
Heat of transformation	4.01 kJ/mol
Heat of fusion	14.10 kJ/mol
Heat of sublimation (at 298 K)	377.8 kJ/mol
Debye temperature (at 0 K)	345.3 K
Electronic specific heat constant	10.334 mJ/mol K <sup>2</sup>
Magnetic susceptibility, $\chi_A^{298}$ (a)	$297.6 \times 10^{-6}$ emu/mol
$\chi_A^{298}$ (c)	$288.6 \times 10^{-6}$ emu/mol
Electrical resistivity, $\rho_a^{300}$	70.90 $\mu\text{ohm-cm}$
$\rho_c^{300}$	26.88 $\mu\text{ohm-cm}$
Thermal expansion, $\alpha_{a,i}$	$7.55 \times 10^{-6}$
$\alpha_{c,i}$	$15.68 \times 10^{-6}$
Isothermal compressibility	$17.8 \times 10^{-12}$ m <sup>2</sup> /N
Bulk modulus	$5.67 \times 10^{10}$ N/m <sup>2</sup>
Young's modulus	$7.52 \times 10^{10}$ N/m <sup>2</sup>
Shear modulus	$2.94 \times 10^{10}$ N/m <sup>2</sup>
Poisson's ratio	0.279

physical properties reported in the literature vary considerably, but the availability of electrotransport-purified scandium has allowed measurement of the intrinsic properties of scandium (see table).

Scandium increases the strength of aluminum. It also strengthens magnesium alloys when added to magnesium together with silver, cadmium, or yttrium. Scandium inhibits the oxidation of the light rare earths and, if added along with molybdenum, inhibits the corrosion of zirconium alloys in high-pressure steam. The addition of ScC to TiC has been reported to form the second-hardest material known.  $\text{Sc}_2\text{O}_3$  can be used in many other oxides to improve electrical conductivity, resistance to thermal shock, stability, and density. Scandium is used in the preparation of the laser material  $\text{Gd}_3\text{ScGa}_4\text{O}_{12}$ , gadolinium scandium gallium garnet (GSGG). This garnet when doped with both  $\text{Cr}^{3+}$  and  $\text{Nd}^{3+}$  ions is said to be  $3^{1/2}$  times as efficient as the widely used  $\text{Nd}^{3+}$ -doped yttrium aluminum garnet ( $\text{YAG:Nd}^{3+}$ ) laser. Ferrites and garnets containing scandium are used in switches in computers; in magnetically controlled switches that modulate light passing through the garnet; and in microwave equipment. Scandium is used in high-intensity lights. Scandium iodide is added because of its broad emission spectrum. Bulbs with mercury, NaI, and  $\text{ScI}_3$  produce a highly efficient light output of a color close to sunlight. This is especially important when televising presentations indoors or at night. When used with night displays, the bulbs give a natural daylight appearance. Scandium metal has been used as a neutron filter. It allows 2-keV neutrons to pass through, but stops other neutrons that have higher or lower energies. See YTRIUM. [J.Cap.; K.A.G.]

**Scanning electron microscope** An electron microscope that builds up its image as a time sequence of points in a manner similar to that employed in television.

The imaging method of the scanning electron microscope (SEM) allows separation of the two functions of a microscope, localization and information transfer. The SEM utilizes a very fine probing beam of electrons which sweeps over the specimen to emit a variety of radiations. The signal, which is proportional to the amount of radiation leaving an individual point of the specimen at any instant, can be used to modulate the brightness of the beam of the display cathode-ray tube as it rests on the corresponding point of the image. In practice, the points follow one another with great rapidity so that the image of each point becomes an image of a line, and the line in turn can move down the screen so rapidly that the human eye sees a complete image

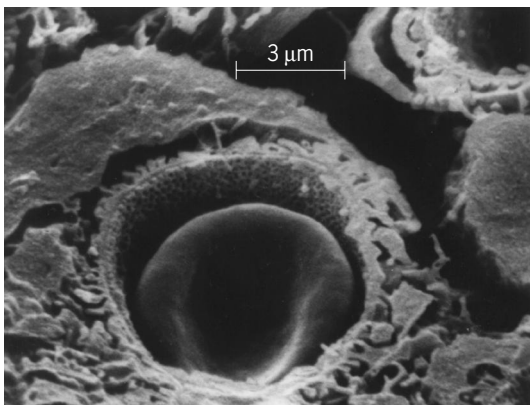

Red blood cell in a capillary of the kidney. Ethanol cryofracture technique was followed by critical-point drying. (From W. J. Humphreys, B. O. Spurdock, and J. S. Johnson, *Critical point drying of ethanol-infiltrated, cryofractured biological specimens for scanning electron microscopy*, *Proceedings of the Scanning Electron Microscopy Symposium*, pp. 275–282, 1974)

as in television. The image can also be recorded in its entirety by allowing the point-by-point information to build up in sequence on a photographic film (see illustration).

As with all microscopy research, it is very often the preparative methodology that determines the success or failure of the research. A specific requirement of scanning electron microscope preparation is that the material be dried. This preparative step must be done very carefully to minimize surface tension effects. The two methods most often used—critical-point drying and freeze drying—have yielded excellent results even for very fragile biological tissue. Alternatively, the drying step can be avoided completely by observing the specimen while it is still frozen. Interior structure can be revealed by using techniques in which the specimen is broken at a low temperature. See ELECTRON MICROSCOPE; MICROTECHNIQUE. [T.L.H.]

**Scanning tunneling microscope** An instrument for producing surface images with atomic-scale lateral resolution, in which a fine probe tip is scanned over the surface at a distance of 0.5–1 nanometer, and the resulting tunneling current, or the position of the tip required to maintain a constant tunneling current, is monitored.

Scanning tunneling microscopes have pointed electrodes that are scanned over the surface of a conducting specimen, with help from a piezoelectric crystal whose dimensions can be altered electronically. They normally generate images by holding the current between the tip of the electrode and the specimen at some constant (set-point) value by using a piezoelectric crystal to adjust the distance between the tip and the specimen surface, while the tip is piezoelectrically scanned in a raster pattern over the region of specimen surface being imaged. By holding the force, rather than the electric current, between tip and specimen at a set-point value, atomic force microscopes similarly allow the exploration of nonconducting specimens. In either case, when the height of the tip is plotted as a function of its lateral position over the specimen, an image that looks very much like the surface topography results.

It is becoming increasingly possible to record other signals (such as lateral force, capacitance, scan-related tip displacement, temperature, light intensity, or magnetic resonance) as the tip scans. For example, modern atomic force microscopes can map lateral force and conductivity along with height, while image pairs from scanning tunneling microscopes scanning to and fro can provide information about friction as well as topography.

Scanning tunneling microscopes make it possible not just to view atoms but to push them and even to rearrange them in unlikely combinations (sometimes whether or not these rearrangements are desirable). A few considerations of scale are important in understanding this process. Atoms comprise a positive nucleus and a surrounding cloud of negative electrons. These charges rearrange when another atom approaches, with unlike charges shifting to give rise to the van der Waals force of attraction between neutral atoms. This force makes gravity (and most accelerations) ignorable when contact between solid objects in the micrometer size range and smaller is involved, since surface-to-volume ratios are inversely proportional to object size.

The electric field in the scanning tunneling microscope allows plucking as well, in which adsorbed or substrate atoms are removed and transferred to the electrode tip with a suitable voltage pulse. Because the electric field from the tip falls off less rapidly with separation than do van der Waals forces, the most weakly attached nearby atom rather than the nearest may end up being removed. One solution to this problem is a hybrid approach. By invoking the tip electric field for bond breaking only when the tip is sufficiently close to the target atom that the van der Waals forces contribute as well, atoms on silicon could be singly removed and redeposited at will.

A third kind of selective bond breaking was also demonstrated. It involved the selective breaking of silicon-hydrogen bonds using electron energies (that is, pulse voltages) below those necessary to break bonds directly. Since the desorption probability was observed to vary exponentially with the tip-specimen current, it is believed that vibrational heating from inelastic electron tunneling mediated the chemical transition in this work. This work involves bond alteration at the level of signal atoms, the ultimate frontier for lithographic miniaturization. [P.B.F.]

**Scaphopoda** A class in the phylum Mollusca, comprising two orders, Gadilida and Dentaliida. The class is wholly marine; it is common and probably most diverse in the deep sea, and poorly represented in brackish, littoral, or estuarine habitats. Scaphopods are characterized by a tapering tubular shell with two apertures: the large ventral aperture that the foot extends out of and a small dorsal aperture. The tapering shells found in the Dentaliida give the class its common names tusk or tooth shells. Adult scaphopods range in length from about 3 to 150 mm. The shell consists of aragonite arranged in three or four layers.

Systematically the class is related to bivalves, and probably arose from a member of the extinct molluscan class, the Rostroconchia. The two orders can be separated on the basis of shell structure. Typically gadilids have the widest part of the shell more toward the middle of the animal, while in the dentaliids the widest part of the shell is the ventral aperture. Gadilid shells are typically highly polished, while dentaliid shells lack this luster. In addition, there are significant internal morphological differences between the two orders.

Scaphopods are bilaterally symmetrical and surrounded by the mantle, which forms a tube. The body is suspended in the tube from the dorsal-anterior part of the shell. The largest part of the mantle cavity is adjacent to the ventral aperture and contains the foot, head, and feeding tentacles, called captacula. Each captaculum consist of a long extendable stalk and a terminal bulb. The captacular bulb is covered with cilia, and the stalk may have a ciliated band or tufts of cilia along it.

Scaphopods eat foraminiferans, and other small shelled organisms such as bivalves or shelled eggs. Dentaliids can also ingest sediment. Prey are captured by the use of the captacula, which have a chemical adhesive system to attach to prey. The foot is used to burrow and construct a feeding cavity.

Scaphopods live in unconsolidated sediments, and most members of any population are typically completely buried at any one time. However, scaphopods back up to the surface and extend the dorsal shell apex to release eggs or sperm, and presumably to flush the mantle cavity with fresh water. See MOLLUSCA. [R.Shi.]

**Scapolite** An aluminosilicate mineral. It is commonly found as light-colored, translucent tetragonal prisms. Scapolite is normally white, but many other colors are known, including some used as semiprecious gems resembling amethyst and citrine. The mineral has a Mohs hardness of 5–6. The formula of scapolite is  $(\text{Na}, \text{Ca})_4(\text{Al}, \text{Si})_6\text{Si}_6\text{O}_{24}(\text{Cl}, \text{CO}_3, \text{SO}_4)$ . In nature significant amounts of K and  $\text{SO}_4$  substitute for Na and  $\text{CO}_3$ .

Scapolite is a common mineral in metamorphic rocks, particularly in those which contain calcite. It is found in marbles, gneisses, skarns, and schists. Scapolite probably forms about 0.1% of the Earth's upper crust. It is commonly found as inclusions in igneous rocks derived from deep within the Earth's crust, and probably makes up several percent of the lower crust. See SILICATE MINERALS. [D.E.E.]

**Scarlet fever** An acute contagious disease that results from infection with *Streptococcus pyogenes* (group A streptococci). It most often accompanies pharyngeal (throat) infections

with this organism but is occasionally associated with wound infection or septicemia. Scarlet fever is characterized by the appearance, about 2 days after development of pharyngitis, of a red rash that blanches under pressure and has a sandpaper texture. Usually the rash appears first on the trunk and neck and spreads to the extremities. The rash fades after a week, with desquamation, or peeling, generally occurring during convalescence. The disease is usually self-limiting, although severe forms are occasionally seen with high fever and systemic toxicity. Appropriate antibiotic therapy is recommended to prevent the onset in susceptible individuals of rheumatic fever and rheumatic heart disease. See MEDICAL BACTERIOLOGY; RHEUMATIC FEVER; STREPTOCOCCUS. [E.D.Gr.]

**Scattering experiments (atoms and molecules)** Experiments in which a beam of incident electrons, atoms, or molecules is deflected by collisions with an atom or molecule. Such experiments provide tests of the theory of scattering as well as information about atomic and molecular forces. Scattering experiments can be designed to simulate conditions in planetary atmospheres, electrical discharges, gas lasers, fusion reactors, stars, and planetary nebulae. See ELECTRICAL CONDUCTION IN GASES; GAS DISCHARGE; LASER; NUCLEAR FUSION; PLANETARY NEBULA; PLANET; STAR.

In general, in any type of collision, scattering occurs, which causes the direction of relative motion of the two systems to be rotated to a new direction after the collision. More than two systems may also result from such an impact. A complete description of a collision event requires measurement of the directions, speeds, and internal states of all the products. See COLLISION (PHYSICS).

There are two basic types of scattering experiments. The simpler involves passing a collimated beam of particles (electrons, atoms, molecules, or ions) through a dilute target gas (in a cell or a jet) and measuring the fraction of incident particles that are deflected into a certain angle relative to the incident beam direction. In the second method, a collimated beam of particles intersects a second beam. The scattering events are usually registered by measuring the deflection or internal-state change of the beam particles. See MOLECULAR BEAMS.

Scattering in a particular type of collision is specified in terms of a differential cross section. The probability that, in a particular type of collision, the direction of motion of the electron is turned through a specified scattering angle into a specified solid angle is proportional to the corresponding differential scattering cross section. Collision cross sections can be measured with appropriately designed experimental apparatus. Depending on the type of collision process, that apparatus may measure the scattering angle, energy, charge, or mass of the scattered systems.

For the simplest case, the scattering of a beam of structureless particles of specified mass and speed by a structureless scattering center, the differential cross section may be calculated exactly by using the quantum theory. In the special case where the Coulomb force fully describes the interaction, both the quantum and classical theory give the same exact value for the differential cross section at all values of the scattering angle. See NONRELATIVISTIC QUANTUM THEORY.

For scattering of systems with internal structure (for example, molecules, and their ions), no exact theoretical calculation of the cross section is possible. Methods of approximation specific to different types of collisions have been developed. The power of modern high-speed computers has greatly increased their scope and effectiveness, with scattering experiments serving as benchmarks. See ATOMIC STRUCTURE AND SPECTRA; SUPERCOMPUTER. [R.A.Ph.]

**Scattering experiments (nuclei)** Experiments in which beams of particles such as electrons, nucleons, alpha particles and other atomic nuclei, and mesons are deflected by elastic

collisions with atomic nuclei. Much is learned from such experiments about the nature of the scattered particle, the scattering center, and the forces acting between them. Scattering experiments, made possible by the construction of high-energy particle accelerators and the development of specialized techniques for detecting the scattered particles, are one of the main sources of information regarding the structure of matter. See NUCLEAR STRUCTURE; PARTICLE ACCELERATOR; PARTICLE DETECTOR; SCATTERING MATRIX. [K.A.Er.]

**Scattering layer** A layer of organisms in the sea which causes sound to scatter and returns echoes. Recordings by sonic devices of echoes from sound scatterers indicate that the scattering organisms are arranged in approximately horizontal layers in the water, usually well above the bottom. The layers are found in both shallow and deep water. [J.B.H.]

**Scattering matrix** An infinite-dimensional matrix or operator that expresses the state of a scattering system consisting of waves or particles or both in the far future in terms of its state in the remote past; also called the S matrix. In the case of electromagnetic (or acoustic) waves, it connects the intensity, phase, and polarization of the outgoing waves in the far field at various angles to the direction and polarization of the beam pointed toward an obstacle. It is used most prominently in the quantum-mechanical description of particle scattering, in which context it was invented in 1937 by J. A. Wheeler to describe nuclear reactions. Because an analog of the Schrödinger equation for the description of particle dynamics is lacking in the relativistic domain, W. Heisenberg proposed in 1943 that the S matrix rather than the hamiltonian or the lagrangian be regarded as the fundamental dynamical entity of quantum mechanics. This program played an important role in high-energy physics during the 1960s but is now largely abandoned. The physics of fundamental particles is now described primarily in terms of quantum gauge fields, and these are used to determine the S matrix and its elements for the collision and reaction processes observed in the laboratory. See ELEMENTARY PARTICLE; GAUGE THEORY; NONRELATIVISTIC QUANTUM THEORY; NUCLEAR REACTION; QUANTUM MECHANICS; RELATIVISTIC QUANTUM THEORY; SCATTERING EXPERIMENTS (ATOMS AND MOLECULES); SCATTERING EXPERIMENTS (NUCLEI).

The mathematical properties of the S matrix in nonrelativistic quantum mechanics have been thoroughly studied and are, for the most part, well understood. If the potential energy in the Schrödinger equation, or the scattering obstacle, is spherically symmetric, the eigenfunctions of the S matrix are spherical harmonics and its eigenvalues are of the form  $\exp(2i\delta_l)$ , where the real number  $\delta_l$  is the phase shift of angular momentum  $l$ . In the nonspherically symmetric case, analogous quantities are called the eigenphase shifts, and the eigenfunctions depend on both the energy and the dynamics. In the relativistic regime, without an underlying Schrödinger equation for the particles, the mathematical properties are not as well known. Causality arguments (no signal should propagate faster than light) lead to dispersion relations, which constitute experimentally verifiable consequences of very general assumptions on the properties of nature that are independent of the detailed dynamics. See ANGULAR MOMENTUM; CAUSALITY; DISPERSION RELATIONS; EIGENFUNCTION; SPHERICAL HARMONICS. [R.G.Ne.]

**Scattering of electromagnetic radiation** The process in which energy is removed from a beam of electromagnetic radiation and reemitted with a change in direction, phase, or wavelength. All electromagnetic radiation is subject to scattering by the medium (gas, liquid, or solid) through which it passes.

It has been known since the work of J. Maxwell in the nineteenth century that accelerating electric charges radiate energy and, conversely, that electromagnetic radiation consists of fields which accelerate charged particles. Light in the visible, infrared, or ultraviolet region interacts primarily with the electrons in gases, liquids, and solids—not the nuclei. The scattering process in these wavelength regions consists of acceleration of the electrons by the incident beam, followed by reradiation from the accelerating charges. See ELECTROMAGNETIC RADIATION.

Scattering processes may be divided according to the time between the absorption of energy from the incident beam and the subsequent reradiation. True “scattering” refers only to those processes which are essentially instantaneous. Mechanisms in which there is a measurable delay between absorption and reemission are usually termed luminescence. See LUMINESCENCE.

Instantaneous scattering processes may be further categorized according to the wavelength shifts involved. Some scattering is “elastic”; there is no wavelength change, only a phase shift. In 1928 C. V. Raman discovered the process in which light was inelastically scattered and its energy was shifted by an amount equal to the vibrational energy of a molecule or crystal.

In liquids or gases two distinct processes generate inelastic scattering with small wavelength shifts. The first is Brillouin scattering from pressure waves. When a sound wave propagates through a medium, it produces alternate regions of high compression (high density) and low compression (or rarefaction). Brillouin scattering of light to higher (or lower) frequencies occurs because the medium is moving toward (or away from) the light source. This is an optical Doppler effect. See DOPPLER EFFECT.

The second kind of inelastic scattering studied in fluids is due to entropy and temperature fluctuations, and is known as Rayleigh scattering. These entropy fluctuations produce a broadening in the scattered radiation centered about the exciting wavelength, rather than sharp, well-defined wavelength shifts. Under the assumption that the scattering in fluids is from particles much smaller than the wavelength of the exciting light, Lord Rayleigh derived in 1871 an equation for such scattering. The dependence of scattering intensity upon the inverse fourth power of the wavelength given in Rayleigh’s equation is responsible for the fact that daytime sky looks blue and sunsets red: blue light is scattered out of the sunlight by the air molecules more strongly than red; at sunset, more red light passes directly to the eyes without being scattered. See ENTROPY.

Rayleigh’s derivation of his scattering equation relies on the assumption of small, independent particles. Under some circumstances of interest, both of these assumptions fail. Colloidal suspensions provide systems in which the scattering particles are comparable to or larger than the exciting wavelengths. Such scattering is called the Tyndall effect and results in a nearly wavelength-independent (that is, white) scattering spectrum. The Tyndall effect is the reason clouds are white (the water droplets become larger than the wavelengths of visible light). See TYNDALL EFFECT.

The breakdown of Rayleigh’s second assumption—that of independent particles—occurs in all liquids. There is strong correlation between the motion of neighboring particles. This leads to fixed phase relations and destructive interference for most of the scattered light. The remaining scattering arises from fluctuations in particle density discussed above. [J.F.S.]

**Scent gland** A specialized skin gland of the tubuloalveolar or acinous variety found in many mammals. These glands produce substances having peculiar odors. In some instances they are large, in others small. Examples of large glands are the civet gland in the civet cat, the musk gland in the musk deer, and the castoreum gland in the beaver. The civet gland is an anal gland, whereas the musk and castoreum are preputial. Examples of small scent glands are the preputial or Tyson’s glands

in the human male which secrete the smegma, and the vulval glands in the female. The secretions in all of the above glands are sebaceous. See GLAND. [O.E.N.]

**Scheduling** A decision-making function that plays an important role in most manufacturing and service industries. Scheduling is applied in procurement and production, in transportation and distribution, and in information processing and communication. A scheduling function typically uses mathematical optimization techniques or heuristic methods to allocate limited resources to the processing of tasks.

Project scheduling is concerned with a set of activities that are subject to precedence constraints, specifying which jobs have to be completed before a given job is allowed to start its processing. All activities belong to a single (and typically large) project that has to be completed in a minimum time; for example, a large real estate development or the construction of an aircraft carrier.

Production or job shop scheduling is important in manufacturing settings, for example, semiconductor manufacturing. Customer orders have to be executed. Each order entails a number of operations that have to be processed on the resources or the machines available. Each order has a committed shipping date that plays the role of a due date. Production scheduling often also includes lot sizing and batching.

Timetabling occurs often in class room scheduling, scheduling of meetings, and reservation systems. In many organizations, especially in the service industries, meetings must be scheduled in such a way that all necessary participants are present; often other constraints have to be satisfied as well (in the form of space and equipment needed). Such problems occur in schools with classroom and examination scheduling as well as in the renting of hotel rooms and automobiles.

Work-force scheduling (crew scheduling, and so on) is increasingly important, especially in the service industries. For example, large call centers in many types of enterprises (airlines, financial institutions, and others) require the development of complicated personnel scheduling techniques.

In order to determine satisfactory or optimal schedules, it is helpful to formulate the scheduling problem as a mathematical model. Such a model typically describes a number of important characteristics. One characteristic specifies the number of machines or resources as well as their interrelationships with regard to the configuration, for example, machines set up in series, machines set up in parallel. A second characteristic of a mathematical model concerns the processing requirements and constraints. These include setup costs and setup times, and precedence constraints between various activities. A third characteristic has to do with the objective that has to be optimized, which may be a single objective or a composite of different objectives. For example, the objective may be a combination of maximizing throughput (which is often equivalent to minimizing setup times) and maximizing the number of orders that are shipped on time.

The scheduling function is often incorporated in a system that is embedded in the information infrastructure of the organization. This infrastructure may be an enterprise-wide information system that is connected to the main databases of the company. Many other decision support systems may be plugged into such an enterprise-wide information system—for example, forecasting, order promising and due date setting, and material requirements planning (MRP).

The database that the scheduling system relies on usually has some special characteristics. It has static data as well as dynamic data. The static data—for example, processing requirements, product characteristics, and routing specifications—are fixed and do not depend on the schedules developed. The dynamic data are schedule-dependent; they include the start times and completion times of all the operations on all the different

machines, and the length of the setup times (since these may also be schedule-dependent).

The economic impact of scheduling is significant. In certain industries the viability of a company may depend on the effectiveness of its scheduling systems, for example, airlines and semiconductor manufacturing. Good scheduling often allows an organization to conduct its operations with a minimum of resources. See MATERIAL RESOURCE PLANNING; PRODUCTION PLANNING. [M.Pi.; S.Se.]

**Scheelite** A mineral consisting of calcium tungstate,  $\text{CaWO}_4$ . Scheelite occurs in colorless to white, tetragonal crystals; it may also be massive and granular. Its fracture is uneven, and its luster is vitreous to adamantine. Scheelite has a hardness of 4.5–5 on Mohs scale and a specific gravity of 6.1. Its streak is white. The mineral is transparent and fluoresces bright bluish-white under ultraviolet light.

Scheelite is an important tungsten mineral and occurs in small amounts in vein deposits. The most important scheelite deposit in the United States is near Mill City, Nevada. See TUNGSTEN. [E.C.T.C.]

**Schematic drawing** Concise, graphical symbolism whereby the engineer communicates to others the functional relationship of the parts in a component and, in turn, of the components in a system. The symbols do not attempt to describe in complete detail the characteristics or physical form of the elements, but they do suggest the functional form which the ensemble of elements will take in satisfying the functional requirements of the component. They are different from a block diagram in that schematics describe more specifically the physical process by which the functional specifications of a block diagram are satisfied.

An electrical schematic is a functional schematic which defines the interrelationship of the electrical elements in a circuit, equipment, or system. The symbols describing the electrical elements are stylized, simplified, and standardized to the point of universal acceptance (Fig. 1).

In a mechanical schematic, the graphical descriptions of elements of a mechanical system are more complex and more intimately interrelated than the symbolism of an electrical system and so the graphical characterizations are not nearly as well standardized or simplified (Fig. 2). However, a mechanical

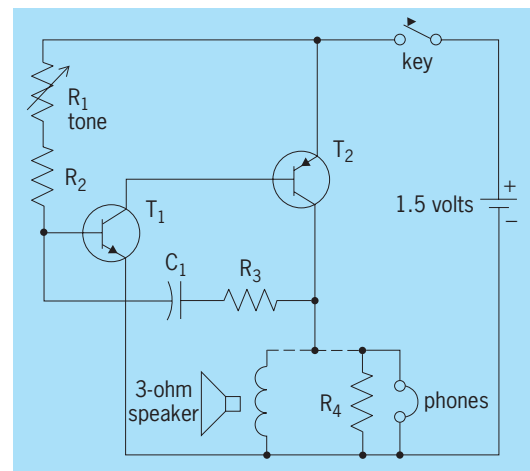
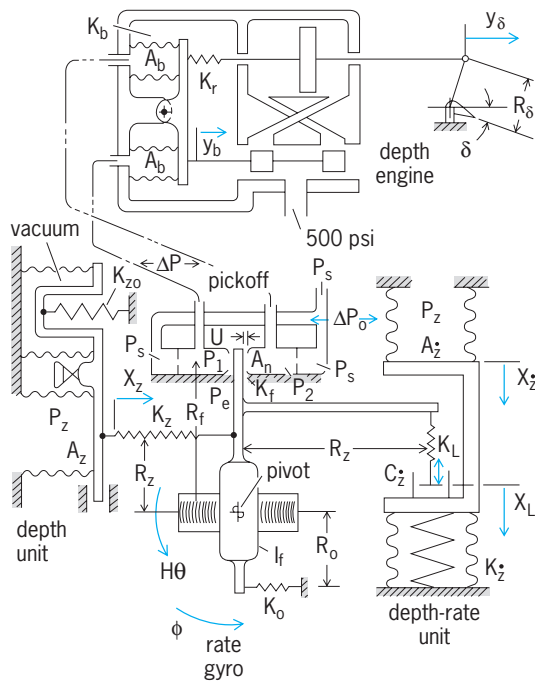

Fig. 1. Simple transistorized code practice oscillator, using standard symbols. (Adapted from J. Markus, *Sourcebook of Electronic Circuits*, McGraw-Hill, 1968)



## Subscripts:

b = differential-pressure bellows	o = ground, or reference
e = environment	r = ram feedback
f = flapper	s = supply
L = depth-rate linkage	z = depth unit
n = nozzles	$\dot{z}$ = depth-rate unit
	$\delta$ = elevator

Fig. 2. Mechanical schematic of the depth-control mechanism of a torpedo.

schematic illustrates such features as components, acceleration, velocity, position force sensing, and viscous damping devices. See DRAFTING; ENGINEERING DRAWING. [R.W.M.]

**Schist** Medium- to coarse-grained, mica-bearing metamorphic rock with well-developed foliation (layered structure) termed schistosity. Schist is derived primarily from fine-grained, mica-bearing rocks such as shales and slates. The schistosity is formed by rotation, recrystallization, and new growth of mica; it is deformational in origin. The planar to wavy foliation is defined by the strong preferred orientation of platy minerals, primarily muscovite, biotite, and chlorite. The relatively large grain size of these minerals (up to centimeters) produces the characteristic strong reflection when light shines on the rock. See BIOTITE; CHLORITE; MUSCOVITE.

Schists are named by the assemblage of minerals that is most characteristic in the field; for example, a garnet-biotite schist contains porphyroblasts of garnet and a schistosity dominated by biotite. Schists can provide important information on the relationship between metamorphism and deformation. See METAMORPHIC ROCKS; METAMORPHISM; PETROFABRIC ANALYSIS. [B.A.V.D.P.]

**Schistosomiasis** A disease in which humans are parasitized by any of three species of blood flukes: *Schistosoma mansoni*, *S. haematobium*, and *S. japonicum*. Adult *S. mansoni* prefer the veins of the hemorrhoidal plexus, *S. haematobium*

those of the vesical plexus, and *S. japonicum* those of the small intestine. The disease is also known as bilharziasis. See DIGENEA.

An embryonated egg passed in feces or urine hatches in fresh water, liberating a miracidium larva which penetrates into specific gastropod snails. The larval cycle in the snail lasts for about 1 month. The cercaria emerges from the mollusk, swims in the water, and penetrates the skin of the final host upon coming in contact with it.

Schistosomiasis is an agricultural hazard for all ages in irrigated lands or swamps. Elsewhere fluvial waters are the main source of infection, in which case incidence is marked in human beings who are less than 15 years old and is higher among boys than among girls. [J.F.M.]

**Schistostegales** An order of the true mosses (subclass Bryidae), consisting of a single species, *Schistostega pennata*, the cave moss, which is especially characterized by its leaf arrangement and the form of its protonema. The plants grow in dimly lit, cavelike places, such as the undersides of upturned tree roots. The cave moss is widely distributed in north temperate regions. An unrelated moss found in Australia and New Zealand, *Mittenia plumula*, has an identical protonema and habitat.

The leafy plants are erect, unbranched, and dimorphous: sterile shoots have leaves wide-spreading in two rows and confluent because of broad basal decurrencies. Fertile plants have leaves in five rows and erect-spreading in a terminal tuft. All leaves are ecostate, entire, and unbordered. The inflorescences are terminal, the setae elongate, and the capsules subglobose, with a flat operculum but no peristome. See BRYIDAE; BRYOPHYTA; BRYOPSIDA. [H.Cr.]

**Schizomida** An order of Arachnida with two families, Protoschizomidae (*Agastoschizomus*, *Protoschizomus*) and Schizomida (*Schizomus*, *Trithyreus*, *Megaschizomus*), including about 130 described species, mainly in the genus *Schizomus*. Schizomids occur in most tropical and warm temperate regions, but each species has a restricted distribution.

Many undescribed species probably occur in tropical leaf litter and caves. Schizomids are most closely related to Uropygi, with which they share several evolutionary novelties. See UROPYGI.

Schizomids are 0.12–0.44 in. (3–11 mm) in size, are white to tan, and lack eyes, although some retain vestigial “eye-spots.” The carapace is distinctively tripartite and the abdomen has a short, terminal flagellum.

Because schizomids are vulnerable to desiccation, they inhabit only moist places such as leaf litter, soil, caves, or beneath stones and logs. They are strict carnivores and fast runners. See ARACHNIDA. [J.A.Co.]

**Schizophrenia** A brain disorder that is characterized by bizarre mental experiences such as hallucinations and severe decrements in social, cognitive, and occupational functioning. Patients with schizophrenia demonstrate a series of biological differences when compared to other groups of psychiatric patients. However, no biological marker has yet been found to conclusively indicate the presence of schizophrenia. A diagnosis is made on the basis of a cluster of symptoms reported by the patient, and of signs identified by the clinician.

People with schizophrenia may report perceptual experiences in the absence of a perceptual stimulus. Most common are auditory hallucinations, often reported in the form of words spoken to the person with schizophrenia. The language is often derogatory, and it can be tremendously frightening. See HALLUCINATION.

People with schizophrenia often maintain beliefs that are not held by the overwhelming majority of the general population. To be considered delusions, the beliefs must be unshakable. In many cases, these beliefs may be bizarre and stem from odd experiences. In some instances, the delusions have an element of suspicion to them, such as the belief that others are planning

to cause the person harm. The delusions may or may not be related to hallucinatory experiences.

Many schizophrenics suffer from social isolation, lack of motivation, lack of energy, slow or delayed speech, and diminished emotional expression, often referred to as blunted affect. They may manifest an odd outward appearance due to the severity of their disorganization. This presentation may include speech that does not follow logically or sensibly, at times to the point of being incoherent. Facial expression may be odd or inappropriate, such as laughing for no reason. In some cases, people with schizophrenia may move in a strange and awkward manner. The extreme aspect of this behavior, referred to as catatonia, has become very rare since pharmacological treatments have become available.

Perhaps the most devastating feature of schizophrenia is the cognitive impairment found in most people with the disorder. On average, such people perform in the lowest 2–10% of the general population on tests of attention, memory, abstraction, motor skills, and language abilities.

The onset of schizophrenia generally occurs in people in the late teens to early twenties. However, schizophrenia is possible throughout the life span. While the onset of symptoms is abrupt in some people, others experience a more insidious process, including extreme social withdrawal, reduced motivation, mood changes, and cognitive and functional decline. The course of schizophrenia is normally characterized by episodes of relative remission in which only subtle symptoms remain, and episodes of exacerbation of symptoms, which are often caused by failure to continue treatment.

It is likely that there are various forms of schizophrenia, perhaps with different causes. Although schizophrenia appears to be inherited in some cases, the influence of genes is far from complete. Many arguments have been put forth regarding environmental factors that could cause schizophrenia. Very few of these theories are consistently supported.

Magnetic resonance imaging (MRI) has revealed that people with schizophrenia often have changes in the structure of their brain such as enlargement of the cerebral ventricles (the fluid-filled spaces in the brain close to the midline). Various brain regions have been found to be smaller in patients with schizophrenia, including the frontal cortex, temporal lobes, and hippocampi. In addition, studies of patients with schizophrenia have found patterns of abnormal activation of the brain while performing tests of memory and problem solving. See BRAIN; MEDICAL IMAGING.

Either a pharmacological or behavioral approach may be used in treating schizophrenia. A variety of antipsychotic medications have been used, and research continues into how to minimize the side effects which are often associated with such drugs. There are several targets for behavioral treatments in schizophrenia. Structured training programs have attempted to teach patients how to function more effectively in social, occupational, and independent living domains. Family interventions have been designed to provide a supportive environment for patients, and have been demonstrated to reduce risk of relapse. Another behavioral treatment area is teaching patients how to cope with hallucinations and delusions. Most patients with schizophrenia do not spontaneously recognize their symptoms as unusual and their experiences as unreal. Cognitive-behavioral treatments have been employed to help patients realize the nature of their symptoms and to develop plans for coping with them. See PSYCHOPHARMACOLOGY; PSYCHOTHERAPY. [R.S.E.K.; P.D.H.]

**Schlieren photography** Any technique for the photographic recording of schlieren, which are regions or stria in a medium that is surrounded by a medium of different refractive index. Refractive index gradients in transparent media cause light rays to bend (refract) in the direction of increasing refractive index. This is a result of the reduced light velocity in a higher-refractive-index material. This phenomenon is exploited

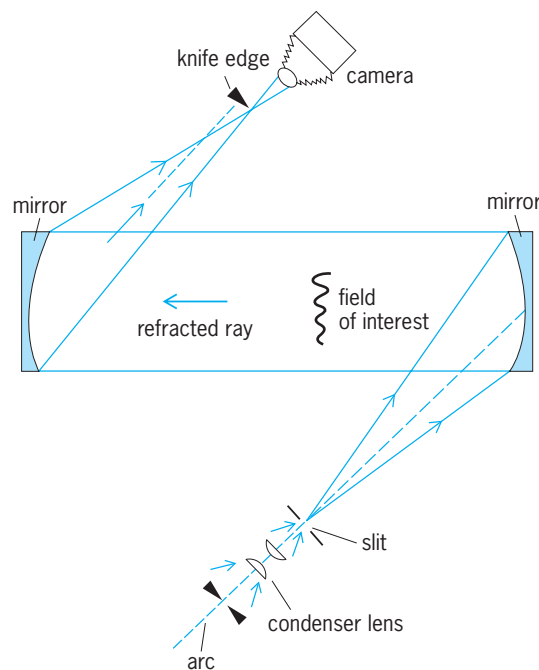

Knife-edge method of viewing schlieren, employing the "z" configuration.

in viewing the schlieren, with schlieren photographs as the result. Electronic video recorders, scanning diode array cameras, and holography are widely used as supplements. See HOLOGRAPHY; OPTICAL DETECTORS; PHOTOGRAPHY; REFRACTION OF WAVES.

There are many techniques for optically enhancing the appearance of the schlieren in an image of the field of interest. In the oldest of these, called the knife-edge method (see illustration), a point or slit source of light is collimated by a mirror and passed through a field of interest, after which a second mirror focuses the light, reimaging the point or slit where it is intercepted by an adjustable knife edge (commonly a razor blade). The illustration shows the "z" configuration which minimizes the coma aberration in the focus. Mirrors are most often used because of the absence of chromatic aberration. See ABERRATION (OPTICS).

Rays of light that are bent by the schlieren in the direction of the knife edge are intercepted and removed from the final image of the region of interest, causing those regions to appear dark. Consequently, the system is most sensitive to the density gradients that are perpendicular to the knife edge. The knife edge is commonly mounted on a rotatable mount so that it can be adjusted during a measurement to optimally observe different gradients in the same field of interest. The intensity in the processed image is proportional to the refractive index gradient. A gradient in the same direction as the knife edge appears dark. Gradients in the opposite direction appear bright. This method, employed with arc light sources, is still one of the simplest ways to view refractive index changes in transparent solids, liquids, and gases. A well-designed schlieren system can easily detect the presence of a refractive index gradient that causes 1 arc-second deviation of a light ray.

Except for locating and identifying schlieren-causing events such as turbulent eddies, shock waves, and density gradients, schlieren systems are usually considered to be qualitative instruments. Quantitative techniques for determining density are possible but are much more difficult to employ. The most common of these is color schlieren. The knife edge is replaced with a multicolored filter. Rays of light refracted through different angles appear in different colors in the final image.

The availability of lasers and new optical components has expanded the method considerably. When a coherent light source such as a laser is used, the knife edge can be replaced by a



variety of phase-, amplitude-, or polarization-modulating filters to produce useful transformations in the image intensity. See INTERFEROMETRY; LASER; POLARIZED LIGHT. [J.D.Tr.]

**Schmidt camera** A wide-field telescope that uses a thin aspheric front lens and a larger concave spherical mirror to focus the image (see illustration); it is also known as a Schmidt telescope. The Estonian optician Bernhard Schmidt devised the scheme in 1930. The field of best focus is located midway between the lens and the mirror and is curved toward the mirror, with a radius of curvature equal to the focal length. Usually film or photographic plates are bent to match this curved focus. A field-flattening lens may be used, allowing recording with charge-coupled devices (CCDs). See CHARGE-COUPLED DEVICES; GEOMETRICAL OPTICS; LENS (OPTICS); MIRROR OPTICS.

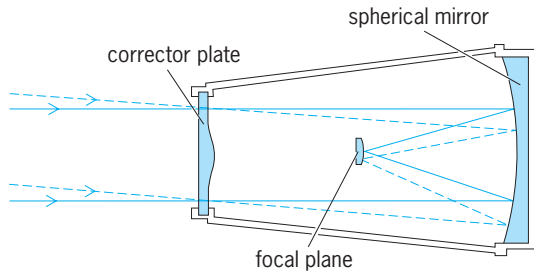

**Cross section of Schmidt camera with aspherical corrector plate.** (After J. M. Pasachoff, *Astronomy: From the Earth to the Universe*, 5th ed., Saunders College Publishing, 1998)

Schmidt telescopes are very fast, some having focal ratios in the vicinity of  $f/1$ . Their distinguishing feature is the very wide angle over which good images are obtained. Thus, under a dark sky they are sensitive to extended objects of low surface brightness. Schmidt telescopes have no coma; because the only lens element is so thin, they suffer only slightly from chromatic aberration and astigmatism. The front element, smaller than the main mirror, is sometimes known as a corrector plate. Often the outer surface of the corrector plate is plane, with the inner surface bearing the figure; however, a slight curvature is sometimes introduced to prevent misleading ghost images. This corrector plate almost eliminates the spherical aberration, giving extremely sharp images. For the most critical work, over a wide range of wavelengths, it must be made achromatic. See ABERRATION (OPTICS); OPTICAL SURFACES.

The largest Schmidt telescopes are 39–53 in. (1.0–1.3 m) in diameter. Most Schmidt telescopes are still used with film or photographic plates, to cover a wide field. Increasingly, Schmidt telescopes, especially several 24 in. (0.6 m) in diameter, are equipped with charge-coupled devices.

The success of the Schmidt design has led to many other types of catadioptric systems, with a combination of lenses and mirrors. Schmidt optics are often used in microscopes, astronomical spectrographs, and projection televisions. [J.M.P.]

**Schottky anomaly** A contribution to the heat capacity of a solid arising from the thermal population of discrete energy levels as the temperature is raised. The effect is particularly prominent at low temperatures, where other contributions to the heat capacity are generally small. See SPECIFIC HEAT.

Discrete energy levels may arise from a variety of causes, including the removal of orbital or spin degeneracy by magnetic fields, crystalline electric fields, and spin orbit coupling, or from the magnetic hyperfine interaction. Such effects commonly occur in paramagnetic ions. See LOW-TEMPERATURE THERMOMETRY.

Corresponding to the Schottky heat capacity, there is a contribution to the entropy. This can act as a barrier to the attainment of low temperatures if the substance is to be cooled either

by adiabatic demagnetization or by contact with another cooled substance. Conversely, a substance with a Schottky anomaly can be used as a heat sink in experiments at low temperatures (generally below 1 K or  $-457.9^\circ\text{F}$ ) to reduce temperature changes resulting from the influx or generation of heat. See ADIABATIC DEMAGNETIZATION; LOW-TEMPERATURE PHYSICS. [W.P.W.]

**Schottky barrier diode** A metal-semiconductor diode (two terminal electrical device) that exhibits a very nonlinear relation between voltage across it and current through it; formally known as a metallic disk rectifier. Original metallic disk rectifiers used selenium of copper oxide as the semiconductor coated on a metal disk. Today, the semiconductor is usually single-crystal silicon with two separate thin metal layers deposited on it to form electrical contacts. One of the two layers is made of a metal which forms a Schottky barrier to the silicon. The other forms a very low resistance, so-called ohmic, contact. The Schottky barrier is an electron or hole barrier caused by an electric dipole charge distribution associated with the contact potential difference which forms between a metal and a semiconductor under equilibrium conditions. The barrier is very abrupt at the surface of the metal because the charge is primarily on the surface. However, in the semiconductor, the charge is distributed over a small distance, and the potential gradually varies across this distance. See CONTACT POTENTIAL DIFFERENCE.

A basic useful feature of the Schottky diode is the fact that it can rectify an alternating current. Substantial current can pass through the diode in one direction but not in the other. If the semiconductor is  $n$ -type, electrons can easily pass from the semiconductor to the metal for one polarity of applied voltage, but are blocked from moving into the semiconductor from the metal by a potential barrier when the applied voltage is reversed. If the semiconductor is  $p$ -type, holes experience the same type of potential barrier but, since holes are positively charged, the polarities are reversed from the case of the  $n$ -type semiconductor. In both cases the applied voltage of one polarity (called forward bias) can reduce the potential barrier for charge carriers leaving the semiconductor, but for the other polarity (called reverse bias) it has no such effect. See DIODE; SEMICONDUCTOR; SEMICONDUCTOR RECTIFIER. [J.E.N.]

**Schottky effect** The enhancement of the thermionic emission of a conductor resulting from an electric field at the conductor surface. Since the thermionic emission current is given by the Richardson formula, an increase in the current at a given temperature implies a reduction in the work function of the emitter.

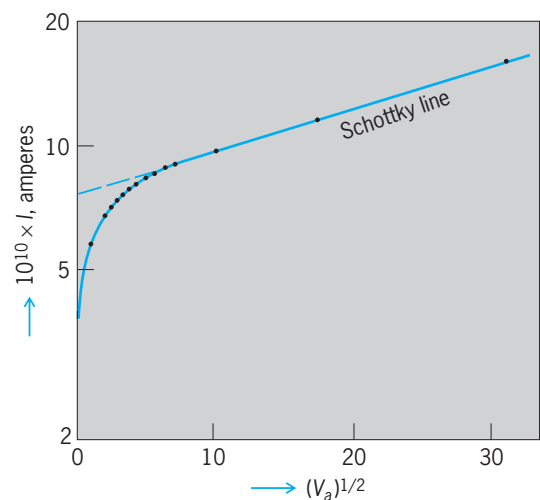

**Logarithm of thermionic emission current  $I$  of tungsten as function of square root of anode voltage  $V_a$ .** (After W. B. Nottingham, *Phys. Rev.*, 58:927–928, 1940)

The reduction in work function can be calculated by considering the effect of a constant externally applied field on the potential energy of an electron near the conductor surface, and is found to be proportional to the square root of the field. See THERMIONIC EMISSION; WORK FUNCTION (ELECTRONICS).

A plot of the logarithm of the current versus the square root of the anode voltage should yield a straight line. An example is given in the illustration for tungsten; the deviation from the straight line for low anode voltages is due to space-charge effects. See SPACE CHARGE. [A.J.D.]

**Schrödinger's wave equation** A linear, homogeneous partial differential equation that determines the evolution with time of a quantum-mechanical wave function.

Quantum mechanics was developed in the 1920s along two different lines, by W. Heisenberg and by E. Schrödinger. Schrödinger's approach can be traced to the notion of wave-particle duality that flowed from A. Einstein's association of particlelike energy bundles (photons, as they were later called) with electromagnetic radiation, which, classically, is a wavelike phenomenon. For radiation of definite frequency  $f$ , each bundle carries energy  $hf$ . The proportionality factor,  $h = 6.626 \times 10^{-34}$  joule-second, is a fundamental constant of nature, introduced by M. Planck in his empirical fit to the spectrum of blackbody radiation. This notion of wave-particle duality was extended in 1923 by L. de Broglie, who postulated the existence of wavelike phenomena associated with material particles such as electrons. See PHOTON; WAVE MECHANICS.

There are certain purely mathematical similarities between classical particle dynamics and the so-called geometric optics approximation to propagation of electromagnetic signals in material media. For the case of a single (nonrelativistic) particle moving in a potential  $V(\mathbf{r})$ , this analogy leads to the association with the system of a wave function,  $\Psi(\mathbf{r})$ , which obeys Eq. (1).

$$-\frac{\hbar^2}{2m}\nabla^2\Psi + V\Psi = E\Psi \quad (1)$$

Here  $m$  is the mass of the particle,  $E$  its energy,  $\hbar = h/(2\pi)$ , and  $\nabla^2$  is the laplacian operator. See CALCULUS OF VECTORS; GEOMETRICAL OPTICS; LAPLACIAN.

It is possible to ask what more general equation a time-, as well as space-dependent wave function,  $\Psi(\mathbf{r}, t)$ , might obey. What suggests itself is Eq. (2), which is now called the Schrödinger equation.

$$i\hbar\frac{\partial\Psi}{\partial t} = -\frac{\hbar^2}{2m}\nabla^2\Psi + V\Psi \quad (2)$$

The wave function can be generalized to a system of more than one particle, say  $N$  of them. A separate wave function is not assigned to each particle. Instead, there is a single wave function,  $\Psi(\mathbf{r}_1, \mathbf{r}_2, \dots, \mathbf{r}_N, t)$ , which depends at once on all the position coordinates as well as time. This space of position variables is the so-called configuration space. The generalized Schrödinger equation is Eq. (3), where the potential  $V$  may now depend on

$$i\hbar\frac{\partial\Psi}{\partial t} = -\sum_{i=1}^N\frac{\hbar^2}{2m_i}\nabla_i^2\Psi + V\Psi \quad (3)$$

all the position variables. Three striking features of this equation are to be noted:

1. The complex number  $i$  (the square root of minus one) appears in the equation. Thus  $\Psi$  is in general complex. See COMPLEX NUMBERS AND COMPLEX VARIABLES.

2. The time derivative is of first order. Thus, if the wave function is known as a function of the position variables at any one instant, it is fully determined for all later times.

3. The Schrödinger equation is linear and homogeneous in  $\Psi$ , which means that if  $\Psi$  is a solution so is  $c\Psi$ , where  $c$  is an arbitrary complex constant. More generally, if  $\Psi_1$  and  $\Psi_2$  are

solutions, so too is the linear combination  $c_1\Psi_1 + c_2\Psi_2$ , where  $c_1$  and  $c_2$  are arbitrary complex constants. This is the superposition principle of quantum mechanics. See SUPERPOSITION PRINCIPLE.

The Schrödinger equation suggests an interpretation in terms of probabilities. Provided that the wave function is square integrable over configuration space, it follows from Eq. (3) that the norm,  $(\Psi|\Psi)$ , is independent of time, where the norm is defined by Eq. (4).

$$(\Psi|\Psi) = \int d^3x_1 d^3x_2 \dots d^3x_N \Psi^* \Psi \quad (4)$$

It is possible to normalize  $\Psi$  (multiply it by a suitable constant) to arrange that this norm is equal to unity. With that done, the Schrödinger equation itself suggests that expression (5) is the

$$\Psi^* \Psi d^3x_1 d^3x_2 \dots d^3x_N \quad (5)$$

joint probability distribution at time  $t$  for finding particle 1 in the volume element  $d^3x_1$ , particle 2 in  $d^3x_2$ , and so forth. [S.Tr.]

**Schuler pendulum** Any apparatus which swings, because of gravity, with a natural period of 84.4 min, that is, with the same period as a hypothetical simple pendulum whose length is the Earth's radius. In 1923 Max Schuler showed that such an apparatus has the unique property that the pendulum arm will remain vertical despite any motions of its pivot. It is therefore useful as a base for navigational instruments. Schuler also showed how gyroscopes can be used to increase the period of a physical pendulum to the desired 84.4 min.

Gyrocompasses employ the Schuler principle to avoid errors due to ship accelerations. The principle has become the foundation of the science of inertial navigation. See GYROCOMPASS; INERTIAL GUIDANCE SYSTEM. [R.H.C.]

**Sciatica** Pain in the lower extremities, hips, and back caused by irritation of the sciatic nerves. The location of the specific pain and the causes producing it are quite varied.

Sciatica may result from mechanical pressure on the nerves or their roots in the cord. Trauma, herniated intervertebral disks, pregnancy, inflammation, or tumors may cause compression. Toxic or metabolic disorders, such as lead poisoning, diabetes mellitus, alcoholism, and vitamin-B deficiency may induce sciatic pain by producing changes in the nerves. Inflammations, both local and systemic, may also cause temporary or permanent nerve injury. Certain viral diseases, syphilis, and local infections act in this manner. See SYPHILIS; VIRUS; VITAMIN.

In addition, lesions in the anal region and the prostate may induce sciatica through reflex stimulation. Joint diseases, pelvic strain, and injury most often precipitate an attack. The pain of sciatica may begin suddenly and violently or gradually, as a nagging discomfort. The pain is usually along the leg, with later extension to the thigh and back. Numbness of the outside of the foot may occur. See PAIN. [E.G.St./N.K.M.]

**Science** In common usage the word science is applied to a variety of disciplines or intellectual activities which have certain features in common. Usually a science is characterized by the possibility of making precise statements which are susceptible of some sort of check or proof. This often implies that the situations with which the special science is concerned can be made to recur in order to submit themselves to check, although this is by no means always the case. There are observational sciences such as astronomy or geology in which repetition of a situation at will is intrinsically impossible, and the possible precision is limited to precision of description.

A common method of classifying sciences is to refer to them as either exact sciences or descriptive sciences. Examples of the former are physics and, to a lesser degree, chemistry; and of the latter, taxonomical botany or zoology. The exact sciences are in general characterized by the possibility of exact measurement.

One of the most important tasks of a descriptive science is to develop a method of description or classification that will permit precision of reference to the subject matter. See PHYSICAL SCIENCE. [P.W.Br./G.Ho.]

**Scientific methods** Strategies or uniform rules of procedure used in some scientific research with a measure of success. Scientific methods differ in generality, precision, and the extent to which they are scientifically justified. Thus, whereas the experimental method can in principle be used in all the sciences dealing with ascertainable facts, the various methods for measuring the electron charge are specific. The search for increasing quantitative precision involves the improvement or invention of special methods of measurement, also called techniques. All scientific methods are required to be compatible with confirmed scientific theories capable of explaining how the methods work. The most general of all the methods employed in science is called the scientific method.

The scientific method may be summarized as the following sequence of steps: identification of a knowledge problem; precise formulation or reformulation of the problem; examination of the background knowledge in a search for items that might help solve the problem; choice or invention of a tentative hypothesis that looks promising; conceptual test of the hypothesis, that is, checking whether it is compatible with the bulk of the existing knowledge on the matter; drawing some testable consequences of the hypothesis; design of an empirical (observational or experimental) test of the hypothesis or a consequence of it; actual empirical test of the hypothesis, involving a search for both favorable and unfavorable evidence (examples and counterexamples); critical examination and statistical processing of the data (for example, calculation of average error and elimination of outlying data); evaluation of the hypothesis in the light of its compatibility with both the background knowledge and the fresh empirical evidence; if the test results are inconclusive, design and performance of new tests, possibly using different special methods; if the test results are conclusive, acceptance, modification, or rejection of the hypothesis; if the hypothesis is acceptable, checking whether its acceptance forces some change (enrichment or correction) in the background knowledge; identifying and tackling new problems raised by the confirmed hypothesis; and repetition of the test and reexamination of its possible impact on existing knowledge.

The scientific method is not a recipe for making original discoveries or inventions; it does not prescribe the pathway that scientists must follow to attain success. The goal of the scientific method is to ascertain whether a hypothesis is true to some degree. Indeed, the nucleus of the scientific method is the confrontation of an idea (hypothesis) with the facts it refers to, regardless of the source of the idea in question. In sum, the scientific method is a means for checking hypotheses for truth rather than for finding facts or inventing ideas. See SCIENCE. [M.Bun.]

**Scientific satellites** Satellites used to gain scientific knowledge. They may be satellites of Earth or of other planets. Satellites used to apply space knowledge and techniques to practical purposes are called applications satellites. Many spacecraft are used for multiple purposes, combining space exploration, science, and applications in various ways. Scientific satellites are often called research satellites, and applications satellites are commonly designated by the application field, for example, navigation satellites. See SATELLITE (SPACECRAFT).

The space environment was one of the first areas investigated in scientific satellites. In this environment are cosmic rays, dust, magnetic fields, and various radiations from the Sun and galaxies. The Van Allen radiation belts were discovered by the first United States satellites. Soon thereafter satellites and space probes confirmed the existence of the solar wind. The continued

investigation of these phenomena by satellites and space probes has led to the knowledge that a planet with a strong magnetic field, like Earth, is surrounded by a complex region, called a magnetosphere.

Numerous investigations are made of the effect of the space environment on materials and processes, including effects of radiation damage, meteoric erosion processes, and extremely high vacuum for very long periods. The influence of prolonged weightlessness on welding, alloying metals, growing crystals, and biological processes constitutes a promising field for future practical applications.

Scientific satellites, sounding rockets, and space probes are having a profound effect on earth science. The Earth and its atmosphere can now be studied in comparison with the other planets and their atmospheres, providing greater insight into the formation and evolution of the solar system. Satellites also make possible precision measurements of the size and shape of Earth and its gravitational field, and even measurements of the slow drifting of continents relative to each other.

Satellites are also having a great influence on astronomy by making it possible to observe celestial objects in all the wavelengths that reach the vicinity of Earth, whereas the ionosphere and atmosphere prevent most of these radiations from reaching telescopes on the ground. Moreover, even in the visible wavelengths, the small-scale turbulence and continuously varying refraction in the lower atmosphere distorts the image of a stellar object viewed at the ground, so that there is a limit to the improvement that can be achieved by increasing the size of a ground-based telescope. See SATELLITE ASTRONOMY.

The applications satellites emphasize the continuing day-to-day practical utilization of the satellite. They are operational in nature, although some of them, either directly or as a by-product of their operational output, contribute significantly to research, for example, with meteorological or Earth survey satellites. An applied research program generally precedes establishment of an applications satellite system. Thus, Tiros and Nimbus laid the groundwork for operational meteorological satellites. Likewise, Syncom satellites preceded the Intelsat communications system. See APPLICATIONS SATELLITES; COMMUNICATIONS SATELLITE; METEOROLOGICAL SATELLITES; MILITARY SATELLITES; SATELLITE NAVIGATION SYSTEMS; SPACE FLIGHT. [H.E.N.]

**Scintillation counter** A particle or radiation detector which operates through emission of light flashes that are detected by a photosensitive device, usually a photomultiplier or a silicon PIN diode. The scintillation counter not only can detect the presence of a particle, gamma ray, or x-ray, but can measure the energy, or the energy loss, of the particle or radiation in the scintillating medium. The sensitive medium may be solid, liquid, or gaseous, but is usually one of the first two. The scintillation counter is one of the most versatile particle detectors, and is widely used in industry, scientific research, medical diagnosis, and radiation monitoring, as well as in exploration for petroleum and radioactive minerals that emit gamma rays. Many low-level radioactivity measurements are made with scintillation counters. See LOW-LEVEL COUNTING; PARTICLE DETECTOR; PHOTOMULTIPLIER.

Scintillation counters are made of transparent crystalline materials, liquids, plastics, or glasses. In order to be an efficient detector, the bulk scintillating medium must be transparent to its own luminescent radiation, and since some detectors are quite extensive, covering meters in length, the transparency must be of a high order. One face of the scintillator is placed in optical contact with the photosensitive surface of the photomultiplier or PIN diode (see illustration). In order to direct as much as possible of the light flash to the photosensitive surface, reflecting material is placed between the scintillator and the inside surface of the container.

In many cases it is necessary to collect the light from a large area and transmit it to the small surface of a photomultiplier. In this case, a "light pipe" leads the light signal from the scintillator surface to the photomultiplier with only small loss. The best light guides and light fibers are made of glass, plastic, or quartz. It is also possible to use lenses and mirrors in conjunction with scintillators and photomultipliers. See OPTICAL FIBERS.

A charged particle, moving through the scintillator, loses energy and leaves a trail of ions and excited atoms and molecules. Rapid interatomic or intermolecular transfer of electronic excitation energy follows, leading eventually to a burst of luminescence characteristic of the scintillator material. When a particle stops in the scintillator, the integral of the resulting light output, called the scintillation response, provides a measure of the particle energy, and can be calibrated by reference to particle sources of known energy. Photomultipliers or PIN diodes may be operated so as to generate an output pulse of amplitude proportional to the scintillation response.

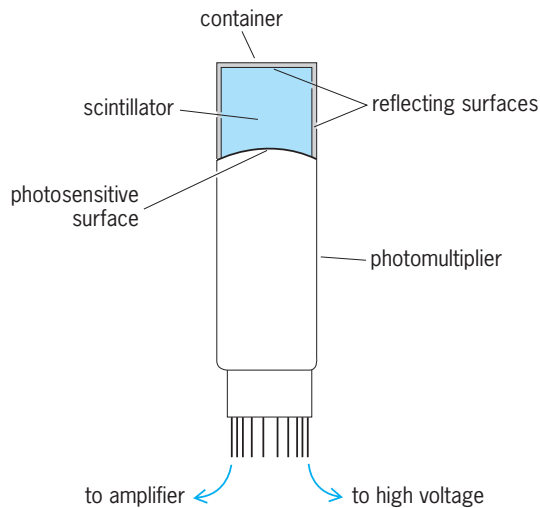

Diagram of a scintillation counter.

When a particle passes completely through a scintillator, the energy loss of the particle is measured. When a gamma ray converts to charged particles in a scintillator, its energy may also be determined. When the scintillator is made of dense material and of very large dimensions, the entire energy of a very energetic particle or gamma ray may be contained within the scintillator, and again the original energy may be measured. Such is the case for energetic electrons, positrons, or gamma rays which produce electromagnetic showers in the scintillator. Energy spectra can be determined in these various cases by using electronic equipment to convert amplitudes of the output pulses from the photomultiplier or PIN diode to digital form, for further processing by computers or pulse-height analyzers. [F.D.B.; R.Ho.]

**Scleractinia** An order of the subclass Zoantharia which comprises the true or stony corals (see illustration). These are solitary or colonial anthozoans which attach to a firm substrate. They are profuse in tropical and subtropical waters and contribute to the formation of coral reefs or islands. Some species are free and unattached.

Most of the polyp is impregnated with a hard calcareous skeleton secreted from ectodermal calcioblasts. The solitary corals form cylindrical, discoidal, or cuneiform skeletons, whereas colonial skeletons are multifarious. The polyps increase rapidly by intra- or extratentacular budding, and the skeletons of polyps which settle in groups may fuse to form a colony. The pyriform, ciliated planula swims with its aboral extremity, which is



Solitary coral polyps, *Oulangia* sp.

composed of an ectodermal sensory layer, directed anteriorly. Planulation occurs periodically in conformity with lunar phases in many tropical species. See ZOANTHARIA. [K.At.]

Scleractinian corals possess robust skeletons, so they have a rich fossil record. Because they are restricted mainly to tropical belts, they help indicate the position of the continents throughout the Mesozoic and Cenozoic periods. They are also important for understanding the evolution of corals and the origin and maintenance of reef diversity through time. Pleistocene corals shows persistent reef coral communities throughout the last several hundred thousand years. Environmental degradation has led to the dramatic alteration of living coral communities during the past several decades. [J.M.Pan.]

**Sclerenchyma** Single cells or aggregates of cells whose principal function is thought to be mechanical support of plants or plant parts. Sclerenchyma cells have thick secondary walls and may or may not remain alive when mature. They vary greatly in form and are of widespread occurrence in vascular plants. Two general types, sclereids and fibers, are widely recognized, but since these intergrade, the distinction is sometimes arbitrary. [N.H.B.]

**Sclerospongiae** A class of sponges that lay down a compound skeleton including an external, basal mass of calcium carbonate, either aragonite or calcite, as well as internal siliceous spicules and protein fibers. The living tissue forms a thin layer over the basal calcareous skeleton and extends into surface depressions of the skeleton; the organization of the tissue is similar to that of encrusting demosponges. Sclerosponges are common inhabitants of cryptic habitats on coral reefs in both the Caribbean and Indo-Pacific biogeographic regions. See DEMOSPONGIAE. [W.D.H.]

**Scorpiones** An order of the Arachnida which have chelate pedipalps and chelicera, a terminal caudal sting, and abdominal pectines (see illustration). The body is divided into a cephalothorax, which is covered by the unsegmented carapace, and a segmented abdomen. This latter division is differentiated into an anterior preabdomen and a postabdomen which, plus the terminal sting, constitutes the "tail" or cauda. The cephalothorax bears the chelicera, the pedipalps, and four pairs of walking legs. The preabdomen contains seven segments, while the postabdomen has five. The carapace bears three groups of small, simple eyes, a median pair and two groups of anterolateral eyes. True cave scorpions lack eyes.

Approximately 1000 species are known. Scorpions are widely distributed throughout the tropical zone and the warmer areas of the temperate zone. About 56 species are found in the United States, 22 of which are in Arizona. California and Florida also

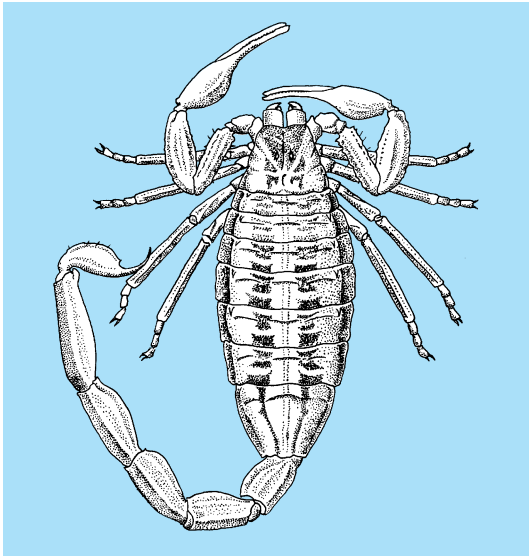

*Centruroides vittatus.*

have a rich scorpion fauna. Scorpions are found over three-fourths of the United States; they are absent from the New England states, Iowa, and areas immediately surrounding the Great Lakes.

The only species in the United States that are known to be lethal are *Centruroides sculpturatus* and *C. gertschi*, found in southern and central Arizona and the adjacent areas of California, New Mexico, and Mexico. The venom of these scorpions has proved fatal to healthy children up to 16 years of age and to adults suffering from hypertension and general debility. See ARACHNIDA. [H.L.St.]

**Scorpius** The Scorpion, in astronomy, one of the most beautiful and vivid constellations in the sky. Scorpius is the eighth sign of the zodiac (see illustration). The bright red star

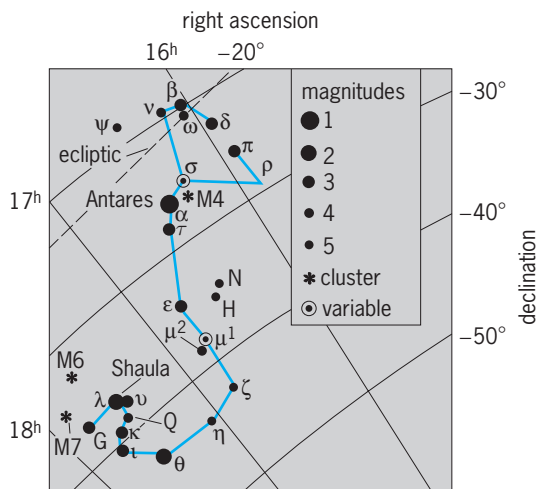

Line pattern of the constellation scorpius. The grid lines represent the coordinates of the sky. The apparent brightness, or magnitudes, of the stars is shown by the sizes of the dots, which are graded by appropriate numbers as indicated.

Antares is situated at the heart. Antares is one of the largest stars known, having a diameter over 450 times that of the Sun. As in Sagittarius, the Milky Way in Scorpius is bright and rich in star clouds and clusters. See CONSTELLATION. [C.S.Y.]

**Scrapie** A transmissible, usually fatal disease of adult sheep characterized by degeneration of the central nervous system. The disease is known in Great Britain, France, Belgium, Iceland, the United States, Canada, and northern India. Scrapie has certain similarities with kuru, a human disease in New Guinea, and mink encephalopathy.

Scrapie affects both sexes and is insidious in its onset, starting with hyperexcitability and progressive itch. Later, loss of wool occurs when the animal rubs against fixed objects or bites and nibbles its skin. Some animals do not rub but are either nervous and tremble when approached or appear sleepy. Incoordination of gait is constant and usually more evident in the hindquarters. In the final stages the sheep, being unable to stand, lie down, become emaciated, and die. See PRION DISEASE. [I.ZI.]

**Screening** A mechanical method of separating a mixture of solid particles into fractions by size. The mixture to be separated, called the feed, is passed over a screen surface containing openings of definite size. Particles smaller than the openings fall through the screen and are collected as undersize. Particles larger than the openings slide off the screen and are caught as oversize. A single screen separates the feed into only two fractions. Two or more screens may be operated in series to give additional fractions. Screening occasionally is done wet, but most commonly it is done dry.

Industrial screens may be constructed of metal bars, perforated or slotted metal plates, woven wire cloth, or bolting cloth. The openings are usually square but may be circular or rectangular. See MECHANICAL CLASSIFICATION; MECHANICAL SEPARATION TECHNIQUES; SEDIMENTATION (INDUSTRY). [W.L.McC.]

**Screw** A cylindrical body with a helical groove cut into its surface. For practical purposes a screw may be considered to be a wedge wound in the form of a helix so that the input motion is a rotation while the output remains translation. The screw is to the wedge much the same as the wheel and axle is to the lever in that it permits the exertion of force through a greatly increased distance.

The screw is by far the most useful form of inclined plane or wedge and finds application in the bolts and nuts used to fasten parts together; in lead and feed screws used to advance cutting tools or parts in machine tools; in screw jacks used to lift such objects as automobiles, houses, and heavy machinery; in screw-type conveyors used to move bulk materials; and in propellers for airplanes and ships. See PROPELLER (AIRCRAFT); PROPELLER (MARINE CRAFT); SCREW FASTENER; SCREW JACK; SCREW THREADS; SIMPLE MACHINE. [R.M.Ph.]

**Screw fastener** A threaded machine part used to join parts of a machine or structure. Screw fasteners are used when a connection that can be disassembled and reconnected and

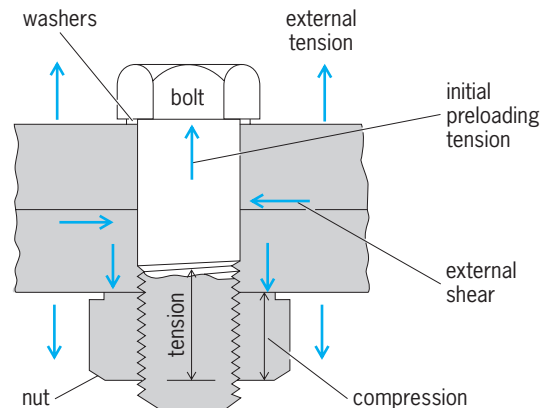

Forces on a bolt fastener under preloading.

that must resist tension and shear is required. A nut and bolt is a common screw fastener. Bolt material is chosen to have an extended stress-strain characteristic free from a pronounced yield point. Nut material is chosen for slight plastic flow.

The nut is tightened on the bolt to produce a preload tension in the bolt (see illustration). This preload has several advantageous effects. It places the bolt under sufficient tension so that during vibration the relative stress change is slight with consequent improved fatigue resistance and locking of the nut. Preloading also increases the friction between bearing surfaces of the joined members so that shear loads are carried by the friction forces rather than by the bolt. See BOLT; JOINT (STRUCTURES); NUT (ENGINEERING); SCREW. [F.H.R.]

**Screw jack** A mechanism for lifting and supporting loads, usually of large size. A screw jack mechanism consists of a thrust collar and a nut which rides on a bolt; the threads between the nut and bolt normally have a square shape. A standard form of screw jack has a heavy metal base with a central threaded hole into which fits a bolt capable of rotation under a collar thrusting against the load. See SCREW; SIMPLE MACHINE. [J.J.R.]

**Screw threads** Continuous helical ribs on a cylindrical shank. Screw threads are used principally for fastening, adjusting, and transmitting power. To perform these specific functions, various thread forms have been developed. A thread on the outside of a cylinder or cone is an external (male) thread; a thread on the inside of a member is an internal (female) thread (Fig. 1). See SCREW.

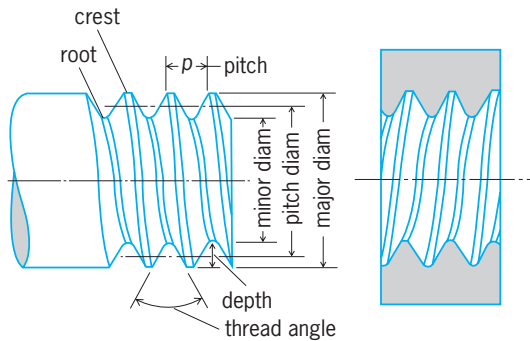

Fig. 1. Screw thread nomenclature.

**Types of thread.** A thread may be either right-hand or left-hand. A right-hand thread on an external member advances into an internal thread when turned clockwise; a left-hand thread advances when turned counterclockwise. If a single helical groove is cut or formed on a cylinder, it is called a single-thread screw. Should the helix angle be increased sufficiently for a second thread to be cut between the grooves of the first thread, a double thread will be formed on the screw. Double, triple, and even quadruple threads are used whenever a rapid advance is desired, as on valves.

Pitch and major diameter designate a thread. Lead is the distance advanced parallel to the axis when the screw is turned one revolution. For a single thread, lead is equal to the pitch; for a double thread, lead is twice the pitch. For a straight thread, the pitch diameter is the diameter of an imaginary coaxial cylinder that would cut the thread forms at a height where the width of the thread and groove would be equal.

Thread forms have been developed to satisfy particular requirements. Where strength is required for the transmission of power and motion, a thread having faces that are more nearly

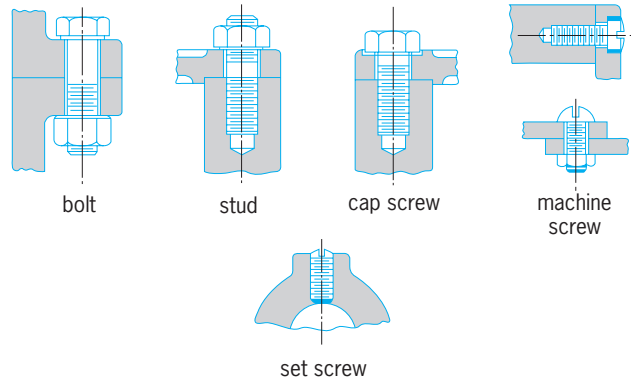

Fig. 2. Common types of fasteners. (After T. E. French and C. J. Vierck, *Engineering Drawing and Graphic Technology*, 12th ed., McGraw-Hill, 1978).

perpendicular to the axis is preferred. These threads, with their strong thread sections, transmit power nearly parallel to the axis of the screw.

**Thread fastener.** Most threaded fasteners are a threaded cylindrical rod with some form of head on one end. Of the many forms available, five types meet most requirements for threaded fasteners and are used for the bulk of production work: bolt, stud, cap screw, machine screw, and set screw (Fig. 2). Bolts and screws can be obtained with varied heads and points.

A bolt is generally used for drawing two parts together. A stud is a rod threaded on both ends. Studs are used for parts that must be removed frequently and for applications where bolts would be impractical.

Cap screws (plated or unplated) are widely used in machine tools and for assembling parts in automotive and aeronautical equipment. They are available in four standard heads: hexagon, flat, round, and fillister. Flathead and roundhead screws have slotted heads (Fig. 3). Machine screws are similar to cap screws

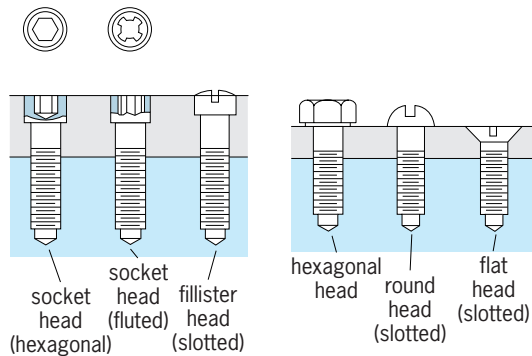

Fig. 3. Cap screws. (After W. J. Luzadder, *Fundamentals of Engineering Drawing*, 8th ed., Prentice-Hall, 1981).

and fulfill the same purpose, being employed principally on small work. Set screws made of hardened steel are used to hold parts in a position relative to one another. Wood screws, lag screws, and hanger bolts are used in wood. [W.J.L.]

**Scrophulariales** An order of flowering plants, division Magnoliophyta (Angiospermae), in the subclass Asteridae of the class Magnoliopsida (dicotyledons). The order consists of 12 families and more than 11,000 species. The largest families are the Scrophulariaceae (about 4000 species), Acanthaceae (about 2500 species), Gesneriaceae (about 2500 species), Bignoniaceae (about 800 species), and Oleaceae (about

600 species). The Scrophulariales are Asteridae, with a usually superior ovary and generally either with an irregular corolla or with fewer stamens than corolla lobes, or commonly both. They uniformly lack stipules.

The Scrophulariaceae are characterized by their usually herbaceous habit; irregular flowers with usually only two or four functional stamens; axile placentation; and dry, dehiscent fruits with more or less numerous seeds that have endosperm. The Acanthaceae are distinguished by their chiefly herbaceous habit, mostly simple and opposite leaves, lack of endosperm, and especially the enlarged and specialized funiculus, which is commonly developed into a jaculator that expels the seeds at maturity.

Some well-known members of the Scrophulariales are the African violet (*Saintpaulia ionantha*, in the Gesneriaceae), catalpa (Bignoniaceae), and lilac (*Syringa vulgaris*, in the Oleaceae). See ASTERIDAE; FLOWER; MAGNOLIOPHYTA; MAGNOLIOPSIDA; OLIVE; PLANT KINGDOM. [A.Cr.; T.M.Ba.]

**Scyphozoa** A class of the phylum Coelenterata, containing five living orders—Stauromedusae, Cubomedusae, Coronatae, Semaestomeae, and Rhizostomeae—and a fossil order, Stomatoporoidea. They are all marine and usually take two forms, the polyp, or scyphopolyp, and the medusa, or scyphomedusa. However, some are polyplike and sessile throughout their lives, while others are always pelagic and lack the sessile polyp stage. Among the Coelenterata, the Scyphozoa are characterized by having well-developed medusae of large size and fairly well-organized polyps of small size.

The scyphomedusae are generally found near the coast. Exceptions are certain pelagic forms and the Coronatae, which are abyssal. Most of the Stauromedusae have a circumpolar distribution, while the Cubomedusae and Rhizostomeae are found mostly in warm and tropical seas. Scyphomedusae are carnivorous, except the Rhizostomeae which are plankton eaters. Some Semaestomeae and Cubomedusae are injurious to humans because of their nematocysts. On the other hand, some Rhizostomeae are used as food in the Orient. See COELENTERATA. [T.U.]

**Sea anemone** Any polyp of the nearly 1000 anthozoan coelenterates belonging to the order Actiniaria. They occur intertidally and subtidally in marine and estuarine habitats, attached to solid substrates or burrowing into soft sediments. No freshwater or truly planktonic species are known. Anemones may be very small, a fraction of an inch long, to large individuals more than 3 ft (90 cm) in length or diameter. See ACTINIARIA.

Sea anemones enter into a number of interesting symbiotic partnerships. Some are host to single-celled marine algae, which grow within the cells of the anemone. The algae provide organic materials which aid in the nutrition of the anemone. Other anemones live on gastropod shells inhabited by hermit crabs. See ANTHOZOA; COELENTERATA. [C.H.]

**Sea breeze** A diurnal, thermally driven circulation in which a surface convergence zone often exists between airstreams having over-water versus over-land histories. The sea breeze is one of the most frequently occurring small-scale (mesoscale) weather systems. It results from the unequal sensible heat flux of the lower atmosphere over adjacent solar-heated land and water masses. Because of the large thermal inertia of a water body, during daytime the air temperature changes little over the water while over land the air mass warms. Occurring during periods of fair skies and generally weak large-scale winds, the sea breeze is recognizable by a wind shift to onshore, generally several hours after sunrise. On many tropical coastlines the sea breeze is an almost daily occurrence. It also occurs with regularity during the warm season along mid-latitude coastlines and even occasionally on Arctic shores. Especially during periods of

very light winds, similar though sometimes weaker wind systems occur over the shores of large lakes and even wide rivers and estuaries (lake breezes, river breezes). At night, colder air from the land often will move offshore as a land breeze. Typically the land breeze circulation is much weaker and shallower than its daytime counterpart. See ATMOSPHERIC GENERAL CIRCULATION; MESOMETEOROLOGY; METEOROLOGY.

The occurrence and strength of the sea breeze is controlled by a variety of factors, including land-sea surface temperature differences; latitude and day of the year; the synoptic wind and its orientation with respect to the shoreline; the thermal stability of the lower atmosphere; surface solar radiation as affected by haze, smoke, and stratiform and convective cloudiness; and the geometry of the shoreline and the complexity of the surrounding terrain. See WIND. [W.A.Ly.]

**Sea-floor imaging** The process whereby mapping technologies are used to produce highly detailed images of the sea floor. High-resolution images of the sea floor are used to locate and manage marine resources such as fisheries and oil and gas reserves, identify offshore faults and the potential for coastal damage due to earthquakes, and map out and monitor marine pollution, in addition to providing information on what processes are affecting the sea floor, where these processes occur, and how they interact. See MARINE GEOLOGY.

Side-scan sonar provides a high-resolution view of the sea floor. In general, a side-scan sonar consists of two sonar units attached to the sides of a sled tethered to the back of a ship. Each sonar emits a burst of sound that insonifies a long, narrow corridor of the sea floor extending away from the sled. Sound reflections from the corridor that echo back to the sled are then recorded by the sonar in their arrival sequence, with echoes from points farther away arriving successively later. The sonars repeat this sequence of "talking" and listening every few seconds as the sled is pulled through the water so that consecutive recordings build up a continuous swath of sea-floor reflections, which provide information about the texture of the sea floor. See ECHO SOUNDER; HYDROPHONE; SONAR; SONOBUOY; UNDERWATER SOUND.

The best technology for mapping sea-floor depths or bathymetry is multibeam sonar. These systems employ a series of sound sources and listening devices that are mounted on the hull of a survey ship. As with side-scan sonar, every few seconds the sound sources emit a burst that insonifies a long, slim strip of the sea floor aligned perpendicular to the ship's direction. The listening devices then begin recording sounds from within a fan of narrow sea-floor corridors that are aligned parallel to the ship and that cross the insonified strip. By running the survey the same way that one mows a lawn, adjacent swaths are collected parallel to one another to produce a complete sea-floor map of an area.

The most accurate and detailed view of the sea floor is provided by direct visual imaging through bottom cameras, submersibles, remotely operated vehicles, or if the waters are not too deep, scuba diving. Because light is scattered and absorbed in waters greater than about 33 ft (10 m) deep, the sea-floor area that bottom cameras can image is no more than a few meters. This limitation has been partly overcome by deep-sea submersibles and remotely operated vehicles, which provide researchers with the opportunity to explore the sea floor close-up for hours to weeks at a time. But even the sea-floor coverage that can be achieved with these devices is greatly restricted relative to side-scan sonar, multibeam sonar, and satellite altimetry.

The technology that provides the broadest perspective but the lowest resolution is satellite altimetry. A laser altimeter is mounted on a satellite and, in combination with land-based radars that track the satellite's altitude, is used to measure variations in sea-surface elevation to within 2 in. (5 cm). Removing elevation changes due to waves and currents, sea-surface height can vary up to 660 ft (200 m). These variations are caused by minute differences in the Earth's gravity field, which in turn result from

heterogeneities in the Earth's mass. These heterogeneities are often associated with sea-floor topography. By using a mathematical function that equates sea-surface height to bottom elevations, global areas of the sea floor can be mapped within a matter of weeks. However, this approach has limitations. Sea-floor features less than 6–9 mi (10–15 km) in length are generally not massive enough to deflect the ocean surface, and thus go undetected. Furthermore, sea-floor density also affects the gravity field; and where different-density rocks are found, such as along the margins of continents, the correlation between Earth's gravity field and sea-floor topography breaks down. See ALTIMETER.

[L.F.P.]

**Sea ice** Ice formed by the freezing of seawater. Ice in the sea includes sea ice, river ice, and land ice. Land ice is principally icebergs. River ice is carried into the sea during spring breakup and is important only near river mouths. The greatest part, probably 99% of ice in the sea, is sea ice. See ICEBERG.

The freezing point temperature and the temperature of maximum density of seawater vary with salinity. When freezing occurs, small flat plates of pure ice freeze out of solution to form a network which entraps brine in layers of cells. As the temperature decreases more water freezes out of the brine cells, further concentrating the remaining brine so that the freezing point of the brine equals the temperature of the surrounding pure ice structure. The brine is a complex solution of many ions.

The brine cells migrate and change size with changes in temperature and pressure. The general downward migration of brine cells through the ice sheet leads to freshening of the top layers to near zero salinity by late summer. During winter the top surface temperature closely follows the air temperature, whereas the temperature of the underside remains at freezing point, corresponding to the salinity of water in contact.

The sea ice in any locality is commonly a mixture of recently formed ice and old ice which has survived one or more summers. Except in sheltered bays, sea ice is continually in motion because of wind and current.

[W.Ly.]

**Sea of Okhotsk** A semienclosed basin adjacent to the North Pacific Ocean, bounded on the north, east, and west by continental Russia, the Kamchatka Peninsula, and northern Japan. On its southeast side the Sea of Okhotsk is connected to the North Pacific via a number of straits and passages through the Kuril Islands. The sea covers a surface area of approximately 590,000 mi<sup>2</sup> (1.5 million km<sup>2</sup>), or about 1% of the total area of the Pacific, and has a maximum depth of over 9000 ft (3000 m). Its mean depth is about 2500 ft (830 m). Owing to the cold, wintertime Arctic winds that blow to the southeast, from Russia toward the North Pacific Ocean, the Sea of Okhotsk is partially covered with ice during the winter months, from November through April. See BASIN; PACIFIC OCEAN.

The amount of water exchanged between the Sea of Okhotsk and the North Pacific Ocean is not well known, but it is thought that the waters of the Sea of Okhotsk that do enter the North Pacific may play an important role in the Pacific's large-scale circulation. The reason is the extreme winter conditions over the Sea of Okhotsk: its waters are generally colder and have a lower salinity than the waters at the same density in the North Pacific. See OCEAN CIRCULATION; SEAWATER.

[S.C.R.]

**Sea squirt** A sessile tunicate of the class Ascidiacea (phylum Chordata), so named because water is squirted from two openings when the animal is touched. Sea squirts may be solitary, colonial, or compound, but always have a permanent enclosing structure, the test or tunic, composed of polysaccharide material structurally similar to cellulose. In colonies, individuals are loosely attached together; in compound ascidians the individual zooids are embedded in a common test.

The individual is roughly cylindrical in shape and attached at the base (see illustration). The mantle encloses a space or

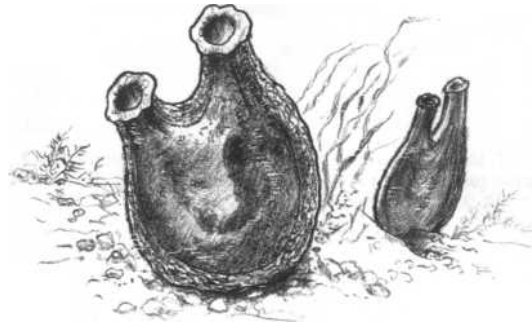

**Sea squirts; these saclike tunicates serve as scavengers and as food for higher forms.**

atrial cavity. Suspended within the atrial cavity is a pharynx or branchial sac perforated by numerous oval slits (stigmata), each one bearing a ring of marginal cilia. Constant beating of the cilia draws in water through the inhalant or oral aperture into the branchial sac. Water passes through the stigmata into the atrial cavity and is discharged at the exhalant or atrial aperture. In the branchial sac, food particles from the water are filtered on a mucous sheet which is then rolled up and passed to the esophagus. Sea squirts are dioecious, and fertilization may be internal or external.

Sea squirts occur in all seas and at all depths in the ocean. Most require a hard substratum on which to settle, but a few live in sand or mud. They are particularly common in shallow-water environments such as rocky shores, piers, and boat hulls, and in mangrove lagoons. See ASCIDIACEA; TUNICATA.

[I.Go.]

**Sea urchin** A marine echinoderm of the class Echinoidea. These invertebrates are found commonly in shallow waters. The soft internal organs are enclosed in and protected by a test or shell (see illustration) consisting of a number of plates which fit closely together and are located under the skin. The oral surface is in contact with the substratum. Five teeth, located in the mouth, form part of Aristotle's lantern, a complex chewing structure. Like many other species of echinoderms, sea urchins use tube feet for locomotion and pincerlike structures called pedicellariae to keep the shell clean. Sea urchins feed on most available animal and vegetable materials.

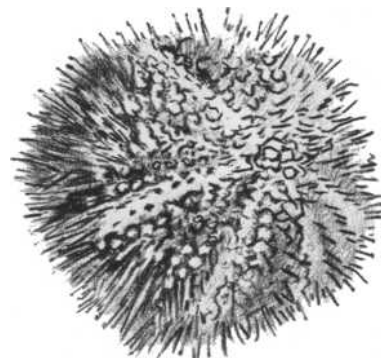

**The sea urchin shell, which protects the soft internal organs, is covered with spines arranged in five broad areas that are separated by narrow unprotected areas.**

Many species burrow into the sand, while others move into rock crevices to protect themselves from severe tidal action. See ECHINOIDEA.

[C.B.C.]



**Seaborgium** A chemical element, symbol Sg, atomic number 106. Seaborgium has chemical properties similar to tungsten. It was synthesized and identified in 1974. This discovery of seaborgium took place nearly simultaneously in two nuclear laboratories, the Lawrence Berkeley Laboratory at the University of California and the Joint Institute for Nuclear Research at Dubna in Russia.

The Berkeley group, under the leadership of A. Ghiorso, used as its source of heavy ions the Super-Heavy Ion Linear Accelerator (SuperHILAC). The production and positive identification of the isotope of seaborgium with the mass number 263 decays with a half-life of  $0.9 + 0.2$  s by the emission of alpha particles of principal energy  $9.06 + 0.04$  MeV. This isotope is produced in the reaction in which four neutrons are emitted:  $^{249}\text{Cf}(^{18}\text{O},4n)$ .

The Dubna group, under the leadership of G. N. Flerov and Y. T. Oganessian, produced its heavy ions with a heavy-ion cyclotron. They found a product that decays by the spontaneous fission mechanism with the very short half-life of 7 ms. They assigned it to the isotope  $^{259}\text{Sg}$ , suggesting reactions in which two or three neutrons are emitted:  $^{207}\text{Pb}(^{54}\text{Cr},2n)$  and  $^{208}\text{Pb}(^{54}\text{Cr},3n)$ . See NOBELIUM; NUCLEAR CHEMISTRY; PERIODIC TABLE; TRANSURANIUM ELEMENTS. [G.T.S.]

**Seamount and guyot** A seamount is a mountain that rises from the ocean floor; a submerged flat-topped seamount is termed a guyot. By arbitrary definition, seamounts must be at least 3000 ft (about 900 m) high, but in fact there is a continuum of smaller undersea mounts, down to heights of only about 300 ft (100 m). Some seamounts are high enough temporarily to form oceanic islands, which ultimately subside beneath sea level. There are on the order of 10,000 seamounts in the world ocean, arranged in chains (for example, the Hawaiian chain in the North Pacific) or as isolated features. In some chains, seamounts are packed closely to form ridges. Very large oceanic volcanic constructions, hundreds of kilometers across, are called oceanic plateaus. See MARINE GEOLOGY; OCEANIC ISLANDS; VOLCANO.

Almost all seamounts are the result of submarine volcanism, and most are built within less than about 1 million years. Seamounts are made by extrusion of lavas piped upward in stages from sources within the Earth's mantle to vents on the seafloor. Seamounts provide data on movements of tectonic plates on which they ride, and on the rheology of the underlying lithosphere. The trend of a seamount chain traces the direction of motion of the lithospheric plate over a more or less fixed heat source in the underlying asthenosphere part of the Earth's mantle. See LITHOSPHERE; PLATE TECTONICS. [E.L.Wi.]

**Seaplane** An airplane capable of navigating on, taking off from, and alighting upon the surface of water. Seaplanes are grouped into two main types: flying boats and float planes. In the flying boat, the hull, which provides buoyancy and planing area, is an integral part of the airframe, a specially designed fuselage which supports the wings and tail surfaces and houses



A single-engine float plane.

the crew, equipment, and cargo. Although multihull flying boats have been built, modern use is confined to single-hull boats with lateral stability on the water provided by small floats or pontoons attached to the wings. The float plane is a standard landplane made capable of water operation by the addition of floats which are attached to the airframe by struts. In practice the twin float is used exclusively, lateral stability on the water being provided by the separation of the two identical floats (see illustration). A seaplane with retracting wheels which permit either land or water operation is known as an amphibian. See AIRPLANE. [R.A.Ho.]

**Seasons** The four divisions of the year based upon variations of sunlight intensity (solar energy per unit area at the Earth's surface) at local solar noon (noontime) and daylight period. The variations in noontime intensity and daylight period are the result of the Earth's rotational axis being tilted  $23.5^\circ$  from the perpendicular to the plane of the Earth's orbit around the Sun. The direction of the Earth's axis with respect to the stars remains fixed as the Earth orbits the Sun. If the Earth's axis were not tilted from the perpendicular, there would be no variation in noontime sunlight intensity or daylight period and no seasons. The Earth-Sun distance does not influence the seasons because it varies only slightly, and it is overwhelmed by the effects of variations in sunlight intensity and daylight period due to the alignment of the Earth's axis.

Sunlight intensity at a location depends upon the angle from the horizon to the Sun at local solar noon; this angle in turn depends upon the location's latitude and the position of the Earth in its orbit. At increased angles, a given amount of sunlight is spread over smaller surface areas, resulting in a greater concentration of solar energy, which produces increased surface heating. Intensity is a more important factor than the number of daylight hours in determining the heating effect at the Earth's surface. See EARTH ROTATION AND ORBITAL MOTION. [H.P.C.]

**Seawater** An aqueous solution of salts of a rather constant composition of elements whose presence determines the climate and makes life possible on the Earth and which constitutes the oceans, the mediterranean seas, and their embayments. The physical, chemical, biological, and geological events therein are the studies that are grouped as oceanography. Water is most often found in nature as seawater (about 98%). The rest is ice, water vapor, and fresh water. The basic properties of seawater, their distribution, the interchange of properties between sea and atmosphere or land, the transmission of energy within the sea, and the geochemical laws governing the composition of seawater and sediments are the fundamentals of oceanography. See HYDROSPHERE; OCEANOGRAPHY.

The major chemical constituents of seawater are cations (positive ions) and anions (negative ions) [see table]. In addition, seawater contains the suspended solids, organic substances, and dissolved gases found in all natural waters. A standard salinity of 35 practical salinity units (psu; formerly parts per thousand, or ‰) has been assumed. While salinity does vary appreciably in oceanic waters, the fractional composition of salts is remarkably

Major constituents of seawater (salinity 35 psu)\*

Positive ions	Amount, g/kg	Negative ions	Amount, g/kg
Sodium ( $\text{Na}^+$ )	10.752	Chloride ( $\text{Cl}^-$ )	19.345
Magnesium ( $\text{Mg}^{2+}$ )	1.295	Bromide ( $\text{Br}^-$ )	0.066
Potassium ( $\text{K}^+$ )	0.390	Fluoride ( $\text{F}^-$ )	0.0013
Calcium ( $\text{Ca}^{2+}$ )	0.416	Sulfate ( $\text{SO}_4^-$ )	2.701
Strontium ( $\text{Sr}^{2+}$ )	0.013	Bicarbonate ( $\text{HCO}_3^-$ )	0.145
		Boron hydroxide ( $\text{B}(\text{OH})_3^-$ )	0.027

\* Water, 965 psu; dissolved materials, 35 psu.

constant throughout the world's oceans. In addition to the dissolved salts, natural seawater contains particulates in the form of plankton and their detritus, sediments, and dissolved organic matter, all of which lend additional coloration beyond the blue coming from Rayleigh scattering by the water molecules. Almost every known natural substance is found in the ocean, mostly in minute concentrations. See SCATTERING OF ELECTROMAGNETIC RADIATION. [J.L.Re.]

**Seawater fertility** A measure of the potential ability of seawater to support life. Fertility is distinguished from productivity, which is the actual production of living material by various trophic levels of the food web. Fertility is a broader and more general description of the biological activity of a region of the sea, while primary production, secondary production, and so on, is a quantitative description of the biological growth at a specified time and place by a certain trophic level. Primary production that uses recently recycled nutrients such as ammonium, urea, or amino acids is called regenerated production to distinguish it from the new production that is dependent on nitrate being transported by mixing or circulation into the upper layer where primary production occurs. New production is organic matter, in the form of fish or sinking organic matter, that can be exported from the ecosystem without damaging the productive capacity of the system. See BIOLOGICAL PRODUCTIVITY.

The potential of the sea to support growth of living organisms is determined by the fertilizer elements that marine plants need for growth. Fertilizers, or inorganic nutrients as they are called in oceanography, are required only by the first trophic level in the food web, the primary producers; but the supply of inorganic nutrients is a fertility-regulating process whose effect reaches throughout the food web. When there is an abundant supply to the surface layer of the ocean that is taken up by marine plants and converted into organic matter through photosynthesis, the entire food web is enriched, including zooplankton, fish, birds, whales, benthic invertebrates, protozoa, and bacteria. See DEEP-SEA FAUNA; FOOD WEB; MARINE FISHERIES.

The elements needed by marine plants for growth are divided into two categories depending on the quantities required: The major nutrient elements that appear to determine variations in ocean fertility are nitrogen, phosphorus, and silicon. The micronutrients are elements required in extremely small, or trace, quantities including essential metals such as iron, manganese, zinc, cobalt, magnesium, and copper, as well as vitamins and specific organic growth factors such as chelators. Knowledge of the fertility consequences of variations in the distribution of micronutrients is incomplete, but consensus among oceanographers is that the overall pattern of ocean fertility is set by the major fertilizer elements—nitrogen, phosphorus, and silicon—and not by micronutrients.

Two types of marine plants carry out primary production in the ocean: microscopic planktonic algae collectively called phytoplankton, and benthic algae and sea grasses attached to hard and soft substrates in shallow coastal waters.

The benthic and planktonic primary producers are a diverse assemblage of plants adapted to exploit a wide variety of marine niches; however, they have in common two basic requirements for the photosynthetic production of new organic matter: light energy and the essential elements of carbon, hydrogen, nitrogen, oxygen, phosphorus, sulfur, and silicon for the synthesis of new organic molecules. These two requirements are the first-order determinants of photosynthetic growth for all marine plants and, hence, for primary productivity everywhere in the ocean.

The regions of the world's oceans differ dramatically in overall fertility. In the richest areas, the water is brown with diatom blooms, fish schools are abundant, birds darken the horizon, and the sediments are fine-grained black mud with a high organic content. In areas of low fertility, the water is blue and clear, fish are rare, and the bottom sediments are well-oxidized carbonate or clay. These extremes exist because the overall pattern

of fertility is determined by the processes that transport nutrients to the sunlit upper layer of the ocean where there is energy for photosynthesis. See SEAWATER. [R.T.B.]

**Sebaceous gland** A gland which produces and liberates sebum, a mixture composed of fat, cellular debris, and keratin. When the gland arises in association with a hair follicle, it forms a thickened outpocketing from the side of the developing follicle near the epidermis. Central cells in these sebaceous glands form oil droplets within the cytoplasm. These cells disintegrate to liberate the sebaceous substance and are therefore of the holocrine type. The Meibomian or tarsal glands, within the tarsus or supporting plate at the edge of the eyelids, are sebaceous and complex tubuloalveolar structures. The numerous separate glands open along the entire edge of the upper and lower lids. Retained secretions of the tarsal glands produce a chalazion or Meibomian cyst. See GLAND. [O.E.N.]

**Second messengers** Molecules used to transmit signals within cells. These molecules trigger a cascade of events by activating other cellular components. The ability of cells to respond to specific extracellular molecules, or agonists, is crucial to growth, development, and homeostasis of multicellular organisms. Signal transduction refers to the movement of a signal initiated outside the cell into the cell interior. Many agonists induce the stimulation of cell growth, differentiation, or expression of specific genes. Signal transduction pathways must, therefore, include mechanisms for the initiation of signals at the cell surface membrane (plasma membrane), as well as a mechanism by which these signals traverse the interior of the cell (cytoplasm), and induce the desired target response. The pathways involve cascades of sequential molecular activation steps that are organized into three major components: (1) a receptor that recognizes and binds agonists, (2) second messengers, or signal transducing molecules, that couple receptors to intracellular pathways, and (3) effectors or molecules responsible for the ultimate response. A central feature of all signaling cascades is that they discriminate among a variety of signals and provide a mechanism for signal amplification. See SIGNAL TRANSDUCTION. [D.M.Ra.]

**Second sound** A type of wave propagated in the superfluid phase of liquid helium (helium II) and in certain other substances under special conditions. The name is misleading since second sound is not in any sense a sound wave, but a temperature or entropy wave. In ordinary or first sound, pressure and density variations propagate with very small accompanying variations in temperature; in second sound, temperature variations propagate with no appreciable variation in density or pressure. See LIQUID HELIUM; SUPERFLUIDITY.

The two-fluid model of helium II provides further insight into the nature of second sound. In this model the liquid can be described as consisting of superfluid and normal components of densities  $\rho_s$  and  $\rho_n$ , respectively, such that the total density  $\rho = \rho_s + \rho_n$ . The superfluid component is frictionless and devoid of entropy; the normal component has a normal viscosity and contains the entropy and thermal energy of the system. In a temperature or second-sound wave, the normal and superfluid flows are oppositely directed so that  $\rho_s \mathbf{V}_s + \rho_n \mathbf{V}_n = 0$ , where  $\mathbf{V}_s$  and  $\mathbf{V}_n$  are the superfluid and normal flow velocities. Thus a variation in relative densities of the two components, and hence a temperature fluctuation, propagates with no change in total density or pressure. In a first-sound wave, the two components move in phase, that is,  $\mathbf{V}_n \cong \mathbf{V}_s$ .

Theoretical predictions that second sound should exist in certain solid dielectric crystals under suitable conditions have been confirmed experimentally for solid helium single crystals at temperatures between 0.4 and 1.0 K (−459.0 and −457.9°F). See DIELECTRIC MATERIALS.

Another quite different class of materials can exhibit second sound. In smectic A liquid crystals, when the wave vector is

oblique with respect to the layers of these ordered structures, a modulation of the interlayer spacing can propagate at nearly constant density. See LIQUID CRYSTALS. [H.A.F.]

**Secondary emission** The emission of electrons from the surface of a solid into vacuum caused by bombardment with charged particles, in particular with electrons. The mechanism of secondary emission under ion bombardment is quite different from that under electron bombardment; it is only in the latter case that the term secondary emission is generally used.

The bombarding electrons and the emitted electrons are referred to, respectively, as primaries and secondaries. Secondary emission has important practical applications because the secondary yield, that is, the number of secondaries emitted per incident primary, may exceed unity. Thus, secondary emitters are used in electron multipliers, especially in photomultipliers, and in other electronic devices such as television pickup tubes, storage tubes for electronic computers, and so on.

The emission of secondary electrons can be described as the result of three processes: (1) excitation of electrons in the solid into high-energy states by the impact of high-energy primary electrons, (2) transport of these secondary electrons to the solid-vacuum interface, and (3) escape of the electrons over the surface barrier into the vacuum. The efficiency of each of these three processes, and hence the magnitude of the secondary emission yield  $\delta$ , varies greatly for different materials.

Most of the materials used in practical devices are semiconductors or insulators whose band-gap energies are much larger than their electron affinities. Examples are magnesium oxide (MgO), beryllium oxide (BeO), cesium antimonide (Cs<sub>3</sub>Sb), and potassium chloride (KCl). Maximum  $\delta$  values in the 8–15 range are typically obtained at primary energies of several hundred volts.

In certain semiconductors the bands are bent downward to such an extent that the vacuum level lies below the bottom of the conduction band in the bulk. A material with this characteristic is said to have negative effective electron affinity. The most important material in this category is cesium-activated gallium phosphide, GaP(Cs). The illustration shows the curve of yield  $\delta$

versus primary energy  $E_p$  for GaP(Cs) by comparison with MgO. Values of  $\delta$  exceeding 100 are readily obtained, with maximum yields at energies in the 5–10-kV region. See BAND THEORY OF SOLIDS; SEMICONDUCTOR. [A.H.So.]

### Secondary ion mass spectrometry (SIMS)

An instrumental technique that measures the elemental and molecular composition of solid materials. SIMS provides methods of visualizing the two- and three-dimensional composition of solids at lateral resolutions approaching several hundred nanometers and depth resolutions of 1–10 nm. This technique employs an energetic ion beam to remove or sputter the atomic and molecular constituents from a surface in a very controlled manner. The sputtered products include atoms, molecules, and molecular fragments that are characteristic of the surface composition within each volume element sputtered by the ion beam. A small fraction of the sputtered atoms and molecules are ionized as either positive or negative ions, and a measurement by SIMS determines the mass and intensity of these secondary ions by using various mass analysis or mass spectrometry techniques. In this technique, the sputtering ions are referred to as the primary ions or the primary ion beam, while the ions produced in sputtering the solid are the secondary ions. Most elements in the periodic table produce secondary ions, and SIMS can quantitatively detect elemental concentrations in the part-per-million to part-per-billion range.

Secondary ions are formed by kinetic and chemical ionization processes in which sputtering is achieved by energy transfer from the primary ions to the solid surface. Typically, SIMS primary ions impact the surface with kinetic energies of 5–20 keV, and this energy is ultimately transferred to the sample atoms and molecules. The energy transfer initiates a collision cascade within the solid that ejects atoms and molecules at the solid surface-vacuum interface.

SIMS analyses are divided into two broad categories known as dynamic and static. In the dynamic type, the most common SIMS method, a relatively intense primary ion beam sputters the sample surface at high sputter rates, providing a very useful way to determine the in-depth concentration of different elements in a solid. The most common secondary ions detected in a dynamic secondary ion mass spectrometry analysis are elemental ions or clusters of elemental ions.

Static or molecular SIMS utilizes a very low intensity primary ion beam, and static analyses are typically completed before a single monolayer has been removed from the surface. Most static analyses are stopped before 1% of the top surface layer has been chemically damaged or eroded; under these conditions, molecular and molecular fragment ions characteristic of the chemical structure of the surface are often detected. Thus, static SIMS is best suited for near-surface analysis of molecular composition or chemical structure information, while dynamic SIMS provides the best technique for bulk and in-depth elemental analysis. See SPUTTERING.

Instrument designs for SIMS require a primary ion gun or column to generate and transport the primary ion beam to the sample surface, a sample chamber with sample mounting facilities, a mass spectrometer which performs mass-to-charge separation of the different secondary ions, and an ion-detection system. The complete instrument is typically housed in an ultrahigh vacuum chamber. See ION SOURCES; MASS SPECTROSCOPE.

Dynamic SIMS has been successfully utilized in diverse applications. The analytical issues are the detection and localization of specific elements on the surface or in the bulk of the materials. The most important and common application area of dynamic SIMS is the bulk and in-depth analysis of semiconductor materials. Another important contribution of SIMS to materials science is the identification and localization of trace elements in metal grain boundaries, providing detailed insight into the chemistry of welds and alloys. Dynamic SIMS also has the unique ability to detect specific catalyst poisons on the surface and in the bulk

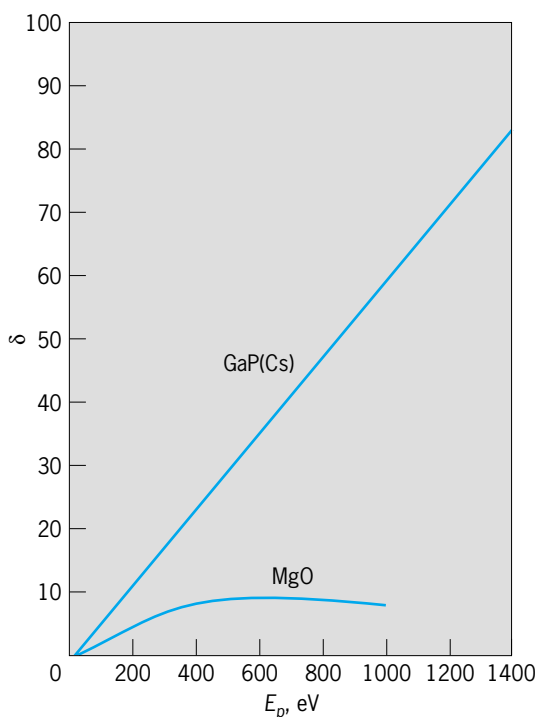

Secondary emission yield versus primary energy for GaP(Cs). The curve for MgO is shown for comparison.

of used or spent catalysts. In geological sciences, SIMS has been used to detect isotopic anomalies in the composition of various geological and meteoritic samples to help determine the age of the universe. Dynamic SIMS has found extensive applications to the characterization of both hard and soft biological tissue. See SEMICONDUCTOR.

Applications of static secondary ion mass spectrometry to analyses of the near-surface region of solids has become increasingly important as ever more sophisticated materials are developed. The near-surface region is generally defined as the top five monolayers (2–3 nm) of a solid. Examples of technology areas in which the chemistry of the near-surface region plays a critical role include high-performance glass coatings, liquid-crystal displays, manufacturing, semiconductor processing, biopolymer and biocompatible materials development, and polymer adhesives and coatings. See MASS SPECTROMETRY; MATERIALS SCIENCE AND ENGINEERING; SEMICONDUCTOR DIODE. [R.W.O.]

**Secretion** The export of proteins by cells. With few exceptions, in eukaryotic cells proteins are exported via the secretory pathway, which includes the endoplasmic reticulum and the Golgi apparatus. Secreted proteins are important in many physiological processes, from the transport of lipids and nutrients in the blood, to the digestion of food in the intestine, to the regulation of metabolic processes by hormones. See CELL (BIOLOGY); CELL ORGANIZATION; ENDOCRINE MECHANISMS.

Proteins destined for export are synthesized on ribosomes attached to the outside of the rough endoplasmic reticulum, a portion of the endoplasmic reticulum that is specialized for the synthesis of secretory proteins and most of the cell's membrane proteins. After they are folded, the proteins enter small vesicles in which they are transported to the Golgi apparatus. When the proteins reach the last cisterna of the Golgi, a highly tubulated region known as the *trans*-Golgi network, they are sorted and packaged again into transport vesicles, some of which are in the form of elongated tubules. From here, there are two pathways that proteins can take to the cell surface, depending on the cell type. Proteins can be transported directly to the plasma membrane (constitutive secretion) or to secretory granules (regulated secretion). See ENDOPLASMIC RETICULUM; GOLGI APPARATUS.

In all cells, there exists a constitutive secretion pathway whereby vesicles and tubules emerging from the *trans*-Golgi network fuse rapidly with the plasma membrane. The emerging vesicles and tubules attach to microtubules, cytoskeletal elements emanating from the Golgi region, that accelerate their transport to the plasma membrane. See ABSORPTION (BIOLOGY); CELL MEMBRANES.

In cells that secrete large amounts of hormones or digestive enzymes, most secretory and membrane proteins emerging from the *trans*-Golgi network are not immediately secreted, but are stored in membrane-bounded secretory granules. Secretory granules release their contents into the extracellular space in a process known as exocytosis, when their membranes fuse with the plasma membrane. Exocytosis occurs only after the cell receives a signal, usually initiated by the binding of a hormone or neurotransmitter to a receptor on the cell surface. The receptor triggers a signal transduction cascade that results in increased concentrations of second messengers such as cyclic adenosine 3', 5'-monophosphate and phosphatidylinositol triphosphate. In most secretory cells, the second messengers or the hormone receptors themselves trigger the opening of calcium channels through which calcium ions stream into the cytoplasm. Calcium initiates the docking of the secretory granules with the plasma membrane and the activation of the fusion apparatus. See ENZYME; HORMONE; SIGNAL TRANSDUCTION.

In exceptional cases, proteins can be exported directly from the cytoplasm without using the secretory pathway. One such protein is fibroblast growth factor, a hormone involved in the growth and development of tissues such as bone and endothelium. Several interleukins, proteins that regulate the immune re-

sponse, are also released via an unconventional route that may involve transport across the plasma membrane through channel proteins. These channels have adenosine 5'-triphosphatase (ATPase) enzyme activity and use the energy derived from the hydrolysis of ATP to catalyze transport. See CELLULAR IMMUNOLOGY. [M.R.]

**Secretory structures (plant)** Cells or organizations of cells which produce a variety of secretions. The secreted substance may remain deposited within the secretory cell itself or may be excreted, that is, released from the cell. Substances may be excreted to the surface of the plant or into intercellular cavities or canals. Some of the many substances contained in the secretions are not further utilized by the plant (resins, rubber, tannins, and various crystals), while others take part in the functions of the plant (enzymes and hormones). Secretory structures range from single cells scattered among other kinds of cells to complex structures involving many cells; the latter are often called glands.

Epidermal hairs of many plants are secretory or glandular. Such hairs commonly have a head composed of one or more secretory cells borne on a stalk. The hair of a stinging needle is bulbous below and extends into a long, fine process above. If one touches the hair, its tip breaks off, the sharp edge penetrates the skin, and the poisonous secretion is released.

Glands secreting a sugary liquid—the nectar—in flowers pollinated by insects are called nectaries. Nectaries may occur on the floral stalk or on any floral organ: sepal, petal, stamen, or ovary.

The hydathode structures discharge water—a phenomenon called guttation—through openings in margins or tips of leaves. The water flows through the xylem to its endings in the leaf and then through the intercellular spaces of the hydathode tissue toward the openings in the epidermis. Strictly speaking, such hydathodes are not glands because they are passive with regard to the flow of water.

Some carnivorous plants have glands that produce secretions capable of digesting insects and small animals. These glands occur on leaf parts modified as insect-trapping structures. In the sundews (*Drosera*) the traps bear stalked glands, called tentacles. When an insect lights on the leaf, the tentacles bend down and cover the victim with a mucilaginous secretion, the enzymes of which digest the insect. See INSECTIVOROUS PLANTS; VENUS' FLYTRAP.

Resin ducts are canals lined with secretory cells that release resins into the canal. Resin ducts are common in gymnosperms and occur in various tissues of roots, stems, leaves, and reproductive structures.

Gum ducts are similar to resin ducts and may contain resins, oils, and gums. Usually, the term gum duct is used with reference to the dicotyledons, although gum ducts also may occur in the gymnosperms.

Oil ducts are intercellular canals whose secretory cells produce oils or similar substances. Such ducts may be seen, for example, in various parts of the plant of the carrot family (*Umbelliferae*).

Laticifers are cells or systems of cells containing latex, a milky or clear, colored or colorless liquid. Latex occurs under pressure and exudes from the plant when the latter is cut. [K.E.]

**Sedative** A medication capable of producing a mild state of inhibition of the central nervous system (CNS) associated with reduced awareness of external stimuli. Numerous pharmacologic agents can induce different degrees of sedation, depending on the following variables: dosage; route of administration; absorption, metabolism, and excretion rates of the compound; specific receptor sites in the central nervous system that are affected by the agent; environmental setting; and state of the patient. See CENTRAL NERVOUS SYSTEM.

Ethanol was probably the first sedative compound and was widely used for its analgesic and hypnotic properties, as well as for its ability to decrease inhibitory anxiety with resultant

relaxation and occasional euphoria. Subsequent sedative compounds include the barbiturates (for example, phenobarbital and secobarbital) and the benzodiazepines (for example, diazepam and alprazolam). Although these sedative compounds possess properties of tolerance and habituation, they vary in their addictive potential according to specific receptor sites and the particular type of patient. *See* ADDICTIVE DISORDERS; BARBITURATES.

Other classes of chemical agents that are used as sedatives include the antihistamines as well as some antidepressant drugs which possess sedative side effects in addition to their primary pharmacologic properties. Since these classes of compounds are not addicting, they can be safely used as hypnotics. *See* ANXIETY STATES; TRANQUILIZER. [D.M.Ga.]

**Sedentaria** A group of 28 or more families of polychaete annelids in which the anterior, or cephalic, region is more or less completely concealed by overhanging peristomial structures, or the body is divided into an anterior thoracic and a posterior abdominal region; the pharynx or proboscis is usually soft and epithelial, lacking hard jaws or paragnaths. *See* POLYCHAETA. [O.H.]

**Sedimentary rocks** Rocks that accumulate at the surface of the Earth, under ambient temperatures. Together with extruded hot lavas, sedimentary rocks form a thin cover of stratified material (the stratisphere) over the deep-seated igneous and metamorphic rocks that constitute the bulk of the Earth's crust. Sediments cover about three-quarters of the land and of the ocean floor. The thickness of the stratisphere is generally measured in kilometers, and locally reaches about 15 km (50,000 ft). *See* EARTH CRUST; IGNEOUS ROCKS; METAMORPHIC ROCKS; ROCK.

Most sediments accumulate as sand and dust or mud. Being deposited from fluids (air, water) under the influence of gravity, they tend to assume level surfaces (though locally steep slopes may be developed, as in dunes and reefs). Changes in supply of sediment and in depositing agencies change the nature of the deposits from day to day and from millennium to millennium, and commonly interrupt the process altogether. As a result, the accumulated mantle of sediment has a layered structure, divided into beds or strata. Sediments become compacted as waters are squeezed out of them during burial and tectonism, and become cemented as remaining pore space becomes filled by newly growing minerals, mainly calcite or quartz. Bacterial degradation of organic matter, invasion by other fluids, and changes in temperature continue to alter the chemical environment, and lead to alteration of unstable mineral phases. Such processes are included in the term diagenesis. Soft sediment thus becomes converted to rock, but the geologist includes both in the concept of sedimentary rocks. *See* CALCITE; DIAGENESIS; QUARTZ.

When sediments are carried to greater depths or are otherwise subjected to high heat or pressure, growth of new minerals and plastic deformation destroy sedimentary structures and metamorphose the rock. Alternatively, the sediment melts in transition to igneous rock. Thus, sedimentary rocks are recycled through geologic time. Most of the crust under the continents, consisting of igneous and metamorphic rocks, has probably passed through the sedimentary state at some point. Despite such losses, sedimentary rocks have locally survived from very early (Archean) times, nearly 4 billion years ago. *See* ARCHEAN.

Sediments are almost entirely derived from transfer of materials within the Earth's crust. First in importance is gradation, the wearing away of the highlands and the deposition of the products in the low spots: subsiding basins and the oceans. Second is crustal volcanism, which produces large ash falls from explosive volcanoes, and recycles ions to the surface in hot springs. Small amounts are contributed from the mantle underlying the crust: mainly pumice produced when mantle-derived oceanic basalts interact with water. A small fraction of sediment consists of organic matter created by organisms from carbon dioxide and water. Water frozen in the atmosphere transiently covers parts of the stratisphere with ice, while traces of extraterrestrial matter

continue to be added from meteorites. *See* COSMIC SPHERULES; METEORITE; WEATHERING PROCESSES.

Though sediments contain such a large range of diverse constituents occurring in a wide variety of mixtures, such mixtures are generally dominated by one or two constituents, and thus may be grouped into a number of classes, each of which can be divided into families.

Detrital sediments are alternately transported and deposited, reroded, and redeposited on their way to a more permanent resting place, so that their constituents may carry the imprints of a complex history, while the structure of the deposit testifies to the last depositional episode. *See* DEPOSITIONAL SYSTEMS AND ENVIRONMENTS.

Pyroclastic sediments originate from volcanic vents. Submarine eruptions form pumice, or frothy glass, much of which floats widely. The important contributions are great eruptions of glass droplets are ejected into atmosphere and stratosphere to fall as a rain of pumice, sand, and silt, in some cases mixed with crystals. Pyroclastic rocks, largely composed of glass, are readily altered to clay minerals (montmorillonite) in weathering. They produce excellent soils. Beds of montmorillonite (bentonites) are mined for preparation of artificial muds such as those used in well drilling. *See* MONTMORILLONITE; PUMICE; VOLCANO; VOLCANOLOGY.

Chemical sediments represent the precipitation of materials carried in solution, either by simple chemical precipitation or by the activity of organisms.

Carbonate rocks form about 20% of all sediments. In natural waters, calcium and magnesium are mainly held in solution by virtue of carbon dioxide. In many fresh waters and in the surficial ocean, withdrawal of carbon dioxide—by warming of the water or by the consumption of carbon dioxide in green-plant photosynthesis—leads to supersaturation and to the deposition of calcium carbonate. This normally yields a lime mud of microscopic crystals. Even more important is the secretion of calcium carbonate skeletons, ultimately deposited on ocean floors, by some algae and by a large variety of animals, ranging from microscopic foraminifera to corals and molluscan shells. Carbonate rocks are a major ingredient of portland cement. They are crushed in large quantities for use in road building, agriculture, and smelting, and in the chemical industry. They also furnish building and ornamental stone. Carbonate rocks contain a large share of the world's petroleum resources. *See* ARAGONITE; CALCITE; CEMENT; DOLOMITE; LIMESTONE; OOLITE; STYLOLITES.

Evaporites are formed in bays, estuaries, and lakes of arid regions. On progressive evaporation, seawater first forms deposits of calcium sulfate as gypsum or anhydrite, followed by halite (NaCl) and ultimately potash and magnesium salts. Evaporation of lake water may yield different precipitates such as trona, borax, and silicates. Much of what is sold as table salt is mined from evaporite deposits, as is potash fertilizer. Plaster of paris is produced from gypsum or anhydrite, and the chemical industry relies on evaporite deposits of various types. *See* FERTILIZER; GYPSUM; HALITE; PLASTER OF PARIS; SALINE EVAPORITES; SALT (FOOD).

Nondetrital siliceous rocks such as silicon dioxide (silica) is second only to carbonate in the dissolved load of most streams. Organisms take up nearly all silica supplied, covering much of the deep-sea floor with radiolarian and diatomaceous ooze. Over geological time spans, diagenetic alteration converts these into dull white opal-ct or quartz porcellanites, or into the solid, waxy-looking mosaics of fine quartz grains known as chert or flint. Diatom ooze is mined for abrasives and filters, as well as for insulation. *See* CHERT; SILICA MINERALS.

Carbonaceous sediments are the result of organic activity, and are of two sorts: the peat-coal series and the kerogens. Peat is used for local fuel in boggy parts of the world. Lignite and bituminous coals continue to be important fuels. *See* COAL; LIGNITE; PEAT. [A.G.F.]

**Sedimentation (industry)** The separation of a dilute suspension of solid particles into a supernatant liquid and a

concentrated slurry. If the purpose of the process is to concentrate the solids, it is termed thickening; and if the goal is the removal of the solid particles to produce clear liquid, it is called clarification. Thickening is the common operation for separating fine solids from slurries. Examples are magnesia, alumina red mud, copper middlings and concentrates, china clay (kaolin), coal tailings, phosphate slimes, and pulp-mill and other industrial wastes. Clarification is prominent in the treatment of municipal water supplies.

The driving force for separation is the difference in density between the solid and the liquid. Ordinarily, sedimentation is effected by the force of gravity, and the liquid is water or an aqueous solution. For a given density difference, the solid settling process proceeds more rapidly for larger-sized particles. For fine particles or small density differences, gravity settling may be too slow to be practical; then centrifugal force rather than gravity can be used. Further, when centrifugal force is inadequate, the more positive method of filtration may be employed. All those methods of separating solids and liquids belong to the generic group of mechanical separations. See CENTRIFUGATION; CLARIFICATION; FILTRATION; THICKENING.

Particles too minute to settle at practical rates may form flocs by the addition of agents such as sodium silicate, alum, lime, and alumina. Because the agglomerated particles act like a single large particle, they settle at a feasible rate and leave a clear liquid behind. [V.W.U.]

**Sedimentology** The study of natural sediments, both lithified (sedimentary rocks) and unlithified, and of the processes by which they are formed. Sedimentology includes all those processes that give rise to sediment or modify it after deposition: weathering, which breaks up or dissolves preexisting rocks so that sediment may form from them; mechanical transportation; deposition; and diagenesis, which modifies sediment after deposition and burial within a sedimentary basin and converts it into sedimentary rock. Sediments deposited by mechanical processes (gravels, sands, muds) are known as clastic sediments, and those deposited predominantly by chemical or biological processes (limestones, dolomites, rock salt, chert) are known as chemical sediments. See SEDIMENTARY ROCKS; WEATHERING PROCESSES.

The raw materials of sedimentation are the products of weathering of previously formed igneous, metamorphic, or sedimentary rocks. In the present geological era, 66% of the continents and almost all of the ocean basins are covered by sedimentary rocks. Therefore, most of the sediment now forming has been derived by recycling previously formed sediment. Identification of the oldest rocks in the Earth's crust, formed more than  $3 \times 10^9$  years ago, has shown that this process has been going on at least since then. Old sedimentary rocks tend to be eroded away or converted into metamorphic rocks, so that very ancient sedimentary rocks are seen at only a few places on Earth. See EARTH CRUST; IGNEOUS ROCKS; METAMORPHIC ROCKS.

**Major controls.** The major controls on the sedimentary cycle are tectonics, climate, worldwide (eustatic) changes in sea level, the evolution of environments with geological time, and the effect of rare events.

Tectonics are the large-scale motions (both horizontal and vertical) of the Earth's crust. Tectonics are driven by forces within the interior of the Earth but have a large effect on sedimentation. These crustal movements largely determine which areas of the Earth's crust undergo uplift and erosion, thus acting as sources of sediment, and which areas undergo prolonged subsidence, thus acting as sedimentary basins. Rates of uplift may be very high (over 10 m or 33 ft per 1000 years) locally, but probably such rates prevail only for short periods of time. Over millions of years, uplift even in mountainous regions is about 1 m (3.3 ft) per 1000 years, and it is closely balanced by rates of erosion. Rates of erosion, estimated from measured rates of sediment transport in rivers and from various other techniques, range from a few

meters per 1000 years in mountainous areas to a few millimeters per 1000 years averaged over entire continents. See BASIN; PLATE TECTONICS.

Climate plays a secondary but important role in controlling the rate of weathering and sediment production. The more humid the climate, the higher these rates are. A combination of hot, humid climate and low relief permits extensive chemical weathering, so that a larger percentage of source rocks goes into solution, and the clastic sediment produced consists mainly of those minerals that are chemically inert (such as quartz) or that are produced by weathering itself (clays). Cold climates and high relief favor physical over chemical processes. See CLIMATOLOGY.

Tectonics and climate together control the relative level of the sea. In cold periods, water is stored as ice at the poles, which can produce a worldwide (eustatic) lowering of sea level by more than 100 m (330 ft). Changes in sea level, whether local or worldwide, strongly influence sedimentation in shallow seas and along coastlines; sea-level changes also affect sedimentation in rivers by changing the base level below which a stream cannot erode its bed.

One of the major conclusions from the study of ancient sediments has been that the general nature and rates of sedimentation have been essentially unchanged during the last billion years of geological history. However, this conclusion, uniformitarianism, must be qualified to take into account progressive changes in the Earth's environment through geological time, and the operation of rare but locally or even globally important catastrophic events. The most important progressive changes have been in tectonics and atmospheric chemistry early in Precambrian times, and in the nature of life on the Earth, particularly since the beginning of the Cambrian. See CAMBRIAN.

Throughout geological time, events that are rare by human standards but common on a geological time scale, such as earthquakes, volcanic eruptions, and storms, produced widespread sediment deposits. There is increasing evidence for a few truly rare but significant events, such as the rapid drying up of large seas (parts of the Mediterranean) and collisions between the Earth and large meteoric or cometary bodies (bolides).

Sediment is moved either by gravity acting on the sediment particles or by the motions of fluids (air, water, flowing ice), which are themselves produced by gravity. Deposition takes place when the rate of sediment movement decreases in the direction of sediment movement; deposition may be so abrupt that an entire moving mass of sediment and fluid comes to a halt (mass deposition, for example, by a debris flow), or so slow that the moving fluid (which may contain only a few parts per thousand of sediment) leaves only a few grains of sediment behind. The settling velocity depends on the density and viscosity of the fluid, as well as on the size, shape, and density of the grains. See STREAM TRANSPORT AND DEPOSITION.

**Chemical sedimentation.** Chemical weathering dissolves rock materials and delivers ions in solution to lakes and the ocean. The concentrations of ions in river and ocean water are quite different, showing that some ions must be removed by sedimentation. Comparison of the modern rate of delivery of ions to the ocean, with their concentration in the oceans, shows that some are removed very rapidly (residence times of only a few thousand years) whereas others, such as chlorine and sodium, are removed very slowly (residence times of hundreds of millions of years).

**Biological effects.** Many so-called chemical sediments are actually produced by biochemical action. Much is then reworked by waves and currents, so that the chemical sediment shows clastic textures and consists of grains rounded and sorted by transport. Depositional and diagenetic processes, however, are often strongly affected by organic action, no matter what the origin of the sediment. Plants in both terrestrial and marine environments tend to trap sediment, enhancing deposition and slowing erosion.

**Sedimentary environments and facies.** Sedimentary rocks preserve the main direct evidence about the nature of the surface environments of the ancient Earth and the way they have changed through geological time. Thus, besides trying to understand the basic principles of sedimentation, sedimentologists have studied modern and ancient sediments as records of ancient environments. For this purpose, fossils and primary sedimentary structures are the best guide. These structures are those formed at the time of deposition, as opposed to those formed after deposition by diagenesis, or by deformation. In describing sequences of sedimentary rocks in the field (stratigraphic sections), sedimentologists recognize compositional, structural, and organic aspects of rocks that can be used to distinguish one unit of rocks from another. Such units are known as sedimentary facies, and they can generally be interpreted as having formed in different environments of deposition. Though there are a large number of different sedimentary environments, they can be classified in a number of general classes, and their characteristic facies are known from studies of modern environments. See FACIES (GEOLOGY); STRATIGRAPHY; TRACE FOSSILS. [G.V.M.]

**Seebeck effect** The generation of a temperature-dependent electromotive force (emf) at the junction of two dissimilar metals. This phenomenon provides the physical basis for the thermocouple. In 1821, T. J. Seebeck discovered that near a closed circuit composed of two linear conductors of two different metals a magnetic needle would be deflected if, and only if, the two junctions were at different temperatures, and that if the temperatures of the two junctions were reversed the direction of deflection would also be reversed. He investigated 35 different metals and arranged them in a series such that at a hot junction, current flows from a metal earlier in the series to a later one. See ELECTROMOTIVE FORCE (EMF).

A thermocouple consists of a pair of wires of dissimilar metals, joined at the ends. One junction is kept at an accurately known cold temperature, usually that of melting ice, and the other is used for the measurement of an unknown temperature, by measuring the emf generated as a result of the Seebeck effect. See THERMOCOUPLE; THERMOELECTRICITY. [A.E.Ba.]

**Seed** A fertilized ovule containing an embryo which forms a new plant upon germination. Seed-bearing characterizes the higher plants—the gymnosperms (conifers and allies) and the angiosperms (flowering plants). Gymnosperm (naked) seeds arise on the surface of a structure, as on a seed scale of a pine cone. Angiosperm (covered) seeds develop within a fruit, as the peas in a pod. See FLOWER; FRUIT.

**Structure.** One or two tissue envelopes, or integuments, form the seed coat which encloses the seed except for a tiny pore, the micropyle (see illustration). The micropyle is near the funiculus (seed stalk) in angiosperm seeds. The hilum is the scar left when the seed is detached from the funiculus. Some seeds have a raphe, a ridge near the hilum opposite the micropyle, and a bulbous strophiole. Others such as nutmeg possess arils, outgrowths of the funiculus, or a fleshy caruncle developed from the seed coat near the hilum, as in the castor bean. The embryo consists of an axis and attached cotyledons (seed leaves). The part of the axis above the cotyledons is the epicotyl (plumule); that below, the hypocotyl, the lower end of which bears a more or less developed primordium of the root (radicle). The epicotyl, essentially a terminal bud, possesses an apical meristem (growing point) and, sometimes, leaf primordia. The seedling stem develops from the epicotyl. An apical meristem of the radicle produces the primary root of the seedling, and transition between root and stem occurs in the hypocotyl. See APICAL MERISTEM; ROOT (BOTANY); STEM.

Two to many cotyledons occur in different gymnosperms. The angiosperms are divided into two major groups according to number of cotyledons: the monocotyledons and the dicotyledons. Mature gymnosperm seeds contain an endosperm (albumen or nutritive tissue) which surrounds the embryo. In some

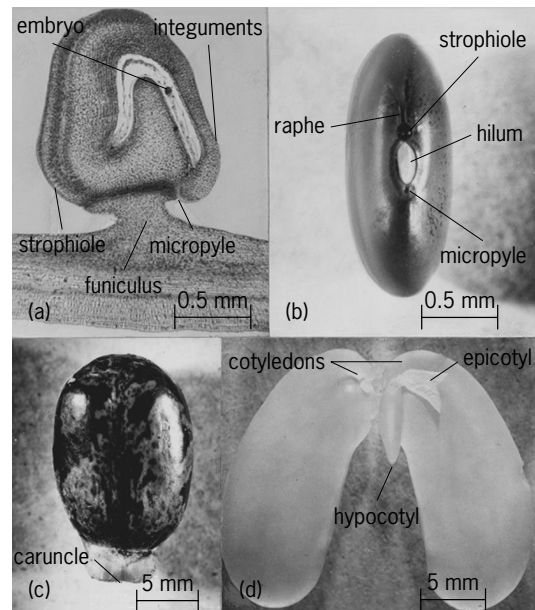

**Seed structures. (a)** Median longitudinal section of pea ovule shortly after fertilization, showing attachment to pod tissues. **(b)** Mature kidney bean. **(c)** Mature castor bean. **(d)** Opened embryo of mature kidney bean.

mature dicotyledon seeds the endosperm persists, the cotyledons are flat and leaflike, and the epicotyl is simply an apical meristem. In other seeds, such as the bean, the growing embryo absorbs the endosperm, and food reserve for germination is stored in fleshy cotyledons. The endosperm persists in common monocotyledons, for example, corn and wheat; and the cotyledon, known as the scutellum, functions as an absorbing organ during germination. Grain embryos also possess a coleoptile and a coleorhiza sheathing the epicotyl and the radicle, respectively. The apical meristems of lateral seed roots also may be differentiated in the embryonic axis near the scutellum of some grains.

Many so-called seeds consist of hardened parts of the fruit enclosing the true seed which has a thin, papery seed coat. Among these are the achenes, as in the sunflower, dandelion, and strawberry, and the pits of stone fruits such as the cherry, peach, and raspberry. Many common nuts also have this structure. Mechanisms for seed dispersal include parts of both fruit and seed. See POPULATION DISPERSAL.

**Economic importance.** Propagation of plants by seed and technological use of seed and seed products are among the most important activities of modern society. Specializations of seed structure and composition provide rich sources for industrial exploitation apart from direct use as food. Common products include starches and glens from grains, hemicelluloses from guar and locust beans, and proteins and oils from soybeans and cotton seed. Drugs, enzymes, vitamins, spices, and condiments are obtained from embryos, endosperms, and entire seeds, often including the fruit coat. Most of the oils of palm, olive, and pine seeds are in the endosperm. Safflower seed oil is obtained mainly from the embryo, whereas both the seed coat and embryo of cotton seed are rich in oils. See FOOD; PLANT ANATOMY; REPRODUCTION (PLANT). [R.M.R.]

**Physiology.** Physical and biochemical processes of seed growth and germination are controlled by genetic and environmental factors. Conditions of light, temperature, moisture, and oxygen affect the timing and ability of a seed to mature and germinate. Seed development (embryogenesis) is concerned with the synthesis and storage of carbohydrate, protein, and oil to supply nutrients to the germinating seedling prior to soil emergence. Seed development occurs in several stages: rapid cell

division, seed fill, and desiccation. The timing of each stage is species-specific and environmentally influenced.

**Dormancy.** Seed dormancy is the inability of a living seed to germinate under favorable conditions of temperature, moisture, and oxygen. Dormancy does not occur in all seeds, but typically occurs in plant species from temperate and colder habitats. This process allows for a delay in seed germination until environmental conditions are adequate for seedling survival. At least three types of seed dormancy are recognized: primary, secondary (induced), and enforced. Primary dormancy occurs during seed maturation, and the seed does not germinate readily upon being shed. Secondary and enforced dormancy occur after the seed is shed and may be caused by adverse environmental factors such as high or low temperature, absence of oxygen or light, low soil moisture, and presence of chemical inhibitors. Seeds with secondary dormancy will not germinate spontaneously when environmental conditions improve, and need additional environmental stimuli. Seeds with enforced dormancy germinate readily upon removal of the environmental limitation. Regulation of dormancy may be partly controlled by hormones. See *ABSCISIC ACID*; *DORMANCY*.

Dormancy is terminated in a large number of species when an imbibed seed is illuminated with white light. Biochemical control of this process is related to the functioning of a single pigment, phytochrome, frequently located in the seed coat or embryonic axis. Phytochrome imparts to the seed the ability to interpret light quality, such as that under an existing vegetative canopy, and to distinguish light from dark with respect to its position in the soil. Phytochrome also is affected by temperature and is involved in the seasonal control of the ending of dormancy. Hormones that promote germination of dormant seeds include gibberellins, cytokinins, ethylene, and auxins. See *AUXIN*; *CYTOKININS*; *ETHYLENE*; *GIBBERELLIN*.

**Germination.** Germination is the process whereby a viable seed takes up water and the radicle (primary root) or hypocotyl emerges from the seed under species-specific conditions of moisture, oxygen, and temperature. Dormant seeds must undergo additional environmental stimuli to germinate. The germinating seed undergoes cell expansion, as well as increases in respiration, protein synthesis, and other metabolic activities prior to emergence of the growing seedling. [C.A.L.]

**Seiche** A short-period oscillation in an enclosed or semi-enclosed body of water, analogous to the free oscillation of water in a dish. The initial displacement of water from a level surface can arise from a variety of causes, and the restoring force is gravity, which always tends to maintain a level surface. Once formed, the oscillations are characteristic only of the geometry of the basin itself and may persist for many cycles before decaying under the influence of friction. The term "seiche" appears to have been first used to describe the rhythmic oscillation of the water surface in Lake Geneva, which occasionally exposed large areas of the lake bed that are normally submerged. See *WAVE MOTION IN LIQUIDS*.

Seiches can be generated when the water is subject to changes in wind or atmospheric pressure gradients or, in the case of semi-enclosed basins, by the oscillation of adjacent connected water bodies having a periodicity close to that of the seiche or of one of its harmonics. Other, less frequent causes of seiches include heavy precipitation over a portion of the lake, flood discharge from rivers, seismic disturbances, submarine mudslides or slumps, and tides. The most dramatic seiches have been observed after earthquakes. [A.Wu.; D.M.F.]

**Seismic exploration for oil and gas** Prospecting for oil and gas using exploration seismology, a geophysical method of determining geologic structure by means of prospector-induced elastic waves. By studying body waves such as compressional and shear waves propagating through the Earth's interior, the constituent and elastic properties of its

solid and liquid core, its solid mantle, and its thin crust are defined. The major differences between earthquake seismology and petroleum exploration seismology are scales and knowledge of the location of seismic disturbances. Earthquake seismology studies naturally generated seismic waves, which have periods in minutes and resolution in kilometers. In exploration seismology, artificial sources are used that have periods of tenths of a second and tens of meters of resolution. Production seismology requires higher-frequency seismic waves and better resolution, often resolution in the order of a few meters. See *EARTH*; *EARTH INTERIOR*.

Computer technology allows resolution of some of the theoretical complexities of elastic wave propagation so that deeper insight into the wave field phenomena can be obtained. The availability of a large number of channels in the recording instrument facilitates three-dimensional and three-component acquisitions. Powerful supercomputers allow manipulation of larger and larger data sets, and they have facilitated display and interpretation of them as a single data unit through the use of advanced computer visualization techniques. See *COMPUTER*; *SUPERCOMPUTER*.

The availability of powerful workstations led to the wide use of interactive processing and interpretation. When such is coupled with technically advanced algorithms, the amount of information that the interpreter can obtain from the data increases significantly. Better quality control is provided, fine-tuning analysis is achieved more easily, and the data can be enhanced to meet specific objectives. If there are discrepancies between the model and the real data, a hypothesis can be proposed based on information derived from the data. This process can be iterated until the Earth model derived is consistent with all available surface and subsurface geophysical, petrophysical, geological, and engineering data sets. See *ALGORITHM*; *MODEL THEORY*; *SIMULATION*.

The seismic method as applied to exploration of oil and gas involves field acquisition, data processing, and geologic interpretation. Seismic field acquisition requires placement of acoustic receivers (geophones) on the surface in the case of land exploration, or strings of hydrophones in the water in the case of marine exploration. Seismic data processing is usually done in large computing centers with digital mainframe computers or a large number of processors in parallel configurations. The end result of seismic data processing is the production of a subsurface profile similar to a geologic cross section. It is commonly plotted in a time scale, but it is also possible to plot it in depth. These time or depth profiles are used for geologic interpretation. Geologic interpretation of seismic data has two key components, structural and stratigraphic. Structural interpretation of seismic data involves mapping of the geologic relief of different subsurface strata by using seismic data as well as information from boreholes and outcrops. Stratigraphic interpretation looks at attributes within a common stratum and interprets changes to infer varying reservoir conditions such as lithology, porosity, and fluid content.

Historically, surface seismic acquisition is done by placing sources and receivers along a straight line so that it can be assumed that all the reflection points fall in a two-dimensional plane formed between the line of traverse and the vertical. This is known as two-dimensional seismic. Three-dimensional seismic is a method of acquiring surface seismic data by placing sources and receivers in an areal pattern. One example of a simple three-dimensional layout is to place the receivers along a line and shoot into these receivers along a path perpendicular to this line. See *COMPUTER GRAPHICS*.

A three-dimensional seismic survey provides a more accurate and detailed image of the subsurface. It offers significantly higher signal quality than the two-dimensional data commonly acquired. It also improves both spatial and temporal resolutions. The three-dimensional seismic technique is being applied to exploration and production of oil and gas, accounting for more than half of the seismic activity in the Gulf of Mexico and North Sea.



Production seismology is the application of seismic techniques to problems related to the production and exploitation of petroleum reservoirs. Since production geophysics is the only effective method available that can image the reservoirs under in-place conditions, it has become an active field of applied research aimed at improving descriptions and understanding of reservoirs and their fluid flow behaviors. See GEOPHYSICAL EXPLORATION; PETROLEUM ENHANCED RECOVERY; PETROLEUM GEOLOGY; PETROLEUM RESERVOIR ENGINEERING; SEISMOLOGY. [T.P.N.]

**Seismic risk** The probability that social or economic consequences of earthquakes will equal or exceed specified values at a site, at several sites, or in an area, during a specified exposure time.

Although the term seismic risk is occasionally used in a general sense to mean the potential for both the occurrence of natural phenomena and the economic and life loss associated with earthquakes, it is useful to differentiate between the concepts of seismic hazard and seismic risk. Seismic hazard may be defined as any physical phenomena that result either from surface faulting during shallow earthquakes or from the ground shaking resulting from an earthquake and that may produce adverse effects on human activities.

The exposure time is the time period of interest for seismic hazard or risk calculations. In practical applications, the exposure time may be considered to be the design lifetime of a building or the length of time over which the numbers of casualties will be estimated. [S.T.A.]

**Seismic stratigraphy** Determination of the nature of sedimentary rocks and their fluid content from analysis of seismic data. Seismic stratigraphy is divided into seismic-sequence (facies) analysis and reflection-character analysis.

In seismic-sequence analysis the first step is to separate seismic-sequence units, also called seismic-facies units. This is usually done by mapping unconformities where they are shown by angularity. Angularity below an unconformity may be produced by erosion at an angle across the former bedding surfaces or by toplap (offlap), and angularity above an unconformity may be produced by onlap or downlap, the latter distinction being based on geometry. The unconformities are then followed along reflections from the points where they cannot be so identified, advantage being taken of the fact that the unconformity reflection is often relatively strong. The procedure often followed is to mark angularities in reflections by small arrows before drawing in the boundaries. See UNCONFORMITY.

Seismic-facies units are three-dimensional, and many of the conclusions from them are based on their three-dimensional shape. The appearance on seismic lines in the dip and strike directions is often very different. For example, a fan-shaped unit might show a progradational pattern in the dip direction and discontinuous, overlapping arcuate reflections in the strike direction. See FACIES (GEOLOGY).

Reflection-character analysis may be based on information from boreholes which suggests that a particular interval may change nearby in a manner which increases its likelihood to contain hydrocarbon accumulations. Lateral changes in the wave shape of individual reflection events may suggest where the stratigraphic changes or hydrocarbon accumulations may be located. See DRILLING AND BORING, GEOTECHNICAL; SEISMIC EXPLORATION FOR OIL AND GAS.

Where sufficient information is available to develop a reliable model, expected changes are postulated and their effects are calculated and compared to observed seismic data. The procedure is called synthetic seismogram manufacture; it usually involves calculating seismic data based on sonic and density logs from boreholes, sometimes based on a model derived in some other way. The sonic and density data are then changed in the manner expected for a postulated stratigraphic change, and if the synthetic seismogram matches the actual seismic data sufficiently

well, it implies that the changes in earth layering are similar to those in the model. See GEOPHYSICAL EXPLORATION; SEISMOGRAPHIC INSTRUMENTATION; SEISMOLOGY; STRATIGRAPHY. [R.E.Sh.]

**Seismographic instrumentation** Various devices or systems of devices for measuring movement in the Earth. Ground motion is generally the result of passing seismic waves, gravitational tides, atmospheric processes, and tectonic processes. Seismographic instrumentation typically consists of a sensing element (seismometer), a signal-conditioning element or elements (galvanometer, mechanical or electronic amplifier, filters, analog-to-digital conversion circuitry, telemetry, and so on), and a recording element (analog visible or direct, frequency modulation, or digital magnetic tape or disk). Seismographs are used for earthquake studies, investigations of the Earth's gravity field, nuclear explosion monitoring, petroleum exploration, and industrial vibration measurement.

Seismographic instruments may be required to measure ground motions accurately over a range approaching 12 orders of magnitude, from as small as  $10^{-11}$  m to as large as several meters (a very large earthquake). The instruments may be required to measure frequencies as low as  $\sim 10^{-5}$  Hz (the semi-diurnal gravitational tides) to as high as  $\sim 10^4$  Hz (as observed from acoustic emissions from rock failures in mines). Seismic waves from earthquakes are observed in the bandwidth of  $\sim 3 \times 10^{-4}$  Hz (the gravest free oscillations of the Earth) to  $\sim 200$  Hz (a local earthquake). In exploration seismology the frequency range of interest is typically 10–1000 Hz.

The seismometer is the basic sensing element in seismographic instruments, and there are two fundamentally different types: inertial and strain. The inertial seismometer generates an output signal that is proportional to the relative motion between its frame (usually attached to the ground or a point of interest) and an internal inertial reference mass. The strain seismometer (or linear extensometer) generates an output that is proportional to the distance between two points.

A seismoscope is a device that indicates only the occurrence of relatively strong ground shaking and not its time of occurrence or duration. A typical seismoscope inscribes a hodograph of horizontal strong ground motion on a smoked watch glass.

A dilatometer continuously and precisely measures volumetric strain. The quantity measured is the change  $\Delta V$  in the reference volume  $V$ , and the ratio  $\Delta V/V$  gives the volumetric strain. Dilatometers are typically installed in a borehole in competent rock (preferably granite) at a depth of 100–300 m (330–1000 ft).

A tiltmeter monitors the relative change in the elevation between two points, usually with respect to a liquid-level surface. The horizontal distance between the reference points may be as little as a few millimeters or as large as several hundred meters.

The gravity meter is just a vertical-component accelerometer, that is, a pendulum sensing ground motion and equipped with a displacement transducer, analogous to the inertial tiltmeter. Gravimeters are widely used in geophysical exploration, in the study of earth tides, and in the recording of very low frequency (0.0003–0.01 Hz) seismic waves from earthquakes. See ACCELEROMETER.

The complete seismograph produces a record of the properly conditioned signal from the seismometer, along with appropriate timing information. The recording system may be as simple as a mechanical stylus scratching a line on a smoke-covered drum in a portable microearthquake seismograph, or as complex as a multichannel computer-controlled system handling 25,000 24-bit digital words per second in a modern seismic reflection survey for petroleum exploration. The range between these extremes includes many special-purpose seismographs, all designed to record ground motion in a particular application. See EARTH TIDES; EARTHQUAKE; GEOPHYSICAL EXPLORATION; SEISMIC EXPLORATION FOR OIL AND GAS; SEISMOLOGY. [T.V.McE.; R.A.U.]

**Seismology** The study of the shaking of the Earth's interior caused by natural or artificial sources. Throughout the period in which plate tectonics was advanced and its basic tenets tested and confirmed in the early 1960s, and into the latest phase of inquiry into basic processes, seismology (and particularly seismic imaging) has provided critical observational evidence upon which discoveries have been made and theory has been advanced regarding the structure of the Earth's crust, mantle, and core. See PLATE TECTONICS.

**Theoretical seismology.** A seismic source is an energy conversion process that over a short time (generally less than a minute and usually less than 1–10 s) transforms stored potential energy into elastic kinetic energy. This energy then propagates in the form of seismic waves through the Earth until it is converted into heat by internal (molecular) friction. Large sources, that is, sources that release large amounts of potential energy, can be detected worldwide. Earthquakes above Richter magnitude 5 and explosions above 50 kilotons or so are large enough to be observed globally before the seismic waves dissipate below modern levels of detection. Small charges of dynamite or small earthquakes are detectable at a distance of a few tens to a few hundreds of kilometers, depending on the type of rock between the explosion and the detector. See EARTHQUAKE.

Seismic vibrations are recorded by instruments known as seismometers that sense the change in the position of the ground (or water pressure) as seismic waves pass underneath. The record of ground motion as a function of time is a seismogram, which may be in either analog or digital form. Advances in computer technology have made analog recording virtually obsolete: most seismograms are recorded digitally, which makes quantitative analysis much more feasible.

The response of the Earth to a seismic disturbance can be approximated by the equation of motion for a disturbance in a perfectly elastic body. This equation holds regardless of the type of source, and is closely related to the acoustic-wave equation governing the propagation of sound in a fluid. The equation of motion for an isotropic perfectly elastic solid separates into two equations describing the propagation of purely dilatational (volume changing, curl-free) and purely rotational (no volume changing, divergence-free) disturbances. These propagate with wave speeds  $\alpha$  and  $\beta$ , respectively. These velocities are also known as the compressional or primary (P) and shear or secondary (S) velocities, and the corresponding waves are called P and S waves. The compressional velocity is always faster than the shear velocity. In the Earth,  $\alpha$  can range from a few hundred meters per second in unconsolidated sediments to more than 13.7 km/s (8.2 mi/s) just above the core–mantle boundary. Wave speed  $\beta$  ranges from zero in fluids (ocean, fluid outer core) to about 7.3 km/s (4.4 mi/s) at the core–mantle boundary. See HOOKE'S LAW; SPECIAL FUNCTIONS.

A P wave has no curl and thus only causes the material to undergo a volume change with no other distortion. An S wave has no divergence, thus causing no volume change, but right angles embedded in the material are distorted. Explosions are relatively efficient generators of compressional disturbances, but earthquakes generate both compressional and shear waves. Compressional waves, by virtue of the mechanical stability condition, always arrive before shear waves.

Compressional and shear waves can exist in an elastic body irrespective of its boundaries. For this reason, seismic waves traveling with speed  $\alpha$  or  $\beta$  are known as body waves. A third type of wave motion is produced if the elastic material is bounded by a free surface. The free-surface boundary conditions help trap energy near the surface, resulting in a boundary or surface wave. This in turn can be of two types. A Rayleigh wave combines both compressional and shear motion and requires only the presence of a boundary to exist. A Love wave is a pure-shear disturbance that can propagate only in the presence of a change in the elastic properties with depth from the free surface. Both are slower than body waves.

Solutions of the elastic-wave equation in which a wave function of a particular shape propagates with a particular speed are known as traveling waves. An important property of traveling waves is their causality; that is, the wave function has no amplitude before the first predicted arrival of energy. The complete seismic wavefield can be constructed by summing up every possible traveling wave.

Traveling-wave or full-wave theory provides the basis for a very useful theoretical abstraction of elastic-wave propagation in terms of the more common notions of wavefronts and their outwardly directed normals, called rays. Ray theory makes the prediction of certain kinematic quantities such as ray path, travel time, and distance by a simple geometric exercise. Ray theory can be developed in the context of an Earth comprising flat-lying layers of uniform velocities; this is a very useful approximation for most problems in crustal seismology and can be extended to spherical geometry for global studies.

Kinematic equations have been developed to describe what happens to rays as they impinge on the boundaries between layers. The illustration shows a single ray propagating in the

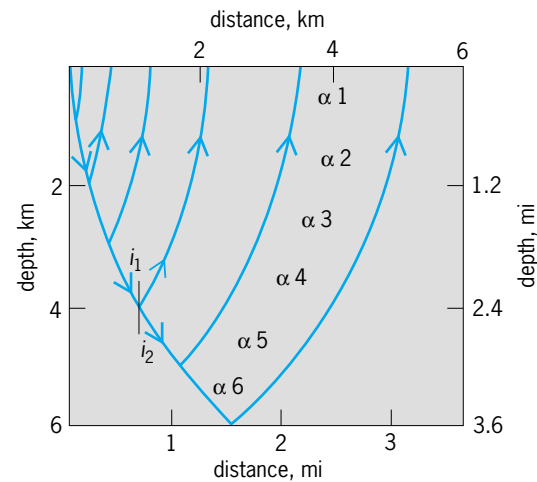

(a)

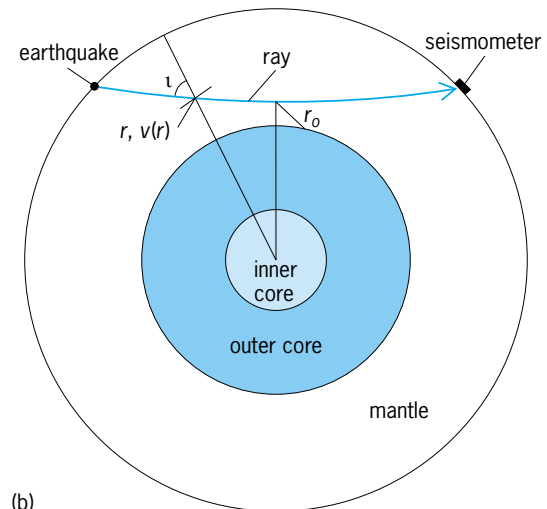

(b)

**Seismic ray paths.** (a) A single ray passing through a multilayered Earth comprising a stack of uniform velocity layers will be reflected from each layer and also be refracted as it passes from one layer into the layer below in a manner that obeys Snell's law. Each ray therefore is considered to give rise to a new system of rays. (b) Ray diagram for a cross section of the spherical Earth. At the point labeled  $v(r)$ ,  $r$  = radial distance and  $v$  = velocity.  $r_0$  = radial distance to the turning point.  $\alpha$  is the angle of incidence.

stack of horizontal layers that define the model Earth. At each interface, part of the ray's energy is reflected, but a portion also passes through into the layer below. The transmitted portion of the ray is refracted; that is, it changes the angle at which it is propagating. The relationship between the incident angle and the refracted angle is exactly the same as that describing the refraction of light between two media of differing refractive index. See REFRACTION OF WAVES.

These simple geometric equations can be extended to the computation of amplitudes provided that there are no sharp discontinuities in the velocity as a function of depth. More exact representations of the amplitudes and wave shapes that solve the full-wave equation to varying extents can be constructed with the aid of powerful computers; these methods are collectively known as seismogram synthesis, and the seismograms thus computed are known as synthetics. Synthetics can be computed for elastic or dissipative media that vary in one, two, or three dimensions.

In a typical experiment for crustal imaging, a source of seismic energy is discharged on the surface, and instruments record the disturbance at numerous locations. Many different types of sources have been devised, from simple explosives to mechanical vibrators and devices known as airguns that discharge a "shot" of compressed air. The details of the source-receiver geometry vary with the type of experiment and its objective, but the work always involves collecting a large number of recordings at increasing distance from the source. This seismogram is complex, exhibiting a number of distinct arrivals with a variety of shapes and having amplitudes that change with distance. Although this seismogram clearly does not resemble the structure of the Earth in any sensible way and is therefore not what would normally be thought of as an image, it can be analyzed to recover estimates of those physical properties of the Earth that govern seismic-wave propagation.

**Two- and three-dimensional imaging.** A volume of the crust can be directly imaged by seismic tomography. In crustal tomography, active sources are used (explosives on land, airguns at sea) so that the source location and shape are already known. Experiments can be constructed in which sources and receivers are distributed in such a way that many rays pass through a particular volume and the tomographic inversion can produce relatively high-resolution images of velocity perturbations in the crust. Crustal tomography uses transmitted rays like those that pass from a surface source through the crust to receivers that are also on the same surface. See GEOPHYSICAL EXPLORATION; GROUP VELOCITY; PHASE VELOCITY; SEISMIC EXPLORATION FOR OIL AND GAS; WAVE EQUATION.

**Seismic source imaging.** Another imaging problem in global seismology is constructing models of the seismic source. So-called first-motion representations of seismic sources (earthquakes) are the result of measurements made on the very first P waves or S waves arriving at an instrument; therefore they represent the very beginning of the rupture on the fault plane. This is not a problem if the rupture is approximately a point source, but this is true in practice only if the earthquake is quite small or exceptionally simple. An alternative is to examine only longer-period seismic phases, including surface waves, to obtain an estimate of the average point source that smooths over the space and time complexities of a large rupture. This so-called centroid-moment-tensor representation is routinely computed for events with magnitudes greater than about 5.5. Because an estimate for a centroid moment tensor is derived from much more of the seismogram than the first arrivals, it gives a better estimate of the energy content of the earthquake. This estimate, known as the seismic moment, represents the total stress reduction resulting from the earthquake; it is the basis for a new magnitude number  $M_W$ . This value is equivalent to the Richter body wave ( $m_b$ ) or surface-wave magnitude ( $M_S$ ) at low magnitudes, but it is much more accurate for magnitudes above about 7.5.

Some large events comprise smaller subevents distributed in space and time and contributing to the total rupture and seismic moment. The position and individual rupture characteristics of these subevents can be mapped with remarkable precision, given data of exceptional bandwidth and good geographical distribution. An outstanding problem is whether the location of these subevents is related to stress heterogeneities within the fault zone. These stress heterogeneities are known as barriers or asperities, depending on whether they stop or initiate rupture. See SEISMOGRAPHIC INSTRUMENTATION. [J.Mu.; A.L.L.]

**Seisonacea** A class of the phylum Rotifera which comprises a group of little-known marine animals. They form a single family with about seven species and are found only in Europe. The Seisonacea are epizoic or possibly ectoparasitic on crustacea. They have a very elongated jointed body with a small

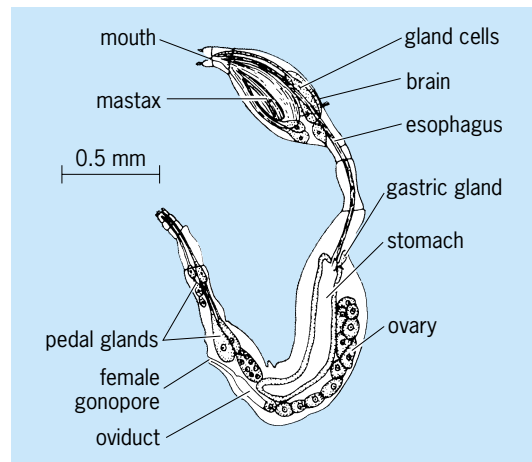

*Seison*, a rotifer. (After Plate, 1887)

head; a long, slender neck region; a thicker, fusiform trunk; and an elongated foot, terminating in a perforated disk (see illustration). The Seisonacea are larger than other rotifers, attaining sizes up to 0.12 in. (3 mm) in length. See ROTIFERA. [E.H.A.]

**Seizure disorders** Conditions in which there are recurrent seizures. Such conditions are also known as epilepsy; the isolated occurrence of a seizure, however, is not designated as epilepsy. A seizure (ictus) is an event in which there is a sudden alteration in function of nerve cells, most commonly involving excessive electrical activity of the cells. This sudden change in nerve cell function is usually relatively brief, lasting seconds to minutes. Soon after a seizure, the brain may function quite normally. The manifestation of a seizure varies depending on which area of the brain is involved. Focal motor epilepsy, temporal lobe seizures, grand mal, and generalized nonconvulsive seizures are the four common seizure types. See BRAIN; NERVOUS SYSTEM (VERTEBRATE).

Focal motor epilepsy, also known as a simple partial seizure with motor symptoms, is manifested by uncontrolled rhythmic jerking of the face, arm, or leg, caused by excessive abnormal discharges of nerve cells within the area of the brain, which under usual circumstances controls movement in that part of the body.

Temporal lobe seizures are known as simple partial seizures and may be manifested by a myriad of symptoms depending upon which part of the lobe is involved. Psychomotor, or complex partial, seizures are the most common type. Clinically, they are characterized by an alteration in the state of consciousness and performance of repetitive, patterned, non-goal-directed activity. These types of seizures are characterized electrically by

abnormal discharges occurring within the temporal lobe for the duration of the seizure.

Grand mal seizures, also referred to as generalized tonic-clonic convulsive seizures, major motor seizures, or convulsions, occur if the abnormal discharges involve the entire brain all at once. In this condition there are forceful, generalized, symmetrical musculature contractions accompanied by loss of consciousness, and, at times, by urinary incontinence and tongue biting.

Generalized nonconvulsive seizures may be atonic seizures, which are characterized by a sudden loss of muscle tone, or they may be absences (*petit mal*), which consist of brief periods of loss of consciousness and immediate recovery. This type of seizure is more frequently seen in children than in adults.

Epilepsy is not a disease in itself. It is a symptom of an underlying disease process. That disease process may be metabolic, such as uremia, decreased brain oxygen, or low calcium levels; or structural brain damage, such as from head trauma at birth, brain injuries, brain tumors, strokes, or congenital malformations, or previous encephalitis or meningitis. In many instances, however, a cause is not found. The disorder is then referred to as idiopathic or primary epilepsy.

Seizures should be distinguished from other conditions which have some clinical similarities. These include fainting from hypoglycemia, cardiovascular disorders, or hysteria. The tools necessary to make this differential diagnosis are the history of the illness, the general physical exam, and a neurologic exam, all of which may be entirely normal or which may demonstrate signs of underlying disease processes. An electroencephalogram may demonstrate abnormal electrical discharges during a time the patient is seizure-free. These discharges may indicate that portion of the brain from which the seizures arise. Computerized tomography scans or magnetic resonance imaging may show any gross structural abnormality. Examination of the blood may demonstrate abnormal circulating chemicals. See COMPUTERIZED TOMOGRAPHY; ELECTROENCEPHALOGRAPHY; MEDICAL IMAGING.

The ideal treatment of epilepsy is removal of the cause. In many instances, however, the cause cannot be established or may not be amenable to direct treatment. When the cause cannot be removed, the symptoms (seizures) are treated. The initial method of obtaining seizure control is antiepileptic drugs. About 80% of the people with epilepsy obtain good control or elimination of seizures with medication. These medications are chemicals of varying structures and may be effective by a number of different brain mechanisms. Brain surgery is a therapeutic potential for some of the 20% of the people with epilepsy who do not achieve control on medication. Surgery may be considered if the abnormally discharging nerve cells which cause the epilepsy are in a dispensable area of brain, that is, one of the frontal or temporal lobes. [L.M.O.]

**Selachii** An order that includes all fossil and Recent sharks, with the possible exception of Devonian cladoselelchians. The selachian endoskeleton is entirely cartilaginous, but it is frequently calcified superficially. The body is covered in minute scales, which in Recent sharks are simple and nongrowing, but which in earlier sharks often fused together and became enlarged during life and may have been more regularly arranged over the body.

Sharks periodically shed their teeth, sometimes replacing several thousand in a lifetime, and their teeth are common in the fossil record. It is therefore rather surprising that the earliest records of sharks are from the Late Devonian, when they were already highly diversified.

There are 5 groups of fossil and living sharks: cladoselelchians, symmoriids, ctenacanthids, hybodontids, and neoselachians. See CHONDRICHTHYES; SHARK. [J.G.Ma.]

**Selaginellales** An order of the class Lycopsidea (club mosses), regarded as more advanced than the extinct Protolepidodendrales because they produce spores of two sizes, but less advanced than the Lepidodendrales and Isoetales because they

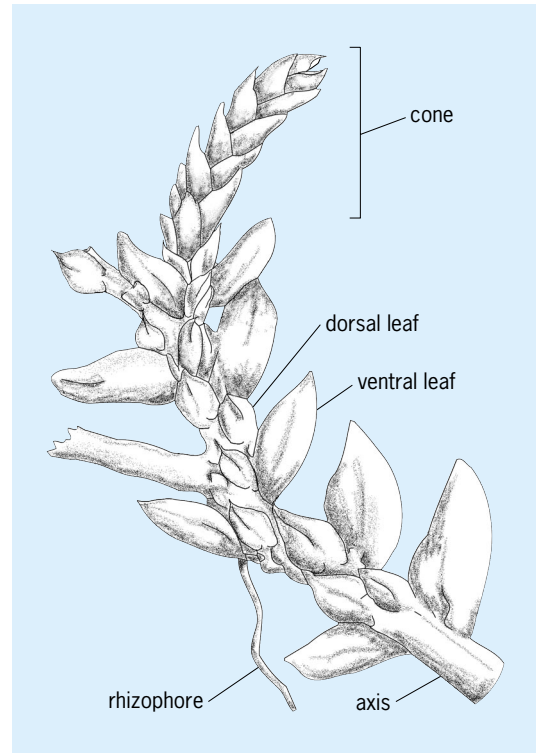

Characteristic features of a typical heterophyllous selaginellalean of the *Stachygynandrum* type. (After T. R. Webster, *Developmental problems in Selaginella in an evolutionary context*, *Ann. Mo. Bot. Gard.*, 79:633-647, 1992)

lack wood and finite growth. All are perennial herbs, varying in growth habit from prostrate to climbing. See ISOETALES; LEPIDODENDRALES; PROTOLEPIDODENDRALES.

Although the approximately 700 extant species are traditionally assigned to a single genus, *Selaginella*, it is possible that this genus should include only the few species that possess undivided steles and microphyllous leaves of a single morphology. The bulk of the selaginellalean species are included in the genus *Stachygynandrum*. Both genera are geographically widespread and occupy a wide range of habitats.

Both selaginellalean genera show several remarkable biological features (see illustration). *Stachygynandrum* has leaves that are positioned both ventrally and dorsally. This character is regarded as an adaptation to efficient light capture. Moreover, in many species the lower surface of the dorsal leaf and upper surface of the ventral leaf consist of more or less cubic cells that contain only one large chloroplast, whose orientation within the cell can be altered to maintain optimal levels of incident light for photosynthesis.

The origin of the rhizophores (specialized aerial rooting structures) is unclear.

Selaginellaleans have a free-sporing heterosporous life history. Sporangia are borne on sporophylls that are aggregated into cones. Many species possess active mechanisms for ejecting either microspores or entire microsporangia. The megaspores and microspores germinate to produce independent, unisexual gametophytes. Both genders remain largely within the spore wall. The megagametophytes produce several archegonia that yield eggs, which chemically attract the swimming biflagellate spermatozooids released by the microspores. See LYCOPHYTA; LYCOPODIALES; LYCOPSIDA. [R.M.Ba.; W.A.DiM.]

**Selection rules (physics)** General rules concerning the transitions which may occur between the states of a quantum-mechanical physical system. They derive in almost all cases from

the symmetry properties of the states and of the interaction which gives rise to the transitions. The system may have a classical (nonquantum) counterpart, and in this case the selection rules may often be related to the classical conserved quantities. A first use of selection rules is in determining the symmetry classes of the states; but in a great variety of ways they may yield other information about the system and the conservation laws. See QUANTUM MECHANICS; SYMMETRY LAWS (PHYSICS).

For an isolated system the total angular momentum is a conserved quantity; this fact derives from a fundamental fact of nature, namely, that space is isotropic. Each state is then classifiable by angular momentum  $J$  and its  $z$  component  $M$  ( $= -J, -J + 1, \dots, +J$ ). Angular momenta combine in a vectorial fashion. Thus, if the system makes a particle-emitting transition  $J_1, M_1 \rightarrow J_2, M_2$ , the emitted particles must carry away angular momentum ( $j, \mu$ ), where  $\mathbf{j} = \mathbf{j}_1 - \mathbf{j}_2$ . This implies that  $\mu = M_1 - M_2$  and that  $j$  takes on values  $J_1 - J_2, J_1 - J_2 + 1, \dots, (J_1 + J_2)$ . Thus in transitions ( $J = 4 \leftrightarrow J = 2$ ) the possible  $j$  values comprise only 2, 3, 4, 5, 6, and, if it is also specified that  $M_1 - M_2 = \pm 4$ , only 4, 5, 6. Observe that  $J_2$  is additive. See ANGULAR MOMENTUM; QUANTUM NUMBERS.

Another fundamental symmetry, the parity, which determines the behavior of a system (or of its description) under inversion of the coordinate axes, is conserved by the strong and electromagnetic interactions, and gives a classification of systems as even ( $\pi = +1$ ) or odd ( $\pi = -1$ ). Under combination the parity combines multiplicatively. Thus, if the transition above is  $4^\pm \rightarrow 2^\pm$ , it follows that  $j^\pi = 2^-, \dots, 6^-$ , while  $4^\pm \rightarrow 2^\pm$  would give  $j^\pi = 2^+, \dots, 6^+$ . The angular momentum  $\mathbf{j}$  may be a combination of intrinsic spin  $\mathbf{s}$  and orbital angular momentum  $\mathbf{l}$ . Scalar, pseudoscalar, vector, and pseudovector particles are respectively characterized by  $s^\pi = 0^+, 0^-, 1^-, 1^+$ , where  $\pi_s$  is the "intrinsic" parity, while  $l$  always carries  $\pi_l = (-1)^l$ . See PARITY (QUANTUM MECHANICS); SPIN (QUANTUM MECHANICS).

The isospin symmetry of the elementary particles is almost conserved, being broken by electromagnetic and weak interactions. It is described by the group SU(2), of unimodular unitary transformations in two dimensions. Since the SU(2) algebra is identical with that of the angular momentum SO(3), isospin behaves like angular momentum with its three generators  $\mathbf{T}$  replacing  $\mathbf{J}$ .

The isospin group is a subgroup of SU(3) which defines a more complex fundamental symmetry of the elementary particles. Two of its eight generators commute, giving two additive quantum numbers,  $T_z$  and strangeness  $S'$  (or, equivalently, charge and hypercharge). The strangeness is conserved ( $\Delta S' = 0$ ) for strong and electromagnetic, but not for weak, interactions. The selection rules and combination laws for SU(3) and its many extensions, and the quark-structure underlying them, correlate an enormous amount of information and make many predictions about the elementary particles. See BARYON; ELEMENTARY PARTICLE; MESON; QUARKS; UNITARY SYMMETRY.

A great variety of other groups have been introduced to define relevant symmetries for atoms, molecules, nuclei, and elementary particles. They all have their own selection rules, representing one aspect of the symmetries of nature. [J.B.Fr.]

**Selectivity** The ability of a radio receiver to separate a desired signal frequency from other signal frequencies, some of which may differ only slightly from the desired value. Selectivity is achieved by using tuned circuits that are sharply peaked and by increasing the number of tuned circuits. With a sharply peaked circuit, the output voltage falls off rapidly for frequencies increasingly lower or higher than that to which the circuit is tuned. See Q (ELECTRICITY); RADIO RECEIVER; RESONANCE (ALTERNATING-CURRENT CIRCUITS). [J.Mar.]

**Selenium** A chemical element, Se, atomic number 34, atomic weight 78.96. The properties of this element are similar to those of tellurium. See PERIODIC TABLE; TELLURIUM.

Selenium burns in air with a blue flame to give selenium dioxide, SeO<sub>2</sub>. The element also reacts directly with a variety of metals and nonmetals, including hydrogen and the halogens. Nonoxidizing acids fail to react with selenium, but nitric acid, concentrated sulfuric acid, and strong alkali hydroxides dissolve the element. The only important compound of selenium with hydrogen is hydrogen selenide, H<sub>2</sub>Se, a colorless flammable gas possessing a distinctly unpleasant odor, and a toxicity greater and a thermal stability less than that of hydrogen sulfide. Selenium oxyhalide, SeOCl<sub>2</sub>, is a colorless liquid widely used as a nonaqueous solvent. The oxybromide, SeOBr<sub>2</sub>, is an orange solid having chemical properties similar to those of SeOCl<sub>2</sub>. The oxyfluoride, SeOF<sub>2</sub>, a colorless liquid with a pungent smell, reacts with water, glass, and silicon, and also forms additional compounds. Compounds in which C-Se bonds appear are numerous and vary from the simple selenols, RSeH, to molecules exhibiting biological activity such as selenoamino acids and selenopeptides. See ORGANOSELENIUM COMPOUND.

The abundance of this widely distributed element in the Earth's crust is estimated to be about  $7 \times 10^{-5}$  % by weight, occurring as the selenides of heavy elements and to a limited extent as the free element in association with elementary sulfur. Examples of the variety of selenide minerals are berzelianite (Cu<sub>2</sub>Se), eucairite (AgCuSe), and jermoite [As(S,Se)<sub>2</sub>]. Selenium minerals do not occur in sufficient quantity to be useful as commercial sources of the element.

Major uses of selenium include the photocopying process of xerography, which depends on the light sensitivity of thin films of amorphous selenium, the decolorization of glasses tinted by the presence of iron compounds, and use as a pigment in plastics, paints, enamels, glass, ceramics, and inks. Selenium is also employed in photographic exposure meters and as a metallurgical additive to improve the machinability of certain steels. Minor uses include application as a nutritional additive for numerous animal species, use in photographic toning, metal-finishing operations, metal plating, high-temperature lubricants, and as catalytic agents, particularly in the isomerization of certain petroleum products. [J.W.Ge.]

The biological importance of selenium is well established, as all classes of organisms metabolize selenium. In humans and other mammals, serious diseases arise from either excessive or insufficient dietary selenium. The toxic effects of selenium have long been known, particularly for grazing animals. In soils with high selenium content, some plants accumulate large amounts of selenium. Animals that ingest these selenium-accumulating plants develop severe toxic reactions. See SOIL CHEMISTRY.

Although toxic at high levels, selenium is an essential micronutrient for mammalian species. The accepted minimum daily requirement of selenium for adult humans is 70 micrograms. Many types of food provide selenium, particularly seafood, meats, grains, and the onion family. Mammals and birds require selenium for production of the enzyme glutathione peroxidase, which protects against oxidation-induced cancers. Other seleno-proteins of unknown function are found in mammalian blood, various tissues, and spermatozoa. See AMINO ACIDS. [M.J.Ax.; T.C.St.]

**Seligerales** An order of the true mosses (Bryidae), consisting of one family and five or six genera. The plants grow on rocks, and may be exceedingly small and gregarious to moderate in size and tufted. The stems are erect and simple or forked. The linear to lance-subulate leaves have a single costa which often fills the subula. The operculate capsules are terminal, and the peristome is usually present. The calyptra is generally cucullate. See BRYIDAE; BRYOPHYTA; BRYOPSIDA. [H.Cr.]

**Semaestomeae** An order of the class Scyphozoa including most of the common medusae. The umbrella of these medusae is more flat than high and is usually domelike. The margin of the umbrella is divided into many lappets. Sensory organs

are situated between the lappets. The tentacles are generally well developed and very long except in a few forms.

The life history of this group shows the typical alternation of generations, with forms passing through several larval stages. The Semaestomeae are distributed mostly in temperate zones and are generally coastal forms with a few exceptions. Some of them are known to have violent poison on their tentacles. Several fossils of this group were found in the strata of the Jurassic period. See SCYPHOZOA. [T.U.]

**Semiconductor** A solid crystalline material whose electrical conductivity is intermediate between that of a metal and an insulator. Semiconductors exhibit conduction properties that may be temperature-dependent, permitting their use as thermistors (temperature-dependent resistors), or voltage-dependent, as in varistors. By making suitable contacts to a semiconductor or by making the material suitably inhomogeneous, electrical rectification and amplification can be obtained. Semiconductor devices, rectifiers, and transistors have replaced vacuum tubes almost completely in low-power electronics, making it possible to save volume and power consumption by orders of magnitude. In the form of integrated circuits, they are vital for complicated systems. The optical properties of a semiconductor are important for the understanding and the application of the material. Photodiodes, photoconductive detectors of radiation, injection lasers, light-emitting diodes, solar-energy conversion cells, and so forth are examples of the wide variety of optoelectronic devices. See INTEGRATED CIRCUITS; LASER; LIGHT-EMITTING DIODE; PHOTODIODE; PHOTOELECTRIC DEVICES; SEMICONDUCTOR DIODE; SEMICONDUCTOR RECTIFIER; THERMISTOR; TRANSISTOR; VARISTOR.

**Conduction in semiconductors.** The electrical conductivity of semiconductors ranges from about  $10^3$  to  $10^{-9}$  ohm $^{-1}$  cm $^{-1}$ , as compared with a maximum conductivity of  $10^7$  for good conductors and a minimum conductivity of  $10^{-17}$  ohm $^{-1}$  cm $^{-1}$  for good insulators. See ELECTRIC INSULATOR; ELECTRICAL CONDUCTIVITY OF METALS.

The electric current is usually due only to the motion of electrons, although under some conditions, such as very high temperatures, the motion of ions may be important. The basic distinction between conduction in metals and in semiconductors is made by considering the energy bands occupied by the conduction electrons. See BAND THEORY OF SOLIDS; IONIC CRYSTALS.

At absolute zero temperature, the electrons occupy the lowest possible energy levels, with the restriction that at most two electrons with opposite spin may be in the same energy level. In semiconductors and insulators, there are just enough electrons to fill completely a number of energy bands, leaving the rest of the energy bands empty. The highest filled energy band is called the valence band. The next higher band, which is empty at absolute zero temperature, is called the conduction band. The conduction band is separated from the valence band by an energy gap, which is an important characteristic of the semiconductor. In metals, the highest energy band that is occupied by the electrons is only partially filled. This condition exists either because the number of electrons is not just right to fill an integral number of energy bands or because the highest occupied energy band overlaps the next higher band without an intervening energy gap. The electrons in a partially filled band may acquire a small amount of energy from an applied electric field by going to the higher levels in the same band. The electrons are accelerated in a direction opposite to the field and thereby constitute an electric current. In semiconductors and insulators, the electrons are found only in completely filled bands, at low temperatures. In order to increase the energy of the electrons, it is necessary to raise electrons from the valence band to the conduction band across the energy gap. The electric fields normally encountered are not large enough to accomplish this with appreciable probability. At sufficiently high temperatures, depending on the magnitude of the energy gap, a significant number of valence electrons gain

enough energy thermally to be raised to the conduction band. These electrons in an unfilled band can easily participate in conduction. Furthermore, there is now a corresponding number of vacancies in the electron population of the valence band. These vacancies, or holes as they are called, have the effect of carriers of positive charge, by means of which the valence band makes a contribution to the conduction of the crystal. See HOLE STATES IN SOLIDS.

The type of charge carrier, electron or hole, that is in largest concentration in a material is sometimes called the majority carrier and the type in smallest concentration the minority carrier. The majority carriers are primarily responsible for the conduction properties of the material. Although the minority carriers play a minor role in electrical conductivity, they can be important in rectification and transistor actions in a semiconductor.

**Intrinsic semiconductors.** A semiconductor in which the concentration of charge carriers is characteristic of the material itself rather than of the content of impurities and structural defects of the crystal is called an intrinsic semiconductor. Electrons in the conduction band and holes in the valence band are created by thermal excitation of electrons from the valence to the conduction band. Thus an intrinsic semiconductor has equal concentrations of electrons and holes. The carrier concentration, and hence the conductivity, is very sensitive to temperature and depends strongly on the energy gap. The energy gap ranges from a fraction of 1 eV to several electronvolts. A material must have a large energy gap to be an insulator.

**Extrinsic semiconductors.** Typical semiconductor crystals such as germanium and silicon are formed by an ordered bonding of the individual atoms to form the crystal structure. The bonding is attributed to the valence electrons which pair up with valence electrons of adjacent atoms to form so-called shared pair or covalent bonds. These materials are all of the quadrivalent type; that is, each atom contains four valence electrons, all of which are used in forming the crystal bonds. See CRYSTAL STRUCTURE.

Atoms having a valence of +3 or +5 can be added to a pure or intrinsic semiconductor material with the result that the +3 atoms will give rise to an unsatisfied bond with one of the valence electrons of the semiconductor atoms, and +5 atoms will result in an extra or free electron that is not required in the bond structure. Electrically, the +3 impurities add holes and the +5 impurities add electrons. They are called acceptor and donor impurities, respectively. Typical valence +3 impurities used are boron, aluminum, indium, and gallium. Valence +5 impurities used are arsenic, antimony, and phosphorus.

Semiconductor material "doped" or "poisoned" by valence +3 acceptor impurities is termed *p*-type, whereas material doped by valence +5 donor material is termed *n*-type. The names are derived from the fact that the holes introduced are considered to carry positive charges and the electrons negative charges. The number of electrons in the energy bands of the crystal is increased by the presence of donor impurities and decreased by the presence of acceptor impurities. See ACCEPTOR ATOM; DONOR ATOM.

At sufficiently high temperatures, the intrinsic carrier concentration becomes so large that the effect of a fixed amount of impurity atoms in the crystal is comparatively small and the semiconductor becomes intrinsic. When the carrier concentration is predominantly determined by the impurity content, the conduction of the material is said to be extrinsic. Physical defects in the crystal structure may have similar effects as donor or acceptor impurities. They can also give rise to extrinsic conductivity.

**Materials.** The group of chemical elements which are semiconductors includes germanium, silicon, gray (crystalline) tin, selenium, tellurium, and boron. Germanium, silicon, and gray tin belong to group 14 of the periodic table and have crystal structures similar to that of diamond. Germanium and silicon are two of the best-known semiconductors. They are used extensively in devices such as rectifiers and transistors.

A large number of compounds are known to be semiconductors. A group of semiconducting compounds of the simple type AB consists of elements from columns symmetrically placed with respect to column 14 of the periodic table. Indium antimonide (InSb), cadmium telluride (CdTe), and silver iodide (AgI) are examples of III-V, II-IV, and I-VI compounds, respectively. The various III-V compounds are being studied extensively, and many practical applications have been found for these materials. Some of these compounds have the highest carrier mobilities known for semiconductors. The compounds have zincblende crystal structure which is geometrically similar to the diamond structure possessed by the elemental semiconductors, germanium and silicon, of column 14, except that the four nearest neighbors of each atom are atoms of the other kind. The II-VI compounds, zinc sulfide (ZnS) and cadmium sulfide (CdS), are used in photoconductive devices. Zinc sulfide is also used as a luminescent material. See LUMINESCENCE; PHOTOCONDUCTIVITY.

The properties of semiconductors are extremely sensitive to the presence of impurities. It is therefore desirable to start with the purest available materials and to introduce a controlled amount of the desired impurity. The zone-refining method is often used for further purification of obtainable materials. The floating zone technique can be used, if feasible, to prevent any contamination of molten material by contact with the crucible. See ZONE REFINING.

For basic studies as well as for many practical applications, it is desirable to use single crystals. Various methods are used for growing crystals of different materials. For many semiconductors, including germanium, silicon, and the III-V compounds, the Czochralski method is commonly used. The method of condensation from the vapor phase is used to grow crystals of a number of semiconductors, for instance, selenium and zinc sulfide. See CRYSTAL GROWTH.

The introduction of impurities, or doping, can be accomplished by simply adding the desired quantity to the melt from which the crystal is grown. When the amount to be added is very small, a preliminary ingot is often made with a larger content of the doping agent; a small slice of the ingot is then used to dope the next melt accurately. Impurities which have large diffusion constants in the material can be introduced directly by holding the solid material at an elevated temperature while this material is in contact with the doping agent in the solid or the vapor phase.

A doping technique, ion implantation, has been developed and used extensively. The impurity is introduced into a layer of semiconductor by causing a controlled dose of highly accelerated impurity ions to impinge on the semiconductor. See ION IMPLANTATION.

An important subject of scientific and technological interest is amorphous semiconductors. In an amorphous substance the atomic arrangement has some short-range but no long-range order. The representative amorphous semiconductors are selenium, germanium, and silicon in their amorphous states, and arsenic and germanium chalcogenides, including such ternary systems as Ge-As-Te. Some amorphous semiconductors can be prepared by a suitable quenching procedure from the melt. Amorphous films can be obtained by vapor deposition.

**Rectification in semiconductors.** In semiconductors, narrow layers can be produced which have abnormally high resistances. The resistance of such a layer is nonohmic; it may depend on the direction of current, thus giving rise to rectification. Rectification can also be obtained by putting a thin layer of semiconductor or insulator material between two conductors of different material.

A narrow region in a semiconductor which has an abnormally high resistance is called a barrier layer. A barrier may exist at the contact of the semiconductor with another material, at a crystal boundary in the semiconductor, or at a free surface of the semiconductor. In the bulk of a semiconductor, even in a single crystal, barriers may be found as the result of a nonuniform

distribution of impurities. The thickness of a barrier layer is small, usually  $10^{-3}$  to  $10^{-5}$  cm.

A barrier is usually associated with the existence of a space charge. In an intrinsic semiconductor, a region is electrically neutral if the concentration  $n$  of conduction electrons is equal to the concentration  $p$  of holes. Any deviation in the balance gives a space charge equal to  $e(p - n)$ , where  $e$  is the charge on an electron. In an extrinsic semiconductor, ionized donor atoms give a positive space charge and ionized acceptor atoms give a negative space charge.

**Surface electronics.** The surface of a semiconductor plays an important role technologically, for example, in field-effect transistors and charge-coupled devices. Also, it presents an interesting case of two-dimensional systems where the electric field in the surface layer is strong enough to produce a potential wall which is narrower than the wavelengths of charge carriers. In such a case, the electronic energy levels are grouped into subbands, each of which corresponds to a quantized motion normal to the surface, with a continuum for motion parallel to the surface. Consequently, various properties cannot be trivially deduced from those of the bulk semiconductor. See CHARGE-COUPLED DEVICES; SURFACE PHYSICS. [H.Y.F.]

**Semiconductor diode** A two-terminal electronic device that utilizes the properties of the semiconductor from which it is constructed. In a semiconductor diode without a  $pn$  junction, the bulk properties of the semiconductor itself are used to make a device whose characteristics may be sensitive to light, temperature, or electric field. In a diode with a  $pn$  junction, the properties of the  $pn$  junction are used. The most important property of a  $pn$  junction is that, under ordinary conditions, it will allow electric current to flow in only one direction. Under the proper circumstances, however, a  $pn$  junction may also be used as a voltage-variable capacitance, a switch, a light source, a voltage regulator, or a means to convert light into electrical power. See SEMICONDUCTOR.

The conductivity of a semiconductor is proportional to the number of electrical carriers (electrons and holes) it contains. In a temperature-compensating diode, or thermistor, the number of carriers changes with temperature. See THERMISTOR.

In a photoconductor the semiconductor is packaged so that it may be exposed to light. Light photons whose energies are greater than the band gap can excite electrons from the valence band to the conduction band, increasing the number of electrical carriers in the semiconductor. See PHOTOCONDUCTIVITY.

In some semiconductors the conduction band has more than one minimum. This results in a region of negative differential conductivity, and a device operated in this region is unstable. The current pulsates at microwave frequencies, and the device, a Gunn diode, may be used as a microwave power source. See MICROWAVE SOLID-STATE DEVICES.

A rectifying junction is formed whenever two materials of different conductivity types are brought into contact. Most commonly, the two materials are an  $n$ -type and a  $p$ -type semiconductor, and the device is called a junction diode. However, rectifying action also occurs at a boundary between a metal and a semiconductor of either type. If the metal contacts a large area of semiconductor, the device is known as a Schottky barrier diode; if the contact is a metal point, a point-contact diode is formed. See SCHOTTKY EFFECT.

The contact potential between the two materials in a diode creates a potential barrier which tends to keep electrons on the  $n$  side of the junction and holes on the  $p$  side. When the  $p$  side is made positive with respect to the  $n$  side by an applied field, the barrier height is lowered and the diode is forward biased. Majority electrons from the  $n$  side may flow easily to the  $p$  side, and majority holes from the  $p$  side may flow easily to the  $n$  side. When the  $p$  side is made negative, the barrier height is increased and the diode is reverse-biased. Then, only a small leakage current flows: Minority electrons from the  $p$  side flow into

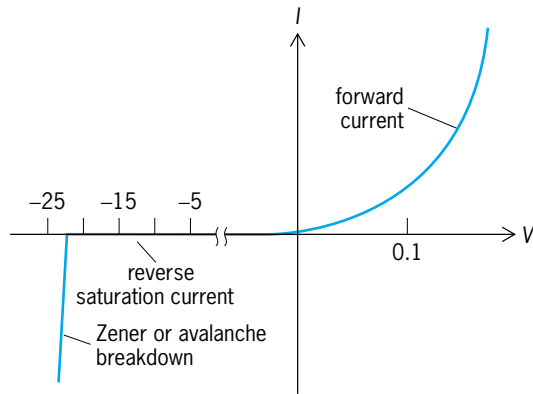

Current-voltage characteristic of a *pn* junction.

the *n* side, and minority holes from the *n* side flow into the *p* side. The current-voltage characteristic of a typical diode is shown in the illustration. Rectifying diodes can be made in a variety of sizes, and much practical use can be made of the fact that such a diode allows current to flow in essentially one direction only. See JUNCTION DIODE; SEMICONDUCTOR RECTIFIER; TUNNEL DIODE. [S.N.]

**Semiconductor heterostructures** Structures consisting of two different semiconductor materials in junction contact, with unique electrical or electrooptical characteristics. A heterojunction is a junction in a single crystal between two dissimilar semiconductors. The most important differences between the two semiconductors are generally in the energy gap and the refractive index. In semiconductor heterostructures, differences in energy gap permit spatial confinement of injected electrons and holes, while the differences in refractive index can be used to form optical waveguides. Semiconductor heterostructures have been used for diode lasers, light-emitting diodes, optical detector diodes, and solar cells. In fact, heterostructures must be used to obtain continuous operation of diode lasers at room temperature. Heterostructures also exhibit other interesting properties such as the quantization of confined carrier motion in ultrathin heterostructures and enhanced carrier mobility in modulation-doped heterostructures. Structures of current interest utilize III-V and IV-VI compounds having similar crystal structures and closely matched lattice constants. See BAND THEORY OF SOLIDS; LASER; LIGHT-EMITTING DIODE; OPTICAL DETECTORS; REFRACTION OF WAVES; SOLAR CELL.

The most intensively studied and thoroughly documented materials for heterostructures are GaAs and  $\text{Al}_x\text{Ga}_{1-x}\text{As}$ . Several other III-V and IV-VI systems also are used for semiconductor heterostructures. A close lattice match is necessary in heterostructures in order to obtain high-quality crystal layers by epitaxial growth and thereby to prevent excessive carrier recombination at the heterojunction interface.

When the narrow energy gap layer in heterostructures becomes a few tens of nanometers or less in thickness, new effects that are associated with the quantization of confined carriers are observed. These ultrathin heterostructures are referred to as superlattices or quantum well structures, and they consist of alternating layers of GaAs and  $\text{Al}_x\text{Ga}_{1-x}\text{As}$ . These structures are generally prepared by molecular-beam epitaxy. Each layer is 5 to 40 nanometers thick.

In the GaAs layers, the motion of the carriers is restricted in the direction perpendicular to the heterojunction interfaces, while they are free to move in the other two directions. The carriers can therefore be considered as a two-dimensional gas. The Schrödinger wave equation shows that the carriers moving in the confining direction can have only discrete bound states. See QUANTUM MECHANICS.

Another property of semiconductor heterostructures is illustrated by a modulation doping technique that spatially separates conduction electrons in the GaAs layer and their parent donor impurity atoms in the  $\text{Al}_x\text{Ga}_{1-x}\text{As}$  layer. Since the carrier mobility in semiconductors is decreased by the presence of ionized and neutral impurities, the carrier mobility in the modulation-doped GaAs is larger than for a GaAs layer doped with impurities to give the same free electron concentration. Higher carrier mobilities should permit preparation of devices that operate at higher frequencies than are possible with doped layers. See SEMICONDUCTOR. [H.C.C.]

**Semiconductor memories** Devices for storing digital information that are fabricated by using integrated circuit technology. Semiconductor memories are widely used to store programs and data in almost every digital system, and have replaced core memory as the main active computer memory.

Many different types of semiconductor memories are used in digital systems to perform various functions—bulk data storage, program storage, temporary storage, and cache (or intermediate) storage. Almost all of the memories are a form of random-access memory (RAM), in which any storage location can be accessed in the same amount of time.

Even though most semiconductor memories can be randomly accessed, they are not all referred to as RAMs. RAMs are memory chips that cannot retain data without power but permit data to be both read from or written into the memory chip's storage locations.

Within the category of read/write RAMs, many subdivisions have been created to satisfy the performance and system architecture requirements of the various applications. Basically there are two types of read/write RAMs—dynamic and static (DRAMs and SRAMs). The terms “dynamic” or “static” refer to the structure of the actual storage circuit (the cell structure) used to hold each data bit within the memory chip. A dynamic memory uses a storage cell based on a transistor and capacitor combination, in which the digital information is represented by a charge stored on each of the capacitors in the memory array. The memory gets the name “dynamic” from the fact that the capacitors are imperfect and will lose their charge unless the charge is repeatedly replenished (refreshed) on a regular basis (every few milliseconds) by externally supplied signals. Static memories, in contrast, do not use a charge-storage technique; instead, they use either four transistors and two resistors to form a passive-load flip-flop, or six transistors to form a flip-flop with dynamic loads for each cell in the array. Once data are loaded into the flip-flop storage elements, the flip-flops will indefinitely remain in that state until the information is intentionally changed or the power to the memory circuit is shut off.

In addition to static and dynamic RAMs, there is an attempt to combine both technologies, thus merging the high storage density of dynamic memory cells with the simplicity of use of static RAMs. Referred to as pseudostatic or pseudodynamic RAMs, these memories include circuits on the chip to automatically provide the refresh signals needed by the dynamic cells in the memory array. Since the signals do not have to be supplied by the external system, the memory appears to function like a static RAM.

There are many other forms of semiconductor memories in use—mask-programmable read-only memories (ROMs), fuse-programmable read-only memories (PROMs), ultraviolet-erasable programmable read-only memories (UV EPROMs), electrically alterable read-only memories (EAROMs), electrically erasable programmable read-only memories (EEPROMs), flash EPROMs, nonvolatile static RAMs (NV RAMs), and ferroelectric memories. Most of these memory types are randomly accessible, but their main distinguishing feature is that once information has been loaded into the storage cells, the information stays there even if the power is shut off.



The ROM is programmed by the memory manufacturer during the actual device fabrication. Here, though, there are two types of ROMs: one is called late-mask or contact-mask programmable, and the other is often referred to as a ground-up design.

As an alternative to the mask-programmable memories, all the other nonvolatile memory types permit the users to program the memories themselves. The fuse PROM is a one-time programmable memory—once the information is programmed in, it cannot be altered.

The birth of the microprocessor in the early 1970s brought with it nonvolatile memory types that offered reusability. Information stored in the memory can be erased—in the case of the UV EPROM, by an ultraviolet light, and in the case of the EAROM, EEPROM, flash EPROM (often referred to as just a flash memory device), nonvolatile (NV) RAM, or ferroelectric memory, by an electrical signal. Then the circuit can be reprogrammed with new information that can be retained indefinitely. All of these memory types are starting to approach the ideal memory element for the computer, an element that combines the flexibility of the RAM with the permanence of the ROM when power is removed. See COMPUTER STORAGE TECHNOLOGY; INTEGRATED CIRCUITS; LOGIC CIRCUITS; MICROPROCESSOR. [D.Bur.]

**Semiconductor rectifier** A semiconductor diode that is used in rectification and power control. The semiconductor diode conducts current preferentially in one direction and inhibits the flow of current in the opposite direction by utilizing the properties of a junction formed from two differently doped semiconductor materials. Doped silicon is by far the most widely used semiconductor. Semiconductor diodes are intrinsic to integrated circuits and discrete device technology and are used to perform a wide variety of isolation, switching, signal processing, level shifting, biasing, control, and alternating-current (ac) to direct-current (dc) conversion (rectification) functions. See CONTROLLED RECTIFIER; RECTIFIER; SEMICONDUCTOR; SEMICONDUCTOR DIODE.

Either as a key element of an integrated circuit or as a discrete packaged part, the silicon rectifier diode is used in a plethora of applications from small power supplies for consumer electronics to very large power-rectification industrial installations. Many semiconductor diodes are used in non-power-conversion applications in signal processing and communications. These include avalanche or Zener diodes; diodes used for amplitude-modulation radio detection, mixing, and frequency translation; IMPATT, PIN, and step-recovery diodes, used at microwave frequencies; diodes fabricated from gallium arsenide and related compounds, used in optoelectronics; and light-emitting diodes (LEDs) and solid-state lasers. See AMPLITUDE-MODULATION DETECTOR; LASER; LIGHT-EMITTING DIODE; MICROWAVE SOLID-STATE DEVICES; MIXER; ZENER DIODE.

**Silicon rectifier diodes.** The electrical heart of the semiconductor diode is the junction between *p*-type and *n*-type doped silicon regions. Discrete silicon diodes are commercially available with forward-current specifications from under 1 A to several thousands of amperes. Diodes may be connected in parallel for greater current capability as long as the design provides for the current being uniformly distributed between the parallel diodes. This is usually done with a ballast resistor in series with each diode. See BALLAST RESISTOR.

Ideally, the current through a reverse-biased diode, called the saturation current ( $I_S$ ) or reverse current ( $I_R$ ), approaches zero. Practically speaking, this current is several orders smaller than the forward current ( $I_F$ ). The maximum value of the reverse blocking voltage is limited primarily by the structure and doping of the semiconductor layers. This maximum voltage is referred to as the avalanche breakdown voltage, or the peak reverse voltage (PRV) or peak inverse voltage (PIV). It is a very important parameter for power supply and power conversion designs. Exceeding the peak inverse voltage is usually destructive unless the circuit design provides for limiting the avalanche current and resultant

heating. In summary, at positive voltages and currents (quadrant I of the voltage-current characteristic), the silicon rectifier diode shows the on-state conducting characteristic, with high current and low forward voltage drop; at negative voltages and currents (quadrant III), it shows the reverse-blocking or reverse-bias, off-state characteristic, with high blocking voltage and low (ideally zero) reverse blocking current. See ELECTRICAL BREAKDOWN.

Integrated-circuit diode-junction avalanche breakdown voltages are of the order of several tens of volts. Single silicon rectifier diodes designed for power conversion applications are available with ratings from a few hundred to a few thousand volts. Several diodes can be connected in series for greater voltage capability. Prepackaged series diode strings can be rated to tens of thousands of volts at several amperes. This series connection must ensure equal voltage division across each diode to guard against catastrophic failure of the entire series. Typically this is done by including a high-value equal-value resistor in parallel with each diode to obtain equal voltages, and a parallel capacitor to provide a low-impedance path for high-voltage transients that are often present in industrial environments. See JUNCTION DIODE.

**Schottky diodes.** Unlike a silicon diode formed from a *pn* junction, the Schottky diode makes use of the rectification effect of a metal-to-silicon interface and the resultant barrier potential. The Schottky diode, sometimes called the Schottky-barrier diode, overcomes the major limitation of the *pn* junction diode; being a majority carrier device, it has a lower forward voltage drop (0.2–0.3 V, compared to 0.7–1.0 V) and faster switching speed than its minority-carrier *pn* junction counterpart. However, other factors confine its use to low-voltage power applications, chiefly the relatively small breakdown voltage, typically 45 V. Secondary shortcomings include a high reverse current and restricted temperature of operation, with commercial devices providing a maximum of 175°C (347°F) compared with 200°C (392°F) for *pn* junction diodes.

Integrated circuits used in computer and instrument systems commonly require voltages less than 15 V and as low as 3.3 V. Thus the advantage of low forward-voltage drop and faster switching favors the Schottky diode. This is particularly true for high-frequency switching voltage regulator power supply applications where voltages at 20–50 kHz must be rectified. The higher reverse current can be tolerated. However, cooling or heat sinking is more critical because of the higher reverse-current temperature coefficient and lower maximum operating temperature. See SCHOTTKY BARRIER DIODE.

**Rectifier circuits.** The greatest usage of rectifier diodes is the conversion of ac to dc. The single diode of a half-wave rectifier for a single-phase ac voltage conducts only on the positive half-cycle. Because of this, the output voltage across the load resistance is unidirectional and has a nonzero average value. This output waveform is called a pulsating dc. Therefore the input ac voltage has been rectified to a dc voltage. For most applications, a filter, usually consisting of large electrolytic capacitors, must be employed at the output to smooth the ripple present on the pulsating dc voltage to come close to a constant dc voltage value. See CAPACITOR; ELECTRIC FILTER; ELECTRONIC POWER SUPPLY; RIPPLE VOLTAGE.

In lower-power applications from a few watts to a few hundred watts, such as used in computers, television receivers, and laboratory instruments, a switching voltage regulator is commonly used to generate a 10-kHz–50-kHz ac signal from the high-ripple ac power supply voltage. The advantage is the ease and lower cost in filtering the ripple resulting from rectifying high-frequency ac as opposed to filtering low-frequency ac. See VOLTAGE REGULATOR.

**Thyristors.** Whereas the basic semiconductor rectifier has two terminals, an anode and cathode, a silicon controlled rectifier (SCR) has three terminals: an anode, cathode, and control electrode called the gate. The silicon controlled rectifier is a four-layer device modeled as two interconnected *pnp* and *npn* transistors.

Normally, there is no current flow from the anode to cathode. Both transistors are off; that is, they are blocking any current flow. By applying a relatively small trigger pulse control signal to the gate electrode, the *npn* transistor is switched on. When the *npn* transistor is switched on, the *pnp* transistor is also switched on. Consequently the silicon controlled rectifier is turned on and a current flows through the silicon controlled rectifier and external circuit. The resultant internal voltages keep both the *npn* and *pnp* transistors on even when the gate voltage is removed. The device is said to exhibit regenerative, positive-feedback, or latching-type switching action. There is a voltage drop of about 1 V across the on-state silicon controlled rectifier. The power dissipation rating required in specifying a silicon controlled rectifier is given by this 1-V drop multiplied by the peak current flowing through the device. See TRANSISTOR.

Current continues to flow even when the gate signal is reduced to zero. To reset the silicon controlled rectifier, the external current must be reduced below a certain value. Thus, the thyristor can be switched into the on state (conducting condition) by applying a signal to the gate, but must be restored to the off state by circuit action. If the anode current momentarily drops below some holding current or if the anode voltage is reversed, the silicon controlled rectifier reverts to its blocking state and the gate terminal regains control. Typical silicon controlled rectifiers turn on in 1–5 microseconds and require 10–100  $\mu$ s of momentary reverse voltage on the anode to regain their forward-blocking ability.

Other semiconductor diode topologies are also used for power control. A generic term for these power-control devices is the thyristor.

Thyristor applications fall into two general categories. The devices can be used from an ac supply, much like silicon rectifier diodes. However, unlike the rectifier diode, which conducts load current as soon as the anode voltage exceeds about 0.7 V, the thyristor will not conduct load current until it is triggered into conduction. Therefore, the power delivered to the load can be controlled. This mode of operation is called ac phase control. It is extensively used in applications requiring conversion from ac to variable-voltage dc output, such as adjustable-speed dc motor drives, and in lighting and heating control. See DIRECT-CURRENT MOTOR.

The other category of applications is operation in dc circuits. This allows power conversion from a battery or rectified ac line to a load requiring either an alternating supply (dc-to-ac conversion) or a variable-voltage dc supply (dc-to-dc conversion). Since the rate of switching the thyristors in dc circuits can be varied by the control circuit, a thyristor inverter circuit can supply an ac load with a variable frequency. The fundamental approach in both cases is to convert a dc voltage to a chopped voltage of controllable duty cycle. Changing the duty cycle either at a variable rate (frequency power modulation) or by varying the pulse width at a fixed frequency (pulse-width power modulation) effectively controls the power delivered to the load. See CHOPPING; PULSE MODULATION.

Important applications for dc-to-dc conversion, dc-to-ac power conversion at variable frequency, and dc-to-ac power conversion at fixed frequency are, respectively, control of battery-powered industrial vehicles such as forklift trucks and mining locomotives, adjustable-speed operation of ac synchronous and induction motors in industrial processing, and power transmission conversion. See ALTERNATING-CURRENT MOTOR; CONVERTER; INDUSTRIAL TRUCKS. [S.G.Bu.]

**Semionotiformes** An order of actinopterygian fishes which appeared first in the upper Permian, reached maximum development in the Triassic and Jurassic, and persists in the Recent fauna as the gars.

In the Semionotiformes the body is encased in a heavy armor of interlocking ganoid scales, which are thick, are more or less rhomboidal, and have an enamel-like surface. Modern forms

have an elongate body and bony jaws provided with enlarged conical teeth (see illustration).

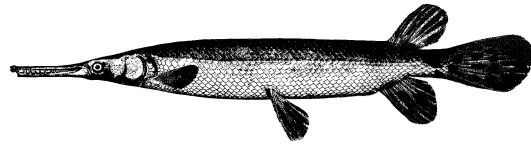

Spotted gar (*Lepisosteus oculatus*). (After G. B. Goode, *Fishery Industries of the United States*, 1884)

The single Recent family, Lepisosteidae, contains one genus, *Lepisosteus*, with seven species restricted to lowland fresh and brackish waters of North and Central America. See ACTINOPTERYGII. [R.M.B.]

**Sendai virus** A member of the viruses in the type species Parainfluenza 1, genus *Paramyxovirus*, family Paramyxoviridae; it is also called hemagglutinating virus of Japan (HVJ). Sendai virus was originally recovered in Sendai, Japan, from mice inoculated with autopsy specimens from newborns who died of fatal pneumonitis in an epidemic in 1952. Subsequent attempts to isolate this virus from humans were, however, mostly unsuccessful, although mice are commonly infected with Sendai virus along with rats, guinea pigs, hamsters, and pigs. It is believed that the natural host of Sendai virus is the mouse and that the virus is usually nonpathogenic for humans. See ANIMAL VIRUS; PARAINFLUENZA VIRUS. [N.I.]

**Sensation** A term commonly used to refer to the subjective experience resulting from stimulation of a sense organ, for instance, a sensation of warm, sour, or green. As a general scientific category, the study of sensation is the study of the operation of the senses. Sense receptors are the means by which information presented as one form of energy, for example, light, is converted to information in the form used by the nervous system, that is, impulses traveling along nerve fibers. See SENSE ORGAN.

Each sense has mechanisms and characteristics peculiar to itself, but all display the phenomena of absolute threshold, differential threshold, and adaptation. Not until sufficient stimulation impinges on a receptor can the presence of a stimulus be detected. The quantity of stimulation required is known as the absolute threshold. Not until a sufficient change occurs in some aspect of a stimulus can the change be detected. The magnitude of the change required is called the differential threshold. Under steady stimulation there is a decrease in sensitivity of the corresponding sense, as indicated by a shift in the absolute threshold and in the magnitude of sensation. After the stimulation ceases, sensitivity increases. An obvious example of visual adaptation occurs when one goes from bright to dim surroundings or vice versa.

With fairly good accuracy humans can localize visual objects, sounds, and cutaneous contacts and can discriminate the spatial orientation of the body and its members. With rather poor accuracy humans can localize many of the stimuli originating within the body.

With the exception of hearing, in which sense localization depends on differences in the acoustic stimuli reaching the two ears, there appears to be a common principle involved in giving spatially separated receptors their different local signs. Stimulation at different points on the receptive surface results in peaks of electrical activity at different loci in the brain. In no sense is there anything like a private wire from each sensory cell to a corresponding point in the brain. In fact, there are so many opportunities for a signal to go astray on its way from the receptor to the brain that it is surprising that spatial discrimination is as good as it is. Nevertheless, there is clear evidence that, by a combination of anatomical and functional arrangements, spatial

differences at the receptor level are translated into topologically similar spatial differences in brain activity. See HEARING (HUMAN).

The nerve fibers between receptor and brain do not serve merely as transmitters of sensory information. Their interconnections enable them to influence one another's sensitivity and to perform logical operations like those carried out inside computers. As a result the information arriving in the sensory areas of the brain is not merely a more or less faithful replica of that presented to the receptors but in addition has had certain aspects of the information selected for special signaling. See CHEMICAL SENSES; PAIN; SOMESTHESIS; TASTE; VISION. [J.F.H.]

**Sense amplifier** An electronic amplifier circuit used to sense and refresh the value of a bit stored in a memory cell of a dynamic random access memory (DRAM) integrated circuit.

In DRAM, bits are represented in memory by the presence or absence of an electric charge stored on tiny capacitors. Cell capacitance is directly proportional to cell area, and since the chip area devoted to each bit-cell must decrease with an increase in the memory capacity of a given size of chip, the resulting cell capacitance is tiny, typically on the order of femtofarads (1 femtofarad =  $10^{-15}$  farad). Since the voltage used to charge these capacitors is usually limited to 5 V or less, the charge stored in each memory cell also is quite small, on the order of femtocoulombs. See CAPACITANCE; CAPACITOR.

In order to read out the value of a given bit of a word in this type of memory, the bit-cell voltage, or equivalently the magnitude of its charge, needs to be sensed, and the results of this sense operation must be delivered to the rest of the circuit. Both the sense amplifier used to read the bit-cell voltage and the interconnect wiring (the bit line) between the bit cell and the amplifier have inherent parasitic capacitances which, in total, are much larger than the bit-cell capacitance. If the sense amplifier is simply switched across the bit cell, the charge on the bit-cell capacitor will redistribute across the parasitic capacitor and the bit-cell capacitor in accordance with Kirchhoff's law, which requires that the two capacitors have the same voltage, where the total charge must come from the original charge stored on the memory-cell capacitor. Thus the voltage seen by the amplifier is equal to the original bit-cell voltage multiplied by the ratio of the bit-cell capacitance to the sum of the two capacitances, and the charge remaining on the memory cell capacitor after sensing would be reduced from the original charge in the same proportion. If the parasitic capacitance is much larger than the cell capacitance, it follows that the voltage available at the sense amplifier input will be small and the voltage and charge remaining on the memory cell will be considerably reduced. More sophisticated approaches need to be taken to sense this tiny voltage and to refresh the memory cell during sense, so that the memory cell capacitor is left fully charged (or fully discharged) when sensing is complete. See KIRCHHOFF'S LAWS OF ELECTRIC CIRCUITS.

The sense amplifier action is based on metal-oxide-semiconductor field-effect transistors (MOSFETs). These can be thought of as simple switches that are opened and closed in a predetermined sequence to carry out the read/refresh memory cycle. To assist the sense, a memory reference cell, containing a capacitor of approximately one-half the capacitance of the bit-cell capacitor, is added to the circuit. See SEMICONDUCTOR MEMORIES; TRANSISTOR. [P.V.L.]

**Sense organ** A structure which is a receptor for external or internal stimulation. A sense organ is often referred to as a receptor organ. External stimuli affect the sensory structures which make up the general cutaneous surface of the body, the exteroceptive area, and the tissues of the body wall or the proprioceptive area. These somatic area receptors are known under the general term of exteroceptors. Internal stimuli which originate in various visceral organs such as the intestinal tract or heart affect the visceral sense organs or interoceptors. A receptor structure is not necessarily an organ; in many unicellular animals it is a

specialized structure within the organism. Receptors are named on the basis of the stimulus which affects them, permitting the organism to be sensitive to changes in its environment.

Photoreceptors are structures which are sensitive to light and in some instances are also capable of perceiving form, that is, of forming images. Light-sensitive structures include the stigma of phytomonads, photoreceptor cells of some annelids, pigment cup ocelli and retinal cells in certain asteroids, the eye-spot in many turbellarians, and the ocelli of arthropods. The compound eye of arthropods, mollusks, and chordates is capable of image formation and is also photosensitive. See PHOTORECEPTION.

Phonoreceptors are structures which are capable of detecting vibratory motion or sound waves in the environment. The most common phonoreceptor is the ear, which in the vertebrates has other functions in addition to sound perception. See EAR; PHONORECEPTION.

Statoreceptors are structures concerned primarily with equilibrium, such as the statocysts found throughout the various phyla of invertebrates and the inner ear or membranous labyrinth filled with fluid.

The sense of smell is dependent upon the presence of olfactory neurons, called olfactory receptors, in the olfactory epithelium of the nasal passages among the vertebrates. See OLFACTION.

The sense of taste is mediated by the taste buds, or gustatory receptors. In most vertebrates these taste buds occur in the oral cavity, on the tongue, pharynx, and lining of the mouth; however, among certain species of fish, the body surface is supplied with taste buds as are the barbels of the catfish. See TASTE.

The surface skin of vertebrates contains numerous varied receptors associated with sensations of touch, pain, heat, and cold. See CHEMICAL SENSES; CUTANEOUS SENSATION; SENSATION. [C.B.C.]

**Sensitivity (engineering)** A property of a system, or part of a system, that indicates how the system reacts to stimuli. The stimuli can be external (that is, an input signal) or a change in an element in the system. Thus, sensitivity can be interpreted as a measure of the variation in some behavior characteristic of the system that is caused by some change in the original value of one or more of the elements of the system.

Sensitivity is commonly used as a figure of merit for characterizing system performance. As a figure of merit, the sensitivity is a numerical indicator of system performance that is useful for predicting system performance in the presence of elemental variations or comparing the relative performance of two or more systems that ideally have the same performance. In the latter case, the performance of the systems relative to some parameter of interest is rank-ordered by the numerical value of the corresponding sensitivity functions. If  $T$  is the performance characteristic and  $X$  is the element or a specified input level, then mathematically sensitivity is expressed as a normalized derivative of  $T$  with respect to  $X$ .

A limiting factor in using the sensitivity of a system to characterize performance at low signal levels is the noise. Noise is a statistical description of a random process inherent in all elements in a physical system. The noise is related to the minimum signal that can be processed in a system as a function of physical variables such as pressure, visual brightness, audible tones, and temperature. See ELECTRICAL NOISE.

There exist many situations where the sensitivity measure indicates the ability of a system to meet certain design specifications. For example, in an electronic system the sensitivity of the output current with respect to the variation of the power-supply voltage can be very critical. In that case, a system with a minimum sensitivity of the output current with respect to the power-supply voltage must be designed. Another example is a high-fidelity audio amplifier whose sensitivity can be interpreted as the capacity of the amplifier to detect the minimum amplifiable signal.

[E.S.Si.]

**Sensory system regeneration** The replacement of receptor cells within a given sensory endorgan (retina, cochlea, taste buds, olfactory epithelium). In order to detect environmental cues efficiently, receptor cells must be exposed to the environment. This exposure makes them susceptible to the damaging effects of the very stimuli they are designed to detect. Such sensory deficits are of great significance to the survival of the organism, and numerous mechanisms have evolved to protect sensory systems from permanent extensive damage. In many systems, one of these protective mechanisms is the ability to regenerate. In the context of sensory systems, regeneration normally involves addition of newly differentiated cells to the system rather than the recuperation of damaged cells.

Generally, regeneration requires that undifferentiated cells known as progenitor cells go through at least one cell division prior to developing as a specific cell type (cell differentiation). However, the presence of progenitor cells within a given epithelium and their propensity to reenter the cell cycle varies greatly from system to system. For example, taste buds and the olfactory epithelium contain relatively large numbers of progenitor cells that undergo constant cell division. Both taste receptor cells and olfactory neurons undergo constant renewal (replacement) in all adult vertebrates. These systems are capable of substantial regeneration. See CELL CYCLE; CELL DIFFERENTIATION; CELL LINEAGE; OLFACTION; TASTE.

In contrast, the regeneration of photoreceptors in the retina and sensory hair cells in the inner ear is dependent upon the species and age of a given animal. Numerous studies in teleost fish and amphibians have demonstrated that both the eye and the inner ear are capable of regeneration long after embryonic development. The retinas of reptiles, birds, and mammals, however, lose their regenerative capability during embryonic development. Consequently, photoreceptor loss in the retinas of adult mammals such as humans is irreversible. See EMBRYONIC DIFFERENTIATION; EMBRYONIC INDUCTION; EYE (VERTEBRATE).

For many years, the inner ears of higher vertebrates were also thought to be totally incapable of regeneration beyond embryonic development. However, landmark studies in the 1980s provided new data that indicated otherwise. Using a radioactive marker that labels dividing cells, these studies demonstrated that sound- or drug-induced damage to the cochleae of adult birds caused dormant progenitor cells to become active and produce new sensory hair cells. It was subsequently shown that a portion of the bird ear responsible for the sense of balance (the vestibular system) is also capable of regeneration in response to damage and maintains a small but constant number of dividing progenitor cells under normal conditions. Finally, it has been demonstrated that the regeneration of sensory cells in the bird inner ear results in a high level of functional recovery in both the auditory and vestibular systems of these animals. See EAR (VERTEBRATE).

Cells in the nonauditory parts of the mammalian inner ear are also capable of very limited hair cell regeneration. It is increasingly clear, however, that the adult mammalian cochlea is not. The adult mammalian cochlea has no innate ability to regenerate and in fact loses its ability to produce new hair cells a day or two prior to the birth of the animal. Consequently, research has turned to the normal embryonic development of the mammalian cochlea to search for molecular factors that might be used to stimulate hair cell addition in the mature animal. Several groups of molecules have been identified that play a significant role. These include the Notch signaling pathway, a genetic program that is present in both vertebrates and invertebrates and which functions as a switching mechanism by which progenitor cells may be directed to develop as one type of cell versus another, or to continue to divide. See HEARING (HUMAN); HEARING IMPAIRMENT. [P.L.]

**Sepioidea** An order of the class Cephalopoda (subclass Coleoidea) including the cuttlefishes (*Sepia*), the bobtail squids (*Sepioteuthis*), and the ram's-horn squid (*Spirula*). The group is char-

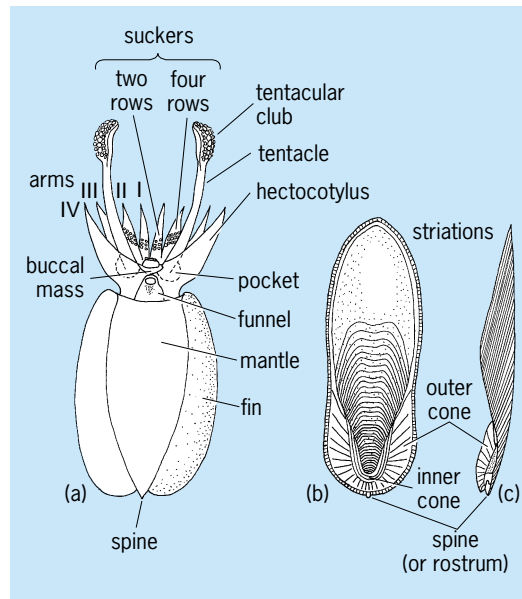

Diagram of some features of (a) a cuttlefish and of (b) a cuttlebone shown in ventral view and (c) in cross section.

acterized by an internal shell that is calcareous and broad with closely packed laminate chambers (the cuttlebones of cuttlefishes). The mouth is surrounded by ten appendages (eight arms and two longer tentacles) that bear suckers with chitinous rings. The tentacles are contractile and retractile into pockets at their bases (see illustration).

Cuttlefishes are common benthic or epibenthic (living on or just above the bottom, respectively) animals that occur in the warm and temperate waters of the nearshore and continental shelf zones of the Old World, but they are excluded from the Western Hemisphere (North and South America). They prey on shrimps, crabs, small fishes, and other cuttlefishes. The sexes are separate, and during mating, which follows a colorful ritualistic courting behavior, sperm is transferred to the female in cylindrical packets (spermatophores) by a modified arm (the hectocotylus) of the male.

The cuttlebones are used to control the buoyancy of the cuttlefishes as fluid is pumped into and out of the laminar chambers. Dried cuttlebones are a source of calcium for cage birds and are used for fine jewelry molds, dentifrices, and cosmetics. The cuttlefishes eject an attention-getting blob of brownish-black ink when threatened by predators, then change color, become transparent, and jet-swim away, leaving the predator to attack the false body (pseudomorph) of ink. Artists have used the ink, called sepia, for centuries. Cuttlefishes are important in world fisheries; about 200,000 metric tons are caught each year for human food. See CEPHALOPODA; COLEOIDEA. [C.F.E.R.]

**Sepiolite** A complex hydrated magnesium silicate mineral named for its resemblance to cuttlefish bone, alternately named meerschau (sea foam). The ideal composition,  $Mg_3(H_2O)_4(OH)_4Si_{12}O_{30}$ , is modified by some additional water of hydration, but is otherwise quite representative. Interlaced disoriented fibers aggregate into a massive stone so porous that it floats on water. These stones are easily carved, take a high polish with wax, and harden when warmed. See CLAY MINERALS; SILICATE MINERALS. [W.F.B.]

**Septibranchia** A subclass of bivalve mollusks (class Bivalvia) that are unique in their possession of a muscular septum instead of a filamentous gill. The Septibranchia equate in great part to the superfamily Poromyacea, which includes the septibranch families Cuspidariidae and Poromyidae, and the Verticordiidae. The Verticordiidae have gills that are greatly

reduced in size. Although there are a few cuspidariid species in shallow seas, the great majority of septibranchs are found at lower slope and abyssal depths which are deficient in food for filter-feeding bivalves. They live close to the surface in soft sediments. Most species are less than 20 mm maximum length. See BIVALVIA; MOLLUSCA.

The term septibranch remains extremely useful because it describes mollusks having a septum and other morphological specializations that relate to the septibranch's unique carnivorous habits. The septum is a muscular, horizontal partition dividing the mantle cavity. It is derived from the enormous gill found in the mollusks of the subclass Lamellibranchia: The filaments are reduced in size and modified. Other modifications include a muscular stomach for crushing the prey and high proteolytic activity of the gastric juice. [J.A.A.]

**Septic tank** A single-story, watertight, on-site treatment system for domestic sewage, consisting of one or more compartments, in which the sanitary flow is detained to permit concurrent sedimentation and sludge digestion. The septic tank is constructed of materials not subject to decay, corrosion, or decomposition, such as precast concrete, reinforced concrete, concrete block, or reinforced resin and fiberglass. The tank must be structurally capable of supporting imposed soil and liquid loads. Septic tanks are used primarily for individual residences, isolated institutions, and commercial complexes such as schools, prisons, malls, fairgrounds, summer theaters, parks, or recreational facilities. Septic tanks have limited use in urban areas where sewers and municipal treatment plants exist. See CONCRETE; REINFORCED CONCRETE; STRUCTURAL MATERIALS.

Septic tanks do not treat sewage; they merely remove some solids and condition the sanitary flow so that it can be safely disposed of to a subsurface facility such as a tile field, leaching pools, or buried sand filter. The organic solids retained in the tank undergo a process of liquefaction and anaerobic decomposition by bacterial organisms. The clarified septic tank effluent is highly odorous, contains finely divided solids, and may contain enteric pathogenic organisms. The small amounts of gases produced by the anaerobic bacterial action are usually vented and dispersed to the atmosphere without noticeable odor or ill effects. See RURAL SANITATION; SEWAGE; SEWAGE TREATMENT. [G.Pa.]

**Sequence stratigraphy** The study of stratigraphic sequences, defined as stratigraphic units bounded by unconformities. With improvements in the acquisition and processing of reflection-seismic data by petroleum exploration companies in the 1970s came the recognition that unconformity-bounded sequences could be recognized in most sedimentary basins. This was the beginning of an important development, seismic stratigraphy, which also included the use of seismic reflection character to make interpretations about large-scale depositional facies and architecture. See SEISMIC STRATIGRAPHY; UNCONFORMITY.

Underpinning sequence-stratigraphic methods are the following interrelated principles: (1) The volume of sediment accumulating in any part of a sedimentary basin is dependent on the space made available for sediment by changes in sea level or basin-floor elevation. This space is referred to as accommodation. (2) Changes in accommodation tend to be cyclic, and they are accompanied by corresponding changes in sedimentary environment and depositional facies. Thus, a rise in base level typically leads to an increase in accommodation, deepening of the water in the basin, with corresponding changes in facies, and a transgression, with a consequent landward shift in depositional environments and in depositional facies. A fall in base level may lead to exposure and erosion (negative accommodation), with the development of a widespread unconformity. (3) These predictable changes provide the basis for a model of the shape and internal arrangement or architecture of a sequence, including the organization and distribution of sedimentary facies and the internal bedding surfaces that link these facies together. See BASIN; DEPOSITIONAL SYSTEMS AND ENVIRONMENTS; FACIES (GEOLOGY).

Clastic-dominated sequences are bounded by unconformities. These surfaces (sequence boundaries) are typically well developed within coastal and shelf sediments, where they form as a result of subaerial exposure and erosion during falling sea level. In deeper-water settings, including the continental slope and base of slope, there may be no corresponding sedimentary break; and sequences may be mapped into such settings only if the unconformity can be correlated to the equivalent conformable surface (the correlative conformity). In some instances, the surface of marine transgression, which develops during the initial rise in sea level from a lowstand, forms a distinctive surface that is close in age to the subaerial unconformity and may be used as the sequence boundary. See MARINE GEOLOGY; MARINE SEDIMENTS.

The cycle of rise and fall of sea level may be divided into four segments: lowstand, transgressive, highstand, and falling stage. The deposits that form at each stage are distinctive, and are assigned to systems tracts named for each of these stages.

Carbonate-dominated sequences are derived from carbonate sedimentation which is most active in warm, clear, shallow, shelf seas. During the sea-level cycle, these conditions tend to be met during the highstand phase. Sediment production may be so active, including that of reef development at the platform margin, that it outpaces accommodation generation, leading to deposition on the continental slope. Oversteepened sediment slopes there may be remobilized, triggering sediment gravity flows and transportation into the deep ocean. This process is called highstand shedding.

There are several processes of sequence generation that range from a few tens of thousands of years to hundreds of millions of years for the completion of a cycle of rise and fall of sea level. More than one such process may be in progress at any one time within a basin, with the production of a range of sequence styles nested within or overlayering each other.

High-frequency sequence generation is driven by orbital forcing of climate (the so-called Milankovitch effects), of which glacial eustasy is the best-known outcome. The effects of glacioeustasy have dominated continental-margin sedimentation since the freeze-up of Antarctica in the Oligocene. Regional tectonism—such as the process of thermal subsidence following rifting, and flexural loading in convergent plate settings—develops changes in basement elevation that drive changes in relative sea level. These cycles have durations of a few millions to a few tens of millions of years, and they are confined to individual basins or the flanks of major orogens or plate boundaries. See PALEOGEOGRAPHY.

Sequence concepts enable petroleum exploration and development geologists to construct predictive sequence models for stratigraphic units of interest from the limited information typically available from basins undergoing petroleum exploration. These models can guide regional exploration, and can also assist in the construction of production models that reflect the expected partitioning of reservoir-quality facies within individual stratigraphic units. See CLIMATE HISTORY; GEOLOGIC TIME SCALE; GEOPHYSICAL EXPLORATION; GLACIOLOGY; PALEOCLIMATOLOGY; STRATIGRAPHY. [A.D.M.]

**Sequoia** The giant sequoia or big tree (*Sequoia gigantea*) occupies a limited area in California and is said to be the oldest and most massive of all living things. The leaves are evergreen, scalelike, and overlapping on the branches. In height sequoia is a close second to the redwood (300–330 ft or 90–100 m) but the trunk is more massive. Sequoia trees may be 27–30 ft (8–9 m) in diameter 10 ft (3 m) from the ground. The stump of one tree showed 3400 annual rings. The red-brown bark is 1–2 ft (0.3–0.6 m) thick and spongy. Vertical grooves in the trunk give it a fluted appearance. The heartwood is dull purplish-brown and lighter and more brittle than that of the redwood. The wood and bark contain much tannin, which is probably the cause of the great resistance to insect and fungus attack. The most

magnificent trees are within the General Grant and Sequoia National Parks. See PINALES; REDWOOD. [A.H.G./K.P.D.]

**Series** The indicated sum of a succession of numbers or terms. Series are used to obtain approximate values of infinite repeating decimals, to solve transcendental equations, to obtain values of logarithms or trigonometric functions, to evaluate integrals, and to solve boundary value problems.

For a finite series, with only a limited number of terms, the sum is found by addition. For an infinite series, with an unlimited number of terms, a sum or value can be assigned only by some limiting process. When the simplest such process yields a value, the infinite series is convergent. Many tests for convergence enable one to learn whether a sum can be found without actually finding it.

If each term of an infinite series involves a variable  $x$  and the series converges for each value of  $x$  in a certain range, the sum will be a function of  $x$ . Often the sum is a given function of  $x$ ,  $f(x)$ , for which a series having terms of some given form is desired. Thus the Taylor's series expansion

$$f(x) = \sum_{n=0}^{\infty} f^{(n)}(a) \frac{(x-a)^n}{n!}$$

can be found for a large class of functions, the analytic functions, and represent such functions for sufficiently small values of  $|x-a|$ . For a much less restricted type of function on the interval  $-\pi < x < \pi$ , a Fourier series expansion of the form

$$\frac{1}{2}A_0 + \sum_{n=1}^{\infty} (A_n \cos nx + B_n \sin nx)$$

can be found.

**Finite series.** Here the problem of interest is to determine the sum of the first  $n$  terms,

$$S_n = u_0 + u_1 + u_2 + \dots + u_{n-1}$$

when  $u_n$  is a given function of  $n$ . Examples are the arithmetic series, with  $u_n = a + nd$  and  $S_n = (n/2)[2a + (n-1)d]$ , and the geometric series, with  $u_n = ar^n$  and  $S_n = a(1-r^n)/(1-r)$ . See PROGRESSION (MATHEMATICS).

**Convergence and divergence.** An infinite series is the indicated sum of an unlimited number of terms

$$u_0 + u_1 + u_2 + \dots u_n \dots$$

or more briefly

$$\sum_{n=0}^{\infty} u_k$$

or simply  $\Sigma u_n$ , read "sigma of  $u_n$ ." The sum  $S_n$  of the first  $n$  terms is known as the  $n$ th partial sum. Thus  $S_n$  is the finite sum

$$\sum_{k=0}^{n-1} u_k$$

If, as  $n$  increases indefinitely or becomes infinite, the partial sum  $S_n$  approaches a limit  $S$ , then the infinite series  $\Sigma u_n$  is convergent.  $S$  denotes the sum or value of the series. For example, if  $|r| < 1$ ,

$$S = \sum ar^n = \frac{a}{1-r} \text{ since } S_n = a \frac{1-r^n}{1-r}$$

If, as  $n$  becomes infinite, the partial sum  $S_n$  does not approach a finite limit, then the infinite series  $\Sigma u_n$  is divergent. For example,  $\Sigma 1$  diverges, since here  $S_n = n$  becomes infinite with  $n$ . Also  $\Sigma (-1)^n$  diverges, since here  $S_n = \frac{1}{2}[1 - (-1)^{n+1}]$  which is alternately one and zero.

Positive series are series each of whose terms is a positive number or zero. For such series, the partial sum  $S_n$  increases as  $n$  increases. If for some fixed number  $A$  no sum  $S_n$  ever exceeds  $A$ , the sums are bounded and admit  $A$  as an upper bound. In this case,  $S_n$  must approach a limit, and the series is convergent. If every fixed number is exceeded by some  $S_n$ , the sums are

unbounded. In this case,  $S_n$  must become positively infinite and the series is divergent. The tests for convergence of positive series are tests for boundedness, and this is shown by a comparison of  $S_n$  with the partial sums of another series or with an integral.

For any series  $\Sigma u_n$ , which may have both positive and negative terms, the series of absolute values,  $\Sigma |u_n|$ , is a positive series whose convergence may be proved by one of the tests for positive series. If  $\Sigma |u_n|$  converges, then  $\Sigma u_n$  necessarily converges and is said to converge absolutely. The sum of an absolutely convergent series is independent of the order of the terms.

A series which converges but which does not converge absolutely is said to be conditionally convergent. For such a series, a change in the order of the terms may change the sum or cause divergence.

**Power series.** There are series with  $u_n = a_n x^n$ . For such a series, it may happen that

$$\lim_{n \rightarrow \infty} \left| \frac{a_{n+1}}{a_n} \right| = A$$

If  $A = 0$ , the series converges for all values of  $x$ . If  $A \neq 0$ , the series converges for all  $x$  of the interval  $-1/A < x < 1/A$ . It will diverge for all  $x$  with  $|x| > 1/A$ . For any power series, the interval of convergence is related in this way to a number  $A$ , which, however, in the general case has to be given by the superior limit of

$$\sqrt{|a_n|}$$

Similar remarks apply to the series with  $u_n = a_n(x-c)^n$ . Here the interval of convergence is  $|x-c| < 1/A$ .

One of the most important power series is the binomial series:

$$1 + mx + \frac{m(m-1)}{1 \cdot 2} x^2 + \dots + \frac{m(m-1)(m-2) \dots (m-n+1)}{n!} x^n + \dots$$

When  $m$  is a positive integer, this is a finite sum of  $m+1$  terms which equals  $(1+x)^m$  by the binomial theorem. When  $m$  is not a positive integer, the interval of convergence is  $-1 < x < 1$ , and for  $x$  in this interval, the sum of the series is  $(1+x)^m$ . See BINOMIAL THEOREM.

Let the power series  $\Sigma a_n(x-c)^n$  have the sum function  $f(x)$ . Then  $a_0 = f(c)$ ,  $a_n = f^{(n)}(c)/n!$ , and the series is the Taylor series of  $f(x)$  at  $x=c$ . Thus, every power series whose interval of convergence has positive length can be put in the form

$$f(x) = f(c) + f'(c) \frac{x-c}{1!} + \dots + f^{(n)}(c) \frac{(x-c)^n}{n!} + \dots$$

where  $f(x)$  is the sum function.

The Maclaurin series is the special case of Taylor series with  $c=0$ :

$$f(x) = f(0) + f'(0) \frac{x}{1!} + \dots + f^{(n)}(0) \frac{x^n}{n!} + \dots$$

**Uniform convergence.** Let each term of a series be a function of  $z$ ,  $u_n = g_n(z)$ . Let  $S_n$  be the sum of the first  $n$  terms, and  $S$  the sum to which the series converges for a particular value of  $z$ . Then  $R_n = S - S_n$  is the remainder after  $n$  terms, and for the particular value of  $z$ ,  $\lim R_n$  must equal zero. If, for a given range of  $z$ , it is possible to make  $R_n(z)$  arbitrarily small for sufficiently large  $n$  without specifying which  $z$  in the range is under consideration, the series converges uniformly. See FOURIER SERIES. [P.F./S.Bo.]

Series sometimes appear in disguised form in arithmetic. Thus the approximation of a rational number by an infinite repeating decimal is really a geometric series.

**Series circuit** An electric circuit in which the principal circuit elements have their terminals joined in sequence so that a common current flows through all the elements. The circuit may consist of any number of passive and active elements, such as resistors, inductors, capacitors, electron tubes, and transistors. See CIRCUIT (ELECTRICITY). [R.L.R.]

**Serology** The division of biological science concerned with antigen-antibody reactions in serum. It properly encompasses any of these reactions, but is often used in a limited sense to denote laboratory diagnostic tests, especially for syphilis. The techniques of blood grouping have come from the study of antigen-antibody reactions in serum, as have techniques for identification of genetic polymorphism and quantitation of numerous serum proteins. With these advances came the means for developing transfusion therapy with cells and plasma. In addition, these techniques led to identification of antibodies involved in incompatibility reactions, such as in erythroblastosis fetalis, and the development of effective measures to prevent their occurrence. Further, extension of these techniques to identification of antigens on white cells led to effective methods of histocompatibility typing, facilitating organ transplantation. See TRANSPLANTATION BIOLOGY. [D.R.]

**Serotonin** A compound, also known as 5-hydroxytryptamine (5-HT), derived from tryptophan, an indole-containing amino acid. It is widely distributed in the animal and vegetable kingdoms. In mammals it is found in gastrointestinal enterochromaffin cells, in blood platelets, and in brain and nerve tissue. Serotonin is a local vasoconstrictor, plays a role in brain and nerve function and in regulation of gastric secretion and intestinal peristalsis, and has pharmacologic properties. It is inactivated by monoamine oxidases (MAO-A and -B), enzymes that also inactivate other neurotransmitters such as norepinephrine and dopamine.

Serotonin is concentrated in certain areas of the brain; the hypothalamus and midbrain contain large amounts, while the cortex and cerebellum contain low concentrations. Like most neurotransmitters, it is stored in granules inside nerve endings, and is thus not exposed to inactivation by monoamine oxidases until it is released into the synaptic space between nerves. When a serotonin-containing nerve fires, serotonin is released and can bind to any one of a series of at least 14 distinct downstream serotonin receptors (5-HT receptors). Release of serotonin or other stored neurotransmitters can also be induced by alkaloids such as reserpine, which have been used as tranquilizing agents in the treatment of nervous and mental disorders. Although pharmacologic doses of serotonin produce a type of sedation and other depressant conditions of the nervous system, several types of clinically useful antidepressants, such as monoamine oxidase (MAO) inhibitors, tricyclic antidepressants, and selective serotonin reuptake inhibitors (SSRIs), act by increasing the amount of active serotonin in nerve synapses in particular brain regions. Conversely, various conditions that lower serotonin levels are associated with depression, suggesting that normal to slightly elevated serotonin levels tend to elevate mood and prevent depression. See AFFECTIVE DISORDERS; BRAIN; NERVOUS SYSTEM (VERTEBRATE); NEUROSECRETION; PSYCHOPHARMACOLOGY. [M.K.S.; B.A.St.]

**Serpentine** The name traditionally applied to three hydrated magnesium silicate minerals, antigorite, chrysotile, and lizardite. All have similar chemical compositions but with three different but closely related layered crystal structures. Serpentine also has been used as a group name for minerals with the same layered structures but with a variety of compositions. The general formula is  $M_3T_2O_5(OH)_4$ , where M may be magnesium (Mg), ferrous iron ( $Fe^{2+}$ ), ferric iron ( $Fe^{3+}$ ), aluminum (Al), nickel (Ni), manganese (Mn), cobalt (Co), chromium (Cr), zinc (Zn), or lithium (Li); and T may be silicon (Si), Al,  $Fe^{3+}$ , or boron (B).

Lizardite has a planar structure, with the misfit accommodated by slight adjustments of the atomic positions within the layers. Chrysotile has a cylindrical structure in which the layers are either concentrically or spirally rolled to produce fiber commonly ranging from 15 to 30 nanometers in diameter, and micrometers to centimeters in length. These fibers have great strength and flexibility and are the most abundant and commonly used form of asbestos. Antigorite has a modulated wave structure,

with wavelengths generally varying between 3 and 5 nm. See ASBESTOS. [F.J.W.]

**Serpentinite** A common rock composed of serpentine minerals; usually formed through the hydration of ultramafic rocks, dunites, and peridotites in a process known as serpentinization. The result is the formation of hydrated magnesium-rich minerals, such as antigorite, chrysotile, or lizardite, commonly with magnetite or, less frequently, brucite. See ASBESTOS; DUNITE; PERIDOTITE.

Serpentinites can be distinguished by, and are named for, the dominant serpentine mineral in the rock, that is, antigorite-serpentinite, chrysotile-serpentinite, and lizardite-serpentinite. Lizardite-serpentinites are the most abundant. They have been formed in retrograde terrains and are characterized by the pseudomorphic replacement of the original olivine, pyroxenes, amphiboles, and talc by lizardite with or without magnetite or brucite. Antigorite-serpentinites can form directly from minerals such as olivine, pyroxene, and so forth in retrograde terrains similar to lizardite, but at a high temperature. Chrysotile-serpentinites usually occur only in chrysotile asbestos deposits. The occurrence of serpentinites is widespread, particularly in greenstone belts, mountain chains, and mid-ocean ridges, where they have formed through the serpentinization of ultramafic rocks. See MID-OCEANIC RIDGE; SERPENTINE. [F.J.W.]

**Serum** The liquid portion that remains when blood is allowed to clot spontaneously and is then centrifuged to remove the blood cells and clotting elements. It has approximately the same volume (55%) as plasma and differs from it only by the absence of fibrinogen. See FIBRINOGEN.

Blood serum contains 6–8% solids, including macromolecules such as albumin, antibodies and other globulins, and enzymes; peptide and lipid-based hormones; and cytokines; as well as certain nutritive organic materials in small amounts, such as amino acids, glucose, and fats. Somewhat less than 1% of the serum consists of inorganic substances. Small amounts of respiratory gases are dissolved in the serum, as is the gas nitric oxide, which serves as a chemical messenger and vasodilator. Small amounts of waste material are also present. These substances, along with other small molecules which are not bound to blood proteins, are filtered out as blood flows through the kidney. See BLOOD; CLINICAL PATHOLOGY; KIDNEY.

Certain types of sera, both human and animals, are used in clinical medicine. Immune serum and hyperimmune serum either are developed by naturally occurring disease or are deliberately prepared by repeated injection of antigens to increase antibody titer for either diagnostic tests or the treatment of active disease. These sera are referred to as antisera, since they have a specific antagonistic action against specific antigens. See ANTIBODY; ANTIGEN; BIOLOGICALS; IMMUNITY.

By custom, the clear portion of any liquid material of animal origin separated from its solid or cellular elements is also referred to as sera. These fluids are more properly referred to as effusions. See SEROLOGY. [R.Str.; B.A.St.]

**Servomechanism** A system for the automatic control of motion by means of feedback. The term servomechanism, or servo for short, is sometimes used interchangeably with feedback control system (servosystem). In a narrower sense, servomechanism refers to the feedback control of a single variable (feedback loop or servo loop). In the strictest sense, the term servomechanism is restricted to a feedback loop in which the controlled quantity or output is mechanical position or one of its derivatives (velocity and acceleration). See CONTROL SYSTEMS.

The purpose of a servomechanism is to provide one or more of the following objectives: (1) accurate control of motion without the need for human attendants (automatic control); (2) maintenance of accuracy with mechanical load variations, changes in the environment, power supply fluctuations, and aging and deterioration of components (regulation and self-calibration);

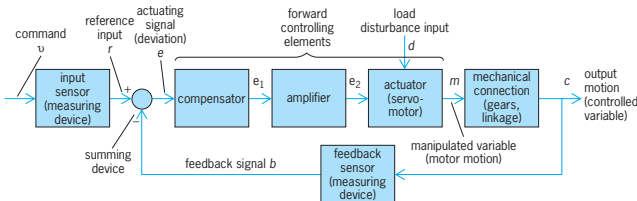

**Servo loop elements and their interconnections. Cause-and-effect action takes place in the directions of arrows. (After American National Standards Institute, Terminology for Automatic Control, ANSI C85.1)**

(3) control of a high-power load from a low-power command signal (power amplification); (4) control of an output from a remotely located input, without the use of mechanical linkages (remote control, shaft repeater).

The illustration shows the basic elements of a servomechanism and their interconnections; in this type of block diagram the connection between elements is such that only a unidirectional cause-and-effect action takes place in the direction shown by the arrows. The arrows form a closed path or loop; hence this is a single-loop servomechanism or, simply, a servo loop. More complex servomechanisms may have two or more loops (multiloop servo), and a complete control system may contain many servomechanisms. See BLOCK DIAGRAM.

Servomechanisms were first used in speed governing of engines, automatic steering of ships, automatic control of guns, and electromechanical analog computers. Today, servomechanisms are employed in almost every industrial field. Among the applications are cutting tools for discrete parts manufacturing, rollers in sheet and web processes, elevators, automobile and aircraft engines, robots, remote manipulators and teleoperators, telescopes, antennas, space vehicles, mechanical knee and arm prostheses, and tape, disk, and film drives. See COMPUTER STORAGE TECHNOLOGY; FLIGHT CONTROLS; GOVERNOR; MAGNETIC RECORDING; REMOTE MANIPULATORS; ROBOTICS. [G.W.]

**Set theory** A mathematical term referring to the study of collections or sets. Consider a collection of objects (such as points, dishes, equations, chemicals, numbers, or curves). This set may be denoted by some symbol, such as  $X$ . It is useful to know properties that the set  $X$  has, irrespective of what the elements of  $X$  are. The cardinality of  $X$  is such a property.

Two sets  $A$  and  $B$  are said to have the same cardinal written  $C(A) = C(B)$ , provided there is a one-to-one correspondence between the elements of  $A$  and the elements of  $B$ . For finite sets this notion coincides with the phrase "A has the same number of elements as B." However, for infinite sets the above definition yields some interesting consequences. For example, let  $A$  denote the set of integers and  $B$  the set of odd integers. The function  $f(n) = 2n - 1$  shows that  $C(A) = C(B)$ . Hence, an infinite set may have the same cardinal as a part or subset of itself.

$A$  is called a subset of  $B$  if each element of  $A$  is an element of  $B$ , and it is expressed as  $A \subset B$ . The collection of odd integers is a subset of itself.

One approved method of forming a set is to consider a property  $P$  possessed by certain elements of a given set  $X$ . The set of elements of  $X$  having property  $P$  may be considered as a set  $Y$ . The expression  $p \in X$  is used to denote the fact that  $p$  is an element of  $X$ . Then  $Y = \{p \mid p \in X \text{ and } p \text{ has property } P\}$ . Another approved method is to consider the set  $Z$  of all subsets of a given set  $X$ . Paradoxically, it is not permissible to regard the collection of all sets as a set.

In set theory, one is interested not only in the properties of sets but also in operations involving sets: addition, subtraction, multiplication, and mapping. The sum of  $A$  and  $B$  ( $A + B$  or  $A \cup B$ ) is the set of all elements in either  $A$  or  $B$ ; that is,  $A + B = \{p \mid p \in A \text{ or } p \in B\}$ . The intersection of  $A$  and  $B$  ( $A \cdot B$ ,

$A \cap B$ , or  $AB$ ) is the set of all elements in both  $A$  and  $B$ ; that is,  $A \cdot B = \{p \mid p \in A \text{ and } p \in B\}$ . If there is no element which is in both  $A$  and  $B$ , one says that  $A$  does not intersect  $B$  and writes  $A \cdot B = 0$ . The expression  $A - B$  is used to denote the collection of elements of  $A$  that do not belong to  $B$ ; that is  $A - B = \{p \mid p \in A \text{ and } p \notin B\}$ . [R.H.Bi]

**Sewage** Water-carried wastes, in either solution or suspension, that flow away from a community. Also known as wastewater flows, sewage is the used water supply of the community. It is more than 99.9% pure water and is characterized by its volume or rate of flow, its physical condition, its chemical constituents, and the bacteriological organisms that it contains. Depending on their origin, wastewaters can be classed as sanitary, commercial, industrial, or surface runoff.

The spent water from residences and institutions, carrying body wastes, ablution water, food preparation wastes, laundry wastes, and other waste products of normal living, are classed as domestic or sanitary sewage. Liquid-carried wastes from stores and service establishments serving the immediate community, termed commercial wastes, are included in the sanitary or domestic sewage category if their characteristics are similar to household flows. Wastes that result from an industrial process or the production or manufacture of goods are classed as industrial wastes. Their flows and strengths are usually more varied, intense, and concentrated than those of sanitary sewage. Surface runoff, also known as storm flow or overland flow, is that portion of precipitation that runs rapidly over the ground surface to a defined channel. Precipitation absorbs gases and particulates from the atmosphere, dissolves and leaches materials from vegetation and soil, suspends matter from the land, washes spills and debris from urban streets and highways, and carries all these pollutants as wastes in its flow to a collection point. Discharges are classified as point-source when they emanate from a pipe outfall, or non-point-source when they are diffused and come from agriculture or unchanneled urban land drainage runoff. See HYDROLOGY; PRECIPITATION (METEOROLOGY).

Wastewaters from all of these sources may carry pathogenic organisms that can transmit disease to humans and other animals; contain organic matter that can cause odor and nuisance problems; hold nutrients that may cause eutrophication of receiving water bodies; and may contain hazardous or toxic materials. Proper collection and safe, nuisance-free disposal of the liquid wastes of a community are legally recognized as a necessity in an urbanized, industrialized society. See ANALYTICAL CHEMISTRY; PUBLIC HEALTH; SEWAGE SOLIDS; SEWAGE TREATMENT; TOXICOLOGY. [G.Pa.]

**Sewage collection systems** Configurations of inlets, catch basins, manholes, pipes, drains, mains, holding basins, pump stations, outfalls, controls, and special devices to move wastewaters from points of collection to discharge. The system of pipes and appurtenances is also known as the sewerage system. Wastewaters may be sanitary sewage, industrial wastes, storm runoff, or combined flows.

A sewer is a constructed ditch or channel designed to carry away liquid-conveyed wastes discharged by houses and towns. Modern sewer systems typically are gravity-flow pipelines installed below the ground surface in streets and following the ground slope. The depth of cover over pipelines is controlled by factors such as the location of rock and ground water, the ability to receive flows from all buildings by gravity, depth to frost line, economics of maintaining gravity flow as compared with pumping, and location and elevation of other existing utilities and infrastructures.

Sewerage systems are designed to carry the liquid wastes smoothly, without deposition, with a minimum of wasted hydraulic energy, and at minimum costs for excavation and construction; they should provide maximum capacity for future populations and flows. Engineered construction, controlled by



availability of time, material, personnel, and finances, affects the choice and use of individual components within sewerage systems. See INDUSTRIAL HEALTH AND SAFETY; SEWAGE; SEWAGE DISPOSAL. [G.Pa.]

**Sewage disposal** The ultimate return of used water to the environment. Disposal points distribute the used water either to aquatic bodies such as oceans, rivers, lakes, ponds, or lagoons or to land by absorption systems, groundwater recharge, and irrigation. Wastewaters must be mixed, diluted, and absorbed so that receiving environments retain their beneficial use, be it for drinking, bathing, recreation, aquaculture, silviculture, irrigation, groundwater recharge, or industry.

Wastewater is treated to remove contaminants or pollutants that affect water quality and use. Discharge to the environment must be accomplished without transmitting diseases, endangering aquatic organisms, impairing the soil, or causing unsightly or malodorous conditions. The type and degree of treatment are dependent upon the absorption capability or dilution capacity at the point of ultimate disposal. See SEWAGE; SEWAGE TREATMENT; SOIL ECOLOGY; SOIL MICROBIOLOGY; STREAM POLLUTION.

Discharges into any aquatic system cannot contravene the standards set for the most beneficial use of that water body. Water quality standards are used to measure an aquatic ecosystem after the discharge has entered and mixed with it. Water quality standards relate to the esthetics and use of the receiving environment for public water supply, recreation, maintenance of aquatic life and wildlife, or agriculture. The parameters of water quality, which define the physical, chemical, and biological limits, include floating and settleable solids, turbidity, color, temperature, pH, dissolved oxygen, biochemical oxygen demand (BOD), numbers of coliform organisms, toxic materials, heavy metals, and nutrients.

Effluent standards define what is allowed within the wastewaters discharged into the aquatic environment. Effluent standards specify the allowed biochemical oxygen demand, suspended solids, temperature, pH, heavy metals, certain organic chemicals, pesticides, and nutrients in the discharge. Point-source wastewater effluent discharge standards, established for ease of sampling, simplicity of repetitive testing, and clarity for enforcement, are more likely to be used by regulatory agencies. See ENVIRONMENTAL ENGINEERING; EUTROPHICATION; FRESH-WATER ECOSYSTEM; LIMNOLOGY; WATER CONSERVATION; WATER POLLUTION. [G.Pa.]

**Sewage solids** The accumulated, semiliquid material consisting of suspended, colloidal, and dissolved organic and inorganic matter separated from wastewater during treatment. Sludges are developed as contained pollutants, and contaminants are separated by mechanical, hydraulic, biological, or chemical processes. The various classes of solids that are removed and collected must be disposed of in a safe, nuisance-free manner without hazard to health or the environment. Collection, handling, transporting, and disposal of removed solids are difficult and costly, since they are offensive and putrescible, with 92–99.5% water content. Sewage solids must be treated by thickening, chemical conditioning, mechanical dewatering, thermal action, biological stabilization, or digestion to convert putrescible organic matter to relatively inert end products, remove water, and reduce weight and volume.

Sewage solids are classified as screenings, scum, grit, septage, or sewage sludges. Screenings are large solids, carried by incoming wastewater, that are captured mechanically on screens or racks with openings of various sizes. These protective units remove floating debris, including wood, clothing, cans, rags, paper, rubber and plastic goods, and stringy material that could damage equipment or create problems in plant maintenance and operation.

Scum is defined as the floating fraction of sewage solids, with specific gravity under 1.0, that, under quiescent conditions, rises

to the surface of the wastewater. Primary tank skimmings contain oils, fats, soaps, rubber and plastic hygienic products, cigarette filter tips, paper, and similar materials.

Heavy suspended solids consisting of sand, cinders, coffee grounds, seeds, small metal objects, and other generally inorganic particles carried in wastewater inflow are collectively known as grit. The amount of grit varies with type of sewer, season, weather, intensity of runoff, condition of streets and sewers, and use of household garbage disposal units.

Septage consists of partially digested material pumped from on-site sanitary waste-water disposal systems. It contains a mixture of grit, scum, and suspended solids, adding to treatment plant sludge. See LEACHING; SEPTIC TANK.

Sludge derives its name from the unit process from which it settles out. Primary sludge, or raw sludge, develops as solids in incoming wastewater settle hydraulically. Raw sludge, containing up to 5% solids by weight, is gray, greasy, viscous, unsightly, contains visible fecal solids and scraps of household wastes, and has a disagreeable odor. Sludge thickening is a process that is used to remove water, increase the concentration of solids, reduce weight and volume, and prepare sludges for further treatment and handling. See PRECIPITATION (CHEMISTRY); WATER TREATMENT.

Solids are generally disposed of in landfills, buried, composted, or recycled as soil amendments. See AIR POLLUTION; HAZARDOUS WASTE; SEWAGE; SEWAGE DISPOSAL; SEWAGE TREATMENT. [G.Pa.]

**Sewage treatment** Unit processes used to separate, modify, remove, and destroy objectionable, hazardous, and pathogenic substances carried by wastewater in solution or suspension in order to render the water fit and safe for intended uses. Treatment removes unwanted constituents without affecting or altering the water molecules themselves, so that wastewater containing contaminants can be converted to safe drinking water. Stringent water quality and effluent standards have been developed that require reduction of suspended solids (turbidity), biochemical oxygen demand (related to degradable organics), and coliform organisms (indicators of fecal pollution); control of pH as well as the concentration of certain organic chemicals and heavy metals; and use of bioassays to guarantee safety of treated discharges to the environment.

In all cases, the impurities, contaminants, and solids removed from all wastewater treatment processes must ultimately be collected, handled, and disposed of safely, without damage to humans or the environment. See SEWAGE SOLIDS.

Treatment processes are chosen on the basis of composition, characteristics, and concentration of materials present in solution or suspension. The processes are classified as pretreatment, preliminary, primary, secondary, or tertiary treatment, depending on type, sequence, and method of removal of the harmful and unacceptable constituents. Pretreatment processes equalize flows and loadings, and precondition wastewaters to neutralize or remove toxics and industrial wastes that could adversely affect sewers or inhibit operations of publicly owned treatment works. Preliminary treatment processes protect plant mechanical equipment; remove extraneous matter such as grit, trash, and debris; reduce odors; and render incoming sewage more amenable to subsequent treatment and handling. Primary treatment employs mechanical and physical unit processes to separate and remove floatables and suspended solids and to prepare wastewater for biological treatment. Secondary treatment utilizes aerobic microorganisms in biological reactors to feed on dissolved and colloidal organic matter. As these microorganisms reduce biochemical oxygen demand and turbidity (suspended solids), they grow, multiply, and form an organic floc, which must be captured and removed in final settling tanks. Tertiary treatment, or advanced treatment, removes specific residual substances, trace organic materials, nutrients, and other constituents that are not removed by biological processes. Most advanced wastewater treatment systems include denitrification and ammonia stripping, carbon

adsorption of trace organics, and chemical precipitation. Evaporation, distillation, electro dialysis, ultrafiltration, reverse osmosis, freeze drying, freeze-thaw, floatation, and land application, with particular emphasis on the increased use of natural and constructed wetlands, are being studied and utilized as methods for advanced wastewater treatment to improve the quality of the treated discharge to reduce unwanted effects on the receiving environment. See ABSORPTION; DISTILLATION; EVAPORATION; SEWAGE; SEWAGE DISPOSAL; ULTRAFILTRATION; WETLANDS.

On-site sewage treatment for individual homes or small institutions uses septic tanks, which provide separation of solids in a closed, buried unit. Effluent is discharged to subsurface absorption systems. See SEPTIC TANK; STREAM POLLUTION; UNIT PROCESSES; WATER TREATMENT. (G.Pa.)

**Sewing machine** A mechanism that stitches cloth, leather, book pages, and other material by means of a double-pointed needle or any eye-pointed needle. In ordinary two-threaded machines, a lock stitch is formed (see illustration). A

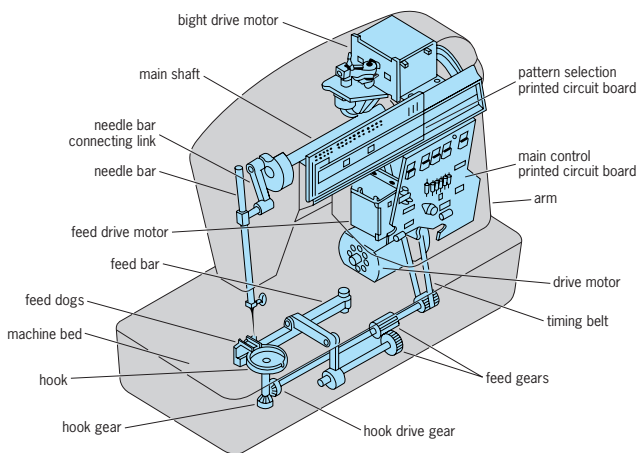

Components of a modern sewing machine. (Singer Co.)

presser foot held against the material with a yielding spring adjusts itself automatically to variations in thickness of material and allows the operator to turn the material as it feeds through the machine. A cluster of cams, any one of which can be selected to guide the needle arm, makes possible a variety of stitch patterns. See CAM MECHANISM. (F.H.R.)

**Sex determination** The genetic mechanisms by which sex is determined in all living organisms. The nature of the genetic basis of sex determination varies a great deal among the various forms of life.

There are two aspects of sexuality: the primary form involves the gametes, and the secondary aspect is gender. In its broadest usage the term "sex" refers to the processes that enable species to exchange materials between homologous chromosomes, that is, to effect recombination. Generally, recombination is essential to their mechanism for reproduction. For most organisms this involves, either exclusively or as one stage in the life cycle, the formation of special cells, known as gametes, by meiosis. See GAMETOGENESIS.

Most sexually reproducing species produce two different kinds of gametes. The relatively large and sessile form, an ovum or egg, usually accumulates nutrients in its cytoplasm for the early development of the offspring. The relatively mobile form, a sperm (or pollen grain in many plants), contributes little beyond a haploid chromosome set. Thus the primary form of

sex differentiation determines which kind of gamete will be produced. The formation of gametes usually involves the concomitant differentiation of specialized organs, the gonads, to produce each kind of gamete. The ova-producing gonad is usually known as an archegonium or ovary (in flowering plants it is part of a larger organ, the pistil or carpel); the gonad producing the more mobile gametes is usually known as a testis in animals and an antheridium or stamen in plants. See OVARY; OVUM; SPERM CELL; TESTIS.

In most animals and many plants, individuals become specialized to produce only one kind of gamete. These individuals usually differ not only in which kind of gonad they possess but also in a number of other morphological and physiological differences, or secondary sex characteristics. The latter may define a phenotypic sex when present, even if the typical gonad for that sex is absent or nonfunctional. The form that usually produces ova is known as female; the one that usually produces sperm or pollen is known as male. Since some sexual processes do not involve gametes, the more universal application of the term "gender" refers to any donor of genetic material as male and the recipient as female.

In plants, sexual reproduction is not always accompanied by the kinds of differentiation described above. The majority of plant species are monoecious, with both kinds of gonads on the same plant. Plants that bear male and female gonads on separate plants are dioecious. They occur in about 60 of the 400 or so families of flowering plants, 20 of which are thought to contain exclusively dioecious species. See REPRODUCTION (PLANT).

Although the sexes are distinct in most animals, many species are hermaphroditic; that is, the same individual is capable of producing both eggs and sperm. This condition is particularly common among sessile or sluggish, slowly moving forms. Some hermaphroditic and monoecious species are homothallic; that is, the eggs and sperm of the same individual can combine successfully; but most are heterothallic, the gametes being capable only of cross-fertilization, often evolving special mechanisms to ensure its occurrence.

Sex differentiations are often accompanied by consistent chromosomal dimorphisms, leading to the presumption that the chromosomal differences are related to, and possibly responsible for, the sex differences. Indeed, the chromosomes that are not alike in the two sexes were given the name sex chromosomes. Some workers use the term "heterosomes" to distinguish them from the autosomes, which are the chromosomes that are morphologically identical in the two sexes.

In most species, one of the sex chromosomes, the X chromosome, normally occurs as a pair in one gender but only singly in the other. The gender with two X chromosomes is known as the homogametic sex, because each of its gametes normally receives an X chromosome after meiosis. The gender with only one X chromosome generally also has a morphologically different sex chromosome, the Y chromosome. The X and Y chromosomes usually pair to some extent at meiosis, with the result that the XY is the heterogametic sex, with half its gametes containing an X and half containing a Y. Geneticists noted that the fundamental dimorphism of X and Y chromosomes lies in their genic contents: X chromosomes of the species share homologous loci, just as do pairs of autosomes, whereas the Y chromosome usually has few, if any, loci that are also represented on the X. Thus X and Y chromosomes are sometimes very similar in shape or size but are almost always very different in genetic materials.

The major factor in sex differentiation in humans is a locus on the short arm of the Y chromosome designated SRY or SrY (for sex-determining region of the Y). This comparatively small gene contains no introns and encodes for a protein with only 204 amino acids. The protein appears to be a deoxyribonucleic acid (DNA)-binding type that causes somatic cells of the developing gonad to become Sertoli cells that secrete a hormone, Müllerian inhibiting substance (MIS), that eliminates the Müllerian duct system (the part that would produce major female

reproductive organs). The gonad is now a testis, and certain cells in it become the Leydig cells that produce testosterone, which causes the primordial Wolffian duct system of the embryo to develop the major male reproductive organs. If no MIS is produced, further development of the Müllerian duct structures occurs, and in the absence of testosterone the Wolffian ducts disappear, producing the normal female structures. Embryos lacking *SRY* or having mutated forms of it normally become females even if they are XY. This system of sex determination is called Y-dominant. It appears to be characteristic of almost all mammals, even marsupials, plus a few other forms. While *SRY* is the primary gene, many other genes, both autosomal and X-chromosomal, are involved in the course of developing the two sexes in mammals. See HUMAN GENETICS; MUTATION. [M.Le.]

**Sex-influenced inheritance** Inherited characteristics that are conditioned by the sex of the individual. These traits are determined by genes that act differently in the two sexes. The usual result is that a given trait appears preponderantly in one sex. The reasons for such inheritance are neither the chromosomal location of the responsible genes, which may therefore be autosomal as well as X-linked, nor the normal sex-determining mechanism of the species. See SEX DETERMINATION.

A special class of sex-influenced genes can be called sex-limited. These are manifested in only one sex because the other lacks the requisite organs. Some examples are milk production in cows and egg production in chickens.

Some traits are sex-influenced because of genes that interact with a substance that is not produced equally in males and females. An example is early pattern baldness. Since male-to-male transmission occurs, the responsible gene must be autosomal. There is a preponderance of this trait in males because the action of the gene depends on the level of male hormones (androgens) present. See GENE ACTION.

Some sex differences in expression of inherited traits may result from genetic imprinting. Genetic imprinting refers to different expression of chromosomes, parts of chromosomes, or single genes, depending on which of the two sexes they are inherited from. To achieve imprinting, some genetic materials can be modified during gamete production or early embryonic development in one of the two sexes, so the traits determined by the imprinted genes are expressed differently than would be expected under typical mendelian inheritance. A growing body of evidence points to methylation of cytosine residues in the context of cytosine-guanine (CpG) dinucleotides as the mechanism of imprinting. Such methylation, especially if it occurs in the promoter regions of genes, can nullify the ability of the genes to be transcribed. Certain genes that can be imprinted will be methylated in the production of sperm, others in the production of ova, and they can be reactivated by demethylation when they pass through gametogenesis in the opposite sex. It is still not known why certain alleles are subject to imprinting while others are not, and why they are more likely to be imprinted in one sex than the other.

Imprinting can involve amplification of genes rather than inactivation; that is, as the gene passes through gametogenesis in one of the sexes, sections of it become duplicated and the gene thereby is enlarged. This is seen in neuroblastoma, where one commonly finds an increased number of DNA segments containing the *N-myc* protooncogene: such amplification is correlated with poor prognosis of the disease. In an overwhelming proportion of cases, it is the paternal *N-myc* gene that is amplified, suggesting that imprinting is responsible. A similar phenomenon occurs in Huntington's chorea, an autosomal dominant condition that usually does not become manifested until middle age or beyond. Earlier manifestation, often even in childhood, is associated with amplification of certain segments of DNA in the gene; but the amplifications, if they occur, are only in *HC* genes inherited from fathers. See DEOXYRIBONUCLEIC ACID (DNA); GENETICS;

HUMAN GENETICS; ONCOGENES; OOGENESIS; SEX DETERMINATION; SEX-LINKED INHERITANCE; SPERMATOGENESIS. [M.Le.]

**Sex-linked inheritance** The inheritance of a trait (phenotype) that is determined by a gene located on one of the sex chromosomes. Genetic studies of many species have been facilitated by focusing on such traits because of their characteristic patterns of familial transmission and the ability to localize their genes to a specific chromosome. As the ability to map a gene to any of an organism's chromosomes has improved markedly, reliance on the specific pattern of inheritance has waned.

The expectations of sex-linked inheritance in any species depend on how the chromosomes determine sex. For example, in humans, males are heterogametic, having one X chromosome and one Y chromosome, whereas females are homogametic, having two X chromosomes. In human males, the entire X chromosome is active (not all genes are active in every cell), whereas one of a female's X chromosomes is largely inactive. Random inactivation of one X chromosome occurs during the early stages of female embryogenesis, and every cell that descends from a particular embryonic cell has the same X chromosome inactivated. The result is dosage compensation for X-linked genes between the sexes. A specific gene on the long arm of the X chromosome, called XIST at band q13, is a strong candidate for the gene that controls X inactivation. This pattern of sex determination occurs in most vertebrates, but in birds and many insects and fish the male is the homogametic sex. See SEX DETERMINATION.

In general terms, traits determined by genes on sex chromosomes are not different from traits determined by autosomal genes. Sex-linked traits are distinguishable by their mode of transmission through successive generations of a family. In humans it is preferable to speak in terms of X-linked or Y-linked inheritance.

Red-green color blindness was the first human trait proven to be due to a gene on a specific chromosome. The characteristics of this pattern of inheritance are readily evident. Males are more noticeably or severely affected than females; in the case of red-green color blindness, women who have one copy of the mutant gene (that is, are heterozygous or carriers) are not at all affected. Among offspring of carrier mothers, on average one-half of their sons are affected, whereas one-half of their daughters are carriers. Affected fathers cannot pass their mutant X chromosome to their sons, but do pass it to all of their daughters, who thereby are carriers. A number of other well-known human conditions behave in this manner, including the two forms of hemophilia, Duchenne muscular dystrophy, and glucose-6-phosphate dehydrogenase deficiency that predisposes to hemolytic anemia. See ANEMIA; COLOR VISION; HEMOPHILIA; MUSCULAR DYSTROPHY.

Refined cytogenetic and molecular techniques have supplemented family studies as a method for characterizing sex-linked inheritance and for mapping genes to sex chromosomes in many species. Over 400 human traits and diseases seem to be encoded by genes on the X chromosome, and over 200 genes have been mapped. Among mammals, genes on the X chromosome are highly conserved. Thus, identifying a sex-linked trait in mice is strong evidence that a similar trait, and underlying gene, exists on the human X chromosome. See GENETICS; HUMAN GENETICS; SEX-INFLUENCED INHERITANCE. [R.E.Py.]

**Sextant** A navigation instrument used for measuring angles, primarily altitudes of celestial bodies. Originally, the sextant had an arc of 60°, or 1/6 of a circle, from which the instrument derived its name. Because of the double-reflecting principle used, such an instrument could measure angles as large as 120°. In modern practice, the name sextant is commonly applied to all instruments of this type regardless of the length of the arc, which is seldom exactly 60°. The optical principles of the sextant are similar to those of the prismatic astrolabe. See PRISMATIC ASTROLABE.

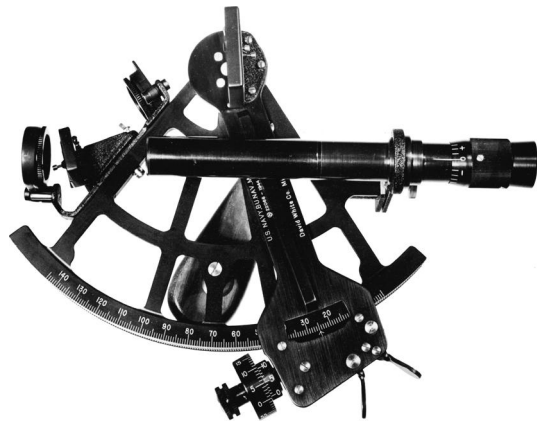

A marine sextant.

Modern sextants may be grouped into two classes, marine and air. The marine sextant (see illustration) is designed for use by mariners. It utilizes the visible sea horizon as the horizontal reference. An instrument designed for use in aircraft is called an air sextant. Such sextants have built-in artificial horizons. Most modern air sextants are periscopic to permit observation of celestial bodies without need of an astrodome in the aircraft. See CELESTIAL NAVIGATION.

[A.B.M.]

**Sexual dimorphism** Any difference, morphological or behavioral, between males and females of the same species. In many animals, the sex of an individual can be determined at a glance. For example, roosters have bright plumage, a comb, and an elaborate tail, all of which are lacking in hens. Sexual dimorphism arises as a result of the different reproductive functions of the two sexes and is a consequence of both natural selection and sexual selection. Primary differences such as the structure of the reproductive organs are driven by natural selection and are key to the individual's function as a mother or father. Other differences such as the peacock's (*Pavo cristatus*) enormous tail are driven by sexual selection and increase the individual's success in acquiring mates. See ORGANIC EVOLUTION.

A less obvious sexual dimorphism is the difference in size of male and female gametes. In nearly all cases, the sperm (or pollen) are substantially smaller and more numerous than the ova. Eggs are large because they contain nutrients essential for development of the embryo. However, the sole purpose of sperm is to fertilize the egg. Sperm do not contain any nutrients and can therefore be small. For the same investment of nutrients, a male can produce more sperm than a female can produce eggs. Human males, for example, produce about 300 million motile sperm per ejaculate, whereas females normally produce only one egg (30,000 times larger than a single sperm) per month. See FERTILIZATION; GAMETOGENESIS; REPRODUCTION (ANIMAL); REPRODUCTIVE SYSTEM.

In nearly all animal groups (apart from mammals and birds), females are larger than males because larger females tend to produce more eggs and contribute more young to the next generation. In contrast, size does not appear to limit males' ability to produce sperm. However, among mammals and birds males are generally the larger sex. Differences in body size and shape can be caused by factors other than reproductive success. Sexual dimorphism can arise as a consequence of competition between the sexes over resources, or because the sexes use different resources. For example, in many species of snake, males and females use different habitats and eat different food, which has led to differences in their head shape and feeding structures.

Plants also differ in showiness. Many plants bear both male and female flowers (simultaneous hermaphrodites), but male flowers are sometimes larger and more conspicuous. For exam-

ple, the female catkins of willow are dull gray compared with the bright yellow male catkins, because male flowers compete with each other to attract pollinators. In plant species with separate sexes (dioecious), males tend to produce more flowers than females. For example, males of the American holly (*Ilex opaca*) produce seven times as many flowers as females in order to increase their chances of pollen transfer to females. See FLOWER; POLLINATION.

Animals and plants show marked sexual dimorphism in other traits. Calling, singing, pheromones, and scent marking can all be explained by competition between males and by female mate choice. See ANIMAL COMMUNICATION.

Associated with morphological sexual dimorphism are several behavioral differences between males and females. Many of these are related to locating a mate, competition between males, and female choosiness. Animals also show sexual dimorphism relating to their roles as parents. Many parents continue to provide for their young after birth, with the female performing the bulk of the care in most species. Female mammals suckle their young, whereas males cannot because they lack mammary glands. However, some mammals (such as gibbons and prairie voles) and many birds share parental duties, with both males and females feeding and protecting the young. See MATERNAL BEHAVIOR.

[A.M.Du.; N.W.]

**Sexually transmitted diseases** Infections that are acquired and transmitted by sexual contact. Although virtually any infection may be transmitted during intimate contact, the term sexually transmitted disease is restricted to conditions that are largely dependent on sexual contact for their transmission and propagation in a population. The term venereal disease is literally synonymous with sexually transmitted disease but traditionally is associated with only five long-recognized diseases (syphilis, gonorrhea, chancroid, lymphogranuloma venereum, and donovanosis). Sexually transmitted diseases occasionally are acquired nonsexually (for example, by newborn infants from their mothers, or by clinical or laboratory personnel handling pathogenic organisms or infected secretions), but in adults they are virtually never acquired by contact with contaminated intermediaries such as towels, toilet seats, or bathing facilities. However, some sexually transmitted infections (such as human immunodeficiency virus infection, viral hepatitis, and cytomegalovirus infection) are transmitted primarily by sexual contact in some settings and by nonsexual means in others. See GONORRHEA; SYPHILIS.

The sexually transmitted diseases may be classified in the traditional fashion, according to the causative pathogenic organisms, as follows:

#### Bacteria

*Chlamydia trachomatis*  
*Neisseria gonorrhoeae*  
*Treponema pallidum*  
*Mycoplasma genitalium*  
*Mycoplasma hominis*  
*Ureaplasma urealyticum*  
*Haemophilis ducreyi*  
*Calymmatobacterium granulomatis*  
*Salmonella* species  
*Shigella* species  
*Campylobacter* species

#### Viruses

Human immunodeficiency viruses (types 1 and 2)  
 Herpes simplex viruses (types 1 and 2)  
 Hepatitis viruses B, C, D  
 Cytomegalovirus  
 Human papillomaviruses  
 Molluscum contagiosum virus  
 Kaposi sarcoma virus

## Protozoa

*Trichomonas vaginalis**Entamoeba histolytica**Giardia lamblia**Cryptosporidium* and related species

## Ectoparasites

*Phthirus pubis* (pubic louse)*Sarcoptes scabiei* (scabies mite)

Sexually transmitted diseases may also be classified according to clinical syndromes and complications that are caused by one or more pathogens as follows:

1. Acquired immunodeficiency syndrome (AIDS) and related conditions
2. Pelvic inflammatory disease
3. Female infertility
4. Ectopic pregnancy
5. Fetal and neonatal infections
6. Complications of pregnancy
7. Neoplasia
8. Human papillomavirus and genital warts
9. Genital ulcer-inguinal lymphadenopathy syndromes
10. Lower genital tract infection in women
11. Viral hepatitis and cirrhosis
12. Urethritis in men
13. Late syphilis
14. Epididymitis
15. Gastrointestinal infections
16. Acute arthritis
17. Mononucleosis syndromes
18. Molluscum contagiosum
19. Ectoparasite infestation

See ACQUIRED IMMUNE DEFICIENCY SYNDROME (AIDS); CANCER (MEDICINE); DRUG RESISTANCE; GASTROINTESTINAL TRACT DISORDERS; HEPATITIS; PUBLIC HEALTH; URINARY TRACT DISORDERS.

Most of these syndromes may be caused by more than one organism, often in conjunction with nonsexually transmitted pathogens. They are listed in the approximate order of their public health impact. [H.H.Ha.]

**Sferics** Electromagnetic radiations produced primarily by lightning strokes from thunderstorms. It is estimated that globally there occur about 2000 thunderstorms at any one time, and that these give rise to about 100 lightning strokes every second. The radiations are short impulses that usually last a few milliseconds, with a frequency content ranging from the low audio well into the gigahertz range. Sferics (short for atmospheric) are easily detected with an ordinary amplitude-modulation (AM) radio tuned to a region between radio stations, especially if there are thunderstorms within a few hundred miles. These sounds or noises have been identified and characterized with specific names, for example, hiss, pop, click, whistler, and dawn chorus. They fall into what is generally known as radio noise. See ATMOSPHERIC ELECTRICITY; DUST STORM; ELECTROMAGNETIC RADIATION; LIGHTNING; THUNDERSTORM.

The various types of sferics include terrestrial, magnetospheric, and Earth-ionospheric. Terrestrial sferics includes anthropogenic noise from sources such as automobile ignition, motor brushes, coronas from high-voltage transmission lines, and various high-current switching devices. Dust storms and dust devils have also been observed to produce sferics. See ELECTRICAL NOISE.

Lightning-generated sferics are sometimes coupled into the magnetosphere, where they are trapped and guided by the Earth's magnetic field. In this mode, the impulse travels in an ionized region. As a result, the frequencies present in the original impulse are separated by dispersion (the higher frequencies

travel faster than the lower) and produce the phenomena known as whistlers. See MAGNETOSPHERE.

By far the dominant and most readily observed sferics are the lightning-produced impulses that travel in the spherical cavity formed by the ionosphere and the Earth's surface. Lightning currents produce strong radiation in the very low-frequency band, 3–30 kHz, and in the extremely low-frequency band, 6 Hz–3 kHz. See IONOSPHERE; RADIO-WAVE PROPAGATION. [M.Br.]

**Shadow** A region of darkness caused by the presence of an opaque object interposed between such a region and a source of light. A shadow can be totally dark only in that part called the umbra, in which all parts of the source are screened off. With a point source, the entire shadow consists of an umbra, since there can be no region in which only part of the source is eclipsed. If the source has an appreciable extent, however, there exists a transition surrounding the umbra, called the penumbra, which is illuminated by only part of the source. Depending on what fraction of the source is exposed, the illumination in the penumbra varies from zero at the edge of the full shadow to the maximum where the entire source is exposed. The edge of the umbra is not perfectly sharp, even with an ideal point source, because of the wave character of light. See DIFFRACTION; ECLIPSE. [F.A.J./W.W.W.]

**Shadowgraph** An optical method of rendering fluid flow patterns visible by using index-of-refraction differences in the flow. The method relies on the fact that rays of light bend toward regions of higher refractive index while passing through a transparent material. The fluid is usually illuminated by a parallel beam of light. The illustration depicts the method as it might be applied to a fluid sample undergoing thermal convection between two parallel plates, with the lower plate being kept warmer than the upper one. As illustrated, the rays bend toward the cooler down-flowing regions, where the refractive index is higher, and away from the warmer up-flowing ones. After they have passed through the fluid layer, the rays tend to focus above the cooler regions and defocus above the warmer regions. If an image of the light beam is recorded not too far from the sample, brighter areas of the image will lie above regions of down flow, where the rays have been concentrated, and darker areas will lie above regions of up flow. Because the light passes completely

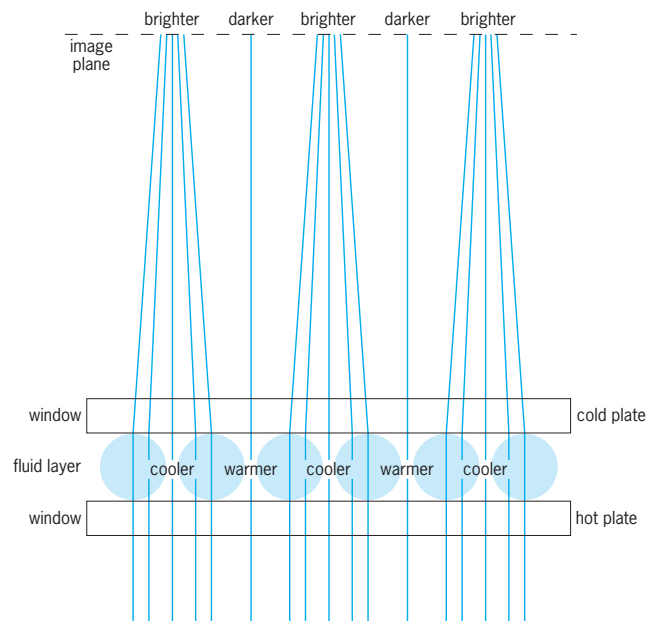

**Schematic of the shadowgraph method applied to reveal convection patterns in a fluid layer. A cross section of the apparatus perpendicular to the convection rolls is shown.**

through the sample, the bending effect for each ray is averaged over the sample thickness. See CONVECTION (HEAT); REFRACTION OF WAVES.

In convection experiments the refractive index varies because of thermal expansion of the fluid, but the method is not restricted regarding the mechanism responsible for disturbing the refractive index. Thus the same method may be used to visualize denser and less dense regions in a gas flowing in a wind tunnel, including Mach waves and shock waves, where the denser regions have a higher-than-average refractive index. See SHOCK WAVE; SUPERSONIC FLOW; WIND TUNNEL.

Images are usually recorded by means of a charge-coupled-device (CCD) camera, digitized, and stored in a computer. Such a digitized image consists of an array of numbers, each number being proportional to the brightness at a particular point in the image. The image points (pixels) form a closely spaced rectangular grid. A reference image may be taken in the absence of any fluid flow, and the reference image may be divided point by point into images taken with the fluid moving. See CHARGE-COUPLED DEVICES. [D.S.Ca.]

**Shaft balancing** The process (often referred to as rotor balancing) of redistributing the mass attached to a rotating body in order to reduce vibrations arising from centrifugal force.

A rotating shaft supported by coaxial bearings (for example, ball bearings together with any attached mass, such as a turbine disk or motor armature) is called a rotor. If the center of mass of a rotor is not located exactly on the bearing axis, a centrifugal force will be transmitted via the bearings to the foundation. The horizontal and vertical components of this force are periodic shaking forces that can travel through the foundation to create serious vibration problems in neighboring components.

Any rigid shaft may be dynamically balanced by adding or subtracting a definite amount of mass at any convenient radius in each of two arbitrary transverse cross sections of the rotor. The so-called balancing planes selected for this purpose are usually located near the ends of the rotor, where suitable shoulders or balancing rings have been machined to permit the convenient addition of mass (lead weights, calibrated bolts, and so on) or the removal of mass (by drilling or grinding). Long rotors, running at high speeds, may undergo appreciable elastic deformations. For such flexible rotors it is necessary to utilize more than two balancing planes. See MECHANICAL VIBRATION. [B.P.]

**Shafting** The machine element that supports a roller and wheel so that they can perform their basic functions of rotation. Shafting, made from round metal bars of various lengths and machined to dimension the surface, is used in a great variety of shapes and applications. Because shafts carry loads and transmit power, they are subject to the stresses and strains of operating machine parts. Most shafting is rigid and carries bending loads without appreciable deflection. Some shafting is highly flexible; it is used to transmit motion around corners.

Shafts used in special ways are given specific names, although fundamentally all applications involve transmission of torque. The primary shafting connection between a wheel and a housing is an axle. A short shaft is a spindle. A short stub shaft mounted as part of a motor or engine or extending directly therefrom is a head shaft. A secondary shaft that is driven by a main shaft and from which power is supplied to a machine part is called a countershaft. See BELT DRIVE; PULLEY. [J.J.R.]

**Shale** A class of fine-grained clastic sedimentary rocks with a mean grain size of less than 0.0625 mm (0.0025 in.), including siltstone, mudstone, and claystone. One-half to two-thirds of all sedimentary rocks are shales. See SEDIMENTARY ROCKS.

Shale is deposited as mud, that is, small particles of silt and clay. The particles are deposited when fluid turbulence caused by currents or waves is no longer adequate to counteract the force of gravity, or if the water evaporates or infiltrates into the

ground. Clay particles often form larger aggregates which settle from suspension more rapidly than individual particles. Silt particles and clay aggregates are often deposited as thin layers less than 10 mm (0.4 in.) thick called laminae. See DEPOSITIONAL SYSTEMS AND ENVIRONMENTS.

Mineralogically, most shales are made up of clay minerals, silt-sized quartz and feldspar grains, carbonate cements, accessory minerals such as pyrite and apatite, and amorphous material such as volcanic glass, iron and aluminum oxides, silica, and organic matter. The most common clay minerals in shales are smectite, illite, kaolinite, and chlorite. The type of clay particles deposited is dependent on the mineralogy, climate, and tectonics of the source area. See CLAY MINERALS; CHLORITE; ILLITE; KAOLINITE.

Shales are usually classified or described according to the amount of silt, the presence and type of lamination, mineralogy, chemical composition, and color. Variations in these properties are related to the type of environment in which the shale was deposited and to postdepositional changes caused by diagenesis and compaction. See DIAGENESIS.

The small size of pores in shale relative to those in sandstone causes shale permeability to be much lower than sand permeability. Although fracturing due to compaction stresses or to tectonic movements can create deviations from this general trend, shales often form permeability barriers to fluid movement; this has important bearing on the occurrence of subsurface water and hydrocarbons. Ground-water aquifers are commonly confined by an underlying low-permeability shale bed or aquiclude, which prevents further downward movement of the water. Hydrocarbon reservoirs are often capped by low-permeability shale which forms an effective seal to prevent hydrocarbons from escaping. See AQUIFER. [J.R.D.]

**Shape memory alloys** A group of metallic materials that can return to some previously defined shape or size when subjected to the appropriate thermal procedure. That is, shape memory alloys can be plastically deformed at some relatively low temperature and, upon exposure to some higher temperature, will return to their original shape. Materials that exhibit shape memory only upon heating are said to have a one-way shape memory, while those which also undergo a change in shape upon recooling have a two-way memory. Typical materials that exhibit the shape memory effect include a number of copper alloy systems and the alloys of gold-cadmium, nickel-aluminum, and iron-platinum. See ALLOY; CRYSTALLOGRAPHY; HEAT TREATMENT (METALLURGY); METAL, MECHANICAL PROPERTIES OF. [M.Sc.]

**Shear** A straining action wherein applied forces produce a sliding or skewing type of deformation. A shearing force acts parallel to a plane as distinguished from tensile or compressive forces, which act normal to a plane. Examples of force systems producing shearing action are forces transmitted from one plate to another by a rivet that tend to shear the rivet, forces in a beam that tend to displace adjacent segments by transverse shear, and forces acting on the cross section of a bar that tend to twist it by torsional shear (see illustration). Shear forces are usually

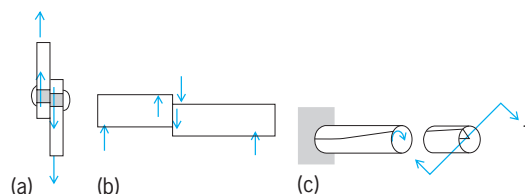

Shearing actions. (a) Single shear on rivet. (b) Transverse shear in beam. (c) Torsion.

accompanied by normal forces produced by tension, thrust, or bending. Shearing stress is the intensity of distributed force expressed as force per unit area. See STRESS AND STRAIN. [J.B.S.]

**Shear center** A point on a line parallel to the axis of a beam through which any transverse force must be applied to avoid twisting of the section. A beam section will rotate when the resultant of the internal shearing forces is not collinear with the externally applied force. The shear center may be determined by locating the line of action of the resultant of the internal shear forces. A rolled wide flange beam section has two axes of symmetry, and therefore the shear center coincides with the geometric center or centroid of the section. When such a beam member is loaded transversely in the plane of the axes, it will bend without twisting. See LOADS, TRANSVERSE. [J.B.S.]

**Sheep** Sheep are members of the family Bovidae in the order Artiodactyla, the even-toed, hoofed mammals. Sheep were possibly the first animals to be domesticated about 11,000 years ago in southwestern Asia. See ARTIODACTYLA.

Wild sheep range over the mountainous areas of the Northern Hemisphere. They have long, curved, massive horns and mixed coats with a hairy outercoat and a woolly undercoat. Although wild sheep vary in size, they are usually larger than domestic sheep and have shorter tails.

Sheep are called lambs until about 12 months of age, from which time to 24 months they are referred to as yearlings, and thereafter as two-year-olds, and so on. The female sheep is called a ewe and the male, a ram or buck; the castrated male is called a wether. Sheep meat is called lamb or mutton depending on the age at slaughter.

A precise definition is difficult since sheep are so variable. Horns, if present, tend to curl in a spiral. If horns occur in both sexes, they are usually larger for the ram. In some breeds only the rams have horns but many breeds are hornless. The hairy outercoat common to wild sheep was eliminated by breeding in most domestic sheep. Wool may cover the entire sheep, or the face, head, legs, and part of the underside may be bare; or wool may be absent as in some breeds (bred for meat) with a short hairy coat or a coat which constantly sheds. Although domestic sheep are mostly white, shades of brown, gray, and black occur, sometimes with spotting or patterns of color. See WOOL.

Hundreds of breeds of sheep of all types, sizes, and colors are found over the world. Wool-type breeds, mostly of Merino origin, are important in the Southern Hemisphere, but both fine- and long-wool types are distributed all over the world. Sheep with fat tails or fat rumps are common in the desert areas of Africa and Asia. These usually produce carpet wool. Milk breeds are found mostly in central and southern Europe. Meat breeds from the British Isles are common over the world. [C.E.T.]

**Sheet-metal forming** The shaping of thin sheets of metal (usually less than  $\frac{1}{4}$  in. or 6 mm) by applying pressure through male or female dies or both. Parts formed of sheet metal have such diverse geometries that it is difficult to classify them. Sheet forming is accomplished basically by processes such as stretching, bending, deep drawing, embossing, bulging, flanging, roll forming, and spinning. In most of these operations there are no intentional major changes in the thickness of the sheet metal. See METAL FORMING.

Stretch forming is a process in which the sheet metal is clamped between jaws and stretched over a form block. The process is used primarily in the aerospace industry to form large panels with varying curvatures.

Bending is one of the most common processes in sheet forming. The part may be bent not only along a straight line, but also along a curved path (stretching, flanging). In addition to male and female dies used in most bending operations, the female die can be replaced by a rubber pad (Fig. 1). The roll-forming process replaces the vertical motion of the dies by the rotary motion of rolls with various profiles. Each successive roll bends the strip a little further than the preceding roll.

While many sheet-forming processes are carried out in a press with male and female dies usually made of metal, there are some

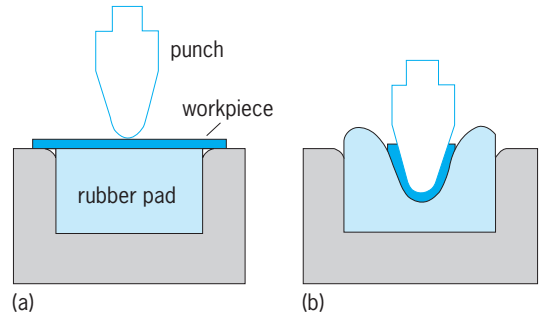

Fig. 1. Bending process with a rubber pad. (a) Before forming. (b) After forming.

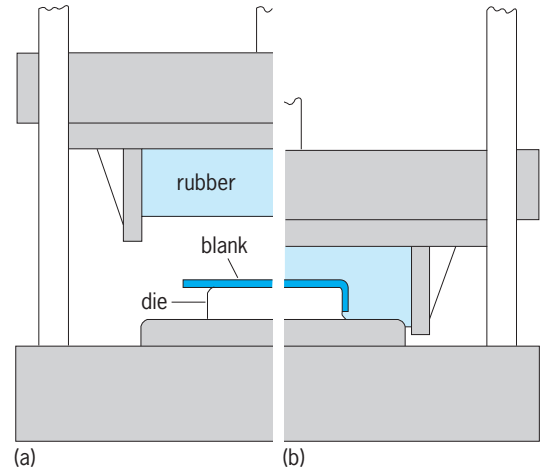

Fig. 2. Guerin process, the simplest rubber forming process. (a) Before forming. (b) After forming.

processes which utilize rubber to replace one of the dies. The simplest of these processes is the Guerin process (Fig. 2).

A great variety of parts are formed by the deep-drawing process (Fig. 3), the successful operation of which requires a careful control of factors such as blank-holder pressure, lubrication, clearance, material properties, and die geometry.

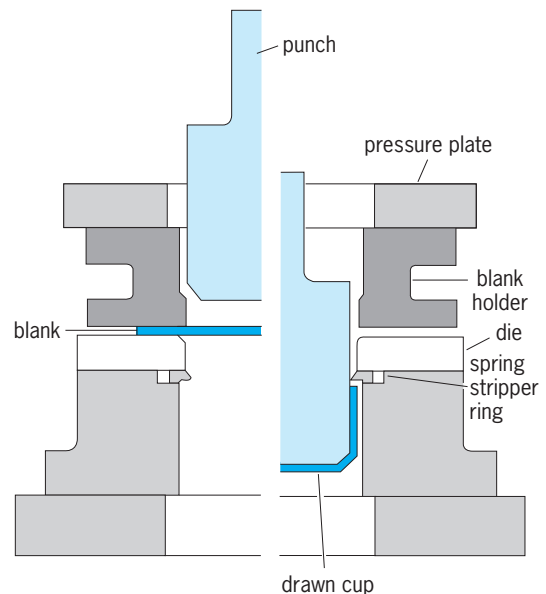

Fig. 3. Deep-drawing process.

Many parts require one or more additional processes. Embossing consists of forming a pattern on the sheet by shallow drawing. Coining consists of putting impressions on the surface by a process that is essentially forging, the best example being the two faces of a coin. Shearing is separation of the material by the cutting action of a pair of sharp tools, similar to a pair of scissors. See COINING.

The spinning process forms parts with rotational symmetry over a mandrel with the use of a tool or roller. There are two basic types of spinning: conventional or manual spinning, and shear spinning. The conventional spinning process forms the material over a rotating mandrel with little or no change in the thickness of the original blank. In shear spinning (hydrospinning, flotrurning) the deformation is carried out with a roller in such a manner that the diameter of the original blank does not change but the thickness of the part decreases by an amount dependent on the mandrel angle. Shear spinning produces parts with various shapes (conical, curvilinear, and also tubular by tube spinning on a cylindrical mandrel) with good surface finish, close tolerances, and improved mechanical properties. See METAL COATINGS; SPINNING (METALS). [S.Ka.]

**Shellac** The lac resin (secreted by the lac insect) when used in flake (or shell) form. Shellac varnish is a solution of shellac in denatured alcohol.

Shellac varnish is used in wood finishing where a fast-drying, light-colored, hard finish is desired. Drying is by simple evaporation of the alcohol. Shellac varnish is not water-resistant and is not suitable for exterior coatings. When used as a finish, it has the distinct advantage that it remains soluble. When touch-up is required, it therefore merges completely with the original finish, and no scratches or worn spots show. See SURFACE COATING; VARNISH. [C.R.Ma.; C.W.St.]

**Ship design** A process which translates a set of owner's requirements into the drawings, specifications, and other technical data necessary to actually build a ship. Naval architects lead the process, but engineers and designers with many other skills contribute. These other skills include marine engineering, structural design, and production engineering. The ship design process is iterative, and is subdivided into several phases during which the design is developed in increasing degrees of detail. Typically, the owner's requirements specify the mission that the new ship must perform and define such parameters as required speed, fuel endurance, and cargo weight and capacity. Generally, the cost to build and operate a ship is constrained by the prospective owner. The ship design process involves numerous trade-off studies in order to achieve the desired capability and, at the same time, stay within the established cost. See NAVAL ARCHITECTURE.

Mission requirements and constraints are unique to each ship being considered. For some ships, such as point-to-point cargo ships, the mission requirements can be simply stated; for example, "Transport 5000 20 ft ISO standard cargo containers at an average sea speed of 18 knots with 10,000 nautical miles between refuelings. On- and off-load the 5000 containers using shore-based cranes in less than XX hours." For other ship types, such as industrial ships performing missions at sea, the mission requirements are more complex. The requirements for a fisheries research vessel, for example, might specify the ability to catch fish using several different techniques, radiated noise limitations, required sonar performance, and several different aspects of maneuvering and seakeeping performance, such as low-speed stationkeeping and the ability to maintain a specified track over the sea floor in the face of cross currents, winds, and seas. See MERCHANT SHIP; OCEANOGRAPHIC VESSELS; SHIP POWERING, MANEUVERING, AND SEAKEEPING.

Cost, both to design and build the ship and to operate it, is usually constrained. The two primary elements of operating cost are crew and fuel, so there is nearly always pressure on the designer

to reduce crew size and fuel consumption. Physical constraints may also be imposed on the design related to construction, operational, or maintenance requirements. Weight or dimensional constraints may be imposed if the ship is to be built or maintained in a specific dry dock. Pier or harbor limitations may also impose dimensional constraints. Ship length may be limited by the requirement to tie up to a certain pier. Ship air draft (vertical distance from the water surface to the highest point on the ship) may be limited by the need to pass under bridges of a certain height. Ship navigational draft (vertical distance from the water surface to the lowest point on the ship) may be limited by the depth of a dredged channel in a particular harbor.

In addition to unique mission requirements and constraints, every ship must satisfy certain physical principles. The fundamental principles are that (1) the ship hull and superstructure must have adequate storage space, and (2) the ship must float at an acceptable waterline (draft neither too great nor too small) when it is fully loaded. Another principle is that the ship must be statically stable; that is, when it is displaced from its equilibrium condition, it must tend to return to that condition. For example, when the ship is heeled to one side by a disturbing force such as a wind gust, it must tend to return to the vertical rather than continuing to roll and capsizing. The ship's hull must have sufficient strength to withstand the forces that will act upon it over a range of loading and sea conditions. The ship must possess sufficient propulsive power to achieve the desired speed even with a fouled bottom and in adverse sea conditions. In addition, it must generate sufficient electric power to satisfy the requirements of mission systems; ship machinery; heating, ventilation, and air conditioning (HVAC) systems; hotel; and other ship services. See BUOYANCY; HYDROSTATICS; MARINE ENGINEERING; MARINE MACHINERY. [P.A.Ga.]

**Ship nuclear propulsion** Nuclear reactors for shipboard propulsion can be of any type used for the production of useful heat. Nuclear power is particularly suitable for vessels which need to be at sea for long periods without refueling or for powerful submarine propulsion. Only the pressurized water reactor and the liquid metal reactor have actually been applied to operating vessels. The pressurized water reactor has been most widely applied since it uses a readily available coolant and has a relatively simple cycle and control system and a large industrial and technical base. The supposed advantages of a liquid metal reactor (compactness, fast response, and higher propulsion plant efficiency) have not been proven in application, and liquid metal reactors are not now in marine service. See NUCLEAR POWER; NUCLEAR REACTOR; REACTOR PHYSICS.

In all the shipboard nuclear power plants that have been built, energy conversion is based on the steam turbine cycle, and that portion of the plant is more or less conventional. There are two types in use: a steam turbine geared to a fixed-pitch propeller (called a geared turbine), and a steam turbine generator whose output drives an electric motor connected to a propeller (called a turboelectric unit). Any energy conversion process that converts heat into mechanical energy could be used to propel a ship. For example, a closed-cycle helium gas turbine has been studied, but none has been built for ship propulsion. See MARINE ENGINE; MARINE MACHINERY; PROPELLER (MARINE CRAFT); SHIP POWERING, MANEUVERING, AND SEAKEEPING. [A.R.N.]

**Ship powering, maneuvering, and seakeeping** The three central areas of ship hydrodynamics. Basic concepts of powering, maneuvering, and seakeeping are critical to an understanding of high-speed craft. See NAVAL ARCHITECTURE; NAVAL SURFACE SHIP; SHIP DESIGN; SHIPBUILDING.

**Powering** The field of powering is divided into two related issues: resistance, the study of forces opposed to the ship's forward speed, and propulsion, the study of the generation of forces to overcome resistance.



A body moving through a fluid experiences a drag, that is, a force in the direction opposite to its movement. In the specific context of a ship's hull, this force is more often called resistance. Resistance arises from a number of physical phenomena, all of which vary with speed, but in different ways. These phenomena are influenced by the size, shape, and condition of the hull, and other parts of the ship. They include frictional resistance and form drag (often grouped together as viscous resistance), wavemaking resistance, and air resistance. See STREAMLINING; VISCOSITY.

Many devices have been used to propel a ship. In approximate historical order they include paddles, oars, sails, draft animals (working on a canal towpath), paddlewheels, marine screw propellers, vertical-axis propellers, airscrews, and waterjets. A key distinction is whether or not propulsive forces are generated in the same body of fluid that accounts for the main sources of the ship's resistance, resulting in hull-propulsor interaction. See PROPELLER (MARINE CRAFT).

Any propulsor can be understood as a power conversion device. Delivered power for a rotating propulsor is the product of torque times rotational speed. The useful power output from the system is the product of ship resistance times ship speed, termed effective power. The efficiency of this power conversion is often termed propulsive efficiency. See BOAT PROPULSION.

**Maneuvering.** Maneuvering (more generally, ship controllability) includes consideration of turning, course-keeping, acceleration, deceleration, and backing performance. The field of maneuvering has also come to include more specialized problems of ship handling, for example, the production of sideways motion for docking or undocking, turning in place, and position-keeping using auxiliary thrusters or steerable propulsion units. In the case of submarines, maneuvering also includes depth-change maneuvers, either independently or in combination with turning.

**Seakeeping.** The modern term "seakeeping" is used to describe all aspects of a ship's performance in waves, affected primarily by its motions in six degrees of freedom (see illustration).

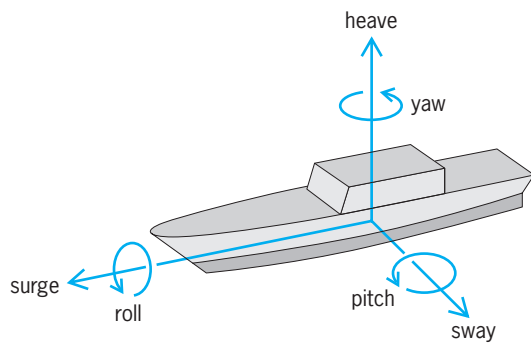

Ship motion degrees of freedom.

Seakeeping issues are diverse, including the motions, accelerations, and structural loads caused by waves. Some are related to the comfort of passengers and crew, some to the operation of ship systems, and others to ship and personnel safety. Typical issues include the incidence of motion sickness, cargo shifting, loss of deck cargo, hull bending moments due to waves, slamming (water impact loads on sections of the hull), added powering in waves, and the frequency and severity of water on deck.

In the past, initial powering, maneuvering, and seakeeping predictions for new designs depended almost entirely on design rules of thumb or, at best, applicable series or regression data from previous model tests, subsequently refined by additional model tests. With the increase in computing power available to the naval architect, computational fluid dynamic methods are now applied to some of these problems in various stages of the ship design process. See COMPUTATIONAL FLUID DYNAMICS.

[R.M.Sc.]

**Ship routing** The selection of the most favorable route for a ship's transit, based upon the environment conditions expected during the voyage, and the effect of these conditions upon the ship's performance. Ship routing is also referred to as weather routing, optimum track ship routing, and meteorological navigation.

Routes can be computed to minimize transit time, avoid waves over a specific height, or, more typically, provide a compromise between travel time and the roughness of the seaway to be encountered. Routing offices compute the initial route based on the long-range weather forecast, but maintain a daily plot of both the ship and the storm positions. If conditions warrant, an amended route is sent to the ship master based on the latest weather changes. See OCEAN WAVES; WEATHER FORECASTING AND PREDICTION.

Although the effect of waves is the predominant factor considered, the ship router also utilizes knowledge of ocean currents, wind, and hazards to navigation such as ice fields or fog banks. On United States east coast runs, the currents are more important than the waves. Most major oil companies have their tankers follow the Gulf Stream on the northbound runs and avoid it on the return trip. See OCEAN CIRCULATION. [R.W.J.]

**Ship salvage** Voluntary response to a maritime peril by other than the ship's own crew. The property in danger can be any type or size of vessel or maritime cargo. Salvage is encouraged by compensating the salvor based on risk to the salvor and the salvor's equipment, conditions under which the salvage service was performed, the value of the vessel and cargo saved and, more recently, minimizing environmental damage.

Salvage services can be performed using either dedicated salvage vessels or vessels hired for the specific operation. Salvage ships are typically large seagoing tugs, usually capable of 5000–10,000 hp (3750–7500 kW), designed and outfitted to work at remote sites in all weather. Salvage ships carry a variety of portable salvage equipment such as firefighting gear, pumps and patching material, electrical generators, compressors, diving equipment, wire and chain, beach gear, pollution control equipment, and the material to make whatever might be needed on-site.

True salvage is time-critical, involving assets that are immediately available. Assistance is provided in situations involving collisions, firefighting, flooding and damage control, damage from hostile action, and breakdowns of propulsion or steering systems. The salvage team may fight fire from off-ship or board the casualty to fight fires. Salvors also may board the ship to control flooding and stabilize the casualty if required. Rescue towing often results from one or more of the above and the need to reach a safe haven or avoid going aground.

Stranding results when a ship drives, or is driven, aground through engine or steering casualty, error, problem with navigation or navigation aid, or bad weather, and cannot extricate itself. Time-criticality may be due to coming bad weather, tidal range, ongoing damage to the ship from the grounding, or other requirement such as clearing a blocked shipping channel. The salvor must assess the condition of the casualty and what is required to refloat it, the potential for further damage to the ship, and the potential for loss of cargo and damage to the environment.

Environmental salvage is the protection of the environment from damage by pollutants that may result from a maritime casualty. International agreements such as the International Convention for the Prevention of Pollution from Ships (MARPOL 73/78) and national laws such as the Oil Pollution Act of 1990 highlight the need for protecting the environment. This is most effectively accomplished by keeping pollutants in a ship during a casualty, minimizing dispersion, and rapidly recovering any spilled pollutants, usually cargo crude oil or petroleum products, or ship's fuel stored in bunkers. Salvage actions such as pumping air into a damaged tank to restore buoyancy may blow oil

out through the damaged hull below the waterline. Salvors must be prepared to deal with pollutants when this occurs, and plan salvage operations to minimize oil release.

Wreck removal involves recovery of a stranded or sunken vessel, and is usually not time-critical. Many salvage techniques can be brought to bear. If the main deck of the stranded or sunken vessel is above water, a combination of patching and pumping may be sufficient to refloat the casualty. If the main deck is not submerged too deeply, a watertight wall, known as a cofferdam, may be built around the main deck to above the water surface. Patching and pumping may then refloat the casualty.

A ship's cargo may be of more value than the ship itself, and the salvor may recover the cargo without recovering the ship. The best-known type of cargo salvage is the recovery of jewels or precious metals. But even something as mundane as copper ingots may be considered worth recovering by both the salvor and the owner or underwriter. [R.P.Fi.]

**Shipbuilding** The construction of large vessels which travel over seas, lakes, or rivers. Many different approaches have been used in the construction of ships. Sometimes a ship must be custom-built to suit the particular requirements of a low-volume trade route with unique cargo characteristics. On the other hand, there are many instances where a significant number of similar ships are constructed, providing an opportunity to employ procedures which take advantage of repetitive processes.

The building of a ship can be divided into seven phases: design, construction planning, work prior to keel laying, ship erection, launching, final outfitting, and sea trials. See SHIP DESIGN.

The construction planning process establishes the construction techniques to be used and the schedules which all of the shipbuilding activities must follow. Construction planners generally start with an erection diagram on which the ship is shown broken down into erection zones and units. To facilitate the fabrication of steel, insofar as possible, the erection units are designed to be identical. The size (or weight) of the erection units selected is usually limited by the amount of crane capacity available. Once the construction planners have established the manner in which the ship is to be erected and the sequence of construction, the schedules for construction can be developed. Working backward from the time an erection unit is required in the dock, with allowances made for the many processes involved, a schedule of working plans and for procurement of purchased equipment is prepared.

Before the keel of a ship is laid (or when the first erection unit is placed in position) a great deal of work must have been accomplished for work to proceed efficiently. The working drawings prepared by ship designers completely define a ship, but often not in a manner that can be used by the construction trades people. Structural drawings prescribe the geometry of the steel plates used in construction, but they cannot be used, in the form prepared, to cut steel plates. Instead, the detailed structural drawings must be translated into cutting sketches, or numerical-control cutting tapes, which are used to fabricate steel. Several organizations have developed sophisticated computer programs which readily translate detailed structural drawings into machine-sensible tapes which can be used to drive cutting torches.

If all of the preceding work has been accomplished properly and on schedule, the erection of a ship can proceed rapidly; however, problem areas invariably arise. When erecting a ship one plate at a time, there are no serious fitting problems; but when 900-metric-ton erection units do not fit (or align) properly, there are serious problems which tend to offset some of the advantages for this practice.

A ship is launched as soon as the hull structure is sufficiently complete to withstand the strain. Ships may be launched endwise, sidewise, or by in-place flotation (for example, graving docks). The use of a graving dock requires a greater investment in facilities than either of the other two methods, but in some cases there may be an overall advantage due to the improved

access to the ship and the simplified launch procedure. See DRY-DOCKING.

The final outfitting of a ship is the construction phase during which checks are made to ensure that all of the previous work has been accomplished in a satisfactory manner; and last-minute details, such as deck coverings and the top coat of paint, are completed. It is considered good practice to subject as much of the ship as possible to an intensive series of tests while at the dock, where corrections and final adjustments are more easily made than when at sea. As a part of this test program, the main propulsion machinery is subjected to a dock trial, during which the ship is secured to the dock and the main propulsion machinery is operated up to the highest power level permissible.

When a comprehensive program of dockside tests have been completed, the only capabilities which have not been demonstrated are the operation of the steering gear during rated-power conditions and the operation of the main propulsion machinery at rated power; these capabilities must be demonstrated during trials at sea. [R.L.Ha.]

**Shipping fever** A severe inflammation of the lungs (pneumonia) commonly seen in North American cattle after experiencing the stress of transport. This disease occurs mainly in 6–9-month-old beef calves transported to feedlots. The characteristic pneumonia is caused primarily by the bacterium *Pasteurella haemolytica* serotype A1; thus a synonym for shipping fever is bovine pneumonic pasteurellosis.

*Pasteurella haemolytica* replicates rapidly in the upper respiratory tract and is inhaled into the lungs, where pneumonia develops in the deepest region of the lower respiratory tract (the pulmonary alveoli). Viruses can also concurrently damage pulmonary alveoli and enhance the bacterial pneumonia.

Symptoms initially include reduced appetite, high fever, rapid and shallow respiration, depression, and a moist cough. During the later stages of disease, cattle lose weight and have labored breathing. The lesion causing these symptoms is a severe pneumonia accompanied by inflammation of the lining of the chest cavity, and is called a fibrinous pleuropneumonia. Without vigorous treatment, shipping fever can cause death in 5–30% of affected cattle.

Treatment is aimed at eliminating bacteria by using antibiotics, reducing inflammation by using nonsteroidal anti-inflammatory drugs, and separating affected cattle. Vaccines can stimulate immunity to the viruses and bacteria associated with shipping fever. See ANIMAL VIRUS; INFLAMMATION; PNEUMONIA; VACCINATION. [A.W.Co.]

**Shipworm** A wood-boring mollusk of the family Teredinidae. These borers, also called pileworms, are found around the world in tropical to boreal and marine to nearly freshwater habitats, from the intertidal to depths of about 2000 ft (600 m). It was not until humans became navigators that shipworms became pests. Before the advent of steel ships, they were greatly feared, and even today hundreds of millions of dollars are spent annually on prevention and repair due to their activity. See BIVALVIA. [R.D.T.]

**Shock absorber** Effectively a spring, a dashpot, or a combination of the two, arranged to minimize the acceleration of the mass of a mechanism or portion thereof with respect to its frame or support.

The spring type of shock absorber is generally used to protect delicate mechanisms, such as instruments, from direct impact or instantaneously applied loads. Such springs are often made of rubber or similar elastic material. See SHOCK ISOLATION.

An example of the dashpot type of shock absorber is the direct-acting shock absorber in an automotive spring suspension system (see illustration). Here the device is used to dampen and control a spring movement. The energy of the mass in motion is converted to heat by forcing a fluid through a restriction, and the

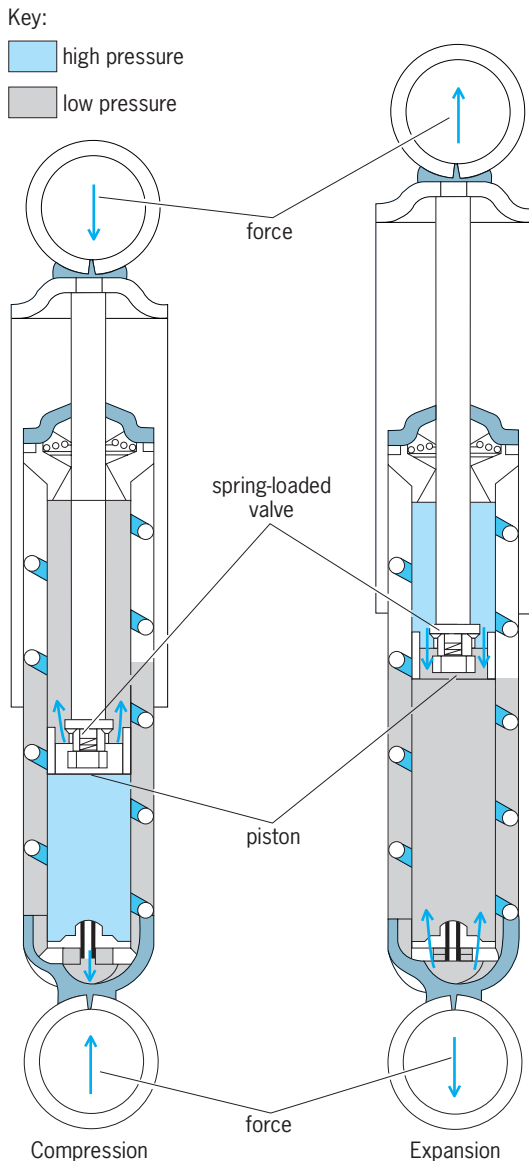

**A dashpot-type shock absorber. (Plymouth Division, Chrysler Corp.)**

heat is dissipated by radiation and conduction from the shock absorber. See VIBRATION DAMPING.

There are also devices available which combine springs and viscous damping (dashpots) in the same unit. They use elastic solids (such as rubber or metal), compressed gas (usually nitrogen), or both for the spring. A flat-viscosity hydraulic fluid is used for the viscous damping. [L.S.L.]

**Shock isolation** The application of isolators to alleviate the effects of shock on a mechanical device or system. The term shock generally denotes suddenness, either in the application of a force or in the inception of a motion. See SHOCK WAVE.

Shock isolation is accomplished by storing energy in a resilient medium (isolator, cushion, and so on) and releasing it at a slower rate. The effectiveness of an isolator depends upon the duration of the shock impact.

Rubber is the most common material used in commercial shock isolators. Rubber isolators are generally used where the shock forces are created through small displacements. For larger displacement shock forces, such as those experienced by shipping containers in rough handling conditions, thick cushions of

felt, rubberized hair, sponge rubber, cork, or foam plastics are used.

The shock load must be divided between the case, the shock cushion, and the equipment. The case, since it must withstand effects of rough handling such as sliding and dropping, is by necessity rigid. The more rigid the case the closer to a 1:1 ratio will be the transfer of the shock from outside to inside. The absorption of the shock is primarily between the cushion and the equipment. See DAMPING; SHOCK ABSORBER; SPRING (MACHINES); VIBRATION DAMPING. [K.W.J.]

**Shock syndrome** A condition clinically recognized as a state of inadequate blood flow to tissues. The etiologic classification of shock syndrome comprises four categories: cardiogenic (inability of the heart to pump adequately); neurogenic (interference with control of size of blood vessels caused by a change in balance in nerve impulses); vasogenic (sepsis; due to serious infection); and hematogenic (reduction in circulating blood volume).

Cardiogenic shock is manifested by low blood pressure when there is adequate blood volume. This form of shock is indicated by cold skin, low body temperature, and fast pulse.

Neurogenic shock is seen with clinical fainting. Similarly, neurogenic shock is often observed with serious paralysis of nervous influences. Although the blood pressure may be extremely low, the pulse rate is usually slower than normal and is accompanied by dry, warm, and even flushed skin.

Although any agent capable of producing infection, including viruses, parasites, and fungi, may result in vasogenic (septic) shock, the most frequent etiologic organisms are those that originate in the body, such as in the bowel or urinary tract. The initial infectious process appears to be only a stimulus for a series of body responses that may be fatal, even in the absence of infection at the time of death. Clinically, these individuals usually have high fever, low blood pressure, and eventually cold skin.

Hematogenic shock is the most common form of shock, and it is usually caused by hemorrhage. Most of the signs of clinical shock from low blood volume are characteristic of low blood flow. The skin is usually cold, clammy, and pale, accompanied by a very rapid pulse. See CARDIOVASCULAR SYSTEM. [G.T.Sh.]

**Shock tube** A laboratory device for rapidly raising confined samples of fluids (primarily gases) to preselected high temperatures and densities. This is accomplished by a shock wave, generated when a partition (diaphragm) that separates a low-pressure (driven) section from a high-pressure (driver) section is rapidly removed. Shock tubes can be circular, square, or rectangular in cross section. In the driven section, gaseous samples can be heated to temperatures as high as 27,500°F (15,000 K) under strictly homogeneous conditions. At the shock front the transition from the unshocked to the high-temperature condition is of short but of finite duration. The incident shock wave generates a slower-moving wave that additionally heats the compressed gas. See SHOCK WAVE.

With the diaphragm in place the driven section is filled to a modest pressure with an inert gas plus the gas of interest. The driver section is filled to a high pressure with a low-molecular-weight gas: helium or hydrogen. When the diaphragm is rapidly ruptured, expansion of the high-pressure gas acts as a low-mass piston that generates a steepening pressure front, which moves ahead of the boundary between the driver and the test gases.

Shock tubes are used to investigate the gas dynamics of shocks and for preparing test samples for equilibrium or kinetic studies. Many gas dynamic problems can be investigated in shock tubes, such as thermal boundary-layer growth, shock bifurcation, and shock-wave focusing and reflection. Shock tubes are used to prepare gases for study at very low or very high temperatures without thermal contact with extraneous surfaces. Significant applications of shock tubes to chemical kinetics includes

the determination of diatom dissociation rates and the study of polyatomic molecules. [S.H.B.]

**Shock wave** A mechanical wave of large amplitude, propagating at supersonic velocity, across which pressure or stress, density, particle velocity, temperature, and related properties change in a nearly discontinuous manner. Unlike acoustic waves, shock waves are characterized by an amplitude-dependent wave velocity. Shock waves arise from sharp and violent disturbances generated from a lightning stroke, bomb blast, or other form of intense explosion, and from steady supersonic flow over bodies.

The abrupt nature of a shock wave in a gas can best be visualized from a schlieren photograph or shadow graph of supersonic flow over objects. Such photographs show well-defined surfaces in the flow field across which the density changes rapidly, in contrast to waves within the range of linear dynamic behavior of the fluid. Measurements of fluid density, pressure, and temperature across the surfaces show that these quantities always increase along the direction of flow, and that the rates of change are usually so rapid as to be beyond the spatial resolution of most instruments. These surfaces of abrupt change in fluid properties are called shock waves or shock fronts. See SCHLIEREN PHOTOGRAPHY; SHADOWGRAPH; WAVE MOTION IN FLUIDS.

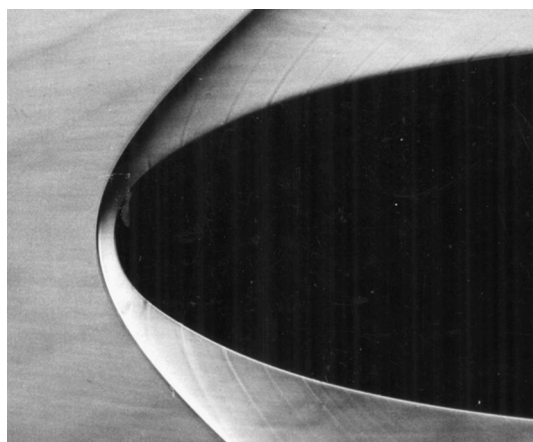

Schlieren photograph of supersonic flow over blunt object. Shock wave is approximately parabolic, and detached from object. (Avco Everett Research Laboratory, Inc.)

Shock waves in supersonic flow may be classified as normal or oblique according to whether the orientation of the surface of abrupt change is perpendicular or at an angle to the direction of flow. A schlieren photograph of a supersonic flow over a blunt object is shown in the illustration. Although this photograph was obtained from a supersonic flow over a stationary model in a shock tube, the general shape of the shock wave around the object is quite typical of those observed in a supersonic wind tunnel, or of similar objects (or projectiles) flying at supersonic speeds in a stationary atmosphere. The shock wave in this case assumes an approximately parabolic shape and is clearly detached from the blunt object. The central part of the wave, just in front of the object, may be considered an approximate model of the normal shock; the outer part of the wave is an oblique shock wave of gradually changing obliqueness and strength. See BALLISTIC RANGE; WIND TUNNEL. [S.C.Li.]

Some common examples of shock waves in condensed materials are encountered in the study of underground or underwater explosions, meteorite impacts, and ballistics problems. The field of shock waves in condensed materials (solids and liquids) has grown into an important interdisciplinary area of research involving condensed matter physics, geophysics, materials science, applied mechanics, and chemical physics. The nonlinear aspect of shock waves is an important area of applied mathematics.

Experimentally, shock waves are produced by rapidly imparting momentum over a large flat surface. This can be accomplished in many different ways: rapid deposition of radiation using electron or photon beams (lasers or x-rays), detonation of a high explosive in contact with the material, or high-speed impact of a plate on the sample surface. The impacting plate itself can be accelerated by using explosives, electrical discharge, underground nuclear explosions, and compressed gases. The use of compressed gas to accelerate projectiles with appropriate flyer plates provides the highest precision and control as well as convenience in laboratory experiments.

Large-amplitude one-dimensional compression and shear waves have been studied in solids. In these experiments, a macroscopic volume element is subjected to both a compression and shear deformation. The combined deformation state is produced by impacting two parallel flyer plates that are inclined at an angle to the direction of the plate motion. Momentum conservation coupled with different wave velocities for compression and shear waves leads to a separation of these waves in the sample interior. These experiments provide direct information about the shear response of shocked solids, and subject samples to more general loading states than the uniaxial strain state. See STRESS AND STRAIN.

Shock waves subject matter to unusual conditions and therefore provide a good test of understanding of fundamental processes. The majority of the studies on condensed materials have concentrated on mechanical and thermodynamic properties. These are obtained from measurements of shock velocity, stress, and particle velocity in well-controlled experiments. Advanced techniques using electromagnetic gages, laser interferometry, piezoelectric gages, and piezoresistance gages have given continuous, time-resolved measurements at different sample thicknesses.

The study of residual effects, that is, the postshock examination of samples subjected to a known pulse amplitude and duration, is of considerable importance to materials science and metallurgy. The conversion of graphite to diamonds is noteworthy. Other effects that have been observed are microstructural changes, enhanced chemical activity, changes in material hardness and strength, and changes in electrical and magnetic properties. The generation of shock-induced lattice defects is thought to be important for explaining these changes in material properties. There has been growing interest in using shock methods for material synthesis and powder compaction. See DIAMOND; HIGH-PRESSURE CHEMISTRY; HIGH-PRESSURE MINERAL SYNTHESIS; HIGH-PRESSURE PHYSICS. [Y.M.G.]

**Short circuit** An abnormal condition (including an arc) of relatively low impedance, whether made accidentally or intentionally, between two points of different potential in an electric network or system. See CIRCUIT (ELECTRICITY); ELECTRICAL IMPEDANCE.

Common usage of the term implies an undesirable condition arising from failure of electrical insulation, from natural causes (lightning, wind, and so forth), or from human causes (accidents, intrusion, and so forth). From an analytical viewpoint, however, short circuits represent a severe condition that the circuit designer must consider in designing an electric system that must withstand all possible operating conditions. See ELECTRIC PROTECTIVE DEVICES; ELECTRICAL INSULATION; LIGHTNING AND SURGE PROTECTION.

In circuit theory the short-circuit condition represents a basic condition that is used analytically to derive important information concerning the network behavior and operating capability. Thus, along with the open-circuit voltage, the short-circuit current provides important basic information about the network at a given point. See ALTERNATING-CURRENT CIRCUIT THEORY; DIRECT-CURRENT CIRCUIT THEORY; NETWORK THEORY; THÉVENIN'S THEOREM (ELECTRIC NETWORKS).

The short-circuit condition is also used in network theory to describe a general condition of zero voltage. Thus the term

short-circuit admittance (or impedance) is used to describe a network condition in which certain terminals have had their voltage reduced to zero, for the purpose of analysis. This leads to the terms short-circuit driving point admittance, short-circuit transfer admittance, and similar references to the zero voltage condition. See ADMITTANCE.

Short-circuit protection is a separate discipline dedicated to the study, analysis, application, and design of protective apparatus that are intended to minimize the effect of unintentional short circuits in power supply systems. For these analyses the short circuit is an important limiting (worst) case, and is used to compute the coordination of fuses, circuit reclosers, circuit breakers, and other devices designed to recognize and isolate short circuits. The short circuit is also an important parameter in the specification of these protective devices, which must have adequate capability for interrupting the high short-circuit current. See CIRCUIT BREAKER; FUSE (ELECTRICITY).

Short circuits are also important on high-frequency transmission lines where shorted stub lines, one-quarter wavelength long and shorted at the remote end, are used to design matching sections of the transmission lines which also act as tuning elements. See TRANSMISSION LINES. [P.M.A.]

**Short takeoff and landing (STOL)** The term applied to heavier-than-air craft that cannot take off and land vertically, but can operate within areas substantially more confined than those normally required by aircraft of the same size. A pure STOL aircraft is a fixed-wing vehicle that derives lift primarily from free-stream airflow over the wing and its high lift system, sometimes with significant augmentation from the propulsion system. Although all vertical takeoff and landing (VTOL) machines, including helicopters, can lift greater loads by developing forward speed on the ground before liftoff, they are still regarded as VTOL (or V/STOL craft), operating in the STOL mode. See VERTICAL TAKEOFF AND LANDING (VTOL).

It has been customary to define STOL capability in terms of the runway length required to take off or land over a 50-ft (15-m) obstacle, the concept of "short" length being variously defined as from 500 to 2000 ft (150 to 600 m), depending on the high-lift concept employed and on the mission of the aircraft. In addition to being able to operate from short runways, STOL aircraft are usually expected to be able to maneuver in confined airspace so as to minimize the required size of the terminal area. Such aircraft must therefore have unusually good slow-flight stability and control characteristics, especially in turbulence and under instrument flight conditions. See AIRPLANE. [R.E.K.]

**Shrew** An insectivorous mammal of the family Soricidae found in Asia, Africa, Europe, and North America. The family includes 265 species grouped into three subfamilies, the red-toothed, white-toothed, and armored shrews. Shrews are small, savage animals with extremely sharp teeth. The tail is moderately long, the eyes are minute, the snout is sharp-pointed, and the ears are small (see illustration).

Shrews are solitary individuals that establish distinct territories. Couples are found together only during mating. The female



Eurasian common shrew (*Sorex araneus*).

builds the nest, a hole in the ground lined with leaves and moss, where she deposits her litter of 5-10 young, born after a gestation period of between 2-3 weeks. The female mates at the age of 1 year; however, since the life-span of the shrew is only 15 months, the females always die during the fall after the litter is born. See INSECTIVORA. [C.B.C.]

**Shrink fit** A fit that has considerable negative allowance so that the diameter of a hole is less than the diameter of a shaft that is to pass through the hole, also called a heavy force fit. Shrink fits are used for permanent assembly of steel external members, as on locomotive wheels. The difference between a shrink fit and a force fit is in method of assembly. In shrink fits, the outer member is heated, or the inner part is cooled, or both, as required. The parts are then assembled and returned to the same temperature. See ALLOWANCE; FORCE FIT. [P.H.B.]

**Shunting** The act of connecting an electrical element in parallel with (across) another element. The shunting connection is shown in illus. a.

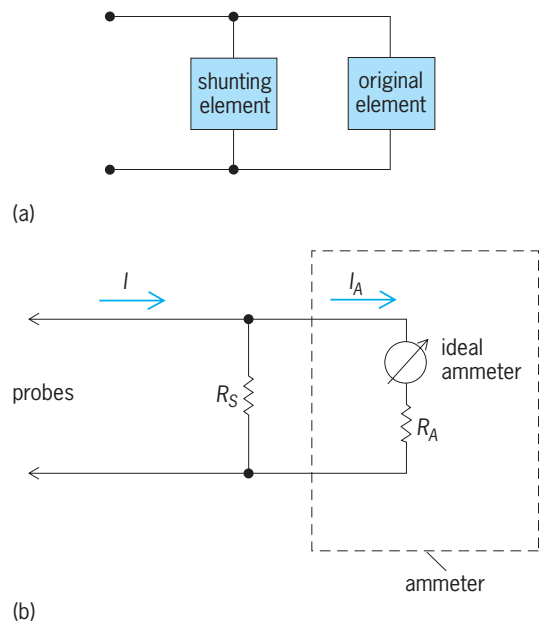

Shunting. (a) Shunting connection. (b) Ammeter shunted by resistor  $R_S$ .

An example of shunting involves a measuring instrument whose movement coil is designed to carry only a small current for a full-scale deflection of the meter. To protect this coil from an excessive current that would destroy it when measuring currents that exceed its rating, a shunt resistor carries the excess current.

Illustration b shows an ammeter (a current-measuring instrument) with internal resistance  $R_A$ . It is shunted by a resistor  $R_S$ . The current through the movement coil is a fraction of the measured current, and is given by the equation below. With differ-

$$I_A = \frac{R_S}{R_A + R_S} I$$

ent choices of  $R_S$ , the measuring range for the current  $I$  can be changed. See AMMETER; CURRENT MEASUREMENT.

Similar connections and calculations are used in a shunt ohmmeter to measure electrical resistance. Shunt capacitors are often used for voltage correction in power transmission lines. A shunt capacitor may be used for the correction of the power factor of a load. In direct current shunt motors, the excitation (field) winding is connected in parallel with the armature. See DIRECT-CURRENT MOTOR; OHMMETER; POWER FACTOR; RESISTANCE MEASUREMENT.

In electronic applications, a shunt regulator is used to divert an excessive current around a particular circuit. In broadband electronic amplifiers, several techniques may be used to extend the bandwidth. For high-frequency extension, a shunt compensation is used where, typically, a capacitor is shunted across an appropriate part of the circuit. Shunt capacitors (or more complicated circuits) are often used to stabilize and prevent undesired oscillations in amplifier and feedback circuits. See ALTERNATING-CURRENT CIRCUIT THEORY; AMPLIFIER; DIRECT-CURRENT CIRCUIT THEORY; FEEDBACK CIRCUIT. [S.Kar.]

**Sickle cell disease** An inherited disorder of red blood cells characterized by lifelong anemia and recurrent painful episodes. The sickle cell mutation is caused by a single nucleotide effecting a change in the  $\beta$ -globin gene, resulting in the substitution of valine for glutamic acid as the sixth amino acid of  $\beta$ -globin. The short circulatory survival of red blood cells that contain sickle cell hemoglobin S results in anemia, and their abnormal rigidity contributes to painful obstruction of small blood vessels. See ANEMIA; GENETIC CODE; HEMOGLOBIN.

The sickle cell gene is found most commonly among individuals of African ancestry, but also has a significant incidence in Mediterranean, Middle Eastern, and Asian Indian populations. Inheritance of one sickle gene and one normal  $\beta$ -globin allele results in a simple heterozygous condition known as sickle cell trait. This benign carrier condition is associated with a normal life expectancy, and it does not cause either anemia or recurrent pain. The large amounts of hemoglobin A within sickle-cell-trait red blood cells protect against the deleterious effects of hemoglobin S. The inheritance of homozygous sickle cell anemia results in sufficiently high intracellular concentration of sickle cell hemoglobin S to cause clinical disease. See HUMAN GENETICS.

The property of sickle cell hemoglobin S responsible for clinical disease is its insolubility when deoxygenated. Oxygenated sickle cell hemoglobin S is as soluble as oxygenated normal hemoglobin, but when it is deoxygenated it aggregates and forms an insoluble polymer. Polymerization of sickle cell hemoglobin within deoxygenated sickle cells reversibly reduces cellular deformability and distorts cells to the sickle shape (see illustration). Sickle cells usually return from the venous circulation to the arterial, where the hemoglobin is reoxygenated and the cells unsickle. Persistent cycles of sickling and unsickling result in the generation of dehydrated, very dense sickle cells; these are irreversibly sickled cells that are incapable of resuming a normal shape when reoxygenated. As a result of the poor deformability of individual sickle red blood cells, sickle cell blood has high viscosity. The impaired rheologic properties of sickle blood are compounded by abnormal adherence of sickle red cells to endothelial cells lining the blood vessels.

The short-lived nature of sickle red blood cells results in lifelong chronic hemolytic anemia with which accelerated red blood cell production cannot keep pace. The increased turnover of red

blood cells results in elevated levels of hemoglobin degradation and bilirubin production by the liver and in very frequent formation of gallstones. Vasoocclusive complications of sickle cell disease include the episodic painful crises and both chronic and acute organ dysfunction. Average life expectancy is in the fifth decade. One disease manifestation that is particularly problematic in young children is susceptibility to infections.

The standard method of diagnosing sickle cell syndromes is hemoglobin electrophoresis. There are a variety of diagnostic tests based on deoxyribonucleic acid (DNA). These DNA-based diagnostic methods are particularly useful for prenatal diagnosis of sickle cell disease. See DEOXYRIBONUCLEIC ACID (DNA); ELECTROPHORESIS; PRENATAL DIAGNOSIS.

Despite the profound understanding of sickle cell disease, treatment of painful episodes often consists of only symptomatic therapy, including analgesics for pain, antibiotics for infections, and transfusions for episodes of severe anemia. Genetic counseling and prenatal diagnosis remain important therapeutic approaches. See BLOOD; GENETIC ENGINEERING. [S.H.E.]

**Sideband** The range of the electromagnetic spectrum located either above (the upper sideband) or below (the lower sideband) the frequency of a sinusoidal carrier signal  $c(t)$ . The sidebands are produced by modulating the carrier signal in amplitude, frequency, or phase in accordance with a modulating signal  $m(t)$  to produce the modulated signal  $s(t)$ . The resulting distribution of power in the sidebands of the modulated signal depends on the modulating signal and the particular form of modulation employed. See AMPLITUDE MODULATION; FREQUENCY MODULATION; MODULATION; PHASE MODULATION. [H.J.He.]

**Sidereal time** One of several kinds of time scales used in astronomy, whose primary application is as part of the coordinate system to locate objects in the sky. It is also the basis for determining the solar time used in everyday living.

The common measurements of time are based on the motions of the Earth that most affect everyday life: Earth's rotation on its axis, and revolution in orbit around the Sun. Objects in the sky reflect these motions and appear to move westward, crossing the meridian each day. A particular object or point is chosen as a marker, and the interval between its successive crossings of the local meridian is defined to be a day, divided into 24 equal parts called hours. The actual length of the day for comparison between systems depends on the reference object chosen. The time of day is reckoned by the angular distance around the sky that the reference object has moved westward since it last crossed the meridian. In fact, the angular distance west of the meridian is called the hour angle. See MERIDIAN.

The reference point for marking sidereal time is the vernal equinox, one of the two points where the planes of the Earth's Equator and orbit appear to intersect on the celestial sphere. The sidereal day is the interval of time required for the hour angle of the equinox to increase by  $360^\circ$ . One rotation of the Earth with respect to the Sun is a little longer, because the Earth has moved in its orbit as it rotates and hence must turn approximately  $361^\circ$  to complete a solar day. A sidereal year is the time required for the mean longitude of the Sun to increase  $360^\circ$ , or for the Sun to make one circuit around the sky with respect to a fixed reference point. See EARTH ROTATION AND ORBITAL MOTION; TIME. [A.D.F.]

**Siderite** A mineral ( $\text{FeCO}_3$ ) with the same space group and hexagonal crystal system as calcite ( $\text{CaCO}_3$ ). Siderite has a gray, tan, brown, dark brown, or red color, has rhombohedral cleavages, and occasionally may show rhombohedral crystal terminations. It may display curved crystal faces like dolomite ( $\text{CaMg}[\text{CO}_3]_2$ ), but more commonly is found as massive, compact, or earthy masses. It has a high specific gravity of 3.94, a medium hardness of 3.5–4, and a high index of refraction, 1.88. See CARBONATE MINERALS; CRYSTAL STRUCTURE; DOLomite.

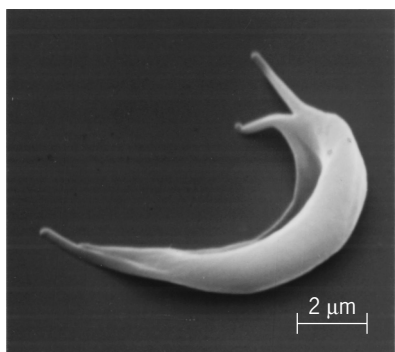

Scanning electron micrograph of a deoxygenated sickle red blood cell. (Electron micrograph by Dr. James White)

Siderite, a widespread mineral in near-surface sediments and ore deposits, occurs in hydrothermal veins, lead-silver ore deposits, sedimentary concretions formed in limestones and sandstones, and Precambrian banded iron formations that precipitated under acidic conditions. Famous localities for siderite are found in Styria (Austria), Westphalia (Germany), Cornwall (Britain), Wawa (Northern Ontario, Canada), Minas Gerais (Brazil), and Llallagua and Potosi (Bolivia). These and other occurrences have provided locally significant quantities of siderite as iron ore. See IRON; MAGNETITE; METAMORPHISM; ORE AND MINERAL DEPOSITS. [E.J.E.]

**Siderophores** Low-molecular-mass molecules that have a high specificity for chelating or binding iron. Siderophores are produced by many microorganisms, including bacteria, yeast, and fungi, to obtain iron from the environment. More than 500 different siderophores have been identified from microorganisms. Some bacteria produce more than one type of siderophore. See BACTERIA; BIOINORGANIC CHEMISTRY; CHELATION; FUNGI; IRON; YEAST.

Iron is required by aerobic bacteria and other living organisms for a variety of biochemical reactions in the cell. Although iron is the fourth most abundant element in the Earth's crust, it is not readily available to bacteria. Iron is found in nature mostly as insoluble precipitates that are part of hydroxide polymers. Bacteria living in the soil or water must have a mechanism to solubilize iron from these precipitates in order to assimilate iron from the environment. Iron is also not freely available in humans and other mammals. Most iron is found intracellularly in heme proteins and ferritin, an iron storage compound. Iron outside cells is tightly bound to proteins. Therefore, bacteria that grow in humans or other animals and cause infections must have a mechanism to remove iron from these proteins and use it for their own energy and growth needs. Siderophores have a very high affinity for iron and are able to solubilize and transport ferric iron ( $\text{Fe}^{3+}$ ) in the environment and also to compete for iron with mammalian proteins such as transferrin and lactoferrin. The majority of bacteria and fungi use siderophores to solubilize and transport iron. Microorganisms can use either siderophores produced by themselves or siderophores produced by other microorganisms. See IRON METABOLISM.

The many different types of siderophores can generally be classified into two structural groups, hydroxamates and catecholate compounds. Despite their structural differences, all form an octahedral complex with six binding coordinates for  $\text{Fe}^{3+}$ .

Siderophores have potential applications in the treatment of some human diseases and infections. Some siderophores are used therapeutically to treat chronic or acute iron overload conditions in order to prevent iron toxicity in humans. Individuals who have defects in blood cell production or who receive multiple transfusions can sometimes have too much free iron in the body. However, in order to prevent infection during treatment for iron overload, it is important to use siderophores that cannot be used by bacterial pathogens.

A second clinical application of siderophores is in antibiotic delivery to bacteria. Some gram-negative bacteria are resistant to antibiotics because they are too big to diffuse through the outer-membrane porins. However, siderophore-antibiotic combination compounds have been synthesized that can be transported into the cell using the siderophore receptor. See ANTIBIOTIC; DRUG RESISTANCE. [P.A.So.]

**Sigma-delta converter** A class of electronic systems containing both analog and digital subsystems whose most common application is to the conversion of analog signals to digital form and vice versa. The device is also known as a delta-sigma converter. The main advantage of the sigma-delta approach to signal conversion is its minimal reliance on the quality of the analog components required. To achieve this end, the system uses pulse density modulation to create a high-rate stream of single-

amplitude pulses. For analog-to-digital conversion, the rate at which the pulses are generated depends on the amplitude of the analog voltage being sensed. For digital-to-analog conversion, the pulse density depends on the numeric digital quantity applied at the converter input. See PULSE MODULATION.

The simplest implementation of a sigma-delta analog-to-digital converter uses an analog circuit to generate the single-valued pulse stream from an analog source, and a digital system to repeatedly sum the number of these pulses over a fixed number of pulse intervals. The summing operation converts the pulses to a numeric value, achieving analog-to-digital conversion. Conversely, in a digital-to-analog converter, a digital circuit is used to convert numeric values from a digital processor to a pulse stream, and these pulses then are low-pass-filtered by a relatively simple analog system to produce an analog waveform. This low-pass filtering effectively sums the uniform analog pulse amplitudes over a fixed interval. The circuit—analogue or digital—used to generate the pulse stream is called a sigma-delta (or delta-sigma) modulator. See ELECTRIC FILTER.

In each case, analog information is contained not in the pulse amplitude but in the number of pulses that occur during the conversion interval. This distribution of the analog information makes the conversion process essentially independent of the amplitude of the pulses and greatly simplifies the design and fabrication of the analog portion of the converter. It does, however, require that the sampling process be rapid, since the resolution of the conversion depends on the number of pulses that can exist in the conversion interval. [P.V.L.]

**Signal detection theory** A theory in psychology which characterizes not only the acuity of an individual's discrimination but also the psychological factors that bias the individual's judgments. Failure to separate these two aspects of discrimination had tempered the success of theories based upon the classical concept of a sensory threshold. The theory provides a modern and more complete account of the process whereby an individual makes fine discriminations.

The theory of signal detection has two parts of quite different origins. The first comes from mathematical statistics and is a translation of the theory of statistical decisions. The major contribution of this part of the theory is that it permits a determination of the individual's discriminative capacity, or sensitivity, that is independent of the judgmental bias or decision criterion the individual may have had when the discrimination was made. The second part of the theory comes from the study of electronic communications. It provides a means of calculating for simple signals, such as tones and lights, the best discrimination that can be attained. The prediction is based upon physical measurements of the signals and their interfering noise.

This opportunity to compare the sensitivity of human observers with the sensitivity of an "ideal observer" for a variety of signals is of considerable usefulness, and of growing interest, in sensory psychology. Signal detection theory has been applied to several topics in experimental psychology in which separation of intrinsic discriminability from decision factors is desirable. Included are attention, imagery, learning, conceptual judgment, personality, reaction time, manual control, and speech.

The analytical apparatus of the theory has been of value in the evaluation of the performance of systems that make decisions based on uncertain information. Such systems may involve only people, or people and machines together, or only machines. Examples come from medical diagnosis, where clinicians may base diagnostic decisions on a physical examination, or on an x-ray image, or where machines make diagnoses, perhaps by counting blood cells of various types. [J.A.Sw.]

**Signal generator** A piece of electronic test equipment that delivers a sinusoidal output of accurately calibrated frequency. The frequency may be anywhere from audio to microwave, depending upon the intended use of the instrument.

The frequency and the amplitude are adjustable over a wide range. The oscillator must have excellent frequency stability, and its amplitude must remain constant over the tuning range.

The Wien-bridge oscillator is commonly used for frequencies up to about 200 kHz. For a radio-frequency signal generator up to about 200 MHz, a resonant circuit oscillator is used (such as a tuned-plate tuned-grid, Hartley, or Colpitts). Beyond this range VHF and microwave oscillators are used. See OSCILLATOR.

[J.Mi.]

**Signal-to-noise ratio** The quantity that measures the relationship between the strength of an information-carrying signal in an electrical communications system and the random fluctuations in amplitude, phase, and frequency superimposed on that signal and collectively referred to as noise. For analog signals, the ratio, denoted  $S/N$ , is usually stated in terms of the relative amounts of electrical power contained in the signal and noise. For digital signals the ratio is defined as the amount of energy in the signal per bit of information carried by the signal, relative to the amount of noise power per hertz of signal bandwidth (the noise power spectral density), and is denoted  $E_b/N_0$ . Since both signal and noise fluctuate randomly with time,  $S/N$  and  $E_b/N_0$  are specified in terms of statistical or time averages of these quantities.

The magnitude of the signal-to-noise ratio in a communications systems is an important factor in how well a receiver can recover the information-carrying signal from its corrupted version and hence how reliably information can be communicated. Generally speaking, for a given value of  $S/N$  the performance depends on how the information quantities are encoded into the signal parameters and on the method of recovering them from the received signal. The more complex encoding methods such as phase-shift keying or quadrature amplitude-shift keying usually result in better performance than simpler schemes such as amplitude- or frequency-shift keying. As an example, a digital communication system operating at a bit error rate of  $10^{-5}$  requires as much as 7 dB less for  $E_b/N_0$  when employing binary phase-shift keying as when using binary amplitude-shift keying. See ELECTRICAL COMMUNICATIONS; ELECTRICAL NOISE; INFORMATION THEORY; MODULATION.

[H.J.He.]

**Signal transduction** The transmission of molecular signals from a cell's exterior to its interior. Molecular signals are transmitted between cells by the secretion of hormones and other chemical factors, which are then picked up by different cells. Sensory signals are also received from the environment, in the form of light, taste, sound, smell, and touch. The ability of an organism to function normally is dependent on all the cells of its different organs communicating effectively with their surroundings. Once a cell picks up a hormonal or sensory signal, it must transmit this information from the surface to the interior parts of the cell—for example, to the nucleus. This occurs via signal transduction pathways that are very specific, both in their activation and in their downstream actions. Thus, the various organs in the body respond in an appropriate manner and only to relevant signals. See CELL (BIOLOGY).

All signals received by cells first interact with specialized proteins in the cells called receptors, which are very specific to the signals they receive. These signals can be in various forms. The most common are chemical signals, which include all the hormones and neurotransmitters secreted within the body as well as the sensory (external) signals of taste and smell. The internal hormonal signals include steroid and peptide hormones, neurotransmitters, and biogenic amines, all of which are released from specialized cells within the various organs. The external signals of smell, which enter the nasal compartment as gaseous chemicals, are dissolved in liquid and then picked up by specialized receptors. Other external stimuli are first received by specialized receptors (for example, light receptors in the eye and touch recep-

tors in the skin), which then convert the environmental signals into chemical ones, which are then passed on to the brain in the form of electrical impulses.

Once a receptor has received a signal, it must transmit this information effectively into the cell. This is accomplished either by a series of biochemical changes within the cell or by modifying the membrane potential by the movement of ions into or out of the cell. Receptors that initiate biochemical changes can do so either directly via intrinsic enzymatic activities within the receptor or by activating intracellular messenger molecules. Receptors may be broadly classified in four groups that differ in their mode of action and in the molecules that activate them.

The largest family of receptors are the G-protein-coupled receptors (GPCRs), which depend on guanosine triphosphate (GTP) for their function. Many neurotransmitters, hormones, and small molecules bind to and activate specific G-protein-coupled receptors.

A second family of membrane-bound receptors are the receptor tyrosine kinases (RTKs). They function by phosphorylating themselves and recruiting downstream signaling components.

Ion channels are proteins open upon activation, thereby allowing the passage of ions across the membrane. Ion channels are responsive to either ligands or to voltage changes across the membrane, depending on the type of channel. The movement of ions changes the membrane potential, which in turn changes cellular function. See BIOPOTENTIALS AND IONIC CURRENTS.

Steroid receptors are located within the cell. They bind cell-permeable molecules such as steroids, thyroid hormone, and vitamin D. Once these receptors are activated by ligand, they translocate to the nucleus, where they bind specific DNA sequences to modulate gene expression. See STEROID.

The intracellular component of signal propagation, also known as signal transduction, is receptor-specific. A given receptor will activate only very specific sets of downstream signaling components, thereby maintaining the specificity of the incoming signal inside the cell. In addition, signal transduction pathways amplify the incoming signal by a signaling cascade (molecule A activates several molecule B's, which in turn activate several molecule C's) resulting in an appropriate physiological response by the cell.

Several small molecules within the cell act as intracellular messengers. These include cAMP, cyclic guanosine monophosphate (cGMP), nitric oxide (NO), and  $Ca^{2+}$  ions. Increased levels of  $Ca^{2+}$  in the cell can trigger several changes, including activation of signaling pathways, changes in cell contraction and motility, or secretion of hormones or other factors, depending on the cell type. Increased levels of nitric oxide cause relaxation of smooth muscle cells and vasodilation by increasing cGMP levels within the cell. Increasing cAMP levels can modulate signaling pathways by activating the enzyme protein kinase A (PKA).

One of the most important functions of cell signaling is to control and maintain normal physiological balance within the body. Activation of different signaling pathways leads to diverse physiological responses, such as cell proliferation, death, differentiation, and metabolism. Signaling pathways in cells may also interact with each other and serve as signal integrators. For example, negative and positive feedback loops in pathways can modulate signals within a pathway; positive interactions between two signaling pathways can increase duration of signals; and negative interactions between pathways can block signals. See CELL NUCLEUS; CELL ORGANIZATION; ENDOCRINE SYSTEM (VERTEBRATE); NORADRENERGIC SYSTEM.

[P.T.R.; R.I.]

**Significant figures** Digits that show the number of units in a measurement expressed in decimal notation.

Scientific notation is useful in showing which digits are significant. In scientific notation, a number is expressed as the product of a number 1 to 10 and a power of 10, or the product of 1 and a power of 10. Thus, the number 123,000 is  $1.23 \times 10^5$ .



The precision of a measurement is based on the size of the unit of measurement. The smaller the unit, the more precise is the measurement.

Computations cannot improve the precision of the measurement. To add measures, they should all be rounded to the unit of the least precise measurement. The sum  $8.6 \text{ cm} + 0.14 \text{ cm} + 2.75 \text{ cm}$  is found by rounding each to tenths:  $8.6 \text{ cm} + 0.1 \text{ cm} + 2.8 \text{ cm} = 11.5 \text{ cm}$ . Even by doing this, the absolute error might be as large as  $0.05 + 0.005 + 0.005$  or  $0.06$ , and affect the result by as much as  $0.1$ .

In multiplying and dividing approximate numbers, the product or quotient is rounded to the number of significant digits in the number with the fewest significant digits. For example,  $6.2 \text{ m} \times 8.75 \text{ m}$  by computation is  $54.25$ . The product needs to be rounded to  $54 \text{ m}^2$  so as to show two significant digits. See NUMERICAL ANALYSIS; STATISTICS. [J.N.P.]

**Silica minerals** Silica ( $\text{SiO}_2$ ) occurs naturally in at least nine different varieties (polymorphs), which include tridymite, cristobalite, coesite, and stishovite, in addition to high ( $\beta$ ) and low ( $\alpha$ ) quartz. These forms are characterized by distinctive crystallography, optical characteristics, physical properties, pressure-temperature stability ranges, and occurrences.

The crystal structures of all silica polymorphs except stishovite contain silicon atoms surrounded by four oxygens, thus producing tetrahedral coordination polyhedra. Each oxygen is bonded to two silicons, creating an electrically neutral framework. Stishovite differs from the other silica minerals in having silicon atoms surrounded by six oxygens (octahedral coordination.) Ideal high tridymite is composed of sheets of  $\text{SiO}_4$  tetrahedra oriented perpendicular to the  $c$  crystallographic axis (Fig. 1) with adjacent tetrahedra in these sheets pointing in opposite directions. High cristobalite, like tridymite, is composed of parallel sheets of  $\text{SiO}_4$  tetrahedra with neighboring tetrahedra pointing in opposite directions. However, the hexagonal rings are distorted and adjacent sheets are rotated  $60^\circ$  with respect to one another,

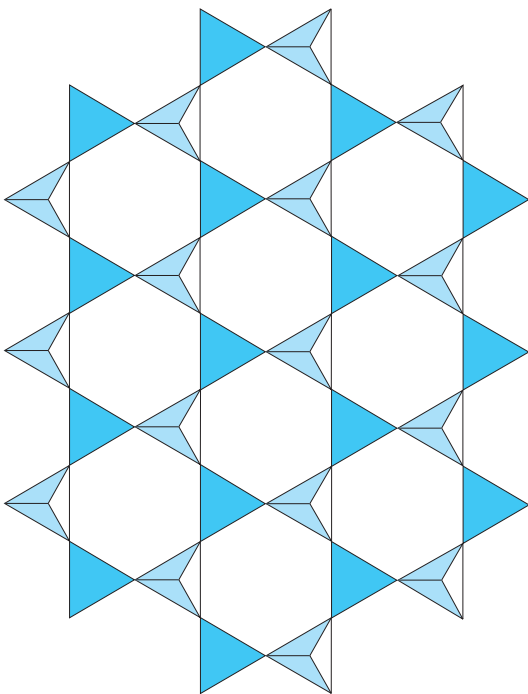

Fig. 1. Portion of an idealized sheet of tetrahedrally coordinated silicon atoms similar to that found in tridymite and cristobalite. Sharing of apical oxygens (which point in alternate directions) between silicons in adjacent sheets generates a continuous framework. (After J. J. Papike and M. Cameron, *Crystal chemistry of silicate minerals of geophysical interest, Rev. Geophys. Space Phys.*, 14:37–80; copyright © 1976 by American Geophysical Union)

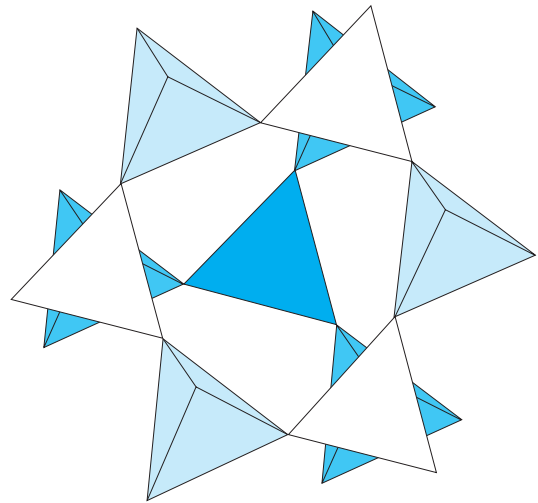

Fig. 2. Portion of cubic high cristobalite illustrating the distortion of tetrahedral sheets, with are oriented parallel to (111), and the  $60^\circ$  rotation of adjacent sheets. (After J. J. Papike and M. Cameron, *Crystal chemistry of silicate minerals of geophysical interest, Rev. Geophys. Space Phys.*, 14:37–80; copyright © 1976 by American Geophysical Union)

resulting in the geometry shown in Fig. 2. Coesite also contains silicon atoms tetrahedrally coordinated by oxygen. These polyhedra share corners to form chains composed of four-membered rings. Silicon in stishovite is octahedrally coordinated by oxygen. These coordination polyhedra share edges and corners to form chains of octahedra parallel to the  $c$  crystallographic axis.

Chemically, all silica polymorphs are ideally 100%  $\text{SiO}_2$ . However, unlike quartz which commonly contains few impurities, the compositions of tridymite and cristobalite generally deviate significantly from pure silica. This usually occurs because of a coupled substitution in which a trivalent ion such as  $\text{Al}^{3+}$  or  $\text{Fe}^{3+}$  substitutes for  $\text{Si}^{4+}$ , with electrical neutrality being maintained by monovalent or divalent cations occupying interstices. In the relatively open structures of these two minerals. See COESITE; QUARTZ. [J.C.D.]

**Silicate minerals** All silicates are built of a fundamental structural unit, the so-called  $\text{SiO}_4$  tetrahedron. The crystal structure may be based on isolated  $\text{SiO}_4$  groups or, since each of the four oxygen ions can bond to either one or two silicon (Si) ions, on  $\text{SiO}_4$  groups shared in such a way as to form complex isolated groups or indefinitely extending chains, sheets, or three-dimensional networks. Mixed structures in which more than one type of shared tetrahedra are present also are known. See SILICON.

Silicates are classified according to the nature of the sharing mechanism, as revealed by x-ray diffraction study. The sharing mechanism gives rise to a characteristic ratio of Si to O, but it is possible for oxygen ions that are not bonded to Si to be present in the structure, and sometimes some or all of any aluminum present must be counted as equivalent to Si.

The detailed crystallographic and physical properties of the various silicates are broadly related to the type of silicate framework that they possess. Thus, the phyllosilicates as a group typically have a platy crystal habit, with a cleavage parallel to the plane of layering of the structure, and are optically negative with rather high birefringence. The inosilicates, based on an extended one-dimensional rather than two-dimensional linkage of the  $\text{SiO}_4$  tetrahedra, generally form crystals of prismatic habit; if cleavage is present, it will be parallel to the direction of elongation. The tectosilicates commonly are equant in habit, without marked preference for cleavage direction, and tend to have a relatively low birefringence.

Silicate minerals make up the bulk of the outer crust of the Earth and form in a wide range of geologic environments. Many silicates are of economic importance. For discussions of certain

silicate mineral groups see AMPHIBOLE; ANDALUSITE; CHLORITE; CHLORITOID; EPIDOTE; FELDSPAR; FELDSPATHOID; GARNET; HUMITE; MICA; OLIVINE; PYROXENE; SCAPOLITE; SERPENTINE; ZEOLITE.

[C.Fr.]

**Silicate phase equilibria** Silicate phase equilibria studies define the conditions of temperature, composition, and pressure at which silicates can stably coexist. Silicate phase equilibria relations are used by geologists, ceramists, and cement manufacturers to explain the variation of composition of silica-bearing minerals, as well as their number and order of appearance in rocks, slags, glasses, and cements. They are also useful to interpret the chemistry of refractories, boiler scale deposits, and welding fluxes.

Silica itself makes up nearly 60% by weight of the Earth's crust. The next most abundant oxides, in decreasing order, are  $Al_2O_3$ , CaO,  $Na_2O$ , FeO, MgO,  $K_2O$ , and  $Fe_2O_3$ ; all of these occur principally combined with silica as silicates. Free silica and the hundreds of silicate minerals make up nearly 97% of the Earth's crust. The study of silicate phase equilibria was initiated by geologists seeking to apply the phase rule of J. Willard Gibbs to these abundant natural substances. See PHASE EQUILIBRIUM; SILICATE MINERALS.

Dynamic and static methods are used to determine equilibrium in silicate systems. Dynamic methods require large samples of silicates that are difficult to prepare, and require also that equilibrium be reached quickly. Silicates in general are slow to react, and supercooling or superheating of hundreds of degrees before reaction occurs is common. Many silicates react sluggishly at temperatures of  $1000^\circ C$  ( $1830^\circ F$ ) or higher.

Most silicate phase equilibria are determined by the static method of holding a sample under controlled conditions until equilibrium is attained, then quenching the sample for examination.

Equilibrium is established when the products obtained by heating a sample to a given temperature are identical with the products of cooling a sample to that temperature; no requirement is made regarding the texture, shape, or grain size of the products. Another criterion used in recognizing equilibrium is that no change of the sample can be observed after holding the charge at a given temperature for very long periods of time.

The use of diagrams to present silicate phase equilibria is customary, since such diagrams express quantitatively the amount and composition of each phase present at any bulk composition in the system at any temperature.

[D.B.St.]

**Siliceous sediment** Fine-grained sediment and sedimentary rock dominantly composed of the microscopic remains of the unicellular, silica-secreting plankton diatoms and radiolarians. Minor constituents include extremely small shards of sponge spicules and other microorganisms such as silicoflagellates. Siliceous sedimentary rock sequences are often highly porous and can form excellent petroleum source and reservoir rocks. See SEDIMENTARY ROCKS.

Given their biologic composition, siliceous sediments provide some of the best geologic records of the ancient oceans. Diatoms did not evolve until the late Mesozoic; thus the majority of siliceous rocks older than approximately 150 million years are formed by radiolarians. Geologists map the distribution of ancient siliceous sediments now pushed up onto land by plate tectonic processes, and can thus determine which portions of the ancient seas were biologically productive; this knowledge in turn can give great insight into regions of the Earth's crust that may be economically productive (for example oil-containing regions). The vast oil reserves of coastal California are predominantly found in the Monterey Formation, a highly porous diatomaceous siliceous sedimentary sequence distributed along the western seaboard of the United States. See CHALK; CHERT; LIMESTONE.

[R.W.Mu.]

**Siliceous sinter** A porous silica deposit formed around hot springs. It is white to light gray and sometimes friable. Geysers is a variety of siliceous sinter formed around geysers. The siliceous sinters are deposited as the hot subterranean waters cool after issuing at the surface and become supersaturated with silica that was picked up at depth. The sinters are frequently deposited on algae that live in the pools around the hot springs. See GEYSER.

[R.Si.]

**Silicoflagellata** A class of unicellular flagellate microorganisms of the plant division Chrysophyta, which are a part of the marine plankton. Their exoskeletons, siliceous and coarsely perforate (see illustration), resemble those of the Radiolaria,

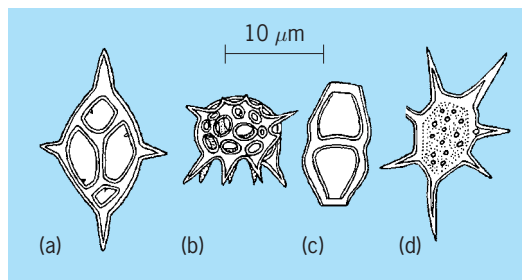

Examples of fossil and modern Silicoflagellata. (a) *Dicotyocha*, Cretaceous to Recent; (b) *Cannopilus*, Miocene; (c) *Naviculopsis*, Eocene to Miocene; and (d) *Vallacerta*, Upper Cretaceous.

with which they have been grouped. They are usually subpyramidal or hemispherical in shape, and delicately filigreed. Two families and 11 genera of silicoflagellates have been described from siliceous sedimentary rocks ranging in age from Upper Cretaceous to Recent, in association with abundant diatoms and siliceous sponge spicules. See MICROPALAEONTOLOGY; PHYTOPLANKTON.

[D.J.J.]

**Silicoflagellida** An order of the phylum Protozoa, class Phytamastigophorea. These organisms are marine flagellates which have an internal, siliceous, tubular skeleton; numerous small, discoid, yellow chromatophores; and a single flagellum. At times the organisms also put forth, from the ends of their skeletal tubes, long, rather threadlike pseudopodia. The skeleton forms a basket within which the moiety of protoplasm lies, but skeletal elements always have at least a thin covering. There is a single genus, *Dictyocha*, with four species. See PHYTAMASTIGOPHOREA.

[J.B.L.]

**Silicon** A chemical element, Si, atomic number 14, and atomic weight 28.086. Silicon is the most abundant electropositive element in the Earth's crust. The element is a metalloid with a decided metallic luster; it is quite brittle. It has a specific gravity of 2.42 at  $20^\circ C$  ( $68^\circ F$ ), melts at  $1420^\circ C$  ( $2588^\circ F$ ), and boils at  $3280^\circ C$  ( $5936^\circ F$ ). The element is usually tetravalent in its compounds, although sometimes divalent, and is decidedly electropositive in its chemical behavior. In addition, pentacoordinate and hexacoordinate compounds of silicon are known. See METALLOID; PERIODIC TABLE.

Crude elementary silicon and its intermetallic compounds are used in alloying constituents to strengthen aluminum, magnesium, copper, and other metals. Metallurgical silicon of 98–99% purity is used as the starting material for manufacturing organosilicon compounds and silicone resins, elastomers, and oils. Silicon chips are used in integrated circuits. Photovoltaic cells for direct conversion of solar energy to electricity use wafers sliced from single crystals of electronic-grade silicon. Silicon dioxide is used as the raw material for making elementary silicon and for silicon carbide. Sizable crystals of it are used for piezoelectric

crystals. Fused quartz sand becomes silica glass, used in chemical laboratories and plants as well as an electrical insulator. A colloidal dispersion of silica in water is used as a coating agent and as an ingredient in certain polishes.

Naturally occurring silicon contains 92.2% of the isotope of mass number 28, 4.7% of silicon-29, and 3.1% of silicon-30. In addition to these stable, natural isotopes, several artificially radioactive isotopes are known. Elementary silicon has the physical properties of a metalloid, resembling germanium below it in group 14 of the periodic table. In very pure form silicon is an intrinsic semiconductor, although the extent of its semiconduction is greatly increased by the introduction of minute amounts of impurities. Silicon resembles the metals in its chemical behavior. It is about as electropositive as tin, and decidedly more positive than germanium or lead. In keeping with this rather metallic character, silicon forms tetrapositive ions and a variety of covalent compounds; it appears as a negative ion in only a few silicides and as a positive constituent of oxy acid or complex anions.

Several series of hydrides are formed, a variety of halides (some of which contain silicon-to-silicon bonds), and also many series of oxygen-containing compounds which may be either ionic or covalent in their properties.

Silicon occurs in many forms of the dioxide and as almost numberless variations of the natural silicates. For a discussion of the structures and compositions of the representative classes, see SILICATE MINERALS.

In abundance, silicon exceeds by far every other element except oxygen. It constitutes 27.72% of the solid crust of the Earth, whereas oxygen constitutes 46.6%, and the next element after silicon, aluminum, accounts for 8.13%.

Silicon is reported to form compounds with 64 of the 96 stable elements, and it probably forms silicides with 18 other elements. Besides the metal silicides, used in large quantities in metallurgy, silicon forms useful and important compounds with hydrogen, carbon, the halogen elements, nitrogen, oxygen, and sulfur. In addition, useful organosilicon derivatives have been prepared. [E.P.P.]

**Silicone resins** Polymers composed of alternating atoms of silicon and oxygen with organic substituents attached to the silicon atoms, as shown in the formula below.

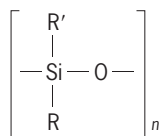

Silicones, also called organopolysiloxanes, may exist as liquids, greases, resins, or rubbers. Silicone polymers have good resistance to water and oxidation, stability at high and low temperatures, and lubricity.

Silicones are obtained by the condensation of hydroxy organosilicon compounds formed by the hydrolysis of organosilicon halides. The first products are usually low in molecular weight ( $n = 2$  to 7), and usually consist of a mixture of linear and cyclic species, especially the tetramer. Fluids having a wide range of viscosity are prepared by polymerizing further, using a monofunctional trichlorosilane to limit molecular weights to the value desired. Elastomers are made by polymerization of the purified tetramer using an alkaline catalyst at 100–150°C (212–302°F). Properties can be varied by partial replacement of some of the methyl groups by other substituents and by the use of reinforcing fillers.

The wide range of structural variations makes it possible to tailor compositions for many kinds of applications. Low-molecular-weight silanes containing amino or other functional groups are used as treating or coupling agents for glass fiber and other reinforcements in order to cause unsaturated polyesters and other resins to adhere better.

The liquids, generally dimethyl silicones of relatively low

molecular weight, have low surface tension, great wetting power and lubricity for metals, and very small change in viscosity with temperature. They are used as hydraulic fluids, as antifoaming agents, as treating and waterproofing agents for leather, textiles, and masonry, and in cosmetic preparations. The greases are particularly desired for applications requiring effective lubrication at very high and at very low temperatures.

Silicone resins are used for coating applications in which thermal stability in the range 300–500°C (570–930°F) is required. The dielectric properties of the polymers make them suitable for many electrical applications, particularly in electrical insulation that is exposed to high temperatures and as encapsulating materials for electronic devices.

Silicone rubbers are compositions containing high-molecular-weight dimethyl silicone linear polymer, finely divided silicon dioxide as the filler, and a peroxidic curing agent. The silicone rubbers have the remarkable ability of remaining flexible at very low temperatures and stable at high temperatures. See INORGANIC POLYMER; PLASTICS PROCESSING; RUBBER; SILICON. [J.A.M.]

**Silk** The lustrous fiber produced by the larvae of silkworms; also the thread or cloth made from such fiber.

The cocoons of the silkworm are delivered to a factory, called a filature, where the silk is unwound from the cocoons and the strands are collected into skeins. The process of unwinding the filament from the cocoon is called reeling. As the filament of a single cocoon is too fine for commercial use, 3–10 strands are usually reeled at a time to produce the desired diameter of raw silk thread. The usable length of the reeled filament is from 1000 to 2000 ft (300 to 600 m). The remaining part of the filament is valuable raw material for the manufacture of spun silk.

The term reeled silk is applied to the raw silk strand that is formed by combining several filaments from separate cocoons. It is reeled into skeins, which are packed in small bundles called books. From the filature, the books of reeled silk go to the throwster where they are transformed into silk yarn, also called silk thread, by a process known as throwing. Silk throwing is analogous to the spinning process that changes cotton, linen, or wool fibers into yarn. The manufacture of those fibers, however, unlike that of silk yarn, does not include carding, combing, and drawing out, the usual processes for producing a continuous yarn. [M.D.P.]

**Sillimanite** A nesosilicate mineral of composition  $Al_2O_3[SiO_4]$ , crystallizing in the orthorhombic system. Sillimanite commonly occurs in slender crystals or parallel groups, and is frequently fibrous, hence the synonym fibrolite. There is one perfect cleavage, luster is vitreous, color is brown, pale green, or white, hardness is 6–7 on Mohs scale, and the specific gravity is 3.23. See HARDNESS SCALE.

Sillimanite, andalusite, and kyanite are polymorphs of  $Al_2O_3[SiO_4]$ . The three  $Al_2O_3[SiO_4]$  polymorphs are important in assessing the metamorphic grade of the rocks in which they crystallized. See ANDALUSITE; KYANITE; SILICATE MINERALS. [P.B.M.]

**Silurian** The third oldest period of the Paleozoic Era, spanning an interval from about 412 to 438 million years before the present. The Silurian system includes all sedimentary rocks deposited and all igneous and metamorphic rocks formed in the Silurian Period. Both the base and top of the Silurian have been designated by international agreement at the first appearances of certain graptolite species in rock sequences at easily examined and well-studied outcrops. See GEOLOGIC TIME SCALE.

The most prominent feature of Silurian paleogeography was the immense Gondwana plate. It included much of present-day South America, Africa, the Middle East, Antarctica, Australia, and the Indian subcontinent. During the Silurian, many plates continued the relative northward motion that had commenced during the mid-Ordovician. Plate positions and plate motions as well as topographic features of the plates controlled depositional

environments and lithofacies. These, in turn, significantly influenced organismal development and distributions. Silurian Northern Hemisphere plates, other than a portion of Siberia, are not known north of the Northern Hemisphere tropics. Presumably, nearly all of the Northern Hemisphere north of the tropics was ocean throughout the Silurian. See CONTINENTS, EVOLUTION OF; PALEOGEOGRAPHY.

Absence of plates bearing continental or shallow shelf marine environments north of about 45° north latitude indicates that ocean circulation in most of the Silurian Northern Hemisphere was zonal. Ocean surface currents in the tropics would have been influenced strongly by the prevailing westerlies. The large size of the Gondwana plate and the presence of land over much of it would have led to development of seasonal monsoon conditions. Surface circulation south of 30° south would have hit the western side of Laurentia and flowed generally northward. See PALEOCEANOGRAPHY.

Collision of the Avalonian and Laurentian plates in the latest Ordovician coincides with development of the Southern Hemisphere continental glaciation. Erosion of the land area formed at the Avalon-Laurentian plate collision generated a large volume of coarse to fine-grained siliclastic materials. That part of South America (modern eastern South America) near the South Pole for the early part of the Silurian was the site of as many as four brief glacial episodes. See PALEOCLIMATOLOGY.

Both nonvascular and vascular plants continued to develop in land environments following their originations in the early mid-Ordovician. Many of these Silurian plants were mosslike and bryophytelike. Psilophytes assigned to the genus *Cooksonia* were relatively widespread in Late Silurian terrestrial environments. The probable lycopod (club moss) *Baragwanathia* apparently lived in nearshore settings in modern Australia during the latter part of the Silurian. Silurian land life also included probable arthropods and annelid worms. Fecal pellets of wormlike activity have been found as well as remains of centipede-, millepede-, and spiderlike arthropods. See PALEOBOTANY; PALEOECOLOGY.

Shallow marine environments in the tropics were scenes of rich growths of algae, mat-forming cyanobacteria, spongelike organisms, sponges, brachiopods, bryozoans, corals, crinoids, and ostracodes. Nearshore marine siliclastic strata bear ostracodes, small clams, and snails and trilobites. Certain nearshore strata bear the remains of horseshoe-crab-like eurypterids. See ALGAE; BRACHIPODA; BRYOZOA; CRINOIDEA; CYANOBACTERIA; OSTRACODA; TRILOBITA.

Fish are prominent in a number of Silurian nearshore and some offshore marine environments. Jawless armored fish include many species of thelodonts that had bodies covered with minute bony scales, heterostracans, and galeaspid that had relatively heavily armored head shields, and anaspids that possessed body armor consisting of scales and small plates. Jawed fish were relatively rare in the Silurian. They were primarily spiny sharks or acanthodians. As well, there are remains of true shark-like fish and fish with interior bony skeletons (osteichthyans) in Late Silurian rocks. See ANASPIDA; HETEROSTRACI; OSTEICHTHYES; THELODONTIDA. [W.B.N.B.]

**Siluriformes** The catfishes, a highly distinctive order (also called Nematognathi) of actinopterygian fishes. In the Siluri-

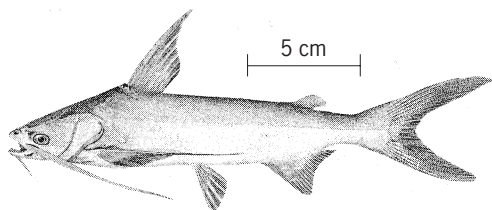

Gafftopsail catfish (*Bagre marinus*). (After G. B. Goode, *Fishery Industries of the United States*, 1884)

formes the Weberian apparatus is more complex than in the related Cypriniformes. The body is usually naked or the scales are enlarged and modified into large, overlapping bony plates. There are one to four pairs of barbels, and both the pectoral and dorsal fins usually have a strong spine (see illustration). This is a large group, including about 26 families and perhaps 2000 species, of which nearly 1200 live in South America. Catfishes are known from Eocene times. See ACTINOPTERYGII; CYPRINIFORMES. [R.M.B.]

**Silver** A chemical element, Ag, atomic number 47, atomic mass 107.868. It is a gray-white, lustrous metal. Chemically it is one of the heavy metals and one of the noble metals; commercially it is a precious metal. There are 25 isotopes of silver with atomic masses ranging from 102 to 117. Ordinary silver is made up of the isotopes of masses 107 (52% of natural silver) and 109 (48%). See PERIODIC TABLE.

Although silver is the most active chemically of the noble metals, it is not very active in comparison with most other elements. It does not oxidize as iron does when it rusts, but it reacts with sulfur or hydrogen sulfide to form the familiar silver tarnish. Electroplating silver with rhodium prevents this discoloration. Silver itself does not react with dilute nonoxidizing acids (hydrochloric or sulfuric acids) or strong bases (sodium hydroxide). However, oxidizing acids (nitric or concentrated sulfuric acids) dissolve it by reaction to form the unipositive silver ion,  $Ag^+$ . The  $Ag^+$  ion is colorless, but a number of silver compounds are colored because of the influence of their other constituents.

Silver is almost always monovalent in its compounds, but an oxide, fluoride, and sulfide of divalent silver are known. Some coordination compounds of silver, also called silver complexes, contain divalent and trivalent silver. Although silver does not oxidize when heated, it can be oxidized chemically or electrolytically to form silver oxide or peroxide, a strong oxidizing agent. Because of this activity, silver finds considerable use as an oxidation catalyst in the production of certain organic materials.

Soluble silver salts, especially  $AgNO_3$ , have proved lethal in doses as small as 0.07 oz (2 g). Silver compounds may be slowly absorbed by the body tissues, with a resulting bluish or blackish pigmentation of the skin (argyria).

Silver is a rather rare element, ranking 63rd in order of abundance. Sometimes it occurs in nature as the free element (native silver) or alloyed with other metals. For the most part, however, silver is found in ores containing silver compounds. The principal silver ores are argentite,  $Ag_2S$ , cerargyrite or horn silver,  $AgCl$ , and several minerals in which silver sulfide is combined with sulfides of other metals; stephanite,  $5Ag_2S \cdot Sb_2S_5$ ; polybasite,  $9(Cu_2S, Ag_2S) \cdot (Sb_2S_3, As_2S_3)$ ; proustite,  $3Ag_2S \cdot As_2S_3$ ; and pyragyrite,  $3Ag_2S \cdot Sb_2S_3$ . About three-fourths of the silver produced is a by-product of the extraction of other metals, copper and lead in particular. See SILVER METALLURGY.

Pure silver is a white, moderately soft metal (2.5–3 on Mohs hardness scale), somewhat harder than gold. When polished, it has a brilliant luster and reflects 95% of the light falling on it. Silver is second to gold in malleability and ductility. Its density is 10.5 times that of water. The quality of silver, its fineness, is expressed as parts of pure silver per 1000 parts of total metal. Commercial silver is usually 999 fine. Silver is available commercially as sterling silver (7.5% copper) and in ingots, plate, moss, sheets, wire, castings, tubes, and powder.

Silver, with the highest thermal and electrical conductivities of all the metals, is used for electrical and electronic contact points and sometimes for special wiring. Silver has well-known uses in jewelry and silverware. Silver compounds are used in many photographic materials. In most of its uses, silver is alloyed with one or more other metals. Alloys in which silver is an ingredient include dental amalgam and metals for engine pistons and bearings. See PHOTOGRAPHIC MATERIALS; SILVER ALLOYS.

[W.E.C.]

**Silver alloys** Combinations of silver with one or more other metals. Pure silver is very soft and ductile but can be hardened by alloying. Copper is the favorite hardener and normally is employed in the production of sterling silver, which must contain a minimum of 92.5% silver, and also in the production of coin silver.

Silver-copper eutectic and modifications containing other elements such as zinc, tin, cadmium, phosphorus, or lithium are widely used for brazing purposes, where strong joints having relatively good corrosion resistance are required. Where higher strengths at elevated temperature are required, silver-copper-palladium alloys and other silver-palladium alloys are suitable. The addition of a small amount of silver to copper raises the recrystallizing temperature without adverse effect upon the electrical conductivity.

Silver may be alloyed with gold or palladium in any ratio, producing soft and ductile alloys; certain of these intermediate alloys are useful for electrical contacts, where resistance to sulfide formation must be achieved.

Silver has proved to be a useful component for high-duty bearings in aircraft engines, where it may be overlaid with a thin layer of lead and finally with a minute coating of indium. Specially developed alloys of silver with tin, plus small percentages of copper and zinc in the form of moderately fine powder, can be mixed with mercury to yield a mass which is plastic for a time and then hardens, developing relatively high strength despite the fact that it contains about 50% mercury. This material was developed specifically for dental use and is generally known as amalgam, although the term amalgam actually includes all the alloys of mercury with other metals. *See* AMALGAM; SILVER. [E.M.Wis.]

**Silver metallurgy** The art and science of extracting silver metal economically from various ores, and the reclamation of silver from the myriad types of industrial processes or scrap produced therefrom. It includes all processes of separating silver from its ores, alloys, and solutions, as well as the smelting, refining, and working of the metal and its alloys and compounds. It deals with the technical application of the chemical and physical properties of silver to its concentration, extraction, purification, alloying, working, and compounding to meet the requirements of technical needs.

Chloridization is an extractive process in which silver is precipitated from aqueous solutions. In chloridization methods the silver contained in ores or metallurgical products is first converted by means of a chloridizing roast into a compound which is soluble in water or in certain aqueous solutions. The silver is then precipitated as an insoluble compound by suitable reagents and the precipitate worked for the metal.

The cyanidation process differs only in minor details, such as strength of the solution and time of treatment, from the cyanide process used in the recovery of gold. No preliminary metallurgical treatment other than fine grinding is required. *See* GOLD METALLURGY.

The Parkes process is based on the greater affinity of silver for zinc than for lead. Slab zinc is added to an argentiferous lead bath, the temperature of which has been raised higher than the melting point of the zinc. When the zinc has been melted and thoroughly mixed into the lead bath, the bath temperature is lowered and a silver-zinc alloy separates and floats on the top of the kettle. This zinc crust, as it is now called, is pressed off to remove the excess lead. The resultant high silver-lead retort bullion is then cupelled to recover the silver and gold.

Cupellation is the oldest and most widely known method of separating and recovering gold and silver from lead. The silver-lead bullion is charged to a reverberatory-type cupellation furnace. After the charge has melted, air is blown across the top of the molten bath, causing oxidation of the lead and other impurities which separate as in impure litharge slag, leaving behind the silver and gold as a doré alloy.

By far the most important method of silver production results from the smelting and subsequent treatment of the silver-rich slimes resulting from the electrolytic refining of copper. Slimes which have been leached with sulfuric acid or air are filtered and charged to a reverberatory-type furnace with appropriate fluxes. The resulting melt slag contains most of the base-metal impurities. Upon completion of this step, the material remaining in the furnace consists of gold, silver, selenium, tellurium, and residual base metals, and is called matte. Treatment of the matte eventually yields dore which is then cast into anodes for subsequent electrolytic refining. *See* SILVER. [R.D.Mu.]

**Silviculture** The theory and practice of controlling the establishment, composition, and growth of stands of trees for any of the goods (including timber, pulp, energy, fruits, and fodder) and benefits (water, wildlife habitat, microclimate amelioration, and carbon sequestration) that they may be called upon to produce. In practicing silviculture, the forester draws upon knowledge of all natural factors that affect trees growing upon a particular site, and guides the development of the vegetation, which is either essentially natural or only slightly domesticated, to best meet the demands of society in general and ownership in particular. Based on the principles of forest ecology and ecosystem management, silviculture is more the imitation of natural processes of forest growth and development than a substitution for them.

The spatial patterns in which old trees are removed and the species that replace them determine the structure and developmental processes of the new stands. If all the trees are replaced at once with a single species, the result is so-called pure stand or monoculture in which all of the trees form a single canopy of foliage that is lifted ever higher as the stand develops. If several species start together from seeds, from small trees already present, or from sprouts, as a single cohort, the different species usually tend to grow at different rates in height. Some are adapted to develop in the shade of their sun-loving neighbors. The result is a stratified mixture. Such stands grow best on soils or in climates, such as in tropical moist forests, where water is not a limiting factor and the vegetation collectively uses most of the photosynthetically active light. If trees are replaced in patches or strips, the result is an uneven-aged stand which may be of one species or many.

These different spatial and temporal patterns of stand structure are created by different methods of reproduction. The simplest is the clear-cutting method, in which virtually all of the vegetation is removed. Although it is sometimes possible to rely on adjacent uncut stands as sources of seed, it is usually necessary to reestablish the new stand by artificial seeding or planting after clear-cutting. The seed tree method differs only in that a limited number of trees are temporarily left on the area to provide seed.

In the shelterwood method, enough trees are left on the cutting area to reduce the degree of exposure significantly and to provide a substantial source of seed. In this method the growth of a major portion of the preexisting crop continues, and the old trees are not entirely removed until the new stand is well established. The three methods just described lead to the creation of essentially even-aged stands.

The choice of methods of regeneration cutting depends on the ecological status of the species and stands desired. Species that characterize the early stages of succession, the so-called pioneers, will endure, and usually require the kind of exposure to sunlight resulting from heavy cutting or, in nature, severe fire, catastrophic windstorms, floods, and landslides. These pioneer species usually grow rapidly in youth but are short-lived and seldom attain large size. The species that attain greatest age and largest size are ordinarily those which are intermediate in successional position and tolerance of shade. Some of them will become established after the severe exposure of clear-cutting, but they often start best with light initial shade such as that created by shelterwood cutting. Their longevity and large size result from the fact that they are naturally adapted to reproduce after

disturbances occurring at relatively long intervals. The shade-tolerant species representing late or climax stages in the succession are adapted to reestablish themselves in their own shade. These species represent natural adaptations to the kinds of fatal disturbance caused by insects, disease, and atmospheric agencies rather than to the more complete disturbance caused by fire. See ECOLOGICAL SUCCESSION; FOREST ECOSYSTEM.

Much silvicultural practice is aimed at the creation and maintenance of pure, even-aged stands of single species. This approach is analogous to that of agriculture and simplifies administration, harvesting, and other operations. The analogy is often carried to the extent of clear-cutting and planting of large tracts with intensive site preparation, especially with species representative of the early or intermediate stages of succession. Mixed stands are more difficult to handle from the operational standpoint but are more resistant to injury from insects, fungi, and other damaging agencies which usually tend to attack single species. They are also more attractive than pure stands and make more complete use of the light, water, and nutrients available on the site. They usually do not develop unless these site factors are comparatively favorable; where soil moisture or some other factor is limiting, it may be possible for only a single well-adapted species to grow. If the site is highly favorable, as in tropical rainforest, river floodplains, or moist ravines, it is so difficult to maintain pure stands that mixed stands are inevitable.

The application of silviculture involves a number of accessory practices other than cutting. In localities of high fire risks, it may be desirable to burn the slash (logging debris) after cutting. Not only does this reduce the potential fuel, but it may also help the establishment of seedlings by baring the mineral soil or reducing the physical barrier represented by the slash. Slash disposal is most often necessary where the cutting has been very heavy or where the climate is so cold or dry that decay is slow. Deliberate prescribed burning of the litter beneath existing stands of fire-resistant species is sometimes carried out even in the absence of cutting to reduce the fuel for wild fires, to kill undesirable understory species, to enhance the production of forage for wild and domestic animals, and to improve seedbed conditions. See FOREST FIRE.

Integrated schedules of treatment for stands are called silvicultural systems. They cover both intermediate and reproduction treatments but are classified and named in terms of the general method of reproduction cutting contemplated. Such programs are evolved for particular situations and kinds of stands with due regard for all the significant biological and economic considerations involved. These considerations include the desired uses of the land, kinds of products and services sought, prospective costs and returns of the enterprise presented by management of the stand, funds available for long-term investment in stand treatments, harvesting techniques and equipment employed, reduction of losses from damaging agencies, and the natural requirements that must be met in reproducing the stand and fostering its growth. See FOREST AND FORESTRY; FOREST MANAGEMENT.

[D.M.S.; M.S.A.]

**Simple machine** Any of several elementary machines, one or more of which is found in practically every machine. The group of simple machines usually includes only the lever, wheel and axle, pulley (or block and tackle), inclined plane, wedge, and screw. However, the gear drive and hydraulic press may also be considered as simple machines. The principles of operation and typical applications of simple machines depend on several closely related concepts. See EFFICIENCY; FRICTION; MECHANICAL ADVANTAGE; POWER; WORK.

Two conditions for static equilibrium are used in analyzing the action of a simple machine. The first condition is that the sum of forces in any direction through their common point of action is zero. The second condition is that the summation of torques about a common axis of rotation is zero. Corresponding to these two conditions are two ways of measuring work. In machines

with translation, work is the product of force and distance. In machines with rotation, work is the product of torque and angle of rotation. See BLOCK AND TACKLE; GEAR DRIVE; HYDRAULIC PRESS; INCLINED PLANE; LEVER; SCREW; TORQUE; WEDGE; WHEEL AND AXLE.

[R.M.Ph.]

**Simulation** A broad collection of methods used to study and analyze the behavior and performance of actual or theoretical systems. Simulation studies are performed, not on the real-world system, but on a (usually computer-based) model of the system created for the purpose of studying certain system dynamics and characteristics. The purpose of any model is to enable its users to draw conclusions about the real system by studying and analyzing the model. The major reasons for developing a model, as opposed to analyzing the real system, include economics, unavailability of a "real" system, and the goal of achieving a deeper understanding of the relationships between the elements of the system.

Simulation can be used in task or situational training areas in order to allow humans to anticipate certain situations and be able to react properly; decision-making environments to test and select alternatives based on some criteria; scientific research contexts to analyze and interpret data; and understanding and behavior prediction of natural systems, such as in studies of stellar evolution or atmospheric conditions.

With simulation a decision maker can try out new designs, layouts, software programs, and systems before committing resources to their acquisition or implementation; test why certain phenomena occur in the operations of the system under consideration; compress and expand time; gain insight about which variables are most important to performance and how these variables interact; identify bottlenecks in material, information, and product flow; better understand how the system really operates (as opposed to how everyone thinks it operates); and compare alternatives and reduce the risks of decisions.

The word "system" refers to a set of elements (objects) interconnected so as to aid in driving toward a desired goal. This definition has two connotations: First, a system is made of parts (elements) that have relationships between them (or processes that link them together). These relationships or processes can range from relatively simple to extremely complex. One of the necessary requirements for creating a "valid" model of a system is to capture, in as much detail as possible, the nature of these interrelationships. Second, a system constantly seeks to be improved. Feedback (output) from the system must be used to measure the performance of the system against its desired goal. Both of these elements are important in simulation. See SYSTEMS ENGINEERING.

Systems can be classified in three major ways. They may be deterministic or stochastic (depending on the types of elements that exist in the system), discrete-event or continuous (depending on the nature of time and how the system state changes in relation to time), and static or dynamic (depending on whether or not the system changes over time at all). This categorization affects the type of modeling that is done and the types of simulation tools that are used.

Models, like the systems they represent, can be static or dynamic, discrete or continuous, and deterministic or stochastic. Simulation models are composed of mathematical and logical relations that are analyzed by numerical methods rather than analytical methods. Numerical methods employ computational procedures to run the model and generate an artificial history of the system. Observations from the model runs are collected, analyzed, and used to estimate the true system performance measures. See MODEL THEORY; STOCHASTIC PROCESS.

There is no single prescribed methodology in which simulation studies are conducted. Most simulation studies proceed around four major areas: formulating the problem, developing the model, running the model, and analyzing the output. Statistical inference methods allow the comparison of various

competing system designs or alternatives. For example, estimation and hypothesis testing make it possible to discuss the outputs of the simulation and compare the system metrics.

Many of the applications of simulation are in the area of manufacturing and material handling systems. Simulation is taught in many engineering and business curricula with the focus of the applications also being on manufacturing systems. The characteristics of these systems, such as physical layout, labor and resource utilization, equipment usage, products, and supplies, are extremely amenable to simulation modeling methods. See COMPUTER-INTEGRATED MANUFACTURING; FLEXIBLE MANUFACTURING SYSTEM. [J.Pom.]

**Sine wave** A wave having a form which, if plotted, would be the same as that of a trigonometric sine or cosine function. The sine wave may be thought of as the projection on a plane of the path of a point moving around a circle at uniform speed. It is characteristic of one-dimensional vibrations and one-dimensional waves having no dissipation. See HARMONIC MOTION.

The sine wave is the basic function employed in harmonic analysis. It can be shown that any complex motion in a one-dimensional system can be described as the superposition of sine waves having certain amplitude and phase relationships. The technique for determining these relationships is known as Fourier analysis. See FOURIER SERIES; WAVE EQUATION; WAVE MOTION; WAVEFORM. [W.J.G.]

**Single crystal** In crystalline solids the atoms or molecules are stacked in a regular manner, forming a three-dimensional pattern which may be obtained by a three-dimensional repetition of a certain pattern unit called a unit cell. When the periodicity of the pattern extends throughout a certain piece of material, one speaks of a single crystal. A single crystal is formed by the growth of a crystal nucleus without secondary nucleation or impingement on other crystals. See CRYSTAL STRUCTURE; CRYSTALLOGRAPHY.

When grown from a melt, single crystals usually take the form of their container. Crystals grown from solution (gas, liquid, or solid) often have a well-defined form which reflects the symmetry of the unit cell. See CRYSTAL GROWTH; CRYSTALLIZATION; ZONE REFINING.

Ideally, single crystals are free from internal boundaries. They give rise to a characteristic x-ray diffraction pattern.

Many types of single crystal exhibit anisotropy, that is, a variation of some of their physical properties according to the direction along which they are measured. For example, the electrical resistivity of a randomly oriented aggregate of graphite crystallites is the same in all directions. This anisotropy exists both for structure-sensitive properties, which are strongly affected by crystal imperfections (such as cleavage and crystal growth rate), and for structure-insensitive properties, which are not affected by imperfections (such as elastic coefficients).

The structure-sensitive properties of crystals (for example, strength and diffusion coefficients) seem governed by internal defects, often on an atomic scale. See CRYSTAL DEFECTS. [D.T.]

**Single sideband** An electronic signal-processing technique in which a spectrum of intelligence is translated from a zero reference frequency to a higher frequency without a change of frequency relationships within the translated spectrum. Single-sideband (SSB) signals have no appreciable carrier.

Amplitude-modulated (AM) signals have identical upper and lower sidebands symmetrically located on each side of the translation frequency, which is often called the carrier. The SSB spectrum differs from the AM spectrum in having little or no carrier and only one sideband. See AMPLITUDE MODULATION.

In the SSB signal-processing action, the intelligence spectrum to be translated is applied to the signal input port of a balanced modulator. A higher-frequency sinusoidal signal, often called a carrier, is applied to the other input port of this circuit. Its func-

tion is to translate the zero reference spectrum to the carrier frequency and to produce the upper and lower sidebands, which are symmetrically located on each side of the carrier. The carrier frequency power is suppressed to a negligible value by the balanced operation of the modulator and does not appear at the output. Generally, the balanced modulator operates at an intermediate frequency which is lower than the frequency of transmission. Following the balanced modulator is a sideband filter which is designed to remove the unwanted sideband signal power and to allow only the desired intelligence spectrum to pass. See AMPLITUDE MODULATOR; MODULATOR.

There are many advantages in the use of SSB techniques for communication systems. The two primary advantages are the reduction of transmission bandwidth and transmission power. The bandwidth required is not greater than the intelligence bandwidth and is one-half that used by amplitude modulation. The output power required to give equal energy in the intelligence bandwidth is one-sixth that of amplitude modulation.

Propagation of radio energy via ionospheric refraction provides the possibility for multiple paths of differing path length which can cause a selective cancellation of frequency components at regular frequency spacings. This produces in amplitude modulation a severe distortion of the intelligence because of the critically dependent carrier-to-sideband amplitude and phase relationships. SSB is much less affected under these conditions. [D.M.H.]

**Sintering** The welding together and growth of contact area between two or more initially distinct particles at temperatures below the melting point, but above one-half of the melting point in kelvins. Since the sintering rate is greater with smaller than with larger particles, the process is most important with powders, as in powder metallurgy and in firing of ceramic oxides.

Although sintering does occur in loose powders, it is greatly enhanced by compacting the powder, and most commercial sintering is done on compacts. Compacting is generally done at room temperature, and the resulting compact is subsequently sintered at elevated temperature without application of pressure. For special applications, the powders may be compacted at elevated temperatures and therefore simultaneously pressed and sintered. This is called hot pressing or sintering under pressure.

Certain compacts from a mixture of different component powders may be sintered under conditions where a limited amount of liquid, generally less than 25 vol%, is formed at the sintering temperature. This is called liquid-phase sintering, important in certain powder-metallurgy and ceramic applications. See CERAMICS; POWDER METALLURGY. [F.V.L.]

**Sinus** Any space in an organ, tissue, or bone, but usually referring to the paranasal sinuses of the face. In humans, four such sinuses, lined with ciliated, mucus-producing epithelium, communicate with each nasal passage through small apertures. The ethmoid and sphenoid sinuses are located centrally between and behind the eyes. The frontal sinuses lie above the nasal bridge, and the maxillary sinuses are contained in the upper jaw beneath the orbits. The mastoid portion of the temporal bone contains air cells lined with similar epithelium. [T.S.P.]

**Siphonaptera** An order of insects commonly known as the fleas. These animals are of importance because they are bloodsucking pests of humans and animals and transmit serious diseases from animals to humans.

Fleas in the adult stage are recognized with ease (see illustration). They are small, dark brown in color, laterally flattened, and with three pairs of legs modified for jumping. The body is more or less oval in shape and armed with spines and setae, adapting the flea for living among the hairs of animals. The head is provided with mouthparts modified for sucking blood.

Fleas have a complete metamorphosis; that is, the life history involves four distinct phases: the egg, larva, pupa, and adult.

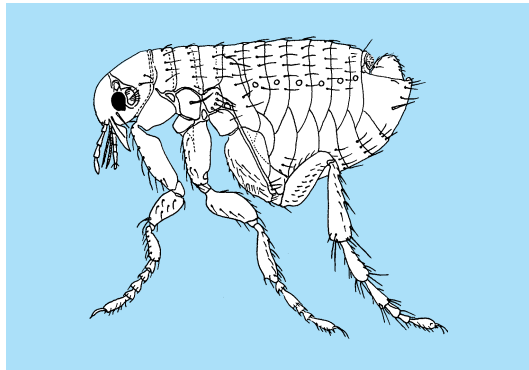

Human flea, *Pulex irritans*. (After E. O. Essig, *College Entomology*, Macmillan, 1942)

Each adult female flea lays a number of eggs, 400 or more in some species, over a long period of time.

The great majority of species are obscure ectoparasites of mammals, and to a lesser extent birds, and do not affect humans. Host specificity is exhibited in that, ordinarily, a certain taxonomic group of fleas will parasitize a specific taxonomic group of hosts. Nevertheless, some species may leave their favored hosts and attack humans, and these species are the pests and disease carriers. Bubonic plague, which was responsible for millions of deaths in India during the first two decades of this century, is a disease of rats. Murine or endemic typhus fever is another disease transmitted from domestic rats to humans by rat fleas. Flea allergy is the term applied to the severe reactions which sometimes result from flea bites. See INSECTA. [I.F.]

**Siphonophora** An order of the class Hydrozoa of the phylum Coelenterata, characterized by an extremely complex organization of components of several different types, some having the basic structure of a jellyfish, others of a polyp. The components may be connected by a stemlike region or may be more closely united into a compact organism.

Most siphonophores possess a float and are animals of the open seas. Best known is the Portuguese man-of-war, *Physalia*, with a float as much as 16 in. (40 cm) long and tentacles which extend downward for many feet. These animals may be swept shoreward and may make swimming not only unpleasant but dangerous. See COELENTERATA; HYDROZOA. [S.Cr.]

**Siphonostomatoida** An order of Copepoda; all members are parasites of marine and fresh-water fishes or a variety of invertebrate hosts. In fact, it is estimated that 67% of copepod parasites of fishes belong to the Siphonostomatoida. Their obvious success in the parasitic mode of life appears at least in part to be a result of two morphologic adaptations. The first is the modification of the buccal apparatus (mouth and appendages) resulting in a mouth cone that has a small opening near the base through which the mandibles are free to enter. The maxillae are subchelate or brachiform and serve as the appendage for attachment to the host. The second adaptation is the development of a frontal filament, which is a larval organ of attachment. In those siphonostomatoids possessing a frontal filament, the brachiform second maxilla may be used to manipulate the frontal organ, and in some species fusion of those two structures forms the attachment structure. See COPEPODA; CRUSTACEA; POECILOSTOMATOIDA. [P.A.McL.]

**Sipuncula** A phylum of sedentary marine vermiform coelomates that are unsegmented, but possibly distantly related to the annelids; they are commonly called peanut worms. Two classes are defined: Sipunculidea and Phascolosomatidea. In all there are 17 genera and approximately 150 species living in a wide variety of oceanic habitats within the sediment or in-

side any protective shelter such as a discarded mollusk shell, foraminiferan test, or crevice in rock or coral.

Adult sipunculans range in trunk length from 2 to over 500 mm (0.08 to over 20 in.). The shape of the body ranges from almost spherical to a slender cylinder. Sipunculans have a variety of epidermal structures (papillae, hooks, or shields). Many species lack color, but shades of yellow or brown may be present. Internal anatomy is relatively simple. The digestive tract has a straight esophagus and a double-coiled intestine extending toward the posterior end of the body and back terminating in a rectum, sometimes bearing small cecum. A ventral nerve cord with lateral nerves and circumenteric connectives to the pair of cerebral ganglia are present. Two or four pigmented eyespots may be present on the cerebral ganglia, and a chemoreceptor (nuchal organ) is usually present.

Knowledge of the reproductive biology of sipunculans is scanty, and good information on breeding cycles is unavailable for most genera. Most sipunculans are dioecious and lack any sexual dimorphism. These worms play a part in the recycling of detritus and probably consume smaller invertebrates in the process. They are in turn preyed on by fishes and probably other predators (including humans). See FEEDING MECHANISMS (INVERTEBRATE). [E.B.Cu.]

**Siren (acoustics)** A sound source that is based on the regular interruption of a stream of fluid (usually air) by a perforated rotating disk or cylinder. The components of a siren are a source of air, a rotor containing a number of ports which interrupt the airflow at the desired frequency, and ports in a stator through which the air escapes. The air is supplied by a compressor, and a motor drives the rotor. The frequency of the sound wave produced by the siren is the product of the speed of rotation and the number of ports in the rotor. The shape of the rotor and stator ports determines the wave shape at the entrance of the stator port. The stator ports feed into a horn in order to improve radiation. Siren performance parameters are sound power output, acoustic pressure, and efficiency, that is, the ratio of acoustic power output to compressor power. See SOUND PRESSURE.

Applications of sirens include acoustic levitation (the use of radiation pressure to levitate small objects), broadband underwater sound projectors, and sonic fatigue (fatigue life and failure of structures subjected to fluctuating pressures generated by acoustic waves). See ACOUSTIC LEVITATION.

Electromechanical sirens use an electric motor instead of a compressed air supply to generate the acoustic signal. A second motor spins the rotor. The stator and horn increase the sound power output and efficiency. Electromechanical sirens are widely used as warning devices. See SOUND. [B.Li.]

**Sirenia** An order of herbivorous aquatic placental mammals, commonly known as sea cows, that includes the living manatees and dugongs and the recently exterminated Steller's sea cow. The order has an extensive fossil record dating from the early Eocene Epoch, some 50 million years ago.

The earliest known sirenians were quadrupedal and capable of locomotion on land. Fossils clearly document the evolutionary transition from these amphibious forms to the modern, fully aquatic species, which have lost the hindlimbs and transformed the forelimbs into paddlelike flippers. The living species have streamlined, fusiform bodies with short necks and horizontal tail fins like those of cetaceans, but no dorsal fins. The skin is thick and nearly hairless. The nostrils are separate, and the ears lack external pinnae.

Sirenians typically feed on aquatic angiosperms, especially seagrasses, but in ecologically marginal situations they also eat algae and even some animal material. They are normally found in tropical or subtropical marine waters, but some have become adapted to fresh water or colder latitudes. Body sizes have ranged from less than 3 m up to 9–10 m (30–33 ft). Sirenians mate and give birth in the water, bearing a single calf



(occasionally twins) after about 13–14 months of gestation and then nursing it from one pair of axillary mammae. The closest relatives of sirenians among living mammals are the Proboscidea (elephants). See PROBOSCIDEA.

A classification scheme is given below.

- Order Sirenia
  - Family: Prorastomidae
    - Protosirenidae
    - Trichechidae
  - Subfamily: Miosireninae
    - Trichechinae
- Family Dugongidae
  - Subfamily: Halitheriinae
    - Hydrodamalinae
    - Dugonginae [D.P.D.]

**Sirius** The star  $\alpha$  Canis Majoris, also referred to as the Dog Star, the brightest of all the stars in the night sky (apparent magnitude  $-1.47$ ). Sirius owes its apparent brightness both to its close distance to Earth, only 2.64 parsecs ( $8.14 \times 10^{13}$  km or  $5.06 \times 10^{13}$  mi), and to its intrinsic luminosity, which is more than 20 times that of the Sun. It is a main-sequence star of spectral type A1 with an effective temperature of about 9400 K ( $16,500^\circ\text{F}$ ). See SPECTRAL TYPE.

Sirius is a very interesting binary system in which the companion is a degenerate star ( $\alpha$  CMA B). It is the brightest among the known white dwarfs (apparent magnitude 8.4) and the closest to the Sun. It orbits around the bright star once every 50 years. The luminosity of the white dwarf is 400 times smaller than that of the Sun, which makes it extremely difficult to see because of the overpowering brightness of the nearby primary. Its temperature is estimated to be 24,790 K ( $44,654^\circ\text{F}$ ), much hotter than the primary. The white dwarf's mass is comparable to the Sun, yet is concentrated in a body the size of the Earth. The mean density of the material in  $\alpha$  CMA B is about  $2 \times 10^6$  times that of water, or 2 metric tons/cm<sup>3</sup> (nearly 40 tons/in.<sup>3</sup>). See BINARY STAR; STAR; STELLAR EVOLUTION; WHITE DWARF STAR. [D.W.L.]

**Sirocco** A southerly or southeasterly wind current from the Sahara or from the deserts of Saudi Arabia which occurs in advance of cyclones moving eastward through the Mediterranean Sea. The sirocco is most pronounced in the spring, when the deserts are hot and the Mediterranean cyclones are vigorous. It is observed along the southern and eastern coasts of the Mediterranean Sea from Morocco to Syria as a hot, dry wind capable of carrying sand and dust great distances from the desert source. The sirocco is cooled and moistened in crossing the Mediterranean and produces an oppressive, muggy atmosphere when it extends to the southern coast of Europe. See AIR MASS; WIND. [F.S.]

**Sisal** A fiber obtained from the leaves of *Agave sisalana*, produced in Brazil, Haiti, and several African countries, including Tanzania, Kenya, Angola, and Mozambique.

Sisal is used mainly for twine and rope, but some of the lower grades are used for upholstery padding and paper. The greatest quantity goes into farm twines, followed by industrial tying twine and rope. Most sisal-fiber ropes made in the United States are small to medium in size, intended for light duty. Sisal is sometimes used for marine cordage in Europe. See NATURAL FIBER. [E.G.N.]

**Skarn** A broad range of rock types made up of calc-silicate minerals such as garnet, regardless of their association with ores, that originate by replacement of precursor rocks. It was a term originally coined by miners in reference to rock consisting of coarse-grained, calc-silicate minerals associated with iron ores in central Sweden. Ore deposits that contain skarn are termed skarn deposits; such deposits are the world's premier sources of

tungsten. They are also important sources of copper, iron, molybdenum, zinc, and other metals. Skarns also serve as sources of industrial minerals such as graphite, asbestos, and magnesite. See ORE AND MINERAL DEPOSITS; SILICATE MINERALS.

Based on mineralogy, three idealized types of skarn are recognized: calcic skarn characterized by calcium- and iron-rich silicates (andradite, hedenbergite, wollastonite); magnesian skarn characterized by calcium- and magnesium-rich silicates (forsterite, diopside, serpentine); and aluminous skarn characterized by aluminum- and magnesium-rich calc-silicates (grossularite, vesuvianite, epidote). [M.T.E.]

**Skeletal system** The supporting tissues of animals which often serve to protect the body, or parts of it, and play an important role in the animal's physiology.

Skeletons can be divided into two main types based on the relative position of the skeletal tissues. When these tissues are located external to the soft parts, the animal is said to have an exoskeleton. If they occur deep within the body, they form an endoskeleton. All vertebrate animals possess an endoskeleton, but most also have components that are exoskeletal in origin. Invertebrate skeletons, however, show far more variation in position, morphology, and materials used to construct them.

The vertebrate endoskeleton is usually constructed of bone and cartilage; only certain fishes have skeletons that lack bone. In addition to an endoskeleton, many species possess distinct exoskeletal structures made of bone or horny materials. This dermal skeleton provides support and protection at the body surface.

Various structural components make up the human skeleton, including collagen, three different types of cartilage (hyaline, fibrocartilage, and elastic), and a variety of bone types (woven, lamellar, trabecular, and plexiform). See BONE; COLLAGEN; CONNECTIVE TISSUE.

The vertebrate skeleton consists of the axial skeleton (skull, vertebral column, and associated structures) and the appendicular skeleton (limbs or appendages). The basic plan for vertebrates is similar, although large variations occur in relation to functional demands placed on the skeleton.

**Axial skeleton.** The axial skeleton supports and protects the organs of the head, neck, and torso, and in humans it comprises the skull, ear ossicles, hyoid bone, vertebral column, and rib cage.

**Skull.** The adult human skull consists of eight bones which form the cranium, or braincase, and 13 facial bones that support the eyes, nose, and jaws. There are also three small, paired ear ossicles—the malleus, incus, and stapes—within a cavity in the temporal bone. The total of 27 bones represents a large reduction in skull elements during the course of vertebrate evolution. The three components of the skull are the neurocranium, dermatocranium, and visceral cranium. See EAR (VERTEBRATE).

The brain and certain sense organs are protected by the neurocranium. All vertebrate neurocrania develop similarly, starting as ethmoid and basal cartilages beneath the brain, and as capsules partially enclosing the tissues that eventually form the olfactory, otic, and optic sense organs. Further development produces cartilaginous walls around the brain. Passages (foramina) through the cartilages are left open for cranial nerves and blood vessels. Endochondral ossification from four major centers follows in all vertebrates, except the cartilaginous fishes. See TETRAPODA.

The visceral skeleton, the skeleton of the pharyngeal arches, is demonstrated in a general form by the elasmobranch fishes, where all the elements are cartilaginous and support the jaws and the gills. The mandibular (first) arch consists of two elements on each side of the body: the palatoquadrate dorsally, which form the upper jaw, and Meckel's cartilages, which join ventrally to form the lower jaw. The hyoid (second) arch has paired dorsal hyomandibular cartilages and lateral, gill-bearing ceratohyals. This jaw mechanism attaches to the neurocranium for support. In all jawed vertebrates except mammals, an articulation between

the posterior ends of the palatoquadrate and Meckel's cartilages occurs between the upper and lower jaws. The bony fishes have elaborated on the primitive condition, where the upper jaw was fused to the skull and the lower jaw or mandible could move only in the manner of a simple hinge. Teleosts are able to protrude the upper and lower jaws. In the course of mammalian evolution, the dentary of the lower jaw enlarged and a ramus expanded upward in the temporal fossa. This eventually formed an articulation with the squamosal of the skull. With the freeing of the articular bone and the quadrate from their function in jaw articulation, they became ear ossicles in conjunction with the columella, that is, a skeletal rod that formed the first ear ossicle. The remaining visceral skeleton has evolved from jaw and gill structures in the fishes to become an attachment site for tongue muscles and to support the vocal cords in tetrapods. See MAMMALIA.

**Vertebral column.** The vertebral column is an endoskeletal segmented rod of mesodermal origin. It provides protection to the spinal cord, sites for muscle attachment, flexibility, and support, particularly in land-based tetrapods where it has to support the weight of the body (see illustration). Hard, spool-shaped bony vertebrae alternate with tough but pliable intervertebral discs. Each typical vertebral body (centrum) has a bony neural arch extending dorsally. The spinal cord runs through these arches, and spinal nerves emerge through spaces. Bony processes and spines project from the vertebrae for the attachment of muscles and ligaments. Synovial articulations between adjacent vertebrae effectively limit and define the range of vertebral motion.

Vertebral morphology differs along the length of the column. There are two recognized regions in fishes (trunk and caudal) and five in mammals (cervical, thoracic, lumbar, sacral, and caudal), reflecting regional specializations linked to function. Humans

have seven cervical, twelve thoracic, five lumbar, five (fused) sacral, and four coccygeal vertebrae. Most amphibians, reptiles, and mammals have seven cervical vertebrae regardless of neck length, whereas the number is variable in birds. Specific modification to the first two cervical vertebrae in most reptiles, birds, and mammals gives the head extra mobility. The presence of large ribs in the thoracic region often limits spinal flexibility. In typical tetrapods, the sacral region is usually modified for support of the pelvic girdle, while the number of caudal vertebrae varies greatly (from 0 to 50) between and within animal groups. See SPINE; VERTEBRA.

**Sternum and ribs.** Jawed fishes have ribs that help maintain the rigidity and support of the coelomic cavity. These ribs typically follow the connective tissue septa that divide successive muscle groups. In the caudal region, they are often small paired ventral ribs, fused on the midline to form the haemal arches. Ancestral tetrapods had ribs on all vertebrae, and their lengths varied between the vertebral regions. Modern amphibia (frogs and toads) have few thoracic ribs, and these are much reduced and never meet ventrally. Reptiles have varied rib arrangements, ranging from snakes with ribs on each vertebra (important for locomotor requirements) to turtles with only eight ribs which are fused to the inside of the carapace. Flying birds and penguins have a greatly enlarged sternum that links the ribs ventrally. In humans there are twelve pairs of ribs which form a strong but movable cage encompassing the heart and lungs.

**Appendicular skeleton.** This section of the skeletal system comprises the pectoral and pelvic limb girdles and bones of the free appendages. The girdles provide a supporting base onto which the usually mobile limbs attach.

**Pectoral girdle.** The pectoral girdle has both endoskeletal and dermal components. The dermal components are derived from postopercular dermal armor of primitive fishes, and are represented by the clavicles and interclavicles in modern vertebrates, except where they are secondarily lost. Endochondral bone forms the scapula. In fishes, the main component of the girdle (the cleithrum) is anchored to the skull by other bony elements. Increased mobility of the girdle is seen in amphibia as it becomes independent of the skull. Further development and skeletal reduction have resulted in a wide range of morphologies, culminating in the paired clavicles and scapulae of mammals.

Birds have fused their paired clavicles and single interclavicle to form the wishbone or furcula. Clavicles have disappeared in certain groups of bounding mammals to allow greater movement of the scapula. Although humans, and most other mammals, have a coracoid process on the scapula, other tetrapods typically have a separate coracoid bracing the scapula against the sternum and forming part of the glenoid fossa.

**Pelvic girdle.** The pelvic girdle forms by endochondral ossification, that is, the conversion of cartilage into bone. In the fishes, it is a small structure embedded in the body wall musculature just anterior to the cloaca. Each half of the girdle provides an anchor and articulation point for the pelvic fins. In tetrapods, the girdle attaches to the vertebral column to increase its stability and assist in the support of body weight and locomotor forces. Humans, like all other tetrapods, have a bilaterally symmetrical pelvic girdle, each half of which is formed from three fused bones: the ischium, ilium, and pubis. A part of each of these elements forms the acetabulum, the socket-shaped component of the hip joint, that articulates with the femoral head.

All urogenital and digestive products have to pass through the pelvic outlet. This accounts for the pelvic sexual dimorphism seen in most mammals, where the pelvic opening is broader in females, because of the physical demands of pregnancy and parturition. In birds (with the exception of the ostrich and the rhea), both sexes have an open pelvic girdle, a condition also found in female megachiropteran bats (flying foxes), gophers, and mole-rats.

**Paired fins and tetrapod limbs.** Paired fins in fishes come in different forms, but all are involved in locomotion. In the simplest

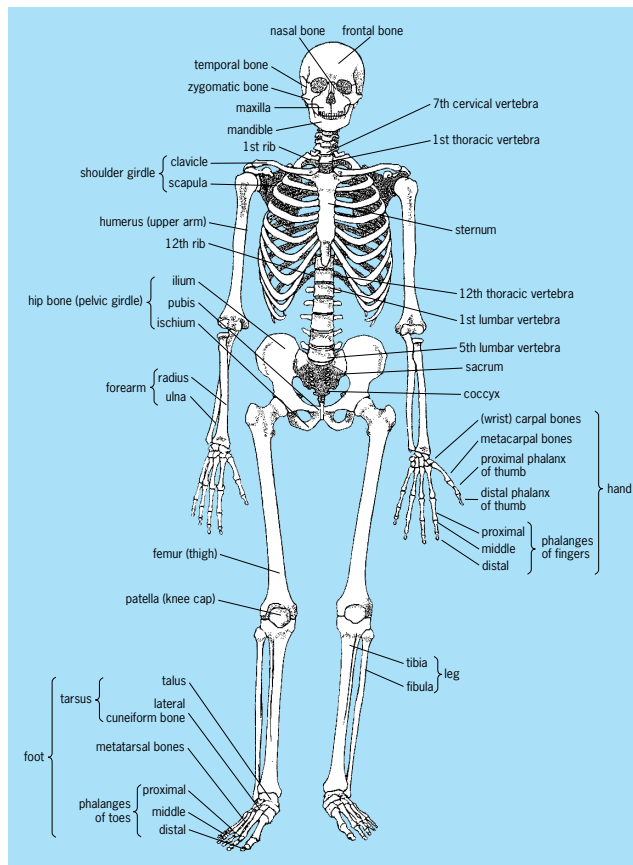

**Human skeleton (anterior view).** (After G. J. Romanes, ed., *Cunningham's Textbook of Anatomy*, 10th ed., Oxford University Press, 1964)

form they are fairly rigid and extend from the body, functioning as stabilizers, but they are also capable of acting like a wing to produce lift as in sharks. In many fishes, the pectoral fins have narrow bases and are highly maneuverable as steering fins for low-speed locomotion. In addition, some fishes use their pectoral and pelvic fins to walk on the river bed, while others have greatly enlarged pectoral fins that take over as the main propulsive structures.

The basic mammalian pectoral limb consists of the humerus, radius, ulna, carpals, five metacarpals, and fourteen phalanges; and the pelvic limb consists of the femur, tibia, fibula, tarsals, five metatarsals, and fourteen phalanges. A typical bird pelvic limb consists of a femur, tibiotarsus (formed by fusion of the tibia with the proximal row of tarsal bones), fibula, and tarsometatarsus (formed by fusion of metatarsals II–IV), metatarsal I, and four digits (each consisting of two to five phalanges). [M.Ben.]

**Skeletal system disorders** Disturbances in the structure and function of the skeletal system. The musculoskeletal system provides a rigid structural frame that permits locomotion through muscle action and aids in the functioning of the other organ systems. It also houses blood-forming marrow tissue and stores calcium, phosphorus, magnesium, and a variety of other ionic species. Bone is unique among the tissues of the body in that it responds to injury by re-forming itself identically over time, without scarring.

**Trauma.** Trauma to the musculoskeletal system can produce a closed or open fracture, a joint dislocation, or a sprain. Fractures are manifested clinically by significant pain, swelling, and false motion, and in long-bone injuries by crepitation. Dislocation occurs more commonly in the shoulder and fingers than in any other joints. Injuries to the ligaments that maintain joint alignment are known as sprains and occur most frequently at the ankle.

Bone healing begins with cellular proliferation and the formation of new blood vessels, which provide provisional stabilization through the formation of a cartilaginous matrix. Calcification of this matrix produces a disorganized bony architecture (callus) that provides mechanical stability at the fracture site until final internal remodeling takes place. The extent and speed of this process depend on both mechanical stress and the age of the individual. See BONE.

**Neoplasms.** Primary neoplasms of bone and connective tissue are relatively uncommon compared with other musculoskeletal conditions. The most frequently occurring malignant neoplasms are multiple myeloma, osteosarcoma, chondrosarcoma, and Ewing's tumor. In young individuals the most common site of a neoplasm is the tibia or femur in the vicinity of the knee, while in older individuals the flat bones, such as the ilium and those of the axial skeleton, are frequently affected.

Benign lesions have many names and are also classified according to the type of tissue primarily affected (bone, cartilage, fibrous tissue). The enchondroma is a lesion of cartilage within the bone; an exostosis is a lesion of cartilage that grows away from bone on a bony pedicle, usually near a joint. Bony lesions include the osteoblastoma and the osteoid osteoma; both of these have the histologic appearance of bone and are benign. Fibrocystic lesions include unicameral bone cysts, fibrous cortical defects, fibrous dysplasia, and giant-cell tumors. Fibrous dysplasia is a developmental lesion that often is characterized by multiply involved bones and is associated with café-au-lait spots on the skin. Unicameral bone cysts occur preferentially on the proximal humerus in adolescent children. They cause thinning of the bone and, occasionally, pathologic fractures. See ONCOLOGY; TUMOR.

**Metabolic bone disease.** Metabolic bone disease is an alteration in the normal bone metabolism. In various metabolic bone diseases, there are disturbances in the balance between osteoblastic and osteoclastic activity that alter the stability of skeletal structures. Vitamin D deficiency results in an inability

to mineralize the osteoid, the consequences of which are rickets in children and osteomalacia in adults. Rickets is characterized by shortness of stature and angular deformities of the weight-bearing bones. Osteomalacia is rare but can result when vitamin D is not absorbed through the gastrointestinal tract. It is associated with significant and widespread pain and tenderness of the bones and deformity of the spine and limbs. See VITAMIN D.

Osteoporosis, the most common metabolic bone disease, occurs in a variety of diseases. In older persons, it can lead to fracture; thoracic vertebral bodies, the hip, and the wrist are the sites most commonly affected. While postmenopausal and senile osteoporosis results from insufficient bone production (decreased osteoblastic activity) and excessive bone destruction (increased osteoclastic activity), the precise etiology of this disorder is unknown. See CALCIUM METABOLISM; OSTEOPOROSIS.

**Osteomyelitis.** Osteomyelitis is an infection of bone that is the result of either the blood-borne spread of an infectious agent or the secondary contamination of a fracture that has penetrated the skin. The bacterium *Staphylococcus aureus* is the most common causative agent. Acute osteomyelitis is characterized by severe bone tenderness and an unwillingness to use the limb, accompanied by loss of appetite and a fever.

**Septic arthritis.** Although infection of a joint can result from direct inoculation with an infectious agent, septic arthritis is most often a blood-borne condition. As with osteomyelitis, *S. aureus* is most often responsible. An individual with an infected joint usually experiences muscle spasm, severe tenderness and pain with the slightest movement, elevated temperature, and swelling of the joint.

**Osteoarthritis.** Osteoarthritis is a premature or excessive deterioration of the cartilage surface of a joint. The local deterioration of the cartilage surface is associated with remodeling of the contiguous bone and subsequent secondary inflammation of the membrane lining the joint. When it reaches this stage, it is referred to as osteoarthritis.

**Rheumatoid arthritis.** Rheumatoid arthritis is one of a family of inflammatory polyarthritides. The condition is thought to be caused by an abnormality in the immune system in which the body produces antibodies against its own tissues. In addition to the joints, other organ systems are often involved. See ARTHRITIS; JOINT DISORDERS; SKELETAL SYSTEM. [H.B.Sk.]

**Skin** The entire outer surface of the body and the principal boundary between the external environment and the body's internal environment of cells and fluids. Skin serves as the primary barrier against the intrusion of foreign elements and organisms into the body, and also as a large and complex sense organ through which animals explore and learn about the external world. In addition, skin functions to maintain the homeostasis of the body's constituents, acting as a barrier to the loss of various ions and nutrients by diffusion. For terrestrial animals, it also serves as an effective barrier to water loss, without which most land animals would rapidly become desiccated and die.

The skin of humans and other mammals can be divided into two distinct regions, the epidermis and the dermis.

The epidermis is the outermost layer of the skin. It varies in thickness from 0.1 mm in most of the protected areas of the skin to approximately 1 mm in those regions exposed to considerable friction, such as the soles of the feet and palms of the hands. The epidermis consists of a great many horizontally oriented layers of cells. The outermost layer, the stratum corneum, consists of many layers of this packed cellular debris, forming an effective barrier to water loss from lower layers of the skin. The lowest levels of stratum germinativum constitute the portion of the skin that contains melanocytes, cells that produce the dark pigment melanin. Different levels of melanin secretion are responsible for the large range of pigmentation observed among humans.

The dermis plays a supportive and nutritive role for the epidermis. The epidermis has no blood supply of its own. However, nutrients and oxygen are apparently provided by diffusion from

the blood supply of the underlying dermis. The average thickness of the dermis is 1–3 mm. It is in this layer that the sebaceous and sweat glands are located and in which the hair follicles originate. The products of all these sets of glands are derived from the rich blood supply of the dermis. Hair, sweat glands, and mammary glands (which are modified sweat glands) are skin inclusions unique to mammals. See HAIR; INTEGUMENTARY PATTERNS; SWEAT GLAND; THERMOREGULATION. [A.F.Be.]

**Skin disorders** The skin is subject to localized and generalized disorders, as well as those of primary occurrence in the skin and those secondary to involvement of other tissue. Diseases and disorders may affect any of the structures of the skin. They may be caused by external agents, either infectious or noninfectious, or by the abnormal accumulation of normal or abnormal skin elements, either inborn or acquired.

**Infectious diseases.** These are classified by the type of infectious agent—bacterial, parasitic, fungal, or viral.

Bacterial infections are distinguished clinically by the skin layer or appendage affected, but treatment is based upon the organism causing the infection. Impetigo and cellulitis are the most common infections of skin. Both infections may be caused by streptococcus, including group B hemolytic streptococcus, and staphylococcus, often species resistant to penicillin. Skin appendages such as hair follicles may be similarly infected. See ANTIBIOTIC; DRUG RESISTANCE; STAPHYLOCOCCUS; STREPTOCOCCUS.

Parasitic skin conditions are most often seen in epidemics among individuals who are in close contact, or where hygiene is poor. Head, body, and pubic lice, and scabies are the most common. Pubic lice and scabies are also often transmitted by sexual contact. See MEDICAL PARASITOLOGY.

Fungal infections are extremely common. In the United States, most fungal infections in humans are with species incapable of infecting tissue other than keratinized epidermis. These organisms are known as dermatophytes; they cause tinea pedis (athlete's foot), tinea cruris (some forms of jock itch), and tinea capitis (a scalp condition responsible for some forms of hair loss). See MEDICAL MYCOLOGY.

Viral diseases often involve the skin; however, viral warts (*verruca vulgaris*) and molluscum contagiosum are the primary examples of viral diseases that affect only the skin. Both are characterized by single or multiple, somewhat contagious, skin tumors that usually are small but can in rare instances exceed 0.4 in. (1 cm) in diameter. See ANIMAL VIRUS; CHICKENPOX AND SHINGLES; HERPES; MEASLES; SMALLPOX.

**Inflammatory disease.** Most itchy rashes are due to inflammation of the skin; they are usually known as eczema or dermatitis. In the acute stage, eczematous dermatitis is characterized by a vesicular, oozing condition. Seborrheic dermatitis is a common eczematous condition affecting primarily the areas of skin that bear sebaceous glands, that is, scalp, central face, chest, axilla, and groin.

**Hereditary disease.** Atopic dermatitis is the skin manifestation of atopy, a clinically apparent hypersensitivity. This condition may also be associated with asthma and pollen allergies. Psoriasis is a common disease of unknown etiology. The typical psoriasis consists of well-defined patches and plaques of red skin with a silvery scale that often results in pinpoint bleeding when removed. The most common and persistent sites are the elbows, knees, and scalp, but any area of skin may be involved; there may be significant morbidity and disability.

**Other conditions.** Acne vulgaris is an extremely common skin disorder, affecting 80–90% of young adults, usually during adolescence. The pilosebaceous organ of the skin is the primary target, particularly the sebaceous gland, its duct, and the infundibulum of the hair follicle. In addition to increased production of sebum, bacteria contribute to the development of acne lesions. These lesions consist of open and closed comedones (blackheads), papules, pustules, and cysts.

Reactions to ingested materials, such as food or medications, often appear in the skin, usually either as a red, itchy, measleslike rash or as urticaria (hives). These reactions indicate allergy to the material, which must then be avoided. See ALLERGY.

**Neoplasms.** Skin neoplasms may be benign or malignant, congenital or acquired, and they may arise from any component of the skin. Almost all skin neoplasms are benign and acquired. The common mole (melanocytic nevus) is a neoplasm of benign melanocytes; usually it is acquired, but it may be present at birth, when it is often known as a birthmark. Other common congenital nevi or birthmarks are of vascular origin, including strawberry and cavernous hemangiomas and port wine stains.

Malignant neoplasms may arise from cellular elements of the epidermis or dermis, or by infiltration of the skin by malignant cells arising from other tissues. By far the most common are basal cell and squamous cell cancers, which arise from basal and squamous keratinocytes of the epidermis, respectively. They usually are characterized by a nonhealing sore, persistent red scaling or crusting patch, or a slowly growing pearly nodule on skin that has been exposed to the sun; they occur mostly on the head, neck, hands, and arms.

Malignant melanoma arises from the pigment-forming melanocyte, and thus it is usually pigmented. It is a metastasizing cancer that is often fatal if not removed surgically in the early stage. It can be recognized as a pigmented lesion, often thought to be a benign nevus initially, that increases in size, changes color, particularly with admixtures of black, blue, red, or white along with the usual tans or browns; and it becomes irregular in size and shape. See CANCER (MEDICINE).

Two unusual multicentric primary skin malignancies are mycosis fungoides and Kaposi's sarcoma. Mycosis fungoides is a lymphoma of the skin, that may remain confined to the skin for 10 or more years before eventually spreading to internal organs and causing death. It may be extremely difficult to diagnose, both clinically, when it can appear only as eczematous patches, and histologically, for months or years. Kaposi's sarcoma occurs in two forms, the classic form seen on the legs of elderly Mediterranean men, and a form associated with HIV-1 infection and AIDS that may occur on any part of the body. It is derived from skin blood vessels, is multicentric, and usually appears as red to violet patches, plaques, or nodules. It is usually not fatal, although it may eventually spread to internal organs and may cause significant morbidity. There are numerous other primary skin cancers, but they are rare. See ACQUIRED IMMUNE DEFICIENCY SYNDROME (AIDS); SKIN. [A.N.M.]

**Skin effect (electricity)** The tendency for an alternating current to concentrate near the outer part or "skin" of a conductor. For a steady unidirectional current through a homogeneous conductor, the current distribution is uniform over the cross section; that is, the current density is the same at all points in the cross section. With an alternating current, the current is displaced more and more to the surface as the frequency increases. The conductor's effective cross section is therefore reduced so the resistance and energy dissipation are increased compared with the values for a uniformly distributed current. The effective resistance of a wire rises significantly with frequency; for example, for a copper wire of 1-mm (0.04-in.) diameter, the resistance at a frequency of 1 MHz is almost four times the dc value. See ALTERNATING CURRENT; ELECTRICAL RESISTANCE.

A skin depth or penetration depth  $\delta$  is frequently used in assessing the results of skin effect; it is the depth below the conductor surface at which the current density has decreased to  $1/e$  (approximately 37%) of its value at the surface. This concept applies strictly only to plane solids, but can be extended to other shapes provided the radius of curvature of the conductor surface is appreciably greater than  $\delta$ .

At a frequency of 60 Hz the penetration depth in copper is 8.5 mm (0.33 in.); at 10 GHz it is only  $6.6 \times 10^{-7}$  m. Waveguide and resonant cavity internal surfaces for use at microwave

frequencies are therefore frequently plated with a high-conductivity material, such as silver, to reduce the energy losses since nearly all the current is concentrated at the surface. Provided the plating material is thick compared to  $\delta$ , the conductor is as good as a solid conductor of the coating material. See CAVITY RESONATOR; MICROWAVE; WAVEGUIDE. [FA.Be.]

**Skin test** A procedure for evaluating the immunity status, involving the introduction of a reagent into or under the skin. Certain toxic antigens applied in minute doses will give a visible, but readily tolerated, lesion if less than a threshold amount of antibody is present in the skin. Examples are the Schick test for diphtheria antitoxin and the Dick test for scarlet fever antitoxin. If sufficient antibody is present, the toxin will be largely or completely neutralized, and the lesion will be minimal or absent. False positive reactions occur in allergies to the reagent toxin, but these can be controlled with inactivated toxins. Other tests involve substances that are not reactive with normal individuals, but give a visible skin reaction in the presence of antibodies acquired as a result of hypersensitivity or allergy to an infecting organism. A positive reaction is thus presumptive for previous contact with a specific infectious agent, for example, the tuberculin and Mantoux tests for tuberculosis, and the Mallein test for glanders. In a few instances, antibody may be injected as a reagent and the neutralization of toxins present in the skin observed, as in the Schultz-Charlton blanching test in scarlet fever. [H.P.T.]

**Skink** A cosmopolitan reptile belonging to the family Scincidae. They are small- to medium-sized, mostly terrestrial or fossorial lizards with a cylindrical body and short legs; in some instances the legs are vestigial. The body scales have cores of bone. In many species the eyelids are transparent. Skinks exhibit pleurodont dentition; that is, the teeth are attached on the side of the jaw. Most species are ovoviviparous. Three genera, *Neoseps*, *Lygosoma*, and *Eumeces*, occur in the United States. A number of species of *Tiliqua*, largest of the skinks, inhabit Malaysia and Australia. See REPTILIA; SQUAMATA. [C.B.C.]

**Skunk** Any one of a group of carnivores in the family Mustelidae, which also includes otters, weasels, badgers, and martens. Skunks are found only in the New World and range from North America to South America, with six species in the United States. They are characterized by their glossy black and white coat and two musk glands at the base of the tail.

The common striped skunk (*Mephitis mephitis*) has a white stripe on each side running into the tail. These animals are terrestrial and somewhat fossorial (burrowing). They are carnivores primarily but eat vegetation such as seeds, leaves, and nuts during the winter. During the summer they feed on insects, fruit, eggs, and rodents. The spotted skunks (*Spilogale*) range from the eastern United States to Colorado and Wyoming. See CARNIVORA; MAMMALIA; MARTEN; OTTER; WEASEL. [C.B.C.]

**Skutterudite** A mineral with composition  $(\text{Co,Ni})\text{AS}_3$ , an ore of cobalt and nickel. Commonly the mineral is massive with metallic luster and tin-white color. The hardness is  $5\frac{1}{2}$ –6 on Mohs scale and the specific gravity 6.6. Skutterudite is found at Freiberg, Annaberg, and Schneeberg in Germany, and at Cobalt, Ontario. See COBALT; NICKEL. [C.S.Hu.]

**Slate** Any of the deformed fine-grained, mica-rich rocks that are derived primarily from mudstones and shales, containing a well-developed, penetrative foliation that is called slaty cleavage. Slaty cleavage is a secondary fabric element that forms under low-temperature conditions (less than 540°F or 300°C), and imparts to the rock a tendency to split along planes. It is a type of penetrative fabric; that is, the rock can be split into smaller and smaller pieces, down to the size of the individual grains. If there is an obvious spacing between fabric elements (practically,

greater than 1 mm), the fabric is called spaced. Slates typically contain clay minerals (for example, smectite), muscovite/illite, chlorite, quartz, and a variety of accessory phases (such as epidote or iron oxides). Under increasing temperature conditions, slate grades into phyllite and schist. See ARGILLACEOUS ROCKS; CLAY MINERALS; PHYLLITE; SCHIST; SHALE.

Slaty cleavage is defined by a strong dimensional preferred orientation of clay in a very clay rich, low-grade metamorphic rock, and the resulting rock is a slate. Slaty cleavage tends to be smooth and planar. Coupled with the penetrative nature of slaty cleavage, these characteristics enable slates to split into very thin sheets. This and the durability of the rock are reasons why slates are used in the roofing industry, in the tile industry, and in the construction of pool tables. [B.A.VD.P.]

**Sleep and dreaming** Sleep is generally defined as an easily reversible (with strong or meaningful sensory stimuli), temporary, periodic state of suspended behavioral activity, unresponsiveness, and perceptual disengagement from the environment. Sleep should not be considered a state of general unconsciousness. The sleeper is normally unconscious (but not always) of the nature of events in the surrounding environment. However, the sleeper's attention may be fully engaged in experiencing a dream. And if reportability is accepted as a sufficient condition for conscious mental processes, any dream that can be recalled must be considered conscious. Dreaming, then, can be simply defined as the world-modeling constructive process through which people have experiences during sleep, and a dream is just whatever the dreamer experienced while sleeping.

**Nature of sleep.** In general, biological organisms do not remain long in states of either rest or activity. For example, if a cat's blood sugar level drops below a certain point, the cat is motivated by hunger to venture from its den in search of a meal. After satisfying the urge to eat, the cat is no longer motivated to expend energy tracking down prey; now its biochemical state motivates a return to its den, to digest in peace, conserve energy, and generally engage in restful, regenerative activities, including sleep. This example tracks a cat through one cycle of its basic rest-activity cycle (BRAC). Such cyclic processes are ubiquitous among living systems.

Sleep and wakefulness are complementary phases of the most salient aspects of the brain's endogenous circadian rhythm, or biological clock. Temporal isolation studies have determined the biological clock in humans to be slightly longer than 24 hours. Several features of sleep are regulated by the circadian system, including sleep onset and offset, depth of sleep, and rapid eye movement (REM) sleep intensity and propensity. In the presence of adequate temporal cues (for example, sunlight, noise, social interactions, and alarm clocks), the internal clock keeps good time, regulating a host of physiological and behavioral processes. See BIOLOGICAL CLOCKS; NORADRENERGIC SYSTEM.

Sleep is not a uniform state of passive withdrawal from the world; a version of the BRAC continues during sleep, showing a periodicity of approximately 90 minutes. There are two distinct kinds of sleep: a quiet phase (also known as quiet sleep or QS, slow-wave sleep) and an active phase (also known as active sleep or AS, REM sleep, paradoxical sleep), which are distinguished by many differences in biochemistry, physiology, psychology, and behavior. Recordings of electrical activity changes of the brain (electroencephalogram or EEG), eye movements (electrooculogram or EOG), and chin muscle tone (electromyogram or EMG) are used to define the various stages and substages of sleep. See ELECTROENCEPHALOGRAPHY.

**Sleep cycle.** If sleepy enough, most people can fall asleep under almost any condition. After lying in bed for a few minutes in a quiet, dark room, drowsiness usually sets in. The subjective sensation of drowsiness can be objectively indexed by a corresponding change in brain waves (EEG activity): formerly continuous alpha rhythms (see illustration) gradually break up

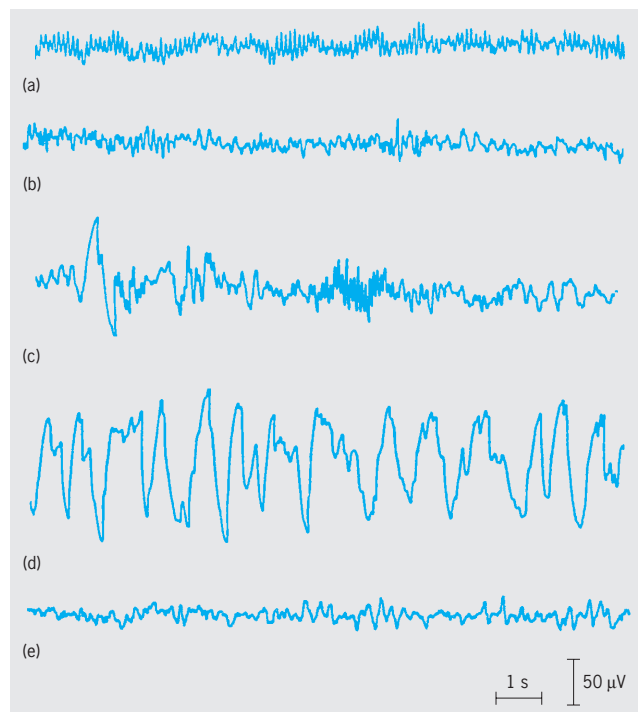

**Human EEG associated with different stages of sleep and wakefulness.** (a) Relaxed wakefulness (eyes shut) shows rhythmic 8–12-Hz alpha waves. (b) Stage 1 non-REM sleep shows mixed frequencies, especially 3–7-Hz theta waves. (c) Stage 2 non-REM sleep shows 12–14-Hz sleep spindles and K-complexes. (d) Delta sleep shows large-amplitude (>75  $\mu\text{V}$ ) 0.5–2-Hz delta waves. (e) REM sleep shows low-amplitude, mixed frequencies with sawtooth waves.

into progressively shorter trains of regular alpha waves and are replaced by low-voltage mixed-frequency EEG activity. When less than half of an epoch [usually the staging epoch is the 20–30 seconds it takes to fill one page of polygraph (sleep recording) paper] is occupied by continuous alpha rhythm, sleep onset is considered to have occurred and stage 1 sleep is scored. At this stage, the EOG usually reveals slowly drifting eye movements (SEMs) and muscle tone might or might not decrease. Awakenings at this point frequently yield reports of hypnagogic (leading into sleep) imagery, which can often be extremely vivid and bizarre.

Stage 1 is a very light stage of sleep described by most subjects as “drowsing” or “drifting off to sleep.” Normally, it lasts only a few minutes before further EEG changes occur, defining another sleep stage. It is at this point that startlelike muscle jerks known as hypnic myoclonias or hypnic jerks occasionally briefly interrupt sleep. As the subject descends deeper into sleep, the EEG of stage 2 sleep is marked by the appearance of relatively high-amplitude slow waves called K-complexes as well as 12–14-Hz rhythms called sleep spindles. The EOG would generally indicate little eye movement activity, and the EMG would show somewhat decreased muscle tone. Reports of mental activity from this stage of sleep are likely to be less bizarre and more realistic than those from stage 1. However, light sleepers sometimes report lengthy and vivid dreams upon awakening from stage 2 sleep.

After several minutes in stage 2, high-amplitude slow waves (delta waves) gradually begin to appear in the EEG. When at least 20% of an epoch is occupied by these (1–2-Hz) delta waves, stage 3 is defined. Usually this slow-wave activity continues to increase until it completely dominates the appearance of the EEG. When the proportion of delta EEG activity exceeds 50% of an epoch, the criterion for the deepest stage of sleep, stage 4, is met. During stages 3 and 4, often collectively referred to as delta sleep, the EOG shows few genuine eye movements

but is obscured by the high-amplitude delta waves. Muscle tone is normally low, although it can be remarkably high, as when sleepwalking or sleep-talking occurs. Recall of mental activity on arousal from delta sleep is generally very poor and fragmentary and is more thoughtlike than dreamlike. It should be noted that cognitive functioning immediately after abrupt wakening from sleep is likely to carry over some of the characteristics of the preceding sleep state. This phenomenon, known as sleep inertia, can be used as an experimental tool for studying cognition during different stages of sleep.

After about 90 minutes, the progression of sleep stages is reversed, back through stage 3 and stage 2 to stage 1 again. But now the EMG shows virtually no activity at all, indicating that muscle tone has reached its lowest possible level, and the EOG discloses the occurrence of rapid eye movements—at first only a few at a time, but later in dramatic profusion. This is REM (or active) sleep. Breathing rate and heart rate become more rapid and irregular, and both males and females show signs of sexual arousal. Brain metabolic rate increases to levels that typically exceed the waking state average. This state of intense brain activation is normally accompanied by experiences that seem vividly real while they last, but often vanish within seconds of waking. When people are abruptly awakened from REM sleep, 80–90% of the time they recall vivid and sometimes extremely detailed dreams.

While all this activity is happening in the brain, the body remains almost completely still (except for small twitches), because it is temporarily paralyzed during REM sleep to prevent dreams from being acted out. The brainstem system that causes the paralysis of REM sleep does not always inactivate immediately upon awakening. The resulting experience, known as sleep paralysis, can be terrifying, but it is quite harmless and normal if it occurs only occasionally. However, frequent sleep paralysis can be a symptom of a disorder of REM sleep called narcolepsy. See SLEEP DISORDERS.

After a REM period lasting perhaps 5 to 15 minutes, a young adult will typically go back through the preceding cycle stages, dreaming vividly three or four more times during the remainder of the night, with two major modifications. First, decreasing amounts of slow-wave EEG activity (stages 3 and 4 or delta sleep) occur in each successive cycle. Later in the night, after perhaps the second or third REM period, no delta sleep appears on the EEG at all, only non-REM, stage-2, and REM sleep. Second, as the night proceeds, successive REM periods tend to increase in length, up to a point. The fact that for humans most REM occurs in the last portion of the sleep cycle as dawn approaches suggests that REM serves a function related to preparation for waking activity.

Finally, after four or five periods of dreaming sleep, the sleeper wakes up (for perhaps the tenth time during the night) and gets up for the day. It may be difficult to believe that brief awakenings occur this frequently during an average night; however, they are promptly forgotten. This retrograde amnesia is a normal feature of sleep: information in short-term memory at sleep onset is usually not transferred into more permanent storage.

**Evolution and function of sleep.** Most organisms are adapted to either the dark or light phase of the day. Therefore, a biological process that limits activity to the phase of the cycle to which the organism is adapted will enhance survival. Most likely sleep developed out of the rest phase of the BRAC, allowing organisms to minimize interactions with the world during the less favorable phase, while engaging in a variety of internal maintenance operations. The fact that different species have many differences in sleep structure, process, and function fits with the idea that sleep serves the specific adaptive needs of each species. Quiet sleep appears to be an older form of sleep with simpler and more universal functions related to energy conservation, growth, and restoration. Active sleep is a mammalian invention with functions that appear to be related to specifically mammalian needs. The portion of total sleep composed of

REM is at its highest level perinatally: newborn humans spend 8 hours per day in REM sleep, with even more time during the last 6 weeks before birth. The time of maximal REM corresponds to the time of maximal growth of the brain. A number of theorists suggest that this points to the main evolutionary function of REM: to provide a source of endogenous stimulation supporting the unfolding of genetic programming and self-organization of the brain. The fact that REM time does not decrease to zero after the full development of the nervous system suggests secondary adaptive advantages afforded by REM during adulthood, which may include facilitation of difficult learning and preparation of the brain for optimal functioning on arousal.

Although the modern understanding of sleep and dreaming has had the benefit of half a century of scientific research, there are still no simple and conclusive answers to the questions of why we sleep.

**Dreams.** From the biological perspective, the basic task of the brain is to predict and control the organism's actions and regulate those actions to achieve optimal outcomes (in terms of survival and reproduction). To accomplish this task, the brain in some sense internally "models" the world. The waking brain bases the features of its world model primarily on the current information received from the senses and secondarily on expectations derived from past experience. In contrast, the sleeping brain acquires little information from the senses. Therefore in sleep, the primary sources of information available to the brain are the current motivational state of the organism and past experience. According to this theory, dreams result from brains using internal information to create a simulation of the external world, in a manner directly parallel to the process of waking perception, minus most sensory input. See PERCEPTION. [S.LaB.]

**Sleep disorders** Sleep is a reversible state during which the individual's voluntary functions are suspended but the involuntary functions, such as circulation and respiration, are uninterrupted; the sleeping subject assumes a characteristic posture with relative immobility and decreased responses to external stimuli.

The sleep state can be divided into nonrapid eye movement (NREM) and rapid eye movement (REM) sleep. NREM sleep is divided into four stages based on electroencephalographic criteria. The first REM in a normal adult occurs 60–90 min after sleep onset, and there are usually four or five NREM-REM cycles, each lasting for 90–110 min. Most dreams occur during REM sleep. The sleep-wake pattern for humans follows a circadian rhythm. An average adult needs approximately 7–8 hours of sleep, but elderly people have frequent awakenings.

**Clinical disorders.** Sleep disorders are classified as dyssomnias (intrinsic, extrinsic, or circadian rhythm disorders), parasomnias, and disorders associated with medical, psychiatric, and neurological illnesses. Obstructive sleep apnea syndrome, narcolepsy, psychophysiological and idiopathic insomnia, and restless legs syndrome are examples of intrinsic sleep disorders. Extrinsic sleep disorders include inadequate sleep hygiene, insufficient sleep syndrome, and hypnotic-, stimulant-, and alcohol-dependent sleep disorders. Circadian-rhythm disorders include jet lag and shift-work sleep disorders.

Parasomnias are characterized by abnormal movements or behavior intruding into sleep (for example, sleep walking, sleep terrors, sleep talking, nightmares, sleep paralysis, tooth grinding, and bed wetting).

Excessive daytime sleepiness, insomnia (sleeplessness), and abnormal movements and behavior during sleep are the major sleep complaints. An individual with insomnia may have difficulty initiating or maintaining sleep; repeated awakenings or early morning awakenings; or daytime fatigue and impairment of performance. Individuals with hypersomnia complain of excessive daytime sleepiness. Circadian-rhythm sleep disorders may be associated with either insomnia or hypersomnia.

There are two forms of sleep apnea. In central apnea, both the airflow at the mouth and nose and the effort by the diaphragm

decrease. In obstructive apnea, the airflow stops but the effort by the diaphragm continues. Obstructive sleep apnea syndrome is common in middle-aged and elderly obese men.

Narcoleptic sleep attacks usually begin in individuals between the ages of 15 and 25. Narcolepsy is characterized by an irresistible desire to sleep, and the attacks may last 15–30 min. Other symptoms may include fearful dreams or feeling of loss of power at sleep onset or offset. Narcolepsy cannot be cured.

The restless legs syndrome occurs during middle age and is characterized by intense disagreeable feelings in the legs at rest and repose with compulsion to move the legs to get relief. Most individuals with this problem also have periodic limb movements in sleep.

The most common cause of insomnia is psychiatric or psychophysiological disorder (for example, depression, anxiety, or stress), but other causes include medical disorders or pain. Early morning awakening is characteristic of depression.

**Diagnosis and treatment.** Overnight polysomnography involves recording of brain waves, muscle activities, eye movements, heart activity, airflow at the nose and mouth, respiratory effort, and oxygen saturation. Polysomnography is needed for individuals with excessive daytime sleepiness, narcolepsy, parasomnias, restless legs-period limb movements, and nocturnal seizures. The multiple sleep latency test is important in documenting pathologic sleepiness and diagnosing narcolepsy; it records brain waves, muscle activities, eye movements, and heart activity.

Treatment of obstructive sleep apnea syndrome consists of avoidance of sedatives or alcohol consumption, weight loss, and use of continuous positive airway pressure which will open the upper airway passage. Narcolepsy is treated by stimulants and short naps. Cataplexy is treated with tricyclics. Chronic insomnia can best be treated by sleep hygiene and behavioral modification. Most parasomnias do not require special treatment; however, psychotherapy may be helpful in some cases. Circadian-rhythm disorders may be treated by bright light and chronotherapy. See BIOLOGICAL CLOCKS; SLEEP AND DREAMING. [S.Cho.]

**Slider-crank mechanism** A four-bar linkage with output crank and ground member of infinite length. A slider crank (see illustration) is most widely used to convert reciprocating to rotary motion (as in an engine) or to convert rotary to reciprocating motion (as in pumps), but it has numerous other applications. Positions at which slider motion reverses are called dead centers. When crank and connecting rod are extended in a straight line and the slider is at its maximum distance from the axis of the crankshaft, the position is top dead center (TDC); when the slider is at its minimum distance from the axis of the crankshaft, the position is bottom dead center (BDC).

The conventional internal combustion engine employs a piston arrangement in which the piston becomes the slider of the slider-crank mechanism. Radial engines for aircraft employ a single master connecting rod to reduce the length of the crankshaft. The master rod, which is connected to the wrist pin in a piston, is part of a conventional slider-crank mechanism. The other pis-

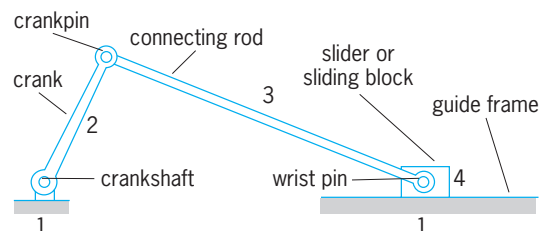

Principal parts of slider-crank mechanism.

tons are joined by their connecting rods to pins on the master connecting rod.

To convert rotary motion into reciprocating motion, the slider crank is part of a wide range of machines, typically pumps and compressors. Another use of the slider crank is in toggle mechanisms, also called knuckle joints. The driving force is applied at the crankpin so that, at TDC, a much larger force is developed at the slider. See FOUR-BAR LINKAGE. [D.P.Ad.]

**Slip (electricity)** A numerical value used in describing the performance of electrical couplings and induction machines. In an electrical coupling, slip is defined simply as the difference between the speeds of the two rotating members. In an induction motor, slip is a measure of the difference between synchronous speed and shaft speed.

When the stator windings of an induction motor are connected to a suitable alternating voltage supply, they set up a rotating magnetic field within the motor. The speed of rotation of this field is called synchronous speed, and is given by Eq. (1) or Eq. (2),

$$\omega_s = \frac{4\pi f}{p} \quad \text{rad/s} \quad (1)$$

$$n_s = 120 \frac{f}{p} \quad \text{rev/min} \quad (2)$$

where  $f$  is the line frequency and  $p$  is the number of magnetic poles of the field. The number of poles is determined by the design of the windings. In accord with Faraday's voltage law, a magnetic field can induce voltage in a coil only when the flux linking the coil varies with time. If the rotor were to turn at the same speed as the stator field, the flux linkage with the rotor would be constant. No voltages would be induced in the rotor windings, no rotor current would flow, and no torque would be developed. For motor action it is necessary that the rotor windings move backward relative to the magnetic field so that Faraday's law voltages may be induced in them. That is, there must be slip between the rotor and the field. See ELECTROMAGNETIC INDUCTION; INDUCTION MOTOR.

The amount of slip may be expressed as the difference between the field and rotor speeds in revolutions per minute or radians per second. However, the slip of an induction motor is most commonly defined as a decimal fraction of synchronous speed, as in Eq. (3) or Eq. (4). Here  $n$  is the motor speed in

$$s = \frac{n_s - n}{n_s} \quad (3)$$

$$s = \frac{\omega_s - \omega}{\omega_s} \quad (4)$$

revolutions per minute,  $\omega$  is its speed in radians per second, and  $s$  is the slip, or more properly the per unit slip. Typical full-load values of slip for an induction motor range from 0.02 to 0.15, depending on rotor design. Slip is sometimes expressed in percent of synchronous speed, rather than per unit. If an induction machine is driven faster than synchronous speed, the slip becomes negative, and the machine acts as a generator, forcing energy back into the electrical supply line. See ELECTRIC ROTATING MACHINERY. [G.McP.]

**Slip rings** Electromechanical components which, in combination with brushes, provide a continuous electrical connection between rotating and stationary conductors. Typical applications of slip rings are in electric rotating machinery, synchros, and gyroscopes. Slip rings are also employed in large assemblies where a number of circuits must be established between a rotating device, such as a radar antenna, and stationary equipment.

Slip rings are usually constructed of steel with the cylindrical outer surface concentric with the axis of rotation. Insulated mountings insulate the rings from the shaft and from each other. Conducting brushes are arranged about the circumference of the slip rings and held in contact with the surface of the rings by spring tension. See ELECTRIC ROTATING MACHINERY; MOTOR. [A.R.E.]

**Slope** The trigonometric tangent of the angle  $\alpha$  that a line makes with the  $x$  axis. In the illustration the slope of a plane curve  $C$  at a point  $P$  of  $C$  is the slope of the line that is tangent

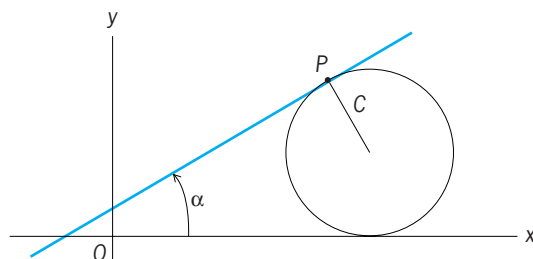

Slope of a curve.

to  $C$  at  $P$ . If  $y = f(x)$  is an equation in rectangular coordinates of curve  $C$ , the slope of  $C$  at  $P(x_0, y_0)$  is the value of the derivative  $dy/dx = f'(x)$  at  $P$ , denoted by  $f'(x_0)$ , and hence an equation of the nonvertical tangent to  $C$  at  $P$  is  $y - y_0 = f'(x_0)(x - x_0)$ . See ANALYTIC GEOMETRY; CALCULUS. [L.M.Bl.]

**Sloth** A mammal, found exclusively in Central and South America, of the family Bradypodidae in the order Edentata. These animals are all slow-moving, arboreal species that cling to branches upside down by means of long, curved claws, and are difficult if not impossible to dislodge. The long hairs of the fur, which are a mixture of white, black, brown, and yellow or green, are unusual in that they are grooved. Algae inhabit the grooves, being green when conditions are damp and turning yellow in times of drought. The sloth has a short stumpy tail, round eyes, a small mouth, and horny lips which assist in eating leaves, a preferred food. The small pinnae of the ears are hidden in the fur. See EDENTATA. [C.B.C.]

**Slow neutron spectroscopy** The use of beams of slow neutrons, from nuclear reactors or nuclear accelerators, in studies of the structure or structural dynamics of solid, liquid, or gaseous matter. Studies of the chemical or magnetic structure of substances are usually referred to under the term neutron diffraction, while studies of atomic and magnetic dynamics go under the terms slow neutron spectroscopy, inelastic neutron scattering, or simply neutron spectroscopy. See NEUTRON DIFFRACTION; NUCLEAR REACTOR; PARTICLE ACCELERATOR; SPECTROSCOPY; X-RAY DIFFRACTION.

In a neutron spectroscopy experiment, a beam of neutrons is scattered by a specimen and the scattered neutrons are detected at various angles to the initial beam. From these measurements, the linear momenta of the incoming and outgoing neutrons (and the vector momentum changes experienced by individual neutrons) can be computed. In general, just those neutrons which have been scattered once only by the specimen are useful for analysis; the specimen must be "thin" with respect to neutron scattering power as well as to neutron absorption. In practice, the experiments are usually intensity-limited, since even the most powerful reactors or accelerators are sources of weak luminosity when, as here, individual slow neutrons are to be considered as quanta of radiation. See NEUTRON.

Neutron spectroscopy requires slow neutrons, with energies of the order of neutrons in equilibrium with matter at room temperature, or approximately 0.025 eV. The corresponding de Broglie wavelengths are approximately 0.2 nanometer, of the order of interatomic spacings in solids or liquids. The fast neutrons emitted in nuclear or slow fission reactions can be slowed down to thermal velocities in matter which is transparent to neutrons and which contains light elements, such as hydrogen, carbon, and beryllium, by a process of diffusion and elastic (billiard-ball) scattering known as neutron moderation. By selection of those diffusing neutrons which travel in a certain restricted range



of directions (collimation), a beam of thermal and near-thermal neutrons can be obtained. See NEUTRON; QUANTUM MECHANICS; THERMAL NEUTRONS.

The bulk of the observations can be accounted for in terms of scattering of semiclassical neutron waves by massive, moving-point scatterers in the forms of atomic nuclei and their bound electron clouds. The spatial structure of the scatterers, time-averaged over the duration of the experiment, gives rise to the elastic scattering from the specimen that is studied in neutron diffraction; the spatial motions of the scatterers give rise to the Doppler-shifted inelastic scattering involved in slow neutron spectroscopy.

Just as (slow) neutron diffraction is the most powerful available scientific tool for study of the magnetic structure of matter on an atomic scale, so slow neutron spectroscopy is the most powerful tool for study of the atomic magnetic and nuclear dynamics of matter in all its phases. The direct nature of the analysis has in some cases added considerable support to the conceptual structure of solid-state and liquid-state physics and thus to the confidence with which the physics is applied. For example, neutron spectroscopy has confirmed the existence of phonons, magnons, and the quasiparticles (rotons) of liquid helium II. Detailed information has been obtained on the lattice vibrations of most of the crystalline elements and numerous simple compounds, on the atomic dynamics of many simple liquids, on the dynamics of liquid helium in different phases, and on the atomic magnetic dynamics of a great variety of ferromagnetic, ferrimagnetic, antiferromagnetic, and modulated magnetic substances. [B.N.B.]

**Slug (zoology)** A terrestrial pulmonate mollusk in which the shell is absent or reduced to a small internal or external rudiment. The slug form has evolved independently several times. The incorporation into the muscular foot region of the body organs (which are contained within the shell in other mollusks) results in a streamlined body shape (see illustration), enabling the animal to enter small holes or crevices.



*Limax maximus*. There are two pairs of tentacles on the head, and the opening to the lung is clearly visible.

Lung respiration occurs as in other pulmonates, but skin respiration is probably at least as important.

A few slugs are carnivorous, such as *Testacella* which eats earthworms, but the majority are herbivores and may become serious horticultural and agricultural pests. See PULMONATA. [N.Ru.]

**Smallpox** An acute infectious viral disease characterized by severe systemic involvement and a single crop of skin lesions that proceeds through macular, papular, vesicular, and pustular stages. Smallpox is caused by variola virus, a brick-shaped, deoxyribonucleic acid-containing member of the Poxviridae family. Strains of variola virus are indistinguishable antigenically, but have differed in the clinical severity of the disease caused. Following a 13-year worldwide campaign coordinated by the World Health Organization (WHO), smallpox was declared eradicated by the World Health Assembly in May 1980. Smallpox is the first human disease to be eradicated.

Humans were the only reservoir and vector of smallpox. The disease was spread by transfer of the virus in respiratory droplets during face-to-face contact. Before vaccination, persons of all ages were susceptible. It was a winter-spring disease; there was

a peak incidence in the drier spring months in the Southern Hemisphere and in the winter months in temperate climates. The spread of smallpox was relatively slow. The incubation period was an average of 10–12 days, with a range of 7–17 days. Fifteen to forty percent of susceptible persons in close contact with an infected individual developed the disease.

There were two main clinically distinct forms of smallpox, variola major and variola minor. Variola major, prominent in Asia and west Africa, was the more severe form, with widespread lesions and case fatality rates of 15–25% in unvaccinated persons, exceeding 40% in children under 1 year. From the early 1960s to 1977, variola minor was prevalent in South America and south and east Africa; manifestations were milder, with a case fatality rate of less than 1%.

There is no specific treatment for the diseases caused by poxviruses. Supportive care for smallpox often included the systemic use of penicillins to minimize secondary bacterial infection of the skin. When lesions occurred on the cornea, an antiviral agent (idoxuridine) was advised.

Edward Jenner, a British general medical practitioner who used cowpox to prevent smallpox in 1796, is credited with the discovery of smallpox vaccine (vaccinia virus). However, the global smallpox eradication program did not rely only on vaccination. Although the strategy for eradication first followed a mass vaccination approach, experience showed that intensive efforts to identify areas of epidemiologic importance, to detect outbreaks and cases, and to contain them would have the greatest effect on interrupting transmission. In 1978, WHO established an International Commission to confirm the absence of smallpox worldwide. The recommendations made by the commission included abandoning routine vaccination except for laboratory workers at special risk. See ANIMAL VIRUS; VACCINATION. [J.Br.]

**Smithsonite** A naturally occurring rhombohedral zinc carbonate ( $ZnCO_3$ ), with a crystal structure similar to that of calcite ( $CaCO_3$ ). Smithsonite has a hardness on the Mohs scale of  $4\frac{1}{2}$ , has a specific gravity of 4.30–4.45, and exhibits perfect rhombohedral cleavage. See CALCITE; CRYSTAL STRUCTURE; HARDNESS SCALES.

Smithsonite most commonly forms as an alteration product of the mineral sphalerite ( $ZnS$ ) during supergene enrichment of zinc ores in arid or semiarid environments. It is seldom pure zinc carbonate, commonly containing other divalent metal ions such as manganese ( $Mn^{2+}$ ), ferrous iron ( $Fe^{2+}$ ), magnesium ( $Mg^{2+}$ ), calcium ( $Ca^{2+}$ ), cadmium ( $Cd^{2+}$ ), cobalt ( $Co^{2+}$ ), or lead ( $Pb^{2+}$ ) substituting for zinc ion. Substitution of other elements for zinc may result in different colors such as blue-green (copper), yellow (cadmium), and pink (cobalt). Smithsonite has been mined as an ore of zinc and has also been used as an ornamental stone. See CARBONATE MINERALS; ZINC. [J.C.D.]

**Smog** The noxious mixture of gases and particles commonly associated with air pollution in urban areas. Harold Antoine des Voeux is credited with coining the term in 1905 to describe the air pollution in British towns. See AIR POLLUTION.

The constituents of smog affect the human cardio-respiratory system and pose a health threat. Individuals exposed to smog can experience acute symptoms ranging from eye irritation and shortness of breath to serious asthmatic attacks. Under extreme conditions, smog can cause mortality, especially in the case of the infirm and elderly. Smog can also harm vegetation and likely leads to significant losses in the yields from forests and agricultural crops in affected areas.

The only characteristic of smog that is readily apparent to the unaided observer is the low visibility or haziness that it produces, due to tiny particles suspended within the smog. Observation of the more insidious properties of smog—the concentrations of toxic constituents—requires sensitive analytical instrumentation. Technological advances in these types of instruments, along with

the advent of high-speed computers to simulate smog formation, have led to an increasing understanding of smog and its causes.

Smog is an episodic phenomenon because specific meteorological conditions are required for it to accumulate near the ground. These conditions include calm or stagnant winds which limit the horizontal transport of the pollutants from their sources, and a temperature inversion which prevents vertical mixing of the pollutants from the boundary layer into the free troposphere. See METEOROLOGY; STRATOSPHERE; TROPOSPHERE.

Smog can be classified into three types: London smog, photochemical smog, and smog from biomass burning.

London smog arises from the by-products of coal burning. These by-products include soot particles and sulfur oxides. During cool damp periods (often in the winter), the soot and sulfur oxides can combine with fog droplets to form a dark acidic fog. As nations switch from coal to cleaner-burning fossil fuels such as oil and gas as well as alternate energy sources such as hydroelectric and nuclear, London smogs cease. See ACID RAIN; COAL.

Photochemical smog is a more of a haze than a fog and is produced by chemical reactions in the atmosphere that are triggered by sunlight. A. J. Hagen-Smit first unraveled the chemical mechanism that produces photochemical smog. He irradiated mixtures of volatile organic compounds (VOC) and nitrogen oxides ( $\text{NO}_x$ ) in a reaction chamber. After a few hours, Hagen-Smit observed the appearance of cracks in rubber bands stretched across the chamber. Knowing that ozone ( $\text{O}_3$ ) can harden and crack rubber, Hagen-Smit correctly reasoned that photochemical smog was caused by photochemical reactions involving VOC and  $\text{NO}_x$ , and that one of the major oxidants produced in this smog was  $\text{O}_3$ . See ATMOSPHERIC CHEMISTRY; OZONE; PHOTOCHEMISTRY.

While generally not as dangerous as London smog, photochemical smog contains a number of noxious constituents. Ozone, a strong oxidant that can react with living tissue, is one of these noxious compounds. Another is peroxyacetyl nitrate (PAN), an eye irritant that is produced by reactions between  $\text{NO}_2$  and the breakdown products of carbonyls. Particulate matter having diameters of about 10 micrometers or less are of concern because they can penetrate into the human respiratory tract during breathing and have been implicated in a variety of respiratory ailments.

Probably the oldest type of smog known to humankind is produced from the burning of biomass or wood. It combines aspects of both London smog and photochemical smog since the burning of biomass can produce copious quantities of smoke as well as VOC and  $\text{NO}_x$ . [W.L.Ch.]

**Smoke** Fumes and smoke are dispersions of finely divided solids or liquids in a gaseous medium. The particle-size range is 0.01–5.0 micrometers. Typical dispersions are smokes from incomplete combustion of organic matter such as tobacco, wood, and coal; soot or carbon black; oil-vapor mists; chemical fumes such as sulfur trioxide ( $\text{SO}_3$ ) and phosphorus pentoxide ( $\text{P}_2\text{O}_5$ ) mists, ammonium chloride ( $\text{NH}_4\text{Cl}$ ), and metal oxides; and the products of hydrolysis of metal chlorides by moist air. Oil-vapor and  $\text{P}_2\text{O}_5$  mists (formed by burning phosphorus in moist air) have been extensively used in military operations to produce screening smokes. See AIR POLLUTION. [H.H.St./A.J.T.]

**Smut (microbiology)** The dark powdery masses of “smut spores” (teliospores) that develop in living plant tissues infected by species of *Ustilago*, *Tilletia*, and similar plant parasitic fungi. Molecular and ultrastructural data show that smut fungi comprise two phylogenetically distinct lines within the Basidiomycota; recent classification places them in two different classes, Ustilaginomycetes and Urediniomycetes. Ustilaginomycetes contains most of the smut fungi, and several groups of morphologically distinct, nonsmut plant parasites, including *Exobasidium*, *Graphiola*, and *Microstroma*. Smut fungi belong-

ing to the genus *Microbotryum*, best known as anther smuts of Caryophyllaceae, are now placed within the Urediniomycetes with rust fungi and allied taxa. Ustilaginomycetes and Urediniomycetes also contain a number of saprotrophic, yeast-like fungi that are related to the plant parasitic smuts. Yeastlike saprotrophs that produce teliospores include *Tilletiaria* in the Ustilaginomycetes, and *Leucosporidium*, *Rhodosporidium*, and *Sporobolomyces* in the Urediniomycetes. Yeastlike saprotrophs in the Ustilaginomycetes that do not form teliospores but reproduce in another manner similar to *Ustilago* and *Tilletia* include *Pseudozyma* and *Tilletiopsis*, respectively. See FUNGI.

Teliospores of plant parasitic smut fungi form in a fruiting structure called a sorus. Sori are commonly produced in the inflorescence, leaves, or stems of the host, although the root is the site of sorus formation in smuts belonging to the genus *Entorrhiza*. Teliospores develop within the sorus by conversion of dikaryotic mycelial cells into thick-walled resistant spores within which paired nuclei fuse. Meiosis also occurs in teliospores of some smut fungi, but meiotic division is more characteristic of the tubular basidium that develops at germination.

There are 1200 species and 50 different genera of known smut fungi that infect over 4000 species of angiosperms. Smut fungi occur on both monocotyledonous and dicotyledonous hosts but are most economically important as pathogens of barley, corn, oats, onions, rice, sorghum, sugarcane, and wheat. Control of smut diseases varies with species and includes fungicidal seed treatments and use of resistant crop varieties. See BASIDIOMYCOTA; PLANT PATHOLOGY. [J.R.Ba.; L.M.Ca.]

**Snail** Any of the approximately 74,000 species in the class Gastropoda of the phylum Mollusca or, alternatively, any of the 12 or so species of land pulmonate gastropods used as human food.

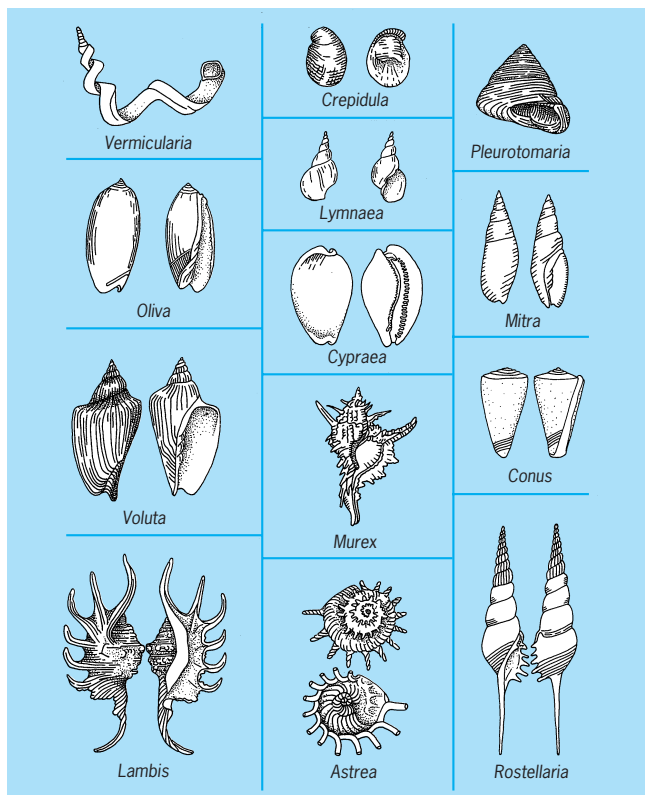

Diversity of snail shells. (After R. R. Shrock and W. H. Twenhofel, *Principles of Invertebrate Paleontology*, 2d ed., McGraw-Hill, 1953)

The shell of snails is in one piece and typically turbinate (see illustration), but may be planospiral or limpet-shaped, or may be secondarily lost (as in land slugs and marine nudibranchs). In development, gastropods have undergone torsion (the visceral mass and the mantle-shell covering it have become twisted through 180° in relation to the head and foot) so that the mantle cavity is placed anteriorly above the head.

In feeding, all snails use a characteristic rasping tongue or radula. This is a chitinous ribbon bearing teeth which is moved over a supporting protrusible “tongue” with a to-and-fro action. The radular apparatus has a twofold function: it serves both for rasping off food material (mechanically like an inverted version of the upper incisor teeth of a beaver) and for transporting the food back into the gut like a conveyor belt.

Both fresh-water and terrestrial snail species serve as vectors (first or sole intermediate hosts) in the transmission of flukes (Trematoda) infecting humans or domestic animals. See CLONORCHIASIS; DIGENEA; FASCIOLIASIS; GASTROPODA; PULMONATA; SCHISTOSOMIASIS. [W.D.R.-H.]

**Snap ring** A form of spring used principally as a fastener. Piston rings are a form of snap ring used as seals. The ring is elastically deformed, put in place, and allowed to snap back toward its unstressed position into a groove or recess. The snap

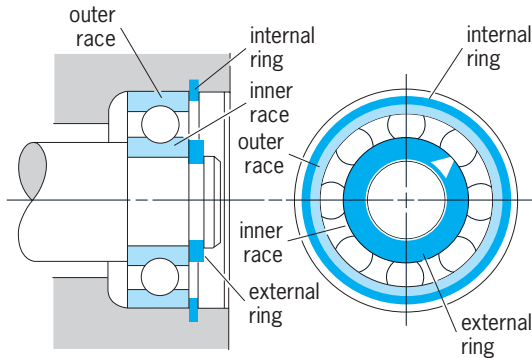

Snap rings hold ball-bearing race in place. Internal ring supports axial thrust of axle. External ring aligns inner race against shoulder of shaft.

ring may be used externally to provide a shoulder that retains a wheel or a bearing race on a shaft, or it may be used internally to provide a construction that confines a bearing race in the bore of a machine frame, as illustrated. [L.S.L.]

**Snow** Frozen precipitation resulting from the growth of ice crystals from water vapor in the Earth's atmosphere.

As ice particles fall out in the atmosphere, they melt to raindrops when the air temperature is a few degrees above 32°F (0°C), or accumulate on the ground at colder temperatures. At temperatures above -40°F (-40°C), individual crystals begin growth on icelike aerosols (often clay particles 0.1 micrometer in diameter), or grow from cloud droplets (10 μm in diameter) frozen by similar particles. At lower temperatures, snow crystals grow on cloud droplets frozen by random molecular motion. At temperatures near 25°F (-4°C), crystals sometimes grow on ice fragments produced during soft hail (graupel) growth. Snow crystals often grow in the supersaturated environment provided by a cloud of supercooled droplets; this is known as the Bergeron-Findeisen process for formation of precipitation. When crystals are present in high concentrations (100 particles per liter) they grow in supersaturations lowered by mutual competition for available vapor.

Ice crystals growing under most atmospheric conditions (air pressure down to 0.2 atm or 20 kilopascals and temperatures 32

to -58°F or 0 to -50°C) have a hexagonal crystal structure, consistent with the arrangement of water molecules in the ice lattice, which leads to striking hexagonal shapes during vapor growth. The crystal habit (ratio of growth along and perpendicular to the hexagonal axis) changes dramatically with temperature. Both field and laboratory studies of crystals grown under known or controlled conditions show that the crystals are platelike above 27°F (-3°C) and between 18 and -13°F (-8 and -25°C), and columnlike between 27 and 18°F (-3 and -8°C) and below -13°F (-25°C).

Individual crystals fall in the atmosphere at velocity up to 0.5 m s<sup>-1</sup> (1.6 ft s<sup>-1</sup>). As crystals grow, they fall at higher velocity, which leads, in combination with the high moisture availability in a supercooled droplet cloud, to sprouting of the corners to form needle or dendrite skeletal crystals.

Under some conditions crystals aggregate to give snowflakes. This happens for the dendritic crystals that grow near 5°F (-15°C), which readily interlock if they collide with each other, and for all crystals near 32°F (0°C). Snowflakes typically contain several hundred individual crystals.

When snow reaches the ground, changes take place in the crystals. At temperatures near 32°F (0°C) the crystals rapidly lose the delicate structure acquired during growth, sharp edges evaporate, and the crystals take on a rounded shape, some 1–2 mm (0.04–0.08 in.) in diameter. These grains sinter together at their contact points to give snow some structural rigidity. The specific gravity varies from ~0.05 for freshly fallen “powder” snow to ~0.4 for an old snowpack. See CRYSTAL GROWTH; PRECIPITATION (METEOROLOGY). [J.Hal.]

**Snow gage** An instrument for measuring the amount of water equivalent in snow; more commonly known as a snow sampler. Frequently snow samplers are made of a lightweight seamless aluminum tube consisting of easily coupled lengths. Other snow samplers have been developed from material such as fiber glass and plastic for use in shallow snow, deep dense snow, and so forth.

To obtain a measurement the sampler is pushed vertically through the snow to the ground surface. The sampler, together with its snow core, is withdrawn and weighed. The water equivalent of the snow layer is obtained by subtracting the weight of the sampler from the total. In addition to any error introduced by the scale, there is usually a 6–8% error in the weight of samples taken in this manner.

Automatic devices that permit the remote observation of the water equivalent of the snow have been developed. These devices also permit telemetering the data to a central location, eliminating the need for travel to the snowfields. See SNOW; SNOW SURVEYING. [R.T.Be.]

**Snow line** A term generally used to refer to the elevation of the lower edge of a snow field. In mountainous areas, it is not truly a line but rather an irregular, commonly patchy border zone, the position of which in any one sector has been determined by the amount of snowfall and ablation. These factors may vary considerably from one part to another. On glacier surfaces the snow line is sometimes referred to as the glacier snow line or névé line (the outer limit of retained winter snow cover on a glacier).

Year-to-year variation in the position of the orographical snow line is great. The mean position over many decades, however, is important as a factor in the development of nivation hollows and protalus ramparts in deglaciated cirque beds. See GLACIOLOGY; SNOWFIELD AND NÉVÉ. [M.M.Mi.]

**Snow surveying** A technique for providing an inventory of the total amount of snow covering a drainage basin or a given region. Most of the usable water in western North America originates as mountain snowfall that accumulates during the winter and spring and appears several months later as streamflow. Snow

surveys were established to provide an estimate of the snow water equivalent (that is, the depth of water produced from melting the snow) for use in predicting the volume of spring runoff. They are also extremely useful for flood forecasting, reservoir regulation, determining hydropower requirements, municipal and irrigation water supplies, agricultural productivity, wildlife survival, and building design, and for assessing transportation and recreation conditions.

Conventional snow surveys are made at designated sites, known as snow courses, at regular intervals each year throughout the winter period. A snow sampler is used to measure the snow depth and water equivalent at a series of points along a snow course. Average depth and water equivalent are calculated for each snow course. Satellite remote sensing and data relay are technologies used to obtain information on snow cover in more remote regions. See REMOTE SENSING; SNOW GAGE; SURFACE WATER. [B.E.Go.]

**Snowfield and névé** The term snowfield is usually applied to mountain and glacial regions to refer to an area of snow-covered terrain with definable geographic margins. Where the connotation is very general and without regard to geographical limits, the term snow cover is more appropriate; but glaciology requires more precise terms with respect to snowfield areas.

These terms differentiate according to the physical character and age of the snow cover. Technically, a snowfield can embrace only new or old snow (material from the current accumulation year). Anything older is categorized as firn or ice. The term névé is a descriptive phrase used to refer to consolidated granular snow not yet changed to glacier ice. Because of the need for simple terms, however, it has become acceptable to use the term névé when specifically referring to a geographical area of snowfields on mountain slopes or glaciers (that is, an area covered with perennial "snow" and embracing the entire zone of annually retained accumulation). See GLACIOLOGY. [M.M.Mi.]

**Soap** A cleansing agent described chemically as an alkali metal salt of a long-carbon-chain monocarboxylic acid, such as sodium myristate ( $\text{NaCOOC}_{13}\text{H}_{27}$ ), as represented below.

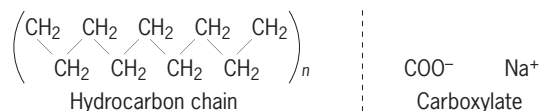

The hydrocarbon portion is hydrophobic and the carboxylate portion is hydrophilic. This duality enables soap to physically remove dirt and oils from surfaces and disperse or emulsify them in water. For detergency purposes, the most useful hydrophobic portion contains 12–18 carbon atoms. When the chain length exceeds 18 carbons, they become insoluble in water.

A soap-making process that was formerly used was based on an alkaline hydrolysis reaction, saponification, according to the reaction below, where R represents the hydrocarbon chain.

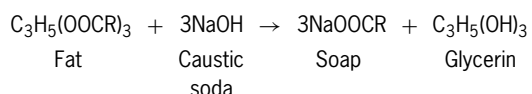

Most soap is now made by a continuous process. Fats and oils may be converted directly to soap by the reaction with caustic, and the neat soap separated by a series of centrifuges or by countercurrent washing. The saponification may be carried out with heat, pressure, and recirculation. Other important modern processes hydrolyze the fats directly with water and catalysts at high temperatures. This permits fractionation of the fatty acids, which are neutralized to soap in a continuous process. Advantages for this process are close control of the soap concentration, the preparation of soaps of certain chain lengths for specific purposes, and easy recovery of the by-product glycerin. Tallow and

coconut oil are the most common fatty materials used for soap-making.

Because of the marked imbalance of polarity within the molecules of synthetic detergents and soaps, they have unusual surface and solubility characteristics. The feature of their molecular structure which causes these properties is the location of the hydrophilic function at or near the end of a long hydrocarbon (hydrophobic) chain. One part of the molecule is water-seeking while the other portion is oil-seeking. Thus these molecules concentrate and orient themselves at interfaces, such as an oil-solution interface where the hydrophobic portion enters the oil and the hydrophilic portion stays in the water. Consequently, the interfacial tension is lowered and emulsification can result. At an agitated air-solution interface, the excess detergent concentration leads to sudsing.

Considerable research has also been done on the aqueous solutions of soap. Many of the phase characteristics now known to occur in most surfactant-water systems were first discovered in soap systems. These include micelle formation where, at a critical concentration, soap molecules in solution form clusters (micelles). The hydrocarbon chains associate with each other in the interior, and the polar groups are on the outside. See MICELLE; SURFACTANT.

There is one serious disadvantage to the use of soap which has largely caused its replacement by synthetic detergents. The problem is that carboxylate ions of the soap react with the calcium and magnesium ions in natural hard water to form insoluble materials which manifest as a floating curd. Bar soap for personal bathing is the greatest remaining market for soap. Some commercial laundries having soft water continue to use soap powders. Metallic soaps are alkaline-earth or heavy-metal long-chain carboxylates which are insoluble in water but soluble in nonaqueous solvents. They are used as additives to lubricating oils, in greases, as rust inhibitors, and in jellied fuels. See DETERGENT. [R.C.Mi.]

**Soapstone** A soft talc-rich rock. Soapstones are rocks composed of serpentine, talc, and carbonates (magnesite, dolomite, or calcite). They represent original periodites which were altered at low temperatures by hydrothermal solutions containing silicon dioxide, carbon dioxide, and other dissolved materials (products of low-grade metasomatism). The whole group of rocks may loosely be referred to as soapstones because of their soft, soapy consistency. [T.F.W.B.]

**Social hierarchy** A fundamental aspect of social organization that is established by fighting or display behavior and results in a ranking of the animals in a group. Social, or dominance, hierarchies are observed in many different animals, including insects, crustaceans, mammals, and birds. In many species, size, age, or sex determines dominance rank. Dominance hierarchies often determine first or best access to food, social interactions, or mating within animal groups.

When two animals fight, several different behavioral patterns can be observed. Aggressive acts and submissive acts are both parts of a fight. Aggression and submission, together, are known as agonistic behavior. An agonistic relationship in which one animal is dominant and the other is submissive is the simplest type of dominance hierarchy. In nature, most hierarchies involve more than two animals and are composed of paired dominant-subordinate relationships. The simplest dominance hierarchies are linear and are known as pecking orders. In such a hierarchy the top individual (alpha) dominates all others. The second-ranked individual (beta) is submissive to the dominant alpha but dominates the remaining animals. The third animal (gamma) is submissive to alpha and beta but dominates all others. This pattern is repeated down to the lowest animal in the hierarchy, which cannot dominate any other group member.

Other types of hierarchies result from variations in these patterns. If alpha dominates beta, beta dominates gamma, but

gamma dominates alpha, a dominance loop is formed. In some species a single individual dominates all members of the social group, but no consistent relationships are formed among the other animals. In newly formed hierarchies, loops or other nonlinear relationships are common, but these are often resolved over time so that a stable linear hierarchy is eventually observed.

Males often fight over access to females and to mating with them. Male dominance hierarchies are seen in many hooved mammals (ungulates). Herds of females use dominance hierarchies to determine access to food. Agonistic interactions among females are often not as overtly aggressive as those among males, but the effects of the dominance hierarchy can easily be observed. In female dairy cattle, the order of entry into the milking barn is determined by dominance hierarchy, with the alpha female entering first. See REPRODUCTIVE BEHAVIOR.

Because dominant animals may have advantages in activities such as feeding and mating, they will have more offspring than subordinate animals. If this is the case, then natural selection will favor genes for enhanced fighting ability. Heightened aggressive behavior may be counterselected by the necessity for amicable social interactions in certain circumstances. Many higher primates live in large groups of mixed sex and exhibit complex social hierarchies. In these groups, intra- and intersexual dominance relationships determine many aspects of group life, including feeding, grooming, sleeping sites, and mating. Macaque, baboon, and chimpanzee societies are characterized by cooperative alliances among individuals that are more important than individual fighting ability in maintaining rank. See PRIMATES.

Social hierarchies provide a means by which animals can live in groups and exploit resources in an orderly manner. In particular, food can be distributed among group members with little ongoing conflict. Another motivation for group living is mutual defense. Even though subordinates receive less food or have fewer opportunities to mate, they may have greatly increased chances of escaping predation. See BEHAVIORAL ECOLOGY; POPULATION ECOLOGY; SOCIAL MAMMALS; TERRITORIALITY. [M.D.Bre.]

**Social insects** Insects that share resources and reproduce cooperatively. The shared resources are shelter, defense, and food (collection or production). After a period of population growth, the insects reproduce in several ways. As social insect groups grow, they evolve more differentiation between members but reintegrate into a more closely organized system known as eusocial. These are the most advanced societies with individual polymorphism, and they contain insects of various ages, sizes, and shapes. All the eusocial insects are included in the orders Isoptera (termites) and Hymenoptera (wasps, bees, and ants). See HYMENOPTERA; INSECTA; ISOPTERA; POLYMORPHISM (GENETICS).

The social insects have evolved in various patterns. In the Hymenoptera, the society is composed of only females; males are produced periodically for their sperm. They usually congregate and attract females, or they visit colonies with virgin females and copulate there. In the Hymenoptera, sex is determined largely by whether the individual has one or two sets of chromosomes. Thus the queen has the power to determine the sex of her offspring: if she lets any of her stored sperm reach the egg, a female is produced; if not, a male results. In the more primitive bees and wasps, social role (caste) is influenced by interaction with like but not necessarily related individuals. The female that can dominate the others assumes the role of queen, even if only temporarily. Domination is achieved by aggression, real or feigned, or merely by a ritual that is followed by some form of salutation by the subordinates. This inhibits the yolk-stimulating glands and prevents the subordinates from contributing to egg production; if it fails to work, the queen tries to destroy any eggs that are laid. Subordinate females take on more and more of the work of the group for as long as the queen is present and well. At first, all the eggs are fertilized and females develop, with the result that virgin females inhabit the nest for the first batches. They are often undernour-

ished, and this, together with their infertility, reduces their urge to leave the nest and start another one. Such workers are said to be produced by maternal manipulation.

Reproductive ants, like termites, engage in a massive nuptial flight, after which the females, replete with sperm, go off to start a new nest. At some stage after the nuptials, the reproductives break off their wings, which have no further use. Workers, however, never have wings because they develop quickly and pass right through the wing-forming stages; their ovaries and genitalia are also reduced. Ant queens can prevent the formation of more queens; as with the honeybee, they do this behaviorally by using pheromones. They also force the workers to feed all larvae the same diet. To this trophogenic caste control is added a blastogenic control; eggs that are laid have a developmental bias toward one caste or another. This is not genetic; bias is affected by the age of the queen and the season: more worker-biased eggs are laid by young queens and by queens in spring. In some ants, workers mature in various sizes. Since they have disproportionately large heads, the biggest workers are used mainly for defense; they also help with jobs that call for strength, like cutting vegetation or cracking nuts.

Social insects make remarkable nests that protect the brood as well as regulate the microclimate. The simplest nests are cavities dug in soil or soft wood, with walls smoothed and plastered with feces that set hard. Chambers at different levels in the soil are frequently connected by vertical shafts so that the inhabitants can choose the chamber with the best microclimate. Termites and ants also make many different types of arboreal nests. These nests are usually made of fecal material, but one species of ant (*Oecophylla*) binds leaves together with silk produced in the salivary glands of their larvae that the workers hold in their jaws and spin across leaves. A whole group of ants (for example, *Pseudomyrmex*) inhabit the pith of plants.

Social bees use wax secreted by their cuticular glands and frequently blended with gums from tree exudates for their nest construction. Cells are made cooperatively by a curtain of young bees that scrape wax from their abdomen, chew it with saliva, and mold it into the correct shape; later it is planed and polished. With honeybees the hexagonal comb reaches perfection as a set of back-to-back cells, each sloping slightly upward to prevent honey from running out. The same cells are used repeatedly for brood and for storage; or they may be made a size larger for rearing males. Only the queen cell is pendant, with a circular cross section and an opening below.

The ubiquity and ecological power of social insects depend as much on their ability to evolve mutualistic relations with other organisms as on the coherence of their social organization. Wood and the cellulose it contains is normally available as a source of energy only to bacteria and fungi. However, it is used as a basic resource by both termites and ants that have evolved a technique of culturing these organisms. Though lower termites have unusual protozoa as intestinal symbionts, higher termites have bacteria in pouches in their hind gut. Many have a fungus that they culture in special chambers in their nests. The termites feed on woody debris, leaves, and grass cuttings; the fungus digests these materials with the aid of termite feces and produces soft protein-rich bodies that the termites share with their juveniles and reproductives, neither of which are able to feed themselves. Protected from the weather, the fungus can remain active throughout the dry seasons—an inestimable advantage in the subtropics.

Many ants collect and store seeds that they mash and feed directly to their larvae. Provided they are collected when dry and stored in well-ventilated chambers, these seeds can remain viable and edible for an entire season. The plants benefit because not all the seeds are eaten; some that start to germinate are thrown out with the rubbish of the colony—in effect a way of planting them. Others are left behind by the ants when they change nests. In this way, grass seeds can extend their range into dry areas that they could not reach alone.

The dispersal of plant pollen by bees is a well-known symbiosis, and it has led to the evolution of many strange shapes, colors, and scents in flowers. Quite specific flower-bee relationships may exist in which one plant may use very few species of bees for the transfer of pollen. See POLLINATION; POPULATION ECOLOGY. [M.V.B.]

**Social mammals** Mammals that exhibit social behavior. This may be defined as any behavior stimulated by or acting upon another animal of the same species. In this broad sense, almost any animal which is capable of behavior is to some degree social. Even those animals which are completely sedentary, such as adult sponges and sea squirts, have a tendency to live in colonies and are social to that extent. Social reactions are occasionally given by species other than the animals' own; an example would be the relations between domestic animals and humans.

The postnatal development of each species is closely related to the social organization typical of the adults. Every highly social animal has a short period early in life when it readily forms attachments to any animal with which it has prolonged contact. The process of socialization begins almost immediately after birth in ungulates like the sheep, and the primary relationship is formed with the mother. In dogs and wolves the process does not begin until about 3 weeks of age, at a time when the mother is beginning to leave the pups. Consequently the strongest relationships are formed with litter mates, thus forming the foundation of a pack. Many rodents stay in the nest long after birth; primary relationships are therefore formed with nest mates. Young primates are typically surrounded by a group of their own kind, but because they are carried for long periods the first strong relationship tends to be with the mother.

Mammals may develop all types of social behavior to a high degree, but not necessarily in every species. Mammals have great capacities for learning and adaptation, which means that social relationships are often highly developed on the basis of learning and habit formation as well as on the basis of heredity and biological differences. The resulting societies tend to be malleable and variable within the same species and to show considerable evidence of cultural inheritance from one generation to the next. Mammalian societies have been completely described in relatively few forms, and new discoveries will probably reveal the existence of a greater variety of social organization.

Basic human social organization and behavior obviously differs from that of all other primates, although it is related to them. At the same time, the range of variability of human societies as seen in the nuclear family does not approach that in mammals as a whole. Human societies are characterized by the presence of all fundamental types of social behavior and social relationships rather than by extreme specialization. See ETHOLOGY; HUMAN ECOLOGY; REPRODUCTIVE BEHAVIOR; SOCIOBIOLOGY. [J.P.S.]

**Sociobiology** A scientific discipline that applies principles of evolutionary biology to the study of animal and human social behavior. It is a synthesis of ethology, ecology, and evolutionary theory in which social behavior is viewed as a product of natural selection and other biological processes. Although most of the research in sociobiology has focused on understanding the behavior of nonhumans, sociobiological explanations have been used to interpret patterns of human behavior as well. See ECOLOGY; ETHOLOGY; ORGANIC EVOLUTION.

Sociobiology predicts that individuals will behave in ways that maximize their fitness (their success at projecting copies of their genetic material into succeeding generations) and argues that such behaviors can arise through the same evolutionary processes that operate on other trait systems. The central principle underlying sociobiology is that an individual's behavior is shaped, in part, by its genes, and thus is heritable and subject to natural selection. Natural selection is simply the result of the differential survival and reproduction of individuals who

show heritable variation in a trait. The variants of a trait that convey greater fitness will increase in frequency in a population over time. The distinctive sociobiological perspective on behavior views behaviors as strategies that have evolved through natural selection to maximize an individual's fitness. Note that under this view there is absolutely no need to assume that maximizing fitness is in any way a conscious goal underlying an animal's behavior—successful behavior is simply an emergent result of the evolutionary process and not the force driving that process. See BEHAVIORAL ECOLOGY.

**Altruism.** Animals sometimes behave in ways that seem to reduce their own personal fitness while increasing that of other individuals. For example, in many species of social mammals and in numerous species of birds, individuals commonly give alarm vocalizations that alert others to the presence of a predator while seemingly rendering themselves more conspicuous to attack. Evolutionary biologists since Charles Darwin have noted that these seemingly altruistic acts pose a challenge to the notion of an animal's behavior being a strategy to maximize individual fitness. See SOCIAL INSECTS; SOCIAL MAMMALS.

One resolution to this paradox comes from taking a "gene's eye view" of evolution, which recognizes that Darwinian fitness (an individual's success in producing offspring) is simply a specific case of the more general concept of inclusive fitness. Because an individual shares genes with its relatives, there are actually two different routes by which it can pass on copies of those genes to the next generation: first, through personal or direct reproduction; and second, by helping relatives to reproduce. Inclusive fitness is a composite measure of an individual's genetic contribution to the next generation that considers both of these routes.

Animals who behave altruistically toward relatives may, in fact, be behaving selfishly in the genetic sense if their behavior sufficiently enhances their inclusive fitness through its effects on the survival and reproduction of relatives. This phenomenon is referred to as kin selection. Because close relatives share more genes, on average, with an individual than do distant relatives, such seemingly altruistic behavior tends to be directed toward closer kin.

Another solution to the altruism paradox—one that can even operate among nonrelatives under certain conditions—is reciprocity. If the recipient of some altruistic behavior is likely to repay a donor in the future, it may be beneficial for the donor to perform the behavior even at some immediate cost to its own fitness. This is especially true if the cost is low and the anticipated benefit is high. Examples include food sharing among unrelated vampire bats and alliance behavior in some primates.

Under some conditions, it is possible for altruism to result from natural selection operating at the level of groups, rather than at the level of individuals or genes (for example, if groups containing altruists were at a sufficient selective advantage compared with groups containing only selfish individuals). However, within such groups, selection acting on individuals would still tend to favor selfishness over altruism. In any event, much of the cogency of sociobiology has resulted from the recognition that selection seems to be most powerful when it acts at lower levels—notably, genes and individuals rather than groups or species.

**Other social strategies.** Over the past three decades, the sociobiological view of behavior as an evolved strategy for maximizing inclusive fitness has proven to be a powerful explanatory paradigm for investigating many other aspects of animal social behavior. The phenomenon of sociality, for example, has been extensively explored from this perspective. Each species—and individuals within each species—can be investigated as to the relative costs and benefits associated with the decision of whether or not to be social. Similar considerations apply to many other strategic (though typically unconscious) decisions that animals make during their lives, such as whether to reproduce sexually, when in life to begin reproducing (with regard to season and age at maturation), how many partners to mate with and who those

partners should be, whether to compete with other individuals over access to partners, and whether to bestow parental care and the level of care to give. See MATERNAL BEHAVIOR; REPRODUCTIVE BEHAVIOR; SEXUAL DIMORPHISM. [D.P.B.; A.Di.F.]

**Soda niter** A nitrate mineral having chemical composition  $\text{NaNO}_3$  (sodium nitrate); also known as nitratite, it is by far the most abundant of the nitrate minerals. It sometimes occurs as simple rhombohedral crystals but is usually massive granular. The mineral has a perfect rhombohedral cleavage, conchoidal fracture, and is rather sectile. Its hardness is 1.5 to 2 on Mohs scale, and its specific gravity is 2.266. It has a vitreous luster and is transparent. It is colorless to white, but when tinted by impurities, it is reddish brown, gray, or lemon yellow. See HARDNESS SCALES.

Soda niter is a water-soluble salt found principally as a surface efflorescence in arid regions, or in sheltered places in wetter climates. It is usually associated with niter, nitrocalcite, gypsum, epsomite, mirabilite, and halite. The only large-scale commercial deposits of soda niter in the world occur in a belt roughly 450 mi (725 km) long and 10–50 mi (16–80 km) wide along the eastern slope of the coast ranges in the Atacama, Tarapaca, and Antofagasta Deserts of northern Chile. Chilean nitrate had a monopoly of the world's fertilizer market for many years, but now occupies a subordinate position owing to the development of synthetic processes for nitrogen fixation which permit the production of nitrogen from the air. See CALICHE; FERTILIZER; NITER; NITRATE MINERALS; NITROGEN. [G.Sw.]

**Sodalite** A mineral of the feldspathoid group with chemical composition  $\text{Na}_4\text{Al}_3\text{Si}_3\text{O}_{12}\text{Cl}$ . Sodalite is usually massive or granular with poor cleavage. The Mohs hardness is 5.5–6.0, and the density 2.3. The luster is vitreous, and the color is usually blue but may also be white, gray, or green. Notable occurrences are at Mount Vesuvius; Bancroft, Ontario; and on the Kola Peninsula of Russia. See FELDSPATHOID; SILICATE MINERALS. [L.Gr.]

**Sodium** A chemical element, Na, atomic number 11, and atomic weight 22.9898. Sodium is between lithium and potassium in the periodic table. The element is a soft, reactive, low-melting metal with a specific gravity of 0.97 at 20°C (68°F). Sodium is commercially the most important alkali metal. The physical properties of metallic sodium are summarized in the table below. See PERIODIC TABLE.

Sodium ranks sixth in abundance among all the elements in the Earth's crust, which contains 2.83% sodium in combined form. Only oxygen, silicon, aluminum, iron, and calcium are

more abundant. Sodium is, after chlorine, the second most abundant element in solution in seawater. The important sodium salts found in nature include sodium chloride (rock salt), sodium carbonate (soda and trona), sodium borate (borax), sodium nitrate (Chile saltpeter), and sodium sulfate. Sodium salts are found in seawater, salt lakes, alkaline lakes, and mineral springs. See ALKALI METALS.

Sodium reacts rapidly with water, and even with snow and ice, to give sodium hydroxide and hydrogen. The reaction liberates sufficient heat to melt the sodium and ignite the hydrogen. When exposed to air, freshly cut sodium metal loses its silvery appearance and becomes dull gray because of the formation of a coating of sodium oxide.

Sodium does not react with nitrogen. Sodium and hydrogen react above about 200°C (390°F) to form sodium hydride. Sodium reacts with ammonia, forming sodium amide. Sodium also reacts with ammonia in the presence of coke to form sodium cyanide.

Sodium does not react with paraffin hydrocarbons but does form addition compounds with naphthalene and other polycyclic aromatic compounds and with arylated alkenes. The reaction of sodium with alcohols is similar to, but less rapid than, the reaction of sodium with water. Sodium reacts with organic halides in two general ways. One of these involves condensation of two organic, halogen-bearing compounds by removal of the halogen, allowing the two organic radicals to join directly. The second type of reaction involves replacement of the halogen by sodium, giving an organosodium compound. See ORGANOMETALLIC COMPOUND.

Sodium chloride, or common salt,  $\text{NaCl}$ , is not only the form in which sodium is found in nature but (in purified form) is the most important sodium compound in commerce as well. Sodium hydroxide,  $\text{NaOH}$ , is also commonly known as caustic soda. Sodium carbonate,  $\text{Na}_2\text{CO}_3$ , is best known under the name soda ash.

The largest single use for sodium metal, accounting for about 60% of total production, is in the synthesis of tetraethyllead, an antiknock agent for automotive gasolines. A second major use is in the reduction of animal and vegetable oils to long-chain fatty alcohols; these alcohols are raw materials for detergent manufacture. Sodium is used to reduce titanium and zirconium halides to their respective metals. Sodium chloride is used in curing fish, meat packing, curing hides, making freezing mixtures, and food preparation (including canning and preserving). Sodium hydroxide is used in the manufacture of chemicals, cellulose film, rayon soap pulp, and paper. Sodium carbonate is used in the glass industry and in the manufacture of soap, detergents, various cleansers, paper and textiles, nonferrous metals, and petroleum products. Sodium sulfate (salt cake) is used in the pulp industry and in the manufacture of flat glass. See GLASS; HALITE; PAPER. [M.Si.]

The sodium ion ( $\text{Na}^+$ ) is the main positive ion present in extracellular fluids and is essential for maintenance of the osmotic pressure and of the water and electrolyte balances of body fluids. Hydrolysis of adenosine triphosphate (ATP) is mediated by the membrane-bound enzyme  $\text{Na}^+, \text{K}^+$ -ATPase (this enzyme is also called sodium pump). The potential difference associated with the transmembrane sodium and potassium ion gradients is important for nerve transmission and muscle contraction. Sodium ion gradients are also responsible for various sodium ion-dependent transport processes, including sodium-proton exchange in the heart, sugar transport in the intestine, and sodium-lithium exchange and amino acid transport in red blood cells. See POTASSIUM. [D.M.DeF.]

**Sodium-vapor lamp** An arc discharge lamp with sodium vapor as the emitting species. Low-pressure and high-pressure types are used commercially.

The low-pressure sodium lamp has remarkably high luminous efficiency, or efficacy, producing as much as 200 lumens per watt

Physical properties of sodium metal

Property	Temperature		Metric (scientific) units	British (engineering) units
	C	F		
Density	0	32	0.972 g/cm <sup>3</sup>	60.8 lb/ft <sup>3</sup>
	100	212	0.928 g/cm <sup>3</sup>	58.0 lb/ft <sup>3</sup>
	800	1472	0.757 g/cm <sup>3</sup>	47.3 lb/ft <sup>3</sup>
Melting point	97.5	207.5		
Boiling point	883	1621		
Heat of fusion	97.5	207.5	27.2 cal/g	48.96 Btu/lb
Heat of vaporization	883	1621	1005 cal/g	1809 Btu/lb
Viscosity	250	482	3.81 millipoises	4.3 kinetic units
	400	752	2.69 millipoises	3.1 kinetic units
Vapor pressure	440	824	1 mm	0.019 lb/in. <sup>2</sup>
	815	1499	400 mm	7.75 lb/in. <sup>2</sup>
Thermal conductivity	21.2	70.2	0.317 cal/(s)(cm)(°C)	76 Btu/(h)(ft)(°F)
	200	392	0.193 cal/(s)(cm)(°C)	46.7 Btu/(h)(ft)(°F)
Heat capacity	20	68	0.30 cal/(g)(°C)	0.30 Btu/(lb)(°F)
	200	392	0.32 cal/(g)(°C)	0.32 Btu/(lb)(°F)
Electrical resistivity	100	212	965 microhm-cm	
Surface tension	100	212	206.4 dynes/cm	
	250	482	199.5 dynes/cm	

of input power. The radiation is nearly monochromatic yellow in color, and is used where color rendition is unimportant. The very high luminous efficacy is due to very stringent control of heat losses from the arc. The key to the heat conservation is the indium oxide film used to reflect infrared energy back to the arc tube and the evacuated outer jacket that minimizes the conducted thermal losses. Lamps at 18 and 10 W of power have been developed for very low-energy-cost uses. The 10-W lamp produces light at 100 lm/W. See ILLUMINATION; LUMINOUS EFFICACY.

When the sodium pressure is increased by a higher liquid-sodium-pool temperature, the yellow sodium D-line resonance radiation reaches a condition where pressure broadening and self-absorption occur, producing a lamp no longer monochromatic yellow but golden-white in color. The high-pressure sodium lamp has a maximum arc tube temperature typically above 2000°F (1100°C) with a sodium amalgam reservoir temperature about 1300°F (700°C). The term high-pressure is used merely to distinguish this light source from the low-pressure sodium lamp. The plasma arc column of the high-pressure sodium lamp has a total pressure of sodium, mercury, and inert gas of typically slightly less than 1 atm ( $10^5$  Pa).

Because of the more compact source size, the light from a high-pressure sodium lamp can be more effectively directed by reflectors and refractors than that from the low-pressure sodium lamp. Therefore the higher efficacy of the low-pressure sodium lamp is offset by its reduced luminous efficiency. Sodium-vapor lamps are replacing high-pressure mercury lamps in many floodlight and roadway applications. More sodium-vapor lamps are manufactured annually than the high-pressure mercury and metal halide lamps combined. See LAMP; VAPOR LAMP. [C.I.McV.]

**Sofar** The acronym for sound fixing and ranging. The concept is based on finding the geographic location of sound that is created by an explosive or other impulsive event, such as a missile impact, by using the time of arrival of the signal at three or more receiving stations. This is known as hyperbolic fixing. This concept was used to locate aircraft that crashed at sea. Although other techniques have replaced this application, the term sofar channel has remained in use, referring to what is also known as the deep sound channel. See HYPERBOLIC NAVIGATION SYSTEM; UNDERWATER SOUND. [R.R.G.]

**Software** A set of instructions that cause a computer to perform one or more tasks. The set of instructions is often called a program or, if the set is particularly large and complex, a system. Computers cannot do any useful work without instructions from software; thus a combination of software and hardware (the computer) is necessary to do any computerized work. A program must tell the computer each of a set of minuscule tasks to perform, in a framework of logic, such that the computer knows exactly what to do and when to do it. See COMPUTER PROGRAMMING.

Programs are written in programming languages, especially designed to facilitate the creation of software. In the 1950s, programming languages were numerical languages easily understood by computer hardware; often, programmers said they were writing such programs in machine language.

Machine language was cumbersome, error-prone, and hard to change. In the latter 1950s, assembler (or assembly) language was invented. Assembler language was nearly the same as machine language, except that symbolic (instead of numerical) operations and symbolic addresses were used, making the code considerably easier to change.

The programmable aspects of computer hardware have not changed much since the 1950s. Computers still have numerical operations, and numerical addresses by which data may be accessed. However, programmers now use high-level languages, which look much more like English than a string of numbers or operation codes. See NUMBERING SYSTEMS; NUMERICAL REPRESENTATION (COMPUTERS); PROGRAMMING LANGUAGES.

Well-known programming languages include Basic, Java, and C. Basic has been modified into Visual Basic, a language useful for writing the portion of a program that the user "talks to" (i.e., the user interface or graphical user interface or GUI). Java is especially useful for creating software that runs on a network of computers. C and C++ are powerful but complex languages for writing such software as systems software and games. See HUMAN-COMPUTER INTERACTION; LOCAL-AREA NETWORKS; WIDE-AREA NETWORKS.

Packaged software such as word processors, spreadsheets, graphics and drawing tools, email systems, and games are widely available and used. Some software packages are enormous; for example, enterprise resource planning (ERP) software can be used by companies to perform almost all of their so-called back-office software work. See COMPUTER GRAPHICS; ELECTRONIC MAIL; VIDEO GAMES; WORD PROCESSING.

Systems software is necessary to support the running of an application program. Operating systems are needed to link the machine-dependent needs of a program with the capabilities of the machine on which it runs. Compilers translate programs from high-level languages into machine languages. Database programs keep track of where and how data are stored on the various storage facilities of a typical computer, and simplify the task of entering data into those facilities or retrieving the data. Networking software provides the support necessary for computers to interact with each other, and with data storage facilities, in a situation where multiple computers are necessary to perform a task, or when software is running on a network of computers (such as the Internet or the World Wide Web). See DATABASE MANAGEMENT SYSTEM; INTERNET; OPERATING SYSTEM; TELEPROCESSING; WORLD WIDE WEB.

Business applications software processes transactions, produces paychecks, and does the myriad of other tasks that are essential to running any business. Roughly two-thirds of software applications are in the business area.

Scientific and engineering software satisfies the needs of a scientific or engineering user to perform enterprise-specific tasks. Because scientific and engineering tasks tend to be very enterprise-specific, there has been no generalization of this application area analogous to the that of the ERP for backoffice business systems. The scientific-engineering application usually is considered to be in second place only to business software in terms of software products built.

Edutainment software instructs (educates) or plays games with (entertains) the user. Such software often employs elaborate graphics and complex logic. This is one of the most rapidly growing software application areas, and includes software to produce special effects for movies and television programs.

Real-time software operates in a time-compressed, real-world environment. Although most software is in some sense real-time, since the users of modern software are usually interacting with it via a GUI, real-time software typically has much shorter time constraints. For example, software that controls a nuclear reactor must make decisions and react to its environment in minuscule fractions of a second.

With the advent of multiple program portions, software development has become considerably more complicated. Whereas it was formerly considered sensible to develop all of a software system in the same programming language, now the different portions are often developed in entirely different languages. The relatively complex GUI, for example, can most conveniently be developed in one of the so-called visual languages, since those languages contain powerful facilities for creating it. The server software, on the other hand, will likely be built using a database package and the database language SQL (a Structured Query Language, for inquiring into the contents of a database). If the server software is also responsible for interacting with a network such as the Internet, it may also be coded in a network-support language such as Java. An object-oriented approach may be adopted in its development, since the software will need to manipulate objects on the Internet. See COMPUTER



PROGRAMMING; OBJECT-ORIENTED PROGRAMMING; SOFTWARE ENGINEERING. [R.L.GI.]

**Software engineering** The process of manufacturing software systems. A software system consists of executable computer code and the supporting documents needed to manufacture, use, and maintain the code. For example, a word processing system consists of an executable program (the word processor), user manuals, and the documents, such as requirements and designs, needed to produce the executable program and manuals. See SOFTWARE.

Software engineering is ever more important as larger, more complex, and life-critical software systems proliferate. The rapid decline in the costs of computer hardware means that the software in a typical system often costs more than the hardware it runs on. Large software systems may be the most complex things ever built. This places great demands on the software engineering process, which must be disciplined and controlled.

To meet this challenge, software engineers have adapted many techniques from older engineering fields, as well as developing new ones. For example, divide and conquer, a well-known technique for handling complex problems, is used in many ways in software engineering. The software engineering process itself, for example, is usually divided into phases. The definition of these phases, their ordering, and the interactions between the phases specify a software life-cycle model. The best-known life-cycle model is the waterfall model consisting of a requirements definition phase, a design phase, a coding phase, a testing phase, and a maintenance phase. The output of each phase serves as the input to the next. See SYSTEMS ENGINEERING.

The purpose of the requirements phase is to define what a system should do and the constraints under which it must operate. This information is recorded in a requirements document. A typical requirements document might include a product overview; a specification of the development, operating, and maintenance environment for the product; a high-level conceptual model of the system; a specification of the user interface; specification of functional requirements; specification of nonfunctional requirements; specification of interfaces to systems outside the system under development; specification of how errors will be handled; and a listing of possible changes and enhancements to the system. Each requirement, usually numbered for reference, must be testable.

In the design phase, a plan is developed for how the system will implement the requirements. The plan is expressed using a design method and notation. Many methods and notations for software design have been developed. Each method focuses on certain aspects of a system and ignores or minimizes others. This is similar to viewing a building with an architectural drawing, a plumbing diagram, an electrical wiring diagram, and so forth.

The coding phase of the software life-cycle is concerned with the development of code that will implement the design. This code is written in a formal language called a programming language. Programming languages have evolved over time from sequences of ones and zeros directly interpretable by a computer, through symbolic machine code, assembly languages, and finally to higher-level languages that are more understandable to humans. See PROGRAMMING LANGUAGES.

Most coding today is done in one of the higher-level languages. When code is written in a higher-level language, it is translated into assembly code, and eventually machine code, by a compiler. Many higher-level languages have been developed, and they can be categorized as functional languages, declarative languages, and imperative languages.

Following the principle of modularity, code on large systems is separated into modules, and the modules are assigned to individual programmers. A programmer typically writes the code using a text editor. Sometimes a syntax-directed editor that "knows" about a given programming language and can provide program-

ming templates and check code for syntax errors is used. Various other tools may be used by a programmer, including a debugger that helps find errors in the code, a profiler that shows which parts of a module spend most time executing, and optimizers that make the code run faster.

Testing is the process of examining a software product to find errors. This is necessary not just for code but for all life-cycle products and all documents in support of the software such as user manuals.

The software testing process is often divided into phases. The first phase is unit testing of software developed by a single programmer. The second phase is integration testing where units are combined and tested as a group. System testing is done on the entire system, usually with test cases developed from the system requirements. Acceptance testing of the system is done by its intended users.

The basic unit of testing is the test case. A test case consists of a test case type, which is the aspect of the system that the test case is supposed to exercise; test conditions, which consist of the input values for the test; the environmental state of the system to be used in the test; and the expected behavior of the system given the inputs and environmental factors.

When software is changed to fix a bug or add an enhancement, a serious error is often introduced. To ensure that this does not happen, all test cases must be rerun after each change. The process of rerunning test cases to ensure that no error has been introduced is called regression testing. See SOFTWARE TESTING AND INSPECTION.

Walkthroughs and inspections are used to improve the quality of the software development process. Consequently, the software products created by the process are improved. A quality system is a collection of techniques whose application results in continuous improvement in the quality of the development process. Elements of the quality system include reviews, inspections, and process audits.

Large software systems are not static; rather, they change frequently both during development and after deployment. Maintenance is the phase of the software life-cycle after deployment. The maintenance phase may cost more than all of the others combined and is thus of primary concern to software organizations. The Y2K problem was, for example, a maintenance problem.

Maintenance consists of three activities: adaptation, correction, and enhancement. Enhancement is the process of adding new functionality to a system. This is usually done at the request of system users. This activity requires a full life-cycle of its own. That is, enhancements demand requirements, design, implementation, and test. Studies have shown that about half of maintenance effort is spent on enhancements.

Adaptive maintenance is the process of changing a system to adapt it to a new operating environment, for example, moving a system from the Windows operating system to the Linux operating system. Adaptive maintenance has been found to account for about a quarter of total maintenance effort. Corrective maintenance is the process of fixing errors in a system after release. Corrective maintenance takes about 20% of maintenance effort.

Since software systems change frequently over time, an important activity is software configuration management. This consists of tracking versions of life-cycle objects, controlling changes to them, and monitoring relationships among them. Configuration management activities include version control, which involves keeping track of versions of life-cycle objects; change control, an orderly process of handling change requests to a system; and build control, the tracking of which versions of work products go together to form a given version of a software product.

[W.B.Fra.]

**Software metric** A rule for quantifying some characteristic or attribute of a computer software entity. For example, a simple one is the FileSize metric, which is the total number of

characters in the source files of a program. The FileSize metric can be used to determine the measure of a particular program, such as 3K bytes. It provides a concrete measure of the abstract attribute of program size. Other metrics can be used for software entities such as requirements documents, design object models, or database structure models. Metrics for requirements and design documents can be used to guide decisions about development and as a basis for predictions, such as for cost and effort. Metrics for programs can be used to support decisions about testing and maintenance and as a basis for comparing different versions of programs. Ideally, metrics for the development cost of software and for the quality of the resultant program are desirable. See COMPUTER PROGRAMMING; SOFTWARE ENGINEERING.

[D.A.G.; W.Han.]

**Software testing and inspection** Procedures for the detection of software faults. When software does not operate as it is intended to do, a software failure is said to occur. Software failures are caused by one or more sections of the software program being incorrect. Each of these incorrect sections is called a software fault. The fault could be as simple as a wrong value. A fault could also be complete omission of a decision in the program. Faults have many causes, including misunderstanding of requirements, overlooking special cases, using the wrong variable, misunderstanding of the algorithm, and even typing mistakes. Software that can cause serious problems if it fails is called safety-critical software. Many applications in aircraft, medicine, nuclear power plants, and transportation involve such software.

Software testing is the execution of the software with the purpose of detecting faults. Software inspection is a manual process of analyzing the source code to detect faults. Many of the same techniques are used in both procedures. Other techniques can also be used to minimize the possibility of faults in the software. These techniques include the use of formal specifications, formal proofs of correctness, and model checking. However, even with the use of these techniques, it is still important to execute software with test cases to detect possible faults.

Software testing involves selecting test cases, determining the correct output of the software, executing the software with each test case, and comparing the actual output with the expected output. More testing is better, but costs time and effort. The value of additional testing must be balanced against the additional cost of effort and the delay in delivering the software. Another consideration is the potential cost of failure of the software. Safety-critical software is usually tested much more thoroughly than any other software.

The number of potential test cases is huge. For example, in the case of a simple program that multiplies two integer numbers, if each integer is internally represented as a 32-bit number (a common size for the internal representation), then there are  $2^{32}$  possible values for each number. Thus, the total number of possible input combinations is  $2^{64}$ , which is more than  $10^{19}$ . If a test case can be done each microsecond ( $10^{-6}$  second), then it will take hundreds of thousands of years to try all of the possible test cases. Trying all possible test cases is called exhaustive testing and is usually not a reasonable approach because of the size of the task.

One approach to software testing is to find test cases so that all statements in a program are executed. A more extensive criterion for test selection is "every branch coverage." This means that each branch coming out of every decision is tested. Instead of just requiring the whole decision to be true or false, the "multiple condition coverage" criterion requires all combinations of truth values for each simple comparison in a decision to be covered. Another approach is called dataflow coverage. The basis for coverage is the execution paths between the statement where a variable is assigned a value (a def or definition) and a statement where that value is used. These paths must be free of other definitions of the variable of interest. See DATAFLOW SYSTEMS.

Functional testing compares the actual behavior of the software with the expected behavior. That expected behavior is usually described in a specification. More involved functional test case selection involves analyzing the conditions inherent in the task.

Another approach to test selection concentrates on the boundaries between the subdomains. This approach recognizes that many faults are related to the boundary conditions. Test cases are chosen to check whether the boundary is correct. Test cases on the boundary and test cases just off the boundary are chosen. See SOFTWARE; SOFTWARE ENGINEERING.

[D.A.G.]

**Soil** Finely divided rock-derived material containing an admixture of organic matter and capable of supporting vegetation. Soils are independent natural bodies, each with a unique morphology resulting from a particular combination of climate, living plants and animals, parent rock materials, relief, the groundwaters, and age. Soils support plants, occupy large portions of the Earth's surface, and have shape, area, breadth, width, and depth. Soil, as used here, differs in meaning from the term as used by engineers, where the meaning is unconsolidated rock material. See PEDOLOGY.

**Origin and classification.** Soil covers most of the land surface as a continuum. Each soil grades into the rock material below and into other soils at its margins, where changes occur in relief, groundwater, vegetation, kinds of rock, or other factors which influence the development of soils. Soils have horizons, or layers, more or less parallel to the surface and differing from those above and below in one or more properties, such as color, texture, structure, consistency, porosity, and reaction (see illustration). The succession of horizons is called the soil profile.

Soil formation proceeds in stages, but these stages may grade indistinctly from one into another. The first stage is the accumulation of unconsolidated rock fragments, the parent material. Parent material may be accumulated by deposition of rock fragments moved by glaciers, wind, gravity, or water, or it may accumulate more or less in place from physical and chemical weathering of hard rocks. The second stage is the formation of horizons. This stage may follow or go on simultaneously with



Photograph of a soil profile showing horizons. The dark crescent-shaped spots at the soil surface are the result of plowing. The dark horizon is the principal horizon of accumulation of organic matter that has been washed down from the surface. The thin wavy lines were formed in the same manner. 1 in. = 2.5 cm.

Soil orders		
Order	Formative element in name	General nature of soils
Alfisols	alf	Gray to brown surface horizons, medium to high base supply, with horizons of clay accumulation; usually moist, but may be dry during summer
Aridisols	id	Pedogenic horizons, low in organic matter, and usually dry
Entisols	ent	Pedogenic horizons lacking
Histosols	ist	Organic (peats and mucks)
Inceptisols	ept	Usually moist, with pedogenic horizons of alteration of parent materials but not of illuviation
Mollisols	oil	Nearly black organic-rich surface horizons and high base supply
Oxisols	ox	Residual accumulations of inactive clays, free oxides, kaolin, and quartz; mostly tropical
Spodosols	od	Accumulations of amorphous materials in subsurface horizons
Ultisols	ult	Usually moist, with horizons of clay accumulation and a low supply of bases
Vertisols	ert	High content of swelling clays and wide deep cracks during some season

the accumulation of parent material. Soil horizons are a result of dominance of one or more processes over others, producing a layer which differs from the layers above and below. See WEATHERING PROCESSES.

Systems of soil classification are influenced by concepts prevalent at the time a system is developed. The earliest classifications were based on relative suitability for different crops, such as rice soils, wheat soils, and vineyard soils. Over the years, many systems of classification have been attempted but none has been found markedly superior. Two bases for classification have been tried. One basis has been the presumed genesis of the soil; climate and native vegetation were given major emphasis. The other basis has been the observable or measurable properties of the soil.

The Soil Survey staff of the U.S. Department of Agriculture and the land-grant colleges adopted the current classification scheme in 1965. This system differs from earlier systems in that it may be applied to either cultivated or virgin soils. Previous systems have been based on virgin profiles, and cultivated soils were classified on the presumed characteristics or genesis of the virgin soils. The new system has six categories, based on both physical and chemical properties. These categories are the order, suborder, great group, subgroup, family, and series, in decreasing rank. The orders and the general nature of the included soils are given in the table. The suborder narrows the ranges in soil moisture and temperature regimes, kinds of horizons, and composition, according to which of these is most important. The taxa (classes) in the great group category group soils that have the same kinds of horizons in the same sequence and have similar moisture and temperature regimes. The great groups are divided into subgroups that show the central properties of the great group, intergrade subgroups that show properties of more than one great group, and other subgroups for soils with atypical properties that are not characteristic of any great group. The families are defined largely on the basis of physical and mineralogical properties of importance to plant growth. The soil series is a group of soils having horizons similar in differentiating characteristics and arrangement in the soil profile, except for texture of the surface portion, and developed in a particular type of parent material.

**Surveys.** Soil surveys include those researches necessary (1) to determine the important characteristics of soils, (2) to classify them into defined series and other units, (3) to establish and map the boundaries between kinds of soil, and (4) to correlate and predict adaptability of soils to various crops, grasses, and trees; behavior and productivity of soils under different manage-

ment systems; and yields of adapted crops on soils under defined sets of management practices. Although the primary purpose of soil surveys has been to aid in agricultural interpretations, many other purposes have become important, ranging from suburban planning, rural zoning, and highway location, to tax assessment and location of pipelines and radio transmitters. This has happened because the soil properties important to the growth of plants are also important to its engineering uses.

Two kinds of soil maps are made. The common map is a detailed soil map, on which soil boundaries are plotted from direct observations throughout the surveyed area. Reconnaissance soil maps are made by plotting soil boundaries from observations made at intervals. The maps show soil and other differences that are of significance for present or foreseeable uses. [G.D.S.]

**Physical properties.** Physical properties of soil have critical importance to growth of plants and to the stability of cultural structures such as roads and buildings. Such properties commonly are considered to be: size and size distribution of primary particles and of secondary particles, or aggregates, and the consequent size, distribution, quantity, and continuity of pores; the relative stability of the soil matrix against disruptive forces, both natural and cultural; color and textural properties, which affect absorption and radiation of energy; and the conductivity of the soil for water, gases, and heat. These usually would be considered as fixed properties of the soil matrix, but actually some are not fixed because of influence of water content. The additional property, water content—and its inverse, gas content—ordinarily is transient and is not thought of as a property in the same way as the others. However, water is an important constituent, despite its transient nature, and the degree to which it occupies the pore space generally dominates the dynamic properties of soil. Additionally, the properties listed above suggest a macroscopic homogeneity for soil which it may not necessarily have. In a broad sense, a soil may consist of layers or horizons of roughly homogeneous soil materials of various types that impart dynamic properties which are highly dependent upon the nature of the layering. Thus, a discussion of dynamic soil properties must include a description of the intrinsic properties of small increments as well as properties it imparts to the system.

From a physical point of view it is primarily the dynamic properties of soil which affect plant growth and the strength of soil beneath roads and buildings. While these depend upon the chemical and mineralogical properties of particles, particle coatings, and other factors discussed above, water content usually is the dominant factor. Water content depends upon flow and retention properties, so that the relationship between water content and retentive forces associated with the matrix becomes a key physical property of a soil. See EROSION; GROUND-WATER HYDROLOGY; SOIL MECHANICS. [W.H.G.]

**Soil chemistry** The study of the composition and chemical properties of soil. Soil chemistry involves the detailed investigation of the nature of the solid matter from which soil is constituted and of the chemical processes that occur as a result of the action of hydrological, geological, and biological agents on the solid matter. Because of the broad diversity among soil components and the complexity of soil chemical processes, the application of a wide variety of concepts and methods employed in the chemistry of aqueous solutions, of amorphous and crystalline solids, and of solid surfaces is required.

**Elemental composition.** The elemental composition of soil varies over a wide range, permitting only a few general statements to be made. Those soils that contain less than 12–20% organic carbon are termed mineral. All other soils are termed organic. Carbon, oxygen, hydrogen, nitrogen, phosphorus, and sulfur are the most important constituents of organic soils and of soil organic matter in general. Carbon, oxygen, and hydrogen are most abundant; the content of nitrogen is often about one-tenth that of carbon, while the content of phosphorus or sulfur is usually less than one-fifth that of nitrogen (Table 1).

**Table 1. Average percentages of total carbon, total nitrogen, and organic phosphorus in selected soils**

Soil	% C	% N	% P
Sand	2.5	.23	.04
Fine sandy loam	3.3	.23	.06
Medium loam	2.3	.22	.05
Clay loam, well drained	4.6	.36	.10
Clay loam, poorly drained	8.0	.43	.05
Peat	46.1	1.32	.03

Besides oxygen, the most abundant elements found in mineral soils are silicon, aluminum, and iron. The distribution of chemical elements will vary considerably from soil to soil and, in general, will be different in a specific soil from the distribution of elements in the crustal rocks of the Earth. The most important micro or trace elements in soil are boron, copper, manganese, molybdenum, and zinc, since these elements are essential in the nutrition of green plants. Also important are cobalt, selenium, cadmium, and nickel. The average distribution of trace elements in soil is not greatly different from that in crustal rocks (Table 2).

The elemental composition of soil varies with depth below the surface because of pedochemical weathering. The principal processes of this type that result in the removal of chemical elements from a given soil horizon are: (1) solvation (ordinary dissolution in water), (2) cheluviation (complexation by organic or inorganic ligands), (3) reduction, and (4) suspension. The principal effect of these four processes is the appearance of alluvial horizons in which compounds such as aluminum and iron oxides, aluminosilicates, or calcium carbonate have been precipitated from solution or deposited from suspension. See WEATHERING PROCESSES.

**Minerals.** The minerals in soils are the products of physical, geochemical, and pedochemical weathering. Soil minerals may be either amorphous or crystalline. They may be classified further, approximately, as primary or secondary minerals, depending on whether they are inherited from parent rock or are produced by chemical weathering, respectively.

The bulk of the primary minerals that occur in soil are found in the silicate minerals. Chemical weathering of the silicate minerals is responsible for producing the most important secondary minerals in soil. These are found in the clay fraction and include aluminum and iron hydrous oxides (usually in the form of coatings on other minerals), carbonates, and aluminosilicates. See CLAY MINERALS; SILICATE MINERALS.

**Ion exchange.** A portion of the chemical elements in soil is in the form of cations that are not components of inorganic salts but that can be replaced reversibly by the cations of leaching salt solutions or acids. These cations are said to be exchangeable, and their total quantity is termed the cation exchange capacity (CEC) of the soil. The CEC of a soil generally will vary directly

**Table 2. Average amounts of trace elements commonly found in soils and crustal rocks**

Trace element	Soil, ppm*	Crustal rocks, ppm
As	6	1.8
B	10	10
Cd	.06	.2
Co	8	25
Cr	100	100
Cu	20	55
Mo	2	1.5
Ni	40	75
Pb	10	13
Se	.2	.05
V	100	135
Zn	50	70

\*ppm = parts per million.

with the amounts of clay and organic matter present and with the distribution of clay minerals.

The stoichiometric exchange of the anions in soil for those in a leaching salt solution is a phenomenon of relatively small importance in the general scheme of anion reactions with soils. Under acid conditions (pH < 5) the exposed hydroxyl groups at the edges of the structural sheets or on the surfaces of clay-sized particles become protonated and thereby acquire a positive charge. The degree of protonation is a sensitive function of pH, the ionic strength of the leaching solution, and the nature of the clay-sized particle.

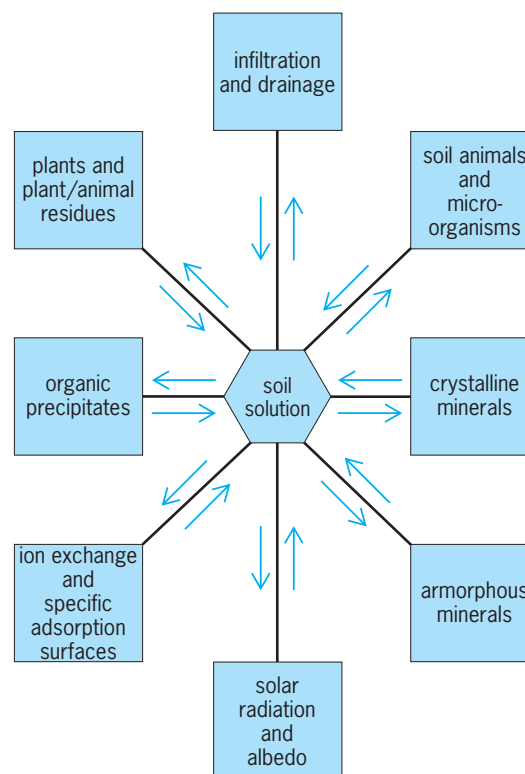

**Factors influencing the chemistry of soil solution. (Modified from J. F. Hodgson, *Chemistry of the micronutrients in soil*, *Adv. Agron.*, 15:141, 1963)**

**Soil solution.** The solution in the pore space of soil acquires its chemical properties through time-varying inputs and outputs of matter and energy that are mediated by the several parts of the hydrologic cycle and by processes originating in the biosphere (see illustration). The soil solution thus is a dynamic and open natural water system whose composition reflects the many reactions that can occur simultaneously between an aqueous solution and an assembly of mineral and organic solid phases that varies with both time and space. [G.Sp.]

**Soil conservation** The practice of arresting and minimizing artificially accelerated soil deterioration. Its importance has grown because cultivation of soils for agricultural production, deforestation and forest cutting, grazing of natural range, and other disturbances of the natural cover and position of the soil have increased greatly in the last 100 years.

**Erosion and deterioration.** The exact extent of accelerated soil erosion in the world today is not known, particularly as far as the rate of soil movement is concerned. However, it may be said that nearly every semiarid area with cultivation or long-continued grazing, every hill land with moderate to dense settlement in humid temperate and subtropical climates, and all cultivated or grazed hill lands in the Mediterranean climate areas suffer to some degree from such erosion. Recognized problems

of erosion are found in such culturally diverse areas as southern China, the Indian plateau, south Australia, the South African native reserves, Russia, Spain, the southeastern and midwestern United States, and Central America.

Within the United States the most critical areas have been the hill lands of the Piedmont and the interior Southeast, the Great Plains, the Palouse area hills of the Pacific Northwest, southern California hills, and slope lands of the Midwest. The high-intensity rainstorms of the Southeast, and the cyclical droughts of the Plains have predisposed the two larger areas to erosion. *See* EROSION.

Soil may deteriorate either by physical movement of soil particles from a given site or by depletion of the water-soluble elements in the soil which contribute to the nourishment of crop plants, grasses, trees, and other economically usable vegetation. The physical movement generally is referred to as erosion. Wind, water, glacial ice, animals, and tools used by humans may be agents of erosion. For purposes of soil conservation, the two most important agents of erosion are wind and water, especially as their effects are intensified by the disturbance of natural cover or soil position.

Depletion of soil nutrients obviously is a part of soil erosion. However, such depletion may take place in the absence of any noticeable amount of erosion. The disappearance of naturally stored nitrogen, potash, phosphate, and some trace elements from the soil also affects the usability of the soil for human purposes. The natural fertility of virgin soils always is depleted over time as cultivation continues, but the rate of depletion is highly dependent on management practices. *See* PLANT MINERAL NUTRITION; SOIL.

Accelerated erosion may be induced by any land use practice which denudes the soil surfaces of vegetative cover. For example, cultivation of any row crop on a slope without soil-conserving practices is an invitation to accelerated erosion. Cultivation of other crops, like the small grains, also may induce accelerated erosion, especially where fields are kept bare between crops to store moisture. Forest cutting, overgrazing, grading for highway use, urban land use, or preparation for other large-scale engineering works also may speed the erosion of soil.

**Causes of soil mismanagement.** One of the chief causes of erosion-inducing agricultural practices in the United States has been ignorance of their consequences. The cultivation methods of the settlers of western European stock who set the pattern of land use in this country came from a physical environment which was far less susceptible to erosion than North America, because of the mild nature of rainstorms and the prevailing soil textures in Europe. Corn, cotton, and tobacco, moreover, were crops unfamiliar to European agriculture. In eastern North America the combination of European cultivation methods and American interfilled crops resulted in generations of soil mismanagement.

On the Plains and in other susceptible western areas, small grain monoculture, particularly of wheat, encouraged the exposure of the uncovered soil surface so much of the time that water and wind inevitably took their toll. On rangelands, lack of knowledge as to the precipitation cycle and range capacity, and the urge to maximize profits every year contributed to a slower, but equally sure denudation of cover.

Finally, the United States has experienced extensive erosion in mountain areas because of forest mismanagement. Clear-cutting of steep slopes, forest burning for grazing purposes, inadequate fire protection, and shifting cultivation of forest lands have allowed vast quantities of soil to wash out of the slope sites where they could have produced timber and other forest values indefinitely.

**Effects on other resources.** Accelerated erosion may have consequences which reach far beyond the lands on which the erosion takes place and the community associated with them. During periods of heavy wind erosion, for example, the dust fall may be of economic importance over a wide area beyond that from which the soil cover has been removed. The most pervasive

and widespread effects, however, are those associated with water erosion. Removal of upstream cover changes the regimen of streams below the eroding area.

A long chain of other effects also ensues. Because of the extremes of low water in denuded areas during dry seasons, water transportation is made difficult or impossible without regulation, fish and wildlife support is endangered or disappears, the capacity of streams to carry sewage and other wastes safely may be seriously reduced, recreational values are destroyed, and run-of-the-river hydroelectric generation reaches a very low level. *See* WATER CONSERVATION. [E.A.A.; D.J.P.]

**Soil degradation** Loss in the quality or productivity of soil as a result of human activities. Degradation is attributed to changes in soil nutrient status, loss of soil organic matter, deterioration of soil structure, and toxicity due to accumulations of naturally occurring or anthropogenic materials. The effects of soil degradation include loss of agricultural productivity, negative impacts on the environment and economic stability, and increased clearing of virgin forest and exploitation of marginally suitable land. *See* SOIL.

Soil degradation may impair the function of soil organisms and thus result in further problems. The soil microbial community is essential to cycling of nutrients and decomposition of wastes; thus hindrance of microbial activities may have serious ecological results. Degradative forces such as erosion that result in loss of organic matter may also result in long-term losses of microbial activity. *See* EROSION; SOIL ECOLOGY.

Soil degradation often affects productivity through depletion of plant nutrients. Excessive leaching of cations involved in buffering soil pH may result in soil acidification, changing the solubility, and thus availability, of certain nutrients to plants. Misuse can also result in concentrations of chemicals that are toxic to plants. *See* SOIL CHEMISTRY; SOIL FERTILITY.

Historically, mining of coal and various metal ores has been among the most devastating forms of land use. Mining often exposes large amounts of reduced (decreased oxidation state) minerals in the form of mine tailings and rubble. The acidic mine tailings are extremely difficult to revegetate, and without intervention they remain exposed, continuing to produce acidic drainage until oxidizable material is depleted. Left untreated, surface (strip) mines may require 50–150 years to recover. *See* AUTOXIDATION; SURFACE MINING.

In some cases, compounds are toxic to soil organisms when present at significant concentrations, and thus produce large shifts in microbial community structure. Eventually, microorganisms present in the soil degrade most organic contaminants, thus alleviating toxic effects.

Unlike organic contaminants, which are degraded to nontoxic forms, toxic metals usually become essentially permanent features of soils. Fortunately, adsorption of metals to soil colloids decreases the availability of the metals for movement in the environment or uptake by plants, animals, and microorganisms. *See* AGRICULTURAL CHEMISTRY. [G.K.S.]

**Soil ecology** The study of the interactions among soil organisms, and between biotic and abiotic aspects of the soil environment. Soil is made up of a multitude of physical, chemical, and biological entities, with many interactions occurring among them. Soil is a variable mixture of broken and weathered minerals and decaying organic matter. Together with the proper amounts of air and water, it supplies, in part, sustenance for plants as well as mechanical support. *See* SOIL.

Abiotic and biotic factors lead to certain chemical changes in the top few decimeters (8–10 in.) of soil. The work of the soil ecologist is made easier by the fact that the surface 10–15 cm (4–6 in.) of the A horizon has the majority of plant roots, microorganisms, and fauna. A majority of the biological-chemical activities occur in this surface layer.

The biological aspects of soil range from major organic inputs, decomposition by primary decomposers (bacteria, fungi, and actinomycetes), and interactions between microorganisms and fauna (secondary decomposers) which feed on them. The detritus decomposition pathway occurs on or within the soil after plant materials (litter, roots, sloughed cells, and soluble compounds) become available through death or senescence. Plant products are used by microorganisms (primary decomposers). These are eaten by the fauna which thus affect flows of nutrients, particularly nitrogen, phosphorus, and sulfur. The immobilization of nutrients into plants or microorganisms and their subsequent mineralization are critical pathways. The labile inorganic pool is the principal one that permits subsequent microorganism and plant existence. Scarcity of some nutrient often limits production. Most importantly, it is the rates of flux into and out of these labile inorganic pools which enable ecosystems to successfully function. See ECOLOGY; ECOSYSTEM; GUILD; SOIL; SYSTEMS ECOLOGY. [D.C.C.]

**Soil fertility** The ability of a soil to supply plant nutrients. Sixteen chemical elements are required for the growth of all plants: carbon, oxygen, and hydrogen (these three are obtained from carbon dioxide and water), plus the elements nitrogen, phosphorus, potassium, calcium, magnesium, sulfur, iron, manganese, zinc, copper, boron, molybdenum, and chlorine. Some plant species also require one or more of the elements cobalt, sodium, vanadium, and silicon. See PLANT MINERAL NUTRITION.

While carbon and oxygen are supplied to plants from carbon dioxide in the air, the other essential elements are supplied primarily by the soil. Of the latter, all except hydrogen from water are called mineral nutrients. Only part of the 13 essential mineral nutrients in soil are in a chemical form that can be immediately used by plants. The unusable (unavailable) parts, which eventually do become available to plants, are of two kind: they may be in organic combination (such as nitrogen in soil humus) or in solid inorganic soil particles (such as potassium in soil clays). The time for complete decomposition and dissolution of these compounds varies widely, from days to hundreds of years.

Soils exhibit a variable ability to supply the mineral nutrients needed by plants. This characteristic allows soils to be classified according to their level of fertility. This can vary from a deficiency to a sufficiency, or even toxicity (too much), of one or more nutrients. A serious deficiency of only one essential nutrient can still greatly reduce crop yields. Several soil properties are important in determining a soil's inherent fertility. One property is the adsorption and storage of nutrients on the surfaces of soil particles. Such adsorption of a number of nutrients is caused by an attraction of positively charged nutrients to negatively charged soil particles. This adsorption is called cation exchange (adsorbed cations can be exchanged with other cations in solution), and the quantity of nutrient cations a soil can adsorb is called its cation-exchange capacity. See ADSORPTION; ION EXCHANGE; SOIL CHEMISTRY.

The negative charge in soils is associated with clay particles, but some of the soil's cation-exchange capacity may arise from organic matter (humus) in the soil. Negative charges of organic matter arise largely from carboxylic and phenolic acid functional groups. Since these functional groups are weak acids, the negative charge from organic matter increases as the soil pH increases. The negative charges of soil organic matter can adsorb the same cations as described for the soil clays. The proportion of cation-exchange capacity arising from mineral clays and from organic matter depends on the proportions of each in the soil and on the kinds of clays. In most mineral soils, the soil clays comprise the greater proportion of cation-exchange capacity. Within the class of mineral soils, those soils with more clay and less sand and silt have the greatest cation-exchange capacity.

The amount and kind of acids on the cation exchange sites can have a substantial influence on a soil's perceived fertility. Two

factors cause soils to become acid: when crops are harvested, exchangeable bases are removed as part of the crop; and exchangeable bases move with drainage water below the crop's root zone (leaching). Since much of the nitrogen fertilizer supplied to crops contains ammonium nitrogen (this is true of both manure and chemical fertilizers), the addition of high rates of nitrogen also enhances soil acidification. See FERTILIZER; NITROGEN CYCLE; SOIL. [D.E.Ki.]

**Soil mechanics** The study of the response of masses composed of soil, water, and air to imposed loads. Because both water and air are able to move through the soil pores, the discipline also involves the prediction of these transport processes. Soil mechanics provides the analytical tools required for foundation engineering, retaining wall design, highway and railway subbase design, tunneling, earth dam design, mine excavation design, and so on. Because the discipline relates to rock as well as soils, it is also known as geotechnical engineering. See ENGINEERING GEOLOGY.

Soil consists of a multiphase aggregation of solid particles, water, and air. This fundamental composition gives rise to unique engineering properties, and the description of the mechanical behavior of soils requires some of the most sophisticated principles of engineering mechanics. The terms multiphase and aggregation both imply unique properties. As a multiphase material, soil exhibits mechanical properties that show the combined attributes of solids, liquids, and gases. Individual soil particles behave as solids, and show relatively little deformation when subjected to either normal or shearing stresses. Water behaves as a liquid, exhibiting little deformation under normal stresses, but deforming greatly when subjected to shear. Being a viscous liquid, however, water exhibits a shear strain rate that is proportional to the shearing stress. Air in the soil behaves as a gas, showing appreciable deformation under both normal and shear stresses. When the three phases are combined to form a soil mass, characteristics that are an outgrowth of the interaction of the phases are manifest. Moreover, the particulate nature of the solid particles contributes other unique attributes. See VISCOSITY.

When dry soil is subjected to a compressive normal stress, the volume decreases nonlinearly; that is, the more the soil is compressed, the less compressible the mass becomes. Thus, the more tightly packed the particulate mass becomes, the more it resists compression. The process, however, is only partially reversible, and when the compressive stress is removed the soil does not expand back to its initial state.

When this dry particulate mass is subjected to shear stress, an especially interesting behavior owing to the particulate nature of the soil solids results. If the soil is initially dense (tightly packed), the mass will expand because the particles must roll up and over each other in order for shear deformation to occur. Conversely, if the mass is initially loose, it will compress when subjected to a shear stress. Clearly, there must also exist a specific initial density (the critical density) at which the material will display zero volume change when subjected to shear stress. The term dilatancy has been applied to the relationship between shear stress and volume change in particulate materials. Soil is capable of resisting shear stress up to a certain maximum value. Beyond this value, however, the material undergoes large, uncontrolled shear deformation. See SHEAR.

The other limiting case is saturated soil, that is, a soil whose voids are entirely filled with water. When such a mass is initially loose and is subjected to compressive normal stress, it tends to decrease in volume; however, in order for this volume decrease to occur, water must be squeezed from the soil pores. Because water exhibits a viscous resistance to flow in the microscopic pores of fine-grained soils, this process can require considerable time, during which the pore water is under increased pressure. This excess pore pressure is at a minimum near the drainage face of the soil mass and at a maximum near the center of the soil

sample. It is this gradient (or change in pore water pressure with change in position within the soil mass) that causes the outflow of water and the corresponding decrease in volume of the soil mass.

Conversely, if an initially dense soil mass is subjected to shear stress, it tends to expand. The expansion, however, may be time-dependent because of the viscous resistance to water being drawn into the soil pores. During this time the pore water will be under decreased pressure. Thus, in saturated soil masses, changes in pore water pressure and time-dependent volume change can be induced by either changes in normal stress or by changes in shear stress. See ROCK MECHANICS; SOIL. [C.A.Mo.]

**Soil microbiology** The study of biota that inhabit the soil and the processes that they mediate. The soil is a complex environment colonized by an immense diversity of microorganisms. Soil microbiology focuses on the soil viruses, bacteria, actinomycetes, fungi, and protozoa, but it has traditionally also included investigations of the soil animals such as the nematodes, mites, and other microarthropods. These organisms, collectively referred to as the soil biota, function in a belowground ecosystem based on plant roots and litter as food sources. Modern soil microbiology represents an integration of microbiology with the concepts of soil science, chemistry, and ecology to understand the functions of microorganisms in the soil environment.

The surface layers of soil contain the highest numbers and variety of microorganisms, because these layers receive the largest amounts of potential food sources from plants and animals. The soil biota form a belowground system based on the energy and nutrients that they receive from the decomposition of plant and animal tissues. The primary decomposers are the bacteria and fungi.

Microorganisms, especially algae and lichen, are pioneering colonizers of barren rock surfaces. Colonization by these organisms begins the process of soil formation necessary for the growth of higher plants. After plants have been established, decomposition by microorganisms recycles the energy, carbon, and nutrients in dead plant and animal tissues into forms usable by plants. Therefore, microorganisms have a key role in the processing of materials that maintain life on the Earth. The transformations of elements between forms are described conceptually as the elemental cycles.

In the carbon cycle, microorganisms transform plant and animal residues into carbon dioxide and the soil organic matter known as humus. Humus improves the water-holding capacity of soil, supplies plant nutrients, and contributes to soil aggregation. Microorganisms may also directly affect soil aggregation. The extent of soil aggregation determines the workability or tilth of the soil. A soil with good tilth is suitable for plant growth because it is permeable to water, air, and roots. See HUMUS.

Soil microorganisms play key roles in the nitrogen cycle. The atmosphere is approximately 80% nitrogen gas ( $N_2$ ), a form of nitrogen that is available to plants only when it is transformed to ammonia ( $NH_3$ ) by either soil bacteria ( $N_2$  fixation) or by humans (manufacture of fertilizers). Soil bacteria also mediate denitrification, which returns nitrogen to the atmosphere by transforming  $NO_3^-$  to  $N_2$  or nitrous oxide ( $N_2O$ ) gas. Microorganisms are crucial to the cycling of sulfur, phosphorus, iron, and many micronutrient trace elements.

In addition to the elemental cycles, there are several interactions between plants and microbes which are detrimental or beneficial to plant growth. Some soil microorganisms are pathogenic to plants and cause plant diseases such as root rots and wilts. Many plants form symbiotic relationships with fungi called mycorrhizae (literally fungus-root). Mycorrhizae increase the ability of plants to take up nutrients and water. The region of soil surrounding plant roots, the rhizosphere, may contain beneficial microorganisms which protect the plant root from pathogens or supply stimulating growth factors. The interactions between

plant roots and soil microorganisms is an area of active research in soil microbiology. See BIOGEOCHEMISTRY; MYCORRHIZAE; NITROGEN CYCLE; NITROGEN FIXATION; NITROGEN OXIDES; RHIZOSPHERE.

The incredible diversity of soil microorganisms is a vast reserve of potentially useful organisms. Many of the medically important antibiotics are produced by filamentous bacteria known as actinomycetes. The soil is the largest reservoir of these medically important microorganisms. See ANTIBIOTIC.

The numerous natural substances that are used by microorganisms indicate that soil microorganisms have diverse mechanisms for degrading a variety of compounds. Human activity has polluted the environment with a wide variety of synthetic or processed compounds. Many of these hazardous or toxic substances can be degraded by soil microorganisms. This is the basis for the treatment of contaminated soils by bioremediation, the use of microorganisms or microbial processes to detoxify and degrade environmental contaminants. Soil microbiologists study the microorganisms, the metabolic pathways, and the controlling environmental conditions that can be used to eliminate pollutants from the soil environment. See HAZARDOUS WASTE.

Microbiologists traditionally isolate pure strains of microorganisms by using culture methods. Methods that do not rely on culturing microorganisms include microscopic observation and biochemical or genetic analysis of specific cell constituents. The rates or controlling factors for microbial processes are studied by using methods from chemistry, biology, and ecology. Typically, these studies involve measuring the rate of production and consumption of a compound of interest. The results of these studies are commonly analyzed by using mathematical models. Models allow the information from one system to be generalized for different environmental conditions. See FLUORESCENCE MICROSCOPE; IMMUNOFLUORESCENCE; MICROBIOLOGY; MOLECULAR BIOLOGY; SOIL; SOIL CHEMISTRY; SOIL ECOLOGY. [J.M.N.]

**Soil sterilization** A chemical or physical process that results in the death of soil organisms. This control method affects many organisms, even though the elimination of only specific weeds, fungi, bacteria, viruses, nematodes, or pests is desirable. Even if complete sterilization is achieved, it is short lived since organisms will recolonize this biological vacuum quite rapidly. Soil sterilization can be achieved through both physical and chemical means. Physical control measures include steam and solar energy. Chemical control methods include herbicides and fumigants. Dielectric heating and gamma irradiation are used less frequently as soil sterilization methods. Composting can be used to sterilize organic materials mixed with soil, but it is not used for the sterilization of soil alone. Soil sterilization is used in greenhouse operations, the production of high-value or specialty crops, and the control of weeds. [C.A.St.]

**Sol-gel process** A chemical synthesis technique for preparing gels, glasses, and ceramic powders. The sol-gel process generally involves the use of metal alkoxides, which undergo hydrolysis and condensation polymerization reactions to give gels.

The production of glasses by the sol-gel method permits preparation of glasses at far lower temperatures than is possible by using conventional melting. It also makes possible synthesis of compositions that are difficult to obtain by conventional means because of problems associated with volatilization, high melting temperatures, or crystallization. In addition, the sol-gel approach is a high-purity process that leads to excellent homogeneity. Finally, the sol-gel approach is adaptable to producing films and fibers as well as bulk pieces. See GLASS.

The sol-gel process comprises solution, gelation, drying, and densification. The preparation of a silica glass begins with an appropriate alkoxide which is mixed with water and a mutual solvent to form a solution. Hydrolysis leads to the formation of silanol groups ( $Si-OH$ ). These species are only intermediates. Subsequent condensation reactions produce siloxane

bonds (Si—O—Si). The silica gel formed by this process leads to a rigid, interconnected three-dimensional network consisting of submicrometer pores and polymeric chains. During the drying process (at ambient pressure), the solvent liquid is removed and substantial shrinkage occurs. The resulting material is known as a xerogel. When solvent removal occurs under hypercritical (supercritical) conditions, the network does not shrink and a highly porous, low-density material known as an aerogel is produced. Heat treatment of a xerogel at elevated temperature produces viscous sintering (shrinkage of the xerogel due to a small amount of viscous flow) and effectively transforms the porous gel into a dense glass.

Materials used in the sol-gel process include inorganic compositions that possess specific properties such as ferroelectricity, electrochromism, or superconductivity. The most successful applications utilize the composition control, microstructure control, purity, and uniformity of the method combined with the ability to form various shapes at low temperatures. Films and coatings were the first commercial applications of the sol-gel process. The development of sol-gel-based optical materials has also been quite successful, and applications include monoliths (lenses, prisms, lasers), fibers (waveguides), and a wide variety of optical films. Other important applications of sol-gel technology utilize controlled porosity and high surface area for catalyst supports, porous membranes, and thermal insulation. See MATERIALS SCIENCE AND ENGINEERING. [B.Du.]

**Solanales** An order of flowering plants, division Magnoliophyta, in the euasterid I group of the asterid eudicotyledons. The order consists of two large and three small families, of approximately 4275 species. Solanaceae and Convolvulaceae account for all but 25 of the species. Solanales are generally characterized by sympetalous flowers with a superior ovary, and alternate leaves. See ASTERIDAE; FLOWER; FRUIT; LEAF; MAGNOLIOPHYTA; MAGNOLIOPSIDA.

Solanaceae, approximately 2600 species, are cosmopolitan herbs, shrubs, lianas, and trees, with branched hairs and often spines and alkaloids. The family is of great economic significance, yielding potatoes, tomatoes, and eggplant (*Solanum*), peppers (*Capsicum*), tobacco (*Nicotiana*) and many ornamentals. Deadly nightshade (*Atropa*), jimson weed (*Datura*), and henbane (*Hyoscyamus*) are well-known poisonous members of the family. See BELLADONNA; EGGPLANT; PEPPER; POTATO, IRISH; SOLANALES; TOBACCO.

Convolvulaceae, approximately 1650 species, include herbaceous and woody members that are often climbers. The main economic crop is sweet potato (*Ipomoea*), but the family also includes ornamentals (morning glory, *Ipomoea*; and *Convolvulus*), noxious weeds (*Calystegia* and *Convolvulus*), and parasites (*Cuscuta*). See POTATO, SWEET; WEEDS. [M.F.F.]

**Solar cell** A semiconductor electrical junction device which absorbs and converts the radiant energy of sunlight directly and efficiently into electrical energy. Solar cells may be used individually as light detectors, for example in cameras, or connected in series and parallel to obtain the required values of current and voltage for electric power generation.

Most solar cells are made from single-crystal silicon and have been very expensive for generating electricity, but have found application in space satellites and remote areas where low-cost conventional power sources have been unavailable.

The conversion of sunlight into electrical energy in a solar cell involves three major processes: absorption of the sunlight in the semiconductor material; generation and separation of free positive and negative charges to different regions of the solar cell, creating a voltage in the solar cell; and transfer of these separated charges through electrical terminals to the outside application in the form of electric current.

When light is absorbed in the semiconductor, a negatively charged electron and positively charged hole are created. The

heart of the solar cell is the electrical junction which separates these electrons and holes from one another after they are created by the light. An electrical junction may be formed by the contact of: a metal to a semiconductor (this junction is called a Schottky barrier); a liquid to a semiconductor to form a photoelectrochemical cell; or two semiconductor regions (called a *pn* junction).

The fundamental principles of the electrical junction can be illustrated with the silicon *pn* junction. Pure silicon to which a trace amount of a group V element (in the periodic table) such as phosphorus has been added is an *n*-type semiconductor, where electric current is carried by free electrons. Each phosphorus atom contributes one free electron, leaving behind the phosphorus atom bound to the crystal structure with a unit positive charge. Similarly, pure silicon to which a trace amount of a group III element such as boron has been added is a *p*-type semiconductor, where the electric current is carried by free holes. The interface between the *p*- and *n*-type silicon is called the *pn* junction. The fixed charges at the interface due to the bound boron and phosphorus atoms create a permanent dipole charge layer with a high electric field. When photons of light energy from the Sun produce electron-hole pairs near the junction, the built-in electric field forces the holes to the *p* side and the electrons to the *n* side. This displacement of free charges results in a voltage difference between the two regions of the crystal. When a load is connected at the terminals, an electron current flows and useful electrical power is available at the load. See SEMICONDUCTOR; SOLAR-ELECTRIC POWER GENERATION; SOLAR ENERGY. [D.G.Sc.]

**Solar constant** The total solar radiant energy flux incident upon the top of the Earth's atmosphere at a standard distance (1 astronomical unit,  $1.496 \times 10^8$  km or  $9.3 \times 10^7$  mi) from the Sun. In 1980 it was discovered that the so-called solar constant actually varies with time, though only by small amounts, around a value of about  $1367 \text{ W} \cdot \text{m}^{-2}$  ( $1.96 \text{ cal} \cdot \text{cm}^{-2} \cdot \text{min}^{-1}$ ).

Both expected and unexpected items contribute to the variability of the so-called solar constant. Sunspots can produce deficits of up to a few tenths of 1% of the solar constant, on typical time scales of 1 week. Other surface manifestations of solar magnetic activity, faculae, contribute excesses rather than deficits. Global oscillations of the solar interior, analogous to seismic waves on the Earth, produce variations of a few parts per million on time scales of a few hundred seconds. Finally, and unexpectedly, there is an apparent 11-year sunspot cycle variation amounting to an approximately 0.1% increase of the solar constant during the sunspot maxima. This long-term effect has the opposite dependence from that found for individual sunspots, which block the solar radiant energy and cause decreases rather than increases. See HELIOSEISMOLOGY; SUN. [H.S.Hu.]

**Solar corona** The outer atmosphere of the Sun. The corona is dominated by intense magnetic forces, which penetrate it from denser regions of the Sun. Coronal gas accumulates around these magnetized regions to produce the shapes seen during a solar eclipse, with a coronagraph, or in x-rays. These shapes include long streamers that penetrate interplanetary space, looplike tubes over the strongest fields, and vast regions of very low density called coronal holes. Coronal holes are the source of solar matter streaming into interplanetary space. The general magnetic field of the Sun, about 1 gauss (0.1 millitesla), is revealed near the north and south poles by polar rays that resemble the pattern formed by iron filings near a bar magnet.

From a minimum in the lower atmosphere (approximately 4000 K or 7000°F), the temperature rises to values in the corona of  $1\text{--}5 \times 10^6$  K ( $2\text{--}9 \times 10^6$  °F) caused by dissipation of mechanical or magnetic energy produced by turbulent flows in the lower atmosphere. The corona is hot enough to emit x-rays, and x-ray telescopes in space can form images of the corona. See SUN. [R.C.A.]



**Solar energy** The energy transmitted from the Sun. The upper atmosphere of Earth receives about  $1.5 \times 10^{21}$  watt-hours (thermal) of solar radiation annually. This vast amount of energy is more than 23,000 times that used by the human population of this planet, but it is only about one two-billionth of the Sun's massive outpouring—about  $3.9 \times 10^{20}$  MW. See SUN.

The power density of solar radiation measured just outside Earth's atmosphere and over the entire solar spectrum is called the solar constant. According to the World Meteorological Organization, the most reliable (1981) value for the solar constant is  $1370 \pm 6$  W/m<sup>2</sup>. See SOLAR CONSTANT.

Solar radiation is attenuated before reaching Earth's surface by an atmosphere that removes or alters part of the incident energy by reflection, scattering, and absorption. In particular, nearly all ultraviolet radiation and certain wavelengths in the infrared region are removed. However, the solar radiation striking Earth's surface each year is still more than 10,000 times the world's energy use. Radiation scattered by striking gas molecules, water vapor, or dust particles is known as diffuse radiation. Clouds are a particularly important scattering and reflecting agent, capable of reducing direct radiation by as much as 80 to 90%. The radiation arriving at the ground directly from the Sun is called direct or beam radiation. Global radiation is all solar radiation incident on the surface, including direct and diffuse. See SOLAR RADIATION.

Solar research and technology development aim at finding the most efficient ways of capturing low-density solar energy and developing systems to convert captured energy to useful purposes. Also of significant potential as power sources are the indirect forms of solar energy: wind, biomass, hydropower, and the tropical ocean surfaces. With the exception of hydropower, these energy resources remain largely untapped. See ENERGY SOURCES.

Five major technologies using solar energy are being developed. (1) The heat content of solar radiation is used to provide moderate-temperature heat for space comfort conditioning of buildings, moderate- and high-temperature heat for industrial processes, and high-temperature heat for generating electricity. (2) Photovoltaics convert solar energy directly into electricity. (3) Biomass technologies exploit the chemical energy produced through photosynthesis (a reaction energized by solar radiation) to produce energy-rich fuels and chemicals and to provide direct heat for many uses. (4) Wind energy systems generate mechanical energy, primarily for conversion to electric power. (5) Finally, a number of ocean energy applications are being pursued; the most advanced is ocean thermal energy conversion, which uses temperature differences between warm ocean surface water and cooler deep water to produce electricity. See BIOMASS; PHOTOVOLTAIC CELL; SOLAR HEATING AND COOLING; WIND.

Solar energy can be converted to useful work or heat by using a collector to absorb solar radiation, allowing much of the Sun's radiant energy to be converted to heat. This heat can be used directly in residential, industrial, and agricultural operations; converted to mechanical or electrical power; or applied in chemical reactions for production of fuels and chemicals.

A solar energy system is normally designed to be able to deliver useful heat for 6 to 10 h a day, depending on the season and weather. Storage capacity in the solar thermal system is one way to increase a plant's operating capacity.

There are four primary ways to store solar thermal energy: (1) sensible-heat-storage systems, which store thermal energy in materials with good heat-retention qualities; (2) latent-heat-storage systems, which store solar thermal energy in the latent heat of fusion or vaporization of certain materials undergoing a change of phase; (3) chemical energy storage, which uses reversible reactions (for example, the dissociation-association reaction of sulfuric acid and water); and (4) electrical or mechanical storage, particularly through the use of storage batteries (electrical) or compressed air (mechanical). See ENERGY STORAGE.

Photovoltaic systems convert light energy directly to electrical

energy. Using one of the most versatile solar technologies, photovoltaic systems can, because of their modularity, be designed for power needs ranging from milliwatts to megawatts. They can be used to provide power for applications as small as a wrist-watch to as large as an entire community. They can be used in centralized systems, such as a generator in a power plant, or in dispersed applications, such as in remote areas not readily accessible to utility grid lines.

Biomass energy is solar energy stored in plant and animal matter. Through photosynthesis in plants, energy from the Sun transforms simple elements from air, water, and soil into complex carbohydrates. These carbohydrates can be used directly as fuel (for example, burning wood) or processed into liquids and gases (for example, ethanol or methane). Biomass is a renewable energy resource because it can be harvested periodically and converted to fuel. See CARBOHYDRATE; PHOTOSYNTHESIS.

Wind is a source of energy derived primarily from unequal heating of Earth's surface by the Sun. Energy from the wind has been used for centuries to propel ships, to grind grain, and to lift water. Wind turbines extract energy from the wind to perform mechanical work or to generate electricity.

Ocean thermal energy conversion uses the temperature difference between surface water heated by the Sun and deep cold water pumped from depths of 2000 to 3000 ft (600 to 900 m). This temperature difference makes it possible to produce electricity from the heat engine concept. Since the ocean acts as an enormous solar energy storage facility with little fluctuation of temperature over time, ocean thermal energy conversion, unlike most other renewable energy technologies, can provide electricity 24 h a day. [R.L.S.M.]

**Solar heating and cooling** The use of solar energy to produce heating or cooling for technological purposes. Beneficial uses include distillation of sea water to produce salt or potable water; heating of swimming pools; space heating; heating of water for domestic, commercial, and industrial purposes; cooling by absorption or compression refrigeration; and cooking. See SOLAR ENERGY.

**Distillation.** Production of potable water from sea water by solar distillation is accomplished in several parts of the world by use of glass-roofed solar stills (see illustration). Production of salt from the sea has been accomplished for hundreds of years by trapping ocean water in shallow ponds at high tide and simply allowing the water to evaporate under the influence of the Sun. See DISTILLATION.

**Swimming pool heating.** Swimming pool heating is a moderate-temperature application which, under suitable weather conditions, can be accomplished with a simple unglazed and uninsulated collector. For applications where a significant temperature difference exists between the fluid within the collector passages and the ambient air, both glazing and insulation are essential.

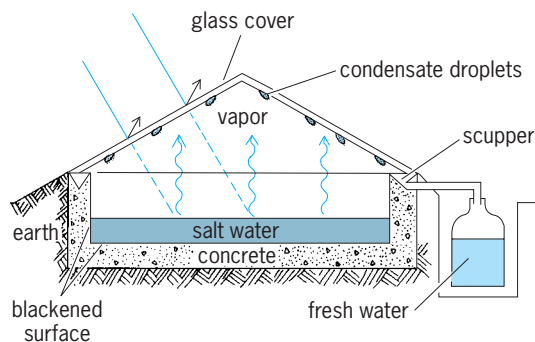

Roof-type solar still.

**Space heating.** Space heating can be carried out by active systems which use separate collection, distribution, and storage subsystems, or by passive designs which use components of a building to admit, store, and distribute the heat resulting from absorbing the incoming solar radiation within the building itself.

Passive systems can be classified as direct-gain when they admit solar radiant energy directly into the structure through large south-facing windows, or as indirect-gain when a wall or a roof absorbs the solar radiation, stores the resulting heat, and then transfers it into the building. Passive systems are generally effective where the number of hours of sunshine during the winter months is relatively high, where moderate indoor temperature fluctuations can be tolerated, and where the need for summer cooling and dehumidification is moderate or non-existent.

Active systems may use either water or air to transport heat from roof-mounted south-facing collectors to storage in rock beds or water tanks. The stored heat may be withdrawn and used directly when air is the transfer fluid. When the heat is collected and stored as hot water, fan-coil units are generally used to transfer the heat to air which is then circulated through the warmed space. Standby energy sources are included in designs for active systems, since some method of providing warmth must be included for use when the Sun's radiant energy is inadequate for long periods of time. The standby heater may be something as simple as a wood-burning stove or fireplace, or as complex as an electrically powered heat pump. See COMFORT HEATING; HEAT PUMP.

**Service water heating.** Solar water heating for domestic, commercial, or industrial purposes is an old and successful application of solar-thermal technology. The most widely used water heater, and one that is suitable for use in relatively warm climates where freezing is a minor problem, is the thermosiphon type. A flat-plate collector is generally used with a storage tank which is mounted above the collector. A source of water is connected near the bottom of the tank, and the hot water outlet is connected to its top. A downcomer pipe leads from the bottom of the tank to the inlet of the collector, and an insulated return line runs from the top of the collector to the upper part of the storage tank which is also insulated.

The system is filled with water, and when the Sun shines on the collector, the water in the tubes is heated. It then becomes less dense than the water in the downcomer, and the heated water rises by thermosiphon action into the storage tank. It is replaced by cool water from the bottom of the tank, and this action continues as long as the Sun shines on the collector with adequate intensity.

For applications where the elevated storage tank is undesirable or where very large quantities of hot water are needed, the tank is placed at ground level. A small pump circulates the water in response to a signal from a controller which senses the temperatures of the collector and the water near the bottom of the tank. Heat exchangers may also be used with water at operating pressure within the tubes of the exchanger and the collector water outside to eliminate the necessity of using high-pressure collectors. See HOT-WATER HEATING SYSTEM.

**Cooling.** Cooling can be provided by both active and passive systems.

The two feasible types of active cooling systems are Rankine cycle and absorption. The Rankine cycle system uses solar collectors to produce a vapor (steam or one of the fluorocarbons generally known as Freon) to drive an engine or turbine. A condenser must be used to condense the spent vapor so it can be pumped back through the vaporizer. The engine or turbine drives a conventional refrigeration compressor which produces cooling in the usual manner. See RANKINE CYCLE; REFRIGERATION.

Passive cooling systems make use of three natural processes: convection cooling with night air; radiative cooling by heat rejection to the sky on clear nights; and evaporative cooling from water surfaces exposed to the atmosphere. The effectiveness of

each of these processes depends upon local climatic conditions. See ENERGY STORAGE; SOLAR CELL. [J.I.Y.]

**Solar magnetic field** The magnetic field rooted in the Sun and extending out past the planets into the solar system. The field at the Sun's surface is detected remotely by its effect (the Zeeman effect) on atoms whose radiation is observed from Earth. This technique was first applied in 1908 by G. E. Hale to detect the fields in sunspots. In 1952, H. D. Babcock and his son H. W. Babcock used a scanning technique to make the first magnetic maps of the entire visible disk of the Sun. Their daily "magnetograms" soon revealed a variety of magnetic features, including bipolar regions associated with sunspot groups, and unipolar regions whose fields extend far from the Sun and are responsible for recurrent geomagnetic activity at Earth. The field strengths range from a few gauss (a few hundred microtesla) in quiet areas to 3500 gauss (0.35 tesla) in sunspots. In 1962, the *Mariner 2* spacecraft, en route to Venus, made the first on-site sampling of the extended solar field in space. The average field strength was only 50 microgauss (5 nanotesla), reflecting the rapid (inverse square) fall-off of field strength with distance from the Sun. See ZEEMAN EFFECT.

Solar magnetic fields are related to the 11-year variation in the occurrence of sunspots. As the new sunspot cycle begins, concentrations of bipolar flux break through the Sun's surface in each hemisphere, beginning at about 40° latitude and gradually progressing toward the solar equator over the next few years. The bipolar regions are oriented approximately east-west with their leading polarities (in the sense of solar rotation) all positive in the northern hemisphere and negative in the southern hemisphere during a given sunspot cycle (Hale's law). They are tilted slightly so that their trailing polarities are closer to the Sun's poles and the leading polarities are closer to the equator. This small but systematic effect ultimately leads to the formation of unipolar regions at the Sun's poles, positive in one hemisphere and negative in the other.

It is presently believed that convection and differential rotation are responsible for the eruption of bipolar magnetic regions. See MAGNETISM; SUN. [N.R.S.]

**Solar neutrinos** Neutrinos produced in nuclear reactions inside the Sun. Neutrinos are produced as well in laboratory nuclear reactions. The first direct tests of how the Sun produces its luminosity (observed most conspicuously on Earth as sunlight) have been carried out by observing solar neutrinos. The results of these experiments confirm the theory of how the Sun shines and stars evolve. Moreover, the results show that neutrinos behave differently than predicted by the standard model of particle physics.

Many explanations have been advanced for the discrepancy between the observed and the predicted event rates in the solar neutrino experiments. These explanations can be divided into three general classes: (1) the standard solar model must be significantly modified; (2) something is seriously wrong with the experiments; (3) the standard model of how neutrinos behave must be significantly modified.

Precise measurements of the thousands of frequencies with which the Sun pulsates on its surface (with characteristic periods of the order of 5 minutes) have confirmed to an accuracy of 0.1% the predictions of the standard solar model for these pulsation frequencies. This agreement is convincing evidence that the standard solar model is an accurate description of the Sun. See HELIOSEISMOLOGY.

All of the solar neutrino experiments have been examined carefully by many different searchers. A variety of checks have been made to test whether there was a significant error or a large uncertainty in one of the experiments that might explain the difference between prediction and observation. No significant previously unknown errors or uncertainties have been found. Moreover, intense laboratory sources of neutrinos have been placed

near the gallium neutrino detectors, and the expected number of events have been observed from these artificial sources. The consensus view among scientists in the field is that the solar neutrino experiments are yielding a valid but surprising result.

The only remaining possibility is that the theory of how the neutrino behaves must be changed. Indeed, in 2000, the results of a decisive experiment showed unequivocally that solar neutrinos change their type on their way from the center of the Sun. All of the results from solar neutrino experiments are consistent with the conclusion that the standard solar model predicts accurately the number of neutrinos of different energies that are emitted by the Sun but that some of the neutrinos change their type on the way from the center of the Sun to the detectors on Earth. See NEUTRINO; STANDARD MODEL; SUN. [J.N.B.]

**Solar radiation** The electromagnetic radiation and particles (electrons, protons, alpha particles, and rarer heavy atomic nuclei) emitted by the Sun. The electromagnetic radiation covers a wavelength range from x-rays to radio waves, that is, from about 0.01 nanometer to 30 km. The annual mean irradiance at Earth, integrated over the whole spectrum, amounts to  $1365 \text{ W} \cdot \text{m}^{-2}$ , and 99% of its energy is carried by radiation with wavelengths between 278 and 4600 nm, with the maximum at 472 nm. See ELECTROMAGNETIC RADIATION; SOLAR CONSTANT.

The Sun also emits a continuous stream of particles, the solar wind, which originates in coronal holes and the upper corona. Explosive events on the Sun, the solar flares and coronal mass ejections, emit particles that are much more energetic and numerous than those of the solar wind. Solar flares are produced by the most powerful explosions, releasing energies of up to  $10^{25}$  joules in 100–1000 s and high-speed electrons that emit intense radiation at radio and x-ray wavelengths. They also produce nuclear reactions in the solar atmosphere with the emission of gamma rays and of neutrons that move nearly at the speed of light. Coronal mass ejections expand away from the Sun at speeds of hundreds of kilometers per second, becoming larger than the Sun and removing up to  $5 \times 10^{13}$  kg of coronal material. Both events are believed to be ignited by the reconnection of magnetic fields. If the emitted particles reach the Earth, they give rise to the aurora at high latitudes, and they can damage satellites, endanger humans in space, and on the Earth disturb telecommunications and even disrupt power systems. See AURORA; COSMIC RAYS; IONOSPHERE; MAGNETOSPHERE; SOLAR WIND; SUN. [C.Fro.]

**Solar system** The Sun and the bodies moving in orbit around it. The most massive body in the solar system is the Sun, a typical single star that is itself in orbit about the center of the Milky Way Galaxy. Nearly all of the other bodies in the solar system—the terrestrial planets, outer planets, asteroids, and comets—revolve on orbits about the Sun. Various types of satellites revolve around the planets; in addition, the giant planets all have orbiting rings. The orbits for the planets appear to be fairly stable over long time periods and hence have undergone little change since the formation of the solar system. It is thought that some  $4.56 \times 10^9$  years ago a rotating cloud of gas and dust collapsed to form a flattened disk (the solar nebula) in which the Sun and other bodies formed. The bulk of the gas in the solar nebula moved inward to form the Sun, while the remaining gas and dust are thought to have formed all the other solar system bodies by accumulation proceeding through collisions of intermediate-sized bodies called planetesimals. Planetary systems are believed to exist around many other stars in the Milky Way Galaxy. Solid evidence for the existence of Jupiter-mass planets around nearby solarlike stars now exists. See PLANET.

**Composition.** The Sun is a gaseous sphere with a radius of about  $7 \times 10^5$  km ( $4 \times 10^5$  mi), composed primarily of hydrogen and helium and small amounts of the other elements. The terrestrial planets (Mercury, Venus, Earth, and Mars) are the closest to the Sun. They are composed primarily of silicate rock (man-

ties) and iron (cores). The Earth is the largest terrestrial planet; Mercury is the smallest, with a mass of 0.053 times that of Earth. See EARTH; MARS; MERCURY (PLANET); PLANETARY PHYSICS; SUN; VENUS.

The outer planets are subdivided into the gas giant or Jovian planets (Jupiter and Saturn), the ice giant planets (Uranus and Neptune), and Pluto. By far the largest planet is Jupiter, with a mass 318 times that of the Earth, while the other giant planets are more massive by a factor of 15 or more than Earth. Jupiter and Saturn are composed primarily of hydrogen and helium gas, like the Sun, but with rock and ices, such as frozen water, methane, and ammonia, concentrated in their cores. Uranus and Neptune also have rock and ice cores surrounded by envelopes with smaller amounts of hydrogen and helium. Pluto, slightly smaller than the Earth's Moon, is probably composed primarily of rock and ice. See JUPITER; NEPTUNE; PLUTO; SATURN; URANUS.

The region between Mars and Jupiter is populated by a large number of rocky bodies called asteroids. The asteroids are smaller than the terrestrial planets, with most known asteroids being about 1 km (0.6 mi) in radius, though a few have radii of hundreds of kilometers. Some asteroids have orbits that take them within the orbits of Earth and the other terrestrial planets. Small fragments of asteroids (or comets) that impact the Earth first appear as meteors in the sky; any meteoric material that survives the passage through the Earth's atmosphere and reaches the surface is called a meteorite. See ASTEROID; METEOR; METEORITE.

Comets are icy bodies (so-called dirty snowballs) with diameters on the order of 10 km (6 mi). In contrast to the orbits of most planets, cometary orbits often are highly elliptical and have large inclinations that take them far from the plane where the planets orbit. The region well beyond Pluto's orbit is populated with a very large number (perhaps  $10^{12}$ ) of comets, out to a limiting distance of about  $10^5$  AU. The distribution of comets within this huge volume, the Oort Cloud, is uncertain. Comets have been detected orbiting in the plane of the solar system at distances of 30 to 50 AU; this flattened distribution is called the Edgeworth-Kuiper Belt. See COMET; KUIPER BELT.

**Origin.** The nebular hypothesis, advanced in 1796 by P. S. de Laplace, holds that the Sun and the rest of the bodies in the solar system formed from the same rotating, flattened cloud of gas and dust, now called the solar nebula. The nebular hypothesis explains the gross orbital properties of the solar system: all planets orbit (and most rotate) in the same sense as the Sun rotates, with their nearly circular orbits being confined largely to a single plane almost perpendicular to the Sun's rotation axis.

Observations of present-day regions of star formation in the Milky Way Galaxy confirm the stellar implications of Laplace's nebular hypothesis: very young stars (protostars) are indeed found embedded in dense clouds of gas and dust that often show evidence for flattening and rotation.

The solar nebula was produced by the collapse of a dense interstellar cloud. Radio telescopes have shown that such clouds exist with masses comparable to that of the Sun. Eventually they enter the collapse phase, where supersonic inward motions develop that lead to the formation of a stellar-sized core at the center of the cloud in about  $10^5$ – $10^6$  years. See INTERSTELLAR MATTER; MOLECULAR CLOUD; RADIO ASTRONOMY; STELLAR EVOLUTION.

In a rotating cloud, not all of the in-falling gas and dust falls directly onto the central protostar, because of the conservation of angular momentum. Instead, a disklike solar nebula forms. The disk must evolve in such a way as to transfer mass inward to feed the growing Sun, while transporting outward the excess angular momentum undesired by the Sun but required for the planets. While this sort of evolution may appear to be contrived if not miraculous, it is actually to be expected on very general grounds for any viscous disk that is undergoing a loss of energy, as the solar nebula will, through radiation to space.

The portion of the nebula that is to form the planets must decouple from the gaseous nebula to avoid being swallowed

by the Sun. This occurs by the process of coagulation of dust grains through mutual collisions; when solid bodies become large enough (roughly kilometer-sized), they will no longer be tied to the nebula through brownian motion (as is the case with dust grains) or gas drag (as happens with smaller bodies).

About  $10^{12}$  kilometer-sized planetesimals are needed to form just the terrestrial planets; significantly greater numbers of similarly sized bodies would be needed to form the giant planets. These planetesimals are already roughly the size of many asteroids and comets, suggesting that many of these bodies are simply leftovers from intermediate phases of the planet formation process.

The subsequent growth of the planetesimals through gravitational accumulation is in two distinct phases. In the first phase, planetesimals grew by accumulation of other planetesimals at essentially the same distance from the Sun. Once the nearby planetesimals were all swept up, this phase ended.

In the second phase, accumulation requires bodies at significantly different distances from the Sun to collide. This phase may have involved violent collisions between planetary-sized bodies. A glancing collision between a Mars-sized and an Earth-sized body appears to be the best explanation for the formation of the Earth-Moon system; debris from the giant impact would end up in orbit around the Earth and later form the Moon.

Forming gas giant planets by the two-step process requires about  $10^7$  years for a 10-Earth-mass core to form and then accrete a massive gaseous envelope. The alternative means for forming the gas giant planets is much more rapid, requiring only about  $10^3$  years for a gravitational instability of the gaseous nebula to produce a massive clump of gas and dust. [A.P.B.]

**Solar wind** The continuous outward flow of ionized solar gas and a "frozen-in" remnant of the solar magnetic field through the solar system. This flow arises from strong outward pressure in the solar corona, becomes supersonic at a few solar radii (1 solar radius =  $6.96 \times 10^5$  km or  $4.32 \times 10^5$  mi) above the visible surface of the Sun (the photosphere), and attains speeds in the range 250–750 km/s (155–465 mi/s) in interplanetary space. The solar wind is believed to remain supersonic out to a distance from the Sun of 50–100 astronomical units (AU), where it is slowed by interaction with the interstellar gas and magnetic field. See INTERSTELLAR MATTER; SOLAR MAGNETIC FIELD.

In 1962, sampling instruments on the *Mariner 2* spacecraft revealed an important pattern in the variations of solar wind speed with time. The observed speed rose systematically from low values to high values in 1 or 2 days and then returned to low values during the next 3 to 5 days. Each of these high-speed streams tended to be seen at approximately 27-day intervals or to recur with the rotation period of the Sun as viewed from the spacecraft. A similar recurrence tendency had been noted in geomagnetic activity, and was widely interpreted as the effect of localized, long-lived streams of particles emitted from the Sun and swept past the Earth once during each solar rotation. The high-speed solar wind streams have been linked to recurrent geomagnetic activity and found to be prominent features of the solar wind much of the time since 1962. See GEOMAGNETISM; MAGNETOSPHERE.

X-ray and ultraviolet images of the Sun have brought attention to the features known as coronal holes. These are regions of abnormally low corona density that appear dim in any radiation emitted (x-rays and the ultraviolet) or scattered (the white-light corona observed at eclipse) from the corona. Detailed examination of these images suggests that the holes are regions where the solar magnetic field is open, with field lines reaching from their visible roots in the photosphere out into interplanetary space. In contrast, the structure seen in the bright or dense corona suggests closed magnetic fields, with field lines connecting separated locations in the photosphere. See SOLAR CORONA.

The largest and longest-lived coronal holes have been observed to occur in the polar regions of the Sun (as defined by

its rotation axis); conspicuous polar holes existed for at least 8 years during the last 11-year sunspot cycle. These polar holes are related to the weak, dipolelike, general magnetic field of the Sun and are thus of opposite polarity in the two hemispheres. See SUN. [A.J.Hu.]

**Soldering** A low-temperature metallurgical joining method in which the solder (joining material) has a much lower melting point than the surfaces to be joined (substrates). Because of its lower melting point, solder can be melted and brought into contact with the substrates without melting them. During the soldering process, molten solder wets the substrate surfaces (spreads over them) and solidifies on cooling to form a solid joint.

The most important technological applications of solders are in the assembly of electronic devices, where they are used to make metallic joints between conducting wires, films, or contacts. They are also used for the routine low-temperature joining of copper plumbing fixtures and other devices. In addition, solder is used in the fusible joints of fire safety devices and other high-temperature detectors; the solder joint liquefies if the ambient temperature exceeds the solder's melting point, releasing a sprinkler head or triggering some other protective operation.

Tin or indium content is included in solder to facilitate bonding to the metals that are most commonly soldered, such as copper (Cu), nickel (Ni), and gold (Au). Tin and indium form stable intermetallic compounds with copper and nickel, and indium also forms intermetallics with gold. The intermetallic reaction at the solder-substrate interface creates a strong, stable bond. See ALLOY; INTERMETALLIC COMPOUNDS. [J.W.Mo.]

**Solenodon** An insectivorous mammal. The two species composing the family Solenodontidae are restricted to the West Indies. The relationship of this family to other insectivores is obscure. Almique (*Atopogale cubana*) is found only in Cuba, while agouta (*Solenodon paradoxus*) is confined to Haiti. Extinct members of the family such as *Apternodus* and *Micropternodus* are known from North America. Both living species are now rare because of the predatory mongoose, which was originally introduced to combat snakes.

Solenodons are about 2 ft (0.6 m) long and have a ratlike body. They resemble tenrecs, except that solenodons have a long tail and no spines. Each of the digits has a powerful claw, with those on the forelimbs being quite large. The eyes are small, the snout is extremely elongate, scent glands are present in both the groin and armpit regions, and the mammary glands are located on the buttocks. They have a total of 40 teeth. Solenodons are nocturnally active, searching for insects, worms, vegetation, and small vertebrates. See DENTITION; INSECTIVORA; TENREC. [C.B.C.]

**Solenoid (electricity)** An electrically energized coil of insulated wire which produces a magnetic field within the coil. If the magnetic field produced by the coil is used to magnetize and thus attract a plunger or armature to a position within the coil, the device may be considered to be a special form of electromagnet and in this sense the words solenoid and electromagnet are synonymous. In a wider scientific sense the solenoid may be used to produce a uniform magnetic field for various investigations. So long as the length of the coil is much greater than its diameter (20 or more times), the magnetic field at the center of the coil is sensibly uniform, and the field intensity is almost exactly that given by the equation for a solenoid of infinite length.

When used as an electromagnet of the plunger type, the solenoid usually has an iron or steel casing. The casing increases the mechanical force on the plunger and also serves to constrain the magnetic field. The addition of a butt or stop at one end of the solenoid greatly increases the force on the plunger when the distance between the plunger and the stop is small. The illustration

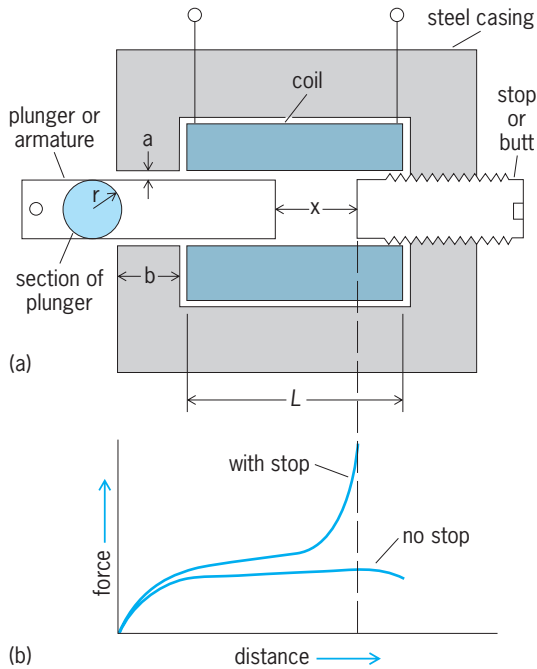

**Steel-clad solenoid. (a) Cross-sectional view. (b) Relation of the force acting on the armature to the displacement of the armature.**

shows a steel-clad solenoid with plunger and plunger stop. The relation of force versus distance with and without the stop is also shown. See ELECTROMAGNET. [J.Me.]

**Solenoid (meteorology)** In meteorological usage, solenoids are hypothetical tubes formed in space by the intersection of a set of surfaces of constant pressure (isobaric surfaces) and a set of surfaces of constant specific volume of air (isosteric surfaces) or density (isopycnic surfaces). The isobaric and isosteric surfaces are such that the values of pressure and specific volume, respectively, change by one unit from one surface to the next. The state of the atmosphere is said to be barotropic when there are no solenoids, that is, when isobaric and isosteric surfaces coincide. The number of solenoids cut by any plane surface element of unit area is a measure of the torque exerted by the pressure gradient force, tending to accelerate the circulation of air around the boundary of the area. See BAROCLINIC FIELD; BAROTROPIC FIELD; ISOPYCNIC. [F.S.; H.B.B.]

**Solid (geometry)** A three-dimensional geometric figure consisting of points continuously connected, and separated from the rest of space by a surface called the boundary of the solid. Points on the boundary are usually considered part of the solid. A solid is bounded if there exists a sphere having finite radius that could enclose the solid. A solid is convex if all points of any line segment having end points on the boundary also are points of the solid. [H.L.Ba.]

**Solid solution** Compositional variation of a crystalline substance due to substitution or omission of various atomic constituents within a crystal structure. Solid solutions can be classified as substitutional, interstitial, or omissional. They may also be categorized by the nature of their thermodynamic properties, such as enthalpy, entropy, and free energy (for example ideal, nonideal, and regular solid solutions).

The concept of solid solution can be understood by considering a specific mineral group such as olivine. Although olivine-group minerals may exhibit a range of compositions they all have a similar crystal structure. Thus all of the minerals in the olivine group are isostructural (having a similar crystal structure). Yet

within this structural framework, compositions vary considerably. Such chemical variation can be described by defining the nature and extent of the atomic substitutions involved or by describing intermediate compositions in terms of limiting end-member compositions. In addition to substitution within the crystal structure, compositional variation may take place by interstitial substitution or omission solid solution. Interstitial solid solution occurs when ions or atoms occupy a position in a crystal structure that is usually vacant. Omission solid solution occurs when an atom or ion is missing from a specific crystallographic position. See OLIVINE.

Solid solution is widespread among minerals. In fact, very few naturally occurring minerals exist as pure end-member substances but exhibit trace to extensive solid solution. The extent of solid solution depends upon the relative sizes of the atoms or ions involved, the charges of the ions, the coexistence and composition of other minerals or liquid (for example, magma), and the temperature and pressure conditions of formation (with temperature having a more pronounced effect). [J.C.D.]

**Solid-state battery** A battery in which both electrodes and the electrolyte are solids (see illustration). Solid electrolytes are a class of materials also known as superionic conductors and fast ion conductors, and their study belongs to an area of science known as solid-state ionics. As a group, these materials are very good conductors of ions but are essentially insulating toward electrons, properties that are prerequisites for any electrolyte. The high ionic conductivity minimizes the internal resistance of the battery, thus permitting high power densities, while the high electronic resistance minimizes its self-discharge rate, thus enhancing its shelf life. Examples of such materials include  $\text{Ag}_4\text{RbI}_5$  for  $\text{Ag}^+$  conduction,  $\text{LiI}/\text{Al}_2\text{O}_3$  mixtures for  $\text{Li}^+$  conduction, and the clay and  $\beta$ -alumina group of compounds ( $\text{NaAl}_{11}\text{O}_{17}$ ) for  $\text{Na}^+$  and other mono- and divalent ions. At room temperature the ionic conductivity of a single crystal of sodium  $\beta$ -alumina is 0.035 S/cm, comparable to the conductivity of a 0.1 M HCl solution. This conductivity, however, is reduced in a battery by a factor of 2–5, because of the use of powdered or ceramic material rather than single crystals. Of much interest are glassy and polymeric materials that can be readily made in thin-film form, thus enhancing the rate capability of the overall system. See ELECTROLYTE; ELECTROLYTIC CONDUCTANCE; IONIC CRYSTALS.

Solid-state batteries generally fall into the low-power-density and high-energy-density category. The former limitation arises because of the difficulty of getting high currents across solid–solid interfaces. However, these batteries do have certain advantages that outweigh this disadvantage: They are easy to miniaturize (for example, they can be constructed in thin-film form), and there

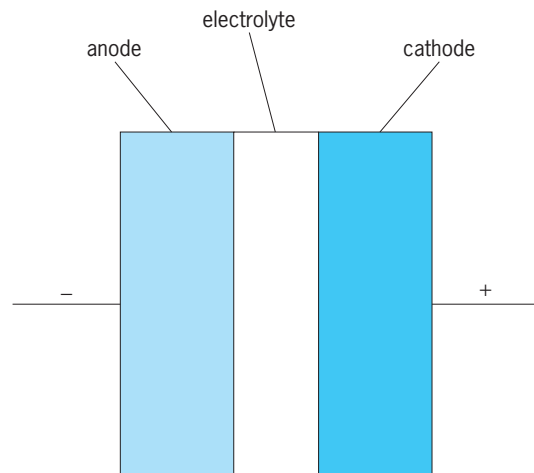

**Schematic diagram of solid-state battery.**

is no problem with electrolyte leakage. They tend to have very long shelf lives, and usually do not have any abrupt changes in performance with temperature, such as might be associated with electrolyte freezing or boiling. Being low-power devices, they are also inherently safer. The major applications of these batteries are in electronic devices such as cardiac pacemakers, cameras, electrochromic displays, watches, and calculators. See BATTERY. [M.S.W.]

**Solid-state chemistry** The science of the elementary, atomic compositions of solids and the transformations that occur in and between solids and between solids and other phases to produce solids. Solid-state chemistry deals primarily with those microscopic features which are uniquely characteristic of solids and which are the causes for the macroscopic chemical properties and the chemical reactions of solids. As with other branches of the physical sciences, solid-state chemistry also includes related areas that furnish concepts and explanations of those phenomena which are more characteristic of the subject itself.

The overlap of solid-state chemistry and solid-state physics is extensive. However, the perspectives of the two are different. In general, solid-state physics treats properties, such as energy and entropy, which are continuously variable in the solid, whereas solid-state chemistry concerns those properties which are discontinuous because of chemical reactions. Also, solid-state chemistry tends to be based on structure in configuration space, whereas solid-state physics tends to be based on momentum space. See INORGANIC CHEMISTRY; SOLID-STATE PHYSICS.

Solid-state chemistry has no single unifying theoretical base and tends to be largely an experimental science supported by several theoretical bases. Consequently, its separation into topics is not well established. Aspects of solid-state chemistry include chemical bonding, crystal defects, crystal structures, crystal field theory, diffusion in solids, ionic crystals, lattice vibrations, and nonstoichiometry. See NONSTOICHIOMETRIC COMPOUNDS.

Studies of structures provide a basis for understanding the chemical bonding in solids, their properties, reactions among them, and their variabilities of composition. Numerous binary compounds or phases have layered structures. The layers are displaced relative to each other in such a way that the structures can be classified in the space groups, but when other elements or compounds are incorporated between the layers, the structure is highly distorted. The most widely recognized material to possess the layered structure and the associated solid-state chemistry is graphite. Structural information is represented by the location of atoms on the lattice network. The structures are determined by diffraction of x-rays, neutrons, or electrons. Two other features of the structure of solids are the local structure about a given atom and the extended structure on a more global scale. See GRAPHITE.

The structure of a solid is the result of the operation of interatomic or interionic forces and the size and shape of the atoms or ions. Hence, logically, bonding should be described first and structure second. However, the detailed role of the electrons in interionic forces is so complex, and the quantitative aspects of the problem of minimizing the potential energy with respect to all the possible configurations is so difficult, that structures cannot be derived. Rather, it is necessary to derive some information about bonding from structures, cohesive energies, refractive indices, electron binding energies, polarizabilities, and other properties through the use of models. Simple, classically based models can be classified generally as ionic, covalent, and metallic bonding and combinations of the three. See CHEMICAL BONDING; STRUCTURAL CHEMISTRY.

The mechanisms of chemical reactions within and between solids are through lattice vibrations, lattice defects, and changes in valence states. These are the structural features through which migration of mass, charge, and energy occur. Consequently, dif-

fusion and conductivity are integral, basic parts of solid-state chemistry. See DIFFUSION; ELECTRICAL CONDUCTIVITY OF METALS.

A feature of the electronic structure of solids, which is particularly essential to solid-state chemistry, is the valence state of the ion and the energy required to change the valency in the solid. See VALENCE.

Many of the photo-induced processes which occur in solids can be imagined to be solid-state chemical reactions. The classical ones, of course, are those involved in photographic plates and films. See PHOTOCHEMISTRY. [R.J.T.]

**Solid-state physics** The study of the physical properties of solids, such as electrical, dielectric, elastic, and thermal properties, and their understanding in terms of fundamental physical laws. Most problems in solid-state physics would be called solid-state chemistry if studied by scientists with chemical training, and vice versa. Solid-state physics emphasizes the properties common to large classes of compounds rather than the dependence of properties upon compositions, the latter receiving greater emphasis in solid-state chemistry. In addition, solid-state chemistry tends to be more descriptive, while solid-state physics focuses upon quantitative relationships between properties and the underlying electronic structure. See SOLID-STATE CHEMISTRY.

Many of the scientists who study the physics of liquids identify with solid-state physics, and the term "condensed-matter physics" has been used by some researchers to replace "solid-state physics" as a division of physics. It includes noncrystalline solids such as glass as well as crystalline solids. See AMORPHOUS SOLID; GLASS.

In solid-state physics it is generally assumed that the electronic states can be described as wavelike. The individual electronic states, called Bloch states, have energies which depend upon the wave number (a vector equal to the momentum divided by  $\hbar$ , which is Planck's constant divided by  $2\pi$ ), and the wave number is restricted to a domain called the Brillouin zone. This energy given as a function of the wave number is called the band structure. There are several curves, called bands, for each line in the Brillouin zone. See BRILLOUIN ZONE.

The total energy of a solid includes a sum of the energies of the occupied electronic states. Since the energy bands depend upon the positions of the atoms, so does the total energy, and the stable crystal structure is that which minimizes this energy. The theory has not proved adequate to really predict the crystal structure of various solids, but it is possible to predict the changes in energy under various distortions of the lattice. There are in fact three times as many independent distortions, called normal modes, as there are atoms in the solid. Each has a wave number, and the frequencies of the normal vibrational modes, as a function of wave number in the Brillouin zone, form vibrational bands in direct analogy with the electronic energy bands. These can be directly calculated from quantum theory or measured by using neutron or x-ray diffraction. See CRYSTAL; LATTICE VIBRATIONS; NEUTRON DIFFRACTION; X-RAY DIFFRACTION. [W.A.H.]

**Solids pump** A device used to move solids upward through a chamber or conduit. It is able to overcome the large dynamic forces at the base of a solids bed and cause the entire bed to move upward.

Solids pumps are used to cause motion of solids in process-type equipment in which treatment of solids under special conditions of temperature, oxidation, and reduction can be combined with upward motion and discharge of the spent solids overhead from the reacting vessel. The solids pump has found its principal application in the operation of oil-shale retorts.

Solids pumps are inherently of the positive displacement type. One practical method uses a reciprocating piston mounted on a trunnion permitting it to swing into an inclined position for filling and then to swing back into vertical position for discharge. The illustration shows a mechanically driven solids pump in four

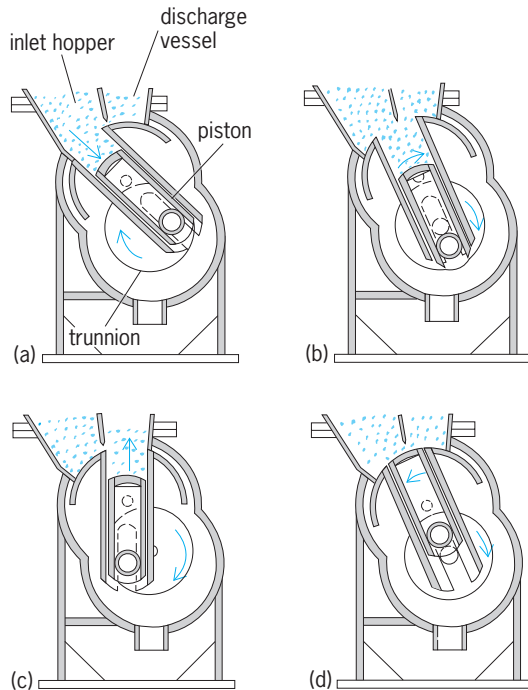

**Operation cycle of mechanically driven solids pump. (a) Filling with solids from inlet hopper. (b) Piston rotating on a trunnion toward its discharge position. (c) The discharge position, with piston pushing charge of solids upward. (d) Piston rotating back toward original filling position.**

positions through its cycle of operation. See BULK-HANDLING MACHINES. [C.Be.]

**Solifugae** An order of nonvenomous, spiderlike predatory arachnids found chiefly in arid and semiarid, tropical, and warm-temperate regions. They are also known as sun spiders. The relatively large anterior appendages, or chelicerae, are used for holding and crushing prey. The sun spiders are agile and usually stalk their prey during the night. A fossil form is known from Pennsylvanian time. See ARACHNIDA. [C.C.Ho.]

**Soliton** An isolated wave that propagates without dispersing its energy over larger and larger regions of space. In most of the scientific literature, the requirement that two solitons emerge unchanged from a collision is also added to the definition; otherwise the disturbance is termed a solitary wave.

There are many equations of mathematical physics which have solutions of the soliton type. Correspondingly, the phenomena which they describe, be it the motion of waves in shallow water or in an ionized plasma, exhibit solitons. The first observation of this kind of wave was made in 1834 by John Scott Russell, who followed on horseback a soliton propagating in the windings of a channel. In 1895, D. J. Korteweg and H. de Vries proposed an equation for the motion of waves in shallow waters which possesses soliton solutions, and thus established a mathematical basis for the study of the phenomenon. Interest in the subject, however, lay dormant for many years, and the major body of investigations began only in the 1950s. Researches done by analytical methods and by numerical methods made possible with the advent of computers gradually led to a complete understanding of solitons. See DIFFERENTIAL EQUATION; WAVE MOTION; WAVE MOTION IN LIQUIDS.

Eventually, the fact that solitons exhibit particlelike properties, because the energy is at any instant confined to a limited region of space, received attention, and solitons were proposed as models for elementary particles. However, it is difficult to

account for all of the properties of known particles in terms of solitons. More recently it has been realized that some of the quantum fields which are used to describe particles and their interactions also have solutions of the soliton type. The solitons would then appear as additional particles, and may have escaped experimental detection because their masses are much larger than those of known particles. In this context the requirement that solitons emerge unchanged from a collision has been found too restrictive, and particle theorists have used the term soliton where traditionally the term solitary wave would be used. See ELEMENTARY PARTICLE; QUANTUM FIELD THEORY. [C.R.]

A hydrodynamic soliton is simply described by the equation of Korteweg and de Vries, which includes a dispersive term and a term to represent nonlinear effects. Easily observed in a wave tank, a bell-shaped solution of this equation balances the effects of dispersion and nonlinearity, and it is this balance that is the essential feature of the soliton phenomenon. Tidal waves in the Firth of Forth were found by Scott Russell to be solitons, as are internal ocean waves and tsunamis. At an even greater level of energy, it has been suggested that the Great Red Spot of the planet Jupiter is a hydrodynamic soliton. See JUPITER; OCEAN WAVES; TSUNAMI.

The most significant technical application of the soliton is as a carrier of digital information along an optical fiber. The optical soliton is governed by the nonlinear Schrödinger equation, and again expresses a balance between the effects of optical dispersion and nonlinearity that is due to electric field dependence of the refractive index in the fiber core. If the power is too low, nonlinear effects become negligible, and the information spreads (or disperses) over an ever increasing length of the fiber. At a pulse power level of about 5 milliwatts, however, a robustly stable soliton appears and maintains its size and shape in the presence of disturbing influences. Present designs for data transmission systems based on the optical soliton have a data rate of  $4 \times 10^9$  bits per second. See OPTICAL COMMUNICATIONS.

A carefully studied soliton system is the transverse electromagnetic (TEM) wave that travels between two strips of superconducting metal separated by an insulating layer thin enough (about 2.5 nanometers) to permit transverse Josephson tunneling. Since each soliton carries one quantum of magnetic flux, it is also called a fluxon if the magnetic flux points in one direction, and an antifluxon if the flux points in the opposite direction. Oscillators based on this system reach into the submillimeter wave region of the electromagnetic spectrum (frequencies greater than  $10^{11}$  Hz). See JOSEPHSON EFFECT; WAVEGUIDE.

The all-or-nothing action potential or nerve impulse that carries a bit of biological information along the axon of a nerve cell shares many properties with the soliton. Both are solutions of nonlinear equations that travel with fixed shape at constant speed, but the soliton conserves energy, while the nerve impulse balances the rate at which electrostatic energy is released from the nerve membrane to the rate at which it is consumed by the dissipative effects of circulating ionic currents. The nerve process is much like the flame of a candle. See BIOPOTENTIALS AND IONIC CURRENTS. [A.Sco.]

**Solstice** The two days during the year when the Earth is so located in its orbit that the inclination (about  $23\frac{1}{2}^\circ$ , or  $23.45^\circ$ ) of the polar axis is toward the Sun. This occurs on June 21, called the summer solstice, when the North Pole is tilted toward the Sun; and on December 22, called the winter solstice, when the South Pole is tilted toward the Sun (see illustration). The adjectives summer and winter, used above, refer to the Northern Hemisphere; seasons are reversed in the Southern Hemisphere.

At the time of the summer solstice every place north of the Arctic Circle will have 24 h of sunlight and the length of day at all places north of the Equator will be more than 12 h, increasing in length with increasing latitude. Identical conditions are found

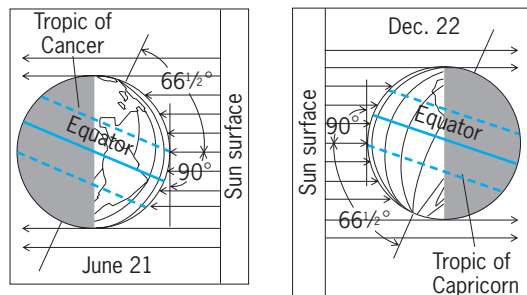

The Earth at the time of the summer and winter solstices. The dates may vary because of the extra one-fourth day in the year.

in the Southern Hemisphere at the time of the Northern Hemisphere's winter solstice. See MATHEMATICAL GEOGRAPHY. [V.H.E.]

**Solubility product constant** A special type of simplified equilibrium constant (symbol  $K_{sp}$ ) defined for, and useful for, equilibria between solids (s) and their respective ions in solution, for example, reaction (1). For this relatively simple equilibrium, Eqs. (2) and (3) apply.

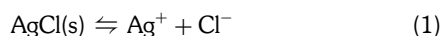

$$[\text{Ag}^+][\text{Cl}^-] \cong K_{sp} \quad (2)$$

$$(\text{Ag}^+)(\text{Cl}^-)/(\text{AgCl}) = K_{sp} \quad (3)$$

It can be demonstrated experimentally that a small increase in the molar concentration of chloride ion  $[\text{Cl}^-]$  causes a reduction in the concentration of silver present as  $\text{Ag}^+$ . Similarly, an increase in  $[\text{Ag}^+]$  reduces  $[\text{Cl}^-]$ . The product of the two concentrations is approximately constant as indicated by Eq. (2) and equal to the  $K_{sp}$  of Eq. (3). Equation (3) is exact since the variables are activities instead of concentrations. In accordance with the choice of standard state usually made for a solid, the activity of solid  $\text{AgCl}$  is unity, hence Eq. (4) holds.

$$(\text{Ag}^+)(\text{Cl}^-) = K_{sp} = 1.8 \times 10^{-10} \text{ mole}^2 \text{ liter}^{-2} \quad (4)$$

In practice, various complications arise: addition of too much of either ion produces more complicated ions and hence actually increases the apparent concentration of the other ion. Addition of a salt without a common ion (that is, a salt supplying neither  $\text{Ag}^+$  nor  $\text{Cl}^-$ ) either may react with  $\text{Ag}^+$  or  $\text{Cl}^-$  or may merely increase the concentration of both ions by a lowering of the mean ionic activity coefficient. See IONIC EQUILIBRIUM; PRECIPITATION (CHEMISTRY). [T.F.Y.]

**Solubilizing of samples** The process by which samples that do not dissolve easily are converted into different chemical compounds that are soluble. The sample may be heated in air to evolve volatile components or to oxidize a component to a volatile higher oxidation state with the formation of an acid-soluble form, as in the roasting of a sulfide to form the oxide and sulfur dioxide. Most frequently, the sample is treated with a solvent which reacts with one or more constituents of the sample. The choice of solvent is determined by the chemical reactions that are required. Reactions used include solvation, neutralization, complex formation, metathesis, displacement, oxidation-reduction, or combinations of these.

Most water-soluble salts dissolve by solvation. Basic oxides such as ferric oxide dissolve in aqueous hydrochloric acid. Metals above hydrogen in the electrochemical series will dissolve in a nonoxidizing acid by reduction of hydrogen ion. Metals such as copper and lead require an oxidizing acid, usually nitric acid. All of the components of brass and bronze are usually dissolved by

nitric acid except tin, arsenic, and antimony, which precipitate as hydrated oxides. Alloy steels are usually dissolved by combinations of hydrochloric, nitric, phosphoric, and hydrofluoric acids. Aluminum-base alloys are treated with sodium hydroxide solution and any residues are dissolved in acid.

Many substances do not dissolve at temperatures obtainable in the presence of liquid water. However, fused salt reactions employing temperatures of 400–1100°C (750–2000°F) are necessary for the attack and decomposition of many types of samples. The material used as the solvent is called a flux, and the process of melting the mixture of dry, solid flux with the sample is called a fusion. [C.L.R.]

**Solution** A homogeneous mixture of two or more components whose properties vary continuously with varying proportions of the components. A liquid solution can be distinguished experimentally from a pure liquid by the fact that during transfers into other single phases at equilibrium (freezing and vaporizing at constant pressure) the temperature and other properties vary continuously, whereas those of a pure liquid remain constant. For an apparent exception see AZEOTROPIC MIXTURE. See also SOLVENT.

Gases, unless highly compressed, are mutually soluble in all proportions.

A solid solution is, similarly, a single phase whose composition and other properties vary continuously with changing composition of the liquid phase with which it is in equilibrium. See SOLID SOLUTION.

The extent to which substances can form solutions depends upon the kind and strength of the attractive forces between the several molecular species involved. It is necessary to consider the attractive forces exerted by molecules of the following types: (1) nonpolar molecules; (2) polar molecules, that is, those containing electric dipoles; (3) ions; and (4) metallic atoms.

Actual solutions may be considered in terms of their departure from a simple idealized model—a mixture of components having the same attractive fields, which mix without change in volume or heat content. This is analogous to an ideal gas mixture, which is formed with no heat of mixing and in which the total pressure is the sum of the partial pressures. In such a solution the escaping tendency of the individual molecules is the same, whether they are surrounded by similar or by different molecules. [J.H.Hi.]

**Solution mining** The extraction of the valuable components from a mineral deposit using an aqueous leaching solution. In its original sense, solution mining refers to evaporite mining, the dissolution of soluble rock material such as salt by using borehole wells to pump water into the deposit and remove the resulting saturated brine. In its current usage, solution mining also includes ore leaching, the in-place (in-situ) leaching of valuable metal components from an orebody, and the mine-site procedures of heap leaching and dump leaching. Often included is the Frasch process of using superheated water to melt sulfur in its deep deposits and recover the molten sulfur in borehole wells. See ORE AND MINERAL DEPOSITS.

Evaporites represent a broad class of water-soluble minerals (salts). Commercially important evaporites include halite (sodium chloride), sylvite and silvinit (potash), bischofite (magnesium chloride), nahcolite (sodium bicarbonate), trona (raw soda ash), and langbeinite and carnallite [both sources of potash and magnesia (magnesium oxide)]. See SALINE EVAPORITES.

Solution mining involves injecting a solvent into the pay zone of the deposit through a cased borehole. For evaporites, the solvent is hot water, which forms brine as the soluble minerals dissolve. The brine is brought to the surface via the casing system in the same or another borehole and sent to a processing facility for recovery by the controlled crystallization of the desired product, followed by dewatering and drying. Some minerals may require additional purification steps, such as the flotation of potash crystals. The depleted brine is chemically reconditioned and injected



back into the deposit. Thus, solution mining creates minimal surface disturbance and little waste, compared to conventional mining. See WELL.

Although solution mining is simple in principle, there are several key issues for successful operation. One is to maintain close control over the solvent parameters, such as pH, oxidation potential, temperature, and pressure. Another issue is isolation of the solution mining zone from the surrounding geologic structures. This requires effective well completion techniques that are compatible with the brine. Once the well is drilled and cased, the casing must be cemented into the formation. This prevents brine from migrating along the annular space outside the casing and contaminating adjacent aquifers. See ELECTROCHEMICAL SERIES; OIL AND GAS WELL COMPLETION. [W.J.S.]

Leaching large stockpiles and mine waste dumps (ore heaps) annually accounts for about one-third of both new copper and gold production in the United States, the world's second largest source of both commodities. Ore leaching is an important contributor to the total world production of these commodities, along with silver. Ore leaching's very low unit processing cost, combined with low-cost earthmoving, allows profitable treatment of huge tonnages of low-grade material that could not otherwise be exploited.

Ore containing rock must first be fragmented to allow chemical leaching solutions to percolate through it. The metal-bearing minerals are liberated using an aqueous wetting fluid that penetrates and saturates the microfractures within the ore particles by capillary action. The ore minerals, originally deposited geochemically from hydrothermal solutions, are typically located in these micropores. Once dissolved, the metals are removed from the ore particles by diffusion through the solution-filled micropores and swept out of the ore heap by the flowing leachate. In effect, nature's ore deposition process has been reversed at a quicker pace. Nevertheless, commercial leaching times are measured in weeks, months, and even years. Leachates, or "pregnant liquors," are processed in surface plants to recover the metal and regenerate the leachant for reuse in the ore heap in a closed-loop system. See HYDROMETALLURGY; LEACHING. [R.W.Ba.]

Modern sulfur mining dates from the invention of the Frasch process in the late nineteenth century. H. Frasch accomplished in-place sulfur mining by using superheated water. Frasch mining begins by drilling wells into the sulfur deposit. Steel tubing (casing) is run into the drill hole to case off the barren overlying formation, and it is cemented in at the top of the sulfur deposit. Within this casing, three concentric strings of pipe are set within the sulfur deposit. Superheated water at 325°F (163°C) can be pumped down the annulus between the two strings of pipe to leave the casing string through the perforations above the packer, and to circulate in the sulfur deposit. Native sulfur melts at 275°F (135°C) in a cone-shaped area of influence around the well, and because liquid sulfur is denser than water, it settles to the bottom of the well.

The pressure from the heated water forces the molten sulfur into the lower set of perforations and into the inner string of casing. The molten sulfur rises to its hydrostatic head. Compressed air pumped through this inner tubing expands when it leaves the tubing, thus "jetting" the sulfur to the well collar, where it is collected in a tank (sulfur pan). [A.F.E.]

**Solvation** The association or combination of a solute unit (ionic, molecular, or particulate) with solvent molecules. This association may involve chemical or physical forces, or both, and may vary in degree from a loose, indefinite complex to the formation of a distinct chemical compound. Such a compound contains a definite number of solvent molecules per solute molecule. Solvation occurring in aqueous solutions is referred to as hydration. In certain colloidal suspensions, solvation is, to a large extent, responsible for the stability of the sol. See COLLOID; HYDRATION; SOLUTION; SOLVENT. [E.J.J.]

**Solvent** By convention, the component present in the greatest proportion in a homogeneous mixture of pure substances (solutions). Components of mixtures present in minor proportions are called solutes. Thus, technically, homogeneous mixtures are possible with liquids, solids, or gases dissolved in liquids; solids in solids; and gases in gases. In common practice this terminology is applied mostly to liquid mixtures for which the solvent is a liquid and the solute can be a liquid, solid, or gas. See SOLUTION.

Three broad classes of solvents are recognized—aqueous, nonaqueous, and organic. Formalistically, the nonaqueous and organic classifications are both not aqueous, but the term organic solvents is generally applied to a large body of carbon-based compounds that find use industrially and as media for chemical synthesis. Organic solvents are generally classified by the functional groups that are present in the molecule, for example, alcohols, halogenated hydrocarbons, or hydrocarbons; such groups give an indication of the types of physical or chemical interactions that can occur between solute and solvent. Nonaqueous solvents are generally taken to be inorganic substances and a few of the lower-molecular-weight, carbon-containing substances such as acetic acid, methanol, and dimethylsulfoxide. Nonaqueous solvents can be solids (for example, fused LiI), liquids (H<sub>2</sub>SO<sub>4</sub>), or gases (NH<sub>3</sub>) at ambient conditions; the solvent properties of fused sodium iodide (NaI) are manifested in the molten state, whereas hydrogen sulfate (H<sub>2</sub>SO<sub>4</sub>) and ammonia (NH<sub>3</sub>) must be liquefied to act as solvents. [J.J.L.]

**Solvent extraction** A technique, also called liquid extraction, for separating the components of a liquid solution. This technique depends upon the selective dissolving of one or more constituents of the solution into a suitable immiscible liquid solvent. It is particularly useful industrially for separation of the constituents of a mixture according to chemical type, especially when methods that depend upon different physical properties, such as the separation by distillation of substances of different vapor pressures, either fail entirely or become too expensive.

Industrial plants using solvent extraction require equipment for carrying out the extraction itself (extractor) and for essentially complete recovery of the solvent for reuse, usually by distillation. See DISTILLATION.

The petroleum refining industry is the largest user of extraction. In refining virtually all automobile lubricating oil, the undesirable constituents such as aromatic hydrocarbons are extracted from the more desirable paraffinic and naphthenic hydrocarbons. By suitable catalytic treatment of lower boiling distillates, naphthas rich in aromatic hydrocarbons such as benzene, toluene, and the xylenes may be produced. The latter are separated from paraffinic hydrocarbons with suitable solvents to produce high-purity aromatic hydrocarbons and high-octane gasoline. Other industrial applications include so-called sweetening of gasoline by extraction of sulfur-containing compounds; separation of vegetable oils into relatively saturated and unsaturated glyceride esters; recovery of valuable chemicals in by-product coke oven plants; pharmaceutical refining processes; and purifying of uranium.

Solvent extraction is carried out regularly in the laboratory by the chemist as a commonplace purification procedure in organic synthesis, and in analytical separations in which the extraordinary ability of certain solvents preferentially to remove one or more constituents from a solution quantitatively is exploited. Batch extractions of this sort, on a small scale, are usually done in separatory funnels, where the mechanical agitation is supplied by handshaking of the funnel. See EXTRACTION. [R.E.Tr.]

**Somatic cell genetics** The study of mechanisms of inheritance in animals and plants by using cells in culture. In such cells, chromosomes and genes can be reshuffled by parasexual methods, rather than having to depend upon the chromosome segregation and genetic recombination that occur during the

meiotic cell divisions preceding gamete formation and sexual reproduction. Genetic analysis is concerned with the role of genes and chromosomes in the development and function of individuals and the evolution of species. Genetic analysis of complex multicellular organisms classically required multiple-generation families, and fairly large numbers of progeny of defined matings had to be scored. As a result, analysis of animals and plants with long generation times, small families, or lack of controlled matings was difficult and slow. Somatic cell genetics circumvents many of these limitations. It has enhanced the scope and speed of genetic analysis in higher plants and animals, especially when combined with the powerful techniques of molecular biology and the ability to generate fertile plants and animals from single cultured cells. With these methods, every gene in any species of interest can be identified and mapped to its position on a particular chromosome, its functions determined, and its evolutionary relationships to genes in other species revealed. Cross-species comparisons have provided essential insights into such poorly understood areas as embryonic differentiation and the development of complex nervous systems. *See* EMBRYONIC DIFFERENTIATION; GENETIC MAPPING; MOLECULAR BIOLOGY.

Foreign genes (transgenes) can be introduced into somatic cells, which grow and differentiate into complete organisms whose sexual reproduction permits both the analysis of the effects of the introduced gene and the development of stocks with desirable characteristics. Transgenic plants have tremendous potential in the development of plants resistant to insects; to viral, fungal, or bacterial disease; and to environmental stress. Transgenic animals are generated in ever-increasing numbers because of their usefulness in studying cell differentiation, morphogenesis, and function. *See* GENE ACTION; GENETIC ENGINEERING; GENETICS. [O.J.M.]

**Somatostatin** A naturally occurring regulatory peptide that carries out numerous functions in the human body, including the inhibition of growth hormone secretion from the anterior pituitary gland. Somatostatin consists of 14 amino acids; two cysteine residues are joined by a disulfide bond so that the peptide forms a ring structure. A larger variant of this peptide, called somatostatin-28, is produced in some cells and has an additional 14 amino acids attached at the amino-terminal end of normal somatostatin (somatostatin-14).

Somatostatin acts primarily as a negative regulator of a variety of different cell types, blocking processes such as cell secretion, cell growth, and smooth muscle contraction. It is secreted from the hypothalamus into the portal circulation and travels to the anterior pituitary gland, where it inhibits the production and release of both growth hormone and thyroid-stimulating hormone. Many tissues other than the hypothalamus contain somatostatin, suggesting that this peptide has numerous roles.

Each of the functions of somatostatin is initiated by the binding of the peptide to one or more of five different cell-surface receptor proteins, thereby activating one or more intracellular G-proteins and initiating biochemical signaling pathways within the cell. *See* SIGNAL TRANSDUCTION.

Analogs of somatostatin have been synthesized that are smaller, more potent, longer-lasting, and more specific in their biological effects than natural somatostatin. Some of these analogs have become useful as drugs. *See* ENDOCRINE SYSTEM (VERTEBRATE); HORMONE; NEUROSECRETION; PITUITARY GLAND. [W.H.Si.]

**Somesthesia** A general term for the somatic sensibilities aroused by stimulation of bodily tissues such as the skin, muscles, tendons, joints, and the viscera. Six primary qualities of somatic sensation are commonly recognized: touch-pressure (including temporal variations such as vibration), warmth, coolness, pain, itch, and the position and movement of the joints. These basic sensory qualities exist because each is served by a different set of sensory receptors (the sensory endings of certain peripheral nerve fibers) which differ not only in their sensitivities to different

types of stimuli, but also in their connections to structures within the central nervous system.

The somatic sensory pathways are dual in nature. One major part, the lemniscal system, receives input from large-diameter myelinated peripheral nerve fibers (for example, those serving the sense of touch-pressure). The second major somatic pathway is called the anterolateral system. It receives input from small-diameter myelinated and unmyelinated peripheral nerve fibers carrying pain and temperature information. *See* CUTANEOUS SENSATION; PAIN; PROPRIOCEPTION. [R.LaM.]

**Sonar** A remote sensing technique or device that uses sound waves to detect, locate, and sometimes identify objects in water. The term is an acronym for sound navigation and ranging. There are many applications, using a wide variety of equipment. Naval uses include detection of submarines, sea mines, torpedoes, and swimmers; torpedo guidance; acoustic mines; and navigation. Civilian uses include determining water depth; finding fish; mapping the ocean floor; locating various objects in the ocean, such as pipelines, wellheads, wrecks, and obstacles to navigation; measuring water current profiles; and determining characteristics of ocean bottom sediments. Sound waves rather than electromagnetic waves (for example, radar and light) are used in these applications because their attenuation in seawater is much less. Some marine mammals use sound waves to find food and to navigate. *See* ACOUSTIC TORPEDO; ANTISUBMARINE WARFARE; ECHOLOCATION; MARINE GEOLOGY; MARINE NAVIGATION; UNDERWATER NAVIGATION; UNDERWATER SOUND.

There are two generic types of sonar: active (echolocation) and passive. An active sonar projects a signal (typically a short pulse of sound) into the water in a narrow beam, which propagates at a speed of about 1500 m/s (5000 ft/s). If there is an object (target) in the beam, it reflects a fraction of the sound energy to the sonar, which detects the echo. By measuring the elapsed time between projection and reception, the range to the target can be computed ( $\text{range} = \text{sound speed} \times \text{travel time} \div 2$ ).

Direction to the target is determined from the orientation of the sound beam at the time of reception. Passive sonar does not radiate sound but depends on detecting sounds radiated by targets such as submarines and ships. Passive sonar determines direction to a target in the same manner as active sonar, but range determination is more difficult.

In an elementary active pulse sonar, a pulse signal of certain frequency and duration is generated, amplified, and sent to an electroacoustic transducer, which converts the electrical signal into a sound signal, which then radiates into the water. If the transducer is reciprocal in character (typically the case), it also can be used to sense (detect) the returning echoes. The receiver amplifies the weak echoes and measures the range to each target, as well as the orientation of the receiving beam at the time of reception. This information is displayed in some form of range-direction plot.

Most active sonar transducers are mounted on the hulls of submarines or near the keels of surface ships. Sometimes, transducers are towed at a water depth that provides better operation. There are three basic transducer orientations. In the conventional depth sounder, the sound beam is directed downward. Echoes are reflected from the ocean bottom (and from fish that may be in the beam), and the depth of the ocean beneath the sonar can be determined. In the side-scan sonar configuration, the beam is oriented to the side of the ship (normal to the direction of travel) and (usually) slightly downward. As the ship moves forward, a volume of water to the side of the ship is searched. Generally, two sonars are used, one searching to the right and one to the left. Side-scan sonars are well suited to search at a constant speed and along straight lines, such as in mapping the ocean bottom and in general searches of an area. The third, and most popular, sonar configuration involves rotating the sound beam about the vertical axis to search (scan) a sector of the water centered on the sonar platform. *See* ECHO SOUNDER.

The range at which a target can be detected depends on the strength of the projected signal (source level), propagation losses to the target and return, reflection characteristics of the target (target strength), and sensitivity of the receiver. Also, the target echo must be stronger than various masking signals (noise and reverberation), which also are received by the sonar. An important sonar performance characteristic is its ability to locate a target accurately and determine whether an echo is from a single target or from several targets close together. The uncertainty in the direction to the target is approximately the width of the receiving beam.

Passive sonars are used primarily to detect submarines and, to a lesser extent, surface ships. Because passive sonar does not radiate any sound that would reveal its location, it is the primary sensor used by submarines. The major weakness is that it cannot directly measure range to a target. To determine target location, the sonar must take bearings on a target from different locations. Passive sonars depend on detecting noise radiated by targets, a mixture of sounds generated by propellers and hull vibrations (caused by motors, engines, pumps, and hydrodynamic forces). The noise has a continuous spectrum and discrete tones related to rotational speeds of propellers, engines, and so forth. By analysis of the received signals the sonar often can identify the type of target. Most of the radiated energy is in the audible frequency band and decreases in intensity with increasing frequency.

Most passive sonars use large receiving transducer arrays in order to achieve high sensitivity, discriminate against ambient noise, and determine precisely the direction to a target. In submarines, these arrays may be recessed into the structure or mounted on the hull. Submarines also may tow long slender line arrays. A number of very large fixed receiving arrays, placed on the ocean floor with cables running to shore stations, constantly observe strategically important ocean areas. Detection ranges for large passive sonars vary from hundreds of kilometers against noisy targets under good conditions to a very few kilometers against quiet targets.

The sonobuoy consists of a small surface buoy with a hydrophone array suspended beneath the water. Sounds received by the array are telemetered by radio link to an aircraft overhead. (There are also active sonobuoys.) Sonobuoys have relatively short detection ranges and are used primarily in tactical situations. See SONOBUOY; ULTRASONICS. [C.M.McK.]

**Sonic boom** An audible sound wave generated by an object that moves faster than the speed of sound (supersonic object). The sonic boom forms because the air is pushed away faster than the air molecules can move. The displaced air becomes highly compressed and creates a very strong sound wave, referred to as a compressional head shock or bow shock. At the back of the supersonic object the air has to fill the void left as the object moves forward; in this case, the gas becomes rarefied and a rarefactional tail shock develops. These shock waves are the main components of a sonic boom, and they are generated the entire time that an object flies faster than the speed of sound, not just when it breaks the sonic barrier. See SHOCK WAVE.

Sonic booms may be natural or generated by human activity. A natural sonic boom is thunder, created when lightning ionizes air, which expands supersonically. Meteors can create sonic booms if they enter the atmosphere at supersonic speeds. Human sources of sonic booms include aircraft, rockets, the space shuttle during reentry, and bullets. See METEOR; THUNDER.

Sonic booms are commonly associated with supersonic aircraft. The shock waves associated with sonic booms propagate away from the aircraft in a unique fashion. These waves form a cone, called the Mach cone, that is dragged behind the aircraft. The illustration shows the outline of the Mach cone generated by an F-18 fighter aircraft flying at Mach 1.4. The schlieren photographic technique was used to display the sonic boom, which is normally invisible. The half-angle of the cone is determined solely by the Mach number of the aircraft,  $\theta = \arctan(1/M)$ ,  $36^\circ$

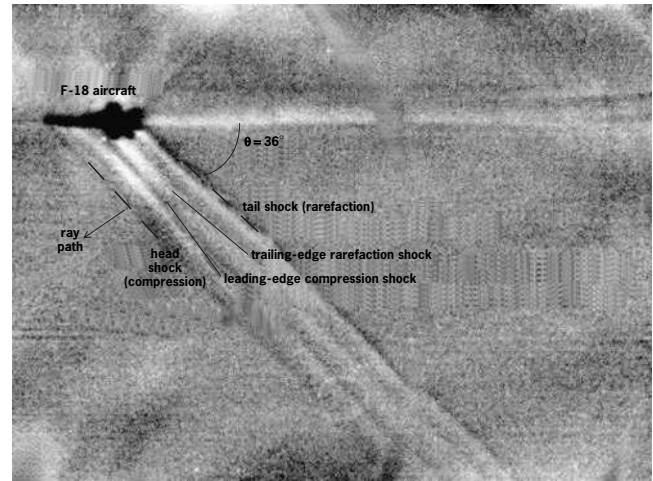

Schlieren image of the shock waves generated by an F-18 aircraft flying at Mach 1.4. The Mach cone generated by the head and tail shocks can be seen as well as the shocks generated by the leading and trailing edges of the wings. (NASA Dryden Flight Research Center)

for  $M = 1.4$ . The shock waves travel along rays that are perpendicular to the Mach cone (see illustration). As the Mach number increases,  $\theta$  becomes smaller and the sound travels almost directly downward. See MACH NUMBER; SCHLIEREN PHOTOGRAPHY; SUPERSONIC FLIGHT.

The typical peak pressure amplitude (or overpressure) of a sonic boom on the ground is about 50–100 pascals. A sonic boom with 50 Pa (1 lbf/ft<sup>2</sup> or 0.007 psi) overpressure will produce no damage to buildings. Booms in the range of 75–100 Pa are considered disturbing by some people. Occasionally there is minor damage to buildings from sonic booms in the range of 100–250 Pa; however, buildings in good condition will be undamaged by overpressures up to 550 Pa. Very low flying aircraft (30 m or 100 ft) can produce sonic booms of 1000–7000 Pa. These pressures are still about five times less than that needed to injure the human ear, but can lead to damage to buildings, such as the breaking of glass windows and the cracking of plaster. Although sonic booms are not dangerous, they can evoke a strong startle response in people and animals. [R.Cl.]

**Sonobuoy** An expendable device that enables aircraft to detect underwater objects, such as submarines, acoustically. Acoustics is the preferred energy form for use in salt water, because it tends to be the least attenuated by the medium.

A sonobuoy consists of an electronic radio link and antenna connected to a miniature sonar system. It contains the means for its launch from the aircraft, its entry into the water, separation of a floating antenna from the underwater transducer and sonar, and activation of a seawater battery upon entry, as well as a scuttling means for final sinking upon completion of its intended useful life. The short life requires that each component be highly reliable and effective at low cost. The package must also be small and lightweight, since large numbers of packages are to be carried on an aircraft. See SONAR.

The simplest sonobuoy is a passive sonar that senses sound with its hydrophone, amplifies and converts it to a radio signal, and transmits the signal from its antenna for analysis, evaluation, and storage in the aircraft. The sonobuoy system may be independently activated by an underwater sound source, usually an explosive device dropped from the aircraft. Two or more simple sonobuoys may be deployed to permit processing of directional information, passively or actively. See HYDROPHONE.

Buoys of various types are used as sensors for oceanographic data such as sound speed, geophysical data such as earthquakes, bioacoustic data such as snapping shrimp, and other signal and

noise sources. Some have been designed for long-term deployment on station, with provision for storing data until interrogated from an aircraft or a ship. See BUOY. [S.L.E.]

**Sonochemistry** The study of the chemical changes that occur in the presence of sound or ultrasound. Industrial applications of ultrasound include many physical and chemical effects, for example, cleaning, soldering, welding, dispersion, emulsification, disinfection, pasteurization, extraction, flotation of minerals, degassing of liquids, defoaming, and production of gas-liquid sols. See SOUND; ULTRASONICS.

When liquids are exposed to intense ultrasound, high-energy chemical reactions occur, often accompanied by the emission of light. There are three classes of such reactions: homogeneous sonochemistry of liquids, heterogeneous sonochemistry of liquid-liquid or liquid-solid systems, and sonocatalysis (which overlaps the first two). In some cases, ultrasonic irradiation can increase reactivity by nearly a millionfold. Especially for liquid-solid reactions, the rate enhancements via ultrasound have proved extremely useful for the synthesis of organic and organometallic compounds. Because cavitation occurs only in liquids, chemical reactions are not generally seen in the ultrasonic irradiation of solids or solid-gas systems.

Ultrasound spans the frequencies of roughly 20 kHz to 10 MHz (human hearing has an upper limit of less than 18 kHz). Ultrasound has acoustic wavelengths of roughly 7.5–0.015 cm which are much larger than molecular dimensions. As a result, the chemical effects of ultrasound are not from direct interaction, but are derived from several different physical mechanisms, depending on the nature of the system. For both sonochemistry and sonoluminescence, the most important of these mechanisms is acoustic cavitation: the formation, growth, and implosive collapse of bubbles in liquids irradiated with high-intensity sound. During the final stages of cavitation, compression of the gas inside the bubbles produces enormous local heating and high pressures. See CAVITATION.

When a liquid-solid interface is subjected to ultrasound, cavitation occurs, but a markedly asymmetric bubble collapse occurs, which generates a jet of liquid directed at the surface with velocities greater than 330 ft/s (100 m/s). The impingement of this jet can create a localized erosion (and even melting), responsible for surface pitting and ultrasonic cleaning. Enhanced chemical reactivity of solid surfaces is associated with these processes.

Ultrasonic irradiation of liquid-powder suspensions produces another effect: high-velocity interparticle collisions. Cavitation and the shock waves that it creates in a slurry can accelerate solid particles to high velocities. The resultant collisions are capable of inducing dramatic changes in surface morphology, composition, and reactivity.

The predominant reactions of homogeneous sonochemistry are bond breaking and radical formation. In addition to the initiation or enhancement of chemical reactions, irradiation of liquids with high-intensity ultrasound generates the emission of visible light. The production of such luminescence is a consequence of the localized hot spot created by the implosive collapse of gas- and vapor-filled bubbles during acoustic cavitation. In general, sonoluminescence may be considered a special case of homogeneous sonochemistry. Under conditions where an isolated, single bubble undergoes cavitation, recent studies on the duration of the sonoluminescence flash suggest that a shock wave may be created within the collapsing bubble. See CHEMILUMINESCENCE; HOMOGENEOUS CATALYSIS.

A major industrial application of ultrasound is emulsification. The first reported and most studied liquid-liquid heterogeneous systems have involved ultrasonically dispersed mercury. The effect of the ultrasound in this system appears to be due to the large surface area of mercury generated in the emulsion. See EMULSION.

The effects of ultrasound on liquid-solid heterogeneous organometallic reactions have been a matter of intense inves-

tigation. Various research groups have dealt with extremely reactive metals, such as lithium (Li), magnesium (Mg), or zinc (Zn), as stoichiometric reagents for a variety of common transformations.

Sonochemistry can be used as a synthetic tool for the creation of unusual inorganic materials. Ultrasound has proved extremely useful in the synthesis of a wide range of nanostructured materials, including high-surface-area transition metals, alloys, carbides, oxides, and colloids. Sonochemistry is also proving to have important applications with polymeric materials. Substantial work has been accomplished in the sonochemical initiation of polymerization and in the modification of polymers after synthesis. Sonochemistry has found another recent application in the preparation of unusual biomaterials, notably protein microspheres. The mechanism responsible for microsphere formation is a combination of two acoustic phenomena: emulsification and cavitation. These protein microspheres have a wide range of biomedical applications, including their use as echo contrast agents for sonography, magnetic resonance imaging contrast enhancement, and drug delivery. See NANO CHEMISTRY; NANOSTRUCTURE; POLYMER; PROTEIN. [K.S.S.]

**Sorghum** Sorghum includes many widely cultivated grasses having a variety of names in various countries. Cultivated sorghums in the United States are classified as a single species, *Sorghum bicolor*, although there are many varieties and hybrids. The two major types of sorghum are the grain, or non-saccharine, type, cultivated for grain production and to a lesser extent for forage, and the sweet, or saccharine, type, used for forage production and for making syrup and sugar.

Grain sorghum is grown in the United States chiefly in the Southwest and the Great Plains. It is a warm-season crop which withstands heat and moisture stress better than most other crops, but extremely high temperatures and extended drought may reduce yields. It is extensively grown in Texas, Kansas, Nebraska, Oklahoma, Missouri, Colorado, and South Dakota. This grain production is fed to cattle, poultry, swine, and sheep primarily. Sorghum is considered nearly equal to corn in feed value.

Sorghums originated in the northeastern quadrant of Africa. Until recent years, practically all grain sorghums of importance introduced into the United States were tall, late maturing, and generally unadapted. Since its introduction into the United States in colonial times, the crop has been altered in many ways, these changes coming as a result of naturally occurring genetic mutations combined with hybridization and selection work of plant breeders. The fact that hybrid grain sorghums with high yield potential could be produced with stems that are short enough for harvesting mechanically made the crop appealing to many farmers. See BREEDING (PLANT).

Grain sorghum is difficult to distinguish from corn in its early growth stages, but at later stages it becomes strikingly different. Sorghum plants may tiller (put out new shoots), producing several head-bearing culms from the basal nodes. Secondary culms may also develop from nodal buds along the main stem. The inflorescence (head) varies from a dense to a lax panicle, and the spikelets produce perfect flowers that are subject to both self- and cross-fertilization. Mature grain in different varieties varies in size and color from white to cream, red, and brown. Grain sorghum seeds are small and should not be planted too deep since sorghum lacks the soil-penetrating ability of corn. The seeds are planted either in rows wide enough for tractor cultivation or in narrower rows if cultivation is not intended. [F.R.M.]

Commonly known as sorgo, sweet sorghum was introduced into North America from China in 1850, although its ancestry traces back to Egypt. It is an annual, rather drought-resistant crop. The culms are from 2 to 15 ft (0.6 to 4.6 m) tall, and the hard cortical layer, or shell, encloses a sweet, juicy pith that is interspersed with vascular bundles. At each node both a leaf and a lateral bud alternate on opposite sides; the internodes are alternately grooved on one side. Leaves are smooth with

glossy or waxy surfaces and have margins with small, sharp, curved teeth. The leaves fold and roll up during drought. The inflorescence is a panicle of varying size having many primary branches with paired ellipsoidal spikelets containing two florets in each fertile sessile spikelet. The plant is self-pollinated. Seed is planted in cultivated rows and fertilized similarly to corn. The main sorghum-syrup-producing area is in the south-central and southeastern United States. See CORTEX (PLANT); PITH. [L.D.B.]

**Sound** The mechanical excitation of an elastic medium. Originally, sound was considered to be only that which is heard. This admitted questions such as whether or not sound was generated by trees falling where no one could hear. A more mechanistic approach avoids these questions and also allows acoustic disturbances too high in frequency (ultrasonic) to be heard or too low (infrasonic) to be classed as extensions of those events that can be heard.

A source of sound undergoes rapid changes of shape, size, or position that disturb adjacent elements of the surrounding medium, causing them to move about their equilibrium positions. These disturbances in turn are transmitted elastically to neighboring elements. This chain of events propagates to larger and larger distances, constituting a wave traveling through the medium. If the wave contains the appropriate range of frequencies and impinges on the ear, it generates the nerve impulses that are perceived as hearing. See HEARING (HUMAN).

**Acoustic pressure.** A sound wave compresses and dilates the material elements it passes through, generating associated pressure fluctuations. An appropriate sensor (a microphone, for example) placed in the sound field will record a time-varying deviation from the equilibrium pressure found at that point within the fluid. The changing total pressure  $P$  measured will vary about the equilibrium pressure  $P_0$  by a small amount called the acoustic pressure,  $p = P - P_0$ . The SI unit of pressure is the pascal (Pa), equal to 1 newton per square meter ( $\text{N/m}^2$ ). Standard atmospheric pressure ( $14.7 \text{ lb/in.}^2$ ) is approximately 1 bar =  $10^6 \text{ dyne/cm}^2 = 10^5 \text{ Pa}$ . For a typical sound in air, the amplitude of the acoustic pressure may be about 0.1 Pa (one-millionth of an atmosphere); most sounds cause relatively slight perturbations of the total pressure. See MICROPHONE; PRESSURE; PRESSURE MEASUREMENT; PRESSURE TRANSDUCER; SOUND PRESSURE.

**Plane waves.** One of the more basic sound waves is the traveling plane wave. This is a pressure wave progressing through the medium in one direction, say the  $+x$  direction, with infinite extent in the  $y$  and  $z$  directions. A two-dimensional analog is ocean surf advancing toward a very long, straight, and even beach. See WAVE (PHYSICS); WAVE EQUATION; WAVE MOTION.

A most important plane wave, called harmonic, is the smoothly oscillating monofrequency plane wave described by Eq. (1). The amplitude of this wave is  $P$ . The phase (argument

$$p = P \cos \left[ 2\pi f \left( t - \frac{x}{c} \right) \right] \quad (1)$$

of the cosine) increases with time, and at a point in space the cosine will pass through one full cycle for each increase in phase of  $2\pi$ . The period  $T$  required for each cycle must therefore be such that  $2\pi fT = 2\pi$ , or  $T = 1/f$ , so that  $f = 1/T$  can be identified as the frequency of oscillation of the pressure wave. During this period  $T$ , each portion of the waveform has advanced through a distance  $\lambda = cT$ , and this distance  $\lambda$  must be the wavelength. This gives the fundamental relation (2) between the frequency,

$$\lambda f = c \quad (2)$$

wavelength, and speed of sound  $c$  in any medium. For example, in air at room temperature the speed of sound is 343 m/s (1125 ft/s). A sound of frequency 1 kHz (1000 cycles per second) will have a wavelength of  $\lambda = c/f = 343/1000 \text{ m} = 0.34 \text{ m}$  (1.1 ft). Lower frequencies will have longer wavelengths: a sound of 100 Hz in air has a wavelength of 3.4 m (11 ft). For comparison, in fresh water at room temperature the speed of sound is

1480 m/s (4856 ft/s), and the wavelength of 1-kHz sound is nearly 1.5 m (5 ft), almost five times greater than the wavelength for the same frequency in air.

**Description of sound.** The characterization of a sound is based primarily on human psychological responses to it. Because of the nature of human perceptions, the correlations between basically subjective evaluations such as loudness, pitch, and timbre and more physical qualities such as energy, frequency, and frequency spectrum are subtle and not necessarily universal.

The strength of a sound wave is described by its intensity. From basic physical principles, the instantaneous rate at which energy is transmitted by a sound wave through unit area is given by the product of acoustic pressure and the component of particle velocity perpendicular to the area. The time average of this quantity is the acoustic intensity. If all quantities are expressed in SI units (pressure amplitude or effective pressure amplitude in Pa, speed of sound in m/s, and density in  $\text{kg/m}^3$ ), then the intensity will be in watts per square meter ( $\text{W/m}^2$ ). See SOUND INTENSITY.

Because of the way the strength of a sound is perceived, it has become conventional to specify the intensity of sound in terms of a logarithmic scale with the (dimensionless) unit of the decibel (dB). An individual with unimpaired hearing has a threshold of perception near  $10^{-12} \text{ W/m}^2$  between about 2 and 4 kHz, the frequency range of greatest sensitivity. As the intensity of a sound of fixed frequency is increased, the subjective evaluation of loudness also increases, but not proportionally. Rather, the listener tends to judge that every successive doubling of the acoustic intensity corresponds to the same increase in loudness. For sounds lying higher than 4 kHz or lower than 500 Hz, the sensitivity of the ear is appreciably lessened. Sounds at these frequency extremes must have higher threshold intensity levels before they can be perceived, and doubling of the loudness requires smaller changes in the intensity with the result that at higher levels sounds of equal intensities tend to have more similar loudnesses. It is because of this characteristic that reducing the volume of recorded music causes it to sound thin or tinny, lacking both highs and lows of frequency. Since most sound-measuring equipment detects acoustic pressure rather than intensity, it is convenient to define an equivalent scale in terms of the sound pressure level. The intensity level and sound-pressure level are usually taken as identical, but this is not always true. See DECIBEL; LOUDNESS.

How "high" sound of a particular frequency appears to be is described by the sense of pitch. A few minutes with a frequency generator and a loudspeaker show that pitch is closely related to the frequency. Higher pitch corresponds to higher frequency, with small influences depending on loudness, duration, and the complexity of the waveform. For the pure tones (monofrequency sounds) encountered mainly in the laboratory, pitch and frequency are not found to be proportional. Doubling the frequency less than doubles the pitch. For the more complex waveforms usually encountered, however, the presence of harmonics favors a proportional relationship between pitch and frequency. See PITCH.

**Propagation of sound.** Plane waves are a considerable simplification of an actual sound field. The sound radiated from a source (such as a loudspeaker, a hand clap, or a voice) must spread outward much like the widening circles from a pebble thrown into a lake. A simple model of this more realistic case is a spherical source vibrating uniformly in all directions with a single frequency of motion. The sound field must be spherically symmetric with an amplitude that decreases with increasing distance from the source, and the fluid elements must have particle velocities that are directed radially.

Not all sources radiate their sound uniformly in all directions. When someone is speaking in an unconfined space, for example an open field, a listener circling the speaker hears the voice most well defined when the speaker is facing the listener. The voice loses definition when the speaker is facing away from the listener. Higher frequencies tend to be more pronounced in front of the

speaker, whereas lower frequencies are perceived more or less uniformly around the speaker.

**Diffraction.** It is possible to hear but not see around the corner of a tall building. However, higher-frequency sound (with shorter wavelength) tends to bend or “spill” less around edges and corners than does sound of lower frequency. The ability of a wave to spread out after traveling through an opening and to bend around obstacles is termed diffraction. This is why it is often difficult to shield a listener from an undesired source of noise, like blocking aircraft or traffic noise from nearby residences. Simply erecting a brick or concrete wall between source and receiver is often an insufficient remedy, because the sounds may diffract around the top of the wall and reach the listeners with sufficient intensity to be distracting or bothersome. See ACOUSTIC NOISE; DIFFRACTION.

**Rays.** Since the speed of sound varies with the local temperature (and pressure, in other than perfect gases), the speed of a sound wave can be a function of position. Different portions of a sound wave may travel with different speeds of phase.

Each small element of a surface of constant phase traces a line in space, defining a ray along which acoustic energy travels. The sound beam can then be viewed as a ray bundle, like a sheaf of wheat, with the rays distributed over the cross-sectional area of the surface of constant phase. As the major lobe spreads with distance, this area increases and the rays are less densely concentrated. The number of rays per unit area transverse to the propagation path measures the energy density of the sound at that point.

It is possible to use the concept of rays to study the propagation of a sound field. The ray paths define the trajectories over which acoustic energy is transported by the traveling wave, and the flux density of the rays measures the intensity to be found at each point in space. This approach, an alternative way to study the propagation of sound, is approximate in nature but has the advantage of being very easy to visualize.

**Reflection and transmission.** If a sound wave traveling in one fluid strikes a boundary between the first fluid and a second, then there may be reflection and transmission of sound. For most cases, it is sufficient to consider the waves to be planar. The first fluid contains the incident wave of intensity  $I_i$  and reflected wave of intensity  $I_r$ ; the second fluid, from which the sound is reflected, contains the transmitted wave of intensity  $I_t$ . The directions of the incident, reflected, and transmitted plane sound waves may be specified by the grazing angles  $\theta_i$ ,  $\theta_r$ , and  $\theta_t$  (measured between the respective directions of propagation and the plane of the reflecting surface). See REFLECTION OF SOUND.

**Absorption.** When sound propagates through a medium, there are a number of mechanisms by which the acoustic energy is converted to heat and the sound wave weakened until it is entirely dissipated. This absorption of acoustic energy is characterized by a spatial absorption coefficient for traveling waves. See SOUND ABSORPTION. [A.B.Co.]

**Sound absorption** The process by which the intensity of sound is diminished by the conversion of the energy of the sound wave into heat. The absorption of sound is an important case of sound attenuation. Regardless of the material through which sound passes, its intensity, measured by the average flow of energy in the wave per unit time per unit area perpendicular to the direction of propagation, decreases with distance from the source. This decrease is called attenuation. In the simple case of a point source of sound radiating into an ideal medium (having no boundaries, turbulent fluctuations, and the like), the intensity decreases inversely as the square of the distance from the source. This relationship exists because the spherical area through which the energy propagates per unit time increases as the square of the propagation distance. This attenuation or loss may be called geometrical attenuation.

In addition to this attenuation due to spreading, there is effective attenuation caused by scattering within the medium. Sound

can be reflected and refracted when incident on media of different physical properties, and can be diffracted and scattered as it bends around obstacles. These processes lead to effective attenuation, for example, in a turbulent atmosphere; this is easily observed in practice and can be measured, but is difficult to calculate theoretically with precision. See DIFFRACTION; REFLECTION OF SOUND; REFRACTION OF WAVES.

In actual material media, geometrical attenuation and effective attenuation are supplemented by absorption due to the interaction between the sound wave and the physical properties of the propagation medium itself. This interaction dissipates the sound energy by transforming it into heat and hence decreases the intensity of the wave. In all practical cases, the attenuation due to such absorption is exponential in character. See SOUND INTENSITY.

The four classical mechanisms of sound absorption in material media are shear viscosity, heat conduction, heat radiation, and diffusion. These attenuation mechanisms are generally grouped together and referred to as classical attenuation or thermoviscous attenuation. See CONDUCTION (HEAT); DIFFUSION; HEAT RADIATION; VISCOSITY.

Sound absorption in fluids can be measured in a variety of ways, referred to as mechanical, optical, electrical, and thermal methods. All these methods reduce essentially to a measurement of sound intensity as a function of distance from the source.

The amount of sound that air absorbs increases with audio frequency and decreases with air density, but also depends on temperature and humidity. Sound absorption in air depends heavily on relative humidity. The reason for the strong dependence on relative humidity is molecular relaxation. One can note the presence of two transition regimes in most of the actual absorption curves, representing the relaxation effects of nitrogen and oxygen, the dominant constituents of the atmosphere. See ATMOSPHERIC ACOUSTICS.

Sound absorption in water is generally much less than in air. It also rises with frequency, and it strongly depends on the amount of dissolved materials (in particular, salts in seawater), due to chemical relaxation. See UNDERWATER SOUND.

The theory of sound attenuation in solids is complicated because of the presence of many mechanisms responsible for it. These include heat conductivity, scattering due to anisotropic material properties, scattering due to grain boundaries, magnetic domain losses in ferromagnetic materials, interstitial diffusion of atoms, and dislocation relaxation processes in metals. In addition, in metals at very low temperature the interaction between the lattice vibrations (phonons) due to sound propagation and the valence of electrons plays an important role, particularly in the superconducting domain. See CRYSTAL DEFECTS; DIFFUSION; FERROMAGNETISM; SUPERCONDUCTIVITY.

[H.E.Ba.; A.J.Ca.; J.P.C.; R.B.L.]

**Sound field enhancement** A system for enhancing the acoustical properties of both indoor and outdoor spaces, particularly for unamplified speech, song, and music. Systems are subdivided into those that primarily change the natural reverberation in the room, increasing its level and decay time (reverberation enhancement systems); and those that essentially replace the natural reverberation (sound field synthesis systems). Both systems may use amplifiers, electroacoustic elements, and signal processing to add sound field components to change the natural acoustics. Sound field enhancement is used to produce variable acoustics, to produce a particular acoustics which is not attainable by passive means, or because a venue has one or all of the following deficiencies: (1) unsuitable ratio between direct, early reflected, and reverberant sound; (2) unsatisfactory early reflection pattern; and (3) short reverberation times. See AMPLIFIER.

The purpose of sound field enhancement systems is not to provide higher speech intelligibility or clarity—in contrast to sound reinforcement systems—but to adjust venue characteristics to best suit the program material and venue, and in such a way

optimize the subjectively perceived sound quality and enjoyment. See SOUND-REINFORCEMENT SYSTEM.

The use of sound field enhancement ranges from systems for homes (surround sound systems and home theater sound systems) to systems for rooms seating thousands of listeners (concert halls, performing arts centers, opera houses, and churches). Outdoor spaces may have elaborate designs to approach the sound quality of indoor spaces (advanced concert pavilions, outdoor concert venues). Systems may be used to improve conditions for both performers and listeners. See ARCHITECTURAL ACOUSTICS; REVERBERATION.

**Basic elements.** A sound field enhancement system may consist of one or more microphones, systems for amplification and electronic signal processing, and one or more loudspeakers. The signal processing equipment may include level controls, equalizers, delays and reverberators, systems for prevention of howl and ringing, as well as frequency dividing networks and crossover networks. See EQUALIZER; LOUDSPEAKER; MICROPHONE.

**Prerequisites.** Many indoor venues have acoustical characteristics unsuitable for communication such as speech, song, or music. Outdoor venues seldom have satisfactory acoustical conditions for unamplified acoustic communication. Satisfactory acoustic conditions include for speech, good speech intelligibility and sound quality; and for music, appropriate loudness, clarity, reverberation envelopment, spaciousness, and other sound quality characteristics for the music to be performed and enjoyed. Rooms with insufficient reverberation are often perceived to be acoustically “dry” or “dead.” Insufficient reverberation usually is due to lack of room volume for the existing sound absorption areas in the room. The reverberation time is essentially proportional to room volume and inversely proportional to sound absorption, as indicated by Sabine’s formula. In these cases, sound field enhancement systems may be used to improve acoustical conditions, by increasing the sound level and reverberation time. Absence of noise is also necessary for good acoustic conditions. See ACOUSTIC NOISE; SOUND ABSORPTION.

**System design.** A simple reverberation enhancement system uses a microphone to pick up the sound signal to be reverberated, amplified, and reradiated in the auditorium. In most cases, reverberation is added to the original signal by electronic digital signal processing. An advanced sound field enhancement system uses several, possibly directional microphones to pick up sound selectively from the stage area. Signal processing and many loudspeakers are used to obtain the desired sound field for the audience and performers. Most performing art centers need variable acoustic conditions that can be changed instantaneously using electronic controls.

**Categories.** Sound field enhancement systems can be classified according to different criteria. One possible scheme is shown in the illustration. Sound field synthesis systems are designed to provide the necessary sound field components, such as early reflections from side walls and ceiling (the latter are usually called envelopmental sound), and reverberation by using digital filters, which can be designed to imitate a specific desired room response. Reverberation enhancement systems are designed to

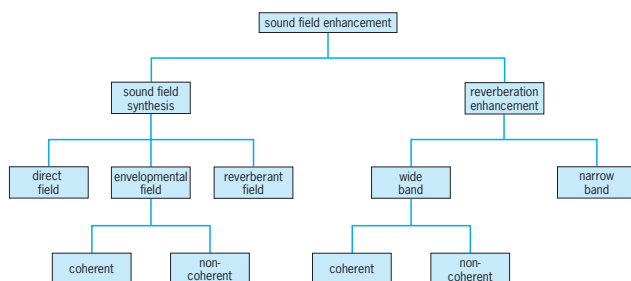

Classification scheme for sound field enhancement systems.

primarily increase the reverberation time and sound level of the reverberant field, while having negligible influence on the direct sound and the early reflected sound. Reverberation enhancement systems can be further subdivided into regenerative systems, based on the acceptance of unavoidable positive feedback between loudspeakers and microphones to increase the reverberation time; and nonregenerative systems, based on the use of electronic reverberators. Regenerative systems can be designed so as to work over a wide or narrow frequency range; nonregenerative systems are usually wide-frequency-range systems. See REFLECTION OF SOUND; SOUND. [M.K.I.]

**Sound intensity** A fundamental acoustic quantity which describes the rate of flow of acoustic energy through a unit of area perpendicular to the flow direction. The unit of sound intensity is watt per square meter. The intensity is calculated at a field point ( $x$ ) as a product of acoustic pressure  $p$  and particle velocity  $u$ . Generally, both  $p$  and  $u$  are functions of time, and therefore an instantaneous intensity vector is defined by the equation below.

$$\vec{I}_i(x, t) = p(x, t) \cdot \vec{u}(x, t)$$

The time-variable instantaneous intensity,  $\vec{I}_i(x, t)$ , which has the same direction as  $\vec{u}(x, t)$ , is a nonmoving static vector representing the instantaneous power flow through a point ( $x$ ). See POWER; SOUND PRESSURE.

Many acoustic sources are stable at least over some time interval so that both the sound pressure and the particle velocity in the field of such a source can be represented in terms of their frequency spectra.

The applications of sound intensity were fully developed after a reliable technique for intensity measurement was perfected. Sound intensity measurement requires measuring both the sound pressure and the particle velocity. Very precise microphones for sound-pressure measurements are available.

An application of the intensity technique is the measurement of sound power radiated from sources. The knowledge of the radiated power makes it possible to classify, label, and compare the noise emissions from various pieces of equipment and products and to provide a reliable input into environmental design. See SOUND. [J.Ti.]

**Sound pressure** The incremental variation in the static pressure of a medium when a sound wave is propagated through it. Sound refers to small-amplitude, propagating pressure perturbations in a compressible medium. These pressure disturbances are related to the corresponding density perturbation via the material equation of state, and the manner in which these disturbances propagate is governed by a wave equation. Since a pressure variation with time is easily observed, the science of sound is concerned with small fluctuating pressures and their spectral characteristics. The unit of pressure commonly used in acoustics is the micropascal ( $1 \mu\text{Pa} = 1 \mu\text{N/m}^2 = 10^{-5} \text{ dyne/cm}^2 = 10^{-5} \mu\text{bar}$ ). One micropascal is approximately  $10^{-11}$  times the normal atmospheric pressure. See PRESSURE; PRESSURE MEASUREMENT; WAVE MOTION.

The instantaneous sound pressure at a point can be harmonic, transient, or a random collection of waves. This pressure is usually measured with an instrument that is sensitive to a particular band of frequencies. A concept widely used in acoustics is “level,” which refers to the logarithm of the ratio of any two field quantities. When the ratio is proportional to a power ratio, the unit for measuring the logarithm of the ratio is called a bel, and the unit for measuring this logarithm multiplied by 10 is called a decibel (dB). The sound intensity, which describes the rate of flow of acoustic energy (acoustic power flow) per unit area, is given by the mean square pressure divided by the acoustic impedance, defined as the product of the medium density and compressional wave speed. See DECIBEL; NOISE MEASUREMENT; SOUND; SOUND INTENSITY. [W.M.C.]

**Sound recording** The technique of entering sound, especially music, on a storage medium for playback at a subsequent time. The storage medium most widely used is magnetic tape. See MAGNETIC RECORDING.

**Monophonic.** In the simplest form of sound recording, a single microphone picks up the composite sound of a musical ensemble, and the microphone's output is recorded on a reel of 1/2-in. (6.4-mm) magnetic tape. This single-track, or monophonic, recording suffers from a lack of dimension, since in playback the entire ensemble will be heard from a single point source: the loudspeaker.

**Stereophonic.** An improved recording, with left-to-right perspective and an illusion of depth, may be realized by using two microphones which are spaced or angled appropriately and whose outputs are routed to separate tracks on the tape recorder. These two tracks are played back over two loudspeakers, one each on the listener's left and right. Under ideal conditions this stereophonic system will produce an impressive simulation of the actual ensemble. See STEREOPHONIC SOUND.

**Binaural.** In this system, two microphones are placed on either side of a small acoustic baffle in an effort to duplicate the human listening condition. The recording is played back over headphones, so that the microphones are, in effect, an extension of the listener's hearing mechanism.

**Multitrack.** To give the recording engineer more technical control over the recording medium, many recordings are now made using a multiple-microphone technique. In place of the stereo microphone, one or more microphones are located close to each instrument or group of instruments. See MICROPHONE.

In the control room the engineer mixes the outputs of all microphones to achieve the desired musical balance. As a logical extension of this technique, the microphone outputs may not be mixed at the time of the recording, but may be routed to 16 or more tracks on a tape recorder, for mixing at a later date.

When many microphones are so used, each instrument in the ensemble is recorded—for all practical purposes—simultaneously. The complex time delay and acoustic relationships within the room are lost in the recording process, and the listener hears the entire ensemble from one perspective only, as though he or she were as close to each instrument as is each microphone. Electronic signal processing devices may not be entirely successful in restoring the missing information, and the listener hears a recording that may be technically well executed, yet lacking the apparent depth and musical cohesiveness of the original. However, the multitrack technique becomes advantageous when it is impractical or impossible to record the entire ensemble at once stereophonically. See SOUND-REPRODUCING SYSTEMS. [J.M.Wor.]

**Sound-recording studio** An enclosure treated acoustically to provide controlled recording of music or speech. Professional sound-recording studios range from small home studios (such as a converted garage or basement) to large facilities using state-of-the-art equipment. They consist of two rooms, the main studio or stage (performance area) and the audio control room. The stage includes one or more microphones, is acoustically isolated to ensure that external sounds do not interfere with the recording, and can be broken up into small booths to separate individual performers. The audio control room contains the mixing console and recording devices. See ACOUSTIC NOISE; ARCHITECTURAL ACOUSTICS; SOUND; SOUND RECORDING. [M.Re.; A.Ca.]

**Sound-reinforcement system** A system that amplifies or enhances the sound of a speaking person, singer, or musical instrument. Sound-reinforcement systems are used to increase the clarity of the original sound as well as to add loudness and reverberation. Those that improve loudness and clarity are often called public address systems, and those that improve reverberation characteristics are called reverberation enhancement systems. Systems for increased loudness are used when listeners

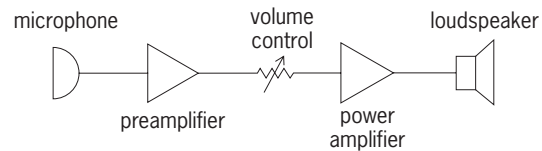

Basic sound-reinforcement system.

are located far from the sound source, as in a large auditorium or outdoors. Systems for increased clarity are used to overcome the effects of unwanted noise or excessive reverberation in a room (such as concert halls and churches with reverberation characteristics designed for music). Reverberation enhancement systems are used to add sound field components, such as reverberation to rooms having unsuitable levels of direct, early reflected sound and reverberant sound or having short reverberation times. See ARCHITECTURAL ACOUSTICS; REVERBERATION; SOUND; SOUND FIELD ENHANCEMENT.

The basic elements of a sound-reinforcement system are (1) one or more microphones, (2) amplification and electronic signal processing systems, and (3) one or more loudspeakers. The signal processing equipment may include level controls, equalizers or tone controls, systems for prevention of howl and ringing, delays and reverberators, as well as frequency dividing and crossover networks.

The illustration shows the signal flow diagram of a simple system. In the simplest systems, all elements are joined as one physical unit. An example of a simple public address system is the hand-held battery-driven electronic megaphone, consisting of a microphone, a frequency-response-shaping filter, an amplifier, and a horn loudspeaker. Most sound-reinforcement systems, however, are assembled from individual elements to optimize and adapt the system performance for the needs of a particular installation. [D.L.K.; M.Kle.]

**Sound-reproducing systems** Systems that attempt to reconstruct some or all of the audible dimensions of an acoustic event that occurred elsewhere. A sound-reproducing system includes the functions of capturing sounds with microphones, manipulating those sounds using elaborate electronic mixing consoles and signal processors, and then storing the sounds for reproduction at later times and different places. See MICROPHONE.

Certain technical variables are relevant to the reliable reconstruction of audio events. These include frequency range, dynamic range, and linear and nonlinear distortions. Traditionally the audible frequency range has been considered to be 20 Hz to 20 kHz. However, lower frequencies can generate interesting tactile impressions, and it is now argued by some that higher frequencies (even 50 kHz and beyond) add other perceptual nuances. See HEARING (HUMAN).

In humans, dynamic range is the range of sound level from the smallest audible sound to the largest sound that can be tolerated. In devices, it is the range from background noise to unacceptable distortion. From the threshold of audibility to the onset of discomfort is about 120 decibels at middle and high frequencies. Microphones are not a limiting factor since the best have dynamic ranges in excess of 130 dB. In the recording studio, dynamics are manipulated by electronic gain compensation, so the ultimate limitation is the storage medium. For example, a 16-bit compact disk (CD) can exceed 100 dB signal-to-noise ratio, while 24-bit digital media can exceed any reasonable need for dynamic range. Background acoustical noise in studios and concert halls sets the lower limit for recordings, just as background noise in homes and cars sets a lower limit for playback. Quiet concert halls and homes are around 25 dB sound pressure level (SPL) at middle and high frequencies. Crescendoes in music and movies approximate 105 dB. See ACOUSTIC NOISE;



COMPACT DISK; DECIBEL; DISTORTION (ELECTRONIC CIRCUITS); GAIN; LOUDNESS; SIGNAL-TO-NOISE RATIO; SOUND; SOUND PRESSURE.

Variations in amplitude and phase as functions of frequency are known as linear distortions, since (ideally) they do not vary with signal level. In practice they often do, and in the process generate nonlinear distortions. In terms of their importance in preserving the timbre of voices and musical instruments, the amplitude versus frequency characteristic, known commonly as the frequency response, is the dominant factor. Humans are very sensitive to variations in frequency response, the amount depending on the bandwidth of the variation. It is convenient to discuss this in terms of the quality factor (*Q*) of resonances, since most such variations are the result of resonances in loudspeaker transducers or enclosures. See DISTORTION (ELECTRONIC CIRCUITS); *Q* (ELECTRICITY); RESONANCE (ACOUSTICS AND MECHANICS); RESPONSE; REVERBERATION.

Nonlinear distortions occur when a device behaves differently at different signal levels. The waveform coming out of a distorting device will be different from the one entering it. The difference in shape, translated into the frequency domain, is revealed as new spectral components. If the input waveform is a single frequency (pure tone), the additional spectral components will be seen to have a harmonic relationship to the input signal. Hence they are called harmonic distortion. If two or more tones are applied to the device, nonlinearities will create harmonics of all of the tones (harmonic distortion) and, in addition, more new spectral components that are sum-and-difference multiples of combinations of the tones. These additional components are called intermodulation distortion.

Perceptually, listeners are aided by a phenomenon called masking, in which loud sounds prevent some less loud sounds from being heard. This means that the music causing the distortion inhibits the ability to hear it. Rough guidelines suggest that, in music, much of the time we can be unaware of distortions measuring in whole percentages, but that occasionally small fractions of a percent can be heard. See MASKING OF SOUND.

Loudspeakers radiate sound in all directions, so that measurements made at a single point represent only a tiny fraction of the total sound output. In rooms, most of the sound we hear from loudspeakers reaches our ears after reflections from room boundaries and furnishings, meaning that our perceptions may be more influenced by measures of reflected and total sound than by a single measurement, say, on the principal axis. See ARCHITECTURAL ACOUSTICS; SOUND FIELD ENHANCEMENT.

To be useful, technical measurements must allow us to anticipate how these loudspeakers might sound in rooms. Consequently, it is necessary to measure sounds radiated in many different directions at points distributed on the surface of an imaginary sphere surrounding the loudspeaker. From these data, it is possible to calculate the direct sound from the loudspeaker to the listener, estimates of strong early reflected sounds from room boundaries, and estimates of later reflected or reverberant sounds. It is also possible to calculate measures of total sound output, regardless of the direction of radiation (sound power) and of the uniformity of directivity as a function of frequency. All of these measured quantities are needed in order to fully evaluate the potential for good sound in rooms. See DIRECTIVITY.

Binaural system configurations are sound-reproduction techniques in which a dummy head, equipped with microphones in the ear locations, captures the original performance. Listeners then audition the reproduced performance through headphones, with the left and right ears hearing, ideally, what the dummy head "heard." The system is good, but flawed in that sounds that should be out in front (usually the most important sounds) tend to be perceived to be inside, or close to, the head. Addressing this limitation, systems have been developed that use two loudspeakers, combined with signal processing to cancel the acoustical crosstalk from the right loudspeaker to the left ear, and vice versa. The geometry of the loudspeakers and listener is fixed. In this mode of listening, sounds that should be behind

are sometimes displaced forward, but the front hemisphere can be very satisfactorily reproduced. See BINAURAL SOUND SYSTEM; EARPHONES; VIRTUAL ACOUSTICS.

Multichannel audio systems began with stereophonic systems using two channels, because in the 1950s the technology was limited to one modulation for each groove wall of a record. Good stereo imaging is possible only for listeners on the axis of symmetry, equidistant from both loudspeakers. See MODULATION; STEREOPHONIC SOUND.

Quadraphonic systems appeared in the 1970s, and added two more loudspeakers behind the listeners, mirroring the ones in front. The most common systems exhibited generous interchannel crosstalk or leakage. To hear the proper spatial perspective, the preferred listening location was restricted to front/back as well as left/right symmetry. The failure to agree on a single standard resulted in the system's demise.

For film sound applications, Dolby Surround modified the matrix technology underlying one of the quadraphonic systems, rearranging the four matrixed channels into a left, center, right, and surround configuration. In cinemas, the single, limited-bandwidth, surround channel information is sent to several loudspeakers arranged along the side walls and across the back of the audience area. For home reproduction, the surround channel is split between two loudspeakers placed above and to the sides of the listeners.

Even with the best active (electronically steered) matrix systems, the channels are not truly discrete. Sounds leak into unintended channels where they dilute and distort directional and spatial impressions. Digital recording systems now provide five discrete full-bandwidth channels, plus a low-frequency special effects channel for movies with truly big bass sounds. For homes, 5.1 channels refers to five satellite loudspeakers, operating with a common low-frequency subwoofer. The subwoofer channel is driven through a bass-management system that combines the low frequencies of all channels, usually crossing over at 80–100 Hz so that, with reasonable care in placement, it cannot be localized. [F.T.]

**Sourwood** A deciduous tree, *Oxydendrum arboreum*, of the heath family, indigenous to the southeastern section of the United States, and found from Pennsylvania to Florida and west to Indiana and Louisiana. It is usually a small or medium-sized tree. The wood is not used commercially. Sourwood is also known as sorrel tree, and it is widely planted as an ornamental. See ERICALES. [A.H.G./K.P.D.]

**South America** The southernmost of the New World or Western Hemisphere continents, with three-fourths of it lying within the tropics. South America is approximately 4500 mi (7200 km) long and at its greatest width 3000 mi (4800 km). Its area is estimated to be about 7,000,000 mi<sup>2</sup> (18,000,000 km<sup>2</sup>). South America has many unique physical features, such as the Earth's longest north-south mountain range (the Andes), highest waterfall (Angel Falls), highest navigable fresh-water lake (Lake Titicaca), and largest expanse of tropical rainforest (Amazonia). The western side of the continent has a deep subduction trench offshore, whereas the eastern continental shelf is more gently sloping and relatively shallow. See CONTINENT.

South America has three distinct regions: the relatively young Andes Mountains located parallel to the western coastline, the older Guiana and Brazilian Highlands located near the eastern margins of the continent, and an extensive lowland plains, which occupies the central portion of the continent. The regions have distinct physiographic and biotic features.

The Andes altitudes often exceed 20,000 ft (6000 m) and perpetual snow tops many of the peaks, even along the Equator. So high are the Andes in the northern half of the continent that few passes lie below 12,000 ft (3600 m). Because of the vast extent of the Andes, a greater proportion of South America than of any other continent lies above 10,000 ft (3000 m). The young,

rugged, folded Andean peaks stand in sharp contrast to the old, worn-down mountains of the eastern highlands. Although the Andes appear to be continuous, most geologists believe that they consist of several structural units, more or less joined. They are a single range in southern Chile, two ranges in Bolivia, and dominantly three ranges in Peru, Ecuador, and Colombia.

Except in Bolivia, where they attain their maximum width of 400 mi (640 km), the Andes are seldom more than 200 mi (320 km) wide. The average height of the Andes is estimated to be 13,000 ft (3900 m). However, it is only north of latitude 35°S that the mountains exceed elevations of 10,000 ft (3000 m).

From the southern tip of Cape Horn north to 41°S latitude, the western coastal zone consists of a broad chain of islands where a mountainous strip subsided and the ocean invaded its valleys. This is one of the world's finest examples of a fiorded coast. Nowhere along the Pacific coast is there a true coastal plain. South of Arica, Chile, the bold, precipitous coast is broken by only a few deep streams, the majority of which carry no water for years at a time. Between Arica and Caldera, Chile, there are no natural harbors and almost no protected anchorages. In fact, South America's coastline is the least indented of all the continents except Africa's. See FIORD.

The Caribbean coast of Colombia is a lowland formed largely of alluvium, deposited by the Magdalena and Cauca rivers, and bounded by mountains on three sides. In Venezuela, the Central Highlands rise abruptly from the Caribbean, with lowlands around Lake Maracaibo, west of Puerto Cabello, and around the mouth of the Río Tuy of the Port of Guanta. The coastal region of Guyana, Suriname, and French Guiana is a low, swampy alluvial plain 10–30 mi (16–48 km) wide, and as much as 60 mi (96 km) wide along the larger rivers. This coastal plain is being built up by sediments carried by the Amazon to the Atlantic and then deflected westward by the equatorial current and cast upon the shore by the trade winds.

There is no broad coastal plain south of the Amazon and east of the Brazilian Highlands to afford easy access to the interior. The rise from the coastal strip to the interior is quite gradual in northeastern Brazil; but southward, between Bahia and Río Grande do Sul, the steep Serra do Mar is a formidable obstacle to transportation.

Along coastal Uruguay there is a transition between the hilly uplands and plateaus of Brazil and the flat Pampas of Argentina, whereas coastal Argentina as far south as the Río Colorado, in Patagonia, is an almost featureless plain. In Patagonia, steep cliffs rise from the water's edge. Behind these cliffs lies a succession of dry, flat-topped plateaus, surmounted occasionally by hilly land composed of resistant crystalline rocks. Separating southern Patagonia from Tierra del Fuego is the Strait of Magellan, which is 350 mi (560 km) long and 2–20 mi (3–32 km) wide. Threading through numerous islands, the strait is lined on each side with fiords and mountains.

There are three great river systems in South America and a number of important rivers that are not a part of these systems. The largest river system is the Amazon which, with its many tributaries, drains a basin covering 2,700,000 mi<sup>2</sup> (7,000,000 km<sup>2</sup>), or about 40% of the continent. The next largest is the system composed of the Paraguay, Paraná, and La Plata rivers, the last being a huge estuary. The third largest river system, located in southern Venezuela, is the Orinoco, which drains 365,000 mi<sup>2</sup> (945,000 km<sup>2</sup>) of land, emptying into the Atlantic Ocean along the northeast edge of the continent.

The plants and animals of the South American tropics are classified as Neotropical, defined by the separation of the South American and African continents during the Middle Cretaceous (95 million years ago). The Paraná basalt flow, which caps the Brazilian shield in southern Brazil and adjacent parts of Uruguay and Argentina, as well as western Africa, indicates the previous linkage between the South American and African continents. South America has many biotic environments, including the constantly moist tropical rainforest, seasonally dry deciduous forests

and savannas, and high-altitude tundra and glaciated environments.

Amazonia contains the largest extent of tropical rainforest on Earth. It is estimated to encompass up to 20% of the Earth's higher plant species and is a critically important source of fresh water and oxygen. Structurally complex, the rainforest is composed of up to four distinct vertical layers of plants and their associated fauna. The layers often cluster at 10, 20, 98, and 164 ft (3, 6, 30, and 50 m) in height. The lower canopy and forest floor are usually open spaces because of the low intensity of light (around 1%) that reaches the forest floor. Over 75% of Amazonian soils are classified as infertile, acidic, or poorly drained, making them undesirable for agriculture because of nutrient deficiencies. Most of the nutrients in the tropical rainforest are quickly absorbed and stored in plant biomass because the high annual rainfall and associated leaching make it impossible to maintain nutrients in the soils. In addition to the high structural complexity of the tropical rainforest, there is considerable horizontal diversity or patchiness. As many as 300 separate species of trees can be found in a square mile (2.6 km<sup>2</sup>) sample tract of rainforest in Brazil. The high complexity and species diversity of the rainforest are the result of long periods of relative stability in these regions. See RAINFOREST.

Deciduous forest are found in areas where there is seasonal drought and the trees lose their leaves in order to slow transpiration. The lower slopes of the Andes, central Venezuela, and central Brazil are areas where these formations are found. Conifer forests occur in the higher elevations of the Andes and the higher latitudes of Chile and Argentina. See DECIDUOUS PLANTS.

Tropical savannas occupy an extensive range in northern South America through southeastern Venezuela and eastern Colombia. Temperate savannas are found in Paraguay, Uruguay, the Pampas of Argentina, and to the south, Patagonia. Savannas are composed of a combination of grass and tree species. The climate in these areas is often quite hot with high rates of evapotranspiration and a pronounced dry season. Most of the plants and animals of these zones are drought-adapted and fire-adapted. Tall grasses up to 12 ft (3.5 m) are common as are thorny trees of the Acacia (Fabaceae) family. Many birds and mammals are found in these zones, including anteater, armadillo, capybara (the largest rodent on Earth), deer, jaguar, and numerous species of venomous snake, including rattlesnake and bushmaster (*mapanare*). See SAVANNA.

South America is unique in having a west-coast desert (the Atacama) that extends almost to the Equator, probably receiving less rain than any on Earth, and an east coast desert located poleward from latitude 40°S (the Patagonian). See DESERT.

In Bolivia and Peru the zone from 10,000 to 13,000 ft (3000 to 3900 m), though occasionally to 15,000–16,000 ft (4500 to 4800 m), is known as the *puna*. Here the hot days contrast sharply with the cold nights. Above the *puna*, from timberline to snowline, is the *paramo*, a region of broadleaf herbs and grasses found in the highest elevations of Venezuela, Colombia, and Ecuador. Many of the plant species in these environments are similar to those found at lower elevations; however, they grow closer to the ground in order to conserve heat and moisture. See PARAMO; PUNA. [D.A.Sa.; C.L.W.]

**South Pole** That end of the Earth's rotational axis opposite the North Pole. It is the southernmost point on the Earth and one of the two points through which all meridians pass (the North Pole being the other point). This is the geographic pole and is not the same as the south magnetic pole. The South Pole lies inland from the Ross Sea, within the land mass of Antarctica, at an elevation of about 9200 ft (2800 m).

There is no natural way to determine local Sun time because there is no noon position of the Sun, and shadows point north at all times, there being no other direction from the South Pole. See MATHEMATICAL GEOGRAPHY; NORTH POLE. [V.H.E.]

**Southeast Asian waters** All the seas between Asia and Australia and the Pacific and the Indian oceans. They form a geographical and oceanographical unit because of their special structure and position, and make up an area of 3,450,000 mi<sup>2</sup> (8,940,000 km<sup>2</sup>), or about 2.5% of the surface of all oceans.

The surface circulation is completely reversed twice a year by the changing monsoon winds. The subsurface circulation carries chiefly the outrunners of the intermediate waters of the Pacific Ocean into these seas. The tides are mostly of the mixed type. Diurnal tides are found in the Java Sea, in the Gulf of Tonkin, and in the Gulf of Thailand. Semidiurnal tides with high amplitudes occur in the Malacca Straits. See INDIAN OCEAN; PACIFIC OCEAN.

[K.W.]

The Southeast Asian seas are characterized by the presence of numerous major plate boundaries. In Southeast Asia the plate boundaries are identified, respectively, by young, small ocean basins with their spreading systems and associated high heat flow; deep-sea trenches and their associated earthquake zones and volcanic chains; and major strike-slip faults such as the Philippine Fault (similar to the San Andreas Fault in California). The Southeast Asian seas are thus composed of a mosaic of about 10 small ocean basins whose boundaries are defined mainly by trenches and volcanic arcs. The dimensions of these basins are much smaller than the basins of the major oceans. The major topographic features of the region are believed to represent the surface expression of plate interactions, the scars left behind on the sea floor. See PLATE TECTONICS.

[D.E.H.]

**Soybean** *Glycine max*, a legume native to China that has become a major source of vegetable protein and oil for human and animal consumption and for industrial usage. The valued portion of the plant is the seed, which contains about 40% protein and 21% oil. Illinois, Iowa, Arkansas, Missouri, Indiana, Mississippi, Minnesota, Ohio, Louisiana, and Tennessee are the major soybean producers in the United States. See FAT AND OIL (FOOD).

[W.R.F.]

**Space** Physically, space is that property of the universe associated with extension in three mutually perpendicular directions. Space, from a newtonian point of view, may contain matter, but space exists apart from matter. Through usage, the term space has come to mean generally outer space or the region beyond Earth. Geophysically, space is that portion of the universe beyond the immediate influence of Earth and its atmosphere. From the point of view of flight, space is that region in which a vehicle cannot obtain oxygen for its engines or rely upon an atmospheric gas for support (either by buoyancy or by aerodynamic effects). Astronomically, space is a part of the space-time continuum by which all events are uniquely located. Relativistically, the space and time variables of uniformly moving (inertial) reference systems are connected by the Lorentz transformations. Gravitationally, one characteristic of space is that all bodies undergo the same acceleration in a gravitational field and therefore that inertial forces are equivalent to gravitational forces. Perceptually, space is sensed indirectly by the objects and events within it. Thus, a survey of space is more a survey of its contents. See EUCLIDEAN GEOMETRY; LORENTZ TRANSFORMATIONS; RELATIVITY; SPACE-TIME.

[S.F.S.]

**Space biology** Collectively, the various biological sciences concerned with the study of organisms and their components when exposed to the environment of space (or of a spacecraft beyond the immediate influence of Earth and its atmosphere). Space biology studies include all the biological science disciplines, such as molecular, cellular, developmental, environmental, behavioral, and radiation biology; physiology; medicine; biophysics; and biochemistry. Space biology encompasses both basic and applied sciences, and focuses on using space research to understand and resolve biological problems on Earth, as well as alleviating or preventing the deleterious physiological changes

associated with space flight or habitation in non-Earth environments. See SPACE.

As crewed space flight developed, medical research focused on the health and well-being of astronauts, which was paramount. This medical research has historically been included in the area of aerospace medicine. From these research efforts, directed at survival of living systems in the space environment, has evolved the broader discipline of space biology, which uses the space environment to gain an understanding of basic biological processes. See AEROSPACE MEDICINE.

Space biology considers all of the inherent physical factors of the space environment and their effects on living organisms: (1) factors due to the environment of space, such as radiation and reduced pressure; (2) factors due to the flight dynamics of spacecraft, including acceleration, weightlessness, and vibration; (3) factors due to the environment of the spacecraft, such as air composition, atmospheric pressure, toxic materials, noise, and confinement; and (4) factors due to the environment on nonterrestrial bodies, such as the level of gravity, composition of soil, and temperature extremes. Of these factors, only weightlessness and space radiation are unique to the space environment, but the effects of the other factors must be considered and mimicked in ground-based or flight controls when conducting space biological experiments. In addition, space experiments must take into consideration the physical effects of weightlessness on the environment surrounding and supporting the organisms. For example, neither gases nor liquids behave in a space environment as they do under the conditions found on Earth, as sedimentation, buoyancy, and convection do not occur in a weightless environment. See ACCELERATION; WEIGHTLESSNESS.

[C.E.Wa.]

**Space charge** The net electric charge within a given volume. If both positive and negative charges are present, the space charge represents the excess of the total positive charge diffused through the volume in question over the total negative charge.

[E.G.R.]

**Space communications** Communications between a vehicle in outer space and Earth, using high-frequency electromagnetic radiation (radio waves). Provision for such communication is an essential requirement of any space mission. The total communication system ordinarily includes (1) command, the transmission of instructions to the spacecraft; (2) telemetry, the transmission of scientific and applications data from the spacecraft to Earth; and (3) tracking, the determination of the distance (range) from Earth to the spacecraft and its radial velocity (range-rate) toward or away from Earth by the measurement of the round-trip radio transmission time and Doppler frequency shift (magnitude and direction). A specialized but commercially important application, which is excluded from consideration here, is the communications satellite system in which the spacecraft serves solely as a relay station between remote points on Earth. See COMMUNICATIONS SATELLITE; DOPPLER EFFECT; MILITARY SATELLITES; SATELLITE (SPACECRAFT); SCIENTIFIC SATELLITES; SPACE FLIGHT; SPACE NAVIGATION AND GUIDANCE; SPACE PROBE; SPACECRAFT GROUND INSTRUMENTATION; TELEMETERING.

Certain characteristic constraints distinguish space communication systems from their terrestrial counterparts. Although only line-of-sight propagation is required, both the transmitter and the receiver are usually in motion. The movement of satellites relative to the rotating Earth, for example, requires geographically dispersed Earth stations to achieve adequate communication with the spacecraft on each orbit.

Because enormous distances are involved (over a billion miles to the planets beyond Jupiter), the signal received on Earth from deep-space probes is so small that local interference, both artificial and natural, has to be drastically reduced. For this purpose, the transmitted frequency has to be sufficiently high, in the gigahertz range, to reduce noise originating in the Milky Way Galaxy (galactic noise background). The receiver site must be remote

from technologically advanced population centers to reduce artificial noise, and at a dry location to avoid precipitation attenuation of the radio signal as well as the higher antenna thermal noise associated with higher atmospheric absolute humidity and relatively warm cloud droplets. The receiving antennas must be steerable and large, typically 85 ft (26 m) or at times 210 ft (64 m) in diameter, to enhance the received signal strength relative to the galactic noise background. Special low-noise preamplifiers such as cooled masers are mounted on the Earth receiver antenna feed to reduce the receiver input thermal noise background. Sophisticated digital data processing is required, and the ground-receiver complex includes large high-speed computers and associated processing equipment. See MASER; PREAMPLIFIER; RADIO RECEIVER; RADIO TELESCOPE.

The spacecraft communications equipment is constrained by severe power, weight, and space limitations. Typical communications equipment mass ranges from 25 to 220 lb (12 to 100 kg). Another major challenge is reliability, since the equipment must operate for years, sometimes for decades, unattended, in the difficult radiation, vacuum, and thermal environment of space. Highly reliable components and equipment have been developed, and redundancy is employed to eliminate almost all single-point failures. For example, it is not unusual to have as many as three redundant command receivers operating continuously, because without at least one such receiver in operation no command can get through, including a command to switch from a failed command receiver to a backup radio. Power can be saved by putting some or all of the redundant radios on timers, and to switch to a backup receiver if no commands have been received through the primary receiver within a predetermined interval; but the saved power may come at the cost of a possible delay in emergency response initiation.

Spacecraft power is always at a premium, and other techniques must also be used to minimize its consumption by the communication system. The transmitter is a major power consumer, so its efficiency must be maximized. All aspects of data transmission must contribute to error-free (very low bit error rate) reproduction of the telemetry data using no more power or bandwidth than is absolutely essential. Pulse-code modulation is a common technique which helps meet this goal. In general terms, space communication systems are far less forgiving than terrestrial systems and must be designed, constructed, and tested to much higher standards. See PULSE MODULATION; SPACE POWER SYSTEMS; SPACE TECHNOLOGY.

The Tracking and Data Relay Satellite System (TDRSS) consists of a series of geostationary spacecraft and an Earth terminal located at White Sands, New Mexico. The purpose of TDRSS is to provide telecommunication services between low-Earth-orbiting (LEO) user spacecraft and user control centers. A principal advantage of the system is the elimination of the need for many of the worldwide ground stations for tracking such spacecraft. The *Tracking and Data Relay Satellite (TDRS)* provides no processing of data; rather, it translates received signals in frequency and retransmits them. User orbits are calculated from range and range-rate data obtained through the *TDRS* by using transponders on the user spacecraft. [J.F.C.I.; D.PI.]

**Space flight** The penetration by humans into the reaches of the universe above the terrestrial atmosphere and investigation of these regions by automated, remote-controlled and crewed vehicles.

The purpose of space flight is to provide significant contributions to the physical and mental needs of humanity on a national and global basis. Such contributions fall specifically in the areas of (1) Earth resources of food, forestry, atmospheric environment, energy, minerals, water, and marine life; (2) Earth and space sciences for research; (3) commercial materials processing, manufacturing in space, and public services. More general goals of space flight include expansion of knowledge; exploration of the unknown, providing a driving force for technology advance-

ment and, hence, improved Earth-based productivity; development and occupation of new frontiers with access to extraterrestrial resources and unlimited energy; strengthening of national prestige, self-esteem, and security; and providing opportunity for international cooperation and understanding.

This article focuses on crewed space flight. For discussion of other missions see COMMUNICATIONS SATELLITE; METEOROLOGICAL SATELLITES; MILITARY SATELLITES; SATELLITE (SPACECRAFT); SATELLITE NAVIGATION SYSTEMS; SCIENTIFIC SATELLITES; SPACE PROBE.

To conduct crewed space flight, the two leading space-faring nations, the United States and Russia, formerly the Soviet Union, have developed spacecraft systems and the necessary ground facilities, research and development base, operational know-how, planning experience, and management skills. In the United States, crewed space programs are conducted by the National Aeronautics and Space Administration (NASA), a federal agency established in 1958 for the peaceful exploration of space. In Russia, crewed space flights have been under the auspices of the U.S.S.R. Academy of Sciences; they are now the responsibility of the Russian Space Agency (RKA). The first spacecraft with a human on board, the *Vostok 1*, piloted by Yuri A. Gagarin, was launched on April 12, 1961, from the Baikonur Cosmodrome in Kazakhstan and returned after completing one revolution of the Earth. The first American space flight of a human took place 3 weeks later, when NASA launched Alan B. Shepard on May 5 on the *Mercury-Redstone 3* for a 15-min suborbital test flight.

The early spacecraft of both nations were built for only one space flight. The first multiply reusable space vehicle, the space shuttle, was launched by the United States on April 12, 1981.

In November 1987, the 13 member nations of the European Space Agency (ESA) agreed to become the third major power engaging in human space flight. European efforts today focus on a two-pronged program: participation as a partner in the International Space Station (ISS), primarily with the Columbus Orbital Facility (COF), and extension of the Ariane family of expendable launch vehicles with the heavy-lift carrier Ariane 5. By joining the original partnership behind the space station and assigning astronauts to United States space shuttle missions (as did the European Space Agency and Russia), Canada and Japan have also entered the ranks of space-faring nations, while other countries, such as Brazil, are preparing to join. On October 15, 2003, the People's Republic of China launched Yang Liwei on a 21-hour orbital flight aboard the spacecraft *Shenzou 5*.

**Crewed spacecraft.** A crewed spacecraft is a vehicle capable of sustaining humans above the terrestrial atmosphere. In a more limited sense, the term crewed spacecraft is usually understood to apply to vehicles for transporting and sustaining human crews in space for time periods limited by prestored on-board supplies, as distinct from orbital space stations which support theoretically unlimited habitation of humans in space by autonomous systems, crewed maintenance, and periodic resupply.

The basic requirements of crewed spacecraft are quite different from those of uncrewed space probes and satellites. The presence of humans on board necessitates a life-sustaining environment and the means to return safely to Earth. The major common feature of all crewed spacecraft, therefore, is the atmospheric return element or reentry module. It consists basically of a pressure-tight cabin for the protection, comfort, and assistance of the crew, similar to the cockpits of fighter aircraft, but shaped externally in accordance with the desired airflow and its forces, and surrounded by heat-resistant material, the thermal protection system (TPS), to cope with the high frictional and radiative heating accompanying the energy dissipation phase of the atmospheric return flight to Earth.

The main system that distinguishes crewed spacecraft from other spacecraft is the environmental control and life support system. It provides the crew with a suitably controlled atmosphere. Because all atmospheric supplies must be carried into space, it is essential to recirculate and purify the spacecraft atmosphere to keep the total weight of the vehicle within reasonable limits.

Space suits or pressure suits are mobile spacecraft or chambers that house the astronauts and protect them from the hostile environment of space. They provide atmosphere for breathing, pressurization, and thermal control; protect astronauts from heat, cold, glare, radiation, and micrometeorites; contain a communication link and hygiene equipment; and must have adequate mobility. The suit is worn during launch, docking, and other critical flight phases.

Because of the potential hazards of space flight to personnel, crewed spacecraft must meet stringent requirements of safety and hardware reliability. Reliability is associated with the probability that the spacecraft systems will operate properly for the required length of time and under the specified conditions. To assure survival and return in all foreseeable emergencies, the design of a crew-rated spacecraft includes standby systems (double or triple redundancy) and allows for launch escape, alternative and degraded modes of operation, contingency plans, emergency procedures, and abort trajectories to provide maximum probability of mission success. The priority order of this reliability requirement is (1) crew safety, (2) minimum achievable mission fulfillment, (3) mission data return, and (4) minimal degradation. See RELIABILITY, AVAILABILITY, AND MAINTAINABILITY.

**Soviet/Russian programs.** After the first *Sputnik* launch on October 4, 1957, developments of crewed space flight capability followed in quick succession, leading from the first-generation *Vostok* (East) to the second-generation *Voskhod* (Ascent) and to the third-generation *Soyuz* (Union) spacecraft. Originally engaged in an aggressive program to land a cosmonaut on the Moon before the United States lunar orbit mission of *Apollo 8* in December 1968, the Soviet Union redirected its aims, after four test failures of its N1 heavy-lift launcher, toward the development of permanent human presence in Earth orbit.

The *Vostok*, a single-seater for short-duration missions and ballistic reentry from Earth orbits, consisted of a near-spherical cabin, having three small viewports and external radio antennas. The 7-ft (2-m) sphere of the cabin was attached to a service module. The second-generation *Voskhod*, essentially a greatly modified *Vostok*, was a short-duration multiperson craft and was designed to permit extravehicular activity or spacewalking by one of the crew.

The *Soyuz* design is much heavier, larger, and more advanced in its orbital systems, permitting extended orbital stay times. It consists of three main sections or modules: a descent vehicle, an orbital module, and an instrument-assembly module. The three elements are joined together, with the descent vehicle in the middle. Shortly before atmospheric reentry, the two outer modules are jettisoned.

*Soyuz* spacecraft carried originally up to three cosmonauts. However, when an accidental explosive decompression of the descent cabin during reentry caused the death of the *Soyuz 11* crew in 1971, the third seat was removed to make room for the necessary additional life-support equipment, and the *Soyuz* thereafter carried only two cosmonauts. An improved version, the *Soyuz T* (for "Transport") was introduced in 1980. A new version, the *Soyuz-TM*, with extended mission duration and new subsystems, replaced this vehicle in February 1987, after a crewless test flight in May 1986.

Between 1971 and 1981, five *Salyut* space stations operated in low Earth orbit successively. The most successful of them, *Salyut 6*, was the first of a "second generation" of such stations. Unlike its predecessors, it had two docking ports, instead of only one. This enabled it to receive visiting crews and resupply ships. Together with other new on-board systems, this feature was the key to missions of considerably extended duration. Its successor, *Salyut 7*, was launched in 1982.

On February 19, 1986, the Soviet Union launched the core vehicle in its *Mir* (Peace) space station complex series. This complex represented a new-generation space station which evolved from the *Salyut* and *Kosmos* series vehicles. The core, an advanced version of *Salyut*, had six docking ports and consisted of

four sections. Connected to various docking ports were four laboratory modules, which were launched separately between 1989 and 1996. These modules were dedicated to different scientific and technical disciplines or functions, including technological production with a shop, astrophysics, biological research, and medical research.

In its later years, *Mir* required increasing maintenance and repairs by its crews, particularly after two serious emergencies in 1997. When U.S. support of *Mir* ended at the conclusion of the joint Shuttle/*Mir* program (ISS Phase 1), further crewed operations of the space station were increasingly difficult and impractical for the Russian Space Agency (RSA). The last crew returned to Earth on August 27, 1999, and the station was deorbited on March 20, 2001. See SPACE STATION.

With the successful first test flight, from Baikonur, of the powerful expendable heavy-lift launcher *Energia* on May 15, 1987, the Soviet Union gained a tremendous new launch capability. With its second, and last, flight on November 15, 1988, the *Energia* launched the Soviet space shuttle *Buran* on its only (crewless) orbital test flight. After the collapse of the Soviet Union, the *Energia/Buran* programs were terminated.

**United States programs.** During the first decade after its inception in 1961, the United States crewed space program was conducted in three major phases—Mercury, Gemini, and Apollo.

*Mercury* was in its basic characteristics similar to the Soviet *Vostok*, but it weighed only about a third as much, as necessitated by the smaller missiles of the United States at that time (the Redstone and Atlas). The one-person *Mercury* capsules used ballistic reentry and were designed to answer the basic questions about humans in space: how they were affected by weightlessness, how they withstood the gravitational forces of boost and entry, how well they could perform in space. See WEIGHTLESSNESS.

The second United States step into space was the Gemini Program. With the two-person *Gemini* capsule, for the first time a crewed spacecraft had been given operational maneuverability in space. Its reentry module flew a lifting reentry trajectory for precise landing point control. In addition, its design permitted extravehicular activity by one of the crew.

The third-generation spacecraft, *Apollo*, had five distinct parts: the command module (CM), the service module (SM), the lunar module (LM), the launch escape system (LES), and the spacecraft/lunar module adapter (SLA). The three modules made up the basic spacecraft; the LES and SLA were jettisoned early in the mission after they had outlived their function. The command module served as the control center for the spacecraft and provided living and working quarters for the three-member crew for the entire flight, except for the period when two persons entered the lunar module for the descent to the Moon and return. The command module was the only part of the spacecraft that returned to Earth, flying a lifting trajectory with computer-steered maneuvers. The lunar module carried two astronauts from the orbiting command/service module (CSM) down to the surface of the Moon, provided a base of operations there, and returned the two astronauts to a rendezvous with the command service module in orbit. On the last three lunar landings, *Apollo 15–17*, lunar exploration was supported by the lunar roving vehicle.

A more powerful booster was required to lift the *Apollo* spacecraft to Earth orbit and thence to the Moon. At the Army Ballistic Missile Agency (ABMA) in 1958, a team of engineers under Wernher von Braun set out to prove that vastly more powerful space rockets could be built from existing hardware by clustering engines and tanks. The project evolved into the Saturn Program of NASA. The Saturn 5, which became the *Apollo* lunar launch vehicle, had the capability to lift 250,000 lb (113 metric tons) into low Earth orbit and to send 100,000 lb (45 metric tons) to the Moon.

In addition to its lunar mission in the *Apollo* program, the Saturn 5, in a two-stage version, served also—in its last and thirteenth flight—to launch the first United States space station, *Skylab*.

**Skylab.** The experimental space station *Skylab* was the largest object placed in space up until that time, and the first crewed project in the U.S. Space Program with the specific purpose of developing the utility of space flight in order to expand and enhance humanity's well-being on Earth. To that end, *Skylab*'s equipment included an Earth resources remote sensing instrument and the first crewed solar telescopes in space. A total of three crews of three astronauts each carried out experiments and observations on *Skylab*. *Skylab* was launched uncrewed by Saturn 5 in 1973. The space station underwent repair in orbit, a first for the space program.

**Space Transportation System.** After the end of the joint American-Soviet space mission, attention began to focus on the routine application of newly acquired know-how systems and experience, specifically in the form of the emerging Space Transportation System (STS), with the ability to transport inexpensively a variety of useful payloads to orbit, as the mainstay and "work horse" of the United States space program. The two major components of the Space Transportation System were the space shuttle and the *Spacelab*.

The space shuttle is a reusable system. It has three major elements: the orbiter, an external tank (ET) containing the liquid propellants to be used by the orbiter main engines for ascent, and two solid-propellant rocket boosters (SRBs) "strapped on" to the external tank. The orbiter and solid rocket booster casings are reusable; the external tank is expended on each launch. See SPACE SHUTTLE.

The orbiter *Columbia* made its first orbital flight on April 12–14, 1981. Three additional shuttles were added by the end of 1985. With the launch of the twenty-fifth shuttle mission, 51-L on January 28, 1986, tragedy struck the American space program. At approximately 11:40 a.m. EST, 73 s after liftoff, the flight of *Challenger*, on its tenth mission, abruptly ended in an explosion triggered by a leak in the right solid rocket booster, killing the seven member crew. Continuation of the United States crewed space program was suspended pending a thorough reassessment of flight safety issues and implementation of necessary improvements. Shuttle flight operations resumed on September 29, 1988.

On February 1, 2003, *Columbia*, on its twenty-eighth flight, was lost with its crew during reentry when it violently disintegrated in the skies over Texas. The Columbia Accident Investigation Board (CAIB) concluded that one of the left wing's leading-edge reinforced-carbon-carbon elements had been punctured during ascent to orbit by a chunk of foam insulation blown off the external tank by the supersonic air stream, rendering the wing unable to withstand reentry heating longer than about eight minutes after entry interface. Further shuttle operations were halted for the duration of the CAIB investigation and subsequent intensive return-to-flight efforts by NASA and its contractors.

The *Spacelab* was a major adjunct of the shuttle. Developed and funded by member nations of the European Space Agency, the large pressurized *Spacelab* module with an external equipment pallet was designed to be the most important payload carrier during the space shuttle era, and was used on numerous shuttle missions between 1983 and 1997. With its large transport capacity (in weight, volume, and power supply), the *Spacelab* was intended to support a wide spectrum of missions in science, applications, and technology by providing versatile and economical laboratory and observation facilities in space for many users. Another objective was to reduce significantly the time from experiment concept to experiment result, compared with previous space practice, and also to reduce the cost of space experimentation. It allowed the direct participation of qualified men and women scientists and engineers to operate their own equipment in orbit.

**International Space Station.** Interest in the development of a permanent crewed platform in Earth orbit dates back to the very beginnings of human space flight. While the practical realization of the concept was accomplished and proven by the



International Space Station with its solar arrays deployed, photographed from the space shuttle *Endeavour* following undocking on December 9, 2000. (NASA)

Soviet *Salyut/Mir* and the American *Skylab* programs, the real breakthrough happened on January 29, 1998, when representatives of 16 nations signed a partnership agreement for the joint development and operation of an International Space Station (ISS). The goal of the ISS program is to establish a permanent platform for humans to live and work in space in support of science and technology research, business, education, and exploration. Its objectives are to provide a world-class laboratory complex uniquely located in a microgravity and vacuum environment where long-term scientific research can be carried out to help fight diseases on Earth, unmask fundamental processes leading to new manufacturing processes and products to benefit life on Earth, and observe and understand the Earth's environment and the universe. When completed, the International Space Station (see illustration) will have a mass of about 1,040,000 lb (470 metric tons). It will be 356 ft (108 m) across and 290 ft (108 m) long, with almost an acre (0.4 hectare) of solar panels to provide up to 110 kilowatts of power to six state-of-the-art laboratories.

The on-orbit assembly of the ISS began with the launch of the Functional Cargo Block (FGB) *Zarya* ("Dawn") on November 20, 1998.

On October 31, 2000, a Soyuz-U carrier lifted off from Baikonur and placed in orbit *Soyuz TM-31*, carrying the first resident crew for the Space Station. Since then, each crew has remained on the station for about six months before rotating with the subsequent crew. Early in 2003, further progress in ISS assembly was halted by the stand-down of space shuttles after the *Columbia* loss. As a consequence of the reduction in resupply missions to the station, crew size was reduced from a three- to a two-person caretaker crew per expedition. [J.V.P.]

**Space navigation and guidance** The determination of the position and velocity of a space probe with respect to a target body or a known reference body such as the Earth (navigation) and, based upon this determination, the application of propulsive maneuvers to alter the subsequent path of the probe (guidance).

Space navigation can be viewed as determining the current position and velocity of the probe and then using that determination as the basis of predicting future motion. This determination is made by taking a series of measurements relating to the probe's motion and combining these measurements in such a manner as to make the most accurate estimate of the probe's current position and velocity, taking into account possible small errors or inaccuracies in the measurements themselves. One of the most powerful (and accurate) measurements which can be made is

the relative velocity between an Earth tracking station and the space probe itself. This is accomplished by broadcasting an electromagnetic signal which consists of a single tone having a stable frequency to the probe. The probe will receive this signal shifted in frequency in exact proportion to the relative station-probe velocity. This frequency shift is known as the Doppler effect. It is also possible to measure the station-probe distance (or range) using electromagnetic signals.

For missions to the outer planets (Jupiter and beyond) or for a mission to a body such as a comet or asteroid, the position of the target may be sufficiently uncertain as to make a strictly Earth-relative navigation scheme inadequate. Here it is necessary to make measurements that directly involve the target. Typical of these is to obtain optical measurements of the location of the target relative to a star as seen from the probe itself.

In its simplest form, guidance consists of comparing the predicted future motion of the probe against that which is desired, and if these are sufficiently different, executing a propulsive maneuver to modify that future position. Typically, the probe will contain a small rocket motor which can be fired in any desired direction by first rotating the spacecraft away from its cruise orientation and then holding the new attitude fixed while the rocket motor is firing.

Multiplanet missions use an accurate delivery to the first target not only to scientifically explore that planet, but also to use the planet's gravitational attraction to change the course of velocity of the probe advantageously for the next leg of the mission toward the second and subsequent targets. The encounter with a planet becomes in itself a type of guidance correction as the planet changes the path of the probe. See GUIDANCE SYSTEMS; SPACE PROBE. [D.W.C.]

**Space power systems** On-board assemblages of equipment to generate, store, and distribute electrical energy on satellites and spacecraft. A reliable source of electrical power is required for supplying energy to the spacecraft and its payloads during launch and through several years of operational lifetime in a space environment. Present-generation spacecraft fly power systems from tens of watts to several kilowatts. Each of the three fuel cells on the space shuttle delivers 12 kW continuous power and 16 kW peak power. The International Space Station's solar arrays will generate 110 kW total power, with approximately 46 kW available for research activities. See SATELLITE (SPACECRAFT); SPACE FLIGHT; SPACE PROBE; SPACE SHUTTLE; SPACE STATION.

With few exceptions, the power systems for United States satellites have used photovoltaic generation for power, batteries for energy storage, and a host of electrical equipment for appropriate regulation, conversion, and distribution. Fuel cells have been limited primarily to use in the crewed space program, supplying power for *Gemini*, *Apollo*, and the space shuttle. Radioisotope thermoelectric generators (RTGs) have powered, or augmented solar power on, many planetary missions and probes, powered lunar instruments left on the Moon by the *Apollo* missions, and augmented the solar-array battery power system on at least one Earth-orbiting spacecraft. See ENERGY STORAGE; FUEL CELL; SOLAR CELL; THERMOELECTRICITY.

Many factors influence the final configuration of a power system. Basic to the initial consideration are the nature of the mission (Earth-orbiting or planetary) and mission lifetime. Other relevant factors include (1) spacecraft and payload requirements with consideration to average and peak power loads; (2) effect of environment such as orbit period, length of time the spacecraft is in sunlight and shadow, radiation particle damage, and space charging; and (3) constraints imposed by the spacecraft such as weight, volume, spacecraft shape and appendages, satellite attitude control, electromagnetic radiation limitations, characteristics of payloads, and thermal dissipation. For spacecraft that are shuttle-launched, additional considerations include compatibility with shuttle payload safety requirements and, in some cases,

the retrievability by the shuttle for return to Earth. The weight of the power system ranges from 15 to 25% of the spacecraft weight. [J.C.Mit.]

**Space probe** An automated, crewless vehicle, the payload of a rocket-launching system, designed for flight missions to other planets, to the Moon, and into interplanetary space, as distinguished from Earth-orbiting satellites (see table).

The space probe is used primarily for scientific purposes, which are stated as the mission objectives. Missions generally fall into three categories according to destination: those to the rocky bodies in the inner solar system, including the Earth-like planets, asteroids, and comets; those to the giant gaseous planets in the outer solar system; and those designed to study solar physics and the properties of interplanetary space. Most spacecraft launched to a planet or other body also study the environment of charged particles and electromagnetic fields in interplanetary space during their cruise phase en route to the destination. See ASTEROID; SOLAR SYSTEM.

Missions may also be categorized by complexity. The simplest are flyby spacecraft, which study their target body during a relatively brief encounter period from a distance of hundreds to thousands of miles as they continue past. Next are orbiters, which circle a planet or other body for extended study; some may carry atmospheric descent probes. Even more complex are lander missions, which touch down on a planet or other body for the collection of on-site data; some may bear exploration rovers designed to range beyond the immediate landing site. Finally, the most complex space probes envisaged are sample-return missions, which would collect specimen material from a target body and return it to Earth for detailed study.

**Spacecraft subsystems.** In the broadest terms, a space probe may be considered a vehicle that transports a payload of sensing instruments to the vicinity of a target body. Thus, the spacecraft must include a number of subsystems to provide power, to communicate with Earth, to maintain and modify attitude and perform maneuvers, to maintain acceptable on-board temperature, and to manage the spacecraft overall. See SPACE TECHNOLOGY.

**Scientific instruments.** The scientific payload may be divided into remote-sensing instruments, such as cameras, and direct-sensing instruments, such as magnetometers or dust detectors. They may be classified as passive instruments, which detect radiation given off by a target body, or active ones, which emit energy such as radar pulses to characterize a target body. See REMOTE SENSING.

**Power subsystem.** Electrical power is required for all spacecraft functions. The total required power ranges from about 300 to 2500 W for current missions, depending on the complexity of the spacecraft. The power subsystem must generate, store, and distribute electrical power. All space probes launched so far have generated power either via solar panels or via radioisotope thermoelectric generators (RTGs). See NUCLEAR BATTERY; SOLAR CELL; SPACE POWER SYSTEMS.

**Telecommunications subsystem.** In order to accomplish its mission, the spacecraft must maintain communications with Earth, such as receiving commands sent from ground controllers, and transmitting scientific data and routine engineering "house-keeping" data. All of these transmissions are made in various segments of the microwave spectrum. The design of the telecommunications subsystem takes into account the volume of data to be transmitted and the distance from Earth at which the spacecraft will operate, dictating such considerations as the size of antennas and the power of the on-board transmitters. See MICROWAVE; TELEMETERING.

Advanced planetary probes have carried a dish-shaped high-gain antenna which is the chief antenna used to both transmit and receive. These antennas typically consist of a large parabolic reflector, with a subreflector mounted at the main reflector's focus in a Cassegrain-type configuration. In the interest of redundancy

## Important space probes

Name	Launch date	Comments
<i>Luna 1</i>	Jan. 2, 1959	Lunar probe; now in solar orbit; passed within 3278 mi (5275 km) of the Moon
<i>Pioneer 4</i>	Mar. 3, 1959	Cosmic rays; passed 37,300 mi (60,000 km) from Moon
<i>Luna 2</i>	Sept. 2, 1959	Impacted Moon
<i>Luna 3</i>	Oct. 4, 1959	Photographed far side of Moon
<i>Pioneer 5</i>	Mar. 11, 1960	First deep-space probe; magnetic fields and cosmic rays
<i>Mariner 2</i>	Aug. 26, 1962	First planetary flyby; Venus probe
<i>Ranger 7</i>	July 28, 1964	Lunar impact and approach photography
<i>Mariner 4</i>	Nov. 28, 1964	Mars encounter; photography, magnetic fields, cosmic rays
<i>Ranger 8</i>	Feb. 17, 1965	Lunar impact and approach photographs
<i>Ranger 9</i>	Mar. 21, 1965	Lunar impact and Alphonsus; approach photography
<i>Zond 3</i>	July 18, 1965	Photographs from lunar encounter
<i>Pioneer 6</i>	Dec. 16, 1965	Solar orbit
<i>Luna 9</i>	Jan. 31, 1966	First photographs from lunar surface
<i>Luna 10</i>	Mar. 31, 1966	Lunar and interplanetary data
<i>Surveyor 1</i>	May 30, 1966	Soft landing on Moon; environmental data and photography
<i>Lunar Orbiter 1</i>	Aug. 10, 1966	Lunar photographs
<i>Pioneer 7</i>	Aug. 17, 1966	Solar orbit
<i>Luna 11</i>	Aug. 24, 1966	Lunar data
<i>Luna 12</i>	Oct. 22, 1966	Lunar orbital photography and other data
<i>Lunar Orbiter 2</i>	Nov. 6, 1966	Lunar orbital photography
<i>Luna 13</i>	Dec. 21, 1966	Lunar surface photography and soil information
<i>Lunar Orbiter 3</i>	Feb. 5, 1967	Lunar orbital photography
<i>Surveyor 3</i>	Apr. 17, 1967	Lunar surface photography and surface properties
<i>Lunar Orbiter 4</i>	May 4, 1967	Lunar orbital photography
<i>Venera 4</i>	June 12, 1967	Analysis of Venus atmosphere; first instrumented landing on another planet
<i>Mariner 5</i>	June 14, 1967	Venus probe; atmospheric and magnetospheric data
<i>Lunar Orbiter 5</i>	Aug. 1, 1967	Lunar orbital photography
<i>Surveyor 5</i>	Sept. 8, 1967	Lunar surface photography and surface properties, including elemental analysis of surface
<i>Surveyor 6</i>	Nov. 7, 1967	Same as <i>Surveyor 5</i> ; landing in Sinus Medii
<i>Pioneer 8</i>	Dec. 13, 1967	Solar orbit
<i>Surveyor 7</i>	Jan. 7, 1968	Same as <i>Surveyor 5</i>
<i>Zond 5</i>	Sept. 14, 1968	Circled Moon; recovered Sept. 21, 1968
<i>Pioneer 9</i>	Nov. 8, 1968	Solar orbit
<i>Zond 6</i>	Nov. 10, 1968	Circled Moon; recovered Nov. 17, 1968
<i>Venera 5</i>	Jan. 5, 1969	Same as <i>Venera 4</i>
<i>Venera 6</i>	Jan. 10, 1969	Same as <i>Venera 4</i>
<i>Mariner 6</i>	Feb. 25, 1969	Photography and analysis of surface and atmosphere of Mars
<i>Mariner 7</i>	Mar. 27, 1969	Same as <i>Mariner 6</i>
<i>Luna 15</i>	July 14, 1969	Lunar reconnaissance (crashed during attempted lunar landing)
<i>Zond 7</i>	Aug. 8, 1969	Reentered Aug. 14, 1969; third uncrewed circumlunar flight; recovered in the Soviet Union
<i>Venera 7</i>	Aug. 17, 1970	Lander capsule transmitted 23 min from surface of Venus, Dec. 15, 1970
<i>Luna 16</i>	Sept. 12, 1970	Reentered Sept. 24, 1970; uncrewed Moon lander touched down on Sea of Fertility Sept. 20, 1970; returned lunar soil samples
<i>Zond 8</i>	Oct. 20, 1970	Circled Moon; recovered Oct. 27, 1970
<i>Luna 17</i>	Nov. 10, 1970	Landed on Moon Nov. 17, 1970; uncrewed Moon rover
<i>Mars 2</i>	May 19, 1971	First Soviet Mars landing
<i>Mars 3</i>	May 28, 1971	Mars probe
<i>Mariner 9</i>	May 30, 1971	Mars probe
<i>Luna 18</i>	Sept. 2, 1971	Impacted Moon Sept. 11, 1971
<i>Luna 19</i>	Sept. 28, 1971	Lunar photography mission
<i>Luna 20</i>	Feb. 14, 1972	Recovered Feb. 25, 1972; returned lunar sample
<i>Pioneer 10</i>	Mar. 2, 1972	Jupiter encounter; transjovian interplanetary probe
<i>Venera 8</i>	Mar. 27, 1972	Venus landing July 22, 1972
<i>Luna 21</i>	Jan. 8, 1972	Moon landing Jan. 16, 1972, with <i>Lunikhod</i> rover
<i>Pioneer 11</i>	Apr. 5, 1973	Jupiter encounter and transjovian interplanetary probe; also Saturn encounter
<i>Mars 4</i>	July 21, 1973	Mars orbiter
<i>Mars 5</i>	July 25, 1973	Mars orbiter
<i>Mars 6</i>	Aug. 5, 1973	Mars lander
<i>Mars 7</i>	Aug. 9, 1973	Mars lander
<i>Mariner 10</i>	Nov. 3, 1973	Venus and Mercury encounter
<i>Luna 22</i>	May 29, 1974	Lunar probe
<i>Helios 1</i>	Dec. 10, 1974	Inner solar system, solar wind exploration
<i>Venera 9</i>	June 8, 1975	Venus probe
<i>Venera 10</i>	June 14, 1975	Venus probe
<i>Viking 1</i>	Aug. 20, 1975	Mars lander and orbiter
<i>Viking 2</i>	Sept. 9, 1975	Mars lander and orbiter
<i>Helios 2</i>	Jan. 15, 1976	Interplanetary; similar objectives to those of <i>Helios 1</i>
<i>Luna 24</i>	Aug. 9, 1976	Recovered Aug. 25, 1976; returned lunar sample
<i>Voyager 2</i>	Aug. 20, 1977	Jupiter, Saturn, Uranus, and Neptune encounters; also satellites and ring systems
<i>Voyager 1</i>	Sept. 5, 1977	Same objectives as <i>Voyager 2</i> with some orbital differences giving differing encounter trajectories
<i>Pioneer Venus Orbiter</i>	May 20, 1978	Returning atmospheric, surface, and particle and field information
<i>Pioneer Venus Multi-Probe Bus</i>	Aug. 8, 1978	Penetration of Venus atmosphere by four probes; returned atmospheric data
<i>Venera 11</i>	Sept. 8, 1978	Venus lander; returned information on surface properties; detection of lightning and thunderlike sounds
<i>Venera 12</i>	Sept. 14, 1978	Similar mission to <i>Venera 11</i>
<i>Venera 13</i>	Oct. 30, 1981	Venus lander
<i>Venera 14</i>	Nov. 4, 1981	Venus lander
<i>Venera 15</i>	June 2, 1983	Venus lander; surface topography
<i>Venera 16</i>	June 7, 1983	Similar mission to <i>Venera 15</i>
<i>International Cometary Explorer (ICE)</i>	—	Originally <i>International Sun-Earth Explorer 3 (ISEE 3)</i> Earth satellite, redirected using a lunar swingby on Dec. 22, 1983, to encounter with Comet Giacobini-Zinner; plasma and magnetic field



## Important space probes (cont.)

Name	Launch date	Comments
<i>Vega 1</i>	Dec. 15, 1984	Venus probe-Halley intercept
<i>Vega 2</i>	Dec. 21, 1984	Venus probe-Halley intercept
<i>Sokigake</i>	Jan. 8, 1985	Halley intercept; precursor to <i>Suisei</i> , upgraded to full mission
<i>Giotto</i>	July 2, 1985	Halley intercept
<i>Suisei</i>	Aug. 19, 1985	Halley intercept; plasma and magnetic field measurements
<i>Phobos 1</i>	July 7, 1988	Mars/Phobos probe, lost by command error
<i>Phobos 2</i>	July 12, 1988	Mars/Phobos probe; some data but communications lost
<i>Magellan</i>	May 4, 1989	Venus radar mapper
<i>Galileo</i>	Oct. 18, 1989	Jupiter orbiter and atmospheric probe
<i>Muses</i>	Jan. 24, 1990	Moon orbiter and relay probe; orbiter transmitter malfunctioned
<i>Ulysses</i>	Oct. 6, 1990	Solar polar orbiter
<i>Mars Observer</i>	Sept. 25, 1992	Contact lost 3 days before Mars arrival
<i>Clementine</i>	Jan. 25, 1994	Orbited Moon; thruster malfunction prevented asteroid flyby
<i>Solar and Heliospheric Observatory (SOHO)</i>	Dec. 2, 1995	Orbits L1 libration point to study the Sun
<i>NEAR-Shoemaker</i>	Feb. 17, 1996	Asteroid orbiter
<i>Mars Global Surveyor</i>	Nov. 7, 1996	Mars orbiter
<i>Mars 96</i>	Nov. 16, 1996	Mars orbiter and landers; launch vehicles failed
<i>Mars Pathfinder</i>	Dec. 4, 1996	Mars lander and rover
<i>Advanced Composition Explorer</i>	Aug. 25, 1997	Orbits L1 libration point to study charged particles
<i>Cassini</i>	Oct. 15, 1997	Saturn orbiter/Titan descent probe
<i>Lunar Prospector</i>	Jan. 6, 1998	Lunar orbiter
<i>Nozomi (Planet-B)</i>	July 4, 1998	Mars orbiter; orbit insertion failed
<i>Deep Space 1</i>	Oct. 24, 1998	Test of ion engine and 11 other advanced technologies; asteroid flyby
<i>Mars Climate Orbiter</i>	Dec. 11, 1998	Lost during Mars arrival
<i>Mars Polar Lander</i>	Jan. 3, 1999	Lost during Mars arrival
<i>Stardust</i>	Feb. 7, 1999	Comet flyby, dust sample return
<i>Mars Odyssey</i>	April 7, 2001	Mars orbiter
<i>Wilkinson Microwave Anisotropy Probe</i>	June 30, 2001	Orbits L2 libration point to study cosmic background radiation
<i>Genesis</i>	August 8, 2001	Orbits L1 libration point to collect solar wind samples and return them
<i>Hyabusa (Muses-C)</i>	May 9, 2003	Asteroid sample return mission
<i>Mars Express</i>	June 2, 2003	Mars orbiter and lander; orbiter was successful but <i>Beagle 2</i> lander failed
<i>MER-A/Spirit</i>	June 10, 2003	Mars rover
<i>MER-B/Opportunity</i>	July 7, 2003	Mars rover
<i>Spitzer Space Telescope (Space Infrared Telescope Facility)</i>	August 25, 2003	Infrared observatory in Earth-trailing orbit
<i>MESSENGER</i>	August 3, 2004	Mercury orbiter

and in the event that Earth pointing is lost, spacecraft virtually always carry other on-board antennas. These may be low-gain antennas, which typically offer nearly omnidirectional coverage except for blind spots shadowed by the spacecraft body, or medium-gain antennas, which provide a beam width of perhaps 20–30°. See ANTENNA (ELECTROMAGNETISM).

**Attitude-control subsystem.** It would be impossible to navigate the spacecraft successfully or point its scientific instruments or antennas without closely controlling its orientation in space, or attitude. Some spacecraft, particularly earlier ones, have been spin-stabilized; during or shortly after launch, the spacecraft is set spinning at a rate on the order of a few revolutions per minute. Much like a rotating toy top, the spacecraft's orientation is stabilized by the gyroscopic action of its spinning mass. Most planetary spacecraft, however, are three-axis-stabilized, meaning that their attitude is fixed in relation to space. The spacecraft's attitude is maintained and changed via onboard thruster jets or reaction wheels, or a combination of both.

**Propulsion subsystem.** Most spacecraft are outfitted with a series of thruster jets, each of which produces approximately 0.2–2 pounds-force (1–10 newtons) of thrust. Thrusters are usually fueled with a monopropellant, hydrazine, which decomposes explosively when it contacts an electrically heated metallic catalyst within the thruster. In addition to maintaining the spacecraft's attitude, on-board thrusters are used for trajectory-correction maneuvers. Spacecraft designed to orbit a planet or similar target body must carry a larger propulsion element capable of decelerating the spacecraft into orbit upon arrival. See SPACECRAFT PROPULSION.

**Thermal control subsystem.** In order to minimize the impact of temperature variations on the electronics on board, spacecraft

nearly always incorporate some form of thermal control. Mechanical louvers, controlled by bimetallic strips similar to those in terrestrial thermostats, are often used to selectively radiate heat from the interior of the spacecraft into space. Other thermal strategies include painting exterior surfaces. In some cases, spacecraft may also carry one or more active forms of heating to maintain temperature at required minimums.

**Command and data subsystem.** This designation is given to the main computer that oversees management of spacecraft functions and handling of collected data. Blocks of commands transmitted from Earth are stored in memory in the command and data subsystem and are executed at prescribed times. This subsystem also contains the spacecraft clock in order to accurately pace its activities, as well as all the activities of the spacecraft.

**Structure subsystem.** The spacecraft's physical structure is considered a subsystem itself for the purposes of planning and design. Usually the heart of this structure is a spacecraft bus, often consisting of a number of bays, which houses the spacecraft's main subsystems. See SPACECRAFT STRUCTURE. [F.O.D.]

**Space processing** Experiments conducted in space in order to take advantage of the reduced gravity in studies of the growth, behavior, and properties of materials. Spacelab, developed by the European Space Agency (ESA), is a laboratory module that flies in the space shuttle payload bay. First launched in 1983 on the *Columbia*, the module has become the workhorse for United States and international science missions emphasizing low gravity. The experiments in fluids, combustion, materials science, and biotechnology conducted on these missions, together

with their related ground-based research, have resulted in more than 2200 scientific publications.

Since biotechnology experiments generally have modest space and power requirements, they were able to be accommodated by middeck lockers in other shuttle missions as well as on the *Spacelab* microgravity emphasis missions, which provided them with many more flight opportunities. Even though the microgravity environment on some of these missions was not ideal, biomolecular crystal growth experiments for structural analysis as well as cell and tissue culturing experiments produced many interesting results, some of which could have commercial applications.

There are two compelling reasons for the study of combustion in microgravity. One is the issue of fire safety in the design and operation procedures of orbiting laboratories; the other is to take advantage of the weightless state to study certain combustion phenomena in more detail and to test various models in which convection has been ignored in order to be mathematically tractable. Examples of the latter are a number of droplet combustion experiments in which the burning of free-floating or tethered droplets was studied. The absence of gravity allowed the droplet size to be increased to as much as 5 mm (0.2 in.) so that more detailed observation could be made. The objective is to test theories of droplet combustion and soot formation that are of importance to improving the efficiency of internal combustion engines, gas turbine engines, and home and industrial oil-burning heating systems. See COMBUSTION; GAS TURBINE; INTERNAL COMBUSTION ENGINE.

In materials science, the processing of metallic alloys and composites has been carried out in space in order to study their microstructure, thermal properties, and crystal growth. [R.J.N.]

**Space shuttle** A reusable crewed orbital transportation system. The space shuttle, along with crewless (robotic) expendable launch vehicles including Delta, Atlas, and Titan, make up the United States Space Transportation System (STS). The shuttle has provided the unique capability for in-flight rendezvous and retrieval of faulty or obsolescent satellites, followed by satellite repair, update, and return to orbit or return to Earth for repair and relaunch. The space shuttle also has played an essential continuing role in the construction and provisioning of the International Space Station (ISS) by transporting major components, such as the giant solar-cell arrays and the Canadian computer-driven double-ended robotic arm, from Earth to the ISS and installing them using extended extravehicular activity (EVA, or space walks) by trained ISS resident and shuttle-visiting astronauts. See SATELLITE (SPACECRAFT); SPACE STATION.

Early in its history the space shuttle was touted as a low-cost replacement for expendable launch vehicles. Following the *Challenger* shuttle accident in 1986, it became clear that crewless vehicles would have a continuing place in the United States launch vehicle stable, that they have advantages over the shuttle such as lower cost and shorter lead time for tasks within their capability, and that the shuttle fleet would be fully occupied for much of the first decade of the twenty-first century doing complex jobs requiring human presence, in particular associated with the ISS, which no other launch system can do. For such reasons the STS was expanded to include the expendable launch vehicle families in use by the Department of Defense (DOD) and the National Aeronautics and Space Administration (NASA).

The space shuttle orbiter accommodates a crew of four to seven for orbital mission durations up to about 10 days. The space shuttle flight system (see illustration) consists of the orbiter, which includes the three liquid-fueled shuttle main engines; an external fuel tank; and two solid-fuel strap-on booster rockets. The external tank is discarded during each launch. The solid-fuel rocket casings are recovered and reused. The orbiter lands horizontally as an unpowered ("dead stick") aircraft on a long runway at the NASA Kennedy Space Center in Florida or, when

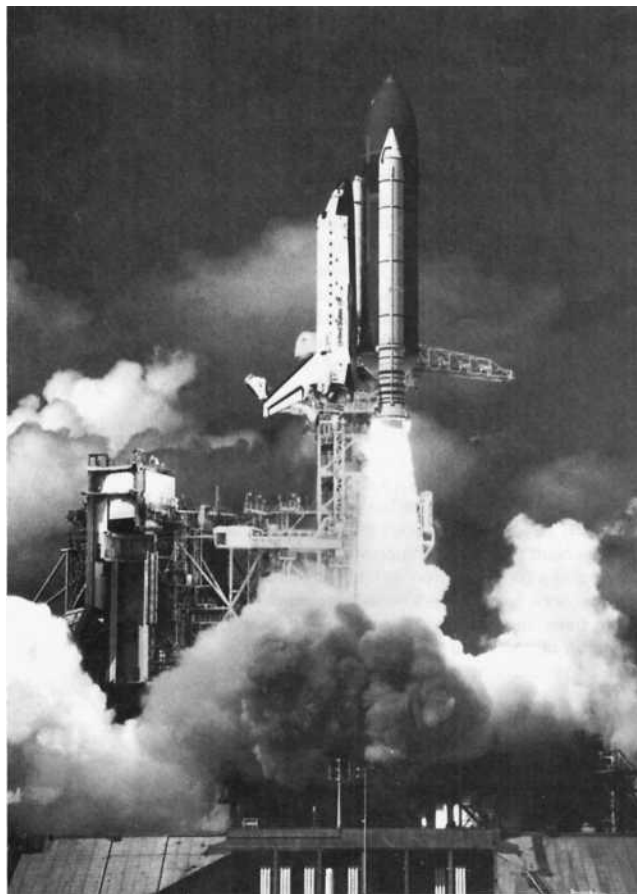

Space shuttle lifting off from the Kennedy Space Center.

conditions for landing these are unacceptable, at the Edwards Air Force Base in California. See ROCKET PROPULSION.

The shuttle is launched with all three main engines and both strap-on solid-fuel booster rockets burning. The booster rockets are separated 2 min after liftoff at an altitude of 30 mi (48 km), 28 mi (44 km) downrange. Main engine cutoff occurs about 8 min after liftoff, nearly 70 mi (110 km) above the Atlantic Ocean, 890 mi (1430 km) downrange from Kennedy. The external tank is separated from the orbiter shortly after the main engine cutoff, before orbital velocity (speed) is reached, so that the relatively light empty tank can burn up harmlessly during its reentry into the atmosphere above the ocean. Main propulsion for the rest of the mission is provided by the orbital maneuvering system engines, whose first task is to complete insertion of the shuttle into its final, nearly circular path during its first orbit (flight once around Earth) after liftoff.

After the shuttle orbiter completes the orbital phase of its mission and is ready to return to Kennedy, its pilot rotates the spacecraft 180° (tail-first relative to the orbiter's direction of motion) and fires the orbital maneuvering system engines to decrease the space vehicle's speed. This maneuver reduces the orbiter's speed just enough to allow the orbiter to fall into the tenuous outer atmosphere, where atmospheric drag causes the orbit to decay (altitude and velocity decrease) along a spiral path. This reentry slowdown occurs in a precise, computer-controlled manner so that the landing may be made manually, halfway around the Earth, on the desired runway at Kennedy or Edwards. At orbital altitudes, small reaction-control engines (jets) maintain the desired orientation of the orbiter. As the spacecraft-becoming-airplane descends into the denser lower air, its aerodynamic control surfaces gradually take over their normal maintenance of heading, pitch, and roll, and the small jets are turned off. Landing is made at a speed of 220 mi/h (100 m/s). The brakes are helped

to bring the vehicle to a stop by a parachute (drag chute) which is deployed from the tail after touchdown of the nose wheel and released well before the vehicle comes to a complete stop.

Major orbiter systems are the environmental control and life support, electric power, hydraulic, avionics and flight control, and the space shuttle main engines. Each system is designed with enough redundancy to permit either continuation of mission operations or a safe return to Earth after any single-element failure. For example, three fuel-cell power plants generate the in-flight electric power. Each fuel cell feeds one of three independent electrical distribution buses. Similarly, three independent hydraulic systems, each powered by an independent auxiliary power unit, operate the aerosurfaces. See FUEL CELL; SPACE POWER SYSTEMS.

The avionics system uses five general-purpose computers, four of which operate in a redundant set while the fifth operates independently. These computers perform guidance, navigation, and control calculations, and operate the attitude (orientation) controls and other vehicle systems. They also monitor system performance and can automatically reconfigure redundant systems in the event of a failure during flight-critical mission phases. Each of the three space shuttle main engines has an independent computer for engine control during ascent. See DIGITAL COMPUTER; MULTIPROCESSING.

The thermal protection system, which is not redundant, presented a major technical challenge to the orbiter development schedule. This system, unlike those of previous single-use spacecraft, has a design requirement of reuse for 100 missions. Performance requirements also dictate that the system withstand temperatures as high as 3000°F (1650°C) while maintaining the vehicle's structure at no more than 350°F (177°C). See ATMOSPHERIC ENTRY.

The key to meeting this challenge was to develop a material possessing an extremely low specific heat capacity and thermal conductivity, together with adequate mechanical strength to withstand the launch and reentry vibration and acceleration. These thermal characteristics must remain stable up to temperatures of at least 3000°F (1650°C). The solution was found in silica ceramic tiles, some 24,000 of which cover most of the orbiter's surface. During the highest thermal load portion of the reentry trajectory (path), the orbiter's wings are level and the nose is elevated well above the flight path. This causes the temperature of the undersurface to be substantially higher than that of the upper surface. For this reason, the undersurface is covered with black borosilicate glass-coated high-temperature tiles. Most of the upper surface of the shuttle is covered with a lower-temperature silica blanket made of two outer layers of woven fabric and an insulating buntinglike center layer stitched together in a quiltlike pattern. Finally, the nose cap and wing leading edges are subject to the highest (stagnation) temperatures, which requires the use of molded reinforced carbon-carbon material.

The first operational shuttle accomplished the first commercial satellite deployments in 1982. In 1984 the first in-orbit satellite repair was accomplished on the *Solar Maximum Mission's* control system and a primary experiment sensor. Later that same year *Palapa* and *Westar*, two communications satellites in useless orbits, were recovered and returned to Earth on the same space shuttle mission. These repair and recovery missions demonstrated the usefulness of humans in these new space tasks.

Shortly before noon on January 28, 1986, *Challenger* lifted off from Kennedy Space Center on the twenty-fifth shuttle mission. At 72 s into the flight, with no apparent warning from real-time data, the external tank exploded and *Challenger* was destroyed. All seven crew members perished, the first to die in NASA's human space-flight program spanning 25 years and 56 crewed launches. Further flight operations were suspended while a Presidential Commission reviewed the circumstances surrounding the accident, determined its probable cause, and developed recommendations for corrective actions. The cause of the accident was determined to be inadequate design of the solid rocket motor field joint. Deflection of the joint with deformation of the seals

at cold temperature allowed hot combustion products to bypass both O-rings, resulting in erosion and subsequent failure of both primary and secondary seals.

In September 1988, a *Tracking and Data Relay Satellite (TDRS)* was launched by the first space shuttle to fly after the *Challenger* accident. The initial TDRS network was completed 6 months later by the second shuttle launch of a TDRS. See SPACE COMMUNICATIONS; SPACECRAFT GROUND INSTRUMENTATION.

In the realm of solar system exploration, shuttle launches of *Magellan* to Venus and *Galileo* to Jupiter in 1989 were followed in 1990 by the shuttle launch of *Ulysses* to investigate the magnetic field configuration and variations around the Sun's poles. STS 32 launched the long-awaited Hubble Space Telescope (HST) in 1990; however, this telescope's most important work was not accomplished until later that decade after two shuttle EVA visits—the first to correct a bad case of astigmatism produced by the HST mirror manufacturer, and the second to update the sensors and replace major spacecraft subsystem components that were failing. See SATELLITE (ASTRONOMY); SPACE PROBE. [J.F.C.I.]

On February 1, 2003, the space shuttle program suffered a serious setback when the Columbia, on its 28th flight, was lost with its crew of seven during reentry 16 min before the planned landing at Kennedy Space Center, as it violently disintegrated over Texas. The Columbia Accident Investigation Board (CAIB) later concluded that, with crew and ground personnel unaware, one of the left wing's leading-edge reinforced carbon-carbon elements or an associated filler strip of the heat shield had been compromised during ascent to orbit by a piece of debris, possibly a chunk of foam insulation blown off the external tank, rendering the wing unable to withstand reentry heating. Further shuttle operations were halted for the duration of the CAIB investigation. [J.V.P.]

**Space station** A complex physical structure specifically designed to serve as a multipurpose platform in low Earth orbit. Functioning independently and often without a crew, a space station contains the structures and mechanisms to operate and maintain such support systems as command and data processing, communications and tracking, motion control, electrical power, and thermal and environmental control. Evolving together with technology and increasing in scope and complexity, the space station has a history in which each program was based upon the developments and achievements of its predecessor.

**Salyut.** The Soviet Union began construction of the world's first space station, called *Salyut*, in 1970. It was the primary Soviet space endeavor for the next 15 years. The design was retained not only through a series of Salyuts that were launched within that decade and later, but also through the development of *Mir*, the most famous, long-lived Russian achievement in space. The Salyuts were cylindrical in shape and contained compartments with specialized functions for operating a space station. The docking compartment was designed to accept the Soyuz spacecraft that transported the cosmonauts. The transfer compartment gave the cosmonauts access to the various work compartments. The work compartments contained the mechanisms that operated and controlled the station, as well as the laboratories in which the cosmonauts performed experiments while they were onboard. *Salyut 1* initially carried a crew of three, but after three cosmonauts died when a valve in the crew compartment of their descent module burst and the air leaked out, the crews were reduced to two cosmonauts, and both crew members were outfitted with pressurized space suits.

**Skylab.** This program was developed by NASA building on the success of its heavy-lift rocket, the Saturn, which had boosted the Apollo rockets and helped place the first human being on the Moon. *Skylab* weighed just less than 100 tons (90 metric tons). It was launched on May 14, 1973, from the Kennedy Space Center aboard a Saturn 5 rocket. Although the launch was flawless, a shield designed to shade *Skylab's* workshop deployed about

a minute after liftoff and was torn away by atmospheric drag. That began a series of problems, most involving overheating, that had to be overcome before *Skylab* was safe for human habitation. Eventually three crews served aboard *Skylab* throughout 1973 for periods of 28, 59, and 84 days, respectively. The single greatest contribution made by each crew was the extravehicular activities that restored *Skylab's* ability to serve as a space station.

**Apollo-Soyuz test program.** In 1975, during the period of détente, plans were made for a joint United States-Soviet space venture, known as the Apollo-Soyuz Test Program (ASTP). For the first time, United States astronauts and Soviet cosmonauts became members of each other's flight teams, training together, touring their launch sites, and working in their mission control rooms. For 15 months, they trained and prepared for their historical joint mission in space. In July 1975, the astronauts of *Apollo 18* linked with the cosmonauts of *Soyuz 22*; their docked configuration functioned as a miniature international space station.

**Mir.** *Mir* was the name of the vehicle for the world's first multipurpose, permanently operating crewed space station. Based upon the Salyut design and configuration, *Mir* essentially was an extension and expansion of the shell of the basic Soviet space vehicle. It would incorporate the standard Salyut/Soyuz/Progress profile. External ports were added for docking of Soyuz vehicles which would carry crew members, and Progress (resupply) vehicles which would bring foodstuffs, drinking water, extra equipment and apparatus, sanitary requisites, medical apparatus, and propellant. These same Progress vehicles would return space "junk" to Earth. Construction was based upon a modular design, permitting the Soviets to replace modules whenever significant improvements in technology made the earlier modules obsolete. Two cylindrical modules formed the basic shape of *Mir* and served as the living and central control compartments for the crews. Additional modules were used for scientific experiments.

The *Mir* core station was a 49-ft (15-m) module. Its launch aboard a Soviet Proton rocket on February 20, 1986, was televised internationally for the first time in Soviet space history. *Mir* was assembled in space and was composed of six modules. In addition to the core, the Kvant-1 module (launched in April 1987) was a 19-ft (6-m) pressurized lab used for astrophysics research. The Kvant-2 module was launched in December 1989, and was used for biological research and for Earth observation. The Kristall module was launched in August 1990, and provided the docking port for the United States space shuttles that visited *Mir*. Between 1994 and 2001, there were nine dockings between space shuttle vehicles and *Mir*. The final two modules, Spektr and Priroda (launched in June 1995 and April 1996, respectively) were remote sensing modules used to study the Earth. *Mir* provided a platform for long-term microgravity research and increased knowledge about living and working in space. By the end of its function in March 2001, the 143-ton (130-metric-ton) *Mir* had spent 15 years in orbit and had orbited the Earth more than 87,600 times with an average orbiting speed of 17,885 mi/h (28,800 km/h). Its superstructure, 109 ft (33 m) long and 90 ft (27 m) wide, burned up upon reentry in to the Earth's atmosphere, and scraps were scattered into the Pacific Ocean just east of New Zealand. See SPACE BIOLOGY; SPACE SHUTTLE.

**International Space Station.** The Soviet successes with *Mir* prompted the United States to respond with what became known as *Space Station Freedom*. Moved from the NASA drawing board in 1993, components of the space station were tested by shuttle crews during a variety of missions. Supporters of this space station advocated such unique opportunities as manufacturing drugs, scientific materials research in microgravity, and studying the health and status of the Earth's environment from outer space. At the direction of President Clinton, the United States transformed the single-nation concept for *Space Station Freedom* into a multinational partnership with the European

Space Agency and the Russian Space Agency to create what is now known as the International Space Station (ISS). See SPACE PROCESSING.

Sixteen nations have united to build the International Space Station. Dwarfing *Mir*, *Skylab*, the Salyuts, and any ground-based civil engineering project built to date, the International Space Station will include six laboratories built by a consortium of nations. United States space shuttle and Russian Soyuz flights will transport the structures and mechanisms necessary to construct the station.

The first permanent crew of the International Space Station launched from the Baikonur Cosmodrome, on October 31, 2000. In addition to serving as a test bed and springboard for future space exploration, the International Space Station will serve as a research laboratory for innovation in science and technology. Research will focus on such topics as biomedical research and countermeasures to understand and control the effects of space and zero gravity on crew members; biological study of gravity's influence on the evolution, development, and internal processes of plants and animals; biotechnology to develop superior protein crystals for drug development; and fluid physics. Advanced research will be oriented toward topics such as human support technology, materials science, combustion science, and fundamental physics. See SPACE FLIGHT; SPACE TECHNOLOGY; SPACECRAFT STRUCTURE. [J.J.P.]

**Space technology** The systematic application of engineering and scientific disciplines to the exploration and utilization of outer space. Space technology developed so that spacecraft and humans could function in this environment that is so different from the Earth's surface. Conditions that humans take for granted do not exist in outer space. Objects do not fall. There is no atmosphere to breathe, to keep people warm in the shade, to transport heat by convection, or to enable the burning of fuels. Stars do not twinkle. Liquids evaporate very quickly and are deposited on nearby surfaces. The solar wind sends electrons to charge the spacecraft, with lightninglike discharges that may damage the craft. Cosmic rays and solar protons damage electronic circuits and human flesh. The vast distances require reliable structures, electronics, mechanisms, and software to enable the craft to perform when it gets to its goal—and all of this with the design requirement that the spacecraft be the smallest and lightest it can be while still operating as reliably as possible.

All spacecraft designs have some common features: structure and materials, electrical power and storage, tracking and guidance, thermal control, and propulsion. The spacecraft structure is designed to survive the forces of launching and ground handling. The structure is made of metals (aluminum, beryllium, magnesium, titanium) or a composite (boron/epoxy, graphite/epoxy). It must also fit the envelope of the launcher. See SPACECRAFT STRUCTURE.

To maintain temperatures at acceptable limits, various active and passive devices are used: coatings or surfaces with special absorptivities and emissivities, numerous types of thermal insulation, such as multilayer insulation and aerogel, mechanical louvers to vary the heat radiated to space, heat pipes, electrical resistive heaters, or radioisotope heating units.

The location of a spacecraft can be measured by determining its distance from the transit time of radio signals or by measuring the direction of received radio signals, or by both. The direction of a spacecraft can be determined by turning the Earth station antenna to obtain the maximum signal, or by other equivalent and more accurate methods. See SPACE NAVIGATION AND GUIDANCE.

The velocity of a spacecraft is changed by firing thrusters. Solid propellant thrusters are rarely used. Liquid propellant thrusters are either monopropellant or bipropellant. Electric thrusters, such as mercury or cesium ion thrusters, have also been used. Electric thrusters have the highest efficiency (specific impulse) but the lowest thrust. See INTERPLANETARY PROPULSION; ION PROPULSION; PROPELLANT; SPACECRAFT PROPULSION.

Most spacecraft are spin-stabilized or are three-axis body-stabilized. The former uses the principles of a gyroscope; the latter uses sensors and thrusters to maintain orientation. Some body-stabilized spacecraft (such as astronomical observatories) are fixed in inertial space, while others (such as Earth observatories) have an axis pointed at the Earth and rotate once per orbit. A body-stabilized spacecraft is simpler than a spinner but requires more hardware. The orientation of a spacecraft is measured with Sun sensors (the simplest method), star trackers (the most accurate), and horizon (Earth or other body) or radio-frequency (rf) sensors (usually to determine the direction toward the Earth). Attitude corrections are made by small thrusters or by reaction or momentum wheels; as the motor applies a torque to accelerate or decelerate the rotation, an equal and opposite torque is imparted to the spacecraft.

Primary electrical power is most often provided by solar cells made from a thin section of crystalline silicon protected by a thin glass cover. Excess power from the solar cells is stored in rechargeable batteries so that when power is interrupted during an eclipse, it can be drawn from the batteries. Other sources of power generation include fuel cells, radio isotope thermoelectric generators (RTGs), tethers, and solar dynamic power. Fuel cells have been used on the Apollo and space shuttle programs and produce a considerable amount of power, with drinkable water as a by-product. See BATTERY; FUEL CELL; SOLAR CELL; SPACE POWER SYSTEMS.

The status and condition of a spacecraft are determined by telemetry. Temperatures, voltages, switch status, pressures, sensor data, and many other measurements are transformed into voltages, encoded into pulses, and transmitted to Earth. This information is received and decoded at the spacecraft control center. Desired commands are encoded and transmitted from the control center, received by the satellite, and distributed to the appropriate subsystem. Commands are often used to turn equipment on or off, switch to redundant equipment, make necessary adjustments, and fire thrusters and pyrotechnic devices. See SPACE COMMUNICATIONS; SPACECRAFT GROUND INSTRUMENTATION; TELEMETERING.

Many spacecraft missions have special requirements and hence necessitate special equipment. Satellites that leave the Earth's gravitational field to travel around the Sun and visit other planets have special requirements due to the greater distances, longer mission times, and variable solar radiation involved.

Spacecraft that return to Earth require special protection for reentry into Earth's atmosphere. In some missions one spacecraft must find, approach, and make contact with another spacecraft. See SATELLITE (SPACECRAFT); SPACE PROBE.

Space is distant not only in kilometers but also in difficulty of approach. Large velocity changes are needed to place objects in space, which are then difficult to repair and expensive to replace. Therefore spacecraft must function when they are launched, and continue to function for days, months, or years. The task is similar to that of building a car that will go 125,000 mi (200,000 km) without requiring mechanical repair or refueling. Not only must space technology build a variety of parts for many missions, but it must achieve a reliability far greater than the average. This is accomplished by building inherent reliability into components and adding redundant subsystems, supported by a rigorous test schedule before launch. Efforts are made to reduce the number of single points of failure, that is, components that are essential to mission success and cannot be bypassed or made redundant.

[G.D.Gor.]

**Space Telescope, Hubble** The Hubble Space Telescope is the largest visible-light observatory ever placed into space. Hubble's orbit, some 612 km (380 mi) above Earth's surface, keeps it above almost all of Earth's atmosphere, at a location where its view of the heavens is much clearer than that of ground-based telescopes. The superior view afforded by Hubble's orbit has made the telescope a unique resource for astronomers worldwide and has led to fundamental discoveries

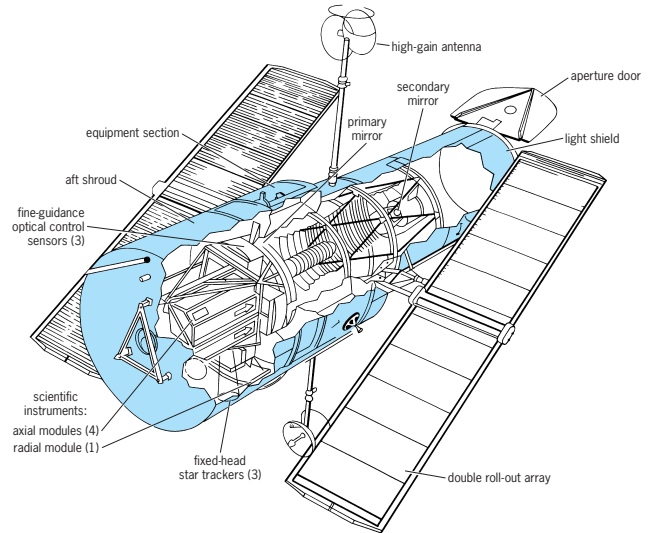

Fig. 1. Diagram of the Hubble Space Telescope.

about the size and age of the universe, the birth and death of stars, and the development of galaxies.

**The spacecraft.** The Hubble Space Telescope orbits Earth once every 96 minutes. At its core is a reflecting telescope with a primary mirror 2.4 m (94.5 in.) in diameter (Fig. 1). The primary mirror directs light from astronomical objects to a 30-cm (12-in.) secondary mirror, which then bounces it back through a hole at the center of the primary mirror to the scientific instruments. The optical design is a Ritchey-Chrétien variant of a Cassegrain telescope.

Hubble's optical system enables the telescope to record astronomical images with unprecedented precision in the optical, ultraviolet, and infrared spectral bands. In order to take full advantage of the clearer view above Earth's atmosphere, Hubble's mirrors had to be polished until they were extremely smooth: The largest bumps on Hubble's primary mirror are analogous to the height of a baseball on a surface as wide as the continental United States. A flaw in the overall shape of the primary mirror hampered observations for several years after launch. However, because the primary mirror was so smooth, corrective optics installed in 1993 were able to realize Hubble's expected performance (Fig. 2). Its angular resolution of 0.05 arcsecond at optical wavelengths is equivalent to being able to distinguish two fireflies 1 m (3 ft) apart at a distance of 5000 km (3000 mi). See INFRARED ASTRONOMY; TELESCOPE; ULTRAVIOLET ASTRONOMY.

Hubble's complement of scientific instruments handles a wide range of observational tasks. Its cameras can record images of astronomical objects at wavelengths ranging from 115 to 2500 nanometers. Hubble's spectrographs can analyze the spectra of these objects between wavelengths of 115 and 1030 nm. Because these instruments can be removed and replaced, they have been upgraded several times during Hubble's stay in orbit.

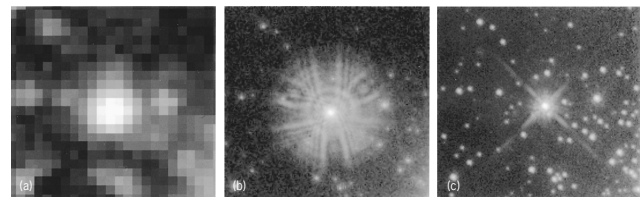

Fig. 2. Comparison of images of a field of stars in the 30 Doradus Nebula. (a) Ground-based image obtained under conditions of good seeing. (b) Same star field at the same scale taken with the Hubble Space Telescope before the first servicing mission. (c) Hubble image after the first servicing mission when the spherical aberration was corrected. (NASA)

A diverse assortment of support equipment surrounds the telescope and its scientific instruments.

**Highlights of Hubble science.** The Hubble Space Telescope's contributions to astronomy are numerous and wide-ranging. The following are a few of the most notable.

Hubble's high resolution has enabled the study of individual Cepheid variable stars in distant galaxies and the measurement of distances to galaxies up to 100 million light-years away. From the distances to these galaxies and the speeds at which they are moving away from each other, astronomers can calculate how long it took for galaxies to reach their current positions. See CEPHEIDS; COSMOLOGY; HUBBLE CONSTANT.

Images such as the Hubble Deep Field reveal a multitude of galaxies, some of them over 10 billion light-years away. Many of them appear quite strange and distorted in comparison to present-day galaxies, leading astronomers to believe that disruptive collisions between galaxies were much more common early in time than they are now. See GALAXY, EXTERNAL.

Observations of clouds in which stars are currently forming show that brand-new stars are generally surrounded by disks of gas and tiny, solid particles called dust grains. The gas and dust in at least some of these disks are eventually expected to clump into planets similar to those that orbit the Sun. See SOLAR SYSTEM; STAR; STELLAR EVOLUTION. [M.V.]

**Space-time** A term used to denote the geometry of the physical universe as suggested by the theory of relativity. It is also called space-time continuum. Whereas in Newtonian physics space and time had been considered quite separate entities, A. Einstein and H. Minkowski showed that they are actually intimately intertwined.

Einstein showed that in general two observers, each using the same techniques of observation but being in motion relative to each other, will disagree concerning the simultaneity of distant events. But if they do disagree, they are also unable to compare unequivocally the rates of clocks moving in different ways, or the lengths of scales and measuring rods. Instead, clock rates and scale lengths of different observers and different frames of reference must be established so as to assure the principal observed fact. Each observer, using his or her own clocks and scales, must measure the same speed of propagation of light. This requirement leads to a set of relationships known as the Lorentz transformations. See LORENTZ TRANSFORMATIONS.

In accordance with the Lorentz transformations, both the time interval and the spatial distance between two events are relative quantities, depending on the state of motion of the observer who carries out the measurements. There is, however, a new absolute quantity that takes the place of the two former quantities. It is known as the invariant, or proper, space-time interval  $\tau$  and is defined by Eq. (1), where  $T$  is the ordinary time interval,  $R$

$$\tau^2 = T^2 - \frac{1}{c^2}R^2 \quad (1)$$

the distance between the two events, and  $c$  the speed of light in empty space. Whereas  $T$  and  $R$  are different for different observers,  $\tau$  has the same value. In the event that Eq. (1) would render  $\tau$  imaginary, its place may be taken by  $\sigma$ , defined by Eq. (2). If both  $\tau$  and  $\sigma$  are zero, then a light signal leaving the

$$\sigma^2 = R^2 - c^2T^2 \quad (2)$$

location of one event while it is taking place will reach the location of the other event precisely at the instant the signal from the latter is coming forth.

The existence of a single invariant interval led the mathematician Minkowski to conceive of the totality of space and time as a single four-dimensional continuum, which is often referred to as the Minkowski universe. In this universe, the history of a single space point in the course of time must be considered as a curve (or line), whereas an event, limited both in space and time, represents a point. So that these geometric concepts in the Minkowski universe may be distinguished from their analogs in

ordinary three-dimensional space, they are referred to as world curves (world lines) and world points, respectively. See GRAVITATION; RELATIVITY. [P.G.B.]

**Spacecraft ground instrumentation** Instrumentation located on the Earth for monitoring, tracking, and communicating with satellites, space probes, and crewed spacecraft. Radars, communication antennas, and optical instruments are classified as ground instrumentation. They are deployed in networks and, to a lesser extent, in ranges. Ranges are relatively narrow chains of ground instruments used to follow the flights of missiles, sounding rockets, and spacecraft ascending to orbit. Some ranges are a few miles long; others, such as the U.S. Air Force's Eastern Test Range, stretch for thousands of miles. Networks, in contrast, are dispersed over wide geographical areas so that their instruments can follow satellites in orbit as the Earth rotates under them at 15° per hour, or space probes on their flights through deep space.

Networks are of two basic kinds: networks supporting satellites in Earth orbit, and networks supporting spacecraft in deep space far from Earth. A third concept was added in the 1980s with the Tracking and Data Relay Satellite System (TDRSS), also called the Space Network (SN). TDRSS replaced most of the ground stations used for Earth orbital support. The *Tracking and Data Relay Satellites (TDRS)* are placed in geosynchronous orbits to relay signals to and from other orbiting spacecraft during more than 85% of each orbit, to and from a single ground station.

Ranges and networks have various technical functions:

1. Tracking: determination of the positions and velocities of space probes and satellites through radio and optical means.
2. Telemetry: reception of telemetered signals from scientific instruments and spacecraft housekeeping functions.
3. Voice reception and transmission: provision for communication with the crew of a spacecraft, such as the space shuttle.
4. Command: transmission of coded commands to spacecraft equipment, including scientific instruments.
5. Television reception and transmission: provision for observation of the crew, spacecraft environment, and so on.
6. Ground communications: telemetry, voice, television, command, tracking data, and spacecraft acquisition data transmission between network sites and the central mission control center, and payload information to user facilities.
7. Computing: calculation of orbital elements and radar acquisition data prior to transmission to users; also, computation of the signals that drive visual displays at a mission control center.

See SPACE COMMUNICATIONS; SPACE NAVIGATION AND GUIDANCE; TELEMETERING.

NASA operates two ground-based networks and the TDRSS. The ground-based networks are the Spaceflight Tracking and Data Network (STDN), which tracks, commands, and receives telemetry from United States and foreign satellites in Earth orbit; and the Deep Space Network (DSN), which performs the same functions for all types of spacecraft sent to explore deep space, the Moon, and solar system planets. The TDRSS provides the same support to Earth orbital spacecraft as the STDN. The U.S. Department of Defense operates two classified networks: the Satellite Control Facility (SCF); and the National Range Division Stations, which include those of all United States military ranges. Russia and the European Space Agency (ESA) also maintain similar networks.

The Laser Tracking Network consists of a series of both fixed and mobile laser systems used for ranging to retroreflector-equipped satellites in highly stable orbits. Laser stations obtain ranging data for these satellites by bouncing a highly concentrated pulse of laser light off the retroreflector corner cube installed on the spacecraft exterior. The exact position of the spacecraft in orbit can then be mathematically determined for a given point in time. By comparing several ranging operations,

orbital predictions can be interpolated and extrapolated. The resultant data have a variety of applications, such as precise prediction of satellite orbit and measurement of the Earth's gravitational field, polar motion, earth tides, Earth rotation, tectonic plate motion, and crustal motion to accuracies within the centimeter range. The Laser Tracking Network is a multinational cooperative effort with over 30 laser sites located in North and South America, Europe, China, Japan, and Australia. [H.W.Wo.]

**Spacecraft propulsion** A system that provides control of location and attitude of spacecraft by using rocket engines to generate motion. Spacecraft propulsion systems come in various forms depending on the specific mission requirements. Each exhibits considerable variation in such parameters as thrust, specific impulse, propellant mass and type, pressurization schemes, cost, and materials. All of these variables must be considered in deciding which propulsion system is best suited to a given mission. Typical spacecraft applications include communications satellites, science and technology spacecraft, and Earth-monitoring missions such as weather satellites. Orbital environments range from low-Earth to geosynchronous to interplanetary. See ASTRONAUTICAL ENGINEERING; ROCKET PROPULSION; SATELLITE (SPACECRAFT); SPACE FLIGHT; SPACE PROBE; SPECIFIC IMPULSE; THRUST.

The two fundamental variables that define the design of spacecraft propulsion systems are the total velocity change to be imparted to the spacecraft for translational purposes, and the impulse necessary to counteract the various external torques imposed on the spacecraft body. From these, the required quantity of a given propellant combination can be specified. Propellant accounts for almost 60% of the lift-off mass of a communications satellite.

The specific impulse has a significant effect on the total propellant load that a spacecraft must carry to perform its assigned mission. Since a massive satellite must be boosted into space by the use of expensive launch vehicles, such as the space shuttle and Ariane, significant cost savings may be gained if smaller, less expensive launch vehicles may be used. The size of the required launch vehicle is directly proportional to the mass of the payload. Since most of the other components that make up spacecraft are relatively fixed in weight, it is critical to utilize propellant combinations that maximize specific impulse.

For modern spacecraft the choices are either bipropellants, which utilize a liquid oxidizer and a separate liquid fuel; solid propellants, which consist of oxidizer and fuel mixed together; or monopropellants, which are liquid fuels that are easily dissociated by a catalyst into hot, gaseous reaction products. High specific impulse is offered by bipropellants, followed by solid propellants and monopropellants.

Spacecraft attitude control schemes play an important role in defining the detailed characteristics of spacecraft propulsion systems. Essentially, there are three methods for stabilizing a spacecraft: three-axis control, spin control, and gravity gradient. In three-axis systems the body axes are inertially stabilized with reference to the Sun and stars, and utilize rocket engines for control in all six degrees of freedom. Spin-stabilized spacecraft use the inertial properties of a gyroscope to permanently align one of the axes by rotating a major portion of the spacecraft body about this axis. This approach significantly reduces the number of thrusters needed for control. Gravity gradient control is a nonactive technique that relies on the Earth's tidal forces to permanently point a preferred body axis toward the Earth's center. See GYROSCOPE; INERTIAL GUIDANCE SYSTEM; SPACECRAFT STRUCTURE.

Translation of a spacecraft, independent of its control technique, requires thrusters aligned parallel to the desired translational axis. Usually, all three axes require translational capability. Combining the two requirements for attitude control and translation results in the minimum number of rocket engines required to perform the mission. These are supplemented with additional thrusters to allow for failures without degrading the performance of the propulsion system. Simplistically, it would be reasonable to assume that the propellant-engine combination with the highest

specific impulse would be the preferable choice. However, the ultimate requirement is the lowest possible mass for the entire propulsion system. The complexity of the system is greatly influenced by, and is roughly proportional to, the specific impulse, since bipropellants require more tanks, valves, and so forth than either solid systems or monopropellant systems. This is primarily due to the differences in density between liquids and solids, and the fact that bipropellants require high-pressure gas sources to expel the fluid from the tanks and into the rocket engine chamber. For communications satellites in the lift-off weight range of 3000 lbm (1360 kg), the trade-off between specific impulse and system mass dictates the use of a solid rocket motor for the main-orbit circularizing burn and a monopropellant propulsion system for on-orbit attitude control and translation. Spacecraft launch masses above about 5000 lbm (2268 kg) require the use of all-bipropellant systems. [K.D.]

**Spacecraft structure** The supporting structure for systems capable of leaving the Earth and its atmosphere, performing a useful mission in space, sometimes returning to the Earth and sometimes landing on other bodies. Among the principal technologies that enter into the design of spacecraft structures are aerodynamics, aerothermodynamics, heat transfer, structural mechanics, structural dynamics, materials technology, and systems analysis. In applying these technologies to the structural design of a spacecraft, trade studies are made to arrive at a design which fulfills system requirements at a minimum weight with acceptable reliability and which is capable of being realized in a reasonable period of time.

The structural aspects of space flight can be divided into six broad regions or phases: (1) transportation, handling, and storage; (2) testing; (3) boosting; (4) Earth-orbiting flight; (5) reentry, landing, and recovery on the Earth; (6) interplanetary flight with orbiting of or landing on other planets. Each phase has its own structural design criteria requiring detailed consideration of heat, static loads, dynamic loads, rigidity, vacuum effects, radiation, meteoroids, acoustical loads, atmospheric pressure loads, foreign atmospheric composition, solar pressure, fabrication techniques, magnetic forces, sterilization requirements, accessibility for repair, and interrelation of one effect with the others. Heavy reliance is placed on computer-generated mathematical models and ground testing.

The basic spacecraft structural design considerations apply equally well to both crewed and crewless spacecraft. The degree of reliability of the design required is, however, much greater for crewed missions. Also, the spacecraft structures in the case of crewed missions must include life-support systems and reentry and recovery provisions. In the case of lunar or planetary missions where landing on and leaving the foreign body are required, additional provisions for propulsion, guidance, control, spacecraft sterilization, and life-support systems must be realized, and the structure must be designed to accommodate them.

**Testing.** To ensure that spacecraft structures will meet mission requirements criteria in general requires testing to levels above the expected environmental conditions by a specific value. The test level must be set to provide for variations in materials, manufacture, and anticipated loads. In cases where structures are required to perform dynamic functions repeatedly, life testing is required to ensure proper operation over a given number of cycles of operation. See INSPECTION AND TESTING.

**Boost.** The purpose of the boost phase is to lift the vehicle above the sensible atmosphere, to accelerate the vehicle to the velocity required, and to place the spacecraft at a point in space, heading in the direction required for the accomplishment of its mission. For space missions, the required velocities range from 26,000 ft/s (8 km/s) for nearly circular Earth orbits to 36,000 ft/s (11 km/s) for interplanetary missions. Achievement of these velocities requires boosters many times the size of the spacecraft itself. Generally, this boosting is accomplished by a chemically powered rocket propulsion system using liquid or solid propellants. Multiple stages are required to reach the velocities for space

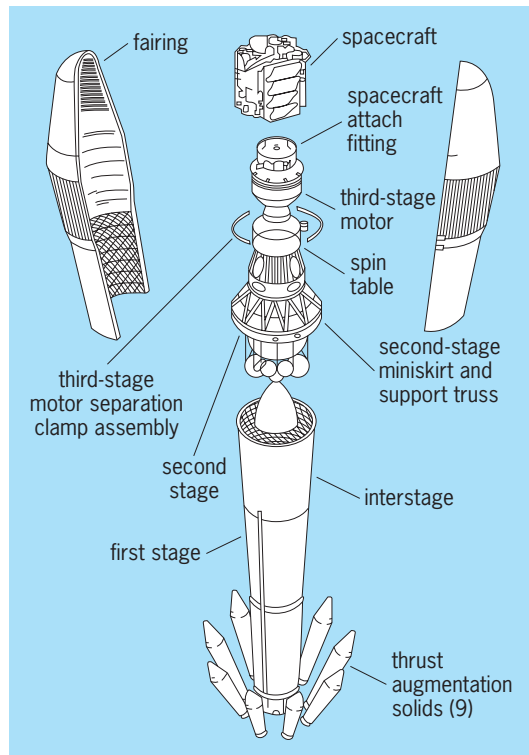

**Exploded view of typical Delta II 7925 three-stage structure.**  
*(After Commercial Delta II Payload Planners Guide, McDonnell Douglas Commercial Delta Inc., 1990)*

missions. Vertical takeoff requires a thrust or propulsive force that exceeds the weight of the complete flight system by approximately 30%. An example of a multiple-stage booster is the Delta launch vehicle used for the crewless missions (see illustration). The Delta II 7925 vehicle has the capability to place 4000 lb (1800 kg) into a geosynchronous transfer orbit. See INTERPLANETARY PROPULSION; PROPELLANT; ROCKET PROPULSION.

**Space phase and design considerations.** The space phase begins after the boost phase and continues until reentry. In this phase, the structures that were stowed for launch are deployed. Important design considerations include control system interaction, thermally induced stress, and minimization of jitter and creaks.

The spacecraft control system imparts inertial loads throughout the structure. In the zero gravity environment, every change in loading or orientation must be reacted through the structure.

Spacecraft structural design usually requires that part of the principal structure be a pressure vessel. Efficient pressure vessel design is therefore imperative. An important material property, especially in pressure vessel design, is notch sensitivity. Notch sensitivity refers to the material's brittleness under biaxial strain. This apparent brittleness contributed to premature failure of some early boosters. See PRESSURE VESSEL.

Meteoroid particles may have extremely high velocities relative to the spacecraft (up to 225,000 ft/s or 68 km/s). Orbital debris also include residual particles resulting from human space-flight activities. Collisions involving these bodies and a space station and other long-duration orbiting spacecraft are inevitable. The worst-case effects of such collisions include the degradation of performance and the penetration of pressure vessels, including high-pressure storage tanks and habitable crew modules. An essential parameter in the design of these structures is the mitigation of these effects. See METEOR.

Radiation shielding is required for some vehicles, particularly those operating for extended times within the Earth's magnetically trapped radiation belts or during times of high sunspot activity. The shielding may be an integral part of the structure. Computer memories are particularly susceptible to radiation and

cosmic-ray activity and must be shielded to survive. Effects of radiation on most metallic structures over periods of 10–20 years is not severe. The durability of composite structures in space is a major concern for long life. Based on available data, the synergistic effects of vacuum, heat, ultraviolet, and proton and electron radiation degrade the mechanical, physical, and optical properties of polymers.

Temperature extremes in the structure and the enclosed environment are controlled by several techniques. Passive control is accomplished by surface coatings and multilayer thermal blankets which control the radiation transfer from the spacecraft to space and vice versa. Because incident solar radiation varies inversely with the square of distance from the Sun, means of adjusting surface conditions are required for interplanetary missions. Heat generated by internal equipment or other sources must be considered in the heat balance design. Other techniques used to actively control spacecraft temperatures are thermal louvers and heat pipes. See HEAT PIPE.

Thermal gradients must be considered in spacecraft design, especially when the spacecraft has one surface facing the Sun continuously. In some cases it is desirable to slowly rotate the spacecraft to eliminate such gradients.

Spacecraft structures usually are required to be lightweight and rigid, which results in the selection of high-modulus materials. Titanium and beryllium have low densities and relatively high modulus-density ratios. Alloys of these metals are relatively difficult to fabricate, and therefore their application is quite limited. The more common aluminum, magnesium, and stainless steel alloys are basic spacecraft structural materials. They are easy to fabricate, relatively inexpensive, and in general quite suitable for use in the space environment. Plastics are used in spacecraft structures when radio-frequency or magnetic isolation is required. They are also used in situations where some structural damping is desired.

The modern requirements for low weight, high strength, high stiffness, and low thermal expansion (for precision optical pointing) have prompted the use of composite materials for spacecraft structure. These materials consist of high-strength reinforcement fibers which are supported by a binder material referred to as the matrix. The fibers are typically made of glass, graphite, or carbon, and the matrix is an epoxy resin. See COMPOSITE MATERIAL.

**Reentry phase.** Although the atmospheric layer of the Earth is relatively thin, it is responsible for the reduction of vehicle velocity and the resulting deceleration loads, as well as for the severe heating experienced by reentering vehicles. A body entering the Earth's atmosphere possesses a large amount of energy. This energy must be dissipated in a manner which allows the reentering vehicle to survive. Most of the vehicle's original energy can be transformed into thermal energy in the air surrounding the vehicle, and only part of the original energy is retained in the vehicle as heat. The fraction that appears as heat in the vehicle depends upon the characteristics of the flow around the vehicle. In turn, the flow around the vehicle is a function of its geometry, attitude, velocity, and altitude. See ATMOSPHERIC ENTRY.

Spacecraft are seldom designed to reenter the Earth's atmosphere (the space shuttle being an exception), but may be designed to enter extraterrestrial atmospheres. In either case, the structural design is similar.

High-speed reentry causes extreme friction and heat buildup on spacecraft that must be dissipated by using high-temperature ceramic or ablative materials. The space shuttle is covered with special thermal insulating tiles that allow the structural elements to remain cool when the surface reaches 1200°F (650°C), and its leading edges are protected by a carbon-carbon reinforced material that can withstand temperatures as high as 2300°F (1260°C).

Satellites whose orbits decay into the Earth's upper atmosphere become flaming objects as they rapidly descend. Generally, most or all of the satellite is consumed before it reaches the surface, but there are exceptions such as the March 22, 2001, reentry of the Russian space station, *Mir*.



In crewed applications, vehicles employing aerodynamic lift during reentry have several advantages over zero-lift ballistic bodies: (1) The use of lift allows a more gradual descent, thus reducing the deceleration forces on both vehicle and occupants. (2) The vehicle's ability to glide and maneuver within the atmosphere gives it greater accuracy in either hitting a target or landing at a predetermined spot. (3) It can accommodate greater errors of guidance systems because for a given deceleration it can tolerate a greater range of entry angles. (4) Greater temperature control is afforded because aerodynamic lift may be varied to control altitude with velocity.

**Structures.** Erectable structures take many and varied shapes. They are sometimes relatively simple hinged booms, while on other occasions they become quite large and massive. Many more spacecraft structures are rigid than erectable or inflatable.

The space shuttle or Space Transportation System (STS) can carry 65,000 lb (30,000 kg) of cargo to and from low Earth orbit. See SPACE SHUTTLE.

The International Space Station (ISS) is a cooperative, 16-nation effort. It will include six laboratories and weigh a million pounds when assembled. See COMMUNICATIONS SATELLITE; METEOROLOGICAL SATELLITES; MILITARY SATELLITES; SATELLITE NAVIGATION SYSTEMS; SCIENTIFIC SATELLITES; SPACE STATION. [W.Hai.; P.S.W.]

**Spallation reaction** A nuclear reaction that can take place when two nuclei collide at very high energy (typically 500 MeV per nucleon and up), in which the involved nuclei are either disintegrated into their constituents (protons and neutrons), light nuclei, and elementary particles, or a large number of nucleons are expelled from the colliding system resulting in a nucleus with a smaller atomic number. This mechanism is clearly different from fusion reactions induced by heavy or light ions with modest kinetic energy (typically 5 MeV per nucleon) where, after formation of a compound nucleus, only a few nucleons are evaporated. A spallation reaction can be compared to a glass that shatters in many pieces when it falls on the ground. The way that the kinetic energy is distributed over the different particles involved in a spallation reaction and the process whereby this results in residues and fluxes of outgoing particles are not well understood. See NUCLEAR FUSION.

Spallation reactions take place in interstellar space when energetic cosmic rays (such as high-energy protons) collide with interstellar gas, which contains atoms such as carbon, nitrogen, and oxygen. This leads to the synthesis of light isotopes, such as  ${}^6\text{Li}$ ,  ${}^9\text{Be}$ ,  ${}^{10}\text{Be}$ , and  ${}^{11}\text{B}$ , that cannot be produced abundantly in nucleosynthesis scenarios in the big bang or stellar interiors. See BIG BANG THEORY; NUCLEOSYNTHESIS.

In terrestrial laboratories spallation reactions are initiated by bombarding targets with accelerated light- or heavy-ion beams, and they are used extensively in basic and applied research, such as the study of the equation of state of nuclear matter, production of energetic neutron beams, and radioactive isotope research. See NEUTRON DIFFRACTION; RELATIVISTIC HEAVY-ION COLLISIONS; SLOW NEUTRON SPECTROSCOPY. [P.V.D.]

**Spark gap** The region between two electrodes in which a disruptive electrical spark may take place. The gap should be taken to mean the electrodes as well as the intervening space. Such devices may have many uses. The ignition system in a gasoline engine furnishes a very important example. Another important case is the use of a spark gap as a protective device in electrical equipment. Here, surges in potential may be made to break down such a gap so that expensive equipment will not be damaged. See BREAKDOWN POTENTIAL; ELECTRIC SPARK. [G.H.M.]

**Spark knock** The sound and related effects produced in spark-ignited internal combustion engines by instantaneous ignition and combustion (autoignition) of the gaseous fuel-air mixture ahead of the advancing flame front.

After spark ignition, a flame travels outward from the spark plug and, under normal combustion, will progressively burn the entire fuel-air charge. The burned gas liberates heat and expands, leading to increased pressure and temperature in the unburned gas ahead of the flame front. The unburned gas may be raised above its autoignition temperature. If the flame front velocity is too small the unburned gas spontaneously ignites and burns instantaneously. The instantaneous combustion results in a very intense pressure wave that produces the audible, high-frequency (pinging) sound known as spark knock. See COMBUSTION CHAMBER; EXPLOSIVE.

Besides sound, spark knock can result in pitting, or erosion, of the combustion chamber, damage to spark plug electrodes, and possible structural damage to the engine. Spark knock also leads to loss of engine efficiency by inducing spark plug preignition, resulting in overly advanced spark timing. Spark knock also causes intense turbulence within the cylinder, aggravating heat loss from the burned gas to the colder cylinder and head surfaces and reducing efficiency. See AUTOMOTIVE ENGINE; COMBUSTION; INTERNAL COMBUSTION ENGINE. [J.R.As.; D.L.An.]

**Spark plug** A device that screws into the combustion chamber of an internal combustion engine to provide a pair of electrodes between which an electrical discharge is passed to ignite the combustible mixture. The spark plug consists of an outer steel shell that is electrically grounded to the engine and a ceramic insulator, sealed into the shell, through which a center electrode passes (see illustration). The high-voltage current jumps the gap between the center electrode and the ground electrode fixed to the outer shell.

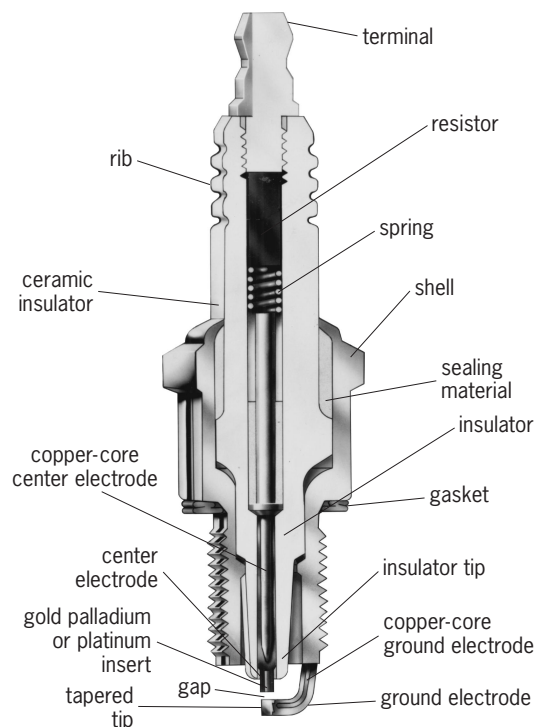

Cross section of a typical spark plug. (Champion Spark Plug Co.)

The electrodes are made of nickel and chrome alloys that resist electrical and chemical corrosion. Some center electrodes have a copper core, while others have a platinum tip. Many spark plugs have a resistor in the center electrode to help prevent radio-frequency interference. The parts exposed to the combustion gases are designed to operate at temperatures hot enough to prevent electrically conducting deposits but cool enough to avoid ignition of the mixture before the spark occurs. See IGNITION SYSTEM. [D.L.An.]

**Spatangoida** An order of exocyclic Euechinoidea in which the posterior ambulacral plates form a shield-shaped area behind the mouth. The plates are arranged in two similar parallel longitudinal series. The apical system is compact. The families are defined mainly by reference to the fascicles, which are ribbonlike bands of minute, close-set uniform ciliated spinules on various parts of the test. The order reached its maximum in the mid-Tertiary, but is still richly represented today in most seas. See EUECHINOIDEA. [H.B.F.]

**Spearmint** Either of two vegetatively propagated, clonal cultivar species (*Mentha spicata* and *M. longifolia*) of mints of the family Lamiaceae (Labiatae). They are grown primarily in Idaho, Indiana, Michigan, Washington, and Wisconsin as a source of essential oil of spearmint.

Principal uses of the oil are in flavoring gum, toothpaste, and candy. Chopped fresh leaves of *M. spicata* preserved in vinegar are used as a condiment served with lamb, especially in England, and dried or freeze-dried leaves of several strains are used in flavoring soups, stews, tea, or sauces. Sprigs of the decorative curly mint *M. crispata* (or *M. spicata* var. *crispata*) are often used in mixed drinks such as mint juleps. See LAMIALES. [M.J.M.]

**Special functions** Functions which occur often enough to acquire a name. Some of these, such as the exponential, logarithmic, and the various trigonometric functions, are extensively taught in school and occur so frequently that routines for calculating them are built into many pocket calculators. See DIFFERENTIATION; LOGARITHM; TRIGONOMETRY.

The more complicated special functions, or higher transcendental functions as they are often called, have been extensively studied by many mathematicians because they arose in the problems which were being studied. Among the more useful functions are the following: the gamma function defined by Eq. (1), which generalizes the factorial; the related beta function defined by Eq. (2), which generalizes the binomial coefficient;

$$\Gamma(x) = \int_0^{\infty} t^{x-1} e^{-t} dt \quad (1)$$

$$B(x, y) = \int_0^1 t^{x-1} (1-t)^{y-1} dt \quad (2)$$

and elliptic integrals, which arose when mathematicians tried to determine the arc length of an ellipse, and their inverses, the elliptic functions. The hypergeometric function and its generalizations includes many of the special functions which occur in mathematical physics, such as Bessel functions, Legendre functions, error functions, and the classical orthogonal polynomials of Jacobi, Laguerre, and Hermite. The zeta function defined by Eq. (3) has many applications in number theory, and it also

$$\zeta(s) = \sum_{n=1}^{\infty} n^{-s} \quad (3)$$

arises in M. Planck's work on radiation. See BESSEL FUNCTIONS; ELLIPTIC FUNCTION AND INTEGRAL; GAMMA FUNCTION; HEAT RADIATION; HYPERGEOMETRIC FUNCTIONS; LEGENDRE FUNCTIONS; NUMBER THEORY; ORTHOGONAL POLYNOMIALS. [R.A.]

**Speciation** The process by which new species of organisms evolve from preexisting species. It is part of the whole process of organic evolution. The modern period of its study began with the publication of Charles Darwin's and Alfred Russell Wallace's *Theory of Evolution by Natural Selection* in 1858, and Darwin's *On the Origin of Species* in 1859.

Belief in the fixity of species was almost universal before the middle of the nineteenth century. Then it was gradually realized that all species continuously change, or evolve; however, the causative mechanism remained to be discovered. Darwin proposed a mechanism. He argued that (1) within any species

population there is always some heritable variation; the individuals differ among themselves in structure, physiology, and behavior; and (2) natural selection acts upon this variation by eliminating the less fit. Thus if two members of an animal population differ from each other in their ability to find a mate, obtain food, escape from predators, resist the ravages of parasites and pathogens, or survive the rigors of the climate, the more successful will be more likely than the less successful to leave descendants. The more successful is said to have greater fitness, to be better adapted, or to be selectively favored. Likewise among plants: one plant individual is fitter than another if its heritable characteristics make it more successful than the other in obtaining light, water, and nutrients, in protecting itself from herbivores and disease organisms, or in surviving adverse climatic conditions. Over the course of time, as the fitter members of a population leave more descendants than the less fit, their characteristics become more common.

This is the process of natural selection, which tends to preserve the well adapted at the expense of the ill adapted in a variable population. The genetic variability that must exist if natural selection is to act is generated by genetic mutations in the broad sense, including chromosomal rearrangements together with point mutations. See GENETICS; MUTATION.

If two separate populations of a species live in separate regions, exposed to different environments, natural selection will cause each population to accumulate characters adapting it to its own environment. The two populations will thus diverge from each other and, given time, will become so different that they are no longer interfertile. At this point, speciation has occurred: two species have come into existence in the place of one. This mode of speciation, speciation by splitting, is probably the most common mode. Two other modes are hybrid speciation and phyletic speciation; many biologists do not regard the latter as true speciation.

Many students of evolution are of the opinion that most groups of organisms evolve in accordance with the punctuated equilibrium model rather than by phyletic gradualism. There are two chief arguments for this view. First, it is clear from the fossil record that many species persist without perceptible change over long stretches of time and then suddenly make large quantum jumps to radically new forms. Second, phyletic gradualism seems to be too slow a process to account for the tremendous proliferation of species needed to supply the vast array of living forms that have come into existence since life first appeared on Earth. See ANIMAL EVOLUTION; POPULATION GENETICS; SPECIES CONCEPT. [E.C.P.]

**Species concept** The species is the fundamental unit of organization of the taxonomic system; of interactions between organisms as described by geneticists and ecologists; and of evolution as studied by phylogeneticists. As a category the term species resists definition; thus, a species concept is adopted as a framework within which biologists of various persuasions delineate the taxa with which they work at the species level. However, no universal concept has been accepted by all biologists for two fundamental reasons: (1) Different groups of organisms in nature are organized differently in terms of reproductive mechanisms and patterns; in degrees of differentiation among species in morphological, genetic, physiological, behavioral, biochemical, and other types of characters; and in the modes of speciation that have given rise to the members of the group. (2) The philosophy, training, working methods, and goals of different of biologists affect the manner in which each perceives the coherence or diversity of the biological world in general and that of the group of organisms in question in particular.

According to the taxonomic concept, a species consists of groups of individuals (populations) that are morphologically similar to one another, and differ morphologically from other such groups. There are several important ideas expressed in this concept. First, there is internal cohesiveness; that is, the members of

the species share certain characteristics. Second, there is external distinction because other species have different characteristics, and thus species may be distinguished from one another. Third, the characteristics that a species possesses may be easily observed because they are phenotypic; that is, a species may be identified by its appearance.

Difficulty in applying the taxonomic concept arises with certain groups of organisms. Bacteria are often identified by physiological and biochemical tests requiring sophisticated laboratories and equipment; in addition, the mutation rate in bacteria is so high that the various traits used to identify them can change rapidly. In insects, the morphological differences between species may be very slight and easily overlooked. In certain groups of plants, hybridization and polyploidy have led to a continuous range of variation of characters, in which no discontinuities sufficient to distinguish species can be discerned. Critics claim that the purely phenetic approach of the taxonomic concept may not reflect real genetic or breeding relationships. However, this concept provides guidelines by which species may be recognized by ordinary (nonexperimental) means. The composition of a species so recognized can then be subjected to hypothesis testing within the framework of other concepts. See BACTERIAL TAXONOMY; TAXONOMIC CATEGORIES.

According to the biological concept, a species is composed of groups of individuals (populations) that normally interbreed with one another. The fundamental ideas expressed by this concept are that the internal cohesiveness of a species is maintained by the exchange of genes through sexual reproduction (gene flow) and that the distinctness of the species is maintained by reproductive isolation (barriers to gene flow) from other groups of populations. If two populations do not exchange genes, they belong to separate species regardless of their morphological similarity.

This concept works well in those groups of organisms that are exclusively outbreeding, such as birds and mammals. However, it is difficult to apply to plants, in which interbreeding between morphologically very distinct species and even genera is common. Also, those organisms that do not reproduce sexually present problems of classification. Even in sexually reproducing organisms, populations that are morphologically identical but reproductively separated by geographic distance (disjuncts) present problems of classification within the framework of the concept. The populations might interbreed if they were in contact, but this can be determined only under artificial conditions and not in nature. However, the development of the biological species concept has contributed greatly to making taxonomy an evolutionary science because of its emphasis on the identification of genetic, rather than the very possibly superficial phenetic, relationship among organisms.

According to the evolutionary concept, a species is a lineage of ancestor-descendant populations that maintains its identity from other such lineages and that has its own evolutionary tendencies and historical fate. The important ideas expressed in this concept are the following. (1) All organisms, regardless of their mode of reproduction, belong to some evolutionary species. (2) Species need be reproductively isolated from one another to the extent that they maintain their distinction from other species. (3) There may or may not be a morphological discontinuity between species but, if there is, it is reasonable to hypothesize that more than one species is present. If there is not, other data such as that on breeding relationships may be used to recognize species.

The evolutionary concept encompasses the taxonomic concept, the biological concept, and other more narrowly defined concepts—for example, the ecological species, the genetic species, and the paleospecies. It is operational in that it provides guidelines for the recognition of species and for testing of hypotheses concerning membership in each species; it also is compatible with the Linnaean taxonomic hierarchy. As it becomes more widely used by working systematists, problems and

difficulties with the concept may appear that will require its refinement. However, the evolutionary concept may in the long run be more acceptable to a wider group of biologists than any other yet proposed. See TAXONOMY. [M.A.La.]

**Specific charge** The ratio of charge to mass expressed as  $e/m$ , of a particle. The acceleration of a particle in electromagnetic fields is proportional to its specific charge. Specific charge can be determined by measuring the velocity which the particle acquires in falling through an electric potential; by measuring the frequency of revolution in a magnetic field; or by observing the orbit of the particles in combined electric and magnetic fields. See ELEMENTARY PARTICLE. [C.J.G.]

**Specific fuel consumption** The ratio of the fuel mass flow of an aircraft engine to its output power, in specified units. Specific fuel consumption (abbreviated *sfc* or *SFC*) is a widely used measure of atmospheric engine performance. For reciprocating engines it is usually given in U.S. Customary units of pound-mass per hour per horsepower [(lbm/h)/hp or lbm/(hp·h)], and International System (SI) units of kilograms per hour per kilowatt [(kg/h)/kW]. See RECIPROCATING AIRCRAFT ENGINE.

For the gas turbine family of atmospheric aircraft engines, and for ramjets, performance is usually given in terms of thrust specific fuel consumption (abbreviated *tsfc* or *TSFC*) expressed as fuel mass flow per unit thrust output with Customary units of pound-mass per hour per pound-force [(lbm/h)/lbf] or SI units of kilograms per hour per newton [(kg/h)/N; 1 N equals approximately 0.225 lbf]. For high-supersonic and hypersonic ramjets, specific fuel consumption is sometimes given in pound-mass per second per pound-force [(lbm/s)/lbf] or kilograms per second per newton [(kg/s)/N]. See AIRCRAFT PROPULSION; JET PROPULSION; PROPULSION; RAMJET; TURBINE PROPULSION; TURBOJET. [J.P.L.]

**Specific gravity** The specific gravity of a material is defined as the ratio of its density to the density of some standard material, such as water at a specified temperature, for example, 60°F (15°C), or (for gases) air at standard conditions of temperature and pressure. Specific gravity is a convenient concept because it is usually easier to measure than density, and its value is the same in all systems of units. See DENSITY. [L.N.]

**Specific heat** A measure of the heat required to raise the temperature of a substance. When the heat  $\Delta Q$  is added to a body of mass  $m$ , raising its temperature by  $\Delta T$ , the ratio  $C$  given in Eq. (1) is defined as the heat capacity of the body. The quantity  $c$  defined in Eq. (2) is called the specific heat capacity or specific

$$C = \frac{\Delta Q}{\Delta T} \quad (1)$$

$$c = \frac{C}{m} = \frac{1}{m} \frac{\Delta Q}{\Delta T} \quad (2)$$

heat. A commonly used unit for heat capacity is joule · kelvin<sup>-1</sup> (J · K<sup>-1</sup>); for specific heat capacity, the unit joule · gram<sup>-1</sup> · K<sup>-1</sup> (J · g<sup>-1</sup> · K<sup>-1</sup>) is often used. Joule should be preferred over the unit calorie = 4.18 J. As a unit of specific heat capacity, Btu · lb<sup>-1</sup> · °F<sup>-1</sup> = 4.21 J · g<sup>-1</sup> · K<sup>-1</sup> is also still in use in English-language engineering literature. If the heat capacity is referred to the amount of substance in the body, the molar heat capacity  $c_m$  results, with the unit J · mol<sup>-1</sup> · K<sup>-1</sup>.

If the volume of the body is kept constant as the energy  $\Delta Q$  is added, the entire energy will go into raising its temperature. If, however, the body is kept at a constant pressure, it will change its volume, usually expanding as it is heated, thus converting some of the heat  $\Delta Q$  into mechanical energy. Consequently, its temperature increase will be less than if the volume is kept constant. It is therefore necessary to distinguish between these two processes, which are identified with the subscripts  $V$  (constant

volume) and  $p$  (constant pressure):  $C_V$ ,  $c_V$ , and  $C_p$ ,  $c_p$ . For gases at low pressures, which obey the ideal gas law, the molar heat capacities differ by  $R$ , the molar gas constant, as given in Eq. (3), where  $R = 8.31 \text{ J} \cdot \text{mol}^{-1} \cdot \text{K}^{-1}$ ; that is, the expanding gas heats up less.

$$c_p - c_V = R \quad (3)$$

For solids, the difference between  $c_p$  and  $c_V$  is of the order of 1% of the specific heat capacities at room temperature. This small difference can often be ignored. See CALORIMETRY; CHEMICAL THERMODYNAMICS; HEAT CAPACITY; SPECIFIC HEAT OF SOLIDS; THERMODYNAMIC PROCESSES. [R.O.P.]

**Specific impulse** The impulse produced by a rocket divided by the mass  $m_p$  of propellant consumed. Specific impulse  $I_{sp}$  is a widely used measure of performance for chemical, nuclear, and electric rockets. It is usually given in seconds for both U.S. Customary and International System (SI) units.

The impulse produced by a rocket is the thrust force  $F$  times its duration  $t$  in seconds. The specific impulse is given by the equation below. Its equivalent, specific thrust  $F_{sp}$ , that is sometimes

$$I_{sp} = \frac{Ft}{m_p} \quad (1)$$

used alternatively, is the rocket thrust divided by the propellant mass flow rate  $F/m_p$ . See IMPULSE (MECHANICS); THRUST.

Calculation of specific impulse for the various forms of electric rockets involves electrothermal, resistance or arc heating of the propellant or its ionization and acceleration to high jet velocity by electrostatic or electromagnetic body forces. Ions in the exhaust jets of these devices must be neutralized so the spacecraft will not suffer from space charging or other effects from the plumes of the devices' operation. See ELECTROTHERMAL PROPULSION; ION PROPULSION; PLASMA PROPULSION; ROCKET PROPULSION; SPACECRAFT PROPULSION. [J.PL.]

**Speckle** The generation of a random intensity distribution, called a speckle pattern, when light from a highly coherent source, such as a laser, is scattered by a rough surface or inhomogeneous medium. See LASER.

The surfaces of most materials are extremely rough on the scale of an optical wavelength (approximately  $5 \times 10^{-7} \text{ m}$ ). When nearly monochromatic light is reflected from such a surface, the optical wave resulting at any moderately distant point consists of many coherent wavelets, each arising from a different microscopic element of the surface. Since the distances traveled by these various wavelets may differ by several wavelengths if the surface is truly rough, the interference of the wavelets of various phases results in the granular pattern of intensity called speckle. If a surface is imaged with a perfectly corrected optical system, diffraction causes a spread of the light at an image point, so that the intensity at a given image point results from the coherent addition of contributions from many independent surface areas. As long as the diffraction-limited point-spread function of the imaging system is broad by comparison with the microscopic surface variations, many dephased coherent contributions add at each image point to give a speckle pattern.

The basic random interference phenomenon underlying laser speckle exists for sources other than lasers. For example, it explains radar "clutter," results for scattering of x-rays by liquids, and electron scattering by amorphous carbon films. Speckle theory also explains why twinkling may be observed for stars, but not for planets. See COHERENCE; DIFFRACTION; INTERFERENCE OF WAVES; TWINKLING STARS.

In metrology, the most obvious application of speckle is to the measurement of surface roughness. If a speckle pattern is produced by coherent light incident on a rough surface, then surely the speckle pattern, or at least the statistics of the speckle pattern, must depend upon the detailed surface properties. An application of growing importance in engineering is the use of

speckle patterns in the study of object displacements, vibration, and distortion that arise in nondestructive testing of mechanical components. [J.C.Wy.]

Astronomical speckle interferometry is a technique for obtaining spatial information on astronomical objects at the diffraction-limited resolution of a telescope, despite the presence of atmospheric turbulence. Speckle interferometry techniques have proven to be an invaluable tool for astronomical research, allowing studies of a wide range of scientifically interesting problems. They have been widely used to determine the separation and position angle of binary stars, and for accurate diameter measurements of a large number of stars, planets, and asteroids. Speckle imaging techniques have successfully uncovered details in the morphology of a range of astronomical objects, including the Sun, planets, asteroids, cool giants and supergiants, young stellar objects, the supernova SN1987A in the Large Magellanic Cloud, Seyfert galaxies, and quasars. See BINARY STAR; INTERFEROMETRY. [M.Ka.]

**Spectral type** An indicator of the physical and chemical characteristics of a star, based on study of the star's spectrum. Stars possess a remarkable variety of spectra, some simple, others complex. To understand the natures of the stars, it was first necessary to bring order to the subject and to classify the spectra.

The modern system of classification was initiated about 1890. The spectra were ordered by letter, A through O, largely on the basis of the strengths of the hydrogen lines. Several letters were found to be unnecessary or redundant, and on the basis of continuity of lines other than hydrogen, it was found that B preceded A and O preceded B. The result is the classical spectral sequence, OBAFGKM. The classes were decimalized, setting up the sequence O5, . . . , O9, B0, . . . , B9, A0, and so forth. (Not all the numbers are used.) The modern standard sequence, called the Harvard sequence after the observatory where it was formulated, runs from O3 to M9. Classes L and T were added to the sequence in 1999.

Class A has the strongest hydrogen lines, B is characterized principally by neutral helium (with weaker hydrogen), and O by ionized helium. Hydrogen weakens notably through F and G, but the metal lines, particularly those of ionized calcium, strengthen. In K, hydrogen becomes quite weak, while the neutral metals grow stronger. The M stars effectively exhibit no hydrogen lines at all but are dominated by molecules, particularly titanium oxide (TiO). L stars are dominated by metallic hydrides and neutral alkali metals, while T is defined as methane. At G, the sequence branches downward into R and N, whose stars are rich in carbon molecules. In class S, the titanium oxide molecular bands of class M are replaced by zirconium oxide (ZrO).

At first appearance, the different spectral types seem to reflect differences in stellar composition. However, within the sequence OBAFGKMLT the elemental abundances are roughly similar. The dramatic variations in spectra are strictly the result of changes in temperature. The different spectra of the R, N, and S stars, however, are caused by true and dramatic variations in the chemical composition, the result of internal thermonuclear processing and convection. See STELLAR EVOLUTION.

In the 1940s, W. W. Morgan, P. C. Keenan, and E. Kellman expanded the Harvard sequence to include luminosity. A system of roman numerals is appended to the Harvard class to indicate position on the Hertzsprung-Russell diagram: I for supergiant, II for bright giant, III for giant, IV for subgiant, and V for dwarf or main sequence. See ASTRONOMICAL CATALOGS; HERTZSPRUNG-RUSSELL DIAGRAM. [J.B.Ka.]

**Spectrograph** An optical instrument that consists of an entrance slit, collimator, disperser, camera, and detector and that produces and records a spectrum. A spectrograph is used to extract a variety of information about the conditions that exist where light originates and along the paths of light. It reveals the details that are stored in the light's spectral distribution, whether

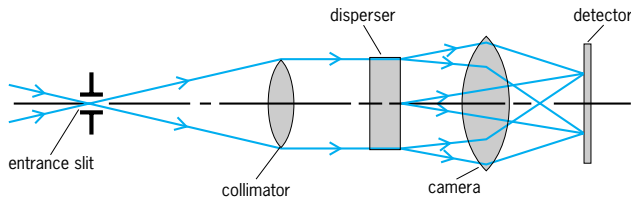

Basic optical components of a spectrograph.

this light is from a source in the laboratory or a quasistellar object a billion light-years away.

Spectrograph design takes into account the type of light source to be measured, and the circumstances under which these measurements will be made. Since observational astronomy presents unusual problems in these areas, the design of astronomical spectrographs may also be unique.

Astronomical spectrographs have the same general features as laboratory spectrographs (see illustration). The width of the entrance slit influences both spectral resolution and the amount of light entering the spectrograph, two of the most important variables in spectroscopy. The collimator makes this light parallel so that the disperser (a grating or prism) may properly disperse it. The camera then focuses the dispersed spectrum onto a detector, which records it for further study.

Laboratory spectrographs usually function properly only in a fixed orientation under controlled environmental conditions. By contrast, most astronomical spectrographs are used on a moving telescope operating at local temperature. Thus, their structures must be mechanically and optically insensitive to orientation and temperature.

The brightness, spectral characteristics, and geometry of laboratory sources may be tailored to experimental requirements and to the capabilities of a spectrograph. Astronomical sources, in the form of images at the focus of a telescope, cannot be manipulated, and their faintness and spectral diversity make unusual and difficult demands on spectrograph performance.

Typical laboratory spectrographs use either concave gratings, which effectively combine the functions of collimator, grating, and camera in one optical element, or plane reflection gratings with spherical reflectors for collimators and cameras. See ASTRONOMICAL SPECTROSCOPY. [R.Hi.]

**Spectroheliograph** A spectrographic instrument that produces mono-chromatic images of the Sun. In a simple form of the instrument, an image of the Sun from a solar telescope is focused on a plane containing the entrance slit of the spectroheliograph (see illustration). The light passing through the slit is collimated by a concave mirror that is tilted such that the light is incident on a plane diffraction grating. Part of the dispersed light from the grating is focused by a second concave mirror, identical to the first mirror, at an exit slit identical to the entrance slit. By symmetry of the optical system, the portion of the solar disk imaged on the entrance slit is reimaged in the plane of the exit slit with the same image scale but in dispersed wavelength. The light imaged along the exit slit then corresponds to the por-

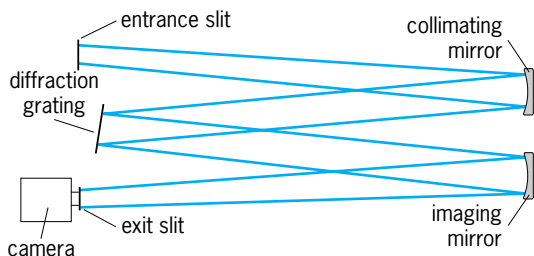

Optical configuration of a simple spectroheliograph.

tion of the solar image falling on the entrance slit, but in the light of only a narrow region of the spectrum, as determined by the spectrographic dispersion. The particular wavelength sampled is set by the grating angle. By uniform transverse motion of the instrument such that the entrance slit is scanned across the solar image, the light passing through the exit slit maps out a corresponding monochromatic image of the Sun, which can be recorded photographically with a stationary camera or digitally by sequential readout of a linear array that moves with the exit slit. See ASTRONOMICAL SPECTROSCOPY; DIFFRACTION GRATING; SUN. [R.N.Sm.]

**Spectroscopy** An analytic technique concerned with the measurement of the interaction (usually the absorption or the emission) of radiant energy with matter, with the instruments necessary to make such measurements, and with the interpretation of the interaction both at the fundamental level and for practical analysis.

A display of such data is called a spectrum, that is, a plot of the intensity of emitted or transmitted radiant energy (or some function of the intensity) versus the energy of that light. Spectra due to the emission of radiant energy are produced as energy is emitted from matter, after some form of excitation, then collimated by passage through a slit, then separated into components of different energy by transmission through a prism (refraction) or by reflection from a ruled grating or a crystalline solid (diffraction), and finally detected. Spectra due to the absorption of radiant energy are produced when radiant energy from a stable source, collimated and separated into its components in a monochromator, passes through the sample whose absorption spectrum is to be measured, and is detected. Instruments which produce spectra are variously called spectroscopes, spectrometers, spectrographs, and spectrophotometers. See SPECTRUM.

Interpretation of spectra provides fundamental information on atomic and molecular energy levels, the distribution of species within those levels, the nature of processes involving change from one level to another, molecular geometries, chemical bonding, and interaction of molecules in solution. At the practical level, comparisons of spectra provide a basis for the determination of qualitative chemical composition and chemical structure, and for quantitative chemical analysis.

**Origin of spectra.** Atoms, ions, and molecules emit or absorb characteristically; only certain energies of these species are possible; the energy of the photon (quantum of radiant energy) emitted or absorbed corresponds to the difference between two permitted values of the energy of the species, or energy levels. (If the flux of photons incident upon the species is great enough, simultaneous absorption of two or more photons may occur.) Thus the energy levels may be studied by observing the differences between them. The absorption of radiant energy is accompanied by the promotion of the species from a lower to a higher energy level; the emission of radiant energy is accompanied by falling from a higher to a lower state; and if both processes occur together, the condition is called resonance.

**Instruments.** Spectroscopic methods involve a number of instruments designed for specialized applications.

An optical instrument consisting of a slit, collimator lens, prism or grating, and a telescope or objective lens which produces a spectrum for visual observation is called a spectroscope.

If a spectroscope is provided with a photographic camera or other device for recording the spectrum, the instrument is called a spectrograph.

A spectroscope that is provided with a calibrated scale either for measurement of wavelength or for measurement of refractive indices of transparent prism materials is called a spectrometer.

A spectrophotometer consists basically of a radiant-energy source, monochromator, sample holder, and detector. It is used for measurement of radiant flux as a function of wavelength and for measurement of absorption spectra.

An interferometer is an optical device that measures differences of geometric path when two beams travel in the same medium, or the difference of refractive index when the geometric paths are equal. Interferometers are employed for high-resolution measurements and for precise determination of relative wavelengths. See INTERFEROMETRY.

**Methods and applications.** Since the early methods of spectroscopy there has been a proliferation of techniques, often incorporating sophisticated technology.

Acoustic spectroscopy uses modulated radiant energy that is absorbed by a sample. The loss of that excess produces a temperature increase that can be monitored around the sample by using a microphone transducer. This is the optoacoustic effect. See PHOTOACOUSTIC SPECTROSCOPY.

In astronomical spectroscopy, the radiant energy emitted by celestial objects is studied by combined spectroscopic and telescopic techniques to obtain information about their chemical composition, temperature, pressure, density, magnetic fields, electric forces, and radial velocity. See ASTRONOMICAL SPECTROSCOPY; SPECTROHELIOGRAPH.

Atomic absorption and fluorescence spectroscopy is a branch of electronic spectroscopy that uses line spectra from atomized samples to give quantitative analysis for selected elements at levels down to parts per million, on the average.

Attenuated total reflectance spectroscopy is the study of spectra of substances in thin films or on surfaces obtained by the technique of attenuated total reflectance or by a closely related technique called frustrated multiple internal reflection. In either method the radiant-energy beam penetrates only a few micrometers of the sample. The technique is employed primarily in infrared spectroscopy for qualitative analysis of coatings and of opaque liquids.

Electron spectroscopy includes a number of subdivisions, all of which are associated with electronic energy levels. The outermost or valence levels are studied in photoelectron spectroscopy. Electron impact spectroscopy uses low-energy electrons (0–100 eV).

X-ray photoelectron spectroscopy (XPS), also called electron spectroscopy for chemical analysis (ESCA), and Auger spectroscopy use x-ray photons to remove inner-shell electrons. Ion neutralization spectroscopy uses protons or other charged particles instead of photons. See AUGER EFFECT; ELECTRON SPECTROSCOPY; SURFACE AND INTERFACIAL CHEMISTRY; SURFACE PHYSICS.

Fourier transform spectroscopy is a technique that has been applied to infrared spectrometry and nuclear magnetic resonance spectrometry to allow the acquisition of spectra from smaller samples in less time, with high resolution and wavelength accuracy. See FOURIER SERIES AND TRANSFORMS.

Gamma-ray spectroscopy employs the techniques of activation analysis and Mössbauer spectroscopy. See ACTIVATION ANALYSIS; MÖSSBAUER EFFECT; NEUTRON SPECTROMETRY.

Information on processes which occur on a picosecond time scale can be obtained by making use of the coherent properties of laser radiation, as in coherent anti-Stokes-Raman spectroscopy. Laser fluorescence spectroscopy provides the lowest detection limits for many materials of interest in biochemistry and biotechnology. Ultrafast laser spectroscopy may be used to study some aspects of chemical reactions, such as transition states of elementary reactions and orientations in bimolecular reactions. See LASER SPECTROSCOPY.

In mass spectrometry, the source of the spectrometer produces ions, often from a gas, but also in some instruments from a liquid, a solid, or a material absorbed on a surface. The dispersive unit provides either temporal or spatial dispersion of ions according to their mass-to-charge ratio. See MASS SPECTROMETRY; SECONDARY ION MASS SPECTROMETRY (SIMS); TIME-OF-FLIGHT SPECTROMETERS.

In multiplex or frequency-modulated spectroscopy, each optical wavelength exiting the spectrometer output is encoded or modulated with an audio frequency that contains the optical

wavelength information. Use of a wavelength analyzer then allows recovery of the original optical spectrum.

When a beam of light passes through a sample, a small fraction of the light exits the sample at a different angle. If the wavelength of the scattered light is different than the original wavelength, it is called Raman scattering. Raman spectroscopy is used in structural chemistry and is a valuable tool for surface analysis. A related process, resonance Raman spectroscopy, makes use of the fact that Raman probabilities are greatly increased when the exciting radiation has an energy which approaches the energy of an allowed electronic absorption. See RAMAN EFFECT.

In x-ray spectroscopy, the excitation of inner electrons in atoms is manifested as x-ray absorption; emission of a photon as an electron falls from a higher level into the vacancy thus created is x-ray fluorescence. The techniques are used for chemical analysis. See X-RAY FLUORESCENCE ANALYSIS; X-RAY SPECTROMETRY.

[M.M.Bu.]

**Spectrum** The term spectrum is applied to any class of similar entities or properties strictly arrayed in order of increasing or decreasing magnitude. In general, a spectrum is a display or plot of intensity of radiation (particles, photons, or acoustic radiation) as a function of mass, momentum, wavelength, frequency, or some other related quantity. For example, a  $\beta$ -ray spectrum represents the distribution in energy or momentum of negative electrons emitted spontaneously by certain radioactive nuclides, and when radionuclides emit  $\alpha$ -particles, they produce an  $\alpha$ -particle spectrum of one or more characteristic energies. A mass spectrum is produced when charged particles (ionized atoms or molecules) are passed through a mass spectrograph in which electric and magnetic fields deflect the particles according to their charge-to-mass ratios. The distribution of sound-wave energy over a given range of frequencies is also called a spectrum. See MASS SPECTROSCOPE; SOUND.

In the domain of electromagnetic radiation, a spectrum is a series of radiant energies arranged in order of wavelength or of frequency. The entire range of frequencies is subdivided into wide intervals in which the waves have some common characteristic of generation or detection, such as the radio-frequency spectrum, infrared spectrum, visible spectrum, ultraviolet spectrum, and x-ray spectrum.

Spectra are also classified according to their origin or mechanism of excitation, as emission, absorption, continuous, line, and band spectra. An emission spectrum is produced whenever the radiations from an excited light source are dispersed. An absorption spectrum is produced against a background of continuous radiation by interposing matter that reduces the intensity of radiation at certain wavelengths or spectral regions. The energies removed from the continuous spectrum by the interposed absorbing medium are precisely those that would be emitted by the medium if properly excited. A continuous spectrum contains an unbroken sequence of waves or frequencies over a long range. Line spectra are discontinuous spectra characteristic of excited atoms and ions, whereas band spectra are characteristic of molecular gases or chemical compounds. See ATOMIC STRUCTURE AND SPECTRA; ELECTROMAGNETIC RADIATION; LINE SPECTRUM; MOLECULAR STRUCTURE AND SPECTRA; SPECTROSCOPY.

[W.F.M./W.W.W.]

**Spectrum analyzer** An instrument for the analysis and measurement of signals throughout the electromagnetic spectrum. Spectrum analyzers are available for subaudio, audio, and radio-frequency measurements, as well as for microwave and optical signal measurements.

Generally, a spectrum analyzer separates the signal into two components: amplitude (displayed vertically) and frequency (displayed horizontally). On some low-frequency analyzers, phase information can also be displayed. Low-frequency analyzers are sometimes grouped under the heading "harmonic analyzers," although this term is becoming less common.

On a conventional spectrum analyzer, a screen with a calibrated graticule displays the components of the input signal. The vertical scale displays the amplitude of each component, and the chosen frequency band is displayed horizontally. Components of the signal being analyzed are displayed as vertical lines whose height is proportional to amplitude and whose horizontal displacement equates to frequency. Originally, cathode-ray tubes were used for the display; solid-state displays such as liquid-crystal displays now are used. See CATHODE-RAY TUBE; ELECTRONIC DISPLAY.

Early radio-frequency and microwave analyzers were developed to measure the performance of microwave radar transmitters and to analyze signals from single-sideband transmitters. See RADAR; SINGLE SIDEBAND.

A typical use for radio-frequency and microwave spectrum analyzers is the measurement of spurious radiation (noise) from electrical machinery and circuits, known as radio-frequency interference (RFI). Other uses include monitoring and surveillance to detect unauthorized or unintended transmissions, such as the civil monitoring of broadcast and communication channels and the detection of electronic warfare signals. Another application is the analysis of radio communication transmitters and receivers, including those used in radio and television broadcasting, satellite systems, and mobile radio and cellular telephone communications. See ELECTRICAL INTERFERENCE; ELECTRONIC WARFARE.

Low-frequency spectrum analyzers are used in a variety of applications. The most obvious use is the measurement of distortion and unwanted signals in all types of audio equipment, from recording and broadcast studios to amplifiers used in the home. See SOUND RECORDING; SOUND-REPRODUCING SYSTEMS.

Further uses include the analysis of speech waveforms, measurement of vibration and resonances in mechanical equipment and structures, determination of echo delays in seismic signals, investigation of noise such as from aircraft engines or from machinery in factories, analysis of sonar signals used to detect objects underwater, and study of ultrasonic waves to determine the internal structure of objects such as human tissue and metal castings. See BIOMEDICAL ULTRASONICS; MECHANICAL VIBRATION; NOISE MEASUREMENT; NONDESTRUCTIVE EVALUATION; SEISMOLOGY; SONAR; ULTRASONICS.

Optical spectrum analyzers use techniques such as a collimating mirror and a diffraction grating or a Michelson interferometer to separate out the light-wave components. They are used for a variety of applications, including measurements on lasers and light-emitting diodes, and for the analysis of optical-fiber equipment used to carry multichannel, digital telephony. See DIFFRACTION GRATING; INTERFEROMETRY; LASER; LIGHT-EMITTING DIODE; OPTICAL COMMUNICATIONS; OPTICAL FIBERS. [S.J.GI.]

**Speech** A set of audible sounds produced by disturbing the air through the integrated movements of certain groups of anatomical structures. Humans attach symbolic values to these sounds for communication. There are many approaches to the study of speech.

**Speech production.** The physiology of speech production may be described in terms of respiration, phonation, and articulation. These interacting processes are activated, coordinated, and monitored by acoustical and kinesthetic feedback through the nervous system.

Most of the speech sounds of the major languages of the world are formed during exhalation. Consequently, during speech the period of exhalation is generally much longer than that of inhalation. The aerodynamics of the breath stream influence the rate and mode of the vibration of the vocal folds. This involves interactions between the pressures initiated by thoracic movements and the position and tension of the vocal folds. See RESPIRATION.

The phonatory and articulatory mechanisms of speech may be regarded as an acoustical system whose properties are comparable to those of a tube of varying cross-sectional dimensions. At the lower end of the tube, or the vocal tract, is the larynx. It is

situated directly above the trachea and is composed of a group of cartilages, tissues, and muscles. The upper end of the vocal tract may terminate at the lips, at the nose, or both. The length of the vocal tract averages 6.5 in. (16 cm) in men and may be increased by either pursing the lips or lowering the larynx.

The larynx is the primary mechanism for phonation, that is, the generation of the glottal tone. The vocal folds consist of connective tissue and muscular fibers which attach anteriorly to the thyroid cartilage and posteriorly to the vocal processes of the arytenoid cartilages. The vibrating edge of the vocal folds measures about 0.92–1.08 in. (23–27 mm) in men and considerably less in women. The aperture between the vocal folds is known as the glottis. The tension and position of the vocal folds are adjusted by the intrinsic laryngeal muscles, primarily through movement of the two arytenoid cartilages. See LARYNX.

When the vocal folds are brought together and there is a balanced air pressure to drive them, they vibrate laterally in opposite directions. During phonation, the vocal folds do not transmit the major portion of the energy to the air. They control the energy by regulating the frequency and amount of air passing through the glottis. Their rate and mode of opening and closing are dependent upon the position and tension of the folds and the pressure and velocity of airflow. The tones are produced by the recurrent puffs of air passing through the glottis and striking into the supralaryngeal cavities.

Speech sounds produced during phonation are called voiced. Almost all of the vowel sounds of the major languages and some of the consonants are voiced. In English, voiced consonants may be illustrated by the initial and final sounds in the following words: “bathe,” “dog,” “man,” “jail.” The speech sounds produced when the vocal folds are apart and are not vibrating are called unvoiced; examples are the consonants in the words “hat,” “cap,” “sash,” “faith.” During whispering all the sounds are unvoiced.

The rate of vibration of the vocal folds is the fundamental frequency of the voice (F0). It correlates well with the perception of pitch. The frequency increases when the vocal folds are made taut. Relative differences in the fundamental frequency of the voice are utilized in all languages to signal some aspects of linguistic information.

Many languages of the world are known as tone languages, because they use the fundamental frequency of the voice to distinguish between words. Chinese is a classic example of a tone language. There are four distinct tones in Chinese speech. Said with a falling fundamental frequency of the voice, *ma* means “to scold.” Said with a rising fundamental frequency, it means “hemp.” With a level fundamental frequency it means “mother,” and with a dipping fundamental frequency it means “horse.” In Chinese, changing a tone has the same kind of effect on the meaning of a word as changing a vowel or consonant in a language such as English.

The activity of the structures above and including the larynx in forming speech sound is known as articulation. It involves some muscles of the pharynx, palate, tongue, and face and of mastication.

The primary types of speech sounds of the major languages may be classified as vowels, nasals, plosives, and fricatives. They may be described in terms of degree and place of constriction along the vocal tract. See PHONETICS.

The only source of excitation for vowels is at the glottis. During vowel production the vocal tract is relatively open and the air flows over the center of the tongue, causing a minimum of turbulence. The phonetic value of the vowel is determined by the resonances of the vocal tract, which are in turn determined by the shape and position of the tongue and lips.

The nasal cavities can be coupled onto the resonance system of the vocal tract by lowering the velum and permitting airflow through the nose. Vowels produced with the addition of nasal resonances are known as nasalized vowels. Nasalization may be used to distinguish meanings of words made up of otherwise

identical sounds, such as *bas* and *banc* in French. If the oral passage is completely constricted and air flows only through the nose, the resulting sounds are nasal consonants. The three nasal consonants in "meaning" are formed with the constriction successively at the lips, the hard palate, and the soft palate.

Plosives are characterized by the complete interception of airflow at one or more places along the vocal tract. The places of constriction and the manner of the release are the primary determinants of the phonetic properties of the plosives. The words "par," "bar," "tar," and "car" begin with plosives. When the interception is brief and the constriction is not necessarily complete, the sound is classified as a flap. By tensing the articulatory mechanism in proper relation to the airflow, it is possible to set the mechanism into vibrations which quasiperiodically intercept the airflow. These sounds are called trills.

These are produced by a partial constriction along the vocal tract which results in turbulence. Their properties are determined by the place or places of constriction and the shape of the modifying cavities. The fricatives in English may be illustrated by the initial and final consonants in the words "vase," "this," "faith," "hash."

The ability to produce meaningful speech is dependent in part upon the association areas of the brain. It is through them that the stimuli which enter the brain are interrelated. These areas are connected to motor areas of the brain which send fibers to the motor nuclei of the cranial nerves and hence to the muscles. Three neural pathways are directly concerned with speech production, the pyramidal tract, the extrapyramidal, and the cerebellar motor paths. It is the combined control of these pathways upon nerves arising in the medulla and ending in the muscles of the tongue, lips, and larynx which permits the production of speech. See NERVOUS SYSTEM (VERTEBRATE).

Six of the 12 cranial nerves send motor fibers to the muscles that are involved in the production of speech. These nerves are the trigeminal, facial, glossopharyngeal, vagus, spinal accessory, and the hypoglossal. See PSYCHOACOUSTICS; PSYCHOLINGUISTICS.

**Development.** In the early stages of speech development the child's vocalizations are quite random. The control and voluntary production of speech are dependent upon physical maturation and learning.

It is possible to describe the development of speech in five stages. In the first stage the child makes cries in response to stimuli. These responses are not voluntary but are part of the total bodily expression. The second stage begins between the sixth and seventh week. The child is now aware of the sounds he or she is making and appears to enjoy this activity. During the third stage the child begins to repeat sounds heard coming from himself or herself. This is the first time that the child begins to link speech production to hearing. During the ninth or tenth month the child enters the fourth stage and begins to imitate without comprehension the sounds that others make. The last stage begins between the twelfth and eighteenth month, with the child intentionally employing conventional sound patterns in a meaningful way. The exact time at which each stage may occur varies greatly from child to child.

**Speech technology.** Speech technology has been developing within three areas. One has to do with identifying a speaker by analyzing a speech sample. Since the idea is analogous to that of identifying an individual by fingerprint analysis, the technique has been called voice print. However, fingerprints have two important advantages over voice prints: (1) they are based on extensive data that have accumulated over several decades of use internationally, whereas no comparable reference exists for voice prints; and (2) it is much easier to alter the characteristics of speech than of fingerprints. Consequently, this area has remained largely dormant. Most courts in the United States, for instance, do not admit voice prints as legal evidence.

The two other areas of speech technology, synthesis and recognition, have seen explosive growth. In many applications where a limited repertoire of speech is required, computer-

synthesized speech is used instead of human speakers. A common technology currently used in speech synthesis involves an inventory of pitch-synchronized, prestored human speech. These prestored patterns are selected according to the particular requirements of the application and recombined with some overlap into the desired sentence by computer, almost in real time. The quality of synthesized speech for English is remarkably good, though it is limited at present to neutral, emotionless speech. Many other languages are being synthesized with varying degrees of success.

The recognition of speech by computer is much more difficult than synthesis. Instead of just reproducing the acoustic wave, the computer must understand something of the semantic message that the speech wave contains, in order to recognize pieces of the wave as words in the language. Humans do this easily because they have a great deal of background knowledge about the world, because they are helped by contextual clues not in the speech wave, and because they are extensively trained in the use of speech. Nonetheless, given various constraints, some of the existing systems do remarkably well. These constraints include (1) stable acoustic conditions in which speech is produced, (2) a speaker trained by the system, (3) limited inventory of utterances, and (4) short utterances. The research here is strongly driven by the marketplace, since all sorts of applications can be imagined where spoken commands are required or highly useful. See SPEECH DISORDERS. [W.S.Y.W.]

**Speech disorders** Speech disorders may be classified according to their causes or symptoms. The major causes are organic, imitative environmental, and psychogenic. Organic disorders may result from disease, impairment, or absence of the organs of speech. Imitative disorders occur when the child imitates defective speech. A speech disorder has a psychogenic origin when there is a psychological basis for its presence. A classification includes disorders of articulation, rhythm, voice, and symbolization.

Disorders of articulation may be so severe that the resultant speech is unintelligible. Specific sounds or groups of sounds may be omitted, added, substituted, or distorted. The following are some examples of this type of disorder: Lalling, involving misarticulated r, l, t, and d sounds, may be caused by poor control of the tongue tip. In lisping, misarticulated sibilant sounds, particularly s and z, are often substituted by the th sound. Delayed speech, involving the absence of many consonants and poor intelligibility, is often caused by slow physical or psychological maturation. Dysarthria, generalized sound substitutions and distortions, is caused by lesions in the peripheral or central nervous system.

Disorders of rhythm are characterized by disruptions of the normal rate of speech. Two common disorders of rhythm are stuttering or stammering and cluttering.

Voice disorders are usually described as defects of pitch, loudness, and voice quality. Improper use of the voice may cause an injury to the vocal folds and intensify an existing voice disorder. Disorders of pitch are characterized as too high, too low, monotonous, and repeated pitch patterns. A high-pitched voice is most often caused by psychological tension. The muscles of the larynx are contracted so that the pitch is raised beyond its normal range. Voice quality disorders are usually described as hoarseness, nasality, denasality, and similar conditions. Hoarseness may be caused by pharyngeal or laryngeal pathologies. Cleft palate speech is a striking example of nasality. Nasal speech may also follow a paralysis of the palatal muscles. The nasal speech results because the palate is unable to aid in achieving nasopharyngeal closure.

Symbolization disorders involve an impairment of language formulation and expression. They may occur without a concomitant impairment of speech production. Common types of these disorders are aphasia and delayed speech. See SPEECH.

[R.S.T.; W.S.Y.W.]



**Speech perception** A term broadly used to refer to how an individual understands what others are saying. More narrowly, speech perception is viewed as the way a listener can interpret the sound that a speaker produces as a sequence of discrete linguistic categories such as phonemes, syllables, or words. See PHONETICS; PSYCHOLINGUISTICS.

Classical work in the 1950s and 1960s concentrated on uncovering the basic acoustic cues that listeners use to hear the different consonants and vowels of a language. It revealed a surprisingly complex relationship between sound and percept. The same physical sound (such as a noise burst at a particular frequency) can be heard as different speech categories depending on its context (as “k” before “ah,” but as “p” before “ee” or “oo”), and the same category can be cued by different sounds in different contexts. Spoken language is thus quite unlike typed or written language, where there is a relatively invariant relationship between the physical stimulus and the perceived category.

The reasons for the complex relationship lie in the way that speech is produced: the sound produced by the mouth is influenced by a number of continuously moving and largely independent articulators. This complex relationship has caused great difficulties in programming computers to recognize speech, and it raises a paradox. Computers readily recognize the printed word but have great difficulty recognizing speech. Human listeners, on the other hand, find speech naturally easy to understand but have to be taught to read (often with difficulty). It is possible that humans are genetically predisposed to acquire the ability to understand speech, using special perceptual mechanisms usually located in the left cerebral hemisphere. See HEMISPHERIC LATERALITY.

Building on the classical research, the more recent work has drawn attention to the important contribution that vision makes to normal speech perception; has explored the changing ability of infants to perceive speech and contrasted it with that of animals; and has studied the way that speech sounds are coded by the auditory system and how speech perception breaks down in those with hearing impairment. There has also been substantial research on the perception of words in continuous speech.

Adult listeners are exquisitely sensitive to the differences between sounds that are distinctive in their language. The voicing distinction in English (between “b” and “p”) is cued by the relative timing of two different events (stop release and voice onset). At a difference of around 30 milliseconds, listeners hear an abrupt change from one category to another, so that a shift of only 5 ms can change the percept. On the other hand, a similar change around a different absolute value, where both sounds are heard as the same category, would be imperceptible. The term categorical perception refers to this inability to discriminate two sounds that are heard as the same speech category.

Categorical perception can arise for two reasons: it can have a cause that is independent of the listener’s language—for instance, the auditory system may be more sensitive to some changes than to others; or it can be acquired as part of the process of learning a particular language. The example described above appears to be language-independent, since similar results have been found in animals such as chinchillas whose auditory systems resemble those of humans. But other examples have a language-specific component. The ability to hear a difference between “r” and “l” is trivially easy for English listeners, but Japanese perform almost at chance unless they are given extensive training. How such language-specific skills are developed has become clearer following intensive research on speech perception in infants.

Newborn infants are able to distinguish many of the sounds that are contrasted by the world’s languages. Their pattern of sucking on a blind nipple signals a perceived change in a repeated sound. They are also able to hear the similarities between sounds such as those that are the same vowel but have different pitches. The ability to respond to such a wide range of distinctions changes dramatically in the first year of life. By 12 months,

infants no longer respond to some of the distinctions that are outside their native language, while infants from language communities that do make those same distinctions retain the ability. Future experience could reinstate the ability, so it is unlikely that low-level auditory changes have taken place; the distinctions, although still coded by the sensory system, do not readily control the infant’s behavior.

Although conductive hearing losses can generally be treated adequately by appropriate amplification of sound, sensorineural hearing loss involves a failure of the frequency-analyzing mechanism in the inner ear that humans cannot yet compensate for. Not only do sounds need to be louder before they can be heard, but they are not so well separated by the ear into different frequencies. Also, the sensorineurally deaf patient tolerates only a limited range of intensities of sound; amplified sounds soon become unbearable (loudness recruitment).

These three consequences of sensorineural hearing loss lead to severe problems in perceiving a complex signal such as speech. Speech consists of many rapidly changing frequency components that normally can be perceptually resolved. The lack of frequency resolution in the sensorineural patient makes it harder for the listener to identify the peaks in the spectrum that distinguish the simplest speech sounds from each other; and the use of frequency-selective automatic gain controls to alleviate the recruitment problem reduces the distinctiveness of different sounds further. These patients may also be less sensitive than people with normal hearing to sounds that change over time, a disability that further impairs speech perception.

Some profoundly deaf patients can identify some isolated words by using multichannel cochlear implants. Sound is filtered into different frequency channels, or different parameters of the speech are automatically extracted, and electrical pulses are then conveyed to different locations in the cochlea by implanted electrodes. The electrical pulses stimulate the auditory nerve directly, bypassing the inactive hair cells of the damaged ear. Such devices cannot reconstruct the rich information that the normal cochlear feeds to the auditory nerve. See HEARING (HUMAN); HEARING AID; HEARING IMPAIRMENT; PERCEPTION; PSYCHOACOUSTICS; SPEECH. [C.J.Da.]

**Speech recognition** In a strict sense, the process of electronically converting a speech waveform (as the acoustic realization of a linguistic expression) into words (as a best-decoded sequence of linguistic units). At times it can be generalized to the process of extracting a linguistic notion from a sequence of sounds, that is, an acoustic event, which may encompass linguistically relevant components, such as words or phrases, as well as irrelevant components, such as ambient noise, extraneous or partial words in an utterance, and so on. Applications of speech recognition include an automatic typewriter that responds to voice, voice-controlled access to information services (such as news and messages), and automated commercial transactions (for example, price inquiry or merchandise order by telephone), to name a few. Sometimes, the concept of speech recognition may include “speech understanding,” because the use of a speech recognizer often involves understanding the intended message expressed in the spoken words. Currently, such an understanding process can be performed only in an extremely limited sense, often for the purpose of initiating a particular service action among a few choices. For example, a caller’s input utterance “I’d like to borrow money to buy a car” to an automatic call-routing system of a bank would connect the caller to the bank’s loan department.

Converting a speech waveform into a sequence of words involves several essential steps. First, a microphone picks up the acoustic signal of the speech to be recognized and converts it into an electrical signal. A modern speech recognition system also requires that the electrical signal be represented digitally by means of an analog-to-digital (A/D) conversion process, so that it can be processed with a digital computer or a microprocessor.

This speech signal is then analyzed (in the analysis block) to produce a representation consisting of salient features of the speech. The most prevalent feature of speech is derived from its short-time spectrum, measured successively over short-time windows of length 20–30 milliseconds overlapping at intervals of 10–20 ms. Each short-time spectrum is transformed into a feature vector, and the temporal sequence of such feature vectors thus forms a speech pattern.

The speech pattern is then compared to a store of phoneme patterns or models through a dynamic programming process in order to generate a hypothesis (or a number of hypotheses) of the phonemic unit sequence. (A phoneme is a basic unit of speech and a phoneme model is a succinct representation of the signal that corresponds to a phoneme, usually embedded in an utterance.) A speech signal inherently has substantial variations along many dimensions. First is the speaking rate variation—a speaker cannot produce a word of identical duration at will. Second, articulation variation is also abundant, in terms both of talker-specific characteristics and of the manner in which a phoneme is produced. Third, pronunciation variation occurs among different speakers and in various speaking contexts (for example, some phonemes may be dropped in casual conversation). Dynamic programming is performed to generate the best match while taking these variations into consideration by compressing or stretching the temporal pattern and by probabilistically conjecturing how a phoneme may have been produced. The latter includes the probability that a phoneme may have been omitted or inserted in the utterance. The knowledge of probability (often called a probabilistic model of speech) is obtained via “training,” which computes the statistics of the speech features from a large collection of spoken utterances (of known identity) according to a mathematical formalism.

The hypothesized phoneme sequence is then matched to a stored lexicon to reach a tentative decision on the word identity. The decoded word sequence is further subject to verification according to syntactic constraints and grammatical rules, which in turn define the range of word hypotheses for lexical matching. This process of forming hypotheses about words and matching them to the observed speech pattern, and vice versa, in order to reach a decision according to a certain criterion is generally referred to as the “search.” In limited domain applications in which the number of legitimate expressions is manageably finite, these constraints can be embedded in an integrated dynamic programming process to reduce search errors.

The degree of sophistication of a speech recognition task is largely a function of the size of the vocabulary it has to deal with. A task involving, say, less than 100 words is called small vocabulary recognition and is mostly for command-and-control applications with isolated word utterances as input. There are usually very few grammatical constraints associated with these types of limited tasks. When the vocabulary size grows to 1000 words, it is possible to construct meaningful sentences, although the associated grammatical rules are usually fairly rigid. For dictation, report writing, or other tasks such as newspaper transcription, a speech recognition system with a large vocabulary (on the order of tens of thousands of word entries) is needed. See LINGUISTICS; PSYCHOACOUSTICS; SPEECH.

The technology of speech recognition often finds applications in speaker recognition tasks as well. Speaker recognition applications can be classified into two essential modes, speaker identification and speaker verification. The goal of speaker identification is to use a machine to find the identity of a talker, in a known population of talkers, using the speech input. Speaker verification aims to authenticate a claimed identity from the voice signal.

[B.H.J.]

**Speed** The time rate of change of position of a body without regard to direction. It is the numerical magnitude only of a velocity and hence is a scalar quantity. Linear speed is commonly

measured in such units as meters per second, miles per hour, or feet per second.

Average linear speed is the ratio of the length of the path traversed by a body to the elapsed time during which the body moved through that path. Instantaneous speed is the limiting value of the foregoing ratio as the elapsed time approaches zero. See VELOCITY.

[R.D.Ru.]

**Speed regulation** The change in steady-state speed of a machine, expressed in percent of rated speed, when the machine load is reduced from rated load to zero. The definition of regulation is usually taken to mean the net change in a steady-state characteristic, and does not include any transient deviation or oscillation that may occur prior to reaching the new operation point. This same definition is used for stating the speed regulation of electric motors as well as for certain drive systems, such as steam turbines.

[P.M.A.]

**Speedometer** A device for indicating the speed of a vehicle. There are three types of speedometers in general use: mechanical analog, quartz electric analog, and digital microprocessor.

The mechanical analog speedometer is driven by a cable housed in a casing and connected to a gear at the transmission. This gear is designed for the particular vehicle model, considering the vehicle's tire size and rear axle ratio. In most cases, the speedometer is designed to convert 1001 revolutions of the drive cable into registering 1 mi on the odometer, which records distance traveled by the vehicle. The speed-indicating portion of the speedometer operates on the magnetic principle. In the speedometer head, the drive cable attaches to a revolving permanent magnet that rotates at the same speed as the cable. Floating on bearings between the upper frame and the revolving permanent magnet is a nonmagnetic movable speed cup. The magnet revolves within the speed cup, producing a rotating magnetic field. The magnetic field is constant, and the amount of speed cup movement is at all times in proportion to the speed of the magnet rotation. A pointer, attached to the speed cup spindle, indicates the speed on the speedometer dial. See MAGNETIC FIELD.

The quartz speedometer utilizes an accurate clock signal supplied by a quartz crystal, along with integrated electronic circuitry to process an electrical speed signal. This signal is generated by a permanent-magnet generator mounted in the transmission. This permanent-magnet generator, designed to be used with both quartz and digital speedometers, provides a sinusoidal speed signal that is proportional to vehicle speed at the rate of 4004 pulses per mile (2503 per kilometer).

In the digital microprocessor speedometer, the vehicle speed is monitored by the permanent speed sensor mounted in the transmission. The signal is transmitted to the microprocessor where the counter converts the speed signal to a digital signal and stores it in memory. The timing circuit has the capacity to handle the counter and memory storage in less than 0.25 s. Memory circuit signals are sent to the electronic display circuit, which selects the display numerals representing the vehicle's speed, according to the number of pulses received from the speed sensor. See AUTOMOTIVE TRANSMISSION; ELECTRONIC DISPLAY.

[R.A.Gr.]

**Spelaeogrifhacea** A crustacean order within the Malacostraca: Peracarida, erected for a single living species. *Spelaeogrifhus lepidops*. This shrimplike animal lives in a stream inside a cave on Table Mountain, South Africa. *Spelaeogrifhus* has a slender, flexible body, seven pairs of walking legs, five pairs of swimmerets, and a very long flagellum on each second antenna. A short carapace is fused to the first thoracic segment, covers the second, and forms ventrolateral branchial chambers, within which are cuplike gills, attached to the first thoracic segment. The animals creep over the stream bottom with their

walking legs and swim by undulations of the whole trunk. See PERACARIDA. (J.H.L.)

**Sperm cell** The male gamete. The typical sperm of most animals has a head containing the nucleus and acrosome, a middle piece with the mitochondria, and a tail with the 9 + 2 microtubule pattern (see illustration). Sperm, as well as the acrosome shape, varies with the species. The nucleus consists of condensed chromatin (deoxyribonucleic acid, DNA) and histone proteins. The acrosome, which is derived from the Golgi complex, contains hydrolytic enzymes, that is, hyaluronidase capable of lysing the egg coats at fertilization. Actin molecules which aid in the interaction between sperm and egg are found in the area between the acrosome and nucleus. The mitochondria in the middle piece apparently provide the energy necessary for the motility created by the tail. The tail has a central core, or axial filament, made up of nine double tubules and two central tubules. See CILIA AND FLAGELLA.

Many groups, including nematodes, myriapods, and crustaceans, have atypical sperm which lack a flagellum and are presumably nonmotile. The sperm of *Ascaris* is round and moves by amoeboid means. The crustacean sperm have a large acrosome of several components. In the anomurans a middle with mitochondria and arms filled with microtubules precedes the nucleus. In the true crabs the nucleus forms arms which possess microtubules and also surrounds the many component acrosomes. The nucleus of crustacean sperm does not condense with mat-

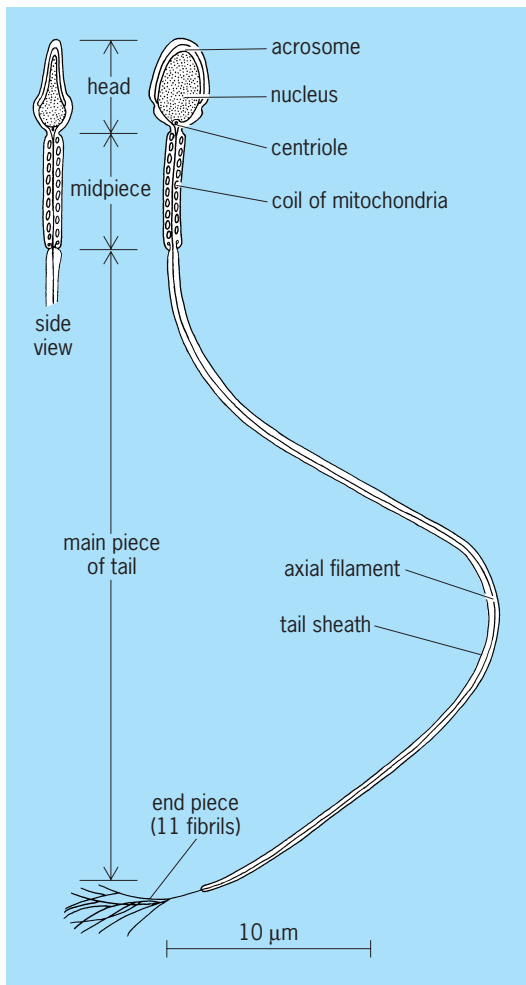
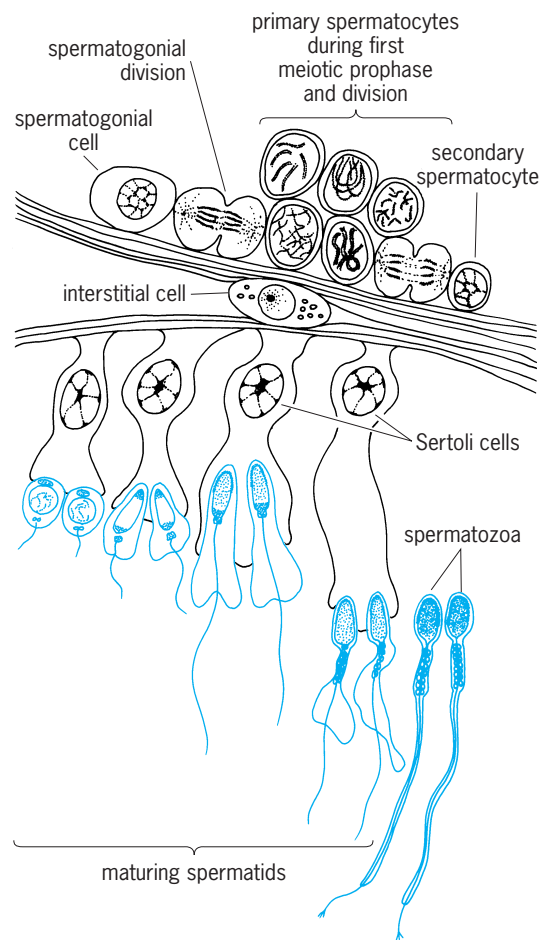

Diagram of a human spermatozoon, based on electron micrographs.

uration as it does in typical sperm mentioned above. See SPERMATOGENESIS. (G.W.H.)

**Spermatogenesis** The differentiation of spermatogonial cells (primordial germ cells in the testes) into spermatozoa (see illustration).



Cellular events in human spermatogenesis.

Spermatogonial divisions occur continuously throughout the life of mammals; these divisions both maintain the stem cell population (spermatogonial cells) and supply cells which develop into sperm. Clusters of spermatogonia maintain communication through cytoplasmic bridges, and these groups become primary spermatocytes when they synchronously enter the first meiotic prophase. The first meiotic prophase is characterized by a series of remarkable changes in chromosome morphology, which are identical to those seen in the corresponding stage of oogenesis. The secondary spermatocyte produced by this division then undergoes a division in which the chromosomes are not replicated; the resulting spermatids contain half the somatic number of chromosomes. See MEIOSIS.

The spermatids become embedded in the cytoplasm of Sertoli cells, and there undergo the distinctive changes which result in formation of spermatozoa. These morphological transformations include the conversion of the Golgi apparatus into the acrosome and progressive condensation of the chromatin in the nucleus. A centriole migrates to a position distal to the nucleus and begins organizing the axial filament which will form the motile tail of the sperm. Mitochondria may fuse to form a nebkern as is the case for many vertebrates, or there may be less extensive fusion as in mammals. In all cases the resulting structures become located around the axial filament in the midpiece. The cytoplasm

of the spermatid is reflected distally away from the nucleus during spermatid maturation; eventually, most of the cytoplasm is sloughed off and discarded.

The Sertoli cells are thought to provide nutrition for the developing sperm, because their cytoplasm contains large stores of glycogen which diminish as spermatids mature. There is no direct evidence for this nutritive function, but some forms of male sterility are associated with the failure to produce normal Sertoli cells. Electron microscopy has revealed distinct plasma membranes surrounding the two cell types at the points of contact, and thus the Sertoli cell-spermatid relationship is not syncytial as once thought.

Spermatogenesis is cyclical to a varying extent depending on the species, and under endocrine control. Spermatogenesis is maintained and regulated by male steroid hormones such as testosterone, which is produced by the interstitial or Leydig cells found in the connective tissue of the testis. Interstitial cells, in turn, are stimulated by luteinizing hormone (LH) which is produced by the pituitary gland. The male testis-regulating hormone was formerly known as interstitial cell-stimulating hormone (ICSH), but it is now known to be identical to LH. See ENDOCRINE MECHANISMS; GAMETOGENESIS; TESTIS. [S.J.B.]

**Sphaeractinoidea** An extinct group of fossil marine sponges closely related to modern Sclerospongiae and fossil Stromatoporoidea. They may have appeared as early as Late Carboniferous (Pennsylvania Period) of the Late Paleozoic Era. They were definitely present during the Permian Period at the close of the Paleozoic and flourished during the Mesozoic Era, especially during the Jurassic and Cretaceous, declining rapidly during the late Cretaceous, and may have persisted until Eocene time, during the Cenozoic Era.

Like the stromatoporooids, they have a radial canal system; in vertical thin section the skeleton is calcareous and characterized by a latticelike pattern. The vertical structures are round, short to long rodlike pillars. However, unlike the stromatoporooids, the horizontal component of the reticulum is trabecular or rodlike rather than separated parallel or concentric plates, or they may be thin, flat, or broadly arched cyst plates. See SCLEROSPONGIAE; STROMATOPOROIDEA. [J.St.J.]

**Sphaerocarpaceae** An order of liverworts in the subclass Marchantiidae, consisting of two families, the terrestrial Sphaerocarpaceae (*Sphaerocarpos* and *Geothallus*) and the aquatic Riellaceae (*Riella*). The plants are characterized by envelopes surrounding each antheridium and archegonium, absence of elaters, poor development of seta, and absence of thickenings in the unilayered wall of an indehiscent capsule.

The rhizoids are smooth, and air chambers and pores are lacking. Oil bodies may be present. The antheridia are separately contained within receptacles on the dorsal surface or at the margins, while the archegonia are separately produced in receptacles dorsally or behind the growing point. The sporophyte consists of a bulbous foot, short or obsolescent seta, and globose indehiscent capsule with a unilayered wall. See BRYOPHYTA. [H.C.]

**Sphaerularoidea** A superfamily of parasitic nematodes in the order Tylenchida. Adult females are hemocoel parasites of insects and mites; a few taxa contain both plant and insect parasites. In general, nematodes belonging to this group have three distinct phases in their life cycles: two free-living and one parasitic. In the free-living phase the female gonad is single, anteriorly directed, and with few developing oocytes and a prominent uterus filled with sperm. In the parasitic phase either the body becomes grossly enlarged and degenerates to a reproductive sac, or the uterus prolapses and gonadal development takes place outside the body. The males are always free-living and not infective. The most interesting taxon is *Sphaerularia bombi*, which prolapses the uterus. When totally prolapsed, the gonad becomes the parasite and the original female a useless appendage. It is

not unusual for the prolapsed gonad to attain a volume 15,000 times that of the original female. See NEMATA. [A.R.M.]

**Sphagnopsida** A class of the plant division Bryophyta containing plants commonly called peatmosses. The spongelike plants grow as perennials in soft cushions or lawns in wet habitats (rarely they grow submerged). The class consists of a single genus, *Sphagnum*, of some 200 species. The thallose protonema, fascicled branches, dimorphous leaf cells, and spores developed from amphithecial tissue are characters unique to the class. The plants are ecologically important, owing to the sponge-like construction of leaves and outer cells of stems and branches, and the ability, whether living or dead, to create acid conditions by exchanging hydrogen ions for cations in solution. The dried plant parts are used as a mulch in horticultural practice, and as fuel where the plant is abundant. See BRYOPHYTA. [H.Cr.]

**Sphalerite** A mineral,  $\beta$ -ZnS, also called blende. It is the low-temperature form and more common polymorph of ZnS. Pure  $\beta$ -ZnS on heating inverts to wurtzite,  $\alpha$ -ZnS, at 1868°F (1020°C).

The mineral is most commonly in coarse to fine, granular, cleavable masses. The luster is resinous to submetallic; the color is white when pure, but is commonly yellow, brown, or black, darkening with increased percentage of iron. There is perfect dodecahedral cleavage; the hardness is  $3\frac{1}{2}$  on Mohs scale; specific gravity is 4.1 for pure sphalerite.

Sphalerite is a common and widely distributed mineral. It occurs both in veins and in replacement deposits in limestones. As the chief ore mineral of zinc, sphalerite is mined on every continent. The United States is the largest producer, followed by Canada, Mexico, Russia, Australia, Peru, the Congo River area, and Poland. See WURTZITE; ZINC. [C.S.Hu.; P.B.M.]

**Sphenisciformes** The penguins, a small monotypic order of flightless, marine swimming birds found in the southern oceans. Classification schemes that hypothesize a link between penguins and loons have no support in fact.

Penguins are medium-sized to large birds. They are completely flightless, their wings having been modified into stiff, flattened flippers. They stand upright on legs that are far posterior and that terminate in four toes, the anterior three of which are webbed. Penguins swim and dive well, using only their wings for propulsion: their feet are used only for steering. Terrestrial locomotion is by walking, hopping, or sliding on the belly while pushing with the wings. The plumage consists of dense, scalelike feathers that are black dorsally and white ventrally. A distinctive pattern or crest, often yellow, occurs on the head. Penguins are gregarious, breeding in large colonies along the coast. The males and females, which are identical, form strong pair bonds and share in the incubation and care of the downy nestlings. The older young of some species are kept in large groups, or creches. The emperor penguin (*Aptenodytes forsteri*) breeds on the ice pack along the Antarctic coasts during the fall. Incubation of the one or two eggs is the responsibility of the male, which remains on the nest for over 2 months in the winter without eating.

Penguins are found only in the cold southern oceans, on the Antarctic continent and its surrounding islands and northward to Australia, New Zealand, South America, and Africa. One species, the Galápagos penguins (*Spheniscus mendiculus*), is found in the Galápagos Islands, which are on the Equator but are surrounded by the cold Humboldt Current. See AVES. [W.J.B.]

**Sphenodontia** One of the two surviving orders of lepidosaurian reptiles; they are represented today, however, by a single species, *Sphenodon punctatus*. They have a typical diapsid skull, and, also typically, the teeth are fused to the edges of the jaws; their only characteristic specialization is that the upper jaw forms an overhanging beak.

*Sphenodon punctatus*, the tuatara, is a moderate-sized (about 2–2½ ft or 0.6–0.8 m long) lizardlike reptile which is strictly conserved on a few small islands off the coast of New Zealand. It formerly inhabited the mainland but was hunted to extinction by humans. Among living reptiles the tuatara is unique in having no penis; its “pineal eye,” however, is neither unique nor as functional as popularly supposed. By day it lives in shallow burrows, often in association with petrels; at night it emerges to feed on land snails and insects, especially crickets. Courtship behavior terminates with mating (fertilization is internal, despite the lack of penis in the male), after which the female leaves the male and buries her small leathery eggs in a burrow to incubate for 12–13 months. See LEPIDOSAURIA; REPTILIA. [A.J.C.]

**Sphenophyllales** An extinct group of articulate land plants, common during Late Pennsylvanian and Early Permian times. They are typified by *Sphenophyllum*, a small, branching plant, probably of trailing habit. The long, jointed stems had superposed, longitudinal, sulcated ribs between nodes. The vascular system contained a solid xylem core with triangular primary wood. The leaves were wedge-shaped and had toothed, notched, or rounded distal margins. Long, terminal cones, when found detached, contained sporangia and spores. Most species were homosporous (produced spores of a single type). See PALEOBOTANY. [S.H.M.]

**Sphenophyta** One of the major divisions (formerly known as Equisetophyta) of vascular plants that includes both living and fossil representatives. The three principal orders are Pseudoborniales (Devonian), Sphenophyllales (Devonian-Triassic), and Equisetales (Devonian-Recent); the Hyeniales (Devonian) may also be sphenophytes. See Equisetales; HYENIALES; PSEUDOBORNIALES; SPHENOPHYLLALES.

All sphenophytes are characterized by axes with distinct nodes that produce whorls of small leaves or branches; branches often contain longitudinal ribs and furrows. Internally the stems of sphenophytes are characterized by longitudinally oriented canals, some of which functioned in gaseous exchange. Secondary tissues were produced in a few fossil forms. The reproductive organs of this group are loosely arranged strobili or cones consisting of a central axis bearing whorls of modified branches, each terminating in a recurved, thick-walled sporangium. Most sphenophytes produced one type of spore (homospory), although a few fossil forms were heterosporous.

Today all that remains of the sphenophytes is the genus *Equisetum*, commonly called the horsetail or scouring rush. Except in Australia and New Zealand, the members are worldwide in distribution and typically grow in damp habitats along the edges of streams, although some species are adapted to mesic conditions. A few species attain considerable size, but none of these produce secondary tissues. See EMBRYOBIONTA. [T.N.T.]

**Sphere** Both in euclidean solid geometry and in common usage the word sphere denotes a solid of revolution obtained by revolving a semicircle of radius  $r$  about its diameter. Its total volume is  $V = \frac{4}{3}\pi r^3$ .

However, in analytic geometry, and more generally in modern mathematics, the word sphere denotes a spherical surface that bounds a solid sphere. In this sense a sphere is the locus of all points  $P$  in three-dimensional space whose distance from a fixed point  $O$  (called the center) is equal to a given number. The word radius may refer either to one of the segments  $OP$ , or to their common length  $r$ . A plane that intersects a sphere in just one point is called a tangent plane and is perpendicular to the radius drawn from the center of the sphere to that point. A plane that intersects a sphere in more than one point intersects it in a circle. The circle is called a great circle or a small circle of the sphere according to whether the plane does or does not pass through the center of the sphere. If two parallel planes intersect a sphere, the spherical surface between them is called a zone.

Any great circle of a sphere divides it into two hemispheres. A second great circle cuts a hemisphere into two lunes. A third great circle cuts each lune into two spherical triangles. See SURFACE AND SOLID OF REVOLUTION. [J.S.F.]

**Spherical harmonics** A spherical harmonic or solid spherical harmonic of degree  $n$  is a homogeneous function,  $R_n(x, y, z)$ , of degree  $n$  which satisfies Laplace's equation below. Here  $n$

$$\Delta R \equiv \frac{\partial^2 R}{\partial x^2} + \frac{\partial^2 R}{\partial y^2} + \frac{\partial^2 R}{\partial z^2} \equiv 0$$

is any number, and  $(x^2 + y^2 + z^2)^{-(n-1)/2} R_n(x, y, z)$  is a spherical harmonic of degree  $-n - 1$ . There are analogous definitions for spaces of any number of dimensions. In the present article,  $n$  is a nonnegative integer and  $R_n$ , a polynomial in  $x, y, z$  (polynomial spherical harmonic). In terms of spherical coordinates  $r, \tau, \pi$ ,  $R_n(x, y, z) = r^n S_n(\tau, \pi)$ , where  $S_n$ , a polynomial in  $\cos \tau, \sin \tau, \cos \pi, \sin \pi$ , is a spherical surface harmonic of degree  $n$ . There are  $2n + 1$  linearly independent spherical surface harmonics of degree  $n$ ; any spherical surface harmonic of degree  $n$  is a linear combination of these, and conversely any linear combination of spherical surface harmonics of degree  $n$  is again a spherical surface harmonic of degree  $n$ .

Spherical harmonics occur in potential theory. They occur in connection with Laplace's equation not only in spherical coordinates but also in spheroidal coordinates (spheroidal harmonics) and confocal coordinates (ellipsoidal surface harmonics). In spherical coordinates, spherical surface harmonics occur in connection with Laplace's and Poisson's equations, the wave equation, and the Schrödinger equation. In mathematical physics, spherical harmonics appear in the theories of gravitation, electricity and magnetism, hydrodynamics, and in other fields. [A.Er.]

**Sphingolipid** Any lipid containing the long-chain amino alcohol sphingosine (structure **1**) or a variation of it, such as dihydrosphingosine, phytosphingosine (structure **2**), or dehydrophy-

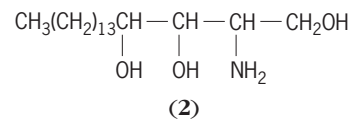
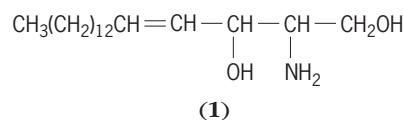

tosphingosine. Sphingosine itself is synthesized by condensing a long-chain fatty acid with the amino acid serine.

Sphingosine is converted into a variety of derivatives to form the family of sphingolipids. The simplest form is a ceramide which contains a sphingosine and a fatty acid residue joined by an amide linkage. Ceramide is the basic building block of practically all of the naturally occurring sphingolipids. It can be further modified by the addition of a phosphorylcholine at the primary alcohol group to form sphingomyelin, a ubiquitous phospholipid in the plasma membranes of virtually all cells. Modification of a ceramide by addition of one or more sugars at the primary alcohol group converts it to a glycosphingolipid, which occurs widely in both the plant and animal kingdoms. See GLYCOSIDE; LIPID.

Sphingolipids participate in diverse cellular functions. A number of inheritable diseases that can cause severe mental retardation and early death occur as the result of a deficiency in one or more of the degradative enzymes, resulting in the accumulation of a particular sphingolipid in tissues. These diseases are collectively called sphingolipidoses and include Niemann-Pick disease, Gaucher disease, Krabbe disease, metachromatic leukodystrophy, and several forms of gangliosidoses, such as

Tay-Sachs disease. Functionally, glycosphingolipids are known to serve as important cell-surface molecules for mediating cell-to-cell recognition, interaction, and adhesion. They also serve as receptors for a variety of bacterial and viral toxins. Many glycosphingolipids can modulate immune responses as well as the function of hormones and growth factors by transmitting signals from the exterior to the interior of the cell. A number of glycolipids are also found to participate in a variety of immunological disorders by serving as autoantigens. Other sphingolipids and their metabolites may serve as second messengers in several signaling pathways that are important to cell survival or programmed cell death (apoptosis). See AUTOIMMUNITY; METABOLIC DISORDERS.

[R.K.Y.]

**Spica** A 1st-magnitude star in the constellation Virgo. Spica ( $\alpha$  Virginis) is a hot main-sequence star of spectral type B1, effective temperature about 25,000 K (45,000°F), at a distance of 80 parsecs from the Sun ( $2.59 \times 10^{15}$  km or  $1.61 \times 10^{15}$  mi). See SPECTRAL TYPE.

It is a double-line spectroscopic binary with an orbital period of almost exactly 4 days. The system constitutes an example of an ellipsoidal variable, where the separation between the two stars is so small that powerful tidal forces distort the stars. The changing aspect of the primary as seen from Earth causes light variations with a period equal to the orbital period. The separation between the two stars is only about 3.5 times the radius of the primary. The primary itself is an intrinsic variable of the  $\beta$  Cephei type and is pulsating with a period of about 4 h. See BINARY STAR; STAR; VARIABLE STAR.

[D.W.L.]

**Spice and flavoring** Ingredients added to food to provide all or a part of the flavor. Spices are pungent or aromatic substances of vegetable origin used in foods at levels that yield no significant nutritive value. Flavor is the perception of those characteristics of a substance taken orally that affect the senses of taste and olfaction. The term flavoring refers to a substance which may be a single chemical species or a blend of natural or synthetic chemicals whose primary purpose is to provide all or part of the particular flavor effect to any food or other product taken orally. Flavorings are categorized by source: animal, vegetable, mineral, and synthetic. See OLFACTION; TASTE.

Other than by source, flavorings can be divided into two groups; one group affects primarily the sense of taste, and the other affects primarily the sense of olfaction. The members of the first group are called seasonings, the members of the second group are called flavors. The same terms can be used to divide flavorings in another way. The term flavors can be applied to those products which provide a characterizing flavor to a food or beverage. The term seasoning can then be applied to those products which modify or enhance the flavor of a food or beverage—spices added to meats, blends added to potato chips, lemon added to apple pie.

In the United States most flavorings are processed. Therefore another classification is by method of manufacture. Chemicals are produced by chemical synthesis or physical isolation and include such substances as vanillin, salt, monosodium glutamate, citric acid, and menthol. Concentrates are powders manufactured by dehydrating vegetables, such as onions and garlic, or concentrated fruit juices. Condiments are single ingredients or blends of flavorful foods, spices, and seasonings, some of which may have been derived by fermentation, enzyme action, roasting, or heating. They are usually designed to be added to prepared food at the table (for example, chutney, vinegar, soy sauce, prepared mustard). Other manufactured flavorings include essential oils, hydrolyzed plant proteins, process flavors, and compounded or blended flavorings. See ESSENTIAL OILS.

Spices are natural substances that have been dehydrated and consist of whole or ground aromatic and pungent parts of plants, for example, anise, cinnamon, dill, nutmeg, and pepper. Such spices are also classified as herbs if grown in temperate climates.

Extracts are natural substances produced by extraction from solutions of the sapid constituents of spices and other botanicals in food-grade solvents. They are also available as synthetics.

[E.J.M.]

**Spilite** An aphanitic (microscopically crystalline) to very-fine-grained igneous rock, with more or less altered appearance, resembling basalt but composed of albite or oligoclase, chlorite, epidote, calcite, and actinolite.

In spite of the highly sodic plagioclase, spilites are generally classed with basalts because of the low silica content (about 50%). They also retain many textural and structural features characteristic of basalt.

Spilites are found most frequently as lava flows and more rarely as small dikes and sills. Spilitic lavas typically show pillow structure, in which the rock appears composed of closely packed, elongated, pillow-shaped masses up to a few feet across. Pillows are typical of subaqueous lava flows. Vesicles, commonly filled with various minerals, may give the rock an amygdaloidal structure. See AMYGDULE; BASALT; IGNEOUS ROCKS.

[W.I.R.]

**Spin (quantum mechanics)** The intrinsic angular momentum of a particle. It is that part of the angular momentum of a particle which exists even when the particle is at rest, as distinguished from the orbital angular momentum. The total angular momentum of a particle is the sum of its spin and its orbital angular momentum resulting from its translational motion. The general properties of angular momentum in quantum mechanics imply that spin is quantized in half integral multiples of  $\hbar$  ( $=h/2\pi$ , where  $h$  is Planck's constant); orbital angular momentum is restricted to half even integral multiples of  $\hbar$ . A particle is said to have spin  $3/2$ , meaning that its spin angular momentum is  $3/2$ . See ANGULAR MOMENTUM.

A nucleus, atom, or molecule in a particular energy level, or a particular elementary particle, has a definite spin. The spin is an intrinsic or internal characteristic of a particle, along with its mass, charge, and isotopic spin. See QUANTUM MECHANICS; SYMMETRY LAWS (PHYSICS).

[C.J.G.]

**Spin glass** One of a wide variety of materials which contain interacting atomic magnetic moments and also possess some form of disorder, in which the temperature variation of the magnetic susceptibility undergoes an abrupt change in slope, that is, a cusp, at a temperature generally referred to as the freezing temperature. At lower temperatures the spins have no long-range magnetic order, but instead are found to have static or quasistatic orientations which vary randomly over macroscopic distances. The latter state is referred to as spin-glass magnetic order. Spin-glass ordering is usually detected by means of magnetic susceptibility measurements, although additional data are required to demonstrate the absence of long-range order. Closely related susceptibility cusps can also be observed by using neutron diffraction. It is not generally agreed whether spin glasses undergo a phase transition or not. See MAGNETIC SUSCEPTIBILITY; NEUTRON DIFFRACTION; PHASE TRANSITIONS.

[R.E.W.]

**Spin label** A molecule which contains an unpaired electron spin which can be detected with electron spin resonance (ESR) spectroscopy. Molecules are labeled when an atom or group of atoms which exhibits some unique physical property is chemically bonded to a molecule of interest. Groups containing unpaired electrons include organic free radicals and a variety of types of transition-metal complexes (such as vanadium, copper, iron, and manganese). Through analysis of ESR spectra, rates of molecular motion whose motion is restrained by surrounding molecules can be determined.

Analysis of the rate and type of motion of a spin label is important for a wide variety of biological problems. The type of label used in these studies is generally a nitroxide free radical. Spin-labeling studies provide a powerful technique for the study of the

geometry and dimensions of receptors in enzymes. Spin labels have been used extensively to study the structure of membranes, and can provide important information about the organization and rates of motion in membranes. Spin labels have also been used to study the structure and organization of synthetic polymers and to study phase transitions. See CELL MEMBRANES; ELECTRON PARAMAGNETIC RESONANCE (EPR) SPECTROSCOPY; ENZYME. [R.Kr.]

**Spinach** A cool-season annual of Asiatic origin. *Spinacia oleracea*, belonging to the plant order Caryophyllales. It is grown for its foliage and served as a cooked vegetable or as a salad. New Zealand spinach (*Tetragonia expansa*) and Mountain spinach (*Atriplex hortense*) are also called spinach but are less commonly grown. Spinach plants are usually dioecious. See CARYOPHYLLALES. [H.J.C.]

**Spinal cord** The portion of the central nervous system within the spinal canal of the vertebral column, that is, the entire central nervous system except the brain. The spinal cord extends from the foramen magnum at the base of the skull to a variable level of the spinal canal; it terminates at the lumbar level in humans and extends well into the caudal region in fishes.

The outer portion of the spinal cord is made up of nerve fibers most of which are oriented longitudinally and carry information between parts of the spinal cord, between spinal cord and brain, and between brain and spinal cord. The outer white matter is divided into dorsal, lateral, and ventral columns. The interior of the spinal cord consists of gray matter and is divided into a dorsal sensory horn (or column) and a ventral motor horn (or column). In the thoracic and lumbar regions of the cord there is also a small lateral horn (or column) which contains preganglionic sympathetic neurons. In the very center of the bilaterally symmetrical spinal cord is a small central canal, containing cerebrospinal fluid. See SYMPATHETIC NERVOUS SYSTEM.

Paired spinal nerves enter the spinal canal between each pair of vertebrae and connect with the spinal cord. The number of spinal nerves varies widely in vertebrates; in humans there are 31 pairs (8 cervical, 12 thoracic, 5 lumbar, 5 sacral, and 1 coccygeal). Each spinal nerve divides into a dorsal sensory root and a ventral motor root before entering the spinal cord. The motor neurons of the ventral horn, in addition to receiving synapses from dorsal root axons, also receive synaptic endings from neurons in other parts of the spinal cord and from long axons coming from the brain. The axons of the ventral horn neurons leave the cord through the ventral root of the spinal nerve and run with peripheral nerves to innervate the muscles of the body. With this complex synaptic and fiber organization, the spinal cord can act as the integrating center for spinal reflexes (such as the knee jerk reflex), send sensory information from the brain, and receive information from the brain to initiate or inhibit muscular activity. See MOTOR SYSTEMS; NERVOUS SYSTEM (VERTEBRATE); SENSATION. [D.B.W.]

**Spinal cord disorders** In addition to those disorders common to the brain, the spinal cord is subject to certain lesions because of its position or structure. A few of the more important are mentioned.

Spinal cord injury results from dislocations, fracture, or compression in many cases, but a special form, called spinal shock, may result from a severe blow without actual distortion of adjacent tissue. In this case, there is a temporary paralysis which gradually clears. In direct damage, the cord may be slightly, partially, or completely damaged at one or more levels. Typical motor and sensory losses follow, with a poor prognosis for recovery if the nerve tissue is severely injured.

A fairly common type of potential cord injury is seen in a number of cases of slipped disks, in which the inner, soft part of the vertebral column extrudes into the spinal canal. If this compresses the cord, functional loss of temporary or permanent

degree can follow; more often, pressure is exerted on spinal roots so that pain, numbness, and some type of muscle weakness intervene.

Spinal cord tumors are not infrequent and most of these are of two types, the metastatic, from a primary source elsewhere in the body, and the tumors of the meninges or connective tissue related to the cord. The latter include neurofibromas, meningiomas, and gliomas, which occur most often. The signs and symptoms and the extent of damage relate largely to the physical compression of the cord at a particular level. See TUMOR.

A few of the more common congenital defects involving the cord include an unclosed neural canal, or spina bifida, and duplicated or otherwise malformed cords, such as those caught in an external sac of other tissues, the meningocele.

Inflammations may result from known or unknown agents and in meningitis may involve primarily the coverings; in myelitis, the cord itself. The meningococcus, pneumococcus, streptococcus, tubercle bacillus, and other microorganisms frequently cause meningitis. The most widely known cause of myelitis, of course, is the poliomyelitis virus group.

An ill-defined group of disorders characterized by degeneration of nerve tracts or myelin sheaths of the cord is found more often than one would suspect. In these, some unknown or poorly understood mechanism causes the deterioration of cells and fibers so that function is altered, then lost, and the nervous tissue is either replaced by a scar or a softening of cystlike area remains. Multiple sclerosis, combined degeneration associated with pernicious anemia, Parkinson's disease, postinfectious encephalomyelitis, and syringomyelia are examples. See MULTIPLE SCLEROSIS; PARKINSON'S DISEASE; SPINAL CORD. [E.G.St.; N.K.M.]

**Spin-density wave** The ground state of a metal in which the conduction-electron-spin density has a sinusoidal variation in space, with a wavelength usually incommensurate with the crystal structure. This antiferromagnetic state normally occurs in metals, alloys, and compounds with a transition-metal component. It occurs also, however, in quasi-one-dimensional organic conductors. See ANTIFERROMAGNETISM; CRYSTAL STRUCTURE; ELECTRON SPIN; ORGANIC CONDUCTOR.

There are well over 100 materials which, over a temperature range, support a spin-density wave. These include some of the rare-earth elements of the lanthanide series and the 3d transition metals, manganese and chromium, the latter being the prototypical itinerant electron antiferromagnet. The occurrence of inelastic neutron-scattering peaks at incommensurate points indicates the existence of spin-density-wave fluctuations in some metals thought to be nonmagnetic (for example, copper and yttrium) when doped with magnetic impurities (manganese and gadolinium, respectively). This behavior suggests that the spin-density-wave instability may be common, even in nontransition metals. See RARE-EARTH ELEMENTS; TRANSITION ELEMENTS. [E.F.]

**Spinel** Any of a family of important  $AB_2O_4$  oxide minerals, where A and B represent cations. Spinel minerals are widely distributed in the earth, in meteorites, and in rocks from the Moon. While the ideal spinel formula is  $MgAl_2O_4$ , some 30 elements, with valences from 1 to 6, are known to substitute in the A or B cation sites, resulting in well over 150 synthetic compounds having the spinel crystal structure. The term spinel is derived from *spina* (Latin, thorn) in reference to its pointed octahedral, crystal habit, and also to its dendritic snowflake form in rapidly chilled high-temperature slags and lavas.

The named spinel minerals that have so far been recorded in nature are oxides that occur as a matrix of  $A^{2+}$  versus  $B^{3+}$  cations. Three spinel series evolve from the classification: spinel, magnetite, and chromite. In addition to these spinels, there are other oxide, sulfur (thiospinels), silicate, and rare selenide-bearing spinels, all of which have relatively simple end-member compositions. See MAGNETITE.

Aluminous spinels are highly refractory, vary from translucent to transparent, and vary from colorless to green, blue, brown, and black. All other oxide and thiospinels are opaque with metallic lusters. Mohs hardness varies from about 4.5 (linnaeite) to about 8 (spinel). Density is approximately 5 g/cm<sup>3</sup> (3 oz/in.<sup>3</sup>). Magnetite and maghemite are ferrimagnetic, with high saturation magnetizations and Curie temperatures of 580°C (1076°F) and 675°C (1247°F), respectively. See CURIE TEMPERATURE; FERROMAGNETISM; HARDNESS SCALES.

Spinel is widely employed to deduce the evolutionary history of rocks because compositions are extremely sensitive to environmental conditions of formation. Emery, the abrasive, is magnetite + corundum. Chromite is the chief source of chromium. Iron, titanium and vanadium are derived from magnetite, and zinc is extracted from franklinite. Spinel also occurs as a semiprecious gem, and it is widely employed as a mechanically robust ceramic. The compass used in ancient times was a mixture of magnetite and maghemite; the entire fields of rock magnetism and paleomagnetism as well as the recorded history of the Earth's magnetic field hinge on the magnetic properties of these inverse spinels. Maghemite is widely employed in magnetic recording tapes and magnetic colloids. See MINERALOGY; PALEOMAGNETISM; PETROLOGY. [S.E.H.]

**Spinicaudata** An order of fresh-water branchiopod crustaceans formerly included in the order Conchostraca. The entire body and its appendages are covered by a bivalve carapace up to about 17 mm (0.7 in.) long, hence the name clam shrimp. The carapace is often bilaterally compressed and usually displays several lines of growth. The head cannot be protruded. Reproduction is usually bisexual. All species frequent temporary pools in many parts of the world, but *Cyclestheria* also occurs in permanent waters. See BRANCHIOPODA. [G.Fr.]

**Spinning (metals)** A production technique for shaping and finishing metal. In the spinning of metal, a sheet is rotated and worked by a round-ended tool. The sheet is formed over a mandrel. Spinning may serve to smooth wrinkles in drawn parts, provide a fine finish, or complete a forming operation as in curling an edge of a deep-drawn part. Spun products range from precision reflectors and nose cones to kitchen utensils. See SHEET-METAL FORMING. [R.L.Fr.]

**Spinning (textiles)** The fabrication of yarn (thread) from either discontinuous natural fibers or bulk synthetic polymeric material. In a textile context the term spinning is applied to two different processes leading to the yarns used to make threads, cords, ropes, or woven or knitted textile products.

Natural fibers, such as wool, cotton, or linen, are generally found as short, entangled filaments. Their conversion into yarn is referred to as spinning. After a carding operation on the raw material to disentangle the short filaments, the filaments are drawn (drafted) to promote alignment in an overlapping pattern and then twisted to form, by mechanical interlocking of the discontinuous filaments, a resistant continuous yarn. See COTTON; LINEN; WOOL.

The term spinning is also used for the production of monofilaments from synthetic polymers—for example, polyamides or nylons, polyesters, and acrylics—or modified natural polymers, such as cellulose-rayon. Generally the monofilaments are stretched (drawn) to increase their strength by promoting molecular orientation and are wound as yarn which can be used directly for threads, cords, or ropes. Such yarn, however, is often cut into relatively short lengths (staple) and reformed by a process similar to that used for natural fibers into a yarn more suitable, in terms of appearance and feel, for making certain textile products. See MANUFACTURED FIBER; NATURAL FIBER; TEXTILE.

[J.M.Cha.]

**Spiral** A term used generically to describe any geometrical entity that winds about a central point or axis while also receding from it. Spiral staircases, helices, and nonplanar loxodromes (curves that intersect those of a given class at a constant angle, for example, rhumb lines, in case the curves are on a sphere whose meridians form the given class) are examples of spirals whose windings do not lie in a plane. See HELIX. [L.M.B.]

**Spiriferida** An extinct order of brachiopods, in the subphylum Rhynchonelliformea, that inhabited shallow seas of the Paleozoic and early Mesozoic. It was the most diverse group of spire-bearing brachiopods (those that contain a spirally coiled calcareous structure called the brachidium used to support the lophophore). Spiriferids also possess unequally biconvex valves that are externally smooth or radially ribbed. The valves are generally strophic (straight hinge) with a well-developed interarea commonly limited to the ventral valve. Shells may be punctate (possessing small perforations filled by outer epithelial tissue) or impunctate. Punctate shells arose in stratigraphically younger spiriferids; the presence or absence of punctae serves to distinguish two major taxonomic groups. Spiriferids were sessile, attached, epifaunal suspension feeders. Most had a functional pedicle, used for attachment to the substrate. See ARTICULATA (ECHINODERMATA); BRACHIOPODA. [M.E.P.]

**Spirometry** The measurement, by a form of gas meter, of volumes of gas that can be moved in or out of the lungs. The classical spirometer is a hollow cylinder (bell) closed at its top. With its open end immersed in a larger cylinder filled with water, it is suspended by a chain running over a pulley and attached to a counterweight. The magnitude of a gas volume entering or leaving is proportional to the vertical excursion of the bell. Volume changes can also be determined from measurements of flow, or rate of volume change, that can be sensed and recorded continuously by a transducer that generates an electrical signal. The flow signal can be continuously integrated to yield a volume trace.

The volume of gas moved in or out with each breath is the tidal volume; the maximal possible value is the vital capacity. Even after the most complete expiration, a volume of gas that cannot be measured by the above methods, that is, the residual volume, remains in the lungs. It is usually measured by a gas dilution method or by an instrument that measures blood flow in the lungs. Lung volumes can also be estimated by radiological or optical methods.

At the end of an expiration during normal resting breathing, the muscles of breathing are minimally active. Passive (elastic and gravitational) forces of the lungs balance those of the chest wall. In this state the volume of gas in the lungs is the functional residual capacity or relaxation volume. Displacement from this volume requires energy from natural (breathing muscles) or artificial (mechanical) sources. See RESPIRATION. [A.B.O.]

**Spirophorida** An order of sponges of the class Demospongiae, subclass Tetractinomorpha, with a globular shape and a skeleton of oxeas and triaenes as megascleres, and microspined, contorted, sigmalike microscleres. Members of this order range down to depths of at least 5900 ft (1800 m). See DEMOSPONGIAE. [W.D.H.]

**Spirotrichia** A major subclass of the class Ciliata which contains those ciliate Protozoa that are typified by conspicuous, compound ciliary structures. The structures are the cirri, which occur on the ventral surface of the body, and the buccal organelles, which include the undulating membrane and the adoral zone of membranelles. This group of ciliates is classified into six orders. (see respective articles):



- Subclass Spirotrichia
  - Order: Heterotrichida
    - Odontostomatida
    - Oligotrichida
    - Tintinnida
    - Entodiniomorpha
    - Hypotrichida

The orders in this subclass contain those organisms that are considered to be the most highly evolved ciliates. [J.O.C.]

**Spirurida** An order of nematodes in which the labial region is usually provided with two lateral labia or pseudolabia; in some taxa there are four or more lips; rarely lips are absent. Because of the variability in lip number, there is variation in the shape of the oral opening, which may be surrounded by teeth. The amphids are most often laterally located; however, in some taxa they may be located immediately posterior to the labia or pseudolabia. The stoma may be cylindrical and elongate or rudimentary. The esophagus is generally divisible into an anterior muscular portion and an elongate swollen posterior glandular region, where the multinucleate glands are located. Ecdysis larvae are usually provided with a cephalic spine or hook and a porelike phasmid on the tail.

All known spirurid nematodes utilize an invertebrate in their life cycle; the definitive hosts are mammals, birds, reptiles, and rarely amphibians. The order contains four superfamilies: Spiruroidea, Physalopteroidea, Filarioidea, and Drilonematodea.

**Spiruroidea.** The Spiruroidea comprise parasitic nematodes whose life cycle always requires an intermediate host for larvae to the third stage. The definitive hosts are mammals, birds, fishes, reptiles, and rarely amphibians; and spirurids may be located in the host's digestive tract, eye, or nasal cavity or in the female reproductive system. Morphologically, the lip region is variable in Spiruroidea, ranging from four lips to none. When lips are present, the lateral lips are well developed and are referred to as pseudolabia. The cephalic and cervical region may be ornamented with cordons, collarettes, or cuticular rings. The stoma is always well developed and is often provided with teeth just inside the oral opening. In birds the nematodes are often associated with the gizzard, and the damage caused results in death, generally by starvation. When the muscles of the gizzard are destroyed, seeds pass intact and cannot be digested.

This superfamily contains the largest of all known nematodes, *Placentonema gigantissima*, parasitic in the placenta of sperm whales. Mature females attain a length of 26 ft (8 m) and a diameter of 1 in. (2.5 cm). The adult female has 32 ovaries, which produce great numbers of eggs. [A.R.M.]

**Filarioidea.** The Filarioidea contain highly specialized parasites of most groups of vertebrates. They are particularly common in amphibians, birds, and mammals. While they cannot be classified as completely harmless, most of the many hundreds of known species are not associated with any recognized disease. A limited number of species produce serious diseases in humans, and a few others produce serious diseases in domestic or wild animals. The filarial parasites of humans are found almost exclusively in the tropics, with some extension into the subtropics.

There are no conspicuous divisions into distinct body regions. Sexual dimorphism is the rule; in common with other nematodes, the female filarioid is at least twice as long as the male, and often the difference is much greater. The adult worms are found in a wide variety of places in the body of the vertebrate host, but each species has its preferred host and preferred location within that host.

All the known filariae require a bloodsucking arthropod intermediate host, usually an insect and commonly a dipteran, in which to complete embryonation. The microfilariae are ingested

as the arthropod feeds. After embryonation is completed, the resulting infective larvae gain entrance into the definitive vertebrate in association with the next feeding of the arthropod. See NEMATODA.

**Filariasis.** Filariasis is a disease caused by Filarioidea in humans or lower animals. The term is loosely used to indicate mere infection by such organisms. In human medicine, filariasis commonly refers to the disease caused by, or to infection with, one of the mosquito-borne, elephantoid-producing filarioids—most frequently *Wuchereria bancrofti*, less frequently *Brugia malayi*, and more recently *B. timori*. The only specific laboratory aid to diagnosis is the detection and identification of the microfilariae.

**Onchocerciasis.** This disease is caused by *Onchocerca volvulus* in the subcutaneous lymphatics. It is characterized by subcutaneous nodules which are most conspicuous where the skin lies close over bony structures, via cranium, pelvic girdle, joints, and shoulder blades. When they are on the head, the microfilariae reach the eyes. Ocular disturbances vary from mild transient blurry vision to total and permanent blindness.

**Loa loa.** The African eye worm, *Loa loa*, is the filarioidean worm most commonly acquired by Caucasian immigrants, including missionaries, in Africa. Transmission is by daytime-feeding sylvan deer-flies, genus *Chrysops*. The only preventive measures are protective clothing, including head nets. Repellents have some value. Fortunately, serious damage is rare even when the worm gets into the eye. The areas of pitting edema known as calabar swellings are painful and diagnostic. They commonly occur on the wrists, hands, arms, or orbital tissues. [G.F.O.]

**Splachnales** An order of the true mosses (subclass Bryidae), whose members are remarkable perennial plants that grow mainly on nitrogenous substrates, such as dung, and show considerable differentiation of neck tissue below the spore-bearing part of the capsule. The order consists of two families with about eight genera.

The plants are gregarious or dense-tufted, erect, and often forked. The leaves are soft, lanceolate or obovate, sometimes bordered at the margins, and commonly toothed. The single costa may be excurrent or terminate at or below the apex. The setae are elongate and the capsules erect with a noticeably differentiated neck. Stomata are very numerous in the neck, and have two guard cells. A single peristome is usually present, entire or forked with 16 teeth sometimes paired or joined in twos and fours. See BRYIDAE; BRYOPHYTA; BRYOPSIDA. [H.Cr.]

**Spleen** An organ of the circulatory system present in most vertebrates, lying in the abdominal cavity usually in close proximity to the left border of the stomach.

In humans the spleen normally measures about 1 by 3 by 5 in. (2.5 × 7.5 × 12.5 cm) and weighs less than 1/2 lb (230 g). It is a firm organ with an oval shape and is indented on its inner surface to form the hilum, or stalk of attachment to the peritoneum. This mesentery fold also carries the splenic artery and vein to the organ.

The spleen is an important part of the blood-forming, or hematopoietic, system; it is also one of the largest lymphoid organs in the body and as such is involved in the defenses against disease attributed to the reticuloendothelial system. Although the chief functions of the spleen appear to be the production of lymphocytes, the probable formation of antibodies, and the destruction of worn-out red blood cells, other less well-understood activities are known. For example, in some animals it may act as a reservoir for red blood cells, contracting from time to time to return these cells to the bloodstream as they are needed. In the fetus and sometimes in later life, the spleen may be a primary center for the formation of red blood cells. Another function of the spleen is its role in biligenesis. Because the spleen destroys erythrocytes, it is one of the sites where extrahepatic bilirubin is formed. See BILIRUBIN; SPLEEN DISORDERS. [W.J.B.]

**Spleen disorders** The spleen is rarely the site of primary disorders except those of vascular origin, but it is frequently involved in systemic inflammations, metabolic diseases, and generalized blood disorders.

Among vascular disturbances, acute and chronic congestion are prominent, particularly chronic congestion caused by cardiac failure, cirrhosis of the liver, and obstruction of the blood flow from the spleen by thrombi, scarring, or tumor tissue. Obstruction of the splenic artery or its branches by thrombi may result in an infarct caused by either cardiac or blood disease.

Inflammations include acute and chronic forms. The characteristic engorgement of blood often causes a marked enlargement of the organ. Bacteremias frequently produce this enlargement, or splenomegaly, and inflammation, but any severe infectious disease such as diphtheria or pneumonia may do so.

The leukemias, especially when of the lymphocytic or neutrophilic varieties cause some of the most prominent cases of splenomegaly as well as other changes.

Tumors originating in the spleen are rare and usually limited to such benign growths as hemangiomas, lymphangiomas, and fibromas, but malignant lymphomas and lymphosarcomas also occur. Secondary tumors, which originate elsewhere and metastasize to the spleen, are not uncommon, particularly the lymphoma group. See SPLEEN. [E.G.St./N.K.M.]

**Splines** A series of projection and slots used instead of a key to prevent relative rotation of cylindrically fitted machine parts. Splines are several projections machined on the shaft; the shaft fits into a mating bore called a spline fitting. Splines are made in two forms, square and involute, as illustrated. Since there are several projections (integral keys) to share the force in transmitting power, the splines can be shallow, thereby not weakening the shaft as much as a standard key.

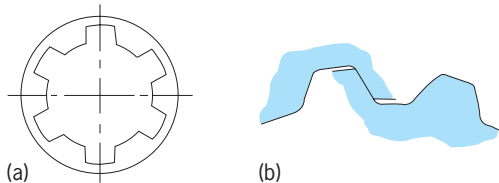

Diagrams of (a) square spline and (b) involute spline profile.

Three classes of fits are used for square splines: sliding (as for gear shifting) under load, sliding when not loaded, and permanent fit. Square splines have been used extensively for machine parts. In the automotive industry, square splines have been replaced generally by involute splines.

Involute splines are used to prevent relative rotation of cylindrically fitted machine parts and have the same functional characteristics as square splines. The involute spline, however, is like an involute gear, and the spline fitting (internal part) is like a mating internal gear. See MACHINE KEY. [P.H.B.]

**Spodumene** The name given to the monoclinic lithium pyroxene  $\text{LiAl}(\text{SiO}_3)_2$ . Spodumene commonly occurs as white to yellowish prismatic crystals, often with a “woody” appearance.

Spodumene is usually found as a constituent in certain granitic pegmatites. The emerald-green variety, hiddenite, and a lilac variety, kunzite, are used as precious stones. Spodumene from pegmatites is used as an ore for lithium. See LITHIUM; PYROXENE. [G.W.DeV.]

**Spongiomorphida** A small extinct order of Triassic and Jurassic marine invertebrate fossils of uncertain biologic affinities. The spongiomorphs had calcareous skeletons composed of small vertical rods called pillars and interconnecting horizontal rods called trabeculae or synapticulae. The pillars consist of upwardly inflected cone-in-cone layers of fibrous calcareous

deposits. The trabeculae are formed from thickened zones at the base of the flare of the cones in the pillars. Spongiomorphs were sessile, benthonic, shallow marine organisms associated with calcareous deposits, especially reefs. See HYDROZOA. [J.St.J.]

**Sporozoa** A subphylum of Protozoa, typically with spores. The spores are simple and have no polar filaments. There is a single type of nucleus. There are no cilia or flagella except for flagellated microgametes in some groups. In most Sporozoa there is an alternation of sexual and asexual stages in the life cycle. In the sexual stage, fertilization is by syngamy, that is, the union of male and female gametes. All Sporozoa are parasitic. The subphylum is divided into three classes—Telosporaea, Toxoplasmea, and Haplosporea. See HAPLOSPOREA; PROTOZOA; TELOSPOREA; TOXOPLASMEA. [N.D.L.]

**Sports medicine** A branch of medicine concerned with the effects of exercise and sports on the human body, including treatment of injuries. Sports medicine can be divided into three general areas: clinical sports medicine, sports surgery, and the physiology of exercise. Clinical sports medicine includes the prevention and treatment of athletic injuries and the design of exercise and nutrition programs for maintaining peak physical performance. Sports surgery is also concerned with the treatment of injuries from contact (human or object) sports. Exercise physiology, a growing field of sports medicine, involves the study of the body's response to physical stress. It comprises the science of fitness, the preservation of fitness, and the role of fitness in the prevention and treatment of disease. [O.A.]

**Spot welding** A resistance-welding process in which coalescence is produced by the flow of electric current through the resistance of metals held together under pressure. Usually the upper electrode moves and applies the clamping force. Pressure must be maintained at all times during the heating cycle to prevent flashing at the electrode faces. Electrodes are water-cooled and are made of copper alloys because pure copper is soft and deforms under pressure. The electric current flows through at least seven resistances connected in series for any one weld (see illustration). After the metals have been fused together, the

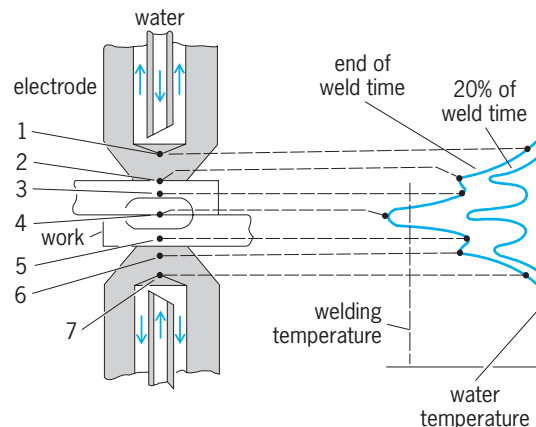

Distribution of temperature in local (numbered) elements of a spot-welding operation.

electrodes usually remain in place sufficiently long to cool the weld. See RESISTANCE WELDING; WELDING AND CUTTING OF METALS. [E.J.L.]

**Spray flow** A special case of a two-phase (gas and liquid) flow in which the liquid phase is the dispersed phase and exists in the form of many droplets. The gas phase is the continuous

phase, so abstract continuous lines (or surfaces) can be constructed through the gas at any instant without intersection of the droplets. The droplets and the gas have velocities that can be different, so both phases can move through some fixed volume or chamber and the droplets can move relative to the surrounding gas. See GAS; LIQUID; PARTICULATES; TWO-PHASE FLOW.

Spray flows have many applications. Sprays are used to introduce liquid fuel into the combustion chambers of diesel engines, turbojet engines, liquid-propellant rocket engines, and oil-burning furnaces. They are used in agricultural and household applications of insecticides and pesticides, for materials and chemicals processing, for fire extinguishing, for cooling in heat exchangers, for application of medicines, and for application of coatings (including paint and various other types of layered coatings). Common liquids (such as water, fuels, and paints) are used in sprays. It is sometimes useful to spray uncommon liquids such as molten metals. In the various applications, the approximately spherical droplets typically have submillimeter diameters that can be as small as a few micrometers. See METAL COATINGS.

Sprays are formed for industrial, commercial, agricultural, and power generation purposes by injection of a liquid stream into a gaseous environment. In addition, sprays can form naturally in a falling or splashing liquid. Injected streams of liquid tend to become unstable when the dynamic pressure (one-half of the gas density times the square of the liquid velocity) is much larger than the coefficient of surface tension divided by the transverse dimension. Typically, the liquid stream disintegrates into ligaments (coarse droplets) and then into many smaller spherical droplets. The breakup (or atomization) process is faster at higher stream velocity, and the final droplet sizes are smaller for higher stream velocities. Spray droplet sizes vary and typically are represented statistically by a distribution function. The number of droplets in a spray can be as high as a few million in a volume smaller than a liter. See ATOMIZATION; JET FLOW; SURFACE TENSION. [W.A.Si.]

**Spread spectrum communication** A means of communicating by purposely spreading the spectrum (frequency extent or bandwidth) of the communication signal well beyond the required bandwidth of the data modulation signal. Spread spectrum signals are typically transmitted by electromagnetic waves in free space, with usage in both nonmilitary and military systems.

Motivation for using spread spectrum signals is based on the following:

1. Spread spectrum systems have the ability to reject hostile as well as unintentional jamming by interfering signals.
2. Spread spectrum signals have a low probability of being intercepted or detected since the power in the transmitted wave is "spread" over a large bandwidth or frequency extent.
3. Since these signals cannot be readily demodulated without knowing the code and its precise timing, a level of message privacy is obtained.
4. The wide bandwidth of the spread spectrum signals provides tolerance to multipath (reflected waves that typically take longer to arrive at the receiver than the direct desired signal so that the two can be distinguished).
5. A high degree of precision in ranging (distance measuring) can be obtained by using one type of spread spectrum signaling called direct sequence, with applications to navigation.
6. Multiple access, or the ability to send many independent signals over the same frequency band, is possible in spread spectrum signaling.

See COMMUNICATIONS SCRAMBLING; ELECTRICAL INTERFERENCE; ELECTRONIC WARFARE; RADIO-WAVE PROPAGATION.

There are four generic types of spread spectrum signals: direct sequence (DS) or pseudonoise (PN), frequency hopping (FH), linear frequency modulation (chirp), and time hopping (TH).

The first two methods are much more commonly used today than the other two.

Direct sequence modulation is characterized by phase-modulating a sine wave by an unending string of pseudonoise code chips (symbols of much smaller time duration than a bit). This unending string is typically based on a pseudonoise code that generates an apparently random sequence of code chips that repeats only after the pseudonoise code period. Digital data representing the information to be transmitted are binary phase-shift keyed onto the carrier. Then the pseudonoise code generator also binary phase-shift keys the carrier, and the composite signal is transmitted. See PHASE MODULATION.

In a direct-sequence system, the phase of the carrier changes pseudorandomly with the pseudonoise code. In a frequency-hopping system, the frequency of the carrier changes according to a pseudonoise code with a consecutive group of pseudonoise code chips defining a particular frequency. Typically either multiple frequency-shift keying (MFSK) or differential phase-shift keying (DPSK) is used as the data modulation. Multiple frequency-shift keying is a modulation scheme in which one of a number of tones (2, 4, 8, and so forth) is transmitted at a given time according to a group of consecutive data bits ( $n$  bits produce  $2^n$  tones). At each hop frequency one of the  $2^n$  tones is selected according to the  $n$  bits, and one of  $2^n$  corresponding frequencies, centered about the hop frequency, is transmitted. In conjunction with frequency hopping, multiple frequency-shift keying would imply, at each instant of time, a given carrier frequency that depends on the hop-pseudonoise code sequence and the consecutive group of the most recent  $n$  data bits. Differential phase-shift keying is similar to phase-shift keying except that only the differences of the phases (not the actual phases) are encoded and noncoherent techniques (not requiring a carrier loop) can be employed at the receiver.

A device called a frequency synthesizer achieves the actual frequency selection. For example, a 12-bit segment of the pseudonoise code may correspond to one of  $2^{12}$  different frequencies, so that one of approximately 4000 ( $2^{12}$ ) frequencies is selected each hop time. Frequency synthesizers are used in both the transmitter and the receiver. The transmitter modulates the data by typically using either multiple frequency-shift keying or differential phase-shift keying modulation, which in turn is frequency-hopped by the frequency synthesizer. At the receiver, an acquisition process is utilized to synchronize the receiver frequency synthesizer with the received hopping signal, and then a tracking system maintains synchronism. Finally a bit synchronizer provides timing for the data demodulator which demodulates the original, transmitted data bits.

An important aspect of spread spectrum communications is multiple access. Code-division multiple access (CDMA) is a method by which spread spectrum signals are utilized to allow the use of multiple signals over the same frequency band. The two common types are direct-sequence CDMA (DS/CDMA) systems and frequency-hopped CDMA (FH/CDMA) systems. See MULTIPLEXING AND MULTIPLE ACCESS.

Although the early evolution of spread spectrum systems was motivated primarily by military interests, nonmilitary applications have enjoyed considerable development. One important example that has both military and nonmilitary users is the Global Positioning Systems (GPS), which is a direct-sequence, CDMA, spread spectrum system for transmitting the satellite ranging codes. See SATELLITE NAVIGATION SYSTEMS.

The space shuttle utilizes a direct-sequence spread spectrum communication system on its forward link. It relays data through the geostationary *Tracking and Data Relay Satellites (TDRS)*. Another example in the military arena is the Milstar system, which utilizes frequency-hopping spread spectrum communication over a very large bandwidth to achieve considerable immunity from unfriendly jamming signals. See MILITARY SATELLITES; SPACE COMMUNICATIONS; SPACE SHUTTLE.

Globalstar is a commercial satellite system that utilizes a CDMA signal structure along with a bent-pipe transponder to provide communications much like a cell phone, except that Globalstar is satellite-based. Currently the handsets are considerably more expensive than cell phones. However, these phones have the advantage that they can be reached beyond the range of cell phones. See COMMUNICATIONS SATELLITE.

The main reception source of news stories for radio and newspapers is small spread spectrum ground stations. Another application of code-division multiple access is transmission directly by satellite from a bank's automatic teller machine to that bank's computer facility. A home security system using spread spectrum techniques imposed on the ac power line has been used in Japan. Many cordless telephones utilize direct-sequence spread spectrum techniques. [J.K.H.]

**Spring (hydrology)** A place where groundwater discharges upon the land surface because the natural flow of groundwater to the place exceeds the flow from it. Springs are ephemeral, discharging intermittently, or permanent, discharging constantly. Springs are usually at mean annual air temperatures. The less the discharge, the more the temperature reflects seasonal temperatures. Spring water usually originates as rain or snow (meteoric water).

Hot-spring water may differ in composition from meteoric water through exchange between the water and rocks. Common minerals consist of component oxides. Oxygen of minerals has more  $^{18}\text{O}$  than meteoric water. Upon exchange, the water is enriched in  $^{18}\text{O}$ . Most minerals contain little deuterium, so that slight deuterium changes occur. Some hot-spring waters are acid from the oxidation of hydrogen sulfide to sulfate.

Mineral spring waters have high concentrations of solutes and wide ranges in chemistry and temperatures; hot mineral springs may be classified as hot springs as well as mineral springs. Most mineral springs are high either in sodium chloride or sodium bicarbonate (soda springs) or both; other compositions are found, such as a high percentage of calcium sulfate from the solution of gypsum.

The chemical compositions of spring waters are seldom in chemical equilibrium with the air. Groundwaters whose recharge is through grasslands may contain a thousand times as much  $\text{CO}_2$  as would be in equilibrium with air, and those whose recharge is through forests may contain a hundred times as much as would be in equilibrium with air. Sulfate in groundwater may be reduced in the presence of organic matter to  $\text{H}_2\text{S}$ , giving some springs the odor of rotten eggs. See GEYSER; GROUND-WATER HYDROLOGY. [I.B.]

**Spring (machines)** A machine element for storing energy as a function of displacement. Force applied to a spring member causes it to deflect through a certain displacement, thus absorbing energy.

A spring may have any shape and may be made from any elastic material. Even fluids can behave as compression springs and do so in fluid pressure systems. Most mechanical springs take on specific and familiar shapes such as helix, flat, or leaf springs. All mechanical elements behave to some extent as springs because of the elastic properties of engineering materials.

The most frequent use of springs is to supply motive power in a mechanism. Common examples are clock and watch springs, toy motors, and valve springs in auto engines. A special case of the spring as a source of motive power is its use for returning displaced mechanisms to their original positions, as in the door-closing device, the spring on the cam follower for an open cam, and the spring as a counterbalance. Frequently a spring in the form of a block of very elastic material such as rubber absorbs shock in a mechanism. Springs also serve an important function in vibration control. See SHOCK ABSORBER; SHOCK ISOLATION.

Springs may be classified into six major types according to their shape. These are flat or leaf, helical, spiral, torsion bar, disk,

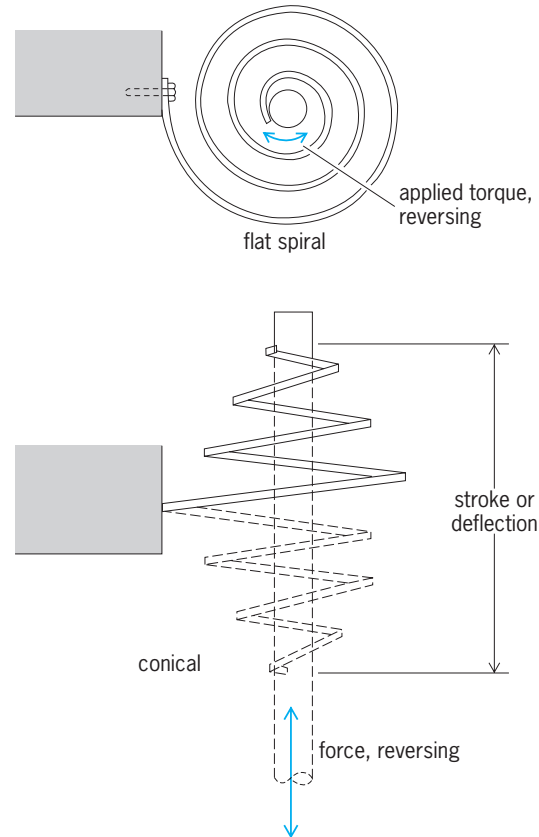

**Spiral spring is unique in responding to torsional or translation forces.**

and constant force springs. A leaf spring is a beam of cantilever design with a deliberately large deflection under a load. The helical spring consists essentially of a bar or wire of uniform cross section wound into a helix. In a spiral spring, the spring bar or wire is wound in an Archimedes spiral in a plane. A spiral spring is unique in that it may be deflected in one of two ways or a combination of both of them (see illustration). A torsion bar spring consists essentially of a shaft or bar of uniform section. The disk spring consists essentially of a disk or washer supported at the outer periphery by one force and an opposing force on the center or hub of the disk. A constant force spring is used when a constant force must be applied regardless of displacement. [L.S.L.]

**Spruce** Evergreen tree belonging to the genus *Picea* of the pine family. The needles are single, usually four-sided, and borne on little peglike projections; the cones are pendulous. Resin ducts in the wood may be seen with a magnifying lens, but they are fewer than in *Pinus*.

The white spruce (*P. glauca*), ranging from northern New England to the Lake States and Montana and northward into Alaska, is distinguished by the somewhat bluish cast of its needles, small cylindrical cones, and gray or pale-brown twigs without pubescence (hairs). Red spruce (*P. rubens*) is a similar tree but with greener foliage; smaller, more oval cones; and more or less pubescent twigs. Occurring naturally with white spruce in the northeastern United States and adjacent Canada, red spruce extends southward along the Appalachians into North Carolina. Black spruce (*P. mariana*) ranges from northern New England and Newfoundland to Alaska. However, it occurs sparingly in the Appalachians to West Virginia. The cones are smaller than in the white and red species and are egg-shaped or nearly spherical and persistent. The twigs are pubescent.

Blue spruce (*P. pungens*), also known as Colorado blue spruce, is probably the best known of the western species because of its

wide use as an ornamental tree. The twigs are glabrous (without pubescence). Engelmann spruce (*P. engelmanni*) has needles usually of a deep blue-green color, sometimes much like those of the blue spruce but the young twigs are slightly hairy. The cones, although cylindrical, are smaller than in blue spruce. This species is also a Rocky Mountain tree like the blue spruce, but it is more widely distributed from British Columbia to Arizona and also in the mountains of Oregon and Washington. Sitka spruce (*P. sitchensis*) is the largest spruce in the Northern Hemisphere. The leaves have a pungent odor, are considerably flattened, and stand out from the twig in all directions. It ranges from Alaska to northern California. The Norway spruce (*P. abies*), the common spruce of Europe, is much planted in the United States for timber, as well as for ornamental purposes. It can be recognized by the dark-green color of the leaves; glabrous, pendent, short branchlets; and large cones, usually near the top of the tree. See PINALES. [A.H.G./K.P.D.]

**Sputtering** The ejection of material from a solid or liquid surface following the impact of energetic ions, atoms, or molecules. Sputtering is the basis of a large variety of methods for the synthesis and analysis of materials.

Sputtering can be classified according to the mode of energy loss of the incident (primary) particle. Nuclear stopping involves billiard ball-like atomic collisions in which a significant momentum transfer occurs; it dominates for incident ion energies below about 1–2 keV per nucleon. Electronic stopping involves collisions in which little momentum is transferred, but significant electronic excitation is caused in the target; it dominates for energies above about 10 keV per nucleon.

Sputtering has also been classified into physical and chemical sputtering. Physical sputtering involves a transfer of kinetic energy from the incident particle to the surface atoms leading to ejection, while chemical sputtering occurs when the incident species react chemically with the target surface leading to the formation of a volatile reaction product which evaporates thermally from the surface.

Sputtering of complex materials—metal alloys, inorganic and organic compounds and polymers, and minerals—can produce complex results. The relative efficiencies with which different elemental species are ejected following ion impact can differ, giving rise to preferential sputtering. When preferential sputtering occurs, the species sputtered with the lower efficiency accumulates to a higher concentration at the surface. Subsurface collisions of the incident ion cause atomic motion leading to atomic mixing of surface and subsurface layers over the ion penetration depth. Chemical bonds can be broken, and sometimes new bonds can be formed. Sputtering of solids which have multiple phases, or which are polycrystalline, leads to the development of surface roughness due to the differences in sputtering yields between different regions. See ION BEAM MIXING.

Sputtering is widely used in the manufacture of semiconductor devices; sputter deposition is used to deposit thin films with a high degree of control by sputtering material from a target onto a substrate; sputter etching is used to remove unwanted films in a reversal of this process. Reactive ion etching is a chemical sputtering process in which chemically active sputtering species form volatile compounds with the target material leading to significantly higher etch rates and great selectivity. For example, fluorine-containing compounds etch silicon rapidly by forming volatile silicon tetrafluoride but do not etch aluminum or other metals used to make electrical interconnections between devices on a semiconductor chip because the metal fluorides are involatile. Sputter etching and reactive ion etching have the useful advantage of being anisotropic—that is, they etch only in one direction so that very fine surface features can be delineated. See CRYSTAL GROWTH; GLOW DISCHARGE; INTEGRATED CIRCUITS.

In materials characterization, sputtering is used to remove surface material controllably, allowing in-depth concentration pro-

files of chemical composition to be determined with a surface-sensitive sampling technique. See SURFACE PHYSICS. [PWi.]

**Squalene** A  $C_{30}$  triterpenoid hydrocarbon. Squalene is made up of six (*trans*-1,4)-isoprene units linked as two farnesyl (head-to-tail) groups that are joined tail to tail in the center (see illustration).

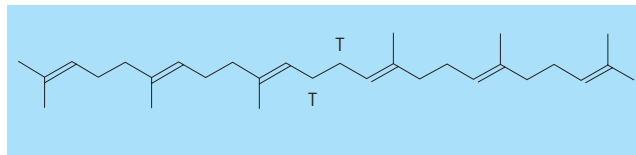

Structure of squalene; the tail-to-tail joining is indicated by T.

Squalene can be isolated in large quantities from the liver oils of the shark and other elasmobranch fishes, and is a relatively inexpensive compound. Complete hydrogenation of the liver oil gives the saturated hydrocarbon squalane, which is used in lotions and skin lubricants.

The major significance of squalene is its role as a central intermediate metabolite in the biogenesis of all steroids and triterpenoids. See STEROID; TERPENE. [J.A.Mo.]

**Squall** A strong wind with sudden onset and more gradual decline, lasting for several minutes. Wind speeds in squalls commonly reach 30–60 mi/h (13–27 m/s), with a succession of brief gusts of 80–100 mi/h (36–45 m/s) in the more violent squalls. Squalls may be local in nature, as with isolated thunderstorms, or may occur over a wide area in the vicinity of a well-developed cyclone, where the squalls locally reinforce already strong winds. Because of their sudden violent onset, and the heavy rain, snow, or hail showers which often accompany them, squalls cause heavy damage to structures and crops and present severe hazards to transportation.

The most common type of squall is the thundersquall or rain squall associated with heavy convective clouds, frequently of the cumulonimbus type. Such a squall usually sets in shortly before onset of the thunderstorm rain, blowing outward from the storm and generally lasting for only a short time. It is formed when cold air, descending in the core of the thunderstorm rain area, reaches the Earth's surface and spreads out. Particularly in desert areas, the thunderstorm rain may largely or wholly evaporate before reaching the ground, and the squall may be dry, often associated with dust storms. See DUST STORM; SQUALL LINE; THUNDERSTORM.

Squalls of a different type result from cold air drainage down steep slopes. The force of the squall is derived from gravity and depends on the descending air which is colder and more dense than the air it replaces. So-called fall winds of this kind are common on mountainous coasts of high latitudes, where cold air forms on elevated plateaus and drains down fiords or deep valleys. Violent squalls also characterize the warm foehn winds of the Alps and the similar chinook winds on the eastern slopes of the Rocky Mountains. See CHINOOK; WIND. [C.W.N.; E.Ke.]

**Squall line** A line of thunderstorms, near whose advancing edge squalls occur along an extensive front. The thundery region, 12–30 mi (20–50 km) wide and up to 1200 mi (2000 km) long, moves at a typical speed of 30 knots (15 m/s) for 6–12 h or more and sweeps a broad area. In the United States, severe squall lines are most common in spring and early summer when northward incursions of maritime tropical air east of the Rockies interact with polar front cyclones. Ranking next to hurricanes in casualties and damage caused, squall lines also supply most of the beneficial rainfall in some regions. See FRONT; SQUALL; THUNDERSTORM. [C.W.N.]

**Squamata** The dominant order of living reptiles composed of the lizards and snakes. The group first appeared in Jurassic times and today is found in all but the coldest regions. Various forms are adapted for arboreal, burrowing, or aquatic lives, but most squamates are fundamentally terrestrial. There are about 4700 Recent species: 2200 lizards and 2500 snakes.

The order is readily distinguished from all known reptiles by its highly modified skull; an enlarged and movable quadrate; and a temporal opening that is lost or reduced in many forms. No other reptiles show these modifications, which allow for great kinesis in the lower jaw since it articulates with the quadrate. In addition, the order is distinct from other living reptile groups because its members have no shells or secondary palates and the males possess paired penes.

Traditionally the Squamata have been divided into two major subgroups, the lizards, suborder Sauria, and the snakes, suborder Serpentes. The latter group is basically a series of limbless lizards, and it is certain that snakes are derived from some saurian ancestor. There are many different legless lizards, and it has been suggested that more than one line has evolved to produce those species currently grouped together as snakes.

**Sauria.** The majority of saurians are insectivorous, but a few feed on plants while others, notably the Varanidae and allies, feed on larger prey including birds and mammals. The largest living lizard is the Komodo dragon (*Varanus komodoensis*).

The majority of lizards are quadrupedal in locomotion and are usually ambulatory scamperers or scansorial. Some forms are bipedal, at least when in haste. The coloration of each species of lizard is characteristic. Most forms exhibit marked differences in coloration between the sexes, at least during the breeding season, and frequently the young are markedly different from the parents. Color changes occur in rapid fashion among some species, and all are capable of metachrosis or changing color to a certain extent. See SEXUAL DIMORPHISM.

There are but two species of venomous lizards, both members of the genus *Heloderma*, in the family Helodermatidae: the Gila monster (*H. suspectum*) and the beaded lizard (*H. horridum*).

The following list indicates the major evolutionary lines and families of lizards. Families indicated by an asterisk contain limbless, snakelike species. All members of the families Pygopodidae, Anelytropsidae, Dibamidae, Amphisbaenidae, Feylinidae, and Anniellidae are snakelike lizards.

Iguania line	Annulata line
Family: Iguanidae	Family: Amphisbaenidae*
Agamidae	Anguimorpha line
Chamaeleontidae	Family: Anguidae*
Gekkota line	Anniellidae*
Family: Gekkonidae	Feyliniidae*
Pygopodidae	Xenosauridae
Scincomorpha line	Helodermatidae
Family: Xantusiidae	Varanidae
Teiidae	Lanthonotidae
Lacertidae	
Gerrhosauridae*	
Scincidae*	
Anelytropsidae*	
Dibamidae*	

**Serpentes.** Snakes are basically specialized, limbless lizards which probably evolved from burrowing forms but have now returned from subterranean habitats to occupy terrestrial, arboreal, and aquatic situations. The following characteristics are typical of all serpents. There is no temporal arch so that the lower jaw and quadrate are very loosely attached to the skull. This gives the jaw even greater motility than is the case in lizards. The body

is elongate with 100–200 or more vertebrae, and the internal organs are elongate and reduced. A spectacle covers the eye.

The largest living snake is the Indian python (*Python reticulatus*), which reaches 30 ft (9 m) in length and a weight of 250 lb (113 kg). The largest venomous snake is the king cobra (*Ophiophagus hannah*), of southern Asia, which is known to attain a length of 18 ft (5.5 m).

The senses of snakes are fundamentally similar to those of all terrestrial vertebrates. Great dependence is placed upon olfaction and the Jacobson's organs (olfactory canals in the nasal mucosa). The tongue of all snakes is elongate and deeply bifurcated. When not in use it can be retracted into a sheath located just anterior to the glottis, but it is protrusible and is constantly being projected to pick up samples for the Jacobson's organs from the surrounding environment. Snakes are deaf to airborne sounds and receive auditory stimuli only through the substratum via the bones of the head. The eyes are greatly modified from those in lizards, and there is no color vision. Some groups are totally blind and have vestigial eyes covered by scales or skin.

Four basic patterns of locomotion are found in snakes, and several may be used by a particular individual at different times. The most familiar type is curvilinear. Snakes using rectilinear locomotion move forward in a straight line, without any lateral undulations, by producing wavelike movements in the belly plates. Laterolateral locomotion, or sidewinding, is used primarily on smooth or yielding surfaces and is very complex. Concertina locomotion movement resembles the expansion and contraction of that musical instrument.

The vast majority of living snakes are harmless to humans, although a number are capable of inflicting serious injury with their venomous bites. The venom apparatus has evolved principally as a method of obtaining food, but it is also advantageous as a defense against attackers. Fangs are teeth modified for the injection of venom into the victim, and the venom glands are modified salivary glands connected to the grooved fangs by a duct. Special muscles are present in all proglyphous snakes to force the venom into the wound. The venom itself is a complex substance containing a number of enzymes. Certain of these enzymes attack the blood, others in the nervous system, and some are spreaders.

The following list indicates the major groups of living snakes.

Family: Typhlopidae	Elapidae
Leptotyphlopidae	Hydrophiidae
Aniliidae	Viperidae
Boidae	Crotalidae
Colubridae	

[J.M.S.]

**Squash** The common name for edible fruits of several species of the genus *Cucurbita*: *C. pepo*, *C. moschata*, *C. maxima*, and *C. mixta*. Those species originated in the Americas but are now grown in most countries around the world. Within squash there is tremendous variation in size, shape, color, and usage.

The most clearly defined group is summer squash, fruit of any species of *Cucurbita* eaten as a vegetable when immature. It is most commonly *C. pepo*. Fruit color may be white, yellow, or light or dark green, and the green may be solid or striped. Shapes may be flattened disks as in Pattypan, cylindrical as in Zucchini and Coccozelle, or with necks as in the straightneck and crookneck types. Summer squash has mild flavor, high water content, and relatively low nutritional value.

Winter squash is fruit of *Cucurbita* eaten when mature and derives its name from its ability to be stored for several weeks or months before consumption. Varieties of winter squash are found in all four species. The Table Queen group, synonymous with Acorn, is *C. pepo*, Butternut belongs to *C. moschata*,

Green-striped Cushaw is *C. mixta*, while *C. maxima* has the widest range of types, including Buttercup, Hubbards, and Delicious of various colors, Banana, and Boston Marrow. Flesh color varies from light yellow to dark orange, and the edible portion ranges from thin to very thick. [H.M.M.]

**Squeezed quantum states** Quantum states for which certain variables can be measured more accurately than is normally possible.

All matter and radiation fluctuate. Much random fluctuation derives from environmental influence, but even if all these influences are removed, there remains the intrinsic uncertainty prescribed by the laws of quantum physics. The position and momentum of a particle, or the electric and magnetic components of an electromagnetic field, are conjugate variables that cannot simultaneously possess definite values (Heisenberg uncertainty principle). It is possible, however, to have the position of a particle more and more accurately specified at the expense of increasing momentum uncertainty; the same applies to electromagnetic field amplitudes. This freedom underlies the phenomenon of squeezing or the possibility of having squeezed quantum states. With squeezed states, the inherent quantum fluctuation may be partly circumvented by focusing on the less noisy variable, thus permitting more precise measurement or information transfer than is otherwise possible. See UNCERTAINTY PRINCIPLE.

According to quantum electrodynamics, the vacuum is filled with a free electromagnetic field in its ground state that consists of fluctuating field components with significant noise energy. If  $\phi$  is a phase angle and  $a(\phi)$  and  $a[\phi + (\pi/2)]$  are two quadrature components of the field (for example, the electric and magnetic field amplitudes), the vacuum mean-square field fluctuation is given by Eq. (1), independently of the phase angle.

$$\langle \Delta a^2(\phi) \rangle = \frac{1}{4} \quad (1)$$

Equation (1) is normalized to a photon; the corresponding equivalent noise temperature at optical frequencies is thousands of kelvins. Equation (1) also gives the general fluctuation of an arbitrary coherent state, which is the quantum state of ordinary lasers. Further environment-induced randomness is introduced in addition to Eq. (1) for other conventional light sources,

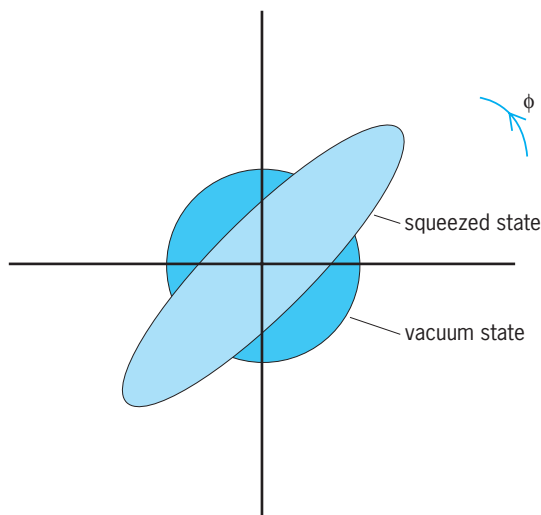

Field-amplitude fluctuation  $\langle \Delta a^2(\phi) \rangle$  as a function of phase angle  $\phi$ . The noise circle of the vacuum state, Eq. (1) in the text, is squeezed to an ellipse according to Eq. (3).

including light-emitting diodes. See COHERENCE; ELECTRICAL NOISE; LASER; QUANTUM ELECTRODYNAMICS.

In a squeezed state, the quadrature fluctuation is reduced below Eq. (1) for some  $\phi$ , as given in Eq. (2). At that point,

$$\langle \Delta a^2(\phi) \rangle < \frac{1}{4} \quad (2)$$

squeezing, that is, reduction of field fluctuation below the coherent state level, occurs. The fluctuation of the conjugate quadrature is correspondingly increased to preserve the uncertainty relation, Eq. (3). In a two-photon coherent state, or squeezed state

$$\langle \Delta a^2(\phi) \rangle \langle \Delta a^2(\phi + \frac{\pi}{2}) \rangle \geq \frac{1}{16} \quad (3)$$

in the narrow sense, Eq. (3) is satisfied with equality. As seen in the illustration, the designation "squeezed state" is partly derived from the fact that the noise circle of Eq. (1) is squeezed to an ellipse when Eq. (3) is satisfied with equality.

Squeezed light can be generated by a variety of processes, especially nonlinear optical processes. The first successful experimental demonstration of squeezing, in 1985, involved a four-wave mixing process in an atomic beam of sodium atoms.

Squeezing was first studied in connection with optical communication, although it is evident that reduced quantum fluctuation might find applications in precision measurements. See NONLINEAR OPTICS; OPTICAL COMMUNICATIONS. [H.P.Yu.]

**Squid** The common name applied to cephalopods of the order Teuthoidea. They are marine mollusks that inhabit the oceans of the world. Squids are characterized by having eight arms and two longer tentacles around the mouth; an elongated, tapered, usually streamlined body; an internal rod- or blade-like shield (gladius); and fins on the body (mantle). The arms have two (infrequently four or six) rows of suckers and occasionally clawlike hooks, and the tentacles have terminal clubs with suckers, hooks, or both. The muscular, elastic tentacles are contractile, not retractile into pockets like those of cuttlefishes (Sepioidea). See SEPIOIDEA.

Squids have an exceptionally well-developed brain and organs of the central nervous system that approach in complexity and function those of fishes and even some birds and mammals. Squids are active, powerful swimmers, driven by jet propulsion as water taken into the mantle cavity is forcefully expelled through the funnel. Prey, normally shrimps, fishes, or other squids, are captured with the two tentacles and held with the arms while the beaks cut off bites that the radula and tongue shove down the throat. See NERVOUS SYSTEM (INVERTEBRATE).

Two groups (suborders) of squids are recognized: Myopsida and Oegopsida. See CEPHALOPODA; COLEOIDEA; TEUTHOIDEA. [C.F.E.R.]

**SQUID** An acronym for superconducting quantum interference device, which actually refers to two different types of device, the dc SQUID and the rf SQUID.

The dc SQUID consists of two Josephson tunnel junctions connected in parallel on a superconducting loop (see illustration). A small applied current flows through the junctions as a supercurrent, without developing a voltage, by means of Cooper pairs of electrons tunneling through the barriers. However, when the applied current exceeds a certain critical value, a voltage is generated. When a magnetic field is applied so that a magnetic flux threads the loop, the critical value oscillates as the magnetic flux is changed, with a period of one flux quantum, weber, where  $h$  is Planck's constant and  $e$  is the electron charge. The oscillations arise from the interference of the two waves describing the Cooper pairs at the two junctions, in a way that is closely analogous to the interference between two coherent electromagnetic waves. See INTERFERENCE OF WAVES; JOSEPHSON EFFECT; SUPERCONDUCTIVITY.

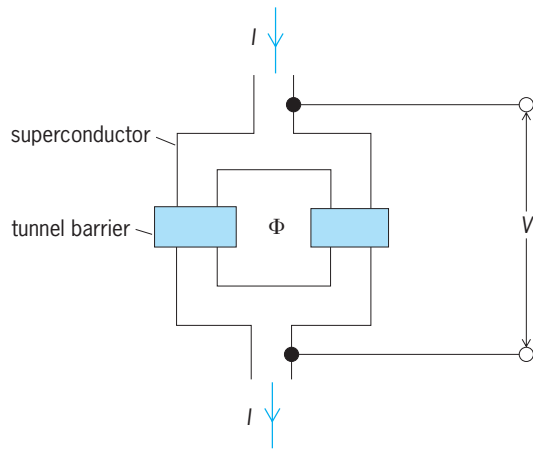

**Direct-current (dc) SQUID with enclosed magnetic flux  $\Phi$ .**  
 $I$  = applied current;  $V$  = generated voltage.

The rf SQUID consists of a single junction interrupting a superconducting loop. In operation, it is coupled to the inductor of an  $LC$ -tank circuit excited at its resonant frequency by a radio-frequency (rf) current. The rf voltage across the tank circuit oscillates as a function of the magnetic flux in the loop, again with a period of one flux quantum. Although SQUIDs were for many years operated while immersed in liquid helium, ceramic superconductors with high transition temperatures make possible devices operating in liquid nitrogen at 77 K.

SQUIDs have important device applications. Usually with the addition of a superconducting input circuit known as a flux transformer, both dc and rf SQUIDs are used as magnetometers to detect tiny changes in magnetic field. The output of the SQUID is amplified by electronic circuitry at room temperature and fed back to the SQUID so as to cancel any applied flux. This makes it possible to detect changes in flux as small as  $10^{-6}$  of one flux quantum with SQUIDs based on low-transition-temperature superconductors, corresponding to magnetic field changes of the order of 1 femtotesla in a 1-hertz bandwidth. Suitable modifications to the input circuit enable the SQUID to measure other physical quantities, including voltages, displacement, or magnetic susceptibility. SQUIDs are also used for logic and switching elements in experimental digital circuits and high-speed analog-to-digital converters. See ANALOG-TO-DIGITAL CONVERTER; INTEGRATED CIRCUITS; MAGNETOMETER; SUPERCONDUCTING DEVICES. [J.C.]

**SS 433** A remarkable stellar object with unique properties: it shows evidence of ejection of two narrow streams of cool gas traveling in oppositely directed beams from a central object at a velocity of almost one-quarter the speed of light—the beams executing a repeating, rotating pattern about the central object once every 164 days.

One peculiar characteristic of SS 443 is that the spectrum possesses not only a set of emission lines due to hydrogen and helium, but two further sets of lines, one displaced to longer (redder) wavelengths from the familiar lines, and the second displaced to shorter (bluer) wavelengths. These displacements can be understood in terms of the Doppler effect. In addition, the wavelengths of the lines change every night in a smoothly progressing pattern, indicating that the velocity of the emitting regions is also changing.

Especially intriguing is the observation that on a given night the average velocity of the approaching and receding beams is not zero, but rather a large positive value, about 7500 mi/s (12,000 km/s), despite the fact that SS 433 is approximately stationary with respect to the Earth. This proves to be a direct consequence of Einstein's special theory of relativity. An outside observer perceives a change in measured times and lengths of

a system moving at very large velocity. The beam velocity in SS 433 is large enough that special relativity is important. See RELATIVITY.

There has been much speculation as to the type of star present in SS 443, with many astronomers now agreeing that the enormous velocities in the beams require a highly collapsed, compact star with a strong gravitational field. A neutron star, the same end point of stellar evolution responsible for pulsars, or possibly a black hole could satisfy this requirement. See BINARY STAR; BLACK HOLE; NEUTRON STAR; PULSAR. [B.M.]

**Stability augmentation** The alteration of the inherent behavior of a system. As an example, ships tend to exhibit significant rolling motions at sea. To dampen these rolling motions, a roll stabilization (feedback) system can be used. Such a system consists of a set of vanes (that is, small wings) extending outward from the hull, below the waterline. By varying the vane incidence angle relative to the hull, a hydrodynamic lift is generated on the vane. The vanes are driven by a feedback system so that the rolling motions are opposed by creating positive lift on one side of the hull and negative lift on the other side.

As a second example, nearly all satellites require some form of stability augmentation to help in keeping the antennas or sensors aligned with receiving equipment on Earth. The stability augmentation is effected by thrusters which receive their commands from a feedback system. See SPACECRAFT PROPULSION.

As a third example, stability augmentation systems are used on aircraft. This is usually achieved by a system which controls one or more flight-control surfaces (or engines) automatically without inputs from the pilot. The inherent stability and response behavior of many modern airplanes tends toward low damping or even instability. The physical reasons have to do with the configuration of the airplane and the combination of flight speed and altitude at which the airplane is operated. Several modern fighters and even some transports are intentionally designed with no or little inherent stability. There are a number of reasons for such a design condition. In the case of fighters, excellent maneuverability in combat is essential. By making a fighter intentionally inherently unstable, it is easy to design the control system so that load factors in pull-ups or in turns can be built up rapidly. In the case of transports, the motivation to design for little or no inherent stability is to lower the size of the tail and thereby achieve a reduction in drag and weight. See AIRPLANE; MILITARY AIRCRAFT.

The control exercised by the stability augmentation system contrasts with that exercised by the pilot. The pilot may be connected with the flight-control surface via a direct mechanical link. Alternatively, in many modern airplanes the pilot cockpit control movement is sensed by a position transducer. The output of the position transducer in turn is sent, via a computer-amplifier combination, to a hydraulic actuator, referred to as a servo, which drives the flight-control surface. Command signals which come from the pilot or from the stability augmentation system are sent by wire (fly-by-wire) or by optical conduit (fly-by-light) to the electromagnetic valve. A valve distributes high-pressure hydraulic fluid either to the left or to the right of the piston so that the piston is forced to move. The piston in turn moves the flight-control surface. See FLIGHT CONTROLS.

With the introduction of fast in-flight digital computers, it has become possible to equip airplanes with so-called full flight envelop protection systems. Such systems are designed to refuse any pilot input which might get the airplane into a flight condition from which recovery is no longer possible. Such systems can easily be arranged to prevent a pilot from rolling a commercial airplane too much or to prevent the pilot from stalling the airplane. Such systems can also be arranged so that loads acting on the wing or tail do not approach dangerously high levels. In that case the system is referred to as a load-alleviation system. [J.Ro.]



**Stabilizer (aircraft)** The horizontal or vertical aerodynamic wing surfaces that provide aircraft stability and longitudinal balance in flight. Horizontal and vertical stabilizers (fins) are similar to the aircraft wing in structural design and function

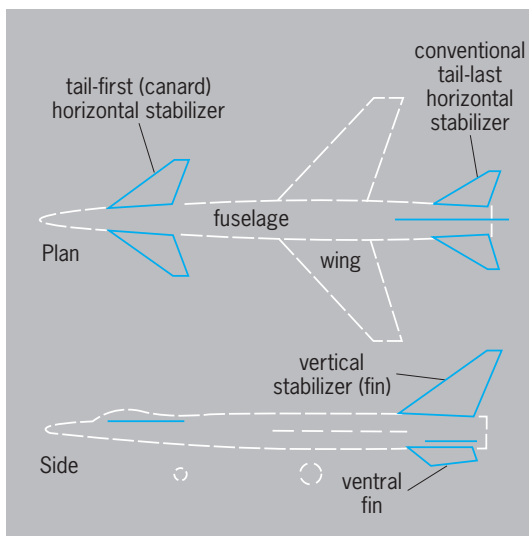

Various stabilizer arrangements.

of providing lift at angle of attack to the wind. However, stabilizers are not required to supply lift to overcome aircraft weight during flight, and when the wing-fuselage center of pressure is behind the aircraft center of gravity, the aerodynamic load on the horizontal stabilizer may be downward. Various stabilizer arrangements are shown in the illustration. See FLIGHT CONTROLS.

[M.J.A.]

**Stabilizer (chemistry)** Any substance that tends to maintain the physical and chemical properties of a material. Degradation, that is, irreversible changes in chemical composition or structure, is responsible for the premature failure of materials. Stabilizers are used to extend the useful life of materials as well as to maintain their critical properties above the design specifications. Oxygen and water are the principal degradants, but ultraviolet radiation also can have a significant effect (photodegradation).

A wide variety of additives has been developed to stabilize polymers against degradation. Stabilizers are available that inhibit thermal oxidation, burning, photodegradation, and ozone deterioration of elastomers. Research in the chemistry of the low-temperature oxidation of natural rubber has revealed that hydrocarbon polymers oxidize by a free-radical chain mechanism. In pure, low-molecular-weight hydrocarbons, an added initiator is required to produce the first radicals. In contrast, initiation of polymer oxidation occurs in the complex molecules of elastomers through impurities already present, for example, hydroperoxides. See CHAIN REACTION (CHEMISTRY); FREE RADICAL.

Stabilization of hydrocarbon polymers can be accomplished with preventative or chain-breaking antioxidants. Preventative antioxidants stabilize by reducing the number of radicals formed in the initiation stage. Where hydroperoxides are responsible for initiation, the induced decomposition of these reactive intermediates into nonradical products provides effective stabilization. Suppressing the catalytic effects of metallic impurities that increase the rate of radical formation can also provide stabilization. Chain-breaking antioxidants interrupt the oxidative chain by providing labile hydrogens to compete with the polymer in reaction with the propagating radicals. The by-product of this reaction is a radical which is not capable of continuing the oxidative chain.

Stabilization of polymers against photooxidation, the principal component of outdoor weathering, is accomplished by addition of ultraviolet absorbers, and radical scavengers. Ultraviolet absorbers absorb and harmlessly dissipate damaging radiation. Another class of additives, known as hindered-amine light stabilizers, function by scavenging destructive radicals. See ANTIOXIDANT; CARBON BLACK; INHIBITOR (CHEMISTRY); PHOTODEGRADATION.

[W.L.H.]

**Stain (microbiology)** Any colored, organic compound, usually called dye, used to stain tissues, cells, cell components, or cell contents. The dye may be natural or synthetic. The object stained is called the substrate. The small size and transparency of microorganisms make them difficult to see even with the aid of a high-power microscope. Staining facilitates the observation of a substrate by introducing differences in optical density or in light absorption between the substrate and its surround or between different parts of the same substrate. In electron microscopy, and sometimes in light microscopy (as in the silver impregnation technique of staining flagella or capsules), staining is accomplished by depositing on the substrate ultraphotoscopic particles of a metal such as chromium or gold (the so-called shadowing process); or staining is done by treating the substrate with solutions of metallic compounds such as uranyl acetate or phosphotungstic acid. Stains may be classified according to their molecular structure. They may also be classified according to their chemical behavior into acid, basic, neutral, and indifferent. This classification is of more practical value to the biologist. See ELECTRON MICROSCOPE; MEDICAL BACTERIOLOGY.

[J.P.T.]

**Stainless steel** The generic name commonly used for that entire group of iron-base alloys which exhibit phenomenal resistance to rusting and corrosion because of chromium (Cr) content. Contents of Cr exceeding 10%, with carbon (C) held suitably low, make iron effectively rustproof.

Other alloy elements, notably nickel (Ni) and molybdenum (Mo), can also be added to the basic stainless composition to produce both variety and improvement of properties. Over 100 different stainless steels are produced commercially, about half as standardized grades. Some are more properly classed as stainless irons since they do not harden as steel; others are true steels to which corrosion resistance becomes an added feature. Still others that are neither properly steels nor irons introduce totally new classes of materials, from both mechanical and chemical standpoints. See ALLOY; STEEL.

[C.A.Z.]

**Stalactites and stalagmites** Stalactites, stalagmites, dripstone, and flowstone are travertine deposits in limestone caverns, formed by the evaporation of waters bearing calcium carbonate. Stalactites grow down from the roofs of caves and tend to be long and thin, with hollow cores. The water moves down the core and precipitates at the bottom, slowly extending the length while keeping the core open for more water to move down.

Stalagmites grow from the floor up and are commonly found beneath stalactites; they are formed from the evaporation of the same drip of water that forms the stalactite. Stalagmites are thicker and shorter than stalactites and have no central hollow core. See CAVE; LIMESTONE.

[R.Si.]

**Stall-warning indicator** A device that determines the critical angle of attack for a given aircraft, at which point the drag coefficient overpowers the lift coefficient and the aircraft will no longer sustain itself in steady-state condition (level flight or climb/descent). The indicator usually operates from vane sensors, airflow pressure sensors, tabs on the leading edge of the wings, and computing devices which include accelerometers, airspeed detectors, and vertical gyros.

[J.W.A.]

**Standard** An accepted reference sample which is used for establishing a unit for the measurement of physical quantities. A physical quantity is specified by a numerical factor and a unit; for example, a mass might be expressed as 8 g, a length as 6 cm, and a time interval as 2 min. Here the gram is a mass unit defined in terms of the international kilogram, which serves as the primary standard of mass. The centimeter is defined in terms of the international meter, which is the primary standard of length and is defined as the length of path traveled by light in a vacuum during a time interval of  $1/299,792,458$  of a second. In similar fashion, the minute is a time interval defined as 60 s, where the second is the international standard of time and is defined as the duration of  $9\,192\,631\,770$  periods of the radiation corresponding to the transition between the two hyperfine energy levels of the ground state of the cesium-133 atom.

The National Institute of Standards and Technology in the United States and comparable laboratories in other countries are responsible for maintaining accurate secondary standards for various physical quantities. See ELECTRICAL UNITS AND STANDARDS; LIGHT; METRIC SYSTEM; PHYSICAL MEASUREMENT; TIME. [D.Wi.]

**Standard model** The theory that explains the three major interactions of elementary particle physics—the strong interaction responsible for nuclear forces, the weak interaction responsible for radioactive decay, and the electromagnetic interaction—in terms of a common physical picture. The model for this picture is quantum electrodynamics, the fundamental theory underlying electromagnetism. In that theory, electrons, viewed as structureless elementary constituents of matter, interact with photons, structureless elementary particles of light. The standard model extends quantum electrodynamics to explain all three interactions of subnuclear physics in terms of similar basic constituents. See ELECTRON; ELECTROWEAK INTERACTION; ELEMENTARY PARTICLE; LIGHT; PHOTON; QUANTUM CHROMODYNAMICS; QUANTUM ELECTRODYNAMICS; STRONG NUCLEAR INTERACTIONS; WEAK NUCLEAR INTERACTIONS. [M.E.Pe.]

**Staphylococcus** A genus of bacteria containing at least 28 species that are collectively referred to as staphylococci. Their usual habitat is animal skin and mucosal surfaces. Although the genus is known for the ability of some species to cause infectious diseases, many species rarely cause infections. Pathogenic staphylococci are usually opportunists and cause illness only in compromised hosts. *Staphylococcus aureus*, the most pathogenic species, is usually identified by its ability to produce coagulase (proteins that affect fibrinogen of the blood-clotting cascade). Since most other species of staphylococci do not produce coagulase, it is useful to divide staphylococci into coagulase-positive and coagulase-negative species. Coagulase-negative staphylococci are not highly virulent but are an important cause of infections in certain high-risk groups. Although *Staphylococcus* infections were once readily treatable with antibiotics, some strains have acquired genes making them resistant to multiple antimicrobial agents. See BACTERIA; DRUG RESISTANCE; MEDICAL BACTERIOLOGY.

*Staphylococcus* cells are spherical with a diameter of 0.5–1.5 micrometers. Clumps of staphylococci resemble bunches of grapes when viewed with a microscope, owing to cell division in multiple planes. The staphylococci have a gram-positive cell composition, with a unique peptidoglycan structure that is highly cross-linked with bridges of amino acids. See STAIN (MICROBIOLOGY).

Most species are facultative anaerobes. Within a single species, there is a high degree of strain variation in nutritional requirements. Staphylococci are quite resistant to desiccation and high-osmotic conditions. These properties facilitate their survival in the environment, growth in food, and communicability.

In addition to genetic information on the chromosome, pathogenic staphylococci often contain accessory elements such as plasmids, bacteriophages, pathogenicity islands (DNA clus-

ters containing genes associated with pathogenesis), and transposons. These elements harbor genes that encode toxins or resistance to antimicrobial agents and may be transferred to other strains. Genes involved in virulence, especially those coding for exotoxins and surface-binding proteins, are coordinately or simultaneously regulated by loci on the chromosome. See BACTERIAL GENETICS; BACTERIOPHAGE; PLASMID; TRANSPOSONS.

Most *Staphylococcus aureus* infections develop into a pyogenic (pus-forming) lesion caused by acute inflammation. Inflammation helps eliminate the bacteria but also damages tissue at the site of infection. Typical pyogenic lesions are abscesses with purulent centers containing leukocytes, fluid, and bacteria. Pyogenic infections can occur anywhere in the body. Blood infections (septicemia) can disseminate the organism throughout the body and abscesses can form internally.

Certain strains of *S. aureus* produce exotoxins that mediate two illnesses, toxic shock syndrome and staphylococcal scalded skin syndrome. In both diseases, exotoxins are produced during an infection, diffuse from the site of infection, and are carried by the blood (toxemia) to other sites of the body, causing symptoms to develop at sites distant from the infection. Toxic shock syndrome is an acute life-threatening illness mediated by staphylococcal superantigen exotoxins. Staphylococcal scalded skin syndrome, also known as Ritter's disease, refers to several staphylococcal toxigenic infections. It is characterized by dermatologic abnormalities caused by two related exotoxins, the type A and B exfoliative (epidermolytic) toxins. See CELLULAR IMMUNOLOGY; TOXIC SHOCK SYNDROME.

Staphylococcal food poisoning is not an infection, but an intoxication that results from ingestion of staphylococcal enterotoxins in food. The enterotoxins are produced when food contaminated with *S. aureus* is improperly stored under conditions that allow the bacteria to grow. Although contamination can originate from animals or the environment, food preparers with poor hygiene are the usual source. Effective methods for preventing staphylococcal food poisoning are aimed at eliminating contamination through common hygiene practices, such as wearing gloves, and proper food storage to minimize toxin production. See FOOD POISONING.

Coagulase-positive staphylococci are the most important *Staphylococcus* pathogens for animals. Certain diseases of pets and farm animals are very prominent. *Staphylococcus aureus* is the leading cause of infectious mastitis in dairy animals. [G.Boh.]

**Star** A self-luminous body that during its life generates (or will generate) energy and support by thermonuclear fusion.

**Names.** Over 6000 stars can be seen with the unaided eye. The brightest carry proper names from ancient times, most of Arabic origin. A more general system names stars within constellations by Greek letters roughly in accord with apparent brightness, followed by the Latin genitive of the constellation name (for example, Vega, in Lyra, is also Alpha Lyrae). More generally yet, brighter stars carry numbers in easterly order within a constellation (Vega also 3 Lyrae). All naked-eye stars also have HR (Harvard Revised) numbers assigned in order east of the vernal equinox. A variety of catalogs list millions of telescopic stars. See ASTRONOMICAL CATALOGS; CONSTELLATION.

**Magnitudes and colors.** About 130 B.C., Hipparchus assigned naked-eye stars to six brightness groups or "apparent magnitudes" ( $m$ ), with first magnitude the brightest. This scheme is now quantified as a logarithmic system such that five magnitudes correspond to a factor of 100 in brightness, rendering first magnitude 2.512... times brighter than second, and so on.

Stars assume subtle colors from red to blue-white, reflecting different spectral energy distributions that result from temperatures ranging from under 2000 K (3100°F) to over 100,000 K (180,000°F). The magnitude of a star therefore depends on the detector's color sensitivity. Numerous magnitude systems range from the ultraviolet into the infrared, though the apparent visual magnitude ( $m_v = V$ ) is still standard. The differences among the

systems allow measures of stellar color and temperature. See COLOR INDEX; MAGNITUDE (ASTRONOMY).

**Distances.** The fundamental means of finding stellar distances is parallax. As the Earth moves in orbit around the Sun, a nearby star will appear to shift its location against the background. The parallax ( $p$  in arcseconds) is defined as one half the total shift, and is the angle subtended by the Earth's orbital radius as seen from the star. Distance in parsecs (pc) is  $1/p$ , where  $1 \text{ pc} = 206,265 \text{ AU} = 3.26 \text{ light-years}$ . (A light-year is the distance that a ray of light will travel in a year.) The nearest star, a telescopic companion to Alpha Centauri, is  $1.29 \text{ pc} = 4.22 \text{ light-years}$  away. See LIGHT-YEAR; PARALLAX (ASTRONOMY); PARSEC.

**Distribution and motions.** All the unaided-eye stars and 200 billion more are collected into the Milky Way Galaxy (or simply, the Galaxy), 98% concentrated into a thin disk over 100,000 light-years across. From the Sun, inside the disk and 27,000 light-years from the Galaxy's center in Sagittarius, the disk appears as the Milky Way. Surrounding the disk is a vast but sparsely populated halo.

Angular proper motions across the line depend on velocities across the line of sight and distances. Statistical analysis of these motions shows the Sun to be moving through the local stars at a speed of 20 km/s (12 mi/s), roughly toward Vega. From radial velocities of sources outside the Galaxy, it is found that the Sun moves in a roughly circular orbit at 220 km/s (137 mi/s), which when combined with the space motions of other stars allows their galactic orbits to be determined. Stars in the disk have closely circular orbits; those in the halo have elliptical ones. See DOPPLER EFFECT; MILKY WAY GALAXY.

**Absolute magnitudes.** The apparent visual magnitude of a star depends on its intrinsic visual luminosity and on the inverse square of the distance. Knowledge of the distance allows the determination of the true visual luminosity, expressed as the absolute visual magnitude,  $M_v$ . This quantity is defined as the apparent visual magnitude that the star would have at a distance of 10 pc. Absolute visual magnitudes range from  $M_v = -10$  to  $+20$  (a factor of  $10^{12}$ ). The Sun's absolute visual magnitude is in the middle of this range,  $+4.83$ .

**Spectral classes.** Stars exhibit a variety of absorption-line spectra. The absorptions, narrow cuts in the spectra, are produced by atoms, ions, and molecules in the stars' thin, semitransparent outer layers, or atmospheres. Over a century ago, Edward C. Pickering lettered them according to the strengths of their hydrogen lines. After he and his assistants dropped some letters and rearranged others for greater continuity, they arrived at the standard spectral sequence, OBAFGKM, which was later decimalized (the Sun is in class G2). Classes L and T were added in 1999. Since the sequence correlates with color, it must also correlate with temperature, which ranges from 55,000 K (100,000°F) for hot class O, through about 6000 K (10,000°F) for solar-type class G, to under 2000 K (3100°F) for class L, and below 1000 K (1300°F) for class T (all of which are brown dwarf substars).

The majority of stars in the galactic disk have chemical compositions like that of the Sun. Differences in spectra result primarily from changes in molecular and ionic composition and in the efficiencies of absorption, all of which correlate with temperature. See ASTRONOMICAL SPECTROSCOPY; SPECTRAL TYPE.

**Hertzsprung-Russell diagram.** Shortly after the invention of the spectral sequence, H. N. Russell and E. Hertzsprung showed that luminosity correlates with spectral class. A graph of absolute visual (or bolometric) magnitude (luminosity increasing upward) plotted against spectral class (or temperature, decreasing toward the right) is called the Hertzsprung-Russell (HR) diagram (see illustration). The majority of stars lie in a band in which luminosity climbs up and to the left with temperature (with the Sun in the middle). But another band begins near the location of the Sun and proceeds up and to the right (to lower temperature), luminosities increasing to thousands solar as tem-

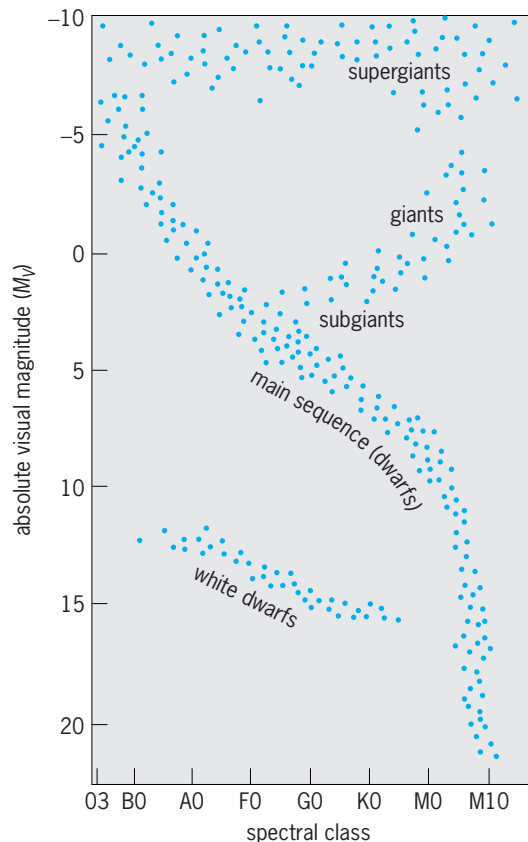

**Hertzsprung-Russell (HR) diagram, showing the positions of the major kinds of stars.**

perature drops to class M. To be bright and cool, such stars must have large radiating areas and radii. To distinguish between the bands, the larger stars are called giants, while those of the main band are termed dwarfs (or main-sequence stars). Yet brighter stars to the cool side of the main sequence, with luminosities approaching  $10^6$  solar, are called supergiants. In between the giants and the dwarfs lie a few subgiants. At the top, superior to the supergiants, are the very rare hypergiants. See DWARF STAR; GIANT STAR; SUBGIANT STAR; SUPERGIANT STAR.

In the lower left corner of the diagram, beneath the main sequence, are stars so dim that they must be very small. Since the first ones found were hot and white, they became known as white dwarfs in spite of their actual temperatures or colors. White dwarfs must be positioned on the HR diagram according to their temperatures (rather than their spectral classes). See WHITE DWARF STAR.

Stars in the galactic halo are deficient in heavy elements. Low metal content makes halo dwarfs bluer than those of the standard main sequence, shifting them to the left and seemingly downward on the HR diagram, where they are known as subdwarfs. See STELLAR POPULATION.

**Double and multiple stars.** Most stars are members of some sort of community, from doubles through multiples (double-doubles, and so forth) to clusters, which themselves contain doubles. Separations between components of double stars range from thousands of astronomical units (with orbital periods of a million years) to stars that touch each other (and orbit in hours). See BINARY STAR.

**Masses and main-sequence properties.** Observations of hundreds of binary stars show that mass ( $M$ ) increases upward along the main sequence from about 8% solar at cool class M to over 20 solar in the cooler end of class O. Extrapolation by theory suggests masses of 120 solar at the extreme hot end (class O3) of the main sequence. Fainter than the Sun, luminosity is

proportional to  $M^3$ ; brighter than solar, luminosity goes as  $M^4$ . This mass-luminosity relation is the result of higher internal temperatures and pressures in more massive stars caused by gravitational compression. See MASS-LUMINOSITY RELATION.

As internal temperature climbs above the  $8 \times 10^6$  K limit, hydrogen fuses to helium via the proton-proton cycle at an ever-increasing rate. Above about  $15 \times 10^6$  K ( $27 \times 10^6$  °F), so does fusion by the carbon cycle, in which carbon acts as a nuclear catalyst. See CARBON-NITROGEN-OXYGEN CYCLES.

The onset of carbon-cycle dominance coincides with a change in stellar structure. The Sun has a radiatively stable core surrounded by an envelope whose outer parts are in a state of convection that helps produce a magnetic field and magnetic sunspots. Hotter dwarfs have shallower convection layers, and above class F, envelope convection disappears, the cores becoming convective. The convective layers of cooler dwarfs deepen, until below about 0.3 solar mass (class M4), convection takes over completely and the stars are thoroughly mixed. See CONVECTION (HEAT).

Below a lower mass limit of 8% solar, internal temperatures and densities are not great enough to allow the proton-proton chain to operate. Such stars, called brown dwarfs, glow dimly and redly from gravitational contraction and from the fusion of natural deuterium ( $^2\text{H}$ ) into helium. See BROWN DWARF.

**Clusters.** Doubles and multiples are highly structured. Clusters are not, the member stars orbiting a common center of mass. Open clusters are fairly small collections in which a few hundred or a thousand stars are scattered across a few tens of light-years. About 150 globular clusters occupy the Galaxy's halo, the poorest about as good as a rich open cluster, the best containing over a million stars within a volume 100 light-years across.

The HR diagrams of clusters are radically different from the HR diagrams of the general stellar field. Those of open clusters differ among themselves in having various portions of the upper main sequence removed. The effect is related to the cluster's age, since high-mass stars die first. Globular clusters, which lack an upper main sequence and are therefore all old, contain a distinctive "horizontal branch" composed of modest giants.

**Variable stars.** Dwarfs are generally stable. Giants and supergiants, however, can have structures that allow them to pulsate. Cepheids (named after the star Delta Cephei) are F and G supergiants and bright giants that occupy a somewhat vertical instability strip in the middle of the HR diagram. They vary regularly by about a magnitude over periods ranging from 1 to 50 days. The pulsation is driven by a deep layer of gas in which helium is becoming ionized. Larger and more luminous Cepheids take longer to pulsate. Once this period-luminosity relationship is calibrated through parallax and main-sequence cluster fitting, the period of a Cepheid gives its absolute magnitude, which in turn gives its distance. Cepheids are vital in finding distances to other galaxies. See CEPHEIDS; HUBBLE CONSTANT.

Miras (after the star Mira, Omicron Ceti), or long-period variables, are luminous giants that can vary visually by more than 10 magnitudes over periods that range from 50 to 1000 days, the pulsations again driven by deep ionization layers. See MIRA.

Duplicity produces its own set of intrinsic variations. If the members of a binary system are close enough together, one of them can transfer mass to the other, and instabilities in the transfer process cause the binary to flicker. If one companion is a white dwarf, infalling compressed hydrogen can erupt in a thermonuclear runaway, producing a sudden nova that can reach absolute magnitude  $-10$ . If the white dwarf gains enough matter such that it exceeds its allowed limit (the Chandrasekhar limit) of 1.4 solar masses, it can even explode as a supernova. See CATAclysmic VARIABLE; NOVA; VARIABLE STAR.

**Off the HR diagram.** Various kinds of stars are not placeable on the classical HR diagram. The most common examples are the central stars of planetary nebulae, which are complex shells and rings of ionized gas that surround hot blue stars. See PLANETARY NEBULA.

Even hotter neutron stars are found associated with the exploded remains of supernovae (supernova remnants). Only 25 or so kilometers (15 mi) across, the visible ones spin rapidly, and are highly magnetic, with fields  $10^{12}$  times the strength of Earth's field. Radiation beamed from tilted, wobbling magnetic axes can strike the Earth to produce seeming pulses of radiation. See NEUTRON STAR; PULSAR.

**Evolution.** The different kinds of stars can be linked through theories of stellar evolution. Stars are born by the gravitational collapse of dense knots within cold dusty molecular clouds found only in the Galaxy's disk. When the new stars are hot enough inside to initiate fusion, their contraction halts and they settle onto the main sequence. The higher the stellar mass, the greater the internal compression and temperature, and the more luminous the star. But the higher the internal temperature, the greater the rate at which hydrogen is fused, and the shorter the star's life. See MOLECULAR CLOUD; PROTOSTAR; STELLAR EVOLUTION. [J.B.Ka.]

**Star clouds** Large groupings of stars with dimensions of 1000 to several thousand light-years. Star clouds are not stable clusterings of stars or even groups of a common origin, such as stellar associations. Instead, they are large areas where the stellar density is higher than average in a galaxy. They are nevertheless physical entities in that they result from large-scale star formation events or series of events that are to some extent limited in size by the characteristics of the galactic environment.

Large star clouds are found commonly in the spiral arms of galaxies such as the Milky Way Galaxy and the Andromeda Galaxy (M31), but are not found in smaller, dwarf galaxies or in very old galaxies. Conspicuous star clouds in the Milky Way Galaxy are found in the constellations Carina, Cygnus, Sagittarius, and Scutum. See ANDROMEDA GALAXY; MILKY WAY GALAXY; STAR. [PHod.]

**Star clusters** Groups of stars held together by mutual gravitational attraction. There are two basic morphological types: open clusters and globular clusters. Typical densities of field stars near the Sun are 0.1 star per cubic parsec. (One parsec equals  $1.9 \times 10^{13}$  mi or  $3.1 \times 10^{13}$  km.) Open clusters, with dozens to thousands of stars, have central densities of 0.3 to 10 stars per cubic parsec, and are often elongated or amorphous in shape. Globular clusters, with a thousand to several million stars, and central densities of a few hundred to over 100,000 stars per cubic parsec, are generally spherical (see illustration). Associations are even looser assemblages, with a few hundred stars and central densities lower than the field. They are often recognized because of unusually large numbers of special types of stars. OB associations are dominated by hot, luminous, young O and B stars. T associations are dominated by young T Tauri variable stars. See SPECTRAL TYPE; T TAURI STAR.

Star clusters are important because, within each cluster, member stars probably are at the same distance from the Sun, and have the same age and the same initial chemical composition. Stars with larger masses begin life hotter and brighter than lower-mass stars and end their lives earlier. Most stars within clusters lie along a band in the luminosity-temperature plane (where temperature is measured by spectral type or color). In older clusters, this main-sequence band terminates at fainter and cooler levels. Ages derived from such observations provide a chronology of which clusters formed first. Differences observed among stars away from the main sequence, such as in luminosity and temperature or in chemical composition, reflect changes to the stars during the ends of their lives and provide laboratories for the study of stellar evolution. See HERTZSPRUNG-RUSSELL DIAGRAM; MILKY WAY GALAXY; STELLAR EVOLUTION.

Open clusters, once called galactic clusters, are found mostly along the band of Milky Way, and are rarely found more than 1000 parsecs from the plane. A dozen are visible to the naked eye, such as Ursa Major, the Hyades (the horns of Taurus), and the Pleiades. Over a thousand are cataloged, and the Milky Way



Great globular cluster in Hercules, Messier 13. Photographed with 200-in. (500-cm) telescope. (California Institute of Technology, Palomar Observatory)

probably contains tens of thousands, most hidden by interstellar obscuration. See HYADES; PLEIADES.

The youngest clusters may be hidden within dark dust clouds opaque to optical light. Infrared methods can reveal such embedded clusters, which have ages of less than  $10^6$  years. The oldest open clusters may reach  $10^{10}$  years. Few old clusters are known, partly because of the dissolution of clusters with time. See INFRARED ASTRONOMY.

Generally more distant, more massive, older, and more deficient in heavy elements than open clusters, globular clusters are dispersed all over the sky, but with a strong concentration in the direction of the galactic center (Sagittarius). In 1917, H. Shapley estimated distances to globulars to infer the distance to the galactic center. A total of 158 globular clusters are known, some of which are visible to the unaided eye.

The nearest globular lies about 2000 parsecs away, while the most distant one in the Milky Way Galaxy lies over 100,000 parsecs from the Sun. There seem to be two chemically distinct classes of globular clusters: metal-deficient clusters, typically 30 times poorer in heavy elements than the Sun; and metal-rich clusters, typically about 3 times more deficient. The metal-deficient globulars have very high velocities relative to the Sun, and so do not belong to the disk of the Milky Way; they are found in a spherical distribution around the galactic center. The more metal-rich globulars have motions characteristic of disk stars and clusters, and are found within a few kiloparsecs of the plane. All globular clusters in the Milky Way are very old, typically about  $1.4 \times 10^{10}$  years. See STAR. [B.W.Ca.]

**Star tracker** A device that automatically measures the angular separation of stellar observations with respect to a reference platform. It is also referred to as an astrotracker.

By using the star tracker in conjunction with a precise time reference (chronometer) and a dead-reckoning device consisting of gyroscopes and accelerometers (inertial navigator), a digital computer can correct many of the inertial navigator errors so that precise, autonomous (free from any radio position aids), terrestrial navigation can be achieved. The major errors corrected by the star tracker are introduced by the inertial navigator's gyroscopes that result in attitude deviations. In this configuration, called a stellar inertial system, very high precision aircraft autonomous navigation is achieved. Since the availability of radio position aids poses no problem for commercial aircraft, stellar inertial navigation technology is applied only on military ve-

hicles. These navigation devices are used when radio position aids, such as Loran and the Global Positioning System (GPS), may be unavailable. See CHRONOMETER; ELECTRONIC WARFARE; INERTIAL GUIDANCE SYSTEM.

Star trackers are also used for both military and nonmilitary applications on space probes, space-based interceptors, and satellites. In these applications the precise attitude capabilities of these devices provide the fiducial precision reference for pointing of the vehicle and Earth or planet sensors. On space missions, star trackers are the only sensor presently available that can provide arc-second attitude accuracy. See SPACE NAVIGATION AND GUIDANCE.

A gimballed stellar inertial system is mounted on the stable element of an inertial navigator. The tracking system measures the telescope azimuth rotation angle and elevation angle to the acquired star with respect to a stable inertial reference. The tracker is programmed to observe different, widely angular separated stars in order to achieve accurate operation. The deviation of the measured stellar observations from their ideal stellar positions is utilized to enhance the performance of the inertial navigator.

The preponderance of modern systems do not contain gimbals. These systems are completely strapped down (that is, with no moving parts) and observe stars at random as the stars come into the rigid, fixed star tracker's field of view. These systems, based on their knowledge of the telescope's location and direction, know which stars should be in the field of view and where their images are located on the star tracker's optical detector. In order to make a three-axis attitude correction, there should be a least two stellar observations ideally separated by  $90^\circ$ . Smaller angular separations lead to a dilution of attitude correction precision. The multiple measurements need not be performed simultaneously since the star tracker corrects the attitude of each axis based on the stellar observations available. Thus, these strap-down startracker systems consist of either multiple telescopes with moderate fields of view or a single telescope with a very wide field of view for proper operation. See CELESTIAL NAVIGATION.

The preponderance of star-tracker photodetectors used to measure the stellar irradiance are solid-state, silicon semiconductor photosensors. These devices have their peak responsivity in the near-infrared region (0.6–1.0 micrometer). Imaging focal-plane arrays have up to a million photosensors on a single semiconductor silicon chip arranged in a rectangular grid matrix. Each of the individual photosensors on the focal-plane array is called a pixel. The devices are similar to the photosensors found in home video-camera recorders. See CHARGE-COUPLED DEVICES.

[S.Le.]

**Starburst galaxy** A galaxy that is observed to be undergoing an unusually high rate of formation of stars. It is often defined as a galaxy that, if it continues to form stars at the currently observed rate, will exhaust its supply of star-forming material, the interstellar gas and dust, in a time period that is very short compared to the age of the universe. For a typical starburst galaxy, this gas exhaustion time scale is less than  $10^8$  years, that is, less than 1% of the age of the universe. Such galaxies must be undergoing a passing burst of star formation.

The term starburst usually also implies that the burst of star formation is occurring in the nuclear regions of the galaxy, because the term was coined to describe a sample of luminous spiral galaxies with bright, pointlike nuclei. However, related objects meet the definition of short gas-exhaustion time scale but exhibit more widespread star formation. These include the nearest, best-studied starburst galaxy, M82.

There are several theories as to why starbursts occur. One likely cause is the interaction between two galaxies as they pass close to, or collide with, one another. The tidal forces generated result in shock-wave compression of the interstellar material and star formation in the compressed clouds. Many star-burst galaxies show evidence of interactions, including distorted appearance

and long, wispy tails of material. Not all starbursts can be due to interactions, however, since some display no evidence for any recent disturbance. Other mechanisms that are thought responsible for high star-formation rates in galaxies are very strong spiral density waves and central bar instabilities. See GALAXY, EXTERNAL. [C.J.L.]

**Starch** A carbohydrate that occurs as discrete, partially crystalline granules in the seeds, roots (tubers), stems (pith), leaves, fruits, and pollen grains of higher plants. Starch functions as the main storage or reserve form of carbohydrate; it is second in abundance only to cellulose, a major structural component of plants. Cereal grains, tuber and root crops, and legumes (seeds) have long been used as major sources of carbohydrate in human diets. See CELLULOSE.

Starch is isolated commercially from the following sources: cereal grain seeds [maize (corn), wheat, rice, sorghum], roots and tubers [potato, sweet potato, tapioca (cassava), arrowroot], and stems and pith (sago). Cereal grains are often steeped first to loosen the starch granules in the endosperm matrix, followed by wet grinding or milling. Roots and tubers are ground to give a suspension containing starch granules. Then follows screening or sieving, washing, centrifuging, dewatering, and drying.

Starch, a polymer of glucose, is an alpha-glucan, predominantly containing alpha-1,4-glucosidic linkages with a relatively small amount of alpha-1,6-glucosidic linkages forming branch points. Two major polymeric components are present: amylose and amylopectin. Normally a white powder of 98–99.5% purity, starch is insoluble in cold water, ethanol, and most common solvents. See GLUCOSE.

Starches are involved in important roles in foods, either naturally occurring in an ingredient or added to achieve a desired functional characteristic. Often the desired functional characteristic (thickening; gelling; adhesive; binding; improving acid, heat, and shear stability) cannot be achieved by using a native starch. Starches may be altered physically, chemically, or enzymatically to produce modified starches with improved functional properties.

The paper, textile, adhesive, chemical, pharmaceutical, and polymer industries use starch and starch derivatives. Organic acids and organic solvents for use as chemical intermediates, enzymes, hormones, antibiotics, and vaccines are industrially produced from starch. See CARBOHYDRATE. [D.R.L.]

**Stark effect** The effect of an electric field on spectrum lines. The electric field may be externally applied; but in many cases it is an internal field caused by the presence of neighboring ions or atoms in a gas, liquid, or solid. Discovered in 1913 by J. Stark, the effect is most easily studied in the spectra of hydrogen and helium, by observing the light from the cathode dark space of an electric discharge. Because of the large potential drop across this region, the lines are split into several components. For observation perpendicular to the field, the light of these components is linearly polarized.

The linear Stark effect exhibits large, nearly symmetrical patterns. The interpretation of the linear Stark effect was one of the first successes of the quantum theory. According to this theory, the effect of the electric field on the electron orbit is to split each energy level of the principal quantum number  $n$  into  $2n - 1$  equidistant levels, of separation proportional to the field strength. See ATOMIC STRUCTURE AND SPECTRA.

The quadratic Stark effect occurs in lines resulting from the lower energy states of many-electron atoms. The quadratic Stark effect is basic to the explanation of the formation of molecules from atoms, of dielectric constants, and of the broadening of spectral lines.

The intermolecular Stark effect is produced by the action of the electric field from surrounding atoms or ions on the emitting atom. The intermolecular effect causes a shifting and broadening of spectrum lines. The molecules being in motion, these fields

are inhomogeneous in space and also in time. Hence the line is not split into resolved components but is merely widened.

[F.A.J./W.W.W.]

The quantum-confined Stark effect is the Stark effect observed in structures in which the hydrogenic system is confined in a layer of thickness much less than its normal diameter. This is not practical with atoms, but the effect is observed with excitons in semiconductor quantum-well heterostructures. It is important that quantum-confined Stark shifts can be much larger than the binding energy of the hydrogenic system. The resulting shifts of the exciton optical absorption lines can be used to make optical beam modulators and self-electrooptic-effect optical switching devices. See ARTIFICIALLY LAYERED STRUCTURES; ELECTROOPTICS; EXCITON; OPTICAL MODULATORS; SEMICONDUCTOR HETEROSTRUCTURES. [D.A.B.M.]

**Static** A hissing, crackling, or other sudden sharp noise that tends to interfere with the reception, utilization, or enjoyment of desired signals or sounds. Perhaps the commonest form of static is that heard in ordinary broadcast receivers during electrical storms. Interference in radio receivers caused by improperly operating electric devices in the vicinity is sometimes also called static. See SPHERICS.

The crackling sounds heard when long-playing plastic phonograph records are played are also called static. These sounds are caused by sudden deflection of the phonograph needle by dust particles, which are attracted by the grooves of the record by surface electric charges caused by friction on dry days. Static appears as momentary white specks in a television picture. See ELECTRICAL INTERFERENCE; ELECTRICAL NOISE. [J.Mar.]

**Static electricity** Electric charge at rest, generally produced by friction or electrostatic induction. Triboelectrification is the process whereby charge transfer between dissimilar materials, at least one of which must have a high electrical resistivity, occurs due to rubbing or mere contact. See ELECTRIC CHARGE; ELECTRICAL RESISTIVITY.

In modern industry, highly insulating synthetic materials, such as plastic powders and insulating liquids, are used in large quantities in an ever-increasing number of applications. Such materials charge up readily, and large quantities of electrical energy may develop with an attendant risk of incendiary discharges. When, for example, powder is pneumatically transported along pipes, charge levels of up to about 100 microcoulombs per kilogram can develop and potentials of thousands of volts are generated within powder layers and the powder cloud. Energetic sparking from charged powder may initiate an explosion of the powder cloud. Similar problems occur when insulating liquids, such as certain fuels, are pumped along pipes, and it is essential that strict grounding procedures are followed during the refueling of aircraft, ships, and other large vehicles.

The capacity of a person for retaining charge depends upon stature, but is typically about 150 picofarads. Even the simple operations of removing items of clothing or sliding off a chair can lead to body discharges to ground of about  $0.1 \mu\text{C}$ , which are energetic enough to ignite a mixture of natural gas and air. Human body capacitance is sufficiently high that, if poorly conducting shoes are worn, body potential may rise to 15,000 V or so above ground during industrial operations such as emptying bags of powder. Sparking may then occur with energy exceeding the minimum ignition energy of powder or fumes, so initiating a fire or explosion. Conducting footwear should be used to prevent charge accumulation on personnel in industrial situations where triboelectrification may occur. See CAPACITANCE.

In the microelectronics industry, extremely low-energy discharges, arising from body potentials of only a few tens of volts, can damage microelectronics systems or corrupt computer data. During the handling of some sensitive semiconductor devices, it is imperative that operators work on metallic grounded

surfaces and are themselves permanently attached to ground by conducting wrist straps. See ELECTROSTATICS. [A.G.B.]

**Static var compensator** A thyristor-controlled (hence static) generator of reactive power, either lagging or leading, or both. The word var stands for volt ampere reactive, or reactive power. The device is also called a static reactive compensator.

**Need for reactive compensation.** Reactive power is the product of voltage times current where the voltage and current are  $90^\circ$  out of phase with one another. Thus, reactive power flows one way for one-quarter of a cycle, the other way for the next quarter of a cycle, and so on (in contrast to the real power, or active power, which flows in one direction only). This back-and-forth flow results in no net power being delivered by the generator to the load. However, current associated with reactive power does flow through the conductor and creates extra losses. See ALTERNATING CURRENT; ELECTRIC POWER MEASUREMENT; VOLTAMPERE.

Most loads draw lagging reactive power, which causes electric power system voltage to sag. On the other hand, under light loads, the capacitance of high-voltage lines can create excessive leading reactive power, causing the voltage at some locations to rise above the nominal value. Finally, it is prudent to keep reactive power flows to a minimum in order to allow the lines to carry more active power.

**Mechanical versus static compensation.** Utilities frequently install capacitors connected from line to ground to compensate for lagging reactive power and reactors connected from line to ground to compensate for leading reactive power. These reactors and capacitors are switched in and out with mechanical switches based on the level of line loading as it varies throughout the day. However, frequent operation of these mechanical switches may reduce their reliability. See CAPACITOR; REACTOR (ELECTRICITY).

It is desirable to have a controllable source of reactive power (leading or lagging); and the static var compensator, controlled with static switches, called thyristors, for higher reliability, fulfills this function. It is more expensive than mechanically switched capacitors and reactors (due to the cost of thyristor valves and associated equipment), and hence its use is based on an economic trade-off of benefits versus cost. See SEMICONDUCTOR RECTIFIER.

[N.G.H.]

**Statics** The branch of mechanics that describes bodies which are acted upon by balanced forces and torques so that they remain at rest or in uniform motion. This includes point particles, rigid bodies, fluids, and deformable solids in general. Static point particles, however, are not very interesting, and special branches of mechanics are devoted to fluids and deformable solids. For example, hydrostatics is the study of static fluids, and elasticity and plasticity are two branches devoted to deformable bodies. Therefore this article will be limited to the discussion of the statics of rigid bodies in two- and three-space dimensions. See BUOYANCY; ELASTICITY; HYDROSTATICS; MECHANICS.

In statics the bodies being studied are in equilibrium. The equilibrium conditions are very similar in the planar, or two-dimensional, and the three-dimensional rigid body statics. These are that the vector sum of all forces acting upon the body must be zero; and the resultant of all torques about any point must be zero. Thus it is necessary to understand the vector sums of forces and torques.

In studying statics problems, two principles, superposition and transmissibility, are used repeatedly on force vectors. They are applicable to all vectors, but specifically to forces and torques (first moments of forces). The principle of superposition of vectors is that the sum of any two vectors is another vector. The principle of transmissibility of a force applied to a rigid body is that the same mechanical effect is produced by any shift of the application of the force along its line of action. To use the superposition principle to add two vectors, the principle of trans-

missibility is used to move some vectors along their line of action in order to add to their components.

The moment of a force about a directed line is a signed number whose value can be obtained by applying these two rules: (1) The moment of a force about a line parallel to the force is zero. (2) The moment of a force about a line normal to a plane containing the force is the product of the magnitude of the force and the least distance from the line to the line of the force. See EQUILIBRIUM OF FORCES; FORCE; TORQUE. [B.DeF.]

**Statistical mechanics** That branch of physics which endeavors to explain the macroscopic properties of a system on the basis of the properties of the microscopic constituents of the system. Usually the number of constituents is very large. All the characteristics of the constituents and their interactions are presumed known; it is the task of statistical mechanics (often called statistical physics) to deduce from this information the behavior of the system as a whole.

**Scope.** Elements of statistical mechanical methods are present in many widely separated areas in physics. For instance, the classical Boltzmann problem is an attempt to explain the thermodynamic behavior of gases on the basis of classical mechanics applied to the system of molecules.

Statistical mechanics gives more than an explanation of already known phenomena. By using statistical methods, it often becomes possible to obtain expressions for empirically observed parameters, such as viscosity coefficients, heat conduction coefficients, and virial coefficients, in terms of the forces between molecules. Statistical considerations also play a significant role in the description of the electric and magnetic properties of materials. See BOLTZMANN STATISTICS; INTERMOLECULAR FORCES; KINETIC THEORY OF MATTER.

If the problem of molecular structure is attacked by statistical methods, the contributions of internal rotation and vibration to thermodynamic properties, such as heat capacity and entropy, can be calculated for models of various proposed structures. Comparison with the known properties often permits the selection of the correct molecular structure.

Perhaps the most dramatic examples of phenomena requiring statistical treatment are the cooperative phenomena or phase transitions. In these processes, such as the condensation of a gas, the transition from a paramagnetic to a ferromagnetic state, or the change from one crystallographic form to another, a sudden and marked change of the whole system takes place. See PHASE TRANSITIONS.

Statistical considerations of quite a different kind occur in the discussion of problems such as the diffusion of neutrons through matter. In this case, the probability of the various events which affect the neutron are known, such as the capture probability and scattering cross section. The problem here is to describe the physical situation after a large number of these individual events. The procedures used in the solution of these problems are very similar to, and in some instances taken over from, kinetic considerations. Similar problems occur in the theory of cosmic-ray showers.

It happens in both low-energy and high-energy nuclear physics that a considerable amount of energy is suddenly liberated. An incident particle may be captured by a nucleus, or a high-energy proton may collide with another proton. In either case, there is a large number of ways (a large number of degrees of freedom) in which this energy may be utilized. To survey the resulting processes, one can again invoke statistical considerations. See SCATTERING EXPERIMENTS (NUCLEI).

Of considerable importance in statistical physics are the random processes, also called stochastic processes or sometimes fluctuation phenomena. The brownian motion, the motion of a particle moving in an irregular manner under the influence of molecular bombardment, affords a typical example. The stochastic processes are in a sense intermediate between purely statistical processes, where the existence of fluctuations may

safely be neglected, and the purely atomistic phenomena, where each particle requires its individual description. See BROWNIAN MOVEMENT; STOCHASTIC PROCESS.

All statistical considerations involve, directly or indirectly, ideas from the theory of probability of widely different levels of sophistication. The use of probability notions is, in fact, the distinguishing feature of all statistical considerations. See PROBABILITY; STATISTICS.

**Methods.** For a system of  $N$  particles, each of the mass  $m$ , contained in a volume  $V$ , the positions of the particles may be labeled  $x_1, y_1, z_1, \dots, x_N, y_N, z_N$ , their cartesian velocities  $v_{x1}, \dots, v_{zN}$ , and their momenta  $P_{x1}, \dots, P_{zN}$ . This simplest statistical description concentrates on a discussion of the distribution function  $f(x, y, z, v_x, v_y, v_z, t)$ . The quantity  $f(x, y, z, v_x, v_y, v_z, t) \cdot (dx dy dz dv_x dv_y dv_z)$  gives the (probable) number of particles of the system in those positional and velocity ranges where  $x$  lies between  $x$  and  $x + dx$ ;  $v_x$  between  $v_x$  and  $v_x + dv_x$ , and so on. These ranges are finite.

Observations made on a system always require a finite time; during this time the microscopic details of the system will generally change considerably as the phase point moves. The result of a measurement of a quantity  $Q$  will therefore yield the time average, as in Eq. (1). The integral is along the trajectory in phase

$$\bar{Q}_t = \frac{1}{t} \int_0^t Q dt \quad (1)$$

space;  $Q$  depends on the variables  $x_1, \dots, P_{zN}$ , and  $t$ . To evaluate the integral, the trajectory must be known, which requires the solution of the complete mechanical problem.

**Ensembles.** J. Willard Gibbs first suggested that instead of calculating a time average for a single dynamical system, a collection of systems, all similar to the original one, should instead be considered. Such an ensemble of systems is to be constructed in harmony with the available knowledge of the single system, and may be represented by an assembly of points in the phase space, each point representing a single system. If, for example, the energy of a system is precisely known, but nothing else, the appropriate representative example would be a uniform distribution of ensemble points over the energy surface, and no ensemble points elsewhere. An ensemble is characterized by a density function  $\rho(x_1, \dots, z_N; p_{x1}, \dots, p_{zN}; t) \equiv p(x, p, t)$ . The significance of this function is that the number of ensemble systems  $dN_e$  contained in the volume element  $dx_1 \dots dz_N; dp_x \dots dp_{zN}$  of the phase space (this volume element will be called  $d\Gamma$ ) at time  $t$  is as given in Eq. (2).

$$\rho(x, p, t) d\Gamma = dN_e \quad (2)$$

The ensemble average of any quantity  $Q$  is given by Eq. (3).

$$\bar{Q}_{\text{ens}} = \frac{\int Q \rho d\Gamma}{\int \rho d\Gamma} \quad (3)$$

The basic idea now is to replace the time average of an individual system by the ensemble average, at a fixed time, of the representative ensemble. Stated formally, the quantity  $\bar{Q}_t$  defined by Eq. (1), in which no statistics is involved, is identified with  $\bar{Q}_{\text{ens}}$  defined by Eq. (3), in which probability assumptions are explicitly made.

**Relation to thermodynamics.** It is certainly reasonable to assume that the appropriate ensemble for a thermodynamic equilibrium state must be described by a density function which is independent of the time, since all the macroscopic averages which are to be computed as ensemble averages are time-independent.

The so-called microcanonical ensemble is defined by Eq. (4a), where  $c$  is a constant, for the energy  $E$  between  $E_0$  and  $E_0 + \Delta E$ ; for other energies Eq. (4b) holds. By using Eq. (3), any micro-

$$\rho(p, x) = c \quad (4a)$$

$$\rho(p, x) = 0 \quad (4b)$$

canonical average may be calculated. The calculations, which

involve integrations over volumes bounded by two energy surfaces, are not trivial. Still, many of the results of classical Boltzmann statistics may be obtained in this way. For applications and for the interpretation of thermodynamics, the canonical ensembles is much more preferable. This ensemble describes a system which is not isolated but which is in thermal contact with a heat reservoir.

There is yet another ensemble which is extremely useful and which is particularly suitable for quantum-mechanical applications. Much work in statistical mechanics is based on the use of this so-called grand canonical ensemble. The grand ensemble describes a collection of systems; the number of particles in each system is no longer the same, but varies from system to system. The density function  $p(N, p, x) d\Gamma_N$  gives the probability that there will be in the ensemble a system having  $N$  particles, and that this system, in its  $6N$ -dimensional phase space  $\Gamma_N$ , will be in the region of phase space  $d\Gamma_N$ . [M.Dr.]

**Statistics** The field of knowledge concerned with collecting, analyzing, and presenting data. Not only workers in the physical, biological, and social sciences, but also engineers, business managers, government officials, market analysts, and many others regularly use statistical methods in their work. The methods range from simple counting to complex mathematical systems designed to extract the maximum amount of information from very extensive data.

In an important sense statistics may be regarded as a field of application of probability theory. The common problem faced by any worker who must collect, analyze, and present data is that of random variation which prevents repetition of exactly the same result when a measurement is repeated. Statistical methods are employed to assess the magnitude of random variation, to minimize it, to balance it out, to remove it by calculation procedures, and to analyze it by suitably arranged patterns of observation. The theory of probability is concerned with the properties of random variables and hence furnishes the basis for developing techniques for controlling them. See PROBABILITY.

Viewing statistics from another direction, it is the science of deriving information about populations by observing only samples of those populations. A population is any well-specified collection of elements. Thus, one may refer to the population of adults in the continental United States viewing television screens at 8:14 P.M. on August 6, 1970. Populations may be finite or infinite. An element of a univariate population is characterized by the value of a random variable which measures some single attribute of interest in the population. Thus, one may be interested in whether or not individuals of the television audience were or were not viewing program A; with each individual one may associate a random variable; let it be  $X$ , which takes on the value of 1 if the individual is watching A and 0 if he or she is not. If one were interested in a second characteristic of the elements of the television audience (such as age), one would be dealing with a bivariate population; a third characteristic (such as economic status) would make it a trivariate or, less specifically, a multivariate population.

**Distributions.** In a univariate population, the population distribution is a curve (function of the random variable which characterizes the elements of the population) from which one can determine the proportion of the population which has elements in a certain range of the random variable. For example, the curve of Fig. 1 provides the distribution of annual incomes of family units in the United States in 1954. The total area under the curve is 1. The area under the curve between any two vertical lines gives the proportion of the families having annual incomes between the two values marked on the horizontal scale by the two vertical lines.

The distribution is also referred to as the distribution function, the density function, the frequency function, or the probability density.



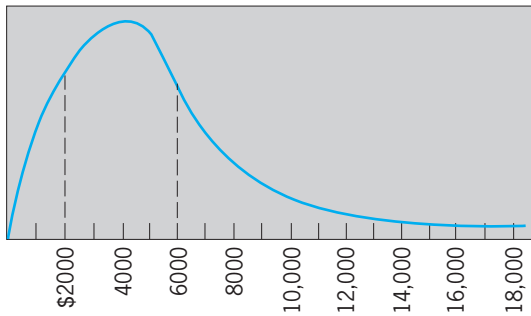

Fig. 1. Distribution of incomes.

The total area under the distribution curve to the left of each point can also be plotted to give a curve which starts at zero and reaches unity as the variable becomes large; the resulting curve is sometimes called the cumulative distribution function, the probability distribution, or simply the distribution. The cumulative form of the curve of Fig. 1 is shown in Fig. 2; the height of the curve at any point on the horizontal scale equals the area to the left of that point under the curve of Fig. 1 and is the proportion of the population having incomes less than the value at that point. The distribution (in either frequency or cumulative form) gives complete information about the way the characterizing variable is spread through the population.

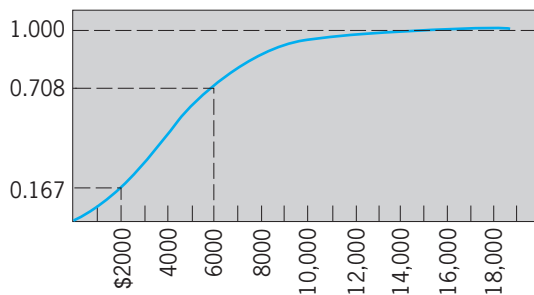

Fig. 2. Cumulative distribution of incomes.

**Population parameters.** Populations (or population distributions) are often specified incompletely by certain population parameters. Some of these parameters are location parameters or measures of central tendency; a second class of important parameters consists of measures of dispersion or scale parameters.

The most widely used location parameters are the mean, the median, and the mode. The mean is the average over all the population of the values of the random variable. It is often represented by the Greek letter  $\mu$ . In mathematical terms, if  $x$  is the random variable,  $f(x)$  the frequency function for a given population, and  $F(x)$  its cumulative form, then the mean is as shown in Eq. (1).

$$\mu = \int_{-\infty}^{\infty} xf(x)dx = \int_{-\infty}^{\infty} x dF(x) \quad (1)$$

The median, often designated by  $Med$ ,  $M$ , or  $X_{50}$ , is a number such that, at most, one-half the values of the variable associated with the elements of the population fall above or below it. The mode is the most frequent value of the random variable; if the frequency function has a unique maximum value, the mode is the value of the random variable at which the frequency function reaches its maximum. Location parameters are numbers near the center of the range over which the random variable of the population varies.

The extent to which a population is scattered on either side of its center is roughly indicated by measures of dispersion such as the standard deviation, the mean deviation, the interquartile range, the range, and sometimes others. The standard deviation

is the square root of the mean square of the deviations from the mean; it is usually denoted by the Greek letter  $\sigma$ ;  $\sigma^2$  is called the variance and is expressed by Eq. (2).

$$\begin{aligned} \sigma^2 &= \int_{-\infty}^{\infty} (x - \mu)^2 f(x)dx \\ &= \int_{-\infty}^{\infty} (x - \mu)^2 dF(x) \end{aligned} \quad (2)$$

The mean deviation, shown in Eq. (3), is the average over the

$$\begin{aligned} \text{Mean deviation} &= \int_{-\infty}^{\infty} |x - \mu| f(x)dx \\ &= \int_{-\infty}^{\infty} |x - \mu| dF(x) \end{aligned} \quad (3)$$

population of the deviations from the mean, all taken to be positive. The interquartile range (often denoted by  $Q$ ) is the difference  $X_{.75} - X_{.25}$ , where  $X_{.75}$  is the value of the random variable such that one-quarter of the population has values larger than  $X_{.75}$ , and  $X_{.25}$  is the number such that one-quarter of the population has values smaller than  $X_{.25}$ . The three numbers,  $X_{.25}$ ,  $X_{.50}$ ,  $X_{.75}$ , are called quartiles; these divide the population into quarters. The range is the difference between the largest and the smallest of the population elements.

**Sampling.** If one examines every element of a population and records the value of the random variable for each, complete information is obtained about the distribution of the random variable in the population, and there is no statistical problem. It is usually impossible or uneconomical to make a complete enumeration (or census) of a population, and one must therefore be content to examine only a part or sample of the population. On the basis of the sample, one draws conclusions about the entire population; the conclusions thus drawn are not certain in the sense that they would likely have been somewhat different if a different sample of the population had been examined. The problem of drawing valid conclusions from samples and of specifying their range of uncertainty is known as the problem of statistical inference.

Simple random sampling is a method of selecting a sample of  $n$  elements out of a population of  $N$  elements so that all such samples have an equal probability of being drawn. This may be done by selecting a first element at random from the population, then a second element at random from the remaining population, and so on until the  $n$  elements are selected.

The observations of a sample, besides providing estimates of population parameters, can also be used to obtain an estimate of the population's frequency function. This estimate is determined by dividing the range of the sample observations into several intervals of equal length  $L$  and counting the number of observations occurring in each interval; these numbers are then divided by  $nL$  to determine fractions giving the relative density of the sample occurring in each interval; then on a sheet of graph paper one lays out the intervals on a horizontal axis and plots horizontal lines above each interval at a height equal to the fraction corresponding to the interval; finally the successive plotted horizontal lines are connected by vertical lines to form a broken line curve known as a histogram (Fig. 3).

When a population can be regarded as being made up of several nonoverlapping subpopulations, one may draw a sample from it by drawing a simple random sample from each

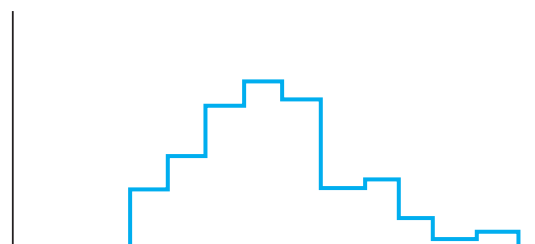

Fig. 3. Histogram.

subpopulation (or stratum); this procedure is called stratified random sampling. Systematic sampling may be regarded as a sampling of units at regular intervals in the population, for example, every tenth unit. When the elements of a population are in mutually exclusive groups called the primary units of the population, then a sample of these primary units might be made, and then, from those selected, a sample of the individual elements would be made. This procedure is called two-stage sampling or subsampling. Multistage sampling can involve more than two stages of sampling.

Many important sampling distributions are derived for random samples drawn from a normal or Gaussian distribution, which is a bell-shaped symmetrical distribution centered at its mean  $\mu$ .

**Estimation.** In making an estimate of the value of a parameter of a population from a sample, a function (called the estimator) of the observations is used. For example, for estimating the mean of a normal population the mean of the sample observations is usually taken as the estimator. Another estimator is the average of the two most extreme observations. In fact, there is an infinitude of estimators. The problem of estimation is to find a "good" estimator.

A good estimator may be regarded as one which results in a distribution of estimates concentrated near the true value of the parameter and which can be applied without excessive effort.

**Tests of hypotheses.** Besides estimation of parameters, another major area of statistical inference is the testing of hypotheses. A hypothesis is merely an assertion that a population has a specific property. The test consists of drawing a sample from the population and determining whether or not it is consistent with the assertion. Very often the hypothesis is a statement about the mean of a population; that it has a given value, that it is the same as that of another population, that it exceeds that of another population by at least 10 units, and the like. Thus, one may be comparing a new blend of gasoline with a current blend, a new drug with a standard one, a new manufacturing process with an existing one.

**Experimental design.** An experiment is performed to obtain information about the relations between several variables. For example, one may study the effect of storage temperature and duration of storage on the flavor of a frozen food. Three variables (flavor, temperature, and duration) are involved; one (flavor) is called the subject of the experiment; the other two are called factors which influence the subject. Sometimes the factors have intrinsic value in themselves; sometimes they are merely nuisance variables which must be taken into account because it is impossible to perform the experiment without them.

There exist in the statistical literature great numbers of specific experimental designs. These are patterns for making experimental observations; the actual construction of the designs requires quite advanced mathematics based on group theory, finite geometries, and combinatorial analysis. The mathematical problem is to find a pattern from which it is possible to extract the desired information and yet minimize the number of observations.

**Regression and correlation.** The regression problem is that of estimating certain unknown constants or parameters occurring in a function which relates several variables; the variables may be random or not. By far the most easily handled cases are those in which the function is linear in the unknown parameters, and it is worth considerable effort to transform the function to that form if at all possible. See ANALYSIS OF VARIANCE; DISTRIBUTION (PROBABILITY). [A.M.M.]

**Statoblasts** Chitin-encapsulated bodies, resistant to freezing and a limited amount of desiccation. They serve as a special means of asexual reproduction in the Phylactolaemata, a class of fresh-water Bryozoa. They are 0.01–0.06 in. (0.26–1.5 mm) long, and their shape and structure are important to the taxonomy of the group.

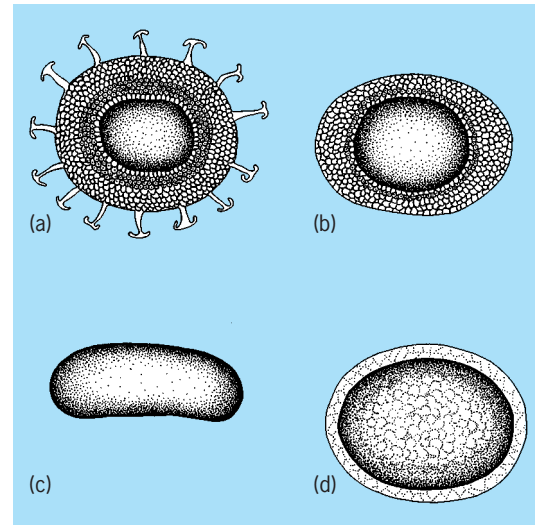

Some types of statoblasts. (a) Spinoblast of *Pectinatella magnifica*. (b) Floatoblast of *Plumatella repens*. (c) Piptoblast or sessoblast of *Fredericella sultana*. (d) Sessoblast of *Stolella indica*.

Statoblasts are classified as follows: sessoblasts, those which attach to zoecial tubes (structures of the outer layer or zoecial of an individual in the colony) or the substratum; floatoblasts and spinoblasts, both of which have a float of "air" cells and therefore are free-floating; and piptoblasts, which are free but have no float (see illustration).

These bodies are produced in enormous quantities from spring to autumn. They develop by organization of masses of peritoneal cells and epidermal cells that bulge into the coelom. Each mass then secretes protective upper and lower chitinous valves, the rims of which often project peripherally. Statoblasts are therefore somewhat disk-shaped.

These bodies remain dormant for variable periods of time and serve to tide species over adverse ecological conditions, such as freezing or drying, which kill the colony. During this time they may be dispersed over considerable distances, being carried by animals, floating vegetation, or the action of water currents. When environmental conditions become favorable, which is usually in the spring, statoblasts germinate and a zooid develops from the mass of cells lying between the two valves. Statoblasts of *Lophopodella* have germinated after 50 months of drying. See BRYOZOA. [S.P.P.]

**Staurolite** A nesosilicate mineral occurring in metamorphic rocks. The chemical formula of staurolite may be written as  $A_4B_4C_{18}D_4T_8O_{40}X_8$ , where A =  $Fe^{2+}$ , Mg; B =  $Fe^{2+}$ , Zn, Co, Mg, Li, Al,  $Fe^{3+}$ ,  $Mn^{2+}$ ; C = Al,  $Fe^{3+}$ , Cr, V, Ti; D = Al, Mg; T = Si, Al; X = OH, F, O. Staurolite occurs as well-formed, often-twinning, prismatic crystals. It is brown-black, reddish brown, or light brown in color and has a vitreous to dull luster. Light color and dull luster can result from abundant quartz inclusions. There is no cleavage, specific gravity is 3.65–3.75, and hardness is 7–7.5 (Mohs scale). See HARDNESS SCALES.

Typical minerals occurring with staurolite are quartz, micas (muscovite and biotite), garnet (almandine), tourmaline, and kyanite, sillimanite, or andalusite. Staurolite is common where pelitic schists reach medium-grade metamorphism. Examples are the Swiss and Italian Alps (notable at Saint Gotthard, Switzerland), and all the New England states, Virginia, the Carolinas, Georgia, New Mexico, Nevada, and Idaho. See METAMORPHISM; SILICATE MINERALS. [F.C.Ha.]

**Stauromedusae** An order of the class Scyphozoa, usually found in circumpolar regions. The egg develops into a

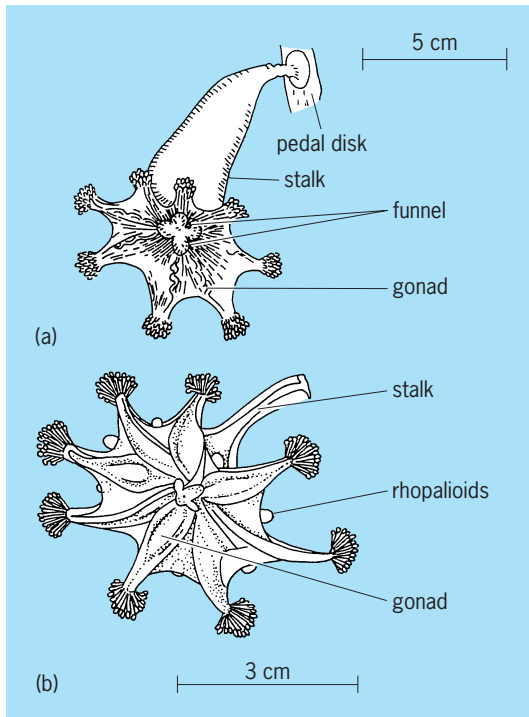

**Stauromedusae.** (a) *Lucernaria*. (b) *Haliclystus*. (After L. H. Hyman, *The Invertebrates*, vol. 1, McGraw-Hill, 1940)

planula which can only creep since it lacks cilia. The planula changes into a polyp that metamorphoses directly into a combined polyp and medusa form. The medusa is composed of a cuplike bell called a calyx (medusan part) and a stem or stalk (polyp part) which terminates in a pedal disk (see illustration). The calyx is eight-sided and has eight groups of short, capped tentacles and eight sensory bodies, called anchors, on its margin. The mouth, situated at the center of the calyx, has four thin lips and leads to the stomach in which gastral filaments are arranged in a row on either side of each interradius. Though sessile, the medusa can move in a leechlike fashion by alternate attachment and release of the pedal disk, using the substratum as an anchor. See SCYPHOZOA. [T.U.]

**Steam** Water vapor, or water in its gaseous state. Steam is the most widely used working fluid in external combustion engine cycles, where it will utilize practically any source of heat, that is, coal, oil, gas, nuclear fuel (uranium and thorium), waste fuel, and waste heat. It is also extensively used as a thermal transport fluid in the process industries and in the comfort heating and cooling of space. The universality of its availability and its highly acceptable, well-defined physical and chemical properties also contribute to the usefulness of steam.

The temperature at which steam forms depends on the pressure in the boiler. The steam formed in the boiler (and conversely steam condensed in a condenser) is in temperature equilibrium with the water. Under these conditions, with steam and water in contact and at the same temperature, the steam is termed saturated. Steam can be entirely vapor when it is 100% dry, or it can carry entrained moisture and be wet. After the steam is removed from contact with the liquid phase, the steam can be further heated without changing its pressure. If initially wet, the additional heat will first dry it and then raise it above its saturation temperature. This is a sensible heat addition, and the steam is said to be superheated. Superheated steam at temperatures well above the boiling temperature for the existing steam pressure follows closely the laws of a perfect gas. Chiefly because of its availability, but also because of its nontoxicity, steam is widely

used as the working medium in thermodynamic processes. It has a uniquely high latent heat of vaporization. Steam has a specific heat about twice that of air and comparable to that of ammonia. The specific heat of steam is relatively high so that it can carry more thermal energy at practical temperatures than can other usable gases. See BOILER; BOYLE'S LAW; CHARLES' LAW; DALTON'S LAW; ENTROPY; STEAM ENGINE; STEAM-GENERATING UNIT; STEAM HEATING; STEAM TURBINE; THERMODYNAMIC CYCLE; THERMODYNAMIC PRINCIPLES; WATER. [T.Ba.]

**Steam condenser** A heat-transfer device used for condensing steam to water by removal of the latent heat of steam and its subsequent absorption in a heat-receiving fluid, usually water, but on occasion air or a process fluid. Steam condensers may be classified as contact or surface condensers.

In the contact condenser, the condensing takes place in a chamber in which the steam and cooling water mix. The direct contact surface is provided by sprays, baffles, or void-effecting fill. In the surface condenser, the condensing takes place separated from the cooling water or other heat-receiving fluid (or heat sink). A metal wall, or walls, provides the means for separation and forms the condensing surface.

Both contact and surface condensers are used for process systems and for power generation serving engines and turbines. Modern practice has confined the use of contact condensers almost entirely to such process systems as those involving vacuum pans, evaporators, or dryers, and to condensing and dehumidification processes inherent in vacuum-producing equipment such as steam jet ejectors and vacuum pumps. The steam surface condenser is used chiefly in power generation but is also used in process systems, especially in those in which condensate recovery is important. Air-cooled surface condensers are used in process systems and in power generation when the availability of cooling water is limited. See STEAM; STEAM TURBINE; VAPOR CONDENSER. [J.F.Se.]

**Steam electric generator** An alternating-current (ac) synchronous generator driven by a steam turbine for 50- or 60-Hz electrical generating systems. See STEAM TURBINE.

The synchronous generator is a relatively simple machine made of two basic parts: a stator (stationary) and a rotor (rotating). The stator consists of a cylindrical steel frame. Inside the frame, a cylindrical iron core made of thin insulated laminations is mounted on a support system. The iron core has equally spaced axial slots on its inside diameter, and wound within the core slots is a stator winding. The stator winding copper is electrically insulated from the core. The rotor consists of a forged solid steel shaft. Wound into axial slots on the outside diameter of the shaft is a copper rotor winding that is held in the slots with wedges. Retaining rings support the winding at the rotor body ends. The rotor winding, commonly called the field, is electrically insulated from the shaft and is arranged in pole pairs (always an even number) to form the magnetic field which produces the flux. The rotor shaft (supported by bearings) is coupled to a steam turbine, and rotates inside the stator core. See ELECTRIC ROTATING MACHINERY; WINDINGS IN ELECTRIC MACHINERY.

The stator winding (armature) is connected to the ac electrical transmission system through the bushings and output terminals. The rotor winding (field) is connected to the generator's excitation system. The excitation system provides the direct-current (dc) field power to the rotor winding via carbon brushes riding on a rotating collector ring mounted on the generator rotor. The synchronous generator's output voltage amplitude and frequency must remain constant for proper operation of electrical load devices. During operation, the excitation system's voltage regulator monitors the generator's output voltage and current. The voltage regulator controls the rotor winding dc voltage to maintain a constant generator stator output ac voltage, while allowing the stator current to vary with changes in load. Field windings typically operate at voltages between 125 and 575 V dc. The synchronous

generator's output frequency is directly proportional to the speed of the rotor, and the speed of the generator rotor is held constant by a speed governor system associated with the steam turbine. See ALTERNATING-CURRENT GENERATOR; GENERATOR.

Synchronous generators range in size from a few kilovoltamperes to 1,650,000 kVA. 60-Hz steam-driven synchronous generators operate at speeds of either 3600 or 1800 rpm; for 50-Hz synchronous generators these speeds would be 3000 or 1500 rpm. These two- and four-pole generators are called cylindrical rotor units. For comparison, water (hydro)-driven and air-driven synchronous generators operate at lower speeds, some as low as 62 rpm (116 poles). The stator output voltage of large (generally greater than 100,000 kVA) units ranges 13,800–27,000 V. See ELECTRIC POWER GENERATION; HYDROELECTRIC GENERATOR.

There are five sources of heat loss in a synchronous generator: stator winding resistance, rotor winding resistance, core, windage and friction, and stray losses. Removing the heat associated with these losses is the major challenge to the machine designer. The cooling requirements for the stator windings, rotor windings, and core increase proportionally to the cube of the machine size. The early synchronous generators were air-cooled. Later, air-to-water coolers were required to remove the heat. [J.R.Mi.]

**Steam engine** A machine for converting the heat energy in steam to mechanical energy of a moving mechanism, for example, a shaft. The steam engine can utilize any source of heat in the form of steam from a boiler. Most modern machine elements had their origin in the steam engine: cylinders, pistons, piston rings, valves and valve gear crossheads, wrist pins, connecting rods, crankshafts, governors, and reversing gears. See BOILER; STEAM.

The 20th century saw the practical end of the steam engine. The steam turbine replaced the steam engine as the major prime mover for electric generating stations. The internal combustion engine, especially the high-speed automotive types which burn volatile (gasoline) or nonvolatile (diesel) liquid fuel, has completely displaced the steam locomotive with the diesel locomotive and marine steam engines with the motorship and motorboat. Because of the steam engine's weight and speed limitations, it was also excluded from the aviation field. See DIESEL ENGINE; GAS TURBINE; INTERNAL COMBUSTION ENGINE; STEAM TURBINE.

A typical steam reciprocating engine consists of a cylinder fitted with a piston (Fig. 1). A connecting rod and crankshaft convert the piston's to-and-fro motion into rotary motion. A flywheel tends to maintain a constant-output angular velocity in the presence of the cyclically changing steam pressure on the piston face. A D slide valve admits high-pressure steam to the cylinder and allows the spent steam to escape (Fig. 2). The power developed by the engine depends upon the pressure and quantity of steam admitted per unit time to the cylinder.

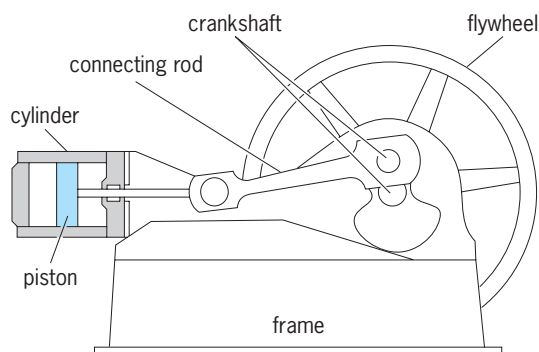

Fig. 1. Principal parts of horizontal steam engine.

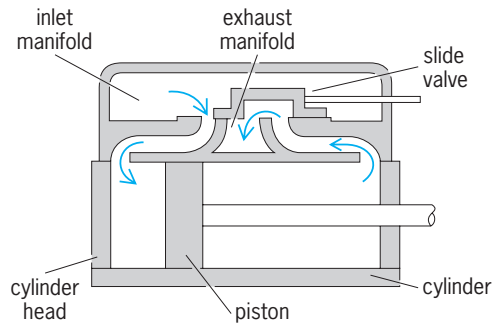

Fig. 2. Single-ported slide valve on counterflow double-acting cylinder.

Engines are classified as single- or double-acting, and as horizontal (Fig. 1) or vertical depending on the direction of piston motion. If the steam does not fully expand in one cylinder, it can be exhausted into a second, larger cylinder to expand further and give up a greater part of its initial energy. Thus, an engine can be compounded for double or triple expansion.

Steam engines can also be classed by functions, and are built to optimize the characteristics most desired in each application. Stationary engines drive electric generators, in which constant speed is important, or pumps and compressors, in which constant torque is important. [T.Ba.]

**Steam-generating furnace** An enclosed space provided for the combustion of fuel to generate steam. The closure confines the products of combustion and is capable of withstanding the high temperatures developed and the pressures used. Its dimensions and geometry are adapted to the rate of heat release, to the type of fuel, and to the method of firing so as to promote complete burning of the combustible and suitable disposal of ash. In water-cooled furnaces the heat absorbed materially affects the temperature of gases at the furnace outlet and contributes directly to the generation of steam. See FURNACE CONSTRUCTION; STEAM; STEAM-GENERATING UNIT. [G.W.K.]

**Steam-generating unit** The wide diversity of parts, appurtenances, and functions needed to release and utilize a source of heat for the practical production of steam at pressures to 5000 lb/in.<sup>2</sup> (34 megapascals) and temperatures to 1100°F (600°C), often referred to as a steam boiler for brevity. See STEAM.

The essential steps of the steam-generating process include (1) a furnace for the combustion of fuel, or a nuclear reactor for the release of heat by fission, or a waste heat system; (2) a pressure vessel in which feedwater is raised to the boiling temperature, evaporated into steam, and generally superheated beyond the saturation temperature; and (3) in many modern central station units, a reheat section or sections for resuperheating steam after it has been partially expanded in a turbine. This aggregation of functions requires a wide assortment of components, which may be variously employed in the interests, primarily, of capacity and efficiency in the steam-production process. The selection, design, operation, and maintenance of these components constitute a complex process. See BOILER; REHEATING; SUPERHEATER. [T.Ba.]

**Steam heating** A heating system that uses steam generated from a boiler. The steam heating system conveys steam through pipes to heat exchangers, such as radiators, convectors, baseboard units, radiant panels, or fan-driven heaters, and returns the resulting condensed water to the boiler. Such systems normally operate at pressure not exceeding 15 lb/in.<sup>2</sup> gage or 103 kilopascals gage, and in many designs the condensed steam returns to the boiler by gravity because of the static head of water in the return piping. With utilization of available operating and

safety control devices, these systems can be designed to operate automatically with minimal maintenance and attention.

In a one-pipe steam heating system, a single main serves the dual purpose of supplying steam to the heat exchanger and conveying condensate from it. Ordinarily, there is but one connection to the radiator or heat exchanger, and this connection serves as both the supply and return. A two-pipe system is provided with two connections from each heat exchanger, and in this system steam and condensate flow in separate mains and branches.

Another source for steam for heating is from a high-temperature water source (350–450°F or 180–230°C) using a high-pressure water to low-pressure steam heat exchanger. See BOILER; COMFORT HEATING; OIL BURNER; STEAM-GENERATING FURNACE. [J.W.J.]

**Steam jet ejector** A steam-actuated device for pumping compressible fluids, usually from subatmospheric suction pressure to atmospheric discharge pressure. A steam jet ejector is most frequently used for maintaining vacuum in process equipment in which evaporation or condensation takes place. Because of its simplicity, compactness, reliability, and generally low first cost, it is often preferred to a mechanical vacuum pump for removing air from condensers serving steam turbines, especially for marine service.

Two or more stages may be arranged in series, depending upon the total compression ratio required. Two or more sets of series stages may be arranged in parallel to accommodate variations in capacity. Vapor condensers are usually interposed between the compression stages of multistage steam jet ejectors to condense and remove a significant portion of the motive steam and other condensable vapors. [J.F.Se.]

**Steam separator** A device for separating a mixture of the liquid and vapor phases of water. Steam separators are used in most boilers and may also be used in saturated steam lines to separate and remove the moisture formed because of heat loss.

Steam separators have many forms and may be as fundamental as a simple baffle that utilizes inertia caused by a change of direction. Most modern, high-capacity boilers use a combination of cyclone separators and steam dryers. Cyclone separators slice the steam-water mixture into thin streams so that the steam bubbles need travel only short distances through the mixture to become disengaged, and then they whirl the mixture in a circular path, creating a centrifugal force many times greater than the force of gravity. Steam dryers remove small droplets of water from the steam by providing a series of changes in direction and a large surface area to intercept the droplets. See BOILER FEEDWATER; STEAM; STEAM TURBINE. [E.E.Co.]

**Steam temperature control** Means for regulating the operation of a steam-generating unit to produce steam at the required temperature. The temperature of steam is affected by the change in the relative heat absorption as load varies, by changes in ash or slag deposits on the heat-absorbing surface, by changes in fuel, by changes in the proportioning of fuel and combustion air, or by changes in feedwater temperature. Low steam temperature lowers the efficiency of the thermal cycle. However, high steam temperature, which increases thermal efficiency, is restricted by the strength and durability of materials used in superheaters. Control of steam temperature is, therefore, a matter of primary concern in the design of modern steam-generating units.

Steam temperature can be controlled by one or more of several methods. These include (1) the damper control of gases to the superheater, to the reheater, or to both, thus changing the heat input; (2) the recirculation of low-temperature flue gas to the furnace, thus changing the relative amounts of heat absorbed in the furnace and in the superheater, reheater, or both; (3) the selective use of burners at different elevations in the furnace or the use of tilting burners, thus changing the location of the combus-

tion zone with respect to the furnace heat-absorbing surface; (4) the attemperation, or controlled cooling, of the steam by the injection of spray water or by the passage of a portion of the steam through a heat exchanger submerged in the boiler water; (5) the control of the firing rate in divided furnaces; and (6) the control of the firing rate relative to the pumping rate of the feedwater to forced-flow once-through boilers. Generally, these various controls are adjusted automatically. See STEAM-GENERATING UNIT. [G.W.K.]

**Steam turbine** A machine for generating mechanical power in rotary motion from the energy of steam at temperature and pressure above that of an available sink. By far the most widely used and most powerful turbines are those driven by steam. Until the 1960s essentially all steam used in turbine cycles was raised in boilers burning fossil fuels (coal, oil, and gas) or, in minor quantities, certain waste products. However, modern turbine technology includes nuclear steam plants as well as production of steam supplies from other sources. See NUCLEAR REACTOR.

The illustration shows a small, simple mechanical-drive turbine of a few horsepower. It illustrates the essential parts for all steam turbines regardless of rating or complexity: (1) a casing, or shell, usually divided at the horizontal center line, with the halves bolted together for ease of assembly and disassembly; it contains the stationary blade system; (2) a rotor carrying the moving buckets (blades or vanes) either on wheels or drums, with bearing journals on the ends of the rotor; (3) a set of bearings attached to the casing to support the shaft; (4) a governor and valve system for regulating the speed and power of the turbine by controlling the steam flow, and an oil system for lubrication of the bearings and, on all but the smallest machines, for operating the control valves by a relay system connected with the governor; (5) a coupling to connect with the driven machine; and (6) pipe connections to the steam supply at the inlet and to an exhaust system at the outlet of the casing or shell.

Steam turbines are ideal prime movers for driving machines requiring rotational mechanical input power. They can deliver constant or variable speed and are capable of close speed control. Drive applications include centrifugal pumps, compressors, ship propellers, and, most important, electric generators.

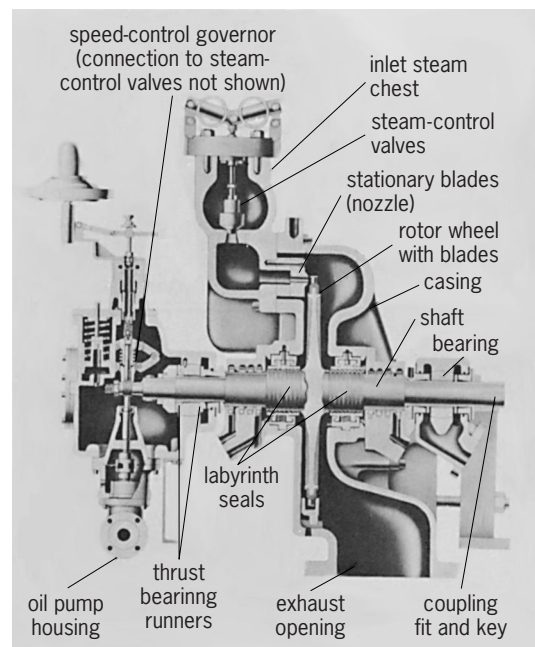

Cutaway of small, single-stage steam turbine. (General Electric Co.)

Steam turbines are classified (1) by mechanical arrangement, as single-casing, cross-compound (more than one shaft side by side), or tandem-compound (more than one casing with a single shaft); (2) by steam flow direction (axial for most, but radial for a few); (3) by steam cycle, whether condensing, noncondensing, automatic extraction, reheat, fossil fuel, or nuclear; and (4) by number of exhaust flows of a condensing unit, as single, double, triple flow, and so on. Units with as many as eight exhaust flows are in use. See TURBINE. [F.G.B.]

**Steel** Any of a great number of alloys that contain the element iron as the major component and small amounts of carbon as the major alloying element. These alloys are more properly referred to as carbon steels. Small amounts, generally on the order of a few percent, of other elements such as manganese, silicon, chromium, molybdenum, and nickel may also be present in carbon steels. However, when large amounts of alloying elements are added to iron to achieve special properties, other designations are used to describe the alloys. For example, large amounts of chromium, over 12%, are added to produce the important groups of alloys known as stainless steels. See STAINLESS STEEL.

Low-carbon steels, sometimes referred to as mild steels, usually contain less than 0.25% carbon. These steels are easily hot-worked and are produced in large tonnages for beams and other structural applications. The relatively low strength and high ductility of the low-carbon steels make it possible also to cold-work these steels. Cold-rolled low-carbon steels are extensively used for sheet applications in the appliance and automotive industries. Cold-rolled steels have excellent surface finishes, and both hot- and cold-worked mild steels are readily welded.

Medium-carbon steels contain between 0.25 and 0.70% carbon, and are most frequently used in the heat-treated condition for machine components that require high strength and good fatigue resistance.

Steels containing more than 0.7% carbon are in a special category because of their high hardness and low toughness. This combination of properties makes the high-carbon steels ideal for bearing applications where wear resistance is important and the compressive loading minimizes brittle fracture that might develop on tensile loading. [G.Kr.]

**Steel manufacture** A sequence of operations in which pig iron and scrap steel are processed to remove impurities and are separated into the refined metal and slag.

Reduction of iron ores by carbonaceous fuel directly to a steel composition was practiced in ancient times, but liquid processing was unknown until development of the crucible process, in which iron ore, coal, and flux materials were melted in a crucible to produce small quantities of liquid steel. Modern steelmaking processes began with the invention of the airblown converter by H. Bessemer in 1856. The Thomas process was developed in 1878; it modified the Bessemer process to permit treatment of high-phosphorus pig iron. The Siemens-Martin process, also known as the open-hearth process, was developed at about the same time. The open-hearth process utilizes regenerative heat transfer to preheat air used with a burner; it can generate sufficient heat to refine solid steel scrap and pig iron in a reverberatory furnace. After World War II, various oxygen steelmaking processes were developed.

Steelmaking can be divided into acid and basic processes depending upon whether the slag is high in silica (acid) or high in lime (basic). The furnace lining in contact with the slag should be a compatible material. A silica or siliceous material is used in acid processes, and a basic material such as burned dolomite or magnesite is used in basic processes. Carbon, manganese, and silicon, the principal impurities in pig iron, are easily oxidized and separated; the manganese and silicon oxides go into the slag, and the carbon is removed as carbon monoxide and carbon dioxide in the off-gases. Phosphorus is also oxidized but

does not separate from the metal unless the slag is basic. Removal of sulfur occurs to some extent by absorption in a basic slag. Thus, the basic steelmaking processes are more versatile in terms of the raw materials they can handle, and have become the predominant steelmaking processes.

A typical pig iron charged to the steelmaking process might contain roughly 4% carbon, 1% manganese, and 1% silicon. The phosphorus and sulfur levels in the pig iron vary. The composition of the steel tapped from the steelmaking furnace generally ranges from 0.04 to 0.80% carbon, 0.06 to 0.30% manganese, 0.01 to 0.05% phosphorus, and 0.01 to 0.05% sulfur, with negligible amounts of silicon.

Electric arc furnace technology began late in the nineteenth century with the original design of P. L. T. Heroult. The three-graphite electrode furnace with a swinging roof for top charging and a rocker base for tilting to tap the finished molten steel has been continuously improved and developed further. See ELECTRIC FURNACE.

The rapid development of steelmaking technology using the electric arc furnace, not only for alloy and stainless steels but especially for carbon steel production, has increased its share of production capacity to about 20% of the steel industry.

Remelting and refining of special alloys are carried out in duplex or secondary processes; the principal ones are argon-oxygen decarburization, electroslag refining, vacuum arc remelting, and vacuum induction melting. See ELECTROMETALLURGY; VACUUM METALLURGY.

Ladle metallurgy was used first to produce high-quality steels, but has been extended to producing many grades of steel because of the economic advantages of higher productivity. The purpose of these ladle treatments is to produce clean steel; introduce reactive additions, such as calcium or rare earths; add alloying additions, as for microalloyed steels, with high recovery; and increase furnace utilization, allowing higher-productivity smelting operations of the blast furnace, and melting and refining operations in steelmaking. Ladle treatments in steel production generally are classified as synthetic slag systems; gas stirring or purging; direct immersion of reactants, such as rare earths; lance injection of reactants; and wire feeding of reactants. These are often used in combination to produce synergistic effects, for example, synthetic slag and gas stirring for desulfurization followed by direct immersion, injection, or wire feeding for inclusion shape control. See METAL CASTING; PYROMETALLURGY; REFRACTORY; STAINLESS STEEL; STEEL. [R.D.Pe]

**Stellar evolution** The large-scale, systematic, and irreversible changes with time of the structure and composition of a star.

**Star formation.** Stars are born from compact knots within dark molecular clouds that are refrigerated by dust that blocks heating starlight. If the random knots, compressed by supernovae or other means, are dense enough, they can contract under their own gravity. Conservation of angular momentum demands that as they collapse they must spin faster. See ANGULAR MOMENTUM; MOLECULAR CLOUD.

High-speed particles (cosmic rays) from exploding stars partially ionize the dusty knots. The ions grab onto the weak magnetic field of the Galaxy and, as a result of their physical interaction with neutral atoms and molecules, provide the initial means to slow the rotation. If the rotation is still too fast, the contracting body may split into a double (or more complex) star, whereupon the angular momentum goes into orbital motion. A contracting protostar still rotates progressively faster until the part of its mass not accreted by the star itself is spun out into a dusty disk, from which planets might later accumulate. From the disk shoot powerful molecular flows that slow the star still more. See PROTOSTAR.

When the protostar's interior reaches about  $10^6$  K ( $1.8 \times 10^6$  °F), it can fuse its internal deuterium. That and convection, which brings in fresh deuterium from outside the nuclear-burning

zone, bring some stability, and a star can now be said to be born. Stars like the Sun shrink at constant temperature until deuterium fusion dies down. Then they heat at roughly constant luminosity until the full proton-proton chain begins, which provides the stars' luminosity and stops the contraction. The stars settle onto the zero-age main sequence. The whole process takes only 10 or so million years.

**Early evolution.** The main sequence is that zone on the Hertzsprung-Russell (HR) diagram in which stars are stabilized against gravitational contraction by fusion. The higher the stellar mass, the greater the internal compression and temperature, and the more luminous the star. Hydrogen fusion is highly sensitive to temperature, a small increase in stellar mass meaning a much higher fusion rate. Although greater mass means a greater nuclear-burning core mass and therefore a larger fuel supply, the increased fusion rate is more than offsetting and thereby shortens stellar life. While the new Sun was destined to survive on the main sequence for  $10^{10}$  years, a 0.1-solar-mass star will live there for  $10^{13}$  years, while a 100-solar-mass star will exhaust its core hydrogen in only  $2.5 \times 10^6$  years.

The main sequence is divided into three parts. Below 0.8 solar mass (roughly class G8), no star has ever had time to evolve. Between 0.8 solar mass and around 10 solar masses (classes G8 to B1), the stars die as white dwarfs. Above it (classes O and B0), they explode. Binary stars contribute further to the richness of stellar phenomena.

**Intermediate mass evolution.** Main-sequence life lasts until the core hydrogen is almost gone, at which time hydrogen fusion rather suddenly shuts down. With no support, the now-quiet helium core can contract more rapidly under gravity's force. It heats, causing hydrogen fusion to spread into a thick enclosing shell that runs on the carbon cycle. With a new (though temporary) energy source, the star first dims some while it expands and cools at the surface, changing its spectrum to class K. The transition takes only a few hundred million years or less, leaving few stars in the middle of the HR diagram, the lower masses appearing as F, G, and K subgiants.

As core contraction proceeds beyond the rightward transition in the HR diagram, stars from about 1 to 5 solar masses (still fusing hydrogen in a shell) suddenly and dramatically increase their luminosities. The future Sun will eventually grow 1000 times brighter than it is today, and a 5-solar-mass star (which begins at about 600 solar luminosities) will reach nearly 3000 solar. At the same time, the stars swell to become red giants. While the core (roughly half a solar mass) of the future Sun shrinks to the size of Earth, the radius will expand to that of Mercury's orbit, or even beyond. When the core temperature climbs to  $10^8$  K, helium nuclei (alpha particles) begin fusing to unstable beryllium ( $^8\text{Be}$ ), which quickly decays back to alpha particles, setting up an equilibrium. The tiny amount of  $^8\text{Be}$  present reacts with additional alpha particles to create helium via the triple alpha process:

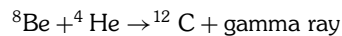

Fusion with additional helium nuclei creates oxygen and even neon. See NUCLEOSYNTHESIS.

The star, now stabilized by a helium-burning core that is surrounded by a hydrogen-fusing shell, retreats about halfway down the red giant branch. The numerous lower-mass stars reside in the class K "red giant clump" (see illustration). Low-mass metal-deficient globular cluster stars spread out from the clump toward higher temperatures to create the distinctive horizontal branch. Energy-generating fusion reactions will try to proceed toward iron (the most stable of all nuclei). Some 80% of the energy is generated in hydrogen burning, so (discounting further burning modes) the helium-burning stage lasts only around 20% of the main-sequence lifetime. Above 5 solar masses, evolution proceeds similarly, but instead of settling into a distinct location on

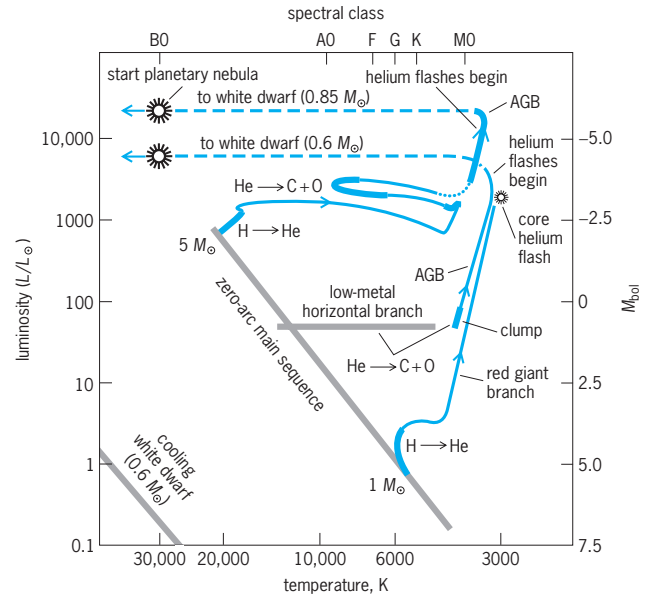

**Hertzsprung-Russell diagram of evolution of intermediate-mass stars.** These stars evolve from the main sequence to become giants that stabilize during helium fusion in a "clump." When helium fusion is done, they brighten again as AGB stars, lose their envelopes, and evolve to the left to produce planetary nebulae, finally at lower left becoming white dwarfs. (After J. B. Kaler, *Stars*, W. H. Freeman, 1992, 1993, from work of I. Iben, Jr.)

the HR diagram, the stars loop to the blue (higher temperatures) where they fuse helium as class G, F, and A giants. See GIANT STAR.

**Asymptotic giant branch (AGB).** When the helium has fused to carbon and oxygen, the core again contracts. Helium fusion spreads outward into a shell, and for the second time the star climbs the HR diagram's giant branch. Since the second climb is roughly asymptotic to the first, the second climb creates the asymptotic giant branch. The shrinking carbon-oxygen core is now surrounded by a shell of fusing helium, while the old hydrogen-fusing shell expands, cools, and shuts down. Eventually, however, the helium shell runs out of fuel, and the hydrogen shell reignites. Hydrogen burning feeds fresh helium into the space between it and the carbon core, and when there is enough of it, helium burning reignites explosively in a helium flash (or thermal pulse) that can affect the star's surface. The flash squelches hydrogen fusion, and the whole process starts again, helium flashes coming at progressively shorter intervals. AGB stars become larger and brighter than before, passing into the cool end of class M, where they eventually become unstable enough to pulsate as long-period variables (Miras). The Sun will become 5000 times brighter than now and will reach out to the Earth's orbit. See MIRA; VARIABLE STAR.

**Mass loss and planetary nebulae.** During the giant stages, stellar winds greatly increase. Mira pulsations cause shock waves that help drive mass from the stellar surfaces, where the cooled gas becomes ever richer in molecules, some even condensing into dust grains. High luminosity pushes the dust outward, and the dust couples with the gas, resulting in slow (10 km/s or 6 mi/s) thick winds tens of millions of times stronger than the solar wind (up to  $10^{-5}$  solar mass per year). Because stars are in this state for hundreds of thousands of years, they will lose much of themselves back into space—the Sun about half of its mass, a 10-solar-mass star over 80%.

So much mass is lost that an evolving star becomes stripped nearly to its fusion zone, which is protected from the outside by a low-mass hydrogen envelope. As the inner region becomes exposed, the wind diminishes in mass but increases in speed and

temperature. Hammering at the surrounding dusty, molecule-filled shroud of lost mass, the high-speed wind compresses the inner edge into a thick ring. Eaten away from the top by the wind and from below by fusion, the stellar envelope shrinks, slowly exposing the hot shell-core structure beneath. When the stripped star's surface reaches 25,000 K (45,000°F), the dense ring that its high-speed wind had previously created is ionized. Subsequent recapture of electrons by ions, along with collisional excitation of heavy atoms, causes the shell to glow, and a planetary nebula is born. See PLANETARY NEBULA.

The star inside first heats at constant luminosity to over 100,000 K (180,000°F), the luminosity and final temperature depending on the old core's mass (which ranges from around 0.5 to nearly 1.4 solar masses, the Chandrasekhar limit, above which white dwarfs cannot exist). As residual nuclear fusion shuts down, the star cools and dims at constant radius to become a white dwarf. See WHITE DWARF STAR.

**High-mass evolution.** As the mass of a star increases, so does the mass of the core. The Sun will turn into a white dwarf of around 0.6 solar mass. At 10 solar masses, the core reaches the Chandrasekhar limit, and the star cannot become a white dwarf. At first, high-mass evolution proceeds similarly to that of stars of lower mass. As high-mass stars use their core hydrogen, they too migrate to the right on the HR diagram, becoming not so much brighter but larger, cooling at their surfaces and turning into supergiants. Though almost all these supergiants vary to some extent, the most massive become unstable and undergo huge eruptions.

While intermediate-star fusion stops at carbon and oxygen, supergiants continue onward. The carbon-oxygen core shrinks and heats to the point that carbon fusion can begin, and then carbon and oxygen convert to a more complex mix dominated by oxygen, neon, and magnesium. Helium fusion now continues in a surrounding shell that is nested in one that is fusing hydrogen. Once carbon burning has run its course, the unsupported oxygen-neon-magnesium core shrinks and heats, and now it is carbon burning's turn to move outward into a shell. When hot enough, the oxygen-neon-magnesium mix fires up to burn to one dominated by silicon and sulfur. Continuing the process, the developed silicon and sulfur core finally becomes hot enough to fuse to iron, the silicon-burning core wrapped in oxygen-neon-magnesium, helium, and hydrogen-burning shells.

**Supernova.** Each nuclear fusion stage generates less energy, and since each takes on the role of supporting the star, each lasts a shorter period of time. While hydrogen fusion takes millions of years, the iron core is created from silicon fusion in a matter of weeks. Iron cannot fuse and produce energy. The core, about 1.5 solar masses and the size of Earth, suddenly collapses at a speed a good fraction that of light. The iron atoms are broken back to neutrons and protons. Under crushing densities, free electrons merge with protons to make yet more neutrons. When the collapsing neutron core hits nuclear densities of  $10^{14}$  g/cm<sup>3</sup> ( $10^{14}$  times the density of water), it violently bounces, and the rebound tears away all the outer layers. From the outside, the observer sees the explosion as a type II supernova that can reach an absolute magnitude of  $-18$ .

The debris of the explosion, the supernova remnant, highly enriched in iron and other heavy elements, expands for centuries into space. Exposed by the explosion is the compact hot neutron star. Only 25 km (15 mi) across, it is stabilized by the pressure of neutron degeneracy. Radiation beams out along a tilted, wobbling magnetic axis, and if Earth is in its path, a "pulse" of radiation is observed, the neutron star now a "pulsar." See NEUTRON STAR; PULSAR.

Beyond the Chandrasekhar limit of 1.4 solar masses, electron degeneracy pressure cannot stabilize a white dwarf, and it must collapse. Neutron stars are similarly limited to around 3 solar masses. Stars at the upper end of the main sequence are expected to create iron cores that exceed even this limiting mass.

The dense remains cannot stabilize, and they too must therefore collapse. When such a collapsing star passes a critical radius at which the escape velocity is about that of light, it becomes invisible and a black hole is born. About half a dozen black hole candidates are recognized in binary systems in which the black hole affects the companion. See BLACK HOLE. [J.B.Ka.]

**Stellar magnetic field** A magnetic field, far stronger than the Earth's magnetic field, which is possessed by many stars. Magnetic fields are important throughout the life cycle of a star. Initially, magnetic fields regulate how quickly interstellar clouds collapse into protostars. Later in the star formation process, circumstellar disk material flows along magnetic field lines, either accreting onto the star or flowing rapidly out along the rotation axis. Outflowing material (stellar winds) carries away angular momentum, slowing rotation at a rate that depends on stellar magnetic field strength. On the Sun, dark sunspots, prominences, flares, and other forms of surface activity are seen in regions where there are strong magnetic fields. There is some evidence that long-term variations in solar activity may affect the Earth's climate. Turbulence in the solar atmosphere drives magnetic waves which heat a tenuous corona (seen during eclipses) to millions of degrees. About 10% of hotter stars (with temperatures of about 10,000 K) with stable atmospheres are Ap stars, which have stronger magnetic fields that control the surface distribution of exotic elements. Even after stars end their internal fusion cycle and become compact remnants, magnetic fields channel accreting material from binary companions, occasionally producing spectacular novae. Despite the enormous gravity around pulsars, magnetic forces far exceed gravitational forces, creating intense electromagnetic beams that spin down (slow the rotation of) the pulsar. See BINARY STAR; CATAclysmic VARIABLE; NOVA; PROTOSTAR; PULSAR; SOLAR MAGNETIC FIELD; STAR; STELLAR EVOLUTION. [J.A.Va.]

**Stellar population** One of the categories into which stars may be classified, based on their place in the evolution of the galaxy containing them. The stellar component of the Milky Way Galaxy consists of three populations: the thin disk, the thick disk, and the halo.

The thin disk, originally referred to as population I, is the youngest component of the galactic stellar population. Still actively forming massive stars from molecular clouds, it is confined to within about 0.35 kiloparsec of the plane. (1 kpc equals 3300 light-years or  $3.1 \times 10^{16}$  km or  $1.9 \times 10^{16}$  mi.) All of the stars have metallicities lying between about one-fifth and twice the solar value, and star formation appears to have remained constant in this population for about the past  $8 \times 10^9$  years. One reason for the relatively small thickness of the disk is the low velocity dispersion of the component stars; their motion is completely dominated by the differential rotation of the disk. These stars are found associated with H II regions and OB associations as well as open clusters. See INTERSTELLAR MATTER; MOLECULAR CLOUD; SUPERNOVA.

The thick disk is an older population, approximately  $9-10 \times 10^9$  years, roughly corresponding to the range between what was once called population II and population I. Its metallicity lies between about one-tenth and one-third of the solar value. The stars in this population are distributed over greater distances from the plane, up to 1.5 kpc, and have correspondingly larger velocity dispersion. This population also includes globular clusters and subdwarfs that overlap at the lowest end of the abundances with the properties of the halo globulars, although the system of old disk globulars is distributed differently than those of the halo.

Lying around the disk and the nuclear spheroidal bulge, there is a halo, roughly corresponding to the original population II, that extends to considerable distances from the plane, some as distant as 30 kpc. This population has an age of order  $10-15 \times 10^9$  years. The stars in this region have very large velocity



dispersions and do not appear to participate in the differential rotation as much as other stars. Their metallicities are all lower than about one-twentieth that of the Sun and may extend down to  $10^{-3}$  of the solar value. The most metal-poor globular clusters belong to this population. This stellar halo is not the same as the dark matter halo, but is probably embedded within it. See MILKY WAY GALAXY; STAR. [S.N.S.]

**Stellar rotation** The spinning of stars, due to their angular momentum. Stars do not necessarily rotate as solid bodies, and their angular momentum may be distributed nonuniformly, depending on radius or latitude. However, it is impossible to resolve the surfaces of stars, or see their interiors, and the limited ability to observe them means that their rotation is generally expressed as a single number,  $v_{eq} \sin i$ . In this measured quantity,  $v_{eq}$  is the star's equatorial rotational velocity (in kilometers per second), and  $i$  is the angle between the star's rotation axis and the line of sight to the star. In other words,  $v_{eq} \sin i$  is the component of a star's rotation that is projected onto the line of sight between the star and the observer. Measurements of  $v_{eq} \sin i$  in stars range from as little as  $1 \text{ km s}^{-1}$  ( $0.6 \text{ mi s}^{-1}$ ) up to  $400 \text{ km s}^{-1}$  ( $250 \text{ mi s}^{-1}$ ) or more. A more physically useful measure of rotation is  $\Omega$ , a star's angular velocity, or  $P_{rot}$ , the rotation period (the inverse of  $\Omega$ ). In some cases it is possible to measure  $P_{rot}$  directly. See ANGULAR MOMENTUM; STAR.

A  $v_{eq} \sin i$  value is determined from the breadth of absorption lines in the star's spectrum. The Doppler effect causes the lines to be broadened because one limb of the star is receding and the other approaching. See DOPPLER EFFECT.

Late-type stars (cooler than about  $6500 \text{ K}$  or  $11,200^\circ\text{F}$ ) exhibit spots on their surfaces analogous to sunspots, and these can be large enough to produce observable changes in the light of the star. In such cases it is possible to measure  $P_{rot}$  directly and, in a few instances, changes in  $P_{rot}$  have led to estimates of differential rotation (the dependence of  $\Omega$  on latitude).

There is a broad trend in which typical rotation rates decline with the mass of the star in going down the main sequence. There is an especially prominent break in rotation such that stars with masses below about 1.2 times the solar mass have very low rotation rates, due to their intrinsic structure.

The early-type stars (types O, B, A, and early-F) typically have  $v_{eq} \sin i$  values of  $50 \text{ km s}^{-1}$  ( $30 \text{ mi s}^{-1}$ ) or more. The high  $v_{eq} \sin i$  values ( $200 \text{ km s}^{-1}$  or  $125 \text{ mi s}^{-1}$  and more) are seen only in the main-sequence O stars.

Late-type stars are cooler than about  $6500 \text{ K}$  ( $11,200^\circ\text{F}$ ) and have spectral types of late-F, G, K, or M. The key property of late-type stars that determines much of their phenomenology is the presence of a convective envelope. In such stars, rotation (especially differential rotation) interacts with the convection to produce complex motions in the electrically conductive plasma of the star. These circulatory patterns enable the star to regenerate a seed magnetic field, the so-called dynamo mechanism. The magnetic field can grip an ionized wind beyond the star's surface, leading to gradual angular momentum loss, a process that is seen occurring on the Sun. More rapidly rotating stars produce stronger magnetic fields. See MAGNETISM; STELLAR MAGNETIC FIELD.

In this scenario, late-type main-sequence stars spin down over their lifetimes, and that is observed to occur because steadily declining rotation rates can be seen among stars in clusters of increasing age. Moreover, stars that are born together but with different rotation rates will tend to end up with the same  $P_{rot}$  because the faster-rotating star will lose angular momentum more quickly. Young stars tend to rotate rapidly because they have not had time to lose the angular momentum with which they formed, while old low-mass stars rotate slowly.

The Sun is a very slowly rotating star ( $v_{eq} \sin i = 1.8 \text{ km s}^{-1}$  or  $1.1 \text{ mi s}^{-1}$ ). Over its 4.5-billion-year main-sequence lifetime, it has gradually lost angular momentum to get to the rate that is

seen today. Helioseismological studies of the Sun's interior show it to rotate as a solid body, so if it ever had a rapidly rotating core, it does no longer. See HELIOSEISMOLOGY; SUN. [D.So.]

**Stem** The organ of vascular plants that usually develops branches and bears leaves and flowers. On woody stems a branch that is the current season's growth from a bud is called a twig. The stems of some species produce adventitious roots. See ROOT (BOTANY).

**General characteristics.** While most stems are erect, aerial structures, some remain underground, others creep over or lie prostrate on the surface of the ground, and still others are so short and inconspicuous that the plants are said to be stemless, or acaulescent. When stems lie flattened immediately above but not on the ground, with tips curved upward, they are said to be decumbent, as in juniper. If stems lie flat on the ground but do not root at the nodes (joints), the stem is called procumbent or prostrate, as in purslane. If a stem creeps along the ground, rooting at the nodes, it is said to be repent or creeping, as in ground ivy.

Most stems are cylindrical and tapering, appearing circular in cross section; others may be quadrangular or triangular.

Herbaceous stems (annuals and herbaceous perennials) die to the ground after blooming or at the end of the growing season. They usually contain little woody tissue. Woody stems (perennials) have considerable woody supporting tissue and live from year to year. A woody plant with no main stem or trunk, but usually with several stems developed from a common base at or near the ground, is known as a shrub. [N.A.]

**External features.** A shoot or branch usually consists of a stem, or axis, and leafy appendages. Stems have several distinguishing features. They arise either from the epicotyl of the embryo in a seed or from buds. The stem bears both leaves and buds at nodes, which are separated by leafless regions or internodes, and sometimes roots and flowers (see illustration).

The nodes are the regions of the primary stem where leaves and buds arise. The number of leaves at a node is usually specific for each plant species. In deciduous plants which are leafless during winter, the place of former attachment of a leaf is marked by the leaf scar. The scar is formed in part by the abscission zone formed at the base of the leaf petiole. The stem regions between nodes are called internodes. Internode length varies greatly among species, in different parts of the same stem, and under different growing conditions.

Lenticels are small, slightly raised or ridged regions of the stem surface that are composed of loosely arranged masses of cells in the bark. Their intercellular spaces are continuous with those in

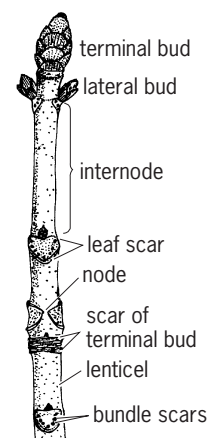

Winter woody twig (horse chestnut) showing apical dominance. (After E. W. Sinnott and K. S. Wilson, *Botany: Principles and Problems*, 5th ed., McGraw-Hill, 1955)

the interior of the stem, therefore permitting gas exchange similar to the stomata that are present before bark initiation.

There are three major types of stem branching: dichotomous, monopodial, and sympodial. Dichotomy occurs by a division of the apical meristem to form two new axes. If the terminal bud of an axis continues to grow and lateral buds grow out as branches, the branching is called monopodial. If the apical bud terminates growth in a flower or dies back and one or more axillary buds grow out, the branching is called sympodial. Often only one bud develops so that what appears to be single axis is in fact composed of a series of lateral branches arranged in linear sequence.

The large and conspicuous stems of trees and shrubs assume a wide variety of distinctive forms. Columnar stems are basically unbranched and form a terminal leaf cluster, as in palms, or lack obvious leaves, as in cacti. Branching stems have been classified either as excurrent, when there is a central trunk and a conical leaf crown, as in firs and other conifers, or as decurrent (or deliquescent), when the trunk quickly divides up into many separate axes so that the crown lacks a central trunk, as in elm. See TREE.

[J.B.F.]

**Internal features.** The stem is composed of the three fundamental tissue systems that are found also in all other plant organs: the dermal (skin) system, consisting of epidermis in young stems and periderm in older stems of many species; the vascular (conducting) system, consisting of xylem (water conduction) and phloem (food conduction); and the fundamental or ground tissue system, consisting of parenchyma and sclerenchyma tissues in which the vascular tissues are embedded. The arrangement of the vascular tissues varies in stems of different groups of plants, but frequently these tissues form a hollow cylinder enclosing a region of ground tissue called pith and separated from the dermal tissue by another region of ground tissue called cortex. See CORTEX (PLANT); EPIDERMIS (PLANT); PARENCHYMA; PHLOEM; PITH; SCLERENCHYMA; XYLEM.

Part of the growth of the stem results from the activity of the apical meristem located at the tip of the shoot. The derivatives of this meristem are the primary tissues; epidermis, primary vascular tissues, and the ground tissues of the cortex and pith. In many species, especially those having woody stems, secondary tissues are added to the primary. These tissues are derived from the lateral meristems, oriented parallel with the sides of the stem: cork cambium (phellogen), which gives rise to the secondary protective tissue periderm, which consists of phellum (cork), phellogen (cork cambium), and phellogen (secondary cortex) and which replaces the epidermis; and vascular cambium, which is inserted between the primary xylem and phloem and forms secondary xylem (wood) and phloem. See APICAL MERISTEM; LATERAL MERISTEM.

The vascular tissues and the closely associated ground tissues—pericycle (on the outer boundary of vascular region), interfascicular regions (medullary or pith rays), and frequently also the pith—may be treated as a unit called the stele. The variations in the arrangement of the vascular tissues serve as a basis for distinguishing the stelar types. The word stele means column and thus characterizes the system of vascular and associated ground tissues as a column. This column is enclosed within the cortex, which is not part of the stele. See PERICYCLE.

[J.E.Gu.]

**Stem cells** Cells that have the ability to self-replicate and give rise to specialized cells. Stem cells can be found at different stages of fetal development and are present in a wide range of adult tissues. Many of the terms used to distinguish stem cells are based on their origins and the cell types of their progeny.

There are three basic types of stem cells. Totipotent stem cells, meaning their potential is total, have the capacity to give rise

to every cell type of the body and to form an entire organism. Pluripotent stem cells, such as embryonic stem cells, are capable of generating virtually all cell types of the body but are unable to form a functioning organism. Multipotent stem cells can give rise only to a limited number of cell types. For example, adult stem cells, also called organ- or tissue-specific stem cells, are multipotent stem cells found in specialized organs and tissues after birth. Their primary function is to replenish cells lost from normal turnover or disease in the specific organs and tissues in which they are found.

Totipotent stem cells occur at the earliest stage of embryonic development. The union of sperm and egg creates a single totipotent cell. This cell divides into identical cells in the first hours after fertilization. All these cells have the potential to develop into a fetus when they are placed into the uterus. The first differentiation of totipotent cells forms a hollow sphere of cells called the blastocyst, which has an outer layer of cells and an inner cell mass inside the sphere. The outer layer of cells will form the placenta and other supporting tissues during fetal development, whereas cells of the inner cell mass go on to form all three primary germ layers: ectoderm, mesoderm, and endoderm. The three germ layers are the embryonic source of all types of cells and tissues of the body. Embryonic stem cells are derived from the inner cell mass of the blastocyst. They retain the capacity to give rise to cells of all three germ layers. However, embryonic stem cells cannot form a complete organism because they are unable to generate the entire spectrum of cells and structures required for fetal development. Thus, embryonic stem cells are pluripotent, not totipotent, stem cells.

Embryonic germ (EG) cells differ from embryonic stem cells in the tissue sources from which they are derived, but appear to be similar to embryonic stem cells in their pluripotency. Human embryonic germ cell lines are established from the cultures of the primordial germ cells obtained from the gonadal ridge of late-stage embryos, a specific part that normally develops into the testes or the ovaries. Embryonic germ cells in culture, like cultured embryonic stem cells, form embryoid bodies, which are dense, multilayered cell aggregates consisting of partially differentiated cells. The embryoid body-derived cells have high growth potential. The cell lines generated from cultures of the embryoid body cells can give rise to cells of all three embryonic germ layers, indicating that embryonic germ cells may represent another source of pluripotent stem cells.

Much of the knowledge about embryonic development and stem cells has been accumulated from basic research on mouse embryonic stem cells. Since 1998, however, research teams have succeeded in growing human embryonic stem cells in culture. Human embryonic stem cell lines have been established from the inner cell mass of human blastocysts that were produced through in vitro fertilization procedures. The techniques for growing human embryonic stem cells are similar to those used for growth of mouse embryonic stem cells. However, human embryonic stem cells must be grown on a mouse embryonic fibroblast feeder layer or in media conditioned by mouse embryonic fibroblasts. Human embryonic stem cell lines can be maintained in culture to generate indefinite numbers of identical stem cells for research. As with mouse embryonic stem cells, culture conditions have been designed to direct differentiation into specific cell types (for example, neural and hematopoietic cells).

Adult stem cells occur in mature tissues. Like all stem cells, adult stem cells can self-replicate. Their ability to self-renew can last throughout the lifetime of individual organisms. But unlike embryonic stem cells, it is usually difficult to expand adult stem cells in culture. Adult stem cells reside in specific organs and tissues, but account for a very small number of the cells in tissues. They are responsible for maintaining a stable state of the specialized tissues. To replace lost cells, stem cells typically generate intermediate cells called precursor or progenitor cells, which are no longer capable of self-renewal. However, they

continue undergoing cell divisions, coupled with maturation, to yield fully specialized cells. Such stem cells have been identified in many types of adult tissues, including bone marrow, blood, skin, gastrointestinal tract, dental pulp, retina of the eye, skeletal muscle, liver, pancreas, and brain. Adult stem cells are usually designated according to their source and their potential. Adult stem cells are multipotent because their potential is normally limited according to their source and their potential. Adult stem cells are multipotent because their potential is normally limited to one or more lineages of specialized cells. However, a special multipotent stem cell that can be found in bone marrow, called the mesenchymal stem cell, can produce all cell types of bone, cartilage, fat, blood, and connective tissues.

Blood stem cells, or hematopoietic stem cells, are the most studied type of adult stem cells. The concept of hematopoietic stem cells is not new, since it has been long realized that mature blood cells are constantly lost and destroyed. Billions of new blood cells are produced each day to make up the loss. This process of blood cell generation called hematopoiesis, occurs largely in the bone marrow. Another emerging source of blood stem cells is human umbilical cord blood. Similar to bone marrow, umbilical cord blood can be used as a source material of stem cells for transplant therapy. However, because of the limited number of stem cells in umbilical cord blood, most of the procedures are performed for young children of relatively low body weight.

Neural stem cells, the multipotent stem cells that generate nerve cells, are a new focus in stem cell research. Active cellular turnover does not occur in the adult nervous system as it does in renewing tissues such as blood or skin. Because of this observation, it had been a dogma that the adult brain and spinal cord were unable to regenerate new nerve cells. However, since the early 1990s, neural stem cells have been isolated from the adult brain as well as fetal brain tissues. Stem cells in the adult brain are found in the areas called the subventricular zone and the ventricle zone. Another location of brain stem cells occurs in the hippocampus, a special structure of the cerebral cortex related to memory function. Stem cells isolated from these areas are able to divide and to give rise to nerve cells (neurons) and neuron-supporting cell types in culture.

Stem cell plasticity refers to the phenomenon of adult stem cells from one tissue generating the specialized cells of another tissue. The long-standing concept of adult organ-specific stem cells is that they are restricted to producing the cell types of their specific tissues. However, a series of studies have challenged the concept of tissue restriction of adult stem cells. Although the stem cells appear able to cross their tissue-specific boundaries, crossing occurs generally at a low frequency and mostly only under conditions of host organ damage. The finding of stem cell plasticity carries significant implications for potential cell therapy. For example, if differentiation can be redirected, stem cells of abundant source and easy access, such as blood stem cells in bone marrow or umbilical cord blood, could be used to substitute stem cells in tissues that are difficult to isolate, such as heart and nervous system tissue. *See* CELL DIFFERENTIATION; EMBRYOLOGY; EMBRYONIC DIFFERENTIATION; GERM LAYERS; HEMATOPOIESIS; REGENERATION (BIOLOGY); TRANSPLANTATION BIOLOGY. [C.Wa.]

**Stenolaemata** An exclusively marine class of Bryozoa. The Stenolaemata include several thousand species distributed among five orders: Cystoporata, Trepostomata, Cryptostomata, Fenestrata, and Cyclostomata. First appearing late in the Early Ordovician, stenolaemates expanded quickly to dominate bryozoan assemblages until the mid-Cretaceous. *See* BRYOZOA; CRYPTOSTOMATA; CYCLOSTOMATA (BRYOZOA); CYSTOPORATA; TREPSTOMATA.

Stenolaemate colonies vary greatly in size and shape. Many Paleozoic through mid-Mesozoic forms were large and massive,

but more recent representatives are commonly small and delicate. Colonies are encrusting, erect, or free-living. Some erect forms have single or regularly spaced, flexible cuticular joints; segments between joints and all other entire colonies are rigidly calcified and enclosed within a thin cuticular membrane. Living stenolaemate colonies are made up of individual feeding units called zooids with lophophores (rings of tentacles) that are circular in basal outline. Zooidal body cavities are enclosed within tubular or prismatic zooecia (skeletons of individual zooids), gradually expanding from their proximal ends. Zooecia typically are relatively thin-walled in colony interiors (endozone) and relatively thick-walled in outer regions (exozone).

Individual colonies are hermaphroditic. Colonies grow by asexual budding. [FK.McK.]

**Stenurida** A Paleozoic order of the subphylum Asterozoa, order Ophiuroidea, comprising the brittle stars. Stenurids have a double row of plates (ambulacra) that abut across the arm axis either directly opposite one another or slightly offset. In contrast, modern ophiuroids have a single series of axial arm plates termed vertebrae. In stenurids, as in modern ophiuroids, lateral plates are present at the sides of ambulacrals, and prominent lateral spines are typical. Stenurids lack the dorsal and ventral arm shields that are found in most ophiuroids. The content of the order is poorly established, and fewer than 10 genera are known.

The relationship among ophiuroids, asteroids, and all other echinoderms provide an enduring problem in invertebrate evolution. Developmental and other studies based on modern organisms imply that asteroids and ophiuroids are not closely related within the echinoderms. Stenurid morphology, in contrast suggests a close common ancestry for the two. *See* ECHINODERMATA; OPHIUROIDEA. [D.B.B.]

**Stepping motor** An electromagnetic incremental-motion actuator which converts digital pulse inputs to analog output motion. The device is also termed a step motor. When energized in a programmed manner by a voltage and current input, usually dc, a step motor can index in angular or linear increments. With proper control, the output steps are always equal in number to the input command pulses. Each pulse advances the rotor shaft one step increment and latches it magnetically at the precise point to which it is stepped. Advances in digital computers and particularly microcomputers revolutionized the controls of step motors. These motors are found in many industrial control systems, and large numbers are used in computer peripheral equipment, such as printers, tape drives, capstan drives, and memory-access mechanisms. Step motors are also used in numerical control systems, machine-tool controls, process control, and many systems in the aerospace industry. *See* COMPUTER GRAPHICS; COMPUTER NUMERICAL CONTROL; COMPUTER PERIPHERAL DEVICES; CONTROL SYSTEMS; DIGITAL-TO-ANALOG CONVERTER; PROCESS CONTROL.

There are many types of step motors. Most of the widely used ones can be classified as variable-reluctance, permanent-magnet, or hybrid permanent-magnet types. A variable-reluctance step motor is simple to construct and has low efficiency. The permanent-magnet types are more complex to construct and have a higher efficiency. [B.C.K.]

**Stereochemistry** The study of the three-dimensional arrangement of atoms or groups within molecules and the properties which follow from such arrangement. Molecules that have identical molecular structures but differ in the relative spatial arrangement of component parts are stereoisomers. Inorganic and organic compounds exhibit stereoisomerism. Examples are structures (1)–(8).

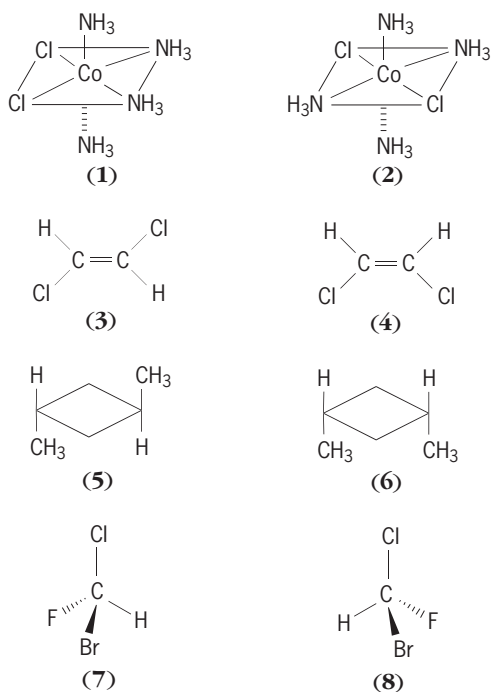

The nature of the stereochemistry of a molecule is determined by its symmetry. The symmetry elements to be considered are: planes of symmetry, axes of symmetry, centers of symmetry, and reflection or mirror symmetry. Two types of stereoisomers are known. Those such as (7) and (8), which are devoid of reflection symmetry—which cannot be superimposed on their image in a mirror—are called enantiomers. All other stereoisomers, such as the pairs (1)–(2), (3)–(4), and (5)–(6), are called diastereomers. The configuration of a stereoisomer designates the relative position of the atoms associated with a specific structure. The structures of stereoisomers (1) and (2) differ only in configuration. The same is true for (3) and (4), (5) and (6), and (7) and (8). See ENANTIOMER. [S.H.W.]

**Stereophonic radio transmission** The transmission of stereophonic audio signals over radio using either amplitude-modulation (AM) or frequency-modulation (FM) techniques. See STEREOPHONIC SOUND.

To be commercially acceptable, the signal transmitted by a stereo broadcast station should be decipherable by either a stereo receiver or a monophonic receiver. For the monophonic receiver to correctly receive a stereo broadcast, some component of that broadcast must be a single signal that includes information from both the left and the right channel. This is called the  $L + R$  signal. A monophonic receiver simply demodulates the  $L + R$  signal and delivers it to the listener.

The stereo receiver must use the  $L + R$  signal and other transmitted information to demodulate separate  $L$  and  $R$  signals. For this, stereo broadcasts include an  $L - R$  signal. In the stereo receiver, after detection of the  $L + R$  and  $L - R$  signals, the  $L$  and  $R$  signals are separated as shown in Eqs. (1) and (2).

$$(L + R) + (L - R) = 2L \quad (1)$$

$$(L + R) - (L - R) = 2R \quad (2)$$

The subtraction used in Eq. (2) is realized through phase shifting and addition. Shifting the phase of a signal by  $180^\circ$  inverts the signal. Thus,  $(L - R)$  put through a  $180^\circ$  phase shift is  $-(L - R)$ .

In FM stereo transmissions, the  $L + R$  signal is directly frequency-modulated onto the radio-frequency carrier, assur-

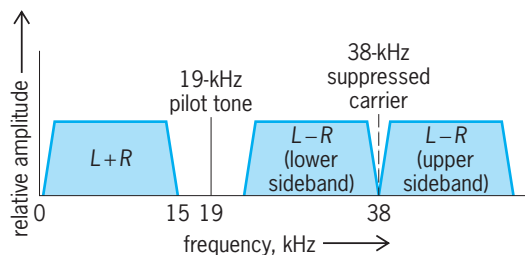

Baseband spectrum of an FM stereo signal. This audio and supersonic spectrum is frequency-modulated onto a radio-frequency carrier.

ing compatibility (see illustration). The  $L - R$  signal is used to amplitude-modulate a 38-kHz hypersonic subcarrier. The 38-kHz carrier is suppressed, creating a double-sideband (DSB), suppressed-carrier AM signal at 38 kHz. This hypersonic signal is then frequency-modulated onto the radio-frequency carrier. A 19-kHz pilot signal is also transmitted to indicate that the broadcast is stereo and to provide an accurate frequency reference for demodulation of the 38-kHz  $L - R$  signal. See AMPLITUDE MODULATION; FREQUENCY MODULATION.

In the FM stereo receiver, the entire baseband signal that has been frequency-modulated onto a radio-frequency carrier ( $L + R$ , pilot, and double-sideband  $L - R$ ) is first detected with an FM discriminator. The  $L + R$  signal is isolated by a low-pass filter. The pilot tone is doubled and mixed with the double-sideband suppressed-carrier  $L - R$  signal, so that the  $L - R$  signal can be demodulated by an AM envelope detector. The  $L + R$  and  $L - R$  audio signals are then passed through a network that implements the functions expressed in Eqs. (1) and (2). The resulting left- and right-channel audio signals are amplified and presented to the listener. See AMPLITUDE-MODULATION DETECTOR; ELECTRIC FILTER; FREQUENCY-MODULATION DETECTOR; FREQUENCY-MODULATION RADIO.

There are five AM stereo modulation systems permitted by the Federal Communications Commission. Several of these mutually incompatible systems are in use. The most widely used system, installed at around one-third of the AM stereo broadcast stations in the United States, is the Compatible Quadrature Amplitude Modulation (C-QUAM) system, which uses two radio-frequency carriers  $90^\circ$  out of phase. One of these carriers is modulated with the  $L + R$  signal, and the other is modulated with the  $L - R$  signal. The carriers are then added to create a single signal and limited to remove amplitude variations. The resulting radio-frequency signal is amplitude-modulated with the  $L + R$  signal. This last step provides compatibility with monophonic AM receivers. A 25-Hz pilot tone is provided for identification of stereo transmissions. A C-QUAM receiver uses a standard AM detector to demodulate the  $L + R$  signal. The  $L - R$  signal is demodulated by a sophisticated synchronous FM detector. See PHASE MODULATION; RADIO RECEIVER. [J.War.]

**Stereophonic sound** A system of sound recording or transmission in which two or more microphone channels are connected to corresponding loudspeakers in the listening room in order to create a sound field at the listener's ears which is perceived to be very much like that in the original space. Binaural is a special form of stereophonic sound in which two microphones replace the ears of a dummy head and are connected through an amplifier/recorder system to a pair of headphones worn by the listener. Quadraphonic is a special case of stereo in which four channels and loudspeakers are employed. See BINAURAL SOUND; QUADRAPHONIC SOUND SYSTEM.

There are three basic microphone techniques for stereophonic pickup: coincident, spaced apart, and individual instrument (also called close milking). The techniques are sometimes combined.

The coincident technique employs two microphones located very close together, often enclosed in the same case. Usually the two microphones will have cardioid pickup patterns, or one will be a cardioid and the other a figure-eight. The coincident technique relies only on differences in sound intensity to determine position of the phantom images. *See* MICROPHONE.

By placing the microphones several feet apart, it is possible to provide a good pickup of a large group without moving the microphones as far into the reverberant field. The spaced-apart technique provides both time and intensity cues.

Beginning in the late 1960s it became common for most popular music to be recorded in an acoustically dead studio using a large number of microphones, each located close to one instrument or small group of instruments. By proportionally mixing the microphone outputs between the two stereo channels, it is possible to provide the intensity cues necessary for perceiving phantom images. No time cues are produced. *See* SOUND RECORDING; SOUND-REPRODUCING SYSTEMS. [R.Br.]

**Stereoscopy** The phenomenon of simultaneous vision with two eyes, producing a visual experience of the third dimension, that is, a vivid perception of the relative distances of objects in space. In this experience the observer seems to see the space between the objects located at different distances from the eyes.

Stereopsis, or stereoscopic vision, is believed to have an innate origin in the anatomic and physiologic structures of the retinas of the eyes and the visual cortex. It is present in normal binocular vision because the two eyes view objects in space from two points, so that the retinal image patterns of the same object points in space are slightly different in the two eyes. The stereoscope, with which different pictures can be presented to each eye, demonstrates the fundamental difference between stereoscopic perception of depth and the conception of depth and distance from the monocular view. *See* VISION. [K.N.O.]

**Stereospecific catalyst** Stereospecific polymerization catalysts lead to the formation of stereoregular (tactic) polymers, that is, polymers where the centers of steric isomerism in the main chain are arranged in a regular fashion with respect to their configurations. Three factors determine the tacticity of a polymeric chain during its formation: (1) the kind of monomer approach to the growing chain end, (2) the kind of attack of the growing chain end on the double bond (cis or trans opening), and (3) the configuration in the initiation step. In addition to a regular head-to-tail configuration and absence of branching, reactions have to be assumed. The kind of monomer approach is strongly affected by electrical and stereochemical forces, and therefore changes in monomer structure and environment greatly influence polymer tacticity. The intermediate radical or ion can be assumed to have a planar or near-planar structure, and in an uncomplexed form it should be able to rotate freely around its axis with cis and trans addition being equally possible. Upon addition of the next monomer this carbon changes into a tetrahedral structure, thereby creating two isomeric forms, isotactic or syndiotactic. *See* ASYMMETRIC SYNTHESIS; CATALYSIS; POLYMERIZATION; STEREOCHEMISTRY. [A.Sc.]

**Steric effect (chemistry)** The influence of the spatial configuration of reacting substances upon the rate, nature, and extent of reaction. The sizes and shapes of atoms and molecules, the electrical charge distribution, and the geometry of bond angles influence the courses of chemical reactions. The steric course of organochemical reactions is greatly dependent on the mode of bond cleavage and formation, the environment of the reaction site, and the nature of the reaction conditions (reagents, reaction time, and temperature). The effect of steric factors is best understood in ionic reactions in solution. *See* STEREOCHEMISTRY. [E.W.]

**Sterilization** An act of destroying all forms of life on and in an object. A substance is sterile, from a microbiological point of view, when it is free of all living microorganisms. Sterilization is used principally to prevent spoilage of food and other substances and to prevent the transmission of diseases by destroying microbes that may cause them in humans and animals. Microorganisms can be killed either by physical agents, such as heat and irradiation, or by chemical substances.

Heat sterilization is the most common method of sterilizing bacteriological media, foods, hospital supplies, and many other substances. Either moist heat (hot water or steam) or dry heat can be employed, depending upon the nature of the substance to be sterilized. Moist heat is also used in pasteurization, which is not considered a true sterilization technique because all microorganisms are not killed; only certain pathogenic organisms and other undesirable bacteria are destroyed. *See* PASTEURIZATION.

Many kinds of radiations are lethal, not only to microorganisms but to other forms of life. These radiations include both high-energy particles as well as portions of the electromagnetic spectrum. *See* RADIATION BIOLOGY.

Filtration sterilization is the physical removal of microorganisms from liquids by filtering through materials having relatively small pores. Sterilization by filtration is employed with liquid that may be destroyed by heat, such as blood serum, enzyme solutions, antibiotics, and some bacteriological media and medium constituents. Examples of such filters are the Berkefeld filter (diatomaceous earth), Pasteur-Chamberland filter (porcelain), Seitz filter (asbestos pad), and the sintered glass filter.

Chemicals are used to sterilize solutions, air, or the surfaces of solids. Such chemicals are called bactericidal substances. In lower concentrations they become bacteriostatic rather than bactericidal; that is, they prevent the growth of bacteria but may not kill them. Other terms having similar meanings are employed. A disinfectant is a chemical that kills the vegetative cells of pathogenic microorganisms but not necessarily the endospores of spore-forming pathogens. An antiseptic is a chemical applied to living tissue that prevents or retards the growth of microorganisms, especially pathogenic bacteria, but which does not necessarily kill them.

The desirable features sought in a chemical sterilizer are toxicity to microorganisms but nontoxicity to humans and animals, stability, solubility, inability to react with extraneous organic materials, penetrative capacity, detergent capacity, noncorrosiveness, and minimal undesirable staining effects. Rarely does one chemical combine all these desirable features. Among chemicals that have been found useful as sterilizing agents are the phenols, alcohols, chlorine compounds, iodine, heavy metals and metal complexes, dyes, and synthetic detergents, including the quaternary ammonium compounds. [C.F.N.]

**Steroid** Any of a group of organic compounds belonging to the general class of biochemicals called lipids, which are easily soluble in organic solvents and slightly soluble in water. Additional members of the lipid class include fatty acids, phospholipids, and triacylglycerides. The unique structural characteristic of steroids is a four-fused ring system. Members of the steroid family are ubiquitous, occurring, for example, in plants, yeast, protozoa, and higher forms of life. Steroids exhibit a variety of biological functions, from participation in cell membrane structure to regulation of physiological events. Naturally occurring steroids and their synthetic analogs are used extensively in medical practice.

Each steroid contains three fused cyclohexane (six-carbon) rings plus a fourth cyclopentane ring (see illustration). Naturally occurring steroids have an oxygen-containing group at carbon-3. Shorthand formulas for steroids indicate the presence of double bonds, as well as the structure and position of oxygen-containing or other organic groups.

The most abundant steroid in mammalian cells is cholesterol. The levels and locations of planar cholesterol molecules,

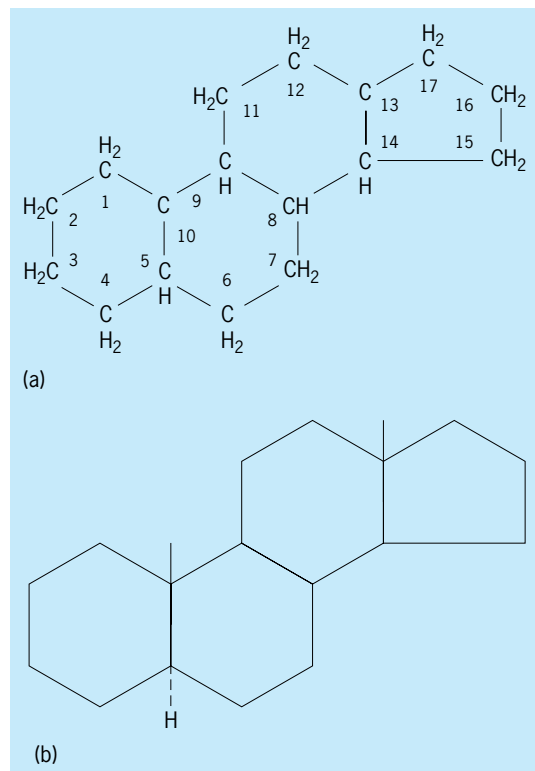

**Steroid skeleton. (a) Structure and numbering. (b) Shorthand formulation; the lines attached to the rings represent methyl groups.**

embedded in the phospholipid bilayers that form cell and organelle membranes, are known to influence the structure and function of the membranes. A second major function of cholesterol is to serve as a precursor of steroids acting as physiological regulators (such as the steroid hormones). Enzyme systems present in a hormone-secreting gland convert cholesterol to the hormone specific for that gland. For example, the ovary produces estrogens (such as estradiol and progesterone); the testis produces androgens (such as testosterone); the adrenal cortex produces hormones that regulate metabolism (such as cortisol) and sodium ion transport (such as aldosterone). A third major function of cholesterol is to serve as a precursor of the bile acids. These detergentlike molecules are produced in the liver and stored in the gall bladder until needed to assist in the absorption of dietary fat and fat-soluble vitamins and in the digestion of dietary fat by intestinal enzymes. See CELL MEMBRANES; CHOLESTEROL; STEROL.

Some examples of diseases treated with naturally occurring or synthetic steroids are allergic reactions, arthritis, some malignancies, and diseases resulting from hormone deficiencies or abnormal production. In addition, synthetic steroids that mimic an action of progesterone are widely used oral contraceptive agents. Other synthetic steroids are designed to mimic the stimulation of protein synthesis and muscle-building action of naturally occurring androgens. See HORMONE; LIPID. [M.E.D.]

**Sterol** Any of a group of naturally occurring or synthetic organic compounds with a steroid ring structure, having a hydroxyl ( $-\text{OH}$ ) group, usually attached to carbon-3. This hydroxyl group is often esterified with a fatty acid (for example, cholesterol ester). The hydrocarbon chain of the fatty-acid substituent varies in length, usually from 16 to 20 carbon atoms, and can be saturated or unsaturated. Sterols commonly contain one or more double bonds in the ring structure and also a variety of substituents attached to the rings. Sterols and their fatty-acid esters are essentially water insoluble. For transport in an aqueous mi-

lieu (for example, the bloodstream of mammals), sterols and other lipids are bound to specific proteins, forming lipoprotein particles. These particles are classified based on their composition and density. One lipoprotein class is abnormally high in the blood of humans prone to heart attacks.

Sterols are widely distributed in nature. Modifications of the steroid ring structure are made by specific enzyme systems, producing the sterol characteristic for each species, such as ergosterol in yeast. The major regulatory step in the sterol biosynthetic pathway occurs early in the process. Drugs that lower blood cholesterol levels in humans are designed to inhibit this regulatory enzyme. In addition to their conversion to sterols, several intermediates in the pathway are precursors of other important biological compounds, including chlorophyll in plants, vitamins A, D, E, and K, and regulators of membrane functions and metabolic pathways.

A universal role of sterols is to function as part of membrane structures. In addition, some insects require sterols in their diets. Cholesterol also serves as a precursor of steroid hormones (estrogens, androgens, glucocorticoids, and mineralocorticoids) and bile acids. See CHOLESTEROL; STEROID. [M.E.D.]

**Stibnite** A mineral with composition  $\text{Sb}_2\text{S}_3$  (antimony trisulfide), the chief ore of antimony. It crystallizes in slender, prismatic, vertically striated crystals which may be curved or bent. It is often in bladed, granular, or massive aggregates. The hardness is 2 on Mohs scale and the specific gravity 4.5–4.6. The luster is metallic and the color lead-gray to black. It is one of few minerals that fuses easily in the match flame ( $525^\circ\text{C}$  or  $977^\circ\text{F}$ ).

Stibnite has been found in various mining districts in Germany, Romania, France, Bolivia, Peru, and Mexico. In the United States the Yellow Pine mine at Stibnite, Idaho, is the largest producer. Other deposits are in Nevada and California. The finest crystals have come from the island of Shikoku, Japan. See ANTIMONY. [C.S.Hu.]

**Stichosomida** An order of nematodes composed of taxa that are parasitic in either vertebrates or invertebrates. The most distinguishing characteristic is the modification of the posterior esophagus into a stichosome, a series of glands exterior to the esophagus proper. The stichosome may be in one or two rows. The early larval stages possess a protrusible stylet that is absent in the adults. Amphids are postlabial.

There are three stichosomid superfamilies: Trichocephaloidea parasitize vertebrates. In Mermithoidea, adult worms are free living, but their larvae are parasitic in a variety of insects, arachnids, and pulmonate snails. Echinomermelloidea parasitize marine invertebrates; the superfamily comprises three families: Echinomermellidae, Marimemithidae, and Benthimermithidae. See NEMATODA. [A.R.M.]

**Stickleback** Any fish which is a member of the family Gasterosteidae in the order Gasterosteiformes. They have a variable number of free spines in front of the dorsal fin. These small, fresh-water and marine fishes are found in cold and temperate waters of the Northern Hemisphere. All species are of some economic importance since they feed largely on mosquito larvae. See GASTEROSTEIFORMES. [C.B.C.]

**Stilbite** A mineral belonging to the zeolite family of silicates. It crystallizes in sheaflike aggregates of thin tabular crystals. There is perfect cleavage parallel to the side pinacoid, and here the mineral has a pearly luster; elsewhere the luster is vitreous. The color is usually white but may be brown, red, or yellow. Hardness is  $3\frac{1}{2}$ –4 on Mohs scale; specific gravity is 2.1–2.2. See ZEOLITE.

Stilbite is found in Iceland, India, Scotland, Nova Scotia, and in the United States at Bergen Hill, New Jersey, and the Lake Superior copper district in Michigan. [C.S.Hu.]

**Stirling engine** An engine in which work is performed by the expansion of a gas at high temperature to which heat is supplied through a wall. Like the internal combustion engine, a Stirling engine provides work by means of a cycle in which a piston compresses gas at a low temperature and allows it to expand at a high temperature. In the former case the heat is provided by the internal combustion of fuel in the cylinder, but in the Stirling engine the heat (obtained from externally burning fuel) is supplied to the gas through the wall of the cylinder (see illustration).

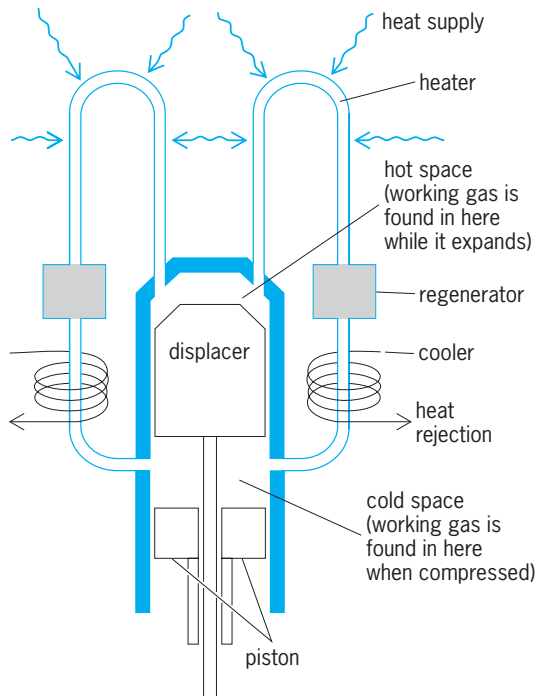

Principle of Stirling engine, displacer type.

The rapid changes desired in the gas temperature are achieved by means of a second piston in the cylinder, called a displacer, which in moving up and down transfers the gas back and forth between two spaces, one at a fixed high temperature and the other at a fixed low temperature. When the displacer is raised, the gas will flow from the hot space via the heater and cooler tubes into the cold space. When it is moved downward, the gas will return to the hot space along the same path. During the first transfer stroke the gas has to yield up a large amount of heat to the cooler; an equal quantity of heat has to be taken up from the heater during the second stroke. See INTERNAL COMBUSTION ENGINE. [R.J.M.]

**Stishovite** Naturally occurring stishovite,  $\text{SiO}_2$ , is a mineral formed under very high pressure with the silicon atom in sixfold, or octahedral, coordination instead of the usual fourfold, or tetrahedral, coordination. The presence of stishovite indicates formation pressures in excess of  $10^6$  lb/in.<sup>2</sup> (7.5 gigapascals). The possibility of the existence of stishovite at great depths strongly influences the interpretations of geophysicists and solid-state physicists regarding the phase transitions of mineral matter, as well as the interpretation of seismic data in the study of such regions of the interior of the Earth. See SILICA MINERALS.

Stishovite occurs in submicrometer size in very small amounts (less than 1% of the rock) in samples of Coconino sandstones from the Meteor Crater of Arizona, which contains up to 10% of coesite, the other high-pressure polymorph of silica. Because of its extremely fine grain size and because of the sparsity of this mineral in the rock, positive identification of the mineral

is possible only by the x-ray diffraction method after chemical concentration. See COESITE; METEORITE.

The specific gravity of stishovite, calculated from the x-ray data, is 4.28, compared with the value of 4.35 for the synthetic material. It is 46% denser than coesite and much denser than other modifications of silica. See RUTILE. [E.C.T.C.]

**Stochastic control theory** A branch of control theory which aims at predicting and minimizing the magnitudes and limits of the random deviations of a control system through optimizing the design of the controller. Such deviations occur when random noise and disturbance processes are present in a control system, so that the system does not follow its prescribed course but deviates from the latter by a randomly varying amount.

In contrast to deterministic signals, random signals cannot be described as given functions of time such as a step, a ramp, or a sine wave. The exact function is unknown to the system designer; only some of its average properties are known.

A random signal may be generated by one of nature's processes, for instance, radar noise and wind- or wave-induced forces and moments on a radar antenna or a ship. Alternatively, it may be generated by human intelligence, for instance, the bearing of a zigzagging aircraft, or the contour to be followed by a duplicating machine.

One outstanding experimental fact about nature's random processes is that these signals are very closely Gaussian. The word "Gaussian" is a mathematical concept which describes one or more signals,  $i_1, i_2, \dots, i_n$  having the following properties:

1. The amplitude of each signal is normally distributed.

2. The joint distribution function of any number of signals at the same or different times taken from the set is a multivariate normal distribution. This experimental fact is not surprising in view of the fact that a random process of nature is usually the sum total of the effects of a large number of independent contributing factors. For instance, thermal noise is due to the thermal motions of billions of electrons and atoms. An ocean-wave height at any particular time and place is the sum of wind-generated waves at previous times over a large area. See DISTRIBUTION (PROBABILITY); ELECTRICAL NOISE; STOCHASTIC PROCESS.

The underlying mechanism that generates a random process can usually be described in physical or mathematical terms. For instance, the underlying mechanism that generates shot-effect noise is thermionic emission. If the generating mechanism does not change with time, any measured average property of the random process is independent of the time of measurement aside from statistical fluctuations, and the random process is called stationary. If the generating mechanism does change, the random process is called nonstationary. See CONTROL SYSTEMS. [S.S.L.C.]

**Stochastic process** A physical stochastic process is any process governed by probabilistic laws. Examples are (1) development of a population as controlled by Mendelian genetics; (2) Brownian motion of microscopic particles subjected to molecular impacts or, on a different scale, the motion of stars in space; (3) succession of plays in a gambling house; and (4) passage of cars by a specified highway point.

In each case, a probabilistic system is evolving; that is, its state is changing with time. Thus the state at time  $t$  depends on chance: It is a random variable  $x(t)$ . The parameter set of values of  $t$  involved is usually (and will always be in this article) either an interval (continuous parameter stochastic process) or a set of integers (discrete parameter stochastic process). Some authors, however, apply the term stochastic process only to the continuous parameter case.

If the state of the system is described by a single number,  $x(t)$  is numerical-valued. In other cases,  $x(t)$  may be vector-valued or even more complicated. For the numerical case, as the state changes, its values determine a function of time, the sample function, and the probability laws governing the process determine

the probabilities assigned to the various possible properties of sample functions.

A mathematical stochastic process is a mathematical structure inspired by the concept of a physical stochastic process, and studied because it is a mathematical model of a physical stochastic process or because of its intrinsic mathematical interest and its applications both in and outside the field of probability. The mathematical stochastic process is defined simply as a family of random variables. That is, a parameter set is specified, and to each parameter point  $t$  a random variable  $x(t)$  is specified. If one recalls that a random variable is itself a function, if one denotes a point of the domain of the random variable  $x(t)$  by  $\omega$ , and if one denotes the value of this random variable at  $\omega$  by  $x(t, \omega)$ , it results that the stochastic process is completely specified by the function of the pair  $(t, \omega)$  just defined, together with the assignment of probabilities. If  $t$  is fixed, this function of two variables defines a function of  $\omega$ , namely, the random variable denoted by  $x(t)$ . If  $\omega$  is fixed, this function of two variables defines a function of  $t$ , a sample function of the process.

Probabilities are ordinarily assigned to a stochastic process by assigning joint probability distributions to its random variables. These joint distributions, together with the probabilities derived from them, can be interpreted as probabilities of properties of sample functions. For example, if  $t_0$  is a parameter value, the probability that a sample function is positive at time  $t_0$  is the probability that the random variable  $x(t_0)$  has a positive value. The fundamental theorem at this level is that, to any self-consistent assignment of joint probability distributions, there corresponds a stochastic process.

Stationary processes are the stochastic processes for which the joint distribution of any finite number of the random variables is unaffected by translations of the parameter; that is, the distribution of  $x(t_1 + h), \dots, x(t_n + h)$  does not depend on  $h$ . See PROBABILITY.

A Markov process is a process for which, if the present is given, the future and past are independent of each other. More precisely, if  $t_1 < \dots < t_n$  are parameter values, and  $1 < j < n$ , then the sets of random variables  $[x(t_1), \dots, x(t_{j-1})]$  and  $[x(t_{j+1}), \dots, x(t_n)]$  are mutually independent for given  $x(t_j)$ . Equivalently, the conditioned probability distribution of  $x(t_n)$  for given  $x(t_{n-1}), \dots, x(t_{j+1})$  depends only on the specified value of  $x(t_{n-1})$  and is in fact the conditional probability distribution of  $x(t_n)$ , given  $x(t_{n-1})$ . An important and simple example is the Markov chain, in which the number of states is finite or denumerably infinite.

A martingale is a stochastic process with the property that, if  $t_1 < \dots < t_n$  are parameter values, the expected value of  $x(t_n)$  for given  $x(t_1), \dots, x(t_{n-1})$  is equal to  $x(t_{n-1})$ . That is, the expected future value, given present and past values, is equal to the present value. The interpretation that a martingale can be thought of as the fortune of a player after the successive plays of a fair gambling game is obvious.

A process with independent increments is a continuous-parameter process with the property that, if  $t_1, < \dots < t_n$  are parameter values, the successive increments in  $x(t_2) - x(t_1), \dots, x(t_n) - x(t_{n-1})$  are mutually independent. If  $y(t) = x(t) - x(t_0)$ , where  $t_0$  is fixed, the  $y(t)$  process is then a Markov process. See GAME THEORY; INFORMATION THEORY; LINEAR PROGRAMMING; OPERATIONS RESEARCH. [J.L.D.]

**Stoichiometry** All chemical measurements, such as the measurements of atomic and molecular weights and sizes, gas volumes, vapor densities, deviation from the gas laws, and the structure of molecules. In determining the relative weights of the atoms, scientists have relied upon combining ratios, specific heats, and measurements of gas volumes. All such measurements, and the calculations that relate them to each other, constitute the field of stoichiometry. Since measurements are expressed in mathematical terms, stoichiometry can be considered to be the mathematics of general chemistry.

In a general usage, the term stoichiometry refers to the relationships between the measured quantities of substances

or of energy involved in a chemical reaction; the calculations of these quantities include the assumption of the validity of the laws of definite proportions and of conservation of matter and energy. See CONSERVATION OF ENERGY; CONSERVATION OF MASS.

A typical stoichiometric problem involves predicting the weight of reactant needed to produce a desired amount of a product in a chemical reaction. For example, phosphorus can be extracted from calcium phosphate,  $\text{Ca}_3(\text{PO}_4)_2$ , by a certain process with a 90% yield (some calcium phosphate fails to react or some phosphorus is lost). In a specific problem, it might be necessary to determine the mass of calcium phosphate required to prepare 16.12 lb of phosphorus by this process. The balanced equation for the preparation is shown in reaction (1). In this reaction,

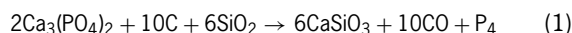

2 moles of calcium phosphate are required to produce 1 mole of phosphorus. Two moles of calcium phosphate have a mass of 620 lb, and 1 mole of phosphorus as  $\text{P}_4$  has a mass of 124 lb. Using these relationships, calculation (2) is made. Since the yield

$$\begin{aligned} \frac{2 \text{ moles } \text{Ca}_3(\text{PO}_4)_2}{1 \text{ mole } \text{P}_4} &= \frac{620 \text{ lb } \text{Ca}_3(\text{PO}_4)_2}{124 \text{ lb } \text{P}_4} \\ &= \frac{X \text{ lb } \text{Ca}_3(\text{PO}_4)_2}{16.12 \text{ lb } \text{P}_4} \quad (2) \\ X &= 80.6 \text{ lb} \end{aligned}$$

of phosphorus is only 90%, extra  $\text{Ca}_3(\text{PO}_4)_2$  must be used: 88.1 lb is the mass of calcium phosphate required to yield 16.12 lb of phosphorus by this process.

Calculations of this sort are important in chemical engineering processes, in which amounts and yields of products must be known. The same reasoning is used in calculations of energy generated or required. In this case, the energy involved in the reaction of a known weight of the material in question must be known or determined.

The calculations discussed involve compounds in which the ratio of atoms is generally simple. For a discussion of compounds in which the relative number of atoms cannot be expressed as ratios of small whole numbers, see NONSTOICHIOMETRIC COMPOUNDS

[J.C.Ba.]

**Stoker** A mechanical means for feeding coal into, and for burning coal in, a furnace. There are three basic types of stokers. Chain or traveling-grate stokers have a moving grate on which the coal burns; they carry the coal from a hopper into the furnace and move the ash out (see illustration). Spreader stokers mechanically or pneumatically distribute the coal from a hopper at the furnace front wall and move it onto the grate which usually moves continuously to dispose of the ash after the coal is burned. Underfeed stokers are arranged to force fresh coal

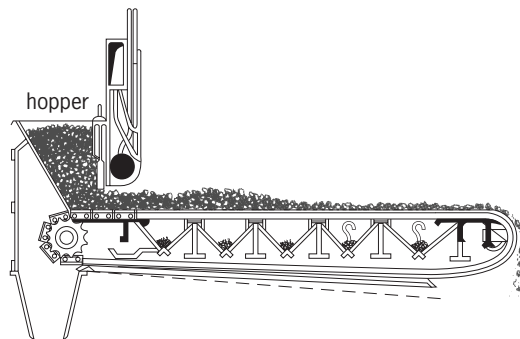

Chain grate stoker.



from the hopper to the bottom of the burning coal bed, usually by means of a screw conveyor. The ash is forced off the edges of the retort peripherally to the ashpit or is removed by hand.

[G.W.K.]

**Stokes' theorem** The assertion that under certain light restrictions the surface integral of  $(\Delta \vec{r} \times \vec{r}) \cdot \mathbf{v}$  over a surface patch  $S$  is equal to the line integral of  $\vec{r} \cdot \tau$  taken around  $C$ , the boundary curve of  $S$ , provided the sense of transcription of  $C$  is right-handed relative to  $\mathbf{v}$ . This can be expressed as

$$\iint_S (\nabla \times \vec{r}) \cdot \mathbf{v} dS = \int_C \vec{r} \cdot \tau ds$$

Here  $\vec{r}$  is a vector function,  $\mathbf{v}$  is one of the two unit normals to the two-sided surface  $S$ ,  $s$  is arc length measured positively in the sense which is right-handed relative to  $\mathbf{v}$ , and  $\tau$  is the unit tangent vector to  $C$  in the sense of increasing  $s$ . See CALCULUS OF VECTORS.

[H.V.C.]

**Stolonifera** An order of the Alcyonaria which lacks coenenchyme. They form either simple or rather complex colonies. The polyp has a cylindrical body with a retractile oral portion which can withdraw into a solid anthostele or calyx protected by many calcareous spicules. The base of the mature polyp is attached to a creeping stolon which is a ribbonlike network or thin flat mat from which daughter polyps arise. Daughter polyps never bud from the wall of the primary polyp. Each polyp is connected by solenial tubes of the stolons, or by transverse platforms. See ALCYONARIA.

[K.At.]

**Stomach** The tubular or saccular abdominal organ of the digestive system adapted for temporary food storage and preliminary stages of food breakdown.

In some primitive vertebrates the stomach may be little more than a simple tube quite similar to other portions of the gastrointestinal tract. In other forms the stomach is a distinct, and frequently large, saclike structure of variable shape. Carnivorous forms typically have a better-developed stomach than herbivores, probably reflecting the larger but less numerous feedings characteristic of the former, but exceptions are numerous.

In birds the stomach consists of a proventriculus and a gizzard. The former is well supplied with glands which secrete softening and digestive enzymes; the latter is a strong, muscular grinding organ whose action is often enhanced by the ingestion of small stones.

Mammals have stomachs which vary considerably in structure. Although a single chamber is most common, some mammals, such as cows and their relatives (ruminants), have as many as four. These chambers may have developed either from modifications of the posterior portions of the esophagus or from alterations of the stomach itself.

The human stomach is located beneath the diaphragm, through which the posterior, terminal end of the esophagus passes. The stomach appears as a dilated tube continuous with the distal end of the esophagus. The upper curvature of the stomach is usually above and to the left of the esophageal orifice. This expanded anterior portion is the fundus and is commonly filled with air or gas. The body (corpus) of the stomach is directed toward the attenuated right extremity or pyloric region and is subject to variations in size and shape, depending upon functional activities, habits, disease, and volume of the contents. The pyloric walls are marked by the heavy sphincter muscle which controls the passage of chyme (a semiliquid fluid produced by the mechanical and chemical changes of preliminary digestion) into the duodenum.

The stomach of vertebrates is lined by a mucous membrane that is usually thrown into longitudinal folds called rugae. Most of the surface is covered with mucus-secreting epithelial cells, but scattered throughout the lining are many small glandular pits which are lined with one or more types of secretory cells. See DIGESTIVE SYSTEM.

[T.S.P.]

**Stomatopoda** The only order of the superorder Holoecarida belonging to the subclass Malacostraca of the class Crustacea. This order of the mantis shrimps contains four families: Lysioquillidae, Bathysquillidae, Squillidae, and Gonodactylidae. Stomatopoda are among the larger Crustacea; the size of an adult ranges from about 0.5 in. (12 mm) to over 12 in. (300 mm).

The bodies of stomatopods are narrow and elongate, almost cruciform. Only part of the cephalic and thoracic somites are fused and covered by the dorsal shield, the carapace. Those cephalic somites which bear the antennulae and the eyes are free and visible anterior to the carapace, and the last four thoracic somites are similarly exposed. The tail fan consists of a well-developed, sometimes peculiarly sculptured or deformed, median plate, the telson, and the two uropods. Anteriorly, the carapace bears a flattened movable plate, the rostrum. The eyes are large, stalked, and movable. Of eight pairs of thoracic appendages the first is narrow, slender, and hairy, probably being used for cleaning purposes. The second thoracic leg is very strong and heavy. It has become a large raptorial claw that shows a great resemblance to that of the praying mantis, and for this reason the Stomatopoda are often given the name mantis shrimps.

The Stomatopoda are marine animals rarely found in brackish water. Most species are confined to tropical and subtropical areas, though some occur in the boreal and antiboreal regions. The majority of stomatopods live in the littoral and sublittoral zones, but a few species have been found in greater depths, down to 2500 ft (760 m). See MALACOSTRACA.

[L.B.Ho.]

**Stone and stone products** The term stone is applied to rock that is cut, shaped, broken, crushed, and otherwise physically modified for commercial use. The two main divisions are dimension stone and crushed stone. Other descriptive terms may be used, for example, building stone, roofing stone, or precious stone. See GEM; ROCK.

The term dimension stone is applied to blocks that are cut and milled to specified sizes, shapes, and surface finishes. The principal uses are for building and ornamental applications. Granites, limestones, sandstones, and marbles are widely used; basalts, diabases, and other dark igneous rocks are used less extensively. Soapstone is used to some extent. Rock suitable for use as dimension stone must be obtainable in large, sound blocks, free from incipient cracks, seams, and blemishes, and must be without mineral grains that might cause stains as a result of weathering. It must have an attractive color, and generally a uniform texture.

Slate differs from other dimension stone because it can be split into thin sheets of any desired thickness. Commercial slate must be uniform in quality and texture and reasonably free from knots, streaks, or other imperfections, and have good splitting properties. Roofing slates are important products of most slate quarries. However, the roofing-slate industry has declined considerably because of competition from other types of roofing. Slate is also used for milled products such as blackboards, electrical panels, window and door sills and caps, baseboards, stair treads, and floor tile. See SLATE.

Nearly all the principal types of stone—granite, diabase, basalt, limestone, dolomite, sandstone, and marble—may be used as sources of commercial crushed stone; limestone is by far the most important. Crushed stone is made from sound, hard stone, free from surface alteration by weathering. Stone that breaks in chunky, more or less cubical fragments is preferred. Commercial stone should be free from certain deleterious impurities, such as opalescent quartz, and free from clay or silt. Crushed stone is used principally as concrete aggregate, as road stone, or as railway ballast. Other uses for limestone are as a fluxing material to remove impurities from ores smelted in metallurgical furnaces, in the manufacture of alkali chemicals, calcium carbide, glass, paper, paint, and sugar, and for filter beds and for making mineral wool.

[R.L.B.]

**Storage tank** A container for storing liquids or gases. A tank may be constructed of ferrous or nonferrous metals or alloys, reinforced concrete, wood, or filament-wound plastics, depending upon its use. Tanks resting on the ground have flat bottoms: those supported on towers have either flat or curved bottoms. Standpipes, which are usually cylindrical shells of steel or reinforced concrete resting on the ground, are frequently of great height and comparatively small diameter. They are built to contain water for a distribution system, and height is required to maintain pressure in the system. Tanks for other liquids and for gases, where storage is more important than pressure, are generally lower and of greater diameter. [C.M.A.]

**Storm** An atmospheric disturbance involving perturbations of the prevailing pressure and wind fields on scales ranging from tornadoes (0.6 mi or 1 km across) to extratropical cyclones (1.2–1900 mi or 2–3000 km across); also, the associated weather (rain storm, blizzard, and the like). Storms influence human activity in such matters as agriculture, transportation, building construction, water impoundment and flood control, and the generation, transmission, and consumption of electric energy. See WIND.

The form assumed by a storm depends on the nature of its environment, especially the large-scale flow patterns and the horizontal and vertical variation of temperature; thus the storms most characteristic of a given region vary according to latitude, physiographic features, and season. Extratropical cyclones and anticyclones are the chief disturbances over roughly half the Earth's surface. Their circulations control the embedded smaller-scale storms. Large-scale disturbances of the tropics differ fundamentally from those of extratropical latitudes. See HURRICANE; SQUALL; THUNDERSTORM; TORNADO; TROPICAL METEOROLOGY.

Cyclones form mainly in close proximity to the jet stream, that is, in strongly baroclinic regions where there is a large increase of wind with height. Weather patterns in cyclones are highly variable, depending on moisture content and thermodynamic stability of air masses drawn into their circulations. Warm and occluded fronts, east of and extending into the cyclone center, are regions of gradual upgliding motions, with widespread cloud and precipitation but usually no pronounced concentration of stormy conditions. Extensive cloudiness also is often present in the warm sector. Passage of the cold front is marked by a sudden wind shift, often with the onset of gusty conditions, with a pronounced tendency for clearing because of general subsidence behind the front. Showers may be present in the cold air if it is moist and unstable because of heating from the surface. Thunderstorms, with accompanying squalls and heavy rain, are often set off by sudden lifting of warm, moist air at or near the cold front, and these frequently move eastward into the warm sector. See CYCLONE; JET STREAM; WEATHER.

Extratropical cyclones alternate with high-pressure systems or anticyclones, whose circulation is generally opposite to that of the cyclone. The circulations of highs are not so intense as in well-developed cyclones, and winds are weak near their centers. In low levels the air spirals outward from a high; descent in upper levels results in warming and drying aloft. Anticyclones fall into two main categories, the warm "subtropical" and the cold "polar" highs.

Between the scales of ordinary air turbulence and of cyclones, there exist a variety of circulations over a middle-scale or mesoscale range, loosely defined as from about one-half up to a few hundred miles. Alternatively, these are sometimes referred to as subsynoptic-scale disturbances because their dimensions are so small that they elude adequate description by the ordinary synoptic network of surface weather stations. Thus their detection often depends upon observation by indirect sensing systems. See METEOROLOGICAL SATELLITES; RADAR METEOROLOGY; STORM DETECTION. [C.W.N.]

**Storm detection** Identifying storm formation, monitoring subsequent storm evolution, and assessing the potential for destruction of life and property through application of various methods and techniques. Doppler radars, satellite-borne instruments, lightning detection networks, and surface observing networks are used to detect the genesis of storms, to diagnose their nature, and to issue warnings when a threat to life and property exists. See STORM.

**Radar surveillance.** Radars emit pulses of electromagnetic radiation that are broadcast in a beam, whose angular resolution is about  $1^\circ$  with a range resolution of about 0.5 km (0.3 mi). The radar beam may intercept precipitation particles in a storm that reflect a fraction of the transmitted energy to the transmitter site (generally called reflectivity or the scatter cross section per unit volume). As the transmitter sweeps out a volume by rotating and tilting the transmitting antenna, the reflectivity pattern of the precipitation particles embodied in the storm is defined. Doppler radars also can measure the velocities of precipitation particles along the beam (radial velocity). Reflectivity and velocity patterns of the storm hydrometeors then make it possible to diagnose horizontal and vertical circulations that may arise within the storm, and to estimate the type and severity of weather elements attending the storm, such as rainfall, hail, damaging winds, and tornadoes. See DOPPLER RADAR; PRECIPITATION (METEOROLOGY); RADAR; RADAR METEOROLOGY; WIND.

**Satellite surveillance.** Since the early 1960s, meteorological data from satellites have had an increasing impact on storm detection and monitoring. In December 1966 the first geostationary *Applications Technology Satellite (ATS 1)* allowed forecasters in the United States to observe storms in animation. A Geostationary Operational Environmental Satellite (GOES) program was initiated within the National Oceanic and Atmospheric Administration (NOAA) with the launch of *GOES 1* in October 1975. The visible and infrared spin scan radiometer (VISSR) provided imagery, which significantly advanced the ability of meteorologists to detect and observe storms by providing frequent-interval visible and infrared imagery of the Earth surface, cloud cover, and atmospheric moisture patterns.

The first of NOAA's next generation of geostationary satellites, *GOES 8* was launched in the spring of 1994. *GOES 8* introduced improved capabilities to detect and observe storms. The *GOES 8* system includes no conflict between imaging and sounding operation, multispectral imaging with improved resolution and better signal-to-noise in the infrared bands, and more accurate temperature and moisture soundings of the storm environment. The Earth's atmosphere is observed nearly continuously.

Derived-product images showing fog and stratus areas from *GOES 8* are created by combining direct satellite measurements, such as by subtracting brightness temperatures at two different wavelengths. *GOES 8* shows the fog and stratus much more clearly because of its improved resolution. This capability enables forecasters to detect boundaries between rain-cooled areas having fog or low clouds, and clear areas. Such boundaries are frequently associated with future thunderstorm development. The sounder on *GOES 8* is capable of fully supporting routine forecasting operations. This advanced sounding capability consists of better vertical resolution in both temperature and moisture, and improved coverage of soundings in and around cloudy weather systems. See CLOUD; FOG; METEOROLOGICAL SATELLITES; SATELLITE METEOROLOGY.

**Surface observing systems.** Larger convective storm systems such as squall lines and mesoscale convective systems can be detected (but not fully described) by the temperature, moisture, wind, and pressure patterns observed by appropriate surface instrumentation. Automatic observing systems provide frequent data on pressure, temperature, humidity, wind, cloud base, and most precipitation types, intensity, and accumulation. Analyses of these data, combined with improved conceptual models of convective storm systems, enable forecasters

to detect and monitor the intense mesoscale fluctuations in pressure and winds that often accompany the passage of convective weather systems such as bow echoes, derechos (strong, straight-line winds), and squall lines. A bow echo is a specific radar reflectivity pattern associated with a line of thunderstorms. The middle portion of the thunderstorm line is observed to move faster than the adjacent portions, causing the line of storms to assume a bowed-out configuration. Other analyses of these mesoscale data fields aid the forecaster in detecting favorable areas for thunderstorm cell regeneration, which may produce slowly moving mesoscale convective storms attended by heavy rains and flash floods. See SQUALL LINE; WEATHER OBSERVATIONS.

**Cloud-to-ground lightning detectors.** Lightning location stations provide forecasters with the location, polarity, peak current, and number of strokes in a flash to ground within seconds of the flash occurrence. Useful applications have emerged with regard to the detection and tracking of thunderstorms, squall lines, other mesoscale convective systems, and the weather activity that accompany these phenomena, such as tornadoes and hail. See LIGHTNING; MESOMETEOROLOGY; SPHERICS; THUNDERSTORM; WEATHER FORECASTING AND PREDICTION. [C.F.Ch.]

**Storm electricity** Processes responsible for the separation of positive and negative electric charges in the atmosphere during storms, including the spectacular manifestation of this charge separation: lightning discharges. Cloud electrification is almost invariably associated with convective activity and with the formation of precipitation in the form of liquid water (rain) and ice particles (graupel and hail). The most vigorous convection and active lightning occurs in the summertime, when the energy source for convection, water vapor, is most prevalent. Winter snowstorms can also be strongly electrified, but they produce far less lightning than summer storms. Electrified storm clouds occasionally occur in complete isolation; more commonly they are found in convective clusters or in lines that may extend horizontally for hundreds of kilometers. See PRECIPITATION (METEOROLOGY).

Measurements of electric field at the ground and from instrumented balloons within thunderclouds have disclosed an electrostatic structure that appears to be fairly systematic throughout the world. The measurements show that the principal variations in charge occur in the vertical and are affected by the temperature of the cloud. The charge structure within a thundercloud is tripolar, with a region of dominant negative charge sandwiched between an upper region of positive charge and a subsidiary lower region of positive charge. In addition to the charge accumulations described within the cloud, electrical measurements disclose the existence of charge-screening layers at the upper cloud boundary and a layer of positive charge near the Earth's surface beneath the cloud. These secondary charge accumulations arising from charge migration outside the cloud are caused by electrostatic forces of attraction set up by the charges within the cloud.

Large differences of electric potential are associated with the distribution of charge maintained by active thunderclouds. These large differences in potential are maintained by charging currents that result from the motions of air and particles. The charging currents range from milliamperes in small clouds that are not producing lightning to several amperes for large storms with high rates of lightning. See CLOUD PHYSICS.

In response to charge separation within a thundercloud, the electric field increases to a value of approximately  $10^6$  V/m (300,000 V/ft) at which point dielectric breakdown occurs and lightning is initiated. Most lightning extends through the cloud at speeds of 10,000–100,000 m/s (22,000–220,000 mi/h). The peak temperature of lightning, which is a highly ionized plasma, may exceed 30,000 K (54,000°F). The acoustic disturbance caused by the sudden heating of the atmosphere by lightning is thunder. See LIGHTNING; THUNDER.

Meteorologists have shown a growing interest in the large-scale display of real-time lightning activity, since lightning is one of the most sensitive indicators of convective activity. Research has expanded into relationships between lightning characteristics and the meteorological evolution of different types of storms. The discovery of the sensitive dependence of local lightning activity on the temperature of surface air has led to research focused on the use of the global electrical circuit as a diagnostic for global temperature change. See ATMOSPHERIC ELECTRICITY; STORM DETECTION; THUNDERSTORM. [E.Wi.]

**Storm surge** An anomalous rise in water elevations caused by severe storms approaching the coast. A storm surge can be succinctly described as a large wave that moves with the storm that caused it. The surge is intensified in the nearshore, shallower regions where the surface stress caused by the strong onshore winds pile up water against the coast, generating an opposing pressure head in the offshore direction. However, there are so many other forces at play in the dynamics of the storm surge phenomenon, such as bottom friction, Earth's rotation, inertia, and interaction with the coastal geometry, that a simple static model cannot explain all the complexities involved. Scientists and engineers have dedicated many years in the development and application of sophisticated computer models to accurately predict the effects of storm surges.

The intensity and dimension of the storm causing a surge, and thus the severity of the ensuing surge elevations, depend on the origin and atmospheric characteristics of the storm itself. Hurricanes and severe extratropical storms are the cause of most significant surges. In general, hurricanes are more frequent in low to middle latitudes, and extratropical storms are more frequent in middle to high latitudes. See HURRICANE; STORM. [S.R.S.]

**Straight-line mechanism** A mechanism that produces a straight-line (or nearly so) output motion from an input element that rotates, oscillates, or moves in a straight line. Common machine elements, such as linkages, gears, and cams, are often used in ingenious ways to produce the required controlled motion. The more elegant designs use the properties of special points on one of the links of a four-bar linkage. See MECHANISM.

Four-bar linkages that generate approximate straight lines are not new. In 1784 James Watt applied the concept to the vertical-cylinder beam engine. By selecting the appropriate link lengths, the designer can easily develop a mechanism with a high-quality approximate straight line. Contemporary kinematicians have contributed to more comprehensive studies of the properties of the mechanisms that generate approximate straight lines. The work not only describes the various classical mechanisms, but also provides design information on the quality (the amount of deviation from a straight line) and the length of the straight-line output. See FOUR-BAR LINKAGE; LINKAGE (MECHANISM).

Gears can also be used to generate straight-line motions. The most common combination would be a rack-and-pinion gear. See GEAR.

Cam mechanisms are generally not classified as straight-line motion generators, but translating followers easily fall into the classical definition. See CAM MECHANISM. [J.A.Sm.]

**Strain gage** A device which measures mechanical deformation (strain). Normally it is attached to a structural element, and uses the change of electrical resistance of a wire or semiconductor under tension. Capacity, inductance, and reluctance are also used.

The strain gage converts a small mechanical motion to an electrical signal by virtue of the fact that when a metal (wire or foil) or semiconductor is stretched, its resistance is increased. The change in resistance is a measure of the mechanical motion. In addition to their use in strain measurement, these gages are used in sensors for measuring the load on a mechanical member,

forces due to acceleration on a mass, or stress on a diaphragm or bellows. See STRAIN. [J.H.Z.]

**Strake** The slender forward extension of the inboard region of the wing of a combat aircraft used to provide increased lift in the high angle-of-attack maneuvering condition. In contrast to the normal attached-flow design principles, these strakes are built to allow the flow to separate along the leading edge in the high angle-of-attack range and to roll up into strong leading-edge vortices. The illustration shows a typical strake installation and the vortices generated. These are highly stable, and

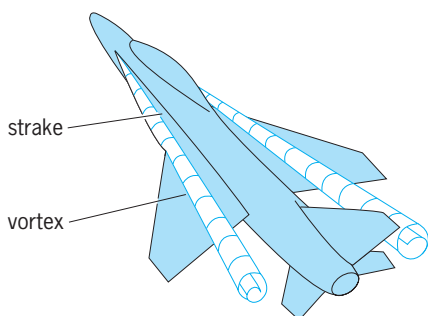

Strake and resulting vortex flow.

their strong swirling motion creates a lower pressure area on the strake upper surface, resulting in a large incremental increase in lift force known as vortex lift. This vortex lift increases rapidly in the high angle-of-attack range and is less susceptible to the normal stalling characteristics encountered with conventional lifting surfaces. See AIRFOIL; SUBSONIC FLIGHT; VORTEX; WING. [E.C.P.]

**Strand line** The line that marks the separation of land and water along the margin of a pond, lake, sea, or ocean; also called the shoreline. The strand line is very dynamic. It changes with the tides, storms, and seasons, and as long-term sea-level changes take place. The sediments on the beach respond to these changes, as do the organisms that live in this dynamic environment. On a beach organisms move with the tides, and on a rocky coast they tend to be organized relative to the strand line because of special limitations or adaptations to exposure.

Geologists who study ancient coastal environments commonly try to establish where the strand line might be in the rock strata. This can sometimes be determined by a combination of the nature and geometry of individual laminations in the rock, by identifying sedimentary structures that occur at or near the strand line. The most indicative of these structures are swash marks, which are very thin accumulations of sand grains that mark the landward uprush of a wave on the beach. See FACIES (GEOLOGY); PALEO GEOGRAPHY; STRATIGRAPHY. [R.A.D.]

**Strange particles** Bound states of quarks, in which at least one of these constituents is of the strange (*s*) type. Strange quarks are heavier than the up (*u*) and down (*d*) quarks, which form the neutrons and protons in the atomic nucleus. Neutrons (*udd*) and protons (*uud*) are the lightest examples of a family of particles composed of three quarks, known as baryons. These and other composite particles which interact dominantly through the strong (nuclear) force are known as hadrons. The first strange hadron discovered (in cosmic rays in 1947) was named the lambda baryon,  $\Lambda$ ; it is made of the three-quark combination *uds*. A baryon containing a strange quark is also called a hyperon. Although strange particles interact through the strong (nuclear) force, the strange quark itself can decay only by conversion to a quark of different type (such as *u* or *d*) through the weak interaction. For this reason, strange particles have very long lifetimes, of the order of  $10^{-10}$  s, compared to the lifetimes

of the order of  $10^{-23}$  s for particles which decay directly through the strong interaction. This long lifetime was the origin of the term strange particles. See BARYON; HADRON; NEUTRON; PROTON; STRONG NUCLEAR INTERACTIONS.

In addition to strange baryons, strange mesons occur. The lightest of these are the kaons ( $K^+ = u\bar{s}$  and  $K^0 = d\bar{s}$ ) and the antikaons ( $\bar{K}^0 = s\bar{d}$  and  $\bar{K}^- = s\bar{u}$ ). Kaons and their antiparticles have been very important in the study of the weak interaction and in the detection of the very weak *CP* violation, which causes a slow transition between neutral kaons and neutral antikaons. See ELEMENTARY PARTICLE; MESON; QUARKS. [T.Bar.]

**Strangles** A highly contagious disease of the upper respiratory tract of horses and other members of the family Equidae, characterized by inflammation of the pharynx and abscess formation in lymph nodes. This disease occurs in horses of all ages throughout the world. The causative agent is *Streptococcus equi*, a clonal pathogen apparently derived from an ancestral strain of *S. zooepidemicus*. It is an obligate parasite of horses, donkeys, and mules. See STREPTOCOCCUS.

Strangles is most common and most severe in young horses, and is very prevalent on breeding farms. The causative agent has been reported to survive for 7 weeks in pus but dies in a week or two on pasture. Transmission is either direct by nose or mouth contact or aerosol, or indirect by flies, drinking buckets, pasture, and feed. The disease is highly contagious under conditions of crowding, exposure to severe climatic conditions such as rain and cold, and prolonged transportation. Carrier animals, although of rare occurrence, are critical in maintenance of the streptococcus and in initiation of outbreaks.

The mean incubation period is about 10 days, with a range of 3–14 days. The animal becomes quieter, has fever of 39–40.5°C (102–105°F), nasal discharge, loss of appetite, and swelling of one or more lymph nodes of the mouth. Pressure of a lymph node on the airway may cause respiratory difficulty. Abscesses in affected lymph nodes rupture in 7–14 days, and rapid clinical improvement and recovery then ensues. Recovery is associated with formation of protective antibodies in the nasopharynx and in the serum. See ANTIBODY.

*Streptococcus equi* is easily demonstrated in smears of pus from abscesses and in culture of pus or nasal swabs on colistin–nalidixic acid blood agar. Acutely affected animals also show elevated white blood cell counts and elevated fibrinogen.

Commercially available vaccines are injected in a schedule of two or three primary inoculations followed by annual boosters. However, the clinical attack rate may be reduced by only 50%, a level of protection much lower than that following the naturally occurring disease. See IMMUNITY.

Procaine penicillin G is the antibiotic of choice and quickly brings about reduction of fever and lymph node enlargement. See BIOLOGICALS. [J.F.T.]

**Stratigraphy** A discipline involving the description and interpretation of layered sediments and rocks, and especially their correlation and dating. Correlation is a procedure for determining the relative age of one deposit with respect to another. The term “dating” refers to any technique employed to obtain a numerical age, for example, by making use of the decay of radioactive isotopes found in some minerals in sedimentary rocks or, more commonly, in associated igneous rocks. To a large extent, layered rocks are ones that accumulated through sedimentary processes beneath the sea, within lakes, or by the action of rivers, the wind, or glaciers; but in places such deposits contain significant amounts of volcanic material emplaced as lava flows or as ash ejected from volcanoes during explosive eruptions. See DATING METHODS; IGNEOUS ROCKS; ROCK AGE DETERMINATION; SEDIMENTARY ROCKS.

Sedimentary successions are locally many thousands of meters thick owing to subsidence of the Earth’s crust over millions of

years. Sedimentary basins therefore provide the best available record of Earth history over nearly 4 billion years. That record includes information about surficial processes and the varying environment at the Earth's surface, and about climate, changing sea level, the history of life, variations in ocean chemistry, and reversals of the Earth's magnetic field. Sediments also provide a record of crustal deformation (folding and faulting) and of large-scale horizontal motions of the Earth's lithospheric plates (continental drift). Stratigraphy applies not only to strata that have remained flat-lying and little altered since their time of deposition, but also to rocks that may have been strongly deformed or recrystallized (metamorphosed) at great depths within the Earth's crust, and subsequently exposed at the Earth's surface as a result of uplift and erosion. As long as original depositional layers can be identified, some form of stratigraphy can be undertaken. See BASIN; CONTINENTAL DRIFT; FAULT AND FAULT STRUCTURES; SEDIMENTOLOGY.

An important idea first articulated by the Danish naturalist Nicolaus Steno in 1669 is that in any succession of strata the oldest layer must have accumulated at the bottom, and successively younger layers above. It is not necessary to rely on the present orientation of layers to determine their relative ages because most sediments and sedimentary rocks contain numerous features, such as current-deposited ripples, minor erosion surfaces, or fossils of organisms in growth position, that have a well-defined polarity with respect to the up direction at the time of deposition (so-called geopetal indicators). This principle of superposition therefore applies equally well to tilted and even overturned strata. Only where a succession is cut by a fault is a simple interpretation of stratigraphic relations not necessarily possible, and in some cases older rocks may overlie younger rocks structurally. See DEPOSITIONAL SYSTEMS AND ENVIRONMENTS.

The very existence of layers with well-defined boundaries implies that the sedimentary record is fundamentally discontinuous. Discontinuities are present in the stratigraphic record at a broad range of scales, from that of a single layer or bed to physical surfaces that can be traced laterally for many hundreds of kilometers. Large-scale surfaces of erosion or nondeposition are known as unconformities, and they can be identified on the basis of both physical and paleontological criteria. See PALEONTOLOGY; UNCONFORMITY.

Most stratal discontinuities possess time-stratigraphic significance because strata below a discontinuity tend to be everywhere older than strata above. To the extent that unconformities can be recognized and traced widely within a sedimentary basin, it is possible to analyze sedimentary rocks in a genetic framework, that is, with reference to the way they accumulated. This is the basis for the modern discipline of sequence stratigraphy, so named because intervals bounded by unconformities have come to be called sequences.

Traditional stratigraphic analysis has focused on variations in the intrinsic character or properties of sediments and rocks—properties such as composition, texture, and included fossils (lithostratigraphy and biostratigraphy)—and on the lateral tracing of distinctive marker beds such as those composed of ash from a single volcanic eruption (tephrostratigraphy). The techniques of magnetostratigraphy and chemostratigraphy are also based on intrinsic characteristics, although these techniques require sophisticated laboratory analysis. Sequence stratigraphy attempts to integrate these approaches in the context of stratal geometry, thereby providing a unifying framework in which to investigate the time relations between sediment and rock bodies as well as to measure their numerical ages (chronostratigraphy and geochronology). Seismic stratigraphy is a variant of the technique of sequence stratigraphy in which unconformities are identified and traced in seismic reflection profiles on the basis of reflection geometry. See GEOCHRONOMETRY; SEISMIC STRATIGRAPHY; SEISMOLOGY.

Conventional stratigraphy currently recognizes two kinds of stratigraphic unit: material units, distinguished on the basis of

some specified property or properties or physical limits; and temporal or time-related units. A common example of a material unit is the formation, a lithostratigraphic unit defined on the basis of lithic characteristics and position within a stratigraphic succession. Each formation is referred to a section or locality where it is well developed (a type section), and assigned an appropriate geographic name combined with the word formation or a descriptive lithic term such as limestone, sandstone, or shale (for example, Tapeats Sandstone). Some formations are divisible into two or more smaller-scale units called members and beds. In other cases, formations of similar lithic character or related genesis are combined into composite units called groups and supergroups.

Sequence stratigraphy differs from conventional stratigraphy in two important respects. The first is that basic units (sequences) are defined on the basis of bounding unconformities and correlative conformities rather than material characteristics or age. The second is that sequence stratigraphy is fundamentally not a system for stratigraphic classification, but a procedure for determining how sediments accumulate. See SEQUENCE STRATIGRAPHY.

[N.C.B.]

**Stratosphere** The atmospheric layer that is immediately above the troposphere and contains most of the Earth's ozone. Here temperature increases upward because of absorption of solar ultraviolet light by ozone. Since ozone is created in sunlight from oxygen, a by-product of photosynthesis, the stratosphere exists because of life on Earth. In turn, the ozone layer allows life to thrive by absorbing harmful solar ultraviolet radiation. The mixing ratio of ozone is largest (10 parts per million by volume) near an altitude of 30 km (18 mi) over the Equator. The distribution of ozone is controlled by solar radiation, temperature, wind, reactive trace chemicals, and volcanic aerosols. See ATMOSPHERE; TROPOSPHERE.

The heating that results from absorption of ultraviolet radiation by ozone causes temperatures generally to increase from the bottom of the stratosphere (tropopause) to the top (stratopause) near 50 km (30 mi), reaching 280 K (45°F) over the summer pole. This temperature inversion limits vertical mixing, so that air typically spends months to years in the stratosphere. See TEMPERATURE INVERSION; TROPOPAUSE.

The lower stratosphere contains a layer of small liquid droplets. Typically less than 1 micrometer in diameter, they are made primarily of sulfuric acid and water. Occasional large volcanic eruptions maintain this aerosol layer by injecting sulfur dioxide into the stratosphere, which is converted to sulfuric acid and incorporated into droplets. Enhanced aerosol amounts from an eruption can last several years. By reflecting sunlight, the aerosol layer can alter the climate at the Earth's surface. By absorbing upwelling infrared radiation from the Earth's surface, the aerosol layer can warm the stratosphere. The aerosols also provide surfaces for a special set of chemical reactions that affect the ozone layer. Liquid droplets and frozen particles generally convert chlorine-bearing compounds to forms that can destroy ozone. They also tend to take up nitric acid and water and to fall slowly, thereby removing nitrogen and water from the stratosphere. The eruption of Mount Pinatubo (Philippines) in June 1991 is believed to have disturbed the Earth system for several years, raising stratospheric temperatures by more than 1 K (1.8°F) and reducing global surface temperatures by about 0.5 K (0.9°F). See AEROSOL.

Ozone production is balanced by losses due to reactions with chemicals in the nitrogen, chlorine, hydrogen, and bromine families. Reaction rates are governed by temperature, which depends on amounts of radiatively important species such as carbon dioxide. Human activities are increasing the amounts of these molecules and are thereby affecting the ozone layer. Evidence for anthropogenic ozone loss has been found in the Antarctic lower stratosphere. Near polar stratospheric clouds, chlorine and bromine compounds are converted to species that, when the Sun comes up in the southern spring, are broken apart by ultraviolet

radiation and rapidly destroy ozone. This sudden loss of ozone is known as the anthropogenic Antarctic ozone hole. See STRATOSPHERIC OZONE. [M.H.H.]

**Stratospheric ozone** While ozone is found in trace quantities throughout the atmosphere, the largest concentrations are located in the lower stratosphere in a layer between 9 and 18 mi (15 and 30 km). Atmospheric ozone plays a critical role for the biosphere by absorbing the ultraviolet radiation with wavelength ( $\lambda$ ) 240–320 nanometers. This radiation is lethal to simple unicellular organisms (algae, bacteria, protozoa) and to the surface cells of higher plants and animals. It also damages the genetic material of cells and is responsible for sunburn in human skin. The incidence of skin cancer has been statistically correlated with the observed surface intensity of ultraviolet wavelength 290–320 nm, which is not totally absorbed by the ozone layer. See OZONE; STRATOSPHERE; ULTRAVIOLET RADIATION (BIOLOGY).

Ozone also plays an important role in photochemical smog and in the purging of trace species from the lower atmosphere. Furthermore, it heats the upper atmosphere by absorbing solar ultraviolet and visible radiation ( $\lambda < 710$  nm) and thermal infrared radiation ( $\lambda \approx 9.6$  micrometers). As a consequence, the temperature increases steadily from about  $-60^\circ\text{F}$  (220 K) at the tropopause (5–10 mi or 8–16 km altitude) to about  $45^\circ\text{F}$  (280 K) at the stratopause (30 mi or 50 km altitude). This ozone heating provides the major energy source for driving the circulation of the upper stratosphere and mesosphere. See ATMOSPHERIC GENERAL CIRCULATION; TROPOPAUSE.

Above about 19 mi (30 km), molecular oxygen ( $\text{O}_2$ ) is dissociated to free oxygen atoms (O) during the daytime by ultraviolet photons, ( $h\nu$ ), as shown in reaction (1). The oxygen atoms produced then form ozone ( $\text{O}_3$ ) by reaction (2), where M is an

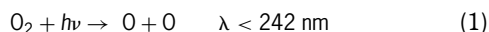

arbitrary molecule required to conserve energy and momentum in the reaction. Ozone has a short lifetime during the day because of photodissociation, as shown in reaction (3). However,

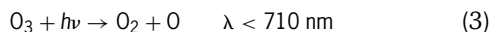

except above 54 mi (90 km), where  $\text{O}_2$  begins to become a minor component of the atmosphere, reaction (3) does not lead to a net destruction of ozone. Instead the O is almost exclusively converted back to  $\text{O}_3$  by reaction (2). If the odd oxygen concentration is defined as the sum of the  $\text{O}_3$  and O concentrations, then odd oxygen is produced by reaction (1). It can be seen that reactions (2) and (3) do not affect the odd oxygen concentrations but merely define the ratio of O to  $\text{O}_3$ . Because the rate of reaction (2) decreases with altitude while that for reaction (3) increases, most of the odd oxygen below 36 mi (60 km) is in the form of  $\text{O}_3$  while above 36 mi (60 km) it is in the form of O. The reaction that is responsible for a small fraction of the odd oxygen removal rate is shown as reaction (4). A significant fraction

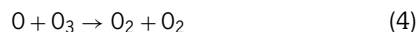

of the removal is caused by the presence of chemical radicals [such as nitric oxide (NO), chlorine (Cl), bromine (Br), hydrogen (H), or hydroxyl (OH)], which serve to catalyze reaction (4) (see illustration).

The discovery in the mid-1980s of an ozone hole over Antarctica, which could not be explained by the classic theory of ozone and had not been predicted by earlier chemical models, led to many speculations concerning the causes of this event, which can be observed each year in September and October. As suggested by experimental and observational evidence, heterogeneous reactions on the surface of liquid or solid particles that

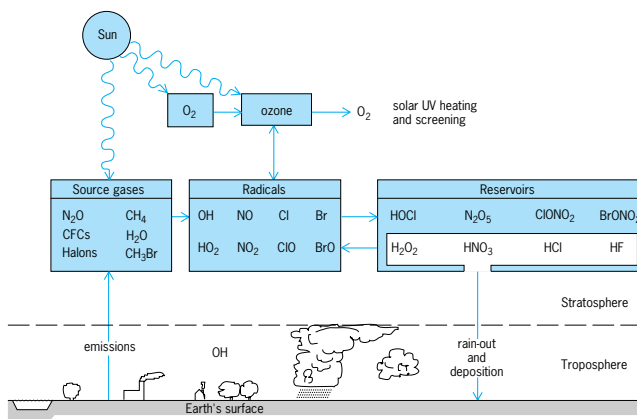

**Principal chemical cycles in the stratosphere. The destruction of ozone is affected by the presence of radicals which are produced by photolysis or oxidation of source gases. Chemical reservoirs are relatively stable but are removed from the stratosphere by transport toward the troposphere and rain-out.**

produce  $\text{Cl}_2$ , HOCl, and  $\text{ClONO}_2$  gas, and the subsequent rapid photolysis of these molecules, produces chlorine radicals (Cl, ClO) which in turn lead to the destruction of ozone in the lower stratosphere by a catalytic cycle [reactions (5)–(7)]. Solar radia-

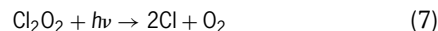
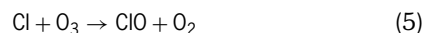

tion is needed for these processes to occur.

Sites on which the reactions producing  $\text{Cl}_2$ , HOCl, and  $\text{ClONO}_2$  can occur are provided by the surface of ice crystals in polar stratospheric clouds (PSCs). These clouds are formed between 8 and 14 mi (12 and 22 km) when the temperature drops below approximately  $-123^\circ\text{F}$  (187 K). Other types of particles are observed at temperatures above the frost point of  $-123^\circ\text{F}$  (187 K). These particles provide additional surface area for these reactions to occur. Clouds are observed at high latitudes in winter. Because the winter temperatures are typically  $20$ – $30^\circ\text{F}$  ( $10$ – $15$  K) colder in the Antarctic than in the Arctic, their frequency of occurrence is highest in the Southern Hemisphere. Thus, the formation of the springtime ozone hole over Antarctica is explained by the activation of chlorine and the catalytic destruction of  $\text{O}_3$  which takes place during September, when the polar regions are sunlit but the air is still cold and isolated from midlatitude air by a strong polar vortex. Satellite observations made since the 1970s suggest that total ozone in the Arctic has been abnormally low during the 1990s, probably in relation to the exceptionally cold winter temperatures in the Arctic lower stratosphere recorded during that decade. [G.P.B.; R.G.Pr.]

**Strawberry** Low-growing perennials, spreading by stolons, with fruit consisting of a fleshy receptacle, and “seeds” in pits or nearly superficial on the receptacle. The strawberry in the United States is derived from two species: *Fragaria chinesis*, which grows along the Pacific Coast of North and South America, and *F. virginiana*, the eastern meadow strawberry, both members of the order Resales. See ROSALES.

The strawberry is the most universally grown of the small fruits, both in the home garden and in commercial plantings. Home garden production is possible in nearly all of the states, provided water can be supplied where rainfall is insufficient. Commercial production is important in probably three-fourths of the states. The following states are large producers: Oregon, California, Tennessee, Michigan, Louisiana, Washington, Arkansas, Kentucky, and New York. See FRUIT. [J.H.C.]

**Stream function** In fluid mechanics, a mathematical idea which satisfies identically, and therefore eliminates completely, the equation of mass conservation. If the flow field consists of only two space coordinates, for example,  $x$  and  $y$ , a single and very useful stream function  $\psi(x, y)$  will arise. If there are three space coordinates, such as  $(x, y, z)$ , multiple stream functions are needed, and the idea becomes much less useful and is much less widely employed.

The stream function not only is mathematically useful but also has a vivid physical meaning. Lines of constant  $\psi$  are streamlines of the flow; that is, they are everywhere parallel to the local velocity vector. No flow can exist normal to a streamline; thus, selected  $\psi$  lines can be interpreted as solid boundaries of the flow.

Further,  $\psi$  is also quantitatively useful. In plane flow, for any two points in the flow field, the difference in their stream function values represents the volume flow between the points. See CREEPING FLOW; FLUID FLOW. [F.M.W.]

**Stream gaging** The measurement of water discharge in streams. Discharge is the rate of movement of the stream's water volume. It is the product of water velocity times cross-sectional area of the stream channel. Several techniques have been developed for measuring stream discharge; selection of the gaging method usually depends on the size of the stream. The most accurate methods for measuring stream discharge make use of in-stream structures through which the water can be routed, such as flumes and weirs.

A flume is a constructed channel that constricts the flow through a control section, the exact dimensions of which are known. Through careful hydraulic design and calibration by laboratory experiments, stream discharge through a flume can be determined by simply measuring the water depth (stage) in the inlet or constricted sections. Appropriate formulas relate stage to discharge for the type of flume used.

A weir is used in conjunction with a dam in the streambed. The weir itself is usually a steel plate attached to the dam that has a triangular, rectangular, or trapezoidal notch over which the water flows. Hydraulic design and experimentation has led to calibration curves and appropriate formulas for many different weir designs. To calculate stream discharge through a weir, only the water stage in the reservoir created by the dam needs to be measured. Stream discharge can be calculated by using the appropriate formula that relates stage to discharge for the type of weir used. See HYDROLOGY; SURFACE WATER. [T.C.Wi.]

**Stream pollution** Biological, or bacteriological, pollution in a stream indicated by the presence of the coliform group of organisms. While nonpathogenic itself, this group is a measure of the potential presence of contaminating organisms. Because of temperature, food supply, and predators, the environment provided by natural bodies of water is not favorable to the growth of pathogenic and coliform organisms. Physical factors, such as flocculation and sedimentation, also help remove bacteria. Any combination of these factors provides the basis for the biological self-purification capacity of natural water bodies.

Nonpolluted natural waters are usually saturated with dissolved oxygen. They may even be supersaturated because of the oxygen released by green water plants under the influence of sunlight. When an organic waste is discharged into a stream, the dissolved oxygen is utilized by the bacteria in their metabolic processes to oxidize the organic matter. The oxygen is replaced by reaeration through the water surface exposed to the atmosphere. This replenishment permits the bacteria to continue the oxidative process in an aerobic environment. In this state, reasonably clean appearance, freedom from odors, and normal animal and plant life are maintained.

An increase in the concentration of organic matter stimulates the growth of bacteria and increases the rates of oxidation and oxygen utilization. If the concentration of the organic pollutant

is so great that the bacteria use oxygen more rapidly than it can be replaced, only anaerobic bacteria can survive and the stabilization of organic matter is accomplished in the absence of oxygen. Under these conditions, the water becomes unsightly and malodorous, and the normal flora and fauna are destroyed. Furthermore, anaerobic decomposition proceeds at a slower rate than aerobic. For maintenance of satisfactory conditions, minimal dissolved oxygen concentrations in receiving streams are of primary importance.

Municipal sewage and industrial wastes affect the oxygen content of a stream. Cooling water, used in some industrial processes, is characterized by high temperatures, which reduce the capacity of water to hold oxygen in solution. Municipal sewage requires oxygen for its stabilization by bacteria. Oxygen is utilized more rapidly than it is replaced by reaeration, resulting in the death of the normal aquatic life. Further downstream, as the oxygen demands are satisfied, reaeration replenishes the oxygen supply.

Polluted waters are deprived of oxygen by the exertion of the biochemical oxygen demand, which is defined as the quantity of oxygen required by the bacteria to oxidize the organic matter. Factors such as the turbulence of the stream flow, biological growths on the stream bed, insufficient nutrients, and inadequate bacteria in the river water influence the rate of oxidation in the stream as well as the removal of organic matter.

When a significant portion of the waste is in the suspended state, settling of the solids in a slow-moving stream is probable. The organic fraction of the sludge deposits decomposes anaerobically, except for the thin surface layer which is subjected to aerobic decomposition due to the dissolved oxygen in the overlying waters. In warm weather, when the anaerobic decomposition proceeds at a more rapid rate, gaseous end products, usually carbon dioxide and methane, rise through the supernatant waters. The evolution of the gas bubbles may raise sludge particles to the water surface. Although this phenomenon may occur while the water contains some dissolved oxygen, the more intense action during the summer usually results in depletion of dissolved oxygen.

Water may absorb oxygen from the atmosphere when the oxygen in solution falls below saturation. Dissolved oxygen for receiving waters is also derived from two other sources: that in the receiving water and the waste flow at the point of discharge, and that given off by green plants.

Unpolluted water maintains in solution the maximum quantity of dissolved oxygen. The saturation value is a function of temperature and the concentration of dissolved substances, such as chlorides. When oxygen is removed from solution, the deficiency is made up by the atmospheric oxygen, which is absorbed at the water surface and passes into solution. The oxygen balance in a stream is determined by the concentration of organic matter and its rate of oxidation, and by the dissolved oxygen concentration and the rate of reaeration. See ESTUARINE OCEANOGRAPHY; FRESH-WATER ECOSYSTEM; SEWAGE DISPOSAL; WATER POLLUTION. [D.J.O.]

**Stream transport and deposition** The sediment debris load of streams is a natural corollary to the degradation of the landscape by weathering and erosion. Eroded material reaches stream channels through rills and minor tributaries, being carried by the transporting power of running water and by mass movement, that is, by slippage, slides, or creep. The size represented may vary from clay to boulders. At any place in the stream system the material furnished from places upstream either is carried away or, if there is insufficient transporting ability, is accumulated as a depositional feature. The accumulation of deposited debris tends toward increased ease of movement, and this tends eventually to bring into balance the transporting ability of the stream and the debris load to be transported. [L.B.L.]

**Streaming potential** The potential which is produced when a liquid is forced to flow through a capillary or a porous

solid. The streaming potential is one of four related electrokinetic phenomena which depend upon the presence of an electrical double layer at a solid-liquid interface. This electrical double layer is made up of ions of one charge type which are fixed to the surface of the solid and an equal number of mobile ions of the opposite charge which are distributed through the neighboring region of the liquid phase. In such a system the movement of liquid over the surface of the solid produces an electric current, because the flow of liquid causes a displacement of the mobile counterions with respect to the fixed charges on the solid surface. The applied potential necessary to reduce the net flow of electricity to zero is the streaming potential. [Q.V.W.]

**Streamlining** The contouring of a body to reduce its resistance (drag) to motion through a fluid.

For fluids with relatively low viscosity such as water and air, effects of viscous friction are confined to a thin layer of fluid on the surface termed the boundary layer. Under the influence of an increasing pressure, the flow within the boundary layer tends to reverse and flow in an upstream direction. Viscosity tends to cause the flow to separate from the body surface with consequent formation of a region of swirling or eddy flow (termed the body wake; illus. *a*). This eddy formation leads to a reduction in the downstream pressure on the body and hence gives rise to a force opposite to the body motion, known as pressure drag. See WAKE FLOW.

In general, streamlining in subsonic flow involves the contouring of the body in such a manner that the wake is reduced and hence the pressure drag is reduced. The contouring should provide for gradual deceleration to avoid flow separation, that is, reduced adverse pressure gradients. These considerations lead to the following general rules for subsonic streamlining: The forward portion of the body should be well rounded, and the body should curve back gradually from the forward section to a tapering aftersection with the avoidance of sharp corners along the body surface. These conditions are well illustrated by teardrop shapes (illus. *b*).

At supersonic speeds the airflow can accommodate sudden changes in direction by being compressed or expanded. Where this change in direction occurs at the nose of the body, a compression wave is created, the strength of which depends upon the magnitude of the change in flow direction. Lowering the body-induced flow angle weakens this compression shock wave. When the flow changes direction again at the midpoint of the body, the air will expand to follow the shape of the body. This change in

direction creates expansion waves. At the tail of the body the direction changes again, creating another compression or shock wave. At each of these shock waves, changes in pressure, density, and velocity occur, and in this process energy is lost. This loss results in a retarding force known as wave drag. See SHOCK WAVE.

Bodies which are streamlined for supersonic speeds are characterized by a sharp nose and small flow deflection angles. Because the intensity of the shock wave and the drag level is dependent upon the magnitude of the change in flow direction, the width or thickness of the body should be minimal. See BOUNDARY-LAYER FLOW. [A.G.H.; D.M.Bu.]

**Strength of materials** A branch of applied mechanics concerned with the behavior of materials under load, relationships between externally applied loads and internal resisting forces, and associated deformations. Knowledge of the properties of materials and analysis of the forces involved are fundamental to the investigation and design of structures and machine elements. See MACHINE DESIGN; STRUCTURAL MATERIALS.

Investigation of the resistance of a member, dealing with internal forces, is called free-body analysis. Determination of the distribution and intensity of the internal forces and the associated deformations is called stress analysis. See STRESS AND STRAIN.

A material offers resistance to external load only insofar as the component elements can furnish cohesive strength, resistance to compaction, and resistance to sliding. The relations developed in strength of materials analysis evaluate the tensile, compressive, and shear stresses that a material is called upon to resist. The most important factors in determining the suitability of a structural or machine element for a particular application are strength and stiffness. See SHEAR. [J.B.S.]

**Strepsiptera** An order of twisted-wing insects that spend most of their life cycle as internal parasitoids of other insects. The adult male is only a few millimeters in wing span, is free living, and has only one pair of full flight wings (the posterior, or metathoracic, pair). The front (mesothoracic) wings are reduced to narrow, clublike organs that may function as halteres, or flight balancers. The male eyes are coarsely faceted and berrylike, and the antennae have four to seven segments, with some segments having finger- or bladelike extensions. Most adult females are immobile, blind, and larviform, and live inside the insect host. Rarely, the female is free living, with legs and eyes but no wings. More than 600 species of Strepsiptera are known, many of them not yet formally described and named. The order's relationship to other insect orders remains uncertain.

Both male and female begin larval life as mobile first-stage organisms with eyes and three pairs of functional legs. These triunguloids eventually attack the immature or adult forms of the host and enter their bodies, where they molt to an apodous instar. Two subsequent molts result in the divergence of the sexes and the differentiation of a hardened forebody that eventually protrudes through the host integument; the molted larval integuments are not shed but are incorporated in the general puparial wall and the neotenous adult female capsule. Males (and some adult females) emerge from the puparium and begin the search for a mate, probably through the mediation of airborne pheromones.

Strepsiptera are found worldwide in temperate and tropical habitats. They parasitize insects, mostly of orders Hemiptera and Hymenoptera, but also some cockroaches, mantids, orthopterans, flies, and silverfish. Their effect on the host is variable, ranging from reproductive failure to death. See ENDOPTERYGOTA; PHEROMONE. [W.L.Bro.]

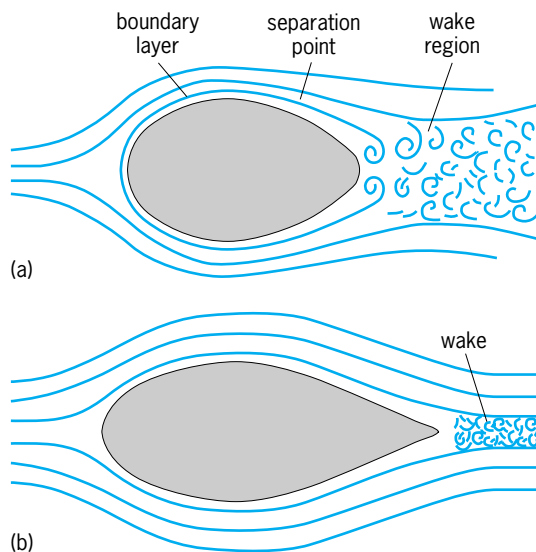

**Flow about bodies in uniform subsonic flow. (a) Blunt body. (b) Streamlined body.**

**Streptococcus** A large genus of spherical or ovoid bacteria that are characteristically arranged in pairs or in chains resembling strings of beads. Many of the streptococci that constitute part of the normal flora of the mouth, throat, intestine,



and skin are harmless commensal forms; other streptococci are highly pathogenic. The cells are gram-positive and can grow either anaerobically or aerobically, although they cannot utilize oxygen for metabolic reactions. Glucose and other carbohydrates serve as sources of carbon and energy for growth. All members of the genus lack the enzyme catalase. Streptococci can be isolated from humans and other animals.

*Streptococcus pyogenes* is well known for its participation in many serious infections. It is a common cause of throat infection, which may be followed by more serious complications such as rheumatic fever, glomerulonephritis, and scarlet fever. Other beta-hemolytic streptococci participate in similar types of infection, but they are usually not associated with rheumatic fever and glomerulonephritis. Group B streptococci, which are usually beta-hemolytic, cause serious infections in newborns (such as meningitis) as well as in adults. Among the alpha-hemolytic and nonhemolytic streptococci, *S. pneumoniae* is an important cause of pneumonia and other respiratory infections. Vaccines that protect against infection by the most prevalent capsular serotypes are available. The viridans streptococci comprise a number of species commonly isolated from the mouth and throat. Although normally of low virulence, these streptococci are capable of causing serious infections (endocarditis, abscesses). See PNEUMONIA.

[K.Ru.]

**Streptothricosis** An acute or chronic infection of the epidermis, caused by the bacterium *Dermatophilus congolensis*, which results in an oozing dermatitis with scab formation. Streptothricosis includes dermatophilosis, mycotic dermatitis, lumpy wool, strawberry foot-rot, and cutaneous streptothricosis—diseases having a worldwide distribution and affecting a wide variety of species, including humans.

The infectious form of the bacterium is a coccoid, motile zoospore that is released when the skin becomes wet. Thus, the disease is closely associated with rainy seasons and wet summers. Zoospores lodge on the skin of susceptible animals and germinate by producing filaments which penetrate to the living epidermis, where the organism proliferates by branching mycelial growth.

Early cutaneous lesion of dermatophilosis in cattle reveals small vesicles, papules, and pus formation under hair plaques. An oozing dermatitis then appears as the disease progresses and exudates coalesce to form scabs, which change to hard crusts firmly adherent to the skin. The crusts enlarge and harden, and are often devoid of hair. Lesions occur on most areas of sheep, but the characteristic lesions in the woolled areas occur as numerous hard masses of crust or scab scattered irregularly over the back, flanks, and upper surface of the neck. Lesion resolution has been found to correlate with the presence of immunoglobulin A-containing plasma cells in the dermis and with the antibody levels to *D. congolensis* at the skin surface of infected sheep and cattle.

No single treatment is considered specific for dermatophilosis. Some observers claim that topical agents are successful for sheep and cattle. A number of systemic antibiotics are effective in treating the disease. A combination of streptomycin and penicillin has given good therapeutic results in both bovine and equine infections.

[S.S.S.]

**Stress (psychology)** Generally, environmental events of a challenging sort as well as the body's response to such events. Of particular interest has been the relationship between stress and the body's adaptation to it on the one hand and the body's susceptibility to disease on the other. Both outcomes involve behavioral and brain changes as well as psychosomatic events, that is, changes in body function arising from the ability of the brain to control such function through neural output as well as hormones. One problem is that both environmental events and bodily responses have been referred to interchangeably as stress. It is preferable to refer to the former as the stressor

and the latter as the stress response. The stress response consists of a cascade of neural and hormonal events that have short- and long-lasting consequences for brain and body alike. A more serious issue is how an event is determined to be a stressor. One view is to define a stressor as an environmental event causing a negative outcome, such as a disease. Another approach is to view stressors as virtually any challenge to homeostasis and to regard disease processes as a failure of the normal operation of adaptive mechanisms, which are part of the stress response. With either view, it is necessary to include psychological stressors, such as fear, that contain implied threats to homeostasis and that evoke psychosomatic reactions. These are reactions that involve changes in neural and hormonal output caused by psychological stress. Psychosomatic reactions may lead to adaptive responses, or they may exacerbate disease processes. Whether the emphasis is on adaptation or disease, it is essential to understand the processes in the brain that are activated by stressors and that influence functions in the body. See HOMEOSTASIS; PSYCHOSOMATIC DISORDERS.

Among the many neurotransmitter systems activated by stress is noradrenaline, produced by neurons with cell bodies in the brainstem that have vast projections up to the forebrain and down the spinal cord. Stressful experiences activate the noradrenergic system and promote release of noradrenaline; severe stress leads to depletion of noradrenaline in brain areas such as the hypothalamus. This release and depletion of noradrenaline stores results in changes at two levels of neuronal function: phosphorylation is triggered by the second-messenger cyclic AMP and occurs in the presynaptic and postsynaptic sites where noradrenaline is released and where it also acts; synthesis of new protein is induced via actions on the genome. Both processes enhance the ability of the brain to form noradrenaline when the organism is once again confronted with a stressful situation. Other neurotransmitter systems may also show similar adaptive changes in response to stressors. See NORADRENERGIC SYSTEM.

Stress also activates the neurally mediated discharge of adrenaline from the adrenal medulla and of hypothalamic hormones that initiate the neuroendocrine cascade, culminating in glucocorticoid release from the adrenal cortex. Thus, the activity of neurons triggered by stressful experiences, physical trauma, fear, or anger leads to hormone secretion that has effects throughout the body. Virtually every organ of the body is affected by stress hormones. The hypothalamic hormone (corticotrophin-releasing hormone) that triggers the neuroendocrine cascade directly stimulates the pituitary to secrete ACTH. In response to certain stressors, the hypothalamus also secretes vasopressin and oxytocin, which act synergistically with corticotrophin-releasing hormone on the pituitary to potentiate the secretion of ACTH. Various stressors differ in their ability to promote output of vasopressin and oxytocin, but all stressors stimulate release of corticotrophin-releasing hormone. Other hormones involved in the stress response include prolactin and thyroid hormone; the metabolic hormones insulin, epinephrine, and glucagon; and the endogenous opiates endorphin and enkephalin. See ENDORPHINS.

Of all the hormones in the endocrine cascade initiated by stress, the glucocorticoids are the most important because of their widespread effects throughout the body and in the brain. The brain contains target cells for adrenal glucocorticoids secreted in stress, and receptors in these cells are proteins that interact with the genome to affect expression of genetic information. Thus, the impact of stress-induced activation of the endocrine cascade that culminates in glucocorticoid release is the feedback of glucocorticoids on target brain cells. The effect is to alter the structure and function of the brain cells over a period of time ranging from hours to days.

In the case of noradrenaline, glucocorticoids have several types of feedback effects that modify how the noradrenergic system responds to stress. Glucocorticoids inhibit noradrenaline release, and they reduce the second-messenger response of brain

structures such as the cerebral cortex to noradrenaline. Glucocorticoid feedback also affects the serotonin system, facilitating serotonin formation during stress but at the same time altering the levels of several types of serotonin receptors in different brain regions, which has the net effect of shifting the balance within the serotonergic system. Taken together, evidence points to a role of glucocorticoid secretion in leading to restoration of homeostatic balance by counteracting the acute neural events such as increased activity of noradrenaline and serotonin, which are turned on by stressful experiences. Other neurotransmitter systems may also respond to glucocorticoid action. Moreover, the other hormones activated by stress have effects on the brain and body that must be considered. See SEROTONIN.

In general, stress hormones are protective and adaptive in the immediate aftermath of stress, and the organism is more vulnerable to many conditions without them. However, the same hormones can promote damage and accelerate pathophysiological changes, such as bone mineral loss, obesity, and cognitive impairment, when they are overproduced or not turned off. This wear-and-tear on the body has been called allostastic load. It is based upon the notion that allostasis is the active process of maintaining stability, or homeostasis, through change, and allostastic load is the almost inevitable cost to the body of doing so.

Stress hormone actions have important effects outside the brain on such systems as the immune response. Glucocorticoids and catecholamines from sympathetic nerves and the adrenal medulla participate in the mobilization and enhancement of immune function in the aftermath of acute stress. These effects improve the body's defense against pathogens but can exacerbate autoimmune reactions. When they are secreted chronically, the stress-related hormones are generally immunosuppressive; such effects can be beneficial in the case of an autoimmune disease but may compromise defense against a virus or bacterial infections. At the same time, glucocorticoids are important agents for containing the acute-phase response to an infection or autoimmune disturbance. In the absence of such containment, the organism may die because of the excessive inflammatory response. See IMMUNOLOGY.

Besides affecting the immune response, stressors are believed to exacerbate endogenous depressive illness in susceptible individuals. Major depressive illness frequently results in elevated levels of cortisol in the blood. It is not clear whether the elevated cortisol is a cause or strictly a result of the brain changes involved in depressive illness. See AFFECTIVE DISORDERS. [B.McE.]

**Stress and strain** Related terms defining the intensity of internal reactive forces in a deformed body and associated unit changes of dimension, shape, or volume caused by externally applied forces. Stress is a measure of the internal reaction between elementary particles of a material in resisting separation, compaction, or sliding that tend to be induced by external forces. Total internal resisting forces are resultants of continuously distributed normal and parallel forces that are of varying magnitude and direction and are acting on elementary areas throughout the material. These forces may be distributed uniformly or nonuniformly. Stresses are identified as tensile, compressive, or shearing, according to the straining action.

Strain is a measure of deformation such as (1) linear strain, the change of length per unit of linear dimensions; (2) shear strain, the angular rotation in radians of an element undergoing change of shape by shearing forces; or (3) volumetric strain, the change of volume per unit of volume. The strains associated with stress are characteristic of the material. Strains completely recoverable on removal of stress are called elastic strains. Above a critical stress, both elastic and plastic strains exist, and that part remaining after unloading represents plastic deformation called inelastic strain. Inelastic strain reflects internal changes in the crystalline structure of the metal. Increase of resistance to continued plastic

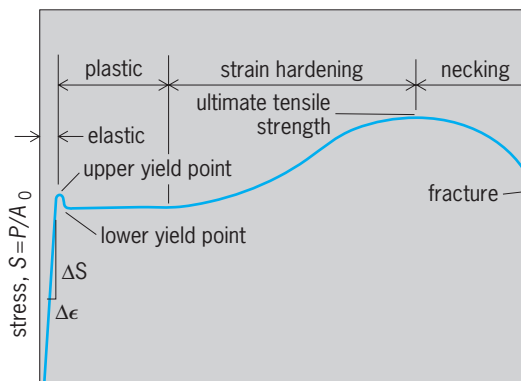

**Stress-strain diagram for a low-carbon steel.**  $\Delta S$  = change in stress;  $\Delta \epsilon$  = change in strain;  $P$  = force;  $A_0$  = area of cross section.

deformation due to more favorable rearrangement of the atomic structure is strain hardening.

A stress-strain diagram is a graphical representation of simultaneous values of stress and strain observed in tests and indicates material properties associated with both elastic and inelastic behavior (see illustration). It indicates significant values of stress-accompanying changes produced in the internal structure. See ELASTICITY; STRENGTH OF MATERIALS. [J.B.S.]

**Strigiformes** The owls, an order of nocturnal, worldwide predacious birds that are probably most closely related to the goatsuckers. The strigiforms are arranged in four families: Ogygoptungidae (fossil), Protostrigidae (fossil), Tytonidae (barn owls; 11 species), and Strigidae (typical owls; 135 species). The bay owls (*Phodilus*), occurring in southern Asia and Africa, are somewhat intermediate between the Tytonidae and the Strigidae and are sometimes placed in a separate family; here they are treated as a subfamily, Phodilinae, of the Tytonidae.

Owls are small to medium in size, with soft plumage of somber colors. The large head has a facial disk that covers the feathered parabolic reflectors of the bird's acute directional hearing system. The eyes are large and capable of sight in very dim light, and the bill is strong and hooked. The wings are long and rounded, and the flight feathers are fringed for silent flight. The ulna has a unique bony arch on the shaft. Their strong legs are short to medium in length and terminate in strong feet. Owls are excellent fliers but walk poorly. Of the four toes on each foot, two point forward and two backward and bear strong claws. Prey is detected by acute night vision or by directional hearing; owls can locate and catch their prey in total darkness. Owls are generally nonmigratory and solitary, but some species live in small flocks. Courtship takes place at night with a male hooting to a female, which answers. A strong pair bond exists between the monogamous male and female, which usually build their nest in a tree cavity. Some species nest on the ground, on cliff ledges, or in abandoned crow or hawk nests. The clutch of up to seven eggs is incubated by both sexes, and after hatching, the young stay in the nest and are cared for by both parents. See AVES. [W.J.B.]

**Stripping** The removal of volatile component from a liquid by vaporization. The stripping operation is an important step in many industrial processes which employ absorption to purify gases and to recover valuable components from the vapor phase. In such processes, the rich solution from the absorption step must be stripped in order to permit recovery of the absorbed solute and recycle of the solvent. See GAS ABSORPTION OPERATIONS.

Stripping may be accomplished by pressure reduction, the application of heat, or the use of an inert gas (stripping vapor). Many processes employ a combination of all three; that is, after absorption at elevated pressure, the solvent is flashed to

atmospheric pressure, heated, and admitted into a stripping column which is provided with a bottom heater (reboiler). Solvent vapor generated in the reboiler or inert gas injected at the bottom of the column serves as stripping vapor which rises countercurrently to the downflowing solvent. When steam is used as stripping vapor for a system not miscible with water, the process is called steam stripping.

In addition to its use in conjunction with gas absorption, the term stripping is also used quite generally in technical fields to denote the removal of one or more components from a mixed system. Such usage covers (1) the distillation operation which takes place in a distilling column in the zone below the feed point, (2) the extraction of one or more components from a liquid by contact with a solvent liquid, (3) the removal of organic or metal coatings from solid surfaces, and (4) the removal of color from dyed fabrics. See DISTILLATION; ELECTROPLATING OF METALS; SOLVENT EXTRACTION. [A.L.K.]

**Stroboscope** An instrument for observing moving bodies by making them visible intermittently and thereby giving them the optical illusion of being stationary. A stroboscope may operate by illuminating the object with brilliant flashes of light or by imposing an intermittent shutter between the viewer and the object.

Stroboscopes are used to measure the speed of rotation or frequency of vibration of a mechanical part or system. They have the advantage over other instruments of not loading or disturbing the equipment under test. Mechanical equipment may be observed under actual operating conditions with the aid of stroboscopes. Parasitic oscillations, flaws, and unwanted distortion at high speeds are readily detected.

The flashing-light stroboscopes employ gas discharge tubes to provide a brilliant light source of very short duration. Tubes may vary from neon glow lamps, when very little light output is required, to special stroboscope tubes capable of producing flashes of several hundred thousand candlepower with a duration of only a few millionths of a second. See NEON GLOW LAMP; VAPOR LAMP. [A.R.E.]

**Stroboscopic photography** Stroboscopic or "strobe" photography generally refers to pictures of both single and multiple exposure taken by flashes of light from electrical discharges. Originally the term referred to multiple-exposed photographs made with a Stroboscopic disk as a shutter. One essential feature of modern Stroboscopic photography is a short exposure time, usually much shorter than can be obtained by a mechanical shutter.

High-speed photography with Stroboscopic light has proved to be one of the most powerful research tools for observing fast motions in engineering and in science. Likewise, the electrical system of producing flashes of light in xenon-filled flash lamps is of great utility for studio, candid, and press photography. See PHOTOGRAPHY; STROBOSCOPE. [H.E.E.]

**Stromatolite** A laminated, microbial structure in carbonate rocks (limestone and dolomite). Stromatolites are the oldest macroscopic evidence of life on Earth, at least 2.5 billion years old, and they are still forming in the seas. During the 1.5 billion years of Earth history before marine invertebrates appeared, stromatolites were the most obvious evidence of life, and they occur sporadically throughout the remainder of the geologic record. In Missouri and Africa, stromatolite reefs have major accumulations of lead, zinc, or copper; and in Montana, New Mexico, and Oman, stromatolites occur within oil and gas reservoirs. For geologists, the shapes of stromatolites are useful indications of their environmental conditions, and variations in form and microstructure of the laminations may be age-diagnostic in those most ancient sedimentary rocks that lack invertebrate fossils. See DOLOMITE; LIMESTONE; REEF.

Stromatolites are readily recognizable in outcrops by their characteristic convex-upward laminated structure. Individual, crescent-shaped laminations, which are generally about a millimeter thick, are grouped together to produce an enormous range of shapes and sizes.

The tiny, filamentous cyanobacteria (blue-green algae) that make present-day stromatolites, and similar filaments associated with the oldest stromatolites known, are considered one of the most successful organisms on Earth. Living stromatolites in the Bahamas and Western Australia possess laminations that record the episodic trapping and binding of sediment particles by the microbial mat. In the modern oceans, stromatolites develop almost exclusively in extreme marine conditions that exclude or deter browsing invertebrates and fish from destroying the microbial mats and inhibit colonization by competing algae. See ALGAE; CYANOBACTERIA. [R.Gi.]

**Stromatoporoidea** An extinct order thought to be sponges because of its close similarity to the class Sclerospongiae. Generally accepted stromatoporoidea first appeared at the beginning of the Middle Ordovician and died out at the end of the Devonian. The Stromatoporoidea are worldwide in distribution, most commonly associated with bedded limestones and fossil reefs.

The stromatoporoidea skeleton is called a coenosteum, which begins development as a thin, encrusting layer of irregular rods and plates called the peritheca. Most coenosteum are hemispherical, or thick laminar or lens-shaped structures. However, some stromatoporoidea are thin and irregularly undulatory and others are cylindrical, cone-shaped, branching, or anastomosing. See SCLEROSPONGIAE. [J.St.J.]

**Strong nuclear interactions** One of the fundamental physical interactions, which acts between a pair of hadrons. Hadrons include the nucleons, that is, neutrons and protons; the strange baryons, such as lambda ( $\Lambda$ ) and sigma ( $\Sigma$ ); the mesons, such as pion ( $\pi$ ) and rho ( $\rho$ ); and the strange meson, kaon ( $K$ ). The nature of the interaction is determined principally through observations of the collision of a hadron pair. From this it is found that the interaction has a short range of about  $10^{-15}$  m ( $10^{-13}$  in.) and is by far the dominant force within this range, being much larger than the electromagnetic interaction, which is next in magnitude. The strong interaction conserves parity and is time-reversal-invariant. See BARYON; HADRON; MESON; NUCLEON; PARITY (QUANTUM MECHANICS); STRANGE PARTICLES; SYMMETRY LAWS (PHYSICS); TIME REVERSAL INVARIANCE.

The interaction between baryons for distances greater than  $10^{-15}$  m arises from the exchange of mesons. At relatively large distances, single-pion exchange dominates (illus. a). At shorter separation distances, the two-pion systems such as the  $\rho$  become important (illus. b). The interaction between the strange baryons, and between the strange baryons and the nucleons, is moderated by kaon exchange. To summarize this description, the interaction between baryons in the SU(3) multiplet is the consequence of the exchange of SU(3) spin 0 and spin 1 bosons. In a second

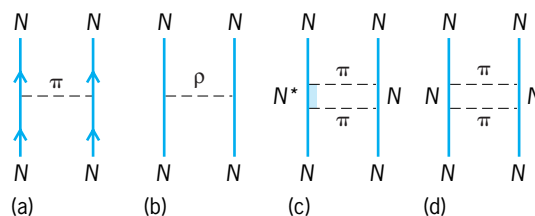

Interaction between nucleons (a) from exchange of single pion, (b) from exchange of  $\rho$ -meson, a two-pion system, (c) from exchange of two separate pions with formation of excited state of nucleon, and (d) without formation of excited state.

approximation, the exchange of two pions (illus. c, d), or more generally, the exchange of two members of the SU(3) spin 0 and spin 1 multiplet, is responsible for a component of the strong nuclear interaction. See UNITARY SYMMETRY.

The range of the interaction generated by these exchanges can be calculated by using the formula below, where  $m$  is the mass

$$\text{Range} = \frac{\hbar}{mc}$$

of the exchanged particles,  $\hbar$  is Planck's constant divided by  $2\pi$ , and  $c$  is the speed of light. According to the above equation, the range of the interaction developed when a single pion is exchanged (illus. 1a) is equal to  $1.4 \times 10^{-15}$  m ( $5.5 \times 10^{-14}$  in.), while that due to two-pion exchange (illus. 1d) is  $0.7 \times 10^{-15}$  m ( $2.8 \times 10^{-14}$  in.).

At short separation distances the quark-gluon structure of the baryons must be taken into account. The interaction must be considered as a property of the six-quark-plus-gluon system. The decisive elements are the Pauli principle obeyed by the quarks, and the mismatch between the six-quark wave function and the two-baryon wave function. Thus, at short distances the interaction is effectively repulsive or more generally independent of the kinetic energy of the baryons at infinite separations. See ELEMENTARY PARTICLE; EXCLUSION PRINCIPLE; FUNDAMENTAL INTERACTIONS; GLUONS; QUARKS. [H.F.]

**Strongylida** An order of nematodes in which the cephalic region may be adorned with three or six labia or the labia may be replaced by a corona radiata. All strongylid nematodes are parasitic. The order embraces eight superfamilies: Strongyloidea, Diaphanocephaloidea, Ancylostomatoidea, Trichostrongyloidea, Metastrongyloidea, Cosmocercidae, Oxyuroidea, and Heterakoidea.

**Strongyloidea.** The Strongyloidea contain important parasites of reptiles, birds, and mammals. The early larval stages may be free-living microbivores, but the adults are always parasitic. Three species are important parasites of horses, *Strongylus vulgaris*, *S. equinus*, and *S. edentatus*. All three undergo direct life cycles; that is, infestations are acquired by ingestion of contaminated food.

**Trichostrongyloidea.** The Trichostrongyloidea comprise obligate parasites of all vertebrates but fishes. Normally they are intestinal parasites, but some are found in the lungs. The species are important parasites of sheep, cattle, and goats. The adult females lay eggs in the intestinal tract, which are passed out with the feces. In the presence of oxygen the eggs hatch in a few days. When the larvae are ingested by an appropriate host, their protective sheath is lost, and they proceed through the fourth larval stage to adulthood in the intestinal tract, where they may enter the mucosa. No migration takes place outside the gastrointestinal tract.

**Metastrongyloidea.** The Metastrongyloidea comprise obligate parasites of terrestrial and marine mammals, found commonly in the respiratory tract. In their life cycle they utilize both paratenic and intermediate hosts, among them a variety of invertebrates, including earthworms and mollusks. Two important species are *Metastrongylus apri* (swine lungworm) and *Angiostrongylus cantonensis* (rodent lungworm).

**Heterakoidea.** The Heterakoidea are capable of parasitizing almost any warm-blooded vertebrate as well as reptiles and amphibians. The species *Ascaridia galli* is the largest known nematode parasite of poultry; males are 2–3 in. (50–76 mm) long, and females 3–4.5 in. (75–116 mm). [A.R.M.]

**Oxyuroidea.** The Oxyuroidea constitute a large group of the phylum Nemata. Hosts include terrestrial mammals, birds, reptiles, amphibians, fishes, insects, and other arthropods.

The species are small to medium sized and thin bodied. With one exception, known life cycles are direct. Typically the eggs pass out of the host's alimentary tract onto the ground, where they become fully embryonated and infective. Normally the in-

fective egg does not hatch until a susceptible animal ingests it. The cecum and colon of the host are the typical locations of these parasites. Larvae in all stages of development and adults occur in the gut.

The human pinworm, *Enterobius vermicularis*, is probably the most contagious of all helminthic diseases. It is estimated that 10% of the world's population suffer from this parasite, the majority being children. Indeed, incidence among schoolchildren in the cool regions of the world often approaches 100%. Infection occurs when eggs are inhaled or ingested. The most common method of transmission is from anus to mouth. Because of the aerial transmission, this disease is highly contagious. Though the infection is seldom serious, the behavioral symptoms are disturbing: nail biting, teeth grinding, anal scratching, insomnia, nightmares, and even convulsions. Several medical treatments are available, but there is often the danger of reinfestation from contaminated objects within the household or institution. See NEMATATA. [J.T.L.]

**Strontianite** The mineral form of strontium carbonate, usually with some calcium replacing strontium. It characteristically occurs in veins with barite or celestite or as masses in certain sedimentary rocks. Strontianite is normally prismatic, but it may also be massive. It may be colorless or gray with yellow, green, or brownish tints. The hardness is 3½ on Mohs scale, and the specific gravity of 3.76. It occurs at Strontian, Scotland, and in Germany, Austria, Mexico, and India and, in the United States, in the Strontium Hills of California. See CARBONATE MINERALS; STRONTIUM. [R.I.Ha.]

**Strontium** A chemical element, Sr, atomic number 38, and atomic weight 87.62. Strontium is the least abundant of the alkaline-earth metals. The crust of the Earth is 0.042% strontium, making this element as abundant as chlorine and sulfur. The main ores are celestite, SrSO<sub>4</sub>, and strontianite, SrCO<sub>3</sub>. See ALKALINE-EARTH METALS; PERIODIC TABLE; STRONTIANITE.

Strontium nitrate is used in pyrotechnics, railroad flares, and tracer bullet formulations. Strontium hydroxide forms soaps and greases with a number of organic acids which are structurally stable, resistant to oxidation and breakdown over a wide temperature range.

Properties of strontium

Property	Value
Atomic number	38
Atomic weight	87.62
Isotopes (stable)	84, 86, 87, 88, 90
Boiling point, °C	1638(?)
Melting point, °C	704(?)
Density, g/cm <sup>3</sup> at 20°C	2.6

Strontium is divalent in all its compounds which are, aside from the hydroxide, fluoride, and sulfate, quite soluble. Strontium is a weaker complex former than calcium, giving a few weak oxy complexes with tartrates, citrates, and so on. Some physical properties of the element are given in the table. [R.F.R.]

**Strophanthus** A genus of woody climbers of the dogbane family (Apocynaceae), natives of tropical Asia and Africa. They are the source of arrow poisons. The dried, greenish, ripe seeds of *Strophanthus hispidus* and *S. kombe* contain the glucoside strophanthin, which is much used in treating heart ailments. Strophanthin acts directly on heart muscle, increasing muscular force. It causes the heart to beat more regularly and decreases the pulse rate. Strophanthin is a precursor of cortisone, which is used in the treatment of arthritis. See GENTIANALES. [P.D.St.; E.L.C.]

**Strophomenida** An extinct order of brachiopods, in the subphylum Rhynchonelliformea, that inhabited shallow shelf seas of the Paleozoic Era. It contains the greatest taxonomic diversity of all rhynchonelliform brachiopod orders, and its members exhibit a diverse range of morphologies and modes of life.

Strophomenida contains four suborders: Strophomenidina, Chonetidina, Productidina, and Strophalosiidina. A fifth suborder, Orthotetidina, shares characteristics with both strophomenids and primitive orthids. Strophomenids are distinguished from all other articulate brachiopods by their concavo-convex or plano-convex lateral profiles and the lack of a functional pedicle in adults. They also possess strophic (straight) hinge lines and variable ornamentation from fine-ribbed early Paleozoic forms to more elaborate spine-bearing late Paleozoic forms. Adult strophomenids were mostly free-living, sessile, epifaunal suspension feeders. The concavo-convex lateral profile and elaborate spines were adaptations for living on soft substrates. *See* BRACHIOPODA; RHYNCHONELLIFORMEA. [M.E.P.]

**Structural analysis** A detailed evaluation intended to assure that, for any structure, the deformations will be sufficiently below allowable values that structural failure will not occur. The deformations may be elastic (fully recoverable) or inelastic (permanent). They may be small, with an associated structural failure that is cosmetic; for example, the deflection of a beam supporting a ceiling may cause cracking of the plaster. They may be large, with an associated structural failure that is catastrophic; for example, the buckling of a column or the fracture of a tension member causes complete collapse of the structure.

Structural analysis may be performed by tests on the actual structure, on a physical model of the structure to some scale, or through the use of a mathematical model. Tests on an actual structure are performed in those cases where many similar structures will be produced, for example, automobile frames, or where the cost of a test is justified by the importance and difficulty of the project, for example, a lunar lander. Physical models are sometimes used where subassemblages of major structures are to be investigated. The vast majority of analyses, however, are on mathematical models, particularly in the field of structural engineering which is concerned with large structures such as bridges, buildings, and dams. *See* BRIDGE; BUILDINGS; DAM; STRUCTURE (ENGINEERING).

The advent of the digital computer made it possible to create mathematical models of great sophistication, and almost all complex structures are now so analyzed. Programs of such generality have been written as to permit the analysis of any structure. These programs permit the model of the structure to be two- or three-dimensional, elastic or inelastic, and determine the response to forces that are static or dynamic. Most of the programs utilize the stiffness method, in which the stiffnesses of the individual elements are assembled into a stiffness matrix for the entire structure, and analysis is performed in which all behavior is assumed to be linearly elastic. *See* DIGITAL COMPUTER; ELASTICITY.

The structural engineer's function continues to require training and experience in conceptualizing the structure, choosing the appropriate model, estimating the loads that will be of importance, coding the information for the program, and interpreting the results. The analyst usually enters the process after the conceptualization. Most structures consist of assemblies of members connected at joints. While all real members transmit axial, torsional, and bending actions, the majority of buildings and bridges are analyzed as trusses, beams, and frames with either axial or bending forces predominant. *See* BEAM; ENGINEERING DESIGN; STRESS AND STRAIN; STRUCTURAL DESIGN; TRUSS.

Whether the model selected is detailed or simplified, one extremely important part of the analysis consists of the estimate of the loads to be resisted. For bridges and buildings, the primary vertical loads are gravity loads. These include the weight of the

structure itself, and such appurtenances as will be permanent in nature. These are referred to as dead loads. The loads to be carried, the live loads, may consist of concentrated loads (heavy objects occupying little space, for example, a printing press), or loads distributed over relatively large areas (such as floor and deck coverings). Horizontal loads on buildings are produced by wind and by the inertia forces created during earthquakes. In seismic analysis, computers are used to simulate the dynamic characteristics of the structure. The accelerations actually measured during earthquakes are then used to determine the response of the structure. *See* LOADS, DYNAMIC; LOADS, TRANSVERSE; SEISMIC RISK. [G.D.B.R.]

**Structural chemistry** Much of chemistry is explainable in terms of the structures of chemical compounds. The understanding of these structures hinges very strongly on understanding the electronic configurations of the elements. The union of atoms, and therefore the formation of compounds from the elements, is associated with interactions among the extranuclear electrons of the individual atoms. Electronic interactions among atoms may occur in two ways: Electrons may be transferred from one atom to another, or they may be shared by two (or more) atoms. The first type of interaction is called electrovalence and results in the formation of electrically charged monatomic ions. The second, covalence, leads to the formation of molecules and complex ions. *See* CHEMICAL BONDING. [D.H.B.]

In considering structures more complex than those derived from simple monoatomic ions, the logical step is to consider single polyhedral aggregates of atoms. In its most precise sense, structure is used to denote a knowledge of the bonding distances and angles between atoms in chemical compounds and, in turn, the geometrical arrangements which they form. These atomic arrangements and the associated distances and angles serve uniquely as "fingerprints" of these atom spatial configurations, and depend very much on the electronic configurations around atoms. The chemical combination of neutral atoms to produce uncharged species results in molecule formation, whereas the similar combination of atoms or ions possessing a net charge results in the formation of complex ions. A basic understanding of the species formed involves the concept of the coordination polyhedron, which allows a simple classification of the structures of many polyatomic molecules and ions. This type of classification is particularly useful because it conveniently explains the packing together of simple chemical molecules or ions in terms of highly symmetrical polyhedra. There is an obvious connection between polyhedra and the structures found in crystalline solids formed from them. Crystal formation often involves the linking of convex polyhedra by the sharing of corners, edges, or faces, ultimately forming space-filling assemblies in which all faces of each polyhedron are in contact with faces of other polyhedra. The most important simple polyhedrons are the tetrahedron, the trigonal bipyramid, the octahedron, the pentagonal bipyramid, and the cube. The most commonly observed of these polyhedral configurations are the tetrahedron (four faces) and the octahedron (six faces).

The simplest correlative device which accurately summarizes a very large number of structures and enables the chemist to predict, with a good chance of success, the geometric array of the atoms in a compound of known composition, is based on an extreme electrostatic model. This model, or theory, represents the bonds in a purely formal way. The central atom is considered to be a positive ion having a charge equal to its oxidation state. The groups attached to the central atom (the ligands) are then treated either as negative ions or as neutral dipolar molecules. The principal justification for this approach lies in its successful correlation of a vast amount of information.

A number of significant observations can be made with regard to these formulations. There are series of ions, or ions and molecules, having the same type of composition, differing only in the nature of the central ion and the net charge

on the aggregate. Examples are found in the series:  $\text{NO}_3^-$ ,  $\text{CO}_3^{2-}$ ,  $\text{BO}_3^{3-}$ ,  $\text{ClO}_3^-$ ,  $\text{SO}_3^{2-}$ ,  $\text{PO}_3^{3-}$ ;  $\text{ClO}_4^-$ ,  $\text{SO}_4^{2-}$ ,  $\text{PO}_4^{3-}$ ,  $\text{SiO}_4^{4-}$ ;  $\text{AlF}_6^{3-}$ ,  $\text{SiF}_6^{2-}$ ,  $\text{PF}_6^-$ . The numbers of atomic nuclei and of electrons are the same for all the members of each series; consequently, these are called isoelectronic series. Not only are the several chemical entities in such series isoelectronic, but they are usually identical in geometrical structure (isostructural).

It may also be observed that corresponding ions from a given vertical family of the periodic table commonly vary in coordination number. A useful example is found in  $\text{N}^{5+}$  and  $\text{P}^{5+}$  which form  $\text{NO}_3^-$  and  $\text{PO}_4^{3-}$ , respectively. In addition, some neutral molecules expand their coordination numbers to form stable anionic halo complexes, whereas others do not. Thus,  $\text{SiF}_4$  reacts with fluoride ion to form  $\text{SiF}_6^{2-}$ , whereas  $\text{CF}_4$  does not form a similar complex ion. The most satisfactory explanation of these and many related observations is conveniently formulated in terms of the electrostatic model chosen here.

The necessary condition for stability of the coordination polyhedron  $\text{MA}_n$  requires that the anions A are each in contact with the central atom M. As a consequence of this condition, the limit of stability of the structure arises in those cases where the anions are also mutually in contact. Larger ligands, or anions, would not be in contact with the central ion. This relationship is usually summarized in terms of the limiting ratio of the radius of the cation,  $r_M$ , to that of the anion,  $r_A$ , below which the anions would no longer be in contact with the cation.

According to the valence-bond theory, the principal requirements for the formation of a covalent bond are a pair of electrons and suitably oriented electron orbitals on each of the atoms being bonded. The geometry of the atoms in the resulting coordination polyhedron is correlated with the orientation of the orbitals on the central atom. The orbitals used depend on the energies of the electrons in them. In general, the order of increasing energy of the electron orbitals is  $(n-1)d < ns < np < nd$ . It is concluded that a nontransition atom having one valence electron will form a covalent bond utilizing an  $s$  orbital. In those cases where an unshared pair of electrons may be assigned to the  $ns$  orbital, as many as three equivalent bonds may be formed by utilizing the three  $np$  orbitals of the central atom. Because of the orientation of these  $p$  orbitals with respect to each other, the three resulting bonds should be at  $90^\circ$  to each other. This expectation is nearly realized in  $\text{PH}_3$ . In order to account for four or six equivalent bonds, or for that matter in order to account for all the remaining polyhedral and polygonal structures, except the angular structure for a coordination number of 2 (with two unshared pairs of electrons on the central atom), an additional assumption is necessary. It is assumed that  $s$  and  $p$ ,  $s$  and  $d$ , or  $s$ ,  $p$ , and  $d$  orbitals, are replaced by new orbitals, called hybridized orbitals. These hybridized orbitals are derived from the original orbitals (mathematically) in such a way that the required number of equivalent bonds may be formed. In the simplest case, it is shown that  $s$  and  $p$  may be combined to form two equivalent  $sp$  hybridized orbitals directed at  $180^\circ$  to each other. Other sets of hybridized orbitals have been shown to be appropriate to describe the bonding in other structures. See LIGAND FIELD THEORY.

Among inert-gas ions of the first row of eight elements in the periodic table, there are four orbitals available for covalent bond formation, one  $2s$  and three  $2p$ . Consequently, a maximum of four bonds may be formed. This is in general agreement with the existence of the tetrahedron as the limiting coordination polyhedron among these elements, for example,  $\text{BeF}_4^{2-}$ ,  $\text{BF}_4^-$ ,  $\text{CCl}_4$ ,  $\text{NH}_4^+$ . Although only  $\text{Li}^+$  deviates from this pattern, having a coordination number of 6 in its crystalline halides, these compounds are best treated as simple electrovalent salts. In keeping with the limitation of only four orbitals, the formation of dou-

ble or triple bonds between atoms of these elements reduces the coordination number of the central atom. Thus, the highest coordination number of a first-row element forming one double bond is 3. This is illustrated by the structures below.

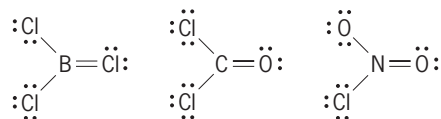

In these and similar examples, the geometric array is determined by the formation of three single bonds utilizing  $sp^2$  hybridized orbitals on the central atom and  $p$  orbitals on the ligand. In general, the bonds determining the geometry of a molecule or ion (in this way) are called  $\sigma$  bonds. The double bond results from the superposition of a second bond, a  $\pi$  bond, between two atoms. In this example the formation of a  $\pi$  bond reduces the number of  $\sigma$  bonds from four to three, thus changing the geometries of the corresponding molecules or ions from tetrahedral to trigonal planar.

The formation of a second  $\pi$  bond (a triple bond or two double bonds) reduces the coordination number of the atom in question still further, resulting in the linear  $sp$  set of hybridized orbitals being utilized in  $\sigma$ -bond formation. See VALENCE.

With regard to the nature of doubly bonded compounds, another problem arises when such structures are viewed from the standpoint of valence-bond theory. In the species  $\text{BCl}_3$ ,  $\text{COCl}_2$ ,  $\text{NO}_2\text{Cl}$ , and many similar substances, nonequivalent bonds are predicted. The doubly bonded oxygen should be closer to the central carbon atom than the singly bonded ones. This is not found to be true experimentally so long as the similar atoms are otherwise equivalent. There is only one observable C—O distance in carbonate, one N—O distance in nitrate, and so on. To account for such facts as these, the concept of resonance must be introduced. If the  $\pi$  bond exists, it must exist equally between the central atom and all the equivalent oxygen atoms. The resonance method of describing this situation is to say that one of the pictorial structures is inadequate to describe the substance properly, but that enough pictorial structures (resonance structures) should be considered to permute the double bond about all the equivalent bonds. The true structure is assumed to be something intermediate to all the resonance structures and more stable than any of them because it exists in preference to any one of them. The resonance structures for  $\text{CO}_3^{2-}$  are the following:

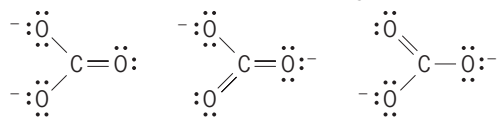

See CONJUGATION AND HYPERCONJUGATION; RESONANCE (MOLECULAR STRUCTURE).

The classic homologous series of compounds in organic chemistry provide useful examples involving the condensation of polyhedrons containing the same central element in the individual units. The general formula,  $\text{C}_n\text{H}_{2n} + 2$ , represents a large number of compounds extending from the lowest member, methane,  $\text{CH}_4$ , to polyethylene, a plastic of economic importance in which  $n$  is a very large number. Two ways exist for the linking together of these tetrahedrons. This gives rise to two molecular forms, both of which are stable, well-known compounds. It is

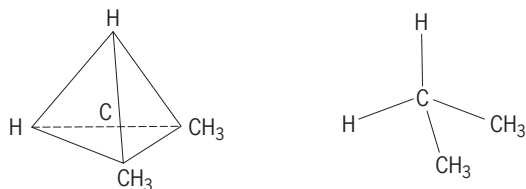

Fig. 1. Geometric structure of propane.

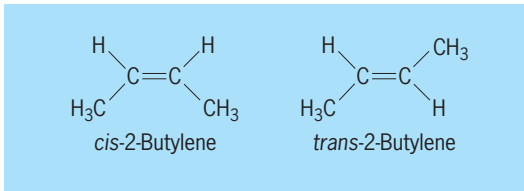

Fig. 2. Cis-trans isomerism among olefins.

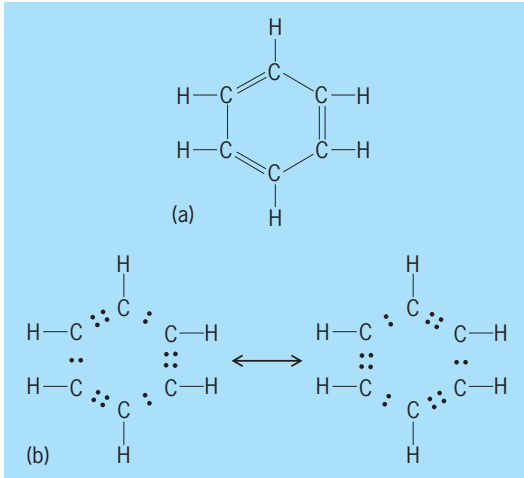

Fig. 3. Benzene molecule. (a) Structural formula. (b) Two forms in resonance.

an essential part of these structures that each  $\text{—C—}$  link is linear (because it is merely a  $\sigma$ -bond); however, when two carbon atoms are linked to a third, the  $\text{C—C—C}$  angle is essentially determined by the bond angle of the central carbon atom (that is, the other carbons may be treated as ligands to the first (Fig. 1). The other familiar homologous series of organic chemistry differ from the saturated hydrocarbons in having at least one unique coordination polyhedron of a different type. The olefins contain two doubly bonded, or unsaturated, carbon atoms, whose polyhedral structures are trigonal planar, and the remainder of the carbons are tetrahedral. As in the case of the aliphatic hydrocarbons, the olefins exhibit an isomerism which is associated with the branching of the chain structure. In addition, the presence of two linked trigonal planar carbon atoms and the fact that the polyhedrons cannot rotate about the double bond give rise to a different kind of isomerism, called cis-trans isomerism (Fig. 2). See BOND ANGLE AND DISTANCE.

The existence of a predicted isomerism provides one of the most important confirmations of the theories of chemical structure. In general, the polyhedral view of molecular structure, as described here, has been thoroughly verified by the discovery of the many types of predicted isomerism. The first really convincing proof of the tetrahedral structures of saturated carbon atoms involved optical isomerism. See OPTICAL ACTIVITY.

The aromatic hydrocarbons are characterized by cyclic arrangements of trigonal planar carbon atoms (Fig. 3a). The highly symmetrical nature of the benzene molecule is not fully represented by such a structure. The figure indicates the presence of three double and three single bonds in the ring. It has been shown that the  $\text{C—C}$  bonds are all the same and, consequently, the true structure of the substance must be represented by two resonance structures which interchange the single and double bonds (Fig. 3b). See BENZENE.

[J.M.Wi.]

**Structural connections** Methods of joining the individual members of a structure to form a complete assembly. The connections furnish supporting reactions and transfer loads from

one member to another. Loads are transferred by fasteners (rivets, bolts) or welding supplemented by suitable arrangements of plates, angles, or other structural shapes. When the end of a member must be free to rotate, a pinned connection is used.

The suitability of a connection depends on its deformational characteristics as well as its strength. Rotational flexibility or complete rigidity must be provided according to the degree of end restraint assumed in the design. A rigid connection maintains the original angles between connected members virtually unchanged after loading. Flexible or nonrestraining connections permit rotation approximately equal to that at the ends of a simply supported beam. Intermediate degrees of restraint are called semirigid.

A commonly used form of connection for rolled-beam sections, called a web connection, consists of two angles which are attached to opposite sides of a member and which are in turn connected to the web of a supporting beam, girder, column, or framing at right angles. A shelf angle may be added to facilitate erection (Fig. 1).

A bracket or seat on which the end of the beam rests is a seat connection; it is intended to furnish the end reaction of the supported beam. Two general types are used: The unstiffened seat provides bearing for the beam by a projecting plate or angle leg which offers resistance only by its own flexural strength (Fig. 2); the stiffened seat is supported by a vertical plate or angle which transfers the reaction force to the supporting member without flexural distortion of the outstanding seat.

When the action line of a transferred force does not pass through the centroid of the connecting fastener group or welds, the connection is subjected to rotational moment which produces additional shearing stresses in the connectors. The load transmitted by diagonal bracing to a supporting column flange through a gusset plate is eccentric with reference to the connecting fastener group.

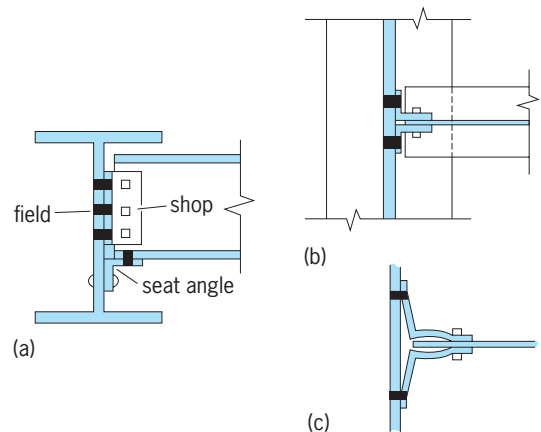

Fig. 1. Riveted or bolted web connections. (a) Beam-to-girder, elevation view. (b) Plan view. (c) Bending of angle legs.

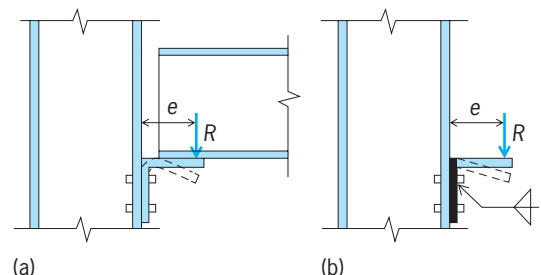

Fig. 2. Unstiffened seat connections. (a) Fastened angle seat. (b) Welded angle seat.  $R$  = reaction load;  $e$  = distance to reaction from column face.

In beam-to-column connections and stiffened seat connections or when members transfer loads to columns by a gusset plate or a bracket, the fasteners are subjected to tension forces caused by the eccentric connection. Although there are initial tensions in the fasteners, the final tension is not appreciably greater than the initial tension.

Rigidity and moment resistance are necessary at the ends of beams forming part of a continuous framework which must resist lateral and vertical loads. Wind pressures tend to distort a building frame, producing bending in the beams and columns which must be suitably connected to transfer moment and shear. The resisting moment can be furnished by various forms of angle T for fasteners or welded or bracket connections.

Where appreciably angular change between members is expected, and in special cases where a hinge support without moment resistance is desired, connections are pinned. Many bridge trusses and large girder spans have pin supports. See BOLT; JOINT (STRUCTURES); RIVET. [J.B.S.]

**Structural deflections** The deformations or movements of a structure and its components, such as beams and trusses, from their original positions. It is as important for the designer to determine deflections and strains as it is to know the stresses caused by loads. See STRESS AND STRAIN.

Deflections may be computed by any of several methods. Generally the computation is based on the assumption that stress is proportional to strain. As a result, deflection equations involve the modulus of elasticity  $E$ , which is a measure of the stiffness of a material.

The relation between deflections at different parts of a structure is indicated by Maxwell's law of reciprocal deflections. This states that if a load  $P$  is applied at any point  $A$  in any direction  $a$  and causes a shift of another point  $B$  in direction  $b$ , the same load applied at  $B$  in direction  $b$  will cause an equal shift of  $A$  in direction  $a$  (see illustration). The law is used in a number of ways such as in simplifying deflection calculations, checking the accuracy of computations, and producing influence lines. See STRUCTURAL ANALYSIS.

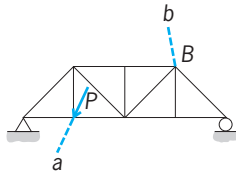

Example of Maxwell's law of reciprocal deflections.

Beam and truss deflections usually are computed by similar methods, except that integration is used for equations and summation for trusses. Beam deflection equations involve bending moments and moments of inertia. Truss deflection equations are based on the stresses and cross-sectional areas of chords and web members. Deflections may also be determined graphically. See BEAM; TRUSS. [J.B.S.]

**Structural design** The selection of materials and member type, size, and configuration to carry loads in a safe and serviceable fashion. In general, structural design implies the engineering of stationary objects such as buildings and bridges, or objects that may be mobile but have a rigid shape such as ship hulls and aircraft frames. Devices with parts planned to move with relation to each other (linkages) are generally assigned to the area of mechanical design.

Structural design involves at least five distinct phases of work: project requirements, materials, structural scheme, analysis, and design. For unusual structures or materials a sixth phase, testing, should be included. These phases do not proceed in a rigid progression, since different materials can be most effective in dif-

ferent schemes, testing can result in changes to a design, and a final design is often reached by starting with a rough estimated design, then looping through several cycles of analysis and redesign. Often, several alternative designs will prove quite close in cost, strength, and serviceability. The structural engineer, owner, or end user would then make a selection based on other considerations.

Before starting design, the structural engineer must determine the criteria for acceptable performance. The loads or forces to be resisted must be provided. For specialized structures this may be given directly, as when supporting a known piece of machinery, or a crane of known capacity. For conventional buildings, building codes adopted on a municipal, county, or state level provide minimum design requirements for live loads (occupants and furnishings, snow on roofs, and so on). The engineer will calculate dead loads (structure and known, permanent installations) during the design process. For the structure to be serviceable or useful, deflections must also be kept within limits, since it is possible for safe structures to be uncomfortably "bouncy." Very tight deflection limits are set on supports for machinery, since beam sag can cause driveshafts to bend, bearings to burn out, parts to misalign, and overhead cranes to stall. Beam stiffness also affects floor "bounciness," which can be annoying if not controlled. In addition, lateral deflection, sway, or drift of tall buildings is often held within approximately height/500 (1/500 of the building height) to minimize the likelihood of motion discomfort in occupants of upper floors on windy days. See LOADS, DYNAMIC; LOADS, TRANSVERSE.

Technological advances have created many novel materials such as carbon fiber- and boron fiber-reinforced composites, which have excellent strength, stiffness, and strength-to-weight properties. However, because of the high cost and difficult or unusual fabrication techniques required, glass-reinforced composites such as fiberglass are more common, but are limited to lightly loaded applications. The main materials used in structural design are more prosaic and include steel, aluminum, reinforced concrete, wood, and masonry. See COMPOSITE MATERIAL; MASONRY; PRECAST CONCRETE; PRESTRESSED CONCRETE; REINFORCED CONCRETE; STRUCTURAL MATERIALS.

In an actual structure, various forces are experienced by structural members, including tension, compression, flexure (bending), shear, and torsion (twist). However, the structural scheme selected will influence which of these forces occurs most frequently, and this will influence the process of material selection. See SHEAR; TORSION.

Analysis of structures is required to ensure stability (static equilibrium), find the member forces to be resisted, and determine deflections. It requires that member configuration, approximate member sizes, and material properties be known or assumed. Aspects of analysis include: equilibrium; stress, strain, and elastic modulus; linearity; plasticity; and curvature and plane sections. Various methods are used to complete the analysis.

Once a structure has been analyzed (by using geometry alone if the analysis is determinate, or geometry plus assumed member sizes and materials if indeterminate), final design can proceed. Deflections and allowable stresses or ultimate strength must be checked against criteria provided either by the owner or by the governing building codes. Safety at working loads must be calculated. Several methods are available, and the choice depends on the types of materials that will be used. Once a satisfactory scheme has been analyzed and designed to be within project criteria, the information must be presented for fabrication and construction. This is commonly done through drawings, which indicate all basic dimensions, materials, member sizes, the anticipated loads used in design, and anticipated forces to be carried through connections. [R.L.T.; L.M.J.]

**Structural geology** The branch of geology that deals with study and interpretation of deformation of the Earth's crust. Deformation brings about changes in size (dilation), shape



(distortion), position (translation), or orientation (rotation). Evidence for the changes caused by deformation are commonly implanted into geologic bodies in the form of recognizable structures, such as faults and joints, folds and cleavage, and foliation and lineation. The geologic record of structures and structural relations is best developed and most complicated in mountain belts, the most intensely deformed parts of the Earth's crust. See MOUNTAIN SYSTEMS.

The discipline of structural geology harnesses three interrelated strategies of analysis: descriptive analysis, kinematic analysis, and dynamic analysis. Descriptive analysis is concerned with recognizing and describing structures and measuring their orientations. Kinematic analysis focuses on interpreting the deformational movements responsible for the structures. Dynamic analysis interprets deformational movements in terms of forces, stresses, and mechanics. The ultimate goal of these interdependent approaches is to interpret the physical evolution of crustal structures, that is, tectonic analysis. A major emphasis in modern structural geology is strain analysis, the quantitative analysis of changes in size and shape of geologic bodies, regardless of scale.

There are many significant practical applications of structural geology. An understanding of the descriptive and geometric properties of folds and faults, as well as mechanisms of folding and faulting, is of vital interest to exploration geologists in the petroleum industry. Ore deposits commonly are structurally controlled, or structurally disturbed, and for these reasons detailed structural geologic mapping is an essential component of mining exploration. Other applications of structural geology include the evaluation of proposals for the disposal of radioactive waste in the subsurface, and the targeting of safe sites for dams, hospitals, and the like in regions marked by active faulting. See FAULT AND FAULT STRUCTURES; FOLD AND FOLD SYSTEMS; ORE AND MINERAL DEPOSITS; PETROLEUM GEOLOGY. [G.H.D.]

**Structural materials** Construction materials which, because of their ability to withstand external forces, are considered in the design of a structural framework.

Brick is the oldest of all artificial building materials. It is classified as face brick, common brick, and glazed brick. Face brick is used on the exterior of a wall and varies in color, texture, and mechanical perfection. Common brick consists of the kiln run of brick and is used behind whatever facing material is employed providing necessary wall thickness and additional structural strength. Glazed brick is employed largely for interiors where beauty, ease of cleaning, and sanitation are primary considerations. See BRICK.

Structural clay tiles are burned-clay masonry units having interior hollow spaces termed cells. Such tile is widely used because of its strength, light weight, and insulating and fire-protection qualities. See TILE.

Architectural terra-cotta is a burned-clay material used for decorative purposes. The shapes are molded either by hand in plaster-of-paris molds or by machine, using the stiff-mud process.

Building stones generally used are limestone, sandstone, granite, and marble. Until the advent of steel and concrete, stone was the most important building material. Its principal use now is as a decorative material because of its beauty, dignity, and durability. See GRANITE; LIMESTONE; MARBLE; SANDSTONE; STONE AND STONE PRODUCTS.

Concrete is a mixture of cement, mineral aggregate, and water, which, if combined in proper proportions, form a plastic mixture capable of being placed in forms and of hardening through the hydration of the cement. See CONCRETE; PRESTRESSED CONCRETE; REINFORCED CONCRETE.

The cellular structure of wood is largely responsible for its basic characteristics, unique among the common structural materials. When cut into lumber, a tree provides a wide range of material which is classified according to use as yard lumber, factory or shop lumber, and structural lumber. Laminated lumber is used for beams, columns, arch ribs, chord members, and other struc-

tural members. Plywood is generally used as a replacement for sheathing, or as form lumber for reinforced concrete structures. See LUMBER; PLYWOOD; WOOD ANATOMY; WOOD PRODUCTS.

Important structural metals are the structural steels, steel castings, aluminum alloys, magnesium alloys, and cast and wrought iron. Steel castings are used for rocker bearings under the ends of large bridges. Shoes and bearing plates are usually cast in carbon steel, but rollers are often cast in stainless steel. Aluminum alloys are strong, lightweight, and resistant to corrosion. The alloys most frequently used are comparable with the structural steels in strength. Magnesium alloys are produced as extruded shapes, rolled plate, and forgings. The principal structural applications are in aircraft, truck bodies, and portable scaffolding. Gray cast iron is used as a structural material for columns and column bases, bearing plates, stair treads, and railings. Malleable cast iron has few structural applications. Wrought iron is used extensively because of its ability to resist corrosion. It is used for blast plates to protect bridges, for solid decks to support ballasted roadways, and for trash racks for dams. See ALUMINUM; CAST IRON; MAGNESIUM ALLOYS; STEEL; STRUCTURAL STEEL; WROUGHT IRON. [C.M.A.]

Composite materials are engineered materials that contain a load-bearing material housed in a relatively weak protective matrix. A composite material results when two or more materials, each having its own, usually different characteristics, are combined, producing a material with properties superior to its components. The matrix material (metallic, ceramic, or polymeric) bonds together the reinforcing materials (whiskers, laminated fibers, or woven fabric) and distributes the loading between them. See COMPOSITE MATERIAL; CRYSTAL WHISKERS.

Fiber-reinforced polymers (FRP) are a broad group of composite materials made of fibers embedded in a polymeric matrix. Compared to metals, they generally have relatively high strength-to-weight ratios and excellent corrosion resistance. They can be formed into virtually any shape and size. Glass is by far the most used fiber in FRP (glass-FRP), although carbon fiber (carbon-FRP) is finding greater application. Although complete FRP shapes and structures are possible, the most promising application of FRP in civil engineering is for repairing structures or infrastructure. FRP can be used to repair beams, walls, slabs, and columns. See POLYMERIC COMPOSITE. [M.Sc.]

**Structural petrology** The study of the structural aspects of rocks, as distinct from the purely chemical and mineralogical studies that are generally emphasized in other branches of petrology. The term was originally used synonymously with petrofabric analysis, but is sometimes restricted to denote the analysis of only microscopic structural and textural features. See PETROFABRIC ANALYSIS; PETROGRAPHY. [J.M.Ch.]

**Structural plate** A simple rolled steel section used as an isolated structural element, as a support of other structural elements, or as part of other structural elements. When isolated plates are extremely thick, their design is controlled by shear; plates of moderate thickness are controlled by bending (with some torsion), and very thin plates carry their loads principally by tensile membrane action. Although stresses of all types exist in all plates, it is usually sufficient to deal with only the most significant. Bending is the most common design criterion.

Plates are commonly used as cover plates on wide-flange beams, as the flanges and webs of plate girders, and as the sides of tube-shaped beams and columns. In all these cases, serious consideration must be given to the fact that the plate may buckle when compressed. Fortunately, the plates have edge supports in the direction of the stress, so they function as panels rather than as beams. Their ratios of length to width are large enough that the resistance to local buckling of the plate element depends upon its width-thickness ratio, practically independent of its length. (The length of the overall section is still significant in

determining the member's capacity.) See BEAM; COLUMN; JOINT (STRUCTURES); LOADS, TRANSVERSE; STRUCTURAL STEEL. [G.D.Br.]

**Structural steel** Steel used in engineering structures, usually manufactured by either the open-hearth or the electric-furnace process. The exception is carbon-steel plates and shapes whose thickness is  $7/16$  in. (11 mm) or less and which are used in structures subject to static loads only. These products may be made from acid-Bessemer steel. The physical properties and chemical composition are governed by standard specifications of the American Society for Testing and Materials (ASTM). Structural steel can be fabricated into numerous shapes for various construction purposes. See STEEL. [W.G.B.]

**Structure (engineering)** An arrangement of designed components that provides strength and stiffness to a built artifact such as a building, bridge, dam, automobile, airplane, or missile. The artifact itself is often referred to as a structure, even though its primary function is not to support but, for example, to house people, contain water, or transport goods. See AIRPLANE; AUTOMOBILE; BRIDGE; BUILDINGS; DAM.

The primary requirements for structures are safety, strength, economy, stiffness, durability, robustness, esthetics, and ductility. The safety of the structure is paramount, and it is achieved by adhering to rules of design contained in standards and codes, as well as in exercising strict quality control over all phases of planning, design, and construction. The structure is designed to be strong enough to support loads due to its own weight, to human activity, and to the environment (such as wind, snow, earthquakes, ice, or floods). The ability to support loads during its intended lifetime ensures that the rate of failure is insignificant for practical purposes. The design should provide an economical structure within the constraints of all other requirements. The structure is designed to be stiff so that under everyday conditions of loading and usage it will not deflect or vibrate to an extent that is annoying to the occupants or detrimental to its function. The materials and details of construction have durability, such that the structure will not corrode, deteriorate, or break under the effects of weathering and normal usage during its lifetime. A structure should be robust enough to withstand intentional or unintentional misuse (for example, fire, gas explosion, or collision with a vehicle) without totally collapsing. A structural design takes into consideration the community's esthetic sensibilities. Ductility is necessary to absorb the energy imparted to the structure from dynamic loads such as earthquakes and blasts. See CONSTRUCTION ENGINEERING; ENGINEERING DESIGN.

Common structural materials are wood, masonry, steel, reinforced concrete, aluminum, and fiber-reinforced composites. Structures are classified into the categories of frames, plates, and shells, frequently incorporating combinations of these. Frames consist of "stick" members arranged to form the skeleton on which the remainder of the structure is placed. Plated structures include roof and floor slabs, vertical shear walls in a multistory building, or girders in a bridge. Shells are often used as water or gas containers, in roofs of arenas, or in vehicles that transport gases and liquids. The connections between the various elements of a structure are made by bolting, welding or riveting. See COMPOSITE MATERIAL; CONCRETE; STEEL; STRUCTURAL MATERIALS. [T.V.G.]

**Struthioniformes** A small order of weak-flying, partridge-like birds and giant flightless ratite birds found in the southern continents. Their relationship to other birds is unknown. The struthioniforms are characterized by a palaeognathous palate which provides freedom of movement between segments of the palate and the jaw. For this reason they are frequently placed in a separate superorder, the Palaeognathae. However, that distinction places too much emphasis on their separation from other birds. Contrary to common opinion, no evidence supports the

concept that the palaeognathous birds are primitive among living birds.

The order Struthioniformes can be divided into three suborders, Lithornithi, Tinami, and Struthioni, each of which includes both fossil and extant representatives.

The struthioniforms are medium-sized to giant birds. The ostriches are the largest extant birds, but some of the moas, elephant birds, and dromornithids were even larger. The head is small; a medium flattened bill is a common feature except in the kiwis, which have a long bill used for probing into the ground for worms. The wings are reduced in all forms except the lithornithids and tinamous, which can still fly, and the plumage is soft. Their legs are strong, and all forms run well. The struthioniforms eat a variety of foods, especially large fruits and other large food items. Breeding is polygamous, with two or more females laying eggs in a single nest. The males are responsible for incubation, and they assume the major or sole role in caring for the downy young, which leave the nest after hatching. See AVES; RATITES. [W.J.B.]

**Strychnine alkaloids** Alkaloid substances derived from the seeds and bark of plants of the genus *Strychnos* (family Loganiaceae). This genus serves as the source of poisonous, nitrogen-containing plant materials, such as strychnine (see structure; R = H). The seeds of the Asian species of *Strychnos* contain 2–3% alkaloids, of which about half is strychnine

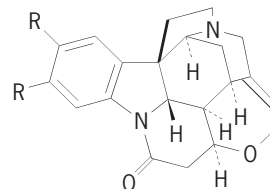

and the rest is closely related materials; for example, brucine (see structure; R = OCH<sub>3</sub>) is a more highly oxygenated relative. Strychnine and brucine are isolated by extraction of basified plant residue with chloroform and then, from the chloroform solution, by dilute sulfuric acid. Precipitation from the dilute acid is accomplished with ammonium hydroxide. Strychnine is separated from brucine by fractional crystallization from ethanol. See CRYSTALLIZATION; STRYCHNOS.

At one time strychnine was used as a tonic and a central nervous system stimulant, but because of its high toxicity (5 mg/kg is a lethal dose in the rat) and the availability of more effective substances, it no longer has a place in human medicine. [D.D.]

**Strychnos** A genus of tropical trees and shrubs belonging to the Logania family (Loganiaceae). *Strychnos nux-vomica*, a native of India and Ceylon, is the source of strychnine. The alkaloid, strychnine, has been used medicinally in the treatment of certain nervous disorders and paralysis. Curare, used by the Indians to poison arrows, is obtained from *S. toxifera* and *S. castelnaei* in Guiana and Amazonas and from *S. tieute* in the Sunda Islands. Curare paralyzes the motor nerve endings in striated muscles and is used in medical practice in cases in which a state of extreme muscular relaxation or even immobility is desirable. It has become an important drug in the field of anesthesiology. See GENTIANALES; STRYCHNINE ALKALOIDS. [PD.St.; E.L.C.]

**Sturgeon** Any of 10 species of large fish which comprise the family Acipenseridae in the order Acipenseriformes. These fish are found in North Temperate Zone waters, where they are almost exclusively bottom-living and feed on organisms such as mollusks, worms, and larvae. The body has five rows of bony plates, of which one is situated dorsally, two laterally, and two ventrally. The snout is elongate and there are four barbels on its lower surface; the mouth is ventrally located, and in the adult

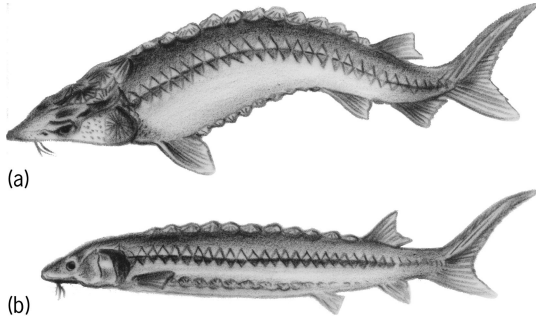

Two species of sturgeons found in United States coastal waters. (a) Atlantic sturgeon (*Acipenser oxyrinchus*). (b) Short-nosed sturgeon (*A. brevirostrus*).

the jaws lack teeth (see illustration). The skeleton is mainly cartilaginous.

Sturgeons are known primarily for the roe, which is processed as caviar. A single female can produce millions of eggs, which may be removed from dead fish or stripped from living fish. The smoked flesh of the sturgeon is a delicacy. See ACIPENSERIFORMES.

[C.B.C.]

**Stylasterina** An order of the class Hydrozoa of the phylum Coelenterata, including several brightly colored branching or encrusting “corals” of warm seas. (True corals belong to a different class, the Anthozoa). The calcareous skeleton is covered by living tissue and is penetrated by ramifying tubes. Nutritive polyps, the gastrozooids, lie in cups on one surface or along certain edges of the skeletal substance. A spine, or style, at the base of each cup gives the order its name.

Some authorities combine the Stylasterina with the Milleporina in a single order, the Hydrocorallina. See ANTHOZOA; HYDROZOA.

[S.Cr.]

**Stylolites** Irregular surfaces occurring in certain rocks, mostly parallel to bedding planes, in which small toothlike projections on one side of the surface fit into cavities of like shape on the other side (see illustration). Stylolites are most common

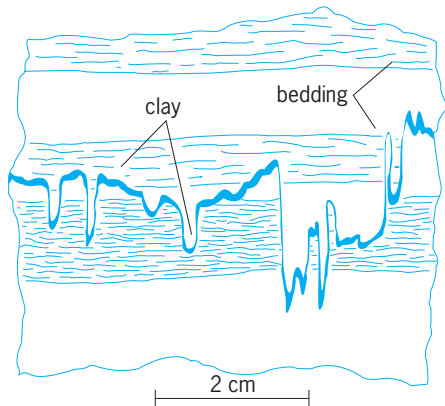

Stylolite in limestone.

in limestones and dolomites but are also present in many other kinds of rock, including sandstones, gypsum beds, and cherts. See DOLOMITE; LIMESTONE; SEDIMENTARY ROCKS.

[R.Si.]

**Stylommatophora** A superorder of the molluscan subclass Pulmonata containing about 20,500 species that are grouped into 56 families. Nearly all land snails without an operculum are stylommatophorans. They have eyespots on the tips of a pair of retractile tentacles, hermaphroditic reproduction with

partial fusion of the male and female system, and, normally, a second pair of retractile tentacles that function as chemoreceptors. All are air-breathing and most are truly terrestrial. Three orders, based on excretory structures, are recognized. The more primitive Orthurethra and Mesurethra have less efficient water conservation devices than do the more specialized members of the order Sigmurethra, in which a closed ureter functions in water conservation. The latter specialization apparently is a prerequisite for evolution toward a sluglike structure, since all 16 families with slugs or sluglike taxa belong to the Sigmurethra. See PULMONATA.

[G.A.S.]

**Styrene** A colorless, liquid hydrocarbon with the formula  $C_6H_5CH=CH_2$ . It boils at  $145.2^\circ C$  ( $293.4^\circ F$ ) and freezes at  $-30.6^\circ C$  ( $-23.1^\circ F$ ). The ethylenic linkage of styrene readily undergoes addition reactions and under the influence of light, heat, or catalysts undergoes self-addition or polymerization to yield polystyrene.

The majority of the styrene used is converted into polystyrene, but other thermoplastic or even thermosetting resins are prepared from styrene by copolymerization with suitable comonomers. A smaller quantity of styrene goes into the manufacture of elastomers or synthetic rubbers.

Styrene is a skin irritant. Prolonged breathing of air containing more than 400 ppm of styrene vapor may be injurious to health. See POLYMERIZATION; POLYSTYRENE RESIN.

[C.K.B.]

**Subduction zones** Regions where portions of the Earth's tectonic plates are diving beneath other plates, into the Earth's interior. Subduction zones are defined by deep oceanic trenches, lines of volcanoes parallel to the trenches, and zones of large earthquakes that extend from the trenches landward.

Plate tectonic theory recognizes that the Earth's surface is composed of a mosaic of interacting lithospheric plates, with the lithosphere consisting of the crust (continental or oceanic) and associated underlying mantle, for a total thickness of about 100 km (60 mi). Oceanic lithosphere is created by sea-floor spreading at mid-ocean ridges (divergent, or accretionary, plate boundaries) and destroyed at subduction zones (at convergent, or destructive, plate boundaries). At subduction zones, the oceanic lithosphere dives beneath another plate, which may be either oceanic or continental. Part of the material on the subducted plate is recycled back to the surface (by being scraped off the subducting plate and accreted to the overriding plate, or by melting and rising as magma), and the remainder is mixed back into the Earth's deeper mantle. This process balances the creation of lithosphere that occurs at the mid-ocean ridge system. The convergence of two plates occurs at rates of 1–10 cm/yr (0.4–4 in./yr) or 10–100 km (6–60 mi) per million years (see illustration).

During subduction, stress and phase changes in the upper part of the cold descending plate produce large earthquakes in the upper portion of the plate, in a narrow band called the Wadati-Benioff zone that can extend as deep as 700 km (420 mi). The plate is heated as it descends, and the resulting release of water leads to melting of the overlying mantle. This melt rises to produce the linear volcanic chains that are one of the most striking features of subduction zones. See LITHOSPHERE.

Subduction zones can be divided in two ways, based either on the nature of the crust in the overriding plate or on the age of the subducting plate. The first classification yields two broad categories: those beneath an oceanic plate, as in the Mariana or Tonga trenches, and those beneath a continental plate, as along the west coast of South America (see illustration). The first type is known as an intraoceanic convergent margin, and the second is known as an Andean-type convergent margin. See MID-OCEANIC RIDGE; PLATE TECTONICS.

Active volcanoes are highly visible features of subduction zones. The volcanoes that have developed above subduction zones in East Asia, Australasia, and the western Americas surround the Pacific Ocean in a so-called Ring of Fire. At

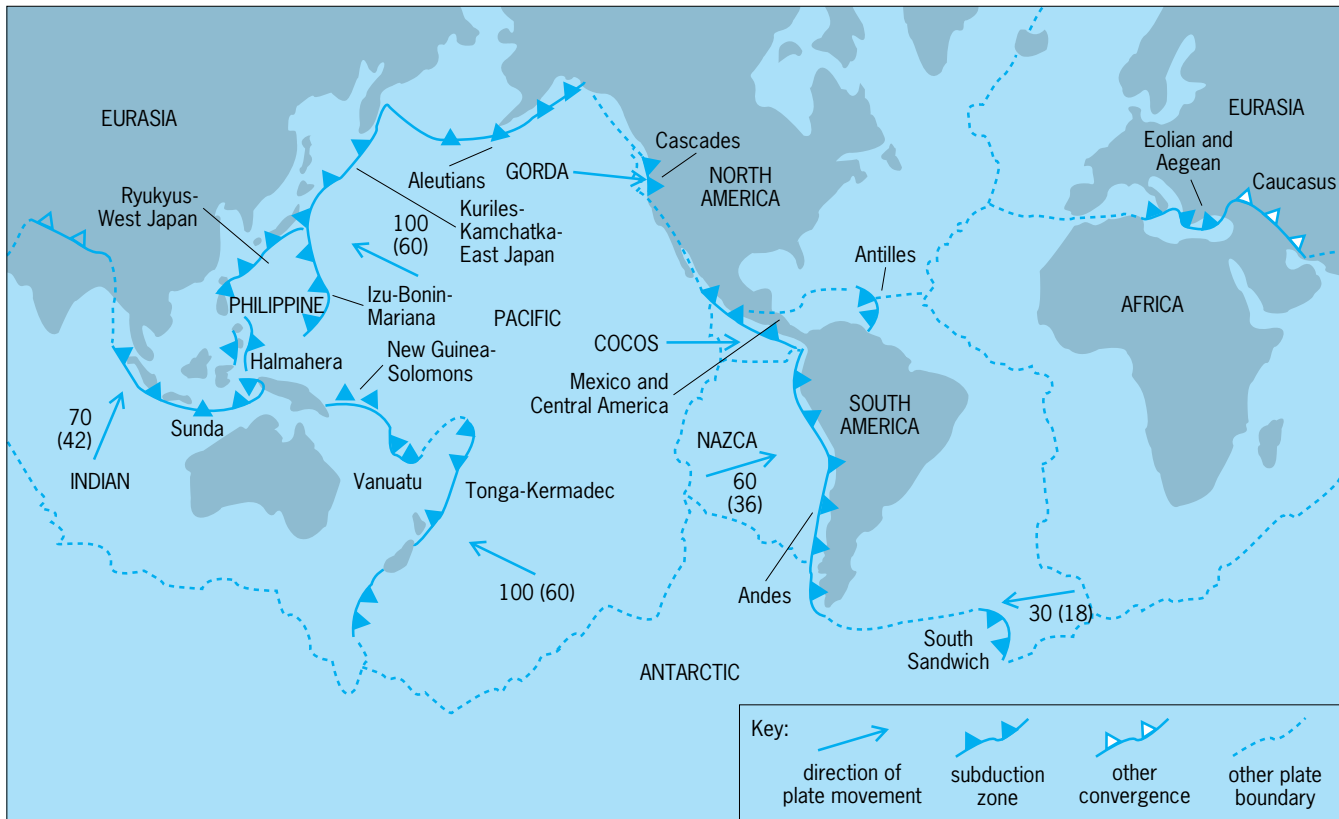

**Principal subduction zones.** Plate names are in all-caps. Numbers at arrows indicate velocity of plate movement in kilometers (miles) per million years. (After J. Gill, *Orogenic Andesites and Plate Tectonics*, Springer-Verlag, 1981)

intraoceanic convergent margins, volcanoes may be the only component above sea level, leading to the name “island arc.” The more general term “volcanic arc” refers to volcanoes built on either oceanic or continental crust. See VOLCANO.

An eventual consequence of subduction is orogeny, or mountain building. Subduction zones are constantly building new crust by the production of volcanic material or the accretion of oceanic sediments. However, the development of the greatest mountain ranges—the Alps or the Himalayas—occurs not during “normal” subduction but during the death of a subduction zone, when it becomes clogged with a large continent or volcanic arc. See OROGENY. [R.J.Ste.; S.H.B.]

**Subgiant star** An evolving star of luminosity class IV. Such a star is brighter than the main-sequence dwarfs and fainter than the true giants in its spectral class, lying between the two on the Hertzsprung-Russell diagram. The classic subgiants fall in a small region from class F to K (with effective temperatures ranging from 7000 to 4000 K or 12,000 to 7000°F). In class G they lie at absolute visual magnitude +3 with luminosities about five times the solar luminosity. Classic subgiants have masses around 1.3 times that of the Sun and violate the mass-luminosity relation as too bright for their masses. The concept is extended to the hot part of the Hertzsprung-Russell diagram from class F to O, in which the distinctions between subgiants and neighboring dwarfs and giants are much smaller, only a magnitude or less.

Main-sequence dwarfs run on the fusion of hydrogen to helium in their cores. The subgiant stage begins when the core hydrogen mass fraction drops to around 0.1, and then continues as the fraction goes to zero and the star evolves toward, but not onto, the red-giant branch with a contracting helium core. See DWARF STAR; GIANT STAR; HERTZSPRUNG-RUSSELL DIAGRAM; SPECTRAL TYPE; STAR; STELLAR EVOLUTION. [J.B.Ka.]

**Sublimation** The process by which solids are transformed directly to the vapor state without passing through the liquid phase. Sublimation is of considerable importance in the purification of certain substances such as iodine, naphthalene, and sulfur.

Sublimation is a universal phenomenon exhibited by all solids at temperatures below their triple points. For example, it is a common experience to observe the disappearance of snow from the ground even though the temperature is below the freezing point and liquid water is never present. The rate of disappearance is low, of course, because the vapor pressure of ice is low below its triple point. Sublimation is a scientifically and technically useful phenomenon, therefore, only when the vapor pressure of the solid phase is high enough for the rate of vaporization to be rapid. See PHASE EQUILIBRIUM; TRIPLE POINT; VAPOR PRESSURE. [N.H.N.]

**Submarine** A ship which can operate completely submerged in the water. The term formerly applied to any ship capable of operating completely underwater, but now usually describes a ship built for military purposes. The term “submersible” usually is applied to small, underwater vehicles that are built for research, rescue, commercial work, or pleasure.

By the end of World War II, antisubmarine warfare had progressed significantly by exploiting the limited underwater endurance and speed of the diesel-electric designs of that era. The application of nuclear power to submarines after World War II reestablished the near-invulnerability of the submarine to antisubmarine warfare from surface ships and aircraft. Nuclear power depends on nuclear fission rather than the oxidation of fossil fuels and thus requires no oxygen source as do diesel engines, allowing the submarine to operate submerged for very long periods. However, advances in submarine technology and

nonnuclear propulsion cause the nonnuclear submarine to remain highly attractive to the navies of many nations. See SHIP NUCLEAR PROPULSION.

Submarines can be classified by their primary military missions. Attack submarines are fast, long-range ships equipped with torpedo tubes or cruise missile launch tubes. They carry sensitive underwater sound receivers and transmitters (sonar) used to detect enemy submarines. They may be armed with torpedoes of various kinds, cruise missiles, mines, and equipment for deployment of small units of clandestine troops.

Ballistic-missile submarines carry long-range missiles fitted with nuclear warheads that can be launched while submerged. The submarine can remain submerged and undetected for many days and, on command, launch missiles on any target within range. The missiles are stowed in and launched from vertical tubes. See MISSILE.

Experimental submarines are occasionally built to test new designs of hull shape, deeper depth capability, power plants, or controls.

Submersibles are usually small, deep-diving vehicles. Their use is for exploration and study of the ocean depths, development of equipment, rescue, or commercial work. Some designs take advantage of the forces of gravity and buoyancy for vertical motion. Other designs use vertically oriented propellers to propel the craft up and down. Movement is restricted to short distances and slow speed because of small size and small battery capacity. See UNDERWATER VEHICLE.

Compared with surface ships, the submarine has features that enable it to submerge and resist great sea pressure. Submarines have a pressure hull and a nonpressure hull. The pressure hull is the watertight, pressure-proof envelope in which equipment operates and the officers and crew live. In certain areas of the submarine there is a nonpressure hull of lighter structure, forming the main ballast tanks. A nonwatertight superstructure provides a smooth, fair envelope to cover pipes, valves, and fittings on top of the hull. Above the superstructure the fairwater similarly encloses the bridge, the periscope, and multiple mast supports. See PERISCOPE; SHIP DESIGN.

The principal means of detecting the presence of a submerged submarine is to listen for sounds which may have been generated on board or by its movement through the water. Very small amounts of acoustic energy can be detected by sophisticated sonars. Therefore, modern submarines are designed with multiple features to greatly reduce the amount of noise they generate.

[M.S.F.; J.H.W.]

**Submarine cable** A cable, primarily for communications, laid on the ocean floor to provide international links. This term is sometimes applied to power cables in water, but these are not usually of great length.

Coaxial cables with 1840 circuits (each having 3-kHz bandwidth) are used extensively for shorter cables. Cables using digital transmission over optical fibers (lightguide transmission) offer a significant cost-per-channel advantage over coaxial systems. Voice signals are transmitted by laser-generated digital light pulses over single-mode fiber pairs. See COAXIAL CABLE; COMMUNICATIONS CABLE; MULTIPLEXING AND MULTIPLE ACCESS; TRANSMISSION LINES.

SL280 digital lightguide transatlantic submarine cables utilize semiconductor laser diodes operating at a wavelength of 1.3-micrometers and carries 280 megabits per second on six hair-thin fibers, of which two pairs are active and the third is available as standby. Each fiber is a glass strand 125  $\mu\text{m}$  in diameter, plastic-coated to 250  $\mu\text{m}$ , and embedded in an elastomer that is part of the unit fiber structure. The fibers are helically wrapped around a central kingwire for strength during manufacture and an outer sheath of nylon to ensure dimensional stability. This structure is then helically wrapped with steel armor wires for strength, ensheathed in a copper conductor, and coated with a final protective layer of polyethylene insulation (see illustration).

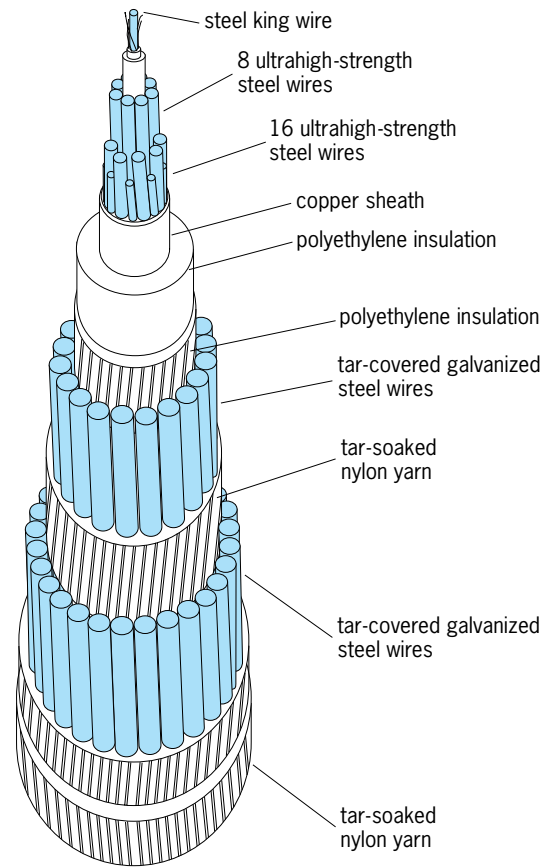

Cutaway view of double-armed SL cable.

The fiber-optic digital repeaters regenerate the signal in its original form, unlike the earlier analog repeaters which were signal amplifiers. The repeaters detect the optical signal entering the repeater, transform it into an electrical signal and amplify it, regenerate it by putting it through a high-speed clocked decision circuit, and then convert the regenerated electrical signal into an optical one by using a 1.3- $\mu\text{m}$  laser transmitter. Transmission rates of 560 megabits per second are provided in the subsequent SL560 design, utilizing lasers operating at 1.5  $\mu\text{m}$ .

Virtually all analog (coaxial) submarine cable systems were configured as a single line from one landing point to another. Traffic requirements, however, are not identical for all countries, and it was realized to be advantageous to implement a tree configuration, where the various branches go to different countries. Digital fiber-optic technology makes branching possible by dedicating certain fiber pairs to certain subsystems.

With the increased volume and capacity of fiber-optic systems, customers and system owners cannot afford or support the potential loss of business and revenue associated with a cable failure. To reduce this risk, many systems employ a ring-network design architecture. These systems use a self-healing loop network with built-in backup and redundancy, which provide fiber-on-fiber restoration and connectivity. In the unlikely event of a cable failure of any nature, communications traffic can be shifted from one fiber cable to another so that digital voice, data, or video communications can continue without disruption. See LASER; OPTICAL COMMUNICATIONS; OPTICAL FIBERS; PULSE MODULATION.

[G.J.S.]

**Submarine canyon** A steep-sided valley developed on the sea floor of the continental slope. Submarine canyons serve as major conduits for sediment transport from land and the continental shelf to the deep sea. Modern canyons are relatively

narrow, deeply incised, steeply walled, often sinuous valleys with predominantly V-shaped cross sections. Most canyons originate near the continental-shelf break, and generally extend to the base of the continental slope. Canyons often occur off the mouths of large rivers, such as the Hudson River or the Mississippi River, although many other canyons, such as the Bering Canyon in the southern Bering Sea, are developed along structural trends. See CONTINENTAL MARGIN.

Modern submarine canyons vary considerably in their dimensions. The average lengths of canyons has been estimated to be about 34 mi (55 km); although the Bering Canyon is more than 680 mi (1100 km) long and is the world's longest submarine canyon. The shortest canyons are those off the Hawaiian Islands, and average about 6 mi (10 km) in length. Submarine canyons are characterized by relatively steep gradients. The average slope of canyon floors is 309 ft/mi (58 m/km). In general, shorter canyons tend to have higher gradients. For example, shorter canyons of the Hawaiian group have an average gradient of 766 ft/mi (144 m/km), whereas the Bering Canyon has a slope of only 42 ft/mi (7.9 m/km).

In comparison to modern canyons, dimensions of ancient canyons are considerably smaller. Deposits of ancient canyons are good hydrocarbon reservoirs. This is because submarine canyons and channels are often filled with sand that has the potential to hold oil and gas. Examples of hydrocarbon-bearing canyon-channel reservoirs are present in the subsurface in California, Louisiana, and Texas.

Physical and biological processes that are common in submarine canyons are mass wasting, turbidity currents, bottom currents, and bioerosion, mass wasting and turbidity currents being the more important. Mass wasting is a general term used for the failure, dislodgement, and downslope movement of sediment under the influence of gravity. Common examples of mass wasting are slides, slumps, and debris flows. Major slumping events can lead to formation of submarine canyons. The Mississippi Canyon in the Gulf of Mexico is believed to have been formed by retrogressive slumping during the late Pleistocene fall in sea level and has been partially infilled during the Holocene rise in sea level. Turbidity currents are one of the most important erosional and depositional processes in submarine canyons. There is considerable evidence to suggest that turbidity currents flow at velocities of 11–110 in./s (28–280 cm/s) in submarine canyons. Therefore, turbidity currents play a major role in the erosion of canyons. See DEPOSITIONAL SYSTEMS AND ENVIRONMENTS; MARINE GEOLOGY; MARINE SEDIMENTS; MASS WASTING; TURBIDITY CURRENT.

[G.Sh.]

**Submillimeter astronomy** Investigation of the universe by probing the electromagnetic spectrum at wavelengths from approximately 0.3 to 1.0 millimeter: the submillimeter waveband. This waveband is bounded at longer wavelengths by the millimeter waveband (1–10 mm), and at shorter wavelengths by the far-infrared waveband (20–300 micrometers). Astronomical objects with temperatures between about 10 kelvins and several hundred kelvins, typically in the interstellar medium of galaxies, emit radiation strongly in the submillimeter waveband. See ELECTROMAGNETIC RADIATION.

The submillimeter waveband is one of the last parts of the electromagnetic spectrum to be investigated. This is due both to the technical challenge of making sensitive detectors, which must be held at temperatures close to absolute zero, and to the effects of the Earth's atmosphere. Atmospheric molecules, primarily water vapor, both absorb (dim) the signal from astronomical sources and emit their own radiation that acts to mask the astronomical signals. The effects are most severe at the shortest wavelengths, and only high mountain sites and air or space-borne platforms can be used for submillimeter astronomy. From high mountains, observations are possible in only three atmospheric windows, at wavelengths of about 0.35, 0.45, and 0.85 mm. Radiation of 0.85 mm penetrates down to about 2 km (1.2 mi) above sea

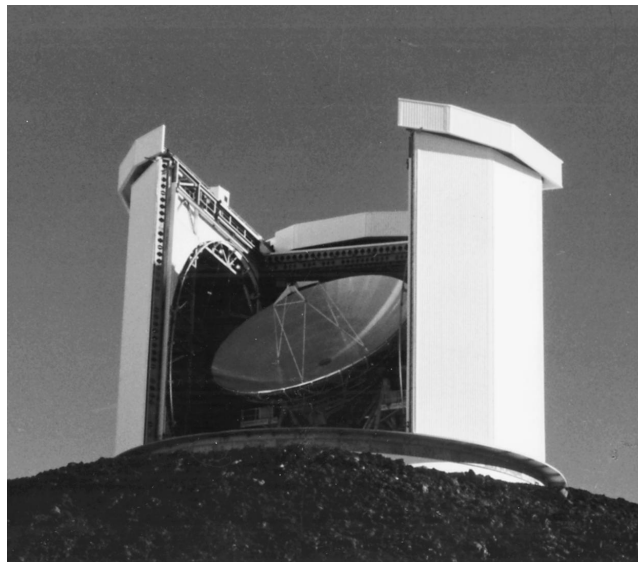

James Clerk Maxwell Telescope, 49-ft-diameter (15-m) submillimeter telescope situated at Mauna Kea, Hawaii.

level; while on the driest nights, only about one-half of photons with wavelengths of 0.35 or 0.45  $\mu\text{m}$  that enter the upper atmosphere can be detected at the 4200-m (14,000-ft) summit of Mauna Kea, Hawaii.

Several submillimeter telescopes operate on high mountain tops, including the 15-m (49-ft) James Clerk Maxwell Telescope (JCMT; see illustration) and the 10.4-m (34-ft) Caltech Submillimeter Observatory (CSO) telescope, both on Mauna Kea, and the 15-m (49-ft) Swedish-ESO Submillimeter Telescope (SEST) in Chile. These telescopes look like satellite antennas, but their surfaces are smooth and precisely shaped to an accuracy of order 10  $\mu\text{m}$ . These ground-based telescopes are subject to more atmospheric absorption than airborne and space telescopes; but because they have larger apertures, they can collect more radiation, boosting their sensitivity. See TELESCOPE.

In 2005 the Stratospheric Observatory for Infrared Astronomy (SOFIA), a 2.5-m-aperture (8.2-ft) telescope in a 747 aircraft, was expected to be operating. Like the former Kuiper Airborne Observatory (KAO), SOFIA will fly at up to 14 km (9 mi) altitude. Stratospheric balloons, flying at altitudes of about 40 km (25 mi), can also be used to carry submillimeter telescopes; an example is the BOOMERANG cosmic microwave background experiment reported in 2000. See INFRARED ASTRONOMY.

The signals from several submillimeter telescopes can be combined together in an interferometer to provide a telescope with resolution as fine as one with an aperture as large as the greatest separation between the individual telescopes. Examples of this type of telescope are the Smithsonian Millimeter Array (SMA) on Mauna Kea, and the United States-Europe-Japan Atacama Large Millimeter Array (ALMA) under development in Chile. See RADIO TELESCOPE.

Submillimeter observations are used by astronomers with a wide range of interests to study matter in the universe at temperatures of about 10–100 K and the cosmic microwave background radiation. Interstellar chemistry in clouds of gas and dust, the formation of protostars embedded in stellar nurseries within the Milky Way, the properties of the interstellar medium in even the most distant galaxies, and the evolution of galaxies are all studied in the submillimeter waveband. Submillimeter observations are especially important for observations of regions that are rich in dust and gas. These are opaque to visible and infrared light, but submillimeter light can still escape, allowing these regions to be studied.

[A.Bl.]

**Submillimeter-wave technology** The generation, detection, and application of radiation in the submillimeter-wave region of the electromagnetic spectrum. In practical terms, this region corresponds to wavelengths between about 30 micrometers and 3 millimeters (see illustration). At its extremes the region overlaps with the microwave and infrared, and a unique feature is that the distinct propagation methods of these adjacent regions, guided-wave and free-space propagation, are used throughout it. See ELECTROMAGNETIC RADIATION; INFRARED RADIATION; MICROWAVE.

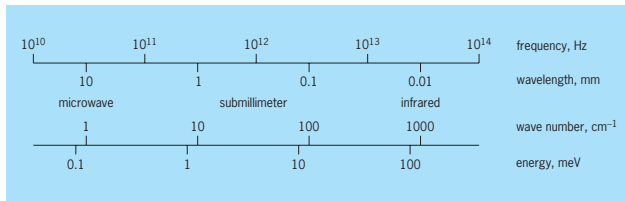

**Electromagnetic spectrum in and near the submillimeter-wave region, showing its frequency, wavelength, wave number, and photon energy equivalents.**

Widespread use of the submillimeter-wave region did not occur until two revolutionary developments in the late 1950s and early 1960s: (1) the practical realization of Fourier transform spectroscopy, which led to significant improvements in the quality of broad band submillimeter-wave spectroscopy; and (2) the discovery of two reasonably intense submillimeter-wave laser sources, the hydrogen cyanide and the water-vapor electrically excited lasers. See INFRARED SPECTROSCOPY; LASER.

**Radiation sources.** The main application of incoherent radiation sources is as broad band sources in Fourier transform spectrometers. The two most commonly used sources are the mercury-vapor lamp and the globar. See MERCURY-VAPOR LAMP; MICROWAVE TUBE.

There are several categories of coherent submillimeter-wave radiation sources: (1) nonrelativistic electron-beam tubes such as klystrons, extended interaction oscillators, orotrons, ledatrons, and carcinotrons or backward-wave oscillators, which oscillate with varying amounts of tunability and output power; (2) relativistic electron-beam devices such as gyrotrons, free-electron lasers, and synchrotrons; and (3) solid-state devices such as Gunn and IMPATT oscillators. With the exception of the free-electron laser, these are long-wave devices. The final category, gas lasers, covers the entire submillimeter-wave region. See GYROTRON; KLYSTRON; MICROWAVE SOLID-STATE DEVICES; SYNCHROTRON RADIATION.

**Detectors.** Most submillimeter-wave detectors are either thermal, rectifying, or photon detectors. The first respond to heat generated by absorbed radiation, the second by rectification of radiation-field-induced currents, the third by absorption of individual photons. They are commonly used in direct and heterodyne detection systems. Thermal detectors include room-temperature thermopile, Golay cell, and pyroelectric detectors, while more sensitive semiconductor bolometers operate at liquid-helium temperatures. Rectifying devices include metal-semiconductor and metal-metal point contacts and Schottky barrier diodes, all room-temperature devices, and Josephson-type devices operated at about 4.2 K (−452°F). Submillimeter-wave photon detectors are based on semiconductors and rely on the absorption of a photon changing the free-carrier density or mobility and hence the conductivity of the detector. See BOLOMETER; PYROELECTRICITY; RADIOMETRY; SUPERCONDUCTING DEVICES.

**Atmospheric transparency.** Between the visible and microwave regions the atmosphere is effectively opaque, with the exception of two windows in the near-infrared and three in the submillimeter-wave region, at 94, 140, and 220 GHz. The significant feature of the submillimeter-wave windows is that the levels of attenuation involved are not as seriously increased by

adverse atmospheric conditions as those of the near-infrared. This makes them attractive for many applications. The attenuation associated with these windows is, nonetheless, quite high and means that ground-level low-frequency submillimeter-wave systems have a relatively limited range. This can be advantageous for some applications.

**Applications.** In the past, applications of radiation in the submillimeter-wave region were distributed evenly over the region and largely concerned research activities. Now, however, as a result of developments toward integrated, inexpensive transmitter and receiver systems, applications include many radar- and telecommunications-related activities centered on the 94-GHz atmospheric window. These applications are mainly military, but spin-offs into the civil area are expected.

Photon energies in the submillimeter-wave region correspond to activation energies of many physical, chemical, and biological phenomena, and the spectroscopic techniques of this region have been widely applied to their study. Other spectroscopic applications have concerned the development of radiometric methods to meet the requirements of fusion plasma diagnostics and astronomy. See SUBMILLIMETER ASTRONOMY.

The submillimeter-wave region has been extensively used for fundamental frequency metrology, relating the frequencies of submillimeter-wave gas lasers directly back to the primary frequency standard. Important consequences have been the definition of the speed of light as a fixed quantity and the redefinition of the meter as a unit derived from it. See LIGHT; PHYSICAL MEASUREMENT.

The submillimeter-wave region impinges on fusion plasma research in two ways. First, in machines such as tokamaks it provides a way of studying the spatial and temporal evolution of the electron temperature. The second application is electron cyclotron heating, in which electron heating by microwave radiation at the electron cyclotron frequency has been demonstrated. High-power gyrotron oscillators are generally used as the radiation sources. See NUCLEAR FUSION; PLASMA (PHYSICS); PLASMA DIAGNOSTICS.

In the study and applications of fast electromagnetic pulse propagation, a number of novel techniques for the submillimeter-wave region have been developed. The generation and detection of such pulses can be done with ultra-short optical pulses driving photoconductive switches, or by all-electronic systems based on nonlinear transmission lines. The submillimeter-wave radiation used in these systems is variously known as T waves or terahertz waves. See OPTICAL PULSES.

[J.R.Bi.]

**Subsonic flight** Movement of a vehicle through the atmosphere at a speed appreciably below that of sound waves. Subsonic flight extends from zero (hovering) to a speed approximately 85% of sonic speed corresponding to the ambient temperature. At higher vehicle velocities the local velocity of air passing over the vehicle surface may exceed sonic speed, and true subsonic flight no longer exists.

Vehicle type may range from a small helicopter, which operates at all times in the lower range of the velocity scale, to an intercontinental ballistic missile, which is operative throughout this and other velocity regimes, but is in subsonic flight for only a few seconds. The design of each is affected by the same principles of subsonic aerodynamics. Subsonic flow of a fluid such as air may be subdivided into a range of velocities in which the flow may be considered incompressible without appreciable error (below a velocity of approximately 300 mi/h or 135 m/s), and a higher range in which the compressible nature of the fluid becomes significant. In both cases the viscosity of the fluid is important. The theories which apply to compressible, inviscid fluids may be used almost without modification in some low-subsonic problems, and in other cases the results offered by these theories may be modified to account for the effects of viscosity and

compressibility. See COMPRESSIBLE FLOW; TRANSONIC FLIGHT; VIS-COSITY.

A typical subsonic wing cross section (airfoil) has a rounded front portion (leading edge) and a sharp rear portion (trailing edge). Air approaching the leading edge comes to rest at some point on the leading edge, with flow above this point proceeding around the upper airfoil surface to the trailing edge, and flow below passing along the lower surface to the same point, where the flow again theoretically has zero velocity. The two points of zero local velocity are known as stagnation points. If the path from front to rear stagnation point is longer along the upper surface than along the lower surface, the mean velocity of flow along the upper surface must be greater than that along the lower surface. Thus, in accordance with the principle of conservation of energy, the mean static pressure must be less on the upper surface than on the lower surface. This pressure difference, applied to the surface area with proper regard to force direction, gives a net lifting force. Lift is defined as a force perpendicular to the direction of fluid flow relative to the body, or more clearly, perpendicular to the free-stream velocity vector. See AIRFOIL; BERNOULLI'S THEOREM.

The wing, as the lifting device, whether fixed, as in the airplane, or rotating, as in the helicopter, is probably the most important aerodynamic part of an aircraft. However, stability and control characteristics of the subsonic airplane depend on the complete structure. Control is the ability of the airplane to rotate about any of the three mutually perpendicular axes meeting at its center of gravity. Static stability is the tendency of the airplane to return to its original flight attitude when disturbed by a moment about any of the axes.

[J.E.Ma.]

**Substitution reaction** One of a class of chemical reactions in which one atom or group (of atoms) replaces another atom or group in the structure of a molecule or ion. Usually, the new group takes the same structural position that was occupied by the group replaced.

Substitution reactions involve the attack of a reagent, which is the source of the new atom or group, on the substrate, the molecule or ion in which the replacement occurs. They involve the formation of a new bond and the breaking of an old bond. Substitution reactions are classified according to the nature of the reagent (electrophilic, nucleophilic, or radical) and according to the nature of the site of substitution (saturated carbon atom or aromatic carbon atom). See ELECTROPHILIC AND NUCLEOPHILIC REAGENTS.

Systematic names for substitution reactions are composed of the parts: name of group introduced + de + name of group replaced + ation, with suitable elision or change of vowels for euphony. Thus, the replacement of bromine by a methoxy group is called methoxydebromination. See ORGANIC REACTION MECHANISM.

[J.F.B.]

**Subsynchronous resonance** The resonance between a series-capacitor-compensated electric system and the mechanical spring-mass system of a turbine-generator at subsynchronous frequencies. Beginning about 1950, series capacitors were installed in long alternating-current transmission lines [250 km (150 mi) or more] to cancel part of the inherent inductive reactance of the line. Until 1971, up to 70% of the 60-Hz inductive reactance was canceled by series capacitors in some long lines with little concern for side effects. (If 70% of a line's inductive reactance is canceled, the line is said to have 70% series compensation.) In 1970, and again in 1971, a turbine-generator at the Mohave Power Plant in southern Nevada experienced shaft damage that required several months of repairs on each occasion, following switching events that placed the turbine-generator radial on a series-compensated transmission line. The shaft damage was due to torsional oscillations between the two ends of the generator-exciter shaft. Shortly after the second event, it was determined that the tor-

sional oscillations were caused by torsional interaction, which is a type of subsynchronous resonance. There have been no reported occurrences of two other types of subsynchronous resonance, the induction generator effect and torque amplification. See ALTERNATING-CURRENT CIRCUIT THEORY; ALTERNATING-CURRENT GENERATOR; TRANSMISSION LINES; TURBINE.

It has been clearly established that subsynchronous resonance can be controlled with the use of countermeasures, thus making it possible to benefit from the distinct advantages of series capacitors. About a dozen countermeasures have been successfully applied such that there has been no reported subsynchronous resonance event since 1971. Subsynchronous resonance countermeasures protect turbine-generator shafts from harmful torsional oscillations by one of two methods. First, the turbine-generator can be tripped when a subsynchronous resonance condition is detected. This limits the number of torsional oscillations experienced by the turbine-generator shafts. This type of countermeasure is relatively inexpensive but is not acceptable if the anticipated subsynchronous resonance conditions are expected to occur frequently. Generally, such a countermeasure will not be applied as the sole subsynchronous resonance protection if it is expected to cause a turbine-generator to be tripped more than once every 10 years. Three types of tripping countermeasures are applied: torsional motion relay, armature current relay, and the generator tripping logic scheme. The second method of protection does not involve turbine-generator tripping, but eliminates or limits harmful torsional oscillations. See ELECTRIC POWER SYSTEMS.

[R.G.F.]

**Subtraction** One of the four fundamental operations of arithmetic and algebra. Subtraction is often regarded as an operation inverse to addition, that is, if  $a$  and  $b$  are numbers, the number  $a - b$  is defined as that number which added to  $b$  gives  $a$ . The more modern viewpoint eliminates subtraction completely by considering the number  $a - b$  as the sum of  $a$  and that number (denoted by  $-b$ ) which added to  $b$  gives 0. The number symbolized by  $-b$  is called the inverse of  $b$  (with respect to addition). Every real number has a unique inverse (the number 0 is its own inverse). In this sense "subtraction" may be performed on objects of many different kinds, and the original numerical operation greatly extended. See ADDITION; ALGEBRA; DIVISION; MULTIPLICATION; NUMBER THEORY.

[L.M.Bl.]

**Subway engineering** The branch of transportation engineering that deals with feasibility study, planning, design, construction, and operation of subway (underground railway) systems. In addition to providing rapid and comfortable service, subways consume less energy per passenger carried in comparison with other modes of transportation such as automobiles and buses. They have been adopted in many cities as a primary mode of transportation to reduce traffic congestion and air pollution.

Subways are designed for short trips with frequent stops, compared to above-ground, intercity railways. Many factors considered in the planning process of subway systems are quite similar to those for railway systems. Subway system planning starts with a corridor study, which includes a forecast of ridership and revenues, an estimation of construction and operational costs, and a projection of the potential benefits from land development. See RAILROAD ENGINEERING; TRANSPORTATION ENGINEERING.

All subway systems have three major types of structures: stations, tunnels, and depots. The most important task in planning a new subway system or a new subway line is to locate stations and depots and to determine the track alignment. Subway lines are normally located within the right-of-way of public roads and as far away as possible from private properties and sites of importance. Because stations and entrances are usually located in densely populated areas, land acquisition is often a major problem. One solution is to integrate entrances into nearby developments such as parks, department stores, and public



buildings, which lessens the visual impact of the entrances and reduces their impediment to pedestrian flow.

Design of the permanent works includes structural and architectural elements and electrical and mechanical facilities. There are two types of structures: stations and tunnels. For stations, space optimization and passenger flow are important. The major elements in a typical station are rails, platform, staircases, and escalators. For handicapped passengers, provisions should be made for the movement of wheelchairs in elevators and at fare gates, and special tiles should be available to guide the blind to platforms.

In both stations and tunnels, ventilation is essential for the comfort of the passengers and for removing smoke during a fire. Sufficient staircases are required for passengers to escape from the station platform to a point of safety in case of a fire. The electrical and mechanical facilities include the rolling stock, signaling, communication, power supply, automated fare collection, and environmental control (air-conditioning) systems. Corrosion has caused problems to structures in some subways; therefore, corrosion-resistant coatings may be required. To minimize noise and vibration from running trains, floating slabs can be used under rails or building foundations in sections of routes crossing densely populated areas and in commercial districts where vibration and secondary airborne noise inside buildings are unacceptable. See VENTILATION.

Underground stations are normally constructed by using an open-cut method. For open cuts in soft ground, the sides of the pits are normally retained by wall members and braced using struts. The pits are fitted with decks for maintaining traffic at the surface. For new lines that pass under existing lines, it is not possible to have open cuts. In such cases, stations have to be constructed using mining methods (underground excavation). See TUNNEL.

Many modern subway systems are fully automated and require only a minimal staff. Train movements are monitored and regulated by computers in a control center. Therefore, engineering is limited to the function and maintenance of the electrical and mechanical facilities. The electrical and mechanical devices requiring constant care include the rolling stock, signaling, communication and broadcasting systems, power supply, elevators and escalators, automated fare collection, and environmental control systems. Also included are depot facilities, and station and tunnel service facilities. See ELECTRIC DISTRIBUTION SYSTEMS; RAILROAD CONTROL SYSTEMS. [Z.C.M.; R.N.Hw.]

**Sucrose** An oligosaccharide,  $\alpha$ -D-glucopyranosyl- $\beta$ -D-fructofuranoside, also known as saccharose, cane sugar, or beet sugar. The structure is shown below. Sucrose is very soluble in

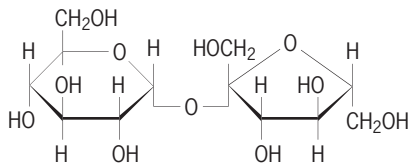

water and crystallizes from the medium in the anhydrous form. The sugar occurs universally throughout the plant kingdom in fruits, seeds, flowers, and roots of plants. Honey consists principally of sucrose and its hydrolysis products. Sugarcane and sugarbeets are the chief sources for the preparation of sucrose on a large scale. Another source of commercial interest is the sap of maple trees. See OLIGOSACCHARIDE; SUGARBEET; SUGARCANE. [W.Z.H.]

**Suctoria** A small specialized subclass of the protozoan class Ciliata whose members were long considered entirely separate from the "true" ciliates. The sole order of this subclass is Suctorida. These forms show a number of highly specialized features. Most conspicuous are their tentacles, often numerous, which serve as mouths. These multiple organelles of ingestion

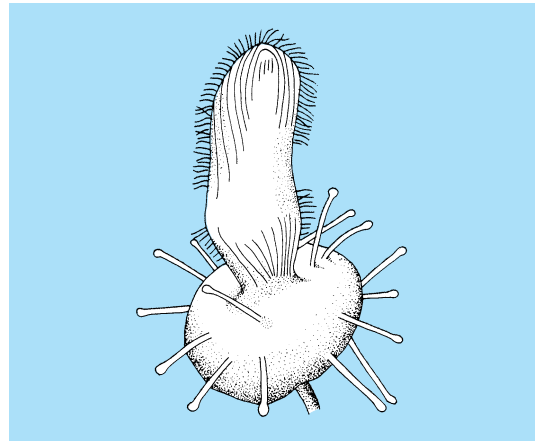

Endogenous budding in the suctorian *Podophrya*, a species which measure 10–28 micrometers.

fasten to the pellicle of prey organisms, generally passing ciliates. By forces not entirely understood, the tentacles are used to suck out the prey's protoplasm to provide sustenance for the suctorian. Nearly all species are stalked, and the sedentary, mature forms are devoid of any external ciliature. Young larval forms are produced by both endogenous and exogenous budding. These forms bear locomotor cilia and serve, as in the case of species of the Peritrichia, for dissemination (see illustration). See CILIATEA; PERITRICHIA. [J.O.C.]

**Sudangrass** An annual, warm-season grass of tropical origin said to have been grown in Egypt since early times, though its value was first recognized in Sudan only in 1909. In that same year it was introduced into the United States as a replacement for johnsongrass, which had become a noxious weed in many southern states. Sudangrass (*Sorghum bicolor* var. *sudanense*, also called *S. sudanense* and *S. vulgare* var. *sudanense*) and its hybrids are commonly used as pasture, greenchop, silage, or hay. They fill an important need in many regions of the United States, because they produce high-quality forage for cattle and sheep during the summer, when other pasture is in short supply or of low quality. Many of the varieties and hybrids produce forage until frost. See GRASS. [M.R.G.]

**Sudden infant death syndrome (SIDS)** The sudden and unexpected death of an apparently normal infant that remains unexplained after an adequate autopsy. Of a group of apparently healthy infants dying suddenly and unexpectedly, 15% will usually manifest pathologic evidence of a disease process which is sufficient to explain the death. The remaining 85% are unexplained and are classified as SIDS. In spite of the probable heterogeneity of diseases in SIDS cases, the consistent and distinctive characteristics of these infant deaths support the notion that many, if not the majority, represent a single disease process.

The incidence of SIDS in the United States is about 2.0 cases per 1000 live births, which makes SIDS the leading cause of death between the ages of 1 month and 1 year. Most SIDS deaths occur at 2–4 months of age, and about 90% occur by 6 months. SIDS is more common in males, prematurely born infants, multiple births, and the economically disadvantaged. SIDS is also increased in infants of teen-age or smoking mothers and in infants who have a history of a severe apparent life-threatening event, usually accompanied by marked cyanosis or pallor and limpness, and absence of breathing. SIDS also occurs more frequently during winter months. The rate among Native Americans is greater than among Blacks, which is greater than among Caucasians; Asians have the lowest rate. While there is slight familial clustering of SIDS, there is probably not a genetic predisposition to SIDS.

The cause of SIDS is unknown; leading hypotheses include respiratory, cardiac, and metabolic mechanisms. Much attention has been focused on the "apnea hypothesis," implicating a primary respiratory arrest due to chronic or transient insufficiency or irregularity of breathing. An imbalance between sympathetic and parasympathetic influences on cardiac activity, leading to potentially fatal cardiac arrhythmias, is a popular cardiac hypothesis.

While there is still no proof that SIDS can be prevented, electronic cardiorespiratory monitors have been prescribed for many infants in high-risk categories for SIDS. Home monitors are recommended only for infants at very high risk for SIDS. See CONGENITAL ANOMALIES; HUMAN GENETICS. [A.St.; K.Wi.; J.G.Br.]

**Sugar** Usually, sucrose, the common sugar of commerce. This sugar is a disaccharide,  $C_{12}H_{22}O_{11}$ , which is split, as shown in the reaction below, by hydrolysis into two monosaccharides,

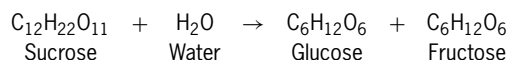

or simple sugars: glucose (dextrose) and fructose (levulose). Sucrose rotates the plane of polarized light to the right, as does glucose, but fructose is so strongly levorotatory that it overcomes the effect of glucose. Thus mixtures of equal amounts of glucose and fructose are levorotatory. The hydrolytic reaction is called inversion of sugar, and the product is invert sugar or, simply, invert. See CARBOHYDRATE; OPTICAL ACTIVITY.

Sucrose is widely distributed in nature, having been found in all green plants that have been carefully examined for its presence. The total quantity of all sugars formed each year has been estimated at a colossal  $4 \times 10^{11}$  tons ( $3.6 \times 10^{11}$  metric tons). In spite of its availability in all green plants, sucrose is obtained commercially in substantial amounts from only two plants: sugarcane, which supplies about 56% of the world total, and the sugarbeet, which provides 44%.

**Cane sugar manufacture.** The manufacture of cane sugar is usually done in two series of operations. First, raw sugar of about 98% purity is produced at a location adjacent to the cane fields. The raw sugar is then shipped to refineries, where a purity that is close to 100% is achieved.

**Raw cane sugar.** The production of raw cane sugar begins with growing the cane in tropical or subtropical areas. The cane is harvested after a season varying from 7 months in subtropical areas to 12–22 months in the tropics. The cane stalks are harvested either mechanically or by heavy hand knives. The trend is toward mechanization. The stalks are transported to a mill by oxcart, rail, or truck. See SUGARCANE.

At the mill the stalks are crushed and macerated between heavy grooved iron rollers while being sprayed countercurrently with water to dilute the residual juice. The expressed juice contains 95% or more of the sucrose present. The fibrous residue, or bagasse, is usually burned under the boilers, although increasing amounts are being made into paper, insulating board, and hardboard as well as furfural, which is a chemical intermediate for the synthesis of furan and tetrahydrofuran.

**Cane juice.** The cane juice is treated with lime to bring its pH to about 8.2. This pH prevents the inversion reaction, which is favored by heat and acid and would lower the yield of crystallizable sugar. The juice is then heated to facilitate the precipitation of impurities, which are removed by continuous filtration.

The purified juice is concentrated by multiple-stage vacuum evaporation (usually four or five stages) and, when sufficiently concentrated, is boiled to grain or seeded with sucrose crystals in a single-stage vacuum pan. Usually three successive crops of crystals are grown, cooled, and centrifuged. The final mother liquor, which is resistant to further crystallization, is called blackstrap molasses. It is used principally as a feed for cattle. Relatively small amounts are still fermented to produce industrial alcohol and rum.

**Raw cane sugar refining.** The refining of raw sugar begins with dissolution of the molasses which remains in a thin film on the crystals in spite of the centrifugation. This step, called affination, brings the purity from about 98 to about 99%. The crystals are dissolved in hot water and percolated through bone char columns to remove color by adsorption. The sucrose is finally concentrated by vacuum evaporation, crystallized by seeding, centrifuged, and dried.

A major step forward has been the use of bone char in a continuous countercurrent manner (Grosvenor patent). The bone char is washed, dried, and burned to remove impurities; it is reused until it wears out mechanically and is discarded as fines. Even the fines have value as fertilizer because of their high calcium phosphate content.

Bone char has been replaced in some refineries by granular carbon derived from coal or wood waste. It is used in columns and regenerated by a process similar to the one used for bone char, which unlike granular carbon is primarily calcium phosphate. Granular carbon is frequently used in combination with decolorizing resins to reduce the color of process liquors coming from the carbon columns. Pulverized activated vegetable carbon is used in a few instances to remove color from raw sugar liquors, but its use is declining. Ion-exchange resins are used to remove ash from raw sugar liquors, especially when the liquor is to be converted directly into refined liquid sugar without going through the crystallization step first. See ION EXCHANGE.

**Beet sugar.** In the United States, sugarbeets are grown under contract by farmers from seed supplied by a beet sugar company. Because sugarbeets, like the other temperate-zone crops, thrive best under crop rotation, they are not well adapted to one-crop agriculture. See SUGARBEET.

**Beet processing.** When beets are delivered to a factory, they are washed and sliced, and the slices are extracted countercurrently with hot water to remove the sucrose. The resulting solution is purified by repeatedly precipitating calcium carbonate, calcium sulfite, or both, in it. Colloidal impurities are entangled in the growing crystals of precipitate and removed by continuous filtration. The resulting solution is nearly colorless, and the sucrose is concentrated by multiple-effect vacuum evaporation. The syrup is seeded, cooled, and centrifuged, and the beet sugar crystals are washed with water and dried.

Beet molasses differs from cane molasses in having a much lower content of invert sugar. It is, therefore, relatively stable to the action of alkali and, in the United States, is usually treated with calcium oxide to yield a precipitate of calcium succrate. This is a mixture of loose chemical aggregates of sucrose and calcium oxide which are relatively insoluble in water. The precipitate is filtered, washed, and added to the incoming crude sugar syrup, where it furnishes calcium for the precipitations of calcium carbonate and sulfite referred to above, which remove impurities. Carbon dioxide in the form of flue gas is the other reagent, and sulfur dioxide from burning sulfur is used to produce sulfite. Ion exclusion processes have been developed for recovery of sucrose from beet molasses.

**Beet residue use.** The beet tops and extracted slices, as well as the molasses, are valuable as feeds. More feed for cattle and other ruminants can be produced per acre-year from beets than from any other crop widely grown in the United States. This is independent of the food energy in the crystallized sucrose, which exceeds that available from any other temperate-zone plant. It is for these reasons that the densely populated countries of Europe have expanded their beet sugar production, in spite of the ready availability of cane sugar from the tropics.

The increased use of nitrogenous fertilizer has resulted in augmenting the protein content of the molasses and other beet by-products.

**Nutritional value.** Sucrose has, in the past, been attacked by some nutritionists on the ground that it provides only "empty calories," without protein, minerals, or vitamins. This argument lost much of its force when it was shown that all the vitamins

and minerals recommended by the National Research Council can be obtained by consuming any of a great variety of foods in amounts that yield a total of only one-half of the caloric requirements of an average person. The wide use by the public of vitamin supplements has caused some nutritionists to express an opposite worry over excessive vitamin consumption.

In addition to the charges that it provides empty calories, sugar has been blamed for such health problems as diabetes mellitus, coronary heart disease, dental caries, and obesity. These charges and the scientific evidence associated with them have been extensively reviewed by a special committee of the Federation of American Societies for Experimental Biology. A report of the committee findings, published by the Food and Drug Administration in 1976, includes the following: Sucrose is a contributor to the formation of dental caries when used at levels and in the manner prevailing in 1976; otherwise, there is no clear evidence in the available information that demonstrates a hazard to the public when sucrose is used at those levels.

**Other sources of sugars.** In Hawaii, the pineapple industry recovers both sucrose and citric acid from the rinds. The residue is fed to cattle. The total quantity of sucrose obtained from waste fruits is statistically negligible. On the other hand, a substantial fraction of the total sucrose consumed is that naturally present in a large number of fruits, vegetables, and nuts. See SUCROSE; SUGAR CROPS.

**Lactose.** Cow's milk, on a dry basis, is about 38% lactose or milk sugar. When milk is converted into cheese, the lactose remains in the whey, from which it may easily be isolated and purified. Lactose is a disaccharide which is split by hydrolysis into glucose and galactose. Lactose is about one-tenth as soluble in water as sucrose and it is one-sixth to one-half as sweet, depending on the concentration. Some of the major uses for lactose are as a direct-compression vehicle for the manufacture of pharmaceutical tablets and as a diluent for pharmaceuticals and synthetic sweeteners. See CHEESE; LACTOSE.

**Starch.** Starches can be hydrolyzed either by dilute acid or by enzymes. The product of acid hydrolysis varies with time and conditions but contains glucose, maltose, maltotriose, maltotetraose, and other sugars up to the dextrans. Only glucose, a monosaccharide, is readily isolated. Crystallized as the monohydrate, it is used in foods as a sweetener. See CORN; GLUCOSE.

Syrups high in maltose, a disaccharide, can be obtained by the action of amylases on starch. This hydrolysis has been of great importance for thousands of years in splitting starches for alcoholic fermentation. As yet, there is no large-scale production of pure maltose. See MALTOSE.

A major type of syrup was developed from starch hydrolyzates by the mid-1980s. An enzyme that isomerizes dextrose (glucose) was commercially developed to manufacture hydrolyzed starch syrups (corn syrups) containing varying amounts of fructose (levulose). The enzyme isomerizes dextrose into fructose theoretically to a 50-50 mixture of dextrose and fructose. In practice, the isomerization is allowed to progress until a syrup containing (on a solids basis) approximately 50% dextrose, 42% fructose, and 8% higher saccharide is achieved. Syrups containing more than 42% fructose (solid basis) can be made by subjecting the 42% fructose syrup to an ion-exclusion process that separates dextrose and fructose. The fructose-rich fraction from the separation is converted into a finished product, and the dextrose-rich fraction is returned to the isomerization process. Commercially produced syrups contain 42% or 55% fructose. The combined processes are also used to manufacture commercial fructose. The high-fructose corn syrups are competitive with sucrose and invert sugar in a variety of food products. The most widely used application for 55% high-fructose corn syrup is in soft drinks, displacing sucrose and invert sugar. See FRUCTOSE; STARCH.

**Maple sugar.** Before America was settled by Europeans, Indians were collecting and concentrating the juice of the hard maple (*Acer saccharum*), making maple syrup. The practice was copied by the new settlers, and production of maple syrup has

been an industry ever since in the regions where hard maples are common, principally the northeastern United States.

The maple flavor does not exist in the sap but is developed by heating it. By additional heating at about 250°F (120°C), a flavor four or five times more intense can be developed. Maple syrup so produced is of special value for adding flavor to the less expensive products of the sucrose industry. Maple sugar is sucrose of about 95-98% purity; the characteristic flavor makes up only a small percent. Fairly satisfactory imitation maple flavors are available.

**Honey.** Honey is a form of relatively pure invert sugar dissolved in water to form a concentrated solution. However, honey also contains flavors derived from the nectar of the flowers from which it was obtained by the bee. Nutritionally, it is nearly equivalent in invert sugar but contains an excess of fructose over glucose. The sucrose found in the flowers is inverted by the enzyme honey invertase. Tupelo honey is remarkable in containing about twice as much fructose as glucose, and hence has little tendency to deposit glucose crystals.

The ready availability of the food energy in honey was known to athletes in ancient Greece. Only in recent times has it been discovered that, paradoxically, the energy of sucrose is still more quickly available. The flavors of various honeys run a wide gamut. That from the Mount Hymettus region, which is flavored by wild thyme, has been known and treasured since the poems of Homer.

**Molasses.** Virtually all molasses is distributed in the form of a concentrated viscous solution, but it can be reduced to a powder by means of spray-drying. It can then be handled without an investment by the consumer in tanks, pipes, and pumps. Unfortunately, later contact with moisture converts the dried molasses to a gummy mass. The availability of vaporproof bags (for example, those lined with polyethylene) has provided one solution to this problem. There are also various additives which, when mixed with molasses, reduce its tendency to pick up moisture. So far, dried molasses has made little headway against the practice of handling concentrated solutions.

**Syrups.** Syrups are relatively concentrated, somewhat viscous, solutions of various sugars, frequently in admixture to hinder crystallization. Large amounts of sucrose have been distributed in the form of high-purity syrups. These syrups consist of sucrose, invert sugar, or both. In some instances syrups include mixtures with dextrose and various corn syrups. The so-called liquid sugars are important for several reasons: the requirement for the use of syrups in a number of food processes (conversion of granular sucrose to a syrup was eliminated at the point of use); economy of handling, being moved with pumps, pipes, tank trucks, and tank cars; the high degree of sanitation inherent in the storage and distribution of sugar within the plant in a closed system, including the elimination of dust from the dumping of bags; and the availability of a combination of sugars with differing characteristics in a single product.

The quantity of sucrose distributed in syrup form has been reduced drastically because of the inroads made by high-fructose corn syrups, which have a composition somewhat comparable to that of invert sugar. These products are available only as syrups. They do not have taste characteristics identical to sucrose and invert sugar syrups, but lower prices catalyze their substitution for sucrose.

It is the aim of the sugar refiner and the beet processor to eliminate color and all flavors other than sweetness. The manufacture of table syrups, which are widely used on waffles and pancakes, aims at a broader spectrum of flavor. Corn syrup, which is somewhat lacking in sweetness, ordinarily has about 15% sucrose added. The high viscosity of the corn syrup, resulting from the content of dextrans, tends to hinder crystallization and is an advantage in the manufacture of certain candies.

Some sugar refiners manufacture so-called refiners' syrups for use in the manufacture of foods and table syrups. In addition to these syrups, a group of products generally referred to as cane

syrup and edible molasses are manufactured from cane juice. Cane syrup is concentrated whole cane juice, while edible molasses is concentrated cane juice from which some sugar has been removed by crystallization. These syrups and molasses contain both sucrose and invert sugar, and have a relatively dark color and a distinctive flavor. They also contain many of the nonsugars found in sugarcane juice. They are used principally by food processors, but substantial amounts are packaged for home use. Sorghum syrup is made by extracting juice from the stalk of sweet sorghum and evaporating the juice to syrup consistency. It is a dark, pungently flavored product that is not widely distributed. See FOOD ENGINEERING; FOOD MANUFACTURING; SUGAR CROPS. [H.B.H.; Ch.B.B.]

**Sugarbeet** The plant *Beta vulgaris*, developed in modern times to fill the need for a sugar crop that could be grown in temperate climates. The sugarbeet was the source of only 5% of the world's commercial sugar in 1840, but by 1890 it supplied almost 50%, and since about 1920 this has dropped to about 40% with 60% derived from sugarcane. European countries produce most of their sugar from sugarbeet, with some countries having surplus sugar for export. See SUGARCANE.

The sugarbeet, fodder beet, garden beet, and leaf beet (Swiss chard) are cultivars of *B. vulgaris* and are genetically related. In addition to *B. vulgaris*, which includes all cultivated forms of beet, there are 12 species of wild beet in the Mediterranean and Middle Eastern regions. These wild beets are of interest in sugarbeet improvement as sources of disease resistance. Most varieties of sugarbeet in the United States are hybrid. [D.Ste.]

**Sugarcane** *Saccharum officinarum*, a member of the grass family. This crop originated in New Guinea about 15,000–8000 B.C., and was later moved by primitive peoples westward into Southeast Asia and India and eastward into Polynesia. Most current commercial varieties are interspecific hybrids involving primarily two or more of the following species: *S. officinarum*, *S. robustum*, and *S. spontaneum*.

Sugar is generally removed from sugarcane in large factories by either milling or diffusion. Milling crushes the stalks as they pass between a series of large metal rollers separating the fiber (bagasse) from the juice laden with sugar. The diffusion process separates sugar from finely cut stalks by dissolving it in hot water or hot juice. Processing of the juice is completed by clarification to remove nonsugar components, by evaporation to remove water, and by removal of molasses in high-speed centrifuges to produce centrifugal sugar. Bagasse and molasses are the principal by-products from processing sugarcane. [R.E.Co.]

**Sulfide phase equilibria** The chemistry of the sulfides is rather simple inasmuch as most sulfide minerals involve only two major elements, although some involve three, and a few four. Understanding of the phase relations among these minerals is important both to the geologist, whose task it is to locate and exploit ore deposits, and to the metallurgist, whose task it is to extract the metals from the ores for industrial use.

Sulfide ore deposits are the most important sources of numerous metals such as lead, zinc, copper, nickel, cobalt, and molybdenum. In addition, sulfide ores provide substantial amounts of noble metals such as platinum, gold, and silver, and of other industrially important elements such as cadmium, rhenium, and selenium. Although iron sulfides usually are the most common minerals in such deposits, most commercial iron is mined from iron oxide ores and most sulfur from elemental sulfur deposits.

Some of the more common sulfide minerals are listed in the table. The first eight sulfide minerals listed may be plotted in the ternary system copper-iron-sulfur. Similarly, the first two and the last two minerals may be plotted in the ternary system iron-nickel-sulfur. Thus, by studying in detail the phase equilibria in two ternary systems a great deal of information can be obtained about many of the common sulfides occurring in ore deposits.

Common sulfide minerals

Mineral name	Chemical formula
Pyrite	FeS <sub>2</sub>
Pyrrhotites (three or more varieties)	Fe <sub>1-x</sub> S
Covellite	CuS
Digenite	Cu <sub>9</sub> S <sub>5</sub>
Chalcocite	Cu <sub>2</sub> S
Bornite	Cu <sub>5</sub> FeS <sub>4</sub>
Chalcocopyrite	CuFeS <sub>2</sub>
Cubanite	CuFe <sub>2</sub> S <sub>3</sub>
Galena	PbS
Sphalerite and wurtzite	ZnS
Metacinnabar and cinnabar	HgS
Argentite and acanthite	Ag <sub>2</sub> S
Molybdenite	MoS <sub>2</sub>
Millerite	NiS
Pentlandite	(Fe,Ni) <sub>9</sub> S <sub>8</sub>

However, before the ternary systems can be explored in a systematic way, the binary systems bounding the ternaries have to be studied in detail. Similarly, it is necessary that the four bounding ternary systems be fully understood before a quaternary system can be systematically investigated. Thus, it is seen that before a systematic study of, for example, the immensely important quaternary system copper-iron-nickel-sulfur can proceed, much preliminary information is required. The prerequisites data include complete knowledge of the four ternary systems Cu-Fe-S, Cu-Fe-Ni, Fe-Ni-S, and Cu-Ni-S. In turn, the phase relations in these ternary systems cannot be systematically studied before the six binary systems Fe-Cu, Fe-Ni, Cu-Ni, Fe-S, Cu-S, and Ni-S have been thoroughly explored. See PHASE EQUILIBRIUM.

The enormous differences in the vapor pressures over the different phases occurring in sulfide systems add complications to the diagrammatic representation. For instance, in the Fe-S system the vapor pressure over pure iron is about 10<sup>-25</sup> atm (10<sup>-20</sup> pascal) at 450°C (840°F), whereas that over pure sulfur is a little more than 1 atm (10<sup>5</sup> pascals) at the same temperature. A complete diagrammatic representation of the relations in such a system, therefore, requires coordinates for composition and temperature, as well as for pressure. In a two-component system, such as the Fe-S system, such a representation is feasible because only three coordinates are necessary. However, in ternary (where such diagrams involve four-dimensional space) and in multicomponent systems, this type of diagrammatic representation is not possible. For this reason it is customary to use composition and temperature coordinates only for the diagrammatic representation of sulfide systems. The relations as shown in such diagrams in reality represent a projection from composition-temperature-pressure space onto a two-dimensional composition-temperature plane or onto a three-dimensional prism, depending upon whether the system contains two or three components.

Pyrite or pyrrhotite, or both, occur almost ubiquitously, not only in ore deposits but in nearly all kinds of rocks. Of the binary systems mentioned above, therefore, the iron-sulfur system is of the most importance to the economic geologist. See PYRITE. [G.Kul.]

**Sulfonamide** One of the group of organosulfur compounds, RSO<sub>2</sub>NH<sub>2</sub>. Many sulfonamides, which are the amides of sulfonic acids, have the marked ability to halt the growth of bacteria. The therapeutic drugs of this group are known as sulfa drugs. See ORGANOSULFUR COMPOUND.

The antibacterial spectrum of sulfonamides comprises a wide variety of gram-positive and gram-negative bacteria, including staphylococci, streptococci, meningococci, and gonococci, as well as the gangrene, tetanus, coli, dysentery, and cholera bacilli. They have only slight activity against *Mycobacterium tuberculosis*, while certain closely related sulfones are quite active against

*M. leprae*. The use of sulfonmethoxine has proved to be effective in the treatment of chloroquine-resistant malaria. The relative potency of sulfonamides against the different microorganisms varies, and their action is bacteriostatic rather than bactericidal.

The antibacterial effect, both in patients and in test tube cultures, is antagonized by *p*-aminobenzoic acid (PABA) and PABA-containing natural or synthetic products, such as folic acid and procaine. Accordingly, the mode of action of sulfonamides is considered to be an antimetabolite activity, dependent upon the inhibition of enzyme systems involving the essential PABA. See BACILLARY DYSENTERY; CHOLERA; LEPROSY; MALARIA; MENINGOCOCCUS; STAPHYLOCOCCUS; STREPTOCOCCUS; TETANUS; TUBERCULOSIS.

Bacterial resistance has developed to all known sulfonamides, and many sulfonamide-resistant strains are encountered among the gram-positive and gram-negative bacteria. The emergence of resistance to sulfonamides, however, seems less rapid and less widespread than resistance to most antibiotics.

Sulfonamides are used today mostly as auxiliary drugs or in combination with antibiotics. In certain infectious diseases, however (for instance, in meningococcal infections and most infections of the urinary tract), sulfonamides deserve preference over antibiotics. See ANTIMICROBIAL AGENTS; DRUG RESISTANCE.

[R.L.M.; E.Gru.]

**Sulfonation and sulfation** Sulfonation is a chemical reaction in which a sulfonic acid group,  $-\text{SO}_3\text{H}$ , is introduced into the structure of a molecule or ion in place of a hydrogen atom. Sulfation involves the attachment of the  $-\text{OSO}_2\text{OH}$  group to carbon, yielding an acid sulfate,  $\text{ROSO}_2\text{OH}$ , or of the  $-\text{SO}_4-$  group between two carbons, forming the sulfate,  $\text{ROSO}_2\text{OR}$ .

Sulfonation of aromatic compounds is the most important type of sulfonation. This is accomplished by treating the aromatic compound with sulfuric acid, as in the reaction below. The product of sulfonation is a sulfonic acid.

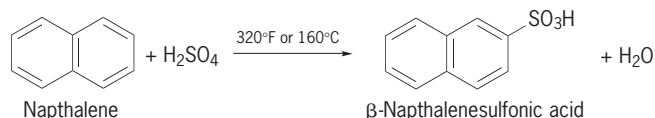

Sulfonation may also be defined as any chemical process by which the sulfonic acid group,  $-\text{SO}_2\text{OH}$ , or the corresponding salt or sulfonyl halide group, for example,  $-\text{SO}_2\text{Cl}$ , is introduced into an organic compound. These groups may be bonded to either a carbon or a nitrogen atom. The latter compounds are designated *N*-sulfonates or sulfamates.

Most sulfonates are employed as such in acid or salt form for applications where the strongly polar hydrophilic  $-\text{SO}_2\text{OH}$  group confers needed properties on a comparatively hydrophobic nonpolar organic molecule. Some sulfonates, such as methanesulfonic and toluenesulfonic acids, are used as catalysts. The major quantity of sulfonates and sulfates is both marketed and used in salt form. This category includes detergents; emulsifying, demulsifying, wetting, and solubilizing agents; lubricant additives; and rust inhibitors. See ORGANOSULFUR COMPOUND; SUBSTITUTION REACTION.

[P.H.G./R.S.K.]

**Sulfonic acid** A derivative of sulfuric acid ( $\text{HOSO}_2\text{OH}$ ) in which an OH has been replaced by a carbon group, as shown in the structure below. Sulfonic acids are strongly acidic,

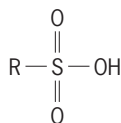

water-soluble, nonvolatile, and hygroscopic; they do not act as oxidizing agents and are typically highly stable compounds.

Sulfonic acids rarely occur naturally. An exception, taurine,  $\text{NH}_2\text{CH}_2\text{CH}_2\text{SO}_3\text{H}$ , occurs in bile.

The aliphatic sulfonic acids are generally made by oxidation of thiols. Several have unique properties. For example, trifluoromethanesulfonic acid,  $\text{CF}_3\text{SO}_3\text{H}$ , is such a strong acid that it will protonate sulfuric acid. A compound derived from natural camphor, 10-camphorsulfonic acid, is used extensively in the optical resolution of amines.

Aromatic sulfonic acids are much more important than those of the aliphatic series. Aromatic sulfonic acids are produced by sulfonation of aromatic compounds with sulfuric acid or fuming sulfuric acid. Sulfonation of aromatic hydrocarbons is a reversible process; treatment of an aromatic sulfonic acid with superheated steam removes the  $-\text{SO}_3\text{H}$  group. This process can be used in purifying aromatic hydrocarbons. Aromatic sulfonic acids and their derivatives, especially metal salts, are important industrial chemicals. See SULFURIC ACID.

The most extensive use of the sulfonation reaction is in the production of detergents. The most widely used synthetic detergents are sodium salts of straight-chain alkylbenzenesulfonic acids. See DETERGENT.

Sulfonated polymers, particularly sulfonated polystyrenes, act as ion-exchange resins which have important applications in water softening, ion-exchange chromatography, and metal separation technology. Both sulfonated polymers and simple aromatic sulfonic acids, particularly *p*-toluenesulfonic acid, are frequently used as acid catalysts in organic reactions such as esterification and hydrolysis. See HOMOGENEOUS CATALYSIS; ION EXCHANGE.

The sulfonic group, in either acid or salt form, is capable of making many substances water soluble, increasing their usefulness. This application is particularly significant in the dyeing industry, in which a majority of the dyes are complex sodium sulfonates. Many acid-base indicators are soluble due to the presence of a sodium sulfonate moiety. Some pigments used in the paint and ink industry are insoluble metal salts or complexes of sulfonic acid derivatives. Most of the brighteners used in detergents compounded for laundering are sulfonic acid derivatives of heterocyclic compounds. See ACID-BASE INDICATOR; DETERGENT; DYE; INK; ORGANOSULFUR COMPOUND; PAINT.

[C.R.J.]

**Sulfur** A chemical element, S, atomic number 16, and atomic weight 32.064. The atomic weight reflects the fact that sulfur is composed of the isotopes  $^{32}\text{S}$  (95.1%),  $^{33}\text{S}$  (0.74%),  $^{34}\text{S}$  (4.2%), and  $^{36}\text{S}$  (0.016%). The ratios of the various isotopes vary slightly but measurably according to the history of the sample. By virtue of its position in the periodic table, sulfur is classified as a main-group element. See PERIODIC TABLE.

The chemistry of sulfur is more complex than that of any other elemental substance, because sulfur itself exists in the largest variety of structural forms. At room temperature, all the stable forms of sulfur are molecular; that is, the individual atoms aggregate into discrete molecules, which in turn pack together to form the solid material. In contrast, other elements near sulfur in the periodic table normally exist as polymers (silicon, phosphorus, arsenic, selenium, tellurium) or as diatomic molecules (oxygen, nitrogen, chlorine). Selenium and phosphorus can exist as molecular solids, but the stable forms of these elements are polymeric.

At room temperature the most stable form of sulfur is the cyclic molecule  $\text{S}_8$ . The molecule adopts a crownlike structure, consisting of two interconnected layers of four sulfur atoms each. The S—S bond distances are 0.206 nanometer and the S—S—S bond angles are  $108^\circ$ . Three allotropes are known for cyclo- $\text{S}_8$ . The most common form is orthorhombic  $\alpha$ -sulfur, which has a density of  $2.069 \text{ g/cm}^3$  ( $1.200 \text{ oz/in.}^3$ ) and a hardness of 2.5 on the Mohs scale. It is an excellent electrical insulator, with a room temperature conductivity of  $10^{18} \text{ ohm}^{-1} \text{ cm}^{-1}$ . Sublimed sulfur and “flowers” of sulfur are generally composed of  $\alpha$ - $\text{S}_8$ . Sulfur is quite soluble in carbon disulfide ( $\text{CS}_2$ ; 35.5/100 g or 1.23 oz/3.52 oz at  $25^\circ\text{C}$  or  $77^\circ\text{F}$ ), poorly soluble in alcohols, and

practically insoluble in water. At 95.3°C (203°F), sulfur changes into the monoclinic  $\beta$  allotrope. This form of sulfur also consists of cyclic  $S_8$  molecules, but it has a slightly lower density at 1.94–2.01 g/cm<sup>3</sup> (1.12–1.16 oz/in.<sup>3</sup>). A third allotrope containing  $S_8$  is triclinic  $\gamma$ -sulfur. The  $\beta$  and  $\gamma$  allotropes of sulfur slowly revert to the  $\alpha$  form at room temperature. Crystals of sulfur are yellow and have an absorption maximum in the ultraviolet at 285 nm, which shifts to higher energy as the temperature decreases. At low temperatures,  $S_8$  is colorless. Even at room temperature, however, finely powdered sulfur can appear to be nearly white.

The best-studied system is  $\alpha$ - $S_8$ , which converts to the  $\beta$  form at 90°C (194°F), which then melts at 120°C (248°F) to give a golden yellow liquid. If this melt is quickly recooled, it refreezes at 120°C (248°F), thus indicating that it consists primarily of  $S_8$  molecules. If the melt is maintained longer at 120°C (248°F), then the freezing point is lowered about 5°C (9°F), indicating the formation of about 5% of other rings and some polymer. At 159.4°C (318.9°F), the melt suddenly assumes a red-brown color. Over the range 159.4–195°C (318.9–383°F), the viscosity of the melt increases 10,000-fold before gradually decreasing again. This behavior is very unusual, since the viscosity of most liquids decreases with increasing temperature. The strong temperature dependence of the viscosity is due to the polymerization and eventual depolymerization of sulfur. Polymeric sulfur retains its elastomeric character even after being cooled to room temperature. There are several polymeric forms of sulfur, but all of them revert to  $\alpha$ - $S_8$  after a few hours.

Sublimation of  $S_8$  occurs when it is maintained in a vacuum at a temperature below its melting point. It vaporizes at 444.61°C (832.30°F). Below 600°C (1110°F), the predominant species in the gas are  $S_8$  followed by  $S_7$  and  $S_6$ . Above 720°C (1328°F), violet  $S_2$  is the major species.

**Principal inorganic compounds.** Hydrogen sulfide ( $H_2S$ ) is the most important compound that contains only sulfur and hydrogen. It is a gas at room temperature with a boiling point of –61.8°C (–79.2°F) and a freezing point of –82.9°C (–117°F). The low boiling point of hydrogen sulfide is attributed to the weakness of intermolecular S...H hydrogen bonding; the O...H hydrogen bond is much stronger, as evidenced by the high boiling point of water. Gaseous hydrogen sulfide is 1.19 times more dense than air, and air- $H_2S$  mixtures are explosive. Hydrogen sulfide has a strong odor similar to that of rotten eggs; its odor is detectable at concentrations below 1 microgram/m<sup>3</sup>. At high concentrations,  $H_2S$  has a paralyzing effect on the olfactory system, which is very hazardous because  $H_2S$  is even more toxic than carbon monoxide (CO).

The most common compound that contains only carbon and sulfur is carbon disulfide ( $CS_2$ ). Carbon disulfide molecules are linear, consisting of two sulfur atoms connected to a central carbon atom. Carbon disulfide is a toxic, highly flammable, and volatile liquid that melts at –111°C (–168°F) and boils at 46°C (115°F). Commercial carbon disulfide has a strong unpleasant odor due to impurities. It is manufactured from methane and elemental sulfur and is used for the production of carbon tetrachloride, rayon, and cellophane. Structurally related to carbon disulfide is carbonyl sulfide (SCO), which forms from carbon monoxide and elemental sulfur. The chlorination of  $CS_2$  gives  $Cl_3CSCl$ , which can be reduced by  $H_2S$  to thiophosphene,  $CSCl_2$ . Thiophosgene ( $CSCl_2$ ) [boiling point 73°C or 163°F] is a planar molecule with the carbon at the center of a triangle defined by the sulfur and two chlorine atoms. Thiocyanate, the linear anion  $NCS^-$ , is prepared by the reaction of cyanide ( $-CN$ ) with elemental sulfur.

Several sulfur oxides exist, but the dioxide and trioxide are of preeminent importance. Sulfur dioxide ( $SO_2$ ) is a colorless gas that boils at –10.02°C (113.97°F) and freezes at –75.46°C (–103.8°F). The density of liquid sulfur dioxide at –10°C (14°F) is 1.46 g/cm<sup>3</sup> (0.84 oz/in.<sup>3</sup>). Liquid sulfur dioxide is an excellent solvent. The sulfur dioxide molecule is bent, with an O—S—O angle of 119°.

Sulfur trioxide ( $SO_3$ ) is a planar molecule that is a liquid at room temperature that exists in equilibrium with a cyclic trimeric structure known as  $\beta$ - $SO_3$ . When  $\beta$ - $SO_3$ , actually  $S_3O_9$ , is treated with traces of water, it converts to either of two polymeric forms referred to as  $\gamma$ - and  $\alpha$ -sulfur trioxide. These are fibrous materials, proposed to have the formula  $(SO_3)_xH_2$ , where  $x$  is in the thousands. Sulfur trioxide is prepared by the oxidation of sulfur dioxide, although at very high temperatures this reaction reverses. Exposure of sulfur trioxide to water yields sulfuric acid ( $H_2SO_4$ ); exposure of  $SO_3$  to sulfuric acid yields disulfuric acid ( $H_2S_2O_7$ ). See SULFURIC ACID.

Chlorine and sulfur react to give a family of compounds with the general formula  $S_xCl_2$ , several members of which have been obtained in pure form. The structures of these compounds are based on an atom or chain of sulfur atoms terminated with Cl. Sulfur monochloride ( $S_2Cl_2$ ), also known as sulfur monochloride, is the most widely available of the series. It is a yellow oil that boils at 138°C (280°F), and reacts with chlorine in the presence of iron(III) chloride ( $FeCl_3$ ) catalyst to give sulfur dichloride ( $SCl_2$ ), which is a red volatile liquid with a boiling point of 59°C (138°F). Treatment of sulfur dichloride with sodium fluoride (NaF) gives  $SF_4$ .

Thionyl chloride ( $OSCl_2$ ) is a colorless reactive compound with a boiling point of 76°C (169°F); it is used to convert hydroxy compounds to chlorides. Important applications include the preparation of anhydrous metal halides and alkyl halides. Sulfuryl chloride ( $O_2SCl_2$ ; boiling point 69°C or 156°F) is used as a source of chlorine.

**Organosulfur compounds.** This family of compounds contains carbon, hydrogen, and sulfur, and it is a particularly vast area of sulfur chemistry. Thiols, also known as mercaptans, feature the linkage C—S—H. Mercaptans are foul-smelling compounds. They are the sulfur analogs of alcohols, but they are more volatile. They can be prepared by the action of hydrogen sulfide ( $H_2S$ ) on olefins. Deprotonation of thiols gives thiolate anions, which form stable compounds with many heavy metals. Thiols and especially thiolates can be oxidized to form disulfides (persulfides), which have the connectivity of C—S—S—C. The organic persulfides are also related to organic polysulfides, which have chains of sulfur atoms terminated with carbon. The introduction of such mono-, di-, and polysulfide linkages is the basis of the vulcanization process, which imparts desirable mechanical properties to natural or synthetic polyolefin rubbers. This is accomplished by heating the polymer with sulfur in the presence of a zinc catalyst. See RUBBER.

Thioethers, also known as organic sulfides, feature the connectivity C—S—C and are often prepared from the reaction of thiolates and alkyl halides. Like mercaptans, thioethers often have strong unpleasant odors, but they are also responsible for the pleasant odors of many foods and perfumes. They are intentionally introduced at trace levels in order to impart an odor to gaseous hydrocarbon fuels. The reaction of alkyl dihalides and sodium polysulfides affords organic polysulfide polymers known as thiokols.

There are many organic sulfur oxides; prominent are sulfonic acids ( $RSO_3H$ ), which are the organic derivatives of sulfuric acid. These compounds are prepared by the oxidation of thiols as well as by treatment of benzene derivatives with sulfuric acid, for example, benzene sulfonic acid. Most detergents are salts of sulfonic acids. See DETERGENT.

**Biochemistry.** Sulfur is required for life. Typical organisms contain 2% sulfur dry weight. Three amino acids contain sulfur, as do many prosthetic groups in enzymes. Some noteworthy sulfur compounds include the disulfide lipoic acid, the thioethers biotin and thiamine (vitamin B<sub>1</sub>), and the thiol coenzyme A. Sulfide ions,  $S^{2-}$ , are found incorporated in metalloproteins and metalloenzymes such as the ferredoxins, nitrogenases, and hydrogenases. See AMINO ACIDS; ENZYME; PROTEIN.

Many bacterial species obtain energy by the oxidations of sulfides. Bacteria of the genus *Thiobacillus* couple the conversion of

carbon dioxide (CO<sub>2</sub>) to carbohydrates to the aerobic oxidation of mineral sulfides to sulfuric acid. This activity can be turned to good use for leaching low-grade mineral ores. Often, however, the sulfuric acid runoff (such as in mines or sewers) has negative environmental consequences. The purple and green bacteria as well as the blue-green algae are remarkable because they are photosynthetic but anaerobic; they oxidize sulfide, not water (as do most photosynthetic organisms). Depending on the species, the sulfur produced in this energy-producing pathway can accumulate inside or outside the cell wall. See BACTERIAL PHYSIOLOGY AND METABOLISM; PHOTOSYNTHESIS.

**Minerals.** Sulfide minerals are among the most important ores for several metals. These compounds are two- or three-dimensional polymers containing interconnected metal cations and sulfide S<sup>2-</sup> or persulfido S<sub>2</sub><sup>2-</sup> anions. In general, metal sulfides are darkly colored, often black, and they are not soluble in water. They can sometimes be decomposed by using strong acids, with liberation of hydrogen sulfide. Certain sulfides will also dissolve in the presence of excess sulfide or polysulfide ions.

Pyrites (FeS<sub>2</sub>), also known as iron pyrites or fool's gold, are the most common sulfide minerals and can be obtained as very large crystals that have a golden luster. Sphalerite (zinc blende; ZnS) and galena (PbS) are major sources of zinc and lead. Orange cinnabar (HgS) and yellow greenockite (CdS) are the major ores for mercury and cadmium, respectively. Molybdenite (MoS<sub>2</sub>) is the major ore of molybdenum.

The sulfur content of fossil fuels results from the sulfur in the ancient organisms as well as from subsequent incorporation of mineral sulfur into the hydrocarbon matrix. Gaseous fossil fuels are often contaminated with hydrogen sulfide, which is an increasingly important source of sulfur. Organic derivatives containing the C—S—C linkage are primarily responsible for the sulfur content of petroleum and coal. The so-called organic sulfur in petroleum can be removed by hydrodesulfurization catalysis, involving reaction with hydrogen over a molybdenum catalyst, to give hydrocarbons and hydrogen sulfide. [T.B.R.]

**Sulfuric acid** A strong mineral acid with the chemical formula H<sub>2</sub>SO<sub>4</sub>. It is a colorless, oily liquid, sometimes called oil of vitriol or vitriolic acid. The pure acid has a density of 1.834 at 25°C (77°F) and freezes at 10.5°C (50.90°F). It is an important industrial commodity, used extensively in petroleum refining and in the manufacture of fertilizers, paints, pigments, dyes, and explosives.

Sulfuric acid is produced on a large scale by two commercial processes, the contact process and the lead-chamber process. In the contact process, sulfur dioxide, SO<sub>2</sub>, is converted to sulfur trioxide, SO<sub>3</sub>, by reaction with oxygen in the presence of a catalyst. Sulfuric acid is produced by the reaction of the sulfur trioxide with water. The lead-chamber process depends upon the oxidation of sulfur dioxide by nitric acid in the presence of water, the reaction being carried out in large lead rooms.

Sulfuric acid reacts vigorously with water to form several hydrates. The concentrated acid, therefore, acts as an efficient drying agent, taking up moisture from the air and even abstracting the elements of water from such compounds as sugar and starch. The concentrated acid also acts as a strong oxidizing agent. It reacts with most metals upon heating to produce sulfur dioxide. See SULFUR. [F.J.J.]

**Sum rules** Formulas in quantum mechanics for transitions between energy levels, in which the sum of the transition strengths is expressed in a simple form. Sum rules are used to describe the properties of many physical systems, including solids, atoms, atomic nuclei, and nuclear constituents such as protons and neutrons. The sum rules are derived from quite general principles, and are useful in situations where the behavior of individual energy levels is too complex to describe by a precise quantum-mechanical theory. See ENERGY LEVEL (QUANTUM MECHANICS).

In general, sum rules are derived by using Heisenberg's quantum-mechanical algebra to construct operator equalities, which are then applied to particles or the energy levels of a system. See QUANTUM MECHANICS. [G.F.Be.]

**Sun** The star around which the Earth revolves, and the planet's source of light and heat, hence life. The Sun is a globe of gas, 1.4 × 10<sup>6</sup> km (8.65 × 10<sup>5</sup> mi) in diameter with a mass 333,000 times the Earth, held together by its own gravity. The surface temperature of the Sun is about 6000 K (10,000°F); since solids and liquids do not exist at these temperatures, the Sun is entirely gaseous. Almost all the gas is in atomic form, although a few molecules exist in the coolest surface regions, such as sunspots.

The Sun is a typical member of the spectral class dG2, stars of surface temperature 6000 K. The d stands for a dwarf, a normal star of that class. See SPECTRAL TYPE.

**Solar structure.** The interior of the Sun can be studied only by inference from the observed properties of the entire star. The great mass of the Sun presses down on the center, requiring a gas with a central density of near 90 g/cm<sup>3</sup> and 2 × 10<sup>7</sup> K (3.6 × 10<sup>6</sup>°F) temperature to support it. At these huge temperatures and densities, nuclear reactions take place. The radiation produced flows outward till it is radiated into space by the surface (photosphere) at 6000 K (10,000°F).

**Energy production.** The energy of the Sun is produced by the conversion of hydrogen into helium. For each hydrogen atom converted, one neutrino is produced. These neutrinos are detected, but less than the expected number. See NEUTRINO; SOLAR NEUTRINOS.

The material at the center of the Sun is so dense that a few millimeters are opaque, so the photons created by nuclear reactions are continually absorbed and reemitted and thus make their way to the surface by a random walk. The atoms in the center of the Sun are entirely stripped of their electrons by the high temperatures, and most of the absorption is by continuum processes, such as the scattering of light by electrons. Because there are so many absorption and emission processes along the way, it can take as long as a million years to complete the random walk to the surface.

**Convection.** In the outer regions of the solar interior, the temperature is low enough for ions and even neutral atoms to form and, as a result, atomic absorption becomes very important. The high opacity makes it very difficult for the radiation to continue outward, so steep temperature gradients are established that result in convective currents. Most of the outer envelope of the Sun is in such convective equilibrium. These large-scale mass motions are responsible for the complex phenomena observed at the surface. See CONVECTION (HEAT).

**Radiation.** Electromagnetic energy is produced by the Sun in essentially all wavelengths. However, more than 95% of the energy is concentrated in the relatively narrow band between 290 and 2500 nm and is accessible to routine observation from ground stations on Earth. The maximum radiation is in the green region, and the eyes of human beings have naturally evolved to be sensitive to this range of the spectrum. The total radiation is called the solar constant. It is not exactly constant but varies slightly (±0.1%) with the solar cycle. The ultraviolet flux, however, varies by substantial factors depending on the exact wavelength, and this affects the Earth's upper atmosphere. See ELECTROMAGNETIC RADIATION; SOLAR CONSTANT.

**Atmosphere.** Although the Sun is gaseous, it can be seen only to the point at which the density is so high that the material is opaque. This layer, the visible surface of the Sun, is termed the photosphere. Light from farther down reaches the Earth by repeated absorption and emission by the atoms, but the deepest layers cannot be seen directly. The surface is actually not sharp, but the Sun is so far away that the smallest distance that can be resolved with the best telescope is about 300 km (200 mi). Since

the density  $e$ -folding height (scale height) is less than 200 km (120 mi), the edge appears sharp. See PHOTOSPHERE.

Above the photosphere the atmosphere is transparent, and its density falls off much more slowly because magnetic fields support the ionized particles. The atmosphere can be seen by using a narrow-band filter or a spectrograph to pick out the isolated wavelengths absorbed by the atmospheric gases. In the upper photosphere it is cooler, and the lines are dark. If the light is imaged in the strongest lines, such as those of hydrogen, a region higher still is seen, called the chromosphere. The light from this region is dominated by the red hydrogen alpha (level  $2 \rightarrow 3$  transition) line, which gives it a rosy color seen at a solar eclipse. The chromosphere is a rapidly fluctuating region of jets and waves coming up from the surface. When all the convected energy coming up from below reaches the surface, it is concentrated in the thin material and produces considerable activity. Where the magnetic field is stronger, these waves are absorbed, and raise the temperature to 7000–8000 K (12,000–14,000°F). The scale height of the chromosphere is 1000 km (600 mi) or more, so there no longer is a sharp edge. See CHROMOSPHERE; ECLIPSE.

When the Moon obscures the Sun at a total solar eclipse, the vast extended atmosphere of the Sun called the corona can be seen. The corona is a million times fainter than the photosphere, so it is visible only when seen against the dark sky of an eclipse or with very special instruments. Its density is low, but its temperature is high (more than  $10^6$  K or  $1.8 \times 10^6$ °F). The hot gas evaporating out from the corona flows steadily to the Earth and farther in the solar wind. See SOLAR CORONA; SOLAR WIND.

**Coronal holes.** Early coronal observations showed that the corona was occasionally absent over certain regions. In particular, at sunspot minimum it was quite weak over the poles. X-ray pictures revealed great bands of the solar surface essentially devoid of corona for many months. These proved to be regions where the local magnetic fields were connected to quite distant places, so the fields actually reached out to heights from which the solar wind could sweep the gas outward. Analysis of solar wind data showed that equatorial coronal holes were associated with high-velocity streams in the solar wind, and recurrent geomagnetic storms were associated with the return of these holes. Thus the relative intensity of the corona over sunspot regions is partly due to their strong, closed magnetic fields which trap the coronal gas.

**Solar activity.** There are a number of transient phenomena known collectively as solar activity. These are all connected with sunspots.

**Sunspots.** Sunspots were discovered around 1610. Heinrich Schwabe announced in 1843 that their number rose and fell with a 10-year period. Subsequent study of the old records revealed an 11-year period since the original discovery.

The number of sunspots peaks soon after the beginning of each cycle and decays to a minimum in 11 years. The first spots of a number cycle always occur at higher latitudes, between  $20^\circ$  and  $35^\circ$ , and the latitude of occurrence decreases as the cycle unfolds (Spörer's law). Almost no spots are observed outside the latitude range of  $5$ – $35^\circ$ . The great majority are small and last a few days, but some last for two rotations. In 1908, George Ellery Hale discovered that sunspots had strong magnetic fields. Each spot group contains positive and negative magnetic polarity (monopoles are forbidden by Maxwell's laws). Hale found that the polarities were mirrored, with the same polarity generally leading in one hemisphere and following in the other. He found that with each new number cycle the lead polarity switches, so that the complete magnetic cycle lasts 22 years. But each new number cycle starts a few years before the end of the previous one, so the average duration of a half-cycle is nearly 14 years. See MAGNETISM.

The darkness of sunspots (Fig. 1) is probably due to the intense magnetic fields (3000 gauss or 0.3 tesla), which cool the surface

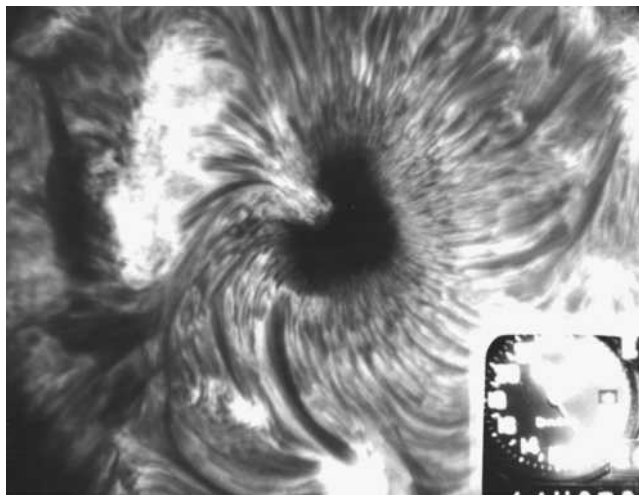

Fig. 1. Large symmetric sunspot photographed in  $H\alpha$  light. Clock indicates time of photograph. (Big Bear Solar Observatory)

by suppressing the normal convective energy flow from below. It takes several days for the darkening to occur.

Although the sunspot is cool, its neighborhood is the scene of the hottest and most intense activity, generally referred to as an active region. Magnetic energy is continually released there. The corona above an active region is hot and dense, roughly three times hotter and denser than in quiet regions.

**Prominences.** The term "prominence" is used for any cloud of cool gas in the corona, where it appears bright against the sky. Because these clouds absorb the chromospheric light and scatter it, they appear dark against the solar disk in  $H\alpha$  and other strong lines. In continuous light they are transparent. At the limb we see the chromospheric light they scatter against the dark sky. Since they are much denser than the corona, something must hold them up against gravity. Prominences are found only in regions of horizontal magnetic fields that support them. Thus filaments on the disk, which may last for weeks, are good markers of the magnetic boundaries. When the magnetic structure changes, prominences become unstable and erupt, always upward. They also may be ejected by solar flares or appear as graceful loops raining from the corona after flares. Erupting prominences are probably the source of coronal mass ejections, in which a bubble of coronal material erupts outward at several hundred kilometers per second and flows out into interplanetary space.

**Plages.** Just as prominences occur when the magnetic field changes from one sign to the other, plages occur whenever the magnetic field is vertical and relatively strong but not strong enough to form a sunspot. They are bright regions in any strong spectrum line, because the chromosphere is heated there. In a typical active region, the preceding magnetic field is clumped in a sunspot and the following field spread out in a plage. In  $H\alpha$  light, the plage is seen to be connected to the sunspot by dark fibrils outlining the lines of force.

**Flares.** The most spectacular activity associated with sunspots is the solar flare (Fig. 2). A flare is defined as an abrupt increase in the  $H\alpha$  emission from the sunspot region. The brightness of the flare may be up to eight times that of the chromosphere; the rise time is seldom longer than a few minutes. The  $H\alpha$  brightening results from heating of the chromosphere at the foot points of the magnetic field by a tremendous energy release in the atmosphere. While flares are usually visible only in chromospheric lines, the foot points of big flares can be seen in white light. From the foot points, a cloud of hot material, up to  $3 \times 10^7$  K ( $5.4 \times 10^7$ °F) arises and concentrates at the arch tops. This cloud condenses out in an array of loop prominences. An active sunspot





Fig. 2. The great "sea horse" flare of August 7, 1972, late in the flare, photographed in the blue wing of the  $H\alpha$  line. The neutral line between two bright strands is crossed by an arcade of bright loop prominences raining down from the corona. (Big Bear Solar Observatory)

group produces a hierarchy of flares, a few big and many small ones.

Flares are often associated with the eruption of filaments. A few minutes after the eruption begins, there is an abrupt acceleration and a storm of energetic particles is produced, heating the corona to flare brightness.

The flare produces a huge stream of solar energetic particles (SEP) as well as shock waves. A huge magnetohydrodynamic shock wave flies out at about 1000 km/s (600 mi/s) and continues into interplanetary space, often reaching the Earth. The wave produces a huge radio burst in the meter-wavelength range as it excites the coronal layers. The energetic nuclei produce gamma-ray lines from nuclear reactions as they penetrate to the photosphere. If they are sufficiently numerous, they heat the photosphere faster than it can reemit energy and a white light flare is observed, usually in the form of bright transient flashes at the foot points of the flare loops. The particles reach the Earth in a great particle storm. [H.Zi.]

**Sun dog** A bright spot of light that sometimes appears on either side of the Sun, the same distance above the horizon as the Sun, and separated from it by an angle of about  $22^\circ$  (see illustration). For higher Sun elevations, the angle increases slightly. These spots are known by many common names: sun



Sun dogs on either side of the Sun. Also visible are the  $22^\circ$  halo and the parhelic circle. (Courtesy of Robert Greenler)

dogs, mock suns, false suns, or the  $22^\circ$  parhelia. They usually show a red edge on the side closest to the Sun. On some occasions the entire spectrum of colors can be spread out in the sun-dog spot but, commonly, the red edge is followed by an orange or yellow band that merges into a diffuse white region. The effects result from the refraction by sunlight through small, flat, hexagonal-shaped ice crystals falling through the air such that their flat faces are oriented nearly horizontally. See HALO; METEOROLOGICAL OPTICS. [R.Gr.]

**Sundew** Any plant of the genus *Drosera* (90 species) of the family Droseraceae. Sundews are small, herbaceous, insectivorous plants that grow on all the continents, especially Australia. Numerous glandular hairs (tentacles) on the leaf secrete a viscous fluid which traps a visiting insect. The tentacles then bend inward about the victim, bringing it into contact with the surface of the leaf where it is digested. The droplets secreted by the glands on the leaves glitter like dewdrops in the morning sunlight; hence, the name, sundew. See INSECTIVOROUS PLANTS; NEPENTHALES; SECRETORY STRUCTURES (PLANT). [P.D.St./E.I.C.]

**Sundial** An instrument for telling time by the Sun. It is composed of a style that casts a shadow and a dial plate, which is the surface upon which hour lines are marked and upon which the shadow falls. The style lies parallel to Earth's axis. The construction of the hour lines is based on the assumption that the apparent motion of the Sun is always on the celestial equator. The most widely used form is the horizontal dial that indicates local apparent time (Sun time). Other forms of the sundial indicate local mean time, and standard time. See TIME. [R.N.M.]

**Sunfish** A name given to certain members of the freshwater family Centrarchidae as well as to members of the marine family Molidae. There are two species of oceanic sunfishes in the genus *Mola*; both are large, stout, deep-bodied fishes with rough skin and are found in warm seas, where they are frequently seen near the surface. These fishes appear to be tailless.

The fresh-water sunfishes are grouped together with the crappies. The warmouth sunfish (*Chaenobryttus gulosus*) is the only species found in the United States, where it occurs in the Mississippi River drainage and in streams along the Atlantic coast. It differs from other sunfishes in having teeth on the tongue.

The crappies are game fish of considerable importance. Crappies are a favorite species for pond culture. They can be readily transplanted and, under favorable conditions, multiply prodigiously. See PERCIFORMES. [C.B.C.]

**Sunflower** *Helianthus annuus*, the most widely distributed of the 50 native North American species of this genus of the family Compositae. It is an extremely variable species, with two main divisions. The first involves wild weedy plants found along roadways and other recently disturbed areas; the second, domesticated plants grown in fields and gardens. See ASTERALES.

Within the domestic type there are two categories of plants: the ornamental, which has a few branches with larger heads than the wild, and the crop type, which has only a single stem and the largest head of all sunflowers (see illustration). Crop types are either oil or nonoil. Plant breeders have modified the plant for adaptation to modern, large-scale farming and have increased the oil content of the seeds. The present worldwide interest in growing sunflowers as a crop is due to the increased yield of the new commercially available oilseed hybrids.

Sunflowers are grown on all the continents and in many countries throughout the world. Russia is the major producer, followed by Argentina, the United States, and Canada. Sunflower oil (sunoil) is the second most important vegetable crop oil. It is



Maturing sunflower. (U.S. Department of Agriculture)

a high-quality oil and is high in linoleic fatty acid. The oil is used in cooking, salad dressing, mayonnaise, margarine, and soap.

[B.H.B.]

**Sunlamp** A special form of mercury arc discharge lamp designed to produce ultraviolet radiation. These lamps also produce some radiant energy in the visible region of the spectrum, thus having a light output as well as an ultraviolet output. The lamps are principally used for producing a skin tan on the human

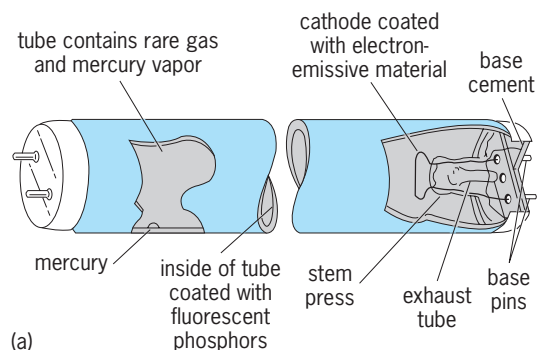

(a)

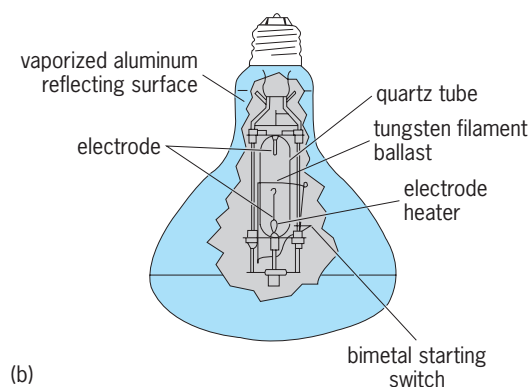

(b)

Structure of sunlamps. (a) FS-40. (b) RS.

body. The less common uses include therapeutically producing vitamin D in the body for the treatment of rickets and causing fluorescence or photochemical reactions.

Sunlamps have ultraviolet radiation at wavelengths above 280 nanometers. The lower limit is set by the fact that the quartz and high-silica glass used for lamp envelopes do not transmit below 280 nm. The two lamps designed for tanning are the FS-40 and the RS. The FS-40 tubular fluorescent lamp (illus. a) operates with a low-pressure mercury arc that causes a special chemical phosphor coating inside the tube to radiate ultraviolet energy. The RS sunlamp (illus. b) is a reflector unit containing a high-pressure mercury arc tube for generating ultraviolet energy plus a tungsten filament (similar to incandescent lamp filaments) in series with the arc tube to serve as a ballast. See MERCURY-VAPOR LAMP; ULTRAVIOLET LAMP. [G.R.P.]

**Superacid** An acid which has an extremely great proton-donating ability. It has proved convenient to define a superacid somewhat arbitrarily as an acid, or more generally, an acidic medium, which has a proton-donating ability equal to or greater than that of anhydrous (100%) sulfuric acid.

Superacids belong to the general class of proton or Brønsted acids. A proton acid is defined as any species which can act as a source of protons and which will therefore protonate a suitable base, as in reaction (1).



The strengths of acids are often compared by measuring the extent of their ionization in water, that is, the extent to which they can protonate the base water, as in reaction (2).

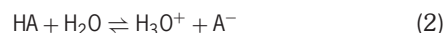

However, all strong acids are fully ionized in dilute aqueous solution, and they therefore appear to have the same strength. Their strengths are said to be reduced or leveled to that of the hydronium ion ( $\text{H}_3\text{O}^+$ ), which is the most highly acidic species that can exist in water. In any case, many of the superacids react with and are destroyed by water. For these reasons, the strengths of superacids cannot be measured by the conventional means of utilizing their aqueous solutions. The acidities of superacids can, however, be conveniently measured in terms of the Hammett acidity function. See ACID AND BASE.

The Hammett acidity function is a method of measuring acidity based on the determination of the ionization ratios of suitable weak bases (indicators), usually by means of the change in absorption spectrum that occurs on protonation of the base, although the nuclear magnetic resonance (NMR) spectrum has also been used. The Hammett acidity function ( $H_0$ ) is defined by Eq. (3), where  $K_{\text{BH}^+}$  is the dissociation constant of the acid

$$H_0 = \text{p}K_{\text{BH}^+} - \log \frac{[\text{BH}^+]}{[\text{B}]} \quad (3)$$

form of the indicator and  $[\text{BH}^+]/[\text{B}]$  is the ionization ratio of the indicator. Hammett acidity function ( $H_0$ ) values for a number of superacids are given in the table. In each case the value refers to the 100% (anhydrous) acid. Each of the superacids in the table

Hammett acidity function values for several superacids

Superacid	Formula	$-H_0$
Sulfuric acid	$\text{H}_2\text{SO}_4$	11.9
Chlorosulfuric acid	$\text{HSO}_3\text{Cl}$	13.8
Trifluoromethane sulfonic acid	$\text{HSO}_3\text{CF}_3$	14.0
Disulfuric acid	$\text{H}_2\text{S}_2\text{O}_7$	14.4
Fluorosulfuric acid	$\text{HSO}_3\text{F}$	15.1
Hydrogen fluoride	$\text{HF}$	15.1

is a liquid at room temperature, and each forms the basis of a solvent system. See IONIC EQUILIBRIUM; SOLUTION. [R.J.Gi.]

**Supercharger** An air pump or blower in the intake system of an internal combustion engine. Its purpose is to increase the air-charge weight and therefore the power output from an engine of a given size. In an aircraft engine, the supercharger counteracts the power loss that results from the decrease of atmospheric pressure with increase of altitude. Various types of pumps and compressors may be used as superchargers, which are either mechanically driven by the engine crankshaft or powered by the engine exhaust gas. See COMPRESSOR; PUMP; TURBOCHARGER.

Some production automobile engines use a spiral-type supercharger, while others use a pressure-wave supercharger. However, automotive, marine, and stationary engines generally use a positive-displacement Roots blower driven from the engine crankshaft. See INTERNAL COMBUSTION ENGINE.

In a supercharged diesel engine, the increased air charge allows the engine to burn more fuel and produce greater power without creating excessive pressure inside the cylinder. Supercharging the diesel engine makes ignition of the fuel easier without requiring a fuel of better quality. See DIESEL ENGINE.

To enable a reciprocating aircraft engine to develop its rated sea-level power at altitude, a supercharger must be used to increase the pressure and weight of the intake air charge. Centrifugal compressors are generally used because of their relatively small size for a given capacity, and are driven either by a gear drive from the crankshaft or by the engine exhaust gas. With gear drive, a lower ratio is commonly used at low and medium altitudes, with a change to a higher ratio at high altitudes. See AIRCRAFT ENGINE. [J.A.B.; D.L.An.]

**Supercomputer** A computer which, among existing general-purpose computers at any given time, is superlative, often in several senses: highest computation rate, largest memory, or highest cost. Predominantly, the term refers to the fastest "number crunchers," that is, machines designed to perform numerical calculations at the highest speed that the latest electronic device technology and the state of the art of computer architecture allow.

The demand for the ability to execute arithmetic operations at the highest possible rate originated in computer applications areas collectively referred to as scientific computing. Large-scale numerical simulations of physical processes are often needed in fields such as physics, structural mechanics, meteorology, and aerodynamics. A common technique is to compute an approximate numerical solution to a set of partial differential equations which mathematically describe the physical process of interest but are too complex to be solved by formal mathematical methods. This solution is obtained by first superimposing a grid on a region of space, with a set of numerical values attached to each grid point. Large-scale scientific computations of this type often require hundreds of thousands of grid points with 10 or more values attached to each point, with 10 to 500 arithmetic operations necessary to compute each updated value, and hundreds of thousands of time steps over which the computation must be repeated before a steady-state solution is reached. See COMPUTATIONAL FLUID DYNAMICS; NUMERICAL ANALYSIS; SIMULATION.

Two lines of technological advancement have significantly contributed to what roughly amounts to a doubling of the fastest computers' speeds every year since the early 1950s—the steady improvement in electronic device technology and the accumulation of improvements in the architectural designs of digital computers.

Computers incorporate very large-scale integrated (VLSI) circuits with tens of millions of transistors per chip for both logic and memory components. A variety of types of integrated circuitry is used in contemporary supercomputers. Several use high-speed complementary metallic oxide semiconductor (CMOS) technology. Throughout most of the history of digital computing, su-

percomputers generally used the highest-performance switching circuitry available at the time—which was usually the most exotic and expensive. However, many supercomputers now use the conventional, inexpensive device technology of commodity microprocessors and rely on massive parallelism for their speed. See COMPUTER STORAGE TECHNOLOGY; CONCURRENT PROCESSING; INTEGRATED CIRCUITS; LOGIC CIRCUITS; SEMICONDUCTOR MEMORIES.

Increases in computing speed which are purely due to the architectural structure of a computer can largely be attributed to the introduction of some form of parallelism into the machine's design: two or more operations which were performed one after the other in previous computers can now be performed simultaneously. See COMPUTER SYSTEMS ARCHITECTURE.

Pipelining is a technique which allows several operations to be in progress in the central processing unit at once. The first form of pipelining used was instruction pipelining. Since each instruction must have the same basic sequence of steps performed, namely instruction fetch, instruction decode, operand fetch, and execution, it is feasible to construct an instruction pipeline, where each of these steps happens at a separate stage of the pipeline. The efficiency of the instruction pipeline depends on the likelihood that the program being executed allows a steady stream of instructions to be fetched from contiguous locations in memory.

The central processing unit nearly always has a much faster cycle time than the memory. This implies that the central processing unit is capable of processing data items faster than a memory unit can provide them. Interleaved memory is an organization of memory units which at least partially relieves this problem.

Parallelism within arithmetic and logical circuitry has been introduced in several ways. Adders, multipliers, and dividers now operate in bit-parallel mode, while the earliest machines performed bit-serial arithmetic. Independently operating parallel functional units within the central processing unit can each perform an arithmetic operation such as add, multiply, or shift. Array processing is a form of parallelism in which the instruction execution portion of a central processing unit is replicated several times and connected to its own memory device as well as to a common instruction interpretation and control unit. In this way, a single instruction can be executed at the same time on each of several execution units, each on a different set of operands. This kind of architecture is often referred to as single-instruction stream, multiple-data stream (SIMD).

Vector processing is the term applied to a form of pipelined arithmetic units which are specialized for performing arithmetic operations on vectors, which are uniform, linear arrays of data values. It can be thought of as a type of SIMD processing, since a single instruction invokes the execution of the same operation on every element of the array. See COMPUTER PROGRAMMING; PROGRAMMING LANGUAGES.

A central processing unit can contain multiple sets of the instruction execution hardware for either scalar or vector instructions. The task of scheduling instructions which can correctly execute in parallel with one another is generally the responsibility of the compiler or special scheduling hardware in the central processing unit. Instruction-level parallelism is almost never visible to the application programmer.

Multiprocessing is a form of parallelism that has complete central processing units operating in parallel, each fetching and executing instructions independently from the others. This type of computer organization is called multiple-instruction stream, multiple-data stream (MIMD). See MULTIPROCESSING. [D.W.M.]

**Superconducting devices** Devices that perform functions in the superconducting state that would be difficult or impossible to perform at room temperature, or that contain components which perform such functions. The superconducting state involves a loss of electrical resistance and occurs in many metals and alloys at temperatures near absolute zero. An enormous impetus was provided by the discovery in 1986 of a new class of ceramic, high-transition-temperature ( $T_c$ )

superconductors, which has resulted in a new superconducting technology at liquid nitrogen temperature. Superconducting devices may be conveniently divided into two categories: small-scale thin-film devices, and large-scale devices which employ zero-resistance superconducting windings made of type II superconducting materials. See SUPERCONDUCTIVITY.

**Small-scale devices.** A variety of thin-film devices offer higher performance than their nonsuperconducting counterparts. The prediction and discovery in the early 1960s of the Josephson effects introduced novel opportunities for ultrasensitive detectors, high-speed switching elements, and new physical standards. Niobium-based devices, patterned on silicon wafers using photolithographic techniques taken over from the semiconductor industry, have reached a high level of development, and a variety of such devices are commercially available. These devices operate at or below 4.2 K (−452°F), the temperature of liquid helium boiling under atmospheric pressure. See LIQUID HELIUM.

The discovery of the high-transition-temperature superconductors has enabled the operation of devices in liquid nitrogen at 77 K (−321°F). Not only is liquid nitrogen much cheaper and more readily available than liquid helium, but it also boils away much more slowly, enabling the use of simpler and more compact dewars or simpler, relatively inexpensive refrigerators. Of the new ceramic superconductors, only  $\text{YBa}_2\text{Cu}_3\text{O}_{7-x}$  (YBCO) has been developed in thin-film form to the point of practical applications, and several devices are available. Intensive materials research has resulted in techniques, notably laser-ablation and radio-frequency sputtering, for the epitaxial growth of high-quality films with their crystalline planes parallel to the surface of the substrate. Most of the successful Josephson-junction devices have been formed at the interface between two grains of YBCO. These so-called grain-boundary junctions are made by depositing the film either on a bicrystal in which the two halves of the substrate have a carefully engineered in-plane misalignment of the crystal axes, or across a step-edge patterned in the substrate. See CRYOGENICS; GRAIN BOUNDARIES.

Two types of superconducting quantum interference device (SQUID) detect changes in magnetic flux: the dc SQUID and the rf SQUID. The dc SQUID, which operates with a dc bias current, consists of two Josephson junctions incorporated into a superconducting loop. The maximum dc supercurrent, known as the critical current, and the current-voltage ( $I$ - $V$ ) characteristic of the SQUID oscillate when the magnetic field applied to the device is changed. The oscillations are periodic in the magnetic flux  $\Phi$  threading the loop with a period of one flux quantum,  $\Phi_0 = h/2e \approx 2.07 \times 10^{-15}$  weber, where  $h$  is Planck's constant and  $e$  is the magnitude of the charge of the electron. Thus, when the SQUID is biased with a constant current, the voltage is periodic in the flux. The SQUID is almost invariably operated in a flux-locked loop. A change in the applied flux gives rise to a corresponding current in the coil that produces an equal and opposite flux in the SQUID. The SQUID is thus the null detector in a feedback circuit, and the output voltage is linearly proportional to the applied flux. See JOSEPHSON EFFECT; SQUID.

The rf SQUID consists of a single Josephson junction incorporated into a superconducting loop and operates with an rf bias. The SQUID is coupled to the inductor of an  $LC$ -resonant circuit excited at its resonant frequency, typically 30 MHz. The characteristics of rf voltage across the tank circuit versus the rf current depends on applied flux. With proper adjustment of the rf current, the amplitude of the rf voltage across the tank circuit oscillates as a function of applied flux. The rf SQUID is also usually operated in a feedback mode.

SQUIDs are mostly used in conjunction with an input circuit. For example, magnetometers are made by connecting a superconducting pickup loop to the input coil to form a flux transformer. A magnetic field applied to the pickup loop induces a persistent current in the transformer and hence a magnetic flux in the SQUID. These magnetometers have found application in

geophysics, for example, in magnetotellurics. See GEOPHYSICAL EXPLORATION; MAGNETOMETER.

Low-transition-temperature SQUIDs are widely used to measure the magnetic susceptibility of tiny samples over a wide temperature range. Another application is a highly sensitive voltmeter, used in measurements of the Hall effect and of thermoelectricity. Low-transition-temperature SQUIDs are used as ultrasensitive detectors of nuclear magnetic and nuclear quadrupole resonance, and as transducers for gravitational-wave antennas. So-called scanning SQUIDs are used to obtain magnetic images of objects ranging from single-flux quanta trapped in superconductors to subsurface damage in two metallic sheets riveted together. See HALL EFFECT; MAGNETIC SUSCEPTIBILITY; NUCLEAR MAGNETIC RESONANCE (NMR); NUCLEAR QUADRUPOLE RESONANCE; THERMOELECTRICITY; VOLTMETER.

Perhaps the single largest area of application is biomagnetism, notably to image magnetic sources in the human brain or heart. In these studies an array of magnetometers or gradiometers is placed close to the subject, both generally being in a magnetically shielded room. The fluctuating magnetic signals recorded by the various channels are analyzed to locate their source. These techniques have been used, for example, to pinpoint the origin of focal epilepsy and to determine the function of the brain surrounding a tumor prior to its surgical removal. See BIOMAGNETISM.

The most sensitive detector available for millimeter and submillimeter electromagnetic radiation is the superconductor-insulator-superconductor (SIS) quasiparticle mixer. In this tunnel junction, usually niobium-aluminum oxide-niobium, the Josephson supercurrent is quenched and only single electron tunneling occurs. The current-voltage characteristic exhibits a very sharp onset of current at a voltage  $2\Delta/e$ , where  $\Delta$  is the superconducting energy gap. The mixer is biased near this onset where the characteristics are highly nonlinear and used to mix the signal frequency with the frequency of a local oscillator to produce an intermediate frequency that is coupled out into a low-noise amplifier. These mixers are useful at frequencies up to about 750 GHz (wavelengths down to 400 micrometers). Such receivers are of great importance in radio astronomy, notably for airborne, balloon-based, or high-altitude, ground-based telescopes operating above most of the atmospheric water vapor. See RADIO ASTRONOMY.

The advent of high-transition-temperature superconductors stimulated major efforts to develop passive radio-frequency and microwave components that take advantage of the low electrical losses offered by these materials compared with normal conductors in liquid nitrogen. The implementation of thin-film YBCO receiver coils has improved the signal-to-noise ratio of nuclear magnetic resonance (NMR) spectrometers by a factor of 3 compared to that achievable with conventional coils. This improvement enables the data acquisition time to be reduced by an order of magnitude. These coils also have potential applications in low-frequency magnetic resonance imaging (MRI). High-transition-temperature bandpass filters have application in cellular communications. See ELECTRIC FILTER; MOBILE RADIO. [J.C.]

**Large-scale devices.** Large-scale applications of superconductivity comprise medical, energy, transportation, high-energy physics, and other miscellaneous applications such as high-gradient magnetic separation. When strong magnetic fields are needed, superconducting magnets offer several advantages over conventional copper or aluminum electromagnets. Most important is lower electric power costs because once the system is energized only the refrigeration requires power input, generally only 5–10% that of an equivalent-field resistive magnet. Relatively high magnetic fields achievable in unusual configurations and in smaller total volumes reduce the costs of expensive force-containment structures. See MAGNET.

Niobium-titanium (NbTi) has been used most widely for large-scale applications, followed by the A15 compounds, which include niobium-tin ( $\text{Nb}_3\text{Sn}$ ), niobium-aluminum (Nb-Al),

niobium-germanium (Nb-Ge), and vanadium-gallium (V<sub>3</sub>Ga). Niobium-germanium held the record for the highest critical field (23 K; -418.5°F) until the announcement of high-temperature ceramic superconductors. See A15 PHASES.

Significant advances have been made in high-temperature superconducting wire development. Small coils have been wound that operate at 20 K (-410°F). Current leads are in limited commercial use. Considerable development remains necessary to use these materials in very large applications.

MRI dominates superconducting magnet systems applications. Most of the MRI systems are in use in hospitals and clinics, and incorporate superconducting magnets. See MEDICAL IMAGING.

Some of the largest-scale superconducting magnet systems are those considered for energy-related applications. These include magnetic confinement fusion, superconducting magnetic energy storage, magnetohydrodynamic electrical power generation, and superconducting generators. See MAGNETOHYDRODYNAMIC POWER GENERATOR; NUCLEAR FUSION.

In superconducting magnetic energy storage superconducting magnets are charged during off-peak hours when electricity demand is low, and then discharged to add electricity to the grid at times of peak demand. The largest systems would require large land areas, for example, an 1100-m-diameter (3600-ft) site for a 5000-MWh system. However, intermediate-size systems are viable. A 6-T peak-field solenoidal magnet system designed for the Alaskan power network stores 1800 megajoules (0.5 MWh). High-purity-aluminum-stabilized niobium-titanium alloy conductor carrying 16 kiloamperes current is used for the magnet winding.

Superconducting magnets have potential applications for transportation, such as magnetically levitated vehicles. In addition, superconducting magnets are used in particle accelerators and particle detectors. See MAGNETIC LEVITATION; PARTICLE ACCELERATOR; PARTICLE DETECTOR. [A.M.Da.]

**Superconductivity** A phenomenon occurring in many electrical conductors, in which the electrons responsible for conduction undergo a collective transition into an ordered state with many unique and remarkable properties. These include the vanishing of resistance to the flow of electric current, the appearance of a large diamagnetism and other unusual magnetic effects, substantial alteration of many thermal properties, and the occurrence of quantum effects otherwise observable only at the atomic and subatomic level.

Superconductivity was discovered by H. Kamerlingh Onnes in Leiden in 1911 while studying the temperature dependence of the electrical resistance of mercury within a few degrees of absolute zero. He observed that the resistance dropped sharply to an unmeasurably small value at a temperature of 4.2 K (-452°F). The temperature at which the transition occurs is called the transition or critical temperature,  $T_c$ . The vanishingly small resistance (very high conductivity) below  $T_c$  suggested the name given the phenomenon.

In 1933 W. Meissner and R. Ochsenfeld discovered that a metal cooled into the superconducting state in a moderate magnetic field expels the field from its interior. This discovery demonstrated that superconductivity involves more than simply very high or infinite electrical conductivity, remarkable as that alone is. See MEISSNER EFFECT.

In 1957, J. Bardeen, L. N. Cooper, and J. R. Schrieffer reported the first successful microscopic theory of superconductivity. The Bardeen-Cooper-Schrieffer (BCS) theory describes how the electrons in a conductor form the ordered superconducting state. The BCS theory still stands as the basic explanation of superconductivity, even though extensive theoretical work has embellished it.

There are a number of practical applications of superconductivity. Powerful superconducting electromagnets guide elementary particles in particle accelerators, and they also provide the magnetic field needed for magnetic resonance imaging. Ultra-

sensitive superconducting circuits are used in medical studies of the human heart and brain and for a wide variety of physical science experiments. A completely superconducting prototype computer has even been built. See MEDICAL IMAGING; PARTICLE ACCELERATOR; SUPERCONDUCTING DEVICES.

**Transition temperatures.** It was realized from the start that practical applications of superconductivity could become much more widespread if a high-temperature superconductor, that is, one with a high  $T_c$ , could be found. For instance, the only practical way to cool superconductors with transition temperatures below 20 K (-424°F) is to use liquid helium, which boils at a temperature of 4.2 K (-452°F) and which is rather expensive. On the other hand, a superconductor with a transition temperature of 100 K (-280°F) could be cooled with liquid nitrogen, which boils at 77 K (-321°F) and which is roughly 500 times less expensive than liquid helium. Another advantage of a high- $T_c$  material is that, since many of the other superconducting properties are proportional to  $T_c$ , such a material would have enhanced properties. In 1986 the discovery of transition temperatures possibly as high as 30 K (-406°F) was reported in a compound containing barium, lanthanum, copper, and oxygen. In 1987 a compound of yttrium, barium, copper, and oxygen was shown to be superconducting above 90 K (-298°F). In 1988 researchers showed that a bismuth, strontium, calcium, copper, and oxygen compound was superconducting below 110 K (-262°F), and transition temperatures as high as 135 K (-216°F) were found in a mercury, thallium, barium, calcium, copper, and oxygen compound.

**Occurrence.** Some 29 metallic elements are known to be superconductors in their normal form, and another 17 become superconducting under pressure or when prepared in the form of thin films. The number of known superconducting compounds and alloys runs into the thousands. Superconductivity is thus a rather common characteristic of metallic conductors. The phenomenon also spans an extremely large temperature range. Rhodium is the element with the lowest transition temperature (370  $\mu$ K), while Hg<sub>0.2</sub>Tl<sub>0.8</sub>Ca<sub>2</sub>Ba<sub>2</sub>Cu<sub>3</sub>O is the compound with the highest (135 K or -216°F).

Despite the existence of a successful microscopic theory of superconductivity, there are no completely reliable rules for predicting whether a metal will be a superconductor. Certain trends and correlations are apparent among the known superconductors, however—some with obvious bases in the theory—and these provide empirical guidelines in the search for new superconductors. Superconductors with relatively high transition temperatures tend to be rather poor conductors in the normal state.

The ordered superconducting state appears to be incompatible with any long-range-ordered magnetic state: Usually the ferromagnetic or antiferromagnetic metals are not superconducting. The presence of nonmagnetic impurities in a superconductor usually has very little effect on the superconductivity, but the presence of impurity atoms which have localized magnetic moments can markedly depress the transition temperature even in concentrations as low as a few parts per million. See ANTIFERROMAGNETISM; FERROMAGNETISM.

Some semiconductors with very high densities of charge carriers are superconducting, and others such as silicon and germanium have high-pressure metallic phases which are superconducting. Many elements which are not themselves superconducting form compounds which are.

Certain organic conductors are superconducting. For instance, brominated polymeric chains of sulfur and nitrogen, known as (SNBr<sub>0.4</sub>)<sub>x</sub>, are superconducting below 0.36 K. Other more complicated organic materials have  $T_c$  values near 10 K (-442°F). See ORGANIC CONDUCTOR.

Although nearly all the classes of crystal structure are represented among superconductors, certain structures appear to be especially conducive to high-temperature superconductivity. The so-called A15 structure, shared by a series of intermetallic compounds based on niobium, produced several superconductors

with  $T_c$  values above 15 K ( $-433^\circ\text{F}$ ) as well as the record holder, NbGe, at 23 K ( $-418^\circ\text{F}$ ). Indeed, the robust applications of superconductivity that depend on the ability to carry high current in the presence of high magnetic fields still exclusively use two members of this class: NbTi with  $T_c = 8$  K ( $-445^\circ\text{F}$ ), and Nb<sub>3</sub>Sn with  $T_c = 18.1$  K ( $-427^\circ\text{F}$ ). See A15 PHASES.

After 1986 the focus of superconductivity research abruptly shifted to the copper-oxide-based planar structures, due to their significantly higher transition temperatures. Basically there are three classes of these superconductors, all of which share the common feature that they contain one or more conducting planes of copper and oxygen atoms. The first class is designated by the chemical formula  $\text{La}_{2-x}\text{A}_x\text{CuO}_4$ , where the A atom can be barium, strontium, or calcium. Superconductivity was originally discovered in the barium-doped system, and systematic study of the substitutions of strontium, calcium, and so forth have produced transition temperatures as high as 40 K ( $-388^\circ\text{F}$ ).

The second class of copper-oxide superconductor is designated by the chemical formula  $\text{Y}_1\text{Ba}_2\text{Cu}_3\text{O}_{7-\delta}$ , with  $\delta < 1.0$ . Here, single sheets of copper and oxygen atoms straddle the rare-earth yttrium ion and chains of copper and oxygen atoms thread among the barium ions. The transition temperature, 92 K ( $-294^\circ\text{F}$ ), is quite insensitive to replacement of yttrium by many other rare-earth ions. See RARE-EARTH ELEMENTS.

The third class is the most complicated. These compounds contain either single thallium-oxygen layers, represented by the chemical formula  $\text{Tl}_1\text{Ca}_{n-1}\text{Ba}_2\text{Cu}_n\text{O}_{2n+3}$ , where  $n$  refers to the number of copper-oxygen planes, or double thallium-oxygen layers, represented by the chemical formula  $\text{Tl}_2\text{Ca}_{n-1}\text{Ba}_2\text{Cu}_n\text{O}_{2n+4}$ . The number of copper-oxygen planes may be varied, and as many as three planes have been included in the structure. Thallium may be replaced by bismuth, thus generating a second family of superconductors. In all of these compounds, the transition temperature appears to increase with the number of planes, but  $T_c$  decreases for larger values of  $n$ .

The spherical molecule comprising 60 carbon atoms ( $\text{C}_{60}$ ), known as a buckyball, can be alloyed with various alkaline atoms which contribute electrons for conduction. By varying the number of conductors in  $\text{C}_{60}$ , it is possible to boost  $T_c$  to a maximum value of 52 K ( $-366^\circ\text{F}$ ). See FULLERENE.

Superconductivity was discovered in magnesium diboride ( $\text{MgB}_2$ ) in January 2001 in Japan. This material may be a good alternative for some of the applications envisioned for high- $T_c$  superconductivity, since this compound has  $T_c$  of 39 K ( $-389^\circ\text{F}$ ), is relatively easy to make, and consists of only two elements.

**Magnetic properties.** The existence of the Meissner-Ochsenfeld effect, the exclusion of a magnetic field from the interior of a superconductor, is direct evidence that the superconducting state is not simply one of infinite electrical conductivity. Instead, it is a true thermodynamic equilibrium state, a new phase which has lower free energy than the normal state at temperatures below the transition temperature and which somehow requires the absence of magnetic flux.

The exclusion of magnetic flux by a superconductor costs some magnetic energy. So long as this cost is less than the condensation energy gained by going from the normal to the superconducting phase, the superconductor will remain completely superconducting in an applied magnetic field. If the applied field becomes too large, the cost in magnetic energy will outweigh the gain in condensation energy, and the superconductor will become partially or totally normal. The manner in which this occurs depends on the geometry and the material of the superconductor. The geometry which produces the simplest behavior is that of a very long cylinder with field applied parallel to its axis. Two distinct types of behavior may then occur, depending on the type of superconductor—type I or type II.

Below a critical field  $H_c$  which increases as the temperature decreases below  $T_c$ , the magnetic flux is excluded from a type I superconductor, which is said to be perfectly diamagnetic. For a type II superconductor, there are two critical fields, the lower crit-

ical field  $H_{c1}$  and the upper critical field  $H_{c2}$ . In applied fields less than  $H_{c1}$ , the superconductor completely excludes the field, just as a type I superconductor does below  $H_c$ . At fields just above  $H_{c1}$ , however, flux begins to penetrate the superconductor, not in a uniform way, but as individual, isolated microscopic filaments called fluxoids or vortices. Each fluxoid consists of a normal core in which the magnetic field is large, surrounded by a superconducting region in which flows a vortex of persistent supercurrent which maintains the field in the core. See DIAMAGNETISM.

**Thermal properties.** The appearance of the superconducting state is accompanied by rather drastic changes in both the thermodynamic equilibrium and thermal transport properties of a superconductor.

The heat capacity of a superconducting material is quite different in the normal and superconducting states. In the normal state (produced at temperatures below the transition temperature by applying a magnetic field greater than the critical field), the heat capacity is determined primarily by the normal electrons (with a small contribution from the thermal vibrations of the crystal lattice) and is nearly proportional to the temperature. In zero applied magnetic field, there appears a discontinuity in the heat capacity at the transition temperature. At temperatures just below the transition temperature, the heat capacity is larger than in the normal state. It decreases more rapidly with decreasing temperature, however, and at temperatures well below the transition temperature varies exponentially as  $e^{-\Delta/kT}$ , where  $\Delta$  is a constant and  $k$  is Boltzmann's constant. Such an exponential temperature dependence is a hallmark of a system with a gap  $\Delta$  in the spectrum of allowed energy states. Heat capacity measurements provided the first indications of such a gap in superconductors, and one of the key features of the macroscopic BCS theory is its prediction of just such a gap. See SPECIFIC HEAT OF SOLIDS.

Ordinarily a large electrical conductivity is accompanied by a large thermal conductivity, as in the case of copper, used in electrical wiring and cooking pans. However, the thermal conductivity of a pure superconductor is less in the superconducting state than in the normal state, and at very low temperatures approaches zero. Crudely speaking, the explanation for the association of infinite electrical conductivity with vanishing thermal conductivity is that the transport of heat requires the transport of disorder (entropy). The superconducting state is one of perfect order (zero entropy), and so there is no disorder to transport and therefore no thermal conductivity. See ENTROPY; THERMAL CONDUCTION IN SOLIDS.

**Two-fluid model.** C. J. Gorter and H. B. G. Casimir introduced in 1934 a phenomenological theory of superconductivity based on the assumption that in the superconducting state there are two components of the conduction electron "fluid" (hence the name given this theory, the two-fluid model). One, called the superfluid component, is an ordered condensed state with zero entropy; hence it is incapable of transporting heat. It does not interact with the background crystal lattice, its imperfections, or the other conduction electron component and exhibits no resistance to flow. The other component, the normal component, is composed of electrons which behave exactly as they do in the normal state. It is further assumed that the superconducting transition is a reversible thermodynamic phase transition between two thermodynamically stable phases, the normal state and the superconducting state, similar to the transition between the liquid and vapor phases of any substance. The validity of this assumption is strongly supported by the existence of the Meissner-Ochsenfeld effect and by other experimental evidence. This assumption permits the application of all the powerful and general machinery of the theory of equilibrium thermodynamics. The results tie together the observed thermodynamic properties of superconductors in a very satisfying way.

**Microscopic (BCS) theory.** The key to the basic interaction between electrons which gives rise to superconductivity was provided by the isotope effect. It is an interaction mediated by the

background crystal lattice and can crudely be pictured as follows: An electron tends to create a slight distortion of the elastic lattice as it moves, because of the Coulomb attraction between the negatively charged electron and the positively charged lattice. If the distortion persists for a brief time (the lattice may ring like a struck bell), a second passing electron will see the distortion and be affected by it. Under certain circumstances, this can give rise to a weak indirect attractive interaction between the two electrons which may more than compensate their Coulomb repulsion.

The first forward step was taken by Cooper in 1956, when he showed that two electrons with an attractive interaction can bind together to form a "bound pair" (often called a Cooper pair) if they are in the presence of a high-density fluid of other electrons, no matter how weak the interaction is. The two partners of a Cooper pair have opposite momenta and spin angular momenta. Then, in 1957, Bardeen, Cooper, and Schrieffer showed how to construct a wave function in which all of the electrons (at least, all of the important ones) are paired. Once this wave function is adjusted to minimize the free energy, it can be used as the basis for a complete microscopic theory of superconductivity.

The successes of the BCS theory and its subsequent elaborations are manifold. One of its key features is the prediction of an energy gap. Excitations called quasiparticles (which are something like normal electrons) can be created out of the superconducting ground state by breaking up pairs, but only at the expense of a minimum energy of  $\Delta$  per excitation;  $\Delta$  is called the gap parameter. The original BCS theory predicted that  $\Delta$  is related to  $T_c$  by  $\Delta = 1.76kT_c$  at  $T = 0$  for all superconductors. This turns out to be nearly true, and where deviations occur they are understood in terms of modifications of the BCS theory. The manifestations of the energy gap in the low-temperature heat capacity and in electromagnetic absorption provide strong confirmation of the theory. [D.N.L.; R.J.So.; M.O.]

**Supercontinent** The six major continents today are Africa, Antarctica, Australia, Eurasia, North America, and South America. Prior to the formation of the Atlantic, Indian, and Southern ocean basins over the past 180 million years by the process known as sea-floor spreading, the continents were assembled in one supercontinent called Pangea (literally "all Earth"). Pangea came together by the collision, about 300 million years ago (Ma), of two smaller masses of continental rock, Laurasia and Gondwanaland. Laurasia comprised the combined continents of ancient North America (known as Laurentia), Europe, and Asia. Africa, Antarctica, Australia, India, and South America made up Gondwanaland (this name comes from a region in southern India). The term "supercontinent" is also applied to Laurasia and Gondwanaland; hence it is used in referring to a continental mass significantly bigger than any of today's continents. A supercontinent may therefore incorporate almost all of the Earth's continental rocks, as did Pangea, but that is not implied by the word. See CONTINENT; CONTINENTS, EVOLUTION OF.

Laurasia, Gondwanaland, and Pangea are the earliest supercontinental entities whose former existence can be proven. Evidence of older rifted continental margins, for example surrounding Laurentia and on the Pacific margins of South America, Antarctica, and Australia, point to the existence of older supercontinents. The hypothetical Rodinia (literally "the mother of all continents") may have existed 800–1000 Ma, and Pannotia (meaning "the all-southern supercontinent") fleetingly around 550 Ma. Both are believed to have included most of the Earth's continental material. There may have been still earlier supercontinents, because large-scale continents, at least the size of southern Africa or Western Australia, existed as early as 2500 Ma at the end of Archean times. See ARCHEAN; CONTINENTAL MARGIN.

The amalgamation and fragmentation of supercontinents are the largest-scale manifestation of tectonic forces within the Earth. The cause of such events is highly controversial. See PLATE TECTONICS. [I.W.O.D.]

**Supercritical fields** Static fields that are strong enough to cause the normal vacuum, which is devoid of real particles, to break down into a new vacuum in which real particles exist. This phenomenon has not yet been observed for electric fields, but it is predicted for these fields as well as others such as gravitational fields and the gluon field of quantum chromodynamics.

**Vacuum decay in quantum electrodynamics.** The original motivation for developing the new concept of a charged vacuum arose in the late 1960s in connection with attempts to understand the atomic structure of superheavy nuclei expected to be produced by heavy-ion linear accelerators. See PARTICLE ACCELERATOR.

The best starting point for discussing this concept is to consider the binding energy of atomic electrons as the charge  $Z$  of a heavy nucleus is increased. If the nucleus is assumed to be a point charge, the total energy  $E$  of the  $1s_{1/2}$  level drops to 0 when  $Z = 137$ . This so-called  $Z = 137$  catastrophe had been well known, but it was argued loosely that it disappears when the finite size of the nucleus is taken into account. However, in 1969 it was shown that the problem is not removed but merely postponed, and reappears around  $Z = 173$ . Any level  $E(nj)$  can be traced down to a binding energy of twice the electronic rest mass if the nuclear charge is further increased. At the corresponding charge number, called  $Z_{cr}$ , the state dives into the negative-energy continuum of the Dirac equation (the so-called Dirac sea). The overcritical state acquires a width and is spread over the continuum. See ANTIMATTER; RELATIVISTIC QUANTUM THEORY.

When  $Z$  exceeds  $Z_{cr}$  a  $K$ -shell electron is bound by more than twice its rest mass, so that it becomes energetically favorable to create an electron-positron pair. The electron becomes bound in the  $1s_{1/2}$  orbital and the positron escapes. The overcritical vacuum state is therefore said to be charged. See POSITRON.

Clearly, the charged vacuum is a new ground state of space and matter. The normal, undercritical, electrically neutral vacuum is no longer stable in overcritical fields: it decays spontaneously into the new stable but charged vacuum. Thus the standard definition of the vacuum, as a region of space without real particles, is no longer valid in very strong external fields. The vacuum is better defined as the energetically deepest and most stable state that a region of space can have while being penetrated by certain fields.

**Superheavy quasimolecules.** Inasmuch as the formation of a superheavy atom of  $Z > 173$  is very unlikely, a new idea is necessary to test these predictions experimentally. That idea, based on the concept of nuclear molecules, was put forward in 1969: a superheavy quasimolecule forms temporarily during the slow collision of two heavy ions. It is sufficient to form the quasimolecule for a very short instant of time, comparable to the time scale for atomic processes to evolve in a heavy atom, which is typically of the order  $10^{-18}$  to  $10^{-20}$ . Suppose a uranium ion is shot at another uranium ion at an energy corresponding to their Coulomb barrier, and the two, moving slowly (compared to the  $K$ -shell electron velocity) on Rutherford hyperbolic trajectories, are close to each other (compared to the  $K$ -shell electron orbit radius). Then the atomic electrons move in the combined Coulomb potential of the two nuclei, thereby experiencing a field corresponding to their combined charge of 184. This happens because the ionic velocity (of the order of  $c/10$ ) is much smaller than the orbital electron velocity (of the order of  $c$ ), so that there is time for the electronic molecular orbits to be established, that is, to adjust to the varying distance between the charge centers, while the two ions are in the vicinity of each other. See QUASI-ATOM.

**Giant nuclear systems.** The energy spectrum for positrons created in, for example, a uranium-curium collision consists of three components: the induced, the direct, and the spontaneous, which add up to a smooth spectrum. The presence of the spontaneous component leads only to 5–10% deviations for normal nuclear collisions along Rutherford trajectories. This situation raises the question as to whether there is any way to get a clear

qualitative signature for spontaneous positron production. Suppose that the two colliding ions, when they come close to each other, stick together for a certain time  $\Delta t$  before separating again. The longer the sticking, the better is the static approximation. For  $\Delta t$  very long, a very sharp line should be observed in the positron spectrum with a width corresponding to the natural lifetime of the resonant positron-emitting state. The observation of such a sharp line will indicate not only the spontaneous decay of the vacuum but also the formation of giant nuclear systems ( $Z > 180$ ). See LINEWIDTH; NUCLEAR MOLECULE.

**Search for spontaneous positron emission.** The search for spontaneous positron emission in heavy-ion collisions began in 1976. Of special interest are peak structures in the positron energy distribution. However, the issue of spontaneous positron production in strong fields remains open. If line structures have been observed at all, they are most likely due to nuclear conversion processes. The observation of vacuum decay very much depends on the existence of sufficiently long-lived (at least  $10^{-20}$  s) giant nuclear molecular systems. Therefore, the investigation of nuclear properties of heavy nuclei encountering heavy nuclei at the Coulomb barrier is a primary task.

**Other field theories.** The idea of overcriticality also has applications in other field theories, such as those of pion fields, gluon fields (quantum chromodynamics), and gravitational fields (general relativity).

A heavy meson may be modeled as an ellipsoidal bag, with a heavy quark  $Q$  and antiquark  $\bar{Q}$  located at the foci of the ellipsoid. The color-electric or glue-electric field lines do not penetrate the bag surface. The Dirac equation may be solved for light quarks  $q$  and antiquarks  $\bar{q}$  in this field of force. In the spherical case the potential is zero, and the solutions with different charges degenerate. As the source charges  $Q$  and  $\bar{Q}$  are pulled apart, the wave functions start to localize. At a critical deformation of the bag, positive and negative energy states cross; that is, overcriticality is reached and the color field is strong enough that the so-called perturbative vacuum inside the bag rearranges so that the wave functions are pulled to opposite sides and the color charges of the heavy quarks are completely shielded. Hence two new mesons of types  $\bar{Q}q$  and  $Q\bar{q}$  appear; the original meson fissions. See GLUONS; QUANTUM CHROMODYNAMICS; QUARKS. [W.Gr.]

**Supercritical fluid** Any fluid at a temperature and a pressure above its critical point; also, a fluid above its critical temperature regardless of pressure. Below the critical point the fluid can coexist in both gas and liquid phases, but above the critical point there can be only one phase. Supercritical fluids are of interest because their properties are intermediate between those of gases and liquids, and are readily adjustable. See CRITICAL PHENOMENA; PHASE EQUILIBRIUM.

In a given supercritical fluid the thermodynamic and transport properties are a function of density, which depends strongly on the fluid's pressure and temperature. The density may be adjusted from a gaslike value of 0.1 g/ml to a liquidlike value as high as 1.2 g/ml. Furthermore, as conditions approach the critical point, the effect of temperature and pressure on density becomes much more significant. Increasing the density of supercritical carbon dioxide from 0.2 to 0.5 g/ml, for example, requires raising the pressure from 85 to 140 atm (8.6 to 14.2 megapascals) at 158°F (70°C), but at 95°F (35°C) the required change is only from 65 to 80 atm (6.6 to 8.1 MPa).

For a given fluid, the logarithm of the solubility of a solute is approximately proportional to the solvent density at constant temperature. Therefore, a small increase in pressure, which causes a large increase in the density, can raise the solubility a few orders of magnitude. While almost all of a supercritical fluid's properties vary with density, some of these properties are more like those of a liquid while others are more like those of a gas. See SUPERCRITICAL-FLUID CHROMATOGRAPHY.

In most supercritical-fluid applications the fluid's critical temperature is less than 392°F (200°C) and its critical pressure is less than 80 atm (8.1 MPa). High critical temperatures require operating temperatures that can damage the desired product, while high critical pressures result in excessive compression costs. In addition to these pure fluids, mixed solvents can be used to improve the solvent strength. [K.Jo.; R.Len.]

**Supercritical-fluid chromatography** Any separation technique in which a supercritical fluid is used as the mobile phase. For any fluid, a phase diagram can be constructed to show the regions of temperature and pressure at which gases and liquids, gases and solids, and liquids and solids can coexist. For the gas-liquid equilibrium, there is a certain temperature and pressure, known as the critical temperature and pressure, below which a gas and a liquid can coexist but above which only a single phase (known as a supercritical fluid) can form.

For example, the density of supercritical fluids is usually between 0.25 and 1.2 g/ml and is strongly pressure-dependent. Their solvent strength increases with density, so that molecules that are retained on the column can often be eluted simply by increasing the pressure under which the fluid is compressed.

Diffusion coefficients of solutes in supercritical fluids are tenfold greater than the corresponding values in liquid solvents (although about three orders of magnitude less than the corresponding values in gases). The high diffusivity of solutes in supercritical fluids decreases their resistance to mass transfer in a chromatographic column and hence allows separations to be made either very quickly or at high resolution. Molecules can be separated in a few minutes or less by using packed columns of the type used for high-performance liquid chromatography (HPLC). See DIFFUSION IN GASES AND LIQUIDS.

Despite the relatively large number of separations made using packed-column supercritical-fluid chromatography that have been described since 1962, supercritical-fluid chromatography became popular only in the late 1980s with the commercial introduction of capillary (open-tubular) supercritical-fluid chromatographs. While supercritical-fluid chromatography may never be as widely used as gas chromatography or high-performance liquid chromatography, it provides a useful complement to these chromatographies. See CHEMICAL SEPARATION TECHNIQUES; CHROMATOGRAPHY; FLUIDS; GAS CHROMATOGRAPHY; LIQUID CHROMATOGRAPHY. [P.R.G.]

**Supercritical wing** A wing with special streamwise sections, or airfoils, which provide substantial delays in the onset of the adverse aerodynamic effects which usually occur at high subsonic flight speeds.

When the speed of an aircraft approaches the speed of sound, the local airflow about the airplane, particularly above the upper surface of the wing, may exceed the speed of sound. Such a condition is called supercritical flow. On previous aircraft, this supercritical flow resulted in the onset of a strong local shock wave above the upper surface of the wing (illus. a). This local

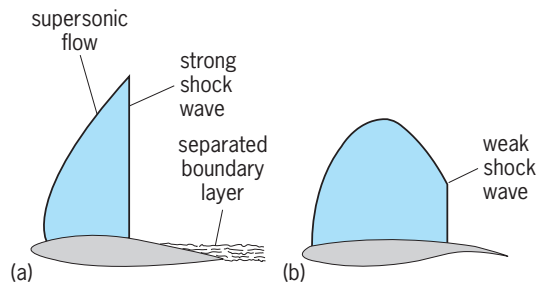

**Comparison of airflow about airfoils. (a) Conventional airfoils, Mach number = 0.7. (b) Supercritical airfoils, Mach number = 0.8.**



wave caused an abrupt increase in the pressure on the surface of the wing, which may cause the surface boundary-layer flow to separate from the surface, with a resulting severe increase in the turbulence of the flow. The increased turbulence leads to a severe increase in drag and loss in lift, with a resulting decrease in flight efficiency. The severe turbulence also caused buffet or shaking of the aircraft and substantially changed its stability or flying qualities. See AERODYNAMIC FORCE; AERODYNAMIC WAVE DRAG; LOW-PRESSURE GAS FLOW; SHOCK WAVE; TRANSONIC FLIGHT.

Supercritical airfoils are shaped to substantially reduce the strength of the shock wave and to delay the associated boundary-layer separation (illus. *b*). Since the airfoil shape allows efficient flight at supercritical flight speeds, a wing of such design is called a supercritical wing. See AIRPLANE; WING. [R.T.Wh.]

**Superfluidity** The frictionless flow of liquid helium at low temperature; also, the flow of electric current without resistance in certain solids at low temperature (superconductivity).

Both helium isotopes have a superfluid transition, but the detailed properties of their superfluid states differ considerably because they obey different statistics.  $^4\text{He}$ , with an intrinsic spin of 0, is subject to Bose-Einstein statistics, and  $^3\text{He}$ , with a spin of  $1/2$ , to Fermi-Dirac statistics. There are two distinct superfluid states in  $^3\text{He}$  called A and B.

The term "superfluidity" usually implies He II or the A and B phases of  $^3\text{He}$ , but the basic similarity between these and the "fluid" consisting of pairs of electrons in superconductors is sufficiently strong to designate the latter as a charged superfluid. Besides flow without resistance, superfluid helium and superconducting electrons display quantized circulating flow patterns in the form of microscopic vortices. See BOSE-EINSTEIN STATISTICS; LIQUID HELIUM; QUANTIZED VORTICES; SECOND SOUND; SUPERCONDUCTIVITY. [L.J.C.]

**Supergiant star** A member of a class of evolved stars that occupy the top of the Hertzsprung-Russell diagram to the right of the main sequence. The absolute visual magnitudes ( $M_V$ ) of supergiants range approximately between  $-4$  and  $-10$ , and they are the largest and brightest stars. They are recognized by their spectroscopic characteristics. For example, those in class A have narrow hydrogen lines. Supergiants are subdivided into classes Ib ( $M_V$  about  $-5$ ) and Ia ( $M_V$  about  $-7$ ). A "hypergiant class zero" was later added near  $M_V = -10$ ; the use of transition class Ia-0 at absolute visual magnitudes near  $-9$  is now common. Red supergiants are the largest of all stars, and at maximum can reach diameters approaching that of the orbit of Saturn.

In an evolutionary sense, supergiants are stars above about 10 solar masses and absolute visual magnitude  $-6$  that began main-sequence life hotter than class B1 and cannot evolve to become white dwarfs. As progeny of O stars, supergiants are exceedingly rare. Supergiant masses allow further burning of carbon and oxygen to oxygen, neon, and magnesium; thence to silicon and sulfur; and thence to iron. The iron cores collapse to produce type II supernovae, the condensed remnants at the centers becoming either neutron stars or, from the most massive stars, black holes. See ASTRONOMICAL SPECTROSCOPY; BLACK HOLE; HERTZSPRUNG-RUSSELL DIAGRAM; NEUTRON STAR; SPECTRAL TYPE; STAR; STELLAR EVOLUTION; SUPERNOVA. [J.B.Ka.]

**Supergranulation** A system of convective cells, with typical diameters of 20,000 km (12,000 mi), that cover the Sun's surface. Solar convection cells are invisible in ordinary photographs.

High-resolution photographs of the Sun's visible surface reveal the granulation, a closely packed cellular grid having bright (hot) centers surrounded by dark (cool) lanes. Granules have lifetimes of 10–30 minutes and average diameters of 1000 km (620 mi). In the 1930s, L. Biermann suggested that, in the outer 30% of the Sun, heat from the Sun's interior is transported to the surface by convection, just like hot rising bubbles in a pot

of boiling soup heated from below. The granules are the boiling bubbles (plumes) of this convective process. Theorists in the 1950s proposed that the bubble sizes are approximately equal to the local scale height  $H$  (the distance in which density or pressure changes by a factor  $e \approx 2.7$ ). Since  $H$  varies from about 1000 km (620 mi) at the Sun's surface to 100,000 km (62,000 mi) at the base of the convection zone, a very large range of plume sizes was hypothesized. See CONVECTION (HEAT).

In 1959, R. Leighton modified the spectroheliograph to image the Sun using the Doppler and Zeeman effects. Images of line-of-sight (approaching and receding) gas motions (Dopplergrams) and of magnetic fields (magnetograms) could be obtained. The Dopplergrams showed a new cell structure with area 400 times that of the granulation, having a mainly horizontal flow pattern. Lifetimes of most supergranules are 1–2 days, but observations in 1998 with the Michelson Doppler Imager (MDI) on the *Solar and Heliospheric Observatory (SOHO)* spacecraft showed that some live longer than 4 days. The cells form an irregular polygonal structure, with most of the down-flow occurring at the polygon vertices. The supergranules fit neatly within an essentially identical network (grid) structure seen in magnetograms. The kinetic energy of the supergranular motions at the Sun's surface exceeds the magnetic field's ability to resist such motions, and thus the magnetic field is dragged forcibly to the supergranule boundaries until the two patterns coincide. This magnetic field, in turn, causes local heating of the upper solar atmosphere (chromosphere), producing a similar chromospheric network pattern seen in high-temperature spectral lines. See DOPPLER EFFECT; FRAUNHOFER LINES; SOLAR MAGNETIC FIELD; SPECTROGRAPH; SPECTROHELIOGRAPH; SUN; ZEEMAN EFFECT. [G.W.Si.]

**Supergravity** A theory that attempts to unify gravitation with the other fundamental interactions. The first, and only, completely successful unified theory was constructed by James Clerk Maxwell, in which the up-to-then unrelated electric and magnetic phenomena were unified in his electrostatics. See FUNDAMENTAL INTERACTIONS; MAXWELL'S EQUATIONS.

**Electroweak theory.** The second stage of unification concerns the unification of electromagnetic and weak interactions, using Maxwell's theory as a guide. This was accomplished making use of the nonabelian gauge theories invented by C. N. Yang and R. L. Mills, and of spontaneous symmetry breaking. The symmetry of Maxwell's theory is very similar to spatial rotations about an axis, rotating the vector potentials while leaving the electric and magnetic fields unchanged. It is a local invariance because the rotations about a fixed axis can be made by different amounts at different points in space-time. Thus, Maxwell's theory is invariant under a one-parameter group of transformations  $U(1)$ . In Yang-Mills theory this local invariance was generalized to theories with larger symmetry groups such as the three-dimensional rotation group  $SO(3) \simeq SU(2)$  which has three parameters. The number of parameters of the local symmetry (gauge) group is also equal to the number of 4-vector potentials in the gauge theory based on that group. A detailed analysis of weak and electromagnetic forces shows that their description requires four 4-vector potentials (gauge fields), so that the gauge group must be a four-parameter group. In fact, it is the product  $SU(2) \cdot U(1)$ . See ELECTROWEAK INTERACTION; GAUGE THEORY; GROUP THEORY; SYMMETRY BREAKING.

**Grand unified theories.** In the third stage of unification, electroweak and strong forces are regarded as different components of a more general force which mediates the interactions of particles in a grand unified model. Strong forces are responsible for the interactions of hadrons and for keeping quarks confined inside hadrons. They are described by eight massless 4-vector potentials (gluons), the corresponding eight-parameter group being  $SU(3)$ . This local symmetry is called color, and the corresponding theory quantum chromodynamics (QCD). The combination  $SU(3) \cdot SU(2) \cdot SU(1)$  has strong experimental

support, and has come to be known as the standard model. Thus the gauge group of any grand unified model must include the standard model as a subsymmetry. The most dramatic prediction of these theories is the decay of protons. See GLUONS; GRAND UNIFICATION THEORIES; PROTON; QUANTUM CHROMODYNAMICS; QUARKS; STANDARD MODEL.

**Supersymmetry and supergravity theories.** A still higher and more ambitious stage of unification deals with the possibility of combining grand unified and gravity theories into a superunified theory, also known as supergravity. To achieve this, use is made of the dual role played by local internal symmetry groups. On the one hand, they describe the behavior of forces. On the other hand, they classify the elementary particles (fields) of the theory into multiplets: spin-zero fields in one multiplet, spin-1/2 fields in another multiplet, and so forth, but never fermions and bosons in a single irreducible multiplet of internal symmetry. This last restriction used to be a major obstacle on the way to superunification. This is because, of all the elementary particles, only the quanta of the gravitational field (gravitons) have spin 2, so that a multiplet of elementary particles including the graviton must of necessity involve particles of different spin. But then by an internal symmetry transformation, which is by definition distinct from space-time (Lorentz) transformations, it is possible to "rotate" particles of different spin into one another, thus altering their space-time transformation properties. This apparent paradox can be circumvented if both the internal symmetry and Lorentz transformations are part of a larger (supersymmetric) transformation group which also includes the spin-changing transformations. The irreducible multiplets of such supergroups naturally contain both fermions and bosons. This is how supersymmetry makes its appearance in supergravity theories. See GRAVITON; LORENTZ TRANSFORMATIONS; RELATIVITY; SUPERSYMMETRY; SYMMETRY LAWS (PHYSICS).

**Effective theory.** If supergravity models are regarded not as fundamental theories but as effective theories describing the low-energy behavior of superstring theories, it is possible to make a strong case for their usefulness. In that case, since supergravity is no longer a fundamental theory, it is no longer crucial that supergravity satisfy very stringent physical requirements such as renormalizability. In its role as an effective theory, supergravity has been used in a number of problems in particle physics. See ELEMENTARY PARTICLE; QUANTUM FIELD THEORY; SUPERSTRING THEORY. [F.M.]

**Superheater** A component of a steam-generating unit in which steam, after it has left the boiler drum, is heated above its saturation temperature. The amount of superheat added to the steam is influenced by the location, arrangement, and amount of superheater surface installed, as well as the rating of the boiler. The superheater may consist of one or more stages of tube banks arranged to effectively transfer heat from the products of combustion. See STEAM-GENERATING UNIT. [G.W.K.]

**Superluminal motion** Proper motion of an astronomical object apparently exceeding the velocity of light,  $c$ . This phenomenon is relatively common in the nuclei of quasars, many of which exhibit systematic changes in images of their radio-frequency emission over periods of months to years. In some cases, features in the image appear to separate at a speed inferred to be more than 10 times the speed of light, given the great distance of the quasars from Earth.

Superluminal motion was one of the most exciting discoveries to emerge from a technique in radio astronomy first developed in the late 1960s and called very long baseline interferometry (VLBI). This method involves the tape recording of radio signals from large antennas at up to 10–15 locations across the Earth, and the combination of these signals in a computer to form a radio image of the quasar at extremely high resolution (less than 0.001 arcsecond). See QUASAR; RADIO ASTRONOMY; RADIO TELESCOPE.

Superluminal motion is seen mostly in quasars but also in some other active galactic nuclei. This rapid motion is confined to within a few tens of parsecs of the nucleus, whose power source is believed to be a massive black hole. At least 30 examples of superluminal motion are now known. Most show apparent speeds less than  $10c$ , but examples of speeds above  $20c$  have been found. A very few objects in the Milky Way Galaxy also show superluminal motion. An example is GRS 1915 + 105, a relativistic jet source, which emits strongly in the x-ray as well as in the radio spectrum. Because the object is within the Milky Way Galaxy, its apparent speed of  $1.25c$  is detectable in less than a day. See GALAXY, EXTERNAL; X-RAY ASTRONOMY.

Announcement of the discovery of superluminal motion in 1972 caused widespread concern because of the apparent violation of Albert Einstein's special theory of relativity, even though the basic explanation still favored now was in fact predicted some years before the announcement. Many explanations were proposed (besides Einstein's theory being incorrect), but only the relativistic jet model has stood the test of time. Superluminal motion is explained in this model as primarily a geometric effect. A feature (perhaps a cloud of relativistic plasma) moves away from the nucleus of the quasar at high (relativistic) speed (but less than  $c$ ) at a small angle to the line of sight to the Earth. Radio waves from the moving feature arrive only slightly later than waves from the nucleus, whereas the feature took a much longer time to reach its current position. The motion appears superluminal because the speed is calculated using this much shorter time interval. As the speed approaches  $c$  and the angle to the line of sight decreases, the apparent speed can be arbitrarily large. In this explanation, no material speeds faster than  $c$  are required, so there is no conflict with special relativity. See RELATIVITY. [S.C.U.]

**Supermassive stars** Hypothetical objects with masses exceeding 60 solar masses, the mass of the largest known ordinary stars (1 solar mass equals  $4.4 \times 10^{30}$  lbm or  $2 \times 10^{30}$  kg). The term is most often used in connection with objects larger than  $10^4$  solar masses that might be the energy source in quasars and active galaxies. These objects probably do not exist. However, their nonexistence is one of the major assumptions that makes the case for giant black holes, rather than supermassive stars, being the central engines of quasars. See BLACK HOLE; QUASAR; STAR. [H.L.Sh.]

**Supermultiplet** A generalization of the concept of a multiplet. A multiplet is a set of quantum-mechanical states, each of which has the same value of some fundamental quantum number and differs from the other members of the set by another quantum number which takes values from a range of numbers dictated by the fundamental quantum number. The number of states in the set is called the multiplicity or dimension of the multiplet. The concept was originally introduced to describe the set of states in a nonrelativistic quantum-mechanical system with the same value of the orbital angular momentum,  $L$ , and different values of the projection of the angular momentum on an axis,  $M$ . The values that  $M$  can take are the integers between  $-L$  and  $L$ ,  $2L + 1$  in all. This is the dimension of the multiplet. If the hamiltonian operator describing the system is rotationally invariant, all states of the multiplet have the same energy. A supermultiplet is a generalization of the concept of multiplet to the case when there are several quantum numbers that describe the quantum-mechanical states. See ANGULAR MOMENTUM; SYMMETRY LAWS (PHYSICS).

Both concepts, multiplet and supermultiplet, acquire a precise mathematical meaning by the use of the theory of group transformations. A multiplet is an irreducible representation of a group,  $G$ . The quantum number called fundamental in the paragraph above labels the representation of the group. The other quantum number labels the representation of a subgroup  $G'$  of  $G$ . For angular momentum, the group  $G$  is the rotation group, called

special orthogonal group in three dimensions,  $SO(3)$ , and its subgroup  $G'$  is the group of special orthogonal transformations in two dimensions,  $SO(2)$ . A supermultiplet is a generalization to the case in which the group  $G$  is not a group of rank one but has larger rank. A group of rank one has only one quantum number to label its representations. The concept of a multiplet or supermultiplet is particularly useful in the classification of states of physical systems. See GROUP THEORY; NONRELATIVISTIC QUANTUM THEORY; QUANTUM MECHANICS; QUANTUM NUMBERS.

The term supermultiplet was first used by E. P. Wigner in 1932 in order to classify the quantum-mechanical states of light atomic nuclei. The constituents of these are protons,  $p$ , and neutrons,  $n$ . Each proton and neutron has an intrinsic spin,  $S$ , of  $1/2$  in units of  $\hbar$ , which is Planck's constant divided by  $2\pi$ . The projection of the intrinsic spin on an axis,  $S_z$ , is then  $S_z = 1/2$  or  $-1/2$  (spin up or down). In addition to having the same spin, the proton and neutron have essentially the same mass but differ in that the proton is charged whereas the neutron is not. They can thus be regarded as different charge states of the same particle, a nucleon. The distinction can be made formal by introducing a quantum number called isotopic spin,  $T$ , which has the value  $1/2$ . The two charge orientations,  $T_z$ , are taken to be  $1/2$  for the proton and  $-1/2$  for the neutron. There are thus four constituents of nuclei, protons and neutrons with spin up and down, that is,  $p \uparrow$ ,  $p \downarrow$ ,  $n \uparrow$ , and  $n \downarrow$ . The set of transformations among these constituents forms a group called  $SU(4)$ , the special unitary group in four dimensions. This is the group  $G$  for Wigner's theory. The representations of  $SU(4)$ , that is, Wigner supermultiplets, are characterized by three quantum numbers ( $\lambda_1, \lambda_2, \lambda_3$ ) with  $\lambda_1 \geq \lambda_2 \geq \lambda_3$ . See I-SPIN; NUCLEAR STRUCTURE. [F.I.]

**Supernova** The catastrophic, explosive death of a star, accompanied by the sudden, transient brightening of the star to an optical luminosity comparable to that of an entire galaxy.

A supernova shines typically for several weeks to several months with a luminosity between  $2 \times 10^8$  and  $5 \times 10^9$  times that of the Sun, then gradually fades away. Each explosion ejects from one to several tens of solar masses at speeds ranging from thousands to tens of thousands of kilometers per second. The total kinetic energy,  $10^{44}$  joules ( $2.5 \times 10^{28}$  megatons of high explosive), is about 100 times the total light output, making supernovae some of the highest-energy explosions in the universe. Unlike its fainter relative, the nova, a supernova does not recur for the same object. See NOVA.

Supernovas may be grouped according to either their observational characteristics or their explosion mechanism. Basically, type I supernovae have no hydrogen in their spectrum; type II supernovae do. Two mechanisms are involved: thermonuclear explosion in white dwarfs and gravitational collapse in massive stars. Type I supernovae of different subclasses can occur by either mechanism, but it is thought that most type II supernovae are powered by gravitational collapse.

During the last thousand years, there have been approximately seven supernovae visible to the unaided eye, in 1006, 1054, 1181, 1408, 1572, 1604, and 1987. SN 1006 may have been as bright as the quarter moon. The first six of these occurred in the Earth's vicinity of the Milky Way Galaxy. But the last, and only, naked-eye supernova since the invention of modern instrumentation occurred in the Large Magellanic Cloud, a small satellite galaxy of the Milky Way about 160,000 light-years away. Supernovae are discovered in other galaxies at a rate of about 150 per year. Most supernovae in the Milky Way Galaxy are obscured by dust, but various arguments suggest that about two type II supernovae per century and one type Ia every other century occur in the Milky Way Galaxy. See MAGELLANIC CLOUDS; MILKY WAY GALAXY.

**Type Ia supernovae.** Type Ia supernovae may be regarded as nature's largest thermonuclear bombs. They occur when an accreting white dwarf, composed of carbon and oxygen, grows to a mass 1.38 times that of the Sun, almost the critical mass that

can be supported by electron degeneracy pressure, and ignites carbon fusion near its center. Ignition occurs when carbon fusion at the center releases energy faster than neutrinos can carry it away. Because the pressure is insensitive to the temperature, a nuclear runaway occurs. Fusion releases energy, which raises the temperature, which makes fusion go faster, but the gas cannot expand and cool. The nuclear runaway spreads in about 1 second through the star. The energy released by this nuclear burning is more than enough to completely blow the white dwarf apart with high velocity. Nothing remains—no neutron star, no black hole, and no burst of neutrino emission. See BINARY STAR; THERMONUCLEAR REACTION.

**Type II supernovae.** A typical type II supernova results from a star somewhat over 8 solar masses, on the main sequence, that spends its last years as a red supergiant burning progressively heavier fuels in its center. The radius of the star, after hydrogen has burned and the star is part way through helium burning, is roughly 500 solar radii, and its luminosity is already about 100,000 times that of the Sun. Each burning stage is shorter than the previous one. The last stage turns silicon and sulfur into a ball of roughly 1.4 solar masses of iron. Once iron has been produced, no more nuclear energy is available. See SUPERGIANT STAR.

A combination of instabilities now leads to the implosion of the iron core to a neutron star. When the density at the center reaches several times that of the atomic nucleus, the collapse halts and briefly springs back owing to the short-range repulsive component of the nuclear force. But the energy of this bounce is soon dissipated, and a hot young neutron star remains which, over the next few seconds, radiates away its heat and binding energy as neutrinos. See NEUTRINO; STRONG NUCLEAR INTERACTIONS.

The energy output in these neutrinos is enormous, about  $3 \times 10^{46}$  joules or 15% of the rest mass of the Sun converted to energy; rivaling the luminosity of the rest of the observable universe in light. A small fraction of these neutrinos, about 0.3%, are absorbed in reactions with neutrons and protons in the regions just outside the neutron star and deposit their energy. Even this small amount of energy is much greater than the gravitational binding of the remaining part of the star external to the newly formed neutron star. A bubble of radiation is inflated by the neutrino energy deposition, the outer boundary of which expands supersonically, driving a shock wave through the rest of the star and ejecting it with high velocity. The main energy of the explosion, though, is carried away as neutrinos. This general picture was confirmed when a neutrino burst of the predicted energy and duration was detected February 23, 1987, from the Large Magellanic Cloud in conjunction with SN 1987A. See NEUTRINO ASTRONOMY; SHOCK WAVE.

**Nucleosynthesis.** Supernovae are major element factories, responsible for producing most of the elements in nature heavier than nitrogen. The largest yields are of the more abundant elements, including oxygen, silicon, magnesium, neon, iron, and a portion of carbon, but dozens of other elements are also made. See NUCLEOSYNTHESIS.

**Type Ia cosmological applications.** Because of their brightness and the regularity of their light curves, type Ia supernovae have long been used as standard candles to survey cosmological distances. More recently it has been realized that the relatively small variation that occurs in the peak brilliance of such supernovae may be correlated with their decline rates. Use of this so-called Phillips relation allows even greater precision in distance determination. Using type Ia supernovae in this fashion reveals a surprising result. Two independent analyses show that the expansion rate of the universe is not slowing as might be expected long after the big bang, but is actually accelerating. The pull of gravity can only cause deceleration, so the acceleration is attributed to an invisible form of dark energy that enters into the cosmological equations as a repulsive term. See ASTROPHYSICS; HIGH-ENERGY; COSMOLOGY; STAR; STELLAR EVOLUTION; UNIVERSE; VARIABLE STAR. [S.E.Wo.]

**Superoxide chemistry** A branch of chemistry that deals with the reactivity of the superoxide ion ( $O_2^-$ ), a one-electron ( $e^-$ ) adduct of molecular oxygen (dioxygen;  $O_2$ ) formed by the combination of  $O_2$  and  $e^-$ . Because 1–15% of the  $O_2$  that is respired by mammals goes through the  $O_2^-$  oxidation state, the biochemistry and reaction chemistry of the species are important to those concerned with oxygen toxicity, carcinogenesis, and aging. Although the name superoxide has prompted many to assume an exceptional degree of reactivity for  $O_2^-$ , the use of the prefix in fact was chosen to indicate stoichiometry. Superoxide was the name given in 1934 to the newly synthesized potassium salt ( $KO_2$ ) to differentiate its two-oxygens-per-metal stoichiometry from that of most other metal–oxygen compounds ( $Na_2O$ ,  $Na_2O_2$ ,  $NaOH$ ,  $Fe_2O_3$ ).

Ionic salts of superoxide (yellow-to-orange solids), which form from the reaction of dioxygen with metals such as potassium, rubidium, or cesium, are paramagnetic, with one unpaired electron per two oxygen atoms.

In 1969, by means of electron spin resonance (ESR) spectroscopy, superoxide ion was detected as a respiratory intermediate, and metalloproteins were discovered that catalyze the disproportionation of superoxide, that is, superoxide dismutases (SODs), as shown in the reaction below.

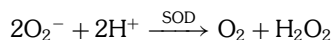

The biological function of superoxide dismutases is believed to be the protection of living cells against the toxic effects of superoxide. The possibility that superoxide might be an important intermediate in aerobic life provided an impetus to the study of superoxide reactivity.

The most general and universal property of  $O_2^-$  is its tendency to act as a strong Brønsted base. Its strong proton affinity manifests itself in any media. Another characteristic of  $O_2^-$  is its ability to act as a moderate one-electron reducing agent. See ACID AND BASE; OXIDATION-REDUCTION.

In general, superoxide ion chemistry does not appear to be sufficiently robust to make superoxide ion a toxin. However, it can interact with protons, halogenated carbons, and carbonyl compounds to yield peroxy radicals that are toxic. See OXYGEN TOXICITY; REACTIVE INTERMEDIATES.

Superoxide does not appear to have exceptional reactivity. Nevertheless, superoxide will continue to be an interesting species for study because of the multiplicity of its chemical reactions and because of its importance as an intermediate in reactions that involve dioxygen and hydrogen peroxide. See BIOINORGANIC CHEMISTRY; OXYGEN. [D.T.S.]

**Superplastic forming** A process for shaping superplastic materials, a unique class of crystalline materials that exhibit exceptionally high tensile ductility. Superplastic materials may be stretched in tension to elongations typically in excess of 200% and more commonly in the range of 400–2000%. There are rare reports of higher tensile elongations reaching as much as 8000%. The high ductility is obtained only for superplastic materials and requires both the temperature and rate of deformation (strain rate) to be within a limited range. The temperature and strain rate required depend on the specific material. A variety of forming processes can be used to shape these materials; most of the processes involve the use of gas pressure to induce the deformation under isothermal conditions at the suitable elevated temperature. The tools and dies used, as well as the superplastic material, are usually heated to the forming temperature. The forming capability and complexity of configurations producible by the processing methods of superplastic forming greatly exceed those possible with conventional sheet forming methods, in which the materials typically exhibit 10–50% tensile elongation. See SUPERPLASTICITY.

There are a number of commercial applications of superplastic forming and combined superplastic forming and diffusion

bonding, including aerospace, architectural, and ground transportation uses. Examples are wing access panels in the Airbus A310 and A320, bathroom sinks in the Boeing 737, turbo-fan-engine cooling-duct components, external window frames in the space shuttle, front covers of slot machines, and architectural siding for buildings. See METAL FORMING. [C.H.Ha.]

**Superplasticity** The unusual ability of some metals and alloys to elongate uniformly thousands of percent at elevated temperatures, much like hot polymers or glasses. Under normal creep conditions, conventional alloys do not stretch uniformly, but form a necked-down region and then fracture after elongations of only 100% or less. The most important requirements for obtaining superplastic behavior include a very small metal grain size, a well-rounded (equiaxed) grain shape, a deformation temperature greater than one-half the melting point, and a slow deformation rate. See ALLOY; CREEP (MATERIALS); EUTECTICS.

Superplasticity is important to technology primarily because large amounts of deformation can be produced under low loads. Thus, conventional metal-shaping processes (for example, rolling, forging, and extrusion) can be conducted with smaller, and cheaper equipment. Nonconventional forming methods can also be used; for instance, vacuum-forming techniques, borrowed from the plastics industry, have been applied to sheet metal to form car panels, refrigerator door linings, and TV chassis parts. See METAL FORMING; PLASTICITY. [E.E.U.]

**Superposition principle** The principle, obeyed by many equations describing physical phenomena, that a linear combination of the solutions of the equation is also a solution.

An effect is proportional to a cause in a variety of phenomena encountered at the level of fundamental physical laws as well as in practical applications. When this is true, equations which describe such a phenomenon are known as linear, and their solutions obey the superposition principle. Thus, when  $f, g, h, \dots$ , solve the linear equation, then  $s$  ( $s = \alpha f + \beta g + \gamma h + \dots$ , where  $\alpha, \beta, \gamma, \dots$ , are coefficients) also satisfies the same equation. See LINEAR ALGEBRA; LINEARITY.

For example, an electric field is proportional to the charge that generates it. Consequently, an electric force caused by a collection of charges is given by a superposition—a vector sum—of the forces caused by the individual charges. The same is true for the magnetic field and its cause—electric currents. Each of these facts is connected with the linearity of Maxwell's equations, which describe electricity and magnetism. See ELECTRIC FIELD; MAXWELL'S EQUATIONS.

The superposition principle is important both because it simplifies finding solutions to complicated linear problems (they can be decomposed into sums of solutions of simpler problems) and because many of the fundamental laws of physics are linear. Quantum mechanics is an especially important example of a fundamental theory in which the superposition principle is valid and of profound significance. This property has proved most useful in studying implications of quantum theory, but it is also a source of the key conundrum associated with its interpretation.

Its effects are best illustrated in the double-slit superposition experiment, in which the wave function representing a quantum object such as a photon or electron can propagate toward a detector plate through two openings (slits). As a consequence of the superposition principle, the wave will be a sum of two wave functions, each radiating from its respective slit. These two waves interfere with each other, creating a pattern of peaks and troughs, as would the waves propagating on the surface of water in an analogous experimental setting. However, while this pattern can be easily understood for the normal (for example, water or sound) waves resulting from the collective motion of vast numbers of atoms, it is harder to understand its origin in quantum mechanics, where the wave describes an individual quantum, which can be detected, as a single particle, in just one spot

along the detector (for example, photographic) plate. The interference pattern will eventually emerge as a result of many such individual quanta, each of which apparently exhibits both wave (interference-pattern) and particle (one-by-one detection) characteristics. This ambivalent nature of quantum phenomena is known as the wave-particle duality. See INTERFERENCE OF WAVES; QUANTUM MECHANICS. [W.H.Z.]

### Superposition theorem (electric networks)

Essentially, that it is permissible, if there are two or more sources of electromotive force in a linear electrical network, to compute at any element of the network the response of voltage or of current that results from one source alone, and then the response resulting from another source alone, and so on for all sources, and finally to compute the total response to all sources acting together by adding these individual responses.

Thus, if a load of constant resistance is supplied with electrical energy from a linear network containing two batteries, two generators, or one battery and one generator, it would be correct to find the current that would be supplied to the load by one source (the other being reduced to zero), then to find the current that would be supplied to the load by the second source (the first source now being reduced to zero), and finally to add the two currents so computed to find the total current that would be produced in the load by the two sources acting simultaneously.

By means of the principle of superposition, effects are added instead of causes. This principle seems so intuitively valid that there is far greater danger of applying superposition where it is incorrect than of failing to apply it where it is correct. It must be recognized that for superposition to be correct the relation between cause and effect must be linear. [H.H.Sk.]

**Supersaturation** A solution is at the saturation point when dissolved solute in it crystallizes from it at the same rate at which it dissolves. Under prescribed experimental conditions of temperature and pressure, a solution can contain at saturation only one fixed amount of dissolved solute. However, it is possible to prepare relatively stable solutions which contain a quantity of a dissolved solute greater than that of the saturation value provided solute phase is absent. Such solutions are said to be supersaturated. They can be prepared by changing the experimental conditions of a system so that greater solubility is obtained, perhaps by heating the solution, and then carefully returning the system to or near its original state. The addition of solute phase will immediately relieve supersaturation. Solutions in which there is no spontaneous formation of solute phase for extended periods of time are said to be metastable. There is no sharp line of demarcation between an unstable and metastable solution. The process whereby initial aggregates within a supersaturated solution develop spontaneously into particles of new stable phase is known as nucleation. The greater the degree of supersaturation, the greater will be the number of nuclei formed. See NUCLEATION; PHASE EQUILIBRIUM; PRECIPITATION (CHEMISTRY). [L.Go./R.W.Mu.]

**Supersonic diffuser** A passive compressor (or shaped duct) in which gas enters at a velocity greater than the speed of sound, is decelerated in a contracting section, and reaches sonic speed at a throat.

Supersonic compression systems can be categorized to three basic types (see illustration). External-compression inlets have the supersonic diffusion taking place at or ahead of the cowl lip (or throat station) and generally employ one or more oblique waves ahead of the normal shock. Internal-compression inlets accomplish supersonic diffusion internally downstream of the cowl lip. Deceleration of the flow is produced by a number of weak reflecting waves in a gradually convergent channel. The

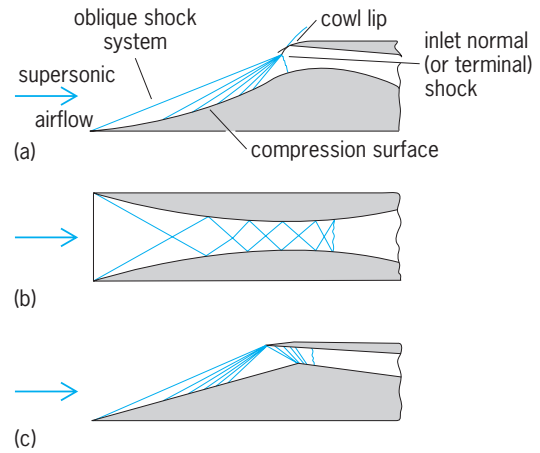

Basic supersonic compression systems. (a) External compression. (b) Internal compression. (c) Combination of external and internal compression.

third system is a combination of external and internal compression and appears to represent an effective compromise. [J.F.C.; L.J.O.]

**Supersonic flight** Relative motion of a solid body and a gas at a velocity greater than that of sound propagation under the same conditions. The general characteristics of supersonic flight can be understood by considering the laws of propagation of a disturbance or pressure impulse, in a compressible fluid.

If the fluid is at rest, the pressure impulse propagates uniformly with the velocity of sound in all directions, the effect always acting along an ever-increasing spherical surface. If, however, the source of the impulse is placed in a uniform stream, the impulse will be carried by the stream simultaneously with its propagation at sonic velocity relative to the stream. Hence the resulting propagation is faster in the direction of the stream and slower against the stream. If the velocity of the stream past the source of disturbance is supersonic, the effect of the impulse is restricted to a cone whose vertex is the source of the impulse and whose vertex angle decreases from  $90^\circ$  (corresponding to Mach number equal to 1) to smaller and smaller values as the Mach number of the stream increases (see illustration). If the source of the pressure impulse travels through the air at rest, the conditions are analogous. See MACH NUMBER.

Consider the supersonic motion of a wing moving into air at rest. Because signals cannot propagate ahead of the wing, the presence of the wing has no effect on the undisturbed air until the wing passes through it. Hence there must be an abrupt change in the properties of the undisturbed air as it begins to flow over the wing. This abrupt change takes place in a shock wave which

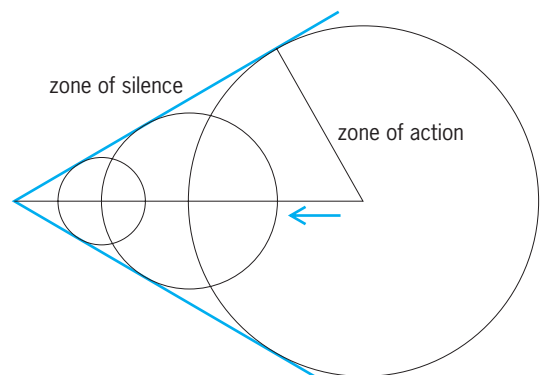

Generation of Mach wave by body at supersonic velocity; zones of action and silence are separated.

is attached to the leading edge of the wing, provided that the leading edge is sharp and the flight Mach number is sufficiently large. As the air passes through the shock wave, its pressure, temperature, and density are markedly increased.

Further aft of the leading edge, the pressure of the air is decreased as the air expands over the surface of the wing. Hence the pressure acting on the front part of the wing is higher than the ambient pressure, and the pressure acting on the rear part of the wing is lower than the ambient pressure. The pressure difference between front and rear parts produces a drag, even in the absence of skin friction and flow separation. The wing produces a system of compression and expansion waves which move with it. This phenomenon is similar to that of a speedboat moving with a velocity greater than the velocity of the surface waves. Because of this analogy, supersonic drag is called wave drag. It is peculiar to supersonic flight, and it may represent the major portion of the total drag of a body. See **HYPERSONIC FLIGHT**; **SUBSONIC FLIGHT**; **TRANSONIC FLIGHT**. [J.E.Sc.]

**Supersonic flow** Fluid motion in which the Mach number  $M$ , defined as the speed of the fluid relative to the sonic speed in the same medium, is more than unity. It is, however, common to call the flow transonic when  $0.8 < M < 1.4$ , and hypersonic when  $M > 5$ . See **MACH NUMBER**.

**Mach waves.** A particle moving in a compressible medium, such as air, emits acoustic disturbances in the form of spherical waves. These waves propagate at the speed of sound ( $M = 1$ ). If the particle moves at a supersonic speed, the generated waves cannot propagate upstream of the particle. The spherical waves are enveloped in a circular cone called the Mach cone. The generators of the Mach cone are called Mach lines or Mach waves.

**Shock waves.** When a fluid at a supersonic speed approaches an airfoil (or a high-pressure region), no information is communicated ahead of the airfoil, and the flow adjusts to the downstream conditions through a shock wave. Shock waves propagate faster than Mach waves, and the flow speed changes abruptly from supersonic to less supersonic or subsonic across the wave. Similarly, other properties change discontinuously across the wave. A Mach wave is a shock wave of minimum strength. A normal shock is a plane shock normal to the direction of flow, and an oblique shock is inclined at an angle to the direction of flow. The velocity upstream of a shock wave is always

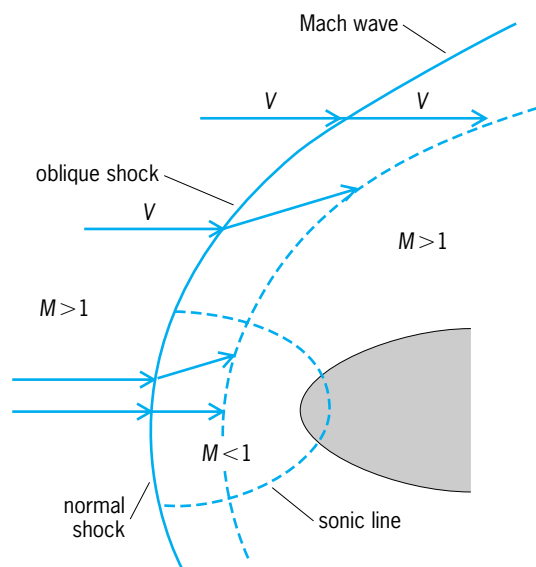

Typical normal shock, oblique shock, and Mach wave pattern in supersonic flow past a blunt body.  $M$  is the Mach number and  $V$  is the particle speed. The curved line parallel to normal and oblique shock waves indicates the end of the velocity vectors.

supersonic. Downstream of an oblique shock, the velocity may be subsonic resulting in a strong shock, or supersonic resulting in a weak shock. The downstream velocity component normal to any shock wave is always subsonic. There is no change in the tangential velocity component across the shock.

In a two-dimensional supersonic flow around a blunt body (see illustration), a normal shock is formed directly in front of the body, and extends around the body as a curved oblique shock. At a sufficient distance away, the flow field is unaffected by the presence of the body, and no discontinuity in velocity occurs. The shock then reduces to a Mach wave. See **COMPRESSIBLE FLOW**; **FLUID FLOW**; **SUPERSONIC FLIGHT**. [M.A.S.]

**Superstring theory** A proposal for a unified theory of all interactions, including gravity. At present, the strong, weak, and electromagnetic interactions are accounted for within the framework of the standard model. This model correctly describes experiments up to the highest energies performed so far, and gives a complete description of the elementary particles and their interactions down to distances of the order of  $10^{-18}$  m. Nevertheless, it has serious limitations, and attempts to overcome them and to unify the forces of nature have been only partly successful. Moreover, these attempts have left standing fundamental difficulties in reconciling gravitation and the laws of quantum mechanics. Superstring theory represents an ambitious program to unify all of the interactions observed in nature, including gravitation, in a theory with no unexplained parameters. In other words, this theory, if successful, should be able to account for all of the particles observed in nature and their interactions. See **ELEMENTARY PARTICLE**; **FUNDAMENTAL INTERACTIONS**.

**String concept.** In string theory, the fundamental objects are not point particles, as in standard theories of elementary particles, but one-dimensional extended objects, the open and closed strings. In such a theory, what are usually called the elementary particles are simply particular quantum states of the string. In superstring theories, space-time is ten-dimensional (space is nine-dimensional). If such theories are to describe nature, six dimensions must be "curled up" or "compact." The main consequence of such extra dimensions is the existence of certain very massive particles. See **SPACE-TIME**.

The essential features of string theories can be understood by analogy with the strings of a musical instrument. Such strings vibrate at a characteristic frequency, as well as any integer multiple of that frequency. Each of these modes of vibration (so-called normal modes) can be excited by plucking or striking the string. In classical physics, the amplitudes of vibration of each mode can take on a continuum of values. If there were a string of atomic dimensions, subject to the laws of quantum mechanics, the energies of this quantum string could take on only discrete values, corresponding to particular quantum states. See **QUANTUM MECHANICS**; **VIBRATION**.

The strings of superstring theory are quite similar. The main difference is that they obey Einstein's principles of special relativity. As a result, since each quantum state has a particular energy, it has a definite mass. Thus, each state of the string behaves as a particle of definite mass. Because it is possible, in principle, to pump an arbitrarily large amount of energy into the string, the theory contains an infinity of different types of particles of arbitrarily large mass. The interactions of these particles are governed by the ways in which the strings themselves interact. To be consistent with the principles of relativity, a string can interact only by splitting into two strings or by joining together with another string to form a third string. As a result, the interactions of strings are nearly unique. This geometric picture of string interactions translates into a precise set of rules for calculating the interaction of individual string states, that is, particles. See **RELATIVITY**.

**Classical solutions.** Obtaining a description of superstring theory analogous to quantum field theory is an active topic of research. However, even though the equations that describe this

field theory are not completely known at present, it is known how to find classical solutions of these equations, and by various techniques, an enormous number of such solutions have been found. These include states in which space-time has any dimension between one and ten, and states with many bizarre symmetries and spectra. Each of these solutions then corresponds to a possible ground state of the system. The theories built around some of these states look very much like the real world. Not only are four dimensions flat while six are compact, but they possess gauge symmetries close to that of the standard model. Some have three or four generations of quarks and leptons, as well as light Higgs particles, which are of crucial importance in the standard model. Many of these solutions possess space-time supersymmetry. See GAUGE THEORY; HIGGS BOSON; LEPTON; QUARKS.

However, if the theory does describe nature, it must have some mechanism that chooses one of the possible ground states. Because the masses and couplings of the elementary particles depend only on the choice of ground state, determining this true ground state will yield a set of predictions for these quantities. If string theory is a correct theory, these predictions must agree with the experimental values. [M.Di.]

**Supersymmetry** A conjectured enhanced symmetry of the laws of nature that would relate two fundamental observed classes of particles, bosons and fermions.

All particles can be classified as fermions, such as the electron and quarks, or bosons, such as the photon and graviton. A fundamental characteristic distinguishing these two classes is that they carry different quantum-mechanical spin. If the amount of spin of an elementary particle is measured in terms of the fundamental quantum unit of angular momentum— $\hbar$ , equal to Planck's constant divided by  $2\pi$ —then bosons always have integer amounts of spin (that is, 0, 1, 2 . . .), while fermions have odd half-integer amounts of spin (that is, 1/2, 3/2, 5/2, . . .). See SPIN (QUANTUM MECHANICS).

There is seemingly a fundamental distinction between particles with differing amounts of spin. For example, bosons like to act collectively (Bose-Einstein statistics), producing such distinctive behavior as the laser, while, conversely, fermions obey the Pauli exclusion principle (and the Pauli-Dirac statistics), which disallows two identical fermions to be in the same state, and explains the stability of matter. Moreover, all the symmetries that are observed in the world relate different particles of the same spin. See BOSE-EINSTEIN STATISTICS; FERMI-DIRAC STATISTICS; QUANTUM STATISTICS; SYMMETRY LAWS (PHYSICS).

In contrast, supersymmetry would relate bosons and fermions. This would be a remarkable step forward in understanding the physical world. However, if supersymmetry were realized as an exact symmetry, the particles so related should have almost all their characteristics, such as mass and charge, preserved. Explicitly, any fermion of spin 1/2 should have a boson superpartner of spin 0, while any gauge boson of spin 1 should have a fermion superpartner of spin 1/2. This is apparently a disaster for the idea of supersymmetry since it predicts, for instance, that there should exist a spin-0 boson partner of the electron, the selectron, with electric charge and mass equal to that of the electron. Such a particle would be easy to detect and is certainly ruled out by very many experiments.

The crucial caveat to this negative result is the condition that supersymmetry be realized as an exact symmetry. A fundamental concept of modern physics is spontaneously broken symmetry. Physics displays many examples of symmetries that are exact symmetries of the fundamental equations describing a system, but not of their solutions. In particle physics the spontaneous breaking of a symmetry usually results in a difference in the masses of the particles related by the symmetry; the amount of breaking can be quantified by this mass difference. See SYMMETRY BREAKING.

If supersymmetry is broken by a large amount, then all the superpartners have masses much greater than the particles that

are currently observed, and there is little hope of seeing evidence for supersymmetry. However, evidence that supersymmetry is broken by only a moderate amount comes from examination of the properties of the fundamental forces at high energy.

Of the four fundamental forces, the three excluding gravity are very similar in their basic formulation; they are all described by gauge theories, generalizations of the quantum theory of electromagnetism, and quantum electrodynamics (QED). The strength of electrical interaction between two electrons can be quantified in terms of a number, the coupling constant  $\alpha_1$ . However, the quantity  $\alpha_1$  is actually not a constant, but depends on the energies at which the interaction strength is measured. In fact, the interaction strengths,  $\alpha_1$ ,  $\alpha_2$ , and  $\alpha_3$ , of the three forces (excluding gravity) all depend on energy,  $\mu$ . The couplings  $\alpha_{1,2,3}$  satisfy differential equations—renormalization group equations—that depend on the types of elementary particles that exist with mass at or below the energy scale  $\mu$  and that are charged with respect to each of the three interactions. If the fundamental particles include not only the observed particles but also their superpartners, taken to have masses not greater than 1000 GeV heavier than their (observed) partners, then from the renormalization group equations, the couplings  $\alpha_i$  are predicted to meet (unify) at a huge energy of  $2 \times 10^{16}$  GeV. In contrast, if either supersymmetry is not an underlying symmetry of the world, or it is very badly broken so that the superpartners are very massive, the couplings fail to unify at a single point. See FUNDAMENTAL INTERACTIONS; GAUGE THEORY; QUANTUM ELECTRODYNAMICS; RENORMALIZATION.

Although the unification of couplings is the most significant indication that supersymmetry is a new law of nature, there are a number of other hints in this same direction. By observing the large-scale motions of the galaxies, the average density of large volumes of the universe can be deduced, resulting in a value that is substantially greater than that directly observed in luminous matter such as stars and hot gas. Therefore, a substantial fraction of the mass of the universe must be composed of some form of nonluminous or dark matter. Remarkably, many attractive models of supersymmetry predict that the lightest of all the superpartners is a weakly interacting massive particle with just the right characteristics to be this dark matter. See COSMOLOGY; UNIVERSE; WEAKLY INTERACTING MASSIVE PARTICLE (WIMP). [J.M.R.]

**Suppression (electricity)** The process or technique of reducing electrical interference to acceptable levels or to situations having no adverse effect. Suppression techniques may be applied to the interference source, the intervening path, the victim or receptor, or any combination. Normal strategy for interference control is to first suppress the source, if possible, since it may disturb many victims.

For intentional transmitters, suppressing interference may include reducing or eliminating harmonic radiations, restricting the bandwidth, or restricting levels of unnecessary or excessive modulation sidebands. These are usually accomplished by radio frequency filters. See ELECTRIC FILTER.

For many devices involving incidental radiators, such as brush-type motors and fluorescent lights, interference suppression may require both filtering and shielding. Electrical filtering may take the form of transient surge suppressors, feed-through capacitors, electromagnetic interference (EMI) filters, ferrite absorbers, isolation transformers, or Faraday shielded isolation transformers. See ELECTRIC PROTECTIVE DEVICES.

Shielding to control radiation involves using metal boxes, cases, cabinet housings, or metalized plastic versions thereof. Since the interconnecting cables between equipment offer the greatest threat as an "antenna farm," the dominant suppression technique is to shield the cables, wires, or harnesses. For the best protection from electromagnetic interference, the cable shield should be designed as an extension of the box or equipment shield. Other forms of interference hardening of cables include twisting parallel wire pairs, multiple-layer shields, and

absorbing jackets. Where possible, best electromagnetic compatibility performance is obtained by replacing the signal cables with fiber-optic links. See ELECTRICAL SHIELDING.

From a system point of view, the radiated emission propensity or pickup susceptibility of interconnected equipment is proportional to the maximum length or dimension and frequency until this length corresponds to an electrical length of about one-half wavelength. Thus, to help suppress electromagnetic interference, the corresponding frequency should not fall within the passband of victims or receptors. See ELECTRICAL INTERFERENCE; ELECTROMAGNETIC COMPATIBILITY. [D.R.J.W.]

**Supramolecular chemistry** A highly interdisciplinary field covering the chemical, physical, and biological features of complex chemical species held together and organized by means of intermolecular (noncovalent) bonding interactions. See CHEMICAL BONDING; INTERMOLECULAR FORCES.

When a substrate binds to an enzyme or a drug to its target, and when signals propagate between cells, highly selective interactions occur between the partners that control the processes. Supramolecular chemistry is concerned with the study of the basic features of these interactions and with their implementation in biological systems as well as in specially designed nonnatural ones. In addition to biochemistry, its roots extend into organic chemistry and the synthetic procedures for receptor construction, into coordination chemistry and metal ion-ligand complexes, and into physical chemistry and the experimental and theoretical studies of interactions. See BIOINORGANIC CHEMISTRY; ENZYME; LIGAND; PHYSICAL ORGANIC CHEMISTRY; PROTEIN.

The field started with the selective binding of alkali metal cations by natural as well as synthetic macrocyclic and macropolycyclic ligands, the crown ethers and cryptands. This led to the emergence of molecular recognition as a new domain of chemical research that, by encompassing all types of molecular components and interactions as well as both oligo and polymeric entities, became supramolecular chemistry. It underwent rapid growth with the development of synthetic receptor molecules of numerous types for the strong and selective binding of cationic, anionic, or neutral complementary substrates of organic, inorganic, or biological nature by means of various interactions (electrostatic, hydrogen bonding, van der Waals, and donor-acceptor). Molecular recognition implies the (molecular) storage and the (supramolecular) retrieval and processing of molecular structural (geometrical and interactional) information. See HYDROGEN BOND; MACROCYCLIC COMPOUND; MOLECULAR RECOGNITION.

Many types of receptor molecules have been explored (crown ethers, cryptands, cyclodextrins, calixarenes, cavitands, cyclophanes, cryptophanes, and so on), and many others may be imagined for the binding of complementary substrates of chemical or biological significance. They allow, for instance, the development of substrate-specific sensors or the recognition of structural features in biomolecules (for example, nucleic acid probes, affinity cleavage reagents, and enzyme inhibitors). See BIOPOLYMER; CYCLOPHANE; ENZYME INHIBITION.

A major step in the development of supramolecular chemistry over the last 20 years involved the design of systems capable of spontaneously generating well-defined, supramolecular entities by self-assembly under a given set of conditions.

The information necessary for supramolecular self-assembly to take place is stored in the components, and the program that it follows operates via specific interactional algorithms based on binding patterns and molecular recognition events. Thus, rather than being preorganized, constructed entities, these systems may be considered as self-organizing, programmed supramolecular systems.

Self-assembly and self-organization have recently been implemented in numerous types of organic and inorganic systems. By clever use of metal coordination, hydrogen bonding, and donor-acceptor interactions, researchers have achieved the sponta-

neous formation of a variety of novel and intriguing species such as inorganic double and triple helices termed helicates, catenates, threaded entities (rotaxanes), cage compounds, grids of metal ions, and so on.

Another major development concerns the design of molecular species displaying the ability to perform self-replication, based on components containing suitable recognition groups and reactive functions. Self-recognition processes involve the spontaneous selection of the correct partner(s) in a self-assembly event—for instance, the correct ligand strand in helicate formation.

A major area of interest is the design of supramolecular devices built on photoactive, electroactive, or ionoactive components, operating respectively with photons, electrons, or ions. Thus, a variety of photonic devices based on photoinduced energy and electron transfer may be imagined. Molecular wires, ion carriers, and channels facilitate the flow of electrons and ions through membranes. Such functional entities represent entries into molecular photonics, electronics, and ionics, which deal with the storage, processing, and transfer of materials, signals, and information at the molecular and supramolecular levels. Dynamic and mechanical devices exploit the control of motion within molecular and supramolecular entities. See INORGANIC PHOTOCHEMISTRY; ION TRANSPORT; PHOTOCHEMISTRY.

The design of systems that are controlled, programmed, and functionally self-organized by means of molecular information contained in their components represents new horizons in supramolecular chemistry and provides an original approach to nanoscience and nanotechnology. In particular, the spontaneous but controlled generation of well-defined, functional supramolecular architectures of nanometric size through self-organization—supramolecular nanochemistry—represents a means of performing programmed engineering and processing of nanomaterials. It offers a powerful alternative to the demanding procedures of nanofabrication and nanomanipulation, bypassing the need for external intervention. A rich variety of architectures, properties, and processes should result from this blending of supramolecular chemistry with materials science. See NANOCHEMISTRY; NANOTECHNOLOGY. [J.M.Le.]

**Surface (geometry)** A two-dimensional geometric figure (a collection of points) in three-dimensional space. The simplest example is a plane—a flat surface. Some other common surfaces are spheres, cylinders, and cones, the names of which are also used to describe the three-dimensional geometric figures that are enclosed (or partially enclosed) by those surfaces. In a similar way, cubes, parallelepipeds, and other polyhedra are surfaces. See CUBE; POLYHEDRON; SOLID (GEOMETRY).

Any bounded plane region has a measure called the area. If a surface is approximated by polygonal regions joined at their edges, an approximation to the area of the surface is obtained by summing the areas of these regions. The area of a surface is the limit of this sum if the number of polygons increases while their areas all approach zero. See AREA; CALCULUS; INTEGRATION; PLANE GEOMETRY; POLYGON.

**Methods of description.** The shape of a surface can be described by several methods. The simplest is to use the commonly accepted name of the surface, such as sphere or cube. In mathematical discussions, surfaces are normally defined by one or more equations, each of which gives information about a relationship that exists between coordinates of points of the surface, using some suitable coordinate system. See COORDINATE SYSTEMS.

Some surfaces are conveniently described by explaining how they might be formed. If a curve, called the generator in three-dimensional space, is allowed to move in some manner, then each position the generator occupies during this motion is a collection of points, and the set of all such points constitutes a surface that can be said to be swept out by the generator. In particular, if the generator is a straight line, a ruled surface is formed. If the generator is a straight line and the motion is such



that all positions of the generator are parallel, a cylindrical surface (or just cylinder) is formed. If the generator is a straight line and all positions of the generator have a common point of intersection, a conical surface (or just cone) is formed. A ruled surface that could be bent to lie in a plane (the bending to take place without stretching or tearing) is called a developable surface. See CONE; CYLINDER.

**Dihedron.** A dihedron is the surface formed by bending a plane along a line in that plane. More formally, a dihedron is the union of two half-planes that share the same boundary line.

**Quadric surfaces.** A surface whose implicit equation  $F(x, y, z) = 0$  is second degree is a quadric surface, a three-dimensional analog of a conic section. A plane section of a quadric surface is either a conic section or one of its degenerate forms (a point, a line, parallel lines, or intersecting lines). See CONIC SECTION; QUADRIC SURFACE.

**Surfaces of revolution.** When a plane curve (the generator) is revolved about a line in that plane (the axis of revolution, or just axis), a surface of revolution can be said to be swept out. The resulting surface will be symmetric about the axis of revolution.

A circular cylinder (a quadric surface) is formed when the generator and the axis of revolution are distinct parallel lines. If the generator is only a segment of a line (rather than the entire line), a bounded circular cylinder is generated.

A circular cone is a quadric surface formed when a straight-line generator intersects the axis of revolution at an acute angle. The cone consists of two parts, the nappes, joined at the point of intersection, which is the vertex of the cone.

A sphere (a quadric surface) is usually defined as a collection of points in three-dimensional space at a fixed distance (the radius) from a given point (the center). However, a sphere can also be defined as the surface of revolution formed when a semicircle (or the entire circle) is revolved about its diameter.

The intersection of any plane with a sphere will be a circle (except for tangent planes). Such a circle is called, respectively, a great circle or a small circle, depending on whether or not the plane contains the center of the sphere.

If only part of a semicircle is revolved about the diameter, a part of a sphere called a zone is formed. If a semicircle is revolved about its diameter through an angle less than one revolution, the surface swept out is a lune (see illustration). See SPHERE.

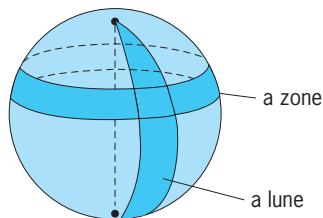

Sphere, with a zone and a lune.

A spheroid (also called an ellipsoid of revolution) is the quadric surface generated when an ellipse is revolved about either its major or minor axis. If the revolving is about the minor axis of the ellipse, the surface can be thought of as a flattened sphere, called an oblate spheroid. If the revolving is about the major axis, the surface can be thought of as a stretched sphere, called a prolate spheroid. A circular paraboloid is the quadric surface formed when a parabola is revolved about its axis. See ELLIPSE; PARABOLA.

A circular hyperboloid is the quadric surface formed when a hyperbola is revolved about either its transverse axis or its conjugate axis. The surface will be, respectively, a hyperboloid of one sheet or two sheets, depending on whether the revolving is about the conjugate axis or the transverse axis of the hyperbola. See HYPERBOLA.

A torus is generated when a circle is revolved about a line that does not intersect the circle. This doughnut-shaped surface has the property that not all points on the surface have the same sign of curvature. See DIFFERENTIAL GEOMETRY; TORUS. [H.L.Ba.]

**Surface-acoustic-wave devices** Devices which employ surface acoustic waves (SAW) in the analog processing of electronic signals with frequencies in the range  $10^7$ – $10^9$  Hz.

Surface acoustic waves which contain both compressional and shear components in phase quadrature, propagating nondispersively along and bound to solid surfaces, were discovered by Lord Rayleigh in the 1880s. As an example, earthquakes furnish sources for propagating these waves on the Earth's surface. It is of importance for electronic applications that if the solid is a piezoelectric material, the surface acoustic energy is complemented by a small amount of electric energy. This electric energy provides the physical mechanism for the coupling between conventional electromagnetic signals and propagating SAW. The coupling is attained by means of inter-digital transducers (IDT). SAW devices have led to a versatile microminiature technology for analog signal processing in the frequency range  $10^7$ – $10^9$  Hz. Notable devices include bandpass filters, resonators, oscillators, pulse compression filters, and fast Fourier transform processors. Application areas include the color television consumer market, radar, sonar, communication systems, and nondestructive testing. See PIEZOELECTRICITY.

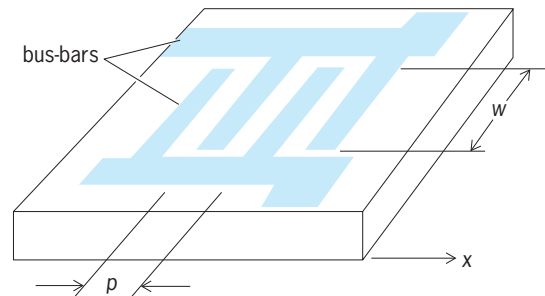

Interdigital construction of surface acoustic-wave transducer.  $x$  is a band-pass filter characteristic.

In the basic arrangement, a piezoelectric substrate, often crystalline quartz, has a polished upper surface on which two transducers are deposited. The input transducer is connected, via fine bonded leads, to the electric source through an electrical matching network. The output transducer drives the load, usually 50 ohms, through another electrical matching network. Because these transducers are bidirectional, they lead to devices with at least 6 decibels (dB) loss even in the passband. The unwanted acoustic waves are absorbed by terminations at the ends of the piezoelectric substrate. A metal baffle serves to isolate electromagnetically the two transducers.

The transducers consist of a set of metal interdigital electrodes, each a few hundred nanometers thick, fed from two bus-bars (see illustration). For this transducer arrangement the period  $p$  of the interdigital electrode structure is constant and equals one surface acoustic wavelength  $\lambda_0$  at the center of frequency  $f_0$  of the response. The width of the metal electrodes is typically  $p/4$ , being 100 micrometers at  $10^7$  Hz and  $1 \mu\text{m}$  at  $10^9$  Hz. The electrode overlap distance  $w$  is also constant and defines the acoustic beam width, which is typically 40 wavelengths. See TRANSDUCER.

The  $100\text{-}\mu\text{m}$  electrodes are readily fabricated by using techniques standard to the semiconductor integrated circuit industry of metallization: photoresist, masking, and chemical etching. The  $1\text{-}\mu\text{m}$  electrodes require more sophisticated

processing techniques. These include conformable optical masks and x-ray lithography coupled with sputter etching by radio-frequency and ion-beam methods for even finer resolutions. See INTEGRATED CIRCUITS. [J.H.Co.]

**Surface and interfacial chemistry** Chemical processes that occur at the phase boundary between gas-liquid, liquid-liquid, liquid-solid, or gas-solid interfaces.

The chemistry and physics at surfaces and interfaces govern a wide variety of technologically significant processes. Chemical reactions for the production of low-molecular-weight hydrocarbons for gasoline by the cracking and reforming of the high-molecular-weight hydrocarbons in oil are catalyzed at acidic oxide materials. Surface and interfacial chemistry are also relevant to adhesion, corrosion control, tribology (friction and wear), microelectronics, and biocompatible materials. In the last case, schemes to reduce bacterial adhesion while enhancing tissue integration are critical to the implantation of complex prosthetic devices, such as joint replacements and artificial hearts. See CRACKING; HETEROGENEOUS CATALYSIS; MEDICAL CHEMICAL ENGINEERING; PROSTHESIS; SURFACE PHYSICS.

Interactions with the substrate may alter the electronic structure of the adsorbate. Those interactions that lower the activation energy of a chemical reaction result in a catalytic process. Adsorption of reactants on a surface also confines the reaction to two dimensions as opposed to the three dimensions available for a homogeneous process. The two-dimensional confinement of reactants in a bimolecular event seems to drive biochemical processes with higher reaction efficiencies at proteins and lipid membranes. See ADSORPTION.

A limitation in the study of surfaces and interfaces rests with the low concentrations of the participants in the chemical process. Concentrations of reactants at surfaces are on the order of  $10^{-10}$  to  $10^{-8}$  mole/cm<sup>2</sup>. Such low concentrations pose a sensitivity problem from the perspective of surface analysis. Experimental techniques with high sensitivity are required to examine the low concentrations of a surface species at interfaces.

Electron spectroscopy methods are widely used in the study of surfaces because of the small penetration depth of electrons through solids. This attribute makes electron spectroscopy inherently surface-sensitive, since only a few of the outermost atomic layers are accessible. The methods of electron spectroscopy used in surface studies have several common characteristics (see table). A source provides the incident radiation to the sample, which can be in the form of electrons, x-radiation, or ultraviolet radiation. Electron beams are generated from the thermionic emission of metal filaments or metal oxide pellets. The incident

radiation induces an excitation at the surface of the sample, which alters the energy distribution of electrons that leave the surface. This distribution provides a diagnostic of the composition or structure of the interface. See ELECTRON SPECTROSCOPY.

Optical spectroscopy techniques (visible and infrared) are also useful for probing the chemical composition and molecular arrangement of surface species. Typical application configurations are the transmission and reflection (both external and internal) modes. Transmission spectroscopy relies on the passage of the probe beam through the sample. External and internal reflection spectroscopies involve the reflection of the probe beam from a medium with a lower refractive index to a medium with a higher refractive index, and from a higher to lower refractive index, respectively. The sample support must be optically transparent to the probe beam for the internal reflection mode. In both cases, the substrates are polished to a smooth, mirrorlike finish. See SPECTROSCOPY. [M.M.W.; M.D.P.]

**Surface coating** A substance applied to other materials to change the surface properties, such as color, gloss, resistance to wear or chemical attack, or permeability, without changing the bulk properties. Surface coatings include such materials as paints, varnishes, enamels, oils, greases, waxes, concrete, lacquers, powder coatings, metal coatings, and fire-retardant formulations. In general, organic coatings are based on a vehicle, usually a resin, which, after being spread out in a relatively thin film, changes to a solid. This change, called drying, may be due entirely to evaporation (solvent or water), or it may be caused by a chemical reaction, such as oxidation or polymerization. Opaque materials called pigments, dispersed in the vehicle, contribute color, opacity, and increased durability and resistance.

Organic coatings are usually referred to as decorative or protective, depending upon whether the primary reason for their use is to change (or preserve) the appearance or to protect the surface. Often both purposes are involved. See DRIER (PAINT); DRYING OIL; ELECTROPLATING OF METALS; LACQUER; METAL COATINGS; PAINT; PIGMENT (MATERIAL); PRIMER (SURFACE COATING); SHELLAC; THINNER; VARNISH. [C.R.Ma.; C.W.Si.]

**Surface condenser** A heat-transfer device used to condense a vapor, usually steam, by absorbing its latent heat in a cooling fluid, ordinarily water. Most surface condensers consist of a chamber containing a large number of corrosion-resisting alloy tubes through which cooling water flows. The vapor contacts the outside surface of the tubes and is condensed on them. The tubes are arranged so that the cooling water passes through the vapor space one or more times. Air coolers are normally an

**Surface-sensitive experimental techniques**

Technique	Source*	Detectors	Level of information
Auger electron spectroscopy (AES)	Electrons 2-3 keV	Cylindrical mirror of retarding field	Elemental composition
X-ray photoelectron spectroscopy (XPS)	X-rays 1254 eV (Mg) 1487 eV (Al)	Hemispherical or cylindrical mirror	Elemental composition and oxidation state
Ultraviolet photoelectron spectroscopy (UPS)	UV radiation 21 eV He(I) 41 eV He(II)	Hemispherical or cylindrical mirror	Electronic properties of adsorbate and/or bulk material
Energy loss spectroscopy (ELS)	Electrons 507-1000 eV	Electron energy analyzer	Electronic structure of surface
High-resolution electron energy loss spectroscopy (HREELS)	Electrons 1-10 eV	Electron energy analyzer	Vibrational losses
Low-energy electron diffraction (LEED)	Electrons 20-500 eV	Retarding fields and phosphorescent screen	Surface structure or periodicity
Infrared spectroscopy (IRS)	Photons	Mercury-cadmium-telluride or indium antimony	Molecular identity
Optical ellipsometry	Photons	Photomultiplier	Adsorbate layer thickness
Scanning tunneling microscopy (STM)	Tunneling current	Ammeter	Substrate roughness and texture

\*Mg = magnesium; Al = aluminum; He = helium.

integral part of the condenser but may be separate and external to it. The condensate is removed by a condensate pump and the noncondensables by a vacuum pump. See STEAM CONDENSER; VAPOR CONDENSER. [J.F.Se.]

**Surface hardening of steel** The selective hardening of the surface layer of a steel product by one of several processes which involve changes in microstructure with or without changes in composition. Surface hardening imparts a combination of properties to the finished product not produced by bulk heat treatment alone. Among these properties are high wear resistance and good toughness or impact properties, increased resistance to failure by fatigue resulting from cyclic loading, and resistance to surface indentation by localized loads. The use of surface hardening frequently is also favored by lower costs and greater flexibility in manufacturing.

The principal surface hardening processes are: (1) carburizing, (2) the modified carburizing processes of carbonitriding, cyaniding, and liquid carburizing, (3) nitriding, (4) flame hardening and induction hardening, and (5) surface working. Carburizing introduces carbon into the surface layer of low-carbon steel parts and converts that layer into high-carbon steel, which can be quenched-hardened by appropriate heat treatment. Carbonitriding, cyaniding, and liquid carburizing, in addition to supplying carbon, introduce nitrogen into the surface layer; this element permits lower case-hardening temperatures and has a beneficial effect on the subsequent heat treatment. In nitriding, only nitrogen is supplied, and reacts with special alloy elements present in the steel. Whereas the foregoing processes change the composition of the surface layer, flame hardening and induction hardening depend on a heat treatment applied selectively to the surface layer of a medium-carbon steel. Surface working by shot peening, surface rolling, or prestressing improved fatigue resistance by producing a stronger case, compressive stresses, and a smoother surface. See HEAT TREATMENT (METALLURGY); STEEL. [M.B.B.; C.F.F.]

**Surface mining** A mining method in which the overburden (earth and rocks) is stripped away completely to reach the underlying coal or other minerals. It has been popularly called strip mining. Surface mining of coal has increased steadily to the point where, in the United States, over 60% of the coal is obtained from such mining activities. Large-scale draglines, shovels, scrapers, front-end loaders, and dozers can reach seams as deep as 1000 ft (305 m) in some open-pit operations, while smaller-size equipment is used effectively in hilly terrain.

Surface mining is safer than underground mining because the miners are not exposed to such potential hazards as roof falls, to explosions caused by methane gas or dust ignitions, and to coal-worker pneumoconiosis (black lung) caused by long-term exposure to respirable coal dust. See RESPIRATORY SYSTEM DISORDERS; UNDERGROUND MINING.

Surface mining is also a more productive method of mining coal. Surface mines average 31 tons (28 metric tons) per worker per day, with some of the larger mines achieving 50 to 90 tons (45 to 82 metric tons) per worker per day. In underground mines the overall daily productivity per worker is about 11 tons (10 metric tons).

There are three general methods of surface mining: contour mining, area mining, and open-pit mining, with variations within each. The contour mining method is practiced commonly in rolling or mountainous terrain where the seams of coal outcrop at the mountain slopes. Mining generally begins by removing the overburden above the coal seam by starting at the outcrop, and proceeding along the hillside. The removed overburden (the spoil) must be essentially hauled back into the mined-out pit, the exposed highwall buried, and the mined land returned approximately to the original contour.

The area mining method is favored where the terrain is flat or only slightly rolling and where the mine site includes large stretches of land. The first cut, often referred to as a box cut,

results in a long pit with a highwall on both sides of the cut. Overburden from the first pit is placed in a convenient hollow or else stored to be available later for filling the final cut. A second cut is started adjacent to the first cut into which the second cut's overburden is placed. Strip by strip, the mining thus proceeds across the property. This type of mining is usually conducted with giant draglines or shovels.

The open-pit mining method is most often used where the coal beds are extremely thick, as in the subbituminous and lignite areas of the West and Southwest in the United States, and in the brown-coal areas of the world such as those in Germany. Open-pit operations generally use the bench-mining approach, in which a series of benches or terraces forms the open pit. Benches are about 200 to 1500 ft (61 to 457 m) wide. Each bench gives access to a 30–50-ft (9–15 m) highwall. Side benches are created for hauling the overburden around the pit to the reclamation area. With proper planning, reclamation can proceed at the same time as mining, so that the pit would seem to move as forward areas are opened and rear areas are restored. See OPEN PIT MINING.

During reclamation all disturbed areas must be restored to enhance wherever practical the premining wildlife and fish habitats. Streams and other drainages must be revegetated to provide natural cover along their banks. See COAL; COAL MINING; LAND RECLAMATION; MINING. [N.P.Ch.]

**Surface physics** The study of the structure and dynamics of atoms and their associated electron clouds in the vicinity of a surface, usually at the boundary between a solid and a low-density gas. Surface physics deals with those regions of large and rapid variations of atomic and electron density that occur in the vicinity of an interface between the two "bulk" components of a two-phase system. In conventional usage, surface physics is distinguished from interface physics by the restriction of the scope of the former to interfaces between a solid (or liquid) and a low-density gas, often at ultrahigh-vacuum pressures  $p = 10^{-10}$  torr ( $1.33 \times 10^{-8}$  newton/m<sup>2</sup> or  $10^{-13}$  atm). See SOLID-STATE PHYSICS.

Surface physics is concerned with two separate but complementary areas of investigation into the properties of such solid-"vacuum" interfaces. Interest centers on the experimental determination and theoretical prediction of surface composition and structure (that is, the masses, charges, and positions of surface species), of the dynamics of surface atoms (such as surface diffusion and vibrational motion), and of the energetics and dynamics of electrons in the vicinity of a surface (such as electron density profiles and localized electronic surface states). As a practical matter, however, the nature and dynamics of surface species are determined experimentally by scattering and emission measurements involving particles or electromagnetic fields (or both) external to the surface itself. Thus, a second major interest in surface physics is the study of the interaction of external entities (that is, atoms, ions, electrons, electromagnetic fields, or mechanical probes) with solids at their vacuum interfaces. It is this aspect of surface physics that most clearly distinguishes it from conventional solid-state physics, because quite different scattering, emission, and local probe experiments are utilized to examine surface as opposed to bulk properties.

Techniques for characterizing the solid-vacuum interface are based on one of three simple physical mechanisms for achieving surface sensitivity. The first, which is the basis for field emission, field ionization, and scanning tunneling microscopy (STM), is the achievement of surface sensitivity by utilizing electron tunneling through the potential-energy barrier at a surface. This concept provides the basis for the development of STM to directly examine the atomic structure of surfaces by measuring with atomic resolution the tunneling current at various positions along a surface. It also has been utilized for direct determinations of the energies of individual electronic orbitals of adsorbed complexes via the measurement of the energy distributions either of emitted electrons or of Auger electrons emitted in the

process of neutralizing a slow (energy  $E \sim 10$  eV) external ion. See FIELD-EMISSION MICROSCOPY; SCANNING TUNNELING MICROSCOPE; TUNNELING IN SOLIDS.

The second mechanism for achieving surface sensitivity is the examination of the elastic scattering or emission of particles which interact strongly with the constituents of matter, for example, "low energy" ( $E \lesssim 10^3$  eV) electrons, thermal atoms and molecules, or "slow" ( $300 \text{ eV} \lesssim E \lesssim 10^3$  eV) ions. Since such entities lose appreciable ( $\Delta E \sim 10$  eV) energy in distances of the order of tenths of a nanometer, typical electron analyzers with resolutions of tenths of an electronvolt are readily capable of identifying scattering and emission processes which occur in the upper few atomic layers of a solid. This second mechanism is responsible for the surface sensitivity of photoemission, Auger electron, electron characteristic loss, low-energy electron diffraction (LEED), and ion scattering spectroscopy techniques. The strong particle-solid interaction criterion that renders these measurements surface-sensitive is precisely the opposite of that used in selecting bulk solid-state spectroscopies. In this case, weak particle-solid interactions (that is, penetrating radiation) are desired in order to sample the bulk of the specimen via, for example, x-rays, thermal neutrons, or fast ( $E \gtrsim 10^4$  eV) electrons. These probes, however, can sometimes be used to study surface properties by virtue of special geometry, for example, the use of glancing-angle x-ray diffraction to determine surface atomic structure. See AUGER EFFECT; ELECTRON DIFFRACTION; ELECTRON SPECTROSCOPY; PHOTOEMISSION; X-RAY CRYSTALLOGRAPHY.

The third mechanism for achieving surface sensitivity is the direct measurement of the force on a probe in mechanical contact or near contact with the surface. At near contact, the van der Waals force can be measured directly by probes of suitable sensitivity. After contact is made, a variety of other forces dominate, for example, the capillary force for solid surfaces covered with thin layers of adsorbed liquid (that is, most solid surfaces in air at atmospheric pressure). When this mechanism is utilized via measuring the deflection of a sharp tip mounted on a cantilever near a surface, the experiment is referred to as atomic force microscopy (AFM) and results in maps of the force across the surface. Under suitable circumstances, atomic resolution can be achieved by this method as well as by STM. Atomic force microscopy opens the arena of microscopic surface characterization of insulating samples as well as electrochemical and biochemical interfaces at atmospheric pressure. Thus, its development is a major driving force for techniques based on surface physics. See INTERMOLECULAR FORCES.

Another reason for the renaissance in surface physics is the capability to generate in a vacuum chamber special surfaces that approximate the ideal of being atomically flat. These surfaces may be prepared by cycles of fast-ion bombardment, thermal outgassing, and thermal annealing for bulk samples (for example, platelets with sizes of the order of  $1 \text{ cm} \times 1 \text{ cm} \times 1 \text{ mm}$ ), molecular beam epitaxy of a thin surface layer on a suitably prepared substrate, or field evaporation of etched tips for field-ion microscopes. Alternatively, the sample may be cleaved in a vacuum chamber. In such a fashion, reasonable facsimiles of uncontaminated, atomically flat solid-vacuum interfaces of many metals and semiconductors have been prepared and subsequently characterized by various spectroscopic techniques. Such characterizations must be carried out in an ultrahigh vacuum ( $p \sim 10^{-8} \text{ N/m}^2$ ) so that the surface composition and structure are not altered by gas adsorption during the course of the measurements. See EPITAXIAL STRUCTURES. [C.B.D.]

**Surface tension** The force acting in the surface of a liquid, tending to minimize the area of the surface. Surface forces, or more generally, interfacial forces, govern such phenomena as the wetting or nonwetting of solids by liquids, the capillary rise of liquids in fine tubes and wicks, and the curvature of free-liquid surfaces. The action of detergents and antifoaming agents and

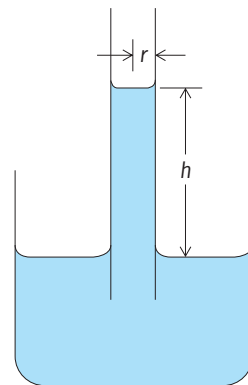

Rise of liquid in capillary tube.

the flotation separation of minerals depend upon the surface tensions of liquids.

In the body of a liquid, the time-averaged force exerted on any given molecule by its neighbors is zero. Even though such a molecule may undergo diffusive displacements because of random collisions with other molecules, there exist no directed forces upon it of long duration. It is equally likely to be momentarily displaced in one direction as in any other. In the surface of a liquid, the situation is quite different; beyond the free surface, there exist no molecules to counteract the forces of attraction exerted by molecules in the interior for molecules in the surface. In consequence, molecules in the surface of a liquid experience a net attraction toward the interior of a drop. These centrally directed forces cause the droplet to assume a spherical shape, thereby minimizing both the free energy and surface area.

Liquids which wet the walls of fine capillary tubes rise to a height which depends upon the tube radius, the surface tension, the liquid density, and the contact angle between the solid and the liquid (measured through the liquid). In the illustration a liquid of a certain density is shown as having risen to a height  $h$  in a capillary whose radius is  $r$ . A balance exists between the force exerted by gravity on the mass of liquid raised in the capillary and the opposing force caused by surface tension.

Detergents, soaps, and flotation agents owe their usefulness to their ability to lower the surface tension of water, thereby stabilizing the formation of small bubbles of air. At the same time, the interfacial tension between solid particles and the liquid phase is lowered, so that the particles are more readily wetted and floated after attachment to air bubbles. See FLOTATION; INTERFACE OF PHASES; SURFACTANT. [N.H.N.]

**Surface water** A term commonly used to designate the water flowing in stream channels. The term is sometimes used in a broader sense as opposed to "subsurface water." In this sense, surface water includes water in lakes, marshes, glaciers, and reservoirs as well as that flowing in streams. In the broadest sense, surface water is all the water on the surface of the Earth and thus includes the water of the oceans. Subsurface water includes water in the root zone of the soil and ground water flowing or stored in the rock mantle of the Earth. Subsurface water differs from surface water in the mechanics of its movement as well as in its location. Surface and subsurface water are two stages of the movement of the Earth's water through the hydrologic cycle. The world's ocean and atmospheric moisture are two other main stages of the grand water cycle of the Earth. See HYDROLOGY.

The table gives estimates of the amounts of water in various parts of the hydrologic cycle and their detention periods. It may be noted that surface water on the continents is but a small part of the world's water and that the bulk of that is in freshwater lakes. However, the detention period is also short. This means that the surface-water part, and especially the water in the streams, is rapidly discharged and replenished. That is why

Distribution of the world's supply of water

Location	Volume of water, 10 <sup>9</sup> acre-ft*	Percentage total	Detention period, years
World's oceans	1,060,000	97.39	5,000
Surface water on the continents			
Glaciers and polar ice caps	20,000	1.83	2,000
Fresh-water lakes	100	0.0093	100
Saline lakes and inland seas	68	0.0063	50
Average in stream channels	0.25	0.00002	0.05
Total surface water	20,200		700 av
Subsurface water on the continents			
Root zone of the soil	10	0.00094	0.25
Ground water above 2500 ft	3,700	0.339	5
Ground water below 2500 ft	4,600	0.425	100
Total subsurface water	8,300		
Atmospheric water	115	0.0011	0.03
Total world water (rounded)	1,088,000	100	3,000

\*109 acre-ft =  $1.233 \times 10^8$  ha · m =  $1.233 \times 10^{12}$  m<sup>3</sup>.  
 †2500 ft = 750 m.

surface water, as well as the shallower ground water, is called a renewable resource. Water that has a detention period of more than a generation is not renewed within sufficient time to be so considered. See GROUND-WATER HYDROLOGY; RIVER.

Precipitation that reaches the Earth is subdivided by processes of evaporation and infiltration into various routes of subsequent travel. Evaporation from wet land surfaces and from vegetation returns some of the water to the atmosphere immediately. Precipitation that falls at rates less than the local rate of infiltration enters the soil. Some of the infiltrated water is retained in the soil, sustaining plant life, and some reaches the ground water. The precipitation that exceeds the capacity of the soil to absorb water flows overland in the direction of the steepest slope and concentrates in rills and minor channels. During storms most of the water in surface streams is derived from that portion of the precipitation which fails to infiltrate the soil. See PRECIPITATION (METEOROLOGY).

The distinction between surface and subsurface water, though useful, should not obscure the fact that water on the surface and water underground is physically connected through pores, cracks, and joints in rock and soil material. In many areas, particularly in humid regions, surface water in stream channels is the visible part of a reservoir, which is partly underground; the water surface of a river is the visible extension of the surface of the ground water. [L.B.L.]

**Surfactant** A member of the class of materials that, in small quantity, markedly affect the surface characteristics of a system; also known as surface-active agent. In a two-phase system, for example, liquid-liquid or solid-liquid, a surfactant tends to locate at the interface of the two phases, where it introduces a degree of continuity between the two different materials. Soaps and detergents are classic examples of surfactants due to their dual (amphipathic) character. These substances consist of a hydrophobic tail portion, usually a long-chain hydrocarbon, and a hydrophilic polar head group, which is often ionic. A material possessing these characteristics is known as an amphiphile. It tends to dissolve in both aqueous and oil phase and to locate at the oil-water interface. See DETERGENT; INTERFACE OF PHASES; SOAP; SURFACE TENSION.

Surfactants are employed to increase the contact of two materials, sometimes known as wettability. Surfactants and surface activity are controlling features in many important systems, including emulsification, detergency, foaming, wetting, lubrication, water repellance, waterproofing, spreading and dispersion, and colloid stability. See EMULSION; LUBRICANT; MICELLE.

In general, surfactants are divided into four classes: amphoteric, with zwitterionic head groups; anionic, with negatively charged head groups; cationic, with positively charged head groups; and nonionic, with uncharged hydrophilic head groups. Those with anionic head groups include long-chain fatty acids, sulfosuccinates, alkyl sulfates, phosphates, and sulfonates. Cationic surfactants may be protonated long-chain amines and long-chain quaternary ammonium compounds. The class of amphoteric surfactants is represented by betaines and certain lecithins, while nonionic surfactants include polyethylene oxide, alcohols, and other polar groups.

Quite different materials, such as polymers and clays, can also exhibit surface activity; many polymeric materials, for example, polyvinyl alcohol and polyacrylamide, are excellent stabilizers for a variety of colloid systems. These entities adsorb at the colloid interface and, by means of steric effects, prevent colloid-colloid adhesion and flocculation. Clays readily adsorb other materials or adsorb onto large particles suspended in solution, so that the particle interface consists of charged clay particles, which increase colloid stability by electrostatic and steric effects. See ADSORPTION; BENTONITE; CLAY MINERALS; COLLOID; ION EXCHANGE; POLYMER; SURFACE AND INTERFACIAL CHEMISTRY. [J.K.T.]

**Surge arrester** A protective device designed primarily for connection between a conductor of an electrical system and ground to limit the magnitude of transient overvoltages on equipment. A lightning arrester is really a voltage-surge arrester.

The valve arrester consists of disks of zinc oxide material that exhibit low resistance at high voltage and high resistance at low voltage. By selecting an appropriate configuration of disk material, the arrester will conduct a low current of a few milliamperes at normal system voltage. During conditions of lightning or switching surge overvoltages, the surge current is limited by the circuit; and for the magnitudes of current that can be delivered to the arrester location, the resulting voltage will be limited to controlled values, and to safe levels as well, when insulation levels of equipment are coordinated with the surge arrester protective characteristics.

A typical surge arrester consists of disks of zinc oxide material sized in cross-sectional area to provide desired energy discharge capability, and in axial length proportional to the voltage capability. The disks are then placed in porcelain enclosures to provide physical support and heat removal, and sealed for isolation from contamination in the electrical environment. See LIGHTNING; LIGHTNING AND SURGE PROTECTION. [G.D.B.]

**Surge suppressor** A device that is designed to offer protection against voltage surges on the power line that supplies electrical energy to the sensitive components in electronic devices and systems. The device offers a limited type of protection to computers, television sets, high-fidelity equipment, and similar types of electronic systems.

A voltage surge is generally considered to be a transient wave of voltage on the power line. The amplitude of the surge may be several thousand volts, and the duration may be as short as 1 or 2 milliseconds or as long as about 100 ms. Typical effects can be damage to the electronics or loss of programs and data in computer memories. Many events can cause the surges, including lightning that strikes the power lines at a considerable distance from the home or office; necessary switching of transmission lines by the utilities; and rapid connections or disconnections of large loads, such as air conditioners and motors, from the power line, or even other appliances in the home. Lightning is perhaps the most common. See LIGHTNING.

The suppressor acts to limit the peak voltage applied to the electronic device to a level that normally will not cause either damage to the device or software problems in the computers. The device may include a pilot light, a fuse, a clipping circuit, resistors, and a main switch. The clipper circuit is the principal item, and the design of this portion is usually proprietary information. See CLIPPING CIRCUIT; FUSE (ELECTRICITY). [E.C.Jo.]

**Surgery** That branch of medicine which generally treats diseases by operative intervention. Surgical procedures may involve relieving mechanical obstruction of a tubular organ, such as the intestine; or removing a diseased organ, which cannot be salvaged by medical treatment, such as a gangrenous appendix or inflamed gallbladder; or removing a malignant tumor with a margin of normal tissue; or repairing an injured organ, or removing it if the organ is irreparable and its absence is compatible with survival.

The field of surgery has become increasingly specialized, primarily by organ system, so that surgical diseases of the kidney, bladder, and other components of the urinary tract are treated by surgeons called urologists; surgery of the central nervous system, including the brain and spinal cord, is done by neurosurgeons; reconstructive and cosmetic surgery is done primarily by plastic surgeons; general surgeons continue to do most abdominal surgery, some head and neck surgery, and surgery of the soft tissues of the extremities; and surgical diseases of the bones and joints are treated by orthopedic surgeons. Some specialties within surgery have also developed into specialties that are not limited to one organ system, such as surgical oncology (cancer surgery), so that cancers in most parts of the body may be treated by surgeons with special training in malignant diseases. See MEDICINE. [R.F.J.]

**Surveillance radar** Any radar equipment used by civil or military authorities for locating aircraft, ships, or ground vehicles; most commonly, in civil air-traffic management, a radar used by controllers to indicate the position of aircraft aloft or on the airport surface. Two types of air-traffic control surveillance radar are employed internationally. Ground-based conventional, or primary, radar operates by transmitting microwave pulses and detecting the resulting energy reflected from the aircraft body (airframe). Secondary surveillance radar employs cooperative radio receiver-transmitter units (transponders) on the aircraft.

Although secondary radar generally provides more reliable and complete surveillance information than does primary radar, air-traffic authorities use both. In the United States, two major examples are the Federal Aviation Administration's Airport Surveillance Radar (ASR) and Air Route Surveillance Radar (ARSR), the latter shared at some locations with the U.S. Air Force. Both normally operate unattended, their outputs fed by a landline or microwave link to their control positions. Primary radar provides backup coverage for nonequipped aircraft and for aircraft with airframe shielding. Primary radar can also detect potentially hazardous precipitation cells and potentially hostile aircraft or inadvertent intruders. Secondary radar is sometimes used without a primary radar backup for long-range, high-altitude surveillance where all aircraft are transponder-equipped, where airframe shielding is rare, and where the sensitivity disadvantage of primary radar requires costly high-power transmitters. The Federal Aviation Administration has authorized use of certain secondary radars having faster update rates and monopulse accuracy for monitoring aircraft conducting multiple parallel approaches in bad weather. See AIR-TRAFFIC CONTROL; MONOPULSE RADAR; RADAR. [R.R.LaF.]

**Surveying** The measurement of dimensional relationships among points, lines, and physical features on or near the Earth's surface. Basically, surveying determines horizontal distances, el-

evation differences, directions, and angles. These basic determinations are applied further to the computation of areas and volumes and to the establishment of locations with respect to some coordinate system.

Surveying is typically used to locate and measure property lines; to lay out buildings, bridges, channels, highways, sewers, and pipelines for construction; to locate stations for launching and tracking satellites; and to obtain topographic information for mapping and charting.

Horizontal distances are usually assumed to be parallel to a common plane. Each measurement has both length and direction. Length is expressed in feet or in meters. Direction is expressed as a bearing of the azimuthal angle relationship to a reference meridian, which is the north-south direction. It can be the true meridian, a grid meridian, or some other assumed meridian. The degree-minute-second system of angular expression is standard in the United States.

Reference, or control, is a concept that applies to the positions of lines as well as to their directions. In its simplest form, the position control is an identifiable or understood point of origin for the lines of a survey. Conveniently, most coordinate systems have the origin placed west and south of the area to be surveyed so that all coordinates are positive and in the northeast quadrant.

Vertical measurement adds the third dimension to an object's position. This dimension is expressed as the distance above some reference surface, usually mean sea level, called a datum. Mean sea level is determined by averaging high and low tides during a lunar month.

**Horizontal control.** The main framework, or control, of a survey is laid out by traverse, triangulation, or trilateration. Some success has been achieved in locating control points from Doppler measurements of passing satellites, from aerial phototriangulation, from satellites photographed against a star background, and from inertial guidance systems. In traverse, adopted for most ordinary surveying, a line or series of lines is established by directly measuring lengths and angles. In triangulation, used mainly for large areas, angles are again directly measured, but distances are computed trigonometrically. This necessitates triangular patterns of lines connecting intervisible points and starting from a baseline of known length. New baselines are measured at intervals. Trigonometric methods are also used in trilateration, but lengths, rather than angles, are measured. The development of electronic distance measurement (EDM) instruments brought trilateration into significant use.

**Distance measurement.** Traverse distances are usually measured with a surveyor's tape or by EDM, but also may sometimes be measured by stadia, subtense, or trig-traverse.

Whether on sloping or level ground, it is horizontal distances that must be measured. In taping, horizontal components of hillside distances are measured by raising the downhill end of the tape to the level of the uphill end. On steep ground this technique is used with shorter sections of the tape. The raised end is positioned over the ground point with the aid of a plumb bob. Where slope distances are taped along the ground, the slope angle can be measured with the clinometer. The desired horizontal distance can then be computed.

In EDM the time a signal requires to travel from an emitter to a receiver or reflector and back to the sender is converted to a distance readout. The great advantage of electronic distance measuring is its unprecedented precision, speed, and convenience. Further, if mounted directly onto a theodolite, and especially if incorporated into it and electronically coupled to it, the EDM instrument with an internal computer can in seconds measure distance (even slope distance) and direction, then compute the coordinates of the sighted point with all the accuracy required for high-order surveying.

In the stadia technique, a graduated stadia rod is held upright on a point and sighted through a transit telescope set up over another point. The distance between the two points is determined



Fig. 1. Subtense bar. (Lockwood, Kessler, and Bartlett Inc.)

from the length of rod intercepted between two horizontal wires in the telescope.

In the subtense technique the transit angle subtended by a horizontal bar of fixed length enables computation of the transit-to-bar distance (Fig. 1). In trig-traverse the subtense bar is replaced by a measured baseline extending at a right angle from the survey line whose distance is desired. The distance calculated in either subtense or trig-traverse is automatically the horizontal distance and needs no correction.

**Angular measurement.** The most common instrument for measuring angles is the transit or theodolite. It is essentially a telescope that can be rotated a measurable amount about a vertical axis and a horizontal axis. Carefully graduated metal or glass circles concentric with each axis are used to measure the angles. The transit is centered over a point with the aid of either a plumb bob suspended by a string from the vertical axis or (on some theodolites) an optical plummet, which enables the operator to sight along the instrument's vertical axis to the ground through a right-angle prism.

**Elevation differences.** Elevations may be measured trigonometrically in conjunction with reduction of slope measurements to horizontal distances, but the resulting elevation differences are of low precision.

Most third-order and all second- and first-order measurements are made by differential leveling, wherein a horizontal line of sight of known elevation is sighted on a graduated rod held vertically on the point being checked (Fig. 2). The transit telescope, leveled, may establish the sight line, but more often a specialized leveling instrument is used. For approximate results a hand level may be used.

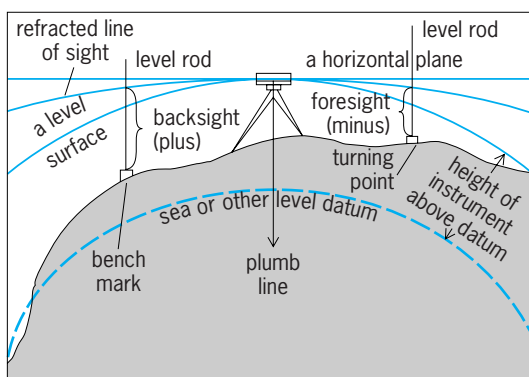

Fig. 2. Theory of differential leveling.

Other methods of measuring elevation include trigonometric leveling which involves calculating height from measurements of horizontal, distance and vertical angle; barometric leveling, a method of determining approximate elevation difference with aid of a barometer; and airborne profiling, in which a radar altimeter on an aircraft is used to obtain ground elevations.

**Astronomical observations.** To determine meridian direction and geographic latitude, observations are made by a theodolite or transit on Polaris, the Sun, or other stars. Direction of the meridian (geographic north-south line) is needed for direction control purposes; latitude is needed where maps and other sources are insufficient. The simplest meridian determination is made by sighting Polaris at its elongation, as the star is rounding the easterly or westerly extremity of its apparent orbit. An angular correction is applied to the direction of sighting, which is referenced to a line on the ground. The correction value is found in an ephemeris. See EPHEMERIS; TOPOGRAPHIC SURVEYING AND MAPPING. [B.A.B.]

**Surveying instruments** Instruments used in surveying operations to measure vertical angles, horizontal angles, and distance. Such devices were originally mechanical only, but technological advances led to mechanical-optical devices, optical-electronic devices, and finally, electronic-only devices.

Four types of levels are available: optical, automatic, electronic, and laser. An optical level is used to project a line of sight that is at a  $90^\circ$  angle to the direction of gravity. Both dumpy and tilting types use a precision leveling vial to orient to gravity. The dumpy type was used primarily in the United States, while the tilting type was of European origin and used in the remainder of the world. Automatic levels use a pendulum device, in place of the precision vial, for relating to gravity. The pendulum mechanism is called a compensator. The pendulum has a prism or mirror, as part of the telescope, which is precisely positioned by gravity. The electronic level has a compensator similar to that on an automatic level, but the graduated leveling staff is not observed and read by the operator. The operator has only to point the instrument at a bar-code-type staff, which then can be read by the level itself. The laser levels actually employ three different types of light sources: tube laser, infrared diode, and laser diode. The instrument uses a rotating head to project the laser beam in a level  $360^\circ$  plane. See LEVEL MEASUREMENT.

The primary purpose of a transit is to measure horizontal and vertical angles. Circles, one vertical and one horizontal, are used for these measurements. The circles are made of metal or glass and have precision graduations engraved or etched on the surface. A vernier is commonly used to improve the accuracy of the circle reading. The theodolite serves the same purpose as the transit, and they have many similar features. The major differences are that the measuring circles are constructed only of glass and are observed through magnifying optics to increase the accuracy of angular readings. The electronic theodolite uses electronic reading circles in place of the optically read ones. See VERNIER.

The U.S. Department of Defense installed a satellite system known as the Global Positioning System for navigation and for establishing the position of planes, ships, vehicles, and so forth. This system uses special receivers and sophisticated software to calculate the longitude and latitude of the receiver. It was discovered early in the program that the distance between two non-moving receivers could be determined very accurately and that the distance between receivers could be many miles apart. This technology has become the standard for highly accurate control surveys, but it is not in general use because of the expense of the precision receivers, the time required for each setup, and the sophistication of the process. See SATELLITE NAVIGATION SYSTEMS; SURVEYING. [K.W.K.]

**Susceptance** The imaginary part of the admittance of an alternating-current circuit.

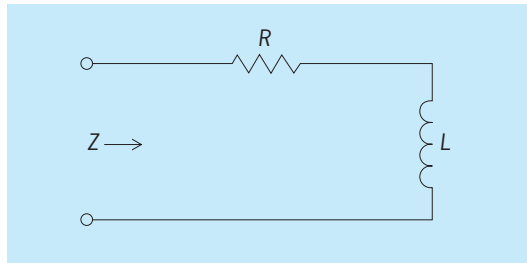

Circuit with a resistor and inductor in series.

The admittance,  $Y$ , of an alternating current circuit is a complex number given by Eq. (1). The imaginary part,  $B$ , is the

$$Y = G + jB \quad (1)$$

susceptance. The units of susceptance like those of admittance are called siemens or mhos. Susceptance may be either positive or negative. For example, the admittance of a capacitor  $C$  at frequency  $\omega$  is given by Eq. (2), and so  $B$  is positive. For an inductor  $L$ , the admittance is given by Eq. (3), and so  $B$  is negative.

$$Y = jC\omega = jB \quad (2)$$

$$Y = -\frac{j}{L\omega} = jB \quad (3)$$

In general, the susceptance of a circuit may depend on the resistors as well as the capacitors and inductors. For example, the circuit in the illustration has impedance given by Eq. (4) and admittance given by Eq. (5), so that the susceptance, given by Eq. (6), depends on the resistor  $R$  as well as the inductor  $L$ .

$$Z = R + jL\omega \quad (4)$$

$$Y = \frac{1}{R + jL\omega} \quad (5)$$

$$B = \frac{-L\omega}{R^2 + L^2\omega^2} \quad (6)$$

See ADMITTANCE; ALTERNATING-CURRENT CIRCUIT THEORY; ELECTRICAL IMPEDANCE. [J.O.S.]

**Swamp, marsh, and bog** Wet flatlands, where mesophytic vegetation is a really more important than open water, which are commonly developed in filled lakes, glacial pits and potholes, or poorly drained coastal plains or floodplains. Swamp is a term usually applied to a wetland where trees and shrubs are an important part of the vegetative association, and bog implies lack of solid foundation. Some bogs consist of a thick zone of vegetation floating on water.

Unique plant associations characterize wetlands in various climates and exhibit marked zonation characteristics around the edge in response to different thicknesses of the saturated zone above the firm base of soil material. Coastal marshes covered with vegetation adapted to saline water are common on all continents. Presumably many of these had their origin in recent inundation due to post-Pleistocene rise in sea level. See GLACIATED TERRAIN; MANGROVE. [L.B.L.]

**Sweat gland** A coiled, tubular gland found in mammals. There are two kinds, merocrine or eccrine, and apocrine. The latter are generally associated with hair follicles (see illustration). Merocrine glands are distributed extensively over the body in the human, whereas the apocrine variety is restricted to the scalp, nipples, axilla, external auditory meatus, external genitals, and perianal areas. Apocrine sweat glands are more numerous in mammals, with the exception of the chimpanzee and human, in which the merocrine variety predominates. The mammary

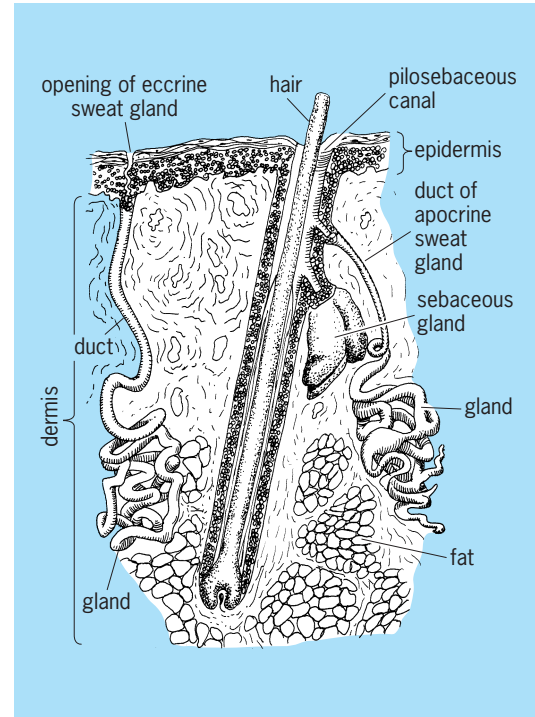

Human skin showing structure of both eccrine and apocrine sweat glands.

glands probably represent modified apocrine sweat glands which grow inward and increase in complexity. See GLAND; MAMMARY GLAND. [O.E.N.]

**Sweetgum** The tree *Liquidambar styraciflua*, also called redgum, a deciduous tree of the southeastern United States. It is found northward as far as southwestern Connecticut, and also grows in Central America. Sweetgum is readily distinguished by its five-lobed, or star-shaped, leaves and by the corky wings or ridges usually developed on the twigs. The erect trunk is a dark gray, but the branches are lighter in color. In winter the persistent, spiny seedballs are an excellent diagnostic feature.

Sweetgum is used for furniture, interior trim, railroad ties, cigar boxes, crates, flooring, barrels, woodenware, and wood pulp, and it is one of the most important materials for plywood manufacture. Sweetgum is one of the most desirable ornamental trees, chiefly because of its brilliant autumn coloration. See HAMAMELIDALES. [A.H.G./K.P.D.]

**Swim bladder** A gas-filled sac found in the body cavities of most bony fishes (Osteichthyes). The swim bladder has various functions in different fishes, acting as a float which gives the fish buoyancy, as a lung, as a hearing aid, and as a sound-producing organ. In many fishes it serves two or three of these functions, and in the African and Asiatic knife fishes (Notopteridae) it may serve all four. The swim bladder contains the same gases that make up air, but often in different proportions. [R.McN.A.]

**Switched capacitor** A module consisting of a capacitor with two metal oxide semiconductor (MOS) switches connected as shown in illus. *a*. These elements in the module are easily realized as an integrated circuit on a silicon chip by using MOS technology. The switched capacitor module is approximately equivalent to a resistor, as shown in illus. *b*. The fact that resistors are relatively difficult to implement gives the switched capacitor a great advantage in integrated-circuit applications requiring resistors. Some of the advantages are that the cost is significantly reduced, the chip area needed is reduced,



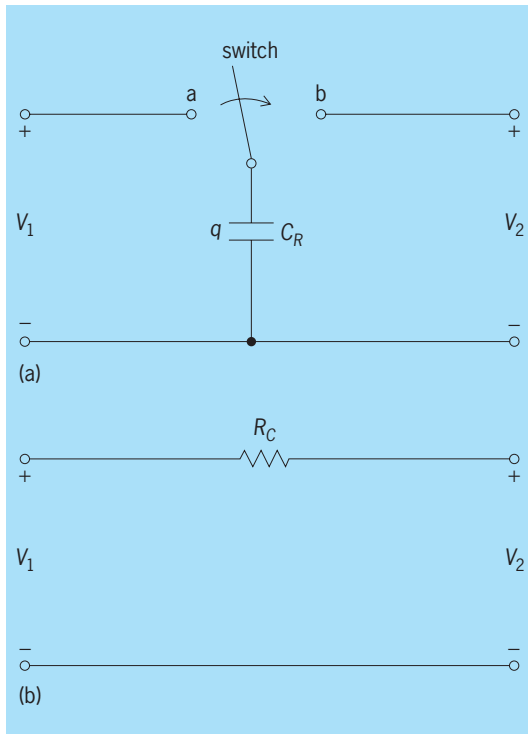

Switched capacitor, (a) Basic circuit, (b) Equivalent resistive circuit.

and precision is increased. Although the switched capacitor can be used for any analog circuit realization such as analog-to-digital or digital-to-analog converters, the most notable application has been to voice-frequency filtering. See ANALOG-TO-DIGITAL CONVERTER; DIGITAL-TO-ANALOG CONVERTER; ELECTRIC FILTER; INTEGRATED CIRCUITS. [M.E.V.V.]

**Switching circuit** A constituent electric circuit of a switching or digital data-processing system which receives, stores, or manipulates information in coded form to accomplish the specified objectives of the system. Examples include digital computers, dial telephone systems, and automatic accounting and inventory systems. See DIGITAL COMPUTER; SWITCHING SYSTEMS (COMMUNICATIONS); SWITCHING THEORY.

Physically, switching circuits consist of conducting paths interconnecting discrete-valued electrical devices. The most generally used switching circuit devices are two-valued or binary, such as switches and relays in which manual or electromagnetic actuation opens and closes electric contacts; vacuum and gas-filled electronic tubes, and semiconductor rectifiers and transistors, which do or do not conduct current; and magnetic structures, which can be saturated in either of two directions.

The electrical conditions controlling these switching circuit devices are also generally two-valued or binary, such as open versus closed path, full voltage versus no voltage, large current versus small current, and high resistance versus low resistance. Such two-valued electrical conditions, as applied to the input of a switching circuit, represent either (1) a combination of events or situations which exist or do not exist; (2) a sequence of events or situations which occur in a certain order; or (3) both combinations and sequences of events or situations. The switching circuit responds to such inputs by delivering at its output, also in two-valued terms, new information which is functionally related to the input information.

Functional characteristics of switching circuits are defined by the logical operation and memory capabilities of the discrete devices from which they are assembled, as well as by the means used to interconnect the devices. For example, switching circuits

embody such logical relationships as output X is to exist only if input A and B occur simultaneously; and output Y is to exist if either input A or input B occurs. The factor of memory, in turn, enables a switching circuit to hold or retain a given state after the condition that produced the state has passed.

**Basic combinational circuits.** A combinational switching circuit is one in which a particular set of input conditions always establishes the same output, irrespective of the history of the circuit.

In electronic switching circuits, so-called gates are used to perform logical functions equivalent to these series-parallel networks of switch contacts. In this sense, an electronic gate is an elementary combinational circuit. Gates do not function by physically inserting or removing metallic conduction paths between contacts of manually operated switches or remotely controlled relays. Instead, they function by control of voltage or current levels at their output.

The most commonly encountered gates are the AND and the OR gates. The AND gate produces an output only if all its inputs are concurrently present; an OR gate produces an output if any one or any combination of its inputs is present. See LOGIC CIRCUITS.

**Basic sequential circuits.** A sequential switching circuit is one whose output depends not only upon the present state of its input, but also on what its input conditions have been in the past. Sequential circuits, therefore, require memory elements.

A typical electronic memory element used in sequential circuits is a simple circuit called a flip-flop. A flip-flop consists of two amplifiers connected so that the output of one amplifier is the input of the other. A voltage pulse will set the flip-flop into one of two states, and that state remains until another voltage pulse resets the flip-flop or returns it to its original state. It can therefore be used to remember that an event has taken place.

Figure 1 is an *n*pn-transistor flip-flop. When set, transistor A is conducting and transistor B is cut off. When reset, transistor B is conducting and transistor A is cut off. A positive output voltage with respect to ground may be obtained from either transistor to indicate the condition of the flip-flop. See TRANSISTOR.

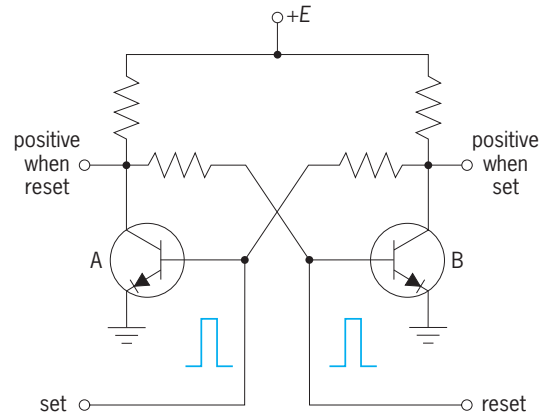

Fig. 1. Transistor switching memory element (flip-flop).

Relays, flip-flops, and similar memory elements provide static, or fixed, memory; they hold the stored information indefinitely, or until they are told to "forget," commonly called "resetting." In contrast, a delay line provides transient memory. A delay line has the property that an electrical signal applied to its input is delayed on its way to the output.

**Selecting circuits.** A selecting circuit receives the identity (called the address) of a particular item and selects that item from among a number of similar ones. The selectable items are often represented by terminals or leads. Selection usually involves marking the specified terminal or lead by applying to it some electrical condition, such as a voltage or current pulse, or a

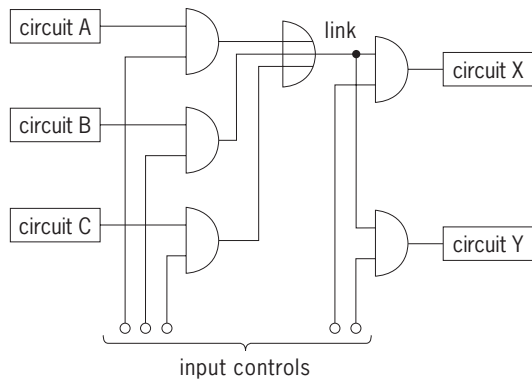

Fig. 2. Connecting circuit using AND and OR gates.

steady-state dc signal. By means of this electrical condition, the selected circuit is alerted, sized, or controlled.

**Connecting circuits.** A switching system is an aggregate of functional circuit units, some of which must sometimes be directly coupled to each other to interchange information. Figure 2 shows a simple electronic connecting circuit using AND and OR gates. In this arrangement a communication path is provided over a single link from any one of the three functional circuits A, B, C, to either the X or Y circuit by an external control circuit activating the appropriate pair of AND gates. To provide a multilead link, or to provide for other simultaneous interconnections, additional AND gates would, of course, be required. The OR gate maintains separation of the inputs at the common junction point.

**Lockout circuits.** In switching systems, situations often arise where several similar circuit units are ready at the same instant to request collaboration with another type of functional circuit. Mutual interference among the requesting circuits is prevented by the lockout circuit (sometimes referred to as hunting or finding circuits). In response to concurrent inputs from a number of external circuits, a lockout circuit provides an output indication corresponding to one, and only one, of these circuits at any time.

**Translating circuits.** Switching systems process information in coded form; the information is generally in the form of numbers. Numerical codes are many and varied, each with its own characteristics and more or less distinct advantages for different switching circuit situations. Therefore, one of the common functional circuits in switching systems is the translating circuit, which translates information received in one code into the same information expressed in another code. These translating circuits are combinational circuits; a given input signal combination representing a code to be translated always produces the same output signals, which represent the desired code.

**Register circuits.** Information received by a switching system is not always used immediately. It must be stored in register circuits for future use.

In a register circuit the coded information to be stored is applied as input and retained by memory elements of the circuit, and when needed, the registered information is taken as output in the same code or in a different code. Register circuits are devised with a great variety of memory elements and have capacities to store from a few to millions of information bits. A frequently encountered form of register circuit is the shift register. This type of register has the ability to shift its stored digital information internally to positions representing higher or lower numerical values in the code employed. For example, in decimal code registration a digit may be shifted from the units to the tens position. An obvious use of such registers is in digital computers when, for example, partial multiplication products have to be lined up for addition.

**Counting circuits.** One of the most frequently encountered circuits in switching systems is the counting circuit whose func-

tion, in general, is to detect and count repeated current or voltage pulses which represent incoming information. [J.A.Pec.]

**Switching systems (communications)** The assemblies of switching and control devices provided so that any station in a communications system may be connected as desired with any other station. A telecommunications network consists of transmission systems, switching systems, and stations. Transmission systems carry messages from an originating station to one or more distant stations. They are engineered and installed in sufficient quantities to provide a quality of service commensurate with the cost and expected benefits. To enable the transmission facilities to be shared, stations are connected to and reached through switching system nodes that are part of most telecommunications networks. Switching systems act under built-in control to direct messages toward their ultimate destination or address.

Most switching systems, known as central or end offices in the public network and as private branch exchanges (PBXs) when applied to business needs, are used to serve stations. These switching systems are at nodes that are strategically and centrally located with respect to the community of interest of the served stations. With improvements in technology, it has become practical to distribute switching nodes closer to stations. In some cases to serve stations within a premise, switching is distributed to take place at the stations themselves. A smaller number of systems serve as tandem (intermediate) switching offices for large urban areas or toll (long-distance) offices for interurban switching. These end and intermediate office functions are sometimes combined in the same switching system. See PRIVATE BRANCH EXCHANGE.

**Switching system fundamentals.** Telecommunications switching systems generally perform three basic functions: they transmit signals over the connection or over separate channels to convey the identity of the called (and sometimes the calling) address (for example, the telephone number), and alert (ring) the called station; they establish connections through a switching network for conversational use during the entire call; and they process the signal information to control and supervise the establishment and disconnection of the switching network connection.

In some data or message switching when real-time communication is not needed, the switching network is replaced by a temporary memory for the storage of messages. This type of switching is known as store-and-forward switching.

**Signaling and control.** The control of circuit switching systems is accomplished remotely by a specific form of data communications known as signaling. Switching systems are connected with one another by telecommunication channels known as trunks. They are connected with the served stations or terminals by lines.

In some switching systems the signals for a call directly control the switching devices over the same path for which transmission is established. For most modern switching systems the signals for identifying or addressing the called station are received by a central control that processes calls on a time-shared basis. Central controls receive and interpret signals, select and establish communication paths, and prepare signals for transmission. These signals include addresses for use at succeeding nodes or for alerting (ringing) the called station.

Most electronic controls are designed to process calls not only by complex logic but also by logic tables or a program of instructions stored in bulk electronic memory. The tabular technique is known as action translator (AT). The electronic memory is now the most accepted technique and is known as stored program control (SPC). Either type of control may be distributed among the switching devices rather than residing centrally. Microprocessors on integrated circuit chips are a popular form of distributed stored program control. See COMPUTER STORAGE TECHNOLOGY; INTEGRATED CIRCUITS; MICROPROCESSOR.

Common channel signaling (CCS) comprises a network of separate data communication paths used for transmitting all signaling information between offices. It became practical as a result of processor control. To reduce the number of data channels between all switching nodes, a signaling network of signal switching nodes is introduced. The switching nodes, known as signal transfer points (STPs), are fully interconnected with each other and the switching offices they serve. All links and signal transfer points are duplicated to ensure reliable operation. Each stored-program-control toll switching system connects to the two signal transfer points in its region.

**Switching fabrics.** Space and time division are the two basic techniques used in establishing connections. When an individual conductor path is established through a switch for the duration of a call, the system is known as space division. When the transmitted speech signals are sampled and the samples multiplexed in time so that high-speed electronic devices may be used simultaneously by several calls, the switch is known as time division.

Most switching is now automatic. The switching fabric frequently comprises two primary-secondary arrangements: first, the line link (LL) frames on which the telephone lines appear and, second, the trunk link (TL) frames on which the trunks appear. A switching entity may grow to a maximum of 60 line link and 30 trunk link frames. Each line link frame is interconnected with every trunk link frame by a network of links called junctions. Each line link frame has a basic capacity for 290 telephone lines and may be supplemented in 50-line increments to a maximum of 590 lines. The size used in a particular office depends upon the calling rate and holding time of the assigned lines.

**Electronic switching.** Stored program control has become the principal type of control for all types of new switching systems throughout the world, including toll, private branch, data, and Telex systems. Two types of data are stored in the memories of electronic switching systems. One type is the data associated with the progress of the call, such as the dialed address of the called line. Another type, known as the translation data, contains infrequently changing information, such as the type of service subscribed to by the calling line and the information required for routing calls to called numbers. These translation data, like the program, are stored in a memory which is easily read but protected to avoid accidental erasure. This information may be readily changed, however, to meet service needs. The flexibility of a stored program also aids in the administration and maintenance of the service so that system faults may be located quickly.

**Untethered switched services.** Modern mobile radio service has a considerable dependency on switching. The territory served by a radio carrier is divided into cells of varying geographical size, from microcells that might serve the floors of a business or domicile to cells several miles across that provide a space diversity for serving low-power radios.

Switching systems reach each radio cell site that detects, by signal strength, when a vehicle is about to move from one cell to another. The switching system then selects a frequency and land line for the communication to continue on another channel in a different cell without interruption. This is known as cellular mobile radio service and is used not only for voice but also facsimile and other forms of telecommunication. See MOBILE RADIO; TELEPHONE; TELEPHONE SERVICE. [A.E.J.]

**Sycamore** American sycamore (*Platanus occidentalis*) a member of the plane tree family, known also as American plane tree, buttonball, or buttonwood, and ranging from southern Maine to Nebraska and south into Texas and northern Florida. It has the most massive trunk of any American hardwood. Characteristic are the white patches which are exposed when outer layers of the bark slough off; the simple, large, lobed leaves whose stalks completely cover the conical winter buds; and the spherical fruit heads that are always borne singly in the American species and persist throughout the winter. The tough, coarse-grained wood is difficult to work, but is useful for butchers' blocks, sad-

dle trees, vehicles, tobacco and cigar boxes, crates, and slack cooperage. See ROSALES. [A.H.G./K.P.D.]

**Sycettida** An order of the subclass Calcareonea in the class Calcarea. This order comprises a rather diverse group of calcareous sponges, and includes the families Sycettidae, Heteropiidae, Grantiidae, Amphoriscidae, and Lelapiidae. Choanocytes with apical nuclei are limited to flagellated chambers and never occur lining the general spongocoel. The family Sycettidae resembles the contrasting order Leucosoleniida in lacking the true dermal membrane or cortex possessed by the other five families. The most massive skeleton (of bundles of modified triradial spicules) is found in the family Lelapiidae. See CALCAREA; LEUCOSOLENIIDA. [W.D.R.H.]

**Syenite** A phaneritic (visibly crystalline) plutonic rock with granular texture composed largely of alkali feldspar (orthoclase, microcline, usually perthitic) with subordinate plagioclase (oligoclase) and dark-colored (mafic) minerals (biotite, amphibole, and pyroxene). If sodic plagioclase (oligoclase or andesine) exceeds the quantity of alkali feldspar, the rock is called monzonite. Monzonites are generally light to medium gray, but syenites are found in a wide variety of colors (gray, green, pink, red), some of which make the material ideal for use as ornamental stone. Syenite is an uncommon plutonic rock and usually occurs in relatively small bodies (dikes, sills, stocks, and small irregular plutons). See IGNEOUS ROCKS. [C.A.C.]

**Symbiotic star** A double star system in the late stage of stellar evolution. Since the symbiotic phase represents a brief span in the life of the binary, symbiotic stars are rare objects. The "near-official" list of symbiotic stars contains 188 safe entries; 15 of them extragalactic, and 30 suspected candidates.

Symbiotics are always associated with a nebular environment. The spectra indicate the presence of a cool M-type star with a surface temperature below 4000 K, and a hot nebula quite similar to a planetary nebula. The light output is variable on time scales of days, months, and years. See ASTRONOMICAL SPECTROSCOPY; LIGHT CURVES; NEBULA; PLANETARY NEBULA; VARIABLE STAR.

Evidence has accumulated that all symbiotics are double stars with periods between one year and many dozens of years. Their orbits are sufficiently wide for the two stars not to be in direct contact, and both stars lie safely within their Roche lobe. Thus, for the two stars stellar evolution proceeds over the whole main-sequence lifetime practically uninfluenced by the partner. That changes dramatically in the later stages of their evolution. See DOPPLER EFFECT; ECLIPSING VARIABLE STARS.

The gas temperature in the symbiotic nebula, approximately 15,000 K, is much too low to collisionally ionize the atoms in the nebula to the observed degree. The nebular gas must be radiatively ionized by a small, very hot star. Observations and model calculations show the cool star to be a red giant. For the hot star, temperatures between 50,000 and 200,000 K are found. The star's size is that of a white dwarf or of a central star in a planetary nebula, between ~0.01 and ~0.1 solar radius.

The symbiotic nebula has, as a rule, the same chemical composition as expected from red giants. This is taken as evidence that the red giant suffers considerable mass loss. Symbiotics began as stars with masses of the order of 5 solar masses. The more massive star evolved faster through the main sequence, and when it arrived in the red giant region, shed most of its mass through a stellar wind. That material can occasionally still be detected in the wider environment. The star has become a hot white dwarf. The originally less massive star has retained its mass and has now entered the red giant phase, with large mass loss. See STELLAR EVOLUTION; WHITE DWARF STAR.

A fraction of the mass lost by the red giant is captured by the white dwarf. The accretion liberates gravitational energy which can convert into radiative energy and be responsible for some of the irregular luminosity variations. When the white dwarf has

accumulated a critical mass of hydrogen, thermonuclear reactions on its surface lead to an energy outburst lasting over 100 years. The energy production outburst can reach many thousand times that of the Sun. The mechanism resembles a nova explosion. However, a classical nova has higher peak energy output and shorter duration than a symbiotic nova. See CATAclysmic VARIABLE; NOVA.

Observations have shown traces of the mass formerly lost by the hot star. However, as noted above, the bulk of the matter now detected as an ionized nebula is due to the present mass loss of the red giant in its stellar wind. In its active phase the white dwarf may have a stellar wind of its own. In that case the nebular environment will be strongly structured by the collision of the two winds. This leads to shock zones with temperatures of several million kelvins. The origin of bipolar gaseous jets observed in several symbiotics is not yet known. Observational evidence indicates that the white dwarf possesses a strong magnetic field which could play a major role. [H.N.]

**Symbolic computing** The process of manipulating numbers and variables according to the rules of mathematical logic. Variables are used to represent a real number or a set of real numbers to exact precision. Numbers can be added, subtracted, multiplied, and divided. Numerical calculations or numerical computations involve performing these operations. For example, if the symbol  $*$  is used to represent multiplication and  $/$  is used to represent division, then the equation

$$(3 * 5 - 1) / 7 = 2$$

represents a numerical computation whose result is 2. In mathematics, it is also possible to use symbols to represent numbers and to do computations with the symbols. For example,

$$ax + b = 0 \quad (\text{with } a \neq 0)$$

can also be expressed as

$$x = -\frac{b}{a}$$

In this calculation or computation, the mathematical rules for subtraction and division are obeyed. The symbol  $x$  is treated as an unknown or variable that is to be solved for, and  $a$  and  $b$  as parameters representing unknown but fixed numbers.

In the 1990s, mathematical software packages became available that could manipulate symbols according to the rules of mathematics. They are also called symbolic computational packages and are programming environments, since any real number has a decimal expansion. These packages have the ability to obtain exact answers as symbols. For example, if

$$x^2 - 2 = 0, \quad x > 0$$

were entered into a symbolic computation package, the software package would return the answer

$$x = \sqrt{2}$$

The software package also allows the user to then ask for an approximation to 2 to any number of digits. The decimal units for 2 are determined using an algorithm that performs numerical calculation (called a numerical algorithm). Symbolic computation packages allow both symbolic and numerical computation. See ALGORITHM; COMPUTER PROGRAMMING; MATHEMATICAL SOFTWARE.

The capability of small computers and hand-held calculators to do extremely complicated calculations in a small amount of time led to the development of mathematical software packages that could do symbolic manipulation. These symbolic manipulation packages (also called computer algebra systems or symbolic computation systems) can do algebra, trigonometry, number theory, calculus, ordinary and partial differential equations, matrix algebra, and other areas of mathematics by manipulating the symbols according to the rules of mathematics much faster than armies of mathematicians. The answers are given exactly in

symbolic form and can then be approximated numerically using routines in the package.

The advent of visualization on the computer has made it possible for these packages to plot data or functions in many forms. The functions are entered symbolically, and the software evaluates them numerically so that numbers can be plotted. The graphs generated by the plot routines can be labeled, rotated, or animated, among many other possibilities.

Hand-held calculators can perform symbolic manipulation, graph data or functions, and be programmed to carry out a sequence of operations. Mathematical software packages have been developed that can perform symbolic manipulation, graph data or functions, and be programmed using routines in the package. These packages run on most commonly used operating systems. They can also be called by computer programs to perform manipulations in the program. There are packages that do statistics, computational finance, computational physics, and computational chemistry. See CALCULATORS; OPERATING SYSTEM; PROGRAMMING LANGUAGES. [J.So.]

**Symmetrodonta** A group of extinct mammals that range from the Late Triassic to Late Cretaceous. Their fossil remains have been found in Mesozoic deposits worldwide. These small insectivorous or carnivorous mammals are the size of a shrew or mouse. They are considered to be distant relatives of the more derived therian mammals, including the extinct eupantotheres, such as dryolestids and the living placental and marsupial mammals.

Symmetrodonts are characterized by a distinctive feature: the main cusps of their cheek teeth are arranged in a symmetrical triangle. The triangular upper and lower cheek teeth fill in the gaps between the adjacent teeth of the opposite tooth row, and are specialized for crushing insects or slicing worms. However, symmetrodonts lack a basinlike heel in the lower teeth that would allow the grinding of the ingested food in the more derived living therian mammals and their kin. Symmetrodonts are also distinguished from more derived therians by lacking the angle on the mandible.

Symmetrodonts are classified as the order Symmetrodonta of the class Mammalia. Three families are notable among the diverse symmetrodonts: Kuehneotheriidae considered to be close to the ancestry of all other therian mammals; Amphidontidae; and Spalacotheriidae, which are characterized by the highly acute triangular cheek teeth and are the most diverse symmetrodont family. [Z.L.]

**Symmetry breaking** A deviation from exact symmetry. According to modern physical theory the fundamental laws of physics possess a very high degree of symmetry. Several deep insights into nature arise in understanding why specific physical systems, or even the universe as a whole, exhibit less symmetry than the laws themselves.

**Spontaneous symmetry breaking.** This mechanism occurs in quite diverse circumstances. The most symmetrical solutions of the fundamental equations governing a given system may be unstable, so that in practice the system is found to be in a less symmetrical, but stable, state. When this occurs, the symmetry is said to have been broken spontaneously.

For example, the laws of physics are unchanged by any translation in space, but a crystalline lattice is unchanged only by special classes of translations. A crystal does retain a large amount of symmetry, for it is unchanged by those finite translations, but this falls far short of the full symmetry of the underlying laws. See CRYSTAL STRUCTURE.

Another example is provided by ferromagnetic materials. The spins of electrons within such materials are preferentially aligned in some particular direction, the axis of the poles of the magnet. The laws of physics governing the interactions among these spins are unchanged by any rotation in space, but the aligned configuration of spins has less symmetry. Indeed, it is left

unchanged only by rotations about the polar axis. See FERRO-MAGNETISM.

In both these examples, the loss of symmetry is associated with the appearance of order. This is a general characteristic of spontaneous symmetry breaking.

**Consequences.** There is a cluster of important observable consequences associated with spontaneous symmetry breaking.

Nambu-Goldstone bosons are a class of low-energy excitations associated with gentle variations of the order. Thus, there is a class of excitations of the ferromagnet, the magnons, that exist as a consequence of the spontaneous symmetry breaking, and that have very low energy. Similarly, in the case of crystals, phonons are associated with gentle distortions of the lattice structure. See MAGNON; PHONON.

At high temperatures the energy gained by assuming an ordered structure is increasingly outweighed by the entropy loss associated with the constraints it imposes, and at some point it will no longer be favorable to have spontaneous symmetry breaking in thermal equilibrium. Changes from broken symmetry to unbroken symmetry are marked by phase transitions. For a magnet, the transition occurs at the Curie temperature. For a crystal, it is melting into a liquid or sublimation into a gas. See CURIE TEMPERATURE; ENTROPY; PHASE TRANSITIONS; THERMODYNAMIC PRINCIPLES.

Defects are imperfections in the ordering. The most familiar examples are domain walls in magnets. See CRYSTAL DEFECTS; DOMAIN (ELECTRICITY AND MAGNETISM).

In systems with long-range forces as well as spontaneous symmetry breaking, it need no longer be true that gradual changes require only a small input of energy, because even distant regions interact significantly. Thus, the Nambu-Goldstone bosons no longer have very low energies, and they are not easily excited. Conversely, the system will exhibit a special rigidity, with strong correlations between distant points. These ideas are central to modern theories of superconductivity and of particle physics (the Higgs mechanism). See ELECTROWEAK INTERACTION; HIGGS BOSON; SUPERCONDUCTIVITY. [FWil.]

**Symmetry laws (physics)** The physical laws which are expressions of symmetries. The term symmetry, as it is used in mathematics and the exact sciences, refers to a special property of bodies or of physical laws, namely that they are left unchanged by transformations which, in general, might have changed them. For example, the geometric form of a sphere is not changed by any rotation of the sphere around its center, and so a sphere can be said to be symmetric under rotations. Symmetry can be very powerful in constraining form. Indeed, referring to the same example, the only sort of surface which is symmetric under arbitrary rotations is a sphere.

The concept that physical laws exhibit symmetry is more subtle. A naive formulation would be that a physical law exhibits symmetry if there is some transformation of the universe that might have changed the form of the law but in reality does not. However, the comparison of different universes is generally not feasible or desirable. A more fruitful definition of the symmetry of physical law exploits locality, the principle that the behavior of a given system is only slightly affected by the behavior of other bodies far removed from it in space or time. Because of locality, it is possible to define symmetry by using transformations that do not involve the universe as a whole but only a suitably isolated portion of it. Thus the statement that the laws of physics are symmetric under rotations means that (say) astronauts in space would not be able to orient themselves—to determine a preferred direction—by experiments internal to their space station. They could do this only by referring to weak effects from distant objects, such as the light of distant stars or the small residual gravity of Earth.

**Symmetries of space and time.** Perhaps the most basic and profound symmetries of physical laws are symmetry under translation in time and under translations in space.

The statement that fundamental physical laws are symmetric under translation in time is equivalent to the statement that these laws do not change or evolve. Time-translation symmetry is supposed to apply, fundamentally, to simple isolated systems. Large complicated systems, and in particular the universe as a whole, do of course age and evolve. Thus in constructing the big-bang model of cosmology, it is assumed that the properties of individual electrons or protons do not change in time, although of course the state of the universe as a whole, according to the model, has changed quite drastically.

The statement that fundamental laws are symmetric under translations in space is another way of formulating the homogeneity of space. It is the statement that the laws are the same throughout the universe. It says that the astronauts in the previous example cannot infer their location by local experiments within their space station. The power of this symmetry is that it makes it possible to infer, from observations in laboratories on Earth, the behavior of matter anywhere in the universe.

The symmetry of physical law under rotations, mentioned above, embodies the isotropy of space.

In the mathematical formulation of dynamics, there is an intimate connection between symmetries and conservation laws. Symmetry under time translation implies conservation of energy; symmetry under spatial translations implies conservation of momentum; and symmetry under rotation implies conservation of angular momentum. See ANGULAR MOMENTUM; CONSERVATION OF ENERGY; CONSERVATION OF MOMENTUM.

The fundamental postulate of the special theory of relativity, that the laws of physics take the same form for observers moving with respect to one another at a fixed velocity, is clearly another statement about the symmetry of physical law. The idea that physical laws should be unchanged by such transformations was discussed by Galileo, who illustrated it by an observer's inability to infer motion while on a calm sea voyage in an enclosed cabin. The novelty of Einstein's theory arises from combining this velocity symmetry with a second postulate, deduced from experiments, that the speed of light is a universal constant and must take the same value for both stationary and uniformly moving observers. See GALILEAN TRANSFORMATIONS; LORENTZ TRANSFORMATIONS; RELATIVITY.

**Discrete symmetries.** Before 1956, it was believed that all physical laws obeyed an additional set of fundamental symmetries, denoted  $P$ ,  $C$ , and  $T$ , for parity, charge conjugation, and time reversal, respectively. Experiments involving particles known as  $K$  mesons led to the suggestion that  $P$  might be violated in the weak interactions, and violations were indeed observed. This discovery led to questioning—and in some cases overthrow—of other cherished symmetry principles.

Parity,  $P$ , roughly speaking, transforms objects into the shapes of their mirror images. If  $P$  were a symmetry, the apparent behavior of the images of objects reflected in a mirror would also be the actual behavior of corresponding real objects. See PARITY (QUANTUM MECHANICS).

Charge conjugation,  $C$ , changes particles into their antiparticles. It is a purely internal transformation; that is, it does not involve space and time. If the laws of physics were symmetric under charge conjugation, the result of an experiment involving antiparticles could be inferred from the corresponding experiment involving particles.

Remarkably, by combining the transformations  $P$  and  $C$ , a result is obtained,  $CP$ , which is much more nearly a valid symmetry than either of its components separately. However, in 1964 it was discovered experimentally that even  $CP$  is not quite a valid symmetry.

Although the preceding discussion has emphasized the failure of  $P$ ,  $C$ , and  $CP$  to be precise symmetries of physical law, both the strong force responsible for nuclear structure and reactions and the electromagnetic force responsible for atomic structure and chemistry do obey these symmetries. Only the weak force, responsible for beta radioactivity and some relatively slow

decays of exotic elementary particles, violates them. Thus these symmetries, while approximate, are quite useful and powerful in nuclear and atomic physics. See ELECTROWEAK INTERACTION; FUNDAMENTAL INTERACTIONS; WEAK NUCLEAR INTERACTIONS.

The operation of time-reversal symmetry,  $T$ , involves changing the direction of motion of all particles. For example, it relates reactions of the type  $A + B \rightarrow C + D$  to their reverse  $C + D \rightarrow A + B$ . No direct violation of  $T$  has been detected. See TIME REVERSAL INVARIANCE.

Time-reversal symmetry, even if valid, applies in a straightforward way only to elementary processes. It does not, for example, contradict the one-way character of the second law of thermodynamics, which states that entropy can only increase with time. See THERMODYNAMIC PRINCIPLES; TIME, ARROW OF.

Fundamental principles of quantum field theory suggest that the combined operation  $PCT$ , which involves simultaneously reflecting space, changing particles into antiparticles, and reversing the direction of time, must be a symmetry of physical law. Existing evidence is consistent with this prediction. See CPT THEOREM.

**Internal symmetry.** Internal symmetries, like  $C$ , do not involve transformations in space-time but change one type of particle into another. An important, although approximate, symmetry of this kind is isospin or  $i$ -spin symmetry. It is observed experimentally that the strong interactions of the proton and neutron are essentially the same. See  $I$ -SPIN.

There have been several successful predictions of the existence and properties of new particles, based on postulates of internal symmetries. Perhaps the most notable was the prediction of the mass and properties of the  $\Omega^-$  baryon, based on an extension of the symmetry group  $SU(2)$  of isospin to a larger approximate  $SU(3)$  symmetry acting on strange particles as well. These symmetries were an important hint that the fundamental strong interactions are at some level universal, that is, act on all quarks in the same way, and thus paved the way toward modern quantum chromodynamics, which does implement such universality. See BARYON; GROUP THEORY; QUANTUM CHROMODYNAMICS; UNITARY SYMMETRY.

Much simpler mathematically than  $SU(2)$  internal symmetry, but quite profound physically, is  $U(1)$  internal symmetry. The important case of the electric charge quantum number will be considered. The action of the  $U(1)$  internal symmetry transformation with parameter  $\lambda$  is to multiply the wave function of a state of electric charge  $q$  by the factor  $e^{i\lambda q}$ . An amplitude between two states with electric charges  $q_r$  and  $q_s$  will therefore be multiplied by a factor  $e^{i\lambda(q_s - q_r)}$ . Since the physical predictions of quantum mechanics depend on such amplitudes, these predictions will be unchanged only if the phase factors multiplying all nonvanishing amplitudes are trivial. This will be true, in turn, only if the amplitudes between states of unequal charge vanish; that is, if charge-changing amplitudes are forbidden, which is just a backhanded way of expressing the conservation of charge. See NONRELATIVISTIC QUANTUM THEORY; QUANTUM MECHANICS; QUANTUM NUMBERS.

**Localization of symmetry.** The concept of local gauge invariance, which is central to the standard model of fundamental particle interactions, and in a slightly different form to general relativity, may be approached as a generalization of the  $U(1)$  internal symmetry transformation, where a parameter  $\lambda$  independent of space and time appears. Such a parameter goes against the spirit of locality, according to which each point in space-time has a certain independence. There is therefore reason to consider a more general symmetry, involving a space-time-dependent transformation in which the wave function is multiplied by  $e^{i\lambda(x,t)q(x,t)}$ , where  $q(x,t)$  is the density of charge at the space-time point  $(x,t)$ . These transformations are much more general than those discussed above, and invariance under them leads to much more powerful and specific consequences.

For electromagnetism, the required interactions of matter with the electromagnetic field are predicted precisely. Thus, the theory of the electromagnetic field—Maxwell's equations and quantum electrodynamics—can be said to be the unique ideal embodi-

ment of the abstract concept of a space-time-dependent symmetry, that is, of local gauge symmetry. See MAXWELL'S EQUATIONS; QUANTUM ELECTRODYNAMICS. [FWil.]

**Symmorphosis** A theory of structural design of biological organisms postulating that structure is quantitatively matched to functional demand as a result of regulated morphogenesis during growth and maintenance. Symmorphosis is a theory of economic design. In biological organisms, all functions depend on structural design, specifically on the morphometric characteristics of the organs. In general terms, the larger the structure the greater the functional capacity. A central postulate of symmorphosis, as a theory of economic design, is that differences in the functional demand on an organ require quantitative adjustments of its structural design parameters in order to match functional capacity to (maximal) functional demand.

The notion that animals, and humans, should be designed economically follows from common sense, but it is also supported by many observations. Blood vessel architecture ensures blood flow distribution with minimal energy loss. Bone structure is patterned according to stress distribution and also quantitatively adapted to total stress. With training, athletes can specifically adjust the structure of their muscles and of their cardiovascular system to higher functional demands, and these modifications are soon reversed when training is stopped.

The theory of symmorphosis postulates ideal adaptation of structural design to functional capacity. This is, however, hardly a reasonable assumption, because good engineering design of complex systems requires some redundancies as safety factors in view of imperfections in functional performance and variable boundary conditions. By using the concept of symmorphosis, such deviations from idealized economic design can be detected. [E.R.W.]

**Sympathetic nervous system** The portion of the autonomic nervous system concerned with nonvolitional

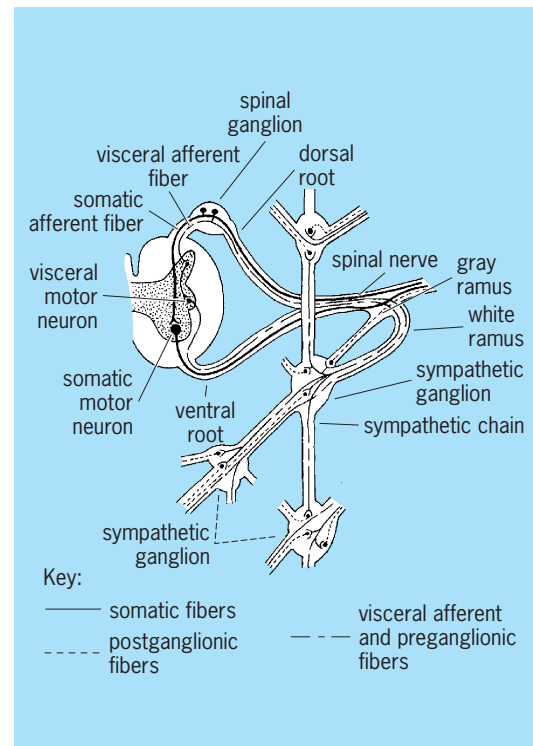

The visceral reflex arc and the sympathetic chain. (After B. A. Houssay et al., *Human Physiology*, 2d ed., McGraw-Hill, 1955)

preparation of the organism for emergency situations. See AUTONOMIC NERVOUS SYSTEM.

The sympathetic nervous system is best understood in mammals. It consists of two neuron chains from the thoracic and lumbar regions of the spinal cord to viscera and blood vessels. The first or preganglionic neuron has its cell body in the spinal cord and sends its axon to synapse with a postganglionic sympathetic neuron, which lies either in a chain of sympathetic ganglia paralleling the spinal cord or in a sympathetic ganglion near the base of the large blood vessels vascularizing the alimentary viscera. The postganglionic axons are longer than the preganglionic axons and extend to glands or smooth muscles of viscera and blood vessels. Sensory visceral nerve fibers innervate blood vessels and viscera and carry sensory information to the spinal cord, thus providing a visceral reflex (see illustration). See NERVOUS SYSTEM (VERTEBRATE); PARASYMPATHETIC NERVOUS SYSTEM. [D.B.W.]

**Sympathetic vibration** The driving of a mechanical or acoustical system at its resonant frequency by energy from an adjacent system vibrating at this same frequency. Examples include the vibration of wall panels by sounds issuing from a loudspeaker, vibration of machinery components at specific frequencies as the speed of a motor increases, and the use of tuned air resonators under the bars of a xylophone to enhance the acoustic output. Increasing the damping of a vibrating system will decrease the amplitude of its sympathetic vibration but at the same time widen the band of frequencies over which it will partake of sympathetic vibration. See RESONANCE (ACOUSTICS AND MECHANICS); VIBRATION. [L.E.K.]

**Symphyla** A class of the Myriapoda. The symphylans, like the pauropods, are tiny, pale, centipede-like creatures that inhabit humans or soil, or live under debris; in general, they live wherever there is sufficient moisture to preclude excessive water loss. They are similar to the Pauropoda and Diplopoda in being progoneate and anamorphic. Each of their mandibles, like those of millipedes, bears a movable gnathal lobe; at the same time their two pairs of maxillae are more reminiscent of the chilopods and lower insects than of the singly maxillate millipedes and pauropods.

The class consists of three families to which not more than 60 species have been assigned. [R.E.Cr.]

**Synapsida** A subclass of extinct reptiles, in general characterized by a temporal fenestra that lies below the junction of the postorbital and squamosal bones, a so-called lower temporal opening. In advanced forms, however, the postorbital-squamosal bridge is absent. Mammals arose from this group of reptiles during the Triassic Period. See REPTILIA.

Synapsids first appear in the geological record in the Upper Carboniferous. They flourished during the Late Paleozoic and Early Mesozoic but became extinct at about the end of the Triassic. During this span of time they underwent a broad adaptive radiation on land and made minor invasions of aquatic habitats. There were two major phases of this radiation: one early, by pelycosaurs, and the other later (Late Permian and Triassic), by therapsids. See PELYCOSAURIA; REPTILIA; THERAPSIDA. [E.C.O.]

**Synaptic transmission** The physiological mechanisms by which one nerve cell (neuron) influences the activity of an anatomically adjacent neuron with which it is functionally coupled. Brain function depends on interactions of nerve cells with each other and with the gland cells and muscle cells they innervate. The interactions take place at specific sites of contact between cells known as synapses. The synapse is the smallest and most fundamental information-processing unit in the nervous system. By means of different patterns of synaptic connections between neurons, synaptic circuits are constructed during development to carry out the different functional operations of the nervous system. See NEURON.

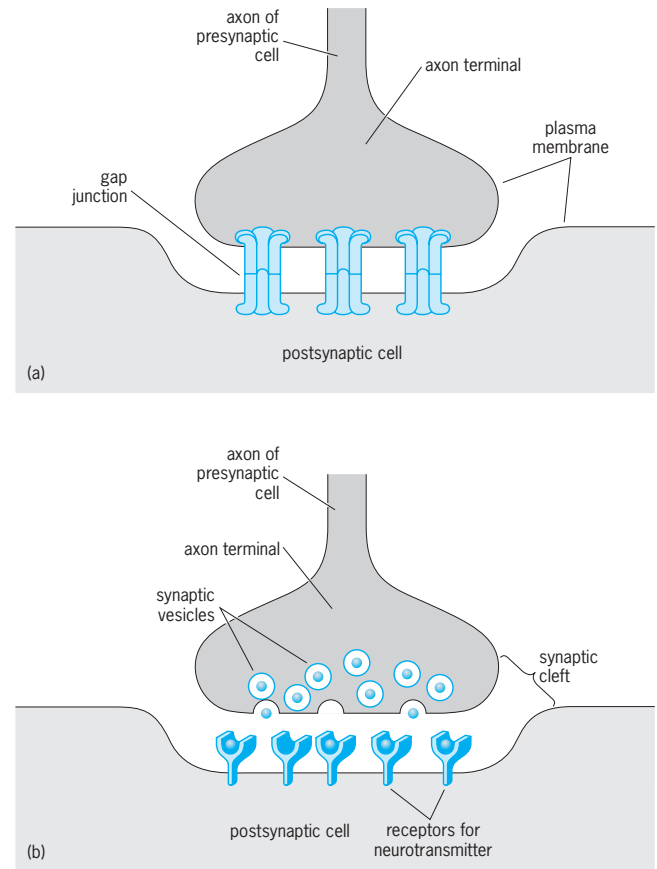

**Types of synapses.** (a) An electrical synapse, showing the plasma membranes of the presynaptic and postsynaptic cells linked by gap junctions. (b) A chemical synapse, showing neurotransmitters released by the presynaptic cell diffusing across the synaptic cleft and binding to receptors on the postsynaptic membrane.

The simplest type of synapse is the electrical synapse (see illustration), which consists of an area of unusually close contact between two cells packed with channels that span the two membranes and the cleft between them. Electrical synapses are also known as gap junctions. Electrical and metabolic communication between two cells is established by the components of the gap junctions. A variety of influences, including calcium ions, pH, membrane potential, neurotransmitters, and phosphorylating enzymes, may act on the channels to regulate their conductance in one direction (rectification) or both directions.

Electrical synapses are present throughout the animal kingdom. In vertebrates, they are numerous in the central nervous systems of fish as well as in certain nuclei of the mammalian brain, in regions where rapid transmission and synchronization of activity is important. Electrical synapses also interconnect glial cells in the brain. See BIOPOTENTIALS AND IONIC CURRENTS; CELL PERMEABILITY.

The most prevalent type of junction between nerve cells is the chemical synapse (see illustration). At chemical synapses neurotransmitters are released from the presynaptic cell, diffuse across the synaptic clefts, and bind to receptors on the postsynaptic cell. Chemical synapses are found only between nerve cells or between nerve cells and the gland cells and muscle cells that they innervate. The neuromuscular junction, that is, the junction between the axon terminals of a motoneuron and a muscle fiber, is a prototypical chemical synapse. Three basic elements constitute this synapse: a presynaptic process (in this case, the motoneuron axon terminal) containing synaptic vesicles; an end plate (a specialized site of contact between the cells); and a postsynaptic

process (in this case, the muscle cell). The postsynaptic membrane contains receptors for the transmitter substance released from the presynaptic terminal.

The chemical substance that serves as the transmitter at the vertebrate neuromuscular junction is acetylcholine (ACh). Within the nerve terminal, acetylcholine is concentrated within small spherical vesicles. At rest, these vesicles undergo exocytosis at low rates, releasing their acetylcholine in quantal packets to diffuse across the cleft and bind to and activate the postsynaptic receptors. Each quantum gives rise to a small depolarization of the postsynaptic membrane. These miniature end-plate potentials are rapid, lasting only some 10 milliseconds, and small in amplitude, only some 500 microvolts, below the threshold for effecting any response in the muscle. They represent the resting secretory activity of the nerve terminal.

When an organism wants to move its muscles, electrical impulses known as action potentials are generated in the motoneurons. These are conducted along the axon and invade the terminal, causing a large depolarization of the presynaptic membrane. This opens special voltage-gated channels for calcium ions, which enter the terminal and bind to special proteins, causing exocytosis of vesicles simultaneously. Calcium ions are the crucial link between the electrical signals in the presynaptic neuron and the chemical signals sent to the postsynaptic neuron. The combined action of this acetylcholine on postsynaptic receptors sets up a large postsynaptic depolarization, which exceeds the threshold for generating an impulse in the surrounding membrane, and causes the muscle to contract. The action of acetylcholine at its receptor is terminated by an enzyme, acetylcholinesterase, which is present in the synaptic cleft and hydrolyzes the acetylcholine to acetate and choline.

In order for neurotransmission to continue, synaptic vesicles have to be regenerated. Vesicles are rapidly and efficiently reformed in the nerve terminal by endocytosis. Specific neurotransmitter transporters within the membrane then fill the synaptic vesicle with appropriate neurotransmitter. The regenerated vesicle either returns to the plasma membrane where it rejoins the releasable pool of vesicles, or remains in the nerve terminal as part of a reserve pool. *See* ACETYLCHOLINE; MUSCLE.

In the central nervous system the presynaptic process containing synaptic vesicles is most often an axon terminal and the postsynaptic process a dendrite, making an axodendritic synapse, but other relationships are also seen. The effect of transmitter on a postsynaptic cell is either excitatory or inhibitory, meaning that it either depolarizes or hyperpolarizes the membrane. Whether a transmitter has an excitatory or inhibitory effect on a cell is determined by the type of ion able to pass through the cell's receptor channels.

There are two principal types of central synapses.

Type 1 central synapses commonly release an amino acid transmitter, such as glutamate, whose action produces an excitatory postsynaptic potential. At low levels of activity the glutamate binds to the glutamate receptor and activates a relatively small conductance increase for sodium and potassium ions. Glutamate is the transmitter at many excitatory synapses throughout the central nervous system. The type 2 central synapse is usually associated with inhibitory synaptic actions. The most common inhibitory transmitter is gamma-amino butyric acid (GABA). Most inhibitory interneurons in different regions of the brain make these kinds of synapses on relay neurons in those regions. The GABA receptor is a complex channel-forming protein with several types of binding sites and several conductance states.

Other classes of synaptic transmitter substances include the biogenic amines, such as the catecholamines, norepinephrine and dopamine, and the indoleamine 5-hydroxytryptamine (also known as serotonin). *See* DOPAMINE; NORADRENERGIC SYSTEM; SEROTONIN.

A final type of transmitter substance consists of a vast array of neuropeptides. They are a diverse group and include sub-

stances that stimulate the release of hormones; those that act at synapses in pain pathways in the brain (the endogenous morphinelike substances, enkephalins and endorphins); and many of still undetermined functions. Peptides may act also indirectly, modifying the state of a receptor in its response to other transmitter substances, and they may do this in an activity-dependent manner. In view of the complexity and slow time course of many of their effects, these peptides are often referred to as neuromodulators. *See* ENDORPHINS; HORMONE.

At central synapses, rapid responses to transmitters (typically within milliseconds) are most commonly the result of direct synaptic transmission, in which the receptor itself is the ion channel. Such receptors are referred to as ionotropic. There are, however, other receptor molecules for each of the neurotransmitters, and many of these are not themselves ion channels. They are known as metabotropic receptors, and they affect neurotransmission indirectly via a set of intermediary proteins called G-proteins. Activated G-proteins have a variety of effects on synaptic processes. Some are mediated by direct interactions with ion channels. However, many other effects are mediated by activation of cellular second messenger systems involving messengers such as calcium and cyclic adenosine monophosphate (cyclic AMP). The time courses for effects caused by activation of G-protein-coupled receptors is much longer than that of ionotropic channels (milliseconds), reflecting the lifetime of the activated G-protein subunits (seconds) and second messengers (seconds to minutes). Such longer lasting signals greatly increase the complexity of chemical neurotransmission and synaptic modulation. *See* SECOND MESSENGERS.

The synapse is a dynamic structure whose function is very dependent on its activity state. In this way the synapse is constantly adjusted for its information load. At glutamatergic synapses, high levels of input activity bring about a different transmission state. The buildup of postsynaptic depolarization relieves the normal block of a specialized glutamate receptor channel, permitting influx of calcium ions into the postsynaptic process. Since the conductance of the channel is dependent on the depolarization state of the membrane, it is said to have a voltage-gated property, in addition to being ligand-gated by its transmitter. The calcium ion acts as a second messenger to bring about a long-lasting increase in synaptic efficacy, a process known as long-term potentiation. The conjunction of increased pre- and postsynaptic activity to give an increase in synaptic efficacy is called Hebbian, and is believed to be the type of plasticity mechanism involved in learning and memory. *See* LEARNING MECHANISMS; MEMORY.

The synapse is one of the primary targets of drug actions. The first example to be identified was the arrow poison curare, which blocks neuromuscular transmission by binding to acetylcholine receptor sites. Many toxic agents have their actions on specific types of receptors; organic fluorophosphates, for example, are widely used pesticides that bind to and inactivate acetylcholinesterase. Most psychoactive drugs exert their effects at the synaptic level. *See* NERVOUS SYSTEM (VERTEBRATE); NEUROBIOLOGY. [G.M.Sh.; P.I.H.]

**Synbranchiformes** An order of eellike fishes that, unlike true eels, has the premaxillae present as distinct bones. The small gill apertures are often confluent across the breast. The gills are poorly developed, and in some species respiration is accomplished in part by highly vascularized buccopharyngeal pouches. There are no fin spines or pectoral fins, and the median fins, if developed, are continuous. Pelvic fins, if present, are small and located on the throat. The body may be naked or scaled. There is no swim bladder. The group, which has no fossil record, is classified into 2 suborders, 3 families, 7 genera, and 12 species. These serpentine fishes inhabit swamps, caves, and sluggish fresh and brackish waters of tropical America, Australia, eastern and southeastern Asia, the East Indies, and tropical Africa. *See* ACTINOPTERYGII. [R.M.B.]



**Syncarida** A unique superorder of malacostracan Crustacea, noted particularly for the total lack of a carapace or carapace shield. Two orders are recognized, Anaspidacea and Bathynellacea. The Stygocarididae, at one time considered a distinct order, are now assigned familial rank within the Anaspidacea.

The syncarid body plan is simple, consisting of a cephalon (head and sometimes one thoracic somite), thorax of seven or eight somites, and an abdomen of six somites and telson or five somites and pleotelson (fused sixth somite-telson). Eyes, with apposition optics, may be stalked or sessile, or sometimes absent. There are six to eight thoracic appendages (thoracopods), usually two to five abdominal appendages (pleopods), and uropods. Sexes are separate. Young hatch as immature adults and pass through several molts before reaching maturity.

Extant syncarids are specially adapted to fresh-water, often interstitial environments. Whereas the Anaspidacea are restricted to the Southern Hemisphere (Australia, Tasmania, New Zealand, South America), bathynellids have been found worldwide, except in Antarctica. See BATHYNELLACEA; CRUSTACEA; MALACOSTRACA. [P.A.McL.]

**Synchronization** The process of maintaining one operation in step with another. The commonest example is the electric clock, whose motor rotates at some integral multiple or sub-multiple of the speed of the alternator in the power station. In television, synchronization is essential in order that the electron beams of receiver picture tubes are at exactly the same spot on the screen at each instant as is the beam in the television camera tube at the transmitter. See TELEVISION. [J.Mar.]

**Synchronous converter** A synchronous machine used to convert alternating current (ac) to direct current (dc), or vice versa. The ac-to-dc converter has been superseded by the mercury arc rectifier (for reasons of efficiency, lower maintenance costs, and less trouble) or by motor-generator sets. Converters are no longer manufactured, but there are converters still in use. See DIRECT-CURRENT GENERATOR; SYNCHRONOUS MOTOR. [L.V.B.]

**Synchronous motor** An alternating-current (ac) motor which operates at a fixed synchronous speed proportional to the frequency of the applied ac power. A synchronous machine may operate as a generator, motor, or capacitor depending only on its applied shaft torque (whether positive, negative, or zero) and its excitation. There is no fundamental difference in the theory, design, or construction of a machine intended for any of these roles, although certain design features are stressed for each of them. In use, the machine may change its role from instant to instant. For these reasons it is preferable not to set up separate theories for synchronous generators, motors, and capacitors. It is better to establish a general theory which is applicable to all three and in which the distinction between them is merely a difference in the direction of the currents and the sign of the torque angles. See ALTERNATING-CURRENT GENERATOR; ALTERNATING-CURRENT MOTOR; SYNCHRONOUS CAPACITOR. For special types of synchronous motors see HYSTERESIS MOTOR; RELUCTANCE MOTOR. [R.T.S.]

**Synchroscope** An instrument used for indicating whether two alternating-current (ac) generators or other ac voltage sources are synchronized in time phase with each other. Its main use is in power supply networks where, if two generators are to be operated in parallel or an additional generator is to be coupled into the grid, it is essential that the generator voltages should be matched in amplitude, frequency, and phase.

New power stations are often equipped with automatic means of synchronizing generators. But many synchrosopes of the traditional types are still in use and are likely to remain so for many years.

The term synchroscope is also sometimes applied to a special type of cathode-ray oscilloscope designed for observing

extremely short pulses, using fast sweeps synchronized with the signal to be observed. See ELECTRIC POWER GENERATION; ELECTRIC POWER SYSTEMS; OSCILLOSCOPE. [A.E.Ba.]

**Synchrotron radiation** Electromagnetic radiation emitted by relativistic charged particles curving in magnetic or electric fields. With the development of electron storage rings, radiation with increasingly high flux, brightness, and coherent power levels has become available for a wide variety of basic and applied research in biology, chemistry, and physics, as well as for applications in medicine and technology. See ELECTROMAGNETIC RADIATION; PARTICLE ACCELERATOR; RELATIVISTIC ELECTRODYNAMICS.

Electron storage rings provide radiation from the infrared through the visible, near-ultraviolet, vacuum-ultraviolet, soft-x-ray, and hard-x-ray parts of the electromagnetic spectrum extending to 100 keV and beyond. The flux [photons/(second, unit bandwidth)], brightness (or brilliance) [flux/(unit source size, unit solid angle)], and coherent power (important for imaging applications and proportional to brightness) available for experiments, particularly in the vacuum-ultraviolet, soft-x-ray, and hard-x-ray parts of the spectrum, are many orders of magnitude higher than is available from other sources.

The radiation has many features (natural collimation, high intensity and brightness, broad spectral bandwidth, high polarization, pulsed time structure, small source size, and high-vacuum environment) that make it ideal for a wide variety of applications in experimental science and technology. Very powerful sources of synchrotron radiation in the ultraviolet and x-ray parts of the spectrum became available when high-energy physicists began operating electron synchrotrons in the 1950s. Although synchrotrons produce large amounts of radiation, their cyclic nature results in pulse-to-pulse intensity changes and variations in spectrum and source shape during each cycle. By contrast, the electron-positron storage rings developed for colliding-beam experiments starting in the 1960s offered a constant spectrum and much better stability. Beam lines were constructed on both synchrotrons and storage rings to allow the radiation produced in the bending magnets of these machines to leave the ring vacuum system and reach experimental stations. In most cases the research programs were pursued on a parasitic basis, secondary to the high-energy physics programs.

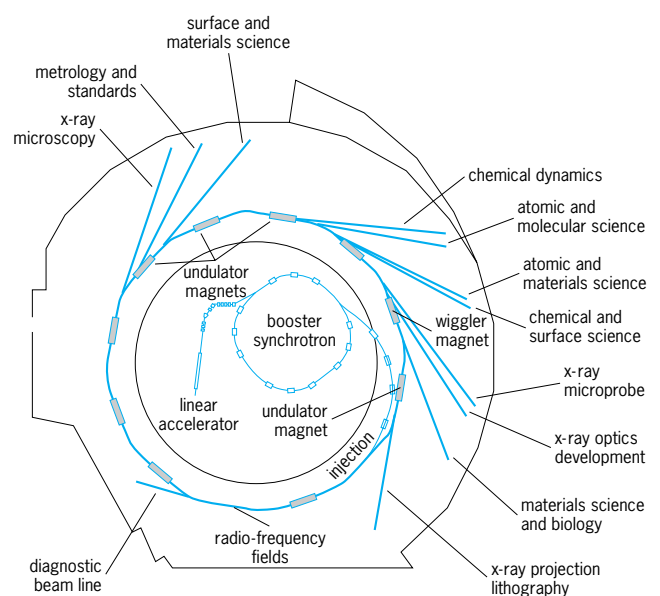

Layout of the 1.5-GeV Advanced Light Source at Lawrence Berkeley National Laboratory, a low-energy, third-generation synchrotron radiation source. Applications of experimental stations on beam lines are indicated.

Since about 1980, fully dedicated storage ring sources have been completed in several countries. They are called second-generation facilities to distinguish them from the first-generation rings that were built for research in high-energy physics.

Special magnets may be inserted into the straight sections between ring bending magnets to produce beams with extended spectral range or with higher flux and brightness than is possible with the ring bending magnets. These devices, called wiggler and undulator magnets, utilize periodic transverse magnetic fields to produce transverse oscillations of the electron beam with no net deflection or displacement. They provide another order-of-magnitude or more improvement in flux and brightness over ring bending magnets, again opening up new research opportunities. However, their potential goes well beyond their performance levels, in first- and second-generation sources.

Third-generation sources are storage rings with many straight sections for wiggler and undulator insertion device sources and with a smaller transverse size and angular divergence of the circulating electron beam. The product of the transverse size and divergence is called the emittance. The lower the electron-beam emittance, the higher the photon-beam brightness and coherent power level. With smaller horizontal emittances and with straight sections that can accommodate longer undulators, third-generation rings provide two or more orders of magnitude higher brightness and coherent power level than earlier sources.

One consequence of the extraordinary brilliance of these sources is that the x-ray beam is partially coherent. By aperturing the beam, a fully coherent beam can be obtained, but at the expense of flux. Nonetheless, there is still sufficient flux remaining to explore the use and application of coherent x-ray beams. See COHERENCE.

Several third-generation rings are in operation. Low-energy (typically 1–2-GeV) third-generation rings (see illustration) are optimized to produce high-brightness radiation in the vacuum ultraviolet (VUV) and soft x-ray spectral range, up to photon energies of about 2–3 keV. High-energy rings (typically 6–8 GeV) aim at harder x-rays with energies of 10–20 keV and above.

The radiation produced by an electron in circular motion at low energy (speed much less than the speed of light) is weak and rather nondirectional. At relativistic energies (speed close to the speed of light) the radiated power increases markedly, and the emission pattern is folded forward into a cone with a half-opening angle in radians given approximately by  $\gamma - 1 = mc^2/E$ , where  $mc^2$  is the rest-mass energy of the electron (0.51 MeV) and  $E$  is the total energy. Thus, at electron energies of the order of 1 GeV, much of the very strong radiation produced is confined to a forward cone with an instantaneous opening angle of about 1 mrad (0.06°). At higher electron energies this cone is even smaller. The large amount of radiation produced combined with the natural collimation gives synchrotron radiation its intrinsic high brightness. Brightness is further enhanced by the small cross-sectional area of the electron beam, which is as low as 0.01 mm<sup>2</sup> in the third-generation rings. [A.Bi.; D.Mi.; G.She.; H.Win.]

**Syncline** In its simplest form, a geologic structure marked by the folding of originally horizontal rock layers into a systematically curved, concave upward profile geometry (illus. a). A syncline is convex in the direction of the oldest beds in the folded sequence, concave in the direction of the youngest beds. Although typically upright, a syncline may be overturned, recumbent, or upside down (illus. d). Synclines occur in all sizes, from microscopic to regional. Profile forms may be curved smoothly (illus. a) to sharply angular (illus. b). Fold tightness of a syncline, as measured by the angle at which the limbs of the syncline join, may be so gentle that the fold is barely discernible, to so tight that the limbs are virtually parallel to one another (illus. c). The orientation of the axis of folding is horizontal to shallowly plunging, but synclines may plunge as steeply as vertical.

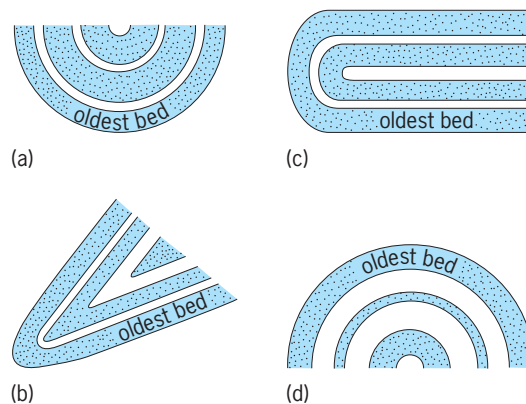

Varieties of synclines as seen in profile view. (a) Upright syncline with smoothly curved limbs. (b) Overturned, sharply angular syncline with planar limbs. (c) Recumbent, isoclinal syncline with parallel limbs. (d) Upside-down syncline, sometimes called an antiformal syncline.

Synclines are products of the layer-parallel compression that arises commonly during mountain building. The final profile form of the fold reflects the mechanical properties of the rock sequence under the temperature-pressure conditions of folding, and the percentage of shortening required by the deformation. See ANTICLINE; FOLD AND FOLD SYSTEMS. [G.H.D.]

**Synthetic aperture radar (SAR)** Radar, airborne or satellite-borne, that uses special signal processing to produce high-resolution images of the surface of the Earth (or another object) while traversing a considerable flight path. The technique is somewhat like using an antenna as wide as the flight path traversed, that being the large “synthetic aperture,” which would form a very narrow beam. Synthetic aperture radar is extremely valuable in both military and civil remote-sensing applications, providing surface mapping regardless of darkness or weather conditions that hamper other methods.

Resolution is the quality of separating multiple objects clearly. In radar imaging, fine resolution is desired in both the down-range and cross-range dimensions. In radar using pulses, down-range resolution is achieved by using broad-bandwidth pulses, the equivalent of very narrow pulses, allowing the radar to sense separate echoes from objects very closely spaced in range. This technique is called pulse compression; resolution of a few nanoseconds (for example, 5 ns =  $5 \times 10^{-9}$  s gives about 0.75 m or 2.5 ft resolution) is readily achieved in modern radar.

Cross-range resolution is much more difficult to achieve. Generally, the width of the radar’s main beam determines the cross-range, or lateral, resolution. For example, a 3° beam width resolves targets at a range of 185 km (100 nautical miles) only if they are separated laterally by more than 100 m (330 ft), not nearly enough resolution for quality imaging.

However, surface objects produce changing Doppler shifts as an airborne radar flies by. In side-looking radar (see illustration), even distant objects actually go from decreasing in range very slightly to increasing in range, producing a Doppler-time function. If the radar can sustain high-quality Doppler processing for as long as the “footprint” of the beam illuminates the scene, these Doppler histories will reveal the lateral placement of objects. In fact, if such processing can be so sustained, the cross-range resolution possible is one-half the physical width of the actual antenna being used, a few feet perhaps. Furthermore, this resolution is independent of range, quite unlike angle-based lateral resolution in conventional radar. See DOPPLER EFFECT.

Many synthetic aperture radars use other than just a fixed side-looking beam. Spotlighting involves steering the beam to sustain illumination for a longer time or to illuminate a designated scene at some other angle. The principles remain unchanged:

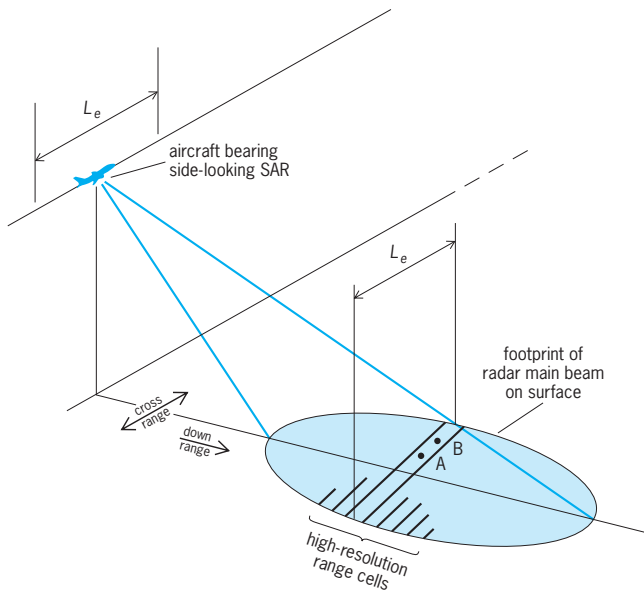

The basic idea of synthetic aperture radar (SAR); a side-looking case is illustrated. Two example scatterers, A and B, are shown in the ground scene.  $L_e$  = maximum flight path length for effective SAR processing.

fine resolution in both down-range and cross-range dimensions (achieved by pulse compression and Doppler processing, respectively) permits imaging with picture cells (pixels) of remarkably fine resolution. Many synthetic aperture radars today achieve pixels of less than 1 m (3 ft) square. [R.T.H.]

**Synthetic fuel** A gaseous, liquid, or solid fuel that does not occur naturally; also known as synfuel. Synthetic fuels can be made from coal, oil shale, or tar sands. Included in the category are various fuel gases, such as substitute natural gas and synthesis gas. See COAL; OIL SAND; OIL SHALE.

Syncrude is a synthetic crude oil, a complex mixture of hydrocarbons somewhat similar to petroleum. It is obtained from coal (liquefaction), from synthesis gas (a mixture of carbon monoxide and hydrogen), or from oil shale and tar sands. Syn-crudes generally differ in composition from petroleum; for example, syn-crude from coal usually contains more aromatic hydrocarbons than petroleum. Gaseous fuels can be produced from sources other than petroleum and natural gas. See PETROLEUM.

The most important source of synthetic crude oil is the tar sand deposit that occurs in northeastern Alberta, Canada. Tar sand is a common term for oil-impregnated sediments that can be found in almost every continent. The routes by which synthetic fuels can be prepared from coal involve either gasification or liquefaction.

Gasification can yield clean gases for combustion or synthesis gas, which has a controlled ratio of hydrogen to carbon monoxide. Catalytic conversion of synthesis gas to liquids (indirect liquefaction) can be carried out in fixed- and fluidized-bed reactors and in dilute-phase systems. Another method for producing synthetic fuels from coal involves gasification of the coal to a fuel gas that may be used as such or as a source of synthetic liquids. See COAL GASIFICATION; FLUIDIZATION.

Coal liquefaction is accomplished by four principal methods: direct catalytic hydrogenation, solvent extraction, pyrolysis, and indirect catalytic hydrogenation (of carbon monoxide). See COAL LIQUEFACTION; HYDROGENATION; PYROLYSIS; SOLVENT EXTRACTION.

Shale oil is readily produced by the thermal processing of oil shales. The basic technology is available, and commercial plants are operated in many parts of the world. [J.G.S.]

**Syphilis** A sexually transmitted infection of humans caused by *Treponema pallidum* ssp. *pallidum*, a corkscrew-shaped motile bacterium (spirochete). Due to its narrow width, *T. pallidum* cannot be seen by light microscopy but can be observed with staining procedures (silver stain or immunofluorescence) and with dark-field, phase-contrast, or electron microscopy. The organism is very sensitive to environmental conditions and to physical and chemical agents. The complete genome sequence of the *T. pallidum* Nichols strain has been determined. The nucleotide sequence of the small, circular treponemal chromosome indicates that *T. pallidum* lacks the genetic information for many of the metabolic activities found in other bacteria. Thus, this spirochete is dependent upon the host for most of its nutritional requirements. See BACTERIAL GENETICS; ELECTRON MICROSCOPE; IMMUNOFLUORESCENCE.

Syphilis is usually transmitted through direct sexual contact with active lesions and can also be transmitted by contact with infected blood and tissues. If untreated, syphilis progresses through various stages (primary, secondary, latent, and tertiary). Infection begins as an ulcer (chancre) and may eventually involve the cardiovascular and central nervous systems, bones, and joints. Congenital syphilis results from maternal transmission of *T. pallidum* across the placenta to the fetus. See SEXUALLY TRANSMITTED DISEASES.

*Treponema pallidum* is an obligate parasite of humans and does not have a reservoir in animals or the environment. Syphilis has a worldwide distribution. Its incidence varies widely according to geographical location, socioeconomic status, and age group. Although syphilis is controlled in most developed countries, it remains a public health problem in many developing countries. Studies have shown that syphilis is a risk factor for infection with the human immunodeficiency virus (HIV) since syphilitic lesions may act as portals of entry for the virus. There is little natural immunity to syphilis infection or reinfection.

Parenteral penicillin G is the preferred antibiotic for treatment of all stages of syphilis. Alternative antibiotics for syphilis treatment include erythromycin and tetracycline. There is currently no vaccine to prevent syphilis. However, it is anticipated that information obtained from the *T. pallidum* genome sequence will lead to further improvements in diagnostic tests for syphilis and to the eventual development of a vaccine that would prevent infection. See ANTIBIOTIC; PUBLIC HEALTH. [L.V.S.]

**Systemellommatophora** A superorder in the subclass Pulmonata containing three families (Rathouisiidae, Veronicellidae, and Onchidiidae) of sluglike mollusks that lack any trace of a shell, have separate external male and female orifices, lack a mantle cavity, have a posterior anus and excretory pore, and bear eyes on the tops of two contractile, but not retractile, tentacles. See PULMONATA. [G.A.S.]

**System design evaluation** A comprehensive and vigorous assessment of the effectiveness and cost of competing system designs, in order to choose the best candidate. System design evaluation is essential within the systems engineering process. It should be embedded appropriately within the process and then pursued continuously as system design and development progress.

The systems engineering process is a morphology for linking technology to customer needs. It is composed of three major activities: synthesis, analysis, and evaluation. Evaluation of each candidate system design is accomplished after receiving design-dependent parameter values for the candidate. It is the specific values for design-dependent parameter's that differentiate (or instance) candidate systems. Each candidate is optimized before being subjected to the design decision schema. It is here that the best candidate is sought (based on the customer's subjective evaluation). See SYSTEMS ENGINEERING.

To be comprehensive, system design evaluation must encompass both system effectiveness and life-cycle cost. To be rigorous,

evaluation should be pursued with the aid of models and simulation. Even when expert opinion must be used in place of formal analytical approaches, a modeling structure may offer guidance. See MODEL THEORY; SIMULATION.

The factors used to evaluate candidate system design must be aggregated to make them apparent. Accordingly, an evaluation process must be followed which combines evaluation factors and decision making. The candidate system design that complies best with the customer's requirement is the preferred choice and may be implemented. See DECISION SUPPORT SYSTEM; OPERATIONS RESEARCH; OPTIMIZATION; SYSTEMS ANALYSIS. [W.J.F.]

**Systems analysis** The application of mathematical methods to the study of complex human physical systems. A system is an arrangement or collection of objects that operate together for a common purpose. The objects may include machines (mechanical, electronic, or robotic), humans (individuals, organizations, or societal groups), and physical and biological entities. Everything excluded from a system is considered to be part of the system's environment. A system functions within its environment. Examples of systems include the solar system, a regional ecosystem, a nation's highway system, a corporation's production system, an area's hospital system, and a missile's guidance system. A system is analyzed so as to better understand the relationships and interactions between the objects that compose it and, where possible, to develop and test strategies for managing the system and for improving its outcomes.

The term "systems analysis" is reserved for the study of systems that include the human element and behavioral relationships between the system's human element and its physical and mechanical components, if any. Examples of public policy systems are the federal government's welfare system, a state's criminal justice system, a county's educational system, a city's public safety system, and an area's waste management system. Examples of industrial systems are a manufacturer's production distribution system and an oil company's exploration, production, refining, and marketing system. Examples with physical environmental components are the atmospheric system and a water supply system. The direct transfer of systems engineering concepts to the study of a system in which the human element must be considered is restricted by limitations in the ability to comprehend and quantify human interactions. (Operations research, a related field of study, is directed toward the analysis of components of such systems. Public policy analysis is the term used for a system study of a governmental problem area.) See DECISION THEORY; OPERATIONS RESEARCH; SYSTEMS ENGINEERING.

Systems comprise interrelated objects, with the objects having a number of measurable attributes. A mathematical model of a system attempts to quantify the attributes and to relate the objects mathematically. The resultant model can then be used to study how the real-world system would behave as initial conditions, attribute values, and relationships are varied systematically. See MODEL THEORY.

The systems analysis process is an iterative one that cycles repeatedly through the following interrelated and somewhat indistinct phases: (1) problem statement, in which the system is defined in terms of its environment, goals, objectives, constraints, criteria, actors (decision makers, participants in the system, impacted constituency), and other objects and their attributes; (2) alternative designs, in which solutions are identified; (3) mathematical formulation, in which a mathematical description of the system is developed, tested, and validated; (4) evaluation of alternatives, in which the mathematical model is used to evaluate and rank the possible alternative designs by means of the criteria; and (5) selection and implementation of the most preferred solution. The process includes feedback loops in which the outcomes of each phase are reconsidered based on the analyses and outcomes of the other phases. For example, during the implementation phase, constraints may be uncovered that hinder the solution's implementation and thus cause the mathematical

model to be reformulated. The analysis process continues until there is evidence that the mathematical structure is suitable; that is, it has enough validity to yield answers that are of value to the system designers or the decision maker. See OPTIMIZATION; SIMULATION.

As originally developed, systems analysis studies have been applied to those areas that are "hard" in that they are well defined and well structured in terms of objectives and feasible alternative systems (for example, blood-bank design, and integrated production and inventory processes). The aim of hard systems analysis is to select the best feasible alternative. In contrast, soft systems are concerned with problem areas that involve ill-defined and unstructured situations, especially those that have strong political, social, and human components. These generally involve public and private organizations (for example, design of a welfare system, and structure and impact of a corporate mission statement). The objectives of soft systems and the means to accomplish them are problematical and, in fact, a systemic view of the problem area is not assumed. The aim of soft systems analysis is to find a plan of action that accommodates the different interests of its human actors.

There is also need for further study of large-scale systems, which by definition are most complex. It is important to find ways to describe mathematically the systems that represent the totality of an industrial organization, the pollution concerns of a country and a continent, or the worldwide agricultural system. These are multicriteria problems with the solutions conflicting across criteria, individuals, and countries. The possibility that such systems may be studied in a computer-based laboratory is very promising. But this challenge must be approached cautiously, with the awareness that the methods and models employed are only abstractions to be used with due consideration of the goals of the individual and society. See LARGE SYSTEMS CONTROL THEORY; LINEAR SYSTEM ANALYSIS. [S.I.Ga.]

**Systems architecture** The discipline that combines system elements which, working together, create unique structural and behavioral capabilities that none could produce alone. The word "architecture" is commonly used to describe the underlying structure of networks, command-and-control systems, spacecraft, and computer hardware and software. The degree to which well-designed systems-level architectures are critical to the success of large-scale projects—or the lack thereof to failure—has been dramatically demonstrated. The explosion of technological opportunities and customer demands has driven up the size, complexity, costs, and investment risks of such projects to levels feasible for only major companies and governments. Without sound systems architectures, these projects lack the firm foundation and robust structure on which to build.

**Complexity and its consequences.** Systems are collections of dissimilar elements which collectively produce results not achievable by the elements separately. Their added value comes from the relationships or interfaces among the elements. (For example, open-loop and closed-loop architectures perform very differently.) But this value comes at a price: a complexity potentially too great to be handled by standard rules or rational analysis alone.

As projects have become ever more complex and multidisciplinary, new structures were needed for projects to succeed. Analytic techniques could not be used to find optimal solutions. Indeed, given the disparate perspectives of different customers, suppliers, and government agencies, unique optimal solutions generally would not exist. Instead, many possibilities might be good enough, with the choice dependent more on ancillary constraints or on the criteria for success than on detailed analysis.

**Conceptual phases.** As increasingly complex systems were built and used, it became clear that success or failure had been determined very early in their projects. In the early phases all the critical assumptions, constraints, choices, and priorities are made that will determine the end result. Unfortunately, no one

knows in the beginning just what the final performance, cost, and schedule will be.

Systems-level architecture specifies how system-level functions and requirements are gathered together in related groups. It indicates how the subsystems are partitioned, the relationships between the subsystems, what communication exists between the subsystems, and what parameters are critical. It makes possible the setting of specifications, the analysis of alternatives at the subsystem level, the beginnings of detailed cost modeling, and the outlines of a procurement strategy.

There rarely is enough information early in the design stage for the client to decide on the relative priority of the requirements without having some idea of what the end system might be. Instead, provisional requirements and alternative system concepts have to be iterated until a satisfactory match is produced. Unavoidably, successful systems architecting in the conceptual phase becomes a joint process in which both client and architect participate heavily. In the ideal situation, the client makes the value judgments and the architect makes the technical decisions.

Systems-level architecture begins with a conceptual model, a top-level abstraction which attempts to discard features deemed not essential at the system level. Such a model is an essential tool of communication between client, architect, and builder, each viewing it from a different perspective. As the system comes into being, the model is progressively refined. See SOFTWARE ENGINEERING. [E.Re.]

**Systems ecology** The analysis of how ecosystem function is determined by the components of an ecosystem and how those components cycle, retain, or exchange energy and nutrients. Systems ecology typically involves the application of computer models that track the flow of energy and materials and predict the responses of systems to perturbations that range from fires to climate change to species extinctions. Systems ecology is closely related to mathematical ecology, with the major difference stemming from systems ecology's focus on energy and nutrient flow and its borrowing of ideas from engineering. Systems ecology is one of the few theoretical tools that can simultaneously examine a system from the level of individuals all the way up to the level of ecosystem dynamics. It is an especially valuable approach for investigating systems so large and complicated that experiments are impossible, and even observations of the entire system are impractical. In these overwhelming settings, the only approach is to break down the research into measurements of components and then assemble a system model that pieces together all components. An important contribution of ecosystem science is the recognition that there are critical ecosystem services such as cleansing of water, recycling of waste materials, production of food and fiber, and mitigation of pestilence and plagues. See ECOLOGICAL COMMUNITIES; ECOLOGICAL ENERGETICS; ECOLOGY; ECOSYSTEM; GLOBAL CLIMATE CHANGE; THEORETICAL ECOLOGY. [P.M.Ka.]

**Systems engineering** A management technology involving the interactions of science, an organization, and its environment as well as the information and knowledge bases that support each. The purpose of systems engineering is to support organizations that desire improved performance. This improvement is generally obtained through the definition, development, and deployment of technological products, services, or processes that support functional objectives and fulfill needs.

Systems engineering has triple bases: a physical (natural) science basis, an organizational and social science basis, and an information science and knowledge basis. The natural science basis involves primarily matter and energy processing. The organizational and social science basis involves human, behavioral, economic, and enterprise concerns. The information science and knowledge basis is derived from the structure and organization inherent in the natural sciences and in the organizational and social sciences.

Systems engineering may also be defined as management technology to assist and support policy making, planning, decision making, and associated resource allocation or action deployment. It accomplishes this by quantitative and qualitative formulation, analysis, and interpretation of the impacts of action alternatives upon the needs perspectives, the institutional perspectives, and the value perspectives of clients to a systems engineering study. Each essential phase of a systems engineering effort—definition, development, and deployment—is associated with formulation, analysis, and interpretation. These enable systems engineers to define the needs for a system, develop the system, and deploy it in an operational setting and provide for maintenance over time, all within time and cost constraints.

Contemporary systems engineering focuses on tools, methods, and metrics, as well as on the engineering of life-cycle processes that enable appropriate use of these tools to produce trustworthy systems. There is also a focus on systems management to enable the wise determination of appropriate processes. See SYSTEMS INTEGRATION.

Much contemporary thought concerning innovation, productivity, and quality can be cast into a systems engineering framework. This framework can be valuably applied to systems engineering in general and information technology and software engineering in particular. The information technology revolution provides the necessary tool base that, together with knowledge management-enabled systems engineering and systems management, allows the needed process-level improvements for the development of systems of all types. The large number of ingredients necessary to accomplish needed change fit well within a systems engineering framework. Systems engineering constructs are useful not just for managing big systems engineering projects according to requirements, but for creative management of the organization itself. See INFORMATION SYSTEMS ENGINEERING; LARGE SYSTEMS CONTROL THEORY; QUALITY CONTROL; SYSTEMS ANALYSIS. [A.P.Sa.]

**Systems integration** A discipline that combines processes and procedures from systems engineering, systems management, and product development for the purpose of developing large-scale complex systems. These complex systems involve hardware and software and may be based on existing or legacy systems coupled with new requirements to add significant added functionality. Systems integration generally involves combining products of several contractors to produce the working system. Systems integration applications range from creation of complex inventory tracking systems to designing flight simulation models and reengineering large logistics systems.

**Life-cycle activities.** Application of systems integration processes and procedures generally follows the life cycle for systems engineering. Minimally, these systems engineering life-cycle phases are requirements definition, design and development, and operations and maintenance. For systems integration, these three phases are usually expanded to include feasibility analysis, program and project plans, logical and physical design, design compatibility and interoperability tests, reviews and evaluations, and graceful system retirement.

**Primary uses.** Systems integration is essential to the design and development of information systems that automate key operations for business and government. It is required for major procurements for the military services and for private businesses.

**Advantages.** Systems integration approaches enable early capture of design and implementation needs. The interactions and interfaces across existing system fragments and new requirements are especially critical. It is necessary that interface and intermodule interactions and relationships across components and subsystems that bring together new and existing equipment and software be articulated. The systems integration approach supports this through application of both a top-down and a bottom-up design philosophy; full compliance with audit trail needs, system-level quality assurance, and risk

assessment and evaluation; and definition and documentation of all aspects of the program. It also provides a framework that incorporates appropriate systems management application to all program aspects. A principal advantage of this approach is that it disaggregates large and complex issues and problems into well-defined sequences of simpler problems and issues that are easier to understand, manage, and build. See INFORMATION SYSTEMS ENGINEERING; SYSTEMS ANALYSIS; SYSTEMS ENGINEERING. [J.D.P.]

**Syzygy** The alignment of three celestial objects within a solar system (or within any other system of objects in orbit about a star). Syzygy is most often used to refer to the alignment of the Sun, Earth, and Moon at the time of new or full moon. Alignments need not be perfect in order for syzygy to occur: because the orbital planes for any three bodies in the solar system rarely coincide, the geometric centers of three objects that are in syzygy almost never lie along the same line. See PHASE; SOLAR SYSTEM.

In general, syzygy occurs whenever an observer on one of the three objects would see the other two objects either in opposition or in conjunction. Opposition occurs when two objects appear  $180^\circ$  apart in the sky as viewed from a third object. Conjunction occurs when two objects appear near one another in the sky as seen from a third object.

Solar and lunar eclipses are dramatic results of syzygy. During a solar eclipse, when the Moon is in its new phase, the alignment of the Sun, Earth, and Moon is so nearly perfect that the Moon's shadow falls on the Earth. During a lunar eclipse, which occurs at the time of the full moon, the Moon passes through the Earth's shadow. See ECLIPSE.

An occultation is another type of eclipse that can occur during syzygy. For an Earth-based observer, an occultation occurs when the Moon is seen to pass in front of a planet or other member of the solar system. The occultation of a star by the Moon does not qualify as syzygy, since the star is far beyond the limits of the solar system. See OCCULTATION. [H.P.C.]

# T

**T Tauri star** A member of a class of very young, optically visible, solar-mass stars with peculiarities such as variability and evidence for mass loss. T Tauri stars were discovered through their unusually strong emission lines. Many radiate unexpectedly intensely at infrared and ultraviolet wavelengths. Two subclasses have been defined, the classical T Tauri stars, identified from hydrogen-emission-line surveys, and the weak-line, or naked, T Tauri stars, discovered through their x-ray emission. Most of the apparently anomalous properties of T Tauri stars can be attributed to the fact that many are still surrounded by remnants of their parent clouds of gas and dust. *See* VARIABLE STAR.

The youth of the T Tauri stars was originally suspected because of their association with star-forming clouds. Their erratic brightness variations also indicated that they had not yet become stable. Ages of 100,000–10,000,000 years are confirmed by their effective temperatures and luminosities.

The unusually strong emission lines observed in the spectra of classical T Tauri stars often have the extended wings characteristic of significant mass outflow. Outflow velocities are high, typically 100 km/s (60 mi/s). In optical images, high-velocity, oppositely directed jets can often be seen emanating from the poles of the stars themselves. Although they are already visible, T Tauri stars are evidently still in the process of shedding the dust and gas from which they formed. From theories about how stars form, the remnant material is expected to be distributed in disks. Such disks are the intrinsic source of the excess infrared radiation. The excess ultraviolet emission, as well as the very strong emission lines, may derive from the boundary layer between the rapidly rotating disk and the more slowly rotating star.

The T Tauri disks are similar to the primitive solar nebula, before the planets formed. If, as seems likely, the Sun experienced a T Tauri phase in its early history, T Tauri stars may be the birth sites of other planetary system. *See* PROTOSTAR; SOLAR SYSTEM; STELLAR EVOLUTION. [A.I.S.]

**Tabulata** One of two principal orders of extinct Paleozoic corals. Tabulate corals were exclusively colonial. Polyps secreted slender calcitic (calcium carbonate) tubes (corallites, ranging 0.5–20 mm in diameter, but predominantly 1–3 mm in diameter), polygonal in cross section when in contact, or cylindrical when surrounded by colonial skeletal material (coenenchyme) or not in contact (*see* illustration). The corallites are almost always partitioned by flat or curved, complete or incomplete plates (tabulae). Septal structures, as spines, or less commonly thin plates radially arranged in corallites, often number 12 when

well developed. However, these structures are usually weakly developed or completely absent. The Tabulata is divided into six suborders—Lichenariina, Sarcinulina, Favositina, Halysitina, Heliolitina, and Auloporina—based mainly on the structural arrangement of corallites in the colony and the presence or absence of communication (mural pores or connecting tubules) between adjacent corallites. Tabulate coral colonies could take on a range of external forms. Shape was determined by the interaction of internal controls on colonial growth with prevailing environmental conditions. Tabulate corals were most abundant and diverse in temperate to warm shelf environments, particularly in biostromes and bioherms. Smaller, laminar to domal massive colonies inhabited deeper, cooler waters. They were an important component of true reefs, particularly in back-reef, reef-flat and fore-reef environments, but their limited ability of secure attachment to hard surfaces restricted their contribution to reef framework. *See* ANTHOZOA; ZOANTHARIA. [C.Scr.]

**Tacan** A member of the rho-theta family of air navigation systems which define an aircraft's position by its distance and bearing to a single beacon. Such systems inherently answer the navigator's questions of "in what direction" and "how far," without additional computation, and are of particular value when the beacon has to be placed on a ship, oil-drilling rig, or small island. The main weakness of such systems is that bearing errors cause spatial error to increase with distance from the beacon. Major attention is therefore given to the reduction of bearing errors.

Tacan allows the distance-measuring equipment (DME) to provide bearing service also, without the large antennas or site errors characteristic of the civil very high-frequency omnidirectional range (VOR). Range and accuracy are the same as DME (300 mi or 480 km, and 0.1 mi or 0.16 km, respectively), with a bearing accuracy of 1°. As in DME, operation is on 252 channels, spaced 1 MHz apart, 962–1213 MHz.

To provide the added bearing service, the DME transponder is first arranged to operate at constant duty cycle. This means that the number of output pulses is held constant, whether the beacon is being interrogated by one or a hundred aircraft.

The total output of the transponder is amplitude-modulated by the rotating directional antenna system (*see* illustration). At the center of this system is the central radiator connected to the DME transponder, just as in the conventional DME. However, rotating around this radiation at 15 revolutions per second are two concentric dielectric cylinders. The inside one, about 6 in. (15 cm) in diameter, contains a single parasitic reflector which imparts a 15-Hz amplitude modulation to the DME replies, and the outside one, about 33 in. (84 cm) in diameter, contains nine parasitic elements which impart a 135-Hz amplitude modulation. On the same rotating shaft are mounted reference pulse generators which additionally modulate the transmitter with coded pulses, once per revolution for the 15-Hz signal (called the north reference burst) and nine times per revolution for the 135-Hz signal (called the auxiliary reference bursts).

In the airborne receiver the 15- and 135-Hz sine waves are detected and filtered and compared with the decoded reference bursts to provide a two-speed or fine-coarse bearing display whose accuracy and site freedom are superior to those of conventional VOR, yet with a ground antenna system which is small

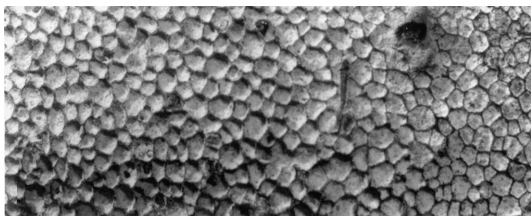

Widespread tabulate coral *Favosites*. Detail of surface showing polygonal corallites,  $\times 1.5$ .

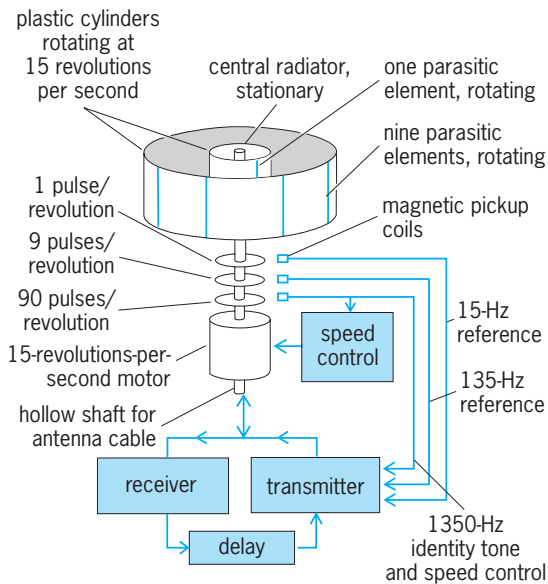

Tacan transponder with rotating directional antenna system.

enough to mount on a ship's mast. See DISTANCE-MEASURING EQUIPMENT; DOPPLER VOR; ELECTRONIC NAVIGATION SYSTEMS; INSTRUMENT LANDING SYSTEM (ILS); RHO-THETA SYSTEM. [S.H.D.]

**Tachometer** An instrument that measures angular speed, as that of a rotating shaft. The measurement may be in revolutions over an independently measured time interval, as in a revolution counter, or it may be directly in revolutions per minute. The instrument may also indicate the average speed over a time interval or the instantaneous speed. Tachometers are used for direct measurement of angular speed and as elements of control systems to furnish a signal as a function of angular speed.

[A.H.W.]

**Tachyon** A hypothetical faster-than-light particle consistent with the special theory of relativity. According to this theory, a free particle has an energy  $E$  and a momentum  $\mathbf{p}$  which form a Lorentz four-vector. The length of this vector is a scalar, having the same value in all inertial reference frames. One writes Eq. (1),

$$E^2 - c^2\mathbf{p}^2 = m^2c^4 \quad (1)$$

where  $c$  is the speed of light and the parameter  $m^2$  is a property of the particle, independent of its momentum and energy. Three cases may be considered:  $m^2$  may be positive, zero, or negative. The case  $m^2 > 0$  applies for atoms, nuclei, and the macroscopic objects of everyday experience. The positive root  $m$  is called the rest-mass. If  $m^2 = 0$ , the particle is called massless. A few of these are known: the electron neutrino, the muon neutrino, the photon, and the graviton. The name tachyons (after a Greek word for swift) has been given to particles with  $m^2 < 0$ .

In general, the particle speed is given by Eq. (2). If  $m^2 < 0$ , Eq. (1) implies  $E > c\mathbf{p}$  and Eq. (2) gives  $v < c$ . If  $m^2 = 0$ , then

$$v = \frac{c\mathbf{p}}{E} c \quad (2)$$

$E = c\mathbf{p}$  and  $v = c$ . In case  $m^2 < 0$ , one finds  $E < c\mathbf{p}$  and  $v > c$ . Tachyons exist only at faster-than-light speeds. See ELEMENTARY PARTICLE; RELATIVITY. [R.H.Go.]

**Taconite** The name given to the siliceous iron formation from which the high-grade iron ores of the Lake Superior district have been derived. It consists chiefly of fine-grained silica mixed with magnetite and hematite. As the richer iron ores approach exhaustion in the United States, taconite becomes more important as a source of iron. [C.S.Hu.]

**Taeniodonta** An extinct order of quadrupedal eutherian land mammals known from the early Cenozoic deposits of the Rocky Mountain intermontane basins of western North America and, based on a single tooth of *Ectoganus gliriformis*, from early Cenozoic rocks in South Carolina. The nine known genera of taeniodonts are classified into two families: (1) the medium-size (5–15 kg or 11–33 lb), relatively primitive, omnivorous conoryctids and (2) the larger (15–110 kg or 33–243 lb) and more advanced stylinodontids. Conoryctids developed enlarged canines, but the lower jaws were unspecialized and the cheek teeth were low-crowned, enamel-enclosed, and cuspidate. Stylinodontid taeniodonts developed deep massive jaws, peglike teeth that were ever-growing, large curved canines bearing enamel bands, and large laterally compressed and recurved claws on the front paws. In terms of modern analogs, an advanced stylinodontid may be thought of as an armadillo with the head of a pig. See EUTHERIA.

[R.M.Scho.]

**Taiga** A zone of forest vegetation encircling the Northern Hemisphere between the arctic-subarctic tundras in the north and the steppes, hardwood forests, and prairies in the south. The chief characteristic of the taiga is the prevalence of forests dominated by conifers. The dominant trees are particular species of spruce, pine, fir, and larch. Other conifers, such as hemlock, white cedar, and juniper, occur locally, and the broad-leaved deciduous trees, birch and poplar, are common associates in the southern taiga regions. Taiga is a Siberian word, equivalent to "boreal forest." See TUNDRA.

The northern and southern boundaries of the taiga are determined by climatic factors, of which temperature is most important. However, aridity controls the forest-steppe boundary in central Canada and western Siberia. In the taiga the average temperature in the warmest month, July, is greater than 50°F (10°C), distinguishing it from the forest-tundra and tundra to the north; however, less than four of the summer months have averages above 50°F (10°C), in contrast to the summers of the deciduous forest further south, which are longer and warmer. Taiga winters are long, snowy, and cold—the coldest month has an average temperature below 32°F (0°C). Permafrost occurs in the northern taiga. It is important to note that climate is as significant as vegetation in defining taiga. Thus, many of the world's conifer forests, such as those of the American Pacific Northwest, are excluded from the taiga by their high precipitation and mild winters.

[J.C.Ri.]

**Tail assembly** An assembly at the rear of an airplane, consisting of the tail cone, the horizontal tail, and one or more vertical tails.

The tail assembly, or empennage, of an airplane is normally composed of a vertical tail and a horizontal tail attached to the rear, or tail cone, of the airplane's fuselage. The vertical tail is composed of the vertical stabilizer and the rudder (see illustration). The vertical stabilizer is attached rigidly to the fuselage and is intended to provide stability about a vertical axis through the airplane's center of gravity. The rudder is attached by hinges to the rear of the vertical stabilizer and can rotate from side to side in response to pilot control input. It also contributes to stability, but its main function is to provide a yawing moment about the airplane's vertical (yaw) axis, thereby causing the airplane to yaw (turn) to the left or right. See AIRCRAFT RUDDER; FLIGHT CONTROLS; FUSELAGE; STABILIZER (AIRCRAFT).

The horizontal tail, similar to the vertical tail, is composed of the horizontal stabilizer and the elevator. The horizontal stabilizer is fixed rigidly to the fuselage and provides stability about a horizontal axis directed along the wing and through the center of gravity, and known as the pitch axis. The elevator is hinged to the rear of the horizontal stabilizer and rotates up and down as the pilot moves the control column fore and aft. The elevator also contributes to stability about the pitch axis, but its main purpose is to provide a pitching moment about the pitch axis,



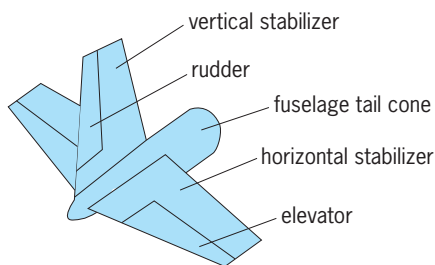

Tail assembly parts (normal configuration).

which causes the airplane to nose up or down. See ELEVATOR (AIRCRAFT).

Airplanes that operate at supersonic speeds usually have the horizontal tail swept back and in one piece that is movable and is controlled by the motion of the pilot's control stick. Such a surface is frequently called a stabilator. See SUPERSONIC FLIGHT.

Many airplanes employ empennages that depart from the normal configuration. See AIRPLANE. [B.W.McC.]

**Takakiales** An order of liverworts in the subclass Jungermanniidae, consisting of a single genus and two species. Some authors put the Takakiales in the Calobryales owing to branching from a prostrate branched stem, lack of rhizoids, copious mucilage secretion, and massive frequently scattered archegonia that lack protective envelopes. However, sporophytes have never been seen, and so it is difficult to demonstrate any meaningful relationship.

The members of the Takakiales consist of a very small gametophyte made up of a branched system of prostrate, leafless stolons and erect, radially organized branches with terete appendages. The "leafy" branches are simple or forked and have a weak central strand of narrow cells enclosed by larger cells. The leafy appendages are small and scalelike below, larger and crowded above, and variable in arrangement. The leaf cells lack oil bodies. Mucilage is secreted by simple filaments on leafy branches and by branched filaments clustered on both leafy and stoloniform branches. The archegonia are scattered and not enclosed by protective structures. See BRYOPHYTA; CALOBRYALES. [H.Cr.]

**Talc** A hydrated magnesium layer silicate (phyllosilicate) with composition close to  $Mg_3Si_4O_{10}(OH)_2$ . Talc commonly is white, but it may appear pale green or grayish depending on the amount of minor impurities. Talc has a greasy feel and pearly luster, and has been used as one of the hardness standards for rock-forming minerals with the value 1 on the Mohs scale. Because talc is soft, it can be scratched by fingernails. See HARDNESS SCALES.

Talc frequently occurs in magnesium-rich metamorphosed serpentinites and siliceous dolomites. Talc-rich rocks include massive soapstones, massive steatite, and foliated talc schists.

Talc is a good insulating material. It has been commonly used in industry as a raw material for ceramics, paints, plastics, cosmetics, papers, rubber, and many other applications. See SILICATE MINERALS. [J.G.L.]

**Tall oil** A by-product from the pulping of pine wood by the kraft (sulfate) process. In the kraft process the wood is digested under pressure with sodium hydroxide and sodium sulfide. The volatilized gases are condensed to yield sulfate turpentine. During the pulping the alkaline liquor saponifies fats and converts the fatty and resin acids to sodium salts. Concentration of the pulping solution (black liquor) prior to recovery of the inorganic pulping chemicals allows the insoluble soaps to be skimmed from the surface. Acidification of the skimmed soap yields crude tall oil.

Crude tall oil from southern pines contains 40–60% resin acids (rosin), 40–55% fatty acids, and 5–10% neutral constituents. Abietic and dehydroabietic acids comprise over 60% of the resin acids, while oleic and linoleic acids predominate in the fatty acid fraction. Fatty acids from tall oil distillation may contain as much as 10–40% resin acids or as little as 0.5%.

Major uses of tall oil fatty acids as chemical raw materials are in coatings, resins, adhesives, and soaps and detergents, and as flotation agents. Tall oil is an important source of rosin in the United States. See PINE TERPENE; ROSIN; WOOD CHEMICALS.

[I.S.G.]

**Tanaidacea** An order of the eumalacostracans of the superorder Peracarida, derived from the genus *Tanais*. These animals have a worldwide distribution and with few exceptions are marine. They occur from the shore down to abyssal depths. They are free-living and benthonic. The order is divided into 2 suborders with 5 families, 44 genera, and about 350 species. The body is linear, more or less cylindrical or dorsoventrally depressed. Thoracic segments 1 and 2 are fused with the head, and the last abdominal segment is fused with the telson. Eight pairs of thoracic legs are present, of which the first pair are maxillipeds, the second pair chelipeds (the first pair of pereopods), and the following six pairs pereopods. See PERACARIDA. [K.L.]

**Tangent** A term describing a relationship of two figures (usually of the same dimension) in the neighborhood of a common point. The figures are tangent at a point  $P$  if they touch at  $P$  but do not intersect in a sufficiently small neighborhood of  $P$ . To be more precise, if  $P$  denotes a point of a curve  $C$  (see illustration), a line  $L$  is a tangent to  $C$  at  $P$  provided  $L$  is the limit

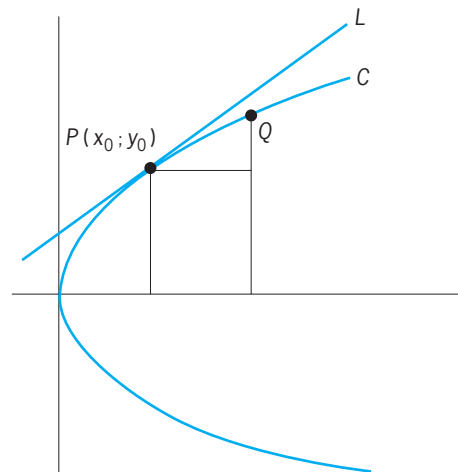

Line  $L$  tangent to curve  $C$  at  $P$ .

of lines joining  $P$  to a variable point  $Q$  of  $C$ , as  $Q$  approaches  $P$  along  $C$  (that is, for  $Q$  sufficiently close to  $P$ , the line  $PQ$  is arbitrarily close to  $L$ ). [L.M.Bl.]

**Tangerine** A name applied to certain varieties of a variable group of loose-skinned citrus fruits belonging to the species *Citrus reticulata*. Although mandarin and tangerine are often used interchangeably to designate the whole group, tangerine is applied more strictly to those varieties (cultivars) having deep-orange or scarlet rinds, whereas the term mandarin is more properly used to include all members of this quite variable group of citrus fruits. See MANDARIN.

The fruits are deep orange, loose-skinned, and small to medium-sized, and possess small seeds with green cotyledons. Tangerines are easily peeled and eaten out of hand as fresh fruit. About one-third of the crop is utilized in juice, sherbets, and canned sections. [F.E.G.; C.J.H.]

**Tantalite** A mineral with composition  $(\text{Fe},\text{Mn})\text{Ta}_2\text{O}_6$ , an oxide of iron, manganese, and tantalum. Niobium substitutes for tantalum in all proportions; a complete series extends to columbite  $(\text{Fe},\text{Mn})\text{Nb}_2\text{O}_6$ . Pure tantalite is rare. Iron and manganese vary considerably in their relative proportions. Tantalite crystallizes in the orthorhombic system and is common in short prismatic crystals. The hardness is 6 on Mohs scale, and the specific gravity 7.95 (pure tantalite). The luster is submetallic and the color iron black. Tantalite is the principal ore of tantalum. It is found chiefly in granite pegmatites and as a detrital mineral, in some places in important amounts, having weathered from such rocks. The chief producing areas are the Congo and Nigeria. See COLUMBITE; HARDNESS SCALES; NIOBIUM; TANTALUM. [C.S.Hu.]

**Tantalum** A chemical element, symbol Ta, atomic number 73, and atomic weight 180.948. It is a member of the vanadium group of the periodic table and is in the 5d transitional series. Oxidation states of IV, III, and II are also known. See PERIODIC TABLE; TRANSITION ELEMENTS.

Tantalum metal is used in the manufacture of capacitors for electronic equipment, including citizen band radios, smoke detectors, heart pacemakers, and automobiles. It is also used for heat-transfer surfaces in chemical production equipment, especially where extraordinarily corrosive conditions exist. Its chemical inertness has led to dental and surgical applications. Tantalum forms alloys with a large number of metals. Of special importance is ferrotantalum, which is added to austenitic steels to reduce intergranular corrosion.

The metal is quite inert to acid attack except by hydrofluoric acid. It is very slowly oxidized in alkaline solutions. The halogens and oxygen react with it on heating to form the oxidation-state-V halides and oxide. At high temperature it absorbs hydrogen and combines with nitrogen, phosphorus, arsenic, antimony, silicon, carbon, and boron. Tantalum also forms compounds by direct reaction with sulfur, selenium, and tellurium at elevated temperatures. [E.M.L.]

**Tantularida** A subclass of the Maxillopoda. Tantularids are minute ectoparasites, less than 0.01 in. (0.3 mm) in length, that infest deep-sea copepods, isopods, tanaids, and ostracods. As a result of their parasitic mode of life, adult females have lost all resemblance to crustaceans; males are free-living but nonfeeding. Infection of the host occurs at the tantulus larval stage, which is believed to occur immediately after the larva is released. The head, or cephalon, of the tantulus larva is covered by a dorsal shield that may protrude anteriorly to form a rostrum. The mechanism of attachment, the mouth tube, is located on the ventral surface with a distal mouth opening, and is surrounded by an oral disk.

Phylogenetic relations of the Tantularida are not clearly understood. Although tantularids lack the antennules and antennae characteristic of Crustacea, two clusters of sensory hairs in adult males are probably antennular in origin. The basic tagmosis exhibited and male gonopore position suggest an affinity with some cirriped taxa. Some researchers include the Tantularida as a subclass of the Maxillopoda; others accept it as a distinct class. See CIRRIPIEDIA; COPEPODA; CRUSTACEA; MAXILLOPODA. [P.A.McL.]

**Taper pin** A tapered self-holding pin used to connect parts together. Standard taper pins have a diametral taper  $\frac{1}{4}$  in. to 12 in. (0.6 cm to 30 cm) and are driven in holes drilled and reamed to fit. The pins are made of soft steel or are cyanidehardened. They are sometimes used to connect a hub or collar to a shaft. Taper pins are frequently used to maintain the location of one surface with respect to another. A disadvantage of the taper pin is that the holes must be drilled and reamed after assembly of the connected parts; hence they are not interchangeable. See COTTER PIN. [P.H.B.]

**Taphonomy** A subdiscipline of paleobiology that investigates the processes of preservation and their influence on information in the fossil record. Processes include events that affected the organism during life, the transferral of organic matter from the biosphere to the lithosphere, and physiochemical interactions from the time of burial until collection. Besides the conspicuous fossil characteristics that reveal the organism's morphological and anatomical features, there are often less prominent details that record the fossil's history. Analyses of these details allow paleontologists to understand the mode of death or disarticulation; biological processes that may have modified the remains before burial, including their use by hominids; the response of the part to transport by animals, water, or wind; the residency time in a depositional setting before final entombment; and the alterations of tissues or skeletal parts within a wide range of chemical environments. The processes of fossilization appear to be environmentally site specific, resulting in a mosaic of preservational traits in terrestrial and marine environs. Few fossil assemblages are exactly identical with regard to formative processes, but general patterns exist. An understanding of taphonomic assemblage features within the environmental context allows for a more accurate interpretation of the fossil record.

Fossilized organic remains have successfully passed through several taphonomic stages, including necrology, biostratinomy, and diagenesis. The first taphonomic stage, necrology, generally refers to the death of an organism, although in the case of plants this is not necessarily a precondition. Plants shed many different parts during their life cycle. Death or part loss may be induced either physiologically (old age, disease, or temporal or climatic shedding) or traumatically (sudden catastrophic death or part loss in response to natural perturbations). Organic remains that are composed of more resistant biochemicals or mineralized hard parts have a higher probability of surviving than those composed of more labile and easily degraded compounds.

Biostratinomy involves all the processes and interactions that follow the necrological stage until final burial. Biotic interactions may include the effects of scavenging on carcasses, the use of discarded parts as domiciles, or borings in resistant structural parts. Abiotic processes include mechanical and physical alteration or degradation under different transport conditions (fragmentation and rounding in river channels), orientation or concentration of resistant parts under varying hydrological regimes, or reexposure and reworking of previously buried remains in response to changing geological circumstances. The biostratinomic stage ends when organic remains are covered by or included within sediment such that they are effectively isolated from the effects of biological degradation.

The processes that affect organic remains following burial belong to the third stage, diagenesis. These processes involve the physical (compaction) and chemical (cementation, recrystallization) changes in the sediment before, during, and after lithification. See FOSSIL; PALEOBOTANY; PALEOECOLOGY; PALEONTOLOGY; TRACE FOSSILS. [R.A.Ga.]

**Tapir** An odd-toed ungulate of the family Tapiridae. These animals, with four species, have a discontinuous distribution in South America and Asia and consequently have a theoretical importance biologically.

These animals have a prehensile, trunklike muzzle, a short tail, and small eyes. The forefoot has four toes, the hindfoot three. The female gives birth to a single young after a gestation period of 13 months. Tapirs are nocturnal, timid animals; they spend the daytime hours in dense thickets. [C.B.C.]

**Tardigrada** A class of microscopic, bilaterally symmetrical invertebrates which are generally less than 1 mm in length. About 400 species are known. Commonly called water bears, bear animalcules, or urslets, they are worldwide in distribution and are found in all habitats.

The tardigrade body consists of an anterior prostomium and five segments. The mouth is located in the prostomium in a centroterminal position. A soft, nonchitinous cuticle surrounds the body and lines the fore- and hindgut. The cuticle may be smooth or sculptured and forms innervated cephalic appendages and spines on the trunk and legs. Four pairs of ventrolateral legs arise from the trunk and terminate in claws or other modified structures. The digestive tract is tubular and more or less lobed due to the presence of diverticular dilations. In the heterotardigrades, separate anal and genital openings occur, while in the eutardigrades there is a single anogenital opening, the cloaca. The sexes are separate and the gonads are unpaired dorsal sacs with paired gonoducts in the male and in theory also in the female. Food storage cells float in the spacious body cavity, the coelom, which lacks a parietal or visceral peritoneum in the adult. Circulatory and respiratory structures are lacking. These animals exhibit the phenomenon known as cell constancy. The number of epidermal cells is the same in all species of a genus.

Tardigrades lay eggs and development is direct. Embryonic development lasts 3–40 days, varying according to the species and surrounding temperature. During their active life of 18 months, tardigrades molt about 12 times. They are unable to feed in the 5–10 days of molting; the buccal cavity requires at least 5 days for renewal.

Tardigrada live as active forms, without encystment, only when surrounded by a pellicle of water. They are mainly herbivorous, and feed by piercing the wall of plant cells with their stylets. When the surrounding medium dries up, most tardigrades continue to live as inactive or anabiotic barrel-shaped structures called cysts without any protective cover. Desiccation begins when there is a loss of oxygen from the water. The animal responds by contraction and loss of body water. Dried eggs also survive. Moistened animals usually revive, but anabiosis and revival cannot be repeated indefinitely.

Most species are widely distributed. Dissemination may be by wind, birds, and certain terrestrial animals which transport tardigrade eggs and barrels. The tropics have few species, and Scutecchiniscidae are rare on the Antarctic continent. Most tardigrades are terrestrial. They are found among lichens, liverworts, densely growing soft-leaved mosses, and also in rather hard-leaved Pottiaceae and Grimmiaceae. See CELL CONSTANCY; EUTARDIGRADA; HETEROTARDIGRADA; POLYCHAETA. [Ev.M.]

**Tarragon** A herb of the genus *Artemisia* in the aster family (Asteraceae) that is used as a spice. Tarragon is often divided into French and Russian types. French tarragon can be distinguished by its highly aromatic leaves, low seed set or fertility, and compact growth habit. Due to its long history of vegetative propagation to preserve its fine scent characteristics, French tarragon has all but lost its ability to form viable seeds. Russian tarragon does produce seeds, but the plant is much lower in overall oil content and is not as fine-scented.

Tarragon is a perennial that grows in one season, and then dies back to the ground with frost. In spring the plant sprouts from underground rhizomes and resumes its growth. The leaves contain volatile oil with an odor similar to anise and chervil. See ASTERALES; SPICE AND FLAVORING. [S.Kir.]

**Tartaric acid** Any of the stereoisomeric forms of 2,3-dihydroxybutanedioic acid: L(+), D(–), and meso [(1), (2), and (3), respectively]. L(+)-Tartaric acid is present in the juice of var-

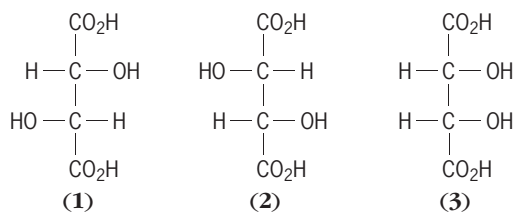

ious fruits and is produced from grape juice as a by-product of the wine industry. The monopotassium salt precipitates in wine vats, and L(+)-tartaric acid is recovered from this residue. On heating in alkaline solution, the L(+) acid is converted to the racemic mixture of (1) and (2), plus a small amount of the meso acid (3).

Tartaric acid has played a central role in the discovery of several landmark stereochemical phenomena. In 1848, L. Pasteur isolated enantiomers (1) and (2) by mechanical separation of hemihedral crystals of the racemic mixture. He also used tartaric acid and its salts to demonstrate a distinction between the meso isomer (3) and the racemic mixture (1) + (2), and between enantiomers and diastereoisomers in general. The difference in properties between (1) [or (2)] and the meso form (3) was later a key in establishing the relative configuration of the pentose and hexose sugars.

Both L(+)- and D(–)-tartaric acid and the esters are inexpensive compounds and are used as chiral auxiliary reagents in the oxidation of alkenes to enantiomerically pure epoxides. This method employs a hydroperoxide oxidant, titanium alkoxide catalyst, and L(+)- or D(–)-tartrate, and involves chirality transfer from the tartrate to the product. See ASYMMETRIC SYNTHESIS; EPOXIDE.

Tartaric acid has some use as an acidulant in foods and also as a chelating agent. Potassium hydrogen tartrate (cream of tartar) is an ingredient of baking powder. The potassium sodium salt, commonly called Rochelle salt, was the first compound used as a piezoelectric crystal. See CHELATION; PIEZOELECTRICITY. [J.A.Mo.]

**Taste** Taste, or gustation, is one of the senses used to detect the chemical makeup of ingested food—that is, to establish its palatability and nutritional composition. Flavor is a complex amalgam of taste, olfaction (smell), and other sensations, including those generated by mechanoreceptor and thermoreceptor sensory cells in the oral cavity. Taste sensory cells respond principally to the water-soluble chemical stimuli present in food, whereas olfactory sensory cells respond to volatile (airborne) compounds. See CHEMICAL SENSES; SENSATION.

The sensory organs of gustation are termed taste buds. In humans and most other mammals, taste buds are located on the tongue in the fungiform, foliate, and circumvallate papillae and in adjacent structures of the throat. There are approximately 5000 taste buds in humans, although this number varies tremendously. Taste buds are goblet-shaped clusters of 50 to 100 long slender cells. Microvilli protrude from the apical (upper) end of sensory cells into shallow taste pores. Taste pores open onto the tongue surface and provide access to the sensory cells. Individual sensory nerve fibers branch profusely within taste buds and make contacts (synapses) with taste bud sensory cells. Taste buds also contain supporting and developing taste cells. See TONGUE.

The basic taste qualities experienced by humans include sweet, salty, sour, and bitter. (In some species, pure water also strongly stimulates taste bud cells). A fifth taste, umami, is now recognized by many as distinct from the other qualities. Umami is a Japanese term roughly translated as “good taste” and is approximated by the English term “savory.” It refers to the taste of certain amino acids such as glutamate (as in monosodium glutamate) and certain monophosphate nucleotides. These compounds occur naturally in protein-rich foods, including meat, fish, cheese, and certain vegetables.

The middorsum (middle top portion) of the tongue surface is insensitive to all tastes. Only small differences, if any, exist for the taste qualities between different parts of the tongue. No simple direct relationship exists between chemical stimuli and a particular taste quality except, perhaps, for sourness (acidity). Sourness is due to H<sup>+</sup> ions. The taste qualities of inorganic salts are complex, and sweet and bitter tastes are elicited by a wide variety of diverse chemicals. [C.P.; N.Cha.; S.Rop.]

**Taurus** The Bull, in astronomy, a winter constellation. Taurus is the second sign of the zodiac. The group contains two notable star clusters, the Hyades and the Pleiades. The Hyades is a V-shaped cluster, the V forming the head of the charging bull, with the fiery bright star Aldebaran in the right eye (see illustration). This star has long been used in navigation. Farther

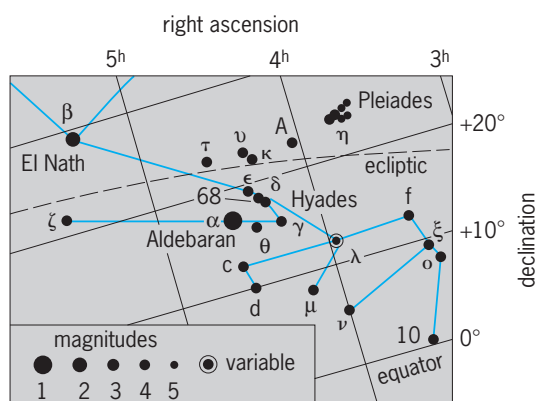

Line pattern of the constellation Taurus. The grid lines represent the coordinates of the sky. The apparent brightness, or magnitude, of the stars is shown by the sizes of the dots, which are graded by appropriate numbers as indicated.

west lies the compact, beautiful cluster of six stars, the famous Pleiades. See CONSTELLATION; HYADES; PLEIADES. [C.S.Y.]

**Tautomerism** The reversible interconversion of structural isomers of organic chemical compounds. Such interconversions usually involve transfer of a proton, but anionotropic rearrangements may be reversible and so be classed as tautomeric interconversions. A cyclic system containing the grouping  $-\text{CONH}-$  is called a lactam, and the isomeric form,  $-\text{COH}=\text{N}-$ , a lactim. These terms have been extended to include the same structures in open-chain compounds when considering the shift of the hydrogen from nitrogen to oxygen.

Molecular grouping (1) may in certain substances exist partly or wholly as (2). The former constitutes the keto form and the latter the enol form. The existence of an enol in an acyclic system requires that a second carbonyl group (or its equivalent, for example, (3) be attached to the same (4) as an aldehyde or ketone

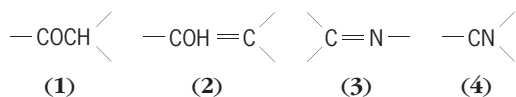

carbonyl. Thus, ethyl acetoacetate tautomerizes demonstrably, but ethyl malonate does not. Where the enol form includes an aromatic ring such as phenol, the existence of the keto form is often not demonstrable, although in some substances there may be either chemical or spectroscopic evidence for both forms. Closely related to keto-enol tautomerism is the prototropic interconversion of nitro and aci forms of aliphatic nitro compounds such as nitromethane.

In general, tautomeric forms exist in substances possessing functional groups which can interact additively and which are so placed that intramolecular reaction leads to a stable cyclic system. The cyclic form usually predominates (especially if it contains five or six members). See MOLECULAR ISOMERISM. [W.R.V.]

**Taxis** A mechanism of orientation by means of which an animal moves in a direction related to a source of stimulation. There exists a widely accepted terminology in which the nature of the stimulus is indicated by a prefix such as phototaxis (light), chemotaxis (chemical compounds), geotaxis (gravity), thigmotaxis (contact), rheotaxis (water current), and anemotaxis (air

current). The directions toward or away from the stimulus are expressed as positive or negative, respectively. Finally, the sensory and locomotory mechanisms by means of which the orientation is achieved are denoted by a second type of prefix forming a compound noun with taxis. Positive phototaxis thus describes a mechanism by means of which an animal carries out a directed movement toward a source of light along a path which permits the animal's paired eyes to receive equal intensities of light throughout the movement. [O.E.L.]

**Taxodonta** An order of bivalves in subclass Lamellibranchia whose hinge dentition is characterized by a series of numerous similar alternating teeth and sockets. Typical genera of so-called ark shells are *Arca*, *Barbatia*, and *Anadara*.

Ark-shell bivalves are probably distantly related to the true marine mussels (Mytilacea), with which they share certain features of gill ciliation and byssal organization. Formerly the name Taxodonta was used to designate a subclass of bivalves consisting of a mixed group of lamellibranch ark shells and primitive protobranchs. See BIVALVIA; LAMELLIBRANCHIA; MOLLUSCA; PROTobranchia. [W.D.R.-H.]

**Taxonomic categories** Any one of a number of formal ranks used for organisms in a traditional Linnaean classification. Biological classifications are orderly arrangements of organisms in which the order specifies some relationship. Taxonomic classifications are usually hierarchical and comprise nested groups of organisms. The actual groups are termed taxa. In the hierarchy, a higher taxon may include one or more lower taxa, and as a result the relationships among taxa are expressed as a divergent hierarchy that is formally represented by tree diagrams. In Linnaean classifications, taxonomic categories are devices that provide structure to the hierarchy of taxa without the use of tree diagrams. By agreement, there is a hierarchy of categorical ranks for each major group of organisms, beginning with the categories of highest rank and ending with categories of lowest rank, and while it is not necessary to use all the available categories, they must be used in the correct order (see table).

Conceptually, the hierarchy of categories is different than the hierarchy of taxa. For example, the taxon Cnidaria, which is ranked as a phylum, includes the classes Anthozoa (anemones), Scyphozoa (jellyfishes), and Hydrozoa (hydras). Cnidaria is a particular and concrete group that is composed of parts. Anthozoa is part of, and included in, Cnidaria. However, categorical ranks are quite different. The category "class" is not part of, nor included in, the category "phylum." Rather, the category "class" is a shelf in the hierarchy, a roadmark of relative position. There are many animal taxa ranked as classes, but there is only one "class" in the Linnaean hierarchy. This is an important strength of the system because it provides a way to navigate through a classification while keeping track of relative hierarchical levels with only a few ranks for a great number of organisms.

When Linnaeus invented his categories, there were only class, order, family, genus, and species. These were sufficient to serve the needs of biological diversity in the late eighteenth century, but were quite insufficient to classify the increasing number of species discovered since 1758. As a result, additional categorical levels have been created. These categories may use prefixes,

**Categories commonly used in botanical and zoological classifications, from highest to lowest rank**

Botanical categories	Zoological categories
Divisio	Phylum
Classis	Class
Ordo	Order
Familia	Family
Genus	Genus
Species	Species

such as super- and sub-, as well as new basic levels such as tribe. An example of a modern expanded botanical hierarchy of ranks between family and species is:

Familia  
Subfamilia  
Tribus  
Subtribus  
Genus  
Subgenus  
Sectio  
Subsectio  
Series  
Subseries  
Species

Linnaean categories are the traditional devices used to navigate the hierarchy of taxa. But categories are only conventions, and alternative logical systems, such as those used by phylogenetic systematists (cladists), are frequently used. See ANIMAL SYSTEMATICS; CLASSIFICATION, BIOLOGICAL; PHYLOGENY; PLANT TAXONOMY; TAXON; ZOOLOGICAL NOMENCLATURE. [E.O.W.]

**Taxonomy** The arrangement or classification of objects according to certain criteria. Systematics is a broader term applied to all comparative biology, including taxonomy. For classifying plants and animals, where the term taxonomy is most often applied, the criteria are characters of structure and function.

A given character usually has two or more states. These variations are used as the basis of biological classification, grouping together like species (in which the majority of the character states are alike) and separating unlike species (in which many of the character states are different). Since the acceptance by biologists of the concept of organic evolution, more and more effort has been made to produce systems of classification that conform to phylogenetic (that is, evolutionary) relationships. Taxonomy is thus concerned with classification, but ultimately classification itself depends upon phylogeny—the amount, direction, and sequence of genetic changes. Scientists try to classify lines, or clusters of lines, of descent. This has not always been the case, and in the past various other criteria have been used, such as whether organisms were edible (ancient times) and whether flowers had five stamens or four or some other number (Linnaean times). Modern taxonomists generally agree that the patterns or clusters of diversity they observe in nature, such as the groups of primates, the rodents, and the bats, are the objective results of purely biological processes acting at different times and places in the past. At the least, animal and plant taxonomy provides a method of communication, a system of naming; at the most, taxonomy provides a framework for the embodiment of all comparative biological knowledge. See ANIMAL SYSTEMATICS; CLASSIFICATION, BIOLOGICAL; NUMERICAL TAXONOMY; ORGANIC EVOLUTION; PHYLOGENY; PLANT TAXONOMY. [W.H.Wa.]

**Tea** A small tree, *Camellia (Thea) sinensis*. A preparation of its leaves dried and cured by various processes; and a beverage made from these leaves. The plant is an evergreen tree of the Theaceae family, native to southeastern Asia, and does best in a warm climate where the rainfall averages 90–200 in. (2200–5000 mm). China, Japan, Taiwan, India, Sri Lanka, and Indonesia are among the leading tea-producing countries, with China contributing about one-half of the world's supply.

Tea leaves contain caffeine, various tannins, aromatic substances attributed to an essential oil, and other materials of a minor nature, including proteins, gums, and sugars. The tannins provide the astringency, the caffeine the stimulating properties. See THEALES. [E.L.C.]

**Technetium** A chemical element, Tc, atomic number 43, discovered by Carlo Perrier and Emilio Segre in 1937. They separated and isolated it from molybdenum (Mo; atomic number 42), which had been bombarded with deuterons in a cyclotron. Technetium does not occur naturally. See ATOMIC NUMBER; ELEMENT (CHEMISTRY).

In the periodic table, technetium is located in the middle of the second-row transition series, situated between manganese and rhenium. Because of the lanthanide contraction, the chemistry of technetium is much more like that of rhenium, its third-row congener, than it is like that of manganese. Its location in the center of the periodic table gives technetium a rich and diverse chemistry. Oxidation states  $-1$  to  $+7$  are known, and complexes with a wide variety of coordination numbers and geometries have been reported. See LANTHANIDE CONTRACTION; PERIODIC TABLE; RHENIUM; TRANSITION ELEMENTS.

The most readily available chemical form of technetium is the ion pertechnetate ( $\text{TcO}_4^-$ ), the starting point for all of its chemistry. In its higher oxidation states ( $+4$  to  $+7$ ), technetium is dominated by oxo chemistry, which is dominated by complexes containing one or two multiply bonded oxygen (oxo) groups.

Since about 1979, inorganic chemists have been very interested in understanding and developing the fundamental chemistry of technetium, utilizing the isotope  $^{99g}\text{Tc}$ . Most of this interest has arisen from the utility of another isotope of technetium,  $^{99m}\text{Tc}$  (where m designates metastable), to diagnostic nuclear medicine. In fact,  $^{99m}\text{Tc}$  in some chemical form is used in about 90% of all diagnostic scans performed in hospitals in the United States. The nuclear properties of  $^{99m}\text{Tc}$  make it an ideal radionuclide for diagnostic imaging. This technetium isotope has a 6-h half-life, emits a 140-keV gamma ray which is ideal for detection by the gamma cameras used in hospitals, and emits no alpha or beta particles. [S.S.J.]

**Technology** Systematic knowledge and action, usually of industrial processes but applicable to any recurrent activity. Technology is closely related to science and to engineering. Science deals with humans' understanding of the real world about them—the inherent properties of space, matter, energy, and their interactions. Engineering is the application of objective knowledge to the creation of plans, designs, and means for achieving desired objectives. Technology deals with the tools and techniques for carrying out the plans. [R.S.S./H.B.M.]

**Tektite** A member of one of several groups of objects that are composed almost entirely of natural glass formed from the melting and rapid cooling of terrestrial rocks by the energy accompanying impacts of large extraterrestrial bodies. Tektites are dark brown to green, show laminar to highly contorted flow structure on weathered surfaces and in thin slices, are brittle with excellent conchoidal fracture, and occur in large masses but are mostly small to microscopic in size.

Five major groups of tektites are known: North American, 34,000,000 years old; Czechoslovakian (moldavites), 15,000,000 years; Ivory Coast, 1,300,000 years old; Russian (irgizites) 1,100,000 years old; and (5) Australasian, 700,000 years old. The North American, Ivory Coast, and Australasian tektites also occur as microtektites in oceanic sediment cores near the areas of their land occurrences. In the land occurrences, virtually all of the tektites are found mixed with surface gravels and recent sediments that are younger than their formation ages.

The chemical compositions of tektites differ from those of ordinary terrestrial rocks principally in that they contain less water and have a greater ratio of ferrous to ferric iron, both of which are almost certainly a result of their very-high-temperature history. [E.A.K.]

**Telecast** A television broadcast, involving the transmission of the picture and sound portions of the program by separate transmitters at assigned carrier frequencies within the channel

assigned to a television station. A telecast is intended for reception by the general public, just as is a radio broadcast. *See* TELEVISION; TELEVISION TRANSMITTER. [J.Mar.]

### **Telecommunications civil defense system**

Warning centers and private-line telecommunications systems that carry vital emergency information and alerts to both the military and the general public. When any possible emergency threatens the security or socioeconomic structure of the United States or any political subdivision, an appropriate warning must be made in order for a reaction to occur within an appropriate period of time. Any such reactions cannot operate without a means of communication to prewarn of impending disaster or attack and to assist the civil defense and military effort after a disaster has occurred.

The Federal Emergency Management Agency has primary responsibility for financial and technical support of the two basic communications systems that meet this need during a crisis situation: the National Warning System (NAWAS) and the Emergency Broadcast System (EBS).

Operating 24 h a day, the National Warning System is a voice-grade service that consists of over 65,000 channel miles (100,000 km) connecting 2300 warning points in the United States with a national primary warning center located with the North American Air Defense (NORAD) Command. Should the primary warning center be rendered inoperative, alternate centers can cover all warning points that were dependent on the inoperative center. Similarly, modern switching facilities are available to replace any portion of the network that may become inoperative. The warning centers are located at key defense installations so that full advantage can be taken of all available information. Warning information can be sent to all points on the network in approximately 15 s. From the 2300 warning points on the network, warning information is relayed through state and local systems to more than 5000 local points in an average time of 7 min.

The mission of the Emergency Broadcast System is to provide the President of the United States with a means of communicating with the general public through the use of nongovernment broadcast stations during the period preceding, during, and following an enemy attack, natural disaster, or other national emergency. The Broadcast System consists of four multipoint private-line services routed to 31 locations at 2400 bits per second. Either of the two point-of-origin, send-receive stations (a primary location and its alternate) can transmit the activation, termination, and National Industry Advisory Council (NIAC) order messages to all other stations. Each point-of-origin send-receive station is equipped with a line controller unit, a 4420 terminal, diagnostic modems, and floppy disk storage units. All other receive-only stations are equipped with 2024 modems and a Model 43 buffered terminal which is programmed to provide an answer with the depression of a key. Activation of a switch at these locations and at the point of origin allows voice confirmation and emergency coordination. *See* RADIO BROADCASTING; TELEPHONE SERVICE. [J.P.McQ.]

**Teleconferencing** Broadly, the various ways and means by which people communicate with one another over some distance. In a narrow sense, a teleconference is a two-way, interactive meeting, between relatively small groups of people (approximately 1 to 10 at each end), who usually use permanent teleconferencing facilities. A teleconference involves audio communication between the locations, but may also involve video or graphics. *See* TELEPHONE SERVICE; VIDEOTELEPHONY.

A teleseminar is utilized for educational purposes; it is primarily one-way communication to many destinations from one source. A teleseminar almost always uses audio communication, and may also use video and some form of graphics. A means is provided for the receiving locations to ask questions of the instructor via microphones or telephone handsets.

A telemeeting is often called an ad hoc teleconference, with the ad hoc referring to places, times, participants, and purpose. A telemeeting is similar to a teleseminar in that it is primarily a one-way communication, usually staged or prepared by video program professionals. It may be set up to order, using temporary equipment or circuits.

Computer conferencing is a method for people to communicate by using computers. The medium is quite flexible, as it can be used between just two people, between one and many people, or among many people. Basically, computer conferencing involves typing a message on a computer terminal and transmitting it to one or more destinations electronically. Sophisticated networks are required to accomplish computer conferencing between many users, or a simple data modem and telephone circuit can allow two people at a time to conference. *See* DATA COMMUNICATIONS; LOCAL-AREA NETWORKS; WIDE-AREA NETWORKS.

Currently, the most popular form of teleconferencing by far is the audio conference. Using plain speaker telephones, special speaker phones, corporate private branch exchange (PBX) systems, or special services, most business people use this form of teleconference regularly. Probably next in popularity is the Teleseminar, used for "distance learning," or formal education and training. The Internet has become a popular medium to facilitate both of these forms of teleconferencing, as high-speed connections such as digital subscriber line (DSL), cable modem, and satellite have become more prevalent. *See* COMMUNICATIONS SATELLITE; INTERNET; PRIVATE BRANCH EXCHANGE. [J.J.B.]

**Telegraphy** A method of communication employing electrical signaling impulses produced and received manually or by machines. Telegraph signals are transmitted over open wire or cable land lines, submarine cables, or radio. Telegraphy as a communication technique uses essentially a narrow frequency band and a transmission rate adapted to machine operations. *See* ELECTRICAL COMMUNICATIONS.

Early equipment devised by Samuel F. B. Morse consisted of a mechanical transmitter and receiver or register. Operators soon learned to handle messages faster using simple manual keys and audible sounders. Subsequently, telegraph transmission and reception again became mechanized. *See* TELETYPEWRITER EXCHANGE (TWX) SERVICE; TELEX. For other ways in which telegraphy may be used, *see* FACSIMILE; TELEPHOTOGRAPHY; TELETYPE-SETTER.

Telegraph facilities for use by the general public to transmit messages both domestically and internationally are provided by communication companies and government administrations. Special telegraph facilities include those for news services, distribution of market prices of securities and commodities, and private lines between such points as the factories and offices of a company for the exchange of messages, orders, payroll data, and inventories. Fire and police alarms are a special form of telegraphy. The armed forces have extensive fixed and mobile telegraph systems.

For manual operation, the telegraph code consists of short dot and long dash signals (see illustration). Most automatic printing telegraph circuits, including American cable operation, use a code of five equally spaced signals or units per letter or other symbol perforated into a paper tape. Machines translate automatic teleprinter code to cable code, cable code to automatic code, or, for special applications, make other translations. For stock quotation systems and teletypesetter operation, a six-unit code is used to provide control of machine action. For data transmission or machine control, a seven- or eight-unit code may be used.

A single circuit provides transmission in only one direction at a time. For transmission in both directions simultaneously, a duplex circuit is used. Multiplex (time-division) apparatus provides two, three, or more channels operable in both directions simultaneously over a single circuit. Carrier-current techniques enable several circuits, each comprising one or more communication

Continental code	Morse code
alphabet	
A	A
B	B
C	C
D	D
E	E
F	F
G	G
H	H
I	I
J	J
K	K
L	L
M	M
N	N
O	O
P	P
Q	Q
R	R
S	S
T	T
U	U
V	V
W	W
X	X
Y	Y
Z	Z
numerals	
1	1
2	2
3	3
4	4
5	5
6	6
7	7
8	8
9	9
0	0
punctuation	
(.)	(.)
(,)	(,)
(?)	(?)
(:)	(:)
(;)	(;)
(-)	(-)
(@)	(@)
(#)	(#)
(/)	(/)
( )	( )
(")	(")

Continental code (International Morse) is commonly used for telegraph communication. Morse code (American Morse) continues in use on a few land lines in the United States and Canada.

channels, to operate through the same wide-band wire, cable, or radio facility. See MULTIPLEXING.

In automatic transmission, an operator at a manual keyboard, operated like a typewriter, perforates a tape. The tape is fed through an electromechanical or photocell tape reader that drives the tape at a rapid and uniform rate and transmits the electrical code. Interconnecting wire lines or other communication channels carry these code pulses to the receiver. The received impulses may automatically actuate a reperforator to produce a duplicate punched tape for retransmission or later transcription; the impulses may actuate a teletypewriter (also called a teleprinter) to retype the original message; or they may actuate other terminal equipment, such as an accounting machine.

Alternatively, the equipment at both terminals may be teletypewriters, in which keyboard and printing mechanisms are combined in one machine. Such machines use a five-unit code but operate without perforated tape. Business firms that originate and receive numerous messages have such equipment installed at their offices for direct service. Also widely used are facsimile instruments that transmit or reproduce a typed or handwritten message as a picture on electrosensitive paper. [G.Hot]

To achieve speed and accuracy in handling messages en route, direct circuits may be set up from the originating keyboard to the distant teleprinter. This is done in TWX and Telex services. This mode of system operation is known as circuit switching. If direct channels are not immediately available, or if the volume of traffic calls for a storage interval, the message is transferred by means of perforated tape at switching centers. This mode is known as message switching or store-and-forward switching. Message switching has the advantage of using the channel capacities of trunk lines more fully than do direct connections. It is used in the United States for public telegram service and on leased-wire switched networks. See TELEX. [W.E.G.]

In overseas communications, telegraph messages or telegrams are transmitted over high-frequency radio (3–30 MHz), transoceanic submarine cables, or satellite communication channels. A decreasing number of messages are carried on high-frequency radio. These types of overseas channels are also used for private-line service, which is referred to as leased-channel service, and customer-to-customer teletypewriter service, which is known as Telex in the international service. [E.D.B.]

**Telemetry** The branch of engineering, also called telemetry, which is concerned with collection of measurement data at a distant or inconvenient location, and display of the data at a convenient location. One example of a complex telemetry system is used to measure temperature, pressure, and electrical systems on board a space vehicle in flight, radio the data to a station on Earth, and present the measurements to one or several users in a useful format. Telemetry involves movement of data over great distances, as in the above example, or over just a few meters, as in monitoring activity on the rotating shaft of a gas turbine. It may involve less than 10 measurement points or more than 10,000.

Telemetry involves a number of separate functions: (1) generating an electrical variable which is proportional to each of several physical measurements; (2) converting each electrical variable to a proportional voltage in a common range; (3) combining all measurements into a common stream; (4) moving the combined measurements to the desired receiving location, as by radio link; (5) separating the measurements and identifying each one; (6) processing selected measurements to aid in mission analysis; (7) displaying selected measurements in a useful form for analysis; and (8) storing all measurements for future analysis.

The largest category is commonly called aerospace telemetry, used in testing developmental aircraft and in monitoring low-orbit space vehicles. Other applications include missile and rocket testing, automobile testing, and testing of other moving vehicles.

The version of telemetry commonly used in an industrial application includes supervisory control of remote stations as well as data acquisition from those stations over a bidirectional communications link. The generic term is supervisory control and data acquisition (SCADA); the technology is normally used in electrical power generation and distribution, water distribution, and other wide-area industrial applications. See ELECTRIC POWER SYSTEMS; WATER SUPPLY ENGINEERING.

One SCADA application involves monitoring wind direction and velocity as indicated by anemometers located on the approach and departure paths near an airport, so that air-traffic controllers can make pilots aware of dangerous differences in wind direction and velocity, known as wind shear. This type of

system is operated over a radio communications link, with the appropriate anemometers being interrogated as their measurements are needed by the computer for wind analysis. Somewhat similar systems are used in oceanographic data collection and analysis, where instrumented buoys send water temperature and other data on command. See AERONAUTICAL METEOROLOGY; INSTRUMENTED BUOYS; WIND MEASUREMENT.

Because two-way communication with a complex and distant Earth synchronous satellite or other spacecraft presents a unique challenge, a technology called packet telemetry is in widespread use for these applications. Here, messages between the Earth station and the spacecraft are formed into groups of measurements or commands called packets to facilitate routing and identification at each end of the link. Each packet begins with a definitive preamble and ends with an error-correcting code for data quality validation. Packet technology is defined by an international committee, the Consultative Committee for Space Data Systems (CCSDA). See PACKET SWITCHING; SPACE COMMUNICATIONS.

Many unique systems are in use. A special multichannel medical telemetry system is used on some ambulances to monitor and radio vital signs from a person being transported to a hospital, so that medical staff can prepare to treat the specific condition which caused the emergency. Another system is possibly the oldest user of radio telemetry, the radiosonde. A data collection and transmission system is lifted by a balloon to measure and transmit pressure, temperature, and humidity measurements from various altitudes as an aid to weather prediction. See BALLOON; METEOROLOGICAL INSTRUMENTATION. [O.J.S.]

**Teleostei** The largest, youngest (first appearing in the Upper Triassic), and most successful group of the actinopterygians (rayfin fishes), and a sister group of the Amiidae (bow fins). The 23,600 species of teleosts make up more than half of all recognized species of living vertebrates, and over 96% of all living fish species. There are 494 families, of which 69 are extinct leaving 425 extant families, 43% of which have no fossil record. See ACTINOPTERYGII; AMIIFORMES.

Much of the evidence for teleost monophyly and relationships comes from the caudal skeleton and concomitant acquisition of a homocercal tail (upper and lower lobes symmetrical). Other characters of the teleosts include the mobile premaxilla bone, the extension of the posterior myodome (the eye muscle canal) into the basioccipital bone, and the development of the swim bladder. See SWIM BLADDER.

The Osteoglossomorpha, Elopomorpha, and Clupeomorpha are now generally regarded as successive clades (groups) above the level of the fossil, paraphyletic pholidophorids. The Clupeomorpha is considered to be the sister group of the Ostariophysii.

**Clupeomorpha and Ostariophysii.** The Clupeomorpha includes almost 80 genera and some 360 Recent species in three main families: Engraulidae (anchovies), Dussumieridae (round herrings), Clupeidae (herrings), as well as Pristigasteridae. The Ostariophysii make up nearly 75% of the fresh-water fishes of the world (over 6000 species) and include the Cypriniformes (carps, loaches, and relatives), Siluriformes (catfishes), Gymnotiformes (knife fishes, electric eel), and *Chanos*. The Clupeomorpha plus Ostariophysii are the sister group of the Euteleostei. See CYPRINIFORMES; OSTEOGLOSSIFORMES; PHOLIDOPHORIFORMES.

**Euteleostei.** The Euteleostei are by far the largest teleost taxon with more than 22,000 species arranged in some 340 families. They comprise two major lineages, the Protacanthopterygii and the Neognathi.

The Protacanthopterygii (often regarded as lower euteleosteans) include four groups: the salmonoids (salmon and allies; 66 species) and the osmeroids (smelts, salangrids, *Lepidogalaxius*; 72 species), which together are the sister group of the alepocephaloids (slickheads; 60+ species) plus the argentinoids (argentinines or herring smelts; 60+ species). The Neognathi, on the other hand, are made up of the esocoids (pike and mud-

minnows; 10+ species) plus the sister group Neoteleostei. See SALMONIFORMES.

The Neoteleostei, with more than 15,319 species, comprise four main clades, the Stomiiformes, Aulopiformes, Myctophiformes, and Acanthomorpha (paracanthopterygians plus acanthopterygians). The acanthopterygians are the largest subgroup of the Euteleostei, distributed among 12 orders and 218 families. The Perciformes form the largest of these orders with 9293 species. See PERCIFORMES. [B.Ga.]

**Teleostomi** This name was originally proposed by R. Owen to include bony fishes with a terminal mouth, excluding the lungfishes or Dipnoi. Later, it was employed in a more inclusive sense to mean a class of fishes, including the bony fishes or subclasses Osteichthyes, and the extinct subclass Acanthodii. Together with class Chondrichthyes and class Placodermi, it forms the group of jawed fishes or Gnathostomata. See ACANTHODII; CHONDRICHTHYES; OSTEICHTHYES; PLACODERMI. [R.H.De.]

**Telephone** An instrument containing a transmitter for converting the acoustic signals of a person's voice to electrical signals, a receiver for reconverting electrical signals to acoustic signals, and associated signaling devices (the dial) for communicating with other persons using similar instruments connected to a network. The term telephone also refers to the complicated system of transmission paths and switching points connected to this instrument. See TELEPHONE SERVICE.

The transmitter is a transducer that converts acoustic energy into electric energy. The carbon transmitter was the key to practical telephony because it amplified the power of the speech signal, making it possible to communicate over distances of many miles. Many of these transmitters are still in service, but they are gradually being replaced by designs based on the charged electret (a condenser microphone) or on electrodynamic principles. Both the electret and electrodynamic transmitters use transistors to provide needed power gain; they introduce less distortion than the carbon transmitter. See ELECTRET TRANSDUCER; MICROPHONE; TRANSDUCER; TRANSISTOR.

Transmitters have a frequency-response range from 250 to 5000 Hz. Even though normal human hearing has a much broader frequency response, speech heard on the telephone resembles closely that heard by a listener.

The heart of an electret transmitter is an electrical capacitor formed by the metal on the diaphragm, a conductive coating on top of the metalized lead frame, and the plastic and air between the metal layers. The diaphragm is made of a special plastic that can be given a permanent electrostatic charge (analogous to the magnetization of a permanent magnet). As sound waves entering the sound port cause pressure changes, the diaphragm moves closer to and farther away from the metalized lead frame. This changes the value of capacitance and produces a varying electric voltage which is the analog of the impinging sound-pressure wave. The signal is amplified by the internal amplifier chip to a level which is suitable for transmission on the telephone network.

The receiver transducer operates on the relatively low power used in the telephone circuit; it converts electric energy back into acoustic energy. Unlike a loudspeaker, the telephone receiver is designed for close coupling to the ear. As in the transmitter, careful design of the relationship of the acoustical and electrical elements produces a desired response-frequency characteristic.

There are two common types of receiver units with fixed coil windings, the ring armature receiver and the bipolar receiver. Moving-coil designs, similar to loudspeakers, are also used in some instances. Fixed-coil receivers are designed to have low acoustic impedance and high available power response over the frequency range 350–3500 Hz. Careful control of both the acoustic and electric design parameters is necessary to achieve the desired response and to avoid undesirable resonances. See ACOUSTIC IMPEDANCE.



Standard telephone sets typically include two cords: a line cord that connects the instrument to the building wiring and telephone network, and a handset cord that connects the telephone handset to the chassis. Cordless telephones use a two-way radio link between the handset and the base unit, which is similar to the chassis of the standard telephone; this replaces the handset cord. The base unit is connected through a normal line cord to the telephone network.

The cellular radio system is a form of mobile radio telephony. Cellular telephones use a two-way radio link to replace the line cord. The telephone communicates with one of a number of base stations spread in cells throughout the service area. As the telephone user changes location, the link is automatically switched from cell to cell to maintain a good connection. *See* MOBILE RADIO. [R.M.Ri.]

**Telephone service** The technology of providing many types of communications services via networks that transmit voice, data, image facsimile, and video by using both analog and digital encoding formats.

Telephone services involve three distinct sectors of components: (1) customer premises equipment (CPE), such as telephones, fax machines, personal and mainframe computers, and systems private branch exchanges (PBXs); (2) transmission systems, such as copper wires, coaxial cables, fiber-optic cables, satellites, point-to-point microwave routes, and wireless radio links, plus their associated components; and (3) switching systems that often can access associated databases, which can add new intelligent controls for the network's users. *See* COAXIAL CABLE; COMMUNICATIONS CABLE; COMMUNICATIONS SATELLITE; MICROWAVE; OPTICAL COMMUNICATIONS; OPTICAL FIBERS; PRIVATE BRANCH EXCHANGE; RADIO; SWITCHING SYSTEMS (COMMUNICATIONS); TELEPHONE.

**Infrastructure.** Made over a web of circuits known as a network, a connection often involves several different telephone companies or carriers. In the United States, there are more than 1300 local exchange companies (LECs) providing switched local service, plus more than 500 large and small interexchange companies (IECs) that provide switched long-distance services.

In addition, wireless mobile telephone services are provided on a city-by-city basis by cellular systems operated by two different companies in each metropolitan area. Each cellular system is connected to the wire networks of the local exchange companies and interexchange companies. *See* MOBILE RADIO.

Local exchange company operations of wired systems are divided geographically into 164 local access and transport areas (LATAs), each containing a number of cities and towns. Within a LATA, the telephone company operates many local switches, installed in facilities known as central offices or exchanges.

Each central office or exchange switch is connected to local telephone customer premises by a system of twisted-pair wires, coaxial cables, and fiber-optic lines called the loop plant. Direct current (dc) electricity that carries signals through the wires (or powers the lasers and photodetectors in the glass-fiber lines) is provided by a large 48-V stationary battery in the central office which is constantly recharged to maintain its power output. If a utility power outage occurs, the battery keeps the transmission system and the office operating for a number of hours, depending on the battery's size.

The transmission is usually analog to and from the customer site, especially for residences. However, in many systems a collection point between the customer and the switch, known as a subscriber loop carrier (SLC), provides a conversion interface to and from one or more digital cable facilities called T1 carriers (each with 24 channels) leading to the switch. In turn, most switches are interconnected by digital fiber-optic, coaxial, or copper-wire cables or by microwave transmission systems either directly or via intermediate facilities called tandem switches between local switches or between a group of central offices and

a long-distance toll switch. *See* TELEPHONE SYSTEMS CONSTRUCTION.

**Switching and transmission designs.** Telephone switching machines used analog technology from 1889 to 1974, when the first all-digital switch was introduced, starting with long-distance or toll service and expanded later to central offices or local exchanges. Digital switching machines are comparable to digital computers in their components and functions. Unlike the analog electromechanical switches of the past, digital switches have no moving parts and can operate at much faster speeds. In addition, digital switches can be modified easily by use of operations systems—special software programs loaded into the switch's computer memory to provide new services or perform operational tasks such as billing, collecting and formatting traffic data from switches, monitoring the status of transmission and switching facilities, testing trunk lines between end offices, and identifying loop troubles. *See* DIGITAL COMPUTER.

In North America, digital switching and transmission are conducted within a hierarchy of multiplexing levels. The single digital telephone line, rated at 64 kilobits per second (kb/s), is known as a digital signal 0 (DS-0) level. The lowest digital network transmission level is DS-1, equivalent to 24 voice channels multiplexed by time-division multiplexing (TDM) to operate at 1.544 megabits per second (Mb/s). DS-1 is the most common digital service to customer premises. Two interim levels, now seldom used, are followed by DS-3, perhaps the most widely used high-speed level. DS-3 operates at 44.736 Mb/s, often rounded out to 45 Mb/s, the highest digital signal rate conventionally provided to customer premises by the telephone network. Of course, groups of DS-3 trunks can be connected to a customer facility if needed. Outside the United States, other digital multiplexing schemes are used. This results, for example, in a DS-1 level having 30 voice channels rather than 24 channels. *See* MULTIPLEXING AND MULTIPLE ACCESS.

A second network hierarchy appeared during the early 1990s and was gradually implemented in the world's industrial nations. Known in North America as SONET (synchronized optical network) and in the rest of the world as SDH (synchronized digital hierarchy), these standards move voice, data, and video information over a fiber network at any of eight digital transmission rates. These range from OC-1 at 51.84 Mb/s to OC-48 at 2.488 gigabits per second (Gb/s), and the hierarchy can be extended to more than 13 Gb/s. The OC designation stands for optical carrier.

Asynchronous transfer mode technology is based on cell-oriented switching and multiplexing. This is a packet-switching concept, but the packets are much shorter (always 53 bytes) and faster (for better response times) than are the packets in such applications as the global Internet and associated service networks which can have up to 4096 bytes of data in one packet. The asynchronous transfer mode cell-relay system moves cells through the network at speeds measured in megabits per second instead of kilobits. With its tremendous speed and capacity, asynchronous transfer mode technology permits simultaneous switching of data, video, voice, and image signals over cell-relay networks. *See* DATA COMMUNICATIONS; PACKET SWITCHING.

**Out-of-band signaling systems.** When the voice or communications information is encoded in a stream of bits, it becomes possible to use designated bits instead of analog tones for the supervisory signaling system. This simplifies the local switching equipment and allows the introduction of sophisticated data into the signaling, which significantly expands the potential range of telephone services.

Operations information now flows between switches as packet-switched signaling data via a connection that is independent of the channel being used for voice or data communications (a technique known as out-of-band signaling). Typically, a channel between two switching systems is known as a trunk. A trunk group between switches carries a number of channels whose combined signaling data are transmitted over a separate

common channel as a signaling link operated at 56 kb/s. This technique is called common-channel interoffice signaling (CCIS).

In 1976, the first United States version of CCIS was introduced as a modification of an international standard, the CCITT No. 6 signaling system. The out-of-band signaling system was deployed in the long-distance (toll) network only, linking digital as well as analog switches via a network of packet-data switches called signal transfer points. Also known as Signaling System 6 (SS6), it helped to make possible numerous customer-controlled services, such as conferencing, call storage, and call forwarding.

A major advance in common-channel signaling was introduced with the CCITT's Signaling System 7 (SS7), which operates at up to 64 kb/s and carries more than 10 times as much information as SS6. In addition, Signaling System 7 is used in local exchange service areas as well as in domestic and international toll networks.

In addition to increasing network call setup efficiency, Signaling System 7 enables and enhances services such as ISDN applications; automatic call distributor (ACD); and local-area signaling services (LASS), known as caller identification. Other innovations include 800 or free-phone service, in which customers can place free long-distance calls to businesses and government offices; 900 services, in which customers pay for services from businesses; and enhanced 911 calls, in which customer names and addresses are automatically displayed in police, fire, or ambulance centers when calls are placed for emergency services. The Signaling System 7 software also can include numerous other custom calling services for residential and business customers such as call waiting and call forwarding.

**Intelligent networks.** The greatest potential for Signaling System 7 use is in emerging intelligent networks, both domestic and international. The intent is to provide customers with much greater control over a variety of network functions, yet to protect the network against misuse or disruption. Intelligent networks are evolving from the expanding use of digital switching and transmission, starting with the toll networks. The complexity of intelligent networks mandates the use of networked computers, programmed with advanced software.

An intelligent network allows the customer to setup and use a virtual private network as needed, and be charged only for the time that network is being used. A conventional private leased network, by contrast, reserves dedicated circuits on a full-time basis and charges for them whether they are used or not. A virtual private network enables a business to simultaneously reap the benefits of a dedicated network and the shared public-switched network by drawing on the infrastructure of intelligent networking.

**Wireless.** The rapid growth of cellular-service subscribers has led to congestion in some cellular systems. The solution is to introduce digital cellular systems, which can handle up to 10 times more calls in the same frequency range. However, in countries such as the United States, which already have an analog infrastructure, the FCC has mandated that any digital system must be compatible with the existing analog system. The initial digital designs, based on a technology called time-division multiple access (TDMA), provide a three-times growth factor. Another digital technology, based on code-division multiple access (CDMA), a spread-spectrum technique, could increase the growth factor to 10 or even 20. See RADIO SPECTRUM ALLOCATIONS; SPREAD SPECTRUM COMMUNICATION.

Personal communications service (PCS) is a sort of cellular system in which a pocket-size telephone is carried by the user. A series of small transmitter-receiver antennas operating at lower power than cellular antennas are installed throughout a city or community (mounted on lampposts and building walls, for example). All the antennas of the personal communications network (PCN) are linked to a master telephone switch that is connected to the main telephone network. [J.H.D.]

**Telephone systems construction** The construction of the transmission facilities portion (or outside plant) of a telephone system. A telephone system or network consists of one or more transmission paths, called channels or circuits, which have been specifically designed and constructed to carry a particular type of electrical information signal between two or more points. Station equipment, switching systems, and transmission facilities are the components of these transmission paths. Voice, data, video, and program signals, in either analog or digital form, are some of the types of information signals (known as traffic) carried over these paths, and their signal characteristics and requirements dictate the physical makeup of the system.

The telephone network has evolved to provide for the transmission requirements of human speech, and must also provide for the transmission of more complicated information signals. The primary objective in the design and construction of any telephone system is to meet these varying transmission requirements in the most economical way possible. See TELEPHONE; TELEPHONE SERVICE.

The telephone network is made up of a variety of transmission systems, each consisting of the transmission medium and its supporting structure. The ideal transmission facility should provide for the safe and satisfactory transmission of information signals under all types of conditions, and should be flexible enough to meet changing traffic requirements with a minimum amount of expense. Certain types of signals are better suited to certain types of transmission media because of bandwidth requirements and loss limits. Bandwidth is simply a measure of the information-carrying capacity of the medium; generally, the greater the bandwidth of a system, the more expensive it is to construct. Some common structures and systems are listed below. See COMMUNICATIONS SATELLITE; MOBILE RADIO; RADIO-WAVE PROPAGATION.

The most common structures used to support telephone systems are pole lines, underground conduit systems, and buried systems. The most common type of transmission facility found in telephone systems is metallic paired cable. Paired cable is composed of copper or aluminum conductors coated with wood-pulp or plastic insulation. These insulated conductors are then twisted together into color-coded cables, ranging in size from 6 to 4200 pairs. These cables are coated with a protective sheath made of lead, aluminum, or polyethylene. These sheaths provide for structural and moisture protection.

Paired cables can carry voice, program, video, and most data signals up to 3.2 megabits/s, although additional cable pairs may be required to meet the required bandwidth. Because of the high attenuation of paired cables, the maximum range of voice-frequency signals is approximately 3 mi (4.8 km). To reduce attenuation, lumped inductances, called load coils, are placed along the transmission line. For digital signals, repeaters are used to eliminate attenuation. See COMMUNICATIONS CABLE.

Fiber-optic transmission systems offer several advantages over other transmission systems. Ideally suited for digital transmission, the information-carrying capacity of glass silica fibers is unlimited, but due to the limitations of electronic terminating equipment, transmission bit rates do not currently exceed 274 megabits/s. Two optical fibers can carry 4032 voice signals simultaneously with very low attenuation. These systems utilize lasers or light-emitting diodes in converting the digital bit stream into an optical signal. See OPTICAL COMMUNICATIONS; OPTICAL FIBERS.

Coaxial cables offer wide bandwidths and can operate at very high frequencies. They are used in long-haul telephone transmission systems and as the transmission medium for most cable television systems. The cables contain 4 to 22 coaxial tubes. Each tube consists of a copper inner conductor that is kept centered within a cylindrical copper outer conductor by polyethylene-insulated disks. Coaxial tubes are spliced together with connectors that have been press-fitted onto the ends of the tube and then screwed together. The splice is then sealed with a moisture-protecting closure. See COAXIAL CABLE. [B.J.H.]

**Telephoto lens** A photographic lens system specially designed to give a large image of a distant object in a camera of relatively short focal length. A telephoto lens generally consists of a positive lens system and a negative lens system, separated by a considerable distance. *See* CAMERA; LENS (OPTICS). [M.J.H.]

**Teleprocessing** The exchange of information between computing devices achieved by sending data over telecommunications lines. Teleprocessing has become increasingly complex as computing has evolved from batch processing to tightly coupled networks of computers.

With any form of data transmission, two distinctions are useful. The first is between digital and analog communications, and the second is between baseband and broadband communications. A digital signal has a fixed number of discrete states; an analog signal has a continuous range of values. Computers use two-state digital or binary communications. It is frequently necessary to transmit a digital signal over an analog communications system. This is done by using a modem, or modulator-demodulator. *See* MODEM.

A baseband signal, either analog or digital, is transmitted at its original frequency. In broadband communications systems, a carrier signal is modulated or varied to carry the desired information. Of particular importance in telecommunications is the use of broadband techniques to frequency-multiplex multiple channels of information onto a single communications line. A voice-grade telephone is designed to respond to frequencies between 300 and 3100 Hz. Since a typical telephone line can respond to a much broader frequency range, multiple conversations can be stacked in 4000-Hz partitions. *See* MODULATION; MULTIPLEXING AND MULTIPLE ACCESS.

The rapid growth of computer communications, combined with the digitization of conventional voice services, will soon result in a national telecommunications infrastructure that is primarily digital rather than analog. Integrated services digital network (ISDN), which integrates voice and computer communications at modest speeds, is available in many communities. Asynchronous transfer mode (ATM), which integrates voice, video, and data communications at very high speeds, is widely used for long-distance transmissions and is being extended to the desktop. *See* INTEGRATED SERVICES DIGITAL NETWORK (ISDN).

Teleprocessing may be divided into two general areas: terminal-to-computer communications and computer-to-computer communications. In terminal-to-computer communications a small number of computers serve as the centralized hosts to a much larger number of relatively unintelligent and inexpensive remote input/output devices. Terminals on a time-shared computer and printers are common examples. *See* MULTIACCESS COMPUTER.

The rapid growth in microcomputers has combined with the favorable economics of distributed processing to make computer-to-computer communications increasingly important. The most common example of computer-to-computer communications is a computer network that links a number of computers, each of which has significant independent computational responsibilities and is recognized by the other computers in the network as an autonomous peer. *See* DISTRIBUTED SYSTEMS (COMPUTERS); MICROCOMPUTER.

Computer networks range from small local-area networks (LANs) that serve a few tens of users to metropolitan-area networks (MANs) and wide-area networks (WANs) that span the globe. All of these networks have four characteristics that distinguish them from each other: signaling technology, transmission media, topology, and access control. *See* LOCAL-AREA NETWORKS; WIDE-AREA NETWORKS.

The set of protocols or standards defining the interface between modules represents an architecture. The U.S. Department of Defense under the aegis of the Defense Advanced Research Project Agency (DARPA) developed a protocol suite commonly known as TCP/IP that is currently used on the Internet and

comes the closest to providing a universal multivendor communications standard. Another important standard is the Open Systems Interconnection (OSI) model, under the leadership of the International Standards Organization (ISO). The OSI model contains seven levels with well-defined interfaces designed to ensure compatibility among devices and software from different vendors. While few vendors have implemented this standard in its entirety, it provides a model that is widely emulated. *See* DATA COMMUNICATIONS; DIGITAL COMPUTER; ELECTRICAL COMMUNICATIONS. [D.S.Ga.]

**Telescope** An instrument used to collect, measure, or analyze electromagnetic radiation from distant objects. A telescope overcomes the limitations of the eye by increasing the ability to see faint objects and discern fine details. In addition, when used in conjunction with modern detectors, a telescope can "see" light that is otherwise invisible. The wavelength of the light of interest can have a profound effect on the design of a telescope. *See* ELECTROMAGNETIC RADIATION; LIGHT.

For many applications, the Earth's atmosphere limits the effectiveness of larger telescopes. The most obvious deleterious effect is image scintillation and motion, collectively known as poor seeing. Atmospheric turbulence produces an extremely rapid motion of the image resulting in a smearing. On the very best nights at ideal observing sites, the image of a star will be spread out over a 0.25-arcsecond seeing disk; on an average night, the seeing disk may be between 0.5 and 2.0 arcseconds.

The upper atmosphere glows faintly because of the constant influx of charged particles from the Sun. The combination of the finite size of the seeing disk of stars and the presence of airglow limits the telescope's ability to see faint objects. One solution is placing a large telescope in orbit above the atmosphere. In practice, the effects of air and light pollution outweigh those of airglow at most observatories in the United States. *See* AIRGLOW.

There are basically three types of optical systems in use in astronomical telescopes: refracting systems whose main optical elements are lenses which focus light by refraction; reflecting systems, whose main imaging elements are mirrors which focus light by reflection; and catadioptric systems, whose main elements are a combination of a lens and a mirror. The most notable example of the last type is the Schmidt camera.

Astronomers seldom use large telescopes for visual observations. Instead, they record their data for future study. Modern developments in photoelectric imaging devices are supplanting photographic techniques for many applications. The great advantages of detectors such as charge-coupled devices is their high sensitivity, and the images can be read out in a computer-compatible format for immediate analysis. *See* CHARGE-COUPLED DEVICES.

Light received from most astronomical objects is made up of radiation of all wavelengths. The spectral characteristics of this radiation may be extracted by special instruments called spectrographs. *See* ASTRONOMICAL SPECTROSCOPY.

As collectors of radiation from a specific direction, telescopes may be classified as focusing and nonfocusing. Nonfocusing telescopes are used for radiation with energies of x-rays and above (x-ray, gamma-ray, cosmic-ray, and neutrino telescopes). Focusing telescopes, intended for nonvisible wavelengths, are similar to optical ones (solar, radio, infrared, and ultraviolet telescopes), but they differ in the details of construction. *See* CERENKOV RADIATION; COSMIC RAYS; GAMMA-RAY ASTRONOMY; INFRARED ASTRONOMY; NEUTRINO ASTRONOMY; RADIO TELESCOPE; SUN; ULTRAVIOLET ASTRONOMY; X-RAY TELESCOPE.

The 5-m (200-in.) Hale telescope at Palomar Mountain, California, was completed in 1950. The primary mirror is 5 m in diameter with a 1.02-m (40-in.) hole in the center.

The 4-m (158-in.) Mayall reflector at the Kitt Peak National Observatory was dedicated in 1973. The prime focus has a field of view six times greater than that of the Hale reflector. An

identical telescope was subsequently installed at Cerro Tololo Inter-American Observatory, in Chile.

The mirrors for these traditional large telescopes were all produced using the same general methodology. A large, thick glass mirror blank was first cast; then the top surface of the mirror was laboriously ground and polished to the requisite shape. The practical and economical limit to the size of traditional mirror designs was nearly reached by the 6-m (236-in.) telescope in the Caucasus Mountains, Russia. Newer telescopes have been designed and built that use either a number of mirrors mounted such that the light collection by them is brought to a common focus, or lightweight mirrors in computer-controlled mounts.

The Keck Telescope on Mauna Kea, Hawaii, completed in 1993, is the largest of the segmented mirror telescopes to be put into operation. The telescope itself is a fairly traditional design. However, its primary mirror is made up of 36 individual hexagonal segments mosaiced together to form a single 10-m (386-in.) mirror. Electronic sensors built into the edges of the segments monitor the relative positions of the segments, and feed the results to a computer-controlled actuator system.

In 1989, the European Southern Observatory put into operation their New Technology Telescope. The 3.58-m (141-in.) mirror was produced by a technique known as spin-casting, where molten glass is poured into a rotating mold.

Worldwide efforts are under way on a new generation of large, ground-based telescopes, using both the spin-casting method and the segmented method to produce large mirrors. The Gemini project of the National Optical Astronomy Observatories is building twin 8.1-m (319-in.) telescopes, Gemini North (see il-

lustration) on Mauna Kea, Hawaii (1999), and Gemini South on Cerro Pachon in Chile (2000).

The Very Large Telescope (VLT), operated by the European Southern Observatory on Cerro Paranal, Chile, consists of four 8-m (315-in.) "unit" telescopes with spin-cast mirrors. The light from the four telescopes is combined to give the equivalent light-gathering power of a 16-m (630-in.) telescope. The last of the four telescopes began collecting scientific data in September 2000.

The ability of large telescopes to resolve fine detail is limited by a number of factors. Distortion due to the mirror's own weight causes problems in addition to those of atmospheric seeing. The Earth-orbiting Hubble Space Telescope, (HST) with an aperture of 2.4 m (94 in.), was designed to eliminate these problems. The telescope operates in ultraviolet as well as visible light, resulting in a great improvement in resolution not only by the elimination of the aforementioned terrestrial effects but by the reduced blurring by diffraction in the ultraviolet. See DIFFRACTION; RESOLVING POWER (OPTICS).

Soon after the telescope was launched in 1990, it was discovered that the optical system was plagued with spherical aberration, which severely limited its spatial resolution. After space-shuttle astronauts serviced and repaired the telescope in 1993, adding what amounted to eyeglasses for the scientific instruments, the telescope exceeded its prelaunch specifications for spatial resolution. Subsequent servicing missions replaced instruments with newer technology. See SPACE TELESCOPE, HUBBLE. [R.D.Ch.; W.M.S.]

**Telestacea** An order of the subclass Alcyonaria. Telestacea are typified by *Telestoa*, which forms an erect branching colony by lateral budding from the body wall of an elongated primary or axial polyp. The stolon is bandlike or membranous. Sclerites are scattered singly, partly fused, or entirely fused to form a rigid tube. See ALCYONARIA. [K.At.]

**Television** The electrical transmission and reception of transient visual images. Like motion pictures, television consists of a series of successive images, which are registered on the brain as a continuous picture because of the persistence of vision. Each visual image impressed on the eye persists for a fraction of a second. In television in the United States, 30 complete pictures are transmitted each second, which with the use of interlaced scanning is fast enough to avoid evident flicker.

At the television transmitter, minute portions of a scene are sampled individually for brightness (and color for color television), and the information for each portion is transmitted consecutively. At the receiver, each portion is synchronized and reproduced in its proper position and with correct brightness (and color) to reproduce the original scene.

The scene is focused through a lens on a photoelectric screen of a camera tube. Each portion of the screen is changed by the photoelectrons to a degree depending upon the brightness of the particular portion of the scene. The screen is scanned by an electron beam just as a reader scans a page of printed type, character by character, line by line. When so scanned, an electric current flows with an instantaneous magnitude proportional to the brightness of the portion scanned. See TELEVISION CAMERA; TELEVISION CAMERA TUBE.

Variations in the current are transmitted to the receiver, where the process is reversed. An electron beam in the picture tube is varied in intensity (modulated) by the incoming signals as it scans the picture-tube screen in synchronism with the scanning at the transmitter. The photoelectric surface of the picture tube produces light in proportion to the intensity of the electron beam which strikes it. In this way the minute portions of the original scene are re-created in their proper positions, brightness, and (for color transmission) color values. See PICTURE TUBE; TELEVISION RECEIVER; TELEVISION TRANSMITTER.

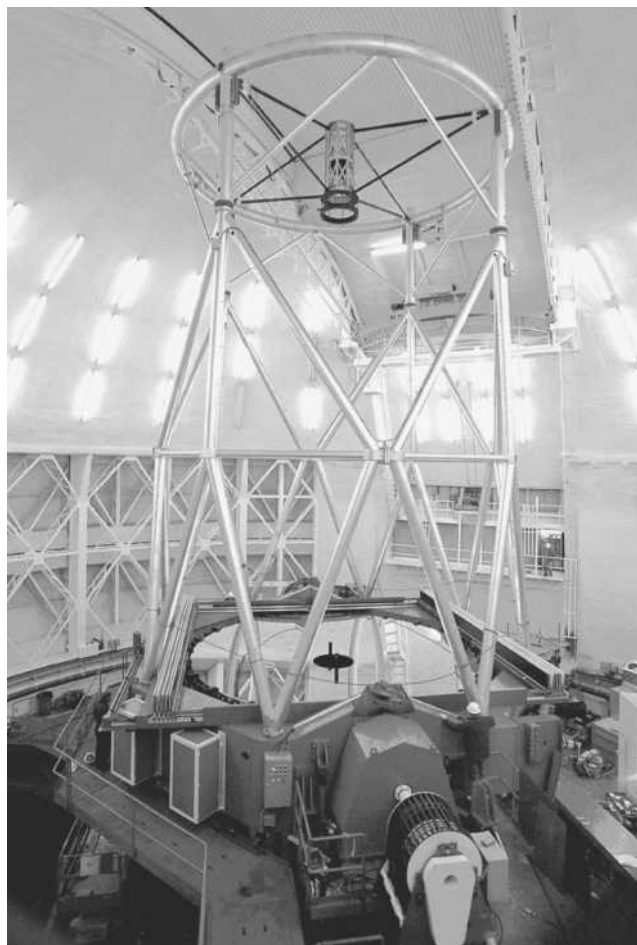

Gemini North telescope in its dome. (Copyright Gemini Observatory/AURA/NOAO/NSF, all rights reserved)

In the Western Hemisphere and Japan, the NTSC (National Television System Committee) system is used, in which an individual picture (frame) is considered to be made up of 525 lines, each line containing several hundred picture elements. All these lines are scanned and the light values are sent to the receiver so that each second 30 pictures are received. The picture is blanked out at the end of each line while the scanning beam is directed to the next line. During these short intervals, synchronizing signals are transmitted to keep the scanning process at the receiver in step with that at the transmitter. To take full advantage of the persistence of vision, each frame is scanned twice, alternate lines being scanned in turn. This technique is called interlaced scanning. See TELEVISION SCANNING; TELEVISION STANDARDS.

The band of frequencies assigned to a television station for the transmission of synchronized picture and sound signals is called a television channel. In the United States a television channel is 6 MHz wide, with the visual carrier frequency 1.25 MHz above the lower edge of the band and the aural carrier 0.25 MHz below the upper edge of the band.

In the United States the sound portion of the program is transmitted by frequency modulation at a carrier frequency 4.5 MHz above the picture carrier. Maximum frequency deviation (bandwidth) of the sound signals is 25 kHz. See FREQUENCY MODULATION. [S.DeS.]

In television broadcasting, videotape recorders are used not only for delayed playback but also for program distribution and, especially, for storage of program segments during postproduction editing. In the latter case, the program tape that is actually broadcast can be several generations removed from that originally recorded at the television camera or telecine film reader. Three or four generations are typically encountered with dramatic programs; whereas, for commercials or productions involving complex special effects, as many as eight to ten rerecording generations are not uncommon. The quality of the image, especially as measured by the signal-to-noise ratio, degrades with each generation, since the recorder itself adds a noncoherent noise in each pass. To minimize the degradation from multiple generations, there has been a long-term effort to replace analog video recorders with digital technology. Digital communications has the advantage that noise does not accumulate in cascade links; thus, digital recorders will not accumulate noise through multiple generations of recording.

A digital system is also useful in the worldwide exchange of television programs, where standards conversions are necessary because of the large number of different scanning and color-encoding standards used in various countries. A single world wide digital studio standard was adopted in 1981, incorporating efforts to maximize commonality between equipments used in different standards, and to base the digital standards on separate luminance and color difference signals rather than on any given country's composite system. In 1986, specifications were completed for the digital recorder named D-1, which can retain good quality after more than 50 generations. [K.H.Po.]

High-definition television (HDTV) was originally conceived as a system for providing cinematic viewing in the home. It was designed to provide much improved resolution with a wider aspect ratio of 16:9 (instead of 4:3 in standard television) and high-fidelity audio quality. High-definition television has twice the horizontal and twice the vertical resolution of standard television, with improved color resolution and multichannel high-fidelity sound. Digital processing offers greater accuracy and stability with a much better signal-to-noise ratio than analog processing can provide for video signals. See TELEVISION NETWORKS; TELEVISION STUDIO. [P.C.Ja.]

**Television camera** An electrooptical system used to pick up and convert a visual image or scene into an electrical signal called video. The video may be transmitted by cable or wireless means to a suitable receiver or monitor some distance



Television studio camera. (Thomson Multimedia)

from the actual scene. It may also be recorded on a video tape recorder for playback at a later time.

A television camera may fall within one of several categories: studio (see illustration), telecine, or portable. It may also be one of several highly specialized cameras used for remote viewing of inaccessible places, such as the ocean bottom or the interior of nuclear power reactors. The camera may be capable of producing color or monochrome (black and white) pictures. Most modern cameras are entirely solid-state, including the light-sensitive element, which is composed of semiconductors called charge-coupled devices (CCDs). Inexpensive or special-purpose cameras, however, may use one or more vacuum tubes, called vidicon, with a light-sensitive surface in lieu of the charge-coupled devices. See CHARGE-COUPLED DEVICES.

Every camera shares certain essential elements: an optical system, one or more picture pickup devices, preamplifiers, scanning circuits, blanking and synchronizing circuits, video processing circuits, and control circuits. Color cameras also include some kind of color-encoding circuit.

Other functions that are necessary to obtain high-quality pictures include gamma correction, aperture correction, registration, and color balance. Gamma correction is required because the pickup devices do not respond linearly to increasing light levels. It allows the camera to capture detail in the dark areas of high-contrast scenes, essentially by "stretching" the video levels in those areas. Aperture correction provides several benefits mainly related to an even overall response to scenes with more or less detail. It also helps to improve the signal-to-noise ratio of the camera's output video. Registration must be adjusted on multiple-tube cameras to ensure that the separate red, blue, and green images are precisely aligned on one another; charge-coupled-device cameras are usually registered once, at the factory. Color balance must be properly set on color cameras and must be consistent from dark scenes to bright scenes, or there will be an objectionable tint to the camera output.

Studio cameras are equipped with several ancillary systems to enhance their operation. An electronic viewfinder (actually a small television monitor) shows the camera operator what the camera is seeing, making it possible to frame and focus the picture. The tally system consists of one or more red lights that illuminate when the camera's picture is "on the line" so that production and on-camera personnel know which camera is active. Generally an intercom system is built into the camera so that the director can communicate with the camera operator. The camera itself may be mounted upon a tripod, but more often it is on a dolly and pedestal, which allows the camera to be moved around on the studio floor and raised or lowered as desired. A pan head permits the camera to be rotated to the left or right

and furnishes the actual mounting plate for the camera. The lens zoom and focus controls are mounted on a panning handle convenient to the operator.

Telecine cameras are used in conjunction with film or slide projectors to televise motion pictures and still images. Many of the usual controls are automatic so as to require less operator attention.

Portable cameras usually combine all of the basic elements into one package and may be used for a multitude of purposes. They have found their way into electronic news gathering for broadcast television, and into electronic field production, where they can be used for production of broadcast programs, commercials, and educational programs. The units often have built-in microphones, videocassette recorders, and batteries for completely self-contained operation.

Cameras used in high-definition television (HDTV) are fundamentally similar in appearance and operation to previous cameras. In fact, some modern cameras are switchable to produce either a conventional output or an HDTV output. The conventional output has a 4:3 aspect ratio raster and the scan rates match the 525-horizontal-line, 59.94-Hz-vertical-field-rate NTSC standard in the United States. When switched to HDTV mode, the aspect ratio becomes 16:9 and the horizontal scan rate is usually increased to either 720 progressively scanned lines or 1080 interlace-scanned lines with a 60-Hz vertical field rate. See TELEVISION; TELEVISION RECEIVER; TELEVISION STANDARDS; TELEVISION STUDIO; TELEVISION TRANSMITTER. [E.F.A.]

**Television camera tube** An electron tube having a light-sensitive receptor that converts an optical image into an electrical television video signal. The tube is used in a television camera to generate a train of electrical pulses representing the light intensities present in an optical image focused on the tube. Each point of this image is interrogated in its proper turn by the tube, and an electrical impulse corresponding to the amount of light at that point of the optical image is generated by the tube. This signal represents the video or picture portion of a television signal. See TELEVISION CAMERA.

**Image orthicon.** The image orthicon made broadcast television practical. It was used for more than 20 years as the primary studio and field camera tube for black and white and color television programming because of its high sensitivity and its ability to handle a wide range of scene contrast and to operate at very low light levels. It is one of the most complicated camera tubes. The image orthicon is divided into an image section, a scanning section, and a multiplier section, within a single vacuum envelope. The image isocon is a further development of the image orthicon.

**Photoconductive tubes.** These types have a photoconductor as the light-sensitive portion. The name vidicon was applied to the first photoconductive camera tube developed by RCA. It is loosely applied to all photoconductive camera tubes, although some manufacturers adopt their own brand names. The vidicon tube is a small tube that was first developed as a closed-circuit or industrial surveillance television camera tube. The development of new photoconductors has improved its performance to the point where it is now utilized in one form or another in most television cameras. Its small size and simplicity of operation make it well suited for use in systems to be operated by relatively unskilled people.

The vidicon is a simply constructed storage type of camera tube (see illustration). The signal output is developed directly from the target of the tube and is generated by a low-velocity scanning beam from an electron gun. The target generally consists of a transparent signal electrode deposited on the faceplate of the tube and a thin layer of photoconductive material, which is deposited over the electrode. The photoconductive layer serves two purposes. It is the light-sensitive element, and it forms the storage surface for the electrical charge pattern that corresponds to the light image falling on the signal electrode.

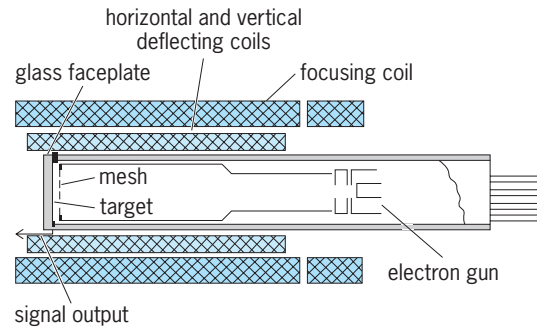

**Cross section of a vidicon tube and its associated deflection and focusing coils.**

Photoconductor properties determine to a large extent the performance of the different types of vidicon tubes. The first and still most widely used photoconductor is porous antimony trisulfide. The latest photoconductors are the lead oxide, selenium-arsenic-tellurium, cadmium selenide, zinc-cadmium telluride, and silicon diode arrays.

**Silicon intensifier.** The silicon intensifier camera tube utilizes a silicon diode target, but bombards it with a focused image of high-velocity electrons. Each high-energy electron can free thousands of electron carriers in the silicon wafer (compared to one carrier per photon of light on a silicon diode vidicon). This high amplification allows the camera to operate at light levels below that of the dark-adapted eye. The silicon intensifier tube is utilized for nighttime surveillance and other extremely low-light-level television uses in industrial, scientific, and military applications.

**Solid-state imagers.** These are solid-state devices in which the optical image is projected onto a large-scale integrated-circuit device which detects the light image and develops a television picture signal. Typical of these is the charge-coupled-device imager. The term charge-coupled device (CCD) refers to the action of the device which detects, stores, and then reads out an accumulated electrical charge representing the light on each portion of the image. The device detects light by absorbing it in a photoconductive substrate, such as silicon. The charge carriers generated by the light are accumulated in isolated wells on the surface of the silicon that are formed by voltages applied to an array of electrodes on top of an oxide insulator formed on the surface of the silicon. A practical CCD imager consists of a structure that forms several hundred thousand individual wells or pixels, and transfers the charges accumulated in these pixel wells out to an output amplifier in the proper sequence. See CHARGE-COUPLED DEVICES. [R.G.N.]

**Television networks** Arrangements of communications channels, suitable for transmission of video and accompanying audio signals, which link together groups of television broadcasting stations or closed-circuit television users in different cities so that programs originating at one point can be fed simultaneously to all others.

In the United States, television network service is furnished by the long-distance or local-exchange carriers (hereafter identified as telephone companies) and satellite carriers, as well as by broadcaster-owned networks. The facilities, when provided by the telephone companies, consist of intercity channels, which interconnect the principal long-distance telephone offices in various cities, and local channels, which connect the telephone offices with the broadcasters' studios or other user locations in each city. In the terminating offices, the intercity and local channels are brought together in a television operating center (TOC) where means are provided for testing, monitoring, and connecting the channels in various patterns as required for service. See TELEPHONE SERVICE.

The principal users of television network facilities are broadcast network organizations (broadcast networks). These may be national, regional, or local in scope, and may be regular or occasional in nature and may be commercial or noncommercial. Broadcast networks typically consist of a programming entity which simultaneously feeds content over the network interconnection facilities to commonly owned and operated stations, as well to other stations (affiliates) that have a contractual relationship with the broadcast network.

Geostationary satellite antenna footprints can be made to cover large areas of the Earth, thus making them ideal for point-to-multipoint transmissions. Direct broadcast satellite systems have been placed into operation in many developed nations. Their implementation in the United States is typical of other systems.

While all satellite television networks once used FM transmission, many operators now use digital video compression to transmit 4–10 signals over a single satellite transponder using quadrature phase-shift keying (QPSK) modulation. This changes the instantaneous amplitude of the two orthogonal carriers (I and Q) at a rate of about 38 Mbps. The received data require good forward error correction for perfect decompression to video and audio. Picture quality at four to six compressed video programs per satellite transponder is as good, or better, than FM-transmitted signals.

Over 96% of television households in the United States have access to cable television, and most of them receive all their television programming in analog format via cable. Programming usually includes the local broadcast stations and satellite services.

Because of the closed nature of cable television systems, all the frequencies between 50 and 750 MHz and higher can be used for distribution. The analog signals received at cable television headends are combined side by side on a frequency-division multiplex (FDM) basis for carriage in the cable systems. Digital satellite signals are decompressed in integrated receiver decoders, and the programs are passed through to the subscribers as analog signals. See MULTIPLEXING AND MULTIPLE ACCESS. [J.B.GI.; C.M.Ha.]

**Television receiver** The equipment used to receive the transmitted modulated radio-frequency signals and produce synchronized visual images and sound. The radio-frequency portion operates on the superheterodyne principle. See MODULATION; RADIO RECEIVER.

The first television receivers to be mass-produced were monochrome; that is, they provided pictures in black and white only. Later, color receivers, which produce pictures in full color as well as black and white, became available. Many television receivers now can receive stereophonic sound or alternate language in accordance with multichannel television sound standards. For basic discussion of a television system see TELEVISION; TELEVISION STANDARDS; STEREOPHONIC RADIO TRANSMISSION.

Early television receivers used vacuum-tube technology. Present-day receivers use solid-state technology with many functions integrated on a few chips. The only function still primarily implemented by using vacuum-tube technology is the display by the cathode-ray tube (CRT). See CATHODE-RAY TUBE; INTEGRATED CIRCUITS; VACUUM TUBE.

Since most broadcast television transmissions in the United States are horizontally polarized, the most basic type of television-receiving antenna is the horizontally mounted half-wave dipole. More complex antennas combine several dipole elements of various lengths, and passive reflectors may be used to achieve some degree of horizontal directivity, which increases the amplitude of the receiver signal and reduces interference from other stations. See ANTENNA (ELECTROMAGNETISM); POLARIZATION OF WAVES; YAGI-UDA ANTENNA.

The tuner of a television receiver selects the desired channel and converts the frequencies received to lower frequencies within the passband of the intermediate-frequency amplifier. The output from the tuner is applied to the intermediate-frequency

(i-f) amplifier. The output of the intermediate-frequency amplifier consists of modulated radio-frequency signals, which when detected provide signals corresponding to the transmitted picture and sound information. See AMPLITUDE MODULATION; AMPLITUDE-MODULATION DETECTOR; FREQUENCY MODULATION.

Picture synchronizing information is obtained from the video signal by means of sync separation circuits. In general, sync separation circuits perform the following functions: (1) separation of the sync information from the picture information; (2) separation of the desired horizontal and vertical timing information by means of frequency selection; and (3) rejection of noise signals. See ELECTRICAL NOISE; TELEVISION SCANNING.

The display device for a monochrome television receiver is a cathode-ray tube, consisting of an evacuated bulb containing an electron gun and a phosphor screen, which emits light when excited by an electron beam. The intensity of the electron beam is controlled by the video signal, which is applied either to the grid or to the cathode of the electron gun. Television receivers designed to produce images in full color are necessarily more complex than those designed to produce monochrome images only. In monochrome systems, the video signal controls only the luminance of the various areas of the image. In color systems, it is necessary to control both the luminance and the chrominance of the picture elements. See PICTURE TUBE.

The chrominance of a color refers to those attributes which cause it to differ from a neutral (white or gray) color of the same luminance. In qualitative terms, chrominance may be regarded as those properties of a color that control the psychological sensations of hue and saturation. For color television purposes, chrominance is most frequently expressed quantitatively in terms of the amounts of two hypothetical, zero-luminance primary colors (usually designated I and Q), which must be added to or subtracted from a neutral color of a given luminance to produce the color in question. As a practical matter, color television receivers produce full-color images as additive combinations of red, green, and blue primary-color images, and it is necessary to process the luminance and chrominance information in a color signal in such a way as to make it usable by a practical reproducing device. See COLOR.

Color television broadcasts in the United States employ signal specifications that are fully compatible with those used for monochrome, making it possible for color programs to be received on monochrome receivers and monochrome programs to be received on color receivers. (Color pictures are produced, of course, only when color programs are viewed through color receivers.) Compatibility is achieved by encoding the color information at the transmitting end of a color television system in such a way that the transmitted signal consists essentially of a normal monochrome signal (conveying luminance information) supplemented by an additional modulated wave conveying chrominance information. Although it is added directly to the monochrome signal component before transmission, the color subcarrier signal does not cause objectionable interference, because of the use of the frequency interlace technique. Because the chrominance information involves two variables, the modulated subcarrier signal varies in both amplitude and phase, and it is necessary to employ synchronous detectors to recover the two variables. A phase reference for the special local oscillator, which provides the synchronized carriers in each color receiver, is transmitted in the form of so-called color synchronizing bursts. These are short samples of unmodulated subcarrier transmitted during the horizontal blanking periods after the horizontal sync pulses.

Special decoding circuits are necessary in a color receiver to process the luminance and chrominance information in a color signal so that it can be used for the control of a practical color cathode-ray tube utilizing red, green, and blue primary colors.

The great majority of color television receivers employ the shadow-mask color cathode-ray tube in which color images are produced in the form of closely intermingled red, green, and blue dots. The primary-color phosphor dots are excited by three

separate electron beams, which are prevented from striking dots of the wrong color by the shadowing effect of an aperture mask located about  $\frac{1}{2}$  in. (1.25 cm) behind the special phosphor screen. The beams in such a cathode-ray tube are deflected simultaneously by the fields produced by a single deflection yoke placed conventionally around the neck of the tube. New cathode-ray-tube designs and deflection yokes are self-converging and do not require auxiliary convergence deflection.

In addition to the same controls required for monochrome receivers (such as brightness and contrast), color receivers normally have controls for convergence, hue, and saturation. The convergence controls, considered servicing adjustments only, adjust the relative amplitudes and phases of the signal components that are added together to form the proper waveforms for the convergence yoke. The hue control usually adjusts the phase of the burst-controlled oscillator and alters all the colors in the image in a systematic manner comparable to the effect achieved when a color circle diagram is rotated in one direction or the other. The proper setting for the hue control is normally determined by observing skin tones of persons on the television screen. The saturation control, frequently labeled chroma or simply color, adjusts the gain of the chrominance circuits relative to the monochrome channel and controls the saturation or vividness of the reproduced colors. When this control is set too low, the colors are all pale or pastel, and when it is reduced to zero, the picture is seen in black and white only. [C.G.E.]

**Television scanning** The process used to convert a three-dimensional image intensity into a one-dimensional television signal waveform. The image information captured by a television camera conveys color intensity (in terms of red, green, and blue primary colors) at each spatial location, with horizontal and vertical coordinates, and at each time instance. Thus, the image intensity is multidimensional, since it involves two spatial dimensions and time. It needs to be converted to a unidimensional signal so that processing, storage, communications, and display can take place.

The television scene is sampled many times per second in order to create a sequence of images (called frames). Then, within each frame, sampling is done vertically to create scan lines. Scanning proceeds sequentially, left to right and top to bottom. In a television camera, an electron beam scans across an electrically photosensitive target upon which the image is focused. At the other end of the television chain, with raster scanned displays, an electronic beam scans and lights up the picture elements in proportion to the light intensity. While it is convenient to think of all the samples of a single frame occurring at a single time (similar to the simultaneous exposure of a single frame for film), the scanning in a camera and in a display results in every sample corresponding to a different instance in time, and successive lines occur later in time. See TELEVISION CAMERA TUBE; TELEVISION RECEIVER.

There are two types of scanning approaches: progressive (also called sequential) and interlaced. In progressive scanning, the television scene is first sampled in time to create frames, and within each frame all the raster lines are scanned from top to bottom. Therefore, all the vertically adjacent scan lines are also temporally adjacent and are highly correlated even in the presence of rapid motion in the scene. Film can be thought of as naturally progressively scanned, since all the lines were originally exposed simultaneously, so the correlation between adjacent lines is guaranteed. Almost all computer displays (except some low-end computers) are sequentially scanned. See ELECTRONIC DISPLAY.

In interlaced scanning, all the odd-numbered lines in the entire frame are scanned first, and then the even numbered lines. This process produces two distinct images per frame, representing two distinct samples of the image sequence at different points in time. The set of odd-numbered lines constitute the odd field, and the even-numbered lines make up the even field. All current

television systems use interlaced scanning. One principal benefit of interlaced scanning is to reduce the scan rate (or the bandwidth). This is done with a relatively high field rate (a lower field rate would cause flicker), while maintaining a high total number of scan lines in a frame (lower number of lines per frame would reduce resolution on static images). Interlace cleverly preserves the high-detail visual information and, at the same time, avoids visible large-area flicker at the display due to temporal postfiltering by the human eye.

An agreement (not a standard) on high-definition formats has been reached and is in use, enabling the transition from analog to digital television. In early 2001, there were more than 150 stations broadcasting high-definition television. The format has 1920 active pixels per line and 1080 active (out of a total of 1125) lines in a frame. The frames may be interlaced or progressive and the frame rate is 29.97 Hz. Progressive frames at a rate of 23.976 Hz are also permitted to accommodate film material. An alternative progressive-only format that provides additional temporal resolution at the expense of some spatial resolution has also been approved and is currently in use. This format has 1280 active pixels per line and 720 active (out of a total of 750) lines per frame, and the frame rates permitted are 23.976 Hz, 29.97 Hz, or 59.94 Hz. Both high-definition formats have square pixels and a  $16 \times 9$  aspect ratio. See DATA COMPRESSION; IMAGE PROCESSING; TELEVISION. [A.N.N.]

**Television standards** The accepted criteria for a television system, including the image aspect ratio, number of lines per frame, type of scanning, original video signal bandwidth, transmission format and bandwidth, reception, demodulation, decoding, and sound system. The implementation of high-definition television (HDTV), where the image resolution and audio fidelity are significantly higher than for conventional television, has required new standards. See TELEVISION.

In the early 1950s, the National Television Systems Committee (NTSC) was formed to set standards for a color television signal (in the United States) that would be fully compatible with the existing monochrome signal. Any color can be formed as a linear combination, that is, a weighted sum, of red (R), green (G), and blue (B). The NTSC standard started with three image signals—R, G, and B—and matrixed these three primary color image signals as linear combinations into one luminance signal (the conventional black-and-white video signal, often called the Y-signal) and two chrominance signals that control hue and saturation. The chrominance signals are termed the in-phase (I) signal and the quadrature (Q) signal. Although the luminance signal retained the original 4.2-MHz bandwidth, the characteristics of human color perception allowed the I-signal to be limited to 1.5 MHz and the Q-signal to only 0.5 MHz.

While NTSC color television standards are used in North America, South America, and Japan, the European International Radio Consultative Committee (CCIR) system is used in England, Germany, Italy, and Spain. The color system employed with CCIR television is called Phase Alternate Line (PAL). A modified CCIR television standard is used in France and Russia, where the color system is called SECAM (Sequential Couleur à Mémoire).

The next generation of television, HDTV, is not compatible with the previous television systems. HDTV relies on digital technology, making it more amenable with computer displays, while taking full advantage of the power and efficiency of digital signal processing (DSP). The desired characteristics of the HDTV system that would replace the NTSC system was expected to have a resolution that would approach the quality of a 35-mm film, that is, approximately twice the horizontal and twice the vertical resolution of conventional television, with a widescreen aspect ratio of 16:9. The target HDTV system standard was required to avoid interlace scanning artifacts, as well as chrominance artifacts and deliver digital multichannel audio. The end result was a 1996



FCC digital television (DTV) standard, and HDTV broadcasting commenced in the United States in 1998.

In Europe, a different transmission standard has been adopted. The European system is referred to as the Digital Video Broadcasting (DVB) standard.

The FCC expects everyone to be using new HDTV receivers by the year 2011, at which time NTSC broadcasting will cease, and all NTSC color television receivers will need to be replaced or modified with some type of converter to be able to decode and display HDTV images. [J.L.LoC.]

**Television studio** A facility designed for the production of television programs, which may be broadcast live concurrently with the production or recorded for later broadcast. A television studio consists of the studio room, wherein the actual program takes place, and various support rooms, which include the control room, the equipment room, and the property room.

The studio room is where the program action occurs and is analogous to a theatrical stage. Studio rooms may be of almost any size, depending on use, but invariably provide certain facilities, such as a flexible lighting and scenery system, one or more cameras, one or more microphones for sound pickup, and a communications system to allow coordination during the program. Most studios use a lighting grid suspended from a high ceiling that allows flexible placement of the various lighting fixtures. See MICROPHONE; SOUND-REPRODUCING SYSTEMS; TELEVISION CAMERA.

The studio control room is the nerve center of the television production facility. The control room usually has a bank of video monitors with screens which display the output of each camera, videotape recorder, or special-effects generator, as well as a previous monitor which shows the director what the next shot will look like and a line monitor which shows the scene currently on the air. The sound engineer operates an audio mixer console which has every microphone used in the studio connected to a separate input. Other sources, such as turntables, audio tape recorders, tape cartridge machines, compact disk players, and audio hard disk recorders (or audio servers), may also be connected to the audio mixer. See SOUND-RECORDING STUDIO. [E.F.A.]

**Television transmitter** An electronic device that converts audio and video signals into modulated radio-frequency (rf) energy which can be radiated from an antenna and received by a television receiver. The term can also refer to the entire television transmitting plant, consisting of the transmitter proper, associated visual and aural input and monitoring equipment, transmission line, the antenna with its tower or other support structure, and the building in which the equipment is housed. In the United States, both analog NTSC (National Television Systems Committee) and digital 8-VSB transmitters are in service. The digital transmitters are used for what is termed high-definition television (HDTV).

An analog television transmitter can be thought of as two separate transmitters integrated into a common cabinet. Video information is transmitted via a visual transmitter, while audio information is transmitted via an aural transmitter. Because video and audio have different characteristics, the two transmitters differ in terms of bandwidth, modulation technique, and output power level. Nevertheless, a common transmitting antenna is generally used, and the two transmitters feed this antenna via an rf diplexer or combiner.

A digital transmitter accepts a single encoded digital bit stream that may contain video, audio, and data. In the United States, the digital terrestrial transmission standard is known as 8-VSB, which is an eight-level, vestigial sideband format. The FCC has mandated that all U.S. television stations convert to digital and terminate analog transmissions.

Television stations are licensed to operate on a particular channel, but since it takes a very wide bandwidth to transmit a television picture, these channels are allocated over a broad range

of frequencies. Channels 2 through 6 are low-band very-high-frequency (VHF) channels, while channels 7 through 13 are high-band VHF channels. Channels 14 through 69 are ultrahigh-frequency (UHF) channels. Each channel is 6 MHz wide. Because of the wide range of frequencies, television transmitters are designed to work in only one of the foregoing groups, and employ specific circuits which are most efficient for the channels involved. See RADIO SPECTRUM ALLOCATIONS.

The horizontal radiation pattern of most television transmitting antennas is circular, providing equal radiated signal strength to all points of the compass. Higher-gain antennas achieve greater power in the direction of the horizon by reducing the power radiated at vertical angles above and below the horizon. Since this could result in weaker signals at some receivers close to the transmitter, beam tilt and null fill are often used to lower the angle of maximum radiated power. Because television signals travel in a "line of sight," transmitting antennas are usually placed as high as possible above ground with respect to the surrounding service area. This allows viewers to orient their receiving antennas in one direction for the best reception from all of the stations. See ANTENNA (ELECTROMAGNETISM).

There are two broad classes of VHF analog visual television transmitter design philosophy. The classical approach modulates the visual carrier at a moderate power level, amplifies the carrier to rated output power by means of high-power linear amplifiers, and then filters this high-power carrier to obtain the required vestigial-sideband signal. The more contemporary approach, used by nearly all transmitter manufacturers, employs modulation at a very low power level of an intermediate-frequency (i-f) signal. The required vestigial-sideband filtering is imposed on this low-level signal, generally by means of a highly stable surface-acoustic-wave filter, whereupon the signal is upconverted to the carrier frequency and amplified by linear amplifiers to rated output power. See AMPLIFIER; SURFACE-ACOUSTIC-WAVE DEVICES; TELEVISION. [E.F.A.]

**Tellurium** A chemical element, Te, atomic number 52, and chemical atomic weight 127.60. There are eight stable isotopes of natural tellurium. Tellurium makes up approximately  $10^{-9}\%$  of the Earth's igneous rock. It is found as the free element, sometimes associated with selenium. It is more often found as the telluride sylvanite (graphic tellurium), nagyagite (black tellurium), hessite, tetradymite, altaite, coloradoite, and other silver-gold tellurides, as well as the oxide, tellurium ochre. See PERIODIC TABLE.

There are two important allotropic modifications of elemental tellurium, the crystalline and the amorphous forms. The crystalline form has a silver-white color and metallic appearance. This form melts at 841.6°F (449.8°C) and boils at 2534°F (1390°C). It has a specific gravity of 6.25, and a hardness of 2.5 on Mohs scale. The amorphous form (brown) has a specific gravity of 6.015. Tellurium burns in air with a blue flame, forming tellurium dioxide, TeO<sub>2</sub>. It reacts with halogens, but not sulfur or selenium, and forms, among other products, both the dinegative telluride anion (Te<sup>2-</sup>), which resembles selenide, and the tetrapositive tellurium cation (Te<sup>4+</sup>) which resembles platinum(IV).

Tellurium is used primarily as an additive to steel to increase its ductility, as a brightener in electroplating baths, as an additive to catalysts for the cracking of petroleum, as a coloring material for glasses, and as an additive to lead to increase its strength and corrosion resistance. See SELENIUM. [S.Ki.]

**Telospora** A class of the subphylum Sporozoa. These protozoa are divided into two subclasses, the Gregarina and Coccidia. All members of the group are either intra- or extracellular parasites, and the life cycles have both sexual and asexual phases. The spores lack a polar capsule and develop from an oocyst. The sporozoite is the usual infective stage which initiates the asexual phase in the life cycle. See COCCIDIA; GREGARINIA; PROTOZOA; SPOROZOA. [E.R.B./N.D.L.]

**Temnopleuroida** An order of Echinacea with a camarodont lantern, smooth or sculptured test, tubercles imperforate or perforate (and usually crenulate), ambulacral plates of diademoid or echinoid type, and branchial slits which are usually shallow. There are three included families, Glyphocyphidae, Temnopleuridae, and Toxopneustidae. See ECHINACEA. [H.B.F.]

**Temnospondyli** The more common of the two major orders of the great extinct subclass Labyrinthodontia. Temnospondyls are differentiated from anthracosaurs by having the cheek suturally attached to the skull table. Their vertebral structure, in which the pleurocentra are seldom prominent and the intercentra are large, resembles that of some members of the rhipidistian crossopterygians, which include the ancestors of all amphibians. Terrestrial temnospondyls achieved their greatest diversity in the upper Carboniferous and lower Permian, during which time they were the most common land vertebrates. The last of the large aquatic temnospondyls occur in the Lower Jurassic of Australia. See AMPHIBIA; ANTHRACOSAURIA; CROSSOPTERYGII; LABYRINTHODONTIA. [R.L.C.]

**Temperature** A concept related to the flow of heat from one object or region of space to another. The term refers not only to the senses of hot and cold but to numerical scales and thermometers as well. Fundamental to the concept are the absolute scale and absolute zero and the relation of absolute temperatures to atomic and molecular motions.

Thermometers do not measure a special physical quantity. They measure length (as of a mercury column) or pressure or volume (with the gas thermometer at the National Institute of Standards and Technology) or electrical voltage (with a thermocouple). The basic fact is that if a mercury column has the same length when touching two different, separated objects when the objects are placed in contact, no heat will flow from one to the other. See THERMOMETER.

The numbers on the thermometer scales are merely historical choices; they are not scientifically fundamental. The most widely used scales are the Fahrenheit ( $^{\circ}\text{F}$ ) and the Celsius ( $^{\circ}\text{C}$ ). The centigrade scale with  $0^{\circ}$  assigned to ice water (ice point) and  $100^{\circ}$  assigned to water boiling under one atmosphere pressure (steam point) was formerly used, but it has been succeeded by the Celsius scale, defined in a different way than the centigrade scale. However, on the Celsius scale the temperatures of the ice and steam points differ by only a few hundredths of a degree from  $0^{\circ}$  and  $100^{\circ}$ , respectively. The illustration shows how the Celsius and Fahrenheit scales compare and how they fit onto the absolute scales. See ICE POINT.

In 1848 William Thomson (Lord Kelvin), following ideas of Sadi Carnot, stated the concept of an absolute scale of temper-

ature in terms of measuring amounts of heat flowing between objects. Most important, Kelvin conceived of a body which would not give up any heat and which was at an absolute zero of temperature. Experiments have shown that absolute zero corresponds to  $-273.15^{\circ}\text{C}$  or  $-459.7^{\circ}\text{F}$ . Two absolute scales, shown in the illustration, are the Kelvin (K) and the Rankine ( $^{\circ}\text{R}$ ).

In practice, absolute temperatures are measured by using low-density helium gas and dilute paramagnetic crystals, the most nearly ideal of real materials. The measurement of a single temperature with a gas or magnetic thermometer is a major scientific event done at a national standards laboratory. Only a few temperatures have been measured, including the freezing point of gold ( $1337.91\text{ K}$  or  $1948.57^{\circ}\text{F}$ ), and the boiling points of sulfur ( $717.85\text{ K}$  or  $832.46^{\circ}\text{F}$ ), oxygen ( $90.18\text{ K}$  or  $-297.35^{\circ}\text{F}$ ), and helium ( $4.22\text{ K}$  or  $-452.07^{\circ}\text{F}$ ). Various types of thermometers (platinum, carbon, and doped germanium resistors; thermocouples) are calibrated at these temperatures and used to measure intermediate temperatures. See TEMPERATURE MEASUREMENT; THERMODYNAMIC PRINCIPLES. [R.A.Hu.]

**Temperature adaptation** The ability of animals to survive and function at widely different temperatures as a result of specific physiological adaptations. Temperature is an all-pervasive attribute of the environment that limits the activity, distribution, and survival of animals.

Changes in temperature influence biological systems, both by determining the rate of chemical reactions and by specifying equilibria. Because temperature exerts a greater effect upon the percentage of molecules that possess sufficient energy to react (that is, to exceed the activation energy) than upon the average kinetic energy of the system, modest reductions in temperature (for example, from  $77$  to  $59^{\circ}\text{F}$  or from  $25$  to  $15^{\circ}\text{C}$ , corresponding to only a 3% reduction in average kinetic energy) produce a marked depression (two- to threefold) in reaction rate. In addition, temperature specifies the equilibria between the formation and disruption of the noncovalent (electrostatic, hydrophobic, and hydrogen-bonding) interactions that stabilize both the higher levels of protein structure and macromolecular aggregations such as biological membranes. Maintenance of an appropriate structural flexibility is a requirement for both enzyme catalysis and membrane function, yet cold temperatures constrain while warm temperatures relax the conformational flexibility of both proteins and membrane lipids, thereby perturbing biological function. See CELL MEMBRANES; ENZYME.

Animals are classified into two broad groups depending on the factors that determine body temperature. For ectotherms, body temperature is determined by sources of heat external to the body; levels of resting metabolism (and heat production) are low, and mechanisms for retaining heat are limited. Such animals are frequently termed poikilothermic or cold-blooded, because the body temperature often conforms to the temperature of the environment. In contrast, endotherms produce more metabolic heat and possess specialized mechanisms for heat retention. Therefore, body temperature is elevated above ambient temperature; some endotherms (termed homeotherms or warm-blooded animals) maintain a relatively constant body temperature. There is no natural taxonomic division between ecto- and endotherms. Most invertebrates, fish, amphibians, and reptiles are ectotherms, while true homeothermy is restricted to birds and mammals. However, flying insects commonly elevate the temperature of their thoracic musculature prior to and during flight (to  $96^{\circ}\text{F}$  or  $36^{\circ}\text{C}$ ), and several species of tuna retain metabolic heat in their locomotory musculature via a vascular counter-current heat exchanger. See ADIPOSE TISSUE; HIBERNATION; THERMOREGULATION. [J.R.Ha.]

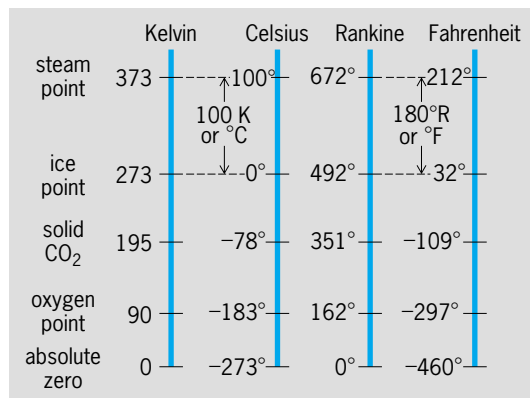

Comparisons of Kelvin, Celsius, Rankine, and Fahrenheit temperature scales. Temperatures are rounded off to nearest degree. (After M. W. Zemansky, *Temperatures Very Low and Very High*, Van Nostrand, 1964)

**Temperature inversion** The increase of air temperature with height; an atmospheric layer in which the upper portion is warmer than the lower. Such an increase is opposite, or inverse, to the usual decrease of temperature with height, or

lapse rate, in the troposphere. However, above the tropopause, temperature increases with height throughout the stratosphere, decreases in the mesosphere, and increases again in the thermosphere. Thus inversion conditions prevail throughout much of the atmosphere much or all of the time, and are not unusual or abnormal. See AIR TEMPERATURE; ATMOSPHERE.

Inversions are created by radiative cooling of a lower layer, by subsidence heating of an upper layer, or by advection of warm air over cooler air or of cool air under warmer air. Outgoing radiation, especially at night, cools the Earth's surface, which in turn cools the lowermost air layers, creating a nocturnal surface inversion a few inches to several hundred feet thick.

Inversions effectively suppress vertical air movement, so that smokes and other atmospheric contaminants cannot rise out of the lower layer of air. California smog is trapped under an extensive subsidence inversion; surface radiation inversions, intensified by warm air advection aloft, can create serious pollution problems in valleys throughout the world; radiation and subsidence inversions, when horizontal air motion is sluggish, create widespread pollution potential, especially in autumn over North America and Europe. See AIR POLLUTION; SMOG. [A.Cou.]

**Temperature measurement** Measurement of the hotness of a body relative to a standard scale. The fundamental scale of temperature is the thermodynamic scale, which can be derived from any equation expressing the second law of thermodynamics. Efforts to approximate the thermodynamic scale as closely as possible depend on relating measurements of temperature-dependent physical properties of systems to thermodynamic relations expressed by statistical thermodynamic equations, thus in general linking temperature to the average kinetic energy of the measured system. Temperature-measuring devices, thermometers, are systems with properties that change with temperature in a simple, predictable, reproducible manner. See TEMPERATURE; THERMODYNAMIC PRINCIPLES.

In the establishment of a useful standard scale, assigned temperature values of thermodynamic equilibrium fixed points are agreed upon by an international body (General Conference of Weights and Measures), which updates the scale about once every 20 years. Thermometers for interpolating between fixed points and methods for realizing the fixed points are prescribed, providing a scheme for calibrating thermometers used in science and industry.

The scale now in use is the International Temperature Scale of 1990 (ITS-90). Its unit is the kelvin, K, arbitrarily defined as  $1/273.16$  of the thermodynamic temperature  $T$  of the triple point of water (where liquid, solid, and vapor coexist). For temperatures above 273.15 K, it is common to use International Celsius Temperatures,  $t_{90}$  (rather than International Kelvin Temperatures,  $T_{90}$ ), having the unit degree Celsius, with symbol  $^{\circ}\text{C}$ . The degree Celsius has the same magnitude as the kelvin. Temperatures,  $t_{90}$ , are defined as  $t_{90}^{\circ}\text{C} = T_{90}/\text{K} - 273.15$ , that is, as differences from the ice-point temperature at 273.15 K. The ice point is the state in which the liquid and solid phases of water coexist at a pressure of 1 atm (101,325 pascals). [The Fahrenheit scale, with symbol  $^{\circ}\text{F}$ , still in common use in the United States, is given by  $t_{\text{F}}^{\circ}\text{F} = (t_{90}^{\circ}\text{C} \times 1.8) + 32$ , or  $t_{\text{F}}^{\circ}\text{F} = (T_{90}/\text{K} \times 1.8) - 459.67$ .] The ITS-90 is defined by 17 fixed points. See TRIPLE POINT.

Primary thermometers are devices which relate the thermodynamic temperature to statistical mechanical formulation. The fixed points of ITS-90 are all based on one or more types of gas thermometry or on spectral radiation pyrometry referenced to gas thermometry. Secondary thermometers are used as reference standards in the laboratory because primary thermometers are often too cumbersome. It is necessary to establish standard secondary thermometers referenced to one or more fixed points for interpolation between fixed points. Lower-order thermometers are used for most practical purposes and, when high accuracy is required, can usually be calibrated against refer-

ence standards maintained at laboratories, such as the U.S. National Institute of Standards and Technology, or against portable reference devices (sealed boiling or melting point cells). See GAS THERMOMETRY; LOW-TEMPERATURE THERMOMETRY; PYROMETER; THERMISTOR; THERMOCOUPLE; THERMOMETER. [B.W.M.]

**Tempering** The reheating of previously quenched alloy to a predetermined temperature below the critical range, holding the alloy for a specified time at that temperature, and then cooling it at a controlled rate, usually by immediate rapid quenching, to room temperature. The term is broadly applied to any process that toughens a material.

In alloys, if the composition is such that cooling produces a supersaturated solid solution, the resulting material is brittle. Heating the alloy to a temperature only high enough to allow the excess solute to precipitate out and then rapidly cooling the saturated solution fast enough to prevent further precipitation or grain growth result in a microstructure combining hardness and toughness.

With steel, the tempering must be carried out by slow heating to avoid steep temperature gradients, stress relief being one of the objectives. Properties produced by tempering depend on the temperature to which the steel is raised and on its alloy composition. For example, if hardness is to be retained, molybdenum or tungsten is used in the alloy. See HEAT TREATMENT (METALLURGY). [F.H.R.]

**Temporary structure (engineering)** A structure erected to aid in the construction of a permanent project. Temporary structures are used to facilitate the construction of buildings, bridges, tunnels, and other above- and below-ground facilities by providing access, support, and protection for the facility under construction, as well as assuring the safety of the workers and the public. Temporary structures either are dismantled and removed when the permanent works become self-supporting or completed, or are incorporated into the finished work. Temporary structures are also used in inspection, repair, and maintenance work.

The many types of temporary structures include cofferdams; earth-retaining structures; tunneling supports; underpinning; diaphragm/slurry walls; roadway decking; construction ramps, runways, and platforms; scaffolding; shoring; falsework; concrete formwork; bracing and guying; site protection structures such as sidewalk bridges, boards, and nets for protection against falling objects, barricades and fences, and signs; and unique structures that are specially conceived, designed, and erected to aid in a specific construction operation.

These temporary works have a primary influence on the quality, safety, speed, and profitability of all construction projects. More failures occur during construction than during the lifetimes of structures, and most of those construction failures involve temporary structures. However, codes and standards do not provide the same scrutiny as they do for permanent structures. Typical design and construction techniques and some industry practices are well established, but responsibilities and liabilities remain complex and present many contractual and legal pitfalls. [R.T.R.]

**Tendon** A cord connecting a muscle to another structure, often a bone. A tendon is a passive material, lengthening when the tension increases and shortening when it decreases. This characteristic contrasts with the active behavior of muscle. Away from its muscle, a tendon is a compact cord. At the muscle, it spreads into thin sheets called aponeuroses, which lie over and sometimes within the muscle belly. The large surface area of the aponeuroses allows the attachment of muscle fibers with a total cross-sectional area that is typically 50 times that of the tendon. See MUSCLE.

Tendons are living tissues that contain cells. In adult tendons, the cells occupy only a very small proportion of the volume and have a negligible effect on the mechanical properties. Like

other connective tissues, tendon depends on the protein collagen for its strength and rigidity. The arrangement of the long, thin collagenous fibers is essentially longitudinal, but incorporates a characteristic waviness known as crimp. The fibers lie within a matrix of aqueous gel. Thus, tendon is a fiber-reinforced composite (like fiberglass), but its collagen is much less stiff than the glass and its matrix is very much less stiff than the resin. See COLLAGEN; COMPOSITE MATERIAL.

The function of tendons is to transmit force. They allow the force from the muscle to be applied in a restricted region. For example, the main muscles of the fingers are in the forearm, with tendons to the fingertips. If the hand had to accommodate these muscles, it would be too plump to be functional. Tendon extension can also be significant in the movement of a joint. For example, the tendon which flexes a human thumb joint is about 7 in. (170 mm) long. The maximum force from its muscle stretches this tendon about 0.1 in. (2.9 mm), which corresponds to rotation of the joint through an angle of about 21°. See JOINT (ANATOMY).

Some tendons save energy by acting as springs. In humans, the Achilles tendon reduces the energy needed for running by about 35%. This tendon is stretched during the first half of each step, storing energy which is then returned during takeoff. This elastic energy transfer involves little energy loss, whereas the equivalent work done by muscles would require metabolic energy in both stages. See CONNECTIVE TISSUE; MUSCULAR SYSTEM; SKELETAL SYSTEM. [R.F.K.]

**Tenrec** An insectivorous mammal indigenous to Madagascar. There are 30 species in 10 genera. These animals are nocturnally active and feed on insects, worms, and mollusks. All tenrecs are essentially primitive unspecialized mammals, with poor vision. The digits are clawed, and the first digit is not opposable to the others. The body of the tenrec is covered with a mixture of hair, spines, and bristles; the tail is rudimentary; and the toes may be separate or webbed, depending on the species. The female is prolific, and has litters of 12–20 young. See INSECTIVORA; MAMMALIA. [C.B.C.]

**Tensor analysis** The systematic study of tensors which led to an extension and generalization of vectors, begun in 1900 by two Italian mathematicians. G. Ricci and T. Levi-Civita, following G. F. B. Riemann's proposal concerning a generalization of euclidean geometry. The principal aim of the tensor calculus (absolute differential calculus) is to construct relationships which are generally covariant in the sense that these relationships or laws remain valid in all coordinate systems. The differential equations for the geodesics in a Riemannian space are covariant expressions; they yield a description of the geodesics which is valid for all coordinate systems. On the other hand, Newton's equations of motion require a preferred coordinate system for their description, namely, one for which force is proportional to acceleration (an inertial frame of reference). Thus Albert Einstein was led to a study of Riemannian geometry and the tensor calculus in order to construct the general theory of relativity. See CALCULUS OF VECTORS; RIEMANNIAN GEOMETRY. [H.La.]

**Terbium** Element number 65, terbium, Tb, is a very rare metallic element of the rare-earth group. Its atomic weight is 158.924, and the stable isotope  $^{159}\text{Tb}$  makes up 100% of the naturally occurring element. See PERIODIC TABLE.

The common oxide,  $\text{Tb}_4\text{O}_7$ , is brown and is obtained when its salts are ignited in air. Its salts are all trivalent and white in color and, when dissolved, give colorless solutions. The higher oxides slowly decompose when treated with dilute acid to give the trivalent ions in solution. Although the metal is attacked readily at high temperatures by air, the attack is extremely slow at room temperatures. The metal has a Néel point at about 229 K and a Curie point at about 220 K. For properties of the metal see RARE-EARTH ELEMENTS. [F.H.Sp.]

**Terebratulida** An order of articulated brachiopods consisting of a group of sessile, suspension-feeding, marine, benthic, epifaunal bivalves with representatives occurring from the Early Devonian Era. It is the most diverse and abundant group of living brachiopods, which probably exhibits maximum diversity in present-day seas.

The shells are biconvex and usually smooth, although some show radial ribbed ornamentation. The valves articulate about a hinge structure and posterior edges of the valves are not coincident with the hinge axis (nonstrophic condition). The shell is calcareous and punctate. A fleshy pedicle usually attaches the animal to the substrate, but in thecidine brachiopods the ventral valve is cemented to the substrate. The tentacular feeding organ (lophophore) occupies the mantle cavity as a looped structure (the ptychophore) in the smaller forms or as a looped and coiled structure (the plectophore) in the larger forms. In the smaller forms the lophophore is supported by a calcareous ridge, but in the larger forms by a calcareous loop.

Three suborders are recognized: Centronellida, Terebratulidina, and Terebratellidina. See BRACHIOPODA; RHYNCHONELLIFORMEA. [M.A.J.]

**Terpene** A class of natural products having a structural relationship to isoprene, as shown below. Over 5000 structurally

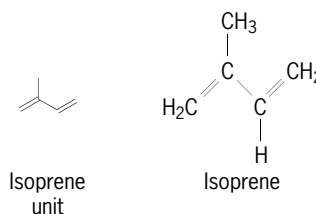

determined terpenes are known; many of these have also been synthesized in the laboratory. Historically terpenes have been isolated from green plants, but new compounds structurally related to isoprene continue to be isolated from other sources as well, so the class is also referred to as terpenoids, reflecting the biochemical origin without specification of the natural source. See ISOPRENE.

Terpenes are classified according to the number of isoprene units of which they are composed, as follows:

5	hemi	25	ses-
10	mono-	30	tri-
15	sesqui-	40	tetra-
20	di-	(5) <sub>n</sub>	poly-

Although they may be named according to the systematic nomenclature and numbering systems set by the International Union of Pure and Applied Chemistry for all organic compounds, it is often easier to refer to terpenes by their common names, which usually reflect the botanical or zoological name of their source. [T.Hu.]

**Terracing (agriculture)** A method of shaping land to control erosion on slopes of rolling land used for cropping and other purposes. In early practice the land was shaped into a series of nearly level benches or steplike formations. Modern practice in terracing, however, consists of the construction of low-graded channels or levees to carry the excess rainfall from the land at nonerosive velocities. The physical principle involved is that, when water is spread in a shallow stream, its flow is retarded by the roughness of the bottom of the channel and its carrying, or erosive, power is reduced. Since direct impact of rainfall on bare land churns up the soil and the stirring effect keeps it in suspension in overland flow and rills, terracing does not prevent sheet erosion. It serves only to prevent destruction of agricultural land by gullying and must be supplemented by other erosion-control practices, such as grass rotation, cover crops, mulching,

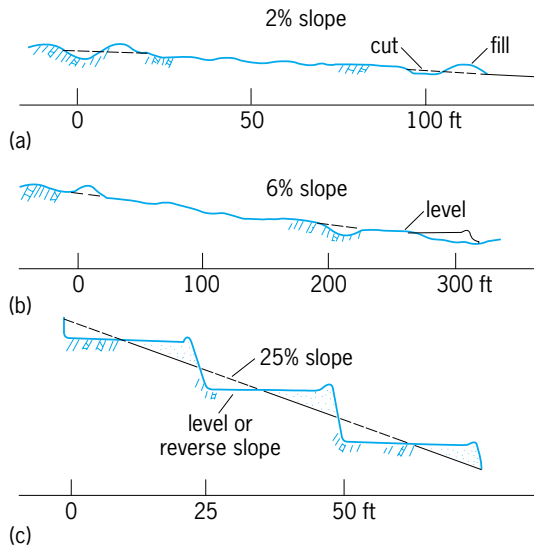

**Types of terraces. (a) Broadbase. (b) Conservation bench. (c) Bench.** 1 ft = 0.3 m. (After *Soil and Water Conservation Engineering, 2d ed., The Ferguson Foundation Agricultural Engineering Series, John Wiley and Sons, Inc., 1966*)

contour farming, strip cropping, and increased organic matter content. See EROSION; SOIL CONSERVATION.

The two major types of terraces are the bench and the broadbase (see illustration). The bench terrace is essentially a steep-land terrace and consists of an almost vertical retaining wall, called a riser, or a steep vegetative slope to hold the nearly level surface of the soil for cultivation, orchards, vineyards, or landscaping. The broadbase terrace has the distinguishing characteristic of farmability; that is, crops can be grown on this terrace and worked with modern-day machinery. These terraces are constructed either to remove or retain water and, based on their primary function, are classified either as graded or level. See LAND DRAINAGE (AGRICULTURE). [C.B.O.]

**Terrain areas** Subdivisions of the continental surfaces distinguished from one another on the basis of the form, roughness, and surface composition of the land. The pattern of landform differences is strongly reflected in the arrangement of such other features of the natural environment as climate, soils, and vegetation. These regional associations must be carefully considered in planning of activities as diverse as agriculture, transportation, city development, and military operations.

Eight classes of terrain are distinguished on the basis of steepness of slopes, local relief (the maximum local differences in elevation), cross-sectional form of valleys and divides, and nature of the surface material. Approximate definitions of terms used and percentage figures indicating the fraction of the world's land area occupied by each class are as follows; (1) flat plains: nearly level land, slight relief, 4%; (2) rolling and irregular plains: mostly gently sloping, low relief, 30%; (3) tablelands: upland plains broken at intervals by deep valleys or escarpments, moderate to high relief, 5%; (4) plains with hills or mountains: plains surmounted at intervals by hills or mountains of limited extent, 15%; (5) hills: mostly moderate to steeply sloping land of low to moderate relief, 8%; (6) low mountains: mostly steeply sloping, high relief, 14%; (7) high mountains: mostly steeply sloping, very high relief, 13%; and (8) ice caps: surface material, glacier ice, 11%. [E.H.Ha.]

**Terrestrial coordinate system** The perpendicular intersection of two curves or two lines, one relatively horizontal and the other relatively vertical, is the basis for finding and describing terrestrial location. The Earth's graticule, consisting of

an imaginary grid of east-to-west-bearing lines of latitude and north-to-south bearing lines of longitude, is derived from the Earth's shape and rotation, and is rooted in spherical geometry. Plane coordinate systems, equivalent to horizontal X and vertical Y coordinates, are based upon cartesian geometry and differ from the graticule in that they have no natural origin or beginning for their grids.

The Earth, which is essentially a sphere, rotates about an axis that defines the geographic North and South poles. The poles serve as the reference points on which the system of latitude and longitude is based (see illustration). See LATITUDE AND LONGITUDE.

Latitude is arc distance (angular difference) from the Equator and is defined by a system of parallels, or lines that run east to west, each fully encompassing the Earth. The Equator is the parallel that bisects the Earth into the Northern and Southern hemispheres, and lies a constant 90° arc distance from both poles. As the only parallel to bisect the Earth, the Equator is considered a great circle. All other parallels are small circles (do not bisect the Earth), and are labeled by their arc distance north or south from the Equator and by the hemisphere in which they fall. Parallels are numbered from 0° at the Equator to 90° at the poles. For example, 42°S describes the parallel 42 degrees arc distance from the Equator in the Southern Hemisphere. For increased location precision, degrees of latitude and longitude are further subdivided into minutes (1° = 60') and seconds (1' = 60"). See EQUATOR; GREAT CIRCLE, TERRESTRIAL.

Longitude is defined by a set of imaginary curves extending between the two poles, spanning the Earth. These curves, called meridians, always point to true geographical north (or south) and converge at the poles. In the present-day system of longitude, meridians are numbered by degrees east or west of the beginning meridian, called the Prime Meridian or the Greenwich Meridian, which passes through the Royal Observatory in Greenwich, England. The Prime Meridian was assigned a longitude of 0°.

Since the Earth is fundamentally a sphere, its circumference describes a circle containing 360°, the arc distance through which the Earth rotates in 24 hours. The arc distance from the Prime Meridian describes the location of any meridian (see illustration).

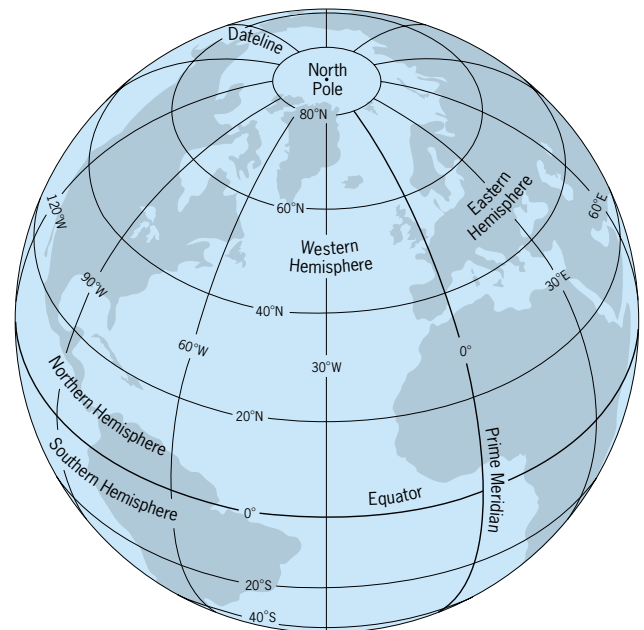

**Earth's graticule.** Meridians of longitude run from north to south, but are measured east or west of the Prime Meridian. Parallels run from east to west, but are measured north or south of the Equator.

The 180° meridian is commonly referred to as the International Dateline. Together, the Prime Meridian and the International Dateline describe a great circle that bisects the Earth, as do all other meridian circles. The west half of the Earth, located between the Prime Meridian and the International Dateline, comprises the Western Hemisphere, and the east half on the opposite side forms the Eastern Hemisphere. Meridians within the Western Hemisphere are labeled with a W, and meridians within the Eastern Hemisphere are labeled with an E. A complete description of longitude includes an angular measurement and a hemispheric label. For example, 78°W is the meridian 78° west of the Prime Meridian. Neither the 0° meridian (Prime) nor the 180° meridian (Dateline) is given a hemispheric suffix because they divide the two hemispheres, and therefore do not belong to either one.

Coordinate system alternatives to the graticule evolved in the early twentieth century because of the complexity of using spherical geometry in determining latitude, longitude, and direction. Plane (two-dimensional) or cartesian coordinate systems presume that a relatively nonspherical Earth exists in smaller areas. Plane coordinates are superimposed upon these small areas, with coordinates being determined by the equivalent of a grid composed of a number of parallel vertical lines (X) and a complementary set of parallel horizontal lines (Y).

The State Plane Coordinate system (SPC) is used only in the United States and partitions each state into zones. Each zone has its own coordinate system. The number of zones designated in each state is determined by the size of the state. Zone boundaries follow either meridians or parallels depending on the shape of the state. All measurements are made in feet.

The Universal Transverse Mercator (UTM) system is a worldwide coordinate system in which locations are expressed using metric units. The basis for the UTM system is the Universal Transverse Mercator map projection. This projection becomes vastly distorted in polar areas above 80°, and for this reason the UTM system is confined to extend from 84°N to 80°S. The UTM system partitions the Earth into 60 north-south elongated zones, each having a width of 6° of longitude. See MAP PROJECTIONS.

A number of other coordinate systems are in use today. Foremost among these are the U.S. Public Land Survey System, the Universal Polar Stereographic (UPS) system, and the World Geographic Reference (GEOREF) system. [S.Lav.]

**Terrestrial ecosystem** A community of organisms and their environment that occurs on the land masses of continents and islands. Terrestrial ecosystems are distinguished from aquatic ecosystems by the lower availability of water and the consequent importance of water as a limiting factor. Terrestrial ecosystems are characterized by greater temperature fluctuations on both a diurnal and seasonal basis than occur in aquatic ecosystems in similar climates. The availability of light is greater in terrestrial ecosystems than in aquatic ecosystems because the atmosphere is more transparent than water. Gases are more available in terrestrial ecosystems than in aquatic ecosystems. Those gases include carbon dioxide that serves as a substrate for photosynthesis, oxygen that serves as a substrate in aerobic respiration, and nitrogen that serves as a substrate for nitrogen fixation. Terrestrial environments are segmented into a subterranean portion from which most water and ions are obtained, and an atmospheric portion from which gases are obtained and where the physical energy of light is transformed into the organic energy of carbon-carbon bonds through the process of photosynthesis.

Terrestrial ecosystems occupy 55,660,000 mi<sup>2</sup> (144,150,000 km<sup>2</sup>), or 28.2%, of Earth's surface. Although they are comparatively recent in the history of life (the first terrestrial organisms appeared in the Silurian Period, about 425 million years ago) and occupy a much smaller portion of Earth's surface than marine ecosystems, terrestrial ecosystems have been a major site of adaptive radiation of both plants and animals. Major plant taxa in terrestrial ecosystems are members of the division Mag-

noliophyta (flowering plants), of which there are about 275,000 species, and the division Pinophyta (conifers), of which there are about 500 species. Members of the division Bryophyta (mosses and liverworts), of which there are about 24,000 species, are also important in some terrestrial ecosystems. Major animal taxa in terrestrial ecosystems include the classes Insecta (insects) with about 900,000 species, Aves (birds) with 8500 species, and Mammalia (mammals) with approximately 4100 species. See ANIMAL SYSTEMATICS; PLANT TAXONOMY; TAXONOMY.

Organisms in terrestrial ecosystems have adaptations that allow them to obtain water when the entire body is no longer bathed in that fluid, means of transporting the water from limited sites of acquisition to the rest of the body, and means of preventing the evaporation of water from body surfaces. They also have traits that provide body support in the atmosphere, a much less buoyant medium than water, and other traits that render them capable of withstanding the extremes of temperature, wind, and humidity that characterize terrestrial ecosystems. Finally, the organisms in terrestrial ecosystems have evolved many methods of transporting gametes in environments where fluid flow is much less effective as a transport medium.

The organisms in terrestrial ecosystems are integrated into a functional unit by specific, dynamic relationships due to the coupled processes of energy and chemical flow. Those relationships can be summarized by schematic diagrams of trophic webs, which place organisms according to their feeding relationships. The base of the food web is occupied by green plants, which are the only organisms capable of utilizing the energy of the Sun and inorganic nutrients obtained from the soil to produce organic molecules. Terrestrial food webs can be broken into two segments based on the status of the plant material that enters them. Grazing food webs are associated with the consumption of living plant material by herbivores. Detritus food webs are associated with the consumption of dead plant material by detritivores. The relative importance of those two types of food webs varies considerably in different types of terrestrial ecosystems. Grazing food webs are more important in grasslands, where over half of net primary productivity may be consumed by herbivores. Detritus food webs are more important in forests, where less than 5% of net primary productivity may be consumed by herbivores. See FOOD WEB; SOIL ECOLOGY.

There is one type of extensive terrestrial ecosystem due solely to human activities and eight types that are natural ecosystems. Those natural ecosystems reflect the variation of precipitation and temperature over Earth's surface. The smallest land areas are occupied by tundra and temperate grassland ecosystems, and the largest land area is occupied by tropical forest. The most productive ecosystems are temperate and tropical forests, and the least productive are deserts and tundras. Cultivated lands, which together with grasslands and savannas utilized for grazing are referred to as agroecosystems, are of intermediate extent and productivity. Because of both their areal extent and their high average productivity, tropical forests are the most productive of all terrestrial ecosystems, contributing 45% of total estimated net primary productivity on land. See DESERT; ECOLOGICAL COMMUNITIES; ECOSYSTEM; FOREST AND FORESTRY; GRASSLAND ECOSYSTEM; SAVANNA; TUNDRA. [S.J.McN.]

**Terrestrial radiation** Electromagnetic radiation emitted from the Earth and its atmosphere. Terrestrial radiation, also called thermal infrared radiation or outgoing longwave radiation, is determined by the temperature and composition of the Earth's atmosphere and surface. The temperature structure of the Earth and the atmosphere is a result of numerous physical, chemical, and dynamic processes. In a one-dimensional context, the temperature structure is determined by the balance between radiative and convective processes.

The Earth's surface emits electromagnetic radiation according to the laws that govern a blackbody or a graybody. A blackbody absorbs the maximum radiation and at the same time emits that same amount of radiation so that thermodynamic equilibrium

is achieved as to define a uniform temperature. A graybody is characterized by incomplete absorption and emission and is said to have emissivity less than unity. The thermal infrared emissivities from water and land surfaces are normally between 90 and 95%. It is usually assumed that the Earth's surfaces are approximately black in the analysis of infrared radiative transfer. Exceptions include snow and some sand surfaces whose emissivities are wavelength-dependent and could be less than 90%. Absorption and emission of radiation by atmospheric molecules are more complex and require a fundamental understanding of quantum mechanics. *See* ATMOSPHERE; BLACKBODY; GRAYBODY; HEAT BALANCE, TERRESTRIAL ATMOSPHERIC; HEAT RADIATION; RADIATIVE TRANSFER.

The radiant energy emitted from a number of temperatures covering the Earth and the atmosphere is measured as a function of wavenumber and wavelength. This energy is called Planck intensity (or radiance), and the units that are commonly used are denoted as watt per square meter per solid angle per wavenumber ( $W/m^2 \cdot sr \cdot cm^{-1}$ ). Terrestrial radiation originating from the Earth-atmosphere-ocean system, as well as solar radiation reflected and scattered back to space, is measured on a daily basis by meteorological satellites. Instruments on meteorological satellites measure visible, ultraviolet, infrared, and microwave radiation. *See* ABSORPTION OF ELECTROMAGNETIC RADIATION; ELECTROMAGNETIC RADIATION; METEOROLOGICAL SATELLITES; REFLECTION OF ELECTROMAGNETIC RADIATION; SCATTERING OF ELECTROMAGNETIC RADIATION.

Each spectral region provides meteorologists and other Earth system scientists with information about atmospheric ozone, water vapor, temperature, aerosols, clouds, precipitation, lightning, and many other parameters. Measuring atmospheric radiation allows the detection of sea and land temperature, snow and ice cover, and winds at the surface of the ocean. By tracking the movement of clouds and other atmospheric features, such as aerosols and water vapor, it is possible to obtain estimates of winds above the surface. *See* SATELLITE METEOROLOGY.

[K.N.L.; T.H.V.H.]

**Terrestrial water** The total inventory of water on the Earth. Water is unevenly distributed over the Earth's surface in oceans, rivers, and lakes. In addition, the world's water is distributed throughout the atmosphere and also occurs as soil moisture, groundwater, ice caps, and glaciers. *See* ATMOSPHERE; GLACIOLOGY; GROUND-WATER HYDROLOGY; HYDROLOGY; LAKE; SURFACE WATER.

[R.L.N.]

**Territoriality** Behavior patterns in which an animal actively defends a space or some other resource. One major advantage of territoriality is that it gives the territory holder exclusive access to the defended resource, which is generally associated with feeding, breeding, or shelter from predators or climatic forces. Feeding and breeding territories can be mobile, such as when an animal defends a newly obtained food source or a temporarily receptive mate. Stationary territories often serve multiple functions and include access to food, a place to rear young, and a refuge site from predators and the elements.

Territoriality can be understood in terms of the benefits and costs accrued to territory holders. Benefits include time saved by foraging in a known area, energy acquired through feeding on territorial resources, reduction in time spent on the lookout for predators, or increase in number of mates attracted and offspring raised. Costs usually involve time and energy expended in patrolling and defending the territorial site, and increased risk of being captured by a predator when engaged in territorial defense.

Because territories usually include resources that are in limited supply, active defense is often necessary. Such defense frequently involves a graded series of behaviors called displays that include threatening gestures such as vocalizations, spreading of wings or gill covers, lifting and presentation of claws, head bobbing, tail

and body beating, and finally, direct attack. Direct confrontation can usually be avoided by advertising the location of a territory in a way that allows potential intruders to recognize the boundaries and avoid interactions with the defender. Such advertising may involve odors that are spread with metabolic by-products, such as urine or feces in dogs, cats, or beavers, or produced specifically as territory markers, as in ants. Longer-lasting territorial marks can involve visual signals such as scrapes and rubs, as in deer and bear. *See* CHEMICAL ECOLOGY; ETHOLOGY; POPULATION ECOLOGY; REPRODUCTIVE BEHAVIOR.

[G.S.H.]

**Tertiary** The older major subdivision (period) of the Cenozoic Era, extending from the Cretaceous (top of the Mesozoic Era) to the beginning of the Quaternary (younger Cenozoic Period). The term Tertiary corresponds to all the rocks and fossils formed during this period. Typical sedimentary rocks include widespread limestones, sandstones, mudstones, marls, and conglomerates deposited in both marine and terrestrial environments; igneous rocks include extrusive and intrusive volcanics as well as rocks formed deep in the Earth's crust (plutonic). *See* CRETACEOUS; FOSSIL; ROCK.

The Tertiary Period is characterized by a rapid expansion and diversification of marine and terrestrial life. In the marine realm, a major radiation of oceanic microplankton occurred following the terminal Cretaceous extinction events. This had its counterpart on land in the rapid diversification of multituberculates, marsupials, and insectivores—holdovers from the Mesozoic—and primates, rodents, and carnivores, among others, in the ecologic space vacated by the demise of the dinosaurs and other terrestrial forms. Shrubs and grasses and other flowering plants diversified in the middle Tertiary, as did marine mammals such as cetaceans (whales), which returned to the sea in the Eocene Epoch. The pinnipeds (walruses, sea lions, and seals) are derived from land carnivores, or fissipeds, and originated in the Neogene temperate waters of the North Atlantic and North Pacific. Indeed, the great diversification on land and in the sea of birds and, particularly, mammals has led to the informal designation of the Tertiary as the Age of Mammals in textbooks on historical geology.

The modern configuration of continents and oceans developed during the Cenozoic Era as a result of the continuing process known as plate tectonics. Mountain-building events (orogenies) and uplifts of large segments of the Earth's crust (epeirogenies) alternated with fluctuating transgressions and regressions of the seas over land. The middle to late Tertiary Alpine-Himalayan orogeny and the late Tertiary Cascadian orogeny led to the east-west and north-south mountain ranges, respectively, which are located in Eurasia and western North America. *See* CORDILLERAN BELT; MOUNTAIN SYSTEMS; OROGENY; PLATE TECTONICS.

[W.A.Ber.]

**Testis** The organ of sperm production. In addition, the testis (testicle) is an organ of endocrine secretion in which male hormones (androgens) are elaborated. In the higher vertebrates (reptiles, birds, and mammals), the testes are paired and either ovoid or elongated in shape. In mammals, the testes are usually ovoid or round. In many species (for example, humans) they are suspended in a pouch (scrotum) outside the main body cavity; in other species they are found in such a pouch only at the reproductive season; in still others the testicles are permanently located in the abdomen (for example, in whales and bats).

Within a firm and thick capsule of connective tissue, the tunica albuginea, the testis contains a varying number of thin but very long seminiferous tubules which are the sites of sperm formation. Essentially, these tubules are simple loops which open with both their limbs into a network of fine, slitlike canals, the rete testis. From this the sperm drains through a few, narrow ducts, the ductuli efferentes, into the epididymis, where sperm mature and are stored.

The seminiferous tubules comprise most of the testis, and in

different species vary greatly in complexity. Each tubule is surrounded by a layer of thin cells which is contractile and enables the tubules to wriggle slowly. The spaces between tubules are filled with connective tissue, blood vessels, an extensive network of very thin-walled lymph vessels, and secretory cells, the interstitial cells or cells of Leydig, which secrete male hormone.

The sperm cells, spermatozoa, develop in the wall of the seminiferous tubules, either periodically, as in most vertebrates, or continually, as in humans. Most of the cells in the tubules are potential spermatozoa (spermatogenic or germ cells). Nursing cells (Sertoli cells) are interspersed at regular intervals between them. The Sertoli cells support and surround the developing spermatogenic cells and provide a specialized environment, which is absolutely necessary for normal sperm development. See SPERM CELL.

Spermatogenesis in the testis is the result of a balance between proliferation and differentiation, and cell degeneration or apoptosis. Apoptosis of the spermatogenic cells is largely hormonally controlled, and specifically directed apoptosis occurs in conditions of testicular damage due to environmental insults such as heat, radiation, or chemical toxicants. Recovery of spermatogenesis is possible provided the stem cells are not depleted by these processes. See SPERMATOGENESIS. [M.P.H.; E.C.R.R.]

The functions of the testis are dependent on the secretion of gonadotropic hormones, the release of which from the pituitary gland is in turn regulated by the central nervous system. In mammals, male-hormone production resides in the Leydig cells, located in the intertubular tissue of the testes.

The principal androgenic hormone released by the testis into the bloodstream is testosterone. The testis is able to form cholesterol and to convert this via a number of pathways to testosterone. Testosterone may be further metabolized into estrogens in the testis. The production of estrogens in the male varies quite widely among species, from relatively low in humans to very high, for example in stallions and boars. Estrogens are important in the development and proper function of the ducts which drain the testis (the rete testis and ductuli efferentes), even in species with relatively low levels of estrogens. See ANDROGEN.

Testosterone synthesis is normally limited by the rate of pituitary gonadotrophin secretion: administration of the luteinizing hormone or of chorionic gonadotrophin results in increased testosterone synthesis and release within minutes. These hormones also stimulate growth and multiplication of Leydig cells. Hypophysectomy leads to cessation of androgen formation. See ADENOHYPOPHYSIS HORMONE; PITUITARY GLAND.

At the ambisexual stage of embryonic development, the testis promotes the growth of the paired Wolffian ducts and their differentiation into the epididymis, vasa deferentia, and seminal vesicles; the fetal testis also causes masculinization of the urogenital sinus, fusion of the labioscrotal folds in the midline, and development of the genital tubercle into a phallus. See EMBRYOLOGY.

Toward puberty, increased secretion of testosterone stimulates the growth of the penis, scrotum, and male accessory glands responsible for the formation of the seminal plasma, for example, the prostate and seminal vesicles. The hormone brings about the appearance of secondary sex characters, such as the male-type distribution of hair and body fat and lowered pitch of voice in man, the growth of the comb and wattles in birds, the clasping pads of amphibians, or the dorsal spine of certain fishes.

Unlike the ovary, the testis remains functional throughout life, with ongoing spermatogenic development. However, the efficiency of spermatogenesis falls away, and androgen levels begin to fall due to a declining Leydig cell activity. These events can lead to reduced fertility, and androgen insufficiency problems in later life in some men. See REPRODUCTIVE SYSTEM. [M.P.H.; H.R.L.]

**Tetanus** An infectious disease, also known as lockjaw, which is caused by the toxin of *Clostridium tetani*. The bacterium may be isolated from fertile soil and the intestinal tract or

fecal material of humans and other animals. Infection commonly follows dirt contamination of deep wounds or other injured tissues.

The incubation period of tetanus is usually 5–10 days, and the disease is characterized by convulsive tonic contraction of voluntary muscles. Prevention of tetanus rests on the proper, prompt surgical care of contaminated wounds and prophylactic use of antitoxin if the individual has not been protected by active immunization with toxoid. See IMMUNOLOGY. [L.S.McC.]

**Tetrahedrite** A mineral having the composition  $(\text{Cu,Fe,Zn,Ag})_{12}\text{Sb}_4\text{S}_{13}$ . It is massive or granular. Its hardness is  $3\frac{1}{2}$ –4 on Mohs scale and the specific gravity varies from 4.6 to 5.1, depending on the composition. The luster is metallic and the color grayish black; thus, in some mining localities, this mineral is called gray copper.

Tetrahedrite is a widely distributed mineral, usually found in silver and copper veins. In some places it has sufficient silver to be a valuable ore, as at Freiberg, Germany, and silver mines of Peru, Bolivia, and Mexico. It is found in silver and copper mines in the western United States. [C.S.Hu.]

**Tetraodontiformes** An order of specialized teleost fishes, also called Plectognathi, that includes the triggerfishes (see illustration), puffers, trunkfishes, ocean sunfishes, and their allies. It is a group of diverse structure. The body is variably armored with bony plates or spines, encased in bone, prickly, thorny, or naked. Fin spines and some fins are variably well developed or wanting. Some species can inflate the body.

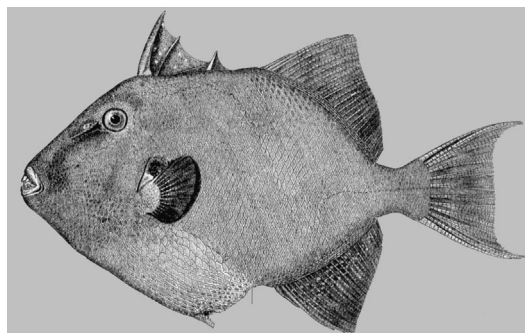

Gray triggerfish (*Batistes capriscus*). (After G. B. Goode, *Fishery Industries of the United States*, sect. 1, 1884)

Tetraodontiforms may be classified conservatively into 7 families, nearly 60 genera, and about 320 Recent species, but some specialists recognize more families and genera. Tetraodontiforms are largely reef and shore fishes of tropical or subtropical seas, but a few are pelagic, enter temperate waters, or ascend tropical rivers. Many are colorful inhabitants of coral reefs. Some are valued as food, but a few have a neurotoxic poison, tetrodotoxin, in the viscera that is sometimes fatal when eaten. See ACTINOPTERYGII. [R.M.B.]

**Tetraphididae** A subclass of the mosses (class Bryopsida) consisting of two families and three genera, especially characterized by growth from protonematal flaps, three-ranked leaves, and peristomes of four teeth made up of whole cells (rather than thickened parts of cells). The Tetraphididae include small acrocarpous mosses with peristome teeth in fours. The plants grow from buds produced on leaflike protonematal flaps. They are erect and simple or merely forked, with oblong-ovate leaves in three rows. The leaves usually have a single costa that ends near the apex. See BRYOPHYTA; BRYOPSIDA. [H.Cr.]

**Tetraphyllidea** An order of tapeworms of the subclass Cestoda. All species are intestinal parasites of elasmobranch



fishes and are small in size, usually less than 2 in. (5 cm) in length. An outstanding feature of the order is the variation in the structure of the holdfast organ or scolex. All species are segmented and segments are usually shed from the body while sexually immature; these develop to sexual maturity as independent units in the host's intestine. Segment anatomy is very similar to that of Proteocephaloidea. A complete life cycle is not known, but larval forms have been found in a variety of invertebrates and bony fishes. See CESTODA; PROTEOCEPHALOIDEA. [C.P.R.]

**Tetrapoda** The superclass of the subphylum Vertebrata whose members typically possess limbs in contrast to the superclass, the Pisces (fishes), whose members have fins. See PISCES (ZOOLOGY).

The animals making up the Tetrapoda typically live part or all of their lives on land, whereas the members of the Pisces live in water. The classes of the Tetrapoda are Amphibia, Reptilia, Aves, and Mammalia. The term Tetrapoda comes from Greek words meaning "four feet," but there are tetrapods that have only two limbs or none at all, such as some amphibians and reptiles. These forms have, however, evolved from four-footed ancestors. See AMPHIBIA; AVES; MAMMALIA; REPTILIA. [R.G.Z.]

**Teuthoidea** An order of the class Cephalopoda (subclass Coleoidea) commonly known as squids. They are characterized by 10 appendages (eight arms and two longer tentacles) around the mouth; an elongate, tapered, usually streamlined body; an internal, rod- or blade-like chitinous shell (gladius); and fins on the body. The two tentacles are strongly elastic, contractile, but not retractile into pockets as in cuttlefishes (Sepioidea). Two rows of suckers (infrequently four or six rows) occur on the arms on muscular stalks, with sucker rings that are chitinous, smooth, toothed, or modified as clawlike hooks. The muscular tentacles have terminal clubs with two rows, usually four, ranging up to many rows of suckers (and/or hooks in some families). Adults of the family Octopoteuthidae and genera *Gonatopsis* and *Lepidoteuthis* characteristically lose their tentacles. See SEPIOIDEA.

The Teuthoidea are divided into two suborders. The Myopsida, the nearshore, shallow-water squids, have a transparent skin (cornea) covering the two eyes, with a minute pore anteriorly, arms and tentacular clubs with suckers only, never hooks, and a single gonoduct in females, not paired. The Oegopsida, the oceanic squids, have no cornea over the eyes and no anterior pore, arms and tentacular clubs with suckers (and/or hooks in many families), and paired gonoducts in females (some exceptions).

Squids inhabit a wide variety of marine habitats, depending on the species, from very shallow grass flats, mangrove roots, lagoons, bays, and along coasts (myopsids) to the open ocean from the surface of the sea (*Ommastrephes*) to nearly 9600 ft (3000 m) in the deep sea (other oegopsids such as *Bathyteuthis*, *Neotheuthis*, and *Grimalditeuthis*). See CEPHALOPODA; COLEOIDEA; SQUID. [C.F.E.R.]

**Textile** A material made mainly of natural or synthetic fibers. Modern textile products may be prepared from a number of combinations of fibers, yards, films, sheets, foams, furs, or leather. They are found in apparel, household and commercial furnishings, vehicles, and industrial products. See MANUFACTURED FIBER; NATURAL FIBER.

The term fabric may be defined as a thin, flexible material made of any combination of cloth, fiber, or polymer (film, sheet, or foams); cloth as a thin, flexible material made from yarns; yarn as a continuous strand of fibers; and fiber as a fine, rodlike object in which the length is greater than 100 times the diameter. The bulk of textile products are made from cloth.

The natural progression from raw material to finished product requires: the cultivation or manufacture of fibers; the twisting of fibers into yarns (spinning); the interlacing (weaving) or inter-

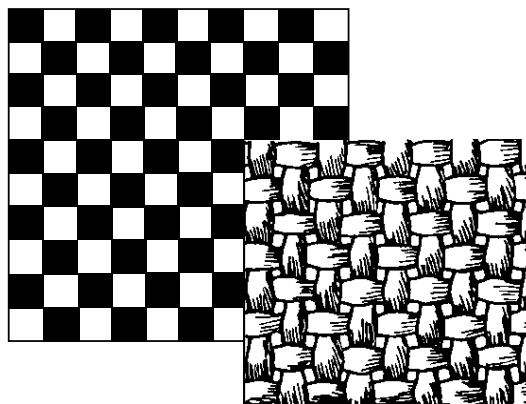

Fig. 1. Construction design for plain weave; filling yarns pass under and over alternate warp yarns, as shown at right. When fabric is closely constructed, there is no distinct pattern. (After M. D. Potter and B. P. Corbman, *Fiber to Fabric*, 3d ed., McGraw-Hill, 1959)

looping (knitting) of yarns into cloth; and the finishing of cloth prior to sale.

The conversion of staple fiber into yarn (spinning) requires the following steps: picking (sorting, cleaning, and blending), carding and combing (separating and aligning), drawing (reblending), drafting (reblended fibers are drawn out into a long strand), and spinning (drafted fibers are further attenuated and twisted into yarn).

The process of weaving allows a set of yarns running in the machine direction (warp) to be interlaced with another set of yarns running across the machine (filling or weft). The weaving process involves four functions: shedding (raising the warp yarns by means of the appropriate harnesses); picking (inserting the weft yarn); battening (pushing the weft into the cloth with a reed); and taking up and letting off (winding the woven cloth onto the cloth beam and releasing more warp yarn from the warp beam; Figs. 1 and 2).

Knit cloth is produced by interlocking one or more yarns through a series of loops. The lengthwise columns of loops are known as the wales, and the crosswise rows of loops are called courses. Filling (weft) knits (Fig. 3) are those in which the courses are composed of continuous yarns, while in warp knits (Fig. 4) the wale yarns are continuous.

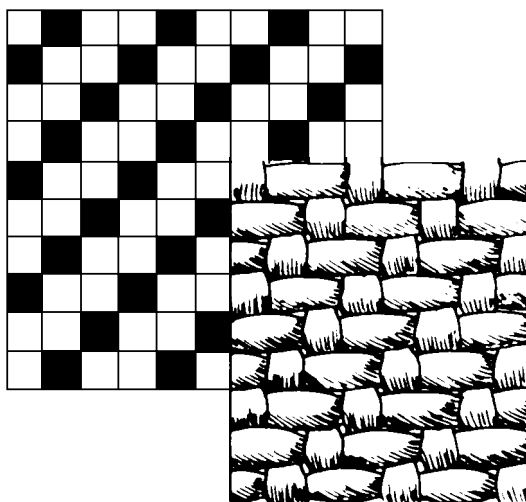

Fig. 2. Three-shaft twill. Two warp yarns are interlaced with one filling yarn. (After M. D. Potter and B. P. Corbman, *Fiber to Fabric*, 3d ed., McGraw-Hill, 1959)

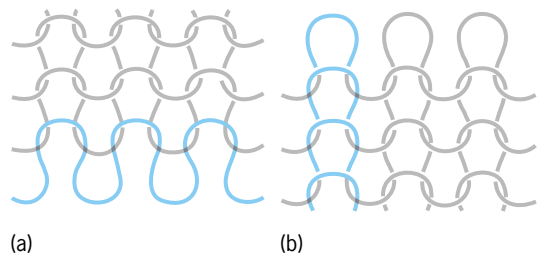

Fig. 3. Interlocking yarns of (a) course and (b) wale in a Jersey knit cloth. (After B. P. Corbman, *Fiber to Fabric*, 5th ed., McGraw-Hill, 1975)

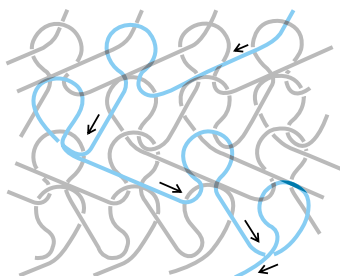

Fig. 4. Single-warp (one-bar) tricot knit. (After B. P. Corbman, *Fiber to Fabric*, 5th ed., McGraw-Hill, 1975)

Newly constructed knit or woven fabric must pass through various finishing processes to make it suitable for its intended purpose. Finishing enhances the appearance of fabric and also adds to its serviceability. Finishes can be solely mechanical, solely chemical, or a combination of the two. Those finishes, such as scouring and bleaching, which simply prepare the fabric for further use are known as general finishes. Functional finishes, such as durable press treatments, impart special characteristics to the cloth. For discussions of important finishing operations see BLEACHING; DYEING; TEXTILE CHEMISTRY; TEXTILE PRINTING. [I.B.]

**Textile chemistry** The applied science of textile materials, consisting of the application of the principles of the many basic fields of chemistry to the understanding of textile materials and to their functional and esthetic modification into useful and desirable items. The study of textile chemistry begins with the knowledge of the textile fibers themselves. These are normally divided into three groups: natural, manufactured, and synthetic. See MANUFACTURED FIBER; NATURAL FIBER; TEXTILE.

**Chemicals.** The enormous number of chemicals used in textile processing may be divided broadly into two categories: those intended to remain on the fiber, and those intended to wet or clean the fiber or otherwise function in some related operation. The former includes primarily dyes and finishes. The latter group consists mainly of surface-active agents, commonly known as surfactants. See SURFACTANT.

**Preparation.** Preparation is a term applied to a group of essentially wet chemical processes having as their object the removal of all foreign matter from the fabric. This results in a clean, absorbent substrate, ready for the subsequent coloring and finishing operations.

The operations constituting preparation depend primarily on the fibers being handled. Synthetic fibers contain little or no natural impurities, so that the only materials that normally must be removed are the oils and lubricants or water-soluble sizes needed to facilitate earlier processing. This is generally accomplished by washing with water and a mild detergent capable of emulsifying the oils and waxes. On the other hand, natural fibers contain relatively high amounts of natural impurities, and in addition frequently are sized with materials presenting difficulties in removal. In the case of cotton, prolonged hot treatment

with alkali, usually sodium hydroxide, and strong detergent is necessary to break down and remove the naturally occurring impurities. Special scours are necessary for cleaning such materials as wool and silk. The protein fibers are very sensitive to alkali and strong detergents; they are usually washed with mild soap or sulfated alcohols.

After other impurities are removed from the fiber, it is usually desirable to remove any coloring material. This process is known as bleaching. By far the major bleaching agent in use is hydrogen peroxide, which is efficient in color removal, while still being considered relatively controllable and safe for use. See BLEACHING; HYDROGEN PEROXIDE.

**Mercerization.** Mercerization is a special process applied only to cotton. The fabric or yarn is treated with a strong sodium hydroxide solution while being held under tension. This process causes chemical and physical changes within the fiber itself, resulting in a substantial increase in luster and smoothness of the fabric, plus important improvements in dye affinity, stabilization, tensile strength, and chemical reactivity.

**Coloring.** Although many textiles reach the consumer in their natural color or as a bleached white, most textiles are colored in one way or another. Coloring may be accomplished either by dyeing or printing, and the coloring materials may be either dyes or pigments.

Dyeing essentially consists of immersing the entire fabric in the solution, so that the whole fabric becomes colored. On the other hand, printing may be considered as localized dyeing. In printing, a thickened solution of dyestuff or pigment is used. This thickened solution, or paste, is applied to specific areas of the fabric by means such as engraved rollers or partially porous screens. Application of steam or heat then causes the dyestuff to migrate from the dried paste into the interior of the fiber, but only in those specific areas where it has been originally applied. See DYE; DYEING; TEXTILE PRINTING.

**Finishing.** Finishing includes a group of mechanical and chemical operations which give the fabric its ultimate feel and performance characteristics. Many desirable characteristics may be imparted to the fabric through the application of various chemical agents at this point.

Softeners are used to give a desirable hand or feel to the fabric. These chemicals are generally long fatty chains, with solubilizing groups which may be cationic, nonionic, or occasionally anionic in character. They are essentially surfactants constructed so as to contain a relatively high proportion of fatty material in the molecule. Conversely, certain types of polymeric material such as polyvinyl acetate or polymerized urea formaldehyde resins are used to impart a stiff or crisp hand to a fabric. See POLYVINYL RESINS; UREA-FORMALDEHYDE-TYPE RESINS.

It is in finishing that the so-called proof finishes are applied, including fire-retardant and water-repellent finishes. A fire-retardant finish is a chemical or mixture containing a high proportion of phosphorus, nitrogen, chlorine, antimony, or bromine. A truly waterproof fabric may be made by coating with rubber or vinyl, but water-repellent fabrics are produced by treating with hydrophobic materials such as waxes, silicones, or metallic soaps.

Many other types of highly specialized treatments, such as antistatic, antibacterial, or soil-repellent finishes, may be applied to fit the fabric to a particular use. [D.H.A.]

**Textile microbiology** That branch of industrial microbiology concerned with textile materials. Most of the microorganisms on textiles—the fungi, actinomycetes, and bacteria—originate from air, soil, and water. Some of the microorganisms are harmful to either the fibers or the consumer. They may decompose the cellulose or protein in the fiber or affect the consumer's health. Since the minimum moisture content for microorganism development is 7%, dry storage is an effective prevention measure. Some of the microorganisms are useful, for example in

the retting process, in which fibers are liberated from the stalks of such fiber plants as flax, hemp, and jute.

In principle, retting consists of a breaking down of pectic substances between the cell walls (middle lamellae) of the individual cells of the tissue surrounding the bundles. As a result, the bundles become separated from the surrounding tissue and can then easily be extracted mechanically. In water retting, the stalks are immersed in cold or warm, slowly renewed water, for from 4 days to several weeks. The active organism is *Clostridium felsineum* and related types, which break down the pectin to a mixture of organic acids (chiefly acetic and butyric), alcohols (butanol, ethanol, and methanol), carbon dioxide (CO<sub>2</sub>), and hydrogen (H<sub>2</sub>). In dew retting the stems are spread out in moist meadows; here the pectin decomposition is accomplished by molds and aerobic bacteria with the formation of CO<sub>2</sub> and H<sub>2</sub>O. See INDUSTRIAL MICROBIOLOGY; TEXTILE CHEMISTRY. [A.N.J.H.]

**Textile printing** The localized application of color on fabrics. In printing textiles, a thick paste of dye or pigment is applied to the fabric by appropriate mechanical means to form a design. The color is then fixed or transferred from the paste to the fiber itself, maintaining the sharpness and integrity of the design. In a multicolor design, each color must be applied separately and in proper position relative to all other colors. Printing is one of the most complex of all textile operations. See DYE.

A design may be applied in three major ways: raising the design in relief on a flat surface (block printing); cutting the design below a flat surface (intaglio or engraved printing); and cutting the design through a flat metal or paper sheet (stencil or screen printing). All three methods have been used for hand printing and reciprocating printing machines. In addition, these methods have been converted into rotary action by replacing blocks or plates with cylinders. Another method of printing utilizes individual computer-controlled nozzles for each color. The nozzles are used to paint a design on the fabric.

Each printing method requires a paste with special characteristics, frequently referred to as flow characteristics. The choice of thickener is dependent not only on the type of dyestuff, but on the type of printing machine on which the printing is to be done, and frequently also on the type of fixation to be used. Most natural thickening agents are based on combinations of starch and gum. The synthetic thickening agents used are generally extremely high-molecular-weight polymers capable of developing a very high viscosity at a relatively low concentration.

The first step is the preparation of print paste, which is made by dissolving the dyestuff and combining it with a solution of the appropriate thickening agent. The fabric is then printed by any of the standard methods and then dried in order to retain a sharp printed mark.

The next operation, steaming, may be likened to a dyeing operation. Before steaming, the bulk of the dyestuff is held in a dried film of thickening agent. During the steaming operation, the printed areas absorb moisture and form a very concentrated dye bath, from which dyeing of the fiber takes place. The thickening agent prevents the dyestuff from spreading outside the area originally printed, because the printed areas act as a concentrated dye bath that exists more in the form of a gel than a solution and restricts any tendency to bleed.

Printed goods are generally washed thoroughly to remove thickening agent, chemicals, and unfixed dyestuff. Drying of the washed goods is the final operation of printing. See TEXTILE CHEMISTRY. [D.H.A.]

**Thaliacea** A small class of pelagic Tunicata especially abundant in warmer seas. This class of animals contains three orders: the Salpida, Doliolida, and Pyrosomida. Oral and atrial apertures occur at opposite ends of the body. Members of the orders Salpida and Doliolida are transparent forms, partly or

wholly ringed by muscular bands. The contractions of these bands produce currents used in propulsion, feeding, and respiration. The order Pyrosomida includes species which form tubular swimming colonies and which are often highly luminescent. See BIOLUMINESCENCE; TUNICATA. [D.P.A.]

**Thallium** A chemical element, Tl, atomic number 81, relative atomic weight of 204.37. The valence electron notation corresponding to its ground state term is 6s<sup>2</sup>6p<sup>1</sup>, which accounts for the maximum oxidation state of III in its compounds. Compounds of oxidation state I and apparent oxidation state II are also known. See PERIODIC TABLE.

Thallium occurs in the Earth's crust to the extent of 0.00006%, mainly as a minor constituent in iron, copper, sulfide, and selenide ores. Minerals of thallium are considered rare. Thallium compounds are extremely toxic to humans and other forms of life.

The insolubility of thallium(I) chloride, bromide, and iodide permits their preparation by direct precipitation from aqueous solution; the fluoride, on the other hand, is water-soluble. Thallium(I) chloride resembles silver chloride in its photosensitivity.

Thallium(I) oxide is a black powder which reacts with water to give a solution from which yellow thallium hydroxide can be crystallized. The hydroxide is a strong base and will take up carbon dioxide from the atmosphere.

Thallium also forms organometallic compounds of the following general classes, R<sub>3</sub>Tl, R<sub>2</sub>TlX, and RTlX<sub>2</sub>, where R may be an alkyl or aryl group and X a halogen. See ORGANOMETALLIC COMPOUND. [E.M.L.]

**Thallobionta** One of the two commonly recognized subkingdoms of plants, encompassing the euglenoids and various classes of algae. In contrast to the more closely knit subkingdom Embryobionta, the Thallobionta (often also called Thallophyta) are diverse in pigmentation, food reserves, cell-wall structure, and flagellar structure. The Thallobionta are united more by the absence of certain specialized tissues or organs than by positive resemblances. They do not have the multicellular sex organs commonly found in most divisions of Embryobionta. Many of the Thallobionta are unicellular, and those which are multicellular seldom have much differentiation of tissues. None of them has tissues comparable to the xylem found in most divisions of the Embryobionta, and only some of the brown algae have tissues comparable to the phloem found in most divisions of the Embryobionta.

A large proportion of the Thallobionta are aquatic, and those which grow on dry land seldom reach appreciable size. The Thallobionta thus consist of all those plants which have not developed the special features that mark the progressive adaptation of the Embryobionta to life on dry land. See CHLOROPHYCOTA; CHRYSOPHYCEAE; EMBRYOBIONTA; EUGLENOPHYCEAE; PHAEOPHYCEAE; PLANT KINGDOM; RHODOPHYCEAE. [A.Cr.]

**Theales** An order of flowering plants, division Magnoliophyta (Angiospermae), in the subclass Dilleniidae of the class Magnoliopsida (dicotyledons). The order consists of 18 families and nearly 3500 species. The largest families are the Clusiaceae, sometimes called Guttiferae (about 1200 species), Theaceae (about 600 species), Dipterocarpaceae (about 600 species), and Ochnaceae (about 400 species). They are mostly woody plants, less often herbaceous, with simple or occasionally compound leaves. The perianth and stamens of the flowers are attached directly to the receptacle; the calyx is arranged in a tight spiral; and the petals are usually separate from each other (see illustration). The stamens are numerous and initiated in centrifugal sequence or, less often, are few and cyclic; the pollen is nearly always binucleate. The tea plant (*Thea sinensis*), *Camellia* (in the



Franklin tree (*Franklinia alatamaha*) flowers, a characteristic member of the family Theaceae in the order Theales, named in honor of Benjamin Franklin. (Photograph by A. W. Ambler, from National Audubon Society)

Theaceae), and St.-John's-wort (*Hypericum*, in the Clusiaceae) are familiar members of the Theales. See DILLENIIIDAE; FLOWER; MAGNOLIOPHYTA; PLANT KINGDOM; TEA. [A.Cr.; T.M.Ba.]

**Thecanephria** An order of Pogonophora, a group of elongate, tentaculated, tube-dwelling, sedentary, nonparasitic marine worms lacking a digestive system. In this order the "coelomic" space in the anterior tentacular region is horse-shoe-shaped, and the excretory (osmoregulatory) portion of its ducts come close together medially near the median, adneuronal blood vessel. The species in this order are multitentaculate.

The order includes four families: Polybrachiidae (with seven genera), Sclerolinidae (one genus), Lamellisabellidae (two genera), and Spirobrachiidae (one genus). See ATHECANEPHRIA; POGONOPHORA. [E.B.Cu.]

**Thelodontida** Sometimes called Coelolepida, this is an extinct group of Agnatha or jawless vertebrates known from the Lower Silurian to Middle Devonian of Europe, Asia, Australia, and North America. Since they had no hard skeleton, their structure and relationships are poorly known. Well-preserved specimens of *Logania* suggest a relationship to Heterostraci in their widely spaced, lateral eyes, nearly terminal mouth, pectoral flaps at the posterior end of the head, and hypocerical tail with a downwardly directed main lobe. *Phlebolepis* resembles Anaspida in general form but lacks the dorsal nostril of that group. See AGNATHA; HETEROSTRACI; OSTEOSTRACI; PTERASPIDOMORPHA. [R.H.De.]

**Theorem** A proposition arrived at by the methods of logical deduction from a set of basic postulates or axioms accepted as primitive and therefore not subject to deductive proof. So long as a theorem is part of a purely formal system, it is not meaningful to speak about the "truth" of a theorem but only about its "correctness." It becomes true when it, or its consequences, can be shown to be in accord with observable facts. See LOGIC. [P.W.Br./H.Ma.]

**Theoretical ecology** The use of models to explain patterns, suggest experiments, or make predictions in ecology. Because ecological systems are idiosyncratic, extremely complex, and variable, ecological theory faces special challenges. Unlike physics or genetics, which use fundamental laws of gravity or of inheritance, ecology has no widely accepted first-principle laws. Instead, different theories must be invoked for different ques-

tions, and the theoretical approaches are enormously varied. A central problem in ecological theory is determining what type of model to use and what to leave out of a model. The traditional approaches have relied on analytical models based on differential or difference equations; but recently the use of computer simulation has greatly increased. See ECOLOGICAL MODELING; ECOLOGY; ECOLOGY, APPLIED; SIMULATION.

The nature of ecological theory varies depending on the level of ecological organization on which the theory focuses. The primary levels of ecological organization are (1) physiological and biomechanical, (2) evolutionary (especially applied to behavior), (3) population, and (4) community.

At the physiological and biomechanical level, the goals of ecological theory are to understand why particular structures are present and how they work. The approaches of fluid dynamics and even civil engineering have been applied to understanding the structures of organisms, ranging from structures that allow marine organisms to feed, to physical constraints on the stems of plants.

At the behavioral evolutionary level, the goals of ecological theory are to explain and predict the different choices that individual organisms make. Underlying much of this theory is an assumption of optimality: the theories assume that evolution produces an optimal behavior, and they attempt to determine the characteristics of the optimal behavior so it can be compared with observed behavior. One area with well-developed theory is foraging behavior (where and how animals choose to feed). Another example is the use of game theory to understand the evolution of behaviors that are apparently not optimal for an individual but may instead be better for a group. See BEHAVIORAL ECOLOGY; GAME THEORY; OPTIMIZATION.

The population level has the longest history of ecological theory and perhaps the broadest application. The simplest models of single-species populations ignore differences among individuals and assume that the birth rates and death rates are proportional to the number of individuals in the population. If this is the case, the rate of growth is exponential, a result that goes back at least as far as Malthus's work in the 1700s. As Malthus recognized, this result produces a dilemma: exponential growth cannot continue unabated. Thus, one of the central goals of population ecology theory is to determine the forces and ecological factors that prevent exponential growth and to understand the consequences for the dynamics of ecological populations. See ECOLOGICAL METHODS; POPULATION ECOLOGY.

Modifications and extensions of theoretical approaches like the logistic model (which uses differential equations to explain the stability of populations) have also been used to guide the management of renewable natural resources. Here, the most basic concept is that of the maximum sustainable yield, which is the greatest level of harvest at which a population can continue to persist. See ADAPTIVE MANAGEMENT; MATHEMATICAL ECOLOGY.

The primary goal of ecological theory at the community level is to understand diversity at local and regional scales. Recent work has emphasized that a great deal of diversity in communities may depend on trade-offs. For example, a trade-off between competitive prowess and colonization ability is capable of explaining why so many plants persist in North American prairies. Another major concept in community theory is the role of disturbance. Understanding how disturbances (such as fires, hurricanes, or wind storms) impacts communities is crucial because humans typically alter disturbance. See BIODIVERSITY; ECOLOGICAL COMMUNITIES. [A.Has.]

**Theoretical physics** The description of natural phenomena in mathematical form. It is impossible to separate theoretical physics from experimental physics, since a complete understanding of nature can be obtained only by the application of both theory and experiment. There are two main purposes of theoretical physics: the discovery of the fundamental laws of

nature and the derivation of conclusions from these fundamental laws.

Physicists aim to reduce the number of laws to a minimum to have as far as possible a unified theory. When the laws are known, it is possible from any given initial conditions of a physical system to derive the subsequent events in the system. Sometimes, especially in quantum theory, only the probability of various events can be predicted. See DETERMINISM; QUANTUM MECHANICS.

The conclusions to be derived from the fundamental laws of nature may be of several different types.

1. Conclusions may be derived in order to test a given theory, particularly a new theory. An example is the derivation of the spectrum of the hydrogen atom from quantum mechanics; the verification of the predictions by accurate measurements is a good test of quantum mechanics. On rather rare occasions an experiment has been found to contradict the predictions of an existing theory, and this has then led to the discovery of important new physical laws. An example is the Michelson-Morley experiment on the constancy of the velocity of light, an experiment which led to special relativity theory. See ATOMIC STRUCTURE AND SPECTRA; LIGHT; RELATIVITY.

2. Theory may be required for experiments designed to determine physical constants. Most fundamental physical constants cannot be accurately measured directly. Elaborate theories may be required to deduce the constant from indirect experiments. See FUNDAMENTAL CONSTANTS.

3. Predictions of physical phenomena may be made in order to gain understanding of the structure of the physical world. In this category fall theories of the structure of the atom leading to an understanding of the periodic system of elements, or of the structure of the nucleus in which various models are tested (for example, shell model or collective model). In the same category fall applications of theoretical physics to other sciences, for example, to chemistry (theory of the chemical bond and of the rate of chemical reactions), astronomy (theory of planetary motion, internal constitution, and energy production of stars), or biology.

4. Engineering applications may be drawn from fundamental laws. All of engineering may be considered an application of physics, and much of it is an application of mathematical physics, such as elasticity theory, aerodynamics, electricity, and magnetism. The generation and propagation of radio waves of all frequencies are examples of application of theoretical physics to direct practice. See AERODYNAMICS; ELASTICITY; ELECTRICITY; MAGNETISM; RADIO-WAVE PROPAGATION.

Apart from the classification of the fields of theoretical physics according to purpose, a classification can also be made according to content. Here one may perhaps distinguish three classification principles: type of force, scale of physical phenomena, and type of phenomena. See MATHEMATICAL PHYSICS; PHYSICS.

[H.A.Be.]

**Therapsida** An order of Reptilia, subclass Synapsida, often called advanced mammallike reptiles, that flourished from the middle Permian through the Late Triassic. The group is highly diverse and subdivided into six suborders. Two of these, Eotitanosuchia and Dinocephalia, include relatively primitive mid-Permian carnivores and herbivores. A third, the Dicynodontia, made up of small to large herbivores, was abundant in the late Permian. Dicynodonts were associated with two carnivorous suborders, the Therocephalia and Gorgonopsia, which are morphologically intermediate between Eotitanosuchia and the cynodonts. Although these five developing lines are distinct, the skulls and skeletons in each became increasingly mammallike.

The trend continued among the highly diverse Cynodontia. This suborder includes a variety of carnivores, omnivores, and herbivores. The most highly derived herbivorous cynodonts were the tritylodonts of the Late Triassic and Early Jurassic. They were very mammallike.

Climatic changes during the Triassic rather than direct competition largely accounted for the decline of the therapsids and the rapid expansion of the Archosauria. Only the very mammallike therapsids, the herbivorous tritylodonts, and the minute derived first mammals survived into the Early Jurassic. See ARCHOSAURIA; MAMMALIA; REPTILIA; SYNAPSIDA. [E.C.O.]

**Theria** One of the four subclasses of the class Mammalia, including all living mammals except the monotremes. The Theria were by far the most successful of the several mammalian stocks that arose from the mammallike reptiles in the Triassic. The subclass is divided into three infraclasses: Pantotheria (no living survivors), Metatheria (marsupials), and Eutheria (placentals). Therian mammals are characterized by the distinctive structural history of the molar teeth. The fossil record shows that all the extremely varied therian molar types were derived from a common tribosphenic type in which three main cusps, arranged in a triangle on the upper molar, are opposed to a reversed triangle and basinlike heel on the lower molar. See MAMMALIA; THERAPSIDA. [D.D.D./F.S.S.]

**Thermal analysis** A group of analytical techniques developed to continuously monitor physical or chemical changes of a sample which occur as the temperature of a sample is increased or decreased. Thermogravimetry, differential thermal analysis, and differential scanning calorimetry are the three principal thermoanalytical methods. See ANALYTICAL CHEMISTRY; COMPUTER; THERMOCHEMISTRY.

The occurrence of physical or chemical changes upon heating a sample may be explained from either a kinetic or thermodynamic viewpoint. Kinetically the rate of a process may be increased by raising the temperature as shown by the Arrhenius equation (1), where  $A$ ,  $E_a$ , and  $R$  represent the preexponential

$$\text{Rate} = Ae^{-E_a/RT} \quad (1)$$

factor, activation energy, and the gas law constant, respectively. At some point the rate becomes significant and readily observable. Similarly an increase in temperature can change the Gibbs free energy [Eq. (2), where  $\Delta G^\circ$  is the Gibbs free energy,  $\Delta H^\circ$

$$\Delta G^\circ = \Delta H^\circ - T\Delta S^\circ \quad (2)$$

is the reaction enthalpy, and  $\Delta S^\circ$  is the entropy change for the process] to a more favorable (that is, more negative) value. In particular,  $\Delta G^\circ$  will become more negative if  $\Delta S^\circ$  is positive and the temperature is increased. In many cases a combination of these factors causes the observed physiochemical process. See CHEMICAL THERMODYNAMICS; KINETICS (CLASSICAL MECHANICS).

Thermogravimetry involves measuring the changes in mass of a substance, typically a solid, as it is heated. Specially designed thermobalances are required to continuously monitor sample mass during the heating process. Modern balances have a capacity of 1–1500 milligrams and can accurately detect mass changes of 0.1 microgram.

Any type of physiochemical process which involves a change in sample mass may be observed by using thermogravimetry. Mass losses are observed for dehydration, decomposition, desorption, vaporization, sublimation, pyrolysis, and chemical reactions with gaseous products. Mass increases are noted with adsorption, absorption, and chemical reactions of the sample with the atmosphere in the oven, such as the oxidation of metals.

Quantitative gravimetric analyses may be performed due to the precise measure of the mass change obtained. Rates of mass change have been used to evaluate the kinetics of a process and to estimate activation energies. Fine details of these thermograms may also be used to deduce reaction intermediates and reaction mechanisms.

Primary applications of thermogravimetry are to deduce stabilities of compounds and mixtures of elevated temperatures and to determine appropriate drying temperatures for compounds

and mixtures. Evaluation of polymers, food products, and pharmaceuticals is a major application of thermogravimetry.

Differential thermal analysis involves the monitoring of the temperature difference  $T_D$  between a sample and inert reference material (such as aluminum oxide) as they are simultaneously heated, or cooled, at a predetermined rate. Multijunction thermocouples and thermistors are the most common temperature sensors used for this purpose; they are arranged in an oven. As enthalpic changes occur,  $T_D$  will be positive if the process is exothermic and negative if it is endothermic.

More physical and chemical processes may be observed using differential thermal analysis as compared to thermogravimetry. Endothermic physical processes include crystalline transitions, fusion, vaporization, sublimation, desorption, and adsorption. Endothermic physical processes include crystalline transitions, fusion, vaporization, sublimation, desorption, and adsorption. Endothermic chemical processes include dehydration, decomposition, gaseous reduction, redox reactions, and solid-state metathesis. Exothermic processes include adsorption, chemisorption, decomposition, oxidation, redox reactions, and solid-state metathesis reactions. Both solids and liquids can be studied by differential thermal analysis. Hermetically sealed capsules are often used for liquids and some solids. Other samples are studied in open or crimped pans.

Analytical applications of this technique include the identification, characterization, and quantitation of a wide variety of materials, including polymers, pharmaceuticals, metals, clays, minerals, and inorganic and organic compounds. Characteristic thermograms can be used to determine purity, heats of reaction, thermal stability, phase diagrams, catalytic properties, and radiation damage.

In differential scanning calorimetry a sample and a reference are individually heated, by separately controlled resistance heaters, at a predetermined rate. Enthalpic (heat-generating or -absorbing) processes are detected as differences in electrical energy supplied to either the sample or the reference material to maintain this heating rate. This difference in electrical energy, in milliwatts per second, of the heat flow into or out of the sample is due to the occurrence of a physical or chemical process. Modulated differential scanning calorimetry is a new method that superimposes a sine wave on the heating ramp. A significant increase in sensitivity is often observed with modulated differential scanning calorimetry.

Analytical uses of differential scanning calorimetry are very similar to those of differential thermal analysis. Usually one calibration standard is sufficient to calibrate the entire operating range of the instrument. Differential scanning calorimetry instruments are highly sensitive and may measure heat flows as small as 1 nanowatt. Differential scanning calorimetry is very useful in determining heat capacities of substances over large temperature ranges. Such evaluation has become important in polymer and biochemical studies. Small (approximately 1–10 mg) samples are used in most cases, although some instruments have been developed which use up to 1 ml of a liquid sample. See CALORIMETRY. [N.D.J.]

**Thermal conduction in solids** Thermal conduction in a solid is generally measured by stating the thermal conductivity  $K$ , which is the ratio of the steady-state heat flow (heat transfer per unit area per unit time) along a long rod to the temperature gradient along the rod. Thermal conductivity varies widely among different types of solids, and depends markedly on temperature and on the purity and physical state of the solids, particularly at low temperatures.

From the kinetic theory of gases the thermal conductivity can be written as  $K = (\text{constant}) Sv l$ , where  $S$  is the specific heat per unit volume,  $v$  is the average particle velocity, and  $l$  is the mean free path. In solids, thermal conduction results from conduction by lattice vibrations and from conduction by electrons. In insulating materials, the conduction is by lattice waves; in pure metals,

the lattice contribution is negligible and the heat conduction is primarily due to electrons. In many alloys, impure metals, and semiconductors, both conduction mechanisms contribute. See CONDUCTION (HEAT); KINETIC THEORY OF MATTER; LATTICE VIBRATIONS; SPECIFIC HEAT.

In superconductors at temperatures below the critical temperature, the electronic conduction is reduced; at sufficiently low temperatures, the thermal conductivity becomes entirely due to lattice waves and is similar to the form of the thermal conductivity of an insulating material. See SUPERCONDUCTIVITY. [K.A.McC.]

**Thermal converters** Devices consisting of a conductor heated by an electric current, with one or more hot junctions of a thermocouple attached to it, so that the output emf responds to the temperature rise, and hence the current. Thermal converters are used with external resistors for alternating-current (ac) and voltage measurements over wide ranges and generally form the basis for calibration of ac voltmeters and the ac ranges of instruments providing known voltages and currents.

In the most common form, the conductor is a thin straight wire less than 0.4 in. (1 cm) long, in an evacuated glass bulb, with a single thermocouple junction fastened to the midpoint by a tiny electrically insulating bead. Thermal inertia keeps the temperature of the heater wire constant at frequencies above a few hertz, so that the constant-output emf is a true measure of the root-mean-square (rms) heating value of the current. The reactance of the short wire is so small that the emf can be independent of frequency up to 10 MHz or more. An emf of 10 mV can be obtained at a rated current less than 5 mA, so that resistors of reasonable power dissipation, in series or in shunt with the heater, can provide voltage ranges up to 1000 V and current ranges up to 20 A. However, the flow of heat energy cannot be controlled precisely, so the temperature, and hence the emf, generally changes with time and other factors. Thus an ordinary thermocouple instrument, consisting of a thermal converter and a millivoltmeter to measure the emf, is accurate only to about 1–3%. See THERMOCOUPLE; VOLTMETER.

To overcome this, a thermal converter is normally used as an ac-dc transfer instrument (ac-dc comparator) to measure an unknown alternating current or voltage by comparison with a known nearly equal dc quantity (see illustration). By replacing the millivoltmeter with an adjustable, stable, opposing voltage  $V_b$  in series with a microvoltmeter  $D$ , very small changes in emf can be detected. The switch  $S$  is connected to the unknown ac voltage  $V_{ac}$ , and  $V_b$  is adjusted for a null (zero) reading of  $D$ . Then  $S$  is immediately connected to the dc voltage  $V_{dc}$ , which is

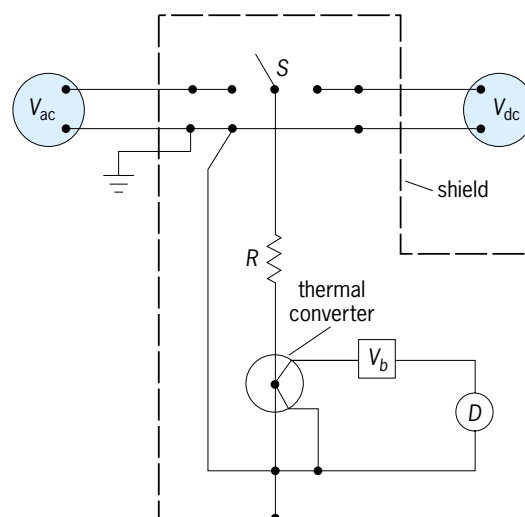

Basic circuit for ac-dc transfer measurements of ac voltages.

adjusted to give a null again, without changing  $V_b$ . Thus  $V_{ac} = V_{dc} (1 + d)$ , where  $d$  is the ac-dc difference of the transfer instrument, which can be as small as a few parts per million (ppm).

In many commercial instruments, all of the components are conveniently packaged in the shield, shown with a broken line, and several ranges are available by taps on  $R$ . Accuracies of 0.001% are attainable at audio frequencies. See ELECTRICAL MEASUREMENT. [F.L.H.; J.R.K.]

**Thermal ecology** The examination of the independent and interactive biotic and abiotic components of naturally heated environments. Geothermal habitats are present from sea level to the tops of volcanoes and occur as fumaroles, geysers, and hot springs. Hot springs typically possess source pools with overflow, or thermal, streams (rheotherms) or without such streams (limnotherms). Hot spring habitats have existed since life began on Earth, permitting the gradual introduction and evolution of species and communities adapted to each other and to high temperatures. Other geothermal habitats do not have distinct communities.

Hot-spring pools and streams, typified by temperatures higher than the mean annual temperature of the air at the same locality and by benthic mats of various colors, are found on all continents except Antarctica. They are located in regions of geologic activity where meteoric water circulates deep enough to become heated. The greatest densities occur in Yellowstone National Park (Northwest United States), Iceland, and New Zealand. Source waters range from 40°C (104°F) to boiling (around 100°C or 212°F depending on elevation), and may even be superheated at the point of emergence. Few hot springs have pH 5–6; most are either acidic (pH 2–4) or alkaline (pH 7–9). [C.Wi.]

**Thermal expansion** Solids, liquids, and gases all exhibit dimensional changes for changes in temperature while pressure is held constant. The molecular mechanisms at work and the methods of data presentation are quite different for the three cases.

The temperature coefficient of linear expansion  $\alpha_l$  is defined by Eq. (1), where  $l$  is the length of the specimen,  $t$  is the temper-

$$\alpha_l = \frac{1}{l} \left( \frac{\partial l}{\partial t} \right)_{p=\text{const}} \quad (1)$$

ature, and  $p$  is the pressure. For each solid there is a Debye characteristic temperature  $\Theta$ , below which  $\alpha_l$  is strongly dependent upon temperature and above which  $\alpha_l$  is practically constant. Many common substances are near or above  $\Theta$  at room temperature and follow approximate equation (2), where  $l_0$  is the

$$l = l_0(1 + \alpha_l t) \quad (2)$$

length at 0°C and  $t$  is the temperature in °C. The total change in length from absolute zero to the melting point has a range of approximately 2% for most substances.

So-called perfect gases follow the relation in Eq. (3), where  $p$  is

$$\frac{pv}{T} = \frac{R}{\text{molecular weight}} \quad (3)$$

absolute pressure,  $v$  is specific volume,  $T$  is absolute temperature, and  $R$  is the so-called gas constant. Real gases often follow this equation closely. See GAS CONSTANT.

The coefficient of cubic expansion  $\alpha_v$  is defined by Eq. (4),

$$\alpha_v = \frac{1}{v} \left( \frac{\partial v}{\partial t} \right)_{p=\text{const}} \quad (4)$$

and for a perfect gas this is found to be  $1/T$ . The behavior of real gases is largely accounted for by the van der Waals equation. See GAS; KINETIC THEORY OF MATTER.

For liquids,  $\alpha_v$  is somewhat a function of pressure but is largely determined by temperature. Though  $\alpha_v$  may often be taken as

constant over a sizable range of temperature (as in the liquid expansion thermometer), generally some variation must be accounted for. For example, water contracts with temperature rise from 32 to 39°F (0 to 4°C), above which it expands at an increasing rate. See THERMOMETER. [R.A.Bu.]

**Thermal hysteresis** A phenomenon in which a physical quantity depends not only on the temperature but also on the preceding thermal history. It is usual to compare the behavior of the physical quantity while heating and the behavior while cooling through the same temperature range. The illustration shows the thermal hysteresis which has been observed in the behavior of the dielectric constant of single crystals of barium titanate. On heating, the dielectric constant was observed to follow the path ABCD, and on cooling the path DCEFG. See DIELECTRIC CONSTANT; FERROELECTRICS.

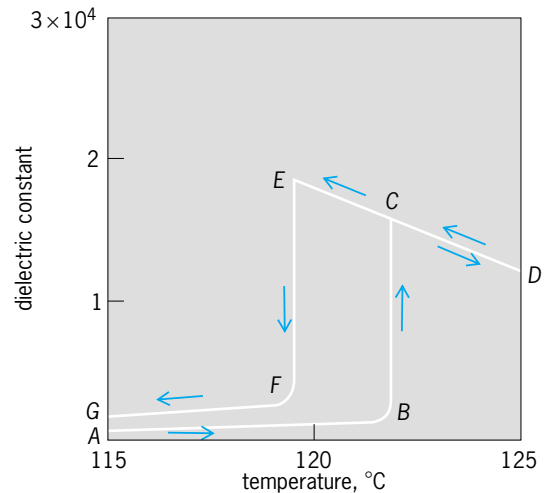

Plot of dielectric constant versus temperature for a single crystal of barium titanate. (After M. E. Drougard and D. R. Young, *Phys. Rev.*, 95:1152–1153, 1954)

Perhaps the most common example of thermal hysteresis involves a phase change such as solidification from the liquid phase. In many cases these liquids can be dramatically supercooled. Elaborate precautions to eliminate impurities and outside disturbances can be instrumental in supercooling 60 to 80°C. On raising the temperature after freezing, however, the system follows a completely different path, with melting coming at the prescribed temperature for the phase change. See CRYSTAL; NUCLEATION; PHASE TRANSITIONS. [H.B.H.; R.K.Mac.C.]

**Thermal neutrons** Neutrons whose energy distribution is governed primarily by the kinetic energy distribution of molecules of the material in which the neutrons are found. See NEUTRON.

The molecules of the material usually have a kinetic energy distribution very close to a Maxwell-Boltzmann distribution. This distribution shows a peak at an energy equal to half the product of the temperature and the Boltzmann constant. At high energies it decreases exponentially, and at low energies it is proportional to the square root of the energy. When the material is large and very weakly absorbing, the neutron energy distribution closely approaches this maxwellian. See BOLTZMANN STATISTICS; KINETIC THEORY OF MATTER.

The most common way of generating thermal neutrons is to allow neutrons from a source—reactor, accelerator, or spontaneous fission neutron emitter—to diffuse outward through a large block or tank of very weakly absorbing moderator. See REACTOR PHYSICS. [B.I.S.]

**Thermal stress** Mechanical stress induced in a body when some or all of its parts are not free to expand or contract in response to changes in temperature. In most continuous bodies, thermal expansion or contraction cannot occur freely in all directions because of geometry, external constraints, or the existence of temperature gradients, and so stresses are produced. Such stresses caused by a temperature change are known as thermal stresses.

Problems of thermal stress arise in many practical design problems, such as those encountered in the design of steam and gas turbines, diesel engines, jet engines, rocket motors, and nuclear reactors. The high aerodynamic heating rates associated with high-speed flight present even more severe thermal-stress problems for the design of spacecraft and missiles. See STRESS AND STRAIN. [S.Y.C.]

**Thermal wind** The difference in the geostrophic wind between two heights in the atmosphere over a given position on Earth. It approximates the variation of the actual winds with height for large-scale and slowly changing motions of the atmosphere. Such structure in the wind field is of fundamental importance to the description of the atmosphere and to processes causing its day-to-day changes. The thermal wind embodies a basic relationship between vertical fluctuations of the horizontal wind and horizontal temperature gradients in the atmosphere. This relationship arises from the combination of the geostrophic wind law, the hydrostatic equation, and the gas law.

The geostrophic wind law applies directly to steady, straight, and unaccelerated horizontal motion and is a good approximation for large-scale and slowly changing motions in the atmosphere. The hydrostatic equation combined with the gas law relates the atmospheric pressure and temperature fields. The relationship is accurate for most atmospheric situations but not for small-scale and rapidly changing conditions such as in turbulence and thunderstorms. The equation gives the change of pressure in the vertical direction as a function of pressure and temperature. The key conclusion is that at a given level in the atmosphere the pressure change (decrease) with height is more rapid in cold air than in warm air. See ATMOSPHERE; GEOSTROPHIC WIND; HYDROSTATICS; TROPOSPHERE. [D.D.H.]

**Thermionic emission** The emission of electrons into vacuum by a heated electronic conductor. In its broadest meaning, thermionic emission includes the emission of ions, but this process is quite different from that normally understood by the term. Thermionic emitters are used as cathodes in electron tubes and hence are of great technical and scientific importance. Although in principle all conductors are thermionic emitters, only a few materials satisfy the requirements set by practical applications. Of the metals, tungsten is an important practical thermionic emitter; in most electron tubes, however, the oxide-coated cathode is used to great advantage. For a detailed discussion of practical thermionic emitters. See VACUUM TUBE.

The thermionic emission of a material may be measured by using the material as the cathode in a vacuum tube and collecting the emitted electrons on a positive anode. If the anode is sufficiently positive relative to the cathode, space charge (a concentration of electrons near the cathode) can be avoided and all electrons emitted can be collected; the saturation thermionic current is then measured. See SCHOTTKY EFFECT.

The emission current density  $J$  increases rapidly with increasing temperature; this is illustrated by the following approximate values for tungsten:

$T(K)$	1000	2000	2500	3000
$J(\text{amperes}/\text{cm}^2)$	$10^{-15}$	$10^{-3}$	0.3	15

The temperature dependence of  $J$  is given by the Richards (or Dushman-Richardson) equation below. Here  $A$  is a constant,  $k$

$$J = AT^2 e^{-(\phi - kT)}$$

is Boltzmann's constant ( $=1.38 \times 10^{-23}$  joule/degree), and  $\phi$  is the work function of the emitter. The work function has the dimensions of energy and is a few electronvolts for thermionic emitters. See WORK FUNCTION (ELECTRONICS). [A.J.D.]

**Thermionic power generator** A device for converting heat into electricity through the use of thermionic emission and no working fluid other than electric charges. An elementary thermionic generator, or thermionic converter, consists of a hot metal surface (emitter) separated from a cooler electrode (collector) by an insulator seal (see illustration). The interelectrode gap is usually a fraction of a millimeter in width. The hermetic enclosure contains a small amount of an easily ionizable gas, such as cesium vapor maintained by a liquid-cesium reservoir. In some experimental devices, the enclosure may be evacuated.

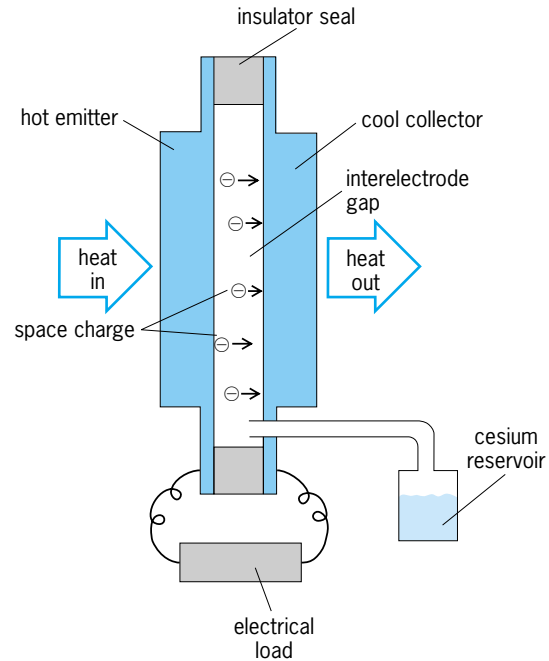

Diagram of thermionic converter.

Electrons evaporated from the emitter cross the interelectrode gap, condense on the collector, and are returned to the emitter via the external electrical load circuit. The thermionic generator is essentially a heat engine utilizing an electron gas as the working fluid. The temperature difference between the emitter and the collector drives the electron current.

Thermionic generators are characterized by high operating temperatures [typically emitter temperatures between 1600 and 2500 K (2420 and 4040°F) and collector temperatures ranging from 800 to 1100 K (980 to 1520°F)]; low output voltage (approximately 0.5 V per converter); high current density (around 5–10 A/cm<sup>2</sup>); and high conversion efficiency (about 10–15%). These characteristics, especially the relatively high heat-rejection temperature, make the thermionic generator attractive for producing electric power in space with nuclear-reactor or radioisotope energy sources. The high electrode temperatures make thermionic generators also attractive as topping units for steam power plants, and for the cogeneration of electricity in combination with heat for intermediate-temperature industrial processes. Topping units increase the overall system efficiency. See COGENERATION; NUCLEAR BATTERY. [E.P.G.Y.; G.N.H.]

**Thermionic tube** An electron tube that relies upon thermally emitted electrons from a heated cathode for tube current.

Thermionic emission of electrons means emission by heat. In practical form an electrode, called the cathode because it forms



the negative electrode of the tube, is heated until it emits electrons. The cathode may be either a directly heated filament or an indirectly heated surface. With a filamentary cathode, heating current is passed through the wire, which either emits electrons directly or is covered with a material that readily emits electrons. Indirectly heated cathodes have a filament, commonly called the heater, located within the cathode electrode to bring the surface of the cathode to emitting temperature. The majority of all vacuum tubes are thermionic tubes. See ELECTRON TUBE; GAS TUBE; THERMIONIC EMISSION; VACUUM TUBE. [L.S.N.]

**Thermistor** An electrical resistor with a relatively large negative temperature coefficient of resistance. Thermistors are useful for measuring temperature and gas flow or wind velocity. Often they are employed as bolometer elements to measure radio-frequency, microwave, and optical power. They also are used as electrical circuit components for temperature compensation, voltage regulation, circuit protection, time delay, and volume control. Thermistors are semiconducting ceramics composed of mixtures of several metal oxides. Metal electrodes or wires are attached to the ceramic material so that the thermistor resistance can be measured conveniently. See BOLOMETER; ELECTRICAL RESISTIVITY; VOLTAGE REGULATOR; VOLUME CONTROL SYSTEMS.

At room temperature the resistance of a thermistor may typically change by several percent for a variation of  $1^\circ$  of temperature, but the resistance does not change linearly with temperature. The temperature coefficient of resistance of a thermistor is approximately equal to a constant divided by the square of the temperature in kelvins. The constant is equal to several thousand kelvins and is specified for a given thermistor and the temperature range of intended use.

The resistance and heat capacity of a thermistor depend upon the material composition, the physical dimensions, and the environment provided by the thermistor enclosure. Thermistors range in form from small beads and flakes less than  $10^{-3}$  in. (25 micrometers) thick to disks, rods, and washers with inch dimensions. The small beads are often coated with glass to prevent changes in composition or encased in glass probes or cartridges to prevent damage. Beads are available with room-temperature resistances ranging from less than  $100 \Omega$  to tens of megohms, with heat capacities as low as tens of microwatts per degree celsius, and with time constants of less than a second. Large disks and washers have heat capacities as high as a few watts per degree Celsius and time constants of minutes. See ELECTRIC POWER MEASUREMENT; FLOW MEASUREMENT; LEVEL MEASUREMENT; MICROWAVE POWER MEASUREMENT; TEMPERATURE MEASUREMENT; TIME CONSTANT. [R.Pow.]

**Thermoacoustics** The study of phenomena that involve both thermodynamics and acoustics. A sound wave in a gas is usually regarded as consisting of coupled pressure and displacement oscillations, but temperature oscillations accompany the pressure oscillations. When there are spatial gradients in the oscillating temperature, oscillating heat flow also occurs. The combination of these four oscillations produces a rich variety of thermoacoustic effects. See ACOUSTICS; OSCILLATION; SOUND; THERMODYNAMIC PRINCIPLES.

Although the oscillating heat transfer at solid boundaries does contribute significantly to the dissipation of sound in enclosures such as buildings, thermoacoustic effects are usually too small to be obviously noticeable in everyday life. However, thermoacoustic effects in intense sound waves inside suitable cavities can be harnessed to produce extremely powerful pulsating combustion, thermoacoustic refrigerators, and thermoacoustic engines.

**Pulsating combustion.** Oscillations can occur whenever combustion takes place in a cavity. In industrial equipment and residential appliances, these oscillations are sometimes encouraged in order to stir or pump the combustion ingredients, while in rocket engines such oscillations must usually be suppressed

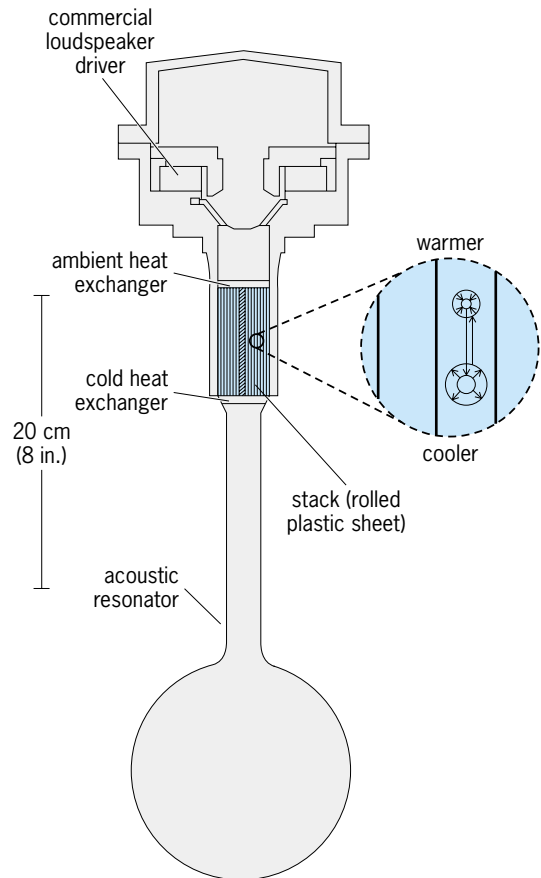

An early standing-wave thermoacoustic refrigerator that cooled to  $-60^\circ\text{C}$  ( $-76^\circ\text{F}$ ). Heat is carried up the temperature gradient in the stack. At the right is a magnified view of the oscillating motion of a typical parcel of gas. The volume of the parcel depends on its pressure and temperature. (After T. J. Hoffer, *Thermoacoustic Refrigerator Design and Performance*, Ph.D. thesis, University of California at San Diego, 1996)

because they can damage the rocket structure. The oscillations occur spontaneously if the combustion progresses more rapidly or efficiently during the compression phase of the pressure oscillation than during the rarefaction (expansion) phase—the Rayleigh criterion. See COMBUSTION; GAS DYNAMICS.

**Thermoacoustic refrigerators.** Thermoacoustic refrigerators use acoustic power to pump heat from a low temperature to ambient temperature (see illustration). The heat-pumping mechanism takes place in the pores of a structure called a stack. As a typical parcel of the gas oscillates along a pore, it experiences changes in temperature. Most of the temperature change comes from adiabatic compression and expansion of the gas by the sound pressure, and the rest is a consequence of the local temperature of the solid wall of the pore. A thermodynamic cycle results from the coupled pressure, temperature, position, and heat oscillations. The overall effect, much as in a bucket brigade, is the net transport of heat from the cold heat exchanger to room temperature. See ADIABATIC PROCESS; SOUND PRESSURE; THERMODYNAMIC CYCLE; THERMODYNAMIC PROCESSES.

**Thermoacoustic engines.** While standing-wave thermoacoustic systems have matured only recently, Stirling engines and refrigerators have a long, rich history. New insights have resulted from applying thermoacoustics to Stirling systems, treating them as traveling-wave thermoacoustic systems in which the extrema in pressure and gas motion are approximately  $90^\circ$  out of phase in time. In the thermoacoustic-Stirling engine, the thermodynamic cycle is accomplished in a traveling-wave acoustic network, and acoustic power is produced from heat with an efficiency of 30%. [G.Swi.]

**Thermochemistry** A branch of physical chemistry concerned with the absorption or evolution of heat that accompanies chemical reactions. Closely related topics are the latent heat associated with a change in phase (crystal, liquid, gas), the chemical composition of reacting systems at equilibrium, and the electrical potentials of galvanic cells. Thermodynamics provides the link among these phenomena.

A knowledge of such heat effects is important to the chemical engineer for the design and operation of chemical reactors, the determination of the heating values of fuels, the design and operation of refrigerators, the selection of heat storage systems, and the assessment of chemical hazards. Thermochemical information is used by the physiologist and biochemist to study the energetics of living organisms and to determine the calorific values of foods. Thermochemical data give the chemist an insight to the energies of, and interactions among, molecules. See CHEMICAL THERMODYNAMICS.

A calorimeter is an instrument for measuring the heat added to or removed from a process. There are many designs, but the following parts can generally be identified: the vessel in which the process is confined, the thermometer which measures its temperature, and the surrounding environment called the jacket. The heat associated with the process is calculated by the equation below, where  $T$  is the temperature. The quantity  $C$ , the

$$q = C[(T(\text{final}) - T(\text{initial})) - q_{\text{ex}} - w$$

energy equivalent of the calorimeter, is obtained from a separate calibration experiment. The work transferred to the process,  $w$ , is generally in the form of an electric current (as supplied to a heater, for example) or as mechanical work (as supplied to a stirrer, for example) and can be calculated from appropriate auxiliary measurements. The quantity  $q_{\text{ex}}$  is the heat exchanged between the container and its jacket during the experiment. It is calculated from the temperature gradients in the system and the measured thermal conductivities of its parts.

Two principal types of calorimeters are used to measure heats of chemical reactions. In a batch calorimeter, known quantities of reactants are placed in the vessel and the initial temperature is measured. The reaction is allowed to occur and then the final equilibrium temperature is measured. If necessary, the final contents are analyzed to determine the amount of reaction which occurred.

In a flow calorimeter, the reactants are directed to the reaction vessel in two or more steady streams. The reaction takes place quickly and the products emerge in a steady stream. The rate of heat production is calculated from the temperatures, flow velocities, and heat capacities of the incoming and outgoing streams, and the rates of work production and heat transfer to the jacket. Dividing this result by the rate of reaction gives the heat of reaction. See CALORIMETRY.

In the past, thermochemical quantities usually have been given in units of calories. A calorie is defined as the amount of heat needed to raise the temperature of 1 gram of water 1°C. However, since this depends on the initial temperature of the water, various calories have been defined, for example, the 15° calorie, the 20° calorie, and the mean calorie (average from 0 to 100°C). In addition, a number of dry calories have been defined. Those still used are the thermochemical calorie (exactly 4.184 joules) and the International Steam Table calorie (exactly 4.1868 J). [R.C.W.]

**Thermocouple** A device in which the temperature difference between the ends of a pair of dissimilar metal wires is deduced from a measurement of the difference in the thermoelectric potentials developed along the wires. The presence of a temperature gradient in a metal or alloy leads to an electric potential gradient being set up along the temperature gradient. This thermoelectric potential gradient is proportional to the temperature gradient and varies from metal to metal. It is the fact that the thermoelectric emf is different in different metals and

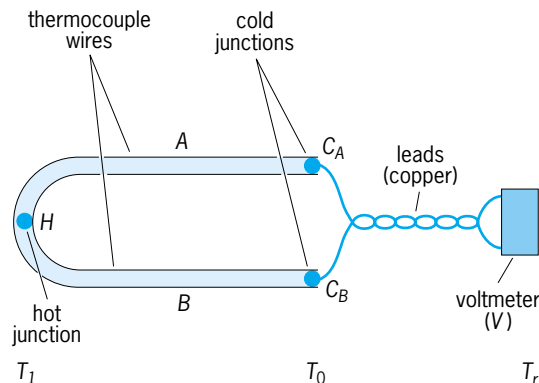

Basic circuit of a thermocouple.

alloys for the same temperature gradient that allows the effect to be used for the measurement of temperature.

The basic circuit of a thermocouple is shown in the illustration. The thermocouple wires, made of different metals or alloys  $A$  and  $B$ , are joined together at one end  $H$ , called the hot (or measuring) junction, at a temperature  $T_1$ . The other ends,  $C_A$  and  $C_B$  (the cold or reference junctions), are maintained at a constant reference temperature  $T_0$ , usually but not necessarily 32°F (0°C). From the cold junctions, wires, usually of copper, lead to a voltmeter  $V$  at room temperature  $T_r$ . Due to the thermoelectric potential gradients being different along the wires  $A$  and  $B$ , there exists a potential difference between  $C_A$  and  $C_B$ . This can be measured by the voltmeter, provided that  $C_A$  and  $C_B$  are at the same temperature and that the lead wires between  $C_A$  and  $V$  and  $C_B$  and  $V$  are identical (or that  $V$  is at the temperature  $T_0$ , which is unusual). Such a thermocouple will produce a thermoelectric emf between  $C_A$  and  $C_B$  which depends only upon the temperature difference  $T_1 - T_0$ . See TEMPERATURE MEASUREMENT; THERMOELECTRICITY.

#### Letter designations and compositions for standardized thermocouples\*

Type designation	Materials
B	Platinum-30% rhodium/platinum-6% rhodium
E	Nickel-chromium alloy/a copper-nickel alloy
J	Iron/another slightly different copper-nickel alloy
K	Nickel-chromium alloy/nickel-aluminum alloy
R	Platinum-13% rhodium/platinum
S	Platinum-10% rhodium/platinum
T	Copper/a copper-nickel alloy

\*After T. J. Quinn, *Temperature*, Academic Press, 1983.

A large number of pure metal and alloy combinations have been studied as thermocouples, and the seven most widely used are listed in the table. The thermocouples in the table together cover the temperature range from about -420°F (-250°C or 20 K) to about 3300°F (1800°C). The most accurate and reproducible are the platinum/rhodium thermocouples, types R and S, while the most widely used industrial thermocouples are probably types K, T, and E. [T.J.Q.]

**Thermodynamic cycle** A procedure or arrangement in which one form of energy, such as heat at an elevated temperature from combustion of a fuel, is in part converted to another form, such as mechanical energy on a shaft, and the remainder is rejected to a lower-temperature sink as low-grade heat.

A thermodynamic cycle requires, in addition to the supply of incoming energy, (1) a working substance, usually a gas or vapor; (2) a mechanism in which the processes or phases can be carried through sequentially; and (3) a thermodynamic sink

to which the residual heat can be rejected. The cycle itself is a repetitive series of operations.

There is a basic pattern of processes common to power-producing cycles. There is a compression process wherein the working substance undergoes an increase in pressure and therefore density. There is an addition of thermal energy from a source such as a fossil fuel, a fissile fuel, or solar radiation. There is an expansion process during which work is done by the system on the surroundings. There is a rejection process where thermal energy is transferred to the surroundings. The algebraic sum of the energy additions and abstractions is such that some of the thermal energy is converted into mechanical work. See HEAT.

The basic processes of the cycle, either open or closed, are heat addition, heat rejection, expansion, and compression. These processes are always present in a cycle even though there may be differences in working substance, the individual processes, pressure ranges, temperature ranges, mechanisms, and heat transfer arrangements.

Many cyclic arrangements, using various combinations of phases but all seeking to convert heat into work, have been proposed by many investigators whose names are attached to their proposals, for example, the Diesel, Otto, Rankine, Brayton, Stirling, Ericsson, and Atkinson cycles. All proposals are not equally efficient in the conversion of heat into work. However, they may offer other advantages which have led to their practical development for various applications. See BRAYTON CYCLE; CARNOT CYCLE; DIESEL CYCLE; OTTO CYCLE; STIRLING ENGINE; THERMODYNAMIC PROCESSES. [T.Ba.]

**Thermodynamic principles** Laws governing the transformation of energy. Thermodynamics is the science of the transformation of energy. It differs from the dynamics of Newton by taking into account the concept of temperature, which is outside the scope of classical mechanics. In practice, thermodynamics is useful for assessing the efficiencies of heat engines (devices that transform heat into work) and refrigerators (devices that use external sources of work to transfer heat from a hot system to cooler sinks), and for discussing the spontaneity of chemical reactions (their tendency to occur naturally) and the work that they can be used to generate.

The subject of thermodynamics is founded on four generalizations of experience, which are called the laws of thermodynamics. Each law embodies a particular constraint on the properties of the world. The connection between phenomenological thermodynamics and the properties of the constituent particles of a system is established by statistical thermodynamics, also called statistical mechanics. Classical thermodynamics consists of a collection of mathematical relations between observables, and as such is independent of any underlying model of matter (in terms, for instance, of atoms). However, interpretations in terms of the statistical behavior of large assemblies of particles greatly enriches the understanding of the relations established by thermodynamics. See STATISTICAL MECHANICS.

**Zeroth law of thermodynamics.** The zeroth law of thermodynamics establishes the existence of a property called temperature. This law is based on the observation that if a system A is in thermal equilibrium with a system B (that is, no change in the properties of B take place when the two are in contact), and if system B is in thermal equilibrium with a system C, then it is invariably the case that A will be found to be in equilibrium with C if the two systems are placed in mutual contact. This law suggests that a numerical scale can be established for the common property, and if A, B, and C have the same numerical values of this property, then they will be in mutual thermal equilibrium if they were placed in contact. This property is now called the temperature. See TEMPERATURE.

**First law of thermodynamics.** The first law of thermodynamics establishes the existence of a property called the internal energy of a system. It also brings into the discussion the concept of heat.

The first law is based on the observation that a change in the state of a system can be brought about by a variety of techniques. Indeed, if attention is confined to an adiabatic system, one that is thermally insulated from its surroundings, then the work of J. P. Joule shows that same change of state is brought about by a given quantity of work regardless of the manner in which the work is done. This observation suggests that, just as the height through which a mountaineer climbs can be calculated from the difference in altitudes regardless of the path the climber takes between two fixed points, so the work,  $w$ , can be calculated from the difference between the final and initial properties of a system. The relevant property is called the internal energy,  $U$ . However, if the transformation of the system is taken along a path that is not adiabatic, a different quantity of work may be required. The difference between the work of adiabatic change and the work of nonadiabatic change is called heat,  $q$ . In general, Eq. (1) is satisfied, where  $\Delta U$  is the change in internal energy

$$\Delta U = w + q \quad (1)$$

between the final and initial states of the system. See ADIABATIC PROCESS; ENERGY; HEAT.

The implication of this argument is that there are two modes of transferring energy between a system and its surroundings. One is by doing work; the other is by heating the system. Work and heat are modes of transferring energy. They are not forms of energy in their own right. Work is a mode of transfer that is equivalent (if not the case in actuality) to raising a weight in the surroundings. Heat is a mode of transfer that arises from a difference in temperature between the system and its surroundings. What is commonly called heat is more correctly called the thermal motion of the molecules of a system.

The first law of thermodynamics states that the internal energy of an isolated system is conserved. That is, for a system to which no energy can be transferred by the agency of work or of heat, the internal energy remains constant. This law is a cousin of the law of the conservation of energy in mechanics, but it is richer, for it implies the equivalence of heat and work for bringing about changes in the internal energy of a system (and heat is foreign to classical mechanics).

**Second law of thermodynamics.** The second law of thermodynamics deals with the distinction between spontaneous and nonspontaneous processes. A process is spontaneous if it occurs without needing to be driven. In other words, spontaneous changes are natural changes, like the cooling of hot metal and the free expansion of a gas. Many conceivable changes occur with the conservation of energy globally, and hence are not in conflict with the first law; but many of those changes turn out to be nonspontaneous, and hence occur only if they are driven.

The second law was formulated by Lord Kelvin and by R. Clausius in a manner relating to observation: "no cyclic engine operates without a heat sink" and "heat does not transfer spontaneously from a cool to a hotter body," respectively (see illustration). The two statements are logically equivalent in the sense that failure of one implies failure of the other. However, both may be absorbed into a single statement: the entropy of an isolated system increases when a spontaneous change occurs. The property of entropy is introduced to formulate the law quantitatively in exactly the same way that the properties of temperature and internal energy are introduced to render the zeroth and first laws quantitative and precise.

The entropy,  $S$ , of a system is a measure of the quality of the energy that it stores. The formal definition is based on Eq. (2),

$$dS = \frac{dq_{\text{reversible}}}{T} \quad (2)$$

where  $dS$  is the change in entropy of a system,  $dq$  is the energy transferred to the system as heat,  $T$  is the temperature, and the subscript "reversible" signifies that the transfer must be carried out reversibly (without entropy production other than in the

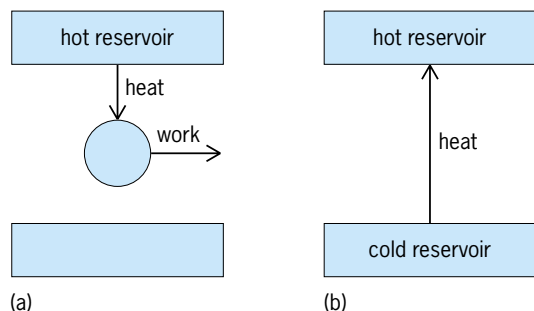

Representation of the statements of the second law of thermodynamics by (a) Lord Kelvin and (b) R. Clausius. In each case, the law states that the device shown cannot operate as shown.

system). When a given quantity of energy is transferred as heat, the change in entropy is large if the transfer occurs at a low temperature and small if the temperature is high.

This definition of entropy is illuminated by L. Boltzmann's interpretation of entropy as a measure of the disorder of a system. The connection can be appreciated qualitatively at least by noting that if the temperature is high, the transfer of a given quantity of energy as heat stimulates a relatively small additional disorder in the thermal motion of the molecules of a system; in contrast, if the temperature is low, the same transfer could stimulate a relatively large additional disorder.

The illumination of the second law brought about by the association of entropy and disorder is that in an isolated system the only changes that may occur are those in which there is no increase in order. Thus, energy and matter tend to disperse in disorder (that is, entropy tends to increase), and this dispersal is the driving force of spontaneous change. See ENTROPY; TIME, ARROW OF.

**Third law of thermodynamics.** The practical significance of the second law is that it limits the extent to which the internal energy may be extracted from a system as work. In order for a process to generate work, it must be spontaneous. For the process to be spontaneous, it is necessary to discard some energy as heat in a sink of lower temperature. In other words, nature in effect exacts a tax on the extraction of energy as work. There is therefore a fundamental limit on the efficiency of engines that convert heat into work.

The quantitative limit on the efficiency,  $\epsilon$ , which is defined as the work produced divided by the heat absorbed from the hot source, was first derived by S. Carnot. He found that, regardless of the details of the construction of the engine, the maximum efficiency (that is, the work obtained after payment of the minimum allowable tax to ensure spontaneity) is given by Eq. (3), where

$$\epsilon = 1 - \frac{T_{\text{cold}}}{T_{\text{hot}}} \quad (3)$$

$T_{\text{hot}}$  is the temperature of the hot source and  $T_{\text{cold}}$  is the temperature of the cold sink. The greatest efficiencies are obtained with the coldest sinks and the hottest sources, and these are the design requirements of modern power plants. See CARNOT CYCLE.

Perfect efficiency ( $\epsilon = 1$ ) would be obtained if the cold sink were at absolute zero ( $T_{\text{cold}} = 0$ ). However, the third law of thermodynamics, which is another summary of observations, asserts that absolute zero is unattainable in a finite number of steps for any process. Therefore, heat can never be completely converted into work in a heat engine. The implication of the third law in this form is that the entropy change accompanying any process approaches zero as the temperature approaches zero. That implication in turn implies that all substances tend toward the same entropy as the temperature is reduced to zero. It is therefore sensible to take the entropy of all perfect crystalline substances (substances in which there is no residual disorder arising

from the location of atoms) as equal to zero. A common short statement of the third law is therefore that all perfect crystalline substances have zero entropy at absolute zero ( $T = 0$ ). This statement is consistent with the interpretation of entropy as a measure of disorder, since at absolute zero all thermal motion has been quenched. See ABSOLUTE ZERO. [P.W.A.]

**Thermodynamic processes** Changes of any property of an aggregation of matter and energy, accompanied by thermal effects.

**Systems and processes.** To evaluate the results of a process, it is necessary to know the participants that undergo the process, and their mass and energy. A region, or a system, is selected for study, and its contents determined. This region may have both mass and energy entering or leaving during a particular change of conditions, and these mass and energy transfers may result in changes both within the system and within the surroundings which envelop the system.

To establish the exact path of a process, the initial state of the system must be determined, specifying the values of variables such as temperature, pressure, volume, and quantity of material. The number of properties required to specify the state of a system depends upon the complexity of the system. Whenever a system changes from one state to another, a process occurs.

The path of a change of state is the locus of the whole series of states through which the system passes when going from an initial to a final state. For example, suppose a gas expands to twice its volume and that its initial and final temperatures are the same. An extremely large number of paths connect these initial and final states. The detailed path must be specified if the heat or work is to be a known quantity; however, changes in the thermodynamic properties depend only on the initial and final states and not upon the path. A quantity whose change is fixed by the end states and is independent of the path is a point function or a property.

**Pressure-volume-temperature diagram.** Whereas the state of a system is a point function, the change of state of a system, or a process, is a path function. Various processes or methods of change of a system from one state to another may be depicted graphically as a path on a plot using thermodynamic properties as coordinates.

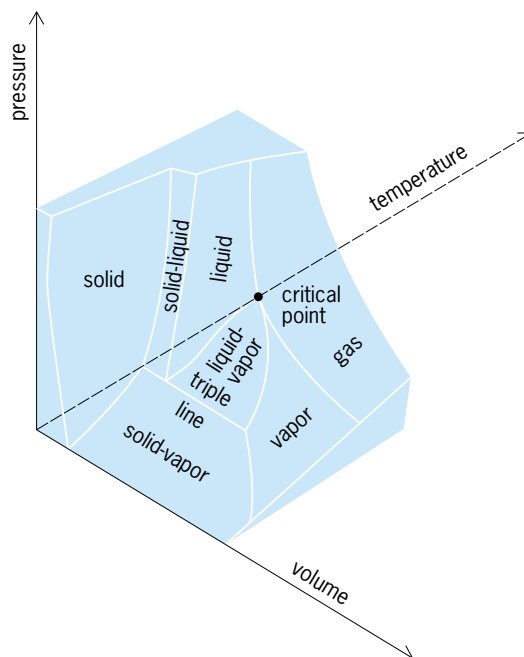

Fig. 1. Portion of pressure-volume-temperature (P-V-T) surface for a typical substance.

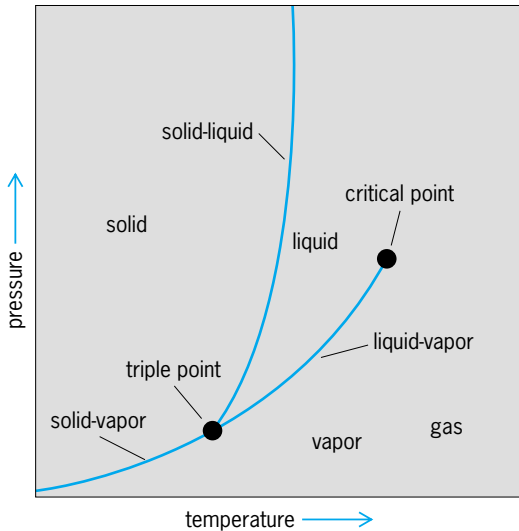

Fig. 2. Portion of equilibrium surface projected on pressure-temperature ( $P$ - $T$ ) plane.

The variable properties most frequently and conveniently measured are pressure, volume, and temperature. If any two of these are held fixed (independent variables), the third is determined (dependent variable). To depict the relationship among these physical properties of the particular working substance, these three variables may be used as the coordinates of a three-dimensional space. The resulting surface is a graphic presentation of the equation of state for this working substance, and all possible equilibrium states of the substance lie on this  $P$ - $V$ - $T$  surface.

Because a  $P$ - $V$ - $T$  surface represents all equilibrium conditions of the working substance, any line on the surface represents a possible reversible process, or a succession of equilibrium states.

The portion of the  $P$ - $V$ - $T$  surface shown in Fig. 1 typifies most real substances; it is characterized by contraction of the substance on freezing. Going from the liquid surface to the liquid-solid surface onto the solid surface involves a decrease in both temperature and volume. Water is one of the few exceptions to this condition; it expands upon freezing, and its resultant  $P$ - $V$ - $T$  surface is somewhat modified where the solid and liquid phases abut.

One can project the three-dimensional surface onto the  $P$ - $T$  plane as in Fig. 2. The triple point is the point where the three phases are in equilibrium. When the temperature exceeds the critical temperature (at the critical point), only the gaseous phase is possible.

**Temperature-entropy diagram.** Energy quantities may be depicted as the product of two factors: an intensive property and an extensive one. Examples of intensive properties are pressure, temperature, and magnetic field; extensive ones are volume, magnetization, and mass. Thus, in differential form, work is the product of a pressure exerted against an area which sweeps through an infinitesimal volume, as in Eq. (1). As a gas expands,

$$dW = P dV \quad (1)$$

it is doing work on its environment. However, a number of different kinds of work are known. For example, one could have work of polarization of a dielectric, of magnetization, of stretching a wire, or of making new surface area. In all cases, the infinitesimal work is given by Eq. (2), where  $X$  is a generalized applied force

$$dW = X dx \quad (2)$$

which is an intensive quantity, and  $dx$  is a generalized displacement of the system and is thus extensive.

By extending this approach, one can depict transferred heat as the product of an intensive property, temperature, and a dis-

tributed or extensive property defined as entropy, for which the symbol is  $S$ . See ENTROPY.

**Reversible and irreversible processes.** Not all energy contained in or associated with a mass can be converted into useful work. Under ideal conditions only a fraction of the total energy present can be converted into work. The ideal conversions which retain the maximum available useful energy are reversible processes.

Characteristics of a reversible process are that the working substance is always in thermodynamic equilibrium and the process involves no dissipative effects such as viscosity, friction, inelasticity, electrical resistance, or magnetic hysteresis. Thus, reversible processes proceed quasistatically so that the system passes through a series of states of thermodynamic equilibrium, both internally and with its surroundings. This series of states may be traversed just as well in one direction as in the other.

Actual changes of a system deviate from the idealized situation of a quasistatic process devoid of dissipative effects. The extent of the deviation from ideality is correspondingly the extent of the irreversibility of the process. See THERMODYNAMIC PRINCIPLES.

[P.E.BI.; W.A.S.]

**Thermoelectric power generator** A solid-state heat engine which employs the electron gas as a working fluid. It directly converts heat energy into electrical energy using the Seebeck effect. This phenomenon can be demonstrated using a thermocouple which comprises two legs (thermoelements) of dissimilar conducting materials joined at one end to form a junction. If this junction is maintained at a temperature which differs from ambient, a voltage is generated across the open ends of the thermoelements. When the circuit is completed with a load, a current flows in the circuit and power is generated. In practice the thermocouples are fabricated generally from  $n$ - and  $p$ -type semiconductors, and several hundred are connected electrically in series to form a module which is the active component of a thermoelectric generator. Provided a temperature difference is maintained across the device, it will generate electrical power. Heat is provided from a variety of sources depending on the application, and they include burning fossil fuels in terrestrial and military applications, decaying long-life isotopes in medical and deep-space applications, and waste heat. The performance of the thermoelectric generator, in terms of efficiency, output power, and economic viability, depends upon its temperature regime of operation; the materials used in the module construction; its electrical, thermal, and geometrical design; and the generator load. The power output spectrum of thermoelectric generators spans 14 orders of magnitude and ranges from nanowatt generators fabricated using integrated circuit technology to the nuclear-reactor-powered 100-kW SP-100 generator intended to provide electrical power to orbiting space stations. See NUCLEAR BATTERY; RADIOACTIVITY AND RADIATION APPLICATIONS; SEEBECK EFFECT; SPACE POWER SYSTEMS; SPACE PROBE; THERMOCOUPLE; THERMOELECTRICITY.

Historically the use of thermoelectric generators has been restricted to specialized applications where combinations of their desirable properties, such as the absence of moving parts, reliability, and silent operation, has outweighed their low overall conversion efficiency, typically 5%. In these applications, fuel cost or weight is a major consideration, and improving the conversion efficiency is the main research target. Improving the figure of merit has been regarded as the most important factor in increasing the conversion efficiency of a thermoelectric generator.

Selection of thermocouple material depends upon the generator's temperature regime of operation. The figures of merit of established thermoelectric materials reach maxima at different temperatures, and semiconductor compounds or alloys based on bismuth telluride, lead telluride, and silicon germanium cover the temperature ranges up to 150°C (300°F), 650°C (1200°F), and 1000°C (1830°F) respectively, with the best materials capable of generating electrical power with an efficiency of around

20%. Material research is focused on improving the figure of merit and to a lesser, though an increasing, extent, the electrical power factor.

The emergence of thermoelectrics as a technology for application in waste heat recovery has resulted in a successful search for materials with high electrical power factors and cheap materials. The rare-earth ytterbium-aluminum compound  $\text{YbAl}_3$  has a power factor almost three times that of bismuth telluride, the established material for low-temperature application, while magnesium tin ( $\text{MgSn}$ ) has almost the same performance as lead telluride but is available at less than a quarter of the cost. [D.M.Row.]

**Thermoelectricity** The direct conversion of heat into electrical energy, or the reverse, in solid or liquid conductors by means of three interrelated phenomena—the Seebeck effect, the Peltier effect, and the Thomson effect—including the influence of magnetic fields upon each. The Seebeck effect concerns the electromotive force (emf) generated in a circuit composed of two different conductors whose junctions are maintained at different temperatures. The Peltier effect refers to the reversible heat generated at the junction between two different conductors when a current passes through the junction. The Thomson effect involves the reversible generation of heat in a single current-carrying conductor along which a temperature gradient is maintained. Specifically excluded from the definition of thermoelectricity are the phenomena of Joule heating and thermionic emission. See ELECTROMOTIVE FORCE (EMF); JOULE'S LAW; PELTIER EFFECT; SEEBECK EFFECT; THERMIONIC EMISSION; THOMSON EFFECT.

The three thermoelectric effects are described in terms of three coefficients: the absolute thermoelectric power (or thermopower)  $S$ , the Peltier coefficient  $\Pi$ , and the Thomson coefficient  $\mu$ , each of which is defined for a homogeneous conductor at a given temperature. These coefficients are connected by the Kelvin relations, which convert complete information about one into complete information about all three. It is therefore necessary to measure only one of the three coefficients; usually the thermopower  $S$  is chosen.

The most important practical application of thermoelectric phenomena is in the accurate measurement of temperature. The phenomenon involved is the Seebeck effect. Of less importance are the direct generation of electrical power by application of heat (also involving the Seebeck effect) and thermoelectric cooling and heating (involving the Peltier effect).

A basic system suitable for all four applications is shown schematically in the illustration. Several thermocouples are connected in series to form a thermopile, a device with increased output (for power generation or cooling and heating) or sensi-

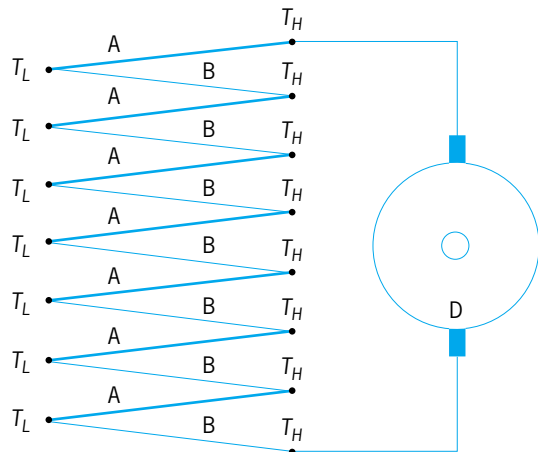

**Thermopile, a battery of thermocouples connected in series.  $D$  is a device appropriate to the particular application;  $A$  and  $B$  are the two different conductors.**

tivity (for temperature measurement) relative to a single thermocouple. The junctions forming one end of the thermopile are all at the same low temperature  $T_L$ , and the junctions forming the other end are at the high temperature  $T_H$ . The thermopile is connected to a device  $D$  which is different for each application. For temperature measurement, the temperature  $T_L$  is fixed, for example, by means of a bath; the temperature  $T_H$  becomes the running temperature  $T$ , which is to be measured; and the device is a potentiometer for measuring the thermoelectric emf generated by the thermopile. For power generation, the temperature  $T_L$  is fixed by connection to a heat sink; the temperature  $T_H$  is fixed at a value determined by the output of the heat source and the thermal conductance of the thermopile; and the device is whatever is to be run by the electricity that is generated. For heating or cooling, the device is a current generator that passes current through the thermopile. If the current flows in the proper direction, the junctions at  $T_H$  will heat up, and those at  $T_L$  will cool down. If  $T_H$  is fixed by connection to a heat sink, thermoelectric cooling will be provided by  $T_L$ . Alternatively, if  $T_L$  is fixed, thermoelectric heating will be provided at  $T_H$ . Such a system has the advantage that at any given location it can be converted from a cooler to a heater merely by reversing the direction of the current.

Thermoelectric power generators, heaters, or coolers made from even the best presently available materials have the disadvantages of relatively low efficiencies and concomitant high cost per unit of output. Their use has therefore been largely restricted to situations in which these disadvantages are outweighed by such advantages as small size, low maintenance due to lack of moving parts, quiet and vibration-free performance, light weight, and long life. See THERMOELECTRIC POWER GENERATOR. [J.B.]

**Thermoluminescence** The emission of light when certain solids are warmed, generally to a temperature lower than that needed to provoke visible incandescence. Two characteristics of thermoluminescence distinguish it from incandescence. First, the intensity of thermoluminescent emission does not remain constant at constant temperature, but decreases with time and eventually ceases altogether. Second, the spectrum of the thermoluminescence is highly dependent on the composition of the material and is only slightly affected by the temperature of heating. If a thermoluminescent material emits both thermoluminescence and incandescent light at some temperature of observation, the transient light emission is the thermoluminescence and the remaining steady-state emission is the incandescence. The transient nature of the thermoluminescent emission suggests that heating merely triggers the release of stored energy previously imparted to the material. Supporting this interpretation is the fact that after the thermoluminescence has been reduced to zero by heating, the sample can be made thermoluminescent again by exposure to one of a number of energy sources: x-rays and gamma rays, electron beams, nuclear particles, ultraviolet light, and, in some cases, even short-wave visible light (violet and blue). A thermoluminescent material, therefore, has a memory of its earlier exposure to an energizing source, and this memory is utilized in a number of applications. Many natural minerals are thermoluminescent, but the most efficient materials of this type are specially formulated synthetic solids (phosphors). See LUMINESCENCE.

In addition to special sites capable of emitting light (luminescent centers), thermoluminescent phosphors have centers that can trap electrons or holes when these are produced in the solid by ionizing radiation. The luminescent center itself is often the hole trap, and the electron is trapped at another center, although the reverse situation can also occur. In the former case, if the temperature is low and the energy required to release an electron from a trap (the trap depth) is large, electrons will remain trapped and no luminescence will occur. If, however, the temperature of the phosphor is progressively raised, electrons will receive increasing amounts of thermal energy and will have an

increased probability of escape from the traps. Freed electrons may then go over to luminescent centers and recombine with holes trapped at or near these centers. The energy liberated by the recombination can excite the luminescent centers, causing them to emit light. *See* HOLE STATES IN SOLIDS; TRAPS IN SOLIDS.

Radiation dosimeters based on thermoluminescence are widely used for monitoring integrated radiation exposure in nuclear power plants, hospitals, and other installations where high-energy radiations are likely to be encountered. The key elements of the dosimeters, thermoluminescent phosphors with deep traps, can store some of the energy absorbed from these radiations for very long periods of time at normal temperatures and release it as luminescence on demand when appropriately heated. The brightness (or light sum) of the luminescence is a measure of the original radiation dose. *See* DOSIMETER. [J.H.S.]

**Thermomagnetic effects** Electrical and thermal phenomena occurring when a conductor or semiconductor which is carrying a thermal current (that is, is in a temperature gradient) is placed in a magnetic field. *See* SEMICONDUCTOR.

Let the temperature gradient be transverse to the magnetic field  $H_z$ , for example, along  $x$ . Then the following transverse-transverse effects are observed:

1. Ettingshausen-Nernst effect, an electric field along  $y$ .
2. Righi-Leduc effect, a temperature gradient along  $y$ .
3. An electric potential change along  $x$ , amounting to a change of thermoelectric power.
4. A temperature gradient change along  $x$ , amounting to a change of thermal resistance.

Let the temperature gradient be along  $H$ . Then changes in thermoelectric power and in thermal conductivity are observed in the direction of  $H$ .

For related phenomena *see* HALL EFFECT; MAGNETORESISTANCE. [E.A.; F.Kc.]

**Thermometer** An instrument that measures temperature. Although this broad definition includes all temperature-measuring devices, they are not all called thermometers. Other names have been generally adopted. For a discussion of two such devices *see* PYROMETER; THERMOCOUPLE. For a general discussion of temperature measurement; TEMPERATURE MEASUREMENT.

**Liquid-in-glass thermometer.** This thermometer consists of a liquid-filled glass bulb and a connecting partially filled capillary tube. When the temperature of the thermometer increases, the differential expansion between the glass and the liquid causes the liquid to rise in the capillary. A variety of liquids, such as mercury, alcohol, toluene, and pentane, and a number of different glasses are used in thermometer construction, so that various designs cover diverse ranges between about  $-300^\circ\text{F}$  and  $+1200^\circ\text{F}$  ( $-184^\circ\text{C}$  and  $+649^\circ\text{C}$ ).

**Bimetallic thermometer.** In this thermometer the differential expansion of thin dissimilar metals, bonded together into a narrow strip and coiled into the shape of a helix or spiral, is used to actuate a pointer. In some designs the pointer is replaced with low-voltage contacts to control, through relays, operations which depend upon temperature, such as furnace controls.

**Filled-system thermometer.** This type of thermometer has a bourdon tube connected by a capillary tube to a hollow bulb. When the system is designed for and filled with a gas (usually nitrogen or helium) the pressure in the system substantially follows the gas law, and a temperature indication is obtained from the bourdon tube. The temperature-pressure-motion relationship is nearly linear. Atmospheric pressure effects are minimized by filling the system to a high pressure. When the system is designed for and filled with a liquid, the volume change of the liquid actuates the bourdon tube.

**Vapor-pressure thermal system.** This filled-system thermometer utilizes the vapor pressure of certain stable liquids to measure temperature. The useful portion of any liquid-vapor pressure curve is between approximately 15 psia (100 kilopascals

absolute) and the critical pressure, that is, the vapor pressure at the critical temperature, which is the highest temperature for a particular liquid-vapor system. A nonlinear relationship exists between the temperature and the vapor pressure, so the motion of the bourdon tube is greater at the upper end of the vapor-pressure curve. Therefore, these thermal systems are normally used near the upper end of their range, and an accuracy of 1% or better can be expected.

**Resistance thermometer.** In this type of thermometer the change in resistance of conductors or semiconductors with temperature change is used to measure temperature. Usually, the temperature-sensitive resistance element is incorporated in a bridge network which has a reasonably constant power supply. Although a deflection circuit is occasionally used, almost all instruments of this class use a null-balance system, in which the resistance change is balanced and measured by adjusting at least one other resistance in the bridge. Metals commonly used as the sensitive element in resistance thermometers are platinum, nickel, and copper.

**Thermistor.** This device is made of a solid semiconductor with a high temperature coefficient of resistance. The thermistor has a high resistance, in comparison with metallic resistors, and is used as one element in a resistance bridge. Since thermistors are more sensitive to temperature changes than metallic resistors, accurate readings of small changes are possible. *See* THERMISTOR. [H.S.B.]

**Thermonuclear reaction** A nuclear fusion reaction which occurs between various nuclei of the light elements when they are constituents of a gas at very high temperatures. Thermonuclear reactions, the source of energy generation in the Sun and the stable stars, are utilized in the fusion bomb. *See* HYDROGEN BOMB; NUCLEAR FUSION; STELLAR EVOLUTION; SUN.

Thermonuclear reactions occur most readily between isotopes of hydrogen (deuterium and tritium) and less readily among a few other nuclei of higher atomic number. At the temperatures and densities required to produce an appreciable rate of thermonuclear reactions, all matter is completely ionized; that is, it exists only in the plasma state. Thermonuclear fusion reactions may then occur within such an ionized gas when the agitation energy of the stripped nuclei is sufficient to overcome their mutual electrostatic repulsions, allowing the colliding nuclei to approach each other closely enough to react. For this reason, reactions tend to occur much more readily between energy-rich nuclei of low atomic number (small charge) and particularly between those nuclei of the hot gas which have the greatest relative kinetic energy. This latter fact leads to the result that, at the lower fringe of temperatures where thermonuclear reactions may take place, the rate of reactions varies exceedingly rapidly with temperature. *See* CARBON-NITROGEN-OXYGEN CYCLES; KINETIC THEORY OF MATTER; MAGNETOHYDRODYNAMICS; NUCLEAR REACTION; PINCH EFFECT; PROTON-PROTON CHAIN. [R.F.P.]

**Thermoregulation** The processes by which many animals actively maintain the temperature of part or all of their body within a specified range in order to stabilize or optimize temperature-sensitive physiological processes. Body temperatures of normally active animals may range from  $32$  to  $115^\circ\text{F}$  ( $0$  to  $46^\circ\text{C}$ ) or more, but the tolerable range for any one species is much narrower.

Animals are commonly classified as warm-blooded or cold-blooded. When the temperature of the environment varies, the body temperature of a warm-blooded or homeothermic animal remains high and constant, while that of a cold-blooded or poikilothermic animal is low and variable. However, supposedly cold-blooded reptiles and insects, when active, may regulate body temperatures within  $2$ – $4^\circ\text{F}$  ( $1$ – $2^\circ\text{C}$ ) of a species-specific value. Supposedly warm-blooded mammals and birds may allow their temperature to drop to  $37$ – $68^\circ\text{F}$  ( $5$ – $20^\circ\text{C}$ ) during hibernation or torpor. Further, optimal temperature varies with

organ, time of day, and circumstance. Thus, this classification is often misleading.

A better classification is based on the principal source of heat used for thermoregulation. Endotherms (birds, mammals) use heat generated from food energy. Ectotherms (invertebrates, fish, amphibians, reptiles) use heat from environmental sources. This classification also has limitations, however. For example, endotherms routinely use external heat sources to minimize the food cost of thermoregulation, and some ectotherms use food energy for thermoregulation. See PHYSIOLOGICAL ECOLOGY (ANIMAL).

Behavior is the most obviously active form of thermoregulation. Most animals are mobile, sensitive to their environment, and capable of complex behaviors. The simplest thermoregulatory behavior consists of moving to a favorable location. Operative temperature may also be altered by changing posture in one place. Lizards face the sun to minimize the area exposed to solar heating, or orient broadside to maximize it, and some ground squirrels use their tail as a sunshade. Some reptiles and amphibians also expand or contract pigmented cells in their skin to increase or decrease solar heating. See CHROMATOPHORE.

Evaporation is an effective means of cooling the body. Evaporation from the respiratory mucous membranes is the most common mechanism. Evaporation from the mucous membranes cools the nose during inhalation. During exhalation, water vapor condenses on the cool nasal membranes and is recovered. Evaporation can be greatly increased by exhaling from the mouth to prevent condensation. Additional increases in evaporation result from panting, that is, rapid breathing at the resonant frequency of the respiratory system. Evaporation from the eyes and the mucous membranes of the mouth and tongue is another source of cooling. Water is also evaporated from the skin of all animals, and can be varied for thermoregulation. Some desert frogs control evaporation by spreading an oily material on the skin. Reptiles, birds, and mammals have relatively impermeable skins, but evaporation can be increased by various means. The sweat glands in the skin of mammals are particularly effective and are one of the few purely thermoregulatory organs known. See SKIN.

Changes in circulation can be used to regulate heat flow. Countercurrent heat exchange is used to regulate heat flow to particular parts of the body while maintaining oxygen supply. Large vessels may be divided into intermingled masses of small vessels to maximize heat exchange, forming an organ called a rete. However, retes can be bypassed by alternative circulation paths to regulate heat flow. Many animals living in warm environments have a rete that regulates brain temperature by cooling the arterial blood supply to the brain with blood draining from the nasal membranes, eyes, ears, or horns. See CARDIOVASCULAR SYSTEM; COUNTERCURRENT EXCHANGE (BIOLOGY).

Heat exchange with the environment is limited by the fur of mammals, feathers of birds, and furlike scales or setae of insects. Erection or compression of this insulation varies heat flow. Insulation thickness varies over the body to exploit variations in local operative temperature. Thermal windows are thinly insulated areas that are either shaded (abdomen of mammals, axilla of birds and mammals) or of small size (ears, face, legs) so that solar heating is minimized.

The oxidation of foodstuffs within the metabolic pathways of the body releases as much heat as if it were burned. Basal metabolism is the energy use rate of a fasting animal at rest. Activity, digestion, and thermoregulation increase metabolism above the basal rate. Endothermy is the utilization of metabolic heat for thermoregulation. Birds and mammals are typical examples, but significant endothermy also occurs in large salt-water fish, large reptiles, and large flying insects. Endotherms regulate only the temperature of the body core, that is, the brain, heart, and lungs. The heat production of these metabolically active organs is often supplemented with heat produced in muscles. Heat produced as a by-product of activity may substitute partially for thermoregulatory heat production, and imposes no thermoreg-

ulatory energy cost. In contrast, shivering produces heat only for thermoregulation and results in an extra cost. Some animals have specialized heater organs for nonshivering thermogenesis, which is more efficient than shivering. Brown adipose tissue is a fatty tissue with a high density of mitochondria. It is found in the thorax of mammals, especially newborns and hibernators, and it warms the body core efficiently. See ADIPOSE TISSUE; METABOLISM.

The variety of mechanisms used in thermoregulation indicates a corresponding complexity in neural control. Temperature sensors distributed over the skin respond nearly immediately to changes in the environment and provide the major input. Nearly all parts of the central nervous system also respond to local thermal stimulation. These peripheral and central thermal inputs are integrated at a series of centers beginning in the spinal cord. This series clearly extends to the cerebral cortex, as a learning period is required before behavioral thermoregulation reaches maximum precision. Various components respond to the rate of temperature change as well as the difference between preferred and actual temperature. The neuroendocrine system then regulates metabolic heat production, the sympathetic nervous system controls blood flow, and the cerebral cortex controls behavioral thermoregulation. See ENDOCRINE SYSTEM (VERTEBRATE); HOMEOSTASIS; NERVOUS SYSTEM (VERTEBRATE). [G.Ba.]

**Thermosbaenacea** A small order of the superorder Peracarida in the superclass Crustacea. In thermosbaenaceans, the carapace, which may cover part of the cephalic region and one to several thoracic somites, is fused only to the first thoracic somite. The carapace of females is expanded to provide a dorsally positioned brood pouch where embryos hatch as subadults. Eyes are reduced or absent. The abdomen consists of six somites and a telson; however, in *Thermosbaena*, at least, the telson and sixth somite are fused to form a pleotelson. The first pair of thoracic appendages are modified as maxillipeds, and may be sexually dimorphic; the remaining five to seven pairs provide the animals with locomotion. Sexes are separate. Thermosbaenaceans have been found principally in thermal, but occasionally in cool, fresh- or brackish-water, lakes, springs, and interstitial coastal areas, and also in cave pools, in a geographic band stretching from the Mediterranean to the Caribbean and Gulf of Mexico. See PERACARIDA. [P.A.McL.]

**Thermosphere** A rarefied portion of the atmosphere, lying in a spherical shell between 50 and 300 mi (80 and 500 km) above the Earth's surface, where the temperature increases dramatically with altitude. The thermosphere responds to the variable outputs of the Sun, the ultraviolet radiation at wavelengths less than 200 nanometers, and the solar wind plasma that flows outward from the Sun and interacts with the Earth's geomagnetic field. This interaction energizes the plasma, accelerates charged particles into the thermosphere, and produces the aurora borealis and aurora australis, which are nearly circular-shaped regions of luminosity that surround the magnetic north and south poles respectively. Embedded within the thermosphere is the ionosphere, a weakly ionized plasma. See IONOSPHERE; MAGNETOSPHERE; PLASMA PHYSICS; SOLAR WIND.

In the thermosphere, these molecular species are subjected to intense solar ultraviolet radiation and photodissociation that gradually turns the molecular species into the atomic species oxygen, nitrogen, and hydrogen. Up to above 60 mi (100 km), atmospheric turbulence keeps the atmosphere well mixed, with the molecular concentrations dominating in the lower atmosphere. Above 60 mi, solar ultraviolet radiation most strongly dissociates molecular oxygen, and there is less mixing from atmospheric turbulence. The result is a transition area where molecular diffusion dominates and atmospheric species settle according to their molecular and atomic weights. Above 60 mi, atomic oxygen is the dominant species. See ATMOSPHERE.



About 60% of the solar ultraviolet energy absorbed in the thermosphere and ionosphere heats the ambient neutral gas and ionospheric plasma; 20% is radiated out of the thermosphere as airglow from excited atoms and molecules; and 20% is stored as chemical energy of the dissociated oxygen and nitrogen molecules, which is released later when recombination of the atomic species occurs. Most of the neutral gas heating that establishes the basic temperature structure of the thermosphere is derived from excess energy released by the products of ion-neutral and neutral chemical reactions occurring in the thermosphere and ionosphere. See AIRGLOW; ULTRAVIOLET RADIATION.

The average vertical temperature profile is determined by a balance of local solar heating by the downward conduction of molecular thermal product to the region of minimum temperature near 50 mi (80 km). For heat to be conducted downward within the thermosphere, the temperature of the thermosphere must increase with altitude. The global mean temperature increases from about 200 K (−100°F) near 50 mi to 700–1400 K (800–2100°F) above 180 mi (300 km), depending upon the intensity of solar ultraviolet radiation reaching the Earth. Above 180 mi, molecular thermal conduction occurs so fast that vertical temperature differences are largely eliminated; the isothermal temperature in the upper thermosphere is called the exosphere temperature.

As the Earth rotates, absorption of solar energy in the thermosphere undergoes a daily variation. Dayside heating causes the atmosphere to expand, and the loss of heat at night causes it to contract. This heating pattern creates pressure differences that drive a global circulation, transporting heat from the warm dayside to the cool nightside. [R.G.R.]

**Thermostat** An instrument which directly or indirectly controls one or more sources of heating and cooling to maintain a desired temperature. To perform this function a thermostat must have a sensing element and a transducer. The sensing element measures changes in the temperature and produces a desired effect on the transducer. The transducer converts the effect produced by the sensing element into a suitable control of the device or devices which affect the temperature.

The most commonly used principles for sensing changes in temperature are (1) unequal rate of expansion of two dissimilar metals bonded together (bimetals), (2) unequal expansion of two dissimilar metals (rod and tube), (3) liquid expansion (sealed diaphragm and remote bulb or sealed bellows with or without

a remote bulb), (4) saturation pressure of a liquid-vapor system (bellows), and (5) temperature-sensitive resistance element.

The most commonly used transducers are (1) switches that make or break an electric circuit, (2) potentiometer with a wiper that is moved by the sensing element, (3) electronic amplifier, and (4) pneumatic actuator.

The most common thermostat application is for room temperature control. The illustration shows a typical on-off heating-cooling room thermostat. In a typical application the thermostat controls a gas valve, oil burner control, electric heat control, cooling compressor control, or damper actuator.

Thermostats are also used extensively in safety and limit application. Thermostats are generally of the following types: insertion types that are mounted on ducts with the sensing element extending into a duct; immersion types that control a liquid in a pipe or tank with the sensing element extending into the liquid; and surface types in which the sensing element is mounted on a pipe or similar surface. See COMFORT HEATING; FURNACE; OIL BURNER. [N.R.]

**Thermotherapy** The treatment of disease by the local or general application of heat. The following discussion is limited to the local application of heat as an adjunct to therapeutic management of musculoskeletal and joint diseases. The most commonly used methods for this form of treatment include hot packs, hydrotherapy, radiant heat, shortwave diathermy, microwave diathermy, ultrasound, and laser therapy.

The reason so many different methods are employed is that each modality heats selectively different anatomical structures, and thus the modality selected for a given treatment is based on the temperature distribution produced in the tissues. For vigorous heat application to a given site, the location of the peak temperature produced by the modality must coincide with the site so that maximally tolerated tissue temperatures can be obtained there without burning elsewhere. Customarily, the modalities are divided into those that heat superficial tissues and those that heat deep-seated tissues. Hot packs, hydrotherapy, and radiant heat are used to heat superficial tissues. Photons of ultraviolet radiation, x-rays, and radium penetrate deeper into the tissues and produce photochemical reactions long before the temperature increases significantly. Other forms of energy used for heating deep-seated tissues include shortwave, microwave, and ultrasound. See ELECTROMAGNETIC RADIATION; MICROWAVE; ULTRASONICS.

The therapeutic effects produced by heating selectively by ultrasound include an increase in the extensibility of collagen tissues. Disease or injury, such as arthritis, burns, scarring, or long-term immobilization in a cast, may cause shortening of collagen tissue producing severe limitation of the range of motion at a joint. This application of heat (mostly ultrasound) is often used in conjunction with physical therapy. Heat applied by using shortwaves and microwaves may reduce muscle spasms secondary to musculoskeletal pathology. Selective heating of muscle with microwave radiation has been used to accelerate absorption of hematomas and to prepare for stretching of the contracted and stiffened muscle. Heat therapy in the form of hyperthermia has been used as an effective adjunct to cancer therapy in combination with ionizing radiation in the form of x-rays or radium therapy.

The most commonly used laser in physical therapy is the helium-neon laser. The depth of penetration and the heating effect are similar to infrared light. However, the major difference between laser light and diffuse light of the same wavelength is that with laser light, any desirable intensity can be easily produced. See LASER PHOTOBIOLOGY. [J.F.Le.]

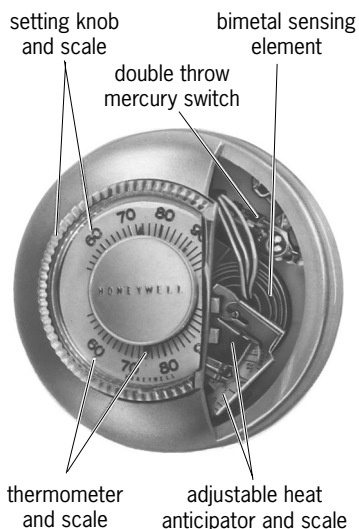

Typical heat-cool thermostat. (Honeywell Inc.)

**Thévenin's theorem (electric networks)** This theorem, from electric circuit theory, is also known as the Helmholtz or Helmholtz-Thévenin theorem, since H. Helmholtz stated it in an earlier form prior to M. L. Thévenin. Closely related

is the Norton theorem, which will also be discussed. Laplace transform notation will be used. See LAPLACE TRANSFORM.

Thévenin's theorem states that at a pair of terminals a network composed of lumped, linear circuit elements may, for purposes of analysis of external circuit or terminal behavior, be replaced by a voltage source  $V(s)$  in series with a single impedance  $Z(s)$ . The source  $V(s)$  is the Laplace transform of the voltage across the pair of terminals when they are open-circuited;  $Z(s)$  is the transform impedance at the two terminals with all independent sources set to zero (Fig. 1).

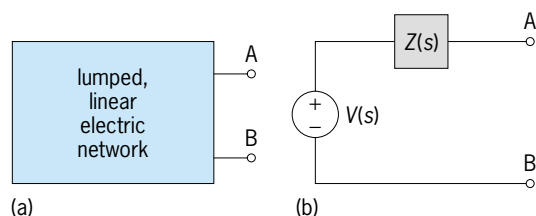

Fig. 1. Network and its Thévenin equivalent. (a) Original network. (b) Thévenin equivalent circuit.

Norton's theorem states that a second equivalent network consists of a current source  $I(s)$  in parallel with an impedance  $Z(s)$ . The impedance  $Z(s)$  is identical with the Thévenin impedance, and  $I(s)$  is the Laplace transform of the current between the two terminals when they are short-circuited (Fig. 2).

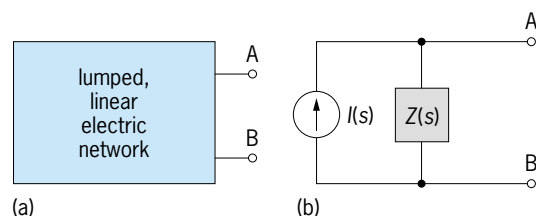
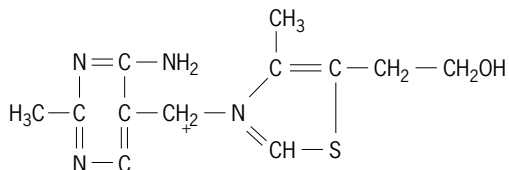

Fig. 2. Network and its Norton equivalent. (a) Original network. (b) Norton equivalent circuit.

Thévenin's and Norton's equivalent networks are related by the equation  $V(s) = Z(s) \cdot I(s)$ .

These theorems are useful for the study of the behavior of a load connected to a (possibly complex) system that is supplying electric power to that load. See SUPERPOSITION THEOREM (ELECTRIC NETWORKS). [E.C.Jo.]

**Thiamine** A water-soluble vitamin found in many foods; pork, liver, and whole grains are particularly rich sources. It is also known as vitamin B<sub>1</sub> or aneurin. The structural formula of thiamine is shown below.



Thiamine deficiency is known as beriberi in humans and polyneuritis in birds. Muscle and nerve tissues are affected by the deficiency, and poor growth is observed. People with beriberi are irritable, depressed, and weak. They often die of cardiac failure. Wernicke's disease observed in alcoholics is associated with a thiamine deficiency. This disease is characterized by brain lesions, liver disease, and partial paralysis, particularly of the motor nerves of the eye. As is the case in all B vitamin diseases, thiamine deficiency is usually accompanied by deficiencies of other vitamins. [S.N.G.]

**Thick-film sensor** A sensor that is based on a thick-film circuit. Thick-film circuits are formed by the deposition of layers of special pastes onto an insulating substrate. The pastes are usually referred to as inks, although there is little resemblance to conventional ink. The printed pattern is fired in a manner akin to the production of pottery, to produce electrical pathways of a controlled resistance. Parts of a thick-film circuit can be made sensitive to strain or temperature. The thick-film pattern can include mounting positions for the insertion of conventional silicon devices, in which case the assembly is known as a thick-film hybrid. The process is relatively cheap, especially if large numbers of devices are produced, and the use of hybrid construction allows the sensor housing to include sophisticated signal conditioning circuits. These factors indicate that thick-film technology is likely to play an increasing role in sensor design.

The three main categories of thick-film inks are conductors, dielectrics (insulators), and resistors. Conductors are used for interconnections, such as the wiring of bridge circuits. Dielectrics are used for coating conducting surfaces (such as steel) prior to laying down thick-film patterns, for constructing thick-film capacitors, and for insulating cross-over points, where one conducting path traverses another. Resistor inks are the most interesting from the point of view of sensor design, since many thick-film materials are markedly piezoresistive. The piezoresistive properties of thick-film resistor inks can be used to form strain sensors. This approach is commonly used to manufacture pressure sensors and is exploited to produce accelerometers. See ACCELEROMETER; PRESSURE TRANSDUCER; STRAIN GAGE.

**Piezoresistive sensors.** Piezoresistive sensors are formed by placing stress-sensitive resistors on highly stressed parts of a suitable mechanical structure. The piezoresistive transducers are usually attached to cantilevers, or other beam configurations, and are connected in a Wheatstone bridge circuit. The beam may carry a seismic mass to form an accelerometer or may deform in response to an externally applied force. The stress variations in the transducer are converted into an electrical output, which is proportional to strain, by the piezoresistive effect. See WHEATSTONE BRIDGE.

**Temperature sensors.** The linear temperature coefficient of resistance possessed by certain platinum-containing conductive inks has allowed thermistors to be printed onto suitable substrates using thick-film fabrication techniques. Thick-film thermistors are very inexpensive and physically small, and have the further advantage of being more intimately bonded to the substrate than a discrete component. It has been shown that thick-film thermistors can have as good, if not better, performance than a comparable discrete component. See THERMISTOR.

**Chemical sensors.** Thick-film materials have been used for a number of chemical sensing applications, including the measurement of gas and liquid composition, acidity (pH), and humidity. A classification based on two categories seems to cover most devices: impedance-based transducers, in which the measurand causes a variation of resistance, capacitance, and so forth; and electrochemical systems, in which the sensed quantity causes a change in electrochemical potential or current. See ELECTRICAL IMPEDANCE; ELECTROCHEMISTRY. [J.D.T.]

**Thickening** The production of a concentrated slurry from a dilute suspension of solid particles in a liquid. In practice, a thickener also usually generates a clear liquid; therefore clarification is generally a concurrent process. Thickening and clarification are outcomes of sedimentation, and both are representative of a group of industrial processes termed mechanical separations. Although thickening may be carried out either batchwise or continuously, the latter method is more common. See CLARIFICATION; SEDIMENTATION (INDUSTRY).

Thickeners are especially useful when large volumes of dilute slurries must be treated, as in manufacture of cement, production

of magnesium from seawater, treatment of sewage, purification of water, treatment of coal, and dressing of metallurgical ores.

[V.W.U.]

**Thigmotrichida** A restricted group of forms constituting an order of the Holotrichia and generally found in association with mollusks from both fresh and salt water. Some are mouthless. Those species with a cytostome are generally equipped with a buccal ciliature which indicates an advance over the primitive hymenostome arrangement. See HOLOTRICHIA; HYMENOSTOMATIDA.

[J.O.C.]

**Thinner** A material used in paints and varnishes to adjust the consistency for application. Thinners are usually solvents for the vehicle used in the coating and are expected to evaporate after application. Water is used as a thinner in emulsion paints and in certain water-soluble paints such as watercolors and calcimines. Petroleum fractions are most commonly used for oil and resin coatings. Stronger solvents contain substantial amounts of aromatic hydrocarbons and may be derived from petroleum or coal tar.

Since numerous coating resins are not sufficiently soluble in hydrocarbons, other materials or mixtures must be used. These include alcohols such as denatured ethyl or isopropyl alcohols for shellac, esters such as amyl acetate for nitrocellulose, and ketones and other compounds for acrylic and vinyl resins. Chlorinated hydrocarbons are used for some materials which are otherwise hard to dissolve, but toxicity limits their usefulness. See PAINT; SOLVENT; SURFACE COATING; TURPENTINE; VARNISH.

[C.R.Ma; C.W.Si.]

**Thiocyanate** A compound containing the  $-\text{SCN}$  group, typically a salt or ester of thiocyanic acid (HSCN). Thiocyanates are bonded through the sulfur(s) and have the structure  $\text{R}-\text{S}-\text{C}\equiv\text{N}$ . They are isomeric with the isothiocyanates,  $\text{R}-\text{N}=\text{C}\equiv\text{S}$ , which are the sulfur analogs of isocyanates ( $-\text{NCO}$ ). The thiocyanates may be viewed as structural analogs of the cyanates ( $-\text{OCN}$ ), where the oxygen (O) atom is replaced by a sulfur atom.

The principal commercial derivatives of thiocyanic acid are ammonium and sodium thiocyanates. Thiocyanates and isothiocyanates have been used as insecticides and herbicides. Specifically, ammonium thiocyanate is used as an intermediate in the manufacture of herbicides and as a stabilizing agent in photography. Sodium and potassium thiocyanates are used in the manufacture of textiles and the preparation of organic thiocyanates.

In living systems, thiocyanates are the product of the detoxification of cyanide ion ( $\text{CN}^-$ ) by the action of 3-mercaptopyruvate sulfur transferase. In addition, thiocyanates can interfere with thyroxine synthesis in the thyroid gland and are part of a class known as goitrogenic compounds. See CYANIDE; SULFUR; THYROXINE.

[T.J.Me.]

**Thiophene** An organic heterocyclic compound containing a diunsaturated ring of four carbon atoms and one sulfur atom. See HETEROCYCLIC COMPOUNDS.

Thiophene (**1**), methylthiophenes, and other alkylthiophenes are found in relatively small amounts in coal tar and petroleum. Thiophene accompanies benzene in the fractional distillation of coal tar. 2,5-Dithienylthiophene (**2**) has been found in the

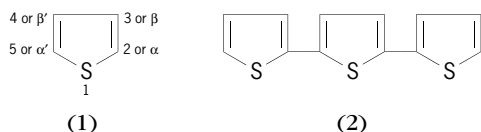

marigold plant. Biotin, a water-soluble vitamin, is a tetrahydrothiophene derivative.

The parent compound (**1**) is nearly insoluble in water, with mp  $-38.2^\circ\text{C}$  ( $-36.8^\circ\text{F}$ ), bp  $84.2^\circ\text{C}$  ( $183.6^\circ\text{F}$ ), and specific gravity (20/4) 1.0644. Thiophene is considered to be an aromatic compound. Thiophenes are stable to alkali and other nucleophilic agents, and are relatively resistant to disruption by acid. See AROMATIC HYDROCARBON; ORGANOSULFUR COMPOUND.

[W.J.Ge.; M.St.]

**Thiosulfate** A salt containing the negative ion  $\text{S}_2\text{O}_3^{2-}$ . This species is an important reducing agent and may be viewed as a structural analog of the sulfate ion ( $\text{SO}_4^{2-}$ ) where one of the oxygen (O) atoms has been replaced by a sulfur (S) atom. The sulfur atoms of the thiosulfate ion are not equivalent. Thiosulfate is tetrahedral, and the central sulfur is in the formal oxidation state 6+ and the terminal sulfur is in the formal oxidation state 2-.

Principal uses of thiosulfates include agricultural, photographic, and analytical applications. Ammonium thiosulfate  $[(\text{NH}_4)_2\text{S}_2\text{O}_3]$  is exploited for both the nitrogen and sulfur content, and it is combined with other nitrogen fertilizers such as urea. Thiosulfate ion is an excellent complexing agent for silver ions (bound through sulfur). The sodium salt and the ammonium salt are well known as the fixing agent "hypo" used in photography. The aqueous thiosulfate ion functions as a scavenger for unreacted solid silver bromide on exposed film and therefore prevents further reaction with light. In nature, thiosulfate is converted into hydrogen sulfide ( $\text{H}_2\text{S}$ ) via enzymatic reduction. Hydrogen sulfide, in turn, is converted into the thiol group of cysteine by the reaction with *O*-acetylserine. See COORDINATION COMPLEXES; OXIDATION-REDUCTION; PHOTOGRAPHIC MATERIALS; SULFUR.

[T.J.Me.]

**Thirst and sodium appetite** The sensations caused by dehydration, the continuing loss of fluid through the skin and lungs and in the urine and feces while there is no water intake into the body. Thirst becomes more and more insistent as dehydration worsens. Water and electrolytes are needed to replace losses, and an adequate intake of sodium as well as water is important for maintaining blood volume. Normally, the amounts of water drunk and taken in food are more than enough to maintain hydration of the body, and the usual mixed diet provides all the electrolytes required.

Deficit-induced drinking occurs when a deficit of fluid in one or both of the major fluid compartments of the body serves as a signal to increase drinking. Cellular dehydration, detected by osmoreceptors, causes thirst and vasopressin release. Hypovolemia (low blood volume), detected by volume receptors in the heart and large veins and the arterial baroreceptors, causes immediate thirst, a delayed increase in sodium appetite, activation of the renin-angiotensin system, and increased mineralocorticoid and vasopressin secretion. Increases or decreases in amounts drunk in disease may result from normal or abnormal functioning of mechanisms of thirst or sodium appetite.

**Cellular dehydration.** Observations using a variety of osmotic challenges have established that hyperosmotic solutions of solutes that are excluded from cells cause more drinking than equiosmolar amounts of solutes that penetrate cells. Thus, the osmotic shift of water out of the cells caused by the excluded solutes provides the critical stimulus to drinking. Continuing water loss in the absence of intake is perhaps a more significant cause of cellular dehydration than administration of an osmotic load, but the same mechanisms apply. See OSMOSIS.

Sharing in the overall cellular dehydration are osmoreceptors which initiate the responses of thirst and renal conservation of water. Osmoreceptors are mainly located in the hypothalamus. The nervous tissue in the hypothalamus surrounding the anterior third cerebral ventricle and, in particular, the vascular organ of the lamina terminalis also respond to osmotic stimuli. Osmoreceptors initiating thirst work in conjunction with osmoreceptors initiating antidiuretic hormone (ADH) release to restore the cellular water to its prehydration level. In addition to reducing urine

loss, ADH may lower the threshold to the onset of drinking in response to cellular dehydration and other thirst stimuli. The cellular dehydration system is very sensitive, responding to changes in effective osmolality of 1–2%.

**Hypovolemia.** The cells of the body are bathed by sodium-rich extracellular fluid that corresponds to the aquatic environment of the unicellular organism. Loss of sodium from the extracellular fluid is inevitably accompanied by loss of water, resulting in hypovolemia with thirst followed by a delayed increase in sodium appetite. If not corrected, continuing severe sodium loss eventually leads to circulatory collapse.

Stretch receptors in the walls of blood vessels entering and leaving the heart and in the heart itself are thought to initiate hypovolemic drinking. Volume receptors in the venoatrial junctions and receptors that register atrial and ventricular pressure respond to the underfilling of the circulation with a reduction in inhibitory nerve impulses to the thirst centers, which results in increased drinking. Angiotensin II and other hormones (such as aldosterone and ADH) are also involved in this response. Arterial baroreceptors function in much the same way as the volume receptors on the low-pressure side of the circulation, exerting continuous inhibitory tone on thirst neurons. A fall in blood pressure causes increased drinking, whereas an acute rise in blood pressure inhibits drinking. The anterior third cerebral ventricle region, which is implicated in angiotensin-induced drinking, plays a crucial role in hypovolemic drinking, body fluid homeostasis, and blood pressure control.

**Renin-angiotensin systems.** It is believed that drinking caused by hypovolemic stimuli partly depends on the kidneys. The renal thirst factor is the proteolytic enzyme renin, which is secreted into the circulation by the kidney in response to hypovolemia. Renin cleaves an inactive decapeptide, angiotensin I, from angiotensinogen, an  $\alpha_2$ -globulin that is synthesized in the liver and released into the circulation. Angiotensin I is converted to the physiologically active octapeptide angiotensin II during the passage of blood through the lungs. Angiotensin II is an exceptionally powerful stimulus of drinking behavior in many animals when administered systemically or into the brain. Increased activation of the renin-angiotensin system may sometimes account for pathologically increased thirst in humans. Angiotensin II also produces (1) a rise in arterial blood pressure, release of norepinephrine from sympathetic nerve endings, and secretion of adrenomedullary hormones; and (2) water and sodium retention by causing release of ADH from the posterior pituitary and stimulation of renal tubular transport of sodium through direct action on the kidney and indirectly through increased aldosterone secretion from the adrenal cortex. See ALDOSTERONE; KIDNEY.

**Neuropharmacology.** Many substances released by neurons, and in some cases by neuroglial cells, affect drinking behavior when injected into the brain and may interact with the brain and modify angiotensin-induced drinking. Substances may stimulate or inhibit drinking, or both, depending on the species and the conditions of the experiment. Acetylcholine is a particularly powerful stimulus to drinking in rats, and no inhibitory effects on drinking have been described. Histamine also seems to be mainly stimulatory. However, a lengthening list of neuroactive substances, including norepinephrine, serotonin, nitric oxide, opioids, bombesin-like peptides, tachykinins, and neuropeptide Y, may either stimulate or inhibit drinking with varying degrees of effectiveness, depending on the species or the site of injection in the brain. Natriuretic peptides, prostaglandins, and gamma-amino butyric acid seem to be exclusively inhibitory. See ACETYLCHOLINE; NEUROBIOLOGY; SYNAPTIC TRANSMISSION.

Many hormones also affect water or sodium intake. Relaxin stimulates water intake, and ADH (or vasopressin) lowers the threshold to thirst in some species. Vasopressin injected into the third cerebral ventricle may stimulate water intake, suggesting a possible role for vasopressinergic neurons. Increased sodium appetite in pregnancy and lactation depends partly on the conjoint action of progesterone, estrogen, adrenocorticotrophic hormone

(ACTH), cortisol, corticosterone, prolactin, and oxytocin. Aldosterone and other mineralocorticoids, the stress hormones of the hypothalamo-pituitary-adrenocortical axis, corticotrophin, ACTH, and the glucocorticoids also stimulate sodium intake. See ENDOCRINE MECHANISMS; NEUROHYPOPHYSIS HORMONE.

The effect of many of these substances on drinking behavior shows both species and anatomical diversity. The multiplicity of effects of many of these substances makes it impossible to generalize on their role in natural thirst, but none of these substances seems to be as consistent and as universal a stimulus of increased thirst and sodium appetite as angiotensin. [J.T.F.]

**Thomson effect** A phenomenon discovered in 1854 by William Thomson, later Lord Kelvin. He found that there occurs a reversible transverse heat flow into or out of a conductor of a particular metal, the direction depending upon whether a longitudinal electric current flows from colder to warmer metal or from warmer to colder. Any temperature gradient previously existing in the conductor is thus modified if a current is turned on. The Thomson effect does not occur in a current-carrying conductor which is initially at uniform temperature. See THERMOELECTRICITY. [J.W.St.]

**Thoracica** The major order of the crustacean subclass Cirripedia. The adult animals are permanently attached. The mantle is usually reinforced by calcareous plates. Six pairs of biramous cirri are present, and the abdomen is absent or represented by caudal appendages. Antennules are present in the adult, and cement glands are strongly developed. Most species are hermaphroditic. Thoracica are subdivided into three suborders: Lepodomorpha, stalked or goose barnacles; Balanomorpha, the common acorn barnacles; and Verrucomorpha, a rare group of asymmetric barnacles. See BALANOMORPHA; BARNACLE; CIRRIPIEDIA; LEPADOMORPHA; VERRUCOMORPHA. [H.G.St.]

**Thorianite** A radioactive mineral with the idealized composition  $\text{ThO}_2$  (thorium dioxide) and isostructural with uraninite (pitchblende). Rare earths and uranium are often present in variable amounts, together with small amounts of radiogenic lead. Thorianite usually occurs as worn cubic crystals. The hardness is about 7 on Mohs scale, and the specific gravity is 9.7–9.8. The color is brownish black to reddish brown, and the luster usually is resinous. Thorianite is a primary mineral found chiefly in pegmatites. It is best known as a detrital mineral. It has been obtained commercially from detrital deposits and pegmatites in Madagascar and Ceylon. See NUCLEAR FUELS; PEGMATITE; RADIOACTIVE MINERALS; RARE-EARTH ELEMENTS; THORIUM; URANINITE; URANIUM. [C.Fr.]

**Thorite** A mineral, thorium silicate. The idealized chemical formula of thorite is  $\text{ThSiO}_4$ . All natural material departs widely from this composition owing to the partial substitution of uranium, rare earths, calcium, and iron for thorium. The specific gravity ranges between about 4.3 and 5.4. The hardness on Mohs scale is about  $4\frac{1}{2}$ . The color commonly is brownish yellow to brownish black and black.

Vein deposits containing thorite occur in Colorado, Idaho, and Montana. A vein deposit of monazite containing thorium is mined at Steenkampskraal near Van Rhynsdorp, Cape Province, South Africa. See METAMICT STATE; RADIOACTIVE MINERALS; SILICATE MINERALS; THORIUM. [C.Fr.]

**Thorium** A chemical element, Th, atomic number 90. Thorium is a member of the actinide series of elements. It is radioactive with a half-life of about  $1.4 \times 10^{10}$  years. See PERIODIC TABLE.

Thorium oxide compounds are used in the production of incandescent gas mantles. Thorium oxide has also been incorporated in tungsten metal, which is used for electric light filaments. It is employed in catalysts for the promotion of certain organic

chemical reactions and has special uses as a high-temperature ceramic material. The metal or its oxide is employed in some electronic tubes, photocells, and special welding electrodes. Thorium has important applications as an alloying agent in some structural metals. Perhaps the major use for thorium metal, outside the nuclear field, is in magnesium technology. Thorium can be converted in a nuclear reactor to uranium-233, an atomic fuel. The energy available from the world's supply of thorium has been estimated as greater than the energy available from all of the world's uranium, coal, and oil combined.

Monazite, the most common and commercially most important thorium-bearing mineral, is widely distributed in nature. Monazite is chiefly obtained as a sand, which is separated from other sands by physical or mechanical means. *See* MONAZITE.

Thorium has an atomic weight of 232. The temperature at which pure thorium melts is not known with certainty; it is thought to be about 1750°C (3182°F). Good-quality thorium metal is relatively soft and ductile. It can be shaped readily by any of the ordinary metal-forming operations. The massive metal is silvery in color, but it tarnishes on long exposure to the atmosphere; finely divided thorium has a tendency to be pyrophoric in air.

All of the nonmetallic elements, except the rare gases, form binary compounds with thorium. With minor exceptions, thorium exhibits a valence of 4+ in all of its salts. Chemically, it has some resemblance to zirconium and hafnium. The most common soluble compound of thorium is the nitrate which, as generally prepared, appears to have the formula  $\text{Th}(\text{NO}_3)_4 \cdot 4\text{H}_2\text{O}$ . The common oxide of thorium is  $\text{ThO}_2$ , thoria. Thorium combines with halogens to form a variety of salts. Thorium sulfate can be obtained in the anhydrous form or as a number of hydrates. Thorium carbonates, phosphates, iodates, chlorates, chromates, molybdates, and other inorganic salts of thorium are well known. Thorium also forms salts with many organic acids, of which the water-insoluble oxalate,  $\text{Th}(\text{C}_2\text{O}_4)_2 \cdot 6\text{H}_2\text{O}$ , is important in preparing pure compounds of thorium. *See* ACTINIDE ELEMENTS; RADIOACTIVITY. [H.A.W.]

**Throat** The region that includes the pharynx, the larynx, and related structures. Both the nasal passages and the oral cavity open into the pharynx, which also contains the openings of the Eustachian tubes from the ears. The lower portion of the pharynx leads into the esophagus and the trachea or windpipe. The rather funnel-shaped pharynx is suspended from the base of the skull and the jaws; it is surrounded by three constrictor muscles that function primarily in swallowing. *See* EAR; PHARYNX.

The larynx, or voice box, is marked externally by the shield-shaped thyroid cartilage which forms the Adam's apple. The larynx contains the vocal cords that act as sphincters for air regulation and permit phonation. The lower end of the larynx is continuous with the trachea, a tube composed of cartilaginous rings and supporting tissues. *See* LARYNX.

The term throat is also used in a general sense to denote the front (ventral side) of the neck. [T.S.P.]

**Thrombosis** The process of forming a thrombus, which is a solid mass or plug in the living heart or vessels composed of the constituents of the blood. Thrombosis usually occurs in a diseased blood vessel, as a result of arteriosclerosis. The consequences of thrombosis include local obstruction causing both tissue death and hemorrhage. Thrombosis is a significant factor in the death of an individual affected by arteriosclerotic cardiovascular disease, malignancy, and infection. *See* HEMORRHAGE; INFARCTION.

Thrombosis is usually initiated by vascular damage and consequent platelet adhesion and clumping. The process is initiated when platelets specifically adhere to the subendothelial collagen at the points of damage to the endothelium. At the same time that the platelets begin to aggregate and release products that will further promote thrombus formation, the protein fac-

tors of the blood, which help to form the insoluble meshwork of the thrombus, become activated. This latter process is known as blood coagulation. The proteins of the coagulation system, through a series of cascading reactions, eventually reach a final common pathway to form fibrin, the insoluble protein that forms the scaffolding of the thrombus. As blood flows by the thrombus, more platelets and fibrin are deposited. Red blood cells and white blood cells become entrapped in the thrombus and are integrated into its structure. *See* FIBRINOGEN.

Once a thrombus forms, it can have one of four fates. (1) It may be digested, destroyed, and removed by proteolytic enzymes of the plasminogen-plasmin system. (2) It may continue to propagate itself and eventually occlude the vessel. (3) It may give rise to an embolus. Emboli may cause tissue damage at sites distant from the origin of the thrombus. (4) It may undergo a process known as organization. Organization helps stabilize the thrombus, and it may result in incorporation of a contracted fibrous mass into the vessel wall. *See* EMBOLISM.

Maintaining good blood flow (especially in the veins) helps prevent thrombosis. Treating hypertension and hypercholesterolemia retards atherosclerosis, which is a major cause of arterial thrombosis. Agents that interfere with platelet function, such as aspirin and fish oils, may help avoid thrombotic episodes. Anticoagulants prevent the formation of fibrin and may also be used to prevent thrombosis. If treatment can be given in the early stages of thrombosis, fibrinolytic therapy, utilizing agents that will help form plasmin, can minimize the tissue damage caused by thrombosis. *See* ARTERIOSCLEROSIS; CIRCULATION DISORDERS; PHLEBITIS. [I.N.; R.A.V.]

**Thrust** The force that propels an aerospace vehicle or marine craft. Thrust is a vector quantity. Its magnitude is usually given in newtons (N) in International System (SI) units or pounds-force (lbf) in U.S. Customary Units. A newton is defined as 1 kilogram mass times an acceleration of 1 meter per second squared. One newton equals approximately 0.2248 lbf. *See* FORCE; UNITS OF MEASUREMENT.

The thrust power of a vehicle is the thrust times the velocity of the vehicle. It is expressed in joules (J) per second or watts (W) in SI units. In U.S. Customary Units thrust power is expressed in foot-pounds per second, which can be converted to horsepower by dividing by 550. *See* JET PROPULSION; POWER; RAMJET; RECIPROCATING AIRCRAFT ENGINE; ROCKET; TURBOJET. [J.P.L.]

**Thulium** A chemical element, Tm, atomic number 69, atomic weight 168.934. It is a rare metallic element belonging to the rare-earth group. The stable isotope  $^{169}\text{Tm}$  makes up 100% of the naturally occurring element. *See* PERIODIC TABLE.

The salts of thulium possess a pale green color and the solutions have a slight greenish tint. The metal has a high vapor pressure at the melting point. When  $^{169}\text{Tm}$  is irradiated in a nuclear reactor,  $^{170}\text{Tm}$  is formed. The isotope then emits strongly an 84-keV x-ray, and this material is useful in making small portable x-ray units for medical use. *See* RARE-EARTH ELEMENTS. [F.H.Sp.]

**Thunder** The acoustic radiation produced by thermal lightning channel processes. The lightning return stroke is a high surge of electric current that has a very short duration, depositing approximately 95% of its electrical energy during the first 20 microseconds. Spectroscopic studies have shown that the lightning channel is heated to temperatures in the 20,000–30,000 K (36,000–54,000°F) range by this process. The pressure of the hot channel exceeds 10 atm ( $>10^6$  pascals). The hot, high-pressure channel expands supersonically and forms a shock wave as it pushes against the surrounding air. Because of the momentum gained in expanding, the shock wave overshoots, causing the pressure in the core of the channel to go below atmospheric pressure temporarily. The outward-propagating wave separates from the core of the channel, forming an N-shaped

wave that eventually decays into an acoustic wavelet. See SHOCK WAVE; STORM ELECTRICITY.

The sound that is eventually heard or detected, thunder, is the sum of many individual acoustic pulses, each a remnant of a shock wave, that have propagated to the point of observation from the generating channel segments. The first sounds arrive from the nearest part of the lightning channel and the last sounds from the most distant parts.

The higher the source of the sound, the farther it can be heard. Frequently, the thunder that is heard originates in the cloud and not in the visible channel. On some occasions, the observer may hear no thunder at all; this is more frequent at night when lightning can be seen over long distances and thunder can be heard only over a limited range (~10 km or 6 mi). See LIGHTNING; THUNDERSTORM. [A.A.F.]

**Thunderstorm** A convective storm accompanied by lightning and thunder and a variety of weather such as locally heavy rainshowers, hail, high winds, sudden temperature changes, and occasionally tornadoes. The characteristic cloud is the cumulonimbus or thunderhead, a towering cloud, generally with an anvil-shaped top. A host of accessory clouds, some attached and some detached from the main cloud, are often observed in conjunction with cumulonimbus. See LIGHTNING; THUNDER.

Thunderstorms are manifestations of convective overturning of deep layers in the atmosphere and occur in environments in which the decrease of temperature with height (lapse rate) is sufficiently large to be conditionally unstable and the air at low levels is moist. In such an atmosphere, a rising air parcel, given sufficient lift, becomes saturated and cools less rapidly than it would if it remained unsaturated because the released latent heat of condensation partly counteracts the expansional cooling. The rising parcel reaches levels where it is warmer (by perhaps as much as 18°F or 10°C over continents) and less dense than its surroundings, and buoyancy forces accelerate the parcel upward. The rising parcel is decelerated and its vertical ascent arrested at altitudes where the lapse rate is stable, and the parcel becomes denser than its environment. The forecasting of thunderstorms thus hinges on the identification of regions where the lapse rate is unstable, low-level air parcels contain adequate moisture, and surface heating or uplift of the air is expected to be sufficient to initiate convection. See CONVECTIVE INSTABILITY; FRONT.

Thunderstorms are most frequent in the tropics, and rare poleward of 60° latitude. Thunderstorms are most common during late afternoon because of the diurnal influence of surface heating.

Radar is used to detect thunderstorms at ranges up to 250 mi (400 km) from the observing site. Much of present-day knowledge of thunderstorm structure has been deduced from radar studies, supplemented by visual observations from the ground and satellites, and in-place measurements from aircraft, surface observing stations, and weather balloons. See METEOROLOGICAL INSTRUMENTATION; RADAR METEOROLOGY; SATELLITE METEOROLOGY.

Thunderstorms are considered severe when they produce winds greater than 58 mi/h (26 m/s or 50 knots), hail larger than 3/4 in. (19 mm) in diameter, or tornadoes. While thunderstorms are generally beneficial because of their needed rains (except for occasional flash floods), severe storms have the capacity of inflicting utter devastation over narrow swaths of the countryside. Severe storms are most frequently supercells which form in environments with high convective instability and moderate-to-large vertical wind shears. The supercell may be an isolated storm or part of a squall line. See HAIL; SQUALL; SQUALL LINE; TORNADO. [R.D.J.]

**Thyme** Any of a large and diverse group of plants in the genus *Thymus* utilized for their essential oil and leaves in both cooking and medicine. Hundreds of different forms, or eco-

types, of thyme are found in the Mediterranean area, where thyme occurs as a wild plant. *Thymus vulgaris*, generally considered to be the true thyme, is the most widely used and cultivated species. Both "French" and "German" thyme are varieties of this species. Most types of thyme are low-growing perennials, typically having small smooth-edged leaves that are closely spaced on stems that become woody with age.

Wild European thyme, the source of much imported material, is usually harvested only once a year, while cultivated plants in the United States are harvested mechanically up to three times a year. As with most herbs, both stems and leaves are harvested and then dehydrated. Dried stems and leaves are separated mechanically. Thyme oil is extracted from fresh material. Thyme is a widely used herb, both alone and in blends such as "fine herbs." Thyme oil is used for flavoring medicines and has strong bactericidal properties. See SPICE AND FLAVORING. [S.Kir.]

**Thymosin** A polypeptide hormone synthesized and secreted by the endodermally derived reticular cells of the thymus gland. Thymosin exerts its actions in several loci: (1) in the thymus gland, either on precursor stem cells derived from fetal liver or from bone marrow, or on immature thymocytes, and (2) in peripheral sites, on either thymic-derived lymphoid cells or on precursor stem cells. The precursor stem cells, which are immunologically incompetent whether in the thymus or in peripheral sites, have been designated as predetermined T cells or T<sub>0</sub> cells, and mature through stages termed T<sub>1</sub> and T<sub>2</sub>, each reflecting varying degrees of immunological competence. Thymosin promotes or accelerates the maturation of T<sub>0</sub> cells to T<sub>1</sub> cells as well as to the final stage of a T<sub>2</sub>. In addition to this maturation influence, the hormone also increases the number of total lymphoid cells by accelerating the rate of proliferation of both immature and mature lymphocytes. See IMMUNITY; THYMUS GLAND. [A.Wr.]

**Thymus gland** An important central lymphoid organ in the neck or upper thorax of all vertebrates from elasmobranchs to mammals. The thymus gland is most prominent during early life. In many laboratory species of mammals and in humans it reaches its greatest relative weight at the time of birth, but its absolute weight continues to increase until the onset of puberty. Thereafter, it begins to undergo an involution and progressively decreases in size throughout adult life.

The thymic stem cells generate a large population of small lymphocytes (thymocytes) through a series of mitotic divisions. Simultaneously these dividing lymphocytes show evidence of cellular differentiation within the special thymic environment. During this division and maturation phase the developing thymocytes undergo an intrathymic migration from the peripheral cortical area to the medullary core of the organ. Some thymocytes degenerate within the organ, but many enter the circulating blood and lymph systems at various stages of maturity. A small percentage of the T lymphocyte population (5–10%) within the thymus is antigenically competent and capable of recognizing antigenic determinants on foreign cells or substances. Some of the T lymphocytes have the capacity to lyse the foreign tissue cells, while others are involved in recognizing the "foreignness" of the antigens and assisting a second sub-population of bone-marrow-derived lymphocytes (B lymphocytes) to respond to the antigen by producing a specific antibody. These two types of immunocompetent T lymphocytes are called killer cells and helper cells, respectively. They are involved in both tissue transplantation and humoral antibody responses. On the other hand, the vast majority of the thymic lymphocytes are immunologically incompetent (90–95%). Some thymocytes are thought to give rise to the smaller pool of immunocompetent T lymphocytes, but many emigrate into the circulating blood. See CELLULAR IMMUNOLOGY; LYMPHATIC SYSTEM; THYMOSIN. [C.E.S.]

**Thyrocalcitonin** A hormone, the only known secretory product of the parenchymal or C cells of the mammalian thyroid and of the ultimobranchial glands of lower forms.

In conjunction with the parathyroid hormone, thyrocalcitonin is of prime importance in regulating calcium and phosphate metabolism. Its major function is to protect the organism from the dangerous consequences of elevated blood calcium. Its sole known effect is that of inhibiting the resorption of bone. It thus produces a fall in the concentration of calcium and phosphate in the blood plasma because these two minerals are the major constituents of bone mineral and are released into the bloodstream in ionic form when bone is resorbed. See BONE; CALCIUM METABOLISM; PARATHYROID GLAND; PARATHYROID HORMONE.

Thyrocalcitonin also causes an increased excretion of phosphate in the urine under certain circumstances, but a question remains as to whether this is a direct effect of the hormone upon the kidney or an indirect consequence of the fall in blood calcium which occurs when the hormone inhibits bone resorption. See PHOSPHATE METABOLISM; THYROID GLAND. [H.Ras.]

**Thyroid gland** An endocrine gland found in all vertebrates that produces, stores, and secretes the thyroid hormones. In humans, the gland is located in front of, and on either side of, the trachea (see illustration). Thyrocalcitonin, one hormone

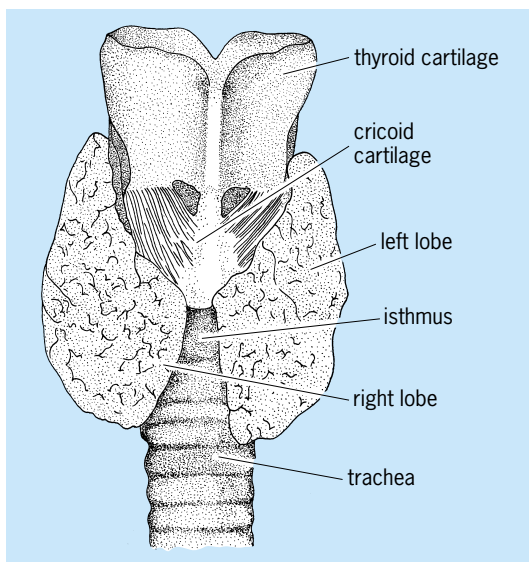

Ventral view of human thyroid gland shown in relation to trachea and larynx. (After C. K. Weichert, *Elements of Chordate Anatomy*, 3d ed., McGraw-Hill, 1967)

of the thyroid gland, assists in regulating serum calcium by reducing its levels. The iodine-containing hormones thyroxine and triiodothyronine regulate metabolic rate in warm-blooded animals and are essential for normal growth and development. To produce these, the thyroid gland accumulates inorganic iodides from the bloodstream and unites them with the amino acid tyrosine. This activity is regulated by thyrotropic hormone from the anterior lobe of the pituitary gland. See THYROID HORMONE; THYROXINE. [G.C.Ke.]

**Thyroid gland disorders** Disorders of the thyroid gland may be classified according to anatomical and functional characteristics. Those thyroid disorders that are primarily anatomical include goiter and neoplasia; those that are primarily functional result in either hyperthyroidism or hypothyroidism.

Thyroid gland enlargement, or goiter, is the most common disorder. Its classification is based upon both the anatomy and function of the gland. An enlarged but normally functioning thyroid gland is termed a nontoxic goiter. This condition affects hun-

dreds of millions of people throughout the world in areas where the diet is deficient in iodine. In other areas it may be caused by subtle disorders in the biosynthesis of thyroid hormone. In both cases, there is compensatory enlargement of the gland that can be diffuse and symmetrical or can produce a multinodular goiter. The multinodular goiter can grow independently from pituitary gland control and produce excess thyroid hormone, causing hyperthyroidism. However, hyperthyroidism is most often the result of Graves' disease. Thyroid enlargement can also be caused by Hashimoto's thyroiditis, in which the individual's immune system develops abnormal antibodies that react with proteins in the thyroid gland. This autoimmunity can make the gland enlarge or become underactive. See AUTOIMMUNITY.

Tumors of the thyroid account for a small fraction of human neoplasms and an even smaller fraction of deaths due to cancer. The vast majority of thyroid neoplasms are follicular adenomas, which are benign; however, some thyroid neoplasms are malignant. Rarely, tumors arising elsewhere in the body can metastasize to the thyroid gland.

Hyperthyroidism is the clinical condition that results from excessive levels of the circulating thyroid hormones thyroxine and triiodothyronine, which are secreted by the thyroid gland. Signs and symptoms include weight loss, tachycardia (increased heart rate), heat intolerance, sweating, and tremor. Graves' disease, the most common form of hyperthyroidism, is mediated by an abnormal antibody directed to the thyroid-stimulating hormone (TSH) receptor on the surface of the thyroid cell, which stimulates secretion of thyroid hormone. Unique to Graves' disease is the associated protrusion of the eyes (exophthalmos).

Hypothyroidism is the clinical state that results from subnormal levels of circulating thyroid hormones. Manifestations in infancy and childhood include growth retardation and reduced intelligence; in adults, cold intolerance, dry skin, weight gain, constipation, and fatigue predominate. Individuals with hypothyroidism often have a slow pulse (bradycardia), puffy dry skin, thin hair, and delayed reflexes. In its most extreme form, hypothyroidism can lead to coma and death if untreated. See THYROID GLAND; THYROID HORMONE. [L.J.DeG.; D.A.E.]

**Thyroid hormone** Any of the chemical messengers produced by the thyroid gland, including thyrocalcitonin, a polypeptide, and thyroxine and triiodothyronine, which are iodinated thyronines. See HORMONE; THYROCALCITONIN; THYROID GLAND; THYROXINE. [H.Ras.]

**Thyroxine** A hormone secreted by the thyroid gland. Thyroxine (structure 1) is quite similar chemically and in biological activity to triiodothyronine (2). Both are derivatives of the amino

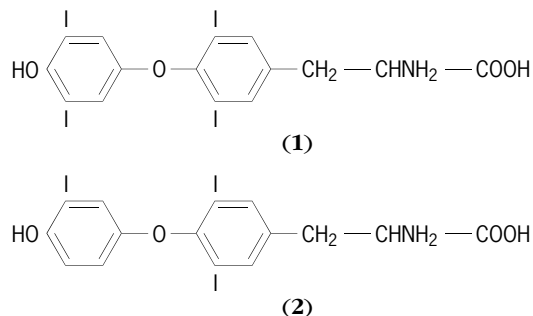

acid tyrosine and are unique in being the only iodine-containing compounds of importance in the economy of all higher forms of animal life. The thyroid gland avidly accumulates the small amount of iodine in the diet. This iodine is oxidized to iodide ion in the gland and then reacts with tyrosine to form mono- and diiodotyrosine. These latter are then coupled to form either thyroxine or triiodothyronine. See THYROID GLAND.

The maintenance of a normal level of thyroxine is critically important for normal growth and development as well as for

proper bodily function in the adult. Its absence leads to delayed or arrested development. It is one of the few hormones with general effects upon all tissues. Its lack leads to a decrease in the general metabolism of all cells, most characteristically measured as a decrease in nucleic acid and protein synthesis, and a slowing down of all major metabolic processes. See THYROID GLAND DISORDERS. [H.Ras.]

**Thysanoptera** An order of small, slender insects, commonly called thrips, having exopterygote development, sucking mouthparts, and highly modified wings. The order is a relatively small one, but individuals are often very numerous in favorable environments. See THRIP.

The mouthparts are conical and used for scraping, piercing, and sucking. The wings are exceptionally narrow, with few or no veins, and are bordered by long hairs. The tarsi terminate in an inflatable membranous bladder, which has remarkable adhesive properties.

The eggs of thrips are laid on the surface of twigs (suborder Tubulifera) or in small cuts made by the ovipositor (suborder Terebrantia). There are usually four nymphal stages, the last of these being quiescent and pupalike. There are from one to several generations produced in a single year. See INSECTA. [F.M.C.]

**Thysanura** Primarily wingless insects, with soft, fusiform bodies from 0.12 to 0.80 in. (3 to 20 mm) long, often covered with scales forming diverse patterns (see illustration). These insects are considered by some authors to constitute two orders: the true Thysanura (silverfish and allies) and the Microcoryphia (machilids). The mouthparts are free. The mandibles are monocondylous in the machilids, and scraping in function; they are dicondylous—as in all winged insects—in the silverfish, in which they are of the chewing type. Machilids have large compound eyes, but silverfish have simple ommatidia, or lack eyes altogether. Many machilids have coxae with styliform appendages. Tarsi are from two- to five-segmented; there are two or three claws. Abdominal ventral plates are entire, or subdivided into a central sternum and posterolateral coxites. Abdominal styli are

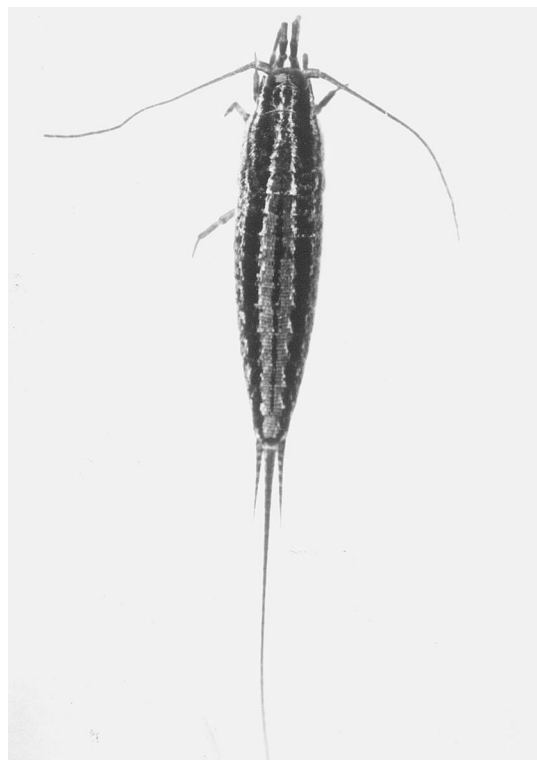

*Machilinus* sp. (Microcoryphia).

present in varied numbers. The females have well-developed ovipositors, and the males have a penis and often one or rarely two pairs of parameres. There are cerci and a median caudal filament.

These primitive insects, fossils of which are known as far back as the Devonian (primitive machilids, the Monura), are worldwide in distribution. Machilids are more numerous in temperate climates, the silverfish in the tropics and subtropics. See APTERYGOTA; INSECTA. [P.W.W.]

**Tick paralysis** A loss of muscle function or sensation in humans or certain animals following the prolonged feeding of female ticks. Paralysis, of Landry's type, usually begins in the legs and spreads upward to involve the arms and other parts of the body. Evidence suggests that paralysis is due to a neurotoxin formed by the feeding ticks rather than the result of infection with microorganisms. See IXODIDES.

The disease has been reported in North America, Australia, South Africa, and occasionally in some European countries and is caused by appropriate species of indigenous ticks. In Australia, *Ixodes holocyclus* causes frequent cases in dogs, and occasional cases in humans, and paralysis has been known to progress even after removal of ticks. *Ixodes cubicundus* is associated with the disease in South Africa. [C.B.P.]

**Tidal bore** A part of a tidal rise in a river which is so rapid that water advances as a wall often several feet high. The phenomenon is favored by a substantial tidal range and a channel which shoals and narrows rapidly upstream, but the conditions are so critical that it is not common. Although the bore is a very striking feature, the tide continues to rise after the passage of the bore. Bores may be eliminated by changing channel depth or shape. See RIVER TIDES; TIDE.

In North America three bores have been observed: at the head of the Bay of Fundy (see illustration), at the head of the Gulf



Tidal bore of the Petitcodiac River, Bay of Fundy, New Brunswick, Canada. Rise of water is about 4 ft (1.2 m). (New Brunswick Travel Bureau)

of California, and at the head of Cook Inlet, Alaska. The largest known bore occurs in the Tsientang Kiang, China. At spring tides this bore is a wall of water 15 ft (4.5 m) high moving upstream at 25 ft/s (7.5 m/s). [B.K.]

**Tidal datum** A reference elevation of the sea surface from which vertical measurements are made, such as depths of the ocean and heights of the land. The intersection of the elevation of a tidal datum with the sloping shore forms a line used as a horizontal boundary. In turn, this line is also a reference from which horizontal measurements are made for the construction of additional coastal and marine boundaries.

Since the sea surface moves up and down from infinitely small amounts to hundreds of feet over periods of less than a second to millions of years, it is necessary to stop the vertical motion in order to have a practical reference. This is accomplished by hydraulic filtering, numerical averaging, and segment definition



of the record obtained from a tide gage affixed to the adjacent shore. Waves of periods up through wind waves are effectively damped by a restricting hole in the measurement well. Recorded hourly heights are averaged to determine the mean of the higher (or only) high tide of each tidal day (24.84 h), all the high tides, all the hourly heights, all the low tides, and the lower (or only) low tide. The length of the averaging segment is a specific 19 year, which averages all the tidal cycles through the regression of the Moon's nodes and the metonic cycle. [The metonic cycle is a time period of 235 lunar months (19 years); after this period the phases of the Moon occur on the same days of the same months.] But most of all, the 19-year segment is meaningful in terms of measurement capability, averaging meteorological events, and for engineering and legal interests. However, the 19-year segment must be specified and updated because of sea-level changes occurring over decades. The present tidal datum epoch is 1983 through 2001.

Tidal datums are legal entities. Because of variations in gravity, semistationary meteorological conditions, semipermanent ocean currents, changes in tidal characteristics, ocean density differences, and so forth, the sea surface (at any datum elevation) does not conform to a mathematically defined spheroid. See GEODESY; TIDE. [S.D.H.]

**Tidal power** Tidal-electric power is obtained by utilizing the recurring rise and fall of coastal waters. Marginal marine basins are enclosed with dams, making it possible to create differences in the water level between the ocean and the basins. The oscillatory flow of water filling or emptying the basins is used to drive hydraulic turbines which propel electric generators.

Large amounts of electric power could be developed in the world's coastal regions having tides of sufficient range, although even if fully developed this would amount to only a small percentage of the world's potential water (hydroelectric) power. See ELECTRIC POWER GENERATION; TIDE. [G.G.A.]

**Tidalites** Sediments of varied composition deposited by tidal processes in subtidal, intertidal, and supratidal environments. Tides along modern coastlines produce flood and ebb currents which advance and retreat between high- and low-water levels and also operate in subtidal environments. These currents are largely responsible for the formation of tidalites. See TIDE.

The tidal flat, including the supratidal and intertidal zones, is the best understood of the tidal environments. In these zones both terrigenous and nonterrigenous tidal flats occur, the former often incised by tidal channels.

Terrigenous tidal flats consist of an intertidal zone that is subdivided into a low, mid, and high tidal flat (see illustration). Each of the specific tidal processes operate to produce sediments with characteristic textures and sedimentary structures. On extensive tidal flats, fine-grained sediments accumulate from suspension near high-water line, and coarser sandy sediments are deposited by bed-load processes around low-water level. On mid flats, interbedded sands and muds are developed under conditions of alternating bed-load and suspension sedimentation (see illustration). The supratidal flat receives limited quantities of marine sediment, and instead comprises salt marshes and mangrove swamps in humid climates, with sabkhas, consisting of evaporite minerals such as gypsum and halite, commonly developed under arid conditions.

Nonterrigenous tidal flats do not receive terrigenous clastic sediment. Instead, sediment which accumulates on these tidal flats consists predominantly of calcium carbonate produced within the basin. Various organisms which live mainly below low-water level form calcium carbonate in their life cycle, and upon death this hard framework breaks down to produce clay, silt, and sand-size carbonate particles. These are available for reworking both within the subtidal zone and onto the tidal flats.

Sedimentation below low-water level and under the influence of tides is occurring today in shallow shelf seas. The best understood is the North Sea, where sand transport by tidal currents

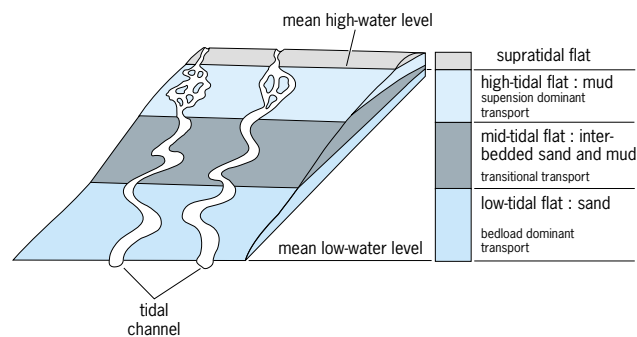

**Tidal-flat sedimentation model for the North Sea coasts of Germany and the Netherlands. (After G. de V. Klein, *Clastic Tidal Facies*, Continuing Educational Publication Company, 1977)**

is taking place down to depths of 150 ft (50 m). Echo sounding has shown that the sands form linear bodies up to 90 ft (30 m) high. They are asymmetric in cross section and, as revealed by seismic profiling, are structured internally by giant cross-strata.

The recognition of tidalites in the geological record requires evidence of a marine environment, ebb and flood current flow, and exposure of the depositional surface during low-water stage for intertidalites. See DEPOSITIONAL SYSTEMS AND ENVIRONMENTS; SEDIMENTOLOGY. [K.A.Eri.]

**Tide** Stresses exerted in a body by the gravitational action of another, and related phenomena resulting from these stresses. Every body in the universe raises tides, to some extent, on every other. This article deals only with tides on the Earth, since these are fundamentally the same as tides on all bodies, and more specifically with variations of sea level, whatever their origin. See GRAVITATION; SEA-LEVEL FLUCTUATIONS.

The tide-generating forces arise from the gravitational action of Sun and Moon, the effect of the Moon being about twice as effective as that of the Sun in producing tides. The tidal effects of all other bodies on the Earth are negligible. The tidal forces act to generate stresses in all parts of the Earth and give rise to relative movements of the matter of the solid Earth, ocean, and atmosphere. In the ocean the tidal forces act to generate alternating tidal currents and displacements of the sea surface.

If the Moon attracted every point within the Earth with equal force, there would be no tide. It is the small difference in direction and magnitude of the lunar attractive force, from one point of the Earth's mass to another, which gives rise to the tidal stresses. The tide-generating force is proportional to the mass of the disturbing body (Moon) and to the inverse cube of its distance. This inverse cube law accounts for the fact that the Moon is 2.17 times as important, insofar as tides are concerned, as the Sun, although the latter's direct gravitational pull on the Earth, which is governed by an inverse-square law, is about 180 times the Moon's pull.

At most places in the ocean and along the coasts, sea level rises and falls in a regular manner. The highest level usually occurs twice in any lunar day, the times bearing a constant relationship with the Moon's meridional passage. The time between the Moon's meridional passage and the next high tide is called the lunitidal interval. The difference in level between successive high and low tides, called the range of the tide, is generally greatest near the time of full or new Moon, and smaller near the times of quadrature. The range of the tide usually exhibits a secondary variation, being greater near the time of perigee (when the Moon is closest to the Earth) and smaller at apogee (when the Moon is farthest away).

The above situation is observed at places where the tide is predominantly semidiurnal. At many other places, it is observed that one of the two maxima in any lunar day is higher than the other. This effect is known as the diurnal inequality and

represents the presence of an appreciable diurnal variation. At these places, the tide is said to be of the "mixed" type. At a few places, the diurnal tide actually predominates, there generally being only one high and low tide during the lunar day.

The range of the ocean tide varies between wide limits. The highest range is encountered in the Bay of Fundy, where values exceeding 50 ft (15 m) have been observed. In some places in the Mediterranean, South Pacific, and Arctic, the tidal range never exceeds 2 ft (0.6 m).

Owing to the rotation of the Earth, there is a gyroscopic, or Coriolis, force acting perpendicularly to the motion of any water particle in motion. In the Northern Hemisphere this force is to the right of the current vector. The horizontal, or tractive, component of the tidal force generally rotates in the clockwise sense in the Northern Hemisphere. As a result of both these influences the tidal currents in the open ocean generally rotate in the clockwise sense in the Northern Hemisphere, and in the counterclockwise sense in the Southern Hemisphere. See CORIOLIS ACCELERATION; EARTH TIDES. [G.W.G.]

**Tie rod** A tie rod or tie bar, usually circular in cross section, is used in structural parts of machines to tie together or brace connected members, or in moving parts of machines or mechanisms it may connect arms or parts to transmit motion. In the first use the rod ends are usually a threaded fastening, while in the latter they are usually forged into an eye for a pin connection. [P.H.B.]

**Tile** As a structural material, a burned clay product in which the coring exceeds 25% of the gross volume; as a facing material, any thin, usually flat, square product. Structural tile used for load bearing may or may not be glazed; it may be cored horizontally or vertically. Two principal grades are manufactured: one for exposed masonry construction, and the other for unexposed construction.

As a facing, clay products are formed into thin flat, curved, or embossed pieces, which are then glazed and burned. Commonly used on surfaces subject to water splash or that require frequent cleaning, such vitreous glazed wall tile is fireproof. Unglazed tile is laid as bathroom floor. By extension, any material formed into a size comparable to clay tile is called tile. Among the materials formed into tile are asphalt, cork, linoleum, vinyl, and porcelain. [F.H.R.]

**Till** The generic term for sediment deposited directly from glacier ice. Till is characteristically nonsorted and nonstratified and is deposited by lodgement or melt-out beneath a glacier or by melt-out on the surface of a glacier. The texture of till varies greatly and all tills are characterized by a wide range, of particle sizes. Till contains a variety of rock and mineral fragments which reflect the source material over which the glacier flowed. The particles in the deposit usually show a preferred orientation related to the nature and direction of the ice flow. The overall character of the fill reflects the source material, position and distance of transport, nature and position of deposition, and postdepositional changes. [W.H.J.]

**Tillodontia** An extinct order of early Cenozoic (about 65 to 40 million years ago) quadrupedal eutherian land mammals, represented by nine known genera, from the late Paleocene to middle Eocene of North America (*Esthonyx* [Azygonyx], *Megalestonyx*, *Trogosus*, and *Tillodon*), early Paleocene to late Eocene of China (*Lofochaius*, *Meiostylodon*, *Adapidium*, *Trogosus* [Kuanchuanus]), middle Eocene of Pakistan (*Basalina*), and the early Eocene of Europe (*Plesiasthonyx*). The tillodonts left no known descendants and were probably most closely related to the extinct order Pantodonta (another group of extinct ungulatelike mammals from the Paleocene and Eocene that in turn may be related to the early eutherian mammals known as arctocyonids).

Tillodonts were medium- to large-sized mammals (their skulls range in length from 5 to 37 cm or 2 to 15 in.) that probably fed primarily on roots and tubers in warm temperate to subtropical habitats. Tillodonts were most common in the early Eocene faunas of North America. They developed large second incisors that became rodentlike, relatively long snouts, massive skeletons, and moderately large claws. See ARCHAIC UNGULATE; MAMMALIA; TOOTH. [R.M.Scho.]

**Time** The dimension of the physical universe which orders the sequence of events at a given place; also, a designated instant in this sequence, such as the time of day, technically known as an epoch, or sometimes as an instant.

**Measurement.** Time measurement consists of counting the repetitions of any recurring phenomenon and possibly subdividing the interval between repetitions. Two aspects to be considered in the measurement of time are frequency, or the rate at which the recurring phenomena occur, and epoch, or the designation to be applied to each instant.

Time units are the intervals between successive recurrences of phenomena, such as the period of rotation of the Earth or a specified number of periods of radiation derived from an atomic energy-level transition. Other units are arbitrary multiples and subdivisions of these intervals, such as the hour being 1/24 of a day, and the minute being 1/60 of an hour. See DAY; MONTH; TIME-INTERVAL MEASUREMENT; YEAR.

**Time bases.** Several phenomena are used as bases with which to determine time. The phenomenon traditionally used has been the rotation of the Earth, where the counting is by days. Days are measured by observing the meridian passages of stars and are subdivided with the aid of precision clocks. The day, however, is subject to variations in duration. Thus, when a more uniform time scale is required, other bases for time must be used.

The angle measured along the celestial equator between the observer's local meridian and the vernal equinox, known as the hour angle of the vernal equinox, is the measure of sidereal time. It is reckoned from 0 to 24 hours, each hour being subdivided into 60 sidereal minutes and the minutes into 60 sidereal seconds. Sidereal clocks are used for convenience in most astronomical observatories because a star or other object outside the solar system comes to the same place in the sky at virtually the same sidereal time.

The hour angle of the Sun is the apparent solar time. The only true indicator of local apparent solar time is a sundial. Mean solar time has been devised to eliminate the irregularities in apparent solar time that arise from the obliquity of the ecliptic and the varying speed of the Earth in its orbit around the Sun. It is the hour angle of a fictitious point moving uniformly along the celestial equator at the same rate as the average rate of the Sun along the ecliptic. Both sidereal and solar time depend on the rotation of the Earth for their time base.

The mean solar time determined for the meridian of 0° longitude from the rotation of the Earth by using astronomical observations is referred to as UT1. Observations are made at a number of observatories around the world. The International Earth Rotation Service (IERS) receives these data and maintains a UT1 time scale. See EARTH ROTATION AND ORBITAL MOTION.

Because the Earth has a nonuniform rate of rotation and since a uniform time scale is required for many timing applications, a different definition of a second was adopted in 1967. The international agreement calls for the second to be defined as 9,192,631,770 periods of the radiation derived from an energy-level transition in the cesium atom. This second is referred to as the international or SI (International System) second and is independent of astronomical observations. International Atomic Time (TAI) is maintained by the International Bureau of Weights and Measures (BIPM) from data contributed by time-keeping laboratories around the world. See ATOMIC TIME.

Coordinated Universal Time (UTC) uses the SI second as its time base. However, the designation of the epoch may be changed at certain times so that UTC does not differ from UT1 by more than 0.9 s. UTC forms the basis for civil time in most countries and may sometimes be referred to as Greenwich mean time. The adjustments to UTC to bring this time scale into closer accord with UT1 consist of the insertion or deletion of integral seconds. These “leap seconds” may be applied at 23 h 59 m 59 s of June 30 or December 31 of each year according to decisions made by the IERS. UTC differs from TAI by an integral number of atomic seconds.

**Civil and standard times.** Because rotational time scales are defined as hour angles, at any instant they vary from place to place on the Earth. Persons traveling westward around the Earth must advance their time 1 day, and those traveling eastward must retard their time 1 day in order to be in agreement with their neighbors when they return home. The International Date Line is the name given to a line where the change of date is made. It follows approximately the 180th meridian but avoids inhabited land. To avoid the inconvenience of the continuous change of mean solar time with longitude, zone time or civil time is generally used. The Earth is divided into 24 time zones, each approximately 15° wide and centered on standard longitudes of 0°, 15°, 30°, and so on. Within each of these zones the time kept is the mean solar time of the standard meridian. See INTERNATIONAL DATE LINE.

Many countries, including the United States, advance their time 1 hour, particularly during the summer months, into “day-light saving time.” [D.D.McC.]

**Time, arrow of** The uniform and unique direction associated with the apparent inevitable flow of time into the future. There appears to be a fundamental asymmetry in the universe. Herein lies a paradox, for all the laws of physics, whether they are the equations of classical mechanics, classical electromagnetism, general relativity, or quantum mechanics, are time reversible in that they admit solutions in either direction of time. This reversibility raises the question of how these fundamentally time-symmetrical equations can result in the perceived asymmetry of temporally ordered events.

The symmetry breaking of temporal order has not yet been fully explained. There are certain indications that an intrinsic asymmetry exists in temporal evolution. Thus it may be that the fundamental laws of physics are not really time symmetric and that the currently known laws are only symmetrized approximations to the truth. Indeed, the decay of the  $K^0$  meson is not time reversible. However, it is not clear how such a rare and exotic instance of time asymmetry could emerge into the world of essentially macroscopic, electromagnetic phenomena as an everyday observable. See TIME REVERSAL INVARIANCE.

Another, more ubiquitous example of a fundamentally time-asymmetric process is the expansion of the universe. It has been speculated that this expansion is the true basis of time asymmetry. See BIG BANG THEORY; COSMOLOGY.

Alternatively, even a time-symmetrical universe will have a statistical behavior in which configurations of molecules and localizations of energy have significant probabilities of recurring only after enormously long time intervals. Indeed, such time intervals are longer than the times required for the ceaseless expansion of the universe and the evolution of its component particles. Time's arrow is destined, either by the nature of space-time or the statistics of large assemblies, to fly into the future. See STATISTICAL MECHANICS. [P.W.A.]

**Time constant** A characteristic time that governs the approach of an exponential function to a steady-state value. When a physical quantity is varying as a decreasing exponential function of time as in Eq. (1), or as an increasing exponential function as in Eq. (2), the approach to the steady-state value achieved

after a long time is governed by a characteristic time  $T$  as given in Eq. (3). This time  $T$  is called the time constant.

$$f(t) = e^{-kt} \quad (1)$$

$$f(t) = 1 - e^{-kt} \quad (2)$$

$$t = \frac{1}{k} = T \quad (3)$$

When time  $t$  is zero,  $f(t)$  in Eq. (1) has the magnitude 1, and when  $t$  equals  $T$  the magnitude is  $1/e$ . Here  $e$  is the transcendental number whose value is approximately 2.71828, and the change in magnitude is  $1 - (1/e) = 0.63212$ . The function has moved 63.2% of the way to its final value. The same factor also holds for Eq. (2). See E (MATHEMATICS).

The initial rate of change of both the increasing and decreasing functions is equal to the maximum amplitude of the function divided by the time constant.

The concept of time constant is useful when evaluating the presence of transient phenomena. [R.L.R.]

**Time-interval measurement** A determination of the duration between two instants of time (epochs). Time intervals are measured with high precision with a digital display counter. An electronic oscillator generates pulses; the count begins with a start signal and ends with a second signal. Two atomic clocks can be compared in epoch to 1 picosecond ( $1 \text{ ps} = 10^{-12} \text{ s}$ ) by electronic interpolation. See ATOMIC CLOCK; DIGITAL COUNTER; OSCILLATOR; OSCILLOSCOPE.

Rapid motions can be studied at short intervals by means of a large variety of high-speed cameras, including stroboscopic, rotating film-drum, rotating mirror, streak, and image converter cameras. An electronic streak camera can separate two pulses 1 ps apart. See PHOTOGRAPHY; STROBOSCOPIC PHOTOGRAPHY.

Ultrashort laser pulses are used to study rapid processes caused by the interaction of photons with an atom or molecule. Pulses as short as three wavelengths of 620-nm light, with  $\tau = 6$  femtoseconds ( $1 \text{ fs} = 10^{-15} \text{ s}$ ), have been formed. See LASER; LASER PHOTOCHEMISTRY; OPTICAL PULSES; ULTRAFAST MOLECULAR PROCESSES.

Radioactive decay is used to measure long time intervals, to about  $5 \times 10^9$  years, concerning human history, the Earth, and the solar system. See GEOCHRONOMETRY; RADIOCARBON DATING. [W.M.]

**Time-of-flight spectrometer** Any of a general class of instruments in which the speed of a particle is determined directly by measuring the time that it takes to travel a measured distance. By knowing the particle's mass, its energy can be calculated. If the particles are uncharged (for example, neutrons), difficulties arise because standard methods of measurement (such as deflection in electric and magnetic fields) are not possible. The time-of-flight method is a powerful alternative, suitable for both uncharged and charged particles.

The time intervals are best measured by counting the number of oscillations of a stable oscillator that occur between the instants that the particle begins and ends its journey. Oscillators operating at 100 MHz are in common use. See MASS SPECTROSCOPY; NEUTRON SPECTROMETRY; TIME-INTERVAL MEASUREMENT. [F.W.K.F.]

**Time-projection chamber** An advanced particle detector for the study of ultra-high-energy collisions of positrons and electrons. The underlying physics of the scattering process can be studied through precise measurements of the momenta, directions, particle species, and correlations of the collision products. The time-projection chamber (TPC) provides a unique combination of capabilities for these studies and other problems in elementary particle physics by offering particle identification over a wide momentum range, and by offering high resolution

of intrinsically three-dimensional spatial information for accurate event reconstruction.

The time-projection chamber concept is based on the maximum utilization of ionization information, which is deposited by high-energy charged particles traversing a gas. The ionization trail, a precise image of the particle trajectory, also contains information about the particle velocity. A strong, uniform magnetic field and a uniform electric field are generated within the time-projection chamber active volume in an exactly parallel orientation. The parallel configuration of the fields permits electrons, products of the ionization processes, to drift through the time-projection chamber gas over great distances without distortion; the parallel configuration offers a further advantage in that the diffusion of the electrons during drift can be greatly suppressed by the magnetic field, thus preserving the quality of track information. See PARTICLE DETECTOR. [D.R.N.]

**Time reversal invariance** A symmetry of the fundamental (microscopic) equations of motion of a system; if it holds, the time reversal of any motion of the system is also a motion of the system. With one exception ( $K_L$  meson decay), all observations are consistent with time reversal invariance ( $T$  invariance).

Time reversal invariance is not evident from casual observation of everyday phenomena. If a movie is taken of a phenomenon, the corresponding time-reversed motion can be exhibited by running the movie backward. The result is usually strange. For instance, water in the ground is not ordinarily observed to collect itself into drops and shoot up into the air. However, if the system is sufficiently well observed, the direction of time is not obvious. For instance, a movie which showed the motion of the planets would look just as right run backward or forward. The apparent irreversibility of everyday phenomena results from the combination of imprecise observation and starting from an improbable situation (a state of low entropy, to use the terminology of statistical mechanics). See ENTROPY; STATISTICAL MECHANICS; TIME, ARROW OF.

If time reversal invariance holds, no particle (a physical system with a definite mass and spin) can have an electric dipole moment. A polar body, for example, a water ( $H_2O$ ) molecule, has an electric dipole moment, but its energy and spin eigenstates (which are particles) do not. No particle has been observed to have an electric dipole moment; for instance, the present experimental upper limit on the electric moment of the neutron is approximately  $10^{-25}$  cm times  $e$ , where  $e$  is the charge of the proton. Even smaller upper limits have been reported for the electric moment of some nuclei. See DIPOLE MOMENT; NEUTRON; POLAR MOLECULE; SPIN (QUANTUM MECHANICS).

Another test of time reversal invariance is to compare the cross sections for reactions which are inverse to one another. The present experimental upper limit on the relative size of the time reversal invariance-violating amplitude of such reactions is approximately  $3 \times 10^{-3}$ ; unfortunately, this is far larger than any expected violation. See NUCLEAR REACTION.

If time reversibility holds, then by the  $CPT$  theorem  $CP$  invariance must hold, that is, invariance of the fundamental equations under the combined operations of charge conjugation  $C$  and space inversion  $P$ . Conversely, violation of  $CP$  invariance implies violation of  $T$  (time reversal invariance). In 1964,  $CP$  violation was observed in the decay of the long-lived neutral  $K$  meson, the  $K_L$ . For many years, no other evidence for  $T$  or  $CP$  violation was seen. From this it was deduced that the interactions which violate  $CP$  are very weak and are evident in  $K_L$  decay only because there are two neutral  $K$  mesons that have practically the same mass and are therefore easily mixed. See  $CPT$  THEOREM; MESON.

Within the current understanding of particle physics, namely the so-called standard model,  $CP$  violation comes from the Kobayashi-Maskawa matrix of coefficients that relate the quark weak  $i$ -spin eigenstates with the quark mass eigenstates. It turns out that because the number of flavors is greater than four, the

Kobayashi-Maskawa matrix can be nonreal, resulting in nonconservation of  $CP$  and  $T$ . See ELECTROWEAK INTERACTION; FLAVOR; QUARKS; STANDARD MODEL; WEAK NUCLEAR INTERACTIONS.

It is also possible that  $CP$  violation comes from yet unknown interactions. More is being learned from observations since 2001 of  $CP$  violation in the decay of the neutral  $B$  mesons at the so-called  $B$  factories, particle accelerators built for the purpose of copiously producing  $B$  mesons. Initial results are consistent with the standard model. See ELEMENTARY PARTICLE; PARTICLE ACCELERATOR; SYMMETRY LAWS (PHYSICS). [C.J.G.]

**Timothy** A plant, *Phleum pratense*, of the order Cyperales, long the most important hay grass for the cooler temperate humid regions. It is easily established and managed, produces seed abundantly, and grows well in mixtures with alfalfa and clover. It is a short-lived perennial, makes a loose sod, and has moderately leafy stems and a dense cylindrical inflorescence. Timothy-legume mixtures still predominate in hay and pasture seedings for crop rotations in the northern half of the United States. See GRASS. [H.B.S.]

**Tin** A chemical element, symbol Sn, atomic number 50, atomic weight 118.69. Tin forms tin(II) or stannous ( $Sn^{2+}$ ), and tin(IV) or stannic ( $Sn^{4+}$ ) compounds, as well as complex salts of the stannite ( $M_2SnX_4$ ) and stannate ( $M_2SnX_6$ ) types. See PERIODIC TABLE.

Tin melts at a low temperature, is highly fluid when molten, and has a high boiling point. It is soft and pliable and is corrosion-resistant to many media. An important use of tin has been for tin-coated steel containers (tin cans) used for preserving foods and beverages. Other important uses are solder alloys, bearing metals, bronzes, pewter, and miscellaneous industrial alloys. Tin chemicals, both inorganic and organic, find extensive use in the electroplating, ceramic, plastic, and agricultural industries.

The most important tin-bearing mineral is cassiterite,  $SnO_2$ . No high-grade deposits of this mineral are known. The bulk of the world's tin ore is obtained from low-grade alluvial deposits. See CASSITERITE.

Two allotropic forms of tin exist: white ( $\beta$ ) and gray ( $\alpha$ ) tin. Tin reacts with both strong acids and strong bases, but it is relatively resistant to solutions that are nearly neutral. In a wide variety of corrosive conditions, hydrogen gas is not evolved from tin and the rate of corrosion becomes controlled by the supply of oxygen or other oxidizing agents. In their absence, corrosion is negligible. A thin film of stannic oxide forms on tin upon exposure to air and provides surface protection. Salts that have an acid reaction in solution, such as aluminum chloride and ferric chloride, attack tin in the presence of oxidizers or air. Most nonaqueous liquids, such as oils, alcohols, or chlorinated hydrocarbons, have slight or no obvious effect on tin. Tin metal and the simple inorganic salts of tin are nontoxic. Some forms of organotin compounds, on the other hand, are toxic. Some important physical constants for tin are shown in the table.

Stannous oxide,  $SnO$ , is a blue-black, crystalline product which is soluble in common acids and strong alkalis. It is used in making stannous salts for plating and glass manufacture. Stannic oxide,  $SnO_2$ , is a white powder, insoluble in acids and alkalis.

Properties of tin

Property	Value
Melting point, °C	231.9
Boiling point, °C	2270
Specific gravity, $\alpha$ form (gray tin)	5.77
$\beta$ form (white tin)	7.29
Specific heat, cal/g*, white tin at 25°C	0.053
Gray tin at 10°C	0.049

\*1 cal = 4.184 joules.

It is an excellent glaze opacifier, a component of pink, yellow, and maroon ceramic stains and of dielectric and refractory bodies. It is an important polishing agent for marble and decorative stones.

Stannous chloride,  $\text{SnCl}_2$ , is the major ingredient in the acid electroplating electrolyte and is an intermediate for tin chemicals. Stannic chloride,  $\text{SnCl}_4$ , in the pentahydrate form is a white solid. It is used in the preparation of organotin compounds and chemicals to weight silk and to stabilize perfume and colors in soap. Stannous fluoride,  $\text{SnF}_2$ , a white water-soluble compound, is a toothpaste additive.

Organotin compounds are those compounds in which at least one tin-carbon bond exists, the tin usually being present in the + IV oxidation state. Organotin compounds that find applications in industry are the compounds with the general formula  $\text{R}_4\text{Sn}$ ,  $\text{R}_3\text{SnX}$ ,  $\text{R}_2\text{SnX}_2$ , and  $\text{RSnX}_3$ . R is an organic group, often methyl, butyl, octyl, or phenyl, while X is an inorganic substituent, commonly chloride, fluoride, oxide, hydroxide, carboxylate, or thiolate. See TIN ALLOYS. [J.B.Lo.]

**Tin alloys** Solid solutions of tin and some other metal or metals. Alloys cover a wide composition range and many applications because tin alloys readily with nearly all metals. See TIN; TIN METALLURGY.

Soft solders constitute one of the most widely used and indispensable series of tin-containing alloys. Common solder is an alloy of tin and lead, usually containing 20–70% tin. See SOLDERING.

Bronzes form an important group of structural metals. Of the true copper-tin bronzes, up to 10% tin is used in wrought phosphor bronzes, and from 5 to 10% tin in the most common cast bronzes. Many bronzes, which are basically copper-zinc alloys, contain 0.75–1.0% tin for additional corrosion resistance. See COPPER ALLOYS.

Other useful tin alloys include babbitt metal (tin containing 4–8% each copper and antimony), an alloy with bearing applications; pewter; a tin-base alloy containing small quantities of antimony and copper; and type metals, which are lead-base alloys containing 3–15% tin. See ALLOY. [B.W.G.]

**Tin metallurgy** The extraction of tin from its ores and its subsequent refining and preparation for use. Most tin concentrates are primarily cassiterite ( $\text{SnO}_2$ ), the naturally occurring oxide of tin. These are comparatively easy to reduce by using carbon at high temperatures. However, this operation differs from the smelting of most common metals because retreatment of the slag is necessary to obtain efficient metal recovery. See CASSITERITE.

In primary smelting, carbon monoxide (CO) formed during heat-up reacts with the solid cassiterite particles to produce tin (Sn) and carbon dioxide ( $\text{CO}_2$ ). As the temperature increases, silica (present in nearly all concentrates) also reacts under reducing conditions with the  $\text{SnO}_2$  to give stannous silicate. Iron, also present as an impurity in all concentrates, reacts with the silica to form ferrous silicate ( $\text{FeSiO}_3$ ). These silicates fuse with the added fluxes to form a liquid slag, at which point unreacted carbon from the fuel becomes the predominant reductant in reducing both stannous silicate to tin and ferrous silicate to iron. The metallic iron then reduces tin from stannous silicate, as shown in the reaction below.

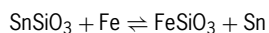

Secondary tin from metal scrap amounts to about one-quarter of the total tin consumed in the United States. Most of this comes from tin-bearing alloys, and secondary smelters rework them into alloys and chemicals. However, additional tin of high purity is recovered from the detinning of tinplate scrap. See ELECTRO-

CHEMICAL PROCESS; ELECTROMETALLURGY; HEAT TREATMENT (METALLURGY); PYROMETALLURGY, NONFERROUS; TIN. [D.May.]

**Tintinnida** An order of the Spirotrichia whose members are conical or trumpet-shaped pelagic forms bearing shells (loricae). These protozoa are planktonic ciliates and are especially abundant in oceans, notably the Pacific. The lorica is composed of a resistant organic compound in which various foreign mineral grains are embedded; its shape may range from trumpet- or bell-form to cylindrical or subspherical.

Fossil tintinnids, representing practically the only fossilized species of ciliate protozoa known to science, are identified on the basis of the shape of the lorica in cross section as seen in randomly oriented thin sections of the rocks in which they are found. Twelve genera of fossil tintinnids have been described from limestones and cherts of the Jurassic and Cretaceous. See CILIOPHORA; SPIROTRICHIA. [J.O.C.; D.J.J.]

**Tire** A continuous pneumatic rubber and fabric cushion encircling and fitting onto the rim of a wheel. In modern tire building, chemicals are compounded into the rubber to help it withstand wear, heat, and aging and to produce desired changes in its characteristics. Fabric (rayon, nylon, or polyester) is used to give the tire body strength and resilience. In belted tires, additional layers of fabric (rayon, fiber glass, finely drawn steel, or aramid) are placed just under the tread rubber to increase mileage and handling. Steel wire is used in the bead that holds the tire to the rim.

A tire is made up of two basic parts: the tread, or road-contacting part, which must provide traction and resist wear and abrasion, and the body or carcass, consisting of rubberized fabric that gives the tire strength and flexibility. In compounding the rubber, large amounts of carbon black are mixed with it to improve abrasion resistance. Other substances, such as sulfur, are added to enable satisfactory processing and vulcanization. See RUBBER.

There are three types of tires: bias, belted bias, and radial (see illustration). For bias tires, cords in the piles extend diagonally

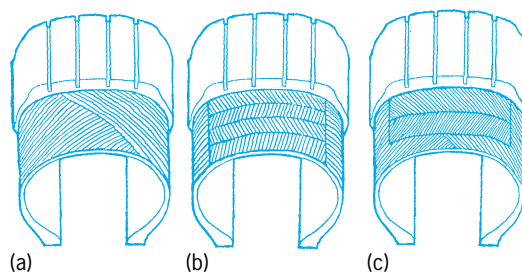

**Tire construction. (a) Bias-ply. (b) Radial-ply. (c) Belted bias-ply. (Goodyear Tire and Rubber Co.)**

across the tire from bead to bead. The cords run in opposite directions in each successive ply, resulting in a crisscross pattern. For belted bias tires, plies are placed in a manner similar to that used in the bias-ply tire, with belts of material placed circumferentially around the tire between the plies and the tread rubber. For radial tires, cords in the plies extend transversely from bead to bead, substantially perpendicular to the direction of travel. Belts are placed circumferentially around the tire. [D.B.H.]

**Tissue** An aggregation of cells more or less similar morphologically and functionally. The animal body is composed of four primary tissues, namely, epithelium, connective tissue (including bone, cartilage, and blood), muscle, and nervous tissue. The process of differentiation and maturation of tissues is called histogenesis. See HISTOLOGY. [C.B.C.]

**Tissue culture** The branch of biology in which tissues or cells of higher animals and plants are grown artificially in a controlled environment. Tissue culture is possible when cells are attached to a solid substrate, such as glass or cellophane, and if the necessary complex nutrient medium is provided. All cultures are now also grown in liquid suspension. Tissue cultures are used in the study of cell growth, multiplication, and differentiation, as well as in cancer research, hereditary mechanisms, radiation biology, all hybridization, and virus studies. See MICROBIOLOGICAL METHODS. [T.T.P.]

**Tissue typing** A procedure involving a test or a series of tests to determine the compatibility of tissues from a prospective donor and a recipient prior to transplantation. The immunological response of a recipient to a transplant from a donor is directed against many cell-surface histocompatibility antigens controlled by genes at many different loci. However, one of these loci, the major histocompatibility complex (MHC), controls antigens that evoke the strongest immunological response. The human MHC is known as the HLA system, which stands for the first (A) human leukocyte blood group system discovered. See CELLULAR IMMUNOLOGY; HISTOCOMPATIBILITY.

The success of transplantation is greatly dependent on the degree of histocompatibility (identity) between the donor and recipient, which is determined by the HLA complex. When the donor and recipient have a low degree of histocompatibility, the organ is said to be mismatched, and the recipient mounts an immune response against the donor antigen. By laboratory testing, the degree of antigenic similarity between the donor and the recipient and the degree of preexisting recipient sensitization to donor antigens (and therefore preformed antibodies) can be determined. This is known as cross-matching.

Phenotyping of HLA-A, -B, and -C (ABC typing) of an individual is determined by reacting that individual's lymphocytes with a large panel of antisera directed against specific HLA antigens. The procedure is known as complement-mediated cytotoxicity assay. The person's lymphocytes are incubated with the different antisera and complement is added. Killing of the cells being tested indicates that they express the HLA antigens recognized by the particular antiserum being used. Killing of potential donor lymphocytes in the complement-mediated cytotoxicity assay is a contraindication to transplantation of tissue from that donor. See COMPLEMENT; HYPERSENSITIVITY; IMMUNOASSAY.

In addition to its important role in organ transplantation, determination of the HLA phenotype is useful in paternity testing, forensic medicine, and the investigation of HLA-disease associations. See TRANSPLANTATION BIOLOGY. [M.W.F.I.; T.Moh.]

**Titanite** A calcium, titanium silicate,  $\text{CaTiOSiO}_4$ , of high titanium content. Titanite is also known as sphene. Titanite is an orthosilicate (nesosilicate) with a hardness of 5–5½ on the Mohs scale, a distinct cleavage, a specific gravity of 3.4–3.55, and an adamantine to resinous luster. It commonly occurs as distinct wedge-shaped crystals that are usually brown in hand specimens. Titanite may also be gray, green, yellow, or black. See CRYSTAL STRUCTURE; HARDNESS SCALES.

Titanite is a common accessory mineral in many igneous and metamorphic rocks. It may be the principal titanium-bearing silicate mineral. It occurs in abundance in the Magnet Cove, igneous complex in Arkansas and in the intrusive alkalic-rocks of the Kola Peninsula, Russia.

The composition of titanite may diverge from pure  $\text{CaTiSiO}_4$  because of a variety of chemical substitutions. Calcium ions ( $\text{Ca}^{2+}$ ) can be partially replaced by strontium ions ( $\text{Sr}^{2+}$ ) and rare-earth ions such as thorium ( $\text{Th}^{4+}$ ) and uranium ( $\text{U}^{4+}$ ). Because titanite commonly contains radioactive elements, it has been used for both uranium-lead and fission track methods of dating. See DATING METHODS; IGNEOUS ROCKS; METAMORPHIC ROCKS; SILICATE MINERALS; TITANIUM. [J.C.D.]

**Titanium** A chemical element, Ti, atomic number 22, and atomic weight 47.90. It occurs in the fourth group of the periodic table, and its chemistry shows many similarities to that of silicon and zirconium. On the other hand, as a first-row transition element, titanium has an aqueous solution chemistry, especially of the lower oxidation states, showing some resemblances to that of vanadium and chromium. See PERIODIC TABLE; TRANSITION ELEMENTS.

The catalytic activity of titanium complexes forms the basis of the well-known Ziegler process for the polymerization of ethylene. This type of polymerization is of great industrial interest since, with its use, high-molecular-weight polymers can be formed. In some cases, desirable special properties can be obtained by forming isotactic polymers, or polymers in which there is a uniform stereochemical relationship along the chain. See POLYOLEFIN RESINS.

The dioxide of titanium,  $\text{TiO}_2$ , occurs most commonly in a black or brown tetragonal form known as rutile. Less prominent naturally occurring forms are anatase and brookite (rhombohedral). Both rutile and anatase are white when pure. The dioxide may be fused with other metal oxides to yield titanates, for example,  $\text{K}_2\text{TiO}_3$ ,  $\text{ZnTiO}_3$ ,  $\text{PbTiO}_3$ , and  $\text{BaTiO}_3$ . The black basic oxide,  $\text{FeTiO}_3$ , occurs naturally as the mineral ilmenite; this is a principal commercial source of titanium.

Titanium dioxide is widely used as a white pigment for exterior paints because of its chemical inertness, superior covering power, opacity to damaging ultraviolet light, and self-cleaning ability. The dioxide has also been used as a whitening or opacifying agent in numerous situations, for example as a filler in paper, a coloring agent for rubber and leather products, a pigment in ink, and a component of ceramics. It has found important use as an opacifying agent in porcelain enamels, giving a finish coat of great brilliance, hardness, and acid resistance. Rutile has also been found as brilliant, diamondlike crystals, and some artificial production of it in this form has been achieved. Because of its high dielectric constant, it has found some use in dielectrics.

The alkaline-earth titanates show some remarkable properties. The dielectric constants range from 13 for  $\text{MgTiO}_3$  to several thousand for solid solutions of  $\text{SrTiO}_3$  in  $\text{BaTiO}_3$ . Barium titanate itself has a dielectric constant of 10,000 near 120°C (248°F), its Curie point; it has a low dielectric hysteresis. These properties are associated with a stable polarized state of the material analogous to the magnetic condition of a permanent magnet, and such substances are known as ferroelectrics. In addition to the ability to retain a charged condition, barium titanate is piezoelectric and may be used as a transducer for the interconversion of sound and electrical energy. Ceramic transducers containing barium titanate compare favorably with Rochelle salt and quartz, with respect to thermal stability in the first case, and with respect to the strength of the effect and the ability to form the ceramic in various shapes, in the second case. The compound has been used both as a generator for ultrasonic vibrations and as a sound detector. See PIEZOELECTRICITY. [A.W.A.]

In addition to important uses in applications such as structural materials, pigments, and industrial catalysis, titanium has a rich coordination chemistry. The formal oxidation of titanium in molecules and ions ranges from –II to +IV. The lower oxidation states of –II and –I occur only in a few complexes containing strongly electron-withdrawing carbon monoxide ligands.

The lower oxidation states of titanium are all strongly reducing. Thus, unless specific precautions are taken, titanium complexes are typically oxidized rapidly to the +IV state. Moreover, many titanium complexes are extremely susceptible to hydrolysis. Consequently, the handling of titanium complexes normally requires oxygen- and water-free conditions. See COORDINATION CHEMISTRY. [L.K.W.]

**Titanium metallurgy** The winning of metallic titanium (Ti) from its ores followed by alloying and processing into forms and shapes that can be used for structural purposes.

All commercial titanium metal is produced from titanium tetrachloride ( $\text{TiCl}_4$ ), an intermediate compound produced during the chlorination process for titanium oxide pigment. The process involves chlorination of ore concentrates; reacting  $\text{TiO}_2$  with chlorine gas ( $\text{Cl}_2$ ) and coke (carbon; C) in a fluidized-bed reactor forms impure titanium tetrachloride. For the production of acceptable metal, purification of the raw tetrachloride is required to remove other metal chlorides that would contaminate the virgin titanium.

The purified titanium tetrachloride is delivered as a liquid to the reactor vessel. In these vessels, constructed of carbon or stainless steel, the titanium tetrachloride is reacted with either magnesium (Mg) or sodium (Na) to form the pure metal called sponge, because of its porous cellular form. To avoid contamination by oxygen or nitrogen, the reaction is carried out in an argon atmosphere. The sponge, removed from the reactor pot by boring, is cleaned by acid leaching.

A mass of sponge, alloy additions, and scrap are mixed, then compressed into compacts and welded together to form a sponge electrode. This is melted by an electric arc into a water-cooled copper crucible in a vacuum or an atmosphere of purified argon. The arc progressively consumes the sponge electrode to form an ingot. Ingots up to 30,000 lb (13,600 kg) are routinely produced by using this consolidation method.

The conversion of the titanium ingot into mill products, such as forging billet, plate, sheet, and tubing, is accomplished for the most part on conventional metalworking equipment. Mills designed to roll and shape stainless or alloy steel are used with only slight modifications. For this reason titanium and its structural alloys are produced in most of the same forms and shapes as stainless steel. See METAL FORMING; STAINLESS STEEL.

Pure titanium is soft, weak, and extremely ductile. However, through appropriate additions of other elements, the titanium metal base is converted to an engineering material having unique characteristics, including high strength and stiffness, corrosion resistance, and usable ductility. The type and quantity of alloy addition determine the mechanical and, to some extent, the physical properties. Some common titanium alloy additions include aluminum, oxygen, nitrogen, carbon, molybdenum, chromium, iron, nickel, zirconium, and tin. See ALLOY; METALLURGY; TITANIUM. [W.W.Mi.; S.R.Se.]

**Titration** A quantitative analytical process that is basically volumetric. However, in high-precision titrimetry the titrant solution is sometimes delivered from a weight buret, so that the volumetric aspect is indirect. Generally, a standard solution, that is, one containing a known concentration of substance X (titrant), is progressively added to a measured volume of a solution of a substance Y (titrand) that will react with the titrant. The addition is continued until the end point is reached.

Ideally, this is the same as the equivalence point, at which an excess of neither X nor Y remains. If the stoichiometry or exact ratio in which X and Y react is known, it is possible to calculate the amount of Y in the unknown solution. See VOLUMETRIC ANALYSIS.

The normal requirements for the performance of a titration are: a standard titrant solution; calibrated volumetric apparatus, including burets, pipets, and volumetric flasks; and some means of detecting the end point. See BURET; PIPET; VOLUMETRIC FLASK.

**Classification by chemical reaction.** For the purposes of titrimetry, chemical reactions can be placed in three general categories: acid-base or neutralization, combination, and oxidation-reduction.

Acid-base titrations involve neutralization of an acid by titration with a base, or vice versa. However, the process is often nonspecific; in the titration of a mixture of nitric and hydrochloric acids, only the total acidity can be found without recourse to additional measurements. A salt derived from a strong base and a very weak acid can often be titrated just as if it were a base. See ACID AND BASE.

In titrimetry, attention is usually focused upon the combination of an ion in the titrant with one of the opposite sign in the titrand solution. Sometimes the combination may involve more than two species, some of which may be nonionic. The combinations may result in precipitation or formation of a complex. See COORDINATION COMPLEXES; PRECIPITATION (CHEMISTRY).

In so-called redox titrations the titrant is usually an oxidizing agent, and is used to determine a substance that can be oxidized and hence can act as a reducing agent. See OXIDATION-REDUCTION.

**Coulometric titration.** The passage of a uniform current for a measured period of time can be used to generate a known amount of a product such as a titrant. This fact is the basis of the technique known as coulometric titration. An obvious requirement is that generation shall proceed with a fixed, preferably 100%, current efficiency. The uniform current is then analogous to the concentration of an ordinary titrant solution, while the total time of passage is analogous to the volume of such a solution that would be needed to reach the end point. See ELECTROLYSIS.

**Classification by end-point techniques.** The precision and accuracy with which the end point can be detected is a vital factor in all titrations. Because of its simplicity and versatility, chemical indication is quite common, especially in acid-base titrimetry.

**Indicators.** An acid-base indicator is a weak acid or a weak base that changes color when it is transformed from the molecular to the ionized form, or vice versa. The color change is normally intense, so that only a low concentration of indicator is needed. The working range, or visual color change, of a typical acid-base indicator is spread over about a hundredfold ( $\sim 2$  pH units) change in hydrogen ion concentration. Available indicators have individual working ranges that together cover the entire range of hydrogen ion concentration likely to be encountered in general acid-base titration. See ACID-BASE INDICATOR; HYDROGEN ION; PH.

Sometimes no suitable chemical indicator can be found for a desired titration. Possibly the concentrations involved may be so low that chemical indication functions poorly. Other situations might be the need for high precision or for the automatic arrest of the titration. Recourse is then made to some physical method of end-point detection.

**Potentiometric titration.** If a pH meter is used, its associated electrodes are first standardized by use of a buffer solution of known pH. By suitable choice of electrodes, potentiometric methods can also be applied to combination titrations and to oxidation-reduction titrations. The advent of modern ion-selective electrodes has greatly extended the scope of potentiometric titration and of other branches of titrimetry. See ELECTRODE POTENTIAL; ION-SELECTIVE MEMBRANES AND ELECTRODES.

**Conductometric titration.** Conductometric titration is sometimes successful when chemical indication fails. The underlying principles of conductometric titration are that the solvent and any molecular species in solution exhibit only negligible conductance; that the conductance of a dilute solution rises as the concentration of ions is increased; and that at a given concentration the hydrogen ion and the hydroxyl ion are much better conductors than any of the other ions. See ELECTROLYTIC CONDUCTANCE.

**Spectrophotometric titration.** The spectrophotometer is an optical device that responds only to radiation within a selected very narrow band of wavelengths in the visual, ultraviolet, or infrared regions of the spectrum. The response can be made both quantitative and linearly related to the concentration of a species that absorbs radiation within this band. Titrations at wavelengths within the visual region are by far the most common. See SPECTROPHOTOMETRIC ANALYSIS.

**Amperometric titration.** By use of a dropping-mercury or other suitable microelectrode, it is possible to find a region of applied electromotive force (emf) in which the current is

proportional to the concentration of one or both of the reactants in a titration.

Biamperometric titration is a closely related technique. An emf that is usually small is applied across two identical microelectrodes that dip into the titrand solution. This arrangement, which involves no liquid-liquid junctions, is valuable in nonaqueous titrations, but also finds much use in aqueous titrimetry. See POLAROGRAPHIC ANALYSIS.

**Thermometric or enthalpimetric titration.** Many chemical reactions proceed with the evolution of heat. If one of these is used as the basis of a titration, the temperature first rises progressively and then remains unchanged as the titration is continued past the end point. If the reaction is endothermic, the temperature falls instead of rising. Thermometric titration is applicable to all classes of reactions. See THERMOCHEMISTRY.

**Nonaqueous titration.** This technique is used to perform titrations that give poor or no end points in water. Although applicable in principle to all classes of reactions, acid-base applications have greatly exceeded all others. Nonaqueous titrations in which the solvent is a molten salt or salt mixture are also possible.

**Automatic titration.** Automation is particularly valuable in routine titrations, which are usually performed repeatedly. One approach is to record the titration curve and to interpret it later. Another method is to stop titrant addition or generation automatically at, or very near to, the end point. Although a constant-delivery device is desirable, an ordinary buret with an electromagnetically controlled valve is often used.

Microcomputer control permits such refinements as the continuous adjustment of the titrant flow rate during the titration. In some cases, it is possible to automate an entire analysis, from the measurement of the sample to the final washout of the titration vessel and the printout of the result of the analysis. See ANALYTICAL CHEMISTRY. [J.T.St.]

**Tobacco** The plant genus *Nicotiana*, certain species in the genus, and dried leaves of these plants are all called tobacco. Most often tobacco means a leaf product containing 1–3% of the alkaloid nicotine, which produces a narcotic effect when smoked, chewed, or snuffed. The plant *N. rustica* provides tobacco in parts of Europe, but the tobacco of world commerce is *N. tabacum*. Tobacco is American in origin. See SOLANALES. [G.S.T.]

**Todorokite** A hydrated manganese oxide mineral containing calcium, barium, potassium, sodium, and sometimes magnesium, general formula  $(\text{Na,Ca,K,Ba,Sr})_{0.3-0.7}(\text{Mn,Mg,Al})_6\text{O}_{12} \cdot 3.2-4.5 \text{H}_2\text{O}$ . Todorokite is a major constituent of manganese nodules, which occur in large quantities ( $>10^{12}$  tons) on the ocean floors. It has been shown to host some of the copper, nickel, and cobalt that occur in some manganese nodules in quantities of up to several weight percent. First described in 1934, todorokite is named for its occurrence at the Todoroki mine, Hokkaido, Japan. Terrestrial todorokite has also been found in deposits in Cuba, Portugal, Austria, France, United States, Brazil, and South Africa.

Todorokite is black to brown and is commonly very fine grained. It occurs as massive samples or as fibrous aggregates. Its hardness on the Mohs scale is low (1.5–2.5), and its reported specific gravity ranges from approximately 3.1 to 3.8.

The basic todorokite structure consists of triple chains of manganese-oxygen octahedra that are linked at roughly right angles to form a tunnel structure. This  $[3 \times 3]$  structure can accommodate large cations and water in the tunnel sites. See CRYSTAL; MANGANESE NODULES. [S.T.]

**Toggle** Any of a wide variety of mechanisms, many used to open or close electrical contacts abruptly and all characterized by the control of a large force by a small one. The basic action of a toggle mechanism is shown in illustration *a*. When  $\alpha = 90^\circ$  the forces *P* and *Q* are independent of each other. Again, when

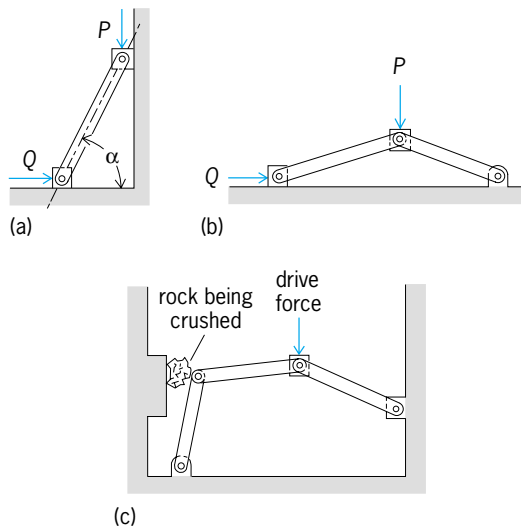

**Toggle mechanism.** (a) Simple structure. (b) Traditional configuration. (c) Typical application.

$\alpha = 0^\circ$  the forces are isolated, force *Q* being sustained entirely by the frame, and force *P* serving only to hold the link in position. At  $\alpha = 45^\circ$  from the symmetry  $|P| = |Q|$ , the mechanism serves to transfer the direction of forces to achieve equilibrium. See COUPLING.

Because the simple configuration of illus. *a* requires low-friction sliders, it is impractical. A more useful structure replaces the vertical slider with a second link pinned to the frame (illus. *b*), in which case input *P* sets up forces in both links. A further modification (illustration *c*) replaces the other slider with a link. See FOUR-BAR LINKAGE; LINKAGE (MECHANISM). [F.H.R.]

**Tolerance** Amount of variation permitted or “tolerated” in the size of a machine part. Manufacturing variables make it impossible to produce a part of exact dimensions; hence the designer must be satisfied with manufactured parts that are between a maximum size and a minimum size. Tolerance is the difference between maximum and minimum limits of a basic dimension. For instance, in a shaft and hole fit, when the hole is a minimum size and the shaft is a maximum, the clearance will be the smallest, and when the hole is the maximum size and the shaft the minimum, the clearance will be the largest.

If the initial dimension placed on the drawing represents the size of the part that would be used if it could be made exactly to size, then a consideration of the operating conditions of the pair of mating surfaces shows that a variation in one direction from the ideal would be more dangerous than a variation in the opposite direction. The dimensional tolerance should be in the less dangerous direction. This method of stating tolerance is called unilateral tolerance and has largely displaced bilateral tolerance, in which variations are given from a basic line in plus and minus values. [P.H.B.]

**Tomato** An important vegetable, belonging to the genus *Lycopersicon*, especially *L. esculentum*, that is grown for its edible fruit. The tomato was first domesticated in Mexico, and was introduced to Europe in the mid-sixteenth century. It has been grown in the United States since colonial days, but it became an important vegetable there only in the past century.

The genus *Lycopersicon* (Greek, “wolf peach”) is a member of the Solanaceae, the nightshade family. *Lycopersicon esculentum*, the familiar tomato, can be hybridized with each of the eight other species of *Lycopersicon*. Tomato breeders have transferred many genes, particularly for disease resistance, from wild *Lycopersicon* species to the tomato. See BREEDING (PLANT).



The tomato is a herbaceous perennial, but is usually grown as an annual in temperate regions since it is killed by frost. Cultivated tomatoes are self-fertile. The fruit is a berry with 2 to 12 locules containing many seeds. Most tomato varieties have red fruit, due to the red carotenoid lycopene. Different single genes are known to produce various shades of yellow, orange, or green fruit. There is no basis for the common belief that yellow-fruited tomatoes are low in acidity.

Tomatoes prefer warm weather. Cool temperature, 10°C (50°F) and below, delays seed germination, inhibits vegetative development, reduces fruit set, and impairs fruit ripening. High temperature, above 35°C (95°F), reduces fruit set and inhibits development of normal fruit color. The tomato plant is day-neutral, flowering when grown with either short or long days. This makes it possible to grow tomatoes outdoors during the short days of winter in frost-free areas as well as in more northern areas during the long days of summer.

The tomato is the most important processed vegetable, constituting over 23 lb (10.4 kg) of the 54 lb (24.3 kg) of processed vegetables the average American consumes each year. Tomatoes for processing are harvested when red ripe and are soon sent to a nearby cannery. Tomatoes for fresh market, however, are often harvested at an earlier stage of maturity when they are still firm and better able to tolerate shipment to distant markets. Most tomatoes for fresh market are harvested by hand, but almost all of the processing tomatoes in California are harvested mechanically. *See* AGRICULTURAL MACHINERY.

The tomato is highly esteemed as a source of vitamin C, and one medium-sized tomato provides about half of the required daily allowance for adults. Tomatoes are also a significant source of vitamin A and are a good source of protein, but most of it is in the seeds. Tomato juice contains 19 amino acids, principally glutamic acid. *See* ASCORBIC ACID; VITAMIN A.

The tomato has been a favored organism for genetic studies. Over a thousand genes are known for the tomato, and several hundred of these have been located on their respective chromosomes. *See* AGRICULTURAL SCIENCE (PLANT); FOOD MANUFACTURING; PLANT PHYSIOLOGY. [R.W.R.]

**Tommot fauna** The first diverse assemblages of unquestionable animal fossils at the Proterozoic-Phanerozoic transition, which marks the change from a predominantly microbial biosphere to a modern type of biosphere abundant with multicellular life. The name derives from the Early Cambrian Tommotian Stage in Siberia, where the significance of this fauna of early skeletal fossils was first realized. However, the concept goes beyond the geographical and temporal boundaries of the Tommotian Stage. It can be traced back to the low-diversity assemblages of skeletal animal fossils appearing near the end of the Neoproterozoic. *See* CAMBRIAN; FOSSIL.

Traditionally, the fauna was considered to predate the earliest trilobites; however, recent stratigraphic studies suggest that at least some of the Tommotian Stage correlates with trilobite-carrying beds elsewhere. A number of the characteristic Tommotian taxa are now also known to continue into post-Tommotian strata. The Tommot fauna is known to have radiated from all continents, but it is particularly diverse and abundant on the Siberian Platform in Russia, in Australia, and in the belt of phosphorite-rich deposits that extends from the South China Platform through Mongolia, Kazakhstan, the Himalayas, and Iran. *See* TRILOBITA.

The Tommot fauna has been instrumental in forming our understanding of the Cambrian explosion (dramatic evolutionary radiation of animals beginning about 545 million years ago), because its preservation is generally not dependent on extraordinary conditions and is therefore less spotty. Also, fossilized embryos of Tommot animals make it possible to understand the complete life cycles of some of the most basal members of the metazoan evolutionary tree. *See* ANIMAL EVOLUTION.

Characteristic morphologic features of the Tommot fauna include mineralized tubes, spicules (knoblike supporting struc-

tures), sclerites (hardened plates), and shells, often belonging to animals of unknown affinities. The minerals involved are opal (a hydrated gel of silica), apatite (calcium phosphate), and aragonite/calcite (calcium carbonate)—the same minerals that are common in animal skeletons today. [S.Be.]

**Ton of refrigeration** A rate of cooling that is equivalent to the removal of heat at 200 Btu/min (200 kilojoules/min), 12,000 Btu/h (13 megajoules/h), or 288,000 Btu/day (300 MJ/day). This unit of measure stems from the original use of ice for refrigeration. One pound of ice, in melting at 32°F (0°C), absorbs as latent heat approximately 144 Btu/lb (335 J/kg), and 1 ton (0.9 metric ton) of ice, in melting in 24 h, absorbs 288,000 Btu/day (300 MJ/day). In Europe, where the metric system is used, the equivalent cooling unit is the frigorie, which is a kilogram calorie, or 3.96 Btu. Thus 3000 frigories/h is approximately 1 ton of refrigeration. A standard ton of refrigeration is one developed at standard rating conditions of 5°F (−15°C) evaporator and 86°F (30°C) condenser temperatures, with 9°F (−13°C) liquid subcooling and 9°F (−13°C) suction superheat. *See* REFRIGERATION. [C.F.K.]

**Tone (music and acoustics)** Physically, a sound that is composed of discrete frequency (or sine-wave) components; psychologically, an auditory sensation that is characterized foremost by its pitch or pitches.

The physical definition distinguishes a tone from a noise, wherein the components form a continuum of frequencies. Tones may be pure, consisting of a single frequency, or they may be complex. Complex tones, in turn, may be periodic or not periodic. Periodic complex tones repeat themselves at rapid regular intervals. They have frequency components that are harmonics—discrete frequencies that are integer multiples of a fundamental frequency. For example, the tone of an oboe consists of a fundamental frequency of 440 hertz, a second harmonic component with a frequency of 880 Hz, a third harmonic at 1320 Hz, and so on. In general, musical instruments that generate continuous sounds—the bowed strings, the brasses, and the woodwinds—create such periodic tones. Tones that are not periodic (aperiodic) have frequency components that do not fit a harmonic series. Percussive instruments such as kettledrums and bells make such aperiodic tones. *See* HARMONIC (PERIODIC PHENOMENA); MUSICAL ACOUSTICS; MUSICAL INSTRUMENTS; PERIODIC MOTION.

Pitch is a sensation of highness or lowness that is the basic element of melody. Periodic complex tones tend to have a single pitch, which listeners will match by a pure tone having a frequency equal to the fundamental frequency of the periodic complex tone. Aperiodic complex tones tend to have multiple pitches. A second psychological attribute of complex tones is tone color or timbre. Tone color is often represented by descriptive adjectives. The adjectives may be linked to the physical spectrum. Thus, a tone with strong harmonics above 1000 Hz may be called “bright.” A tone with no harmonics at all above 1000 Hz may be called “dull” or “stuffy.” *See* PITCH; PSYCHOACOUSTICS; SOUND. [W.M.Ha.]

**Tongue** An organ located at the base of the oral cavity and found in all vertebrate animals. It is best developed in terrestrial vertebrates, where it takes on the functions of food procurement, food transport, and acquisition of chemosensory signals. The tongue generally is not a significant independent organ in fish, and it is secondarily reduced in organisms that feed aquatically, such as crocodilians and some turtles.

Within terrestrial vertebrates, there is considerable variability in the specific structure of the tongue, the degree of participation of the hyoid skeleton (that is, a complex of bones at the base of the tongue which supports the tongue and its muscles), and the mechanisms of movement. In birds the tongue is merely a thickened epithelium that overlies the hyoid apparatus. Movement is

produced by moving various hyoid elements. In most amphibians, including both frogs and salamanders, the hyoid provides extensive support, but considerable intrinsic tongue musculature exists. In squamate reptiles (lizards and snakes) and mammals the tongue is largely independent of the hyoid apparatus and is composed entirely of muscle. The musculature is tightly packed in the tongue and is generally arranged in three mutually perpendicular planes. In the mammalian tongue the musculature is arranged into longitudinal, transverse, and vertical bundles. Organs composed entirely of muscle and lacking independent skeletal systems, termed muscular hydrostats, are widespread. One of the primary advantages of a muscular hydrostat is that bending is not restricted to movement at joints, and the highly subdivided muscular and neural systems seen in mammalian tongues in particular produce movements that are remarkably specific, complex, and diverse.

While muscular-hydrostatic movements characterize the tongue of most mammals and many lizards and snakes, many of the most spectacular tongue projectors, such as chameleon lizards and plethodontid salamanders, do not use this mechanism in protrusion. These organisms have developed separate mechanisms in which the muscular tongue is projected ballistically from the body. In both, a muscle squeezes a process of the hyoid apparatus to generate the projectile force. See TASTE.

[K.K.S.]

**Tonsil** Localized aggregation of diffuse and nodular lymphoid tissue found in the region where the nasal and oral cavities open into the pharynx. The tonsils are important sources of blood lymphocytes. They often become inflamed and enlarged, necessitating surgical removal. See TONSILLITIS.

The two palatine (faucial) tonsils are almond-shaped bodies measuring 1 by 0.5 in. (2.5 by 1.2 cm) and are embedded between folds of tissue connecting the pharynx and posterior part of the tongue with the soft palate. These are the structures commonly known as the tonsils. The lingual tonsil occupies the posterior part of the tongue surface. It is really a collection of 35–100 separate tonsillar units, each having a single crypt surrounded by lymphoid tissue. Each tonsil forms a smooth swelling about 0.08–0.16 in. (2–4 mm) in diameter. The pharyngeal tonsil (called adenoids when enlarged) occupies the roof of the nasal part of the pharynx. This tonsil may enlarge to block the nasal passage, forcing mouth breathing. See LYMPHATIC SYSTEM. [T.Sn.]

**Tonsillitis** An inflammation of the tonsil. Tonsillitis is a non-specific term usually referring to bacterial or viral infection involving all or part of Waldeyer's ring, a collection of lymphatic tissue encircling the pharynx. It consists primarily of the tonsils (palatine tonsils), adenoids (pharyngeal tonsils), and lingual tonsils.

The complication of tonsillitis depend on which tonsil is involved. Recurrent adenoiditis with adenoid hypertrophy is frequently associated with recurrent otitis media, middle-ear fluid, and at times nasal obstruction with mouth breathing and snoring. Acute palatine tonsillitis may be complicated by peritonsillar abscess which may develop lateral to the tonsillar capsule. Removal of the adenoids is considered when there is residual middle-ear fluid. Palatine tonsils must be removed after peritonsillar abscess, but otherwise their removal depends upon the frequency of recurrent attacks of bacterial pharyngotonsillitis in relation to the patient's age. See TONSIL.

[J.A.D.]

**Tooth** One of the structures found in the mouth of most vertebrates which, in their most primitive form, were conical and were usually used for seizing, cutting up, or chewing food, or for all three of these purposes. The basic tissues that make up the vertebrate tooth are enamel, dentin, cementum, and pulp (see illustration).

Enamel is the hardest tissue in the body because of the very high concentration, about 96%, of mineral salts. The remaining 4% is water and organic matter. The enamel has no nerve supply,

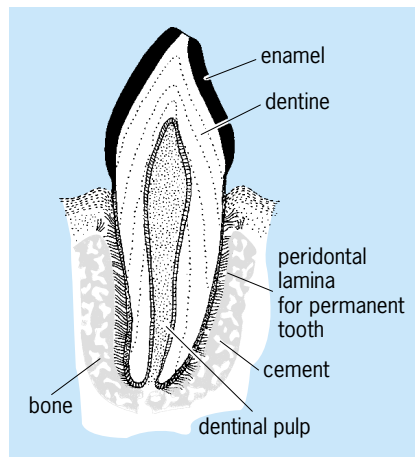

Structure of a tooth.

although it is nourished to a very slight degree from the dentin it surrounds. The fine, microscopic hexagonal rods (prisms) of apatite which make up the enamel are held together by a cementing substance.

Dentin, a very bonelike tissue, makes up the bulk of a tooth, consisting of 70% of such inorganic material as calcium and phosphorus, and 30% of water and organic matter, principally collagen. The rich nerve supply makes dentin a highly sensitive tissue; this sensitivity serves no obvious physiological function.

Cement is a calcified tissue, a type of modified bone less hard than dentin, which fastens the roots of teeth to the alveolus, the bony socket into which the tooth is implanted. A miscellaneous tissue, consisting of nerves, fibrous tissue, lymph, and blood vessels, known as the pulp, occupies the cavity of the tooth surrounded by dentin.

The dentition of therian mammals, at least primitively, consists of four different kinds of teeth. The incisors (I) are usually used for nipping and grasping; the canines (C) serve for stabbing or piercing; the premolars (Pm) grasp, slice, or function as additional molars; and the molars (M) do the chewing, cutting, and grinding of the food. Primitively the placentals have 40 teeth and the marsupials 50.

In therian mammals, probably because of the intricacies and vital importance of tooth occlusion, only part of the first (or "milk") dentition is replaced. This second, or permanent, dentition is made up of incisors, canines, and premolars; as a rule only one premolar is replaced in marsupials. Although the molars erupt late in development and are permanent, that is, not replaced, they are part of the first, or deciduous, dentition. See TOOTH DISORDERS.

[F.S.S.]

**Tooth disorders** Diseases and disturbances of the teeth and associated structures, including abnormal formation and growth of the teeth and jaws, tooth decay, inflammation of the tissues housing the roots of the teeth, and various diseases of the jaw bones.

Defective formation of dentin and enamel are referred to respectively as dentinogenesis and amelogenesis imperfecta, and may be caused by febrile illness during the period of tooth formation, or by faulty calcium or phosphorus metabolism, such as occurs in rickets. Some or all of the teeth may fail to form completely, or extra or supernumerary teeth may be present.

In most societies, dental decay, or caries, is one of the most important and common tooth disorders. Decay occurring during the adolescent years is caused by a class of microorganisms referred to as the cariogenic streptococci, of which *Streptococcus mutans* is a predominant member. However, a susceptible host and a cariogenic diet containing sucrose are also essential factors. Although the mechanism by which bacteria cause decay is

not completely understood, most experts believe that cariogenic organisms, by using sucrose, and to a lesser extent other sugars, produce polymers which bind the organisms to the tooth surface and acids which cause demineralization resulting in cavity formation. Fluoride administration, either in the drinking water or by other routes, effectively reduces dental decay about 50–70%. The mechanism by which fluoride causes decreased decay rates is not understood.

Whereas dental decay is the principal cause of tooth loss in young individuals, inflammatory disease of the tissues surrounding the teeth, referred to as periodontal disease, causes most of the tooth loss in adults. See PERIODONTAL DISEASE.

Diseases of the jaws may affect the teeth. The most common jaw disorders fall into four categories: (1) inflammation of the jawbone caused by infections such as osteomyelitis; (2) cysts associated with the teeth as well as those located in bone sutures of the jaws; (3) benign and malignant tumors of the jaws; and (4) systemic diseases such as generalized skeletal abnormalities produced by endocrine dysfunction in which the jaws are affected. See DENTISTRY; TOOTH. [R.C.P.]

**Topaz** A mineral best known for its use as a gemstone. Crystals are usually colorless but may be red, yellow, green, blue, or brown. The wine-yellow variety is the one usually cut and most highly prized as a gem. Corundum of similar color sometimes goes under the name of Oriental topaz. Citrine, a yellow variety of quartz, is the most common substitute and may be sold as quartz topaz.

Topaz is a nesosilicate with chemical composition  $\text{Al}_2\text{SiO}_4(\text{F},\text{OH})_2$ . The mineral crystallizes in the orthorhombic system and is commonly found in well-developed prismatic crystals with pyramidal terminations. It has a perfect basal cleavage which enables it to be distinguished from minerals otherwise similar in appearance. Hardness is 8 on Mohs scale; specific gravity is 3.4–3.6. See HARDNESS SCALES.

Fine yellow and blue crystals have come from Siberia and much of the wine-yellow gem material from Minas Gerais, Brazil. In the United States topaz has been found near Florissant, Colorado; in Thomas Range, Utah; in San Diego County, California; and near Topsham, Maine. See GEM; SILICATE MINERALS. [C.S.Hu.]

**Topographic surveying and mapping** The measurement of surface features and configuration of an area or a region, and the graphic expression of those features. Surveying is the art and science of measurement of points on, above, or under the surface of the Earth. Topographic maps show the natural and cultural features of a piece of land. The natural features include configuration (relief), hydrography, and vegetation. The cultural features include roads, buildings, bridges, political boundaries, and the sectional breakdown of the land. Topographic maps are used by a wide variety of people, such as engineers designing a new road; backpackers finding their way into remote areas; scientists describing soil or vegetation types, wildlife habitat, or hydrology; and military personnel planning field operations. See CARTOGRAPHY; MAP PROJECTIONS; MAP REPRODUCTION.

Topographic maps that show natural and cultural features only in plan view are called planimetric maps, while maps that show relief are called hypsometric maps. Contour lines join points along a line of the same elevation across the ground. Contours show not only the elevation of the ground but also the geomorphic shape of features. See CONTOUR.

A digital terrain model (DTM) is a computer-generated grid laid over the topographic information, which can then be rotated, tilted, and vertically exaggerated to give a three-dimensional view of the ground from different perspectives, including oblique representations. This technology is an excellent presentation tool: it utilizes the advances that have been made in computer mapping and drafting software.

Prior to starting collection of data, a network of known horizontal and vertical control points must be established. The network also allows measurements made from several different locations in the same coordinate system to fit together into the same reference datum (the basis for the coordinate system). Field methods that are used to make measurements include ground surveys, geographic positioning systems, and hydrographic surveys. Photogrammetry and remote sensing techniques involve the use of photography to obtain reliable measurements. Photographs can be taken from airplanes, helicopters, and even satellites; thus the term remote sensing is applied to this technology. See AERIAL PHOTOGRAPH; HYDROGRAPHY; PHOTOGRAMMETRY; REMOTE SENSING; SURVEYING INSTRUMENTS. [C.Br.]

**Topology** The branch of mathematics that studies the qualitative properties of spaces, as opposed to the more delicate and refined geometric or analytic properties. While there are earlier results that belong to the field, the beginning of the subject as a separate branch of mathematics dates to the work of H. Poincaré during 1895–1904. The ideas and results of topology have a central place in mathematics, with connections to almost all the other areas of the subject.

The difference between topological and geometric properties is illustrated by the example of a space with three separate pieces. The exact shapes of the pieces constitute a geometric property of the space, and the study of these shapes is in the domain of differential geometry, but the fact that the space has three separate pieces is a qualitative or topological property. As another example, if a round sphere is deformed to be pear-shaped (or even more irregularly shaped, like the surface of the Earth), then the geometric notions of distance, straight line, and angle are changed, but the topological properties of the surface are left unchanged. However, if a handle is added by cutting two holes in the sphere and connecting them by a curved pipe, then the topology of the surface is changed (see illustration).

Four major areas of topology are algebraic topology, homotopy theory, general topology, and manifold theory. Algebraic topology, the first area of modern topology to be developed, is concerned with associating algebraic invariants to geometric spaces in order to measure higher-dimensional analogs of the number of pieces of a space or the number of handles of a surface. (An algebraic invariant of a space is an algebraic object associated to the space that remains unchanged if the space is replaced by a homeomorphic space. By an algebraic object is meant either an algebraic structure, such as a group, ring, or field, or an element of an algebraic structure.) Algebraic topology has tremendous influence on other branches of mathematics, both direct (application of the invariants of algebraic topology to problems from other areas of mathematics and physics)

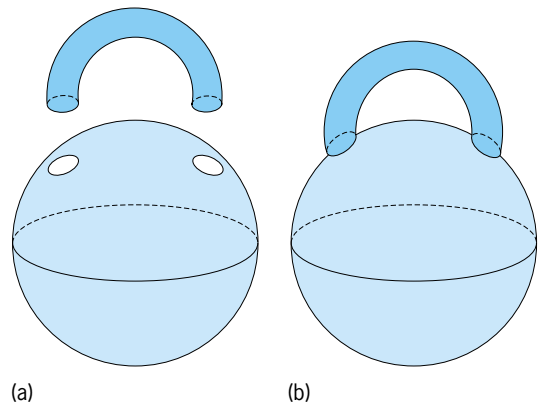

Process of adding a handle to a 2-sphere. (a) Cutting of holes in sphere. (b) Connecting of holes by a curved pipe.

and indirect (application in other contexts of ideas arising from algebraic topology).

As algebraic topology developed, it became clear that if one function could be continuously deformed to another (that is, if they were homotopic), then these two functions behaved in the same way as far as the invariants of algebraic topology were concerned. This led naturally to the study of invariants that remain unchanged as the maps are deformed by homotopies, that is, homotopy invariants. This study, which is an offshoot of algebraic topology, is called homotopy theory. Some of the most interesting homotopy invariants are the higher homotopy groups. These proved extremely difficult to compute, even for spaces as simple as the sphere, and are the subject of much investigation.

Early in the development of topology it was realized that the foundations of the subject needed attention. General or point-set topology studies the relationships between the basic topological properties that spaces may possess.

Before abstract topological spaces were defined, there were numerous examples of spaces arising from geometric and analytic problems. The most important of these is a class of spaces known as manifolds. Both because of their ubiquitous appearance throughout mathematics and because they possess extraordinarily rich topological properties, manifolds became one of the central objects of study in topology. The basic theme in manifold theory is to find sufficient algebraic invariants to classify, that is, to list comprehensively, all manifolds, and to give methods for evaluating these invariants in geometric cases. See MANIFOLD (MATHEMATICS).

[J.W.Mor.]

**Torbanite** A variety of coal that resembles a carbonaceous shale in outward appearance. It is fine-grained, brown to black, and tough, and breaks with a conchoidal or subconchoidal fracture. Torbanite is synonymous with boghead coal and is related to cannel coal. It is derived from colonial algae identified with the modern species of *Botryococcus braunii* and antecedent forms. High-assay torbanite yields paraffinic oil, whereas low-assay material yields asphaltic oil. See COAL.

[I.A.B.]

**Torch** A gas-mixing and burning tool that produces a hot flame for the welding or cutting of metal. The torch usually delivers acetylene and commercially pure oxygen producing a flame temperature of 5000–6000°F (2750–3300°C), sufficient to melt the metal locally. The torch thoroughly mixes the two gases and permits adjustment and regulation of the flame. Acetylene can produce a higher flame temperature than other fuel gases. See ACETYLENE; WELDING AND CUTTING OF METALS.

Torches are of two types: low-pressure and high-pressure. In a low-pressure, or injector, torch, acetylene enters a mixing chamber, where it meets a jet of high-pressure oxygen. The amount of acetylene drawn into the flame is controlled by the velocity of this oxygen jet. In a high-pressure torch both gases are delivered under pressure.

A welding torch mixes the fuel and gas internally and well ahead of the flame. For cutting, the torch delivers an additional jet of pure oxygen to the center of the flame. The oxyacetylene flame produced by the internally mixed gases raises the metal to its ignition temperature. The central oxygen jet oxidizes the metal, the oxide being blown away by the velocity of the gas jet to leave a narrow slit or kerf.

[F.H.R.]

**Tornado** A violently rotating, tall, narrow column of air (vortex), typically about 300 ft (100 m) in diameter, that extends to the ground from a cumulonimbus cloud. The vast majority of tornadoes rotate cyclonically (counterclockwise in the Northern Hemisphere). Of all atmospheric storms, tornadoes are the most violent. See CLOUD; CYCLONE.

Tornadoes are made visible by a generally sharp-edged, funnel-shaped cloud pendant from the cloud base, and a swirling cloud of dust and debris rising from the ground (see illustration).



The Cordell, Oklahoma, tornado of May 22, 1981, in its decay stage. (National Severe Storms Laboratory/University of Mississippi Tornado Intercept Project)

The funnel consists of small water droplets that form as moist air entering the tornado's partial vacuum expands and cools. The condensation funnel may not extend all the way to the ground and may be obscured by dust. Many condensation funnels exist aloft without tangible signs that the vortex is in contact with the ground; these are known as funnel clouds. Tornado funnels assume various forms: a slender smooth rope, a cone (often truncated by the ground), a thick turbulent black cloud on the ground, or multiple funnels (vortices) that revolve around the axis of the overall tornado.

Many tornadoes evolve as follows: The tornado begins outside the precipitation region as a dust whirl on the ground and a short funnel pendant from a wall cloud on the southwest side of the thunderstorm; it intensifies as the funnel lengthens downward, and attains its greatest power as the funnel reaches its greatest width and is almost vertical; then it shrinks and becomes more tilted, and finally becomes contorted and ropelike as it decays. A downdraft and curtain of rain and large hail gradually spiral from the northeast cyclonically around the tornado, which often ends its life in rain. See HAIL; PRECIPITATION (METEOROLOGY); THUNDERSTORM.

Most tornadoes and practically all violent ones develop from a larger-scale circulation, the mesocyclone, which is 2–6 mi (3–9 km) in diameter and forms in a particularly virulent variety of thunderstorm, the supercell. The mesocyclone forms first at midaltitudes of the storm and in time develops at low levels and may extend to high altitudes as well. The tornado forms on the southwest side (Northern Hemisphere) of the storm's main updraft, close to the downdraft, after the development of the mesocyclone at low levels. Some supercells develop up to six mesocyclones and tornadoes repeatedly over great distances at roughly 45-min intervals. Tornadoes associated with supercells are generally of the stronger variety and have larger parent cyclones. Hurricanes during and after landfall may spawn numerous tornadoes from small supercells located in their rainbands. See HURRICANE.

Tornadoes are classified as weak, strong, or violent, or from F0 to F5 on the Fujita (F) scale of damage intensity. Sixty-two percent of tornadoes are weak (F0 to F1). These tornadoes have maximum windspeeds less than about 50 m/s (110 mi/h) and inflict only minor damage, such as peeling back roofs, overturning mobile homes, and pushing cars into ditches. Thirty-six percent of tornadoes are strong (F2 to F3) with maximum windspeeds estimated to be 50–90 m/s (110–200 mi/h). Strong tornadoes extensively damage the roofs and walls of houses but leave some walls partially standing. They demolish mobile homes, and lift and throw cars. The remaining 2% are violent (F4 to F5), with windspeeds in excess of about 90 m/s (200 mi/h). They level houses to their foundations, strew heavy debris over hundreds of yards, and make missiles out of heavy objects such as roof sections, vehicles, utility poles, and large, nearly empty storage tanks. See WIND.

Tornadoes occur most often at latitudes between 20° and 60°, and they are relatively frequent in the United States, Russia, Europe, Japan, India, South Africa, Argentina, New Zealand, and parts of Australia. Violent tornadoes are confined mainly to the United States, east of the Rocky Mountains.

Essentially, there are five atmospheric conditions that set the stage for wide-spread tornado development: (1) a surface-based layer, at least 3000 ft (1 km) deep, of warm, moist air, overlain by dry air at midlevels; (2) an inversion separating the two layers, preventing deep convection until the potential for explosive overturning is established; (3) rapid decrease of temperature with height above the inversion; (4) a combination of mechanisms, such as surface heating and lifting of the air mass by a front or upper-level disturbance, to eliminate the inversion locally; (5) pronounced vertical wind shear (variation of the horizontal wind with height). Specifically, storm-relative winds in the lowest 6000 ft (2 km) should exceed 20 knots (10 m/s) and veer (turn anticyclonically) with height at a rate of more than 10°/1000 ft (30°/km). Such conditions are prevalent in the vicinity of the jet stream and the low-level jet.

The first three conditions above indicate that the atmosphere is in a highly metastable state. There is a strong potential for thunderstorms with intense updrafts and downdrafts. The fourth condition is the existence of a trigger to release the instability and initiate the thunderstorms. The fifth is the ingredient for updraft rotation. See AIR MASS; FRONT; JET STREAM; TEMPERATURE INVERSION. [R.D.J.]

**Torque** The product of a force and its perpendicular distance to a point of turning; also called the moment of the force. Torque produces torsion and tends to produce rotation. Torque arises from a force or forces acting tangentially to a cylinder or from any force or force system acting about a point. A couple, consisting of two equal, parallel, and oppositely directed forces, produces a torque or moment about the central point. A prime mover such as a turbine exerts a twisting effort on its output shaft, measured as torque. In structures, torque appears as the sum of moments of torsional shear forces acting on a transverse section of a shaft or beam. See COUPLE; TORSION. [N.S.F.]

**Torque converter** A device for changing the torque-speed ratio or mechanical advantage between an input shaft and an output shaft. A pair of gears is a mechanical torque converter. A hydraulic torque converter is an automatically and continuously variable torque converter, in contrast to a gear shift, whose torque ratio is changed in steps by an external control. See AUTOMOTIVE TRANSMISSION; GEAR DRIVE.

A mechanical torque converter transmits power with only incidental losses; thus, the power, which is the product of torque  $T$  and rotational speed  $N$ , at input  $I$  is substantially equal to the power at output  $O$  of a mechanical torque converter, or  $T_I N_I = k T_O N_O$ , where  $k$  is the efficiency of the gear train. This equal-power characteristic is in contrast to that of a fluid coupling in

which input and output torques are equal during steady-state operations. See FLUID COUPLING.

In a hydraulic torque converter, efficiency depends intimately on the angles at which the fluid enters and leaves the blades of the several parts. Because these angles change appreciably over the operating range,  $k$  varies, being by definition zero when the output is stalled, although output torque at stall may be three times engine torque for a single-stage converter and five times engine torque for a three-stage converter. Depending on its input absorption characteristics, the hydraulic torque converter tends to pull down the engine speed toward the speed at which the engine develops maximum torque when the load pulls down the converter output speed toward stall. [H.J.Wir.]

**Torricelli's theorem** The speed of efflux of a liquid from an opening in a reservoir equals the speed that the liquid would acquire if allowed to fall from rest from the surface of the reservoir to the opening.

Torricelli, a student of Galileo, observed this relationship in 1643. In equation form,  $v^2 = 2gh$ , in which  $v$  is the speed of efflux,  $h$  the head (or elevation difference between reservoir surface and center line of opening if in a vertical plane), and  $g$  the acceleration due to gravity. (The equation is the same as that for a solid particle dropped a distance  $h$  in a vacuum.) The relationship can be derived from the energy equation for flow along a streamline, if energy losses are neglected. See FLOW MEASUREMENT. [V.L.S.]

**Torsion** A straining action produced by couples that act normal to the axis of a member. Torsion is identified by a twisting deformation.

In practice, torsion is often accompanied by bending or axial thrust as in the case of line shafting driving gears or pulleys, or propeller shafts for ship propulsion. Other important examples include springs and machine mechanisms usually having circular sections, either solid or tubular. Members with noncircular sections are of interest in special applications, such as structural members subjected to unsymmetrical bending loads that twist and buckle beams. See SPRING (MACHINES); TORSION BAR.

When subjected only to torque, the member is in pure torsion, which produces pure shear stresses. The shear properties of materials are determined by a torsion test. See SHEAR; TORQUE. [J.B.S.]

**Torsion bar** A spring flexed by twisting about its axis. Design of a torsion bar spring is primarily based on the relationships between the torque applied in twisting the spring, the angle through which the torsion bar twists, and the physical dimensions and material (modulus of elasticity in shear) from which the torsion bar is made. The illustration shows the elements of a simple

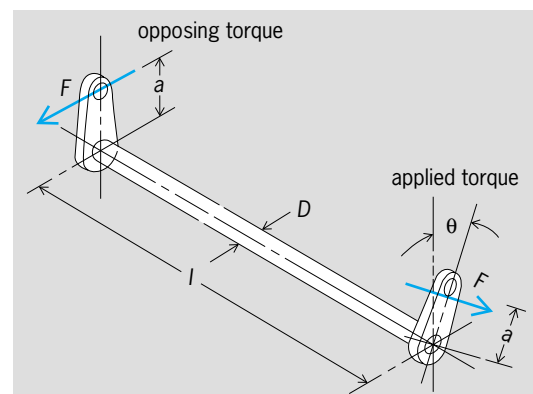

Diagram of torsion bar.

torsion bar and the important dimensions involved in its design. The equation below relates these dimensions. Here  $\theta$  is angle

$$\theta = \frac{32Fal}{\pi D^4G}$$

of twist in radians,  $F$  is force in pounds,  $a$  is radius arm of force in inches,  $l$  is length of torsion bar in inches,  $D$  is diameter of torsion bar in inches, and  $G$  is modulus of elasticity in shear in pounds per square inch.

Torsion bar springs are found in the spring suspension of truck and passenger car wheels, in production machines where space limitations are critical, and in high-speed mechanisms where inertia forces must be minimized. See SPRING (MACHINES). [L.S.L.]

**Torus** A surface obtained by rotating a circle about a line that lies in its plane, but which has no points in common (see

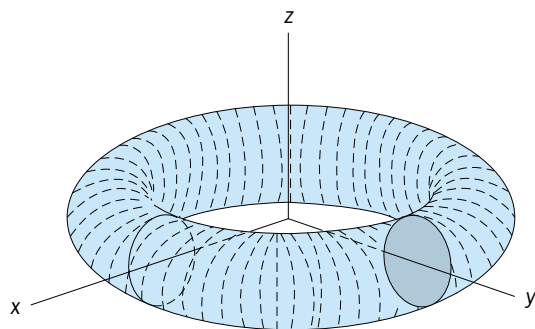

Diagram of a torus.

illustration). It is a two-dimensional manifold of genus 1 and connectivity 3. See MANIFOLD (MATHEMATICS); TOPOLOGY. [L.M.B.I.]

**Tourette's syndrome** A neurobehavioral disorder characterized by frequent, recurrent motor and vocal tics. The motor tics include brief, rapid, and darting movements of almost any muscle group, and can include eye blinking, eye rolling or deviations, nose wrinkling, facial grimacing, and head shaking. Some motor tics are more complex, are slow, and appear purposeful such as head turning, shoulder shrugging, touching, hopping, or twirling. Vocal tics are brief guttural sounds such as recurrent sniffing, throat clearing, coughing, and grunting or barking sounds. Complex vocal tics can be more meaningful and include verbal expressions. Tourette's syndrome has been described in nearly every country and ethnic group, with an estimated prevalence of one or two occurrences per 2000 people.

The motor and vocal tics begin in childhood, often worsen during adolescence, and tend to improve during the twenties and thirties. Symptoms increase with stress and excitement and decrease with activities that require focused effort. While the motor and vocal tics are involuntary, they can be suppressed for brief periods of time, giving the false impression that the movements and sounds are voluntary.

The pattern of inheritance is consistent with a single autosomal dominant gene whose expression is variable and dependent on the sex of the person. Tic symptoms can vary from transient tics to Tourette's syndrome and can include obsessive-compulsive symptoms. The complexity of symptoms is likely related to the various brain regions implicated in the development of Tourette's syndrome. Treatment can be targeted toward suppressing tics and the specific associated behavioral problems. Methods for tic suppression include medications that affect the brain by blocking the neurotransmitter dopamine at the site of nerve-to-nerve connections. See BRAIN; HUMAN GENETICS; NERVOUS SYSTEM DISORDERS. [J.T.W.; M.A.Ri.]

**Tourmaline** A cyclosilicate mineral family with  $(BO_3)$  triangular groups and a complex chemical composition. The general formula can be written  $XY_3Al_6(OH)_4(BO_3)_3(Si_6O_{18})$ , in which  $X = Na, Ca$ , and  $Y = Al, Fe^{3+}, Li, Mg, Mn^{2+}$ . The more common tourmalines are dravite ( $X, Y = Na, Mg$ ), schorl ( $X, Y = Na, Fe$ ), uvite ( $X, Y = Ca, Mg$ ), and elbaite ( $X, Y = Na, Li$ ). Fluorine commonly substitutes in the hydroxyl position. Tourmaline is a hard ( $7\frac{1}{2}$  on Mohs scale), varicolored mineral which can be an important semiprecious gemstone. See GEM; SILICATE MINERALS.

The tourmaline crystal is polar; thus it is piezoelectric; that is, if pressure is exerted at one end, opposite electrical charges will occur at opposite poles. It is also pyroelectric, with the electrical charges developed at the ends of the polar axis on a change in temperature. Because of its piezoelectric property, tourmaline can be cut into gages to measure transient pressures. See PIEZOELECTRICITY; PYROELECTRICITY. [P.B.M.]

**Tower** A concrete, metal, or timber structure that is relatively high for its length and width. Towers are constructed for many purposes, including the support of electric power transmission lines, radio and television antennas, and rockets and missiles prior to launching.

Transmission towers are rectangular in plan and are not steadied by guy wires. A transmission tower is subjected to a number of forces; its own weight, the pull of the cables at the top of the tower, the effect of wind and ice on the cable, and the effect of wind on the tower itself.

Radio and television towers are either guyed or freestanding. Freestanding towers are usually rectangular in plan. In addition to their own weight, freestanding towers support the weight of the antenna and accessories and the weight of ice, unless a deicing circuit is installed. Wind forces must also be carefully considered. Guyed towers are usually triangular in plan, with the main structural members, or legs, at the vertexes of the triangle. The legs are usually solid round steel bars. See ANTENNA (ELECTROMAGNETISM); TRANSMISSION LINES. [C.M.A.]

**Towing tank** A tank of water used to determine the hydrodynamic performance of waterborne bodies such as ships and submarines, as well as torpedoes and other underwater forms. In the narrow sense, towing tanks are considered to be experimental facilities used to measure the forces, such as drag, on ship models and in turn to predict the performance of the full-scale prototype. In general, towing tanks are rectangular in planform with a uniform cross section. Different section shapes are used, ranging from rectangular to semicircular.

The principal measurements made in a towing tank are force measurements, particularly drag or resistance of a towed ship model or other body. One of two principal systems for towing a model is used in most towing tanks. The simpler system consists of a gravity dynamometer and an endless cable attached to the model. A weight provides a constant towing force (see illustration). The time to traverse a fixed distance is measured when the model reaches a constant speed, thus establishing the

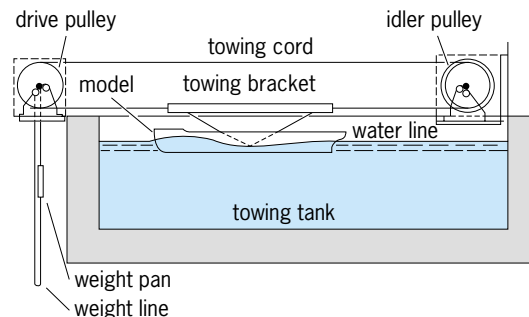

Tank with model towed by falling weight.

speed-resistance relationship for the model. This dynamometer is simple and capable of high accuracy, but is limited to the measurement of the drag force of waterborne bodies. It is used in the smaller towing tanks in which the models are generally under 6 ft (1.8 m) in length.

In larger towing tanks the model is towed by a towing carriage mounted on rails at the side of the towing tank or suspended from an overhead track system. Speed can be controlled and measured precisely on these carriages. Most carriages are equipped with a drag dynamometer as a permanent component. [J.B.H.]

**Townsend discharge** A particular part of the voltage-current characteristic curve for a gaseous discharge device named for J. S. Townsend, who studied it about 1900. It is that part for low current where the discharge cannot be maintained by the field alone. Thus, if the agents producing the initial ionization were removed, conduction would cease. See ELECTRICAL CONDUCTION IN GASES. [G.H.M.]

**Toxic shock syndrome** A serious, sometimes life-threatening disease usually caused by a toxin produced by some strains of the bacterium *Staphylococcus aureus*. The signs and symptoms are fever, abnormally low blood pressure, nausea and vomiting, diarrhea, muscle tenderness, and a reddish rash, followed by peeling of the skin.

Toxic shock syndrome was first reported in 1978 in seven pediatric patients. However, in 1980 hundreds of cases were reported among young women without apparent staphylococcal infections. Epidemiologists observed that the illness occurred predominantly in young women who were menstruating and were using tampons, especially those that contained so-called superabsorbent synthetic materials. A toxin [toxic shock syndrome toxin number 1 (TSST-1)] that occurs in some strains of staphylococci was later identified. These bacteria are known to proliferate in the presence of foreign particles in human infections, and it has been postulated that the tampons acted as foreign particles, allowing toxin-producing staphylococci to multiply in the vagina.

Several hundred cases of toxic shock syndrome not associated with menstruation have been reported. In these cases, which occurred in males as well as females, there was almost always an overt staphylococcal infection. Susceptibility may depend on lack of antibodies to the toxin that occur in most adults.

The toxin has been shown to occur in only about 1% of the staphylococcal strains studied. Moreover, there is some evidence that the syndrome may be caused also by other staphylococcal toxins, particularly enterotoxins. Cases of toxic shock syndrome that were caused by streptococci have been reported. A toxin distinct from TSST-1 appears involved. Persons with the symptoms of toxic shock syndrome should receive immediate medical care to reduce the chance of death. See STAPHYLOCOCCUS; TOXIN.

[J.O.Co.]

**Toxicology** The study of the adverse effects of chemical and physical agents on living organisms. Toxicology has also been referred to as the science of poisons. See ENVIRONMENTAL TOXICOLOGY; POISON.

The most important factor that influences the toxic effect of a specific chemical is the dose. All chemicals, including essential substances such as oxygen and water, produce toxic effects when administered in large enough doses. Another significant factor is the route of exposure. Living organisms may be exposed to a chemical by inhalation (into the lungs), ingestion (into the stomach), penetration through the skin, or, in special circumstances, injection into the body. In general, substances are absorbed into the body most efficiently through the lungs so that inhalation is often the most serious route of exposure.

A third factor is the fate of the chemical after the organism is exposed. The chemical may not be absorbed at all, limiting its possible adverse effects to the site of exposure. If it is absorbed, then it may travel throughout the body and has the potential

to cause toxic effects at one or more sites remote from the site of entry. The remote sites where these adverse effects occur are called target organs.

Another significant variable is the time course of the exposure. A quantity of chemical administered at one time may have an effect even though the same quantity administered in small doses over time has no effect.

In view of the importance of timing in producing adverse effects, toxicologists distinguish between two broad classes of toxicity, acute and chronic. Acute toxicity refers to effects that occur shortly after a single exposure or small number of closely spaced exposures. Chronic toxicity refers to delayed effects that occur after long-term repeated exposures.

Traditionally, the effect of most concern for acute toxicants (such as cyanide) is death. Acute toxicity is generally measured by using an assay to determine the lethal dose; rodents are given single doses and the number that have died 14 days later is recorded. The data are plotted for each dose, and the dose that is lethal for 50% of the animals (lethal dose 50 or LD<sub>50</sub>) is used as the criterion for acute toxicity. See LETHAL DOSE 50.

Some synthetic chemicals, such as polychlorinated biphenyls (PCBs) and dichlorodiphenyltrichloroethane (DDT), exhibit their effects only after a number of repeated exposures and are considered chronic hazards, with cancer and reproductive effects being of greatest concern. To determine the dose at which chronic effects occur, rodents are exposed to daily doses of the chemical under study for long periods of time—from a few months to a lifetime. The highest dose at which no effects can be observed, the no observed effect level (NOEL), is used as a measure of chronic toxicity. See MUTAGENS AND CARCINOGENS. [M.Kam.; R.W.L.]

**Toxin** Properly, a poisonous protein, especially of bacterial origin. However, nonproteinaceous poisons, such as fungal aflatoxins and plant alkaloids, are often called toxins. See AFLATOXIN; ALKALOID.

Bacterial exotoxins are proteins of disease-causing bacteria that are usually secreted and have deleterious effects. Several hundred are known. In some extreme cases a single toxin accounts for the principal symptoms of a disease, such as diphtheria, tetanus, and cholera. Bacteria that cause local infections with pus often produce many toxins that affect the tissues around the infection site or are distributed to remote organs by the blood. See CHOLERA; DIPHTHERIA; STAPHYLOCOCCUS; TETANUS.

Toxins may assist the parent bacteria to combat host defense systems, to increase the supply of certain nutrients such as iron, to invade cells or tissues, or to spread between hosts. Sometimes the damage suffered by the host organism has no obvious benefit to the bacteria. For example, botulin neurotoxin in spoiled food may kill the person or animal that eats it long after the parent bacteria have died. In such situations it is assumed that the bacteria benefit from the toxin in some other habitat and that the damage to vertebrates is accidental. See FOOD POISONING.

Certain bacterial and plant toxins have the unusual ability to catalyze chemical reactions inside animal cells. Such toxins are always composed of two functionally distinct parts termed A and B, and they are often called A-B toxins. The B part binds to receptor molecules on the animal cell surface and positions the toxin upon the cell membrane. Subsequently, the enzymically active A portion of the toxin crosses the animal cell membrane and catalyzes some intracellular chemical reaction that disrupts the cell physiology or causes cell death. See IMMUNOLOGIC CYTOTOXICITY.

A large group of toxins breach the normal barrier to free movement of molecules across cell membranes. In sufficient concentration such cytolytic toxins cause cytolysis, a process by which soluble molecules leak out of cells, but in lower concentration they may cause less obvious damage to the cell's plasma membrane or to its internal membranes. See CELL MEMBRANES; CELL PERMEABILITY.

Tetanus and botulin neurotoxins block the transmission of nerve impulses across synapses. Tetanus toxin blockage results

in spastic paralysis, in which opposing muscles contract simultaneously. The botulinal neurotoxins principally paralyze neuromuscular junctions and cause flaccid paralysis.

Gram-negative bacteria, such as *Salmonella* and *Hemophilus*, have a toxic component in their cell walls known as endotoxin or lipopolysaccharide. Among other detrimental effects, endotoxins cause white blood cells to produce interleukin-1, a hormone responsible for fever, malaise, headache, muscle aches, and other nonspecific consequences of infection. The exotoxins of toxic shock syndrome and of scarlet fever induce interleukin-1 and also tumor necrosis factor, which has similar effects. See ENDOTOXIN; FEVER; SCARLET FEVER; TOXIC SHOCK SYNDROME.

Toxoids are toxins that have been exposed to formaldehyde or other chemicals that destroy their toxicities without impairing immunogenicity. When injected into humans, toxoids elicit specific antibodies known as antitoxins that neutralize circulating toxins. Such immunization (vaccination) is very effective for systemic toxinoses, such as diphtheria and tetanus. See ANTIBODY; IMMUNITY; VACCINATION. [D.M.G.]

**Toxin-antitoxin reaction** A term used in serology to denote the combination of a toxic antigen with its corresponding antitoxin. If the antitoxin is derived from any species other than the horse, precipitation occurs over a wide range of reactant ratios, 20 × or more, as in other antigen-antibody reactions. With horse antitoxin, flocculation occurs only if toxin and antitoxin are near equivalence, a twofold excess of either reactant giving soluble complexes. In most instances, the reaction results in partial or complete neutralization of the toxic activity of the antigen. See ANTIBODY; ANTIGEN; ANTITOXIN; NEUTRALIZATION REACTION (IMMUNOLOGY); SEROLOGY. [H.P.T.]

**Toxoplasmea** A class of the subphylum Sporozoa. The organisms are small and crescent-shaped. They move by body flexion or gliding and have no flagella or pseudopodia. Characteristic structures are the two-layered pellicle and underlying longitudinal microtubules, micropyle, a conoid, paired organelles, and micronemes.

The most distinguishing characteristic of the Toxoplasmea is the unique means of reproduction. Electron microscope studies indicate that endodyogeny is the sole method. Endodyogeny is an internal budding wherein two daughter cells are produced within a mother cell which is destroyed in the process.

Only two stages are known in the life cycle most animals. One stage, the proliferative form or trophozoite, occurs singly or in groups within host cells. The other stage, the so-called cysts, consists of a large number of organisms which, with minor differences, are structurally similar to the proliferative forms. See SPOROZOA; TOXOPLASMIDA. [H.G.Sh.]

**Toxoplasmoda** An order of the class Toxoplasmea. Four genera, *Toxoplasma*, *Besnoitia*, *Sarcocystis*, and *Encephalitozoon*, make up the order. The organisms are parasites of vertebrates. *Toxoplasma* is often found encysted in nerve tissue, *Besnoitia* in connective tissue, and *Sarcocystis* in muscle. Very little is known about *Encephalitozoon*, but the parasite has been found in the brain of rabbits. See TOXOPLASMIDA; TOXOPLASMOSIS. [H.G.Sh.]

**Trace fossils** Fossilized evidence of animal behavior, also known as ichnofossils, biogenic sedimentary structures, bioerosion structures, or lebensspuren. The fossils include burrows, trails, and trackways created by animals in unconsolidated sediment (see illustration), as well as borings, gnawings, raspings, and scrapings excavated by organisms in harder materials, such as rock, shell, bone, or wood. Some workers also consider coprolites (fossilized feces), regurgitation pellets, burrow excavation pellets, rhizoliths (plant root penetration structures), and algal stromatolites to be trace fossils. See STROMATOLITE.



Agrichnial farming traces (burrows produced in order to farm or trap food inside the sediment) of unknown organisms, including a double-spiral tunnel (*Spirorhaphe*) and a meshlike network of tunnels (*Paleodictyon*). Tertiary, Austria. (Photograph by W. Häntzschel)

Trace fossils are important in paleontology and paleoecology, because they provide information about the presence of unpreserved soft-bodied members of the original communities, life habits of fossil organisms, evolution of certain behavior patterns through geologic time, and biostratigraphy of otherwise unfossiliferous deposits. Trace fossils also are useful in sedimentology and paleoenvironmental studies, because they are sedimentary structures that are preserved in place and are very rarely reworked and transported, as body fossils of animals and plants commonly are. This fact allows trace fossils to be regarded as reliable indicators of original conditions in the sedimentary environment. The production of trace fossils involves disruption of original stratification and sometimes results in alteration of sediment texture or composition. See FOSSIL; PALEOECOLOGY; PALEONTOLOGY; SEDIMENTOLOGY.

Trace fossils occur in sedimentary deposits of all ages from the late Precambrian to the Recent. Host rocks include limestone, sandstone, siltstone, shale, coal, and other sedimentary rocks. These deposits represent sedimentation in a broad spectrum of settings, ranging from subaerial (such as eolian dunes and soil horizons) to subaqueous (such as rivers, lakes, swamps, tidal flats, beaches, continental shelves, and the deep-sea floor). See DEPOSITIONAL SYSTEMS AND ENVIRONMENTS.

Organisms may produce fossilizable traces on the sediment surface (epigenic structures) or within the sediment (endogenic structures). Trace fossils may be preserved in full three-dimensional relief (either wholly contained within a rock or weathered out as a separate piece) or in partial relief (either as a depression or as a raised structure on a bedding plane). Simply because a trace fossil is preserved on a bedding plane does not indicate that it originally was an epigenic trace. Diagenetic alteration of sediment commonly enhances the preservation of trace fossils by differential cementation or selective mineralization. In some cases, trace fossils have been preferentially replaced by chert, dolomite, pyrite, glauconite, apatite, siderite, or other minerals. See DIAGENESIS.

The study of trace fossils is known as ichnology. The prefix “ichno-” (as in ichnofossil and ichnotaxonomy) and the suffix “-ichnia” (as in epichnia and hypichnia) commonly are employed to designate subjects relating to trace fossils. The suffix “-ichnus” commonly is attached to the ichnogenus name of many trace fossils (as in *Dimorphichnus* and *Teichichnus*).

[A.A.E.]



**Trachylina** An order of jellyfish of the class Hydrozoa of the phylum Coelenterata. These jellyfish are of moderate size. They differ from other hydrozoan jellyfish in having balancing organs which develop partly from the digestive epithelium and in having only a small polyp stage or none at all. Many authorities recognize three distinct orders of trachylines—Limnomedusae, Trachymedusae, and Narcomedusae—and in this case the older term Trachylina is abandoned. See HYDROZOA. [S.Cr.]

**Trachyte** A light-colored, aphanitic (very finely crystalline) rock of volcanic origin, composed largely of alkali feldspar with minor amounts of dark-colored (mafic) minerals (biotite, hornblende, or pyroxene). If sodic plagioclase (oligoclase or andesine) exceeds the quantity of alkali feldspar, the rock is called latite. Trachyte and latite are chemically equivalent to syenite and monzonite, respectively. See LATITE; MONZONITE; SYENITE.

Streaked, banded, and fluidal structures due to flowage of the solidifying lava are commonly visible in many trachytes and may be detected by a parallel arrangement of tabular feldspar phenocrysts. A distinctive microscopic feature is trachytic texture in which the tiny, lath-shaped sanidine crystals of the rock matrix are in parallel arrangement and closely packed.

Trachyte is not an abundant rock, but it is widespread. It occurs as flows, tuffs, or small intrusives (dikes and sills). It may be associated with alkali rhyolite, latite, or phonolite. See IGNEOUS ROCKS; MAGMA; SPILITE. [C.A.C.]

**Tractor** A wheeled, self-propelled vehicle for hauling other vehicles or equipment and for operating the towed implements; also, a crawler which runs on an endless, self-laid track and performs similar functions.

A farm tractor is a multipurpose power unit. It has a drawbar for drawing tillage tools and a power takeoff device for driving implements or operating a belt pulley. The acreage to be worked, type of crops grown, and the terrain all impose their requirements on tractor design. Accordingly, models vary in such details as power generated, weight, ground clearance, turning radius, and facilities for operating equipment. All models can, however, be grouped under four general types: four-wheel, row-crop or high-wheel, tricycle, and crawler.

Tractors are rated by the horsepower they deliver at the drawbar and at the belt. On small models, the drawbar and belt horsepower may run as low as 10 (7.5 kW); on large models the drawbar horsepower runs as high as 132 (98 kW), while belt horsepower reaches about 144 (107 kW).

The major components are engine, clutch, and transmission. These components are intimately related and designed to work in conjunction with each other to accomplish specific work. Tractor engines are relatively low-speed; their maximum horsepower is generated at crankshaft speeds in the neighborhood of 2000 rpm. These engines have one, two, three, four, six, or eight cylinders and operate on gasoline, kerosine, liquid petroleum gas, or diesel fuel. They are of the spark-ignition or diesel type, operating on the four-stroke-cycle principle, and are cooled by water or air.

Power is transmitted to the rear wheels or to all four wheels. Drive to the front wheels is mechanical or hydrostatic, its purpose being to increase drawbar pull at the will of the operator. Transmissions have 3, 4, 5, 6, 8, 10, or 12 forward speeds and one or two reverse gears. Clutchless hydraulic transmissions are also used, making it possible to shift gears while in motion. Vehicle speeds are low, ranging from slightly more than 1 mi/h (1.6 km/s) to about 18 mi/h (13 km/h) in high gear. See CLUTCH; TORQUE CONVERTER.

The basic design of an industrial tractor for hauling and for operating construction equipment departs little from that of a farm tractor, and differences in design of models fit the vehicle to its intended work. Because high ground clearance is not needed for industrial work, the tractor is commonly built with a lower center of gravity and is capable of traveling a few miles per hour

faster than a farm tractor. If its use is confined to hauling, it may not be equipped with hydraulic power. If it is to be used for operating a scraper, backhoe, or front-end loader, its structure may be heavier and more rugged. See BULK-HANDLING MACHINES.

[P.H.S.]

**Tractrix** A plane curve for which the length of any tangent between the curve and a fixed line is constant  $c$  (see illustration).

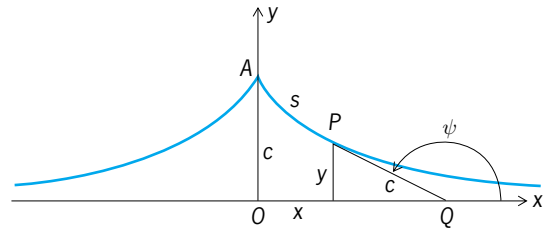

Tractrix (upper half).

If the  $x$  axis is the fixed line, its differential equation is Eq. (1). With  $\psi$ , the inclination of the tangent, as parameter, this yields equations (2). The tractrix has the  $x$  axis as asymptote and cusps at  $(0, \pm c)$ . The arc  $AP$ , measured from a cusp, is as in Eq. (3).

$$(dy/dx)^2 = y^2/(c^2 - y^2) \quad (1)$$

$$x = c \log \tan \frac{1}{2}|\psi| + c \cos \psi \quad (2)$$

$$y = c \sin \psi$$

$$s = -c \log \sin \psi = c \log \frac{c}{y} \quad (3)$$

[L.Br.]

**Traffic-control systems** Systems that act to control the movement of people, goods, and vehicles in order to ensure their safe, orderly, and expeditious flow throughout the transportation system. Each of the five areas of transportation—roadways, airports and airways, railways, coastal and inland waterways, and pipelines—have unique systems of control.

Roadway traffic-control systems are intended to improve safety, increase the operational efficiency and capacity of the roadway, and contribute to the traveler's comfort and convenience. They range from simple control at isolated intersections using signs and markings, to sophisticated traffic-control centers which have the ability to react to changes in the traffic environment. Traffic-control systems are used at roadway intersections, on highways and freeways, at ramp entrances to freeways, and in monitoring and controlling wider-area transportation networks. Intelligent roadway traffic control, now known as intelligent transportation systems (ITS), is a very sophisticated form of traffic control for roadway and other areas. See HIGHWAY ENGINEERING.

The U.S. federal government has designated airspace as either uncontrolled or controlled. In uncontrolled airspace, pilots may conduct flights without specific authorization. In controlled airspace, pilots may be required to maintain communications with the appropriate air-traffic control facility to receive authorization and instruction on traversing, taking off from, or landing, in that controlled area. Air-traffic control systems for controlled areas may be divided loosely into en route and terminal systems. See AIR NAVIGATION; AIR-TRAFFIC CONTROL; AIR TRANSPORTATION.

Railroads operate high-speed freight and passenger services essentially over an exclusive right of way. Railroads use both semaphore and light signals for traffic control. Semaphores convey visual messages to train operators according to predetermined rules indicating how the train is to be operated in specified areas. Automatic block signaling prevents rear-end and head-on

collisions on signal tracks. In this system, track sections are divided into blocks. Only one train is permitted to occupy a block at any time. Blocks are monitored by automatic circuitry that controls traffic signals, indicating the appropriate clear or stop signals to following or approaching trains. Similar block systems are used for subway systems. Centralized traffic-control systems may control hundreds of miles of track signals and switches. A dispatcher at a central location monitors the location of trains by means of visual displays of colored lights on a large track diagram, and can operate the switches and signals at key points from the central control console. See RAILROAD CONTROL SYSTEMS; RAILROAD ENGINEERING.

Vessel traffic control consists largely of marine aides that function more for informational, advisory, and guidance purposes than as positive traffic-control devices. Lighted or unlighted buoys indicate navigable areas in coastal waters and within waterways. Lightships and lighthouses with fog signals and radio beacons are placed as markers at prominent points during periods of limited visibility. Radar devices have become common, even on smaller ships. Navigation systems often employ the Differential Global Positioning System. The Vessel Traffic Service (VTS) is available in selected areas. Services may range from the provision of single advisory messages to extensive management of traffic communication and radar services. See BUOY; LIGHTHOUSE; MARINE NAVIGATION; NAVIGATION.

The 450,000 mi (750,000 km) of pipelines in the United States are a major part of the nation's transportation network, carrying about 25% of all intercity freight-ton mileage. The primary goods moved through pipelines are oil and oil by-products, natural gas, and fertilizers. The movement of goods in pipelines is controlled by systems of valves, pumps, and compressors. See PIPELINE; TRANSPORTATION ENGINEERING. [J.Cos.; D.C.N.]

**Trajectory** The curve described by a body moving through space, as of a meteor through the atmosphere, a planet around the Sun, a projectile fired from a gun, or a rocket in flight. In general, the trajectory of a body in a gravitational field is a conic section—ellipse, hyperbola, or parabola—depending on the energy of motion. The trajectory of a shell or rocket fired from the ground is a portion of an ellipse with the Earth's center as one focus; however, if the altitude reached is not great, the effect of gravity is essentially constant, and the parabola is a good approximation. See BALLISTICS. [J.P.H.]

**Tranquilizer** A psychopharmacologic drug that tends to have a calming effect, and is unique in inducing drowsiness without impairing ready arousal and in restraining hyperactivity without inducing coma or arrest of respiratory muscles.

According to basic chemical structure, five categories of tranquilizers can be delineated: (1) phenothiazines (for example, chlorpromazine) and rauwolfia derivatives (for example, reserpine) are major or antipsychotic tranquilizers; (2) propanediols (for example, meprobamate, or Miltown), (3) diphenylmethanes (for example, benactyzine), (4) chlordiazepoxide and derivatives (for example, Librium and Valium), and (5) a miscellaneous group used generally for nighttime sedation (for example, ectylurea, glutethimide, and methylparafynol) are termed minor or sedative antianxiety tranquilizers. The antipsychotic tranquilizers in greatest use are phenothiazines, of which there are many derivatives and trade names. The sedative antianxiety agents are generally used in crisis situations or in neurotic episodes of intense anxiety or panic. Their effectiveness is more difficult to establish and is less specific than that of drugs for the treatment of psychosis. In high dosages such drugs have an addiction liability and can produce convulsions on withdrawals. [D.X.F.]

**Transamination** The transfer of an amino group from one molecule to another without the intermediate formation of ammonia. Enzymatic reactions of this type play a prominent role in the formation and ultimate breakdown of amino

acids by living organisms. Enzymes that catalyze such reactions are widely distributed and are termed transaminases, or amino-transferases. Perhaps the most prominent transamination reactions in higher animals are those in which glutamate is formed from  $\alpha$ -ketoglutarate and other amino acids. See PROTEIN METABOLISM. [E.E.S.]

**Transducer** A device that converts variations in one energy form into corresponding variations in another, usually electrical form. Measurement transducers or input transducers may exploit a wide range of physical, chemical, or biological effects to achieve transduction, and their design principles usually revolve around high sensitivity and minimum disturbance to the measurand, that is, the quantity to be measured. Output transducers or actuators are designed to achieve some end effect, for example, opening of a valve or deflection of a control surface on an aircraft. Actuators, therefore, normally operate at high power levels. The term sensor is often used instead of transducer, but strictly a sensor does not involve energy transformation; the term should be reserved for devices such as a thermistor, which is not energy-changing but simply changes its intrinsic electrical resistance in response to changes in temperature.

Both input and output transducers, together with the instrumentation to which they are connected, may be called upon to respond to both slowly varying or dynamic signals. This means that the transducer, together with its instrumentation system, must be designed to meet such a specification. Some prior knowledge is therefore required of the type of signal to be transduced, and the bandwidth of the transducer and instrumentation system must be suitably matched to this signal.

Transducers are often described in terms of their sensitivity to input signals (responsivity). This is simply defined as the ratio of the output signal to the corresponding input signal. Once again, the responsivity of a transducer must be matched to the expected levels of signal to be transduced. See SENSITIVITY (ENGINEERING).

The measurement of force is very often accomplished by allowing an elastic member (spring or cantilever beam) to deflect and then measuring the deflection by using some form of displacement transducer. Transducers designed to measure acceleration are frequently based on the simple equation below, where

$$f = ma$$

$f$  is force,  $m$  is mass, and  $a$  is acceleration. Thus, if the force due to the movement of a known mass can be measured, it is possible to derive the acceleration. Very often, the measurement technique employed uses piezoelectric, magnetostrictive, or mechanoresistive materials. Acceleration transducers or accelerometers are frequently employed for the measurement of vibration. See ACCELEROMETER; FORCE; MAGNETOSTRICTION.

Transducers for a wide range of chemical species are available, but probably the most widely applied is the pH transducer for the measurement of hydrogen-ion concentration. The traditional method has relied on a glass membrane electrode used to make up an electrochemical cell. See HYDROGEN ION; ION-SELECTIVE MEMBRANES AND ELECTRODES; pH.

Measurements of the partial pressure of oxygen ( $pO_2$ ) may be accomplished by the use of a Clark oxygen cell, which comprises a gas-permeable membrane controlling the rate of arrival of oxygen molecules at a noble-metal cathode that is held at 600–800 mV potential with respect to the anode. The ensuing reduction process gives rise to a cathode current from which oxygen concentration can be derived.

Other electrochemical transducers are used in such applications as voltametry, polarography, and amperometry. Chemical transduction is also possible by adsorbing a species onto a surface and detecting its presence by mass change, electrical property change, color change, and so on. See ELECTROCHEMICAL TECHNIQUES; POLAROGRAPHIC ANALYSIS; TITRATION.

Measurements of the partial pressure of oxygen and the partial pressure of carbon dioxide ( $p\text{CO}_2$ ) are also of particular importance in the context of blood gas analysis in medicine, and by using the Clark cell they can be performed without removing the blood from the body and noninvasively, that is, without puncturing the skin.

There have been remarkable advances in the area of biological transducers or biosensors. Examples are the ion-selective field-effect transducer (ISFET), the insulated-gate field-effect transducer (IGFET), and the chemically sensitive field-effect transducer (CHEMFET).

A smart transducer or smart sensor is a device that not only undertakes measurement but also can adapt to the environment in which it is placed. Such adaptation may range from simple changes in the characteristics of the transducer in response to changes in temperature, to more complex procedures such as adaptation of the transducer's performance to conform to overall system requirements. In integrated transducers, much of the signal processing that might previously be done remotely is brought into the transducer packaging.

The development of inexpensive fiber-optic materials for communications has led to an examination of the potential for using these devices as the basis for transduction. Two major types of devices have resulted: fiber-optic transducers for physical variables and similar devices devoted to chemical and biological determinations. The advantages of the all-optical transducer are its lack of susceptibility to electrical interference and its intrinsic safety. Small deformations of an optical-fiber waveguide cause a change in the light transmission of the fiber, and this has been exploited to produce force and pressure transducers. Alternatively, miniature transducers based on color chemistry can be fabricated at the end of a fiber and the color change can be sensed remotely. Devices of this type have been developed for measuring pH, the partial pressures of oxygen and carbon dioxide, and glucose. *See* FIBER-OPTIC SENSOR.

The most important recent technological development in the area of transducers, sensors, and actuators is micro-electromechanical systems (MEMS). There are a wide variety of MEMS devices, mostly fabricated in silicon. *See* MICRO-ELECTRO-MECHANICAL SYSTEMS (MEMS). [P.A.P.]

**Transduction (bacteria)** A mechanism for the transfer of genetic material between cells. The material is transferred by virus particles called bacteriophages (in the case of bacteria), or phages. The transfer method differentiates transduction from transformation. In transformation the genetic material (deoxyribonucleic acid) is extracted from the cell by chemical means or released by lysis. *See* BACTERIAL GENETICS; BACTERIOPHAGE; DEOXYRIBONUCLEIC ACID (DNA); TRANSFORMATION (BACTERIA).

The transduction mechanism has two features to distinguish it from the more usual mechanism of gene recombination, the sexual process. The most striking feature is the transfer of genetic material from cell to cell by viruses. The second feature is the fact that only a small part of the total genetic material of any one bacterial cell is carried by any particular transducing particle. However, in general transduction, all of the genetic material is distributed among different particles.

Transduction is not accomplished by all bacteriophages. It is done by some that are classified as "temperate." When such temperate bacteriophages infect sensitive bacteria, some of the bacteria respond by producing more bacteriophage particles. These bacteria donate the transducing material. Other bacteria respond to the infection by becoming more or less permanent carriers of the bacteriophage, in a kind of symbiotic relationship; these are called lysogenic bacteria. Bacteria in this latter class survive the infection, and it is among these that transduced cells are found. The proportion of bacteria in any culture that responds to infection in either manner can be influenced by the particular environment at the time of infection. *See* LYSOGENY.

Certain phages carry out a more restricted kind of transduction. They carry only a specific section of bacterial genetic material; they transduce only a few genes. Retroviruses carry out specific or restricted transduction. It has long been known that these viruses can cause the formation of tumors (oncogenesis) in animals. It is now known that these viruses exchange a small portion of their genome for a mutant cellular gene that has a role in gene regulation or replication. These viruses carrying mutant genes infect cells, causing them to be transformed into tumor cells. *See* ANIMAL VIRUS; RETROVIRUS. [N.D.Z.]

**Transfer cells** Plant cells characterized by the elaboration of an unligified, secondary cell wall to form fingerlike projections or wall ingrowths which protrude into the cytoplasm of the cell. These ingrowths are enveloped by plasma membrane, forming a wall-membrane apparatus which increases the surface-volume ratio of the cell.

The location of transfer cells within the plant provides circumstantial evidence for their involvement in solute transport. They are situated at many sites in the plant where secretion or absorption takes place. Transfer cells are most frequently associated with the conducting elements of the xylem and phloem, where they may play a role in either loading or unloading solutes from these cells. Four main categories of secretion or absorption involving transfer cells are generally recognized: (1) absorption of solutes from the external environment; (2) secretion of solutes to the external environment; (3) absorption of solutes from internal, extracytoplasmic compartments; and (4) secretion of solutes into internal, extracytoplasmic compartments. *See* PHLOEM; SECRETORY STRUCTURES (PLANT); XYLEM. [R.L.Pe.]

**Transform fault** One of the three fundamental types of boundaries between the mobile lithospheric plates that cover the surface of the Earth. Whereas spreading centers mark sites where crust is created between diverging plates, and subduction zones are where crust is destroyed between convergent plates, transform faults separate plates that are sliding past each other with neither creation nor destruction of crust. The primary tectonic feature of all transform faults is a strike-slip fault zone, a generally vertical fracture parallel to the relative motion between the two plates that it separates. Strike-slip fault zones are described as right-lateral if the far side is moving right relative to the near side or left-lateral if it is moving to the left. Not all such fault zones are plate-bounding transform faults. Small-scale strike-slip faulting is a common secondary feature of many subduction zones, especially where plate convergence is oblique, and of some spreading centers, especially those with propagating rifts; it also occurs locally deep in plate interiors. The distinguishing characteristic of a transform fault is that both ends extend to a junction with another type of plate boundary. At these junctions the divergent or convergent motion along the other boundaries is transformed into purely lateral slip. *See* EARTH CRUST; PLATE TECTONICS; SUBDUCTION ZONES.

Transform faults are most readily classified by the types of plate boundary intersected at their ends, the variety of lithosphere (oceanic or continental) they separate, and by whether they are isolated or are part of a multifault system. The common oceanic type is the ridge-ridge transform, linking two literally offset axes of a spreading center. Also common are transform faults that link the end of a spreading center to a triple junction, the meeting place of three plates and three plate boundaries. *See* LITHOSPHERE; MID-OCEANIC RIDGE.

Other types are long trench-trench transforms at the northern and southern margins of the Caribbean plate, and the combined San Andreas/Gulf of California transform, which separates the North American and Pacific plates for 1500 mi (2400 km) between triple junctions at Cape Mendocino (California) and the mouth of the Gulf of California. Strike-slip faulting in the Gulf of California (and on the northern Caribbean plate boundary) occurs along several parallel zones linked by short spreading

centers, and the overall structure is more properly called a transform fault system; similar fault patterns are found at many ridge-ridge transforms. Along a few strike-slip fault zones, lithospheric plates slide quietly and almost continuously past each other by the process called aseismic creep. Much more often, frictional resistance to the sliding in the brittle crust causes the accumulation of shear stresses that are episodically or periodically relieved by sudden shifts of crustal blocks, creating earthquakes. The largest lateral shifts (slips) of the ground surface along major continental transform faults have been associated with some of the largest earthquakes on record; in 1906 the Pacific plate alongside 270 mi (450 km) of the San Andreas Fault suddenly moved an average of 15 ft (4.5 m) northwest relative to the North American plate on the other side, and the resulting magnitude-8.2 earthquake destroyed much of San Francisco. The average slip in this single event was equivalent to about 150–250 years of Pacific–North American plate motion. See EARTHQUAKE; FAULT AND FAULT STRUCTURES; SEISMOLOGY. [PLo.]

**Transformation (bacteria)** The addition of deoxyribonucleic acid (DNA) to living cells, thereby changing their genetic composition and properties. The recipient bacteria are usually closely related to the donor strain. The process may occur in natural conditions, for example, in a host animal infected with two parasitic strains, and indeed it might play a part in the rapid evolution of pathogenic bacteria. There are several species of bacteria in which transformation has been achieved in the laboratory.

That bacterial transformation is true genetic transmission on a small scale, rather than controlled mutation, is demonstrated by the following characteristics: (1) A specific trait is introduced, coming always from donors bearing the trait. (2) The trait is transferred by determinant, genelike material far less complex than whole cells or nuclei, and this material, DNA, is known to be present in gene-carrying chromosomes. (3) The trait is inherited by the progeny of the changed bacteria. (4) The progeny produce, when they grow, increased amounts of DNA carrying the specific property. (5) The traits are transferred as units exactly in the patterns in which they appear or in which they are induced by mutation. (6) The DNA transmits the full potentialities of the donor strain, whether these are in an expressed or in a latent state. (7) The traits are often attributable to the presence of a specific gene-determined enzyme protein. (8) Certain groups of determinants may occur “linked” within DNA molecules, just as genes may be linked, and if so, heat denaturation, radiation, or enzyme action will inactivate or separate them just to the extent that they can damage or break apart the DNA molecules. (9) Linked determinants, while transforming a new cell, may become exchanged (recombined) between themselves and their unmarked or unselective alternate forms in such a way that they bring about genetic variation, and in a pattern indicating the existence of larger organized genetic units. See BACTERIAL GENETICS; GENE.

Through the application of a number of procedures prior to adding the DNA, transformation was extended first to many different bacterial species and then to eukaryotic cells. Today almost any cell type can be transformed. In some cases, tissues can be injected directly with naked DNA and transformed. However, unlike with bacteria, the naked DNA adds almost anywhere in the genome rather than recombining with its indigenous homolog. However, with special highly selective procedures, homologous recombination can be obtained. By treating embryonic stem cells and adding them to embryos that then go to term, specific and nonspecific transgenic animals can be obtained (for example, mice). See GENETIC ENGINEERING.

When the source of the DNA is some entity capable of independent replication, such as a virus or plasmid, the phenomenon is called transfection. If foreign DNA is then inserted into these entities, the result is recombinant DNA that can

lead to transduction. See MOLECULAR BIOLOGY; TRANSDUCTION (BACTERIA). [R.D.H.; N.D.Z.]

**Transformer** An electrical component used to transfer electric energy from one alternating-current (ac) circuit to another by magnetic coupling. Essentially it consists of two or more multiturn coils of insulated conducting material, so arranged that any magnetic flux linking one coil will link the others also. That is to say, mutual inductance exists between the coils. The mutual magnetic field acts to transfer energy from one input coil or primary winding to the other coils, which are called secondary windings. Under steady-state conditions, only one winding can serve as a primary. See COUPLED CIRCUITS; INDUCTANCE.

The transformer accomplishes one or more of the following effects between two circuits: (1) a developed voltage of different magnitude, (2) a developed current of different magnitude, (3) a difference in phase angle, (4) a difference in impedance level, and (5) a difference in voltage insulation level, either between the two circuits or to ground.

Transformers are used to meet a wide range of requirements. Pole-type distribution transformers supply relatively small amounts of power to residences. Power transformers are used at generating stations to step up the generated voltage to high levels for transmission. The transmission voltages are then stepped down by transformers at the substations for local distribution. Instrument transformers are used to measure voltages and currents accurately. Audio- and video-frequency transformers must function over a broad band of frequencies. Radio-frequency transformers transfer energy in narrow frequency bands from one circuit to another. See INSTRUMENT TRANSFORMER.

**Power transformers.** Power transformers, as a class, may be defined as those designed to operate at power-system frequencies: 60 Hz in the United States and Canada, and 50 Hz in much of the rest of the world. The largest power transformers connect generators to the power grid. Since a generator, together with its driving turbine and prime energy source, is called a generating unit, such transformers are called unit transformers. The classification “distribution transformers” refers to those supplying power to the ultimate consumers. They are designed for lower power and output-voltage ratings than the other transformers in the system.

Typical configurations for single-phase transformers are shown in Fig. 1. The arrangement in Fig. 1a is called a shell-form transformer, while that in Fig. 1b is called a core-form transformer. Each of the rectangles labeled “windings” in this figure represents at least two coils. The coils may be concentric, or interleaved. In the shell form, all of the windings are on the center leg. In the core form, half of the turns of the primary winding and half of those of the secondary are on each leg. The two halves of a given winding may be connected in series or in parallel.

Power transformers operate on the basis of two fundamental physical laws: Faraday’s voltage law and Ampère’s law. Faraday’s

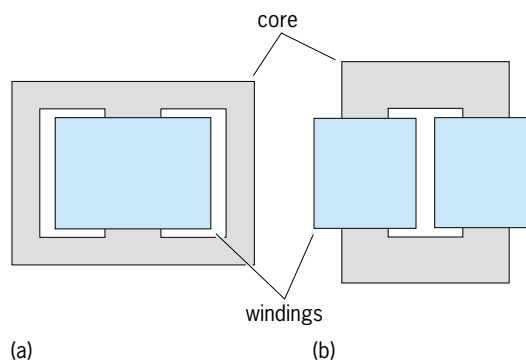

Fig. 1. Location of windings in single-phase cores. (a) Shell form. (b) Core form.

law states that the voltage induced in a winding by a magnetic flux linking that winding is proportional to the number of turns and the time rate of change of the flux; that is, Eq. (1) holds,

$$e_i = N_i \frac{d\phi_i}{dt} \quad \text{volts} \quad (1)$$

where  $e_i$  is the voltage induced in a coil of  $N_i$  turns which is threaded by a flux of  $\phi_i$  webers changing at a rate of  $d\phi_i/dt$  webers per second. The ratio of the voltages induced in two windings of a transformer by the core flux is, then, given by Eq. (2).

$$\frac{e_1}{e_2} = \frac{N_1 \frac{d\phi_{\text{core}}/dt}{d\phi_{\text{core}}/dt}}{N_2 \frac{d\phi_{\text{core}}/dt}{d\phi_{\text{core}}/dt}} = \frac{N_1}{N_2} \quad (2)$$

In other words, the voltages induced in the windings are proportional to the numbers of turns in the windings. This is the basic law of the transformer. A high-voltage winding will have many turns, and a low-voltage winding only a few. The  $N_1/N_2$  ratio is usually called the turns ratio or transformation ratio and is designated by the symbol  $a$ , so that Eq. (3) holds.

$$\frac{e_1}{e_2} = a \quad (3)$$

See FARADAY'S LAW OF INDUCTION.

Since the flux must change to induce a voltage, steady-state voltages can be obtained only by a cyclically varying flux. This means that alternating voltages and fluxes are required for normal transformer operation, and that is the fundamental reason for ac operation of power systems. Devices operated on ac have fewer losses when the voltages and fluxes are sinusoidal in form, and sinusoidal fluxes and terminal voltages will be assumed in this discussion. See ALTERNATING-CURRENT CIRCUIT THEORY.

Figure 2 shows the elements of a two-winding, shell-form transformer. The center leg of the core carries the full mutual flux, and each of the outside legs carries half of it. Thus the cross-sectional area of each outside leg is half of that of the center leg.

Efficiency is defined by Eq. (4). The output power is equal to

$$\eta = \frac{\text{output power}}{\text{input power}} \quad (4)$$

the input power, less the internal losses of the transformer. These losses include the ohmic ( $I^2R$ ) loss in the windings, called copper loss and the core loss, called the no-load loss. The input power is thus the sum of the output power and the copper and core losses. Typical efficiency for a 20,000-kVA power transformer at full load is 99.4%, while that of a 5-kVA transformer is 94%.

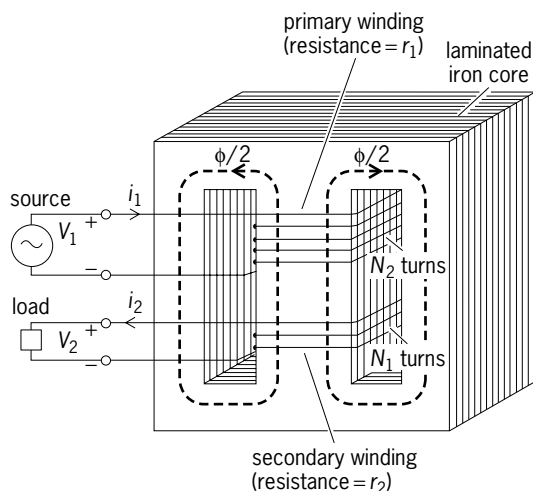

Fig. 2. Elements of a transformer.

Transformer losses in the windings and core generate heat, which must be removed to prevent deterioration of the insulation and the magnetic properties of the core. Most power transformers are contained in a tank of oil. The oil is especially formulated to provide good electrical insulation, and also serves to carry heat away from the core and windings by convection. Transformers which are designed to operate in air are called "dry-type" transformers. [G.McP]

**Audio- and radio-frequency transformers.** Audio or video (broad-frequency-band) transformers are used to transfer complex signals containing energy at a large number of frequencies from one circuit to another. Radio-frequency (rf) and intermediate-frequency (i-f) transformers are used to transfer energy in narrow frequency bands from one circuit to another. Audio and video transformers are required to respond uniformly to signal voltages over a frequency range three to five or more decades wide (for example, from 10 to 100,000 Hz), and consequently must be designed so that very nearly all of the magnetic flux threading through one coil also passes through the other.

Audio and video transformers have two resonances (caused by existing stray and circuit capacitances) just as many tuned transformers do. One resonance point is near the low-signal-frequency limit; the other is near the high limit. As the coefficient of coupling in a transformer is reduced appreciably below unity by removal of core material and separation of the windings, tuning capacitors are added to provide efficient transfer of energy. The two resonant frequencies combine to one when the coupling is reduced to the value known as critical coupling, then stay relatively fixed as the coupling is further reduced.

The rF and i-f transformers use two or more inductors, loosely coupled together, to limit the band of operating frequencies. Efficient transfer of energy is obtained by resonating one or more of the inductors. By using higher than critical coupling, a wider bandwidth than that from the individual tuned circuits is obtained, while the attenuation of side frequencies is as rapid as with the individual circuits isolated from one another. [K.A.P.]

**Transfusion** The administration of blood or its components as a part of a medical treatment. There are certain fairly well-delineated indications for the use of some form of transfusion. Hemorrhage, severe burns, and certain forms of shock are perhaps the most important conditions for which blood transfusion is utilized. Other disorders in which hemotherapy may be indicated include hemophilia, leukemia, certain anemias, and rare hereditary or familial disorders in which some portion of the blood is lacking or deficient. See HEMATOLOGIC DISORDERS.

In order for a recipient to accept a blood transfusion, the donor blood cells must be immunologically compatible with the recipient. That is, the recipient must recognize certain molecules (antigens) on donor blood cells as "self" and not foreign. The three main antigen systems on blood cells are the ABO, Rh, and HLA. See BLOOD GROUPS; RH INCOMPATIBILITY.

Donated blood is tested for blood groups, blood-group antibodies, and laboratory evidence of syphilis, hepatitis B, AIDS, human T-cell lymphotropic virus type I (HTLV-I, which is associated with adult T-cell leukemia), and hepatitis C. As a result, blood transfusions have become safer. However, persons who may have been exposed to AIDS should not donate blood, because it has been found that blood may test negative for AIDS and yet still be capable of transmitting AIDS to recipients. This situation can arise because there is a period of time during which a recently infected individual has not yet made sufficient antibody to test positive. Because of the concern that AIDS can be transmitted by blood transfusion, patients sometimes request donations from specific family members and friends. In general, such directed donations are statistically no safer than volunteer blood donation. More patients are donating their own blood (autologous blood) before elective surgery, for their own use during and after the surgery. Autologous blood is the safest blood for transfusion. See ACQUIRED IMMUNE DEFICIENCY SYNDROME (AIDS).

Shortly before transfusion, the blood of the donor and recipient is tested once again to make sure that the blood groups are compatible. In an emergency, these tests are abbreviated, or type O red blood cells which can be transfused safely to any individual, are used. Transfusion of blood and blood components is essential to support many patients undergoing surgery, treatment for cancer, or organ transplantation, as well as premature infants.

In addition to transmission of infections, adverse effects of blood transfusion are due to immune reactions between donor and recipient. Fever, the most frequent reaction, is caused by reaction of recipient antibody against donor white blood cells. Hives are due to allergic reactions to substances in donor plasma. Destruction of donor red cells (hemolytic reaction) occurs if the wrong type of blood is inadvertently given, or if recipient antibody is not detected prior to transfusion. See BLOOD. [PTo.]

**Transistor** A solid-state device involved in amplifying small electrical signals and in processing of digital information. Transistors act as the key element in amplification, detection, and switching of electrical voltages and currents. They are the active electronic component in all electronic systems which convert battery power to signal power. Almost every type of transistor is produced in some form of semiconductor, often single-crystal materials, with silicon being the most prevalent. There are several different types of transistors, classified by how the internal mobile charges (electrons and holes) function. The main categories are bipolar junction transistors (BJTs) and field-effect transistors (FETs).

Single-crystal semiconductors, such as silicon from column 14 of the periodic table of chemical elements, can be produced with two different conduction species, majority and minority carriers. When made with, for example, 1 part per million of phosphorus (from column 15), the silicon is called *n*-type because it adds conduction electrons (negative charge) to form the majority carrier. When doped with boron (from column 13), it is called *p*-type because it has added positive mobile carriers called holes. For *n*-type doping, electrons are the majority carrier while holes become the minority carrier. For *p*-type doping holes are in larger numbers, hence they are the majority carriers, while electrons are the minority carriers. All transistors are made up of regions of *n*-type and *p*-type semiconducting material. See SEMICONDUCTOR; SINGLE CRYSTAL.

The bipolar transistor has two conducting species, electrons and holes. Field-effect transistors can be called unipolar because their main conduction is by one carrier type, the majority carrier. Therefore, field-effect transistors are either *n*-channel (majority electrons) or *p*-channel (majority holes). For the bipolar transistor, there are two forms,  $n^+pn$  and  $p^+np$ , depending on which carrier is majority and which is the minority in a given region. As a result the bipolar transistor conducts by majority as well as by minority carriers. The  $n^+pn$  version is by far the most used as it has several distinct performance advantages, as does the *n*-channel for the field-effect transistors. (The  $n^+$  indicates that the region is more heavily doped than the other two regions.)

**Bipolar transistors.** Bipolar transistors have additional categories: the homojunction for one type of semiconductor (all silicon), and heterojunction for more than one (particularly silicon and silicon-germanium,  $\text{Si}/\text{Si}_{1-x}\text{Ge}_x/\text{Si}$ ). At present the silicon homojunction, usually called the BJT, is by far the most common. However, the highest performance (frequency and speed) is a result of the heterojunction bipolar transistor (HBT).

Bipolar transistors are manufactured in several different forms, each appropriate for a particular application. They are used at high frequencies, for switching circuits, in high-power applications, and under extreme environmental stress. The bipolar junction transistor may appear in discrete form as an individually encapsulated component, in monolithic form (made in and from a common material) in integrated circuits, or as a so-called chip in a thick-film or thin-film hybrid integrated circuit. In the  $pn$ -

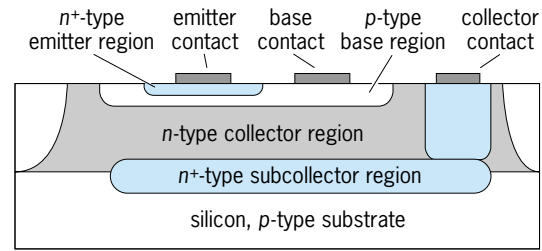

Fig. 1. Isolated  $n^+pn$  bipolar junction transistor for integrated-circuit operation.

junction isolated integrated-circuit  $n^+pn$  bipolar transistor, an  $n^+$  subcollector, or buried layer, serves as a low-resistance contact which is made on the top surface (Fig. 1). See INTEGRATED CIRCUITS; JUNCTION TRANSISTOR.

**Field-effect transistors.** Majority-carrier field-effect transistors are classified as metal-oxide-semiconductor field-effect transistor (MOSFET), junction "gate" field-effect transistor (JFET), and metal "gate" on semiconductor field-effect transistor (MESFET) devices. MOSFETs are the most used in almost all computers and system applications. However, the MESFET has high-frequency applications in gallium arsenide (GaAs), and the silicon JFET has low-electrical noise performance for audio components and instruments. In general, the *n*-channel field-effect transistors are preferred because of larger electron mobilities, which translate into higher speed and frequency of operation.

An *n*-channel MOSFET (Fig. 2) has a so-called source, which supplies electrons to the channel. These electrons travel through the channel and are removed by a drain electrode into the external circuit. A gate electrode is used to produce the channel or to remove the channel; hence it acts like a gate for the electrons, either providing a channel for them to flow from the source to the drain or blocking their flow (no channel). With a large enough voltage on the gate, the channel is formed, while at a low gate voltage it is not formed and blocks the electron flow to the drain. This type of MOSFET is called enhancement mode because the gate must have sufficiently large voltages to create a channel through which the electrons can flow. Another way of saying the same idea is that the device is normally "off" in a nonconducting state until the gate enhances the channel.

In the JFET (Fig. 3), a conducting majority-carrier *n* channel exists between the source and drain. When a negative voltage is applied to the  $p^+$  gate, the depletion regions widen with reverse

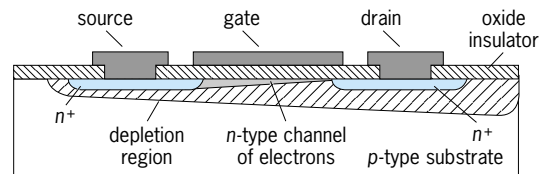

Fig. 2. An *n*-channel enhancement-mode metal-oxide-semiconductor field-effect transistor (MOSFET).

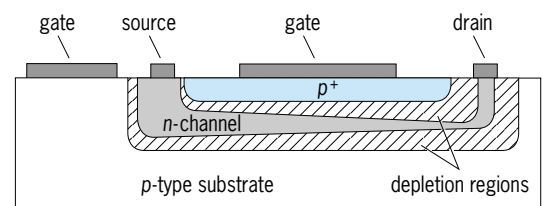

Fig. 3. An *n*-channel junction field-effect transistor (JFET).

bias and begin to restrict the flow of electrons between the source and drain. At a large enough negative gate voltage (symbolized  $V_p$ ), the channel pinches off.

The MESFET is quite similar to the JFET in its mode of operation. A conduction channel is reduced and finally pinched off by a metal Schottky barrier placed directly on the semiconductor. Metal on gallium arsenide is extensively used for high-frequency communications because of the large mobility of electrons, good gain, and low noise characteristics. Its cross section is similar to that of the JFET (Fig. 3), with a metal used as the gate. See SCHOTTKY BARRIER DIODE. [G.W.N.]

**Transit (astronomy)** The apparent passage of a celestial body across the apparent disk of a larger body, such as a planet across its parent star or of a satellite across its parent planet; also, the apparent passage of a celestial object or reference point across an adopted line of reference in a celestial coordinate system. Classically, the observed data were instants of internal and external tangency of the disks (contacts) at ingress and egress of the smaller body. In the modern era, data may also include the differential brightness of the two disks and the duration of any change of brightness.

Mercury and Venus are the only planets whose orbits lie between the Earth and the Sun and thus can be seen from Earth to cross the disk of the Sun. The conditions are that the planet is in inferior conjunction at the same time that it passes one of the two nodes of its orbit, thus putting it essentially in a straight line between the Earth and the Sun. Historically, transits of Mercury were observed for the purpose of getting precise positions of the planet to improve knowledge of its orbit, and transits of Venus to determine the solar parallax. In a century, there are 13 or 14 transits of Mercury. The size, shape, and orientation of the orbit of Venus causes transits to be very rare. Transits usually occur in pairs separated by 8 years, with 105.5 or 121.5 years between pairs. A pair occurs on June 8, 2004, and June 6, 2012. See MERCURY (PLANET); PLANET; VENUS.

Transits of the galilean satellites of Jupiter are used mainly to estimate the albedo (reflectivity) of the satellites relative to that of Jupiter. As each satellite passes in front of the planet, it casts its shadow on the planet's disk and causes the phenomenon of shadow-transit. See JUPITER; SATELLITE (ASTRONOMY).

Until the close of the twentieth century, passages of stars and other celestial bodies across the local meridian were observed extensively for determining precise coordinates of the stars and planets, accurate time, or the position of the observer. The instrument commonly used is often called a transit circle. This type of observation has been almost completely superseded by interferometric methods from Earth's surface and orbiting satellites, and by other astrometric observations from spacecraft. See ASTRONOMICAL COORDINATE SYSTEMS; ASTRONOMICAL TRANSIT INSTRUMENT.

The search for planets around solarlike stars other than the Sun yielded the first positive results in 1995. The most recently developed of several techniques is to detect photometrically the minute decrease in brightness of a star as an orbiting planet crosses its face. This can occur only if the planet's orbital plane lies edge-on to the Earth. The first planetary companion detected this way was reported in 1999, orbiting the star HD 209458 in Pegasus. Even though that companion was larger than Jupiter, the technique is considered the most mature for detecting Earth-class extrasolar planets, that is, those that are 0.5–10 times the size of Earth. [A.D.F.]

**Transition elements** In broad definition, the elements of atomic numbers 21–31, 39–49, and 71–81, inclusive. A more restricted classification of the transition elements, preferred by many chemists, is limited to elements with atomic numbers 22–28, 40–46, and 72–78, inclusive. All of the elements in this classification have one or more electrons present in an unfilled  $d$  subshell in at least one well-known oxidation state.

All the transition elements are metals and, in general, are characterized by high densities, high melting points, and low vapor pressures. Within a given subgroup, these properties tend to increase with increasing atomic weight. Facility in the formation of metallic bonds is demonstrated also by the existence of a wide variety of alloys between different transition metals.

The transition elements include most metals of major economic importance, such as the relatively abundant iron, nickel, and zinc, on one hand, and the rarer coinage metals, copper, silver, and gold, on the other. Also included are the rare and relatively unfamiliar element, rhenium, and technetium, which is not found naturally in the terrestrial environment, but is available in small amounts as a product of nuclear fission.

In their compounds, the transition elements tend to exhibit multiple valency, the maximum valence increasing from +3 at the beginning of a series (Sc, Y, Lu) to +8 at the fifth member (Mn, Re). One of the most characteristic features of the transition elements is the ease with which most of them form stable complex ions. Features which contribute to this ability are favorably high charge-to-radius ratios and the availability of unfilled  $d$  orbitals which may be used in bonding.

Most of the ions and compounds of the transition metals are colored, and many of them are paramagnetic. Both color and paramagnetism are related to the presence of unpaired electrons in the  $d$  subshell. Because of their ability to accept electrons in unoccupied  $d$  orbitals, transition elements and their compounds frequently exhibit catalytic properties.

Broadly speaking, the properties of the transition elements are intermediate between those of the so-called representative elements, in which the subshells are completely occupied by electrons (alkali metals, halogen elements), and those of the inner or  $f$  transition elements, in which the subshell orbitals play a much less significant role in influencing chemical properties (rare-earth elements, actinide elements). See ACTINIDE ELEMENTS; ATOMIC STRUCTURE AND SPECTRA; RARE-EARTH ELEMENTS. [B.B.Cu.]

**Transition point** The point at which a substance changes from one state of aggregation to another. This general definition would include the melting point (transition from solid to liquid), boiling point (liquid to gas), or sublimation point (solid to gas); but in practice the term transition point is usually restricted to the transition from one solid phase to another, that is, to the temperature (for a fixed pressure, usually 1 atm or  $10^5$  pascals) at which a substance changes from one crystal structure to another.

Another kind of transition point is the culmination of a gradual change (for example, the loss of ferromagnetism in iron or nickel) at the lambda point, or Curie point. This behavior is typical of second-order transitions. See BOILING POINT; MELTING POINT; PHASE EQUILIBRIUM; SUBLIMATION; TRIPLE POINT. [R.L.S.]

**Transition radiation detectors** Detectors of energetic charged particles that make use of radiation emitted as the particle crosses boundaries between regions with different indices of refraction. An energetic charged particle moving through matter momentarily polarizes the material nearby. If the particle crosses a boundary where the index of refraction changes, the change in polarization gives rise to the emission of electromagnetic transition radiation. About one photon is emitted for every 100 boundaries crossed, for transitions between air and matter of ordinary density. Transition radiation is emitted even if the velocity of the particle is less than the light velocity of a given wavelength, in contrast to Cerenkov radiation. Consequently, this radiation can take place in the x-ray region of the spectrum where there is no Cerenkov radiation, because the index of refraction is less than one. See CERENKOV RADIATION; PARTICLE DETECTOR; REFRACTION OF WAVES. [W.J.W.]

**Translucent medium** A medium which transmits rays of light so diffused that objects cannot be seen distinctly; that is, the medium is only partially transparent. Familiar examples are

various forms of glass which admit considerable light but impede vision. Inasmuch as the term translucent seems to imply seeing, usage of the term is ordinarily limited to the visible region of the spectrum. [M.G.M.]

**Transmission lines** A system of conductors suitable for conducting electric power or signals between two or more termini. Transmission lines take many forms in practice and have application in many disciplines. For example, they traverse the countryside, carrying telephone signals and electric power. The same transmission lines, with similar functions, may be hidden above false ceilings in urban buildings. With the need to reliably and securely transmit ever larger amounts of data, the required frequency of operation has increased from the high-frequency microwave range to the still higher frequency of light. Optical fibers are installed in data-intensive buildings and form a nationwide network. Increasing demand also requires that transmission lines handle greater values of electric power.

Transmission lines can, in some cases, be analyzed by using a fairly simple model that consists of distributed linear electrical components. Models of this type, with some permutations, can also be used to describe wave propagation in integrated circuits and along nerve fibers in animals. The study of hollow metal waveguides or optical fibers is usually based upon an analysis starting from Maxwell's equations rather than employing transmission-line models. Fundamentals and definitions that can initially be obtained from a circuit model of a transmission line carry over to waveguides, where the analysis is more complicated. See OPTICAL FIBERS; WAVEGUIDE.

**Coaxial cables and strip lines.** Two particular types of transmission lines for communication that have received considerable attention are the coaxial cable and the strip line. The coaxial cable is a flexible transmission line and typically is used to connect two electronic instruments together. In the coaxial cable, a dielectric separates a center conducting wire from a concentric conducting sleeve. The strip line is used in integrated circuits to connect, say, two transistor circuits together. A strip line also has a dielectric that separates the top conducting element from the base, which may be an electrical ground plane in the circuit. See COAXIAL CABLE; INTEGRATED CIRCUITS.

**Circuit model.** These transmission lines can be most easily analyzed in terms of electrical circuit elements consisting of distributed linear inductors and capacitors. The values of these elements are in terms of the physical dimensions of the coaxial cable and the strip line, and the permittivity of the dielectric. Each of the elements is interpreted to be measured in terms of a unit length of the element. An equivalent circuit represents either the coaxial cable or the strip line as well as other transmission lines such as two parallel wires. See ALTERNATING-CURRENT CIRCUIT THEORY; CAPACITANCE; CAPACITOR; INDUCTANCE; INDUCTOR; PERMITTIVITY.

Losses are incorporated into the transmission-line model with the addition of a distributed resistance in series with the inductor and a distributed conductance in parallel with the capacitor. Additional distributed circuit elements can be incorporated into the model in order to describe additional effects. For example, the linear capacitors could be replaced with reverse-biased varactor diodes and the propagation of nonlinear solitons could be studied. See CONDUCTANCE; ELECTRICAL RESISTANCE; SOLITON; VARACTOR. [K.E.Lo.]

**Power transmission lines.** Electric power generating stations and load consumption centers are connected by a network of power transmission lines, mostly overhead lines. Power transmitted is generally in the form of three-phase alternating current (ac) at 60 or 50 Hz. In a few instances, where a clear technical or economic advantage exists, direct-current (dc) systems may be used. As the distances over which the power must be transmitted become great and as the amount of power transmitted increases, the power lost in the transmission lines becomes an important component of the production cost of electricity, and

it becomes advantageous to increase the transmission voltage. This basic consideration has led to electric power networks which use higher voltages for long-distance bulk power transfers, with several layers of underlying regional networks at progressively lower voltages which extend over shorter distances. The most common transmission voltages in use are 765, 500, 400, 220 kV, and so forth. Voltages below 69 kV are termed subtransmission or distribution voltages, and at these and lower voltages the networks may have fewer alternative supply paths (loops) or may be entirely radial in structure. See ALTERNATING CURRENT; DIRECT CURRENT; DIRECT-CURRENT TRANSMISSION; ELECTRIC DISTRIBUTION SYSTEMS; ELECTRIC POWER TRANSMISSION. [A.G.Ph.]

**Transmutation** The nuclear change of one element into another, either naturally, in radioactive elements, or artificially, by bombarding an element with electrons, deuterons, or  $\alpha$ -particles in particle accelerators or with neutrons in atomic piles.

Natural transmutation was first explained by Marie Curie about 1900 as the result of the decay of radioactive elements into others of lower atomic weight. Ernest Rutherford produced the first artificial transmutation (nitrogen into oxygen and hydrogen) in 1919. Artificial transmutation is the method of origin of the heavier, artificial transuranium elements, and also of hundreds of radioactive isotopes of most of the chemical elements in the periodic table. See NUCLEAR REACTION; PERIODIC TABLE. [F.H.R.]

**Transonic flight** In aerodynamics, flight of a vehicle at speeds near the speed of sound. When the velocity of an airplane approaches the speed of sound (roughly 660 mi/h or 1056 km/h at 35,000 ft or 10.7 km altitude), the flight characteristics become radically different from those at subsonic speeds. The drag increases greatly, the lift at a given altitude decreases, the moments acting on the airplane change abruptly, and the vehicle may shake or buffet. Such phenomena usually persist to flight velocities somewhat above the speed of sound. These flight characteristics, as well as the speeds at which they occur, are usually referred to as transonic. The extent of the speed range of these changes depends on the form of the airplane; for configurations designed for subsonic flight they may occur at velocities of 70–110% of the speed of sound (Mach numbers of 0.7–1.1); for airplanes intended for transonic or supersonic flight they may be present only at Mach numbers of 0.95–1.05. See MACH NUMBER.

The transonic flight characteristics result from the development of shock waves about the airplane. Because of the accelerations of airflow over the various surfaces, the local velocities become supersonic while the airplane itself is still subsonic. (The flight speed at which such local supersonic flows first occur is called the critical speed.) Shock waves are associated with deceleration of these local supersonic flows to subsonic flight velocities. Such shock waves cause abrupt streamwise increases of pressure on the airplane surfaces. These gradients may cause a reversal and separation of the flow in the boundary layer on the wing surface in roughly the same manner as do similar pressure changes at lower subcritical speeds. See AERODYNAMIC FORCE; AERODYNAMIC WAVE DRAG; BOUNDARY-LAYER FLOW; SCHLIEREN PHOTOGRAPHY; SHOCK WAVE.

As for boundary-layer separation at lower speeds, the flow breakdown in this case leads to increases of drag, losses of lift, and changes of aerodynamic moments. The unsteady nature of the separated flow results in an irregular change of the aerodynamic forces acting on the airplane with resultant buffeting and shaking. As the Mach number is increased, the shock waves move aft so that at Mach numbers of about 1.0 or greater, depending on the configurations, they reach the trailing edges of the surfaces. With the shocks in these positions, the associated pressure gradients have relatively little effect on the boundary layer, and the shock-induced separation is greatly reduced. See SUBSONIC FLIGHT; SUPERSONIC FLIGHT. [R.T.Wh.]



**Transplantation biology** The science of transferring a graft from one part of the body to another or from one individual to another. The graft may consist of an organ, tissue, or cells. If donor and recipient are the same individual, the graft is autologous. If donor and recipient are genetically identical (monozygotic), it is syngeneic. If donor and recipient are any other same-species individuals, the graft is allogeneic. If the donor and recipient are of different species, it is called xenogeneic.

In theory, virtually any tissue or organ can be transplanted. The principal technical problems have been defined and, in general, overcome. Remaining major problems concern the safety of methods used to prevent graft rejection and the procurement of adequate numbers of donor organs.

Living volunteers can donate one of a pair of organs, such as a kidney, only one of which is necessary for normal life. Volunteer donors may also be employed for large unpaired organs such as small bowel, liver, or pancreas, segments of which can be removed without impairment of function. Living donors can also provide tissues capable of regeneration; these include blood, bone marrow, and the superficial layers of the skin. In the case of a vital, unpaired organ, such as the heart, the use of cadaver donors is obligatory. In practice, with the exception of blood and bone marrow, the great majority of transplanted organs are cadaveric in origin, a necessity that presents difficult logistic problems.

Autografts are used for an increasing number of purposes. Skin autografts are important in the treatment of full-thickness skin loss due to extensive burns or other injuries. Provided that the grafts comprise only the superficial levels of the skin, the donor sites reepithelialize spontaneously within a week or two. The saphenous vein of the ankle is frequently transplanted to the heart to bypass coronary arteries obstructed by atherosclerosis. Autologous hematopoietic stem cell transplantation is sometimes used to restore blood cells to cancer patients who receive forms of chemotherapy that are lethal to their bone marrow.

The most serious problem restricting the use of allografts is immunological. Because cells in the donor graft express on their surface a number of genetically determined transplantation antigens that are not present in the recipient, allografts provoke a defensive reaction analogous to that evoked by pathogenic microorganisms. As a consequence, after a transient initial period of apparent well-being, graft function progressively deteriorates and the donor tissue is eventually destroyed. The host response, known as allograft rejection, involves a large number of immunological agents, including cytotoxic antibodies and effector lymphocytes of various types. There are a few special exemptions from rejection that apply to certain sites in the body or to certain types of graft. For example, the use of corneal allografts in restoring sight to individuals with corneal opacification succeeds because of the absence of blood vessels in the host tissue.

Successful transplantation of allografts such as kidneys and hearts currently requires suppressing the recipient's immune response to the graft without seriously impairing the immunological defense against infection. Treatment of individuals with so-called immunosuppressive drugs and other agents prevents allograft rejection for prolonged periods, if not indefinitely. Under cover of nonspecific immunosuppression, the recipient's immune system appears to undergo an adaptation to the presence of the graft, allowing the dosage of the drugs to be reduced. However, in almost all successfully transplanted individuals, drug therapy at some low dose is required indefinitely. See IMMUNOSUPPRESSION.

An individual's response against an allograft is directed against a large number of cell-surface transplantation antigens controlled by allelic genes at many different loci. However, in all species, one of these loci, the major histocompatibility complex (MHC), transcends all the other histocompatibility loci in terms of its genetic complexity and the strength of the antigenic response it controls. In humans, the MHC, known as the HLA (human leukocyte

antigen) complex, is on the sixth chromosome; its principal loci are designated A, B, C, DR, and DQ. The allelic products of the HLA genes can be detected by serology, polymerase chain reaction technology, or microcytotoxicity assays. The ABO red cell antigens are also important because they are expressed on all tissues. See BLOOD GROUPS; HISTOCOMPATIBILITY.

In kidney transplants between closely related family members, the degree of HLA antigen matching can be determined very precisely, and there is a very good correlation between the number of shared HLA antigens and the survival of the graft. With grafts from unrelated donors, HLA matching is more difficult and can delay transplantation, but it may be beneficial. HLA matching is not as clearly beneficial in the case of most other solid organ grafts, and no attempt is made to HLA-match heart, lung, liver, and pancreas grafts. With few exceptions, however, most donors and recipients are matched for the expression of ABO blood group antigens.

Bone marrow transplantation presents a unique problem in its requirements for HLA matching and for immunosuppression in advance of grafting. In addition to the possibility of rejection of the graft by the recipient, by virtue of immunologically competent cells still present in the recipient, bone marrow grafts can react against the transplantation antigens of their hosts. These are known as graft-versus-host reactions, and they can be fatal. See IMMUNOLOGY.

The immunological events that lead to the rejection of xenografts are different from and less well understood than those responsible for allograft rejection. The small number of xenografts attempted to date have failed. In particular, xenografts are susceptible to hyperacute rejection by humans. This is due to the presence of certain glycoproteins in blood vessels of many species that are recognized by antibodies present in the blood of all humans. [J.P.Mo.; R.E.Bi.; D.L.Gr.; A.A.R.]

**Transport processes** The processes whereby mass, energy, or momentum are transported from one region of a material to another under the influence of composition, temperature, or velocity gradients. If a sample of a material in which the chemical composition, the temperature, or the velocity vary from point to point is isolated from its surroundings, the transport processes act so as to eventually render these quantities uniform throughout the material. The nonuniform state required to generate these transport processes causes them to be known also as nonequilibrium processes. Associated with gradients of composition, temperature, and velocity in a material are the transport processes of diffusion, thermal conduction, and viscosity, respectively. See DIFFUSION IN GASES AND LIQUIDS; DIFFUSION IN SOLIDS; THERMAL CONDUCTION IN SOLIDS; VISCOSITY. [W.A.W.]

**Transportation engineering** That branch of engineering related to the movements of goods and people by highway, rail, air, water, and pipeline. Special categories include urban and intermodal transportation.

Engineering for highway transportation involves planning, construction, and operation of highway systems, urban streets, roads, and bridges, as well as parking facilities. Important aspects of highway engineering include (1) overall planning of routes, financing, environmental impact evaluation, and value engineering to compare alternatives; (2) traffic engineering, which plans for the volumes of traffic to be handled, the methods to accommodate these flows, the lighting and signing of highways, and general layout; (3) pavement and roadway engineering, which involves setting of alignments, planning the cuts and fills to construct the roadway, designing the base course and pavement, and selecting the drainage system; and (4) bridge engineering, which involves the design of highway bridges, retaining walls, tunnels, and other structures. See HIGHWAY ENGINEERING; TRAFFIC-CONTROL SYSTEMS; VALUE ENGINEERING.

Engineering for railway transportation involves planning, construction, and operation of terminals, switchyards,

loading/unloading facilities, trackage, bridges, tunnels, and traffic-control systems for freight and passenger service. For freight operations, there is an emphasis on developing more efficient systems for loading, unloading, shifting cars, and operating trains. Facilities include large marshaling yards where electronic equipment is used to control the movement of railroad cars. Also, there is a trend to developing more automated systems on trackage whereby signals and switches are set automatically by electronic devices. To accommodate transportation of containers, tunnels on older lines are being enlarged to provide for double-stack container cars. See RAILROAD ENGINEERING; TUNNEL.

Engineering for air transportation encompasses the planning, design, and construction of terminals, runways, and navigation aids to provide for passenger and freight service. High-capacity, long-range, fuel-efficient aircraft, such as the 440-seat Boeing 777 with a range of 7200 mi (12,000 km), are desirable. Wider use of composites and the substitution of electronic controls for mechanical devices reduce weight to improve fuel economy. Smaller planes are more efficient for shorter runs. See AIR NAVIGATION; AIR-TRAFFIC CONTROL; AIR TRANSPORTATION; COMPOSITE MATERIAL.

Engineering for water transportation entails the design and construction of a vast array of facilities such as canals, locks and dams, and port facilities. The transportation system ranges from shipping by barge and tugboat on inland waterways to shipping by oceangoing vessels. Although there is some transportation of passengers, such as on ferries and cruise ships, water transportation is largely devoted to freight. See CANAL; DAM; RIVER ENGINEERING.

Pipeline engineering embraces the design and construction of pipelines, pumping stations, and storage facilities. Pipelines are used to transport liquids such as water, gas, and petroleum products over great distances. Also, products such as pulverized coal and iron ore can be transported in a water slurry. See PIPELINE; STORAGE TANK.

Engineering for urban transportation concerns the design and construction of light rail systems, subways, and people-movers, as well as facilities for traditional bus systems. To enhance public acceptance of new and expanded systems, increased use is being made of computer-aided design (CAD) to visualize alternatives for stations and facilities. Also, animated video systems are used for interactive visualization of plans. See COMPUTER-AIDED ENGINEERING; HARBORS AND PORTS; SUBWAY ENGINEERING.

Intermodal transportation, often referred to as containerization, entails the use of special containers to ship goods by truck, rail, or ocean vessel. Engineers must design and construct intermodal facilities for efficient operations. The containers are fabricated from steel or aluminum, and they are designed to withstand the forces from handling. The ships are constructed with a cellular grid of compartments for containers below deck, and they can accommodate one or two layers on deck as well. Advantages include savings in labor costs, less pilferage, and lower insurance costs. See HOISTING MACHINES; MARINE CONTAINERS; MERCHANT SHIP.

The environment and energy consumption are taken into major consideration when planning, designing, and constructing transportation facilities. Efforts to curb energy use arise from a variety of concerns, including security issues and environmental implications. Efforts to relieve congestion in urban areas through incentives to make greater use of car pooling, such as special freeway lanes, and encouraging greater use of mass transit, deserve further emphasis. [R.L.Broc.]

**Transposons** Types of transposable elements which comprise large discrete segments of deoxyribonucleic acid (DNA) capable of moving from one chromosome site to a new location. In bacteria, the transposable elements can be grouped into two classes, the insertion sequences and the transposons. The ability of transposable elements to insert into plasmid or bacterial

virus (bacteriophage) which is transmissible from one organism to another allows for their rapid spread. See BACTERIOPHAGE; PLASMID.

The insertion sequences were first identified by their ability to induce unusual mutations in the structural gene for a protein involved in sugar metabolism. These insertion sequences are relatively small (about 500–1500 nucleotide pairs) and can only be followed by their ability to induce these mutations. Most bacterial chromosomes contain several copies of such insertion sequence elements.

The transposons are larger segments of DNA (2000–10,000 base pairs) that encode several proteins, usually one or two required for the movement of the element and often an additional protein that imparts a selective advantage to the host containing a copy of that element. The structure of many transposons suggests they may have evolved from the simpler insertion sequence elements.

All transposable elements, both the simple insertion sequence elements and the more complex transposons, have a similar structure and genetic organization. The ends of the element represent recognition sites and define the segment of DNA undergoing transposition. A short sequence present at one end of the element is repeated in an inverted fashion at the other end. These terminal inverted repeats are characteristic for each element.

Members of a widespread group of transposons, the Tn3 family, all have a similar structure and appear to move by a similar mechanism. Transposase, one protein encoded by the element, promotes the formation of intermediates called cointegrates, in which the element has been duplicated by replication. A second element-encoded protein, resolvase, completes the process by converting the cointegrates into the end products of transposition, a transposon inserted into a new site. A third protein encoded by the Tn3 element imparts resistance to the antibiotic ampicillin.

Transposons are known that encode resistances to almost all antibiotics as well as many toxic metals and chemicals. In addition, some transposons have acquired the ability to direct the synthesis of proteins that metabolize carbohydrates, petroleum, and pesticides. Other transposable elements produce enterotoxins that cause travelers to become ill from drinking water contaminated with bacteria carrying the element. The broad spectrum of activities encoded by the transposable elements demonstrates the strong selective advantage that has accompanied their evolution.

Transposable elements are not restricted to prokaryotes. Yeast as well as higher eukaryotes have DNA segments that move and cause mutations. The eukaryotic elements have much in common with their prokaryotic counterparts: the termini of the elements are composed of inverted repeats, and many of the larger elements are composed of two small insertion sequence-like regions flanking a unique central region. One class of eukaryotic virus, the ribonucleic acid (RNA) retrovirus, also has this structure and is thought to integrate into the host chromosome through a transpositionlike mechanism. See ANTIBIOTIC; GENE; GENE ACTION; RETROVIRUS; VIRUS. [R.Re.]

**Transuranium elements** Those synthetic elements with atomic numbers larger than that of uranium (atomic number 92). They are the members of the actinide series, from neptunium (atomic number 93) through lawrencium (atomic number 103), and the transactinide elements (with higher atomic numbers than 103). Of these elements, plutonium, an explosive ingredient for nuclear weapons and a fuel for nuclear power because it is fissionable, has been prepared on the largest (ton) scale, while some of the others have been produced in kilograms (neptunium, americium, curium) and in much smaller quantities (berkelium, californium, and einsteinium).

The concept of atomic weight in the sense applied to naturally occurring elements is not applicable to the transuranium elements, since the isotopic composition of any given sample

depends on its source. In most cases the use of the mass number of the longest-lived isotope in combination with an evaluation of its availability has been adequate. Good choices at present are neptunium, 237; plutonium, 242; americium, 243; curium, 248; berkelium, 249; californium, 249; einsteinium, 254; fermium, 257; mendelevium, 258; nobelium, 259; lawrencium, 260; rutherfordium, 261; dubnium, 262; and seaborgium, 263. The actinide elements are chemically similar and have a strong chemical resemblance to the lanthanide, or rare-earth, elements (atomic numbers 57–71). The transactinide elements, with atomic numbers 104–118, appear in an expanded periodic table under the row of elements beginning with hafnium, number 72, and ending with radon, number 86. This arrangement allows prediction of the chemical properties of these elements and suggests that they will have a chemical analogy with the elements which appear immediately above them in the periodic table.

The transuranium elements up to and including fermium (atomic number 100) are produced in largest quantity through the successive capture of neutrons in nuclear reactors. The yield decreases with increasing atomic number, and the heaviest to be produced in weighable quantity is einsteinium (number 99). Many additional isotopes are produced by bombardment of heavy target isotopes with charged atomic projectiles in accelerators; beyond fermium, all elements are produced by bombardment with heavy ions.

Beyond darmstadtium (atomic number 110), transactinide elements 111–116 have been produced, although their acceptance is pending. See ACTINIDE ELEMENTS; AMERICIUM; BERKELIUM; BOHRIUM; CALIFORNIUM; CURIUM; DUBNIUM; EINSTEINIUM; ELEMENT 111; ELEMENT 112; FERMIUM; HASSIUM; LAWRENCIUM; MEITNERIUM; MENDELEVIUM; NEPTUNIUM; NOBELIUM; NUCLEAR CHEMISTRY; NUCLEAR FISSION; NUCLEAR REACTION; PERIODIC TABLE; PLUTONIUM; RARE-EARTH ELEMENT; RUTHERFORDIUM; SEABORGIUM.

[P.J.R.; G.T.S.]

**Traps in solids** Localized regions in a material that can capture and localize an electron or hole, thus preventing the electron or hole from moving through the material until supplied with sufficient thermal or optical energy. Traps in solids are associated with imperfections in the material caused by either impurities or crystal defects. See BAND THEORY OF SOLIDS; CRYSTAL DEFECTS; HOLE STATES IN SOLIDS.

Imperfections that behave as traps are commonly distinguished from imperfections that behave as recombination centers. If the probability for a captured electron (or hole) at the imperfection to be thermally reexcited to the conduction (or valence) band before recombination with a free hole (or free electron) is greater than the probability for such recombination, then the imperfection is said to behave like an electron (or hole) trap. If the probability for a captured electron (or hole) at the imperfection to recombine with a free hole (or free electron) is greater than the probability for being thermally reexcited to the band, the imperfection is said to behave like a recombination center. It is possible for a specific chemical or structural imperfection in the material to behave like a trap under one set of conditions of temperature and light intensity, and as a recombination center under another.

Traps play a significant role in many phenomena involving photoconductivity and luminescence. In photoconductors, for example, the presence of traps decreases the sensitivity and increases the response time. Their effect is detectable through changes in the rise and decay transients of photoconductivity and luminescence, thermally stimulated conductivity and luminescence in which the traps are filled at a low temperature and then emptied by increasing the temperature in a controlled way, electron spin resonance associated with trapped electrons with unpaired spins, and a variety of techniques involving the capacitance of a semiconductor junction such as photocapacitance and deep-level transient spectroscopy. See ELECTRON PARAMAGNETIC

RESONANCE (EPR) SPECTROSCOPY; LUMINESCENCE; PHOTOCONDUCTIVITY; THERMOLUMINESCENCE.

[R.H.Bu.]

**Trauma** Injury to tissue by physical or chemical means. Mechanical injury includes abrasions, contusions, lacerations, and incisions, as well as stab, puncture, and bullet wounds. Trauma to bones and joints results in fractures, dislocations, and sprains. Head injuries are often serious because of the complications of hemorrhage, skull fracture, or concussion.

Thermal, electrical, and chemical burns produce severe damage partly because they coagulate tissue and seal off restorative blood flow. Asphyxiation, including that caused by drowning, produces rapid damage to the brain and respiratory centers, as well as to other organs.

Frequent complications of trauma are shock, the state of collapse precipitated by peripheral circulatory failure, and also hemorrhage, infection, and improper healing. See HEMORRHAGE; INFECTION; SHOCK SYNDROME.

[E.G.St./N.K.M.]

**Traveling-wave tube** A microwave electronic tube in which a beam of electrons interacts continuously with a wave that travels along a circuit, the interaction extending over a distance of many wavelengths. Traveling-wave tubes can provide amplification over exceedingly wide bandwidths. Typical bandwidths are 10–100% of the center frequency, with gains of 20–60 dB. Low-noise traveling-wave tube amplifiers serve as the inputs to sensitive radars or communications receivers. High-efficiency medium-power traveling-wave tubes are the principal final amplifiers used in communication satellites, the space shuttle communications transmitter, and deep-space planetary probes and landers. High-power traveling-wave amplifiers operate as the final stages of radars, wide-band radar countermeasure systems, and scatter communication transmitters. They are capable of delivering continuous-wave power levels in the kilowatt range and pulsed power levels exceeding a megawatt. See COMMUNICATIONS SATELLITE; ELECTRONIC WARFARE; RADAR; SPACE COMMUNICATIONS; SPACE PROBE.

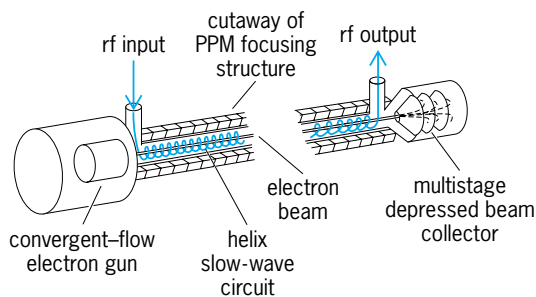

**Periodic-permanent-magnet (PPM) focused traveling-wave tube.**

In a forward-wave, traveling-wave tube amplifier (see illustration), a thermionic cathode produces the electron beam. An electron gun initially focuses the beam, and an additional focusing system retains the electron stream as a beam throughout the length of the tube until the beam is captured by the collector electrode. The microwave signal to be amplified enters the tube near the electron gun and propagates along a slow-wave circuit. The tube delivers amplified microwave energy into an external matched load connected to the end of the circuit near the collector. The slow-wave circuit serves to propagate the microwave energy along the tube at approximately the same velocity as that of the electron beam. Interaction between beam and wave is continuous along the tube with contributions adding in phase.

The principle use of this technique is to create a voltage-tunable microwave oscillator. Typically it uses a hollow, linear electron beam and a helix circuit designed to emphasize the backward-wave fields. This represents the earliest type of

voltage-tunable microwave oscillator. It is capable of generating power levels of 10–100 milliwatts with a tuning range of 2:1 in frequency. Its use has almost disappeared with the development of magnetically tuned microwave transistor oscillators using yttrium-iron-garnet (YIG) spherical resonators. See FERROMAGNETIC GARNETS; MAGNETRON; MICROWAVE TUBE; OSCILLATOR.

[L.A.Ro.]

**Travertine** A rather dense, banded limestone, sometimes moderately porous, that is formed either by evaporation about springs, as is tufa, or in caves, as stalactites, stalagmites, or dripstone. Where travertine or tufa (calcareous sinter) is deposited by hot springs, it may be the result of the loss of carbon dioxide from the waters as pressure is released upon emerging at the surface; the release of carbon dioxide lowers the solubility of calcium carbonate and it precipitates. High rates of evaporation in hot-spring pools also lead to supersaturation. Travertine formed in caves is simply the result of complete evaporation of waters containing mainly calcium carbonate. See LIMESTONE; STALACTITES AND STALAGMITES; TUFFA.

[R.Si.]

**Tree** A perennial woody plant at least 20 ft (6 m) in height at maturity, having an erect stem or trunk and a well-defined crown or leaf canopy. However, no sharp lines can be drawn between trees, shrubs, and lianas (woody vines). The essence of the tree form is relatively large size, long life, and a slow approach to reproductive maturity. The difficulty of transporting water, nutrients, and storage products over long distances and high into the air against the force of gravity is a common problem of large tree-like plants and one that is not shared by shrubs or herbs.

**Classification.** Almost all existing trees belong to the seed plants (Spermatophyta). An exception are the giant tree ferns which were more prominent in the forests of the Devonian Period and today exist only in the moist tropical regions. The Spermatophyta are divided into the Pinophyta (gymnosperms) and the flowering plants, Magnoliophyta (angiosperms). The gymnosperms bear their seed naked on modified leaves, called scales, which are usually clustered into structures called cones—for example, pine cones. By contrast the seed of angiosperms is enclosed in a ripened ovary, the fruit. See MAGNOLIOPHYTA; PINOPHYTA; POLYPODIALES; TREE FERNS.

The orders Cycadales, Ginkgoales, and Pinales of the Pinophyta contain trees. *Ginkgo biloba*, the ancient maidenhair tree, is the single present-day member of the Ginkgoales. The Cycadales, characteristic of dry tropical areas, contain many species which are small trees. The Pinales, found throughout the world, supply much of the wood, paper, and building products of commerce. They populate at least one-third of all existing forest and include the pines (*Pinus*), hemlocks (*Tsuga*), cedars (*Cedrus*), spruces (*Picea*), firs (*Abies*), cypress (*Cupressus*), larches (*Larix*), Douglas-fir (*Pseudotsuga*), sequoia (*Sequoia*), and other important genera. The Pinales are known in the lumber trade as softwoods and are popularly thought of as evergreens, although some (for example, larch and bald cypress) shed their leaves in the winter. See CEDAR; CYCADALES; CYPRESS; DOUGLAS-FIR; FIR; HEMLOCK; LARCH; PAPER; PINALES; PINE; PINOPHYTA; SEQUOIA; SPRUCE.

In contrast to the major orders of gymnosperms which contain only trees, many angiosperm families are herbaceous and include trees only as an exception. Only a few are exclusively arboreal. The major classes of the angiosperms are the Liliopsida (monocotyledons) and the Magnoliopsida (dicotyledons). The angiosperm trees, commonly thought of as broad-leaved and known as hardwoods in the lumber market, are dicotyledons. Examples of important genera are the oaks (*Quercus*), elms (*Ulmus*), maples (*Acer*), and poplars (*Populus*). See ELM; LILIOPSIDA; MAGNOLIOPSIDA; MAPLE; OAK; POPLAR.

The Liliopsida contain few tree species, and these are never used for wood products, except in the round as posts. Examples of monocotyledonous families are the palms (Palmae),

yucca (Liliaceae), bamboos (Bambusoideae), and bananas (Musaceae). See BAMBOO; BANANA.

**Morphology.** The morphology of a tree is similar to that of other higher plants. Its major organs are the stem, or trunk and branches; the leaves; the roots; and the reproductive structures. Almost the entire bulk of a tree is nonliving. Of the trunk, branches, and roots, only the tips and a thin layer of cells just under the bark are alive. Growth occurs only in these meristematic tissues. Meristematic cells are undifferentiated and capable of repeated division. See FLOWER; LATERAL MERISTEM; LEAF; PLANT GROWTH; ROOT (BOTANY); STEM.

**Growth.** Height is a result of growth only in apical meristems at the very tips of the twigs. A nail driven into a tree will always remain at the same height, and a branch which originates from a bud at a given height will never rise higher. The crown of a tree ascends as a tree ages only by the production of new branches at the top and by the death and abscission of lower, older branches as they become progressively more shaded. New growing points originate from the division of the apical meristem and appear as buds in the axils of leaves. See APICAL MERISTEM; BUD; PLANT GROWTH.

In the gymnosperms and the dicotyledonous angiosperms, growth in diameter occurs by division in only a single microscopic layer, three or four cells wide, which completely encircles and sheaths the tree. This lateral meristem is the cambium. It divides to produce xylem cells (wood) on the inside toward the core of the tree and phloem cells on the outside toward the bark. In trees of the temperate regions the growth of each year is seen in cross section as a ring. See BARK; PHLOEM; XYLEM.

Xylem elements become rigid through the thickening and modification of their cell wall material. The tubelike xylem cells transport water and nutrients from the root through the stem to the leaves. In time the xylem toward the center of the trunk becomes impregnated with various mineral and metabolic products, and it is no longer capable of conduction. This nonfunctional xylem is called heartwood and is recognizable in some stems by its dark color. The light-colored, functional outer layer of the xylem is the sapwood. See WOOD ANATOMY.

The phloem tissue transports dissolved carbohydrates and other metabolic products manufactured by the leaves throughout the stem and the roots. Most of the phloem cells are thin-walled and are eventually crushed between the bark and the cambium by the pressures generated in growth. The outer bark is dead and inelastic but the inner bark contains patches of cork cambium which produce new bark. As a tree increases in circumference, the old outer bark splits and fissures develop, resulting in the rough appearance characteristic of the trunks of most large trees.

In the monocotyledons the lateral cambium does not encircle a central core, and the vascular or conducting tissue is organized in bundles scattered throughout the stem. The trunk is not wood as generally conceived although it does in fact have secondary xylem. See DENDROLOGY; FOREST AND FORESTRY; FOREST TIMBER RESOURCES; PLANT PHYSIOLOGY; PLANT TAXONOMY. [F.T.L.]

**Tree diseases** Diseases of both shade and forest trees have the same pathogens, but the trees differ in value, esthetics, and utility. In forests, disease is significant only when large numbers of trees are seriously affected. Diseases with such visible symptoms as leaf spots may be alarming on shade trees but hardly noticed on forest trees. Shade trees with substantial rot may be ornamentals with high value, whereas these trees would be worthless in the forest. Emphasis on disease control for the same tree species thus requires a different approach, depending on location of the tree.

**Forest trees.** From seed to maturity, forest trees are subject to many diseases. Annual losses of net sawtimber growth from disease (45%) are greater than from insects and fire combined. Young, succulent seedlings, especially conifers, are killed by certain soil-inhabiting fungi (damping-off). Root systems of

older seedlings may be destroyed by combinations of nematodes and such fungi as *Cylindrocladium*, *Sclerotium*, and *Fusarium*. Chemical treatment of seed or soil with formulations containing nematicides and fungicides, and cultural practices unfavorable to root pathogens help to avoid these diseases.

Roots rots are caused by such fungi as *Heterobasidion* (= *Fomes*) *annosus* (mostly in conifers) and *Armillariella* (= *Armillaria*) *mellea* (mostly in hardwoods). These fungi cause heart rot in the roots and stems of large trees and also invade and kill young, vigorous ones.

In natural forests, leaf diseases are negligible, but in nurseries and plantations, fungal infections cause severe defoliation, retardation of height growth, or death. *Scirrhia acicola* causes brown spot needle blight and prevents early height growth of lingleaf pine in the South; it defoliates Christmas tree plantations of Scotch pine (*Pinus sylvestris*) in northern states. Fungicides and prescribed burning are used successfully for control.

Oak wilt is a systemic disease, with the entire tree affected through its water-conducting system. The causal fungus, *Ceratocystis fagacearum*, spreads to nearby healthy trees by root grafts and to trees at longer distances by unrelated insects. The sporulating mats of the fungus develop between bark and wood, producing asexual and, sometimes, sexual spores, which are disseminated by insects. Control is possible by eradicating infected trees and by disruption of root grafts by trenching or by chemicals.

Stem rust diseases occur as cankers or galls on coniferous hosts and as minor lesions on other ones. A few, such as white pine blister rust and southern fusiform rust, are epidemic, lethal, and economically important. Others of less immediate importance (such as western gall rust) are capable of serious, widespread infection. Resistant varieties are favored for control. Other control measures include pruning out early infections and spraying nursery trees with chemicals during periods favoring needle infection.

Stem infections by numerous fungi, resulting in localized death of cambium and inner bark, range from lesions killing small stems in a year (annual) to gross stem deformities (perennial), where cankers enlarge with stem growth. Chestnut blight, first known in the United States in 1904, destroyed the American chestnut as a commercial species; and is an example of the annual lesion type. The less dramatic or devastating *Nectria* canker destroys stems of timber value, and is an example of the perennial lesion type.

All tree species, including decay-resistant ones such as redwood, are subject to ultimate disintegration by fungi. Decay fungi (Hymenomycetes) are associated with nondecay fungi (Deuteromycetes) and bacteria. These microflora enter the tree through wounds, branch stubs, and roots, and are confined to limited zones of wood by anatomical and wound-stimulated tissue barriers. The extent of decay is limited by compartmentalization of decay in trees. Trees aged beyond maturity are most often invaded by wood-rotting fungi; losses can be minimized by avoiding wounds and by shortening cutting rotations. Losses from rot are especially serious in overmature coniferous stands in the western United States, Canada, and Alaska. See FOREST PEST CONTROL; WOOD DEGRADATION.

**Shade trees.** Many shade trees are grown under conditions for which they are poorly adapted, and are subject to environmental stresses not common to forest trees. Both native and exotic trees planted out of natural habitats are predisposed to secondary pathogens following environmental stress of noninfectious origins. They are also susceptible to the same infectious diseases as forest trees. Appearance is more important than the wood produced, and individual value is higher per tree than for forest trees. Thus, disease control methods differ from those recommended for forest trees.

The most important and destructive shade tree disease known is Dutch elm disease, introduced from Europe to North America before 1930. The causal fungus, *Ophiostoma ulmi* (*Ceratocystis*

*ulmi*), is introduced to the water-conducting system of healthy elms by the smaller European elm bark beetle (*Scolytus multistriatus*) or the American elm bark beetle (*Hylurgopinus rufipes*). One or more new and more aggressive strains of the fungus have arisen since 1970. More devastating than the original ones, they are destroying the elms in North America and Europe that survived earlier epidemics. Effective means of prevention are sanitation (destroying diseased and dying and dead elm wood); insecticidal sprays; disruption of root systems; and early pruning of new branch infections. Of much promise are resistant varieties of elm, systemic fungicides, and insect pheromones.

The most common bacterial disease of shade trees is wetwood of elm and certain other species. It is reported to be caused by a single bacterial species (*Erwinia nimipressuralis*), although causal associations of other bacteria are now suspected. The bacteria are normally present in the heartwood of mature elms and cause no disease unless they colonize sapwood by exterior wounds. Fermented sap under pressure bleeds from wounds and flows down the side of the tree. Sustained bleeding kills underlying cambial tissue. Internal gas pressure and forced spread of bacterial toxins inside living tissues of the tree can be reduced by strategic bleeding to avoid seepage into bark and cambium.

A second bacterial disease of elm, elm yellows, is caused by a mycoplasma-like organism, considered to be a unique kind of bacterium. Elm yellows is as lethal as Dutch elm disease but is more limited in distribution. The pathogen is carried by the elm leafhopper (*Scaphoideus luteolus*), which sucks phloem juice from leaf veins. Spread of disease also occurs through grafted root systems. Control measures include early destruction of infected trees, disruption of root systems, and insecticidal sprays. Injection with tetracycline and other antibiotics helps to slow the progress of the bacterium.

The most common and complex diseases of shade trees are diebacks and declines (such as maple decline). Many species show similar patterns of symptoms caused by multiple factors, but no single causal factor is known to cause any one of these diseases. Noninfectious agents of shade tree diseases are drought, soil compaction, mineral deficiency, soil pollution from waste or salt, air pollution, and so on. Trees affected experience chlorosis, premature fall coloration and abscission, tufting of new growth, dwarfing and sparseness of foliage, progressive death of terminal twigs and branches, and decline in growth. Such trees are often infested with borers and bark beetles, and infected by branch canker and root rot fungi. Noninfectious stress predisposes trees to infectious disease that is caused by different kinds of weakly parasitic fungi as secondary pathogens. See PLANT PATHOLOGY.

[R.J.C.]

**Tree ferns** Plants belonging to the families Cyatheaceae and Dicksoniaceae, whose members typically develop tall trunks crowned with leaves (fronds) which often reach some 20 ft (6.1 m) in length and 5–6 ft (1.5–1.8 m) in width. Tree ferns reach their greatest development in the rainforests and cloud forests of the mountainous tropics. See RAINFOREST.

Tree fern trunks may reach 65 ft (19.8 m) tall; their diameters vary from 0.4 in. (1.0 cm) to 4 ft (1.2 m). The lower trunk is often densely covered with matted adventitious roots which greatly increase its diameter. Certain specimens branch near the base of the trunk or higher up; perhaps this branching occurs in response to injury.

The degree of division of the leaves varies from simple to four or five pinnate. The leaflets (pinnae) are usually smaller toward the base of the leaf; when these basal leaflets are branched into threadlike divisions, they are called aplebiae. The Dicksoniaceae have marginal sori terminal on the veins and protected by a bivalved indusium. The Cyatheaceae produce sori well away from the margin, usually seated at the forking of a vein or midway along a simple vein.

The typical vascular system of both families is dictyostelic. The Cyatheaceae have accessory vascular strands in the pith

and cortex. Fibrous sheaths around the vascular tissue and just inside the epidermis provide mechanical support. The xylem consists of scalariform tracheids and parenchyma, the phloem of sieve tubes and parenchyma. Numerous mucilage canals are embedded in the pith and cortex. *See* STEM; TREE. [G.J.G.]

**Tree physiology** The study of how trees grow and develop in terms of genetics; biochemistry; cellular, tissue, and organ functions; and interaction with environmental factors. While many physiological processes are similar in trees and other plants, trees possess unique physiologies that help determine their outward appearance. These physiological processes include carbon relations (photosynthesis, carbohydrate allocation), cold and drought resistance, water relations, and mineral nutrition.

Three characteristics of trees that define their physiology are longevity, height, and simultaneous reproductive and vegetative growth. Trees have physiological processes that are more adaptable than those in the more specialized annual and biennial plants. Height allows trees to successfully compete for light, but at the same time this advantage creates transport and support problems. These problems were solved by the evolution of the woody stem which combines structure and function into a very strong transport system. Simultaneous vegetative and reproductive growth in adult trees causes significant competition for carbohydrates and nutrients, resulting in decreased vegetative growth. Trees accommodate both types of growth by having cyclical reproduction: one year many flowers and seeds are produced, followed by a year or more in which few or no flowers are produced.

**Carbon relations.** While biochemical processes of photosynthesis and carbon assimilation and allocation are the same in trees and other plants, the conditions under which these processes occur in trees are more variable and extreme. In evergreen species, photosynthesis can occur year round as long as the air temperature remains above freezing, while some deciduous species can photosynthesize in the bark of twigs and stem during the winter.

Carbon dioxide fixed into sugars moves through the tree in the phloem and xylem to tissues of high metabolism which vary with season and development. At the onset of growth in the spring, sugars are first mobilized from storage sites, primarily in the secondary xylem (wood) and phloem (inner bark) of the woody twigs, branches, stem, and roots. The sugars, stored as starch, are used to build new leaves and twigs, and if present, flowers. Once the new leaves expand, photosynthesis begins and sugars are produced, leading to additional leaf growth. Activation of the vascular cambium occurs at the same time, producing new secondary xylem and phloem. In late spring, the leaves begin photosynthesizing at their maximum rates, creating excess sugars which are translocated down the stem to support further branch, stem, and root growth. From midsummer through fall until leaf abscission (in deciduous trees) or until temperatures drop to freezing (in evergreen trees), sugars replenish the starch used in spring growth. Root growth may be stimulated at this time by sugar availability and warm soil temperatures. Throughout the winter, starch is used for maintenance respiration, but sparingly since low temperatures keep respiration rates low. *See* PHLOEM; PHOTOSYNTHESIS; XYLEM.

In adult trees, reproductive structures (flowers in angiosperms or strobili in gymnosperms) develop along with new leaves and represent large carbohydrate sinks. Sugars are preferentially utilized at the expense of leaf, stem, and root growth. This reduces the leaf area produced, affecting the amount of sugars produced during that year, thereby reducing vegetative growth even further. The reproductive structures are present throughout the growing season until seed dispersal and continually utilize sugars that would normally go to stem and root growth.

**Cold resistance.** The perennial nature of trees requires them to withstand low temperatures during the winter. Trees develop

resistance to freezing through a process of physiological changes beginning in late summer. A tree goes through three sequential stages to become fully cold resistant. The process involves reduced cell hydration along with increased membrane permeability. The first stage is initiated by shortening days and results in shoot growth cessation, bud formation, and metabolic changes. Trees in this stage can survive temperatures down to 23°F (−5°C). The second stage requires freezing temperatures which alter cellular molecules. Starch breakdown is stimulated, causing sugar accumulation. Trees can survive temperatures as low as −13°F (−25°C) at this stage. The last stage occurs after exposure to very low temperatures (−22 to −58°F or −30 to −50°C), which increases soluble protein concentrations that bind cellular water, preventing ice crystallization. Trees can survive temperatures below −112°F (−80°C) in this stage. A few days of warmer temperatures, however, causes trees to revert to the second stage.

**Water relations.** Unlike annual plants that survive drought as seeds, trees have evolved traits that allow them to avoid desiccation. These traits include using water stored in the stem, stomatal closure, and shedding of leaves to reduce transpirational area. All the leaves can be shed and the tree survives on stored starch. Another trait of some species is to produce a long tap root that reaches the water table, sometimes tens of meters from the soil surface. On a daily basis, trees must supply water to the leaves for normal physiological function. If the water potential of the leaves drops too low, the stomata close, reducing photosynthesis. To maintain high water potential, trees use water stored in their stems during the morning which is recharged during the night. *See* PLANT-WATER RELATIONS.

**Transport and support.** Trees have evolved a means of combining long-distance transport between the roots and foliage with support through the production of secondary xylem (wood) by the vascular cambium. In older trees the stem represents 60–85% of the aboveground biomass. However, 90% of the wood consists of dead cells. These dead cells function in transport and support of the tree. As these cells develop and mature, they lay down thick secondary walls of cellulose and lignin that provide support, and then they die with the cell lumen becoming an empty tube. The interconnecting cells provide an efficient transport system, capable of moving 106 gal (400 liters) of water per day. The living cells in the wood (ray parenchyma) are the site of starch storage in woody stems and roots. *See* PLANT TRANSPORT OF SOLUTES.

**Mineral nutrition.** Nutrient deficiencies are similar in trees and other plants because of the functions of these nutrients in physiological processes. Tree nutrition is unique because trees require lower concentrations, and they are able to recycle nutrients within various tissues. Trees adapt to areas which are low in nutrients by lowering physiological functions and slowing growth rates. In addition, trees allocate more carbohydrates to root production, allowing them to exploit large volumes of soil in search of limiting nutrients. Proliferation of fine roots at the organic matter-mineral soil interface where many nutrients are released from decomposing organic matter allows trees to recapture nutrients lost by leaf fall. *See* PLANT MINERAL NUTRITION; PLANT PHYSIOLOGY; TREE. [J.D.Jo.]

**Trematoda** A loose grouping of acoelomate, parasitic flatworms of the phylum Platyhelminthes formerly accorded class rank and containing the subclasses (or orders) Digenea, Monogenea, and Aspidobothria. These organisms commonly occur as adults in or on all vertebrate groups. They exhibit cephalization, bilateral symmetry, and well-developed anterior and ventral, or anterior and posterior, holdfast structures. The mouth is anterior, and usually a blind, forked gut occurs, as well as three muscle layers. The excretory system consists of flame cells and collecting tubules. These animals are predominantly hermaphroditic and oviparous with operculated egg capsules. The life histories

of the Digenea are complex, while those of the Monogenea and Aspidobothria are simple.

Trematodes parasitize a wide variety of invertebrates and vertebrates and occupy almost every available niche within these hosts. The adaptations demanded of the worms for survival are as varied as the characteristics of the microhabitats. Over the millions of years of coevolution of the hosts and their parasites, delicate balances have, for the most part, been attained, and under normal conditions it is probable that trematodes rarely demand more than the host can supply without undue strain. It seems axiomatic that the host must survive until the parasite can again gain access to another host or until the life cycle is completed. Those parasites which cause the least disruption of the host's activities are probably the oldest as well as the most successful. Immunities are sometimes developed by the hosts. Many trematodes seem to possess such rigid requirements and such responses to particular hosts that host specificity is a phenomenon of considerable significance. Monogeneids appear more host-specific than digeneids, and aspidobothreids seem less specific than both. Trematodes are of considerable veterinary and medical importance because under certain conditions they cause debility, even death. See ASPIDOGASTREA; DIGENEA; MONOGENEA; PLATYHELMINTHES. [W.J.Ha.]

**Tremolite** The name given to magnesium-rich monoclinic calcium amphibole  $\text{Ca}_2\text{Mg}_5\text{Si}_8\text{O}_{22}(\text{OH})_2$ . The mineral is white to gray, but colorless in thin section. Unlike other end-member compositions of the calcium amphibole group, very pure tremolite is found in nature. Substitution of Fe for Mg is common, but pure ferrotremolite,  $\text{Ca}_2\text{Fe}_3\text{Si}_8\text{O}_{22}(\text{OH})_2$  is rare. Intermediate compositions between tremolite and ferrotremolite are referred to as actinolites, and are green in color and encompass a large number of naturally occurring calcium amphiboles. See AMPHIBOLE. [B.L.D.]

**Trepostomata** An extinct order of bryozoans in the class Stenolaemata. Trepostomes possess generally robust colonies, composed of tightly packed, moderately complex, long, slender, tubular or prismatic zooecia, with solid calcareous zooecial walls. Colonies show a moderately gradual transition from endozone to exozone regions, and they are exclusively free-walled. Trepostome colonies range from small and delicate to large and massive; they can be thin to thick encrusting sheets; tabular, nodular, hemispherical, or globular masses; or bushlike or frondlike erect growths.

Apparently exclusively marine, the trepostomes first appeared about the start of the Middle Ordovician; they apparently share a common ancestor with cystoporates. They remained abundant through Silurian time, declined during the Devonian, and died out in the Late Triassic. See BRYOZOA; CYSTOPORATA; STENOLAE-MATA. [R.J.Cu.; FK.McK.]

**Trestle** A succession of towers of steel, timber, or reinforced concrete supporting the horizontal beams of a roadway, bridge, or other structure. Little distinction can be made between a trestle and a viaduct, and the terms are used interchangeably by many engineers. A viaduct is defined as a long bridge consisting of a series of short concrete or masonry spans supported on piers or towers, and is used to carry a road or railroad over a valley, a gorge, another roadway, or across an arm of the sea. See BRIDGE.

A trestle or a viaduct usually consists of alternate tower spans and spans between towers. For low trestles the spans may be supported on bents, each composed of two columns adequately braced in a transverse direction. A pair of bents braced longitudinally forms a tower. See TOWER. [C.M.A.]

**Triassic** The oldest period of the Mesozoic Era. The Triassic encompasses a time frame between about 248 and 213 million years ago (m.y.a.) that was named for the threefold division of

rocks at its type locality in central Germany, where continental redbeds and evaporites are separated by a marine limestone. See MESOZOIC.

The Triassic Period uniquely embraces both the final consolidation of Pangaea and the initial breakup of the landmass, which in the Middle Jurassic led to the origin of the Central Atlantic ocean basin. The Triassic thus marks the beginning of a new cycle of ocean-basin opening, through continental extension, and oceanic closing through subducting oceanic lithospheres along continental margins. See LITHOSPHERE; PALEO GEOGRAPHY; PLATE TECTONICS.

The most important tectonic event in the Mesozoic Era was the rifting of the Pangaea craton, which began in the Late Triassic, culminating in the Middle Jurassic with the formation of the Central Atlantic ocean basin. Rifting began in the Tethys region in the Early Triassic, and progressed from western Europe and the Mediterranean into the Central Atlantic off Morocco and eastern North America by the Late Triassic. As crustal extension continued throughout the Triassic, the Tethys seaway spread farther westward and inland. By that time, rifting and sea-floor spreading extended into the Gulf of Mexico, separating North and South America.

Continental rift basins, passive continental margins, and ocean basins form in response to divergent stresses that extend the crust. Crustal extension, as it pertains to the Atlantic, embraces a major tectonic cycle marked by Late Triassic–Early Jurassic rifting and Middle Jurassic to Recent (Holocene) drifting. The rift stage, involving heating and stretching of the crust, was accompanied by uplift, faulting, basaltic igneous activity, and rapid filling of deep elongate rift basins. The drift stage, involving the slow cooling of the lithosphere over a broad region, was accompanied by thermal subsidence with concomitant marine transgression of the newly formed plate margin. The transition from rifting to drifting, accompanied by sea-floor spreading, is recorded by the postrift unconformity. See CONTINENTAL DRIFT; CONTINENTAL MARGIN; HOLOCENE; UNCONFORMITY.

Permian-to-Triassic consolidation of Pangaea in western North America led to the Sonoma orogeny (mountain building), which resulted from overthrusting and suturing of successive island-arc and microcontinent terranes to the western edge of the North American Plate. However, toward the end of the Triassic Period, as crustal extension was occurring in the Central Atlantic region, the plate moved westward, overriding the Pacific Plate along a reversed subduction zone. This created for the remainder of the Mesozoic Era an Andean-type plate edge with a subducting sea floor and associated deep-sea trench and magmatic arc. These effects can be studied in the Cordilleran mountain belt. See CORDILLERAN BELT; OROGENY.

As these epicontinental seas regressed westward, nonmarine fluvial, lacustrine, and windblown sands were deposited on the craton. Today many of these red, purple, ash-gray, and chocolate-colored beds are some of the most spectacular and colorful scenery in the American West. For example, the Painted Desert of Arizona, which is known for its petrified logs of conifer trees, was developed in the Chinle Formation. See CRATON; PETRIFIED FORESTS.

Triassic faunas are distinguished from earlier ones by newly evolved groups of plants and animals. In marine communities, molluscan stocks proliferated vigorously. Bivalves diversified greatly and took over most of the niches previously occupied by brachiopods; ammonites proliferated rapidly from a few Permian survivors. The scleractinian (modern) corals appeared, as did the shell-crushing placodont reptiles and the ichthyosaurs. In continental faunas, various groups of reptiles appeared, including crocodiles and crocodilelike forms, the mammal-like reptiles, and the first true mammals, as well as dinosaurs. See CEPHALOPODA; CROCODYLIA; DINOSAUR; MAMMALIA; MOLLUSCA; PLACODONTIA; SCLERACTINIA.

Triassic land plants contain survivors of many Paleozoic stocks, but the gymnosperms became dominant and cycads appeared. See CYCADEOIDALES; PALEOZOIC; PINOPHYTA. [W.Man.]

**Tribology** The science and technology of interactive surfaces in relative motion. It incorporates various scientific and technological disciplines such as surface chemistry, fluid mechanics, materials, lubricants, contact mechanics, bearings, and lubrication systems. It is customarily divided into three branches: friction, lubrication, and wear.

**Friction.** This phenomenon is encountered whenever there is relative motion between contacting surfaces, and it always opposes the motion. As no mechanically prepared surfaces are perfectly smooth, when the surfaces are first brought into contact under light load, they touch only along the asperities (real area of contact). The early theories attributed friction to the interlocking of asperities; however, it is now understood that the phenomenon is far more complicated. See FRICTION.

**Lubrication.** When clean surfaces are brought into contact, their coefficient of friction decreases drastically if even a single molecular layer of a foreign substance (for example, an oxide) is introduced between the surfaces. For thicker lubricant films, the coefficient of friction can be quite small and no longer dependent on the properties of the surfaces but only on the bulk properties of the lubricant. Most common lubricants are liquids and gases, but solids such as molybdenum disulfide or graphite may be used. See LUBRICATION.

**Wear.** This is the progressive loss of substance of one body because of rubbing by another body. There are many different types of wear, including sliding wear, abrasive wear, corrosion, and surface fatigue. See WEAR. [A.Z.S.]

**Trichomycetes** A polyphyletic class of Eumycota in the subdivision Zygomycotina, containing the orders Amoebidiales, Asellariales, Eccrinales, and Harpellales. These orders are grouped together because they usually exist only as commensals in the mid- and hindgut of arthropods (*Amoebidium parasiticum* can be found on the outside of its hosts).

Asexual reproduction is accomplished by the formation of trichospores (Harpellales), arthrospores (Asellariales), sporiospores (Eccrinales), or amoeboid cells, cystospores, or rigid-walled spores (Amoebidiales). Sexual reproduction (zygospore formation) is known only in Harpellales, although conjugations have been observed in Asellariales. The thallus of Amoebidiales is aseptate, but is regularly septate in the other three orders; septa with plugs in the lenticular cavities are produced by Asellariales and Harpellales. Similar septa and plugs are formed by Dimargaritales and Kickxellales (Zygomycetes). Classification is based on the type of reproduction; thallus branching pattern, complexity, and septation; and nature of the holdfast. Trichomycetes occur worldwide and may be found anywhere a suitable host exists; they inhabit a more or less aquatic environment (the gut); and the spores are discharged with feces. See EUMYCOTA; FUNGI; ZYGOMYCETES; ZYGOMYCOTINA. [G.L.Be.]

**Trichoptera** An aquatic order of the class Insecta commonly known as the caddis flies. The adults have two pairs of well-veined hairy wings, long antennae, and mouthparts capable of lapping only liquids. The larvae are wormlike, with distinct heads, three pairs of legs on the thorax, and a pair of hook-bearing legs at the end of the body. The pupae are delicate, with free appendages held close to the body, and have a pair of sharp mandibles, or jaws, which are used to cut an exit from the cocoon.

The Trichoptera include about 10,000 described species, divided into 34 families, and occur in practically all parts of the world. Except for a brackish-water species in New Zealand and a few moss-inhabiting species in Europe and North America, caddis flies occur only in fresh water. They abound in cold or running water relatively free from pollution. Altogether they compose a large and important segment of the biota of such habitats and of the fish feed economy. See INSECTA. [H.H.R.]

**Trichostomatida** An order of the Holotrichia, composed of a small group of ciliates whose species show some advance in structural complexity over the gymnostomes. No true buccal ciliature is present, but a vestibulum, a passageway leading from the outside of the body into the cytostome or true cell-mouth, is characteristically present. These animals exist in a wide range of habitats. A few forms live in cattle, sheep, and horses, but cause no harm to these hosts. *Balantidium* is of some medical significance as it contains the sole ciliated protozoan species parasitic in humans. *Balantidium coli* lives in the large intestine and is the causative agent of the fairly uncommon disease balantidiasis. See BALANTIDIASIS; HOLOTRICHIA. [J.O.C.]

**Trichroism** When certain optically anisotropic transparent crystals are subjected to white light, a cube of the material is found to transmit a different color through each of the three pairs of parallel faces. Such crystals are sometimes termed trichroic, and the phenomenon is called trichroism. This expression is used only rarely today since the colors in a particular crystal can appear quite different if the cube is cut with a different orientation with respect to the crystal axes. Accordingly, the term is frequently replaced by the more general term pleochroism. Even this term is being replaced by the phrase linear dichroism or circular dichroism to correspond with linear birefringence or circular birefringence. See BIREFRINGENCE; CRYSTAL OPTICS; DICHROISM; PLEOCHROISM. [B.H.Bi.]

**Tricladida** An order of the Turbellaria known commonly as planaria. They have a diverticulated intestine with a single anterior branch and two posterior branches separated by the plicate pharynx or pharynges. Rhabdites are numerous and, except in cave planarians, two to many eyes are present. See PLANARIA; TURBELLARIA. [E.R.J.]

**Triconodonta** Extinct mammals that are members of many latest Triassic, Jurassic, and Cretaceous faunas in the Northern Hemisphere. Their records in the Southern Hemisphere include a species of earliest Jurassic age from Africa and questionably referable specimens from the Middle Jurassic of Africa and Late Cretaceous of South America. In all triconodontans the dentary and squamosal bones formed at least part of the articulation of the jaw to the skull (the temporomandibular joint). In some, among the most primitive species referred to the Mammalia, the articular, quadratojugal, and quadrate also participated in this articulation. See CRETACEOUS; JURASSIC; TRIASSIC.

Many modern classifications limit the contents of Triconodonta to the family Triconodontidae and establish new groupings for other, closely related families. This reflects an emerging, poorly understood picture of complex evolutionary interrelationships among the earliest mammals and advanced therapsids, members of the group commonly but inappropriately named the mammallike reptiles. See ANIMAL EVOLUTION; THERAPSIDA.

Triconodontids, the central family of the Triconodonta, were relatively large (lower jaw about the size of that of a mink, *Mustella vison*) common members of European and North American, Late Jurassic mammalian faunas. Their temporomandibular joint was formed entirely by the dentary and squamosal.

Occurrence of a specialized mode of occlusion of the molars of triconodontids and *Dinnetherium*, from the earliest Jurassic of North America, suggests the latter is a very primitive relative of the triconodontids that had not lost the quadrate and articular from its temporomandibular joint. Another primitive group characterized by a complex temporomandibular joint, the morganucodontids, also might be primitive relatives of the triconodontids. The amphilestids (Middle and Late Jurassic, North American and Europe) and gobiconodontids (Middle Jurassic and Early Cretaceous, North America and Asia) were



triconodontanlike mammals. Members of both families had temporomandibular joints formed exclusively by the dentary and squamosal. *Sinoconodon* (Early Jurassic, Asia), another primitive triconodontanlike mammal about the size of contemporaneous morganucodontids, had a complex temporomandibular joint. See DOCODONTA; MAMMALIA. [W.A.C.]

**Trigger circuit** An electronic circuit that generates or modifies an existing waveform to produce a pulse of short time duration with a fast-rising leading edge. This waveform, or trigger, is normally used to initiate a change of state of some relaxation device, such as a multivibrator. The most important characteristic of the waveform generated by a trigger circuit is usually the fast leading edge. The exact shape of the falling portion of the waveform often is of secondary importance, although it is important that the total duration time is not too great. A pulse generator such as a blocking oscillator may also be used and identified as a trigger circuit if it generates sufficiently short pulses. See BLOCKING OSCILLATOR; PULSE GENERATOR.

Peaking circuits, which accent the higher-frequency components of a pulse waveform, cause sharp leading and trailing edges and are therefore used as trigger circuits. The simplest form of peaking circuits are the simple  $RC$  and  $RL$  networks shown in the illustration. If a steep wavefront of amplitude  $V$  is applied to

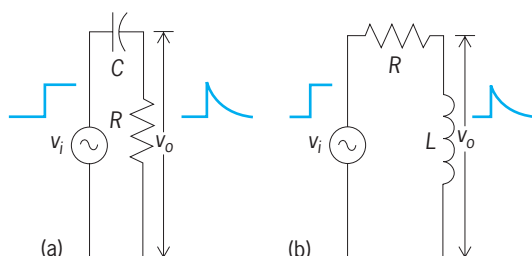

Diagrams of simple peaking circuits. (a) Resistance-capacitance network. (b) Resistance-inductance network.  $v_i$  = input voltage;  $v_o$  = output voltage.

either of these circuits, the output will be a sudden rise followed by an exponential decay. These circuits are often called differentiating circuits because the outputs are rough approximations of the derivative of the input waveforms, if the  $RC$  or  $R/L$  time constant is sufficiently small.

A circuit that is highly underdamped, or oscillatory, and is supplied with a step or pulse input is often referred to as a ringing circuit. When used in the output of a field-effect or bipolar transistor, this circuit can be used as a trigger circuit. See WAVE-SHAPING CIRCUITS. [G.M.G.]

**Triglyceride** A simple lipid. Triglycerides are fatty acid triesters of the trihydroxy alcohol glycerol which are present in plant and animal tissues, particularly in the food storage depots, either as simple esters in which all the fatty acids are the same or as mixed esters in which the fatty acids are different. The triglycerides constitute the main component of natural fats and oils.

The generic formula of a triglyceride is shown below, where

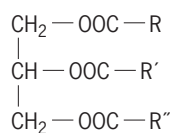

$\text{RCO}_2\text{H}$ ,  $\text{R}'\text{CO}_2\text{H}$ , and  $\text{R}''\text{CO}_2\text{H}$  represent molecules of either the same or different fatty acids, such as butyric or caproic (short chain), palmitic or stearic (long chain), oleic, linoleic, or linolenic (unsaturated). Saponification with alkali releases glycerol and the alkali metal salts of the fatty acids (soaps). The triglycerides in the food storage depots represent a concentrated energy source,

since oxidation provides more energy than an equivalent weight of protein or carbohydrate. See LIPID METABOLISM; SOAP.

The physical and chemical properties of fats and oils depend on the nature of the fatty acids present. Saturated fatty acids give higher-melting fats and represent the main constituents of solid fats, for example, lard and butter. Unsaturation lowers the melting point of fatty acids and fats. Thus, in the oil of plants, unsaturated fatty acids are present in large amounts, for example, oleic acid in olive oil and linoleic and linolenic acids in linseed oil. See FAT AND OIL (FOOD); LIPID. [R.H.G.; H.E.Ca.]

**Trigonometry** The study of triangles and the trigonometric functions. Trigonometry has evolved from use by surveyors, engineers, and navigators to applications involving ocean tides, the rise and fall of food supplies in certain ecologies, brain-wave patterns, the analysis of alternating-current electricity, and many other phenomena of a vibratory character.

**Plane trigonometry.** Plane trigonometry mostly deals with the relationships among the three sides and three angles of a triangle that lies in a plane.

A ray is that portion of a line that starts at a point on the line and extends indefinitely in one direction. The starting point of a ray is called its vertex. If two rays are drawn with a common vertex, they form an angle. One of the rays of an angle is called the initial side, and the other ray is the terminal side. The angle that is formed is identified by showing the direction and amount of rotation from the initial side to the terminal side. If the rotation is in the counterclockwise direction, the angle is positive; if the rotation is clockwise, the angle is negative.

The angle formed by rotating the initial side exactly once in the counterclockwise direction until it coincides with itself (1 revolution) is said to measure 360 degrees, written  $360^\circ$ . Thus, one degree,  $1^\circ$ , is  $1/360$  of a revolution. One-sixtieth of a degree is called a minute, written  $1'$ .

By using a circle of radius  $r$ , an angle can be constructed whose vertex is at the center of this circle and whose rays subtend an arc on the circle whose length equals  $r$ . Such an angle measures 1 radian. For a circle of radius  $r$ , a central angle of  $\theta$  radians subtends an arc whose length  $s$  is given by Eq. (1):

$$s = r\theta \quad (1)$$

Because a central angle of 1 revolution ( $360^\circ$ ) subtends an arc equal to the circumference of the circle ( $2\pi r$ ), it follows that an angle of 1 revolution equals  $2\pi$  radians; that is,  $2\pi$  radians =  $360^\circ$ . See PLANE GEOMETRY; RADIAN MEASURE.

**Trigonometric functions.** A unit circle is a circle whose radius is one and whose center is at the origin of a rectangular system of coordinates. For the unit circle, Eq. (1) states that a central angle of  $\theta$  radians subtends an arc whose length  $s = \theta$ . If  $t$  is any real number, let  $\theta$  be the angle equal to  $t$  radians and  $P$  be the point on the unit circle that is also on the terminal side of  $\theta$ . If  $t \geq 0$ , then the point  $P$  is reached by moving counterclockwise along the unit circle, starting at the point with coordinates  $(1,0)$ , for a length of arc equal to  $t$  units (Fig. 1a). If  $t < 0$ , this point  $P$  is reached by moving clockwise along the unit circle beginning at  $(1,0)$ , for a length of arc equal to  $|t|$  units (Fig. 1b). Thus, to each real number  $t$  there corresponds a unique point  $P = (a,b)$  on the unit circle. The coordinates of this point  $P$  are used to define the six trigonometric functions: If  $\theta = t$  radians, the sine, cosine, tangent, cosecant, secant, and cotangent of  $\theta$ , respectively abbreviated as  $\sin \theta$ ,  $\cos \theta$ ,  $\tan \theta$ ,  $\csc \theta$ ,  $\sec \theta$ ,  $\cot \theta$ , are given by Eqs. (2), (3), and (4).

$$\sin \theta = b \quad \cos \theta = a \quad (2)$$

$$\text{if } a \neq 0, \quad \tan \theta = b/a, \quad \sec \theta = 1/a \quad (3)$$

$$\text{if } b \neq 0, \quad \cot \theta = a/b, \quad \csc \theta = 1/b \quad (4)$$

See COORDINATE SYSTEMS.

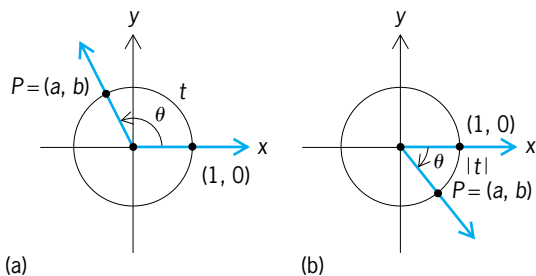

Fig. 1. Point  $P$  on the unit circle corresponding to  $\theta = t$  radians. (a)  $t \geq 0$ : length of arc from  $(1,0)$  to  $P$  is  $t$  units. (b)  $t < 0$ : length of arc from  $(1,0)$  to  $P$  is  $|t|$  units.

For example, for  $\theta = 0$ , the point  $(1,0)$  is on the terminal side of  $\theta$  and is on the unit circle so that Eqs. (5) hold, with  $\csc 0$  and

$$\sin 0 = 0 \quad \cos 0 = 1 \quad \tan 0 = 0 \quad \sec 0 = 1 \quad (5)$$

$\cot 0$  not defined. The trigonometric functions of angles that are integral multiples of  $\pi/2$  ( $90^\circ$ ) are found similarly (Table 1).

Table 1. Values of trigonometric functions at integral multiples of  $\pi/4$  ( $90^\circ$ )

$\theta$ , radians	$\theta$	$\sin \theta$	$\cos \theta$	$\tan \theta$	$\csc \theta$	$\sec \theta$	$\cot \theta$
0	$0^\circ$	0	1	0	n.d.	1	n.d.
$\pi/2$	$90^\circ$	1	0	n.d.	1	n.d.	0
$\pi$	$180^\circ$	0	-1	0	n.d.	-1	n.d.
$3\pi/2$	$270^\circ$	-1	0	n.d.	-1	n.d.	0

\*n.d. = not defined.

The coordinates of points on the unit circle that are on the terminal sides of angles that are integral multiples of  $\pi/6$  ( $30^\circ$ ),  $\pi/4$  ( $45^\circ$ ), and  $\pi/3$  ( $60^\circ$ ) can be found. With Eqs. (2), (3), and (4), the trigonometric functions of these angles are obtained (Table 2).

**Properties of trigonometric functions.** Based on Eqs. (2) and the above geometric construction (Fig. 1) for  $\sin \theta$  and  $\cos \theta$ ,  $\theta$  can be any angle, so the domain of the sine and cosine functions is all real numbers. In Eqs. (3), if  $a = 0$ , the tangent and secant functions are not defined, so the domain of these functions is all real numbers, except odd multiples of  $\pi/2$  ( $90^\circ$ ). In Eqs. (4), if  $b = 0$ , the cotangent and cosecant functions are not defined, so the domain of these functions is all real numbers, except multiples of  $\pi$  ( $180^\circ$ ). Also, since  $|a| \leq 1$  and  $|b| \leq 1$ , the range of the sine and cosine functions is  $-1$  to  $1$  inclusive. Since  $|b| = |\sin \theta| \leq 1$  and  $|a| = |\cos \theta| \leq 1$ , it follows that  $|\csc \theta| = 1/|b| \geq 1$  and  $|\sec \theta| = 1/|a| \geq 1$ . Thus the range of the secant and cosecant functions consists of all real numbers less than or

Table 2. Values of trigonometric functions at integral multiples of  $\pi/6$  ( $30^\circ$ ),  $\pi/4$  ( $45^\circ$ ), and  $\pi/3$  ( $60^\circ$ )

$\theta$ , radians	$\theta$	$\sin \theta$	$\cos \theta$	$\tan \theta$	$\csc \theta$	$\sec \theta$	$\cot \theta$
$\pi/6$	$30^\circ$	$1/2$	$\sqrt{3}/2$	$\sqrt{3}/3$	2	$2\sqrt{3}/3$	$\sqrt{3}$
$\pi/4$	$45^\circ$	$\sqrt{2}/2$	$\sqrt{2}/2$	1	$\sqrt{2}$	$\sqrt{2}$	1
$\pi/3$	$60^\circ$	$\sqrt{3}/2$	$1/2$	$\sqrt{3}$	$2\sqrt{3}/3$	2	$\sqrt{3}/3$
$2\pi/3$	$120^\circ$	$\sqrt{3}/2$	$-1/2$	$-\sqrt{3}$	$2\sqrt{3}/3$	-2	$-\sqrt{3}/3$
$3\pi/4$	$135^\circ$	$\sqrt{2}/2$	$-\sqrt{2}/2$	-1	$\sqrt{2}$	$-\sqrt{2}$	-1
$5\pi/6$	$150^\circ$	$1/2$	$-\sqrt{3}/2$	$1-\sqrt{3}/3$	2	$-2\sqrt{3}/3$	$-\sqrt{3}$
$7\pi/6$	$210^\circ$	$-1/2$	$-\sqrt{3}/2$	$\sqrt{3}/3$	-2	$-2\sqrt{3}/3$	$\sqrt{3}$
$5\pi/4$	$225^\circ$	$-\sqrt{2}/2$	$-\sqrt{2}/2$	1	$-\sqrt{2}$	$-\sqrt{2}$	1
$4\pi/3$	$240^\circ$	$-\sqrt{3}/2$	$-1/2$	$\sqrt{3}$	$-2\sqrt{3}/3$	-2	$\sqrt{3}/3$
$5\pi/3$	$300^\circ$	$-\sqrt{3}/2$	$1/2$	$-\sqrt{3}$	$-2\sqrt{3}/3$	2	$-\sqrt{3}/3$
$7\pi/4$	$315^\circ$	$-\sqrt{2}/2$	$\sqrt{2}/2$	-1	$-\sqrt{2}$	$\sqrt{2}$	-1
$11\pi/6$	$330^\circ$	$-1/2$	$\sqrt{3}/2$	$-\sqrt{3}/3$	-2	$2\sqrt{3}/3$	$-\sqrt{3}$

equal to  $-1$  or greater than or equal to  $1$ . The range of both the tangent and cotangent functions consists of all real numbers.

Equations (2), (3), and (4) also reveal the reciprocal identities, given in Eqs. (6). Two other useful identities, given in Eqs. (7), also follow.

$$\csc \theta = 1/\sin \theta \quad \sec \theta = 1/\cos \theta \quad \cot \theta = 1/\tan \theta \quad (6)$$

$$\tan \theta = \sin \theta / \cos \theta \quad \cot \theta = \cos \theta / \sin \theta \quad (7)$$

Since  $(a,b)$  is on the unit circle,  $a^2 + b^2 = 1$ , and so  $(\sin \theta)^2 + (\cos \theta)^2 = 1$ . This is called a pythagorean identity and is written as Eq. (8).

$$\sin^2 \theta + \cos^2 \theta = 1 \quad (8)$$

**Sum and difference formulas.** The sum and difference formulas for the cosine function are given in Eqs. (9) and (10), and for the sine function they are given in Eqs. (11) and (12).

$$\cos(\alpha + \beta) = \cos \alpha \cos \beta - \sin \alpha \sin \beta \quad (9)$$

$$\cos(\alpha - \beta) = \cos \alpha \cos \beta + \sin \alpha \sin \beta \quad (10)$$

$$\sin(\alpha + \beta) = \sin \alpha \cos \beta + \cos \alpha \sin \beta \quad (11)$$

$$\sin(\alpha - \beta) = \sin \alpha \cos \beta - \cos \alpha \sin \beta \quad (12)$$

**Inverse trigonometric functions.** In the equation  $x = \sin y$ , if  $y$  is restricted so that  $-\pi/2 \leq y \leq \pi/2$ , then the solution of the equation for  $y$  is unique and is denoted by  $y = \sin^{-1}x$  (read “ $y$  is the inverse sine of  $x$ ”). Sometimes  $y = \sin^{-1}x$  is written as  $y = \text{Arcsin } x$ . Thus,  $y = \sin^{-1}x$  is a function whose domain is  $-1 \leq x \leq 1$  and whose range is  $-\pi/2 \leq y \leq \pi/2$ . For example,  $\sin^{-1} 1/2 = \pi/6$  and  $\sin^{-1}(-1) = -\pi/2$ .

Likewise in the equation  $x = \cos y$ , if  $y$  is restricted so that  $0 \leq y \leq \pi$ , then the solution of the equation for  $y$  is unique and is denoted by  $y = \cos^{-1}x$  (read “ $y$  is the inverse cosine of  $x$ ”). Thus,  $y = \cos^{-1}x$  is a function whose domain is  $-1 \leq x \leq 1$  and whose range is  $0 \leq y \leq \pi$ . Finally, in the equation  $x = \tan y$ , if  $y$  is restricted so that  $-\pi/2 < y < \pi/2$ , then the solution of the equation for  $y$  is unique and is denoted by  $y = \tan^{-1}x$  (read “ $y$  is the inverse tangent of  $x$ ”). Thus,  $y = \tan^{-1}x$  is a function whose domain is  $-\infty < x < \infty$  and whose range is  $-\pi/2 < y < \pi/2$ .

**Solution of right triangles.** The trigonometric functions can be expressed as ratios of the sides of a right triangle. Indeed, by Eqs. (6), (7), and (8), it follows that  $\sin \beta = b/c$ ,  $\cos \beta = a/c$ ,  $\tan \beta = b/a$ , and so on, where  $a$  and  $b$  are the sides adjacent to the right angle,  $c$  is the hypotenuse, and  $\alpha$  and  $\beta$  are the angles opposite  $a$  and  $b$  respectively (Fig. 2). If an angle and a side or else two sides of a right triangle are known, then the remaining angles and sides can be found.

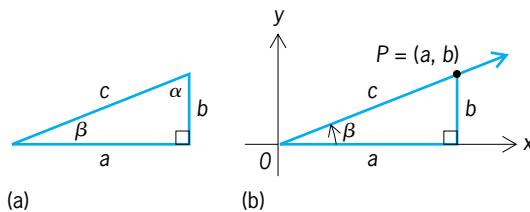
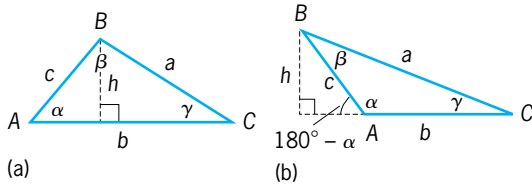

Fig. 2. Right triangle. (a) Labeling of sides and angles. (b) Relationship of sides to coordinates defining trigonometric functions.

**Solution of oblique triangles.** If none of the angles of a right triangle is a right angle, the triangle is oblique. To solve such triangles, there are four possibilities to consider: (1) one side and two angles are given; (2) two sides and the angle opposite one of them are given; (3) two sides and the included angle are given; and (4) three sides are given. In the following discussion, the sides are labeled  $a$ ,  $b$ , and  $c$ ; the angles opposite these sides are  $\alpha$ ,  $\beta$ , and  $\gamma$  respectively; and the corresponding vertices are  $A$ ,  $B$ , and  $C$  (Fig. 3).



**Fig. 3. Labeling of sides, angles, and vertices of oblique triangle, with altitude  $h$  used in proving the law of sines. (a) Angle  $\alpha$  is acute. (b) Angle  $\alpha$  is obtuse.**

The law of sines, Eq. (13), is used to solve possibilities (1) and

$$\frac{\sin \alpha}{a} = \frac{\sin \beta}{b} = \frac{\sin \gamma}{c} \quad (13)$$

(2). The law of cosines, used to solve possibilities (3) or (4), may be stated by three equivalent formulas, Eqs. (14), (15), and (16).

$$c^2 = a^2 + b^2 - 2ab \cos \gamma \quad (14)$$

$$b^2 = a^2 + c^2 - 2ac \cos \beta \quad (15)$$

$$a^2 = b^2 + c^2 - 2bc \cos \alpha \quad (16)$$

**Infinite series representation.** With the definition  $n! = 1 \cdot 2 \cdot 3 \cdots n$ , the sine and cosine functions may be represented by the two infinite series, given in Eqs. (17) and (18). These series converge for all  $x$ . Thus, to find a value of  $\sin x$

$$\sin x = \sum_{k=0}^{\infty} (-1)^k \frac{x^{2k+1}}{(2k+1)!} = x - \frac{x^3}{3!} + \frac{x^5}{5!} - \cdots \quad (17)$$

$$\cos x = \sum_{k=0}^{\infty} (-1)^k \frac{x^{2k}}{(2k)!} = 1 - \frac{x^2}{2!} + \frac{x^4}{4!} - \cdots \quad (18)$$

or  $\cos x$ , only as many terms of the series need to be used, as required to ensure required accuracy. [M.Su.]

**Trihedron** A geometric figure bounded by three non-coplanar rays called edges that emanate from a common point called the vertex, and by the plane sectors called faces that are formed by each pair of edges (see illustration). A trihedron has

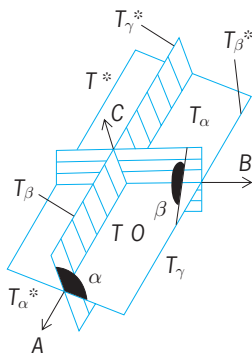

**Trihedron and trihedral angles.** Three planes having a common point  $O$  cut space into eight trihedrons,  $T$ ,  $T^*$ ,  $T_{\alpha}$ ,  $T_{\alpha}^*$ ,  $T_{\beta}$ ,  $T_{\beta}^*$ ,  $T_{\gamma}$ , and  $T_{\gamma}^*$ .  $A$ ,  $B$ , and  $C$  are directions of common edges of pairs of planes;  $\alpha$ ,  $\beta$ , and  $\gamma$  are face angles.

three dihedral angles formed by pairs of face planes, and three face angles formed by pairs of edges. [J.S.F.]

**Trilobita** A class of extinct Paleozoic arthropods, occurring in marine rocks of Early Cambrian through late Permian age.

Their closest living relatives are the chelicerates, including spiders, mites, and horseshoe crabs (Xiphosura). About 3000 described genera make trilobites one of the most diverse and best-known fossil groups. Species diversity peaked during the Late Cambrian then declined more or less steadily until the Late Devonian mass extinction. Only four families survived to the Mississippian, and only one lasted until the group's Permian demise. Their dominance in most Cambrian marine settings is essential to biostratigraphic correlation of that system. See ARTHROPODA; CAMBRIAN; CHELICERATA; DEVONIAN; INDEX FOSSIL; PERMIAN.

Trilobites are typically represented in the fossil record by the mineralized portion of their exoskeleton, either as carcass or molt remains. The mineralized exoskeleton was confined mostly to the dorsal surface (see illustration) curved under as a rimlike



**Griffithides, Mississippian (Indiana). Dorsal view of exoskeleton.**

doubleure, a single mineralized ventral plate, the hypostome, was suspended beneath the median region of the head. The mineralized exoskeleton was composed of low magnesian calcite and a minor component of organic material. Most of the ventral exoskeleton, including the appendages, was unmineralized.

Most trilobites were benthic deposit feeders or scavengers, living on the sediment-water interface or shallow-burrowing just beneath it. Some were evidently carnivores, equipped with sharp spines and processes projecting ventrally from their appendages. The morphology and broad geographic and environmental ranges of these groups suggest they were active swimmers. Through their history, trilobites became adapted to all marine environments, from shallow high-energy shorefaces to deep-water, disaerobic habitats. [G.D.E.; J.Ad.]

**Trimerophytosida** Mid-Early-Devonian into Middle-Devonian vascular plants at a higher evolutionary level than Rhyniopsida. Branching was profuse and varied, dichotomous, pseudomonopodial, helical to subopposite and almost whorled, and often trifurcate. Vegetative branches were often in a tight helix, terminated by tiny recurved branchlets simulating leaf precursors. The axes were leafless and glabrous or spiny. Xylem is known only in *Psilophyton*. See EMBRYOBIONTA; RHYNIOPSIDA. [H.P.B.]

**Triple point** A particular temperature and pressure at which three different phases of one substance can coexist in equilibrium. In common usage these three phases are normally solid, liquid, and gas, although triple points can also occur with two solid phases and one liquid phase, with two solid phases and one gas phase, or with three solid phases.

According to the Gibbs phase rule, a three-phase situation in a one-component system has no degrees of freedom (that is, it is invariant). Consequently, a triple point occurs at a unique temperature and pressure, because any change in either variable

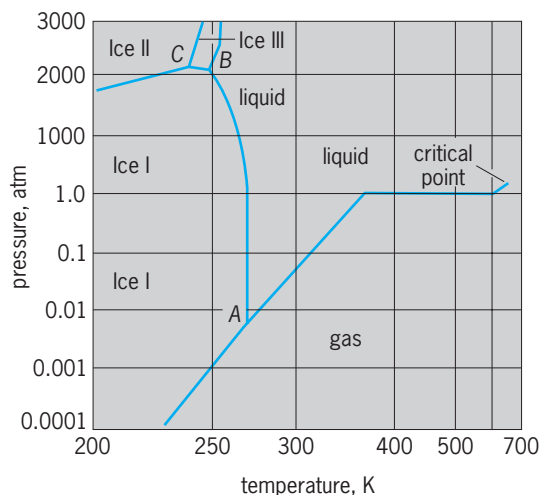

Phase diagram for water, showing gas, liquid, and several solid (ice) phases; triple points at A, B, and C. The pressure scale changes at 1 atm from logarithmic scale at low pressure to linear at high pressure. 1 atm =  $10^2$  kilopascals.

will result in the disappearance of at least one of the three phases. Triple points are shown in the illustration of part of the phase diagram for water. See PHASE EQUILIBRIUM.

For most substances the solid-liquid-vapor triple point has a pressure less than 1 atm ( $10^2$  kilopascals); such substances then have a liquid-vapor transition at 1 atm (normal boiling point). However, if this triple point has a pressure above 1 atm, the substance passes directly from solid to vapor at 1 atm. See BOILING POINT; ICE POINT; MELTING POINT; SUBLIMATION; TRANSITION POINT; VAPOR PRESSURE; WATER. [R.L.S.]

**Triplet state** An electronic state of a molecule that occurs when its total spin angular momentum quantum number  $S$  is equal to one. The triplet state is an important intermediate of organic chemistry. In addition to the wide range of triplet molecules available through photochemical excitation techniques, numerous molecules exist in stable triplet ground states, for example, oxygen molecules. See ATOMIC STRUCTURE AND SPECTRA; MOLECULAR STRUCTURE AND SPECTRA; SPIN (QUANTUM MECHANICS).

A triplet may result whenever a molecule possesses two electrons which are both orbitally unpaired and spin unpaired. Orbital unpairing of electrons results when a molecule absorbs a photon of visible or ultraviolet light. Direct formation of a triplet as a result of this photon absorption is a very improbable process since both the orbit and spin of the electron would have to change simultaneously. Thus, a singlet state is generally formed by absorption of light. However, quite often the lifetime of this singlet state is sufficiently long to allow the spin of one of the two electrons to invert, thereby producing a triplet. See MOLECULAR ORBITAL THEORY. [N.J.T.]

**Tripylida** An order of nematodes in which the cephalic cuticle is simple and not duplicated; there is no helmet. The body cuticle is smooth or sometimes superficially annulated. Cephalic sensilla follow the typical pattern in which one whorl is circumoral and the second whorl is often the combination of circlets two and three. The pouchlike amphids have apertures that are inconspicuous or transversally oval. The stoma is variable, being simple, collapsed, funnel shaped or cylindrical, and armed or unarmed. In most taxa the stoma is surrounded by esophageal tissue; that is, it is entirely esophastome. When the stoma is expanded, both the cheilostome and esophastome are evident. Esophagi are cylindrical-conoid. Esophageal glands open anterior to the nerve ring. Males generally have three supplementary

organs, more in some taxa. A gubernaculum accompanies the spicules. Caudal glands are generally present.

The two tripylid superfamilies are the Tripyloidea and Ironoidea. The characteristically well-developed cuticular annulation of the Tripyloidea is only rarely seen in other Enopliida. These nematodes are commonly found in fresh water or very moist soils; however, some are found in brackish water and marine habitats. Intestinal contents indicate that their food consists primarily of small microfauna that often include nematodes and rotifers. The Ironoidea contain species (presumably carnivorous) occurring in both fresh-water and soil habitats. See NEMATODA. [A.R.M.]

**Triterpene** A hydrocarbon or its oxygenated analog containing 30 carbon atoms and composed of six isoprene units. Triterpenes form the largest group of terpenoids, but are classified into only a few major categories. Resins and saps contain triterpenes in the free state as well as in the form of esters and glycosides.

Biogenetically triterpenes arise by the cyclization of squalene and subsequent skeletal rearrangements. Apart from the linear squalene itself and some bicyclic, highly substituted skeletons, most triterpenes are either tetracyclic or pentacyclic compounds. The various structural classes are designated by the names of representative members. See ISOPRENE; TERPENE. [T.Hu.]

**Triticale** A cereal grass plant ( $\times$  *Triticosecale*) obtained from hybridization of wheat (*Triticum*) with rye (*Secale cereale*). It is a crop plant with a small-seeded cereal grain that is used for human food and livestock feed. Worldwide, triticale is slowly gaining importance as a cereal grain. The European continent dominates triticale production with 70% of the total area.

Triticale was first developed in 1876, but not until the 1960s were types developed that were suitable for cultivation. Modern varieties are called secondary triticales because they were selected after interbreeding of various triticales, including primary types. In some triticale varieties, one or more rye chromosomes have been replaced by wheat chromosomes, giving secondary-substituted triticales, as contrasted to complete triticale having all seven rye chromosomes.

Triticale is produced by deliberate hybridization of either bread wheat [*Triticum aestivum*; diploid number of chromosomes ( $2n$ ) = 42] or durum wheat (*T. turgidum* var. *durum*;  $2n$  = 28) with rye ( $2n$  = 14), followed by the doubling of the chromosome number of the hybrid plant. Hexaploid triticale (durum wheat  $\times$  rye;  $2n$  = 42) is a more successful crop plant than octoploid triticale. The octoploid form ( $2n$  = 56) is produced by hybridization of bread wheat ( $2n$  = 42) with rye ( $2n$  = 14).

Triticale is grown from seeds sown in soil by using cultivation practices similar to those of wheat or rye. Both winter-hardy and nonhardy types exist, the latter used where winters are mild or for spring sowing. Triticale tends to have a greater ability than wheat to grow in adverse environments, such as saline or acid soils or under droughty conditions.

Being a cereal grain, triticale can be used in food products made from wheat flour. Varieties tend to have large, somewhat irregularly shaped grains that produce a lower yield of milled flour than wheat. Bread and pastry products can be made very well with triticale flour. As a livestock feed, triticale grain is a good source of carbohydrate and protein.

Intense breeding and selection have made very rapid genetic improvements in triticale seed quality. The agronomic advantages and improved end-use properties of the grain of triticale over wheat make triticale an attractive option for increasing global food production. See BREEDING (PLANT); RYE; WHEAT. [C.O.Q.]

**Tritium** The heaviest isotope of the element hydrogen and the only one which is radioactive. Tritium occurs in very small amounts in nature but is generally prepared artificially by

## Properties of hydrogen and tritium

Property	H <sub>2</sub>	T <sub>2</sub>
Melting point	-259.20°C (-434.56°F)	-252.54°C (-422.57°F)
Boiling point at 1 atm (10 <sup>5</sup> pascals)	-252.77°C (-423.00°F)	-248.12°C (-414.62°F)
Heat of vaporization	216 cal/mol (904 J/mol)	333 cal/mol (1390 J/mol)
Heat of sublimation	247 cal/mol (1030 J/mol)	393 cal/mol (1640 J/mol)

processes known as nuclear transmutations. It is widely used as a tracer in chemical and biological research and is a component of the so-called thermonuclear or hydrogen bomb. It is commonly represented by the symbol  ${}^3_1\text{H}$  indicating that it has an atomic number of 1 and an atomic mass of 3, or by the special symbol T. For information about the other hydrogen isotopes see DEUTERIUM; HYDROGEN. See also TRANSMUTATION.

Both molecular tritium, T<sub>2</sub>, and its counterpart hydrogen, H<sub>2</sub>, are gases under ordinary conditions. Because of the great difference in mass, many of the properties of tritium differ substantially from those of ordinary hydrogen, as indicated in the table. Chemically, tritium behaves quite similarly to hydrogen. However, because of its larger mass, many of its reactions take place more slowly than do those of hydrogen.

The nucleus of the tritium atom, often called a triton and symbolized *t*, consists of a proton and two neutrons. It undergoes radioactive decay by emission of a  $\beta$ -particle to leave a helium nucleus of mass 3. No  $\gamma$ -rays are emitted in this process. The half-life for the decay is 12.26 years. When tritium is bombarded with deuterons of sufficient energy, a nuclear reaction known as fusion occurs and energy considerably greater than that of the bombarding particle is released. This reaction is one of those which supply the energy of the thermonuclear bomb. It is also of major importance in the development of controlled thermonuclear reactors. See HEAVY WATER; NUCLEAR FUSION; TRITON. [L.K.]

**Triton** The nucleus of  ${}^3_1\text{H}$  (tritium); it is the only known radioactive nuclide belonging to hydrogen. The triton is produced in nuclear reactors by neutron absorption in deuterium ( ${}^2_1\text{H} + {}^1_0n \rightarrow +\gamma$ ), and decays by  $\beta^-$  emission to  ${}^3_2\text{He}$  with a half-life of 12.4 years. Much of the interest in producing  ${}^3_1\text{H}$  arises from the fact that the fusion reaction  ${}^3_1\text{H} + {}^1_1\text{H} \rightarrow {}^4_2\text{He}$  releases about 20 MeV of energy. Tritons are also used as projectiles in nuclear bombardment experiments. See NUCLEAR REACTION; TRITIUM. [H.E.D.]

**Triuridales** A small order of flowering plants, division Magnoliophyta (Angiospermae), subclass Alismatidae of the class Liliopsida (monocotyledons). The order consists of 2 families, the Triuridaceae, with about 70 species, and the Petrosaviaceae, with only 2 species. They are terrestrial, mycotrophic herbs without chlorophyll, and with separate carpels, trinucleate pollen, and well-developed endosperm. They grow in moist, tropical regions, especially of the Old World, and have attracted little botanical attention. See ALISMATIDAE; LILIOPSIDA; MAGNOLIOPHYTA. [A.Cr.; T.M.Ba.]

**Trochodendrales** An order of flowering plants, division Magnoliophyta (Angiospermae), in the Eudicotyledon. The order consists of two families, the Trochodendraceae and Tetracentraceae, each with only a single species. The group is of considerable botanical and evolutionary interest, as it is situated near the base of the advanced Eudicotyledon and links this larger group with more primitive flowering plants. Trochodendrales comprise trees of eastern and southeastern Asia with primitive (without vessels) wood. The flowers have a much reduced perianth with scarcely sealed carpels that are only slightly fused to each other. See EUDICOTYLEDONS; MAGNOLIOPHYTA. [K.J.Sy.]

**Trochophore** A generalized but distinct type of free-swimming larva found in several invertebrate groups, including nemerteans, marine turbellarians, brachiopods, bryozoans, phoronids, mollusks, sipunculids, and some annelids. The form is somewhat pear-shaped (see illustration), and it is provided

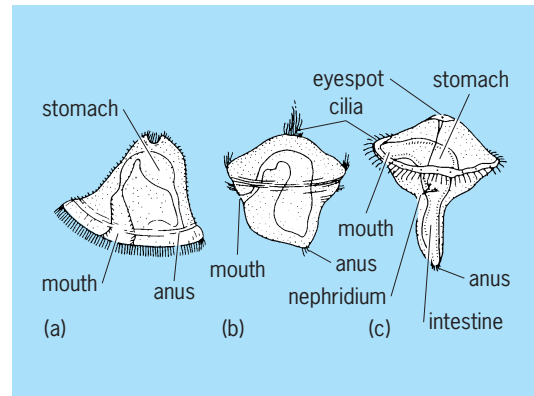

Some trochophore larvae. Pear-shaped form is common in all groups. (a) Bryozoan. (b) *Patella*, a mollusk. (c) *Polygordius*, an annelid. (After T. I. Storer et al. *General Zoology*, 4th ed., McGraw-Hill, 1976)

externally with a prominent circlet of cilia (a troch) and one or sometimes two accessory circlets. Anterior and posterior apical ciliary tufts and eyespots are often present. The digestive tract is complete and functional; paired nephridia with excretory tubules are present; muscle and nerve fibers, sense organs, and a band of mesoderm complete the internal structure. Presumably, the larva, which develops ontogenetically along many divergent lines, indicates the close evolutionary relationships of the groups it represents. See ANNELIDA; BRACHIPODA; BRYOZOA; MOLLUSCA; PHORONIDA; SIPUNCULIDA; TURBELLARIA. [S.P.P.]

**Trogoniformes** A small order of birds that contains only the family Trogonidae, which has 37 species distributed pantropically. The trogons and quetzals are jay-sized birds with large heads, and tails that vary from medium length and squared to elongated and tapered. The dorsal plumage of trogons and quetzals is predominantly metallic green, with blue, violet, red, black, or gray in a few. The ventral feathers are bright red, yellow, or orange. Despite their vivid coloration, the birds are inconspicuous when sitting quietly. The legs of quetzals are short and their feet are weak, with the toes arranged heterodactylously, with the first and second toes reverted. Their flight is rapid, undulating, and brief; trogons rarely walk. Their diet consists of fruit and small invertebrates, and insects caught in flight as the bird darts out from a perch.

Trogoniformes are nonmigratory, arboreal, and sedentary, and they can remain on a perch for hours. The monogamous pairs nest in solitude in a hollow tree or termite nest. After the eggs have been incubated by both parents, the naked hatchlings remain in the nest and are cared for by both. See AVES. [W.J.B.]

**Trojan asteroids** Asteroids located near the equilateral lagrangian stability points of the Sun-Jupiter system (see illustration). As shown by J. L. Lagrange in 1772, these are two of the five stable points in the circular, restricted, three-body system, the other three points being located along a line through the two most massive bodies in the system. In 1906 Max Wolf discovered an asteroid located near the lagrangian point preceding Jupiter in its orbit. Within a year, two more were found, one of which was located near the following lagrangian point. It was quickly decided to name these asteroids after participants in the Trojan War as given in Homer's *Iliad*.

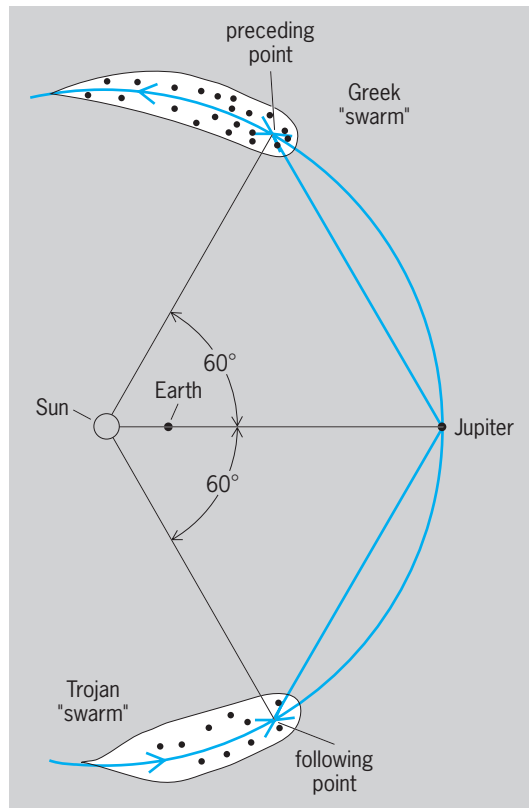

Lagrangian points and Trojan asteroids.

The term “Trojans” is sometimes used in a generic sense to refer to hypothetical objects occupying the equilateral lagrangian points of other pairs of bodies. In 1990 Edward Bowell discovered an asteroid, later named (5261) Eureka, occupying the following lagrangian point of the planet Mars, and in 2001 the first Trojan of Neptune (2001 QR<sub>322</sub>) was discovered. As of December 2003, as many as five additional potential Martian Trojans had been discovered. As of August 2004 there were 1682 known Jupiter Trojans. See ASTEROID. [E.F.T.]

**Trombidiformes** A suborder of the Acarina (also known as Prostigmata) commonly called the trombidiform mites, more closely related to the Sarcoptiformes than to the other suborders. They are usually distinguished by presence of a respiratory system opening at or near the base of the chelicerae.

The Trombidiformes are probably the most heterogeneous group of mites, both morphologically and ecologically, varying from baglike forms with degenerate legs to the highly evolved, fully developed, parasitic forms. Economically, this group contains two families of plant-feeding mites of great importance to agriculture: the Tetranychidae (spider mites) and the Eriophyidae (bud mites or gall mites). Medically, the Trombiculidae (chiggers or red bugs) are important because the larval forms, which are parasites of vertebrates, can cause intense irritation to their hosts by their feeding. More seriously, some transmit a rickettsial disease, scrub typhus, to humans in the Far East and South Pacific regions. [E.W.B.]

**Trophic ecology** The study of the structure of feeding relationships among organisms in an ecosystem. Researchers focus on the interplay between feeding relationships and ecosystem attributes such as nutrient cycling, physical disturbance, or the rate of tissue production by plants and the accrual of detritus (dead organic material). Feeding or trophic relationships can be represented as a food web or as a food chain. Food webs depict trophic links between all species sampled in a habitat, whereas

food chains simplify this complexity into linear arrays of interactions among trophic levels. Thus, trophic levels (for example, plants, herbivores, detritivores, and carnivores) are amalgamations of species that have similar feeding habits. (However, not all species consume prey on a single trophic level. Omnivores are species that feed on more than one trophic level.) See ECOLOGY; ECOSYSTEM; FOOD WEB.

The three fundamental questions in the field of trophic ecology are: (1) What is the relationship between the length of food chains and plant biomass (the relative total amount of plants at the bottom of the food chain)? (2) How do resource supply to producers (plants) and resource demand by predators determine the relative abundance of organisms at each trophic level in a food chain? (3) How long are real food chains, and what factors limit food chain length?

A central theory in ecology is that “the world is green” because carnivores prevent herbivores from grazing green plant biomass to very low levels. Trophic structure (the number of trophic levels) determines trophic dynamics (as measured by the impact of herbivores on the abundance of plants). Indirect control of plant biomass by a top predator is called a trophic cascade. Cascades have been demonstrated to varying degrees in a wide variety of systems, including lakes, streams, subtidal kelp forests, coastal shrub habitats, and old fields. In all of these systems, the removal of a top predator has been shown to precipitate dramatic reductions in the abundance of species at lower trophic levels. Food chain theory predicts a green world when food chains have odd numbers of trophic levels, but a barren world (plants suppressed by herbivores) in systems with even numbers of trophic levels.

Although predators often have strong indirect effects on plant biomass as a result of trophic cascades, both predation (a top-down force) and resource supply to producers (a bottom-up force) play strong roles in the regulation of plant biomass. The supply of inorganic nutrients at the bottom of a food chain is an important determinant of the rate at which the plant trophic level produces tissue (primary production, or productivity). However, the degree to which nutrient supply enhances plant biomass accrual depends on two factors: (1) how many herbivores are present (which in turn depends on how many trophic levels there are in the system) and (2) the degree to which the herbivores can respond to increases in plant productivity and control plant biomass. The relative importance of top-down (demand) versus bottom-up (supply) forces is well illustrated by lake systems, in which the supply of phosphorus (bottom-up force) and the presence of piscivorous (fish-eating) fish (top-down force) have significant effects on the standing stock of phytoplankton, the plant trophic level in lake water columns. See BIOLOGICAL PRODUCTIVITY; BIOMASS; FRESH-WATER ECOSYSTEM; LAKE; PHYTOPLANKTON.

Increases in productivity may act to lengthen food chains. However, food chain length may be limited by the efficiency at which members of each trophic level assimilate energy as it moves up the food chain; the resilience of the chain (measured as the inverse of the time required for all trophic levels to return to previous abundance levels after a disturbance); and the size of the ecosystem—small habitats are simply not large enough to support the home range or provide ample habitat for larger carnivorous species. See ECOLOGICAL ENERGETICS; SYSTEMS ECOLOGY; THEORETICAL ECOLOGY. [J.L.S.; L.R.G.]

**Tropic of Cancer** The parallel of latitude about  $23\frac{1}{2}^\circ$  ( $23.45^\circ$ ) north of the Equator. The importance of this line lies in the fact that its degree of angle from the Equator is the same as the inclination of the Earth's axis from the vertical to the plane of the ecliptic. Because of this inclination of the axis and the revolution of the Earth in its orbit, the vertical overhead rays of the Sun may progress as far north as  $23\frac{1}{2}^\circ$ . At no place north of the Tropic of Cancer will the Sun, at noon, be  $90^\circ$  overhead.

On June 21, the summer solstice (Northern Hemisphere), the Sun is vertical above the Tropic of Cancer. On this same day

the Sun is  $47^\circ$  above the horizon at noon at the Arctic Circle, and at the Tropic of Capricorn, only  $43^\circ$  above the horizon. The Tropic of Cancer is the northern boundary of the equatorial zone called the tropics, which lies between the Tropic of Cancer and Tropic of Capricorn. See LATITUDE AND LONGITUDE; MATHEMATICAL GEOGRAPHY; SOLSTICE. [V.H.E.]

**Tropic of Capricorn** The parallel of latitude approximately  $23\frac{1}{2}^\circ$  ( $23.45^\circ$ ) south of the Equator. It was named for the constellation Capricornus (the goat), for astronomical reasons which no longer prevail.

Because the Earth, in its revolution around the Sun, has its axis inclined  $23\frac{1}{2}^\circ$  from the vertical to the plane of the ecliptic, the Tropic of Capricorn marks the southern limit of the zenithal position of the Sun. Thus, on December 22 (Southern Hemisphere summer, but northern winter solstice) the Sun, at noon, is  $90^\circ$  above the horizon.

The Tropic of Capricorn is the southern boundary of the equatorial zone referred to as the tropics, which lies between the Tropic of Capricorn and the Tropic of Cancer. See MATHEMATICAL GEOGRAPHY; SOLSTICE; TROPIC OF CANCER. [V.H.E.]

**Tropical meteorology** The study of atmospheric structure and behavior in the areas astride the Equator, roughly between  $30^\circ$  north and south latitude. The weather and climate of the tropics involve phenomena such as trade winds, hurricanes, intertropical convergence zones, jet streams, monsoons, and the El Niño Southern Oscillation. More energy is received from the Sun over the tropical latitudes than is lost to outer space (infrared radiation). The reverse is true at higher latitudes, poleward of  $30^\circ$ . The excess energy from the tropics is transported by winds to the higher latitudes, largely by vertical circulations that span roughly  $30^\circ$  in latitudinal extent. These circulations are known as Hadley cells.

For the most part, the oceanic tropics (the islands) experience very little change of day-to-day weather except when severe events occur. Tropical weather can be more adverse during the summer seasons of the respective hemispheres. The near equatorial belt between  $5^\circ\text{S}$  and  $5^\circ\text{N}$  is nearly always free from hurricanes and typhoons: the active belt lies outside this region over the tropics. The land areas experience considerable heating of the Earth's surface, and the summer-to-winter contrasts are somewhat larger there. For instance, the land areas of northern India experience air temperatures as high as  $108^\circ\text{F}$  ( $42^\circ\text{C}$ ) in the summer (near the Earth's surface), while in the winter season the temperatures remain  $72^\circ\text{F}$  ( $22^\circ\text{C}$ ) for many days. The diurnal range of temperature is also quite large over land areas on clear days during the summer ( $32^\circ\text{F}$  or  $18^\circ\text{C}$ ) as compared to winter ( $18^\circ\text{F}$  or  $10^\circ\text{C}$ ).

The steady northeast surface winds over the oceans of the Northern Hemisphere between  $5^\circ$  and  $20^\circ\text{N}$  and southeast winds over the corresponding latitudes of the southern oceans constitute the trade winds. Trade winds have intensities of around 5–10 knots (2.5–5 m/s). They are the equatorial branches of the anticyclonic circulation (known as the subtropical high pressure). The steadiness of wind direction is quite high in the trades. See WIND.

Hurricanes are also known as typhoons in the west Pacific and tropical cyclones in Indian Ocean and south Pacific. If the wind speed exceeds 65 knots (33 m/s) in a tropical storm, the storm is labeled a hurricane. A hurricane usually forms over the tropical oceans, north or south of  $5^\circ$  latitude from the Equator. See HURRICANE.

Intertropical convergence zones are located usually between  $5^\circ$  and  $10^\circ\text{N}$  latitude. They are usually oriented west to east and contain cloud clusters with rainfall of the order of 1.2–2 in. (30–50 mm) per day. The trade winds of the two hemispheres supply moisture to this precipitating system. See CLOUD PHYSICS; PRECIPITATION (METEOROLOGY).

A number of fast-moving air currents, known as jets, are important elements of the tropical general circulation. With speeds in excess of 30 knots (15 m/s), they are found over several regions of the troposphere. See ATMOSPHERIC GENERAL CIRCULATION; JET STREAM; TROPOSPHERE.

Basically the entire landmass from the west coast of Africa to Asia and extending to the date line experiences a phenomenon known as the monsoon. Monsoon circulations are driven by differential heating between relatively cold oceans and relatively warm landmasses. See MONSOON METEOROLOGY.

Every 2–6 years the eastern equatorial Pacific Ocean experiences a rise in sea surface temperature of about  $5\text{--}9^\circ\text{F}$  ( $3\text{--}5^\circ$ ). This phenomenon is known as El Niño, which is part of a larger cycle referred to as the El Niño Southern Oscillation (ENSO). The other extreme in the cycle is referred to as La Niña. El Niño has been known to affect global-scale weather. See EL NIÑO; MARITIME METEOROLOGY. [T.N.Kr.]

**Tropopause** The boundary between the troposphere and the stratosphere in the atmosphere. The tropopause is broadly defined as the lowest level above which the lapse rate (decrease) of temperature with height becomes less than  $5.8^\circ\text{F mi}^{-1}$  ( $2^\circ\text{C km}^{-1}$ ). In low latitudes the tropical tropopause is at a height of 9.3–11 mi at about  $-135^\circ\text{F}$  (15–17 km at about 180 K), and the polar tropopause between tropics and poles is at about 6.2 mi at about  $-63^\circ\text{F}$  (10 km at about 220 K). There is a well-marked "tropopause gap" or break where the tropical and polar tropopauses overlap at  $30\text{--}40^\circ$  latitude. The break is in the region of the subtropical jet stream and is of major importance for the transfer of air and tracers (humidity, ozone, radioactivity) between stratosphere and troposphere. The height of the tropopause varies seasonally and also daily with the weather systems, being higher and colder over anticyclones than over depressions. See AIR TEMPERATURE; ATMOSPHERE; STRATOSPHERE; TROPOSPHERE. [R.J.Mu.]

**Troposphere** The lowest major layer of the atmosphere. The troposphere extends from the Earth's surface to a height of 6–10 mi (10–16 km), the base of the stratosphere. It contains about four-fifths of the mass of the whole atmosphere. See ATMOSPHERE.

On the average, the temperature decreases steadily with height throughout this layer, with a lapse rate of about  $19^\circ\text{F mi}^{-1}$  ( $6.5^\circ\text{C km}^{-1}$ ), although shallow inversions (temperature increases with height) and greater lapse rates occur, particularly in the boundary layer near the Earth's surface. Appreciable water-vapor contents and clouds are almost entirely confined to the troposphere. Hence it is the seat of all important weather processes and the region where interchange by evaporation and precipitation (rain, snow, and so forth) of water substance between the surface and the atmosphere takes place. See CLIMATOLOGY; CLOUD PHYSICS; METEOROLOGY; WEATHER. [R.J.Mu.]

**Tropospheric scatter** A term applied to propagation of radio waves caused by irregularities in the refractive index of air. The phenomenon is predominant in the lower atmosphere; little or no scattering of importance occurs above the troposphere. Tropospheric scatter propagation provides very useful communication services but also causes harmful interference. For example, it limits the geographic separation required for frequency assignments to services such as television and frequency-modulation broadcasting, very-high-frequency omnidirectional ranges (VOR), and microwave relays. It is used extensively throughout most of the world for long-distance point-to-point services, particularly where high information capacity and high reliability are required. Typical tropospheric scatter relay facilities are commonly 200–300 mi (320–480 km) apart. Some single hops in excess of 500 mi (800 km) are in regular use. High-capacity circuits carry 200–300 voice circuits simultaneously. [R.S.Ki.]

**Truck** A motor vehicle carrying its load on its own wheels and primarily designed for the transportation of goods or cargo. A truck is similar to a passenger car in many basic aspects, but truck construction is usually heavier throughout with strengthened chassis and suspension, and lower transmission and drive-axle ratios to cope with hilly terrain. Other common truck characteristics include cargo-carrying features such as rear doors or tailgate, and a flat floor. However, there are many different kinds of trucks, often specially designed with unique features for performing a particular job. See AUTOMOBILE; AUTOMOTIVE ELECTRICAL SYSTEM; BUS.

A truck is rated by its gross vehicle weight (gvw), which is the combined weight of the vehicle and load. Trucks are classified as light-, medium-, or heavy-duty according to gross vehicle weight. Although a variety of models and designs are available in each category, there are two basic types of vehicles, the straight truck and the truck tractor. The straight truck has the engine and body mounted on the same chassis. The truck tractor is essentially a power unit that is the control and pulling vehicle for truck trailers such as full trailers or semitrailers. A full trailer has a front axle and one or more rear axles and is constructed so that all its own weight and that of its load rests on its own wheels. A semitrailer has one or more axles at the rear, and is constructed so that the front end and a substantial part of its own weight and that of its load rests upon another vehicle. A retractable mechanism mounted at the front end of the semitrailer is lowered to support it when the pulling vehicle is disconnected. A full trailer may be drawn by a truck, or behind a semitrailer.

The tractor-semitrailer combination permits the use of longer bodies with greater carrying capacity and better maneuverability than is possible with a straight truck. The forward positioning of the cab, the short wheelbase of the tractor, and the multiplicity of axles provide maximum payloads and operating economy in the face of restriction on overall length imposed by some states, and regulations limiting the weight carried on a single axle. [D.L.An.]

**Truss** An assemblage of structural members joined at their ends to form a stable structural assembly. If all members lie in one plane, the truss is called a planar truss or a plane truss. If the members are located in three dimensions, the truss is called a space truss.

A plane truss is used like a beam, particularly for bridge and roof construction. A plane truss can support only weight or loads contained in the same plane as that containing the truss. A space truss is used like a plate or slab, particularly for long span roofs where the plan shape is square or rectangular, and is most efficient when the aspect ratio (the ratio of the length and width) does not vary above 1.5. A space truss can support weight and loads in any direction.

Because a truss can be made deeper than a beam with solid web and yet not weigh more, it is more economical for long spans and heavy loads, even though it costs more to fabricate. See BRIDGE; ROOF CONSTRUCTION.

The simplest truss is a triangle composed of three bars with ends pinned together. If small changes in the lengths of the bars are neglected, the relative positions of the joints do not change when loads are applied in the plane of the triangle at the apexes.

Multiple-span plane trusses (defined as statically indeterminate or redundant) and space trusses require very complex and tedious hand calculations. Modern high-speed digital computers and readily available computer programs greatly facilitate the structural analysis and design of these structures. See COMPUTER; STRUCTURAL ANALYSIS. [C.Th.; I.P.H.]

**Trypanorhyncha** An order of tapeworms of the subclass Cestoda, also known as the Tetrarhynchoidea. All are parasitic in the intestine of elasmobranch fishes. They are distinguished from all other tapeworm groups by having spiny, eversible proboscides on the head. The head also bears two or four shallow, weakly muscular suckers. A complete life history is not known

for any trypanorhynchid, although larval forms have been found in the tissues of various marine invertebrates and teleost fishes. See CESTODA. [C.PR.]

**Trypanosomatidae** A family of Protozoa, order Kinetoplastida, containing flagellated parasites which change their morphology; that is, they exhibit polymorphism during their life cycles. The life cycles of the organisms may involve only an invertebrate host, or an invertebrate and a vertebrate host, or an invertebrate and a plant host. Several distinct morphological forms are recognized: trypanosomal, crithidial, leptomonad, and leishmanial. Differentiation into genera is dependent upon the host infected as well as the morphologic types involved. None of the stages possesses a mouth opening, and nutritive elements are absorbed through the surface of the body; that is, the organisms are saprozoic.

*Trypanosoma* is the important genus of the family Trypanosomatidae from a number of standpoints. It contains the largest number of species infecting a wide variety of hosts such as mammals, birds, fishes, amphibians, and reptiles. Although most of the species cause no damage to the hosts, there are several which produce serious diseases in humans, domesticated animals, and wild animals. The pathogenic species are prevalent in Africa.

*Leishmania* is the second most important genus. Three species parasitize humans but have also been found naturally infecting dogs, cats, and perhaps other lower animals. The sand fly, *Phlebotomus*, transmits the parasite from vertebrate to vertebrate. See LEISHMANIASIS. [M.M.B./H.W.S.]

**Trypanosomiasis** A potentially fatal infection caused by parasites of the genus *Trypanosoma*.

The African trypanosomes, the cause of African trypanosomiasis or African sleeping sickness, are flagellated protozoan parasites. *Trypanosoma brucei rhodesiense* and *T. b. gambiense* cause disease in humans. *Trypanosoma brucei* is restricted to domestic and wild animals. The trypanosomes are transmitted by the tsetse fly (*Glossina*), which is restricted to the African continent. The trypanosomes are taken up in a blood meal and grow and multiply within the tsetse gut. After 2–3 weeks, depending upon environmental conditions, they migrate into the salivary glands, where they become mature infective forms, and are then transmitted by the injection of infected saliva into a new host during a blood meal. The survival of the tsetse fly is dependent upon temperature and humidity, and the fly is confined by the Sahara to the north and by the colder drier areas to the south, an area about the size of the United States. Approximately 50 million people live within this endemic area, and 15,000–20,000 new human cases of African trypanosomiasis are reported annually.

In humans and other mammals the trypanosomes are extracellular. During the early stages of infection, the trypanosomes are found in the blood and lymph but not in cerebrospinal fluid. There are fever, malaise, and enlarged lymph nodes. In the absence of treatment the disease becomes chronic and the trypanosomes penetrate into the cerebrospinal fluid and the brain. The symptoms are headaches, behavioral changes, and finally the characteristic sleeping stage. Without treatment the individual sleeps more and more and finally enters a comatose stage which leads to death. Treatment is more difficult if the infection is not diagnosed until the late neurological stage.

*Trypanosoma cruzi*, the cause of American trypanosomiasis (Chagas' disease), is predominantly an intracellular parasite in the mammalian host. During the intracellular stage, *T. cruzi* loses its flagellum and grows predominantly in cells of the spleen, liver, lymphatic system, and cardiac, smooth, and skeletal muscle. The cells of the autonomic nervous system are also frequently invaded. See MEDICAL PARASITOLOGY; PARASITOLOGY. [J.R.See.]

**Tsunami** A set of ocean waves caused by any large, abrupt disturbance of the sea surface. If the disturbance is close to the coastline, tsunamis can demolish local coastal communities



within minutes. A very large disturbance can both cause local devastation and export tsunami destruction thousands of miles away. Since 1850, tsunamis have been responsible for the loss of over 120,000 lives and billions of dollars of damage to coastal structures and habitats. Methods for predicting when and where the next tsunami will strike have not been developed; but once the tsunami is generated, forecasting its arrival and impact is possible through wave theory and measurement technology. See OCEAN WAVES.

Tsunamis are most commonly generated by earthquakes in marine and coastal regions. Major tsunamis are produced by large (greater than 7 on the Richter scale), shallow-focus (<30-km or 19-mi depth in the Earth) earthquakes associated with the movement of oceanic and continental plates. They frequently occur in the Pacific, where dense oceanic plates slide under the lighter continental plates. When these plates fracture, they cause a vertical movement of the sea floor that allows a quick and efficient transfer of energy from the solid earth to the ocean. The resulting tsunami propagates as a set of waves whose energy is concentrated at wavelengths corresponding to the earth movements (~100 km or 60 mi), at wave heights determined by vertical displacement (~1 m or 3 ft), and at wave directions determined by the adjacent coastline geometry. Because each earthquake is unique, every tsunami has unique wavelengths, wave heights, and directionality. From a warning perspective, this makes the problem of forecasting tsunamis in real time daunting. See EARTHQUAKE; PLATE TECTONICS.

Other large-scale disturbances of the sea surface that can generate tsunamis are explosive volcanoes and asteroid impacts. The eruption of the volcano Krakatoa in the East Indies on August 27, 1883, produced a 30-m (100-ft) tsunami that killed over 36,000 people. See ASTEROID; VOLCANO. [E.N.B.]

**Tuberculosis** An infectious disease caused by the bacillus *Mycobacterium tuberculosis*. It is primarily an infection of the lungs, but any organ system is susceptible, so its manifestations may be varied. Effective therapy and methods of control and prevention of tuberculosis have been developed, but the disease remains a major cause of mortality and morbidity throughout the world. The treatment of tuberculosis has been complicated by the emergence of drug-resistant organisms, including multiple-drug-resistant tuberculosis, especially in those with HIV infection. See ACQUIRED IMMUNE DEFICIENCY SYNDROME (AIDS).

*Mycobacterium tuberculosis* is transmitted by airborne droplet nuclei produced when an individual with active disease coughs, speaks, or sneezes. When inhaled, the droplet nuclei reach the alveoli of the lung. In susceptible individuals the organisms may then multiply and spread through lymphatics to the lymph nodes, and through the bloodstream to other sites such as the lung apices, bone marrow, kidneys, and meninges.

The development of acquired immunity in 2 to 10 weeks results in a halt to bacterial multiplication. Lesions heal and the individual remains asymptomatic. Such an individual is said to have tuberculous infection without disease, and will show a positive tuberculin test. The risk of developing active disease with clinical symptoms and positive cultures for the tubercle bacillus diminishes with time and may never occur, but is a lifelong risk. Only 5% of individuals with tuberculous infection progress to active disease. Progression occurs mainly in the first 2 years after infection; household contacts and the newly infected are thus at risk.

Many of the symptoms of tuberculosis, whether pulmonary disease or extrapulmonary disease, are nonspecific. Fatigue or tiredness, weight loss, fever, and loss of appetite may be present for months. A fever of unknown origin may be the sole indication of tuberculosis, or an individual may have an acute influenzalike illness. Erythema nodosum, a skin lesion, is occasionally associated with the disease.

The lung is the most common location for a focus of infection to flare into active disease with the acceleration of the growth

of organisms. There may be complaints of cough, which can produce sputum containing mucus, pus- and, rarely, blood. Listening to the lungs may disclose rales or crackles and signs of pleural effusion (the escape of fluid into the lungs) or consolidation if present. In many, especially those with small infiltration, the physical examination of the chest reveals no abnormalities.

Miliary tuberculosis is a variant that results from the blood-borne dissemination of a great number of organisms resulting in the simultaneous seeding of many organ systems. The meninges, liver, bone marrow, spleen, and genitourinary system are usually involved. The term miliary refers to the lung lesions being the size of millet seeds (about 0.08 in. or 2 mm). These lung lesions are present bilaterally. Symptoms are variable.

Extrapulmonary tuberculosis is much less common than pulmonary disease. However, in individuals with AIDS, extrapulmonary tuberculosis predominates, particularly with lymph node involvement. Fluid in the lungs and lung lesions are other common manifestations of tuberculosis in AIDS. The lung is the portal of entry, and an extrapulmonary focus, seeded at the time of infection, breaks down with disease occurring.

Development of renal tuberculosis can result in symptoms of burning on urination, and blood and white cells in the urine; or the individual may be asymptomatic. The symptoms of tuberculous meningitis are nonspecific, with acute or chronic fever, headache, irritability, and malaise.

A tuberculous pleural effusion can occur without obvious lung involvement. Fever and chest pain upon breathing are common symptoms.

Bone and joint involvement results in pain and fever at the joint site. The most common complaint is a chronic arthritis usually localized to one joint. Osteomyelitis is also usually present.

Pericardial inflammation with fluid accumulation or constriction of the heart chambers secondary to pericardial scarring are two other forms of extrapulmonary disease.

The principal methods of diagnosis for pulmonary tuberculosis are the tuberculin skin test (an intracutaneous injection of purified protein derivative tuberculin is performed, and the injection site examined for reactivity), sputum smear and culture, and the chest x-ray. Culture and biopsy are important in making the diagnosis in extrapulmonary disease.

A combination of two or more drugs is used in the initial therapy of tuberculous disease. Drug combinations are used to lessen the chance of drug-resistant organisms surviving. The preferred treatment regimen for both pulmonary and extrapulmonary tuberculosis is a 6-month regimen of the antibiotics isoniazid, rifampin, and pyrazinamide given for 2 months, followed by isoniazid and rifampin for 4 months. Because of the problem of drug-resistant cases, ethambutol can be included in the initial regimen until the results of drug susceptibility studies are known. Once treatment is started, improvement occurs in almost all individuals. Any treatment failure or individual relapse is usually due to drug-resistant organisms. See DRUG RESISTANCE.

The community control of tuberculosis depends on the reporting of all new suspected cases so case contacts can be evaluated and treated appropriately as indicated. Individual compliance with medication is essential. Furthermore, measures to enhance compliance, such as directly observed therapy, may be necessary. See MYCOBACTERIAL DISEASES. [G.Lo.]

**Tubeworms** The name given to marine polychaete worms (particularly to many species in the family Serpulidae) which construct permanent calcareous tubes on rocks, seaweeds, dock pilings, and ship bottoms. The individual tubes with hard walls of calcite-aragonite are firmly cemented to any hard substrate and to each other. Economically they are among the most important fouling organisms both on ship hulls (where they are second only to barnacles) and inside sea-water cooling pipes of power stations.

About 340 valid species of serpulid tubeworms have been described. The majority are truly marine, but several species thrive in brackish waters of low salinity, and one species occurs in fresh waters in Karst limestone caves. The wide geographical distribution of certain abundant species owes much to human transport on the bottoms of relatively fast ships and occurred within the last 120 years. See ANNELIDA; BARNACLE; POLYCHAETA.

[W.D.R.-H.]

**Tubulidentata** An order of mammals which contains a single living genus, the armadillo (*Oryzomys*) of Africa. Little is directly known of the origin and history of this peculiar group of mammals. The oldest undoubted record of the Tubulidentata is an early Miocene discovery in East Africa. Pliocene records in India and the Mediterranean border indicate the armadillos had dispersed from Africa by that time. Tubular dentine reminiscent of the armadillos occurs in *Tubulodon* from the early Eocene of North America, but the fragmentary material does not permit further comparison. See AARDVARK; MAMMALIA.

[R.H.T.]

**Tufa** A spongy, porous limestone formed by precipitation from evaporating spring and river waters; also known as calcareous sinter. Calcium carbonate commonly precipitates from supersaturated waters on the leaves and stems of plants growing around the springs and pools and preserves some of their plant structures. Tufa tends to be fragile and friable. See LIMESTONE; TRAVERTINE.

[R.Si.]

**Tuff** Fragmental volcanic products from explosive eruptions that are consolidated, cemented, or otherwise hardened to form solid rock. In strict scientific usage, the term "tuff" refers to consolidated volcanic ash, which by definition consists of fragments smaller than 2 mm. However, the term is also used for many pyroclastic rocks composed of fragments coarser than ash and even for pyroclastic material that has undergone limited posteruption reworking. If the thickness, temperature, and gas content of a tuff-forming pyroclastic flow are sufficiently high, the constituent fragments can become compacted and fused to form welded tuff. The term "tuff" is also used in the naming of several related types of small volcanic edifices formed by hydrovolcanic eruptions, triggered by the explosive interaction of hot magma or lava with water. See IGNIMBRITE; PYROCLASTIC ROCKS; VOLCANO.

[R.Ti.]

**Tularemia** A worldwide disease caused by infection with the bacterium *Francisella tularensis*, which affects multiple animal species. Infection in humans occurs frequently from skinning infected animals bare-handed or from the bites of infected animals, ticks, deer flies. The mortality rate varies by species, but with treatment it is low. Ungulates are frequently infected but generally suffer low mortality.

Tularemia can be difficult to differentiate from other diseases because it can have multiple clinical manifestations. Nonspecific signs frequently include fever, lethargy, anorexia, and increased pulse and respiration rates. The disease can overlap geographically with plague, and both may lead to enlarged lymph nodes (buboes). However, with tularemia, the buboes are more likely to ulcerate. If tularemic infection results from inhalation of dust from contaminated soil, hay, or grain, either pneumonia or a typhoidal syndrome can occur. Rarely, the route of entry for the bacteria is the eyes, leading to the oculoglandular type of tularemia. If organisms are ingested, the oropharyngeal form can develop, characterized by abdominal pain, diarrhea, vomiting, and ulcers. See PLAGUE.

Tularemia is not transmitted directly from individual to individual. If the infected person or animal is untreated, blood remains infectious for 2 weeks and ulcerated lesions are infectious for a month. Deer flies (*Chrysops discalis*) are infective for 2 weeks, and ticks are infective throughout their lifetime (usually 2 years).

A number of antibacterial agents are effective against *F. tularensis*, the most effective being streptomycin. Penicillin and the sulfonamides have no therapeutic effect. See ANTIBIOTIC.

[M.Ei.]

**Tulip tree** A tree *Liriodendron tulipifera*, also known in forestry as yellow poplar, belonging to the magnolia family, Magnoliaceae. One of the largest and most valuable hardwoods of eastern North America, it is native from southern New England and New York westward to southern Michigan, and south to Louisiana and northern Florida.

Botanically, this tree is distinguished by leaves which are squarish at the tip as if cut off, true terminal buds flattened and covered by two valvate scales, an aromatic odor resembling that of magnolia, and cone-shaped fruit which is persistent in winter. The name tulip refers to the large greenish-yellow and orange-colored flowers.

The wood of the tulip tree is light yellow to brown, hence the common name yellow poplar, which is a misnomer. It is a soft and easily worked wood, used for construction, interior finish, containers (boxes, crates, baskets), woodenware, excelsior, veneer, and sometimes for paper pulp. See MAGNOLIALES.

[A.H.G./K.P.D.]

**Tumbling mill** A grinding and pulverizing machine consisting of a shell or drum rotating on a horizontal axis. The material to be reduced in size is fed into one end of the mill. The mill is also charged with grinding material such as iron balls. As the mill rotates, the material and grinding balls tumble against each other, the material being broken chiefly by attrition.

Tumbling mills are variously classified as pebble, ball, or rod depending on the grinding material, and as cylindrical, conical, or tube depending on the shell shape. See CRUSHING AND PULVERIZING; GRINDING MILL; PEBBLE MILL.

[R.M.H.]

**Tumor** Literally, a swelling; in the past the term has been used in reference to any swelling of the body, no matter what the cause. However, the word is now being used almost exclusively to refer to a neoplastic mass, and the more general usage is being discarded.

A neoplastic mass or neoplasm is a pathological lesion characterized by the progressive or uncontrolled proliferation of cells. The cells involved in the neoplastic growth have an intrinsic heritable abnormality such that they are not regulated properly by normal methods. The stimulus which elicits this growth is not usually known.

It is common to divide tumors into benign or malignant. The decision as to which category a tumor should be assigned is usually based on information gained from gross or microscopic examination, or both. Benign neoplasms usually grow slowly, remain so localized that they cause little harm, and generally can be successfully and permanently removed. Malignant or cancerous neoplasms tend to grow rapidly, spread throughout the body, and recur if removed. Not all tumors which have been classified as benign are harmless to the host, and some can cause serious problems. Difficulties may occur as a result of mechanical pressure.

The cells of benign tumors are well differentiated. This means that the cells are very like the normal tissue in size, structure, and spatial relationship. The cells forming the tumor usually function normally. Cell proliferation usually is slow enough so that there is not a large number of immature cells. As the cellular mass increases in size, most benign tumors develop a fibrous capsule around them which separates them from the normal tissue. The cells of a benign tumor remain at the site of origin and do not spread throughout the body. Anaplasia (loss of differentiation) is not seen in benign tumors.

The cells of malignant tumors may be well differentiated, but most have some degree of anaplasia. Anaplastic cells tend to be larger than normal and are abnormal, even bizarre, in shape. The nuclei tend to be very large, and irregular, and they often

stain darkly. Malignant tumors may be partially but never completely encapsulated. The cells of the cancer infiltrate and destroy surrounding tissue. They have the ability to metastasize; that is, cells from the primary tumor are disseminated to other regions of the body where they are able to produce secondary tumors called metastases.

In most cases the formation of a neoplasm is irreversible. It results from a permanent cellular defect which is passed on to daughter cells. Tumors should undergo medical appraisal to determine what treatment, if any, is needed. [N.K.M.; C.Qu.]

Tumor suppressor genes are a class of genes which, when mutated, predispose an individual to cancer. The mutations result in the loss of function of the particular tumor suppressor protein encoded by the gene. Although this class of genes was named for its link to human cancer, it is now clear that these genes play a critical role in the normal development, growth, and proliferation of cells and organs within the human body. The protein product of many tumor suppressor genes constrains cell growth and proliferation so that these events occur in a controlled manner. Thus, these genes appear to act in a manner antagonistic to that of oncogenes, which promote cell growth and proliferation.

The retinoblastoma (RB), p53, and p16 genes are the best-understood tumor suppressors. Inactivating mutations in the RB gene have been observed in retinoblastomas, osteosarcomas (cancer of the bone), as well as cancers of the lung, breast, and bladder. The p16 mutations have been observed in cancers of the skin, lung, breast, brain, bone, bladder, kidney, esophagus, and pancreas. The tumor suppressor p53 is the most frequently mutated gene associated with the development of many different types of human cancer, including those of the breast, lung, and colon. It is also associated with the rare inherited disease, Li-Fraumeni syndrome. Affected individuals manifest an increased likelihood of breast carcinomas, soft tissue sarcoma, brain tumors, osteosarcoma, leukemia, and adrenocortical carcinoma. Like RB and p16, p53 has a role in cell cycle regulation. In addition, p53 functions in the cell's decision on whether to undergo programmed cell death (apoptosis). Deregulated cell proliferation and escape from apoptosis appear to be two common pathways leading to tumor formation. See CANCER (MEDICINE); GENE; GENE ACTION; MUTATION; ONCOLOGY; TUMOR VIRUSES. [M.Ew.]

**Tumor viruses** Viruses associated with tumors can be classified in two broad categories depending on the nucleic acid in the viral genome and the type of strategy to induce malignant transformation.

**RNA viruses.** The ribonucleic acid (RNA) tumor viruses are retroviruses. When they infect cells, the viral RNA is copied into deoxyribonucleic acid (DNA) by reverse transcription and the DNA is inserted into the host genome, where it persists and can be inherited by subsequent generation of cells. Transformation of the infected cells can be traced to oncogenes that are carried by the viruses but are not necessary for viral replication. The viral oncogenes are closely similar to cellular genes, the proto-oncogenes, which code for components of the cellular machinery that regulates cell proliferation, differentiation, and death. Incorporation into a retrovirus may convert proto-oncogenes into oncogenes in two ways: the gene sequence may be altered or truncated so that it codes for proteins with abnormal activity; or the gene may be brought under the control of powerful viral regulators that cause its product to be made in excess or in inappropriate circumstances. Retroviruses may also exert similar oncogenic effects by insertional mutation when DNA copies of the viral RNA are integrated into the host-cell genome at a site close to or even within proto-oncogenes. See RETROVIRUS.

RNA tumor viruses cause leukemias, lymphomas, sarcomas, and carcinomas in fowl, rodents, primates, and other species. The human T-cell leukemia virus (HTLV) types I and II are endemic in Southeast Asian populations and cause adult T-cell

leukemia and hairy-cell leukemia. See AVIAN LEUKOSIS; LEUKEMIA; LYMPHOMA; ROUS SARCOMA.

**DNA viruses.** DNA viruses replicate lytically and kill the infected cells. Transformation occurs in nonpermissive cells where the infection cannot proceed to viral replication. The transforming ability of DNA tumor viruses has been traced to several viral proteins that cooperate to stimulate cell proliferation, overriding some of the normal growth control mechanisms in the infected cell and its progeny. Unlike retroviral oncogenes, DNA virus oncogenes are essential components of the viral genome and have no counterpart in the normal host cells. Some of these viral proteins bind to the protein products of two key tumor suppressor genes of the host cells, the retinoblastoma gene and the p53 gene, deactivating them and thereby permitting the cell to replicate its DNA and divide. Other DNA virus oncogenes interfere with the expression of cellular genes either directly or via interaction with regulatory factors. There is often a delay of several years between initial viral infection in the natural host species and the development of cancer, indicating that, in addition to virus-induced transformation, other environmental factors and genetic accidents are involved. A specific or general impairment of the host immune responses often plays an important role.

DNA tumor viruses belong to the families of papilloma, polyoma, adeno, hepadna, and herpes viruses and produce tumors of different types in various species. DNA tumor viruses are thought to play a role in the pathogenesis of about 15–20% of human cancers. These include Burkitt's lymphoma, nasopharyngeal carcinoma, immunoblastic lymphomas in immunosuppressed individuals and a proportion of Hodgkin's lymphomas that are all associated with the Epstein-Barr virus of the herpes family; and liver carcinoma associated with chronic hepatitis B virus infection. See ANIMAL VIRUS; CANCER (MEDICINE); EPSTEIN-BARR VIRUS; HODGKIN'S DISEASE; INFECTIOUS PAPILLOMATOSIS; MUTATION; ONCOLOGY. [M.G.Ma.]

**Tuna** Any of the large pelagic marine fishes which form the family Thunnidae, usually included in the order Perciformes. These fishes have a worldwide distribution.

The tunas have no scales on the posterior part of the body, and those on the anterior are fused to form an armored covering. The flesh of any is dark red. The body of these fish is streamlined, with a crescent-shaped tail and a narrow caudal peduncle. See PERCIFORMES. [C.B.C.]

**Tundra** An area supporting some vegetation beyond the northern limit of trees, between the upper limit of trees and the lower limit of perennial snow on mountains, and on the fringes of the Antarctic continent and its neighboring islands. The term is of Lapp or Russian origin, signifying treeless plains of northern regions. Biologists, and particularly plant ecologists, sometimes use the term tundra in the sense of the vegetation of the tundra landscape. Tundra has distinctive characteristics as a kind of landscape and as a biotic community, but these are expressed with great differences according to the geographic region.

Characteristically tundra has gentle topographic relief, and the cover consists of perennial plants a few inches to a few feet or a little more in height. The general appearance during the growing season is that of a grassy sward in the wetter areas, a matted spongy turf on mesic sites, and a thin or sparsely tufted lawn or lichen heath on dry sites. In winter, snow mantles most of the surface. By far, most tundra occurs where the mean annual temperature is below the freezing point of water, and perennial frost (permafrost) accumulates in the ground below the depth of annual thaw and to depths at least as great as 1600 ft (500 m). See PERMAFROST. [W.S.B.]

**Tung tree** The plant *Aleurites fordii*, a species of the spurge family (Euphorbiaceae). The tree, native to central and western

China, is the source of tung oil. It has been grown successfully in the southern United States. The globular fruit has three to seven large, hard, rough-coated seeds containing the oil, which is expressed after the seeds have been roasted. Tung oil is used to produce a hard, quick-drying, superior varnish, which is less apt to crack than other kinds. The foliage, sap, fruit, and commercial tung meal contain a toxic saponin, which causes gastroenteritis in animals that eat it. See DRYING OIL; EUPHORBIALES; VARNISH.

[P.D.St./E.L.C.]

**Tungsten** A chemical element, W, atomic number 74, and atomic weight 183.85. Naturally occurring tungsten consists of five stable isotopes having the following mass numbers and relative abundances: 180 (0.14%), 182 (26.4%), 183 (14.4%), 184 (30.6%), and 186 (28.4%). Twelve radioactive isotopes ranging from 173 to 189 also have been characterized. See PERIODIC TABLE.

Tungsten crystallizes in a body-centered cubic structure in which the shortest interatomic distance is 274.1 picometers at 25°C (77°F). The pure metal has a lustrous, silver-white appearance. It possesses the highest melting point, lowest vapor pressure, and the highest tensile strength at elevated temperature of all metals. Some important physical properties of tungsten are compiled in the table.

At room temperature tungsten is chemically resistant to water, oxygen, most acids, and aqueous alkaline solutions, but it is attacked by fluorine or a mixture of concentrated nitric and hydrofluoric acids.

Tungsten is used widely as a constituent in the alloys of other metals, since it generally enhances high-temperature strength. Several types of tool steels and some stainless steels contain tungsten. Heat-resistant alloys, also termed superalloys, are nickel-, cobalt-, or iron-based systems containing varying amounts (typically 1.5–25 wt %) of tungsten. Wear-resistant alloys having the trade name Stellites are composed mainly of cobalt, chromium, and tungsten. See ALLOY; HIGH-TEMPERATURE MATERIALS.

The major use of tungsten in the United States is in the production of cutting and wear-resistant materials. Tungsten carbides (representing 60% of total tungsten consumption) are used for cutting tools, mining and drilling tools, dies, bearings, and armor-piercing projectiles.

Unalloyed tungsten (25% of tungsten consumption) in the form of wire is used as filaments in incandescent and fluorescent lamps, and as heating elements for furnaces and heaters. Because of its high electron emissivity, thorium-doped (thoriated) tungsten wire is employed for direct cathode electronic filaments. Tungsten rods find use as lamp filament supports, electrical contacts, and electrodes for arc lamps.

Tungsten compounds (5% of tungsten consumption) have a number of industrial applications. Calcium and magnesium tungstates are used as phosphors in fluorescent lights and television tubes. Sodium tungstate is employed in the fireproofing

of fabrics and in the preparation of tungsten-containing dyes and pigments used in paints and printing inks. Compounds such as  $WO_3$  and  $WS_2$  are catalysts for various chemical processes in the petroleum industry. Both  $WS_2$  and  $WSe_2$  are dry, high-temperature lubricants. Other applications of tungsten compounds have been made in the glass, ceramics, and tanning industries.

Miscellaneous uses of tungsten account for the remainder (2%) of the metal consumed. [C.Ku.]

**Tunicata** A subphylum of marine animals (also known as Urochordata) of the Chordata. They are characterized by a perforated pharynx or branchial sac used for food collection, a dorsal notochord restricted to the tail of the larva (and the adult in one class), absence of mesodermal segmentation or a recognizable coelom, and secretion of an outer covering (the test or tunic) which contains large amounts of polysaccharides related to cellulose. Three classes are usually recognized: the sessile Ascidiacea (sea squirts or ascidians); planktonic Thaliacea (salps, doliolids, and pyrosomids); and Appendicularia, minute planktonic forms with tails living inside a specialized test or house adapted for filtering and food gathering. Approximately 2000 species of Tunicata are recognizable. The group is found in all parts of the ocean. Tunicates have little economic importance except as fouling organisms. A few species have pharmacological properties, and a few larger ascidians are used for food. See APPENDICULARIA; ASCIDIACEA; CHORDATA; THALIACEA.

[I.Go.]

**Tuning** The process of adjusting the frequency of a vibrating system to obtain a desired result. In electronic circuits, there are a variety of frequency-determining elements. The most widely used is a combination of an inductance  $L$  (which stores energy in a magnetic field) and a capacitance  $C$  (which stores it in an electric field). The frequency of oscillation is determined by the rate of exchange of the energy between the two fields, and is inversely proportional to  $LC$ . Tuning is accomplished by adjusting the capacitor or the inductor until the desired frequency is reached. The desired frequency may be one that matches (resonates with) another frequency. Another purpose of tuning may be to match a frequency standard, as when setting an electronic watch to keep accurate time. The frequency-determining element in such watches, as well as in radio transmitters, digital computers, and other equipment requiring precise frequency adjustment, is a vibrating quartz crystal. The frequency of vibration of such crystals can be changed over a narrow range by adjusting a capacitor connected to it. See QUARTZ CLOCK; RESONANCE (ALTERNATING-CURRENT CIRCUITS).

Another function of tuning in electronics is the elimination of undesired signals. Filters for this purpose employ inductors and capacitors, or crystals. The filter is tuned to the frequency of the undesired vibration, causing it to be absorbed elsewhere in the circuit. See ELECTRIC FILTER.

Automatic tuning by electrical control is accomplished by a varactor diode. This is a capacitor whose capacitance depends on the direct-current (dc) voltage applied to it. The varactor serves as a portion of the capacitance of the tuned circuit. Its capacitance is controlled by a dc voltage applied to it by an associated circuit, the voltage and its polarity depending on the extent and direction of the mismatch between the desired frequency and the actual frequency. See VARACTOR. [D.G.F.]

**Tuning fork** A steel instrument consisting of two prongs and a handle which, when struck, emits a tone of fixed pitch. Because of their simple mechanical structure, purity of tone, and constant frequency, tuning forks are widely used as standards of frequency in musical acoustics. In its electrically driven form, a tuning fork serves to control electric circuits by producing

Physical properties of tungsten

Property	Value
Melting point	3410 ± 20°C (6170 ± 36°F)
Boiling point	5700 ± 200°C (10,300 ± 360°F)
Density, 27°C (81°F)	19.3 g/cm <sup>3</sup> (11.2 oz/in. <sup>3</sup> )
Specific heat, 25°C (77°F)	0.032 cal/g·°C (0.13 J/g·°C)
Heat of fusion	52.2 ± 8.7 cal/g (218 ± 36 J/g)
Vapor pressure, 2027°C (3681°F)	6.4 × 10 <sup>-12</sup> atm (6.5 × 10 <sup>-7</sup> Pa)
3382°C (6120°F)	2.3 × 10 <sup>-5</sup> atm (2.3 Pa)
5470°C (9878°F)	0.53 atm (5.4 × 10 <sup>4</sup> Pa)
Electrical resistivity, 27°C (81°F)	5.65 microhm-cm
1027°C (1881°F)	34.1
3027°C (5481°F)	103.3
Thermal conductivity, 27°C (81°F)	0.43 cal/cm-s·°C (1.8 J/cm-s·°C)
1027°C (1881°F)	0.27 (1.1)
Absorption cross section, 0.025-eV neutrons	18.5 ± 0.5 barns (18.5 ± 0.5 × 10 <sup>-24</sup> cm <sup>2</sup> )

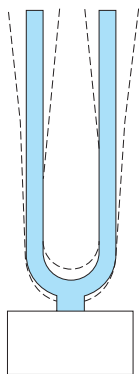

A tuning fork vibrating at its fundamental frequency.

frequency standards of high accuracy and stability. A tuning fork is essentially a transverse vibrator (see illustration). See VIBRATION. [L.E.K.]

**Tunnel** An underground space of substantial length, usually having a tubular shape. Tunnels can be either constructed or natural and are used as passageways, storage areas, carriageways, and utility ducts. They may also be used for mining, water supply, sewerage, flood prevention, and civil defense.

Tunnels are constructed in numerous ways. Shallow tunnels are usually constructed by burying sections of tunnel structures in trenches dug from the surface. This is a preferred method of tunneling as long as space is available and the operation will not cause disturbance to surface activities. Otherwise, tunnels can be constructed by boring underground. Short tunnels are usually bored manually or by using light machines. If the ground is too hard to bore, a drill-and-blast method is frequently used. For long tunnels, it is more economical and much faster to use tunneling boring machines which work on the full face (complete diameter of the opening) at the same time. In uniform massive rock formations without fissures or joints, tunnels can be bored without any temporary supports to hold up the tunnel crowns. However, temporary supports are usually required because of the presence of destabilizing fissures and joints in the rock mass. See DRILLING AND BORING, GEOTECHNICAL.

For tunnels to be constructed across bodies of water, an alternative to boring is to lay tunnel boxes directly on the prepared seabed. These boxes, made of either steel or reinforced concrete, are usually buried in shallow trenches dug for this purpose and covered by ballast so they will not be affected by the movement of the water. The joints between tunnel sections are made watertight by using rubber gaskets, and water is pumped out of the tunnel to make it ready for service. See CONCRETE; STEEL. [Z.C.M.; R.N.Hw.]

**Tunnel diode** A two-terminal semiconductor junction device (also called the Esaki diode) which does not show rectification in the usual sense, but exhibits a negative resistance region at very low voltage in the forward-bias characteristic and a short circuit in the negative-bias direction.

This device is a version of the semiconductor *pn* junction diode which is made of a *p*-type semiconductor, containing mobile positive charges called holes (which correspond to the vacant electron sites), and an *n*-type semiconductor, containing mobile electrons (the electron has a negative charge). The densities of holes and electrons in the respective regions are made extremely high by doping a large amount of the appropriate impurities with an abrupt transition from one region to the other. In semiconductors, the conduction band for mobile electrons is separated from the valence band for mobile holes by an energy gap, which corresponds to a forbidden region. Therefore, a narrow transition layer from *n*-type to *p*-type, 5 to 15 nanometers thick,

consisting of the forbidden region of the energy gap, provides a tunneling barrier. Since the tunnel diode exhibits a negative incremental resistance with a rapid response, it is capable of serving as an active element for amplification, oscillation, and switching in electronic circuits at high frequencies. The discovery of the diode, however, is probably more significant from the scientific aspect because it opened up a new field of research—tunneling in solids. See BAND THEORY OF SOLIDS; JUNCTION DIODE; NEGATIVE-RESISTANCE CIRCUITS; SEMICONDUCTOR; SEMICONDUCTOR DIODE; TUNNELING IN SOLIDS. [L.E.]

**Tunneling in solids** A quantum-mechanical process which permits electrons to penetrate from one side to the other through an extremely thin potential barrier to electron flow. The barrier would be a forbidden region if the electron were treated as a classical particle. A two-terminal electronic device in which such a barrier exists and primarily governs the transport characteristic (current-voltage curve) is called a tunnel junction. See QUANTUM MECHANICS.

During the infancy of the quantum theory, L. de Broglie introduced the fundamental hypothesis that matter may be endowed with a dualistic nature—particles such as electrons, alpha particles, and so on, may also have the characteristics of waves. This hypothesis found expression in the definite form now known as the Schrödinger wave equation, whereby an electron or an alpha particle is represented by a solution to this equation. The nature of such solutions implies an ability to penetrate classically forbidden regions of negative kinetic energy and a probability of tunneling from one classically allowed region to another. The concept of tunneling, indeed, arises from this quantum-mechanical result. The subsequent experimental manifestations of this concept, such as high-field electron emission from cold metals, alpha decay, and so on, in the 1920s, can be regarded as one of the early triumphs of the quantum theory. See FIELD EMISSION; RADIOACTIVITY; SCHRÖDINGER'S WAVE EQUATION.

The tunnel diode (also called the Esaki diode), discovered in 1957 by L. Esaki, demonstrated the first convincing evidence of electron tunneling in solids. See TUNNEL DIODE.

Negative resistance phenomena can be observed in novel tunnel structures in semiconductors. Double tunnel barriers and periodic structures with a combination of semiconductors exhibit resonant tunneling and negative resistance effects. See SEMICONDUCTOR HETEROSTRUCTURES.

Tunneling had been considered to be a possible electron transport mechanism between metal electrodes separated by either a narrow vacuum or a thin insulating film usually made of metal oxides. In 1960, I. Giaever demonstrated that, if one or both of the metals were in a superconducting state, the current-voltage curve in such metal tunnel junctions revealed many details of that state.

In 1962, B. Josephson made a penetrating theoretical analysis of tunneling between two superconductors by treating the two superconductors and the coupling process as a single system, which would be valid if the insulating oxide were sufficiently thin, say 2 nanometers. His theory predicted the existence of a supercurrent, arising from tunneling of the bound electron pairs. This led to two startling conclusions: the dc and ac Josephson effects. The dc effect implies that a supercurrent may flow even if no voltage is applied to the junction. The ac effect implies that, at finite voltage *V*, there is an alternating component of the supercurrent which oscillates at a frequency of 483.6 MHz per microvolt of voltage across the junction, and is typically in the microwave range. See JOSEPHSON EFFECT. [L.E.]

**Tupelo** A tree belonging to the genus *Nyssa* of the sour gum family, Nyssaceae. The most common species is *N. sylvatica*, variously called pepperidge, black gum, or sour gum, the authorized name being black tupelo. Tupelo grows in the easternmost third of the United States; southern Ontario, Canada; and Mexico.

The tree can be identified by the comparatively small, obovate, shiny leaves and by branches that develop at a wide angle from the axis. The fruit is a small blue-black drupe, a popular food for birds. The wood is yellow to light-brown and hard to split because of the twisted grain. Tupelo is used for boxes, baskets, and berry crates, and as backing on which veneers of rarer and more expensive woods are glued. It is also used for flooring, rollers in glass factories, hatters' blocks, and gunstocks. *See MYRTALES.* [A.H.G./K.P.D.]

**Turbellaria** A class of the phylum Platyhelminthes commonly known as the flatworms. These animals are chiefly free-living and have simple life histories. The bodies are elongate and flat to oval or circular in cross section. Their length ranges from less than 0.04 in. (1 mm) to several inches, but may exceed 20 in. (50 cm) in land planaria. Large forms are often brightly colored. This class, which numbers some 3400 described species, is ordinarily subdivided into the orders Acoela, with 200 species; Rhabdocoela, 1110 species; Alloecoela, 350 species; Tricladida, 1000 species; and Polycladida, 750 species. Although widely distributed in fresh and salt water and moist soil, they are usually overlooked because of their generally small size, secretive habits, and inconspicuous color. *See ACOELA; ALLOEOCOELA; POLYCLADIDA; RHABDOCOELA; TRICLADIDA.* [E.R.J.]

**Turbidite** A bed of sediment or sedimentary rock that was deposited from a turbidity current. The term turbidite is fundamentally genetic and interpretive in nature, rather than being a descriptive term (like common rock names). Turbidites are clastic sedimentary rocks, but they may be composed of silicic grains (quartz, feldspar, rock fragments) and therefore be a type of sandstone, or they may be composed of carbonate grains and therefore be a type of limestone. A geologist's description of a rock as a turbidite is actually an expression of an opinion that the rock was deposited by a turbidity current, rather than being a description of a particular type of rock. *See TURBIDITY CURRENT.*

No single feature of a deposit is sufficient to identify it as a turbidite and not all turbidites are marine. There are well-documented examples of modern turbidity currents and turbidites described from lakes. Although probably most turbidites were originally deposited in water of considerable depth (hundreds to thousands of meters), it is generally difficult to be specific about estimating the depth of deposition. The most that can be said is that (in most cases) there is no sign of sedimentary structures formed by the action of waves. *See DEPOSITIONAL SYSTEMS AND ENVIRONMENTS; SEDIMENTARY ROCKS; SEDIMENTOLOGY.* [G.V.M.]

**Turbidity current** A flow of water laden with sediment that moves downslope in an otherwise still body of water. The driving force of a turbidity current is obtained from the sediment, which renders the turbid water heavier than the clear water above. Turbidity currents occur in oceans, lakes, and reservoirs. They may be triggered by the direct inflow of turbid water, by wave action, by subaqueous slumps, or by anthropogenic activities such as dumping of mining tailings and dredging operations.

Turbidity currents are characterized by a well-defined front, also known as head, followed by a thinner layer known as the body of the current. They are members of a larger class of stratified flows known as gravity or density currents. Sediment can be entrained from or deposited on the bed, thus changing the total amount of sediment in suspension. A turbidity current must generate enough turbulence to hold its sediment in suspension. Under certain conditions, a turbidity current might erode its bed, pick up sediment, become heavier, accelerate, and pick up even more sediment, increasing its driving force in a self-reinforcing cycle akin to the formation of a snow avalanche. *See DEPOSITIONAL SYSTEMS AND ENVIRONMENTS.*

Turbidity currents constitute a major mechanism for the transport of fluvial, littoral, and shelf sediments onto the ocean floor.

These flows are considered to be responsible for the scouring of submarine and sublacustrine canyons. These canyons are often of massive proportions and rival the Grand Canyon in scale. Below the mouths of most canyons, turbidity currents form vast depositional fans that have many of the features of alluvial fans built by rivers and constitute major hydrocarbon reservoirs. The sedimentary deposits created by turbidity currents, known as turbidites, are a major constituent of the geological record. *See MARINE GEOLOGY; MARINE SEDIMENTS; SUBMARINE CANYON; TURBIDITE.* [M.H.Ga.]

**Turbine** A machine for generating rotary mechanical power from the energy in a stream of fluid. The energy, originally in the form of head or pressure energy, is converted to velocity energy by passing through a system of stationary and moving blades in the turbine. Changes in the magnitude and direction of the fluid velocity are made to cause tangential forces on the rotating blades, producing mechanical power via the turning rotor. Turbines effect the conversion of fluid to mechanical energy through the principles of impulse, reaction, or a mixture of the two (see illustration).

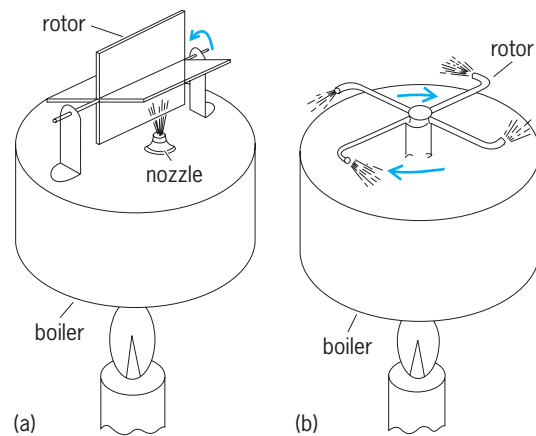

**Turbine principles. (a) Impulse. (b) Reaction.**

The fluids most commonly used in turbines are steam, hot air or combustion products, and water. Steam raised in fossil fuel-fired boilers or nuclear reactor systems is widely used in turbines for electrical power generation, ship propulsion, and mechanical drives. The combustion gas turbine has these applications in addition to important uses in aircraft propulsion. Water turbines are used for electrical power generation. *See GAS TURBINE; HYDRAULIC TURBINE; IMPULSE TURBINE; PELTON WHEEL; REACTION TURBINE; STEAM TURBINE; TURBINE PROPULSION; TURBOJET.* [F.G.B.]

**Turbine propulsion** Propulsion of a vehicle by means of a gas turbine. Gas turbines have come to dominate most areas of common carrier aircraft propulsion, have made significant inroads into the propulsion of surface ships, and are being incorporated into military tanks.

The primary power producer common to all gas turbines used for propulsion is the core or gas generator, operating on a continuous flow of air as working fluid. The air is compressed in a rotating compressor, heated at constant pressure in a combustion chamber burning a liquid hydrocarbon fuel, and expanded through a core turbine which drives the compressor. This manifestation of the Brayton thermodynamic cycle generates a continuous flow of high-pressure, high-temperature gas which is the primary source of power for a large variety of propulsion schemes. The turbine is generally run as an open cycle; that is, the airflow is ultimately exhausted to the atmosphere rather than being recycled to the inlet. *See BRAYTON CYCLE.*

The residual energy available in the high-temperature, high-pressure airstream exiting from the core is used for propulsion in

a variety of ways. For traction-propelled vehicles (buses, trucks, automobiles, military tanks, and most railroad locomotives), the core feeds a power turbine which extracts the available energy from the core exhaust and provides torque to a high-speed drive shaft as motive power for the vehicle. With a free-turbine arrangement, this power turbine is a separate shaft, driving at a speed not mechanically linked to the core speed. With a fixed turbine, this power turbine is on the same shaft as the core turbine, and must drive at the same speed as the core spool. In traction vehicles the power turbine generally drives through a transmission system which affords a constant- or a variable-speed reduction to provide the necessary torque-speed characteristics to the traction wheels.

Aircraft, ships, and high-speed land vehicles, which cannot be driven by traction, are propelled by reaction devices. Some of the ambient fluid around the vehicle (that is, the water for most ships, and the air for all other vehicles) is accelerated by some turbomachinery (a ship propeller, aircraft propeller, helicopter rotor, or a fan integrated with the core to constitute a turbofan engine). The reaction forces on this propulsion turbomachinery, induced in the process of accelerating the ambient flow, provide the propulsion thrust to the vehicle. In all these cases, motive power to the propeller or fan is provided by a power turbine extracting power from the gas generator exhaust. In the case of a jet engine, exhaust from the gas generator is accelerated through a jet nozzle, so that the reaction thrust is evolved in the gas generator rather than in an auxiliary propeller or fan. Indeed, in turboprop and turbofan engines, both forms of reaction thrust (from the stream accelerated by the propeller or fan and from the stream accelerated by the core and not fully extracted by the power turbine) are used for propulsion. See GAS TURBINE; JET PROPULSION; TURBOFAN; TURBOJET; TURBOPROP. [F.F.E.]

**Turbocharger** An air compressor or supercharger on an internal combustion piston engine that is driven by the engine exhaust gas to increase or boost the amount of fuel that can be burned in the cylinder, thereby increasing engine power and performance. On an aircraft piston engine, the turbocharger allows the engine to retain its sea-level power rating at higher altitudes despite a decrease in atmospheric pressure. See RECIPROCATING AIRCRAFT ENGINE; SUPERCHARGER.

The turbocharger is a turbine-powered centrifugal supercharger. It consists of a radial-flow compressor and turbine mounted on a common shaft. The turbine uses the energy in the exhaust gas to drive the compressor, which draws in outside air, precompresses it, and supplies it to the cylinders at a pressure above atmospheric pressure.

Common turbocharger components include the rotor assembly, bearing housing, and compressor housing. The shaft bearings usually receive oil from the engine lubricating system. Engine coolant may circulate through the housing to aid in cooling. See ENGINE COOLING; INTERNAL COMBUSTION ENGINE. [D.L.An.]

**Turbodrill** A rotary tool used in drilling oil or gas wells in which the bit is rotated by a turbine motor inside the well. The principal difference between rotary and turbodrilling lies in the manner in which power is applied to the rotating bit or cutting tool. In the rotary method, the bit is attached to a drill pipe rotated through power supplied on the surface. In the turbodrill method, power is generated at the bottom of the hole by a mud-operated turbine. See ROTARY TOOL DRILL.

The turbodrill (see illustration) consists of four basic components: the upper, or thrust, bearing; the turbine; the lower bearing; and the bit. In operation, mud is pumped through the drill pipe, passing through the thrust bearing and into the turbine. In the turbine, stators attached to the body of the tool divert the mud flow onto rotors attached to the shaft. This causes the shaft, which is connected to the bit, to rotate. The mud passes through a hollow part of the shaft in the lower bearing and through the bit, as in rotary drilling, to remove cuttings, cool the bit, and

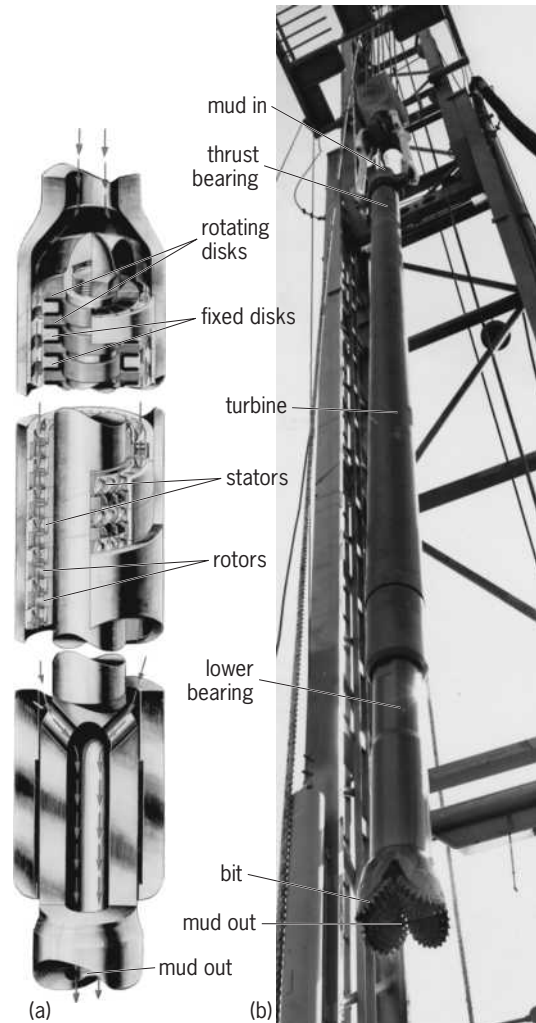

The components of a turbodrill. (a) Cutaway view of turbine, bearings, and bit. (b) Drill string suspended above hole. (Dresser Industries)

perform the other functions of drilling fluid. Capacity of the mud pump, which is the power source, determines rotational speed. See OIL AND GAS WELL DRILLING; TURBINE. [A.L.P.]

**Turbofan** An air-breathing aircraft gas turbine engine with operational characteristics between those of the turbojet and the turboprop. Like the turboprop, the turbofan consists of a compressor-combustor-turbine unit, called a core or gas generator, and a power turbine. This power turbine drives a low- or medium-pressure-ratio compressor, called a fan, some or most

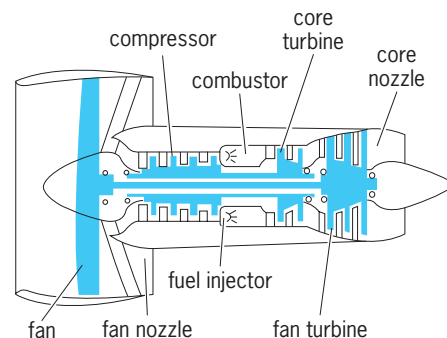

High-bypass, separate-flow turbofan configuration.

of whose discharge bypasses the core (see illustration). See TURBOJET; TURBOPROP.

The gas generator produces useful energy in the form of hot gas under pressure. Part of this energy is converted by the power turbine and the fan it drives into increased pressure of the fan airflow. This airflow is accelerated to ambient pressure through a fan jet nozzle and is thereby converted into kinetic energy. The residual core energy is converted into kinetic energy by being accelerated to ambient pressure through a separate core jet nozzle. The reaction in the turbomachinery in producing both streams produces useful thrust. See GAS TURBINE; TURBINE PROPULSION. [F.F.E.]

**Turbojet** A gas turbine power plant used to propel aircraft, where the thrust is derived within the turbo-machinery in the process of accelerating the air and products of combustion out an exhaust jet nozzle. See GAS TURBINE.

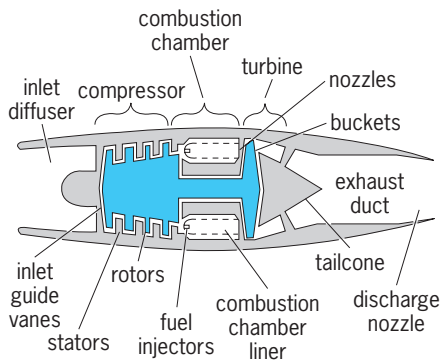

Basic turbojet engine with axial-flow components.

In its most elementary form (see illustration), the turbojet operates on the gas turbine or Brayton thermodynamic cycle. The working fluid, air drawn into the inlet of the engine, is first compressed in a turbo-compressor with a pressure ratio of typically 10:1 to 20:1. The high-pressure air then enters a combustion chamber, where a steady flow of a hydrocarbon fuel is introduced in either spray or vapor form and burned continuously at constant pressure. The exiting stream of hot high-pressure air, at an average temperature whose maximum value may range typically from 1800 to 2800°F (980 to 1540°C), is then expanded through a turbine, where energy is extracted to power the compressor. Because heat had been added to the air at high pressure, there is a surplus of energy left in the stream of combustion products that exits from the turbine and that can be harnessed for propulsion. See BRAYTON CYCLE; GAS TURBINE.

Turbojets have retained a small niche in the aircraft propulsion spectrum, where their simplicity and low cost are of paramount importance, such as in short-range expendable military missiles, or where their light weight may be an overriding consideration, such as for lift jets in prospective vertical takeoff and landing aircraft. See AIRCRAFT PROPULSION; JET PROPULSION; TURBINE PROPULSION; VERTICAL TAKEOFF AND LANDING (VTOL). [F.F.E.]

**Turboprop** A gas turbine power plant producing shaft power to drive a propeller or propellers for aircraft propulsion. Because of its high propulsive efficiency at low flight speeds, it is the power plant of choice for short-haul and low-speed transport aircraft where the flight speeds do not exceed Mach 0.5–0.6. Developments in high-speed, highly loaded propellers have extended the range of propellers to flight speeds up to Mach 0.8–0.9, and there are prospects of these extremely efficient prop-fans assuming a much larger role in powering high-speed transport aircraft. See GAS TURBINE.

As with all gas turbine engines, the basic power production in the turboprop is accomplished in the gas generator or core of the

engine, where a steady stream of air drawn into the engine inlet is compressed by a turbocompressor. The high-pressure air is next heated in a combustion chamber by burning a steady stream of hydrocarbon fuel injected in spray or vapor form. The hot, high-pressure air is then expanded in a turbine that is mounted on the same rotating shaft as the compressor and supplies the energy to drive the compressor. By virtue of the air having been heated at higher pressure, there is a surplus of energy in the turbine that may be extracted in additional turbine stages to drive a useful load, in this case a propeller or propellers.

A large variety of detailed variations are possible within the core. The compressor may be an axial-flow type, a centrifugal (that is, radial-flow) type, or a combination of stages of both types (that is, an axi-centrifugal compressor). In modern machines, the compressor may be split in two sections (a low-pressure unit followed by a high-pressure unit), each driven by its own turbine through concentric shafting, in order to achieve very high compression ratios otherwise impossible in a single spool. See AIRCRAFT PROPULSION; COMPRESSOR; PROPELLER (AIRCRAFT); TURBINE PROPULSION. [F.F.E.]

**Turboramjet** An aircraft engine that is a hybrid of a turbofan and a ramjet. When operated as a ramjet, the engine is capable of relatively efficient propulsion for flight at very high supersonic cruise speeds in the range of Mach numbers 5 to 6. The engine can also be operated as a turbofan engine to give it the capability of relatively efficient propulsion for the low-flight-speed segments of the aircraft's mission such as takeoff, acceleration, approach, and landing. One variation of the engine also includes a rocket engine, which gives the system the additional capability of transatmospheric propulsion. See RAMJET; ROCKET PROPULSION; TURBOFAN.

For operation at subsonic and transonic flight speeds, fuel together with an appropriate amount of an oxidizer such as liquid oxygen is introduced into the preburner in the middle of the engine, where the mixture is burned (see illustration). The resultant hot high-pressure gas stream is expanded through a turbine that drives the fuel and oxidizer pumps and also powers a large fan in the front of the engine. The front-fan discharge air bypasses the preburner and turbine and enters the main burner through a mixer, where it joins the gas stream exiting from the turbine. The stream of mixed gases is then accelerated through a variable-area exhaust nozzle to provide the required propulsive thrust. Thrust augmentation may be obtained by injecting an excess of fuel in the preburner so that, when the fan air is mixed with the fuel-rich turbine exhaust, additional combustion, or afterburning, takes place in the main burner. See AFTERBURNER.

At very high flight speed, with air at very high ram pressure entering the engine, the pumping action of the fan is no longer necessary and the fan may be feathered, or otherwise made inoperative, while permitting the ram air to pass through. Propulsion is now provided exclusively by the combustion of the ram air in the main burner with the fuel-rich gas stream from the preburner.

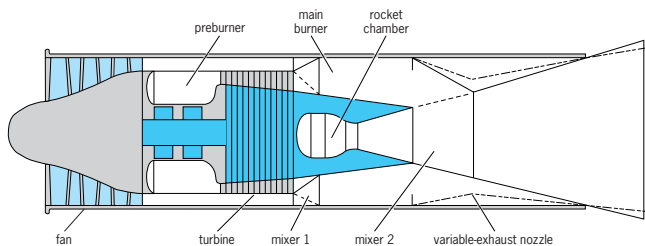

Section drawing of an air turboramjet with rocket combustion chamber for exoatmospheric flight. Such a power plant would combine turbojet, ramjet, and rocket propulsion modes. (Aerojet)



For aircraft that are designed to proceed from high-speed atmospheric flight to transatmospheric flight, a rocket chamber may be provided in the engine where fuel and oxidant are burned in greater quantity than is possible in the preburner, and the exhaust stream may be discharged through the thrust nozzle without having to pass through the turbine. See TURBINE PROPULSION.

[F.F.E.]

**Turbulent flow** A fluid motion in which velocity, pressure, and other flow quantities fluctuate irregularly in time and space. The illustration shows a slice of a water jet emerging from a circular orifice into a tank of still water. A small amount of fluorescent dye mixed in the jet makes it visible when suitably illuminated by laser light, and tags the water entering the tank. There is a small region close to the orifice where the dye concentration does not vary with position, or with time at a given position. This represents a steady laminar state. Generally in laminar motion, all variations of flow quantities, such as dye concentration, fluid velocity, and pressure, are smooth and gradual in time and space. Farther downstream, the jet undergoes a transition to a new state in which the eddy patterns are complex, and flow quantities (including vorticity) fluctuate randomly in time and three-dimensional space. This is the turbulent state. See JET FLOW; LAMINAR FLOW.

Turbulence occurs nearly everywhere in nature. It is characterized by the efficient dispersion and mixing of vorticity, heat, and contaminants. In flows over solid bodies such as airplane wings or turbine blades, or in confined flows through ducts and pipelines, turbulence is responsible for increased drag and heat transfer. Turbulence is therefore a subject of great engineering interest. On the other hand, as an example of collective interaction of many coupled degrees of freedom, it is also a subject at the forefront of classical physics. See DEGREE OF FREEDOM (MECHANICS); DIFFUSION; HEAT TRANSFER; PIPE FLOW; PIPELINE.

The illustration demonstrates the principal issues associated with turbulent flows. The first is the mechanism (or mechanisms) responsible for transition from the steady laminar state to the turbulent state. A second issue concerns the description of fully developed turbulence typified by the complex state far downstream of the orifice. Finally, it is of technological importance to be able to alter the flow behavior to suit particular needs. Less is known about eddy motions on the scale of centimeters and millimeters than about atomic structure on the subnanometer scale, reflecting the complexity of the turbulence problem. See NAVIER-STOKES EQUATION.

**Origin of turbulence.** A central role in determining the state of fluid motion is played by the Reynolds number. In general, a

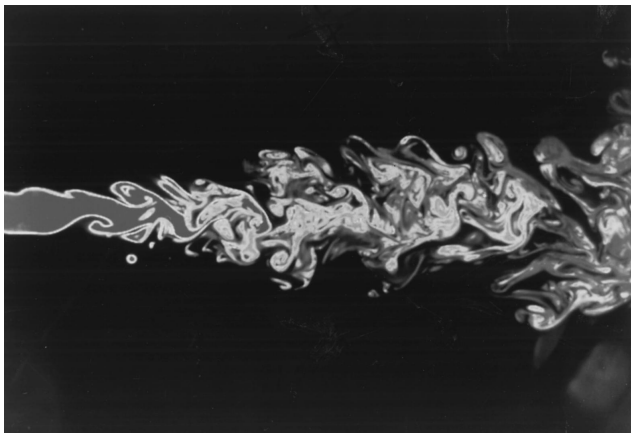

Two-dimensional image of an axisymmetric water jet, obtained by the laser-induced fluorescence technique. (From R. R. Prasad and K. R. Sreenivasan, *Measurement and interpretation of fractal dimension of the scalar interface in turbulent flows*, *Phys. Fluids A*, 2:792–807, 1990)

given flow undergoes a succession of instabilities with increasing Reynolds number and, at some point, turbulence appears more or less abruptly. It has long been thought that the origin of turbulence can be understood by sequentially examining the instabilities. This sequence depends on the particular flow and, in many circumstances, is sensitive to a number of details. A careful analysis of the perturbed equations of motion has resulted in a good understanding of the first two instabilities in a variety of circumstances. See REYNOLDS NUMBER.

**Fully developed turbulence.** Quite often in engineering, the detailed motion is not of interest, but only the long-time averages or means, such as the mean velocity in a boundary layer, the mean drag of an airplane or pressure loss in a pipeline, or the mean spread rate of a jet. It is therefore desirable to rewrite the Navier-Stokes equations for the mean motion. The basis for doing this is the Reynolds decomposition, which splits the overall motion into the time mean and fluctuations about the mean. These macroscopic fluctuations transport mass, momentum, and matter (in fact, by orders of magnitude more efficiently than molecular motion), and their overall effect is thus perceived to be in the form of additional transport or stress. This physical effect manifests itself as an additional stress (called the Reynolds stress) when the Navier-Stokes equations are rewritten for the mean motion (the Reynolds equations). The problem then is one of prescribing the Reynolds stress, which contains the unknown fluctuations in quadratic form. A property of turbulence is that the Reynolds stress terms are comparable to the other terms in the Reynolds equation, even when fluctuations are a small part of the overall motion. An equation for the Reynolds stress itself can be obtained by suitably manipulating the Navier-Stokes equations, but this contains third-order terms involving fluctuations, and an equation for third-order terms involves fourth-order quantities, and so forth. This is the closure problem in turbulence. The Navier-Stokes equations are themselves closed, but the presence of nonlinearity and the process of averaging result in nonclosure.

Given this situation, much of the progress in the field has been due to (1) exploratory experiments and numerical simulations of the Navier-Stokes equations at low Reynolds numbers; and (2) plausible hypotheses in conjunction with dimensional reasoning, scaling arguments, and their experimental verification.

**Control of turbulent flows.** Some typical objectives of flow control are the reduction of drag of an object such as an airplane wing, the suppression of combustion instabilities, and the suppression of vortex shedding behind bluff bodies. Interest in flow control has been stimulated by the discovery that some turbulent flows possess a certain degree of spatial coherence at large scales. Successful control has also been achieved through the reduction of the skin friction on a flat plate by making small longitudinal grooves, the so-called riblets, on the plate surface, imitating shark skin. See FLUID FLOW; FLUID-FLOW PRINCIPLES.

[K.R.S.]

**Turmeric** A dye or a spice obtained from the plant *Curcuma longa*, which belongs to the ginger family (Zingiberaceae). It is a stout perennial with short stem, tufted leaves, and short, thick rhizomes which contain the colorful condiment. As a natural dye, turmeric is orange-red or reddish brown, but it changes color in the presence of acids or bases. As a spice, turmeric has a decidedly musky odor and a pungent, bitter taste. It is an important item in curry and is used to flavor and color butter, cheese, pickles, and other food. See SPICE AND FLAVORING; ZINGIBERALES.

[P.D.St./E.L.C.]

**Turn and bank indicator** A combination instrument which provides an aircraft pilot with two distinct pieces of information: the aircraft's rate of turn about the vertical axis, and the relationship between this rate and the aircraft's angle of bank. It is also known as the needle and ball indicator or the turn and slip indicator. The turn needle is operated by a gyroscope and

indicates the rate at which the aircraft is turning about the vertical axis in degrees per second. In a turn, gyroscopic precession causes the rotor to tilt in the direction opposite the turn with a magnitude proportional to the turn rate. A mechanical linkage converts this precession to reversed movement of a turn needle, thus indicating proper turn direction. See GYROSCOPE.

The bank or slip indicator is a simple inclinometer consisting of a curved glass tube containing fluid and a black ball bearing which is free to move in the fluid. The indicator is actually a balance indication, showing the relationship between the rate of turn and the angle of bank of the aircraft. See AIRCRAFT INSTRUMENTATION; ROTATIONAL MOTION. [G.W.W.]

**Turnbuckle** A device for tightening a rod or wire rope. Its parts are a sleeve with a screwed connection at one end and a swivel at the other or, more commonly, a sleeve with screwed connections of opposite hands (left and right) at each end so that by turning the sleeve, the connected parts will be drawn together, taking up slack and producing tension (see illustration). Types of

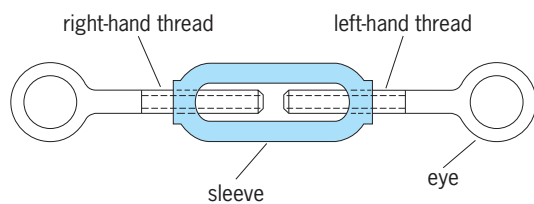

Turnbuckle with eyes.

ends are hook, eye, and clevis. The turn-buckle can be connected at any convenient place in the rod or rope, and several may be used in series if required. [P.H.B.]

**Turning (woodworking)** The shaping of wood by rotating it in a lathe and cutting it with a chisel. The lathe consists essentially of a bed on which are mounted a headstock, a tailstock, and a tool rest (see illustration). The headstock is rotated by a

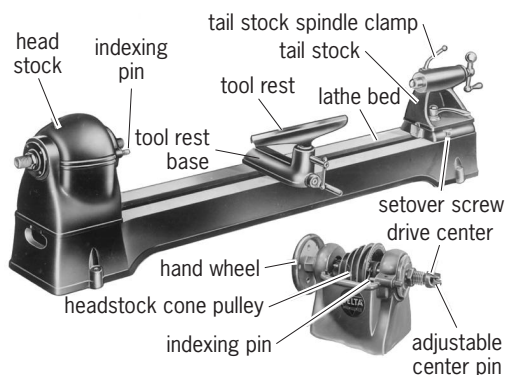

Wood-turning lathe and detail of headstock. (Delta)

motor and holds one end of the wood to be turned. The tailstock holds the other end of the wood, allowing it to rotate freely. The tool rest provides a fixed guide along which the operator can handle the chisels if the turning is by hand, or along which the tool is driven if the turning is mechanized. See WOODWORKING. [A.H.T.]

**Turnip** The plant *Brassica rapa*, or *B. campestris* var. *rapa*, a cool-season, hardy crucifer of Asiatic origin belonging to the order Capparales which is grown for its enlarged root and its foliage, which are eaten cooked as a vegetable. Popular white-fleshed varieties (cultivars) grown for their roots are Purple Top

Globe and White Milan; Yellow Globe and Golden Ball are common yellow-fleshed varieties. Shogoin is a popular variety grown principally in the southern United States for turnip greens. Principal areas of production in the United States are in the South. See CAPPARALES. [H.J.C.]

**Turquoise** A mineral of composition  $\text{CuAl}_6(\text{PO}_4)_4(\text{OH})_8 \cdot 5\text{H}_2\text{O}$  in which considerable ferrous ion ( $\text{Fe}^{2+}$ ) may substitute for copper. Ferric ion ( $\text{Fe}^{3+}$ ) may also substitute for part or all of the aluminum (Al), forming a complete chemical series from turquoise to chalcociderite  $[\text{CuFe}_6(\text{PO}_4)_4(\text{OH})_8 \cdot 5\text{H}_2\text{O}]$ . Turquoise with a strong sky-blue or bluish-green to apple green color is easily recognized, and such material is commonly used as a gem. Some variscite, of composition  $\text{AlPO}_4 \cdot 2\text{H}_2\text{O}$  with minor chemical substitutions of  $\text{Fe}^{3+}$  and or chromium ion ( $\text{Cr}^{3+}$ ) for aluminum and with a soft, clear green color, may be marketed as green turquoise. See GEM.

Most turquoise is massive, dense, and cryptocrystalline to fine-granular. It commonly occurs as veinlets or crusts and in stalactitic or concretionary shapes. It has a hardness on the Mohs scale of about 5 to 6 and a vitreous to waxy luster. The distinctive light blue coloration of much turquoise is the result of the presence of cuprous ion ( $\text{Cu}^{2+}$ ); limited substitution of the copper by  $\text{Fe}^{2+}$  produces greenish colors. See HARDNESS SCALES.

Turquoise is a secondary mineral, generally formed in arid regions by the interaction of surface waters with high-alumina igneous or sedimentary rocks. It occurs most commonly as small veins and stringers traversing more or less decomposed volcanic rocks. Since the times of antiquity, turquoise of very fine quality has been produced from a deposit in Persia (now Iran) near Nishapur. It occurs also in Siberia, Turkistan, China, the Sinai Peninsula, Germany, and France.

The southwestern United States has been a major source of turquoise, especially the states of Nevada, Arizona, New Mexico, and Colorado. Extensive deposits in the Los Cerillos Mountains, near Santa Fe, New Mexico, were mined very early by Native Americans and were a major early source of gem turquoise. However, much of the gem-quality turquoise has been depleted in the Southwest. [C.K.]

**Twilight** The period between sunset and darkness in the evening, and between darkness and sunrise in the morning. The characteristic light is caused by atmospheric scattering, which transmits sunlight to the observer for some time after sunset and before sunrise. It depends geometrically on latitude, longitude, and elevation of the observer, and on the time of year. Physically it depends also on local conditions, particularly the weather. [G.M.C.]

**Twinkling stars** A phenomenon by which light from the stars, as it passes through fluctuations in the Earth's atmosphere, is rapidly modulated and redirected to make the starlight appear to flicker. The twinkling phenomenon affects all wavelengths that manage to penetrate the Earth's atmosphere, from the visible to the radio wavelengths. At visible wavelengths, atmospheric fluctuations are caused predominantly by temperature irregularities along the line of sight. Such irregularities introduce slight changes in the index of refraction of air, and these changes affect light waves in two ways: they modulate the intensity of the light, and they deflect the light waves in one direction and then another. At radio wavelengths, electron density irregularities in the ionosphere modulate and redirect radio waves. See REFRACTION OF WAVES.

The twinkling phenomenon is of utmost interest to astronomers who view the skies from ground-based telescopes. While modulation variations are present, it is the deflection of light that causes the most serious problems. The composite star image produced by a large telescope is a blurry circle that results when the randomly deflected light waves are added together in an extended time exposure. To diminish atmospheric effects,

telescopes are built on high mountains, and are placed at least 30–45 m (100–150 ft) above the ground. See ASTRONOMICAL OBSERVATORY.

To completely remove the twinkling effects of the atmosphere, there are two alternatives. The first is to place a telescope in orbit above the atmosphere, as with the Hubble Space Telescope. The second alternative is to monitor the random deflections of the atmosphere and, within the telescope, to bend the deflected light back onto its original path. This optical technique is given the name adaptive optics. See ADAPTIVE OPTICS; SATELLITE ASTRONOMY. [L.A.T.]

**Twinning (crystallography)** A process in which two or more crystals, or parts of crystals, assume orientations such that one may be brought to coincidence with the other by reflection across a plane or by rotation about an axis. Crystal twins represent a particularly symmetric kind of grain boundary; however, the energy of the twin boundary is much lower than that of the general grain boundary because some of the atoms in the twin interface are in the correct positions relative to each other. See GRAIN BOUNDARIES. [R.M.T.]

**Twins (human)** Two babies born to a mother at one birth. There are two types of twins, monozygotic and dizygotic. Members of a twin pair are called co-twins.

Controversy surrounding the definition of a twin arose with the advent of reproductive technologies enabling the simultaneous fertilization of eggs, with separate implantation. The unique “twinlike” relationships that would result between parents and cloned children (who would be genetically identical to their parents) also challenge current conceptions of twinning. Monozygotic twins are clones (genetically identical individuals derived from a single fertilized egg), but parents and cloned children would not be twins for several reasons, such as their differing prenatal and postnatal environments. See REPRODUCTIVE TECHNOLOGY.

**Monozygotic twins.** The division of a single fertilized egg (or zygote) between 1 and 14 days postconception results in monozygotic twins. They share virtually all their genes and, with very rare exception due to unusual embryological events, are of the same sex. A common assumption is that because monozygotic co-twins have a shared heredity, their behavioral or physical differences are fully explained by environmental factors. However, monozygotic twins are never exactly alike in any measured trait, and may even differ for genetic reasons.

Sometimes chromosomes fail to separate after fertilization, causing some cells to contain the normal chromosome number (46) and others to contain an abnormal number. This process, mosaicism, results in monozygotic co-twins who differ in chromosomal constitution. There are several other intriguing variations of monozygotic twinning. Splitting of the zygote after day 7 or 8 may lead to mirror-image reversal in certain traits, such as handedness or direction of hair whorl. The timing of zygotic division has also been associated with placentation. Monozygotic twins resulting from earlier zygotic division have separate placentae and fetal membranes (chorion and amnion), while monozygotic twins resulting from later zygotic division share some or all of these structures. Should the zygote divide after 14 days, the twins may fail to separate completely. This process, known as conjoined twinning, occurs in approximately 1 monozygotic twin birth out of 200. The many varieties of conjoined twins differ as to the nature and extent of their shared anatomy. Approximately 70% of such twins are female. There do not appear to be any predisposing factors to conjoined twinning. See MOSAICISM.

**Dizygotic twins.** Dizygotic twins result when two different eggs undergo fertilization by two different spermatozoa, not necessarily at the same time. Dizygotic twins share, on average, 50% of their genes, by descent, so that the genetic relationship between dizygotic co-twins is exactly the same as that of ordinary brothers or sisters. Dizygotic twins may be of the same or

opposite sex, outcomes that occur with approximately equal frequency.

There are some unusual variations of dizygotic twinning. There is the possibility of polar body twinning, whereby divisions of the ovum prior to fertilization by separate spermatozoa could result in twins whose genetic relatedness falls between that of monozygotic and dizygotic twins. Blood chimerism, another variation, refers to the presence of more than one distinct red blood cell population, derived from two zygotes, and has been explained by connections between two placentae. In humans, chimerism can occur in dizygotic twins. Superfecundation is the conception of dizygotic twins following separate fertilizations, usually within several days, in which case each co-twin could have a different father. Superfetation, which refers to multiple conceptions occurring several weeks or even one month apart, may be evidenced by delivery of full-term infants separated by weeks or months and by the birth or abortion of twin infants displaying differential developmental status. See FERTILIZATION; OOGENESIS.

**Epidemiology.** According to conventional twinning rates, monozygotic twins represent approximately one-third of twins born in Caucasian populations and occur at a rate of 3–4 per 1000 births. The biological events responsible for monozygotic twinning are not well understood. It is generally agreed that monozygotic twinning occurs randomly and not as a genetically transmitted tendency. Some recent evidence from Sweden suggests an increased tendency for mothers who are monozygotic twins to bear same-sex twins themselves; further work will be needed to resolve this question.

Dizygotic twinning represents approximately two-thirds of twins born in Caucasian populations. The dizygotic twinning rate is lowest among Asian populations (2 per 1000 births), intermediate among Caucasian populations (8 per 1000 births), and highest among African populations (50 per 1000 births in parts of Nigeria). The natural twinning rate increases with maternal age, up to between 35 and 39 years, and then declines. Dizygotic twinning has also been linked to increased parity, or the number of children to which a woman has previously given birth. Mothers of dizygotic twins are also significantly taller and heavier, on average, than mothers of monozygotic twins and singletons. Dizygotic twinning appears to be genetically influenced, although the pattern of transmission within families is unknown.

Twinning rates have risen dramatically since about 1980 mainly due to advances in fertility treatments (for example, in vitro fertilization and ovulation induction), but also due to delays in the child-bearing years. The increase has mainly involved dizygotic twinning in which multiple ovulation and maternal age matter. [N.L.S.]

**Two-phase flow** The simultaneous flow of two phases or two immiscible liquids within common boundaries. Two-phase flow has a wide range of engineering applications such as in the power generation, chemical, and oil industries. Flows of this type are important for the design of steam generators (steam-water flow), internal combustion engines, jet engines, condensers, cooling towers, extraction and distillation processes, refrigeration systems, and pipelines for transport of gas and oil mixtures.

The most important characteristic of two-phase flow is the existence of interfaces, which separate the phases, and the associated discontinuities in the properties across the phase interfaces. Because of the deformable nature of gas-liquid and liquid-liquid interfaces, a considerable number of interface configurations are possible. Consequently, the various heat and mass transfers that occur between a two-phase mixture and a surrounding surface, as well as between the two phases, depend strongly on the two-phase flow regimes. Multiphase flow, when the flow under consideration contains more than two separate phases, is a natural extension of these principles. See FLUID MECHANICS; INTERFACE OF PHASES.

From a fundamental point of view, two-phase flow may be classified according to the phases involved as (1) gas-solid mixture, (2) gas-liquid mixture, (3) liquid-solid mixture, and (4) two-immiscible-liquids mixture. See GAS; LIQUID; PHASE EQUILIBRIUM.

Industrial applications of two-phase flow include systems that convert between phases, and systems that separate or mix phases without converting them (adiabatic systems). Many of the practical cycles used to convert heat to work use a working fluid. In two or more of the components of these cycles, heat is either added to or removed from the working fluid, which may be accompanied by a phase-change process. Examples of these applications include steam generators, evaporators, and condensers, air conditioning, and refrigeration systems, and steam power plants.

In adiabatic systems, the process of phase mixing or separation occurs without heat transfer or phase change. Examples of these systems are airlift pumps, pipeline transport of gas-oil mixtures, and gas-pulverization of solid particles. See ADIABATIC PROCESS.

[H.H.Br.; F.H.; B.K.P.]

**Tylenchida** An order of nematodes in which the labial region is variable and may be distinctly set off or smoothly rounded and well developed; the hexaradiate symmetry is most often retained or discernible. The hollow stylet is the product of the cheilostome (conus, guiding apparatus, and framework) and the esophastome (shaft and knobs). Throughout the order the stylet may be present or absent and may be adorned with knobs. The variable esophagus is most often divisible into the corpus, isthmus, and glandular posterior bulb. The corpus is divisible into the procorpus and metacorporus. The metacorporus is generally valved but may not occur in some females and males, and the absence is characteristic of some taxa. The orifice of the dorsal esophageal gland opens either into the anterior procorpus or just anterior to the metacorporal valve. The excretory system is asymmetrical, and there is but one longitudinal collecting tubule. Females have one or two genital branches; when only one branch is present, it is anteriorly directed. Except for sex-reversed males, there is only one genital branch. Males may have one (=phasmid) or more caudal papillae. The spicules are always paired and variable in shape; they may be accompanied by a gubernaculum. The order comprises five superfamilies: Tylenchoidea, Criconematoidea, Saphaerularoidea, Aphelenchoidea, and Aphelenchoidoidea. See NEMATATA; PLANT PATHOLOGY.

[A.R.M.]

**Tyndall effect** Visible scattering of light along the path of a beam of light as it passes through a system containing discontinuities. The luminous path of the beam of light is called a Tyndall cone. An example is shown in the illustration. In colloidal systems the brilliance of the Tyndall cone is directly dependent on the magnitude of the difference in refractive index between the particle and the medium.

For systems of particles with diameters less than one-twentieth the wavelength of light, the light scattered from a polychromatic beam is predominantly blue in color and is polarized to a degree which depends on the angle between the observer and the

incident beam. The blue color of tobacco smoke is an example of Tyndall blue. As particles are increased in size, the blue color of scattered light disappears and the scattered radiation appears white. If this scattered light is received through a nicol prism which is oriented to extinguish the vertically polarized scattered light, the blue color appears again in increased brilliance. This is called residual blue, and its intensity varies as the inverse eighth power of the wavelength. See COLLOID; SCATTERING OF ELECTROMAGNETIC RADIATION.

[Q.V.W.]

**Type (printing)** The intelligible images organized into readable text of various styles and sizes. Type used in printing on paper or video display is divided into four categories: foundry, machine-cast, photocomposed, and digitized type. In the first two the face of the letter is raised on one end of a piece of metal. It is from that surface, when inked, that the impression of type was made from its invention until the 1970s. In photocomposition, the type is reproduced photographically. Digitized methods assemble dots into typographic letters, lines, or pages.

**Classification.** Foundry type, also known as hand type, is cast as single characters. Machine-cast metal type is produced by Linotype, Intertype, Ludlow, and Monotype machines. Very few of these machines are still in operation. All but the last cast type in lines, or slugs. The Monotype—in reality two devices, a keyboard and a caster—produces individual types that are then manually set in lines of desired lengths.

The output of the photographic type machine is the image of type on film or on photosensitized paper in negative or positive form.

The term cold type is applied to text matter produced on a typewriter or laser printer and to words or lines made up of individual printed characters assembled or pasted together for photographic reproduction. Digital type uses a number of print-out technologies, imaging small dots into lines (called rasters) and positioning them on pages from patterns of zeros and ones called bitmaps. Because this method is electronic, more sizes and variations (for example, condensing or expanding or other distortion) are possible.

About 6000 styles of type are in everyday use throughout the world. The most widely used method for classifying them is the serif-evolution system, based on the different shapes of the terminals or endings of letters. This provides eight classifications: Venetian, Old Style (Dutch-English and French), Transitional, Modern, Contemporary (sans serif and square serif), Scripts, Black Letter, and Decorative Letters.

**Type measurements.** The American point system made the unit of type measurement a point, 0.01383 in. (0.35128 mm) or nearly  $\frac{1}{72}$  in. This system replaced the sixteenth-century practice of giving all type sizes names such as pearl, agate, nonpareil, brevier, long primer, and pica. Some names remained and have been assigned other functions. Agate,  $5\frac{1}{2}$ -point type or 14 lines of type to an inch, has come to be used for measuring newspaper advertising space. Publications quote small space rates by the agate line. Nonpareil is used to designate 6 points of space in and around type. The word pica is commonly used to denote a unit of space measuring 12 points. It is applied as a dimensional unit to the length of type lines and to the width and depth of page. With the advent of desktop publishing, many software programs have standardized on 72 points equaling exactly 1 inch. With these programs, the point now equals 0.01389 in., compared with the traditional point, 0.01383 in. Some of these programs allow the user to select which point system to use.

The standard height of metal type in the United States is 0.918 in. (2.3 cm), a dimension called type-high and one observed by photoengravers and electrotypers who make plates to be combined with cast type. Letterpress printing presses are adjusted to fit this standard height.

**Fonts.** A complete complement of letters of one size and style from A to Z, together with the arabic numerals, punctuation, reference marks and symbols, is called a font. Most fonts also

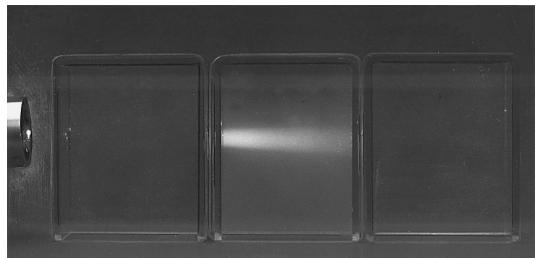

The luminous light path known as the Tyndall cone or Tyndall effect. (Courtesy of H. Steeves and R. G. Babcock)



A family of type.

include the ampersand and currency symbols and the ligatures, ff, fe, ffi, fl, ffl, æ, and œ. A letter from a different font that is included by accident in type composition is known as a wrong font. All typographic images, from letters to symbols to oriental ideographs, are called glyphs.

**Type families.** A family of type may be likened to the shades of a color in that it includes variations of a given type face or design. Weights are varied, from light to medium, bold, and extra bold; letters are condensed and expanded, as well as outlined, inlined, and shadowed (see illustration).

**Type for desktop publishing.** Most typesetting today is performed using desktop publishing (DTP), which refers to the creation of documents through the use of an inexpensive personal computer off-the-shelf software that uses page description language, and laser-based output devices that convert the digital information into images on paper and other surfaces, such as printing plates for offset lithography. [E.M.E.; F.J.Ro.; T.De.]

**Typewriter** A machine that produces printed copy, character by character, as it is operated. Its essential parts are a keyboard, a set of raised characters or a thermal print head, an inked ribbon, a platen for holding paper, and a mechanism for advancing the position at which successive characters are printed. The QWERTY keyboard (named for the sequence of letters of the top row of the alphabet worked by the left hand) was designed in the 1870s. It contains a complete alphabet, along with numbers and the symbols commonly used in various languages and technical disciplines. The manual typewriter was introduced in 1874, followed by the electrically powered typewriter in 1934. By the late 1970s, electronic typewriters offered memory capability, additional automatic functions, and greater convenience. Further advances in electronic technology led to additional capabilities, including plug-in memory and function diskettes and cartridges, visual displays, nonimpact printing, and communications adapters. Although many typewriters are still in use, computers and word processing software largely have supplanted them. See WORD PROCESSING. [E.W.G.; R.A.Rah.]



# U

**Ulcer** A lesion on the surface of the skin or a mucous membrane characterized by a superficial loss of tissue. Ulcers are most common on the skin of the lower extremities and in the gastrointestinal tract, although they may be encountered at almost any site. The diverse causes of ulcers range from circulatory disturbances or bacterial infections to complex, multifactorial disorders. The superficial tissue sloughs, leaving a crater that extends into the underlying soft tissue, which then becomes inflamed and is subject to further injury by the original offender or secondary infection.

Peptic ulcer is the most common ulcer of the gastrointestinal tract and refers to breaks in the mucosa of the stomach or the proximal duodenum that are produced by the action of gastric secretions. It is still unknown why peptic ulcers develop. However, with rare exceptions, a person who does not secrete hydrochloric acid will not develop a peptic ulcer. Ulcers of the stomach tend to develop as a result of superficial inflammation of the stomach. These individuals tend to have normal or decreased amounts of hydrochloric acid. By contrast, most individuals with peptic ulcers of the proximal duodenum secrete excessive amounts of acid. Importantly, a bacterium, *Helicobacter pylori*, has been isolated from the stomach of most people with peptic ulcers and is thought to play a causative role. Although stress has been anecdotally related to peptic ulcers for at least a century, serious doubt has been cast upon this concept. See INFLAMMATION.

Ulcerative colitis is a disease of the large intestine characterized by chronic diarrhea and rectal bleeding. The disorder is common in the Western world, occurring principally in young adults. Its cause is not known, but there is some evidence for a familial predisposition to the disease.

Other ulcers of the gastrointestinal tract are caused by infectious agents. Bacterial and viral infections produce ulcers of the oral cavity. Diseases such as typhoid, tuberculosis, and bacillary dysentery and parasitic infestation with ameba lead to ulcers of the small and large intestines. Narrowing of the arteries to the legs caused by atherosclerosis, particularly in persons with diabetes mellitus, often causes ulcers of the lower extremities. See ARTERIOSCLEROSIS; BACILLARY DYSENTERY; DIABETES; TUBERCULOSIS.

[E.Ru.]

**Ultracentrifuge** A centrifuge of high or low speed which provides convection-free conditions and which is used for quantitative measurement of sedimentation velocity or sedimentation equilibrium or for the separation of solutes in liquid solution. See CENTRIFUGATION.

The ultracentrifuge is used (1) to measure molecular weights of solutes and to provide data on molecular weight distributions in polydisperse systems; (2) to determine the frictional coefficients, and thereby the sizes and shapes, of solutes; and (3) to characterize and separate macromolecules on the basis of their buoyant densities in density gradients. See MOLECULAR WEIGHT.

The ultracentrifuge is most widely used to study high polymers, particularly proteins, nucleic acids, viruses, and other macromolecules of biological origin. However, it is also used to study solution properties of small solutes. In applications to macromolecules, the analytical ultracentrifuge, which is used for accurate determination of sedimentation velocity or equilibrium, is

distinguished from the preparative ultracentrifuge, which is used to separate solutes on the basis of their sedimentation velocities or buoyant densities.

The application of a centrifugal field to a solution causes a net motion of the solute. If the solution is denser than the solvent, the motion will be away from the axis of rotation. The nonuniform concentration distribution produced in this way leads to an opposing diffusion flux tending to reestablish uniformity. In sedimentation-velocity experiments, sedimentation prevails over diffusion, and the solute sediments with finite velocity toward the bottom of the cell, although the concentration profile may be markedly influenced by diffusion. In sedimentation-equilibrium experiments, centrifugal and diffusive forces balance out, and an equilibrium concentration distribution results which may be analyzed by thermodynamic methods. See CENTRIFUGAL FORCE.

[V.A.B.]

**Ultrafast molecular processes** Various types of physical and molecular changes occurring on time scales of  $10^{-14}$  to  $10^{-9}$  s that are studied in the field of photophysics, photochemistry, and photobiography. The time scale ranges from near the femtosecond regime ( $10^{-15}$  s) on the fast side, embodies the entire picosecond regime ( $10^{-12}$  s), and borders the nanosecond regime ( $10^{-9}$  s) on the slow side.

A typical experiment is initiated with an ultrashort pulse of energy—radiation (light) or particles (electrons). Rapid changes in the system under study are brought about by the absorption of these ultrashort energy pulses. These changes can be measured by ultrafast detection methods. Such methods are usually based on some type of linear or nonlinear spectroscopic monitoring of the system, or on optical delay lines that employ the speed of light itself to create a yardstick of time (a distance of 3 mm equals a time of 10 picoseconds). These studies are important because elementary motion, such as rotation, vibrational exchange, chemical bond breaking, and charge transfer, takes place on these ultrafast time scales. The relationship between such motions and overall physical, chemical, or biological changes can thus be observed directly. See CHEMICAL DYNAMICS; OPTICAL PULSES; SPECTROSCOPY.

Just as a very fast shutter speed is necessary to obtain a sharp photograph of a fast-moving object, energy pulses for the study of ultrafast molecular motions must be extremely narrow in time. The basic technique for producing ultrashort light pulses is mode-locking a laser. One way to do this is to put a nonlinear absorption medium in the laser cavity, which functions somewhat like a shutter. In the time domain, the developing light pulse, bouncing back and forth between the laser cavity reflectors, experiences an intensity-dependent loss each time it passes through the nonlinear absorption medium. High-intensity light penetrates the medium, and its intensity is allowed to build up in the laser cavity; weak-intensity light is blocked. This process shaves off the low-amplitude edges of a pulse, thus shortening it. One of the laser cavity reflectors has less than 100% reflectance at the laser wavelength, so part of the pulse energy is coupled out of the cavity each time the pulse reaches that reflector. In this way, a train of pulses is emitted from the mode-locked laser, each pulse separated from the next by the round-trip time for a pulse traveling at the speed of light in the laser cavity, about

13 nanoseconds for a 2-m (6.6-ft) laser cavity length. See LASER; NONLINEAR OPTICS.

In addition to the extremely narrow energy pulses in the time domain, special ultrafast detection techniques are required in order to preserve the time resolution of an experiment.

A photobiological process, which has received considerable attention by spectroscopists studying the femtosecond regime, is light-driven transmembrane proton pumping in purple bacteria (*Halobacterium halobium*). Each link in the complex chain of molecular processes, such as an ultrafast photoionization event, is "fingerprinted" by a somewhat different absorption spectrum, making it possible to sort out these events by methods of ultrafast laser spectroscopy. The necessity for use of fast primary events in nature concerns overriding unwanted competing chemical and energy loss processes. The faster the wanted process, the less is the likelihood that unwanted, energy-wasting processes will take place. See LASER PHOTOBIOLOGY; LASER SPECTROSCOPY. [G.W.R.; N.L.]

**Ultrafiltration** A filtration process in which particles of colloidal size are retained by a filter medium while solvent and accompanying low-molecular-weight solutes are allowed to pass through. Ultrafilters are used (1) to separate colloid from suspending medium, (2) to separate particles of one size from particles of another size, and (3) to determine the distribution of particle sizes in colloidal systems by the use of filters of graded pore size.

Ultrafilter membranes have been prepared from various types of gel-forming substances: Unglazed porcelain has been impregnated with gels such as gelatin or silicic acid. Filter paper has been impregnated with glacial acetic acid collodions. Another type of ultrafilter membrane is made up of a thin plastic sheet containing millions of tiny pores evenly distributed over its surface. See COLLOID; FILTRATION. [Q.V.W.]

**Ultralight aircraft** A lightweight, single-seat aircraft with low flight speed and power, used for sport or recreation. Ultralights evolved from hang gliders. See GLIDER.

There have been tremendous variety of ultralight airframe configurations and control systems. Airframe types include powered weight-shift hang gliders, flying wings, canard designs, antique biplane replicas, and traditional, monoplane structures with conventional tail designs. Control systems can be either weight-shift systems, two-axis controls, or conventional three-axis controls. In weight-shift designs pilots must shift their weight, using a movable seat, to change the attitude. Two-axis designs use controls to the elevator and rudder only; there are no ailerons. Modern designs use three-axis control systems; weight-shift and two-axis control systems are no longer in production. Three-axis controls resemble those of a standard airplane and include either ailerons or spoilerons (spoiler-type systems used to make turns). Some more sophisticated ultralights are equipped with wing flaps, used to steepen approach profiles and to land at very slow airspeeds. See AIRFRAME; FLIGHT CONTROLS.

Typically, ultralight airframes are made of aircraft-grade aluminum tubes covered with Dacron sailcloth. Areas of stress concentration are reinforced with double-sleeving or solid aluminum components. Most ultralights are cable-braced and use aircraft-grade stainless steel cables with reinforced terminals. Wingspans average 30 ft (9 m), and glide ratios range from 7:1 to 10:1, depending primarily on gross weight and wing aspect ratio. See AIRFOIL; ASPECT RATIO; WING.

Ultralight engines are lightweight, two-stroke power plants with full-power values in the 28–35-hp (21–26-kW) range. They operate on a mixture of gasoline and oil, and most transmit power to the propeller via a reduction or belt drive, a simple transmission that enables the propeller to rotate at a lower, more efficient rate than the engine shaft. See AIRPLANE; PROPELLER (AIRCRAFT); RECIPROCATING AIRCRAFT ENGINE. [T.A.Ho.]

**Ultrasonics** The science of sound waves having frequencies above the audible range, that is, above about 20,000 Hz. Original workers in this field adopted the term supersonics. However, this name was also used in the study of airflow for velocities faster than the speed of sound. The present convention is to use the term ultrasonics as defined above. Since there is no marked distinction between the propagation and the uses of sound waves above and below 20,000 Hz, the division is artificial. See SOUND.

**Ultrasonic generators and detectors.** Ultrasonic transducers have two functions: transmission and reception. There may be separate transducers for each function or a single transducer for both functions. The usual types of generators and detectors for air, liquids, and solids are piezoelectric and magnetostrictive transducers. Quartz and lithium niobate ( $\text{LiNbO}_3$ ) crystals are used to produce longitudinal and transverse waves; thin-film zinc oxide ( $\text{ZnO}$ ) transducers can generate longitudinal waves at frequencies up to 96 GHz. Another class of materials used to generate ultrasonic signals is the piezoelectric ceramics. In contrast to the naturally occurring piezoelectric crystals, these ceramics have a polycrystalline structure. The most commonly produced piezoelectric ceramics are lead zirconate titanate (PZT), barium titanate ( $\text{BaTiO}_3$ ), lead titanate ( $\text{PbTiO}_3$ ), and lead metaniobate ( $\text{PbNb}_2\text{O}_6$ ). Composite transducers are transducers in which the radiating or receiving element is a diced piezoelectric plate with filler between the elements. They are called "composite" to account for the two disparate elements, the piezoelectric diced into rods and the compliant adhesive filler. See MAGNETOSTRICTION; PIEZOELECTRICITY.

High-power ultrasound (typically 600 W) can be obtained with sonicators, consisting of a converter, horn, and tip. The converter transforms electrical energy to mechanical energy at a frequency of 20 kHz. Oscillation of piezoelectric transducers is transmitted and focused by a titanium horn that radiates energy into the liquid being treated. Horn and tip sizes are determined by the volume to be processed and the intensity desired. As the tip diameter increases, intensity or amplitude decreases.

**Engineering applications.** The engineering applications of ultrasonics can be divided into those dealing with low-amplitude sound waves and those dealing with high-amplitude (usually called macrosonics) waves.

**Low-amplitude applications.** Low-amplitude applications are in sonar (an underwater-detection apparatus), in the measurement of the elastic constants of gases, liquids, and solids by a determination of the velocity of propagation of sound waves, in the measurement of acoustic emission, and in a number of ultrasonic devices such as delay lines, mechanical filters, inspectors, thickness gages, and surface-acoustic-wave devices. All these applications depend on the modifications that boundaries and imperfections in the materials cause in wave propagation properties. The attenuation and scattering of the sound in the media are important factors in determining the frequencies used and the sizes of the pieces that can be utilized or investigated. See SONAR.

**High-amplitude applications.** High-amplitude acoustic waves (macrosonic) have been used in a variety of applications involving gases, liquids, and solids. Some common applications are mentioned below.

A liquid subjected to high-amplitude acoustic waves can rupture, resulting in the formation of gas- and vapor-filled bubbles. When such a cavity collapses, extremely high pressures and temperatures are produced. The process, called cavitation, is the origin of a number of mechanical, chemical, and biological effects.

Cavitation plays an integral role in a wide range of processes such as ultrasonic cleaning and machining, catalysis of chemical reactions, disruption of cells, erosion of solids, degassing of liquids, emulsification of immiscible liquids, and dispersion of solids in liquids. Cavitation can also result in weak emission of light, called sonoluminescence. See CAVITATION; SONOCHEMISTRY.



One of the principal applications of ultrasonics to gases is particle agglomeration. This technique has been used in industry to collect fumes, dust, sulfuric acid mist, carbon black, and other substances.

Another industrial use of ultrasonics has been to produce alloys, such as lead-aluminum and lead-tin-zinc, that could not be produced by conventional metallurgical techniques. Shaking by ultrasonic means causes lead, tin, and zinc to mix.

**Analytical uses.** In addition to their engineering applications, high-frequency sound waves have been used to determine the specific types of motions that can occur in gaseous, liquid, and solid mediums. Both the velocity and attenuation of a sound wave are functions of the sound frequency. By studying the changes in these properties with changes of frequency, temperature, and pressure, indications of the motions taking place can be obtained. See SOUND ABSORPTION.

**Medical applications.** Application of ultrasonics in medicine can be generally classified as diagnostic and therapeutic. The more common of these at present is the diagnostic use of ultrasound, specifically ultrasonic imaging. See BIOMEDICAL ULTRASONICS; MEDICAL IMAGING; NONLINEAR ACOUSTICS.

Ultrasonic fields of sufficient amplitude can generate bioeffects in tissues. Although diagnostic ultrasound systems try to limit the potential for these effects, therapeutic levels of ultrasound have been used in medicine for a number of applications. Conventional therapeutic ultrasound is a commonly available technique used in physical therapy. High-frequency acoustic fields (typically 1 MHz) are applied through the skin to the affected area in either a continuous wave or long pulses.

Extracorporeal shock-wave lithotripsy (ESWL) disintegrates kidney stones with a high-amplitude acoustic pulse passing through the skin of the patient. The procedure eliminates the need for extensive surgery. Bioeffects are limited to the location of the stone by using highly focused fields which are targeted on the stone by imaging techniques such as ultrasound or fluoroscopy. [H.E.Ba.; J.B.Fo.; V.M.K.]

**Ultraviolet astronomy** Astronomical observations carried out in the region of the electromagnetic spectrum with wavelengths from approximately 10 to 350 nanometers. Ultraviolet radiation from astronomical sources contains important diagnostic information about the composition and physical conditions of these objects. This information includes atomic absorption and emission lines of all the most abundant elements in many states of ionization. The hydrogen molecule ( $H_2$ ), the most abundant molecule in the universe, has its absorption and emission lines in the far-ultraviolet. See ASTRONOMICAL SPECTROSCOPY; ULTRAVIOLET RADIATION.

Ultraviolet radiation with wavelengths less than 310 nm is strongly absorbed by molecules in the atmosphere of the Earth. Therefore, ultraviolet observations must be carried out by using instrumentation situated above the atmosphere. Ultraviolet astronomy began with instrumentation aboard sounding rockets. The first major ultraviolet satellite observatories to be placed in space were the United States *Orbiting Astronomical Observatories* (OAOs). The *International Ultraviolet Explorer* (IUE), launched into a geosynchronous orbit in 1978, realized the full potential of ultraviolet astronomy. See ROCKET ASTRONOMY; SATELLITE ASTRONOMY.

NASA's *Extreme Ultraviolet Explorer* (EUVE) satellite (1992–2001) contained telescopes designed to produce images of the extreme-ultraviolet sky and spectra of bright extreme-ultraviolet sources in the wavelength range from approximately 10 to 90 nm. Most of the sources of radiation detected with the EUVE were stars with hot active outer atmospheres (or coronae) and hot white dwarf stars. See WHITE DWARF STAR.

Although it had an inauspicious beginning, the Hubble Space Telescope, launched in 1990, has become the centerpiece of both ultraviolet and visible astronomy. The complement of instruments aboard the Hubble Space Telescope has included

imaging cameras operating at ultraviolet, visual, and infrared wavelengths, and spectrographs operating at ultraviolet and visual wavelengths. See SPACE TELESCOPE, HUBBLE; SPECTROGRAPH; TELESCOPE.

The *Far-ultraviolet Spectrograph Explorer* (FUSE) satellite, launched in 1999, is designed to explore the universe in the 90–120-nm region of the spectrum at high spectral resolution. *Galaxy Evolution Explorer* (GALEX), launched in 2003, is a modest-sized ultraviolet imaging and spectroscopic survey mission that probes star formation over 80% of the age of the universe.

The important discoveries of ultraviolet astronomy span all areas of modern astronomy and astrophysics. Some of the notable discoveries in the area of solar system astronomy include new information on the upper atmospheres of the planets, including planetary aurorae and the discovery of the enormous hydrogen halos surrounding comets. In studies of the interstellar medium, ultraviolet astronomy has provided fundamental information about the molecular hydrogen content of cold interstellar clouds along with the discovery of the hot phase of the interstellar medium, which is created by the supernova explosions of stars. In stellar astronomy, ultraviolet measurements led to important insights about the processes of mass loss through stellar winds and have permitted comprehensive studies of the conditions in the outer chromospheric and coronal layers of cool stars. The IUE, Hubble Space Telescope, and FUSE observatories have contributed to the understanding of the nature of the hot gaseous corona surrounding the Milky Way Galaxy. Ultraviolet observations of exotic astronomical objects, including exploding stars, active galactic nuclei, and quasars, have provided new insights about the physical processes affecting the behavior of matter in extreme environments. The spectrographs aboard the Hubble Space Telescope have revealed the existence of large numbers of hydrogen clouds in the intergalactic medium. These intergalactic clouds may contain as much normal (baryonic) matter as there exists in the known luminous galaxies and stars. See COMET; COSMOLOGY; GALAXY, EXTERNAL; INTERSTELLAR MATTER; MILKY WAY GALAXY; PLANETARY PHYSICS; QUASAR; SATELLITE (ASTRONOMY); STAR; SUPERNOVA. [B.D.S.]

**Ultraviolet lamp** A mercury-vapor lamp designed to produce ultraviolet radiation. Also, some fluorescent lamps and mercury-vapor lamps that produce light are used for ultraviolet effects. See FLUORESCENT LAMP; MERCURY-VAPOR LAMP.

Fluorescent and mercury lamps can be filtered so that visible energy is absorbed and emission is primarily in the near-ultraviolet or black-light spectrum (320–400 nanometers). The ultraviolet energy emitted is used to excite fluorescent pigments in paints, dyes, or natural materials.

Mercury-vapor lamps are sometimes designed with pressures that produce maximum radiation in the middle ultraviolet region (280–320 nm), using special glass bulbs that freely transmit this energy. One such lamp type is the sunlamp. Other lamps designed for middle-ultraviolet radiation are known as photochemical lamps. See SUNLAMP.

Some radiation in the 220–280-nm wavelength band has the capacity to destroy certain kinds of bacteria. Mercury lamps designed to produce energy in this region (the 253.7-nm mercury line) are electrically identical with fluorescent lamps; they differ from fluorescent lamps in the absence of a phosphor coating and in the use of glass tubes that transmit far ultraviolet. See ULTRAVIOLET RADIATION (BIOLOGY). [A.M.]

**Ultraviolet radiation** Electromagnetic radiation in the wavelength range 4–400 nanometers. The ultraviolet region begins at the short wavelength (violet) limit of visibility and extends to the wavelength of long x-rays. It is loosely divided into the near (400–300 nm), far (300–200 nm), and extreme (below 200 nm) ultraviolet regions (see illustration). In the extreme ultraviolet, strong absorption of the radiation by air requires the use

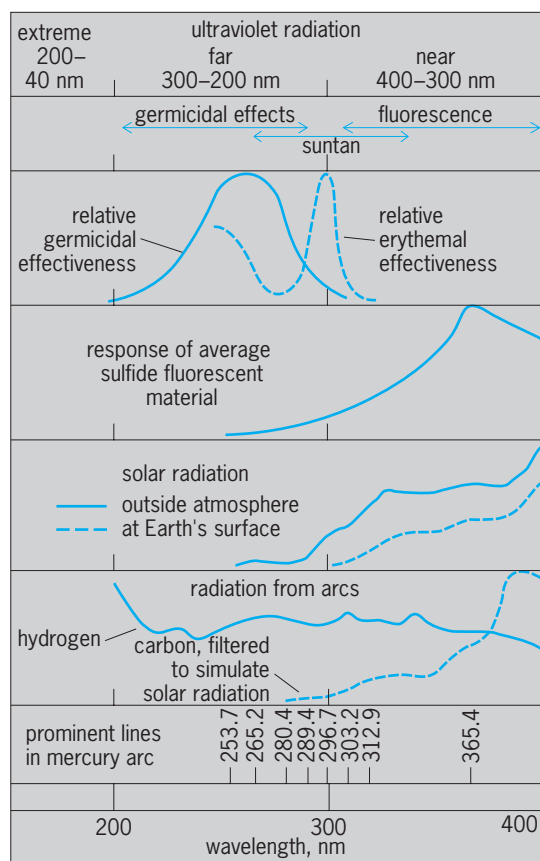

Phenomena associated with ultraviolet radiation. (After L. R. Koller and General Electric)

of evacuated apparatus; hence this region is called the vacuum ultraviolet. Important phenomena associated with ultraviolet radiation include biological effects and applications, the generation of fluorescence, and chemical analysis through characteristic absorption or fluorescence. See ULTRAVIOLET RADIATION (BIOLOGY).

Sources of ultraviolet radiation include the Sun (although much solar ultraviolet radiation is absorbed in the atmosphere); arcs of elements such as carbon, hydrogen, and mercury; and incandescent bodies. See ULTRAVIOLET LAMP. [F.W.B.]

**Ultraviolet radiation (biology)** Radiations between 200 and 300 nanometers are selectively absorbed by organic matter, and produce the best-known effects of ultraviolet radiations on organisms. Ultraviolet radiations, in contrast to x-rays, do not penetrate far into larger organisms; therefore, the effects they produce are surface effects, such as sunburn and development of D vitamins from precursors present in skin or fur. The effects of ultraviolet radiations on life have, therefore, been assayed chiefly with unicellular organisms such as bacteria, yeast, and protozoans, although suspensions of cells of higher organisms, for example, eggs and blood corpuscles, have been useful as well.

**Photobiological effects.** Only the ultraviolet radiations which are absorbed can produce photobiological action. All life activities are shown to be affected by ultraviolet radiations, the effect depending upon the dosage. Small dosages activate unfertilized eggs of marine animals, reduce the rate of cell division, decrease the synthesis of nucleic acid, especially in the nucleus, reduce the motility of cilia and of contractile vacuoles, and sensitize cells to heat. Large doses increase the permeability of cells to various substances, inhibit most synthetic processes, produce mutations, stop division of cells, decrease the rate of respiration,

and may even disrupt cells. The effect of ultraviolet radiations upon cells is invariably deleterious.

**Effects on the skin.** Erythema is the reddening of the skin following exposure to ultraviolet radiation of wavelength shorter than 320 nm, wavelength 296.7 nm being most effective. These radiations injure cells in the outer layer of the skin, or epidermis, liberating substances which diffuse to the inner layer of the skin, or dermis, causing enlargement of the small blood vessels. A minimal erythral dose just induces reddening of the skin observed 10 h after exposure. A dose several times the minimal gives a sunburn, killing some cells in the epidermis after which serum and white blood cells accumulate, causing a blister. After the dried blister peels, the epidermis is temporarily thickened and pigment develops in the lower layers of the epidermis, both of these factors serving to protect against subsequent exposure to ultraviolet.

Both thickening of the epidermis and tanning may occur without blistering. Since the pigment in light-skinned races develops chiefly below the sensitive cells in the epidermis, it is not as effective as in dark-skinned races where the pigment is scattered throughout the epidermis. Consequently, the minimal erythral dose is much higher for the dark- than for the light-skinned races.

Excessive exposure to ultraviolet radiation has been found to lead to cancer in mice, and it is claimed by some to cause cutaneous cancer in humans.

**Clinical use.** Ultraviolet radiations were once used extensively in the treatment of rickets, many skin diseases, tuberculosis other than pulmonary, especially skin tuberculosis (lupus vulgaris), and of many other diseases. The enthusiasm for sun bathing is, in part, a relic of the former importance of ultraviolet radiation as a clinical tool. Vitamin preparations, synthetic drugs, and antibiotics have either displaced ultraviolet radiations in such therapy or are used in conjunction with the radiations.

Ultraviolet radiations alone are still employed to treat rickets in individuals sensitive to vitamin D preparations. In conjunction with chemicals, they are used in treating skin diseases, for example, psoriasis, pityriasis rosea, and sometimes acne, as well as for the rare cases of sensitivity to visible light. Ultraviolet radiations, however, are more important in research than in clinical practice. [A.C.Gi.]

**Umklapp process** A concept in the theory of transport properties of solids which has to do with the interaction of three or more waves in the solid, such as lattice waves or electron waves. In a continuum, such interactions occur only among waves described by wave vectors  $\mathbf{k}_1$ ,  $\mathbf{k}_2$ , and so on, such that the interference condition, given by Eq. (1), is satisfied. The sign of

$$\mathbf{k}_1 + \mathbf{k}_2 + \mathbf{k}_3 = 0 \quad (1)$$

$\mathbf{k}$  depends on whether the wave absorbs or emits energy. Since  $\hbar\mathbf{k}$  is the momentum of a quantum (or particle) described by the wave, Eq. (1) corresponds to conservation of momentum. In a crystal lattice further interactions occur, satisfying Eq. (2),

$$\mathbf{k}_1 + \mathbf{k}_2 + \mathbf{k}_3 = \mathbf{b} \quad (2)$$

where  $\mathbf{b}$  is any integral combination of the three inverse lattice vectors  $\mathbf{b}_i$ , defined by  $\mathbf{a} \cdot \mathbf{b}_i = 2\pi\delta_{ij}$ , the  $\mathbf{a}$ 's being the periodicity vectors. The group of processes described in Eq. (2) are the Umklapp processes or flip-over processes, so called because the total momentum of the initial particles or quanta is reversed. See CRYSTAL. [P.G.Kl.]

**Uncertainty principle** A fundamental principle of quantum mechanics, which asserts that it is not possible to know both the position and momentum of an object with arbitrary accuracy. This contrasts with classical physics, where the position and momentum of an object can both be known exactly. In quantum mechanics, this is no longer possible, even in principle. More precisely, the indeterminacy or uncertainty principle, derived by W. Heisenberg, asserts that the product of

$\Delta x$  and  $\Delta p$ —measures of indeterminacy of a coordinate and of momentum along that coordinate—must satisfy inequality (1).

$$\Delta x \times \Delta p \gtrsim \hbar = \frac{h}{2\pi} \quad (1)$$

The Planck constant,  $h \simeq 6.63 \cdot 10^{-34}$  joule-second, is very small, which makes inequality (1) unimportant for the measurements that are carried out in everyday life. Nevertheless, the consequences of the inequality are critically important for the interactions between the elementary constituents of matter, and are reflected in many of the properties of matter that are ordinarily taken for granted. For example, the density of solids and liquids is set to a large degree by the uncertainty principle, because the sizes of atoms are determined with decisive help of inequality (1).

In classical physics, simultaneous knowledge of position and momentum can be used to predict the future trajectory of a particle. Quantum indeterminacy and the limitations it imposes force such classical notions of causality to be abandoned.

Another well-known example of indeterminacy involves energy and time, as given by inequality (2). Physically, its origins

$$\Delta E \times \Delta t \gtrsim \hbar \quad (2)$$

are somewhat different from those of inequality (1). Inequality (2) relates, for example, lifetimes of unstable states with the widths of their lines. See LINEWIDTH.

In quantum physics, relations similar to inequalities (1) and (2) hold for pairs of many other quantities. They demonstrate that the acquisition of the information about a quantum object cannot be usually achieved without altering its state. Much of the strangeness of quantum physics can be traced to this impossibility of separating the information about the state from the state itself. See NONRELATIVISTIC QUANTUM THEORY; QUANTUM MECHANICS. [W.H.Z.]

**Unconformity** In the stratigraphic sequence of the Earth's crust, a surface of erosion that cuts the underlying rocks and is overlain by sedimentary strata. The unconformity represents an interval of geologic time, called the hiatus, during which no deposition occurred and erosion removed preexisting rock. The result is a gap, in some cases encompassing millions of years, in the stratigraphic record. See STRATIGRAPHY.

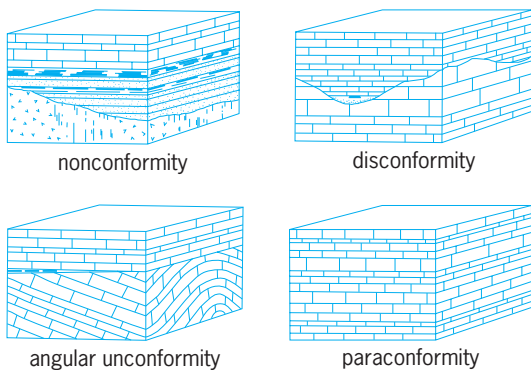

Four types of unconformity. (After C.O. Dunbar and J. Rodgers, *Principles of Stratigraphy*, Wiley, 1957)

There are four kinds of unconformable relations (see illustration): *Nonconformity*—underlying rocks are not stratified, such as massive crystalline rocks formed deep in the Earth. *Angular unconformity*—underlying rocks are stratified but were deformed before being eroded, resulting in angular discordance; this was the first type to be recognized; the term unconformity was originally used to describe the geometric relationship between the underlying and overlying bedding planes. *Disconformity*—underlying strata are undeformed and parallel

to overlying strata, but separated by an evident erosion surface. *Paraconformity*—strata are parallel and the erosion surface is subtle, or even indistinguishable from a simple bedding plane. [C.W.By.]

**Underground mining** The extraction of ore from beneath the surface of the ground. Underground mining is also applied to deposits of industrial (nonmetallic) minerals and rocks, and underground or deep methods are used in coal mining. Some ores and industrial minerals can be recovered from beneath the ground surface by solution mining or in-place leaching using boreholes. See COAL MINING; SOLUTION MINING.

Underground mining is done where mineral deposits are situated beyond the economic depth of open pit mining; it is generally applied to steeply dipping or thin deposits and to disseminated or massive deposits for which the cost of removing the overburden and the maintaining of a slope angle in adjacent waste rock would be prohibitive. See OPEN PIT MINING.

Underground mine entries are by shaft, adit, incline, or spiral ramp (see illustration). Development workings, passageways for gaining access to the orebody from stations on individual mine levels, are called drifts if they follow the trend of the mineralization, and cross-cuts if they are driven across the mineralization. Workings on successive mine levels are connected by raises, passageways that are driven upward. Winzes are passageways that are sunk downward, generally from a lowermost mine level.

In a fully developed mine with a network of levels, sublevels, and raises for access, haulage, pumping, and ventilation, the ore is mined from excavations referred to as stopes. Pillars of unmined material are left between stopes and other workings for temporary or permanent natural support. In large-scale mining methods and in methods where an orebody and its overlying waste rock are allowed to break and cave under their own weight, the ore is extracted in large collective units called blocks, panels, or slices. See MINING.

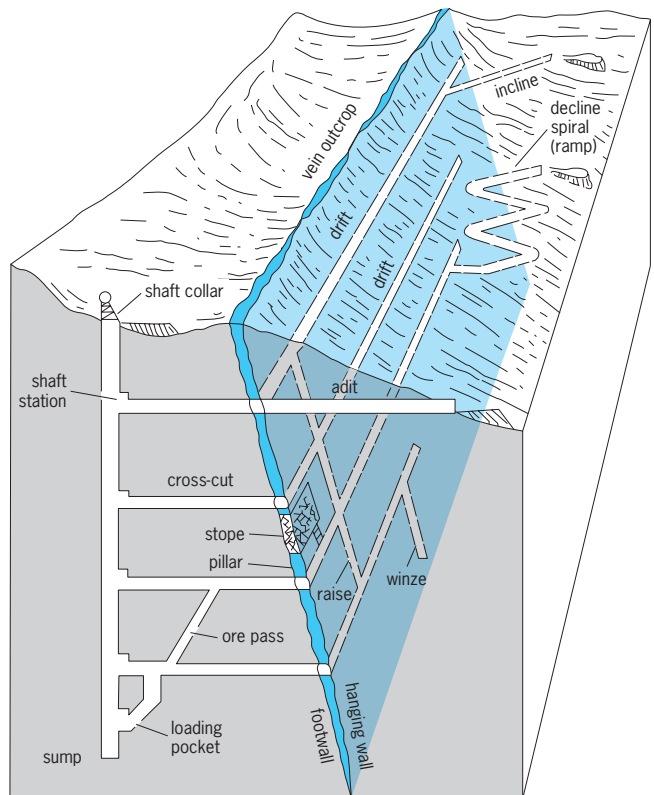

Underground mining entries and workings.

Information on the size, shape, and attitude of a deposit and information for estimating the tonnage and grade of the ore is taken from drill holes and underground exploration workings. Underground exploration workings are used for bulk and detailed sampling, rock mechanics testing, and the siting of machinery for underground drilling.

Where high topographic relief allows for an acceptable tonnage of ore above a horizontal entry site, an adit or blind tunnel is driven as a cross-cut to the deposit or as a drift following the deposit from a portal at a favorable location for the surface plant, drainage facilities, and waste disposal. In situations where the deposit lies below or at a great distance from any portal site for an adit, entry must be made from a shaft collar or from an incline or decline portal. A large mine will commonly have a main multi-purpose entry and several more shafts or adits to accommodate personnel, supplies, ventilation, communication, and additional production.

A fundamental condition in the choice of mining method is the strength of the ore and wall rock. Strong ore and rock permit relatively low-cost methods with naturally supported openings or with a minimum of artificial support. Weaker ore and wall rock necessitate more costly methods requiring widespread temporary or permanent artificial support such as rock bolting. Large deposits with weak ore and weak walls that collapse readily and provide suitably broken material for extraction may be mined by low-cost caving methods. Few mineral deposits are so uniform that a single method can be used without modification in all parts of the mine. [W.C.Pe.]

**Underwater demolition** The controlled use of explosives to achieve specific underwater work requiring cutting, fragmenting, perforating, or pounding.

In addition to wreck removal and channel widening and deepening uses, a wide range of commercial applications has been developed for underwater demolition. In the offshore oil and gas industries, charges may be placed and fired well below the ocean floor to open fissures in the rock, cut off steel pipe, open trenches, and remove old structures. The military uses underwater demolition to remove obstacles to amphibious assault.

Special charge shapes and sizes allow very precise work to be done with explosives. While charges for military purposes are usually placed by divers, explosives used commercially can also be placed by crewed submersibles or remote-operated vehicles. See DIVING; EXPLOSIVE; SHIP SALVAGE. [W.I.M.]

**Underwater navigation** The process of directing the movements of submersible vehicles, and divers, from one point to another. The development of improved submersible vehicles, coupled with advances in saturated diving, has resulted in new requirements for underwater navigation. Various methods which have proved successful include acoustic transponder systems, dead reckoning, surface-referenced navigation from a support ship, homing, and various combinations of these. The choice of the navigation system depends on such factors as precision required, area to be covered, availability of surface vessels, sea state under which they are expected to operate, and for crewed vehicles the redundancy necessary for safety. See DIVING; SUBMARINE; UNDERWATER VEHICLE.

**Acoustic transponders.** The most accurate undersea navigation systems use acoustic transponders to precisely determine position with respect to points on the sea floor. A minimum of two transponders are normally dropped from a surface or submerged vehicle to establish a bottom-tethered array. The transponders can be interrogated by surface vessels, submersible vehicles, or divers. When the navigation solution is computed on the surface vessel, the submerged vehicle also carries a transponder, and the position of the submerged vehicle is computed relative to the bottom-tethered array.

**Dead reckoning.** An undersea vehicle needs sensors to show distance traveled and direction of travel for dead-reckoning estimation of position. The most promising sensor for operation near the sea floor is a Doppler sonar. Ground speed, fore-aft and athwartship, can be determined from the Doppler shift in frequency of signals returned from the sea floor. Pulse-type and continuous-wave Doppler sonars are available. The pulse type, which makes use of a frequency tracker circuit to lock on the received pulse, appears to offer the best accuracy, and it has the ability to operate to 600 ft (180 m) above the sea floor. See SONAR.

In addition to Doppler sonar, some specialized submersibles carry inertial dead reckoning in the form of a small, stabilized platform. See DEAD RECKONING; INERTIAL GUIDANCE SYSTEM.

**Other methods.** Most submersible vehicles carry additional navigation sensors. The horizontal obstacle sonar (HOS) which is a constant-transmission frequency-modulated sonar (CTFM), is normally used to detect objects ahead of the submersible. This sonar also has a transponder channel for determining bearing and range to specially designed transponders. An altitude-depth sonar provides vertical navigation by furnishing depth and altitude off the bottom. Finally, a vertical obstacle sonar (VOS) determines heights of objects in the path of the vehicle. Both horizontal and vertical obstacle-avoidance sonars are useful in under-ice navigation. See HOMING; PILOTING.

An acoustic tracking system allows the monitoring and vectoring of the position of a vehicle from a surface vessel, where space and weight are not at a premium, and Loran C, the Global Positioning System, Omega, or other radio techniques can be used to determine the ship's own position in geographic coordinates. Surface tracking systems are of two types: ultrashort baseline, employing orthogonal line hydrophone arrays; and short baseline, employing four separate hydrophones. See MARINE NAVIGATION.

Submarines must operate over wide areas of the ocean and often under highly secure and covert conditions; therefore, navigation techniques which depend upon sonic or electromagnetic emissions, or which restrict movements of the vehicle to either near-bottom or near-surface regions, are judged to be too restrictive. The ability of inertial navigation systems to operate without frequent recourse to external position updates makes them prime candidates for submarine navigation. The need for covert and secure long-duration navigation has resulted in the evolution of a navigation configuration that uses a pair of electrostatic gyroscope navigators (ESGNs) as the primary elements of an integrated navigation subsystem. The very stable, low-drift characteristics of the electrostatic gyroscope result in an inertial navigation system with a low and highly predictable error growth. Weapons system accuracy is further enhanced by velocity derived from both gyroscopes and secure correlation velocity sonar techniques to give a direct measure of the submarine ground speed. Vertical deflection maps, which are used for vertical-axis tilt compensation of the gyroscopes, are generated from combined satellite and oceanographic surveys of the Earth's gravity field. The relatively rare position resets are selected from either Global Positioning System satellite or bathymetric sonar data. The passive electromagnetic-log, which measures vehicle velocity relative to the water and is therefore subject to ocean current errors, is used primarily to damp the gyroscope computational (Schuler) oscillations. The various data are processed in a central navigation computer which uses statistical estimation algorithms. See ESTIMATION THEORY.

Navigation has always been a difficult problem for divers. Some of the same sonars developed for submersible pilotage offer an answer for a diver. A horizontally swept constant-transmission frequency-modulated sonar is well matched to the excursions of saturated divers, who are limited in allowable vertical movement. By communication with the habitat, divers who stray too far or lose their orientation can be guided back to safety.

[C.J.Hr.; J.A.C.; E.St.G.]

**Underwater photography** The techniques involved in using photographic equipment underwater. By far the greatest percentage of underwater photography is done within sport-diving limits in the tropical oceans.

Underwater photographers are faced with specific technical challenges. Water is 600 times denser than air and is predominantly blue in color. Depth affects light and creates physiological considerations for the photographer. As a result, underwater photography requires an understanding of certain principles of light beneath the sea.

As in all photography, consideration of the variables of light transmission is crucial to underwater photography. When sunlight strikes the surface of the sea, its quality and quantity change in several ways. As light travels from air to a denser medium, such as water, the light rays are bent (refracted); one result is magnification of underwater objects by one-third as compared to viewing them in air. The magnification effect must be considered when estimating distances underwater, which is critical for both focus and exposure. Light is absorbed when it propagates through water. Variables affecting the level of light penetration include the time of day (affects the angle at which the sunlight strikes the surface of the water); cloud cover; clarity of the water; depth (light is increasingly absorbed with increasing depth); and surface conditions (if the sea is choppy, more light will be reflected off the surface and less light transmitted to the underwater scene). See LIGHT; PHOTOGRAPHY; REFRACTION OF WAVES.

Depth affects not only the quantity of light but also the quality of light. Once light passes from air to water, different wavelengths of its spectrum are absorbed as a function of the color of the water and depth. Even in the clearest tropical sea, water serves as a powerful cyan (blue-green) filter. Natural full-spectrum photographs can be taken only with available light in very shallow depths. In ideal daylight conditions and clear ocean water, photographic film fails to record red at about 15 ft (4.5 m) in depth. Orange disappears at 30 ft (9 m), yellow at 60 ft (18 m), green at 80 ft (24 m), and at greater depth only blue and black are recorded on film. To restore color, underwater photographers must use artificial light. See SEAWATER.

The water column between photographer and subject degrades both the resolution of the image and the transmission of artificial light (necessary to restore color). Therefore, the most effective underwater photos are taken as close as possible to the subject, thereby creating the need for a variety of optical tools to capture subjects of various sizes within this narrow distance limitation.

There are two types of underwater cameras—amphibious and housed. Amphibious cameras may be used either underwater or topside, although some lenses are for underwater use only (known as water contact lenses). A housed camera is a conventional above-water camera that has been protected from the damaging effects of seawater by a waterproof enclosure. The amphibious camera is protected by a series of O-rings, primarily located at the lens mount, film loading door, shutter release, and other places where controls are necessary. The O-rings make the system not only resistant to leaks but also impervious to dust or inclement weather when used above water. [S.Fri.]

Deep-sea underwater photography—approximately 150 ft (35 m)—requires the design and use of special camera and lighting equipment. Watertight cases are required for both camera and light source, and they must be able to withstand the pressure generated by the sea. For each 33 ft (10 m) of depth, approximately one additional atmosphere ( $\sim 10^2$  kilopascals) of pressure is exerted. At the greatest ocean depths, about 40,000 ft (12,000 m), a case must be able to withstand 17,600 lb/in.<sup>2</sup> (1200 kg/cm<sup>2</sup>). The windows for the lens and electrical seals must also be designed for such pressure to prevent water intrusion.

Auxiliary lighting is required, since daylight is absorbed in both intensity and hue. The camera must be positioned and triggered to render the desired photograph, and the great depths preclude a free-swimming human operator. Operation is often from a

cable via sonar sensing equipment or from deep-diving underwater vehicles. Bottom-sensing switches can operate deep-sea cameras for photographing the sea floor, and remotely operated vehicles (ROVs) can incorporate both video and still cameras. See SONAR; UNDERWATER VEHICLE.

When an observer descends to great depths in a diving vehicle, the camera can assist in documentation by recording what is seen. Furthermore, the visual data will assist in accurate description of the observed phenomena. Elapsed-time photography with a motion picture camera in the sea is important in studying sedimentation deposits caused by tides, currents, and storms. Similarly, the observation of biological activity taken with the elapsed-time camera and then speeded up for viewing may reveal processes that cannot ordinarily be observed. See DIVING; PHOTOGRAPHY; UNDERWATER TELEVISION. [H.E.E.; S.Fri.]

**Underwater sound** The production, propagation, reflection, scattering, and reception of sound in seawater. The sea covers approximately 75% of the Earth's surface. In terms of exploration, visible observation of the sea is limited due to the high attenuation of light, and radar has very poor penetrability into salt water. Because of the extraordinary properties that sound has in the sea, and because of some of the inherent characteristics of the sea, acoustics is the principal means by which the sea has been explored. See OCEAN.

**Absorption.** Sound has a remarkably low loss of energy in seawater, and it is that property above all others that allows it to be used in research and other application. Absorption is the loss of energy due to internal causes, such as viscosity. Over the frequency range from about 100 Hz (cycles per second) to 100 kHz, absorption is dominated by the reactions of two molecules, magnesium sulfate (MgSO<sub>4</sub>) and boric acid [B(OH)<sub>3</sub>]. These molecules are normally in equilibrium with their ionic constituents. The pressure variation caused by an acoustic wave changes the ionic balance and, during the passage of the pressure-varying acoustic field, it cannot return to the same equilibrium, and energy is given up. This is called chemical relaxation. At about 65 kHz magnesium sulfate dominates absorption, and boric acid is important near 1 kHz. See SEAWATER; SOUND; SOUND ABSORPTION.

**Sound speed.** The speed of sound in seawater and its dependence on the parameters of the sea, such as temperature, salinity, and density, have an enormous effect on acoustics in the sea. Generally the environmental parameter that dominates acoustic processes in oceans is the temperature, because it varies both spatially and temporally. Solar heating of the upper ocean has one of the most important effects on sound propagation. As the temperature of the upper ocean increases, so does the sound speed. Winds mix the upper layer, giving rise to a layer of water of approximately constant temperature, below which is a region called the thermocline. Below that, most seawater reaches a constant temperature. All these layers depend on the season and the geographical location, and there is considerable local variation, depending on winds, cloud cover, atmospheric stability, and so on. Shallow water is even more variable due to tides, fresh-water mixing, and interactions with the sea floor. Major ocean currents, such as the Gulf Stream and Kuroshio, have major effects on acoustics. The cold and warm eddies that are spun off from these currents are present in abundance and significantly affect acoustic propagation. See GULF STREAM; KUROSHIO; OCEANOGRAPHY.

**Pressure waves.** The science of underwater sound is the study of pressure waves in the sea over the frequency range from a few hertz to a few megahertz. The International System (SI) units are the pascal (Pa) for pressure (equal to one newton per square meter) and the watt per square meter (W/m<sup>2</sup>) for sound intensity (the flow of energy through a unit area normal to the direction of wave propagation). In acoustics, it is more convenient to refer to pressures, which are usually much smaller than a pascal, and the consequent intensities with a different reference,

the decibel. Intensity in decibels (dB) is ten times the logarithm to the base ten of the measured intensity divided by a reference intensity. See DECIBEL; SOUND INTENSITY; SOUND PRESSURE.

**Wave propagation.** The mathematical equation that sound obeys is known as the wave equation. Its derivation is based on the mathematical statements of Newton's second law for fluids (the Navier-Stokes equation), the equation of continuity (which essentially states that when a fluid is compressed, its mass is conserved), and a law of compression, relating a change of volume to a change in pressure. By the mathematical manipulation of these three equations, and the assumption that only very small physical changes in the fluid are taking place, it is possible to obtain a single differential equation that connects the acoustic pressure changes in time to those in space by a single quantity, the square of the sound speed ( $c$ ), which is usually a slowly varying function of both space and time. See NAVIER-STOKES EQUATION; WAVE EQUATION.

Knowing the sound speed as a function of space and time allows for the investigation of the spatial and temporal properties of sound, at least in principle. The mathematics used to find solutions to the wave equation are the same as those that are used in other fields of physics, such as optics, radar, and seismics. See WAVE MOTION.

In addition to knowing the speed of sound, it is necessary to know the location and nature of the sources of sound, the location and features of the sea surface, the depth to the sea floor, and, in many applications, the physical structure of the sea floor. It is not possible to know the sound speed throughout the water column or know the boundaries exactly. Thus the solutions to the wave equation are never exact representations of nature, but estimates, with an accuracy that depends on both the quality of the knowledge of the environment and the degree to which the mathematical or numerical solutions to the wave equation represent the actual physical situation.

**Ambient noise.** A consequence of the remarkable transmission of sound is that unwanted sounds are transmitted just as efficiently. One of the ultimate limitations to the use of underwater sound is the ability to detect a signal above the noise. In the ocean, there are four distinct categories of ambient sound: biological, oceanographic physical processes, seismic, and anthropogenic. See ACOUSTIC NOISE; INFRASOUND.

**Scattering and reverberation.** The other source of unwanted sound is reverberation. Sound that is transmitted inevitably finds something to scatter from in the water column, at the sea surface, or at the sea floor. The scatter is usually in all directions, and some of it will return to the system that processes the return signals. Sources of scattering in the water column are fish, particulates, and physical inhomogeneities. The sea surface is, under normal sea conditions, agitated by winds and has the characteristic roughness associated with the prevailing atmospheric conditions. Rough surfaces scatter sound with scattering strengths that depend on the roughness, the acoustic frequency (or wavelength), and the direction of the signal. The scattering is highly time-dependent, and needs to be studied with an appropriate statistical approach. The sea floor has inherent roughness and is usually inhomogeneous, both properties causing scatter. Although scatter degrades the performance of sonars, the characteristics of the return can be determined to enable its cancellation through signal processing or array design. Scattering can also be used to study the sea surface, the sea floor, fish types and distribution, and inhomogeneities in the water column. See SCATTERING LAYER; SONAR. [R.R.G.]

**Underwater television** Any type of electronic camera that is located underwater in order to collect and display images. It must be packaged in a waterproof housing. The underwater camera may be packaged with its own recording device, or it can be attached to a television that is located on a ship, in a laboratory, or at a remote site. In the latter case, the images by the camera are real-time images. An underwater television may

be used for sport, ocean exploration, industrial applications, or military purposes. Common imaged subjects are animals, coral reefs, underwater shipwrecks, and underwater structures such as piers, bridges, and offshore oil platforms.

During the daytime and at minimal depths, underwater television can be used to view objects illuminated with natural sunlight. For nighttime viewing or at very deep depths, artificial lights must be used. Light in the ocean is reduced in intensity quite severely: even in the clearest natural waters, a beam of blue or green light will be reduced in intensity by approximately 67% every 230 ft (70 m). Light that is propagating through an aqueous medium such as seawater or lake water will also be selectively reduced in intensity, based on wavelength. In most situations, the extreme reds and blues will be most severely attenuated, with the region of highest clarity being the yellow to blue-green wavelengths. See ELECTROMAGNETIC RADIATION.

Modern advances in television cameras have opened up a host of applications for underwater viewing, such as of standard-video, charge-injection-device, silicon-intensified-target, or charge-coupled-device cameras. These cameras can be adapted for high frame rate, low light level, or underwater color imaging. Computer modeling of underwater images can be used to predict the performance of an underwater imaging system in terms of range of viewing and quality of images as a function of the clarity of the water. See CHARGE-COUPLED DEVICES; TELEVISION; TELEVISION CAMERA; UNDERWATER PHOTOGRAPHY. [J.S.J.]

**Underwater vehicle** A submersible work platform designed to be operated either remotely or directly. Underwater vehicles are grouped into three categories: deep submersible vehicles (DSVs), remotely operated vehicles (ROVs), and autonomous underwater vehicles (AUVs). There are also hybrid vehicles which combine two or three categories on board a single platform. Within each category of submersible there are specially adapted vehicles for specific work tasks. These can be purpose-built or modifications of standard submersibles.

There are five types of DSVs: one-atmosphere untethered vehicles; one-atmosphere tethered vehicles, including observation/work bells; atmospheric diving suits; diver lockout vehicles; and wet submersibles. While they differ mainly in configuration, source of power, and number of crew members, all carry a crew at 1-atm ( $10^2$ -kilopascal) pressure within a dry chamber. An exception is the wet submersible, where the crew is exposed to full depth pressure. The purpose of the DSV is to put the trained mind and eye to work inside the ocean. The earliest submersibles had very small viewing ports fitted into thick-walled steel hulls. In the mid-1960s, experimental work began on use of massive plastics (acrylics) as pressure hull materials. Today, submersibles with depth capabilities to 3300 ft (1000 m) are being manufactured with pressure hulls made entirely of acrylic. Essentially the hull is now one huge window.

The first ROVs were developed in the late 1950s for naval use. By the mid-1970s, they were used in the civil sector. The rapid acceptance of these submersibles is due to their relatively low cost and the fact that they do not put human life at risk when undertaking hazardous missions. However, their most important attribute is that they are less complex. By virtue of their surface-connecting umbilical cable, they can operate almost indefinitely since there is no human inside requiring life support and no batteries to be recharged. There are four types of ROV: tethered free-swimming vehicles, towed vehicles, bottom reliant vehicles, and structurally reliant vehicles.

AUVs are crewless and untethered submersibles which operate independent of direct human control. Their operations are controlled by a preprogrammed, on-board computer. They were first developed in the military where applications include such tasks as minefield location and mapping, minefield installation, submarine decoys, and covert intelligence collection. Civilian tasks include site monitoring, basic oceanographic data gathering, under-ice mapping, offshore structure and pipeline

inspection, and bottom mapping. These submersibles are particularly useful where long-duration measurements and observations are to be made and where human presence is not required.

AUVs span a wide range of sizes and capabilities, related to their intended missions. Each is a mobile instrumentation platform with propulsion, sensors, and on-board intelligence designed to complete sampling tasks autonomously. At the large end of the scale, transport-class platforms in the order of 10 m (33 ft) length and 10 metric ton (11 tons) weight in air have been designed for missions requiring long endurance, high speed, large payloads, or high-power sensors. At the small end of the scale, network-class platforms in the order of 1 m (3.3 ft) length and 100 kg (220 lb) weight in air address missions requiring portability, multiple platforms, adaptive spatial sampling, and sustained presence in a specific region. Vehicles can also be categorized in terms of propulsion method (propeller-driven or buoyancy-driven) or in terms of their maximum operating depth.

Hybrid vehicles are those that combine crewed vehicles, remotely operated vehicles, and divers. For example, the hybrid *DUPLUS II* can operate either as a tethered free-swimming ROV or as a 1-atm tethered crewed vehicle. This evolved to provide capability for remotely conducting those tasks for which human skills are not needed, and then to put the human at the place where those skills are required. Other hybrid examples include ROVs that can be controlled remotely from the surface or at the work site by a diver performing maintenance and repair tasks.

[D.Wal.; T.B.C.]

**Uninterruptible power system** A system that provides protection against commercial power failure and variations in voltage and frequency. Uninterruptible power systems (UPS) have a wide variety of applications where unpredictable changes in commercial power will adversely affect equipment. This equipment may include computer installations, telephone exchanges, communications networks, motor and sequencing controls, electronic cash registers, hospital intensive care units, and a host of others. The uninterruptible power system may be used on-line between the commercial power and the sensitive load to provide transient free well-regulated power, or off-line and switched in only when commercial power fails.

There are three basic types of uninterruptible power system. These are, in order of complexity, the rotary power source, the standby power source, and the solid-state uninterruptible power system.

The rotary power source consists of a battery-driven dc motor that is mechanically connected to an ac generator. The battery is kept in a charged state by a battery charger that is connected to the commercial power line. In the event of a commercial power failure, the battery powers the dc motor which mechanically drives the ac generator. The sensitive load draws its power from the ac generator and operates through the outage.

The standby power source consists of a battery connected to a dc-to-ac static inverter. The inverter provides ac power for the sensitive load through a switch. A battery charger, once again, keeps the battery on full charge. Normally, the load operates directly from the commercial power line. In the event of commercial power failure, the switch transfers the sensitive load to the output of the inverter.

The solid-state uninterruptible power system has a general configuration much like that of the standby power system with one important exception. The sensitive load operates continually from the output of the static inverter. This means that all variations on the commercial power lines are cleaned and regulated through the output of the uninterruptible power system. A commercial power line, known as a bypass, is provided around the uninterruptible power system through a switch. Should the uninterruptible power system fail at some point, the commercial power is automatically transferred to the sensitive load through the switch. This scheme is known as an on-line automatic reverse-transfer uninterruptible power system.

An uninterruptible power system consists of four major subsystems: a method to put energy into a storage system, a battery charger; an energy storage system, the battery; a system to convert the stored energy into a usable form, the static inverter; and a circuit that electrically connects the sensitive load to either the output of the uninterruptible power system or to the commercial power line, the transfer switch. The position of the transfer switch is controlled by a monitor circuit. Generally the switch in an uninterruptible power system is a high-speed solid-state device that can transfer the load from one ac source to another with little or no break in power. See ELECTRIC POWER SYSTEMS; ELECTRIC SWITCH.

[J.Su.]

**Unit operations** A structure of logic used for synthesizing and analyzing processing schemes in the chemical and allied industries, in which the basic underlying concept is that all processing schemes can be composed from and decomposed into a series of individual, or unit, steps. If a step involves a chemical change, it is called a unit process; if physical change, a unit operation. These unit operations cut across widely different processing applications, including the manufacture of chemicals, fuels, pharmaceuticals, pulp and paper, processed foods, and primary metals. The unit operations approach serves as a very powerful form of morphological analysis, which systematizes process design, and greatly reduces both the number of concepts that must be taught and the number of possibilities that should be considered in synthesizing a particular process.

Most unit operations are based mechanistically upon the fundamental transport processes of mass transfer, heat transfer, and fluid flow (momentum transfer). Unit operations based on fluid mechanics include fluid transport (such as pumping), mixing/agitation, filtration, clarification, thickening or sedimentation, classification, and centrifugation. Operations based on heat transfer include heat exchange, condensation, evaporation, furnaces or kilns, drying, cooling towers, and freezing or thawing. Operations that are based on mass transfer include distillation, solvent extraction, leaching, absorption or desorption, adsorption, ion exchange, humidification or dehumidification, gaseous diffusion, crystallization, and thermal diffusion. Operations that are based on mechanical principles include screening, solids handling, size reduction, flotation, magnetic separation, and electrostatic precipitation. The study of transport phenomena provides a unifying and powerful basis for an understanding of the different unit operations. See ABSORPTION; ADSORPTION; CENTRIFUGATION; CHEMICAL ENGINEERING; CLARIFICATION; COOLING TOWER; CRYSTALLIZATION; DEHUMIDIFIER; DIFFUSION; DISTILLATION; DRYING; ELECTROSTATIC PRECIPITATOR; EVAPORATION; FILTRATION; FLOTATION; HEAT EXCHANGER; HUMIDIFICATION; ION EXCHANGE; KILN; LEACHING; MAGNETIC SEPARATION METHODS; MECHANICAL SEPARATION TECHNIQUES; MIXING; PUMP; PUMPING MACHINERY; SEDIMENTATION (INDUSTRY); SOLIDS PUMP; SOLVENT EXTRACTION; THICKENING; TRANSPORT PROCESSES; UNIT PROCESSES.

[C.J.Ki.]

**Unit processes** Processes that involve making chemical changes to materials, as a result of chemical reaction taking place. For instance, in the combustion of coal, the entering and leaving materials differ from each other chemically: coal and air enter, and flue gases and residues leave the combustion chamber. Combustion is therefore a unit process. Unit processes are also referred to as chemical conversions.

Together with unit operations (physical conversions), unit processes (chemical conversions) form the basic building blocks of a chemical manufacturing process. Most chemical processes consist of a combination of various unit operations and unit processes.

The basic tools of the chemical engineer for the design, study, or improvement of a unit process are the mass balance, the energy balance, kinetic rate of reaction, and position of equilibrium (the last is included only if the reaction does not go to completion). See CHEMICAL ENGINEERING; UNIT OPERATIONS.

[W.F.F.]

**Unitary symmetry** A type of symmetry law, an important example of which is flavor symmetry, one of the approximate internal symmetry laws obeyed by the strong interactions of elementary particles. According to the successful theory of strong interactions, quantum chromodynamics, flavor symmetry is the consequence of the fact that the so-called glue force (mediated by the  $SU_3^{\text{color}}$  gauge field) is the same between all the kinds (flavors) of quarks. If the quarks all had the same mass, they then would be dynamically equivalent constituents of hadrons, and hadrons would occur as degenerate multiplets of the group  $SU_N$ , where  $N$  is the number of quark flavors. The lightest quarks ( $u$  and  $d$ ) have similar masses, so the lightest hadrons, made of  $u$  and  $d$  quarks, do exhibit an  $SU_2^{\text{flavor}}$  symmetry known as  $i$ -spin invariance. The mass of the next heavier quark ( $s$ ) is much larger than the masses of the  $u$  and  $d$  quarks, but much smaller than the masses of the yet heavier quarks ( $c$ ,  $b$ , ...); consequently the hadrons that contain no quarks heavier than the  $s$  quark clearly may be grouped into  $SU_3^{\text{flavor}}$  multiplets. See COLOR (QUANTUM MECHANICS); FLAVOR; HADRON; QUANTUM CHROMODYNAMICS; QUARKS.

An example of unitary symmetry is the approximate spin independence of the forces on electrons (as in an atom): There is a fundamental doublet, comprising the spin-up electron and the spin-down electron. Denoting these two states by  $|u\rangle$  and  $|d\rangle$ , all physical properties (energy eigenvalues, charge density, and so on) are unchanged by the replacements shown in the equations below, where  $\alpha$  and  $\beta$  are complex numbers. The group

$$\begin{aligned} |u\rangle &\rightarrow \alpha|u\rangle + \beta|d\rangle \\ |d\rangle &\rightarrow -\beta^*|u\rangle + \alpha^*|d\rangle \\ |\alpha|^2 + |\beta|^2 &= 1 \end{aligned}$$

of all the transformations of two states that preserves their hermitean scalar products [ $\langle u|d\rangle = 0$ ,  $\langle u|u\rangle = \langle d|d\rangle = 1$ ] is known as the two-dimensional unitary group,  $U_2$ ; the transformations of the equations above form a subgroup  $SU_2$  which merely lacks the uninteresting transformations of the form  $|u\rangle \rightarrow e^{i\varphi}|u\rangle$  and  $|d\rangle \rightarrow e^{i\varphi}|d\rangle$ , that is, an equal change of phase of the two states.

The strong interactions are approximately invariant to an  $SU_2$  group; the fundamental doublet can be taken to be the nucleon, with the up and down states proton and neutron. This  $SU_2$  symmetry is known as charge independence, or, loosely, as  $i$ -spin conservation, the analog to the electron spin being known as  $i$ -spin I. See I-SPIN.

When a sufficient number of strange particles had been observed, it was seen that they, together with the old nonstrange particles, were grouped into multiplets of particles with the same space-time quantum numbers (except for mass; the masses of the members are only similar, not equal). This suggested the existence of a yet larger symmetry; it has turned out that this symmetry is the group of all unitary transformations of a triplet of fundamental particles,  $U_3$ , or  $SU_3$  if the uninteresting equal phase change of all particles is omitted. This symmetry is often loosely called unitary symmetry. See STRANGE PARTICLES.

A striking difference in the manifestations of  $SU_2$  and  $SU_3$  is that whereas all possible multiplets of the former appear in nature, only those multiplets of the latter appear that can be regarded as compounds of the fundamental triplet in which the net number of component fundamental particles (number of particles minus number of antiparticles) is an integral multiple of 3. In particular, no particle that could be regarded as the fundamental triplet is found. Despite this nonappearance, it turns out that a great deal about the strongly interacting particles (hadrons) is at least qualitatively explained if they are regarded as physical compounds of a fundamental triplet of particles, to which the name quark has been given. The color theory (quantum chromodynamics) of strong interactions explains why single quarks are never observed.

According to the argument given above, hadrons have the approximate symmetry  $SU_N$ , where  $N$  is the number of kinds of

quarks, or flavors. Six flavors of quark are known; in addition to the quarks with the flavors up, down, and strange described above, three more quarks, charm, bottom, and top, have been found. See CHARM; ELEMENTARY PARTICLE; J/PSI PARTICLE; UPSILON PARTICLES. [C.J.G.]

**Units of measurement** Values, quantities, or magnitudes in terms of which other such are expressed. Units are grouped into systems, suitable for use in the measurement of physical quantities and in the convenient statement of laws relating physical quantities. A quantity is a measurable attribute of phenomena or matter.

A given physical quantity  $A$ , such as length, time, or energy, is the product of a numerical value or measure  $\{A\}$  and a unit  $[A]$ . Thus Eq. (1) holds.

$$A = \{A\}[A] \quad (1)$$

The unit  $[A]$  can be chosen arbitrarily, but it is desirable to define units in such a way that they are derived from a few base units by equations without numerical factors other than unity, and that the equations between numerical values of quantities have exactly the same form as the equations between the quantities. For example, the kinetic energy  $E$  of a body is given in terms of its mass  $M$  and speed  $V$  by Eq. (2), where  $E = \{E\}[E]$ ,

$$E = \frac{1}{2}MV^2 \quad (2)$$

$M = \{M\}[M]$ ,  $V = \{V\}[V]$ , and  $\frac{1}{2}$  is called a definitional factor and is dimensionless. If the units of  $E$ ,  $M$ , and  $V$  are defined in such a way that Eq. (3) holds, then the equation between the numerical values is Eq. (4). A system of units defined in this way

$$[E] = [M][V]^2 \quad (3)$$

$$\{E\} = \frac{1}{2}\{M\}\{V\}^2 \quad (4)$$

is called a coherent system. It is constructed by defining the units of a few base quantities independently; these are called base units. The units of all other quantities are defined by equations similar to Eq. (3) with no numerical factors other than unity, and are called derived units.

In 1960 the General Conference on Weights and Measures (CGPM) gave official status to a single practical system, the International System of Units, abbreviated SI in all languages. The system is a modernized version of the metric system. The SI, as subsequently extended, includes seven base units and twenty-two derived units with special names. These derived units, and others without special names, are derived from the base units in a coherent manner. A set of prefixes is used to form decimal multiples and submultiples of the SI units. Certain units which are not part of the SI but which are widely used or are useful in specialized fields have been accepted for use with the SI or for temporary use in those fields. See METRIC SYSTEM.

**Geometrical units.** Units of plane angle and solid angle are purely geometrical. The SI units of plane and solid angle are regarded as dimensionless derived units.

**Plane angle units.** The radian (rad), the SI unit of plane angle, is the plane angle between two radii of a circle which cut off on the circumference an arc equal in length to the radius. Since the circumference of a circle is  $2\pi$  times the radius, the complete angle about a point is  $2\pi$  rad. See RADIAN MEASURE.

The degree and its decimal submultiples can be used with the SI when the radian is not a convenient unit. By definition,  $2\pi$  rad =  $360^\circ$ . The minute [ $1' = (1/60)^\circ$ ] and the second [ $1'' = (1/60)'$ ] can also be used.

**Steradian.** The steradian (sr), the SI unit of solid angle, is the solid angle which, having its vertex at the center of a sphere, cuts off an area on the surface of the sphere equal to that of a square with sides of length equal to the radius of the sphere.

**Mechanical units.** In mechanics, it is convenient to have three base quantities, and two of these are generally chosen to be length and time. Systems of mechanical units may be classified



as absolute systems, in which the third base quantity is mass, and gravitational systems, in which the third base quantity is force.

Two absolute systems of metric units are commonly employed, each named for its base units of length, mass, and time: the mks (meter-kilogram-second) absolute system, and the cgs (centimeter-gram-second) absolute system. The mks absolute system is the mechanical portion of the SI. A coherent absolute system of British units is based on the foot, the pound (1 lb  $\cong$  0.4536 kg), and the second.

Gravitational systems, in which the base quantities are length, force, and time, have been frequently employed by engineers, and are therefore sometimes called technical systems.

**Length units.** The meter (m) is the SI base unit of length. The use of special names for decimal submultiples of the meter should be avoided, and units formed by attaching appropriate SI prefixes to the meter should be used instead.

The angstrom ( $\text{\AA}$ ) is equal to  $10^{-10}$  m. Although it has been accepted for temporary use with the SI, it is preferable to replace this unit with the nanometer, using the relation  $1 \text{\AA} = 0.1 \text{ nm}$ .

The nautical mile (nmi), equal to 1852 m, has been accepted for temporary use with the SI in navigation. See NAVIGATION.

The foot (ft) is, as discussed above, the unit of length in the British systems of units, and it is also in customary use in the United States. Since 1959 the foot has been defined as exactly 0.3048 m. The yard (yd) is defined as exactly 3 ft or 0.9144 m. See LENGTH; MEASURE.

Relative measurements of x-ray wavelengths can be made to a higher accuracy than absolute measurements. Before 1965, most x-ray wavelengths were expressed in terms of the X-unit, which is approximately  $10^{-13}$  m. The X-unit has been superseded by the  $A^*$  unit, which is based on the tungsten  $K\alpha_1$  line as a standard. The peak of this line is defined as exactly 0.2090100  $A^*$ . X-ray wavelength tables have been published in terms of this unit. At the time the  $A^*$  unit was defined, it was thought to equal  $10^{-10}$  m (the angstrom unit,  $\text{\AA}$ ) to within 5 parts per million, but the  $A^*$  unit is now believed to be  $20 \pm 5$  parts per million larger than  $10^{-10}$  m.

Special units whose values are obtained experimentally are used in astronomy. For their definitions See ASTRONOMICAL UNIT; LIGHT-YEAR; PARSEC.

**Area units.** The square meter ( $\text{m}^2$ ), the SI unit of area, is the area of a square with sides of length 1 m. Other area units are defined by forming squares of various length units in the same manner. See AREA.

Cross sections, which measure the probability of interaction between an atomic nucleus, atom, or molecule and an incident particle, have the dimensions of area, and the appropriate SI unit for expressing them is therefore the square meter. The barn (b), a unit of cross section equal to  $10^{-28}$   $\text{m}^2$ , has been accepted for temporary use with the SI.

**Units of volume.** The cubic meter ( $\text{m}^3$ ), the SI unit of volume, is the volume of a cube with sides of length 1 m. Other units of volume are defined by forming cubes of various length units in the same manner. The liter (symbol L in the United States) is equal to 1 cubic decimeter (1  $\text{dm}^3$ ), or equivalently to  $10^{-3}$   $\text{m}^3$ . It has been accepted for use with the SI for measuring volumes of liquids and gases.

**Time units.** The second (s) is the SI base unit of time. However, other units of time in customary use, such as the minute (1 min = 60 s), hour (1 h = 60 min), and day (1 d = 24 h), are acceptable for use with the SI. See TIME.

**Frequency units.** The hertz (Hz), the SI unit of frequency, is equal to 1 cycle per second. A periodic oscillation has a frequency of  $n$  hertz if it goes through  $n$  cycles in 1 s. See FREQUENCY (WAVE MOTION).

**Speed and velocity units.** The meter per second (m/s), the SI unit of speed or velocity, is the magnitude of the constant velocity at which a body traverses 1 m in 1 s. Other speed and velocity units are defined by dividing a unit of length by a unit of time in the same manner. See SPEED; VELOCITY.

The knot (kn) is equal to 1 nautical mile per hour (1 nmi/h); it has been accepted for temporary use with the SI.

**Acceleration units.** The meter per second squared ( $\text{m/s}^2$ ), the SI unit of acceleration, is the acceleration of a body whose velocity changes by 1 m/s in 1 s. Other units of acceleration are defined by dividing a unit of velocity by a unit of time in the same manner. See ACCELERATION.

The gal or galileo (symbol Gal) is equal to  $1 \text{ cm/s}^2$ , or equivalently to  $10^{-2} \text{ m/s}^2$ .

**Mass units.** The kilogram (kg), the SI base unit of mass, is the only SI unit whose name, for historical reasons, contains a prefix. Names of decimal multiples and submultiples of the kilogram are formed by attaching prefixes to the word gram (g). The metric ton (t), which is equal to  $10^3$  kg or 1 megagram (Mg), is permitted in commercial usage of the SI.

The pound (lb), the unit of mass in British absolute system, is also in customary use in the United States. In 1959 the pound was defined to be exactly 0.45359237 kg.

The slug is the unit of mass in the British gravitational system. By definition 1 pound force (lbf) acting on a body of mass 1 slug produces an acceleration of 1 foot per second squared (1  $\text{ft/s}^2$ ). The slug is equal to approximately 32.174 lb or 14.594 kg. See MASS.

**Force units.** The newton (N), the SI unit of force, is the force which imparts an acceleration of 1 meter per second squared (1  $\text{m/s}^2$ ) to a body having a mass of 1 kg.

The dyne, the cgs absolute unit of force, is the force which imparts an acceleration of 1 centimeter per second squared (1  $\text{cm/s}^2$ ) to a body having a mass of 1 g.

The unit of force in the British absolute system is the poundal (pdl), the force which imparts an acceleration of 1 foot per second squared (1  $\text{ft/s}^2$ ) when applied to a body of mass 1 lb. One poundal is approximately 0.13825 N.

The units of force in the mks gravitational, cgs gravitational, and British gravitational systems are the forces which impart an acceleration equal to the standard acceleration of gravity,  $g_n = 9.80665 \text{ m/s}^2 \cong 32.174 \text{ ft/s}^2$ , when applied to bodies having masses of 1 kg, 1 g, and 1 lb, respectively. These units are named the kilogram force (kgf), gram force (gf), and pound force (lbf), respectively. Unfortunately, these units have also been called simply the kilogram, gram, and pound, giving rise to confusion with the mass units of the same name. See FORCE.

**Pressure and stress units.** The pascal (Pa), the SI unit of pressure and stress, is the pressure or stress of 1 newton per square meter ( $\text{N/m}^2$ ). Other units of pressure can also be formed by dividing various units of force by various units of area, such as the pound force per square inch ( $\text{lbf/in.}^2$ , frequently abbreviated psi).

Pressure has been frequently expressed in terms of the bar and its decimal submultiples, where 1 bar =  $10^6$  dynes/ $\text{cm}^2$  =  $10^5$  Pa. Pressures are also frequently expressed in terms of the height of a column of either mercury or water which the pressure will support.

Two other units which have been frequently used for measuring pressure are the standard atmosphere and the torr. The standard atmosphere (atm) is exactly 101,325 Pa, which is approximately the average value of atmospheric pressure at sea level. The torr is exactly 1/760 atmosphere, or approximately 133.322 Pa. To within 1 part per million, the torr equal to the pressure of a column of mercury of height 1 millimeter (1 mmHg) at a temperature of  $0^\circ\text{C}$  when the acceleration due to gravity has the standard value  $g_n = 9.80665 \text{ m/s}^2$ . See ATMOSPHERE; PRESSURE; PRESSURE MEASUREMENT.

**Energy and work units.** The joule (J), the SI unit of energy or work, is the work done by a force of magnitude 1 newton when the point at which the force is applied is displaced 1 m in the direction of the force. Thus, joule is a short name for newton-meter (N-m) of energy or work. See ENERGY; WORK.

Units of energy or work in other systems are defined by forming the product of a unit of force and a unit of length in precisely

the same manner as in the definition of the joule. Thus, the erg, the cgs absolute unit of energy or work, is the product of 1 dyne and 1 cm.

The foot-poundal (ft·pdl), the British absolute unit of energy or work, is the product of 1 poundal and 1 foot. The foot-pound, or, more properly, the foot-pound force (ft·lbf), the British gravitational unit of energy or work, is the product of 1 lbf and 1 ft.

Sometimes energy is measured in units which are products of a unit of power and a unit of time. Since 1 watt (W) of power equals 1 joule per second (1 J/s), as discussed below, the joule is equivalent to 1 watt-second (1 W · s). In electrical power applications, energy is frequently measured in kilowatthours (kWh), where 1 kWh = (10<sup>3</sup> W) (3600 s) = 3.6 × 10<sup>6</sup> J.

The calorie was originally defined as the quantity of heat required to raise the temperature of 1 g of air-free water 1°C under a constant pressure of 1 atm. However, the magnitude of the calorie, so defined, depends on the place on the Celsius temperature scale at which the measurement is made. The International (Steam) Table calorie is defined as exactly 4.1868 J; this is the type of calorie most frequently used in mechanical engineering. The thermochemical calorie, which has been used in thermochemistry in preference to the other types of calorie, is exactly 4.184 J.

The British thermal unit (Btu) was originally defined as the quantity of heat required to raise the temperature of 1 lb of air-free water 1°F under a constant pressure of 1 atm. The International Table Btu is approximately 1055.056 J, and the thermochemical Btu is approximately 1054.350 J.

**Power units.** The watt (W), the SI unit of power, is the power which gives rise to the production of energy at the rate of 1 joule per second (1 J/s). Other units of power can be defined by forming the ratio of a unit of energy to a unit of time in the same manner. See POWER.

The horsepower (hp) is equal to exactly 550 ft · lbf/s, or approximately 745.700 W.

**Torque units.** The newton-meter (N · m), the SI unit of torque, is the magnitude of the torque produced by a force of 1 newton acting at a perpendicular distance of 1 m from a specified axis of rotation. The joule should never be used as a synonym for this unit.

Units of torque in other systems are defined by forming the product of a unit of force and a unit of length in precisely the same manner as in the definition of the newton-meter.

The foot-poundal (ft · pdl), the British absolute unit of torque, is the product of 1 poundal and 1 foot. The foot-pound (ft · lbf), the British gravitational unit of torque, is the product of 1 lbf and 1 ft. These units are sometimes called the poundal-foot (pdl · ft) and pound-foot (lbf · ft) to distinguish them from the units of energy or work. See TORQUE.

**Electrical units.** For a general discussion of electrical units, including the SI or mks system, three cgs systems [electrostatic system of units (esu), electromagnetic system of units (emu), and gaussian system], and definitions of the SI units ampere (A), volt (V), ohm (Ω), coulomb (C), farad (F), henry (H), weber (Wb), and tesla (T) see ELECTRICAL UNITS AND STANDARDS.

This section discusses some additional SI units and some units in the cgs electromagnetic system which are frequently encountered in scientific literature in spite of the fact that their use has been discouraged.

**Siemens.** The siemens (S), the SI unit of electrical conductance, is the electrical conductance of a conductor in which a current of 1 ampere is produced by an electric potential difference of 1 volt. See CONDUCTANCE; ELECTRICAL RESISTANCE.

The siemens was formerly called the mho (Ω) to illustrate the fact the unit is the reciprocal of the ohm.

**Abampere.** The abampere (abA), the cgs electromagnetic unit of current, is that current which, if maintained in two straight, parallel conductors of infinite length, of negligible circular cross section, and placed 1 cm apart in vacuum, would produce between

these conductors a force equal to 2 dynes per centimeter of length. The abampere is equal to exactly 10 A.

**Abvolt.** The abvolt (abV), the cgs electromagnetic unit of electrical potential difference and electromotive force, is the difference of electrical potential between two points of a conductor carrying a constant current of 1 abA, when the power dissipated between these points is equal to 1 erg per second. Then 1 abV = 10<sup>-8</sup> V.

**Maxwell.** The maxwell (Mx), the cgs electromagnetic unit of magnetic flux, is the magnetic flux which, linking a circuit of one turn, produces in it an electromotive force of 1 abV as it is reduced to zero in 1 s. Then 1 maxwell = 10<sup>-8</sup> weber.

**Units of magnetic flux density.** The gauss (Gs), the cgs electromagnetic unit of magnetic flux density (also called magnetic induction), is a magnetic flux density of 1 maxwell per square centimeter (1 Mx/cm<sup>2</sup>). Then 1 gauss = 10<sup>-4</sup> tesla.

**Units of magnetic field strength.** The SI unit of magnetic field strength is 1 ampere per meter (1 A/m), which is the magnetic field strength at a distance of 1 m from a straight conductor of infinite length and negligible circular cross section which carries a current of 2π A. This definition is based on the definition, in the SI, of the magnetic field strength  $H_{SI}$ . At a distance  $r$  from a long straight conductor carrying  $I$ ,  $H_{SI}$  is given by Eq. (5). The

$$2\pi r H_{SI} = I \quad (5)$$

left-hand side of this equation is the line integral of  $H_{SI}$  around a circular path, all of whose points are at distance  $r$  from the conductor. Substituting  $r = 1$  m, and  $I = 2\pi$  A in this equation gives  $H_{SI} = 1$  A/m.

The oersted (Oe), the cgs electromagnetic unit of magnetic field strength, is the magnetic field strength at a distance of 1 cm from a straight conductor of infinite length and negligible circular cross section which carries a current of 0.5 abA.

**Units of magnetic potential and mmf.** The ampere serves as the SI unit of magnetic potential difference and magnetomotive force (mmf), as well as the unit of current. In the SI, the magnetomotive force around a closed path equals the current passing through a surface enclosed by the path. Thus, 1 A is the magnetomotive force around a closed path when a current of 1 A passes through an enclosed surface.

The gilbert (Gb), the cgs electromagnetic unit of magnetic potential difference and magnetomotive force, is the magnetomotive force around a closed path enclosing a surface through which flows a current of (1/4π) abA.

**Photometric units.** Photometric units involve a new base quantity, luminous intensity. For the definition of the candela (cd), the SI unit of luminous intensity, see PHOTOMETRY; PHYSICAL MEASUREMENT.

For a general discussion of photometric units, including units of illuminance (illumination) and luminance, and in particular the SI units lux (lx) and candela per square meter (cd/m<sup>2</sup>), see ILLUMINATION. See also LUMINANCE.

**Lumen.** The lumen (lm), the SI unit of luminous flux, is the luminous flux emitted within a unit solid angle (1 steradian) by a point source having a uniform intensity of 1 candela. See LUMINOUS FLUX.

**Luminous energy units.** The lumen-second (lm·s), the SI unit of luminous energy (also called quantity of light), is the luminous energy radiated or received over a period of 1 s by a luminous flux of 1 lumen. This unit is also called the talbot. See LUMINOUS ENERGY.

**Radiation units.** Certain quantities and units are used particularly in the area of ionizing radiation. The special units curie, roentgen, rad, and rem, which were previously adopted for use in this area, are not coherent with the SI, but their temporary use with the SI has been approved while the transition to SI units takes place.

**Activity units.** The becquerel (Bq), the SI unit of activity (radioactive disintegration rate), is the activity of a radionuclide

decaying at the rate of one spontaneous nuclear transition per second. Thus  $1 \text{ Bq} = 1 \text{ s}^{-1}$ .

The curie (Ci), the special unit of activity, is equal to  $3.7 \times 10^{10} \text{ Bq}$ . See RADIOACTIVITY.

**Exposure units.** The SI unit of exposure to ionizing radiation, 1 coulomb per kilogram (1 C/kg), is the amount of electromagnetic radiation (x-radiation or gamma radiation) which in 1 kg of pure dry air produces ion pairs carrying 1 coulomb of charge of either sign. (The ionization arising from the absorption of bremsstrahlung emitted by electrons is not to be included in measuring the charge.) See BREMSSTRAHLUNG.

The roentgen (R), the special unit of exposure, is equal to  $2.58 \times 10^{-4} \text{ C/kg}$ .

**Absorbed dose units.** The gray (Gy), the SI unit of absorbed dose, is the absorbed dose when the energy per unit mass imparted to matter by ionizing radiation is 1 joule per kilogram (1 J/kg).

The rad (rd), the special unit of absorbed dose, is equal to  $10^{-2} \text{ Gy}$ .

**Dose equivalent units.** Different types of radiation cause slightly different effects in biological tissue. For this reason, a weighted absorbed dose called the dose equivalent is used in comparing the effects of radiation on living systems. The dose equivalent is the product of the absorbed dose and various dimensionless modifying factors.

The sievert (Sv), the SI unit of dose equivalent, is the dose equivalent when the absorbed dose of ionizing radiation multiplied by the stipulated dimensionless factors is 1 joule per kilogram (1 J/kg).

The rem, the special unit of dose equivalent, is equal to  $10^{-2} \text{ Sv}$ .

**Other units.** Logarithmic measures may be used with the SI. See DECIBEL; NEPER; pH; VOLUME UNIT (VU).

For units of loudness (sone, phon) see LOUDNESS. For units of sound absorption by surfaces see ARCHITECTURAL ACOUSTICS. For units of pitch see PITCH. For quantities and units pertaining to sound transmission see SOUND.

For temperature scales see TEMPERATURE.

For units measuring quantities in chemistry see ATOMIC MASS UNIT; CONCENTRATION SCALES; ELECTROCHEMICAL EQUIVALENT; GRAM-MOLECULAR WEIGHT; MOLE (CHEMISTRY); MOLECULAR WEIGHT; RELATIVE ATOMIC MASS; RELATIVE MOLECULAR MASS.

For quantities and units pertaining to nuclear reactors see REACTOR PHYSICS.

For units of information content see BIT; INFORMATION THEORY. [J.F.We.]

**Universal joint** A linkage that transmits rotation between two shafts whose axes are coplanar but not coinciding. The universal joint is used in almost every class of machinery: machine tools, instruments, control devices, and, most familiarly, automobiles.

A simple universal joint, known in English-speaking countries as Hooke's joint and in continental Europe as a Cardan joint, is shown in the illustration. It consists of two yokes attached to their respective shafts and connected by means of a spider. The angle between the shafts may have any value up to approximately  $35^\circ$ , if angular velocity is moderate when the angle is large. Although one shaft must make a single revolution for each revolution of the second shaft, the instantaneous angular displacement of the first shaft is the same as that of the second shaft only at the end of each  $90^\circ$  of shaft rotation. Thus, only at four positions during each revolution is angular velocity of both shafts the same.

The variation in angular displacement and angular velocity between driving and driven shafts, which is objectionable in many mechanisms, can be eliminated by using two Hooke's joints, with an intermediate shaft. This arrangement is conventional for an automobile drive shaft. The axes of the driving and driven shafts need not intersect; however, it is necessary that the axes of the two yokes attached to the intermediate shaft lie respectively

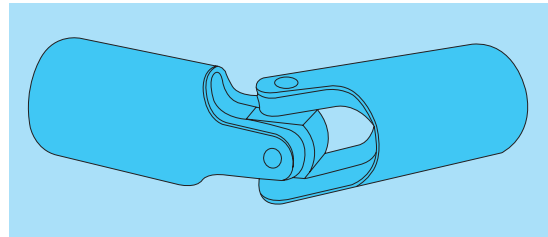

Simple universal joint. (After C. W. Ham, E. J. Crane, and W. L. Rogers, *Mechanics of Machinery*, McGraw-Hill, 1958)

in planes containing the axes of adjoining shafts. See FOUR-BAR LINKAGE. [D.PAd.]

**Universal motor** A series motor built to operate on either alternating current (ac) or direct current (dc). It is normally designed for capacities less than 1 hp (0.75 kW). It is usually operated at high speed, 3500 revolutions per minutes (rpm) loaded and 8000 to 10,000 revolutions per minute unloaded. For lower speeds, reduction gears are often employed, as in the case of electric hand drills or food mixers. As in all series motors, the rotor speed increases as the load decreases and the no-load speed is limited only by friction and windage. See ALTERNATING-CURRENT MOTOR; DIRECT-CURRENT MOTOR. [I.L.K.]

**Universe** The universe comprises everything in existence, including all matter and energy, and the enormous volume which contains them. The observable universe currently spans about  $6 \times 10^{22} \text{ km}$  ( $4 \times 10^{22} \text{ mi}$ ), and contains  $2 \times 10^{50}$  to  $1 \times 10^{51} \text{ kg}$  ( $4 \times 10^{50}$  to  $2 \times 10^{51} \text{ lb}$ ) of matter, yielding an average density of a few atoms per cubic meter. Most of the universe, then, is empty space; the matter is distributed thinly throughout, forming objects and structures at a variety of different sizes.

**Constituents.** This article will start the cosmic survey with the more familiar objects, following a sequence of increasing size. A number of lesser-known and less tangible entities will complete the survey.

**Baryonic matter.** Most of the matter encountered in everyday life is in the form of atoms. An atom consists of a positively charged nucleus of protons and neutrons, surrounded by clouds or shells of negatively charged electrons. The protons and neutrons are responsible for most of the mass of the atom. Since both protons and neutrons belong to a class of subatomic particles known as baryons, this ordinary form of atomic matter is called baryonic matter in astronomical contexts. See BARYON.

A large fraction of the visible matter elsewhere in the universe—planets, stars, nebulae, galaxies—is also baryonic in nature, but the relative proportions of the chemical elements are very different from here on Earth. Hydrogen is by far the most abundant element in the universe, representing 75% of the total baryonic mass. Helium is also plentiful at about 23% of the total mass. All the heavier elements make up the remaining 2%.

**Stars and stellar evolution.** The most plentiful denizens of the nearby universe, as seen in the night sky, are the stars. These points of light are objects much like the Sun, which appear faint due to their great distance from Earth. Most visible stars are enormous balls of hot gas (primarily hydrogen and helium) held together by their own gravitation. They are powered by nuclear reactions deep in their interiors, where temperatures and pressures are high enough to fuse hydrogen atoms into helium, releasing energy in the process. See CARBON-NITROGEN-OXYGEN CYCLES; NUCLEAR FUSION; PROTON-PROTON CHAIN.

Once a star has used up all of its core hydrogen, it must change its internal structure to burn new fuel sources. A low-mass star (less than a few solar masses) will burn helium for a time, but as the helium fuel is exhausted and its internal furnace wanes, the

outer layers of the star are ejected into space, and the core will gradually shrink into a tiny, dense ember, a white dwarf, glowing only from its residual heat.

Higher-mass stars will burn helium, then carbon, and then a succession of even heavier elements, each for a progressively shorter time, until fusible material of any sort abruptly runs out and the star collapses catastrophically. Much of the interior mass of the star is compacted into an ultradense core; the outer layers rebound off this core and explode into space, forming an exceptionally bright type II supernova, shining for several weeks at a billion times the luminosity of the Sun. The stellar core is usually left behind as a neutron star, a small, rapidly rotating body consisting almost entirely of neutrons. Powerful magnetic fields on the surface of a neutron star produce radio waves which appear to blink on and off as the star spins, and the neutron star is observed as a pulsar. In the most extreme cases, the stellar core is compressed so far that it collapses to an infinitesimal point, forming a black hole. See BLACK HOLE; NEUTRON STAR; NUCLEOSYNTHESIS; PULSAR; STAR; STELLAR EVOLUTION.

**Solar system.** The Sun is accompanied by a number of smaller objects of various sizes and compositions. The Sun's gravitational domain extends out to almost half a parsec (1 parsec equals  $3.1 \times 10^{13}$  km or  $1.9 \times 10^{13}$  mi) but the planets, the best-known elements of the solar system, lie much closer, within about  $5 \times 10^9$  km ( $3 \times 10^9$  mi) of the center. See PLANET; SOLAR SYSTEM.

**Extrasolar planets.** In recent years, strong evidence has been mounting that the Sun is not the only star with a planetary system. At least 60 nearby stars, similar in type to the Sun, exhibit subtle periodic shifts in their motion which are most likely due to the gravitational influence of small orbiting companions.

**Interstellar material.** The "empty" space between the stars actually contains significant amounts of matter—some of it distributed continuously, some of it concentrated in enormous dark clouds—collectively known as the interstellar medium. Also scattered throughout space are denser clouds of molecular hydrogen ( $H_2$ ), which contain traces of carbon monoxide (CO) and more complex molecules, and are sprinkled with the heavier elements. These clouds often are the site of star formation, when external gravitational disturbances or shock waves trigger the collapse of portions of these clouds. See INTERSTELLAR MATTER; MOLECULAR CLOUD.

**Galaxies.** Stars and interstellar matter are not distributed uniformly throughout the universe but cluster together in vast units known as galaxies, each containing from 10 million to 1 trillion stars. Galaxies are categorized into three types—spiral, elliptical, and irregular—with numerous subclasses based on size and structure. The Milky Way Galaxy is a typical spiral galaxy—a flattened disk of some  $10^{11}$  stars. See GALAXY, EXTERNAL.

**Quasars.** Supermassive black holes, similar to the stellar-sized black holes which form during the supernova explosion of a massive star but containing  $10^6$  to  $10^7$  solar masses instead of only a few, are thought to exist at the centers of many galaxies—including, perhaps, the Milky Way. As stellar or interstellar matter is drawn into the black hole, it forms an accretion disk around the central point, where it is heated by friction to temperatures of millions of kelvins and glows brightly with a luminosity equivalent to  $10^{12}$  Suns. At the far reaches of the universe, these galaxy cores appear to observers as starlike point sources, and were thus labeled quasistellar objects or quasars when first discovered. See QUASAR.

**Groups, clusters, and large-scale structure.** Galaxies themselves are usually bound together in groups (up to about 50 galaxies) and clusters (50 to thousands of galaxies) spanning regions 2–10 Mpc in diameter. Clusters accumulate into yet larger agglomerations called superclusters. Groups and clusters seem to be concentrated in thin sheets, surrounding enormous voids with very few galaxies. Superclusters sit at the edges and vertices where several surfaces intersect.

**Antimatter.** All subatomic particles have oppositely charged antiparticle counterparts. When a particle and its corresponding antiparticle collide, they annihilate one another, converting all their mass to energy. Both matter and antimatter are expected to have been formed in the early universe, but clearly not in precisely equal amounts, since the universe (at least the part that observers can see) is predominantly composed of matter. See ANTIMATTER.

**Nonbaryonic particles.** Although most of the matter observed is baryonic in nature, several kinds of nonbaryonic matter also exist in the universe or have been predicted by particle physicists, and may also account for a substantial fraction of the mass of the universe.

Neutrinos are electrically neutral, very low mass particles that are generated in nuclear reactions. They were once suspected to be completely massless entities, but theoretical and experimental evidence is now mounting that they have a tiny but nonzero mass, so that they could exert a small gravitational influence on the universe at large. See NEUTRINO.

Other particle species, also appear in cosmic contexts. WIMPs, a sort of slow-moving superneutrino, have been proposed as being responsible for the missing dark mass component of the universe. See WEAKLY INTERACTING MASSIVE PARTICLE (WIMP).

**Dark matter.** A large fraction of the mass of the universe is in some form which cannot be seen but which is evident from its gravitational effect on the motions of bright objects, such as stars and galaxies. This dark matter, or "missing mass," is present on many different scales, from galaxies to clusters to the universe as a whole.

**Energy.** Energy is a physical entity as real as matter, but somewhat less tangible, which makes it more difficult to categorize easily. Like matter, energy comes in many different forms, which can be readily transformed from one to another. Energy can also be converted to and from matter.

The four basic forces of nature—gravity, electromagnetism, and the strong and weak nuclear forces—may in fact be different facets of a single fundamental force. Particle physics experiments show that under conditions of extremely high energy, the weak nuclear force and electromagnetism merge into a single "electroweak" force. Theoretical efforts are being made to devise a grand unified theory under which the strong force and gravity are also incorporated. Such a unified force may have existed during the moments following the big bang and then fragmented into separate forces as the universe expanded and cooled. See ELECTROWEAK INTERACTION; FUNDAMENTAL INTERACTIONS; GRAND UNIFICATION THEORIES; STANDARD MODEL.

**Origin and fate.** The universe is a dynamically evolving system. By closely studying the current distribution and motion of matter and energy, and collecting the "fossil light" from distant objects, scientists have constructed a fairly consistent picture of the creation of the universe, the big bang theory, which explains the observations fairly well.

**Big bang.** The observable universe originated some 9–18 billion years ago in a fiery cataclysm termed the big bang. This was not an explosion of compressed matter and energy into a previously empty space. Instead, space itself, as well as everything contained therein, sprang from a single point of infinite density and temperature, and grew to the volume observed today. As it expanded, it cooled, allowing familiar forms of matter to condense from the high-energy "soup" of subatomic particles that constituted the very early universe.

**Cosmological redshifts.** Distinct spectral features, characteristic of the different chemical elements that are present, appear at well-established locations in the spectrum of an astronomical object, but the entire spectrum is shifted toward shorter wavelengths (bluewards) for an object approaching the observer, or toward longer wavelengths (redwards) for a receding object. The amount of this Doppler shift is closely related to the actual relative speed of the object. See DOPPLER EFFECT.

With the exception of a few nearby galaxies, all of the galaxies exhibit redshifts of varying amounts, implying that they are all moving away from the Earth. Edwin Hubble extended this work by determining the distances to these galaxies, and found that the redshift was directly proportional to the distance; that is, translating redshift into recession velocity, the more distant the galaxy, the faster it is moving away from the Earth. The constant of proportionality relating speed and distance now bears Hubble's name, and an accurate determination of this Hubble constant ( $H_0$ ) is a central pursuit of modern astronomy. Recent studies seem to be converging towards a value of  $H_0 = 72 \text{ km/(s)(Mpc)}$ .

If space itself is expanding uniformly in all directions, and the galaxies are being carried along in this general expansion, then any point in the universe would see all other points moving away. The greater the distance between two points, the more space exists between them, and the faster this distance increases. Hubble's law is therefore a consequence of the uniform expansion of space, which causes more distant galaxies to exhibit larger redshifts because they are receding from the Earth faster.

If space is expanding uniformly in all directions, then it follows that in the past the universe was smaller. At some point in the past, all matter and energy may have existed in a single point of infinite temperature and density. See HUBBLE CONSTANT; REDSHIFT.

**Cosmic background radiation.** If this picture is correct, and the current universe was spawned from a primordial fireball, then observers should see a residual afterglow from the era when the matter in the universe was hot and emitting strongly, in much the same way that the surfaces of stars shine today. This microwave background was first observed in 1961. The *Cosmic Background Explorer (COBE)* satellite mission in 1990 that the spectrum was measured its spectrum over a wide range of wavelengths, establishing the cosmic background radiation temperature at 2.726 K.

Since the cosmic background radiation is an intrinsic characteristic of the universe, observers expect to see it reaching the Earth uniformly from all directions in space. However, reanalysis of the *COBE* data, as well as more recent observations of the cosmic background radiation, shows minute ripples or anisotropies in the temperature of the background radiation. The amplitude and spatial scale of these ripples are of keen interest, since they probably result from the very first clumps of matter that accreted in the early universe. See COSMIC BACKGROUND RADIATION.

**Evolution of the universe.** The best models for the beginning of the universe start at  $10^{-43}$  second after the big bang itself. At  $10^{-43}$  s, the universe was  $10^{30}$  times smaller than it is today (barely larger than an atom), and had a mean temperature of  $10^{30}$  K. At such temperatures, matter as presently known cannot exist, because the energies are so enormous that even the protons and neutrons themselves are torn apart into separate subatomic particles called quarks. The universe was a featureless mixture of quarks, leptons (another class of particles including electrons and neutrinos), and high-energy photons. See LEPTON; QUANTUM GRAVITATION; QUARKS; SUPERGRAVITY; SUPERSYMMETRY.

At  $10^{-34}$  s, when the temperature had dropped to  $3 \times 10^{26}$  K, heavier exotic particles such as magnetic monopoles could have emerged. Around this time, the rapidly enlarging structure of space may have undergone even faster expansion, driven by the energy of space itself. This era of hyperfast inflation helps explain features of the present-day observable universe, such as the uniformity of the cosmic background radiation over the entire sky, and the way in which the average mass density of the universe is high enough for structures like stars and galaxies to form, but not so large that it would recollapse quickly. See INFLATIONARY UNIVERSE COSMOLOGY; MAGNETIC MONOPOLES.

When the temperature had dropped further, to about  $3 \times 10^{12}$  K, protons and neutrons condensed out of the quark mixture. It was still much too hot for electrons to join them and form atoms, but more complex atomic nuclei were created in a fashion

similar to stellar core fusion. This era of big bang nucleosynthesis established the initial composition of the universe, about three-quarters hydrogen, one-quarter helium, and small amounts of lithium, from which all subsequent stellar and supernova nucleosynthesis has proceeded.

Until a time about 100,000 years after the big bang, temperatures were still too high for electrons to join these nuclei to make complete atoms. Up to this point, the universe was relatively opaque, since free charged particles like electrons are very good at absorbing light and other electromagnetic radiation. Once the temperature fell below 3000 K, however, atoms formed, and the universe suddenly became transparent to most wavelengths. The cosmic background radiation formed at this point and has had little interaction with matter since. The formation of structure—the development of clumpiness in the universe, which is seen today as stars, galaxies, and clusters—started slightly before matter-radiation decoupling.

**Ultimate fate of the universe.** The motions of galaxies indicate that the universe has continued to expand after the initial impulse of the big bang, but it is not known whether this expansion will continue. The situation is complicated by the possible presence of an additional cosmological force, predicted by general relativity, which has the opposite effect from gravitational mass. This cosmological constant, represented by  $\Lambda$ , pushes outward instead of pulling inward like gravity, adding an acceleration term to the expansion of the universe. Interest in  $\Lambda$  has revived in recent years in an attempt to explain deviations in redshift velocities of some very distant galaxies. If  $\Lambda > 0$ , as some researchers now think, then this would make an infinite expansion more likely, even with significant amounts of dark matter. Currently favored models yield a topologically flat universe. See BIG BANG THEORY; COSMOLOGY. [B.B.Be.]

**Upper-atmosphere dynamics** The motion of the atmosphere above 50 km (30 mi). The predominant dynamical phenomena of the upper atmosphere are quite different from those encountered in the lower atmosphere. Among those encountered in the lower atmosphere are cyclones, anticyclones, tropical hurricanes, thunderstorms and shower clouds, tornadoes, and dust devils. Even the largest of these phenomena do not penetrate far into the upper atmosphere. Above an altitude of about 50 km (30 mi), the predominant dynamical phenomena are internal gravity waves, tides, sound waves (including infrasonic), turbulence, and large-scale circulation.

Except under meteorological conditions characterized by convection, the atmosphere is stable against small vertical displacements of small air parcels; this results from buoyancy forces that tend to restore displaced air parcels to their original levels. An air parcel therefore tends to oscillate around its undisturbed position at a frequency known as the Brunt-Vaisala frequency  $\omega_B$ . If pressure waves are generated in the atmosphere with frequencies much greater than  $\omega_B$ , they propagate as sound waves. For frequencies much less than  $\omega_B$ , the waves propagate as internal gravity waves; in this case, the restoring forces for the wave motion are provided primarily by buoyancy (that is, gravity) rather than by compression.

Tides are internal gravity waves of particular frequencies. The term tidal usually implies that the exciting force is gravitational attraction by the Moon or Sun. However, it is conventional in the case of atmospheric tides to include also those waves that are excited by solar heating. One is therefore concerned with three separate excitation functions—lunar gravitation, solar gravitation, and solar heating.

Tidal wind patterns in the upper atmosphere generate electrical currents in the ionosphere through a dynamo action. These in turn give rise to diurnal variations in the geomagnetic field that can be observed at the Earth's surface. See ATMOSPHERIC TIDES; GEOMAGNETIC VARIATIONS; IONOSPHERE.

Sound waves generated in the lower atmosphere may propagate upward; to maintain continuity of energy flow, the waves

might be expected to grow in relative amplitude as they move into the more rarefied upper atmosphere. However, higher temperatures in the upper atmosphere refract most of the energy back toward the Earth's surface, giving rise to the phenomenon known as anomalous propagation. This involves the redirection of upward-moving sound waves back to the surface beyond the point where the source can be heard by waves propagating along the surface. Infrasonic waves with periods from 20 to 80 s have been observed occasionally with detectors at the Earth's surface in connection with auroral activity. See SOUND.

There is clear visual evidence of turbulence in the upper atmosphere; this evidence is obtained by examination of vapor trails released from rockets or of long-persisting meteor trails. The source of the turbulence is not clear. The atmosphere is thermodynamically stable against vertical displacements throughout the region above the troposphere, and work has to be done against buoyancy forces in order to produce and maintain turbulence. The only apparent source of energy is internal gravity waves, either tidal or of random period.

There are prevailing patterns of atmospheric circulation in the upper atmosphere, but they are very different from those that occur in the lower atmosphere, which are associated with weather systems and have complicated structures resulting from growth of instabilities. The upper atmospheric large-scale wind systems are mainly diurnal in nature and global in scale.

The main heat source that is responsible for the upper atmospheric circulation is ultraviolet radiation from the Sun, radiation that is mainly absorbed at altitudes between 100 and 200 km (60 and 120 mi). The atmosphere is not a good infrared radiator in this altitude region, so the temperature rises rapidly with altitude, providing a temperature gradient of such a magnitude that molecular conduction transfers the absorbed heat downward to altitudes below 100 km (60 mi) where the atmosphere does have the capability of radiating the energy back to space. Above about 300 km (180 mi), the temperature becomes roughly constant with altitude because very little energy is absorbed there (the gas is exceedingly rarefied) and the thermal conductivity is good enough under these circumstances to virtually eliminate vertical temperature gradients. See SOLAR RADIATION.

The region of rising temperature above 80 km (48 mi) is known as the thermosphere. The exosphere is that region of the atmosphere that is so rarefied that for many purposes collisions between molecules can be neglected; it is roughly the region above 500 km (300 mi).

At high latitudes, the ionosphere moves in response to electric fields imposed as a consequence of interactions between the Earth's magnetic field and the solar wind. The imposed electric field causes the ionosphere to drift in a generally antisunward direction over the polar caps (regions at higher latitudes than the auroral zone, or magnetic latitudes greater than about 68°), with a return circulation (that is, generally sunward in direction) just outside the polar caps. See ATMOSPHERIC GENERAL CIRCULATION; SOLAR WIND; WIND.

Ultraviolet radiation of suitable wavelengths can photodissociate atmospheric molecules—something of great importance in the upper atmosphere. It is even important in the stratosphere, where ozone is formed as a result of absorption by molecular oxygen of ultraviolet radiation, the important wavelengths being below 242 nanometers. See OZONE; STRATOSPHERE. [F.S.J.]

**Upsilon particles** A family of elementary particles whose first three members were discovered in 1977. The up-silon mesons,  $\Upsilon$ , are the heaviest known vector mesons, with masses greater than 10 times that of the proton. They are bound states of a heavy quark and its antiquark. The quarks which bind to form the upsilons carry a new quantum number called beauty or bottomness, and they are called *b*-quarks or *b*. The mass of the *b*-quark is around 5 GeV. The anti-*b*-quark or *b* carries anti-beauty, and therefore the upsilons carry no beauty and are often called hidden beauty states. Direct proof of the existence of the

*b*-quark was obtained by observing the existence of *B* mesons which consist of a *b*-quark bound to a lighter quark. Thirteen *bb*-mesons have also been observed thus far. See ELEMENTARY PARTICLE; MESON; QUARKS. [P.F.]

**Upwelling** The phenomenon or process involving the ascending motion of water in the ocean. Vertical motions are an integral part of ocean circulation, but they are a thousand to a million times smaller than the horizontal currents. Vertical motions are inhibited by the density stratification of the ocean because with increasing depth, as the temperature decreases, the density increases, and energy must be expended to displace water vertically. The ocean is also stratified in other properties; for example, nutrient concentration generally increases with depth. Thus even weak vertical flow may cause a significant effect by advecting nutrients to a new level. See GEOPHYSICAL FLUID DYNAMICS.

There are two important upwelling processes. One is the slow upwelling of cold abyssal water, occurring over large areas of the world ocean, to compensate for the formation and sinking of this deep water in limited polar regions. The other is the upwelling of subsurface water into the euphotic (sunlit) zone to compensate for a horizontal divergence of the flow in the surface layer, usually caused by winds. See OCEAN CIRCULATION. [R.L.Sm.]

**Uraninite** The chief ore mineral of uranium. Uraninite has the idealized chemical composition  $\text{UO}_2$ , uranium dioxide. Thorium and rare earths, chiefly cerium, are usually present in variable and sometimes large amounts. Lead always is present by radioactive decay of the thorium and uranium present. Complete solid-solution series extend between  $\text{UO}_2$ ,  $\text{ThO}_2$  (thorianite), and  $\text{CeO}_2$  (cerianite). See RADIOACTIVE MINERALS; RARE-EARTH ELEMENTS; THORIANITE; URANIUM.

The color of uraninite is black, grading to brownish black and dark brown in the more highly oxidized material. The luster of fresh material is steel-gray. The hardness is  $5\frac{1}{2}$ –6 on Mohs scale. The specific gravity of pure  $\text{UO}_2$  is 10.9, but that of most natural material is 9.7–7.5. [C.Fr.]

**Uranium** A chemical element, symbol U, atomic number 92, atomic weight 238.03. The melting point is 1132°C (2070°F) and the boiling point is 3818°C (6904°F). Uranium is one of the actinide series. See ACTINIDE ELEMENTS; PERIODIC TABLE.

Uranium in nature is a mixture of three isotopes:  $^{234}\text{U}$ ,  $^{235}\text{U}$ , and  $^{238}\text{U}$ . Uranium is believed to be concentrated largely in the Earth's crust, where the average concentration is 4 parts per million (ppm). The total uranium content of the Earth's crust to a depth of 15 mi (25 km) is calculated to be  $2.2 \times 10^{17}$  lb ( $10^{17}$  kg); the oceans may contain  $2.2 \times 10^{13}$  lb ( $10^{13}$  kg) of uranium. Several hundred uranium-containing minerals have been identified, but only a few are of commercial interest. See RADIOACTIVE MINERALS; URANINITE.

Because of the great importance of the fissile isotope  $^{235}\text{U}$ , rather sophisticated industrial methods for its separation from the natural isotope mixture have been devised. The gaseous diffusion process, which in the United States is operated in three large plants (at Oak Ridge, Tennessee; Paducah, Kentucky; and Portsmouth, Ohio) has been the established industrial process. Other processes applied to the separation of uranium include the centrifuge process, in which gaseous uranium hexafluoride is separated in centrifuge cascades, the liquid thermal diffusion process, the separation nozzle, and laser excitation. See ISOTOPE (STABLE) SEPARATION.

Uranium is a very dense, strongly electropositive, reactive metal; it is ductile and malleable, but a poor conductor of electricity. Many uranium alloys are of great interest in nuclear technology because the pure metal is chemically active and anisotropic and has poor mechanical properties. However, cylindrical rods of pure uranium coated with silicon and canned in aluminum tubes (slugs) are used in production reactors. Uranium alloys

can also be useful in diluting enriched uranium for reactors and in providing liquid fuels. Uranium depleted of the fissile isotope  $^{235}\text{U}$  has been used in shielded containers for storage and transport of radioactive materials. See NUCLEAR FUELS; NUCLEAR REACTOR.

Uranium reacts with nearly all nonmetallic elements and their binary compounds. Uranium dissolves in hydrochloric acid and nitric acid, but nonoxidizing acids, such as sulfuric, phosphoric, or hydrofluoric acid, react very slowly. Uranium metal is inert to alkalis, but addition of peroxide causes formation of water-soluble peruranates. See URANIUM METALLURGY.

Uranium reacts reversibly with hydrogen to form  $\text{UH}_3$  at  $250^\circ\text{C}$  ( $482^\circ\text{F}$ ). Correspondingly, the hydrogen isotopes form uranium deuteride,  $\text{UD}_3$ , and uranium tritide,  $\text{UT}_3$ . The uranium-oxygen system is extremely complicated. Uranium monoxide,  $\text{UO}$ , is a gaseous species which is not stable below  $1800^\circ\text{C}$  ( $3270^\circ\text{F}$ ). In the range  $\text{UO}_2$  to  $\text{UO}_3$ , a large number of phases exist. The uranium halides constitute an important group of compounds. Uranium tetrafluoride is an intermediate in the preparation of the metal and the hexafluoride. Uranium hexafluoride, which is the most volatile uranium compound, is used in the isotope separation of  $^{235}\text{U}$  and  $^{238}\text{U}$ . The halides react with oxygen at elevated temperatures to form uranyl compounds and ultimately  $\text{U}_3\text{O}_8$ . [FWe.]

**Uranium metallurgy** The processing treatments for the production of uranium concentrates and the recovery of pure uranium compounds, as well as the conversion chemistry for producing uranium metal and the processes employed for preparing uranium alloys.

The procedures to recover uranium from its ores are numerous, because of the great variety in the nature of uranium minerals and associated materials and the wide range of concentration in the naturally occurring ores. Recovery of uranium requires chemical processing; however, preliminary treatment of the ore may involve a roasting operation, a physical or chemical concentration step, or a combination of these. In general, one of two leaching treatments—acid leaching and carbonate leaching—is used as the initial step in chemical concentration. The choice depends on the nature of the ore, which largely determines the efficiency and the cost of the process employed. See LEACHING.

The concentrate, whether obtained by chemical or physical means, is treated chemically to give a uranyl nitrate solution that can be further purified by solvent extraction. The impurities remain in the aqueous phase, while the uranium is extracted into the organic phase. See SOLVENT EXTRACTION.

Uranium metal can be obtained from its halides by fused-salt electrolysis or by reduction with more reactive metals. The reaction of  $\text{UO}_2$  with calcium yields metal of fair quality. The largest tonnages of good-quality uranium have been produced by metallothermic reduction of finely divided  $\text{UF}_4$  with calcium or magnesium in steel bombs lined with fused dolomitic oxide (Ames process). The charge, consisting of an intimate mixture of  $\text{UF}_4$  with the reductant metal in granular form together with a suitable booster (usually calcium plus iodine), is placed into the reduction bomb, the lid is bolted down, and the bomb is heated to ignition temperature. The shape of the metal ingot (also referred to as a biscuit) depends on the shape of the reduction bomb.

Uranium alloys are prepared by fusing the components together. All procedures following conventional metallurgical techniques, however, may have to be carried out inside inert-gas glove boxes because many alloys are attacked by oxygen or moisture. See NUCLEAR FUELS; NUCLEAR FUELS REPROCESSING; URANIUM. [FWe.]

**Uranus** The first planet to be discovered with the telescope and the seventh in the order of distance from the Sun. It was found accidentally by W. Herschel in England on March 13, 1781. See PLANET.

The obliquity (inclination of rotational axis to orbit plane) of Uranus is  $98^\circ$ , exceeded only by the obliquities of Pluto and Venus. This means that the axis is almost in the plane of the orbit, and thus the seasons on Uranus are very unusual. During summer in one hemisphere, the pole points almost directly toward the Sun while the other hemisphere is in total darkness. Forty-two years later, the situation is reversed. See PLUTO; VENUS.

The linear equatorial diameter is 31,770 mi (51,120 km). The mass is 14.5 times the mass of the Earth. The corresponding mean density is greater than that of Saturn even though Uranus is smaller than Saturn. This means that Uranus is richer than Saturn (or Jupiter) in elements heavier than hydrogen and helium but not nearly so rich in these elements as Earth. The same is true for Neptune. See JUPITER; NEPTUNE; SATURN.

The temperature that Uranus would assume in simple equilibrium with incident solar radiation at this distance is about 55 K ( $-360^\circ\text{F}$ ). This is essentially identical with the value found by direct measurement. There is thus no evidence for the existence of an internal energy source as observed for Jupiter, Saturn, and Neptune.

Through the telescope, Uranus appears as a small, slightly elliptical blue-green disk. This appearance is confirmed in the nearly featureless pictures of the planet obtained by *Voyager 2*. Uranus owes its characteristic aquamarine color to the relatively high proportion of methane in its atmosphere. The methane abundance is 20 to 30 times the amount corresponding to a solar distribution of the elements, in agreement with the enrichment of heavy elements in the planet deduced from its average density. In striking contrast, the proportion of helium to hydrogen, the two most abundant gases in the planet's atmosphere, is essentially equal to that observed in the Sun. Like Jupiter and Saturn, Uranus exhibits zonal winds that are parallel to the equator, despite the unusual orientation of the planet's rotational axis.

Before the *Voyager 2* encounter, only five satellites of Uranus had been discovered. They form a remarkably regular system with low orbital eccentricities and inclinations close to the plane of the planet's equator. The *Voyager* cameras found 10 additional small satellites, including two that may serve as gravitational "shepherds" for the outermost ring. Like Jupiter, Saturn, and Neptune, Uranus also has more distant, irregular satellites (moons that move in orbits with high inclinations or eccentricities). As of August 2004, six of these unusual moons were definitely established, all discovered since 1997.

A system of 10 narrow rings can be observed around Uranus. The mean width of the widest is only 36 mi (58 km) which is still six to seven times larger than that of the next widest rings. [T.C.O.]

**Urban climatology** The branch of climatology concerned with urban areas. These locales produce significant changes in the surface of the Earth and the quality of the air. In turn, surface climate in the vicinity of urban sites is altered. The era of urbanization on a worldwide scale has been accompanied by unintentional, measurable changes in city climate. See CLIMATOLOGY.

The process of urbanization changes the physical surroundings and induces alterations in the energy, moisture, and motion regime near the surface. Most of these alterations may be traced to causal factors such as air pollution; anthropogenic heat; surface waterproofing; thermal properties of the surface materials; and morphology of the surface and its specific three-dimensional geometry—building spacing, height, orientation, vegetative layering, and the overall dimensions and geography of these elements. Other factors that must be considered are relief, nearness to water bodies, size of the city, population density, and land-use distributions.

In general, cities are warmer than their surroundings, as documented over a century ago. They are islands or spots on the broader, more rural surrounding land. Thus, cities produce a heat island effect on the spatial distribution of temperatures. The

timing of a maximum heat island is followed by a lag shortly after sundown, as urban surfaces, which absorbed and stored daytime heat, retain heat and affect the overlying air. Meantime, rural areas cool at a rapid rate.

A number of energy processes are altered to create warming, and various features lead to those alterations. City size, the morphology of the city, land-use configuration, and the geographic setting (such as relief, elevation, and regional climate) dictate the intensity of the heat island, its geographic extent, its orientation, and its persistence through time. Individual causes for heat island formation are related to city geometry, air pollution, surface materials, and anthropogenic heat emission. There are two atmosphere layers in an urban environment, besides the planetary boundary layer outside and extending well above the city: (1) The urban boundary layer is due to the spatially integrated heat and moisture exchanges between the city and its overlying air. (2) The surface of the city corresponds to the level of the urban canopy layer. Fluxes across this plane comprise those from individual units, such as roofs, canyon tops, trees, lawns, and roads, integrated over larger land-use divisions (for example, suburbs). [A.J.B.]

**Urea** A colorless crystalline compound, formula  $\text{CH}_4\text{N}_2\text{O}$ , melting point  $132.7^\circ\text{C}$  ( $270.9^\circ\text{F}$ ). Urea is also known as carbamide and carbonyl diamide, and has numerous trade names as well. It is highly soluble in water and is odorless in its pure state, although most samples of even high purity have an ammonia odor. The diamide of carbonic acid, urea has the structure below.

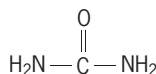

Urea occurs in nature as the major nitrogen-containing end product of protein metabolism by mammals, which excrete urea in the urine. The adult human body discharges almost 50 g (1.8 oz) of urea daily. Urea was first isolated in 1773 by G. F. Rouelle. By preparing urea from potassium cyanate ( $\text{KCNO}$ ) and ammonium sulfate ( $\text{NH}_4\text{SO}_4$ ) in 1828, F. Wöhler achieved a milestone, the first synthesis of an organic molecule from inorganic starting materials, and thus heralded the modern science of organic chemistry. See NITROGEN; PROTEIN METABOLISM.

Because of its high nitrogen content (46.65% by weight), urea is a popular fertilizer. About three-fourths of the urea produced commercially is used for this purpose. After application to soil, usually as a solution in water, urea gradually undergoes hydrolysis to ammonia (or ammonium ion) and carbonate (or carbon dioxide). Another major use of urea is as an ingredient for the production of urea-formaldehyde resins, extremely effective adhesives used for laminating plywood and in manufacturing particle board, and the basis for such plastics as malamine. See FERTILIZER; UREA-FORMALDEHYDE RESINS.

Other uses of urea include its utilization in medicine as a diuretic. In the past, it was used to reduce intracranial and intraocular pressure, and as a topical antiseptic. It is still used for these purposes, to some extent, in veterinary medicine and animal husbandry, where it also finds application as a protein feed supplement for cattle and sheep. Urea has been used to brown baked goods such as pretzels. It is a stabilizer for nitrocellulose explosives because of its ability to neutralize the nitric acid that is formed from, and accelerates, the decomposition of the nitrocellulose. Urea was once used for flameproofing fabrics. Mixed with barium hydroxide, urea is applied to limestone monuments to slow erosion by acid rain and acidic pollutants. [R.D.Wa.]

**Urea-formaldehyde-type resins** The condensation products obtained by the reaction of urea or melamine with formaldehyde. Resinous condensation products of formaldehyde with other nitrogen-containing compounds, for example,

aniline and amides, also belong to this group of resins but have gained only limited utility.

The urea- and melamine-formaldehyde resins (amino resins) possess an excellent combination of physical properties and can be easily fabricated in a variety of colors. They are widely used as adhesives, laminating resins, molding compounds, paper and textile finishes, and surface coatings.

The aniline- and sulfonamide-formaldehyde resins are produced from other compounds containing  $-\text{NH}_2$  groups that condense with formaldehyde to form methylol derivatives which are capable of further reaction. These resins have received limited attention except for aniline and *p*-toluenesulfonamide. Because of their resistance to the absorption of water, the aniline-formaldehyde resins have been used in electrical applications, such as insulation or panels, where their natural brown color is not objectionable. The sulfonamide-formaldehyde polymers are less colored than the aniline-type resins and have been employed in surface coatings. See CONDENSATION REACTION; FORMALDEHYDE; POLYMERIZATION; UREA. [J.A.M.]

**Uredinales** An order of fungi known as plant rusts that belong to the division (phylum) Basidiomycota. In nature, all 7000 species are obligate parasites of many vascular plant species. They cause diseases known as rust on numerous cultivated crops, and many trees are also attacked. Each rust species infects one or just a few closely related plant host species. Rust fungi occur on all continents except Antarctica.

The body of a rust fungus consists of numerous microscopic, threadlike, branching hyphae that grow inside the tissues and between the cells of the host plant. Specialized feeding structures, haustoria, grow from these hyphae into the host cells of the plant and provide nourishment for the hyphae. Hyphal cells are binucleate. Depending upon the rust species and environmental conditions, up to six different kinds of spore-producing structures, the sori, may be produced by one rust species. These sori may be powdery, waxy, or crustlike, and whitish, yellow, orange, brown, or blackish.

Rust teliospores that are produced in sori called telia are essential elements for classification. Teliospores consist of one or more specialized probasidial cells. During the development of each of these cells, nuclei fuse and meiosis occurs, resulting in a septate metabasidium from which four haploid meiospores (basidiospores) are formed. Basidiospores are forcibly ejected from the tips of their tiny stalks and are wind-disseminated. After landing on a susceptible host, under proper conditions basidiospores produce new infections. In cold regions, a rust may survive the winter as dormant, thick-walled, dark-colored teliospores. In many rust species, teliospores mature and produce basidiospores with no or little dormancy, especially in the tropics.

Although most rust species require only one host species to complete their life cycles (autoecious rusts), some of the best-known rusts require two taxonomically unrelated hosts (heteroecious rusts).

Rust diseases are controlled most effectively by breeding resistant host varieties. Fungicides are used for some rusts. In the case of some heteroecious rusts, eradication of one of the hosts (the noneconomic one) has been successful. Some rust species are used to aid in biological control of weeds. See BASIDIOMYCOTA; EUMYCOTA; FUNGI; PLANT PATHOLOGY. [J.F.Hen.]

**Uric acid** The main excretory end product of protein metabolism in certain species of birds and reptiles. In mammals, uric acid is derived from purines; in higher primates, including humans, it is excreted as such and is not oxidized to allantoin, the main excretory purine metabolism product of most species. In humans, uric acid levels are increased following excessive intake of dietary purines, primary synthesis in certain diseases (gout, Lesch-Nyhan syndrome), endogenous nucleic acid metabolism (leukemia, an abnormal number of erythrocytes



in blood, chemotherapy-induced tumor lysis), and restricted renal excretion (renal diseases, ketoacidosis, lacticidosis, diuretics). Uric acid levels are lowered by the use of drugs causing increased uric acid excretion, and by renal tubular defects. See GOUT; KIDNEY DISORDERS; LEUKEMIA; LIVER; NUCLEIC ACID; PROTEIN METABOLISM; PURINE; TUMOR. [M.K.S.]

**Uridine diphosphoglucose (UDPG)** A compound in which  $\alpha$ -glucopyranose is esterified, at carbon atom 1, with the terminal phosphate group of uridine-5'-pyrophosphate (that is, uridine diphosphate, UDP). On very mild acid hydrolysis, glucose and UDP are liberated. Uridine diphosphoglucose occurs in animal, plant, and microbial cells and is synthesized enzymatically from uridine triphosphate (UTP) and  $\alpha$ -glucose-1-phosphate. This compound functions as a key in the transformation of glucose to other sugars.

In general, UDP-glucose is a prominent member of a family of compounds composed of sugars activated as derivatives of nucleoside diphosphates. In these active forms they can be used directly as glycosyl donors, or they may be transformed to other more complex sugars before their utilization for the biosynthesis of both simple saccharides and complex polysaccharides. See CARBOHYDRATE METABOLISM; NUCLEIC ACID. [J.L.Str.]

**Urinalysis** Laboratory examination of urine. Urine is a filtrate of the blood and is produced in the kidneys. It is a reflection of the metabolic activity of the body; conditions that affect the normal homeostatic mechanisms are often revealed by a careful analysis of the composition of the urine. Modern routine urinalysis can be divided into two basic procedures: macroscopic and chemical examination, and microscopic analysis.

**Macroscopic and chemical examination.** Macroscopic examination includes noting the color and clarity of the urine. Normal urine is pale yellow or straw colored and is usually transparent or clear; abnormal urine may vary greatly in color and may show varying degrees of cloudiness. The specific gravity of urine, that is, the ratio of the weight of a volume of urine to that of the same volume of water, is measured routinely. Specific gravity is an indicator of the kidney's ability to concentrate or dilute the urine and thus of renal tubular function. The normal range is 1.003–1.032.

Most routine chemical urinalysis is now carried out by dipstick testing, which involves the use of plastic strips, or dipsticks, bearing pads embedded with chemical reactants and color indicators. The reaction of each pad represents a separate chemical test for a specific product in the urine. Dipstick testing includes the following categories: protein, glucose, ketone bodies, blood, and bile. See PROTEIN.

**Microscopic examination.** The urine normally contains a wide variety of formed elements that can be identified by using a light microscope. Together these elements form the urinary sediment.

Cells in the urine originate in the bloodstream or in the epithelium lining the urinary tract. The main types of epithelial cells are renal tubular cells, transitional (urothelial) cells, and squamous cells. All three types occur in relatively small numbers in the normal sediment. Blood cells occur normally in the urine in small numbers, and consist mainly of polymorphonuclear neutrophils (a type of granular leukocyte) and red blood cells.

Casts, proteinaceous products of the kidney, are of major importance when present in increased numbers or seen in abnormal forms, because they usually indicate intrinsic renal disease. Casts are cylindrical and are named on the basis of their microscopic appearance and the cells they contain.

Normally, urine is sterile, and the urinary sediment should not contain microorganisms. However, in patients with serious urinary tract infections, microorganisms are usually present in the urine in considerably greater numbers. See CLINICAL PATHOLOGY.

Mucus is frequently found in urine sediment and has no known pathologic significance. A wide variety of crystals appear in the

urine; their presence may be normal or may indicate an abnormal state. See KIDNEY; KIDNEY DISORDERS. [M.H.Ha.]

**Urinary bladder** A distensible, muscular sac in most vertebrates which serves as a reservoir for urine. Snakes, crocodilians, birds (with the exception of the ostrich), most lizards, and a few fish lack a urinary bladder. In these organisms, urine empties directly into the cloaca. The development of the urinary system is intimately associated with the development of the reproductive system. Three general types of urinary bladder are recognized among the vertebrates: tubal, cloacal, and allantoic. See URINE.

Most fish possess tubal bladders, that is, enlargements of the mesonephric ducts. The cloacal bladder is found in monotremes, amphibians, and some dipnoans. There is no direct connection between the excretory ducts and this type of bladder. The bladder is an outpouching or diverticulum of the cloacal wall. The cloacal opening is closed by a sphincter muscle and the urine which seeps into the cloaca from the excretory ducts is forced into the bilobed bladder.

The allantoic bladder is derived from the ventral wall of the cloaca and possibly the allantoic diverticulum. The role of the allantois in the formation of this type of bladder, which is found in most mammals, the turtles, and those lizards which have a bladder, is questioned by some embryologists. See ALLANTOIS.

The mammalian bladder is lined with a special epithelium composed of transitional cells. The muscular layer is composed of vertical, horizontal, and oblique fibers. The bladder drains through the urethra, the opening being controlled by a sphincter. Innervation is by the hypogastric sympathetic plexus and partly by parasympathetic fibers from the second and third sacral nerves. Stimulation of the parasympathetic causes the bladder muscle to contract and relaxes the internal sphincter. Micturition is a reflex act which is initiated voluntarily except in children. See PARASYMPATHETIC NERVOUS SYSTEM; SYMPATHETIC NERVOUS SYSTEM; URINARY SYSTEM. [C.B.C.]

**Urinary system** The urinary system consists of the kidneys, urinary ducts, and bladder. Similarities are not particularly evident among the many and varied types of excretory organs found among vertebrates. The variations that are encountered are undoubtedly related to problems with which vertebrates have had to cope in adapting to different environmental conditions.

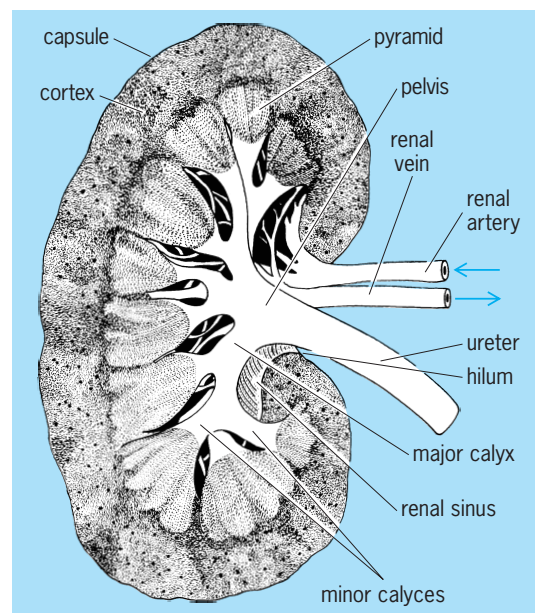

Fig. 1. Sagittal section of a human metanephric kidney (semidiagrammatic). (After C. K. Weichert and W. Presch, *Elements of Chordate Anatomy*, 4th ed., McGraw-Hill, 1975)

**Kidneys.** In reptiles, birds, and mammals three types of kidneys are usually recognized: the pronephros, mesonephros, and metanephros. These appear in succession during embryonic development, but only the metanephros persists in the adult.

The metanephric kidneys of reptiles lie in the posterior part of the abdominal cavity, usually in the pelvic region. They are small, compact, and often markedly lobulated. The posterior portion on each side is somewhat narrower. In some lizards the hind parts may even fuse. The degree of symmetry varies.

The kidneys of birds are situated in the pelvic region of the body cavity; their posterior ends are usually joined. They are lobulated structures with short ureters which open independently into the cloaca.

A rather typical mammalian metanephric kidney (Fig. 1) is a compact, bean-shaped organ attached to the dorsal body wall outside the peritoneum. The ureter leaves the medial side at a depression, the hilum. At this point a renal vein also leaves the kidney and a renal artery and nerves enter it. The kidneys of mammals are markedly lobulated in the embryo, and in many forms this condition is retained throughout life. See KIDNEY. [C.K.W.]

**Urinary bladder.** At or near the posterior ends of the nephric ducts there frequently is a reservoir for urine. This is the urinary bladder. Actually there are two basic varieties of bladders in vertebrates. One is found in fishes in which the reservoir is no more than an enlargement of the posterior end of each urinary duct. Frequently the urinary ducts are conjoined and a small bladder is formed by expansion of the common duct. The far more common type of bladder is that exhibited by tetrapods. This is a sac which originates embryonically as an outgrowth from the ventral side of the cloaca. Present in all embryonic life, it is exhibited differentially in adults. All amphibians retain the bladder, but it is lacking in snakes, crocodilians, and most lizards; birds, also, with the exception of the ostrich, lack a bladder. It is present in all mammals. See URINARY BLADDER. [T.W.T.]

**Physiology.** Urine is produced by individual renal nephron units which are fundamentally similar from fish to mammals (Fig. 2); however, the basic structural and functional pattern of these nephrons varies among representatives of the vertebrate classes in accordance with changing environmental demands. Kidneys serve the general function of maintaining the chemical and physical constancy of blood and other body fluids. The most

striking modifications are associated particularly with the relative amounts of water made available to the animal. Alterations in degrees of glomerular development, in the structural complexity of renal tubules, and in the architectural disposition of the various nephrons in relation to one another within the kidneys may all represent adaptations made either to conserve or eliminate water.

**Regulation of volume.** Except for the primitive marine cyclostome *Myxine*, all modern vertebrates, whether marine, freshwater, or terrestrial, have concentrations of salt in their blood only one-third or one-half that of seawater. The early development of the glomerulus can be viewed as a device responding to the need for regulating the volume of body fluids. Hence, in a hypotonic fresh-water environment the osmotic influx of water through gills and other permeable body surfaces would be kept in balance by a simple autoregulatory system whereby a rising volume of blood results in increased hydrostatic pressure which in turn elevates the rate of glomerular filtration. Similar devices are found in fresh-water invertebrates where water may be pumped out either as the result of work done by the heart, contractile vacuoles, or cilia found in such specialized "kidneys" as flame bulbs, solenocytes, or nephridia that extract excess water from the body cavity rather than from the circulatory system. Hence, these structures which maintain a constant water content for the invertebrate animal by balancing osmotic influx with hydrostatic output have the same basic parameters as those in vertebrates that regulate the formation of lymph across the endothelial walls of capillaries. See OSMOREGULATORY MECHANISMS.

**Electrolyte balance.** A system that regulates volume by producing an ultrafiltrate of blood plasma must conserve inorganic ions and other essential plasma constituents. The salt-conserving operation appears to be a primary function of the renal tubules which encapsulate the glomerulus. As the filtrate passes along their length toward the exterior, inorganic electrolytes are extracted from them through highly specific active cellular resorptive processes which restore plasma constituents to the circulatory system.

**Movement of water.** Concentration gradients of water are attained across cells of renal tubules by water following the active movement of salt or other solute. Where water is free to follow the active resorption of sodium and covering anions, as in the proximal tubule, an isosmotic condition prevails. Where water is not free to follow salt, as in the distal segment in the absence of antidiuretic hormone, a hypotonic tubular fluid results.

**Nitrogenous end products.** Of the major categories of organic foodstuffs, end products of carbohydrate and lipid metabolism are easily eliminated mainly in the form of carbon dioxide and water. Proteins, however, are more difficult to eliminate because the primary derivative of their metabolism, ammonia, is a relatively toxic compound. For animals living in an aquatic environment ammonia can be eliminated rapidly by simple diffusion through the gills. However, when ammonia is not free to diffuse into an effectively limitless aquatic environment, its toxicity presents a problem, particularly to embryos of terrestrial forms that develop wholly within tightly encapsulated eggshells or cases. For these forms the detoxication of ammonia is an indispensable requirement for survival. During evolution of the vertebrates two energy-dependent biosynthetic pathways arose which incorporated potentially toxic ammonia into urea and uric acid molecules, respectively. Both of these compounds are relatively harmless, even in high concentrations, but the former needs a relatively large amount of water to ensure its elimination, and uric acid requires a specific energy-demanding tubular secretory process to ensure its efficient excretion. See UREA; URIC ACID.

**Urine concentration.** The unique functional feature of the mammalian kidney is its ability to concentrate urine. Human urine can have four times the osmotic concentration of plasma, and some desert rats that survive on a diet of seeds without drinking any water have urine/plasma concentration ratios as

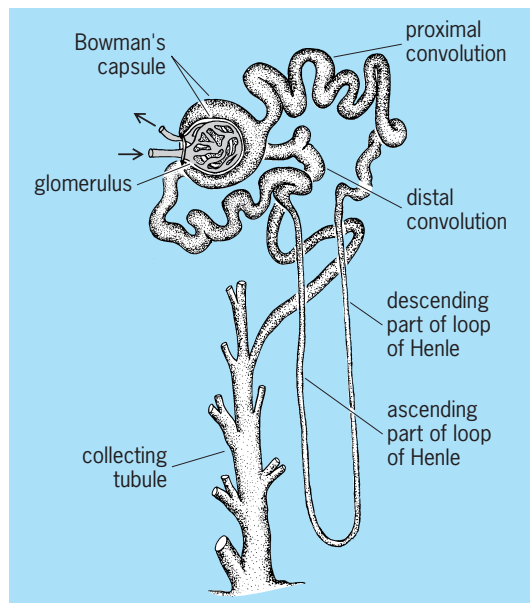

Fig. 2. A mammalian metanephric tubule, showing the renal corpuscle and secretory and collecting portions. (After C. K. Weichert and W. Presch, *Elements of Chordate Anatomy*, 4th ed., McGraw-Hill, 1975)

high as 17. More aquatic forms such as the beaver have correspondingly poor concentrating ability.

The concentration operation depends on the existence of a decreasing gradient of solute concentration that extends from the tips of the papillae in the inner medulla of the kidney outward toward the cortex. The high concentration of medullary solute is achieved by a double hairpin countercurrent multiplier system which is powered by the active removal of salt from urine while it traverses the ascending limb of Henle's loop (Fig. 2). The salt is redelivered to the tip of the medulla after it has diffused back into the descending limb of Henle's loop. In this way a hypertonic condition is established in fluid surrounding the terminations of the collecting ducts. Urine is concentrated by an entirely passive process as water leaves the lumen of collecting ducts to come into equilibrium with the hypertonic fluid surrounding its terminations. See URINE; UROGENITAL SYSTEM. [R.P.F.]

**Urinary tract disorders** Disorders of the outflow tract of the urinary system from the renal pelvis to the external portion of the urethra. Disorders of the kidney itself are considered in a separate article. See KIDNEY DISORDERS.

**Renal pelvises.** The renal pelvises, the sacs that carry urine from the kidney to the ureter, are subject to a number of disorders.

Anomalies of the renal pelvis are common. The pelvis may be subdivided into two or more sacs which may end in a single or separate ureters. By itself such an anomaly is harmless, but if there is associated obstruction there may be symptoms of pain and also destruction of the renal tissue.

Calculi may arise in the renal pelvis, usually below the epithelial layer. The cause of calculi is usually some metabolic defect with excessive excretion of a waste material such as oxalates, urates, cystine, or calcium salts.

Fibrous bands and aberrant vessels to the kidneys are usually blamed for obstruction when no other intrinsic cause can be found for uretero-pelvic obstruction.

Acute infection of the pelvis is usually associated with infection of the kidney (pyelonephritis). Most commonly occurring in young girls, it produces fever, back pain, and dysuria.

Tumors of the pelvis are rare; when they do occur they are usually transitional-cell carcinomas of varying degrees of malignancy. They cause obstruction and blood in the urine (hematuria).

**Ureters.** These long thin tubes carry the urine from the renal pelvis to the bladder; they are subject to the same diseases as are the renal pelvises.

Reduplication of the ureters at any point, from a double beginning and later fusion, to complete separation and separate implantation into the bladder, may be found. This anomaly is generally harmless unless obstruction is produced.

One of the commonest causes of excruciating abdominal and flank pain, often radiating to the groin or testicle, is the passage of small calculi or even showers of crystals through the ureter.

Occasionally the ureter is obstructed by external pressure from retroperitoneal fibrosis, tumor, or aortic aneurysm.

If the normal valvelike mechanism that prevents bladder urine from going back into the ureter is defective, vesico-ureteral reflux results. When the individual, usually a young girl, voids, some of the urine goes back into the ureter so the bladder is not completely emptied. This residual urine is subject to bacterial infection.

Tumors are usually transitional-cell carcinomas and do not differ appreciably from those seen in the pelvis and bladder.

**Bladder.** The urinary bladder is subject to anomalies, obstructions, inflammations, calculi, fistulae, and tumors.

A fairly common, distressing anomaly is exstrophy of the bladder, which is a failure of both the lower abdominal wall and anterior bladder wall to close. The urine appears directly through the abdominal wall defect.

Interference with normal complete emptying of the bladder

may be the result of various factors. In one form, an elevation of the internal urethral opening above its normal dependent position creates an unemptied pool of residual urine in the bottom of the bladder. This elevation is usually caused in the male by prostatic enlargement and in the female by cystocele, a bulging of the lower bladder wall into the vagina. Another form of obstruction is blockage of the bladder neck or urethra by such diverse lesions as anomalous congenital valves, prostatic enlargement, calculi, tumors, or postgonorrhoeal urethral strictures. A third major cause of inadequate emptying is neurogenic, usually following spinal cord injury or disease.

Cystitis or inflammation of the urinary bladder is an extremely common affliction, annoying because of the accompanying painful, frequent micturition. Bladder calculi usually develop as a result of infection and obstruction. They often reach a considerable size, up to several inches in diameter. They are usually composed of multiple urinary constituents, particularly phosphates and urates.

Abnormal openings between the bladder or female urethra and the vagina are not unusual. Such fistulae most often follow injury during childbirth. The chief effects are infection and the constant leakage of urine through the vagina.

The bladder is frequently the site of tumors which are almost always of transitional-cell epithelial origin. Malignant change into transitional-cell carcinoma is common.

**Female urethra.** This structure is not often diseased. In older women a painful raspberrylike swelling composed of inflammatory tissue may appear at the external urethral opening and is known as a caruncle. [R.N.B.]

**Male urethra.** The prostate gland may develop cancer. However, options are available to treat this disease if detected at an early stage.

The urethra is prone to obstruction. The most common cause is a noncancerous growth of the prostate called benign prostatic hyperplasia. This growth is a natural process associated with aging and can occlude the prostatic urethra, causing progressive difficulty in starting the urinary stream and completely emptying the bladder. See REPRODUCTIVE SYSTEM DISORDERS. [B.K.R.; M.L.St.]

**Urine** An aqueous solution of organic and inorganic substances, mostly waste products of metabolism. The kidneys maintain the internal milieu of the body by excreting these waste products and adjusting the loss of water and electrolytes to keep the body fluids relatively constant in amount and composition. The urine normally is clear and has a specific gravity of 1.017–1.020, depending upon the amount of fluid ingested, perspiration, and diet. The increase in specific gravity above that of water is due to the presence of dissolved solids, about 60% of which are organic substances such as urea, uric acid, creatinine, and ammonia; and 40% of which are inorganic substances such as sodium, chloride, calcium, potassium, phosphates, and sulfates. Its reaction is usually acid (pH 6) but this too varies with the diet. It usually has a faint yellow color due to a urochrome pigment, but the color varies depending upon the degree of concentration, and the ingestion of certain foods (for example, rhubarb) or cathartics. It usually has a characteristic aromatic odor, the cause of which is not known. See KIDNEY; UREA; URIC ACID; URINALYSIS; URINARY SYSTEM. [R.Str.]

**Urodela** One of the orders of the class Amphibia, also known as the Caudata. The members of this order are the tailed amphibians, or salamanders, and are distinguished superficially from the frogs and toads (order Anura) by the possession of a tail, and from the caecilians (order Apoda) by the possession of limbs. Salamanders resemble lizards in that members of both groups normally have a relatively elongate body, four limbs, and a tail. The similarity is however, only superficial. The most obvious external difference, the moist glandular skin of the amphibian and dry scaly skin of the reptile, is underlain by the numerous characters that distinguish reptiles from amphibians. See ANURA.

The vast majority of salamanders are well under a foot (0.3 m) in length. The largest is the giant salamander of Japan and China, which may attain a length of 5 ft (1.5 m). A close relative, the hellbender, which lives in streams in the eastern United States, grows to over 2 ft (0.6 m) in length.

Four well-developed limbs are typically present in salamanders, but the legs of the mud eel (*Amphiuma*) of the southeastern United States are very tiny appendages and of no use in locomotion. The sirens (*Siren* and *Pseudobranchius*), also aquatic salamanders of the same region, have undergone even further degeneration of the limbs and retain only tiny forelimbs. Salamanders with normal limbs usually have four toes on the front feet and five on the rear, though a few have only four on all feet. A feature of the Urodela not shared with the Anura is the ability to regenerate limbs.

The moist and highly vascularized skin of a salamander serves as an organ of respiration, and in some forms shares with the buccal region virtually the whole burden. In one entire family of salamanders, the Plethodontidae, lungs are not present. Even in those forms with lungs and gills, dermal respiration plays a very important part. The tympanum is absent in salamanders and the middle ear is degenerate. Hence these animals are deaf to airborne sounds. Undoubtedly correlated with this is the reduction of voice; salamanders are mute or produce only slight squeaking or, rarely, barking sounds when annoyed. However, salamanders can detect sounds carried through ground or water.

Salamanders live in a variety of aquatic or moist habitats. Many forms are wholly aquatic, living in streams, rivers, lakes, and ponds. Others live on land most of the year but must return to water to breed. The most advanced species live out their lives in moist places on land or, in the case of some tropical species, in trees, and never go in the water.

Producing the young alive rather than by laying eggs is very rare among salamanders. The eggs of salamanders may be deposited in water or in moist places on land. Presumably, aquatic breeding is the more primitive. Fertilization is external in most of the Cryptobranchioidea, internal by means of spermatophores in the remaining suborders. See NEOTENY.

The greatest concentration of families and genera of salamanders is found in the eastern United States, and these animals are one of the few major groups of vertebrate animals that is distinctly nontropical. No salamander occurs south of the Equator in the Old World, and only 18 species of the evolutionarily advanced family Plethodontidae are found as far south as South America in the New World.

The Urodela are readily arranged in seven families, but authorities differ as to the relationships among these families and their classification into suborders. Three to five suborders may be recognized, and one of these is thought by some to merit ordinal rank, equivalent to the Urodela. About 300 species of salamanders are known to be living today, and these are distributed among about 54 genera. See AMPHIBIA. [R.G.Z.]

**Urogenital system** The combined structures composing the urinary and genital, or reproductive, organs of vertebrates. The terms urinogenital or genitourinary system are equally applicable and just as frequently used. During embryonic development, the urinary and reproductive systems are closely interrelated, as their ducts arise in associated mesodermal regions. Common passages are associated with both these systems in various vertebrates, such as the single orifice for emission of urine and sperm. See KIDNEY; REPRODUCTIVE SYSTEM; URINARY SYSTEM. [C.B.C.]

**Urokinase** An enzyme that is a plasminogen activator. Urokinase cleaves the plasma protein plasminogen, forming the active enzyme plasmin, which subsequently degrades fibrin. Thus urokinase is an essential component in the fibrinolytic clot-dissolving system in the human body. See FIBRINOGEN.

Urokinase is found in human urine and in much lower concentrations in human plasma. In the body, urokinase is produced

by kidney cells, and its presence in the urine promotes the dissolution of any blood clots in the urine-collecting system of the kidneys or the bladder. Urokinase is also produced by a variety of tumor cells, and it is thought to be involved in the formation of tumor metastases. Urokinase can be inhibited by plasma inhibitor proteins. The presence of cell receptors and inhibitors suggests that the regulation of urokinase function is complex.

Urokinase is employed in clinical medicine in the treatment of venous blood clots (thrombophlebitis and pulmonary emboli), acute myocardial infarction, and arterial blood clots in the legs and arms. It is also used to prevent the accumulation of blood clots in intravenous catheters used to administer long-term chemotherapy. See BLOOD; ENZYME; PLASMIN. [P.C.C.]

**Uropygi** An order of arachnids, the tailed whip scorpions, comprising about 70 species from tropical and warm temperate Asia and the Americas. Most are dark reddish-brown, of medium to giant size, 0.7–2.6 in. (18–65 mm), the largest one being *Mastigoproctus giganteus* of the southern United States and Mexico. The elongate, flattened body bears in front a pair of greatly thickened, raptorial pedipalps set with many sharp spines and used to hold and crush insect prey. The first pair of legs is elongated and modified into feelers. The abdomen terminates in a slender, many jointed, whiplike flagellum. The uropygids are harmless, nocturnal creatures without poison glands that live in dark places and burrow into the soil. When disturbed, they expel a volatile liquid, with the strong odor of acetic acid, from a gland at the base of the tail. This accounts for the name “vinegaroon” given by many Americans to these much-feared animals. See ARACHNIDA. [W.J.Ger.]

**Uropygial gland** A relatively large, compact, bilobed, secretory organ located at the base of the tail (uropygium) of most birds having a keeled sternum. It is known also as the preen, oil, or scent gland. This is the only true skin gland possessed by this class of vertebrates.

The glandular secretion, predominantly oily and sometimes of offensive odor (musk-duck, hoopoe, petrel) is discharged through an orifice at the tip of a nipplelike protuberance often encircled by short, bristly feathers. The act of preening induces a flow of secretion from the nipple which is transferred by the beak to the body plumage. In water fowl there is some evidence that this oily secretion assists in maintaining the water-repellent quality of the feathers, either directly or by preserving their physical structure. See FEATHER; SCENT GLAND. [M.E.R.]

**Ursa Major** The most widely known and oldest of the astronomical constellations. Ursa Major, or the Great Bear, is a

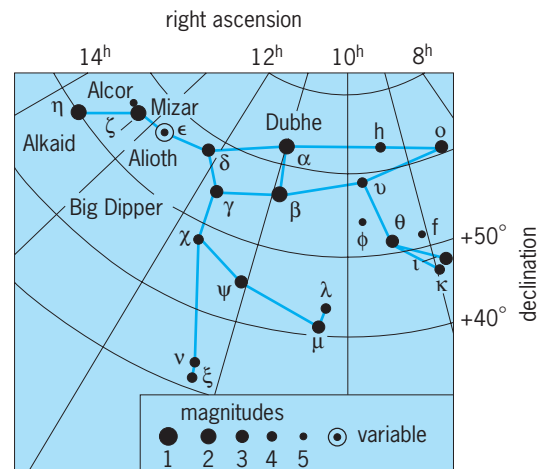

Line pattern of the constellation Ursa Major. The grid lines represent the coordinates of the sky. The apparent brightness, or magnitude, of the stars is shown by the sizes of the dots, which are graded by appropriate numbers as indicated.

circumpolar group as viewed from the middle latitudes of the Northern Hemisphere. One part of the configuration, a group of seven bright stars, which is pictured as the tail of the Great Bear, is commonly known in the United States as the Big Dipper which it resembles (see illustration). The two stars  $\alpha$  and  $\beta$  at the front of the bowl of the dipper are called pointers, because a line joining them points to Polaris, the North Star. See CONSTELLATION. [C.S.Y.]

**Ursa Minor** The astronomical constellation Little Bear, Ursa Minor is a circumpolar constellation whose brightest star, Polaris, is almost at the north celestial pole. Seven of the eight stars appear to form a dipper, hence the constellation is alternately known as the Little Dipper (see illustration). The two bright

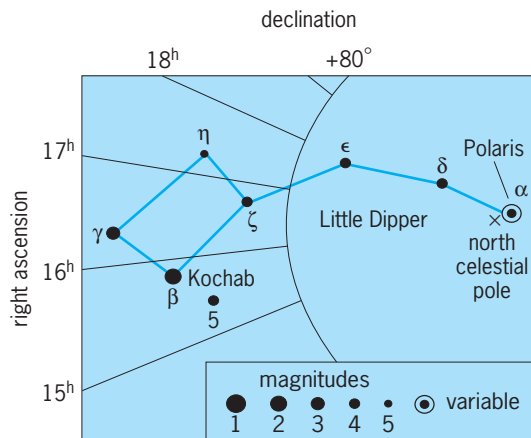

Line pattern of the constellation Ursa Minor. The grid lines represent the coordinates of the sky. The apparent brightness, or magnitude, of the stars is shown by the sizes of the dots, which are graded by appropriate numbers as indicated.

stars  $\beta$  and  $\gamma$  at the front of the bowl are often called the Guardian of the Pole, because they circle about Polaris closer than other conspicuous stars. See CONSTELLATION; URSA MAJOR. [C.S.Y.]

**Ustilaginomycetes** A class of the subdivision Basidiomycotina. These microscopic plant-parasitic fungi are commonly known as smut fungi. Many species may have a shorter or longer saprophytic life cycle, capable of yeastlike reproduction. Several nonparasitic yeasts have been identified as closely related to the smuts. About 1500 true Ustilaginales species are known. Until recently, the Ustilaginales have been divided into two families: Ustilaginaceae and Tilletiaceae. In the new classification the true smut fungi are divided into 2 classes, 8 orders, 17 families, and 62 genera.

The body (mycelium) of the smut fungi consists of hyphae that are thin, transparent, branched, septate, and binucleate. Usually parasitic, the fungus grows in the host tissues and gives little,

if any, evidence of its presence before spore formation sets in. The smut spores (teliospores or ustilospores) are the organs of dispersion and resistance, and are thick walled, pigmented, and variously ornamented. They are formed in great number in the sori, which consist of host tissues, spore masses, and sometimes modified fungal cells or tissues. The smut fungi develop variable sori in different organs (such as the roots, stems, leaves, inflorescences, flowers, anthers, and seeds) filled with powdery or agglutinated, usually colored (black, brown, violet, or yellow) spore masses. The spores may develop singly, in pairs, or in aggregates of spore balls. Spore germination results in a basidium (promycelium or ustidium) which gives rise to hyaline basidiospores. See BASIDIOMYCOTA; EUMYCOTA; FUNGI; SMUT (MICROBIOLOGY).

Many smut fungi produce severe losses of cereals and other cultivated plants. [K.V.]

**Uterus** The hollow, muscular womb, being an enlarged portion of the oviduct in the adult female. An adult human uterus, before pregnancy, measures  $3 \times 2 \times 1$  in. ( $7.5 \times 5 \times 2.5$  cm) in size and has the shape of an inverted, flattened pear. The paired Fallopian tubes enter the uterus at its upper corners; the lower, narrowed portion, the cervix, projects into the vagina (see illustration). Normally the uterus is tilted slightly forward and lies behind the urinary bladder.

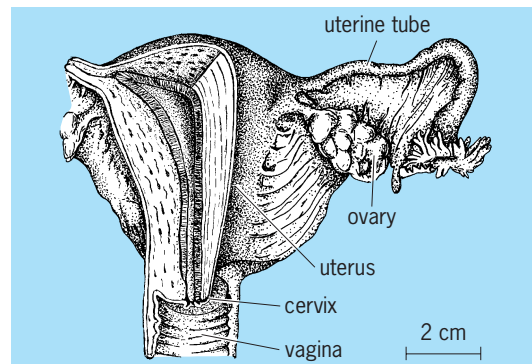

Human uterus and associated structures. (After L. B. Arey, *Developmental Anatomy, 7th ed., Saunders, 1965*)

The lining, or mucosa, responds to hormonal stimulation, growing in thickness with a tremendous increase in blood vessels during the first part of the menstrual cycle. If fertilization does not occur, the thickened vascular lining is sloughed off, producing the menstrual flow at the end of the cycle, and a new menstrual cycle begins with growth of the mucosa. When pregnancy occurs, the mucosa continues to thicken and forms an intimate connection with the implanted and enlarging placenta. See MENSTRUATION; PREGNANCY; REPRODUCTIVE SYSTEM. [W.J.B.]



# V

**Vaccination** Active immunization against a variety of microorganisms or their components, with the ultimate goal of protecting the host against subsequent challenge by the naturally occurring infectious agent. The terms vaccine and vaccination were originally used only in connection with Edward Jenner's method for preventing smallpox, introduced in 1796. In 1881 Louis Pasteur proposed that these terms should be used to describe any prophylactic immunization. Vaccination now refers to active immunization against a variety of bacteria, viruses, and parasites (for example, malaria and trypanosomes). See SMALL-POX.

Implicit within Jenner's method of vaccinating against smallpox was the recognition of immunologic cross-reactivity together with the notion that protection can be obtained through active immunization with a different, but related, live virus. It was not until the 1880s that the next immunizing agents, vaccines against rabies and anthrax, were introduced by Pasteur. Two facts of his experiments on rabies vaccines are particularly noteworthy.

First, Pasteur found that serial passage of the rabies agent in rabbits resulted in a weakening of its virulence in dogs. During multiple passages in an animal or in tissue culture cells, mutations accumulate as the virus adapts to its new environment. These mutations adversely affect virus reproduction in the natural host, resulting in lessened virulence. Only as the molecular basis for virulence has begun to be elucidated by modern biologists has it become possible to deliberately remove the genes promoting virulence so as to produce attenuated viruses.

Second, Pasteur demonstrated that rabies virus retained immunogenicity even after its infectivity was inactivated by formalin and other chemicals, thereby providing the paradigm for one class of noninfectious virus vaccine, the "killed"-virus vaccine.

Attenuated-live and inactivated vaccines are the two broad classifications for vaccines. Anti-idiotypic antibody vaccines and deoxyribonucleic acid (DNA) vaccines represent innovations in inactivated vaccines. Recombinant-hybrid viruses are novel members of the live-virus vaccine class recently produced by genetic engineering.

Because attenuated-live-virus vaccines reproduce in the recipient, they provoke both a broader and more intense range of antibodies and T-lymphocyte-associated immune responses than noninfectious vaccines. Live-virus vaccines have been administered subdermally (vaccinia), subcutaneously (measles), intramuscularly (pseudorabies virus), intranasally (infectious bovine rhinotracheitis), orally (trivalent Sabin poliovirus), or by oropharyngeal aerosols (influenza). Combinations of vaccines have also been used. Live-virus vaccines administered through a natural route of infection often induce local immunity, which is a decided advantage. However, in the past, attenuated-live virus vaccines have been associated with several problems, such as reversion to virulence, natural spread to contacts, contaminating viruses, lability, and viral interference. See ANIMAL VIRUS; VIRULENCE; VIRUS CLASSIFICATION; VIRUS INTERFERENCE.

Noninfectious vaccines include inactivated killed vaccines, subunit vaccines, synthetic peptide and biosynthetic polypeptide vaccines, oral transgenic plant vaccines, anti-idiotypic antibody vaccines, DNA vaccines, and polysaccharide-protein conjugate vaccines. With most noninfectious vaccines a suitable formulation is essential to provide the optimal antigen delivery for

maximal stimulation of protective immune responses. Development of new adjuvant (a substance that enhances the potency of the antigen) and vector systems is pivotal to produce practical molecular vaccines. See ANTIBODY; ANTIGEN; IMMUNITY. [S.Kit.]

**Vacuole** An intracellular compartment, bounded by a single membrane bilayer, which functions as a primary site of protein and metabolite degradation and recycling in animals, but serves additional complex functions in fungi and plants (see illustration). Scientists who study vacuoles also define them as the terminal product of the secretory pathway. The secretory pathway functions to transport protein and metabolite-containing membrane vesicles from sites of synthesis or uptake to the vacuole. See CELL MEMBRANES; CELL METABOLISM; GOLGI APPARATUS; SECRETION.

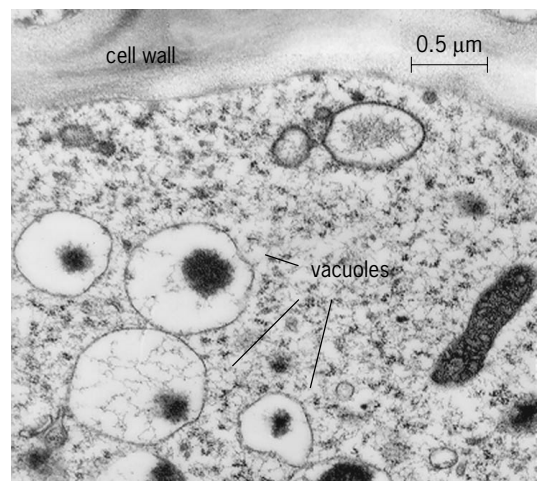

Electron micrograph of a barley root tip cell, showing multiple vacuoles within the cytoplasm.

In animals, a lytic vacuole known as the lysosome typically functions to process macromolecules. Such macromolecules can be targeted to the lysosome from sites of synthesis. For example, proteins that assemble incorrectly in the endoplasmic reticulum (ER) can be degraded in the lysosome and their constituent amino acids recycled. Proteins that can serve as nutrients are also targeted to the lysosome from the cell surface. An important process for the recycling of cytoplasm in eukaryotic cells is autophagy, in which molecules or organelles are encapsulated in membrane vesicles that fuse with the lysosome. See ENDOCYTOSIS; ENDOPLASMIC RETICULUM; LYSOSOME.

In the mammalian immune system, macrophages and neutrophils take up particles and pathogens in the process of phagocytosis, during which the pathogen is eventually digested in the lysosome. A number of diseases in humans can be caused when intracellular pathogens evade destruction in the lysosome. See PHAGOCYTOSIS.

In fungi, vacuoles can serve functions not found in animals. Besides a lytic function, they serve in the storage of ions as well as amino acids for protein synthesis. In yeast, vacuoles

can also function in the destruction and recycling of cellular organelles, such as peroxisomes, which help protect the cell from toxic oxygen-containing molecules. The process of peroxisome digestion by vacuoles is known as pexophagy.

The most complex vacuoles are found in plants. Some contain hydrolytic enzymes and store ions similar to those found in lysosomes, whereas others serve a role in storing pigments which impart color to flowers to attract pollinators. Specialized ER-derived vacuoles in plant seeds, known as protein bodies, function in the storage of proteins called prolamines that are common in the endosperm of cereals. Upon germination, the proteins are degraded and used as a source of amino acids and nitrogen for the growing plant. Toxins, such as alkaloids, are stored in vacuoles in parts of the plant, such as the leaves, which are subject to frequent herbivory. Scientists have learned that plants produce and store in their vacuoles a vast array of unique chemicals which may, in addition to their natural functions, have medicinal value. See PLANT CELL.

Another unique function that vacuoles serve in plants is in cell growth. As a consequence of the accumulation of ions, metabolites, and water, plant vacuoles are under considerable internal osmotic pressure. The vacuolar membrane in plants, known as the tonoplast, as well as the cell itself would burst under this pressure if not for the rigid wall that surrounds the cells. The resulting turgor pressure provides mechanical stability to plant stems. Loss of osmotic pressure in the vacuole due to a lack of water results in plant wilting. The osmotic pressure of the vacuoles also provides the driving force that allows plants to grow by enlarging their cell volume. Enzymes reduce the rigidity of the cell wall, which permits cell expansion under the force of turgor. This is a fundamental process in plants and explains why vacuoles can occupy as much as 95% of the volume of some cells. See CELL WALLS (PLANT). [G.R.Hi.; N.Ra.]

**Vacuum fusion** A technique of analytical chemistry for determining the oxygen, hydrogen, and sometimes nitrogen content of metals.

The metal sample is either fused or dissolved in a bath, or flux, of a second metal in a heated graphite crucible supported inside an evacuated glass or quartz vessel. Oxygen is released from the metal as carbon monoxide by reaction of oxides or dissolved oxygen with carbon from the graphite crucible at high temperature. Metal nitrides dissociate to form elemental nitrogen. Hydrogen is evolved as elemental hydrogen. The mixture of carbon monoxide, nitrogen, and hydrogen is analyzed to determine individual component concentrations by various techniques.

Inert gas fusion has been developed for determination of gases in metals. The techniques used are similar to vacuum fusion but substitute inert gases for the vacuum environment. See VACUUM METALLURGY. [F.C.B.]

**Vacuum measurement** The determination of a gas pressure that is less in magnitude than the pressure of the atmosphere. This low pressure can be expressed in terms of the height in millimeters of a column of mercury which the given pressure (vacuum) will support, referenced to zero pressure. The height of the column of mercury which the pressure will support may also be expressed in micrometers. The unit most commonly used is the torr, equal to 1 mm (0.03937 in.) of mercury (mmHg). Less common units of measurement are fractions of an atmosphere and direct measure of force per unit area. The unit of pressure in the International System (SI) is the pascal (Pa), equal to 1 newton per square meter (1 torr = 133.322 Pa). Atmospheric pressure is sometimes used as a reference. The pressure of the standard atmosphere is 29.92 in. or 760 mm of mercury (101,325 Pa or 14.696 lbf/in.<sup>2</sup>).

Pressures above 1 torr can be easily measured by familiar pressure gages, such as liquid-column gages, diaphragm-pressure gages, bellows gages, and bourdon-spring gages. At pressures below 1 torr, mechanical effects such as hysteresis, ambient

errors, and vibration make these gages impractical. See MANOMETER; PRESSURE MEASUREMENT.

Pressures below 1 torr are best measured by gages which infer the pressure from the measurement of some other property of the gas, such as thermal conductivity or ionization. The thermocouple gage, in combination with a hot- or cold-cathode gage (ionization type), is the most widely used method of vacuum measurement today. See IONIZATION GAGE.

Other gages used to measure vacuum in the range of 1 torr or below are the McLeod gage, the Pirani gage, and the Knudsen gage. The McLeod gage is used as an absolute standard of vacuum measurement in the 10–10<sup>-4</sup> torr (10<sup>3</sup>–10<sup>-2</sup> Pa) range. See MCLEOD GAGE; PIRANI GAGE.

The Knudsen gage is used to measure very low pressures. It measures pressure in terms of the net rate of transfer of momentum (force) by molecules between two surfaces maintained at different temperatures (cold and hot plates) and separated by a distance smaller than the mean free path of the gas molecules. [R.C.]

**Vacuum metallurgy** The making, shaping, and treating of metals, alloys, and intermetallic and refractory metal compounds in a gaseous environment where the composition and partial pressures of the various components of the gas phase are carefully controlled. In many instances, this environment is a vacuum ranging from subatmospheric to ultrahigh vacuum (less than 760 torr or 101 kilopascals to 10<sup>-12</sup> torr or 10<sup>-10</sup> pascal). In other cases, reactive gases are deliberately added to the environment to produce the desired reactions, such as in reactive evaporation and sputtering processes and chemical vapor deposition. The processes in vacuum metallurgy involve liquid/solid, vapor/solid, and vapor/liquid/solid transitions. In addition, they include testing of metals in controlled environments.

There are three basic reasons for vacuum processing of metals: elimination of contamination from the processing environment, reduction of the level of impurities in the product, and deposition with a minimum of impurities. Contamination from the processing environment includes the container for the metal and the gas phase surrounding the metal. In the vacuum process, impurities, particularly oxygen, nitrogen, hydrogen, and carbon, are released from the molten metal and pumped away; and metals, alloys, and compounds are deposited with a minimum of entrained impurities. There are numerous and varied application areas for vacuum metallurgy including special areas of extractive metallurgy, melting processes, casting of shaped products, degassing of molten steel, heat treatment, surface treatment, vapor deposition, space processing, and joining processes. See ARC WELDING; STEEL MANUFACTURE; WELDING AND CUTTING OF METALS. [R.F.Bu.]

**Vacuum pump** A device that reduces the pressure of a gas (usually air) in a container. When gas in a closed container is lowered from atmospheric pressure, the operation constitutes an increase in vacuum in this container. See PRESSURE.

Vacuum pumps are evaluated for the degree of vacuum they can attain and for how much gas they can pump in a unit of time. In practice, where high vacuum is required, two or more different types of pumps are used in series.

In the rotary oil-seal pump (see illustration), gas is sucked into chamber A through the opening intake port by the rotor. A sliding vane partitions chamber A from chamber B. The compressed gas that has been moved from position A to position B is pushed out of the exit port through the valve, which prevents the gas from flowing back. The valve and the rotor contact point are oil-sealed. Since each revolution sweeps out a fixed volume, it is called a constant-displacement pump. Other mechanical pumps are the rotary blower pump, which operates by the propelling action of one or more rapidly rotating lobelike vanes, and the molecular drag pump, which operates at very high speeds, as much as 16,000 rpm. Pumping is accomplished by imparting a



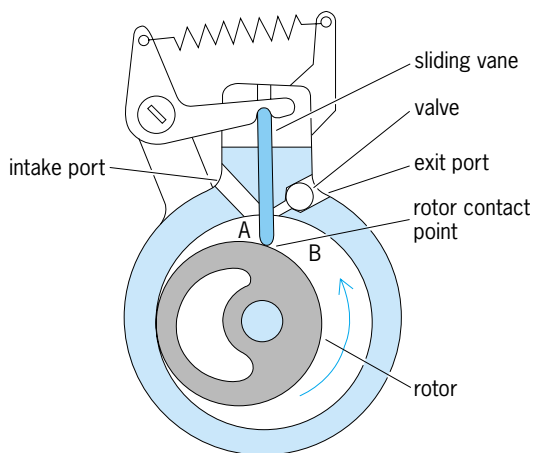

Chief components of a typical mechanical pump, the rotary oil-seal pump.

high momentum to the gas molecules by the impingement of the rapidly rotating body.

The water aspirator is an ejector pump. When water is forced under pressure through the jet nozzle, it will force the gas in the inlet chamber to go through the diffuser, thus lowering the pressure in the inlet chamber. When high-pressure steam is used instead of water, it is called a steam ejector.

In addition, a number of pumps have been developed which meet special pumping requirements. The ion pump operates electronically. Electrons that are generated by a high voltage applied to an anode and a cathode are spiraled into a long orbit by a high-intensity magnetic field. These electrons colliding with gas molecules ionize the molecules, imparting a positive charge to them. These are attracted to, and are collected on, the cathode. Thus a pumping action takes place. Sorption pumping is the removal of gases by adsorbing and absorbing them on a granular sorbent material such as a molecular sieve held in a metal container. Cryogenic pumping is accomplished by condensing gases on surfaces that are at extremely low temperatures. [E.S.Ba.]

**Vacuum tube** An electron device in which use is made of the electrostatically or magnetically controlled flow of electrons in an evacuated space, or of the phenomena accompanying the electron emission, acceleration, and collection associated with the flow. In common usage, completely evacuated tubes are called hard tubes; tubes containing a small amount of deliberately added gas or vapor are called soft tubes, but they are usually included in the family of vacuum tubes.

Vacuum tubes are used as active and passive electrical circuit elements. In suitable circuitry they rectify, detect, gate, amplify, and oscillate. They can also scan and display images; generate heat, light, and radiation; ionize and accelerate atoms and molecules; and measure high vacuum.

Most vacuum tubes employ the Edison effect, in which a unidirectional flow of current takes place through a vacuum by thermionic emission of electrons from a hot surface (the cathode). The electrons are collected by a nearby positively charged electrode (the anode or plate). Two-electrode Edison-effect tubes were first employed as radio-frequency detectors, but the enormous potential of the device was not realized until it was shown that the current could be controlled with large amplification ratios and great sensitivity by small electrical charges on a third, meshlike electrode (the grid) interposed between cathode and anode. From the resulting three-element tube (the triode) came all the characteristic inventions of the modern electronic age. See ELECTRON EMISSION; ELECTRON MOTION IN VACUUM; THERMIONIC EMISSION.

Later refinements included additional grids by which certain problems inherent in triodes were overcome, and combination tubes were developed in which several functions were combined within one vacuum envelope. Elaborations of the basic idea include camera and picture tubes and magnetrons, klystrons, and traveling-wave tubes for microwave radar. See KLYSTRON; MAGNETRON; MICROWAVE TUBE; PICTURE TUBE; RADAR; TELEVISION CAMERA TUBE; TRAVELING-WAVE TUBE.

Originally, vacuum tubes were enclosed in cylindrical glass structures. Through the walls or base of the tube were sealed the metal electrodes which emitted, controlled, or collected the electrons traversing the empty space within. Up through the 1960s, vast numbers of small tubes were used in radio and television broadcast receivers. They also found their way into industrial instruments and controls, and into the early electronic computers, but their size, fragility, inordinate power consumption, and short lifetimes made them unpopular for these more demanding purposes. Since that time, such vacuum tubes have been almost entirely replaced by the much smaller, cheaper, and longer-lived solid-state devices. Only a few standard receiving-tube types still remain in production, and are used where their electrical characteristics are particularly apt, or where environmental or circuit conditions would destroy solid-state devices. A significant exception is the cathode-ray tube (CRT), which is still made in great numbers for consumer applications. Though bulky, complex, and fragile, it is highly versatile, and so remains in favor as a display device for television, computers, and instruments of all kinds. See CATHODE-RAY TUBE; ELECTRONIC DISPLAY.

Other vacuum tubes in widespread use are high-power transmitting and microwave tubes; x-ray and accelerator tubes; mass spectrometer, electron microscope, night-vision, and surface-analytical tubes; and electron beam guns (partial tubes) for evaporators and welders. Since there is no prospect that any of these types will be replaced by solid-state devices, research and development on them continues, and new types occasionally appear. See ELECTRON MICROSCOPE; IMAGE TUBE (ASTRONOMY); ION SOURCES; LIGHT AMPLIFIER; MASS SPECTROSCOPE; PARTICLE ACCELERATOR; PHOTOMULTIPLIER; PHOTOTUBE; SURFACE PHYSICS; WELDING AND CUTTING OF MATERIALS; X-RAY TUBE. [N.Re.]

**Valence** A term commonly used by chemists to characterize the combining power of an element for other elements, as measured by the number of bonds to other atoms which one atom of the given element forms upon chemical combination. The term also has come to signify the theory of all the physical and chemical properties of molecules that specially depend on molecular electronic structure.

Thus, in water,  $H_2O$ , the valence of each hydrogen atom is 1; the valence of oxygen, 2. In methane,  $CH_4$ , the valence of hydrogen again is 1; of carbon, 4. In  $NaCl$  and  $CCl_4$  the valence of chlorine is 1, and in  $CH_2$  the valence of carbon is 2. See CHEMICAL BONDING.

Most of the simple facts of valence (though certainly not all) follow from the postulate that atoms combine in such a way as to seek closed-shell or inert-gas structures (rule of eight) by the transfer of electrons between them or the sharing of a pair of electrons between them. Many molecular structures may be obtained by inspection using these rules; letting a dot represent an electron:

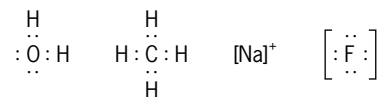

In these electron-dot symbols, the electrons in the *K* shell are not included for atoms after He, nor are the electrons in the *K* and *L* shells for atoms following Ne.

As generally used and here defined, the word valence is ambiguous. Before a value can be assigned to the valence of an atom in a molecule, the electronic structure of the molecule must

be exactly known, and this structure must be describable simply in terms of simple bonds. In practice neither of these conditions is ever precisely fulfilled. A term not so ambiguous is oxidation number or valence number. Oxidation numbers are useful for the balancing of oxidation-reduction equations, but they are not related simply to ordinary valences. Thus the valence of carbon in  $\text{CH}_4$ ,  $\text{CHCl}_3$ , and  $\text{CCl}_4$  is 4; oxidation numbers of carbon in these three substances are  $-4$ ,  $+2$ , and  $+4$ . See CHEMICAL STRUCTURES; ELECTRONEGATIVITY; MOLECULAR ORBITAL THEORY; OXIDATION-REDUCTION. [R.G.P.]

**Valence band** The highest electronic energy band in a semiconductor or insulator which can be filled with electrons. The electrons in the valence band correspond to the valence electrons of the constituent atoms. In a semiconductor or insulator, at sufficiently low temperatures, the valence band is completely filled and the conduction band is empty of electrons. Some of the high energy levels in the valence band may become vacant as a result of thermal excitation of electrons to higher energy bands or as a result of the presence of impurities. The net effect of the valence band is then equivalent to that of a few particles which are equal in number and similar in motion to the missing electrons but each of which carries a positive electronic charge. These "particles" are referred to as holes. See BAND THEORY OF SOLIDS; CONDUCTION BAND; ELECTRIC INSULATOR; HOLE STATES IN SOLIDS; SEMICONDUCTOR; VALENCE. [H.Y.F.]

**Value engineering** A thinking system (also called value management or value analysis) used to develop decision criteria when it is important to secure as much as possible of what is wanted from each unit of the resource used. The resource may be money, time, material, labor, space, energy, and so on. The system is unique in that it effectively uses both knowledge and creativity, and provides step-by-step techniques for maximizing the benefits from both. It promotes development of alternatives suitable for the future as well as the present. This is accomplished by identifying and studying each function that is wanted by the customer or user, then applying knowledge and creativity to achieve the desired function. Resources are converted into costs to achieve direct, meaningful comparisons. By using the methods of value engineering, 15 to 40% reduction in the required resources often results.

Value engineering has applications in five broad areas: in design, purchase, and manufacture of products; in administrative groups, private or public, where the task is to achieve accomplishment through people; in all areas of social service work, such as hospitals, insurance services, or colleges; in architectural design and construction; and in development as well as research.

The system is used to improve value in either or both of two situations: (1) The product or service as used or as planned may provide 100% of the functions the user wants, but lower costs may be needed. The system then holds those functions but achieves them at lower cost. (2) The product or service may have deficiencies, that is, it does not perform the desired functions or lacks quality, and so also lacks good value. The system aims at correcting those deficiencies, providing the functions wanted, while at the same time holding the use of resources (costs) at a minimum. See INDUSTRIAL COST CONTROL; INDUSTRIAL ENGINEERING; METHODS ENGINEERING; OPERATIONS RESEARCH; OPTIMIZATION; PROCESS ENGINEERING; PRODUCTION ENGINEERING; PRODUCTION PLANNING. [L.D.M.]

**Valvatida** An order of Asteroidea in which pedicellariae, when present, are valvate and sunk into the skeletal ossicles. The mouth plates are inconspicuous, and the inferomarginal and superomarginal plates correspond and lack intermarginal grooves. There are two rows of tube feet. The order is thought to include seven families. See ASTEROIDEA; ECHINODERMATA. [A.C.C.]

**Valve** A flow-control device. Valves are used to regulate the flow of fluids in piping systems and machinery. In machinery the flow phenomenon is frequently of a pulsating or intermittent character and the valve, with its associated gear, contributes a timing feature.

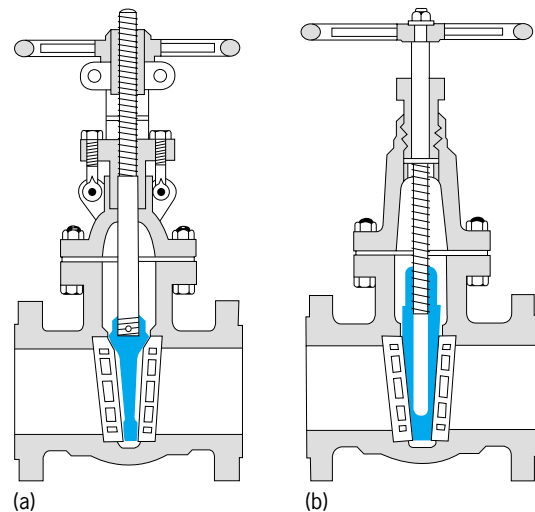

Fig. 1. Gate valves with disk gates shown in color. (a) Rising threaded stem shows when valve is open. (b) Nonrising stem valve requires less overhead.

The valves commonly used in piping systems are gate valves (Fig. 1), usually operated closed or wide open and seldom used for throttling; globe valves, frequently fitted with a renewable disk and adaptable to throttling operations; check valves, for automatically limiting flow in a piping system to a single direction; and plug cocks, for operation in the open or closed position by turning the plug through  $90^\circ$  and with a shearing action to clear foreign matter from the seat. Safety and relief valves are automatic protective devices for the relief of excess pressure. See SAFETY VALVE.

For hydraulic turbines and hydroelectric systems, valves and gates control water flow for (1) regulation of power output at sustained efficiency and with minimum wastage of water, and (2) safety under the inertial flow conditions of large masses of water.

To control the kinematics of the cycle, steam-engine valves range from simple D-slide and piston valves to multiported types. Many types of reversing gear have been perfected which use the same slide valve or piston valve for both forward and backward

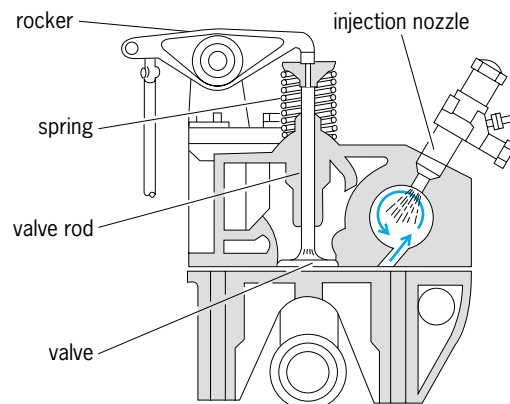

Fig. 2. Poppet valve for internal combustion engine. (After T. Baumeister, ed., *Marks' Standard Handbook for Mechanical Engineers*, 8th ed., McGraw-Hill, 1978)

rotation of an engine, as in railroad and marine service. See STEAM ENGINE.

Poppet valves are used almost exclusively in internal combustion reciprocating engines because of the demands for tightness with high operating pressures and temperatures (Fig. 2). Two-cycle engines utilize ports, alternately covered and uncovered by the main piston, for inlet or exhaust. See CAM MECHANISM; INTERNAL COMBUSTION ENGINE; VALVE TRAIN.

In compressors, valves are usually automatic, operating by pressure difference on the two sides of a movable, springloaded member and without any mechanical linkage to the moving parts of the compressor mechanism. Like those for compressors, pump valves are usually of the automatic type operating by pressure difference. [T.Ba.]

**Valve train** The valves and valve-operating mechanism by which an internal combustion engine takes air or fuel-air mixture into the cylinders and discharges combustion products to the exhaust. See VALVE.

Mechanically, an internal combustion engine is a reciprocating pump, able to draw in a certain amount of air per minute. Since the fuel takes up little space but needs air with which to combine, the power output of an engine is limited by its air-pumping capacity. The flow through the engine should be restricted as little as possible. This is the first requirement for valves. The second is that the valves close off the cylinder firmly during the compression and power strokes. See INTERNAL COMBUSTION ENGINE.

In most four-stroke engines the valves are the inward-opening poppet type, with the valve head ground to fit a conical seat in the cylinder block or cylinder head. The valve is streamlined and as large as possible to give maximum flow, yet of low inertia so that it follows the prescribed motion at high engine speed.

Engine valves are usually opened by cams that rotate as part of a camshaft, which may be located in the cylinder block or cylinder head. Riding on each cam is a cam follower or valve lifter, which may have a flat or slightly convex surface or a roller, in contact with the cam. The valve is opened by force applied to the end of the valve stem. A valve rotator may be used to rotate the valve slightly as it opens. In engines with the camshaft and valves in the cylinder head, the cam may operate the valve directly through a cup-type cam follower. To ensure tight closing of the valve even after the valve stem lengthens from thermal expansion, the valve train is adjusted to provide some clearance when the follower is on the low part of the cam. See CAM MECHANISM. [D.L.An.]

**Valvifera** A suborder of isopod crustaceans resembling woodlice and pill bugs. They are distinguished from these and other isopods by having a pair of flat, valvelike uropods which hinge laterally and fold inward beneath the rear part of the body. The uropods open like doors to reveal five pairs of leaflike appendages, or pleopods, which are used for respiration and swimming. Members of the group are almost exclusively marine. Some species are omnivorous and have been found in dense populations on accumulations of broken algae and fish waste. See ISOPODA. [E.N.]

**Vampyromorpha** An order of coleoid cephalopods that contains only one species, *Vampyroteuthis infernalis*. It is characterized by a flat, broad, leaflike, chitinous internal shell (gladius); eight arms around the mouth connected by a deep web; no tentacles, but two small sensory filaments that retract into pockets between the bases of the first and second arms; fingerlike cirri and a single row of suckers with chitinous rings along the arms; one pair of paddle-shaped fins on the body in adults (two pairs at the juvenile stage); very dark maroon, mostly black pigmentation; and photophores on the body, head, and arms. Vampyromorphs superficially resemble cirrate octopods, but they bear features that show distinct teuthoid (squid) relationships, and

in many characteristics are intermediate between teuthoids and octopods.

*Vampyroteuthis infernalis* is a gelatinous bathypelagic (very deep, midwater living) species that inhabits worldwide tropical, subtropical, and temperate waters. It occurs mostly at depths of 1600–3800 ft (500–1200 m), occasionally to 4800 ft (150 m). See CEPHALOPODA; COLEOIDEA; OCTOPODA; TEUTHOIDEA. [C.F.E.R.]

**Van Allen radiation** The high-energy, charged particles that are trapped into orbits by the geomagnetic field, forming radiation belts that surround the Earth. The belts consist primarily of electrons and protons and extend from a few hundred kilometers above the Earth to a distance of about  $8 R_e$  ( $R_e$  = radius of Earth = 6371 km = 3959 mi). James Van Allen and coworkers discovered them in 1958 using radiation detectors carried on satellites *Explorer 1* and *3*, and they are often referred to as the Van Allen belts.

A charged particle under the influence of the geomagnetic field follows a trajectory that can be conveniently described as a superposition of three separate motions. The first motion, produced by the magnetic force acting at right angles to both the particle velocity and the magnetic field, is a rapid spiral about magnetic field lines. As the spiraling particle moves along the field line toward either the North Pole or South Pole, the increase in magnetic field strength causes the particle to be reflected so that it bounces between the Earth's two hemispheres. Superimposed on the spiral and bounce motions is a slow east-west drift; electrons drift eastward and protons or heavier ions drift westward. (The resulting current, called the ring current, acts to decrease the strength of the Earth's (surface) northward magnetic field at low latitudes.) Thus, individual trapped particles move completely around the Earth in a complicated pattern, their motion being constrained to lie on magnetic shells.

The spatial structure of trapped radiation shows two maxima: an inner radiation belt centered at about  $1.5R_e$  and an outer belt centered at  $4-5R_e$ . In the inner radiation belt, the most penetrating particles are protons with energies extending to several hundred mega-electronvolts (MeV). However, the flux of high-energy protons decreases rapidly with increasing distance from the Earth and becomes insignificant beyond  $4R_e$ . Electrons and low-energy protons with energies up to a few MeV occur throughout the stable trapping region. The electron energies extend to several MeV, and in the outer radiation belt electrons are the most penetrating component.

The intensity, energy spectrum, and spatial distribution of particles within the radiation belts vary with time. The most dramatic variations are associated with magnetic storms. The changes are most pronounced for particles in the outer belt where the magnetic variations are the largest. During a magnetic storm, the electron flux in the outer belt may increase by an order of magnitude or more.

It is believed that most of the very high energy protons (>50 MeV) in the inner belt result from the spontaneous decay of high-energy neutrons, produced by collisions of cosmic rays with atmospheric atoms. However, the vast majority of the radiation belt populations are ions and electrons that originate from either the atmosphere or the solar wind and are accelerated by processes only partly understood.

The radiation belts are just one feature of the space plasma environment. For example, plasma from the Sun is continually impinging on the Earth's magnetic field, resulting in a "cavity" known as the magnetosphere.

Because the conditions that lead to the formation of Earth's radiation belts are so general, it is believed that any planet or moon that has a large enough magnetic field will also have radiation belts. Jupiter, Saturn, Uranus, and Neptune have strong magnetic fields and very large, intense radiation belts analogous to those of the Earth.

The term “space weather” describes the conditions in space that affect Earth and its technological systems. It is a consequence of the behavior of the Sun, and the interaction of the solar wind with the Earth’s magnetic field. The fluxes of electrons and protons trapped in the radiation belts can injure both personnel and equipment on board spacecraft if the vehicle is exposed to these energetic particles for a sufficiently long time. Because of the spatial structure of the belts, the degree of damage will be strongly dependent on the position in space and hence on the orbit of the vehicle. In the inner belt region, high-energy protons can pass through several centimeters of aluminum structure and injure components in the interior of the spacecraft. In most other regions of the radiation belts, the trapped particles are less penetrating, and damage is confined to exposed equipment such as solar cells. [PRI.; M.W.]

**Van der Waals equation** An equation of state of gases and liquids proposed by J. D. van der Waals in 1873 that takes into account the nonzero size of molecules and the attractive forces between them. He expressed the pressure  $p$  as a function of the absolute temperature  $T$  and the molar volume  $V_m = V/n$ , where  $n$  is the number of moles of gas molecules in a volume  $V$  (see equation below). Here  $R = 8.3145 \text{ J K}^{-1} \text{ mol}^{-1}$  is the

$$p = \frac{RT}{V_m - b} - \frac{a}{V_m^2}$$

universal gas constant, and  $a$  and  $b$  are parameters that depend on the nature of the gas. Parameter  $a$  is a measure of the strength of the attractive forces between the molecules, and  $b$  is approximately equal to four times the volume of the molecules in one mole, if those molecules can be represented as elastic spheres. The equation has no rigorous theoretical basis for real molecular systems, but is important because it was the first to take reasonable account of molecular attractions and repulsions, and to emphasize the fact that the intermolecular forces acted in the same way in both gases and liquids. It is accurate enough to account for the fact that all gases have a critical temperature  $T_c$  above which they cannot be condensed to a liquid. The expression that follows from this equation is  $T_c = 8a/27Rb$ . See CRITICAL PHENOMENA; GAS; INTERMOLECULAR FORCES; LIQUID.

In a gas mixture, the parameters  $a$  and  $b$  are taken to be quadratic functions of the mole fractions of the components since they are supposed to arise from the interaction of the molecules in pairs. The resulting equation for a binary mixture accounts in a qualitative but surprisingly complete way for the many kinds of gas-gas, gas-liquid, and liquid-liquid phase equilibria that have been observed in mixtures. See PHASE EQUILIBRIUM.

The equation is too simple to represent quantitatively the behavior of real gases, and so the parameters  $a$  and  $b$  cannot be determined uniquely; their values depend on the ranges of density and temperature used in their determination. For this reason, the equation now has little practical value, but it remains important for its historical interest and for the concepts that led to its derivation. See THERMODYNAMIC PRINCIPLES. [J.S.Ro.]

**Vanadium** A chemical element, V, with atomic number 23. Natural deposits contain two isotopes,  $^{50}\text{V}$  (0.24%), which is weakly radioactive, and  $^{51}\text{V}$  (99.76%). Commercially important as an oxidation catalyst, vanadium also is used in the production of alloy steel and ceramics and as a coloring agent. Studies have demonstrated the biological occurrence of vanadium, especially in marine species; in mammals, vanadium has a pronounced effect on heart muscle contraction and renal function. See PERIODIC TABLE; TRANSITION ELEMENTS.

Very pure vanadium is difficult to prepare because the metal is highly reactive at temperatures above the melting point of its oxide (663°C or 1225°F) from which it is produced. Vanadium is a bright white metal that is soft and ductile. It has a melting point of 1890°C (3434°F), a boiling point of 3380°C (6116°F), and a density of 6.11 g/cm<sup>3</sup> (3.53 oz/in.<sup>3</sup>) at 18.7°C (65.7°F).

The thermal and electrical conductivity of vanadium is superior to that of titanium.

At room temperature, the metal is resistant to corrosion by oxygen, salt water, alkalies, and nonoxidizing acids, the exception being hydrogen fluoride (HF). Vanadium cannot withstand the oxidizing conditions presented by nitric acid or aqua regia. At elevated temperatures it will combine with most nonmetals to form oxides, nitrides, carbides, arsenides, and other such compounds.

The physical properties of vanadium are very sensitive to interstitial impurities. The strength varies from 30,000 lb/in.<sup>2</sup> (200 megapascals) in the purest form to 80,000 lb/in.<sup>2</sup> (550 MPa) in the commercial grade. The melting point is markedly altered by small impurities; vanadium containing 10% carbon has a melting point of 2700°C (4892°F).

Vanadium has a low fission neutron cross section. This property combined with the metal’s excellent retention of strength at elevated temperatures has made its use in atomic energy applications attractive.

Carbon and alloy steels consume more than half the vanadium produced in the United States. Many plate, structural, bar, and pipe steels contain vanadium to enhance strength and toughness. The basis for the unique properties of these carbon alloy steels is the formation of vanadium carbide. These carbides are extremely hard and wear-resistant; they do not coalesce readily, but maintain a state of fine dispersion. Many large steel forgings contain vanadium in the range 0.05–0.15%; here vanadium acts as a grain refiner, and also improves the mechanical properties of the forgings. Tool steels are another large class of vanadium-containing steels; vanadium ensures the retention of hardness and cutting ability at the elevated temperatures generated by the rapid cutting of metals.

The production of ferrovanadium, an iron alloy, is very important since the primary commercial use of vanadium is in steel. Ferrovanadium is produced by aluminum or silicon reduction of V<sub>2</sub>O<sub>5</sub> in the presence of iron in an electric arc furnace. The commonly practiced aluminum reduction is exothermic, so that little additional heat from the arc is required. Silicon processing requires a two-stage reduction to achieve efficient operation. See FERROALLOY; STEEL MANUFACTURE.

Vanadium compounds, especially V<sub>2</sub>O<sub>5</sub> and NH<sub>4</sub>VO<sub>3</sub>, are excellent oxidation catalysts in the chemical industry. Processes that employ such catalysts include the manufacture of polyamides, such as nylon; sulfuric acid production by the contact process; phthalic and maleic anhydride syntheses; and various oxidations of organic compounds such as the conversion of anthracene to anthraquinone, ethanol to acetaldehyde, and sugar to oxalic acid. Vanadium pentoxide is used as a mordant in dyeing and printing fabrics and in producing aniline black for the dye industry. Vanadium compounds are used in the ceramics industry for glazes and enamels. A wide range of colors can be obtained with combinations of vanadium oxide, zirconia, silica, lead, tin, zinc, cadmium, and selenium. See CERAMICS; DYEING; MORDANT.

Vanadium has long been recognized as an essential element in biological systems; however, the role of the metal often is obscure. Tunicates accumulate vanadium to levels 1 million times greater than the surrounding seawater. This vanadium was once thought to act as an oxygen carrier but now is believed to be an oxidation catalyst that repairs damage to the polymeric, protective tunic of these animals. The first vanadium-dependent enzyme, vanadium bromoperoxidase, was isolated from brown, red, and green marine algae (for example, *Ascophyllum nodosum*); this enzyme catalyzes the bromination of a variety of organic molecules by using hydrogen peroxide and bromide. This activity may be the source of many important brominated compounds that potentially may be used as antifungal and antineoplastic agents. See ENZYME.

A variety of physiological effects in mammalian systems have been reported, the most significant being in cardiovascular and renal function. Vanadate causes constriction of veins in the

kidney and can alter the retention and excretion of sodium and chloride ions. Cardiac effects of vanadium are species-specific, with observed increases (rabbit and rat) and decreases (guinea pig and cat) in heart muscle contractility. Because vanadate is a potent inhibitor of Na,K-ATPase in the laboratory, it has been suggested that this is the site of the metal's action. However, the physiology of vanadate is probably more complicated, since vanadium behaves as a hormone mimic by elevating intracellular calcium ion ( $\text{Ca}^{2+}$ ) levels in a process that is poorly understood. See BIOINORGANIC CHEMISTRY. [V.L.P.]

**Vanilla** A choice flavoring obtained from a climbing orchid, *Vanilla fragrans*, a native of tropical American forests. Its fruits are pods called vanilla beans. These are picked at the proper time before they have fully matured.

Vanillin (4-hydroxy-3-methoxybenzaldehyde) is the principal component of vanilla, although other components contribute to the distinctive flavor of the extract compared to synthetic vanilla. When they are harvested, the beans contain no free vanillin; it develops during the curing period from glucosides that break down during the fermentation and sweating of the beans. The sweating process consists of alternately drying the beans in sunlight and bunching them so that they heat and ferment. [P.D.St./E.L.C.]

**Vapor condenser** A heat-transfer device that reduces a thermodynamic fluid from its vapor phase to its liquid phase. The vapor condenser extracts the latent heat of vaporization from the vapor, as a higher-temperature heat source, by absorption in a heat-receiving fluid of lower temperature. The vapor to be condensed may be wet, saturated, or superheated. The heat receiver is usually water but may be a fluid such as air, a process liquid, or a gas. When the condensing of vapor is primarily used to add heat to the heat-receiving fluid, the condensing device is called a heater and is not within the normal classification of a condenser.

Condensers may be divided into two major classes according to use: those used as part of a processing system (process condensers) and those used for serving engines or turbines in a steam power plant cycle (power cycle condensers). Condensers may be further classified according to mode of operation as surface condensers or as contact condensers. See CONTACT CONDENSER; SURFACE CONDENSER.

Condensers are required, almost without exception, to condense impure vapors, that is, vapors containing air or other noncondensable gases. Because most condensers operate at subatmospheric pressures, air leaking into the apparatus or system becomes a common cause for vapor contamination, and a variety of designs have been developed to reduce such problems. Accumulation of noncondensable gases seriously affects heat transfer, and means must be provided to direct them to a suitable outlet. Most surface and contact condensers are arranged with a separate zone of heat-transfer surface within the condenser and located at the outlet end of the vapor flow path for efficient removal of the noncondensable gases through dehumidification. [J.F.Se.]

**Vapor cycle** A thermodynamic cycle, operating as a heat engine or a heat pump, during which the working substance is in, or passes through, the vapor state. A vapor is a substance at or near its condensation point. It may be wet, dry, or slightly superheated. One hundred percent dryness is an exactly definable condition which is only transiently encountered in practice. See HEAT PUMP; THERMODYNAMIC CYCLE.

A steam power plant operates on a vapor cycle where steam is generated by boiling water at high pressure, expanding it in a prime mover, exhausting it to a condenser, where it is reduced to the liquid state at low pressure, and then returning the water by a pump to the boiler (Fig. 1).

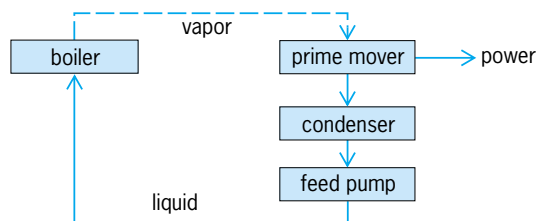

Fig. 1. Rudimentary steam power plant flow diagram.

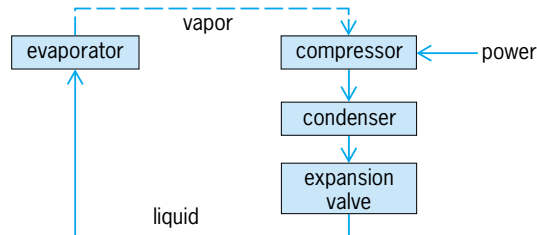

Fig. 2. Rudimentary vapor-compression refrigeration plant flow diagram.

In the customary vapor-compression refrigeration plant, the process is essentially reversed with the refrigerant evaporating at low temperature and pressure, being compressed to high pressure, condensed at elevated temperature, and returned as liquid refrigerant through an expansion valve to the evaporating coil (Fig. 2). See REFRIGERATION.

The Carnot cycle, between any two temperatures, gives the limit for the efficiency of the conversion of heat into work. This efficiency is independent of the properties of the working fluid. The Rankine cycle is more realistic in describing the ideal performance of steam power plants and vapor-compression refrigeration systems. See CARNOT CYCLE; RANKINE CYCLE. [T.Ba.]

**Vapor deposition** Production of a film of material often on a heated surface and in a vacuum. Vapor deposition technology is used in a large variety of applications. Coatings are produced from a wide range of materials, including metals, alloys, compound, cermets, and composites. The vapor deposition processes can be classified into the two basic groups, physical (evaporation and sputtering) and chemical. In addition, there are hybrid processes such as ion plating, which is a subset of evaporation or sputter deposition. This process involves an electrically biased substrate and uses a working gas such as argon, which results in ion bombardment of the substrate/depositing film that produces changes in microstructure, residual stress, and impurity content. See ALLOY; CERMET; COMPOSITE MATERIAL; METAL.

All deposition processes consist of three major steps: generation of the depositing species, transport of the species from source to substrate, and film growth on the substrate. In chemical vapor deposition, these steps occur simultaneously at or near the substrate. Physical vapor deposition processes are more versatile, because the steps occur sequentially and can be controlled independently.

In physical vapor deposition the first step involves generation of the depositing species by evaporation using resistance, induction, electron-beam, or laser-beam heating, or by sputtering using direct-current or radio-frequency plasma generation. The second step involves transport from source to substrate.

The third step is film growth on the substrate. The two basic processes for physical vapor deposition are evaporation deposition and sputter deposition. In evaporation, thermal energy converts a solid or liquid target material to the vapor phase. In sputtering, the target is biased to a negative potential and bombarded by positive ions of the working gas from the plasma, which knock out the target atoms and convert them to vapor by momentum transfer. See SPUTTERING.

In the basic thermal chemical vapor deposition process, the reactants flow over a heated substrate and react at or near the substrate surface to deposit a film. The kinetics of the process are dependent on diffusion through the boundary layer between the substrate and the bulk gas-flow region. See DIFFUSION IN SOLIDS.

Chemical vapor deposition is one of several process steps for fabrication of integrated circuits. Thus, much effort is being directed at lowering the deposition processing temperatures in order to achieve more economical processing as well as increasing the compatibility with preceding and subsequent steps in device processing. See INTEGRATED CIRCUITS.

Coatings provided by vapor deposition have many applications. For optical functions they are used as reflective or transmitting coatings for lenses, mirrors, and headlamps; for energy transmission and control they are used in glass, optical, or selective solar absorbers and in heat blankets; for electrical and magnetic functions they are used for resistors, conductors, capacitors, active solid-state devices, photovoltaic solar cells, and magnetic recording devices; for mechanical functions they are used for solid-state lubricants, tribological coatings for wear and erosion resistance in cutting and forming tools and other engineering surfaces; and for chemical functions they are used to provide resistance to chemical and galvanic corrosion in high-temperature oxidation, corrosion, and catalytic applications as well as to afford protection in the marine environment. Decorative applications include toys, costume jewelry, eyeglass frames, watchcases and bezels, and medallions. Vapor-deposited coatings also act as moisture barriers for paper and polymers. They can be used for bulk or free-standing shapes such as sheet or foil tubing, and they can be formulated into submicrometer powders. See VACUUM METALLURGY. [R.F.Bu.]

**Vapor lamp** A source of radiant energy excited by a supply of electricity which creates a current of ionized gas between electrodes in an enclosure that contains the arc while permitting transmission of the radiant energy. Gaseous-discharge lamps or vapor lamps are given various names relating to the element responsible for the majority of the radiation (mercury, sodium metal-halide, xenon), to the physical attribute of the lamp (short-arc, high-pressure), or, in the case of fluorescent lamps, to the way a phosphor on the bulb wall fluoresces as a result of the lamp's low-pressure mercury-vapor excitation. See ARC DISCHARGE; ELECTRICAL CONDUCTION IN GASES.

Gaseous-discharge lamps are broadly used throughout the world because the conversion of electric energy to radiant energy in a gaseous discharge provides radiation in narrow bands within the range of visible light in which the rods and cones of the eye are most sensitive. These light sources have high efficiency in conversion of electricity to light.

For discussions of common types of vapor lamps see FLUORESCENT LAMP; MERCURY-VAPOR LAMP; NEON GLOW LAMP; SODIUM-VAPOR LAMP. [T.F.N.]

**Vapor lock** Interruption of fuel flow to an engine due to blockage of passages in the fuel system by fuel vapor.

To promote easy starting, all gasolines contain volatile constituents that under some conditions, such as high ambient temperature, tend to produce more vapor than the fuel-system vents can handle. The action of an engine-mounted fuel pump, in decreasing the pressure at its inlet, tends to vaporize the fuel. If the vapor forms faster than the pump can draw it from the fuel line, the flow of fuel to a carburetor is effectively stopped and the engine stalls. Vapor lock is much less likely on a fuel-injected engine with an electric pump in the fuel tank. However, an engine with port fuel injection may experience vapor lock if the injector or fuel overheats, or if the Reid vapor pressure of the fuel is too high. See CARBURETOR; FUEL SYSTEM; GASOLINE; INTERNAL COMBUSTION ENGINE; VAPOR PRESSURE. [D.L.An.]

**Vapor pressure** The saturation pressures exerted by vapors which are in equilibrium with their liquid or solid forms. One of the most important physical properties of a liquid, the vapor pressure, enters into many thermodynamic calculations and underlies several methods for the determination of the molecular weights of substances dissolved in liquids. For a discussion of the vapor pressure relationships of solids see SUBLIMATION. See MOLECULAR WEIGHT; SOLUTION.

If a liquid is introduced into an evacuated vessel at a given temperature, some of the liquid will vaporize, and the pressure of the vapor will attain a maximum value which is termed the vapor pressure of the liquid at that temperature. Although the quantity of liquid remaining does not diminish thereafter, the process of evaporation does not cease. A dynamic equilibrium is established, in which molecules escape from the liquid phase and return from the vapor phase at equal rates. See EVAPORATION.

It is important to make a distinction between the vapor pressure of a liquid, as described above, and the pressure of a vapor. The vapor pressure of a pure liquid is a unique and characteristic property of the liquid and depends only upon the temperature. A gas or vapor may, on the other hand, exert any pressure within reason, depending upon the volume to which it is confined, provided it is not in contact with its liquid phase. See PHASE EQUILIBRIUM. [N.H.N.]

**Varactor** A solid-state device which has a capacitance that varies with the voltage applied across it. The name varactor is a contraction of the words variable and reactor. Typically the device consists of a reverse-biased *pn* junction that has been doped to maximize the change in capacitive reactance for a given change in the applied bias voltage. The device has two primary applications: frequency-tuning of radio-frequency circuits including frequency-modulation (FM) transmitters and solid-state receivers, and nonlinear frequency conversion in parametric oscillators and amplifiers. See CAPACITANCE; FREQUENCY MODULATOR; PARAMETRIC AMPLIFIER; REACTANCE.

A *pn* junction in reverse bias has two adjacent microscopic space-charge or depletion regions which function like the plates of a capacitor. These depletion regions get larger as the applied reverse-bias voltage is increased; however, the increase in the width of the depletion region is not linear with bias voltage, but instead is sublinear, the exact nature of the relationship depending upon the doping profile in the *pn* junction. For example, in a *pn* junction with constant doping density, the depletion region width varies as the square root of the applied reverse-bias voltage. Because the capacitance of the device is proportional to the width of the depletion region, the nonlinear relationship between bias voltage and depletion width results in a nonlinear voltage-capacitance relationship as well. The *pn* junction doping profile is adjusted by the device designer to obtain the desired capacitive nonlinearity.

The frequency response of the varactor is governed by the relationship between the series linear resistance of the diode and its nonlinear capacitance. The highest frequency for which the device will function properly is that at which the capacitive reactance (the reciprocal of the product of nonlinear capacitance and frequency) is equal to the series resistance of the device. Thus, designing a varactor for maximum frequency response involves choosing a doping density high enough for a small series resistance but low enough so that the capacitance of the device is small.

Varactors, as well as other solid-state devices, possess the advantage that they are compact and robust, permitting their use in hostile environments, as well as improving the reliability of the circuits in which they are employed. See JUNCTION DIODE; MICROWAVE SOLID-STATE DEVICES; SEMICONDUCTOR; SEMICONDUCTOR DIODE. [D.R.A.]

**Variable (mathematics)** A symbol *x* is usually defined to be a variable if it may denote any member of a set of

objects. A variable is discrete or continuous according to whether its range (the set) is discrete (for example, a subset of the natural numbers) or continuous (for example, all real numbers between two real numbers), respectively. See ANALYTIC GEOMETRY; NUMBER THEORY; PARAMETRIC EQUATION. [L.M.Bi.]

**Variable star** A star that has a detectable change in brightness which is often accompanied by other physical changes. During the life of a star, changes in brightness occur in the early stages, while it is forming, or in the late stages, close to its death. Therefore, variability provides important clues about the evolution and nature of stars. Depending upon the type of star, variability in brightness can provide information about its size, radius, mass, temperature, luminosity, internal and external structure, composition, and distance from the Earth. Over 31,900 stars are known to vary in brightness.

Variable stars can be divided into two major types: extrinsic and intrinsic variables. The extrinsic variables are those stars in which the variability in brightness occurs because of the occultation of one star by another (eclipsing binary) or rotation of a star that has dark or bright spots on its surface, similar to sunspots. See BINARY STAR; ECLIPSING VARIABLE STARS.

Intrinsic variables are those stars in which the variability of brightness occurs because of physical change in or on the star itself. These stars are divided into two classes: pulsating and eruptive (see table).

**Pulsating variables.** Periodic pulsation (contraction and expansion) of the star and its outer layer results in the variation in brightness, as well as variations in the star's temperature, spectrum, and radius.

Cepheids are rare, highly luminous (supergiant), yellow variable stars. They vary with periods from 1 to 100 days, and have a range of variation from 0.1 to 2 magnitudes. Cepheids show an important correlation between their period of variation and their relative brightness, in that those stars with longer periods are also brighter. Due to this period-luminosity relationship, cepheids have been used to measure distances to nearby galaxies and in the determination of the distance scale of the universe.

A similar group of variable stars, W Virginis stars, found in globular star clusters and the corona of the Milky Way Galaxy, are bluer (and thus hotter) and older (population II) than the cepheids. They have periods from 10 to 30 days, and obey a similar period-luminosity relationship. They are sometimes called type II cepheids to distinguish them from the classical type I cepheids. See CEPHEIDS.

RR Lyrae variables are the second most common type of variable in the Galaxy. They have periods of less than 1 day, and have a small range of variation, from 0.5 to 1.5 magnitudes. They are particularly numerous in globular clusters, and thus are sometimes referred to as cluster variables. All RR Lyrae variables have the same intrinsic luminosity, of magnitude 0.5. Thus, if an RR Lyrae star can be identified in a star cluster and its apparent magnitude determined, the above equation and the star's known absolute magnitude can be used to obtain the distance to the cluster.

Long-period variable stars are the most abundant of all variables in the Milky Way Galaxy. They are red, cool, giant or supergiant stars with spectral class M or R, S, or C carbon types. Long-period variables are old stars which have evolved from the main sequence and are in the late stages of their evolution. See STELLAR EVOLUTION.

The prototype of long-period variables is  $\alpha$  Ceti (Mira), which has given its name to those long-period variables that have a range of variation of 2.5 magnitudes and more. Mira variables have periods ranging from 100 to 1000 days. Although the change in brightness is periodic, some cycles may be much brighter or fainter than others. See MIRA.

Red giant and supergiant stars with less regularity of variation, shorter periods, and smaller ranges of variation, less than 2.5 magnitudes, are called semiregular variables. Other red variable stars that do not exhibit any regularity in their brightness change are called irregular stars.

Rare, very luminous, yellow supergiant stars that generally show alternating shallow and deep fadings are called RV Tauri stars. These pulsating variables vary by 2 to 3 magnitudes within 30 to 150 days.

**Eruptive variables.** Eruptive variables are those stars that have one or more eruptions—the ejection of matter into space—in their lifetime. The most spectacular type of stellar explosion is that of a supernova, wherein a star's luminosity suddenly increases to tens of thousands of times the original brightness and the star outshines the total brightness of its galaxy. The gigantic explosion may be due to the gravitational collapse of a very hot and massive star that has exhausted the energy available from nuclear reactions; the collapse then creates enormous energy to blast outward the layers surrounding the stellar core. Alternatively, the explosion may occur in a close binary system in which one of the components is a massive white dwarf, an Earth-sized, very compact, old star, that explodes when it receives too much material from the other component. See SUPERNOVA.

Representative types of intrinsic variables

Type	Range of period, days	Amplitude, magnitude	Spectra and luminosity	Example	Number known
<b>Pulsating</b>					
RR Lyrae	<1	<2	A to F (blue), giants	RR Lyrae	6107
Cepheids (types I and II)	1–70	0.1–2	F to G (yellow), supergiants	$\delta$ Cephei	812
Long-period					
Mira	80–1000	2.5–6+	M (red), giants	$\alpha$ Ceti (Mira)	5827
Semiregular	30–1000	1–2	M (red), giants and supergiants	Z Ursae Majoris	3383
RV Tauri	30–150	Up to 3	G to K (yellow and red), supergiants	RV Tauri	122
Irregular	Irregular	Up to several magnitudes	All types		2391
Others					359
<b>Eruptive</b>					
Supernovae	?	15 or more		CM Tauri (Crab Nebula)	7
Novae	Centuries?	7–16	O to A, subdwarfs	GK Persei	281
Recurrent novae	20 years?	7–9		RS Ophiuchi	8
Dwarf novae	10–600	2–6	A to F, subdwarfs	SS Cygni, Z Camelopardalis	332
(U Geminorum and Z Camelopardalis)					
Flare	?	Up to 6	M, dwarfs	UV Ceti	1144
Nebular	Rapid and erratic	Up to a few magnitudes	B to M, main sequence and subgiants	T Tauri	1444
R Coronae Borealis		1–9	F to K, supergiants	R Coronae Borealis	37
Others					277

Cataclysmic variables are very close binary systems made up of an evolved, hot, dense white dwarf and a less evolved cool star which transfers mass onto the white dwarf accretion disk. The best known of the cataclysmic variables are stars that brighten by 7 to 16 magnitudes within about a day. They stay at maximum brightness for a few days or weeks and then slowly fade. The word nova, meaning new, was used for these stars. Actually a nova is not a new star, but an already existing star which due to the eruption has become very luminous and thus visible. Recurrent novae are stars that about every 20 years or more have eruptions during which the system brightens by 7 to 9 magnitudes. Dwarf novae have smaller-scale eruptions, in which the star brightens by 2 to 6 magnitudes within a day, stays bright 1 to 2 weeks, and then fades to the original brightness.

R Coronae Borealis stars, instead of brightening through eruptions, irregularly decrease in brightness every 2 to 3 years by 1 to 9 magnitudes. The decrease in brightness is caused by the veiling of the star by thick carbon clouds expelled to the star's atmosphere. See CATAclysmic VARIABLE; STAR.

Nebular variables are young stars in the early stages of stellar formation. [J.A.Ma.]

**Variational methods (physics)** Methods based on the principle that, among all possible configurations or histories of a physical system, the system realizes the one that minimizes some specified quantity. Variational methods are used in physics both for theory construction and for calculational purposes.

The earliest use of a variational principle for physics is Fermat's principle in optics, which states that when a light ray traverses a medium with nonuniform index of refraction its path is such as to minimize its travel time. An integral expresses the time that the light takes to travel from one point to another along a particular path, and an application of the calculus of variations to this integral makes it possible to determine the particular path for which the travel time is a minimum. This problem is mathematically identical to the variational principle that determines a geodesic, the path of shortest distance, in a given geometry. In that form, the same principle determines the world lines of all objects in the general theory of relativity. See RELATIVITY; RIEMANNIAN GEOMETRY.

Similarly, in mechanics, Hamilton's principle for the action is defined for any system of point particles by an integral (called the action) that extends over an arbitrarily prescribed path  $\Gamma$  in configuration space. Hamilton's principle asserts that the trajectories of all the particles are determined by the requirement that  $\Gamma$  be such that, for given initial and final times, the action is a minimum; for this reason it is also called the principle of least action. If the calculus of variations is applied to implement this principle, the corresponding Euler-Lagrange equations are obtained. These are the lagrangian equations of motion, that is, Newton's equations of motion in lagrangian form. See ACTION; HAMILTON'S PRINCIPLE; LAGRANGIAN FUNCTION; LEAST-ACTION PRINCIPLE.

The principle of least action has been generalized to systems with infinitely many degrees of freedom, that is, fields. A Lagrange density function is then defined, which is a function of the fields and their time derivatives at any given point in space and time. For any field theory, only the Lagrange density needs to be given; the field equations are then derivable as the corresponding Euler-Lagrange equations. A similar technique makes it possible to derive the Schrödinger equation and the Dirac equation in quantum mechanics from specific Lagrange density functions. See QUANTUM MECHANICS; QUANTUM THEORY OF MATTER; RELATIVISTIC QUANTUM THEORY.

This method has great procedural advantages. For example, it facilitates a check of whether the theory satisfies certain invariance principles (such as relativistic invariance or rotational invariance) by simply ascertaining whether the Lagrange density satisfies them. The corresponding conservation laws can also be derived directly from the lagrangian. See CONSERVATION LAWS (PHYSICS); QUANTUM FIELD THEORY; SYMMETRY LAWS (PHYSICS).

The variational method also plays an important role in quantum-mechanical calculations. For the computation of needed quantities in terms of functions that result from the solution of differential equations, it is always of great advantage to use formulas that have the special form required to make them stationary with respect to small variations of the input functions in the vicinity of the unknown, exact solutions. See MINIMAL PRINCIPLES. [R.G.Ne.]

**Varistor** Any two-terminal solid-state device in which the electric current  $I$  increases considerably faster than the voltage  $V$ . This nonlinear effect may occur over all, or only part, of the current-voltage characteristic. It is generally specified as  $I \propto V^n$ , where  $n$  is a number ranging from 3 to 35 depending on the type of varistor. The main use of varistors is to protect electrical and electronic equipment against high-voltage surges by shunting them to ground. See ELECTRIC PROTECTIVE DEVICES.

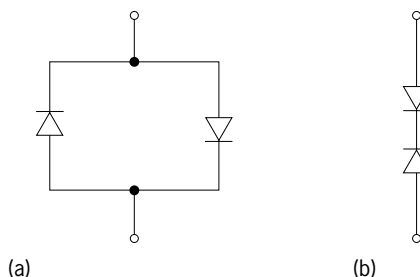

Symmetrical rectifier varistors. (a) Low voltage. (b) High voltage.

One type of varistor comprises a sintered compact of silicon carbide particles with electrical terminals at each end. It has symmetrical characteristics (the same for either polarity of voltage) with  $n$  ranging from 3 to 7. These devices are capable of application to very high power levels, for example, lightning arresters. See LIGHTNING AND SURGE PROTECTION.

Another symmetrical device, the metal-oxide varistor, is made of a ceramiclike material comprising zinc oxide grains and a complex amorphous intergranular material. It has a high resistance (about  $10^9$  ohms) at low voltage due to the high resistance of the intergranular phase, which becomes nonlinearly conducting in its control range (100–1000 V) with  $n > 25$ .

Semiconductor rectifiers, of either the  $pn$ -junction or Schottky barrier (hot carrier) types, are commonly utilized for varistors. A single rectifier has a nonsymmetrical characteristic which makes it useful as a low-voltage varistor when biased in the low-resistance (forward) polarity, and as a high-voltage varistor when biased in the high-resistance (reverse) polarity. Symmetrical rectifier varistors are made by utilizing two rectifiers connected with opposing polarity, in parallel (illus. a) for low-voltage operation and in series (illus. b) for high-voltage use. For the high-voltage semiconductor varistor,  $n$  is approximately 35 in its control range, which can be designed to be anywhere from a few volts to several hundred. See SEMICONDUCTOR RECTIFIER. [L.A.Le.]

**Varnish** A transparent surface coating which is applied as a liquid and then changes to a hard solid. Varnishes are solutions of resinous materials in a solvent, and dry by the evaporation of the solvent or by a chemical reaction, either with oxygen from the air or by some other means, including absorption of atmospheric moisture.

Spirit varnishes are those in which the evaporation of solvent is the only drying process; the solvent is usually alcohol, although the term is used for similar coatings made with other solvents. Shellac varnish, made by dissolving shellac in alcohol, is the most common of this type. Oleoresinous varnishes are made by treating a drying oil with a resin, usually with heat, and dissolving the reaction product in a solvent, usually a petroleum



fraction; drying results from the evaporation of the solvent, followed by polymerization of the drying oil portion, a reaction which is accelerated by metallic driers added to the varnish. For a discussion of the mechanism of this drying action. See DRIER (PAINT); SHELLAC; SOLVENT.

Varnish coatings on wood are used to protect against abrasion, staining, and weather and to reduce the penetration of water and other materials without obscuring the grain or changing the color materially. Varnishes are used on masonry to reduce the penetration of moisture and the damage from freezing. Paper is coated with varnish to resist moisture and keep printing from being damaged. See PRINTING; SURFACE COATING. [C.R.Ma.; C.N.S.]

**Varnish tree** The plant *Toxicodendron vernicifluum* (previously known as *Rhus vernicifera*), also called lacquer tree, a member of the sumac family (Anacardiaceae). It is a native of China, but has long been cultivated in Japan. When the bark is cut, it exudes a milky juice which darkens and thickens on exposure. This is the lacquer long used in China and Japan. When properly applied, the thin transparent film becomes a varnish of extreme hardness. See LACQUER; SAPINDALES. [P.D.St.; E.L.C.]

**Varve** Any of a variety of distinct sediment laminations or beds deposited within the span of a single year. They are formed commonly in saline or fresh-water lakes, but examples from marine environments are known as well. Usually, varves occur in repetitive series and thus comprise vertical sequences of annual cyclic deposits. Varves range in thickness from less than a millimeter (0.04 in.) to over a meter (3 ft), but typically are a few millimeters or centimeters thick.

The classic varves are found in glacial lake sediments formed during the Pleistocene ice ages. These glacial varves occur typically as couplets of light-colored silt or sand and dark clay. The relatively coarse silt-sand layers are formed during the warm summer months when meltwater inflows and sediment yields to the lake are large. During winter when meltwater inflow is greatly reduced or stopped, the fine-grained clay settles slowly to the lake bottom to deposit the fine, dark winter layer of the varve. Similar varved sediments are found commonly in modern glacier-fed lakes that undergo large seasonal variations in inflow. See GLACIATED TERRAIN; PLEISTOCENE.

Varves can be used as tools for correlation as well as for chronological reconstructions. In addition to their use in dating sedimentary deposits, varves have been used to investigate sedimentation rates, cyclic deposition, climate variations, glacial histories, and as standards of comparison for other dating techniques. Varves have been identified occasionally in ancient sedimentary rocks. See DATING METHODS; GLACIAL EPOCH; MARINE SEDIMENTS; SEDIMENTARY ROCKS; SEDIMENTOLOGY. [N.D.S.]

**Vascular disorders** Those disorders that involve the arteries, veins, and lymphatics.

**Arteries.** Diseases of the large and medium-sized arteries are the major cause of morbidity and mortality in the Western world.

Arteriosclerotic vascular disease, also known as arteriosclerosis, affects large and medium arteries and is particularly common in the arteries supplying the heart, those supplying the brain, and those supplying the lower extremities. Progressive narrowing and finally total occlusion of these arteries lead to the development of angina pectoris, myocardial infarction, stroke, and vascular insufficiency in the limbs. Although the cause of the disease is not known, certain factors appear to predispose to its development. These include cigarette smoking, hypertension, elevated serum cholesterol, and diabetes mellitus. There can also be a genetic predisposition to the disorder. See ARTERIOSCLEROSIS; DIABETES; HYPERTENSION; INFARCTION.

Much less common are diseases that lead to arteritis, an inflammation of the large or medium arteries, with subsequent occlusion or rupture of the artery. The causes include bacterial

infection, syphilis, allergic disorders, and hypersensitivity states. See HYPERSENSITIVITY; SYPHILIS.

Several generalized disorders can involve the small arteries. These include scleroderma, periarteritis nodosa, lupus erythematosus, rheumatoid arthritis, and dermatomyositis. The involvement can produce areas of cell death (necrosis) and ulceration of the skin, particularly of the limbs. This appears to occur because of the occlusion of the involved small arteries, with consequent loss of blood supply. Such involvement often is preceded by a type of hypersensitivity to cold, a condition known as Raynaud's syndrome. See CONNECTIVE TISSUE DISEASE.

**Veins.** The most common disorder of the venous circulation is varicose veins. It develops because of the loss of function of the valves in the superficial veins of the limbs. The two most commonly involved veins are the greater and lesser saphenous. In this condition, the veins are enlarged and often tortuous. If the deep veins are not involved, the varicose veins are termed primary. Varicose veins tend to cluster in families and are more common in women than men. Primary varicose veins may be cosmetically unpleasing, but they rarely cause serious symptoms in the involved limbs. A more serious problem develops when the varicose veins are associated with destruction of valves in the deep veins, secondary to deep-vein thrombosis. When varicose veins develop because of problems within the deep venous system, they are called secondary varicose veins.

When patients undergo major surgery or are confined to bed because of a serious medical illness, thrombosis of the veins of the leg can occur. The thrombosis occurs most commonly in the deep veins of the calf but can progress and extend proximally to involve the popliteal, femoral, and iliac veins. See THROMBOSIS.

**Lymphatics.** When the drainage function is disturbed by obstruction of the lymphatics by tumors, parasites, or surgical excision, serious swelling (edema) can occur. This condition is called lymphedema. The pattern of swelling involves not only the lower leg but the foot and toes as well. Obstruction of the lymphatics can also be congenital or can appear unexpectedly at the time of the onset of the menses. Regardless of its cause, lymphedema is a permanent condition. See EDEMA; LYMPHATIC SYSTEM.

**Arteriovenous communications.** If there are anomalous communications between the arteries and veins proximal to the capillaries, blood is shunted away from the capillary bed. Such shunting can be congenital or acquired.

The congenital form can occur at almost any site in the vascular system. When these communications are present, they may appear as prominent veins that are much larger and more numerous than normal. These are commonly referred to as hemangiomas. The extent to which they cause problems depends upon their location, their size, and numbers of feeding communications that are present. If a foreign body such as a bullet or knife passes between a major artery and vein, an artificial communication can develop that results in the shunting of a large volume of blood. When the communication is between very large vessels such as the abdominal aorta and inferior vena cava, the amount of blood shunted may be so large that heart failure occurs. See CARDIOVASCULAR SYSTEM. [D.E.Str.]

**Vector (mathematics)** A directed line segment. As such, vectors have magnitude and direction. Many physical quantities, for example, velocity, acceleration, and force, are vectors. Vectors are widely used in mathematical physics. See CALCULUS OF VECTORS. [M.Ye.]

**Vector methods (physics)** Methods that make use of the behavior of physical quantities under coordinate transformations.

From the point of view of physics, the most appropriate definition of a vector in three-dimensional space is a quantity that has three components which transform under rotations of the coordinate system like the coordinates of a point in space.

What characterizes rotations is that the distance from the origin—

$$\sqrt{x_1^2 + x_2^2 + x_3^2}$$

of all points  $\mathbf{x}$  with cartesian coordinates  $x_i$ ,  $i = 1, 2, 3$ —remains unchanged. Specifically, if the rotation takes the  $x_i$  to new coordinates  $x'_i$ , given by Eqs. (1) [in which  $\det\{a_{ij}\}$  is the determinant

$$x'_i = \sum_{j=1}^3 a_{ij} x_j \quad i = 1, 2, 3 \quad (1)$$

$$\sum_{k=1}^3 a_{ik} a_{jk} = \begin{cases} 1 & \text{if } i = j, \\ 0 & \text{if } i \neq j, \end{cases} \quad \det\{a_{ij}\} = 1$$

of the matrix  $\{a_{ij}\}$ , then the three quantities  $V_i$ ,  $i = 1, 2, 3$ , form the components of a vector  $\mathbf{V}$ , if in the new coordinate system the transformed coordinates are given by Eq. (2).

$$V'_i = \sum_{j=1}^3 a_{ij} V_j \quad i = 1, 2, 3 \quad (2)$$

If the coordinate transformation of Eqs. (1) is such that  $|a_{ij}| = 1$  for  $i = j$  and  $a_{ij} = 0$  for  $i \neq j$ , but such that  $\det\{a_{ij}\} = -1$  rather than  $+1$  as in Eqs. (1), then it describes a reflection, in which a right-handed coordinate system is replaced by a left-handed one. If, for such a transformation, Eq. (2) also holds, then  $\mathbf{V}$  is called a polar vector, whereas if the components of  $\mathbf{V}$  do not change sign, it is called an axial vector or pseudovector. The vector  $\mathbf{V}$  can also be looked upon as a quantity with a direction, with the magnitude

$$\sqrt{V_1^2 + V_2^2 + V_3^2}$$

pointing from the origin of the coordinate system to the point in space with the cartesian coordinates  $(V_1, V_2, V_3)$ .

A quantity that remains invariant under a rotation of the coordinate system is called a scalar. The importance of vectors and scalars in physics derives from the assumed isotropy of the universe, which implies that all general physical laws should have the same form in any two coordinate systems that differ only by a rotation. It is therefore useful to classify physical quantities according to their transformation properties under coordinate rotations. Examples of scalars include the mass of an object, its electric charge, its volume, its surface area, the energy of a system, and its temperature. Other quantities have a direction and thus are vectors, such as the force exerted on a body, its velocity, its acceleration, its angular momentum, and the electric and magnetic fields. Since the sum of two scalars is a scalar, and the sum of two vectors is a vector, it is important in the formulation of physical laws not to mix quantities that have different transformation properties under coordinate rotations. The sum of a vector and a scalar has no simple transformation properties; a law that equated a vector to a scalar would have different forms in different coordinate systems and would thus not be acceptable. [R.G.Ne.]

**Vega** The fifth brightest of all stars, and the third brightest in the northern sky. It will be the north polar star in about 12,000 years. In moving through the Milky Way Galaxy, the Sun is generally heading toward the position now occupied by Vega. At a distance of 7.8 parsecs (25.3 light-years, or  $2.4 \times 10^{14}$  km, or  $1.49 \times 10^{14}$  mi), Vega, or  $\alpha$  Lyrae, is the prototypical star of spectral class A0V, indicating that it has an effective surface temperature of 9600 K (16,800°F) and derives its energy from the thermonuclear burning of hydrogen in a stable core region. Stars of this class have main-sequence lifetimes of about  $5 \times 10^8$  years, 20 times shorter than the Sun. In comparison with the Sun, Vega is approximately 2.9 times larger in diameter, 2.5 times more massive, and 60 times more luminous. See PRECESSION OF EQUINOXES; SPECTRAL TYPE.

Vega emits far more radiation at infrared wavelengths than would be expected. This radiation originates from a shell or disk

of particles with a temperature of 100 K ( $-280^\circ\text{F}$ ) surrounding Vega out to a distance of  $1.3 \times 10^{10}$  km ( $8 \times 10^9$  mi), twice the radius of the solar system. See INFRARED ASTRONOMY; STAR. [H.A.McA.]

**Vegetable ivory** The seed of the tagua palm (*Phytelphas macrocarpa*) of tropical America. Each drupelike fruit contains six to nine bony seeds. The extremely hard endosperm of the seed is used as a substitute for ivory. Vegetable ivory can be carved and tooled to make buttons, chessmen, knobs, inlays, and various ornamental articles. See ARECALES. [P.D.St./E.L.C.]

**Vegetation and ecosystem mapping** The graphic portrayal of spatial distributions of vegetation, ecosystems, or their characteristics. Vegetation is one of the most conspicuous and characteristic features of the landscape and has long been a convenient way to distinguish different regions; maps of ecosystems and biomes have been mainly vegetation maps. As pressure on the Earth's natural resources grows and as natural ecosystems are increasingly disturbed, degraded, and in some cases replaced completely, the mapping of vegetation and ecosystems, at all scales and by various methods, has become more important. See BIOME; ECOSYSTEM.

Three approaches have arisen for mapping general vegetation patterns, (1) based on vegetation structure or gross physiology, (2) based on correlated environmental patterns, and (3) based on important floristic taxa. The environmental approach provides the least information about the actual vegetation but succeeds in covering regions where the vegetation is poorly understood. Most modern classification systems use a combination of physiognomic and floristic characters. See PLANT GEOGRAPHY.

Mapping has expanded to involve other aspects of vegetation and ecosystems as well as new methodologies for map production. Functional processes such as primary production, decomposition rates, and climatic correlates (such as evapotranspiration) have been estimated for enough sites so that world maps can be generated. Structural aspects of ecosystems, such as total standing biomass or potential litter accumulations, are also being estimated and mapped. Quantitative maps of these processes or accumulations can be analyzed geographically to provide first estimates of important aspects of world biogeochemical budgets and resource potentials.

Computer-produced maps, using Geographic Information Systems (GIS), often coupled directly with predictive models, remote-sensing capabilities, and other techniques, have also revolutionized vegetation and ecosystem mapping. This gives scientists a powerful tool for modeling and predicting the outcome from global climate change, in that feedback from the world's vegetation can be accounted for. Before computer technology exploded in the early 1980s, the spatial scale and related resolution or grain of vegetation and ecosystem mapping was limited by the static nature of hard-copy maps. The advent of GIS technology enabled the analysis of digital maps at any spatial scale, and the only limitation was the resolution at which the data were originally mapped. In addition, GIS software is used for sophisticated spatial analyses on maps, and this was virtually impossible before. See CARTOGRAPHY; CLIMATE MODELING; GEOGRAPHIC INFORMATION SYSTEMS; REMOTE SENSING. [B.E.F.; E.O.B.]

**Velocity** The time rate of change of position of a body in a particular direction. Linear velocity is velocity along a straight line, and its magnitude is commonly measured in such units as meters per second (m/s), feet per second (ft/s), and miles per hour (mi/h). Since both a magnitude and a direction are implied in a measurement of velocity, velocity is a directed or vector quantity, and to specify a velocity completely, the direction must always be given. The magnitude only is called the speed. See SPEED.

A body need not move in a straight line path to possess linear velocity. When a body is constrained to move along a curved

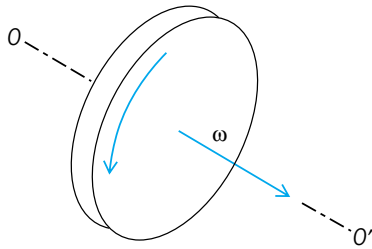

Angular velocity shown as an axial vector. Axis of rotation is  $OO'$ .

path, it possesses at any point an instantaneous linear velocity in the direction of the tangent to the curve at that point. The average value of the linear velocity is defined as the ratio of the displacement to the elapsed time interval during which the displacement took place.

The representation of angular velocity  $\omega$  as a vector is shown in the illustration. The vector is taken along the axis of spin. Its length is proportional to the angular speed and its direction is that in which a right-hand screw would move. If a body rotates simultaneously about two or more rectangular axes, the resultant angular velocity is the vector sum of the individual angular velocities. [R.D.Ru.]

**Velocity analysis** A technique for the determination of the velocities of the parts of a machine or mechanism. Graphical and analytical analyses of plane mechanisms are the two main methods that are used. Visualization is an inherent part of the graphical analysis and generally gives a better physical feel for the problem than most purely analytical methods. Analytical methods, however, are necessary for computer analyses. See VELOCITY.

In a high-speed machine it is important that the inertia forces be determined. This requires an acceleration analysis of the machine, and the first step in an acceleration analysis usually is a velocity analysis. In the analysis of some machines, the velocity of a particular point in the machine may itself be the important thing to be determined in the analysis—for example, the cutting speed and return speed of the cutting tool in a shaper, or the shuttle velocity in a textile machine.

In the graphical method of velocity analysis, the geometry of the mechanism is known in each phase of its motion cycle from the drawing of the mechanism in each position. In an analytical velocity analysis, the geometry is usually determined analytically; that is, a position analysis of the mechanism is performed by using trigonometry, vector mathematics, or some other analytical method as the first step in the velocity analysis.

One analytical method for the position analysis of mechanisms, developed by M. A. Chace, makes use of vector mathematics. It consists essentially of solving vector triangles containing two unknowns. Computer subprograms for Chace solutions to the plane vector equation and for all the various vector operations have been written, thus making the position and velocity analyses (as well as the acceleration analysis) of mechanisms by computer using Chace's method quite convenient. Computer analyses are particularly useful when complex mechanisms must be analyzed in many positions of their cycle of motion. See STRAIGHT-LINE MECHANISM; VECTOR (MATHEMATICS). [J.C.Wo.]

**Veneer** A thin sheet of wood of uniform thickness produced by peeling, slicing, or sawing. Depending on the manner of production and the portion of wood from which a veneer is made, the grain may be flat, vertical, or biased. Most veneer is rotary-cut from a bolt of wood, called a flitch, centered in chucks of a lathe. A nose bar bears against the flitch parallel to the center line of the lathe and a knife, also extending nearly the length of

the lathe, peels off the veneer. Knives near the ends of the flitch cut the edges of the veneer.

Veneers cut from selected hardwoods, burls, crotches, and stumps are used for facings on furniture and the interior decoration of buildings. Other uses of veneer include plate separators in storage batteries, boxes for fruit and vegetables, drums for cheeses, and crates, hampers, and baskets for transportation and storage. Most veneer is used in plywood panels. See PLYWOOD; WOOD PRODUCTS. [F.H.R.]

**Ventilation** The supplying of air motion in a space by circulation or by moving air through the space. Ventilation may be produced by any combination of natural or mechanical supply and exhaust. Such systems may include partial treatment such as heating, humidity control, filtering or purification, and, in some cases, evaporative cooling. More complete treatment of the air is generally called air conditioning. See AIR CONDITIONING.

Natural ventilation may be provided by wind force, convection, or a combination of the two. Although largely supplanted by mechanical ventilation and air conditioning, natural ventilation still is widely used in homes, schools, and commercial and industrial buildings.

Mechanical supply ventilation may be of the central type consisting of a central fan system with distributing ducts serving a large space or a number of spaces, or of the unitary type with little or no ductwork, serving a single space or a portion of large space. Outside air connections are generally provided for all ducted systems. Outside air is needed in controlled quantities to remove odors and to replace air exhausted from the various building spaces and equipment.

Exhaust ventilation is required to remove odors, fumes, dust, and heat from an enclosed occupied space. Such exhaust may be of the natural variety or may be mechanical by means of roof or wall exhaust fans or mechanical exhaust systems. The mechanical systems may have minimal ductwork or none at all, or may be provided with extensive ductwork which is used to collect localized hot air, gases, fumes, or dust from process operations. Where it is possible to do so, the process operations are enclosed or hooded to provide maximum collection efficiency with the minimum requirement of exhaust air. [J.H.Cl.]

**Venturi tube** A device that consists of a gradually decreasing nozzle through which the fluid in a pipe is accelerated, followed by a gradually increasing diffuser section that allows the fluid to nearly regain its original pressure head (see illustration). It can be used to measure the flow rate in the pipe, or it can be used to pump a secondary fluid by aspirating it at the nozzle exit. The ability of the venturi tube to regain much of the original pressure head makes it especially useful in measuring the flow rate in systems which have a low pressure differential or pressure head that drives the fluid through the pipe or where the cost of pumping the fluid is an important factor. Conserving the pressure head decreases the amount of energy required to pump the fluid through the pipe.

A gradual expansion of flow downstream of a nozzle eliminates flow separation, allowing recovery of most of the original pressure head. In the case where the main flow separates from the wall, a large percentage of the fluid energy is lost in the eddies caused by the separation.

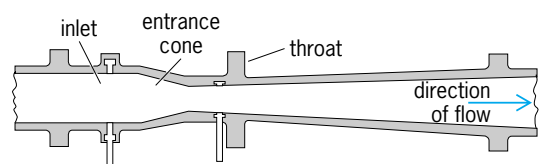

Proportions of a Herschel-type venturi tube for standard fluid-flow measurement.

The flow through the device obeys Bernoulli's equation, and the formula for calculating the flow is similar to the equation for orifices. The venturi meter belongs to the class of differential pressure-sensing devices that are used to indicate flow. See BERNOULLI'S THEOREM; FLOW MEASUREMENT; METERING ORIFICE. [M.P.W.]

**Venus** The second planet in distance from the Sun. This neighbor of the Earth is very similar to it in such gross characteristics as mass, radius, and density. In other ways Venus is apparently different. Its atmospheric mass is almost a hundred times that of the Earth; its atmosphere is mostly carbon dioxide instead of nitrogen and oxygen; an extensive cloud layer of concentrated sulfuric acid is present; its surface temperature is an unbearable 850°F (730 K); and it rotates with a period of 243 days, and from east to west, in the opposite sense of most other planets. Some of these differences are due more to alternate evolutionary paths of the two planets than to totally different initial conditions.

To the naked eye, Venus is the brightest starlike object in the sky. It is usually visible during the night either soon after sunset or close to sunrise. It can sometimes be seen during the daytime.

The light seen coming from Venus is entirely due to sunlight that is reflected from a dense cloud layer whose top is located about 45 mi (70 km) above the surface and whose bottom lies within 30 mi (50 km) of the surface. In contrast to the Earth's approximately 50% cloud cover, the clouds of Venus are present over the entire planet. The clouds of Venus consist of a large number of tiny particles, about 1 micrometer in size, that are made of a water solution of concentrated sulfuric acid.

By far, the chief gas species of Venus's atmosphere is carbon dioxide, which makes up 96% of the atmospheric molecules, while nitrogen accounts for almost all the remainder. In contrast to the dominance of carbon dioxide in Venus's atmosphere, the Earth's atmosphere consists mostly of nitrogen and oxygen, with carbon dioxide being present at a level of only 340 ppm. In part, this difference may stem more from temperature differences than from intrinsic differences. Over the lifetime of the Earth, an amount of carbon dioxide comparable to that in Venus's atmosphere was vented out of the Earth's hot interior, but almost all of it participated with rain in dissolving land rocks, and rivers carried the dissolved rock and carbon dioxide into the oceans, where they subsequently precipitated to form carbonate rocks, such as limestone. Venus's surface is much too hot for oceans of water to be present, and hence its atmosphere has been able to retain essentially all of the carbon dioxide vented from its interior. See ATMOSPHERIC CHEMISTRY.

The atmospheric temperature has a relatively cool value of -10°F (250 K) near the top of the cloud layer, which is at a pressure of about 1/20 that at the Earth's surface. The temperature gradually increases with decreasing altitude until it reaches 850°F (730 K) at the surface, where the pressure is 90 times that at the Earth's surface. The high value of Venus's surface temperature is not due to its being closer to the Sun than the Earth. Because its cloud layer reflects to space about 75% of the incident sunlight, Venus actually absorbs less solar energy than does the Earth. Rather, the high temperature is the result of a very efficient greenhouse effect that allows a small but significant fraction of the incident sunlight to penetrate to the surface (about 2.5%), but prevents all except a negligible fraction of the heat generated by the surface from escaping directly to space. See GREENHOUSE EFFECT.

The very similar mean densities of Venus and the Earth imply that Venus is made of rocks similar to those that make up the Earth. Venus's interior may be qualitatively similar to that of the Earth in having a central iron core, a middle mantle made of rocks rich in silicon, oxygen, iron, and magnesium, and a thin outer crust containing rocks enriched in silicon in comparison with the rocks of the mantle. However, in contrast to the situation for the Earth, Venus's core may now be either entirely

solid or entirely liquid, which could account for the absence of a detectable magnetic field. See EARTH INTERIOR. [J.B.Po.]

Venus has been more intensely explored by spacecraft than any other planet. United States and Soviet spacecraft provided data on the composition of the surface and atmosphere, and the dynamics of the upper atmosphere. The Soviet *Venera* landers transmitted back the first images from the surface of another planet. The United States *Magellan* mapped nearly 98% of the surface. See SPACE PROBE.

*Magellan*'s mapping mission revealed a unique global volcanic and tectonic style on Venus. Broad volcanic plains make up about 85% of the surface of Venus. The rest is tectonically deformed, higher-standing terrains with complex systems of folds and faults. Regional tectonism is evident in the widespread compressional and extensional deformation of much of the surface material. Venus apparently has had a dynamic mantle that has driven crustal warping, which may be ongoing. However, while various regions of the planet show evidence of motion, no evidence of Earth-like plate tectonics has been found. See PLATE TECTONICS.

Long, narrow troughs are seen in many areas where the crust has ruptured; these linear rift zones are associated with extensive broad, domical rises and shield-volcano complexes. The planet also has some unexplained surface features, including long channels meandering across the plains. Also seen are oval to circular volcanic-tectonic structures called coronae that range in diameter from 60 to 1300 mi (100 to 2100 km). Impact craters are much less abundant on Venus than on the Moon or Mars, and currently active volcanism has not been detected on Venus. See PLANET; PLANETARY PHYSICS. [R.S.Sa.]

**Venus' flytrap** *Dionaea muscipula*, an insectivorous plant of North and South Carolina (see illustration). The two halves

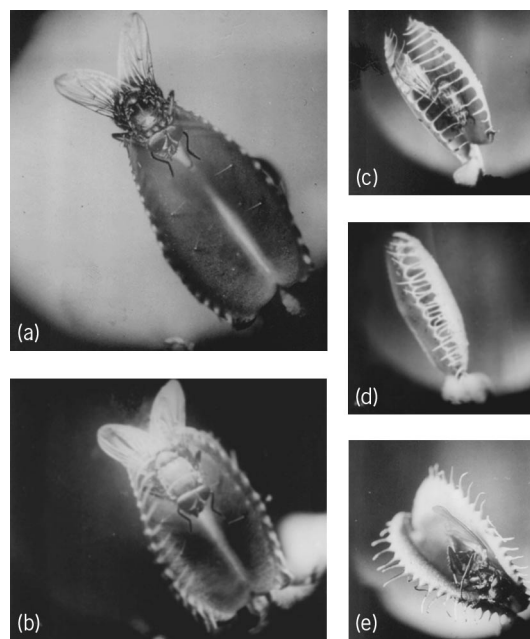

Stages a-e in capture and digestion of fly by leaf of Venus' flytrap. (General Biological Supply House)

of a leaf blade can move as if they were hinged along the midrib and, swinging upward and inward, the two surfaces come together. Any insect alighting on a leaf triggers this sensitive motor mechanism, and is caught between the closing halves of the leaf blade. In this trap, the insect is slowly digested by enzymes secreted by cells in the leaf. See INSECTIVOROUS PLANTS; NEPENTHALES; SECRETORY STRUCTURES (PLANT). [P.D.St./E.L.C.]

**Vermiculite** A group of minerals common in some soils and clays and belonging to the family of minerals called layer silicates. Species within the vermiculite group are denoted as either dioctahedral vermiculite or trioctahedral vermiculite, with two or three octahedral cation sites occupied per formula unit, respectively. Trioctahedral vermiculite is a 2:1 layer silicate with a fundamental unit similar to that of mica. An octahedral sheet forms the basis of the layer and is sandwiched between two opposing tetrahedral sheets. See MICA.

Perfect basal cleavage develops by the layerlike structure. Density varies but is near  $2.4 \text{ g/cm}^3$ ; hardness on Mohs scale is near 1.5; and luster is pearly. Thin sheets deform easily and may be yellow to brown. See HARDNESS SCALES.

Heat-treated and expanded vermiculite is used as an insulator in construction. Mixed with plaster and cement, vermiculite is used to make lightweight versions of these materials. Vermiculite is also useful as an absorbent for some environmentally hazardous liquids. See CLAY MINERALS; SILICATE MINERALS. [S.Gu.]

**Vernalization** The induction in plants of the competence or ripeness to flower by the influence of cold, that is, temperatures below the optimal temperature for growth. Vernalization thus concerns the first of the three phases of flower formation in plants. In the second stage, for which a certain photoperiod frequently is required, flowers are initiated. In the third stage flowers are unfolded. See FLOWER; PHOTOPERIODISM; PLANT GROWTH. [K.N.Z.]

**Vernier** A short, auxiliary scale placed along the main instrument scale to permit accurate fractional reading of the least main division of the main scale. The auxiliary, or vernier, scale is graduated in one or both directions from the fiducial (index) mark in numbered divisions which are fractionally shorter (in a direct vernier) or longer (in a retrograde vernier) than those on the main scale (see illustration). The position of the fiducial

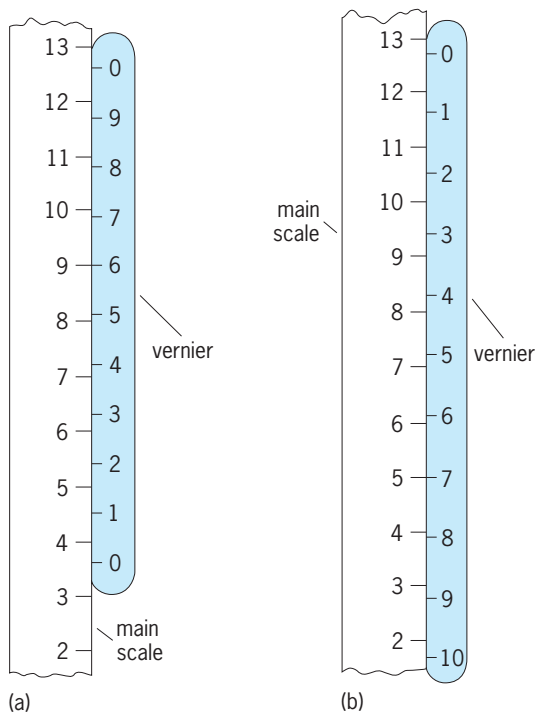

Two types of vernier scales. (a) Direct (reading 3.6). (b) Retrograde (reading 12.7)

mark (the zero mark of the vernier scale) between divisions on the main scale is indicated by the number of the graduation on

the vernier scale which lines up exactly with a graduation on the main scale. [W.A.Wi.]

**Verrucomorpha** A suborder of the Thoracica comprising one Recent genus, *Verruca*, and one fossil, *Proverruca*, from the Lower Devonian. These barnacles are sessile and asymmetrical. In *Verruca* only four plates form the wall, rostrum, carina, and scutum and tergum of one side. In *Proverruca* two additional lateral plates are inserted between the rostrum and the carina. These barnacles are hermaphroditic. Most species live in deep water, though *V. stroemia* is from the lower intertidal and sublittoral. See THORACICA. [H.G.St.]

**Vertebra** The basic unit of the vertebral column. Collectively, the vertebrae surround and protect the spinal cord and provide some type of axial support for the body. The stresses that the vertebral column must meet change somewhat from one end of the animal to the other, and also differ greatly between aquatic and terrestrial vertebrates because the problems of support and locomotion in these media are quite different. Accordingly, vertebral structure varies widely; yet all vertebrae have many features in common. See SPINE.

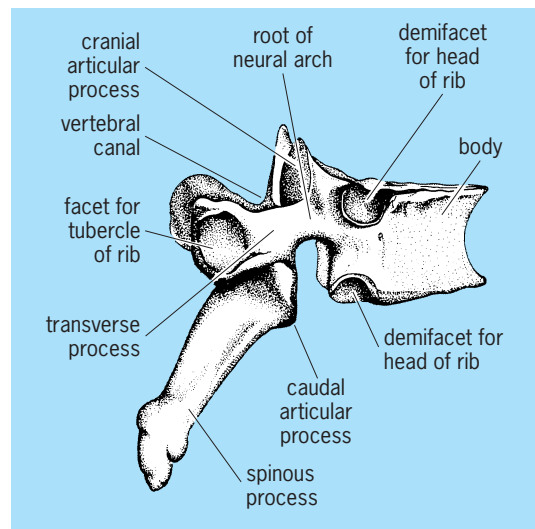

Lateral view of a human thoracic vertebra. Anterior is toward the right.

A vertebra from the thoracic region of a mammal illustrates the basic morphology well (see illustration). The ventral portion consists of a disc-shaped mass of bone known as the body or centrum. An arch of bone, the neural arch, extends dorsally from the centrum and encompasses a space, the vertebral canal, in which the spinal cord lies. The bases, or roots, of the arch are narrower than other parts so that clefts, the intervertebral foramina, lie between the arch bases of successive vertebrae. Spinal nerves pass through these foramina.

Certain muscles and ligaments attach onto the spinous process, which extends dorsally from the top of the arch, and onto a pair of transverse processes, which extend laterally from the arch. One pair of articular processes, or zygapophyses, extends forward from the neural arch, and another pair extends posteriorly. Articular processes of successive vertebrae overlap and help to hold the vertebrae together. The centra of adjacent vertebrae are also joined together by intervertebral discs of fibrocartilage. Numerous ligaments interlace the vertebrae.

Ribs articulate onto the thoracic vertebrae. Typically, each mammalian rib has two articular surfaces—a terminal head and a tubercle situated a short distance distal to the head. The tubercle articulates with a facet located on the end of the transverse

process; the head usually articulates intervertebrally onto the intervertebral disc and adjacent parts of the bordering centra.

In mammals different parts of the column are clearly specialized to subservise certain functions in addition to their general supportive role.

The head moves independently of the trunk, and a distinct neck region, consisting of cervical vertebrae, is present. With few exceptions all mammals from a shrew to a giraffe have seven cervical vertebrae.

Well-developed ribs, which play an important role in respiratory movements, articulate with the anterior trunk or thoracic vertebrae of mammals. The number of thoracic vertebrae varies between species but is on the order of 11 (bat) to 18 or 20 (horse). Humans have 12.

Lumbar vertebrae occupy the posterior part of the mammal trunk region. They are characterized by relatively large transverse processes to which certain of the powerful back muscles attach. Again the number of lumbar vertebrae vary between species but is on the order of 5 (bat) to 8 (whale). Humans have 5.

Correlated with the greater efficiency of terrestrial locomotion and the need for strong support for the powerful hindlegs, the number of sacral vertebrae increases during evolution from the single one of amphibians. Reptiles usually have two, and most mammals have three which are fused together, along with their embryonic rib rudiments, into a solid complex of bone called the sacrum. Humans, which are bipeds, have 5, and certain of the powerful hoofed mammals, for example, the horse, also have 5. Birds, whose hindlegs act as shock absorbers upon landing, have between 10 and 23 vertebrae fused together in their synsacrum.

The tail and caudal musculature no longer play an important role in the locomotion of most mammals (the Cetacea being a conspicuous exception), and the tail is greatly reduced in size. The spinal cord of mammals ends within the lumbar region, and only a few spinal nerves continue through the vertebrae canal into the tail. Caudal vertebrae are small and become progressively incomplete as one moves distally along the tail until only centra are left. Tail length, and hence the number of caudal vertebrae, vary widely. Some opossums have as many as 35, and humans, in which the tail is absent as an external structure, have only 3 to 5 caudal vertebrae. These form an internal coccyx to which certain anal muscles attach.

**Vertebrata** The major subphylum of the phylum Chordata, comprising the backboned animals, including humans. The subphylum is sometimes called the Craniata, because of the common possession of a cranium or braincase, but that term has dropped out of use in scientific nomenclature.

The characteristic features of the Vertebrata are a vertebral column, or backbone, and a cranium, which protects the central nervous system (brain and spinal cord) and major sense organs; the presence of bone, which is a tissue unique to vertebrates; and a neural crest of nerve cells that remain after the formation of the central nervous system. Other distinctive vertebrate features are a kidney, with the nephron as its functional unit; a heart; red and white blood cells; a liver and a pancreas; specialized sense organs, such as a complex eye, a lateral-line system, ears, and a sense of smell; several unique endocrine organs, such as the pituitary and thyroid; and a complex skin comprising an epidermis and dermis. See CHORDATA; VERTEBRA.

Vertebrates evolved from a lower chordate similar to the present-day Cephalochordata (amphioxus). They originated in fresh water and developed a kidney as their organ of water balance. They became free-swimming, with several evolutionary lines invading the oceans. The main line of evolution in the vertebrates, that which led to the tetrapods, remained in fresh waters.

The Vertebrata are divided into the following eight classes, which are arranged into several partly overlapping informal groups, and often two superclasses, Pisces and Tetrapoda, are

used to differentiate the aquatic and the terrestrial vertebrates. See PISCES (ZOOLOGY); TETRAPODA.

Superclass Pisces	Superclass Tetrapoda
Class: Agnatha	Class: Amphibia
Placodermi	Reptilia
Chondrichthyes	Aves
Osteichthyes	Mammalia

The term Gnathostomata designates the seven classes of jawed vertebrates, in contrast to the jawless Agnatha. The Amniota include the Pisces (fishes) and the Amphibia (amphibians). The Amniota consists of the Reptilia, Aves, and Mammalia. See AMNIOTA; ANIMAL KINGDOM. [W.J.B.]

**Vertebrate brain (evolution)** A highly complex organ consisting of sensory and motor systems that constitutes part of the nervous system. Virtually all of the brain systems that are found in mammals occur in birds, reptiles, and amphibians, as well as in fishes and sharks. These systems have become more complex and sophisticated as the adaptive requirements of the animals changed. Occasionally, new sensory systems arose, most likely as specializations of existing systems; however, some of these disappeared as animals left the aquatic world. Some sensory systems arose and declined several times in different lineages. In spite of the many changes in brain structure, some of them quite dramatic, the evolution of the nervous system, from the earliest vertebrates through to those of today, has been relatively conservative. See NERVOUS SYSTEM (INVERTEBRATE); NERVOUS SYSTEM (VERTEBRATE).

**Central nervous system.** The nervous system consists of two main divisions: the central nervous system, which is made up of the brain and the spinal cord, and the peripheral nervous system. The peripheral nervous system consists of the nerves that bring information from the outside world via the sensory systems, and the nerves that carry information from the body's interior to the spinal cord and brain. These nerves also convey commands from the brain and spinal cord to the external muscles that move the skeleton, as well as to various internal organs and glands. See CENTRAL NERVOUS SYSTEM.

The brain consists of a variety of systems, some of which are sensory and deal with the acquisition of information from the internal and external environments. Other systems are motor and are involved with the movement of the skeletal muscles; the muscles of the internal organs, such as the heart and the digestive and respiratory systems; and the secretions of certain glands, such as the salivary and tear glands. The bulk of the brain, however, is composed of systems that are integrative and organize, coordinate, and direct the activities of the sensory and motor systems. These integrative systems regulate such processes as sleep and wakefulness, attention, the coordination of various muscle groups, emotion, social behavior, learning, memory, thinking, planning, and other aspects of mental life. Social behavior itself is highly complex and includes such interactions between individuals as courtship, mating, parental care, and the organization and structure of groups of individuals. See BRAIN; MOTOR SYSTEMS.

**Development.** The nervous system develops in the embryo as a hollow tube. The remnants of this hollow tube in the adult are known as the brain ventricles and are filled with the cerebrospinal fluid. Two types of overall brain organization are found among vertebrates based on the relationship of the neurons to these ventricles. In brains with laminar organization, the neurons have not migrated very far from the layer immediately surrounding the hollow ventricular core of the brain. This type of organization is typical of amphibia and is also found in the brains of some sharks, fishes (especially those in which their skeletons are partly or mostly made of cartilage rather than bone), and lampreys. In contrast, in the brains of those vertebrates with the elaborated

type of organization, the neurons have migrated from the zone around the ventricles to occupy nearly all of the interior of the brain. This type of organization is typical of reptiles, mammals, birds, fishes (with fully bony skeletons), as well as skates, rays, some sharks, and hagfishes. See NEURON.

In general, brain size or weight varies in proportion to the size of the body. In some species, however, brain size or weight is greater than would be expected for that body weight, for example, in humans, chimpanzees, and porpoises. Birds have brains that are comparable to those of mammals of equivalent body weight. In fact, crows have brain weights that would be expected of a small primate of equivalent body weight. In contrast to birds and mammals, amphibians, reptiles, and bony fishes have relatively small brains for their body weights, as do jawless fishes.

**Subdivisions of brain.** The brain is divided into a hindbrain, a midbrain, and a forebrain.

**Hindbrain.** The hindbrain is a region that contains nerve endings that receive information from the outside world and from the body interior; these are known as sensory cranial nerves. The neuron groups upon which they terminate are known as sensory cranial nuclei. Also found in the hindbrain are motor nerves that control internal and skeletal muscles and glands, which are called motor cranial nerves; the neuron groups from which they originate are known as motor cranial nerve nuclei.

Many animals possess senses that humans do not possess. One such is the lateral line sense, which derives from receptors located in the lateral line organ which can easily be seen on most bony fishes as a thin, horizontal line running the length of the body from behind the gill opening to the tail. Other lateral line organs can be found on the head and jaws. These organs contain mechanoreceptors that respond to low-frequency pressure waves that might be produced by other fishes nearby or the bow wave of a fast-swimming predator about to strike. Lateral line systems and a special region of the hindbrain dedicated to lateral line sense are found in fishes and sharks, jawless fishes, and bony fishes of various sorts.

Electroreception is another way of dealing with a murky environment. Scientists have described two types of electroreception: active and passive. The receptors are also located in the lateral line canals and sometimes on the skin. Animals with passive electroreception, such as sharks and rays, platypuses, and echidna, can detect the presence of the very weak electric fields that are generated around a living body, which they then follow to capture their prey. Animals with active electroreception generate stronger electric fields around themselves using specialized electric organs. By detecting changes in these electric fields, they can derive a picture of their environment. Electrosensory cranial nerves terminate in a region of the hindbrain known as the electrosensory area. A second group of active electrosensory fishes are capable of generating electric fields so powerful they can stun a prey or an enemy. Among these are the electric eel, the electric catfish, and an electric shark (the torpedo). These animals also use their low-level electric fields to detect objects and creatures in the environment. See ELECTRIC ORGAN (BIOLOGY).

Not only did the hindbrain change in response to sensory evolution, but it also underwent major motor transformations; for example, motor-neuron groups involved in swallowing, chewing, and salivating evolved as a consequence of the transition to land and the loss of the water column to carry food from the opening of the mouth into the throat.

The hindbrain also contains two important coordinating or integrating systems: the cerebellum and the reticular formation. The functions of the cerebellum are varied; they include the integration of a sense of balance with aspects of movement and motor learning and motor memory, as well as playing an important role in electrosensory reception.

The reticular formation coordinates the functions of various muscle groups. For example, the actions of the jaws and tongue must be coordinated so that an animal does not eat its own tongue while eating its meal. It also coordinates the motor-

neuron groups that control the air column that enters and leaves the mouth and throat, which produces the various vocalizations of land animals, including speech. The reticular formation also is involved in sleep, wakefulness, and attention.

**Midbrain.** The midbrain contains the motor cranial nerves that move the eyes. It also contains neuron groups that are organized to form maps of visual space, auditory space, and the body. These maps are coordinated with each other such that a sudden, unexpected sound will cause the head and eyes to move to the precise region of space from which the sound originated. In those animals that make extensive use of sound localization, such as owls and bats, the map areas of the midbrain are very highly developed. In addition, certain snakes, such as rattlesnakes and boa constrictors, have infrared detectors on the snout or under the eyes that can sense the minute heat from a small animal's body at a distance of 1 m (3 ft) or more. The midbrains of these animals also have infrared maps that are in register with the auditory, visual, and body maps to permit the animal to correlate all the necessary information to make a successful strike on prey in virtually total darkness.

**Forebrain.** The forebrain is a very complex region that consists of the thalamus, the hypothalamus, the epithalamus, and the cerebrum or telencephalon. In addition, the forebrain contains the limbic system, which has components in all regions of the forebrain as well as continuing into the midbrain. The thalamus processes and regulates a large quantity of the information that enters and emanates from the forebrain. As the cerebrum increases in size and complexity in land animals, the thalamus increases accordingly. The hypothalamus regulates autonomic functions as well as behaviors such as feeding, drinking, courtship and reproduction, parental, territoriality, and emotional, which it controls in conjunction with the limbic system. The hypothalamus also regulates the endocrine system. The size and complexity of the hypothalamus, relative to the rest of the brain, is greatest in fishes and sharks; it declines considerably in proportion to the rest of the brain in land animals. The epithalamus contains the pineal gland, which is involved in various biological rhythms that depend on daylight, including seasonal changes. In some animals, such as certain reptiles, the pineal takes on the form of an eye, located on the top of the head and known as the parietal eye. This eye has a lens and a primitive retina that capture light and transmit information, such as the amount of daylight, to the hypothalamus. The epithalamus, like the hypothalamus, is relatively smaller in the brains of land animals.

The greatest evolutionary expansion of the forebrain is seen in the cerebrum. The cerebrum consists of an outer layer, the pallium, and a series of deep structures, known as the subpallium. The subpallium is composed of the corpus striatum, the amygdala, and the hippocampus. The outer layer of the cerebrum in mammals is known as the cerebral cortex. Considerable debate surrounds the evolutionary relationship between the cerebral cortex of mammals and the pallium and subpallium of nonmammals. Most specialists, however, seem to agree that the mammalian cortex arose from the pallium and certain regions of the subpallium. The cerebrum is relatively small in animals with laminar brains and larger in those with complex brains. Scientists have only begun to catalog the many complicated behavioral functions of the cerebrum. Among them appear to be memory, thinking and reasoning, and planning. With the advent of life on the land, the cerebrum underwent an extreme degree of elaboration in reptiles and birds and especially in mammals. See ENDOCRINE SYSTEM (VERTEBRATE). [W.Ho.]

**Vertical takeoff and landing (VTOL)** A flight technique in which an aircraft rises directly into the air and settles vertically onto the ground. Such aircraft do not need runways but can operate from a small pad or, in some cases, from an unprepared site. The helicopter was the first aircraft that could

hover and take off and land vertically, and is now the most widely used VTOL concept. See HELICOPTER.

The helicopter is ideally suited for hovering flight, but in cruise its rotor must move essentially edgewise through the air, causing vibration, high drag, and large power losses. The aerodynamic efficiency of the helicopter in cruising flight is only about one-quarter of that of a good conventional airplane. The success of the helicopter in spite of these deficiencies started a wide-ranging study of aircraft concepts that could take off like a helicopter and cruise like an airplane. The term VTOL is usually used to designate the aircraft other than the helicopter that can take off and land vertically. The term V/STOL indicates an aircraft that can take off vertically when necessary, but can also use a short running takeoff, when space is available, to lift a greater load. See SHORT TAKEOFF AND LANDING (STOL).

The tiltrotor is closest to the conventional helicopter and relies heavily on helicopter technology. The rotor disks are horizontal in VTOL operation and are tilted 90° to act as propellers in cruising flight. Such aircraft can have cruise efficiencies at least twice those of the helicopter, making them especially useful for helicopter missions where greater range, speed, and time on station are desired.

Numerous advanced rotorcraft concepts are being investigated in research programs. These include designs that take off and land as a rotor system and fix the blades to act as wings for cruise flight. Other concepts feature tiltrotor technology for vertical flight, but fold the blades and employ other propulsion modes for cruise.

The vectored-thrust concept features an engine with four rotating nozzles that deflect the thrust from horizontal for conventional flight to vertical for VTOL operation. This activity led to the very successful British Harrier aircraft, which is considered to be a V/STOL aircraft because its normal mode of operation is to use a short takeoff run, when space is available, to greatly increase its payload and range capability.

With the success of the Harrier, design studies and technology development programs have been directed at expanding the flight envelope of this class of aircraft to include supersonic capability. The term STOVL (short takeoff vertical landing) is used to define this supersonic fighter-attack aircraft since the large benefits in payload and range of a short takeoff will be factored into the basic design. See CONVERTIPLANE. [W.P.N.]

**Vessel traffic service** An interactive system for improving the safety and efficiency of marine vessel traffic and protecting the environment within designated service areas. A vessel traffic service (VTS) system improves order and predictability throughout its service area by providing an organizational structure, a communications network, and standard procedures for enhanced information sharing and decision making in response to developing traffic situations. Opportunities for human error are reduced through the acquisition, interpretation, and broadcasting of traffic position, and navigation safety information and alerts for use by captains, mates, and marine pilots (local-area experts) in directing and controlling the maneuvering of participating vessels.

Traditional vessel traffic service systems consist of a crewed vessel traffic center (VTC) or centers, operational policies, a voice radio network with dedicated frequencies, radar surveillance, and when needed, regulated navigation areas or routing measures. Visual overlooks and closed-circuit television are sometimes available, and multimedia displays are increasingly common. Remote vessel traffic centers and communications and surveillance equipment are linked by microwave or dedicated land-line networks, such as telephone lines. Although participation is voluntary in some vessel traffic service systems, requirements for mandatory participation are increasing worldwide to help prevent shipping accidents.

Advanced shipboard and aviation radar technology has been developed specifically for vessel traffic service applications. Ship-

board collision avoidance radar with automatic target acquisition and tracking features, known as ARPA (automatic radar plotting aid), has been installed in some traffic centers. Advanced multimedia displays have been developed for vessel traffic service use or adapted from technology transferred from defense or air-traffic control applications. The most advanced systems use high-fidelity, multicolor electronic display systems that correlate and fuse radar data from multiple sensors, closed-circuit television video, vessel-specific data, automated data management, electronic charts, and expert system decision aids. Technology capable of integrating position transponders, digital selective calling, meteorological and hydrological sensors, and other features has appeared. Portable interactive communications and positioning systems with integrated electronic charts and data links provide comprehensive information for on-board interpretation and use by operators of participating vessels and marine pilots. See COMPUTER GRAPHICS; ELECTRONIC NAVIGATION SYSTEMS; EXPERT SYSTEMS; MARINE NAVIGATION; NAVIGATION. [W.Y.]

**Vestibular system** The system that subserves the bodily functions of balance and equilibrium. It accomplishes this by assessing head and body movement and position in space, generating a neural code representing this information, and distributing this code to appropriate sites located throughout the central nervous system. Vestibular function is largely reflex and unconscious in nature.

The centrifugal flow of information begins at sensory hair cells located within the peripheral vestibular labyrinth. These hair cells synapse chemically with primary vestibular afferent nerve fibers, causing them to fire with a frequency code of action potentials that include the parameters of head motion and position. These vestibular afferents, in turn, enter the brain and terminate within the vestibular nuclei and cerebellum. Information carried by the firing patterns of these afferents is combined within these central structures with incoming sensory information from the

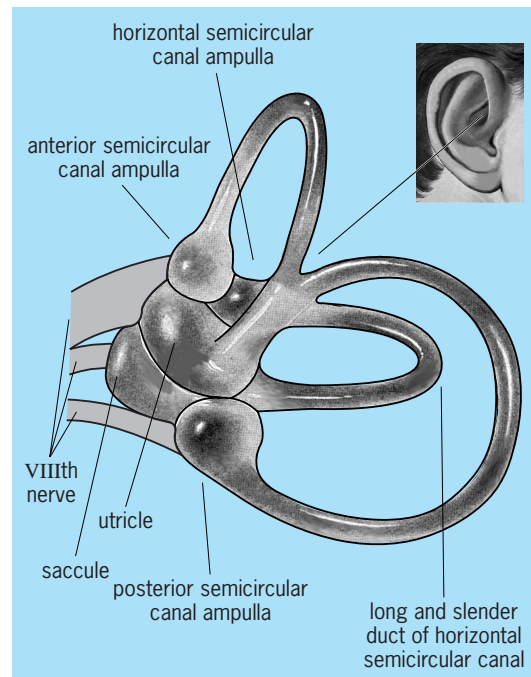
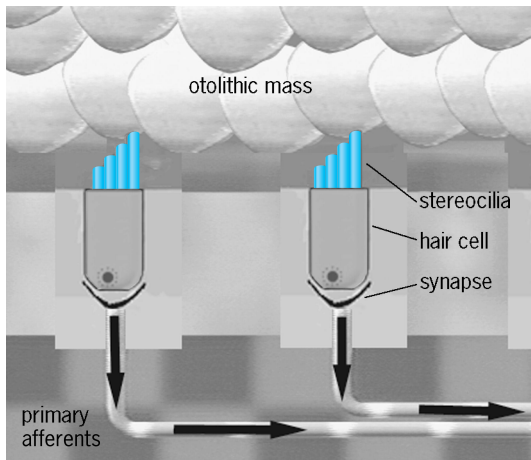

**Fig. 1.** The vestibular labyrinth is located within the inner ear. It communicates with the brain via the VIIIth nerve. Each of the three semicircular canals has an ampulla and a long and slender duct. The utricle primarily senses motion in an earth-parallel plane, while the saccule primarily senses motion and gravity in an earth-perpendicular plane.



visual, somatosensory, cognitive, and visceral systems to compute a central representation of head and body position in space. This representation is called the gravito-inertial vector and is an important quantity that the central nervous system employs to achieve balance and equilibrium. See BRAIN; NERVOUS SYSTEM (VERTEBRATE); POSTURAL EQUILIBRIUM; REFLEX.

The vestibular labyrinth is housed within the petrous portion of the temporal bone of the skull along with the cochlea, the organ of hearing (Fig. 1). The receptor element or primary motion sensor within the labyrinth is the hair cell (Fig. 2). Hair



**Fig. 2.** Otolithic macula at rest. The arrows within the primary afferents or VIIIth nerve fibers indicate spontaneous activity in these fibers in the absence of motion of the otolithic mass relative to the hair cell stereocilia. (The otolithic membrane is not illustrated for clarity.)

cells respond to bending of their apical sensory hairs by changing the electrical potential across their cell membranes. These changes are called receptor potentials, and the apical surface of the hair cell thus functions as a mechanical-to-electrical transducer. The frequency of the resulting action potentials in the VIIIth cranial (vestibulocochlear) nerve encodes the parameters of angular and linear motion. See BIOPOTENTIALS AND IONIC CURRENTS; EAR (VERTEBRATE); SYNAPTIC TRANSMISSION.

Hair cells are the common sensory element in both the angular and linear labyrinthine sensors as well as within the cochlea. The particular frequency of energy that hair cells sense within these diverse end organs arises because of the accessory structures surrounding the hair cells. Thus, angular motion is sensed by the semicircular canals, linear motion by the otolith organs, and sound energy by the cochlea.

The primary afferents innervated by hair cells are the peripheral processes of bipolar neurons having cell bodies located in Scarpa's ganglion within the internal auditory meatus. The central processes of these cells contact neurons in the brainstem of the central nervous system. The vestibular nuclei complex is defined as the brainstem region where primary afferents from the labyrinth terminate. It is composed of four main nuclei: the superior, medial, lateral, and descending nuclei. The axonal projections of vestibular nuclear neurons travel to all parts of the neuraxis, including the brainstem, cerebellum, spinal cord, and cerebrum. See MOTOR SYSTEMS.

In all vertebrates, there is an efferent system that originates from cell bodies within the central nervous system and terminates upon labyrinthine hair cells and primary afferents. The efferent vestibular system is presently a subject of intense study but undoubtedly is in place to enhance vestibular function. It is interesting that evolution felt it necessary to modify incoming vestibular information before it could enter the central nervous system. [S.M.H.]

**Vestimentifera** A phylum of benthonic marine worms that is restricted to habitats rich in sulfide (for example, hydrothermal vents and sulfide seeps) and that as adults lack a mouth, gut, and anus, so they are nourished by internal symbionts. All vestimentiferans live in tubes of varying hardness and rigidity. Tube material is secreted by internal glands and is a mixture of chitin and protein. See HYDROTHERMAL VENT.

The phylum has two classes based on the arrangement and orientation of lamellae formed by fusion of branchial filaments: Axonobranchia with one order, Riftiida, and one monogeneric family with one species; and Basibranchia with two orders, Lamellibranchiida and Tevniida.

Vestimentiferans have four regions along their length. The most anterior, obturacular region is provided with a mass of well-vascularized filaments supported by a paired structure, the obturaculum. Normally these branchial filaments protrude from the opening of the tube and act as a gill, allowing for the exchange of dissolved substances between the worm's body and the seawater. The second region, the vestimentum, is quite muscular and serves to maintain the plume of branchial filaments in the open seawater by pressure on the inner tube surface at its opening. The vestimentum is the site of many glands that contribute material for lengthening the tube and thickening it near the opening. The third region, the trunk, is a single segment and constitutes about 75% of the total length of the worm. It is provided with a pair of large longitudinal blood vessels. The remains of the larval gut containing sulfide-oxidizing bacteria and the gonads are also present. The fourth and most posterior region, the opisthosome, is made up of many segments, each segment in the anterior portion bearing a row of small hooks that can be set into the inner surface of the tube. This provides an anchor against which the body of the worm retracts when the longitudinal muscles of the trunk contract during withdrawal into the tube. [M.L.J.]

**Vesuvianite** A sorosilicate mineral of complex composition crystallizing in the tetragonal system; also known by the name idocrase. Crystals, frequently well formed, are usually prismatic with pyramidal terminations. It commonly occurs in columnar aggregates but may be granular or massive. The luster is vitreous to resinous; the color is usually green or brown but may be yellow, blue, or red. Hardness is 6½ on Mohs scale; specific gravity is 3.35–3.45. See HARDNESS SCALES.

The composition of vesuvianite is expressed by the formula  $\text{Ca}_{10}\text{Al}_4(\text{Mg,Fe})_2\text{Si}_9\text{O}_{34}(\text{OH})_4$ . Magnesium and ferrous iron are present in varying amounts, and boron or fluorine is found in some varieties. Beryllium has been reported in small amounts.

Vesuvianite is found characteristically in crystalline limestones resulting from contact metamorphism. It is there associated with other contact minerals such as garnet, diopside, wollastonite, and tourmaline. Noted localities are Zermatt, Switzerland; Christiansand, Norway; River Vilui, Siberia; and Chiapas, Mexico. In the United States it is found in Sanford, Maine; Franklin, New Jersey; Amity, New York; and at many contact metamorphic deposits in western states. A compact green variety resembling jade is found in California and is called californite. See SILICATE MINERALS. [C.S.Hu.]

**Vetch** Any of a group of plants which are mostly annual and perennial legumes with weak viny stems often terminating in tendrils. There are about 150 species in the temperate zones of four continents. The leaves are compound with many leaflets. Vetches are used mainly for green manure, cover crops, hay, and pasture and silage. The seeds are used as concentrate in animal feeds, and some vetches are used as a vegetable for human consumption. Cool temperatures promote best development. In general, are vetches more tolerant of acidic soil conditions than are most legume crops, but they have a relatively high requirement for phosphorus. Identification of vetches is difficult until pods and seeds develop. See LEAF; LEGUME.



Purple vetch in flower. (USDA)

By the 1960s, some 35 vetch species and subspecies had been found in the United States. Of these 35 species, 16 are native to the United States.

The vetch complex *Vicia villosa* is the most widely grown. The subspecies of this complex (*V. villosa* ssp. *villosa*), commonly known as hairy vetch, is the most winter-hardy and is mostly adapted to the eastern and southern United States, where it is grown as a winter annual or biannual. A second subspecies of this group is woollypod or smooth vetch (*V. villosa* ssp. *varia*). It is less winter-hardy than the hairy vetch type and is adapted to the Pacific Coast states.

The vetch complex *V. sativa* is the second most important species in use in the United States. Common vetch (*V. sativa* ssp. *sativa*) is used throughout the United States. Narrow-leaf or blackpod vetch (*V. sativa* ssp. *nigra*) occurs mostly as a weed in waste places in the United States. Underground vetch (*V. sativa* ssp. *amphicarpa*) produces pods above and below the ground and is being studied for revegetation on marginal lands of the Far East.

Commonly known as the faba bean, horsebean, or broad-bean, *V. faba* produces coarse, upright plants with large leaves and pods. It is one of only several vetches that are important sources of food for human beings.

Purple vetch (*V. bengalensis*) possesses poor winter hardiness; however, it is useful in the California rice-growing area, where it is used as a soil-improving crop in rotation with the rice (see illustration). Hungarian vetch (*V. pannonica*), a more winter-hardy type from Central Europe, is grown in the Pacific Northwest for forage, green manure, and seed.

One-flowered vetch (*V. articulata*) has fine leaves and stems but, lacking winter hardiness, is confined to warm regions. Its flat seeds distinguish it from its nearest look-alike, bard or barn vetch (*V. monantha*), which is very restricted in adaptation. Bitter vetch (*V. ervilia*) is an erect vetch without tendrils. Bigflower or large yellow vetch (*V. grandiflora*), an introduced annual that has naturalized in the southern states, the western seaboard states, and

the Great Lakes states, has promise as winter cover and reseeds freely. Tiny vetch (*V. hirsuta*) is an introduced annual that has naturalized along the southern states bordering the Mississippi River, Texas, the eastern seaboard states, the Great Lakes states, and the Pacific Coast states. Narbonne or French vetch (*V. narbonensis*), a possible wild relative of *V. faba*, has been cultivated as a forage crop in the eastern United States and has locally established as a weed in Maryland and the District of Columbia. Bird or purple-white tufted vetch (*V. cracca*) is a winter-hardy perennial, and its subspecies, cow or bramble vetch (*V. cracca* ssp. *tenuifolia*), is considered to be an invasive weed in the eastern United States and parts of Canada. Four-seeded, sparrow, or lentil vetch (*V. tetrasperma*), also considered an invasive weed, is an introduced annual that has naturalized along and east of the Mississippi River and in the Pacific states.

Crown vetch, *Coronilla varia*, is a long-lived, winter-hardy perennial legume, but it is not a true vetch. Spreads by seeds and rhizomes to form a dense, weed-free, erosion-resisting ground cover. Its greatest use is for erosion and weed control on unmowed slopes of highways, industrial developments, and military installations. Its forage value is being studied. See COVER CROPS; SOIL CONSERVATION. [F.V.G.; W.Gra.]

**Vibration** The term used to describe a continuing periodic change in the magnitude of a displacement with respect to a specified central reference. The periodic motion may range from the simple to-and-fro oscillations of a pendulum, through the more complicated vibrations of a steel plate when struck with a hammer, to the extremely complicated vibrations of large structures such as an automobile on a rough road. Vibrations are also experienced by atoms, molecules, and nuclei. See PENDULUM.

A mechanical system must possess the properties of mass and stiffness or their equivalents in order to be capable of self-supported free vibration. Stiffness implies that an alteration in the normal configuration of the system will result in a restoring force tending to return it to this configuration. Mass or inertia implies that the velocity imparted to the system in being restored to its normal configuration will cause it to overshoot this configuration. It is in consequence of the interplay of mass and stiffness that periodic vibrations in mechanical systems are possible.

Mechanical vibration is the term used to describe the continuing periodic motion of a solid body at any frequency. When the rate of vibration of the solid body ranges between 20 and 20,000 hertz (Hz), it may also be referred to as an acoustic vibration, for if these vibrations are transmitted to a human ear they will produce the sensation of sound. The vibration of such a solid body in contact with a fluid medium such as air or

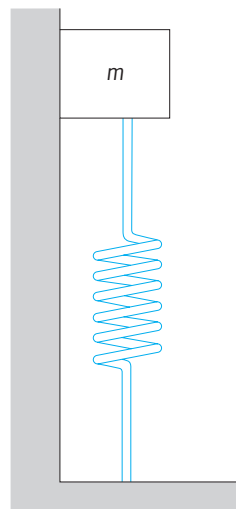
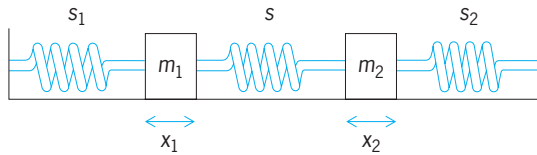

Fig. 1. Simple oscillator.



**Fig. 2. Simple oscillator with two degrees of freedom.** Masses  $m_1$  and  $m_2$ , with displacements  $x_1$  and  $x_2$ , are connected by springs  $s_1$ ,  $s$ , and  $s_2$ .

water induces the molecules of the medium to vibrate in a similar fashion and thereby transmit energy in the form of an acoustic wave. Finally, when such an acoustic wave impinges on a material body, it forces the latter into a similar acoustic vibration. In the case of the human ear it produces the sensation of sound. See MECHANICAL VIBRATION; SOUND.

Systems with one degree of freedom are those for which one space coordinate alone is sufficient to specify the system's displacement from its normal configuration. An idealized example known as a simple oscillator consists of a point mass  $m$  fastened to one end of a massless spring and constrained to move back and forth in a line about its undisturbed position (Fig. 1). Although no actual acoustic vibrator is identical with this idealized example, the actual behavior of many vibrating systems when vibrating at low frequencies is similar and may be specified by giving values of a single space coordinate.

When the restoring force of the spring of a simple oscillator on its mass is directly proportional to the displacement of the latter from its normal position, the system vibrates in a sinusoidal manner called simple harmonic motion. This motion is identical with the projection of uniform circular motion on a diameter of a circle. See HARMONIC MOTION.

When two simple vibrating systems are interconnected by a flexible connection, the combined system has two degrees of freedom (Fig. 2). Such a system has two normal modes of vibration of two frequencies. Both of these frequencies differ from the respective natural frequencies of the individual uncoupled oscillators.

A vibrating system is said to have several degrees of freedom if many space coordinates are required to describe its motion. One example is  $n$  masses  $m_1, m_2, \dots, m_n$  constrained to move in a line and interconnected by  $(n - 1)$  coupling springs with additional terminal springs leading from  $m_1$  and  $m_n$  to rigid supports. This system has  $n$  normal modes of vibration, each of a distinct frequency. See DAMPING; VIBRATION DAMPING; VIBRATION ISOLATION. [L.E.K.]

**Vibration damping** The processes and techniques used for converting the mechanical vibrational energy of solids into heat energy. While vibration damping is helpful under conditions of resonance, it may be detrimental in many instances to a system at frequencies above the resonant point. This is due to the fact that the relative motion between the base of the vibration isolator and the mounted body tends to become smaller as the isolator becomes more efficient at the higher frequencies. With damping

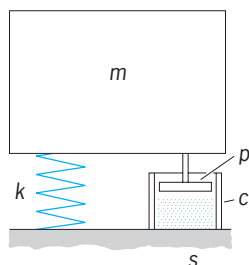

**Fig. 1. Automobile shock absorber.**

present, the force transmitted by the elastic element is unable to overcome the damping force; this leads to a resulting increase in transmissibility. See DAMPING; VIBRATION; VIBRATION ISOLATION.

All metal springs which include structural members such as brackets and shelves have some damping. However, such damping is insufficient for vibration isolators and must be augmented by special damping devices. See SPRING (MACHINES).

Several different types of damping devices have been developed and used successfully. Probably the most familiar is that used on automobiles, which, although known as a shock absorber, is in reality a damper, and functions as a limiter to the spring system of spring constant  $k$ . The system is shown in Fig. 1. A piston  $p$  is attached to the body  $m$  and is arranged to move vertically through the liquid in a cylinder  $c$  which is secured to the support  $s$ . As the piston moves, the force required to cause the liquid to flow from one side of the piston to the other is approximately proportional to the velocity of the piston in the cylinder. This type of damping is known as viscous damping. The damping force is controlled by the viscosity of the liquid and by the size of the orifice in the piston. See SHOCK ABSORBER.

Some of the disadvantages of viscous damping may be overcome by using air instead of liquid as the damping medium. Air, being compressible, will add to the effective spring force with large displacements. If the air is housed within a flexible bellows, damping will be attainable horizontally as well as vertically. Such a system is illustrated in Fig. 2. This type of damping has proved very effective in vibration isolators.

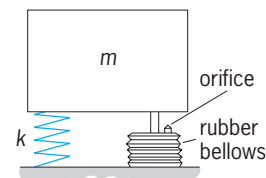

**Fig. 2. System employing viscous damping with air.**

Damping forces may be generated by causing one dry member to slide on another. This is known as dry friction or coulomb damping. Friction damping is used in several commercially available isolators because it provides a simple means to control the damping forces.

Magnetic damping is attainable as a result of the electric current induced in a conductor moving through a magnetic field. The damping force can be made proportional to the velocity of the conductor moving through the field. See ELECTROMAGNETIC INDUCTION. [K.W.J.]

**Vibration isolation** The isolation, in structures, of those vibrations or motions that are classified as mechanical vibration. Vibration isolation involves the control of the supporting structure, the placement and arrangement of isolators, and control of the internal construction of the equipment to be protected.

The simplest kind of mechanical vibration has the waveform of sinusoidal motion. Vibrations in structures, although generally more complex in waveform, exist wherever movement takes place. Such movement may be caused, for example, by the engine in an automobile, by engines or wind buffeting in aircraft, or by a punch press in a building. Delicate electronic equipment and precision instruments must normally be isolated from these motions if accurate measurements are to be obtained. See MECHANICAL VIBRATION; VIBRATION.

Vibration, in most cases, may be effectively isolated by placing a resilient medium, or vibration isolator, between the source of vibration and its surrounding area to reduce the magnitude of the force transmitted from a structure to its support or, alternatively, to reduce the magnitude of motion transmitted from a vibrating support to the structure. Isolating vibration at its source is

commonly termed active or source isolation; isolating an instrument from its surroundings is known as passive isolation.

The vibration isolators may be positioned and arranged in many different ways, all variations of three basic types, each of which requires a definite amount of space: (1) isolators attached underneath equipment, known as an underneath mounting system; (2) isolators located in the plane of the center of gravity of the equipment, known as a center-of-gravity system; (3) mountings arranged four on each side in the plane of the radius of gyration, known as a double side-mounted system or radius-of-gyration system. See CENTER OF GRAVITY; RADIUS OF GYRATION.

[K.W.J.]

**Vibration machine** A device for subjecting a system to controlled and reproducible mechanical vibration. Vibration machines, commonly called shake tables, are widely used in vibration measurement and analysis. There are three types of vibration machines in general use. These are the mechanical direct-drive type, the mechanical reaction type, and the electrodynamic type. Other types, such as hydraulic excitation devices, resonant systems, piezoelectric vibration generators used for instrument calibration, and machines for testing packages, have only limited or specialized applications. See MECHANICAL VIBRATION; VIBRATION.

[K.W.J.]

**Vibration pickup** An electromechanical transducer capable of converting mechanical vibrations into electrical voltages. Depending upon their sensing element and output characteristics, such pickups are referred to as accelerometers, velocity pickups, or displacement pickups.

The accelerometer consists essentially of a mass which is seismically supported with respect to a surrounding case by means of a spring and guided to prevent motions other than those along the seismic direction of support. The mass exerts a force on the spring's support which is directly proportional to the acceleration being measured. This, in turn, is converted into an electrical voltage by means of stresses produced in a piezoelectric crystal. See ACCELEROMETER.

The velocity pickup generates a voltage proportional to the relative velocity between two principal elements of the pickup, the two elements usually being a coil of wire and a source of magnetic field (see illustration).

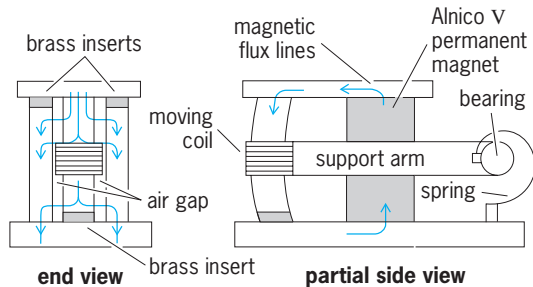

**Velocity pickup.** The coil swings on one end of an arm which is supported by bearings at the opposite end. The case follows the motion of the structure to which it is attached. (MB Manufacturing Co.)

The displacement pickup is a device that generates an output voltage which is directly proportional to the relative displacement between two elements of the instrument. These pickups are similar in construction and behavior to velocity pickups. The only essential difference is the use of a frequency-weighting network, required to make them direct-reading. See VIBRATION.

[L.E.K.]

**Vibrotaction** The response of tactile nerve endings to varying forces on the skin and to oscillatory motion of the skin. Grasping, holding, and tactile exploration of an object are part

of everyday experience. The performance of all these activities is dependent on the dynamic response of specialized nerve endings located in the skin.

Knowledge of the neural and psychophysical processes involved in vibrotaction is necessary to develop effective tactile communication systems, such as vibrotactile pagers, and multipin vibrotactile stimulators used to produce images on an extended skin surface. Potential users range from business people to the visually and hearing impaired: potential applications range from activities involving visual and aural sensory saturation (such as pilots in high stress situations) to those requiring sensory stimulation (for example, virtual reality).

Small electrical impulses, or action potentials, generated by a single nerve ending can be recorded by inserting a microelectrode into the arm of an alert human subject and positioning the electrode tip in a nerve fiber. Studies of the action potentials produced when the skin is locally depressed at a fingertip have identified activity in four networks of distinctive nerve endings lying within 1–2 mm of the skin surface. These nerve endings, which transform skin motion into neural signals, consist of physically and functionally different mechanoreceptors.

Three types of mechanoreceptor in the fingertip have been implicated in vibrotaction. One of these is a population of slowly adapting mechanoreceptors (SA type I, or SAI); their action potentials persist for some time after a transient skin indentation. The two others are populations of rapidly adapting receptors (FAI and FAII types). Type I receptors respond only to skin indentation within a few millimeters of the nerve ending, whereas type II receptors also respond to stimuli at a greater distance from the nerve ending. A fourth mechanoreceptor type appears to respond primarily to skin stretch (denoted SAII). See CUTANEOUS SENSATION; MECHANORECEPTORS.

[A.J.Br.]

**Vicuna** A rare animal whose fiber makes the world's most costly and most exquisite cloth, surpassing all others in fineness and beauty. It is found in an almost inaccessible area of the Andes Mountains.

A single animal yields only approximately  $\frac{1}{4}$  lb (0.11 kg) of hair; thus 40 animals are required to provide enough hair for the average coat. The fiber of the vicuna is the softest and most delicate of the known animal fibers; yet it is strong for its weight, is resilient, and has a marked degree of elasticity and surface cohesion. See ALPACA; CAMEL'S HAIR; CASHMERE; LLAMA; MOHAIR; NATURAL FIBER; WOOL.

[M.D.P.]

**Video amplifier** A low-pass amplifier having a bandwidth in the range from 2 to 100 MHz. Typical applications are in television receivers, cathode-ray-tube computer terminals, and pulse amplifiers. The function of a video amplifier is to amplify a signal containing high-frequency components without introducing distortion.

Modern video amplifiers use specially designed integrated circuits. With one chip and an external resistor to control the voltage gain, it is possible to make a video amplifier with a bandwidth between 50 and 100 MHz having voltage gains ranging from 20 to 500. See AMPLIFIER; INTEGRATED CIRCUITS.

[H.F.K.]

**Video disk** A medium used to record, distribute, and play video information. The video disk exists in three major forms: the Digital Video Disk (DVD; sometimes also called the Digital Versatile Disk); the Laser Video disk (sometimes called the Laser Vision disk); and the Video CD. See COMPACT DISK.

The advantages of DVD and Laser Video disks over videocassette tapes include very high video quality (because the signal-to-noise ratio is very high); use of a full television frame on playback; multiple audio channels, digital and analog; archival quality, since there is no disk deterioration over time; the possibility of interactivity, whereby cues, branches, and so forth can be programmed in; a freeze-frame option with no loss of quality; the ability to interface and interact with computers using digital cues;

the availability of rapid access to any point in the recording; the possibility of auto-stop, whereby a frame is preselected for freezing; frame-by-frame viewing, providing slow motion with no loss of quality; and programmability with certain systems. The Video CD does not possess these advantages, but is a lower-cost option with limited image quality and minimal interactivity.

All three types of video disks have basic elements in common, notably a solid-state laser a fraction of a square millimeter in size that emits a few milliwatts of coherent light focused to a micrometer-sized spot. This laser spot becomes essentially an optical stylus that performs various functions such as tracking, focusing, and reading the total integrated light. See LASER.

The laser spot follows a track on the rotating disk that is either the data itself or a groove. It does this by sensing the symmetry of the laser light reflected back to a split segmented detector; if the spot is not symmetric, the position of the head is jogged until it is back to a perfectly registered spot on the detector. The jogging movement is created by a small motor, often a voice coil motor, that is driven by an electronic servo system that "closes the loop" in an iterative manner. The laser spot and the disk are kept in focus through a similar servo-based controller that uses the image of the laser on the detector.

By adding up the total integrated light on the detector, it is possible to read the total light returned from the disk. While the laser light travels over the disk, differences in the intensity of the light, affected by the disk features that represent the data, are detected. These disk features can be pits in the surface (using the phase contrast of light coming off the disk) or the absorbed light in a dye or other material. This change in intensity is detected and the pulse train decoded by the system to produce a series of data bits that are then reconstructed to form a video image. This principle is used by all the above video disk applications. See OPTICAL RECORDING. [D.H.Da.]

**Video games** Entertainment systems in which a computer is used to drive a video display and interact with players using a variety of input devices. Video games can be divided into arcade systems, home computers, and game consoles. The distinction between a home computer and a game console is that a computer can be used for a variety of other applications such as word processing and Internet access while a game console is specifically designed for entertainment purposes.

Arcade systems are typically built for a particular game or set of related games. Everything from the choice of controls to the design on the sides and face of the unit are geared toward the game itself. The display is typically larger than that on a home computer, providing a greater sense of immersion. In some cases, specialized optics are used to further increase the sense of breadth and depth. In some racing simulations, for example, multiple screens are arranged side by side in an arc around the player in order to give an even greater feeling of being "in" the game. A combination of conventional arcade games and specialized high-end systems involve virtual reality gear, large rear-projection screens, motion platforms, and sophisticated input devices. See SIMULATION; VIRTUAL REALITY.

A game console typically does not include its own display, but is hooked up to a television set. This provides only limited resolution. The input devices on game consoles are limited to simple multipurpose controllers that are included with the console. Most consoles come with two controllers in order to support two-player competitive games. Consoles are much less expensive than the average home computer system and often have specialized hardware for fast graphics and high-quality sound. The games are distributed either as cartridges ("carts") or compact disks (CDs) that contain the game logic programmed into read-only memory (ROM). See COMPACT DISK.

Home computer systems have grown steadily more powerful to the point where they are more than capable of serving as game machines. Since they use an actual computer monitor rather than relying on a television set, the resolution and overall

image quality is much higher than that of game consoles and often rivals or exceeds that of the arcade systems. A variety of controllers are available for the personal computer, ranging from simple analog joysticks to sophisticated input devices with full-force feedback. Production, packaging, and distribution costs for computer games are similar to those for game consoles that use CD-ROM. However, widespread Internet access allows game companies to make their games available for download. See COMPUTER GRAPHICS; COMPUTER STORAGE TECHNOLOGY; INTERNET; MICROPROCESSOR.

Regardless of the platform (home computer, game console, arcade system), there are a number of basic genres of game. Some of these genres are more common on one type of platform than another, mostly due to technical limitations. Action games are popular on all platforms. Adventure games are mostly popular on home computers, though some game consoles do support them. Simulation games usually involve operating some sort of vehicle, such as an aircraft or a high-performance race car. Simulators can also be found on all popular platforms. Strategy games are based on planning and anticipating future events. There are two subcategories: war games and system simulators. War games are often based on reenacting historic battles of land, sea, or air. System simulators work by simulating a system such as a city, an ant colony, or an entire planet. Strategy games are found mostly on home computers and are not seen in arcade systems. [B.Roe.]

**Video microscopy** The use of a high-quality video camera or other fast camera (such as a charge-coupled device) attached to a research-quality light microscope for the purpose of real-time or high-speed imaging of samples on a microscope stage. These images are recorded at regular intervals (often at "video rate" of 30 images per second), and the time-lapse sequence can be played back in the form of a movie. The term "video microscopy" originally referred to microscope imaging using true video (30 frames per second) but now generally refers to rapid time-lapse imaging techniques. Video microscopy is used frequently to image small structures that move rapidly within cells as well as movement of whole cells. This motion can be quantitated, and in the case of fluorescence microscopy, changes in fluorescent intensity (reflecting the local chemical environment of the fluorescent molecule or the number of fluorescent molecules) can be quantitated as well. See CAMERA; CELL MOTILITY; CHARGE-COUPLED DEVICES; FLUORESCENCE; FLUORESCENCE MICROSCOPE; IMAGE PROCESSING; MICROSCOPE. [G.M.La.; J.F.Pr.]

**Videotelephony** A means of simultaneous, two-way communication comprising both audio and video elements. Participants in a video telephone call can both see and hear each other in real time. Videotelephony is a subset of teleconferencing, broadly defined as the various ways and means by which people communicate with one another over some distance. Initially conceived as an extension to the telephone, videotelephony is now possible using computers with network connections. See TELECONFERENCING.

Small residential video telephones, computer-based desktop video telephones, and small videoconferencing setups have been introduced to fulfill diverse needs. One such commercially available residential videophone is about as big as a typical office desk telephone with a small flip-up screen that has an eyeball camera above it. Although it will work with several standards, this phone is primarily designed for use over Integrated Services Digital Network (ISDN) lines in which a residence gets three circuits; one circuit is used for control and the other two for voice and video. See INTEGRATED SERVICES DIGITAL NETWORK (ISDN).

An example of a computer-based desktop videophone consists of a PCI (Peripheral Component Interconnect) video/audio CODEC board to add to a personal computer, a composite color camera, audio peripherals, and visual collaboration software.

Videotelephony software has been developed and made widely available that permits real-time collaboration and conferencing, including multipoint and point-to-point conferencing. Multipoint means, for example, that three people in three different locations could have a video telephone conference call in which each could see and hear the others. In addition to the basic audio and video capabilities, such software provides several other features such as a whiteboard, background file transfer, program sharing, and remote desktop sharing. [J.Bl.]

**Vinegar** A food condiment containing mainly acetic acid that is produced by the bacterial oxidative fermentation of various ethanolic solutions. Vinegar is one of the oldest fermented foods used by humans. Babylonian records indicate that vinegars prepared from wines and beer were widely used as early as 5000 B.C. See ACETIC ACID; WINE.

The names for the different vinegars are based on the substrates from which they are made. These include the juices from different fruits, starchy vegetables, cereals, and distilled ethanol (ethyl alcohol). In the United States, white distilled vinegar makes up over 80% of the annual production. Much of the white distilled vinegar is made from denatured synthetic ethanol. Nitrogen compounds, minerals, and other nutrients must be added to the alcohol medium to support the growth and metabolism of the acetic acid bacteria. Most other vinegars are made from ethanolic solutions generated by a yeast fermentation. Cider vinegar is produced from yeast-fermented apple juice, wine vinegar (such as Balsamic vinegar) from fermented grape juice. Other juices such as pineapple, orange, and pear, as well as sugarcane syrup and molasses, can serve as fermentation substrates. Vinegar is also produced from starchy vegetables such as potatoes and from cereals such as barley, corn, and rice. Malt vinegar is made from an infusion of barley malt and other cereals in which the enzymes in the malt have converted the starch to fermentable sugars. See ENZYME; ETHYL ALCOHOL.

Vinegar sold in the United States must contain at least 4 g of acetic acid per 100 ml of solution (40-grain vinegar). Other federal specifications describe permitted color, odor, presence of trace metals, and alcohol content. Nondistilled vinegars possess distinctive colors and flavors that reflect the properties of the original substrate.

Bacteria belonging to the genus *Acetobacter* are primarily responsible for the vinegar fermentation. Four species are recognized; they are distinguished on the basis of nutrient requirements, production of brown pigments, and tolerance to ethanol. All acetic acid bacteria require oxygen for growth and metabolism. See INDUSTRIAL MICROBIOLOGY.

A variety of methods are used for the production of vinegar. The simplest fermentations are slow and inefficient but are relatively foolproof and utilize inexpensive equipment. Submerged fermenters produce 120–150-grain vinegar in minimal time, but they are expensive and system failures can occur. See FERMENTATION. [D.F.Sp.]

**Violales** An order of flowering plants, division Magnoliophyta (Angiospermae), in the subclass Dilleniidae of the class Magnoliopsida (dicotyledons). The order consists of 24 families and more than 5000 species, including most of the families that have been referred to the Englerian order Parietales. The largest families are the Flacourtiaceae (about 800 species), Violaceae (about 800 species), Cucurbitaceae (about 900 species), Begoniaceae (about 1000 species), and Passifloraceae (about 650 species).

The most characteristic feature of this morphologically heterogeneous order is the unilocular, compound ovary with mostly parietal placentation. When the stamens are numerous they are initiated in centrifugal sequence. The more primitive members of the order, such as some of the Flacourtiaceae, are trees with stipulate, alternate leaves; perfect, polypetalous flowers with numerous centrifugal stamens; a compound pistil with free styles



Downy yellow violet (*Viola pubescens*). (Photograph by Elsie M. Rodgers, National Audubon Society)

and parietal placentation; and seeds with a well-developed endosperm. Tendencies toward unisexuality, reduction in the number of stamens, fusion of filaments, development of a corona, reduction in the number of carpels, fusion of styles, and loss of endosperm from the seed can all be seen in the Flacourtiaceae. These are also some of the prominent characteristics used in combination to define many of the other families of the order. See FLOWER; LEAF; SEED.

Cucumbers and melons (species of *Cucumis*, in the Cucurbitaceae), pumpkins and squashes (species of *Cucurbita*), begonias, and violets (*Viola*; see illustration) are familiar members of the Violales. See CANTALOUPE; CUCUMBER; DILLENIIDAE; HONEY DEW MELON; MAGNOLIOPHYTA; MAGNOLIOPSIDA; MUSKMELON; PERSIAN MELON; PLANT TAXONOMY; PUMPKIN; SQUASH; WATERMELON. [A.Cr.; T.M.Ba.]

**Viral inclusion bodies** Abnormal structures which appear within the cell nucleus, the cytoplasm, or both, during the course of virus multiplication. In general, the inclusion bodies are concerned with the developmental processes of the virus. In some virus infections, such as molluscum contagiosum, inclusion bodies may be simply masses of maturing virus particles. In other infections (herpes simplex), typical inclusion bodies do not appear until after the virus has multiplied. Such inclusions may be remnants of the process of virus multiplication.

The presence of inclusion bodies is often important in diagnosis. A cytoplasmic inclusion in nerve cells, the Negri body, is pathogenic for rabies. See RABIES; VIRUS. [J.L.Me.]

**Virgo** In astronomy, a constellation handed down from antiquity, visible throughout the summer months. This sixth sign of

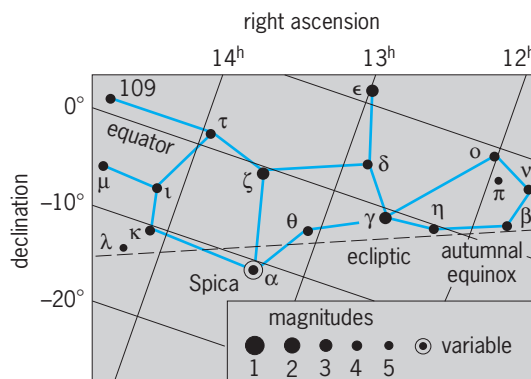

Line pattern of the constellation Virgo. The grid lines represent the coordinates of the sky. The apparent brightness, or magnitude, of the stars is shown by the sizes of the dots, which are graded by appropriate numbers as indicated.

the zodiac represents a maiden (see illustration). The brightest star in the constellation, Spica, is a spectroscopic binary with a massive dark companion. It is a fine first-magnitude star of the purest white tint, and also a navigational star. See CONSTELLATION; LIBRA. [C.S.Y.]

**Virgo Cluster** The nearest large cluster of galaxies, forming a conspicuous clump in the distribution of easily visible elliptical and spiral galaxies. The clump lies mostly in the constellation of Virgo but also extends into neighboring constellations, especially Coma Berenices. See CONSTELLATION; VIRGO.

Besides the 100 or so bright galaxies in Virgo, more than 2000 fainter galaxies show up in deeper searches of the cluster. Furthermore, the cluster includes the Southern Extension, where several dozen additional galaxies lie. G. de Vaucouleurs promoted the idea, now universally recognized, that the Virgo Cluster is so extensive in size that it includes a giant halo of many outlying groups, including the Local Group, to which the Milky Way Galaxy belongs. He called this structure the Local Supercluster. See LOCAL GROUP; UNIVERSE.

The Virgo Cluster is an example of a mixed-population cluster, with both early-type (elliptical and S0) and late-type (spiral and irregular) galaxies present. As the nearest large cluster, it provides a good testing ground for theories of how the dense cluster environment affects the properties of galaxies. The most obvious peculiarity of the Virgo galaxies is the limited extent of the disks of the spirals. The spiral galaxies have possibly been stripped of their outer gas by encounters with other galaxies in the cluster. A related phenomenon is the presence of anemic galaxies, spirals that have unusually low surface brightness and inconspicuous spiral arms.

Determining the distance to the Virgo Cluster has been an important task of twentieth-century astronomy. The Virgo Cluster forms an essential stepping stone for the cosmic distance scale, as it provides a connection between local distance criteria and the use of the Hubble law of gauging distances. The best measurements give a mean distance of 16 megaparsecs ( $5 \times 10^7$  light-years). When the infall velocity of the Milky Way Galaxy toward the center of the Virgo Cluster is taken into account, this distance indicates that the local cosmic value of the Hubble constant, which relates expansion velocity to distance, is about 70 kilometers per second per megaparsec. See COSMOLOGY; HUBBLE CONSTANT. [P.H.]

**Virial equation** An equation of state of gases that has additional terms beyond that for an ideal gas, which account for the interactions between the molecules. The pressure  $p$  can be expressed in terms of the molar volume  $V_m = V/n$  (where  $n$  is the number of moles of gas molecules in a volume  $V$ ), the absolute temperature  $T$ , and the universal gas constant  $R = 8.3145 \text{ J K}^{-1} \text{ mol}^{-1}$  or, in more commonly used practical units,  $0.082058 \text{ L atm K}^{-1} \text{ mol}^{-1}$  [Eq. (1)]. In the equation the virial coefficients

$$\frac{V_m}{RT} = 1 + \frac{B_2(T)}{V_m} + \frac{B_3(T)}{V_m^2} + \frac{B_4(T)}{V_m^3} + \dots \quad (1)$$

$B_n(T)$  are functions only of the temperature and depend on the nature of the gas. In an ideal gas, in which all interactions between the molecules can be neglected because  $V_m$  is sufficiently large, only the first term, unity, survives on the right-hand side. See GAS.

The equation is important because there are rigorous relations between the coefficients  $B_2$ ,  $B_3$ , and so on, as well as the interactions of the molecules in pairs, triplets, and so forth. It provides a valuable route to a knowledge of the intermolecular forces. Thus if the intermolecular energy of a pair of molecules at a separation  $r$  is  $u(r)$ , then the second virial coefficient can be expressed as

Eq. (2). Here  $N_A = 6.0221 \times 10^{23} \text{ mol}^{-1}$  is the Avogadro con-

$$B_2(T) = 2\pi N_A \int_0^\infty (1 - e^{-u(r)/kT}) r^2 dr \quad (2)$$

stant, and  $k = R/N_A$ . In a gas mixture,  $B_n$  is a polynomial of order  $n$  in the mole fractions of the components. See INTERMOLECULAR FORCES.

The virial equation is useful in practice because it represents the pressure accurately at low and moderate gas densities, for example, up to about  $4 \text{ mol L}^{-1}$  for nitrogen at room temperature, which corresponds to a pressure of about 100 atm (10 MPa). It is not useful at very high densities, where the series may diverge, and is inapplicable to liquids. It can be rearranged to give the ratio  $pV_m/RT$  as an expansion in powers of the pressure instead of the density, which is equally useful empirically, but the coefficients of the pressure expansion are not usually called virial coefficients, and lack any simple relation to the intermolecular forces or, in a mixture, to the composition of the gas. See VAN DER WAALS EQUATION. [J.S.Row.]

**Virial theorem** A theorem in classical mechanics which relates the kinetic energy of a system to the virial of Clausius, as defined below. The theorem can be generalized to quantum mechanics and has widespread application. It connects the average kinetic and potential energies for systems in which the potential is a power of the radius. Since the theorem involves integral quantities such as the total kinetic energy, rather than the kinetic energies of the individual particles that may be involved, it gives valuable information on the behavior of complex systems. For example, in statistical mechanics the virial theorem is intimately connected to the equipartition theorem; in astrophysics it may be used to connect the internal temperature, mass, and radius of a star and to discuss stellar stability. The virial theorem makes possible a very easy derivation of the counterintuitive result that as a star radiates energy and contracts it heats up rather than cooling down. See STAR; STATISTICAL MECHANICS; STELLAR EVOLUTION.

The virial theorem states that the time-averaged value of the kinetic energy in a confined system (that is, a system in which the velocities and position vectors of all the particles remain finite) is equal to the virial of Clausius. The virial of Clausius is defined to equal  $-1/2$  times the time-averaged value of a sum over all the particles in the system. The term in this sum associated with a particular particle is the dot product of the particle's position vector and the force acting on the particle. Alternatively, this term is the product of the distance,  $r$ , of the particle from the origin of coordinates and the radial component of the force acting on the particle.

In the common case that the forces are derivable from a power-law potential,  $V$ , proportional to  $r^k$ , where  $k$  is a constant, the virial is just  $-k/2$  times the potential energy. Thus, in this case the virial theorem simply states that the kinetic energy is  $k/2$  times the potential energy. For a system connected by Hooke's-law springs,  $k = 2$ , and the average kinetic and potential energies are equal. For  $k = 1$ , that is, for gravitational or Coulomb forces, the potential energy is minus twice the kinetic energy. See COULOMB'S LAW; GRAVITATION; HARMONIC MOTION. [A.G.P.]

**Viroids** The smallest known agents of infectious disease. Conventional viruses are made up of nucleic acid encapsulated in protein (capsid), whereas viroids are uniquely characterized by the absence of a capsid. In spite of their small size, viroid ribonucleic acids (RNAs) can replicate and produce characteristic disease syndromes when introduced into cells. Viroids thus far identified are associated with plants.

Nine different viroids have been described from widely separated geographical locations and from an assortment of herbaceous and woody plants. Viroid infections in some plant species produce profound disease symptoms ranging from stunting and

leaf epinasty to plant death, whereas infections in other species produce few detectable symptoms compared to uninoculated control plants. Viroids generally have a restricted host range, although several viroids can infect the same hosts and cause similar symptoms in these hosts. Good controls are not available for diseases caused by these small infectious agents other than indexing procedures to provide viroid-free propagules. See PLANT VIRUSES AND VIROIDS; VIRUS. [R.K.Ho.]

**Virtual acoustics** The stimulation of the complex acoustic field experienced by a listener within an environment. The technology is also known as three-dimensional sound and auralization. Going beyond the simple left-right volume adjustment of normal stereo techniques, the goal is to process sounds so that they appear to come from particular locations in three-dimensional space. Although loudspeaker systems have been developed, much of the work in the field focuses on using headphones for playback and is the outgrowth of earlier analog techniques. For example, in binaural recording, the sound of an orchestra playing classical music is recorded through small microphones in the two imitation ear canals of an artificial or dummy head placed in the audience of a concert hall. When the recorded piece is played back over headphones, the listener passively experiences the illusion of hearing the violins on the left and the cellos on the right, along with all the associated echoes, resonances, and ambience of the original environment. Techniques use digital signal processing to synthesize the acoustical properties that people use to localize a sound source in space. Thus, they provide the flexibility of a kind of digital dummy head, allowing a more active experience in which a listener can both design and move around or interact with a simulated acoustic environment in real time. See BINAURAL SOUND.

The success of virtual acoustics is critically dependent on whether the acoustical cues used by humans to locate sounds have been adequately synthesized. There may be many cumulative effects on the sound as it makes its way to the eardrum, but all of these effects can be expressed as a single filtering operation much like the effects of a graphic equalizer in a stereo system. The exact nature of this filter can be measured by an experiment in which an impulse (a single, very short sound pulse or click) is produced by a loudspeaker at a particular location. The acoustic shaping by the two ears is then measured by recording the outputs of small probe microphones placed inside the ear canals of the individual or an artificial head. If the measurement of the two ears occurs simultaneously, the responses, when taken together as a pair of filters, include an estimate of the interaural differences as well. Thus, this technique makes it possible to measure all of the relevant spatial cues together for a given source location, for a given listener, and in a given room or environment. See EAR; EQUALIZER; HEARING; PSYCHOACOUSTICS; SOUND. [E.M.We.]

**Virtual manufacturing** The modeling of manufacturing systems using audiovisual or other sensory features to simulate or design alternatives for an actual manufacturing environment, or the prototyping and manufacture of a proposed product using computers. The motivation for virtual manufacturing is to enhance people's ability to predict potential problems and inefficiencies in product functionality and manufacturability before real manufacturing occurs. See MANUFACTURING ENGINEERING; MODEL THEORY.

The concepts underlying virtual manufacturing include virtual reality, high-speed networking and software interfaces, agile manufacturing, and rapid prototyping.

Virtual reality is broadly defined as the ability to create and interact in cyberspace, that is, a simulated space that represents an environment very similar to the actual environment. The subset of virtual reality that is used in virtual manufacturing is commonly known as virtual environment. The perceived visual space is three-dimensional rather than two-dimensional, the human-machine interface is multimodal, and the user is immersed in

the computer-generated environment; the screen separating the user and the computer becomes invisible to the user. The virtual environment for virtual manufacturing is simulated through immersion in computer graphics coupled with an acoustic interface, domain-independent interacting devices such as wands, and domain-specific devices such as steering and brakes for cars or earthmovers or instrument clusters for airplanes. See VIRTUAL REALITY.

High-speed networking and software interfaces are concerned with computer-aided-design (CAD) model portability among systems, trade-offs of high-detail models versus real-time interaction and display, rapid prototyping, collaborative design using virtual reality over distance, use of the Web for small- or medium-business virtual manufacturing, use of qualitative information (illumination, sound levels, ease of supervision, handicap accessibility) to design manufacturing systems, use of intelligent and autonomous agents in virtual environments, and the validity of virtual reality versus reality.

Agile manufacturing integrates an organization's people and technologies through innovative management and organization, knowledgeable and empowered people, and flexible and intelligent technologies. Virtual manufacturing provides a model for making rapid changes in products and processes based on customer requirements, and an agile manufacturing system attempts to implement it.

Rapid prototyping is an area in which virtual manufacturing has made an impact in processes such as stereolithography, selective laser sintering, and fused deposition modeling. A CAD drawing of a part is processed to create a layered file of the part. The part is built one layer at a time, precisely depositing layer upon layer of material.

Global virtual manufacturing extends the definition of virtual manufacturing to include the use of the Internet and intranets (global communications networks) for virtual component sourcing, and the use of virtual collaborative design and testing environments by multiple organizations or sites. [PBa.]

**Virtual reality** A form of human-computer interaction in which a real or imaginary environment is simulated and users interact with and manipulate that world. Users travel within the simulated world by moving toward where they want to be, and interact with things in that world by grasping and manipulating simulated objects. In the most successful virtual environments, users feel that they are truly present in the simulated world and that their experience in the virtual world matches what they would experience in the environment being simulated. This sensation is referred to as engagement, immersion, or presence, and it is this quality that distinguishes virtual reality from other forms of human-computer interaction. See HUMAN-COMPUTER INTERACTION.

When a user interacts with a virtual environment, the computer-generated graphics display must be updated with each turn of the head or movement of the hand. The virtual environment must be able to generate and display realistic-looking views of the simulated world quickly enough that the interaction feels responsive and natural. See COMPUTER GRAPHICS.

**Hardware.** Virtual reality relies on a variety of specialized input and output devices to achieve this sense of natural interaction.

The most important of the input devices used in a virtual environment, a tracker is capable of reporting its location in space and its orientation. Tracking devices can be optical, magnetic, or acoustic. A tracker is sometimes combined with a traditional computer input device, such as a mouse or a joystick. See COMPUTER PERIPHERAL DEVICES.

An attempt to provide a truly natural input device, the data glove is outfitted with sensors that can read the angle of each of the finger joints in the hand. Wearing such a glove, users can interact with the virtual world through hand gestures, such as pointing or making a fist. See FIBER-OPTIC SENSOR; STRAIN GAGE.



The real-world visual experience is approximated in virtual environments by using stereoscopic displays. Two views of the simulated world are generated, one for each eye, and a stereoscopic display device is used to show the correct view to each eye.

**Applications.** Virtual reality can be applied in a variety of ways. In scientific and engineering research, virtual environments are used to visually explore whatever physical world phenomenon is under study. Training personnel for work in dangerous environments or with expensive equipment is best done through simulation. Airplane pilots, for example, train in flight simulators. Virtual reality can enable medical personnel to practice new surgical procedures on simulated individuals. As a form of entertainment, virtual reality is a highly engaging way to experience imaginary worlds and to play games. Virtual reality also provides a way to experiment with prototype designs for new products. See AIRCRAFT DESIGN; COMPUTER-AIDED DESIGN AND MANUFACTURING. [M.PBa.]

**Virtual work principle** The principle stating that the total virtual work done by all the forces acting on a system in static equilibrium is zero for a set of infinitesimal virtual displacements from equilibrium. The infinitesimal displacements are called virtual because they need not be obtained by a displacement that actually occurs in the system. The virtual work is the work done by the virtual displacements, which can be arbitrary, provided they are consistent with the constraints of the system. See CONSTRAINT.

The principle of virtual work is equivalent to the conditions for static equilibrium of a rigid body expressed in terms of the total forces and torques. That is, the principle of virtual work can be derived from these conditions, and conversely. See EQUILIBRIUM OF FORCES; STATICS.

One advantage of the principle of virtual work is that it can serve as a basis for all of statics. In the solution of problems the principle of virtual work is often useful for eliminating the need for consideration of the forces of constraint, since these forces often are perpendicular to the virtual displacements and consequently do no work. [P.W.S.]

**Virulence** The ability of a microorganism to cause disease. Virulence and pathogenicity are often used interchangeably, but virulence may also be used to indicate the degree of pathogenicity. Scientific understanding of the underlying mechanisms of virulence has increased rapidly due to the application of the techniques of biochemistry, genetics, molecular biology, and immunology. Bacterial virulence is better understood than that of other infectious agents.

Virulence is often multifactorial, involving a complex interplay between the parasite and the host. Various host factors, including age, sex, nutritional status, genetic constitution, and the status of the immune system, affect the outcome of the parasite-host interaction. Hosts with depressed immune systems, such as transplant and cancer patients, are susceptible to microorganisms not normally pathogenic in healthy hosts. Such microorganisms are referred to as opportunistic pathogens. The attribute of virulence is present in only a small portion of the total population of microorganisms, most of which are harmless or even beneficial to humans and other animals. See OPPORTUNISTIC INFECTIONS.

The spread of an infectious disease usually involves the adherence of the invading pathogen to a body surface. Next, the pathogen multiplies in host tissues, resisting or evading various nonspecific host defense systems. Actual disease symptoms are from damage to host tissues caused either directly or indirectly by the microorganism's components or products.

Most genetic information in bacteria is carried in the chromosome. However, genetic information is also carried on plasmids, which are independently replicating structures much smaller than the chromosome. Plasmids may provide bacteria with additional virulence-related capabilities (such as pilus formation, iron

transport systems, toxin production, and antibiotic resistance). In some bacteria, several virulence determinants are regulated by a single genetic locus. See BACTERIA; CELLULAR IMMUNOLOGY; PLASMID; VIRUS. [B.Wi.]

**Virus** Any of a heterogeneous class of agents that share three characteristics: (1) They consist of a nucleic acid genome surrounded by a protective protein shell, which may itself be enclosed within an envelope that includes a membrane; (2) they multiply only inside living cells, and are absolutely dependent on the host cells' synthetic and energy-yielding apparatus; (3) the initial step in multiplication is the physical separation of the viral genome from its protective shell, a process known as uncoating, which differentiates viruses from all other obligatorily intracellular parasites. In essence, viruses are nucleic acid molecules, that is, genomes that can enter cells, replicate in them, and encode proteins capable of forming protective shells around them. Terms such as "organism" and "living" are not applicable to viruses. It is preferable to refer to them as functionally active or inactive rather than living or dead.

The primary significance of viruses lies in two areas. First, viruses destroy or modify the cells in which they multiply; they are potential pathogens capable of causing disease. Many of the most important diseases that afflict humankind, including rabies, smallpox, poliomyelitis, hepatitis, influenza, the

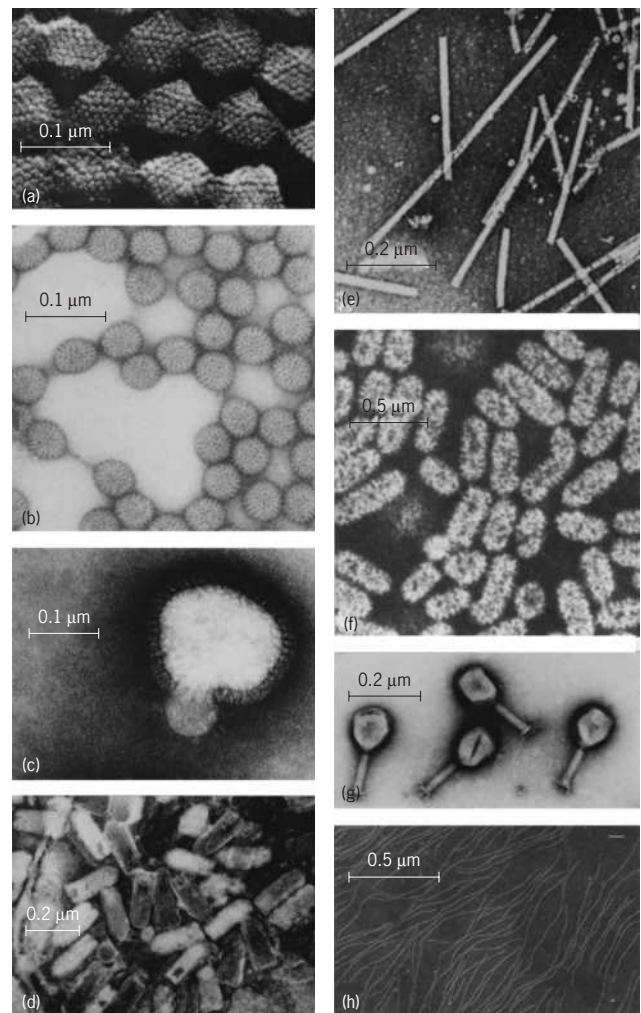

Electron micrographs of highly purified preparations of some viruses. (a) Adenovirus. (b) Rotavirus. (c) Influenza virus (courtesy of George Leser). (d) Vesicular stomatitis virus. (e) Tobacco mosaic virus. (f) Alfalfa mosaic virus. (g) T4 bacteriophage. (h) M13 bacteriophage.

common cold, measles, mumps, chickenpox, herpes, rubella, hemorrhagic fevers, and the acquired immunodeficiency syndrome (AIDS) are caused by viruses. Viruses also cause diseases in livestock and plants that are of great economic importance. See ACQUIRED IMMUNE DEFICIENCY SYNDROME (AIDS); PLANT PATHOLOGY.

Second, viruses provide the simplest model systems for many basic problems in biology. Their genomes are often no more than one-millionth the size of, for example, the human genome; yet the principles that govern the behavior of viral genes are the same as those that control the behavior of human genes. Viruses thus afford unrivaled opportunities for studying mechanisms that control the replication and expression of genetic material. See HUMAN GENOME PROJECT.

Although viruses differ widely in shape and size (see illustration), they are constructed according to certain common principles. Basically, viruses consist of nucleic acid and protein. The nucleic acid is the genome which contains the information necessary for virus multiplication and survival, the protein is arranged around the genome in the form of a layer or shell that is termed the capsid, and the structure consisting of shell plus nucleic acid is the nucleocapsid. Some viruses are naked nucleocapsids. In others, the nucleocapsid is surrounded by a lipid bilayer to the outside of which "spikes" composed of glycoproteins are attached; this is termed the envelope. The complete virus particle is known as the virion, a term that denotes both intactness of structure and the property of infectiousness.

Viral genomes are astonishingly diverse. Some are DNA, others RNA; some are double-stranded, others single-stranded; some are linear, others circular; some have plus polarity, other minus (or negative) polarity; some consist of one molecule, others of several (up to 12). They range from 3000 to 280,000 base pairs if double-stranded, and from 5000 to 27,000 nucleotides if single-stranded. See VIRUS CLASSIFICATION.

Viral genomes encode three types of genetic information. First, they encode the structural proteins of virus particles. Second, most viruses encode enzymes capable of transcribing their genomes into messenger RNA molecules that are then translated by host-cell ribosomes, as well as nucleic acid polymerases capable of replicating their genomes; many viruses also encode non-structural proteins with catalytic and other functions necessary for virus particle maturation and morphogenesis. Third, many viruses encode proteins that interact with components of host-cell defense mechanisms against invading infectious agents. The more successful these proteins are in neutralizing these defenses, the more virulent viruses are.

The two most commonly observed virus-cell interactions are the lytic interaction, which results in virus multiplication and lysis of the host cell; and the transforming interaction, which results in the integration of the viral genome into the host genome and the permanent transformation or alteration of the host cell with respect to morphology, growth habit, and the manner in which it interacts with other cells. Transformed animal and plant cells are also capable of multiplying; they often grow into tumors, and the viruses that cause such transformation are known as tumor viruses. See CANCER (MEDICINE); ONCOLOGY; RETROVIRUS; TUMOR VIRUSES.

There is little that can be done to interfere with the growth of viruses, since they multiply within cells, using the cells' synthetic capabilities. The process, interruption of which has met with the most success in preventing virus multiplication, is the replication of viral genomes, which is almost always carried out by virus-encoded enzymes that do not exist in uninfected cells and are therefore excellent targets for antiviral chemotherapy. Another viral function that has been targeted is the cleavage of polyproteins, precursors of structural proteins, to their functional components by virus-encoded proteases; this strategy is being used with some success in AIDS patients. See CHEMOTHERAPY; CYTOMEGALOVIRUS INFECTION; HERPES; INFLUENZA; RESPIRATORY SYNCYTIAL VIRUS; VIRUS CHEMOPROPHYLAXIS.

Antiviral agents on which much interest is focused are the interferons. Interferons are cytokines or lymphokines that regulate cellular genes concerned with cell division and the functioning of the immune system. Their formation is strongly induced by virus infection; they provide the first line of defense against viral infections until antibodies begin to form. Interferons interfere with the multiplication of viruses by preventing the translation of early viral messenger RNAs. As a result, viral capsid proteins cannot be formed and no viral progeny results.

By far the most effective means of preventing viral diseases is by means of vaccines. There are two types of antiviral vaccines, inactivated virus vaccines and attenuated active virus vaccines. Most of the antiviral vaccines currently in use are of the latter kind. The principle of antiviral vaccines is that inactivated virulent or active attenuated virus particles cause the formation of antibodies that neutralize a virulent virus when it invades the body. See ANIMAL VIRUS; PLANT VIRUSES AND VIROIDS; VACCINATION; VIRUS, DEFECTIVE. [W.K.J.]

**Virus, defective** A virus that by mutation has lost the ability to be replicated in the host cell without the aid of a helper virus. The virus particles (virions) contain all the viral structural components; they can attach, penetrate, and release their nucleic acid (RNA; DNA) within the host cell. However, since the mutation has destroyed an essential function, new virions will not be made unless the cell was simultaneously infected with the helper virus, which can provide the missing function. Only then will the cell produce a mixed population of new helper and defective viruses. Occasionally, when their nucleic acids become integrated in the DNA of the host cell, defective viruses persist in nature by propagation from mother cell to daughter cell. See ANIMAL VIRUS; MUTATION; VIRULENCE.

The most important group of defective viruses are deletion mutants. They are derived from their homologous nondefective (wild-type) virus through errors in the nucleic acid replication that result in the deletion of a fragment in the newly synthesized molecules. The defective nucleic acid must be capable of self-replication, at least in the presence of the wild-type virus, and must combine with other viral components to form a particle in order to exit the cell.

The defective RNA tumor viruses are deletion mutants. Mammalian and most avian sarcoma viruses require a nondefective leukemia virus as a helper virus. Usually the specificity for a certain type of host cell exhibited by the defective virion depends on the helper virus, indicating that one of the virion surface proteins has been furnished by the helper virus gene. These proteins are involved in interactions with cellular surface receptors, and thus determine whether a cell can serve as a host for viral infection. See ONCOLOGY; TUMOR VIRUSES. [M.E.Re.]

**Virus classification** There is no evidence that viruses possess a common ancestor or are in any way phylogenetically related. Nevertheless, classification along the lines of the Linnean system into families, genera, and species has been utilized. Based on the organisms they infect, the first broad division of viruses is into bacterial, plant, and animal viruses. Within these classes, other criteria for subdivision are used. Among these are general morphology; envelope or the lack of it; nature of the genome (DNA or RNA); structure of the genome (single- or double-stranded, linear or circular, fragmented or nonfragmented); mechanisms of gene expression and virus replication (positive- or negative-strand RNA); serological relationship; host and tissue susceptibility; pathology (symptoms, type of disease).

**Animal viruses.** The families of animal viruses are sometimes subdivided into subfamilies; the suffix *-virinae* may then be used. The subgroups of a family or subfamily are equivalent to the genera of the Linnean classification. See ANIMAL VIRUS.

The animal DNA viruses are divided into five families: Poxviridae, Herpesviridae, Adenoviridae, Papovaviridae, and Parvoviridae. RNA animal viruses may be either single-stranded

or double-stranded. The single-stranded are further subdivided into positive-strand and negative-strand RNA viruses, depending on whether the RNA contains the messenger RNA (mRNA) nucleotide sequence or its complement, respectively. Further, the RNA genes may be located on one or several RNA molecules (nonfragmented or fragmented genomes, respectively). The positive-strand RNA animal viruses contain six families: Picornaviridae, Calciviridae, Coronaviridae, Togaviridae, Retroviridae, and Nodamuraviridae. The nucleocapsid of negative-strand RNA animal viruses contains an RNA-dependent RNA polymerase required for the transcription of the negative strand into the positive mRNAs. Virion RNA is neither capped nor polyadenylated. The group is divided into five families: Arenaviridae, Orthomyxoviridae, Paramyxoviridae, Rhabdoviridae, and Bunyaviridae. The double-stranded RNA animal viruses contain only one group, the Reoviridae.

**Bacterial viruses.** Bacterial viruses are also known as bacteriophages or phages. They may be tailed or nontailed. Nontailed phages are further subdivided into those with envelopes and those without. Tailed phages, which do not have envelopes, are divided into three families: Myoviridae, Styloviridae, and Pedoviridae. The group of nontailed DNA bacteriophages contains seven families, each with a distinctive morphology: Tectiviridae, Corticoviridae, Inoviridae, Microviridae, Leviviridae, Plasmaviridae, and Cystoviridae. Only the latter two families have envelopes. See BACTERIOPHAGE.

**Plant viruses.** Plant viruses are divided into groups, rather than families, except those which belong to families of rhabdoviridae and reoviridae. The group, and correspondingly subgroup and type, can be viewed as analogous to family, genus, and species, respectively. Most common among plant viruses are those with a single-stranded, capped but not polyadenylated, positive-strand RNA. See PLANT VIRUSES AND VIROIDS. [M.E.Re.]

**Virus interference** Inhibition of the replication of a virus by a previous infection with another virus. The two viruses may be unrelated, related, or identical. In some cases, virus interference may take place even if the first virus was inactivated. The term mutual exclusion has been applied to this phenomenon in bacterial viruses.

Several mechanisms of interference can be distinguished: (1) Inactivation of cell receptors by one virus may prevent subsequent adsorption and penetration by another virus. (2) The first virus may inhibit or modify cellular enzymes or proteins required for replication of the superinfecting virus. (3) The first virus may generate destructive enzymes or induce the cell to synthesize protective substances which prevent superinfection. (4) The first virus may generate defective interfering particles or mutants which may inhibit the replication of the infecting virus by competing with it for a protein (or enzyme) available in limited quantities; this type of viral interference has been called autointerference, and depends on a greater replicative efficiency of the defective interfering particles or mutants, compared to the infecting virus. See ANIMAL VIRUS; VIRULENCE; VIRUS; VIRUS, DEFECTIVE. [M.E.Re.]

**Viscosity** The material property that measures a fluid's resistance to flowing. For example, water flows from a tilted jar more quickly and easily than honey does. Honey is more viscous than water, so although gravity creates nearly the same stresses in honey and water, the more viscous fluid flows more slowly.

The viscosity can be measured where the fluid of interest is sheared between two flat plates which are parallel to one another (see illustration). This is known as planar Couette flow. The shear stress is the ratio of the tangential force  $F$  needed to maintain the moving plate at a constant velocity  $V$  to the plate area  $A$ . The shear flow created between the plates has the velocity profile

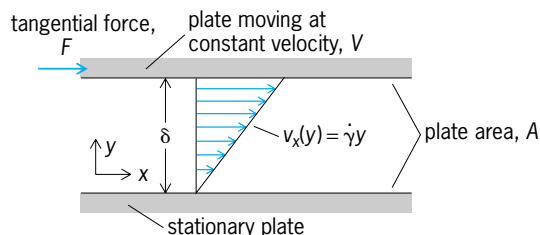

**Planar Couette flow.**  $v_x$  = fluid velocity at distance  $y$  above the stationary plate,  $\dot{\gamma}$  = velocity gradient or shear rate,  $\delta$  = distance between plates.

given by Eq. (1), where  $v_x$  is the velocity parallel to the plates

$$v_x = \dot{\gamma} y \quad (1)$$

at a perpendicular distance  $y$  above the stationary plate. The coefficient  $\dot{\gamma}$ , called the velocity gradient or shear rate, is given by  $V/\delta$ , where  $\delta$  is the distance between the plates. It is expected that the shear stress increases with increasing shear rate but that the ratio of these two quantities depends only on the fluid between the plates. This ratio is used to define the shear viscosity,  $\eta$ , as in Eq. (2). The shear viscosity may depend on temperature, pressure, and shear rate.

$$\eta \equiv \frac{\text{shear stress}}{\text{shear rate}} = \frac{F/A}{V/\delta} \quad (2)$$

Isaac Newton is credited with first suggesting a model for the viscous property of fluids in 1687. Newton proposed that the resistance to flow caused by viscosity is proportional to the velocity at which the parts of the fluid are being separated from one another because of the flow. Although Newton's law of viscosity is an empirical idealization, many fluids, such as low-molecular-weight liquids and dilute gases, are well characterized by it over a large range of conditions. However, many other fluids, such as polymer solution and melts, blood, ink, liquid crystals, and colloidal suspensions, are not described well by Newton's law. Such fluids are referred to as non-newtonian.

For planar Couette flow, Newton's law of viscosity is given mathematically by Eq. (3), where  $\tau_{yx}$  is the shear stress, and  $\mu$ , a

$$\tau_{yx} = \mu \frac{dv_x}{dy} = \mu \dot{\gamma} \quad (3)$$

function of temperature and pressure, is the coefficient of viscosity or simply the viscosity. Therefore, by comparing Eqs. (2) and (3) the shear viscosity is equal to the coefficient of viscosity (that is,  $\eta = \mu$ ) for a newtonian fluid. Because of this relation the shear viscosity is also often referred to as the viscosity. However, it should be clear that the two quantities are not equivalent;  $\mu$  is a newtonian-model parameter, which varies only with temperature and pressure, while  $\eta$  is a more general material property which may vary nonlinearly with shear rate. See FLUID FLOW; NEWTONIAN FLUID.

From Eqs. (2) and (3), the units of viscosity are given by force per area per inverse time. If in planar Couette flow, for example, 1 dyne of tangential force is applied for every 1 cm<sup>2</sup> area of plate to create a velocity gradient of 1 s<sup>-1</sup>, then the fluid between the plates has a viscosity of 1 poise (=1 dyne · s/cm<sup>2</sup>). Several viscosity units are in common use (see table). Comparison of the viscosities of different fluids demonstrates some general trends. For example, the viscosity of gases is generally much less than that of liquids. Whereas gases tend to become more viscous as temperature is increased, the opposite is true of liquids. Other data also show that increasing pressure tends to increase the viscosity of dense gases, but pressure has only a small effect on the viscosity of dilute gases and liquids.

Whereas dilute gas molecules interact primarily in pairs as they collide, molecules in the liquid phase are in continuous interaction with many neighboring molecules. The concepts of average

## Viscosity conversions

Unit	poise	cp	Pa · s	lb <sub>m</sub> /(ft · s)	lb <sub>f</sub> · s/ft <sup>2</sup>
1 poise*	1	100	0.1	$6.72 \times 10^{-2}$	$2.089 \times 10^{-3}$
1 centipoise	0.01	1	0.001	$6.72 \times 10^{-4}$	$2.089 \times 10^{-5}$
1 pascal-second <sup>†</sup>	10	1000	1	0.672	$2.089 \times 10^{-2}$
1 lb <sub>m</sub> /(ft · s)	14.88	1488	1.488	1	$3.108 \times 10^{-2}$
1 lb <sub>f</sub> · s/ft <sup>2</sup>	478.8	$4.788 \times 10^4$	47.88	32.17	1

\*1 poise = 1 dyne · s/cm<sup>2</sup> = 1 g/(cm · s).

<sup>†</sup>1 Pa · s = 1 kg/(m · s).

velocity and mean free path have little meaning for liquids. It is clear, however, that increasing temperature increases the mobility of molecules, thus allowing neighboring molecules to more easily overcome energy barriers and slip past one another. Such arguments lead to an exponential relation for the dependence of viscosity on temperature. See GAS; LIQUID.

Many non-newtonian fluids not only exhibit a viscosity which depends on shear rate (pseudoplastic or dilatant) but also exhibit elastic properties. These viscoelastic fluids require a large number of strain-rate-dependent material properties in addition to the shear viscosity to characterize them. The situation can become more complex when the material properties are time dependent (thixotropic or rheopectic). Fluids that are nonhomogeneous or nonisotropic require even more sophisticated analysis. The field of rheology attempts to deal with these complexities. See RHEOLOGY. [L.E.W.]

**Vision** The sense of sight, which perceives the form, color, size, movement, and distance of objects. Of all the senses, vision provides the most detailed and extensive information about the environment. In the higher animals, especially the birds and primates, the eyes and the visual areas of the central nervous system have developed a size and complexity far beyond the other sensory systems.

Visual stimuli are typically rays of light entering the eyes and forming images on the retina at the back of the eyeball (Fig. 1). Human vision is most sensitive for light comprising the visible spectrum in the range 380–720 nanometers in wavelength. In general, light stimuli can be measured by physical means with respect to their energy, dominant wavelength, and spectral purity. These three physical aspects of the light are closely related to the perceived brightness, hue, and saturation, respectively. See COLOR; LIGHT.

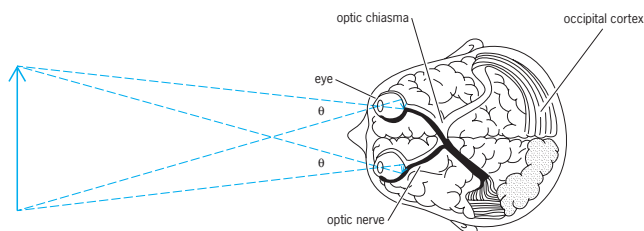

Fig. 1. Diagram showing the eyes and visual projection system. The visual angle  $\theta$  is measured in degrees.

**Anatomical basis for vision.** The anatomical structures involved in vision include the eyes, optic nerves and tracts, optic thalamus, primary visual cortex, and higher visual areas of the brain. The eyes are motor organs as well as sensory; that is, each eye can turn directly toward an object to inspect it. The two eyes are coordinated in their inspection of objects, and they are able to converge for near objects and diverge for far ones. Each eye can also regulate the shape of its crystalline lens to focus the rays from the object and to form a sharp image on the retina. Furthermore, the eyes can regulate the amount of light reaching the sensitive cells on the retina by contracting and expanding

the pupil of the iris. These motor responses of the eyes are examples of involuntary action that is controlled by various reflex pathways within the brain. See EYE (VERTEBRATE).

The process of seeing begins when light passes through the eye and is absorbed by the photoreceptors of the retina. These cells are activated by the light in such a way that electrical potentials are generated. These potentials serve to generate nerve responses in various successive neural cells in the vicinity of excitation. Impulses emerge from the eye in the form of repetitive discharges in the fibers of the optic nerve, which do not mirror exactly the excitation of the photoreceptors by light. Complex interactions within the retina serve to enhance certain responses and to suppress others. Furthermore, each eye contains more than a hundred times as many photoreceptors as optic nerve fibers. Thus it would appear that much of the integrative action of the visual system has already occurred within the retina before the brain has had a chance to act.

The optic nerves from the two eyes traverse the optic chiasma. Figure 1 shows that the fibers from the inner (nasal) half of each retina cross over to the opposite side, while those from the outer (temporal) half do not cross over but remain on the same side. The effect of this arrangement is that the right visual field, which stimulates the left half of each retina, activates the left half of the thalamus and visual cortex. Conversely the left visual field affects the right half of the brain. This situation is therefore similar to that of other sensory and motor projection systems in which the left side of the body is represented by the right side of the brain and vice versa.

The visual cortex includes a projection area in the occipital lobe of each hemisphere. Here there appears to be a point-for-point correspondence between the retina of each eye and the cortex. Thus the cortex contains a “map” or projection area, each point of which represents a point in visual space as seen by each eye. Other important features of an object such as its color, motion, orientation, and shape are simultaneously perceived. The two retinal maps are merged to form the cortical projection area. This allows the separate images from the two eyes to interact with each other in stereoscopic vision, binocular color mixture, and other phenomena. In addition to the projection areas on the right and left halves of the cortex, there are visual association areas and other brain regions that are involved in vision. Complex visual acts, such as form recognition, movement perception, and reading, are believed to depend on widespread cortical activity beyond that of the projection areas. See BRAIN.

**Scotopic and photopic vision.** Night animals have eyes that are specialized for seeing with a minimum of light. This type of vision is called scotopic. Day animals have predominantly photopic vision. They require much more light for seeing, but their daytime vision is specialized for quick and accurate perception of fine details of color, form, and texture, and location of objects. Color vision, when it is present, is also a property of the photopic system. Human vision is duplex; humans are in the fortunate position of having both photopic and scotopic vision. Some of the chief characteristics of human scotopic and photopic vision are enumerated in the table.

Scotopic vision occurs when the rod receptors of the eye are stimulated by light. The outer limbs of the rods contain a photosensitive substance known as visual purple or rhodopsin. This

**Characteristics of human vision**

Characteristic	Scotopic vision	Photopic vision
Photochemical substance	Rhodopsin	Cone pigments
Receptor cells	Rods	Cones
Speed of adaptation	Slow (30 min or more)	Rapid (8 min or less)
Color discrimination	No	Yes
Region of retina	Periphery	Center
Spatial summation	Much	Little
Visual acuity	Low	High
Number of receptors per eye	120,000,000	7,000,000
Cortical representation	Small	Large
Spectral sensitivity peak	505 nm	555 nm

substance is bleached away by the action of strong light so that the scotopic system is virtually blind in the daytime. In darkness, however, the rhodopsin is regenerated by restorative reactions based on the transport of vitamin A to the retina by the blood. One experiences a temporary blindness upon walking indoors on a bright day, especially into a dark room. As the eyes become accustomed to the dim light the scotopic system gradually begins to function. This process is known as dark adaptation. Complete dark adaptation is a slow process during which the rhodopsin is restored in the rods. A 10,000-fold increase in sensitivity is often found to occur during a half-hour period of dark adaptation. By this time some of the rod receptors are so sensitive that only one photon is necessary to trigger each rod into action. Faulty dark adaptation or night blindness is found in persons who lack rod receptors or have a dietary deficiency in vitamin A. This scotopic vision is colorless or achromatic. See VITAMIN A.

Normal photopic vision has the characteristics enumerated in the table. Emphasis is placed on the fovea centralis, a small region at the very center of the retina of each eye.

Foveal vision is achieved by looking directly at objects in the daytime. The image of an object falls within a region almost exclusively populated by cone receptors, closely packed together in the central fovea, each of which is provided with a series of specialized nerve cells that process the incoming pattern of stimulation and convey it to the cortical projection area. In this way the cortex is supplied with superbly detailed information about any pattern of light that falls within the fovea centralis.

Peripheral vision takes place outside the fovea centralis. Vision extends out to more than 90° from center, so that one can detect moving objects approaching from either side. This extreme peripheral vision is comparable to night vision in that it is devoid of sharpness and color.

There is a simple anatomical explanation for the clarity of foveal vision as compared with peripheral vision. The cones become less and less numerous in the retinal zones that are more and more remote from the fovea. In the extreme periphery there are scarcely any, and even the rods are more sparsely distributed. Furthermore, the plentiful neural connections from the foveal cones are replaced in the periphery by network connections in which hundreds of receptors may activate a single optic nerve fiber. This mass action is favorable for the detection of large or dim stimuli in the periphery or at night, but it is unfavorable for

visual acuity (the ability to see fine details of an object) or color vision, both of which require the brain to differentiate between signals arriving from closely adjacent cone receptors.

**Space and time perception.** Vernier and stereoscopic discrimination are elementary forms of space perception. Here, the eye is required to judge the relative position of one object in relation to another (Fig. 2). The left eye, for example, sees the lower line as displaced slightly to the right of the upper. This is known as vernier discrimination. The eye is able to distinguish fantastically small displacements of this kind, a few seconds of arc under favorable conditions. If the right eye is presented with similar lines that are oppositely displaced, then the images for the two eyes appear fused into one and the subject sees the lower line as nearer than the upper. This is the principle of the stereoscope. Again it is true that displacements of a few seconds of arc are clearly seen, this time as changes in distance. The distance judgment is made not at the level of the retina but at the cortex where the spatial patterns from the separate eyes are fused together. The fineness of vernier and stereoscopic discrimination transcends that of the retinal mosaic and suggests that some averaging mechanism must be operating in space or time or both.

The spatial aspects of the visual field are also of interest. Good acuity is restricted to a narrowly defined region at the center of the visual field. Farther out, in the peripheral regions, area and intensity are reciprocally related for all small sizes of stimulus field. A stimulus patch of unit area, for example, looks the same as a patch of twice the same area and half the luminance. This high degree of areal summation is achieved by the convergence of hundreds of rod receptors upon each optic nerve fiber. It is the basis for the ability of the dark-adapted eye to detect large objects even on a dark night.

In daytime vision, spatial inhibition, rather than summation, is most noticeable. The phenomenon of simultaneous contrast is present at a border between fields of different color or luminance. This has the effect of heightening contours and making forms more noticeable against their background.

The temporal characteristics of vision are revealed by studying the responses of the eye to various temporal patterns of stimulation. When a light is first turned on, there is a vigorous burst of nerve impulses that travel from the eye to the brain. Continued illumination results in fewer and fewer impulses as the eye adapts itself to the given level of illumination. Turning the light off elicits another strong neural response. The strength of a visual stimulus depends upon its duration as well as its intensity. Below a certain critical duration, the product of duration and intensity is found to be constant for threshold stimulation. A flash of light lasting only a few milliseconds may stimulate the eye quite strongly, providing its luminance is sufficiently high. A light of twice of the original duration will be as detectable as the first if it is given half the original luminance.

Voluntary eye movements enable the eyes to roam over the surface of an object of inspection. In reading, for example, the eyes typically make four to seven fixational pauses along each line of print, with short jerky motions between pauses. An individual's vision typically takes place during the pauses, so that one's awareness of the whole object is the result of integrating these separate impressions over time.

A flickering light is one that is going on and off (or undergoing lesser changes in intensity) as a function of time. At a sufficiently high flash rate (called the critical frequency of fusion, *cff*) the eye fails to detect the flicker, and the light pulses seem to fuse to form a steady light that cannot be distinguished from a continuous light that has the same total energy per unit of time. As the flash rate is reduced below the *cff*, flicker becomes noticeable, and at very low rates the light may appear more conspicuous than flashes occurring at higher frequency. The *cff* is often used clinically to indicate a person's visual function as influenced by drugs, fatigue, or disease. See COLOR VISION; PERCEPTION. [L.A.R.; C.E.Ste.]

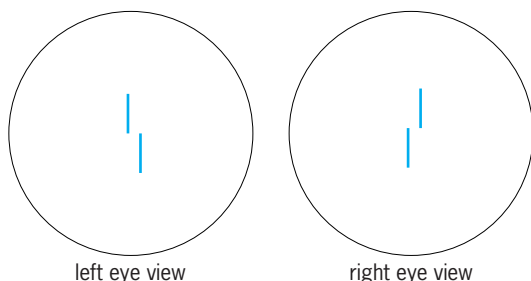

Fig. 2. Vernier and stereoscopic discriminations of space.

**Visual debugging** Visualization of computer program state and program execution to facilitate understanding and, if necessary, alteration of the program. Debuggers are universal tools for understanding what is going on when a program is executed. Using a debugger, one can execute the program in a specific environment, stop the program under specific conditions, and examine or alter the content of the program variables or pointers. Traditional command-line oriented debuggers allowed only a simple textual representation of the program variables (program state).

Textual representation did not change even when modern debuggers came with a graphical user interface. Although variable names became accessible by means of menus, the variable values were still presented as text, including structural information, such as pointers and references. Likewise, the program execution is available only as a series of isolated program stops. (Pointers are variables that contain the “addresses” of other variables.) Compared to traditional debuggers, the techniques of visual debugging allow quicker exploration and understanding of what is going on in a program. See COMPUTER PROGRAMMING; PROGRAMMING LANGUAGES; SOFTWARE; SOFTWARE ENGINEERING.

The GNU Data Display Debugger (DDD), for example, is a graphical front-end to a command-line debugger, providing menus and other graphical interfaces that eventually translate into debugger commands. As a unique feature, DDD allows the visualization of data structures as graphs. The concept is simple: Double-clicking on a variable shows its value as an isolated graph node. By double-clicking on a pointer, the dereferenced value or the variable pointed to is shown as another graph node, with an edge relating pointer and dereferenced value. By subsequent double-clicking on pointers, the programmer can unfold the entire data structure.

If a pointer points to a value that is already displayed (for example, in a circular list), no new node is created; instead, the edge is drawn to the existing value. Using this alias recognition, the programmer can quickly identify data structures that are referenced by multiple pointers.

In principle, DDD can render arbitrary data structures by means of nodes and edges. However, the programmer must choose what to unfold, as the screen size quickly limits the number of variables displayed. Nonetheless, DDD is one of the most popular debugging tools under Unix and Linux. [A.Z.]

**Visual impairment** Abnormal visual acuity. The term is used to describe visual acuity substantially less than normal. The World Health Organization defines visual impairment as acuity less than 20/60 (normal being 20/20). The legal definition of blindness in the United States is visual acuity of 20/200 or worse (or severely restricted peripheral vision). The World Health Organization defines blindness as visual acuity worse than 20/400. Visual impairment and blindness increase substantially with age. The major causes of blindness differ substantially by race. Cataracts, which involve opacification of the normally clear lens, and diabetic retinopathy, which is an accumulation of fluid or the growth of abnormal blood vessels in the retina (most commonly in insulin-dependent diabetics), are important causes of blindness. A large proportion of people having blindness caused by cataracts can be treated by surgery.

A growing proportion of blindness caused by diabetic retinopathy can be prevented by laser surgery.

Other important causes of blindness are glaucoma and macular degeneration. Early detection of glaucoma requires routine, careful screening and examination, since many patients remain asymptomatic until much of the optic nerve is destroyed. Macular degeneration involves atrophy of that portion of the retina responsible for fine (reading) vision. People with macular degeneration rarely suffer the total blindness of advanced glaucoma or diabetic retinopathy. See DIABETES.

Visual problems are far more common in developing countries, where there are limited resources for dealing with prob-

lems that are otherwise readily treated, such as cataract, or prevented, such as trachoma or xerophthalmia (“blinding malnutrition” caused by vitamin A deficiency). See CATARACT; GLAUCOMA; VISION. [A.So.]

**Vitamin** An organic compound required in very small amounts for the normal functioning of the body and obtained mainly from foods. Vitamins are present in food in minute quantities compared to the other utilizable components of the diet, namely, proteins, fats, carbohydrates, and minerals.

Synthetic and natural vitamins usually have the same biological value. Different vitamins, which are often not related to each other chemically or functionally, are conventionally divided into a fat-soluble group (vitamins A, D, E, and K) and a water-soluble group [vitamin C (ascorbic acid) and the various B vitamins: thiamine, vitamin B, riboflavin, vitamin B<sub>2</sub>, vitamin B<sub>6</sub>, niacin, folic acid, vitamin B<sub>12</sub>, biotin, and pantothenic acid]. The vitamins, particularly the water-soluble ones, occur almost universally throughout the animal and plant kingdoms individual articles on each vitamin.

The B vitamins function as coenzymes that catalyze many of the anabolic and catabolic reactions of living organisms necessary for the production of energy; the synthesis of tissue components, hormones, and chemical regulators; and the detoxification and degradation of waste products and toxins. On the other hand, vitamin C and the fat-soluble vitamins do not function as coenzymes. Vitamins C and E and  $\beta$ -carotene (a precursor of vitamin A) act as antioxidants, helping to prevent tissue injury from free-radical reactions. In addition, vitamin C functions as a cofactor in hydroxylation reactions. Vitamin D has hormone-like activity in calcium metabolism; vitamin A plays a critical role in night vision, growth, and maintaining normal differentiation of epithelial tissue; and vitamin K has a unique posttranscriptional role in the formation of active blood-clotting factors. See ANTIOXIDANT; CAROTENOID; COENZYME; NUTRITION. [L.J.M.]

**Vitamin A** A pale-yellow alcohol, soluble in fat but not in water. In pure form, it is readily destroyed by oxidation and light, which may cause losses during storage. Vitamin A is found in all animal tissues, although it is particularly concentrated in the liver. There are two different dietary sources for the vitamin: animal sources which contain vitamin A itself, mostly in the form of retinyl esters, and plant sources which contain carotenoids that are converted to vitamin A in animal tissues such as the absorptive cells in the intestine. The most vitamin A-enriched animal food source is fish liver oil. Plant carotenoids are found in green and yellow fruits and vegetables such as carrots, apricots, asparagus, broccoli, and green leafy vegetables. See CAROTENOID.

In vitamin A deficiency, the epithelial tissues of many organs are affected. Growth failure occurs, and young animals can suffer from neurological symptoms resulting from pressures on the central nervous system. Vitamin A deficiency is also strongly associated with depressed immune function and higher morbidity and mortality due to infectious diseases such as diarrhea, measles, and respiratory infections. A severe manifestation of vitamin A deficiency is night blindness and inflammation of the eyes (xerophthalmia), followed by irreversible blindness.

The symptoms seen in vitamin A deficiency reflect the multiple roles of this compound in animals. These roles are fulfilled by two compounds that are synthesized from vitamin A in the body: vitamin A aldehyde (retinaldehyde), which is critical for vision, and vitamin A acid (retinoic acid), which controls many physiological functions in both the embryo and the adult. See VISION.

Studies of many mammalian species suggested that approximately 20 IU (6  $\mu$ g) of vitamin A per kilogram of body weight will support growth and prevent symptoms of deficiency. The current intake recommendations of vitamin A in the United States is 3 mg/day and about 1 mg/day in the European Union. See VITAMIN. [S.N.G.; N.N.]

**Vitamin B<sub>6</sub>** A vitamin which exists as three chemically related and water-soluble forms found in food; pyridoxine, pyridoxal, and pyridoxamine. All three forms have equal activity for animals and yeast.

Vitamin B<sub>6</sub> deficiency is accompanied by poor growth, dermatitis, microcytic anemia, epileptiform convulsions, and kidney and adrenal lesions. There is evidence that some women in the third trimester of pregnancy may have a special requirement for vitamin B<sub>6</sub> in that its administration often relieves the nausea of pregnancy. Some types of human dermatitis respond to local application of this vitamin.

It is difficult to set requirements for vitamin B<sub>6</sub>, since no single set of assay conditions or criteria has received universal acceptance. Adults probably require about 1.5–2 milligrams per day, and a dietary intake of 0.4 milligrams per day would probably be satisfactory for most infants. See VITAMIN. [S.N.G.]

**Vitamin B<sub>12</sub>** A group of closely related polypyrrrole compounds, with the structure shown, containing trivalent cobalt; it

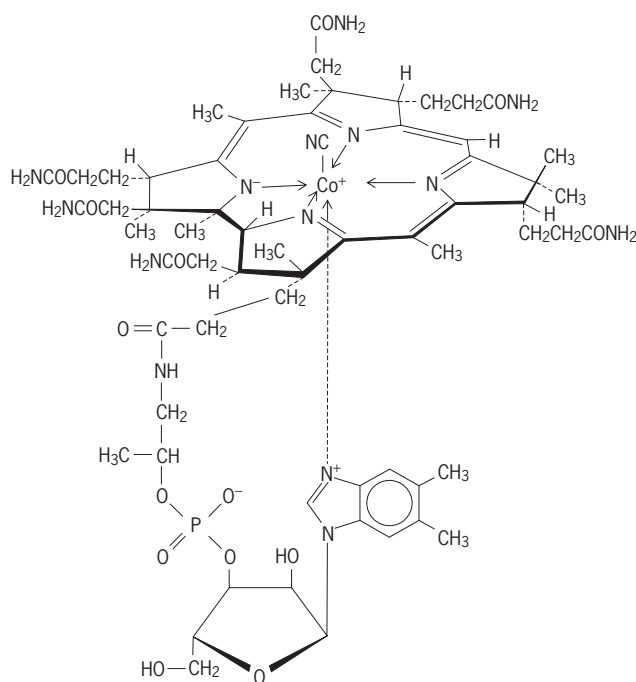

is often called cobalamin. The vitamin is a dark-red crystalline compound; in aqueous solution and at room temperature it is most stable at pH 4–7.

Vitamin B<sub>12</sub> deficiency in animals is characterized primarily by anemia and neuropathy. In humans, this deficiency is called pernicious anemia. People suffering from this disease lack a factor secreted in gastric juice which, by affecting absorption directly and by protecting vitamin B<sub>12</sub> from intestinal destruction, enables the vitamin to be absorbed. See ANEMIA.

Requirements for vitamin B<sub>12</sub> are increased by reproduction or hyperthyroidism. Of the known vitamins B<sub>12</sub> is the most active biologically. A daily injection of 1 microgram of vitamin B<sub>12</sub> will prevent the recurrence of symptoms in people with pernicious anemia. For normal people a diet containing 3–5  $\mu\text{g}$  per day (providing 1–1.5  $\mu\text{g}$  absorbed) will satisfy vitamin B<sub>12</sub> requirements. See VITAMIN. [S.N.G.]

**Vitamin D** Either of two fat-soluble sterol-like compounds, ergocalciferol (vitamin D<sub>2</sub>) and activated cholecalciferol (vitamin D<sub>3</sub>). Vitamin D<sub>2</sub> is formed from the irradiation of ergosterol, a plant sterol. However, vitamin D<sub>3</sub> is normally manufactured

in the skin, where ultraviolet light activates the compound 7-dehydrocholesterol. Vitamins D<sub>3</sub> and D<sub>2</sub> are about equal in activity in all mammals except New World monkeys and birds, in which vitamin D<sub>2</sub> is approximately one-tenth as active as vitamin D<sub>3</sub>. See VITAMIN.

Vitamin D as acquired from the diet or produced in the skin is biologically inactive. It must be metabolized by the liver to produce 25-hydroxyvitamin D<sub>3</sub>. However, this compound is also biologically inactive under physiological circumstances and must be activated by the kidney to produce the final vitamin D hormone, 1,25-dihydroxyvitamin D<sub>3</sub>. This hormonal form of vitamin D plays an essential role in stimulating intestinal absorption of calcium and phosphorus, in the mobilization of calcium from bone, and in renal reabsorption of calcium. The function of vitamin D has been expanded beyond regulating plasma calcium and phosphorus levels, and hence healing the diseases of rickets and osteomalacia. It is now known that the vitamin D hormone controls parathyroid gland growth and production of the parathyroid hormone. It is an immunomodulator. Vitamin D hormone also appears to play a role in the regulation of insulin production or secretion. Finally, it is required for female reproduction. These new sites of action of vitamin D are under intense investigation. See HORMONE.

Vitamin D is largely absent from the food supply. It is found in large amounts in fish liver oils; cod liver oil has long been known to be an important source of vitamin D. Fortified foods are the major dietary source of vitamin D, but the major overall source is the production of vitamin D in skin by exposure to sunlight or ultraviolet irradiation. In winter months at temperate latitudes, insufficient amounts of vitamin D are produced in skin, and unless it is replaced by a dietary source, danger of insufficiency exists.

A deficiency of vitamin D in growing animals results in the disease rickets. A similar disease, osteomalacia, occurs in adult animals. By far the most serious disorder of vitamin D deficiency is the low-blood calcium levels which result in convulsions known as hypocalcemic tetany. Moderate deficiency of vitamin D may contribute to osteoporosis, especially in the elderly. See BONE; OSTEOPOROSIS.

The recommended daily requirement for vitamin D<sub>3</sub> is 10 micrograms or 400 international units (IU). Higher requirements are reported for the elderly and for rapidly growing adolescents: 20  $\mu\text{g}$  or 800 IU per day. It is possible that the average requirement is lower than 10  $\mu\text{g}$  per day. The exact absolute requirement has never been determined. [H.F.D.]

**Vitamin E** A group of compounds,  $\alpha$ ,  $\beta$ ,  $\gamma$ , and  $\delta$  tocopherols, that have a chromanol ring and phytyl side chain and are widely distributed in nature, especially in edible vegetable oils (wheat germ, sunflower, cottonseed, safflower, canola, soybean, and corn oil). Unprocessed grains, nuts, and vegetables are other sources. When used as supplements, there are two vitamin E products available: natural source RRR  $\alpha$ -tocopherol and synthetic all-rac- $\alpha$ -tocopherol. The latter is a mixture of eight different stereoisomers, of which only one is RRR  $\alpha$ -tocopherol. See VITAMIN.

The terms "vitamin E" and " $\alpha$ -tocopherol" are frequently used interchangeably in human nutrition, but it is imperative to distinguish between supplements of RRR  $\alpha$ -tocopherol and of synthetic  $\alpha$ -tocopherol because their biological activity is different. Since the major function of vitamin E is to serve as a chain-breaking antioxidant, protecting cell membranes against free-radical damage, the most potent form of the vitamin should be used as a supplement. Although gastrointestinal absorption of all forms of vitamin E is equivalent, the subsequent physiological steps are sharply in favor of the RRR form. This action is mediated by a cellular liver transfer protein that is specific for the RRR form of  $\alpha$ -tocopherol. It maintains the plasma level by selectively choosing the RRR form and recycling it into plasma

lipoproteins for distribution of the vitamin to every tissue and organ in the body.

When deficiencies of the vitamin occur in humans as a consequence of acquired malabsorption or genetic abnormalities of lipoproteins or of the transfer protein, the major symptoms that develop are in the nervous system. Ataxia (lack of muscular coordination) and other neurologic symptoms result in severe incoordination and subsequent musculoskeletal changes.

The recommended daily allowance for vitamin E is 15 milligrams, which is present in the usual Western diet. [H.J.K.]

**Vitamin K** A group of compounds derived from 2-methyl-1,4-naphthoquinone that prevent bleeding in mammals and birds. Vitamin K<sub>1</sub> (phylloquinone) is produced by green plants; a related form, vitamin K<sub>2</sub> (menaquinone), is produced by intestinal bacteria. Chemically synthesized forms include vitamin K<sub>1</sub>, K<sub>2</sub>, and menadione (vitamin K<sub>3</sub>). All of these compounds are fat-soluble liquids at room temperature that become biologically inactive when exposed to light or alkali. See VITAMIN.

Vitamin K<sub>1</sub> (phylloquinone) is a photosynthesis cofactor in plants, and various forms of vitamin K<sub>2</sub> (menaquinones) participate in energy transfer reactions in bacteria. Mammals and many other animals need vitamin K hydroquinone (the active form) as a cofactor for the specific synthesis of the amino acid  $\gamma$ -carboxyglutamate (Gla) in certain proteins, which enable the proteins to bind calcium and phospholipids with high specificity. Gla is an essential part of coagulation factors and of other proteins that regulate blood clotting (hence the disruption of blood clotting and internal bleeding associated with vitamin K deficiency). See AMINO ACIDS; BLOOD; COENZYME; PROTEIN.

Humans depend on continuous vitamin K supplies, since storage is minimal. Good dietary sources of vitamin K<sub>1</sub> are green vegetables and fruits; certain fermented Asian foods, especially natto, have a high vitamin K<sub>2</sub> content.

Intestinal bacteria produce vitamin K<sub>2</sub>, and under most circumstances enough is absorbed to prevent bleeding. However, spontaneous bleeding occurs if both dietary intake and production by intestinal bacteria are persistently low. Other health risks related to inadequate vitamin K intake may include accelerated loss of bone minerals and hardening of arteries. [M.Koh.]

**Vivianite** A mineral of the vivianite group, other important members of which are annabergite and erythrite.

Vivianite is a hydrated ferrous phosphate, Fe<sub>3</sub>(PO<sub>4</sub>)<sub>2</sub> · 8H<sub>2</sub>O; usually ferric iron is present as the result of oxidation. It crystallizes in the monoclinic system, with crystals generally prismatic. Vivianite also occurs in earthy form and as globular and encrusting masses of fibrous structure. Crystals are colorless and transparent when fresh. Oxidation changes the color progressively to pale blue, greenish blue, dark blue, or bluish black. [W.R.Lo.]

**Vocal cords** The pair of elastic, fibered bands inside the human larynx. The cords are covered with a mucous membrane and pass horizontally backward from the thyroid cartilage (Adam's apple) to insert on the smaller, paired arytenoid cartilages at the back of the larynx. The vocal cords act as sphincters for air regulation and may be vibrated to produce sounds. Separation, approximation, and alteration of tension are produced by action of laryngeal muscles acting on the pivoting arytenoids. Vibration of the cords produces fundamental sounds and overtones. These can be modified by the strength of the air current, the size and shape of the glottis (the opening between the cords), and tension in the cords. See LARYNX; SPEECH. [W.J.B.]

**Voice response** The generation of synthetic speech signals in order to convey information to listeners, usually based upon a verbal or textual request by the users. This speech synthesis typically employs a computer program and requires access to storage of portions of speech previously spoken by humans. The

naturalness of the synthetic voice depends on several factors, including the vocabulary of words to pronounce, the amount of stored speech, and the complexity of the synthesis programs. The most basic voice response simply plays back appropriate short verbal responses, which are only copies of human speech signals stored using digital sampling technology. The most universal systems are capable of transforming any given text into comprehensible speech for a given language. These latter systems so far exist for only 20 or so of the world's major languages, and are flawed in producing speech that, while usually intelligible, sounds unnatural.

Voice response is also known as text-to-speech synthesis (TTS) because the task usually has as input a textual message (to be spoken by the machine). The text could be in tabular form (for example, reading aloud a set of numbers), or, more typically, formatted as normal sentences. Speech synthesizers are much more flexible and universal than their speech-recognition counterparts, for which human talkers must significantly constrain their verbal input to the machines in order to achieve accurate recognition. In TTS, a computer database usually determines the text to be synthetically spoken, following an automatic analysis of each user request. The user may pose the request in response to a menu of inquiries (for example, by an automated telephone dialogue, by pushing a sequence of handset keys, or by a series of brief verbal responses). Thus, the term "voice response" is used to describe the synthetic speech as an output to a user inquiry. The value of such a synthetic voice is the capability of efficiently receiving information from a computer without needing a computer screen or printer. Given the prevalence of telephones, as well as the difficulty of reading small computer screens on many portable computer devices, voice response is a convenient way to get data. See SPEECH RECOGNITION.

The simplest approach to voice response is to digitally sample natural speech and output the samples later as needed. A common Nyquist sampling rate is 10,000 samples per second, which preserves sound frequencies up to almost 5 kHz, allowing quite natural speech. High-frequency energy in fricative sounds is severely attenuated (but less so than on telephone lines), but this usually has little impact on intelligibility. Straightforward sampling requires 12 bits per sample, which requires memory at 120 kbits/s. Such high data rates are prohibitive except for applications with very small vocabularies. Even in cases with more limited bandwidth (for example, 8000 samples per second in telephone applications) and more advanced coding schemes, the straightforward playback approach is unacceptable for general TTS. Despite rapidly decreasing costs for computer memory, it will remain impossible to store all the necessary speech signals except for applications with very restricted vocabulary needs. See COMPACT DISK; DATA COMPRESSION; INFORMATION THEORY; PULSE MODULATION.

A voice response system which minimizes memory needs generates synthetic speech from sequences of brief basic sounds and has great flexibility. Since most languages have only 30–40 phonemes (distinct linguistic sounds), storing units of such size and number is trivial. However, the spectral features of these short concatenated sounds (lasting 50–200 ms) must be adjusted at their frequent boundaries to avoid severely discontinuous speech. Normal pronunciation of each phoneme in an utterance depends heavily on its phonetic context (for example, on neighboring phonemes, intonation, and speaking rate). The adjustment process and the need to calculate an appropriate intonation for each context lead to complicated synthesizers with correspondingly less natural output speech.

Current synthesizers usually compromise between the extremes of minimizing storage and complexity. One approach is to store thousands of speech units of varying size, which can be automatically extracted from natural speech. In contrast to automatic speech recognition, where segmentation of speech into pertinent units is very difficult, TTS training exploits prior knowledge of the text (the training speaker reads a furnished text).



Synthesizers that accept general text as input need a linguistic processor to convert the text into phonetic symbols in order to access the appropriate stored speech units. One task is to convert letters into phonemes. This may be as simple as a table look-up: a computer dictionary with an entry for each word in the chosen language, noting its pronunciation (including syllable stress), syntactic category, and possibly some semantic information. Many systems also have language-dependent rules, which examine the context of each letter in a word to determine how it is pronounced; for example, the letter [p] in English is pronounced /p/, except before the letter [h] (for example, in “telephone”; however, it has normal pronunciation in “cupholder”). English needs hundreds of such rules. TTS often employs these rules as a backup procedure to handle new words, foreign words, and typographical mistakes (that is, cases not in the dictionary). See PHONETICS.

The problem of determining an appropriate intonation for each input text continues to confound TTS. In simple voice response, the stored units are large (for example, phrases), and pitch and intensity are usually stored explicitly with the spectral parameters or implicitly in the signals of waveform synthesizers. However, when smaller units are concatenated, the synthetic speech sounds unnatural unless the intonation is adjusted for context. Intonation varies significantly among languages. Although automatic statistical methods show some promise, intonation analysis has mostly been manual.

Simple voice-response systems work equally well for all languages since they just play back previously stored speech units. For general TTS, however, major synthesizer components are highly language-dependent. The front end of TTS systems, dealing with letter-to-phoneme rules, the relationship between text and intonation, and different sets of phonemes, is language-dependent. The back end, representing simulation of the vocal track via digital filters, is relatively invariant across languages. Even languages with sounds (for example, clicks) other than the usual pulmonic egressives require only simple modifications.

Commercial synthesizers are widely available for about 10 languages. They often combine software, memory, and processing chips, and range from expensive systems providing close-to-natural speech to inexpensive personal computer programs. General digital signal processing chips are widely used for TTS. Current microprocessors can easily handle the speeds for synthesis, and indeed synthesizers exist entirely in software. Memory requirements can still be a concern, especially for some of the newer waveform concatenation systems. See MICROPROCESSOR; SPEECH. [D.O'S.]

**Volatilization** The process of converting a chemical substance from a liquid or solid state to a gaseous or vapor state. Other terms used to describe the same process are vaporization, distillation, and sublimation. A substance can often be separated from another by volatilization and can then be recovered by condensation of the vapor. The substance can be made to volatilize more rapidly either by heating to increase its vapor pressure or by removal of the vapor using a stream of inert gas or a vacuum pump. Chemical reactions are sometimes utilized to produce volatile products. Volatilization methods are generally characterized by great simplicity and ease of operation, except when high temperatures or highly corrosion-resistant materials are needed. See CHEMICAL SEPARATION TECHNIQUES; DISTILLATION; SUBLIMATION; VAPOR PRESSURE. [L.Go./R.W.Mu.]

**Volcanic glass** A natural glass formed by rapid cooling of magma. Magmas typically comprise crystals and bubbles of gas within a silicate liquid. On slow cooling, the liquid portion of the magma usually crystallizes, but if cooling is sufficiently rapid, it may convert to glass—an amorphous, metastable solid that lacks the long-range microscopic order characteristic of crystalline solids. See LAVA; MAGMA.

Silica-rich, rhyolitic magmas frequently quench to glass during explosive eruptions and make up the bulk of the solid material in many pyroclastic deposits (usually as shards, pumice lumps, and other fragments); but they also can erupt quiescently to form massive glassy rocks (known as obsidian, the most common source of volcanic glass on land) even in the slowly cooled interiors of flows tens of meters thick. In contrast, more basic, basaltic glasses (sometimes known as tachylite) are less common and rarely form in more than small quantities unless rapidly cooled in a volcanic eruption. Pele's hair is an example of basaltic glass formed in this way. See BASALT; OBSIDIAN; RHYOLITE. [E.M.St.]

**Volcano** A mountain or hill, generally steep-sided, formed by accumulation of magma (molten rock with associated gas and crystals) erupted through openings or volcanic vents in the Earth's crust; the term volcano also refers to the vent itself. During the evolution of a long-lived volcano, a permanent shift in the locus of principal vent activity can produce a satellitic volcanic accumulation as large as or larger than the parent volcano, in effect forming a new volcano on the flanks of the old.

Planetary exploration has revealed dramatic evidence of volcanoes and their products on the Earth's Moon, Mars, Mercury, Venus, and the moons of Jupiter, Neptune, and Uranus on a scale much more vast than on Earth. However, only the products and landforms of terrestrial volcanic activity are described here. See MARS; MERCURY (PLANET); MOON; NEPTUNE; URANUS; VENUS; VOLCANOLOGY.

**Volcanic vents.** Volcanic vents, channelways for magma to ascend toward the surface, can be grouped into two general types: fissure and central (pipelike). Magma consolidating below the surface in fissures or pipes forms a variety of igneous bodies, but magma breaking the surface produces fissure or pipe eruptions. Fissures, most of them less than 10 ft (3 m) wide, may form in the summit region of a volcano, on its flanks, or near its base; central vents tend to be restricted to the summit area of a volcano. For some volcanoes or volcanic regions, swarms of fissure vents are clustered in swaths called rift zones.

**Volcanic products.** Magma erupted onto the Earth's surface is called lava. If the lava is chilled and solidifies quickly, it forms volcanic glass; slower rates of chilling result in greater crystallization before complete solidification. Lava may accrete near the vent to form various minor structures or may pour out in streams called lava flows, which may travel many tens of miles from the vents. During more violent eruption, lava torn into fragments and hurled into the air is called pyroclastic (fire-broken materials). See CRYSTALLIZATION; LAVA; MAGMA; PYROCLASTIC ROCKS; VOLCANIC GLASS.

**Volcanic gases.** Violent volcanic explosions may throw dust and aerosols high into the stratosphere, where it may drift across the surface of the globe for many thousands of miles. Most of the solid particles in the volcanic cloud settle out within a few days, and nearly all settle out within a few weeks, but the gaseous aerosols (principally sulfuric acid droplets) may remain suspended in the stratosphere for several years. Such stratospheric clouds of volcanic aerosols, if sufficiently voluminous and long-lived, can have an impact on global climate. See ACID RAIN; AEROSOL; AIR POLLUTION.

In general, water vapor is the most abundant constituent in volcanic gases; the water is mostly of meteoric (atmospheric) origin, but in some volcanoes can have a significant magmatic or juvenile component. Excluding water vapor, the most abundant gases are the various species of carbon, sulfur, hydrogen, chlorine, and fluorine.

Mudflows are common on steep-side volcanoes where poorly indurated or nonwelded pyroclastic material is abundant. Probably by far the most common cause, however, is simply heavy rain saturating a thick cover of loose, unstable pyroclastic material on the steep slope of the volcano, transforming the material into a mobile, water-saturated “mud,” which can rush downslope at a speed as great as 50–55 mi (80–90 km) per hour. Such

a dense, fast-moving mass can be highly destructive, sweeping up everything loose in its path.

**Volcanic landforms.** Much of the Earth's solid surface, on land and below the sea, has been shaped by volcanic activity. Landscape features of volcanic origin may be either positive (constructional) forms, the result of accumulation of volcanic materials, or negative forms, the result of the lack of accumulation or collapse.

Not all volcanoes show a graceful, symmetrical cone shape, such as that exemplified by Mount Fuji, Japan. Most volcanoes, especially those near tectonic plate boundaries, are more irregular, though of grossly conical shape. Such volcanoes, called stratovolcanoes or composite volcanoes, typically erupt explosively and are composed dominantly of andesitic, relatively viscous and short lava flows, interlayered with beds of ash and cinder that thin away from the principal vents. Volcanoes constructed primarily of fluid basaltic lava flows, which may spread great distances from the vents, typically are gentle-sloped, broadly upward convex structures. Such shield volcanoes, classic examples of which are Mauna Loa volcano, Hawaii, tend to form in oceanic intraplate regions and are associated with hot-spot volcanism. The shape and size of a volcano can vary widely between the simple forms of composite and shield volcanoes, depending on magma viscosity, eruptive style (explosive versus nonexplosive), migration of vent locations, duration and complexity of eruptive history, and posteruption modifications.

Some of the largest volcanic edifices are not shaped like the composite or shield volcanoes. In certain regions of the world, voluminous extrusions of very fluid basaltic lava from dispersed fissure swarms have built broad, nearly flat-topped accumulations. These voluminous outpourings of lava are known as flood basalts or plateau basalts. See *BASALT*.

**Submarine volcanism.** Deep submarine volcanism occurs along the spreading ridges that zigzag for thousands of miles across the ocean floor, and it is exposed above sea level only in Iceland. Because of the logistical difficulties in making direct observations posed by the great ocean depths, no deep submarine volcanic activity has been actually observed during eruption. However, evidence that deep-sea eruptions are happening is clearly indicated by (1) seismic and acoustic monitoring networks; (2) the presence of deep-ocean floor hydrothermal vents; (3) episodic hydrothermal discharges, measured and mapped as thermal and geochemical anomalies in the ocean water; and (4) the detection of new lava flows in certain segments of the oceanic ridge system. See *HYDROTHERMAL VENT*; *MID-OCEANIC RIDGE*.

Volcanic eruptions in shallow water are very similar in character to those on land but, on average, are probably somewhat more explosive, owing to heating of water and resultant violent generation of supercritical steam. Much of the ocean basin appears to be flooded by basaltic lava. See *OCEANIC ISLANDS*.

**Fumaroles and hot springs.** Vents at which volcanic gases issue without lava or after the eruption are known as fumaroles. They are found on active volcanoes during and between eruptions and on dormant volcanoes, persisting long after the volcano itself has become inactive. Fumaroles grade into hot springs and geysers. The water of most, if not all, hot springs is predominantly of meteoric origin, and is not water liberated from magma. Some hot springs are of volcanic origin and the water may contain volcanic gases. See *GEYSER*.

**Distribution of volcanoes.** Over 500 active volcanoes are known on the Earth, mostly along or near the boundaries of the dozen or so lithospheric plates that compose the Earth's solid surface. Lithospheric plates show three distinct types of boundaries: divergent or spreading margins—adjacent plates are pulling apart; convergent margins (subduction zones)—plates are moving toward each other and one is being destroyed; and transform margins—one plate is sliding horizontally past another. All these types of plate motion are well demonstrated in the Circum-Pacific region, in which many active volcanoes form the so-called Ring of Fire. Some volcanoes, however, are not as-

sociated with plate boundaries, and many of these so-called intraplate volcanoes form roughly linear chains in the interior parts of the oceanic plates, for example, the Hawaiian-Emperor, Austral, Society, and Line archipelagoes in the Pacific Basin. Intraplate volcanism also has resulted in voluminous outpourings of fluid lava to form extensive plateau basalts, or of more viscous and siliceous pyroclastic products to form ash flow plains. [R.I.T.]

**Volcanology** The scientific study of volcanic phenomena, especially the processes, products, and hazards associated with active or potentially active volcanoes. It focuses on eruptive activity that has occurred within the past 10,000 years of the Earth's history, particularly eruptions during recorded history. Strictly speaking, it emphasizes the surface eruption of magmas and related gases, and the structures, deposits, and other effects produced thereby. Broadly speaking, however, volcanology includes all studies germane to the generation, storage, and transport of magma, because the surface eruption of magma represents the culmination of diverse physicochemical processes at depth. This article considers the activity of erupting volcanoes and the nature of erupting lavas. For a discussion of the distribution of volcanoes and the surface structures and deposits produced by them, see *PLATE TECTONICS*; *VOLCANO*.

On average, about 50 to 60 volcanoes worldwide are active each year. About half of these constitute continuing activity that began the previous year, and the remainder are new eruptions. Analysis of historic records indicates that eruptions comparable in size to that of Mount St. Helens or El Chichón tend to occur about once or twice per decade, and larger eruptions such as Pinatubo about once per one or two centuries. On a global basis, eruptions the size of that at Nevado del Ruiz in November 1985 are orders of magnitude more frequent.

Modern volcanology perhaps began with the founding of well-instrumented observations at Asama Volcano (Japan) in 1911 and at Kilauea Volcano (Hawaii) in 1912. The Hawaiian Volcano Observatory, located on Kilauea's caldera rim, began to conduct systematic and continuous monitoring of seismic activity preceding, accompanying, and following eruptions, as well as other geological, geophysical, and geochemical observations and investigations.

The eruptive characteristics, products, and resulting landforms of a volcano are determined predominantly by the composition and physical properties of the magmas involved in the volcanic processes (see table). Formed by partial melting of existing solid rock in the Earth's lower crust or upper mantle, the discrete blebs of magma consist of liquid rock (silicate melt) and dissolved gases. Driven by buoyancy, the magma blebs, which are lighter than the surrounding rock, coalesce as they rise toward the surface to form larger masses. See *IGNEOUS ROCKS*; *LITHOSPHERE*; *MAGMA*.

Magma consists of three phases: liquid, solid, and gas. Volcanic gases generally are predominantly water; other gases include various compounds of carbon, sulfur, hydrogen, chlorine, and fluorine. All volcanic gases also contain minor amounts of nitrogen, argon, and other inert gases, largely the result of atmospheric contamination at or near the surface.

**Generalized relationships between magma composition, relative viscosity, and common eruptive characteristics**

Magma composition	Relative viscosity	Common eruptive characteristics
Basaltic	Fluidal	Lava fountains, flows, and pools
Andesitic	Less fluidal	Lava flows, explosive ejecta, ashfalls, and pyroclastic flows
Dacitic-rhyolitic	Viscous	Explosive ejecta, ashfalls, pyroclastic flows, and lava domes

Temperatures of erupting magmas have been measured in lava flows and lakes, pyroclastic deposits, and volcanic vents by means of infrared sensors, optical pyrometers, and thermocouples. Reasonably good and consistent measurements have been obtained for basaltic magmas erupted from Kilauea and Mauna Loa volcanoes, Hawaii, and a few other volcanoes. Measured temperatures typically range between 2100 and 2200°F (1150 and 1200°C), and many measurements in cooling Hawaiian lava lakes indicate that the basalt becomes completely solid at about 1800°F (980°C). See GEOLOGIC THERMOMETRY.

The character of a volcanic eruption is determined largely by the viscosity of the liquid phase of the erupting magma and the abundance and condition of the gas it contains. Viscosity is in turn affected by such factors as the chemical composition and temperature of the liquid, the load of suspended solid crystals and xenoliths, the abundance of gas, and the degree of vesiculation. The subsequent violent expansion during eruption shreds the frothy liquid into tiny fragments, generating explosive showers of volcanic ash and dust, accompanied by some larger blocks (volcanic “bombs”); or it may produce an outpouring of a fluidized slurry of gas, semisolid bits of magma froth, and entrained blocks to form high-velocity pyroclastic flows, surges, and glowing avalanches. See PYROCLASTIC ROCKS; VISCOSITY.

Types of eruptions customarily are designated by the name of a volcano or volcanic area that is characterized by that sort of activity, even though all volcanoes show different modes of eruptive activity on occasion and even at different times during a single eruption.

Eruptions of the most fluid lava, in which relatively small amounts of gas escape freely with little explosion, are designated Hawaiian eruptions. Most of the lava is extruded as successive, thin flows that travel many miles from their vents. An occasional feature of Hawaiian activity is the lava lake, a pool of liquid lava with convectional circulation that occupies a preexisting shallow depression or pit crater. See LAVA.

Strombolian eruptions are somewhat more explosive eruptions of lava, with greater viscosity, and produce a larger proportion of pyroclastic material. Many of the volcanic bombs and lapilli assume rounded or drawn-out forms during flight, but commonly are sufficiently solid to retain these shapes on impact.

Generally still more explosive are the vulcanian type of eruptions. Angular blocks of viscous or solid lava are hurled out, commonly accompanied by voluminous clouds of ash but with little or no lava flow.

Peléeian eruptions are characterized by the heaping up of viscous lava over and around the vent to form a steep-sided hill or volcanic dome. Explosions, or collapses of portions of the dome, may result in glowing avalanches (*nuées ardentes*).

Plinian eruptions are paroxysmal eruptions of great violence—named after Pliny the Elder, who was killed in A.D. 79 while observing the eruption of Vesuvius—and are characterized by voluminous explosive ejections of pumice and by ash flows. The copious expulsion of viscous siliceous magma commonly is accompanied by collapse of the summit of the volcano, forming a caldera, or by collapse of the broader region, forming a volcano-tectonic depression. See CALDERA.

A major component of the science of volcanology is the systematic and, preferably, continuous monitoring of active and potentially active volcanoes. Scientific observations and measurements—of the visible and invisible changes in a volcano and its surroundings—between eruptions are as important, perhaps even more crucial, than during eruptions. Measurable phenomena important in volcano monitoring include earthquakes; ground movements; variations in gas compositions; and deviations in local gravity, electrical, and magnetic fields. These phenomena reflect pressure and stresses induced by subsurface magma movements and or pressurization of the hydrothermal envelope surrounding the magma reservoir. The monitoring of volcanic seismicity and ground deformations

before, during, and following eruptions has provided the most useful and reliable information. See EARTHQUAKE; SEISMOLOGY.

Volcanoes are in effect windows into the Earth’s interior; thus research in volcanology, in contributing to an improved understanding of volcanic phenomena, provides special insights into the chemical and physical processes operative at depth. However, volcanology also serves an immediate role in the mitigation of volcanic and related hydrologic hazards (mudflows, floods, and so on). Progress toward hazards mitigation can best be advanced by a combined approach. One aspect is the preparation of comprehensive volcanic hazards assessments of all active and potentially active volcanoes, including a volcanic risk map for use by government officials in regional and local land-use planning to avoid high-density development in high-risk areas. The other component involves improvement of predictive capability by upgrading volcano-monitoring methods and facilities to adequately study more of the most dangerous volcanoes. An improved capability for eruption forecasts and predictions would permit timely warnings of impending activity, and give emergency-response officials more lead time for preparation of contingency plans and orderly evacuation, if necessary. [R.I.T.]

**Volt-ampere** The apparent-power index of drive level for sinusoidal alternating-current loads. A circuit branch with  $E$  volts across its two terminals, carrying  $I$  amperes from one to the other, is said to be receiving  $EI$  volt-amperes of apparent power, whatever may be the phase lag  $\theta$  of current behind voltage. If such a load is driven through a transformer, the volt-amperes into the transformer primary is the same number as the volt-amperes into the load.

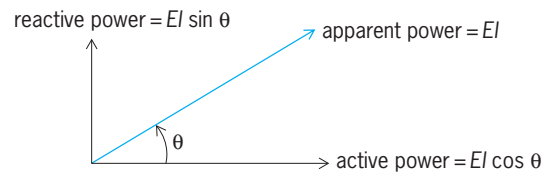

Apparent, active, and reactive power.

Practical computation of real power, reactive power, and apparent power is usually done with complex-number algebra using the geometrical diagram of the illustration. [M.G.F.]

**Voltage amplifier** An electronic circuit whose function is to accept an input voltage and produce a magnified, accurate replica of this voltage as an output voltage. The voltage gain of the amplifier is the amplitude ratio of the output voltage to the input voltage. Often, electronic amplifiers designed to operate in different environments are categorized by criteria other than their voltage gain, even though they are voltage amplifiers in fact. Many specialized circuits are designed to provide voltage amplification. See AUDIO AMPLIFIER; CASCODE AMPLIFIER; VIDEO AMPLIFIER.

Voltage amplifiers are distinguished from other categories of amplifiers whose ability to amplify voltages, or lack thereof, is of secondary importance. Amplifiers in other categories usually are designed to deliver power gain (power amplifiers, including push-pull amplifiers) or to isolate one part of a circuit from another (buffers and emitter followers). Power amplifiers may or may not have voltage gain, while buffers and emitter followers generally produce power gain without a corresponding voltage gain. See BUFFERS (ELECTRONICS); EMITTER FOLLOWER; POWER AMPLIFIER; PUSH-PULL AMPLIFIER.

Transistor amplifiers, such as the junction field-effect transistor (JFET) or the bipolar junction transistor (BJT) amplifier, will not operate properly without proper gate (JFET) or base (BJT) bias voltages applied in series with the signal voltage. These bias circuits can be modeled as ideal voltage sources. The bias and signal voltages are chosen so that the total input voltage—bias

plus signal—will not cut off or saturate the amplifier for any value in the range of the input signal voltage. In addition to a bias voltage source, well-designed bipolar transistor amplifiers require negative feedback at dc to protect the transistor from thermal runaway. *See* BIAS (ELECTRONICS).

To obtain high gain, cascades of single amplifier circuits are used, usually with a coupling network, actually a simple filter, inserted between the stages of amplification. One such filter is a high-pass network formed by a coupling capacitor, the output resistances of the driving stage, and the input resistance of the driven stage. Since dc voltages are blocked by the capacitor, this ac coupling permits independently setting dc bias voltages for each amplifier stage in the cascade. The coupling network also rejects signals with ac frequency components below a cutoff. The capacitor must be sufficiently large not to attenuate any of the frequencies that are to be amplified. If dc is to be amplified, a direct-coupled amplifier is required, and the design is somewhat more complicated since dc bias voltages on each transistor now cannot be set independently. *See* DIRECT-COUPLED AMPLIFIER; ELECTRIC FILTER.

The amplifiers discussed above are called single-ended amplifiers, since their input and output voltages are referred to a common reference point which by convention is called ground. These single-ended circuits, while satisfactory for most noncritical applications, have several weaknesses which degrade their performance in high-gain, weak-signal applications. Their unbalanced construction and their use of a common ground point for return currents makes them susceptible to noise pickup.

To minimize noise on sensitive signal lines, special balanced differential amplifier circuits are often used in critical amplifier applications. Differential amplifiers are designed to have equal impedances to ground for each side of the signal line and to have an output voltage proportional to the difference of the voltages from each signal line to ground. This symmetry cancels common-mode noise voltages, voltages which tend to appear on each of the signal lines as equal voltages to ground. Proper circuit design, with attention to the symmetry of the input circuit construction, can ensure that the majority of undesired noise pickup will be common-mode noise and, hence, will be attenuated by the differential amplifier. *See* DIFFERENTIAL AMPLIFIER; INSTRUMENTATION AMPLIFIER.

In cases where a voltage amplifier is required for some special purpose, operational amplifiers are often used to fill the need. The operational amplifier is an integrated circuit containing a cascade of differential amplifier stages, usually followed by a push-pull amplifier acting as a buffer. The differential voltage gain of the operational amplifier is very high, about 100,000 at low frequencies, while its input impedance is in the megohm range and its output impedance is usually under 100 ohms. The amplifier is designed to be used in a negative-feedback configuration, where the desired gain is controlled by a resistive voltage divider feeding a fraction of the output voltage to the inverting input of the operational amplifier.

With needed amplification built into many integrated circuits and with the availability of operational amplifiers for special-purpose amplification needs, there is seldom a need to design and build a voltage amplifier from discrete components. *See* AMPLIFIER; OPERATIONAL AMPLIFIER. [P.V.L.]

**Voltage measurement** Determination of the difference in electrostatic potential between two points. The unit of voltage in the International System of Units (SI) is the volt, defined as the potential difference between two points of a conducting wire carrying a constant current of 1 ampere when the power dissipated between these two points is equal to 1 watt.

**Direct-current voltage measurement.** The chief types of instruments for measuring direct-current (constant) voltage are potentiometers, resistive voltage dividers, pointer instruments, and electronic voltmeters.

The most fundamental dc voltage measurements from 0 to a little over 10 V can now be made by direct comparison against Josephson systems. At a slightly lower accuracy level and in the range 0 to 2 V, precision potentiometers are used in conjunction with very low-noise electronic amplifiers or photo-coupled galvanometer detectors. Potentiometers are capable of self-calibration, since only linearity is important, and can give accurate measurements down to a few nanovolts. When electronic amplifiers are used, it may often be more convenient to measure small residual unbalance voltages, rather than to seek an exact balance. *See* AMPLIFIER; GALVANOMETER; JOSEPHSON EFFECT.

Voltage measurements of voltages above 2 V are made by using resistive dividers. These are tapped chains of wire-wound resistors, often immersed in oil, which can be self-calibrated for linearity by using a buildup method. Instruments for use up to 1 kV, with tapings typically in a binary or binary-coded decimal series from 1 V, are known as volt ratio boxes, and normally provide uncertainties down to a few parts per million. Another configuration allows the equalization of a string of resistors, all operating at their appropriate power level, by means of an internal bridge. The use of series-parallel arrangements can provide certain easily adjusted ratios.

Higher voltages can be measured by extending such chains, but as the voltage increases above about 15 kV, increasing attention must be paid to avoid any sharp edges or corners, which could give rise to corona discharges or breakdown. High-voltage dividers for use up to 100 kV with an uncertainty of about 1 in  $10^5$ , and to 1 MV with an uncertainty of about 1 in  $10^4$ , have been made. *See* CORONA DISCHARGE; ELECTRICAL BREAKDOWN.

For most of the twentieth century the principal dc indicating voltmeters have been moving-coil milliammeters, usually giving full-scale deflection with a current between 20 microamperes and 1 milliamperes and provided with a suitable series resistor. Many of these will certainly continue to be used for many years, giving an uncertainty of about 1% of full-scale deflection.

The digital voltmeter has become the principal means used for voltage measurement at all levels of accuracy, even beyond one part in  $10^7$ , and at all voltages up to 1 kV. Essentially, digital voltmeters consist of a power supply, which may be fed by either mains or batteries; a voltage reference, usually provided by a Zener diode; an analog-to-digital converter; and a digital display system. This design provides measurement over a basic range from zero to a few volts, or up to 20 V. Additional lower ranges may be provided by amplifiers, and higher ranges by resistive attenuators. The accuracy on the basic range is limited to that of the analog-to-digital converter. *See* ANALOG-TO-DIGITAL CONVERTER; ELECTRONIC POWER SUPPLY.

Most modern digital voltmeters use an analog-to-digital converter based on a version of the charge balance principle. In such converters the charge accumulated from the input signal during a fixed time by an integrator is balanced by a reference current of opposite polarity. This current is applied for the time necessary to reach charge balance, which is proportional to the input signal. The time is measured by counting clock pulses, suitably scaled and displayed. Microprocessors are used extensively in these instruments. *See* MICROPROCESSOR.

**Alternating-current voltage measurements.** Since the working standards of voltage are of the direct-current type, all ac measurements have to be referred to dc through transfer devices or conversion systems. A variety of techniques can be used to convert an ac signal into a dc equivalent automatically. All multimeters and most ac meters make use of ac-dc conversion to provide ac ranges. These are usually based on electronic circuits. Rectifiers provide the most simple example. *See* MULTIMETER.

In a commonly used system, the signal to be measured is applied, through a relay contact, to a thermal converter. In order to improve sensitivity, a modified single-junction thermal converter may be used in which there are two or three elements in a single package, each with its own thermocouple. The output of the thermal converter is measured by a very sensitive,

high-resolution analog-to-digital converter, and the digital value memorized. When a measurement is required, the relay is operated, and the thermal converter receives its input, through a different relay contact, from a dc power supply, the amplitude of which is controlled by a digital and analog feedback loop in order to bring the analog-to-digital converter output back to the memorized level. The dc signal is a converted value of the ac input and can be measured. Modern versions of this type of instrument make use of microprocessors to control the conversion process, enhance the speed of operation, and include corrections for some of the errors in the device and range-setting components.

As in the dc case, digital voltmeters are now probably the instruments in widest use for ac voltage measurement. The simplest use diode rectification of the ac to provide a dc signal, which is then amplified and displayed as in dc instruments. This provides a signal proportional to the rectified mean. For most purposes an arithmetic adjustment is made, and the root-mean-square value of a sinusoidal voltage that would give the same signal is displayed. Several application-specific analog integrated circuits have been developed for use in instruments that are required to respond to the root-mean-square value of the ac input. More refined circuits, based on the logarithmic properties of transistors or the Gilbert analog multiplier circuit, have been developed for use in precision instruments. The best design, in which changes in the gain of the conversion circuit are automatically compensated, achieves errors less than 10 ppm at low and audio frequencies.

Sampling digital voltmeters are also used, in which the applied voltage is switched for a time very short compared with the period of the signal into a sample-and-hold circuit, of which the essential element is a small capacitor. The voltage retained can then be digitized without any need for haste. At low frequencies this approach offers high accuracy and great versatility, since the voltages can be processed or analyzed as desired. At higher frequencies, for example, in the microwave region, it also makes possible the presentation and processing of fast voltage waveforms using conventional circuits. See OSCILLOSCOPE.

Voltage measurements at radio frequencies are made by the use of rectifier instruments at frequencies up to a few hundred megahertz, single-junction converters at frequencies up to 500 MHz, or matched bolometers or calorimeters. At these higher frequencies the use of a voltage at a point must be linked to information regarding the transmission system in which it is measured, and most instruments effectively measure the power in a matched transmission line, usually of 50 ohms characteristic impedance, and deduce the voltage from it. See BOLOMETER; MICROWAVE MEASUREMENTS; MICROWAVE POWER MEASUREMENT; TRANSMISSION LINES.

Pulse voltage measurements are made most simply by transferring the pulse waveform to an oscilloscope, the deflection sensitivity of which can be calibrated by using low-frequency sine waves or dc. Digital sampling techniques may also be used. See ELECTRICAL MEASUREMENTS; VOLTMETER. [R.B.D.K.]

**Voltage-multiplier circuit** A circuit which produces a dc output voltage that is a fixed multiple of the input dc voltage or the peak voltage of an ac input waveform. This fixed multiple is approximately an integer ( $\pm 2, \pm 3, \pm 4, \dots$ ). Voltage multipliers are used to produce a high dc voltage where modest load current is required. The circuit can be implemented with diodes and capacitors or with switched capacitors.

A diode passes conventional current in only one direction. In the diode-capacitor voltage doubler, this current through one of the diodes charges one of the capacitors to approximately the peak value of the input voltage. The series combination of the input source and the capacitor generates a voltage across the diode that varies from approximately 0 to  $-2$  times the peak input voltage. The diode is reverse biased except for short intervals to replace charge drained from the capacitor to supply the load current or leakage. A second diode and capacitor form another

peak detecting circuit with the voltage across the first diode as the input. This results in a negative dc output voltage equal to twice the peak of the input waveform. The polarity of the output can be reversed by simply reversing both diodes. Another version of the voltage doubler produces two outputs, one equal to the peak input voltage and the other to its negative, using the same components. This is realized by connecting a positive and a negative peak detector across the input. See CAPACITOR; DIODE.

A typical voltage-multiplier circuit that uses switched capacitors is a dc-to-dc converter that generates  $+10\text{-V}$  and  $-10\text{-V}$  dc sources from a single  $+5\text{-V}$  dc source. A common application for this circuit is to use a  $+5\text{-V}$  dc power supply to power integrated circuits which require positive and negative voltages. Such switched-capacitor applications are well suited to integrated circuits because the transistor switches and the associated control circuitry take up very little space and the added cost is negligible. See ELECTRONIC POWER SUPPLY; INTEGRATED CIRCUITS; SWITCHED CAPACITOR; TRANSISTOR. [N.G.Di.]

**Voltage regulation** The change in voltage magnitude that occurs when the load (at a specified power factor) is reduced from the rated or nominal value to zero, with no intentional manual readjustment of any voltage control, expressed in percent of nominal full-load voltage. Voltage regulation is a convenient measure of the sensitivity of a device to changes in loading. See GENERATOR; TRANSFORMER; VOLTAGE REGULATOR. [P.M.A.]

**Voltage regulator** A device or circuit that maintains a load voltage nearly constant over a range of variations of input voltage and load current. Voltage regulators are used wherever the unregulated voltage would vary more than can be tolerated by the electrical equipment using that voltage. Alternating-current distribution feeders use regulators to keep the voltage supplied to the user within a prescribed range. Electronic equipment often has voltage regulators in dc power supplies.

**Electronic regulator.** A dc power supply is an essential component in any electronic system. The illustration shows a

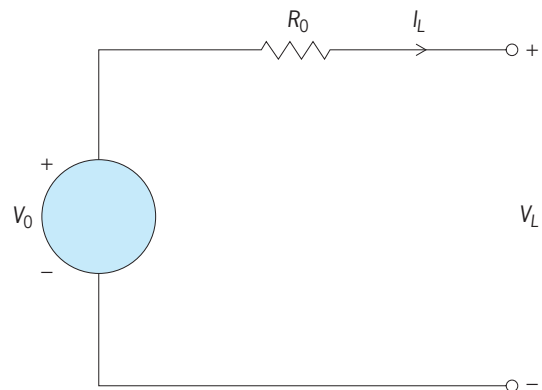

Equivalent circuit of a basic dc power supply.

Thévenin equivalent circuit of a power supply voltage source having an open-circuit (no-load) voltage  $V_0$  and output resistance  $R_0$ . When a load with resistance  $R_L$  is connected to the output of this supply, a load current  $I_L = V_L/R_L$  flows through  $R_0$ , resulting in a drop in load voltage  $V_L$  as given by Eq. (1).

$$V_L = V_0 - I_L R_0 \quad (1)$$

A basic power supply as modeled above exhibits two undesirable characteristics. The first is that the load voltage  $V_L$  decreases with increasing load current  $I_L$ . This effect can be severe in supplies with large effective output resistances. Such supplies are said to have poor load regulation. The second problem is that

$V_L$  depends directly on the source  $V_0$ . In practice,  $V_0$  might be derived from a relatively inaccurate source such as the ac line voltage (after suitable rectification and filtering) or a battery. Fluctuations in  $V_0$  reflect directly onto the voltage experienced by the load. In this case, the supply is said to have poor line regulation. An ideal power supply would exhibit perfect load regulation ( $V_L$  independent of  $I_L$ ) and perfect line regulation ( $V_L$  independent of  $V_0$ ) and would provide an output voltage of the form of Eq. (2), where  $V_{\text{ref}}$  is a well-defined reference voltage and  $k$  is a con-

$$V_L = kV_{\text{ref}} \quad (2)$$

stant scaling factor. The task of an electronic voltage regulator is to provide an output voltage characteristic that closely approximates the ideal of Eq. (2), given an unregulated supply voltage as an input.

**Feedback network.** Typically, electronic voltage regulators employ a feedback network, where a high-gain amplifier compares a fraction of the load voltage  $V_L/k$  with a constant reference  $V_{\text{ref}}$ . Any difference between these two voltages is amplified and used to control a series pass device in a manner whereby this difference is minimized. For an ideal amplifier with zero offset and infinite voltage gain, the difference is reduced to zero and the ideal relationship of Eq. (2) is realized. See FEEDBACK CIRCUIT.

The wide range of applications for electronic voltage regulators has led to the development of these circuits in fully monolithic integrated circuit technology, where all or most of the required circuit components are realized on a single chip of silicon. Offering various output current and voltage ratings, and output voltages of either positive or negative polarity, several commercial regulator integrated circuits are now available to suit the requirements of most applications. The designs of these regulators have matured and have become rather sophisticated. In addition to implementation of the high-gain feedback amplifier, the series pass element, and an accurate voltage reference, all on a single silicon die, built-in protection against overload conditions (such as output short circuits and excessive operating temperature) is now standard. Novel circuit-design, processing, and packaging techniques have been developed and implemented to achieve increased accuracy, temperature stability, efficiency, reliability, and power-handling capability, while reducing package size and cost. See INTEGRATED CIRCUITS. [A.P.N.]

**Power-system regulator.** Voltage regulators are used on distribution feeders to maintain voltage constant, irrespective of changes in either load current or supply voltage. Voltage variations must be minimized for the efficient operation of industrial equipment and for the satisfactory functioning of domestic appliances, television in particular. Voltage is controlled at the system generators, but this alone is inadequate because each generator supplies many feeders of diverse impedance and load characteristics. Regulators are applied either in substations to control voltage on a bus or individual feeder or on the line to reregulate the outlying portions of the system. These regulators are variable autotransformers with the primary connected across the line. The secondary, in which an adjustable voltage is induced, is connected in series with the line to boost or buck the voltage. See AUTOTRANSFORMER; ELECTRIC DISTRIBUTION SYSTEMS; ELECTRIC POWER SUBSTATION. [D.D.Mac.]

Voltage regulators are used on rotating machines in power generation applications to automatically control the field excitation so as to maintain a desired machine output voltage. Rotating machines, both small (down to 1 kW) and large (up to 1,000,000 kW), are the predominant means of power generation throughout the world, and voltage regulators of varying design and sophistication are employed on most of them. Even ac generators (or alternators) in automotive applications employ voltage regulators utilizing similar principles. See DIRECT-CURRENT GENERATOR; ELECTRIC POWER GENERATION; ELECTRIC ROTATING MACHINERY; GENERATOR. [J.D.Hu.]

**Voltmeter** An instrument for the measurement of the electric potential difference between two conductors. Many different kinds of instruments are available to suit different purposes. Voltages of the order of picovolts ( $10^{-12}$  V) to megavolts ( $10^6$  V) can be measured. Frequencies from zero (dc) to many megahertz and accuracies in the range from a fraction of part per million (ppm) to a few percent may be covered. See ELECTRICAL UNITS AND STANDARDS; VOLTAGE MEASUREMENT.

**Analog voltmeters.** Where no great accuracy is required, a voltage may be indicated by a mechanical displacement of a pointer against a scale. There is a wide variety of principles on which instruments of this type can be based. The d'Arsonval movement (see illustration) is one of the most popular constructions. This is basically a current-sensing instrument and is used in conjunction with a suitable resistance in series to measure voltage. A further variant, taut-band suspension, uses a pair of resilient strips under tension to carry the current to the coil, locate it, and provide the rotational restoring force. See AMMETER; MULTIMETER.

The permanent-magnet, moving-coil instrument is very sensitive, but by its nature is responsive only to the average value of the current flowing through the coil. It is therefore unsuitable for ac. A rectifier circuit can be used in order to combine the sensitivity of the movement with ac response. A transformer can be used to reduce the nonlinearity that results from the forward voltage drop of the diode rectifiers, at the expense of current drain. See RECTIFIER; TRANSFORMER.

**Electronic voltmeters.** The movements so far described require energy from the signal being measured to cause the deflection. The resulting current is liable to modify the voltage at the measurement point. To reduce this loading effect, active circuits are often used between the input terminals and the indicating movement. Once an independent source of power is available, electronic circuits can be used to provide other features, including a variety of kinds of signal processing and digital presentation of the results.

**Digital voltmeters.** Digital voltmeters (DVMs) are now the preferred instruments for ac and dc measurements at all levels of accuracy and at all voltages up to 1 kV. Essentially a digital voltmeter consists of a voltage reference, usually provided by a Zener diode, an analog-to-digital converter and digital display system, and a power supply, which may be derived from either the mains or a battery. The basic range of the instrument provides measurement from zero to 10 or 20 V. Additional lower ranges may be provided by amplifiers, whose gain is stabilized by precision resistors. These electronic input amplifiers often provide a very high input impedance, perhaps exceeding  $10^{10}$   $\Omega$ . Since this impedance is obtained by active means, a much lower impedance may be found when the instrument is switched off. Higher voltage ranges are provided by the use of resistive

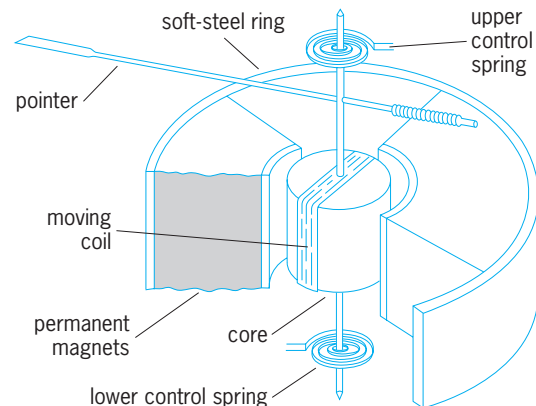

D'Arsonval moving-coil instrument. (General Electric Co.)

attenuators, usually limited to a value of 10 M $\Omega$  by economic restraints. The best accuracy is always obtained on the basic range, where it is limited to that of the analog-to-digital converter. See AMPLIFIER; ANALOG-TO-DIGITAL CONVERTER; ELECTRONIC POWER SUPPLY; ZENER DIODE.

**Sampling voltmeters.** A sampling voltmeter is an instrument that uses sampling techniques and has advantages at very low frequencies, that is, below 1 Hz, and also at very high frequencies, where conventional measuring circuits become difficult or even impossible. Low-frequency sampling instruments achieve uncertainties as small as 50 ppm with 10-V signals; high-frequency instruments can achieve a few percent with frequencies as high as 12 GHz and amplitudes as small as 1 mV. Measurements are generally of rectified-mean or root-mean-square voltage. Modern digital sampling voltmeters may also be capable of calculating and displaying voltages or energy density as a function of frequency. Sampling voltmeters, like conventional voltmeters, may use scale and pointer meters, graphic recorders, cathode-ray tubes, or digital indicators for readout of measured quantities. See WAVEFORM DETERMINATION. [R.B.D.K.]

**Volume control systems** Systems that maintain proper audio signal levels in applications such as sound recording, public address systems, and broadcasting. Two types of electronic devices, compressors and limiters, perform this operation automatically without the need for human intervention, but differ in the way that they perform.

A compressor slowly varies its gain so as to maintain its output volume level at some constant average value. When used to process the audio signal from a microphone, a compressor equalizes the loudness of speech from different talkers. It compresses the dynamic range of the signal. A limiter controls the peak levels of an audio signal. Limiters are used to prevent overmodulation of transmitters in broadcast facilities, to prevent peak clipping in public address system audio amplifiers, and to prevent overload of audio recorders. A compressor followed by a limiter can be used to dramatically enhance the loudness of an audio signal without an increase in the peak level. This is a common practice in broadcasting to increase signal range and to maximize program loudness.

The input of a compressor or a limiter is applied to a variable-gain amplifier. A gain-control circuit monitors the level of the output and generates a voltage which controls the amplifier gain. Manual controls at the input and output allow setting the levels for proper interface to external devices. See AUTOMATIC GAIN CONTROL (AGC); GAIN; LIMITER CIRCUIT; RADIO BROADCASTING; SOUND RECORDING; SOUND-REINFORCEMENT SYSTEM; SOUND-REPRODUCING SYSTEM. [W.M.L.]

**Volume unit (vu)** A unit used to measure the strength of electrical waves produced by microphones. In sound recording, broadcasting, and public address systems, microphones convert acoustical signals into electrical waves that are nonperiodic and cannot be simply described in terms of voltage, current, power, or frequency. To provide a practical means of assigning a numerical value to the strength of such waves, the concept of "volume" is used. The volume of an audio program wave is the magnitude of the wave as measured with a standard volume indicator. This is a meter calibrated to read in volume units (vu, pronounced vee-you). [W.M.L.]

**Volumetric efficiency** In describing an engine or gas compressor, the ratio of volume of working substance actually admitted, measured at specified temperature and pressure, to the full piston displacement volume. For a liquid-fuel engine, such as a diesel engine, volumetric efficiency is the ratio of volume of air drawn into a cylinder to the piston displacement. For a gas-fuel engine, such as a gasoline engine with carburetor, throttle body, or port injection, volumetric efficiency is based on the charge of fuel and air drawn into the cylinder. See COMPRESSOR; ENGINE.

Volumetric efficiency of naturally aspirated automobile and aircraft reciprocating engines may be 85–90% at rated speed. Supercharging or turbocharging increases volumetric efficiency, giving values over 100%. Air compressors, refrigerator compressors, and dry vacuum pumps are generally specified for a volumetric efficiency of 60–90%. See INTERNAL COMBUSTION ENGINE; RECIPROCATING AIRCRAFT ENGINE. [D.L.An.]

**Volvocales** A large order of green algae (Chlorophyceae) comprising all forms that normally are flagellate and motile. In zoological classification, it is called Volvocida, in the class Phytomastigophora. The cells are solitary or united into colonies of definite structure (coenobia), often with morphological and functional differentiation among the component cells. Some taxonomists place the unicellular forms in a separate order, Chlamydomonadales. Unicells that have volvocalean cytological features but are nonflagellate and sedentary in their vegetative phase are considered here to constitute the order Tetrastorales. Or these sedentary forms may be retained in the Chlamydomonadales or Volvocales. See CHLOROPHYCEAE.

Of the unicellular forms, *Chlamydomona*, which is presumed to be similar to ancestral Volvocales, has a very small cell body (usually 7–40 micrometers in greatest dimension) that is spherical, ellipsoid, or pyriform. The wall (or theca), which consists primarily of glycoproteins, is usually smooth, but may have blunt protuberances. The cell bears two smooth flagella of equal length at its apex, with contractile vacuoles and an eye-spot at the anterior end. Chloroplasts contain one or more pyrenoids. As in all Volvocales, the cells are uninucleate. Other genera with chlamydomonad features are distinguished on the basis of flagellar number, presence or absence of photosynthetic pigments, presence or absence of pyrenoids, and cell shape. Together with *Chlamydomonas* they constitute the family Chlamydomonadaceae. Two other families of unicellular Volvocales are recognized: Dunaliellaceae, in which the unicells are naked; and Phacotaceae, in which the unicells are surrounded by a lorica—a rigid, hyaline or dark brown, wall-like structure, which is often impregnated with compounds of calcium, iron, or manganese and which may be sculptured. Unicellular Volvocales are ubiquitous in fresh, brackish, and coastal marine waters and in such terrestrial habitats as soil, snow, and ice. They are especially abundant in organically enriched bodies of fresh water.

Most colonial (coenobial) Volvocales are placed in the family Volvocaceae. In this family, coenobia are composed of *Chlamydomonas*-like biflagellate cells embedded in a firm gelatinous matrix. Coenobia have the form of a slightly curved plate or are ellipsoid to spherical. The component cells are arranged according to a predetermined pattern. Asexual reproduction is by repeated bipartition of the protoplast of an ordinary or specialized cell to form a new coenobium (autocoenobium) that is a miniature of the parent. Sexual reproduction forms a phylogenetic series from isogamy through anisogamy to oogamy. The Volvocaceae are abundant in organically enriched bodies of fresh water, especially temporary pools. [PC.Si.; R.L.Moe.]

**Volvocida** An order of the class Phytomastigophorea. The protozoans, also known as the Phytomonadida, are grass-green, but a few are colorless (*Polytoma*). Individual cells may be as small as 8 micrometers. They closely relate the flagellates to the algae. They have one, two, four, or eight flagella; plural flagella are usually equal. The group is large and about one-fourth of the approximately 100 genera form colonies, with flagella only in reproductive cells. Cell walls are of cellulose and often they are thick. Chromatophores contain the same chlorophylls as higher plants. Pyrenoids have the usual form commonly found with starch as the reserve material. See CILIA AND FLAGELLA; PHYTAMASTIGOPHOREA. [J.B.L.]

**VOR (VHF omnidirectional range)** A short-range air navigation aid, which provides azimuth aid by visual means of

cockpit instruments. A VOR system provides properly equipped aircraft with bearing information relative to the VOR station and magnetic north. The VOR system is used for landing, terminal, and en route guidance. It also gives virtually static-free regular weather broadcasts, special flight instructions, and voice and code station identification. The VOR service operates in the very high frequency (VHF) band between 108 and 118 MHz, sharing alternate channels with the localizer in the instrument landing system. Typically, VOR stations are co-located with a distance measuring equipment (DME) system or a tactical area navigation (TACAN) system. The combined systems are referred to as VOR/DME or VORTAC stations and provide both azimuth and distance information. See DISTANCE-MEASURING EQUIPMENT; INSTRUMENT LANDING SYSTEM (ILS); TACAN.

The VOR operates on the principle that the phase difference between two signals can be employed as a means of determining azimuth if one of the signals maintains a fixed phase through  $360^\circ$ , so it can be used as a reference, while the other is made to vary as a direct function of azimuth. The phase difference between these two signals will then equal the azimuth of the aircraft. In practice, two demodulated 30-Hz signals are used. These are called the reference-phase and variable-phase signals. See ELECTRONIC NAVIGATION SYSTEMS.

There are two types of VOR equipment. One employs a four-loop antenna array and is called conventional VOR. The other, Doppler VOR, having a 50-loop or larger antenna array located around a single-loop carrier antenna, is based on the Doppler principle and is designed for installation at locations which present especially difficult siting problems due to multipath conditions. Although the two types differ in design, from the standpoint of air navigation they function in essentially the same manner and can be received by the same equipment. Both types are used to define route intersections and most domestic airways. See DOPPLER EFFECT; DOPPLER VOR.

As the United States national airspace is increasingly congested, serious consideration is being given to replacing or supplementing the VOR system with satellite-based navigation. It is believed that satellites will enable more flexible routing and that satellite positioning can be effectively integrated into air-traffic surveillance systems. However, VOR is expected to remain in place at least until the integrity of satellite-based services improves to the level of VOR services and until the costs of transitioning to satellite services are reduced to an acceptable level. See SATELLITE NAVIGATION SYSTEMS. [W.I.Th.; R.B.F.]

**Vortex** In common usage, a fluid motion dominated by rotation about an isolated curved line in space, as in a tornado, a whirlpool, a hurricane, or a similar natural phenomenon. The importance of vortices is due to two characteristics: general fluid flows can be represented by a superposition of vortices; and vortices, once created, have a persistence that increases as the effects of viscosity are reduced. The aerodynamic lift forces and most other contributors to the forces and moments on aircraft and other bodies moving through fluids do not exist in the absence of vortices. See AERODYNAMIC FORCE; HURRICANE; TORNADO; WATERSPOUT.

The strength of rotation is measured by a vector called the vorticity,  $\omega$ , defined as the curl of the velocity vector. A region of flow devoid of vorticity is known as irrotational. The spatial distribution of the vorticity vector provides a precise characterization of the rotation effects in fluids, and the nature of what subjectively and popularly would be called a vortex. See CALCULUS OF VECTORS; LAPLACE'S IRRATIONAL MOTION.

The vorticity vector field can be constructed by measuring the instantaneous angular velocity of small masses of fluid. The vorticity vector is twice the local angular velocity vector. Starting at any arbitrary point in the fluid, a line, called a vortex line, can be drawn everywhere parallel to the vorticity vector.

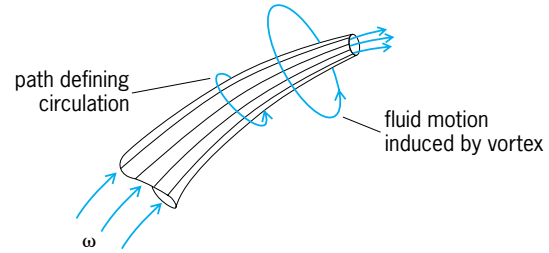

Vortex tube;  $\omega$  is the vorticity.

A bundle of vortex lines defines a tubular region of space, called a vortex tube, with a boundary surface that no vortex line crosses.

Two simple rules follow from the definitions: (1) a vortex tube must either close on itself or end on a boundary of the fluid (including extending to "infinity" if the fluid is imagined to fill all space); and (2) at every cross section of a given vortex tube, the area integral of the normal vorticity has the same value at any given instant. The area integral is, by Stokes' theorem, equal to a line integral around the periphery of the tube, namely, the line integral of the velocity component parallel to the direction of the line integral. This quantity is also known as the circulation around the line, so at an instant of time a vortex tube has a unique value of the circulation applying to all cross sections (see illustration).

Vortex lines confined to a layer rather than a tube describe fluid motion of a different character. This is most easily visualized when the direction of the vorticity does not vary, so all of the vortex lines are straight and parallel. Assuming the vorticity has zero magnitude outside the layer, this vortex layer represents a flow with a different speed and direction on either side of the layer. Such a change in speed occurs at the edge of wakes produced by wind passing over an obstacle. Reducing the thickness of this layer of vorticity to zero leads to an idealization known as a vortex sheet, a surface in space across which there is a finite jump in velocity tangent to the surface. Vortex sheets have a tendency to roll up, because of self-induction. [S.Lei.]

**Vorticity** A vector proportional to the local angular velocity of a fluid flow. The vorticity,  $\vec{\omega}$ , is a derived quantity in fluid mechanics, defined, for a flow field with velocity  $\vec{u}$ , by Eq. (1). As the

$$\vec{\omega} = \nabla \times \vec{u} \quad (1)$$

curl of the velocity vector, the vorticity is a vector with the dimensions of both a frequency and an angular velocity [ $\vec{\omega}$ ] = [s<sup>-1</sup>]. The component of vorticity along a particular axis is related to the rate of rotation of the fluid about the axis. For this reason, flows for which  $\vec{\omega} = 0$  are described as irrotational. See CALCULUS OF VECTORS; DIMENSIONAL ANALYSIS; VELOCITY.

**Circulation.** Closely related to vorticity is the fluid circulation,  $\Gamma$ , defined, for any closed contour,  $C$ , in a fluid, by Eq. (2). In

$$\Gamma = \oint_C \vec{u} \cdot d\vec{l} = \iint_S \vec{\omega} \cdot \vec{n} dS \quad (2)$$

this definition,  $\oint_C$  indicates the conventional counterclockwise contour integral around the contour  $C$ ,  $\vec{l}$  is a unit vector tangent to the contour, and  $S$  is an arbitrary curved surface bounded by the contour  $C$ . [The equality of the two integrals in Eq. (2) may be deduced by the application of Stokes' theorem.] The circulation is thus a scalar quantity equal to the integrated component of vorticity normal to the surface around which  $\Gamma$  is taken. Circulation is important because the Kutta-Joukowski law of aerodynamics states that the lift generated by a two-dimensional airfoil is  $L = \rho U \Gamma$ . In this expression,  $\rho$  is the fluid density,  $U$  is



the free-stream velocity, and  $\Gamma$  is the bound circulation of the airfoil, defined conventionally as the negative of the definition above. See AERODYNAMICS; AIRFOIL; STOKES' THEOREM; SUBSONIC FLIGHT.

**Vortex line and vortex tube.** A vortex line is defined as a line that is everywhere tangent to the local vorticity vector (analogous to a streamline). A series of adjacent vortex lines is referred to as a vortex tube. The first Helmholtz vortex law states that at any instant in time the circulation about all loops taken around the exterior of a vortex tube is the same. Thus, vortex tubes must either form loops entirely within a fluid or terminate at some fluid boundary. See VORTEX.

**Kelvin's theorem.** Kelvin's theorem considers how the circulation  $\Gamma$  around a material loop in a fluid (a loop that moves with the fluid) varies in time. Starting with the Navier-Stokes equations, Lord Kelvin showed that if (1) the fluid is inviscid along the loop, (2) the fluid is subject only to potential body forces, and (3) the fluid pressure is a function of density alone, then the rate of change of  $\Gamma$  is 0. In other words, the circulation around a material loop is time-independent. Kelvin's theorem may also be stated slightly differently: subject to the above three constraints, vortex lines are material lines, convected with the local fluid velocity. See KELVIN'S CIRCULATION THEOREM.

**Generation.** Kelvin's theorem can tell what happens when vorticity is already present in a flow, but it sheds no light on how vorticity is generated. To answer this question, it is useful to consider situations for which Kelvin's theorem is inapplicable: flow with viscosity, with nonpotential body forces, and for which the pressure is not solely a function of the density.

The action of viscosity has two effects on vorticity. One effect of viscosity is to cause the diffusion of vorticity in a fluid. A second effect of viscosity is the generation of vorticity at a wall where there is a pressure gradient at the wall. See VISCOSITY.

A common example of a nonpotential body force is the Coriolis force, which is present in a rotating frame of reference. This force generates vorticity in a fluid, and is a major cause of the large-scale circulation in the atmosphere and oceans. See CORIOLIS ACCELERATION.

There are many flows for which the pressure may not be solely a function of the density (so-called baroclinic flows), such as the flow of gas with heat addition and the flow of water with salinity variations. Pressure gradients in such flows generate vorticity. This source of vorticity is called baroclinic torque, and is important in atmospheric flow, buoyancy-driven flow, and oceanographic flow. See BAROCLINIC FIELD; DYNAMIC INSTABILITY; DYNAMIC METEOROLOGY. [S.I.G.]



# W

**Wake flow** The flow downstream of a body immersed in a stream or the flow behind a body propagating through a fluid. Wakes are narrow elongated regions, filled with large and small eddies. The wake eddies of a bridge pier immersed in a river stream, or of a ship propelled through the water, are often visible on the surface. On windy days, similar wakes form downstream of smoke stacks or other structures, but the eddies in the air are not visible unless some smoke or dust is entrained in them.

Turbulence in the wake of bluff bodies consists of all sizes of eddies, which interact with each other in their unruly motion. Yet, out of this chaos emerges some organization, whereby large groups of eddies form a well-ordered sequence of vortices. The sense of rotation of these vortices alternates, and their spacing is quite regular. As a result, they can drive a structure that they encounter, or they can exert on the body that created them a force alternating in sign with the same frequency as that of the formation of the vortices. Such forces can impose on structures unwanted vibrations which often lead to serious damage. Flow-induced forces can be catastrophic if they are in tune with the frequency of vibration of the structure. See FLUID FLOW; FLUID-FLOW PRINCIPLES; KÁRMÁN VORTEX STREET; TURBULENT FLOW.

Wakes are sustained for very large distances downstream of a body. Ship wakes retain their turbulent character for miles behind a vessel and can be detected by special satellites hours after their generation. Similarly, condensation in the wake of aircraft sometimes makes it look like a narrow braided cloud, traversing the sky. [D.P.T.]

**Wall construction** Methods for constructing walls for buildings. Walls are constructed in different forms and of various materials to serve several functions. Exterior walls protect the building interior from external environmental effects such as heat and cold, sunlight, ultraviolet radiation, rain and snow, and sound, while containing desirable interior environmental conditions. Walls are also designed to provide resistance to passage of fire for some defined period of time, such as a one-hour wall. Walls often contain doors and windows, which provide for controlled passage of environmental factors and people through the wall line.

Walls are designed to be strong enough to safely resist the horizontal and vertical forces imposed upon them, as defined by building codes. Such loads include wind forces, self-weight, possibly the weights of walls and floors from above, the effects of expansion and contraction as generated by temperature and humidity variations as well as by certain impacts, and the wear and tear of interior occupancy. See LOADS, DYNAMIC; LOADS, TRANSVERSE.

Modern building walls may be designed to serve as either bearing walls or curtain walls or as a combination of both in response to the design requirements of the building as a whole. Both types may appear similar when complete, but their sequence of construction is usually different.

Bearing-wall construction may be masonry, cast-in-place or precast reinforced concrete, studs and sheathing, and composite types. The design loads in bearing walls are the vertical loading from above, plus horizontal loads, both perpendicular and

parallel to the wall plane. Bearing walls must be erected before supported building components above can be erected.

Curtain-wall construction takes several forms, including lighter versions of those used for bearing walls. These walls can also comprise assemblies of corrugated metal sheets, glass panels, or ceramic-coated metal panels, each laterally supported by light subframing members. The curtain wall can be erected after the building frame is completed, since it receives vertical support by spandrel beams, or relieving angles, at the wall line.

Masonry walls are a traditional, common, and durable form of wall construction used in both bearing and curtain walls. They are designed in accordance with building codes and are constructed by individual placement of bricks, blocks of stone, cinder concrete, cut stone, or combinations of these. The units are bonded together by mortar. See CONCRETE; MASONRY; MORTAR.

Reinforced concrete walls are used for both strength and esthetic purposes. Such walls may be cast in place or precast, and they may be bearing or curtain walls. Some precast concrete walls are constructed of tee-shaped or rectangular prestressed concrete beams, which are more commonly used for floor or roof deck construction. They are placed vertically, side by side, and caulked at adjacent edges. See CONCRETE BEAM; REINFORCED CONCRETE.

Stud and sheathing walls are a light type of wall construction, commonly used in residential or other light construction where they usually serve as light bearing walls. They usually consist of wood sheathing nailed to wood or steel studs, usually with the dimensions 2 × 4 in. (5 × 10 cm) or 2 × 6 in. (5 × 15 cm), and spaced at 16 in. (40 cm) or 24 in. (60 cm) on center—all common building module dimensions. The interior sides of the studs are usually covered with an attached facing material. This is often sheetrock, which is a sandwich of gypsum between cardboard facings. Composite walls are essentially a more substantial form of stud walls. They are constructed of cementitious materials, such as weatherproof sheetrock or precast concrete as an exterior sheathing, and sheetrock as an interior surface finish. See GYPSUM; PRECAST CONCRETE.

Prefabricated walls are commonly used for curtain-wall construction and are frequently known as prefab walls. Prefabricated walls are usually made of corrugated steel or aluminum sheets, although they are sometimes constructed of fiber-reinforced plastic sheets, fastened to light horizontal beams (girts) spaced several feet apart. Prefab walls are often made of sandwich construction: outside corrugated sheets, an inside liner of flat or corrugated sheet, and an enclosed insulation are fastened together by screws to form a thin, effective sandwich wall. These usually have tongue-and-groove vertical edges to permit sealed joints when the units are erected at the building site by being fastened to framing girts.

Glass, metal, or ceramic-coated metal panel walls are a common type of curtain wall used in high-rise construction. They are typically assembled as a sandwich by using glass, formed metal, or ceramic-coated metal sheets on the outside, and some form of liner, including possibly masonry, on the inside; insulation is enclosed.

Tilt-up walls are sometimes used for construction efficiency. Here, a wall of any of the various types is fabricated in a

horizontal position at ground level, and it is then tilted up and connected at its edges to adjacent tilt-up wall sections. Interior partitions are a lighter form of wall used to separate interior areas in buildings. They are usually nonbearing, constructed as thinner versions of some of the standard wall types; and they are often designed for some resistance to fire and sound. Retaining walls are used as exterior walls of basements to resist outside soil pressure. They are usually of reinforced concrete; however, where the basement depth or exterior soil height is low, the wall may be constructed as a masonry wall. See BUILDINGS; RETAINING WALL; STRUCTURAL MATERIALS. [M.A.]

**Walnut** This name is applied to about a dozen species of large deciduous trees widely distributed over temperate North and South America, southeastern Europe, and central and eastern Asia. The genus (*Juglans*) is characterized by pinnately compound aromatic leaves and chambered or laminate pith. The staminate (male) flowers are borne in unbranched catkins on the previous season's growth, and the pistillate (female) flowers are terminal on the current season's shoots. The shells of the nuts of most species are deeply furrowed or sculptured.

Two species, the black walnut (*J. nigra*) and the Persian or English walnut (*J. regia*), are of primary importance for their timber and nuts. The butternut finds local use in the northeastern United States. The other species are sparingly used as shade trees, as grafting stocks, and as sources of nuts. See JUGLANDALES. [L.H.Mac.D.]

**Warm-air heating system** In a general sense, a heating system which circulates warm air. Under this definition both a parlor stove and a steam blast coil circulate warm air. Strictly speaking, however, a warm-air system is one containing a direct-fired furnace surrounded by a bonnet through which air circulates to be heated.

When air circulation is obtained by natural gravity action, the system is referred to as a gravity warm-air system. If positive air circulation is provided by means of a centrifugal fan (referred to in the industry as a blower), the system is referred to as a forced-air heating system.

Direct-fired furnaces are available for burning of solid, liquid, or gaseous fuels. Furnaces have also been designed which have air circulating over electrical resistance heaters. A completely equipped furnace-blower package consists of furnace, burner, bonnet, blower, filter, and accessories. The furnace shell is usually of welded steel. The burner supplies a positively metered rate of fuel and a proportionate amount of air for combustion. A casing, or jacket, encloses the furnace and provides a passage for the air to be circulated over the heated furnace shell. The casing is insulated and contains openings to which return-air and warm-air ducts can be attached. The blower circulates air against static pressure. The air filter removes dust particles from the circulating air. See OIL BURNER.

The complete forced-air heating system consists of the furnace-blower package unit; the return-air intake, or grille, together with return-air ducts leading from the grille to the return-air plenum chamber at the furnace; and the supply trunk duct and branch ducts leading to the registers located in the different spaces to be heated. See COMFORT HEATING. [S.Ko.]

**Washer** A flattened, ring-shaped device used to improve the tightness of a screw fastener. Three types of washer are in common use: plain, spring-lock, and antiturn (tooth-lock washers). Standard plain washers are used to protect a part from damage or to provide for a wider distribution of the load. Because a plain washer will not prevent a nut from turning, a locking-type washer should be used to prevent a bolt or nut from loosening under vibration (see illustration). Lock washers create a continuous pressure between the parts and the fastener. The antiturn-type washers may be externally serrated, internally serrated, or both.

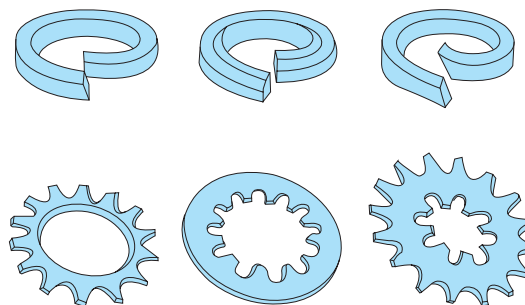

Lock washers. (After W. J. Luzadder, *Fundamentals of Engineering Drawing, 6th ed.*, Prentice-Hall, 1971)

The bent teeth bite into the bearing surface to prevent the nut from turning and the fastening from loosening under vibration. See SCREW FASTENER. [W.J.L.]

**Watch** A portable timepiece. Its operation may be described as mechanical, electromechanical, or electronic.

In the mechanical watch a mainspring in the barrel stores operating energy; the user retightens the spring daily by means of the winding stem. The wheel train advances the spring daily by five increments per second under control by the escapement. From there the dial train turns the minute and hour hands across the watch face. See CLOCK; ESCAPEMENT; GEAR TRAIN; JEWEL BEARING; SPRING (MACHINES).

Among the variety of features incorporated into modern watches are: self-winding mechanisms, substitution of an electrochemical cell for the mechanical mainspring, and several forms of electromechanical escapement in place of the balance-and-hairspring mechanism.

When solid-state electronic integrated circuits became available in quantity, the all-electronic watch became a commercial reality. In it an electrochemical cell supplies the energy. A chain of binary dividers triggered from a crystal oscillator develops a train of seconds pulses. These pulses drive a digital counter or sealer, which develops minute and hour pulses to activate the digital display. See DIGITAL COUNTER; INTEGRATED CIRCUITS; OSCILLATOR; PIEZOELECTRICITY.

One form of readout uses a light-emitting diode (LED). Because illumination of the readout consumes most of the power in an electronic watch, a liquid crystal display (LCD) is used where low power consumption is a first consideration. See ELECTRONIC DISPLAY; HOROLOGY; LIGHT-EMITTING DIODE; LIQUID CRYSTALS. [F.H.R.]

**Water** The chemical compound with two atoms of hydrogen and one atom of oxygen in each of its molecules. It is formed by the direct reaction (1) of hydrogen with oxygen. The other



compound of hydrogen and oxygen, hydrogen peroxide, readily decomposes to form water, reaction (2). Water also is formed in



the combustion of hydrogen-containing compounds, in the pyrolysis of hydrates, and in animal metabolism. Some properties of water are given in the table.

**Gaseous state.** Water vapor consists of water molecules which move nearly independently of each other. The relative positions of the atoms in a water molecule are shown in the illustration. The dotted circles show the effective sizes of the isolated atoms. The atoms are held together in the molecule by chemical bonds which are very polar, the hydrogen end of each bond being electrically positive relative to the oxygen. When two molecules near each other are suitably oriented, the positive hydrogen of one molecule attracts the negative oxygen of the other,

## Properties of water

Property	Value
Freezing point	0°C (32°F)
Density of ice, 0°C (32°F)	0.92 g/cm <sup>3</sup> (0.53 oz/in. <sup>3</sup> )
Density of water, 0°C (32°F)	1.00 g/cm <sup>3</sup> (0.578 oz/in. <sup>3</sup> )
Heat of fusion	80 cal/g (335 J/g)
Boiling point	100°C (212°F)
Heat of vaporization	540 cal/g (2260 J/g)
Critical temperature	347°C (657°F)
Critical pressure	217 atm (22.0 MPa)
Specific electrical conductivity at 25°C	1 × 10 <sup>-7</sup> /ohm-cm
Dielectric constant, 25°C (77°F)	78

and while in this orientation, the repulsion of the like charges is comparatively small. The net attraction is strong enough to hold the molecules together in many circumstances and is called a hydrogen bond. See CHEMICAL BONDING; ELECTRONEGATIVITY; GAS; VALENCE.

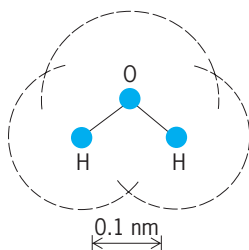

The water molecule.

**Solid state.** Ordinary ice consists of water molecules joined together by hydrogen bonds in a regular arrangement. It appears that there is considerable empty space between the molecules. This unusual feature is a result of the strong and directional hydrogen bonds taking precedence over all other intermolecular forces in determining the structure of the crystal. See CRYSTAL; HYDROGEN BOND.

**Liquid state.** The molecules in liquid water also are held together by hydrogen bonds. When ice melts, many of the hydrogen bonds are broken, and those that remain are not numerous enough to keep the molecules in a regular arrangement. As water is heated from 0°C (32°F), it contracts until 4°C (39°F) is reached and then begins the expansion which is normally associated with increasing temperature. This phenomenon and the increase in density when ice melts both result from a breaking down of the open, hydrogen-bonded structure as the temperature is raised. See LIQUID.

**Properties.** The electrical conductivity of water is at least 1,000,000 times larger than that of most other nonmetallic liquids at room temperature. The current in this case is carried by ions produced by the dissociation of water according to reaction (3).



Water is an excellent solvent for many substances, but particularly for those which dissociate to form ions. Its principal scientific and industrial use as a solvent is to furnish a medium for purifying such substances and for carrying out reactions between them. See SOLUTION; SOLVENT.

Water is not a strong oxidizing agent, although it may enhance the oxidizing action of other oxidizing agents, notably oxygen. Water is an even poorer reducing agent than oxidizing agent. One of the few substances that it reduces rapidly is fluorine. See OXIDATION-REDUCTION.

Substances with strong acidic or basic character react with water. For example, calcium oxide, a basic oxide, reacts in a process called the slaking of lime, reaction (4). Another type of sub-

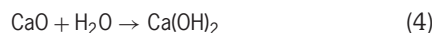

stance with strong acidic character is an acid chloride. An example and its reaction with water is boron trichloride, reaction (5).

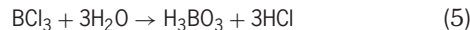

This is termed hydrolysis, as is the reaction of an ester with water. See HYDROLYSIS.

Water also reacts with a variety of substances to form solid compounds in which the water molecule is intact, but in which it becomes a part of the structure of the solid. Such compounds are called hydrates. See HYDRATE.

For various aspects of water, its uses, and occurrence see HEAVY WATER; HYDROGEN; HYDROLOGY; IRRIGATION (AGRICULTURE); NUTRITION; OXYGEN; PLANT-WATER RELATIONS; PRECIPITATION (METEOROLOGY); SEAWATER; TRIPLE POINT; VAPOR PRESSURE; WATER ANALYSIS; WATER CONSERVATION; WATER MICROBIOLOGY; WATER POLLUTION; WATER PURIFICATION; WATER SOFTENING; WATER SUPPLY ENGINEERING; WATER TABLE; WATER TREATMENT; WATERPOWER. [H.L.F.]

**Water-borne disease** Disease acquired by drinking water contaminated at its source or in the distribution system, or by direct contact with environmental and recreational waters. Water-borne disease results from infection with pathogenic microorganisms or chemical poisoning.

These pathogenic microorganisms include viruses, bacteria, protozoans, and helminths. A number of microbial pathogens transmitted by the fecal-oral route are commonly acquired from water in developing countries where sanitation is poor. Viral pathogens transmitted via fecally contaminated water include hepatitis viruses A and E. Important bacterial pathogens transmitted via fecally contaminated water in the developing world are *Vibrio cholerae*, enterotoxigenic *Escherichia coli*, *Shigella*, and *Salmonella enterica* serotype Typhi. Water-borne protozoan pathogens in the developing world include *Giardia lamblia* and *Entamoeba histolytica*. The major water-borne helminthic infection is schistosomiasis; however, transmission is not fecal-oral. Another water-borne helminthic infection is dracunculiasis (guinea worm infection).

In developed countries, fecal contamination of drinking water supplies is less likely. However, there have been outbreaks of diseases such as shigellosis and giardiasis associated with lapses in proper water treatment, such as cross-contamination of wastewater systems and potable water supplies. Animals are therefore more likely to play a role in water-borne disease in developed countries. Bacterial pathogens acquired from animal feces such as nontyphoid *S. enterica*, *Campylobacter jejuni*, and *E. coli* serotype O157:H7 have caused outbreaks of water-borne disease in developed countries where water is not properly chlorinated. Hikers frequently acquire *G. lamblia* infections from drinking untreated lake and stream water. *Giardia lamblia* may have animal reservoirs and can persist in the environment. A recently recognized pathogen apparently resistant to standard chlorination and filtration practices is the protozoan *Cryptosporidium parvum*. This organism is found in the feces of farm animals and may enter water supplies through agricultural runoff.

Chemical poisoning of drinking water supplies causes disease in both developing and developed countries. Lead, copper, and cadmium have been frequently involved. See CHOLERA; ESCHERICHIA; MEDICAL PARASITOLOGY; SCHISTOSOMIASIS. [S.L.M.]

**Water conservation** The protection, development, and efficient management of water resources for beneficial purposes. Nearly every human activity—from agriculture to transportation to daily living—relies on water resources and affects the availability and quality of those resources. Water resource development has played a role in flood control, agricultural production, industrial and energy development, fish and wildlife resource management, navigation, and a host of other activities.

As a result of these impacts, natural hydrologic features have changed through time, pollution has decreased the quality of remaining water resources, and global climate change may affect the distribution of water in the future. See HYDROLOGY.

Water availability varies substantially between geographic regions, but it is also affected strongly by the population of the region. Asia, for example, has an extremely large total runoff but the lowest per-capita water availability. In addition, nearly 40% of the world's population lives in areas that experience severe to moderate water stress. Thus the combination of water and population distribution has resulted in a large difference in per-capita water use between countries.

Worldwide, nearly 4000 km<sup>3</sup> of water is withdrawn every year from surface and ground waters. This is a sixfold increase from the levels withdrawn in 1900 (since which time population has increased four times). Agriculture accounts for the greatest proportion of water use, with about two-thirds of water withdrawals and 85% of water consumption. It also accounts for a great proportion of the increase in water use, with irrigated cropland more than doubling globally since 1960. However, in Europe and North America particularly, industry consumes a large proportion of available water; industrial uses for water are anticipated to grow on other continents as well.

Land development has substantially affected the distribution of water resources. It is estimated that one-half of the natural wetlands in the world have been lost in the last century. In some areas, such as California, wetland loss is estimated to be greater than 90%. The vast majority of wetlands loss has been associated with agricultural development, but urban and industrial changes have reduced wetlands as well. River channels have also been altered to enhance irrigation, navigation, power production, and a variety of other human activities.

Ground-water resources have been depleted in the last century, with many aquifers or artesian sources being depleted more rapidly than they can be recharged. This is called ground-water overdraft. In the United States, ground-water overdraft is a serious problem in the High Plains from Nebraska to Texas and in parts of California and Arizona. See GROUND-WATER HYDROLOGY.

Streams have traditionally served for waste disposal. Towns and cities, industries, and mines provide thousands of pollution sources. Pollution dilution requires large amounts of water. Treatment at the source is safer and less wasteful than flushing untreated or poorly treated wastes downstream. However, sufficient flows must be released to permit the streams to dilute, assimilate, and carry away the treated effluents. See WATER POLLUTION.

The availability of fresh water is also likely to be affected by global climate change. There is substantial evidence that global temperatures have risen and will continue to rise. Although the precise effects of this temperature risk on water distribution are challenging to predict, most models of climate change do anticipate increased global precipitation. It is likely that some areas, particularly those at mid to high latitudes, will become wetter, but the increased precipitation will be more seasonal than current patterns. Other areas are likely to receive less precipitation than they do currently. In addition, many models predict increases in the intensity and frequency of severe droughts and floods in at least some regions. These changes will affect natural stream flow patterns, soil moisture, ground-water recharge, and thus the timing and intensity of human demands for fresh-water supplies. See GLOBAL CLIMATE CHANGE.

Land management vitally influences the distribution and character of runoff. Inadequate vegetation or surface organic matter; compaction of farm, ranch, or forest soils by heavy vehicles; frequent crop-harvesting operations; repeated burning; or excessive trampling by livestock or wild ungulates all expose the soil to the destructive energy of rainfall or rapid snowmelt. On such lands little water enters the soil, soil particles are dislodged

and quickly washed into watercourses, and gullies may form. See LAND-USE PLANNING; SOIL CONSERVATION.

There are a variety of measures that can be taken to reduce water consumption. In the United States, for example, per-capita water usage dropped 20% from 1980 to 1995. In many cases, improvements to existing systems would contribute to additional water savings. In the United States, an average of 15% of the water in public supply systems (for cities with populations greater than 10,000) is unaccounted for, and presumably lost.

Improvements can also be achieved by changing industrial and agricultural practices. Agricultural water consumption has an estimated overall water use efficiency of 40%. More effective use of water in agricultural systems can be achieved, for example, with more efficient delivery methods such as drip irrigation. More accurate assessment of soil and plant moisture can allow targeted delivery of water at appropriate times. In industrial settings, recycling and more efficient water use has tremendous potential to reduce water consumption. Overall, industrial water usage dropped by 30% in California between 1980 and 1990, with some sectors achieving even greater reductions. Japan has achieved a 25% reduction in industrial water use since the 1970s. Additional potential to reduce this usage still exists even in locations where many conservation measures are already in place.

Residential water consumption can also be reduced through conservation measures. High-efficiency, low-flow toilets can reduce the water required to flush by 70% or more. Additional savings are possible with efficient faucet fixtures and appliances.

Water conservation in the United States faces a number of institutional as well as technological challenges. States must administer the regulatory provisions of their pollution-control laws, develop water quality standards and waste-treatment requirements, and supervise construction and maintenance standards of public service water systems. Some states can also regulate ground-water use to prevent serious overdrafts. Artesian wells may have to be capped, permits may be required for drilling new wells, or reasonable use may have to be demonstrated. Federal responsibilities consist largely of financial support or other stimulation of state and local water management. Federal legislation permits court action on suits involving interstate streams where states fail to take corrective action following persistent failure of a community or industry to comply with minimum waste-treatment requirements.

The watershed control approach to planning, development, and management rests on the established interdependence of water, land, and people. Coordination of structures and land-use practices is sought to prevent erosion, promote infiltration, and retard high flows (to prevent flooding). The Natural Resources Conservation and Forest Services of the Department of Agriculture administer the program. The Natural Resources Conservation Service cooperates with other federal and state agencies and operates primarily through the more than 2000 soil conservation districts.

Because watersheds often span political boundaries, many efforts to conserve and manage water require cooperation between states and countries. Many countries currently have international treaties addressing water allocation and utilization. In 1997, the United Nations adopted the Convention on the Law of the Non-navigational Uses of International Watercourses, which includes an obligation not to cause significant harm to other watercourse states, as well as provisions for dispute resolution. In addition, in 1996 the Global Water Partnership and the World Water Council were formed for the purpose of addressing ongoing international water concerns. [B.F.; M.McC.; G.Pr.]

The increasing utilization of the continental shelf for oil drilling and transport, siting of nuclear power plants, and various types of planned and inadvertent waste disposal, as well as for food and recreation, requires careful management of human

activities in this ecosystem. Nearshore waters are presently subject to both atmospheric and coastal input of pollutants in the form of heavy metals, synthetic chemicals, petroleum hydrocarbons, radionuclides, and other urban wastes. Overfishing is an additional human-induced stress. Physical transport of pollutants, their modification by the coastal food web, and demonstration of transfer to humans are sequential problems of increasing complexity on the continental shelf.

One approach to quantitatively assess the above pollutant impacts is to construct simulation models of the coastal food web in a systems analysis of the continental shelf. Models of physical transport of pollutants have been the most successful, for example, as in studies of beach fouling by oil. Incorporation of additional biological and chemical terms in a simulation model, however, requires dosage response functions of the natural organisms to each class of pollutants, as well as a quantitative description of the "normal" food web interactions of the continental shelf. See ECOLOGICAL MODELING; FOOD WEB.

In addition to toxic materials introduced by oil spills, sewage, and agricultural and industrial run-off, coastal waters are vulnerable to thermal pollution. Thermal pollution is caused by the discharge of hot water from power plants or factories and from desalination plants. A large power installation may pump in  $10^6$  gal/min ( $63 \text{ m}^3/\text{s}$ ) of seawater to act as a coolant and discharge it at a temperature approximately  $18^\circ\text{F}$  ( $10^\circ\text{C}$ ) above that of the ambient water. In a shallow bay with restricted tidal flow, the rise in temperature can cause gross alterations to the natural ecology. Federal standards prohibit heating of coastal waters by more than  $0.9^\circ\text{F}$  ( $0.5^\circ\text{C}$ ). See THERMAL ECOLOGY.

Finally, dredging waters to fill wetlands for house lots, parking lots, or industrial sites destroys the marshes that provide sanctuary for waterfowl and for the young of estuarine fishes. As the bay bottom is torn up, the loosened sediments shift about with the current and settle in thick masses on the bottom, suffocating animals and plants. In this way, the marshes are eliminated and the adjoining bays are degraded as aquatic life zones. The northeast Atlantic states have lost 45,000 acres ( $182 \text{ km}^2$ ) of coastal wetlands in only 10 years, and San Francisco Bay has been nearly half obliterated by filling. Dredging to remove sand and gravel has the same disruptive effects as dredging for landfill or other purposes, whether the sand and gravel are sold for profit or used to replenish beach sand eroded away by storms. The dredging of boat channels adds to the siltation problem, and disposal of dredge spoils is being regulated in coastal areas. [J.J.W.]

**Water desalination** The removal of dissolved minerals (including salts) from seawater or brackish water. This may occur naturally as part of the hydrologic cycle, or as an engineered process. Engineered water desalination processes, which produce potable water from seawater or brackish water, have become important because many regions throughout the world suffer from water shortages caused by the uneven distribution of the natural water supply and by human use. See WATER SUPPLY ENGINEERING.

Seawater, brackish water, and fresh water have different levels of salinity, which is often expressed by the total dissolved solids (TDS) concentration. Seawater has a TDS concentration of about 35,000 mg/L, and brackish water has a TDS concentration of 1000–10,000 mg/L. Water is considered fresh when its TDS concentration is below 500 mg/L, which is the secondary (voluntary) drinking water standard for the United States. Salinity is also expressed by the water's chloride concentration, which is about half of its TDS concentration. See SEAWATER.

Water desalination processes separate feed water into two streams: a fresh-water stream with a TDS concentration much less than that of the feed water, and a brine stream with a TDS concentration higher than that of the feed water.

Distillation is a process that turns seawater into vapor by boiling, and then condenses the vapor to produce fresh water.

Boiling water is an energy-intensive operation, requiring about 4.2 kilojoules of energy (or latent heat) to raise the temperature of 1 kg of water by  $1^\circ\text{C}$ . After water reaches its boiling point, another 2257 kJ of energy (or the heat of vaporization) is required to convert it to vapor. The boiling point depends on ambient atmospheric pressure—at lower pressure, the boiling point of water is lower. Therefore, keeping water boiling can be accomplished either by providing a constant energy supply or by reducing the ambient atmospheric pressure. See DISTILLATION.

Reverse osmosis, the process that causes water in a salt solution to move through a semipermeable membrane to the fresh-water side, is accomplished by applying pressure in excess of the natural osmotic pressure to the salt solution. The operational pressure of reverse osmosis for seawater desalination is much higher than that for brackish water, as the osmotic pressure of seawater at a TDS concentration of 35,000 mg/L is about 2700 kJ while the osmotic pressure of brackish water at a TDS concentration of 3000 mg/L is only about 230 kJ.

Salts dissociate into positively and negatively charged ions in water. The electro dialysis process uses semipermeable and ion-specific membranes, which allow the passage of either positively or negatively charged ions while blocking the passage of the oppositely charged ions. An electro dialysis membrane unit consists of a number of cell pairs bound together with electrodes on the outside. These cells contain an anion exchange membrane and cation exchange membrane. Feed water passes simultaneously in parallel paths through all of the cells, separating the product (water) and ion concentrate. See DIALYSIS; ION EXCHANGE.

[C.C.K.L.; J.W.P.]

**Water hammer** The propagation in a liquid of an acoustic wave that is caused by a rapid change in fluid velocity. Such relatively sudden changes in the liquid velocity are due to events such as the operation of pumps or valves in pipelines, the collapse of vapor bubbles within the liquid, underwater explosions, or the impact of water following the rapid expulsion of air from a vent or a partially open valve. Alternative terms such as pressure transients, pressure surge, hydraulic transients, and hydraulic shock are often employed. Although the physics and mathematical characterization of water hammer and underwater acoustics (employed in sonar) are identical, underwater sound is always associated with very small pressure changes compared to the potential of moderate to very large pressure differences associated with water hammer. See CAVITATION; SOUND; UNDERWATER SOUND.

A pressure change  $\Delta p$  is always associated with the rapid velocity change  $\Delta V$  across a water hammer wave, as formulated from the basic physics of mass and momentum conservation by the Joukowski equation,  $\Delta p = -\rho a \Delta V$ . Here  $\rho$  is the liquid mass density and  $a$  is the sonic velocity of the pressure wave in the fluid medium. In a pipe, this velocity depends on the ratio of the bulk modulus of the liquid to the elastic modulus of the pipe wall, and on the ratio of the inside diameter of the pipe to the wall thickness. In water in a very rigid pipe or in a tank, or even the sea, the acoustic velocity is approximately 1440 m/s (4720 ft/s), a value many times that of any liquid velocity.

Liquid-handling systems are designed so that water hammer does not result from sudden closure, but is limited to more gradual flow changes initiated by valves or other devices. The dramatic pressure rise (or drop) results can be significantly reduced by reflections of the original wave from pipe-area changes, tanks, reservoirs, and so forth. Although the Joukowski equation applies across every wavelet, the effect of complete valve closure over a period of time greater than a minimum critical time can be quite beneficial. This critical time is the time required for an acoustic wave to propagate twice the distance along the pipe from the point of wave creation to the location of the first pipe-area change. See HYDRODYNAMICS; PIPE FLOW.

[C.S.Ma.]

**Water-jet cutting** The use of high-pressure water jets, which may contain abrasive powder, for cutting and removing materials. For example, water accelerated up to twice the speed of sound [343 m/s (1125 ft/s) at 20°C (68°F)] can penetrate and cut rock in a few seconds.

Among the methods of cutting metal and nonmetallic materials, pure and abrasive water-jet cutting techniques have a distinct advantage because of their versatility and speed. They can cut all materials, including hard-to-machine materials such as superalloy, Kevlar, and boron carbide. They can also easily cut aerospace materials such as graphite composite and titanium, and brittle materials such as advanced ceramics, granite, marble, and glass (see illustration). The pure water jet is used by the food industry to cut candy and chocolate bars, meats, vegetables, and fruits. It is being tested for orthopedic surgery applications in bone cutting and scaling the flesh from bones. Other biomedical applications include a nonsurgical water-jet system for rapidly removing clots from blood vessels, and a water jet for corneal surgery.

The advantages of pure and abrasive water-jet cutting are (1) absence of thermal distortion and work hardening; (2) non-contact during cutting, thus eliminating tool wear and contact force; and (3) omnidirectional cutting, allowing the cutting of complex shapes and contours.

Although the use of the water-jet system is rapidly growing, the technique has some drawbacks and limitations. Water-jet technology has not yet developed fully for high-tolerance and -precision machining. The initial capital investment for the system, including the motion-control equipment and operating costs, is relatively high. The noise level (80 adjusted decibels) is somewhat high, but the system can be specially designed to isolate the noise source. See MACHINABILITY OF METALS.

The water-jet pump and its delivery system are designed to produce a high-velocity jet stream within a relatively short trajectory distance, since the kinetic energy of the water and abrasive particles is directly proportional to the square of the jet velocity. In abrasive jet cutting applications, the abrasives entrained in the jet stream usually attain approximately 80% of the water-droplet velocity at the nozzle tip. The jet cuts the material by a rapid erosion process, when its force exceeds the compressive strength of the material. Since the area eroded by the abrasive is also swept by the water stream, the heat generated during the cutting is dissipated immediately, resulting in a small rise in tem-

perature (less than 90°F or 50°C) in the workpiece. Therefore, no thermal distortion or work hardening is associated with water-jet cutting. The cutting by rapid erosion also significantly reduces the actual force exerted on the material, enabling the water jet to cut fragile or deformable materials such as glass and honeycomb structures. See JET FLOW; METAL, MECHANICAL PROPERTIES OF; SHEAR. [T.J.K.]

**Water pollution** A change in the chemical, physical, biological, and radiological quality of water that is injurious to its existing, intended, or potential uses (for example, boating, waterskiing, swimming, the consumption of fish, and the health of aquatic organisms and ecosystems). The term "water pollution" generally refers to human-induced (anthropogenic) changes to water quality. Thus, the discharge of toxic chemicals from a pipe or the release of livestock waste into a nearby water body is considered pollution. Conversely, nutrients that originate from animals in the wild or toxins that originate from natural processes are not considered pollution.

The contamination of ground water, rivers, lakes, wetlands, estuaries, and oceans can threaten the health of humans and aquatic life. Sources of water pollution are generally divided into two categories. The first is point-source pollution, in which contaminants are discharged from a discrete location. Sewage outfalls and oil spills are examples of point-source pollution. The second category is non-point-source or diffuse pollution, referring to all of the other discharges that deliver contaminants to water bodies. Acid rain and unconfined runoff from agricultural or urban areas are examples of non-point-source pollution. The principal contaminants of water include toxic chemicals, nutrients and biodegradable organics, and bacterial and viral pathogens.

Water pollution can threaten human health when pollutants enter the body via skin exposure or through the direct consumption of contaminated food or drinking water. Priority pollutants, including dichlorodiphenyl trichloroethane (DDT) and polychlorinated biphenyls (PCBs), persist in the natural environment and bioaccumulate in the tissues of aquatic organisms. These persistent organic pollutants are transferred up the food chain (in a process called biomagnification), and they can reach levels of concern in fish species that are eaten by humans. Finally, bacteria and viral pathogens can pose a public health risk for those who drink contaminated water or eat raw shellfish from polluted water bodies. See ENVIRONMENTAL TOXICOLOGY; FOOD WEB.

Contaminants have a significant impact on aquatic ecosystems. For example, enrichment of water bodies with nutrients (principally nitrogen and phosphorus) can result in the growth of algae and other aquatic plants that shade or clog streams. If wastewater containing biodegradable organic matter is discharged into a stream with inadequate dissolved oxygen, the water downstream of the point of discharge will become anaerobic and will be turbid and dark. Settleable solids, if present, will be deposited on the streambed, and anaerobic decomposition will occur. Over the reach of stream where the dissolved-oxygen concentration is zero, a zone of putrefaction will occur with the production of hydrogen sulfide, ammonia, and other odorous gases. Because many fish species require a minimum of 4–5 mg of dissolved oxygen per liter of water, they will be unable to survive in this portion of the stream.

Direct exposures to toxic chemicals is also a health concern for individual aquatic plants and animals. Chemicals (e.g., pesticides) are frequently transported to lakes and rivers via runoff, and they can have unintended and harmful effects on aquatic life. Toxic chemicals have been shown to reduce the growth, survival, reproductive output, and disease resistance of exposed organisms. These effects can have important consequences for the viability of aquatic populations and communities. See INSECTICIDE.

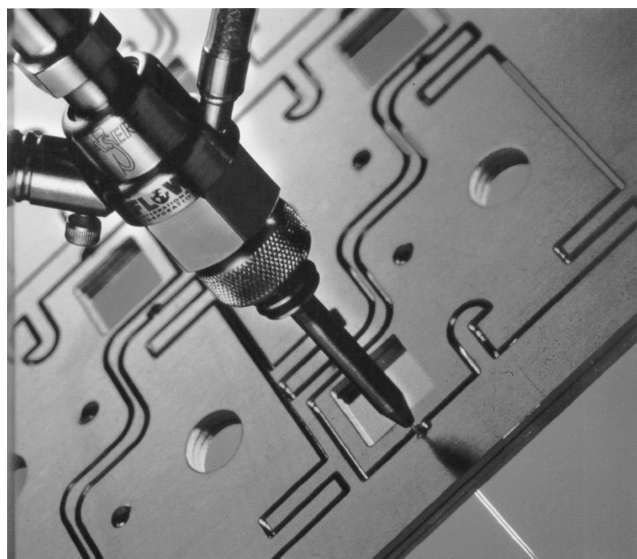

Abrasive water-jet cutting of 0.5-in.-thick (12.5-mm) titanium at a pressure of 45,000 lb/in.<sup>2</sup> (310 MPa). (Flow International Corp.)



Wastewater discharges are most commonly controlled through effluent standards and discharge permits. Under this system, discharge permits are issued with limits on the quantity and quality of effluents. Water-quality standards are sets of qualitative and quantitative criteria designed to maintain or enhance the quality of receiving waters. Receiving waters are divided into several classes depending on their uses, existing or intended, with different sets of criteria designed to protect uses such as drinking water supply, bathing, boating, fresh-water and shellfish harvesting, and outdoor sports for seawater. For toxic compounds, chemical-specific or whole-effluent toxicity studies are used to develop standards and criteria. In the chemical-specific approach, individual criteria are used for each toxic chemical detected in the wastewater. Criteria can be developed to protect aquatic life against acute and chronic effects and to safeguard humans against deleterious health effects, including cancer. In the whole-effluent approach, toxicity or bioassay tests are used to determine the concentration at which the wastewater induces acute or chronic toxicity effects. See HAZARDOUS WASTE; SEWAGE DISPOSAL; SEWAGE TREATMENT. [N.Sc.; G.Tc.]

**Water softening** The process of removing divalent cations, usually calcium or magnesium, from water. When a sample of water contains more than 120 mg of these ions per liter (0.016 oz/gal), expressed in terms of calcium carbonate ( $\text{CaCO}_3$ ), it is generally classified as a hard water. Hard waters are frequently unsuitable for many industrial and domestic purposes because of their soap-destroying power and tendency to form scale in equipment such as boilers, pipelines, and engine jackets. Therefore it is necessary to treat the water either to remove or to alter the constituents for it to be fit for the proposed use.

The principal water-softening processes are precipitation, cation exchange, electrical methods, or combinations of these. The factors to be considered in the choice of a softening process include the raw-water quality, the end use of softened water, the cost of softening chemicals, and the ways and costs of disposing of waste streams. See ION EXCHANGE; WATER TREATMENT. [Y.H.M.]

**Water supply engineering** A branch of civil engineering concerned with the development of sources of supply, transmission, distribution, and treatment of water. The term is used most frequently in regard to municipal water works, but applies also to water systems for industry, irrigation, and other purposes.

Water obtained from subsurface sources, such as sands and gravels and porous or fractured rocks, is called ground water. Ground water flows toward points of discharge in river valleys and, in some areas, along the seacoast. The flow takes place in water-bearing strata known as aquifers. In an unconfined stratum the water table is the top or surface of the ground water. It may be within a few inches of the ground surface or hundreds of feet below. See AQUIFER; GROUND-WATER HYDROLOGY; WATER TABLE.

Wells are vertical openings, excavated or drilled, from the ground surface to a water-bearing stratum or aquifer. Pumping a well lowers the water level in it, which in turn forces water to flow from the aquifer. Thick, permeable aquifers may yield several million gallons daily with a drawdown (lowering) of only a few feet. Thin aquifers, or impermeable aquifers, may require several times as much drawdown for the same yields, and frequently yield only small supplies.

Dug wells, several feet in diameter, are frequently used to reach shallow aquifers, particularly for small domestic and farm supplies. They furnish small quantities of water, even if the soils penetrated are relatively impervious. Large-capacity dug wells or caisson wells, in coarse sand and gravel, are used frequently for municipal supplies. Drilled wells are sometimes several thousand feet deep.

The distance between wells must be sufficient to avoid harmful interference when the wells are pumped. In general, economical well spacing varies directly with the quantity of water to be pumped, and inversely with the permeability and thickness of the aquifer. It may range from a few feet to a mile or more.

Specially designed pumps, of small diameter to fit inside well casings, are used in all well installations, except in flowing artesian wells or where the water level in the well is high enough for direct suction lift by a pump on the surface (about 15 ft or 5 m maximum). Well pumps are set some distance below the water level, so that they are submerged even after the drawdown is established. See ARTESIAN SYSTEMS; WELL.

Natural sources, such as rivers and lakes, and impounding reservoirs are sources of surface water. Water is withdrawn from rivers, lakes, and reservoirs through intakes. The simplest intakes are pipes extending from the shore into deep water, with or without a simple crib and screen over the outer end. Intakes for large municipal supplies may consist of large conduits or tunnels extending to elaborate cribs of wood or masonry containing screens, gates, and operating mechanisms. Intakes in reservoirs are frequently built as integral parts of the dam and may have multiple ports at several levels to permit selection of the best water. See DAM; RESERVOIR; SURFACE WATER.

The water from the source must be transmitted to the community or area to be served and distributed to the individual customers. The major supply conduits, or feeders, from the source to the distribution system are called mains or aqueducts. The oldest and simplest type of aqueducts, especially for transmitting large quantities of water, are canals. Canals are used where they can be built economically to follow the hydraulic gradient or slope of the flowing water. If the soil is suitable, the canals are excavated with sloping sides and are not lined. Otherwise, concrete or asphalt linings are used. Gravity canals are carried across streams or other low places by wooden or steel flumes, or under the streams by pressure pipes known as inverted siphons. Tunnels are used to transmit water through ridges or hills; tunnels may follow the hydraulic grade line and flow by gravity or may be built below the grade line to operate under considerable pressure. Pipelines are a common type of transmission main, especially for moderate supplies not requiring large aqueducts or canals. See CANAL; PIPELINE; TUNNEL.

Included in the distribution system are the network of smaller mains branching off from the transmission mains, the house services and meters, the fire hydrants, and the distribution storage reservoirs. The network is composed of transmission or feeder mains, usually 12 in. (30 cm) or more in diameter, and lateral mains along each street, or in some cities along alleys between the streets. The mains are installed in grids so that lateral mains can be fed from both ends where possible. Valves at intersections of mains permit a leaking or damaged section of pipe to be shut off with minimum interruption of water service to adjacent areas.

Distribution reservoirs are used to supplement the source of supply and transmission system during peak demands, and to provide water during a temporary failure of the supply system. Ground storage reservoirs, if on high ground, can feed the distribution system by gravity, but otherwise it is necessary to pump water from the reservoir into the distribution system. Circular steel tanks and basins built of earth embankments, concrete, or rock masonry are used. Elevated storage reservoirs are tanks on towers, or high cylindrical standpipes resting on the ground. Storage reservoirs are built high enough so that the reservoir will maintain adequate pressure in the distribution system at all times. Elevated tanks are usually of steel plate, mounted on steel towers, but wood is sometimes used for industrial and temporary installations.

Pumps are required wherever the source of supply is not high enough to provide gravity flow and adequate pressure in the

distribution system. The pumps may be high or low head depending upon the topography and pressures required. Booster pumps are installed on pipelines to increase the pressure and discharge, and adjacent to ground storage tanks for pumping water into distribution systems. Pumping stations usually include two or more pumps, each of sufficient capacity to meet demands when one unit is down for repairs or maintenance. The station must also include piping and valves arranged so that a break can be isolated quickly without cutting the whole station out of service. [R.H.]

Drinking water comes from surface and ground-water sources. Surface waters normally contain suspended matter, pathogenic organisms, and organic substances. Ground water normally contains dissolved minerals and gases. Both require treatment. Conventional water treatment processes include pretreatment, aeration, rapid mix, coagulation and flocculation, sedimentation, filtration, disinfection, and other unit processes to meet specific requirements. See FILTRATION; SEDIMENTATION (INDUSTRY); WATER TREATMENT.

Aeration (air or oxygen into water) and air stripping (water into air) primarily are used to remove dissolved gases, such as hydrogen sulfide which causes taste and odor, and to oxidize iron and manganese. [R.A.Cor.]

**Water table** The upper surface of the zone of saturation in permeable rocks not confined by impermeable rocks. It may also be defined as the surface underground at which the water is at atmospheric pressure. Saturated rock may extend a little above this level, but the water in it is held up above the water table by capillarity and is under less than atmospheric pressure; therefore, it is the lower part of the capillary fringe and is not free to flow into a well by gravity. Below the water table, water is free to move under the influence of gravity.

The position of the water table is shown by the level at which water stands in wells penetrating an unconfined water-bearing formation. Where a well penetrates only impermeable material, there is no water table and the well is dry. But if the well passes through impermeable rock into water-bearing material whose hydrostatic head is higher than the level of the bottom of the impermeable rock, water will rise approximately to the level it would have assumed if the whole column of rock penetrated had been permeable. This is called artesian water. See ARTESIAN SYSTEMS; GROUND-WATER HYDROLOGY; WELL. [A.N.S./R.K.L.]

**Water treatment** Physical and chemical processes for making water suitable for human consumption and other purposes. Drinking water must be bacteriologically safe, free from toxic or harmful chemicals or substances, and comparatively free of turbidity, color, and taste-producing substances. Excessive hardness and high concentration of dissolved solids are also undesirable, particularly for boiler feed and industrial purposes. The treatment processes of greatest importance are sedimentation, coagulation, filtration, disinfection, softening, and aeration.

Sedimentation occurs naturally in reservoirs and is accomplished in treatment plants by basins or settling tanks. Plain sedimentation will not remove extremely fine or colloidal material within a reasonable time, and the process is used principally as a preliminary to other treatment methods.

Fine particles and colloidal material are combined into masses by coagulation. These masses, called floc, are large enough to settle in basins and to be caught on the surface of filters.

Suspended solids, colloidal material, bacteria, and other organisms are filtered out by passing the water through a bed of sand or pulverized coal, or through a matrix of fibrous material supported on a perforated core. Soluble materials such as salts and metals in ionic form are not removed by filtration. See FILTRATION.

There are several methods of treatment of water to kill living organisms, particularly pathogenic bacteria; the application of

chlorine or chlorine compounds is the most common. Less frequently used methods include the use of ultraviolet light, ozone, or silver ions. Boiling is the favored household emergency measure.

Municipal water softening is common where the natural water has a hardness in excess of 150 parts per million. Two methods are used: (1) The water is treated with lime and soda ash to precipitate the calcium and magnesium as carbonate and hydroxide, after which the water is filtered; (2) the water is passed through a porous cation exchanger which has the ability of substituting sodium ions in the exchange medium for calcium and magnesium in the water. For high-pressure steam boilers or some other industrial processes, almost complete deionization of water is needed, and treatment includes both cation and anion exchangers. See ION EXCHANGE.

Aeration is a process of exposing water to air by dividing the water into small drops, by forcing air through the water, or by a combination of both. Aeration is used to add oxygen to water and to remove carbon dioxide, hydrogen sulfide, and taste-producing gases or vapors. See WATER POLLUTION; WATER SUPPLY ENGINEERING. [R.H.]

**Water-tube boiler** A steam boiler in which water circulates within tubes and heat is applied from outside the tubes. The outstanding feature of the water-tube boiler is the use of small tubes [usually 1–3 in. (2.5–7.5 cm) outside diameter] exposed to the products of combustion and connected to steam and water drums which are shielded from these high-temperature gases. Thus, possible failure of boiler parts exposed to direct heat transfer is restricted to the small-diameter tubes and, in the event of failure, the energy released is reduced and explosion hazards are minimized.

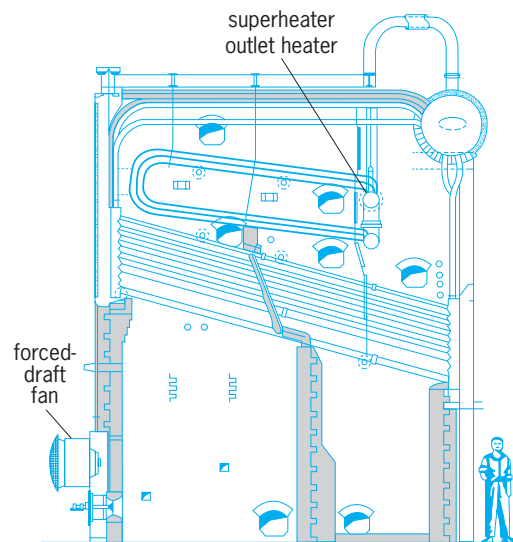
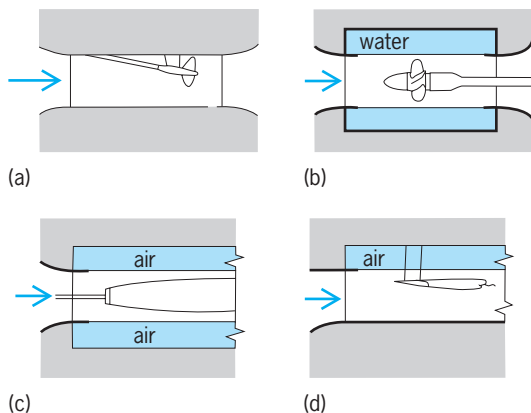

Diagram of a straight-tube-type boiler.

There are many types of water-tube boilers but, in general, they can be grouped into two categories: the straight-tube (see illustration) and the bent-tube types. In essence, both types consist of banks of parallel tubes which are connected to, or by, headers or drums. Most modern water-tube boilers utilize a water-cooled surface in the furnace, and this surface is an integral part of the boiler's circulatory system. Further, modern water-tube boilers generally incorporate the use of superheaters, economizers, or air heaters to utilize more efficiently the heat from the fuel and to provide steam at a high potential for useful work in an engine or turbine. See BOILER; STEAM; STEAM-GENERATING FURNACE; STEAM-GENERATING UNIT. [G.W.K.]

**Water tunnel** A hydrodynamic facility used for research, test, and evaluation, comprising a well-guided and controlled stream of water in which items for test are placed. The water tunnel is in many ways similar in appearance, arrangement, and operation to a subsonic wind tunnel. It is related to and complementary to the towing tank, in which the test item, usually a scale model of a ship or ship component, is towed through stationary water and evaluated through observation and measurement. In a water tunnel the test item is held stationary while the water is circulated around it. Many water tunnels are capable of operation with variable internal pressure to simulate the phenomenon of cavitation. See CAVITATION; TOWING TANK; WIND TUNNEL.



Types of water-tunnel test sections with typical models. (a) Closed throat. (b) Open throat. (c) Free jet. (d) Free surface.

Water tunnels may be classified, in part, by the type of test section used. The most common section is the closed throat (illus. a) in which the test section flow has solid boundaries. The advantage of this arrangement is its simplicity and efficiency, but the model must be small relative to the tunnel cross section to avoid large wall effects. Small wall effects are theoretically correctable. In an open-throat test section (illus. b) the water jet passes through a water-filled chamber of larger diameter. This minimizes wall effects, and many tunnels dedicated to propeller testing use such an arrangement. When very low test section cavitation numbers are required, or for fully cavitating flows, a free jet (illus. c) in which the water jet passes through an air-filled chamber is useful. However, capture of the free jet and removal of excess entrained air prior to recirculation is not easily achieved over a broad range of test conditions. To study cavity flows on surface-piercing components or hydrofoils which operate near a free surface, a free-surface tunnel (illus. d) is required in which three sides of the water flow are bounded by solid walls and the upper surface is open to air at controlled pressure levels. This arrangement is often referred to as a water channel. See HYDROFOIL CRAFT; OPEN CHANNEL.

Another distinction among water tunnel types is whether or not they recirculate the flow. If the tunnel is nonrecirculating, water may “blow down” from a pressurized or elevated water tank or water may be diverted from a continuous source such as a waterfall or dam on a river. The blow-down tunnel has a limited test period proportional to the size of the storage tank. All water tunnels make use of transparent test-section viewing windows.

Water tunnels are used to investigate the dynamics, hydrodynamics, and cavitation of submerged and semisubmerged bodies such as propellers, ships, submarines, torpedoes, and hydrofoils and of turbomachinery. They are also indispensable to research on general flow phenomena in liquids. An application of great

importance has been the acoustic characterization of propellers under both cavitating and noncavitating conditions. See HYDRODYNAMICS; PROPELLER (MARINE CRAFT). [R.S.Ro.; R.J.E.]

**Watermelon** The edible fruit of *Citrullus lanatus*, of the family Cucurbitaceae. The plant is an annual prostrate vine with multiple stems.

The numerous cultivars of watermelon are highly diverse in fruit size (5–85 lb; 2.3–38.3 kg), shape (round, oval, oblong-cylindrical), rind color (very light to very dark green and often striped or mottled), flesh color (red, pink, orange, yellow, white), and seed size and color. The flesh contains 6–12% sugar, depending upon variety and condition of growth, with 8% sugar being acceptable on most markets.

Watermelon juice of the sweet cultivars can be reduced to edible sugar and syrup. Watermelon seeds are relished as food in some Near East countries and in China. Fresh watermelon flesh has a unique melting quality that has proved impossible to preserve in palatable form through any processing technique. The flesh consists of water (91%), fiber, and sugar, and little else of obvious nutritional value, but may have some as yet unproved health-promoting value. It is said to have diuretic properties, and both frozen concentrate and canned juice have been available for the treatment of nephritis. The seeds also are said to contain substances effective in the control of hypertension. [C.F.A.]

**Waterspout** An intense columnar vortex (not necessarily containing a funnel-shaped cloud) of small horizontal extent, over water. Typical visible vortex diameters are of the order of 33 ft (10 m), but a few large waterspouts may exceed 330 ft (100 m) across. In the case of Florida waterspouts, only rarely does the visible funnel extend from parent cloudbase to sea surface. Like the tornado, most of the visible funnel is condensate. Therefore, the extension of the funnel cloud downward depends

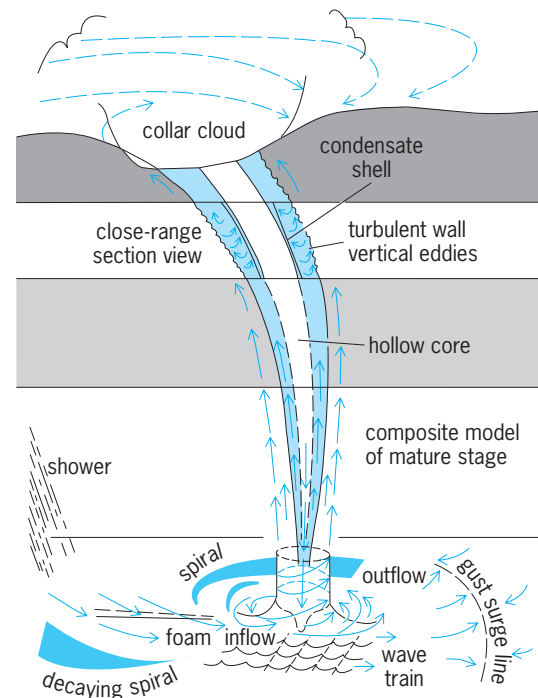

Composite schematic model of a mature waterspout. For scaling reference, the maximum funnel diameters in this stage, just below the collar cloud, range from 10 to 460 ft (3 to 140 m).

upon the distribution of ambient water vapor, ambient temperature, and pressure drop due to the vortex circulation strength. These vortices are most frequently observed during the warm season in the oceanic tropics and subtropics.

All waterspouts undergo a regular life cycle composed of five discrete but overlapping stages. (1) The dark-spot stage signifies a complete vortex column extending from cloud-base to sea surface. (2) The spiral-pattern stage is characterized by development of alternating dark- and light-colored bands spiraling around the dark spot on the sea surface. (3) The spray ring (incipient spray vortex) stage is characterized by a concentrated spray ring around the dark spot, with a lengthening funnel cloud above. (4) The mature waterspout stage (see illustration) is characterized by a spray vortex of maximum intensity and organization. (5) The decay stage occurs when the waterspout dissipates (often abruptly).

Waterspouts and tornadoes are qualitatively similar, differing only in certain quantitative aspects: tornadoes are usually more intense, move faster, and have longer lifetimes—especially maxi-tornadoes. Tornadoes are associated with intense, baroclinic (frontal), synoptic-scale disturbances with attendant strong vertical wind shear, while waterspouts are associated with weak, quasibarotropic disturbances (weak thermal gradients) and consequent weak vertical wind shear. See **TORNADO**; **WIND**.

[J.H.G.]

**Watt-hour meter** An electrical energy meter, that is, an electricity meter that measures and registers the integral, with respect to time, of the power in the circuit in which it is connected. This instrument can be considered as having two parts: a transducer, which converts the power into a mechanical or electrical signal, and a counter, which integrates and displays the value of the total energy that has passed through the meter. Either or both of these parts can be based on mechanical or electronic principles.

In its wholly mechanical form the transducer is an electric motor designed so that its torque is proportional to the electric power in the circuit. The motor spindle carries a conducting disk that rotates between the poles of one or more strong permanent magnets. These provide a braking torque that is proportional to the disk rotational speed, so the motor runs at a rate that accurately represents the circuit power. The integrating register is simply connected to the motor through a gear train that gives the required movement of the dials in relation to the passage of electrical energy. See **MOTOR**.

Mechanical meters can measure either dc or ac energy. Some form of commutator motor similar to those with a shunt field winding is commonly used for dc energy measurement. It is most convenient for the field to carry the circuit current, while the armature is fed with a signal from the circuit voltage. The Ferraris, or induction-type, meter is used for ac energy measurement. The stator carries two windings. An ordinary energy meter will easily achieve an accuracy of 2% over a wide range of loads; precision models may reach 0.1%. Ferraris meters are in very wide use and measure the consumption of the vast majority of domestic and industrial users of electric power throughout the world.

Electronic meters have an electronic watt transducer, which is a solid-state circuit that performs the multiplication of current and voltage signals, and delivers an output in the form of a pulse train at a rate proportional to power. The simplest solid-state watt-hour meter is completed by adding an electronic register to record the energy consumed. Precision electronic energy meters can give errors less than 0.005%. Electronic instruments are available in which six registers are provided, to record consumption at four different times of day and two levels of maximum demand. See **TRANSDUCER**; **VOLTMETER**.

Intelligent, or smart, meters can provide a wide variety of load and tariff-control functions, as well as remote reading of energy consumption.

Electronic and mechanical techniques can be combined in a variety of ways. Signals from a mechanical transducer may be used to operate electronic registers in order to obtain the advantages of the facilities that they can provide. A mechanical impulse register may be used in conjunction with an electronic transducer, where it is considered important to maintain a record without the need for batteries or nonvolatile memory elements.

Watt-hour meters that operate at potentials of 100–250 V and currents up to 100 A are widely manufactured. At higher levels, voltage or current transformers are used to reduce the signals handled by the meter to more convenient values, frequently 110 V and 5 A. By this means it is possible to carry out energy metering at any level required, including hundreds of kilovolts and tens of kiloamperes. See **ELECTRIC POWER MEASUREMENT**; **ELECTRICAL ENERGY MEASUREMENT**; **INSTRUMENT TRANSFORMER**; **TRANSFORMER**. [R.B.D.K.]

**Wattmeter** An instrument that measures electric power. See **ELECTRIC POWER MEASUREMENT**.

A variety of wattmeters are available to measure the power in ac circuits. They are generally classified by names descriptive of their operating principles. Determination of power in dc circuits is almost always done by separate measurements of voltage and current. However, some of the instruments described will also function in dc circuits, if desired.

Probably the most useful instrument in the measurement of ac power at commercial frequencies is the indicating (deflecting) electrodynamic wattmeter. It is similar in principle to the double-coil dc ammeter or voltmeter in that it depends on the interaction of the fields of two sets of coils, one fixed and the other movable. The moving coil is suspended, or pivoted, so that it is free to rotate through a limited angle about an axis perpendicular to that of the fixed coils. As a single-phase wattmeter, the moving (potential) coil, usually constructed of fine wire, carries a current proportional to the voltage applied to the measured circuit, and the fixed (current) coils carry the load current. This arrangement of coils is due to the practical necessity of designing current coils of relatively heavy conductors to carry large values of current. The potential coil can be lighter because the operating current is limited to low values. See **AMMETER**; **VOLTMETER**.

A thermal converter consists of a resistive heater in close thermal contact with one or more thermocouples. When current flows through the heater, the temperature rises. Thermocouples give an output voltage proportional to the temperature difference between their junctions, in this case proportional to the square of the current, and so make suitable transducers for the construction of thermal wattmeters. See **ELECTRICAL RESISTANCE**; **THERMAL CONVERTERS**; **THERMOCOUPLE**; **THERMOELECTRICITY**.

The electrostatic force between two conductors is proportional to the product of the square of the potential difference between them and the rate of change of capacitance with displacement. A differential electrostatic instrument may therefore be used to construct a quarter-squares wattmeter. In spite of the problems of matching the capacitance changes of the two elements and the small forces available, electrostatic wattmeters were used as standards for many years.

Digital wattmeters combine the advantages of electronic signal processing and a high-resolution, easily read display. Electrical readout of the measurement is also possible. A variety of electronic techniques for carrying out the necessary multiplication of the signals representing the current and voltage have been used. Usually the electronic multiplier is an analog system which gives as its output a voltage proportional to the power indication required. This voltage is then converted into digital form in one of the standard ways. Many of the multipliers were originally developed for use in analog computers. See **ANALOG COMPUTER**; **ELECTRONIC DISPLAY**.

The instruments described are designed for single-phase power measurement. In polyphase circuits, the total power is the algebraic sum of the power in each phase. This summation is assisted by simple modifications of single-phase instruments. See ALTERNATING CURRENT. [R.B.D.K.]

**Wave (physics)** The general term applied to the description of a disturbance which propagates from one point in a medium to other points without giving the medium as a whole any permanent displacement.

Waves are generally described in terms of their amplitude, and how the amplitude varies with both space and time. The actual description of the wave amplitude involves a solution of the wave equation and the particular boundary conditions for the case being studied. See WAVE EQUATION; WAVE MOTION.

Acoustic waves, or sound waves, are a particular kind of the general class of elastic waves. Elastic waves are propagated in media having two properties, inertia and elasticity. Electromagnetic waves (for example, light waves and radio waves) are not elastic waves and therefore can travel through a vacuum. The velocity of the wave depends on the medium through which the wave travels. See ELECTROMAGNETIC WAVE. [W.J.G.]

**Wave equation** The name given to certain partial differential equations in classical and quantum physics which relate the spatial and time dependence of physical functions. In this article the classical and quantum wave equations are discussed separately, with the classical equations first for historical reasons.

In classical physics the name wave equation is given to the linear, homogeneous partial differential equations which have the form of Eq. (1). Here  $v$  is a parameter with the dimensions

$$\left[ \nabla^2 - \frac{1}{v^2} \frac{\partial^2}{\partial t^2} \right] f(\mathbf{r}, t) = 0 \quad (1)$$

of velocity;  $\mathbf{r}$  represents the space coordinates  $x, y, z$ ;  $t$  is the time; and  $\nabla^2$  is Laplace's operator defined by Eq. (2). The function

$$\nabla^2 = \frac{\partial^2}{\partial x^2} + \frac{\partial^2}{\partial y^2} + \frac{\partial^2}{\partial z^2} \quad (2)$$

$f(\mathbf{r}, t)$  is a physical observable; that is, it can be measured and consequently must be a real function.

The simplest example of a wave equation in classical physics is that governing the transverse motion of a string under tension and constrained to move in a plane.

A second type of classical physical situation in which the wave equation (1) supplies a mathematical description of the physical reality is the propagation of pressure waves in a fluid medium. Such waves are called acoustical waves, the propagation of sound being an example. A third example of a classical physical situation in which Eq. (1) gives a description of the phenomena is afforded by electromagnetic waves. In a region of space in which the charge and current densities are zero, Maxwell's equations for the photon lead to the wave equations (3). Here  $\mathbf{E}$  is

$$\left[ \nabla^2 - \frac{1}{c^2} \frac{\partial^2}{\partial t^2} \right] \mathbf{E}(\mathbf{r}, t) = 0 \quad (3)$$

$$\left[ \nabla^2 - \frac{1}{c^2} \frac{\partial^2}{\partial t^2} \right] \mathbf{B}(\mathbf{r}, t) = 0$$

the electric field strength and  $\mathbf{B}$  is the magnetic flux density; they are both vectors in ordinary space. The parameter  $c$  is the speed of light in vacuum. See ELECTROMAGNETIC RADIATION; MAXWELL'S EQUATIONS.

The nonrelativistic Schrödinger equation is an example of a quantum wave equation. Relativistic quantum-mechanical wave

equations include the Schrödinger-Klein-Gordon equation and the Dirac equation. See QUANTUM MECHANICS; RELATIVISTIC QUANTUM THEORY. [D.L.We.]

**Wave mechanics** The modern theory of matter holding that elementary particles (such as electrons, protons, and neutrons) have wavelike properties. In 1924 L. de Broglie postulated that the wave-particle duality which had been demonstrated for electromagnetic radiation also was a property of the elementary particles making up the atoms and molecules forming ordinary matter. In particular, de Broglie postulated that a particle has an associated wavelength obeying the same relation as was found to hold for photons, namely: the wavelength equals Planck's constant divided by the particle's momentum (as customarily defined in elementary mechanics). This hypothesis was verified in 1927 in an experiment in which a beam of electrons having known momentum is diffracted by a crystal into special directions. Such diffraction seems understandable only on the hypothesis that the electrons are waves. Furthermore, the wavelength of the electrons in the incident beam, computed via the same formula as was used to derive x-ray wavelengths in x-ray diffraction experiments, agreed precisely with the de Broglie relation. See ELECTRON DIFFRACTION; X-RAY DIFFRACTION.

Subsequent experiments have confirmed that not merely electrons but material particles in general, such as neutrons and neutral sodium atoms, manifest the wave-particle duality and obey the de Broglie relation. The de Broglie relation and the qualitative wave-particle duality concept have been incorporated into the highly successful modern theory of quantum mechanics. See ATOM OPTICS; DE BROGLIE WAVELENGTH; INTERFERENCE OF WAVES; QUANTUM MECHANICS. [E.G.]

**Wave motion** The process by which a disturbance at one point in space is propagated to another point more remote from the source with no net transport of the material of the medium itself. For example, sound is a form of wave motion; wind is not. Wave motion can occur only in a medium in which energy can be stored in both kinetic and potential form. In a mechanical medium, kinetic energy results from inertia and is stored in the velocity of the molecules, while potential energy results from elasticity and is stored in the displacement of the molecules.

**Media.** In a free traveling wave (as distinguished from a stationary or standing wave) one part of the medium disturbs an adjacent part, thereby imparting energy to it. This portion of the medium, in turn, disturbs another part, thereby causing a flow of energy in a given direction away from the source. More technically, wave propagation is the result of kinetic energy at one point being transferred into potential energy at an adjacent point, and vice versa. The rate of travel of the disturbance, or velocity of propagation, is determined by the constants of the medium. A stationary wave is the combination of two waves of the same frequency and strength traveling in opposite directions so that no net transfer of energy away from the source takes place. A standing wave is the same but with the returning wave (toward the source) being of lesser intensity than the outwardly traveling wave so that a net transfer of energy away from the source does take place.

Wave motion can occur in a vacuum (electromagnetic waves), in gases (sound waves), in liquids (hydrodynamic waves), and in solids (vibration waves). Electromagnetic waves can also travel in gases, liquids, and solids provided that the electrical conductivity of the medium is not perfect or that the imaginary part of the dielectric constant is not infinitely great. By current usage, elastic waves propagated in gases, liquids, and solids, regardless of whether one can hear them or not, are called acoustic waves.

**Fundamental relations.** A wave is commonly referred to in terms of either its wavelength or its frequency. In any type

of wave motion, these two quantities are related to a third quantity, velocity of propagation, by the simple relation  $f\lambda = c$ , where  $f$  = frequency,  $\lambda$  = wavelength, and  $c$  = velocity of propagation. The period  $T$  is the reciprocal of the frequency, and the amplitude  $A$  is the maximum magnitude taken on by the variable of the wave at a given point in space. It is a basic property of wave motion that the frequency of a wave remains constant under all circumstances except for a relative motion between the source of the wave and the observer. The velocity of propagation is dependent on the properties of the medium (and, sometimes, also on the frequency) and the wavelength will vary with the velocity in accordance with the equation above.

**Electromagnetic waves.** The media in which electromagnetic waves travel possess no elasticity or inertia, but rather the ability to store energy in the electric and magnetic fields. J. C. Maxwell recognized in about 1863 that the basic equations governing these fields could be combined to yield an equation resembling the wave equation for mechanical wave motion. Thus he predicted the existence of electromagnetic waves which had not been suspected theretofore. Later, electromagnetic waves proved to be identical with light waves. See ELECTROMAGNETIC RADIATION; LIGHT; MAXWELL'S EQUATIONS; WAVE EQUATION.

[L.L.B.]

**Motion in fluids.** Wave motion within a fluid is generated by successive compression and expansion of adjacent volume elements. Because compression and expansion of an ordinary fluid can only proceed along the direction of propagation of the disturbance, waves within a fluid are mostly longitudinal waves.

Waves in a fluid can be classified as compression waves and expansion waves, according to whether the disturbance is a compression or an expansion. They can further be classified according to the amplitude of the disturbance and the chemical nature of the fluid. For example, waves of small amplitude are called acoustic (or sound) waves; compression waves propagating in chemically inert fluids are called shock waves; waves propagating in the Earth are seismic waves; and waves of large amplitude generated by rapid chemical reactions in explosive fluids are called detonation waves and can propagate much faster than sound waves. Waves in an electrically conducting fluid in the presence of strong magnetic fields are called magnetohydrodynamic waves. See MAGNETOHYDRODYNAMICS; SEISMOLOGY; SHOCK WAVE; SOUND.

[S.C.Li.]

**Motion in liquids.** Disturbances propagated at a gas-liquid interface are primarily dependent upon the gravitational fluid property (surface tension and viscosity being of secondary importance). Wave motions which occur in confined fluids (either liquid or gaseous) are primarily dependent upon the elastic property of the medium.

Oscillatory waves may be generated in a rectangular channel by a simple harmonic translation of a vertical wall forming one end of the flume. A standing wave can be considered to be composed of two equal oscillatory wave trains traveling in opposite directions.

A solitary wave consists of a single crest above the original liquid surface which is neither preceded nor followed by another elevation or depression of the surface. Such a wave is generated by the translation of a vertical wall starting from an initial position at rest and coming to rest again some distance downstream. In practice, solitary waves are generated by a motion of barges in narrow waterways or by a sudden change in the rate of inflow into a river; they are therefore related to a form of flood wave.

[D.R.F.H.]

**Wave optics** The branch of optics which treats of light (or electromagnetic radiation in general) with explicit recognition of its wave nature. The counterpart to wave optics is ray optics or geometrical optics, which does not assume any wave character but treats the propagation of light as a straight-line

phenomenon except for changes of direction induced by reflection or refraction. See ELECTROMAGNETIC RADIATION; GEOMETRICAL OPTICS; OPTICS.

Any optical phenomenon which is correctly describable in terms of geometrical optics can also be correctly described in terms of wave optics. However, the many phenomena of interference, diffraction, and polarization are incontrovertible evidence of the wave nature of light, and geometrical optics often gives an incomplete or incorrect description of the behavior of light in an optical system. This is especially true if changes of refractive index occur within a space which is of the order of several wavelengths of the light. See DIFFRACTION; INTERFERENCE OF WAVES; POLARIZED LIGHT.

[R.C.L.]

**Wave-shaping circuits** Electronic circuits used to create or modify specified time-varying electrical voltage or current waveforms using combinations of active electronic devices, such as transistors or analog or digital integrated circuits, and resistors, capacitors, and inductors. Most wave-shaping circuits are used to generate periodic waveforms. See INTEGRATED CIRCUITS; TRANSISTOR.

The common periodic waveforms include the square wave, the sine and rectified sine waves, the sawtooth and triangular waves, and the periodic arbitrary wave. The arbitrary wave can be made to conform to any shape during the duration of one period. This shape then is followed for each successive cycle. See FUNCTION GENERATOR; WAVEFORM.

A number of traditional electronic and electromechanical circuits are used to generate these waveforms. Sine-wave generators and LC, RC, and beat-frequency oscillators are used to generate sine waves; rectifiers, consisting of diode combinations interposed between sine-wave sources and resistive loads, produce rectified sine waves; multivibrators can generate square waves; electronic integrating circuits operating on square waves create triangular waves; and electronic relaxation oscillators can produce sawtooth waves. See ALTERNATING CURRENT; DIODE; MULTIVIBRATOR; OPERATIONAL AMPLIFIER; OSCILLATOR; RECTIFIER.

In many applications, generation of these standard waveforms is now implemented using digital circuits. Digital logic or microprocessors generate a sequence of numbers which represent the desired waveform mathematically. These numerical values then are converted to continuous-time waveforms by passing them through a digital-to-analog converter. Digital waveform generation methods have the ability to generate waveforms of arbitrary shape, a capability lacking in the traditional approaches. See CIRCUIT (ELECTRONICS); DIGITAL-TO-ANALOG CONVERTER; LOGIC CIRCUITS; MICROPROCESSOR.

[P.V.L.]

**Waveform** The pictorial representation of the form or shape of a wave, obtained by plotting the amplitude of the wave with respect to time. There are an infinite number of possible waveforms (see illustration). One such waveform is the square wave, in which a quantity such as voltage alternately assumes two discrete values during repeating periods of time. Other waveforms of particular interest in electronics are the sine wave and rectified sine wave, the sawtooth wave and triangular wave, and the arbitrary wave—a recurrent waveform which takes on an arbitrary shape over one complete cycle; this shape is then repeated in successive cycles.

Each of these waveforms has a shape which repeats periodically in time. It is possible to characterize any of them mathematically by a Fourier series, a weighted sum of terms consisting of the basic periodic trigonometric functions: sines and cosines. A periodic waveform thus can be represented as a constant or dc term, plus a sum of harmonically related sine and cosine terms where the sine and cosine frequencies are integral multiples of the fundamental frequency. The Fourier series is given

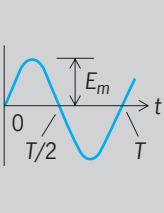
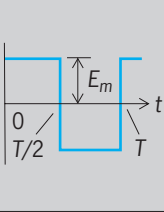
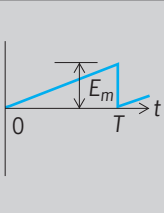
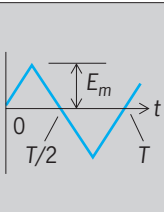
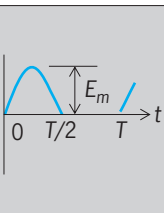
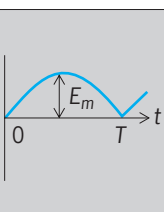
	$E_m \sin(2\pi t/T)$ <p><b>sine wave</b></p>
	$\frac{4E_m}{\pi} \sum_{n=1, 3, 5, \dots} \frac{1}{n} \sin(2\pi nt/T)$ <p><b>square wave</b></p>
	$\frac{E_m}{2} - \frac{E_m}{\pi} \sum_{n=1, 2, 3, \dots} \frac{1}{n} \sin(2\pi nt/T)$ <p><b>sawtooth wave</b></p>
	$\frac{8E_m}{\pi^2} \sum_{n=1, 3, 5, \dots} (-1)^{(n-1)/2} \frac{1}{n^2} \sin(2\pi nt/T)$ <p><b>triangular wave</b></p>
	$\frac{E_m}{\pi} \left[ 1 + \frac{\pi}{2} \sin(2\pi t/T) - 2 \sum_{n=1, 2, 3, \dots} \frac{1}{4n^2 - 1} \cos(4\pi nt/T) \right]$ <p><b>half-wave rectified sine wave</b></p>
	$\frac{2E_m}{\pi} \left[ 1 - 2 \sum_{n=1, 2, 3, \dots} \frac{1}{4n^2 - 1} \cos(2\pi nt/T) \right]$ <p><b>full-wave rectified sine wave</b></p>

Common electrical waveforms.

beside each waveform in the illustration as a function of time  $t$ , where  $E_m$  is the maximum value of the wave and  $T$  is the period. See FOURIER SERIES AND TRANSFORMS; NONSINUSOIDAL WAVEFORM; WAVE-SHAPING CIRCUITS. [P.V.L.]

**Waveform determination** The definition of a waveform, which describes the variation of a quantity with respect to time. The necessary measurements are normally carried out and presented in one of two ways: the amplitude may be presented

as a function of time (time domain), or an analysis may be given of the relative amplitudes and phases of the frequency components (frequency domain). Although the simplest instruments measure and display the information in the same domain, it is possible to convert the data in either direction by mathematical processing.

Waveforms may be divided into two classes, depending on whether the signal is repeated at regular intervals or represents a unique event. The former signal is defined as a periodic or continuous wave, the latter as an aperiodic signal or transient. See ELECTRIC TRANSIENT; NONSINUSOIDAL WAVEFORM; WAVEFORM.

The oscilloscope is an example of an instrument that measures and displays directly in the time domain, by deflecting an electron beam in a vertical direction in accordance with the signal while scanning at a uniform rate in the horizontal direction. The position of the beam is revealed by a fluorescent screen. See OSCILLOSCOPE.

Several methods may be used to obtain the spectral content of a waveform. In the simplest, the signal is applied to a filter that is manually tuned in turn to each frequency that is expected to be present. In order to automate the measurement, the tuning of a filter may be varied by a linear, logarithmic, or other sweep and the resulting output displayed. However, there are important restrictions that limit the technique to continuous waveforms. A fleeting appearance of a signal at a frequency away from that to which the filter happens to be tuned at the instant will be completely missed. In order to provide high resolution, the tuned circuit must have high selectivity, or high  $Q$ . Its response to changes in amplitude is therefore slow, and the rate of sweeping has to be limited. By using this technique, it is possible to construct instruments that cover extremely wide frequency ranges. See ELECTRIC FILTER; HETERODYNE PRINCIPLE.

In order to overcome the limitations of the swept filter, an array of separate fixed tuned filters may be used, each adjusted to respond to a slightly different frequency. The amplitude of the signal in each filter is sampled in turn and displayed, giving a histogram of the frequency components of the waveform. The number of filters and their selectivities depend on the resolution required. Though simple in concept, such instruments are inclined to be bulky if high resolution is needed. They have the great advantage that all frequency components are taken into account throughout the measurement and their amplitudes can be examined continuously. Such instruments are useful for the analysis of music and speech.

Since the purpose of such instruments is to display the frequency components of the signal, they are often called spectrum or harmonic analyzers. See HARMONIC ANALYZER; SPECTRUM ANALYZER.

Many modern instruments use techniques in which the signal to be measured is sampled and digitized. In sampling oscilloscopes a sufficiently large number of samples is taken to define the waveform. The sampling rate is not necessarily high; where the waveform is repetitive, the Nyquist requirement that more than two samples should be available per cycle of the highest frequency of interest can be satisfied by obtaining the samples over a large number of periods of the signal. Each sample is digitized and stored. The waveform is then displayed by plotting the data on a cathode-ray tube or similar display in the correct order. As the data can be read out of digital storage at any convenient speed, this process can be relatively slow and low bandwidth display circuits are adequate. See ANALOG-TO-DIGITAL CONVERTER.

Once the data have been collected in digital form, they can be processed in many different ways. The application of a discrete Fourier transformation (DFT) to the amplitude data enables the information to be presented in the frequency domain. In this way, harmonic distortion which was invisible on a directly displayed waveform can be made obvious. See FOURIER SERIES AND TRANSFORMS. [R.B.D.K.]

**Waveguide** A device that constrains or guides the propagation of electromagnetic radiation along a path defined by the physical construction of the guide. Electromagnetic waves may propagate in space, as radio waves, but for many purposes waves need to be guided with minimum loss from the generating point to a point of application. Several guiding systems are of importance, including two-conductor transmission lines, various forms of striplines used in microwave integrated circuits, hollow-pipe waveguides, and dielectric waveguides. Hollow-pipe guides are used primarily in the microwave region of the spectrum, dielectric guides primarily in the optical region. See COAXIAL CABLE; ELECTROMAGNETIC WAVE TRANSMISSION; MICROWAVE; TRANSMISSION LINES.

Hollow-pipe waveguides consist of a dielectric region, usually air, surrounded by a closed good conductor such as silver, copper, aluminum, or brass. The cross-sectional shape is usually rectangular, but may be circular or of a variety of other shapes. Voltage and current concepts, so useful for transmission lines, are not so useful for waveguides. Distributions of electric and magnetic fields, obtained from Maxwell's equations, are needed. See MAXWELL'S EQUATIONS.

Solution of the field equations shows that there is an infinite number of modes for these guides, where a mode is a solution that maintains its transverse pattern but attenuates and shifts in phase as it propagates along the guide. These modal patterns may be likened to the resonant modes of a drumhead, with low-order modes having only a few transverse variations and high-order modes having many.

All modes in these guides have cutoff properties. Below a certain critical frequency, the mode will not propagate but only attenuates if excited; above the cutoff frequency, though, it may propagate with a finite phase velocity and small attenuation (zero attenuation for perfect dielectric and conductor). Higher-order modes usually have higher cutoff frequencies.

If the guiding pipe is perfectly conducting, the modes may be divided into transverse magnetic (TM) and transverse electric (TE) types. For the former, the magnetic field is confined to the transverse plane, while the electric field is so confined for the latter. These classifications remain useful for the practical metallic conductors used for such guides.

A variety of circuit elements is required for exciting desired modes, filtering, coupling to passive and active elements, and other necessary networking functions. Excitation of a particular mode may be by probes, along the direction of the mode's electric field, by loops normal to magnetic field lines, or by the charge streams of an active vacuum-tube or semiconductor device placed within the guide.

Other important waveguide elements are the directional coupler and isolator. In the directional coupler, there is coupling to an auxiliary guide in such a way that the output of one of its ports is proportional to the wave traveling in the forward direction, and the output of the other is proportional to the reverse wave. The isolator makes use of the nonreciprocal properties of ferrites with an applied magnetic field to pass the forward-traveling wave of the guide but to eliminate the reflected wave. See DIRECTIONAL COUPLER.

A dielectric waveguide consists of one dielectric material, called the core, surrounded by a different dielectric, called the cladding. The permittivity (dielectric constant), or refractive index, of the core is larger than that of the cladding, and under proper conditions electromagnetic energy is confined largely to the core through the phenomenon of total reflection at the boundary between the two dielectrics. See PERMITTIVITY; REFLECTION OF ELECTROMAGNETIC RADIATION; REFRACTION OF WAVES.

Early dielectric guides were so lossy that they could be used only over short distances. Dielectric light pipes found surgical and laboratory use. In 1969 silica fibers were developed with attenuations of 32 dB/mi (20 dB/km), low enough to be of use for optical communication applications. Since then, further improvements have reduced losses to as low as 0.3 dB/mi (0.2 dB/km). Fiber

guides are now the basis for a worldwide optical communication network. See FIBER-OPTICS IMAGING.

Planar, rectangular, and thin-film forms of dielectric guides are also important in guiding optical energy from one device to another in optoelectronic and integrated optic devices, for example, from a semiconductor laser to an electrooptic modulator on a gallium arsenide substrate. Because of the simpler geometry, the planar forms will be used to explain the principle. See INTEGRATED OPTICS; LASER; OPTICAL MODULATORS.

By far the most important dielectric guide at present is the optical fiber used for optical communications. Here the round core is surrounded by a cladding of slightly lower refractive index. The combination is surrounded by a protective jacket to prevent corrosion and give added strength, but this jacket plays no role in the optical guiding. See OPTICAL FIBERS. [J.R.W.]

**Wavelength** The distance between two points on a wave which have the same value and the same rate of change of the value of a parameter, for example, electric intensity,

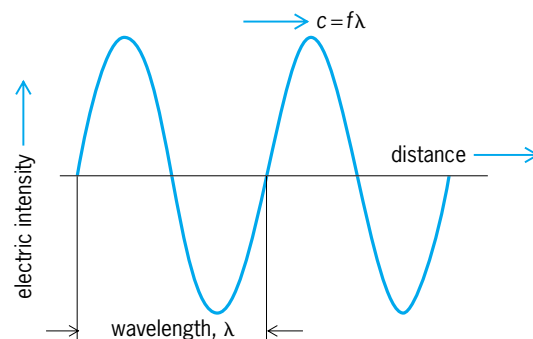

Wavelength  $\lambda$  and related quantities.

characterizing the wave. The wavelength, usually designated by the Greek letter  $\lambda$ , is equal to the speed of propagation  $c$  of the wave divided by the frequency of vibration  $f$ ; that is,  $\lambda = c/f$  (see illustration). See WAVE (PHYSICS); WAVE MOTION. [W.J.G.]

**Wavelength measurement** Determination of the distance between successive wavefronts of equal phase of a wave. See ELECTROMAGNETIC RADIATION; WAVE MOTION; WAVELENGTH.

From the relation  $\lambda = c/f$  between wavelength  $\lambda$ , speed  $c$ , and frequency  $f$ , the wavelength of a wave motion can be calculated if the speed is known and its frequency is measured. The ease and accuracy of electronic counting and timing make frequency measurement the most precise of all physical measurements. This method of wavelength determination is thus one of the most accurate, but only if the speed (phase velocity) is known. In free space the speed of an electromagnetic wave  $c_0$  is, through the 1983 definition of the meter, fixed at exactly 299,792,458 m/s (186,282.397 mi/s), or roughly 300,000 km/s. Unless otherwise specified, it is general practice to quote the wavelength of an electromagnetic wave as the free-space value  $\lambda_0$ , given by the equation below.

$$\lambda_0 = \frac{c_0}{f}$$

See FREQUENCY MEASUREMENT; PHASE VELOCITY.

**Radio and microwave regions.** The presence of any dielectric material (such as air) or any magnetic matter with a permeability greater than unity will cause the wave to travel at a velocity lower than its free-space value. The speed is also altered if the waves pass through an aperture, are focused by a lens or mirror, or are constrained by a wave-guide or transmission line. In such cases it may be more appropriate to measure



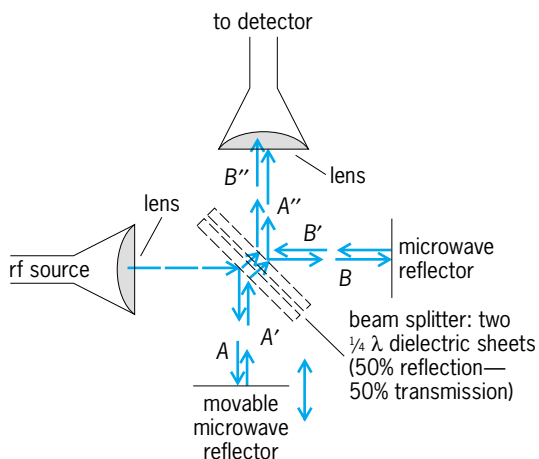

**Wavelength measurement by the Michelson interferometer used at millimeter wavelengths.**

the wavelength directly. In the pioneering experiments on radio waves, it was found that standing waves existed in space whenever reflections occurred and that these provided a convenient means of measuring the wavelength. It thus became the convention to characterize waves by their wavelength, rather than by their frequency as is now more commonly the case. Specifying the frequency is preferred because, unlike the wavelength, it is independent of the speed of propagation and does not change as the wave moves from one medium to another. See ELECTROMAGNETIC WAVE TRANSMISSION; TRANSMISSION LINES; WAVEGUIDE.

In the microwave region the wavelengths are sufficiently short that it is convenient to measure them by using interferometer techniques directly analogous to those used with light.

In a typical interferometer used in the millimeter wavelength range (see illustration), a microwave beam is directed at a beam splitter, which splits the beam into two parts, *A* and *B*, by partial reflection. The *A* beam is reflected to a movable reflector and reflected again as *A'*. The beam splitter transmits part of this as *A''*. The transmitted part *B* of the original beam is reflected by a fixed microwave reflector as *B'*. This is partially reflected by the beam splitter as *B''*. The beams *A''* and *B''* combine to form standing waves, which are then detected. Movement of the movable reflector causes the position of the standing wave to move, which causes the detected signal to pass through successive points of maximum and minimum amplitude. The distance between points of successive maxima or minima is one-half wavelength. This distance may be determined from the motion of the movable reflector. See INTERFEROMETRY.

**Infrared and optical regions.** The free-space wavelengths of monochromatic visible and infrared radiations can be derived directly, if their corresponding frequencies are known. The wavelengths of a few stabilized laser radiations have been precisely determined in this way, by reference to the cesium-133 primary frequency standard. These wavelength standards, with uncertainties between  $4.5 \times 10^{-10}$  and  $3 \times 10^{-12}$ , are used particularly for the practical realization of the unit of length, but they also serve as reference standards for interferometric wavelength measurements and for the calibration of wavelength comparators based on dispersion methods. See LENGTH; LIGHT; PHYSICAL MEASUREMENT; WAVELENGTH STANDARDS.

Wavelength values to an accuracy of 1 part in  $10^5$  can be determined with a spectrometer, spectrograph, or monochromator, in which a prism or diffraction grating is used as a dispersive element. Each wavelength forms a line image of the entrance slit at a particular angle. An unknown wavelength can be determined by interpolation with the pattern formed by a lamp emitting the tabulated characteristic wavelengths of a particular element. See DIFFRACTION GRATING; OPTICAL PRISM; SPECTROSCOPY.

The most precise wavelength measurements use an interferometer to compare the unknown wavelength  $\lambda_1$  with a standard wavelength  $\lambda_2$ . Usually either the two-beam Michelson form or the multiple-beam Fabry-Perot form of interferometer is used.

When a number of wavelengths are mixed together in the input to a moving-carriage two-beam interferometer, the output signal is the summation of the many separate sine-wave signals having different periods. A Fourier analysis of this composite signal enables the separate wavelengths to be identified. This Fourier transform method is particularly useful for the measurement of complex spectra in the infrared. See FOURIER SERIES AND TRANSFORMS; INFRARED SPECTROSCOPY. [W.R.C.R.]

**Wavelength standards** Accurately known wavelengths of spectral radiation emitted from specified sources that are used to measure the wavelengths of other spectra. In the past, the radiation from the standard source and the source under study were superimposed on the slit of a spectrometer (prism or grating) and then the unknown wavelengths could be determined from the standard wavelengths by using interpolation. This technique has evolved into the modern computer-controlled photoelectric recording spectrometer. Accuracy of many more orders of magnitude can be obtained by the use of interferometric techniques, of which Fabry-Perot and Michelson interferometers are two of the most common. See INTERFEROMETRY; SPECTROSCOPY.

The newest definition of the meter is in terms of the second. The wavelength of radiation from the cesium atomic clock is not used to realize length because diffraction problems at this wavelength are severe. Instead, lasers at shorter wavelengths whose frequencies have been measured are used. Frequency measurements can now be made even into the visible spectral region with great accuracy. Hence, when the 1983 Conférence Générale des Poids et Mesures redefined the meter, it also gave a list of very accurate wavelengths of selected stabilized lasers which may be used as wavelength standards; these are shown in the table. Nearly ten times better accuracy can be achieved by using these wavelengths than by using the radiation from the krypton lamp which provided the previous standard. See FREQUENCY MEASUREMENT; HYPERFINE STRUCTURE; LASER; LASER SPECTROSCOPY; LENGTH; MOLECULAR STRUCTURE AND SPECTRA; PHYSICAL MEASUREMENT.

The progress in laser frequency measurements since 1974 has established wavelength standards throughout the infrared spectral region. This has been accomplished with the accurate frequency measurement of rotational-vibrational transitions of selected molecules. The OCS molecule is used in the 5-micrometer spectral region. At 9–10  $\mu\text{m}$ , the carbon dioxide ( $\text{CO}_2$ ) laser itself with over 300 accurately known lines is used. From 10 to 100  $\mu\text{m}$ , rotational transitions of various molecules are used; most are optically pumped laser transitions. The increased accuracy of frequency measurements makes this technique mandatory where ultimate accuracy is needed. See WAVELENGTH. [D.A.J.]

**Wavelets** The elementary building blocks in a mathematical tool for analyzing functions. The functions can be very diverse; examples are solutions of a differential equation, and one- and two-dimensional signals. The tool itself, the wavelet transform, is the result of a synthesis of ideas from many different fields, ranging from pure mathematics to quantum physics and electrical engineering.

In many practical applications, it is desirable to extract frequency information from a signal—in particular, which frequencies are present and their respective importance. An example is the decomposition into spectral lines in spectroscopy. The tool that is generally used to achieve this is the Fourier transform. Many applications, however, concern nonstationary signals, in which the makeup of the different frequency components is constantly shifting. An example is music, where this shifting nature

has been recognized for centuries by the standard notation, which tells a musician which note (frequency information) to play when and how long (time information). For signals of this nature, a time-frequency representation is needed. See FOURIER SERIES.

There exist many different mathematical tools leading to a time-frequency representation of a given signal, each with its own strengths and weaknesses. The wavelet transform is such a time-frequency analysis tool. Its strength lies in its ability to deal well with transient high-frequency phenomena, such as sudden peaks or discontinuities, as well as with the smoother portions of the signal. (An example is a crack in the sound from a damaged record, or the attack at the start of a music note.) The wavelet transform is less well adapted to harmonically oscillating parts in the signal, for which Fourier-type methods are more indicated.

Applications of wavelets include various forms of data compression (such as for images and fingerprints), data analysis (nuclear magnetic resonance, radar, seismograms, and sound), and numerical analysis (fast solvers for partial differential equations). See DIFFERENTIAL EQUATION; INTEGRAL TRANSFORM; NUMERICAL ANALYSIS. [I.D.]

**Wavellite** A hydrated phosphate of aluminum mineral with composition  $\text{Al}_3(\text{OH})_3(\text{PO}_4)_2 \cdot 5\text{H}_2\text{O}$ , in which small amounts of fluorine and iron may substitute for the hydroxyl group (OH) and aluminum (Al), respectively. Wavellite crystallizes in the orthorhombic system. The crystals are stout to long prismatic, but are rare. Wavellite commonly occurs as globular aggregates of fibrous structure and as encrusting and stalactitic masses. Wavellite crystals range in color from colorless and white to different shades of blue, green, yellow, brown, and black. Wavellite is found at many places in Europe and North America; it is also abundant in tin veins at Llallagua, Bolivia. See PHOSPHATE MINERALS. [W.R.Lo.]

**Wax, animal and vegetable** Any of the substances containing esters of higher fatty acids and long-chain monohydric alcohols. From a practical standpoint, this definition is inadequate because it allows liquids such as sperm whale oil and jojoba oil to be called waxes, and it fails to indicate the complexity of waxes. While waxes do contain wax esters, they are seldom if ever pure. They are usually mixtures that may contain high-molecular-weight acids, alcohols, esters, ketones, hydrocarbons, sterols, diesters, hydroxyacids, and so forth, as well as the wax esters. See ESTER.

Practical wax formulators use physical, rather than chemical, properties to define waxes. Waxes must: be a solid at 68°F (20°C); be crystalline; melt above 140°F (40°C) without decomposition; have relatively low viscosity above the melting point; have consistency and solubility properties that are strongly dependent upon temperature; and be capable of being polished under slight pressure.

Wax sources are abundant. They have been isolated from the outer layers of bacteria, the roots, stems, leaves, fruit, and flowers of plants, the exudates of insects, the skin and hair of some animals, and the bodies of certain marine and land animals. Carnauba wax is extracted from an exudate on the leaves of the carnauba palm (*Copernicia prunifera*). Candelilla wax is obtained from a coating on the stem of *Euphorbia antisiphilitica*, a leafless desert shrub. Beeswax is an exudate of the honeybee. Wool wax is obtained from sheep wool. Many other waxes have been of commercial importance from time to time, but their availability or cost has forced them from the market. See CARNAUBA WAX; FAT AND OIL. [H.M.H.]

**Wax, petroleum** A substance produced primarily from the dewaxing of lubricating-oil fractions of petroleum. It may be of either the crystalline or microcrystalline type. Petroleum wax has a wide variety of uses. It is used to coat paper products, to blend with other waxes for the manufacture of candles,

in the manufacture of electrical equipment and many polishes for home and industry, and as a source material for oxidized products. The softer waxes, such as petroleum jelly, after proper purification, are being used as medicinal products. See DEWAXING OF PETROLEUM; PETROLEUM PROCESSING; PETROLEUM PRODUCTS.

[W.E.Ku.]

**Weak nuclear interactions** Fundamental interactions of nature that play a significant role in elementary particle and nuclear physics, and are distinguished from other such interactions by special properties such as participation of all the fundamental fermions and failure to conserve parity. The weak force has very short range (less than  $10^{-17}$  m) and is extremely feeble compared to strong and electromagnetic forces, but can be distinguished from these two by its special character. For example, according to the present view, all of matter consists of certain fundamental spin- $1/2$  constituents, the quarks and leptons, collectively called the fundamental fermions. While only the quarks participate in strong interactions, and only the quarks and charged leptons  $e$ ,  $\mu$ , and  $\tau$  participate in electromagnetic interactions, all of the fundamental fermions, including neutrinos, engage in weak interactions. Also, the strong and electromagnetic interactions respect spatial inversion symmetry (they conserve parity) and are also particle-antiparticle (charge conjugation) symmetric, whereas the weak interaction violates these two symmetries. See FUNDAMENTAL INTERACTIONS; LEPTON; PARITY (QUANTUM MECHANICS); QUARKS; SYMMETRY LAWS (PHYSICS).

Weak interactions are classified as “charged” or “neutral,” depending on whether or not a particle participating in a weak reaction suffers a change of electric charge of one electronic unit. Observed charged weak interactions include nuclear beta decay and electron capture, muon capture on nuclei, and the slow decays of unstable elementary particles such as the  $\mu$  and  $\tau$  leptons,  $\pi$ ,  $K$ , and charmed mesons, and hyperons and charmed baryons. Also, there are the charged neutrino-nucleon and neutrino-lepton scattering reactions. Neutral weak interactions include neutrino-nucleon and neutrino-lepton scattering as well as the electron-nucleon reaction which can also occur by electromagnetic interaction. See BARYON; ELEMENTARY PARTICLE; HYPERON; MESON.

The most important development in the study of weak interactions has been the creation of a successful theory based on the principles of local gauge invariance and spontaneous symmetry breaking. This theory proposes a single basis for the weak and electromagnetic interactions, and indeed, despite striking differences in the observed characteristics of strong, electromagnetic, and weak interactions, important theoretical ideas of a similar type suggest that all these interactions possess a common origin. [E.D.C.]

### Weakly interacting massive particle (WIMP)

A hypothetical elementary particle that might make up most of the matter in the universe, and that is also predicted to exist in supersymmetry theory. Most matter is detected only through its gravitational effects; this “dark matter” has not been observed to emit, absorb, or reflect light of any wavelength. The total amount of dark matter appears to be approximately ten times as great as all the ordinary matter in the universe, and about one hundred times as great as all the visible matter. The nature of the dark matter is not yet known, although many experiments are under way to try to discover it directly or indirectly. See COSMOLOGY; UNIVERSE.

Almost all the currently available data in elementary particle physics can be accounted for by a theory called the standard model, in which matter is made of quarks (the building blocks of protons and neutrons) and leptons (including electrons and neutrinos), while the strong, weak, and electromagnetic forces are transmitted by particles like the photon (the carrier of electromagnetic forces). However, the standard model does not predict the existence of any particle—say, X—that could be the dark

matter. Most efforts to go beyond the standard model of particle physics have been based on the idea of supersymmetry, and most versions of supersymmetry predict that there will be a stable weakly interacting massive particle (WIMP) that would be a natural candidate for the X particles. Dark matter made of WIMPs would be “cold” dark matter (CDM), and a version of CDM theory has become the standard theory of structure formation in cosmology. See ELEMENTARY PARTICLE; STANDARD MODEL; SUPERSYMMETRY.

There is now abundant evidence for dark matter around galaxies and clusters of galaxies, and on larger scales in the universe. Gas and satellites at large distances from galaxies have orbital velocities similar to those at smaller distances from the center, which indicates that most of the mass in the galaxy must not be near the center, where most stars are, but in a roughly spherical dark matter halo that extends to perhaps ten times the optical size of the galaxy and has a mass at least ten times that of all the stars. Confirmation of the existence of such dark-matter halos has come from gravitational lensing observations, showing that light from more distant galaxies is bent by the gravity of nearer galaxies. See CELESTIAL MECHANICS; GALAXY, EXTERNAL; GRAVITATIONAL LENS; MILKY WAY GALAXY.

There is also much evidence for dark matter in clusters of galaxies. The astronomer Fritz Zwicky pointed out in 1933 that the galaxies in one nearby cluster were moving at such high speeds that they would not be held together gravitationally unless there was much more mass than was indicated by the light from their stars. This same was subsequently found to be true of other clusters. Later, similar conclusions were reached from x-ray observations and gravitational lensing observations of clusters. See X-RAY ASTRONOMY.

Supersymmetry is the hypothesis that there is a relationship between the two known classes of particles, bosons and fermions. According to supersymmetry, for every kind of boson in the universe, there must also be a corresponding fermion with the same electric charge and very similar interactions with other particles. Since these hypothetical supersymmetric partner particles have not been discovered yet, if supersymmetry is right their masses must be too large for them to have been produced at current particle accelerators. Thus far, the evidence for supersymmetry is only indirect, but if the theory is right many supersymmetric partner particles should be produced at accelerators such as the Large Hadron Collider (LHC) being built in Geneva, Switzerland. See PARTICLE ACCELERATOR; QUANTUM STATISTICS.

Efforts to detect WIMPs directly are based on detecting their scattering from nuclei. WIMPs can also be detected indirectly, for example by looking for particles coming from their annihilation. WIMPs are also expected to be produced at accelerators such as the LHC from rapid decays of heavier supersymmetric partner particles, and this could be where they are discovered first if they are not seen before that in direct or indirect search experiments. Failure to see supersymmetric particles at LHC energies would mean that current ideas about supersymmetry are wrong.

[J.R.Pr.]

**Wear** The removal of material from a solid surface as a result of sliding action. It constitutes the main reason why the artifacts of society (automobiles, washing machines, tape recorders, cameras, clothing) become useless and have to be replaced. There are a few uses of the wear phenomenon, but in the great majority of cases wear is a nuisance, and a tremendous expenditure of human and material resources is required to overcome the effects.

Adhesive wear is the only universal form of wear, and in many sliding systems it is also the most important. It arises from the fact that, during sliding, regions of adhesive bonding, called junctions, form between the sliding surfaces. If one of these junctions does not break along its original interface, then a chunk from one of the sliding surfaces will have been transferred to the other surface. In this way, an adhesive wear particle will have

been formed. Initially adhering to the other surface, adhesive particles soon become loose and can disappear from the sliding system. See FRICTION.

Abrasive wear is produced by a hard, sharp surface sliding against a softer one and digging out a groove. The abrasive agent may be one of the surfaces (such as a file), or it may be a third component (such as sand particles in a bearing abrading material from each surface). Abrasive wear coefficients are large compared to adhesive ones. Thus, the introduction of abrasive particles into a sliding system can greatly increase the wear rate; automobiles, for example, have air and oil filters to catch abrasive particles before they can produce damage.

Corrosive wear arises when a sliding surface is in a corrosive environment, and the sliding action continuously removes the protective corrosion product, thus exposing fresh surface to further corrosive attack. See CORROSION.

Surface fatigue wear occurs as result of the formation and growth of cracks. It is the main form of wear of rolling devices such as ball bearings, wheels on rails, and gears. During continued rolling, a crack forms at or just below the surface and gradually grows until a large particle is lifted right out of the surface.

Most manifestations of wear are highly objectionable, but the phenomenon does have a few uses. Thus, a number of systems for recording information (pencil and paper, chalk and blackboard) operate via a wear mechanism. Some methods of preparing solid surfaces (filling, sandpapering, sandblasting) also make use of wear. See ABRASIVE.

[E.R.]

**Weasel** The common name for at least 12 species of carnivores which are members of the family Mustelidae. They have a varied distribution in many regions of the world (see table).

Common names and distribution of 12 species of weasel

Scientific name	Common name	Distribution
<i>Mustela rixosa</i>	Pygmy weasel	North America
<i>M. frenata</i>	Long-tailed weasel	North and South America
<i>M. nivalis</i>	Common weasel	Europe, Asia, and Africa
<i>M. altaica</i>	Alpine weasel	Asia
<i>M. sibirica</i>	Siberian weasel	Asia
<i>M. kathiah</i>	Yellow-bellied weasel	Asia
<i>M. strigidorsa</i>	Back-striped weasel	Southern Asia
<i>M. lutreolina</i>	Java weasel	Java
<i>M. nudipes</i>	Bare-footed weasel	Malaysia
<i>Lyncodon patagonicus</i>	Patagonian weasel	South America
<i>Poecilictis libyca</i>	Libyan striped weasel	North Africa
<i>Poecilogale albinucha</i>	White-naped weasel	Africa

The common or European weasel is *Mustela nivalis*. This animal is a slim, voracious carnivore with a long body. The limbs are short and the body is muscular. Although the claws are nonretractile, these animals climb with agility. The gestation period is 5 weeks, and four to six young are born in a nest made in a hollow tree or rabbit burrow. One or two litters are born each year, and the life-span is about 8 years.

The common weasel has a wide distribution throughout Europe, North Africa, and Asia, and has managed to survive because of its size and ability to escape detection. It preys upon small rodents, such as mice, voles, and rats, and has been incriminated in attacking domestic animals, such as poultry. See GARNIVORA; FERRET; FISHER; MARTEN; MINK; OTTER; SKUNK; WOLVERINE.

[C.B.C.]

**Weather** The state of the atmosphere, as determined by the simultaneous occurrence of several meteorological phenomena at a geographical locality or over broad areas of the Earth. When such a collection of weather elements is part of an interrelated physical structure of the atmosphere, it is termed a weather system, and includes phenomena at all elevations above the

ground. More popularly, weather refers to a certain state of the atmosphere as it affects humans' activities on the Earth's surface. In this sense, it is often taken to include such related phenomena as waves at sea and floods on land.

A weather element is any individual physical feature of the atmosphere. At a given locality, at least seven such elements may be observed at any one time. These are clouds, precipitation, temperature, humidity, wind, pressure, and visibility. Each of these principal elements is divided into many subtypes. See WEATHER MAP.

The various forms of precipitation are included by international agreement among the hydrometeors, which comprise all the visible features in the atmosphere, besides clouds, that are due to water in its various forms. For convenience in processing weather data and information, this definition is made to include some phenomena not due to water, such as dust and smoke. Some of the more common hydrometeors include rain, snow, fog, hail, dew, and frost. See PRECIPITATION (METEOROLOGY).

Certain optical and electrical phenomena have long been observed among the weather elements. These include lightning, aurora, solar or lunar corona, and halo. See AIR MASS; ATMOSPHERE; AURORA; CLOUD; FRONT; LIGHTNING; METEOROLOGY; STORM; WEATHER OBSERVATIONS; WIND. [P.F.C.]

**Weather forecasting and prediction** Processes for formulating and disseminating information about future weather conditions based upon the collection and analysis of meteorological observations. Weather forecasts may be classified according to the space and time scale of the predicted phenomena. Atmospheric fluctuations with a length of less than 100 m (330 ft) and a period of less than 100 s are considered to be turbulent. The study of atmospheric turbulence is called micrometeorology; it is of importance for understanding the diffusion of air pollutants and other aspects of the climate near the ground. Standard meteorological observations are made with sampling techniques that filter out the influence of turbulence. Common terminology distinguishes among three classes of phenomena with a scale that is larger than the turbulent microscale: the mesoscale, synoptic scale, and planetary scale. See MICRO-METEOROLOGY.

The mesoscale includes all moist convection phenomena, ranging from individual cloud cells up to the convective cloud complexes associated with prefrontal squall lines, tropical storms, and the intertropical convergence zone. Also included among mesoscale phenomena are the sea breeze, mountain valley circulations, and the detailed structure of frontal inversions. Most mesoscale phenomena have time periods less than 12 h. The prediction of mesoscale phenomena is an area of active research. Most forecasting methods depend upon empirical rules or the short-range extrapolation of current observations, particularly those provided by radar and geostationary satellites. Forecasts are usually couched in probabilistic terms to reflect the sporadic character of the phenomena. Since many mesoscale phenomena pose serious threats to life and property, it is the practice to issue advisories of potential occurrence significantly in advance. These "watch" advisories encourage the public to attain a degree of readiness appropriate to the potential hazard. Once the phenomenon is considered to be imminent, the advisory is changed to a "warning," with the expectation that the public will take immediate action to prevent the loss of life. See MESOMETEOROLOGY; SQUALL.

The next-largest scale of weather events is called the synoptic scale, because the network of meteorological stations making simultaneous, or synoptic, observations serves to define the phenomena. The migratory storm systems of the extratropics are synoptic-scale events, as are the undulating wind currents of the upper-air circulation which accompany the storms. The storms are associated with barometric minima, variously called lows, depressions, or cyclones. The synoptic method of forecasting

consists of the simultaneous collection of weather observations, and the plotting and analysis of these data on geographical maps. An experienced analyst, having studied several of these maps in chronological succession, can follow the movement and intensification of weather systems and forecast their positions. This forecasting technique requires the regular and frequent use of large networks of data. See WEATHER MAP.

Planetary-scale phenomena are persistent, quasistationary perturbations of the global circulation of the air with horizontal dimensions comparable to the radius of the Earth. These dominant features of the general circulation appear to be correlated with the major orographic features of the globe and with the latent and sensible heat sources provided by the oceans. They tend to control the paths followed by the synoptic-scale storms, and to draw upon the synoptic transients for an additional source of heat and momentum. See ATMOSPHERE; METEOROLOGICAL INSTRUMENTATION; WEATHER OBSERVATIONS.

Numerical weather prediction is the prediction of weather phenomena by the numerical solution of the equations governing the motion and changes of condition of the atmosphere. Numerical weather prediction techniques, in addition to being applied to short-range weather prediction, are used in such research studies as air-pollutant transport and the effects of greenhouse gases on global climate change. See AIR POLLUTION; GREENHOUSE EFFECT; JET STREAM; UPPER-ATMOSPHERE DYNAMICS. [J.P.G.; J.R.G.]

The first operational numerical weather prediction model consisted of only one layer, and therefore it could model only the temporal variation of the mean vertical structure of the atmosphere. Computers now permit the development of multilevel (usually about 10–20) models that could resolve the vertical variation of the wind, temperature, and moisture. These multilevel models predict the fundamental meteorological variables for large scales of motion. Global models with horizontal resolutions as fine as 125 mi (200 km) are being used by weather services in several countries. Global numerical weather prediction models require the most powerful computers to complete a 10-day forecast in a reasonable amount of time.

Research models similar to global models could be applied for climate studies by running for much longer time periods. The extension of numerical predictions to long time intervals (many years) requires a more accurate numerical representation of the energy transfer and turbulent dissipative processes within the atmosphere and at the air-earth boundary, as well as greatly augmented computing-machine speeds and capacities.

Long-term simulations of climate models have yielded simulations of mean circulations that strongly resemble those of the atmosphere. These simulations have been useful in explaining the principal features of the Earth's climate, even though it is impossible to predict the daily fluctuations of weather for extended periods. Climate models have also been used successfully to explain paleoclimatic variations, and are being applied to predict future changes in the climate induced by changes in the atmospheric composition or characteristics of the Earth's surface due to human activities. See CLIMATE HISTORY; CLIMATE MODIFICATION; PALEOCLIMATOLOGY. [R.A.An.]

Surface meteorological observations are routinely collected from a vast continental data network, with the majority of these observations obtained from the middle latitudes of both hemispheres. Commercial ships of opportunity, military vessels, and moored and drifting buoys provide similar in-place measurements from oceanic regions. Information on winds, pressure, temperature, and moisture throughout the troposphere and into the stratosphere is routinely collected from (1) balloon-borne instrumentation packages (radiosonde observations) and commercial and military aircraft which sample the free atmosphere directly; (2) ground-based remote-sensing instrumentation such as wind profilers (vertically pointing Doppler radars), the National Weather Service Doppler radar network, and lidars; and (3) special sensors deployed on board polar orbiting or geostationary satellites. The remotely sensed observations

obtained from meteorological satellites have been especially helpful in providing crucial measurements of areally and vertically averaged temperature, moisture, and winds in data-sparse (mostly oceanic) regions of the world. Such measurements are necessary to accommodate modern numerical weather prediction practices and to enable forecasters to continuously monitor global storm (such as hurricane) activity. See LIDAR; METEOROLOGICAL INSTRUMENTATION; RADAR METEOROLOGY.

Forecast products and forecast skill are classified as longer term (greater than 2 weeks) and shorter term. These varying skill levels reflect the fact that existing numerical prediction models such as the medium-range forecast have become very good at making large-scale circulation and temperature forecasts, but are less successful in making weather forecasts. An example is the prediction of precipitation amount and type given the occurrence of precipitation and convection. Each of these forecasts is progressively more difficult because of the increasing importance of mesoscale processes to the overall skill of the forecast. See PRECIPITATION (METEOROLOGY). [L.F.B.]

Nowcasting is a form of very short range weather forecasting. The term nowcasting is sometimes used loosely to refer to any area-specific forecast for the period up to 12 h ahead that is based on very detailed observational data. However, nowcasting should probably be defined more restrictively as the detailed description of the current weather along with forecasts obtained by extrapolation up to about 2 h ahead. Useful extrapolation forecasts can be obtained for longer periods in many situations, but in some weather situations the accuracy of extrapolation forecasts diminishes quickly with time as a result of the development or decay of the weather systems. See WEATHER. [K.A.B.]

Forecasts of time averages of atmospheric variables, for example, sea surface temperature, where the lead time for the prediction is more than 2 weeks, are termed long-range or extended-range climate predictions. Extended-range predictions of monthly and seasonal average temperature and precipitation are known as climate outlooks. The accuracy of long-range outlooks has always been modest because the predictions must encompass a large number of possible outcomes, while the observed single event against which the outlook is verified includes the noise created by the specific synoptic disturbances that actually occur and that are unpredictable on monthly and seasonal time scales. According to some estimates of potential predictability, the noise is generally larger than the signal in middle latitudes. [E.A.O.L.]

**Weather map** A map or a series of maps that is used to depict the evolution and life cycle of atmospheric phenomena at selected times at the surface and in the free atmosphere. Weather maps are used for the analysis and display of in-place observational measurements and computer-generated analysis and forecast fields derived from weather and climate prediction models by research and operational meteorologists, government research laboratories, and commercial firms. Similar analyses derived from sophisticated computer forecast models are displayed in map form for forecast periods of 10–14 days in advance to provide guidance for human weather forecasters. See METEOROLOGICAL INSTRUMENTATION; WEATHER OBSERVATIONS.

Rapid advances in computer technology and visualization techniques, as well as the continued explosive growth of the Internet distribution of global weather observations, satellite and radar imagery, and model analysis and forecast fields, have revolutionized how weather, climate, and forecast data and information can be conveyed to both the general public and sophisticated users in the public and commercial sectors. People and organizations with access to the Internet can access weather and climate information in a variety of digital or map forms in support of a wide range of professional and personal activities. See CLIMATOLOGY; METEOROLOGICAL SATELLITES; METEOROLOGY; RADAR METEOROLOGY; WEATHER FORECASTING AND PREDICTION. [L.F.B.]

**Weather modification** Human influence on the weather and, ultimately, climate. This can be either intentional, as with cloud seeding to clear fog from airports or to increase precipitation, or unintentional, as with air pollution, which increases aerosol concentrations and reduces sunlight. Weather is considered to be the day-to-day variations of the environment—temperature, cloudiness, relative humidity, wind-speed, visibility, and precipitation. Climate, on the other hand, reflects the average and extremes of these variables, changing on a seasonal basis. Weather change may lead to climate change, which is assessed over a period of years. See AIR POLLUTION; CLIMATE HISTORY; CLOUD PHYSICS.

Specific processes of weather modification are as follows: (1) Change of precipitation intensity and distribution result from changes in the colloidal stability of clouds. For example, seeding of supercooled water clouds with dry ice (solid carbon dioxide, CO<sub>2</sub>) or silver iodide (AgI) leads to ice crystal growth and fallout; layer clouds may dissipate, convective clouds may grow. (2) Radiation change results from changes of aerosol or clouds (deliberately with a smoke screen, or unintentionally with air pollution from combustion), from changes in the gaseous constituents of the atmosphere (as with carbon dioxide from fossil fuel combustion), and from changes in the ability of surfaces to reflect or scatter back sunlight (as replacing farmland by houses.) (3) Change of wind regime results from change in surface roughness and heat input, for example, replacing forests with farmland. See PRECIPITATION (METEOROLOGY). [J.Hal.]

**Weather observations** The measuring, recording, and transmitting of data of the variable elements of weather. In the United States the National Weather Service (NWS), a division of the National Oceanic and Atmospheric Administration (NOAA), has as one of its primary responsibilities the acquisition of meteorological information. The data are sent by various communication methods to the National Meteorological Center.

At the Center, the raw data are fed into large computers that are programmed to plot, analyze, and process the data and also to make prognostic weather charts. The processed data and the forecast guidance are then distributed by special National Weather Service systems and conventional telecommunications to field offices, other government agencies, and private meteorologists. They in turn prepare forecasts and warnings based on both processed and raw data. See WEATHER MAP.

A wide variety of meteorological data are required to satisfy the needs of meteorologists, climatologists, and users in marine activities, forestry, agriculture, aviation, and other fields. This has led to a dual surface-observation program: the Synoptic Weather Program and the Basic Observations Program. See AERONAUTICAL METEOROLOGY; AGRICULTURAL METEOROLOGY; INDUSTRIAL METEOROLOGY.

The Synoptic Weather Program is designed to assist in the preparation of forecasts and to provide data for international exchange. Worldwide surface observations are taken at standard times [0000, 0600, 1200, and 1800 Universal Time Coordinated (UTC)] and sent in synoptic code.

The Basic Observations Program routinely provides meteorological data every hour. Special observations are taken at any intervening time to report significant weather events or changes. Observation sites are located primarily at airports; a few are in urban centers. At these sites, human observers report the weather elements.

Present weather consists of a number of hydrometers, such as liquid or frozen precipitation, fog, thunderstorms, showers, and tornadoes, and of lithometers, such as haze, dust, smog, dust devils, and blowing sand. The amount of cloudiness is also reported. See FOG; METEOROLOGICAL OPTICS; PRECIPITATION (METEOROLOGY); SMOG; THUNDERSTORM; TORNADO.

Pressure measurements are read from either a mercury or precision aneroid barometer located at the station. A microbarograph provides a continuous record of the pressure, from

which changes in specific intervals of time are reported. Pressure changes are frequently quite helpful in short-range prediction of weather events. See AIR PRESSURE.

Temperature and humidity are measured by a hygrometer, located near the center of the runway complex at many airport stations. The readings are transmitted to the observation site. The temperature dial indicator is equipped with pointers to determine maximum and minimum temperature extremes. See HUMIDITY; HYGROMETER; TEMPERATURE MEASUREMENT.

Wind speed and direction measurements are telemetered into most airport stations. The equipment, consisting of an anemometer and a wind vane, is located near the center of the runway complex at participating airports; elsewhere it is placed in an unsheltered area. See WIND MEASUREMENT.

Various types of clouds and their heights are reported. The lowest height of opaque clouds covering half or more of the sky is known as the ceiling, and is normally measured by a ceilometer at first-order stations. See CLOUD.

Upper-air observations have been made by the National Weather Service with radiosondes. The radiosonde is a small, expendable instrument package that is suspended below a 6-ft-diameter (2-m) balloon filled with hydrogen or helium. As the radiosonde is carried aloft, sensors on it measure profiles of pressure, temperature, and relative humidity. By tracking the position of the radiosonde in flight with a radio direction finder or radio navigation system, such as Loran or the Global Positioning System (GPS), information on wind speed and direction aloft is also obtained.

Understanding and accurately predicting changes in the atmosphere requires adequate observations of the upper atmosphere. Radiosonde observations, plus routine aircraft reports, radar, and satellite observations, provide meteorologists with a three-dimensional picture of the atmosphere. See LORAN; METEOROLOGICAL INSTRUMENTATION; SATELLITE NAVIGATION SYSTEMS; WEATHER OBSERVATIONS; WIND MEASUREMENT.

Weather radars distributed throughout the United States are used to observe precipitation within a radius of about 250 nmi (460 km), and associated wind fields (utilizing the Doppler principle) within about 125 nmi (230 km). The primary component of this set of weather radars is known as NEXRAD (Next Generation Weather Radar). These radars provide information on rainfall intensity, likelihood of tornadoes or severe thunderstorms, projected paths of individual storms (both ambient and within-storm wind fields), and heights of storms for short-range (up to 3 h) forecasts and warnings. See DOPPLER RADAR; RADAR METEOROLOGY.

Geostationary weather satellites near 22,000 mi (36,000 km) above the Earth transmit pictures depicting the cloud cover over vast expanses of the hemisphere. Using still photographs and animated images, the meteorologist can determine, among other things, areas of potentially severe weather and the motion of clouds and fog. In addition, the satellite does an outstanding job of tracking hurricanes over the ocean where few other observations are taken. See HURRICANE; METEOROLOGICAL SATELLITES.

Ground-based lightning detection systems detect the electromagnetic wave that emanates from the lightning path as the lightning strikes the ground. Lightning information has proven to be operationally valuable to a wide variety of users and as a supplement to other observing systems, particularly radar and satellites. See LIGHTNING; LIGHTNING AND SURGE PROTECTION; MESOMETEOROLOGY; METEOROLOGY; WEATHER FORECASTING AND PREDICTION. [F.S.Z.; R.L.L.]

**Weathering processes** The response of geologic materials to the environment (physical, chemical, and biological) at or near the Earth's surface. This response typically results in a reduction in size of the weathering materials; some may become as tiny as ions in solution.

The agents and energies that activate weathering processes and the products resulting therefrom have been classified tra-

ditionally as physical and chemical in type. In classic physical weathering, rock materials are broken by action of mechanical forces into smaller fragments without change in chemical composition, whereas in chemical weathering the process is characterized by change in chemical composition. In practice, however, the two processes commonly overlap.

Specific agents of weathering may be recognized and correlated with the types of effects they produce. Important agents of weathering are water in all surface occurrences (rain, soil and ground water, streams, and ocean); the atmosphere ( $H_2O$ ,  $O_2$ ,  $CO_2$ , wind); temperature (ambient and changing, especially at the freezing point of water); insolation (on large bare surfaces); ice (in soil and glaciers); gravity; plants (bacteria and macroforms); animals (micro and macro, including humans). Human modifications of otherwise geologic weathering that have increased exponentially during recent centuries include construction, tillage, lumbering, use of fire, chemically active industry (fumes, liquid, and solid effluents), and manipulation of geologic water systems.

Products of physical weathering include jointed (horizontal and vertical) rock masses, disintegrated granules, frost-riven soil and surface rock, and rock and soil flows. Products of chemical weathering include the soil, and the clays used in making ceramic structural products, whitewares, refractories, various fillers and coating of paper, portland cement, absorbents, and vanadium. These are the relatively insoluble products of weathering; characteristically they occur in clays, siltstones, and shales. Sand-size particles resulting from both physical and chemical weathering may accumulate as sandstones.

After precipitation, the relatively soluble products of chemical weathering give rise to products and rocks such as limestone, gypsum, rock salt, silica, and phosphate and potassium compounds useful as fertilizers. [W.D.K.]

**Wedge** A piece of resistant material whose two major surfaces make an acute angle. It is closely related to the inclined plane and is used to multiply the applied force and to change the direction in which it acts (see illustration). See INCLINED PLANE.

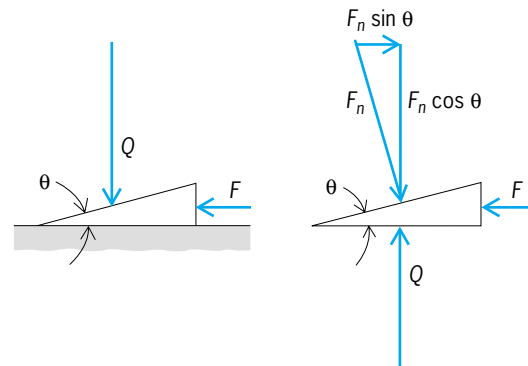

Forces acting on a wedge.

Force  $F$  is the smaller applied force and  $Q$  is the larger force to be exerted. In the absence of friction, forces must act normal to their surfaces; thus the actual force on the inclined surface is not  $Q$  but a larger force  $F_n$ . Summing up forces in the horizontal and vertical directions gives Eqs. (1).

$$\begin{aligned} F_n \sin \theta - F &= 0 \\ Q - F_n \cos \theta &= 0 \end{aligned} \quad (1)$$

Combining the expressions for  $F$  and  $Q$  and solving for  $F$  gives Eq. (2).

$$F = Q \tan \theta \quad (2)$$

If angle  $\theta$  is small, the reaction of  $Q$  against  $F$  is exceeded by the friction between the face of the wedge and the adjacent body on which it rests. Thus the wedge tends to remain in position even when loaded by a large force  $Q$ . See SIMPLE MACHINE. [R.M.Ph.]

**Weeds** Unwanted plants or plants whose negative values outweigh the positive values in a given situation. Weeds impact growers each year in reduced yield and quality of agricultural products. Especially in tropical areas, irrigation systems have become unusable because of clogging with weeds. Weeds can harbor deleterious disease organisms and insects that harm crops and livestock. In addition, weeds can cause allergic reactions and serious skin problems (poison ivy), break up pavement, slow or stop water flow in municipal water supplies, interfere with power lines, cause fire hazards around buildings and along railroad tracks, and produce poisonous plant parts. See ALLERGY.

The most serious weeds are those that succeed in invading new areas and surviving at the expense of other plants by monopolizing light, nutrients, and water or by releasing chemicals detrimental to the growth of surrounding vegetation (allelopathy). In the plant kingdom, dozens of species have been shown to release allelopathic chemicals from roots, leaves, and stems. See ALLELOPATHY.

**Classification.** Weeds can be classified as summer annuals, which germinate in the spring, set seed, and die in the fall (crabgrass); winter annuals, which germinate in the fall, set seed, and die in the spring (common chickweed); biennials, which germinate one year, overwinter, set seed, and die the following summer (wild carrot); simple perennials, which live for several years but spread only by seed (dandelion); and creeping perennials, which live for several years and can spread both by seed and by underground roots or rhizomes (field bindweed).

**Control methods.** Hand pulling, fire, flooding, and tillage are useful for controlling weeds. Insects and pathogens have also been introduced to control certain weed species. Techniques such as herbicides, computerization of spray and tillage technology, remote sensing for weed mapping and identification, and laser treatment have also been explored. Herbicides have resulted in large improvements in the availability and quality of food. They have increased the feasibility of no-till agriculture, leading to significant reductions in soil erosion. They commonly kill weeds by disrupting a physiological process that is not present in animals. Some, however, are moderately high in toxicity and must be used carefully. Rare individual weeds that are genetically resistant to the herbicide have flourished and reproduced, leading to populations of weeds resistant to that herbicide. See HERBICIDE. [A.P.A.]

**Biological control.** Biological control involves the use of natural enemies (parasites, pathogens, and predators) to control pest populations. In the case of weed pests, the primary natural enemy groups utilized are arthropods, fungal pathogens, and vertebrates. The two major approaches are classical and inundative biological control. Biocontrol can be a highly effective and cost-efficient means of controlling weeds without the use of chemical herbicides.

Classical biocontrol (also termed the inoculative or importation method) is based on the principle of population regulation by natural enemies. Most naturalized weeds leave behind their natural enemies when they colonize new areas, and so can increase to significant densities. Classical biocontrol involves the importation of natural enemies, usually from the area of origin of the weed (and preferably from a part of its native range that is a good climatic match with the intended control area), and their field release. Imported biocontrol agents must be host specific to the target weed.

Inundative control is the mass production and periodic release of large numbers of biocontrol agents to achieve controlling densities. It can be used where existing populations of agents are lacking or where existing populations that are not self-sustaining at high, controlling densities can be augmented. A chief advan-

tage of this method is that it can be integrated with conventional fanning practices on cultivated croplands.

Arthropods, especially insects, are heavily utilized as imported biocontrol agents in uncultivated environments such as grasslands and aquatic systems.

Rusts (Uredinales) are the fungal group most frequently employed as imported agents in classical biocontrol programs. The rust *Puccinia chondrillina*, imported from Italy, controlled the narrow-leaf form of skeletonweed (*Chondrilla juncea*) in Australia. Formulations of spores of foreign and endemic pathogens can be used as mycoherbicides in inundative applications.

Vertebrate animal agents, such as goats, typically do not possess a high degree of host-plant specificity, and their feeding has to be carefully managed to focus it on the target weeds. See ARTHROPODA; FUNGI. [C.E.Tu.]

**Weight** The gravitational weight of a body is the force with which the Earth attracts the body. By extension, the term is also used for the attraction of the Sun or a planet on a nearby body. This force is proportional to the body's mass and depends on the location. Because the distance from the surface to the center of the Earth decreases at higher latitudes, and because the centrifugal force of the Earth's rotation is greatest at the Equator, the observed weight of a body is smallest at the Equator and largest at the poles. The difference is sizable, about 1 part in 300. At a given location, the weight of a body is highest at the surface of the Earth. Weight is measured by several procedures. See BALANCE; MASS; WEIGHT MEASUREMENT. [H.S.B.]

**Weight measurement** Weight is the resultant force acting on a mass (in a vacuum) due to the Earth's gravitational field corrected for the effect of the Earth's rotation. Units of weight are based upon an acceleration of gravity. When the weight of an unknown is determined by comparison with a known weight, there is no error in the readings due to gravity variations. The varying buoyant effect of the atmosphere is negligible when the density of the unknown is approximately the same as that of the standard. In precision weighing, the buoyant effect of air must be considered. See GRAVITY.

The equal-arm balance is probably the most common form of instrument for measuring weight. These balances are made in many designs and sizes; in some the knife-edge fulcrums are replaced with flexure plates; others have arms of unequal length. Conventionally, the unknown weight is placed on one pan, the known weight on the other. The final securing of a balance is done by adjusting the position of a rider, or small weight, on a bar of the balance arm bridge. The condition of balance is indicated when the pointer swings equal distances from its rest point. See BALANCE.

The mechanical-type industrial scale incorporates a number of levers with precisely located fulcrums to permit heavy objects to be balanced (weighed) with small, convenient counterweights or counterpoises.

The pendulum-type mechanical scale balances the force of the load by the rotation of a bent lever. With this construction, the deflection of the load on the scale moves the counterweights through the lever system so that their center of gravity is at a greater distance from the final fulcrum. Thus the increased lever arm of the counterweights automatically balances the load.

The spring scale utilizes the deflection of a spring to measure the load. If sensitive enough, such a scale can detect and indicate the effect of differences in the weight of a body due to changes in elevation.

In hydraulic systems, the load applied to the load cell piston is converted to hydraulic pressure. The effective area of the piston must be known. The pressure may be measured at a remote point by a pressure-gage, such as a Bourdon tube.

Pneumatic systems detect the load by a sensitive nozzle and flapper system and balance the load by modulating an air pressure in an opposing capsule.

Electrical weighing systems usually involve the electrical measurement of the elastic deformation of a mechanical element under stress. The strain gage is attached to the weighing element in a manner to produce the maximum resistance change per unit of load. The change in resistance with load is measured and amplified by electronic means, and the load is read on a potentiometer. See WEIGHT. [H.S.B.]

**Weightlessness** A condition induced by the effective lack of resistance to gravitational force on an object or organism, sometimes known as free fall.

Newton proposed the law of universal gravitation, which states that two bodies of matter in the universe attract each other with a force that is directly proportional to the product of their masses and inversely proportional to the square of the distance between their centers. According to this law, even a small increase in the distance between bodies will produce a large decrease in the gravitational force, since the force decreases with the square of the distance. As a body moves from the Earth's surface to a location an infinite distance from the Earth, the gravitational force approaches zero and the body approaches weightlessness. In the true sense, a body can be weightless only when it is an infinite distance from all other objects.

Weightlessness is also defined as a condition in which no acceleration, whether of gravity or any other force, can be detected by an object or organism within the system in question. According to Albert Einstein's principle of equivalence, there is no way to distinguish between the forces of gravitational fields and the forces due to inertial motion. When a gravitational force on a body is opposed by an equal and opposite inertial force, a weightless state is produced. This is based on the fact that the mass that determines the gravitational force of a body is the same as the mass related to the acceleration produced by an inertial force of any kind. These inertial forces have no external physical origin, but are the consequences of an accelerated state of motion. Because of inertia, a moving object always tends to follow a straight line. When a person swings a bucket by the handle in a large circle, he or she feels a pull on his or her hand, because inertial force (also called centrifugal force in this case) tends to keep the bucket moving in a straight line, while the bucket holder exerts a counterforce constraining the bucket to move along the circle. A similar situation exists in a spaceship orbiting the Earth 200 mi (320 km) above the Earth's surface, where the gravitational field is only slightly weaker than at sea level. The ship, in free fall with negligible atmospheric drag, is pulled toward the Earth by the Earth's gravitational attraction force, while the inertial or centrifugal force of the moving ship is directed radially outward from the Earth; consequently, the force of gravity on the orbiting ship is opposed and nullified by the centrifugal force, and apparent weightlessness results. See GRAVITATION; GRAVITY; INERTIA; NEWTON'S LAWS OF MOTION; SPACE FLIGHT; SPACE PROCESSING. [T.W.H.]

**Welded joint** The joining of two or more metallic components by introducing fused metal (welding rod) into a fillet between the components or by raising the temperature of their surfaces or edges to the fusion temperature and applying pressure (flash welding).

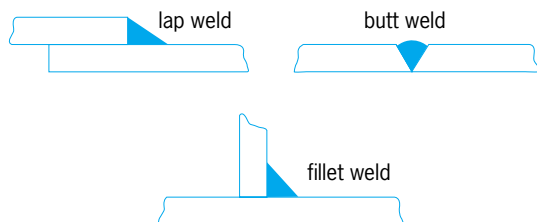

Fig. 1. Three types of welded joints.

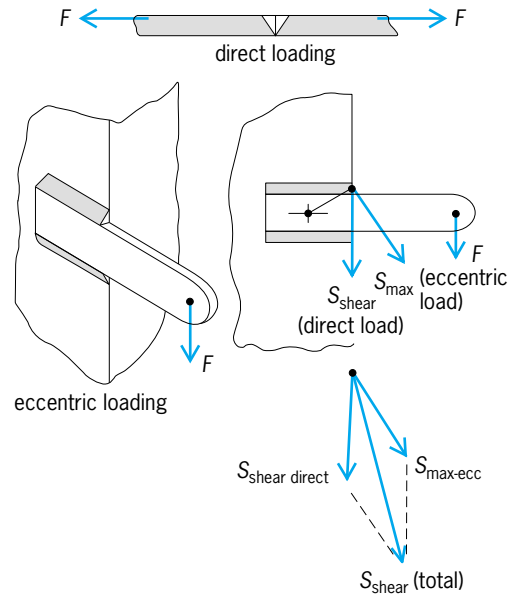

Fig. 2. Loading forces on a welded joint.

Figure 1 shows three types of welded joints. In a lap weld, the edges of a plate are lapped one over the other and the edge of one is welded to the surface of the other. In a butt weld, the edge of one plate is brought in line with the edge of a second plate and the joint is filled with welding metal or the two edges are resistance-heated and pressed together to fuse. For a fillet weld, the edge of one plate is brought against the surface of another not in the same plane and welding metal is fused in the corner between the two plates, thus forming a fillet. The joint can be welded on one or both sides.

Because welded joints are usually exposed to a complex stress pattern as a result of the high temperature gradients present when the weld is made, it is customary to design joints by use of arbitrary and simplified equations and generous safety factors. The force  $F$  of direct loading, and consequently the stress  $S$ , is applied directly along or across a weld. The stress-force equation is then simply  $F = SA$ , in which  $A$  is the area of the plane of failure (Fig. 2). For eccentric loading, the force  $F$  causes longitudinal and transverse forces of varying magnitudes along the weld. See RIVETED JOINT; STRUCTURAL CONNECTIONS; WELDING AND CUTTING OF METALS. [L.S.L.]

**Welding and cutting of materials** Processes based on heat to join and sever metals. Welding and cutting are grouped together because, in many manufacturing operations, severing precedes welding and involves the same production personnel. Welding is one of the joining processes, others being riveting, bolting, gluing, and adhesive bonding. See BOLTED JOINT; WELDED JOINT.

The American Welding Society's definition of welding is "a metal-joining process wherein coalescence is produced by heating to suitable temperatures with or without the application of pressure, and with or without the use of filler metal." Brazing is defined as "a group of welding processes wherein coalescence is produced by heating to suitable temperature and by using a filler metal, having a liquidus above 800°F (427°C) and below the solidus of the base metals. The filler metal is distributed between the closely fitted surfaces of the joint by capillary attraction." Soldering is similar in principle, except that the melting point of solder is below 800°F (427°C). The adhesion of solder depends not so much on alloying as on its keying into small irregularities in the surfaces to be joined. See JOINT (STRUCTURES); BRAZING; SOLDERING.



Cutting is one of the severing and material-shaping processes, some others being sawing, drilling, and planning. Thermal cutting is defined as a group of cutting processes wherein the severing or removing of metals is effected by melting or by the chemical reaction of oxygen with the metal at elevated temperatures. Welding and cutting are widely used in building ships, machinery, boilers, spacevehicles, structures, atomic reactors, aircraft, railroad cars, missiles, automobiles, buses and trailers, and pressure vessels, as well as in constructing piping and storage tanks of steel, stainless steel, aluminum, nickel, copper, lead, titanium, tantalum, and their alloys. For many products, welding is the only joining process that achieves the desired economy and properties, particularly leak-tightness. See TORCH.

Nearly all industrial welding involves fusion. The edges or surfaces to be welded are brought to the molten state. The liquid metal bridges the gap between the parts. After the source of welding heat has been removed, the liquid solidifies, thus joining or welding the parts together. The principal sources of heat for fusion welding are electric arc, electric resistance, flame, laser, and electron-beam. See ARC WELDING; LASER WELDING; RESISTANCE WELDING. [M.M.S.]

**Well** An artificial excavation made to extract water, oil, gas, brine, or other fluid substance from the earth. Most wells are of the drilled type. Dug wells are almost obsolete, because of the greater speed of drilling and the greater efficiency of drilled wells. See ARTESIAN SYSTEMS; OIL AND GAS WELL DRILLING.

Drilled wells, commonly 2–36 in. (5–90 cm) in diameter, usually are fitted with a steel tube or casing inserted in the drilled hole to the desired depth. Where the water-bearing formation is competent to stand without support, the casing is set, or finished, at the top of solid rock. Where there is danger of caving, as in sand or gravel, the casing is carried below the top of the water-bearing bed, and a perforated pipe or screen extends below the casing to the bottom of the hole. The construction includes a considerable period of pumping, surging, or other treatment (called well development), during which the finer particles of the formation are drawn into the well and removed. This process substantially increases the initial yield of the well.

Most wells of large capacity are equipped with pumps of the deep-well turbine type to lift the water to the surface. When a well is pumped, the pressure head at the well is lowered and a hydraulic gradient toward the well is established which causes water to flow toward the well. This lowering of head is called drawdown. See GROUND-WATER HYDROLOGY; PUMPING MACHINERY. [A.N.S./R.K.Li.]

**Well logging** The technique of making measurements in drill holes with probes designed to measure the physical and chemical properties of rocks and their contained fluids. Much information can be obtained from samples of rock brought to the surface in cores or bit cuttings, or from other clues while drilling, such as penetration rate; however, the greatest amount of information comes from well logs. See BOREHOLE LOGGING.

Well logs result from a probe lowered into the borehole at the end of an insulated cable. The resulting measurements are recorded graphically or digitally as a function of depth. These records are known as geophysical well logs, petrophysical logs, or more commonly well logs, or simply logs.

Although the most common uses of logs are for correlation of geological strata and location of hydrocarbon zones, there are many other important subsurface parameters that need to be detected or measured. Also, different borehole and formation conditions can require different tools to measure the same basic property. In petroleum engineering, logs are used to: identify potential reservoir rock; determine bed thickness; determine porosity; estimate permeability; locate hydrocarbons; estimate water salinity; quantify amount of hydrocarbons; estimate type and rate of fluid production; estimate formation pressure; identify fracture zones; measure borehole inclination and azimuth; mea-

sure hole diameter; aid in setting casing; evaluate quality of cement bonding; locate entry, rate, and type of fluid into borehole; and trace material injected into formations (such as artificial fractures). In geology and geophysics, they are used to: correlate between wells; locate faults; determine dip and strike of beds; identify lithology; deduce environmental deposition of sediments; determine thermal and pressure gradients; create synthetic seismograms; calibrate seismic amplitude anomalies to help identify hydrocarbons from surface geophysics; calibrate seismic with velocity surveys; and calibrate gravity surveys with borehole gravity meter. Other applications include: locating fresh-water aquifers; locating solid minerals; and studying soil and rock conditions for foundations of large structures.

Electrical devices employ instruments that generate data based on electrical measurements. The spontaneous potential, usually recorded along with resistivity curves, is a simple but valuable aid to help geologists correlate from one well to another and to assist them in inferring the depositional environment of the sediments. It defines permeable zones from surrounding non-permeable shales and can be used to estimate the salinity of formation water. Resistivity is one of the most important physical properties to record. A sand filled with salt water will conduct electricity much easier (and therefore has a lower resistivity) than a sand in which most of the salt water is replaced with a nonconducting oil or gas. The primary purpose of resistivity measurements is to determine hydrocarbon saturation.

Quantitative interpretation of hydrocarbon saturation requires a knowledge of porosity. One of the most widely used porosity logs is the acoustic log, also known as a sonic log, acoustilog, or velocity log. The acoustical log measures the shortest time for sound waves to travel through 1 ft (or 1 m) of formation. This log is used for many other purposes, including identification of lithology, prediction of pressures, and assisting with geophysical interpretation. In addition, information from the amplitude of the acoustic wave aids in detection of fractures and gas zones, determination of mechanical properties of rocks, and analysis of cement bond behind pipe.

Nuclear devices are instruments which generate data based on measurements of nuclear particles. In most cases the gamma-ray log may be considered as a shale log; that is, clays or shaly rocks will give a higher radioactive count than clean sands or carbonates. Like the spontaneous potential, this provides a good correlation curve, defines bed thicknesses, and aids interpretation of environmental deposition. Almost all the naturally occurring radioactivity that is detected by the gamma-ray log comes from three elements: potassium, thorium, and uranium.

An important porosity tool is the density log, which emits a beam of gamma rays into the rock and these rays interact with electrons in the formation through Compton scattering. The tool provides a bulk density measurement. Another important device for determination of porosity is the neutron log. These logs respond primarily to hydrogen atoms. Therefore, in clean or shale-free formations the neutron log reflects the amount of liquid-filled porosity. A tool developed to distinguish hydrocarbon from salt water behind casing is the pulsed neutron capture tool which employs a neutron generator that repeatedly emits pulses of high-energy neutrons. After these neutrons are slowed down to the thermal state, they are captured by nuclei of the various atoms surrounding the tool. With each capture a corresponding emission of gamma rays occurs.

Production logging tools are designed to locate fluid movement behind the casing and into the well bore, to detect the type of fluid, and to determine the flow rate. Production logging tools include various types of flow meters, fluid density devices, sensitive thermometers, radioactive tracer devices, noise loggers, and capacitance logs. In addition, these tools usually record some correlation curve such as gamma-ray or collar locator to tie the production curves to the formation and casing. Closely related to production tools are logging devices that either magnetically or mechanically inspect the condition of the casing in the borehole.

Small but rugged and powerful computers designed for field operation record logs on magnetic tapes as they are run and mathematically manipulate them in the logging trucks at the well site. Detailed computations are made quickly on a foot by foot basis to give information on fluid and rock properties. The digital information from practically every curve can be incorporated into some type of analysis or interpretation program. [R.E.Wy.]

**Wellpoint systems** A method of keeping an excavated area dry by intercepting the flow of groundwater with pipe wells located around the excavation area. Intercepting the flow before it reaches the excavated area also improves the stability of the edge of the excavation, permitting steeper bank slopes and often eliminating the need for supporting or shoring the banks. See CONSTRUCTION METHODS; GROUND-WATER HYDROLOGY; WELL.

Wellpoint systems are most effective in coarse-grained soils, such as gravel or sand. They are not effective in fine soils, such as silts and clays, where the small size of the pores between grains restricts the flow of water.

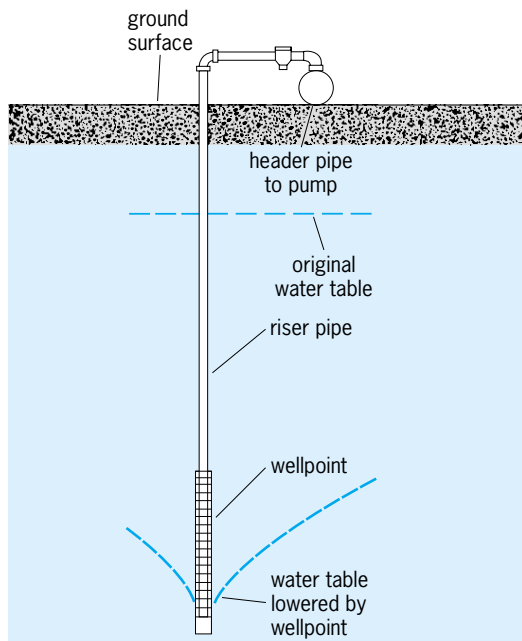

Components of a wellpoint system.

The basic components of a wellpoint system are the wellpoint, the riser pipe, the header pipe or manifold, and the pump (see illustration). The wellpoint consists of a perforated pipe equipped with a ball valve to regulate the flow of water, a screen to prevent the entry of sand during pumping, and a jetting tip. The steel riser pipe brings the groundwater to the surface, where it is collected by the horizontal manifold pipe or header pipe. The pumps are located above the water table and collect the water from the header pipes for discharge away from the excavation area. See PUMP; PUMPING MACHINERY. [W.Her.]

**Welwitschiales** An order of the class Cycadopsida having one species, *Welwitschia mirabilis*. This plant is native to the very arid deserts of southwestern Africa. Its appearance is bizarre—it has a very short, unbranched, woody stem (sometimes to 3 ft or 1 m in diameter), which is cushion- or saucer-shaped and tapers quickly to a long taproot. There are only two leaves, and these persist throughout the life of the plant. The leaf is broadly strap-shaped, as wide as the stem, firm, and leathery, and gradually splits lengthwise between the veins. The leaf (of indefinite growth) develops from a meristem at this point of connection to the stem. The species is dioecious; the cones are borne on branched axes originating between the crown of the stem and

the base of the leaf. The order is known only from the one living species and not from any fossils. See CYCADOPSIDA; PINOPHYTA; PLANT KINGDOM. [T.A.Z.]

**Wentzel-Kramers-Brillouin method** A special technique for obtaining an approximation to the solutions of the one-dimensional time-independent Schrödinger equation, valid when the wavelength of the solution varies slowly with position. It is named after G. Wentzel, H. A. Kramers, and L. Brillouin, who independently in 1926 contributed to its understanding in the quantum-mechanical application. It is also called the WKB method, BWK method, the classical approximation, the quasi-classical approximation, and the phase integral method. See QUANTUM MECHANICS; SCHRÖDINGER'S WAVE EQUATION. [R.H.Go.]

**West Indies** An archipelago, including the Bahamas, the Greater Antilles (including Cuba, Jamaica, Hispaniola—the Dominican Republic and Haiti—and Puerto Rico), the Lesser Antilles, and other islands, curving 2500 mi (4000 km) from Yucatan Peninsula and southeastern Florida to northern Venezuela and enclosing the Caribbean Sea. Situated between latitude 10° and 27°N and longitude 59° and 85°W, in the zone of the northeast trade winds, the West Indies have a subtropical and predominantly oceanic climate, with even warmth and steady breezes. Temperatures vary little from season to season, ranging from means of 80–85°F (27–29°C) in July to 70–78°F (21–26°C) in January at sea level. Freezing is unknown, and the hottest temperatures rarely exceed 90°F (32°C). Precipitation ranges from a low of 25–50 in. (64–127 cm) a year on low-lying islands and drier coasts up to 300 in. (7.6 m) on the highest peaks, which are almost perpetually cloud-capped. At lower elevations, rainfall is erratic from year to year and from season to season, but reaches a maximum in the summer and fall, when the northeast trades are replaced by light, variable winds. This is also the season of hurricanes, destructive tropical cyclones which sweep west and northwest across the Caribbean, sparing only the southernmost islands. The winter months are generally dry, and there is frequently a shorter dry season in July or August. See CARIBBEAN SEA; TROPICAL METEOROLOGY.

The West Indian flora is chiefly derived from Central and South America, but there are a number of endemic species, notably palms; many mainland plants failed to colonize the islands, which are floristically poor. The effect of isolation and small size is evident in the meager character of West Indian fauna. Animal species are limited; there are few mammals and no large ones, except for domesticated animals and, especially on Hispaniola, feral cattle, goats, pigs, and horses. [D.Low.]

**Wetlands** Ecosystems that form transitional areas between terrestrial and aquatic components of a landscape. Typically they are shallow-water to intermittently flooded ecosystems, which results in their unique combination of hydrology, soils, and vegetation. Examples of wetlands include swamps, fresh- and salt-water marshes, bogs, fens, playas, vernal pools and ponds, floodplains, organic and mineral soil flats, and tundra. As transitional elements in the landscape, wetlands often develop at the interface between drier uplands such as forests and farmlands, and deep-water aquatic systems such as lakes, rivers, estuaries, and oceans. Thus, wetland ecosystems are characterized by the presence of water that flows over, ponds on the surface of, or saturates the soil for at least some portion of the year.

Wetland soils can be either mineral (composed of varying percentages of sand, silt, or clay) or organic (containing 12–20% organic matter). Through their texture, structure, and landscape position, soils control the rate of water movement into and through the soil profile (the vertical succession of soil layers). Retention of water and organic carbon in the soil environment controls biogeochemical reactions that facilitate the functioning of wetland soils. See BIOGEOCHEMISTRY.

Vegetated wetlands are dominated by plant species, called hydrophytes, that are adapted to live in water or under saturated soil conditions. Adaptations that allow plants to survive in a water-logged environment include morphological features, such as pneumatophores (the "knees," or exposed roots, of the bald cypress), buttressed tree trunks, shallow root systems, floating leaves, hypertrophied lenticels, inflated plant parts, and adventitious roots. Physiological adaptations also allow plants to survive in a wetland environment. These include the ability of plants to transfer oxygen from the root system into the soil immediately surrounding the root (rhizosphere oxidation); the reduction or elimination of ethanol accumulation due to low concentrations of alcohol dehydrogenase; and the ability to concentrate malate (a nontoxic metabolite) instead of ethanol in the root system. See ROOT (BOTANY).

Wetlands differ with respect to their origin, position in the landscape, and hydrologic and biotic characteristics. For example, work has focused on the hydrology as well as the geomorphic position of wetlands in the landscape. This hydrogeomorphic approach recognizes and uses the fundamental physical properties that define wetland ecosystems to distinguish among classes of wetlands that occur in riverine, depression, estuarine or lake fringe, mineral or organic soil flats, and slope environments.

The extent of wetlands in the world is estimated to be  $2\text{--}3 \times 10^6 \text{ mi}^2$  ( $5\text{--}8 \times 10^6 \text{ km}^2$ ), or about 4–6% of the Earth's land surface. Wetlands are found on every continent except Antarctica and in every climate from the tropics to the frozen tundra. Rice paddies, which comprise another  $500,000\text{--}600,000 \text{ mi}^2$  ( $1.3\text{--}1.5 \times 10^6 \text{ km}^2$ ), can be considered as a type of domesticated wetland of great value to human societies worldwide. See BOG; MANGROVE; MUSKEG; PLAYA; SALT MARSH; TUNDRA.

Wetlands are often an extremely productive part of the landscape. They support a rich variety of waterfowl and aquatic organisms, and represent one of the highest levels of species diversity and richness of any ecosystem. Wetlands are an extremely important habitat for rare and endangered species.

Wetlands often serve as natural filters for human and naturally generated nutrients, organic materials, and contaminants. The ability to retain, process, or transform these substances is called assimilative capacity, and is strongly related to wetland soil texture and vegetation. The assimilative capacity of wetlands has led to many projects that use wetland ecosystems for wastewater treatment and for improving water quality. Wetlands also have been shown to prevent downstream flooding and, in some cases, to prevent ground-water depletion as well as to protect shorelines from storm damage. The best wetland management practices enhance the natural processes of wetlands by maintaining conditions as close to the natural hydrology of the wetland as possible. See GROUND-WATER HYDROLOGY.

The world's wetlands are becoming a threatened landscape. Loss of wetlands worldwide currently is estimated at 50%. Wetland loss results primarily from habitat destruction, alteration of wetland hydrology, and landscape fragmentation. Global warming may soon be added to this list, although the exact loss of coastal wetlands due to sea-level rise is not well documented. Worldwide, destruction of wetland ecosystems primarily has been through the conversion of wetlands to agricultural land.

Hydrologic modifications that destroy, alter, and degrade wetland systems include the construction of dams and water diversions, ground-water extraction, and the artificial manipulation of the amount, timing, and periodicity of water delivery. The primary impact of landscape fragmentation on wetland ecosystems is the disruption and degradation of wildlife migratory corridors, reducing the connectivity of wildlife habitats and rendering wetland habitats too small, too degraded, or otherwise irreversibly altered to support the critical life stages of plants and animals.

The heavy losses of wetlands in the world, coupled with the recognized values of these systems, have led to a number of policy initiatives at both the national and international levels.

Wetland restoration usually refers to the rehabilitation of degraded or hydrologically altered wetlands, often involving the reestablishment of vegetation. Wetland enhancement generally refers to the targeted restoration of one or a set of ecosystem functions over others, for example, the focused restoration of a breeding habitat for rare, threatened, or endangered amphibians. Wetland creation refers to the construction of wetlands where they did not exist before. Created wetlands are also called constructed or artificial wetlands. Restoring, enhancing, or creating a wetland requires a comprehensive understanding of hydrology and ecology, as well as engineering skills. See DAM; ECOSYSTEM; ESTUARINE OCEANOGRAPHY; HYDROLOGY; RIVER ENGINEERING; RESTORATION ECOLOGY. [W.J.M.; P.L.Fi.; L.C.Le.; S.R.St.]

**Wheat** A food grain crop. Wheat is the most widely grown food crop in the world, and is increasing in production. It ranks first in world crop production and is the national food staple of 43 countries. At least one-third of the world's population depends on wheat as its main staple. The principal food use of wheat is as bread, either leavened or unleavened. The United States is second to Russia in total production, but the average yield per acre in the United States is about twice that of Russia. Other major wheat-producing countries in the world are Canada, China, India, France, Argentina, and Australia.

Wheat is best adapted to a cool dry climate, but is grown in a wide range of soils and climates. Much of the world's wheat is seeded in the fall season and, after being dormant or growing very slowly during winter, it makes rapid growth in the spring and develops grain for harvest in early summer.

Wheat for milling is classified according to hardness, color, and best use. In the United States, there are seven official market classes of which the following five are the most important: (1) hard red winter, for bread; (2) hard red spring, for bread and rolls; (3) soft red winter, for cake and pastries; (4) white, for bread, breakfast foods, and pastries; and (5) durum, for macaroni products.

The wheat inflorescence is a spike bearing sessile spikelets arranged alternately on a zigzag rachis. Two, three, or more florets may develop in each spikelet and bear grains. The grain may be white, red (brown), or purple, and it may be hard or soft in texture. Size of the grain or caryopsis may be large, as in durum, or very small, as in shot wheat (*Triticum sphaerococcum*). Wheats vary in plant height and in the ability to produce tillers. The stems are usually hollow. The wheat grain is composed of the endosperm and embryo enclosed by bran layers. The endosperm portion is principally starch and is therefore used as energy food. Wheat is also an important protein source, especially for those people who use wheat as their main staple. See SEED.

Botanically, wheat is a member of the grass family to which rice, barley, corn, and several other cereal grain crops also belong. The *Triticum* genus includes a wide range of wheat forms. Taxonomic studies place the goat grasses (*Aegilops*) and wheat (*Triticum*) in one genus, *Triticum*. Wheat has been crossed with rye (*Secale*) and with *Agropyron* (a grass). New forms, called *Triticale*, have been derived from crossing rye and wheat followed by doubling the chromosomes in the hybrid. See TRITICALE.

Most countries in which wheat is grown have wheat breeding programs in which the objective is to develop more productive and more stable varieties (cultivars). Many methods are combined in these programs, but in nearly all of them specially selected parent types are crossbred followed by pure-line selection among the progeny to develop new combinations of merit. Varieties and genetic types from all over the world become candidate parents to provide the desired recombinations of good quality, winter and drought hardiness, straw strength, yield, and disease resistance. Wheats must be bred for specific milling processes and to provide quality end-use products. Many new varieties have complex pedigrees. See BREEDING (PLANT); GRAIN CROPS.

[L.P.R.]

Milling of wheat has evolved from rudimentary crushing or cracking to sophisticated separation and refining. The main purpose of milling is isolation of the starch-protein matrix, that is, separation of the endosperm from the high-fiber bran and high-lipid germ. Under optimal conditions, milling yields a high-quality, uniformly colored flour with a relatively stable shelf-life. The flours of hard wheats (11 to 13% protein) develop strong gluten complexes during mixing and are therefore suitable for making bread. Whole soft wheats (9 to 11% protein) yield flours that are used primarily for cakes, cookies, and pastries. Durum wheat is used to produce a relatively coarse flour, semolina, used for manufacture of pasta products. See FOOD MANUFACTURING. [M.A.U.]

**Wheatstone bridge** A device used to measure the electrical resistance of an unknown resistor by comparing it with a known standard resistance. This method was first described by S. H. Christie in 1833. Since 1843 when Sir Charles Wheatstone called attention to Christie's work, Wheatstone's name has been associated with this network.

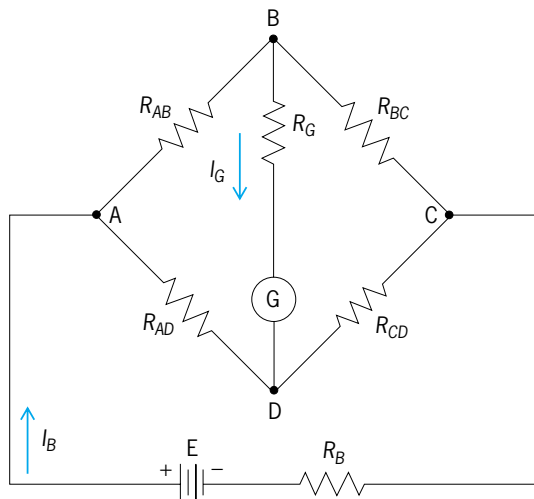

Wheatstone bridge circuit.

The Wheatstone bridge network consists of four resistors  $R_{AB}$ ,  $R_{BC}$ ,  $R_{CD}$ , and  $R_{AD}$  interconnected as shown in the illustration to form the bridge. A detector  $G$ , having an internal resistance  $R_G$ , is connected between the  $B$  and  $D$  bridge points; and a power supply, having an open-circuit voltage  $E$  and internal resistance  $R_B$ , is connected between the  $A$  and  $C$  bridge points. See BRIDGE CIRCUIT.

If the network is adjusted so that Eq. (1) is satisfied, the detector

$$R_{BC}R_{AD} - R_{AB}R_{CD} = 0 \tag{1}$$

current will be zero and this adjustment will be independent of the supply voltage, the supply resistance, and the detector resistance. Thus, when the bridge is balanced, Eq. (2) holds, and, if it is

$$R_{BC}R_{AD} = R_{AB}R_{CD} \tag{2}$$

assumed that the unknown resistance is the one in the  $CD$  arm of the bridge, then it is given by Eq. (3).

$$R_{CD} = \left( \frac{R_{BC}}{R_{AB}} \right) \times R_{AD} \tag{3}$$

See RESISTANCE MEASUREMENT. [C.E.A.]

**Wheel and axle** A wheel and its axle or, more generally, two wheels with different diameters or a wheel and drum, as in a windlass, rigidly connected together so that they rotate as a unit on a common axis. The principle of operation is the same

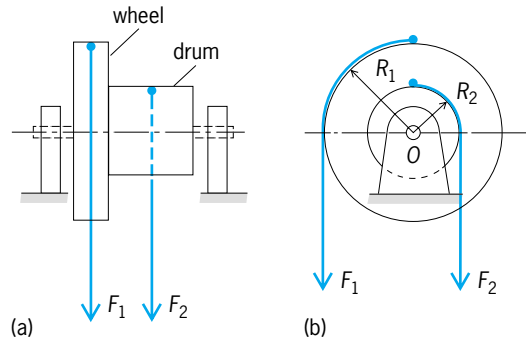

Wheel and axle. (a) Side view. (b) Front view.

as that of the lever in that, for static equilibrium, the summation of torques about the axis of rotation equals zero. Where flexible members, such as ropes, have been firmly attached to a wheel and axle (see illustration) and the machine is mounted on frictionless bearings,  $F_1R_1 - F_2R_2 = 0$ .

The main difference between the lever and the wheel and axle is that the wheel and axle permits the forces to operate through a much greater distance. In the illustration the wheel and drum could be allowed to rotate any number of revolutions if the ropes were wrapped the required number of times around each before they were attached. See FORCE; SIMPLE MACHINE. [R.M.Ph.]

**Wheel base** The distance in the direction of travel from front to rear wheels of a vehicle, measured between centers of ground contact under each wheel. For a vehicle with two rear axles, the rear measuring point is on the ground midway between rear axles. Tread of a vehicle is the distance perpendicular to the direction of travel between front wheels, or between rear wheels, measured from centers of ground contact. [F.H.R.]

**White dwarf star** The smallest kind of ordinary star, about the size of the Earth. In most white dwarf stars, an amount of matter equal to 60% of the Sun's mass is compressed into this small volume. One quarter liter (about 1 cup) of white dwarf material has a mass of 600 tons. Several thousand white dwarf stars have been discovered.

Some of the other properties of white dwarf stars reach extreme values. The hottest known stars are either white dwarfs or stars that are just about to become white dwarfs, and have temperatures of a few hundred thousand kelvins. A few white dwarf stars have very strong magnetic fields, with field strengths exceeding  $10^8$  gauss ( $10^4$  teslas), many times stronger than can be generated in laboratories. Some white dwarf stars rotate every few minutes, and some others rotate so slowly that no spin has been detected over several decades. The coolest white dwarf stars emit less energy per second than any other type of visible star. See HIGH MAGNETIC FIELDS.

White dwarfs are the final stages in the life cycles of low-mass stars like the Sun, the most common types of stars. At present, the Sun is on the main sequence, fusing hydrogen to form helium in its core. Five billion years from now, the hydrogen in the center of the Sun will run out, and the Sun will become a red giant star as it turns to other nuclear reactions to provide its internal heat. Stars like the Sun will become only hot enough inside that they will fuse helium nuclei to form a mixture of carbon and oxygen. They will then reach the end of the nuclear fusion road, and will no longer be able to generate their own sources of energy. At this point in their life cycle, they will be on the way to becoming white dwarf stars, the most common types of stellar remnants. See NUCLEOSYNTHESIS; STELLAR EVOLUTION.

Just before a star becomes a white dwarf star, it will shed its outer layers as its stellar wind strengthens at the very end of the red giant stage of its life cycle. In many and perhaps all cases, the

expelled gas will become visible as a glowing gas cloud called a planetary nebula. See PLANETARY NEBULA.

A star becomes a bona fide white dwarf when it contracts to a state where heat pressure plays a very small role in determining its internal structure. The material in white dwarf stars is a form of matter called degenerate matter. The electron clouds in degenerate matter actually touch each other, and this touching gives white dwarf matter a resistance to compression that balances the force of gravity.

White dwarf stars have no nuclear energy sources, so they simply cool. The hottest star to have compacted itself to the white dwarf state has a temperature of 190,000 K (350,000°F), while the coolest white dwarf stars have temperatures near 3800 K (6400°F), still hotter than the coolest main-sequence stars. The internal structure of these two stars is virtually the same.

However, the surface layers of white dwarfs are much more varied than is the case of other types of stars. For example, white dwarf stars come in two basic flavors, hydrogen-rich stars, whose hydrogen/helium ratios can exceed  $10^7$ , and helium-rich stars, whose hydrogen/helium ratio can be less than  $10^{-7}$ . (In virtually every other type of star, the hydrogen/helium ratio is near its cosmic value of approximately 10:1.) At least part of this extraordinary variation (over 14 orders of magnitude) probably comes from subtle differences in the way that white dwarfs form in the late stages of red giant life cycles. [H.L.Sh.]

**Whooping cough** An acute infection of the tracheo-bronchial tree caused by *Bordetella pertussis*, a bacteria species exclusive to infected humans. The disease (also known as pertussis) follows a prolonged course beginning with a runny nose, and finally develops into violent coughing, followed by a slow period of recovery. The coughing stage can last 2–4 weeks, with a whooping sound created by an exhausted individual rapidly breathing in through a narrowed glottis after a series of wrenching coughs. The classical disease occurs in children 1–5 years of age, but in immunized populations infants are at greatest risk and adults with attenuated (and unrecognized) disease constitute a major source of transmission to others. *Bordetella pertussis* is highly infectious, particularly following face-to-face contact with an individual who is coughing. The disease is caused by structural components and extracellular toxins elaborated by *B. pertussis*. Multiple virulence factors produced by the organism play important roles at various stages of pertussis.

A vaccine produced from whole *B. pertussis* cells and combined with diphtheria and tetanus toxoids has been used throughout the world for routine childhood immunization. Concern over vaccine morbidity has caused immunization rates to decline in some developed countries. These drops in immunization rates have often been followed by widespread outbreaks of disease, including deaths. Considerable effort has been directed toward the development of a vaccine which would minimize side effects but maintain efficacy. A new acellular vaccine is available and has fewer side effects than the whole-cell vaccine. See DIPHTHERIA; TETANUS; VACCINATION.

Although *B. pertussis* is susceptible to many antibiotics, their use has little effect once the disease reaches the coughing stage. Erythromycin is effective in preventing spread to close contacts and in the early stage. [K.J.R.]

**Wide-area networks** Communication networks that are regional, nationwide, or worldwide in geographic area, with a minimum distance typical of that between major metropolitan areas. Smaller networks include metropolitan and local-area networks. A communication network provides common transmission, multiplexing, and switching functions that enable users to transport data between many sources and many destinations. Under ideal circumstances, the data that arrive at the destination are identical to the data that were sent. The rate of arrival

of bits at any point in the network is said to be the data rate at that point and is typically measured in bits per second. These bits may come from one source or from a multiplicity of sources. The capacity of a network to transmit at a certain data rate is known as its bandwidth. See LOCAL-AREA NETWORKS.

There are several fundamental attributes and concepts that facilitate the accurate transmission of data within and between digital networks. To communicate between computers, a set of rules, formats, and delivery procedures known as protocols must be established.

Part of the communications protocol allows for definition of where the packets of digital data are to be routed. Each packet of data contains the unique address of a computer or other network as its destination. The routing of the data is known as packet switching since the nodes in the network can switch the packet to various transmission paths. Networks are interconnected by means of routers. See PACKET SWITCHING.

Another part of the communications protocol allows for including error detection and correction information in the data packets. The destination computer or network will verify the data in the packet utilizing the error control data, such as a checksum. Protocols are also used to implement flow control. This allows the receiving computer or network to communicate back to the sender when it can or cannot receive additional data. See DIGITAL COMPUTER.

Certain protocols have become standards for a majority of wide-area networks. Asynchronous Transfer Mode (ATM) is a protocol used in business-to-business (B2B) communications when high data rates are needed. Typically, one ATM port supports 45 megabits per second (Mbps). Frame Relay is another business-to-business protocol. The advantage of Frame Relay is that the data rate can be scaled to the individual company's needs. The third protocol, and the one having the most worldwide impact on both business and personal communications, is the Internet Protocol, or IP. See INTEGRATED SERVICES DIGITAL NETWORK (ISDN).

Wide-area networks may operate on a mix of transmission media for either fixed or mobile applications. Fixed applications mean that the receiver of digital data is stationary. Examples of wireline transmission media for fixed applications are fiber-optic cable, copper wire, and coaxial cable. For copper, a technique known as digital subscriber line (DSL) allows for transmission in excess of 1 Mbps over regular phone lines. In fiber, a technique known as wave division multiplexing (WDM) allows the simultaneous transmission of different streams of digital data over each spectral component of the light wave. This allows bundles of fiber-optic cable to transport billions of bits (gigabits) and even trillions of bits (terabits) of data per second. See COMMUNICATIONS CABLE; OPTICAL COMMUNICATIONS; OPTICAL FIBERS; TRANSMISSION LINES.

Wide-area networks also operate over a variety of wireless media. Wireless media can support either fixed or mobile applications. Another common distinction in wireless networks is whether it is point-to-point or point-to-multipoint. In point-to-point the originating transmission has one receiver, whereas in point-to-multipoint the originating transmission has multiple receivers. Examples of wireless media include radio-wave, microwave, cellular, and satellite. See COMMUNICATIONS SATELLITE; MOBILE RADIO; RADIO SPECTRUM ALLOCATIONS; RADIO-WAVE PROPAGATION.

There are many different types of content transmitted over WANs. Examples of content are data, voice, video, audio, paging messages, and fax. By virtue of the ability to digitize all of this content, the major difference in transmission requirements is the bandwidth, or capacity, required to transmit digital packets of any type of content. See DATA COMMUNICATIONS; ELECTRICAL COMMUNICATIONS; FACSIMILE.

In order to utilize the bandwidth capacity of WANs more efficiently, digital compression techniques are now used in many applications. Fundamentally, digital compression reduces the

amount of bits in data packets by removing repetitive strings of bits and replacing them with shorter packets that numerically describe the amount of repetitive data. See DATA COMPRESSION.

With massive amounts of information being transmitted over WANs using both public and private infrastructure, data security is increasingly important. In order to secure digital data transmitted over networks, encryption techniques have been developed. Encryption of digital data involves using hardware and software to manipulate the bits in a data packet, making it unrecognizable and unusable to anyone not authorized to use the data. See COMMUNICATIONS SCRAMBLING; COMPUTER SECURITY; CRYPTOGRAPHY.

The Internet, using the IP, has become by far the most ubiquitous WAN in the world. Internet users are able to transmit video clips, electronic mail (e-mail), telephone calls (called Voice over IP), to digitized x-rays over the Internet. There are three basic variations of IP networks. First is the overall Internet itself which encompasses all personal and business users of the Internet. The second type of IP-based networks is intranets. An intranet is usually deployed within a specific organization or company. A company intranet may be used to manage human resources and financial processes and keep employees updated on company news. The third type of IP-based networks is extranets. Typically, extranets are used to link multiple organizations or companies for some common business purpose. In both intranets and extranets, a technology known as a firewall is employed to prevent unauthorized access to the network or unauthorized URL (Uniform Resources Locator) from the network. The URL is the basic unique address or location for any Web site or other Internet service. See ELECTRONIC MAIL; INTERNET. [R.L.Je.]

**Wiedemann-Franz law** An empirical law of physics which states that the ratio of the thermal conductivity of a metal to its electrical conductivity is a constant times the absolute temperature, as given by the equation below. Here  $K_c$  is the thermal

$$K_c = L_0 \sigma T$$

conductivity due to the conduction electrons,  $\sigma$  is the electrical conductivity,  $T$  is the absolute temperature, and  $L_0$  is known as the Lorentz number. The Wiedemann-Franz law provides an important check on theories of electrical and thermal conductivity. See CONDUCTION (HEAT); THERMAL CONDUCTION IN SOLIDS. [F.J.B.]

**Willemite** A rare nesosilicate mineral, composition  $Zn_2SiO_4$ , crystallizing in the hexagonal system. It is usually massive or granular with a vitreous luster; crystals are rare. The mineral may be variously colored, most commonly green, red, or brown. Hardness is  $5\frac{1}{2}$  on Mohs scale; specific gravity is 3.9–4.2. Willemite forms a valuable ore of zinc at Franklin, New Jersey. At this famous zinc deposit Willemite fluoresces a yellow-green. See SILICATE MINERALS. [C.S.Hu.]

**Willow** A deciduous tree and shrub of the genus *Salix*, order Salicales, common along streams and in wet places in the United States, Europe, and China. The twigs are often yellow-green and bear alternate leaves which are characteristically long, narrow, and pointed, usually with fine teeth along the margins. Flowers occur in catkins. The fruit contains several silky seeds. See SALICALES.

Willow lumber is used for fuel and in making charcoal, excelsior, ball bats, boxes, crates, boats, waterwheels, and wicker furniture. The tough, pliable shoots of many species are used to make baskets; the bark of other species is used for tanning. Willows are of great value in checking soil erosion. A few species are ornamental shade trees. [J.F.F.]

**Wind** The motion of air relative to the Earth's surface. The term usually refers to horizontal air motion, as distinguished from vertical motion, and to air motion averaged over a chosen period of 1–3 min. Micrometeorological circulations (air motion over

periods of the order of a few seconds) and others small enough in extent to be obscured by this averaging are thereby eliminated.

The direct effects of wind near the surface of the Earth are manifested by soil erosion, the character of vegetation, damage to structures, and the production of waves on water surfaces. At higher levels wind directly affects aircraft, missile and rocket operations, and dispersion of industrial pollutants, radioactive products of nuclear explosions, dust, volcanic debris, and other material. Directly or indirectly, wind is responsible for the production and transport of clouds and precipitation and for the transport of cold and warm air masses from one region to another. See ATMOSPHERIC GENERAL CIRCULATION; WIND MEASUREMENT.

Cyclonic and anticyclonic circulation are each a portion of the pattern of airflow within which the streamlines (which indicate the pattern of wind direction at any instant) are curved so as to indicate rotation of air about some central point of the cyclone or anticyclone. The rotation is considered cyclonic if it is in the same sense as the rotation of the surface of the Earth about the local vertical, and is considered anticyclonic if it is the opposite sense. Thus, in a cyclonic circulation, the streamlines indicate counterclockwise (clockwise for anticyclonic) rotation of air about a central point on the Northern Hemisphere or clockwise (counterclockwise for anticyclonic) rotation about a point on the Southern Hemisphere. When the streamlines close completely about the central point, the pattern is denoted respectively a cyclone or an anticyclone. Since the gradient wind represents a good approximation to the actual wind, the center of a cyclone tends strongly to be a point of minimum atmospheric pressure on a horizontal surface. Thus the terms cyclone, low-pressure area, or low are often used to denote essentially the same phenomenon. See GRADIENT WIND.

Convergent or divergent patterns are said to occur in areas in which the (horizontal) wind flow and distribution of air density is such as to produce a net accumulation or depletion, respectively, of mass of air. The horizontal mass divergence or convergence is intimately related to the vertical component of motion. For example, since local temporal rates of change of air density are relatively small, there must be a net vertical export of mass from a volume in which horizontal mass convergence is taking place. Only thus can the total mass of air within the volume remain approximately constant.

The horizontal mass divergence or convergence is closely related to the circulation. In a convergent wind pattern the circulation of the air tends to become more cyclonic; in a divergent wind pattern the circulation of the air tends to become more anticyclonic. A convergent surface wind field is typical of fronts. As the warm and cold currents impinge at the front, the warm air tends to rise over the cold air, producing the typical frontal band of cloudiness and precipitation. See FRONT.

Zonal surface winds patterns result from a longitudinal averaging of the surface circulation. This averaging typically reveals a zone of weak variable winds near the Equator (the doldrums) flanked by northeasterly trade winds in the Northern Hemisphere and southeasterly trade winds in the Southern Hemisphere, extending poleward in each instance to about latitude  $30^\circ$ . The doldrum belt, particularly at places and times at which it is so narrow that the trade winds from the two hemispheres impinge upon it quite sharply, is designated the intertropical convergence zone, or ITCZ. The resulting convergent wind field is associated with abundant cloudiness and locally heavy rainfall. See MONSOON METEOROLOGY.

Local winds commonly represent modifications by local topography of a circulation of large scale. They are often capricious and violent in nature and are sometimes characterized by extremely low relative humidity. Examples are the mistral which blows down the Rhone Valley in the south of France, the bora which blows down the gorges leading to the coast of the Adriatic Sea, the foehn winds which blow down the Alpine valleys, the williwaws which are characteristic of the fiords of the Alaskan coast and the Aleutian Islands, and the chinook which is

observed on the eastern slopes of the Rocky Mountains. See CHINOOK. [F.S.; H.B.B.]

**Wind measurement** The determination of three parameters: the size of an air sample, its speed, and its direction of motion. Air movement or wind is a vector that is specified by speed and direction; meteorological convention indicates wind direction is the direction from which the wind blows (for example, a southeast wind blows toward the northwest). Anemometers measure wind speed, while wind vanes indicate direction. On average, the wind blows horizontally over flat terrain; however, gusts, thermals, cloud outflows, and many other conditions have associated with them significant short-term vertical wind components. While research wind instruments typically measure both horizontal and vertical air movement, operational and personal wind sensors measure only the horizontal component. See ANEMOMETER.

There are many types of wind measurement instruments. In situ devices measure characteristics of air in contact with the instrument; often they are referred to as immersion sensors because they are immersed in the fluid (air) they measure. Remote wind sensors make measurements without physical contact with the portion of the atmosphere measured. Active remote sensors emit electromagnetic (for example, light or radio waves) or sound waves into the atmosphere and measure the amount and nature of the electromagnetic or acoustic power returned from the atmosphere. See LIDAR; METEOROLOGICAL INSTRUMENTATION; METEOROLOGICAL RADAR; WIND. [W.F.D.]

**Wind power** The extraction of kinetic energy from the wind and conversion of it into a useful type of energy: thermal, mechanical, or electrical. Wind power has been used for centuries.

It has been estimated that the total wind power in the atmosphere averages about  $3.6 \times 10^{12}$  kW, which is an annual energy of about 107,000 quads (1 quad =  $2.931 \times 10^{11}$  kWh). Only a fraction of this wind energy can be extracted, estimated to be a maximum of 4000 quads per year. According to what is commonly known as the Betz limit, a maximum of 59% of this power can be extracted by a wind machine. Practical machines actually extract from 5 to 45% of the available power. Because the available wind power varies with the cube of wind speed, it is very important to find areas with high average wind speeds to locate wind machines. See WIND.

Most research on wind power has been concerned with producing electricity. Wind power is a renewable energy source that has virtually no environmental problems. However, wind power has limitations. Wind machines are expensive and can be located only where there is adequate wind. These high-wind areas may not be easily accessible or near existing high-voltage lines for transmitting the wind-generated energy. Another disadvantage occurs because the demand for electricity varies with time, and electricity production must follow the demand cycle. Since wind power varies randomly, it may not be available when needed. The storage of electrical energy is difficult and expensive, so that wind power must be used in parallel with some other type of generator or with nonelectrical storage. Wind power teamed with hydroelectric generators is attractive because the water can be used for energy storage, and operation with underground compressed-air storage is another option. See ELECTRIC POWER GENERATION; ENERGY SOURCES; ENERGY STORAGE.

The most common type of wind turbine for producing electricity has a horizontal axis, with two or more aerodynamic blades mounted on the horizontal shaft. With a horizontal-axis machine, the blade tips can travel at several times the wind speed, which results in a high efficiency. The blade shape is designed by using the same aerodynamic theory as for aircraft. See PROPELLER (AIRCRAFT); TURBINE. [G.Th.]

**Wind rose** A diagram in which statistical information concerning the direction and speed of the wind at a particular location may be conveniently summarized. In the standard wind rose a line segment is drawn in each of perhaps eight compass directions from a common origin (see illustration). The length of

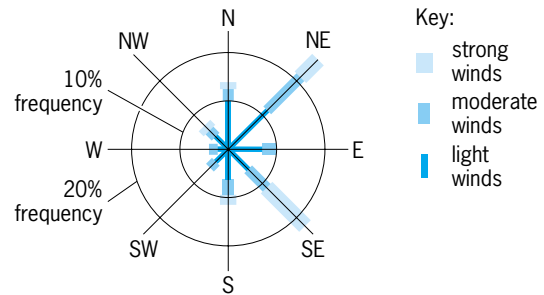

Standard wind rose.

a particular segment is proportional to the frequency with which winds blow from that direction. Parts of a given segment are given various thicknesses, indicating frequencies of occurrence of various classes of wind speed from the given direction. See WIND MEASUREMENT. [F.S.]

**Wind stress** The drag or tangential force per unit area exerted on the surface of the Earth by the adjacent layer of moving air. Erosion of ground surfaces and the production of waves on water surfaces are manifestations of wind stress. Surface wind stress determines the exchange of momentum between the Earth and the atmosphere and exerts a strong influence on the typical variation of wind through the lowest kilometer of the atmosphere. Estimated values of the surface wind stress range up to several dynes per square centimeter (0.1 pascal), depending on the nature of the surface and the character of the adjacent airflow. See METEOROLOGY.

Significant stresses arise within the lower atmosphere because of the strong shear of the wind between the slowly moving air near the ground and the more rapidly moving air a kilometer above and because of the turbulent nature of the airflow in this region. The turbulent eddies referred to here have characteristic dimensions ranging up to a few hundreds of meters.

Wind pressure is the force exerted by the wind per unit area of solid surface exposed normal to the wind direction and is also known as dynamic pressure. In contrast to shearing stresses, the wind pressure arises from the difference in pressure between the windward and lee sides of the exposed surface. Wind pressure thus represents a substantial force when the wind speed is high. See WIND. [F.S.]

The drag or tangential force of the wind on the sea is expressed in units of dynes per square centimeter or micronewtons per square meter but is normally taken to represent the mean drag over an undefined area, perhaps several kilometers square, containing many waves. It is usually related to an appropriate time and space average of the wind near the sea surface (at 10 m above the mean level, for example).

The drag coefficient over the sea is an important quantity in both meteorology and oceanography since it relates the wind speed to the drag, which generates ocean waves, drives the ocean currents, and sets the scale of the atmospheric turbulence that transfers water vapor and heat from the ocean to the atmosphere to provide the energy for clouds and weather systems. The drag coefficient of the sea surface depends on the wave field and on the turbulent structure of the flow in the air and the water. Present knowledge of the complicated fluid mechanics involved is not sufficient to allow theoretical calculation of it. See ATMOSPHERIC GENERAL CIRCULATION; MARITIME METEOROLOGY; OCEAN CIRCULATION; OCEAN WAVES.

There is substantial agreement that the drag of the wind on the sea is small relative to that of a fixed soil surface with the same geometry. It is largely independent of the fetch and so seems to depend less on the larger waves than on the short waves and ripples. Surface-active agents, which affect the shortest waves, may therefore be important. [H.C.]

**Wind tunnel** A duct in which the effects of airflow past objects can be determined. The steady-state forces on a body held still in moving air are the same as those when the body moves through still air, given the same body shape, speed, and air properties. Scaling laws permit the use of models rather than full-scale objects, such as aircraft or automobiles. Models are less costly and may be modified more easily, and conditions may be simulated in the wind tunnel that would be impossible or dangerous in full scale.

Most data are secured from wind tunnels through measurement of forces and moments, surface pressures, changes produced in the airstream by the model, local temperatures, and motions of dynamically scaled models, and by visual studies.

A balance system separates and measures the six components of the total force. The three forces taken parallel and perpendicular to a flight path are lift, drag, and side force. The three moments about these axes are yawing moment, rolling moment, and pitching moment, respectively.

Surface pressures are measured by connecting orifices flush with the model surface to pressure-measuring devices. Local air load, total surface load, moment about a control surface hinge line, boundary-layer characteristics, and local Mach number may be obtained from pressure data.

Measurements of stream changes produced by the model may be interpreted in terms of forces and moments on the model. In two-dimensional tunnels, where an aircraft model spans the tunnel, it is possible to determine the lift and center of pressure by measuring the pressure changes on the floor and ceiling of the tunnel. The parasite drag of a wing section may be determined by measuring the total pressure of the air which has passed over the model and calculating its loss of momentum.

Measurements of surface temperatures indicate the rate of heat transfer or define the amount of cooling that may be necessary.

In elastically and dynamically scaled models used for flutter testing, measurements of amplitude and frequency of motion are made by using accelerometers and strain gages in the structure. In free-flight models, such as bomb or missile drop tests, data are frequently obtained photographically.

At low speeds, smoke and tufts are often used to show flow direction. A mixture of lampblack and kerosine painted on the model shows the surface streamlines. A suspension of talcum powder and a detergent in water is also used.

For aircraft at velocities near or above the speed of sound, some flow features may be made visible by optical devices. See INTERFEROMETRY; SCHLIEREN PHOTOGRAPHY; SHADOWGRAPH.

The V/STOL wind tunnel is a newer development of low-speed wind tunnels having a large very-low-speed section to permit testing of aircraft designed for vertical or short takeoff and landing (V/STOL) while operating in the region between vertical flight and cruising flight. [R.G.Jo.]

**Windings in electric machinery** Windings can be classified in two groups: armature windings and field windings. The armature winding is the main current-carrying winding in which the electromotive force (emf) or counter-emf of rotation is induced. The current in the armature winding is known as the armature current. The field winding produces the magnetic field in the machine. The current in the field winding is known as the field or exciting current. See ELECTRIC ROTATING MACHINERY; GENERATOR; MOTOR.

The location of the winding depends upon the type of machine. The armature windings of dc motors and generators are

located on the rotor, since they must operate in conjunction with the commutator, and the field windings are mounted on stator field poles. See DIRECT-CURRENT GENERATOR; DIRECT-CURRENT MOTOR.

Alternating-current synchronous motors and generators are normally constructed with the armature winding on the stator and the field winding on the rotor. There is no clear distinction between the armature and field windings of ac induction motors or generators. One winding may carry the main current of the machine and also establish the magnetic field. It is customary to use the terms stator winding and rotor winding to identify induction motor windings. The word armature, when used with induction motors, applies to the winding connected to the power source (usually the stator). See ALTERNATING-CURRENT GENERATOR; ALTERNATING-CURRENT MOTOR; SYNCHRONOUS MOTOR. [A.R.E.]

**Wine** Alcoholic beverages made by fermentation of the juice of fruits or berries, essentially grape juice. Wines from other materials are always required to show their source on the label, for example, apple wine, berry wine, and cherry wine. California produces the largest percentage of the grape wine made in the United States, and well over a hundred varieties of the cultivated grape (*Vitis vinifera*) are used.

Classification of wine depends on the color, relative sweetness, alcoholic content, presence of carbon dioxide, the variety of grape, and the region where the grapes are grown. Wines may be red or white. The terms dry and sweet refer to the relative sugar content of a wine. Table wines contain less than 14% alcohol by volume, and dessert wines contain over 14%, usually 20%, alcohol. The higher alcohol content of dessert wines is obtained by the addition of brandy, which is called fortification. Sparkling wines such as champagne and sparkling Burgundy contain carbon dioxide.

Grapes are harvested and go through a crusher-stemmer, which crushes the berries, but not the seeds, and removes the stems. The must, still containing seeds and skins, is pumped to fermentation tanks where it receives sulfur dioxide gas. This controls, to a large extent, the growth of bacteria and wild yeasts, whereas the various strains of wine yeast are adapted to this amount of SO<sub>2</sub>. A pure yeast starter is then added. In the production of white wines, the juice is separated from the skins and seeds at an early stage of fermentation. See FERMENTATION.

After the initial fermentation, the wine is transferred to the storage cellar for completion of fermentation, clarification, aging, stabilization, and bottling. These operations are called cellar practices. The sediment of yeast and other insoluble matter is called lees. The new wine is drawn off, or racked, from the lees to avoid picking up undesirable flavors from the lees. Aging is then continued. Wines are often chilled to precipitate excess cream of tartar, the potassium acid tartrate from the grape, which otherwise might precipitate upon chilling of bottled wine. Champagne is made by allowing a secondary fermentation to occur with a special flocculating type of yeast, either in bottles, by the original French procedure, or in bulk, using pressure tanks followed by bottling. The carbon dioxide, CO<sub>2</sub>, of sparkling wines is produced by yeast fermentation. See ALCOHOLIC BEVERAGES.

[E.M.M.; H.J.P.]

**Wing** A lifting surface of a heavier-than-air object, either bird or airplane. Lift is created by a pressure difference between the upper and lower surfaces of the wing, the average pressure on the upper surface being lower. The average velocity on the upper surface is larger than on the lower surface, resulting in the lifting pressure difference in accordance with Bernoulli's theorem. The velocity difference is caused by having a greater curvature on the wing upper surface, or a positive wing angle of attack (that is, leading edge up), or both. The amount of lift is proportional to the angle of attack, the wing area, the air density, and the square of the velocity. See AERODYNAMIC FORCE; BERNOULLI'S THEOREM; SUBSONIC FLIGHT.



The important physical characteristics of a wing are wing area, measured in the plan or top view, the span or distance from the left wing tip to the right wing tip, the aspect ratio, the taper ratio, and the thickness ratios of the airfoils. The aspect ratio is the ratio of the span to the average chord. The chord of a wing is the distance from the leading edge to the trailing edge. In all but the simplest airplanes, the chord varies along the span, being largest at the root. The taper ratio is the ratio of the tip chord to the root chord. Airfoils are the cross-sectional shapes of wings as defined by the intersections with planes parallel to the oncoming airstream and perpendicular to the plane of the wing surface. The thickness ratio is the ratio of the maximum thickness of an airfoil to the chord and often varies between the root and tip. If an airfoil has greater curvature on the upper surface than on the lower surface, the mean line midway between the upper and lower surfaces is curved. The amount of this curvature is called camber. All of these wing characteristics affect flight efficiency and must be carefully chosen. See AIRCRAFT DESIGN; AIRFOIL.

There is a particular angle of attack of a wing that provides the necessary lift with the least drag. Wing area selection attempts to have the airplane fly at this angle of attack at the desired speed and within the range of desirable altitudes. Of course, takeoff and landing fields are important in area selection. A larger wing area permits slower flight, which is associated with shorter take-off acceleration distances and shorter stopping distances after landing.

Wings must be designed to stall safely. Above the maximum angle of attack at which the flow will remain smoothly attached to the wing surface, there is a sharp loss of lift and a large increase in drag. This is known as the stall, a condition that is normally avoided. Wings are designed to stall near the root first so that the tendency to roll sharply is minimized and the ailerons on the outer wing remain effective. This is done by varying the airfoil sections and thickness ratios across the span in a careful manner.

The flight of airplanes is controlled primarily by varying the magnitude and direction of the wing lift and by varying the thrust or power contributed by the engines. An important aspect of flight is the speed, which is controlled by adjusting the wing angle of attack with respect to the oncoming airstream. The angle of attack is adjusted by varying the angle of the elevator, a control surface usually located on the horizontal tail. After adjusting the flight speed by using the elevators, the angle of the flight path, zero for level flight, is controlled by setting the engine thrust. See ELEVATOR (AIRCRAFT).

The direction of flight is basically controlled by the angle of bank of the wing. When the wing is level and the resultant force, or lift, is vertical, the airplane flies in a straight line. Ailerons are trailing-edge flaps on the outer part of the wing that deflect in opposite directions on the left and right sides of the airplane. When the airplane banks or rolls because of the deflection of ailerons, the lift force is tilted toward the side since it remains perpendicular to the banked wing. This provides a sidewise force which accelerates the airplane in a direction perpendicular to the flight path and thereby curves the flight path. Application of the rudder keeps the airplane pointed into the wind during the turn, although the vertical tail will do much of that job even without rudder deflection. See AILERON; ELEVON.

High-speed aircraft also use spoilers, essentially plates ahead of the flaps, to lose lift on only one side to roll the airplane. These spoilers are also used symmetrically to slow down an airplane and increase the rate of descent. Spoilers are also used after touchdown to quickly reduce lift and dump the weight on the braked wheels, thereby greatly improving the stopping effectiveness.

Wings also carry moving elements that serve lift-increase functions. Trailing-edge flaps (see illustration) inboard of the ailerons increase the lift that can be carried before the stall. Thus the minimum flight speed can be decreased. Leading-edge flaps and slats (see illustration) are used to increase the angle of attack for stall and further reduce the minimum flight speed. The primary

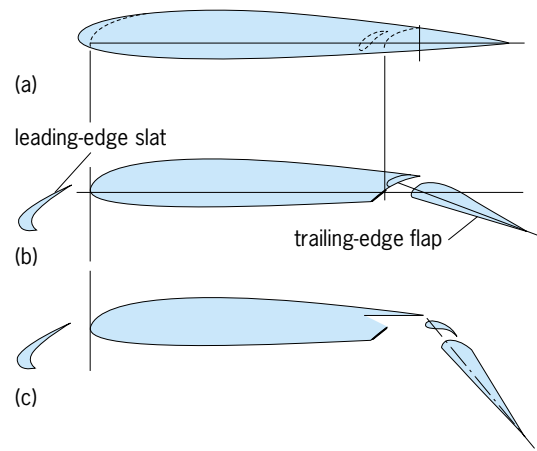

Trailing-edge flaps and leading-edge slats in (a) cruise, (b) takeoff, and (c) landing settings.

purpose of increasing the lift capability and obtaining the lowest flight speed is to reduce the required field lengths for takeoff and landing or to reduce the necessary wing area. See AILERON; ELEVATOR (AIRCRAFT); ELEVON; FLIGHT CONTROLS.

Wings also serve as fuel tanks, a function that sometimes sets the minimum wing area—especially on small aircraft such as executive jets. Wing thickness ratio is important in determining the volume available for fuel within the wing. Wings often house all or part of the landing gear. Engines are mounted on the wing of many aircraft. See AIRCRAFT ENGINE; AIRPLANE; LANDING GEAR; WING STRUCTURE. [R.S.Sh.]

**Winged bean** A plant (*Psophocarpus tetragonolobus*), also known as four-cornered bean, asparagus pea, goa bean, and manila bean, in the family Leguminosae. It is a climbing perennial that is usually grown as an annual. It has been suggested that it originated either in East Africa or Southeast Asia, but there is more evidence to support an African origin. However, Southeast Asia and the highlands of Papua New Guinea represent two foci of its domestication.

Traditionally, winged bean is grown as a backyard vegetable in Southeast Asia and a few islands of the Pacific. It is grown as a field crop in Burma and Papua New Guinea. However, between 1980 and 1990 winged bean was introduced throughout the tropical world.

Almost all parts of this plant are edible and are rich sources of protein. The green pods, tubers, and young leaves can be used as vegetables, and the flowers can be added to salads. The dry seeds are similar to soybeans and can be used for extracting edible oil, feeding animals, and making milk and traditional Southeast Asian foods such as tempeh, tofu, and miso. Flour from the winged bean can also be used as a protein supplement in bread making.

A number of diseases and insect pests may limit winged bean yield. The most widespread and damaging disease appears to be false rust or orange gall (caused by *Synchytrium psophocarpi*). See BREEDING (PLANT); PLANT PATHOLOGY; ROSALES. [T.N.K.]

**Wire** A thread or slender rod of metal. Wire is usually circular in cross section and is flexible. If it is of such a diameter or composition that it is fairly stiff, it is termed rod. The wire may be of several small twisted or woven strands, but if used for lifting or in a structure, it is classed as cable. Wire may be used structurally in tension, as in a suspension bridge, or as an electrical conductor, as in a power line. The working of metal into wire greatly increases its tensile strength. Thus, a cable of stranded small-diameter wires is stronger as well as more flexible than a corresponding solid rod. See MAGNET WIRE. [F.H.R.]

**Wire bonding** An interconnect technique widely used in microchip manufacturing to provide electrical continuity between the metal pads of an integrated circuit (IC) chip and the electrical leads of the package housing the chip. The two common methods of wire bonding are thermocompression and ultrasonic bonding. In these, a fine aluminum or gold wire is bonded at one end to the metal pad of the IC, and at the other to the electrical lead of the package. In ultrasonic bonding, the metallurgical bond is achieved through a combination of ultrasonic energy and pressure to break the few surface layers of the material and form the bond between the contamination-free surfaces. In thermocompression bonding, the metallurgical bond is formed by applying heat and pressure without melting. Thermocompression bonding has higher throughput and speed than ultrasonic bonding. See CIRCUIT (ELECTRONICS); ELECTRONIC PACKAGING; INTEGRATED CIRCUITS; ULTRASONICS. [L.M.]

**Wire drawing** The reduction of the diameter of a metal rod or wire by pulling it through a die. The working region of dies are typically conical (see illustration). The tensile stress on the

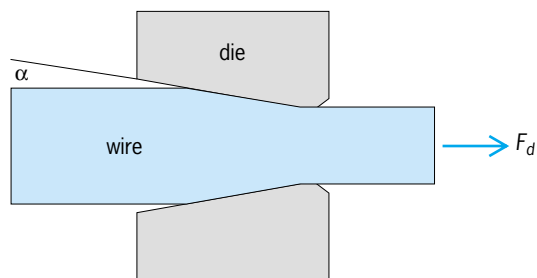

Wire being drawn through a die.

drawn wire, that is, the drawing stress, must be less than the wire's yield strength. Otherwise the drawn section will yield and fail without pulling the undrawn wire through the die. Because of this limitation on the drawing stress, there is a maximum reduction that can be achieved in a single drawing pass. After large drawing reductions, wires or rods develop crystallographic textures or preferred orientations of grains. The textures are characteristic of the crystal structure of the metal. See ALLOY; CRYSTAL STRUCTURE; METAL; METAL, MECHANICAL PROPERTIES OF; METALLURGY. [W.F.Ho.]

**Wiring** A system of electric conductors, components, and apparatus for conveying electric power from source to the point of use. In general, electric wiring for light and power must convey energy safely and reliably with low power losses, and must deliver it to the point of use in adequate quantity at rated voltage. Electric wiring systems are designed to provide a practically constant voltage to the load within the capacity limits of the system. There are a few exceptions, notably series street-lighting circuits which operate at constant current. The building wiring system originates at a source of electric power, conventionally the distribution lines or network of an electric utility system. See ELECTRICAL CODES.

**Systems and service.** Wiring systems are generally three-phase to conform to the supply systems. Energy is transformed to the desired voltage levels by a bank of three single-phase transformers. The transformers may be connected in either a delta or Y configuration.

Service provided at the primary voltage of the utility distribution system, typically 13,800 or 4160 volts, is termed primary service. Service provided at secondary or utilization voltage, typically 120/208 or 277/480 volts, is called secondary service.

Service at primary voltage levels is often provided for large industrial, commercial, and institutional buildings, where the higher voltage can be used to advantage for power distribution within the buildings. Where primary service is provided,

power is distributed at primary voltage from the main switchboard through feeders to load-center substations installed at appropriate locations throughout the building.

Most secondary services in the United States are 120/208 volts, three-phase, four-wire, or 120/240 volts, single-phase, three-wire serving both light and power. For relatively large buildings where the loads are predominantly fluorescent lighting and power (as for air conditioning), the service is often 277/480 volts, three-phase, four-wire, supplying 480 volts for power and 277 volts, phase-to-neutral, for the lighting fixtures.

From the service entrance, power is carried in feeders to the main switchboard, then to distribution panelboards. Smaller feeders extend from the distribution panelboards to light and power panelboards. Branch circuits then carry power to the outlets serving the various lighting fixtures, plug receptacles, motors, or other utilization devices.

**Methods.** Methods of wiring in common use for light and power circuits are as follows: (1) insulated wires and cables in raceways; (2) nonmetallic sheathed cables; (3) metallic armored cables; (4) busways; (5) copper-jacketed, mineral-insulated cables; (6) aluminum-sheathed cables; (7) nonmetallic sheathed and armored cables in cable support systems; and (8) open insulated wiring on solid insulators (knob and tube).

The selection of the wiring method or methods is governed by a variety of considerations, which usually include code rules limiting the use of certain types of wiring materials; suitability for structural and environmental conditions; installation (exposed or concealed); accessibility for changes and alterations; and costs.

**Circuit design.** The design of a particular wiring system is developed by considering the various loads, establishing the branch-circuit and feeder requirements, and then determining the service-entrance requirements. Outlets for lighting fixtures, motors, portable appliances, and other utilization devices are indicated on the building plans and the load requirement of each outlet noted in watts or horsepower. Lighting fixtures and plug receptacles are then grouped on branch circuits and connections to the lighting panelboard indicated.

Lighting branch circuits may be loaded to 80% of circuit capacity. However, there is a reasonable probability that the lighting equipment will be replaced at some future time by equipment of higher output and greater load. Therefore, in modern practice, lighting branch circuits are loaded only to about 50% capacity. Lighting branch circuits are usually rated at 20 A. Smaller 15-A branch circuits are used mostly in residences. [W.T.S./J.F.McP.]

**Wiring diagram** A drawing illustrating electrical and mechanical relationships between parts of a component between which electrical wiring must be connected.

A wiring diagram is distinguished from an electrical schematic in that the arrangement of the schematic bears no necessary relationship to the mechanical arrangement of the electrical elements in the component. The wiring diagram provides an accurate picture of how the wiring on the components and between components should appear in order that the electrical wiring technician can install the wiring in the manner that will best contribute to the optimum performance of the device.

Wiring diagrams also include such information as type of wire, color coding, methods of wire termination, and methods of wire and cable clamping. See SCHEMATIC DRAWING. [R.W.M.]

**Witherite** The mineral form of barium carbonate. Witherite has orthorhombic symmetry and the aragonite structure type. Crystals, often twinned, may appear hexagonal in outline. It may be white or gray with yellow, brown, or green tints. Its hardness is 3.5 and its specific gravity 4.3.

Witherite may be found in veins with barite and galena. It is found in many places in Europe, and large crystals occur at Rosiclare, Illinois. See BARIUM; CARBONATE MINERALS; HARDNESS SCALES. [R.I.Ha.]

**Wolf-Rayet star** A type of hot, luminous star that is distinguished by its extremely dense and fast wind. The spectacularly bright, discrete bands of atomic emission from these winds greatly facilitated their discovery with the aid of a visual spectroscope by the French astronomers Charles Wolf and Georges Rayet at the Paris Observatory in 1867. See ASTRONOMICAL SPECTROSCOPY.

The Wolf-Rayet phenomenon is a typical phase in the advanced evolution of a massive star (about 20–100 times the Sun's mass), or sometimes among lower-mass stars in the planetary nebula stage. The first fusion process in the core of a massive star involves the conversion of hydrogen into helium via the carbon-nitrogen-oxygen (CNO) cycle, in which helium and nitrogen are enhanced at the expense of the initially abundant hydrogen and traces of carbon and oxygen. When such fusion products are visible in the winds, a WN-type Wolf-Rayet star is seen, whose spectrum is dominated by Doppler-broadened atomic lines of helium and nitrogen in various stages of ionization. Later, when the second fusion process occurs, helium is converted mainly into carbon and oxygen, with nitrogen being virtually destroyed. A WC-type Wolf-Rayet star is then seen with lines mainly of carbon and helium. A brief oxygen-rich phase may occur (WO), after which all other phases are so rapid that the chances of seeing them are negligible. At that point, it is believed that the Wolf-Rayet star will explode as a supernova, resulting in the collapse to a black hole in most cases. See BLACK HOLE; DOPPLER EFFECT; NUCLEOSYNTHESIS; PLANETARY NEBULA; SUPERNOVA.

Beneath the dense winds that often hide the stellar surface, massive Wolf-Rayet stars have surface temperatures ranging from 30,000 to 150,000 (54,000 to 270,000°F), radii of 1 to 15 solar units, and luminosities of  $10^5$  to  $10^6$  times that of the Sun. They are losing matter at a rate that is typically  $10^9$  times that of the Sun's wind, at speeds ranging from 1000 to 3000 km/s (600 to 1800 mi/s). Although massive Wolf-Rayet stars appear to be rare (only 200 are known so far in the Milky Way Galaxy, out of an estimated total population of 1000–2000), all massive stars likely pass through a Wolf-Rayet stage toward the end of their relatively short lives. See SOLAR WIND; STAR; STELLAR EVOLUTION.

[A.F.J.M.]

**Wolframite** A mineral with composition  $(\text{Fe},\text{Mn})\text{WO}_4$ , intermediate between ferberite and huebnerite, which form a complete solid solution series. Wolframite occurs commonly in short, brownish-black, monoclinic, prismatic, bladed crystals. It is probably the most important tungsten mineral. China is the major producer of wolframite. Tungsten minerals of the wolframite series occur in many areas of the western United States; the major producing district is Boulder and northern Gilpin counties in Colorado. See HUEBNERITE.

[E.C.T.C.]

**Wollastonite** A mineral inosilicate with composition  $\text{CaSiO}_3$ . Commonly it is massive, or in cleavable to fibrous aggregates. Hardness is 5–5½ on Mohs scale; specific gravity is 2.85. On the cleavages the luster is pearly or silky; the color is white to gray.

Wollastonite is found in large masses in the Black Forest of Germany; Brittany, France; Chiapas, Mexico; and Willsboro, New York, where it is mined as a ceramic material. See SILICATE MINERALS.

[C.S.H.]

**Wolverine** A carnivorous mammal, *Gulo gulo*, also known as the glutton, which is the largest and most vicious member of the family Mustelidae, to which the ferrets, minks, martens, weasels, badgers, otters, and skunks belong. It ranges throughout northern Europe, Asia, and North America, where it is found in coniferous forests during the winter and on the tundras during summer.

This animal is about 40 in. (100 cm) long and weighs about 40 lb (18 kg) (see illustration). It feeds primarily on mice, lem-



The wolverine (*Gulo gulo*), a stoutly built carnivore with strong teeth and claws.

mings, and birds but will attack large animals when they are sick or trapped and exhausted in deep snow. It is a solitary animal, and the male remains with the female only during the courtship period, after which the female is left to rear the cubs. The wolverine lives in a den or burrow and does not hibernate. See BADGER; CARNIVORA; FISHER; MARTEN; OTTER; SKUNK; WEASEL. [C.B.C.]

**Wood anatomy** Wood is composed mostly of hollow, elongated, spindle-shaped cells that are arranged parallel to each other along the trunk of a tree. The characteristics of these fibrous cells and their arrangement affect strength properties, appearance, resistance to penetration by water and chemicals, resistance to decay, and many other properties.

Just under the bark of a tree is a thin layer of cells, not visible to the naked eye, called the cambium. Here cells divide and eventually differentiate to form bark tissue to the outside of the cambium and wood or xylem tissue to the inside. This newly formed wood (termed sapwood) contains many living cells and conducts sap upward in the tree. Eventually, the inner sapwood cells become inactive and are transformed into heartwood. This transformation is often accompanied by the formation of extractives that darken the wood, make it less porous, and sometimes provide more resistance to decay. The center of the trunk is the pith, the soft tissue about which the first wood growth takes place in the newly formed twigs. See STEM.

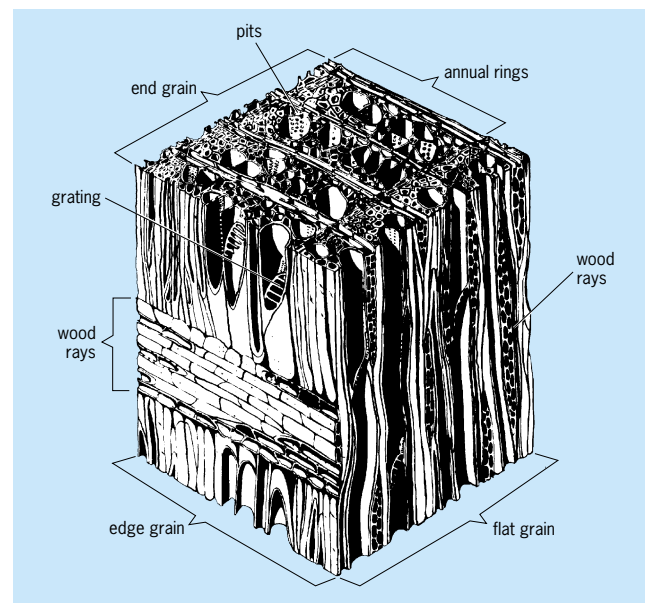

Structure of a typical hardwood. (USDA)

In temperate climates, trees often produce distinct growth layers. These increments are called growth rings or annual rings when associated with yearly growth; many tropical trees, however, lack growth rings. These rings vary in width according to environmental conditions.

Many mechanical properties of wood, such as bending strength, crushing strength, and hardness, depend upon the density of wood; the heavier woods are generally stronger. Wood density is determined largely by the relative thickness of the cell wall and the proportions of thick- and thin-walled cells present. See WOOD PROPERTIES.

In hardwoods (for example, oak or maple), these three major planes along which wood may be cut are known commonly as end-grain, quarter-sawed (edge-grain) and plain-sawed (flat-grain) surfaces (see illustration).

Hardwoods have specialized structures called vessels for conducting sap upward. Vessels are a series of relatively large cells with open ends, set one above the other and continuing as open passages for long distances. In most hardwoods, the ends of the individual cells are entirely open; in others, they are separated by a grating. On the end grain, vessels appear as holes and are termed pores. The size, shape, and arrangement of pores vary considerably between species, but are relatively constant within a species.

Most smaller cells on the end grain are wood fibers which are the strength-giving elements of hardwoods. They usually have small cavities and relatively thick walls. Thin places or pits in the walls of the wood fibers and vessels allow sap to pass from one cavity to another. Wood rays are strips of short horizontal cells that extend in a radial direction. Their function is food storage and lateral conduction. See PARENCHYMA; SECRETORY STRUCTURES (PLANT).

The rectangular units that make up the end grain of softwood are sections through long vertical cells called tracheids or fibers. Because softwoods do not contain vessel cells, the tracheids serve the dual function of transporting sap vertically and giving strength to the wood. The wood rays store and distribute sap horizontally.

The principal compound in mature wood cells is cellulose, a polysaccharide of repeating glucose molecules which may reach 4  $\mu\text{m}$  in length. These cellulose molecules are arranged in an orderly manner into structures about 10–25 nm wide called microfibrils. The microfibrils wind together like strands in a cable to form macrofibrils that measure about 0.5  $\mu\text{m}$  in width and may reach 4  $\mu\text{m}$  in length. These cables are as strong as an equivalent thickness of steel.

This framework of cellulose macrofibrils is cross-linked with hemicelluloses, pectins, and lignin. Lignin, the second most abundant polymer found in plants, gives the cell wall rigidity and the substance that cements the cells together. See CELL WALLS (PLANT); CELLULOSE; LIGNIN; PECTIN; PLANT ANATOMY; TREE. [R.B.M.]

**Wood chemicals** Substances derived from wood. Woody plants comprise the greatest part of the organic materials produced by photosynthesis on a renewable basis, and were the precursors of the fossil coal deposits. The derivation of chemicals from wood is carried out wherever technical utility and economic conditions have combined to make it feasible.

Wood is a mixture of three natural polymers—cellulose, hemicelluloses, and lignin—in an approximate abundance of 50:25:25. In addition to these polymeric cell wall components which make up the major portion of the wood, different species contain varying amounts and kinds of extraneous materials called extractives. The nature of the chemicals derived from wood depends on the wood component involved. See CELLULOSE; HEMICELLULOSE.

Chemicals derived from wood include: bark products, cellulose, cellulose esters, cellulose ethers, charcoal, dimethyl sulfoxide, ethyl alcohol, fatty acids, furfural, hemicellulose extracts,

kraft lignin, lignin sulfonates, pine oil, rayons, rosin, sugars, tall oil, turpentine, and vanillin. Most of these are either direct products or by-products of wood pulping, in which the lignin that cements the wood fibers together and stiffens them is dissolved away from the cellulose. High-purity chemical cellulose or dissolving pulp is the starting material for such polymeric cellulose derivatives as viscose rayon and cellophane, cellulose esters such as the acetate and butyrate for fiber, film, and molding applications, and cellulose ethers such as carboxymethylcellulose, ethylcellulose, and hydroxyethylcellulose for use as gums. See CELLOPHANE; DIMETHYL SULFOXIDE; ETHYL ALCOHOL; FURFURAL; ROSIN; TURPENTINE; VANILLA; WAX, ANIMAL AND VEGETABLE; WOOD PRODUCTS. [I.S.G.]

**Wood degradation** Decay of the components of wood. Despite its highly integrated matrix of cellulose, hemicellulose, and lignin, which gives wood superior strength properties and a marked resistance to chemical and microbial attack, a variety of organisms and processes are capable of degrading wood. The decay process is a continuum, often involving a number of organisms over many years. Wood degrading agents are both biotic and abiotic, and include heat, strong acids or bases, organic chemicals, mechanical wear, and sunlight (uv degradation).

**Abiotic degradation.** Heat degrades both cellulose and hemicellulose, reducing strength and causing the wood to darken. At temperatures above 451°F (219°C), combustion occurs. Strong acids eventually degrade the carbohydrate portion of wood, reducing its strength. Strong bases attack the lignin, leaving the wood appearance bleached and white. Other chemicals, such as concentrated organics or salt solutions, can also disrupt the lignocellulosic matrix, reducing material properties of the wood. Sunlight, primarily through the action of ultraviolet light, also degrades wood through the creation of free radicals which then degrade the wood polymers. Mechanical wear of wood can occur in a variety of environments.

**Biotic degradation.** Biotic damage can occur from a variety of agents, including bacteria, fungi, insects, marine borers, and birds and animals. Birds and animals generally cause mechanical damage in isolated instances. All biotic agents have four basic requirements: adequate temperature (32–104°F or 0–40°C) with most optima between 77–90°F (25–32°C), oxygen (or other suitable terminal electron acceptor), water, and a food source. Water is a critical element for biotic decay agents: it serves as reactant in degradative reactions, a medium for diffusion of enzymes into wood and degradative products back to the organism, and a wood swelling agent.

Bacteria are not major degraders of wood products, but they can damage pit membranes, thereby increasing permeability, and some are capable of cell wall degradation. See BACTERIA.

Fungi are among the most important wood-degrading organisms because they play an important role in terrestrial carbon cycling. Wood-degrading fungi can be classified as molds, stainers, soft rotters, brown rotters, and white rotters on the basis of the attack patterns. Molds, stainers, and soft rotters are members of the ascomycetes and the deuteromycetes (Fungi Imperfecti). See ASCOMYCOTA; DEUTEROMYCOTINA; FUNGI.

A number of insects have evolved to attack wood, including termites (Isoptera), beetles (Coleoptera), and bees and ants (Hymenoptera). Termites are the most important wood-degrading insects in most environments, and their activity causes severe economic losses. See COLEOPTERA; HYMENOPTERA; ISOPTERA.

In saline environments, marine borers can cause significant wood losses. Three groups of marine borers—shipworms, pholads, and gribbles (*Limnoria*)—cause most wood damage in these areas. See BORING BIVALVES; SHIPWORM.

**Wood protection.** Protecting wood from degradation can take a number of forms. By far the simplest method is to employ designs which limit wood exposure to moisture. In some cases, however, water exclusion is not possible and alternative methods must be employed. The simplest of these methods is the use

of heartwood from naturally durable species. Decay- or insect-resistant species include redwood (*Sequoia sempervirens*), western red cedar (*Thuja plicata*), and ekki (*Lophira alata*), while marine-borer-resistant heartwoods include greenheart (*Ocotea rodiaei*) and ekki. Most marine-borer-resistant woods contain high levels of silica which discourages marine borer attack, while species resistant to terrestrial decay agents often contain toxic phenolics. Wood can also be protected from degradation by spraying, dipping, soaking, or pressure treatment with preservatives. See WOOD PROPERTIES. [J.J.Mo.]

**Wood engineering design** The process of creating products, components, and structural systems with wood and wood-based materials. Wood engineering design applies concepts of engineering in the design of systems and products that must carry loads and perform in a safe and serviceable fashion. Examples include structural systems such as buildings or electric power transmission structures, components such as trusses or prefabricated stressed-skin panels, and products such as furniture or pallets and containers. The design process considers the shape, size, physical and mechanical properties of the materials, type and size of the connections, and the type of system response needed to resist both stationary and moving (dynamic) loads and to function satisfactorily in the end-use environment. See ENGINEERING DESIGN; STRUCTURAL DESIGN.

Wood is used in both light frame structures and heavy timber structures. Light frame structures consist of many relatively small wood elements such as lumber covered with a sheathing material such as plywood. The lumber and sheathing are connected to act together as a system in resisting loads; an example is a residential house wood floor system where the plywood is nailed to lumber bending members or joists. In this system, no one joist is heavily loaded because the sheathing spreads the load out over many joists. Service factors such as deflections or vibration often govern the design of floor systems rather than strength. Light frame systems are often designed as diaphragms or shear walls to resist lateral forces resulting from wind or earthquake. See FLOOR CONSTRUCTION; WOOD PROCESSING.

In heavy timber construction, such as bridges or industrial buildings, there is less reliance on system action and, in general, large beams or columns carry more load transmitted through decking or panel assemblies. Strength, rather than deflection, often governs the selection of member size and connections. There are many variants of wood construction using poles, wood shells, folded plates, prefabricated panels, logs, and combinations with other materials. See WOOD PRODUCTS. [T.E.McL.]

**Wood processing** Peeling, slicing, sawing, and chemically altering hardwoods and softwoods to form finished products such as boards or veneer; particles or chips for making paper, particle, or fiber products; and fuel. See PAPER; VENEER.

A high percentage of the weight of freshly cut or green wood is water. Green wood contains free water in the cell cavities and bound water in the cell walls. When all the free water has been extracted and before any of the bound water has been removed, the wood is said to be at the fiber saturation point. As the moisture content falls below the fiber saturation point, the bound water leaves the cell walls and the wood shrinks. During the drying process, differential shrinkage can cause internal stresses in the wood. If not controlled, this can result in defects such as cracks, splits, and warp. Below the fiber saturation point, wood takes on and gives off water molecules depending on the relative humidity of the air around it and swells and shrinks accordingly.

Wood is machined to bring it to a specific size and shape for fastening, gluing, or finishing. With the exception of lasers, which have a limited application at this time, all machining is based on a sharpened wedge that is used to sever wood fibers. Tools for sawing, boring holes, planing, and shaping, as well as the particles in sandpaper, use some version of the sharpened wedge. See WOOD ENGINEERING.

Wood is ground to fibers for hardboard, medium-density fiberboard, and paper products. It is sliced and flaked for particleboard products, including wafer boards and oriented strand boards. Whether made from waste products (sawdust, planer shavings, slabs, edgings) or roundwood, the individual particles generally exhibit the anisotropy and hygroscopicity of larger pieces of wood. The negative effects of these properties are minimized to the degree that the three wood directions (longitudinal, tangential, and radial) are distributed more or less randomly. See WOOD PRODUCTS. [C.J.Ga.]

**Wood products** Materials developed from use of the hard fibrous substance (wood) which makes up the greater part of the trunks and limbs of trees.

Solid wood products include lumber, veneer and plywood, furniture, poles, piling, mine timbers, and posts; and composite wood products such as laminated timbers, insulation board, hard-board, and particle board. See PLYWOOD.

Fiber wood products can be referred to as those which develop initially from the various processes for pulping wood. All are intended to separate the cellulose fibers one from another in relatively pure form to be recombined into layers of pulp, paper sheets, or paperboards. See PAPER.

Chemical wood products result from the chemical modification or conversion of cellulose, lignin, and extractives. Chief among these products are textile fibers such as rayon, and many cellulose plastics products such as cellophane, nitrocellulose, photographic film, telephone parts, and plastic housewares and toys. See CELLULOSE; TEXTILE; WOOD CHEMICALS. [W.S.Br.]

**Wood properties** Physical and mechanical characteristics of wood which are controlled by specific anatomy, moisture content, and to a lesser extent, mineral and extractive content. The properties are also influenced by wood's directional nature, which results in markedly different properties in the longitudinal, tangential, and radial directions or axes. Wood properties within a species vary greatly from tree to tree and within a single axis.

**Physical properties.** The physical properties (other than appearance) are moisture content, shrinkage, density, permeability, and thermal and electrical properties.

Moisture content is a major factor in the processing of wood because it influences all physical and mechanical properties, and durability and performance during use. Normal in-use moisture content of processed wood that has been dried ranges 8–13%. Moisture content for wood is expressed on either a fractional or percentage basis. Moisture content is defined as the ratio of the mass of water contained in the wood to the mass of the same sample of dry wood.

Shrinkage occurs when wood loses moisture below the fiber saturation point. Above that point, wood is dimensionally stable. The amount of the shrinkage depends on its direction relative to grain orientation and the amount of moisture lost below the fiber saturation point. Wood shrinks significantly more in the radial and tangential directions than in the longitudinal direction.

The density of wood is determined by the amount of cell wall substance and the volume of voids caused by the cell cavities (lumens) of the fibers. Density can vary widely across a growth or annual ring. The percentage of earlywood and latewood in each growth ring determines the overall density of a wood sample.

Permeability is a measure of the flow characteristics of a liquid or gas through wood as a result of the total pressure gradient. Permeability is influenced by the anatomy of the wood cells, the direction of flow (radial, tangential, and longitudinal), and the properties of the fluid being measured. Permeability is also affected by the species, by whether the wood is sapwood or heartwood, and by the chemical and physical properties of the fluid.

The primary thermal properties of wood are conductivity, specific heat, and coefficient of thermal expansion. The conductivity of wood is determined by density, moisture content, and

direction of conduction. Thermal conductivity in the transverse directions (radial and tangential) is approximately equal. Conductivity in the longitudinal direction is greater than in the transverse directions. For most processing operations, the dominant heating direction is transverse. Thermal conductivity is important to wood processing because heating—whether for drying, curing, pressing, or conditioning—is an integral step. Specific heat of wood is dependent on moisture content and, to less extent, on temperature. See SPECIFIC HEAT.

Dry wood is an excellent insulator. By measuring wood's electrical resistance, electrical moisture meters accurately determine the moisture content of wood in the 5–25% range. Two other electrical properties of interest are the dielectric constant and the dielectric power factor for alternating current. These dielectric properties are dependent on density, moisture content, frequency of current, grain orientation, and temperature. The power factor is a measure of the stored energy that is converted to heat.

**Mechanical properties.** The mechanical properties of wood include elastic, strength, and vibration characteristics. These properties are dependent upon species, grain orientation, moisture content, loading rate, and size and location of natural characteristics such as knots.

Wood is both an elastic and plastic material. Elasticity manifests itself during loading and at moisture contents and temperatures that occur in most service uses of wood. The elastic stiffness or modulus of elasticity of wood is dependent on grain orientation, moisture content, species, temperature, and rate of loading. The stiffness of wood in the longitudinal (fiber) direction is utilized in the manufacture of composite products such as oriented strand board, in which the grain or fiber direction is controlled. See ELASTICITY.

The strength of wood, like its elastic properties, is dependent upon rate of loading, species, moisture content, orientation, temperature, size and location of natural characteristics such as knots, and specimen size. The strength of individual wood fibers in the longitudinal direction can be significantly greater than that of larger samples with their complex anatomy and many defects. As with stiffness, the excellent strength characteristics of wood in the direction of the fiber can be maximized during the manufacture of wood composites by controlling fiber alignment.

Damping and sound velocity are two primary vibration phenomena of interest in structural applications. Damping occurs when internal friction dissipates mechanical energy as heat. The velocity of a sound wave through wood can be used to estimate mechanical stiffness and strength: the higher the velocity, the higher the stiffness and strength. Like other properties of wood, the velocity of sound along the three principal axes differs. Sound velocity in the longitudinal direction is two to four times greater than in the transverse directions. See WOOD ANATOMY. [J.B.W.]

**Woodward-Hoffmann rule** A concept which can predict or explain the stereochemistry of certain types of reactions in organic chemistry. It is also described as the conservation of orbital symmetry, and is named for its developers, R. B. Woodward and Roald Hoffmann. The rule applies to a limited group of reactions, called pericyclic, which are characterized by being more or less concerted (that is, one-step, without a distinct intermediate between reactants and products) and having a cyclic arrangement of the reacting atoms of the molecule in the transition state. Most pericyclic reactions fall into one of three major classes: electrocyclic, cycloaddition, or sigmatropic. See STEREOCHEMISTRY. [D.L.D.]

**Woodworking** The shaping and assembling of wood and wood products into finished articles such as mold patterns, furniture, window sashes and frames, and boats. The pronounced grain of wood requires modifications in the working techniques when cutting with the grain and when cutting across it. Five principal woodworking operations are sawing, planing, steam

bending, gluing, and finishing. To shape round pieces, wood is worked on a lathe. See TURNING (WOODWORKING).

Wood is sawed by cutting or splitting its fibers by the continuous action of a series of uniformly spaced teeth alternately staggered to move in closely parallel work planes. Action of the cutting teeth produces a path or kerf of uniform width through the workpiece from which the fibers have been severed and removed. Sawing across the grain or cell structure of the wood is called crosscutting. Cutting parallel with the grain of the piece is referred to as ripping. Saw teeth are bent alternately to the left and right to provide clearance for the blade. Some blades include straight raker teeth for cleaning fibers from the cut.

Flat or uniformly contoured surfaces of wood are roughed down, smoothed, or made level by the shaving and cutting action of a wide-edged blade or blades. Planing may be accomplished either manually or by power-operated tools.

Wooden members are bent or formed to a desired shape by pressure after they have been softened or plasticized by heat and moisture. If thick pieces of wood are to be bent to a permanent shape without breaking, some form of softening or plasticizing such as steaming is necessary. When a piece of wood is bent, its outer or convex side is actually stretched in tension while its concave side is simultaneously compressed. Actually, plasticized wood can be stretched but little. It can, however, be compressed a considerable amount. When a piece of plasticized wood is successfully bent, the deformation is chiefly compression distributed almost uniformly over the curved portion. Curvature results from many minute folds, wrinkles, and slippages in the compressed area.

Wood pieces may be fastened together by the adhesive qualities of a substance that sets or hardens into a permanent bond. Adhesives for wood are of two principal types, synthetic and natural-origin. The term glue was first applied to bonding materials of natural origin, while adhesive has been used to describe those of synthetic composition. See ADHESIVE.

The finishing operation is the preparation and sealing or covering of a surface with a suitable substance in order to preserve it or to give it a desired appearance. The preparation and conditioning of a surface may include cleaning, sanding, use of steel wool, removing or covering nails and screws, gluing or fastening loose pieces, filling cracks and holes with putty or crack filler, shellacking, and dusting. An inconsequential item with a painted surface does not require the thorough surface preparation that a piece of fine furniture does. The quality of surface conditioning directly affects the end result. See WOOD PROPERTIES. [A.H.T.]

**Wool** A textile fiber made of the undercoat of various animals, especially sheep. Wool provides warmth and physical comfort that cotton and linen fabrics cannot give. These qualities, combined with its soft resiliency, make wool a necessity for apparel and for rugs and blankets.

Sheep are generally shorn of their fleeces in the spring, but the time of shearing varies in different parts of the world. Each fleece contains different grades, or sorts, of wool, and the raw stock must be carefully graded and segregated according to length, diameter, and quality of fiber. Wool from different parts of the body of the lamb differs greatly. The shoulders and sides generally yield the best quality of wool, because the fibers from those parts are longer, softer, and finer.

Wool's major physical characteristics include fiber diameter (fineness or grade), staple length, and clean wool yield. Also significant are soundness, color, luster, and content of vegetable matter. Grade refers specifically to mean fiber diameter and its variability. Fiber diameter is the most important manufacturing characteristic. Fleeces are commercially graded visually through observation and handling by men of long experience in the industry. Degree of crimp and relative softness of the fleece are important deciding factors employed by the graders.

The inherent advantages of wool have been exploited, and its limitations as a textile fiber have been overcome by the

application of technology to manufacturing processes. The use of the insecticide dieldrin as a dye renders wool mothproof for life. Permanent pleats have been imparted to garments which are shrinkproofed and can be home laundered. Each such technological advance enables wool to hold its competitive place in the field of textile manufacture and use. See TEXTILE. [T.D.W.]

**Word processing** The use of a computer and specialized software to write, edit, format, print, and save text. In addition to these basic capabilities, the latest word processors enable users to perform a variety of advanced functions. Although the advanced features vary among the many word processing applications, most of the latest software facilitates the exchange of information between different computer applications, allows easy access to the World Wide Web for page editing and linking, and enables groups of writers to work together on a common project. See COMPUTER; SOFTWARE; WORLD WIDE WEB.

Writing is accomplished by using the computer's typewriterlike keyboard. The characters appear on the computer screen as they are typed. A finite number of characters can be typed across the computer screen. The word processor "knows" when the user has reached this limit and automatically moves the cursor to the next line for uninterrupted typing. The position on the computer screen where a character can be typed is marked by a blinking cursor. The cursor can be positioned anywhere on the screen by using the mouse, or the keys marked with arrows on the keyboard. See COMPUTER PERIPHERAL DEVICES; ELECTRONIC DISPLAY.

In addition to writing, the latest word processors provide tools to create and insert drawings anywhere in the document. Typical features allow users to draw lines, rectangles, circles, and arrowheads, and to add text.

Editing allows users to correct typographical errors, add new sentences or paragraphs, move entire blocks of text to a different location, delete portions of the document, copy text and paste it somewhere else in the document, or insert text or graphics from an entirely different document. Most word processing programs can automatically correct many basic typographical errors, such as misspelled words, two successive capital letters in a word, and failure to capitalize the first letter of the names of days and of the first word in a sentence. Some other helpful editing tools commonly found in word processors include an automatic spelling checker, a thesaurus, and a grammar checker.

Formatting enables users to define the appearance of the elements in a document, such as the font and type size of all headings and text, the left, right, top, and bottom margins of each page, and the space before and after sentences and paragraphs. Most word processors allow all the elements in a document to be formatted at once. This is accomplished by applying a "style."

Word processors are approaching the formatting power of full-featured desktop publishing applications. The formatted page can be viewed on the computer screen exactly as it will be printed. This is referred to as "what you see is what you get" (WYSIWYG).

The latest word processors have many features for allowing groups of people to work together on the same document. For instance, multiple versions of a document can be saved to a single file for version control; access levels can be assigned so that only a select group of people can make changes to a document; edits can be marked with the date, time, and editor's name; and text colors can be assigned to differentiate editors. In addition, some word processors have editing features that include highlighting text, drawing lines through text to represent deleted text, and using red underscoring to identify changed text. [C.Qui.]

**Work** In physics, the term work refers to the transference of energy that occurs when a force is applied to a body that is moving in such a way that the force has a component in the direction of the body's motion. Thus work is done on a weight that is being

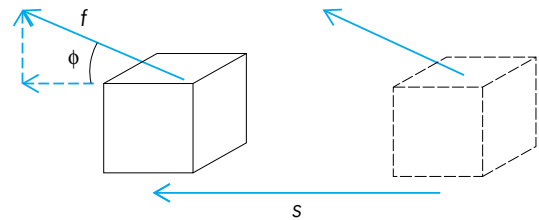

Work of constant force  $f$  is  $fs \cos \phi$ .

lifted, or on a spring that is being stretched or compressed, or on a gas that is undergoing compression in a cylinder.

When the force acting on a moving body is constant in magnitude and direction, the amount of work done is defined as the product of just two factors: the component of the force in the direction of motion, and the distance moved by the point of application of the force. Thus the defining equation for work  $W$  is given below, where  $f$  and  $s$  are the magnitudes of the force and

$$W = f \cos \phi \cdot s$$

displacement, respectively, and  $\phi$  is the angle between these two vector quantities (see illustration). Because  $f \cos \phi \cdot s = f \cdot s \cos \phi$ , work may be defined alternatively as the product of the force and the component of the displacement in the direction of the force.

The work done is positive in sign whenever the force or any component of it is in the same direction as the displacement; one then says that work is being done by the agent exerting the force and on the moving body. The work is said to be negative whenever the direction of the force or force component is opposite to that of the displacement; then work is said to be done on the agent and by the moving body. From the point of view of energy, an agent doing positive work is losing energy to the body on which the work is done, and one doing negative work is gaining energy from that body.

The work principle, which is a generalization from experiments on many types of machines, asserts that, during any given time, the work of the forces applied to the machine is equal to the work of the forces resisting the motion of the machine, whether these resisting forces arise from gravity, friction, molecular interactions, or inertia.

The work done by any conservative force, such as a gravitational, elastic, or electrostatic force, during a displacement of a body from one point to another has the important property of being path-independent: Its value depends only on the initial and final positions of the body, not upon the path traversed between these two positions. On the other hand, the work done by any nonconservative force, such as friction due to air, depends on the path followed and not alone on the initial and final positions, for the direction of such a force varies with the path, being at every point of the path tangential to it. See ENERGY; FORCE.

[L.N.]

**Work function (electronics)** A quantity with the dimensions of energy which determines the thermionic emission of a solid at a given temperature. For metals, the work function may also be determined by measuring the photoemission as a function of the frequency of the incident electromagnetic radiation: the work function is then equal to the minimum (threshold) frequency for which electron emission is observed times Planck's constant  $h$  ( $= 6.63 \times 10^{-34}$  joule second). The work function of a solid is usually expressed in electronvolts.

The work function of metals varies from one crystal plane to another and also varies slightly with temperature. For a metal, the work function has a simple interpretation. At absolute zero, the energy of the most energetic electrons in a metal is referred to as the Fermi energy; the work function of a metal is then equal to the energy required to raise an electron with the Fermi energy to the energy level corresponding to an electron

at rest in vacuum. The work function of a semiconductor or an insulator has the same interpretation, but in these materials the Fermi level is in general not occupied by electrons and thus has a more abstract meaning. See FIELD EMISSION; PHOTOEMISSION; THERMIONIC EMISSION. [A.J.D.]

**Work function (thermodynamics)** The thermodynamic function better known as the Helmholtz energy,  $A = U - TS$ , where  $U$  is the internal energy,  $T$  is the thermodynamic (absolute) temperature, and  $S$  is the entropy of the system. At constant temperature, the change in work function is equal to the maximum work that can be done by a system ( $\Delta A = w_{max}$ ). See FREE ENERGY. [P.W.A.]

**Work measurement** The determination of a set of parameters associated with a task. There are four reasons, common to most organizations whether profit seeking or not, why time, effort, and money are spent to measure the amount of time a job takes. These are cost accounting, evaluation of alternatives, acceptable day's work, and scheduling. The fifth, pay by results, is used only by a minority of organizations.

There are three common ways to determine time per job: stopwatch time study (sequential observations), occurrence sampling (nonsequential observations), and standard data.

Stopwatch time study can be used for almost any existing job. It is reasonable in cost and gives reasonable accuracy. However, it does require the worker to be rated. Once the initial cost of standard data system has been incurred, standard data may be the lowest-cost, most accurate, and most accepted technique.

Occurrence sampling is also called work sampling or ratio-delay sampling. If time study is a "movie," then occurrence sampling is a "series of snapshots." The primary advantage of this approach may be that occurrence sampling standards are obtained from data gathered over a relatively long time period, so the sample is likely to be representative of the universe. That is, the time from the study is likely to be representative of the long-run performance of the worker.

Reuse of previous times (standard data) is an alternative to measuring new times for an operation. There are three levels of detail: micro, elemental, and macro (see table). Micro-level

systems have times of the smallest component ranging from about 0.01 to 1 s. Components usually come from a predetermined time system such as methods-time-measurement (MTM) or Work-Factor. Elemental level systems have the time of the smallest component, ranging from about 1 to 1000 s. Components come from time study or micro-level combinations. Macro-level systems have times ranging upward from about 1000 s. Components come from elemental-level combinations, from time studies, and from occurrence sampling. See METHODS ENGINEERING; PERFORMANCE RATING; PRODUCTIVITY. [S.A.K.]

**Work standardization** The establishment of uniformity of technical procedures, administrative procedures, working conditions, tools, equipment, workplace arrangements, operation and motion sequences, materials, quality requirements, and similar factors which affect the performance of work. It involves the concepts of design standardization applied to the performance of jobs or operations in industry or business. See DESIGN STANDARDS; WORK MEASUREMENT.

Work standardization is part of methods engineering and, where it is practiced, usually precedes the setting of time standards. The objectives of work standardizations are lower costs, greater productivity, improved quality of workmanship, greater safety, and quicker and better development of skills among workers. See METHODS ENGINEERING; PRODUCTIVITY.

One of the best known of the more formal techniques of work standardization is group technology. This is the careful description of a heterogeneous lot of machine or other piece parts with a view to discovering as many common features in materials and dimensions as can be identified. It is then possible to start a rather large lot of a basic part through the production process, doing the common operations on all of them. Any changes or additional operations required to produce the final different parts can then be made at a later stage. The economy is realized in being able to do the identical jobs at one time.

There has been considerable progress in computerized systems to facilitate group technology. The techniques are closely linked to computer-aided design and to formalized codes that permit the detailed description of many operations. See COMPUTER-AIDED DESIGN AND MANUFACTURING. [J.E.U.]

**World Wide Web** A part of the Internet that contains linked text, image, sound, and video documents. Before the World Wide Web (WWW), information retrieval on the Internet was text-based and required that users know basic UNIX commands. The World Wide Web has gained popularity largely because of its ease of use (point-and-click graphical interface) and multimedia capabilities, as well as its convenient access to other types of Internet services (such as e-mail, Telnet, and Usenet). See INTERNET.

Improvements in networking technology, the falling cost of computer hardware and networking equipment, and increased bandwidth have helped the Web to contain richer content. The Web is the fastest medium for transferring information and has universal reach (crossing geographical and time boundaries). It is also easy to access information from millions of Web sites using search engines (systems that collect and index Web pages, and store searchable lists of these pages). The Web's unified networking protocols make its use seamless, transparent, and portable. As the Web has evolved, it has incorporated complementary new technologies for developing online commerce and video on demand, to name a few.

Individual documents are called Web pages, and a collection of related documents is called a Web site. All Web documents are assigned a unique Internet address called a Uniform Resource Locator (URL) by which they can be accessed by all Web browsers. A URL (such as <http://www.hq.nasa.gov/office/procurement/index.html>) identifies the communication protocol used by the site (http), its location [domain name

**Three levels of detail for standard time systems**

*Micro system* (typical component time range from 0.01 to 1 s; MTM nomenclature)

Element	Code	Time
Reach	R10C	12.9 TMU* <sub>o</sub>
Grasp	G4B	9.1
Move	M10B	12.2
Position	P1SE	5.6
Release	RL1	2.0

*Elemental system* (typical component time range from 1 to 1000 s)

Element	Time
Get equipment	1.5 min
Polish shoes	3.5
Put equipment away	2.0

*Macro system* (typical component times vary upward from 1000 s)

Element	Time
Load truck	2.5 h
Drive truck 200 km	4.0
Unload truck	3.4

\*27.8 TMU = 1 s; 1 s = 0.036 TMU.

SOURCE: S. A. Konz, *Work Design*, published by Grid, 4666 Indianola Avenue, Columbus, OH 43214, 1979.



or server ([www.hq.nasa.gov](http://www.hq.nasa.gov)], the path to the server (office/procurement), and the type of document (html).

The language used to create and link documents is called Hypertext Markup Language (HTML). Markup is the process of adding information to a document that is not part of the content but identifies the structure or elements. Markup languages are not new. HTML is based on the Standard Generalized Markup Language (SGML).

Though the initial format for creating a Web site was pure HTML, new and extended HTML has the ability to include programming language scripts such as common gateway interface (CGI), active server page (ASP), and Java server page (JSP), which can be used to create dynamic and interactive Web pages as opposed to just static HTML text. Dynamic Web pages allow users to create forms for transactions and data collection; perform searches on a database or on a particular Web site; create counters and track the domain names of visitors; customize Web pages to meet individual user preferences; create Web pages on the fly; and create interactive Web sites.

XML, developed by the World Wide Web Consortium, is another derivative of SGML and is rapidly becoming the standard information protocol for all commercial software such as office tools, messaging, and distributed databases. XML is a flexible way to create common information formats and share both the format and the data on the World Wide Web, intranets, and other Web-based services. [A.V.]

**Wrought iron** As defined by the American Society for Testing and Materials, "a ferrous material, aggregated from a solidifying mass of pasty particles of highly refined metallic iron, with which, without subsequent fusion, is incorporated a minutely and uniformly distributed quantity of slag." This slag is a ferrous silicate resulting from the oxidizing reactions of refining, and it varies in amount from 1 to 3% in various types of final product. It is in purely mechanical association with the iron base metal, as contrasted with the alloying relationships of the metalloids present in steel. See STEEL.

A distinguishing characteristic of wrought iron is a fragmented or irregular fracture, as contrasted with a fibrous or crystalline

type in steel. Metallographic analysis shows that this results from the fiberlike slag inclusions. Although wrought iron once held competitive merit in certain uses, notably where corrosion- and shock-resistance were important, very little wrought iron is produced at present. See IRON ALLOYS. [J.As./J.F.W.]

**Wulfenite** A mineral consisting of lead molybdate,  $PbMoO_4$ . Wulfenite occurs commonly in yellow, orange, red, and grayish-white crystals, with a luster from adamantine to resinous. Wulfenite may also be massive or granular. Its fracture is uneven. Its hardness is 2.7–3 on Mohs scale and its specific gravity 6.5–7. Its streak is white.

Wulfenite is found in numerous localities in the western and southwestern United States. Brilliant orange tabular wulfenite crystals up to 2 in. (5 cm) in size have been found from the Red Cloud and Hamburg mines in Yuma County, Arizona. See MOLYBDENUM. [E.C.T.C.]

**Wurtzilite** A black, infusible carbonaceous substance occurring in Uinta County, Utah. It is insoluble in carbon disulfide, has a density of about 1.05, and consists of 79–80% carbon, 10.5–12.5% hydrogen, 4–6% sulfur, 1.8–2.2% nitrogen, and some oxygen. Wurtzilite is derived from shale beds deposited near the close of Eocene (Green River) time. The material was introduced into the calcareous shale beds as a fluid after which it polymerized to form nodules or veins. See ASPHALT AND ASPHALTITE; ELATERITE; IMPSONITE. [I.A.B.]

**Wurtzite** A mineral with composition  $ZnS$  (zinc sulfide). It exists most commonly in fibrous or columnar aggregates and banded crusts with resinous luster and brownish-black color. Hardness is  $3\frac{1}{2}$  on Mohs scale and its specific gravity 4.0. Zinc sulfide is dimorphous, crystallizing as both the high-temperature form wurtzite,  $\alpha$ - $ZnS$ , and the low-temperature form sphalerite,  $\beta$ - $ZnS$ . Wurtzite is the rarer and at room temperature the less stable form and, unlike sphalerite, is rarely mined as an ore of zinc. Wurtzite usually contains iron and cadmium, and a complete solid solution series extends to greenockite,  $CdS$ . See GREENOCKITE; SPHALERITE. [C.S.Hu.]



# X

**X-ray astronomy** The study of x-ray emission from extrasolar sources, including virtually all types of astronomical objects from stars to galaxies and quasars. The x-ray region of the electromagnetic spectrum extends from wavelengths of about 10 picometers to a few tens of nanometers, with shorter wavelengths corresponding to higher-energy photons (1 nm corresponds to about 1000 eV). X-ray astronomy is traditionally divided into broad bands—soft and hard—depending on the energy of the radiation being studied. Observations in the soft band (below about 10 keV) must be carried out above the atmosphere from rockets or satellites, while hard x-ray observations can be made at high altitudes achievable by balloons. See ELECTROMAGNETIC RADIATION; ROCKET ASTRONOMY; SATELLITE ASTRONOMY; X-RAYS.

Most observations have been in the soft band. Sky surveys, particularly the *ROSAT* all-sky survey, have located tens of thousands of sources at a sensitivity of about 1/100,000 of the strength of the brightest source, Sco X-1. Some of these sources are concentrated along the galactic equator. Such a concentration corresponds to objects in the Milky Way Galaxy, particularly in the disk, which contains most of the galactic stars and the spiral arms. Other x-ray sources are uniformly spread over the sky, associated mainly with extragalactic objects, such as individual galaxies, clusters of galaxies, and quasars. See MILKY WAY GALAXY.

**Galactic sources.** Galactic x-ray sources have been identified with different types of unusual objects. The Crab Nebula, which was the first nonsolar x-ray source to be identified with a specific celestial object, is a supernova remnant left over from the explosive death of a star. It contains a rapidly rotating neutron star at its center as well as a nebula consisting of hot gas and energetic particles. About 10% of the x-ray emission from the Crab is pulsed radiation from the neutron star; the rest is extended emission associated with the nebula. Many other galactic supernova remnants have been detected as x-ray sources, and there have also been detections of supernova remnants in the nearest neighboring galaxies, especially in the Large Magellanic Cloud. See CRAB NEBULA; NEUTRON STAR; PULSAR; SUPERNOVA.

While normal stars radiate some energy in the x-ray band, most of their luminosity is output in the visible region of the spectrum. X-ray surveys have discovered a class of objects where the majority of energy is radiated in the x-ray portion of the electromagnetic spectrum. These are known as x-ray stars. With accurate locations, it has been possible to identify them with binary star systems. The combination of x-ray and optical data leads to the conclusion that these systems usually consist of a relatively normal visible star and one subluminous star in a gravitationally bound orbit about each other. The x-ray star is often a collapsed object, such as a white dwarf, neutron star, or even a black hole. Such compact sources form the majority of galactic emitters.

The theoretical model for x-ray emission in these systems consists of matter being transferred from the normal star to the compact object. This process, known as accretion, usually leads to the creation of a disk of infalling material spiraling down toward the surface of the compact star. During infall the matter reaches very high temperatures as gravitational energy is converted to heat, which is then radiated as x-rays. It is believed that similar

processes are involved regardless of whether the compact object is a white dwarf, neutron star, or black hole. However, different types of detailed behavior are expected for each of these objects. Rotating neutron stars lead to x-ray pulsars. For white dwarfs, there appear to be fluctuations in x-ray intensity on time scales of hours to days that might be indicative of changes at the surface of the star where accreted material is collecting, and then flashing in a burst of thermonuclear energy release. In the case of black hole candidates, there are variations in x-ray intensity at extremely short time scales that indicate very small regions of x-ray emission.

Another type of time behavior is represented by the so-called bursters. These sources emit at some constant level, with occasional short bursts or flares of increased brightness. These outbursts may well be instabilities in the x-ray emission processes associated with this type of source. See BINARY STAR; BLACK HOLE; CATAclysmic VARIABLE; STELLAR EVOLUTION; WHITE DWARF STAR.

**Extragalactic sources.** Among the more interesting types of objects detected have been apparent normal galaxies, galaxies with active nuclei, radio galaxies, clusters of galaxies, and quasars.

In active nuclei galaxies (those with strong optical emission lines and nonthermal continuum spectra), x-ray emission is usually orders of magnitude in excess of that from normal galaxies. In most cases the emission comes from the galactic nucleus, and must be confined to a relatively small region on the basis of variability and lack of structure at the current observational limits of a few seconds of arc. Many astrophysicists believe that galactic nuclei are the sites of massive black holes, at least  $10^6$ – $10^9$  times the mass of the Sun, and that the radiation from these objects is due to gravitational energy released by infalling material. The broad range of properties, such as x-ray luminosity, may reflect the size of the black hole and availability of infalling matter. Quasars may represent the extreme case of this mechanism. Many of the observable properties depend on the viewing angle of the observer as well as the size of the nuclear black hole. See QUASAR.

Clusters of galaxies are collections of hundreds to thousands of individual galaxies which form a gravitationally bound system. The space between galaxies in such clusters has been found to contain hot (approximately  $10^7$ – $10^8$  K) tenuous gas which glows in x-rays, and whose mass is equal to (or exceeds) the mass of the visible galaxies. See ASTROPHYSICS, HIGH-ENERGY; GALAXY, EXTERNAL. [S.S.M.]

**X-ray crystallography** The study of crystal structure by x-ray diffraction techniques. For the experimental aspects of x-ray diffraction See X-RAY DIFFRACTION.

Structurally, a crystal is a three-dimensional periodic arrangement in space of atoms, groups of atoms, or molecules. If the periodicity of this pattern extends throughout a given piece of material, one speaks of a single crystal. The exact structure of any given crystal is determined if the locations of all atoms making up the three-dimensional periodic pattern called the unit cell are known. The very close and periodic arrangement of the atoms in a crystal permits it to act as a diffraction grating for x-rays. See CRYSTALLOGRAPHY. [L.F.D.]

**X-ray diffraction** The scattering of x-rays by matter with accompanying variation in intensity in different directions due to interference effects. X-ray diffraction is one of the most important tools of solid-state chemistry, since it constitutes a powerful and readily available method for determining atomic arrangements in matter. X-ray diffraction methods depend upon the fact that x-ray wavelengths of the order of 1 nanometer are readily available and that this is the order of magnitude of atomic dimensions. When an x-ray beam falls on matter, scattered x-radiation is produced by all the atoms. These scattered waves spread out spherically from all the atoms in the sample, and the interference effects of the scattered radiation cause the intensity of the scattered radiation to exhibit maxima and minima in various directions. See DIFFRACTION.

**Uses.** Some of the uses of x-ray diffraction are: (1) differentiation between crystalline and amorphous materials; (2) determination of the structure of crystalline materials (crystal axes, size and shape of the unit cell, positions of the atoms in the unit cell); (3) determination of electron distribution within the atoms, and throughout the unit cell; (4) determination of the orientation of single crystals; (5) determination of the texture of polygrained materials; (6) identification of crystalline phases and measurement of the relative proportions; (7) measurement of limits of solid solubility, and determination of phase diagrams; (8) measurement of strain and small grain size; (9) measurement of various kinds of randomness, disorder, and imperfections in crystals; and (10) determination of radial distribution functions for amorphous solids and liquids.

**Techniques.** The techniques employed in the study of crystalline substances, gases, and liquids are discussed below.

**Laue method.** The Laue pattern uses polychromatic x-rays provided by the continuous spectrum from an x-ray tube operated at 35–50 kV. The different diffracted beams have different wavelengths, and their directions are determined solely by the orientations of the set of planes with Miller indices  $hkl$ . Transmission Laue patterns were once used for structure determinations, but their many disadvantages have made them practically obsolete. On the other hand, the back-reflection Laue pattern is used a great deal in the study of the orientation of crystals.

**Rotating crystal method.** The original rotating crystal method was employed in the Bragg spectrometer. A sufficiently monochromatic beam, of wavelength of the order of  $1 \text{ \AA}$ , is collimated by a system of slits and then falls on the large extended face of a single crystal as shown by Fig. 1. The Bragg spectrometer has been used extensively in obtaining quantitative measurements of the integrated intensity from planes parallel to the face of the crystal. The chamber is set at the correct

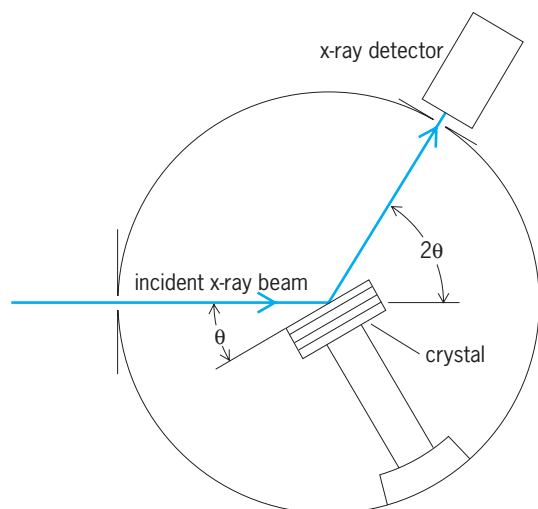

Fig. 1. Schematic of Bragg spectrometer.

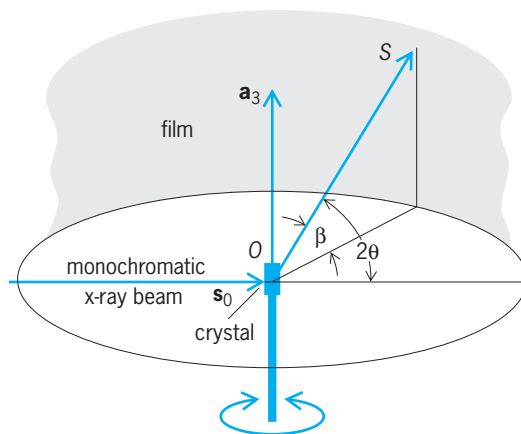

Fig. 2. Schematic of rotation camera.

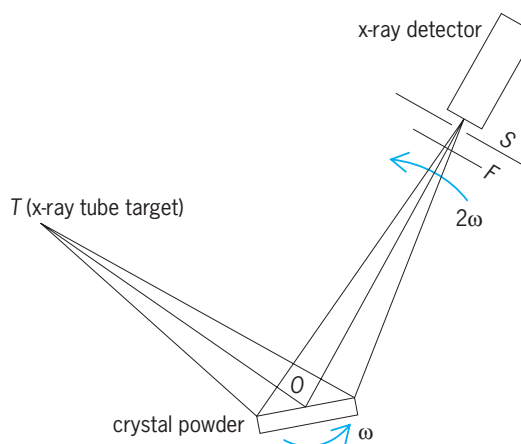

Fig. 3. Schematic representation of the Geiger counter diffractometer for powder samples.

$2\theta$  angle with a slit so wide that all of the radiation reflected from the crystal can enter and be measured. The crystal is turned at constant angular speed through the Bragg law position, and the total diffracted energy received by the ionization chamber during this process is measured. Similar readings with the chamber set on either side of the peak give a background correction.

The rotation camera, which is frequently used for structure determinations, is illustrated in Fig. 2. The monochromatic primary beam  $s_0$  falls on a small single crystal at  $O$ . The crystal is mounted with one of its axes (say,  $a_3$ ) vertical, and it rotates with constant velocity about the vertical axis during the exposure. The various diffracted beams are registered on a cylindrical film concentric with the axis of rotation.

**Powder method.** The powder method involves the diffraction of a collimated monochromatic beam from a sample containing an enormous number of tiny crystals having random orientation. Powder pattern studies are made with Geiger counter, or proportional counter, diffractometers. The apparatus is shown schematically in Fig. 3. X-rays diverging from a target at  $T$  fall on the sample at  $O$ , the sample being a flat-faced briquet of powder. Diffracted radiation from the sample passes through the receiving slit at  $s$  and enters the Geiger counter. During the operation the sample turns at angular velocity  $\omega$  and the counter at  $2\omega$ . The distances  $TO$  and  $OS$  are made equal to satisfy approximate focusing conditions. A filter  $F$  before the receiving slit gives the effect of a sufficiently monochromatic beam. A chart recording of the amplified output of the Geiger counter gives directly a plot of intensity versus scattering angle  $2\theta$ . [B.E.W.]

**Gases.** Gases and liquids are found to give rise to x-ray diffraction patterns characterized by one or more halos or

interference rings which are usually somewhat diffuse. These diffraction patterns, which are similar to those for glasses and amorphous solids, are due to interference effects depending both upon the electronic distribution of each of the individual atoms or molecules and upon their relative positions in the system.

For monatomic gases the only appreciable interference effects giving rise to a distribution of scattered intensities are those produced by the electronic distribution about each nucleus. These interference effects giving rise to so-called coherent intensities are the result of the interference of the individual waves scattered by electrons in different parts of the atom. The electronic distribution of an atom is described in terms of a characteristic atomic scattering factor which is defined as the ratio of the resultant amplitude scattered by an atom to the amplitude that a free electron would scatter under the same conditions.

**Liquids.** One cannot, as in the cases of dilute gases and crystalline solids, derive unambiguous, detailed descriptions of liquid structures from diffraction data. Nevertheless, diffraction studies of liquids do provide most useful information. Instead of comparing the experimental intensity distributions with theoretical distributions computed for various models, the experimental results are usually provided in the form of a radial distribution function which specifies the density of atoms or electrons as a function of the radial distance from any reference atom or electron in the system without any prior assumptions about the structure. From the radial distribution function one can obtain (1) the average interatomic distances most frequently occurring in the structure corresponding to the positions of the first, second, and possibly third nearest neighbors; (2) the distribution of distances; and (3) the average coordination number for each interatomic distance. [L.F.D.]

**X-ray fluorescence analysis** A nondestructive physical method used for chemical elemental analysis of materials in the solid or liquid state. The specimen is irradiated by photons or charged particles of sufficient energy to cause its elements to emit (fluoresce) their characteristic x-ray line spectra. The detection system allows the determination of the energies of the emitted lines and their intensities. Elements in the specimen are identified by their spectral line energies or wavelengths for qualitative analysis, and the intensities are related to their concentrations for quantitative analysis. Computers are widely used in this field, both for automated data collection and for reducing the x-ray data to weight-percent and atomic-percent chemical composition or area-related mass (of films). See FLUORESCENCE.

The materials to be analyzed may be solids, powders, liquids, or thin foils and films. The crystalline state normally has no effect on the analysis, nor has the state of chemical bonding, except for very light elements. All elements above atomic number 12 can be routinely analyzed in a concentration range from 0.1 to 100 wt %. Special techniques are required for the analysis of elements with lower atomic numbers (4–11) or of lower concentrations, and for trace analysis. The counting times required for analysis range from a few seconds to several minutes per element, depending upon specimen characteristics and required accuracy; but they may be much longer for trace analysis and thin films. The results are in good agreement with wet chemical and other methods of analysis. The method is generally nondestructive for most inorganic materials in that a suitably prepared specimen is not altered by the analytical process.

There are two general methods for producing x-ray spectra for fluorescence analysis excitation by photons and excitation by charged particles. The most common method is to expose the specimen to the entire spectrum emitted from a standard x-ray tube. It is sometimes modified by using a secondary target material (or monochromator) outside the x-ray tube to excite fluorescence. This has the advantage of selecting the most efficient energy close to the absorption edge of the element to be analyzed and reducing or not exciting other interfering elements,

but the intensity is reduced by two or three orders of magnitude. Further alternatives are radioactive sources and synchrotron radiation.

The other method, used in electron microscopes and the electron microprobe, uses an electron beam directly on the specimen, and each element generates its own x-ray spectrum, under electron bombardment, as in an x-ray tube. See ELECTRON MICROSCOPE.

The output signals from a detector are fed into the analyzer, where the photon counts are stored in memory locations (1024–8192 channels are generally used) that are related to the energies of these photons. This also allows visual observation on a cathode-ray-tube screen of the accumulated spectrum and of the simultaneous counting process. Analyzers are usually provided with cursor markers to easily identify the peaks in the spectrum. Computer memories can be used for storage of the spectral counts, thus providing efficient access to computer routines for further data evaluation.

The electron microprobe is widely used for elemental analysis of small areas. An electron beam of 1 micrometer (or smaller) is used, and the x-ray spectrum is analyzed with a focusing (curved) crystal spectrometer or with an energy dispersive solid-state detector. Usually two or three spectrometers are used to cover different spectral regions. Light elements down to beryllium, boron, and carbon can be detected. An important use of the method is in point-to-point analysis with a few cubic micrometers of spatial resolution. X-Y plots of any element can be made by moving the specimen to determine the elemental distribution. See ELECTRON-PROBE MICROANALYSIS. [W.P.; M.Man.]

**X-ray microscope** A technique and an instrument or combination of instruments which utilize x-radiation for chemical analysis and for magnification of 100–1000 diameters. The resolution possible is about 0.25 micrometer. The contrast in the x-ray microscopic image is caused by the varying x-ray attenuation in the specimen. The advantage of x-ray microscopy is that it yields quantitative chemical information, besides structural information, about objects, including those which are opaque to light. It is a reliable ultramicrochemical analytical technique by which amounts of elements and weights of samples as small as  $10^{-12}$  to  $10^{-14}$  g can be analyzed with an error of only a few percent. See MICRORADIOGRAPHY.

There are four general principles of image formation in x-ray microscopy: (1) contact microradiography (illus. a), (2) projection x-ray microscopy (illus. b), (3) reflection x-ray microscopy (illus. c), and (4) x-ray image spectrography (illus. d).

In contact microradiography the thin specimen is placed in close contact with an extremely fine-grained photographic emulsion which has a resolution of more than 25,000 lines/in. (1000 lines/mm), and radiographed with x-rays of suitable wavelength. Thus an absorption image in scale 1:1 is obtained, and this image is subsequently viewed in a light microscope. The maximal resolution is that of the optical microscope ( $0.25 \mu\text{m}$ ), but the image has more information, which can be obtained by examining the microradiogram in the electron microscopes. See ELECTRON MICROSCOPE.

Projection x-ray microscopy, or x-ray shadow microscopy, is based on the possibility of producing an extremely fine x-ray focal spot. This is achieved by an electronic lens system similar to that in the electron microscope. The fine focal spot is produced on a very thin metal foil which serves as a transmission target. The x-rays are generated on the target by the impact of the electrons. The sample is placed near the target, and the primary magnification depends on the ratios of the distances from focal spot to sample and sample to film. Resolution is of the same order as the size of the focal spot; the best value is about  $0.1 \mu\text{m}$  in favorable objects.

The method of reflection x-ray microscopy is based on the fact that the refractive index for x-rays in solids is a very small amount less than 1. Thus at grazing incidence (that is, incidence at very

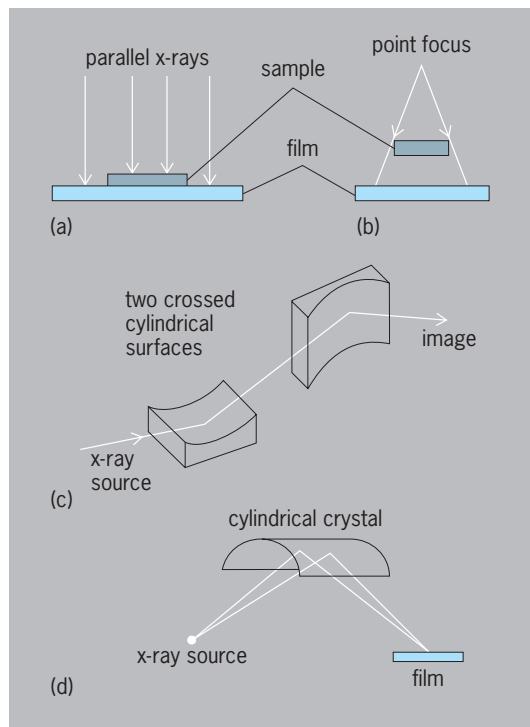

**Principles for x-ray microscopy. (a) Contact microradiography; (b) projection x-ray microscopy; (c) reflection x-ray microscopy; and (d) x-ray image spectroscopy.**

small angles), the x-rays are totally reflected, and if the reflecting surface is made cylindrical, there will be a focusing action in one dimension. By crossing two such surfaces a true image formation can be obtained, although with some astigmatism, which can be corrected by giving the surfaces a complicated optical shape. The resolution by this procedure is about  $0.5\text{--}1\ \mu\text{m}$ .

X-ray image spectroscopy utilizes Bragg reflections in a cylindrically bent crystal and produces slightly enlarged emission images; this technique is best classified as a micromodification of x-ray fluorescence analysis. The resolution is about  $50\ \mu\text{m}$ . See X-RAY DIFFRACTION; X-RAY FLUORESCENCE ANALYSIS.

In biology, x-ray microscopy has been utilized for the quantitative determination of the dry weight, water content, and elementary composition of many tissues, especially mineralized tissues. [A.E.]

**X-ray optics** By analogy with the science of optics, those aspects of x-ray physics in which x-rays exhibit properties similar to those of light waves. X-ray optics may also be defined as the science of manipulating x-rays with instruments analogous to those used in visible-light optics. These instruments employ optical elements such as mirrors to focus and deflect x-rays, zone plates to form images, and diffraction gratings to analyze x-rays into their spectral components. X-ray optics is important in many fields, including x-ray astronomy, biology, medical research, thermonuclear fusion, and x-ray microlithography. It is essential to the construction of instruments that manipulate and analyze x-rays from synchrotrons and particle storage rings for synchrotron radiation research. See GEOMETRICAL OPTICS; OPTICS; PHYSICAL OPTICS; X-RAYS.

When W. C. Roentgen discovered x-rays in 1895, he unsuccessfully attempted to reflect, refract, and focus them with mirrors, prisms, and lenses of various materials. The reason for his lack of success became evident after it was established that x-rays are electromagnetic waves of very short wavelength for which the refractive index of all materials is smaller than unity by a only a small decrement. In addition, x-rays are absorbed by materi-

als. The refractive index can be written as a complex quantity, as in Eq. (1), where  $1 - \delta$  represents the real part,  $n$ , of the

$$\tilde{n} = 1 - \delta - i\beta \quad (1)$$

refractive index and  $\beta$  is the absorption index. These quantities are strongly dependent on the wavelength of the x-rays and the material. X-rays of wavelength about 0.1 nanometer or less are called hard x-rays and are relatively penetrating, while x-rays of wavelength 1–10 nm are less penetrating and are called soft x-rays. Radiation in the wavelength range 10–50 nm, called the extreme-ultraviolet (EUV) region, is very strongly absorbed by most materials. Values of  $\delta$  remain very small throughout the x-ray and extreme-ultraviolet regions with the consequence that radiation is very weakly refracted by any material. Thus lenses for x-rays would have to be very strongly curved and very thick to achieve an appreciable focusing effect. However, because the absorption index,  $\beta$ , is so high in comparison, such thick lenses would absorb most of the incident radiation, making such lenses impractical. See ABSORPTION OF ELECTROMAGNETIC RADIATION; REFRACTION OF WAVES; ULTRAVIOLET RADIATION.

If radiation is incident normally (that is, perpendicular) to a surface between two media of differing refractive index, the fraction of the energy that is reflected is  $1/4(\delta^2 + \beta^2)$ . This is clearly impractically small for a normal-incidence mirror for x-rays. However, useful mirrors can be constructed by using the principle of total reflection. If electromagnetic waves are incident on the boundary between one material of refractive index  $n_1$  and another of lower refractive index  $n_2$ , there exists an angle of incidence  $I_c$ , called the critical angle, given by Eq. (2). If the angle of incidence

$$\sin I_c = \frac{n_2}{n_1} \quad (2)$$

(the angle of incident radiation with respect to the normal to the surface) is greater than this critical angle, all the wave energy is reflected back into the first medium. This phenomenon can be seen when looking upward into an aquarium tank; objects in the tank are reflected in the surface of the water, which acts as a perfect mirror. An analogous situation occurs for x-rays. Since the refractive index for all materials is slightly less than 1, x-rays incident from vacuum (or air) on a polished surface of, say, a metal encounter a lower refractive index and there exists a critical angle given by  $\sin I_c = 1 - \delta$ . Since  $\delta$  is very small,  $I_c$  is very close to  $90^\circ$ . In this case the angle of incidence is customarily measured from the tangent to the surface rather than from the normal, and the angle  $\theta_c = 90^\circ - I_c$  is termed the angle of glancing (or grazing) incidence. This angle is typically in the range  $0.1\text{--}1.0^\circ$ . See REFLECTION OF ELECTROMAGNETIC RADIATION.

Although the reflectivity of surfaces at glancing angles greater than the critical angle is very small, this reflectivity can be enhanced by depositing a stack of ultrathin films having alternately high and low values of  $\delta$  on the surface. The individual thicknesses of these films is adjusted so that the reflections from each interface add in phase at the top of the stack in exact analogy to the multilayer mirrors used for visible light. However, whereas visible multilayers require film thicknesses of hundreds of nanometers, in the x-ray region the thickness of each film must be between 1 and 100 nm. Such ultrathin films can be made by a variety of vacuum deposition methods, commonly sputtering and evaporation. The response of these artificial multilayers is strongly wavelength-selective. See X-RAY DIFFRACTION.

As a coating for glancing-incidence optics, multilayers allow a mirror to be used at a shorter wavelength (higher x-ray energy) for a given glancing angle, increasing the projected area and thus the collection efficiency of the mirror. At wavelengths longer than 3 or 4 nm, multilayer mirrors can be used to make normal-incidence mirrors of relatively high reflecting power. For example, stacks consisting of alternating layers of molybdenum and silicon can have reflectivities as high as 65% at wavelengths of 13 nm and longer. These mirrors have been used to construct optical systems that are exact analogs of mirror optics

used for visible light. For example, normal-incidence x-ray telescopes have photographed the Sun's hot outer atmosphere at wavelengths of around 18 nm. Multilayer optics at a wavelength of 13.5 nm can be used to perform x-ray microlithography by the projection method to print features of dimensions less than 100 nm.

Crystals are natural multilayer structures and thus can reflect x-rays. Many crystals can be bent elastically (mica, quartz, silicon) or plastically (lithium fluoride) to make x-ray focusing reflectors. These are used in devices such as x-ray spectrometers, electron-beam microprobes, and diffraction cameras to focus the radiation from a small source or specimen on a film or detector. Until the advent of image-forming optics based on mirrors and zone plates, the subject of x-ray diffraction by crystals was called x-ray optics. See X-RAY CRYSTALLOGRAPHY; X-RAY SPECTROMETRY.

Zone plates are diffraction devices that focus x-rays and form images. They are diffracting masks consisting of concentric circular zones of equal area, and are alternately transparent and opaque to x-rays. Whereas mirrors and lenses focus radiation by adjusting the phase at each point of the wavefront, zone plates act by blocking out those regions of the wavefront whose phase is more than a half-period different from that at the plate center. Thus a zone plate acts as a kind of x-ray lens. Zone-plate microscopy is the most promising candidate method for x-ray microscopy of biological specimens. See DIFFRACTION. [J.H.U.]

**X-ray powder methods** Physical techniques used for the identification of substances, and for other types of analyses, principally for crystalline materials in the solid state. In these techniques, a monochromatic beam of x-rays is directed onto a polycrystalline (powder) specimen, producing a diffraction pattern that is recorded on film or with a diffractometer. This x-ray pattern is a fundamental and unique property resulting from the atomic arrangement of the diffracting substance. Different substances have different atomic arrangements or crystal structures, and hence no two chemically distinct substances give identical diffraction patterns. Identification may be made by comparing the pattern of the unknown substance with patterns of known substances in a manner analogous to the identification of people by their fingerprints. The analytical information is different from that obtained by chemical or spectrographic analysis. X-ray identification of chemical compounds indicates the constituent elements and shows how they are combined.

The x-ray powder method is widely used in fundamental and applied research; for instance, it is used in the analysis of raw materials and finished products, in phase-diagram investigations, in following the course of solid-state chemical reactions, and in the study of minerals, ores, rocks, metals, chemicals, and many other types of material. The use of x-ray powder diffraction methods to determine the actual atomic arrangement, which has been important in the study of chemical bonds, crystal physics, and crystal chemistry, is described in related articles. See X-RAY CRYSTALLOGRAPHY; X-RAY DIFFRACTION.

There are many types of powder diffractometer available ranging from simple laboratory instruments to versatile and complex instruments using a synchrotron source. Specialized instruments allow recording of diffraction patterns under nonambient conditions, including variable temperature, pressure, and atmosphere. Completely automated equipment for x-ray analysis is available. Most laboratory instruments consist of a high-voltage generator which provides stabilized voltage for the x-ray tube, so that the x-ray source intensity varies by less than 1%. A diffractometer goniometer is mounted on a table in front of the x-ray tube window. Electronic circuits use an x-ray detector to convert the diffracted x-ray photons to measurable voltage pulses, and to record the diffraction data. [R.Je.]

**X-ray spectrometry** A rapid and economical technique for quantitative analysis of the elemental composition of specimens. It differs from x-ray diffraction, whose purpose is

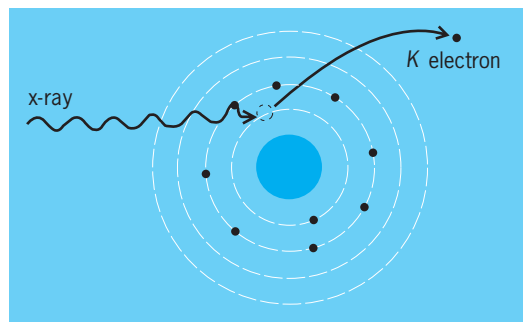

Removal of a *K* electron from an atom by a primary x-ray photon. (After L. S. Birks, *X-Ray Spectrochemical Analysis*, 2d ed., Wiley-Interscience, 1969)

the identification of crystalline compounds. It differs from spectrometry in the visible region of the spectrum in that the x-ray photons have energies of thousands of electronvolts and come from tightly bound inner-shell electrons in the atoms, whereas visible photons come from the outer electrons and have energies of only a few electronvolts.

In x-ray spectrometry the irradiation of a sample by high-energy electrons, protons, or photons ionizes some of the atoms, which then emit characteristic x-rays whose wavelength depends on the atomic number of the element, and whose intensity is related to the concentration of that element. Generally speaking, the characteristic x-ray lines are independent of the physical state (solid or liquid) and of the type of compound (valence) in which an element is present, because the x-ray emission comes from inner, well-shielded electrons in the atom. The illustration shows the removal of one of the innermost, *K*-shell, electrons by a high-energy photon. The photon energy must be greater than the binding energy of the electron; the difference in energy appears as the kinetic energy of the ejected electron. The *K* ionized atom is unstable, and one of the *L*- or *M*-shell electrons drops into the *K*-shell vacancy. As this transition occurs, a characteristic x-ray photon is emitted with an energy equal to the difference in energy between the *K* and the *L* (or *M*) shell, or an additional electron, called an Auger electron, is ejected from the atom. Either the x-rays or the Auger electrons may be used for analysis. See AUGER EFFECT.

X-ray spectrometry generally does not require any separation of elements before measuring, because the x-ray lines are easily resolved. However, preconcentration methods are sometimes useful as a means for improving the limit of detection. One limitation of x-ray spectrometry is the progressive difficulty of measurement below atomic number 11. See SPECTROSCOPY. [L.S.B.]

**X-ray telescope** An instrument designed to collect and detect x-rays emitted from a source outside the Earth's atmosphere and to resolve the x-rays into an image. Absorption by the atmosphere requires that x-ray telescopes be carried to high altitudes. Balloons are used for detection systems designed for higher-energy (hard) x-ray observations, whereas rockets and satellites are required for softer x-ray detectors. See X-RAY ASTRONOMY; X-RAYS.

**Image formation.** An image-forming telescope lens for x-ray wavelengths can be based either on the phenomenon of total external reflection at a surface where the index of refraction changes (grazing-incidence telescope) or on the principles of constructive interference (multilayer telescope).

In the case of x-rays, the index of refraction in matter is slightly less than unity. By application of Snell's law, the condition for total external reflection is that the radiation be incident at small grazing angles, less than a critical angle of about  $1^\circ$ , to the reflecting surface. Based on these properties, x-ray mirrors have been constructed which focus an image in two dimensions.

Various configurations of surfaces are possible. See REFLECTION OF ELECTROMAGNETIC RADIATION; REFRACTION OF WAVES.

A second type of x-ray telescope is based on the principles of constructive interference in extremely thin layers of material deposited on a mirror surface. Unlike the grazing-incidence telescope, multilayer telescopes do not require the x-rays to strike at shallow angles in order to be reflected. Instead these mirrors are similar to normal optical telescope mirrors where the incoming radiation strikes the mirror at nearly normal incidence to be reflected and focused. See INTERFERENCE OF WAVES.

The advantage of a multilayer mirror is that all of the mirror area is used in collecting the x-ray radiation, whereas the grazing-incidence telescopes have only a small projected area of the actual mirror surface collecting radiation. There is an offsetting disadvantage, as the multilayer mirror reflects x-rays only within a very narrow range of energy while the grazing-incidence mirror reflects over a broad range of energies. The effect is similar to using a narrow-band filter with an optical telescope, and in some cases this can be very useful. The first astronomical use of multilayer, normal-incidence x-ray telescopes was in photographing the Sun.

**Image detection.** The high angular resolution of the grazing-incidence telescope requires a camera that has correspondingly good spatial resolution. One type of detector uses microchannel plates and yields about 20 micrometers resolution for x-rays in the soft energy band (about 100–10,000 eV). The microchannel plate is an array of small hollow tubes or channels (about 10–15  $\mu\text{m}$  in diameter) which are processed to have high secondary electron yield from their inner walls.

The charge-coupled device (CCD) has been developed for x-ray imaging applications. This solid-state detector consists of microscopic silicon picture elements (pixels) in which electronic charges produced by the passage of an x-ray photon are collected. Typical charge-coupled devices have pixels that are 15–25  $\mu\text{m}$  on a side, and there are up to  $4096 \times 4096$  pixels on one such device. The charge-coupled device not only records the position of an event but can also yield information on the energy of the photon. See CHARGE-COUPLED DEVICES.

A position-sensitive proportional counter is a gas-filled counter in which x-rays are photoelectrically absorbed, yielding an electron which is detected by the ionization it produces in the gas. By operation of the counter in the proportional mode and use of planes of wires to localize the electrical signals, the position and amplitude of each event can be recorded. These detectors generally have lower spatial resolution (about 200  $\mu\text{m}$ ) than do microchannel plate or charge-coupled-device detectors, but they can be made larger in size and provide better energy resolution than microchannel plate detectors. See IONIZATION CHAMBER.

Another class of detectors consists of very low-temperature devices that detect the heat deposited in an absorber when an x-ray is stopped. These devices promise improved energy resolution and efficiency over a broad range of energies. See TELESCOPE.

[S.S.M.]

**X-ray tube** An electronic device used for the generation of x-rays. X-rays are produced in the x-ray tube by accelerating electrons to a high velocity by an electrostatic field and then suddenly stopping them by collision with a solid body, the so-called target, interposed in their path. The x-rays radiate in all directions from the spot on the target where the collisions take place. The x-rays are due to the mutual interaction of the fast-moving electrons with the electrons and positively charged nuclei which constitute the atoms of the target. Depending upon the method used in generating the electrons, x-ray tubes may all be classified in two general groups, gas tubes and high-vacuum tubes. See X-RAYS.

In gas tubes electrons are freed from a cold cathode by positive ion bombardment. For the existence of the positive ions a certain gas pressure is required without which the tube will allow no current to pass. Metals, such as platinum and tungsten, are

placed in the path of the electron beam to serve as the target. Concave metal cathodes are used to focus the electrons on a small area of the metal target and increase the sharpness of the resulting shadows on the fluorescent screen or the photographic film. Many designs of gas tubes have been built for useful application, particularly in the medical field.

The operational difficulties and erratic behavior of gas x-ray tubes are inherently associated with the gas itself and the positive ion bombardment that takes place during operation. The high-vacuum x-ray tube eliminates these difficulties by using other means of emitting electrons from the cathode. The original type of high-vacuum x-ray tube had a hot tungsten-filament cathode and a solid tungsten target. This tube permitted stable and reproducible operation with relatively high voltages and large masses of metals. A modern commercial hot-cathode high-vacuum x-ray tube is built with a liquid-cooled, copper-backed tungsten target. [E.E.C.]

**X-rays** X-rays, or roentgen rays, are electromagnetic waves in which periodically variable electric and magnetic fields are perpendicular to each other and to the direction of propagation. Thus they are identical in nature with visible light and all the other types of radiation that constitute the electromagnetic spectrum. In general, x-rays are generated as the result of energy transitions of atomic electrons caused by the bombardment of a material of high atomic weight by high-energy electrons. See ELECTROMAGNETIC RADIATION.

Following W. R. Röntgen's discovery of "a new kind of ray" in 1895, other scientists found the essential experimental conditions to prove that x-rays can be polarized, diffracted by crystals, refracted in prisms and in crystals, reflected by mirrors, and diffracted by ruled gratings. See X-RAY OPTICS.

The range of x-rays in the electromagnetic spectrum, as excited in x-ray tubes by the bombardment of anode targets by cathode electrons under a high accelerating potential, overlaps the ultraviolet range on the order of 100 nanometers on the long-wavelength side, and the shortest-wavelength limit moves downward as voltages increase. An accelerating potential of  $10^9$  volts, now readily generated, produces a wavelength of  $10^{-15}$  m ( $10^{-6}$  nm). An average wavelength used in research is 0.1 nm, or about 1/6000 the wavelength of yellow light. See X-RAY TUBE.

In diffraction, refraction, polarization, and interference phenomena, x-rays, together with all other related radiations, appear to act as waves. In other phenomena—such as the appearance of sharp spectral lines, a definite short-wavelength limit of the continuous "white" spectrum, the shift in wavelength of x-rays scattered by electrons in atoms (Compton effect), and the photoelectric effect—the energy seems to be propagated and transferred in quanta, called photons. See COMPTON EFFECT; ELECTRON DIFFRACTION; NEUTRON DIFFRACTION; PHOTOEMISSION; QUANTUM MECHANICS.

Important uses have been found for x-rays in many fields of scientific endeavor, for example, roentgen spectrometry and roentgen diffractometry. Extensive tables of the wavelengths of x-ray emission lines in series (*K*, *L*, *M*, and so on) and so-called absorption edges, characteristic of the chemical elements, afford the necessary information for chemical analyses, exactly as in the case of optical emission spectra and for derivation of theories of atomic structure to account for the origin of spectra. See HISTORADIOGRAPHY; MICRORADIOGRAPHY; RADIATION BIOLOGY; RADIOGRAPHY; RADIOLOGY; X-RAY CRYSTALLOGRAPHY; X-RAY DIFFRACTION; X-RAY FLUORESCENCE ANALYSIS; X-RAY MICROSCOPE; X-RAY POWDER METHODS. [G.L.C.]

**Xanthophyceae** A class of plants, comprising the yellow-green algae, in the chlorophyll *a-c* phyletic line (Chromophycota). Alternate names are Tribophyceae, derived from *Tribonema*, a filamentous member of the class, and Heterokontae, referring to the presence of two kinds of flagella on each motile



cell. The absence of starch is an important characteristic in distinguishing yellow-green algae from green algae, which they may resemble superficially in form and color. See ALGAE; CHROMOPHYCOTA.

Motile cells have two unequal flagella borne apically or laterally. One (usually the longer) is directed forward and is pleurone-matic (hairy); the other is directed backward and is acronematic (smooth). The compound zoospore (synzoospore) of *Vaucheria* is exceptional in having numerous pairs of slightly unequal smooth flagella. There are usually two chloroplasts in each motile cell, the ventral one with a reddish refractile eyespot at its anterior end. One or two contractile vacuoles occur at the anterior end of a motile cell. Cells in most Xanthophyceae are uninucleate, but in some genera they are multinucleate. The mitochondria have tubular cristae. Each vegetative cell contains one to many yellow-green, laminate or discoid, parietal chloroplasts.

Most Xanthophyceae occur in fresh water, especially soft water. Frequently, they are epiphytic on aquatic plants. The chief exception is *Vaucheria*, which has fresh-water, brackish-water, and marine species. Xanthophyceae also occur in and on soil and mud, in snow and ice, and on tree trunks and damp walls.

[P.C.Si.; R.L.Moe]

**Xenacanthida** An order of Paleozoic sharklike fishes abundant in fresh-water deposits of the Carboniferous and Early Permian. Although primitive in cranial structures, the pleuracanth differ notably from other sharks in several regards (see illustration). The teeth are two-pronged; there is a long spine

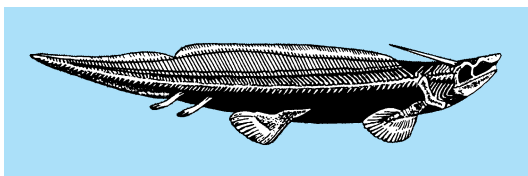

*Xenacanthus (Pleuracanthus)*, Carboniferous and Permian sharklike form; perhaps 2½ ft (75 cm) long. (After Fritsch)

projecting upward and backward from the posterior part of the braincase; the tail extends directly backward, in contrast with the upturned heterocercal caudal fin of other sharks; and the paired fins have the archipterygial skeletal pattern of a central axis and side branches, in contrast with a fan-shaped arrangement in typical sharks. See ELASMOBRANCHII.

[A.S.R.]

**Xenolith** A rock fragment enclosed in another rock, and of varying degrees of foreignness. Cognate xenoliths, for example, are pieces of rock that are genetically related to the host rock that contains them, such as pieces of a border zone in the interior of the same body. Included blocks of unrelated rocks are more deserving of the xenolith label. Such foreign rocks help establish the once molten condition of invading magma capable of incorporating and mixing an assemblage of unrelated rock inclusions. See LAVA; MAGMA.

Xenoliths tend to react with the enclosing magma, so that their constituent minerals become like those in equilibrium with the melt. Reaction is rarely complete, however. Even completely equilibrated xenoliths may be conspicuous because the equilibration process does not require either the texture or the proportions of the minerals in the xenolith to match those in the enclosing rock. See PLUTON.

Xenoliths may be angular to round, millimeters to meters in diameter, aligned or haphazard, and sharply or gradationally bounded. Xenoliths are present in most bodies of igneous rock. See IGNEOUS ROCKS.

[A.T.A.]

**Xenon** A chemical element, Xe, atomic number 54. It is a member of the family of noble gases, group 18 in the periodic table. Xenon is colorless, odorless, and tasteless; it is a gas under ordinary conditions (see table). See INERT GASES; PERIODIC TABLE.

Xenon is the only one of the nonradioactive noble gases which forms chemical compounds that are stable at room temperature. Xenon also forms weakly bonded clathrates with such substances as water, hydroquinone, and phenol. See CLATHRATE COMPOUNDS.

#### Physical properties of xenon

Property	Value
Atomic number	54
Atomic weight (atmospheric xenon only)	131.30
Melting point (triple point)	-111.8°C (-169.2°F)
Boiling point at 1 atm pressure	-108.1°C (-162.6°F)
Gas density at 0°C and 1 atm pressure, g/liter	5.8971
Liquid density at its boiling point, g/ml	3.057
Solubility in water at 20°C, ml xenon (STP) per 1000 g water at 1 atm partial pressure of xenon	108.1

The three fluorides, XeF<sub>2</sub>, XeF<sub>4</sub>, and XeF<sub>6</sub>, are thermodynamically stable compounds at room temperature, and they may be prepared simply by heating mixtures of xenon and fluorine at 300–400°C (570–750°F).

The reaction of XeF<sub>6</sub> with water gives XeOF<sub>4</sub>; if the reaction is allowed to continue, XeO<sub>3</sub> is formed. XeO<sub>3</sub> is a colorless, odorless, and dangerously explosive white solid of low volatility. Gaseous xenon tetroxide, XeO<sub>4</sub>, is formed by the reaction of sodium perxenate, Na<sub>4</sub>XeO<sub>6</sub>, with concentrated H<sub>2</sub>SO<sub>4</sub>. The vapor pressure of XeO<sub>4</sub> is about 3.3 kPa at 0°C (32°F). It is unstable and has a tendency to explode.

Xenon is produced commercially in an air-separation plant. The air is liquefied and distilled. The oxygen is redistilled; the least volatile portion contains small amounts of xenon and krypton, which are adsorbed on silica gel directly from the liquid oxygen. The crude xenon and krypton thus obtained are separated and further purified by distillation and selective absorption, at controlled low temperatures, on activated carbon. Remaining impurities are removed by passing the xenon over hot titanium, which reacts with all but the inert gases. See AIR SEPARATION.

Xenon is used to fill a type of flashbulb used in photography and called an electronic speed light. These bulbs produce a white light with a good balance of all the colors in the visible spectrum, and can be used 10,000 times or more before burning out.

A xenon-filled arc lamp gives a light intensity approaching that of the carbon arc; it is particularly valuable in projecting motion pictures. See VAPOR LAMP.

An important development in high-energy physics was the detection of nuclear radiation, such as gamma rays and mesons, by bubble chambers, in which a liquid is kept at a temperature just above its boiling point. Nucleation by the radiation results in bubble formation along the path of the particle. The tracks made by the particles are then photographed. Liquid xenon is one of the liquids used in these bubble chambers.

Xenon is used to fill neutron counters, x-ray counters, gas-filled thyratrons, and ionization chambers for cosmic rays; it is also used in high-pressure arc lamps to produce ultraviolet radiation.

Between 3 and 5% of the fissions in a nuclear reactor using uranium as fuel lead to the formation of xenon-135. [A.W.F.]

**Xenophyphorida** An order of Protozoa in the subclass Granuloreticulosia. The group includes deep-sea forms which are multinucleate at maturity. They develop as discoid to fan-shaped or algalike branching forms (illus. *a* and *b*) covered with a hyaline organic layer and sometimes measuring 2 mm or more overall. The aggregate contains many tubes which vary in diameter and form netlike or branching patterns. The lack of detailed information makes the taxonomic status of these

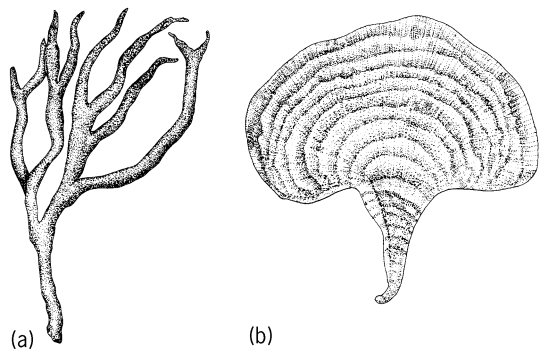

Xenophyophorids. (a) *Stanomma dendroides*. (b) *Stannophyllum zonarium*.

organisms somewhat uncertain. The genera included are *Psammetta*, *Stanomma*, and *Stannophyllum*. See GRANULORETICULOSIA. [R.P.H.]

**Xenungulata** An order of large, primitive, digitigrade, hoofed, tapirlike mammals with relatively short, slender limbs and five-toed feet with broad, flat phalanges. They are restricted to the Paleocene deposits of Brazil and Argentina. Only one genus (*Carodnia*) constitutes the single family (Carodniidae) in the order. The dentition is complete with strong, procumbent, chisel-shaped incisors, strong sharp-pointed canines, and low-crowned cheek teeth with bilophodont molars. See DENTITION; EUTHERIA.

The affinities of the Xenungulata remain uncertain. Affinities with the Dinocerata are strongly supported by the dental characteristics, but the structure of the tarsus suggests that the xenungulates had common ancestry with the Pyrotheria, to which they were tentatively assigned originally. See DINO CERATA; PYROTHERIA. [G.T.J.; E.C.O.]

**Xiphosurida** An order of the subclass Xiphosura in the class Merostomata. These "sword-tailed" arthropods have three distinct body divisions: a prominent horseshoe-shaped, fused head and thorax, the prosoma; a segmented "abdomen," or opisthosoma; and a spikelike terminal segment, the telson. The Xiphosurida have an extensive fossil record. The two suborders, Synziphosurina and Limulina, span over 500,000,000 years of evolution. The Synziphosurina usually lacked compound eyes. Some species had a distinct axial, or cardiac, region, free segments in the opisthosoma, and a broad, short telson. Superfamilies Belinuracea and Limulacea of the Limulina have the clearly recognizable horseshoe "crab" form.

The carapace (test or shell) is composed of chitin, strengthened internally in the adults by bridgelike struts within the shell margins. Sensory structures on the carapace include chemoreceptors for taste on the bases of the legs and a pair of simple

eyes, or ocelli. The multilensed compound eyes form mosaic images and are sensitive to polarized light. The organ systems, except the peripheral blood vessels and nerves, digestive, and reproductive glands, which branch extensively into the lateral portions of the prosoma, are mainly within the prominent axial region. This region contains the musculature of the paired appendages, hinge, and telson, the digestive tube, the coxal (excretory) gland, and the respiratory, central circulatory, and nervous structures. The dorsally situated tubular heart lies within a sinus which receives venous blood from the book gills, the respiratory structures, and the body. The central nervous system and the major nerve branches are sheathed by arteries. A plate of "cartilaginous" chitin, the endocranium, forms a roof over the brain. See MEROSTOMATA. [C.N.Sh.]

**Xylem** The principal water-conducting tissue and the chief supporting system of higher plants. This tissue and the associated phloem constitute the vascular system of vascular plants. Xylem is composed of various kinds of cells, living or nonliving. The structure of these cells differs in their functions, but characteristically all have a rigid and enduring cell wall that is well preserved in fossils.

In terms of their functions, the kinds of cells in xylem are those related principally to conduction and support, tracheids; to conduction, vessel members; to support, fibers; and to food storage, parenchyma. Vessel members and tracheids are often called tracheary elements. The cells in each of the four categories vary widely in structure. See PARENCHYMA.

Xylem tissues arise in later stages of embryo development of a given plant and are added to by differentiation of cells derived from the apical meristems of roots and stems. Growth and differentiation of tissues derived from the apical meristem provide the primary body of the plant, and the xylem tissues formed in it are called primary. Secondary xylem, when present, is produced by the vascular cambium. See LATERAL MERISTEM.

In the trade, softwood is a name for xylem of gymnosperms (conifers) and hardwood for xylem of angiosperms. The terms do not refer to actual hardness of the wood. Woods of gymnosperms are generally composed only of tracheids, wood parenchyma, and small rays, but differ in detail. Resin ducts are present in many softwoods. Woods of angiosperms show extreme variation in both vertical and horizontal systems, but with few exceptions have vessels. [V.I.C.; K.E.]

**Xylose** A pentose sugar, referred to in the early literature as L-xylose. It is present in many woody materials. The polysaccharide xylan, which is closely associated with cellulose, consists practically entirely of D-xylose. Corncobs, cottonseed hulls, pecan shells, and straw contain considerable amounts of this sugar. This pentose sugar is also a component of the hemicelluloses and the rare disaccharide, primeverose. See CARBOHYDRATE; POLYSACCHARIDE. [W.Z.H.]

# Y

**Y-delta transformations** Electrically equivalent networks with three terminals, one being connected internally by a Y configuration and the other being connected internally by a  $\Delta$  configuration.

If a network connects three terminals with one another, it is called a three-terminal network. The simplest configurations of three-terminal networks are the Y or star (illus. a) and the  $\Delta$  or mesh (illus. b).

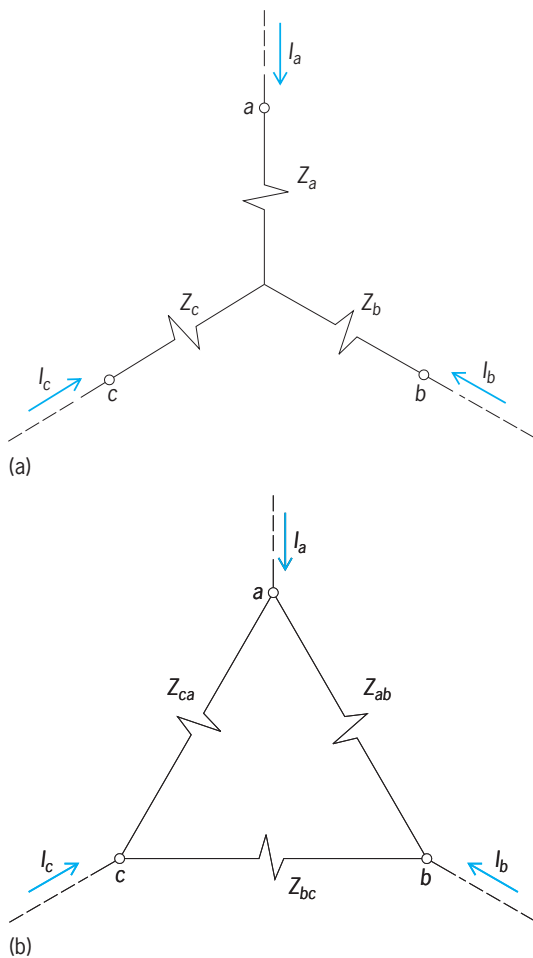

Three-terminal networks: (a) Y or star, (b)  $\Delta$  or mesh.

If a given three-terminal network, passive and linear, has a Y configuration, it is possible to determine an equivalent  $\Delta$  network that could be substituted for the Y without changing the relations of voltage and current at the network terminals, or elsewhere external to the network. Similarly, if a  $\Delta$  network is given, an equivalent Y network can be found. Impedances of equivalent networks are usually functions of frequency, and realization of these impedances by use of physically possible elements is usually limited to a single frequency. [H.H.Sk.]

**Yagi-Uda antenna** An antenna in which the gain of a single dipole element is enhanced by placing a reflector element behind the dipole (the driver) and one or more director elements in front of it (see illustration). It was invented in 1926 by H. Yagi and S. Uda in Japan. The gain is slightly increased by the reflector and further enhanced by the first director element. Additional director elements further increase the gain and improve the front-to-back ratio, up to a point of diminishing returns. This type of antenna has traditionally been used for local television reception. Its variants have found applications in the more modern communication systems at higher frequencies and smaller sizes, and have even been adapted to printed-circuit techniques in some applications. The same electromagnetic induction principle used in such linear elements can be applied to loop and disk elements as well with similar results. See DIRECTIVITY; ELECTROMAGNETIC INDUCTION; GAIN; PRINTED CIRCUIT.

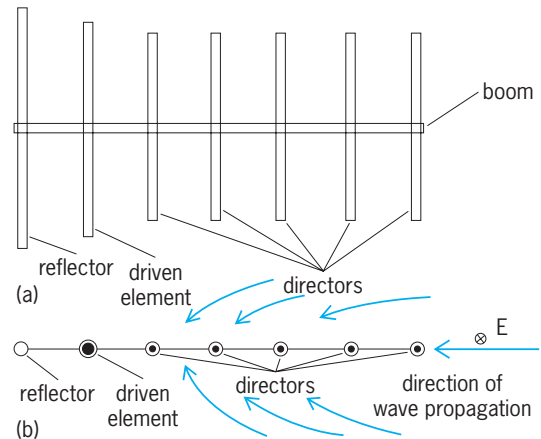

Yagi-Uda antenna. Typical radiation patterns are shown. (a) Side view with radiation pattern in the E plane (the plane containing the electric field). (b) Top view with radiation pattern in the H plane (the plane containing the magnetic field).

Since these antennas can be made highly directive with good radiation efficiency, they have found new applications and new manufacturing techniques with miniaturization. They can be printed on microwave circuit substrates with high dielectric constants, which reduces their size even further. The parasitic electromagnetic coupling demonstrated in the Yagi-Uda antenna has been adapted to many new types of miniaturized antennas applicable to mobile communication devices in wide use, and will be used in future wireless Internet devices. See ANTENNA (ELECTROMAGNETISM); INTERNET; MICROWAVE SOLID-STATE DEVICES; MOBILE RADIO. [J.S.I.]

**Yak** A heavily built mammal, *Poepagus grunniens*, of the order Artiodactyla that has been domesticated but still exists in the wild state in Tibet and high areas of China, living at elevations of 13,000–20,000 ft (about 4–6 km). It is related to the bison, which it resembles anatomically in having 14 pairs of ribs instead of the 13 pairs more usual of the order. Economically, it is probably the most important animal in Tibet, being used as

## 2410 Yaw indicator

a beast of burden and for its excellent milk. The dung is used as fuel, the hair is used for making cloth, and the flesh is eaten. Calving occurs in the autumn after a gestation period of about 10 months. See ARTIODACTYLA; BISON. [C.B.C.]

**Yaw indicator** An aircraft instrument that provides a measure of the sideslip or yaw of the aircraft, defined as the angular measure of the relative wind in relation to a vertical plane passing through the longitudinal center of the aircraft. This device is not common to production aircraft, being found in only a few vertical takeoff and landing (VTOL) aircraft which operate in the low-speed regime. The measurement of yaw is accomplished either by a balanced vane which aligns with the wind, or through a set of pressure sensors that determine the difference in static pressure on each side of the vertical plane and hence the sideslip. The device provides equivalent information in the lateral-directional (yaw and roll) axis to the angle of attack in the longitudinal (pitch) axis. See AIRCRAFT INSTRUMENTATION; VERTICAL TAKEOFF AND LANDING (VTOL). [G.W.W.]

**Yaws** An infectious disease of humans caused by the spirochete *Treponema pertenue*. It is also known as frambesia and is largely confined to the tropics. Usually yaws is contracted in childhood by direct contact or from small flies feeding in succession on infected lesions and open wounds. No race or age possesses natural immunity. [T.B.T.]

**Year** The period of the Earth's revolution around the Sun. This period can be measured in several ways.

The most commonly used type of year, known as the tropical year, is the mean period for the Sun to go around the sky from one vernal equinox to the next. The tropical year varies slightly over time. Tropical year 2000 was approximately 365.242190 mean solar days, or 365 d 5 h 48 m 45.2 s. Seasons repeat with intervals of a tropical year.

The sidereal year is the average period of the Earth's revolution around the Sun until the Earth-Sun line returns to the same direction in space as measured by the star background. A sidereal year is approximately 365.25636 mean solar days long, or 365 d 6 h 9 m 10 s.

The anomalistic year is the average period of the Earth's return to perihelion in its orbit around the Sun. An anomalistic year is approximately 365.25964 days, or 365 d 6 h 13 m 53 s.

An eclipse year is the duration between alternate eclipse seasons, measured as the interval between the Moon passing alternate nodes. An eclipse year lasts only 346.62005 days, or 346 d 14 h 52 m 52 s.

A Gaussian year, defined as the period derived from Kepler's law for 1 astronomical unit, is 365.25690 days, or 365 d 6 h 9 m 56 s. See ASTRONOMICAL UNIT; KEPLER'S LAWS.

The term "year" is also used for the period of the orbit of other planets, both inside the solar system and around other stars. For example, a Jupiter year is 5.2 Earth years long. See TIME. [J.M.P.]

**Yeast** A collective name for those fungi which possess, under normal conditions of growth, a vegetative body (thallus) consisting, at least in part, of simple, single cells. The cells making up the thallus occur in pairs, in groups of three, or in straight or branched chains consisting of as many as 12 or more cells. Vegetative reproduction is characterized by budding or fission. Sexual reproduction also occurs in yeast, and is differentiated from that of other fungi by sexual states that are not enclosed in a fruiting body. Yeasts are a phylogenetically diverse group of organisms that occur in two divisions of fungi (Ascomycotina and Basidiomycotina) and 100 genera. The 700 or more species that have been described possibly represent only 1% of the species in nature, so the majority of the yeasts have yet to be discovered. Yeast plays a large part in industrial fermentation processes such as the production of industrial enzymes and chemicals, food products, industrial ethanol, and malt beverage and wine; in

diseases of humans, animals and plants; in food spoilage; and as a model of molecular genetics. See DISTILLED SPIRITS; FOOD MICROBIOLOGY; GENETIC ENGINEERING; MALT BEVERAGE; MEDICAL MYCOLOGY; WINE.

The shape and size of the individual cells of some species vary slightly, but in other species the cell morphology is extremely heterogeneous. The shape of yeast cells may be spherical, globose, ellipsoidal, elongate to cylindrical with rounded ends, more or less rectangular, pear-shaped, apiculate or lemon-shaped, ogival or pointed at one end, or tetrahedral. The diameter of a spherical cell may vary from 2 to 10 micrometers. The length of cylindrical cells is often 20–30  $\mu\text{m}$  and, in some cases, even greater.

The asexual multiplication of yeast cells occurs by a budding process, by the formation of cross walls or fission, and sometimes by a combination of these two processes. Yeast buds are sometimes called blastospores or blastoconidia. When yeast reproduces by a fission mechanism, the resulting cells are termed arthrospores or arthroconidia.

Yeasts are categorized into two groups, based on their methods of sexual reproduction: the ascomycetous (Division Ascomycotina) and basidiomycetous (Division Basidiomycotina) yeasts.

The sexual spores of the ascomycetous yeasts are termed ascospores, which are formed in simple structures, often a vegetative cell. Such asci are called naked asci because of the absence of an ascocarp, which is a more complex fruiting body found in the higher Ascomycetes. If the vegetative cells are diploid, a cell may transform directly into an ascus after the  $2n$  nucleus undergoes a reduction or meiotic division. See ASCOMYCOTA.

Certain yeasts have been shown to be heterothallic; that is, sporulation occurs when strains of opposite mating type (usually indicated by "a" and  $\alpha$ ) are mixed on sporulation media. However, some strains may be homothallic (self-fertile), and reduction division and karyogamy (fusion of two haploid nuclei) take place during formation of the sexual spore. Yeasts that produce sporogenous cells represent the teleomorphic form of the life cycle. In cases, in which sexual cycles are unknown, the yeast represents the asexual or anamorphic form. A species of yeast may be originally discovered in the anamorphic form and named accordingly; subsequently, the sexual state may be found and a name applied to represent the teleomorph. Consequently, the anamorphic and teleomorphic names will differ.

Basidiospores and teliospores are the sexual spores that are produced in the three classes of basidiomycetous yeasts: Urediniomycetes, Hymenomycetes, and Ustilaginomycetes. Sexual reproduction and life cycle in these yeasts is typical of other basidiomycetes in that it can include both unifactorial (bipolar) and bifactorial (tetrapolar) mating systems. See BASIDIOMYCOTA.

Some yeasts have the ability to carry out an alcoholic fermentation. Other yeasts lack this property. In addition to the fermentative type of metabolism, fermentative yeasts as a rule have a respiratory type of metabolism, whereas nonfermentative yeasts have only a respiratory, or oxidative, metabolism. Both reactions produce energy, with respiration producing by far the most, which is used in part for synthetic reactions, such as assimilation and growth. Part is lost as heat. In addition, small or sometimes large amounts of by-products are formed, including organic acids, esters, aldehydes, glycerol, and higher alcohols. When a fermenting yeast culture is aerated, fermentation is suppressed and respiration increases. This phenomenon is called the Pasteur effect. See FERMENTATION.

Yeasts are ubiquitous in nature. They exist on plants and animals; in waters, sediments, and soils; and in terrestrial, aquatic, and marine habitats. Yeasts require oxygen for growth and reproduction; therefore they do not inhabit anaerobic environments such as anoxic sediments. Many species have highly specific habitats, whereas others are found on a variety of substrates in nature. [J.W.Fe.; H.J.P.]

**Yeast infection** An infection mainly caused by fungi of the genus *Candida*. Although members of the genus *Candida*

continue to be the most common agents of yeast infections, numerous nosocomial (related to medical treatment) factors have altered this etiologic pattern over the last 20 years. Reports in professional publications have described over 200 species in 25 yeast genera as being associated with human infections. See FUNGAL INFECTIONS; FUNGI; YEAST.

**Etiologic agents.** *Candida*, species particularly *C. albicans*, cause almost 70% of all yeast infections. However, recent changes in medical practices such as the use of broad-spectrum antibiotics, steroids, and immunosuppressive drugs, along with the recognition of new and highly debilitating diseases [for example, acquired immune deficiency syndrome (AIDS)], have increased the diversity of the agents of these infections. Species that were once rarely encountered in patient specimens (for example, *C. parapsilosis*, *C. krusei*, and *C. guilliermondii*) are being isolated with increased frequency. Equally important is the fact that yeasts that have never been described as the cause of human infections, (for example, *Blastoschizomyces capitatus*, *C. dubliniensis*, and *Trichosporon cutaneum*) are now being associated, albeit rarely, with human disease. See ACQUIRED IMMUNE DEFICIENCY SYNDROME (AIDS); MEDICAL MYCOLOGY; OPPORTUNISTIC INFECTIONS.

**Predisposing factors.** Since yeasts are not as adept as other microbial pathogens at evading or overwhelming the body's immune defenses, they generally require some disruption in the natural protective mechanisms of humans to initiate an infection. Minor breaks in the skin (such as those caused by a cut or scrape) to more significant disruptions in the integrity of the skin (as created by the delivery of medications or nutrients through intravenous catheters) can provide the means by which the yeasts on human skin may enter the body and potentially initiate an infection. The use of broad-spectrum antibacterial agents eliminates a large portion of the normal bacterial flora, allowing the yeasts in the mouth and intestines to grow rapidly and seed the blood to create a temporary benign infection or a chronic, potentially life-threatening infection. Natural hormonal imbalances as created by pregnancy or diabetes mellitus, as well as those caused by the use of medications such as corticosteroids, depress the immune system and predispose the individual to possible yeast infections. The common use of immunosuppressive drugs, and the depressed immunity associated with newer human diseases such as AIDS cause a decrease in the immune system's ability to prevent and eliminate yeast infections. Finally, the longer human life expectancy created by modern medical practices has contributed to an ever-increasing population of senior citizens with naturally lowered resistance to all forms of microbial infections. See IMMUNOSUPPRESSION.

**Clinical symptomology.** Although yeast infections usually affect the skin and mucous membranes, the illness can take several different forms, each with different symptoms. For example, in newborns and infants, candidiasis can appear as reddening and blisterlike lesions of skin infections (diaper rash), or it can present as white-gray lesions on the mucosal tissue lining the oral cavity (thrush). The symptoms observed in the vast majority of yeast infections mimic those of other microbial pathogens and thus are generally of little value in establishing their etiology. The diagnosis of most yeast infections involves obtaining detailed medical histories from patients, conducting extensive physical examinations, analyzing clinical laboratory data, and utilizing the education, training, and experience of the attending physicians and infectious disease specialists. See CLINICAL MICROBIOLOGY.

**Treatment.** The introduction of the first clinically effective antifungal antibiotic (nystatin) closely followed the use of antibacterial drugs (penicillin). However, nystatin was found to be effective only when brought into direct contact with the infectious agent. The broad-spectrum and fungicidal (killing fungi) activity of amphotericin B, another member of the same chemical family, maintains its use as the drug of choice for several yeast infections and as the antifungal of last resort when all other anti-

otics have failed. Two closely related families of drugs, the azoles and triazoles, were introduced in the early 1970s and quickly established themselves as the first-line antibiotics for yeast infections. However, the newer triazoles are fungistatic (limiting growth) rather than fungicidal. As a result, recurrences of infection happen frequently once therapy is discontinued. Although new antifungal antibiotics continue to be introduced, the perfect drug with broad-spectrum and fungicidal activity, easy delivery, and limited side effects has yet to be found. See ANTIBIOTIC; ANTIMICROBIAL AGENTS; FUNGISTAT AND FUNGICIDE; PENICILLIN. [I.F.S.]

**Yellow fever** An acute, febrile, mosquito-borne viral disease characterized in severe cases by jaundice, albuminuria, and hemorrhage. Inapparent infections also occur.

The agent is a flavivirus, an arbovirus of group B. The virus multiplies in mosquitoes, which remain infectious for life. After the mosquito ingests a virus-containing blood meal, an interval of 12–18 days (called the extrinsic incubation period) is required for it to become infectious. See ANIMAL VIRUS; ARBOVIRAL ENCEPHALITIDES.

The virus enters the body through a mosquito bite and multiplies in lymph nodes, circulates in the blood, and localizes in the liver, spleen, kidney, bone marrow, and lymph glands. The severity of the disease and the major signs and symptoms which appear depend upon where the virus localizes and how much cell destruction occurs. The incubation period is 3–6 days. At the onset, the individual has fever, chills, headache, and backache, followed by nausea and vomiting. A short period of remission often follows. On about the fourth day, the period of intoxication begins with a slow pulse relative to a high fever and moderate jaundice. In severe cases, there are high levels of protein in the urine, and manifestations of bleeding appear; the vomit may be black with altered blood; and there is an abnormally low number of lymphocytes in the blood. When the disease progresses to the severe stage (black vomit and jaundice), the mortality rate is high. However, the infection may be mild and go unrecognized. Diagnosis is made by isolation of the virus from the serum obtained from an individual as early as possible in the disease, or by the rise in serum antibody. See ANTIBODY; COMPLEMENT-FIXATION TEST; NEUTRALIZATION REACTION (IMMUNOLOGY).

There are two major epidemiological cycles of yellow fever: classical or urban epidemic yellow fever, and sylvan or jungle yellow fever. Urban yellow fever involves person-to-person transmission by *Aedes aegypti* mosquitoes in the Western Hemisphere and West Africa. This mosquito breeds in the accumulations of water that accompany human settlement. Jungle yellow fever is primarily a disease of monkeys. In South America and Africa, it is transmitted from monkey to monkey by arboreal mosquitoes (*Haemagogus* and *Aedes* species) that inhabit the moist forest canopy. The infection in animals ranges from severe to inapparent. Persons who come in contact with these mosquitoes in the forest can become infected. Jungle yellow fever may also occur when an infected monkey visits a human habitation and is bitten by *A. aegypti*, which then transmits the virus to a human.

Vigorous mosquito abatement programs have virtually eliminated urban yellow fever. However, with the speed of modern air travel, the threat of a yellow fever outbreak exists where *A. aegypti* is present. An excellent attenuated live-virus vaccine is available. See VACCINATION. [J.L.Me.]

**Yersinia** A genus of bacteria in the Enterobacteriaceae family. The bacteria appear as gram-negative rods and share many physiological properties with related *Escherichia coli*. Of the 11 species of *Yersinia*, *Y. pestis*, *Y. enterocolitica*, and *Y. pseudotuberculosis* are etiological agents of human disease. *Yersinia pestis* causes flea-borne bubonic plague (the black death), an extraordinarily acute process believed to have killed over 200 million people during human history. Enteropathogenic *Y. pseudotuberculosis* and *Y. enterocolitica* typically cause mild chronic enteric infections. The remaining species either

promote primary infection of fish (*Y. ruckeri*) or exist as secondary invaders or inhabitants of natural environments (*Y. al-douae*, *Y. bercovieri*, *Y. frederiksenii*, *Y. intermedia*, *Y. kristensenii*, *Y. mollaretii*, and *Y. rohdei*). See MEDICAL BACTERIOLOGY; PLAGUE. [R.R.B.]

**Yew** A genus of evergreen trees and shrubs, *Taxus*, with a fruit containing a single seed surrounded by a scarlet, fleshy, cuplike envelope (aril). The leaves are flat and acicular (needle-shaped), green below, with stalks extending downward on the stem. The only native American species of commercial importance is the Pacific yew (*T. breuifolia*), a medium-sized tree of the Pacific Coast and northern Rocky Mountain regions. Although it is not a common tree, its wood is sometimes used for poles, paddles, bows, and small cabinetwork.

The English yew (*T. baccata*), native in Europe, North Africa, and northern Asia, and the Japanese yew (*T. cuspidate*) are much cultivated in the United States as evergreen ornamentals. See TAXALES. [A.H.G./K.P.D.]

**Ylide** A variety of organic compounds that contain two adjacent atoms bearing formal positive and negative charges, and in which both atoms have full octets of electrons. Heteroatoms most commonly utilized as the positive atom are phosphorus, nitrogen, sulfur, selenium and oxygen, and the negative atom usually involves carbon, nitrogen, oxygen, or sulfur. The ylide may be in an alicyclic or cyclic environment, and in the latter the ylide function may be endocyclic or exocyclic. Ylides most useful in organic synthesis are those containing phosphorus or sulfur and an adjacent carbanion.

A phosphorus ylide is known as a phosphorane. Ylides of this type are highly reactive. Sulfur-containing ylides ( $\pi$ -sulfuranes) are of two types, sulfonium ylides and oxosulfonium ylides, which differ in having an oxygen atom attached to the sulfur in the latter. See REACTIVE INTERMEDIATES.

The ylide function may also be incorporated into heterocyclic systems. For example, the meso-ionic sydnone molecule contains an azomethine imine ylide, and the mesomeric betaine derived from 3-hydroxypyridine contains an azomethine ylide. These ylides are often referred to as masked ylides. [K.T.P.]

**Yolk sac** An extraembryonic membrane which extends through the umbilicus in vertebrates. In some elasmobranchs, birds, and reptiles, it is laden with yolk which serves as the nutritive source of embryonic development.

In mammals, as in birds, the yolk sac generally develops from extraembryonic splanchnopleure, and extends beneath the developing embryo. A blood vessel network develops in the mammalian yolk sac lining. Though these blood vessels are empty, they play an important role in absorbing nourishing food and oxygen from the mother. Thus, although the yolk sac in higher

mammals may be considered an evolutionary vestige from its yolk-egged ancestors, it still serves important functions in the young embryo. As the embryo ages, the yolk sac shrinks in size, and the allantois takes over the role of nutrition. See ALLANTOIS. [S.B.O.]

**Young's modulus** A constant designated  $E$ , the ratio of stress to corresponding strain when the material behaves elastically. Young's modulus is represented by the slope  $E = \Delta S / \Delta \epsilon$  of the initial straight segment of the stress-strain diagram. More correctly,  $E$  is a measure of stiffness, having the same units as stress: pounds per square inch or pascals. When stress and strain are not directly proportional,  $E$  may be represented as the slope of the tangent or the slope of the secant connecting two points on the stress-strain curve. The modulus is then designated as tangent modulus or secant modulus at stated values of stress. The modulus of elasticity applying specifically to tension is called Young's modulus. See ELASTICITY; HOOKE'S LAW; STRESS AND STRAIN. [W.J.K./W.G.B.]

**Ytterbium** A chemical element, Yb, atomic number 70, and atomic weight 173.04. Ytterbium is a metal element of the rare-earth group. There are 7 naturally occurring stable isotopes. See PERIODIC TABLE.

The common oxide,  $Yb_2O_3$ , is colorless and dissolves readily in acids to form colorless solutions of trivalent salts which are paramagnetic. Ytterbium also forms a series of divalent compounds. The divalent salts are soluble in water but react very slowly with water to liberate hydrogen.

The metal is best prepared by distillation. It is a silvery soft metal which corrodes slowly in air and resembles the calcium-strontium-barium series more than the rare-earth series. For a discussion of the properties of the metal and its salts see RARE-EARTH ELEMENTS. [F.H.Sp.]

**Yttrium** A chemical element, Y, atomic number 39, and atomic weight 88.905. Yttrium resembles the rare-earth elements closely. The stable isotope  $^{89}Y$  constitutes 100% of the natural element, which is always found associated with the rare earths and is frequently classified as one. See PERIODIC TABLE.

Yttrium metal absorbs hydrogen, and in alloys up to a composition of  $YH_2$  they resemble metals very closely. In fact, in certain composition ranges, the alloy is a better conductor of electricity than the pure metal.

Yttrium forms the matrix for the europium-activated yttrium phosphors which emit a brilliant, clear-red light when excited by electrons. The television industry uses these phosphors in manufacturing television screens.

Yttrium is used commercially in the metal industry for alloy purposes and as a "getter" to remove oxygen and nonmetallic impurities in other metals. For properties of the metal and its salts see RARE-EARTH ELEMENTS. [F.H.Sp.]

# Z

**Z transform** The preferred operational-calculus tool for analysis and design of discrete-time systems. (It should not be confused with the  $z$  transformation.) The role of the  $z$  transform with regard to discrete-time systems is similar to that of the Laplace transform for continuous systems. In fact, the Laplace transform is a specialized case of the  $z$  transform. The  $z$  transform is by far the more insightful tool, and the Laplace transform is just the limiting case of the  $z$  transform in a practical as well as a conceptual way. See CONTROL SYSTEMS; DIGITAL FILTER; LAPLACE TRANSFORM; LINEAR SYSTEM ANALYSIS.

It is useful to consider a band-limited real continuous signal,  $x(t)$ , with no significant amount of energy above a frequency,  $f_c$ . This signal is sampled at uniformly spaced intervals of time,  $T, 2T, 3T, \dots, nT, \dots$ , where the sampling interval,  $T$ , and the sampling frequency,  $f_s$ , are reciprocals of one another, and where  $f_s$  is greater than  $2f_c$ , a condition necessary for unambiguous interpretation of the sampled signal. If the common shorthand notation  $x(nT) = x_n$  is used, the definition of the  $z$  transform of  $x(t)$  is given by the equation

$$X(z) = x_0 + x_1 z^{-1} + x_2 z^{-2} + x_3 z^{-3} + \dots$$

The coefficient of  $z^{-p}$  is therefore the value of the  $p$ th sample of the time signal. This gives a great deal of physical insight to the use of the  $z$  transform, a feature not shared by the Laplace transform. The Laplace transform can be found by evaluating the limit of the  $z$  transform as  $T$  approaches zero. See ANALOG-TO-DIGITAL CONVERTER; INFORMATION THEORY. [S.A.Wh.]

**Zebra** Three species belonging to the family Equidae and indigenous to Africa. These animals are odd-toed ungulates (order Perissodactyla) which are monodactyl; that is, the middle digit is functional while the second and fourth digits are vestigial. The striped coat is considered to be an example of protective coloration since they live on open plains. Zebras are sociable and graze with other animals, such as deer, gnu, and ostriches. The gestation period is 13 months and a single young is born. The maximum life-span is 30 years. See PERISSODACTYLA. [C.B.C.]

**Zebu** A domestic breed of cattle, indigenous to India, belonging to the family Bovidae in the order Artiodactyla. This animal,

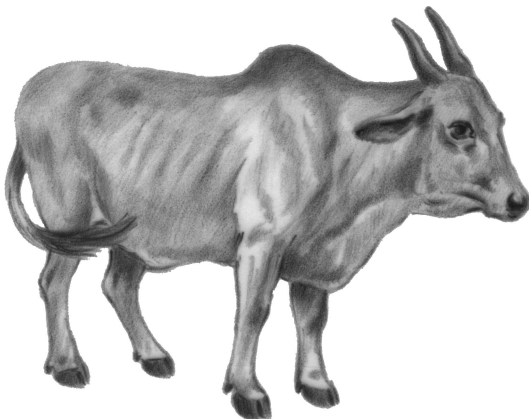

The zebu, or Brahman, characterized by a dorsal hump between the shoulders and loose skin which forms a dewlap under the chin.

*Bos indicus*, known as the Brahman in the United States, is protected as the sacred cow in India, where it is used as a draft animal as well as for milk. The ears are long and drooping (see illustration); the color is quite variable. One of the most notable cross breeds is the Santa Gertrudis, in which Brahman bulls are crossed with short-horn cows. This produces one of the heaviest beef breeds. See ARTIODACTYLA. [C.B.C.]

**Zeeman effect** A splitting of spectral lines when the light source being studied is placed in a magnetic field. Discovered by P. Zeeman in 1896, the effect furnishes information of prime importance in the analysis of spectra. Each kind of spectral term has its characteristic mode of splitting, and the types of terms are most definitely identified by this property. Furthermore, the effect allows an evaluation of the ratio of charge to mass of the electron and an evaluation of its precise magnetic moment.

The normal Zeeman effect is a splitting into two or three lines, depending on the direction of observation, as shown in the illustration. The light of these components is polarized in ways indicated in the illustration. The normal effect is observed for all lines belonging to singlet systems, those for which the spin quantum number  $S = 0$ . The change of frequency of the shifted components can be evaluated on classical electromagnetic principles.

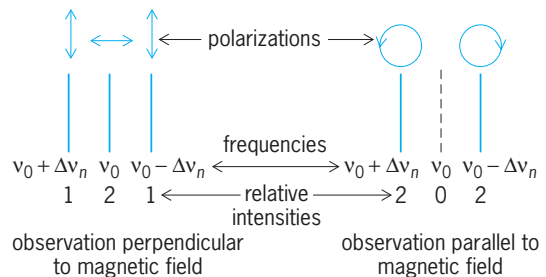

Triplet observed in normal Zeeman effect.  $\nu_0$  = unshifted frequency;  $\Delta\nu_n$  = frequency shift.

The anomalous Zeeman effect is a more complicated type of line splitting, so named because it did not agree with the predictions of classical theory. It occurs for any spectral line arising from a combination of terms of multiplicity greater than one. Since multiplicity in spectral lines is caused by the presence of a resultant spin vector  $S$  of the electrons, the anomalous effect must be attributed to a nonclassical magnetic behavior of the electron spin.

The quadratic Zeeman effect, which depends on the square of the field strength, is of two kinds. The first results from second-order terms, and the second from the diamagnetic reaction of the electron when revolving in large orbits.

The inverse Zeeman effect is the Zeeman effect of absorption lines. It is closely related to the Faraday effect, the rotation of plane-polarized light by matter situated in a magnetic field. See FARADAY EFFECT.

The Zeeman effect in molecules is, in general, so small as to be unobservable, even for molecules which have a permanent magnetic moment. An exception occurs for some light molecules where the magnetic moment is coupled so lightly to the frame of

the molecule that it can orient itself freely in the magnetic field just as for atoms.

A clear Zeeman effect also can be observed in many crystals with sharp spectrum lines in absorption or fluorescence. Such crystals are found particularly among rare-earth salts.

The magnetic moment of the nucleus causes a Zeeman splitting in atomic spectra which is of an order of magnitude a thousand times smaller than the ordinary Zeeman effect. This Zeeman effect of the hyperfine structure usually is modified by a nuclear Paschen-Back effect. See PASCHEN-BACK EFFECT.

[F.A.J.; G.H.Di./W.W.W.]

**Zeiformes** A small order of teleost fishes, structurally intermediate between the Beryciformes and the Perciformes. This group is also known as the Zeomorphi or Zeoidea; commonly the fish are known as dories. There is no orbitosphenoid bone; the pelvic fin has a spine and from five to nine soft rays; and there is a more or less distinct anterior, spinous anal fin of one to four spines, as well as a spinous dorsal fin (see illustration).

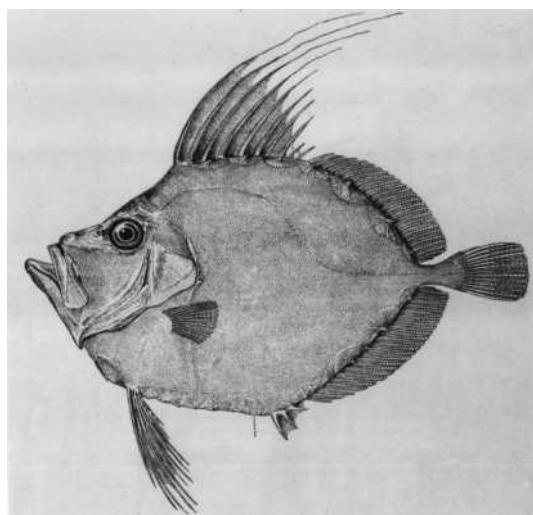

John dory (*Zenopsis ocellata*). (After G. B. Goode, *Fishery Industries of the United States*, sect. 1, 1884)

The zeiform fishes, which are known from the Paleocene on, are grouped into 6 families, perhaps 12 genera, and fewer than 50 species. All are marine, living in shore waters and chiefly at moderate depths off tropical and temperate coasts. Most are of small size and of minor economic importance. See ACTINOPTERYGII; BERYCIFORMES; PERCIFORMES. [R.M.B.]

**Zener diode** A two-terminal semiconductor junction device with a very sharp voltage breakdown as reverse bias is applied. The device is used to provide a voltage reference. It is named after C. Zener, who first proposed electronic tunneling as a mechanism of electrical breakdown in insulators. See SEMICONDUCTOR; TUNNELING IN SOLIDS.

A classic circuit to define a very stable current uses an operational amplifier and three stable resistors (see illustration). The voltage across the Zener itself defines a higher level from which the current is drawn. Thus, a stable noise-free Zener defines its own stable noise-free current. See OPERATIONAL AMPLIFIER.

The effect of temperature on the breakdown voltage can be nulled by having a second forward-biased junction, which has a small negative temperature coefficient, in series with the Zener junction. Such a device is called compensated Zener and has a breakdown voltage of 6.2 V rather than the normal 5.6 V (for the smallest possible temperature coefficient). Alternatively, a Zener junction can be part of an integrated circuit which adds a whole temperature controller to keep the silicon substrate at a constant

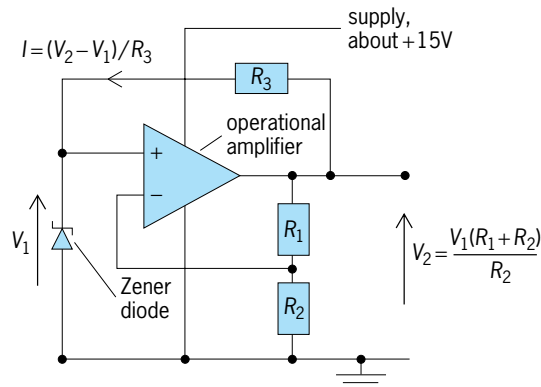

Zener diode circuit to define a very stable current,  $I$ , using an operational amplifier and three stable resistors,  $R_1$ ,  $R_2$ , and  $R_3$ . The voltage  $V_1$  across the Zener itself defines a higher level  $V_2$  from which the current  $I$  is drawn.

temperature. For the very best performance, only four components are integrated into the silicon: the Zener, a heater resistor, a temperature-sensing transistor, and a current-sensing transistor. A separate selected dual operational amplifier then completes the current-and-temperature-control circuit. Such a circuit sets the chip temperature at, say 122°F (50°C), and the junction condition is then largely independent of ambient temperature. See INTEGRATED CIRCUITS.

The compact, robust Zener diode, with the circuits described to set its current and temperature, makes a fine portable voltage standard. This is used to disseminate the voltage level from national or accredited calibration laboratories to industry and to research laboratories. See JUNCTION DIODE; SEMICONDUCTOR DIODE; VOLTAGE MEASUREMENT; VOLTAGE REGULATOR. [P.J.Sp.]

**Zenith** The point in the sky directly above an observer. If the observer is at a pole, then the observer's zenith is a celestial pole; but for observers at midlatitudes the zenith is a point in the sky that corresponds to a changing right ascension but a constant declination as the sky rotates overhead. The point directly below the observer is the observer's nadir, and is 180° in longitude and in latitude from the observer's zenith.

The zenith distance of an object in the sky is the angle across the sky from the zenith to the object. The zenith distance is 90° minus the altitude of an object above the horizon. See ASTRONOMICAL COORDINATE SYSTEMS; CELESTIAL SPHERE. [J.M.P.]

**Zeolite** Any mineral belonging to the zeolite family of minerals and synthetic compounds characterized by an aluminosilicate tetrahedral framework, ion-exchangeable large cations, and loosely held water molecules permitting reversible dehydration. The general formula can be expressed as  $X_y^{1+2+}Al_x^{3+}Si_{1-x}^{4+}O_2 \cdot nH_2O$ . The amount of large cations (X) present is conditioned by the aluminum/silicon (Al:Si) ratio and the formal charge of these large cations. Typical large cations are the alkalis and alkaline earths such as sodium ( $Na^+$ ), potassium ( $K^+$ ), calcium ( $Ca^{2+}$ ), strontium ( $Sr^{2+}$ ), and barium ( $Ba^{2+}$ ). The large cations, coordinated by framework oxygens and water molecules, reside in large cavities in the crystal structure; these cavities and channels may even permit the selective passage of organic molecules. Thus, zeolites are extensively studied from theoretical and technical standpoints because of their potential and actual use as molecular sieves, catalysts, and water softeners. See MOLECULAR SIEVE; SILICATE MINERALS; WATER SOFTENING.

Zeolites are low-temperature and low-pressure minerals and commonly occur as late minerals in amygdaloidal basalts, as devitrification products, as authigenic minerals in sandstones and other sediments, and as alteration products of feldspars and nepheline. Phillipsite and laumontite occur extensively in



sediments on the ocean floor. Stilbite, heulandite, analcime, chabazite, and scolecite are common as large crystals in vesicles and cavities in various basalts.

Zeolites are usually white, but often may be colored pink, brown, red, yellow, or green by inclusions; the hardness is moderate (3–5) and the specific gravity low (2.0–2.5) because of their rather open framework structures. [P.B.M.]

The porous, yet crystalline nature of zeolites has been exploited commercially in three main areas—as sorbents, as cation-exchange materials, and as catalysts.

Most aluminosilicate zeolites have an extremely high (yet reversible) affinity for water and are widely used as desiccants. The discrimination between molecules on the basis of their size as compared to the zeolite pore size is the basis of several extremely important separation processes in a procedure known as molecular sieving. See CHEMICAL SEPARATION TECHNIQUES.

The major commodity use of zeolites takes advantage of their cation-exchange ability and leads to their use in low-phosphate detergents. Mineral zeolites have found utility in agricultural and wastewater treatment applications, where they either ion-exchange harmful metal ions out of the stream being treated or absorb ammonia by reacting, as their acidic form, to produce the absorbed ammonium ion. See ION EXCHANGE.

The most important and expanding area of application for zeolites is as heterogeneous catalysts. By combining the properties of excellent thermal stability (>800°C or 1500°F), a pore size of molecular dimensions, and the ready introduction of a wide assortment of cations via ion exchange, numerous very selective catalysts can be prepared. See HETEROGENEOUS CATALYSIS.

[N.Her.]

**Zero** In mathematics, the concept zero is used in two ways: as a number and as a value of a variable. The positional system of number notation, developed first by the Babylonians (about 500 B.C.) with the base 60, and a millennium later by the Hindus and the Chinese with the base 10, required for greater clarity a special marker of the empty, nonoccupied position.

The zero as a number, however, is a new concept, introduced by the Hindus and Chinese about the same time (6th century). Brahmagupta (born A.D. 598) remarked that the number 0 has special properties:  $a \pm 0 = a$ , and  $a \cdot 0 = 0$ , where  $a$  may be any number (integer).

In a modern way, zero can be called the identity element of the infinite Abelian additive group of integers. If in an integral domain a product is equal to zero, then at least one factor of the product is zero. In the second concept zero is the value of a variable for which a function is equal to zero. [H.R.; E.Gr.]

**Zinc** A chemical element, Zn, atomic number 30, and atomic weight 65.38. Zinc is a malleable, ductile, gray metal. Because of chemical similarities among zinc, cadmium, and mercury, these three metals are classed together in a transition-elements subgroup of the periodic table. See METAL; PERIODIC TABLE; TRANSITION ELEMENTS.

Fifteen isotopes of zinc are known, of which five are stable, having atomic masses of 64, 66, 67, 68, and 70. About half of ordinary zinc occurs as the isotope of atomic mass 64. The half-lives of the radioactive isotopes range from 88 s for  $^{61}\text{Zn}$  to 244 days for  $^{65}\text{Zn}$ .

Zinc is a fairly active metal chemically. It can be ignited with some difficulty to give a blue-green flame in air and to discharge clouds of zinc oxide smoke. Zinc ranks above hydrogen in the electrochemical series, so that metallic zinc in an acidic solution will react to liberate hydrogen gas as the zinc passes into solution to form dipositively charged zinc ions,  $\text{Zn}^{2+}$ . This reaction is slow with very pure zinc, but the presence of small amounts of impurities, addition of a trace of copper sulfate, or contact between the zinc surface and such metals as nickel or platinum facilitates formation of gaseous hydrogen and speeds the reaction. The combination of zinc and dilute acid is often used to gen-

#### Atomic and ionic properties of zinc

Property	Value
Electronic configuration	$1s^2, 2s^2, 2p^6, 3s^2, 3p^6, 3d^{10}, 4s^2$
Ionization potentials	
1st electron loss	9.39 eV
2d electron loss	17.9 eV
Ionic radius, $\text{Zn}^{2+}$	0.072 nm
Covalent radius (tetrahedral)	0.131 nm
Oxidation potentials	$\text{Zn} \rightleftharpoons \text{Zn}^{2+} + 2e^-, E^\circ = 0.76 \text{ V}$ $\text{Zn} + 4\text{OH}^- \rightleftharpoons \text{ZnO}_2^{2-} + 2\text{H}_2\text{O} + 2e^-, E^\circ = 1.22 \text{ V}$

erate small quantities of hydrogen in the laboratory. Zinc also dissolves in strongly alkaline solutions, such as sodium hydroxide, to liberate hydrogen and form dinegatively charged tetrahydrozincate ions,  $\text{Zn}(\text{OH})_4^{2-}$ , sometimes written as  $\text{ZnO}_2^{2-}$  in the formulas of the zincate compounds. Zinc also dissolves in solutions of ammonia or ammonium salts. The common soluble zinc compounds undergo to some extent the process of hydrolysis, which makes their solutions slightly acidic. The ion  $\text{Zn}^{2+}$  is colorless, so that the relatively few zinc compounds that are not colorless in large crystals, or white as powders, receive their color through the influence of the other constituents. Some of the atomic and ionic properties of zinc are shown in the table. See ELECTROCHEMICAL SERIES; HYDROLYSIS.

Zinc also forms many coordination compounds. The zincates are actually coordination compounds, or complexes, in which hydroxide ions,  $\text{OH}^-$ , are bound to the zinc ions. Ammonia,  $\text{NH}_3$ , forms complexes with zinc, such as the typical tetrammine zinc ion,  $[\text{Zn}(\text{NH}_3)_4]^{2+}$ . Zinc cyanide, usually given the simple formula  $\text{Zn}(\text{CN})_2$ , is a coordination compound in which many alternating zinc and cyanide ions are three-dimensionally bound together in a very large molecule. This compound is still widely used in zinc plating, but concern over environmental pollution has led to increasing use of zinc chloride plating baths. In most coordination compounds of zinc, the fundamental structural unit is a central zinc ion surrounded by four coordinated groups arranged spatially at the corners of a regular tetrahedron. See COORDINATION CHEMISTRY; COORDINATION COMPLEXES.

Pure, freshly polished zinc is bluish-white, lustrous, and moderately hard (2.5 on Mohs scale). Moist air brings about a superficial tarnish to give the metal its usual grayish color. Pure zinc is malleable and ductile enough to be rolled or drawn, but small amounts of other metals present as contaminants may render it brittle. Malleability of even pure zinc is improved by heating zinc to 100–150°C (212–300°F). If heated zinc is mechanically worked; it does not embrittle on cooling. Zinc melts at 420°C (788°F) and boils at 907°C (1665°F). Its density is 7.13 times that of water, so that 1 ft<sup>3</sup> (0.028 m<sup>3</sup>) of zinc weighs 445 lb (200 kg).

As a conductor of heat and of electricity, zinc ranks fairly high. However, its electrical resistivity (5.92 microhm-cm at 20°C or 68°F) is almost four times that of silver, the best conductor. As a conductor of heat, zinc is likewise only about one-fourth as efficient as silver. At 0.91 K zinc is an electrical superconductor. Pure zinc is not ferromagnetic, but the alloy compound  $\text{ZrZn}_2$  displays ferromagnetism below 35 K.

The most important uses of zinc are in its alloys and as a protective coating on other metals. Coating iron or steel with zinc is known as galvanizing, and it may be done by immersing the article in melted zinc (hot-dip process), depositing zinc electrolytically onto the article in a plating bath (electro galvanizing), exposing the article to powdered zinc near its melting point (sherardizing), or spraying the article with melted zinc (metallizing). The mere physical presence of the zinc coat prevents corrosion of iron, and even if breaks in the coat expose portions of the iron, the greater chemical activity of the zinc causes it to be consumed in preference to the iron. Adding small amounts of other metals to galvanizing baths has been found to improve the adhesion

and weathering qualities of the coating. See ELECTROPLATING OF METALS; GALVANIZING.

Even such nonstructural materials as cardboard can be zinc-coated by low-temperature flame spraying. Other important uses of zinc are in brass and zinc die-casting alloys, in zinc sheet and strip, in electrical dry cells, in making certain zinc compounds, and as a reducing agent in chemical preparations.

A so-called tumble-plating process coats small metal parts by applying zinc powder to them with an adhesive, then tumbling them with glass beads to roll out the powder into a continuous coat of zinc. Rechargeable nickel-zinc batteries offer higher energy densities than conventional dry cells. Foamed zinc metal has been suggested for use in lightweight structures such as aircraft and spacecraft. Some other uses of zinc are in dry cells, roofing, lithographic plates, fuses, organ pipes, and wire coatings. Zinc dust, a flammable material when dry, is used in fireworks and as a chemical catalyst and reducing agent. Radioactive  $^{65}\text{Zn}$  is used medically in the study of metabolism of zinc, and also in determining rates of wear for zinc-containing alloys. See METAL COATINGS; ZINC ALLOYS. [W.E.C.]

Zinc is believed to be needed for normal growth and development of all living species, including humans; actually, life without zinc would be impossible. Zinc is a common element that is present in virtually every type of human food, and zinc deficiency is therefore not considered to be a common problem in humans. Zinc is a trace element; that is, it is present in biological fluids at a concentration below 1 ppm, and only a small amount (normally <25 mg) is required in the daily diet. (The recommended daily allowance for zinc is 15 mg/day for adults and 10 mg/day for growing children.) It is relatively nontoxic, without noticeable side effects at intake levels of up to 10 times the normal daily requirement. [J.FRI.; K.H.F.]

**Zinc alloys** Combinations of zinc with one or more other metals. If zinc is the primary constituent of the alloy, it is a zinc-base alloy. Zinc also is commonly used in varying degrees as an alloying component with other base metals, such as copper, aluminum, and magnesium. A familiar example of the latter is the association of varying amounts of zinc (up to 45%) with copper to produce brass. See BRASS; COPPER ALLOYS.

Zinc-base alloys have two major uses: for casting and for wrought applications. Casting includes both die casting and gravity casting, which differs from die casting primarily in that no pressure is applied, except the force of gravity, in forcing the molten metal into the mold. See METAL CASTING.

The great bulk of zinc die casting is carried out with two alloys, commonly identified as alloys 3 and 5. A third alloy has been added and is commonly designated as alloy 7. The entire group in the United States is often spoken of by its original trade name as Zamak alloys, and in England as the Mazak alloys.

Aluminum, the major alloying constituent in alloys 3 and 5, is added in amounts of about 4%, which has proved to be the optimum composition from the standpoint of strength, ductility, and stability. The aluminum content also sharply reduces the rate of attack of molten zinc on iron containers. Aluminum also avoids "soldering," or sticking of the casting to the die. This permits the casting of these zinc alloys in the more productive hot-chamber (plunger) type of die-casting machine. See ALUMINUM.

Alloys 3 and 5 differ primarily in their copper content. Copper additions increase strength and hardness and improve corrosion resistance. The copper content of alloys is held to a specified maximum of 1.25% (in alloy 5) to avoid making the alloy unstable through aging and to avoid reducing the impact strength to a very low value.

Alloy 7 is considered a modification of alloy 3. It has a lower magnesium content, and iron, lead, tin, and cadmium are also held to lower levels. A small amount of nickel is added. When the alloys are compared, alloy 7 exhibits improved casting properties, making it easier to secure high-quality surfaces for finishing (mostly chromium plating) and to obtain higher production rates.

In the wrought zinc area, numerous compositions and alloys are used, depending on ultimate product requirements. Alloying metals can be used to improve various properties, such as stiffness, for special applications. The zinc-copper-titanium alloy has become the dominant wrought-zinc alloy for applications demanding superior performance. See ZINC; ZINC METALLURGY.

[A.L.P.]

**Zinc metallurgy** Separating and extracting zinc from ores, refining it, and preparing it into usable forms. Ordinarily, after being mined, ores must first be separated into a concentrated mineral and a waste rock. This concentrate then is reduced to the metal in a metallurgical works. Finally, the metal may be further refined and alloyed to commercially usable form. Commonly, these three extractive metallurgical operations are conducted at separate locations and are broadly categorized as concentrating, smelting, and refining, respectively.

Zinc sulfide ores are usually beneficiated (concentrated or oredressed) adjacent to the mine site. First, the ore must be crushed and ground in order to free the mineral lattices from those of the waste rock (gangue). Next, the finely divided ore is mixed into a slurry with water and the mineral and gangue particles are separated utilizing the effect of gravity. The most common means of separation is the froth flotation process. See FLOTATION; ORE DRESSING.

The second operation, smelting, involves first the chemical or physical changes required in the source material to prepare it into a crude zinc oxide form and a specified particle size (depending upon the particular smelting method contemplated). Such process steps variously entail the operations of roasting, sintering, or pyroconcentration. The other basic part of smelting is the reduction step, wherein the zinc is reduced from its oxide to its elemental form. Several very successful and varied processes accomplish this function, including horizontal retort, vertical retort, electrothermic furnace, and blast furnace (all of which are pyrometallurgical and use carbon as a reducing agent). See PYROMETALLURGY; SINTERING.

Purity of zinc produced by the various smelting processes is largely dependent upon controls and operating procedures practiced during the preparation steps. The quality produced is variously suitable for hot-dip galvanizing, continuous-line galvanizing, and in some cases for brass manufacture and rolled (wrought) zinc; however, for the sizable usage in die-casting alloys, output from this type of smelter must undergo a refining step. Fractional distillation in reflux refining columns is the leading method of upgrading the lower-purity zinc metal. See ZINC ALLOYS. [C.H.Co.]

**Zincite** A mineral with composition  $\text{ZnO}$  (zinc oxide). It crystallizes in the hexagonal system with a wurtzite-type structure. Thus its principal axis is polar and different forms appear at top and bottom of crystals. Such crystals are rare and the mineral is usually massive. Its hardness is 4 and its specific gravity 5.6. The mineral has a subadamantine luster and a deep-red to orange-yellow color. Zincite is rare except at the zinc deposits at Franklin and Sterling Hill, N.J. There, associated with franklinite and willemite, it is mined as a valuable ore of zinc. See FRANKLINITE; WILLEMITE; ZINC. [C.S.Hu.]

**Zingiberales** An order of flowering plants, division Magnoliophyta, in the monocots, consisting of eight families and about 1800 species. Zingiberales (also known as Scitamineae or Scitaminales) are morphologically well defined and clearly circumscribed in DNA sequence analyses. The largest families are Zingiberaceae (about 1000 species), Marantaceae (about 400 species), Costaceae (about 150 species), and Heliconiaceae (about 100 species). Zingiberales are most closely related to Commelinales.

Zingiberales are herbs or scarcely branched trees or shrubs with pinnately veined leaves and irregular flowers that have

well-differentiated sepals and petals, an inferior ovary, septal or septa-derived nectaries, and usually either one or five functional stamens. The economic crops, ginger (*Zingiber officinale*) in Zingiberaceae and banana (*Musa*) in Musaceae, and the ornamentals, bird of paradise flower (*Strelitzia*) in Strelitziaceae and *Canna* in Cannaceae, are familiar members of Zingiberales. See BANANA; COMMELINALES; FLOWER; FRUIT; GINGER; LILIOPSIDA; MAGNOLIOPHYTA. [M.F.F.]

**Zingiberidae** A subclass of Liliopsida (monocotyledons) of the division Magnoliophyta (Angiospermae), the flowering plants, containing two orders (Bromeliales and Zingiberales), with nine families and about 3800 species. The subclass has been associated with the Commelinidae and the Liliidae, sharing some features with each but aberrant in either, and it differs from both in usually having four or more supporting cells around each stomate. The flowers are usually epigynous, usually bisexual, and often irregular, and they are usually showy and adapted to pollination by insects or other animals. The pistil consists of three united carpels, often with septal nectaries opening at the top of the ovary. The seeds usually have well-developed, mealy or starchy endosperm. See BROMELIALES; LILIOPSIDA; MAGNOLIOPHYTA; PLANT KINGDOM; SECRETORY STRUCTURES (PLANT); ZINGIBERALES. [T.M.Ba.]

**Zircon** A mineral with the idealized composition  $ZrSiO_4$ , one of the chief sources of the element zirconium. Structurally, zircon is a nesosilicate, with isolated  $SiO_4$  groups. See SILICATE MINERALS; ZIRCONIUM.

Zircon often occurs as well-formed crystals. The color is variable, usually brown to reddish brown, but also colorless, pale yellowish, green, or blue. The transparent colorless or tinted varieties are popular gemstones. Hardness is  $7\frac{1}{2}$  on Mohs scale; specific gravity is 4.7, decreasing in metamict types. See METAMICT STATE.

Because of its chemical and physical stability, zircon resists weathering and accumulates in residual deposits and in beach and river sands, from which it has been obtained commercially in Florida and in India, Brazil, and other countries. See HEAVY MINERALS. [C.Fr.]

**Zirconium** A chemical element, Zr, atomic number 40, atomic weight 91.22. Its naturally occurring isotopes are 90, 91, 92, 94, and 96. Zirconium is one of the more abundant elements, and is widely distributed in the Earth's crust. Being very reactive chemically, it is found only in the combined state. Under most conditions, it bonds with oxygen in preference to any other element, and it occurs in the Earth's crust only as the oxide,  $ZrO_2$ , baddeleyite, or as part of a complex of oxides as in zircon, elpidite, and eudialyte. Zircon is commercially the most important ore. Zirconium and hafnium are practically indistinguishable in chemical properties, and occur only together. See HAFNIUM; PERIODIC TABLE; ZIRCON.

Most of the zirconium used has been as compounds for the ceramic industry: refractories, glazes, enamels, foundry mold and core washes, abrasive grits, and components of electrical ceramics. The incorporation of zirconium oxide in glass significantly increases its resistance to alkali. The use of zirconium metal is almost entirely for cladding uranium fuel elements for nuclear power plants. Another significant use has been in photo flashbulbs.

Zirconium is a lustrous, silvery metal, with a density of  $6.5 \text{ g/cm}^3$  ( $3.8 \text{ oz/in.}^3$ ) at  $20^\circ\text{C}$  ( $68^\circ\text{F}$ ). It melts at about  $1850^\circ\text{C}$  ( $3362^\circ\text{F}$ ). Estimates of the boiling point from appropriate data have commonly been of the order of  $3600^\circ\text{C}$  ( $6500^\circ\text{F}$ ), but observations suggest about  $8600^\circ\text{C}$  ( $15,500^\circ\text{F}$ ). The free energies of formation of its compounds indicate that zirconium should react with any nonmetal, other than the inert gases, at ordinary temperatures. In practice, the metal is found to be nonreactive near room temperature because of an invisible, impervious

oxide film on its surface. The film renders the metal passive, and it remains bright and shiny in ordinary air indefinitely. At elevated temperatures it is very reactive to the non-metallic elements and many of the metallic elements, forming either solid solutions or compounds.

Zirconium generally has normal covalency of 4, and commonly exhibits coordinate covalencies of 5, 6, 7, and 8. Zirconium is at oxidation number 4 in nearly all of its compounds, Halides in which its oxidation numbers are 3 and 2 have been prepared. While zirconium is often part of cationic or anionic complexes, there is no definite evidence for a monatomic zirconium ion in any of its compounds.

Most handling and testing of zirconium compounds have indicated no toxicity. There has generally been no ill consequence of contact of zirconium compounds with the unabraded skin. However, some individuals appear to have allergic sensitivity to zirconium compounds, characteristically manifested by appearance of nonmalignant granulomas. Inhalation of sprays containing some zirconium compounds and of metallic zirconium dusts have had inflammatory effects. [W.B.B.]

**Zoantharia** A subclass of the Anthozoa. Zoantharians are monomorphic anthozoans, most of which have retractile, simple, tubular tentacles. The tentacles vary from six to several hundred. The mesenteries are six or some multiple of six and may be complete or incomplete in the Actiniaria and Scleractinia, while in other groups they are not constant. When a skeleton is present, it is secreted by ectodermal cells, and free spicules are found. Actiniaria and Scleractinia embrace many species, whereas the other orders, notably the Ceriantheria, include only a few. See ANTHOZOA; ZOANTHIDEA. [K.At.]

**Zoanthidea** An order of the subclass Zoantharia. These animals are mostly colonial, sedentary, skeletonless, anemone-like anthozoans. They live in warm, shallow waters or on coral reefs. The body is in the form of a polyp. The pedal disk is indistinguishable. The column, bearing tubercles, is often encrusted with sand grains, sponge spicules, formaniferous shells, and other detritus. The tentacles are arranged in two cycles. The life cycle is incompletely known. Daughter polyps arise by budding from the stolon or the polyp base, or by longitudinal fission. See ZOANTHARIA. [K.At.]

**Zodiac** The band of sky through which the Sun, Moon, and planets apparently move in the course of the year. The Babylonians, about 2500 years ago, divided the zodiac into 12 parts, which correspond to constellations. These zodiacal constellations, in order around the sky, are Aries, the Ram; Taurus, the Bull; Gemini, the Twins; Cancer, the Crab; Leo, the Lion; Virgo, the Virgin; Libra, the Scales; Scorpius, the Scorpion; Sagittarius, the Archer, Capricornus, the Sea Goat; Aquarius, the Water Carrier; and Pisces, the Fish. These constellations are based on Greek myths.

Because of the precession of the equinoxes, the positions of the constellations in the sky have drifted from the dates of the year with which they were associated thousands of years ago. Thus the popular astrological "signs" of the zodiac are not actually those that currently correspond to the sky. Though the vernal equinox is often called the first point of Aries, precession has moved it into Pisces, not far from Aquarius. See PRECESSION OF EQUINOXES.

The Sun actually passes through parts of 13 constellations, as currently defined. Also, if the zodiac is defined as the region within latitudes  $\pm 8^\circ$ , which accommodates the eight planets through Neptune, it contains all or part of 24 constellations. See CONSTELLATION; ECLIPTIC. [J.M.P.]

**Zodiacal light** A diffuse, night-sky luminosity easily seen at low to middle geographic latitudes in the absence of moonlight. It is caused by sunlight scattered and absorbed by

interplanetary (solar system) dust particles. Zodiacal light extends over the entire sky, but it is brightest toward the Sun and in the zodiacal band. It is best seen in the west after evening twilight and in the east before morning twilight when the ecliptic is close to the vertical. In the Northern Hemisphere this corresponds to spring evenings and autumn mornings. See ECLIPTIC; INTERPLANETARY MATTER.

The density of particles responsible for the zodiacal light falls off somewhat faster than  $1/R$ , where  $R$  is heliocentric distance. The particles are primarily in the size range of tens to hundreds of micrometers in diameter, and are believed to originate primarily from comets. See COMET.

The visual zodiacal light brightness decreases monotonically with elongation (angular distance from the Sun) to a relatively flat minimum in the ecliptic at  $120$  to  $140^\circ$ , after which it gradually increases out to the antisolar point at  $180^\circ$ . The enhanced brightness near the antisolar point is called the Gegenschein or counter glow. It is barely above the visible threshold and is described by visual observers as being oval in appearance, 6 by  $10^\circ$  or larger, with the long axis in the ecliptic. Space observations have shown the Gegenschein to be an intrinsic part of the zodiacal light; that is, the zodiacal dust particles have an increased scattering efficiency near backscattering.

Although the Earth's atmosphere complicates attempts to observe zodiacal light closer than approximately  $30^\circ$  to the Sun, eclipse and space observations have shown the brightness to increase smoothly all the way in to the F-corona. The F-corona or inner zodiacal light and the "primary" zodiacal light seen at larger elongations come primarily from dust particles located relatively close to the Sun. See SOLAR CORONA; SUN. [J.L.Wei.]

**Zone refining** One of a number of techniques used in the preparation of high-purity materials. The technique is capable of producing very low impurity levels, namely, parts per million or

less in a wide range of materials, including metals, alloys, intermetallic compounds, semiconductors, and inorganic and organic chemical compounds. In principle, zone refining takes advantage of the fact that the solubility level of an impurity is different in the liquid and solid phases of the material being purified; it is therefore possible to segregate or redistribute an impurity within the material of interest. In practice, a narrow molten zone is moved slowly along the complete length of the specimen in order to bring about the impurity segregation. See SOLUTION; SOLVENT.

Impurity atoms either raise or lower the melting point of the host material. There is also a difference in the concentration of the impurity in the liquid phase and in the solid phase when the liquid and solid exist together in equilibrium. In zone refining, advantage is taken of this difference, and the impurity atoms are gradually segregated to one end of the starting material. To do this, a molten zone is passed from one end of the impure material to the other, as in *illus. a*, and the process is repeated several times. The end to which the impurities are segregated depends on whether the impurity raises or lowers the melting point of the pure material; a lowering of the melting point is more common, in which case impurities are moved in the direction of travel of the molten zone. The effect of multiple zone passes (in the same direction) on impurity content along the material is illustrated in *illus. b*. See METALLURGY. [A.La.]

**Zooarcheology** Zooarcheology or archeozoology is the study of animal remains from archeological sites. Most such remains derive from people's meals. In other words, zooarcheology is essentially the study of ancient garbage, mainly bones and teeth of mammals, as well as birds, fish, mollusks, and even insects. Zooarcheology helps to provide a more complete picture of people's environment and way of life, especially their economy, as reflected in the relationship between people and animals 100,000 or even just 100 years ago. It is a multidisciplinary endeavor requiring knowledge of anatomy and biometry as well as an appreciation of the archeological questions that need to be addressed. Unlike most paleontological collections, zooarcheological collections are usually well dated and comprise large numbers of bones. They provide excellent opportunities to study microevolution. However, much remains to be explored in this relatively new science. See ANTHROPOLOGY; ARCHEOLOGY; FOSSIL HUMANS; ZOOLOGY. [S.J.M.D.]

**Zoogeography** The subdivision of the science of biogeography that is concerned with the detailed description of the distribution of animals and how their past distribution has produced present-day patterns. Scientists in this field attempt to formulate theories that explain the present distributions as elucidated by geography, physiography, climate, ecological correlates (especially vegetation), geological history, the canons of evolutionary theory, and an understanding of the evolutionary relationships of the particular animals under study.

The field of zoogeography is based upon five observations and two conclusions. The observations are as follows. (1) Each species and higher group of animals has a discrete nonrandom distribution in space and time (for example, the gorilla occurs only in two forest areas in Africa). (2) Different geographical regions have an assemblage of distinctive animals that coexist (for example, the fauna of Africa south of the Sahara with its monkeys, pigs, and antelopes is totally different from the fauna of Australia with its platypuses, kangaroos, and wombats). (3) These differences (and similarities) cannot be explained by the amount of distance between the regions or by the area of the region alone [for example, the fauna of Europe and eastern Asia is strikingly similar although separated by 6900 mi (11,500 km) of land, while the faunas of Borneo and New Guinea are extremely different although separated by a tenth of that distance across land and water]. (4) Faunas strikingly different from those found today previously occurred in all geographical regions (for example, dinosaurs existed over much

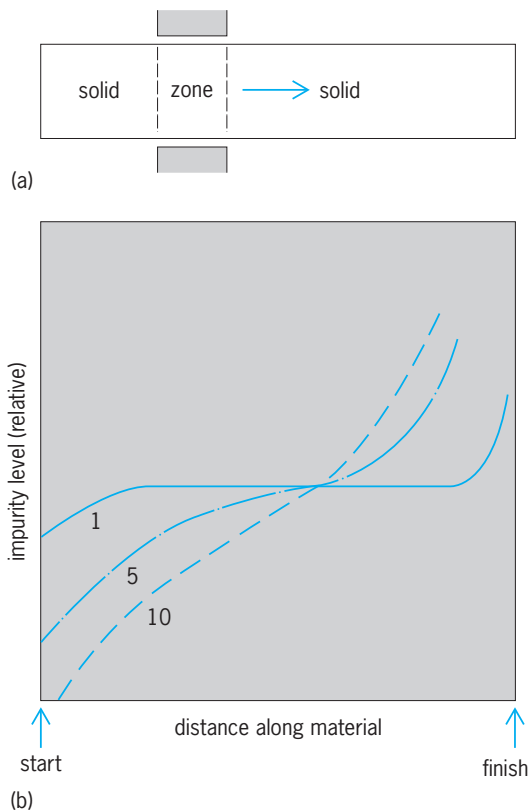

**Zone refining.** (a) Passage of a molten zone along the material to be purified. (b) Effect of 1, 5, and 10 zone passes on the impurity distribution along the material.

of the world in the Cretaceous). (5) Faunas resembling those found today or their antecedents previously occurred, sometimes at sites far distant from their current range (for example, the subtropical-warm temperate fauna of Eocene Wyoming, including many fresh-water fishes, salamander, and turtle groups, is now restricted to the southeastern United States).

The conclusions are as follows. (1) There are recognizable recurrent patterns of animal distribution. (2) These patterns represent faunas composed of species and higher groups that have evolved through time in association with one another.

Two rather different approaches have dominated the study of zoogeography since the beginning of the nineteenth century: ecological and historical. Ecological zoogeography attempts to explain current distribution patterns principally in terms of the ecological requirements of animals, with particular emphasis on environmental parameters, physiological tolerances, ecological roles, and adaptations. The space and time scales in this approach are narrow, and emphasis is upon the statics and dynamics of current or very recent events. Historical zoogeography recognizes that each major geographical area has a different assemblage of species, that certain systematic groups of organisms tend to cluster geographically, and that the interaction of geography, climate, and evolutionary processes over a long time span is responsible for the patterns or general tracks. Emphasis in this approach is upon the statics and dynamics of major geographical and geological events ranging across vast areas and substantial time intervals of up to millions of years. The approach is based on concordant evolutionary association of diverse groups through time. See ECOLOGY. [J.M.S.]

**Zoological nomenclature** The system of naming animals that was adopted by zoologists and detailed in the International Code of Zoological Nomenclature, which applies to both living and extinct animals. The present system is founded on the 10th edition of C. Linnaeus's *Systema Naturae* (1758) and has evolved through international agreements culminating in the Code adopted in 1985. The primary objective of the Code is to promote the stability of the names of taxa (groups of organisms) by providing rules concerning name usage and the activity of naming new taxa. The rules are binding for taxa ranked at certain levels and nonbinding on taxa ranked at other levels. See ANIMAL SYSTEMATICS.

Zoological nomenclature is built around four basic features. (1) The correct names of certain taxa are either unique or unique combinations. (2) These names are formed and treated as Latin names and are universally applicable, regardless of the native language of the zoologist. (3) The Code for animals is separate and independent from similar codes for plants and bacteria. (4) No provisions of the Code are meant to restrict the intellectual freedom of individual scientists to pursue their own research.

There are four common reasons why nomenclature may change. (1) New species are found that were once considered parts of other species. (2) Taxonomic revisions may uncover older names or mistakes in identification of types. (3) Taxa may be combined, creating homonyms that require replacement. (4) Concepts of the relationships of animals change. Stability is subservient to progress in understanding animal diversity.

The articles in the Code are directed toward the names of taxa at three levels. The family group includes taxa ranked as at the family and tribe levels (including super- and subfamilies). The genus group includes taxa below subtribe and above species. The species group includes taxa ranked as species or subspecies. Taxa above the family group level are not specifically treated, and their formation and use are not strictly regulated. For each group, provisions are made that are either binding or recommended.

**Binominal nomenclature.** The basis for naming animals is binominal nomenclature, that is, a system of two-part names. The first name of each species is formed from the generic name, and the second is a trivial name, or species epithet. The two names agree in gender unless the specific epithet is a patronym

(named for a person). The combination must be unique; no other animal can have the same binominal. The formal name of a species also includes the author, so the formal name for humans is *Homo sapiens* Linnaeus. The genus, as a higher taxon, may have one or many species, each with a different epithet. *Homo* includes *H. sapiens*, *H. erectus*, *H. habilis*, and so forth. One feature of the Linnaean binominal system is that species epithets can be used over and over again, so long as they are used in different genera. *Tyrannosaurus rex* is a large dinosaur, and *Percina rex* is a small fresh-water fish. The epithet *rex* is not the species name of *Percina rex* because all species names are binominal in form. It is recommended that names of genera and species be set in a different typeface from normal text; italics is conventional. Different names for the same species are termed synonyms, and the senior synonym is usually correct (principle of priority). Modern species descriptions are accompanied by a description that attempts to show how the species is different from others, and the designation of one or more type specimens.

**Higher taxa.** All higher taxonomic names have one part (uninominal) and are plural. Names of taxa of the family and genus groups must be unique. The names of genera are in Latin or latinized, are displayed in italics, and may be used alone. The names of the family group are formed by a root and an ending specific to a particular hierarchical level: family Hominidae (root + idae), subfamily Homininae (root + inae). The endings of superfamilies (root + oidea) and tribes (root + ini) are recommended but not mandated. The endings of taxa higher than the family group vary. For example, orders of fishes are formed by adding -iformes to the root (Salmoniformes), while in insects the ending is usually -ptera (Coleoptera). See CLASSIFICATION, BIOLOGICAL; TAXONOMIC CATEGORIES. [E.O.W.]

**Zoology** The science that deals with knowledge of animal life. With the great growth of information about animals, zoology has been much subdivided. Some major fields are anatomy, which deals with gross and microscopic structure; physiology, with living processes in animals; embryology, with development of new individuals; genetics, with heredity and variation; parasitology, with animals living in or on others; natural history, with life and behavior in nature; ecology, with the relation of animals to their environments; evolution, with the origin and differentiation of animal life; and taxonomy, with the classification of animals. See ANATOMY, REGIONAL; DEVELOPMENTAL BIOLOGY; GENETICS; PARASITOLOGY; PHYLOGENY; PLANT EVOLUTION; TAXONOMY. [T.I.S.]

**Zoom lens** A system of lenses in which two or more parts are moved with respect to each other to obtain a continuously variable focal length and hence magnification, while the image is kept in the same image plane.

The system must be constructed so that the errors do not vary too much in the shifting. Thus the designer must strive for a design in which the image errors are small, at least for the beginning and end positions of the "zooming" procedure, and do not become too large for intermediate positions.

Some early variable-focal-length lenses contained 15 or more separated elements, but this number has been reduced to as few as 4. The zoom ratio (the ratio of maximum to minimum power) is in general 3:1, but it has been possible in some designs to increase the range to 4:1 or even more. See LENS (OPTICS).

[M.J.H.]

**Zoomastigophorea** A class of protozoans of the subphylum Sarcostigophora. Zoomastigophorea, also known as Zoomastigina, are flagellates. Some are simple, some are specialized; some have pseudopodia besides flagella. One group engulfs solid food at any body point; another shows localized ingestive areas. All are colorless. None produce starch or paramylum, and lipids and glycogen are assimilation products. Cells are

naked or have delicate membranes. Colony formation is common. Colonies differ greatly in form and may be amorphous, linear, spherical, arboroid, or plane. Flagella vary from none to many.

Nine orders are included in this class: the Choanoflagellida, Bicosoecida, Rhizomastigida, Kinetoplastida, Retortomonadida, Diplomonadida, Oxymonadida, Trichomonadida, and Hypermastigida. See articles on these classes. See also SARCOMASTIGOPHORA. [J.B.L.]

**Zoonoses** Infections of humans caused by the transmission of disease agents that naturally live in animals. People become infected when they unwittingly intrude into the life cycle of the disease agent and become unnatural hosts. Zoonotic helminthic diseases, caused by parasitic worms, involve many species of helminths, including nematodes (roundworms), trematodes (flukes), cestodes (tapeworms), and acanthocephalans (thorny-headed worms). Helminthic zoonoses may be contracted from domestic animals such as pets, from edible animals such as seafood, or from wild animals. Fortunately, most kinds of zoonotic helminthic infections are caused by rare human parasites.

The best-recognized example of a food-borne zoonotic helminthic disease is trichinosis, caused by the trichina worm, *Trichinella spiralis*, a tiny nematode. People commonly become infected by eating inadequately prepared pork, but a sizable proportion of victims now contract the worms by eating the meat of wild carnivores, such as bear. Trichinosis is usually a mild disease, manifested by symptoms and signs of intestinal and muscular inflammation, but in heavy infections damage done by the larvae to the heart and central nervous system can be life threatening. Because of public awareness about properly cooking pork and federal regulations about feeding pigs, trichinosis has become uncommon in the United States. People who eat inadequately prepared marine fish may become infected with larval nematodes. Of the many potential (and rare) helminthic zoonoses from wild animals in the United States, *Baylisascaris procyonis* is particularly dangerous. The nematode is highly prevalent in raccoons, the definitive host. See CESTODA; FOOD SAFETY; MEDICAL PARASITOLOGY; NEMATA; TREMATODA. [D.E.No.]

**Zooplankton** Animals that inhabit the water column of oceans and lakes and lack the means to counteract transport currents. Zooplankton inhabit all layers of these water bodies to the greatest depths sampled, and constitute a major link between primary production and higher trophic levels in aquatic ecosystems. Many zooplankton are capable of strong swimming movements and may migrate vertically from tens to hundreds of meters; others have limited mobility and depend more on water turbulence to stay afloat. All zooplankton, however, lack the ability to maintain their position against the movement of large water masses.

Zooplankton can be divided into various operational categories. One means of classification is based on developmental stages and divides animals into meroplankton and holoplankton. Meroplanktonic forms spend only part of their life cycles as plankton and include larvae of benthic worms, mollusks, crustaceans, echinoderms, coral, and even insects, as well as the eggs and larvae of many fishes. Holoplankton spend essentially their whole existence in the water column. Examples are chaetognaths, pteropods, larvaceans, siphonophores, and many copepods. Nearly every major taxonomic group of animals has either meroplanktonic or holoplanktonic members.

Size is another basis of grouping all plankton. A commonly accepted size classification scheme includes the groupings: picoplankton (<2 micrometers), nanoplankton (2–20  $\mu\text{m}$ ), microplankton (20–200  $\mu\text{m}$ ), mesoplankton (0.2–20 mm), macroplankton (20–200 mm), and megaplankton (>200 mm).

The classic description of the trophic dynamics of plankton is a food chain consisting of algae grazed by crustacean zooplankton

which are in turn ingested by fishes. This model may hold true to a degree in some environments such as upwelling areas, but it masks the complexity of most natural food webs. Zooplankton have an essential role in linking trophic levels, but several intermediate zooplankton consumers can exist between the primary producers (phytoplankton) and fish. Thus, food webs with multiple links to different organisms indicate the versatility of food choice and energy transfer and are a more realistic description of the planktonic trophic interactions.

Size is of major importance in planktonic food webs. Most zooplankton tend to feed on organisms that have a body size smaller than their own. However, factors other than size also modify feeding interactions. Some phytoplankton are noxious and are avoided by zooplankton, and others are ingested but not digested. Furthermore, zooplankton frequently assume different feeding habits as they grow from larval to adult form. They may ingest bacteria or phytoplankton at one stage of their life cycle and become raptorial feeders later. Other zooplankton are primarily herbivorous but also ingest heterotrophic protists and can opportunistically become carnivorous. Consequently, omnivory, which is considered rare in terrestrial systems, is a relatively common trophic strategy in the plankton. In all food webs, some individuals die without being consumed and are utilized by scavengers and ultimately by decomposers (bacteria and fungi). See ECOLOGY; ECOSYSTEM; MARINE ECOLOGY; PHYTOPLANKTON. [R.W.Sa.]

**Zoraptera** An order of insects which is related to the termites and psocids. Zoraptera are about 0.08–0.1 in. (2–2.5 mm) long and not important economically. They are of great interest because of their rarity, relatively recent discovery in 1913, and intriguing habits and relationships.

Zoraptera live sheltered from light, in decaying wood, usually in logs and stumps, except during the emergence of winged adults. The winged adults are well pigmented, have eyes, and often shed their wings. In the southeastern United States they occur especially on slabs buried in old sawdust piles. They apparently scavenge, mainly on microscopic molds. Most individuals are of the wingless caste, pale in color, and blind. Metamorphosis is gradual.

Zoraptera are distributed nearly worldwide in warm countries. The best known of the two United States species, *Zorotypus hubbardi*, occurs from Pennsylvania to Florida, west to Iowa, Kansas, Missouri, and Texas. Approximately 23 species are known; all are in the genus *Zorotypus* of the family Zorotypidae. See INSECTA. [A.B.Gu.]

**Zosterophylloids** An extinct class of the division Lycopphyta, comprising primitive vascular land plants that evolved from the rhyniophytes and reached a relatively brief peak in the late Early Devonian, when they were an ecologically important and widely distributed element of the exclusively herbaceous terrestrial flora.

The Zosterophylloids consists of approximately 18 genera, although few of these include species that have been fully reconstructed from their disarticulated organs. All genera exhibited rhizomatous growth. The rhizomes produced adventitious roots and upright aerial branches, which were typically densely crowded. The group is united by the key lycopphyte characters of exarch protoxylem maturation and laterally borne, vascularized, kidney-shaped sporangia with multilayered walls and complete distal dehiscence.

The most primitive generally accepted lycopphyte is *Zosterophyllum*. *Sawdonia* and *Gosslingia* are more advanced zosterophylloids, possessing characters that are absent from the lycopsids. Although briefly successful as dense stands on floodplains and channel margins, these more sophisticated zosterophylloids were virtually extinct by the end of the Devonian. See LYCOPHYTA; LYCOPSIDA. [R.M.Ba.; W.A.DiM.]

**Zygnematales** A large order of green algae (Chlorophyceae) that is characterized by the lack of flagellate cells. Sexual reproduction is effected by the fusion of amoeboid or passive gametes in conjugation tubes, which give rise to the alternate name Conjugates. Biochemical and ultrastructural features indicate that the Zygnematales are more closely related to charophytes than they are to most other green algae. Members of this order are essentially restricted to fresh-water and subaerial habitats. They are sometimes placed in their own class, with each family elevated to the rank of order. The order Zygnematales is frequently divided into two suborders, Zygnematineae and Desmidiineae. [P.C.Si.; R.L.Moe]

**Zygomycetes** A class of terrestrial fungi in the phylum Zygomycota, comprising organisms commonly known as the bread molds. Sexual reproduction is by the formation of zygospores. Asexual reproduction is by endospores (sporangiospores) produced in sporangia, or uni- or multispored sporangiola or merosporangia, conidia, yeast cells, chlamydo-spores, or arthrospores. These fungi occur as haustorial (having food-absorbing cells in the host) or nonhaustorial parasites of fungi, plants, or animals (including humans), or as saprobes, especially in soil or dung; but other substrates with soluble nutrients may also contain Zygomycetes. Some taxa are endo- or ectomycorrhizal on vascular plants.

The mature spore-bearing structures are dry and readily dispersed by air currents, or are wet and are distributed by direct contact with small animals or are ingested by animals and disseminated in their feces. Water droplets also may disperse the spores or the intact spore-bearing structures.

Classification is based on mode of nutrition, morphology of the zygospore (if formed), type of asexual reproduction, branching pattern of sporophores, and frequency of septa (if formed) and septal morphology. Zygomycetes are currently placed in seven orders: Dimargaritales, Endogonales, Entomophthorales, Glomales, Kickxellales, Mucorales, and Zoopagales.

Zygomycetes are distributed worldwide, although many taxa are rarely encountered; they may be relatively common on a particular host or substrate. See EUMYCOTA; FUNGI; ZYGOMYCOTINA. [G.L.Be.]

**Zygomycotina** Subdivision of fungi characterized by distinctive sexual and asexual reproductive stages. The sexual zygospore results from fusion of two gametangia. Asexual reproduction may be sporangial (containing one to many, always nonmotile, sporangiospores) to conidial. The various asexual forms found in different taxa are interpreted as representing evolutionary development from sporangial to conidial. Asexual reproduction is more common than sexual; in fact, sexual reproduction is unknown in many species and within certain orders. Zygomycotina are cosmopolitan. Many are free-living saprobes. Others, even entire orders, are saprophytic, parasitic, or obligate symbionts, especially in arthropods. There are two classes (Zygomycetes and Trichomycetes), but it is uncertain whether they are naturally related or appear similar through convergent evolution. [D.J.S.B.]

**Zygophyllales** An order of flowering plants in the eurosid I group of the rosid eudicots. This order comprises just two small families of distant relationship (as evidenced by DNA sequence studies) to all other rosid eudicots: Krameriaceae and Zygophyllaceae. Krameriaceae (25 species) are photosynthetic parasitic plants ("hemiparasites") found from the southwestern United States to South America, whereas Zygophyllaceae (240 species) are free-living and widely distributed in arid to semiarid zones throughout the warmer regions of the world. Some species of the latter family produce especially hard woods such as lignumvitate (*Bulnesia* and *Guaicum*), and a few others produce medicinal compounds, such as the creosote bush (*Larrea*). See FLOWER; LIGNUMVITAE; MAGNOLIOPHYTA; MAGNOLIOPSIDA; POLYGALALES; ROSIDAE; SAPINDALES. [M.W.C.]





**Appendix**  
**Contributors**  
**Index**



# Bibliographies

## ACOUSTICS

- Berg, R. E., and D. G. Stork**, *The Physics of Sound*, 2d ed., 1994.
- Blackstock, D. T.**, *Fundamentals of Physical Acoustics*, 2000.
- Crocker, M.**, *Handbook of Acoustics*, 1998.
- Frisk, G. V.**, *Ocean and Seabed Acoustics: A Theory of Wave Propagation*, 1998.
- Kinsler, L. E., et al.**, *Fundamentals of Acoustics*, 4th ed., 1999.
- Levy, M., H. E. Bass, and R. R. Stern** (eds.), *Handbook of Elastic Properties of Solids, Liquids, and Gases* (4-vol. set), 2000.
- Mason, W. P., R. N. Thurston, and A. D. Pierce** (eds.), *Physical Acoustics: Principles and Methods*, vols. 1–25, 1964–1999.
- Mechel, F. P.**, *Formulas of Acoustics*, 2002.
- Pierce, A. D.**, *Acoustics: An Introduction to Its Physical Principles and Applications*, 1981, reprint 1989.
- Rossing, T. D., et al.**, *The Science of Sound*, 3d ed., 2001.
- Speaks, C. E.**, *Introduction to Sound Acoustics for Hearing and Speech Science*, 3d ed., 1999.
- Urlick, R. J.**, *Principles of Underwater Sound*, 3d ed., 1983, reprint 1996.

*Journal of the Acoustical Society of America*, American Institute of Physics, monthly.

## AERODYNAMICS

- Anderson, J. D., Jr.**, *Fundamentals of Aerodynamics*, 3d ed., 2001.
- Bertin, J. J., Smith**, *Aerodynamics for Engineers*, 4th ed., 2001.
- Houghton, E., et al.**, *Aerodynamics for Engineering Students*, 5th ed., 2001.
- Kuethe, A. M., and C. Y. Chow**, *Foundations of Aerodynamics: Bases of Aerodynamics Design*, 5th ed., 1997.

- McCormick, B. W.**, *Aerodynamics, Aeronautics and Flight Mechanics*, 2d ed., 1994.
- Smith, H. C.**, *The Illustrated Guide to Aerodynamics*, 2d ed., 1982.
- Wegener, P.**, *What Makes Airplanes Fly?: History, Science and Applications of Aerodynamics*, 2d ed., 1996.

## AERONAUTICAL ENGINEERING

- Anderson, J. D.**, *Aircraft Performance*, 1999.
- Anderson, J. D.**, *Fundamentals of Aerodynamics*, 3d ed., 2001.
- Anderson, J. D., Jr.**, *Introduction to Flight*, 5th ed., 2004.
- Barnard R. H.**, *Aircraft Flight*, 2d ed., 1995.
- Bertin, J.**, *Aerodynamics for Engineers*, 4th ed., 2002.
- Davies, M.**, *The Standard Handbook for Aeronautical and Astronautical Engineers*, 2002.
- Etkin, B., and L. D. Reid**, *Dynamics of Flight Stability and Control*, 3d ed., 1995.
- Hancock, G. J.**, *An Introduction to the Flight Dynamics of Rigid Aeroplanes*, 1995.
- Kermode, A. C., R. H. Barnard, and D. R. Philpott**, *Mechanics of Flight*, 1996.
- Kroes, M. J., and J. R. Rardon**, *Aircraft Basic Science*, 7th ed., 1993.
- McCormick, B. W.**, *Aerodynamics, Aeronautics and Flight Mechanics*, 2d ed., 1995.
- Peery, D., and J. J. Azar**, *Aircraft Structures*, 2d ed., 1982.
- Schmidt, L. V.**, *Introduction to Aircraft Flight Dynamics*, 1998.
- Wagtendonk, W. J.**, *Principles of Helicopter Flight*, 1996.
- AIAA Journal*, American Institute of Aeronautics and Astronautics, monthly.
- Aviation and Aerospace Almanac*, Aviation Daily and Aerospace Daily, yearly.
- Aviation Week and Space Technology*, weekly.

**AGRICULTURE**

- Adams, C. R., K. Bamford, and M. P. Early**, *Principles of Horticulture*, 3d ed., 1998.
- Barrick, R. K., and H. Harmon**, *Animal Science*, 1984.
- Blakely, J., and D. H. Bade**, *The Science of Animal Husbandry*, 5th ed., 1989.
- Brady, N. C.** (ed.), *Advances in Agronomy*, vols. 28–45, 1976–1991.
- Ensminger, M. E.** (ed.), *Animal Science*, 9th ed., 1991.
- Heath, E., et al.**, *Forages: The Science of Grassland Agriculture*, 4th ed., 1985.
- Lockhart, J. A., and A. J. Wiseman**, *Introduction to Crop Husbandry: Including Grassland*, 6th ed., 1988.
- Martin, J. H., et al.**, *Principles of Field Crop Production*, 4th ed., 1986.
- Miller, D. A.**, *Forage Crops*, 1984.
- Rechcigl, M., Jr.** (ed.), *Handbook of Agricultural Productivity*, vol. 1: *Plant Productivity*, vol. 2: *Animal Productivity*, 1982.
- Sparks, D. L.** (ed.), *Advances in Agronomy*, vols. 47–49, 1992–1993.

*Agronomy Journal*, American Society of Agronomy, bimonthly.

*Journal of Agricultural Science* (England), bimonthly.

*Journal of Animal Science*, American Society of Animal Science, monthly.

**ALGEBRA**

- Auvil, D., and C. Poluga**, *Algebra for College Students*, 1996.
- Birkhoff, G., and S. MacLane**, *A Survey of Modern Algebra*, 5th ed., 1996.
- Blitzer, R. F.**, *College Algebra*, 3d ed., 2003.
- Durbin, J. R.**, *Modern Algebra: An Introduction*, 5th ed., 2004.
- Fraleigh, J. B.**, *A First Course in Abstract Algebra*, 7th ed., 2002.
- Hungerford, T. W.**, *Algebra* (Graduate Texts in Mathematics), 8th print ed., 1997.
- Jacobson, N.**, *Basic Algebra*, vol. 1, 2d ed., 1985, vol. 2, 2d ed., 1989.
- Kaufman, J. E., and K. L. Schwitters**, *Algebra for College Students*, 6th ed., 1999.
- Keedy, M. L., and M. Bittenger**, *Introductory Algebra*, 9th ed., 2003.
- Lang, S. A.**, *Algebra*, 3d ed., 2002.
- Lial, M. L., J. Hornsby, and T. McGinnis**, *Beginning Algebra*, 9th ed., 2003.
- Siever, N.**, *Intermediate Algebra*, 1990.
- Streeter, J., D. Hutchinson, and L. Hoelzle**, *Beginning Algebra*, 4th ed., 1998.
- Sullivan, M.**, *College Algebra*, 7th ed., 2004.

*Journal of Algebra*, semimonthly.

*Journal of Pure and Applied Algebra*, approximately 18 issues per year.

**ANATOMY**

- Chee, A. N.**, *Anatomy and Physiology: A Dynamic Approach*, 4th ed., 1991.
- Fong, E., and A. Senisiscott**, *Body Structures and Functions*, 10th ed., 2003.

- Guyton, A.**, *Physiology of the Human Body*, 6th ed., 1984.
- Marieb, E. N.**, *Human Anatomy and Physiology*, 6th ed., 2003.
- Schlossberg, L., and G. D. Zuidema**, *The John Hopkins Atlas of Human Functional Anatomy*, 4th ed., 1997.
- Tortora, G.**, *Principles of Anatomy and Physiology*, Learning Guide, 10th ed., 2002.
- Williams, P. L., et al.**, *Gray's Anatomy*, Deluxe Set, 38th rev. ed., 1995.

*Anatomical Record*, Wiston Institute Press, monthly.

*Journal of Anatomy* (England), bimonthly.

**ANTHROPOLOGY AND ARCHEOLOGY**

- Campbell, B. J. Loy**, *Humankind Emerging*, 8th ed., 1999.
- Ember, C. R., M. Ember, and P. Perengrine**, *Anthropology*, 10th ed., 2001.
- Fagan, B.**, *World Prehistory: A Brief Introduction*, 8th ed., 2002.
- Fagan, B. M.**, *People of the Earth*, 11th ed., 2003.
- Klein, R. G., and B. Edgar**, *The Dawn of Human Culture*, 2002.
- Renfrew, C., and P. Bahn**, *Archaeology: Theories, Methods and Practice*, 3d ed., 2000.
- Strier, K. B.**, *Primate Behavioral Ecology*, 1999.
- Thomas, D. H.**, *Archaeology*, 3d ed., 1997.
- Whitten, P., and D. E. Hunter**, *Anthropology: Contemporary Perspectives*, 8th ed., 2000.

*Evolutionary Anthropology*, Wiley-Liss, monthly.

**ARCHITECTURAL ENGINEERING**

- Allen, E.**, *How Buildings Work: The Natural Order of Architecture*, 2d ed., 1995.
- Ambrose, J. E.**, *Building Structures*, 2d ed., 1993.
- Guthrie, P.**, *The Architect's Portable Handbook*, 3d ed., 2003.
- Harris, C. M.** (ed.), *Dictionary of Architecture and Construction*, 3d ed., 2000.
- McGraw-Hill**, *Architecture Engineer's Solutions Suite* (CD-ROM), 1996.
- Roth L. M.**, *Understanding Architecture: Its Elements, History, and Meaning*, 1993.
- Zampi, G., and C. L. Morgan**, *Virtual Architecture*, 1996.

*Architectural Record*, McGraw-Hill, monthly.

*Journal of Architectural Engineering*, American Society of Civil Engineers, quarterly.

**ASTRONOMY**

- Beatty, J. K., C. Collins Petersen, and A. L. Chaikin** (eds.), *The New Solar System*, 4th ed., 1998.
- Chaisson, E., and S. McMillan**, *Astronomy Today*, 4th ed., 2004.
- Foukal, P.**, *Solar Astrophysics*, 2004.
- Fraknoi, A., D. Morrison, and S. Wolff**, *Voyages Through the Universe*, 3d ed., 2004.
- Golub, L., and J. M. Pasachoff**, *Nearest Star: The Exciting Science of Our Sun*, 2002.
- Kutner, M.**, *Astronomy: A Physical Perspective*, 2d ed., 2003.

- Pasachoff, J. M.**, *Astronomy: From the Earth to the Universe*, 6th ed., 2002.  
**Pasachoff, J. M., and A. Filippenko**, *The Cosmos: Astronomy in the New Millennium*, 2d ed., 2004.  
**Seeds, M.**, *Foundations of Astronomy*, 8th ed., 2005.  
**Zeilik, M.**, *Astronomy: The Evolving Universe*, 9th ed., 2002.

*Annual Review of Astronomy and Astrophysics*, annually.  
*Astronomical Calendar*, Universal Workshop, yearly.  
*Astronomical Journal*, American Astronomical Society, monthly.  
*Astronomy*, monthly.  
*Astrophysical Journal*, American Astronomical Society, three issues per month.  
*Mercury*, Astronomical Society of the Pacific, monthly.  
*Monthly Notices of the Royal Astronomical Society*, three issues per month.  
*Observers' Handbook*, Royal Astronomical Society of Canada, annually.  
*The Planetary Report*, The Planetary Society, bimonthly.  
*Sky & Telescope*, monthly.

## ATOMIC PHYSICS

- Adam, S.**, *Frontiers*, 2000.  
**Beiser, A.**, *Concepts of Modern Physics*, 6th ed., 2002.  
**Brehm, J. J., and W. J. Mullins**, *Introduction to the Structure of Matter: A Course in Modern Physics*, 1989.  
**Cowan, R. D.**, *The Theory of Atomic Structure and Spectra*, 1981.  
**Haken, H., H. C. Wolf, and W. Brewer**, *The Physics of Atoms and Quanta: Introduction to Experiments and Theory*, 6th rev. ed., 2000.  
**Ohanian, H. C.**, *Modern Physics*, 2d ed., 1996.  
**Serway, R. A., and J. Faughn**, *Modern Physics*, 2d ed., 1996.  
**Thornton, T., and A. Rex**, *Modern Physics for Scientists and Engineers*, 2d ed., 1999.  
**Yang, F., and J. H. Hamilton**, *Modern Atomic and Nuclear Physics*, 1996.

*Physical Review A*, American Physical Society, monthly.

## AUTOMOTIVE ENGINEERING

- Robert Bosch GmbH**, *Automotive Handbook*, 5th ed., 2000.  
**Crouse, W. H., and D. L. Anglin**, *Automotive Mechanics*, 10th ed., 1993.  
**Duffy, J. E.**, *Modern Automotive Technology*, 2003.

*Automotive Engineering*, International Society of Automotive Engineers, monthly.

## BIOCHEMISTRY

- Alberts, B., et al.**, *Molecular Biology of the Cell*, 4th ed., 2002.  
**Devlin, T. M.** (ed.), *Textbook of Biochemistry*, 5th ed., 2001.  
**Elliott, W. H., and D. C. Elliott**, *Biochemistry and Molecular Biology*, 2d ed., 2001.  
**Horton, H. R., et al.**, *Principles of Biochemistry*, 3d ed., 2002.

- Murray, R. K., et al.**, *Harper's Illustrated Biochemistry*, 2003.  
**Nelson, D., and M. Cox**, *Lehninger Principles of Biochemistry*, 4th ed., 2004.  
**Stipanuk, M. H.**, *Biochemical and Physiological Aspects of Human Nutrition*, 2000.  
**Stryer, L.**, *Biochemistry Extended*, 2002.  
**Van Holde, K. E., C. Johnson, and P. Ho**, *Principles of Physical Biochemistry*, 1998.  
**Voet, D., and J. Voet**, *Biochemistry*, 3d ed., 2004.

*Annual Review of Biochemistry*, annually.  
*Archives of Biochemistry and Biophysics*, biweekly.  
*Biochemical Journal*, biweekly.  
*Biochemistry, Centcom Ltd.*, biweekly.  
*Biochimica et Biophysica Acta*, 100+ issues per year.  
*European Journal of Biochemistry*, semimonthly.  
*Journal of Biological Chemistry*, American Society of Biological Chemists, semimonthly.  
*Trends in Biochemical Sciences*, monthly.

## BIOMEDICAL ENGINEERING

- Bronzino, J. D.** (ed.), *The Biomedical Engineering Handbook*, 2d ed., 2000.  
**Domach, M. F.**, *Introduction to Biomedical Engineering*, 2004.  
**Dyro, J. F.** (ed.), *Clinical Engineering Handbook*, 2004.  
**Khandpur, R. S.**, *Biomedical Instrumentation*, 2005.  
**Kutz, M.** (ed.), *Standard Handbook of Biomedical Engineering & Design*, 2003.

*Annals of Biomedical Engineering*, monthly.  
*Annual Review of Biomedical Engineering*, annually.  
*IEEE Transactions on Biomedical Engineering*, monthly.

## BIOPHYSICS

- Austin, R. H., and S. Chan**, *Biophysics for Physicists*, 2003.  
**Cerdonio, M., and R. W. Noble**, *Introductory Biophysics*, 1988.  
**Kreighbaum, E., and K. Barthels**, *Biomechanics: A Qualitative Approach for Studying Human Movements*, 4th ed., 1995.  
**Sybesma, C.** (ed.), *Biophysics: An Introduction*, 1989.  
**Valenta, J.** (ed.), *Biomechanics*, 1993.  
**Wainwright, S. A., et al.**, *Mechanical Design in Organisms*, 1982.

*Annual Review of Biophysics and Bioengineering*, annually.  
*Biophysical Journal*, monthly.

## CALCULUS

- Berkey, D. D., and P. Blanchard**, *Calculus*, 3d ed., 1992.  
**Courant, R., and F. John**, *Introduction to Calculus and Analysis*, 2 vols., 1999.  
**Grossman, S., and R. B. Lane**, *Calculus*, 1993.  
**Kaplan, W.**, *Advanced Calculus*, 5th ed., 2002.  
**Lang, S. A.**, *A First Course in Calculus*, 5th ed., 1986, reprint 1993.  
**Larson, R.**, *Calculus with Analytic Geometry*, 7th ed., 2002.

- Hille, E., S. Salas, and G. Etgen**, *Salas and Hille's Calculus*, 8th ed., 1998.  
**Taylor, A. E., and R. W. Mann**, *Advanced Calculus*, 3d ed., 1982.  
**Thomas, G. B.**, *Calculus and Analytic Geometry*, 9th ed., 1996.

## CELESTIAL MECHANICS

See Astronomy.

## CELL AND MOLECULAR BIOLOGY

- Alberts, B., et al.**, *Molecular Biology of the Cell*, 4th ed., 2002.  
**Drew, H. R., et al.**, *Understanding DNA: The Molecule and How It Works*, 3d ed., 2004.  
**Lodish, H., et al.**, *Molecular Cell Biology*, 5th ed., 2003.  
**Pollard, T.**, *Cell Biology*, 2d ed., 2002.  
**Watson, J. D., et al.**, *Molecular Biology of the Gene*, 5th ed., 2003.

*Cell*, biweekly.

*Current Opinion in Cell Biology*, bimonthly.

*EMBO Journal*, European Molecular Biology Organization, bimonthly.

*Journal of Cell Biology*, monthly.

*Journal of Molecular Biology*, biweekly.

*Molecular and Cellular Biology*, American Society for Microbiology, monthly.

*Molecular Biology*, bimonthly.

*Molecular Biology of the Cell*, monthly.

*Nature Cell Biology*, monthly.

*Trends in Cell Biology*, monthly.

## CIVIL ENGINEERING

- Ambrose, J.**, *Simplified Design of Concrete Structures*, 7th ed., 1997.  
**Chen, W. F. (ed.)**, *Handbook of Structural Engineering*, 1997.  
**Chopra, A. K.**, *Dynamics of Structures: Theory and Applications to Earthquake Engineering*, 2d ed., 2000.  
**Derucher, K. N., G. P. Korgiatis, and A. S. Ezeldin**, *Materials for Civil and Highway Engineers*, 4th ed., 1998.  
**Hart, G. C., and K. Wong**, *Structural Dynamics for Structural Engineers*, 1999.  
**Merritt, F. S., M. K. Loftin, and J. T. Ricketts (eds.)**, *Standard Handbook for Civil Engineering*, 5th ed., 2003.  
**Scott, J. S.**, *Dictionary of Civil Engineering*, 4th ed., 1993.  
**Toneas, D. E.**, *Bridge Engineering*, 1994.

*Civil Engineering*, American Society of Civil Engineers, monthly.

## CLASSICAL MECHANICS

- Ayra, A. P.**, *Introduction to Classical Mechanics*, 1997.  
**Baierlein, R.**, *Newtonian Dynamics*, 1983.  
**Barger, V. D., and M. G. Olsson**, *Classical Mechanics: A Modern Perspective*, 2d ed., 1995.  
**Chow, T. L.**, *Classical Mechanics*, 1995.

- Halliday, D., and R. Resnick**, *Fundamentals of Physics*, 6th ed., 2002.  
**José, J. V., and E. J. Saletan**, *Classical Dynamics, A Contemporary Approach*, 1998.  
**Goldstein, H., C. P. Poole, and J. L. Safko**, *Classical Mechanics*, 3d ed., 2002.  
**Reichert J. F.**, *A Modern Introduction to Mechanics*, 1991.  
**Shepley, L., and R. Matzner**, *Classical Mechanics*, 1991.

*Archive for Rational Mechanics and Analysis*, 16 times a year.

*Quarterly Journal of Mechanics and Applied Mathematics*, quarterly.

## CLIMATOLOGY AND METEOROLOGY

- Ahrens, C. D.**, *Meteorology Today*, 5th ed., 1994.  
**Berger, A. L., S. H. Schneider, and J. C. Duplessy (eds.)**, *Climate and Geo-Sciences*, 1989.  
**Bryant, E.**, *Climate Process and Change*, 1997.  
**Danielson, E. W., and J. Levin**, *Meteorology*, 1997.  
**Finlayson-Pitts, B. J., and J. N. Pitts, Jr.**, *Chemistry of the Upper and Lower Atmosphere*, 2000.  
**Glantz, M. H. (ed.)**, *The Role of Regional Organizations in Context of Climate Change*, 1993.  
**Hidore, J. J., and J. E. Oliver**, *Climatology: An Atmospheric Science*, 1997.  
**Hornak, K. A.**, *Dictionary of Meteorology and Climatology, English/Spanish*, 1997.  
**Houghton, J. R.**, *An Introduction to Dynamic Meteorology*, 1992.  
**Liou, K. N.**, *An Introduction to Atmospheric Radiation*, 2d ed., 2002.  
**Lutgens, F., E. Tarbuck, and D. Tasa**, *The Atmosphere: An Introduction to Meteorology*, 9th ed., 2003.  
**Pruppacher, H. R., and J. D. Klett**, *Microphysics of Clouds and Precipitation*, 1997.  
**Scorer, R. S.**, *Dynamics of Meteorology and Climate*, 1997.  
**Wang, P. K.**, *Ice Microdynamics*, 2002.

*Bulletin of the American Meteorological Society*, American Meteorological Society, monthly.

*Journal of the Atmospheric Sciences*, American Meteorological Society, semimonthly.

*Journal of Climate*, American Meteorological Society, monthly.

*Journal of Applied Meteorology*, American Meteorological Society, monthly.

## COMMUNICATIONS

See Data communications; Radio communication; Telecommunications.

## COMPUTER SCIENCE

- Abelson, H., G. Sussman, and J. Sussman**, *Structure and Interpretation of Computer Science*, 2d ed., 1997.  
**Baase, S.**, *Computer Algorithms: Introduction to Design and Analysis*, 1999.  
**Hamacher, V. C., Z. G. Vranesic, and S. G. Zaky**, *Computer Organization*, 5th ed., 2001.

- Hayes, J. P.**, *Computer Architecture and Organization*, 3d ed., 1997.
- Hennessey, J. L., and D. A. Patterson**, *Computer Organization and Design*, 1994.
- Long, L., and N. Long**, *Computers: Information Technology in Perspective*, 11th ed., 2003.
- Maxfield, C., and P. Waddell**, *Bebop to Boolean Boogie*, 2002.
- Null, L., and J. Lobur**, *The Essentials of Computer Organization and Architecture*, 2003.
- Ralston, A., and E. D. Reilly** (eds.), *Encyclopedia of Computer Science and Engineering*, 4th ed., 2003.
- Sebesta, R.**, *Concepts of Programming Languages*, 2003.
- Sommerville, I.**, *Software Engineering*, 2004.
- Tabak, D.**, *Advanced Microprocessors*, 2d ed., 1995.
- Tanenbaum, A.**, *Modern Operating Systems*, 2001.
- Tjaden, B.**, *Fundamentals of Secure Computing Systems*, 2002.

- Communications of the Association for Computing Machinery*, monthly.
- Computer and Control Abstracts* (Science Abstracts, Section C), INSPEC, Institution of Electrical Engineers, monthly.
- IEEE Spectrum*, Institute of Electrical and Electronics Engineers, Inc., monthly.
- Journal of the Association for Computing Machinery*, bimonthly.

## CONSERVATION

- Dasmann, R. F.**, *Environmental Conservation*, 6th ed., 2004.
- Frankham, R., J. D. Ballou, and D. A. Briscoe**, *A Primer of Conservation Genetics*, 2004.
- Hambler, C.**, *Conservation* (Studies in Biology), 2004.
- Meffe, G. K., and C. R. Carroll**, *Principles of Conservation Biology*, 3d ed., 2005.
- Kircher, H. B.**, *Our Natural Resources and Their Conservation*, 7th rev. ed., 1992.
- Owen, O., and D. D. Chiras**, *Natural Resources Conservation: An Ecological Approach*, 5th ed., 1990.
- Primack, R. B.**, *Essentials of Conservation Biology*, 2004.
- American Institute for Conservation Journal*, semi-annually.
- Audubon Magazine*, Audubon Society, bimonthly.
- Conservation*, bimonthly.
- New York State Conservationist*, New York State Department of Environmental Conservation, bimonthly.

## CONTROL SYSTEMS

- Clark, R. N.**, *Control System Dynamics*, 1996.
- Close, C. M., and D. K. Frederick**, *Modeling and Analysis of Dynamic Systems*, 3d ed., 2002.
- D'Azzo, J. J., and C. H. Houpis**, *Linear Control System Analysis and Design*, 1995.
- Dorf, R. C., and R. H. Bishop**, *Modern Control Systems*, 10th ed., 2004.
- Grantham, W. J., and T. L. Vincent**, *Modern Control Systems Analysis and Design*, 1993.
- Kuo, B. C.**, *Automatic Control Systems*, 7th ed., 1995.
- Lewis, F. L., and V. L. Symos**, *Optimal Control*, 2d ed., 1995.
- Phillips, C. L., and R. Harbor**, *Feedback Control Systems*, 4th ed., 1999.

- Raven, F.**, *Automatic Control Engineering*, McGraw-Hill Series in Mechanical Engineering, 5th ed., 1994.

- Computer and Control Abstracts* (Science Abstracts, Section C0), INSPEC, Institution of Electrical Engineers, monthly.
- Control Engineering*, monthly.

## COSMOLOGY

- Danielson, D.**, *The Book of the Cosmos*, 2000.
- Goldsmith, D.**, *Connecting with the Cosmos*, 2002.
- Kirshner, R. P.**, *The Extravagant Universe*, 2002.
- Lemonick, M.**, *Echo of the Big Bang*, 2003.
- Rees, M.**, *Our Cosmic Habitat*, 2001.
- Rowan-Robinson, M.**, *Cosmology*, 4th ed., 2003.
- Stern, S. A.**, *Our Universe: The Thrill of Extragalactic Exploration as Told by Leading Experts*, 2001.

## CRYSTALLOGRAPHY

- Borchardt-Ott, W.**, *Crystallography*, 2d ed., 1995.
- Engel, P.**, *Geometric Crystallography: An Axiomatic Introduction to Crystallography*, 1986.
- Giacovazzo, C.** (ed.), *Fundamentals of Crystallography*, 1992.
- Glusker, J. P., and K. N. Trueblood**, *Crystal Structure Analysis: A Primer*, 2d ed., 1985.
- Guinier, A.**, *X-Ray Diffraction*, reprint ed., 1994.
- Hammond, C.**, *The Basics of Crystallography and Diffraction* (International Union on Crystallography Texts on Crystallography), 2d ed., 2001.
- Klug, H., and L. Alexander**, *X-Ray Diffraction Procedures*, 1974.
- O'Keefe, M., and B. G. Hyde**, *Symmetry and Structures of Crystal*, 1999.
- Vainshtein, B. K.**, *Fundamentals of Crystals*, 2d ed., 1995.
- Acta Crystallographica*, Sections A, B, and D, bimonthly; Section C, monthly.

## DATA COMMUNICATIONS

- Bertsekas, D. P.**, *Data Networks*, 2d ed., 1991.
- De Prycker, M.**, *Asynchronous Transfer Mode: Solution for Broadband ISDN*, 3d ed., 1995.
- Forouzan, B. A.**, *Data Communications and Networking*, 3d ed., 2003.
- Ginsburg, D.**, *ATM Solutions for Enterprise Internetworking*, 2d ed., 1999.
- Halsall, F.**, *Data Communications, Computer Networks and Open Systems*, 4th ed., 1996.
- Kurose, J. F., and K. W. Ross**, *Computer Networking: A Top-Down Approach Featuring the Internet*, 3d ed., 2005.
- Stallings, W.**, *Data and Computer Communications*, 7th ed., 2003.
- Tanenbaum, A. S.**, *Computer Networks*, 4th ed., 2002.
- White, C. M.**, *Data Communications and Computer Networks*, 2d ed., 2002.

- Data Communications*, 18 issues per year.

**DATA PROCESSING**

- Fuori, W. M., and L. Gioia**, *Computers and Information Processing*, 4th ed., 1994.
- Fuller, F.**, *Computers and Information Processing*, 1996.
- Harris, M. L.**, *Introduction to Data Processing*, 3d ed., 1991.
- Long, L.**, *Introduction of Computers and Information Systems*, 4th ed., 1996.
- Murdock, E. E.**, *Computers Today!*, 1995.
- O'Brien, J. A.**, *Introduction to Information Systems*, 12th ed., 2004.
- Stern, N. B., and R. A. Stern**, *Computing in the Information Age*, 1993.

*Datamation*, monthly.

*IBM Systems Journal*, International Business Machines Corp., quarterly.

**DESIGN ENGINEERING**

- Amirouche, F. M.**, *Principles of Computer-Aided Design and Manufacturing*, 2d ed., 2003.
- Dieter, G.**, *Engineering Design: A Materials and Processing Approach*, 3d ed., 1999.
- Earle, J. H.**, *Engineering Design Graphics*, 9th ed., 1997.
- Juvinal, R. C., and K. Marshek**, *Fundamentals of Machine Component Design*, 3d ed., 2003.

*Journal of Mechanical Design*, American Society of Mechanical Engineers, quarterly.

**DEVELOPMENTAL BIOLOGY**

- Beysens, D., G. Forgacs, and F. Gaill**, *Interplay of Genetic and Physical Processes in the Development of Biological Form*, 1995.
- Browder, L. W., C. A. Erickson, and W. R. Jeffrey**, *Developmental Biology*, 3d ed., 1991.
- Carlson, B. M.**, *Human Embryology and Developmental Biology*, 2d ed., 1999.
- Gilbert, S. F.**, *Developmental Biology*, 6th ed., 2000.
- Vander Zanden, J. W., et al.**, *Human Development*, 7th updated edition, 2002.
- Hall, B. K.**, *Evolutionary Developmental Biology*, 1998.
- Oppenheimer, S. B.**, *Introduction to Embryonic Development*, 3d rev. ed., 1988.
- Russo, V. E., et al.**, *Development: The Molecular Genetic Approach*, 1993.

*Current Opinion in Genetics and Development*, bimonthly.

*Developmental Biology*, monthly.

*Excerpta Medica*, Section 21: Developmental Biology and Teratology, 10 issues per year.

*Genes and Development*, Cold Spring Harbor Laboratory Press, bimonthly.

*Roux' Archives of Developmental Biology*, semiannually.

**ECOLOGY**

- Bolen, E. G., and W. L. Robinson**, *Wildlife Ecology and Management*, 5th ed., 2002.

**Conner, J. K., and D. L. Hartl**, *A Primer of Ecological Genetics*, 2004.

**Gotelli, N. J.**, *A Primer of Ecology*, 3d ed., 2001.

**Molles, Jr., M. C.**, *Ecology: Concepts and Applications*, 2d ed., 2002.

**Pianka, E. R.**, *Evolutionary Ecology*, 6th ed., 1999.

**Ricklefs, R. E., and G. Miller**, *Ecology*, 4th ed., 1999.

**Roughgarden J., et al.** (eds.), *Perspectives in Ecological Theory*, 1989.

**Smith, R. L., and T. Smith**, *Ecology and Field Biology*, 6th ed., 2001.

**Walker, L. R., and R. del Moral**, *Primary Succession and Ecosystem Rehabilitation* (Cambridge Studies in Ecology), 2003.

**Westman, W. E.**, *Ecology Impact, Assessment and Environmental Planning*, 1985.

*Annual Review of Ecology and Systematics*, annually.

*Ecological Monographs*, Ecological Society of America, quarterly.

*Ecology*, Ecological Society of America, 6 issues per year.

*Journal of Environmental Sciences*, Institute of Environmental Sciences, bimonthly.

**ELECTRICAL POWER ENGINEERING**

**Bobrow, L. S.**, *Fundamentals of Electrical Engineering*, 2d ed., 1996.

**Chapman, S. J.**, *Electric Machinery Fundamentals* (McGraw-Hill Series in Electrical and Computer Engineering), 4th ed., 2003.

**El-Hawary, M. E.**, *Electrical Energy Systems*, 2000.

**El-Hawary, M. E.**, *Principles of Electric Machines with Power Electronic Applications*, 2002.

**Fink, D. G., and H. W. Beaty** (eds.), *Standard Handbook for Electrical Engineering*, 14th ed., 1999.

**Fitzgerald, A. E., C. Kingsley, and S. Umans**, *Electric Machinery*, 6th ed., 2002.

**Grainger, J. J., and W. D. Stevenson**, *Power System Analysis*, 1994.

**Guru, B. S., and H. R. Hiziroglu**, *Electric Machinery and Transformers*, 2d ed., 1994.

**Hambley, A. R.**, *Electrical Engineering: Principles and Applications*, 2d ed., 2001.

**Nasar, S. A.**, *Electric Machines and Power Systems*, 1995.

**Paul, C. R., S. A. Nasar, and L. Unnewehr**, *Introduction to Electrical Engineering*, 2d ed., 1992.

**Richardson, D. V., and A. J. Caisse, Jr.**, *Rotating Electric Machinery and Transformer Technology*, 4th ed., 1996.

**Ryff, P. F.**, *Electric Machinery*, 2d ed., 1994.

**Saadat, H.**, *Power System Analysis*, 2002.

*C&M* (Electrical Construction and Maintenance), monthly.

*Electric Power and Energy Magazine*, IEEE Power Engineering Society, bimonthly.

*Electrical and Electronics Abstracts* (Science Abstracts, Section B), INSPEC, Institution of Electrical Engineers, monthly.

*Electrical World*, monthly.

*IEEE Spectrum*, Institute of Electrical and Electronics Engineers, Inc., monthly.

**ELECTRICITY AND MAGNETISM**

- Cottingham, W. N., and D. A. Greenwood**, *Electricity and Magnetism*, 1991.



- Duffin, W. J.**, *Electricity and Magnetism*, 4th ed., 1990.  
**Fowler, R. J.**, *Electricity: Principles and Applications*, 4th ed., 1993.  
**Jackson, J. D.**, *Classical Electrodynamics*, 3d ed., 1998.  
**Morley, A., and E. Hughes**, *Principles of Electricity*, 5th ed., 1994.  
**Purcell, E. M.**, *Electricity and Magnetism*, Berkeley Physics Course, vol. 2, 2d ed., 1985.  
**Schwartz, M.**, *Principles of Electrodynamics*, reprint, 1987.

*Journal of Magnetism and Magnetic Materials*, 3 issues per month.

## ELECTROMAGNETIC FIELDS AND RADIATION

- Guru, B., and H. Hiziroğlu**, *Electromagnetic Field Theory Fundamentals*, 2d ed., 2004.  
**Inan, U., and A. Inan**, *Engineering Electromagnetics*, 1999.  
**Lorrain, P.**, *Electromagnetic Fields and Waves*, 3d ed., 1995.  
**Paul, C. R., S. A. Nasar, and K. Whites**, *Introduction to Electromagnetic Fields*, 3d ed., 1997.  
**Popović, Z., and B. D. Popović**, *Introductory Electromagnetics*, 2000.  
**Rohan, P.**, *Introduction to Electromagnetic Wave Propagation*, 1991.  
**Sadiku, M.**, *Elements of Electromagnetics* (Oxford Series in Electrical and Computer Engineering), 3d ed., 2000.  
**Smith, G. S.**, *An Introduction to Classical Electromagnetic Radiation*, 1997.

## ELECTRONIC CIRCUITS

- Bogart, T. F.**, *Electronic Devices and Circuits*, 4th ed., 1997.  
**Boylestad, R., et al.**, *Electronic Devices and Circuit Theory*, 6th ed., 1995.  
**Brophy, J. J.**, *Basic Electronics for Scientists*, 5th ed., 1990.  
**Burns, S. G., and P. R., Bond**, *Principles of Electronic Circuits*, 2d ed., 1997.  
**Rabaey, J. M., A. Chandraka, and B. Nikolic**, *Digital Integrated Circuits*, 2d ed., 2002.  
**Grey, P. R., et al.**, *Analysis and Design of Analog Integrated Circuits*, 4th ed., 2001.  
**Malvino, A. P.**, *Electronic Principles*, 6th ed., 1998.  
**Millman, J., and A. Grabel**, *Microelectronics* (McGraw-Hill Series in Electrical Engineering), 2d ed., 1987.  
**Paynter, R. T.**, *Introductory Electronic Devices and Circuits* (Electron Flow Version), 5th ed., 1999.  
**Reed, D. G.**, *The AARL Handbook for Radio Communications*, Association for Amateur Radio, annually.  
**Sedra, A. S., and K. C. Smith**, *Microelectronic Circuits* (Oxford Series in Electrical Engineering), 4th ed., 1997.

*Electrical and Electronics Abstracts* (Science Abstracts, Section B), INSPEC, Institution of Electrical Engineers, monthly.

*Electronic Design*, biweekly.

*Electronics*, biweekly.

*IEEE Spectrum*, Institute of Electrical and Electronics Engineers, Inc., monthly.

## ELECTRONICS

See Electronic circuits; Physical electronics.

## ELEMENTARY PARTICLES

- Alliday, J.**, *Quarks, Leptons and the Big Bang*, 2d ed., 2002.  
**Coughlan, G. D., and J. E. Dodd**, *The Ideas of Particle Physics: An Introduction for Scientists*, 2d ed., 1991.  
**Griffiths, D.**, *Introduction to Elementary Particles*, 1987.  
**Halzen, F., and A. D. Martin**, *Quarks and Leptons: An Introductory Course in Modern Particle Physics*, 1984.  
**Huang, K.**, *Quarks, Leptons and Gauge Fields*, 1992.  
**Hughes, I. S.**, *Elementary Particles*, 3d ed., 1991.  
**Kane, G.**, *Modern Elementary Particle Physics: The Fundamental Particle and Forces*, updated ed., 1993.  
**Perkins, D. H.**, *An Introduction to High Energy Physics*, 4th ed., 2000.  
**Riazuddin, F.**, *A Modern Introduction to Particle Physics*, 1994.  
**Rolnick, W. B.**, *The Fundamental Particles and Their Interactions*, 1994.  
**Weinberg, S.**, *The Discovery of Subatomic Particles*, revised, 2d ed., 2003.

*Nuclear Physics*, Section B, 81 issues per year.

*Physical Review D*, American Physical Society, semimonthly.

## EMBRYOLOGY

See Developmental biology.

## ENGINEERING

See Aeronautical engineering; Architectural engineering; Automotive engineering; Biomedical engineering; Chemical engineering; Civil engineering; Design engineering; Electrical power engineering; Environmental engineering; Food engineering; Genetic engineering; Industrial engineering; Marine engineering; Mechanical engineering; Metallurgical engineering; Mining engineering; Nuclear engineering; Petroleum engineering; Production engineering; Systems engineering; Transportation engineering.

## ENVIRONMENTAL CHEMISTRY

- Armour, M.**, *Hazardous Laboratory Chemicals Disposals Guide*, 3d spiral ed., 2003.  
**Burke, R.**, *Hazardous Materials Chemistry for Emergency Responders*, 2d ed., 2002.  
**Furr, K. A.**, *CRC Handbook of Laboratory Safety*, 5th ed., 2000.  
**Hathaway, G. J., N. H. Proctor, and J. P. Hughes**, *Proctor and Hughes' Chemical Hazards of the Workplace*, 4th ed., 1996.  
**Lund, H. F.** (ed.), *The McGraw-Hill Recycling Handbook*, 1993.  
**Manahan, S. E.**, *Environmental Chemistry*, 8th ed., 2004.  
**Parkin, G.**, *Chemistry for Environmental Engineering and Science*, 2002.  
**Pawłowski, L., et al.** (eds.), *Chemistry for Protection of the Environment*, 1998.  
**Quigley, D. R.**, *The Essential Pocket Book of Emergency Chemical Management*, spiral ed., 1996.

- Environmental Science and Technology*, American Chemical Society, semimonthly.  
*Journal of Environmental Engineering*, American Society of Civil Engineers, monthly.

## ENVIRONMENTAL ENGINEERING

- Banham, R.**, *The Architecture of the Well-Tempered Environment*, 2d rev. ed., 1984.  
**Barrett, G. W., and R. Rosenberg** (eds.), *Stress Effects on Natural Ecosystems*, 1982.  
**Holmes, J. R.**, *Practical Waste Management*, 1990.  
**Kiely, G.**, *Environmental Engineering*, 1996.  
**Lin, S. D.**, *Handbook of Environmental Engineering Calculations*, 2000.  
**Linaweaver, F. P.** (ed.), *Environmental Engineering*, 1992.  
**Revelle, C. S., E. E. Whitlatch, and J. R. Wright**, *Civil Engineering Systems*, 2d ed., 2003.  
**Salvato, J. A., N. L. Nemerow, and F. J. Agardy**, *Environmental Engineering and Sanitation*, 5th ed., 2003.  
**White, I. D., D. Mottershead, and S. J. Harrison**, *Environmental Systems: An Introductory Text*, 2d ed., 1993.
- The Diplomat*, American Academy of Environmental Engineers, quarterly.  
*Environmental Engineering Science*, monthly.  
*Journal of Environmental Engineering*, monthly.  
*Journal of Environmental Sciences*, Institute of Environmental Engineers, bimonthly.

## EVOLUTION

- Bell, G.**, *Selection: The Mechanisms of Evolution*, 1996.  
**Futuyma, D. J.**, *Evolutionary Biology*, 3d ed., 1998.  
**Hall, B. K.**, *Evolutionary Developmental Biology*, 2d ed., 1998.  
**Li, W.-H.**, *Molecular Evolution*, 1997.  
**Strickberger, M. W.**, *Evolution*, 3d ed., 2000.  
**Williams, G. C.**, *Adaptation and Natural Selection: A Critique of Some Current Evolutionary Thought*, 1996.
- Evolution*, The Society for the Study of Evolution, bimonthly.  
*Journal of Molecular Evolution*, Springer-Verlag, New York, bimonthly.

## FLUID MECHANICS

- Currie, I. G.**, *Fundamental Mechanics of Fluids* (Mechanical Engineering), 3d ed., 2002.  
**Douglas, J. F., J.M. Gaisorek, and J. A. Swaffield**, *Fluid Mechanics*, 3d ed., 1996.  
**Evett, J., and C. Liu**, *Fundamentals of Fluid Mechanics*, 1987.  
**Fay, J. A.**, *Introduction to Fluid Mechanics*, 1994.  
**Fox, R. W., A. T. McDonald, and P. J. Pritchard**, *Introduction to Fluid Mechanics*, 6th ed., 2003.  
**Franzini, J. B., and J. E. Finnemore**, *Fluid Mechanics with Engineering Applications*, 10th ed., 2001.  
**C. T. Crowe, D. F. Elger, and J. A. Roberson**, *Engineering Fluid Mechanics*, 7th ed., 2000.  
**Kindu, P. K., and I. M. Cohen**, *Fluid Mechanics*, 3d ed., 2004.

- Munsor, B. R., D. F. Young, and T. H. Dkishi**, *Fundamentals of Fluid Mechanics*, 4th ed., 2002.  
**Shames, I. H.**, *Mechanics of Fluids*, 4th ed., 2002.  
**Streeter, V. L., E. B. Wylie, and K. W. Bedford**, *Fluid Mechanics*, 9th ed., 1997.  
**White, F. M.**, *Fluid Mechanics with Student Resources* (CD-ROM), 5th ed., 2002.

- Applied Scientific Research*, Central National Organization for Applied Scientific Research in the Netherlands, quarterly.  
*Physics of Fluids*, American Institute of Physics, monthly.

## FOOD ENGINEERING

- Griffin, Jr., R. C., S. Sacharow, and A. L. Brody**, *Principles of Package Development*, 2d ed., 1993.  
**Heldman, D. R., and D. B. Lund**, *Handbook of Food Engineering*, 2d ed., 2004.  
**Jay, J. M.**, *Modern Food Microbiology*, 6th ed., 2000.  
**Singh, R. P., and D. R. Heldman**, *Introduction to Food Engineering*, 3d ed., 2001.

- Food Chemistry*, Elsevier, monthly.  
*Food Technology*, Institute of Food Technologists, monthly.  
*Journal of Agricultural and Food Chemistry*, American Chemical Society, biweekly.

## FORENSIC SCIENCE

- Fisher, B. A. J.**, *Techniques of Crime Scene Investigation*, 7th ed., 2004.  
**Nordby, J. J.**, *Forensic Science: An Introduction to Scientific and Investigative Techniques*, 2005.  
**Saferstein, R. E.**, *Criminalistics: An Introduction to Forensic Science*, 8th ed., 2003.
- Forensic Science Communications*, FBI, quarterly.  
*Forensic Science International*, Elsevier, semimonthly.  
*Journal of Analytical Toxicology*, Society of Forensic Toxicologists, 8 issues per year.  
*Journal of Forensic Identification*, International Association for Identification, bimonthly.  
*Journal of Forensic Sciences*, American Academy of Forensic Sciences, bimonthly.  
*Science and Justice*, Forensic Science Society, U.K., quarterly.

## FORESTRY

- Anderson, D., and I. I. Holland** (eds.), *Forests and Forestry*, 4th ed., 1997.  
**Gholz, H. L.** (ed.), *Agroforestry: Realities, Possibilities and Potentials*, 1987.  
**Landsberg, J. J., and S. T. Gower**, *Applications of Physiological Ecology to Forest Management*, 1996.  
**Leuschner, W. A.**, *Introduction to Forest Resource Management*, 1992.  
**Matthews, J. D.**, *Silvicultural Systems*, 1991.  
**Sharpe, G. W., and C. Hendes**, *Introduction to Forestry*, 6th ed., 1995.

- Shugart, H. H.**, *A Theory of Forest Dynamics: The Ecological Implications of Forest Succession Models*, 2003.
- Young, A.**, *Agroforestry for Soil Conservation* (Science and Practice of Agroforestry), 1989.

*Forest Products Journal*, Forest Products Research Society, monthly.

*Forest Science*, Society of American Foresters, quarterly.

*Journal of Forestry*, Society of American Foresters, monthly.

## GENETIC ENGINEERING

- Bourgaize, D. B., T. P. Jewell, and R. Bruiser**, *Introduction to Biotechnology*, 1999.
- Nicholl, D. S. T.**, *An Introduction to Genetic Engineering*, 2002.
- Primrose, S. B., R. W. Old, and R. M. Twyman**, *Principles of Gene Manipulation*, 6th ed., 2002.
- Setlow, J. K.** (ed.), *Genetic Engineering: Principles and Methods*, 2002.
- Singer, M., and P. Berg**, *Exploring Genetic Mechanisms*, 1997.
- Watson, J. D.**, *Recombinant DNA*, 2d ed., 1995.
- Weaver, R. F.**, *Molecular Biology*, 3d ed., 2005.

*Biotechnology News*, biweekly.

*Biotechnology Progress*, bimonthly.

*Genetic Engineering News*, biweekly.

*Nature Biotechnology*, monthly.

## GENETICS

- Dobzhansky, T.**, *Genetics and the Origin of Species*, 1982.
- Hall, J. C., J. C. Dunlap, and T. Friedman**, *Advances in Genetics*, vol. 49, 2003.
- Hartwell, L., et al.**, *Genetics: From Genes to Genomes*, 2004.
- King, R. C., and W. D. Stansfield**, *Dictionary of Genetics*, 6th ed., 2002.
- Klug, W. S., and M. R. Cummings**, *Concepts of Genetics*, 6th ed., 2002.
- Scriver, C. R., et al.**, *The Metabolic Basis of Inherited Disease*, 8th ed., 2001.
- Starr, C., and Taggart, R.**, *Cell Biology and Genetics* (with CD-ROM and InfoTrac), 10th ed., 2003.
- Vogel, F., and A. G. Motulsky**, *Human Genetics: Problems and Approaches*, 1997.
- Watson, J. D., and A. Berry**, *DNA: The Secret of Life*, 2003.
- Watson, J. D., et al.**, *Molecular Biology of the Gene*, 5th ed., 2003.

*American Journal of Human Genetics*, bimonthly.

*Annual Review of Genetics*, annually.

*Annual Review of Genomics and Human Genetics*, annually.

*Gene*, semiweekly.

*Genetics*, Genetics Society of America, monthly.

*Journal of Heredity*, American Genetic Association, bimonthly.

*Molecular and General Genomics*, monthly.

## GEOCHEMISTRY

- Brownlow, A. H.**, *Geochemistry*, 2d ed., 1995.
- Chester, R.**, *Marine Geochemistry*, 2d ed., 2003.
- Engel, M., and S. Mako** (eds.), *Organic Chemistry, Principles and Applications* (Topics in Geobiology), 1993.
- Faure, G.**, *Principles and Applications of Inorganic Geochemistry*, 2d ed., 1997.
- Hoefs, J.**, *Stable Isotope Geochemistry*, 5th ed., 2004.

*Chemical Geology*, Elsevier, monthly.

*Geochimica et Cosmochimica Acta*, Elsevier, semimonthly.

## GEOGRAPHY

- Gaile, G. L., and C. J. Willmott** (eds.), *Geography in America at the Dawn of the 21st Century*, 2004.
- Gould, P.**, *Becoming a Geographer (Space, Place, and Society)*, 2000.
- McKnight, T. L., and D. Hess**, *Physical Geography: A Landscape Appreciation*, 8th ed., 2004.
- Muehrcke, P. C.**, *Map Use: Reading, Analysis and Interpretation*, 1998.
- Robinson, A. H., et al.**, *Elements of Cartography*, 1995.
- Strahler, A. H., and A. N. Strahler**, *Introducing Physical Geography*, 3d ed., 2002.
- Wieden, F. T.**, *Physical Geography*, 1995.

*Focus*, American Geographical Society, quarterly.

*Geographical Review*, American Geographical Society, quarterly.

*The Professional Geographer*, Association of American Geographers, quarterly.

## GEOLOGY

- Ager, D. V.**, *Nature of the Stratigraphical Record*, 3d ed., 1993.
- Condie, K. C., and R. E. Sloon**, *Origin and Evolution of Earth: Principles of Historical Geology*, 1998.
- Hallam, A.**, *Great Geological Controversies*, 2d ed., 1990.
- Lutgens, F. K., E. J. Tarbuck, and D. Tasa**, *Essentials of Geology*, 8th ed., 2002.
- Montgomery, C. W.**, *Physical Geology*, 3d ed., 1992.
- Press, F., and R. Siever**, *Understanding Earth*, 3d ed., 2000.
- Skinner, B. J., and S. C. Porter**, *Dynamic Earth: An Introduction to Physical Geology*, 5th ed., 2003.
- Tarbuck, E. J., F. K. Lutgens, and D. Tasa**, *The Earth: An Introduction to Physical Geology*, 8th ed., 2004.

*Annual Reviews of Earth and Planetary Sciences*, annually.

*Episodes, International Union of Geological Sciences*, quarterly.

*Geotimes*, American Geological Institute, monthly.

*GSA Bulletin*, Geological Society of America, monthly.

*Journal of Geology*, University of Chicago Press, bimonthly.

## GEOMETRY

- Baldwin, H. L., Jr.**, *Essential Geometry*, 1993.
- Coxeter, H. S. M.**, *Non-Euclidean Geometry*, 1998.
- Coxeter, H. S. M.**, *Projective Geometry*, 2d ed., 2003.

- Do Carmo, M. P.**, *Riemannian Geometry*, 1994.
- Greenberg, M.**, *Euclidean and Non-Euclidean Geometries: Development and History*, 3d ed., 1995.
- Gustafson, R. D., and P. D. Frisk**, *Elementary Geometry*, 3d ed., 1991.
- Hartshorne, R.**, *Algebraic Geometry*, rev. ed., 1991.
- Jacobs, H. R.** (ed.), *Geometry, Seeing, Doing, Understanding*, 3d ed., 2003.
- Lang, S., and G. Murrow**, *Geometry*, 2d ed., 2001.
- O'Daffer, P. G., and S. R. Clemens**, *Geometry: An Investigative Approach*, 2d ed., 1992.
- O'Neil, B.**, *Elementary Differential Geometry*, 2d ed., 1997.
- Pare, E. G., et al.**, *Descriptive Geometry*, 9th ed., 1996.
- Smith, K. E., et al.**, *An Invitation to Algebraic Geometry*, 2001.
- Woodwark, J.** (ed.), *Geometric Reasoning* (Oxford Science Publication), 1990.

## GEOMORPHOLOGY

- Bloom, A. L.**, *Geomorphology: A Systematic Analysis of Late Cenozoic Landforms*, 3d ed., 1997.
- Easterbrook, D. J.**, *Surface Processes and Landforms*, 2d ed., 1998.
- Goudie, A.**, *The Changing Earth: Geomorphological Processes and Time*, 1995.
- Leopold, L. B., M. G. Wolmon, and J. P. Miller**, *Fluvial Process in Geomorphology*, 1995.
- Thomas, D. S.** (ed.), *Arid Zone Geomorphology: Process, Form and Change in Drylands*, 2d ed., 1999.
- Walker, H. J., and W. E. Grabau** (eds.), *The Evolution of Geomorphology: A Nation-by-Nation Summary of Development*, 1993.

*Earth Surface Processes and Landforms*, Wiley, bimonthly.

## GEOPHYSICS

- Bertotti, B., and P. Farinella**, *Physics of the Earth and the Solar System, Dynamics, Evolution, Space, Navigation, Space-time Structure* (Geophysics and Astrophysics Monographs), 1990.
- Fowler, C. M.**, *The Solid Earth: An Introduction to Global Geophysics*, 1990.
- Shearer, P.**, *Introduction to Seismology*, 1999.
- Telford, W. M., L. P. Geldart, and R. E. Sheriff**, *Applied Geophysics*, 2d ed., 1990.
- Turcotte, D. L., and G. Schubert**, *Geodynamics*, 2d ed., 2001.

*Eos*, American Geophysical Union, weekly.

*Journal of Geophysical Research* (issued in three parts), American Geophysical Union, monthly.

*Reviews in Geophysics*, American Geophysical Union, quarterly.

## GRAPHIC ARTS

- Adams, J. M., and D. D. Faux**, *Printing Technology: A Medium of Visual Communications*, 4th ed., 1995.

- Conover, T. E.**, *Graphic Communications Today*, 3d ed., 1996.
- Glassman, A.** (ed.), *Printing Fundamentals*, 1997.
- Grotta, S. W., and D. Grotta**, *The Illustrated Digital Imaging Dictionary*, 1998.
- Ihrig, S., and E. Ihrig**, *Preparing Digital Images for Print*, 1996.
- Levenson, H. R.**, *Graphic Arts and Desktop Publishing Pocket Dictionary*, 1995.
- Stevenson, G. A.**, *Graphic Arts Encyclopedia*, 3d ed., revised by W. A. Pagan, 1992.

*Journal of Imaging Science and Technology*, Society for Imaging Science and Technology, bimonthly.

## HYDROLOGY

- Barcelona, M.**, *Contamination of Groundwater: Prevention Assessment, Restoration* (Pollution Technology Review), 1990.
- Black, P. E.**, *Watershed Hydrology*, 2d ed., 1996.
- Dunne, T., and L. B. Leopold**, *Water in Environmental Planning*, 1995.
- Gupta, R. S. S.**, *Hydrology and Hydraulic Systems*, 2001.
- Linsley, R. K., et al.**, *Hydrology for Engineers*, 3d ed. (McGraw-Hill Series in Water Resources & Environmental Engineering), 1982.
- Ponce, V. M.**, *Engineering Hydrology: Principles and Practices*, 1989.
- Wilson, E. M.**, *Engineering Hydrology*, 4th ed., 1990.

*Hydrological Sciences Journal*, International Association of Hydrological Sciences (U.K.), quarterly.

*Journal of Hydrology*, Elsevier, monthly.

## ILLUMINATION

- Coaton, J. R., and M. Marsden**, *Lamps and Lighting*, 4th ed., 1996.
- Educational Materials Committee Staff, Illumination Engineering Society of North America**, *Introduction to Light and Lighting*, 1991.
- Fitt, B., and J. Thornley**, *The Control of Light*, 1993.
- Gardner, C., and B. Hannaford**, *Lighting Design: An Introductory Guide for Professionals*, 1993.
- Grosslight, J.**, *Light, Light, Light: Effective use of Daylight and Electric Lighting in Residential and Commercial Spaces*, 2d ed., 1991.
- Helms, R., and M. C. Belcher**, *Lighting for Energy Efficient Luminous Environments*, 1991.
- Lindsey, J. L.**, *Applied Illumination Engineering*, 2d ed., 1997.
- Murdoch, J. B.**, *Illumination Engineering: From Edison's Lamp to the Laser*, 1985, reprint 1995.
- Rea, M.** (ed.), *IESNA Lighting Handbook*, Illuminating Engineering Society of North America, 9th ed., 2000.
- Thumann, A.**, *Lighting Efficiency Applications*, 2d ed., 1991.

*LD & A* (Lighting Design & Application), Illuminating Engineering Society, monthly.

## IMMUNOLOGY

- R. Coico et al.**, *Immunology: A Short Course*, 5th ed., 2003.

- Goldsby, R. A., T. J. Kindt, and B. A. Osborne**, *Kuby Immunology*, 4th ed., 2003.
- Janeway, C. A., et al.**, *Immunobiology: The Immune System in Health and Disease*, 5th ed., 2001.
- Parham, P.**, *The Immune System*, 2000.
- Parslow, T. G., et al.**, *Medical Immunology*, 10th ed., 2001.
- Sell, S., and E. Max**, *Immunology, Immunopathology, and Immunity*, 6th ed., 2001.

*Advances in Immunology*, annually.

*Annual Review of Immunology*, annually.

*Immunobiology*, 10 issues per year.

*Immunology*, Abstracts (England), monthly.

*Immunology Letters*, bimonthly.

*Journal of Immunology*, American Association of Immunologists, monthly.

*Trends in Immunology*, Elsevier, monthly.

## INDUSTRIAL ENGINEERING

- Aft, L. S.**, *Work Measurement and Methods Improvement (Engineering Design and Automation)*, 2000.
- Bestfield, D. H.**, *Quality Control*, 7th ed., 2003.
- Chopra, S. and P. Meindl**, *Supply Chain Management*, 2d ed., 2003.
- Groover, M. P.**, *Automation, Production Systems, and Computer-Aided Manufacturing*, 2d ed., 2000.
- Hobbs, D. P.**, *Lean Manufacturing Implementation: A Complete Execution Manual for Any Size Manufacturer*, 2003.
- Salvendy, G.** (ed.), *Handbook of Industrial Engineering: Technology and Operations Management*, 2001.

## INFORMATION THEORY

- Blahut, R. E.**, *Digital Transmission of Information*, 1990.
- Cover, T. M., and J. A. Thomas**, *Elements of Information Theory*, 1991.
- Golomb, S. W., R. E. Peile, and R. A. Scholtz**, *Basic Concepts in Information Theory and Coding*, 1994.
- Ihara, S.**, *Information Theory for Continuous Systems*, 1993.
- Kogan, I. M.**, *Applied Information Theory (Studies in Cybernetics)*, 1988.
- Roman, S.**, *Coding and Information Theory (Graduate Texts in Mathematics)*, 1992.
- Sacco, W., et al.**, *Information Theory: Saving Bits (Contemporary Applied Mathematics)*, 1988.
- Usher, M. J.**, *Information Theory for Information Technologists (Computer Science Series)*, 1984.
- Van Der Lubbe, J. C., and H. J. Hoeve**, *Information Theory*, 2001.
- Vickery, B. C., and A. Vickery**, *Information Sciences Theory and Practice (Guides to Information Sources)*, 1992.

*IEEE Transactions on Information Theory*, Institute of Electrical and Electronics Engineers, Information Theory Group, bimonthly.

*Information Sciences*, 36 issues per year.

## INVERTEBRATE ZOOLOGY

See Zoology.

## LASERS

- P. W. Milonni, and J. H. Eberly**, *Lasers (Wiley Series in Pure and Applied Optics)*, 1988.
- Hecht, J.**, *The Laser Guidebook*, 2d ed., 1992.
- Hecht, J.**, *Understanding Lasers: An Entry-Level Guide (IEEE Press Understanding Science & Technology Series)*, 2d ed., 1993.
- Meschede, D.**, *Optics Light and Lasers*, 2004.
- Saleh, B. E. A., and M. C. Teich**, *Fundamentals of Photonics*, 1991.
- Shimoda, K.**, *Introduction to Laser Physics*, 2d ed., 1991.
- Siegman, A. E.**, *Lasers*, 1986.
- Svelto, O., et al.**, *Principles of Lasers*, 4th ed., 1998.
- Veldyey, J. T.**, *Laser Electronics*, 3d ed., 1994.
- Yariv, A.**, *Optical Electronics*, 5th ed., 1995.
- Young, M.**, *Optics and Lasers: Including Fibers and Optical Waveguides (Advanced Texts in Physics)*, 5th rev. ed., 2000.

*Applied Optics*, Optical Society of America, American Institute of Physics, 36 issues per year.

*Applied Physics B*, Deutsche Physikalische Gesellschaft, 12 issues per year.

*Journal of the Optical Society of America, A, B*, American Institute of Physics, monthly.

## LOW-TEMPERATURE PHYSICS

- Betts, D. S., et al.**, *Introduction to Millikelvin Technology (Cambridge Studies in Low Temperature Physics)*, 1989.
- Brewer, D. F., et al.** (eds.), *Progress in Low Temperature Physics*, vols. 1–14, 1956–1995.
- Clark, A. F., et al.** (eds.), *Advances in Cryogenic Engineering*, vols. 1–14, 1956–1996.
- Dahl, P. F.**, *Superconductivity: Its Historical Roots and Development from Mercury to the Ceramic Oxides*, 1992.
- De Gennes, P. G.**, *Superconductivity of Metals and Alloys (Advanced Book Classics)*, 1999.
- Flynn, T. M.**, *Cryogenic Engineering*, 1996.
- Khalatnikov, I. M.**, *Introduction to the Theory of Superfluidity (Advanced Book Classics)*, 1989.
- Pobell, F.**, *Matter and Methods at Low Temperatures*, 2d ed., 1996.
- Poole, C. P., et al.**, *Superconductivity*, 1996.
- Richardson, R. C., and E. N. Smith**, *Experimental Techniques in Condensed Matter Physics at Low Temperatures (Advanced Book Classics)*, 1998.
- Schrieffer, J. R.**, *Theory of Superconductivity (Advanced Book Classics)*, 1999.
- Tilley, D. R., and J. Tilley**, *Superfluidity and Superconductivity*, 3d ed., 1990.
- Tinkham, M.**, *Introduction to Superconductivity (Dover Books on Physics)*, 2d ed., 2004.
- Wilks, J., and D. S. Betts**, *An Introduction to Liquid Helium*, 2d reprint ed., 1990.

*Cryogenics*, monthly.

*Journal of Low Temperature Physics*, 24 issues per year.

## MAGNETISM

See Electricity and magnetism.

**MARINE ENGINEERING**

- Blank, D. A., and A. E. Bock** (eds.), *Introduction to Naval Engineering*, 2d ed., 1986.
- Harrington, R. L.** (ed.), *Marine Engineering*, rev. ed., 1992.
- Hunt, E. C., et al.**, *Modern Marine Engineer's Manual*, 3d ed., 1999.
- McGeorge H. D.**, *Marine Auxiliary Machinery*, 7th ed., 1999.
- Taylor, D. A.**, *Introduction to Marine Engineering*, 2d ed., 1996.

- Journal of Ship Research*, Society of Naval Architects and Marine Engineers, quarterly.
- Marine Engineers Review*, Institute of Marine Engineers, monthly.
- Marine Technology*, SNAME NEWS, Society of Naval Architects and Marine Engineers, quarterly.
- Transactions of the Society of Naval Architects and Marine Engineers*, annually.

**MATERIALS SCIENCE**

- P. Ball, P.**, *Made To Measure: New Materials for the 21st Century*, 1997.
- Barton A.**, *States of Matter: States of Mind*, 1997.
- Cahn, R. W., P. Haasen, and E. J. Kramer**, *Materials Science and Technology, A Comprehensive Treatment*, 1991.
- Callister, W. D., Jr.**, *Fundamentals of Materials Science and Engineering: An Interactive e-Text*, 5th ed., 2001.
- de Podesta, M.**, *Understanding the Properties of Matter*, 1996.
- Interrante, L. V., and M. J. Hampden-Smith** (eds.), *Chemistry of Advanced Materials: An Overview*, 1998.
- Jones, I. P.**, *Materials Science for Electrical and Electronic Engineers*, 2001.
- Sass, S. L.**, *The Substance of Civilization: Materials and Human History from the Stone Age to the Age of Silicon*, 1998.
- White, M. A.**, *Properties of Materials*, 1999.

- Advanced Materials*, Wiley-VHC, monthly.
- MRS Bulletin*, Materials Research Society, monthly.
- Materials Today*, Elsevier, monthly.
- Nature Materials*, Nature Publishing Group, monthly.
- Nano Letters*, American Chemical Society, monthly.

**MATHEMATICS**

- Bittenger, M.**, *Essential Mathematics*, 7th ed., 1996.
- Korn, G. A., and T. Korn**, *Mathematics Handbook for Scientists and Engineers: Definitions, Theorems, and Formulas for Reference and Review*, 2d rev. ed., 2000.
- Kramer, E. E.**, *The Nature and Growth of Modern Mathematics*, 1983.
- Maki, D. P., and M. Thompson**, *Finite Mathematics*, 4th ed., 1995.
- Mathematical Society of Japan**, *Encyclopedic Dictionary of Mathematics*, 2d ed., 2 vols., edited by K. Ito, 1993.
- Research and Education Association Staff**, *The Essentials of Numerical Analysis*, no. 1 and 2, rev. ed., 1994.

- Setek, W. M., and M. A. Gallo**, *Fundamentals of Mathematics*, 9th ed., 2001.
- Shapiro, S.**, *Thinking About Mathematics: The Philosophy of Mathematics*, 2000.

- Advances in Mathematics*, 16 issues per year.
- American Journal of Mathematics*, bimonthly.
- American Mathematical Monthly*, Mathematical Association of America, 10 issues per year.
- Annals of Mathematics*, bimonthly.

**MECHANICAL ENGINEERING**

- Avallone, E. A., and T. Baumeister III** (eds.), *Marks' Standard Handbook for Mechanical Engineers*, 10th ed., 1996.
- Hicks, T. G.**, *Handbook of Mechanical Engineering Calculations*, 1997.
- Nayler, G. H.F.**, *Dictionary of Mechanical Engineering*, 4th ed., 1996.
- Rothbart, H. A.**, *Mechanical Design Handbook*, 1996.
- Shigley, J. E., C. R. Mischke, and R. Budynas**, *Mechanical Engineering Design*, 7th ed., 2003.

- Mechanical Engineering*, American Society of Mechanical Engineers, monthly.

**MECHANICS**

- See Classical mechanics; Fluid mechanics; Quantum mechanics; Statistical mechanics.

**MEDICAL MICROBIOLOGY**

- Brooks, G. F., et al.**, *Jawetz, Melnick & Adelberg's Medical Microbiology*, 23d ed., 2004.
- Levinson, W.**, *Medical Microbiology and Immunology*, 8th ed., 2004.
- C. A. Mims, H. M. Dockrell, and R. V. Goering**, *Medical Microbiology*, 3d ed., 2004.
- Ryan, K. J., and C. G. Ray**, *Sherris Medical Microbiology: An Introduction to Infectious Diseases*, 4th ed., 2003.

- Annual Review of Microbiology*, annually.
- Antimicrobial Agents and Chemotherapy*, monthly.
- Journal of Clinical Microbiology*, monthly.
- Journal of Medical Microbiology*, monthly.

**MEDICINE AND PATHOLOGY**

- Johnson, L. R., and J. H. Byrne** (eds.), *Essential Medical Physiology*, 3d ed., 2003.
- Kasper, D. L., et al.** (eds.), *Harrison's Principles of Internal Medicine*, 15th ed., 2004.
- Kumar, V., N. Fausto, and A. Abbas**, *Robbins & Cotran Pathologic Basis for Disease*, 7th ed., 2004.
- Rosai, J.**, *Rosai and Ackerman's Surgical Pathology*, 9th ed., 2004.

- Tamparo, C., and M. A. Lewis**, *Diseases of the Human Body*, 3d ed., 2000.  
**Williams, R. H., et al.**, *Williams Textbook of Endocrinology*, 10th ed., 2002.

- American Journal of Cardiology*, monthly.  
*American Journal of Diseases of Children*, American Medical Association, monthly.  
*American Journal of Medical Technology*, American Society for Medical Technology, monthly.  
*American Journal of Medicine*, monthly.  
*American Journal of Pathology*, monthly.  
*American Journal of Surgery*, monthly.  
*Annals of Internal Medicine*, American College of Physicians, monthly.  
*Cancer*, American Cancer Society, semimonthly.  
*Cardiovascular News*, monthly.  
*Circulation*, American Heart Association, monthly.  
*Contemporary Surgery*, monthly.  
*Endocrinology*, monthly.  
*Human Pathology*, monthly.  
*JAMA: Journal of the American Medical Association*, monthly.  
*Journal of Nuclear Medicine*, monthly.  
*Modern Medicine*, monthly.  
*New England Journal of Medicine*, weekly.

## METALLURGICAL ENGINEERING

- Dieter, G.**, *Mechanical Metallurgy*, 1986.  
**Reed-Hill, R. E., and R. Abbaschian**, *Physical Metallurgy Principles*, 3d ed., 1991.  
**Sass, S. L.**, *The Substance of Civilization: Materials and Human History from the Stone Age to the Age of Silicon*, 1998.  
**Sinha, A.**, *Physical Metallurgy Handbook*, 2002.  
**Smallman, R. E., and R. J. Bishop**, *Modern Physical Metallurgy and Materials Engineering*, 1999.

- Iron & Steel Technology*, The Association for Iron & Steel Technology (AIST), monthly.  
*JOM: The Member Journal of The Minerals, Metals & Materials Society*, monthly.  
*Metallurgical and Materials Transactions A*, The Minerals, Metals & Materials Society, monthly.  
*Metallurgical and Materials Transactions B*, The Minerals, Metals & Materials Society, bimonthly.  
*Mineral Processing and Extractive Metallurgy: Transactions of the Institute of Mining and Metallurgy, Section C*, several times per year (irregular).

## METEOROLOGY

See Climatology and meteorology.

## MICROBIOLOGY

- Balows, A.** (ed.), *Manual of Clinical Microbiology*, 5th ed., 1991.  
**Balows, A., et al.**, *The Prokaryotes*, 2d ed., 1992.  
**Garrity, G., D. R. Boone, and R. W. Castenholz** (eds.), *The Bergey's Manual of Systematic Bacteriology*, 2d ed., 2001.

- Lengeler, J., H. G. Schlegel, and G. Drews**, *Biology of the Prokaryotes*, 1999.  
**Maddigan, M. T., J. Martinko, and J. Parker**, *Brock Biology of Microorganisms*, 10th ed., 2002.  
**Tortora, G. J., C. L. Case, and B. R. Funke**, *Microbiology: An Introduction*, 2003.

- Advances in Applied Microbiology*, annually.  
*Advances in Microbial Physiology*, irregularly.  
*Annual Reviews of Microbiology*, annually.  
*Applied and Environmental Microbiology*, monthly.  
*International Journal of Systematic and Evolutionary Microbiology*, bimonthly.  
*Journal of Bacteriology*, biweekly.  
*Journal of General Microbiology* (England), monthly.  
*Microbiological Reviews*, American Society for Microbiology, quarterly.  
*Microbiology*, monthly.  
*Microbiology and Molecular Biology Reviews*, quarterly.

## MICROSCOPY

- Bradbury, S.**, *An Introduction to the Optical Microscope*, vol. 1., 1989.  
**Briggs, A.**, *An Introduction to Scanning Acoustic Microscopy* (Microscopy Handbooks no. 12), 1986.  
**Duke, P. J., and A. G. Michette** (eds.), *Modern Microscopy: Techniques and Applications*, 1990.  
**Goldstein, J. I., et al.**, *Scanning Electron Microscopy and X-Ray Microanalysis*, 3d ed., 2003.  
**Johari, O., et al.** (eds.), *Scanning Electron Microscopy*, 1983.  
**Mayer, O., and D. J. Mayer**, *Clinical Wide-Field Specular Microscopy*, 1984.  
**Shotton, D. M.** (ed.), *Electronic Light Microscopy: The Principles and Practice of Video-enhanced, Contrast Digital Intensified Fluorescence, and Confocal, and Scanning Light Microscopy*, 1993.  
**Slyter, E. M., and H. S. Slyter**, *Light and Electron Microscopy*, 1992.  
**Wilson, T. C., and J. R. Sheppard**, *Theory and Practice of Scanning Optical Microscopy*, 1984.  
**Wilson, T.** (ed.), *Confocal Microscopy*, 1990.  
**Wischnitzer, S.**, *Introduction to Electron Microscopy*, 3d ed., 1981.

- Micron*, quarterly.  
*Microscope*, Cutter Laboratories, 10 issues per year.  
*The Microscope*, McCrone Research Institute, quarterly.

## MINERALOGY

- Klein, C.**, *Manual of Mineral Science*, 22d ed., 2001.  
**Howie, R. A., J. Zussman, and W. A. Deer**, *An Introduction to the Rock-Forming Minerals*, 2d ed., 1992.  
**Reviews in Mineralogy and Geochemistry** (Series 1974–2004), P. H. Ribbe (series editor), Mineralogical Society of America.

- American Mineralogist*, Mineralogical Society of America, monthly.  
*Mineralogical Magazine*, Mineralogical Society of Great Britain, monthly.

*Physics and Chemistry of Minerals*, Springer-Verlag, monthly.

## MINING ENGINEERING

**Hartman, H. L., et al.**, *SME Mining Engineering Handbook*, 2d rev. ed., 1992.

**Hartman, H. L., and J. Mutmanský**, *Introductory Mining Engineering*, 2d ed., 2002.

**Peng, S. S.**, *Surface Subsidence Engineering*, 1992.

**Shackleton, W. G.**, *Economic and Applied Geology: An Introduction*, 1986.

*Mining Engineering*, Society of Mining Engineers (of AIME), monthly.

## MOLECULAR BIOLOGY

See Cell and molecular biology.

## MOLECULAR PHYSICS

**Atkins, P. W.**, *Atkins' Molecules*, 2d ed., 2003.

**Atkins, P. W., and R. S. Friedman**, *Molecular Quantum Mechanics*, 3d ed., 1999.

**Banwell, C. N., and E. M. McCash**, *Fundamentals of Molecular Spectroscopy*, 4th ed., 1995.

**Bernath, P. F.**, *Spectra of Atoms and Molecules* (Topics in Physical Chemistry), 1995.

**Bransden, B. H., and C. J. Joachain**, *Physics of Atoms and Molecules*, 2d ed., 2003.

**Erkoc, S., and T. Uzer**, *Lecture Notes on Atomic and Molecular Physics*, 1996.

**R. McWeeny**, *Methods of Molecular Quantum Mechanics* (Theoretical Chemistry), 2d ed., 1992.

**Richards, W. G., and P. R. Scott**, *Structure and Spectra of Molecules*, 1985.

**Struve, W.**, *Fundamentals of Molecular Spectroscopy*, 1989.

**Svanberg, S.**, *Atomic and Molecular Spectroscopy: Basic Aspects and Practical Applications*, 3d ed., 2001.

*Journal of Molecular Structure*, 48 issues per year.

*Molecular Physics*, 18 issues per year.

## MYCOLOGY

**Ainsworth, G. C., et al.**, *Ainsworth and Bisby's Dictionary of Fungi*, 9th ed., 2001.

**Burnett, J. H.**, *Fungal Populations and Species* (Life Science), 2003.

**Carlile, M. J., et al.**, *The Fungi*, 2d ed., 2001.

**Khachatourians, G. G., et al.**, *Applied Mycology and Biotechnology: Fungal Genomics*, 2003.

**Ulloa, M., and R. T. Hanlin**, *Illustrated Dictionary of Mycology*, 2000.

**Watanabe, T.**, *Pictorial Atlas of Soil and Seed Fungi: Morphologies of Cultured Fungi and Key to Species*, 2d ed., 2002.

*FEMS Yeast Research*, Elsevier, quarterly.

*Fungal Genetics and Biology*, Elsevier, 9 issues per year.

*Medical Mycology*, Taylor & Francis, bimonthly.

*Mycological Research*, British Mycological Society, monthly.

*Mycologist*, British Mycological Society, monthly.

## NAVAL ARCHITECTURE

**Benford, H.**, *Naval Architecture for Non-Naval Architects*, 1991.

**Eyres, D. J.**, *Ship Construction*, 5th ed., 2001.

**Gillmer, T., and B. Johnson**, *Introduction to Naval Architecture*, 1982.

**Lewis, E. V. (ed.)**, *Principles of Naval Architecture*, 3 vols., 1988.

**Taylor, D. A.**, *Merchant Ship Construction*, 4th ed., 1998.

**Tupper, E. C.**, *Introduction to Naval Architecture*, 3d ed., 1996.

**Zubaly, R. B.**, *Applied Naval Architecture*, 2d ed., 1996.

*Naval Architect*, Royal Institution of Naval Architects, 10 issues per year.

*Transactions of the Society of Naval Architects and Marine Engineers*, annually.

*U. S. Naval Institute Proceedings*, monthly.

## NAVIGATION

**Clausing, D. J.**, *Aviator's Guide to Navigation*, 3d ed., 1997.

**Cunliffe, T.**, *Coastal and Offshore Navigation*, 2d ed., 1999.

**Cutler, T. J.**, *Dutton's Nautical Navigation*, 15th ed., 2003.

**Davies, A.**, *Celestial Navigation* (Practical Guide Series), 1993.

**Hobbs, R. R.**, *Marine Navigation: Piloting and Celestial Electronic Navigation*, 4th ed., 1998.

**Kaplan, E. (ed.)**, *Understanding GPS: Principles and Applications*, 1996.

**Kayton, M., and W. Fried**, *Avionics Navigation Systems*, 2d ed., 1997.

**Misra, P., and P. Enge**, *Global Positioning System*, 2001.

**Parkinson, B., and J. Spilker** (eds.), *Global Positioning System: Theory and Applications* (vols. 1 and 2), 1996.

**Tetley, L., and D. Calcutt**, *Electronic Aids to Navigation*, 3d ed., 2001.

*Navigation*, Journal of the Institute of Navigation, quarterly.

## NUCLEAR ENGINEERING

**Almenas, K., and R. Lee**, *Nuclear Engineering: An Introduction*, 1992.

**Foster, A. R., and R. L. Wright, Jr.**, *Basic Nuclear Engineering* (Allyn and Bacon Series in Engineering), 4th ed., 1983.

**Glasstone, S., and W. H. Jordan**, *Nuclear Power and Its Environmental Effects*, 1980.

**Glasstone, S., and A. Sesonske**, *Nuclear Reactor Engineering* (Reactor Systems Engineering), 4th ed., 1995.

**Knief, R. A.**, *Nuclear Engineering: Theory and Technology of Commercial Nuclear Power* (SCPP), 2d ed., 1992.

**Lamarsh, J. R., and A. J. Barrata**, *Introduction to Nuclear Engineering*, 3d ed., 2001.

**Lewins, J., and M. Becker** (eds.), *Advances in Nuclear Science & Technology*, vols. 1–26, 1962–1999.



- Ligou, J. P., and S. Mitter**, *Elements of Nuclear Engineering*, rev ed., 1987.
- Murray, R. L.**, *Nuclear Energy: An introduction to the Concepts, Systems, and Applications of Nuclear Processes*, 5th ed., 2001.
- Weisman, J.**, *Elements of Nuclear Reactor Design*, 2d ed., 1983.
- IEEE Transactions on Nuclear Science*, Institute of Electrical and Electronics Engineers, Nuclear and Plasma Sciences Society, monthly.
- Nuclear Science and Engineering*, American Nuclear Society, 9 issues per year.

## NUCLEAR PHYSICS

- Burcham, W. E., and M. Jobs**, *Nuclear and Particle Physics*, 1995.
- Cottingham, W. N., and D. A. Greenwood**, *An Introduction to Nuclear Physics*, 2d ed., 2001.
- Das, A., and T. Ferbel**, *Introduction to Nuclear and Particle Physics*, 2d ed., 2004.
- Eisenberg, J. M., and W. Greiner**, *Nuclear Theory*, vol. 1, 3d ed., 1988; vol. 2, 3d ed., 1988; and vol. 3, 2d ed., 1976.
- Enge, H. A., and R. P. Redwine**, *Introduction to Nuclear Physics*, 2d ed., 1999.
- Krane, K. S.**, *Introductory Nuclear Physics*, 1987.
- Lilley, J. S.**, *Nuclear Physics*, 2001.
- Walecka, J. D.**, *Theoretical Nuclear and Subnuclear Physics* (Oxford Studies in Nuclear Physics), 1995.
- Wong, S. S. M.**, *Introductory Nuclear Physics*, 2d ed., 1999.

- Annual Review of Nuclear and Particle Science*, annually.
- Nuclear Physics*, Section A, 68 issues per year.
- Physical Review C*, American Physical Society, monthly.

## NEUROPSYCHOLOGY

- Beaumont, J. G., P. Kenealy, and M. J. Rogers**, *The Blackwell Dictionary of Neuropsychology*, 1996.
- Gazzaniga, M. S., R. B. Ivry, and G. R. Mangun**, *Cognitive Neuroscience: The Biology of the Mind*, 2d ed., 2002.
- Heilman, K., and E. Valenstein**, *Clinical Neuropsychology* (Medicine), 2003.
- Kolb, B., and I. Q. Whishaw**, *Fundamentals of Neuropsychology*, 2003.
- M. D. Lezak**, *Neuropsychological Assessment*, Oxford University Press, 2004.
- Loring, D. W., and K. J. Meador**, *Dictionary of Neuropsychology*, 1999.
- Spreen, O., and E. Strauss**, *Compendium of Neuropsychological Tests: Administration, Norms, and Commentary*, 2d ed., 1998.

## NEUROSCIENCE

- Bear, M., B. Connors, and M. Paradiso**, *Neuroscience: Exploring the Brain*, 2d ed., 2002.

- Butler, A. B., and W. Hodos**, *Comparative Vertebrate Neuroanatomy: Evolution and Adaptation*, 1996.
- Cooper, J. R., F. E. Bloom, and R. H. Roth**, *Biochemical Basis of Neuropharmacology*, 8th ed., 2002.
- Kandel, E. R., J. H. Schwartz, and T. M. Jessell** (eds.), *Principles of Neuroscience*, 4th ed., 2000.
- Levitan, I. B., and L. Kaczmarek**, *The Neuron*, 3d ed., 2001.
- Nestler, E. J., S. E. Hyman, and R. C. Malenka**, *Molecular Basis of Neuropharmacology*, 2001.
- Nicholls, J. G., et al.**, *From Neuron to Brain*, 4th ed., 2001.
- Purves, D., et al.** (eds.), *Neuroscience*, 3d ed., 2004.
- Shepherd, G. M.** (ed.), *Synaptic Organization of the Brain*, 5th ed., 2003.
- Shepherd, G. M.**, *Neurobiology*, 3d ed., 1994.

- Annual Review of Neuroscience*, Annual Reviews, yearly.
- Journal of Neuroscience*, Society for Neuroscience, weekly.
- Nature Neuroscience*, Nature Publishing, monthly.
- Neuron*, Cell Press, bimonthly.
- Trends in Neurosciences*, Elsevier, monthly.

## OCEANOGRAPHY

- Colling, A.**, *Ocean Circulation*, 2d ed., 2001.
- Garrison, T. S.**, *Oceanography: An Invitation to Marine Science*, 5th ed., 2005.
- Knauss, J. A.**, *An Introduction to Physical Oceanography*, 2d ed., 1996.
- Lalli, C. M.**, *Biological Oceanography*, 2d ed., 1997.
- Pilson, M. E. Q.**, *An Introduction to the Chemistry of the Sea*, 1998.
- Thurman, H. V., and A. P. Trujillo**, *Essentials of Oceanography*, 8th ed., 2004.
- Journal of Physical Oceanography*, American Meteorological Society, monthly.
- Oceanus*, Woods Hole Oceanographic Institute, semiannually.

## OPTICS

- Born, M., and E. Wolf**, *Principles of Optics*, 7th ed., 1999.
- Hecht, E., and K. Guardino**, *Optics*, 4th ed., 2001.
- Jenkins, F. A., and H. E. White**, *Fundamentals of Optics*, 4th ed., 2001.
- Meyer-Arendt, J.**, *Introduction to Classical and Modern Optics*, 4th ed., 1994.
- Optical Society of America**, *Handbook of Optics*, 2d ed., 4 vols., 1995–2001.
- Pedrotti, F. J., and L. S., Pedrotti**, *Introduction to Optics*, 2d ed., 1992.
- Smith, W. J.**, *Modern Optical Engineering*, 3d ed., 2000.
- Yu, F. T., and X. Yang**, *Introduction to Optical Engineering*, 1997.

- Applied Optics*, Optical Society of America, American Institute of Physics, 36 issues per year.
- Journal of the Optical Society of America, A, B*, American Institute of Physics, monthly.

**PALEONTOLOGY**

- Benton, M. J., and J. Sibbock**, *Vertebrate Paleontology*, 2000.
- Briggs, D., D. Erwin, and F. J. Collier**, *The Fossils of the Burgess Shale*, 1995.
- Briggs, D. E. G., and P. R. Crowther**, *Palaeobiology II*, 2002.
- Carroll, R.**, *Vertebrate Paleontology and Evolution*, 1987.
- Clack, J. A.**, *Gaining Ground: The Origin and Early Evolution of Tetrapods*, 2002.
- Gould, S. J.**, *The Book of Life: An Illustrated History of the Evolution of Life on Earth*, 2d ed., 2001.
- Jackson, J. B. C., S. Lidgard, and A. H. Cheetham**, *Evolutionary Patterns: Growth, Form, and Tempo in the Fossil Record*, 2001.
- Knoll, A. H.**, *Life on a Young Planet: The First Three Million Years of Evolution on Earth*, 2003.
- Lowell, D., and T. Rowe**, *The Mistaken Extinction: Dinosaur Evolution and the Origin of Birds*, 1997.
- Minkoff, E. C., E. H. Colbert, and M. Morales**, *Colbert's Evolution of the Vertebrates*, 2001.
- Prothero, D. R.**, *Bringing Fossils to Life: An Introduction to Paleobiology*, 2003.
- Rudwick, M. J.**, *The Meaning of Fossils: Episodes in the History of Paleontology*, 2d ed., 1985.
- Simpson, G. G.**, *Life in the Past: An Introduction to Paleontology*, 2003.
- Vermeij, G. J.**, *Evolution and Escalation: An Ecological History of Life*, 1987.
- Willis, K., and J. McElwain**, *The Evolution of Plants*, 2002.

*Journal of Paleontology*, Society of Economic Paleontologists and Mineralogists, bimonthly.

*Journal of Vertebrate Paleontology*, Society of Vertebrate Paleontology, quarterly.

*Palaeontology*, Palaeontological Association, bimonthly.

*Paleobiology*, Paleontology Society, quarterly.

**PETROLEUM ENGINEERING**

- Drew, L. J.**, *Oil and Gas Forecasting: Reflections of a Petroleum Geologist*, 1990.
- Hyne, N. J.**, *Nontechnical Guide to Petroleum Geology, Exploration, Drilling, and Production*, 2001.
- Meyers, R. A.**, *Handbook of Petroleum Refining Process*, 3d ed., 2003.
- Mian, M. A.**, *Petroleum Engineering Handbook for the Practicing Engineer*, 1992.
- Nind, T. E.**, *Hydrocarbon Reservoir and Well Performance*, 1989.
- Speight, J. G.**, *The Chemistry and Technology of Petroleum* (Chemical Industries), 3d rev. ed., 1999.
- Terry, R. E., M. Hawkins, and B. C. Craft**, *Applied Petroleum Reservoir Engineering*, 2d rev. ed., 1991.
- Visher, G.**, *Exploration Stratigraphy*, 2d ed., 1990.

*Hydrocarbon Processing*, Gulf Publishing Company, monthly.

*Journal of Petroleum Technology*, Society of Petroleum Engineers, monthly.

**PETROLOGY**

- Best, M. G.**, *Igneous and Metamorphic Petrology*, 2d ed., 2002.

**Greensmith, J. T.**, *Petrology of the Sedimentary Rocks*, 7th ed., 1988.

**Hyndman, D. W.**, *Petrology of Igneous and Metamorphic Rocks*, 2d ed., 1985.

**Krumbein, W. C., and F. J. Pettijohn**, *Manual of Sedimentary Petrography*, reprint ed., 1990.

**McBirney, A. R.**, *Igneous Petrology*, 2d ed., 1992.

**Philpotts, A. R.**, *Principles of Igneous and Metamorphic Petrology*, 1990.

**Wilson, M.**, *Igneous Petrogenesis*, 1989.

**Yardley, B. W. D.**, *Introduction to Metamorphic Petrology*, 1989.

*Contributions to Mineralogy and Petrology*, Springer-Verlag, monthly.

*Journal of Petrology* (England), quarterly.

**PHARMACOLOGY**

**Hardman, J. G., and L. E. Limbird** (eds.), *Goodman and Gilman's The Pharmacological Basis of Therapeutics*, 10th ed., 2001.

**Katzung, B. G.** (ed.), *Basic and Clinical Pharmacology*, 8th ed., 2000.

**Licino, J., and M.-L. Wong**, *Pharmacogenomics: The Search for Individualized Therapies*, 2002.

**Neal, M. J.**, *Medical Pharmacology at a Glance*, 4th ed., 2002.

*Physicians' Desk Reference*, 2004.

*Advances in Pharmacology and Chemotherapy*, irregularly.

*American Pharmacy*, American Pharmaceutical Association, monthly.

*Biochemical Pharmacology*, monthly.

*Excerpta Medica*, Section 80: Pharmacology and Toxicology, 30 issues per year.

*Hospital Pharmacy Today*, monthly.

**PHYSICAL ELECTRONICS**

**Enderlein, R., and N. J. Horing**, *Fundamentals of Semiconductor Physics and Devices*, 1997.

**Ferendeci, A. M.**, *Physical Foundations of Solid State and Electron Devices*, 1991.

**Ghandi, S. K.**, *VLSI Fabrication Principles: Silicon and Gallium Arsenide*, 2d ed., 1994.

**Grasserbauer, M., and H. W. Werner** (eds.), *Analysis of Microelectronic Materials and Devices*, 1991.

**Neaman, D.**, *Semiconductor Physics and Devices*, 3d ed., 2002.

**Ng, K. K.**, *Complete Guide to Semiconductor Devices*, 2d ed., 2002.

**Pierret, R. F.**, *Semiconductor Device Fundamentals*, 1995.

**Seeger, K.**, *Semiconductor Physics: An Introduction*, 8th ed., 2002.

**Singh, J.**, *Semiconductor Devices: An Introduction*, 1994.

**Sze, S. M.**, *Semiconductor Devices: Physics and Technology*, 2d ed., 2001.

**Yu, P. Y., and M. Cardona**, *Fundamentals of Semiconductors*, 3d ed., 2001.

**Electrical and Electronics Abstracts** (Science Abstracts, Section B), INSPEC, Institution of Electrical Engineers, monthly.  
**IEEE Spectrum**, Institute of Electrical and Electronics Engineers, Inc., monthly.  
**IEEE Transactions on Electron Devices**, Institute of Electrical and Electronics Engineers, Electron Devices Society, monthly.  
**Sold State Technology**, monthly.

## PHYSICS

**Beiser, A.**, *Concepts of Modern Physics*, 6th ed., 2002.  
**Brown, L., A. Pais, and B. Pippard**, *Twentieth Century Physics*, 1995.  
**Bueche, F.**, *Principles of Physics* (McGraw-Hill Schaum's Outline Series in Science), rev. 6th ed., 1994.  
**Halliday, D., R. Resnick, and J. Walker**, *Fundamentals of Physics*, 6th ed., 2002.  
**Hartle, J. B.**, *Gravity: An Introduction to Einstein's General Relativity*, 2003.  
**Lightman, A. P.**, *Great Ideas in Physics*, 3d ed., 2000.  
**Serway, R. A.**, *College Physics* (with PhysicsNow), 6th ed., 2003.  
**Young, H. D., and R. A. Freedman**, *University Physics: Solutions Manual*, 11th ed., 2003.

**American Journal of Physics**, American Institute of Physics, monthly.  
**Annals of Physics**, 18 issues per year.  
**Journal of Applied Physics**, American Institute of Physics, monthly.  
**Journal of Physics, A, B, D, and G**, Institute of Physics, Section G, monthly; other sections, semimonthly.  
**Physical Review**, American Physical Society, American Institute of Physics, Section B, 4 issues per month; Section D, semimonthly; Sections A, C, E, monthly.  
**Physical Review Letters**, American Physical Society, American Institute of Physics, weekly.  
**Physics Abstracts** (Science Abstracts, Section A), INSPEC, Institution of Electrical Engineers, biweekly.  
**Physical Letters**, Section A, 78 issues per year; Section B, 108 issues per year.  
**Physics Reports**, 90 issues per year.  
**Physics Today**, American Institute of Physics, monthly.  
**Proceedings of the Royal Society of London**, Series A: Mathematical, Physical and Engineering Sciences, monthly.  
**Reviews of Modern Physics**, American Physical Society, American Institute of Physics, quarterly.

## PHYSIOLOGY

**Berne, R. M., et al.** (eds.), *Physiology*, 5th ed., 2003.  
**Costanzo, L. S.**, *Physiology*, 1998.  
**Dantzler, W. H.**, *Comparative Physiology*, 1997.  
**Fong, E.**, *Body Structures and Functions*, 1998.  
**Ganong, W. A.**, *Review of Medical Physiology*, 21st ed., 2003.  
**Guyton, A. C., and J. E. Hall**, *Textbook of Medical Physiology*, 10th ed., 2001.  
**Malvin, R. L., et al.**, *Concepts of Human Physiology*, 1997.  
**Porterfield, S. P.**, *Endocrine Physiology*, 2d ed., 2001.  
**Prosser, C. L.**, *Comparative Animal Physiology*, 4th ed., 1991.

**Randall, D., et al.**, *Eckert Animal Physiology: Mechanisms and Adaptations*, 2001.  
**Rhoades, R. A., and R. G. Pflanzner**, *Human Physiology*, 4th ed., 2002.  
**Sherwood, L., H. Klandorf, and P. H. Yancy**, *Animal Physiology*, 2005.  
**Sperelakis, N.**, *Cell Physiology Source Book: A Molecular Approach*, 2001.

**American Journal of Physiology**, American Physiological Society, monthly.  
**Annual Review of Physiology**, annually.  
**Journal of Comparative Physiology, A: Sensory, Neural, and Behavioral Physiology, and B: Systematic and Environmental Physiology**, irregularly.  
**Journal of General Physiology**, monthly.  
**Journal of Physiology** (England), monthly.  
**Physiological Reviews**, American Physiological Society, quarterly.

## PLANT ANATOMY

**Bowes, B. G.**, *A Colour Atlas of Plant Structure*, 1996.  
**Dickison, W. C.**, *Integrative Plant Anatomy*, 2000.  
**Fahn, A.**, *Plant Anatomy*, 4th ed., 1990.  
**Mauseth, J. D.**, *Plant Anatomy*, 1988.  
**Nabors, M.**, *Introduction to Botany*, 2004.  
**Northington, D. K., et al.**, *The Botanical World*, 2d ed., 1995.  
**Pearson, L. C.**, *The Diversity of Evolution of Plants*, 1995.  
**Raven, P. H., R. F. Evert, and S. E. Eichhorn**, *Biology of Plants*, 1999.  
**Rudall, P.**, *Anatomy of Flowering Plants: An Introduction to Structure and Development*, 1987.

## PLANT PATHOLOGY

**Agrios, G. N.**, *Plant Pathology*, 4th ed., 1997.  
**Dickinson, M., and J. Beynon** (eds.), *Molecular Plant Pathology*, 2000.  
**Lucas, G. B., C. L. Campbell, and L. T. Lucas**, *Introduction to Plant Diseases: Identification and Management*, 2d ed., 1992.  
**Lucas, J. A.**, *Plant Pathology and Plant Pathogens*, 1998.  
**Matthews, R. E., et al.**, *Plant Virology*, 4th ed., 2001.  
**Sinclair, W. A., H. Lyon, and W. T. Johnson**, *Diseases of Trees and Shrubs*, 1987.  
**Strange, R. N.**, *Introduction of Plant Pathology*, 2003.  
**Talbot, N.**, *Plant-Pathogen Interactions*, 2004.  
**Vidhyasekaran, P.**, *Concise Encyclopedia of Plant Pathology*, 2004.  
**Zamir K. P.** (ed.), *Fungal Disease Resistance in Plants: Biochemistry, Molecular Biology, and Genetic Engineering*, 2004.

**Annual Review of Phytopathology**, annually.  
**Plant Disease**, American Phytopathological Society, monthly.

## PLANT PHYSIOLOGY

**Baker, N. R.**, *Photosynthesis and the Environment* (Advances in Photosynthesis), 1996.

- Bewley, J. D., and M. Black**, *Seeds: Physiology Development and Germination* (The Language of Science), 2d ed., 1994.
- Blankenship, R. E.**, *Molecular Mechanisms of Photosynthesis*, 2002.
- Chrispeels, M. J., and D. E. Sadava**, *Plants, Genes, and Crop Biotechnology*, 2d ed., 2003.
- Davies, P. J.**, *Plant Hormones: Physiology, Biochemistry and Molecular Biology*, 1995.
- Epstrin, E., and A. J. Bloom**, *Mineral Nutrition of Plants: Principles and Perspectives*, 2d ed., 2004.
- Kramer, P. J., and J. S. Boyer**, *Water Relations of Plants and Soils*, 1995.
- Leyser, O., and S. Day**, *Mechanisms in Plant Development*, 2003.
- Raven, P. H., et al.**, *Biology of Plants*, 6th ed., 1998.
- Taiz, L., and E. Zeiger**, *Plant Physiology*, 3d ed., 2002.

- Current Opinion in Plant Biology*, Elsevier, bimonthly.
- The Plant Cell*, American Society of Plant Biologists, monthly.
- Plant Cell and Environment*, monthly.
- Plant Journal*, bimonthly.
- Plant Physiology*, American Society of Plant Biologists, monthly.
- Planta*, Springer-Verlag, monthly.
- Trends in Plant Science*, monthly.

## PLASMA PHYSICS

- Chen, F. F.**, *Introduction to Plasma Physics and Controlled Fusion* (Plasma Physics), 2d ed., 1984.
- Dendy, R. O.** (ed.), *Plasma Physics: An Introductory Course*, new edited ed., 1995.
- Goldston, R., and P. H. Rutherford**, *Introduction to Plasma Physics* (Plasma Physics Series), 1995.
- Hutchinson, I. H.**, *Principles of Plasma Diagnostics*, 2d ed., 2002.
- Leontovich, M. A., and B. B. Kadomstev** (eds.), *Reviews of Plasma Physics*, vols. 1–19, 1965–1996.
- Manos, D. M., and D. L. Flam** (eds.), *Plasma Etching*, 1989.
- Parks, G. K.**, *Physics of Space Plasmas*, 2d ed., 2004.
- Stix, T. H.**, *Waves in Plasmas*, 1992.
- Sturrock, P. A.**, *Plasma Physics: An Introduction to the Theory of Astrophysical, Geophysical, and Laboratory Plasmas*, new edited ed., 1994.
- Wesson, J., et al.**, *Tokamaks* (The International Series on Monographs on Physics), 3d ed., 2004.

- IEEE Transactions on Plasma Science*, Institute of Electrical and Electronics Engineers, Plasma Sciences Society, bimonthly.
- Plasma Physics and Controlled Fusion*, Institute of Physics, monthly.

## POLYMER CHEMISTRY

- Allcock, H., et al.**, *Contemporary Polymer Chemistry*, 3d ed., 2004.
- Allen, G., and J. C. Bevington** (eds.), *Comprehensive Polymer Science: The Synthesis, Characterization, Reactions and Applications of Polymers: Polymer Characterization*, 1990.
- Elias, H. G.**, *An Introduction to Polymer Science*, 1997.
- Feldman, D., and A. Barbalata**, *Synthetic Polymers: Technology, Properties, and Applications*, 1996.

- Fried, J., and J. Hunger**, *Polymer Science and Technology*, 2d ed., 2003.
- Kirk-Othmer Encyclopedia of Chemical Technology*, 4th ed., 27 vols., 1998.
- Mark, H. F.** (ed.), *Encyclopedia of Polymer Science and Technology*, 3d ed., 19 vols., 2004.
- Morawetz, H.**, *Polymers: The Origins and Growth of a Science*, 1985.
- Odian, G.**, *Principles of Polymerization*, 3d ed., 1991.
- Seymour, R. B., and C. E. Carraher, Jr.**, *Seymour/Carraher's Polymer Chemistry*, 5th ed., 2000.
- Stevens, M. P.**, *Polymer Chemistry: An Introduction*, 3d ed., 1998.
- Young, R. J., and P. Lovell**, *Introduction to Polymers*, 2d rev. ed., 1991.

- Macromolecules*, American Chemical Society.
- Polymer*, Elsevier.
- Progress in Polymer Science*, Elsevier.

## PRODUCTION ENGINEERING

- Bolling, G. F.**, *The Art of Manufacturing Development*, 1995.
- Buffa, E. S., and R. K. Sarin**, *Modern Production/Operations Management*, 8th ed., 1987.
- Groover, M. P., et al.**, *Industrial Robotics: Technology, Programming, and Applications*, 1986.
- Kalpakjian, S., and S. R. Schmid**, *Manufacturing Engineering and Technology*, 4th ed., 2000.
- Keonig, D. T.**, *Manufacturing Engineering: Principles for Optimization*, 2d ed., 1994.
- Schmenner, R. W.**, *Production-Operations Management: Concepts and Situations*, 5th ed., 1992.
- Sodhi, R. S., M. Zhou, and S. Das** (eds.), *Advances in Manufacturing Systems: Design, Modeling and Analysis*, 1994.
- White, J. A.**, *Production Handbook*, 4th ed., 1987.

## PROPULSION

- Crumpsty, N.**, *Jet Propulsion*, 2003.
- Hill, P., and C. Peterson**, *Mechanics and Thermodynamics of Propulsion*, 2d ed., 1992.
- Hünecke, K.**, *Jet Engines*, 1998.
- Kerrebrock, J. L.**, *Aircraft Engines and Gas Turbines*, 2d ed., 1992.
- Kroes, M. J., and T. W. Wild**, *Aircraft Powerplants*, 7th ed., 1994.
- Mattingly, J. D.**, *Elements of Gas Turbine Propulsion*, with IBM 3.5 disk, 1996.
- Oates, G. C.**, *Aircraft Propulsion Systems Technology and Design*, 1989.
- Sutton, G. P.**, *Rocket Propulsion Elements: An Introduction to the Engineering of Rockets*, 6th ed., 1992.
- Treager, I. E.**, *Aircraft Gas Turbine Engine Technology*, 3d ed., 1995.

## PSYCHIATRY

- American Psychiatric Association**, *Diagnostic and Statistical Manual of Mental Disorders*, text revision, 4th ed., 1994.
- Freud, S., et al.**, *Outline of Psychoanalysis*, rev. ed., 1989.

- Garfield, S. L.**, *Psychotherapy: An Eclectic Integrative Approach* (Wiley Series on Personality Processes), 2d ed., 1995.
- Tasman, A., J. Kay, and J. A. Lieberman**, *Psychiatry*, 2d ed., vols. 1 and 2, 2003.
- Waldinger, R. J.**, *Psychiatry for Medical Students*, 3d ed., 1997.

*American Journal of Psychiatry*, American Psychiatric Association, monthly.

*Psychiatric News*, American Psychiatric Association, biweekly.

## PSYCHOLOGY

- Aronson, E.**, *The Social Animal*, 8th ed., 1999.
- Carlson, N. R.**, *Physiology of Behavior*, 7th ed., 2000.
- Gerow, J. R.**, *Essentials of Psychology*, 2d ed., 1996.
- Gerow, J. R., and K. Bordens**, *Psychology: An Introduction*, 7th ed., 2001.
- Kalat, J. W.**, *Introduction to Psychology*, 6th ed., 2001.

*American Psychologist*, American Psychological Association Inc., monthly.

*Annual Review of Psychology*, annually.

*Contemporary Psychology*, American Psychological Association, Inc., monthly.

## QUANTUM MECHANICS

- Bohm, A.**, *Quantum Mechanics: Foundation and Applications*, 3d ed., 1994.
- Dirac, P. A.**, *Principles of Quantum Mechanics*, 4th ed., 1982.
- Eisberg, R., and R. Resnick**, *Quantum Physics: Of Atoms, Molecules, Solids, Nuclei and Particles*, 2d ed., 1985.
- Gottfried, K., and T. M. Yan**, *Quantum Mechanics: Fundamentals*, 2d ed., 2004.
- Liboff, R.**, *Introductory Quantum Mechanics*, 4th ed., 2002.
- Mandl, F.**, *Quantum Mechanics*, 1992, reprint, 1994.
- Morrison, M.**, *Understanding Quantum Mechanics*, 1996.
- Ohanian, H. C.**, *Principles of Quantum Mechanics*, 1989.
- Park, D.**, *Introduction to the Quantum Theory* (International Series in Pure and Applied Physics), 3d ed., 1992.
- Polkinghorne, J.**, *Quantum Mechanics: A Very Short Introduction*, 2002.
- Shankar, R.**, *Principles of Quantum Mechanics*, 2d ed., 1994.
- Zettili, N.**, *Quantum Mechanics: Concepts and Applications*, 2001.

## RADAR

- Barton, D. K.**, *Radar Technology Encyclopedia* (CD-ROM), 1998.
- Cole, H.**, *Understanding Radar*, 2d ed., 1992.
- Edde, B.**, *Radar: Principles, Technology, Applications*, 1992.
- Peebles, P. Z., Jr.**, *Radar Principles*, 1998.
- Raemer, H. R.**, *Radar Systems Principles*, 1996.
- Ragavan, S.**, *Radar Meteorology*, 2003.
- Skolnik, M. I.**, *Introduction to Radar Systems*, 3d ed., 2003.
- Skolnik, M. I.** (ed.), *Radar Handbook*, 2d ed., 1990.
- Stimson, G. W.**, *Introduction to Airborne Radar*, 2d ed., 1998.

- Toomay, J. C.**, *Radar Principles for the Non-Specialist*, 3d ed., 2004.

*IEE Proceedings: Radar, Sonar and Navigation*, Institution of Electrical Engineers, semimonthly.

## RADIO COMMUNICATIONS

- American Radio Relay League**, *The ARRL Handbook for the Radio Amateur*, annually.
- Carson, R.**, *Radio Communications Concepts: Analog*, 1990.
- Mazda, R.**, *Radio Technologies*, 1996.
- Sabin, W., and E. Schoenike** (eds.), *Single-Sideband Systems and Circuits*, 2d ed., 1995.
- Sennitt, A. G.** (ed.), *World Radio TV Handbook*, annually.
- Shrader, R. I.**, *Electronic Communications*, 6th ed., 1991.
- Steele, R., and L. Hanzo**, *Mobile Radio Communications*, 2d ed, 1999.
- Valkenburg, M., and W. Middleton** (eds.), *Reference Data for Engineers: Radio, Electronics, Computer, and Communications*, 9th ed., 2001.
- Wilby, P., and A. Conroy**, *The Radio Handbook* (Media Practice), 1994.

*IEEE Transactions on Broadcasting*, Institute of Electrical and Electronics Engineers, Broadcast Technology Society, quarterly.

## RADIOCHEMISTRY

- Adloff, J. P., and R. Guillaumont**, *Fundamentals of Radiochemistry*, 1993.
- Arnikar, H. J.**, *Essentials of Nuclear Chemistry*, 2d ed., 1987.
- Choppin, G. R., J.-O. Liljenzin, and J. Rydberg**, *Radiochemistry and Nuclear Chemistry: Nuclear Chemistry, Theory and Applications*, 2d ed., 1995.

*Journal of Labelled Compounds and Radiopharmaceuticals*, Wiley, monthly.

*Radiation Physics and Chemistry*, Elsevier, monthly.

## RELATIVITY

- Bohm, D.**, *The Special Theory of Relativity*, reprint, 1996.
- Hartle, J. B.**, *Gravity: An Introduction to Einstein's General Relativity*, 2003.
- Misner, C., K. Thorne, and J. Wheeler**, *Gravitation*, 1973.
- Rindler, W.**, *Essential Relativity*, rev. ed., reprint 2000.
- Schutz, B.**, *Gravity From the Ground Up*, 2003.
- Schwarz, P. M., and J. H. Schwarz**, *Special Relativity: From Einstein to Strings*, 2004.
- Stephani, H.**, *General Relativity: An Introduction to Special and General Relativity*, 4th ed., 2004.
- Taylor, E. F., and J. A. Wheeler**, *Spacetime Physics: Introduction to Special Relativity*, 2d ed., 1992.
- Wald, R.**, *General Relativity*, 1984.
- Will, C. M.**, *Was Einstein Right? Putting General Relativity to the Test*, 2d rev. ed., 1993.

**General Relativity and Gravitation**, International Committee on General Relativity and Gravitation, monthly.

## SOIL

- Bowles, J. E.**, *Engineering Properties of Soils and Their Measurement*, 4th ed., 1992.
- Brady, N. C., and R. R. Weil**, *The Nature and Properties of Soils*, 13th ed., 2001.
- Crunkilton, J. R., et al.**, *The Earth and Agriscience*, 1995.
- Daniels, R. B., and R. D. Hammer**, *Soil Geomorphology*, 1992.
- Dowdy, R. H.** (ed.), *Chemistry in the Soil Environment*, 1981.
- Foster, A. B., and D. A. Bosworth**, *Approved Practices in Soil Conservation*, 5th ed., 1982.
- Foth, H. D.**, *Fundamentals of Soil Science*, 8th ed., 1990.
- Hanks, R. J.**, *Applied Soil Physics: Soil Water and Temperature Applications*, 2d ed., 1992.
- Morgan, R. P. C.**, *Soil Erosion and Conservation*, 2d ed., 1995.
- Plaster, E. J.**, *Soil Science and Management*, 3d ed., 1997.

*Agronomy Journal*, American Society of Agronomy, bimonthly.

## SOLID-STATE PHYSICS

- Chaikin, P. M., and T. C. Lubensky**, *Principles of Condensed Matter Physics*, 1995, paperback 2000.
- Ehrenreich, H., et al.** (eds.), *Solid State Physics*, vols. 1–56, 1955–2001.
- Hook, J. R., and H. E. Hall**, *Solid State Physics*, 2d ed., 1995.
- Ibach, H., and H. Luth**, *Solid State Physics: An Introduction to Principles of Materials Science* (Advanced Texts in Physics), 3d ed., 2003.
- Kittel, C.**, *Introduction to Solid State Physics*, 7th ed., 1995.
- Marder, M. P.**, *Condensed Matter Physics*, 2000.
- Myers, H. P.**, *Introductory Solid State Physics*, 2d ed., 1997.
- Omar, M. A.**, *Elementary Solid State Physics*, 1996.
- Rudden, M. N., and J. Wilson**, *Elements of Solid State Physics*, 2d ed., 1993.
- Tanner, B. K.**, *Introduction to the Physics of Electrons in Solids*, 1995.

*Applied Physics A*, Deutsche Physikalische Gesellschaft, 12 issues per year.

*Journal of Physics: Condensed Matter*, Institute of Physics, 50 issues per year.

*Journal of Physics and Chemistry of Solids*, monthly.

*Physica B*, 60 issues per year.

*Physical Review B*, American Institute of Physics, 4 issues per month.

*Solid State Communications*, 48 issues per year.

## SPACE TECHNOLOGY

**Boden, D. S., and W. J. Larson**, *Cost-Effective Space Mission Operations*, 1996.

**Bouquet, F. L.**, *Spacecraft Design: Thermal & Radiation*, 1991.

**Griffin, M. D., and J. B. French**, *Space Vehicle Design* (AIAA Education Series), 2004.

**Pisacane, V. L., and R. C. Moore** (eds.), *Fundamentals of Space Systems* (The John Hopkins University/Applied Physics Laboratory Series in Science & Engineering), 1994.

**Roddy, D.**, *Satellite Communications*, 3d ed., 2001.

**Rummel, J. D., V. M. Ivanov, and J. Rummel** (eds.), *Space and Its Exploration*, 1993.

**Sellers, J., and W. J. Larson et al.**, *Understanding Space: An Introduction to Astronautics*, 4th ed., 2003.

**Wertz, J. R., and W. J. Larson** (eds.), *Space Mission Analysis and Design*, 3d ed., 1999.

*Aerospace America*, American Institute of Aeronautics and Astronautics, monthly.

*Journal of Spacecraft and Rockets*, American Institute of Aeronautics and Astronautics, bimonthly.

## SPECTROSCOPY

**Andrews, D. L., and A. A. Demidov** (eds.), *An Introduction to Laser Spectroscopy*, 1995.

**Bernath P. F.**, *Spectra of Atoms and Molecules* (Topics in Physical Chemistry), 1995.

**Briggs, D., and M. P. Seah** (eds.), *Practical Surface Analysis: Auger and X-Ray Photoelectron Spectroscopy*, 2d ed., 1990.

**De Hoffman, E., and V. Stroobant**, *Mass Spectrometry: Principles and Applications*, 2d ed., 2002.

**Demtröder, W.**, *Laser Spectroscopy*, 3d ed., 1996.

**Dickson, D. P., and F. J. Berry** (eds.), *Mössbauer Spectroscopy*, 1987.

**Graybeal, W. D.**, *Molecular Spectroscopy*, rev. ed., 1993.

**Günther, H.**, *NMR Spectroscopy*, 2d ed., 1995.

**Hollas, J. M.**, *Modern Spectroscopy*, 4th ed., 2004.

**Hüfner, S.**, *Photoelectron Spectroscopy*, 3d ed., 2003.

**Laserna, J. J.** (ed.), *Modern Techniques in Raman Spectroscopy*, 1996.

**Schmidt, V., et al.**, *Electron Spectrometry of Atoms Using Synchrotron Radiation*, 1997.

**Smith, B. C.**, *Fundamentals of Fourier Transform Infrared Spectroscopy*, 1995.

**Tsuji, K., J. Injuk, and R. Van Grieken** (eds.), *X-Ray Spectrometry: Recent Technological Advances*, 2004.

*Applied Spectroscopy*, Society for Applied Spectroscopy, monthly.

*Journal of Magnetic Resonance Spectroscopy*, 4 copies per year.

*Spectrochimica Acta*, Parts A and B, monthly.

## STATISTICAL MECHANICS

**Baracca, A., and R. Livi**, *Statistical Mechanics: Foundations, Problems, Perspectives*, 1998.

**Betts, D. S., and R. E. Turner**, *Introductory Statistical Mechanics*, 1992.

**Bowley, R., and M. Sanchez**, *Introductory Statistical Mechanics*, 2d ed., 1999.

**Garrod, C.**, *Statistical Mechanics and Thermodynamics* (Book and Windows CE-ROM IBM ed.), 1995.

- Kubo, R.**, *Statistical Mechanics*, 1990.  
**McQuarrie, D. A.**, *Statistical Mechanics*, 2000.  
**Pathria, R. K.**, *Statistical Mechanics*, 2d ed., 1996.  
**Ter Harr, D.**, *Elements of Statistical Mechanics*, 3d ed., 1995.  
**Zwanzig, R.**, *Nonequilibrium Statistical Mechanics*, 2001.

*Journal of Statistical Physics*, 12 issues per year.  
*Physica A*, 52 issues per year.

## STATISTICS AND PROBABILITY

- Coolidge, F. L.**, *Statistics: A Gentle Introduction*, 2001.  
**Johnson, R. A., and G. K. Bhattacharyya**, *Statistics: Principles and Methods*, 4th ed., 2000.  
**Larsen, R. J., and M. L. Marx**, *Statistics* (Facsimile), 1990.  
**Markley, N. G.**, *Introduction to Probability*, rev ed., 1991.  
**Naiman, A., R. Rosenfeld, and G. Zirkel**, *Understanding Statistics*, 4th ed., 1996.  
**Rohatgi, V. K., and A. K. M. Ehsanes Saleh**, *An Introduction to Probability and Statistics*, 2001.  
**Ross, S. M.**, *A First Course in Probability*, 6th ed., 2001.  
**Sanders, D. H., et al.**, *Statistics: A First Course*, 6th ed., 1999.  
**Spence, J. T., et al.**, *Elementary Statistics*, 5th ed., 1991.  
**Triola, M. F.**, *Elementary Statistics*, 9th ed., 2003.  
**Weiss, N. A.**, *Elementary Statistics: Student Solutions Manual*, 4th ed., 1999.  
**Wonnacott, T. H., and R. J. Wonnacott**, *Introductory Statistics*, 5th ed., 1990.

*Annals of Statistics*, Institute of Mathematical Statistics, bi-monthly.  
*Journal of the American Statistical Association (JASA)*, quarterly.

## SYSTEMATICS

- Avise, J. C.**, *Phylogeography: The History and Formation of Species*, 2000.  
**Brooks, D. R., and D. A. McLennan**, *The Nature of Diversity: An Evolutionary Voyage of Discovery*, 2002.  
**Ereshefsky, M.**, *The Poverty of the Linnaean Hierarchy: A Philosophical Study of Biological Taxonomy*, 2001.  
**Felsenstein, J.**, *Inferring Phylogenies*, 2004.  
**Ghiselin, M. T.**, *Metaphysics and the Origin of Species*, 1997.  
**Hillis, D. M., C. Moritz, and B. K. Mable** (eds.), *Molecular Systematics*, 2d ed., 1996.  
**Schuh, R. T.**, *Biological Systematics: Principles and Applications*, 2000.  
**Wilson, R. A.** (ed.), *Species: New Interdisciplinary Essays*, 1999.

*Cladistics*, Willi Hennig Society, bimonthly.  
*Systematic Biology*, Society of Systematic Zoology, bi-monthly.

## SYSTEMS ENGINEERING

- Blanchard, B. S.**, *System Engineering Management*, 3d ed, 2003.  
**Booher, H.** (ed.), *Handbook of Human Systems Integration*, 2003.

- Haimes, Y. Y.**, *Risk Modeling, Assessment, and Management*, 2d ed, 2004.  
**Kossiakoff, A., and W. N. Sweet**, *Systems Engineering Principles and Practice*, 2002.  
**Rouse, W. B.**, *Essential Challenges of Strategic Management*, 2001.  
**Sage, A. P., and W. B. Rouse** (eds.), *Handbook of Systems Engineering and Management*, 1999.  
**Sage, A. P., and J. E. Armstrong**, *Introduction to Systems Engineering*, 2000.  
**Sheridan, T. B.**, *Humans and Automation: System Design and Research Issues*, 2002.

## TELECOMMUNICATIONS

- Clayton, J.**, *McGraw-Hill Illustrated Telecom Dictionary*, 2002.  
**Freeman, R. L.**, *Telecommunication System Engineering*, 2004.  
**Frenzel, L. E.**, *Principles of Electronic Communication Systems*, Student Edition, 2002.  
**Goleniewski, L.**, *Telecommunications Essentials*, 2001.  
**Haykin, S.**, *Communications Systems*, 2000.  
**Haykin, S., and M. Moher**, *Modern Wireless Communication*, 2004.  
**Proakis, J.**, *Digital Communications*, 2000.  
**Rappaport, T.**, *Wireless Communications: Principles and Practice*, 2d ed., 2001.  
**Roddy, D.**, *Satellite Communications*, 2001.  
**Lathi, B. P.**, *Modern Digital and Analog Communication Systems* (Oxford Series in Electrical and Computer Engineering), 3d ed., 1998.  
**Peterson, R. L., D. E. Borth, and R. E. Ziemer**, *An Introduction to Spread Spectrum Communication*, 1995.  
**Roddy, D.**, *Satellite Communications*, 3d ed., 2001.

*Bell Labs Technical Journal*, John Wiley, quarterly.  
*IEEE Spectrum*, Institute of Electrical and Electronics Engineers, Inc. monthly.

## TELEPHONY

- Bellamy, J. C.**, *Digital Telephony* (Wiley Series in Telecommunications and Signal Processing), 3d ed., 2000.  
**Bigelow, S. J., J. J. Carr, and S. Winder**, *Understanding Telephone Electronics*, 4th ed., 2001.  
**Noll, A. M.**, *Introduction to Telephones and Telephone Systems* (Artech House Telecommunications Library), 3d ed., 1999.  
**Ohrman, F.**, *Softswitch: Architecture for VoIP*, 2002.

## TELEVISION

- Lenk, J. D.**, *Lenk's Television Handbook: Operation and Troubleshooting*, 1995.  
**Noll, A. M.**, *Television Technology: Fundamentals and Future Prospects* (Telecommunications Management Library), 1988.  
**Poynton, C.**, *Digital Video and HDTV Algorithms and Interfaces*, 2003.  
**Robin, M. and M. Poulin**, *Digital Television Fundamentals*, 2000.  
**Rzeszewski, T.**, *Digital Video: Concepts and Applications Across Industries*, 1995.  
**Watkinson, J.**, *Television Fundamentals*, 1996.

- Whitaker, J.**, *HDTV: The Revolution in Electronic Imaging* (McGraw-Hill Video/Audio Engineering Series), 1998.
- Whitaker, J.** (ed.), *National Association of Broadcasters Engineering Handbook*, 1999.
- Whitaker, J.**, and **B. K. Benson**, *Standard Handbook of Video and Television Engineering*, 4th ed., 2003.

## TEXTILES AND FIBERS

- Collier, B. J.**, and **P. G. Tortora**, *Understanding Textiles*, 6th ed., 2000.
- Kadolph, S. J.**, and **A. L. Langford**, *Textiles* 9th ed., 2001.
- Joseph, M. L.**, et al., *Joseph's Introductory Textile Science*, 6th ed., 1993.
- Smith, B.**, and **I. Block**, *Textiles in Perspective* (Facsimile), 1996.

*Textile Research Journal*, Textile Research Institute, monthly.

## THEORETICAL PHYSICS

- Arfken, G. B.**, and **H. J. Weber** (eds.), *Mathematical Methods for Physicists*, 5th ed., 2000.
- Courant, R.**, and **D. Hilbert**, *Methods of Mathematical Physics*, vol 1., 1989.
- Honerkamp, J.**, **H. Pollack**, and **H. Romer**, *Theoretical Physics: A Classical Approach*, 1993.
- Lam, L.** (ed.), *Nonlinear Physics for Beginners: Fractals, Chaos, Solitons, Pattern Formation, Cellular Automata, and Complex Systems*, 1998.
- Landau, L. D.**, et al., *Course of Theoretical Physics*, 9 vols., 1959–1987.
- Reed, M.**, and **B. Simon**, *Methods of Modern Mathematical Physics*, 4 vols., 1975–1980.
- Thirring, W. E.**, *Course in Mathematical Physics*, 4 vols., 1997.

*Communications in Mathematical Physics*, 18 issues per year.

*Journal of Mathematical Physics*, American Institute of Physics, monthly.

## THERMODYNAMICS AND HEAT

- Black, W. Z.**, and **J. G. Hartley**, *Thermodynamics* (English/SI Version), 3d ed., 1997.
- Cengel, Y. A.**, and **M. A. Boles**, *Thermodynamics: An Engineering Approach*, 4th ed., 2001.
- Gocken, N. A.**, and **R. G. Reddy**, *Thermodynamics*, 2d ed., 1999.
- Holman, J. P.**, *Thermodynamics*, 4th ed., 1988.
- Modell, M.**, and **J. W. Tester**, *Thermodynamics and Its Applications*, 3d ed., 1996.
- Moran, M. J.**, and **H. N. Shapiro**, *Fundamentals of Engineering Thermodynamics*, 5th ed., 2003.
- Soontag, R. E.**, **C. Borgnakke**, and **G. J. Van Wylen**, *Fundamentals of Thermodynamics*, 6th ed., 2002.
- Wark, K.**, and **D. E. Richards**, *Thermodynamics*, 6th ed., 1999.
- Wood, S. E.**, and **R. Battino**, *Thermodynamics of Chemical Systems*, 1990.

- Zemansky, M. W.**, and **R. H. Dittman**, *Heat and Thermodynamics*, 7th ed., 1997.

## TRANSPORTATION ENGINEERING

- Ashford, N.**, and **P. H. Wright**, *Airport Engineering*, 3d ed., 1992.
- Diebold, J.**, *Transportation Infostructures: The Development of Intelligent Transportation Systems*, 1995.
- Khisty, C. J.**, and **K. Lall**, *Transportation Engineering: An Introduction*, 2d ed., 1997.
- Papacostas, C. S.**, and **P. D. Prevedouros**, *Transportation Engineering*, 3d ed., 2000.
- Robertson, D.**, and **J. E. Hummer**, *Manual of Transportation Engineering Studies*, 5th ed., 1994.
- Sheets, E.**, and **A. R. De Old**, *Activities for Transportation Technology Systems*, 1993.
- Wright, P. H.**, and **K. Dixon**, *Highway Engineering*, 7th ed., 2003.

*Journal of Transportation Engineering*, American Society of Civil Engineering, bimonthly.

*Transportation Journal*, American Society of Traffic and Logistics, quarterly.

## TRIGONOMETRY

- Aufmann, R. N.**, **V. C. Barker**, and **R. D. Nation**, *College Trigonometry*, 4th ed., 2002.
- Drooyan, I.**, and **C. C. Carico**, *Trigonometry: An Analytical Approach*, 6th ed., 1991.
- Heineman, E. R.**, and **J. D. Tarwater**, *Plane Trigonometry*, 7th ed., 1993.
- Hungerford, T. W.**, and **R. Mercer**, *Trigonometry*, 1992.
- Smith, K. J.**, *Trigonometry for College Students*, 7th ed., 1998.
- Sullivan, M.**, *Trigonometry*, 6th ed., 2001.

## VERTEBRATE ZOOLOGY

See Zoology.

## VETERINARY MEDICINE

- Aiello, S. E.** (ed.), *The Merck Veterinary Manual*, 8th ed., 1998.
- Ettinger, S. J.**, and **E. C. Feldman**, *Textbook of Veterinary Internal Medicine*, 4th ed., 1995.
- Fenner, W. R.**, *Quick Reference to Veterinary Medicine*, 3d ed., 2000.
- Howard, J. L.**, and **R. A. Smith**, *Current Veterinary Therapy 4: Food Animal Practice*, 1999.
- Timoney, J. F.**, *Hagan and Bruner's Microbiology and Infectious Diseases of Domestic Animals*, 8th ed., 1988.

## VIROLOGY

- Belshe, R. B.**, *Textbook of Human Virology*, 2d ed., 1990.
- Diener, T. O.** (ed.), *The Viroids* (The Viruses), 1987.
- Dimmock, N. J.**, **P. D. Griffiths**, and **C. R. Madeley** (eds.), *Control of Virus Diseases*, 1990.



**Fields, B. N.**, *Virology*, 3d ed., 1995.

**Flint, S. J., et al.** (eds.), *Principles of Virology: Molecular Biology, Pathogenesis, and Control*, 2d ed., 2000.

ICTVdB: The Universal Virus Database of the International Committee on Taxonomy of Viruses, maintained by C. Büchen-Osmond [<http://www.ncbi.nlm.nih.gov/ICTVdB/ICTVdBintro.htm>].

**Knipe, D. M.** *Fundamental Virology*, 4th ed., 2001.

**Matthews, R. E., et al.**, *Matthew's Plant Virology*, 4th ed., 2001.

**Nathanson, N.** (ed.), *Viral Pathogenesis*, 1997.

**Voyles, B. A.**, *Biology of the Viruses*, 2d ed., 2002.

**Wagner, E. K., and M. J. Hewlett**, *Basic Virology*, 1999.

*Advances in Virus Research*, irregularly.

*Excerpta Medica*, Section 47: Virology, 10 issues per year.

*Journal of Virology*, American Society for Microbiology, bimonthly.

## ZOOLOGY

**Alcock, J.**, *Animal Behavior: An Evolutionary Approach*, 7th ed., 2001.

**Barnes, R. D., R. S. Fox, and E. E. Ruppert**, *Invertebrate Zoology*, 7th ed., 2003.

**Bond, C. E.**, *Biology of Fishes*, 2d ed., 1996.

**Dorit, R., W. F. Walker, and R. D. Barnes**, *Zoology*, 1991.

**Feduccia, A., and E. McCrady**, *Torrey's Morphogenesis of the Vertebrates*, 5th ed., 1991.

**Grzimek, B.** (ed.), *Grzimek's Encyclopedia of Mammals*, 2d ed., 1989.

**Hickman, C. P., L. S. Roberts, and A. Larson**, *Integrated Principles of Zoology*, 11th ed., 2000.

**Hildebrand, M., and G. Goslow**, *Analysis of Vertebrate Structure*, 5th ed., 2001.

**Kardong, K. V.**, *Vertebrates*, 2d ed., 1998.

**Linzey, D. W.**, *Vertebrate Biology*, 2001.

**McFarland, D.**, *Animal Behavior, Psychobiology, Ethology, and Evolution*, 3d ed., 1998.

**Meglitsch, P. A., and F. R. Schram**, *Invertebrate Zoology*, 3d ed., 1991.

**Miller, S. A., and J. P. Harley**, *Zoology*, 6th ed., 2004.

**Pearse, V., et al.**, *Living Invertebrates*, 1987.

**Pough, F., et al.**, *Vertebrate Life*, 6th ed., 2001.

*Integrative and Comparative Biology*, Society for Integrative and Comparative Biology, bimonthly.

*Journal of Zoology*, monthly.



# Measurement systems

## U.S. Customary System and the metric system

Over the past 200 years or so, scientists and engineers have used two major systems of units in measurement. These are commonly called the U.S. Customary System (inherited from the British Imperial System) and the metric system (developed at the time of the French Revolution).

In the U.S. Customary System the units yard and pound with their divisions, such as the inch, and multiples, such as the ton, are basic. The metric system has been adopted for general use by most countries. It is used nearly everywhere for precise measurements in science. The meter and kilogram with their multiples, such as the kilometer, and fractions, such as the gram, are basic to the metric system. Until the second half of the twentieth century, most of the base units in these systems were defined in terms of specific physical artifacts, such as the International Prototype Kilogram, a platinum-iridium cylinder maintained in Sèvres, France.

In the U.S. Customary System, units of the same kind are related almost at random. For example, there are the units of length, the inch, yard, and mile. In the metric system the relationships between units of the same kind are strictly decimal (millimeter, meter, and kilometer).

However, in technical writing there is no uniformity within each of these two systems as to the choice of units for the same quantities. For example, the hour or the second, the foot or the inch, and the centimeter or the millimeter could be chosen as the unit of measurement for the quantities time and length.

## International System

To simplify matters and to make communication more understandable, an internationally accepted system of units came into use in 1960. This is termed the International System of Units, which is abbreviated SI in all languages (from the French *Système International d'Unités*).

Fundamentally the system is metric, with base units whose definitions have been modified from time to time in order to allow for their more accurate realization as techniques of measurement have evolved. In several instances, artifact standards have been replaced by physically invariant quantities, such as atomic transition frequencies and fundamental physical constants. For example, the meter in the SI is defined as the length of the path traveled by light in vacuum during a time interval of  $1/299\,792\,458$  of a second. The effect of this definition, which was adopted in 1983, is to fix the speed of light at exactly  $299\,792\,458$  meters per second.

The second in the SI is defined as the duration of  $9\,192\,631\,770$  periods of the radiation corresponding to the transition between two hyperfine levels of the ground state of the cesium-133 atom.

Interestingly, the kilogram, the SI unit of mass, is still the mass of the kilogram kept at Sèvres. However, it is probable that eventually the unit will be redefined in terms of atomic mass or through a definition that will fix the value of the Planck constant  $h$ .

Although the SI is increasingly used by scientists and engineers, there are some other units in everyday use which will probably remain, for example, minute, hour, day, degree (angle), and liter. The point should be made, however, that these terms will not be employed in a scientific context if the SI is fully adopted.

Because of their extremely common use among scientists, several units are still permitted in conjunction with SI units, for example, the electronvolt, rad, roentgen, barn, and curie. In time their usage might be phased out.

One further point is that in October 1967 the Thirteenth General Conference of Weights and Measures decided to name the SI unit of thermodynamic temperature "kelvin" (symbol K) instead of "degree Kelvin" (symbol °K). For example, the notation is 273 K and not 273°K.

The base units and derived units of the SI are shown in **Table 1** and **2**.

In the SI the prefixes differ from a unit in steps of  $10^3$ . A list of prefix terms, symbols, and their factors is given in **Table 3**. Some examples of the use of these prefixes follow:

$$\begin{aligned}1000 \text{ m} &= 1 \text{ kilometer} &&= 1 \text{ km} \\1000 \text{ V} &= 1 \text{ kilovolt} &&= 1 \text{ kV} \\1\,000\,000 \text{ } \Omega &= 1 \text{ megohm} &&= 1 \text{ M}\Omega \\0.000\,000\,001 \text{ s} &= 1 \text{ nanosecond} &&= 1 \text{ ns}\end{aligned}$$

Only one prefix is to be employed for a unit. For example:

$$\begin{aligned}1000 \text{ kg} &= 1 \text{ Mg} &&\text{not } 1 \text{ kkg} \\10^{-9} \text{ s} &= 1 \text{ ns} &&\text{not } 1 \text{ m}\mu\text{s} \\1\,000\,000 \text{ m} &= 1 \text{ Mm} &&\text{not } 1 \text{ kkm}\end{aligned}$$

Also, when a unit is raised to a power, the power applies to the whole unit including the prefix. For example:

$$\begin{aligned}\text{km}^2 &= (\text{km})^2 = (1000 \text{ m})^2 = 10^6 \text{ m}^2 \\&\text{not } 1000 \text{ m}^2\end{aligned}$$

Some common units defined in terms of SI units are given in **Table 4** (the definitions in the fourth column are exact).

## Conversion factors for the measurement systems

This Encyclopedia has retained the U.S. Customary and metric systems, but has incorporated SI units in many cases. Conversion factors between the three measurement systems are given in **Table 5** for some prevalent units; in each of the subtables the user proceeds as follows:

To convert a quantity expressed in a unit in the left-hand column to the equivalent in a unit in the top row of a subtable, multiply the quantity by the factor common to both units. For example, to convert 7 ft to the equivalent in meters, go to subtable A, "Units of length," and find 1 ft in the left-hand column and m in the top row. The conversion factor common to these units is 0.3048. Therefore,  $7 \text{ ft} = 7 \times 0.3048 = 2.1336 \text{ m}$ .

The conversion factors have been carried out to seven significant figures, as derived from the fundamental constants and the definitions of the units. However, this does not mean that the factors are always known to that accuracy. Numbers followed by ellipses are to be continued indefinitely with repetition of the same pattern of digits. Factors written with fewer than seven significant digits are exact values. Numbers followed by an asterisk are definitions of the relation between the two units.

TABLE 1. Base units of the International System

Quantity	Name of unit	Unit symbol
length	meter	m
mass	kilogram	kg
time	second	s
electric current	ampere	A
temperature	kelvin	K
luminous intensity	candela	cd
amount of substance	mole	mol

TABLE 2. Derived units of the International System\*

Quantity	Name of unit	Unit symbol, or unit expressed in terms of other SI units	Unit expressed in terms of SI base units
plane angle	radian	rad	m/m = 1
solid angle	steradian	sr	m <sup>2</sup> /m <sup>2</sup> = 1
area	square meter		m <sup>2</sup>
volume	cubic meter		m <sup>3</sup>
frequency	hertz	Hz	s <sup>-1</sup>
density	kilogram per cubic meter		kg/m <sup>3</sup>
velocity	meter per second		m/s
angular velocity	radian per second	rad/s	m/(m · s) = s <sup>-1</sup>
acceleration	meter per second squared		m/s <sup>2</sup>
angular acceleration	radian per second squared	rad/s <sup>2</sup>	m/(m · s <sup>2</sup> ) = s <sup>-2</sup>
volumetric flow rate	cubic meter per second		m <sup>3</sup> /s
force	newton	N	kg · m/s <sup>2</sup>
surface tension	newton per meter, joule per square meter	N/m, J/m <sup>2</sup>	kg/s <sup>2</sup>
pressure	pascal, newton per square meter	Pa, N/m <sup>2</sup>	kg/(m · s <sup>2</sup> )
viscosity, dynamic	pascal-second, newton-second per square meter	Pa · s, N · s/m <sup>2</sup>	kg/(m · s)
viscosity, kinematic	meter squared per second		m <sup>2</sup> /s
work, torque, energy, quantity of heat	joule, newton-meter, watt-second	J, N · m, W · s	kg · m <sup>2</sup> /s <sup>2</sup>
power, heat flux	watt, joule per second	W, J/s	kg · m <sup>2</sup> /s <sup>3</sup>
heat flux density	watt per square meter	W/m <sup>2</sup>	kg/s <sup>3</sup>
volumetric heat release rate	watt per cubic meter	W/m <sup>3</sup>	kg/(m · s <sup>3</sup> )
heat transfer coefficient	watt per square meter kelvin	W/(m <sup>2</sup> · K)	kg/(s <sup>3</sup> · K)
heat capacity (specific)	joule per kilogram kelvin	J/kg · K	m <sup>2</sup> /(s <sup>2</sup> · K)
capacity rate	watt per kelvin	W/K	kg · m <sup>2</sup> /(s <sup>3</sup> · K)
thermal conductivity	watt per meter kelvin	W/(m · K), $\frac{J \cdot m}{s \cdot m^2 \cdot K}$	kg · m/(s <sup>3</sup> · K)
quantity of electricity	coulomb	C	A · s
electromotive force	volt	V, W/A	kg · m <sup>2</sup> /(A · s <sup>3</sup> )
electric field strength	volt per meter	V/m	kg · m/(A · s <sup>3</sup> )
electric resistance	ohm	Ω, V/A	kg · m <sup>2</sup> /(A <sup>2</sup> · s <sup>3</sup> )
electric conductance	siemens	S, A/V	A <sup>2</sup> · s <sup>3</sup> /(kg · m <sup>2</sup> )
electric conductivity	ampere per volt meter	A/(V · m)	A <sup>2</sup> · s <sup>3</sup> /(kg · m <sup>3</sup> )
electric capacitance	farad	F, A · s/V	A <sup>2</sup> · s <sup>4</sup> /(kg · m <sup>2</sup> )
magnetic flux	weber	Wb, V · s	kg · m <sup>2</sup> /A · s <sup>2</sup>
inductance	henry	H, V · s/A	kg · m <sup>2</sup> /(A <sup>2</sup> · s <sup>2</sup> )
magnetic permeability	henry per meter	H/m	kg · m/(A <sup>2</sup> · s <sup>2</sup> )
magnetic flux density	tesla, weber per square meter	T, Wb/m <sup>2</sup>	kg/(A · s <sup>2</sup> )
magnetic field strength	ampere per meter		A/m
magnetomotive force	ampere		A
luminous flux	lumen	lm, cd · sr	cd · m <sup>2</sup> /m <sup>2</sup> = cd
luminance	candela per square meter		cd/m <sup>2</sup>
illumination	lux, lumen per square meter	lx, lm/m <sup>2</sup> , cd · sr/m <sup>2</sup>	cd · m <sup>2</sup> /m <sup>4</sup> = cd/m <sup>2</sup>
activity (of radionuclides)	becquerel	Bq	s <sup>-1</sup>
absorbed dose	gray	Gy, J/kg	m <sup>2</sup> /s <sup>2</sup>
dose equivalent	sievert	Sv, J/Kg	m <sup>2</sup> /s <sup>2</sup>
catalytic activity	katal	kat	mol/s

\*The degree Celsius (°C), listed in Table 4, is also a derived unit of the International System.

TABLE 3. Prefixes for units in the International System

Prefix	Symbol	Power	Example	Prefix	Symbol	Power	Example
yotta	Y	$10^{24}$		deci	d	$10^{-1}$	
zetta	Z	$10^{21}$		centi	c	$10^{-2}$	centimeter (cm)
exa	E	$10^{18}$		milli	m	$10^{-3}$	milligram (mg)
peta	P	$10^{15}$		micro	$\mu$	$10^{-6}$	microgram ( $\mu\text{g}$ )
tera	T	$10^{12}$	terawatt (TW)	nano	n	$10^{-9}$	nanosecond (ns)
giga	G	$10^9$	gigawatt (GW)	pico	p	$10^{-15}$	picofarad (pF)
mega	M	$10^6$	megahertz (MHz)	femto	f	$10^{-15}$	femtosecond (fs)
kilo	k	$10^3$	kilometer (km)	atto	a	$10^{-18}$	
hecto	h	$10^2$		zepto	z	$10^{-21}$	
deka	da	$10^1$		yocto	y	$10^{-24}$	

TABLE 4. Some common units defined in terms of SI units

Quantity	Name of unit	Unit symbol	Definition of unit
length	inch	in.	$2.54 \times 10^{-2}$ m
mass	pound (avoirdupois)	lb	0.45359237 kg
force	kilogram-force	kgf	9.80665 N
pressure	atmosphere	atm	101325 Pa
pressure	torr	torr	(101325/760) Pa
pressure	conventional millimeter of mercury*	mmHg	$13.5951 \times 980.665 \times 10^{-2}$ Pa
energy	kilowatt-hour	kWh	$3.6 \times 10^6$ J
energy	thermochemical calorie	cal	4.184 J
energy	international steam table calorie	cal <sub>IT</sub>	4.1868 J
thermodynamic temperature ( $T$ )	degree Rankine	$^{\circ}\text{R}$	(5/9) K
customary temperature ( $t$ )	degree Celsius	$^{\circ}\text{C}$	$t(^{\circ}\text{C}) = T(\text{K}) - 273.15$
customary temperature ( $t$ )	degree Fahrenheit	$^{\circ}\text{F}$	$t(^{\circ}\text{F}) = [1.8 \times t(^{\circ}\text{C})] + 32 = T(^{\circ}\text{R}) - 459.67$
radioactivity	curie	Ci	$3.7 \times 10^{10}$ Bq
energy <sup>†</sup>	electronvolt	eV	$\text{eV} = 1.60218 \times 10^{-19}$ J
mass <sup>†</sup>	unified atomic mass unit	u	$u = 1.66054 \times 10^{-27}$ kg

\*The conventional millimeter of mercury, symbol mmHg (not mm Hg), is the pressure exerted by a column exactly 1 mm high of a fluid of density exactly  $13.5951 \text{ g cm}^{-3}$  in a place where the gravitational acceleration is exactly  $980.665 \text{ cm} \cdot \text{s}^{-2}$ . The mmHg differs from the torr by less than  $2 \times 10^{-7}$  torr.

<sup>†</sup>These units defined in terms of the best available experimental values of certain physical constants may be converted to SI units. The factors for conversion of these units are subject of change in the light of new experimental measurements of the constants involved.

TABLE 5. Conversion factors for the U.S. Customary System, metric system, and International System

<b>A. Units of length</b>							
Units	cm	m	in.	ft	yd	mi	
1 cm	= 1	0.01*	0.3937008	0.03280840	0.01093613	$6.213712 \times 10^{-6}$	
1 m	= 100.	1	39.37008	3.280840	1.093613	$6.213712 \times 10^{-4}$	
1 in.	= 2.54*	0.0254	1	0.08333333...	0.02777777...	$1.578283 \times 10^{-5}$	
1 ft	= 30.48	0.3048	12.*	1	0.3333333...	$1.893939... \times 10^{-4}$	
1 yd	= 91.44	0.9144	36.	3.*	1	$5.681818... \times 10^{-4}$	
1 mi	= $1.609344 \times 10^5$	$1.609344 \times 10^3$	$6.336 \times 10^4$	5280.*	1760.	1	
<b>B. Units of area</b>							
Units	cm <sup>2</sup>	m <sup>2</sup>	in. <sup>2</sup>	ft <sup>2</sup>	yd <sup>2</sup>	mi <sup>2</sup>	
1 cm <sup>2</sup>	= 1	$10^{-4}$ *	0.1550003	$1.076391 \times 10^{-3}$	$1.195990 \times 10^{-4}$	$3.861022 \times 10^{-11}$	
1 m <sup>2</sup>	= $10^4$	1	1550.003	10.76391	1.195990	$3.861022 \times 10^{-7}$	
1 in. <sup>2</sup>	= 6.4516*	$6.4516 \times 10^{-4}$	1	$6.944444... \times 10^{-3}$	$7.716049 \times 10^{-4}$	$2.490977 \times 10^{-10}$	
1 ft <sup>2</sup>	= 929.0304	0.09290304	144.*	1	0.7777777...	$3.587007 \times 10^{-8}$	
1 yd <sup>2</sup>	= 8361.273	0.8361273	1296.	9.*	1	$3.228306 \times 10^{-7}$	
1 mi <sup>2</sup>	= $2.589988 \times 10^{10}$	$2.589988 \times 10^6$	$4.014490 \times 10^9$	$2.78784 \times 10^7$ *	$3.0976 \times 10^6$	1	
<b>C. Units of volume</b>							
Units	m <sup>3</sup>	cm <sup>3</sup>	liter	in. <sup>3</sup>	ft <sup>3</sup>	qt	gal
1 m <sup>3</sup>	= 1	$10^6$	$10^3$	$6.102374 \times 10^4$	$35.31467 \times 10^{-3}$	1.056688	264.1721
1 cm <sup>3</sup>	= $10^{-6}$	1	$10^{-3}$	0.06102374	$3.531467 \times 10^{-5}$	$1.056688 \times 10^{-3}$	$2.641721 \times 10^{-4}$
1 liter	= $10^{-3}$	1000.*	1	61.02374	0.03531467	1.056688	0.2641721
1 in. <sup>3</sup>	= $1.638706 \times 10^{-5}$	16.38706*	0.01638706	1	$5.787037 \times 10^{-4}$	0.01731602	$4.329004 \times 10^{-3}$
1 ft <sup>3</sup>	= $2.831685 \times 10^{-2}$	28316.85	28.31685	1728.*	1	2.992208	7.480520
1 qt	= $9.463529 \times 10^{-4}$	946.3529	0.9463529	57.75	0.0342014	1	0.25
1 gal (U.S.)	= $3.785412 \times 10^{-3}$	3785.412	3.785412	231.*	0.1336806	4.*	1
<b>D. Units of mass</b>							
Units	g	kg	oz	lb	metric ton	ton	
1 g	= 1	$10^{-3}$	0.03527396	$2.204623 \times 10^{-3}$	$10^{-6}$	$1.102311 \times 10^{-6}$	
1 kg	= 1000.	1	35.27396	2.204623	$10^{-3}$	$1.102311 \times 10^{-3}$	
1 oz (avdp)	= 28.34952	0.02834952	1	0.0625	$2.834952 \times 10^{-5}$	$3.125 \times 10^{-5}$	
1 lb (avdp)	= 453.5924	0.4535924	16.*	1	$4.535924 \times 10^{-4}$	$5. \times 10^{-4}$	
1 metric ton	= $10^6$	1000.*	35273.96	2204.623	1	1.102311	
1 ton	= 907184.7	907.1847	32000.	2000.*	0.9071847	1	

\*Usage of the asterisk is defined in the accompanying text.

TABLE 5. Conversion factors for the U.S. Customary System, metric system, and International System (cont.)

<b>E. Units of density</b>											
Units	$\text{g} \cdot \text{cm}^{-3}$	$\text{g} \cdot \text{L}^{-1}, \text{kg} \cdot \text{m}^{-3}$	$\text{oz} \cdot \text{in.}^{-3}$	$\text{lb} \cdot \text{in.}^{-3}$	$\text{lb} \cdot \text{ft}^{-3}$	$\text{lb} \cdot \text{gal}^{-1}$					
$1 \text{ g} \cdot \text{cm}^{-3}$	= 1	1000.	0.5780365	0.03612728	62.42795	8.345403					
$1 \text{ g} \cdot \text{L}^{-1}, \text{kg} \cdot \text{m}^{-3}$	= $10^{-3}$	1	$5.780365 \times 10^{-4}$	$3.612728 \times 10^{-5}$	0.06242795	$8.345403 \times 10^{-3}$					
$1 \text{ oz} \cdot \text{in.}^{-3}$	= 1.729994	1729.994	1	0.0625	108.	14.4375					
$1 \text{ lb} \cdot \text{in.}^{-3}$	= 27.67991	27679.91	16.	1	1728.	231.					
$1 \text{ lb} \cdot \text{ft}^{-3}$	= 0.01601847	16.01847	$9.259259 \times 10^{-3}$	$5.787037 \times 10^{-4}$	1	0.1336806					
$1 \text{ lb} \cdot \text{gal}^{-1}$	= 0.1198264	119.8264	$4.749536 \times 10^{-3}$	$4.329004 \times 10^{-3}$	7.480519	1					
<b>F. Units of pressure</b>											
Units	$\text{Pa}, \text{N} \cdot \text{m}^{-2}$	$\text{dyn} \cdot \text{cm}^{-2}$	bar	atm	$\text{kgf} \cdot \text{cm}^{-2}$	mmHg (torr)	in. Hg	lbf $\cdot$ in. $^{-2}$			
$1 \text{ Pa}, 1 \text{ N} \cdot \text{m}^{-2}$	= 1	10	$10^{-5}$	$9.869233 \times 10^{-6}$	$1.019716 \times 10^{-5}$	$7.500617 \times 10^{-3}$	$2.952999 \times 10^{-4}$	$1.450377 \times 10^{-4}$			
$1 \text{ dyn} \cdot \text{cm}^{-2}$	= 0.1	1	$10^{-6}$	$9.869233 \times 10^{-7}$	$1.019716 \times 10^{-6}$	$7.500617 \times 10^{-4}$	$2.952999 \times 10^{-5}$	$1.450377 \times 10^{-5}$			
1 bar	= $10^5$ *	$10^6$	1	0.9869233	1.019716	750.0617	29.52999	14.50377			
1 atm	= 101325*	1013250	1.01325	1	1.033227	760.	29.92126	14.69595			
$1 \text{ kgf} \cdot \text{cm}^{-2}$	= 98066.5	980665	0.980665	0.9678411	1	735.5592	28.95903	14.22334			
1 mmHg (torr)	= 133.3224	1333.224	$1.333224 \times 10^3$	$1.315789 \times 10^{-3}$	$1.3595510 \times 10^{-3}$	1	0.03937008	0.01933678			
1 in. Hg	= 3386.388	33863.88	0.03386388	0.03342105	0.03453155	25.4	1	0.4911541			
$1 \text{ lbf} \cdot \text{in.}^{-2}$	= 6894.757	68947.57	0.06894757	0.06804596	0.07030696	51.71493	2.036021	1			
<b>G. Units of energy</b>											
Units	$\text{g mass (energy equiv)}$	J	eV	cal	$\text{cal}_T$	$\text{Btu}_T$	kWh	hp-h	ft-lbf	$\text{ft}^3 \cdot \text{lbf} \cdot \text{in.}^{-2}$	liter-atm
$1 \text{ g mass (energy equiv)}$	= 1	$8.987552 \times 10^{13}$	$5.609589 \times 10^{32}$	$2.148076 \times 10^3$	$2.146640 \times 10^{13}$	$8.518555 \times 10^{10}$	$2.496542 \times 10^7$	$3.347918 \times 10^7$	$6.628878 \times 10^{13}$	$4.603388 \times 10^{11}$	$8.870024 \times 10^{11}$
1 J	= $1.112650 \times 10^{-14}$	1	$6.241509 \times 10^{18}$	0.2390057	0.2388459	$9.478172 \times 10^{-4}$	$2.777777... \times 10^{-7}$	3.725062	0.7375622	$5.121960 \times 10^{-3}$	$9.869233 \times 10^{-3}$
1 eV	= $1.782662 \times 10^{-33}$	$1.602177 \times 10^{-19}$	1	$3.829294 \times 10^{-20}$	$3.826733 \times 10^{-20}$	$1.518570 \times 10^{-22}$	$4.450490 \times 10^{-26}$	$5.968206 \times 10^{-26}$	$1.181705 \times 10^{-19}$	$8.206283 \times 10^{-22}$	$1.581225 \times 10^{-21}$
1 cal	= $4.655328 \times 10^{-14}$	4.184*	$2.611448 \times 10^{19}$	1	0.9993312	$3.965667 \times 10^{-3}$	$1.1622222... \times 10^{-6}$	$1.558562 \times 10^{-6}$	3.085960	$2.143028 \times 10^{-2}$	0.04129287
$1 \text{ cal}_T$	= $4.658443 \times 10^{-14}$	4.1868*	$2.613195 \times 10^{19}$	1.000669	1	$3.968321 \times 10^{-3}$	$1.163 \times 10^{-6}$	$1.559609 \times 10^{-6}$	3.088025	$2.144462 \times 10^{-2}$	0.04132050
$1 \text{ Btu}_T$	= $1.173908 \times 10^{-11}$	1055.056	$6.585141 \times 10^{21}$	252.1644	251.9958	1	$2.930711 \times 10^{-4}$	$3.930148 \times 10^{-4}$	778.1693	5.403953	10.41259
1 kWh	= $4.005540 \times 10^{-8}$	3600000.*	$2.246943 \times 10^{25}$	860420.7	859845.2	3412.142	1	1.341022	2655224.	18349.06	35529.24
1 hp-h	= $2.986931 \times 10^{-8}$	2384519.	$1.675545 \times 10^{25}$	641615.6	641186.5	2544.33	0.7456998	1	1980000.*	13750.	26494.15
1 ft-lbf	= $1.508551 \times 10^{-14}$	1.355818	$8.462351 \times 10^{18}$	0.3240483	0.3238315	$1.285067 \times 10^{-3}$	$3.766161 \times 10^{-7}$	$5.050505... \times 10^{-7}$	1	$6.944444... \times 10^{-3}$	0.01338088
$1 \text{ ft}^3 \text{ lbf} \cdot \text{in.}^{-2}$	= $2.172313 \times 10^{-12}$	195.2378	$1.218578 \times 10^{21}$	46.66295.	46.63174	0.1850497	$5.423272 \times 10^{-5}$	$7.272727... \times 10^{-5}$	144.*	1	1.926847
1 liter-atm	= $1.127393 \times 10^{-12}$	101.325	$6.3242109 \times 10^{20}$	24.21726	24.20106	0.09603757	$2.814583 \times 10^{-5}$	$3.774419 \times 10^{-5}$	74.73349	0.5189825	1

\*Usage of the asterisk is defined in the accompanying text.

## Units of temperature in measurement systems

Temperature is a basic physical quantity. It is a measure of the thermal energy of random motion of particles in a system. As such it has been chosen as one of the base quantities in the SI. It is to be treated as are the units of length, mass, time, electric current, and luminous intensity. In the SI the unit of length is the meter, the unit of time the second, and so on. The question arises as to the choice of the unit of temperature in the SI.

In the past it was customary to refer to scales of temperature, for example, the Celsius and Fahrenheit scales. On the Celsius scale, 0 designates the freezing point (ice point) and 100 the boiling point (steam point) of water. Corresponding numbers on the Fahrenheit scale are 32 and 212. There are 100 units between the ice point and steam point on the Celsius scale, and 180 units between these points in the Fahrenheit system.

By measuring the volume changes of a gas within the 100-unit interval for the ice point and steam point of water on the Celsius scale, it was found that a numerical value could be assigned for a basic unit of temperature. Careful measurement of this ice-steam interval in a gas thermometer determined that the ice point of water should be assigned the value of 273.15 kelvins. The unit of temperature was thus called the kelvin with the symbol K. Further experiments led to the decision to define the kelvin in the SI along the same lines but in terms of the triple point of water. This is the temperature and pressure at which ice, liquid water, and water vapor coexist at equilibrium. The triple point was chosen because it was a more reproducible value than the ice point.

This change led to the SI definition of temperature in terms of the temperature of the triple point of water, which contains exactly 273.16 kelvins.

It follows that the Celsius temperature ( $^{\circ}\text{C}$ ) is an intermediate scale. It is useful in defining Kelvin temperature in the SI. Celsius

temperature ( $t$ ) is related to Kelvin temperature ( $K$ ) as follows:

$$\begin{aligned} t_{\text{ice point}} &= 0^{\circ}\text{C} \\ t_{\text{steam point}} &= 100^{\circ}\text{C} \\ 0\text{ K} &= -273.15^{\circ}\text{C} \end{aligned}$$

A summary of the conventions in the SI as proposed in the Thirteenth General Conference of Weights and Measures pertaining to temperature units is given below.

1. The unit of SI temperature is the kelvin, symbol K.
2. The word "scale" is not to be used except in terms of measurement of temperature between certain fixed points on the Celsius scale.
3. The terms "thermodynamic scale" or "absolute scale" are not to be used to describe temperature. The degree sign is to be eliminated with the symbol K.
4. When Celsius temperatures are used ( $^{\circ}\text{C}$ ), it is understood that the temperature unit is the kelvin.

Not all scientists and engineers have adopted the SI of temperature terminology. Furthermore, many engineers in the United States still use the Fahrenheit system in discussing practical engineering systems.

In converting Fahrenheit ( $^{\circ}\text{F}$ ) to Celsius ( $^{\circ}\text{C}$ ) the following formula applies.

$$^{\circ}\text{C} = \frac{^{\circ}\text{F} - 32^{\circ}}{1.8}$$

In converting Celsius to Fahrenheit the following formula can be used.

$$^{\circ}\text{F} = (^{\circ}\text{C} \times 1.8) + 32^{\circ}$$

In changing from Celsius terminology ( $t$ ) to kelvin units ( $K$ ) the following formula can be used.

$$K = t + 273.15$$

# Chemistry

## Symbols for the chemical elements

The mass number, atomic number, number of atoms, and ionic charge of an element are often indicated by means of four indices placed around the symbol. The positions occupied are left upper index, mass number; left lower index, atomic number; right upper index, ionic charge; and right lower index, number of atoms of an element in a molecule or formula unit of a given species: for example,  $^{12}_6\text{C}$ ,  $\text{Ca}^{2+}$ ,  $\text{O}_2$ , and  $\text{Al}_2\text{O}_3$ . The atomic number, which is redundant, is omitted in most cases: that is,  $^{12}\text{C}$  can be written as  $^{12}\text{C}$ .

Ionic charge is indicated by a plus or minus superscript following the symbol of the ion; for multiple charges an arabic superscript numeral precedes the plus or minus sign, for example,  $\text{Na}^+$ ,  $\text{NO}_3^-$ ,  $\text{Ca}^{2+}$ ,  $\text{PO}_4^{3-}$ .

An alphabetical list of the elements, their symbols, and their atomic numbers is shown in **Table 6**. Elements 111 and 112 have been reported, but no official names have been assigned.

## Chemical nomenclature

The International Union of Pure and Applied Chemistry (IUPAC) has established definitive rules for chemical

nomenclature. Chemical species are identified in the Dictionary by a systematic name, frequently accompanied by a formula. Occasionally common names are used.

For inorganic compounds, systematic names of compounds are formed by identifying the constituents and their proportions in a specific order, for example, dinitrogen oxide ( $\text{N}_2\text{O}$ ). Also accepted by IUPAC is Stock's system, in which the proportions of the constituents are indicated indirectly, and roman numerals are used to represent the oxidation number or stoichiometric valence of an element, for example, iron(II) chloride ( $\text{FeCl}_2$ ). Complex compounds are also named according to rules specified by IUPAC; an example is potassium oxodichloroimidophosphate,  $\text{K}[\text{POCl}_2(\text{NH})]$ . Examples of accepted trival names are diborane ( $\text{B}_2\text{H}_6$ ), silane ( $\text{SiH}_4$ ), and ammonia ( $\text{NH}_3$ ).

There also are definitive rules for naming organic compounds. Because of the infinite variety of disciplines and industrial applications involving organic compounds, the rules encompass different types of names. Sometimes a single compound can correctly be identified by a number of names; for example, chloral hydrate is also known as 2,2,2-trichloro-1,1-ethanediol and trichloroacetaldehyde monohydrate.



TABLE 6. The chemical elements

Name	Symbol	At. no.	Name	Symbol	At. no.	Name	Symbol	At. no.
Actinium	Ac	89	Germanium	Ge	32	Praseodymium	Pr	59
Aluminum	Al	13	Gold	Au	79	Promethium	Pm	61
Americium	Am	95	Hafnium	Hf	72	Protactinium	Pa	91
Antimony	Sb	51	Hassium	Hs	108	Radium	Ra	88
Argon	Ar	18	Helium	He	2	Radon	Rn	86
Arsenic	As	33	Holmium	Ho	67	Rhenium	Re	75
Astatine	At	85	Hydrogen	H	1	Rhodium	Rh	45
Barium	Ba	56	Indium	In	49	Rubidium	Rb	37
Berkelium	Bk	97	Iodine	I	53	Ruthenium	Ru	44
Beryllium	Be	4	Iridium	Ir	77	Rutherfordium	Rf	104
Bismuth	Bi	83	Iron	Fe	26	Samarium	Sm	62
Bohrium	Bh	107	Krypton	Kr	36	Scandium	Sc	21
Boron	B	5	Lanthanum	La	57	Seaborgium	Sg	106
Bromine	Br	35	Lawrencium	Lr	103	Selenium	Se	34
Cadmium	Cd	48	Lead	Pb	82	Silicon	Si	14
Calcium	Ca	20	Lithium	Li	3	Silver	Ag	47
Californium	Cf	98	Lutetium	Lu	71	Sodium	Na	11
Carbon	C	6	Magnesium	Mg	12	Strontium	Sr	38
Cerium	Ce	58	Manganese	Mn	25	Sulfur	S	16
Cesium	Cs	55	Meitnerium	Mt	109	Tantalum	Ta	73
Chlorine	Cl	17	Mendelevium	Md	101	Technetium	Tc	43
Chromium	Cr	24	Mercury	Hg	80	Tellurium	Te	52
Cobalt	Co	27	Molybdenum	Mo	42	Terbium	Tb	65
Copper	Cu	29	Neodymium	Nd	60	Thallium	Tl	81
Curium	Cm	96	Neon	Ne	10	Thorium	Th	90
Darmstadtium	Ds	110	Neptunium	Np	93	Thulium	Tm	69
Dubnium	Db	105	Nickel	Ni	28	Tin	Sn	50
Dysprosium	Dy	66	Niobium	Nb	41	Titanium	Ti	22
Einsteinium	Es	99	Nitrogen	N	7	Tungsten	W	74
Element 111*		111	Nobelium	No	102	Uranium	U	92
Element 112*		112	Osmium	Os	76	Vanadium	V	23
Erbium	Er	68	Oxygen	O	8	Xenon	Xe	54
Europium	Eu	63	Palladium	Pd	46	Ytterbium	Yb	70
Fermium	Fm	100	Phosphorus	P	15	Yttrium	Y	39
Fluorine	F	9	Platinum	Pt	78	Zinc	Zn	30
Francium	Fr	87	Plutonium	Pu	94	Zirconium	Zr	40
Gadolinium	Gd	64	Polonium	Po	84			
Gallium	Ga	31	Potassium	K	19			

\*This element does not have an official name or symbol.

## Symbols in scientific writing

Symbols commonly encountered in scientific writing are listed in **Table 7**. Symbols following the ellipses and separated by commas are alternatives that are used only when there is some reason for not using the symbol given first. The letters of the Greek alphabet, frequently used to represent terms, are shown in **Table 8**.

Some frequently encountered symbols for particles and quanta are as follows:

neutron	$n$	pion	$\pi$
proton	$p$	muon	$\mu$
deuteron	$d$	electron	$e$
triton	$t$	neutrino	$\nu$
alpha particle	$\alpha$	photon	$\gamma$

The meaning of abbreviated notations for nuclear reactions should be the following:

initial nuclide (incoming particle(s) or quanta,  
outgoing particle(s) or quanta) final nuclide

Some examples are:

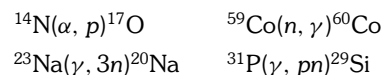

TABLE 7. Commonly used symbols in scientific writing

**Space, time, mass, and related quantities**

length  $l$   
 height  $h$   
 radius  $r$   
 diameter  $d$   
 path, length of arc  $s$   
 plane angle  $\alpha, \beta, \gamma, \theta, \phi, \psi$   
 solid angle  $\omega$   
 area  $A, S$   
 volume  $V \dots v$   
 specific volume  $v$   
 wavelength  $\lambda$   
 wavenumber  $\sigma, \nu$   
 time  $t$   
 period or other characteristic interval  $T, \tau$   
 frequency  $\nu, f$   
 angular frequency ( $2\pi\nu$ )  $\omega$   
 velocity  $v \dots u, w$   
 angular velocity  $\omega$   
 acceleration  $a$   
 acceleration of free fall  $g$   
 mass  $m$   
 moment of inertia  $I$   
 density  $\rho$   
 relative density  $d$

**Molecular and related quantities**

molecular mass  $m$   
 molar mass  $M$   
 Avogadro's number  $N_0, L, N$   
 number of molecules  $N$   
 number of moles  $n$   
 mole fraction  $x \dots X, y$   
 molality  $m$   
 concentration  $c$   
 molar concentration of substance B  $c_B, [B], c(B)$   
 molecular concentration  $C$   
 partition function  $Q$   
 statistical weight  $g \dots p$   
 symmetry number  $\sigma$   
 characteristic temperature  $\theta$   
 diameter of molecule  $\sigma \dots D$   
 mean free path  $l$   
 diffusion coefficient  $D$   
 osmotic pressure  $\Pi$   
 surface concentration  $\Gamma$

**Mechanical and related quantities**

force  $F$   
 force due to gravity (weight)  $G \dots W$   
 moment of force  $M$   
 power  $P$   
 pressure  $p, P$   
 traction  $\sigma$   
 shear stress  $\tau$   
 modulus of elasticity  $E$   
 shear modulus  $G$   
 compressibility  $\kappa$   
 compression modulus ( $1/\kappa$ )  $K$   
 viscosity  $\eta$   
 fluidity  $\phi$   
 kinematic viscosity  $\nu$   
 friction coefficient  $f$   
 surface tension  $\gamma \dots \sigma$   
 angle of contact  $\theta$

**Thermodynamic and related quantities**

temperature  $\theta \dots t$   
 temperature, absolute  $T$   
 gas constant  $R$   
 Boltzmann constant  $k$   
 heat  $q, Q$   
 work  $w, A$   
 energy (Gibbs  $e$ )  $E \dots U$   
 entropy (Gibbs  $\eta$ )  $S$   
 \*Helmholtz free energy (Gibbs  $\Psi$ )  $A$   
 enthalpy (Gibbs  $\chi$ )  $H$   
 \*Gibbs function ( $\zeta$ )  $G \dots F$   
 heat capacity  $C$   
 specific heat at constant pressure  $c_p$   
 specific heat at constant volume  $c_v$   
 ratio of specific heats  $c_p/c_v$   $\gamma, \kappa$   
 chemical potential  $\mu$   
 activity, absolute  $\lambda$   
 activity, relative  $a$   
 activity coefficient  $f, \gamma$   
 osmotic coefficient  $g, \phi$   
 thermal conductivity  $\gamma$   
 Joule-Thomson coefficient  $\mu$

\*The terms for the Helmholtz and Gibbs energies were modified by action of the IUPAC Council, Montreal, August 1961, as follows:  
 Helmholtz energy (Gibbs  $\Psi = E_2TS$ ):  $A$       Gibbs energy (Gibbs  $\zeta = H_2TS$ ):  $G$



# Mathematics

## Mathematical signs and symbols

Symbol	Definition	Symbol	Definition	Symbol	Definition
+	plus (sign of addition)	$\neq$	not equal to	$\partial u/\partial x$	partial derivative of $u$ with respect to $x$
+	positive	$\rightarrow \doteq$	approaches	$\int$	integral of
-	minus (sign of subtraction)	$\propto$	varies as	$\int_a^b$	integral of, between limits $a$ and $b$
-	negative	$\infty$	infinity	$\oint$	line integral around a closed path
$\pm$ ( $\mp$ )	plus or minus (minus or plus)	$\sqrt{\quad}$	square root of	$\Sigma$	(sigma) summation of
$\times$	times, by (multiplication sign)	$\sqrt[3]{\quad}$	cube root of	$f(x), F(x)$	functions of $x$
$\cdot$	multiplied by	$\therefore$	therefore	$\nabla$	del or nabla, vector differential operator
$\div$	sign of division	$\parallel$	parallel to	$\nabla^2$	Laplacian operator
/	divided by	$() [] \{ \}$	parentheses, brackets and braces; quantities enclosed by them to be taken together in multiplying	$\mathcal{E}$	Laplace operational symbol
:	ratio sign, divided by, is to		dividing, etc.	$4!$	factorial $4 = 1 \times 2 \times 3 \times 4$
$::$	equals, as (proportion)	$\overline{AB}$	length of line from $A$ to $B$	$ x $	absolute value of $x$
$<$	less than	$\pi$	(pi) = 3.14159 +	$\dot{x}$	first derivative of $x$ with respect to time
$>$	greater than	$^\circ$	degrees	$\ddot{x}$	second derivative of $x$ with respect to time
$\ll$	much less than	'	minutes	$\mathbf{A} \times \mathbf{B}$	vector product; magnitude of $\mathbf{A}$ times magnitude of $\mathbf{B}$ times sine of the angle from $\mathbf{A}$ to $\mathbf{B}$ ; $AB \sin \overline{AB}$
$\gg$	much greater than	"	seconds	$\mathbf{A} \cdot \mathbf{B}$	scalar product of $\mathbf{A}$ and $\mathbf{B}$ ; magnitude of $\mathbf{A}$ times magnitude of $\mathbf{B}$ times cosine of the angle from $\mathbf{A}$ to $\mathbf{B}$ ; $AB \cos \overline{AB}$
$=$	equals	$\angle$	angle		
$\equiv$	identical with	$dx$	differential of $x$		
$\sim$	similar to	$\Delta$	(delta) difference		
$\approx$	approximately equals	$\Delta x$	increment of $x$		
$\cong$	approximately equals, congruent				
$\leq$	equal to or less than				
$\geq$	equal to or greater than				

## Mathematical notation

### Mathematical logic

$p, q, P(x)$	Sentences, propositional functions, propositions
$\neg p, \sim p, \text{non } p, Np$	Negation, read "not $p$ " ( $\neq$ : read "not equal")
$p \vee q, p + q, Apq$	Disjunction, read " $p$ or $q$ ," " $p, q$ ," or both
$p \wedge q, p \cdot q, p \& q, Kpq$	Conjunction, read " $p$ and $q$ "
$p \rightarrow q, p \supset q, p \Rightarrow q, Cpq$	Implication, read " $p$ implies $q$ " or " $p$ then $q$ "
$p \leftrightarrow q, p \equiv q, p \Leftrightarrow q, Epq, p \text{ iff } q$	Equivalence, read " $p$ is equivalent to $q$ " or " $p$ if and only if $q$ "
n.a.s.c.	Read "necessary and sufficient condition"
$() , [] , \{ \} , \dots$	Parentheses
$\forall, \forall, \Sigma$	Universal quantifier, read "for all" or "for every"
$\exists, \exists, \Pi$	Existential quantifier, read "there is a" or "there exists"
$\vdash$	Assertion sign ( $p \vdash q$ : read " $q$ follows from $p$ "; $\vdash p$ : read " $p$ is or follows from an axiom," or " $p$ is a tautology")
0, 1	Truth, falsity (values)
$=$	Identity
$\stackrel{\text{df}}{=} , \stackrel{\text{df}}{=} , \stackrel{\text{df}}{=} , \stackrel{\text{df}}{=} , \equiv$	Definitional identity
■	"End of proof"; "QED"

### Set theory, relations, functions

$X, Y$	Sets
$x \in X$	$x$ is a member of the set $X$
$x \notin X$	$x$ is not a member of $X$
$A \subset X, A \subseteq X$	Set $A$ is contained in set $X$
$A \not\subset X, A \not\subseteq X$	$A$ is not contained in $X$
$X \cup Y, X + Y$	Union of sets $X$ and $Y$
$X \cap Y, X \cdot Y$	Intersection of sets $X$ and $Y$
$+, +, \circ$	Symmetric difference of sets
$\cup X_i, \Sigma X$	Union of all the sets $X_i$
$\cap X_i, \Pi X_i$	Intersection of all the sets $X_i$
$\emptyset, 0, \Lambda$	Null set, empty set
$X', [X, CX$	Complement of the set $X$
$X - Y, X \setminus Y$	Difference of sets $X$ and $Y$
$\mathcal{X}(P(x)), \{x P(x)\}, \{x:P(x)\}$	The set of all $x$ with the property $P$
$(x,y,z), (x, y, z)$	Ordered set of elements $x, y, \text{ and } z$ ; to be distinguished from $\{x,y,z\}$ , for example
$\{x,y,z\}$	Unordered set, the set whose elements are $x, y, z, \text{ and } \text{no others}$
$\{a_1, a_2, \dots, a_n\}, \{a_i\}_{i=1,2,\dots,n}, \{a_i\}_{i=1}^n$	The set whose members are $a_i$ , where $i$ is any whole number from 1 to $n$
$\{a_1, a_2, \dots\}, \{a_i\}_{i=1,2,\dots}, \{a_i\}_{i=1}^\infty$	The set whose members are $a_i$ , where $i$ is any positive whole number
$X \times Y$	Cartesian product, set of all $(x,y)$ such that $x \in X, y \in Y$

$\{a_i\}_{i \in I}$	The set whose elements are $a_i$ , where $i \in I$
$xRy, R\{x,y\}$	Relation
$\equiv, \cong, \sim, =$	Equivalence relations, for example, congruence
$\cong, \geq, >, \varepsilon, \gg, \leq, <$	Transitive relations, for example, numerical order
$f: X \rightarrow Y, X \xrightarrow{f} Y, X \rightarrow Y, f \in Y^X$	Function, mapping, transformation
$f^{-1}, f^{-1}, X \xleftarrow{f^{-1}} Y$	Inverse mapping
$g \circ f$	Composite functions: $(g \circ f)(x) = g(f(x))$
$f(X)$	Image of $X$ by $f$
$f^{-1}(X)$	Inverse-image set, counter image
1-1, one-one	Read "one-to-one correspondence"
$X \xrightarrow{f} Y$ $\phi \downarrow \downarrow \psi$ $W \xrightarrow{g} Z$	Diagram: the diagram is commutative in case $\psi \circ f = g \circ \phi$
$f _A$	Partial mapping, restriction of function $f$ to set $A$
$=$	Cardinal of the set $A$
$X, \text{card } X,  X $	Denumerable infinity
$\aleph_0, d$	Power of continuum
$c, c, 2^{\aleph_0}$	Order type of the set of positive integers
$\omega$	Read "countably"

**Number, numerical functions**

1.4; 1.4; 1-4	Read "one and four-tenths"
1(1)2(10)100	Read "from 1 to 20 in intervals of 1, and from 20 to 100 in intervals of 10"
const	Constant
$A \cong 0$	The number $A$ is nonnegative, or the matrix $A$ is positive definite, or the matrix $A$ has nonnegative entries
$x y$	Read "x divides y"
$x \equiv y \pmod p$	Read "x congruent to y modulo p"
$a_0 + \frac{1}{a_1} + \frac{1}{a_2} + \dots$	Continued fractions
$a_0 + \frac{1}{ a_1} + \dots$	
$[a,b]$	Closed interval
$[a,b), [a,b[$	Half-open interval (open at the right)
$(a,b), ]a,b[$	Open interval
$[a,\infty), [a,\rightarrow[$	Interval closed at the left, infinite to the right
$(-\infty, \infty), ]\leftarrow, \rightarrow[$	Set of all real numbers
$\max_{x \in X} f(x), \max \{f(x)   x \in X\}$	Maximum of $f(x)$ when $x$ is in the set $X$
min	Minimum
sup, l.u.b.	Supremum, least upper bound
inf, g.l.b.	Infimum, greatest lower bound
$\lim_{x \rightarrow a} f(x) = b, \lim_{x \rightarrow a} f(x) = b,$ $f(x) \rightarrow b$ as $x \rightarrow a$	$b$ is the limit of $f(x)$ as $x$ approaches $a$
$\lim_{x \rightarrow a} f(x), \lim_{x \rightarrow a-0} f(x), f(a-)$	Limit of $f(x)$ as $x$ approaches $a$ from the left
$\lim \sup, \lim$	Limit superior
$\lim \inf, \lim$	Limit inferior
l.i.m.	Limit in the mean
$z = x + iy = re^{i\theta}, \xi = \xi + i\eta,$ $w = u + iv = \rho e^{i\phi}$	Complex variables
$z^*$	Complex conjugate
Re, $\Re$	Real part
Im, $\Im$	Imaginary part
arg	Argument
$\frac{\partial(u,v)}{\partial(x,y)}, \frac{D(u,v)}{D(x,y)}$	Jacobian, functional determinant
$\int_E f(x) d\mu(x)$	Integral (for example, Lebesgue integral) of function $f$ over set $E$ with respect to measure $\mu$
$f(n) \sim \log n$ as $n \rightarrow \infty$	$f(n)/\log n$ approaches 1 as $n \rightarrow \infty$
$f(n) = O(\log n)$ as $n \rightarrow \infty$	$f(n)/\log n$ is bounded as $n \rightarrow \infty$
$f(n) = o(\log n)$	$f(n)/\log n$ approaches zero
$f(x) \nearrow b, f(x) \uparrow b$	$f(x)$ increases, approaching the limit $b$
$f(x) \downarrow b, f(x) \searrow b$	$f(x)$ decreases, approaching the limit $b$

a.e., p.p.	Almost everywhere
ess sup	Essential supremum
$C^0, C^0(X), C(X)$	Space of continuous functions
$C^k, C^k[a,b]$	The class of functions having continuous $k$ th derivative (on $[a,b]$ )
$C'$	Same as $C^1$
Lip $_\alpha, \text{Lip } \alpha$	Lipschitz class of functions
$L^p, L_p, L^p[a,b]$	Space of functions having integrable absolute $p$ th power (on $[a,b]$ )
$L^1$	Same as $L^1$
$(C, \alpha), (C, p)$	Cesàro summability

**Special functions**

$[x]$	The integral part of $x$
$\binom{n}{k}, {}^n C_k, {}_n C_k$	Binomial coefficient $n!/k!(n-k)!$
$\left(\frac{n}{p}\right)$	Legendre symbol
$e^x, \exp x$	Exponential function
$\sinh x, \cosh x, \tanh x$	Hyperbolic functions
$\text{sn } x, \text{cn } x, \text{dn } x$	Jacobi elliptic functions
$\wp(x)$	Weierstrass elliptic function
$\Gamma(x)$	Gamma function
$J_\nu(x)$	Bessel function
$\chi_X(x)$	Characteristic function of the set $X$ : $\chi_X(x) = 1$ in case $x \in X$ , otherwise $\chi_X(x) = 0$
sgn $x$	Signum: $\text{sgn } 0 = 0$ , while $\text{sgn } x = x/ x $ for $x \neq 0$
$\delta(x)$	Dirac delta function

**Algebra, tensors, operators**

$+, \cdot, \times, \circ, \tau, \tau$	Laws of composition in algebraic systems
$e, 0$	Identity, unit, neutral element (of an additive system)
$e, 1, I$	Identity, unit, neutral element (of a general algebraic system)
$e, e, E, P$	Idempotent
$a^{-1}$	Inverse of $a$
$\text{Hom}(M,N)$	Group of all homomorphisms of $M$ into $N$
$G/H$	Factor group, group of cosets
$[K:k]$	Dimension of $K$ over $k$
$\oplus, +$	Direct sum
$\otimes$	Tensor product, Kronecker product
$\wedge$	Exterior product, Grassmann product
$\vec{x}, \underline{x}, \tau, x$	Vector
$\vec{x} \cdot \vec{y}, \mathbf{x} \cdot \mathbf{y}, (\tau, \delta)$	Inner product, scalar product, dot product
$\mathbf{x} \times \mathbf{y}, [\tau, \delta], \mathbf{x} \wedge \mathbf{y}$	Outer product, vector product, cross product
$ \mathbf{x} ,  x , \ \mathbf{x}\ , \ \mathbf{x}\ _p$	Norm of the vector $x$
$Ax, xA$	The image of $x$ under the transformation $A$
$\delta_{ij}$	Kronecker delta: $\delta_{ij} = 1$ , while $\delta_{ij} = 0$ for $i \neq j$
$A', tA, A', 'A$	Transpose of the matrix $A$
$A^*, \bar{A}$	Adjoint, Hermitian conjugate of $A$
$\text{tr } A, \text{Sp } A$	Trace of the matrix $A$
$\det A,  A $	Determinant of the matrix $A$
$\Delta^n f(x), \Delta_\kappa^n f, \frac{\Delta^n f(x)}{h^n}$	Finite differences
$[x_0, x_1], [x_0, x_1, x_2], \frac{\Delta u_{x_0}}{x_1}, [x_0, x_1]_f$	Divided differences
$\nabla f, \text{grad } f$	Read "gradient of $f$ "
$\nabla \cdot \mathbf{v}, \text{div } \mathbf{v}$	Read "divergence of $\mathbf{v}$ "
$\nabla \times \mathbf{v}, \text{curl } \mathbf{v}, \text{rot } \mathbf{v}$	Read "curl of $\mathbf{v}$ "
$\nabla^2, \Delta, \text{div grad}$	Laplacian
$[X, Y]$	Poisson bracket, or commutator, or Lie product
$\text{GL}(n, R)$	Full linear group of degree $n$ over field $R$
$O(n, R)$	Full orthogonal group
$\text{SO}(n, R), O^+(n, R)$	Special orthogonal group

**Topology**

$E^n$	Euclidean $n$ space
$S^n$	$n$ sphere
$\rho(p, q), d(p, q)$	Metric, distance (between points $p$ and $q$ )
$\bar{\phantom{x}}, X^-, \text{cl } X, X^c$	Closure of the set $X$
$\text{Fr}X, \text{fr}X, \partial X, \text{bdry } X$	Frontier, boundary of $X$
$\text{int } X, \overset{\circ}{X}$	Interior of $X$
$T_2$ space	Hausdorff space
$F_\sigma$	Union of countably many closed sets
$G_\delta$	Intersection of countably many open sets
$\dim X$	Dimensionality, dimension of $X$
$\pi_1(X)$	Fundamental group of the space $X$
$\pi_n(X), \pi_n(X, A)$	Homotopy groups
$H_n(X), H_n(X, A; G), H_*(X)$	Homology groups
$H^p(X), H^p(X, A; G), H^*(X)$	Cohomology groups

**Probability and statistics**

$X, Y$	Random variables
$P(X \leq 2), \text{Pr}(X \leq 2)$	Probability that $X \leq 2$
$P(X \leq 2   Y \geq 1)$	Conditional probability
$E(X), E(X)$	Expectation of $X$
$E(X Y \geq 1)$	Conditional expectation
c.d.f.	Cumulative distribution function
p.d.f.	Probability density function
c.f.	Characteristic function
$\bar{x}$	Mean (especially, sample mean)
$\sigma, \text{s.d.}$	Standard deviation
$\sigma^2, \text{Var, var}$	Variance
$\mu_1, \mu_2, \mu_3, \mu_i, \mu_{ij}$	Moments of a distribution
$\rho$	Coefficient of correlation
$\rho_{12,34}$	Partial correlation coefficient

**Fundamental constants**

Recommended values (2002) of selected fundamental constants of physics and chemistry<sup>a</sup>

Quantity	Symbol	Numerical value <sup>b</sup>	Unit <sup>c</sup>	Relative uncertainty (standard deviation)
<b>UNIVERSAL CONSTANTS</b>				
Speed of light in vacuum	$c, c_0$	299 792 458	$\text{m s}^{-1}$	(exact)
Magnetic constant	$\mu_0$	$4\pi \times 10^{-7}$ $= 12.566 370 614 \dots \times 10^{-7}$	$\text{N A}^{-2}$	(exact)
Electric constant, $1/\mu_0 c^2$	$\epsilon_0$	$8.854 187 817 \dots \times 10^{-12}$	$\text{F m}^{-1}$	(exact)
Characteristic impedance of vacuum, $\sqrt{\mu_0/\epsilon_0} = \mu_0 c$	$Z_0$	376.730 313 461 ...	$\Omega$	(exact)
Newtonian constant of gravitation	$G$	$6.6742(10) \times 10^{-11}$	$\text{m}^3 \text{kg}^{-1} \text{s}^{-2}$	$1.5 \times 10^{-4}$
	$G/\hbar c$	$6.7087(10) \times 10^{-39}$	$(\text{GeV}/c^2)^{-2}$	$1.5 \times 10^{-4}$
Planck constant	$h$	$6.626 0693(11) \times 10^{-34}$	J s	$1.7 \times 10^{-7}$
in eV s		$4.135 667 43(35) \times 10^{-15}$	eV s	$8.5 \times 10^{-8}$
$hc$ in eV m		$1.239 841 91(11) \times 10^{-6}$	eV m	$8.5 \times 10^{-8}$
$h/2\pi$	$\hbar$	$1.054 571 68(18) \times 10^{-34}$	J s	$1.7 \times 10^{-7}$
in eV s		$6.582 119 15(56) \times 10^{-16}$	eV s	$8.5 \times 10^{-8}$
$\hbar c$ in eV m		$197.326 968(17) \times 10^{-9}$	eV m	$8.5 \times 10^{-8}$
Planck mass, $(\hbar c/G)^{1/2}$	$m_P$	$2.176 45(16) \times 10^{-8}$	kg	$7.5 \times 10^{-5}$
Planck length, $\hbar/m_P c = (\hbar G/c^3)^{1/2}$	$l_P$	$1.616 24(12) \times 10^{-35}$	m	$7.5 \times 10^{-5}$
Planck time, $l_P/c = (\hbar G/c^5)^{1/2}$	$t_P$	$5.391 21(40) \times 10^{-44}$	s	$7.5 \times 10^{-5}$
<b>ELECTROMAGNETIC CONSTANTS</b>				
Elementary charge	$e$	$1.602 176 53(14) \times 10^{-19}$	C	$8.5 \times 10^{-8}$
Magnetic flux quantum, $h/2e$	$\Phi_0$	$2.067 833 72(18) \times 10^{-15}$	Wb	$8.5 \times 10^{-8}$
Josephson constant <sup>d</sup> , $2e/h$	$K_J$	$483 597.879(41) \times 10^9$	$\text{Hz V}^{-1}$	$8.5 \times 10^{-8}$
von Klitzing constant <sup>e</sup> , $h/e^2 = \mu_0 c/2\alpha$	$R_K$	25 812.807 449(86)	$\Omega$	$3.3 \times 10^{-9}$
Bohr magneton, $e\hbar/2m_e$	$\mu_B$	$9.27 400 949(80) \times 10^{-26}$	$\text{J T}^{-1}$	$8.6 \times 10^{-8}$
in eV T <sup>-1</sup>		$5.788 381 804(39) \times 10^{-5}$	$\text{eV T}^{-1}$	$6.7 \times 10^{-9}$
	$\mu_B/h$	$13.996 2458(12) \times 10^9$	$\text{Hz T}^{-1}$	$8.6 \times 10^{-8}$
	$\mu_B/\hbar c$	46.686 4507(40)	$\text{m}^{-1} \text{T}^{-1}$	$8.6 \times 10^{-8}$
	$\mu_B k$	0.671 7131(12)	$\text{K T}^{-1}$	$1.8 \times 10^{-6}$
Nuclear magneton, $e\hbar/2m_p$	$\mu_N$	$5.050 783 43(43) \times 10^{-27}$	$\text{J T}^{-1}$	$8.6 \times 10^{-8}$
in eV T <sup>-1</sup>		$3.152 451 259(21) \times 10^{-8}$	$\text{eV T}^{-1}$	$6.7 \times 10^{-9}$
	$\mu_N/h$	7.622 593 71(65)	$\text{MHz T}^{-1}$	$8.6 \times 10^{-8}$
	$\mu_N/\hbar c$	$2.542 623 58(22) \times 10^{-2}$	$\text{m}^{-1} \text{T}^{-1}$	$8.6 \times 10^{-8}$
	$\mu_N/k$	$3.658 2637(64) \times 10^{-4}$	$\text{K T}^{-1}$	$1.8 \times 10^{-6}$
<b>ATOMIC AND NUCLEAR CONSTANTS</b>				
<b>General</b>				
Fine-structure constant, $e^2/4\pi\epsilon_0\hbar c$	$\alpha$	$7.297 352 568(24) \times 10^{-3}$		$3.3 \times 10^{-9}$
Inverse fine-structure constant	$\alpha^{-1}$	137.035 999 11(46)		$3.3 \times 10^{-9}$
Rydberg constant, $\alpha^2 m_e c/2\hbar$	$R_\infty$	10 973 731.568 525(73)	$\text{m}^{-1}$	$6.6 \times 10^{-12}$
	$R_\infty c$	$3.289 841 960 360(22) \times 10^{15}$	Hz	$6.6 \times 10^{-12}$
$R_\infty \hbar c$ in eV		13.605 6923(12)	eV	$8.5 \times 10^{-8}$
Bohr radius, $\alpha/4\pi R_\infty = 4\pi\epsilon_0\hbar^2/m_e e^2$	$a_0$	$0.529 177 2108(18) \times 10^{-10}$	m	$3.3 \times 10^{-9}$
Hartree energy, $e^2/4\pi\epsilon_0 a_0 = 2R_\infty \hbar c$	$E_h$	$4.359 744 17(75) \times 10^{-18}$	J	$1.7 \times 10^{-7}$
in eV		27.211 3845(23)	eV	$8.5 \times 10^{-8}$
<b>Electroweak</b>				
Fermi coupling constant <sup>f</sup>	$G_F/(\hbar c)^3$	$1.166 39(1) \times 10^{-5}$	$\text{GeV}^{-2}$	$8.6 \times 10^{-6}$

<sup>a</sup>Footnotes are at table end.

Recommended values (2002) of selected fundamental constants of physics and chemistry<sup>a</sup> (cont.)

Quantity	Symbol	Numerical value <sup>b</sup>	Unit <sup>c</sup>	Relative uncertainty (standard deviation)
<b>ATOMIC AND NUCLEAR CONSTANTS (cont.)</b>				
<b>Electron, e<sup>-</sup></b>				
Electron mass	$m_e$	$9.109\,3826(16) \times 10^{-31}$	kg	$1.7 \times 10^{-7}$
in u		$5.485\,799\,0945(24) \times 10^{-4}$	u	$4.4 \times 10^{-10}$
Energy equivalent in MeV	$m_e c^2$	0.510 998 918(44)	MeV	$8.6 \times 10^{-8}$
Electron charge to mass quotient	$-e/m_e$	$-1.758\,820\,12(15) \times 10^{11}$	C kg <sup>-1</sup>	$8.6 \times 10^{-8}$
Compton wavelength, $h/m_e c$	$\lambda_C$	$2.426\,310\,238(16) \times 10^{-12}$	m	$6.7 \times 10^{-9}$
$\lambda_C/2\pi = \alpha a_0 = \alpha^2/4\pi R_\infty$	$\lambda_C$	$386.159\,2678(26) \times 10^{-15}$	m	$6.7 \times 10^{-9}$
Classical electron radius, $\alpha^2 a_0$	$r_e$	$2.817\,940\,325(28) \times 10^{-15}$	m	$1.0 \times 10^{-8}$
Thomson cross section, $(8\pi/3)r_e^2$	$\sigma_e$	$0.665\,245\,873(13) \times 10^{-28}$	m <sup>2</sup>	$2.0 \times 10^{-8}$
Electron magnetic moment	$\mu_e$	$-928.476\,412(80) \times 10^{-26}$	J T <sup>-1</sup>	$8.6 \times 10^{-8}$
Electron magnetic moment anomaly, $ \mu_e/\mu_B - 1 $	$a_e$	$1.159\,652\,1859(38) \times 10^{-3}$		$3.2 \times 10^{-9}$
Electron gyromagnetic ratio, $2 \mu_e /\hbar$	$\gamma_e$	$1.760\,859\,74(15) \times 10^{11}$	s <sup>-1</sup> T <sup>-1</sup>	$8.6 \times 10^{-8}$
	$\gamma_e/2\pi$	28 024.95 32(24)	MHz T <sup>-1</sup>	$8.6 \times 10^{-8}$
<b>Muon, <math>\mu^-</math></b>				
Muon mass	$m_\mu$	$1.883\,531\,40(83) \times 10^{-28}$	kg	$1.7 \times 10^{-7}$
in u		0.113 428 9264(30)	u	$2.6 \times 10^{-8}$
Energy equivalent in MeV	$m_\mu c^2$	105.658 3692(94)	MeV	$8.9 \times 10^{-8}$
Muon-electron mass ratio	$m_\mu/m_e$	206.768 2838(54)		$2.6 \times 10^{-8}$
Muon Compton wavelength, $h/m_\mu c$	$\lambda_{C,\mu}$	$11.734\,441\,05(30) \times 10^{-15}$	m	$2.5 \times 10^{-8}$
$\lambda_{C,\mu}/2\pi$	$\lambda_{C,\mu}$	$1.867\,594\,298(47) \times 10^{-15}$	m	$2.5 \times 10^{-8}$
Muon magnetic moment	$\mu_\mu$	$-4.490\,447\,99(40) \times 10^{-26}$	J T <sup>-1</sup>	$8.9 \times 10^{-8}$
Muon magnetic moment anomaly, $ \mu_\mu/(e\hbar/2m_\mu) - 1 $	$a_\mu$	$1.165\,919\,81(62) \times 10^{-3}$		$5.3 \times 10^{-7}$
<b>Tau, <math>\tau^-</math></b>				
Tau mass <sup>g</sup>	$m_\tau$	$3.167\,77(52) \times 10^{-27}$	kg	$1.6 \times 10^{-4}$
in u		1.907 68(31)	u	$1.6 \times 10^{-4}$
Energy equivalent in MeV	$m_\tau c^2$	1776.99(29)	MeV	$1.6 \times 10^{-4}$
Tau-electron mass ratio	$m_\tau/m_e$	3 477.48(57)		$1.6 \times 10^{-4}$
<b>Proton, p</b>				
Proton mass	$m_p$	$1.672\,621\,71(29) \times 10^{-27}$	kg	$1.7 \times 10^{-7}$
in u		1.007 276 466 88(13)	u	$1.3 \times 10^{-10}$
Energy equivalent in MeV	$m_p c^2$	938.272 029(80)	MeV	$8.6 \times 10^{-8}$
Proton-electron mass ratio	$m_p/m_e$	1836.152 672 61(85)		$4.6 \times 10^{-10}$
Proton charge to mass quotient	$e/m_p$	$9.578\,833\,76(82) \times 10^7$	C kg <sup>-1</sup>	$8.6 \times 10^{-8}$
Proton Compton wavelength, $h/m_p c$	$\lambda_{C,p}$	$1.321\,409\,8555(88) \times 10^{-15}$	m	$6.7 \times 10^{-9}$
$\lambda_{C,p}/2\pi$	$\lambda_{C,p}$	$0.210\,308\,9104(14) \times 10^{-15}$	m	$6.7 \times 10^{-9}$
Proton magnetic moment	$\mu_p$	$1.410\,606\,71(12) \times 10^{-26}$	J T <sup>-1</sup>	$8.7 \times 10^{-8}$
to nuclear magneton ratio	$\mu_p/\mu_N$	2.792 847 351(28)		$1.0 \times 10^{-8}$
Shielded proton magnetic moment <sup>h</sup>	$\mu_p$	$1.410\,570\,47(12) \times 10^{-26}$	J T <sup>-1</sup>	$8.7 \times 10^{-8}$
to nuclear magneton ratio	$\mu_p'/\mu_N$	2.792 775 604(30)		$1.1 \times 10^{-8}$
Proton gyromagnetic ratio, $2\mu_p/\hbar$	$\gamma_p$	$2.675\,222\,05(23) \times 10^8$	s <sup>-1</sup> T <sup>-1</sup>	$8.6 \times 10^{-8}$
	$\gamma_p/2\pi$	42.577 4813(37)	MHz T <sup>-1</sup>	$8.6 \times 10^{-8}$
Shielded proton gyromagnetic ratio <sup>h</sup> , $2\mu_p'/\hbar$	$\gamma_p'$	$2.675\,153\,33(23) \times 10^8$	s <sup>-1</sup> T <sup>-1</sup>	$8.6 \times 10^{-8}$
	$\gamma_p'/2\pi$	42.576 3875(37)	MHz T <sup>-1</sup>	$8.6 \times 10^{-8}$
<b>Neutron, n</b>				
Neutron mass	$m_n$	$1.674\,927\,28(29) \times 10^{-27}$	kg	$1.7 \times 10^{-7}$
in u		1.008 664 915 60(55)	u	$5.5 \times 10^{-10}$
Energy equivalent in MeV	$m_n c^2$	939.565 360(81)	MeV	$8.6 \times 10^{-8}$
Neutron magnetic moment	$\mu_n$	$-0.966\,236\,45(24) \times 10^{-26}$	J T <sup>-1</sup>	$2.5 \times 10^{-7}$
to nuclear magneton ratio	$\mu_n/\mu_N$	-1.913 042 73(45)		$2.4 \times 10^{-7}$
<b>Deuteron, d</b>				
Deuteron mass	$m_d$	$3.343\,583\,35(57) \times 10^{-27}$	kg	$1.7 \times 10^{-7}$
in u		2.013 553 212 70(35)	u	$1.7 \times 10^{-10}$
Energy equivalent in MeV	$m_d c^2$	1 875.612 82(16)	MeV	$8.6 \times 10^{-8}$
Deuteron magnetic moment	$\mu_d$	$0.433\,073\,482(38) \times 10^{-26}$	J T <sup>-1</sup>	$8.7 \times 10^{-8}$
to nuclear magneton ratio	$\mu_d/\mu_N$	0.857 438 2329(92)		$1.1 \times 10^{-8}$

<sup>a</sup>Footnotes are at table end.

Recommended values (2002) of selected fundamental constants of physics and chemistry<sup>a</sup> (cont.)

Quantity	Symbol	Numerical value <sup>b</sup>	Unit <sup>c</sup>	Relative uncertainty (standard deviation)
<b>PHYSICOCHEMICAL CONSTANTS</b>				
Avogadro constant	$N_A, L$	$6.022\,1415(10) \times 10^{23}$	mol <sup>-1</sup>	$1.7 \times 10^{-7}$
Atomic mass constant, $m_u = \frac{1}{12} m(^{12}\text{C}) = 1\text{ u}$ $= 10^{-3}\text{ kg mol}^{-1}/N_A$	$m_u$	$1.660\,538\,86(28) \times 10^{-27}$	kg	$1.7 \times 10^{-7}$
Energy equivalent in MeV	$m_u c^2$	931.494 043(80)	MeV	$8.6 \times 10^{-8}$
Faraday constant, $N_A e$	$F$	96 485.3383(83)	C mol <sup>-1</sup>	$8.6 \times 10^{-8}$
Molar Planck constant	$N_A h$	$3.990\,312\,716(27) \times 10^{-10}$	J s mol <sup>-1</sup>	$6.7 \times 10^{-9}$
	$N_A h c$	0.119 626 565 72(80)	J m mol <sup>-1</sup>	$6.7 \times 10^{-9}$
Molar gas constant	$R$	8.314 472(15)	J mol <sup>-1</sup> K <sup>-1</sup>	$1.7 \times 10^{-6}$
Boltzmann constant, $R/N_A$ in eV K <sup>-1</sup>	$k$	$1.380\,6505(24) \times 10^{-23}$	J K <sup>-1</sup>	$1.8 \times 10^{-6}$
		$8.617\,343(15) \times 10^{-5}$	eV K <sup>-1</sup>	$1.8 \times 10^{-6}$
	$k/h$	$2.083\,6644(36) \times 10^{10}$	Hz K <sup>-1</sup>	$1.7 \times 10^{-6}$
	$k/hc$	69.503 56(12)	m <sup>-1</sup> K <sup>-1</sup>	$1.7 \times 10^{-6}$
$k^{-1}$ in K eV <sup>-1</sup>		11 604.505(20)	K eV <sup>-1</sup>	$1.8 \times 10^{-6}$
Molar volume of ideal gas, $RT/p$ , for $T = 273.15\text{ K}$ , $p = 101.325\text{ kPa}$	$V_m$	$22.413\,996(39) \times 10^{-3}$	m <sup>3</sup> mol <sup>-1</sup>	$1.7 \times 10^{-6}$
Loschmidt constant, $N_A/V_m$	$n_0$	$2.686\,7773(47) \times 10^{25}$	m <sup>-3</sup>	$1.8 \times 10^{-6}$
Stefan-Boltzmann constant, $(\pi^2/60)k^4/h^3c^2$	$\sigma$	$5.670\,400(40) \times 10^{-8}$	W m <sup>-2</sup> K <sup>-4</sup>	$7.0 \times 10^{-6}$
First radiation constant, $2\pi hc^2$	$c_1$	$3.741\,771\,38(64) \times 10^{-16}$	W m <sup>2</sup>	$1.7 \times 10^{-7}$
Second radiation constant, $hc/k$	$c_2$	$1.438\,7752(25) \times 10^{-2}$	m K	$1.7 \times 10^{-8}$
Wien displacement law constant, $b = \lambda_{\text{max}} T = c_2/4.965\,114\,231\dots$	$b$	$2.897\,7685(51) \times 10^{-3}$	m K	$1.7 \times 10^{-6}$
<b>NON-SI UNITS ACCEPTED FOR USE WITH THE SI</b>				
Electronvolt: (e/C) J	eV	$1.602\,176\,53(14) \times 10^{-19}$	J	$8.5 \times 10^{-8}$
(Unified) atomic mass unit: $1\text{ u} = m_u = \frac{1}{12} m(^{12}\text{C})$	u	$1.660\,538\,86(28) \times 10^{-27}$	kg	$1.7 \times 10^{-7}$

<sup>a</sup>This table presents a selection of the values of the fundamental constants recommended by the Committee on Data for Science and Technology (CODATA). These "2002 CODATA recommended values" form a self-consistent set based on the data available through December 31, 2002, and are generally recognized for use in all fields of science and technology. A detailed description of the data and analysis that led to these results will be published in 2004. The 2002 adjustment was carried out under the auspices of the CODATA Task Group on Fundamental Constants. The recommended values are available on the World Wide Web at <http://physics.nist.gov/cuu/Constants/index.html>.

<sup>b</sup>The digits in parentheses represent one-standard-deviation uncertainties in the final two digits of the quoted values.

<sup>c</sup>A = ampere, C = coulomb, F = farad, Hz = hertz, J = joule, K = kelvin, kg = kilogram, m = meter, mol = mole, N = newton, Pa = pascal, s = second, T = tesla, W = watt, Wb = weber,  $\Omega$  = ohm, eV = electronvolt, u = (unified) atomic mass unit. Prefixes: k = 10<sup>3</sup>, M = 10<sup>6</sup>, G = 10<sup>9</sup>.

<sup>d</sup>The conventional value of the Josephson constant, adopted internationally for realizing representations of the volt using the Josephson effect, is  $K_{J-90} = 483\,597.9\text{ GHz V}^{-1}$ .

<sup>e</sup>The conventional value of the von Klitzing constant, adopted internationally for realizing representations of the ohm using the quantum Hall effect, is  $R_{k-90} = 25\,812.807\ \Omega$ .

<sup>f</sup>Value recommended by the Particle Data Group in the 2002 Review of Particle Physics [K. Hagiwara et al. (Particle Data Group), *Physical Review D*, vol. 66, Paper 010001, 2002 (<http://pdg.lbl.gov>)].

<sup>g</sup>This and all other values involving  $m_e$  are based on the value of  $m_e c^2$  in MeV recommended by the Particle Data Group in the 2002 Review of Particle Physics (*ibid.*), but with a standard uncertainty of 0.29 MeV rather than the quoted uncertainty of  $-0.26\text{ MeV}$ ,  $+0.29\text{ MeV}$ .

<sup>h</sup>Based on nuclear magnetic resonance (NMR) frequency of protons in a sphere of pure water (H<sub>2</sub>O) at 25°C surrounded by vacuum.

<sup>i</sup>The numerical value of  $F$  to be used in coulometric chemical measurements is 96 485.336(16) [relative uncertainty =  $1.7 \times 10^{-7}$ ] when the relevant current is measured in terms of representations of the volt and ohm based on the Josephson and quantum Hall effects and the conventional values of the Josephson and von Klitzing constants,  $K_{J-90}$  and  $R_{k-90}$ .



The fundamental particles <sup>a</sup>						
<b>Gauge bosons</b>		$J_C^P = 1^-$	Self-conjugate except $\bar{W}^\pm = W^\mp$ .			
Name	Symbol	Charge <sup>b</sup>	Mass and width, GeV		Couplings	
Photon	$\gamma$	0	0		$A \Rightarrow \gamma A$	
Gluon <sup>c</sup>	$g$	0	0		$A \Rightarrow gA'$	
<b>Weak bosons</b>						
Charged <sup>d</sup>	$W^\pm$	$\pm 1$	80.4, 2.1		$U \Rightarrow W^+D$	
Neutral <sup>e</sup>	$Z^0$	0	91.2, 2.5		$A \Rightarrow Z^0A$	
<b>Fermions<sup>f</sup></b>		$J = 1/2$	All have distinct antiparticles, except perhaps the neutrinos.			
Name	Charge <sup>b</sup>	Symbol and mass, GeV		Symbol and mass, GeV		Symbol and mass, GeV
<b>Leptons</b>						
Neutrinos	0	$\nu_e$	$< 3 \times 10^{-9}$	$\nu_\mu$	$< .0002$	$\nu_\tau$ $< .02$
Charged leptons <sup>g</sup>	-1	$e$	.00051	$\mu$	.106 <sup>h</sup>	$\tau$ 1.78 <sup>h</sup>
<b>Quarks<sup>c</sup></b>						
Up type	$2/3$	$u$	.0015-.004	$c$	1.55-1.35	$t$ 170-180 <sup>i</sup>
Down type	$-1/3$	$d$	.004-.008	$s$	.08-.13	$b$ 4.1-4.4
<sup>a</sup> The graviton, with $J_C^P = 2^+$ , has been omitted, since it plays no role in high-energy particle physics. <sup>b</sup> In units of the proton charge. <sup>c</sup> The gluon is a color SU <sub>3</sub> octet (8); each quark is a color triplet (3). These colored particles are confined constituents of hadrons; they do not appear as free particles. <sup>d</sup> The branching ratios (%) of the decay modes of the $W^+$ are: $u\bar{d}, c\bar{s}$ 34 each $\nu_e e^+, \nu_\mu \mu^+, \nu_\tau \tau^+$ 11 each <sup>e</sup> The branching ratios (%) of the decay modes of the $Z^0$ are: $d\bar{d}, s\bar{s}, b\bar{b}$ 16.6 each $u\bar{u}, c\bar{c}$ 10.1 each $\nu_e \bar{\nu}_e, \nu_\mu \bar{\nu}_\mu, \nu_\tau \bar{\nu}_\tau$ 6.7 each $e^+ e^-, \mu^+ \mu^-, \tau^+ \tau^-$ 3.4 each <sup>f</sup> The three known families (generations) of fermions are displayed in three columns. <sup>g</sup> Any further charged leptons have mass greater than 40 GeV. <sup>h</sup> The $\mu$ and $\tau$ leptons are unstable, with the following mean life and principal decay modes (branching ratios in %): $\mu$ $\tau_\mu = 2.2 \times 10^{-6}$ s $e\bar{\nu}_e \nu_\mu$ 100 $\tau$ $\tau_\tau = 2.9 \times 10^{-13}$ s $\mu\bar{\nu}_\mu \nu_\tau$ 17, $e\bar{\nu}_e \nu_\tau$ 18, (hadrons) $\bar{\nu}_\tau$ 63 <sup>i</sup> The $t$ quark has a width $\approx 1.4$ GeV, with dominant decay to $Wb$ .						

## Geologic time scale and related aspects

Eon	Era	Period (Interval length, × 10 <sup>6</sup> years)	Epoch	Beginning of epoch, × 10 <sup>6</sup> years ago	Forms of life	Other features	
Phanerozoic	Cenozoic "Age of Mammals"	Quaternary (1.8)	Recent	0.01	Modern humans	Extensive glaciation during portions of Quaternary  Formation of most present mountain ranges	
			Pleistocene	1.8	Early humans		
		Tertiary (63.2)	Pliocene	5.3	Large carnivores		
			Miocene	23.8	Whales, apes, grazing animals		
			Oligocene	33.7	Large browsing animals		
			Eocene	54.8	Rise of modern floras		
			Paleocene	65	First placental mammals		
	Mesozoic "Age of Reptiles"	Cretaceous (79)	Upper (Base Santonian)	144	Last of dinosaurs	Widespread seas over much of present-day Europe, North Africa, and North America  Beginning of formation of Atlantic Ocean	
			Middle (Base Albian)		Last of ammonites		
			Lower		Rise of flowering plants		
		Jurassic (62)	Upper (Base Callovian)	206	Toothed birds		
			Middle (Base Bajocian)		Flying reptiles		
			Lower		First primitive mammals		
		Triassic (44)	Upper	250	Rise of dinosaurs		
			Middle		Rise of ammonites		
			Lower		Rise of cycads		
	Paleozoic "Age of Invertebrates"	Permian (40)	Upper (Base Ochoan)	290	Primitive reptiles	Mountain building during late Paleozoic  Widespread coal swamps	
			Middle (Base Guadalupian)		Last of trilobites		
			Lower		Glossopteris flora		
		Carboniferous <sup>a</sup>	Pennsylvanian (32)	Upper	322		Spread of amphibians
				Middle			Great coal forests
				Lower			Climax of spore-forming plants
		Mississippian (32)	Upper	354	Abundant sharks		
			Middle		Climax of crinoids and blastoids		
			Lower				
		Devonian (63)	Upper	417	First forests		
			Middle		Rise of ferns		
			Lower		Earliest known amphibians		
		Silurian (26)	Upper	443	Appearance of land plants		
			Middle		First known scorpions		
			Lower		Expansion of brachiopods and corals		
	Ordovician (47)	Upper	490	Appearance of primitive fishes			
		Middle		Climax of trilobites			
Lower		Rise of cephalopods					
Cambrian (53)	Upper (Base Croixian)	543	Abundant trilobites				
	Middle		Many kinds of shelled invertebrates				
	Lower						
Proterozoic	Precambrian	Neoproterozoic (357 <sup>b</sup> )	900	Marine algae, wormlike organisms, other simple forms	Extensive glaciation Oldest dated rocks (Greenland)		
		Mesoproterozoic (700 <sup>b</sup> )	1600				
		Paleoproterozoic (900 <sup>b</sup> )	~2500				
Archean <sup>c</sup>		Late (500 <sup>b</sup> )	3000	Blue-green algae (cyanobacteria)	Abundant dark sediments Formation of earliest known rocks		
		Middle (400 <sup>b</sup> )	3400				
		Early (>400 <sup>b</sup> )	>3800	Bacteria			

<sup>a</sup>The period known as Carboniferous in Europe is divided into two periods in North American usage.

<sup>b</sup>Length of epoch, × 10<sup>6</sup> years.

<sup>c</sup>The beginning of the Archean corresponds to the age of the oldest preserved continental crust.

# Biographical Listing

- Abbe, Ernst** (1840–1905), German physicist. Developed optical instruments, such as an apochromatic objective and a crystal refractometer.
- Abel, Frederick Augustus** (1827–1902), English chemist. Expert on the chemistry of explosives; originated the Abel test for determination of the flash point of petroleum.
- Abel, John Jacob** (1857–1938), American pharmacologist and physiologist. Isolated epinephrine, and insulin in crystal form.
- Abel, Niels Henrik** (1802–1829), Norwegian mathematician. Contributed to the theory of elliptical functions.
- Abell, George Ogden** (1927–1983), American astronomer. Research in problems relating to organization, structure, and distribution of galaxies; observational cosmology; and planetary nebulae.
- Abney, William de Wiveleslie** (1843–1920), English photographic chemist and physicist. Photographed the infrared solar spectrum.
- Abrikosov, Alexei A.** (1928– ), Russian-born American physicist. Applied the Ginzburg-Landau theory to explain the behavior of type II superconductors. Nobel Prize, 2003.
- Adams, John Couch** (1819–1892), English astronomer. Discovered, independently of U. J. J. Leverrier, Neptune.
- Adanson, Michel** (1727–1806), French naturalist. Classified plants in his *Les Familles Naturelles des Plantes*.
- Addison, Thomas** (1793–1860), English physician. Identified pernicious anemia and Addison's disease of the adrenal cortex.
- Adler, Alfred** (1870–1937), Austrian psychiatrist and psychologist. Founded the school of individual psychology.
- Adrian of Cambridge, Edgar Douglas Adrian, Baron** (1889–1977), English physiologist. Investigated physiology of nervous system; showed that change in electric potential in electroencephalograph is due to electrical activity of cortex; Nobel Prize, 1932.
- Afzelius, Adam** (1750–1837), Swedish botanist. Founded the Linnaean Institute.
- Agassiz, Jean Louis Rudolphe** (1807–1873), Swiss-born American naturalist. Wrote books on ichthyology, especially relating to classification.
- Agnesi, Maria Gaetana** (1718–1799), Italian mathematician. Author of *Istituzioni Analitiche*, a complete treatment of algebra and analysis; shared in the discovery of a cubic curve ("witch of Agnesi").
- Agre, Peter** (1949– ), American medical doctor and scientist. Discovered water channels in cell membranes; Nobel Prize, 2003.
- Agricola, Georgius**, real name Georg Bauer (1494–1555), German physician and mineralogist. Known as the father of systematic mineralogy.
- Ahlfors, Lars Valerian** (1907–1996), Finnish-American mathematician. Did research on covering surfaces related to Riemann surfaces of inverse functions of entire and meromorphic functions; opened up new fields of analysis; Fields Medal, 1936.
- Airy, George Biddell** (1801–1892), English astronomer. Discovered inequality in the motions of Venus and the Earth; determined the mass of the Earth.
- Aitken, John** (1839–1919), Scottish physicist. Studied dust particles in the atmosphere, known as Aitken nuclei.
- Aitken, Robert Grant** (1864–1951), American astronomer. Discovered more than 3000 binary stars.
- Alder, Kurt** (1902–1958), German chemist. Co-developer of the Diels-Alder reaction for diene synthesis; contributed to stereochemistry; Nobel Prize, 1950.
- Alembert, Jean le Rond d'** (1717–1783), French mathematician. Developed d'Alembert's principle and the calculus of partial differences.
- Alferov, Zhores Ivanovich** (1930– ), Russian physicist and electronics engineer. Developed semiconductor heterostructures used in high-speed and opto-electronics, including fast transistors, laser diodes, and light-emitting diodes; Nobel Prize, 2000.
- Alfvén, Hannes Olof Gösta** (1908–1995), Swedish physicist. Studies in magnetohydrodynamics, planetary physics, antiferromagnetism, and ferrimagnetism; Nobel Prize, 1970.
- Alhazen** (965–1038), Arab mathematician and astronomer. Provided the first accounts of atmospheric refraction and reflection from concave surfaces; constructed spherical and parabolic mirrors.
- al-Khwarizmi** (780–850), Arab mathematician. Wrote treatises on arithmetic and algebra, which were important in the mathematical knowledge of medieval Europe.
- Allen, Edgar** (1892–1943), American biologist. Discovered estrogen; investigated hormonal mechanisms controlling female reproductive cycle.
- Allen, Willard Myron** (1904–1993), American physician. With G. W. Corner, discovered progesterone, and proved it necessary for development of embryo in early pregnancy; with O. Wintersteiner, synthesized crystalline progesterone.
- Altman, Sidney** (1939– ), American chemist. Discovered an unusual enzyme that contains ribonucleic acid (RNA) in addition to a protein, leading to the discovery that RNA molecules have catalytic properties similar to those of enzymes; Nobel Prize, 1989.
- Alvarez, Luis Walter** (1911–1988), American physicist. Pioneer in building liquid hydrogen bubble chambers, and in developing measurement devices and computer systems to analyze data from these chambers; discovered large numbers of short-lived elementary particles; Nobel Prize, 1968.
- Amagat, Émile** (1841–1915), French physicist. Investigated relationship of pressure, density, and temperature in gases and liquids, particularly at high pressure.
- Amici, Giovanni Battista** (1786–1863), Italian astronomer, optician, and naturalist. Invented the Amici microscope; designed parabolic mirrors for reflecting telescopes.
- Ampère, André Marie** (1775–1836), French physicist and mathematician. Founder of electrodynamics; formulated Ampère's law; invented the astatic needle.
- Anaximander** (611–547 B.C.), Greek astronomer and mathematician. Reputed inventor of geographical maps; formulated the concept of the universe as infinite (apeiron).
- Anderson, Carl David** (1905–1991), American physicist. Discovered the meson in cosmic rays; discovered the positron; Nobel Prize, 1936.
- Anderson, Philip Warren** (1923– ), American physicist. Demonstrated existence of electronic localization in disordered solids, and of localized magnetism in metals; Nobel Prize, 1977.
- Andrade, Edward Neville da Costa** (1887–1971), English physicist. Discovered Andrade's creep law and a law governing variation of viscosity of liquids with temperature.
- Andrews, Roy Chapman** (1884–1960), American naturalist. Discovered many plant and animal fossils.
- Anfinsen, Christian Boehmer** (1916–1995), American biochemist. Discovered how three-dimensional structures of ribonuclease and other proteins are formed; Nobel Prize, 1972.
- Angström, Anders Jonas** (1814–1874), Swedish physicist. Mapped the solar spectrum; discovered hydrogen in the solar atmosphere.
- Apollonius of Perga** (247–205 B.C.), Greek mathematician. Wrote about conic sections; coined the terms parabola, ellipse, and hyperbola.
- Appleton, Edward Victor** (1892–1965), English physicist. Demonstrated the existence of the ionosphere and discovered its region known as the Appleton layer; contributed to the development of radar; Nobel Prize, 1947.
- Arago, Dominique François** (1786–1853), French astronomer and physicist. Discovered the magnetic properties of nonferrous materials, and the production of magnetism by electricity.
- Arber, Werner** (1929– ), Swiss molecular biologist. Determined the molecular mechanism of host-controlled restriction modification of bacterial viruses and discovered the restriction enzymes; Nobel Prize, 1978.
- Archimedes** (287–212 B.C.), Greek physicist and mathematician. Formulated Archimedes' principle; invented the compound pulley and Archimedes' screw.
- Argand, Jean Robert** (1768–1822), Swiss mathematician. Developed the Argand diagram.
- Argelander, Friedrich Wilhelm August** (1799–1875), German astronomer. Prepared a star catalog; introduced decimal division of stellar magnitudes.
- Aristarchus of Samos** (310–250 B.C.), Greek astronomer. Invented the hemispherical sundial; determined the movement of the Earth around the stationary Sun; added a correction factor of 1/1623 of a day to the length of the year.
- Aristotle** (384–322 B.C.), Greek philosopher. Exponent of the methodology and division of sciences; contributed to physics, astronomy, meteorology, psychology, and biology.
- Arkwright, Richard** (1732–1792), English inventor. Developed the first practical mechanized spinning frame, utilizing rollers.
- Arrhenius, Svante August** (1859–1927), Swedish physicist and chemist. Developed theory of electrolytic dissociation; investigated osmosis and viscosity of solutions; Nobel Prize, 1903.
- Arsonval, Jacques Arsène d'** (1851–1940), French physicist and physiologist. Pioneered in electrotherapy; invented d'Arsonvalgalvanometer.
- Aston, Francis William** (1877–1945), English physicist and chemist. Discovered isotopes in non-radioactive elements by using the mass spectrograph he invented; Nobel Prize, 1922.
- Atiyah, Michael Francis** (1929– ), British mathematician. Work centered on the interaction between geometry and analysis; developed K theory in collaboration with F. Hirzebruch; with I. M. Singer, proved the index theorem concerning elliptic differential operators on compact differentiable manifolds, which was later seen to have applications to theoretical physics; Fields Medal, 1966; Abel Prize, 2004.
- Atwood, George** (1746–1807), English mathematician. Invented the Atwood machine.
- Audubon, John James** (1785–1851), Haitian-born American ornithologist and artist. Made drawings and paintings of birds and animals.
- Auger, Pierre Victor** (1899–1993), French physicist. Discovered the Auger effect.
- Avicenna** (979–1037), Arab physician. Wrote the medical text *Canon Medicinae*.
- Avogadro, Amedeo** (1776–1856), Italian physicist. Formulated Avogadro's law.
- Axel, Richard** (1946– ), American molecular biologist. Recognized along with Linda Buck for pioneering research of the olfactory system, which led to the discovery of the genes and proteins involved in the transmission of olfactory information. Later independent work clarified the cellular and molecular mechanisms underlying the olfactory system. Nobel Prize, 2004.
- Axelrod, Julius** (1912– ), American biochemist and pharmacologist. Showed that many drugs act by modifying storage of neurotransmitters at nerve terminals; made discoveries concerning metabolism, and mechanisms for formation and inactivation of norepinephrine; Nobel Prize, 1970.
- Ayrton, William Edward** (1847–1908), English physicist and electrical engineer. Invented the ammeter, voltmeter, and other electrical measuring instruments.

- Baade, Walter** (1893–1960), German-born American astronomer. Formulated concept of stellar populations; increased distance scale of universe by factor of 2.
- Babbage, Charles** (1792–1851), English mathematician. Devised a primitive computer to calculate and print mathematical and astronomical tables.
- Babcock, Harold Delos** (1882–1968) and **Horace Welcome** (1912–2003), American astronomers. Invented the Babcock magnetograph, observed weak solar magnetic fields, and discovered stellar magnetic fields.
- Babcock, Stephen Moulton** (1843–1931), American agricultural chemist. Pioneer in nutrition; devised the Babcock test to measure fat content in milk.
- Babinet, Jacques** (1794–1872), French physicist. Invented a polariscope and a goniometer.
- Back, Ernst E. A.** (1881–1959), German physicist. Developed improved spectrographs; made spectroscopic observations leading to Paschen-Back effect.
- Badger, Richard McLean** (1896–1974), American physical chemist and spectroscopist. Studied structures of polyatomic molecules; formulated Badger's rule concerning molecular bonds.
- Baekeland, Leo Hendrik** (1864–1944), Belgian-born, American chemist. Invented the phenol-formaldehyde polymer, Bakelite, the first commercial synthetic polymer.
- Baer, Karl Ernst von** (1792–1876), Estonian embryologist. Discovered the mammalian ovum and the notochord; developed the theory of embryonic germ layers.
- Baeyer, Johann Friedrich Wilhelm Adolf von** (1835–1917), German chemist. Synthesized indigo and hydroaromatic compounds; Nobel Prize, 1905.
- Baily, Francis** (1774–1844), English astronomer. A founder of the Royal Astronomical Society; first observed phenomenon of Baily's beads.
- Baire, René Louis** (1874–1932), French mathematician. Contributed to theory of functions of real variables; introduced concept of Baire functions.
- Baker, Alan** (1939– ), British mathematician. Proved a generalization of the Gelfond-Schneider theorem; from this work, generated transcendental numbers not previously identified and solved problems in the theory of Diophantine equations; Fields Medal, 1970.
- Balfour, Francis Maitlant** (1851–1882), English biologist. Founder of comparative embryology.
- Balmer, Johann Jakob** (1825–1898), Swiss physicist. Expressed the mathematical formula for frequencies of hydrogen lines in the visible spectrum.
- Baltimore, David** (1938– ), American virologist. Investigated interaction between ribonucleic acid tumor viruses and genetic material; independently of H. M. Temin, discovered reverse transcriptase; Nobel Prize, 1975.
- Banach, Stefan** (1892–1945), Polish mathematician. Laid foundations of contemporary functional analysis; introduced concept of Banach space and discovered its fundamental properties.
- Bang, Bernhard Laurits Frederik** (1848–1932), Danish veterinarian. Discovered method of eradicating bovine tuberculosis; discovered *Brucella abortus*, the agent of contagious abortion (Bang's disease) and brucellosis.
- Banting, Frederick Grant** (1891–1941), Canadian physician. With J. J. R. Macleod and C. H. Best, discovered insulin and its role in diabetes; Nobel Prize, 1923.
- Barány, Robert** (1876–1936), Austrian physician. Developed new methods of diagnosing ear diseases; Nobel Prize, 1914.
- Bardeen, John** (1908–1991), American physicist. With L. N. Cooper and J. R. Schrieffer, formulated a theory of superconductivity; invented the transistor; Nobel Prize, 1956 and 1972.
- Barkhausen, Heinrich Georg** (1881–1956), German electronic engineer and physicist. Contributed to theory and application of electron tubes; with K. Kurz, developed Barkhausen-Kurz oscillator; discovered Barkhausen effect.
- Barkla, Charles Glover** (1877–1944), English physicist. Described characteristics of x-rays and other short-wave emissions of elements.
- Barnard, Edward Emerson** (1857–1923), American astronomer. Discovered 16 comets, the fifth satellite of Jupiter, and dark nebulae; contributed to celestial photography.
- Barnett, Samuel Jackson** (1873–1956), American physicist. Discovered Barnett effect and used it to measure the gyromagnetic ratio of ferromagnetic materials; gave experimental proof of existence of ionosphere.
- Barr, Murray Llewellyn** (1908–1995), Canadian anatomist. Discovered the Barr body on the X chromosome of the human female.
- Bartholin, Kaspar** (1655–1738), Danish physician. Discovered Bartholin's glands of the vagina and a sublingual duct.
- Bartholin, Thomas** (1616–1680), Danish physician. Discovered lymphatic glands; described the lymphatic system.
- Bartlett, James Holly** (1904–2000), American physicist. Introduced concept of Bartlett force; did research on nuclear shell model, electrochemical potentiostat, and restricted three-body problem.
- Barton, Derek Harold Richard** (1918–1998), British chemist. Developed and expanded concept of conformation to include large molecules with complex ring systems; Nobel Prize, 1969.
- Basov, Nicolai Gennediyevich** (1922–2001), Soviet physicist. Conducted fundamental studies in quantum electronics; with A. M. Prokhorov, developed quantum optical generators; Nobel Prize, 1964.
- Bassham, James Alan** (1922– ), American chemist. Helped to elucidate basic photosynthetic carbon cycle.
- Bates, Henry Walter** (1825–1892), English naturalist. Discovered Batesian mimicry among butterflies and moths.
- Baudot, Émile** (1845–1903), French engineer. Invented an improved telegraph transmitter.
- Baumé, Antoine** (1728–1804), French chemist. Invented a graduated hydrometer which utilizes the Baumé scale.
- Bautz, Laura Patricia** (1940– ), American astronomer. Collaborated with W. W. Morgan in developing Bautz-Morgan classification of galaxy clusters.
- Bayer, Johann** (1572–1624), German astronomer. Charted 12 constellations; first to use Greek letters to designate the order of brightness of stars in a constellation.
- Bayes, Thomas** (1702–1761), English mathematician. Formulated a basis for statistical inference.
- Bayliss, William Maddock** (1860–1924), English physiologist. Did research on electrophysiology of heart action; discovered the hormone secretin.
- Beadle, George Wells** (1903–1989), American geneticist. With E. L. Tatum, proved that genes affect heredity by controlling cell chemistry; Nobel Prize, 1958.
- Beams, Jesse Wakefield** (1898–1977), American physicist. Developed vacuum-type ultracentrifuges, used in purification and molecular weight determination of large-molecular-weight substances, isotope separation, and determination of the gravitational constant.
- Beattie, James Alexander** (1895–1981), American chemist and physicist. Studied ionic theory and thermodynamics; with P. W. Bridgman, proposed Beattie and Bridgman equation for gases.
- Beaufort, Francis** (1774–1857), English hydrographer. Devised scale of wind velocity.
- Beaumont, William** (1785–1853), American physician. Did pioneering studies of digestion and gastric juices.
- Béchamp, Pierre Jacques Antoine** (1816–1908), French chemist. Discovered a method of preparing aniline.
- Beckmann, Ernst Otto** (1853–1923), German chemist. Discovered Beckmann molecular transformation; invented the Beckmann thermometer.
- Becquerel, Antoine César** (1788–1878), French physicist. Pioneer in electrochemistry; first to extract metals from ore by electrolysis.
- Becquerel, Antoine Henri** (1852–1908), French physicist. A discoverer of radioactivity in uranium.
- Bednorz, Johannes Georg** (1950–), German physicist. With K. A. Müller, discovered high-temperature superconductivity in copper oxide ceramic materials; Nobel Prize, 1987.
- Beebe, Charles William** (1877–1962), American naturalist. Pioneer in deep-sea exploration; made ornithological collections.
- Beer, August** (1825–1863), German physicist. Discovered Beer's law of light absorption.
- Behring, Emil Adolph von** (1854–1917), German bacteriologist. Produced diphtheria and tetanus antitoxins; Nobel Prize, 1901.
- Békésy, Georg von** (1889–1972), Hungarian-born American physicist. Studied hearing processes, especially inner-ear mechanics; Nobel Prize, 1961.
- Bell, Alexander Graham** (1847–1922), Scottish-born American inventor. Invented the telephone, pho-to-phonograph, graphophone, and one of the earliest gramophones.
- Bell, Charles** (1774–1842), Scottish anatomist. Discovered that sensory and motor nerves are anatomically and functionally distinct.
- Bellman, Richard Ernest** (1920–1984), American mathematician. Research in analytic number theory, differential equations, stochastic processes, dynamic programming, and mathematical biosciences; discovered Bellman's principle of optimality.
- Benacerraf, Baruj** (1920–), American immunologist. Discovered immune-response (I<sub>r</sub>) genes that control specific immune responses to thymus-dependent antigens; Nobel Prize, 1980.
- Benioff, Hugo** (1899–1968), American geophysicist. Investigated earthquakes, particularly through instrumental seismology.
- Bentham, George** (1800–1884), English botanist. With J. Hooker, wrote *Genera Plantarum*.
- Berg, Paul** (1926– ), American biochemist. Investigated the biochemistry of deoxyribonucleic acid (DNA) and designed a technique for gene splicing; Nobel Prize, 1980.
- Bergey, David Hendricks** (1860–1937), American bacteriologist. Authority on classification of bacteria.
- Bergius, Friedrich** (1884–1949), Polish-born German chemist. Developed Bergius process for hydrogenation of coal to a petroleumlike oil; Nobel Prize, 1931.
- Bergström, Sune Carl** (1916–2004), Swedish biochemist and medical scientist. Studied the metabolism of unsaturated fatty acids and determined the chemical structure of prostaglandins; Nobel Prize, 1982.
- Bernard, Claude** (1813–1878), French physiologist. Studied digestion; discovered that glycogen is produced by the liver.
- Berners-Lee, Tim** (1955– ), British-born physicist and software engineer. Proposed the World Wide Web, and then invented hypertext markup language (HTML), HyperText Transfer Protocol (HTTP), the Internet addressing scheme (Universal Resource Locator or URL), and the first Web browser.
- Bernoulli, Daniel** (1700–1782), Swiss mathematician born in the Netherlands. Founder of mathematical physics; worked on hydrodynamics and differential equations; formulated the Bernoulli equation.
- Bernoulli, Jacques or Jacob** (1654–1705), Swiss mathematician. Contributed to mathematics of curves, calculus, and probability; developed the Bernoulli number.
- Bernoulli, Jean or Johann** (1667–1748), Swiss mathematician. A founder of calculus of variations; contributed to exponential calculus, complex numbers, geodesics, and trigonometry.
- Berthelot, Pierre Eugène Marcellin** (1827–1907), French chemist. Founder of thermochemistry; first to synthesize organic compounds; demonstrated nitrogen fixation.
- Bertrand, Joseph Louis Francois** (1822–1900), French mathematician. Contributed to analysis, differential geometry, and probability theory.
- Berzelius, Jöns Jakob** (1779–1848), Swedish chemist. Discovered the elements cerium,

- selenium, thorium, and silicon; developed a system for classification and nomenclature of compounds.
- Bessel, Friedrich Wilhelm** (1784–1846), German astronomer and mathematician. Developed Bessel functions; determined parallax of the star 61 Cygni; postulated existence of Neptune and dark stars.
- Bessemmer, Henry** (1813–1898), English engineer. Invented the Bessemmer process, the first method for manufacturing steel on a large scale.
- Best, Charles Herbert** (1899–1978), Canadian physiologist and medical researcher. Associated with F. G. Banting and J. J. R. Macleod in the discovery of insulin.
- Bethe, Hans Albrecht** (1906– ), German-born American physicist. Formulated the theory of energy production in stars; research on nuclear physics; Nobel Prize, 1967.
- Bhabha, Homi Jehangir** (1909–1966), Indian physicist. With W. Heitler, developed theory of cascade showers of cosmic rays; observed slowing of decay rate of high-velocity mesons.
- Bianchi, Luigi** (1856–1928), Italian mathematician. Contributed to differential geometry and study of noneuclidean geometries; discovered Bianchi identity.
- Bichat, Marie François Xavier** (1771–1802), French anatomist and physiologist. Founder of animal histology; originated the term “tissues,” and distinguished 21 types in his particular scheme.
- Bieberbach, Ludwig** (1886–1982), German mathematician. Research on complex function theory, differential equations, geometry, and algebra; postulated Bieberbach’s conjecture.
- Bienaymé, Irénée Jules** (1796–1878), French mathematician. Studied calculus of probabilities and its application to financial science; with P. L. Chebyshev, discovered Bienaymé-Chebyshev inequality.
- Billet, Felix** (1808–1882), French physicist. Invented Billet split lens.
- Binet, Alfred** (1857–1911), French psychologist. Investigated development and measurement of intelligence.
- Binnig, Gerd** (1947– ), German physicist. With H. Rohrer, developed scanning tunneling microscope; Nobel Prize, 1986.
- Biot, Jean Baptiste** (1774–1862), French mathematician and physicist. Discovered circular polarization of light; invented a polariscope; with D. Brewster, discovered biaxial crystals; helped formulate Biot-Savart law.
- Birkhoff, George David** (1884–1944), American mathematician. Investigated differential equations, dynamical systems, ergodic theory, mechanics of fluids, and foundations of relativity and quantum mechanics.
- Bishop, John Michael** (1936– ), American virologist and biochemist. With H. Varmus, researched the genetic basis of human cancers; their work led to the identification of over 50 cellular genes that can become oncogenes; Nobel Prize, 1989.
- Bjerknes, Vilhelm Fremann Doren** (1862–1951), Norwegian physicist. Research on electric waves; originated the polar-front theory in meteorology.
- Black, James** (1924– ), British pharmacologist. Developed the first beta blocker drug, propranolol; also credited with the discovery of another important class of drugs, the H<sub>2</sub> antagonists; Nobel Prize, 1988.
- Black, Joseph** (1728–1799) Scottish physicist and chemist. Established the concepts of latent heat and specific heat, and discovered carbon dioxide.
- Blackett, Patrick Maynard Stuart** (1897–1974), English physicist. Built an improved cloud chamber used to photograph tracks of a nuclear disintegration and of a cosmic-ray shower; discovered the positron; Nobel Prize, 1948.
- Blobel, Günter** (1936– ), German-born American cell and molecular biologist. Discovered that proteins carry signals that help direct their movement among the organelles of the cell; Nobel Prize, 1999.
- Bloch, Felix** (1905–1983), Swiss-born American physicist. Discovered a technique for studying magnetism of atomic nuclei in normal matter; Nobel Prize, 1952.
- Bloch, Konrad Emil** (1912–2000), German-born American biochemist. Traced the transformations of fat and carbohydrate metabolites to cholesterol; Nobel Prize, 1964.
- Bloodgett, Katharine Burr** (1898–1979), American chemical physicist. Studied surface science, and is best known for her work with Irving Langmuir and the development of the Langmuir-Bloodgett film.
- Bloembergen, Nicolaas** (1920– ), Netherlands-born American physicist. Contributed to development of maser; made extensive contributions to theoretical and experimental development of nonlinear optics; Nobel Prize, 1981.
- Blumberg, Baruch Samuel** (1925– ), American physician and biologist. Research leading to a test for hepatitis viruses in blood and to an experimental hepatitis vaccine; Nobel Prize, 1976.
- Boas, Franz** (1858–1942), American anthropologist. Pioneered in physical anthropology; contributed to stratigraphic archeology in Mexico; emphasized importance of linguistic analysis.
- Bobillier, Étienne** (1798–1840), French mathematician and physicist. Contributed to geometry and statics; discovered Bobillier’s law.
- Bode, Johann Elert** (1747–1826), German astronomer. Prepared a celestial atlas showing about 17,000 stars; formulated Bode’s law.
- Boerhaave, Hermann** (1668–1738), Dutch physician. A great teacher at the University of Leyden; wrote the physiology textbook *Institutiones Medicae*.
- Bohm, David** (1917–1992), American-born British physicist. Research in quantum theory and new modes of description in physics.
- Bohr, Aage** (1922– ), Danish physicist. With B. R. Mottelson, developed theory which unifies shell and liquid-drop models of the atomic nucleus, and which explains nonspherical nuclei; Nobel Prize, 1975.
- Bohr, Niels** (1885–1962), Danish physicist. Devised an atomic model; codveloped the quantum theory, applying it to atomic structure in Bohr’s theory; Nobel Prize, 1922.
- Boltzmann, Ludwig Eduard** (1844–1906), Austrian physicist. An authority on the kinetic theory of gases; demonstrated the Stefan-Boltzmann law of blackbody radiation, Boltzmann’s law of energy, and the Boltzmann constant.
- Bolyai, János** (1802–1860), Hungarian mathematician. Independently of K. F. Gauss and N. I. Lobachevski, originated a system of noneuclidean geometry.
- Bolzano, Bernard** (1781–1848), Czechoslovakian philosopher, logician, and mathematician. Contributed to theory of real functions; proved Bolzano’s theorem and Bolzano-Weierstrass theorem.
- Bombieri, Enrico** (1940– ), Italian mathematician. Made major contributions to the study of prime numbers, partial differential equations and minimal surfaces, univalent functions and the local Bieberbach conjecture, and functions of several complex variables; Fields Medal, 1974.
- Bond, George Phillips** (1825–1865), American astronomer. Introduced concept of Bond albedo; pioneered astronomical photography.
- Boole, George** (1815–1864), English mathematician and logician. Developed new system of mathematical logic, which is known as Boolean algebra.
- Borchers, Richard Ewan** (1959– ), British mathematician. Worked in algebra and geometry; proved the moonshine conjecture, which relates the so-called monster group and elliptical curves, using methods borrowed from string theory in theoretical physics; Fields Medal, 1998.
- Borda, Jean Charles** (1733–1799), French physicist and mathematician. Introduced Borda mouthpiece; developed instruments for navigation, geodesy, and determination of weights and measures.
- Bordet, Jules Jean Baptiste Vincent** (1870–1961), Belgian physiologist. Made discoveries in immunology; with O. Gengou, developed the technique of the complement fixation reaction; Nobel Prize, 1919.
- Borel, Félix Edouard Émile** (1871–1956), French mathematician. Work in infinitesimal calculus and the calculus of probabilities.
- Born, Max** (1882–1970), German-born British theoretical physicist. Pioneered in the development of quantum mechanics; Nobel Prize, 1954.
- Bosch, Carl** (1874–1940), German chemist. Developed chemical high-pressure methods, and the Haber-Bosch process for ammonia synthesis; Nobel Prize, 1931.
- Bose, Jagadis Chandra** (1858–1937), Indian plant physiologist and physicist. Founded the Bose Research Institute in Calcutta; investigated photosynthesis, “nervous mechanism” of plants, and other plant subjects.
- Bose, Satyendra Nath** (1894–1974), Indian physicist. Originated Bose-Einstein statistics to describe photons.
- Bothe, Walter** (1891–1957), German physicist. Devised the coincidence method for the investigation of nuclear reactions and cosmic radiation; Nobel Prize, 1954.
- Bouguer, Pierre** (1698–1758), French geodesist, hydrographer, and physicist. Laid foundations of photometry; discovered Bouguer-Lambert law of light intensity.
- Bourdon, Eugène** (1808–1884), French inventor. Invented Bourdon pressure gage.
- Bourgain, Jean** (1954– ), Belgian mathematician. Worked in several areas of mathematical analysis, including the geometry of Banach spaces, convexity in high dimensions, harmonic analysis, ergodic theory, and nonlinear partial differential equations; Fields Medal, 1994.
- Boussinesq, Joseph Valentin** (1842–1929), French mathematical physicist. Research in hydrodynamics; introduced Boussinesq approximation.
- Bovet, Daniel** (1907–1992), Swiss-born Italian pharmacologist. Research on synthetic compounds that inhibit the action of the vascular system and skeletal muscles; Nobel Prize, 1957.
- Bowditch, Nathaniel** (1773–1838), American navigator and mathematician. Produced navigation guide; translated and improved P. S. de Laplace’s *Mécanique céleste*.
- Bowen, Norman Levi** (1887–1956), Canadian-born American geologist. Studied physical chemistry of geological processes and phase equilibria of silicates; discovered significance of reaction principle in petrogenesis.
- Boyer, Paul D.** (1918– ), American chemist. Made major contributions toward elucidating the enzymatic mechanism underlying the synthesis of adenosine triphosphate (ATP) by proposing the binding change mechanism; Nobel Prize, 1997.
- Boyle, Robert** (1627–1691), British physicist and chemist. Conducted experiments on properties of the air pump; his law concerning gases is named for him; advanced the atomistic theory of matter.
- Bradley, James** (1693–1762), English astronomer. Discovered aberration of light due to the Earth’s motion, and nutation of the Earth’s axis; prepared astronomical tables and star catalogs.
- Bragg, William Henry** (1862–1942), English physicist. Codeveloper, with W. L. Bragg, of the x-ray spectrometer; used x-ray diffraction to determine crystal structure; Nobel Prize, 1915.
- Bragg, William Lawrence** (1890–1971), British physicist. With W. H. Bragg, developed x-ray analysis of the atomic arrangement in crystalline structures; Nobel Prize, 1915.
- Brahe, Tycho or Tyge** (1546–1601), Danish astronomer. Made painstaking observations of the planetary system; wrote *Astronomiae Instauratae Progymnasmatia*.
- Brattain, Walter Houser** (1902–1987), American physicist. Investigated properties of semiconductors; research on surface properties of solids; Nobel Prize, 1956.
- Braun, Karl Ferdinand** (1850–1918), German physicist. Research on cathode rays and wireless telegraphy; Nobel Prize, 1909.

- Bravais, Auguste** (1811–1863), French physicist. Studied relationship between crystal form and structure; derived Bravais lattices.
- Breit, Gregory** (1899–1981), Russian-born American physicist. Research on quantum theory, quantum electrodynamics, hyperfine structure, and ionosphere.
- Brenner, Sydney** (1927– ), South African-born British molecular biologist. Established the nematode *Caenorhabditis elegans* as an experimental model system for studying genetic regulation of cell division, cell specialization, and organ development in multicellular animals. Also credited with the identification of messenger ribonucleic acid (mRNA). Nobel Prize, 2002.
- Breuer, Josef** (1842–1925), Austrian neurologist. Evolved abreaction method for treatment of neuroses.
- Brewster, David** (1781–1868), Scottish physicist. Formulated Brewster's law on polarization of light; codiscoverer, with J. B. Biot, of biaxial crystals.
- Brianchon, Charles Julien** (1783–1864), French mathematician. Proved Brianchon's theorem.
- Bridgman, Percy Williams** (1882–1961), American physicist. Worked in high-pressure physics and thermodynamics of liquids; Nobel Prize, 1946.
- Briggs, Henry** (1561–1631), English mathematician. Prepared logarithmic tables (later known as common logarithms); devised sophisticated interpolation techniques.
- Bright, Richard** (1789–1858), English physician. Made biochemical study of disease; researched Bright's disease of the kidneys.
- Brillouin, Leon** (1889–1969), French physicist. With G. Wentzel and H. A. Kramers, developed Wentzel-Kramers-Brillouin method; originated concept of Brillouin zones.
- Brillouin, Louis Marcel** (1854–1948), French physicist. Work on crystal structure, viscosity of liquids and gases, radiotelegraphy, and relativity.
- Brinell, Johann August** (1849–1925), Swedish engineer. Invented the Brinell machine to measure the hardness of alloys and metals in terms of the Brinell number.
- Brockhouse, Bertram Neville** (1918–2003), Canadian physicist. Developed slow neutron spectroscopy technique for studying dynamics of atoms in solids and liquids; Nobel Prize, 1994.
- Broglie, Louis Victor de** (1892–1987), French physicist. Worked in nuclear physics; first to link wave and corpuscular theory; Nobel Prize, 1929.
- Bromwich, Thomas John l'Anson** (1875–1929), English mathematician. Showed how the Heaviside calculus could be developed in a manner acceptable to pure mathematicians through use of contour integrals.
- Brønsted, Johannes Nicolaus** (1879–1947), Danish chemist. Researched kinetic properties of ions, catalysis, and nitramide; formulated the Brønsted theory of acid-base reactions.
- Brown, Herbert Charles** (1912– ), British-born American chemist. Developed methods for chemical synthesis of diborane and organoboranes; Nobel Prize, 1979.
- Brown, Michael S.** (1941– ), American biochemist and geneticist. With Joseph L. Goldstein, discovered low-density lipoprotein receptors and their function in cholesterol metabolism; Nobel Prize, 1985.
- Browning, John Moses** (1855–1926), American inventor. Invented the Browning machine gun.
- Brun, Viggo** (1885–1978), Norwegian mathematician. Worked in number theory, introducing what is now known as the Brun's sieve, which made some progress in the resolution of such problems as Goldbach's conjecture and the twin prime problem.
- Brunauer, Stephen** (1903–1986), Hungarian-born American chemist. Contributed to surface and colloid chemistry; with P. H. Emmett and E. Teller, developed Brunauer-Emmett-Teller equation for surface area determinations.
- Brunel, Isambard Kingdom** (1806–1859), English engineer. Constructed great bridges in England; designed important steamships.
- Buchner, Eduard** (1860–1917), German chemist. Studied alcoholic fermentation of sucrose; Nobel Prize, 1907.
- Buck, Linda** (1947– ), American molecular biologist. Recognized along with Richard Axel for pioneering research of the olfactory system, which led to the discovery of the large gene family encoding the different odorant receptors located on the membrane of olfactory receptor cells. Later independent work clarified the olfactory system, from the molecular level to the organization of the cells. Nobel Prize, 2004.
- Buckingham, Edgar** (1867–1940), American physicist. Worked on thermodynamics and dimensional analysis; derived Buckingham's  $\pi$  theorem.
- Buffon, Georges Louis Leclerc, Comte de** (1707–1788), French naturalist. Compiled *Histoire Naturelle*, a monumental work on natural history.
- Bullen, Keith Edward** (1906–1976), Australian applied mathematician. Carried out mathematical studies of earthquake waves; with H. Jeffreys, prepared the Jeffreys-Bullen tables on seismic travel time.
- Bunsen, Robert Wilhelm** (1811–1899), German chemist. Discovered, with G. R. Kirchhoff, spectrum analysis; invented the Bunsen burner, Bunsen cell, and Bunsen ice calorimeter; formulated law of reciprocity with H. E. Roscoe.
- Burbank, Luther** (1849–1926), American horticulturist. Experimented on crossing and in-breeding of plant varieties.
- Burnet, Frank Macfarlane** (1899–1985), Australian immunologist. With P. B. Medawar, studied the body's tolerance of antigenic substances; Nobel Prize, 1960.
- Bush, Vannevar** (1890–1974), American electrical engineer. Originated the concept of hypertext.
- Butenandt, Adolph Friedrich Johann** (1903–1995), German chemist. Researched sex hormones; Nobel Prize (declined), 1939.
- Buys-Ballot, Christoph Hendrik Didericus** (1817–1890), Dutch meteorologist. Devised a system of storm signals; formulated Buys-Ballot's law for determination of wind direction.
- Byron, Augusta Ada, Countess of Lovelace** (1815–1852), English mathematician. Daughter of the poet Lord Byron; wrote the first program for Charles Babbage's analytical engine; often described as the first computer programmer.
- Cailletet, Louis Paul** (1832–1913), French chemist. Researched liquefaction of gases; first to obtain liquid oxygen, hydrogen, nitrogen, and air.
- Callendar, Hugh Longbourne** (1863–1930), English physicist and engineer. Developed platinum resistance thermometer and continuous-flow calorimeter.
- Callow, John Michael** (1867–1940), English-born American mining engineer and metallurgist. Invented Callow flotation cell and Callow screen.
- Calvin, Melvin** (1911–1997), American chemist. With J. A. Bassham, traced the path of carbon in photosynthesis; Nobel Prize, 1961.
- Cannizzaro, Stanislao** (1826–1910), Italian chemist. Promulgated Avogadro's work as related to atomic weights; discovered Cannizzaro's reaction in organic chemistry.
- Cantor, Georg** (1845–1918), Russian-born German mathematician. Founded set theory; introduced fundamental concepts in topology; worked on the theory and representations of real numbers.
- Carathéodory, Constantin** (1873–1950), German mathematician. Developed calculus of variations for curves with corners; introduced Carathéodory outer measure; gave mathematical formulation of second law of thermodynamics (Carathéodory's principle).
- Cardano, Geronimo, or Jerome Cardan** (1501–1576), Italian physician and mathematician. Wrote on algebra, medicine, and astronomy; invented the Cardan shaft.
- Carlsson, Arvid** (1923– ), Swedish pharmacologist. Did research on dopamine, leading to the discovery of its role as a key neurotransmitter in the brain and in the control of movement; the development of L-dopa, a precursor of dopamine, into a drug to treat Parkinson's disease; the elucidation of the mode of action of antipsychotic drugs, which affect synaptic transmission by blocking dopamine receptors; did work (along with that of Paul Greengard and Eric Kandel) leading to the elucidation of the molecular mechanisms involved in slow synaptic transmission in the nervous system; Nobel Prize, 2000.
- Carnot, Nicolas Léonard Sadi** (1796–1832), French physicist. Formulated Carnot's theorems in thermodynamics.
- Carrel, Alexis** (1873–1944), French surgeon and biologist. Worked on transplanting organs, suturing blood vessels, treating deep wounds, and prolonging tissue life; Nobel Prize, 1912.
- Carrington, Richard Christopher** (1826–1875), English astronomer. Investigated motions of sunspots.
- Carver, George Washington** (1864–1943), American botanist. Did research on industrial uses of the peanut.
- Cassegrain, N.** (17th century), French physician. Designed the Cassegrain reflecting telescope.
- Cassini, Jean Dominique** (1625–1712), Italian-born French astronomer. Director of the Paris Observatory; discovered four new satellites of Saturn and the Cassini division in Saturn's ring; conducted pendulum experiments related to the shape of the Earth.
- Castigliano, Carlo Alberto** (1847–1884), Italian structural engineer. Proved Castigliano's theorem.
- Cauchy, Augustin Louis, Baron** (1789–1857), French mathematician. Wrote extensively on wave propagation, calculus, and elasticity.
- Cavendish, Henry** (1731–1810), English physicist and chemist. Determined the density of the Earth and the composition of the atmosphere; studied properties of carbon dioxide and hydrogen.
- Cayley, Arthur** (1821–1895), English mathematician. Proposed the theory of matrices; developed the theory of invariants and covariants; worked on quantics and the theory of groups.
- Cech, Thomas R.** (1947– ), American chemist. By studying the single-cell organisms *Tetrahymena* and *Thermophila*, discovered that molecules of ribonucleic acid (RNA) have catalytic properties similar to those of enzymes; Nobel Prize, 1989.
- Celsius, Anders** (1701–1744), Swedish astronomer. Constructed the thermometer using the Celsius (centigrade) scale.
- Cerenkov, Pavel Alexeyevich** (1904–1990), Soviet physicist. Discovered the Cerenkov effect of radiation; devised the Cerenkov counter for particle detection; Nobel Prize, 1958.
- Cerf, Vinton G.** (1943– ), American computer scientist. Co-invented (with Robert E. Kahn) Transmission Control Protocol/Internet Protocol (TCP/IP).
- Cesalpino, Andrea** (1519–1603), Italian physician and botanist. First to attempt to classify plants according to characteristics of fruit and seed in his *De Plantis*.
- Cesàro, Ernesto** (1859–1906), Italian mathematician. Formulated an intrinsic geometry; introduced the Cesàro summation.
- Ceva, Giovanni** (1647?–1734), Italian mathematician. Formulated a theorem on the concurrency of straight lines passing through the vertices of a triangle.
- Chadwick, James** (1891–1974), English physicist. Established experimentally the existence of the neutron; Nobel Prize, 1935.
- Chain, Ernst Boris** (1906–1979), German-born British biochemist. With H. W. Florey, worked on the chemical structure of penicillin and its first clinical trials; Nobel Prize, 1945.
- Chamberlain, Owen** (1920– ), American physicist. With E. G. Segrè, demonstrated the existence of the antiproton; Nobel Prize, 1959.
- Chamberlin, Thomas Chrowder** (1843–1928), American geologist. Studied the fundamental geology of the solar system.
- Chandler, Seth Carlo** (1846–1913), American astronomer. Discovered the Chandler wobble.
- Chandrasekhar, Subrahmanyan** (1910–1995), Indian astrophysicist. Developed a theory of white dwarf stars; Nobel Prize, 1983.

- Chaplygin, Sergel Alekseevich** (1869–1942), Russian physicist, engineer, and mathematician. Made contributions to fluid mechanics, particularly aerodynamics.
- Chapman, Sydney** (1888–1970), English mathematician and physicist. Discovered (independently of D. Enskog) gaseous thermal diffusion; studied the daily variations of the geomagnetic field and magnetic storms.
- Chaptal, Jean Antoine Claude, Comte de Chanteloup** (1756–1832), French chemist. Wrote on technical chemistry; introduced the metric system after the Revolution.
- Charcot, Jean Martin** (1825–1893), French neurologist. Director of the Salpêtrière clinic, where he made systematic clinical studies of chronic nervous disorders, including cerebrospinal disease.
- Charles, Jacques Alexandre César** (1746–1823), French physicist, chemist, and inventor. Formulated Charles' law, relating gas volume to pressure.
- Charpak, Georges** (1924– ), French physicist. Invented the multiwire proportional chamber, used as a detector in high-energy physics experiments; Nobel Prize, 1992.
- Chebyshev, Pafnuti Lvovich** (1821–1894), Russian mathematician. Research on convergence of Taylor series, prime numbers, probability theory, quadratic forms, and integral theory.
- Chladni, Ernst Florenz Friedrich** (1756–1827), German physicist. Discovered Chladni's figures and used them to study vibrations of solid plates.
- Christoffel, Elwin Bruno** (1829–1900), Swiss mathematician. Worked in higher analysis, geometry, mathematical physics, and geodesy.
- Chu, Ching-Wu** (1941– ), Chinese-born American physicist. Discovered superconductivity at temperatures over 90 K (–298°F) in yttrium-barium-copper-oxygen compounds.
- Chu, Steven** (1948– ), American physicist. Developed a system of opposed laser beams to cool atoms to extremely low temperatures, and a magneto-optical trap to capture them; Nobel Prize, 1997.
- Ciechanover, Aaron** (1947– ), Israeli medical doctor and scientist. Discovered ubiquitin-mediated protein degradation; Nobel Prize, 2004.
- Clairaut, Alexis Claude** (1713–1765), French mathematician. Studied the shape of the Earth, evolving Clairaut's theorem; made astronomical calculations concerning Halley's comet.
- Claisen, Ludwig** (1851–1930), German organic chemist. Developed Claisen condensation; contributed to understanding of tautomerism; worked on rearrangement of allyl aryl ethers into phenols.
- Clapeyron, Benoit Paul Émile** (1799–1864), French engineer. Developed N. L. S. Carnot's concept of a universal function of temperature.
- Clarke, Alexander Ross** (1828–1914), British geodesist. Worked on the triangulation of the British Isles; proposed Clarke ellipsoids as geodetic standards.
- Claude, Albert** (1899–1983), American cytologist, born in Luxembourg. Pioneered in applying electron microscopy to cell studies and in using centrifuge to separate cell components; Nobel Prize, 1974.
- Clausius, Rudolf Julius Emmanuel** (1822–1888), German physicist. A founder of thermodynamics; worked out the Clausius-Clapeyron equation for the universal temperature function.
- Clebsch, Rudolf Friedrich Alfred** (1833–1872), German mathematician. Contributions to theory of invariants and algebraic geometry.
- Cockcroft, John Douglas** (1897–1967), English physicist. With E. T. S. Walton, split nuclei by bombarding them with accelerated protons.
- Cohen, Paul Joseph** (1934– ), American mathematician. Proved that the axiom of choice is independent of the other axioms of set theory, and that the continuum hypothesis is independent of the axiom of choice, a result with profound implications for the foundations of mathematics; Fields Medal, 1966.
- Cohen, Stanley** (1922– ), American biochemist. With R. Levi-Montalcini, made landmark studies of nerve growth factor and its functions; Nobel Prize, 1986.
- Cohen-Tannoudji, Claude** (1933– ), French physicist. Helped develop methods to cool and trap atoms with laser light, and explained how atoms could be cooled to temperatures lower than the previously calculated theoretical limits; Nobel Prize, 1997.
- Cohn, Ferdinand Julius** (1828–1898), German botanist. A founder of bacteriology; did research in plant pathology; first to classify bacteria according to genus and species.
- Cole, Kenneth Stewart** (1900–1984), American biophysicist. Research on structure and function of living cell membranes and nerve membranes in particular, concentrating on electrical approach; with brother, R. H. Cole, introduced Cole-Cole plot of dielectric behavior.
- Cole, Robert Hugh** (1914–1990), American chemist and physicist. Research on dielectric properties of matter and intermolecular forces; with brother, K. S. Cole, introduced Cole-Cole plot of dielectric behavior.
- Collins, Samuel Cornette** (1898–1984), American engineer. Invented Collins helium liquefier.
- Compton, Arthur Holly** (1892–1962), American physicist. Discovered the Compton effect of x-rays; studied cosmic rays; helped develop the atomic bomb; Nobel Prize, 1927.
- Conant, James Bryant** (1893–1978), American chemist. Researched free radicals, hemoglobin, and chlorophyll; contributed to atomic energy development.
- Condon, Edward Uhler** (1902–1974), American physicist. Contributed to the Franck-Condon principle, by extending and giving quantum-mechanical treatment to J. Franck's concept of nuclear motion to molecules in transition from one energy level to another.
- Connes, Alain** (1947– ), French mathematician. Did fundamental work on the theory and application of operator algebras, particularly von Neumann algebras; Fields Medal, 1982.
- Coolidge, William David** (1873–1975), American physicist. Invented Coolidge tube; discovered method for making tungsten strong and ductile.
- Cooper, Leon N.** (1930– ), American physicist. Showed that electrons could form Cooper pairs; with J. R. Schrieffer and J. Bardeen, formulated a theory of superconductivity; Nobel Prize, 1972.
- Copernicus, Nicolaus** (1473–1543), Polish (or Prussian) astronomer. Proposed the Copernican system, with the Sun as the center of planetary orbits.
- Corey, Elias James** (1928– ), American chemist. Developed theories and methods of organic chemical synthesis that have made possible the production of a wide variety of complex biologically active substances and useful chemicals; Nobel Prize, 1990.
- Cori, Carl Ferdinand** (1896–1984), and **Cori, Gerty Theresa Radnitz** (1896–1957), Czechoslovakian-born American biochemists. Discovered the enzymatic mechanism of glucose-glycogen interconversion and the effects of hormones on this mechanism; Nobel Prize, 1947.
- Coriolis, Gaspard Gustave de** (1792–1843), French physicist. Contributed to theoretical and applied mechanics; clarified and supplied concepts of work and kinetic energy; derived Coriolis acceleration.
- Cormack, Allan MacLeod** (1924–1998), American physicist. Contributed to the development of computerized axial tomography; Nobel Prize, 1979.
- Cornell, Eric Allin** (1961– ), American physicist. With C. E. Wieman, succeeded for the first time in producing Bose-Einstein condensates in a dilute gas of alkali (rubidium) atoms, and carried out fundamental studies of their properties, including studies of collective excitations and vortex formation in condensates; Nobel Prize, 2001.
- Corner, George Washington** (1889–1981), American medical biologist. Contributed to understanding of anatomical details of menstrual cycle and functions of estrogen and progesterone.
- Cornforth, John Warcup** (1917– ), Australian-born British chemist. Investigated stereochemistry of enzyme-catalyzed reactions; Nobel Prize, 1975.
- Cornu, Marie Alfred** (1841–1902), French physicist. Used Cornu spiral for determination of intensities in interference phenomena.
- Coster, Dirk** (1889–1950), Dutch physicist. Work in x-ray spectroscopy; with G. von Hevesy, discovered hafnium; with R. Kronig, discovered Coster-Kronig transitions.
- Cottrell, Frederick Gardner** (1877–1948), American chemist. Invented the Cottrell process for precipitation of particles from gas; researched nitrogen fixation, liquefaction of gases, and recovery of helium.
- Coulomb, Charles Augustin de** (1736–1806), French physicist. Formulated Coulomb's law of electric charges.
- Courant, Richard** (1888–1972), German-born American mathematician. Research in geometric function theory, differential equations of mathematical physics, and transition by limiting processes from finite difference equations to differential equations.
- Cournand, André Frédéric** (1895–1988), French-born American physician. Studied normal and abnormal human cardiovascular and pulmonary functions; Nobel Prize, 1956.
- Cowan, Clyde L., Jr.** (1919–1974), American physicist. With F. Reines, made first detection of the neutrino, a fundamental particle.
- Crafts, James Mason** (1839–1917), American chemist. With C. Friedel, discovered the Friedel-Crafts reaction, wherein anhydrous aluminum chloride acts as a catalyst.
- Cram, Donald J.** (1919–2001), American chemist. Expanded the field of crown ether chemistry by using crown ethers to synthesize structures that mimic the action of biological molecules; Nobel Prize, 1987.
- Cramer, Gabriel** (1704–1752), Swiss mathematician. Contributed to Cramer's rule for solving linear equations.
- Crick, Francis Harry Compton** (1916–2004), English molecular biologist. With J. D. Watson, proposed a double-helix structure for the deoxyribo-nucleic acid molecule; Nobel Prize, 1962.
- Cronin, James Watson** (1931– ), American physicist. Collaborated with V. L. Fitch on experiment showing that the principle of time-reversal invariance is violated in the decay of neutral *K* mesons; Nobel Prize, 1980.
- Cronstedt, Axel Fredrik, Baron** (1722–1765), Swedish mineralogist. Discovered nickel; developed a chemical classification system for minerals.
- Crookes, William** (1832–1919), English physicist and chemist. Invented Crookes tube to study electrical discharges in high vacuum, and a radiometer; discovered thallium.
- Cruzen, Paul J.** (1933– ), Dutch chemist. Demonstrated that nitrogen oxides react catalytically with ozone, thus accelerating the rate of reduction of the ozone layer; Nobel Prize, 1995.
- Curie, Marie, born Marya Skłodowska** (1867–1934), Polish physical chemist in France. Explored nature of radioactivity; codiscoverer of radium, and first to separate polonium; Nobel Prize, 1903 and 1911.
- Curie, Pierre** (1859–1906), French chemist and physicist. Codiscoverer of radium; formulated the Curie point, relating magnetic properties and temperature; discovered the piezoelectric effect; Nobel Prize, 1903.
- Curl, Robert F., Jr.** (1933– ), American chemist. Made major contributions toward the discovery of fullerenes; Nobel Prize, 1996.
- Cushing, Harvey** (1869–1930), American surgeon. Innovator in neurosurgical techniques; research on function and diseases of the pituitary gland.
- Cuvier, Georges Léopold Chrétien Frédéric Dagobert, Baron** (1769–1838), French naturalist. Made a detailed classification of the animal kingdom; wrote on comparative anatomy.

- Daguerre, Louis Jacques Mandé** (1787–1851), French inventor. Invented the daguerreotype photographic process.
- Dale, Henry Hallett** (1875–1968), British pharmacologist and physiologist. Isolated acetylcholine and recognized its effect to be similar to that brought about by parasympathetic nerves; Nobel Prize, 1936.
- Dalén, Nils Gustaf** (1869–1937), Swedish physicist. Invented automatic gas lighting for unsuper-vised lighthouses and railroad signals; Nobel Prize, 1912.
- Dalitz, Richard Henry** (1925– ), Australian-born British theoretical physicist. Research on properties of mesons and baryons and nuclear interactions of the lambda hyperon; proposed models for elementary particles; introduced the Dalitz plot.
- Dalton, John** (1766–1844), English chemist and physicist. Proposed the atomic theory of chemical reactions; developed the law of partial pressures of gases; studied color-blindness.
- Dam, Carl Peter Henrik** (1895–1976), Danish biochemist and nutritionist. Discovered vitamin K and studied its role in human hemorrhagic disease; Nobel Prize, 1943.
- Danckwerts, Peter Victor** (1916–1984), British chemical engineer. Proposed the surface-renewal model of liquids.
- Daniell, John Frederic** (1790–1845), English physicist and chemist. Invented the Daniell cell.
- Darwin, Charles Robert** (1809–1882), English naturalist. Proposed far-reaching theory of evolution of species and theory of natural selection in his *Origin of Species*.
- Darwin, George Howard** (1845–1912), English mathematician and astronomer. Applied detailed dynamical analysis to cosmological and geological problems.
- Dausset, Jean** (1916– ), French biologist and medical scientist. Studied antigen in human leukocytes and their role in transplant acceptance or rejections; Nobel Prize, 1980.
- Davis, Raymond, Jr.** (1914– ), American physicist. Developed pioneering experiments to detect solar neutrinos, and observed deficit in their number. Nobel Prize, 2002.
- Davison, Clinton Joseph** (1881–1958), American physicist. Studied magnetism, radiant energy, and electricity; independent of G. P. Thomson, discovered electron diffraction by crystals; Nobel Prize, 1937.
- Davy, Humphry** (1778–1829), English chemist. Discovered potassium and sodium; invented the Davy safety lamp for use in coal mines; proposed theoretical explanations of electrolysis and voltaic action.
- Debye, Peter Joseph William** (1884–1966), American physical chemist born in the Netherlands. Worked on dipole moments and the diffraction of x-rays in gases; formulated Debye-Hückel theory on the behavior of strong electrolytes; Nobel Prize, 1936.
- Dedekind, Julius Wilhelm Richard** (1831–1916), German mathematician. Worked in number theory and analysis, particularly with algebraic integers, algebraic functions, and ideals; defined real numbers by Dedekind cuts.
- de Duve, Christian René** (1917– ), Belgian biochemist and cytologist. Refined centrifuge technique for studying cell components; discovered lysosomes; Nobel Prize, 1974.
- De Forest, Lee** (1873–1961), American inventor. Pioneer in radio technology; invented audio amplifier and the four-electrode valve; incorporated the grid into the thermionic valve.
- de Gennes, Pierre-Gilles** (1932– ), French physicist. Applied physical principles to the study of complex systems, including liquid crystals and polymers; Nobel Prize, 1991.
- de Haas, Wander Johannes** (1878–1960), Dutch physicist. Demonstrated the Einstein-de Haas effect; worked on production of extremely low temperatures by adiabatic demagnetization; with P. Van Alphen, discovered de Haas-Van Alphen effect.
- Dehmelt, Hans Georg** (1922– ), German-born American physicist. Developed the Penning trap, which uses magnetic and electric fields to hold ions in a small volume; used the traps to isolate a single electron and carry out extremely accurate measurements of atomic properties; Nobel Prize, 1989.
- Deisenhofer, Johann** (1943– ), German chemist. With R. Huber and M. Hartmut, elucidated the structure of a bacterial protein that performs photosynthesis; Nobel Prize, 1988.
- Delbruck, Max** (1906–1981), German-born American biologist. Pioneered in molecular biology; research on bacterial viruses; Nobel Prize, 1969.
- Deligne, Pierre René** (1944– ), Belgian mathematician. Solved three conjectures of A. Weil concerning generalizations of the Riemann hypothesis to finite fields—work which brought together algebraic geometry and algebraic number theory; Fields Medal, 1978.
- Demoivre, Abraham** (1667–1754), French-born English mathematician. Originated two theorems on expansions of trigonometrical expansions; proposed methods to approximate functions of large numbers, and the concept of the normal distribution curve.
- De Morgan, Augustus** (1806–1871), English mathematician. Wrote textbooks and treatises on arithmetic, algebra, and trigonometry; formulated the De Morgan theorem.
- Desargues, Gérard** (1593–1662), French mathematician. A founder of modern geometry; proposed the theory of involution and transversals.
- Descartes, René** (1596–1650), French mathematician. Originated cartesian, or coordinate, geometry.
- de Sitter, Willem** (1872–1934), Dutch astronomer. Worked on the application of Einstein's theory to the problems of the universe; computed the size of the universe.
- De Vries, Hugo** (1848–1935), Dutch botanist. Formulated the mutation theory of evolution.
- Dewar, James** (1842–1923), British chemist. Made pioneering studies of matter at low temperatures; first to liquefy hydrogen; invented the Dewar vacuum flask.
- Dick, George Frederick** (1881–1967), American physician and bacteriologist. Isolated scarlet fever streptococci, developed scarlet fever streptococcus antitoxin, and developed Dick test.
- Dicke, Robert Henry** (1916–1997), American physicist. Developed new relativistic theory of gravitation with C. Brans; investigated cosmic blackbody radiation; worked on development of radar.
- Diels, Otto Paul Hermann** (1876–1954), German chemist. Codiscoverer of the Diels-Alder reaction (diene synthesis); worked on sterol chemistry; discovered carbon suboxide; Nobel Prize, 1950.
- Diesel, Rudolf** (1858–1913), German inventor. Designed and built the diesel engine.
- Deisenhofer, Johann** (1943– ), German chemist. With R. Huber and M. Hartmut, elucidated the structure of a bacterial protein that performs photosynthesis; Nobel Prize, 1988.
- Diocles** (2d century B.C.), Greek mathematician. Contributions to theory of conics and geometry.
- Diophantus of Alexandria** (3d century), Greek mathematician. Known as the father of algebra; the first to use conventional algebraic notation.
- Dirac, Paul Adrien Maurice** (1902–1984), English physicist. Worked in quantum mechanics; his theory of negative-energy holes predicted existence of the positron; Nobel Prize, 1933.
- Dirichlet, Peter Gustave Lejeune** (1805–1859), German mathematician. Applied higher analysis to the theory of numbers; work on definite integrals.
- Djerassi, Carl** (1923– ), Austrian-born, American chemist. Synthesized the first oral contraceptive.
- Dobzhansky, Theodosius** (1900–1975), Russian-born American biologist. Elucidated the mechanisms of heredity and variation through studies of *Drosophila*.
- Doherty, Peter C.** (1940– ), Australian-born American immunologist. Collaborated with R. M. Zinkernagel in the discovery of specificity of cell-mediated immune defense; Nobel Prize, 1996.
- Dolsy, Edward Adelbert** (1893–1986), American biochemist. Isolated pure crystalline compounds important to human health, such as sex hormones and vitamins; Nobel Prize, 1943.
- Domagk, Gerhard** (1895–1964), German biochemist. Discovered sulfamidocryosidin, the first synthetic microbial of broad clinical usefulness. Nobel Prize (declined), 1939.
- Donaldson, Simon Kirwan** (1957– ), British mathematician. Worked on topology of four-manifolds and showed that there exist exotic four-spaces, that is, four-dimensional differentiable manifolds that are topologically but not differentially equivalent to the standard Euclidean four-space; Fields Medal, 1986.
- Donati, Giovanni Battista** (1826–1873), Italian astronomer. Studied stellar spectra; discovered six comets.
- Donnan, Frederick George** (1870–1956), Irish chemist born in Ceylon. Research in chemical kinetics; originated the Donnan theory of membrane equilibrium.
- Doppler, Christian Johann** (1803–1853), Austrian physicist and mathematician. Formulated Doppler's principle, relating the frequency of wave motion to velocity; described the Doppler effect.
- Douglas, Jesse** (1897–1965), American mathematician. Solved the Plateau problem (the problem of determining the existence of a minimal surface with a given space curve as its boundary) about the same time as T. Radó and studied generalizations of this problem; Fields Medal, 1936.
- Drake, Frank Donald** (1930– ), American astronomer. Research on solar system, 21-centimeter radio line, search for extraterrestrial intelligence (introduced Drake equation), and radio telescope development.
- Draper, Henry** (1837–1882), American scientist. Research in spectroscopy; the Draper catalog is named in his honor.
- Drinfeld, Vladimir Gershonovich** (1954– ), Ukrainian mathematician. Worked in algebraic geometry, number theory, and the theory of quantum groups; proved a special case of the Langlands conjecture; Fields Medal, 1990.
- Drude, Paul Karl Ludwig** (1863–1906), German physicist. Attempted to correlate and account for optical, electrical, thermal, and chemical properties of substances; developed theory of properties of metals based on free electrons treated as a gas.
- Duane, William** (1872–1935), American physicist and radiologist. Developed treatment of cancer by radioisotopes and x-rays; with F. L. Hunt, discovered Duane-Hunt law of x-rays.
- Du Bois-Reymond, Emil** (1818–1896), German physiologist. Pioneer work in electrical properties of living tissues, especially nerves.
- DuBridge, Lee Alvin** (1901–1994), American physicist. Developed Fowler-DuBridge theory of photoelectric emission.
- Ducrey, Augusto** (1860–1940), Italian dermatologist. Discovered *Hemophilus ducreyi*, the agent of chancroid.
- Dufay, Charles François de Cisternay** (1698–1739), French chemist. Discovered positive and negative types of electricity.
- Dulbecco, Renato** (1914– ), Italian-born American virologist. Developed techniques for studying animal viruses; investigated interaction between deoxyribonucleic acid tumor viruses and genetic material; Nobel Prize, 1975.
- Dulong, Pierre Louis** (1785–1838), French chemist and physicist. With A. T. Petit, formulated the law of the constancy of atomic heats; developed the Dulong formula for heat value of fuels.
- Dumas, Jean Baptiste André** (1800–1884), French chemist. Research on organic compounds; determined many atomic weights.
- Dürer, Albrecht** (1471–1528), German painter, graphic artist, and mathematician. Work on scientific perspective and mathematical proportion.
- du Vigneaud, Vincent** (1901–1978), American biochemist. Synthesized a polypeptide hormone, oxytocin; worked on other biologically important sulfur compounds; Nobel Prize, 1955.



- Eccles, John Carew** (1903–1997), Australian physiologist. Elucidated the action of nerve impulses across zones of close contact between nerve cells; Nobel Prize, 1963.
- Eddington, Arthur Stanley** (1882–1944), English astronomer and writer. Theoretical research on stellar movements and internal makeup of stars; wrote on theory of relativity.
- Edelman, Gerald Maurice** (1929– ), American biochemist. Worked to determine chemical structure of immunoglobulins; Nobel Prize, 1972.
- Edison, Thomas Alva** (1847–1931), American electrician and inventor. Invented the gramophone, carbon transmitter for the telephone, incandescent electric lamp, moving pictures, and the duplex method of telegraphy.
- Ehrenfest, Paul** (1880–1933), Austrian-born Dutch theoretical physicist. Contributed to statistical mechanics and quantum mechanics; developed Ehrenfest's principle; proved Ehrenfest's theorem.
- Ehrlich, Paul** (1854–1915), German bacteriologist. Research in chemotherapy, notably the discovery of Salvarsan for treatment of syphilis; pioneered in the study of hematology and immunity; Nobel Prize, 1908.
- Eigen, Manfred** (1927– ), German chemist. Devised relaxation techniques to study high-speed chemical reactions; Nobel Prize, 1967.
- Eijkman, Christiaan** (1858–1930), Dutch physician. Studied dietary deficiency disease, in particular beriberi; Nobel Prize, 1929.
- Einstein, Albert** (1879–1955), German-born American physicist. Proposed the theory of relativity; extended the application of quantum theory; Nobel Prize, 1921.
- Einthoven, Willem** (1860–1927), Dutch physiologist born in Java. Used the string galvanometer to record electrical activity of the heart, thereby inventing the electrocardiograph; Nobel Prize, 1924.
- Elion, Gertrude Belle** (1918–1999), American biochemist. With G. H. Hitchings, pioneered research that led them to the development of drugs for the treatment of leukemia, malaria, gout, herpes, bacterial and fungal infections, and autoimmune diseases and organ-transplant rejection; Nobel Prize, 1988.
- Elsasser, Walter Maurice** (1904–1991), German-born American geophysicist. Formulated the dynamo theory of the Earth's permanent terrestrial magnetic force.
- Elster, Johann Philipp Ludwig Julius** (1854–1920), German experimental physicist. With H. F. Geitel, studied atmospheric electricity, radioactivity, and photoelectricity, and invented photocell.
- Emmett, Paul Hugh** (1900–1985), American chemist. Worked on catalysts for ammonia synthesis and the water-gas conversion reaction; with S. Brunauer and E. Teller, formulated Brunauer-Emmett-Teller equation for surface area determinations.
- Encke, Johann Franz** (1791–1865), German astronomer. Determined period of revolution of Encke's comet, discovered by J. L. Pons; measured the distance of the Sun from the Earth.
- Enders, John Franklin** (1897–1985), American microbiologist. With F. C. Robbins and T. H. Weller, discovered the capacity of poliomyelitis virus to grow in various tissue cultures; Nobel Prize, 1954.
- Enskog, David** (1884–1947), Swedish physicist. With S. Chapman, developed the Chapman-Enskog theory for solving the Boltzmann transport equation.
- Eötvös, Roland, Baron** (1848–1919), Hungarian physicist. Research on gravitation and terrestrial magnetism; formulated a law which relates surface tension to temperature of liquids; designed the Eötvös torsion balance.
- Erasistratus** (3d century B.C.), Greek physician and anatomist. Founder of physiology; distinguished between the cerebrum and cerebellum, and sensory and motor nerves.
- Eratosthenes** (3d century B.C.), Greek astronomer. Suggested an extra day in the calendar every fourth year; made a determination of the size of the Earth; measured obliquity of the ecliptic.
- Erdős, Paul** (1913–1996), Hungarian mathematician. Did wide-ranging work in algebra, analysis, combinatorial theory, geometry, topology, number theory, and graph theory; with A. Selberg, gave an elementary proof of the prime number theorem.
- Erlanger, Joseph** (1874–1965), American physiologist. With H. S. Gasser, created new methods for amplifying and recording electrical impulses in nerves; research on the function of the synapse; Nobel Prize, 1944.
- Erlenmeyer, Richard August Carl Emil** (1825–1909), German organic chemist. Research on synthesis and constitution of aliphatic compounds; introduced modern structural notation; invented Erlenmeyer flask.
- Ernst, Richard R.** (1933– ). Swiss chemist. Developed methods that transformed nuclear magnetic resonance (NMR) spectroscopy from a tool with a narrow application to a key analytical technique in chemistry as well as many other fields; Nobel Prize, 1991.
- Esaki, Leo** (1925– ), Japanese physicist. Discovered a new negative-resistance characteristic in semiconductor *pn* junctions, leading to the discovery of the tunnel, or Esaki, diode; Nobel Prize, 1973.
- Euclid** (ca. 330-ca. 275 B.C.), Greek mathematician. Wrote geometry textbooks; euclidean geometry is named after him.
- Eudoxus of Cnidus** (ca. 408-ca. 355 B.C.). Greek astronomer and mathematician. Expounded theory of motion of planets based on homocentric spheres; developed theory of proportions and methods of measuring areas and volumes of geometrical figures.
- Euler, Leonhard** (1707–1783), Swiss mathematician. Contributed to algebraic series and differential and integral calculus; realized the significance of coefficients (Euler numbers) of certain trigonometrical expansions.
- Euler-Chelpin, Hans Karl August Simon von** (1873–1964), German-Swedish chemist. Research on enzyme action and fermentation of sugars; Nobel Prize, 1929.
- Ewald, Paul Peter** (1888–1985), German-born American physicist. Developed dynamic theory of x-ray interference in crystals.
- Ewing, William Maurice** (1906–1974), American geophysicist. Made fundamental contributions to seismology, geodesy, oceanography, and submarine geology.
- Eyring, Henry** (1901–1981), Mexican-born American chemist. Pioneered in the application of quantum and statistical mechanics to chemistry; conceived the theory of absolute reaction rates and the significant structures theory of liquids.
- Fabrizius, Hieronymus, or Girolamo Fabrizio** (ca. 1533–1619), Italian anatomist. Made painstaking descriptions of valves in veins; did comparative research in animal embryology.
- Fabry, Charles** (1867–1945), French physicist. With A. Pérot, invented Fabry-Pérot interferometer; experimentally verified Doppler broadening and Doppler effect.
- Fahrenheit, Gabriel Daniel** (1686–1736), German physicist. Constructed thermometers; invented the Fahrenheit temperature scale.
- Fallopio, Gabriele** (1523–1562), Italian anatomist. Discovered Fallopian tubes; gave first clear description of organs of inner and middle ear.
- Faltings, Gerd** (1954– ), German mathematician. Used methods of arithmetic algebraic geometry to prove the Mordell conjecture, which states that there are only finitely many rational points on a curve of genus greater than 1; this was a step toward the later proof of Fermat's last theorem by A. Wiles; Fields Medal, 1986.
- Fanning, John Thomas** (1837–1911), American civil engineer. Designed water works and water supply systems.
- Faraday, Michael** (1791–1867), English chemist and physicist. Discovered electromagnetic induction; formulated two laws of electrolysis; invented the dynamo.
- Fechner, Gustav Theodor** (1801–1887), German psychologist. Founded psychophysics; developed the Fechner law concerning intensity of sensation produced by a stimulus.
- Fefferman, Charles Louis** (1949– ), American mathematician. Worked in Fourier analysis, partial differential equations, and the theory of functions of several complex variables; discovered the dual of the Hardy space  $H^1$ ; Fields Medal, 1978.
- Feit, Walter** (1930–2004), Austrian-born American mathematician. Worked in group theory; with J. G. Thompson, proved that all noncyclic finite simple groups have even order.
- Fenn, John B.** (1917– ), American chemist. Developed soft desorption ionization method for mass spectrometric analyses of biological macromolecules; Nobel Prize, 2002.
- Fermat, Pierre de** (1601–1665), French mathematician. Founder of the modern theory of numbers; originated Fermat's last theorem, and Fermat's principle in optics.
- Fermi, Enrico** (1901–1954), Italian-born American physicist. Research on producing radioactive isotopes by neutron bombardment; directed construction of the first atomic pile; Nobel Prize, 1938.
- Feynman, Richard Phillips** (1918–1988), American physicist. Proposed a theory to eliminate difficulties that had arisen in the study of the interaction of electrons, positrons, and radiation; Nobel Prize, 1965.
- Fibiger, Johannes Andreas Grib** (1867–1928), Danish pathologist. First to produce cancer experimentally; Nobel Prize, 1926.
- Finsen, Niels Ryberg** (1860–1904), Danish physician. Originated ultraviolet light therapy for certain diseases; Nobel Prize, 1903.
- Fischer, Edmond H.** (1920– ), American biochemist. With E. G. Krebs, discovered phosphorylation processes that play a critical role in cell-protein regulation; they isolated the first protein kinase, a class of enzymes that transfer phosphate from adenosinetriphosphate to proteins; Nobel Prize, 1992.
- Fischer, Emil Hermann** (1852–1919), German chemist. Synthesized many natural substances, including purines, D-glucose and other sugars, and the first nucleotide; studied polypeptides and proteins; Nobel Prize, 1902.
- Fischer, Ernst Otto** (1918– ), German chemist. Studied how metals and organic molecules combine to form unique molecules with sandwichlike structures; Nobel Prize, 1973.
- Fischer, Hans** (1881–1945), German organic chemist. Investigated and synthesized pyrrole pigments; studied structure of chlorophylls; Nobel Prize, 1930.
- Fisher, Ronald Aylmer** (1890–1962), English geneticist and statistician. Developed statistical techniques for analysis of variance, and for use and validation of small samples; developed theory of the evolution of dominance.
- Fitch, Val Logsdon** (1923– ), American physicist. Collaborated with J. W. Cronin on experiment showing that the principle of time-reversal invariance is violated in the decay of neutral *K* mesons; Nobel Prize, 1980.
- FitzGerald, George Francis** (1851–1901), Irish physicist. Proposed Lorentz-FitzGerald contraction, relating to a material moving through an electromagnetic field.
- Fizeau, Armand Hippolyte Louis** (1819–1896), French physicist. First to accurately measure the velocity of light; conducted experiments on the velocity of electricity, use of light wavelength to measure length, and measurement of diameter of stars through the method of interference.
- Flamsteed, John** (1646–1719), English astronomer. Made a trustworthy catalog of stars; invented conical projection in mapmaking.
- Fleming, Alexander** (1881–1955), British bacteriologist. Discovered lysozyme and penicillin; Nobel Prize, 1945.
- Fleming, John Ambrose** (1849–1945), English electrical engineer. Invented the thermionic valve; contributed to widespread application of electric lighting and heating.

- Florey, Howard Walter** (1898–1968), British pathologist born in Australia. Contributed, with E. B. Chain, to development of penicillin as a chemotherapeutic agent; Nobel Prize, 1945.
- Flory, Paul John** (1910–1985), American physical chemist. Developed analytic techniques to explore properties and molecular structures of long-chain molecules; Nobel Prize, 1974.
- Fock (Fok), Vladimir Alexandrovitch** (1898–1974), Soviet theoretical physicist. Contributions to quantum electrodynamics, quantum field theory, electromagnetic diffraction and propagation, and general relativity; developed Hartree-Fock approximation of wave functions.
- Forbush, Scott Ellsworth** (1904–1984), American geophysicist. Discovered the worldwide decrease in cosmic-ray intensity associated with some magnetic storms.
- Forssmann, Werner Theodor Otto** (1904–1979), German physician. Developed the technique of cardiac catheterization; Nobel Prize, 1956.
- Foucault, Jean Bernard Léon** (1819–1868), French physicist. Accurately determined the velocity of light; constructed the Foucault pendulum and the Foucault prism; determined experimentally the rotation of the Earth.
- Fourier, Jean Baptiste Joseph, Baron** (1768–1830), French geometer and physicist. Proposed the Fourier series on arbitrary functions; formulated the law of heat propagation.
- Fowler, Ralph Howard** (1889–1944), English physicist. Applied statistical mechanics to matter at high temperatures and high pressures; explained structure of white dwarf stars; with E. A. Guggenheim, R. F. Peierls, and others, developed Ising model.
- Fowler, William Alfred** (1911–1995), American physicist. Fundamental contributions to understanding of nuclear reactions that generate the energy of stars and synthesize the elements of the universe; Nobel Prize, 1983.
- Franck, James** (1882–1964), German physicist. With G. Hertz, studied energy transfer in collisions of molecules; formulated Franck-Condon principle of transition from one energy state to another; Nobel Prize, 1925.
- Frank, Ilya Mikhailovich** (1908–1990), Soviet physicist. With I. Y. Tamm, proposed a theoretical interpretation of Cerenkov radiation; Nobel Prize, 1958.
- Franklin, Benjamin** (1706–1790), American physicist, oceanographer, meteorologist, and inventor. Formulated a theory of general electrical “action”; introduced principle of conservation of charge; showed that lightning is an electrical phenomenon; invented lightning rod.
- Fraunhofer, Joseph von** (1787–1826), German optician and physicist. First to study the dark lines in the solar spectrum (Fraunhofer lines); invented a heliometer; improved the spectroscope.
- Fredholm, Eric Ivar** (1866–1927), Swedish mathematician. Developed the theory of integral equations (Fredholm equations).
- Freedman, Michael Hartley** (1951– ), American mathematician. Developed new methods for topological analysis of four-manifolds and applied them to prove the Poincaré conjecture for dimension 4; Fields Medal, 1986.
- Frenet, Jean Frédéric** (1816–1900), French mathematician. Helped to develop Frenet-Serret formulas.
- Frenkel, Yakov Ilyich** (1894–1954), Soviet physicist. Pioneered in modern atomic theory of solids; developed quantum-mechanical explanations for electron mean free path in metals, and for paramagnetism and ferromagnetism; postulated excitons, Frenkel excitons, and Frenkel defects.
- Fresnel, Augustin Jean** (1788–1827), French physicist. Investigated effects (Fresnel’s fringes) due to the interference of light; developed a wave theory of light; originated Fresnel’s reflection formula.
- Freud, Sigmund** (1856–1939), Austrian psychoanalyst. Founder of psychoanalysis, with emphasis on dream interpretation and free association; developed a theory of personality involving id, ego, and superego, and stressing importance of the libido.
- Friedel, Charles** (1832–1899), French chemist and mineralogist. With J. M. Crafts, described the Friedel-Crafts reaction; work on artificial production of minerals; studied crystals, ketones, and aldehydes.
- Friedman, Jerome Isaac** (1930– ), American physicist. Collaborated in experiments that demonstrated that protons, neutrons, and similar particles are made up of quarks; Nobel Prize, 1990.
- Frisch, Karl von** (1886–1982), Austrian zoologist. Discovered means by which bees communicate information about the distance and direction of food; Nobel Prize, 1973.
- Frobenius, Georg Ferdinand** (1849–1917), German mathematician. Developed representation theory of finite groups and method for solving linear homogeneous ordinary differential equations.
- Froude, William** (1810–1879), English engineer. Discovered the Froude law of comparison, concerning the towing of an object in a liquid.
- Fubini, Guido** (1879–1943), Italian mathematician. Worked in algebra, analysis, and differential projective geometry; proved Fubini’s theorem.
- Fukui, Kenichi** (1918–1998), Japanese chemist. Developed frontier orbital theory, a quantum-mechanical model useful in prediction of the combinative properties of molecules; Nobel Prize, 1981.
- Fuller, R. Buckminster** (1895–1983), American engineer and architect. Designed geodesic dome; the carbon molecular form  $C_{60}$  was named buckminsterfullerene because of its structured resemblance to the geodesic dome, and the name fullerene was given to any closed-cage molecule containing an even number of carbon atoms.
- Furchgott, Robert F.** (1916– ), American pharmacologist. Discovered endothelium-derived relaxing factor (EDRF), a signaling molecule in the cardiovascular system that makes vascular smooth muscle cells relax (Louis J. Ignarro, working independently and with Furchgott, later concluded that EDRF was nitric oxide); Nobel Prize, 1998.
- Gabor, Dennis** (1900–1979), Hungarian-born British physicist and engineer. Invented holography; Nobel Prize, 1971.
- Gajdusek, Daniel Carleton** (1923– ), American physician and virologist. Discovered causal virus and transmission mechanism of kuru; Nobel Prize, 1976.
- Galen** (2d century), Greek physician and medical writer. Wrote treatises long used as textbooks; experimented on animal nervous systems; made anatomical descriptions of structure and functions of body parts.
- Galileo Galilei** (1564–1642), Italian astronomer. First to use the telescope for observational purposes; made many discoveries related to the planets and the Sun; did theoretical work on classical physics.
- Galois, Evariste** (1811–1832), French mathematician. Developed Galois theory of polynomials.
- Gamow, George** (1904–1968), Russian-born American physicist. Made theoretical contributions to nuclear physics, astronomy, and biology; with E. Teller, formulated the selection rule for beta emission; proposed theoretically the genetic code.
- Garvey, Gerald Thomas** (1935– ), American physicist. Research in experimental nuclear physics, particularly nuclear reactions, isobaric spin studies, and weak interactions in nuclear systems.
- Gasser, Herbert Spencer** (1888–1963), American physiologist. With J. Erlanger, provided a new method for recording electrical impulses of nerves; studied functions of nerve fibers; Nobel Prize, 1944.
- Gatterman, Friedrich August Ludwig** (1860–1920), German chemist. Originated Gatterman-Koch synthesis of aldehydes; isolated and analyzed nitrogen trichloride; synthesized aromatic carboxylic acids, thionaphthalene, and thioanilide.
- Gauss, Karl Friedrich** (1777–1855), German mathematician, astronomer, and physicist. Formulated the Gauss theorem in the mathematics of electricity; made many contributions to pure and applied mathematics; determined orbits of planets and comets from observational data.
- Gay-Lussac, Joseph Louis** (1778–1850), French chemist and physicist. Discovered the law of expansion of gases by heat, and the law of combining volumes of gases; studied chemistry of iodine and cyanogen.
- Geiger, Hans Wilhelm** (1882–1945), German physicist and inventor. Invented the Geiger counter to detect alpha particles; investigated properties of alpha particles, cosmic rays, and artificial radiation.
- Geissler, Johann Heinrich Wilhelm** (1815–1879), German instrument maker. Developed Geissler pump and Geissler tube.
- Geitel, Hans Friedrich** (1855–1923), German experimental physicist. With J. Elster, studied atmospheric electricity, radioactivity, and photoelectricity, and invented photocell.
- Gell-Mann, Murray** (1929– ), American physicist. Proposed law of conservation of strangeness; used unitary symmetry to classify and explain elementary particles; postulated concept of quarks; Nobel Prize, 1969.
- Gesner, Konrad von** (1516–1565), Swiss naturalist. Wrote *Historia Animalium*, beginning zoology as a science.
- Giacconi, Riccardo** (1931– ), Italian-born American astrophysicist. Pioneered the field of x-ray astronomy, working out the principles of an x-ray telescope and leading the development of the early x-ray telescopes. Nobel Prize, 2002.
- Giaever, Ivar** (1929– ), Norwegian-born American physicist. Discovered that current-voltage characteristics of an electron tunneling across a thin insulating film separating two metals, one or both of which is in a superconducting state, can be used to obtain electron density of states of superconductors; Nobel Prize, 1973.
- Giauque, William Francis** (1895–1982), Canadian-born American chemist. Developed adiabatic demagnetization technique for production of extremely low temperatures; collaborated in discovery of isotopes of oxygen; Nobel Prize, 1949.
- Gibbs, Josiah Willard** (1839–1903), American mathematician and physicist. Made a mathematical treatment of chemical subjects, notably thermodynamics; worked on statistical mechanics, leading to the basis for the phase rule of heterogeneous equilibria.
- Gilbert, Walter** (1932– ), American biochemist. Developed methods for determining nucleotide sequence (independently of F. Sanger), advancing the technology of DNA recombination; Nobel Prize, 1980.
- Gilman, Alfred G.** (1941– ), American pharmacologist. With M. Rodbell, discovered G-proteins and their role in cellular signal transduction; Nobel Prize, 1994.
- Ginzburg, Vitaly Lazarevich** (1916– ), Soviet physicist. Developed Ginzburg-Landau and Ginzburg-London theories of superconductivity; Nobel Prize, 2003.
- Giorgi, Giovanni** (1871–1950), Italian electrical engineer, physicist, and mathematician. Developed the meter-kilogram-second-ampere system of units.
- Glaser, Donald Arthur** (1926– ), American physicist. Invented the bubble chamber for detecting the paths of high-energy atomic particles; Nobel Prize, 1960.
- Glashow, Sheldon Lee** (1932– ), American physicist. Contributed to development of theory uniting electromagnetism and weak nuclear interactions; postulated existence of charmed particles; Nobel Prize, 1979.
- Glauber, Johann Rudolf** (1604–1670), German chemist. Discovered Glauber’s salt (sodium sulfate) and hydrochloric acid; conducted experiments on compounds of mercury, arsenic, and antimony.
- Gmelin, Leopold** (1788–1853), German chemist. Wrote *Handbuch der Chemie*, first systematic treatment of chemical knowledge; devised

- Gmelin's test for presence of bile pigments; studied cyanides.
- Goldbach, Christian** (1690–1764), German-born Russian mathematician. Research on number theory and analysis; proposed the Goldbach conjecture.
- Goldhaber, Maurice** (1911– ), Austrian-born American physicist. With J. Chadwick, discovered photodisintegration and disintegration of light elements by slow neutrons; with L. Grodzins and A. W. Sunyar, discovered that the neutrino has left-handed spin.
- Goldstein, Joseph L.** (1940– ), American biochemist and geneticist. With M. S. Brown, discovered low-density lipoprotein receptors and their function in cholesterol metabolism; Nobel Prize, 1985.
- Golgi, Camillo** (1843–1926), Italian physician. Pioneered in the study of histology of the nervous system; discovered the Golgi bodies; Nobel Prize, 1906.
- Gordan, Paul Albert** (1837–1912), German mathematician. Worked on the theory of invariants and on solutions of algebraic equations and their groups of substitutions.
- Gordon, Walter** (1893–1940), German-born Swedish physicist. Contributed to relativistic quantum theory; with O. B. Klein, originated the Klein-Gordon equation.
- Goudsmit, Samuel Abraham** (1902–1978), Dutch-born American physicist. With G. E. Uhlenbeck, discovered electron spin.
- Gowers, William Timothy** (1963– ), British mathematician. Contributed to functional analysis, in particular, to the theory of Banach spaces, using methods of combinatorial theory; Fields Medal, 1998.
- Gram, Hans Christian Joachim** (1853–1938), Danish physician. Developed the Gram method for staining and differentiating bacteria.
- Gram, Jorgen Pedersen** (1850–1916), Danish mathematician. Worked in number theory and analysis; with E. Schmidt, originated Gram-Schmidt process for obtaining orthogonal set of vectors.
- Granit, Rangar Arthur** (1900–1991), Finnish-born Swedish physiologist. Research on vision and on motor control by afferent neurons; Nobel Prize, 1967.
- Grashof, Franz** (1826–1893), German mechanical engineer. Applied mathematics and physics to engineering problems; derived fundamental equations in the theory of elasticity; introduced Grashof number.
- Gray, Henry** (1825–1861), English anatomist. Wrote *Anatomy of the Human Body*.
- Green, George** (1793–1841), English mathematician. Worked in analysis; derived Green's theorem and Green's identities; introduced Green's function.
- Greengard, Paul** (1925– ), American neurobiologist. Discovered the mechanism by which dopamine and other chemical neurotransmitters (such as norepinephrine and serotonin) affect the nervous system—work contributing to the elucidation of the molecular mechanisms involved in slow synaptic transmission in the nervous system; Nobel Prize, 2000.
- Gregory, James** (1638–1675), Scottish geometer. Provided first proof of the theorem of calculus; gave first description of the reflecting telescope; discovered the series from which  $\pi$  can be calculated.
- Grignard, François Auguste Victor** (1871–1935), French chemist. Discovered organomagnesium compounds, or Grignard reagents, useful in synthesis of organic and organometallic compounds; Nobel Prize, 1912.
- Gross, David J.** (1941– ), American physicist. Discovered asymptotic freedom in the strong interactions (in collaboration with F. Wilczek, and independent of H. D. Politzer). Nobel Prize, 2004.
- Grothendieck, Alexander** (1928– ), German-born French mathematician. Made fundamental advances in algebraic geometry and related fields, providing unifying themes in geometry, number theory, topology, and complex analysis; introduced the idea of K theory; revolutionized homological algebra; developed theory of schemes, allowing conjectures in number theory to be solved; Fields Medal, 1966.
- Gruneisen, Eduard** (1877–1949), German physicist. Formulated laws relating specific heat and other properties of solids.
- Guillaume, Charles Edouard** (1861–1938), Swiss-born French physicist. Studied nickel-steel alloys and invented Invar; Nobel Prize, 1920.
- Guillemin, Ernst Adolph** (1898–1970), American electrical engineer. Worked on network analysis and synthesis problems; invented Guillemin line; developed network to produce loran pulses.
- Guillemin, Roger Charles Louis** (1924– ), French-born American physiologist. With A. V. Schally, isolated and analyzed peptide hormones secreted in hypothalamic region of brain which control anterior pituitary hormone secretion; Nobel Prize, 1977.
- Gullstrand, Allvar** (1862–1930), Swedish ophthalmologist. Discovered intracapsular accommodation of the eye lens; improved techniques for studying eye structure; Nobel Prize, 1911.
- Gunn, John Battiscombe** (1928– ), Egyptian-born American physicist. Discovered Gunn effect and used it to develop Gunn oscillator.
- Gunter, Edmund** (1581–1626), English mathematician and astronomer. Invented Gunter's chain used in surveying, and the logarithmic scale (Gunter's scale) which is the principle of the slide rule.
- Gutenberg, Johann** (ca. 1397–1468), German inventor. Invented the movable-type printing press.
- Haar, Alfred** (1885–1933), Hungarian mathematician. Studied orthogonal systems of functions, complex functions, partial differential equations, and calculus of variations; introduced the Haar measure on groups.
- Haber, Fritz** (1868–1934), German chemist. Developed the Haber-Boch process for synthesis of ammonia; made electrochemical studies; Nobel Prize, 1918.
- Hadamard, Jacques** (1865–1963), French mathematician. Proved theorem on the asymptotic behavior of the function giving the number of prime numbers less than a given number; introduced concept of "the problem correctly posed" in the solution of partial differential equations.
- Haeckel, Ernst Heinrich** (1834–1919), German biologist. Studied various invertebrates; classified animals as uni- and multicellular organisms; proposed the theory of recapitulation: ontogeny repeats phylogeny.
- Hagen, Carl Ernst Bessel** (1851–1923), German physicist. With H. Rubens, conducted experiments confirming Maxwell's electromagnetic theory of light, permitting determination of electrical conductivity of metals by optical measurements alone.
- Hagen, Gotthilf Heinrich Ludwig** (1797–1884), German hydraulic engineer. Discovered Hagen-Poiseuille law independently of J. L. M. Poiseuille; directed construction of dikes, harbor installations, and dune fortifications.
- Hahn, Hans** (1879–1934), Austrian mathematician. With S. Banach, proved the Hahn-Banach theorem of linear functionals.
- Hahn, Otto** (1879–1968), German chemist. With L. Meitner and F. Strassman, discovered that fission of heavy nuclei was possible by irradiation with neutrons; discovered protactinium with Meitner; Nobel Prize, 1944.
- Hahnemann, Christian Friedrich Samuel** (1775–1843), German physician. Founder of homeopathy.
- Haldane, John Bourdon Sanderson** (1892–1964), British geneticist and physiologist. Pioneered in mathematical treatment of population genetics; studied respiration in humans; wrote about enzymes.
- Haldane, John Scott** (1860–1936), British physiologist. Research on respiration, particularly the effects of high and low atmospheric pressures.
- Hale, George Ellery** (1868–1938), American astronomer. Established the Mount Wilson and Mount Palomar observatories; proved existence of magnetic fields in sunspots; invented the spectroheliograph.
- Hall, Charles Martin** (1863–1914), American commercial chemist. Discovered Hall process for extracting aluminum.
- Hall, Edwin Herbert** (1855–1938), American physicist. Discovered Hall effect and conducted studies of this and other galvanomagnetic and thermomagnetic effects.
- Halley, Edmond** (1656–1742), English astronomer. Published a southern star catalog; computed orbits of 24 comets; discovered Halley's comet.
- Hamel, Georg Karl Wilhelm** (1877–1954), German mathematician. Research on analysis and applied mathematics; introduced Hamel basis of vectors.
- Hamilton, William Rowan** (1805–1865), Irish mathematician and mathematical physicist. Discovered quaternions; developed mathematical theories encompassing wave and particle optics and mechanics; introduced Hamilton's principle and a form of the Hamilton-Jacobi theory.
- Hankel, Hermann** (1839–1873), German mathematician. Studied complex and hypercomplex numbers, theory of functions, and Hankel functions; proved that no hypercomplex number system can satisfy all the laws of ordinary arithmetic.
- Hansen, Armauer** (1841–1912), Norwegian bacteriologist. Discovered the bacillus of leprosy, or Hansen's disease.
- Harden, Arthur** (1865–1940), English chemist. Research on enzymes and alcoholic fermentation; Nobel Prize, 1929.
- Hardy, Godfrey Harold** (1877–1947), English mathematician. With S. Ramanujan, discovered formula for number of ways of writing a positive integer as the sum of positive integers; proved that the Riemann zeta function has an infinite number of zeros with real part equal to 1/2.
- Harker, David** (1906–1991), American crystallographer. Completed development of Patterson-Harker method of x-ray diffraction analysis of crystal structure.
- Hartley, Ralph Vinton Lyon** (1888–1970), American electrical engineer. Invented Hartley oscillator; developed Hartley principle in information theory.
- Hartline, Haldan Keffer** (1903–1983), American biophysicist. Elucidated cellular electrical activity in the eye and optic nerve; Nobel Prize, 1967.
- Hartmann, Johannes Franz** (1865–1936), German astronomer. Derived Hartmann dispersion formula relating index of refraction and wavelengths; devised Hartmann test for telescope mirrors; gave first observational proof of interstellar matter.
- Hartree, Douglas Rayner** (1897–1958), English mathematician and mathematical physicist. Developed methods of numerical analysis which made it possible to apply Hartree method to calculation of atomic wave functions.
- Hartwell, Leland H.** (1939– ), American geneticist. Discovered more than 100 genes that control the cell cycle and introduced the concept of cell cycle checkpoints, ordered groups of genes and protein which halt progress through the cell cycle if DNA is damaged, allowing time for DNA repair; Nobel Prize, 2001.
- Harvey, William** (1578–1657), English anatomist and physician. Described the true circulation of blood and the action of the heart.
- Hassel, Odd** (1897–1981), Norwegian chemist. Developed concept of conformation by studying three-dimensional structure of cyclohexane molecule, and explaining the orientation of attached atoms or functional groups; Nobel Prize, 1969.
- Hauptman, Herbert A.** (1917– ), American chemist. With J. Karle, developed computer-aided mathematical techniques for use in x-ray crystallography to determine three-dimensional structures of molecules; Nobel Prize, 1985.
- Hausdorff, Felix** (1868–1942), German mathematician. Founded and advanced general topology and the general theory of metric spaces.

- Haüy, René Just, Abbé** (1743–1822), French mineralogist. Formulated the geometrical law of crystallization; pioneer in the science of crystallography.
- Havers, Clopton** (1665–1702), English osteologist. Provided the first full discussion of Haversian lamellae and Haversian canals.
- Haworth, Walter Norman** (1883–1950), English chemist. Synthesized ascorbic acid; studied carbohydrates, including the structure of sugars; Nobel Prize, 1937.
- Heaviside, Oliver** (1850–1925), English physicist. Proposed the Heaviside layer in the upper atmosphere.
- Heeger, Alan J.** (1936– ), American physicist. Discovered and developed conductive polymers with Alan MacDiarmid and Hideki Shirakawa; Nobel Prize, 2000.
- Hefner-Alteneck, Friedrich Franz von** (1845–1904), German engineer. Invented Hefner candle as a standard of luminous intensity.
- Heine, Heinrich Eduard** (1821–1881), German mathematician. Formulated concept of uniform continuity.
- Heisenberg, Werner** (1901–1976), German physicist. Founder of quantum mechanics; studied structure of the atom and the Zeeman effect; formulated the principle of indeterminacy in nuclear physics; Nobel Prize, 1932.
- Heitler, Walter Heinrich** (1904–1981), German-born Swiss theoretical physicist. Developed Heitler-London covalence theory of chemical bonding.
- Helmholtz, Hermann Ludwig Ferdinand von** (1821–1894), German physicist, anatomist, and physiologist. Physiological research on the nervous system and the human eye and ear, and theoretical work on conservation of force in physics; invented the ophthalmoscope.
- Hench, Philip Showalter** (1896–1965), American physiologist. Discovered that ACTH and cortisone could be used to treat rheumatoid arthritis; Nobel Prize, 1950.
- Henle, Friedrich Gustav Jacob** (1809–1885), German pathologist and anatomist. Wrote *Handbuch der Rationellen Pathologie*, integrating the study of physiology and pathology; discovered looped portion of the kidney tubules, and the epithelium.
- Henry, Joseph** (1797–1878), American physicist. Studied electromagnetic induction, solar phenomena, meteorology, and acoustics.
- Henry, William** (1775–1836), English chemist and physician. Formulated Henry's law of solubility of gases in liquid.
- Henry, Louis George** (1910–1970), American astronomer. Research on reflection nebulae, interstellar matter, stellar atmospheres and evolution, and optical design.
- Hermite, Charles** (1822–1901), French mathematician. First to solve a fifth-degree equation; investigated  $e$ , the base of natural logarithms.
- Hero of Alexandria** (3d century or earlier), Greek mathematician. Wrote on the geometry of plane and solid figures, mechanics, and simple machines; showed that the angle of incidence equals the angle of reflection.
- Héroult, Paul Louis Toussaint** (1863–1914), French metallurgist. Designed the Héroult furnace for electric steel; developed the Héroult process for aluminum extraction.
- Herschbach, Dudley R.** (1932– ), American chemist. With Y. T. Lee, developed crossed molecular-beam technique for tracing chemical reactions; Nobel Prize, 1986.
- Herschel, John Frederick William** (1792–1871), English mathematician, physicist, and astronomer. Discovered many nebulae and clusters; pioneered in celestial photography.
- Herschel, William or Friedrich Wilhelm** (1738–1822), German-born English astronomer. Discovered Uranus, two of its satellites, and two satellites of Saturn; discovered the Sun's intrinsic motion; proposed the concept of the form of the Milky Way.
- Hershey, Alfred Day** (1908–1997), American biologist. With M. Chase, experimented with bacteriophage, confirming earlier indications that the material basis of heredity is contained in nucleic acids; Nobel Prize, 1969.
- Hershko, Avram** (1937– ), Israeli medical doctor and scientist. Discovered ubiquitin-mediated protein degradation; Nobel Prize, 2004.
- Hertz, Gustav** (1887–1975), German physicist. With J. Franck, studied effects of electron impacts on atoms; Nobel Prize, 1925.
- Hertz, Heinrich Rudolph** (1857–1894), German physicist. Discovered Hertzian waves in the ether; proved experimentally Maxwell's theories of electricity and magnetism.
- Hertzprung, Ejnar** (1873–1967), Danish astronomer. Discovered method of spectroscopic parallax for measuring stellar distances; determined relation between color and luminosity of stars; with H. N. Russell, developed Hertzsprung-Russell diagram.
- Hertzberg, Gerhard** (1904–1999), German-born Canadian physicist. Determined electronic structure and geometry of diatomic and polyatomic molecules, particularly free radicals; Nobel Prize, 1971.
- Hess, Victor Franz** (1883–1964), Austrian physicist. Studied alpha particles from radium; discovered cosmic rays; Nobel Prize, 1936.
- Hess, Walter Rudolf** (1881–1973), Swiss physiologist. Discovered the organizer function of the middle brain in coordinating activity of internal organs; developed technique of using electrodes to stimulate localized brain areas; Nobel Prize, 1949.
- Hevelius or Hewel, Johannes** (1611–1687), Danzig-born astronomer. Discovered four comets; charted surface of the Moon; cataloged numerous stars.
- Hevesy, George von** (1886–1966), Hungarian chemist. Experimented with radioisotope indication, leading to the technique of isotope tracing of biological and chemical processes; Nobel Prize, 1943.
- Hevroský, Jaroslav** (1890–1967), Czechoslovakian physical chemist. Developed the technique of polarographic analysis; Nobel Prize, 1959.
- Hewish, Antony** (1924– ), British astronomer. Pioneered in discovery of pulsars, by means of radio telescopes; Nobel Prize, 1974.
- Heymans, Corneille** (1892–1968), French-Belgian physiologist. Investigated the carotid sinus in connection with the mechanism of breathing; Nobel Prize, 1938.
- Hilbert, David** (1862–1943), German mathematician. Contributed to theory of numbers and theory of invariants; applied integral equations to physical problems.
- Hill, Archibald Vivian** (1886–1977), English physiologist. Worked on heat loss and oxygen consumption in muscle contraction; Nobel Prize, 1922.
- Hinshelwood, Cyril Norman** (1897–1967), British chemist. Elucidated chain reaction and chain branching mechanisms; Nobel Prize, 1956.
- Hippias of Elis** (5th century B.C.), Greek philosopher and mathematician. Discovered quadratrix.
- Hipparchus of Rhodes** (fl. 130 B.C.), Greek astronomer. Calculated the inclination of the ecliptic and the precession of the equinoxes; invented trigonometry; made the first star catalog.
- Hippocrates** (460?–377 B.C.), Greek physician. Known as the father of medicine; writings attributed to him contain clinical observations of diseases, descriptions of surgical practice, and the Hippocratic doctrine of the four humors.
- Hironaka, Heisuke** (1931– ), Japanese-American mathematician. Worked in algebraic geometry; solved the problem of the resolution of singularities on an algebraic variety for algebraic varieties of any dimension over a field of characteristic 0, generalizing work of O. Zariski; Fields Medal, 1970.
- Hirzebruch, Friedrich Ernst Peter** (1927– ), German mathematician. Collaborated with M. F. Atiyah in the development of K theory.
- Hitchings, George Herbert** (1905–1998), American biochemist. With G. B. Elion, pioneered research that led them to the development of drugs for the treatment of leukemia, malaria, gout, herpes, bacterial and fungal infections, and autoimmune diseases and organ-transplant rejection; Nobel Prize, 1988.
- Hittorf, Johann Wilhelm** (1824–1914), German physicist. Described effects of Hittorf rays in vacuum tubes; studied electrolysis, and electrical discharge in rarefied gases with the Hittorf tube.
- Hodgkin, Alan Lloyd** (1914–1998), British biophysicist. With A. Huxley, devised a system of mathematical equations describing the nerve impulse; presented evidence for the sodium theory of nervous conduction; Nobel Prize, 1963.
- Hodgkin, Dorothy Crowfoot** (1910–1994), Egyptian-born British chemist. Determined the structure of the vitamin B<sub>12</sub> molecule through x-ray crystallographic analysis; Nobel Prize, 1964.
- Hodgkin, Thomas** (1798–1866), English physician. First to describe Hodgkin's disease, a glandular disorder.
- Hoffmann, Roald** (1937– ), Polish-born American chemist. Developed methods for predicting whether a chemical reaction is possible based on molecular orbital models; Nobel Prize, 1981.
- Hofmann, August Wilhelm von** (1818–1892), German chemist. Studied reactions of derivatives; developed the Hofmann reaction for preparing primary amines.
- Hofmeister, Wilhelm Friedrich Benedict** (1824–1877), German botanist. Did fundamental work on plant embryology; explained the alternating life cycles of mosses and ferns.
- Hofstadter, Robert** (1915–1990), American physicist. Investigated the properties and behavior of the proton and neutron; determined the size and shape of many nuclei; discovered the construction scheme of fundamental atomic nuclei; Nobel Prize, 1961.
- Hölder, Otto Ludwig** (1859–1937), German mathematician. Contributed to analysis and group theory; introduced Hölder condition; proved Hölder inequality and Jordan-Hölder theorem.
- Holley, Robert William** (1922–1993), American biochemist. With coworkers, made first determination of a nucleotide sequence of a nucleic acid; Nobel Prize, 1968.
- Holmberg, Erik Bertil** (1908–2000), Swedish astronomer. Investigations of galaxies, especially photometry of galaxies.
- Hooke, Robert** (1635–1703), English inventor. Invented the compound microscope, wheel barometer, universal (Hooke's) joint, and the reflecting telescope; formulated theories on light and on the motion of the Earth.
- Hooker, Joseph Dalton** (1817–1911), English botanist. With G. Benthams, wrote *Genera Plantarum*; prepared works on the flora of New Zealand, Antarctica, and India.
- Hopkins, Frederick Gowland** (1861–1947), English biochemist. Discovered the amino acid tryptophan and the tripeptide glutathione; did experimental work leading to the discovery of vitamins; Nobel Prize, 1929.
- Hopper, Grace** (1906–1992), American mathematician and computer scientist. Pioneered in the development of computer software, including the invention of the first compiler. Credited with having discovered the first computer "bug," a moth that literally had to be removed from the wiring of an early computer.
- Hörmander, Lars** (1931– ), Swedish mathematician. Worked on partial differential equations; in particular, made major contributions to the general theory of linear differential operators; Fields Medal, 1962.
- Horvitz, H. Robert** (1947– ), American geneticist and neurobiologist. Identified and characterized the genes controlling programmed cell death in the nematode *Caenorhabditis elegans*. Showed that these genes interact with each other in cell death and correspond to existing genes in humans. Nobel Prize, 2002.
- Houdry, Eugene J.** (1892–1962), French-born American engineer. Devised catalytic method of producing oil.
- Hounsfield, Godfrey Newbold** (1919–2004), British electronics engineer. Invented computerized axial tomography; Nobel Prize, 1979.

- Houssay, Bernardo Alberto** (1887–1971), Argentine physiologist. Research on the functions and effects of the hypophysis, including its relationship to carbohydrate metabolism; Nobel Prize, 1947.
- Howell, William Henry** (1860–1945), American physiologist. Discovered heparin; isolated thrombin and thromboplastin; discovered Howell-Jolly bodies; proved that blood platelets are formed in lungs.
- Hubble, Edwin Powell** (1889–1953), American astronomer. Studied nebulae; formulated Hubble's law of extragalactic nebulae.
- Hubel, David Hunter** (1926– ), American neurobiologist. Contributed to the study of the processing of visual information in the brain; Nobel Prize, 1981.
- Huber, Robert** (1937– ), German chemist. With J. Deisenhofer and M. Hartmut, elucidated the structure of a bacterial protein that performs photosynthesis; Nobel Prize, 1988.
- Hückel, Erich** (1896–1980), German chemist. With P. J. W. Debye, formulated Debye-Hückel theory of strong electrolytes; devised theoretical explanation of electron properties of aromatic hydrocarbons.
- Huggins, Charles Brenton** (1901–1997), Canadian-born American surgeon and cancer researcher. Developed treatment of cancers using endocrinologic methods; Nobel Prize, 1966.
- Hughes, David Edward** (1831–1900), English-born American inventor. Invented the Hughes electromagnet, a printing telegraph, microphone, and induction balance.
- Hugoniot, Pierre Henry** (1851–1887), French physicist. Developed theory of shock waves.
- Hulse, Russell A.** (1950– ), American astronomer and physicist. With J. H. Taylor, discovered the binary pulsar and studied it to observe phenomena predicted by general relativity; worked in plasma physics; Nobel Prize, 1993.
- Humboldt, Friedrich Heinrich Alexander, Baron von** (1769–1859), German naturalist. Founder of physical geography; made scientific explorations of South America and Central Asia.
- Hume-Rothery, William** (1899–1968), English metallurgist and chemist. Discovered Hume-Rothery rule concerning electron compounds.
- Hunt, Franklin Livingston** (1883–1973), American physicist. Research on x-ray spectroscopy; with W. Duane, discovered and applied Duane-Hunt law.
- Hunt, R. Timothy** (1943– ), British biologist who discovered cyclins, proteins that regulate cyclin-dependent kinase activity, and found that their periodic degradation is an important general control mechanism of the cell cycle; Nobel Prize, 2001.
- Hurwitz, Adolf** (1859–1919), German-born Swiss mathematician. Worked on modular functions, number theory, Riemann surfaces, complex function theory, and analytic number theory; formulated condition satisfied by Hurwitz polynomials.
- Huxley, Andrew Fielding** (1917– ), British physiologist. With A. L. Hodgkin, discovered the ionic mechanism involved in excitation in the cell membrane of peripheral nerves; Nobel Prize, 1963.
- Huygens, Christiaan** (1629–1695), Dutch mathematician, physicist, and astronomer. Discovered Saturn's rings; contributed to dynamics and optics; proposed the wave theory of light.
- Hylleraas, Egil Andersen** (1898–1965), Norwegian physicist. Applied quantum theory to helium atom, negative hydrogen ion, and other atoms, molecules, and crystals; developed variational method and other methods for mathematical solution of quantum-mechanical problems.
- Ignarro, Louis J.** (1941– ), American pharmacologist. Working independently and with Robert Furchgott, he concluded that endothelium-derived relaxing factor was identical to nitric oxide; Nobel Prize, 1998.
- Ingenhousz, Jan** (1730–1799), Dutch physician and naturalist. Demonstrated the cycle of photosynthesis in plants.
- Ising, Ernest** (1900–1998), German-born American physicist. Introduced Ising model of ferromagnetic material; research in solid-state physics and ferromagnetism.
- Itô, Kiyosi** (1915– ), Japanese mathematician. Studied stochastic processes; introduced Itô's integral and Itô's formula.
- Jacob, François** (1920– ), French biologist. Discovered episomes, a class of genetic elements; with J. Monod, proposed the concepts of messenger ribonucleic acid and of the operon; Nobel Prize, 1965.
- Jacobi, Karl Gustav Jacob** (1804–1851), German mathematician. Worked on elliptic functions and differential equations; developed the theory of determinants.
- Jacquard, Joseph Marie** (1752–1834), French inventor. Designed and built the Jacquard loom for figured weaving.
- Jaeger, Frans Maurits** (1877–1945), Dutch crystallographer and physical chemist. Measured physical properties of molten salts and silicates at extremely high temperatures.
- James, William** (1842–1910), American psychologist and writer. Coformulator of James-Lange theory that emotions are the perception of physiological changes.
- Janet, Pierre Marie Félix** (1859–1947), French psychologist. Studied hysteria, obsession, and neurosis; wrote a textbook on the theory of hysteria.
- Jeans, James Hopwood** (1877–1946), English physicist and astronomer. Worked in stellar dynamics; proposed the tidal theory of the origin of planets.
- Jenner, Edward** (1749–1823), English physician. Discovered vaccination.
- Jensen, J. Hans D.** (1906–1973), German physicist. With M. G. Mayer, formulated the nuclear shell model; Nobel Prize, 1963.
- Jerne, Niels Kaj** (1911–1994), Swiss immunologist. Formulated three important theories involving the immune system: how the body produces specific antibodies, how the immune system develops and matures, and how the various interrelated aspects of the immune response are coordinated by the body; Nobel Prize, 1984.
- Johnson, Harold Lester** (1921–1980), American astronomer. Research in astrophysics, astronomical photometry, infrared astronomy, applications of electronics to astronomy, and Fourier transform spectroscopy; collaborated with W. W. Morgan in developing Johnson-Morgan system of stellar magnitudes.
- Joliot-Curie, Irène** (1897–1956), French physicist. With M. Curie, discovered projection of atomic nuclei by neutrons; with J. F. Joliot-Curie, discovered artificial radiation; Nobel Prize, 1935.
- Joliot-Curie, Jean Frédéric** (1900–1958), French physicist. With I. Joliot-Curie, produced an artificial radioactive substance by bombarding boron with fast alpha particles; Nobel Prize, 1935.
- Jones, Vaughn Frederick Randal** (1952– ), New Zealand-American mathematician. Proved an index theorem for von Neumann algebras, discovered a relationship between these algebras and geometric topology, and discovered a new polynomial invariant for knots; this work provided a connecting link for widely separated areas of mathematics and physics; Fields Medal, 1990.
- Jordan, Camille** (1838–1921), French mathematician. Discovered many fundamental results in group theory; gave a proof of the Jordan curve theorem (later shown to be incorrect).
- Jordan, Pascual** (1902–1980), German physicist. Contributed to formulation of quantum mechanics; introduced Jordan algebra in an attempt to generalize quantum mechanics.
- Josephson, Brian David** (1940– ), British physicist. Predicted the Josephson effect concerning electron pairs; Nobel Prize, 1973.
- Joukowski, Nikolai Jegorowitch** (1847–1921), Russian applied mathematician and aerodynamicist. Helped to introduce concept of Kutta-Joukowski airfoil and to prove Kutta-Joukowski theorem.
- Joule, James Prescott** (1818–1889), English physicist. Formulated a mechanical theory of heat; demonstrated Joule-Thomson effect relating to the fall in temperature of a gas; first to estimate the velocity of a gas molecule.
- Jung, Carl Gustav** (1875–1961), Swiss psychologist and psychiatrist. Evolved a theory of complexes; founded the analytical school of psychoanalysis and psychotherapy.
- Jussieu, Antoine Laurent de** (1748–1836), French botanist. Wrote *Genera Plantarum*, the basis of modern natural botanical classification.
- Kahn, Robert E.** (1938– ), American electrical engineer. Co-invented (with Vinton G. Cerf) Transmission Control Protocol/Internet Protocol (TCP/IP).
- Kalman, Rudolf Emil** (1930– ), Hungarian born American mathematician and electrical engineer. Worked on mathematical theory of control systems; developed the Kalman filter; introduced concepts of controllability and observability.
- Kaluza, Theodor Franz Eduard** (1885–1954), German mathematical physicist. Developed theory which attempted to unify gravitation and electromagnetism.
- Kamerlingh Onnes, Heike** (1853–1926), Dutch physicist. Research on cryogenics, critical phenomena, and low temperatures; discovered the phenomenon of superconductivity; Nobel Prize, 1913.
- Kandel, Eric R.** (1929– ), Austrian-born American neurobiologist. Discovered that protein phosphorylation plays an important role in the molecular mechanisms underlying learning and memory formation; his work contributed to the elucidation of the molecular mechanisms involved in slow synaptic transmission in the nervous system; Nobel Prize, 2000.
- Kapitza, Pjotr Leonidovich** (1894–1984), Russian physicist. Studied magnetism and low temperature; designed hydrogen and helium liquefaction plants; Nobel Prize, 1978.
- Kapteyn, Jacobus Cornelius** (1851–1922), Dutch astronomer. Studied the proper motion of stars; with P. J. van Rhijn, evolved a theory of the universe.
- Karle, Jerome** (1918– ), American crystallographer. With H. A. Hauptman, developed computer-aided mathematical techniques for use in x-ray crystallography to determine three-dimensional structures of molecules; Nobel Prize, 1985.
- Karrer, Paul** (1889–1971), Swiss chemist. Pioneering research on vitamins A and B<sub>2</sub> and on the flavins and carotenoids; Nobel Prize, 1937.
- Kastler, Alfred** (1902–1984), French physicist. Developed a double-resonance method to study energy levels of atoms in excited states; Nobel Prize, 1966.
- Kater, Henry** (1777–1835), English geodesist. Developed Kater's reversible pendulum to obtain accurate values of acceleration of gravity.
- Katz, Bernard** (1911–2003), German-born British physiologist. Made discoveries concerning mechanism for release of transmitter substances at nerve-muscle junction; Nobel Prize, 1970.
- Keesom, Willem Hendrik** (1876–1956), Dutch physicist. Worked in low-temperature physics; first to solidify helium; studied molecular structure of liquids and compressed gases.
- Kekulé von Stradonitz, Friedrich August** (1829–1896), German chemist. A founder of structural organic chemistry; made theoretical proposal of the structure of benzene.
- Kelvin, William Thomson, 1st Baron** (1824–1907), British mathematician and physicist. Invented the Kelvin balance; formulated Kelvin's laws concerning electric cables; contributed to thermodynamics.
- Kendall, Edward Calvin** (1886–1972), American biochemist. Chemical investigation of the adrenal cortex, leading to the isolation of crystalline cortical hormones, especially cortisone; Nobel Prize, 1950.
- Kendall, Henry Way** (1926–1999), American physicist. Collaborated in experiments that

- demonstrated that protons, neutrons, and similar particles are made up of quarks; Nobel Prize, 1990.
- Kendrew, John Cowdery** (1917–1997), British molecular biologist. First to successfully determine the structure of a protein; Nobel Prize, 1962.
- Kennelly, Arthur Edwin** (1861–1939), American electrical engineer. Discovered the ionized layer in the atmosphere, independently of O. Heaviside; proposed the theory of alternating currents.
- Kepler, Johannes** (1571–1630), German astronomer. Proposed Kepler's three laws of planetary motion; worked in optics.
- Kerr, John** (1824–1907), Scottish physicist. Discovered the Kerr magnetooptic effect.
- Ketterle, Wolfgang** (1957– ), German physicist. Produced Bose-Einstein condensates in a dilute gas of sodium atoms (independent of the work of E. A. Cornell and C. E. Wieman) and carried out fundamental studies of their properties, including the production of interference patterns and atom lasers; Nobel Prize, 2001.
- Khorana, Har Gobind** (1922– ), Indian-born American biochemist. Synthesized complicated nucleic acids; proved that genetic code consists of nonoverlapping triplets of bases without gaps between triplets; Nobel Prize, 1968.
- Kilby, Jack St. Clair** (1923– ), American physicist, electronics engineer, and inventor. Participated in the invention of the integrated circuit; Nobel Prize, 2000.
- Kirchhoff, Gustav Robert** (1824–1887), German physicist. With R. W. Bunsen, discovered method of spectrum analysis; formulated Kirchhoff's law of electric currents and electromotive forces in a network.
- Kirkwood, Daniel** (1814–1895), American astronomer. Discovered Kirkwood gaps; studied nature, origin, and evolution of solar system, particularly role of asteroids, comets, meteors, and meteorites.
- Kitasato, Shibasaburo** (1852–1931), Japanese bacteriologist. Independently of A. E. J. Yersin, discovered the bacillus of bubonic plague; isolated bacilli of symptomatic anthrax, dysentery, and tetanus.
- Klebs, Edwin** (1834–1913), German pathologist. Described diphtheria (Klebs-Löffler) bacillus; studied bacteriology of malaria, anthrax, and tuberculosis.
- Klein, Christian Felix** (1849–1925), German mathematician. Contributed to function theory, nonEuclidean geometry, group theory, and applied mathematics; introduced Klein bottle.
- Klein, Oskar Benjamin** (1894–1977), Swedish physicist. Codeveloper of Klein-Gordon equation. Klein-Nishina formula, and Klein-Rydberg method; proposed theory of overall structure of the universe.
- Kleinrock, Leonard** (1934– ), American electrical engineer. Developed the basic principles of packet switching for communication networks, the underlying technology of the Internet.
- Klitzing, Klaus von** (1943– ), German physicist. Discovered quantum Hall effect; Nobel Prize, 1985.
- Klug, Aaron** (1926– ), South African-born British biochemist. Developed crystallographic electron microscopy and elucidated biologically important nucleic acid-protein complexes; Nobel Prize, 1982.
- Knowles, William S.** (1917– ), American chemist. Developed chirally catalyzed hydrogenation reactions; Nobel Prize, 2001.
- Knudsen, Martin Hans Christian** (1871–1949), Danish physicist and hydrographer. Studied flow and diffusion of gases at low pressure; developed Knudsen cell and Knudsen gage; developed methods to measure the properties of seawater.
- Koch, Robert** (1843–1910), German physician and bacteriologist. Studied cholera, tuberculosis, and bubonic plague; showed a specific bacillus to be the cause of anthrax; discovered the tubercle bacillus; Nobel Prize, 1905.
- Kocher, Emil Theodor** (1841–1917), Swiss surgeon. Studied the functions and malfunctions of the thyroid gland; Nobel Prize, 1909.
- Kodaira, Kunihiko** (1915–1997), Japanese mathematician. Did research on harmonic integrals and harmonic forms with applications to Kählerian and more specifically algebraic varieties; demonstrated, by sheaf cohomology, that such varieties are Hodge manifolds; Fields Medal, 1954.
- Köhler, Georges J. F.** (1946–1995), Swiss immunologist. With C. Milstein, discovered a laboratory technique for producing monoclonal antibodies, highly uniform immune bodies that are selective in responding to target substances; Nobel Prize, 1984.
- Kohn, Walter** (1923– ), Austrian-born American physicist. Developed density-functional theory, which solves equations for electron density rather than positions of individual electrons; it is one of the developments that has significantly sped up computational quantum chemistry; Nobel Prize, 1998.
- Kolbe, Adolf Wilhelm Hermann** (1818–1884), German chemist. Contributed to the synthesis concept of compound formation, doing much to eliminate the division of chemistry into two branches: organic and inorganic.
- Kolmogorov, Andrei Nikolaevich** (1903–1987), Soviet mathematician. Formulated set-theoretic basis of probability theory.
- Kontsevich, Maxim** (1964– ), Russian mathematician and mathematical physicist. Worked in algebraic geometry, algebraic topology, string theory, and quantum field theory; demonstrated equivalence of two models of quantum gravitation; discovered an invariant for classifying knots; Fields Medal, 1998.
- Kornberg, Arthur** (1918– ), American biochemist. Discovered deoxyribonucleic acid polymerase, providing the first rational enzymatic mechanism for the replication of genetic material of the cell; Nobel Prize, 1959.
- Korteweg, Diederik Johannes** (1848–1941), Dutch mathematician. Worked in applied mathematics, mechanics, and hydrodynamics; with G. de Vries, proposed equation of wave motion with soliton solution.
- Kosiba, Masatoshi** (1926– ), Japanese physicist. Developed large water detectors (Kamiokande and Super Kamiokande) that observed solar and atmospheric neutrinos and neutrinos from Supernova 1987A, and found evidence for neutrino oscillations. Nobel Prize, 2002.
- Kossel, Albrecht** (1853–1927), German chemist. Investigated the chemistry of cells and of proteins; Nobel Prize, 1910.
- Krafft-Ebing, Richard, Baron von** (1840–1902), German neurologist. Authority on psychological disorders and their forensic implications; wrote *Psychopathia Sexualis*, a collection of case histories.
- Kramers, Hendrik Anthony** (1894–1952), Dutch physicist. Developed quantum theory of dispersion, establishing Kramers-Kronig relation; with G. Wentzel and L. Brillouin, developed Wentzel-Kramers-Brillouin method.
- Krebs, Edwin Gerhard** (1918– ), American biochemist. With E. H. Fischer, discovered phosphorylation processes that play a critical role in cell-protein regulation; they isolated the first protein kinase, a class of enzymes that transfer phosphate from adenosine triphosphate to proteins; Nobel Prize, 1992.
- Krebs, Hans Adolf** (1900–1981), German-born British biochemist. Elucidated metabolic pathways, including the tricarboxylic acid cycle; Nobel Prize, 1953.
- Kroemer, Herbert** (1928– ), German-American physicist and electronics engineer. Developed semiconductor heterostructures used in high-speed and opto-electronics, including fast transistors, laser diodes, and light-emitting diodes; Nobel Prize, 2000.
- Krogh, Schack August Steenberg** (1874–1949), Danish physiologist. Discovered the regulation of the vasomotor mechanism of capillaries; devised the nitrous oxide method for measuring human circulation; Nobel Prize, 1920.
- Kronecker, Leopold** (1823–1891), German mathematician. Contributed to theory of elliptical functions, algebra, and number theory, and attempted to unify these disciplines; attempted to base all mathematics on integers and finite processes.
- Kroto, Harold W.** (1939– ), British chemist. Studied long-chain molecules found in radioastronomy by using microwave spectroscopy, which ultimately led to the discovery of fullerenes; Nobel Prize, 1996.
- Kruskal, Martin David** (1925– ), American mathematician and physicist. Research in plasma physics, asymptotic phenomena, relativity, and minimal surfaces.
- Kuhn, Richard** (1900–1967), German chemist. Research on the structures and synthesis of vitamins and carotenoids; Nobel Prize, 1938 (declined).
- Kundt, August Adolph** (1839–1894), German physicist. Used Kundt tube to determine speed of sound in gases; determined ratio of specific heats of monatomic gases; with W. K. Röntgen, demonstrated Faraday effect in gases.
- Kurchatov, Igor Vasilievich** (1903–1960), Soviet physicist. Discovered nuclear isomers; studied nuclear reactions; developed nuclear weapons and nuclear power.
- Kusch, Polykarp** (1911–1993), German-born American physicist. Precisely determined the magnetic moment of the electron; Nobel Prize, 1955.
- Kutta, Wilhelm Martin** (1867–1944), German applied mathematician. Helped introduce concept of Kutta-Joukowski airfoil, prove Kutta-Joukowski theorem, and develop Runge-Kutta method.
- Kwolek, Stephanie** (1923– ), American polymer chemist. Developed Kevlar, poly(*p*-phenylene terephthalamide), a lightweight synthetic fiber that is stronger than steel.
- Lacaille, Nicolas Louis de** (1713–1762), French astronomer and geodesist. Determined positions of nearly 10,000 stars in southern skies; measured lunar and solar parallax; showed that Earth has equatorial bulge.
- Lafforgue, Laurent** (1966– ), French mathematician. Proved the global Langlands correspondence for function fields, a major advance toward the realization the Langlands program, which deals with deep connections between number theory, analysis, and group representation. Fields Medal, 2002.
- Lagrange, Joseph Louis, Count** (1736–1813), French geometer and astronomer. Invented the calculus of variations; studied the mathematics of sound; wrote *Mécanique Analytique*, concerning statics and dynamics.
- Laguerre, Édmond Nicolas** (1834–1886), French mathematician. Discovered Laguerre's differential equations and Laguerre polynomials.
- Lamarck, Jean Baptiste Pierre Antoine de Monet, Chevalier de** (1744–1829), French naturalist. Proposed theory that changes in animal and plant structure are caused by changes in environment; classified animals into vertebrates and invertebrates.
- Lamb, Willis Eugene, Jr.** (1913– ), American physicist. Made precise atomic measurements leading to a new understanding of the theory of electron interactions and electromagnetic radiation; Nobel Prize, 1955.
- Lambert, Johann Heinrich** (1728–1777), German physicist. Formulated the Lambert theorem concerning the illumination of a surface.
- Lamé, Gabriel** (1795–1870), French mathematician, physicist, and engineer. Introduced curvilinear coordinates and applied them to differential equations, elasticity, thermodynamics, and number theory.
- Landau, Lev Davydovich** (1908–1968), Soviet physicist. Made theoretical explanation of the nature and properties of liquid helium; investigated condensed matter; Nobel Prize, 1962.
- Landé, Alfred** (1888–1975), German-born American physicist. Introduced Landé *g* factor; discovered Landé interval rule and Landé  $\Gamma$ -permanence rule.
- Landsteiner, Karl** (1868–1943), Austrian-born American pathologist. Discovered human blood

- groups and factors M and N; with A. S. Weiner, discovered the Rh factor; Nobel Prize, 1930.
- Lange, Carl Georg** (1834–1900), Danish physician and psychologist. With W. James, proposed the James-Lange theory of emotion.
- Langerhans, Paul** (1847–1888), German pathologist and anatomist. Studied human and animal microscopical anatomy, particularly structures of skin and pancreas; discovered islets of Langerhans.
- Langevin, Paul** (1872–1946), French physicist. Developed quantitative theories of paramagnetism and diamagnetism; helped to elucidate the theory of relativity; contributed to the development of sonar.
- Langley, Samuel Pierpont** (1834–1906), American astronomer and airplane pioneer. Studied infrared solar spectrum; constructed in 1896 the first mechanical heavier-than-air machine to fly.
- Langmuir, Irving** (1881–1957), American chemist. With G. N. Lewis, proposed the Lewis-Langmuir atomic theory; studied surface chemistry and thermionic emission; Nobel Prize, 1932.
- Laplace, Pierre Simon, Marquis de** (1749–1827), French astronomer and mathematician. Contributed to celestial mechanics, especially to the study of the Moon, Saturn, and Jupiter; formulated the theory of probability; discovered the Laplace differential equation.
- Larmor, Joseph** (1857–1942), British physicist. Developed electron theory which fused electromagnetic and optical concepts; introduced Larmor precession and derived Larmor formula.
- Latimer, Louis Howard** (1848–1928), American inventor. A collaborator of Alexander Graham Bell and Thomas Edison, this self-educated son of an escaped slave is best known for key inventions in the field of electric lighting.
- Laue, Max Theodor Felix von** (1879–1960), German physicist. Proposed the theory of x-ray diffraction by crystals; developed the Laue method of investigating crystal structure; Nobel Prize, 1914.
- Laughlin, Robert Betts** (1950– ), American physicist. Provided a theoretical explanation for the fractional quantum Hall effect by showing how electrons acting together in strong magnetic fields can form new types of quasiparticles with charges that are fractions of electron charges; Nobel Prize, 1998.
- Laurent, Pierre Alphonse** (1813–1854), French mathematician and physicist. Introduced Laurent series; research on wave theory of light.
- Lauterbur, Paul C.** (1929– ), American chemist. Discovered that it was possible to create a two-dimensional image of the body with magnetic resonance by introducing gradations in the external magnetic field, providing the basis for the development of magnetic resonance as a useful medical imaging technique. Nobel Prize, 2003.
- Laveran, Charles Louis Alphonse** (1845–1922), French physician. Discovered the malaria parasite; researched sleeping sickness; Nobel Prize, 1907.
- Lavoisier, Antoine Laurent** (1743–1794), French chemist. The founder of modern chemistry; studied combustion and respiration; published a table of the elements.
- Lawrence, Ernest Orlando** (1901–1958), American physicist. Discovery, development, and use of the cyclotron; Nobel Prize, 1939.
- Lebesgue, Henry Léon** (1875–1941), French mathematician. Developed theory of measure and integration; studied trigonometric series.
- Le Chatelier, Henry Louis** (1850–1936), French chemist and metallurgist. Research on cement chemistry, gas combustion, blast furnace reactions, chemical equilibria, alloy properties, and chemistry and metallurgy of iron and steel; formulated Le Chatelier's principle.
- Leclanché, Georges** (1839–1882), French chemist and electrician. Invented the Leclanché galvanic cell.
- Lederberg, Joshua** (1925– ), American geneticist. With E. L. Tatum, discovered genetic recombination in bacteria and organization of genetic material; Nobel Prize, 1958.
- Lederman, Leon Max** (1922– ), American physicist. Collaborated in experiment that demon-
- strated the existence of two types of neutrino; led an experiment that discovered the epsilon particle; Nobel Prize, 1988.
- Lee, David Morris** (1931– ), American physicist. With D. D. Osheroff and R. C. Richardson, discovered superfluidity in helium-3; Nobel Prize, 1996.
- Lee, Tsung-Dao** (1926– ), Chinese-born American physicist. With C. N. Yang disproved the parity principle; worked on statistical mechanics, astrophysics, nuclear and subnuclear physics, and field theory; Nobel Prize, 1957.
- Lee, Yuan Tseh** (1936– ), American chemist. With Dudley R. Herschbach, developed crossed molecular-beam technique for tracing chemical reactions; Nobel Prize, 1986.
- Legendre, Adrien Marie** (1752–1833), French mathematician. Worked on elliptic functions, the theory of numbers, and the method of least squares.
- Leggett, Anthony J.** (1938– ), British and American physicist. Developed a theory explaining the complex behavior of superfluid helium-3. Nobel Prize, 2003.
- Lehn, Jean-Marie** (1939– ), French chemist. Studied crown ethers and developed the synthesis of related structures known as cryptands; Nobel Prize, 1987.
- Leibniz, Gottfried Wilhelm, Baron von** (1646–1716), German mathematician. Contributed to the development of differential calculus.
- Leloir, Luis Federico** (1906–1987), French-born Argentine biochemist. Discovered sugar nucleotides and their role in carbohydrate biosynthesis; Nobel Prize, 1970.
- Lenard, Philipp Eduard Anton** (1862–1947), Hungarian-born German physicist. Studied cathode rays outside the discharge tube; worked on photoelectricity; Nobel Prize, 1905.
- L'Enfant, Pierre Charles** (1754–1825), French engineer. Designed Washington, D.C.
- Lennard-Jones, John Edward** (1894–1954), English physicist and chemist. Proposed Lennard-Jones potential for interatomic forces; contributed to quantum theory of molecular structure and statistical mechanics of liquids, gases, and surfaces.
- Lenz, Heinrich Friedrich Emil** (1804–1865), German physicist. Formulated Lenz's law governing induced current.
- Leverrier, Urbain Jean Joseph** (1811–1877), French astronomer. Studied Mercury, Uranus, and Neptune; credited, with J. C. Adams in England, as discoverer of Neptune.
- Levi-Civita, Tullio** (1873–1941), Italian mathematician and mathematical physicist. With G. Ricci-Curbastro, developed tensor analysis; introduced concept of parallelism in curved spaces.
- Levi-Montalcini, Rita** (1909– ), Italian biologist. With S. Cohen, made landmark studies of nerve growth factor and its functions; Nobel Prize, 1986.
- Lewis, Edward B.** (1918–2004), American geneticist. Shared in discoveries showing the genetic involvement of early embryonic development with C. Nusselin-Volhard and E. F. Wieschaus; Nobel Prize, 1995.
- Lewis, Gilbert Newton** (1875–1946), American chemist. Collaborated in developing the Lewis-Langmuir atomic theory; worked on the electronic theory of valency and chemical thermodynamics.
- Leydig, Franz von** (1821–1908), German histologist and anatomist. Founder of comparative histology; promoted use of microscope in anatomical study; described cells in testes believed to secrete male hormones.
- L'Hôpital (l'Hôpital), Guillaume François Antoine de, Marquis de Sainte-Mesme, Comte d'Entremont** (1661–1704), French mathematician. Wrote first textbook on differential calculus, which gives l'Hôpital's rule.
- Libby, Willard Frank** (1908–1980), American chemist. Developed the method of radiocarbon dating; Nobel Prize, 1960.
- Lie, Marius Sophus** (1842–1899), Norwegian mathematician. Originated the theory of tangential transformations.
- Liebig, Justus, Baron von** (1803–1873), German chemist. Discovered chloroform and chloral;
- founded agricultural chemistry; invented the Liebig condenser.
- Linnaeus, Carolus, real name Carl von Linné** (1707–1778), Swedish botanist. Developed the Linnaean system of biological classification.
- Lions, Pierre-Louis** (1956– ), French mathematician. Made important contributions to the theory of nonlinear partial differential equations; Fields Medal, 1994.
- Liouville, Joseph** (1809–1882), French mathematician. Proved existence of transcendental functions; developed concept of geodesic curvature; originated theory of doubly periodic functions.
- Lipmann, Fritz Albert** (1899–1986), German-born American biochemist. Formulated general rules for the biotechnology of energy transmission; discovered coenzyme A; Nobel Prize, 1953.
- Lippmann, Gabriel** (1845–1921), French physicist. Produced the first colored photograph of the light spectrum; invented the Lippmann capillary electrometer; Nobel Prize, 1908.
- Lipscomb, William Nunn, Jr.** (1919– ), American physical chemist. Studied structure and bonding of boranes, providing insight into nature of chemical bonding; Nobel Prize, 1976.
- Lissajous, Jules Antoine** (1822–1880), French physicist. Invented the vibration microscope, involving Lissajous figures.
- Lister, Joseph, 1st Baron** (1827–1912), English surgeon. Introduced antiseptics to surgery; pioneered in bacteriology.
- Littlewood, John Endensor** (1885–1977), British mathematician. Work on diophantine approximation, Tauberian theorems, Fourier series and associated function theory, the zeta function, additive number theory, and inequalities.
- Littrow, Joseph Johann von** (1781–1840), Austrian astronomer. Studied light refraction; worked on telescope construction.
- Lloyd, Humphrey** (1800–1881), Irish physicist. Discovered Lloyd's mirror interference; verified W. R. Hamilton's prediction of conical refraction.
- Lobachevski, Nikola Ivanovich** (1793–1856), Russian mathematician. Originated the first comprehensive system of noneuclidean geometry.
- Loewi, Otto** (1873–1961), German pharmacologist. Investigated nerve impulses; proved the role of ace-tylcholine in nerve impulse transmission; Nobel Prize, 1936.
- Löffler, Friedrich August Johannes** (1852–1915), German bacteriologist. Isolated the diphtheria (Klebs-Löffler) bacillus; developed protective serum against foot-and-mouth disease.
- London, Fritz** (1900–1954), German-born American physicist. Developed, with W. Heitler, theory of covalent bonding; with H. London, theory of superconductivity; and theory of superfluidity.
- London, Heinz** (1907–1970), German-born English physicist. Research on electrodynamic and thermodynamic behavior of superconductors and properties of superfluid helium.
- Lorentz, Hendrik Antoon** (1853–1928), Dutch physicist. Proposed the electron theory to explain electromagnetic properties of materials; proposed the Lorentz-FitzGerald contraction and the Lorentz transformation, contributing to the theory of relativity; studied Zeeman effect; Nobel Prize, 1902.
- Lorenz, Konrad Zacharias** (1903–1989), Austrian zoologist. Pioneered in study of animal behavior patterns; discovered imprinting in birds; Nobel Prize, 1973.
- Loschmidt, Johann Joseph** (1821–1895), Austrian physicist and chemist, born in Bohemia. Worked on graphical and structural molecular formulas; attempted to estimate size of air molecules and number of air molecules per unit volume.
- Lowry, Thomas Martin** (1874–1936), British chemist. Simultaneously with Johannes Brønsted, defined acid-base theory in terms of proton transfer—the Brønsted-Lowry theory (of acids and bases).
- Lummer, Otto Richard** (1860–1925), German physicist. Codeveloper of Lummer-Brodhun sight box and Lummer-Gehrcke plate; constructed an improved bolometer.
- Luria, Salvador Edward** (1912–1991), Italian-born American biologist. Devised fluctuation test

- to demonstrate and study spontaneous mutations in bacteria and viruses; Nobel Prize, 1969.
- Lwoff, André Michael** (1902–1994), French biologist. Explained the phenomenon of lysogeny in bacteria; Nobel Prize, 1965.
- Lyapunov, Aleksandr Mikhailovich** (1857–1918), Soviet mathematician and physicist. Determined in what cases linear approximations can be used to solve the problem of stability of a mechanical system with a finite number of degrees of freedom; proved existence of various figures of equilibrium for a rotating liquid.
- Lyell, Charles** (1797–1875), British geologist. Wrote *Principles of Geology*, refuting catastrophic theory of geological changes.
- Lyman, Theodore** (1874–1954), American physicist. Observed ultraviolet spectra; clarified nature of Lyman ghosts; discovered Lyman series.
- Lynen, Feodor** (1911–1979), German biochemist. Research on the formation of the cholesterol molecule; discovered chemistry of biotin; Nobel Prize, 1964.
- Lyot, Bernard Ferdinand** (1879–1952), French astronomer. Invented the coronagraph and developed monochromatic filters that greatly extended knowledge of the solar corona.
- MacDiarmid, Alan G.** (1927– ), New Zealand-born American chemist. Discovered and developed conductive polymers with Hideki Shirakawa and Alan Heeger; Nobel Prize, 2000.
- Mach, Ernst** (1838–1916), Austrian physicist. Research on supersonic flight, leading to Mach angle and Mach number; studied airflow over objects at high speeds.
- MacKinnon, Roderick** (1956– ), American medical doctor and scientist. Determined structure and mechanism of ion channels in cell membranes; Nobel Prize, 2003.
- Maclaurin, Colin** (1698–1746), Scottish mathematician. Systematized and developed Newton's calculus; introduced Maclaurin series and Maclaurin-Cauchy test.
- Macleod, John James Rickard** (1876–1935), Scottish physiologist. Shared in discovery of insulin with F. G. Banting and C. H. Best; Nobel Prize, 1923.
- Magnus, Heinrich Gustav** (1802–1872), German physicist and chemist. Made first quantitative analysis of blood gases; showed that arterial blood has higher oxygen content than venous blood; discovered Magnus effect.
- Majorana, Ettore** (1906–1938), Italian physicist. Studied properties of elementary particles; postulated Majorana force.
- Maksutov, Dmitry Dmitrievich** (1896–1964), Soviet physicist and astronomer. Developed general theory of aplanatic optical systems; developed Maksutov system.
- Malpighi, Marcello** (1628–1694), Italian anatomist. Discovered the capillaries; made microscopic studies in embryology; discovered the Malpighian layer of the epidermis and the Malpighian corpuscles in the kidney.
- Malus, Étienne Louis** (1775–1812), French engineer and physicist. Formulated Malus' cosine-squared law concerning polarized light and Malus' law of rays.
- Mandelstam, Stanley** (1928– ), American physicist, born in South Africa. Research in theoretical physics of elementary particles; introduced Mandelstam plane and Mandelstam representation.
- Mansfield, Peter** (1933– ), British physicist. Developed mathematical techniques for capturing, analyzing, and processing magnetic resonance signals more efficiently, making it possible to produce three-dimensional images of internal organs. Nobel Prize, 2003.
- Marconi, Guglielmo, Marquis** (1874–1937), Italian electrician and inventor. Developed commercial wireless telegraphy; Nobel Prize, 1909.
- Margulis, Gregori Aleksandrovich** (1946– ), Russian mathematician. Worked in combinatorics, differential geometry, ergodic theory, dynamical systems, and Lie groups; developed innovative analysis of the structure of Lie groups, describing their discrete subgroups; Fields Medal, 1978.
- Mariotte, Edmé** (?–1684), French physicist and physiologist. Discovered blind spot; studied circulation of sap in plants, collisions of bodies, properties of air, refraction and color of light, hydrostatics, hydraulics, and meteorology.
- Marcus, Rudolph Arthur** (1923– ), Canadian-born American chemist. Developed the mathematical analysis for electron transfer reactions in chemical systems; Nobel Prize, 1992.
- Mark, Herman Francis** (1895–1992), Austrian-born American chemist. Elucidated molecular structures of natural and synthetic polymers; developed theory of polymerization; studied relation between structure and properties of macromolecular systems.
- Markov, Andrei Andreevich** (1856–1922), Russian mathematician. Formulated rigorous proofs of law of large numbers and central-limit theorem; introduced Markov chain.
- Martin, Archer John Porter** (1910–2002), English chemist. With R. L. M. Synge, developed partition chromatography; Nobel Prize, 1952.
- Mascheroni, Lorenzo** (1750–1800), Italian mathematician. Calculated Euler's constant; proved that all plane construction problems that can be solved with a ruler and compass can also be solved with a compass alone.
- Mathieu, Emile Leonard** (1835–1890), French mathematician and physicist. Worked on solution of partial differential equations; research in celestial and analytical mechanics; studied Mathieu equation and introduced Mathieu functions.
- Matthias, Bernd Teo** (1919–1980), German-born American physicist. Tested metals and alloys for superconductivity; developed empirical rules to predict new superconducting materials.
- Mauder, Edward Walter** (1851–1928), British astronomer. Observations of the sun, sunspots and eclipses.
- Maupeirtuis, Pierre Louis Moreau de** (1698–1759), French mathematician and astronomer. Discovered the principle of least action; mathematical writings on the properties of curves.
- Maxwell, James Clerk** (1831–1879), Scottish physicist. Formulated the electromagnetic theory of light and the Maxwell distribution of molecular velocities of gases; invented the Maxwell disk concerning color vision.
- Mayall, Nicholas Ulrich** (1906–1993), American astronomer. Research on nebulae, globular star clusters, and external galaxies.
- Mayer, Julius Robert von** (1814–1878), German physicist. Discovered the principle of conservation of energy.
- Mayer, Maria Goeppert** (1906–1972), German-born American nuclear physicist. With J. H. D. Jensen, discovered nuclear shell structure; Nobel Prize, 1963.
- McClintock, Barbara** (1902–1992), American geneticist. Discovered mobile genetic elements known as jumping genes; Nobel Prize, 1983.
- McCoy, Elijah** (1844–1929), Canadian-born American inventor. Educated in Scotland as a mechanical engineer, this son of former slaves is best known for inventing automatic lubricating systems for steam engines and industrial machines, greatly advancing the Industrial Revolution; the popularity of his products is believed to have led to the American expression "the real McCoy."
- McMillan, Edwin Mattison** (1907–1991), American physicist. Discovered element 93 (neptunium), which led to the creation of element 94 (plutonium); conceived the theory of phase stability; Nobel Prize, 1951.
- McMullen, Curtis Tracy** (1958– ), American mathematician. Worked in hyperbolic geometry and in complex dynamics, also known as chaos theory; Fields Medal, 1998.
- Meckel, Johann Friedrich** (1781–1833), German anatomist and embryologist. Gave first comprehensive description of birth defects; described Meckel's cartilage; discovered Meckel's diverticulum.
- Medawar, Peter Brian** (1915–1987), Brazilian-born British biologist and medical scientist. Discovered acquired immunological tolerance; Nobel Prize, 1960.
- Meissner, Alexander** (1883–1958), Austrian-born German radio engineer. Helped develop improved electrical insulators and continuous-wave transmission; invented Meissner oscillator.
- Meissner, Walther** (1882–1974), German physicist. Research in low-temperature physics; discovered Meissner effect.
- Meitner, Lise** (1878–1968), German physicist. With O. Hahn, discovered protactinium; found evidence of four other radioactive elements; with Hahn and F. Strassmann, accomplished fission of uranium.
- Mendel, Gregor Johann** (1822–1884), Austrian botanist. Formulated Mendel's laws of heredity, the foundation of genetics.
- Mendeleev, Dmitri Ivanovich** (1834–1907), Russian chemist. Formulated Mendeleev's periodic law and table of the elements; research on interatomic and intermolecular forces.
- Menelaus of Alexandria** (1st century), Greek mathematician and astronomer. Founded spherical trigonometry.
- Mercator, Gerhardus, real name Gerhard Kreamer** (1512–1594), Flemish geographer. Created a chart of the world (Mercator projection); made surveying instruments.
- Mercer, John** (1791–1866), English chemist. Invented the mercerizing process for cotton.
- Merrifield, Robert Bruce** (1921– ), American biochemist. Developed methods of protein synthesis, including solid-phase peptide synthesis that produces proteins by assembling amino acids sequentially into peptide chains; Nobel Prize, 1984.
- Mersenne, Marin** (1588–1648), French physicist. Showed that pitch is proportional to frequency and calculated frequencies of musical notes; discovered Mersenne's law for vibrating strings, and similar relations for wind and percussion instruments.
- Messier, Charles** (1730–1817), French astronomer. Credited with discovering 21 comets; compiled a catalog of nebulae.
- Metchnikoff, Élie** (1845–1916), Russian-born French zoologist and bacteriologist. Work on cholera and immunology; Nobel Prize, 1908.
- Meusnier de la Place, Jean Baptiste Marie Charles** (1754–1793), French mathematician, physicist, and chemist. Derived Meusnier's theorem of curvature of surface curve; with A. L. Lavoisier, did research on analysis and synthesis of water.
- Meyerhof, Otto Fritz** (1884–1951), German physiologist. Studied the glycogen-lactic acid cycle of muscles; Nobel Prize, 1923.
- Michaelis, Leonor** (1875–1949), German-born American biochemist. Developed theory of kinetics of enzyme-catalyzed reactions.
- Michel, Hartmut** (1948– ), German chemist. With J. Deisenhofer and R. Huber, elucidated the structure of a bacterial protein that performs photosynthesis; Nobel Prize, 1988.
- Michelson, Albert Abraham** (1852–1931), American physicist. Experimented on the velocity of light with S. Newcomb; invented the Michelson interferometer; performed, with E. W. Morley, an experiment to determine the Earth's motion through the ether; Nobel Prize, 1907.
- Mie, Gustav** (1868–1957), German physicist. Carried out rigorous electrodynamic calculation of Mie scattering; attempted to formulate theory of matter.
- Miller, William Hallows** (1801–1880), British crystallographer and mineralogist. Introduced Miller indices for identifying crystallographic planes.
- Millikan, Robert Andrews** (1868–1953), American physicist. Determined an accurate value for Planck's constant; originated the "oil drop" experiment to measure electronic charge; work on x-rays and cosmic rays; Nobel Prize, 1923.
- Milnor, John Willard** (1931– ), American mathematician. Proved that a seven-dimensional sphere can have several differential structures, opening up the new field of differential topology; contributions to algebraic K theory, differential



- geometry, and algebraic topology; Fields Medal, 1962.
- Milstein, César** (1927–2002), British immunologist. With Georges J. F. Köhler, discovered a laboratory technique for producing monoclonal antibodies, highly uniform immune bodies that are selective in responding to target substances; Nobel Prize, 1984.
- Minkowski, Hermann** (1864–1909), Russian-born German mathematician. Studied the mathematical basis of relativity, notably the concept of the space-time continuum.
- Minot, George Richards** (1885–1950), American physician. With W. P. Murphy, first to recognize the value of liver therapy for pernicious anemia; studied arthritis, cancer, and vitamin B deficiency; Nobel Prize, 1934.
- Mitchell, Peter** (1920–1992), British chemist. Explained how plant and animal cells store and transfer energy by creating protonic gradients in the oxidative and photosynthetic phosphorylation processes; Nobel Prize, 1978.
- Möbius, August Ferdinand** (1790–1868), German mathematician and astronomer. Founder of topology; developed the Möbius strip.
- Mohl, Hugo von** (1805–1872), German botanist. Worked on the anatomy and physiology of higher plant forms; discovered protoplasm.
- Mohorovičić, Andrija** (1857–1936), Yugoslav meteorologist and seismologist. Discovered Mohorovičić seismic discontinuity.
- Mohr, Carl Friedrich** (1806–1879), German chemist. Developed titration procedures, including use of Mohr's salt.
- Mohr, Christian Otto** (1835–1918), German civil engineer. Studied stresses and strains of bodies, and failure of materials; introduced Mohr's stress circle.
- Mohs, Friedrich** (1773–1839), German mineralogist. Developed Mohs scale of hardness.
- Moissan, Ferdinand Frédéric Henri** (1852–1907), French chemist. First to isolate fluorine; invented an electric furnace and used it to produce synthetic metal compounds and samples of less common metals; Nobel Prize, 1906.
- Molina, Mario J.** (1943– ), American chemist. Demonstrated that chemically inert chlorofluorocarbon (CFC) could be transported up to the ozone layer and could react with ultraviolet light and deplete the ozone layer; Nobel Prize, 1995.
- Mollier, Richard** (1863–1935), German physicist and engineer. Presented properties of thermodynamic media in form of charts and diagrams; introduced concept of enthalpy and Mollier diagram.
- Moniz, Antonio Egas** (1874–1955), Portuguese neurosurgeon. Developed cerebral angiography; introduced the prefrontal lobotomy; Nobel Prize, 1949.
- Monod, Jacques** (1910–1976), French biologist. With F. Jacob, proposed the concepts of messenger ribonucleic acid and of the operon; Nobel Prize, 1965.
- Moody, Lewis Ferry** (1880–1953), American hydraulic engineer. Made improvements in hydraulic turbines, pumps, and accessories.
- Moore, Stanford** (1913–1982), American biochemist. With W. H. Stein, developed technique for determining amino acid sequence in proteins, and applied it to ribonuclease; Nobel Prize, 1972.
- Mordell, Louis Joel** (1888–1972), American-born British mathematician. Worked in number theory; proved the finite basis theorem concerning the finite generation of the group of rational points on an elliptic curve; conjectured that there are only finitely many rational points on a curve of genus greater than 1 (the Mordell conjecture).
- Morgagni, Giovanni Battista** (1682–1771), Italian anatomist. Founded pathological anatomy; first to describe liver cirrhosis.
- Morgan, Thomas Hunt** (1866–1945), American geneticist, embryologist, and zoologist. Proposed the chromosome theory of heredity; Nobel Prize, 1933.
- Morgan, William Wilson** (1906–1994), American astronomer. Developed methods for investigating more precisely the structure of the Milky Way Galaxy and of other galaxies; collaborated in developing the Johnson-Morgan system of stellar magnitudes (with H. L. Johnson) and Bautz-Morgan classification of galaxy clusters (with L. P. Bautz).
- Mori, Shigefumi** (1951– ), Japanese mathematician. Worked in algebraic geometry, particularly on the classification of algebraic varieties of dimension three; Fields Medal, 1990.
- Morley, Edward Williams** (1838–1923), American chemist and physicist. Associated with A. A. Michelson in an experiment on ether drift; research on variations of atmospheric oxygen content.
- Morse, Samuel Finley Breese** (1871–1872), American inventor. Invented the receiving and sending instruments for the telegraph, and a code for sending messages.
- Moseley, Henry Gwyn Jeffries** (1887–1915), English physicist. Discovered Moseley's law for frequency of x-ray spectral lines.
- Mössbauer, Rudolf Ludwig** (1929– ), German physicist. Discovered the property of recoilless resonance absorption, the ability of some nuclei to emit and absorb gamma rays without energy loss; Nobel Prize, 1961.
- Mossotti, Ottaviano Fabrizio** (1791–1863), Italian physicist. Developed theory of dielectrics, from which he derived the Clausius-Mossotti equation.
- Mott, Nevill Francis** (1905–1996), British physicist. Applied quantum mechanics to study of charged particle scattering; with R. W. Gurney, developed Gurney-Mott theory of photographic process; introduced fundamental concepts elucidating electronic properties of disordered materials; Nobel Prize, 1977.
- Mottelson, Ben Roy** (1926– ), American-born Danish physicist. With A. Bohr, developed theory which unifies shell and liquid-drop models of atomic nucleus, and which explains nonspherical nuclei; Nobel Prize, 1975.
- Muller, Hermann Joseph** (1890–1967), American geneticist. Studied genetic mutation rates under natural and artificial conditions; discovered the effect of x-rays on mutation rate; Nobel Prize, 1946.
- Müller, Johannes Peter** (1801–1858), German physiologist and anatomist. Proposed the principle of specific nerve energies, concerning stimuli to sense organs; discovered the Müllerian duct, an early embryonic structure.
- Müller, Karl Alex** (1927– ), Swiss physicist. With J. G. Bednorz, discovered high-temperature superconductivity in copper oxide ceramic materials; Nobel Prize, 1987.
- Müller, Paul Hermann** (1899–1965), Swiss chemist. Discovered the insecticidal properties of DDT; Nobel Prize, 1948.
- Mulliken, Robert Sanderson** (1896–1986), American chemist. Applied principles of quantum mechanics to study of chemical bonding; with F. Hund, systematized electronic states of molecules in terms of molecular orbitals; Nobel Prize, 1966.
- Mullis, Kary B.** (1944– ), American chemist. Invented the polymerase chain reaction (PCR) method used for studying DNA molecules; Nobel Prize, 1993.
- Mumford, David Bryant** (1937– ), American mathematician. Worked in algebraic geometry, especially on problems of the existence and structure of varieties of moduli and on the theory of algebraic surfaces; Fields Medal, 1974.
- Murad, Ferid** (1936– ), American pharmacologist. Analyzed the action of nitroglycerin and related vasodilating compounds, leading to the discovery that they release nitric oxide, which relaxes smooth muscle cells; his work, along with the research of Robert F. Furchgott and Louis J. Ignarro, led to the discovery of nitric oxide as a signaling molecule in the cardiovascular system; Nobel Prize, 1998.
- Murchison, Roderick Impey** (1792–1871), British geologist. Studied the order of rock formations in Great Britain; with A. Sedgwick, differentiated the Silurian and Devonian.
- Murphy, William Parry** (1892–1987), American physician. With G. R. Minot, first to suggest liver diet as a treatment for pernicious anemia; Nobel Prize, 1934.
- Murray, Joseph** (1919– ), American physician. Performed the first successful transplant of a human organ, a kidney; with E. D. Thomas, helped define and then overcome the immunological mechanisms behind organ rejection; Nobel Prize, 1990.
- Napier or Neper, John, Laird of Merchiston** (1550–1617), Scottish mathematician. Invented the theory of logarithms and developed methods to compute them.
- Nathans, Daniel** (1928–1999), American biologist. Pioneered in the use of restriction enzymes to study the structure and functions of deoxyribonucleic acid (DNA) molecules; Nobel Prize, 1978.
- Natta, Giulio** (1903–1979), Italian chemist. Discovered stereospecific polymerization, making possible the production of new classes of macromolecules from inexpensive raw materials; Nobel Prize, 1963.
- Navier, Claude Louis Marie Henri** (1785–1836), French physicist and engineer. Studied analytical mechanics and its application to strength of materials, machines, and motion of solid and liquid bodies; formulated Navier-Stokes equations.
- Néel, Louis Eugène Félix** (1904–2000), French physicist. Proposed the theory of behavior of antiferromagnetic and other ferrimagnetic materials in which the crystal lattice is divided into one or more sublattices; Nobel Prize, 1970.
- Neher, Erwin** (1944– ), German biophysicist. With B. Sakmann, using the "patch clamp" technique they developed, showed how individual ion channels control the passage of charged ions into and out of cells; Nobel Prize, 1991.
- Nernst, Hermann Walther** (1864–1941), German chemist. Proposed the heat theorem (third law of thermodynamics); determined the specific heat of solids at low temperatures; proposed the chain reaction theory in photochemistry; Nobel Prize, 1920.
- Neumann, Carl Gottfried** (1832–1925), German mathematician. Believed to be founder of logarithmic potentials; developed the potential theory.
- Newcomb, Simon** (1835–1909), American astronomer. With A. A. Michelson, determined the velocity of light; studied the motions of the Moon and planets.
- Newton, Isaac** (1642–1727), English mathematician. Proposed a dynamical theory of gravitation; discovered three basic laws of motion which are the foundation of practical mechanics; made discoveries in optics and mathematics.
- Neyman, Jerzy** (1894–1981), Russian-born American statistician. Developed methodology for making decisions based only on results of experiments or observations subject to chance.
- Nicholson, Seth Barnes** (1891–1963), American astronomer. Discovered four satellites of Jupiter; with E. Petit, invented a thermocouple to measure surface temperature of planets.
- Nicol, William** (1763–1851), Scottish physicist. Invented the Nicol prism for investigating the polarization of light.
- Nicolle, Charles Jules Henri** (1866–1936), French physician. Discovered the louse to be the transmission vector of typhus; Nobel Prize, 1928.
- Nicomedes** (3d century B.C.), Greek mathematician. Discovered the conchoid.
- Nirenberg, Marshall Warren** (1927– ), American biochemist. Pioneered in deciphering genetic code; Nobel Prize, 1968.
- Nishina, Yoshio** (1890–1951), Japanese physicist. Pioneer in study of cosmic rays; with O. B. Klein, originated the Klein-Nishina formula.
- Nobel, Alfred Bernhard** (1833–1896), Swedish chemist and engineer. Invented dynamite and a blasting gelatin containing nitroglycerin; established the annual Nobel prizes.
- Noguchi, Hideyo** (1876–1928), Japanese bacteriologist. First to produce pure cultures of syphilis spirochetes; discovered the parasite of yellow fever.
- Norrish, Ronald George Wreyford** (1897–1978), British physical chemist. With G. Porter and colleagues, developed methods of flash photolysis

- and kinetic spectroscopy for the study of very fast reactions; Nobel Prize, 1967.
- Northrop, John Howard** (1891–1987), American biochemist. Isolated several enzymes and proved them to be proteins; isolated the first bacterial virus; established the chemical nature of enzymes and viruses; Nobel Prize, 1946.
- Novikov, Sergi Petrovich** (1938– ), Russian mathematician. Worked in algebraic topology; proved the topological invariance of the Pontryagin classes of a differentiable manifold; studied the cohomology and homotopy of Thom spaces; Fields Medal, 1970.
- Noyce, Robert Norton** (1927–1990), American physicist, electronics engineer, and inventor. Participated in the invention of the integrated circuit.
- Noyori, Ryoji** (1938– ), Japanese chemist. Developed chirally catalyzed hydrogenation reactions; Nobel Prize, 2001.
- Nurse, Paul M.** (1949– ), British biologist. Identified, cloned, and characterized a key regulator of the cell cycle, cyclin-dependent kinase; Nobel Prize, 2001.
- Nusselt, Ernst Kraft Wilhelm** (1882–1957), German mechanical engineer and physicist. Used dimensional analysis to derive functional form of solutions to equations for heat flux in a flowing fluid.
- Nüsslein-Volhard, Christiane** (1942– ), German developmental biologist. Using *Drosophila*, she and Eric Wieschaus identified and classified a small number of genes that are important in determining the body plan and the formation of body segments; their work, along with that of American developmental biologist Edward B. Lewis, led to the discovery of important genetic mechanisms which control early embryonic development; Nobel Prize, 1995.
- Nyquist, Harry** (1889–1976), Swedish-born American physicist and engineer. Discovered conditions necessary to keep feedback control circuits stable; determined Nyquist rate for communications channels.
- Ochoa, Severo** (1905–1993), Spanish-born American biochemist. Discovered a bacterial enzyme that synthesizes ribonucleic acid from nucleoside diphosphates; first to synthesize a ribonucleic acid; Nobel Prize, 1959.
- Ockham, William** of (ca. 1284–1347), English philosopher and theologian. Developed nominalist school of thought; postulated Ockham's razor.
- Oersted, Hans Christian** (1777–1851), Danish physicist, chemist, and electromagnetist. Discovered a fundamental principle of electromagnetism: a magnetic needle turns at right angles to an electric current.
- Ohm, Georg Simon** (1787–1854), German physicist. Discovered Ohm's law relating electrical resistance to voltage and current.
- Olah, George A.** (1927– ), American chemist. Made fundamental contributions in carbocation chemistry; Nobel Prize, 1994.
- Olbers, Heinrich Wilhelm Matthias** (1758–1840), German astronomer. Devised new method for computing cometary orbits; proposed Olbers' paradox.
- Onsager, Lars** (1903–1976), Norwegian-born American chemist. Laid the foundation of irreversible thermodynamics; contributed to theories of dielectrics, electrolytes, and cooperative phenomena; Nobel Prize, 1968.
- Oort, Jan Hendrik** (1900–1992), Dutch astronomer. Research on the structure and dynamics of the galactic system; investigated the origin of comets.
- Oppenheimer, J. Robert** (1904–1967), American physicist. Research on nuclear disintegration, quantum theory, cosmic rays, and relativity; directed production of the atomic bomb.
- Orr, John Boyd, Baron** (1880–1971), Scottish physiologist and nutritionist. Work on animal nutrition; pioneer in science of human nutrition; Nobel Peace Prize, 1949.
- Osheroff, Douglas D.** (1945– ), American physicist. With D. M. Lee and R. C. Richardson, discovered superfluidity in helium-3; Nobel Prize, 1996.
- Ostwald, Friedrich Wilhelm** (1853–1932), German chemist born in Latvia. Researches on affinity and mass action; discovered the Ostwald dilution law; worked on the catalytic oxidation of ammonia; Nobel Prize, 1909.
- Otto, Nikolaus August** (1832–1891), German inventor. Built the first four-stroke internal combustion engine.
- Paget, James** (1814–1899), English surgeon and pathologist. Studied pathology of tumors and bone and joint diseases; described osteitis deformans (Paget's disease).
- Palade, George Emil** (1912– ), Rumanian born American cytologist. Applied electron microscope and centrifuge techniques to study of ultrastructure of cells; discovered ribosomes; Nobel Prize, 1974.
- Papanicolaou, George Nicholas** (1883–1962), Greek-born American cytologist and anatomist. Developed the Papanicolaou test for diagnosis of uterine cervical and endometrial cancer.
- Pappus, Alexandrinus** (ca. 3d–4th century), Greek mathematician. Wrote *Mathematical Collection*, an account of Greek geometry; formulated Pappus' theorems.
- Paracelsus, Philippus Aureolus, real name Theophrastus Bombastus von Hohenheim** (1493–1541), Swiss physician. Emphasized use of chemicals in medicine; advocated that diseases are specific and require specific remedies.
- Paré, Ambroise** (1509–1590), French surgeon. Advocated the treatment of wounds by tying arteries with ligatures rather than by cauterization; proposed improvements in operating methods.
- Parkinson, James** (1755–1824), English physician and paleontologist. Described parkinsonism.
- Parseval des Chenes, Marc Antoine** (1755–1836), French mathematician. Introduced an equation from which the theorem now known as Parseval's theorem is derived.
- Pascal, Blaise** (1623–1662), French mathematician and physicist. Contributed to the geometry of conics; formulated Pascal's law, relating to the pressure of a liquid at rest; applied Pascal's triangle to the calculation of probabilities.
- Paschen, Louis Carl Heinrich Friedrich** (1865–1947), German physicist. Established Paschen's law; with E. Back, discovered Paschen-Back effect; verified predictions of relativistic fine structure made by Bohr-Sommerfeld theory.
- Pasteur, Louis** (1822–1895), French biologist. Founder of microbiology; discovered the role of bacteria in fermentation; discovered anaerobic bacteria; developed the pasteurization process; demonstrated the efficacy of vaccination, especially for rabies.
- Patterson, Arthur Lindo** (1902–1966), New Zealand-born American physicist and crystallographer. Developed Patterson-Harker method of x-ray diffraction analysis of crystal structure.
- Paul, Wolfgang** (1913–1993), German physicist. Invented the Paul trap, which uses radio-frequency radiation to hold ions in a small volume; Nobel Prize, 1989.
- Pauli, Wolfgang** (1900–1958), Austrian-born American physicist. Worked on quantum theory; formulated the Pauli exclusion principle; contributed to matrix mechanics; Nobel Prize, 1945.
- Pauling, Linus Carl** (1901–1994), American chemist. Applied quantum theory to chemistry; research on molecular structure and chemical bonds; contributed to electrochemical theory of valency; Nobel Prize, 1954; Nobel Peace Prize, 1963.
- Pavlov, Ivan Petrovich** (1849–1936), Russian pathologist. Discovered the nerve fibers affecting heart action and the secretory nerves of the pancreas; research on the physiology of digestive glands; studied conditioned reflexes; Nobel Prize, 1904.
- Peano, Giuseppe** (1858–1932), Italian mathematician. Pioneer in symbolic logic and foundations of mathematics; promoted axiomatic method in mathematics; formulated postulates for natural numbers.
- Pearl, Raymond** (1879–1940), American biologist and statistician. Applied statistics to the study of population changes; introduced logistic curve describing population growth.
- Pearson, Karl** (1857–1936), English applied mathematician, statistician, and biometrician. Pioneered in application of statistics to biology; introduced chi-square test.
- Pedersen, Charles J.** (1904–1989), American chemist. Developed the synthesis of cyclic polyethers known as crown ethers; Nobel Prize, 1987.
- Peierls, Rudolf Ernst** (1907–1995), German-born British physicist. Developed theory of heat conduction in nonmetallic crystals; with O. R. Frisch, calculated critical mass of uranium-235.
- Peirce, Charles Santiago Sanders** (1839–1914), American mathematician, logician, and physicist. Laid foundation for logical analysis of mathematics; contributed to probability theory.
- Pelletier, Pierre Joseph** (1788–1842), French chemist. Discovered quinine, strychnine, and other alkaloids.
- Peltier, Jean Charles Athanase** (1785–1845), French physicist. Discovered the Peltier effect in thermoelectricity.
- Penrose, Roger** (1931– ), British mathematician and physicist. Developed twistor theory of space-time geometry; studied singularities in classical general relativity theory.
- Penzias, Arno A.** (1933– ), American astrophysicist. With R. W. Wilson, discovered cosmic background radiation, confirming the big bang theory of the origin of the universe; Nobel Prize, 1978.
- Perl, Martin L.** (1927– ), American physicist. Discovered the tau lepton, a fundamental particle; Nobel Prize, 1995.
- Pérot, Jean Baptiste Gaspard Gustav Alfred** (1863–1925), French physicist. With C. Fabry, developed Fabry-Pérot interferometer.
- Perrin, Jean Baptiste** (1870–1942), French physicist. Research on the particle nature of cathode rays; found values for Avogadro's number, thereby proving the existence of molecules; Nobel Prize, 1926.
- Perutz, Max Ferdinand** (1914–2002), Austrian-born British crystallographer and molecular biologist. Worked on the structure of hemoglobin; introduced the method of isomorphous replacement with heavy atoms into protein crystallography; Nobel Prize, 1962.
- Petit, Alexis Thérèse** (1791–1820), French physicist. With P. L. Dulong, formulated the law of constancy of atomic heats; devised methods for determining thermal expansion and specific heats of solids.
- Pettit, Edison** (1890–1962), American astronomer. Studied the Sun and formulated laws alleged to govern the movement of prominences; constructed the interference polarizing monochromator; with S. B. Nicholson, devised a sensitive thermocouple to measure the surface temperatures of planets.
- Pfaff, Johann Friedrich** (1765–1825), German mathematician. Developed theory of Pfaffian differential equations, which is basic to general solution of partial differential equations.
- Pfeiffer, Richard Friedrich Johann** (1858–1945), German bacteriologist. Discovered Pfeiffer's bacillus in influenza; described Pfeiffer's reaction for determination of cholera.
- Phillips, William Daniel** (1948– ), American physicist. Developed a method of slowing and trapping atoms in an atomic beam by using an opposed laser beam and a magnetic trap, and cooled these atoms to temperatures lower than the previously calculated theoretical limits; Nobel Prize, 1997.
- Piaget, Jean** (1896–1980), Swiss psychologist. Elucidated development of cognitive functions in the child.
- Picard, Charles Émile** (1856–1941), French mathematician. Formulated Picard's theorem relating to functions.
- Piccard, Auguste** (1884–1962), Swiss physicist. Conducted a data-collecting exploration of the stratosphere in an airtight gondola of a balloon; constructed and tested a bathysphere for deep-sea exploration.

- Pickering, Edward Charles** (1846–1919), American astronomer. Invented the meridian photometer; pioneered in stellar spectroscopy.
- Pierce, George Washington** (1872–1956). American physicist and electronic engineer. Developed theoretical basis of electrical communications; developed Pierce oscillator; with A. E. Kennelly, discovered concept of motional impedance.
- Pitzer, Kenneth Sanborn** (1914–1997), American chemist. Pioneered in the development of useful approximations which made possible the calculation of chemical thermodynamic properties of broad classes of chemical substances.
- Planck, Max Karl Ernst Ludwig** (1858–1947), German physicist. Presented the quantum theory; introduced Planck's constant, or quantum of action.
- Planté, Gaston** (1834–1889), French physicist. Constructed a storage battery, the first primitive accumulator.
- Plateau, Joseph Antoine Ferdinand** (1801–1883), Belgian physicist. Experimented with soapy films bounded by wires, noting that the surfaces formed were minimal surfaces; from this he formulated the Plateau problem (the problem of determining the existence of a minimal surface with a given space curve as its boundary).
- Podolsky, Boris** (1896–1966), Russian-born American physicist. Collaborated in formulation of Einstein-Podolsky-Rosen paradox; research on quantum electrodynamicism.
- Poggendorff, Johann Christian** (1796–1877), German physicist. Introduced the small mirror on a suspended system to magnify small deflections of a light beam; invented the galvanometer.
- Poincaré, Jules Henri** (1854–1912), French mathematician. Worked on the theory of functions, on differential equations, and on the theory of orbits in astronomy.
- Poinsoot, Louis** (1777–1859), French mathematician. Originated theory of couples.
- Poiseuille, Jean Léonard Marie** (1797–1869), French physiologist and physicist. Studied physiology of arterial circulation; invented improved methods for measuring blood pressure; discovered Hagen-Poiseuille law independently of G. H. L. Hagen.
- Poisson, Siméon Denis** (1781–1840), French mathematician. Worked on mathematical physics; contributed to the wave theory of light; formulated the Poisson ratio concerning the elasticity of materials.
- Poltzer, H. David** (1949– ), Discovered asymptotic freedom in the strong interactions (independent of D. J. Gross and F. Wilczek). Nobel Prize, 2004.
- Polonyi, John C.** (1929– ), Canadian chemist. Studied chemiluminescence, a phenomenon in which the energy states of excited molecules are revealed by their emission of light; Nobel Prize, 1986.
- Pomeranchuk, Isaak Yakolevich** (1913–1966), Soviet physicist. Showed that energy of cosmic-ray electrons reaching the atmosphere is limited by their radiation in Earth's magnetic field; proved the Pomeranchuk theorem for scattering cross sections.
- Pons, Jean Louis** (1761–1831), French astronomer. Discovered 37 comets, including Encke's comet.
- Pople, John A.** (1925–2004), British-born chemist. Developed computational methods in quantum chemistry; Nobel Prize, 1998.
- Porro, Ignazio** (1801–1875), Italian topographer, geodesist, and physicist. Invented optical surveying instruments, Porro prism erecting system, and modern prism binoculars.
- Porter, George** (1920–2002), British chemist. With R. G. W. Norrish, developed the technique of flash photolysis to initiate and record very fast chemical reactions; Nobel Prize, 1967.
- Porter, Rodney Robert** (1917–1985), British biochemist. Research to determine chemical structure of immunoglobulins; Nobel Prize, 1972.
- Powell, Cecil Frank** (1903–1969), British physicist. Made practical the use of photographic emulsions in nuclear research; with G. P. S. Occhialini and others, discovered and investigated production of pions from cosmic radiation in the Earth's atmosphere; Nobel Prize, 1950.
- Poynting, John Henry** (1852–1914), English physicist. Determined the constant of gravitation and explained why a comet's tail points away from the Sun.
- Prandtl, Ludwig** (1875–1953), German physicist. Contributed to fluid mechanics, particularly aerodynamics; introduced concept of boundary layer.
- Pregl, Fritz** (1869–1930), Austrian chemist. Developed microchemical methods of analysis; Nobel Prize, 1923.
- Prelog, Vladimir** (1906–1998), Yugoslavian-born Swiss chemist. Investigated stereochemistry of organic molecules and reactions; Nobel Prize, 1975.
- Prevost, Pierre** (1751–1839), Swiss physicist. Developed theory of exchanges, explaining nature of heat.
- Priestley, Joseph** (1733–1804), English chemist and physicist. Discovered oxygen, ammonia, oxides of nitrogen, hydrochloric acid gas, nitrogen, carbon monoxide, and sulfur dioxide.
- Prigogine, Ilya** (1917–2003), Soviet-born Belgian chemist. Contributed to nonequilibrium thermodynamics, particularly the theory of dissipative structures; Nobel Prize, 1977.
- Prokhorov, Aleksandr Mikhailovich** (1916–2002), Soviet physicist. With N. G. Basov, devised a new method for amplifying electromagnetic radiation; Nobel Prize, 1964.
- Prout, William** (1785–1850), English physician and chemist. Formulated Prout's hypothesis concerning atomic weights.
- Prusiner, Stanley B.** (1942– ), American neurologist. Discovered prions, a new biological agent of infection; Nobel Prize, 1997.
- Ptolemy** (2d century), Greco-Egyptian astronomer, geographer, and geometer at Alexandria. Proposed the Ptolemaic system, with the Earth as the center of the universe.
- Pupin, Michael** (1858–1935), Yugoslavian-born American physicist and electrical engineer. Developed inductance coils for telephone lines; contributed to x-ray fluoroscopy, design of radio transmitters, and network theory.
- Purcell, Edward Mills** (1912–1997), American physicist. Developed the method of nuclear resonance absorption; Nobel Prize, 1952.
- Purkinje, Johannes Evangelista** (1787–1869), Czech physiologist. Discovered the Purkinje effect in eye physiology and Purkinje cells in the cerebral cortex.
- Pythagoras** (6th century B.C.), Greek mathematician. Originated a system of geometry, including the Pythagorean theorem.
- Quételet, Lambert Adolphe Jacques** (1796–1874), Belgian statistician. Did pioneer work on statistics; applied the calculus of probabilities to sociological studies.
- Quillen, Daniel Gray** (1940– ), American mathematician. Developed algebraic K-theory, an extension of ideas of A. Grothendieck to commutative rings, which employed geometric and topological methods and ideas to formulate and solve major problems in algebra, particularly ring theory and module theory; Fields Medal, 1978.
- Rabi, Isidor Isaac** (1898–1988), Austrian-born American physicist. Research on neutrons, magnetism, quantum mechanics, and nuclear physics; Nobel Prize, 1944.
- Radó, Tibor** (1895–1965), Hungarian-American mathematician. Solved the Plateau problem (the problem of determining the existence of a minimal surface with a given space curve as its boundary) about the same time as J. Douglas.
- Radon, Johann** (1887–1956), Bobemian-born Austrian mathematician. Work in calculus of variations and integration theory.
- Rainwater, Leo James** (1917–1986), American physicist. Suggested that shell-model potentials of certain atomic nuclei are not spherical but are deformed into spheroids, and proposed mechanism for this distortion; Nobel Prize, 1975.
- Raman, Chandrasekhara Venkata** (1888–1970), Indian physicist. Research on diffraction and oscillation; discovered the Raman effect; Nobel Prize, 1930.
- Ramón y Cajal, Santiago** (1852–1934), Spanish histologist. Isolated the neuron and made discoveries concerning nerve cells in gray matter and the spinal cord; Nobel Prize, 1906.
- Ramsay, William** (1852–1916), British chemist. With J. W. S. Rayleigh, discovered argon; with M. W. Travers, discovered neon, krypton, and xenon; Nobel Prize, 1904.
- Ramsden, Jesse** (1735–1800), English mathematical-instrument maker. Invented an eyepiece containing cross-wires as a measuring scale; introduced equatorial mounting for telescopes.
- Ramsey, Norman Foster** (1915– ), American physicist. Invented an accurate method of measuring differences between atomic energy levels that formed the basis for the cesium atomic clock; worked on the hydrogen maser; Nobel Prize, 1989.
- Rankine, William John Macquorn** (1820–1872), Scottish civil engineer. Contributed to thermodynamics and theories of elasticity and waves; wrote textbooks on the steam engine and civil engineering.
- Raoult, François Marie** (1830–1901), French chemist. Formulated Raoult's law concerning vapor pressure of a solution.
- Rathke, Martin Heinrich** (1793–1860), German biologist. Discovered gill slits and gill arches in embryo birds and mammals, and Rathke's pocket in developing vertebrates.
- Ray or Wray, John** (1627?–1706), English naturalist. Identified the difference between mono- and dicotyledons; arranged plants according to their natural form, the foundation of the natural system of classification.
- Rayleigh, John William Strutt, 3d Baron** (1842–1919), English physicist. Worked on the theory of sound and on physical optics; with W. Ramsay, discovered argon; Nobel Prize, 1904.
- Réaumur, René Antoine Ferchault de** (1683–1757), French entomologist. Worked in biology and metallurgy; invented the Réaumur thermometer scale.
- Regge, Tullio** (1931– ), Italian physicist. Played a role in introducing the idea of complex angular momenta into elementary particle physics.
- Regiomontanus, real name Johann Müller** (1436–1476), German astronomer. Erected the first European observatory, in 1471 in Nürnberg; produced mathematical tables.
- Reichstein, Tadeus** (1897–1996), Polish-born Swiss organic chemist. Isolated about 30 of the 40 substances produced by the adrenal cortex; synthesized and described the structure and properties of many of these substances; Nobel Prize, 1950.
- Reines, Frederick** (1918–1998), American physicist. With C. L. Cowan, made first detection of the neutrino, a fundamental particle; Nobel Prize, 1995.
- Reynolds, Osborne** (1842–1912), British engineer and physicist. Demonstrated streamline and turbulent flow in pipes, and showed that transition between them occurs at a critical velocity determined by Reynolds' number; introduced Reynolds' analogy.
- Riccati, Jacopo Francesco** (1676–1754), Italian mathematician. Research on analysis, particularly differential equations, and geometry.
- Ricci-Curbastro, Gregorio** (1853–1924), Italian mathematician and mathematical physicist. Developed theory of tensor analysis, providing mathematical foundation for general relativity.
- Richards, Dickinson Woodruff** (1895–1973), American physician. With A. F. Courmand, utilized the technique of cardiac catheterization and proved its value as a diagnostic tool; Nobel Prize, 1956.
- Richards, Theodore William** (1868–1928), American chemist. Worked on atomic weights; experimentally confirmed the existence of isotopes of lead from uranium and thorium; Nobel Prize, 1914.

- Richardson, Owen Willans** (1879–1959), English physicist. Studied the emission of electricity from hot bodies and the electron theory of matter; Nobel Prize, 1928.
- Richardson, Robert Coleman** (1937– ), American physicist. With D. M. Lee and D. D. Osheroff, discovered superfluidity in helium-3; Nobel Prize, 1996.
- Richet, Charles Robert** (1850–1935), French physiologist. Studied serum therapy and discovered anaphylaxis; Nobel Prize, 1913.
- Richter, Burton** (1931– ), American physicist. Independently of S. C. C. Ting, discovered a new heavy elementary particle, which he named the psi particle; Nobel Prize, 1976.
- Richter, Jeremias Benjamin** (1762–1807), German chemist. Discovered the law of equivalent proportions.
- Riemann, Georg Friedrich Bernhard** (1826–1866), German mathematician. Originated Riemannian geometry, a nonEuclidean system.
- Riesz, Frigyes or Frederic** (1880–1956), Hungarian mathematician. Did research on abstract and general theories related to mathematical analysis, particularly functional analysis; independently of E. Fischer, discovered Riesz-Fisher theorem.
- Righi, Augusto** (1850–1920), Italian physicist. Discovered magnetic hysteresis and Righi-Leduc effect, independently of S. A. Leduc; demonstrated that microwaves have all properties characteristic of light waves.
- Ritchey, George Wills** (1864–1945), American astronomer. Made important astronomical observations, particularly on the Andromeda nebula; with H. Chrétien, developed Ritchey-Chrétien optics.
- Ritz, Walter** (1878–1909), Swiss-born German physicist. Introduced Ritz combination principle; developed Ritz method for numerical solution of boundary-value problems.
- Robbins, Frederick Chapman** (1916–2003), American microbiologist. Discovered that poliomyelitis virus can be grown in various human tissue cultures; Nobel Prize, 1954.
- Roberts, Richard J.** (1943– ), British geneticist. Independently of P. Sharp, discovered split genes; Nobel Prize, 1993.
- Robinson, Robert** (1886–1975), English chemist. Worked on plant pigments, alkaloids, and phenanthrene derivatives; Nobel Prize, 1947.
- Roche, Edouard Adolbert** (1820–1883), French physicist, mathematician, and meteorologist. Studied the internal structure and free-surface form of the celestial bodies; applied results to study of cosmogonic hypotheses.
- Rodbell, Martin** (1925–1998), American pharmacologist. With A. Gilman, discovered G-proteins and the role of these proteins in cellular signal transduction; Nobel Prize, 1994.
- Rohrer, Heinrich** (1933– ), Swiss physicist. With G. Binnig, developed scanning tunneling microscope; Nobel Prize, 1986.
- Rolle, Michel** (1652–1719), French mathematician. Worked on Diophantine analysis and algebra of equations.
- Röntgen, Wilhelm Konrad** (1845–1923), German physicist. Discovered x-rays; Nobel Prize, 1901.
- Roscoe, Henry Enfield** (1833–1915), English chemist. With R. W. Bunsen, evolved the law of reciprocity and invented the actinometer; first to isolate metallic vanadium.
- Rose, Irwin** (1926– ), American biochemist. Discovered ubiquitin-mediated protein degradation; Nobel Prize, 2004.
- Rosen, Nathan** (1909–1995), American-born Israeli physicist. Collaborated in formulation of Einstein-Podolsky-Rosen paradox; research on general relativity and gravitational waves.
- Ross, Ronald** (1857–1932), British physician. Proved that malaria is transmitted by the female *Anopheles* mosquito; Nobel Prize, 1902.
- Rosby, Carl Gustaf Arvid** (1898–1957), Swedish-born American meteorologist. Formulated theories of large-scale air movements; derived the Rossby formula, relating speed of propagation of perturbations to airflow and wavelengths of perturbations; devised the Rossby diagram, used to plot air mass properties.
- Roth, Klaus Friedrich** (1925– ), German-born British mathematician. Solved a problem previously studied by A. Thue and C. Siegel concerning the approximation to algebraic numbers by rational numbers; proved that a sequence with no three numbers in arithmetic progression has zero density; Fields Medal, 1958.
- Rous, Francis Peyton** (1879–1970), American physician and virologist. Produced cancer in chickens by inoculating them with filterable virus procured from tissue of chickens with tumors; Nobel Prize, 1966.
- Routh, Edward John** (1831–1907), British mathematical physicist. Made contributions to classical mechanics, including procedure for eliminating cyclic coordinates from equations of motion.
- Roux, Pierre Paul Emile** (1853–1933), French physician and bacteriologist. Helped develop modern serum therapeutics, especially concerning diphtheria.
- Rowland, F. Sherwood** (1927– ), American chemist. Demonstrated that chemically inert chlorofluorocarbon (CFC) could be transported up to the ozone layer and could react with ultraviolet light and deplete the ozone layer; Nobel Prize, 1995.
- Rowland, Henry Augustus** (1848–1901), American physicist. Developed the Rowland grating in spectroscopy; studied electromagnetism and heat.
- Rubbia, Carlo** (1934– ), Italian physicist. Principal architect of experiment that first detected intermediate vector bosons, an important step in confirming theory uniting electromagnetic and weak nuclear interactions; Nobel Prize, 1984.
- Rubens, Heinrich** (1865–1922), German physicist. With E. B. Hagen, conducted electromagnetic experiments; built new types of galvanometer and bolometer.
- Runford, Benjamin Thompson, Count** (1753–1814), British physicist. Carried out research on heat.
- Runge, Carl David Tolme** (1856–1927), German mathematician and physicist. Research on theoretical and experimental spectroscopy, particularly data reduction and development of series formulas; developed methods for numerical and graphical computation, including Runge-Kutta method.
- Ruska, Ernst** (1906–1988), German electronic engineer. Developed the electron microscope; Nobel Prize, 1986.
- Russell Bertrand Arthur William** (1872–1970), English mathematician and philosopher. With A. N. Whitehead, pioneered in study of mathematical logic.
- Russell, Henry Norris** (1877–1957), American astronomer and physicist. Analyzed eclipsing binary stars; with E. Hertzsprung, introduced Hertzsprung-Russell diagram; determined abundance of chemical elements in solar atmosphere; with F. A. Saunders, devised theory of Russell-Saunders coupling.
- Rutherford, Ernest, 1st Baron** (1871–1937), British physicist. Discovered alpha, beta, and gamma rays; suggested the divisible nuclear atom; effected the transmutation of an atom; Nobel Prize, 1908.
- Ružička, Leopold** (1887–1976), Swiss chemist born in Croatia. Research on many-membered rings and higher terpenes (including male sex hormones); Nobel Prize, 1939.
- Rydberg, Johannes Robert** (1854–1919), Swedish physicist. Developed a formula for series of spectral lines, involving Rydberg's constant.
- Ryle, Martin** (1918–1984), British astronomer. Devised aperture synthesis method in radiotelescope; designed equipment and made observations in radio astronomy; Nobel Prize, 1974.
- Sabatier, Paul** (1854–1941), French chemist. Discovered, with J. B. Senderens, the process for catalytic hydrogenation of oils to solid fat; Nobel Prize, 1912.
- Sabin, Albert Bruce** (1906–1993), Polish-born American physician and virologist. Studied nature, mode of transmission, and epidemiology of human poliomyelitis; developed oral polio virus vaccine.
- Sabine, Edward** (1788–1883), British physicist and astronomer. Headed a magnetic survey of the world which discovered a connection between sunspots and terrestrial magnetic disturbances.
- Sabine, Wallace Clement Ware** (1868–1919), American physicist. Pioneered in architectural acoustics; discovered law determining reverberation time in acoustics.
- Sachs, Julius von** (1832–1897), German botanist. Studied the connection between sunlight and chlorophyll; worked on heliotropism and geotropism.
- Saha, Meghnad** (1894–1956), Indian physicist. Developed theory for degree of ionization of hot gases, a basic component of modern astrophysics.
- Sakmann, Bert** (1942– ), German physiologist. With E. Neher, using the "patch clamp" technique they developed, showed how individual ion channels control the passage of charged ions into and out of cells; Nobel Prize, 1991.
- Salam, Abdus** (1926–1996), Pakistani physicist. Independently of S. Weinberg, developed theory uniting two of the basic forces of nature, electromagnetism and the weak nuclear interactions; Nobel Prize, 1979.
- Salk, Jonas Edward** (1914–1995), American physician. Produced killed-virus vaccine effective in preventing poliomyelitis.
- Salpeter, Edwin Ernest** (1924– ), Austrian-born American physicist. Research in quantum theory of atoms, quantum electrodynamics, nuclear theory, energy production of stars, and theoretical astrophysics; with H. A. Bethe, introduced Bethe-Salpeter equation.
- Samuelsson, Bengt Ingemar** (1934– ), Swedish biochemist and medical scientist. Studied prostaglandin metabolism and the formation of prostaglandin from arachidonic acid; Nobel Prize, 1982.
- Sanctorius, real name Santorio Santorio** (1561–1636), Italian physician. Invented the clinical thermometer; experimented with metabolism.
- Sanger, Frederick** (1918– ), English chemist. Determined the exact order of amino acids in insulin; first to establish amino acid sequence for a protein; developed methods for determining nucleotide sequences (independently of W. Gilbert), advancing the technology of DNA recombination; Nobel Prizes, 1958 and 1980.
- Savart, Félix** (1791–1841), French physicist. Helped formulate the Biot-Savart law in electromagnetism.
- Schally, Andrew Victor** (1926– ), Polish-born American physiologist. With R. Guillemin, isolated and analyzed peptide hormones secreted in hypothalamic region of brain which control anterior pituitary hormone secretion; Nobel Prize, 1977.
- Schawlow, Arthur Leonard** (1921–1999), American physicist. Contributed to invention of laser; made numerous contributions to laser spectroscopy, particularly the development of Doppler-free spectroscopy; Nobel Prize, 1981.
- Scheele, Karl Wilhelm** (1742–1786), Swedish chemist. Made many discoveries, including oxygen (independently of J. Priestley), chlorine, and glycerin; synthesized many organic acids.
- Schiaparelli, Giovanni Virginio** (1835–1910), Italian astronomer. Discovered the connection between comets and meteorites, and the "canals" of Mars.
- Schiff, Hugo Josef** (1834–1915). German-born Italian organic chemist. Discovered Schiff bases; devised Schiff test; devised an improved nitrometer.
- Schmidt, Bernhard Voldemar** (1879–1935), Estonian-born German astronomer. Invented Schmidt system for astronomical telescopes.
- Schmidt, Erhard** (1876–1959), German mathematician. Extended D. Hilbert's work on integral equations; formalized and developed concept of Hilbert space.

- Schoenflies, Arthur Moritz** (1853–1928), German mathematician and crystallographer. Classified the 230 crystallographic space groups.
- Schottky, Walter** (1886–1976), Swiss-born German physicist. Discovered Schottky effect; invented screen grid and tetrode; developed Schottky theory of semiconductor-metal junctions.
- Schrieffer, John Robert** (1931– ), American physicist. With J. Bardeen and L. N. Cooper, formulated a theory of superconductivity; Nobel Prize, 1972.
- Schrödinger, Erwin** (1887–1961), German physicist. Proposed concept of atomic structure based on wave mechanics; contributed to quantum theory and color theory; Nobel Prize, 1933.
- Schur, Issai** (1875–1941), Russian-born German mathematician. Contributed to representation theory of groups; research on group theory, matrices, algebraic equations, and number theory.
- Schwartz, Laurent** (1915–2002), French mathematician. Developed the theory of distributions, which provided an abstract and rigorous mathematical foundation for methods of formal calculation such as the Dirac delta function, and greatly extended their range of application; Fields Medal, 1950.
- Schwartz, Melvin** (1932– ), American physicist. Collaborated in an experiment that demonstrated the existence of two types of neutrino; Nobel Prize, 1988.
- Schwarz, Hermann Amandus** (1843–1921), German mathematician. Introduced Schwarz-reflection principle and Schwarz's lemma while proving the Riemann mapping theorem.
- Schwarzschild, Karl** (1873–1916), German astronomer. Developed photographic methods for measuring brightness of stars; discovered Schwarzschild solution of equations of general relativity.
- Schwarzschild, Martin** (1912–1997), German-born American astronomer. Numerical studies of the internal structure and evolution of stars; astronomical observations with balloon-borne telescopes.
- Schwinger, Julian Seymour** (1918–1994), American physicist. Made fundamental contributions to the quantum theory of radiation; worked out the mathematical formalism of interaction between charged particles and an electromagnetic field; Nobel Prize, 1965.
- Seaborg, Glenn Theodore** (1912–1999), American chemist. Synthesized and identified eight transuranium elements and over a hundred isotopes; Nobel Prize, 1951.
- Secchi, Pietro Angelo** (1818–1878), Italian astronomer. Originated the spectroscopic survey of the heavens; made the first classification of stars according to spectral type.
- Sedgwick, Adam** (1785–1873), English geologist. With R. I. Murchison, established the Devonian system.
- Seebeck, Thomas Johann** (1770–1831), German physicist. Investigated thermoelectricity and invented the thermocouple.
- Segrè, Emilio Gino** (1905–1989), Italian-born American physicist. Codiscovered the elements technetium, astatine, and plutonium, slow neutrons, and the antiproton; Nobel Prize, 1959.
- Seidel, Philipp Ludwig von** (1821–1896), German astronomer and mathematician. Developed theory of aberrations; made first accurate photometric measurements of stars and planets, and evaluated them with probability theory.
- Selberg, Atle** (1917– ), Norwegian-American mathematician. Worked on generalizations of the sieve methods of V. Brun; proved major results on zeros of the Riemann zeta function; with P. Erdős, gave an elementary proof of the prime number theorem, with a generalization to numbers in an arbitrary arithmetic progression; Fields Medal, 1950.
- Semenov, Nikolai Nikolaevich** (1896–1986), Soviet chemist. Elucidated the mechanisms of chemical reactions, especially the chain mechanism; Nobel Prize, 1956.
- Senderens, Jean Baptiste** (1856–1937), French chemist. With P. Sabatier, discovered hydrolysis of oils by catalysis.
- Serber, Robert** (1909–1997), American physicist. Laid foundations of orbit theory of high-energy particle accelerators; introduced Serber potential to describe nuclear forces.
- Serre, Jean-Paul** (1926– ), French mathematician. Applied spectral sequences to discover fundamental connections between the homology groups and homotopy groups of a space and to prove important results on the homotopy groups of spheres; reformulated and extended some of the main results of complex variable theory in terms of sheaves; Fields Medal, 1954; Abel Prize, 2003.
- Serret, Joseph Alfred** (1819–1885), French mathematician and astronomer. Helped develop Frenet-Serret formulas in the theory of space curves.
- Servetus, Michael** (1511–1553), Spanish physician. Discovered the pulmonary circulation and the purification of the blood by the lungs.
- Shannon, Claude Elwood** (1916–2001), American mathematician. Developed mathematical theory of communication, making use of analogy between concepts of entropy and information.
- Shapley, Harlow** (1885–1972), American astronomer. Worked on a theory to explain cepheid variables; made an estimate of the size of the universe; provided a description of the universe's form of construction.
- Sharp, Phillip A.** (1944– ), American geneticist. Independently of R. Roberts, discovered split genes; Nobel Prize, 1993.
- Sharpless, K. Barry** (1941– ), American chemist. Developed chiral catalyzed oxidation reactions; Nobel Prize, 2001.
- Sherrington, Charles Scott** (1861–1952), English physiologist. Studied the neuron and its function and other aspects of the nervous system; Nobel Prize, 1932.
- Shirakawa, Hideki** (1936– ), Japanese polymer scientist. Discovered and developed conductive polymers with Alan Heeger and Alan MacDiarmid; Nobel Prize, 2000.
- Shockley, William** (1910–1989), English-born American physicist. Discovered the transistor effect for electronic amplification by means of solid-state semiconductors; Nobel Prize, 1956.
- Shor, Peter** (1959– ), American mathematician. Worked in combinatorial analysis and the theory of quantum computing; developed a computational method for factorizing large numbers on quantum computers, which, theoretically, could be used to break many of the coding systems currently employed.
- Shubnikov, Aleksei Vasilevich** (1887–1970), Soviet crystallographer. Classified Shubnikov groups; developed techniques for growing crystals, including synthetic rubies used in lasers.
- Shull, Clifford G.** (1915–2001), American physicist. Developed the neutron diffraction technique for studying the atomic structure of solids and liquids; Nobel Prize, 1994.
- Siegbahn, Kai Manne Börje** (1918– ), Swedish physicist. Pioneered the development of high-resolution electron spectroscopy; Nobel Prize, 1981.
- Siegbahn, Karl Manne Georg** (1886–1978), Swedish physicist. Studied x-ray spectroscopy, in which he discovered the M series; Nobel Prize, 1924.
- Siegel, Carl Ludwig** (1896–1981), German mathematician. Worked on number theory, functions of one or several complex variables, and differential equations.
- Siemens, Ernst Werner von** (1816–1892), German engineer and electrician. Developed telegraphy and self-acting dynamo.
- Siemens, William or Karl Wilhelm** (1823–1883), German inventor in London. Made many inventions, including a differential governor, bathometer, dynamometer, and electric furnace.
- Simpson, Thomas** (1710–1761), English mathematician. Formulated the Simpson rule for finding the area of a figure, given only a limited number of data.
- Singer, Isadore Manual** (1924– ), American mathematician. Worked in global analysis, especially the theory of elliptic operators and their applications to topology and geometry, and in mathematical physics; collaborated with M. F. Atiyah in proving the index theorem; Abel Prize, 2004.
- Skou, Jens C.** (1918– ), Dutch chemist. Discovered an ion-transporting enzyme—sodium, potassium-stimulated adenosine triphosphatase (Na<sup>+</sup>, K<sup>+</sup>-ATPase)—maintaining the balance of sodium and potassium ions in the living cell; Nobel Prize, 1997.
- Slater, John Clarke** (1900–1976), American physicist. Introduced Slater determinant describing many-electron systems; developed theory of magnetrons.
- Smale, Stephen** (1930– ), American mathematician. Worked in differential topology, differential equations, and dynamical systems; proved that the sphere can be turned inside out and that the generalized Poincaré conjecture is valid for dimensions greater than 4; discovered strange attractors that lead to chaotic dynamical systems; Fields Medal, 1966.
- Smalley, Richard E.** (1943– ), American chemist. Designed and built a special laser-supersonic cluster beam apparatus that was used in the discovery of fullerenes; Nobel Prize, 1996.
- Smith, Hamilton Othanel** (1931– ), American geneticist. Isolated a restriction enzyme that cleaves deoxyribonucleic acid (DNA) molecules at a specific site; Nobel Prize, 1978.
- Smith, Michael** (1927–2000), Canadian chemist. Made fundamental contribution toward oligonucleotide-based, site-directed mutagenesis and its development for protein studies within DNA-based chemistry; Nobel Prize, 1993.
- Smith, Robert** (1689–1768), English physicist. Developed a particulate theory of light; developed geometric propositions for computing properties of optical systems; derived a special case of the Smith-Helmholtz law.
- Snell, George Davis** (1903–1996), American immunogeneticist. Demonstrated the x-ray induction of mutational changes in a mammal; contributed to the study of immunological systems and to the development of transplant immunology; Nobel Prize, 1980.
- Snell, Willebrod van Roijen** (1591–1626), Dutch mathematician. Formulated Snell laws concerning angles of incidence and refraction; conceived the idea of measuring the Earth by triangulation.
- Soddy, Frederick** (1877–1956), English chemist. With E. Rutherford, developed theory of atomic disintegration of radioactive substances; research on isotopes; Nobel Prize, 1921.
- Solvay, Ernest** (1838–1922), Belgian industrial chemist. Developed the Solvay process for production of sodium carbonate.
- Sommerfeld, Arnold** (1868–1951), German physicist. Developed quantum theory, especially in its application to spectral lines and the Bohr atomic model.
- Sørensen, Sören Peter Lauritz** (1868–1939), Danish biochemist. Did pioneer work on hydrogen ion concentration; invented the symbol pH.
- Spemann, Hans** (1869–1941), German zoologist. Studied embryonic development and discovered the organizer function of certain tissues; Nobel Prize, 1935.
- Sperry, Roger Wolcott** (1913–1994), American neuroscientist. Discovered the functional split between the left and right hemispheres of the brain; Nobel Prize, 1981.
- Spörer, Gustav Friedrich Wilhelm** (1822–1895), German astronomer. Observations of the sun and sunspots.
- Stanley, Wendell Meredith** (1904–1971), American biochemist. Discovered that a virus is a nucleoprotein and can be crystallized; Nobel Prize, 1946.
- Stanton, Thomas Ernest** (1865–1931), English engineer. Studied surface friction of fluids; built

- wind tunnel for wind velocity investigations; studied strength of materials, heat transmission, and lubrication.
- Stark, Johannes** (1874–1957), German physicist. Studied radiation and atomic theory; discovered the Stark effect on spectrum lines and the Doppler effect in canal rays; Nobel Prize, 1919.
- Staudinger, Hermann** (1881–1965), German chemist. Conceived and elaborated the explanation of phenomenon of polymerization; Nobel Prize, 1953.
- Steenrod, Norman Earl** (1910–1971), American mathematician. Worked in topology; introduced Steenrod algebra.
- Stefan, Josef** (1835–1893), Austrian physicist. Originated Stefan's (or Stefan-Boltzmann) law of blackbody radiation; proposed theory of diffusion of gases; studied gas conductivity.
- Stein, William Howard** (1911–1980), American biochemist. With S. Moore, developed technique for determining amino acid sequence in proteins, and applied it to ribonuclease; Nobel Prize, 1972.
- Steinberger, Jack** (1931– ), German-born American physicist. Collaborated in an experiment that demonstrated the existence of two types of neutrino; Nobel Prize, 1988.
- Steinmetz, Charles Proteus** (1865–1923), German-born American electrical engineer. Developed complex number technique for analyzing alternating-current circuits; made numerous electrical inventions; applied mathematical methods to solution of electrical engineering problems.
- Stern, Otto** (1888–1969), German-born American physicist. Developed the molecular beam method and used it to prove directly the existence of the magnetic moment of atoms and nuclei and to measure their magnitudes; Nobel Prize, 1943.
- Stieltjes, Thomas Jan** (1856–1894), Dutch-born French mathematician. Developed analytic theory of continued fractions, and Stieltjes integral as a tool for their study.
- Stirling, James** (1692–1770), British mathematician. Discovered Stirling's formula and Stirling's interpolation formula.
- Stokes, George Gabriel** (1819–1903), British mathematician and physicist. Originated the idea of determining the chemical composition of the Sun and stars from their spectra; studied double refraction and electromagnetic waves.
- Stone, Marshall Harvey** (1903–1989), American mathematician. Studied structural aspects of mathematical situations having origins in classic problems of analysis, geometry, and logic.
- Störmer, Carl Fredrik Mülertz** (1874–1957), Norwegian mathematician and geophysicist. Studied atmospheric phenomena; discovered the Stormer cone concerning cosmic rays.
- Störmer, Horst Ludwig** (1949– ), German-American physicist. With D. C. Tsui, discovered the fractional quantum Hall effect, a manifestation of a new form of quantum fluid with fractionally charged excitations; Nobel Prize, 1998.
- Strassman, Fritz** (1902–1980), German chemist. With O. Hahn and L. Meitner, discovered nuclear fission; research on uranium and thorium isotopes.
- Strömgren, Bengt Georg Daniel** (1908–1987), Swedish-born American astronomer. Developed theory of nebululae consisting of hydrogen ionized by hot stars.
- Struve, Friedrich Georg Wilhelm von** (1793–1864), German-born Russian astronomer. Authority on double stars and nebulae; one of the first to measure a stellar parallax.
- Struve, Otto Wilhelm von** (1819–1905), Russian astronomer. Discovered some 500 new double stars; calculated the constant of precession.
- Sturgeon, William** (1783–1850), English electrician and inventor. Constructed the first useful electromagnet and the first moving-coil galvanometer.
- Sturm, Jacques Charles François** (1803–1855), French mathematician. Formulated the Sturm theorems, concerning real roots of an equation.
- Suhl, Harry** (1922– ), German-born American physicist. Discovered Suhl effect; invented Suhl amplifier; studied resonance in magnetic materials, superconductivity, and general theory of magnetism.
- Sulston, John E.** (1942– ), British geneticist. Using the nematode *Caenorhabditis elegans* as a model system, discovered that specific cells in the cell lineage always die through programmed cell death. Described the visible steps in the cellular death process and demonstrated the first mutations of genes participating in programmed cell death. Nobel Prize, 2002.
- Sumner, James Batcheller** (1887–1955), American biochemist. First to isolate an enzyme in pure, crystalline form and characterize it as a protein; Nobel Prize, 1946.
- Sutherland, Earl Wilbur, Jr.** (1915–1974), American physiologist. Uncovered intermediary role of cyclic adenylic acid in the mechanism of hormone control over human metabolic activities; Nobel Prize, 1971.
- Svedberg, Theodor** (1884–1971), Swedish chemist. An authority on colloid chemistry (dispersed phase); developed a centrifuge for colloidal particles and protein molecules; Nobel Prize, 1926.
- Sydenham, Thomas** (1624–1689), English physician. Gave classic descriptions of gout, venereal disease, fevers, hysteria, and Sydenham's chorea.
- Syng, Richard Laurence Millington** (1914–1994), English chemist. Developed partition chromatography with A. J. P. Martin; Nobel Prize, 1952.
- Szent-Györgyi, Albert von Nagrapolt** (1893–1986), Hungarian biochemist. Isolated vitamin C; research on combustion processes in plant and animal tissues, muscular contraction, and cell division; Nobel Prize, 1937.
- Talbot, William Henry Fox** (1800–1877), English inventor and mathematician. Invented the calotype photographic process.
- Tamm, Igor Yevgenevich** (1895–1971), Soviet physicist. With I. M. Frank, formulated the mathematical theory explaining the physical origin and properties of Cerenkov radiation; Nobel Prize, 1958.
- Tanaka, Koichi** (1959– ), Japanese engineer. Developed soft desorption ionization method for mass spectrometric analyses of biological macromolecules; Nobel Prize, 2002.
- Tatum, Edward Lawrie** (1909–1975), American biochemist and geneticist. Researched the relation of genes to biochemical reactions in bacterial, yeast, and mold cells; with G. W. Beadle, discovered the phenomenon of genetic recombination in bacteria; Nobel Prize, 1958.
- Taube, Henry** (1915– ), American chemist. Elucidated the mechanisms of electron transfer reactions, especially in metal complexes; Nobel Prize, 1983.
- Taylor, Brook** (1685–1731), English mathematician. Formulated Taylor's theorem and worked on mathematics of physical problems.
- Taylor, Geoffrey Ingram** (1886–1975), British mathematician. Work in theoretical hydrodynamics, particularly turbulence and effect of rotation on fluid flow.
- Taylor, Joseph Hooten, Jr.** (1941– ), American astronomer. With R. A. Hulse, discovered a binary pulsar and studied it to observe phenomena predicted by general relativity; Nobel Prize, 1993.
- Taylor, Richard Edward** (1929– ), American physicist. Collaborated in experiments that demonstrated that protons, neutrons, and similar particles are made up of quarks; Nobel Prize, 1990.
- Taylor, Richard Lawrence** (1962– ), British mathematician. Assisted A. Wiles in the proof of Fermat's last theorem; collaborated with C. Breuil, B. Conrad, and F. Diamond in extending this work by proving the Taniyama-Shimura conjecture on elliptic curves.
- Teisserenc de Bort, Léon Philippe** (1855–1913), French meteorologist. Discovered the stratosphere.
- Teller, Edward** (1908–2003), Hungarian-born American physicist. With associates, developed the concept which led to the construction of the first hydrogen bomb; with G. Gamow, proposed the Gamow-Teller interaction and Gamow-Teller selection rules.
- Temin, Howard Martin** (1934–1994), American virologist. Proposed that genetic information is transferred from ribonucleic acid tumor viruses to deoxyribonucleic acid; independently of D. Baltimore, discovered reverse transcriptase; Nobel Prize, 1975.
- Tesla, Nikola** (1856–1943), American inventor born in what is now Croatia of Serbian parents. Invented the induction motor, a high-frequency electric coil; improved design of dynamos, transformers, and electric bulbs.
- Thales** (ca. 640-ca. 546 B.C.), Greek mathematician and astronomer. First to scientifically predict an eclipse of the Sun; discovered static electricity; credited with formulating several theorems.
- Theiler, Max** (1899–1972), South African physician and virologist. Developed a vaccine to prevent human yellow fever; Nobel Prize, 1951.
- Theorell, Axel Hugo Teodor** (1903–1982), Swedish biochemist. Made discoveries concerning the nature and mode of action of oxidative enzymes; Nobel Prize, 1955.
- Thiele, F. K. Johannes** (1865–1918), German chemist. Research on nitrogen compounds and the theory of unsaturated organic molecules.
- Thom, René** (1923–2002), French mathematician. Invented and developed the theory of cobordism in algebraic topology, a classification of manifolds that used homotopy theory in a fundamental way; developed catastrophe theory; Fields Medal, 1958.
- Thomas, Edward Donnell** (1920– ), American physician. Performed the first successful transfer of bone marrow from one individual to another; with J. Murray, helped define and then overcome the immunological mechanisms behind organ rejection; Nobel Prize, 1990.
- Thomas, Llewellyn Hilleth** (1903–1992), English-born American physicist. Discovered Thomas precession; with E. Fermi, developed Thomas-Fermi atomic model; developed basic theory for Thomas cyclotron.
- Thompson, John Griggs** (1932– ), American-British mathematician. Worked on theory of finite groups; with W. Feit, proved that all noncyclic finite simple groups have even order; determined the finite simple groups whose proper subgroups are solvable (minimal simple groups); Fields Medal, 1970.
- Thomson, George Paget** (1892–1975), English physicist. Discovered, independently of C. J. Davison, the diffraction of electrons by crystals; Nobel Prize, 1937.
- Thomson, Joseph John** (1856–1940), English physicist. Discovered that cathode rays consist of negatively charged particles, or electrons; Nobel Prize, 1906.
- 't Hooft, Gerardus** (1946– ), Dutch physicist. With M. J. G. Veltman, elucidated the quantum structure of the electroweak interactions, placing the theory of these interactions and similar particle physics theories on a firmer mathematical foundation by showing how they may be used for precise calculations of physical quantities; Nobel Prize, 1999.
- Thouless, David James** (1934– ), British physicist. Studied many-body problem and its applications to nuclear and condensed matter physics, including phase transitions in superfluid helium films and electrons in disordered systems.
- Thue, Axel** (1863–1922), Norwegian mathematician. Worked on number theory, especially algebraic numbers and Diophantine equations.
- Thurston, William Paul** (1946– ), American mathematician. Advanced the study of topology in two and three dimensions, showing relationships between analysis, topology, and geometry; suggested that a very large class of closed three-manifolds carry a hyperbolic structure; Fields Medal, 1982.
- Tinbergen, Nikolaas** (1907–1988), Dutch-born British zoologist. Pioneered in study of social behavior of animals and their responses to complex

- stimuli; conducted experimental studies of the effects of selection pressures and evolutionary response to them; Nobel Prize, 1973.
- Ting, Samuel Chao Chung** (1936– ), American physicist. Independently of B. Richter, discovered a new heavy elementary particle, which he named the J particle; Nobel Prize, 1976.
- Tiselius, Arne Wilhelm Kaurin** (1902–1971), Swedish biochemist. Research on electrophoresis and absorption analysis; made discoveries concerning the complex nature of serum proteins; Nobel Prize, 1948.
- Todd of Trumpington, Alexander Robertus Todd, Baron** (1907–1997), British chemist. Worked on the structure and synthesis of nucleotides, and nucleotide coenzymes, and the related problem of phosphorylation; Nobel Prize, 1957.
- Tomlinson, Ray** (1941– ), American computer engineer. Invented electronic mail, including the use of @ in the address.
- Tomonaga, Sin-Itiro** (1906–1979), Japanese physicist. Showed the modern theory of quantum electrodynamics to be quantitatively consistent with observed physical phenomena; Nobel Prize, 1965.
- Tonegawa, Susumu** (1939– ), Japanese immunologist. Discovered how a limited number of genes are capable of producing a vast number of diverse antibodies, each designed for a specific invading foreign substance; Nobel Prize, 1987.
- Torricelli, Evangelista** (1608–1647), Italian physicist. Invented the mercury barometer.
- Townes, Charles Hard** (1915– ), American physicist. Invented the maser; Nobel Prize, 1964.
- Townsend, John Sealy Edward** (1868–1957), British physicist. Developed collision theory of ionization of gases in an electric field.
- Travers, Morris William** (1872–1961), English chemist. Discovered, with W. Ramsay, krypton, xenon, and neon; investigated low-temperature phenomena.
- Ts'ai Lun** (fl. 105), Chinese inventor. Invented paper.
- Tsui, Daniel Chee** (1939– ), Chinese-born American physicist. With H. L. Störmer, discovered the fractional quantum Hall effect, a manifestation of a new form of quantum fluid with fractionally charged excitations; Nobel Prize, 1998.
- Turing, Alan Mathison** (1912–1954), English mathematician. Developed concept of Turing machine; research on mathematical logic, group theory, and computer technology.
- Tychonoff (Tikhonov), Andrei Nikolaevich** (1906–1993), Soviet mathematician and geophysicist. Proved Tychonoff theorem in topology and introduced concept of Tychonoff space.
- Tyndall, John** (1820–1893), British physicist. Studied temperature waves in metals and diathermancy of gases; discovered the effect of atmospheric density on sound transmission.
- Uhlenbeck, George Eugene** (1900–1988), Javanese-born American physicist. With S. Goudsmit, developed hypothesis of electron spin.
- Urey, Harold Clayton** (1893–1981), American chemist. Isolated heavy water and thus discovered the heavy isotope of hydrogen; Nobel Prize, 1934.
- Urysohn, Pavel Samuilovich** (1898–1924), Soviet mathematician. Proved Urysohn's lemma in topology.
- Van Allen, James Alfred** (1914– ), American physicist. Discovered that the Earth is circled by two high-energy radiation belts, leading to major revisions in concepts of the Earth's atmosphere and magnetic field.
- Van de Graaff, Robert Jemison** (1901–1967), American physicist. Contributed to the development of the direct particle accelerator and invented the electrostatic belt generator.
- van der Meer, Simon** (1925– ), Dutch physicist. Devised method to ensure frequent and efficient collision of accelerated protons and antiprotons in the superproton synchrotron at CERN, contributing to discovery of intermediate vector bosons; Nobel Prize, 1984.
- Vandermonde, Alexandre Théophile** (1735–1796), French mathematician. Gave first logical exposition of theory of determinants; developed methods to test solvability of algebraic equations.
- van der Waals, Johannes Diderik** (1837–1923), Dutch physicist. Formulated van der Waals equation; investigated van der Waals forces, concerning intermolecular attraction; Nobel Prize, 1910.
- Vane, John Robert** (1927– ), English pharmacologist. Discovered prostaglandin X (prostaglyclin) and the role of aspirinlike drugs as blocking agents in the prostaglandin synthesis; Nobel Prize, 1982.
- van Rhijn, Pieter Johannes** (1886–1960), Dutch astrophysicist. With J. C. Kapetyn, evolved a theory of the universe.
- van't Hoff, Jacobus Hendricus** (1852–1911), Dutch chemist. Pioneered in the study of stereochemistry; studied reaction rates, thermodynamics applied to chemistry, and the theory of dilute solutions; Nobel Prize, 1901.
- Van Vleck, Jan Hasbrouck** (1899–1980), American mathematical physicist. Pioneer in the development of the modern quantum-mechanical theory of magnetism; Nobel Prize, 1977.
- Varmus, Harold** (1939– ), American researcher in molecular virology and oncogenesis. With J. M. Bishop, researched the genetic basis of human cancers; their work led to the identification of over 50 cellular genes that can become oncogenes; Nobel Prize, 1989.
- Vauquelin, Louis Nicola** (1763–1829), French chemist. Discovered chromium and its compounds and beryllium compounds.
- Vega, George, Baron von** (1756–1802), Austrian mathematician. Prepared logarithmic tables.
- Veltman, Martinus J. G.** (1931– ), Dutch physicist. With G. 't Hooft, elucidated the quantum structure of the electroweak interactions, placing the theory of these interactions and similar particle physics theories on a firmer mathematical foundation by showing how they may be used for precise calculations of physical quantities; Nobel Prize, 1999.
- Verdet, Marcel Emile** (1824–1866), French physicist. Determined dependence of Faraday effect on magnetic field strength, wavelength of the light, and index of refraction of the material.
- Vernier, Pierre** (1580–1637), French technician. Invented the Vernier scale.
- Vesalius, Andreas** (1514–1564), Belgian anatomist in Italy. Known as the father of modern anatomy; corrected many of Galen's mistaken doctrines.
- Viète, François, or Franciscus Vieta** (1540–1603), French mathematician. Worked on the solution of equations up to the fourth degree and laid the foundation of modern algebra.
- Virtanen, Artturi Ilmari** (1895–1973), Finnish biochemist. Research on problems of human nutrition and agriculture; investigated acidity (pH) and biological nitrogen fixation; Nobel Prize, 1945.
- Voevodsky, Vladimir** (1966– ), Russian mathematician. Developed a new cohomology theory for algebraic varieties, which represented an important advance in number theory and algebraic geometry. Fields Medal, 2002.
- Vogel, Hermann Wilhelm** (1834–1898), German photochemist. Invented the orthochromatic photographic plate and designed a photometer.
- Voigt, Woldemar** (1850–1919), German physicist. Introduced transformation equations (later known as Lorentz transformations).
- Volta, Alessandro, Count** (1745–1827), Italian physicist. Invented the voltaic pile; developed the theory of current electricity.
- Volterra, Vito** (1860–1940), Italian mathematician. Developed method of solving Volterra equations; pioneered in developing functional analysis.
- Von Braun, Wernher** (1912–1977), German-born American rocket engineer. Directed development of the German V-2 and Wassefall missiles; instrumental in launch of *Explorer 1*, first American artificial satellite; supervised development of Saturn rockets for the Apollo program.
- Von Euler, Ulf Svante** (1905–1983), Swedish physiologist. Identified norepinephrine as neurotransmitter of sympathetic nervous system; isolated and characterized norepinephrine storage granules in nerves; Nobel Prize, 1970.
- von Kármán, Theodore** (1881–1963), American aerodynamicist. Theoretical contributions to aerodynamics; formulated von Kármán's theory of vortex streets, an early step in the mathematical treatment of turbulent motion.
- von Neumann, John** (1903–1954), Hungarian-born American mathematician. Research in logic, theory of quantum mechanics, theory of high-speed computing machines, and mathematical theory of games and strategy.
- Wagner von Jauregg (Wagner-Jauregg), Julius** (1857–1940), Austrian psychiatrist. Developed use of malarial infection to treat general paresis; Nobel Prize, 1927.
- Waksman, Selman Abraham** (1888–1973), Russian-born American bacteriologist. Isolated the antibiotic streptomycin; Nobel Prize, 1952.
- Wald, George** (1906–1997), American biologist and biochemist. Discovered the role of vitamin A in vision; Nobel Prize, 1967.
- Walker, John E.** (1941– ), British chemist. Made major contributions toward elucidating the enzymatic mechanism underlying the synthesis of adenosine triphosphate (ATP) by clarifying the structural conditions of the enzyme; Nobel Prize, 1997.
- Wallace, Alfred Russel** (1823–1913), English naturalist. Originated, independently of C. Darwin, theory of natural selection; postulated Wallace's line regarding geographical distribution of animals.
- Wallach, Otto** (1847–1931), German chemist. Research on essential oils and the terpenes; Nobel Prize, 1910.
- Wallis, John** (1616–1703), English mathematician. Worked on algebraic curves, interpolation, evaluation of integrals, infinite series, mechanics, and algebra; derived Wallis product and Wallis formulas.
- Walton, Ernest Thomas Sinton** (1903–1995), British physicist. With J. D. Cockcroft, devised high-voltage apparatus capable of producing fast atomic particles with energies up to 700,000 electronvolts; showed the capability of these particles to disintegrate many light elements; Nobel Prize, 1951.
- Wannier, Gregory Hugh** (1911–1983), Swiss-born American physicist. Developed harmonization of localized and nonlocalized descriptions of electrons in solids.
- Warburg, Otto Heinrich** (1883–1970), German physiologist. Worked on chemistry of respiration and on cancer; Nobel Prize, 1931.
- Wassermann, August von** (1866–1925), German physician. Discovered the Wassermann test for the detection of syphilis.
- Watson, James Dewey** (1928– ), American biochemist. With F. H. C. Crick, determined the double-helix structure of deoxyribonucleic acid; Nobel Prize, 1962.
- Watson, John Broadus** (1878–1958), American psychologist. Founded the behaviorist school of psychology.
- Watt, James** (1736–1819), Scottish inventor. Improved the steam engine, making it a commercial success.
- Weber, Ernst Heinrich** (1795–1878), German anatomist and physiologist. Discovered Weberian apparatus; applied hydrodynamics to study of blood circulation; discovered inhibitory power of vagus nerve; proposed Weber's law of stimuli.
- Weber, Heinrich** (1842–1913), German mathematician. Introduced Weber differential equation; demonstrated Abel theorem in its most general form; proved that absolute Abelian fields are cyclotomic.
- Weber, Wilhelm Eduard** (1804–1891), German physicist. Devised instruments for measurement of electrical and magnetic quantities; formulated absolute electrical and magnetic units.

- Wegener, Alfred Lothar** (1880–1930), German geologist. Presented the idea of continental drift.
- Welerstrass, Karl Theodor** (1815–1897), German mathematician. Worked on the theory of functions and on the calculus of variations.
- Weil, Adolf** (1848–1916), German physician. Gave classic description of Weil's disease.
- Weil, André** (1906–1998), French-born American mathematician. Laid the foundations for abstract algebraic geometry and the modern theory of algebraic varieties, starting a rapid advance in both algebraic geometry and number theory.
- Weinberg, Steven** (1933– ), American physicist. Independently of A. Salam, developed theory uniting two of the basic forces of nature, electromagnetism and the weak nuclear interactions; Nobel Prize, 1979.
- Weismann, August** (1834–1914), German biologist. Contributed to the theory of heredity, which he attributed to variations in "germ-plasm."
- Weiss, Pierre** (1865–1940), French physicist. Developed phenomenological theory of ferromagnetism.
- Weizsäcker, Carl Friedrich von** (1912– ), German physicist. Helped develop method for calculating bremsstrahlung in high-energy collisions; developed a theory of origin of solar system.
- Weller, Thomas Huckle** (1915– ), American virologist and parasitologist. Isolated the virus of chickenpox and herpes zoster and proved the common etiology of the two diseases; first to propagate German measles virus; Nobel Prize, 1954.
- Wentzel, Gregor** (1898–1978), German-born American physicist. Helped develop Wentzel-Kramers-Brillouin method; research on theory of atomic spectra, wave mechanics, quantum electrodynamics, meson field theories, and statistical mechanics of many-body problems, especially superconductivity.
- Werner, Alfred** (1866–1919), Swiss chemist. Formulated the coordination theory of valency; Nobel Prize, 1913.
- Weyl, Hermann** (1885–1955), German-born American mathematician and mathematical physicist. Basic research on group representations and Riemann surfaces.
- Wheatstone, Charles** (1802–1875), English physicist and inventor. Conducted experiments on sound; invented Wheatstone's bridge, an instrument for comparing electrical resistances.
- Wheeler, John Archibald** (1911– ), American physicist. Introduced the concepts of the scattering matrix and resonating group structure into nuclear physics; with N. Bohr, elucidated the mechanism of nuclear fission and predicted the fissibility of plutonium.
- Whewell, William** (1794–1866), British astronomer. Work on the tides, and on the history and philosophy of science.
- Whipple, George Hoyt** (1878–1976), American pathologist. Studied anemia and liver treatment; Nobel Prize, 1934.
- Whitehead, Alfred North** (1861–1947), English mathematician, physicist, and philosopher. With B. Russell, pioneered in mathematical logic and foundations of mathematics.
- Whittaker, Edmund Taylor** (1873–1956), British mathematician and physicist. Studied special functions of mathematical physics and equations satisfied by them, particularly Whittaker's differential equation; found general integral representation for harmonic functions; made major contributions to analytical dynamics.
- Wiedemann, Gustave Heinrich** (1826–1899), German physicist and physical chemist. With R. Franz, discovered Wiedemann-Franz law of thermal conductivity of metals; discovered Wiedemann effect.
- Wieland, Heinrich** (1877–1957), German chemist. Studied bile acids, chlorophyll, and hemoglobin; Nobel Prize, 1927.
- Wieman, Carl Edwin** (1951– ), American physicist. With E. A. Cornell, succeeded in producing Bose-Einstein condensates in a dilute gas of alkali (rubidium) atoms, and carried out fundamental studies of their properties, including studies of collective excitations and vortex formation in condensates; Nobel Prize, 2001.
- Wien, Wilhelm** (1864–1928), German physicist. Formulated the two Wien laws pertaining to radiation from blackbodies; Nobel Prize, 1911.
- Wiener, Norbert** (1894–1964), American mathematician. Formulated a mathematical theory of Brownian motion; founded science of cybernetics.
- Wieschaus, Eric F.** (1947– ), American developmental biologist. Using *Drosophila*, he and the German developmental biologist Christiane Nüsslein-Volhard identified and classified a small number of genes that are important in determining the body plan and the formation of body segments; their work, along with that of American developmental biologist Edward B. Lewis, led to the discovery of important genetic mechanisms which control early embryonic development; Nobel Prize, 1995.
- Wiesel, Torsten Nils** (1924– ), Swedish physiologist. Contributed to the study of the processing of visual information in the brain; Nobel Prize, 1981.
- Wigner, Eugene Paul** (1902–1995), Hungarian-born American mathematical physicist. With G. Breit, worked out the Breit-Wigner formula for resonant nuclear reactions; proposed the Wigner theorem of conservation of the angular momentum of electron spin; Nobel Prize, 1963.
- Wilczek, Frank** (1951– ), Discovered asymptotic freedom in the strong interactions (in collaboration with D. J. Gross, and independent of H. D. Politzer); Nobel Prize, 2004.
- Wiles, Andrew John** (1953– ), British mathematician. Proved Fermat's last theorem with assistance of R. Taylor.
- Wilkins, Maurice Hugh Frederick** (1916–2004), English biophysicist born in New Zealand. Made x-ray diffraction studies that contributed to the structural determination of deoxyribonucleic acid; Nobel Prize, 1962.
- Wilkinson, Geoffrey** (1921–1996), British chemist. Research to determine how metals and organic molecules combine to form unique molecules which have sandwichlike structures; Nobel Prize, 1973.
- Williamson, William Crawford** (1816–1895), English naturalist. Laid the foundation for paleobotany and showed the importance of plant life forms in coal.
- Willstätter, Richard** (1872–1942), German chemist. Worked on plant pigments; investigated alkaloids and their derivatives; Nobel Prize, 1915.
- Wilson, Charles Thomson Rees** (1869–1959), British physicist. Worked on ionization; originated the cloud chamber method of studying ionized particles; Nobel Prize, 1927.
- Wilson, Kenneth Geddes** (1936– ), American physicist. Used renormalization group theory to analyze critical phenomena in the behavior of matter at phase transitions; Nobel Prize, 1982.
- Wilson, Robert Woodrow** (1936– ), American astrophysicist. With A. A. Penzias, discovered cosmic background radiation, confirming the big bang theory of the origin of the universe; Nobel Prize, 1978.
- Windaus, Adolf** (1876–1959), German chemist. Worked on sterols; discovered that ultraviolet light activates ergosterol and gives vitamin D<sub>2</sub>; Nobel Prize, 1928.
- Witten, Edward** (1951– ), American mathematical physicist. Applied advanced mathematical tools to theoretical physics, particularly quantum field theory, supersymmetry, and string theory; his physical insights were the basis for major developments in mathematics; Fields Medal, 1990.
- Wittig, Georg** (1897–1987), German chemist. Work on the linking of carbon and phosphorus (Wittig reaction) made it possible to synthesize new types of compounds, including metal-organic complex compounds; Nobel Prize, 1979.
- Wöhler, Friedrich** (1800–1882), German chemist. First to synthesize an organic compound, urea.
- Wolf, Maximilian Franz Joseph Cornelius** (1863–1932), German astronomer. Invented the photographic method of discovering asteroids.
- Wollaston, William Hyde** (1766–1828), English chemist and physicist. Discovered the lines in the solar spectrum; discovered palladium and rhodium; invented the Wollaston lens.
- Woodward, Robert Burns** (1917–1979), American chemist. Contributed to the development of total synthesis of complex natural products, and structural determination of several complex natural molecules, later confirmed by total synthesis; Nobel Prize, 1965.
- Wright, Almroth Edward** (1861–1947), British physician and pathologist. Studied parasitic disease; introduced inoculation against typhoid.
- Wright, Wilbur** (1867–1912) and **Orville** (1871–1948), American pioneers in aviation. Built the first successful airplane, which each flew at Kitty Hawk, North Carolina, on Dec. 17, 1903.
- Wundt, Wilhelm Max** (1832–1920), German physiologist and psychologist. Founded the first laboratory for experimental psychology.
- Wurtz, Charles Adolphe** (1817–1884), French chemist. Discovered methyl and ethyl amines; evolved the Wurtz reaction for synthesis of hydrocarbons.
- Wüthrich, Kurt** (1938– ), Swiss chemist. Developed nuclear magnetic resonance spectroscopy for determining the three-dimensional structure of biological macromolecules in solution; Nobel Prize, 2002.
- Yalow, Rosalyn Sussman** (1921– ), American medical physicist. Developed a radioimmunoassay technique to detect and measure minute levels of substances such as hormones in the body; Nobel Prize, 1977.
- Yang, Chen Ning** (1922– ), Chinese-born American physicist. With T. Lee, disproved the law of conservation of parity for weak interactions; Nobel Prize, 1957.
- Yau, Shing-Tung** (1949– ), Chinese-born American mathematician. Worked in differential geometry and partial differential equations; solved the Calabi conjecture in algebraic geometry and the positive mass conjecture of general relativity theory; Fields Medal, 1982.
- Yersin, Alexandre Émile Jean** (1863–1943), Swiss bacteriologist. Discovered the bubonic plague bacillus in Hong Kong, working independently of S. Kitasato, and developed a serum for it.
- Yoccoz, Jean-Christophe** (1957– ), French mathematician. Worked on the theory of dynamical systems; Fields Medal, 1994.
- Young, Thomas** (1773–1829), English physicist and physician. Discovered the effect of the ciliary muscle on the shape of the eye lens (the mechanism of accommodation).
- Yukawa, Hideki** (1907–1981), Japanese physicist. Postulated the existence of a new fundamental particle, the meson; Nobel Prize, 1949.
- Zariski, Oscar** (1899–1986), Russian-born American mathematician. Worked in algebraic geometry, in particular, on local uniformization and reduction of singularities of algebraic varieties.
- Zeeman, Pieter** (1865–1943), Dutch physicist. Discovered the Zeeman effect in magnetooptics; Nobel Prize, 1902.
- Zelmanov, Efim Isaakovich** (1955– ), Russian mathematician. Contributed to the theory of Jordan algebras and the theory of Lie algebras; solved the restricted Burnside problem, one of the fundamental questions in group theory; Fields Medal, 1994.
- Zener, Clarence Melvin** (1905–1993), American physicist. Proposed mechanism of Zener breakdown.
- Zeno of Elea** (ca. 490–425 B.C.), Greek philosopher and mathematician. Formulated a group of paradoxes, important for their stimulation of philosophical and mathematical thought, which appear to deny the possibility of motion.
- Zernike, Fritz** (1888–1966), Dutch physicist. Developed the phase-contrast microscope, making possible the first microscopic examination of the internal structure of living cells; Nobel Prize, 1953.



**Zewail, Ahmed H.** (1946– ), Egyptian-born American chemist. Studies the transition states of chemical reactions using femtosecond spectroscopy; Nobel Prize, 1999.

**Ziegler, Karl** (1898–1973), German organic chemist. Developed a low-pressure process for production of polyethylene; Nobel Prize, 1963.

**Zinkernagel, Rolf M.** (1944– ), Swiss-born American immunologist and physician. Shared in the discovery of the specificity of cell-mediated immune defense with P. C. Doherty; Nobel Prize, 1996.

**Zinsser, Hans** (1878–1940), American bacteriologist. Developed methods of immunization against typhus.

**Zsigmondy, Richard** (1865–1929), German chemist. Studied colloidal solutions; introduced the ultramicroscope; Nobel Prize, 1925.

**Zworykin, Vladimir Kosma** (1889–1982), Russian-born American physicist. Pioneer in the development of television and the electron microscope.



# Contributor Initials

Each article in the Encyclopedia is signed with the contributor's initials; coauthors' initials are separated by semicolons. The section below, Contributor Initials, gives all such initials, alphabetized according to the capital letters in each initials combination (lowercase letters have been added to differentiate contributors with like initials). The contributor's name is provided. The contributor's affiliation can then be found by turning to the next section, Contributor Affiliations.

## A

<b>A.A.</b>	Anthony Aguirre	<b>A.E.Br.</b>	Arthur E. Bryson, Jr.	<b>A.H.T.</b>	Alan H. Turtle
<b>A.A.B.P.</b>	A. Alan B. Pritsker	<b>A.E.Bro.</b>	Arthur E. Broadus	<b>A.H.W.</b>	Alfred H. Wolferz
<b>A.A.E.</b>	A. A. Ekdale	<b>A.E.Ca.</b>	Anders E. Carlsson	<b>A.H.Wa.</b>	Arthur H. Walz, Jr.
<b>A.A.F.</b>	Arthur A. Few	<b>A.E.D.</b>	A. E. Drake	<b>A.I.</b>	Alexander Illis
<b>A.A.G.</b>	Albert A. Gunkler	<b>A.E.Fr.</b>	A. E. Freeman	<b>A.I.D.</b>	Alex I. Donaldson
<b>A.A.L.</b>	Andrew A. Lacis	<b>A.E.J.</b>	Amos E. Joel, Jr.	<b>A.I.S.</b>	Anneila I. Sargent
<b>A.A.M.</b>	Aly A. Mahmoud	<b>A.E.L.</b>	Albert E. Lintherland	<b>A.J.A.</b>	Anthony J. Appleby
<b>A.A.R.</b>	Aldo A. Rossini	<b>A.E.M.</b>	A. E. Martell	<b>A.J.Ba.</b>	Alain J. Baronnet
<b>A.B.</b>	Alexander Baumgarten	<b>A.E.Mo.</b>	Alice E. Moore	<b>A.J.Bar.</b>	Allen J. Bard
<b>A.Bi.</b>	Arthur Bienenstock	<b>A.E.S.</b>	A. E. Siegman	<b>A.J.Br.</b>	Anthony J. Brammer
<b>A.Bl.</b>	Andrew Blain	<b>A.E.Ta.</b>	Angus E. Taylor	<b>A.J.C.</b>	Aaron J. Ciechanover: Protein
<b>A.Bo.</b>	A. Bo	<b>A.E.V.D.</b>	Albert E. Von Doenhoff	<b>A.J.C.</b>	Alan J. Charig: Reptilia etc.
<b>A.Bre.</b>	Alan Breier	<b>A.E.Wo.</b>	Albert E. Wood	<b>A.J.D.</b>	Adrianus J. Dekker
<b>A.Bu.</b>	Allison Butts	<b>A.Er.</b>	A. Erdelyi	<b>A.J.Fr.</b>	Albert J. Fry
<b>A.Bur.</b>	Alan Burkhalter	<b>A.Erd.</b>	Arthur Erdman	<b>A.J.F.G.</b>	A. J. F. Griffiths
<b>A.B.C.</b>	All B. Cambel	<b>A.Fe.</b>	Alan Feduccia	<b>A.J.H.</b>	Armin J. Hill
<b>A.B.Co.</b>	Alan B. Coppens	<b>A.Fl.</b>	Abraham Fleminger	<b>A.J.Hu.</b>	A. J. Hundhausen
<b>A.B.G.</b>	Alfred B. Garrett	<b>A.F.Be.</b>	Albert F. Bennett	<b>A.J.L.</b>	Anthony J. Leggett
<b>A.B.Gu.</b>	Ashley B. Gurney	<b>A.F.E.</b>	Alan F. Edwards	<b>A.J.M.</b>	Anthony J. Mazzo
<b>A.B.M.</b>	Alton B. Moody	<b>A.F.H.</b>	A. F. Hagner	<b>A.J.R.</b>	A. J. Rowell
<b>A.B.McG.</b>	Ann B. McGuire	<b>A.F.J.M.</b>	Anthony F. J. Moffat	<b>A.J.S.</b>	Anthony J. Stone
<b>A.B.O.</b>	Arthur B. Otis	<b>A.F.P.</b>	Albert F. Puchstein	<b>A.J.T.</b>	Aaron J. Teller
<b>A.B.S.</b>	Andrew B. Smith	<b>A.F.R.</b>	Austen F. Riggs	<b>A.J.W.</b>	Alexander J. Walt
<b>A.B.Sa.</b>	Alan B. Salisbury	<b>A.F.Ru.</b>	Arthur F. Rupp	<b>A.K.</b>	Arthur Kclman
<b>A.B.W.</b>	A. B. Watts	<b>A.F.T.</b>	Alex Francis Trendall	<b>A.K.H.</b>	Ardith K. Hansel
<b>A.Ca.</b>	Angelo Campanella	<b>A.F.T.C.</b>	Albert F.-T. Chen	<b>A.K.M.</b>	Alfred K. Mann
<b>A.Ch.</b>	Alan Chodos	<b>A.Gh.</b>	Albert Ghiorso	<b>A.K.R.</b>	Anant K. Ramdas
<b>A.Ci.</b>	Alex Ciegler	<b>A.G.B.</b>	A. G. Bailey	<b>A.Ko.</b>	Allan Konopka
<b>A.Cou.</b>	Arnold Court	<b>A.G.C.</b>	Albert C. Conrad	<b>A.L.</b>	Anton Lang
<b>A.Cr.</b>	Arthur Cronquist	<b>A.G.F.</b>	Alfred G. Fischer	<b>A.La.</b>	Alan Lawley
<b>A.C.C.</b>	Andrew C. Campbell	<b>A.G.H.</b>	Arthur G. Hansen	<b>A.Lar.</b>	Allan Larson
<b>A.C.Ca.</b>	A. Charles Catania	<b>A.G.Hu.</b>	Arthur G. Humes	<b>A.Lo.</b>	Alan Longacre
<b>A.C.G.</b>	Arch C. Gerlach	<b>A.G.L.</b>	Allan G. Lochhead	<b>A.L.A.</b>	Albert Louis Alfred
<b>A.C.Go.</b>	Arthur C. Gossard	<b>A.G.M.</b>	Antonios G. Mikos	<b>A.L.Al.</b>	Alice L. Alldredge
<b>A.C.L.</b>	Alcinda C. Lewis	<b>A.G.P.</b>	A. G. M. Barrett	<b>A.L.Ba.</b>	Alan L. Balch
<b>A.C.P.</b>	Andrew C. Pike	<b>A.G.Ph.</b>	Albert G. Petschek	<b>A.L.Be.</b>	Ann L. Beyer
<b>A.C.U.</b>	Arthur C. Upton	<b>A.G.W.C.</b>	Arun G. Phadke	<b>A.L.Bi.</b>	A. L. Bisno
<b>A.DeV.</b>	A. DeVolpi	<b>A.Ha.</b>	A. G. W. Cameron	<b>A.L.DeV.</b>	Arthur L. DeVries
<b>A.DiF.</b>	Anthony Di Fiore	<b>A.Ha.</b>	A. Hallam: Jurassic	<b>A.L.deW.</b>	A. L. de Week
<b>A.Do.</b>	Ali Dogramaci	<b>A.Had.</b>	A. Harriman: Photolysis	<b>A.L.G.</b>	Arnold L. Gordon
<b>A.D.F.</b>	Alan D. Fiala	<b>A.Has.</b>	A. Hadni	<b>A.L.H.</b>	Allen L. Hanson
<b>A.D.H.</b>	Arthur D. Hasler	<b>A.Ho.</b>	Alan Hastings	<b>A.L.I.</b>	Anthony L. Imbembo
<b>A.D.M.</b>	Andrew D. Miall	<b>A.Ho.</b>	Arthur Horwich	<b>A.L.K.</b>	Arthur L. Kohl
<b>A.D.P.</b>	Allan D. Pierce	<b>A.H.B.</b>	Alan H. Brush	<b>A.L.Ko.</b>	Arthur L. Koch
<b>A.D.S.</b>	A. Douglas Stone	<b>A.H.G.</b>	Arthur H. Graves	<b>A.L.L.</b>	Art Lerner-Lam
<b>A.D.Sk.</b>	A. Douglas Skinner	<b>A.H.K.</b>	Alan H. Karp	<b>A.L.M.</b>	A. L. Myers
<b>A.D.Z.</b>	Andrew D. Zeitlin	<b>A.H.M.</b>	Anne H. Morgan	<b>A.L.P.</b>	A. L. Ponikvar
<b>A.E.</b>	Arne Engstrom	<b>A.H.Ro.</b>	Arthur H. Robinson	<b>A.L.R.</b>	Alan L. Rowen
<b>A.E.Ba.</b>	A. Earle Bailey	<b>A.H.S.</b>	Amelie H. Scheltema	<b>A.L.S.</b>	Arthur L. Schawlow
		<b>A.H.Sa.</b>	Ali H. Sayed	<b>A.L.She.</b>	Albert L. Sheffer
		<b>A.H.Sn.</b>	Arthur H. Snell	<b>A.M.</b>	Alfred Makulec: Neon glow lamp
		<b>A.H.So.</b>	Alfred H. Sommer		
		<b>A.H.St.</b>	Alfred H. Sturtevant		

- A.M.** Albert Marden: Riemann surface  
**A.M.C.** Arthur M. Chickering  
**A.M.D.** Andrew M. Davis  
**A.M.Da.** Alberta M. Dawson  
**A.M.D'A.** Amelio M. D'Arcangelo  
**A.M.G.** Alan M. Gaines  
**A.M.H.** A. M. Hartley  
**A.M.I.** Aly M. Ibrahim  
**A.M.J.** Arthur M. James  
**A.M.K.** A. Murty Kanury: Fire technology  
**A.M.K.** Albert M. Kudo: Gabbro  
**A.M.M.** Alexander M. Mood  
**A.M.Ma.** Abe M. Macher  
**A.M.Mo.** A. M. Morrell  
**A.M.P.** Arthur M. Perrin  
**A.M.Pa.** Ana M. Parma  
**A.M.S.** Aephraim M. Steinberg: Coherence  
**A.M.S.** Alastair M. Stuart: Isoptera  
**A.M.Sp.** Allen M. Spiegel  
**A.M.W.** Andrew M. Weitzenhoffer  
**A.M.We.** Adrian M. Wenner  
**A.Ma.** Albert Marden  
**A.Mac.** Albert Machiels  
**A.McC.** Allysa McCabe  
**A.McI.** Andrew McIntyre  
**A.Me.** Anthony Mescher  
**A.Mo.** Albert Moscovitz  
**A.Mor.** Andrew Morton  
**A.Mot.** Allen Mottershead  
**A.My.** Arvid Mykleburst  
**A.N.** Allen Newell  
**A.Na.** Alexandra Navrotsky  
**A.N.C.** Archie N. Carter  
**A.N.H.** Alex N. Halliday  
**A.N.J.H.** A. N. J. Heyn  
**A.N.L.** Arnold N. Lowan  
**A.N.M.** Alan N. Moshell  
**A.N.N.** Arun N. Netravali  
**A.N.P.** Arthur N. Popper  
**A.N.S.** Albert N. Sayre  
**A.O.** Albert Overhauser  
**A.O.N.** Alfred O. Nier  
**A.O.T.** Alade O. Tokuta  
**A.Pe.** Astor Perry  
**A.Pu.** Andy Purvis  
**A.Pug.** Andrew Pugel  
**A.PA.** Arnold P. Appleby  
**A.PAn.** Alan P. Anderson  
**A.PB.** Alan P. Boss  
**A.PM.** Alan P. Marchand  
**A.PN.** Ashok P. Nedungadi  
**A.PR.** Andrew P. Roberts  
**A.PS.** Andrew Paul Somlyo  
**A.PSa.** Andrew P. Sage  
**A.PT.** Anne Pike-Tay  
**A.R.** Arthur Roberts  
**A.Ri.** Arthur Rich  
**Ar.R.** Arthur Rich  
**A.R.A.** Arthur R. Ayers  
**A.R.B.** Anna Ruth Brummett  
**A.R.C.** Anthony R. Cooper  
**A.R.E.** Arthur R. Eckels  
**A.R.F.** A. Roberto Frisancho  
**A.R.I.** Anthony R. Ives  
**A.R.J.** Arthur R. Jensen  
**A.R.L.** Alfred R. Loeblich, Jr.  
**A.R.M.** Armand R. Maggenti  
**A.R.Mo.** Aage R. Møller  
**A.R.N.** Alan R. Newhouse  
**A.R.P.** Allison R. Palmer  
**A.R.P.R.** A. R. P. Rau  
**A.R.R.** Augustus R. Rogowski  
**A.R.Ra.** A. R. Ravishankara  
**A.R.U.** Arthur R. Uppgren  
**A.S.** Abdus Salam  
**A.Sa.** Allan Sandage  
**A.San.** Anthony Sanchez  
**A.Sc.** Anton Schindler  
**A.Sche.** Alexander Scheeline  
**A.Sco.** Alwyn Scott  
**A.Se.** Amita Sehgal  
**A.Sel.** Ahmet Selamet  
**A.Si.** Abraham Silberschatz  
**A.Sm.** Andrew Smith  
**A.So.** Alfred Sommer  
**A.St.** Alfred Steinschneider  
**A.S.C.** Alden S. Crafts  
**A.S.Co.** Alan S. Cohen  
**A.S.L.H.** A. S. L. Hu  
**A.S.P.** Albert S. Palmerlee  
**A.S.R.** Alfred S. Romer  
**A.S.Ru.** Allen S. Russell  
**A.S.W.** Arthur S. Wightman  
**A.T.** Albert Tyler  
**A.To.** Alfonso Torres  
**A.Tol.** Alexandra Tolstoy  
**A.Tu.** Angelo Turturro  
**A.TA.** Alfred T. Anderson, Jr.  
**A.TMcD.** Alan T. McDonald  
**A.T.W.** Andrew T. Weil  
**A.T.Z.** Andrew T. Zander  
**A.V.** Alladi Venkatesh  
**A.VA.** Allison V. Andors  
**A.V.E.** Alexey V. Eliseev  
**A.V.P.** Alphonsus V. Pocius  
**A.W.** Abraham White  
**A.We.** Alison Weiss  
**A.Wu.** Alfred Wüest  
**A.WA.** Arthur W. Adamson  
**A.W.C.** Arthur W. Cooper  
**A.W.Co.** Anthony W. Confer  
**A.W.Cz.** Anthony W. Czarnik  
**A.W.C.V.G.** Alexander W. C. von Graevenitz  
**A.W.F.** Arthur W. Francis  
**A.W.G.** Arthur W. Galston: Reproduction (plant)  
**A.W.G.** Arthur W. Guy: Electrotherapy  
**A.W.H.D.** Antoni W. H. Damman  
**A.W.Je.** Andrew W. Jenike  
**A.W.K.** Anthony W. Knapp  
**A.W.N.** Arch W. Naylor  
**A.W.O.** Albert W. Overhauser  
**A.W.W.** Andrew W. Wayne  
**A.Y.** Anne Young  
**A.Z.** Andreas Zeller  
**A.Z.S.** Andras Z. Szeri  
**B.A.B.** B. Austin Barry  
**B.A.G.** Bernard A. Galler  
**B.A.Ga.** Bruce A. Garetz  
**B.A.M.** Brian A. Mauer  
**B.A.S.** B. A. Summers  
**B.A.St.** Bruce A. Stanley  
**B.A.T.** Brian A. Tinsley  
**B.A.VD.P.** Ben A. van der Pluijm  
**B.B.** Benjamin Bederson  
**B.Bal.** Bruce Balick  
**B.Be.** Bruce Beutler  
**B.BI.** Brooke Blades  
**B.Br.** Bill Bruce  
**B.Bro.** Barbara Brodsky  
**B.B.Ch.** Bruno B. Chromel  
**B.B.Cr.** Burton B. Crocker  
**B.B.Cu.** Burris B. Cunningham  
**B.B.D.** Bruce B. Dan  
**B.B.Da.** Benjamin B. Dayton  
**B.B.P.** Benjamin B. Peterson  
**B.C.** Benjamin Chu  
**B.Ca.** Blas Cabrera  
**B.C.C.** Bryan C. Chakoumakos  
**B.C.H.** Bruce C. Heezen  
**B.C.K.** Benjamin C. Kuo  
**B.C.R.** Benoit Cushman-Roisin  
**B.C.S.** B. C. Sutton  
**B.C.Sc.** B. Charlotte Schreiber  
**B.DeF.** Brian DeFazio  
**B.Dr.** Barry Dropping  
**B.Du.** Bruce Dunn  
**B.D.D.** Bernard D. Davis  
**B.D.S.** Blair D. Savage  
**B.D.Sh.** Bruce D. Shepard  
**B.E.** Baltus Erasmus  
**B.E.Be.** Brian E. Bent  
**B.E.Bow.** Bruce E. Bowler  
**B.E.F.** Blake E. Feist  
**B.E.G.** Bruce E. Gnade  
**B.E.Go.** Barry E. Goodison  
**B.E.K.** Bernhard E. Keiser  
**B.E.R.** Bryant E. Rees  
**B.E.S.G.** Brian E. S. Gunning  
**B.E.W.** Bertram E. Warren  
**B.F.** Bernard Frank  
**B.Fr.** Benjamin Fruchter  
**B.FH.** Benjamin F. Howell, Jr.  
**B.FJ.** B. Frank Jones, Jr.  
**B.FM.** Barry F. Madore  
**B.FT.** Benjamin F. Trump  
**B.FW.** B. F. Wilson  
**B.G.** Bernard Goodman  
**B.Ga.** Brian Gardiner  
**B.Gi.** Barrie Gilbert  
**B.G.B.** Brian G. Bagley  
**B.G.Ba.** Bruce G. Baldi  
**B.G.Bu.** Bruce G. Buchanan  
**B.G.D.** B. Gale Dick  
**B.H.** Bernard Haber  
**B.Ha.** Babak Hassibi  
**B.He.** Bernd Heinrich  
**B.Hi.** Bruce Hicks  
**B.Hog.** Brigid Hogan  
**B.H.B.** Benjamin H. Beard  
**B.H.Bi.** Bruce H. Billings  
**B.H.J.** Biing Hwang Juang  
**B.H.Ki.** Bryan H. King  
**B.H.L.** Bruce H. Lipshutz  
**B.H.McC.** Bayard H. McConnaughey  
**B.I.** Brent Iverson  
**B.I.S.** Bernard I. Spinrad  
**B.J.Ba.** B. Jayant Baliga  
**B.J.C.** Bernard J. Conkley

## B

**B.J.D.M.** Bastiaan J. D. Mccusc  
**B.J.F.** Barry J. Feldman  
**B.J.H.** Brian J. Hodgson  
**B.J.K.** Brian J. Kilbey  
**B.J.M.** Basil J. Mason  
**B.J.Ma.** Bella J. May  
**B.J.McP.** Brian J. McPartland  
**B.J.Mu.** Brent J. Muus  
**B.J.S.** Brian J. Skinner  
**B.J.W.** Ben J. Wattenberg  
**B.J.Wo.** B. J. Wood  
**B.J.Wu.** Bernhardt J. Wuensch  
**B.K.** Blair Kinsman  
**B.Ka.** Bernd Kahn  
**B.Kal.** Bengt Kallen  
**B.K.P.** B. K. Pierscionek  
**B.Li.** Bart Lipkens  
**B.L.A.** Benjamin L. Averbach  
**B.L.B.** Blaine L. Blad  
**B.L.D.** Barry L. Doolan  
**B.L.G.** Bob L. Gregory  
**B.L.I.** B. Lynn Ingram  
**B.L.S.** Bernard L. Segal  
**B.M.** Bruce Margon  
**B.Ma.** Bahram Mashhoon  
**B.McE.** Bruce McEwen  
**B.Mi.** Barry Miller  
**B.M.A.** Bernard M. Abraham  
**B.M.Ch.** Bruce M. Christiansen  
**B.M.McC.** Barry M. McCoy  
**B.M.R.** Bruce M. Rothschild  
**B.M.S.** Bruce M. Sankey  
**B.M.Si.** Benjamin M. Siegel  
**B.M.St.** Benton M. Stidd  
**B.N.B.** Bertram N. Brockhouse  
**B.O.B.** Berthold O. Bergh  
**B.P.** Burton Paul  
**B.Pi.** Benjamin Pinkel  
**B.Po.** Bogdan Povh  
**B.PK.** Bryan P. Kibble  
**B.PKI.** Barbara P. Klein  
**B.PL.** B. P. Lathi  
**B.R.** U.S. Bureau of Reclamation  
**B.Ro.** Barry Rosen  
**B.Roe.** Bernie Roehl  
**B.Ru.** Brace Runnegar  
**B.Rus.** Brian Rust  
**B.R.A.** Braden R. Allenby  
**B.R.L.** Bruce R. Lipin  
**B.R.M.** Bruce R. Munson  
**B.R.O.** Ben R. Oppenheimer  
**B.R.R.** Brian R. Rust  
**B.R.S.** Brian Robert Shaw  
**B.R.W.** Bennie R. Ware  
**B.S.** Bobb Schaeffer  
**B.Si.** Barry Simon  
**B.S.G.** Bernard S. Greensfelder  
**B.S.Gl.** Benjamin S. Glick  
**B.S.M.** Bernard S. Meyer  
**B.S.N.** Bodil Schmidt-Nielsen  
**B.S.O.** Bruce S. Old  
**B.S.S.** Bellave S. Shivaram  
**B.T.** Barry Tibbits  
**B.T.B.** Bernard T. Bormann  
**B.T.L.** Beverly T. Lynds  
**B.T.S.** Bradley T. Scheer  
**B.U.H.** Bilal U. Haq  
**B.V.** Bernard Vonnegut  
**B.W.** Bonnie Webber  
**B.Wa.** Ben Waggoner

**B.Wi.** Brian Wilkinson  
**B.W.Ba.** Byron W. Battles  
**B.W.C.** Bruce W. Calnek  
**B.W.Ca.** Bruce W. Carney  
**B.W.G.** Bruce W. Gonser  
**B.W.M.** B. W. Mangum: Physical measurement etc.  
**B.W.M.** Bernard W. Minifie: Cocoa powder and chocolate  
**B.W.McC.** Barnes W. McCormick, Jr.  
**B.W.N.** Benjamin W. Niebel  
**B.Y.H.L.** Benjamin Y. H. Liu  
**B.Y.T.** Bor-Yeu Tsauro  
**B.Y.Ta.** Bernard Y. Tao  
**B.Z.B.** Barbara Zakrewska Borowieka

## C

**C.A.** Chris Adams  
**C.An.** Christian Andreasen  
**C.Ar.** Cyril Arney  
**C.A.A.** Chester A. Arnold  
**C.A.C.** Carleton A. Chapman  
**C.A.Co.** Charles A. Cohen  
**C.A.F.** Charles A. Francis  
**C.A.H.** Carol A. Hoffman  
**C.A.L.** Cadence A. Lowell  
**C.A.L.B.** C. Andrew L. Bassett  
**C.A.Me.** Charles A. Mebus  
**C.A.Mi.** Clyde A. Miller  
**C.A.Mo.** Charles A. Moore  
**C.A.R.** Charles A. Ross  
**C.A.Sa.** Charles A. Sandberg  
**C.A.Sch.** Chailes A. Schroeder  
**C.A.Sp.** Carol A. Spiegel  
**C.A.St.** Carl A. Strausbaugh  
**C.A.V.** Chris A. Veale  
**C.A.Z.** Carl A. Zapffe  
**C.B.** Charles Baltay  
**C.Be.** Clyde Berg  
**C.Bea.** Christine Beall  
**C.Bi.** Charles Birnstiel  
**C.Bin.** Carrol Bingham  
**C.Br.** Chris Brod  
**C.Bu.** Charles Butler  
**C.B.B.** Charles B. Beck  
**Ch.B.B.** Charles B. Broeg  
**C.B.C.** Charles B. Curtin  
**C.B.D.** C. B. Duke  
**C.B.G.** C. B. Gillies  
**C.B.McK.** Chris B. McKesson  
**C.B.O.** Charles B. Ogburn  
**C.B.P.** Cornelius B. Philip  
**C.B.S.** C. B. Skotland  
**C.B.V.N.** Cornelis B. Van Niel  
**C.B.W.** Curtis B. Wilson  
**C.C.** Charles Collinson  
**C.Cr.** Carol Creutz  
**C.C.A.** Cyril C. Addison  
**C.C.C.** Chapin C. Cutler  
**C.C.H.** Christos C. Halkias  
**C.C.Ha.** C. C. Hang  
**C.C.Ho.** C. Clayton Hoff  
**C.C.K.** Clifford C. Klick  
**C.C.K.L.** Clark C. K. Liu

**C.C.L.** Ching Chun Li  
**C.C.La.** Conrad C. Labandeira  
**C.C.W.** Carl C. Wamser  
**C.C.Wa.** Carl C. Wamser  
**C.D.** Carl Dover  
**C.De.** Carter Denniston  
**C.DeB.** Carl de Boor  
**C.DiT.** Cynthia Di Tallo  
**C.D.C.** C. Denise Caldwell  
**C.E.** U. S. Army Corps of Engineers  
**C.E.A.** Charles E. Applegate  
**C.E.Ba.** Clinton E. Ballou  
**C.E.Br.** Carlton E. Brett  
**C.E.C.** Chester E. Cross  
**C.E.Ca.** Charles E. Carraher, Jr.  
**C.E.H.** Carl E. Howe  
**C.E.L.** Cecil E. Land  
**C.E.La.** Charles E. Lapple  
**C.E.LaM.** C. E. LaMotte  
**C.E.Lu.** Craig E. Lunte  
**C.E.Ma.** Christoph E. Mahle  
**C.E.Mi.** Charles E. Mitchell  
**C.E.S.** Charles E. Slonecker  
**C.E.St.** C. Edward Stevens  
**C.E.Ste.** Charles E. Sternheim  
**C.E.T.** Clair E. Ten-ill  
**C.E.Tu.** Charles E. Turner  
**C.E.V.** Cecil E. Vanderzee  
**C.E.W.** Clyde E. Wiegand  
**C.E.Wa.** Charles Edwin Wade  
**C.Fo.** Christopher Fox  
**C.Fr.** Clifford Frondel  
**C.Fro.** Claus Fröhlich  
**C.FA.** C. F. Andrus  
**C.FB.** Charles F. Beam  
**C.F.C.** Charles F. Curtis  
**C.F.Ch.** Charles F. Chappell  
**C.FE.R.** Clyde F. E. Roper  
**C.FF.** Carl F. Floe  
**C.FG.** Clarence F. Goodheart  
**C.FH.** Charles F. Hagar  
**C.FK.** Carl F. Kayan  
**C.FN.** Charles F. Niven, Jr.  
**C.FP.** Colin F. Poole  
**C.FW.** Carl F. Wellstead  
**C.G.** Charles Goebel  
**C.G.C.** Charles G. Cook  
**C.G.E.** Carl G. Eilers  
**C.G.G.** Chauncey G. Goodchild  
**C.G.J.** Clive G. Jones  
**C.G.S.** C. George Segeler  
**C.H.** Cadet Hand  
**C.Ha.** Carlyn Halde  
**C.Ho.** Cecil Hougie  
**C.H.B.** Catherine H. Bailey  
**C.H.C.** Clarence H. Cleminshaw  
**C.H.Co.** Carl H. Cotterill  
**C.H.Di.** Cyril H. Dix  
**C.H.H.** Clarence H. Hanson  
**C.H.Ha.** C. Howard Hamilton  
**C.H.He.** Charles H. Henry  
**C.H.L.** Choh Hao Li  
**C.H.M.** Carl H. Meyer  
**C.H.Mo.** Clyde H. Moore  
**C.H.S.** Christopher H. Scholz  
**C.H.St.** Calvin H. Stevens  
**C.H.T.** Charles H. Townes  
**C.In.** Chuck Ingels  
**C.I.McV.** Charles I. McVey

**C.J.** Christine Janis  
**C.J.B.** Charles J. Baer  
**C.J.Bi.** Christopher J. Biermann  
**C.J.C.** C. J. Carpenter  
**C.J.Da.** C. J. Darwin  
**C.J.G.** Charles J. Goebel  
**C.J.Ga.** Charles J. Gatchell  
**C.J.H.** C. Jack Hearn  
**C.J.He.** Carl J. Helmers  
**C.J.Her.** C. J. Herman  
**C.J.I.** Charles J. Issel  
**C.J.K.** Charles J. Kensler  
**C.J.Ka.** Clarence J. Kado  
**C.J.Ki.** C. Judson King  
**C.J.L.** Carol J. Lonsdale  
**C.J.Li.** C. J. Lister  
**C.J.S.** Charles J. Sheviak  
**C.J.W.** Chris J. Welham: Microsensor  
**C.J.W.** Christopher J. Wood: Decontamination of radioactive materials  
**C.K.** Cornelis Klein  
**C.Ku.** Charles Kutal  
**C.K.B.** Charles K. Bradsher  
**C.K.J.** C. K. Jen  
**C.K.L.** Cynthia K. Larive  
**C.K.N.P.** C. K. N. Fatal  
**C.K.S.** Charles K. Shearer  
**C.K.W.** Charles K. Weichert  
**C.La.** Carll Ladd  
**C.L.A.** Charles L. Alley  
**C.L.Ch.** Charles L. Christ  
**C.L.D.** Clive L. Dym  
**C.L.F.W.** C. L. F. Woodcock  
**C.L.M.** Charles L. Mantell  
**C.L.Ma.** Clement L. Markert  
**C.L.Mas.** Colin L. Masters  
**C.L.R.** Charles L. Rulfs  
**C.L.Ru.** Clyde L. Ruthroff  
**C.L.W.** C. Langdon White  
**C.M.** Charles Mangion  
**C.M.A.** Charles M. Antoni  
**C.M.C.** Cheng-maw Chen  
**C.M.G.** Carlos M. Grilo  
**C.M.H.** Cyril M. Harris  
**C.M.Ha.** Clifford M. Harrington  
**C.M.McK.** Chester M. McKinney  
**C.M.S.** Cheng-Mei Shaw  
**C.M.T.** Charles B. Tompkins  
**C.No.** Charles Noback  
**C.N.G.** Charles N. Gaylord  
**C.N.S.** C. N. Sisler  
**C.N.Sh.** Carl N. Shuster  
**C.O.** Cristian Orrego  
**C.O.D.** Carl O. Dunbar  
**C.O.D.B.** C. O. Dietrich-Buchecker  
**C.O.Q.** Calvin O. Qualset  
**C.P.** Carl Pfaffmann  
**C.Pa.** Camille Parmesan  
**C.Po.** Claud Powell  
**C.PB.** Charles P. Brewer  
**C.PBu.** C. Patrick Burns  
**C.PL.** Charles P. Lyman  
**C.PP.** Charles P. Pfleeger  
**C.PR.** Clark P. Read  
**C.PS.** Charles P. Slichter  
**C.Q.** Chris Quigg  
**C.Qu.** Carol Quaiife  
**C.Qui.** Carlos Quiroga  
**C.R.** Claudio Rebbi

**C.Ru.** Charles Rulfs  
**C.R.C.** Clark R. Chapman  
**C.R.Ca.** C. Ronald Carroll  
**C.R.F.** Charles R. Fourtner  
**C.R.J.** Carl R. Johnson  
**C.R.Lo.** Christopher R. Lowe  
**C.R.M.** Charles R. Marsland  
**C.R.Ma.** C. R. Martinson  
**C.R.Sc.** Christopher R. Scotese  
**C.Sc.** Charlotte Schreiber: Gypsum  
**C.Sc.** Cheryl Schultz: Land-use planning  
**C.Sch.** Curt Schimmel  
**C.Scr.** Colin Scrutton  
**C.Si.** Carol Simpson  
**C.S.C.** Charles S. Cox  
**C.S.Co.** Christine S. Cozzens  
**C.S.G.** Chester S. Gardner  
**C.S.H.** C. S. Hammen  
**C.S.He.** Carl S. Herz  
**C.S.Hu.** Cornelius S. Hurlbut, Jr.  
**C.S.M.** Craighton S. Mauk  
**C.S.Ma.** C. Samuel Martin  
**C.S.Y.** Ching-Sung Yu  
**C.T.** Curt Teichert  
**C.TCr.** Clayton T. Crowe  
**C.TH.** Carl T. Herakovich  
**C.T.K.** Charles T. Kowal  
**C.T.S.** Chester T. Sims  
**C.V.** Charles Vitek  
**C.V.C.** Charles V. Crittenden  
**C.W.** Colin White  
**C.Wa.** Changchang Wang: Impulse generator  
**C.Wa.** Chen Wang: Stem cells  
**C.Wi.** Conrad Wickstrom  
**C.W.B.** Carl W. Boothroyd  
**C.W.Be.** Curt W. Beck  
**C.W.Bu.** Charles W. Burnham  
**C.W.By.** Charles W. Byers  
**C.W.D.** Clifton W. Draper  
**C.W.E.** C. Wayne Ellett  
**C.W.H.** C. W. Hesselstine  
**C.W.K.** Chung W. Kim  
**C.W.N.** Chester W. Newton  
**C.W.S.** C. W. Siegmund  
**C.W.Sc.** Charles W. Scouten  
**C.W.Si.** C. W. Sisler  
**C.Y.W.** C. Y. Wang  
**C.Z.M.** Carolyn Z. Mutter

**D.A.** David Adler  
**D.AI.** David Altman  
**D.A.B.** D. Allan Bromley  
**D.A.Be.** David A. Bemis  
**D.A.B.M.** David A. B. Miller  
**D.A.C.** David A. Clark  
**D.A.Ca.** David A. Caughey  
**D.A.D.** Donald A. Dewsbury  
**D.A.D.P.** David A. D. Parry  
**D.A.E.** David A. Ehrmann  
**D.A.G.** David A. Gustafson  
**D.A.J.** Donald A. Jennings  
**D.A.Ja.** Daniel A. Japuntich

## D

**D.A.Lo.** D. A. Lowe  
**D.A.M.** Douglas A. Marsland  
**D.A.Me.** Duncan A. Mellichamp  
**D.A.Men.** Daniel A. Menascé  
**D.A.Mi.** Dorothy A. Miller  
**D.A.P.** David A. Palzkill  
**D.A.Pi.** Donald A. Pierre  
**D.A.R.** David A. Reid  
**D.A.Re.** David A. Reay  
**D.A.S.** David A. Shirley  
**D.A.Sa.** Deborah A. Salazar  
**D.A.T.** David A. Thomas  
**D.A.W.** Donald A. Wilbur, Sr.  
**D.A.Y.** David A. Young  
**D.B.** David Barr  
**D.BI.** Donald Blough  
**D.Br.** Dirk Brouwer  
**D.Bur.** Dave Bursky  
**D.B.B.** Daniel B. Blake  
**D.B.Bi.** David B. Bieler  
**D.B.F.** David B. Fogel  
**D.B.H.** David B. Harrison  
**D.B.Ha.** Denise B. Harris  
**D.B.J.** Deane B. Judd  
**D.B.L.** Don B. Lichtenberg: Magnetron  
**D.B.L.** Dorothy B. Lee: Atmospheric entry  
**D.B.Lo.** D. B. Loope  
**D.B.M.** David B. Meyer  
**D.B.R.K.** D. B. R. Kenning  
**D.B.So.** David B. South  
**D.B.St.** David B. Stewart  
**D.B.V.** Douglas B. Vickers  
**D.B.W.** Douglas B. Webster  
**D.B.Wi.** David B. Williams  
**D.C.** David Cohen  
**D.Ca.** David Casasent  
**D.CI.** Douglas Cline  
**D.C.Ba.** Donald C. Backer  
**D.C.C.** David C. Coleman  
**D.C.F.** Derek C. Ford  
**D.C.Ga.** Donald C. Gasaway  
**D.C.H.** David C. Hazen  
**D.C.J.** Donald C. Jackson  
**D.C.M.** David C. Morrison  
**D.C.N.** Donna C. Nelson  
**D.D.** David Dalton  
**D.DiB.** David DiBiase  
**D.D.C.** Denise Dellarosa Cummins: Cognition  
**D.D.C.** Dennis Di Cicco: Equation of time  
**D.D.D.** D. Dwight Davis  
**D.D.E.** Dennis D. Eberl  
**D.D.F.** Dudley D. Fuller  
**D.D.Fo.** Dennis D. Focht  
**D.D.H.** David D. Houghton  
**D.D.J.** Dennis D. Juranek  
**D.D.M.** David D. Meisel  
**D.D.MacC.** Donnell D. MacCarthy  
**D.D.McC.** Dennis D. McCarthy  
**D.D.R.** D. D. Robb  
**D.D.Ru.** David D. Rubis  
**D.D.S.** Dragoslav Diljak  
**D.D.S.T.** Donovan Des S. Thomas  
**D.Eb.** Dennis Eberl  
**D.En.** Derek Enlander  
**D.Ev.** Doris Evans  
**D.E.As.** David E. Aspnes

- D.E.Br.** Don E. Brownlee, II  
**D.E.C.** Dale E. Cavanaugh  
**D.E.D.** D. E. Daney  
**D.E.E.** David E. Ellis  
**D.E.G.** David E. Giannasi  
**D.E.Go.** David E. Goldberg  
**D.E.G.B.** Derek E. G. Briggs  
**D.E.H.** Dennis E. Hayes  
**D.E.J.** Dorothy E. Jegla  
**D.E.K.** Dale E. Hester  
**D.E.Ki.** David E. Kissel  
**D.E.Kr.** David E. Kretschmann  
**D.E.N.** Dale E. Niesz  
**D.E.No.** Donald E. Norris  
**D.E.P.** David E. Pritchard  
**D.E.R.** Duane E. Roller  
**D.E.S.** Donald E. Savage  
**D.E.St.** David E. Stock  
**D.E.Str.** D. Eugene Strandness, Jr.  
**D.E.Te.** Dennis E. Teegarden  
**D.E.Wi.** Dennis E. Wisnosky  
**D.F.** Denis Forster  
**D.Fi.** Daniele Finotello  
**D.Fo.** Derek Ford  
**D.Fr.** David Franklin  
**D.FM.** Daniel F. Moorer, Jr.: Military satellites  
**D.FM.** David F. Malin: Astronomical photography  
**D.FO.** Donald F. Othmer  
**D.F.Ow.** Denis F. Owen  
**D.FP.** Donald F. Poulson  
**D.FS.** Dale F. Stein  
**D.FSp.** Don F. Splittstoesser  
**D.G.** D. Gauss  
**D.Ge.** Dennis Genito  
**D.Gr.** David Gross  
**D.Gu.** D. Gruber  
**D.G.B.** David G. Barkalow  
**D.G.F.** Donald G. Fink  
**D.G.H.** Dennis G. Hall  
**D.G.K.** Dennis G. Kovar  
**D.G.M.** David G. Messerschmitt: Equalizer  
**D.G.M.** Douglas G. Mook: Motivation  
**D.G.Sc.** Donald G. Schueler  
**D.H.** Dorothy Hill  
**D.He.** Donald Heyneman  
**D.Ho.** Derek Horton  
**D.H.A.** David H. Abrahams  
**D.H.B.** Daryle H. Busch  
**D.H.D.** David H. Douglass  
**D.H.Da.** David H. Davies  
**D.H.G.** David H. Goodstein  
**D.H.H.** Dieter H. Hartmann  
**D.H.K.** David H. Klein  
**D.H.O.** Douglas H. Ohlendorf  
**D.H.S.** Daniel H. Sheingold  
**D.H.T.** D. H. Tarling  
**D.H.Th.** David Hurst Thomas  
**D.H.W.** Denys H. Wilkinson  
**D.I.** Duane Isely  
**D.J.** David Joravsky  
**D.Ja.** David Japikse  
**D.J.A.** Diogenes J. Angelakos  
**D.J.C.** Donald J. Cohen  
**D.J.Ca.** D. J. Carlsson  
**D.J.D.** Daniel J. Diekema: Drug resistance  
**D.J.D.** David J. Dabbs: Herpes  
**D.J.D.** Durk J. Doornbos: Earth interior  
**D.J.Da.** David J. Daniels  
**D.J.Dep.** Donald J. DePaulo  
**D.J.Du.** David J. Dunlop  
**D.J.E.** Don J. Easterbrook  
**D.J.Ev.** Doyle J. Evans, Jr.  
**D.J.F.** Dennis J. Frailey  
**D.J.Fu.** Douglas J. Futuyama  
**D.J.G.** D. J. Goldstein  
**D.J.Ho.** D. J. Horen  
**D.J.Hor.** David J. Horn  
**D.J.J.** Daniel J. Jones  
**D.J.K.** D. J. Kushner  
**D.J.L.** Douglas J. Loftus  
**D.J.Me.** David J. Meltzer  
**D.J.Na.** David J. Nagel  
**D.J.O.** Donald J. O'Connor  
**D.J.Ov.** D. J. Over  
**D.J.P.** Donald J. Patton  
**D.J.Pa.** Daniel J. Pasto: Confirmational analysis  
**D.J.Pa.** David J. Patterson: Centrohelida etc.  
**D.J.Pe.** David J. Pegg  
**D.J.Pi.** Donald J. Pinkava  
**D.J.R.** Dewey J. Raski  
**D.J.S.** David J. Sellmyer  
**D.J.St.** Dan J. Stein  
**D.J.S.B.** Donald J. S. Barr  
**D.J.Wa.** Deborah Jean Warner  
**D.Kl.** Daniel Kleppner  
**D.K.Y.** Donald K. Yeomans  
**D.L.** David Lagunoff  
**D.L.A.** Daniel L. Azarnoff  
**D.L.Ak.** Donald L. Akers  
**D.L.An.** Donald L. Anglin  
**D.L.B.** Daniel L. Birkenheuer  
**D.L.C.** D. Linn Coursen  
**D.L.D.** David L. Dalrymple  
**D.L.F.** Diane L. France  
**D.L.G.** Dwight L. Glasscock  
**D.L.Gr.** Dale L. Greiner  
**D.L.H.** Donald L. Holt  
**D.L.Ha.** Dennis L. Hartmann  
**D.L.I.** Douglas L. Inman  
**D.L.J.** Donald Lee Johnson  
**D.L.K.** David Lloyd Klepper  
**D.L.L.** Dan L. Longo  
**D.L.Pa.** Darwin L. Palmer  
**D.L.S.** David L. Spector: Cell nucleus  
**D.L.S.** David L. Stocum: Animal morphogenesis  
**D.L.Ta.** David L. Tait  
**D.L.Tay.** Danny L. Taylor  
**D.L.W.** Donald L. Waidelich  
**D.L.We.** David L. Weaver  
**D.La.** David Layzer  
**D.Lam.** Dennis Lamb  
**D.Low.** David Lowenthal  
**D.Ma.** Don Marsh  
**D.May.** Daniel Maykuth  
**D.McN.** Donald McNellis  
**D.Mi.** Dennis Mills  
**D.M.B.** Dennis M. Buede  
**D.M.Bu.** Dennis M. Bushnell  
**D.M.C.** D. Martinez-Carrera  
**D.M.Ca.** Don M. Carlson  
**D.M.D.** David M. Dawson  
**D.M.DeF.** Duarte Mota de Freitas  
**D.M.DeL.** Dwight M. DeLong  
**D.M.F.** David M. Farmer  
**D.M.Fi.** David M. Findlay  
**D.M.Fo.** David M. Fountain  
**D.M.Fr.** David M. Fradkin  
**D.M.G.** David M. Greenberg  
**D.M.Ga.** Donald M. Gallant  
**D.M.Gi.** D. Michael Gill  
**D.M.Gr.** Dieter M. Gruen  
**D.M.Gre.** Daniel M. Greenberger  
**D.M.Gree.** David M. Green  
**D.M.H.** David M. Hodgkin  
**D.M.L.** David M. Larsen  
**D.M.Le.** David M. Lee  
**D.M.P.** Daniel M. Popper  
**D.M.Po.** David M. Pozar  
**D.M.Pr.** David M. Prescott  
**D.M.R.** David M. Rust  
**D.M.Ro.** D. Max Roundhill  
**D.M.Row.** D. M. Rowe  
**D.M.S.** David M. Smith  
**D.M.Se.** Denise M. Seliskar  
**D.M.W.** D. M. Wiles  
**D.M.Y.** Don M. Yost  
**D.N.L.** D. N. Langenberg  
**D.N.La.** Daniel N. Lapedes  
**D.N.S.** David N. Spergel  
**D.O'H.** David O'Hagen  
**D.O'S.** Douglas O'Shaughnessy  
**D.O.H.** David O. Haynes  
**D.P.** David Park  
**D.PI.** Donald Platt  
**D.P.A.** Donald P. Abbott  
**D.PAd.** Douglas P. Adams  
**D.PB.** David P. Barash  
**D.PD.** Daryl P. Domning  
**D.PH.** Donald P. Havens  
**D.PH.T.** David P. H. Tucker  
**D.PT.** Demetri P. Telionis  
**D.R.** Donald Raum  
**D.Ru.** Dorothea Rudnick  
**D.Rum.** Douglas Rumble III  
**D.R.A.** David R. Anderson  
**D.R.B.** Donald R. Baer  
**D.R.Co.** Dean R. Collins  
**D.R.D.** Donald R. Dimmel  
**D.R.Da.** Donald R. Davis  
**D.R.FH.** Donald R. F. Harleman  
**D.R.H.** Dennis R. Heldman  
**D.R.J.** David R. Jones  
**D.R.J.W.** Donald R. J. White  
**D.R.L.** David R. Lineback  
**D.R.N.** David R. Nygren  
**D.R.P.** Donald R. Peacor  
**D.R.Pr.** Donald R. Prothero  
**D.R.S.** Donald R. Stranks  
**D.R.Sa.** Donald R. Sadoway  
**D.R.V.** David R. Veblen  
**D.R.W.** David R. Wones  
**D.S.** Dave Scott  
**D.Sha.** Dudley Shapere  
**D.Sim.** Daniel Simberloff  
**D.Sk.** David Skelly  
**D.Sn.** David Snoke: Exciton  
**D.Sn.** Dianne Snavelly: Laser photochemistry  
**D.So.** David Soderblom  
**D.Ste.** Dcwcy Stewart  
**D.S.B.** Douglas S. Billington  
**D.S.Ba.** Daniel S. Barker

- D.S.Br.** David S. Breslow  
**D.S.C** Dennis S. Charney  
**D.S.Ca.** David S. Cannell  
**D.S.G.** D. S. Grosch  
**D.S.Ga.** Douglas S. Gale  
**D.S.Ge.** Donald S. Gemmel  
**D.S.Hi.** Daniel S. Hirschberg  
**D.S.K.** Douglas S. Kellogg  
**D.S.Kl.** Dean S. Klivans  
**D.S.P.** David S. Palermo  
**D.T.** David Turnbull  
**D.T.G.** Dana T. Griffen  
**D.T.L.** David T. Lykken  
**D.T.Ra.** D. Tab Rasmussen  
**D.T.S.** Donald T. Sawyer  
**D.Th.** Douglas Theis  
**D.V.M.** Dal V. Maddalon  
**D.V.Mo.** Donald V. Moore  
**D.V.W.** David V. Widder  
**D.W.** Daniel Wellner  
**D.Wa.** David Ward  
**D.Wi.** Dudley Williams  
**D.Wo.** David Wollesheim  
**D.W.B.** Donald W. Banner  
**D.W.Bo.** Donald W. Bouldin  
**D.W.C.** David W. Curkendall  
**D.W.Ce.** Daniel W. Celandier  
**D.W.D.** Donald W. Douglas, Jr.  
**D.W.K.** Donald W. Kerst  
**D.W.Ki.** Donald W. King  
**D.W.Ku.** Donald W. Kupke  
**D.W.L.** David W. Latham  
**D.W.M.** David W. Mizell  
**D.W.Ma.** Daniel W. Martin  
**D.W.Me.** David W. Meinke  
**D.W.Mo.** David W. Mohr  
**D.W.N.** Donald W. Novotny  
**D.W.P.** Darrell W. Pepper  
**D.W.Po.** D. W. Pohl  
**D.W.Sl.** Donald W. Slocum  
**D.X.F.** Daniel X. Freedman  
**D.Z.A.** Dana Z. Anderson
- E**
- E.A.** Elihu Abrahams  
**E.Ad.** Elijah Adams  
**E.At.** Elisha Atkins  
**E.A.A.** Edward A. Ackerman  
**E.A.Ad.** Edward A. Adelberg  
**E.A.B.** Edward A. Boyden  
**E.A.C.** Edsel A. Caine  
**E.A.F.** E. A. Freundt  
**E.A.H.** Eugene A. Hollowell  
**E.A.I.** Eugene A. Irene  
**E.A.K.** Elbert A. King  
**E.A.L.** Edmund A. Laport  
**E.A.M.** Eugene A. Milus  
**E.A.O'L.** Edward A. O'Lenic  
**E.B.** E. Bauer: Electron diffraction  
**E.B.** Edouard Brézin: Random matrices  
**E.B.Cu.** Edward B. Cutler  
**E.B.F.** E. B. Ford  
**E.B.L.** Edward B. Lewis  
**E.B.R.** Evans B. Reid  
**E.Ca.** Eleanor Campbell
- E.Co.** Ernest Coleal  
**E.C.A.** Ellsworth C. Alvord, Jr.  
**E.C.J.** Earl C. Joseph  
**E.C.Jo.** Edwin C. Jones, Jr.  
**E.C.L.** Edward C. Luckenbach  
**E.C.O.** Everett C. Olson  
**E.C.Ol.** Edward C. Olson  
**E.C.P.** E. C. Pielou  
**E.C.Po.** Edward C. Polhamus  
**E.C.R.R.** Edward C. Roosen-Runge  
**E.C.S.** Eugene C. Starr  
**E.C.Sh.** E. C. Shuman  
**E.C.St.** Edward C. Stevenson  
**E.C.Stu.** Edwin Charles Stumm  
**E.C.T.C** Edward C. T. Chao  
**E.C.W.** Eugene C. Whitney  
**E.D.** Eric Delson  
**E.Do.** Erling Dorf  
**E.Dr.** Eric Drexler  
**E.D.A.** E. Dwight Adams  
**E.D.B.** Eugene D. Becken  
**E.D.C.** Eugene D. Commins  
**E.D.Gr.** Ernest D. Gray  
**E.E.C.** Ernest E. Charlton  
**E.E.Co.** Earl E. Coulter  
**E.E.F.** Eberhard E. Fetz  
**E.E.H.** Edward E. Hammer  
**E.E.S.** Esmond E. Snell  
**E.E.U.** Erwin E. Underwood  
**E.E.W.** E. Eugene Weaver  
**E.F.** Eric Fawcett  
**E.Fr.** Ernesto Freire  
**E.FA.** Earl F. Arbuckle III  
**E.FB.** Edmour F. Blouin  
**E.FL.** Edward F. Leonard  
**E.FLo.** Elizabeth F. Loftus  
**E.FMcB.** Earle F. McBride  
**E.FN.** Ernest F. Nippes  
**E.FS.** Emil F. Steinert  
**E.FT.** Edward F. Tedesco  
**E.FW.** Elliott F. Wright  
**E.G.** Edward Gerjuoy  
**E.Gr.** Emil Grosswald  
**E.Gre.** Ehud Greenspan  
**E.Gru.** Emanuel Grunberg  
**E.Gry.** Ellen Gryj  
**E.G.C.** Elizabeth G. Cutter  
**E.G.H.** E. G. Heyne  
**E.G.Ho.** Edward G. Hoffman  
**E.G.N.** Elton G. Nelson  
**E.G.P.** Edward G. Partridge  
**E.G.R.** Edward G. Ramberg  
**E.G.Ro.** Eugene C. Rochow  
**E.G.St.** Edward G. Stuart  
**E.G.W.** Ernest G. Wever  
**E.G.Wi.** Earl G. Williams  
**E.H.** Edward Harrison  
**E.Ha.** Everett Hausen  
**E.Ho.** Eric Holtzman  
**E.H.A.** Elbert H. Ahlstrom  
**E.H.C.** Edward H. Cole  
**E.H.H.** Elbert H. Hadley  
**E.H.Ha.** Edwin H. Hammond  
**E.H.Q.** Edith H. Quimby  
**E.H.W.** Earl H. Wood  
**E.I.** Earl Ingerson  
**E.I.S.** Edward I. Steifel  
**E.Jo.** Edward Johnson  
**E.Jor.** E. Jordon  
**E.Ju.** Evan Just
- E.J.Ba.** Eric J. Barron  
**E.J.Bo.** Edgar J. Boell  
**E.J.E.** Eric J. Essene  
**E.J.L.** Eugene J. Limpel  
**E.J.M.** Earl J. Merwin  
**E.J.Q.** Edward J. Quirin  
**E.J.S.** Eric J. Swanson  
**E.J.T.** Edward J. Triebe  
**E.Ke.** Edwin Kessler  
**E.Kr.** Ernest Kramar  
**E.Kro.** Edward Krol  
**E.K.B.** Elizabeth K. Berner  
**E.K.H.** Earl K. Hyde  
**E.K.K** Edward K. Kaprelian  
**E.L.** E. Lazarides  
**E.Le.** Edward Leete  
**E.Li.** Eva Lindroth  
**Eva.Li.** Eva Lindroth  
**E.Lo.** Earl Logan, Jr.  
**E.L.C.** Earl L. Core  
**E.L.CI.** Elmond L. Claridge  
**E.L.E.** Ernest L. Eliel  
**E.L.Hi.** Edward L. Hill  
**E.L.J.** Ellis L. Johnson  
**E.L.L.** Elbert L. Little, Jr.  
**E.L.P.** E. Lowe Pierce  
**E.L.S.** Everett L. Saul  
**E.L.T.** Edwin L. Turner  
**E.L.VC** Ernest L. Van Campenhout  
**E.L.W.** Erwin L. Weber  
**E.L.Wi.** Edward L. Winterer  
**E.L.Y** Ellis L. Yochelson  
**E.L.Z.** Edwin L. Zebroski  
**E.M.** Ernesto Marcus  
**Ev.M.** Eveline Marcus  
**E.Ma.** E. Margoliash  
**E.M.B.** Elliott M. Blass  
**E.M.Br.** Edward M. Breinan  
**E.M.Co.** Esther M. Conwell  
**E.M.DiG.** Edmund M. DiGiulio  
**E.M.E.** Eugene M. Ertenberg  
**E.M.Ey.** Edward M. Eyring  
**E.M.Ha.** Elaine M. Halbedel  
**E.M.L.** Edwin M. Larsen  
**E.M.M** Emil M. Mrak  
**E.M.P.** E. M. Parmentier  
**E.M.R.** Eugene M. Rasmusson  
**E.M.Re.** Edward M. Reingold  
**E.M.S.** Edith M. Sheppard  
**E.M.St.** Edward M. Stolper  
**E.M.We.** Elizabeth M. Wenzel  
**E.M.Wis.** Edmund M. Wise  
**E.M.Y.** Edward M. Young  
**E.N.** Ernest Naylor  
**E.N.B.** Eddie N. Bernard  
**E.N.G.** Edgar N. Gilbert  
**E.N.H.** E. Newton Harvey  
**E.N.S.** E. N. Skinner  
**E.O.** Edward Olsen  
**E.Ok.** Ender Okandan  
**E.O.B.** Elgene O. Box  
**E.O.F.** Eugene O. Frye  
**E.O.H.** E. O. Huffman  
**E.O.W.** Edward O. Wiley  
**E.P.** Elliot Postow  
**E.Pa.** Eric Paterson  
**E.PG.** E. Patrick Groody  
**E.PGo.** Eric P. Goosby  
**E.PG.Y.** Elias P. Gyftopoulos  
**E.PK.** E. Philip Krider



**E.PP.** Edwin P. Plueddemann  
**E.PS.** Ellis P. Steinberg  
**E.R.** Ernest Rabinowicz  
**E.Re.** Eberhardt Rehtin  
**E.Ros.** Eugene Rosenberg  
**E.R.B.** Elery R. Becker  
**E.R.Co.** E. Richard Cohen  
**E.R.Cr.** Eric R. Craine  
**E.R.D.S.** Edward R. D. Scott  
**E.R.H.** Egbert R. Hardesty  
**E.R.J.** E. Ruffin Jones  
**E.R.L.** E. R. Leadbetter  
**E.R.R.** Elmar R. Reiter  
**E.R.W.** Ewald R. Weibel  
**E.S.** Ernest Schweizer  
**E.So.** E. So  
**E.St.** Edward Stolper  
**E.S.B.** Elso S. Barghoorn  
**E.S.Ba.** Edward S. Barnitz  
**E.S.F.** Edward S. Fry  
**E.S.R.** Edward S. Ross  
**E.S.S.** Edward S. Sarachik  
**E.S.Si.** Edgar Sánchez-Sinencio  
**E.T.** Erik Trinkaus  
**E.Tr.** Elmar Träbert  
**E.W.** Ernest Wenkert  
**E.Wa.** Everett Waters  
**E.Wi.** Earle Williams  
**E.W.B.** Edward W. Baker  
**E.W.Ba.** Er-Wei Bai  
**E.W.C.** Edward W. Comings  
**E.W.G.** Edward W. Gore, Jr.  
**E.W.Ge.** Erwin W. Gelfand  
**E.W.H.** E. William Heinrich  
**E.W.He.** E. Wendell Hewson  
**E.W.K.** Edward W. Kimbark  
**E.W.Ko.** Elmer W. Koneman  
**E.W.O.** Ernst W. Otten  
**E.W.S.** E. W. Sankey  
**E.W.V.** Edward W. Voss, Jr.  
**E.Y.C.** Edgar Y. Choueiri  
**E.Z.** Ernest Zelnick  
**E.Zi.** Ernst Zinner

## F

**F.A.Be.** Frank A. Benson  
**F.A.Ch.** Fenner A. Chace, Jr.  
**F.A.J.** Francis A. Jenkins  
**F.A.L.** Franklin A. Long  
**F.A.L.C.** F. A. L. Clowes  
**F.A.M.** Frederick A. Murphy  
**F.A.S.** Fay Ajzenberg-Selove  
**FB.** Fred Barker  
**FBa.** Fred Basolo  
**FB.B.** France B. Berger  
**FB.Go.** Frank B. Golley  
**FB.S.** Frank B. Salisbury  
**FB.Sh.** Frederick B. Shuman  
**FB.VH.** Franklyn B. Van Houten  
**FB.W.** Frank B. Wood  
**FC.** Francis Clark  
**FCa.** Frank Cardullo  
**FCi.** Frank Civardi  
**FCo.** F. Collins: Human Genome Project

**F.Co.** Friedrich Constabel: Breeding (plant)  
**FCr.** Friedrich Cramer  
**FC.B.** Frank C. Benner  
**FC.Br.** Frederick C. Brown  
**FC.D.** Franklin C. Daiber  
**FC.E.** Francis C. Evans  
**FC.Ha.** Frank C. Hawthorne  
**FC.PY.** Frank C. P. Yin  
**FC.S** Ferris C. Standiford  
**FD.** Farrington Daniels  
**FdelacC.** Felix de la Cruz  
**FDu.** Floyd Dunn  
**FD.B.** Frank D. Brooks  
**FD.DeV.** Fred D. DeVaney  
**FD.L.** Frank D. Lewis  
**FE.G.** Frank E. Gardner  
**FE.Gr.** Frederick E. Grine  
**F.E.L.** F. E. Luborsky  
**F.E.N.** Fred E. Nicodemus  
**FF.** Ferdinand Freudenstein  
**FFB.** Francis F. Busta  
**FFE.** Fredric F. Ehrich  
**FFR.** Frank F. Richards  
**FG.** Fabio Garbassi  
**FGo.** Fraser Goff  
**FG.B** Frederick G. Baily  
**FG.E.** F. G. Ely  
**FG.Et.** Frank G. Ethridge  
**FG.H.** Frank G. Hawksworth  
**FH.** F. Hamad  
**FH.Fr.** F. H. Froes  
**FH.L.** Fritz H. Laves  
**FH.Lu.** Frank H. Ludlam  
**FH.M.** F. H. May  
**FH.R.** Frank H. Rockett  
**FH.Ra.** Frederick H. Raab  
**FH.Ro.** Frederick Hayes-Roth  
**FH.S** Frank H. Shelton  
**FH.Sp.** Frank H. Spedding  
**FH.W.** F. H. Westheimer  
**FI.** Franco Iachello  
**FJA.** Frederick J. Almgren, Jr.  
**FJ.An.** Francis J. Anscombe  
**FJ.B.** Frank J. Blatt  
**FJ.J.** Francis J. Johnson  
**FJ.L.** Frank J. Lockhart  
**FJ.P.** F. J. Pierce  
**FJ.R.** Fred J. Rosenbaum  
**FJ.Ra.** Frank J. Rahn  
**FJ.Ro.** Frank J. Romano  
**FJ.Sc.** Francis J. Schmidlin  
**FJ.Sp.** Frank J. Spedding  
**FJ.V.** Ferdinand J. Venditti, Jr.  
**FJ.W.** Fred J. Weibell: Biomedical engineering  
**FJ.W.** Frederick J. Wicks: Serpentine etc.  
**FK.** Fritz Kalhammer  
**FKe.** Frederic Keffer  
**FKr.** Franklin Kramer  
**FK.H.** Forest K. Harris  
**FK.McK.** Frank K. McKinney  
**FK.O.** Fredrick K. Orkin  
**FL.H.** F. L. Hermach  
**FL.L.** Frank L. Lewis  
**FL.M.** Florence Lansana Margai  
**FL.P.** Fred L. Palmer  
**FL.Sc.** Frederick L. Schuster  
**FL.W.** Frank L. Warner

**FM.** Freydoon Mansouri  
**FM.C.** Frank M. Carpenter  
**FM.Cl.** Fergus M. Clydesdale  
**FM.D.** Frank Matthews Dugan  
**FM.P** Francis M. Pipkin  
**FM.R.** Francis M. Rogallo  
**FM.Re.** Frederick M. Remley  
**FM.W.** Floyd M. Wahl  
**FM.Wh.** Frank M. White  
**FO'D.** Franklin O'Donnell  
**FP.** Francesco Paresce  
**FPH.** Frederick P. Heinzel  
**FR.** Floyd Ratliff  
**FRi.** Frank Riley  
**FRo.** F. Rohrllich  
**FRu.** Fritz Ruch  
**FR.B.** F. R. Boyd  
**FR.E.** F. R. Eirich  
**FR.Ko.** F. Ralph Kotter  
**FR.M.** Frederick R. Miller  
**FR.V.** Frank R. Voorhees  
**FR.Vo.** Fred R. Volkmar  
**FS.** Frederick Sanders  
**FSa.** Fred Sauer  
**FSte.** Fred Stern  
**FS.B.** Francis H. Brown  
**FS.Bi.** Frederick S. Billig  
**FS.G.** Frederick S. Goulding  
**FS.Ga.** F. Stephen Gauss  
**FS.J.** Francis S. Johnson  
**FS.M** Frederick S. Merritt  
**FS.R.** Fred S. Rosen  
**FS.S.** Frederick S. Szalay  
**FS.Z.** Frederick S. Zbar  
**FT.** Floyd Toole  
**FTA.** Fredrich T. Addicott  
**FT.L.** F. Thomas Ledig  
**FV.** Felix Viro: Gelatin  
**FV.** Friedrich Vogel: Human genetics  
**FVo.** F. Vogtle  
**FV.B.** Ferdinando V. Boero  
**FV.G.** Fred V. Grau  
**FV.K.** Frank V. Kosikowski  
**FV.L.** F. V. Lenel  
**FW.** Frank Wagner  
**FWe.** Fritz Weigel  
**FWi.** Fred Wilt  
**FWil.** Franz Wilczek  
**FW.Ko.** Frederick W. Koerker  
**FW.K.F.** Frank W. K. Firk  
**FW.M.** Franklin W. Martin  
**FW.S.** Fred W. Smith  
**FW.Sw.** F. W. Sweat  
**FW.Sy.** Frank W. Symons  
**FW.Z.** Frank W. Zink

## G

**G.** Govindjee  
**G.AI.** Gene Alexander  
**G.An.** Giuseppe Angrisano  
**G.A.A.** Gregory A. Ahern  
**G.A.B.** Gerald A. Berkowitz  
**G.A.D.** Gregory A. Davis  
**G.A.Da.** Gilles A. Daigle  
**G.A.E.** George A. Economou

- G.A.Ho.** G. A. Morton  
**G.A.J.** G. A. Jackson  
**G.A.K.** Georgia-Ann Klutke  
**G.A.M.** Gordon A. Macdonald  
**G.A.Ma.** George A. Maul  
**G.A.Mo.** Gary A. Moll  
**G.A.S.** G. Alan Solem  
**G.A.W.** Gary A. Williams  
**G.Ba.** George Bakken  
**G.Bi.** Garrett Birkhoff  
**G.Bo.** Gerard Bond  
**G.Boh.** Greg Bohach  
**G.B.B.** Günther B. Blobel  
**G.B.L.** Glen B. Lesins  
**G.B.M.** Gairdner B. Moment  
**G.B.P.** Gayle B. Priester  
**G.C.** George Cocks: Chemical microscopy  
**G.C.** Gerald Cook: Guidance systems  
**G.Ch.** George Christou: Manganese  
**G.Ch.** Gregory Cherlin: Logic  
**G.C.A.** Gyan C. Agarwal  
**G.C.B.** George C. Brainard  
**G.C.G.** Gerard C. Gamsb  
**G.C.H.** Gary C. Hess  
**G.C.Ke.** George C. Kent, Jr.  
**G.C.M.** George C. Messenger  
**G.C.N.** George C. Nelson  
**G.D.** Gerhard Derge  
**G.D.B.** Glenn D. Breuer  
**G.D.Br.** G. Donald Brandt  
**G.D.C.** Gene D. Cohen  
**G.D.E.** Gregory D. Edgecombe  
**G.D.F.** George D. Fulford  
**G.D.Gor.** Gary D. Gordon  
**G.D.K.** Garry D. Karner  
**G.D.S.** Guy D. Smith  
**G.E.L.** George E. Liedholm  
**G.E.Li.** Gene E. Likens  
**G.E.P.** George E. Pake  
**G.E.Pe.** Gertrude E. Perlmann  
**G.E.Sti.** Gregory E. Stillman  
**G.E.W.** Gary E. Wnek  
**G.E.W.P.** Gerhard W. E. Plant  
**G.F.** Gioacchino Failla  
**G.Fa.** Gerhard Fankhauser  
**G.Fau.** Gunter Faure  
**G.Fr.** Geoffrey Fryer  
**G.F.B.** George F. Bobart  
**G.F.Be.** George F. Bertsch  
**G.F.Bi.** Giovanni F. Bignami  
**G.F.F.** Gordon F. Ferris  
**G.F.H.** G. F. Herzog  
**G.F.L.** George F. Ludvik  
**G.F.O.** Gilbert F. Otto  
**G.F.P.** George F. Pinder  
**G.F.R.** George F. Reddish  
**G.F.S.** G. F. Sprague  
**G.G.** Gerald Gilardi: Moraxella  
**G.G.** Gerson Goldhaber: Goldhaber triangle  
**G.Gu.** G. Guzinski  
**G.G.A.** George G. Adkins  
**G.G.K.** George G. Karady  
**G.He.** Gilbert Held  
**G.Hi.** Gertrude Hirsch  
**G.Ho.** Gerald Holton  
**G.Hot.** Grosvenor Hotchkiss  
**G.Hr.** Geza Hrazdina  
**G.Hy.** Geoffrey Hyde  
**G.H.B.** Glenn H. Brown  
**G.H.C.** Gilbert H. Cady  
**G.H.D.** George H. Davis  
**G.H.Di.** G. H. Dieke  
**G.H.F.** George H. Fried  
**G.H.M.** Glenn H. Miller  
**G.H.Mo.** George H. Morrison  
**G.H.O.** Gordon H. Orians  
**G.H.R.** Gilbert H. Reiling  
**G.H.Ra.** G. H. Rayner  
**G.H.T.** Gerold H. Tenney  
**G.H.W.** George H. Way  
**G.J.** Giles Johnson  
**G.J.C.** Gerald J. Canter  
**G.J.G.** Gerald J. Gastony  
**G.J.Ga.** Gerald J. Gray  
**G.J.R.** Gerald J. Romick: Aeronomy  
**G.J.R.** Gregory J. Retallack: Paleosol  
**G.J.S.** Gary J. Stout  
**G.J.W.** George J. Wilder  
**G.J.Z.** George J. Zissis  
**G.Kr.** George Krauss  
**G.Ku.** Glenn Kuntz  
**G.Kul.** Gunnar Kullerud  
**G.K.C.** George K. Celler  
**G.K.Cz.** Gerald K. Czamanske  
**G.K.S.** Gerald K. Sims  
**G.L.** Gary Levy  
**G.LeB.** Gretchen LeBuhn  
**G.Lo.** George Lordi  
**G.L.B.** Gordon L. Brownell  
**G.L.Be.** Gerald L. Benny  
**G.L.Cl.** George L. Clark  
**G.L.E.** Gunther L. Eichhorn  
**G.L.Ee.** Gary L. Eesley  
**G.L.K.** George L. Gaines  
**G.L.Gi.** Gerald L. Gilardi  
**G.L.H.** Gary L. Haller  
**G.L.St.** G. Ledyard Stebbins  
**G.L.T.** Gerald L. Thompson  
**G.L.To.** Gregory L. Tonkay  
**G.M.** George Mandler  
**G.Ma.** Gleb Mamantov  
**G.McP.** George McPherson, Jr.  
**G.Mo.** Giuliana Moreno  
**G.Mu.** Glenn Murphy  
**G.M.C.** Gerald M. Clemence  
**G.M.G.** Glenn M. Glasford  
**G.M.Gu.** Gay M. Guzinski  
**G.M.H.** Gary M. Hieftje  
**G.M.K.** Glen M. Kohls  
**G.M.L.** George M. Lordi  
**G.M.La.** George M. Langford  
**G.M.M.** George M. Malacinski  
**G.M.McK.** Guy M. McKhann  
**G.M.R.** Gardner M. Reynolds  
**G.M.S.** George M. Savage  
**G.M.Se.** Gerhard M. Sessler  
**G.M.Sh.** Gordon M. Shepherd  
**G.M.Y.** Grant M. Young  
**G.N.A.** George N. Agrios  
**G.N.H.** George N. Hatsopoulos  
**G.O.** Gerald Oster  
**G.Ow.** Guillermo Owen  
**G.P.** George Papageorgiou  
**G.Pa.** Gary Pacella: Army armament  
**G.Pa.** Gerald Palevsky: Civil engineering etc.  
**G.Pas.** Gavril Pasternak  
**G.Po.** Guido Pontecovo  
**G.Pos.** German Posada  
**G.Pr.** George Press  
**G.PB.** Guy P. Brasseur  
**G.PKr.** Graham P. Krasen  
**G.P.S.** George P. Sutton  
**G.R.** George Rapp, Jr.  
**G.R.C.** Georgeanne R. Caughlan  
**G.R.Ca.** G. R. Carter  
**G.R.G.** G. Ronald Gray  
**G.R.H.** George R. Harrison  
**G.R.Hi.** Glenn R. Hicks  
**G.R.N.** Gerald R. North  
**G.R.P.** G. R. Peirce  
**G.R.Po.** Gerald R. Popelka  
**G.R.S.** G. R. Schoonmaker  
**G.R.St.P.** George R. St. Pierre  
**G.S.** George Sistere, Jr.  
**G.Sh.** G. Shanmugam  
**G.She.** Gopal Shenoy  
**G.Sl.** George Slomp  
**G.Slu.** Greenfield Sluder  
**G.Sm.** Gaylord Smith  
**G.Sp.** Garrison Sposito  
**G.Sw.** George Switzer  
**G.Swi.** Grag Swift  
**G.S.E.** Ginger Sunday Evans  
**G.S.G.** Gary S. Grest  
**G.S.H.** G. S. Hurst: Acoustic interferometer  
**G.S.H.** Gene S. Helfman: Territoriality  
**G.S.K.** George S. Kobayashi  
**G.S.K.W.** George S. K. Wong  
**G.S.M.** George S. Mill  
**G.S.S.** Gary S. Stein  
**G.S.T.** Gordon S. Taylor  
**G.S.W.** George S. Wilson  
**G.T.** Geza Teleki  
**G.Tc.** George Tchobanoglous  
**G.Th.** Gary Thomann  
**G.T.C.** G. T. Csanady  
**G.T.J.** Gideon T. James  
**G.T.S.** Glenn T. Seaborg  
**G.T.Sh.** G. Tom Shires  
**G.T.Si.** Glenn T. Sincerbox  
**G.V.K.** George V. Keller  
**G.V.M.** Gerard V. Middleton  
**G.V.S.R.** G. V. S. Raju  
**G.W.** Gerald Weiss  
**G.We.** Gerold Wefer: Paleoceanography  
**G.We.** Gunter Weller: Antarctica  
**G.W.Br.** George W. Brindley  
**G.W.Bu.** G. W. Butler  
**G.W.Bur.** Glenn W. Burton  
**G.W.DeV.** George W. DeVore  
**G.W.E.** Gordon W. Ellis  
**G.W.F.** George W. Flathers II  
**G.W.G.** George W. Gokel: Macrocyclic compound  
**G.W.G.** Gordon W. Groves: Tide  
**G.W.H.** Gertrude W. Hirsch  
**G.W.Ha.** Gerald W. Hart  
**G.W.Hay.** G. W. Hay  
**G.W.K.** George W. Kessler  
**G.W.M.** George W. Mackey  
**G.W.N.** Gerold W. Neudeck  
**G.W.S.** George W. Stroke

**G.W.Sa.** Gary W. Saunders  
**G.W.Si.** George W. Simon  
**G.W.Sie.** Gary W. Siebein  
**G.W.W.** Grady W. Wilson  
**G.Y.C** Gilbert Y. Chin  
**G.Z.** Geoffrey Zubay

## H

**H.A.** Herbert Athenstaedt  
**H.A.B.** Horace A. Barker  
**H.A.Be.** Hans A. Bethe  
**H.A.Bec.** Henry A. Becker  
**H.A.F.** Henry A. Fairbank  
**H.A.Fr.** Henry A. Fribourg  
**H.A.L.** Herbert A. Laitinen  
**H.A.McA.** Harold A. McAlister  
**H.A.W.** Harley A. Wilhelm  
**H.B.** Hans Brintzinger  
**H.Be.** Harold Berger  
**H.Bi.** Hans Bichsel  
**H.Bl.** Harvey Blatt  
**H.Bu.** Heinz Buell  
**H.B.A.** H. Burnham Allport  
**H.B.B.** Howard B. Bluestein  
**H.B.F.** Howard B. Fell  
**H.B.Gr.** Harry B. Gray  
**H.B.H.** H. B. Huntington  
**H.B.J.** Howard B. Jensen  
**H.B.M.** Harold B. Maynard  
**H.B.Ma.** Harry B. Marks, Jr.  
**H.B.Mi.** Harlow B. Mills  
**H.B.Pi.** Harry B. Pionke  
**H.B.S.** Howard B. Sprague  
**H.B.Sk.** Harry B. Skinner  
**H.B.T** Harold B. Tukey  
**H.C.** Henry Charnock  
**H.Cl.** Hartwig Cleve  
**H.Co.** Helen Couclelis  
**H.Cr.** Howard Crum  
**H.Cu.** Harold Cummins  
**H.C.B.** Herbert C. Brown  
**H.C.C.** H. C. Casey, Jr.  
**H.C.Co.** Herbert C. Corben  
**H.C.L.** Henry C. Lee  
**H.C.R** Harold C. Ries  
**H.C.Ro.** Harry C. Rogers  
**H.C.W** Harold C. Weber  
**H.C.Wi.** Kurd C. Willett  
**H.C.Y.** Harry C. Yeatman  
**H.D.** H. Date  
**H.De.** Hans Dehmelt  
**H.deC.P.** Hart de Coudres Peterson  
**H.Di.** Hugh Dingle  
**H.D.D.** H. D. Dooley  
**H.D.G.M.** Henri D. Grissino-Mayer  
**H.D.J.** Hugh D. Jones  
**H.D.O** Harold D. Orville  
**H.D.P** Harry D. Patton  
**H.D.S.** Hugh D. Sisler  
**H.E.B.** Harold E. Burkhart  
**H.E.Ba.** Henry E. Bass  
**H.E.Ca.** Herbert E. Carter  
**H.E.D.** Henry E. Duckworth  
**H.E.E.** Harold E. Edgerton  
**H.E.L.** H. E. Landsberg

**H.E.McG.** Harold E. McGannon  
**H.E.N.** Homer E. Newell  
**H.E.W.** Harvey E. Wegner  
**H.E.We.** H. E. Wendler  
**H.F.** Herman Feshbach  
**H.Fi.** Harold Fischer  
**H.Frei.** Henry Freiser  
**H.FD.** Hector F. Deluca  
**H.FK.** Harold F. Klock  
**H.FKo.** Henry F. Korth  
**H.FO.** Harry F. Olson  
**H.FR** Harry F. Remde  
**H.F.S.** Henry F. Schaefer III  
**H.FV.** Herbert F. Volk  
**H.G.** Harold Goodglass  
**H.Gr.** H. Granicher  
**H.Gro.** Hallstein Gronstol  
**H.G.B.** Harriet G. Barclay  
**H.G.Bo.** Holbrook G. Botset  
**H.G.M.** H. G. Marshall  
**H.G.S.** Heinz G. Sell  
**H.G.Sh.** Harley G. Sheffield  
**H.G.St.** H. G. Stubbings  
**H.G.W.** H. G. Wittmann  
**H.H.** Henry Hellmers  
**H.Ha.** Harold Hart  
**H.H.Br.** H. H. Bruun  
**H.H.C.** Howard H. Chang  
**H.H.D.** Heinz H. Damberger  
**H.H.F.** H. Hugh Fudenberg  
**H.H.H.** Henry H. Hausner  
**H.H.Ha.** H. Hunter Handsfield  
**H.H.J.N.** Herbert H. J. Nesbitt  
**H.H.Mu.** Haydn H. Murray  
**H.H.R.** Herbert H. Ross  
**H.H.S.** Harry H. Sisler  
**H.H.Sk.** Hugh H. Skilling  
**H.H.St.** Henry H. Storch  
**H.H.T.** H. Holden Thorp  
**H.J.** Hans Jakobi  
**H.J.A.** Henry J. Albert  
**H.J.B.D.** Henry J. B. Dick  
**H.J.C.** H. John Carew  
**H.J.He.** Hermann J. Helgert  
**H.J.K.** Herbert J. Kayden  
**H.J.L.** Harry J. Lipner  
**H.J.M.** H. J. Melosh  
**H.J.Ma.** Humphrey J. Maris  
**H.J.P.** Herman J. Phaff  
**H.J.R.** Herbert J. Reich  
**H.J.S.** Harlan J. Smith  
**H.J.Wi.** Herold J. Wiens  
**H.J.Wir.** Henry J. Wirry  
**H.K.** Herwig Kogelnik  
**H.K.E.** Hany K. Eldeib  
**H.La.** Harry Lass  
**H.Le.** Henry Leland  
**H.Lei.** Hoyle Leigh  
**H.Lem.** Harvey Lemont  
**H.Li.** Helmut Lieth  
**H.L.Ba.** Harry L. Baldwin, Jr.  
**H.L.D.** Herbert L. Dupont  
**H.L.F.** Harold L. Friedman  
**H.L.G.S.** Henry L. G. Stroyan  
**H.L.H.** Howard L. Hamilton  
**H.L.Ha.** Howard L. Hamilton  
**H.L.O.** H. L. Ostergaard  
**H.L.Sc.** Hilary Lappin-Scott  
**H.L.Sh.** Harry L. Shipman  
**H.L.St.** Herbert L. Stahnke

**H.Ma.** Henry Margenau  
**H.Mar.** Harvey Marshak  
**H.Mark.** Hershel Markovitz  
**H.Mor.** Helmut Moritz  
**H.M.C.** Heather Miller Coyle  
**H.M.F.** Harry M. Freeman  
**H.M.H** Howard M. Hickman  
**H.M.M.** H. M. Munger  
**H.M.T.** Howard M. Temin  
**H.M.Ts.** Henry M. Tsuchiya  
**H.N.** Harry Nussbaumer  
**H.N.P.** Henry N. Pollack  
**H.N.W.** Henry N. Wagner, Jr.  
**H.O.A.M.** Henry O. A. Meyer  
**H.O.H.** Harlyn O. Halverson  
**H.P.** Hal Pastner  
**H.P.B.** Harland P. Banks  
**H.P.C.** Harold P. Coyle  
**H.P.S.** Hans-Peter Schultz  
**H.P.T.** Henry P. Treffers  
**H.P.W.** Hilda P. Willett  
**H.P.Yu.** Horace P. Yuen  
**H.R.** Hans Rademacher  
**H.Ras.** Howard Rasmussen  
**H.R.A.** Harry R. Anderson  
**H.R.C.** Hollis R. Cooley  
**H.R.J.** Howard R. Jory  
**H.R.L** Hans R. Lindner  
**H.S.** Hymin Shapiro  
**H.Sa.** Helmut Sauer  
**H.Sc.** Harvey Schugar  
**H.So.** Harry Sohon  
**H.S.A.** H. S. Aldwinckle  
**H.S.B.** Howard S. Bean  
**H.S.Be.** H. Stanley Bennett  
**H.S.Bl.** Harold S. Black  
**H.S.C.** H. S. Chen  
**H.S.H.** Helen S. Hogg  
**H.S.Hu.** Hugh S. Hudson  
**H.S.L.** Harry S. Ladd  
**H.S.La.** Hugh S. Landes  
**H.S.M.C.** H. S. M. Coxeter  
**H.Ta.** Henry Taube  
**H.T.Ha.** Hudson T. Hartman  
**H.T.L.** Helen Tappan Loeblich  
**H.T.R.** H. Thomas Rossby  
**H.V.B.** Henry V. Borst  
**H.V.C.** Homer V. Craig  
**H.W.** Hermann Wollnik  
**H.We.** Herb Welhener  
**H.Wh.** Harry Wheeler  
**H.Wi.** Hugh Wilcox  
**H.Win.** Herman Winick  
**H.W.Be.** H. Wayne Beaty  
**H.W.Bl.** H. Weston Blaser  
**H.W.C.** Howard W. Campbell  
**H.W.F.** Henry W. Fischer  
**H.W.J.** Holger W. Jannasch  
**H.W.K.** Harold W. Keller  
**H.W.Ki.** H. W. Kirby  
**H.W.Kr.** Harold W. Kroto  
**H.W.L.** H. W. Levi  
**H.W.M.** Hans W. Meissner  
**H.W.Mo.** Harland W. Mossman  
**H.W.R.** H. W. Ritchey  
**H.W.Ra.** Harley W. Radin  
**H.W.Ru.** Howard W. Russell  
**H.W.S.** Horace W. Stunkard  
**H.W.W.** Howard W. Wainwright  
**H.W.Wo.** H. William Wood

**H.Y.** Howard Yokelson  
**H.Ya.** Hongjun Yang  
**H.Y.F.** Hsu Y. Fan  
**H.Zi.** Harold Zirin

## I

**I.A.** Igor Alexeff  
**I.A.B.** Irving A. Breger  
**I.A.Le.** I. A. Lesk  
**I.A.S.** Ivan A. Sellin  
**I.B.** Ivan Barnes  
**I.Ba.** Itzhak Bars  
**I.Bl.** Ira Block  
**I.B.W.** Irwin B. Wilson  
**I.D.** Ingrid Daubechies  
**I.D.H.** Ian D. Hutcheon  
**I.E.L.** I. E. Levine  
**I.Fr.** Irwin Fridovich  
**I.FK.** Isaac F. Kinnard  
**I.F.S.** Ira F. Salkin  
**I.G.** Isidore Gersh  
**I.Gi.** Ian Gibbons  
**I.Go.** Ivan Goodbody  
**I.H.H.** I. H. Hutchinson  
**I.J.G.** Irving J. Good  
**I.J.Go.** Ira J. Goldberg  
**I.K.M.** Innes K. Mackenzie  
**I.K.S.** Ivan K. Schuller  
**I.L.** Irving Lefkowitz  
**I.Le.** Use Lehiste  
**I.L.B.** I. Lehr Brisbin, Jr.  
**I.L.K.** Irving L. Kosow  
**I.M.B.** I. M. Bernstein  
**I.M.L.** I. Michael Lerner  
**I.M.M.** Ian M. Mills  
**I.M.P.** Ingrid M. Parker  
**I.M.R.** Ira M. Rutkow  
**I.N.** Irwin Nash  
**I.N.L.** Ira N. Levine  
**I.P.H.** I. Paul Hew  
**I.P.K.** Ivan P. Kaminow  
**I.PL.** I. Paul Lew  
**I.P.T.** Irwin P. Ting  
**I.R.** Irvin Rock  
**I.R.M.** Ian R. Mackay  
**I.S.** Irving Sheft  
**I.S.G.** Irving S. Goldstein  
**I.T.** Isao Tanihata  
**I.Ta.** Ian Tattersall  
**I.W.O.D.** Ian W. O. Dalziel  
**I.Z.** Israel Zelitch  
**I.ZI.** I. Zlotnik

## J

**J.Ad.** Jonathan Adrain  
**J.As.** James Aston  
**J.A.A.** John A. Allen  
**J.A.B.** J. A. Bolt  
**J.A.Cla.** Jennifer A. Clack  
**J.A.Co.** Jonathan A. Coddington  
**J.A.D.** James A. Donaldson  
**J.A.Da.** John A. Davies

**J.A.Do.** James A. Doyle  
**J.A.H.** John A. Harvey  
**J.A.Hr.** John A. Hrones  
**J.A.Hy.** J. Allen Hynek  
**J.A.K.** John A. Knauss  
**J.A.Li.** James A. Liggett  
**J.A.M.** John A. Manson  
**J.A.Ma.** Janet Akyüz Mattei  
**J.A.McG.** John A. McGinley  
**J.A.Mo.** James A. Moore  
**J.A.Pe.** Jan A. Pechenik  
**J.A.Pec.** Joseph A. Pecar  
**J.A.Ph.** James A. Phillips  
**J.A.R.** John A. Robbins  
**J.A.Ri.** James A. Rillema  
**J.A.Sc.** Joseph A. Schetz  
**J.A.Shi.** John A. Shields  
**J.A.Sim.** James A. Simmons  
**J.A.Sm.** John A. Smith  
**J.A.Smi.** Jerome A. Smith  
**J.A.Sp.** J. Alexander Speer  
**J.A.Sw.** John A. Swets  
**J.A.T.** J. A. Turley  
**J.A.V.** Jose A. Ventura  
**J.A.Va.** Jeff A. Valenti  
**J.A.Ve.** Judith A. Vessey  
**J.A.Wr.** James A. Wright  
**J.B.** Jack Bass: Thermoelectricity  
**J.B.** Jesús Benito: Enteropneusta, etc.

**J.Ba.** John Bally  
**J.Be.** Jesse Beams  
**J.Ben.** Jesús Benito  
**J.Bi.** Joseph Biederman  
**J.Big.** Jacob Bigeleisen  
**J.Bl.** John Bleiweis  
**J.Br.** John Brunski  
**J.Bre.** Joel Breman  
**J.B.D.** John B. Dunning, Jr.  
**J.B.Da.** James B. Dale  
**J.B.F.** Jack B. Fisher  
**J.B.Fr.** J. Bruce French  
**J.B.G.** Jeffrey B. Graham: Hibernation

**J.B.G.** John B. Goodenough: Electric insulator  
**J.B.Gl.** Joseph B. Glaab  
**J.B.H.** Jacques B. Hadler  
**J.B.J.** J. B. Jennings  
**J.B.Jo.** Jeremy B. Jones  
**J.B.K.** J. B. Ketterson  
**J.B.Ka.** James B. Kaler  
**J.B.L.** James B. Lackey  
**J.B.Lo.** Joseph B. Long  
**J.B.M.** J. B. Messerger  
**J.B.P.** Jon B. Pangborn  
**J.B.Po.** James B. Pollack  
**J.B.S.** John B. Scalzi  
**J.B.T.** Joyce B. Turner  
**J.B.W.** John B. Woodward  
**J.B.Wi.** Jame B. Wilson  
**J.C.** Joseph Callaway  
**J.Ca.** John Catchpole  
**J.Cai.** Joseph Cain  
**J.Cap.** Jennings Capellen  
**J.Cl.** John Clarke  
**J.Co.** Jerome Cohen  
**J.Cos.** James Costantino  
**J.Cr.** Joel Cracraft  
**J.C.B.** John C. Brandt

**J.C.Ba.** Jogn C. Bailar, Jr.  
**J.C.Bo.** John C. Bouwkamp  
**J.C.C.** John C. Couch  
**J.C.Ch.** Jean-Claude Chambron  
**J.C.Co.** Jonathan C. Comer  
**J.C.Cr.** Julian C. Crane  
**J.C.D.** John C. Drake  
**J.C.L.** John C. Lane  
**J.C.M.** Julian C. Miller  
**J.C.Ma.** J. Carson Mark  
**J.C.Mi.** J. Creighton Miller, Jr.  
**J.C.Mit.** Jeffrey C. Mitchell  
**J.C.P.** John C. Polking  
**J.C.R.** John C. Reilly, Jr.  
**J.C.Ri.** J. C. Ritchie  
**J.C.Ro.** Jerome C. Rozen, Jr.  
**J.C.S.** John C. Schelleng  
**J.C.Sc.** Jack C. Schultz  
**J.C.Sm.** Julian C. Smith  
**J.C.So.** James C. Solomon  
**J.C.St.** James C. Sternberg  
**J.C.W.** James C. Warf  
**J.C.Wo.** James C. Wolford  
**J.C.Wy.** James C. Wyant  
**J.D.** Jack David  
**J.Da.** Jaime Davidson  
**J.Do.** Joe Downey  
**J.D.A.** John D. Anderson, Jr.  
**J.D.Ar.** J. David Archibald  
**J.D.Br.** John D. Briggs  
**J.D.Bu.** James D. Burke  
**J.D.C.** J. Donald Capra: Immunoglobulin

**J.D.C.** John De Cicco: Noneuclidean geometry  
**J.D.Co.** James D. Cobine  
**J.D.Coh.** Jerry D. Cohen  
**J.D.Ga.** Joe D. Gamble  
**J.D.H.** J. Donald Harris  
**J.D.Hu.** J. D. Hurley  
**J.D.J.** James D. Johnston  
**J.D.Jo.** Jon D. Johnson  
**J.D.L.** J. Dennis Lawrence  
**J.D.MacD.** J. D. MacDougall  
**J.D.Me.** James D. Metzger  
**J.D.P.** James D. Palmer  
**J.D.Ro.** J. David Robertson  
**J.D.S.** James D. Schoeffler  
**J.D.Si.** John D. Singleton  
**J.D.T.** John D. Turner  
**J.D.Tr.** James D. Trolinger  
**J.E.** John Ehrlich  
**J.El.** Joseph Elgomayel  
**J.Ev.** John Everetts, Jr.  
**J.E.A.** James E. Anders, Sr.  
**J.E.B.** James E. Bayfield  
**J.E.Ba.** John E. Banks  
**J.E.Be.** James E. Beck  
**J.E.Bi.** John E. Biegel  
**J.E.Bla.** James E. Blankenship  
**J.E.D.B.** John E. D. Ball  
**J.E.E.** James E. Eckenwalder  
**J.E.F.** James E. Ferrell  
**J.E.Fi.** J. E. Fischer  
**J.E.G.** John E. Gibson  
**J.E.Gr.** Jonathan E. Grindlay  
**J.E.Gu.** James E. Guckel  
**J.E.H.** John E. Haines  
**J.E.Ho.** J. Edgar Hoover  
**J.E.Jo.** James E. Johnson

- J.E.K.** Jessica Elzea Kogel: Kaolinite  
**J.E.K.** John E. Kutzbach: Climate history
- J.E.Lo.** James E. Loughlin  
**J.E.Ma.** James E. May  
**J.E.McC.** John E. McCarty  
**J.E.N.** James E. Nordman  
**J.E.O.** John E. Oliver  
**J.E.O'L.** John E. O'Leary  
**J.E.R.** Johannes E. Rijnsdorp  
**J.E.Ro.** James E. Rodman  
**J.E.S.** James E. Schindler  
**J.E.Sc.** John E. Scott, Jr.  
**J.E.U.** John E. Ullmann  
**J.E.We.** J. E. Webb  
**J.E.Wi.** Judith E. Winston  
**J.E.Wo.** James E. Woodall  
**J.Fa.** Joseph Farell  
**J.Fi.** John Firor  
**J.Fo.** Joseph Ford  
**J.FA.** John F. Aloia  
**J.FB.** Joseph F. Bunnett  
**J.FBa.** J. F. Bash  
**J.FC.** James F. Connors  
**J.FCl.** John F. Clark  
**J.FCr.** James F. Crow  
**J.FDi.** J. F. Dillon, Jr.  
**J.FE.** John F. Endicott  
**J.FF.** James F. Ferry: Willow  
**J.FF.** James F. Fitzsimons: Egg (fowl)  
**J.FH.** John F. Hahn  
**J.FHe.** J. F. Herbst  
**J.FHu.** John F. Hubert  
**J.FJa.** John F. Jarvis  
**J.FL.** J. F. Lonergan  
**J.FLe.** Justus F. Lehmann  
**J.FLi.** Joel F. Liebman  
**J.FM.** Jose F. Maldonado-Moll  
**J.FMcM.** John F. McMahan  
**J.FMcP.** Joseph F. McPartland  
**J.FMe.** John F. Meyer  
**J.FP.** J. F. Parr: Fertilizer  
**J.FP.** James F. Price: Geography etc.  
**J.FPr.** John F. Presley  
**J.FR.** John F. Reintjes  
**J.FRi.** James F. Riordan  
**J.FS.** James F. Scott  
**J.FSe.** Joseph F. Sebald  
**J.FT.** John F. Timoney  
**J.FW.** John F. Wallace  
**J.FWe.** Jonathan F. Weil  
**J.FWeb.** Jacqueline F. Webb  
**J.G.** John Garcia  
**J.Ga.** John Gamble: Andesite  
**J.Ga.** John Garland: Logging  
**J.Ge.** John Gergely  
**J.Gei.** Jon Geist  
**J.Ger.** Janos Gertler  
**J.Gi.** J. Gijskuenen: Chemostat  
**J.Gi.** Jacques Gilloteau: Gallbladder  
**J.Gr.** Jerry Grey  
**J.Gre.** Jack Greenberg  
**J.G.B.** James B. Blencoe  
**J.G.Br.** John G. Brooks  
**J.G.C.** J. G. Carter  
**J.G.D.** John G. Dorsey  
**J.G.F.** J. G. Futral
- J.G.H.** James G. Horsfall  
**J.G.J.** James G. Johnson  
**J.G.Ja.** J. Gordon Jarvis  
**J.G.L.** John G. Liou  
**J.G.Le.** John G. Leonard  
**J.G.Ma.** John G. Maisey  
**J.G.Pe.** John G. Peacey  
**J.G.S.** James G. Speight  
**J.Ha.** John Hansen  
**J.Hal.** John Hallett  
**J.Ham.** John Hamilton  
**J.Hard.** John Hardy  
**J.Hare.** Jonathan Hare  
**J.Hart.** Jack Hartstein  
**J.He.** Jeff Hester  
**J.Ho.** James Hodgdon  
**J.Hu.** Jack Huebler  
**J.Hur.** J. Hurl  
**J.H.Bi.** Jesse H. Bidanset  
**J.H.C.** Joseph H. Camin  
**J.H.Ca.** James H. Calderwood  
**J.H.Car.** Jack H. Carlson  
**J.H.Cl.** J. Harold Clarke  
**J.H.Co.** J. H. Collins  
**J.H.Cr.** John H. Crowe  
**J.H.D.** John H. Davis  
**J.H.F.** J. Homer Ferguson  
**J.H.Fe.** Janos H. Fendler  
**J.H.Fi.** Joseph H. Field  
**J.H.G.** Joseph H. Golden  
**J.H.H.** Joseph H. Hamilton  
**J.H.Hi.** Joel H. Hildebrand  
**J.H.L.** Jean H. Langenheim  
**J.H.Le.** John H. Lewis  
**J.H.Lo.** John H. Lockhead  
**J.H.Ma.** John H. Madison  
**J.H.Me.** John H. Merold  
**J.H.Na.** James H. Natland  
**J.H.O.** John H. Ostrom  
**J.H.S.** James H. Schulman  
**J.H.Sa.** John H. Saylor  
**J.H.Sh.** John H. Shergold  
**J.H.T.** J. Herbert Taylor  
**J.H.U.** James H. Underwood  
**J.H.W.** J. H. Walker  
**J.H.Z.** John H. Zifcak  
**J.I.K.** Joseph I. Karash  
**J.I.Y.** John I. Yellott  
**J.J.** Jules Janick  
**J.J.B.** John J. Bleiweis  
**J.J.Ca.** James J. Carberry  
**J.J.G.** Janos J. Gertler  
**J.J.Gr.** J. J. Griffin  
**J.J.K.** Joseph J. Katz  
**J.J.Ka.** James J. Kasmierczak  
**J.J.L.** J. J. Lagowski  
**J.J.La.** James J. Laidler  
**J.J.Lo.** J. J. Love  
**J.J.M.** Joseph J. Moder  
**J.J.Ma.** John J. Marcholonis  
**J.J.McD.** John J. McDonald  
**J.J.Mo.** Jeffrey J. Morrell  
**J.J.P.** James J. Pelosi  
**J.J.R.** James J. Ryan  
**J.J.Sc.** John J. Schilling  
**J.J.Se.** J. John Sepkoski, Jr.  
**J.J.St.** Julian J. Steyn  
**J.J.W.** John J. Walsh  
**J.K.** Jan Klein  
**J.K.B.** J. Kelly Beatty
- J.K.Ba.** Jennifer Kehlet Barton  
**J.K.Bu.** Jeremy K. Burdett  
**J.K.H.** Jack K. Holmes  
**J.K.Ha.** Janine K. Hasey  
**J.K.Hu.** James K. Hurst  
**J.K.L.** James K. Lewis  
**J.K.Le.** Jonathan K. Leland  
**J.K.M.** June Kan-Mitchell  
**J.K.M.P.** John K. M. Pryke  
**J.K.R.** J. K. Roberts  
**J.K.Ri.** J. Keith Rigby  
**J.K.St.** Jeffrey K. Stone  
**J.K.T.** J. Kerry Thomas  
**J.K.W.** Jean K. Whelan  
**J.Li.** Juhn Liou  
**J.Lu.** Jane Luu  
**J.Ly.** John Lyman  
**J.L.A.** Jose L. Aguiar  
**J.L.B.** J. Laurens Barnard  
**J.L.Ba.** Jeffrey L. Bada  
**J.L.Bl.** J. Lewis Blackburn  
**J.L.Br.** Judith L. Bronstein  
**J.L.D.** Joseph L. Doob  
**J.L.Go.** James L. Gooding  
**J.L.Gr.** Jesse L. Greenstein  
**J.L.Gro.** Jonathan L. Gross  
**J.L.J.** Julian L. Jenkins  
**J.L.K.** J. Laurence Kulp  
**J.L.Ka.** Jack L. Katz  
**J.L.L.** Jack L. Lambert: Colorimetry  
**J.L.L.** Jeffrey L. Linsky: Qualitative chemical analysis  
**J.L.La.** J. L. Larimer  
**J.L.Lo.** John L. Loeb  
**J.L.LoC.** Joseph L. LoCicero  
**J.L.M.** John L. Margrave  
**J.L.McG.** James L. McGaugh  
**J.L.McH.** J. L. McHugh  
**J.L.Me.** Joseph L. Melnick  
**J.L.Mey.** Judy L. Meyer  
**J.L.N.** J. L. Nevins  
**J.L.Re.** Joseph L. Reid  
**J.L.S.** John L. Sabo  
**J.L.St.** Janet L. Stein  
**J.L.Sta.** J. L. Stanford  
**J.L.Sto.** Jeffrey L. Stott  
**J.L.T.** J. L. Turk  
**J.L.W.** Joseph L. Walsh  
**J.L.We.** James L. Weaver  
**J.L.We.** J. L. Weinberg  
**J.L.Wi.** James L. Wilson  
**J.L.Wr.** John L. Wray  
**J.M.** Jonathan Marks  
**J.Ma.** Jack Major  
**J.Mar.** John Markus  
**J.Marr.** John Marr  
**J.Mas.** Jeam Massion  
**J.Mau.** John Mauchline  
**J.McC.** J. McCarthy  
**J.Me.** Jane Meinklejohn  
**J.Mee.** Jean Meeus  
**J.Mei.** Jerome Meisel  
**J.Mein.** J. Meinwald  
**J.Meix.** Josef Meixner  
**J.Mel.** John Melander  
**J.Men.** Joshua Menkes  
**J.Mi.** Jacob Millman  
**J.Mo.** James Moore  
**J.Mu.** John Murray: Iron metabolism  
**J.Mu.** John Mutter: Seismology

## 2500 Contributors

- J.M.A.D.** J. M. A. Danby  
**J.M.Ba.** Janice M. Bahr  
**J.M.Be.** Janos M. Beer  
**J.M.Bo.** James M. Bobbitt  
**J.M.C.** John M. Carroll  
**J.M.Ch.** John M. Christie  
**J.M.Cha.** J. M. Charrier  
**J.M.D.** James M. Daniels  
**J.M.Di.** James M. Dille  
**J.M.F.** Jean-Marie Franc  
**J.M.Ha.** J. Milton Harris  
**J.M.Hu.** John M. Hughes  
**J.M.K.** John M. Kays  
**J.M.Ke.** Joseph M. Keller  
**J.M.L.** Jack M. Linthicum  
**J.M.La.** John M. Last  
**J.M.Le.** Jean-Marie Lehn  
**J.M.M.** James M. Manning: Albumin  
**J.M.M.** John M. Marek: Open-pit mining etc.  
**J.M.MacD.** J. M. MacDonald  
**J.M.McK.** James M. McKenzie  
**J.M.N.** Jeanette M. Norton  
**J.M.Os.** Jeffrey M. Osborn  
**J.M.P.** Jay M. Pasachoff  
**J.M.Pa.** Jeevak M. Parpia  
**J.M.Pan.** John M. Pandolfi  
**J.M.Pl.** Joseph M. Plecnik  
**J.M.Q.** John M. Quarles  
**J.M.R.** John March-Russell  
**J.M.S.** Jay M. Savage  
**J.M.Sa.** Jose M. Sasian  
**J.M.Tr.** James M. Trappe  
**J.M.V.** Jane M. Vanderkooi  
**J.M.Wa.** John M. Wallace  
**J.M.Wi.** Jack M. Williams  
**J.M.Wie.** John M. Wiest  
**J.M.Win.** John M. Winter, Jr.  
**J.M.Woo.** Jerry M. Woodall  
**J.M.Wor.** John M. Woram  
**J.N.** Jerome Namias  
**J.N.B** John N. Bahcall  
**J.N.Ba.** J. Norman Bardsley  
**J.N.BeM.** James N. BeMiller  
**J.N.Bu.** Judith N. Burstyn  
**J.N.F.** Jordon N. Fink  
**J.N.L.** James N. Little  
**J.N.Lu.** James N. Luthin  
**J.N.P.** Joseph N. Payne  
**J.N.R.** J. N. Rutger  
**J.O.C.** John O. Corliss  
**J.O.Co.** Jay O. Cohen  
**J.O.Cu.** Joseph O. Culbertson  
**J.O.E.** John O. Edwards  
**J.O.H.** J. O. Hirschfelder  
**J.O.K.** John O. Kraehenbuehl  
**J.O.S.** J. O. Scanlan  
**J.O.Sm.** Julius O. Smith III  
**J.P.** John Polking  
**J.Pa.** Jacques Paul  
**J.Po.** John Postgate  
**J.Pol.** Joseph Polchinski  
**J.Pom.** James Pomykalski  
**J.Pop.** Joseph Pope  
**J.P.C.** James P. Chambers  
**J.P.D.H.** J. P. Den Hartog  
**J.P.deN.** John P. de Neufville  
**J.P.Fr.** Jeremiah P. Freeman  
**J.P.G.** J. P. Gerrity  
**J.P.Go.** James P. Gordon  
**J.P.Gr.** John P. Grotzinger  
**J.P.H.** John P. Hagen  
**J.P.Ha.** James Penner-Hahn: Kapitza resistance  
**J.P.Ha.** John P. Harrison: Extended x-ray absorption fine structure (EXAFS)  
**J.P.Hay.** John P. Hayes  
**J.P.L.** J. Preston Layton  
**J.P.M.** J. Patrick Muffler: Geothermal power  
**J.P.M.** Joseph P. Mascarenhas: Gametogenesis  
**J.P.McQ.** James P. McQuillan  
**J.P.Mo.** John P. Mordess  
**J.P.O'C.** John P. O'Connell  
**J.P.S.** John P. Scott  
**J.P.Sa.** J.-P. Sauvage  
**J.P.Tr.** J. P. Truant  
**J.P.V.E.** James P. Van Etten  
**J.P.W.** Jon P. Woods  
**J.Ra.** John Rakovan  
**J.Re.** John Reeve  
**J.Ro.** John Ross  
**J.Ru.** Jamie Ruffing  
**J.R.As.** Joseph R. Asik  
**J.R.B.** James R. Boles: Authigenic minerals  
**J.R.B.** James R. Bamberg: Neurobiology  
**J.R.Ba.** J. R. Bandoni  
**J.R.Bo.** James R. Bolton  
**J.R.Bru.** J. Robert Brunner  
**J.R.C.** Joseph R. Curray  
**J.R.C.B.** J. R. Casey Bralla  
**J.R.Co.** James R. Cochran  
**J.R.D.** James R. Daniel  
**J.R.F.** J. R. Fulks  
**J.R.G.** John R. Gyakum  
**J.R.G.T.** John R. G. Turner  
**J.R.H.** James R. Holton  
**J.R.Ha.** Jeffrey R. Hazel  
**J.R.Har.** Jay R. Harman  
**J.R.Hau.** John R. Haug  
**J.R.He.** James R. Hein  
**J.R.Hu.** John R. Huizenga  
**J.R.K.** Joseph R. Kinard  
**J.R.M.** Joan R. Marsden  
**J.R.McI.** J. Richard McIntosh  
**J.R.Mi.** James R. Michalec  
**J.R.P.** J. R. Pilbrow: Electron paramagnetic resonance (EPR) spectroscopy  
**J.R.P.** Julian R. Pleasants: Gnotobiotics  
**J.R.Po.** Jeffrey R. Powell  
**J.R.Pr.** Joel R. Primack  
**J.R.Ra.** John R. Raper  
**J.R.S.F.** J. R. S. Fincham  
**J.R.Se.** John R. Sellars  
**J.R.See.** John Richard Seed  
**J.R.Su.** J. R. Sutherland  
**J.R.V.W.** John R. Van Wazer  
**J.R.W.** J. R. Whinnery  
**J.R.Z.** John R. Zimmerman  
**J.S.** Julius Schachter  
**J.Sc.** Jonathan Schooler  
**J.Sch.** Jack Schubert  
**J.Sel.** Jane Selverstone  
**J.Ses.** John Sessions  
**J.Sh.** John Shortreed  
**J.Si.** Joseph Silk  
**J.Sil.** Joseph Silverman  
**J.Sim.** Joanne Simpson  
**J.So.** James Sochacki  
**J.Sp.** James Sprinkle  
**J.St.J.** Joseph St. Jean, Jr.  
**J.Sup.** John Suppe  
**J.S.B.** John S. Belrose  
**J.S.Bro.** James Steve Browder  
**J.S.C.** John S. Campbell  
**J.S.F.** James S. Frame  
**J.S.Fe.** Jay S. Fein  
**J.S.Fra.** J. Sutherland Frame  
**J.S.G.** Joseph S. Gots  
**J.S.H.** Jeffrey S. Hanor  
**J.S.I.** Jamal S. Izadian  
**J.S.L.** J. S. Lindsey  
**J.S.Mo.** Jeffrey S. Moore  
**J.S.O.** Jerry S. Olson  
**J.S.P.** Johan S. Ploem  
**J.S.R.** John S. Ryland  
**J.S.Ro.** James S. Robertson  
**J.S.Row.** J. S. Rowlinson  
**J.S.S.** Jeffrey S. Shaw  
**J.S.V.** James S. Vanick  
**J.T.** Juergen Tonndorf  
**J.Te.** James Terrell  
**J.Ti.** Jiri Tichy  
**J.Tr.** John Trowsdale  
**J.T.D.** J. Thomas Dutro, Jr.  
**J.T.F.** James T. Fitzsimons  
**J.T.G.** Joseph T. Gregory  
**J.T.K.** John T. Kuo  
**J.T.L.** John T. Lucker  
**J.T.Le.** J. T. Lee  
**J.T.O.** James T. Oris  
**J.T.P.** Judith Totman Parrish  
**J.T.St.** John T. Stock  
**J.T.W.** John T. Walkup  
**J.V.** Joseph Veverka  
**J.Va.** Jacob Vaya  
**J.Ve.** Joseph Vellozzi  
**J.V.C.** J. V. Chernosky  
**J.V.H.** Joseph V. Hollweg  
**J.V.P.** Jesco Von Puttkamer  
**J.V.S.** Jan Van der Spiegel  
**J.Wa.** John Warren  
**J.War.** Jeffrey Ward  
**J.We.** James Wejsa  
**J.Wi.** Jennifer Widom  
**J.Wy.** John Wyke  
**J.W.A.** James W. Angus  
**J.W.B.** Joseph W. Barker  
**J.W.Be.** J. W. Bennett  
**J.W.Bl.** J. W. Blanton  
**J.W.Br.** Jason W. Brown  
**J.W.C.** J. W. Costerton  
**J.W.Ca.** John W. Carson  
**J.W.D.** J. William Doane  
**J.W.Ez.** John W. Ezzell  
**J.W.F.** J. W. Faller  
**J.W.Fe.** Jack W. Fell  
**J.W.Fo.** Jackson W. Foster  
**J.W.Fu.** James W. Fulton  
**J.W.Ga.** Julian W. Gardner  
**J.W.Ge.** James W. Gewartowski  
**J.W.Gei.** John W. Geissman  
**J.W.Goo.** Joseph W. Goodman  
**J.W.G.B.** Jerzy W. Grzymala-Busse

**J.W.H.** J. Woodland Hastings  
**J.W.Ha.** John W. Hardy  
**J.W.He.** Joel W. Hedgpeth  
**J.W.J.** John W. James  
**J.W.M.** James W. Murray  
**J.W.Mo.** J. W. Morris, Jr.  
**J.W.Mor.** John W. Morgan  
**J.W.O.** John W. Olcott  
**J.W.Ol.** J. W. Olness  
**J.W.P.** Jae-Woo Park  
**J.W.R.** James W. Rohlf  
**J.W.Ru.** James W. Rumsey  
**J.W.S.** John Ward Smith  
**J.W.St.** John W. Stewart  
**J.W.St.G.** Joseph W. St. Geme  
**J.W.T.** John W. Taylor  
**J.W.Tr.** James W. Truman  
**J.W.V.** James W. Valentine  
**J.Z.** Joseph Zohar

## K

**K.A.** Knut Aagaard  
**K.Arn.** Karl Arnstein  
**K.At.** Kenji Atoda  
**K.A.A.** Kenneth A. Arndt  
**K.A.B.** Keith A. Browning  
**K.A.Em.** Kerry A. Emanuel  
**K.A.Er.** K. A. Erb  
**K.A.Eri.** Kenneth A. Eriksson  
**K.A.F.** Kenneth A. Food  
**K.A.G.** Karl A. Gschneider, Jr.  
**K.A.J.** Kenneth A. Jackson  
**K.A.McC.** Kathryn A. McCarthy  
**K.A.P.** Keats A. Pullen, Jr.  
**K.A.Pr.** Keith A. Prisbrey  
**K.A.S.** Kaj Aa. Strand  
**K.A.Sn.** Kurt A. Smoker  
**K.B.** Klaus Brodersen  
**K.Bu.** Kevin Burke  
**K.B.C.** Kenneth B. Cumberland  
**K.B.L.** Kenny B. Lipkowitz  
**K.C.** Kenneth Christiansen  
**K.C.C.** Kent C. Condie  
**K.C.K.** Kailash C. Kapur  
**K.C.Po.** Ken C. Pohlmann  
**K.C.S.** Kumares C. Sinha  
**K.C.Ta.** K. C. Tan  
**K.D.K.** Karl D. Kryter  
**K.D.P.** Kirk D. Peterson  
**K.E.** Katherine Esau  
**K.E.L.** Kenneth E. Lassila  
**K.E.Lo.** Karl E. Lonngren  
**K.E.M.** Kenneth E. Moyer  
**K.F.** Kenneth Franzese  
**K.F.G.** Kathleen F. George  
**K.F.K.** Karl F. Koopman  
**K.FM.** Karl F. Meyer  
**K.G.** K. Grasshoff  
**K.Ga.** Kathleen Gardiner  
**K.G.F.** Karen Grady Ford  
**K.G.S.** Kenneth G. Stone  
**K.Ha.** Kevin Harrigan  
**K.Ho.** Kip Hodges  
**K.Hu.** Keith Hutchison  
**K.H.F.** Kenneth H. Falchuk  
**K.H.M.** Kenneth H. Mann

**K.H.N.** Kenneth H. Nealson  
**K.H.Po.** Kerns H. Powers  
**K.H.R.** Kenneth H. Rosen  
**K.J.** Kjell Johansen  
**K.Jo.** Keith Johnston  
**K.J.A.** Karl J. Astrom  
**K.J.D.** Kerry J. Dawson  
**K.J.F.** Kenneth J. Frey  
**K.J.H.** Katherine J. Hansen  
**K.J.He.** Kevin J. Hemker  
**K.J.Hi.** Kenneth J. Hintz  
**K.J.M.** Kenneth J. Morrison  
**K.J.McN.** Kenneth J. McNamara  
**K.J.R.** Kenneth J. Ryan  
**K.J.S.** Kenneth J. Stuckas  
**K.J.Sy.** K. J. Sytsma  
**K.J.W.** Kimerly J. Wilcox  
**K.Kr.** Karl Kristofferson  
**K.K.H.** K. K. Hunt  
**K.K.R.** K. Keith Roe  
**K.K.S.** Kathleen K. Smith  
**K.K.T.** K. K. Tan  
**K.K.W.** K. K. Wang  
**K.L.** Karl Lang  
**K.Lo.** Kenneth Longmore  
**K.L.C.** Karen L. Chobor  
**K.L.D.** Kenneth L. Duke  
**K.L.K.** K. L. Klierer  
**K.M.** Karl Maramorosch  
**K.M.B.** Karl M. Beck  
**K.M.C.** Kenneth Mark Colby  
**K.M.E.** Kenneth M. Evenson  
**K.M.K.** Katherine M. Kocan  
**K.M.M.** Kenneth M. Marsh  
**K.M.N.** Kenneth M. Noll  
**K.M.S.** Kaye M. Shedlock  
**K.M.W.** Kathleen M. Williams  
**K.N.L.** K. N. Liou  
**K.N.O.** Kenneth N. Ogle  
**K.N.P.** Kathleen N. Potter  
**K.N.Z.** Klaus Napp-Zinn  
**K.O.** Kanji Ono  
**K.Pa.** Kevin Padian  
**K.P.A.** Kenneth P. Able  
**K.P.D.** Kenneth P. Davis  
**K.P.W.** K. Preston White, Jr.  
**K.R.** Karl Rundman  
**K.Ra.** Krishna Rajan  
**K.Ru.** Kathryn Ruoff  
**K.R.D.** K. R. Dyer  
**K.R.McC.** Ken R. McConnell  
**K.R.S.** K. R. Sreenivasan  
**K.S.** Kai Siegbahn  
**K.Sh.** Ken Shortman  
**K.Si.** Kerry Sieh  
**K.S.K.** Kaiser S. Kunz  
**K.S.S.** Kenneth S. Suslick  
**K.S.Th.** Keith S. Thompson  
**K.S.W.** Katherine S. Waldmann  
**K.T.** Keith Thomson  
**K.T.C.** Kang-tsung Chang  
**K.T.P.** Kevin T. Potts  
**K.U.S.** Karl U. Smith  
**K.V.K.** Karl V. Krombein  
**K.V.M.** Kenneth V. Manning  
**K.V.S.** Karlene V. Schwartz  
**K.W.** Klaus Wyrтки  
**K.Wi.** Kevin Winn  
**K.W.B.** Kenneth W. Bagnall  
**K.W.F.** Karl W. Flessa

**K.W.H.** Keith W. Hipel  
**K.W.J.** K. W. Johnson  
**K.W.K.** Kerry W. Kemper  
**K.W.Li.** Kirk W. Lindstrom  
**K.Y.T.** K. Y. Tang  
**K.Z.M.** Karl Z. Morgan

## L

**L.A.** Lester Andrews  
**L.Ap.** L. Apker  
**L.A.B.** Leslie A. Bryan  
**L.A.C.** Louis A. Chiodo  
**L.A.Gr.** Les A. Grivell  
**L.A.H.** Lawrence A. Harris  
**L.A.K.** Lee A. Kilgore  
**L.A.Ka.** Leonard A. Katz  
**L.A.R.** Lorrin A. Riggs  
**L.A.Ro.** Lester A. Roberts  
**L.A.T.** Laird A. Thompson  
**L.B.** Lane Barksdale  
**L.Ber.** Lewis Berner  
**L.Bl.** Leo Blitz  
**L.Br.** Louis Brand  
**L.B.A.** Leslie B. Arey  
**L.B.H.** Louis B. Holdeman  
**L.B.Ho.** Lipke B. Holthuis  
**L.B.L.** Luna B. Leopold  
**L.B.Lu.** Lee B. Lusted  
**L.B.M.** Laurence B. Milstein  
**L.B.R.** Lee B. Reichman  
**L.B.S.** Louis B. Slichter  
**L.B.T.** Louise B. Tyrer  
**L.Co.** Lee Conch  
**L.C.A.** Leland C. Allen  
**L.C.F.** Leonard C. Feldman  
**L.C.G.** Louis C. Green  
**L.C.L.** Leonard C. Lutter  
**L.C.Le.** Lyndon C. Lee  
**L.C.P.** Leanne C. Pitchford  
**L.C.R.** Lemuel C. Robertson  
**L.C.T.** Lee C. Teng  
**L.D.A.** Louis D. Albright  
**L.D.B.** Leonard D. Bayer  
**L.D.M.** Lawrence D. Miles  
**L.D.R.** Louis D. Roberts  
**L.E.** Leo Esaki  
**L.E.C.** Lee E. Cuckler  
**L.E.K.** Lawrence E. Kinsler  
**L.E.M.** Lawrence E. Marks  
**L.E.Mo.** Leonard E. Mortenson  
**L.E.T.** Lawrence E. Tannas, Jr.  
**L.E.Th.** L. E. Thelemaque  
**L.E.W.** L. E. Wittmers: Hypothermia  
**L.E.W.** Lewis E. Wedgewood: Viscosity  
**L.Fe.** Louise Ferguson  
**L.Fel.** Leonard Feldman  
**L.Fi.** L. Finkelstein  
**L.Fr.** Lewis Friedman  
**L.FA.** Lyle F. Albright  
**L.FB.** Lance F. Bosart  
**L.F.C.** L. F. Cleveland  
**L.FCu.** Leon G. Curtiss  
**L.FD.** Lawrence F. Dahl  
**L.FH.** L. F. Hough

**L.F.M.** Leonard F. Mausner  
**L.FPr.** Lincoln F. Pratson  
**L.FS.** Lee F. Schuchardt  
**L.G.** Leonard Goland  
**L.Go.** Louis Gordon  
**L.Gol.** Leon Golub  
**L.Gr.** Lawrence Grossman  
**L.Gra.** Lance Grande  
**L.Gre.** Larry Green  
**L.Gro.** Lee Grodzins  
**L.G.C.** L. G. Christophorou  
**L.G.H.** Llewellyn G. Hoxton  
**L.H.** Leonard Hayflick  
**L.H.AI.** Lawrence H. Allen  
**L.H.L.** Lawrence H. Lattman  
**L.H.MacD.** Laurence H. MacDaniels  
**L.H.P.** L.H. Princen  
**L.H.V.V.** Lawrence H. Van Vlack  
**L.H.W.** Laura Hood Watchman  
**L.H.Z.** Leroy H. Zimmerman  
**L.J.A.** Leslie J. Audus  
**L.J.C.** Lawrence J. Campbell  
**L.J.Ca.** Linda J. Cassens  
**L.J.D.** Laurence J. Doyle  
**L.J.DeG.** Leslie J. DeGroot  
**L.J.E.** L. J. Ehrenberger  
**L.J.G.** Louis J. Guido  
**L.J.Gr.** Lazar J. Greenfield  
**L.J.KI.** Lewis J. Kleinsmith  
**L.J.M.** Lawrence J. Machlin  
**L.J.O.** Leonard J. Obery  
**L.K.** Louis Kaplan  
**L.Ke.** Ljuba Kerschofer  
**L.Lo.** L. Lorand: Fibrinogen  
**L.Lo.** Luca Longo: Metallocene catalyst  
**L.L.B.** Leo L. Beranek  
**L.L.K.** Lloyd L. Kohnhorst  
**L.L.Y.C.** Luke L. Y. Chang  
**L.M.** L. Madestau  
**L.Ma.** Luigi Marzilli  
**L.M.BI.** Leonard M. Blumcnthal  
**L.M.C.** Lucy M. Cranwell  
**L.M.Ca.** Lori M. Carris  
**L.M.Co.** Lisa M. Cohen  
**L.M.G.** Lawrence M. Graves  
**L.M.J.** Leonard M. Joseph  
**L.M.K.** Lyman M. Kells  
**L.M.Kr.** Lawrence M. Krauss  
**L.M.La.** Leslie M. Lackman  
**L.M.O.** Linda Moretti Ojemann  
**L.M.P.** Lawrence M. Palmer  
**L.M.Sa.** Lawrence M. Sayre  
**L.N.** Leo Nedelsky  
**L.Na.** Laurette Nacamulli  
**L.N.L.** Lin-Nau Lee  
**L.N.McC.** Leslie N. McClellan  
**L.O.B.** Lawrence O. Brockway  
**L.P.** Lester Packer  
**L.P.C.** Leo P. Clements  
**L.P.E.** Lewis P. Emerson  
**L.PH.** Lloyd P. Hunter  
**L.PHu.** Lawrence P. Huelsman  
**L.PM.** Laurence P. Madin  
**L.PR.** Louis P. Reitz  
**L.PS.** Laurance P. Sadwick  
**L.Q.** Lawrence Que, Jr.  
**L.R.** L. Rozeanu  
**L.R.D.** Leslie R. Dahl  
**L.R.G.** Leah R. Gerber

**L.R.M.** Lee R. Mahoney  
**L.R.M.C.** L. R. M. Cocks  
**L.R.S.** L. R. Shannon  
**L.R.Wh.** Lawrence R. White  
**L.S.** Louis Schmerling  
**L.S.B.** L. S. Birks  
**L.S.Be.** Laurence S. Bernson  
**L.S.H.** Lawrence S. Hill  
**L.S.L.** L. Sigfred Linderoth, Jr.  
**L.S.McC.** Leland S. McClung  
**L.S.N.** Leon S. Nergaard  
**L.S.S.** Lee S. Schroeder  
**L.T.** Lawrence Talbot  
**L.T.R.** Leon T. Rosenberg  
**L.V.** Louis Vaickus  
**L.V.B.** Loyal V. Bewley  
**L.V.M.** Larry V. McIntire  
**L.V.S.** Lola V. Stamm  
**L.W.J.** Lawrence W. Jones  
**L.W.Y.** Leland W. Younker

## M

**M.A.** Milton Alpern  
**M.A.A.** Michael A. Adewumi  
**M.A.Ar.** Michael A. Arthur  
**M.A.B.** Morton A. Bell  
**M.A.Co.** Miles A. Copeland  
**M.A.C.P.** Michael A. C. Perryman  
**M.A.D.** Michel A. Duguay  
**M.A.DeP.** Mark A. DePlasco  
**M.A.F.** Marye Anne Fox  
**M.A.H.** Mel A. Hagood  
**M.A.J.** Mark A. James  
**M.A.Je.** Michael A. Jenike  
**M.A.L.** Max A. Lauffer  
**M.A.La.** Meredith A. Lane  
**M.A.Lo.** Mark A. Lovell  
**M.A.M.** Milton A. Miller  
**M.A.Ma.** Michelle A. Marvier: Biodiversity  
**M.A.Ma.** Miguel A. Mariño: Hydrology  
**M.A.R.** Martin A. Rizack  
**M.A.Ri.** Mark A. Riddle  
**M.A.Ric.** Michael A. Rice  
**M.A.S.** Michael A. Saad  
**M.A.U.** Mark A. Uebersax  
**M.A.W.** Michael A. Walsh  
**M.A.Z.** Mark A. Zumberge  
**M.Be.** Manson Benedict  
**M.Ben.** Mike Bennett  
**M.BI.** Meredith Blackwell  
**M.Bo.** Mark Bothwell  
**M.Boh.** M. Bohm  
**M.Br.** Mead Bradner  
**M.Bro.** Marx Brook  
**M.Bu.** Martin Bucher  
**M.Bun.** Mario Bunge  
**M.B.B.** Michael B. Bever: Metallurgy etc.  
**M.B.B.** Michael B. Bragg: Aircraft icing  
**M.B.M.** Mark B. Moffett  
**M.B.Ma.** M. Brian Maple  
**M.B.McC.** Mary B. McCann  
**M.B.P.** Morton B. Panish  
**M.B.S.** Mary Betty Stevens  
**M.B.St.** Murray B. Stein  
**M.C.** Michel Copel  
**M.Ca.** Michael Callaham  
**M.Cad.** Mark Cadwallader  
**M.Ch.** Martha Christensen  
**M.C.C.** M. C. Chang  
**M.C.G.** Martin C. Gutzwiller  
**McC.G.** McChesney Goodall  
**M.C.K.** Michael C. Kelley  
**M.C.McK.** Malcolm C. McKenna  
**M.C.P.** Mary C. Proctor  
**M.C.W.** Mark C. Willingham  
**M.C.Wo.** Marc S. Wold  
**M.D.** Michael Doudoroff  
**M.De.** Margaret Deacon  
**M.Di.** Michael Dine  
**M.Do.** Mike Doyle  
**M.Dr.** Max Dresden: Boltzmann constant etc.  
**M.Dr.** Michael Drake: Eye disorders etc.  
**M.D.A.** Mark D. Ardema  
**M.D.Ar.** Mary D. Archer  
**M.D.B.** Mark D. Barton  
**M.D.Br.** Michael D. Brown  
**M.D.Bre.** Michael D. Brown  
**M.D.C.** M. Donald Cave  
**M.D.Ha.** M. D. Hassialis  
**M.D.K.** Morris D. Kerstein  
**M.D.L.** Michael D. Lebowitz  
**M.D.P.** M. David Potter  
**M.D.Pa.** Michael D. Papagiannis  
**M.D.U.** Michale D. Uhler  
**M.E.** Merrill Eisenbud  
**M.Ed.** Marshall Edelson  
**M.Ei.** Millicent Eidson  
**M.Ew.** Maurice Ewing  
**M.E.B.** Milton E. Bailey  
**M.E.D.** Mary E. Dempsey  
**M.E.H.** Mason E. Hale, Jr.  
**M.E.Hi.** M. E. Hines  
**M.E.Jo.** Morton E. Jones  
**M.E.L.** Malcolm E. Lines  
**M.E.P.** Mark E. Patzkowsky  
**M.E.Pe.** Michael E. Peskin  
**M.E.Re.** M. E. Reichmann  
**M.E.Ri.** Mary E. Rice  
**M.E.T.** Helmet E. Thiess  
**M.E.VV.** M. E. Van Valkenburg  
**M.E.W.** Michael E. Wright  
**M.E.Wa.** Mial E. Warren  
**M.E.Z.** Michael E. Zeller  
**M.F.** Milton Fingerman  
**M.FB.** Mark F. Bocko  
**M.FD.** M. F. Doherty  
**M.F.F.** Michael F. Fay  
**M.F.H.** Mark F. Hamilton  
**M.FR.** Mark F. Reynolds  
**M.FS.** Matthew F. Schlecht: Conjugation and hyperconjugation  
**M.F.S.** Michael F. Skrutskie: Infrared astronomy  
**M.G.** Martin Gibbs  
**M.GI.** Michael Glowatz, Jr.  
**M.Go.** Marjorie Goldfarb  
**M.Gol.** Marvin Goldman  
**M.Goo.** Morris Goodman  
**M.Gr.** Martin Greenspan  
**M.Gu.** Michael Gurevich  
**M.G.F.** Mark G. Foster



- M.G.H.** Malcolm G. Haines  
**M.G.Ma.** Maria G. Masucci  
**M.G.W.** M. G. Wurtele  
**Mo.H.** Monto Ho  
**M.Ha.** Marcia Harrison: Apical dominance  
**M.Ha.** Michael Hanna: Cellular adhesion  
**M.Hag.** Maura Hagan  
**M.He.** Michelle Heath  
**M.Her.** Max Herzberger  
**M.Ho.** Michael Koran  
**M.H.B.** Michael H. Bruno  
**M.H.C.** Marvin H. Carruthers  
**M.H.Ch.** Malcolm H. Chisholm  
**M.H.Cr.** Michael H. Crawford  
**M.H.G.** Michael H. Glantz  
**M.H.Ga.** Marcelo H. Garcia  
**M.H.H.** Matthew H. Hitchman: Stratosphere  
**M.H.H.** McAllister H. Hull, Jr.: Absorption  
**M.H.W.C.** Moses H. W. Chan  
**M.I.V.A.** Margot I. Van Allen  
**M.J.** Mark Johnson  
**M.Ja.** Mohammad Jamshidi  
**M.J.A.** Malcolm J. Abzug  
**M.J.Ax.** Milton J. Axley  
**M.J.C.** Michael J. Camp  
**M.J.Ca.** Michael J. Cavey  
**M.J.Co.** Michael J. Coyne  
**M.J.Cou.** Mary J. Coulombe  
**M.J.Cr.** Malcolm J. Crocker  
**M.J.Cru.** Michael J. Cruickshank  
**M.J.F.** Mitchell J. Feigenbaum  
**M.J.G.A.** M. J. G. Appel  
**M.J.H.** M. J. Holdaway: Kyanite etc.  
**M.J.H.** Max J. Herzberger: Chromatic aberration etc.  
**M.J.J.** Mark J. Johnson  
**M.J.Kr.** Mary Jeanne Kreek  
**M.J.Kuc.** Marc J. Kuchner  
**M.J.K.H.** Michael J. K. Harper  
**M.J.L.** M. J. Lewis  
**M.J.M.** Merritt J. Murray  
**M.J.Po.** Margaret J. Polley  
**M.J.Se.** M. J. Selby  
**M.J.Si.** Michell J. Sienko  
**M.K.** Matti Krusius  
**M.Ka.** Margarita Karovska  
**M.Kam.** Michael Kamrin  
**M.Kl.** Maren Klich: Mycotoxin  
**M.Kl.** Mendel Kleiner: Sound field enhancement  
**M.Kle.** Mendel Kleiner  
**M.Ko.** Michelle Kominz  
**M.Koh.** Martin Kohlmeier  
**M.K.G.** Marjorie K. Gross  
**M.K.S.** Morton K. Schwartz  
**M.K.W.** Michael K. Wilkinson  
**M.L.** Martin Lotz  
**M.La.** Meredith Lane  
**M.Le.** M. Levitan  
**M.Lo.** Maichael Lopiano  
**M.L.Be.** Myron L. Bender  
**M.L.Bi.** Michael L. Billet  
**M.L.Bo.** Marci L. Bortman  
**M.L.H.** Marc L. Helman  
**M.L.J.** Meredith L. Jones  
**M.L.K.** M. L. Knotek  
**M.L.P.** Martin L. Perl  
**M.L.S.** Murrell L. Salutsky  
**M.L.Sp.** M. Leroy Spearman  
**M.L.St.** Marshall L. Stoller  
**M.L.Sw.** M. L. Swanson  
**M.L.T.** Mary Louise Trivett  
**M.L.V.** Mary Lynne Vickers  
**M.Ma.** Marvin Marcus  
**M.Man.** Michael Mantler  
**M.McC.** Michelle McClure  
**M.My.** Michelle Mynlieff  
**M.M.B.** M. M. Brooke  
**M.M.Ba.** M. M. Barry  
**M.M.Br.** M. Michael Briggs  
**M.M.Bu.** Maurice M. Bursey  
**M.M.G.** Madan M. Gupta  
**M.M.Mi.** Maynard M. Miller  
**M.M.S.** Mel M. Schwartz  
**M.M.W.** Mary M. Walczak  
**M.N.** Marion Nestle  
**M.O.** Michael Osofsky  
**M.O'B.** Michael O'Brien  
**M.O.McW.** Michael O. McWilliams  
**M.P.** Michael Perch  
**M.Pa.** Michael Parente: Communications systems protection  
**M.Pa.** Miguel Pascual: Fisheries ecology  
**M.Pi.** Michael Pinedo  
**M.Ple.** Michael Plesset  
**M.Po.** Michael Pope  
**M.P.A.J.** M. P. A. Jackson  
**M.PBa.** M. Pauline Baker  
**M.PH.** Mark P. Hedger  
**M.PS.** Martin P. Schreiberman  
**M.PW.** Mason P. Wilson, Jr.  
**M.Re.** Michael Rettinger  
**M.Ri.** Michael Rindler  
**M.Ro.** Malcolm Ross  
**M.Ru.** Manfred Ruddat  
**M.R.C.** Michael R. Cummings  
**M.R.F.** Mark Roy Fuller  
**M.R.G.** Melvin R. George  
**M.R.Gr.** Martha R. Grabowski  
**M.R.Gu.** Mark R. Guidry  
**M.R.H.** Milton R. Hales  
**M.R.J.S.** M. R. J. Salton  
**M.R.L.** Mark R. Lehto  
**M.R.R.** Murray R. Robinovitch  
**M.S.** Max Samter  
**M.Sc.** Mel Schwartz  
**M.Si.** Marshall Sittig  
**M.Sn.** Martin Snelgrove  
**M.So.** Myron Solberg  
**M.Sol.** Mark Soldate  
**M.Sou.** Mott Souders  
**M.St.** Martin Stiles  
**M.Su.** Michael Sullivan  
**M.Sy.** Megan Sykes  
**M.S.A.** Mark S. Ashton  
**M.S.C.** Mo-Shing Chen  
**M.S.F.** Millard S. Firebaugh  
**M.S.G.** Michael S. Gazzaniga  
**M.S.Go.** Matthew S. Goodman  
**M.S.K.** Marilyn S. Kerr  
**M.S.Kn.** Morris S. Knebelman  
**M.S.Mi.** Malcolm S. Mitchell  
**M.S.S.** Michael S. Smith  
**M.S.W.** M. Stanley Whittingham  
**M.Tu.** Moshe Tur  
**M.TE.** Marco T. Einaudi  
**M.TH.** Michel T. Halbouty  
**M.T.W.** Malcolm T. Wane  
**M.U.T.** Marlin U. Thomas  
**M.V.** Mark Volt  
**M.V.B.** M. V. Brian  
**M.V.L.B.** Michael V. L. Bennett  
**M.V.P.** Milind V. Purohit  
**M.V.Z.** Marvin V. Zelkowitz  
**M.W.** Martin Walt  
**M.Wa.** Michael Watts  
**M.We.** Marc Weiss: Atomic time  
**M.We.** Martin Weitz: Rydberg constant  
**M.Wi.** M. Wilkening: Kunoshiro etc.  
**M.Wi.** Mark Wimbush: Radon  
**M.Wr.** Maynard Wright  
**M.W.A.** M. W. Adams  
**M.W.C.** Mark W. Chase  
**M.W.F.** Merrill W. Foster  
**M.W.Fl.** M. Wayne Flye  
**M.W.G.** Michael W. Gray  
**M.W.N.** Matthew W. Nyman  
**M.W.S.** Malcolm W. Sinclair  
**M.W.T.** Margaret W. Thompson  
**M.Y.** M. Yamaguchi  
**M.Ye.** Marvin Yelles  
**M.Y.D.** M. Yusoff Dawood  
**M.Y.E.** Mohamed Y. Eltoweissy  
**M.Y.W.** Michelle Y. Walker  
**M.Z.** Milton Zaitlin  
**M.Ze.** Michael Zeilik
- ## N
- N.A.** Nelle Ammons  
**N.Ah.** Narendra Ahuja  
**N.Ar.** Naveen Arya  
**N.A.C.** Noel A. Clark  
**N.Ba.** Neil Barbour  
**N.Be.** Neil Berglund  
**N.B.A.** Norman B. Akesson  
**N.B.C.** Nancy B. Clark  
**N.B.M.** Norman B. Marshall  
**N.B.S.** N. B. Simmons  
**N.C.** Nel Caine  
**N.Ch.** Nicholas Christy  
**N.Cha.** Nirupa Chaudhari  
**N.C.B.** Nicholas Christie-Blick  
**N.C.P.** Niels C. Pedersen  
**N.C.R.** Norman C. Rasmussen  
**N.D.** Nachum Dershowitz  
**N.DeC.** Nicholas De Claris  
**N.Do.** Nowell Donovan  
**N.D.G.** Neville D. Grace  
**N.D.J.** Neil D. Jespersen  
**N.D.L.** Norman D. Levine  
**N.D.S.** Norman D. Smith  
**N.D.Z.** Norton D. Zinder  
**N.E.** Niles Eldredge  
**N.E.S.** Norman E. Steenrod  
**N.F.** Nicholas Farrel: Platinum  
**N.F.** Norman Friedman: Antisubmarine warfare  
**N.F.B.** Nicole Fr. Bolender  
**N.F.R.** Norman Ramsey  
**N.G.** Nigel Girgraph

**N.G.D.** Nancy G. Dengler  
**N.G.Di.** N. G. Dillman  
**N.G.H.** Narain G. Hingorani  
**N.G.L.** N. Gary Lane  
**N.He.** Noah Hershkowitz  
**N.Her.** Norman Herron  
**N.Ho.** Nigel Holder  
**N.H.B.** Norman H. Boke  
**N.H.G.** Nafsika H. Georgapadakou  
**N.H.N.** Norman H. Nachtrieb  
**N.H.T.** Noel H. Turner  
**N.I.** Nakao Ishida  
**N.Im.** Nori Imal  
**N.J.** Nathan Jacobson  
**N.J.Go.** Nicholas J. Gottelli  
**N.J.T.** Nicholas J. Turro  
**N.J.Y.** N. J. Young  
**N.K.** Norman Kharasch  
**N.Ko.** Noemie Holler  
**N.K.M.** N. Karle Mottet  
**N.Le.** Nicholas Leventis  
**N.L.C.L.** Naomi L. C. Luban  
**N.L.K.** N. L. Kusters  
**N.L.N.** Neil L. Norcross  
**N.L.S.** Nancy L. Segal  
**N.MacC.** Neil MacCoull  
**N.N.** Noa Noy  
**N.N.L.** Norman N. Li  
**N.N.Li.** Norman N. Li  
**N.N.P.** Norman N. Potter  
**N.O.** Norman Olson  
**N.Ot.** Norman Otto  
**N.P.C.** Nicholas P. Christy  
**N.P.Ch.** Nicholas P. Chironis  
**N.P.S.** Nicholas P. Samios  
**N.R.** Nathaniel Robbins, Jr.  
**N.Ra.** Natasha Raikhel  
**N.Re.** Nicholas Reinhardt  
**N.Ru.** Norman Runham  
**N.R.B.** Norman R. Bell  
**N.R.S.** Neil R. Sheeley, Jr.  
**N.Sc.** Nathaniel Scholz  
**N.Sh.** Nathan Sharon  
**N.S.B.** Norbert S. Baer  
**N.S.F.** Nelson S. Fisk  
**N.S.G.** Newell S. Gingrich  
**N.S.Gr.** Neil S. Grigg  
**N.S.J.** Norman S. Jones  
**N.S.S.** Norman S. Stoloff  
**N.S.T.** Nancy S. Timmerman  
**N.T.** Neil Turok  
**N.To.** Nicholas Toth  
**N.T.S.** Nelson T. Spratt, Jr.  
**N.U.R.** Natalie U. Roy  
**N.W.** Nina Wedell  
**N.W.P.** Norman W. Patrick  
**N.W.R.** Norman W. Radforth

## O

**O.A.** Otto Appenzeller  
**O.A.L.** Oscar A. Lorenz  
**O.C.J.** Owen C. Jones  
**O.D.R.** Oscar D. Ratnoff  
**O.E.L.** Otto E. Lowenstein  
**O.E.N.** Olin E. Nelsen  
**O.G.S.** Orest G. Symko  
**O.H.** Olga Hartman

**O.He.** Oscar Henriquez  
**O.J.M.** Orlando J. Miller  
**O.J.S.** O. J. Strock  
**O.L.B.** Orus L. Bennett  
**O.L.F.** Oscar L. Frick  
**O.R.** Oscar Reed, Jr.  
**O.R.A.** O. Roger Anderson  
**O.W.R.** Oscar W. Richards  
**O.W.W.** Owen W. Webster

## P

**P.A.** Peter Andrews  
**P.Ar.** Peter Armbruster  
**P.A.B.** Paul A. Baker  
**P.A.E.** Peter A. Edwards  
**P.A.G.** Paul A. Giguere  
**P.A.Ga.** Peter A. Gale  
**P.A.H.** Per A. Hoist  
**P.A.He.** Paul A. Heiney  
**P.A.Ma.** Preston A. Marx  
**P.A.Mar.** Patricia A. Marzilli  
**P.A.McL.** Patsy A. McLaughlin  
**P.A.N.** Philip A. Nelson  
**P.A.P.** Peter A. Payne  
**P.A.S.** Paul A. Souder  
**P.A.Sa.** Philip A. Sandberg  
**P.A.Sc.** P. A. Scholle  
**P.A.So.** Pamela A. Sokol  
**P.A.V.** Paul A. Vestal  
**P.B.** Pedro Barbosa  
**P.Ba.** Pat Banerjee  
**P.Bo.** Peter Bogucki  
**P.B.C.** Philip B. Cowles  
**P.B.Co.** Peter B. Coates  
**P.B.F.** Philip B. Fraundorf  
**P.B.M.** Paul B. Moore  
**P.B.P.** P. Buford Price, Jr.  
**P.C.** Praveen Chaudhari  
**P.Ch.** Patrick Choy  
**P.Cl.** Preston Cloud  
**P.C.B.** Peter C. Badgley  
**P.C.Be.** Philippe C. Becker  
**P.C.H.** Perry C. Holt  
**P.C.J.** Philip C. Johnson  
**P.C.Ja.** P. C. Jain  
**P.C.M.** Paul C. Marino  
**P.C.P.** Philip C. Peters  
**P.C.Pa.** Peter C. Patton  
**P.C.S.** Peter C. Sandretto  
**P.C.Se.** Peter C. Searson  
**P.C.Si.** P. C. Silva  
**P.D.** Patricia Dell'Arciprete  
**P.De.** Paul Delahay  
**P.Du.** Paul Duby  
**P.D.A.** P. Douglas Arbuckle  
**P.D.B.** Peter D. Barnett  
**P.D.C.** Paul D. Carey  
**P.D.H.** Philip D. Harvey  
**P.D.P.** P. David Polly  
**P.D.St.** Perry D. Strausbaugh  
**P.DeT.A.** Paulo De T. Alvim  
**P.D.V.M.** Paul D. V. Manning  
**P.D.W.** P. D. Walton  
**P.E.** Paul Evenson  
**P.E.A.** Phillip E. Allen  
**P.E.Bi.** Pierre E. Biscaye

**P.E.Bi.** Philip E. Bloomfield  
**P.E.Br.** Peter E. Bressler  
**P.E.D.** Pol E. Duwez  
**P.E.F.** Paul E. Fanta  
**P.E.H.** Philip E. Hicks  
**P.E.L.** Paul E. Leopard  
**P.E.Li.** Peter E. Liley  
**P.E.R.** Peter E. Raad  
**P.E.So.** Paul E. Sojka  
**P.F.** Paulo Franzini  
**P.Fr.** Peter Frumhoff  
**P.F.C.** Philip F. Clapp  
**P.F.K.** Paulden F. Knowles  
**P.F.M.** Paul F. Maderson  
**P.Ge.** P. Gepts  
**P.G.B.** Peter G. Bergmann  
**P.G.Bu.** Peter G. Burnett  
**P.G.Kl.** Paul G. Klemens  
**P.G.M.** Peter G. Martin  
**P.G.Re.** Placidus G. Reischmann  
**P.G.Ri.** Paul G. Risser  
**P.G.Ro.** Paul G. Rossmmeissl  
**P.G.S.** Paul G. Smith  
**P.H.** Philip Hodgen  
**P.Ho.** Paul Hoffman  
**P.Hod.** Paul Hodge  
**P.Hw.** Patrick Hwang  
**P.H.B.** Paul H. Black  
**P.H.C.** Philip H. Cook  
**P.H.E.** Philip H. Enslow, Jr.  
**P.H.E.M.** Paul H. E. Meijer  
**P.H.G.** P. H. Groggins  
**P.H.H.** P. H. Heckel  
**P.H.Ha.** Paul H. Harvey  
**P.H.Ho.** Peter H. Homann  
**P.H.O.** Philip H. Osberg  
**P.H.Oo.** Patrick H. Oosthuizen  
**P.H.R.** Paul H. Ribbe  
**P.H.S.** Peter H. Schur  
**P.H.Sy.** Peter H. Sydenham  
**P.I.H.** Phyllis I. Hanson  
**P.I.S.** Peter I. Somlo  
**P.J.B.** Paul J. Bender  
**P.J.Br.** Peter J. Brofman  
**P.J.Bre.** Patrick J. Breen  
**P.J.Bro.** Perry J. Brown  
**P.J.D.** Peter J. Davies  
**P.J.Da.** Peter J. Parragh  
**P.J.H.** Peter J. Heaney  
**P.J.M.** Philip J. Morris  
**P.J.McN.** Peter J. McNamara  
**P.J.R.** Paul J. Roper  
**P.J.S.** Perry J. Sampson  
**P.J.Sp.** Peter J. Spreadbury  
**P.J.W.** Peter J. Walsh  
**P.J.Wi.** Paul J. Wilbur  
**P.J.Wy.** Peter J. Wyllie  
**P.J.Z.** Paul J. Zwerman  
**P.K.** Peter Karlson  
**P.Ka.** Peter Kareiva  
**P.Ki.** Paul Kindstedt  
**P.Ku.** Polykarp Kusch  
**P.K.C.** Pauline K. Cushman  
**P.K.M.** Pamela K. Mulligan  
**P.K.S.** P. K. Seidelmann  
**P.K.Si.** P. K. Sinha  
**P.K.V.** Pramode K. Verma  
**P.L.** Pamela Lanford  
**P.Lo.** Peter Lonsdale  
**P.L.A.** Philip L. Alger

**P.L.Ba.** Pier L. Bargellini  
**P.L.C.** Peter L. Carlton  
**P.L.D.** Peter L. Duren  
**P.L.F.** Peter L. Forey  
**P.L.Fi.** Peggy L. Fiedler  
**P.L.M.** Peter L. Marshall  
**P.L.S.** Peter L. Steponkus  
**P.M.** Peter Mohr  
**P.Ma.** Philip Massey  
**P.McG.** Prestor McGain  
**P.McL.** Patsy McLaughlin  
**P.Mo.** Pierre Morel  
**P.M.A.** Paul M. Anderson  
**P.M.Ac.** Phillip M. Achey  
**P.M.B.** Percy M. Butler  
**P.M.J.** Patricia M. Jones  
**P.M.K.** Peter M. Koch  
**P.M.Ka.** P. M. Kareiva  
**P.M.M.R.** Peter M. M. Rae  
**P.M.N.** Phyllis M. Novikoff  
**P.M.R.** Patricia M. Rodier  
**P.M.S.** Philip M. Stehle  
**P.M.VanP.** Peter M. Van Peteghem  
**P.N.** P. Nowak  
**P.O.E.** Patrick O. Egan  
**P.P.** Pekka Parviainen  
**P.P.C.** Peter P. Chen  
**P.R.** Philip Richardson  
**P.Ran.** Peter Randerson  
**P.Ri.** Paul Risser  
**P.Ril.** Pete Riley  
**P.Ro.** Patricia Rosa  
**P.Ry.** Peter Ryge  
**P.R.A.** Peter R. Almond  
**P.R.B.** Philip R. Brooks  
**P.R.E.** Paul R. Ehrlich  
**P.R.F.** Paul R. Fields  
**P.R.G.** Peter R. Griffiths  
**P.R.M.** Peter R. Marker  
**P.R.N.** Philip R. Nachtsheim  
**P.R.V.** Peter R. Vogt  
**P.S.** Peter Satir  
**P.Sa.** Pavol Sajgalik  
**P.Sae.** Peter Saenger  
**P.Sc.** Paul Schimmel  
**P.Sh.** Peter Shaw  
**P.Si.** Philip Siekevitz  
**P.Sz.** Paula Szkody  
**P.S.Br.** Patricia S. Bridges  
**P.S.D.** Peter S. Dahl  
**P.S.DeC.** P. S. De Carli  
**P.S.G.** Paul S. Gleim  
**P.S.H.** Paul S. Hoffman  
**P.S.N.** Park S. Nobel  
**P.S.S.** Pill-Soon Song  
**P.S.W.** Peter S. Weinberger  
**P.T.** Paul Tabor  
**P.To.** Pearl Toy  
**P.T.B.** Paul T. Boggs  
**P.T.C.** Peter T. Cummings  
**P.T.G.** Paul T. Greiling  
**P.T.M.** Paul T. Magee  
**P.T.R.** Prahlad T. Ram  
**P.V.** Peter Villiger  
**P.V.D.** Piet Van Duppen  
**P.V.L.** Philip V. Lopresti  
**P.Wi.** Peter Williams  
**P.Wo.** Peter Wolf  
**P.W.A.** P. W. Atkins  
**P.W.B.** Philip W. Brandt

**P.W.Br.** Percy W. Bridgman  
**P.W.K.** Paul W. Kruse  
**P.W.P.** Peter W. Price  
**P.W.S.** Paul W. Schmidt  
**P.W.W.** Pedro W. Wygodzinsky  
**P.Z.** Petr Zuman

## Q, R

**Q.F.** Quintus Fernando  
**Q.V.W.** Quentin Van Winkle  
**R.A.** Richard Askey  
**R.Ad.** Robert Ader  
**R.Al.** Roger Allan  
**R.Au.** Robert Austrian  
**R.A.A.** Rudolph A. Abramovitch  
**R.A.An.** Richard A. Anthes  
**R.A.B.** Richard A. Bambach  
**R.A.Ba.** Robert A. Bales  
**R.A.Be.** Ross A. Beaumont  
**R.A.Ber.** Robert A. Berner  
**R.A.Bo.** Rush A. Bowman  
**R.A.Bu.** Ralph A. Burton  
**R.A.Buc.** Richard A. Buchroeder  
**R.A.C.** Richard A. Chapman  
**R.A.Cor.** Robert A. Corbitt  
**R.A.Cr.** Roy A. Crowson  
**R.A.D.** Richard A. Davis, Jr.: Barrier islands, etc.  
**R.A.D.** Richard A. Durst: pH  
**R.A.D.W.** R. A. D. Wentworth  
**R.A.De.** Richard A. Deno  
**R.A.E.** Ralph A. Ernst  
**R.A.F.** Robert A. Fisher  
**R.A.Fi.** Russell A. Fisher  
**R.A.Fin.** Richard A. Finkelstein  
**R.A.G.** Richard A. Gould  
**R.A.Ga.** Robert A. Gastaldo  
**R.A.Go.** Richard A. Goodman  
**R.A.Gr.** Robert A. Grimm  
**R.A.He.** Ronald A. Hess  
**R.A.Ho.** Richard A. Hoffman  
**R.A.Hu.** Roland A. Hultsch  
**R.A.J.** R. Alan Jones  
**R.A.K.** Robert A. Kaplan  
**R.A.Ko.** Robert A. Kolvoord  
**R.A.L.** Roy A. Larson  
**R.A.M.** R. A. Miller  
**R.A.Mo.** Roger A. Morse  
**R.A.Mu.** Richard A. Müller  
**R.A.M.T.** Ramon A. Mata-Toledo  
**R.A.Pe.** Robert A. Penneman  
**R.A.Pf.** Robert A. Pfeffer  
**R.A.Ph.** Ronald A. Phaneuf  
**R.A.Pi.** Robert A. Pierotti  
**R.A.R.** Richard A. Rohde  
**R.A.Ra.** Richard A. Rachubinski  
**R.A.Rah.** Robert A. Rahenkamp  
**R.A.S.** Robert A. Shaw  
**R.A.Sc.** Richard A. Scott  
**R.A.Sp.** Robert A. Spurgin  
**R.A.U.** Robert A. Uhrhammer  
**R.A.V.** Romeo A. Vidone  
**R.A.We.** Robert A. Weller  
**R.A.Web.** Richard A. Webb  
**R.Ba.** Robert Barer  
**R.Bet.** Russell Betts

**R.Bra.** Robert Bradley  
**R.Bri.** R. Brimacombe  
**R.Bro.** Rollins Brook  
**R.Bu.** Ron Burghard  
**R.B.C.** Richard B. Couch  
**R.B.D.K.** R. B. D. Knight  
**R.B.F.** Robert B. Flint  
**R.B.H.** Rolla B. Hill  
**R.B.He.** Ronald B. Herberman  
**R.B.L.** R. Bruce Lindsay  
**R.B.M.** Regis B. Miller  
**R.B.N.** Richard B. Nelson  
**R.B.Se.** Richard B. Setlow  
**R.B.T.** R. Brent Tully  
**R.B.W.** Robert B. Willey  
**R.C.** Richard Comeau  
**R.Ch.** Robert Chen  
**R.Cl.** Robin Cleveland  
**R.C.A.** Richard C. Altmock  
**R.C.D.** Richard C. Dorf  
**R.C.Ew.** Rodney C. Ewing  
**R.C.Fo.** Richard C. Fox  
**R.C.G.** Robert C. Gunning  
**R.C.L.** Richard C. Lord  
**R.C.La.** Richard C. Lamb  
**R.C.M.** Roy C. Mast  
**R.C.MacD.** Robert C. McDonald  
**R.C.Mo.** Raymond C. Moore  
**R.C.N.** R. C. Newton  
**R.C.P.** Roy C. Page  
**R.C.Po.** Robert C. Powell  
**R.C.Pu.** Russell C. Putnam  
**R.C.S.** Randy C. Stauffer  
**R.C.Tr.** Robert C. Truax  
**R.C.W.** Randolph C. Wilhoit  
**R.D.A.** Raymond D. Adams  
**R.D.Anw.** Robert D. Anwyl  
**R.D.B.** Robert D. Barnes  
**R.D.Ber.** R. D. Berger  
**R.D.Bi.** Roger D. Blandford  
**R.D.Ch.** Robert D. Chapman  
**R.D.Che.** Robert D. Chellis  
**R.D.Co.** Robert D. Compton  
**R.D.D.** Raymond D. Douglass  
**R.D.E.** Robley D. Evans  
**R.D'E.A.** Robert d'E. Atkinson  
**R.DeL.** Robert de Levie  
**R.DeLF.** Raymond Del Fava  
**R.D.H.** Rollin D. Hotchkiss  
**R.D.J.** Robert Davies-Jones  
**R.D.K.** Roger D. Kempers  
**R.D.M.** Reginald D. Manwell  
**R.D.Ma.** R. D. Martin  
**R.D.Mu.** R. D. Mushlitz  
**R.D.P.** Richard D. Purchon  
**R.D.Pe.** Robert D. Pelhke  
**R.D.Pi.** Roger D. Pience  
**R.D.Ru.** Rogers D. Rusk  
**R.D.T.** Ruth D. Turner  
**R.D.V.** Richard D. Vierstra  
**R.D.W.** Robert D. Waldron  
**R.D.Wa.** Robert D. Walkup  
**R.Eb.** Ray Eberts  
**R.Ew.** Rod Eving  
**R.E.A.** Robert E. Apfel  
**R.E.Bel.** Robin E. Bell  
**R.E.Bi.** Rupert E. Billingham  
**R.E.C.** Richard E. Chipkin  
**R.E.Car.** Richard E. Carbone  
**R.E.Co.** Robert E. Coleman

- R.E.Cr.** Ralph E. Crabill, Jr.  
**R.E.D.** Robert E. Dickinson  
**R.E.DeM.** Robert E. DeMar  
**R.E.F.** Richard E. Faw  
**R.E.Ga.** Roger E. Garrett  
**R.E.Gr.** Ralph E. Grim  
**R.E.H.** Robert E. Hungate  
**R.E.Ho.** Ralph E. Hoffman  
**R.E.K.** R. E. Kallio  
**R.E.L.** Robert E. Lund  
**R.E.Le.** Richard E. Leach  
**R.E.M.** Roy Earl Morse  
**R.E.Ma.** Rex E. Marx  
**R.E.O.** Richard E. Orville  
**R.E.P.** Raymond E. Peck  
**R.E.Py.** Reed E. Pyeritz  
**R.E.R.** Ralph E. Ricksecker  
**R.E.R.H.** Robert E. Reed-Hill  
**R.E.Sh.** Robert E. Sheriff  
**R.E.St.** Robert E. Stall  
**R.E.T.** R. E. Taylor  
**R.E.Th.** R. E. Thomas  
**R.E.Tr.** Robert E. Treybal  
**R.E.W.** R. E. Walstedt  
**R.E.Wy.** Richard E. Wyman  
**R.E.Z.** Rodger E. Ziemer  
**R.F.** Robert Fusco: Metallocene catalyst  
**R.F.** Ronald Fuchs: Boltzmann transport equation  
**R.FB.** Robert F. Black  
**R.FBo.** R. F. Bozarth  
**R.FBu.** Rointan F. Bunshah  
**R.FCl.** Richard F. Clark  
**R.FCo.** R. Frank Cook  
**R.FDi.** Robert F. Dill  
**R.FDu.** R. F. Dubiel  
**R.FDz.** Ronald F. Dziuba  
**R.FFa.** R. F. Farrell  
**R.FFl.** Richard F. Flint  
**R.FFr.** Raymond F. Fremed  
**R.FG.** Robert F. Goddu  
**R.FGr.** Richard F. Green  
**R.FH.** R. F. Horsnail  
**R.FK.** Robert F. Ker  
**R.FM.** R. G. Merwin  
**R.FN.** Ross F. Nigrelli  
**R.FP.** Richard F. Post  
**R.FR.** Reed F. Riley  
**R.FS.H.** R. F. S. Hearmon  
**R.FW.** Robert F. Wing  
**R.G.** Raymond Giese  
**R.Gi.** Robert Ginsburg  
**R.Go.** Ronald Gold  
**R.Gom.** Robert Gomer  
**R.Gov.** R. Govindjee  
**R.Gr.** Robert Greenler  
**R.Gre.** Richard Greenspan  
**R.GBo.** Richard G. Bowman  
**R.GBu.** Roger G. Burns  
**R.G.C.** Robert G. Carroll, Jr.  
**R.G.E.M.** R. G. E. Murray  
**R.G.F.** Richard G. Farmer  
**R.G.Gr.** R. G. Grogan  
**R.G.Jo.** Robert G. Joppa  
**R.G.Jon.** R. Gareth Jones  
**R.G.K.** Richard G. Klein  
**R.G.L.** Robert G. Larsen  
**R.G.M.** R. G. Martin  
**R.G.N.** Robert G. Neuhauser  
**R.G.Ne.** Roger G. Newton  
**R.G.No.** R. Glenn Northcutt  
**R.G.P.** Robert G. Parr  
**R.G.Pr.** Ronald G. Prinn  
**R.G.S.** Robert G. Strom  
**R.G.Wi.** Rolf G. Winter  
**R.G.W.A.** Richard G. W. Anderson  
**R.G.Z.** Richard G. Zweifel  
**R.H.** Richard Hazen  
**R.Ha.** Ronald Hazen  
**R.Hac.** Ralph Hackl  
**R.Hal.** Robert Hall  
**R.Hi.** Ron Hilliard  
**R.Ho.** Robert Hofstadter  
**R.Hog.** Robert Hogan  
**R.Hol.** Robert Holt  
**R.H.Bi.** R. H. Bing  
**R.H.Bo.** Richard H. Boyd  
**R.H.Bu.** Richard H. Bube  
**R.H.C.** Robert H. Cannon, Jr.  
**R.H.Co.** Richard H. Converse  
**R.H.Cr.** Robert H. Crabtree  
**R.H.D.** Richard H. Dalitz  
**R.H.De.** Robert H. Denison  
**R.H.Do.** Robert H. Dodds  
**R.H.Dot.** Robert H. Dott, Jr.  
**R.H.E.** Richard H. Eyde  
**R.H.F.H.** R. H. F. Hunter  
**R.H.G.** Roy H. Gigg  
**R.H.Go.** Roland H. Good  
**R.H.He.** Rolfe H. Herber  
**R.H.Hew.** Roger H. Hewins  
**R.H.J.** Richard H. Jahns  
**R.H.K.** R. H. Kaufmann  
**R.H.L.** Ralph H. Luebbers  
**R.H.McF.** Richard H. McFarland  
**R.H.N.** R. H. Noble  
**R.H.P.** R. H. Pearce  
**R.H.R.** Robert H. Rownd  
**R.H.Ri.** Reinhard H. Richter: Isocyanate etc.  
**R.H.Ri.** Rufus H. Ritchie: Ketene  
**R.H.S.** Ralph H. Sharpe  
**R.H.T.** Richard H. Tedford  
**R.H.Tu.** Russell H. Tuttle  
**R.H.W.** Robert H. Wentorf, Jr.  
**R.H.Wa.** Robert H. Wald  
**R.I.B.** Robert I. Bernstein  
**R.I.D.** Ralph I. Dorfman  
**R.I.E.** Robert I. Edelman  
**R.I.F.** Richard I. Felver  
**Ri.H.** Richard Hong  
**R.I.H.** R. I. Hamilton  
**R.I.Ha.** Robert I. Harker  
**R.I.MacD.** Ruby I. MacDonald  
**R.I.P.** R. I. Papendick  
**R.I.S.** Robert I. Stirton  
**R.I.T.** Robert I. Tilling  
**R.J.** Roman Jackiw  
**R.Je.** Ron Jenkins  
**R.J.A.** Ronald J. Adler  
**R.J.Al.** Richard J. Aldridge  
**R.J.C.** Richard J. Campana  
**R.J.Co.** R. J. Collier  
**R.J.Cu.** Roger J. Cuffey  
**R.J.D.** Raymond J. Deland  
**R.J.Do.** R. J. Doviak  
**R.J.E.** Robert J. Etten  
**R.J.F.** Robert J. Foster  
**R.J.G.** Raymond J. Gagne  
**R.J.Gi.** Ronald J. Gillespie  
**R.J.Ha.** Richard J. Hartnett  
**R.J.K.** R. J. Keddy: Crystal counter  
**R.J.K.** Robert J. Kempainen: Adrenal gland  
**R.J.M.** Roelof J. Meijer  
**R.J.Ma.** Richard J. Martin  
**R.J.Me.** Robert J. Menzies  
**R.J.Mo.** R. J. Motekaitis  
**R.J.Mu.** R. J. Murgatroyd  
**R.J.Mun.** R. J. Munz  
**R.J.N.** Robert J. Naumann  
**R.J.Ne.** Raymond J. Nelson  
**R.J.R.** Rupert J. Riedel  
**R.J.Re.** Richard J. Reeder  
**R.J.S.** R. J. Stephenson  
**R.J.So.** Robert J. Soulen, Jr.  
**R.J.St.** Robert J. Strohl  
**R.J.Ste.** R. J. Stern  
**R.J.T.** Robert J. Thorn  
**R.J.Ta.** Robert J. Taylor  
**R.J.Tr.** Robert J. Tracy  
**R.J.W.** Robert J. Weaver  
**R.J.Wi.** Rodger J. Williams  
**R.Ko.** Richard Korál  
**R.Kor.** Roger Korus  
**R.Kr.** Robert Kreilik  
**R.Krz.** Roman Krzysztofowicz  
**R.K.A.** Robert K. Adair  
**R.K.B.** Robert K. Barnes  
**R.K.Ba.** Robert K. Barnes  
**R.K.C.** Richard K. Cook  
**R.K.Ca.** Ralph K. Cavin III  
**R.K.D.** R. K. Downey  
**R.K.E.** Russell K. Edwards  
**R.K.Ho.** R. K. Horst  
**R.K.L.** Ronald K. Linde  
**R.K.Li.** Ray K. Linsley  
**R.K.M.** Raman K. Mehra  
**R.K.MacC.** Robert K. MacCrone  
**R.K.Mo.** Richard K. Moore  
**R.K.Mu.** Roger K. Murray, Jr.  
**R.K.So.** R. K. Soost  
**R.K.Y.** Robert K. Yu  
**R.LaM.** Robert LaMotte  
**R.Le.** Roberto Lee  
**R.LeB.H.** Roger LeB. Hooke  
**R.Len.** Richard Lennert  
**R.Leo.** Roberto Leo  
**R.Lev.** Rachmiel Levine  
**R.Lh.** Roger Lhermitte  
**R.L.A.** Richard L. Armstrong  
**R.L.At.** Ronald L. Atwood  
**R.L.B.** Robert L. Bates  
**R.L.Ba.** Richard L. Barton  
**R.L.Bi.** Raymond L. Bisplinghoff  
**R.L.Br.** Robert L. Bradley, Jr.  
**R.L.Bri.** Robert L. Brickley  
**R.L.Bro.** Robert L. Brown  
**R.L.Broc.** Roger L. Brockenbrough  
**R.L.Bu.** Robert L. Burwell  
**R.L.C.** Robert L. Carroll  
**R.L.Ca.** Ronald L. Calabrese  
**R.L.Ch.** Roy L. Chenault  
**R.L.Cha.** Russell L. Chapman  
**R.L.Chr.** Richard L. Christiansen  
**R.L.Du.** Raynor L. Duncombe  
**R.L.E.** Robert L. Edmonds  
**R.L.F.** R. L. Fleischer  
**R.L.Fi.** Robert L. Fisher

- R.L.Fr.** Ralph L. Freeman  
**R.L.Ge.** Randall L. Geigel  
**R.L.Gl.** Robert L. Glass  
**R.L.Ha.** Roy L. Harrington  
**R.L.Han.** Robert L. Haney  
**R.L.He.** Robert L. Heinrichson  
**R.L.Ho.** Richard L. Hoffman  
**R.L.Hu.** Robert L. Hulbary  
**R.L.Ja.** Robert L. Jaffe  
**R.L.Je.** Richard L. Jensen  
**R.L.K.** Richard L. Koral  
**R.L.Ka.** Roger L. Kaesler  
**R.L.L.** Ronald L. Lavoie  
**R.L.M.** R. L. Mower: Ergot and ergotism  
**R.L.M.** Rudolph L. Mayer: Sulfonamide  
**R.L.Ma.** Holland L. Mays  
**R.L.Moe.** Richard L. Moe  
**R.L.N.** Raymond L. Nace  
**R.L.P.** Robert L. Peaslee  
**R.L.Pe.** R. L. Peterson  
**R.L.R.** Robert L. Ramey  
**R.L.Re.** Russell L. Regnery  
**R.L.S.** Robert L. Scott  
**R.L.S.M.** Robert L. San Martin  
**R.L.Sm.** Robert Leroy Smith  
**R.L.Sw.** R. L. Swanson  
**R.L.T.** Richard L. Tomasetti  
**R.L.W.** Ray L. Watterson  
**R.L.Wh.** Roy L. Whistler  
**R.McN.A.** R. McNeill Alexander  
**R.Miy.** Ritsuro Miyawaki  
**R.Mu.** Richard Muther  
**R.Mur.** Robert Murphy  
**R.M.A.** Ronald M. Atlas  
**R.M.Al.** R. McNeill Alexander  
**R.M.B.** Reeve M. Bailey  
**R.M.Ba.** Richard M. Bateman  
**R.M.Bo.** Robert M. Boynton  
**R.M.C.** Raymond M. Cable  
**R.M.F.** Robert M. Finks  
**R.M.Fe.** Rodney M. Feldman  
**R.M.Fo.** Robert M. Fox  
**R.M.H.** Ralph M. Hardgrove  
**R.M.K.** Richard M. Klein  
**R.M.Ke.** Robert M. Kelly  
**R.M.Kr.** Reinhardt Møbjerg Kristensen  
**R.M.L.** R. M. Latanision  
**R.M.M.** Richard M. Mitterer  
**R.M.Ma.** Robert M. Malina  
**R.M.No.** Richard M. Noyes  
**R.M.Ph.** Richard M. Phelan  
**R.M.R.** Roger M. Reeve  
**R.M.Ra.** Robert M. Rauber  
**R.M.Ri.** Richard M. Rickert  
**R.M.Ro.** Roger M. Rowell  
**R.M.S.** R. M. Sorensen  
**R.M.Sc.** Robert M. Scher  
**R.M.Sch.** Robert M. Schultz  
**R.M.Scho.** Robert M. Schoch  
**R.M.Sm.** Raymond M. Smullyan  
**R.M.So.** Robert M. Sorensen  
**R.M.T.** Robb M. Thomson  
**R.M.Th.** Robert M. Thorogood  
**R.M.U.** Reha M. Uzsoy  
**R.M.W.** R. M. Walker  
**R.M.Wa.** Robert M. Warner  
**R.M.Wal.** Robert M. Wald  
**R.M.Wh.** Robert M. White  
**R.M.Wi.** Robert M. Wienski  
**R.M.Wr.** Raymond M. Wright  
**R.N.** Ronald New  
**R.N.Br.** Ronald N. Bracewell  
**R.N.H.** Rodney N. Hader  
**R.N.Hw.** Richard N. Hwang  
**R.N.M.** Robert N. Mayall  
**R.N.Sm.** Raymond N. Smartt  
**R.Nu.** Richard Nuccitelli  
**R.O.** Rufus Oldenburger  
**R.Ol.** Richard Olmstead  
**R.O'Ra.** Ronan O'Rahilly  
**R.O.P.** Robert O. Pohl  
**R.O.R.** Rodney O. Radke  
**R.P.** Robert Pecora  
**R.Pan.** Richard Pantell  
**R.Pe.** Roger Penrose  
**R.Pl.** Roy Plotnick  
**R.Po.** Richard Porter  
**R.Pow.** Robert Powell  
**R.PB.** Richard P. Buck  
**R.PBu.** R. Paul Butler  
**R.PD.** Robertson P. Dinsmore  
**R.PE.** Robert P. Erickson  
**R.PFi.** Richard P. Fiske  
**R.PG.** Robert P. Giblon  
**R.PH.** Richard P. Hall  
**R.PHi.** Robert P. Higgins  
**R.PHu.** Ralph P. Hudson  
**R.PL.** R. Paul Larsen  
**R.PLe.** Rafael Pont-Lezica  
**R.PN.** Robert P. Nolan  
**R.PS.** Robert P. Searles  
**R.PS.J.** R. P. S. Jeffries  
**R.PV.** Richard P. Voelker  
**R.PW.** Robert P. Wagner  
**R.PWi.** Ralph P. Winch  
**R.Re.** Randall Reed  
**R.Ri.** Ralph Riley  
**R.Ro.** Richard Roberts: Restriction enzyme  
**R.Ro.** Robert Rosen: Mathematical biology  
**R.Ros.** Robert Roskoski, Jr.  
**R.R.B.** Robert R. Brubaker  
**R.R.C.** Rita R. Colwell  
**R.R.De.** Ralph R. Deakins  
**R.R.F.** Richard R. Fay  
**R.R.G.** Ralph R. Goodman  
**R.R.H.** Robert H. Hibbard  
**R.R.J.** Robert R. Jacobson  
**R.R.LaF.** Raymond R. LaFrey  
**R.R.S.** Robert R. Shannon  
**R.R.Sc.** Ronald R. Schnabel  
**R.R.Sh.** R. R. Shively  
**R.S.** Rudolf Schmid  
**R.Sc.** Rolf Schaumann  
**R.Se.** Robert Searles  
**R.Sh.** Robert Shprintzen  
**R.Shi.** Ronald Shimek  
**R.Si.** Raymond Siever  
**R.Sil.** Robert Silman  
**R.Sim.** Robert Simpson  
**R.Sk.** Richard Skalak  
**R.Str.** Reuben Straus  
**R.Stro.** Robert Strohl  
**R.Su.** Richard Suds  
**R.S.B.** Robert S. Boynton  
**R.S.E.K.** Richard S. E. Keefe  
**R.S.G.** Reginald S. Gagliardo  
**R.S.H.** R. Scott Hawley  
**R.S.J.** Richard S. Juvet, Jr.  
**R.S.K.** Robert S. Kapner  
**R.S.Ki.** Robert S. Kirby  
**R.S.L.** Richard S. Lindzen  
**R.S.Le.** Richard S. Lewis  
**R.S.M.** Robert S. Mulliken  
**R.S.McD.** Robin S. McDowell  
**R.S.McE.** Robert S. McEwen  
**R.S.R.** Robert S. Ross  
**R.S.Ro.** Richard Stone Rothblum  
**R.S.S.** Robert S. Sherwood  
**R.S.Sa.** R. Stephen Saunders  
**R.S.Sh.** Richard S. Shevell  
**R.S.Sy.** Robert S. Symons  
**R.S.T.** Robert S. Tikofsky  
**R.S.W.** Ralph S. Wolfe  
**R.S.Wa.** Richard S. Wagner  
**R.S.We.** Richard S. Westfall  
**R.S.Y.** Rosalyn S. Yalow  
**R.Ti.** Robert Tilling  
**R.T.B.** Richard T. Barber  
**R.T.Be.** Robert T. Beaumont  
**R.T.D.** Raymond T. Damien  
**R.T.H.** Richard T. Hanlin: Discomycetes  
**R.T.H.** Robert T. Hill: Airborne radar etc.  
**R.T.Ha.** Richard T. Hanlin  
**R.T.J.** Richard T. Jones  
**R.T.L.** Richard T. Liddicoat, Jr.  
**R.T.P.** Rachel T. Pinker  
**R.T.R.** Robert T. Ratay  
**R.T.S.** Richard T. Smith  
**R.T.W.** Robert T. Weil, Jr.  
**R.T.Wh.** Richard T. Whitcomb  
**R.U.** R. Ullrich  
**R.V.** Richard Vallee  
**R.V.I.** Raymond V. Ingersoll  
**R.V.S.** Roland V. Shack  
**R.W.** Roff Weil  
**R.We.** Richard Wetzel  
**R.Wo.** Rachel Wood  
**R.W.B.** Robert W. Belfit, Jr.  
**R.W.Ba.** Robert W. Bartlett  
**R.W.Buk.** Richard W. Bukowski  
**R.W.But.** Robert W. Butler  
**R.W.C.** Robert W. Carson  
**R.W.Ch.** R. W. Christie  
**R.W.E.** Ralph W. Engstrom  
**R.W.H.** Robert W. Holmes  
**R.W.Ha.** Richard W. Harris  
**R.W.Hai.** Roger W. Haines  
**R.W.J.** Richard W. James  
**R.W.J.B.** R. W. J. Barker  
**R.W.K.** Randall W. Kreutel  
**R.W.L.** Robert W. Leader  
**R.W.M.** Robert W. Mann  
**R.W.Mo.** Robert W. Morse  
**R.W.Mu.** Royce W. Murray  
**R.W.N.** Robert W. Noyes  
**R.W.Ne.** Robert W. Newcomb  
**R.W.O.** Robert W. Odom  
**R.W.P.** Robert W. Pennak  
**R.W.Po.** Robert S. Pozos  
**R.W.R.** Richard W. Robinson  
**R.W.Ri.** Robert W. Risebroh  
**R.W.S.** Roy W. Simonson  
**R.W.Sa.** Robert W. Sanders

**R.W.Sc.** Raymond W. Schmitt: Double diffusion  
**R.W.Sc.** Robert W. Schwab: Aircraft compass system  
**R.W.Si.** Richard W. Siegel  
**R.W.St.** Russell W. Strandtmann  
**R.W.T.** Raymond W. Tennant  
**R.W.Wo.** R. W. Woody  
**R.W.Y.** Robert W. Young  
**R.W.Ye.** Ralph W. Yell  
**R.Y.Z.** R. Y. Zhang  
**R.Z.** Rainer Zangerl

## S

**S.A.Co.** Steven A. Cohn  
**S.A.K.** Stephen A. Konz  
**S.A.L.** Simon A. Levin  
**S.A.M.** Shelby A. Miller  
**S.A.Mo.** Stephen A. Morse  
**S.A.R.** Scott A. Redhead  
**S.A.Ru.** Steven A. Rutledge  
**S.A.St.** Steven A. Stage  
**S.A.Wh.** Stanley A. White  
**S.A.Wi.** S. A. Williams  
**S.Be.** Stefan Bengtson  
**S.Bo.** Solomon Bochner  
**S.B.E.** Stuart B. Elston  
**S.B.M.** S. B. Morris: Radar-absorbing materials  
**S.B.M.** Stoney B. Martin: Fire technology  
**S.B.O.** Steven B. Oppenheimer  
**S.B.P.** Steward B. Peck  
**S.B.S.** Steven B. Simon  
**S.B.Se.** Shlomo Bar-Sela  
**S.B.V.** S. B. Vinson  
**S.C.** Sydney Chapman  
**S.Ca.** Sandra Carlson  
**S.Ch.** Steven Chu  
**S.Chi.** Shu Chien  
**S.Cho.** Sudhansu Chokroverty  
**S.Co.** Sheryl Coombs  
**S.Cr.** Sears Crowell  
**S.C.B.** Simon C. Brassell  
**S.C.C.T.** Samuel C. C. Ting  
**S.C.E.** Stephen C. Encleson  
**S.C.H.** Standish C. Hartman  
**S.C.Hs.** Samuel C. Hsieh  
**S.C.J.** Shung-Chang Jong  
**S.C.Jo.** S. C. Jong  
**S.C.K.S.** Charles Kendeigh  
**S.C.Li.** Shao-Chi Lin  
**S.C.M.** Simon Conway Morris  
**S.C.Ri.** Stephen C. Riser  
**S.C.T.** Samuel C. Tease  
**S.C.U.** Stephen C. Unwin  
**S.D.** Seymour Diamond  
**S.D.H.** Steacy D. Hicks  
**S.DeS.** Steve deSatnick  
**S.E.** Steven Edwards  
**S.E.Cr.** Sheldon E. Cremer  
**S.E.H.** Stephen E. Haggerty  
**S.E.W.** S. E. Weaver  
**S.E.Wh.** Sidney E. White  
**S.E.Wo.** Stan E. Woosley

**S.F.** Sherman Fried  
**S.Fo.** Simon Foner  
**S.F.J.** Stephen F. Jacobs  
**S.F.P.** Stephen F. Perry  
**S.F.S.** S. F. Singer  
**S.F.Y.** S. F. Yates  
**S.Gr.** S. Granick  
**S.Gu.** Stephen Guggenheim  
**S.G.B.** S. Gaylen Bradley  
**S.G.Bu.** Stanley G. Burns  
**S.G.L.** Spencer G. Lucas  
**S.G.P.** S. George Philander  
**S.G.S.** Stephen G. Simpson  
**S.G.T.** Stanley G. Thompson  
**S.H.** Sven Horstadius  
**S.Hi.** Simon Hillson  
**S.H.B.** Simon H. Bauer  
**S.H.Bo.** Stefan H. Boshkov  
**S.H.D.** Sven H. Dodington  
**S.H.E.** Stephen H. Embury  
**S.H.G.** Sidney H. Goodman  
**S.H.L.** Sam H. Liu  
**S.H.M.** Sergius H. Mam ay  
**S.H.W.** Samuel H. Wilcn  
**S.H.Y.** Sulhi H. Yungui  
**S.I.A.** S.-I. Akasofu  
**S.I.G.** Shelton I. Green  
**S.I.Ga.** Saul I. Gass  
**S.I.M.** Sidney I. Miller  
**S.I.Ma.** Sameer I. Madanshetty  
**S.I.S.** Stanley I. Sandier  
**S.J.** S. Jafarey  
**S.Jo.** S. Joseph  
**S.J.A.** Stephen J. Andriole  
**S.J.B.** Spencer J. Berry: Cell lineage etc.  
**S.J.B.** Spencer J. Bloch: Algebraic geometry  
**S.J.C.** S. Joseph Campanella  
**S.J.Co.** Steven J. Collins  
**S.J.G.** Stephen J. Gould  
**S.J.Ga.** Stephen J. Galli  
**S.J.Gl.** S. J. Gledhill  
**S.J.M.D.** Simon J. M. Davis  
**S.J.McN.** Samuel J. McNaughton  
**S.J.O.** Steven J. Ostro  
**S.Ka.** Serope Kalpakjian  
**S.Kar.** Shlomo Karni  
**S.Ki.** Stanley Kirschner  
**S.Kir.** Seth Kirby  
**S.Kit.** Saul Kit  
**S.Ko.** Seichi Konzo  
**S.Kr.** Seth Kirby  
**S.K.F.** Sheldon K. Friedlander  
**S.K.J.** Subodh K. Jain  
**S.La.** Samuel Lambert  
**S.Lab.** Samuel Labi  
**S.LaB.** Stephen LaBerge  
**S.Lav.** Stephen Lavin  
**S.Lei.** Sidney Leibovich  
**S.Lu.** Susan Lunte  
**S.L.A.** Sandra L. Anagnostakis  
**S.L.E.** Stanley L. Ehrlich  
**S.L.G.** Sol L. Garfield  
**S.L.K.** Stephen L. Keil  
**S.L.M.** Steve L. Moseley  
**S.L.S.** Stephen L. Sass  
**S.Ma.** Stephen Mann  
**S.Man.** Steve Mansfield  
**S.Mar.** Shige Maruyama

**S.Marg.** Simeon Margolis  
**S.Maru.** S. Maruyama  
**S.M.A.** Stanley M. Alcorn  
**S.M.D.** S. M. Dilworth  
**S.M.F.** Sydney M. Finegold  
**S.M.G.** Steven M. Girvin  
**S.M.K.** S. Morris Kupchan  
**S.M.L.** Scott M. Lewandowski  
**S.M.M.** Stephen M. Matyas  
**S.M.S.** Suelo M. Shiino  
**S.M.So.** Stephen M. Sauthwick  
**S.M.St.** Steven M. Standaert  
**S.M.Su.** S. Mark Sumi  
**S.M.W.** Stephanie M. White  
**S.N.** Stephen Nygren  
**S.N.G.** Stanley N. Gershoff  
**S.N.Sh.** Sargur N. Srihari  
**S.N.U.A.K.** Syed N. U. A. Kirmani  
**S.O.** Steven Onishi  
**S.Pi.** Stuart Pimm  
**S.Pu.** Seth Putterman  
**S.P.H.** Samuel P. Hammer  
**S.P.P.** Sybil P. Parker  
**S.P.S.** Soren P. Sorensen  
**S.R.** Sidney Raffel  
**S.Ra.** Shirley Raps  
**S.Ri.** Saul Rich  
**S.Ro.** Sidney Ross  
**S.Rop.** Stephen Roper  
**S.R.B.** Sebastian R. Borrello  
**S.R.Bo.** Steven R. Bolin  
**S.R.E.** Steven R. Emerson  
**S.R.G.** Steven R. Goodman  
**S.R.H.** Steven R. Hanna  
**S.R.K.** Shrinivas R. Kulkarni  
**S.R.N.** Suzanne R. Nagel  
**S.R.O.** Stanford R. Ovshinsky  
**S.R.R.** Sue R. Rubinstein  
**S.R.S.** Sergio R. Signorini  
**S.R.Se.** Stanley R. Seagle  
**S.R.St.** Scott R. Stewart  
**S.R.T.** Stuart Ross Taylor  
**S.S.** Sidney Siggia  
**S.Sa.** Shamachary Sathish  
**S.Sal.** Stanley Salek  
**S.Se.** Sridhar Seshadri  
**S.Si.** Stanley Singer  
**S.Sim.** Steven Simon  
**S.Sir.** S. Sircar  
**S.So.** Stevern Southwick  
**S.Su.** S. Sudarshan  
**S.S.B.** S. S. Brown  
**S.S.C.** S. S. Chern: Riemannian geometry  
**S.S.C.** Shoei-Sheng Chen: Flow-induced vibration  
**S.S.D.** S. Sovonick-Dunford  
**S.S.G.** Samuel S. Goldich  
**S.S.J.** Silvia S. Jurisson  
**S.S.K.** Sudhir S. Kulkarni  
**S.S.L.C.** S. S. L. Chang  
**S.S.M.** Stephen S. Murray  
**S.S.N.** Samuel S. Naistat  
**S.S.S.** Shelley S. Sutherland  
**S.T.** Shirley Turner  
**S.Tr.** Sam Treiman  
**S.T.A.** S. T. Algermissen  
**S.T.B.** S. Theodore Brewer  
**S.T.H.** S. T. Hastiotis  
**S.U.W.** S. U. Walkley

**S.V.** Steve Vogel  
**S.V.B.** Steven V. Beer  
**S.W.B.** Sharon W. Bachinski  
**S.W.Ba.** S. W. Bailey  
**S.W.F.** Stephen W. Feldberg  
**S.W.L.** Stephen W. Lam  
**S.W.MacD.** Samuel W. MacDowell  
**S.W.P.** Stella W. Pang: Ion implantation  
**S.W.P.** Stephen W. Porges: Auto-nomic nervous system  
**S.W.Pe.** S. William Pelletier  
**S.Y.C.** Shih-Yuan Chen

## T

**T.Ap.** Thomas Appelquist  
**T.A.D.** T. A. Deacon  
**T.A.H.** T. A. Howells  
**T.A.K.** Thomas A. Kaplan  
**T.A.M.** Terry A. Miller  
**T.A.Wa.** Thomas A. Waldmann  
**T.A.Wi.** Thomas A. Wikle  
**T.A.Z.** Thomas A. Zanoni  
**T.B.** T. Balderes  
**T.Ba.** Theodore Baumeister  
**T.Bar.** Ted Barnes  
**T.Br.** Thomas Brylawski  
**T.B.M.** Thomas B. Mills  
**T.B.R.** T. B. Rauchfuss  
**T.B.S.** Thomas B. Sheridan  
**T.B.St.** Thomas B. Sturges III  
**T.B.T.** Thomas B. Turner  
**T.Ca.** Tom Carey  
**T.C.C.** T. C. Cheng  
**T.C.F.** Thomas C. Fuller  
**T.C.H.** Thomas C. Hoering  
**T.C.Hi.** Thomas C. Hinrichs  
**T.C.L.** Theodore C. Labotka  
**T.C.O.** Tobias C. Owen  
**T.C.P.** Tram C. Pritchard  
**T.C.R.** Theodore C. Ruch  
**T.C.St.** Thressa C. Stadtman  
**T.C.W.** Thomas C. Waddington  
**T.C.Wh.** T. C. Whitmore  
**T.C.Wi.** Thomas C. Winter  
**T.De.** Thomas Destree  
**T.D.B.** Thomas D. Bird  
**T.D.G.** Thomas D. Getman  
**T.D.M.** Tom D. Milster  
**T.D.R.** Thomas D. Rossing  
**T.D.S.** Thomas D. Sharkey  
**T.D.W.** Thomas D. Watkins  
**T.D.Wi.** Todd D. Williams  
**T.E.B.** Thomas E. Bowman  
**T.E.C.** Thomas E. Cowan  
**T.E.D.** T. E. Dawson  
**T.E.L.** Thomas E. Leontis  
**T.E.M.** Thomas E. Miler  
**T.E.McL.** Thomas E. McLain  
**T.E.P.** Thomas E. Parker  
**T.E.S.** Thomas E. Schroeder  
**T.E.S.** Thomas E. Summers  
**T.E.T.** T. E. Thompson  
**T.F.N.** T. F. Neubecker  
**T.F.W.B.** T. F. W. Barth

**T.F.Y.** Thomas F. Young  
**T.Ge.** Todd Georgi  
**T.Go.** Turan Gönen  
**T.G.B.** Thomas G. Back  
**T.G.Bi.** Theodore G. Birdsall  
**T.G.G.** Thomas G. Giallorenzi  
**T.G.H.** Tyler G. Hicks  
**T.Ha.** Terry Harrison  
**T.Har.** Terry Harrison  
**T.He.** Thomas Herring  
**T.Hu.** Tomas Hudlicky  
**T.H.D.** Theodore H. Dexter  
**T.H.F.** Thomas H. Fields  
**T.H.L.** Thomas H. Lee  
**T.H.Le.** T. H. Lee  
**T.H.S.** Tom H. Sanders, Jr.  
**T.H.VA.** Tjeerd H. Van Andel  
**T.H.VH.** Thomas H. Vender Haar  
**T.I.** Teruo Ishihara  
**T.I.S.** Tracy I. Storer  
**T.J.B.** Thomas J. Bouchard  
**T.J.B.H.** Timothy J. B. Holland  
**T.J.G.** Timothy J. Gaudin  
**T.J.M.** Tobin J. Marks  
**T.J.Me.** Thomas J. Meade  
**T.J.Mo.** Thomas J. Montville  
**T.J.Q.** T. J. Quinn  
**T.J.T.** T. J. Toy  
**T.J.W.** Theodore J. Weiss  
**T.K.** Taku Komai  
**T.Ka.** Thomas Kailath  
**T.Ki.** Toichiro Kinoshita  
**T.Kl.** Terrie Klinger  
**T.K.B.** Tomasz K. Baumiller  
**T.K.M.** Thomas K. Miles  
**T.L.** Tanzhuo Liu  
**T.L.F.** Thomas L. Ferrell  
**T.L.H.** Thomas L. Hayes  
**T.L.Ha.** Thomas L. Hale  
**T.L.M.** Tom L. McKnight  
**T.L.O.W.** Terry L. Orr-Weaver  
**T.L.P.** Tom L. Phillips  
**T.L.S.** Thomas L. Saaty  
**T.L.W.** Timothy L. White  
**T.M.** Theodore Monod  
**T.Moh.** T. Mohanakumar  
**T.M.B.** Thomas M. Buermann  
**T.M.Ba.** T. M. Barkley  
**T.M.C.** Ted M. Cavender  
**T.M.Ch.** T. Ming Chu  
**T.M.D.** Todd M. Doscher  
**T.M.De.** Thomas M. Destree  
**T.M.DeJ.** Theodore M. De Jong  
**T.M.F.** Thomas M. Flynn: Liquefaction of gases  
**T.M.F.** Thomas M. Frost: Fresh-water ecosystem  
**T.M.Gu.** Turgut M. Gür  
**T.M.K.** Todd M. Kana  
**T.M.M.** Terence M. Murphy  
**T.M.Y.** Tuncel M. Yegulalp  
**T.N.K.** Tanveer N. Khan  
**T.N.Kr.** T. N. Krishnamurti  
**T.N.T.** Thomas N. Taylor  
**T.Po.** Thomas Pollard  
**T.P.M.** Thomas P. Murray  
**T.P.N.** Tai. P. Ng  
**T.P.S.** Theodore P. Schilb  
**T.Ra.** Tzvi Raz  
**T.R.C.** Todd R. Christenson

**T.R.McC.** Thomas R. McCormick  
**T.R.S.** Thomas R. Schneider  
**T.R.Sm.** T. R. Smithson  
**T.S.** Tsunemasa Saito  
**T.Sc.** Tim Schowalter  
**T.Sn.** Theodore Snook  
**T.Su.** Terry Surles  
**T.S.D.** Thomas S. Dean  
**T.S.P.** Thomas S. Parsons  
**T.T.** Tom Thompson  
**T.T.N.** Thomas T. Noguchi  
**T.T.P.** Theodore T. Puck  
**T.T.T.** Tien Tzou Tsong  
**T.T.W.** Tai Tsun Wu  
**T.U.** Tohru Uchida  
**T.V.G.** Theodore V. Galambos  
**T.V.McE.** Thomas V. McEvilly  
**T.W.** Thomas Wartik  
**T.Wi.** Therese Wilson  
**T.W.A.** Thomas W. Amsden  
**T.W.C.** Thomas W. Cronin  
**T.W.D.** T. W. Dreschel: Hydroponics  
**T.W.D.** T. Wijesekera Dolphint: Porphyrin  
**T.W.H.** Thora W. Halstead  
**T.W.Ha.** Theo W. Hansch  
**T.Ya.** Takehiko Yagi  
**T.Y.L.** Tae Young Lee

## U, V

**U.F.** Ugo Fano: Multipole radiation  
**U.F.** Usama Fayyad: Data mining  
**U.L.** Ulrich Lutgde  
**U.M.N.** Ulla M. Norberg  
**U.R.** Uwe Radok  
**VA.** Vera Alexander  
**VAh.** Vernon Ahmadjian  
**V.A.F.** Victoria A. Fromkin  
**VB.** V. Balzani  
**V.C.C.** Valeria Cizerski Culotta  
**VD.B.** Vernon D. Barger  
**VD.P.** Victor D. Petershack  
**VE.B.** Vladimir E. Bondybey  
**VE.G.** Victor E. Goldenberg  
**VF.** Val L. Fitch  
**VFR.** Vincent F. Rafferty  
**VGA.** Vincent G. Allfrey  
**VHE.** Van H. English  
**VI.C.** Vernon I. Cheadle  
**VJ.B.** Victor J. Brzozowski  
**VJ.W.** Verner J. Wulff  
**VK.B.** V. K. Balakrishnan  
**VK.D.** V. K. Dhir  
**VK.S.** V. K. Sawhney  
**VLE.** Virginia L. Ernster  
**VLP.** Vincent L. Pecoraro  
**VLS.** Victor L. Streeter  
**VM.** Vincent Madison  
**VMa.** Vincent Massey  
**VMA.** Vincent M. Altamura  
**VN.M.R.** V. N. M. Rao  
**VR.B.** Victor R. Baker  
**VR.S.** Victor R. Stefanovic  
**VT.B.** Vincent T. Breslin  
**VVL.** V. V. Levasheff

**V.W.** Virginia Walbot  
**V.W.U.** Vincent W. Uhl

## W

**W.A.** William Allan  
**W.An.** Warren Andrew  
**W.Ar.** Walter Aron  
**W.A.B.** William A. Brodsky  
**W.A.Be.** William A. Beresford  
**W.A.Ber.** W. A. Berggren  
**W.A.C.** William A. Clemens  
**W.A.DiM.** William A. DiMichele  
**W.A.G.** William A. Gruver  
**W.A.H.** Walter A. Harrison  
**W.A.Ho.** William A. Horton  
**W.A.L.** William A. Lanford  
**W.A.Li.** Werner A. Lindenmaier  
**W.A.Ly.** Walter A. Lyons  
**Wi.A.P.** William A. Pryor  
**W.A.S.** William A. Steele  
**W.A.Se.** William A. Sethares  
**W.A.Si.** William A. Sirignano  
**W.A.V.** Wesley A. Volk  
**W.A.W.** W. A. Wakeham  
**W.A.Wi.** William A. Wildhack  
**W.A.Y.** W. A. Yost  
**W.B.** William Bradford  
**W.Be.** William Bemis  
**W.Bu.** Willy Burgdorfer  
**W.B.A.** Walter B. Ayers  
**W.B.B.** Warren B. Blumenthal  
**W.B.Bo.** Warren B. Boast  
**W.B.C.** William B. Campbell  
**W.B.F.** W. Beall Fowler  
**W.B.Fr.** William B. Fretter  
**W.B.Fra.** William B. Frakes  
**W.B.N.B.** William B. N. Berry  
**W.B.P.** Wayne B. Powell  
**W.B.S.** William B. Storey  
**W.Ca.** William Cain  
**W.Ch.** Wallace Chinitz  
**W.C.Co.** W. Charles Cooper  
**W.C.H.** William C. Hayes  
**W.C.Jo.** Walter C. Johnson  
**W.C.L.** W. C. Lineberger  
**W.C.Li.** William C. Livingston  
**W.C.P.** Walter C. Pitman, HI  
**W.C.Pe.** William C. Peters  
**W.C.Sh.** William C. Shoemaker  
**W.C.Wo.** William C. Wonders  
**W.D.** William Dent  
**W.D.Bo.** Walter D. Bonner, Jr.  
**W.D.C.** William D. Callister  
**W.D.H.** Willard D. Hartman  
**W.D.Hu.** William D. Hummon  
**W.D.J.** William D. Jackson  
**W.D.K.** Walter D. Keller  
**W.D.L.** W. David Lambert  
**W.D.Mo.** Walter D. Mooney  
**W.D.N.** William D. Nix  
**W.D.P.** William D. Phillips  
**W.D.R.H.** W. D. Russell-Hunter  
**W.D.T.** W. Dean Trautman  
**W.D.W.** W. Dexter Whitehead  
**W.E.B.** William E. Bell  
**W.E.C.** William E. Cooley

**W.E.D.** William E. Dossel  
**W.E.De.** Walter E. Dean  
**W.E.Go.** William E. Gordon  
**W.E.H.** William E. Howell  
**W.E.K.** William E. Keller  
**W.E.Ku.** Wayne E. Kuhn  
**W.E.Kup.** Walter E. Kupper  
**W.E.S.** W. E. Sterrer  
**W.E.Sm.** Warren E. Smith  
**W.F.** William Feller  
**W.F.B.** William F. Bradley  
**W.F.D.** Walter F. Dabberdt  
**W.F.F.** W. F. Furter  
**W.F.Ho.** William F. Hosford  
**W.F.J.** William F. Jaep  
**W.F.M.** William F. Meggers  
**W.F.Mo.** William F. Morris  
**W.F.S.** William F. Smith  
**W.F.W.** Warren F. Walker, Jr.  
**W.G.** William Grierson  
**W.Go.** William Gosling  
**W.Gr.** Walter Greiner  
**W.Gra.** Walter Graves  
**W.G.A.** Warren G. Abrahamson  
**W.G.B.** Waldo G. Bowman  
**W.G.D.** William G. Duncan  
**W.G.L.** William G. Lesso  
**W.G.M.** William G. Metcalf  
**W.G.McG.** William G. McGinnies  
**W.G.P.** William G. Pollard  
**W.G.W.** W. Gordon Whaley  
**W.H.** Wilbur Hague  
**W.Hai.** William Haile  
**W.Han.** William Hankley  
**W.Hap.** William Happer  
**W.Her.** William Hershleder  
**W.Ho.** William Hodos  
**W.H.B.** Wolfgang H. Berger  
**W.H.C.** Wallis H. Clark, Jr.  
**W.H.Ca.** Wallace H. Campbell  
**W.H.Cr.** William H. Crouse  
**W.H.D.** William H. Day  
**W.H.G.** Walter H. Gardner  
**W.H.Ga.** William H. Gaasch  
**W.H.Gr.** William H. Gross  
**W.H.H.** Walter H. Hartung  
**W.H.Ha.** William H. Hartwig  
**W.H.J.** W. Hilton Johnson  
**W.H.K.** William H. Konigsberg  
**W.H.L.** Wim H. Laarhoven  
**W.H.Li.** Wen-Hwang Lin  
**W.H.M.** William H. Miller  
**W.H.P.** William H. Phillips  
**W.H.S.** Wendell H. Slabaugh  
**W.H.Si.** William H. Simmons  
**W.H.W.** Winona H. Welch  
**W.H.Wa.** Warren H. Wagner, Jr.  
**W.H.Z.** Wojciech Hubert Zurek  
**W.I.R.** William Ingersoll Rose, Jr.  
**W.I.Th.** William I. Thompson, III  
**W.J.A.** William J. Adelman, Jr.  
**W.J.B.** Walter J. Bock  
**W.J.Ge.** Walter J. Gensler  
**W.J.Ger.** Willis J. Gertsch  
**W.J.H.** Walter J. Hamer  
**W.J.Ha.** William J. Hargis, Jr.  
**W.J.Hag.** William J. Hagan, Jr.  
**W.J.J.** W. John Judd  
**W.J.K.** William J. Krefeld  
**W.J.L.** Warren J. Luzadder

**W.J.Le.** W. John Lee  
**W.J.LeN.** William J. Le Noble  
**W.J.M.** William J. Mitsch  
**W.J.M.M.** W. J. M. Moore  
**W.J.S.** W. Joseph Schlitt  
**W.J.V.W.** Willem J. Van Wagtendonk  
**W.J.W.** William J. Willis  
**W.K.** Werner Kanzig  
**W.Ket.** Wolfgang Ketterle  
**W.Ku.** Wietse Kuis  
**W.K.J.** W. K. Joklik  
**W.L.** Willy Ley  
**W.Lu.** William Luth  
**W.Ly.** Waldo Lyon  
**W.Lyo.** Walter Lyons  
**W.L.Bro.** William L. Brown, Jr.  
**W.L.C.** Wen L. Chow  
**W.L.Ch.** William L. Chameides  
**W.L.F.** Wendy L. Freedman  
**W.L.Fi.** William L. Fisher  
**W.L.H.** W. Lincoln Hawkins  
**W.L.McC.** Warren L. McCabe  
**W.L.Ny.** William L. Nyhan  
**W.L.S.** Waldo L. Schmitt  
**W.L.V.** Willem L. Vos  
**W.L.Wo.** William L. Wolfe  
**W.M.** William Markowitz  
**W.Ma.** Walter Mannheim  
**W.Man.** Warren Manspeizer  
**W.McG.** William McGinnis  
**W.Mi.** Wesley Minnis  
**W.Mil.** William Milsom  
**W.Mos.** William Mosher  
**W.Mu.** William Murray  
**W.M.C.** William M. Carey  
**W.M.H.** Waren M. Hagist  
**W.M.Ha.** William M. Hartmann  
**W.M.Hu.** W. M. Hubbard  
**W.M.I.** Wayne M. Itano  
**W.M.L.** W. Marshall Leach, Jr.  
**W.M.S.** William M. Sinton  
**W.M.Sa.** W. Mark Saltzman  
**W.M.W.** Walter M. Walsh  
**W.O.M.** W. O. Milligan  
**W.Po.** William Porter  
**W.PB.** William P. Banks  
**W.P.Cu.** William P. Cunnane  
**W.PK.** Wiley P. Kirk  
**W.PN.** W. P. Nelms  
**W.PR.** William P. Rodden  
**W.PS.** Walter P. Siegmund  
**W.PW.** W. P. Wolf  
**W.R.** William Rostoker  
**W.Re.** Walter Reid  
**W.Ro.** Willard Roth  
**W.R.B.** William R. Boggess  
**W.R.Br.** Winslow R. Briggs  
**W.R.Bu.** William R. Burg  
**W.R.C.R.** W. R. C. Rowley  
**W.R.D.** William R. Dickinson  
**W.R.E.** William R. Engels  
**W.R.El.** Walther R. Ellis, Jr.  
**W.R.Ep.** W. R. Epperly  
**W.R.F.** Walter R. Fehr  
**W.R.Fr.** Walter R. Fried  
**W.R.J.** William R. Judd  
**W.R.L.** Werner R. Loewenstein  
**W.R.Lo.** Wayne R. Lowell  
**W.R.M.** William R. Marshall, Jr.



**W.R.Ma.** William R. Mann  
**W.R.N.** Walter R. Nagel  
**W.R.P.** William R. Philipson  
**W.R.R.** William R. Riedel  
**W.R.Se.** W. Rudolf Seitz  
**W.R.Si.** W. Rex Sittner  
**W.R.Sm.** William R. Smythe  
**W.R.V.** Wyman R. Vaughan  
**W.R.V.S.** W. Randall Van Schmus  
**W.R.W.** William R. Wilcox  
**W.S.** Wolfram Saenger  
**W.Scha.** William Schaeffner  
**W.Sh.** William Shive  
**W.Sp.** William Spackman  
**W.Stu.** Wilson Sturges  
**W.Sw.** William Swider  
**W.Swe.** Will Swearingen  
**W.S.Y.W.** William S.-Y. Wang  
**W.S.A.** Wendall S. Arbuckle  
**W.S.B.** William S. Benninghof  
**W.S.Ba.** W. Scott Baldrige  
**W.S.Br.** Willard S. Bromley  
**W.S.Cr.** William S. Cramer  
**W.S.J.** William S. Janna

**W.S.L.** W. S. Lyon  
**W.S.P.** Wilson S. Pritchett  
**W.T.** Wallace Tucker  
**W.T.K.** William T. Keeton  
**W.T.S.** William T. Stuart  
**W.V.R.** W. V. Robinson  
**W.W.** William West  
**W.W.B.** William W. Ballard  
**W.W.Be.** Wallace W. Beaver  
**W.W.Br.** William W. Bradley  
**W.W.Bro.** William W. Bromer  
**W.W.E.** W. W. Epstein  
**W.W.Ho.** William W. Howells  
**W.W.K.** William W. Korth  
**W.W.L.A.** Whitlow W. L. Au  
**W.W.M.** W. Wayne Meinke  
**W.W.Mi.** Ward W. Minkler  
**W.W.Mo.** W. W. Moyer  
**W.W.Sn.** William W. Snow  
**W.W.Sp.** Wesley W. Spink  
**W.W.W.** William W. Watson  
**W.W.We.** Wesley W. Wendlandt  
**W.Wo.** William Wolovich  
**W.Y.** Wayne Young

**W.Z.** William Zuk  
**W.Z.H.** William Z. Hassid  
**W.Z.S.** Wieslaw Z. Stepniewski  
**W.Zh.** Wei Zhao

## X, Y, Z

**X.J.M.** X. J. Musacchia  
**Y.C.F.** Y. C. Fung  
**Y.E.M.** Youssef El-Mansy  
**Y.H.M.** Yi Hua Ma  
**Y.I.** Yedy Israel  
**Y.M.G.** Y. M. Gupta  
**Y.O.** Yoshi Ogasawara  
**Y.S.** Yoichiro Suzuki  
**Y.W.** Y. Waisel  
**Y.W.K.** Yoke Wah Row  
**Z.C.M.** Za-Chieh Moh  
**Z.L.** Zhexi Luo  
**Z.R.W.** Zelda R. Wasserman  
**Z.S.** Zdenek Sekera



# Contributor Affiliations

The list below comprises an alphabetical sequence, according to surname, of all contributors to the Encyclopedia. A brief affiliation is provided for each author. This list may be used in conjunction with the previous section, Contributor Initials, to fully identify the contributor of each article.

## A

- Aagaard, Prof. Knut.** Department of Oceanography, University of Washington.
- Abbott, Dr. Donald P.** Professor of Biology, Hopkins Marine Station, Stanford University, Pacific Grove, California.
- Able, Dr. Kenneth P.** Department of Biological Sciences, State University of New York, Albany.
- Abraham, Dr. Bernard M.** Solid State Science Division, Argonne National Laboratory, Argonne, Illinois.
- Abrahams, David H.** Dexter Chemical Corporation, Bronx, New York.
- Abrahams, Prof. Elihu.** Department of Physics, Rutgers University.
- Abrahamson, Prof. Warren G., II.** Department of Biology, Bucknell University, Lewisburg, Pennsylvania.
- Abramovitch, Dr. Rudolph A.** Department of Chemistry and Geology, Clemson University.
- Abzug, Dr. Malcolm J.** Senior Staff Engineer, Systems Group, TRW, Inc., Redondo Beach, California.
- Achey, Prof. Phillip M.** Institute of Food and Agricultural Sciences, University of Florida.
- Ackerman, Dr. Edward A.** Deceased; formerly, Carnegie Institution of Washington.
- Adair, Dr. Robert K.** Department of Physics, Yale University.
- Adams, Dr. Chris.** Unilever Research, Merseyside, England.
- Adams, Prof. Douglas P.** Department of Mechanical Engineering, Massachusetts Institute of Technology.
- Adams, Dr. E. Dwight.** Department of Physics, University of Florida.
- Adams, Dr. Elijah.** Professor and Head, Department of Biological Chemistry, School of Medicine, University of Maryland.
- Adams, Prof. M. W.** Department of Crop and Soil Sciences, Michigan State University.
- Adams, Dr. Raymond D.** Bullard Professor Emeritus of Neuropathology, Massachusetts General Hospital.
- Adamson, Prof. Arthur W.** Department of Chemistry, University of Southern California.
- Addicott, Prof. Fredrick T.** Department of Botany, University of California, Davis.
- Addison, Cyril C.** Professor of Inorganic Chemistry, University of Nottingham, England.
- Adelberg, Dr. Edward A.** Department of Microbiology, Yale University.
- Adelman, Dr. William J., Jr.** National Institutes of Health, Bethesda, Maryland.
- Ader, Prof. Robert.** Department of Psychiatry, University of Rochester, New York.
- Adewumi, Prof. Michael A.** Petroleum and Natural Gas Engineering, Pennsylvania State University.
- Adkins, George G.** Retired; formerly, Chief, Department of River Basins, Bureau of Power, Federal Power Commission.
- Adler, Dr. David.** Department of Electrical Engineering, Massachusetts Institute of Technology.
- Adler, Dr. Ronald J.** Lockheed Palo Alto Research Laboratories, Palo Alto, California.
- Adrain, Dr. Jonathan.** University of Iowa, Department of Geosciences, Iowa City.
- Agarwal, Dr. Gyan C.** Department of Electrical Engineering, University of Illinois.
- Agrios, Dr. George N.** Department of Plant Pathology, University of Massachusetts.
- Aguiar, Jose L.** Farm Advisor, University of California Cooperative Extension, Riverside County, Indio.
- Ahearn, Prof. Gregory A.** Department of Zoology, University of Hawaii, Manoa.
- Ahlstrom, Dr. Elbert H.** Deceased; formerly, Fishery Oceanography Center, U.S. Bureau of Commercial Fisheries, La Jolla, California.
- Ahmadjian, Dr. Vernon.** Department of Biology, Clark University, Worcester, Massachusetts.
- Ahuja, Prof. Narendra.** Department of Electrical and Computer Engineering, Beckman Institute and Coordinated Science Laboratory, University of Illinois, Urbana.
- Ajmone-Marsan, Dr. Cosimo.** Chief, Branch of Electroencephalography and Clinical Neurophysiology, National Institute of Neurological Diseases and Stroke, National Institutes of Health, Bethesda, Maryland.
- Ajzenberg-Selove, Prof. Fay.** Physics Department, University of Pennsylvania.
- Akasofu, S.-I.** Director, International Arctic Research Center, University of Alaska, Fairbanks.
- Akers, Dr. Donald L.** School of Medicine, Tulane University.
- Akesson, Dr. Norman G.** Agricultural Engineering Department, University of California, Davis.
- Albert, Dr. Henry J.** Manager, Physics and Metallurgy Laboratory, Research and Development Department, Engelhard Industries Division, Engelhard Minerals and Chemicals Corporation, Newark, New Jersey.
- Albright, Dr. Louis D.** Department of Agricultural and Biological Engineering, Cornell University, Ithaca, New York.
- Albright, Dr. Lyle F.** Department of Chemical Engineering, Purdue University.
- Alcorn, Prof. Stanley M.** Department of Plant Pathology, College of Agriculture, University of Arizona.
- Aldridge, Dr. R. J.** Department of Geology, University of Nottingham, England.
- Aldwinckle, Prof. H. S.** Department of Plant Pathology, Cornell University.
- Alexander, Dr. Gene.** Laboratory of Neurosciences, National Institutes of Aging and Health, Bethesda, Maryland.
- Alexander, Prof. R. McNeill.** Department of Biology, University of Leeds, England.
- Alexander, Dr. Vera.** Institute of Marine Science, University of Alaska.
- Alexeff, Prof. Igor.** Department of Electrical and Computer Engineering, University of Tennessee, Knoxville.
- Alger, Prof. Philip L.** Deceased; formerly, Consulting Professor of Electrical Engineering, Rensselaer Polytechnic Institute.
- Algermissen, Dr. S. T.** Aurora, Colorado.
- Allan, Roger.** Executive Editor, "Electronic Design Magazine," Rochelle Park, New Jersey.
- Allan, William.** Dean (retired), School of Engineering, City College of the City University of New York.

- Allredge, Alice L.** Department of Biological Sciences, University of California, Santa Barbara.
- Allen, Dr. John A.** U.M.B.S.M., Marine Station, Isle of Cumbrae, Scotland.
- Allen, Prof. Lawrence H.** Department of Astronomy, University of California, Los Angeles.
- Allen, Prof. Leland C.** Department of Chemistry, Princeton University.
- Allen, Prof. Phillip E.** School of Electrical and Computer Engineering, Georgia Institute of Technology, Atlanta.
- Allenby, Dr. Braden R.** Vice President, AT&T Environment, Health and Safety, Basking Ridge, New Jersey.
- Alley, Prof. Charles L.** Department of Electrical Engineering, University of Utah.
- Allfrey, Dr. Vincent G.** Department of Cell Biology, Rockefeller University.
- Allport, H. Burnham.** Union Carbide Chemical Company, Cleveland, Ohio.
- Allred, Dr. Albert L.** Department of Chemistry, Northwestern University.
- Almgren, Dr. Frederick J., Jr.** Department of Mathematics, Princeton University.
- Almond, Dr. Peter R.** Department of Biophysics, University of Texas, Houston.
- Aloia, Dr. John F.** Department of Medicine, Winthrop-University Hospital, Mineola, New York.
- Alpern, Milton.** Manager, Special Projects Division, Shah Associates, P.C., Bellmore, New York.
- Altaian, Dr. David.** Division Vice President and Technical Director, United Technology Center, Sunnyvale, California.
- Altamuro, Vincent M.** President, Robotics Research, Division of VMA, Inc., Toms River, New Jersey.
- Altrock, Dr. Richard C.** National Optical Astronomy Observatories, National Solar Observatory/Sacramento Peak, Sunspot, New Mexico.
- Alvim, Dr. Paulo dc T.** Centre de Pesquisas Do Cacau (CEPEC), Itabuna, Bahia, Brazil.
- Alvord, Dr. Ellsworth C., Jr.** Department of Neuropathology, University of Washington.
- Ammons, Dr. Nelle.** Retired; Department of Biology, West Virginia University.
- Amsden, Dr. Thomas W.** Geologist, Oklahoma Geological Survey, Norman.
- Anagnostakis, Dr. Sandra L.** Department of Pathology & Ecology, Connecticut Agriculture Experimental Station, New Haven.
- Anders, James E., Sr.** President, Hydraulics Associates, Bethlehem, Pennsylvania.
- Andersen, Prof. David R.** Department of Electrical and Computer Engineering, University of Iowa, Iowa City.
- Anderson, Prof. Alan P.** Department of Electronic and Electrical Engineering, University of Sheffield, England.
- Anderson, Dr. Alfred T., Jr.** Department of Geophysical Sciences, University of Chicago.
- Anderson, Prof. Dana Z.** Joint Institute for Laboratory Astrophysics, University of Colorado.
- Anderson, Harry R.** H. R. Anderson and Associates, Inc., Consulting Engineers, Eugene, Oregon.
- Anderson, Jr., Dr. John D.** Jet Propulsion Laboratory, California Institute of Technology.
- Anderson, Dr. O. Roger.** Lamont-Doherty Geological Observatory, Palisades, New York.
- Anderson, Dr. Paul M.** Department of Electrical and Computer Engineering, Arizona State University.
- Anderson, Prof. Richard G. W.** Department of Cell Biology and Neuroscience, University of Texas Southwestern Medical Center, Dallas.
- Andors, Dr. Allison V.** Department of Ornithology, American Museum of Natural History, New York.
- Andreasen, Dr. Christian.** Bureau Hydrographique International, Monaco.
- Andrew, Dr. Warren.** Chairman, Department of Anatomy, School of Medicine, Indiana University.
- Andrews, Dr. Lester.** Department of Chemistry, University of Virginia.
- Andrews, Dr. Peter.** Department of Palaeontology, British Museum (Natural History), London.
- Andriole, Dr. Stephen J.** Department of Information Systems and Systems Engineering, George Mason University, Fairfax, Virginia.
- Andrus, Dr. C. F.** Agricultural Consultant; formerly, U.S. Department of Agriculture, Charleston, South Carolina.
- Angelakos, Dr. Diogenes J.** Deceased; formerly, College of Engineering, University of California, Berkeley.
- Anglin, Donald L.** Consultant, Automotive and Technical Writing, Charlottesville, Virginia.
- Angrisano, Rear Admiral Guisepp.** Bureau Hydrographique International, Monaco.
- Angus, James W.** Staff Engineer, Avionics Division, Kollsman Instrument Corporation, Elmhurst, New York.
- Ancombe, Prof. Francis J.** Department of Statistics, Yale University.
- Anthes, Prof. Richard A.** Department of Meteorology, College of Earth and Mineral Sciences, Pennsylvania State University.
- Antoni, Dr. Charles M.** Department of Civil Engineering, Syracuse University.
- Anwyl, Robert D.** Retired; formerly, Photographic Consultant, Eastman Kodak Company, Rochester, New York.
- Apfel, Prof. Robert E.** Department of Engineering and Applied Science, Yale University.
- Apker, Dr. L.** General Electric Research Laboratory, Schenectady, New York.
- Appel, Dr. Max J. G.** James A. Baker Institute for Animal Health, Cornell University, Ithaca, New York.
- Appenzeller, Dr. Otto.** Department of Neurology, University of New Mexico School of Medicine.
- Appleby, Dr. Anthony J.** Center for Electrochemical Systems and Hydrogen Research, Texas Engineering Experiment Station, Texas A & M University System.
- Appleby, Dr. Arnold P.** Professor Emeritus of Crop Science, Oregon State University, Corvallis.
- Applegate, Charles E.** Consulting Engineer, Weston, Maryland.
- Applequist, Dr. Thomas.** Sloane Laboratory, Department of Physics, Yale University.
- Arbuckle, P. Douglas.** NASA, Langley Research Center, Hampton, Virginia.
- Arbuckle, Earl F., III.** Engineering Supervisor, WPIX, Inc., New York, New York.
- Arbuckle, Prof. Wendell S.** Deceased; formerly, Department of Dairy Science, University of Maryland.
- Archer, Mary D.** Grantchester, Cambridge, United Kingdom.
- Archibald, Dr. J. David.** Department of Biology, San Diego State University, San Diego, California.
- Ardema, Dr. Mark D.** Research Scientist, National Aeronautics and Space Administration, Ames Research Center, Moffett Field, California.
- Arey, Prof. Leslie B.** Professor Emeritus of Anatomy, Northwestern University.
- Armstrong, Dr. Richard L.** Institute of Arctic and Alpine Research, University of Colorado.
- Arndt, Dr. Kenneth A.** Department of Dermatology, Beth Israel Hospital, Boston, Massachusetts.
- Arney, Cyril.** Engineering & Technology, Marathon Oil Company, Houston, Texas.
- Arnold, Dr. Chester A.** Professor of Botany and Geology and Curator of Paleobotany, University of Michigan.
- Arnstein, Dr. Karl.** Vice President in Charge of Engineering (retired), Goodyear Aircraft Corporation, Akron, Ohio.
- Aron, Dr. Walter.** Consultant, Menlo Park, California.
- Arthur, Dr. Michael A.** Graduate School of Oceanography, University of Rhode Island.
- Ashton, Dr. Mark S.** Yale School of Forestry and Environmental Studies, New Haven, Connecticut.
- Asik, Dr. Joseph R.** Scientific Research Laboratories, Ford Motor Company, Dearborn, Michigan.
- Askey, Dr. Richard.** Mathematics Research Center, University of Wisconsin.
- Aspnes, Dr. David E.** Department of Physics, North Carolina State University, Raleigh.
- Aston, Dr. James.** Deceased; formerly, Consulting Metallurgist, A. M. Beyers Company.
- Astrom, Prof. Karl J.** Department of Automatic Control, Lund Institute of Technology, Lund, Sweden.

**Athenstaedt, Dr. Herbert.** Director, Institut für Molekular-Physikalische Physiologie, Hanover, Germany.

**Atkins, Dr. Elisha.** School of Medicine, Yale University.

**Atkins, Dr. P. W.** Department of Chemistry, Oxford University, England.

**Atlas, Dr. Ronald M.** Department of Biology, University of Louisville, Kentucky.

**Atoda, Dr. Kenji.** Professor of Zoology, Tohoku University, Sendai, Japan.

**Atwood, Dr. Ronald L.** Foote Mineral Company, Kings Mountain, North Carolina.

**Au, Dr. Whitlow W. L.** Marine Mammal Research Program, Hawaii Institute of Marine Biology, Kailua.

**Audus, Dr. Leslie J.** Professor of Botany (retired), Bedford College, University of London, England.

**Austrian, Dr. Robert.** Department of Research Medicine, School of Medicine, University of Pennsylvania.

**Averbach, Prof. Benjamin L.** Department of Materials Science and Engineering, Massachusetts Institute of Technology.

**Axley, Milton J.** Department of Health and Human Services, National Heart, Lung and Blood Institute, Bethesda, Maryland.

**Ayers, Arthur R.** Assistant Professor, Cellular and Development Biology, Harvard University.

**Ayers, Dr. Walter B.** Bureau of Economic Geology, University of Texas, Austin.

**Azarnoff, Dr. Daniel L.** President, Searle Research and Development, G. D. Searle & Co., Skokie, Illinois.

## B

**Bachinski, Dr. Sharon W.** Department of Geology, University of New Brunswick, Fredericton, Canada.

**Back, Dr. Thomas G.** Department of Chemistry, Faculty of Science, University of Calgary, Alberta, Canada.

**Backer, Dr. Donald C.** Department of Astronomy, University of California.

**Backstrom, Prof. Gunnar.** Institute of Physics, University of Umea, Sweden.

**Bada, Dr. Jeffrey L.** Scripps Institution of Oceanography, University of California, San Diego-La Jolla.

**Badgley, Dr. Peter C.** Earth Science Division, Office of the Naval Reserve, Arlington, Virginia.

**Baer, Prof. Charles J.** Department of Mechanical Engineering, University of Kansas.

**Baer, Dr. Donald R.** Jackson Laboratory, Organic Chemical Department, E. I. du Pont de Nemours and Company, Wilmington, Delaware.

**Baer, Dr. Norbert S.** Conservation Center of the Institute of Fine Arts, New York University.

**Bagley, Dr. Brian G.** Bell Laboratories, Murray Hill, New Jersey.

**Bagnall, Dr. Kenneth W.** Research Chemist, Atomic Energy Research Establishment, Harwell, England.

**Bahcall, Dr. John N.** Institute for Advanced Studies, Princeton, New Jersey.

**Bahr, Dr. Janice M.** Professor of Animal Science and Physiology, Department of Animal Sciences, College of Agriculture, University of Illinois, Urbana-Champaign.

**Bai, Dr. Er-Wei.** Department of Electrical & Computer Engineering, University of Iowa, Iowa City.

**Bailar, Prof. John C., Jr.** Deceased; formerly, School of Chemical Sciences, University of Illinois, Urbana-Champaign.

**Bailey, Prof. A. Earle.** Department of Electrical Engineering, University of Southampton, England.

**Bailey, Prof. A. G.** Department of Electrical Engineering, University of Southampton, England.

**Bailey, Prof. Catherine H.** Department of Horticulture, Rutgers University.

**Bailey, Frederick G.** Large Steam Turbine-Generator Department, General Electric Company, Schenectady, New York.

**Bailey, Prof. Milton E.** Department of Food Science and Nutrition, College of Agriculture, University of Missouri-Columbia.

**Bailey, Dr. Reeve M.** Deceased; formerly, Curator of Fishes, Museum of Zoology, University of Michigan.

**Bailey, Dr. S. W.** Department of Geology, University of Wisconsin.

**Baker, Edward W.** Entomology Research Division, Agricultural Research Service, U.S. Department of Agriculture.

**Baker, Dr. Paul A.** Department of Geology, Duke University.

**Baker, Dr. M. Pauline.** National Center for Supercomputing Applications, University of Illinois, Urbana.

**Baker, Dr. Victor R.** Department of Geosciences, University of Arizona.

**Bakken, Prof. George S.** Center Director, Center for Biodiversity Studies, Indiana State University, Terre Haute.

**Balakrishnan, Dr. V. K.** Department of Mathematics, University of Maine.

**Balch, Dr. Alan L.** Department of Chemistry, University of California, Davis.

**Balderes, Dr. T.** Engineering Specialist, Grumman Aerospace Corporation, Bethpage, New York.

**Baldi, Dr. Bruce G.** Plant Hormone Laboratory, U.S. Department of Agriculture, Beltsville, Maryland.

**Baldrige, Dr. W. Scott.** Earth and Space Science Division, Los Alamos National Laboratory.

**Baldwin, Harry L., Jr.** Department of Mathematics, San Diego City College, San Diego, California.

**Bales, Robert A.** Center for Advanced Aviation Development, MITRE Corporation, McLean, Virginia.

**Balick, Prof. Bruce.** Department of Astronomy, University of Washington, Seattle.

**Baliga, Prof. B. Jayant.** Department of Electrical and Computer Engineering, North Carolina State University.

**Ball, Dr. John E. D.** Telecommunications Consultant, Vienna, Virginia.

**Ballard, Prof. William W.** Department of Biological Sciences, Dartmouth College.

**Ballou, Prof. Clinton E.** Department of Molecular and Cell Biology, University of California, Berkeley.

**Bally, Dr. John.** Center of Astrophysics and Space Astronomy, University of Colorado, Boulder.

**Baltay, Dr. Charles.** Department of Physics, Yale University.

**Balzani, Prof. Vincenzo.** Dipartimento de Chimica, Università di Bologna, Italy.

**Bambach, Dr. Richard A.** Department of Geological Sciences, Virginia Polytechnic Institute.

**Bamburg, Prof. James R.** Department of Biochemistry, Colorado State University.

**Banerjee, Dr. Pat.** Associate Professor, Mechanical Engineering, University of Illinois, Chicago.

**Banks, Dr. Harlan P.** Emeritus Professor of Botany, Division of Biological Sciences, Cornell University.

**Banks, Prof. William P.** Chairperson, Department of Psychology, Pomona College, Claremont, California.

**Banner, Dr. Donald W.** Banner, Birch, McKie and Beckett, Washington, D.C.

**Bar-Sela, Dr. Shlomo.** Department of Medicine, Allergy-Immunology Section, Medical College of Wisconsin.

**Barash, Prof. David P.** Department of Psychology, University of Washington, Seattle.

**Barber, Dr. Richard T.** Duke University Marine Laboratory.

**Barbosa, Dr. Pedro.** Department of Entomology, College of Life Sciences, University of Maryland.

**Barbour, Dr. Neil.** Charles Stark Draper Laboratory, Inc., Cambridge, Massachusetts.

**Barclay, Dr. Harriet G.** Professor of Botany, Department of Life Sciences, University of Tulsa.

**Bard, Dr. Allen J.** Department of Chemistry, College of Natural Sciences, University of Texas, Austin.

**Bardsley, Dr. James Norman.** Lawrence Livermore National Laboratory, University of California.

**Barer, Prof. Robert.** Department of Human Biology and Anatomy, University of Sheffield, England.

**Bargellini, Dr. Pier L.** Retired; formerly, COMSAT Laboratories, Clarksburg, Maryland.

**Barger, Prof. Vernon D.** Department of Physics, University of Wisconsin, Madison.

**Barghoorn, Prof. Elso S.** Department of Biology and Botanical Museum, Harvard University.

- Barkalow, Dr. David G.** Department of Biochemistry, Purdue University.
- Barker, Prof. Daniel S.** Department of Geological Sciences, University of Texas, Austin.
- Barker, Dr. Fred.** Geological Survey, U.S. Department of the Interior, Denver, Colorado.
- Barker, Dr. Horace A.** Department of Biochemistry, University of California, Berkeley.
- Barker, Dr. Joseph W.** Chairman of the Board (retired), Research Corporation, New York, New York.
- Barker, Dr. R. W. J.** Department of Electrical and Electronic Engineering, Trent Polytechnic, Peterborough, Ontario, Canada.
- Barkley, Prof. T. M.** Division of Biology, Kansas State University.
- Barksdale, Dr. Lane.** Department of Microbiology, School of Medicine, New York University Medical Center.
- Barnard, Dr. J. Laurens.** Curator of Crustacea, Smithsonian Institution.
- Barnes, Dr. Robert K.** Research and Development Department, Chemicals and Plastics Operations Division, Union Carbide Corporation, South Charleston, West Virginia.
- Barnes, Dr. Ted.** Physics Division, Oak Ridge National Laboratory, Oak Ridge, Tennessee.
- Barnes, Ivan.** Water Resources Division, Geological Survey, U.S. Department of the Interior, Menlo Park, California.
- Barnett, Peter D.** Forensic Science Associates, Richmond, California.
- Barnitz, Edward S.** Consultant in Vacuum Engineering, Rochester, New York.
- Barr, Dr. David.** Department of Entomology, Royal Ontario Museum, Toronto, Ontario, Canada.
- Barr, Dr. Donald J. S.** Principal Research Scientist, Centre for Land and Biological Resources Research, Ottawa, Ontario, Canada.
- Barrett, Dr. A. G. M.** Department of Chemistry, Northwestern University.
- Barron, Prof. Eric.** Director, Earth System Science Center, Pennsylvania State University, University Park.
- Barronet, Dr. Alain.** Centre de Recherche sur les Mécanismes de la Croissance Cristalline, Marseille, France.
- Barry, Brother B. Austin.** Civil Engineering Department, Manhattan College.
- Barry, Dr. Michelle M.** Department of Medical Microbiology and Immunology, University of Alberta, Edmonton, Canada.
- Bars, Dr. Itzhak.** Department of Physics, Yale University.
- Barth, Prof. T. F. W.** Deceased; formerly, Geologic Museum, Oslo.
- Bartlett, Prof. Robert W.** Dean, College of Mines, University of Idaho, Moscow.
- Barton, Dr. Jennifer Kehlet.** Biomedical Engineering Program, University of Arizona, Tucson.
- Barton, Dr. Mark D.** Department of Earth and Space Sciences, University of California, Los Angeles.
- Barton, Richard L.** National Aeronautics and Space Administration, Lyndon B. Johnson Space Center, Houston, Texas.
- Bash, Dr. Jack.** University–National Oceanographic System Office, University of Rhode Island, Saunderstown.
- Basolo, Prof. Fred.** Department of Chemistry, Northwestern University.
- Bass, Prof. Henry E.** National Center for Physical Acoustics, University of Mississippi.
- Bass, Prof. Jack.** Department of Physics and Astronomy, Michigan State University.
- Bassett, Dr. C. Andrew L.** Department of Orthopaedic Surgery, Bioelectric Research Center, Columbia University, Riverdale.
- Bates, Dr. Robert L.** Department of Geology, Ohio State University.
- Battles, Byron W.** The Battles Group, LLC, Silver Spring, Maryland.
- Bauer, Prof. E.** Department of Physics, Arizona State University, Tempe.
- Bauer, Dr. Simon H.** Department of Chemistry, Cornell University.
- Baumeister, Prof. Theodore.** Deceased; formerly, Consulting Engineer; Stevens Professor of Mechanical Engineering, Emeritus, Columbia University; Editor in Chief, "Standard Handbook for Mechanical Engineers."
- Baumgarten, Dr. Alexander.** Department of Laboratory Medicine, School of Medicine, Yale University.
- Baumiller, Dr. Tomasz.** Department of Geological Sciences, University of Michigan, Ann Arbor.
- Baver, Prof. Leonard D.** Retired; formerly, Agronomy Department, Ohio State University.
- Bayfield, Dr. James E.** Department of Physics, University of Pittsburgh.
- Beall, Christine.** Consulting Architect, Columbus, Texas.
- Beam, Dr. Charles F.** Department of Chemistry, College of Charleston, South Carolina.
- Beams, Dr. Jesse.** Deceased; formerly, Department of Physics, University of Virginia.
- Bean, Howard S.** Deceased; formerly, Consultant on Fluid Metering, Liquids and Gases, Sedona, Arizona.
- Beard, Dr. Benjamin H.** Agronomy and Range Science Extension, University of California, Davis.
- Beatty, J. Kelly.** Consultant, Chelmsford, Massachusetts.
- Beaty, H. Wayne.** Consultant, Fairfax, Virginia.
- Beaumont, Robert T.** Director of Meteorological Operations, E. G. G., Inc., Boulder, Colorado.
- Beaumont, Prof. Ross A.** Department of Mathematics, University of Washington.
- Beaver, Dr. Wallace W.** Deceased; formerly, Director of Research and Development, Brush Beryllium Company, Cleveland, Ohio.
- Beck, Dr. Charles B.** Professor of Botany, University of Michigan.
- Beck, Prof. Curt W.** Department of Chemistry, Amber Research Laboratory, Vassar College, Poughkeepsie, New York.
- Beck, James.** Boeing Defense and Space Group, Rocketdyne Division, Boeing North American Inc., Canoga Park, California.
- Beck, Karl M.** Abbott Laboratories, North Chicago, Illinois.
- Becken, Eugene D.** Vice President, Operations, RCA Global Communications, Inc., New York.
- Becker, Dr. Elery R.** Deceased; formerly, Division of Life Sciences, Arizona State University.
- Becker, Dr. Henry A.** Department of Chemical Engineering, Queen's University, Kingston, Ontario, Canada.
- Becker, Dr. Philippe.** AT&T Bell Laboratories, Murray Hill, New Jersey.
- Bederson, Dr. Benjamin.** Department of Physics, New York University.
- Beer, Dr. Steven V.** Department of Plant Pathology, College of Agriculture and Life Sciences, Cornell University.
- Belfit, Dr. Robert W.** Manager, Quality Standards, Quality Assurance Department, Dow Chemical Company, Midland, Michigan.
- Bell, Morton A.** American Air Filter Company, Inc., New York.
- Bell, Prof. Norman R.** Department of Electrical Engineering, North Carolina State University.
- Bell, Robin E.** Lamont-Doherty Geological Observatory of Columbia University, Palisades, New York.
- Bell, Dr. William E.** Department of Pediatrics, University of Iowa.
- Belrose, Dr. John S.** Communications Research Centre, Department of Communications, Ottawa, Ontario, Canada.
- BeMiller, Prof. James N.** Director, Whistler Center for Carbohydrate Research, Purdue University.
- Bemis, Dr. David A.** Director, Clinical Bacteriology and Mycology Services, University of Tennessee, Knoxville.
- Bender, Prof. Myron L.** Department of Chemistry, Northwestern University.
- Bender, Prof. Paul J.** Professor of Physical Chemistry, University of Wisconsin.
- Benedict, Dr. Manson.** Institute Professor Emeritus, Department of Nuclear Engineering, Massachusetts Institute of Technology.
- Bengston, Dr. Stefan.** Senior Curator (Invertebrate Fossils), Swedish Museum of Natural History, Department of Palaeozoology, Stockholm, Sweden.
- Benito, Dr. Jesús.** Department of Animal Biology I—Zoology of Invertebrates, University Complutense, Madrid, Spain.
- Benner, Dr. Frank C.** Assistant Director, Research and Development Department, Norton Company, Worcester, Maine.

- Bennett, Prof. Albert F.** Department of Ecology and Evolutionary Biology, University of California, Irvine.
- Bennett, Dr. H. Stanley.** Department of Molecular, Cellular and Developmental Biology, University of Colorado.
- Bennett, Prof. Joan W.** Department of Cell and Molecular Biology, Tulane University, New Orleans, Louisiana.
- Bennett, Dr. M. B.** Senior Lecturer, Anatomical Sciences, University of Queensland, Brisbane, Australia.
- Bennett, Prof. Michael V. L.** Department of Neuroscience, Albert Einstein College of Medicine, New York.
- Bennett, Dr. Orus L.** Vice President, GRC Panels Unlimited, Leeds, Alabama.
- Benninghoff, Dr. William S.** Department of Botany, University of Michigan.
- Benny, Dr. Gerald L.** Department of Plant Pathology, University of Florida, Gainesville.
- Benson, Prof. Frank A.** Department of Electronic and Electrical Engineering, University of Sheffield, England.
- Bent, Prof. Brian E.** Department of Chemistry, Columbia University, New York.
- Beranek, Dr. Leo L.** Chief Scientist (retired), Bolt Beranek and Newman, Inc., Cambridge, Massachusetts.
- Beresford, Dr. William A.** Department of Anatomy, West Virginia University.
- Berg, Dr. Clyde.** Clyde Berg and Associates, Long Beach, California.
- Berger, Dr. France B.** Kearfott Division, The Singer Company, Little Falls, New Jersey.
- Berger, Harold.** Industrial Quality, Inc., Gaithersburg, Maryland.
- Berger, Dr. Richard D.** Department of Plant Pathology, University of Florida.
- Berger, Prof. Wolfgang H.** Geological Research Division, Scripps Institution of Oceanography, La Jolla, California.
- Bergren, Dr. W. A.** Woods Hole Oceanographic Institution, Woods Hole, Massachusetts.
- Bergh, Dr. Berthold O.** Department of Plant Sciences, University of California, Riverside.
- Berglund, Neil.** Manager of Technology Development, Intel Corporation, Aloha, Oregon.
- Bergmann, Prof. Peter G.** Department of Physics, Syracuse University.
- Berkowitz, Dr. Gerald A.** Institute for Photobiology of Cells and Organelles, Brandeis University.
- Bernard, Dr. E. N.** National Oceanic and Atmospheric Administration, Pacific Marine Environmental Laboratory, Seattle, Washington.
- Berner, Dr. Elizabeth K.** Department of Geology and Geophysics, Yale University.
- Berner, Prof. Lewis.** Acting Director, Division of Biological Sciences, University of Florida.
- Berner, Dr. Robert A.** Department of Geology and Geophysics, Yale University.
- Bernson, Dr. Laurence.** Environmental Management Department, AT&T Bell Laboratories, Murray Hill, New Jersey.
- Bernstein, Dr. I. M.** Department of Metallurgy and Materials Science, Carnegie-Mellon University.
- Bernstein, Dr. Robert I.** Professor of Electrical Engineering and Associate Director, Electronics Research Laboratories, Columbia University.
- Berry, Dr. Spencer J.** Department of Biology, Wesleyan University.
- Berry, Dr. William B. N.** Museum of Paleontology, University of California, Berkeley.
- Bertsch, Dr. George F.** Department of Physics, Michigan State University.
- Bethe, Prof. Hans A.** Floyd R. Newman Laboratory of Nuclear Studies, Cornell University.
- Betts, Dr. Russell.** Argonne National Laboratory, Argonne, Illinois.
- Beutler, Dr. Bruce.** Howard Hughes Medical Institute, University of Texas, Dallas.
- Bever, Prof. Michael B.** Department of Materials Science and Engineering, Massachusetts Institute of Technology.
- Bewley, Dr. Loyal V.** Dean (retired), College of Engineering, Lehigh University.
- Beyer, Dr. Ann L.** Department of Microbiology, University of Virginia.
- Bichsel, Dr. Hans.** Department of Radiology, University of Washington.
- Bicknell, Prof. Joseph.** Department of Aeronautics and Astronautics, Massachusetts Institute of Technology.
- Biederman, Dr. Joseph.** Pediatric Psychopharmacological Unit, Massachusetts General Hospital, Boston.
- Biegel, Prof. John E.** Department of Engineering, University of Central Florida.
- Bieler, David B.** Department of Geology and Geophysics, Centenary College of Louisiana, Shreveport.
- Bienenstock, Dr. Arthur.** Professor of Applied Physics, Stanford University; Director, Stanford Synchrotron Radiation Laboratory.
- Biermann, Dr. Christopher.** Department of Forest Products, Forest Research Laboratory, Oregon State University, Corvallis.
- Bigeleisen, Prof. Jacob.** Department of Chemistry, University of Rochester.
- Bignami, Prof. Giovanni F.** Istituto per Ricerche in Fisica Cosmica e Tecnologie Relative, Milan, Italy.
- Billet, Prof. Michael.** Head, Fluid Dynamics Department, Applied Research Laboratory, Pennsylvania State University, State College.
- Billig, Dr. Frederick S.** Applied Physics Laboratory, Johns Hopkins University, Laurel, Maryland.
- Billingham, Dr. Rupert E.** Department of Biology, University of Texas Health and Science Center, Dallas.
- Billings, Dr. Bruce H.** Special Assistant to the Ambassador of Science and Technology, Embassy of the United States of America, Taipei.
- Billington, Dr. Douglas S.** Senior Staff Advisor for Materials Science, Metals and Ceramics Division, Oak Ridge National Laboratory, Oak Ridge, Tennessee.
- Bing, Prof. R. H.** Department of Mathematics, University of Wisconsin.
- Bingham, Prof. Carol.** Department of Physics, University of Tennessee, Knoxville.
- Bingham, Dr. Richard.** Department of Chemistry, Princeton University.
- Bird, Dr. Thomas D.** University of Washington, School of Medicine, Seattle.
- Birkenheuer, Dr. Daniel L.** Lakewood, Colorado.
- Birkhoff, Prof. Garrett.** Department of Mathematics, Harvard University.
- Birks, Dr. L. S.** Retired; formerly, Radiation Technology Division, Naval Research Laboratory, Washington, D.C.
- Biscaye, Dr. Pierre E.** Lamont-Doherty Geological Observatory, Palisades, New York.
- Bisno, Dr. A. L.** Veterans Administration Medical Center, Miami, Florida.
- Bisplinghoff, Raymond L.** Dean, School of Engineering, Massachusetts Institute of Technology.
- Black, Dr. Harold S.** Communications Consultant, Summit, New Jersey.
- Black, Prof. Paul H.** Department of Mechanical Engineering, Ohio University.
- Black, Dr. Robert F.** Department of Geology, University of Connecticut.
- Blackburn, J. Lewis.** Consulting Engineer, Bothell, Washington.
- Blackwell, Dr. Meredith.** Department of Plant Biology, Louisiana State University, Baton Rouge.
- Blad, Dr. Blaine L.** Agricultural Meteorology Section, University of Nebraska.
- Blades, Dr. Brooke.** Department of Anthropology, University of Maryland, College Park.
- Blain, Dr. Andrew.** Institute of Astronomy, Cambridge, United Kingdom.
- Blake, Dr. Daniel B.** Department of Geology, University of Illinois, Urbana.
- Blandford, Prof. Roger D.** Department of Theoretical Astrophysics, California Institute of Technology, Pasadena.
- Blankenship, Dr. James E.** Department of Physiology and Biophysics, Marine Biomedical Institute, University of Texas, Galveston.
- Blanton, J. W.** General Manager, Advanced Component Technology Department, General Electric Company, Cincinnati, Ohio.
- Blaser, Prof. H. Weston.** Department of Botany, University of Washington.
- Blass, Dr. Elliott M.** Department of Psychology, Johns Hopkins University.
- Blatt, Prof. Frank J.** Department of Physics, Michigan State University.
- Blatt, Dr. Harvey.** Hebrew University of Jerusalem, Givat Ram, Jerusalem, Israel.

- Bleiweis, John J.** Consultant, Great Falls, Virginia.
- Blencoe, Dr. James G.** Chemistry Division, Oak Ridge National Laboratory.
- Blitz, Dr. Leo.** Laboratory for Millimeter-Wave Astronomy, University of Maryland.
- Blobel, Dr. Günter B.** Department of Cell Biology, Rockefeller University, New York; Nobelist.
- Bloch, Dr. Spencer J.** Department of Mathematics, University of Chicago.
- Block, Dr. Ira.** Department of Textiles-Consumer Economics, University of Maryland.
- Bloomfield, Prof. Philip E.** Department of Physics, University of Pennsylvania; City College of the City University of New York, Bloomfield.
- Blough, Prof. Donald S.** Department of Psychology, Brown University.
- Blouin, Dr. Edmour F.** College of Veterinary Medicine, Oklahoma State University, Stillwater.
- Bluestein, Prof. Howard B.** Department of Meteorology, University of Oklahoma.
- Blumenthal, Prof. Leonard M.** Deceased; formerly, Defoe Distinguished Professor of Mathematics, University of Missouri.
- Blumenthal, Warren B.** Blumenthal-Zirconium, North Tonawanda, New York.
- Boast, Dr. Warren B.** Anson Marston Distinguished Professor Emeritus of Electrical Engineering, Iowa State University.
- Bobart, George F.** Manager, Induction Heating and Ultrasonic Cleaning Department, Westinghouse Electric Corporation, Sykesville, Maryland.
- Bobbitt, Dr. James M.** Department of Chemistry, University of Connecticut.
- Bochner, Dr. Salomon.** Deceased; formerly, Department of Mathematics, Rice University.
- Bock, Dr. Walter J.** Professor of Evolutionary Biology, Department of Biological Sciences, Columbia University.
- Bocko, Dr. Mark F.** Department of Physics and Astronomy, College of Arts and Science, University of Rochester.
- Boell, Dr. Edgar J.** Department of Biology, Yale University.
- Boero, Dr. Ferdinando.** Professor of Zoology, Università di Lecce, Dipartimento di Biologia, Stazione di Biologia Marina, Lecce, Italy.
- Boggs, Dr. Paul T.** Computational Sciences and Mathematics Research Department, Sandia National Laboratories, Livermore, California.
- Bogucki, Dr. Peter.** Department of Anthropology, Princeton University, Princeton, New Jersey.
- Bohach, Dr. Greg.** Department of Microbiology, Molecular Biology, and Biochemistry, University of Idaho, Moscow.
- Bohme, Prof. M.** Department of Chemistry, Friedrich-Wilhelms University, Germany.
- Boke, Dr. Norman H.** George Lynn Cross Research Professor of Botany, University of Oklahoma.
- Boles, Prof. James R.** Department of Geological Sciences, University of California, Santa Barbara.
- Bolin, Dr. Steven R.** Research Leader, Virolgy Cattle Research, Agricultural Research Service, U.S. Department of Agriculture, Ames, Iowa.
- Bolt, Prof. J. A.** Department of Mechanical Engineering, University of Michigan.
- Bond, Dr. Gerard.** Lamont-Doherty Geological Observatory, Palisades, New York.
- Bondybey, Dr. Vladimir E.** Bell Laboratories, Murray Hill, New Jersey.
- Bonner, Dr. Walter D., Jr.** Department of Biochemistry and Biophysics, School of Medicine, University of Pennsylvania.
- Boothroyd, Dr. Carl W.** Department of Plant Pathology, Cornell University.
- Bormann, Dr. Bernard T.** Department of Forest Sciences, Oregon State University, Corvallis.
- Borowiecki, Prof. Barbara Z.** Department of Geography, University of Wisconsin, Milwaukee.
- Borrello, Sebastian R.** Central Research Laboratories, Texas Instruments Inc., Dallas, Texas.
- Borst, Henry V.** Henry V. Borst & Associates, Wayne, Pennsylvania.
- Bortman, Dr. Marci L.** Waste Management Institute, Marine Sciences Research Center, State University of New York, Stony Brook.
- Bosart, Prof. Lance F.** Department of Atmospheric Sciences, State University of New York, Albany.
- Boshkov, Prof. Stefan H.** Henry Krumb School of Mines, Columbia University.
- Boss, Dr. Alan P.** Carnegie Institution of Washington, Department of Terrestrial Magnetism, Washington, D.C.
- Bothwell, Dr. Mark.** Biochemical Sciences Laboratory, Princeton University.
- Botset, Holbrook G.** Professor Emeritus of Petroleum Engineering, University of Pittsburgh.
- Bouchard, Prof. Thomas J.** Chairman, Department of Psychology, University of Minnesota.
- Bouldin, Dr. Donald W.** Electrical and Computer Engineering, University of Tennessee.
- Bouwkamp, Dr. John C.** Department of Horticulture, College of Agriculture, University of Maryland.
- Bowler, Dr. Bruce E.** Division of Chemistry and Chemical Engineering, California Institute of Technology.
- Bowman, Richard G.** Deceased; formerly, Technical Assistant to the President, Republic Aviation Corporation, Farmingdale, New York.
- Bowman, Rush A.** Consulting Engineer, Memphis, Tennessee.
- Bowman, Dr. Thomas E.** Division of Crustacea, Smithsonian Institution.
- Bowman, Waldo G.** Editor (retired), "Engineering News Record." Boyd, Dr. F. R. Geophysical Laboratory, Washington, D.C.
- Box, Dr. Elgene O.** Department of Geography, University of Georgia.
- Boyd, Dr. Richard H.** Department of Chemical Engineering, University of Utah.
- Boyden, Prof. Edward A.** Department of Biological Structure, School of Medicine, University of Washington.
- Boynton, Dr. Robert M.** Department of Psychology, University of California, San Diego.
- Boynton, Dr. Robert S.** National Lime Association, Washington, D.C.
- Bozarth, Dr. Robert F.** Department of Life Science, Indiana State University, Terre Haute.
- Bozorth, Dr. Richard M.** Research Physicist (retired), Bell Telephone Laboratories, Murray Hill, New Jersey.
- Bracewell, Dr. Ronald N.** Professor of Electrical Engineering, Emeritus, Stanford University, Stanford, California.
- Bradley, Dr. Robert L., Jr.** Department of Food Science, College of Agricultural and Life Sciences, University of Wisconsin.
- Bradley, Prof. S. Gaylen.** Department of Microbiology and Immunology, Virginia Commonwealth University, Richmond.
- Bradley, Prof. William F.** Department of Chemical Engineering, University of Texas, Austin.
- Bradley, Prof. William W.** Department of Civil Engineering and Institute of Colloid and Surface Science, Clarkson College of Technology.
- Bradner, Mead.** Technical Director, Foxboro Company, Foxboro, Massachusetts.
- Bradsher, Prof. Charles K.** Department of Chemistry, Duke University.
- Bragg, Prof. Michael B.** Department of Aeronautical and Astronautical Engineering, University of Illinois at Urbana-Champaign.
- Brainard, Dr. George C.** Department of Neurology, Thomas Jefferson University, Jefferson Medical College, Philadelphia, Pennsylvania.
- Bralla, J. R. Casey.** Consultant, Mechanical Engineering, Martinez, Georgia.
- Brammer, Dr. Anthony J.** Institute for Microstructural Science, National Research Council of Canada, Ottawa, Ontario.
- Brand, Dr. Louis.** Deceased; formerly, M. D. Anderson Professor of Mathematics, Department of Mathematics, University of Houston.
- Brandt, Dr. G. Donald.** Professor Emeritus, City University of New York.
- Brandt, Prof. John C.** Department of Physics and Astronomy, Institute for Astrophysics, University of New Mexico, Albuquerque.
- Brandt, Dr. Philip W.** Department of Anatomy, College of Physicians and Surgeons, Columbia University.
- Brassell, Prof. Simon C.** Professor of Geological Sciences, Biogeochemical



- Laboratories, Indiana University, Bloomington.
- Brasseur, Dr. Guy P.** Director, Atmospheric Chemistry Division, National Center for Atmospheric Research, Boulder, Colorado.
- Breed, Dr. Michael D.** Environmental Population and Organismic Biology, University of Colorado.
- Breen, Dr. Patrick J.** Department of Horticulture, Oregon State University.
- Breger, Dr. Irving A.** Deceased; formerly, Office of Energy Resources, U.S. Geological Survey, Reston, Virginia.
- Breier, Dr. Alan.** Department of Psychiatry, Yale University School of Medicine, and Connecticut Mental Health Center, New Haven.
- Breinan, Dr. Edward M.** Materials Science Laboratory, United Technologies Research Center, East Hartford, Connecticut.
- Breman, Dr. Joel D.** Division of Parasitic Diseases, Centers for Disease Control, Department of Health and Human Services, Atlanta, Georgia.
- Breslin, Dr. Vincent T.** Waste Management Institute, Marine Sciences Research Center, State University of New York, Stony Brook.
- Breslow, Dr. David S.** David S. Breslow Associates, Wilmington, Delaware.
- Bressler, Dr. Peter E.** Endocrine & Diabetes Associates of Texas, Dallas.
- Brett, Dr. Carlton.** Department of Geological Sciences, University of Rochester.
- Breuer, Glenn D.** Consulting Engineer, Transmission Systems Development and Engineering Department, General Electric Company, Schenectady, New York.
- Brewer, Dr. Charles P.** Shell Development Corporation, Emeryville, California.
- Brewer, S. Theodore.** Deceased; formerly, Head, Undersea and Lightwave Engineering Department, Bell Laboratories, Holmdel, New Jersey.
- Brian, Dr. M. V.** Institute of Terrestrial Ecology, Furzebrook Research Station, Wareham, England.
- Brickley, Robert L.** Marketing Manager, Westinghouse Electric Corporation, Springfield, Massachusetts.
- Bridges, Prof. Patricia S.** Deceased; formerly, Department of Anthropology, Queens College and CUNY Graduate Center, Flushing, New York.
- Bridgman, Prof. Percy W.** Deceased; formerly, Harvard University.
- Briggs, Dr. Derek E. G.** Department of Geology, University of Nottingham, England.
- Briggs, Dr. John D.** Department of Entomology, Ohio State University.
- Briggs, M. Michael.** Missile Systems Division, Integrated Systems Inc., Santa Clara, California.
- Briggs, Dr. Winslow R.** Department of Plant Biology, Carnegie Institution of Washington, Stanford, California.
- Brimacombe, Dr. R.** Max-Planck Institut für Molekulare Genetik, Berlin, Germany.
- Brindley, Dr. George W.** Department of Geosciences, Pennsylvania State University.
- Brintzinger, Dr. Hans.** Fachbereich Biologie-Chemie, Universität Konstanz, Germany.
- Brisbin, Dr. I. Lehr.** Savannah River Ecology Laboratory, University of Georgia, Aiken, South Carolina.
- Broadus, Dr. Arthur E.** Associate Professor of Medicine, Department of Medicine, Yale University.
- Brockenbrough, Dr. Roger L.** R. L. Brockenbrough Associates, Inc., Pittsburgh, Pennsylvania.
- Brockhouse, Dr. Bertram N.** Institute for Materials Research, McMaster University.
- Brockway, Prof. Lawrence O.** Deceased; formerly, Department of Chemistry, University of Michigan.
- Brod, Dr. Chris.** Glen Canyon Environmental Studies, Bureau of Reclamation, Flagstaff, Arizona.
- Brodersen, Prof. Klaus.** Professor of Inorganic and Analytical Chemistry, University of Erlangen-Nurnberg, Germany.
- Brodsky, Dr. Barbara.** Department of Biochemistry, UMDNJ-Robert Wood Johnson Medical School, Piscataway, New Jersey.
- Brodsky, Dr. William A.** Mount Sinai School of Medicine of the City University of New York; Institute for Medical Research and Studies, New York.
- Brofman, Dr. Peter J.** Senior Engineering, General Technology Division, IBM Corp., Hopewell Junction, New York.
- Bromley, Prof. D. Allan.** Science Adviser to the President of the United States.
- Bromley, Willard S.** Consulting Forester and Association Consultant, New Rochelle, New York.
- Bronstein, Dr. Judith.** Department of Ecology and Evolutionary Biology, University of Arizona, Tucson.
- Brook, Dr. Marx.** Department of Physics, New Mexico Institute of Mining and Technology, Socorro.
- Brook, Rollins.** Bolt Beranek and Newman Inc., Canoga Park, California.
- Brooke, Dr. M. M.** Deceased; formerly, Deputy Chief, Licensure and Development Branch, Center for Disease Control, U.S. Public Health Service, Atlanta, Georgia.
- Brooks, Dr. Frank D.** Department of Physics, University of Capetown, Rondebosch, South Africa.
- Brooks, Prof. Philip R.** Department of Chemistry, Wise School of Natural Sciences, Rice University.
- Brotner, Dr. William W.** Research Advisor, Eli Lilly and Company, Indianapolis, Indiana.
- Brouwer, Prof. Dirk.** Deceased; formerly, Director, Observatory, Yale University.
- Browder, Dr. James Steve.** Department of Physics, Division of Science and Mathematics, Jacksonville University, Jacksonville, Florida.
- Brown, Prof. Frederick C.** Department of Physics, University of Illinois.
- Brown, Dr. Glenn H.** Professor of Chemistry and Director of the Liquid Crystal Institute, Kent State University.
- Brown, Prof. Herbert C.** Department of Chemistry, Purdue University.
- Brown, Dr. Jason W.** Institute for Research in Behavioral Neuroscience, Department of Neurology, New York University Medical Center.
- Brown, Michael D.** Department of Biochemistry and Molecular Biology, Colorado State University.
- Brown, Dr. Perry.** Dean, School of Forestry, Montana Forest and Conservation Experiment Station, University of Montana, Missoula.
- Brown, Dr. Robert L.** National Radio Astronomy Observatory, Charlottesville, Virginia.
- Brown, Dr. Steven S.** National Oceanic and Atmospheric Administration Aeronomy Laboratory, Boulder, Colorado, and Cooperative Institute for Research in the Environmental Sciences, University of Colorado, Boulder.
- Brown, Dr. William L., Jr.** Emeritus Professor of Entomology, Cornell University.
- Brownell, Dr. Gordon L.** Head, Physics Research Laboratory, Massachusetts General Hospital, Boston.
- Browning, Dr. Keith A.** Chief, Meteorological Office, Radar Research Laboratory, Royal Signals and Radar Establishment, Worcester, England.
- Brownlee, Dr. Donald E., II.** Department of Astronomy, University of Washington, Seattle.
- Brubaker, Prof. Robert R.** Department of Microbiology, Michigan State University, East Lansing.
- Bruce, Bill.** LID Standards Laboratory, Hewlett-Packard, Loveland, Colorado.
- Brummett, Prof. Anna Ruth.** Associate Professor of Biology and Associate Dean, Oberlin College.
- Brunner, Dr. J. Robert.** Department of Food Science and Human Nutrition, Michigan State University.
- Bruno, Michael H.** Graphics Arts Consultant, Bradenton, Florida.
- Brunski, Dr. John B.** Department of Biomedical Engineering, Rensselaer Polytechnic Institute.
- Brush, Dr. Alan H.** Department of Biology, University of Connecticut.
- Bruun, Dr. Hans H.** Department of Mechanical and Medical Engineering, University of Bradford, United Kingdom.
- Bryan, Prof. Leslie A.** Director, Institute of Aviation, University of Illinois.
- Brylawski, Prof. Thomas.** Department of Mathematics, University of North Carolina.
- Bryson, Prof. Arthur E., Jr.** Chairman, Department of Aeronautics and Astronautics, Stanford University.

**Brzozowski, Dr. Victor J.** Electronic Systems Group, Baltimore, Maryland.

**Brézin, Dr. Edouard.** Laboratoire de Physique Theorique, Ecole Normale Supérieure, Paris, France.

**Bube, Dr. Richard H.** Professor of Electrical Engineering, Department of Material Sciences, Stanford University.

**Buchanan, Prof. Bruce.** Computer Science Department, University of Pittsburgh, Pennsylvania.

**Bucher, Dr. Martin A.** Department of Physics, Princeton University.

**Buchroeder, Dr. Richard A.** Optical Design Service, Tucson, Arizona.

**Buck, Dr. Richard P.** Department of Chemistry, University of North Carolina.

**Buede, Dr. Dennis.** Department of Systems Engineering, George Mason University, Fairfax, Virginia.

**Buell, Dr. Heinz.** Plessey Electronic Systems Corporation, Wayne, New Jersey.

**Buermann, Thomas M.** President, Gibbs & Cox, Inc., New York, New York.

**Bukowski, Richard W.** U.S. Department of Commerce, Washington, D.C.

**Bunge, Prof. Mario.** Foundations and Philosophy of Science Unit, McGill University, Montreal, Canada.

**Bunnett, Prof. Joseph F.** Department of Chemistry, University of California, Santa Cruz.

**Bunshah, Dr. Rointan F.** Department of Material Science and Engineering, University of California, Los Angeles.

**Burdett, Prof. Jeremy K.** Department of Chemistry, University of Chicago.

**Bureau of Reclamation.** U.S. Department of the Interior, Denver, Colorado.

**Burgdorfer, Dr. Willy.** Scientist Emeritus, Laboratory of Pathology, Rocky Mountain Laboratories, National Institutes of Health, Department of Health and Human Services, Hamilton, Montana.

**Burghard, Ronald A.** Gould Semiconductors, Pocatello, Indiana.

**Burke, Dr. James D.** Jet Propulsion Laboratory, California Institute of Technology.

**Burke, Prof. Kevin C.** Department of Geosciences, University of Houston.

**Burkhalter, Dr. Alan.** Department of Pharmacology, School of Medicine, University of California, San Francisco.

**Burkhart, Dr. Harold E.** Department of Forestry, College of Forestry and Wildlife Resources, Virginia Polytechnic Institute and State University, Blacksburg.

**Burnett, Peter G.** Petroleum Engineer, Chicago, Illinois.

**Burnham, Prof. Charles W.** Department of Earth and Planetary Sciences, Harvard University.

**Burns, Dr. C. Patrick.** Professor and Director, Division of Hematology, Oncology, and Blood and Marrow Transplantation, Department of Medicine and University of Iowa Cancer Center, Iowa City.

**Burns, Roger G.** Department of Earth Science, Massachusetts Institute of Technology.

**Burns, Prof. Stanley G.** Department of Electrical Engineering and Computer Engineering, Iowa State University.

**Bursey, Prof. Maurice M.** Department of Chemistry, University of North Carolina.

**Bursky, Dave.** "Electronic Design Magazine," Sunnyvale, California.

**Burstyn, Dr. Judith N.** Department of Chemistry, University of Wisconsin, Madison.

**Burton, Prof. Ralph A.** Chairman, Department of Mechanical Engineering and Astronautical Sciences, Northwestern University.

**Burwell, Dr. Robert L.** Department of Chemistry, Northwestern University.

**Busch, Prof. Daryle H.** Department of Chemistry, Ohio State University.

**Bushnell, Dennis M.** Langley Research Center, National Aeronautics and Space Administration, Hampton, Virginia.

**Busta, Dr. Francis F.** Department of Food Science and Human Nutrition, University of Florida.

**Butler, Charles.** Consultant, Pescadero, California.

**Butler, Dr. G. W.** Olin Rocket Research Company, Redmond, Washington.

**Butler, Dr. Percy M.** Egham, Surrey, United Kingdom.

**Butler, Dr. R. Paul.** Staff Scientist, Carnegie Institute of Washington, Terrestrial Magnetism, Washington, D.C.

**Butler, Dr. Robert W.** Department of Psychology, Child Development and Rehabilitation Center, Oregon Health Sciences University, Portland.

**Butts, Prof. Allison.** Professor Emeritus of Metallurgy and Materials Science, Lehigh University.

**Byers, Dr. Charles W.** Department of Geology, University of Wisconsin.

## C

**Cable, Prof. Raymond M.** Department of Biological Sciences, Purdue University.

**Cabrera, Dr. Blas.** Department of Physics, Stanford University.

**Cady, Dr. Gilbert H.** Deceased; formerly, Consulting Coal Geologist, Urbana, Illinois.

**Cain, Dr. Joseph C.** Department of Geology, Florida State University.

**Cain, Dr. William S.** John B. Pierce Foundation Laboratories, New Haven, Connecticut.

**Caine, Dr. Edsel A.** Associate Professor of Marine Sciences, University of South Carolina.

**Caine, Nel.** Institute of Arctic and Alpine Research, University of Colorado at Boulder.

**Calabrese, Dr. Ronald L.** Department of Biology, Emory University.

**Calderwood, Dr. James H.** Department of Electronic Engineering, University College, Galway, Ireland.

**Caldwell, Prof. C. Denise.** Department of Physics, Yale University.

**Callahan, Dr. Michael.** Director, Emergency Medical Services, School of Medicine, University of California, San Francisco.

**Callaway, Prof. Joseph.** Department of Physics and Astronomy, Louisiana State University.

**Caller, Dr. Bernard A.** Computing Center, University of Michigan.

**Calnek, Dr. Bruce W.** Chairperson, Department of Avian and Aquatic Animal Medicine, College of Veterinary Medicine, Cornell University.

**Cambel, Dr. Ali B.** Executive Vice President for Academic Affairs, Wayne State University.

**Cameron, Dr. A. G. W.** Associate Director for Planetary Sciences, Center for Astrophysics, Harvard College Observatory.

**Camín, Dr. Joseph H.** Department of Entomology, University of Kansas.

**Campana, Dr. Richard J.** Department of Botany and Plant Pathology, University of Maine.

**Campanella, Dr. Angelo J.** Campanella Associates, Hilliard, Ohio.

**Campanella, Dr. S. Joseph.** Retired; formerly, COMSAT Laboratories, Clarksburg, Maryland.

**Campbell, Dr. Andrew C.** Department of Zoology and Comparative Physiology, Queen Mary College, University of London, England.

**Campbell, Dr. Eleanor.** Max-Born-Institut, Berlin, Germany.

**Campbell, Harold E.** Senior Engineer, Power Distribution Systems Engineering, General Electric Company, Schenectady, New York.

**Campbell, Dr. Howard W.** National Fisheries and Wildlife Laboratory, Gainesville, Florida.

**Campbell, Dr. John S.** Department of Biological Sciences, University of Lethbridge, Alberta, Canada.

**Campbell, Dr. Laurence J.** Low Temperature Physics Group, Los Alamos Scientific Laboratory, Los Alamos, New Mexico.

**Campbell, Dr. Wallace H.** U.S. Geological Survey, Denver, Colorado.

**Campbell, Dr. William B.** Professor and Chairman, Department of Pharmacology and Toxicology, Medical College of Wisconsin, Milwaukee.

**Cannell, Prof. David S.** Department of Physics, University of California, Santa Barbara.

**Cannon, Dr. Robert H., Jr.** Assistant Secretary of Transportation.

**Canter, Prof. Gerald J.** Department of Communicative Disorders, Northwestern University.

**Capellen, Dr. Jennings.** Rare Earth Information Center, Iowa State University.

- Capra, Dr. J. Donald.** Department of Microbiology, Southwestern Medical School, University of Texas, Dallas.
- Carberry, Dr. James J.** Department of Chemical Engineering, University of Notre Dame.
- Carbone, Dr. Richard E.** Director, Atmospheric Technology Division, National Center for Atmospheric Research, Boulder, Colorado.
- Cardullo, Dr. Frank.** Watson School, Engineering Technology, State University of New York.
- Carew, Dr. H. John.** Professor of Horticulture, Michigan State University.
- Carlson, Dr. Don M.** Division of Biological Sciences, University of California, Davis.
- Carlson, Dr. Jack H.** Rhone Merieux, Inc., Athens, Georgia.
- Carlson, Dr. Sandra J.** Associate Professor and Research Geologist, Department of Geology/University of California, Davis.
- Carlson, William C.** Tree Physiologist, Weyerhaeuser Company, Hot Springs, Arkansas.
- Carlsson, Prof. Anders E.** Department of Physics, Washington University, St. Louis, Missouri.
- Carlsson, Dr. D. J.** National Research Council of Canada, Ottawa, Ontario.
- Carlton, Dr. Peter L.** Department of Psychiatry, University of Medicine and Dentistry of New Jersey, Rutgers Medical School.
- Carney, Prof. Bruce W.** Department of Physics & Astronomy, University of North Carolina, Chapel Hill.
- Carpenter, Dr. C. J.** Bath, Avon, England.
- Carpenter, Dr. Frank M.** Department of Biology, Harvard University.
- Carris, Dr. Lori M.** Department of Plant Pathology, Washington State University, Pullman.
- Carroll, Dr. C. Ronald.** Institute of Ecology, University of Georgia, Athens.
- Carroll, Dr. John M.** Department of Computer Science, University of Western Ontario, Canada.
- Carroll, Robert G., Jr.** Manager of Technical Development, Mirafi, Inc., Charlotte, North Carolina.
- Carroll, Dr. Robert L.** Redpath Museum, McGill University, Montreal, Quebec, Canada.
- Carruthers, Dr. Marvin H.** Department of Chemistry, University of Colorado.
- Carson, Dr. John W.** President, Jenike & Johanson Inc., North Billerica, Massachusetts.
- Carson, Robert W.** Formerly, Managing Editor, "Product Engineering," New York.
- Carter, Archie N.** Buan, Carter & Associates, Inc., Minneapolis, Minnesota.
- Carter, Dr. G. R.** Professor Emeritus, Department of Patho-biology, Virginia-Maryland Regional College of Veterinary Medicine, Virginia Polytechnic Institute and State University, Blackburg.
- Carter, Dr. Joseph G.** Department of Geology, University of North Carolina.
- Carter, Prof. Herbert E.** Vice Chancellor for Academic Affairs, University of Illinois.
- Casasent, Prof. David.** Department of Electrical and Computer Engineering, Carnegie-Mellon University.
- Casey, Dr. H. C., Jr.** Department of Electrical Engineering, Duke University.
- Cassens, Prof. Linda J.** Department of Plant Sciences, College of Agriculture, University of Arizona.
- Catania, Prof. A. Charles.** Department of Psychology, University of Maryland.
- Catchpole, Dr. John.** Admiralty Materials Laboratory, Dorset, England.
- Caughey, Prof. David A.** Sibley School of Mechanical and Aerospace Engineering, Cornell University, Ithaca, New York.
- Caughlan, Prof. Georgeanne R.** Department of Physics, Montana State University.
- Cavanagh, Dr. Dale E.** Naples, Florida.
- Cave, Dr. M. Donald.** Department of Anatomy, University of Arkansas for Medical Sciences.
- Cavender, Ted M.** Museum of Zoology, University of Michigan.
- Cavey, Michael J.** Department of Biology, University of Calgary, Alberta, Canada.
- Cavin, Dr. Ralph K., III.** Director, Design Sciences, Semiconductor Research, Research Triangle Park, North Carolina.
- Celander, Dr. Daniel W.** Department of Microbiology, University of Illinois, Urbana.
- Celler, Dr. George K.** AT&T Laboratories, Murray Hill, New Jersey.
- Chace, Dr. Fenner A., Jr.** Senior Zoologist, Department of Invertebrate Zoology, Smithsonian Institution.
- Chakoumakos, Dr. Bryan C.** Department of Geology, Northrup Hall, University of New Mexico.
- Chambers, Dr. James P.** Research Scientist and Research Assistant Professor of Mechanical Engineering, University of Mississippi.
- Chambon, Dr. Jean-Claude.** Laboratoire de Chimie Organo-Minérale, Institut le Bel, Université Louis Pasteur, Strasbourg, France.
- Chameides, Prof. William L.** School of Earth and Atmospheric Sciences, Georgia Institute of Technology, Atlanta.
- Chan, Dr. Moses H. W.** Department of Physics, Pennsylvania State University.
- Chang, Dr. Alan J.** Chief Curator of Fossil Amphibians, Reptiles and Birds, British Museum, London, England.
- Chang, Prof. Howard H.** Department of Civil and Environmental Engineering, San Diego State University, San Diego, California.
- Chang, Prof. Kang-tsung.** Department of Geography, University of Idaho, Moscow.
- Chang, Dr. Luke L. Y.** Department of Geology, University of Maryland, College Park.
- Chang, Dr. M. C.** Worcester Foundation for Experimental Biology, Shrewsbury, Massachusetts.
- Chang, Prof. S. S. L.** Department of Electrical Sciences, State University of New York, Stony Brook.
- Chao, Dr. Edward C. T.** Geological Survey, U.S. Department of the Interior, Reston, Virginia.
- Chapman, Dr. Carleton A.** Department of Geology, University of Illinois.
- Chapman, Dr. Clark R.** Planetary Science Institute, Tucson, Arizona.
- Chapman, Dr. Richard A.** Central Research Laboratories, Texas Instruments Inc., Dallas, Texas.
- Chapman, Dr. Robert D.** Section Head, Laboratory for Solar Physics and Astrophysics, NASA Goddard Space Flight Center, Beltsville, Maryland.
- Chapman, Prof. Russell L.** Chairperson, Department of Botany, Louisiana State University, Baton Rouge.
- Chapman, Dr. Sydney.** Deceased; formerly, High Altitude Observatory, University of Colorado.
- Chappell, Dr. Charles F.** University Corporation for Atmospheric Research, COMET, Boulder, Colorado.
- Charlton, Dr. Ernest E.** Research Engineer (retired), Schenectady, New York.
- Charney, Dr. Dennis S.** Department of Psychiatry, Yale University School of Medicine, and Connecticut Mental Health Center, New Haven.
- Charnock, Dr. Henry.** Department of Oceanography, University of Southampton, England.
- Charrier, Dr. J. M.** Department of Chemical Engineering, McGill University, Montreal, Quebec, Canada.
- Chandhari, Dr. Nirupa.** University of Miami School of Medicine, Department of Physiology and Biophysics, Rosentiel Medical Sciences Building, Miami, Florida.
- Chaudhari, Praveen.** Thomas J. Watson Research Center, IBM, Yorktown Heights, New York.
- Chadle, Prof. Vernon I.** Chancellor, University of California, Santa Barbara.
- Chellis, Robert D.** Deceased; formerly, Structural Engineer, Wellesley Hills, Massachusetts.
- Chen, Dr. Albert Fu-Tai.** Principal Research Chemist, Applied Research Department, Beckman Instruments, Brea, California.
- Chen, Dr. Chong-maw.** Department of Life Sciences, Biological Sciences/Biomedical Research Institute, University of Wisconsin, Parkside.
- Chen, Dr. H. S.** AT&T Bell Laboratories, Murray Hill, New Jersey.
- Chen, Prof. Peter P.** Director of the Institute of Computer and Information Systems Research, Louisiana State University.
- Chen, Dr. Robert T.** Medical Epidemiologist, Infant Immunization Section, Centers for Disease Control, Surveillance Investigations and Research Branch, Atlanta, Georgia.

- Chen, Dr. Shoen-Sheng.** Argonne National Laboratory, Argonne, Illinois.
- Chenault, Roy L.** Chief Research Engineer (retired), Oilwell Division, U.S. Steel Corporation, Dallas, Texas.
- Cheng, Dr. T. C.** Department of Electrical Engineering, University of Southern California.
- Cherlin, Dr. Gregory L.** Mathematical Sciences Research Institute and Rutgers University, Berkeley, California.
- Chern, Prof. S. S.** Mathematical Sciences Research Institute, University of California, Berkeley.
- Chernosky, Prof. J. V.** Department of Geological Science, University of Maine.
- Chickering, Dr. Arthur M.** Museum of Comparative Zoology, Harvard University.
- Chien, Dr. Shu.** Institute for Biomedical Engineering, University of California, La Jolla, California.
- Chin, Dr. Gilbert Y.** AT&T Bell Telephone Laboratories, Murray Hill, New Jersey.
- Chinitz, Dr. Wallace.** Department of Mechanical Engineering, Cooper Union.
- Chiodo, Prof. Louis A.** Chairperson, Department of Pharmacology, Texas Tech University Health Sciences Center, Lubbock.
- Chipkin, Dr. Richard E.** Department of Pharmacology, Schering Corporation, Bloomfield, New Jersey.
- Chironis, Nicholas P.** Senior Editor, "Coal Age," McGraw-Hill, Inc., New York.
- Chisholm, Dr. Malcolm.** Department of Chemistry, Indiana University.
- Chobor, Karen L.** Institute for Research in Behavioral Neuroscience, Department of Neurology, New York University Medical Center.
- Chodos, Dr. Alan.** Department of Physics, Yale University.
- Chokroverty, Prof. Sudhansu.** Chief, Neurology Service, VA Medical Center, Lyons, New Jersey.
- Choueiri, Dr. Edgar Y.** Electric Propulsion Laboratory, Engineering Quadrangle, Princeton University.
- Chow, Dr. Wen L.** Department of Mechanical Engineering, College of Engineering, Florida Atlantic University, Boca Raton.
- Choy, Dr. Patrick C.** Department of Biochemistry, University of Manitoba Faculty of Medicine, Winnipeg, Canada.
- Christ, Dr. Charles L.** Physicist, U.S. Geological Survey.
- Christensen, Dr. Bruce M.** Assistant Professor, Department of Veterinary Science, University of Wisconsin, Madison.
- Christensen, Dr. Martha.** Professor Emeritus, Department of Botany, University of Wyoming, Laramie.
- Christenson, Dr. Todd R.** Photonics and Microfabrication Department, Sandia National Laboratories, Albuquerque, New Mexico.
- Christiansen, Dr. Kenneth.** Professor Emeritus of Biology, Department of Biology, Grinnell College, Iowa.
- Christiansen, Dr. R. L.** Petroleum Engineering Department, Colorado School of Mines, Golden.
- Christie, Dr. John M.** Department of Geology, University of California, Los Angeles.
- Christie, Richard W.** Hardesty & Hanover, New York.
- Christie-Blick, Dr. Nicholas.** Professor of Geology, Lamont-Doherty Earth Observatory, Columbia University, Palisades, New York.
- Christophorou, Dr. L. G.** Head, Atomic, Molecular and High Voltage Physics Group, Oak Ridge National Laboratory, Oak Ridge, Tennessee.
- Christou, Dr. George.** Department of Chemistry, Indiana University.
- Christy, Dr. Nicholas.** College of Physicians and Surgeons, Columbia University.
- Chu, Prof. Benjamin.** Department of Chemistry, State University of New York, Stony Brook.
- Chu, Dr. Steven.** Department of Physics, Stanford University.
- Chu, Dr. T. Ming.** Roswell Park Memorial Institute, Buffalo, New York.
- Ciechanover, Dr. Aaron J.** Department of Biochemistry, The Bruce Rappaport Faculty of Medicine, Technion-Israel Institute of Technology.
- Ciegler, Dr. Alex.** Southern Regional Research Center, USDA Science and Education Administration, New Orleans.
- Civardi, Dr. Frank P.** Civardi Engineers, Wayne, New Jersey.
- Clack, Dr. Jennifer A.** University Museum of Zoology, Cambridge, England.
- Clapp, Philip F.** National Weather Service, National Oceanic and Atmospheric Administration, Washington, D.C.
- Claridge, Dr. Elmond L.** Retired; formerly, Director of Graduate Program in Petroleum Engineering, Chemical Engineering Department, University of Houston Central Campus, Houston.
- Clark, Dr. David A.** Department of Medicine, McMaster University, Ontario, Canada.
- Clark, Prof. Francis.** Department of Microbiology, University of Illinois.
- Clark, Prof. George L.** Deceased; formerly, Emeritus Research Professor of Analytical Chemistry, University of Illinois.
- Clark, Prof. John F.** Director, Graduate Studies, and Professor, Space Systems, Spaceport Graduate Center, Florida Institute of Technology, Satellite Beach.
- Clark, Dr. Nancy Barnes.** Department of Physiology and Neurobiology, University of Connecticut.
- Clark, Noel A.** Department of Physics, University of Colorado at Boulder.
- Clark, Richard F.** Division of Physics, National Research Council of Canada, Ottawa, Ontario.
- Clark, Prof. Wallis H., Jr.** Director, Aquaculture Program, University of California, Davis.
- Clarke, Dr. J. Harold.** Horticulturist, Clarke Nursery, Long Beach, Washington.
- Clarke, Prof. John.** Department of Physics, University of California, Berkeley.
- Clemence, Dr. Gerald M.** Deceased; formerly, Observatory, Yale University.
- Clemens, Dr. William A.** Museum of Paleontology, University of California, Berkeley.
- Clements, Dr. Leo P.** Emeritus Professor of Anatomy, School of Medicine, Creighton University.
- Cleminshaw, Dr. Clarence H.** Deceased; formerly, Director Emeritus, Griffith Observatory, Los Angeles, California.
- Cleve, Dr. Hartwig.** Institute for Anthropology and Human Genetics, University of Munich, Germany.
- Cleveland, Prof. L. F.** Department of Electrical Engineering, Northeastern University.
- Cleveland, Dr. Robin.** Department of Aerospace And Mechanical Engineering, Boston University, Boston, Massachusetts.
- Cline, Dr. Douglas.** Nuclear Structure Laboratory, University Of Rochester, New York.
- Cloud, Dr. Preston E., Jr.** Department of Geology, University of California, Santa Barbara.
- Clowes, Dr. F. A. L.** Botany Department, University of Oxford, England.
- Clydesdale, Dr. Fergus M.** Department of Food Science and Nutrition, University of Massachusetts.
- Coates, Dr. Peter B.** Retired; formerly, Division of Electrical Science, National Physical Laboratory, Teddington, United Kingdom.
- Cobine, Dr. James D.** Deceased; formerly, Professor and Senior Scientist, Atmospheric Sciences Research Center, State University of New York, Albany.
- Cochran, Dr. James R.** Lamont-Doherty Earth Observatory, Columbia University, Palisades, New York.
- Cocks, Dr. George.** Los Alamos National Laboratory, Los Alamos, New Mexico.
- Cocks, Dr. L. R. M.** Department of Palaeontology, Natural History Museum, London, United Kingdom.
- Coddington, Dr. Jonathan A.** National Museum of Natural History, Smithsonian Institution, Washington, D.C.
- Cohen, Dr. Alan S.** Director, Thorndike Memorial Laboratory, Boston City Hospital, Boston, Massachusetts.
- Cohen, Charles A.** Research Associate (retired), Exxon Research and Engineering Company, Florham Park, New Jersey.
- Cohen, Dr. David.** National Magnetic Laboratory, Massachusetts Institute of Technology.
- Cohen, Dr. Donald J.** Assistant Professor, Child Study Center, Yale University.
- Cohen, Dr. E. Richard.** Rockwell International Science Center, Thousand Oaks, California.

- Cohen, Dr. Gene.** National Institute on Aging, National Institutes of Health, Bethesda, Maryland.
- Cohen, Dr. Jay O.** Deceased; formerly, Microbiologist, Department of Health and Human Services, Public Health Service, Centers for Disease Control, Atlanta, Georgia.
- Cohen, Dr. Jerome.** Department of Psychiatry, Medical School, Northwestern University.
- Cohen, Dr. Jerry D.** Plant Hormone Laboratory, U.S. Department of Agriculture, Beltsville, Maryland.
- Cohen, Dr. Lisa M.** Department of Dermatology, Beth Israel Hospital, Boston, Massachusetts.
- Cohen, Dr. Steven A.** Senior Research Scientist, Polymers Business Group, Amoco Corporation, Alpharetta, Georgia.
- Colby, Dr. Kenneth Mark.** Department of Psychiatry and Behavioral Sciences, School of Medicine, University of California, Los Angeles.
- Cole, Dr. Edward H.** Department of Immunopathology, Scripps Clinic and Research Foundation, La Jolla, California.
- Coleal, Dr. Ernest.** Formerly, Assistant for Facilities Development, Flight Research Division, Edwards Air Force Base, California.
- Coleman, Dr. David C.** Department of Entomology, University of Georgia.
- Coleman, Dr. Robert E.** Staff Scientist, Sugar Crops Production, National Program Staff, BARC-WEST, Beltsville, Maryland.
- Collier, R. J.** Bell Telephone Laboratories, Murray Hill, New Jersey.
- Collins, Dr. Dean R.** Director, CCD Technology Laboratory, Central Research Laboratories, Texas Instruments Inc., Dallas, Texas.
- Collins, Dr. Francis.** Department of Health and Human Services, National Human Genome Research Institute, Bethesda, Maryland.
- Collins, Prof. J. H.** Department of Electrical Engineering, University of Texas, Arlington.
- Collins, Dr. Steven J.** Department of Clinical Neurosciences, St. Vincent's Hospital, Melbourne, and Department of Pathology, University of Melbourne, Australia.
- Collinson, Dr. Charles.** Department of Geology, University of Illinois.
- Colwell, Dr. Rita R.** Department of Microbiology, Division of Agricultural and Life Sciences, University of Maryland.
- Comeau, Richard.** The Foxboro Company, Foxboro, Massachusetts.
- Comer, Prof. Jonathan.** Department of Geography, Oklahoma State University, Stillwater.
- Comings, Dr. Edward W.** University of Petroleum and Minerals, Dhahran, Saudi Arabia.
- Commins, Prof. Eugene D.** Department of Physics, University of California, Berkeley.
- Compton, Robert D.** Electro-Optical Systems Design, Milton S. Kiver Publications, Inc., Chicago, Illinois.
- Condie, Dr. Kent C.** Department of Earth and Environmental Sciences, New Mexico Institute of Mining and Technology, Socorro.
- Confer, Prof. Anthony W.** Head, Department of Veterinary, Pathology, Oklahoma State University, Stillwater.
- Connors, Dr. James F.** Propulsion Aerodynamics Division, National Aeronautics and Space Administration.
- Conrad, Prof. Albert G.** Dean Emeritus and Professor of Electrical Engineering, College of Engineering, University of California, Santa Barbara.
- Constabel, Dr. Fred.** Plant Biotechnology Institute, National Research Council, Saskatoon, Saskatchewan, Canada.
- Converse, Dr. Richard H.** Department of Botany, Oregon State University.
- Conway Morris, Dr. Simon.** Department of Earth Sciences, The Open University, Milton Keynes, England.
- Conwell, Dr. Esther M.** Xerox Webster Research Center, Rochester, New York.
- Cook, Dr. Charles G.** Research Geneticist, Agricultural Research Service, U.S. Department of Agriculture, Weslaco, Texas.
- Cook, Dr. Frank.** Research Assistant Professor, Department of Veterinary Science, Gluck Equine Research Center, University of Kentucky, Lexington.
- Cook, Dr. Gerald.** Department of Electrical and Computer Engineering, George Mason University, Fairfax, Virginia.
- Cook, Philip H.** Plastics Department, Texas Division, Dow Chemical U.S.A., Freeport, Texas.
- Cook, Dr. Richard K.** Formerly, National Bureau of Standards.
- Cooley, Dr. William E.** Winton Hill Technical Center, Proctor and Gamble Company, Cincinnati, Ohio.
- Cooley, Prof. Hollis R.** Professor Emeritus of Mathematics, New York University.
- Coombs, Dr. Sheryl.** Professor of Hearing Sciences, Parmlly Hearing Institute, Loyola University, Chicago, Illinois.
- Cooper, Dr. Arthur W.** Department of Botany, North Carolina State University.
- Cooper, Prof. W. Charles.** Department of Metallurgical Engineering, Queens University, Kingston, Ontario, Canada.
- Copel, Michel.** Acoustronics, Inc., Huntington, New York.
- Copeland, Prof. Miles A.** Faculty of Engineering, Carleton University, Ottawa, Ontario, Canada.
- Coppens, Dr. Alan B.** Associate Professor of Physics, U.S. Navy Post Graduate School, Pacific Grove, California.
- Corben, Dr. Herbert C.** Deceased; formerly, Ramo-Wooldridge Corporation, Los Angeles, California.
- Corbitt, Robert A.** Associate, Metcalf & Eddy, Inc., Atlanta, Georgia.
- Core, Prof. Earl L.** Professor of Botany, Department of Biology, West Virginia University.
- Corliss, Dr. John O.** Department of Zoology, University of Maryland.
- Costantino, Dr. James.** Intelligent Transportation Society of America, Washington, D.C.
- Costerton, Dr. J. William F.** Department of Biology, University of Calgary, Alberta, Canada.
- Cotterill, Carl H.** Chief, Division of Statistical and Technical Services, Bureau of Mines, U.S. Department of the Interior.
- Couch, Dr. John C.** Matson Navigation Company, San Francisco, California.
- Couch, Dr. Richard B.** Professor of Naval Architecture and Marine Engineering, Ship Hydrodynamics Laboratory, University of Michigan.
- Couclelis, Prof. Helen.** Department of Geography, University of California, Santa Barbara.
- Coulombe, Dr. Mary J.** Director, Timber Access and Supply, American Forest and Paper Association, Washington, D.C.
- Coulter, Earl E.** Manager, Mechanical Technology, Babcock and Wilcox Company, Barberton, Ohio.
- Coursen, D. Linn.** Dynatec Explosives Consultants, Inc., Española, New Mexico.
- Court, Dr. Arnold.** Retired; formerly, Department of Climatology, California State University.
- Cowan, Dr. Thomas E.** General Atomics, Photonics Division, San Diego, California.
- Cowles, Prof. Philip B.** Professor Emeritus of Microbiology, School of Medicine, Yale University.
- Cox, Dr. Charles S.** Department of Oceanography, University of California, San Diego.
- Coxeter, Prof. H. S. M.** Department of Mathematics, University of Toronto, Ontario, Canada.
- Coyle, Harold P.** Harvard-Smithsonian Center for Astrophysics, Harvard College Observatory, Cambridge, Massachusetts.
- Coyle, Dr. Heather.** Connecticut State Police Forensic Science Laboratory, Meriden.
- Coyne, Dr. Michael J.** Senior Veterinarian Technical Services, SmithKline Beecham Animal Health, Exton, Pennsylvania.
- Cozzens, Christine S.** Biology Laboratory, Harvard University.
- Crabill, Dr. Ralph E., Jr.** Curator and Supervisor of the Division of Myriapoda and Arachnida, Department of Entomology, Smithsonian Institution, National Museum of Natural History.
- Cracraft, Dr. Joel.** Department of Ornithology, American Museum of Natural History, New York.
- Crafts, Dr. Alden S.** Professor Emeritus, Department of Botany, University of California, Davis.
- Craig, Prof. Homer V.** Department of Mathematics, University of Texas, Austin.
- Craine, Dr. Eric R.** Western Research Company, Inc., Tucson, Arizona.

- Cramer, Dr. Friedrich.** Max Planck Institut für Experimentelle Medizin, Göttingen, Germany.
- Cramer, Dr. William S.** Ship Acoustics Department, Naval Ship Research and Development Center, Washington, D.C.
- Crane, Julian C.** Professor of Pomology, Agricultural Experimental Station, University of California, Davis.
- Cranwell, Dr. Lucy M.** Department of Geosciences, University of Arizona.
- Crawford, Prof. Michael H.** Chief, Division of Cardiology, University of New Mexico School of Medicine, Albuquerque.
- Cremer, Prof. Sheldon E.** Department of Chemistry, Marquette University.
- Creutz, Dr. Carol.** Department of Chemistry, Brookhaven National Laboratory, Associated University Inc., Upton, New York.
- Crittenden, Dr. Charles V.** Geographer, Economic Development Administration, U.S. Department of Commerce.
- Crocker, Dr. Burton B.** Monsanto Company, St. Louis, Missouri.
- Crocker, Prof. Malcolm J.** Department of Mechanical Engineering, Purdue University.
- Cronin, Dr. Thomas.** Department of Biological Sciences, University of Maryland, Baltimore County.
- Cronquist, Dr. Arthur.** Director of Botany, New York Botanical Gardens, Bronx, New York.
- Cross, Dr. Chester E.** Agricultural Experiment Station, University of Massachusetts.
- Crouse, William H.** Consulting Editor, Automotive Books, McGraw-Hill Book Company, New York.
- Crow, Dr. James F.** Department of Genetics, University of Wisconsin.
- Crowe, Prof. Clayton T.** Department of Mechanical and Materials Engineering, Washington State University, Pullman.
- Crowe, Dr. John H.** Department of Zoology, University of California, Davis.
- Crowell, Dr. Sears.** Department of Zoology, Indiana University.
- Crowson, Dr. Roy A.** Department of Zoology, University of Glasgow, Scotland.
- Cruickshank, Dr. Michael J.** Look Laboratory, University of Hawaii.
- Crum, Dr. Howard.** Herbarium, University of Michigan.
- Csanady, Dr. G. T.** Department of Physical Oceanography, Old Dominion University, Norfolk, Virginia.
- Cuckler, Lee E.** Interdivisional Coordinator, Aeronautical and Instrument Division, Robertshaw Controls Company, Anaheim, California.
- Cuffey, Dr. Roger J.** Department of Geology and Geophysics, Pennsylvania State University.
- Culbertson, Dr. Joseph O.** Assistant Chief (retired), Oil-seed and Industrial Crops Research Branch, Crops Research Division, U.S. Department of Agriculture, Beltsville, Maryland.
- Culotta, Prof. Valeria Cizewski.** Associate Professor, Johns Hopkins University School of Public Health, Department of Environmental Health Sciences, Baltimore, Maryland.
- Cumberland, Prof. Kenneth B.** Professor of Geography, University of Auckland, New Zealand.
- Cummings, Dr. Michael R.** Department of Biological Sciences, University of Illinois.
- Cummins, Dr. Denise Dellarosa.** Department of Psychology, University of Arizona.
- Cummins, Prof. Harold.** Professor Emeritus, School of Medicine, Tulane University.
- Cunnane, William P.** Assistant Commissioner, Office of Network Services, Information Resources Management, General Services Administration, Washington, D.C.
- Cunningham, Prof. Burris B.** Deceased; formerly, Radiation Laboratory, University of California, Berkeley.
- Curkendall, Dr. David W.** NASA Jet Propulsion Laboratory, Pasadena, California.
- Curray, Dr. Joseph R.** Scripps Institution of Oceanography, University of California, La Jolla.
- Curtin, Dr. Charles B.** Department of Biology, Creighton University.
- Curtis, Prof. Charles F.** Department of Chemistry, University of Wisconsin.
- Curtiss, Leon F.** Formerly, National Bureau of Standards.
- Cushman, Dr. Pauline K.** College of Integrated Science and Technology, James Madison University, Harrisonburg, Virginia.
- Cushman-Roisin, Dr. Benoit.** Thayer School of Engineering, Dartmouth College, Hanover, New Hampshire.
- Cutler, Prof. Chapin C.** Professor of Applied Physics, Stanford University.
- Cutler, Dr. Edward B.** Department of Biology, Utica College of Syracuse University.
- Cutter, Dr. Elizabeth G.** Department of Cryptogamic Botany, University of Manchester, England.
- Czamanske, Dr. Gerald K.** U.S. Geological Survey, Menlo Park, California.
- Czarnik, Dr. Anthony W.** Senior Director, Chemistry, IRORI Quantum Microchemistry, La Jolla, California.
- Dahl, Dr. Lawrence F.** Department of Chemistry, University of Wisconsin.
- Dahl, Dr. Leslie R.** Consultant, General Electric Company, San Jose, California.
- Dahl, Dr. Peter S.** Department of Geology, Kent State University, Kent, Ohio.
- Daiber, Dr. Franklin C.** College of Marine Studies, University of Delaware.
- Daigle, Dr. Gilles A.** National Research Council, Institute for Microstructural Sciences, Ottawa, Canada.
- Dale, Dr. James B.** Veteran Affairs Medical Center, Memphis, Tennessee.
- Dalitz, Prof. Richard H.** Department of Theoretical Physics, Oxford University.
- Dalrymple, Dr. David L.** Department of Chemistry, University of Delaware.
- Dalton, Dr. David R.** Department of Chemistry, College of Arts and Sciences, Temple University.
- Dalziel, Dr. Ian W. O.** Department of Geological Sciences, University of Texas at Austin.
- Damberger, Dr. Heinz H.** Illinois State Geological Survey, Coal Section, Champaign.
- Damian, Dr. Raymond T.** Department of Zoology, Franklin College of Arts and Sciences, University of Georgia.
- Damman, Prof. Antoni W. H.** Department of Biology, University of Connecticut.
- Danby, Dr. J. M. A.** Department of Mathematics, North Carolina State University.
- Daney, Dr. David E.** Los Alamos National Laboratory, Los Alamos, New Mexico.
- Daniel, James R.** Department of Biochemistry, Purdue University.
- Daniels, Dr. D. J.** ERA Technology, Leatherhead, Surrey, England.
- Daniels, Dr. Farrington.** Deceased; formerly, Professor Emeritus, Solar Energy Laboratory, University of Wisconsin.
- Daniels, Prof. James M.** Department of Physics, University of Toronto.
- D'Arcangelo, Prof. Amelio M.** Department of Naval Architecture, University of Michigan.
- Darwin, Dr. C. J.** Experimental Psychology, University of Sussex, England.
- Date, Prof. Hikaru.** Acoustics Department, Kyushu Institute of Design, Fukuoka, Japan.
- Daubechies, Dr. Ingrid.** AT&T Bell Laboratories, Murray Hill, New Jersey.
- Davidson, Dr. Jaime A.** Endocrine & Diabetes Associates of Texas, Dallas, Texas.
- Davies, David H.** DataPlay Inc., Boulder, Colorado.
- Davies, Dr. Peter J.** Department of Botany, Cornell University.
- Davies-Jones, Dr. Robert P.** Meteorologist, National Severe Storms Laboratory, U.S. Department of Commerce, Norman, Oklahoma.
- Davis, Dr. Andrew M.** Enrico Fermi Institute, University of Chicago, Illinois.
- Davis, Dr. Bernard D.** Deceased; formerly, Bacterial Physiology Unit, Harvard Medical School.

## D

- Dabberdt, Dr. Walter F.** Atmospheric Technology Division, National Center for Atmospheric Research, Boulder, Colorado.
- Dabbs, Dr. David J.** Pathologist, Department of Pathology, University of Washington.

- Davis, D. Dwight.** Deceased; formerly, Curator of Vertebrate Anatomy, Chicago Museum of Natural History.
- Davis, Dr. George H.** Department of Geological Sciences, University of Arizona.
- Davis, Prof. Gregory A.** Department of Geological Sciences, University of Southern California.
- Davis, Dr. Jack.** Deceased; formerly, Research and Development, Bright Star Industries, Inc., Clifton, New Jersey.
- Davis, Dr. John H.** Professor Emeritus of Botany, University of Florida.
- Davis, Prof. Kenneth P.** Deceased; formerly, School of Forestry, Yale University.
- Davis, Dr. Richard A., Jr.** Department of Geology, University of South Florida.
- Davis, Dr. Simon J. M.** Ancient Monuments Laboratory, Saville Row, London, England.
- Dawood, Dr. M. Yusoff.** Department of Obstetrics and Gynecology, University of Illinois College of Medicine, Chicago.
- Dawson, Dr. David M.** West Roxbury Veterans Affairs Medical Center, West Roxbury, Massachusetts.
- Dawson, Prof. Kerry J.** Environmental Horticulture, University of California, Davis.
- Dawson, Dr. Todd E.** Ecology and Systematics, Cornell University, Carson Hall, Ithaca, New York.
- Day, Dr. William H.** Manager, Advanced Industrial Programs, Pratt & Whitney, East Hartford, Connecticut.
- Dayton, Benjamin B.** Consulting Physicist, East Flatrock, North Carolina.
- Deacon, Margaret.** Department of Oceanography, University of Southampton, United Kingdom.
- Deacon, T. A.** Deceased; formerly, Division of Electrical Science, National Physical Laboratory, Teddington, Middlesex, England.
- Deakins, Dr. Ralph R.** Director, Computer-Aided Systems, Rockwell International Corporation, El Segundo, California.
- Dean, Dr. Thomas S.** Architectural Engineer, Lawrence, Kansas.
- Dean, Dr. Walter E.** U.S. Geological Survey, Denver Federal Center, Denver, Colorado.
- de Boor, Dr. Carl.** Mathematical Research Center, University of Wisconsin.
- DeCarli, Dr. P. S.** Poulter Laboratory, Stanford Research Institute.
- De Cicco, John.** Department of Mathematics, Illinois Institute of Technology.
- DeClaris, Dr. Nicholas.** Division of Emerging Energy Technologies, National Science Foundation, Washington D.C.
- DeFacio, Prof. Brian.** Department of Physics and Astronomy, University of Missouri.
- de Freitas, Prof. Duarte Mota.** Department of Chemistry, Loyola University, Chicago, Illinois.
- Dehmelt, Dr. Hans.** Department of Physics, University of Washington.
- De Jong, Dr. Theodore M.** Pomology Department, University of California, Davis.
- Dekker, Dr. Adrianus J.** Professor of Solid State Physics, University of Groningen, Netherlands.
- de la Cruz, Felix.** Chief, Mental Retardation and Development Disabilities Branch, National Institute of Child Health and Human Development, Bethesda.
- Delahay, Prof. Paul.** Department of Chemistry, New York University.
- Deland, Dr. Raymond J.** Retired; formerly, Department of Meteorology and Oceanography, New York University.
- de Levie, Prof. Robert.** Department of Chemistry, Georgetown University, Washington, DC.
- Dell'Arciprete, Dr. Patricia.** Central Nacional Patagónico (CONICET), Chubut, Argentina.
- DeLong, Dr. Dwight M.** College of Biological Sciences, Ohio State University.
- Delson, Dr. Eric.** Department of Vertebrate Paleontology, American Museum of Natural History.
- DeLuca, Dr. Hector F.** Department of Biochemistry, University of Wisconsin, Madison.
- Demar, Dr. Robert E.** Department of Geology, University of Illinois, Chicago.
- Dempsey, Prof. Mary E.** Department of Biochemistry, University of Minnesota Medical School, Minneapolis.
- de Neufville, Dr. John P.** President, Voltaix, Inc., North Branch, New Jersey.
- Dengler, Dr. Nancy G.** Department of Botany, University of Toronto, Ontario, Canada.
- Den Hartog, Prof. J. P.** Retired; formerly, Department of Mechanical Engineering, Massachusetts Institute of Technology.
- Denison, Dr. Robert H.** Deceased; formerly, Curator of Fossil Fishes, Field Museum of Natural History, Chicago, Illinois.
- Denniston, Dr. Carter L.** Department of Medical Genetics, University of Wisconsin, Madison.
- Deno, Dr. Richard A.** Professor of Pharmacognosy, University of Michigan.
- Dent, Dr. William.** Department of Physics and Astronomy, University of Massachusetts.
- DePaolo, Dr. Donald J.** Department of Geology and Geophysics, University of California, Berkeley.
- DePlasco, Mark A.** Air Force Flight Standard Agency, Washington, D.C.
- Derge, Prof. Gerhard.** Department of Metallurgy and Material Science, Carnegie-Mellon University.
- Dershowitz, Dr. Nachum.** Department of Computer Science, Illinois Institute of Technology, Chicago.
- Des S. Thomas, Dr. Donovan.** Department of Biology, University of Windsor, Ontario, Canada.
- deSatnick, Steve.** Vice President, Operations and Engineering, KCET-TV, Los Angeles, California.
- Destree, Thomas M.** Editor in Chief, Graphic Arts Technical Foundation, Sewickley, Pennsylvania.
- DeVaney, Fred D.** Consulting Metallurgist, Duluth, Minnesota.
- DeVolpi, Dr. A.** Argonne National Laboratory, Argonne, Illinois.
- DeVore, Dr. George W.** Department of Geology, Florida State University.
- DeVries, Dr. Arthur L.** Department of Physiology and Biophysics, University of Illinois, Urbana-Champaign.
- de Week, Dr. A. L.** Institut für Klinische Immunologic Inselspital, Universität Bern, Switzerland.
- Dewsbury, Dr. Donald A.** Department of Psychology, University of Florida, Gainesville.
- Dexter, Dr. Theodore H.** Research Supervisor, Inorganic Chemistry, Hooker Chemical Corporation Research Center, Niagara Falls, New York.
- Dhir, Prof. Vijay K.** Department of Mechanical and Aerospace Engineering, University of California, Los Angeles.
- Diamond, Dr. Seymour.** Director, Diamond Headache Clinic, Ltd., Chicago, Illinois.
- DiBiase, Dr. David.** Department of Geography, Pennsylvania State University, University Park.
- Dick, Prof. B. Gale.** Department of Physics, University of Utah.
- Dick, Dr. Henry J. B.** Senior Scientist, Department of Geology and Geophysics, Woods Hole Oceanographic Institution, Woods Hole, Massachusetts.
- Dickinson, Prof. Robert E.** Department of Atmospheric Physics, University of Arizona, Tucson.
- Dickinson, Dr. W. R.** Department of Geosciences, University of Arizona, Tucson.
- Dieke, Prof. G. H.** Deceased; formerly, Chairman, Department of Physics, Johns Hopkins University.
- Diekema, Dr. Daniel James.** University of Iowa College of Medicine, Department of Pathology, Division of Medical Microbiology, Iowa City.
- Dietrich-Buchecker, Dr. C. O.** Laboratoire de Chimie Organo-Minérale, Institut le Bel, Université Louis Pasteur, Strasbourg, France.
- Di Fiore, Dr. Anthony.** Department of Anthropology, New York University, New York.
- Di Giulio, Edmund M.** Cinema Products Corporation, Los Angeles, California.
- Dill, Dr. Robert F.** Ocean Mining Administration, U.S. Department of the Interior.
- Dille, Dr. James M.** Deceased; formerly, Professor and Chairman, Department of Pharmacology, School of Medicine, University of Washington.
- Dillman, Prof. Norman G.** Department of Electrical and Computer Engineering, Kansas State University, Manhattan.
- Dillon, J. F., Jr.** Bell Telephone Laboratories, Murray Hill, New Jersey.

- DiMichele, Dr. William A.** Department of Paleobotany, Smithsonian Institution, Washington, D.C.
- Dimmel, Prof. Donald R.** Research Associate, Wood Sciences, Chemical Sciences Division, Institute of Paper Chemistry, Appleton, Wisconsin.
- Dine, Dr. Michael.** Physics Department, City College of New York.
- Dingle, Prof. Hugh.** Department of Entomology, College of Agricultural and Environmental Sciences, University of California, Davis.
- Dinsmore, Robertson P.** International Ice Patrol, Woods Hole Oceanographic Institution, Woods Hole, Massachusetts.
- DiTallo, Cynthia.** United Technologies, Otis Elevator Company, Farmington, Connecticut.
- Dix, Dr. Cyril H.** Bishop Monkton, North Yorkshire, England.
- Doane, Dr. J. William.** Liquid Crystal Institute, Kent State University, Kent, Ohio.
- Dodds, Robert H.** Deceased; formerly, Personnel Manager, Gibbs and Hill, Inc., New York.
- Dogramaci, Prof. AH.** Department of Industrial and Management Engineering, Columbia University.
- Doherty, Dr. Michael F.** Head, Department of Chemical Engineering, University of Massachusetts.
- Domning, Dr. Daryl P.** Department of Anatomy, Howard University, Washington, DC.
- Donaldson, Dr. Alex I.** Pirbright Laboratory, Pirbright, Surrey, United Kingdom.
- Donaldson, Dr. James A.** Professor and Chairman, Department of Otolaryngology, School of Medicine, University of Washington.
- Donovan, Dr. Nowell.** Department of Geology, Texas Christian University, Fort Worth.
- Doob, Prof. Joseph L.** Department of Mathematics, University of Illinois, Urbana-Champaign.
- Doolan, Barry L.** Department of Geology, Memorial University of Newfoundland, St. John's, Canada.
- Dooley, H. D.** Marine Laboratory, Department of Agriculture and Fisheries, Aberdeen, Scotland.
- Doornbos, Dr. Durk J.** Deceased; formerly, Institute for Geophysics, University of Oslo, Norway.
- Dorf, Prof. Erling.** Department of Geology, Princeton University.
- Dorf, Dean Richard C.** Division of Extended Learning, University of California, Davis.
- Dorfman, Dr. Ralph I.** Senior Vice President and Director, Syntex Research Center, Palo Alto, California.
- Dorsey, Prof. John G.** Department of Chemistry, Florida State University, Tallahassee.
- Doscher, Dr. Todd M.** Department of Petroleum Engineering, University of Southern California.
- Dossel, Dr. William E.** Professor and Chairman, Department of Anatomy, School of Medicine, Creighton University.
- Dott, Dr. Robert H., Jr.** Department of Geology, University of Wisconsin.
- Doubiel, Dr. Russell F.** Geological Survey, U.S. Department of the Interior, Denver, Colorado.
- Doudoroff, Dr. Michael.** Deceased; formerly, Department of Bacteriology, University of California, Berkeley.
- Douglas, Donald W., Jr.** Corporate Vice President—Administration, McDonnell Douglas Corporation, St. Louis, Missouri; Chairperson and President, Douglas Aircraft Company of Canada, Toronto, Ontario.
- Dougllass, Prof. David H.** Department of Physics and Astronomy, College of Art and Science, University of Rochester.
- Douglass, Prof. Raymond D.** Department of Mathematics, Massachusetts Institute of Technology.
- Dover, Dr. Carl B.** Department of Physics, Brookhaven National Laboratory, Upton, New York.
- Doviak, R. J.** National Severe Storms Laboratory, National Oceanic and Atmospheric Administration, Norman, Oklahoma.
- Downey, Dr. Joe.** Dow Chemical Company, Midland, Michigan.
- Downey, Dr. R. K.** Agricultural Research Station, Saskatoon, Saskatchewan, Canada.
- Doyle, Prof. James A.** Department of Biological Sciences, University of California, Davis.
- Doyle, Laurence.** Senior Scientist, ITT Aerospace/Communications, Clifton, New Jersey.
- Doyle, Prof. Michael P.** Director, Center for Food Safety and Quality Enhancement, University of Georgia, Griffin.
- Drake, A. E.** Division of Electrical Science, National Physical Laboratory, United Kingdom.
- Drake, Prof. John C.** Department of Geology, University of Vermont.
- Drake, Dr. Michael V.** Department of Ophthalmology, School of Medicine, University of California, San Francisco.
- Draper, Dr. Clifton W.** Laser Studies Group, Western Electric Company, Princeton, New Jersey.
- Dreschel, Dr. Thomas W.** Biologist/Chemist, Bionetics Corporation, Environmental Monitoring and Research Program, Kennedy Space Center, Florida.
- Dresden, Prof. Max.** Institute for Theoretical Physics, State University of New York, Stony Brook.
- Drexter, Dr. Eric.** Foresight Institute, Palo Alto, California.
- Dropping, Barry.** Hewlett-Packard, Santa Clara, California.
- Duby, Prof. Paul.** Henry Krumb School of Mines, Columbia University.
- Duckworth, Dr. Henry E.** Department of Physics, University of Manitoba, Canada.
- Dugan, Dr. Frank M.** American Type Culture Collection, Manassas, Virginia.
- Duguay, Dr. Michel A.** Laser Development, Sandia Laboratories, Albuquerque, New Mexico.
- Duke, Dr. C. B.** Manager, Molecular and Organic Materials Area, Xerox Corporation, Rochester, New York.
- Duke, Kenneth L.** Department of Anatomy, Duke University Medical Center.
- Dunbar, Prof. Carl O.** Deceased; formerly, Professor Emeritus of Paleontology and Stratigraphy, Yale University.
- Duncan, Prof. William G.** Department of Agronomy, University of Kentucky.
- Duncombe, Dr. Raynor L.** Department of Aerospace Engineering, University of Texas, Austin.
- Dunlop, Prof. David J.** Department of Physics, University of Toronto, Ontario, Canada.
- Dunn, Prof. Bruce.** Department of Materials Science & Engineering, University of California, Los Angeles.
- Dunn, Prof. Floyd.** Department of Electrical and Computer Engineering, University of Illinois at Urbana-Champaign.
- Dunning, Dr. John B., Jr.** Department of Forestry and Natural Resources, Purdue University.
- DuPont, Dr. Herbert L.** Medical School, University of Texas, Houston.
- Duren, Prof. Peter L.** Department of Mathematics, University of Michigan.
- Durst, Prof. Richard A.** Director, Analytical Chemistry Laboratories, New York State Agricultural Experimental Station, Cornell University, Geneva.
- Dutro, Dr. J. Thomas, Jr.** Museum of Natural History, U.S. Department of the Interior, Washington, D.C.
- Duwez, Dr. Pol E.** Deceased; formerly, W. M. Keck Laboratory of Engineering Materials, California Institute of Technology.
- Dyer, Dr. K. R.** Institute of Oceanographic Sciences, Somerset, England.
- Dym, Prof. C. L.** Department of Civil Engineering, University of Massachusetts.
- Dzuiba, Ronald.** Senior Member, Electrical Measurements Laboratory, National Institute of Standards and Technology, Gaithersburg, Maryland.

## E

- Easterbrook, Don J.** Department of Geology, Western Washington University, Bellingham.
- Eberl, Dr. Dennis D.** U.S. Geological Survey, Denver Federal Center, Denver, Colorado.
- Eberts, Prof. Ray.** Department of Industrial Engineering, Purdue University.



- Eckels, Dr. Arthur R.** Department of Electrical Engineering, North Carolina State University.
- Economou, George A.** Formerly, J. W. Pecker Division, American Optical Company, Pittsburgh, Pennsylvania.
- Edelman, Robert I.** Corporate Communications, Eastman Kodak Company, Rochester, New York.
- Edelson, Dr. Marshall.** Department of Psychiatry, Yale University.
- Edgecombe, Gregory D.** American Museum of Natural History, New York.
- Edgerton, Dr. Harold E.** Institute Professor, Emeritus, Massachusetts Institute of Technology.
- Edmonds, Dr. Robert L.** College of Forest Resources, University of Washington, Seattle.
- Edwards, Alan F.** Freeport-McMoran Inc., New Orleans, Louisiana.
- Edwards, Prof. John O.** Department of Chemistry, Brown University.
- Edwards, Dr. Peter A.** Department of Biological Chemistry, University of California School of Medicine, Los Angeles.
- Edwards, Dr. Russell K.** Argonne National Laboratory, Argonne, Illinois.
- Edwards, Dr. Steven.** Department of Virology, Central Veterinary Laboratory-Weybridge, United Kingdom.
- Eesley, Dr. Gary L.** GM Research and Development Center, Warren, Michigan.
- Egan, Patrick.** Department of Physics, Yale University.
- Ehernberger, L. J.** NASA Dryden Flight Research Facility, Edwards, California.
- Ehrlich, Dr. John.** Formerly, Laboratory Director in Antibiotic Research, Parke, Davis and Company, Detroit, Michigan.
- Ehrlich, Dr. Paul R.** Professor of Biological Sciences and Curator of the Entomological Collections, Stanford University.
- Ehrlich, Dr. Stanley L.** Middletown, Rhode Island.
- Ehrmann, Dr. David A.** Department of Medicine, Section of Endocrinology, University of Chicago Medical Center.
- Eichorn, Dr. Gunther L.** Gerontology Research Center, National Institutes of Health, Baltimore, Maryland.
- Eidson, Dr. Millicent.** Veterinarian, Santa Fe, New Mexico.
- Eilers, Carl G.** Manager, Electronics Systems Research and Development, Zenith Radio Corporation, Glenview, Illinois.
- Einaudi, Prof. Marco T.** Department of Applied Earth Science, Stanford University.
- Eirich, Dr. F. R.** Chemistry/Life Sciences Department, Polytechnic University, New York.
- Eisenbud, Dr. Merrill.** Institute of Environmental Medicine, New York University Medical Center.
- Ekdale, Dr. Allan A.** Department of Geology and Geophysics, College of Mines and Earth Sciences, University of Utah.
- Eldeib, Dr. Hany K.** Department of Electrical and Computer Engineering, George Mason University, Fairfax, Virginia.
- Elderfield, Prof. Robert C.** Deceased; formerly, Department of Chemistry, University of Michigan.
- Eldredge, Dr. Niles.** American Museum of Natural History, New York.
- Elgomayel, Prof. Joseph.** School of Industrial Engineering, Purdue University.
- Eliel, Prof. Ernest L.** Department of Chemistry, University of North Carolina.
- Ellen, Dr. C. Wayne.** Department of Plant Pathology, Ohio State University.
- Ellis, Dr. David E.** Research and Development Department, Continental Oil Company, Ponca City, Oklahoma.
- Ellis, Dr. Gordon W.** Department of Biology, School of Art and Sciences, University of Pennsylvania, Leidy Laboratory of Biology, Philadelphia.
- Ellis, Dr. Walther R.** Division of Chemistry and Chemical Engineering, California Institute of Technology.
- El-Mansy, Youssef.** Intel Corporation, Aloha, Oregon.
- Elston, Dr. Stuart B.** Department of Physics and Astronomy, University of Tennessee, Knoxville.
- Eltoweissy, Dr. Mohamed Y.** Department of Computer Science, James Madison University, Harrisonburg, Virginia.
- Ely, F. G.** Retired; Research and Development Division, Babcock and Wilcox Company.
- Emanuel, Dr. Kerry Andrew.** Department of Earth, Atmospheric and Planetary Sciences, Massachusetts Institute of Technology.
- Emerson, Lewis P.** Engineer in Charge of Flow Measurement, Foxboro Company, Foxboro, Massachusetts.
- Emerson, Dr. Steven.** Department of Oceanography, University of Washington.
- Encleson, Stephen C.** Technical Editor, Corporate Communications, Dow Chemical Company, Midland, Michigan.
- Endicott, Prof. John F.** Department of Chemistry, Wayne State University.
- Engels, Dr. William R.** Department of Genetics, University of Wisconsin, Madison.
- English, Prof. Van H.** Department of Geography, Dartmouth College.
- Engstrom, Prof. Arne.** Head, Department of Medical Physics, Karolinska Institute, Stockholm, Sweden.
- Engstrom, Dr. Ralph W.** Electro-Optics and Devices, RCA Laboratories, Lancaster, Pennsylvania.
- Enkenfelder, Dr. W. Wesley, Jr.** Eckenfelder, Inc., Nashville, Tennessee.
- Enlander, Dr. Derek.** New York, New York.
- Enrich, Fredric F.** Aircraft Engine Business Group, General Electric Company, Lynn, Massachusetts.
- Enslow, Prof. Philip H., Jr.** School of Information and Computer Science, Georgia Institute of Technology.
- hEocha, Colm.** Department of Biochemistry, University College, Galway, Ireland.
- Epperly, W. R.** Exxon Research and Engineering, Annandale, New Jersey.
- Epstein, Dr. W. W.** Department of Chemistry, University of Utah.
- Erasmus, Dr. Baltus J.** Head, Onderstepoort Vaccine Factory, Republic of South Africa.
- Erb, Dr. Karl A.** Oak Ridge National Laboratory, Oak Ridge, Tennessee.
- Erdelyi, Prof. A.** Professor of Mathematics, University of Edinburgh, Scotland.
- Erdman, Dr. Arthur.** Department of Mechanical Engineering, University of Minnesota.
- Erickson, Dr. Robert P.** Department of Pediatrics, University of Arizona College of Medicine, Tucson.
- Eriksson, Dr. Kenneth A.** Department of Geology, University of Texas, Richardson.
- Ernst, Dr. Ralph A.** Extension Poultry Specialist, Avian Sciences, University of California, Davis.
- Ernster, Dr. Virginia L.** Department of Epidemiology and International Health, School of Medicine, University of California, San Francisco.
- Esaki, Leo. Thomas J.** Watson Research Center, IBM, Yorktown Heights, New York.
- Esau, Prof. Katherine.** Department of Botany, University of California, Santa Barbara.
- Essene, Prof. Eric J.** Department of Geological Sciences, University of Michigan, Ann Arbor.
- Ethridge, Dr. Frank G.** Department of Earth Resources, Colorado State University.
- Ettenberg, Dr. Eugene M.** Formerly, Lecturer in Graphic Arts, New York.
- Etter, Robert J.** David W. Taylor Naval Ship Research and Development Center, Bethesda, Maryland.
- Evans, Doris L.** Deceased; formerly, Research and Development Division, Corning Glass Works, Corning, New York.
- Evans, Dr. Doyle J.** Chief, Bacterial Enteropathogens Laboratory, Veterans Affairs Medical Center, Houston, Texas.
- Evans, Prof. Francis C.** Division of Biological Sciences, University of Michigan.
- Evans, Dr. Ginger.** Denver, Colorado.
- Evans, Prof. Robley D.** Retired; Department of Physics, Massachusetts Institute of Technology.
- Evenson, Dr. Kenneth M.** Time and Frequency Division, National Institute of Standards and Technology, Boulder, Colorado.
- Evenson, Dr. Paul.** Bartol Research Institute, University of Delaware.
- Everetts, Dr. John Jr.** Professor of Architectural Engineering, Pennsylvania State University.
- Ewing, Dr. Maurice.** Deceased; formerly, Lamont-Doherty Geological Observatory, Palisades, New York.
- Ewing, Prof. Rodney.** Department of Earth and Planetary Sciences, University of New Mexico, Albuquerque.
- Eyde, Dr. Richard H.** Department of Botany, Smithsonian Institution.

- Eyring, Dr. Edward M.** Department of Chemistry, University of Utah.
- Eyring, Prof. Henry.** Deceased; formerly, Institute for the Study of Rate Processes, University of Utah.
- Ezzell, Dr. John W.** Chief, Special Pathogens Branch, U.S. Army Medical Research Institute, Fort Detrick, Maryland.

## F

- Failla, Dr. Gioacchino.** Deceased; formerly, Argonne National Laboratory, Argonne, Illinois.
- Fairbank, Prof. Henry A.** Department of Physics, Duke University.
- Falchuck, Dr. Kenneth A.** Center for Biochemical and Bio-physical Sciences and Medicine, Harvard Medical School.
- Faller, Dr. John W.** Department of Chemistry, Yale University.
- Fan, Prof. Hsu Y.** Department of Physics, Purdue University.
- Fankhauser, Dr. Gerhard.** Deceased; formerly, Department of Biology, Princeton University.
- Fano, Prof. U.** Deceased; formerly, James Franck Institute, University of Chicago.
- Fanta, Prof. Paul E.** Department of Chemistry, Illinois Institute of Technology.
- Farmer, Dr. David M.** Department of the Environment, Pacific Region, Institute of Ocean Sciences, Sidney, British Columbia, Canada.
- Farmer, Richard G.** Department of Electrical Engineering, Arizona State University, Tempe.
- Farrel, Dr. Nicholas.** Department of Chemistry, Virginia Commonwealth University, Richmond.
- Farrell, R. F.** General Manager, Glidden Coatings and Resins, Division of SCM Corporation, Charlotte, North Carolina.
- Faure, Dr. Gunter.** Department of Geological Sciences, Ohio State University.
- Faw, Prof. Richard E.** Head, Department of Nuclear Engineering, Kansas State University.
- Fawcett, Prof. Eric.** Department of Physics, University of Toronto, Ontario, Canada.
- Fay, Dr. Richard R.** Parmlly Hearing Institute and Department of Psychology, Loyola University of Chicago, Illinois.
- Fayyad, Dr. Usama.** Microsoft Research, Redmond, Washington.
- Feduccia, Dr. Alan.** Department of Biology, University of North Carolina, Chapel Hill.
- Fehr, Prof. Walter R.** Department of Agronomy, Iowa State University.
- Feigenbaum, Mitchell J.** Professor, Department of Physics, Cornell University.
- Fein, Dr. Jay S.** Division of Atmospheric Sciences, National Science Foundation, Washington, D.C.
- Feist, Dr. Blake E.** Northwest Fisheries Science Center, Environmental Conservation Division—Watershed Program, Seattle, Washington.
- Feldberg, Dr. Steven W.** Department of Applied Science, Brookhaven National Laboratory, Upton, New York.
- Feldman, Dr. Barry J.** Los Alamos Scientific Laboratory, Los Alamos, New Mexico.
- Feldman, Leonard.** Electronics Laboratories, Great Neck, New York.
- Feldman, Dr. Leonard C.** AT&T Bell Laboratories, Murray Hill, New Jersey.
- Feldmann, Dr. Rodney M.** Department of Geology, Kent State University, Kent, Ohio.
- Fell, Prof. Howard B.** Museum of Comparative Zoology, Harvard University.
- Fell, Dr. Jack W.** University of Miami, Rosenstiel School of Marine and Atmospheric Science, Marine Biology and Fisheries, Key Biscayne, Florida.
- Feller, Prof. William.** Deceased; formerly, Department of Mathematics, Princeton University.
- Felver, Prof. Richard I.** Designer, Carnegie Institute of Technology.
- Fendler, Dr. Janos H.** Department of Chemistry, Center for Research in Membranes and Colloid Science, Syracuse University.
- Ferguson, Prof. J. Homer.** Department of Biological Science, University of Idaho.
- Ferguson, Dr. Louise.** Extension Pomologist, Kearney Agricultural Center, University of California, Parlier.
- Fernando, Dr. Quintus.** Department of Chemistry, University of Arizona.
- Ferrell, Dr. James E., Jr.** Department of Molecular Pharmacology, Stanford University, School of Medicine.
- Ferrell, Prof. Thomas L.** Health and Safety Research Division, Oak Ridge National Laboratory, Oak Ridge, Tennessee.
- Ferris, Prof. Gordon F.** Deceased; formerly, National History Museum, Stanford University.
- Ferry, Dr. James F.** Department of Biology, Madison College.
- Feshbach, Dr. Herman.** Department of Physics, Massachusetts Institute of Technology.
- Fetz, Dr. Eberhard E.** Department of Physiology and Biophysics, University of Washington School of Medicine.
- Few, Prof. Arthur.** Department of Space Physics and Astronomy, Rice University.
- Fiala, Dr. Alan D.** U.S. Naval Observatory, Washington, D.C.
- Fidecaro, Dr. Giuseppe.** EP Division, CERN, Geneva, Switzerland.
- Fiedler, Dr. Peggy L.** Piedmont, California.
- Fields, Paul R.** Senior Chemist, Argonne National Laboratory, Argonne, Illinois.
- Fields, Thomas H.** Physics Division, Argonne National Laboratory, Argonne, Illinois.
- Fincham, Prof. J. R. S.** Department of Genetics, University of Leeds, England.
- Findlay, Dr. David M.** Department of Orthopedics and Trauma, University of Adelaide, Royal Adelaide Hospital, Adelaide, Australia.
- Finegold, Dr. Sydney M.** Chief, Infectious Disease Section, Veterans Administration Wadsworth Hospital Center, Los Angeles, California.
- Fingerman, Dr. Milton.** Department of Biology, Tulane University.
- Fink, Donald G.** Director Emeritus, IEEE; Editor in Chief, "Electronics Engineers' Handbook," McGraw-Hill Book Company, New York.
- Fink, Prof. Jordan N.** Chief, Allergy-Immunology Section, Department of Medicine, Medical College of Wisconsin.
- Finkelstein, Prof. L.** Department of Physics, The City University, London, England.
- Finkelstein, Dr. Richard.** Department of Microbiology, University of Missouri School of Medicine, Columbia.
- Finks, Dr. Robert M.** Department of Geology, Queens College, City University of New York.
- Finotello, Dr. Daniele.** Liquid Crystal Institute, Kent State University, Kent, Ohio.
- Firebaugh, Millard S.** Naval Sea Systems Command, Washington, D.C.
- Firk, Prof. Frank W. K.** Electron Accelerator Laboratory, Yale University.
- Firor, Dr. John W.** Director, Advanced Study Program, National Center for Atmospheric Research, Boulder, Colorado.
- Fischer, Prof. Alfred G.** San Pedro, California.
- Fischer, Harold.** General Motors Corporation, Flint, Michigan.
- Fischer, Henry W.** Hardesty & Hanover, New York.
- Fischer, Prof. J. E.** Department of Materials Science and Engineering, University of Pennsylvania, Philadelphia.
- Fisher, Dr. Jack B.** Fairchild Tropical Garden and Research Center, Miami, Florida.
- Fisher, Dr. Robert A.** Los Alamos Scientific Laboratory, Los Alamos, New Mexico.
- Fisher, Dr. Robert L.** Geological Research Division, Scripps Institution of Oceanography, La Jolla, California.
- Fisher, Prof. Russell A.** Department of Physics, Northwestern University.
- Fisher, Dr. William L.** Department of Geological Science, University of Texas, Austin.
- Fisk, Prof. Nelson S.** Department of Civil Engineering, Columbia University.
- Fiske, Capt. Richard P.** Retired; formerly, Director of Ocean Engineering/Supervisor of Salvage and Diving, U.S. Navy.
- Fitch, Prof. Val.** Department of Physics, Princeton University.
- Fitzsimons, James T.** Physiological Laboratory, University of Cambridge, United Kingdom.
- Flathers, George W., II.** MITRE Corporation, McLean, Virginia.
- Fleischer, Dr. R. L.** Physical Science Branch, General Physics Laboratory, General Electric Company, Schenectady, New York.

- Fleminger, Dr. Abraham.** Research Biologist, Scripps Institution of Oceanography, La Jolla, California.
- Flessa, Dr. Karl Walter.** Division of Earth Sciences, National Science Foundation, Washington, D.C.
- Flint, Dr. Richard F.** Department of Geology and Geophysics, Yale University.
- Flint, Robert B.** VORTAC Consultant, Havana, Illinois.
- Floe, Prof. Carl f.** Department of Metallurgy, Massachusetts Institute of Technology.
- Flye, Prof. M. Wayne.** Surgery, Microbiology and Immunology, Washington University School of Medicine, St. Louis, Missouri.
- Flynn, Dr. Thomas M.** Consultant, Cryogenic Engineering, Boulder, Colorado.
- Focht, Prof. Dennis D.** Department of Soil and Environmental Sciences, University of California, Riverside.
- Fogel, Dr. David B.** Natural Selection, Inc., La Jolla, California.
- Foon, Dr. Kenneth A.** Roswell Park Memorial Institute, Buffalo, New York.
- Ford, Prof. Derek C.** Department of Geography, McMaster University, Hamilton, Ontario, Canada.
- Ford, Prof. E. B.** Deceased; formerly, Genetics Laboratory, Department of Zoology, Oxford University, England.
- Ford, Dr. Karen Grady.** Department of Biology, College of Charleston, South Carolina.
- Forey, Dr. Peter.** Department of Paleontology, Natural History Museum, London, England.
- Forster, Dr. Denis.** Monsanto Company, St. Louis, Missouri.
- Foster, Prof. Jackson W.** Deceased; formerly, Professor of Microbiology, University of Texas.
- Foster, Dr. Mark G.** Retired; Department of Electrical Engineering, School of Engineering and Applied Science, University of Virginia.
- Foster, Prof. Merrill W.** Department of Geology, Bradley University.
- Foster, Dr. Robert J.** Department of Physics, San Jose State University.
- Fountain, Dr. David M.** Department of Geology and Geophysics, University of Wyoming.
- Fourtner, Dr. Charles R.** Department of Biological Science, State University of New York, Buffalo.
- Fowler, Prof. W. Beall.** Department of Physics, Lehigh University.
- Fox, Dr. Christopher.** Department of Computer Science, James Madison University, Harrisonburg, Virginia.
- Fox, Dr. Marye Anne.** Department of Chemistry, University of Texas, Austin.
- Fox, Dr. Richard.** Department of Biological Sciences, University of Alberta, Edmonton, Canada.
- Fox, Dr. Robert M.** Department of Electrical Engineering, College of Engineering, University of Florida.
- Fradkin, Dr. David M.** Department of Physics, Wayne State University.
- Frailey, Dr. Dennis J.** Texas Instruments, Inc., Austin, Texas.
- Frakes, Dr. William B.** Virginia Tech, Northern Virginia Center, Falls Church.
- Frame, Prof. J. Sutherland.** Professor Emeritus of Mathematics, Michigan State University.
- Franc, Dr. Jean-Marie.** Laboratoire d'Histologie et Biologie Tissulaire, Université Claude Bernard, Villeurbanne, France.
- France, Dr. Diane L.** Fort Collins, Colorado.
- Francis, Dr. Arthur W.** Union Carbide Corporation, Tarrytown, New York.
- Frank, Prof. Bernard.** Deceased; formerly, Professor of Watershed Management, Colorado State University.
- Franklin, David.** Program Manager, Nuclear Systems and Materials, Electric Power Research Institute, Palo Alto, California.
- Franzese, Dr. Kenneth.** Research and Development, Bright Star Industries, Inc., Clifton, New Jersey.
- Franzini, Dr. Paolo.** Dipartimento di Fisica, Università di Roma I, Italy.
- Freeman, Dr. A. E.** Department of Animal Science, Iowa State University.
- Freedman, Dr. Daniel X.** Department of Psychiatry and Behavioral Sciences, University of California School of Medicine.
- Freeman, Harry M.** Chief, Waste Minimization Branch, Risk Reduction Engineering Laboratory, U.S. Environmental Protection Agency, Cincinnati, Ohio.
- Freeman, Prof. Jeremiah P.** Department of Chemistry, University of Notre Dame.
- Freeman, Prof. Ralph L.** Retired; Department of Mechanical Engineering, Iowa State College.
- Freedman, Dr. Wendy L.** Observatories of the Carnegie Institution of Washington, Pasadena, California.
- Freire, Prof. Ernesto.** Director, Biocalorimetry Center, Johns Hopkins University, Baltimore, Maryland.
- Freiser, Prof. Henry.** Department of Chemistry, University of Arizona, Tucson.
- Fremed, Raymond F.** Burson-Marsteller Associates, New York.
- French, Dr. J. Bruce.** Department of Physics, University of Rochester.
- Fretter, Prof. William B.** Department of Physics, University of California, Berkeley.
- Freudenstein, Dr. Ferdinand.** Department of Mechanical Engineering, Columbia University.
- Freundt, Dr. E. A.** Institute for Medical Microbiology, Aarhus University, Denmark.
- Frey, Dr. Kenneth J.** Department of Agronomy, Iowa State University.
- Fribourg, Prof. Henry A.** Department of Plant and Soil Science, University of Tennessee, Knoxville.
- Frick, Dr. Oscar L.** Department of Pediatrics, University of California Medical Center.
- Fridovich, Dr. Irwin.** Department of Biochemistry, Duke University Medical Center.
- Fried, Dr. George H.** Brooklyn College, City University of New York.
- Fried, Dr. Sherman.** Chemistry Division, Argonne National Laboratory, Argonne, Illinois.
- Fried, Walter R.** Deceased; formerly, Navigation Systems Consultant, Hughes Aircraft Company, Santa Ana, California.
- Friedlander, Prof. Sheldon K.** Department of Chemical Engineering, University of California, Los Angeles.
- Friedman, Prof. Harold L.** Department of Chemistry, State University of New York, Stony Brook.
- Friedman, Lewis.** Brookhaven National Laboratory, Upton, New York.
- Friedman, Norman.** U.S. Naval Institute, Annapolis, Maryland.
- Frisancho, Dr. A. Roberto.** Center for Human Growth and Development, University of Michigan, Ann Arbor.
- Fritsch, J. Michael.** Associate Professor, Department of Meteorology, College of Earth and Mineral Sciences, Pennsylvania State University.
- Froes, Dr. F. H. Sam.** Director, Institute for Materials and Advanced Processes, University of Idaho.
- Fromkin, Dr. Victoria A.** Dean, Vice Chancellor, Graduate Programs, Department of Linguistics, University of California, Los Angeles.
- Frondel, Prof. Clifford.** Retired; Department of Geological Sciences, Harvard University.
- Frost, Dr. Thomas M.** Center for Limnology, University of Wisconsin.
- Fruchter, Dr. Benjamin.** Department of Educational Psychology, University of Texas, Austin.
- Frumhoff, Dr. Peter.** Department of Entomology, University of California, Davis.
- Fry, Prof. Albert J.** Department of Chemistry, Wesleyan University, Middletown, Connecticut.
- Fry, Prof. Edward S.** Department of Physics, Texas A&M University.
- Frye, Gene.** Retired; formerly, Technical Staff, Collins Division, Rockwell International, Cedar Rapids, Iowa.
- Fryer, Dr. Geoffrey.** Freshwater Biological Association, Cumbria, United Kingdom.
- Fröhlich, Dr. Claus.** Physikalisch-Meteorologisches Observatorium Davos, World Radiation Center, Davos Dorf, Switzerland.
- Fuchs, Prof. Ronald.** Department of Physics, Iowa State University.
- Fudenberg, Dr. H. Hugh.** Section of Hematology and Immunology, San Francisco Medical Center, University of California.
- Fulford, Prof. George D.** Department of Chemical Engineering, University of Waterloo, Ontario, Canada.
- Fulks, J. R.** Retired; formerly, National Weather Service, Chicago, Illinois.

**Fuller, Prof. Dudley D.** (Retired)  
Department of Mechanical Engineering,  
Columbia University.

**Fuller, Dr. Mark Roy.** Patuxent Wildlife  
Reserve Center, Laurel, Maryland.

**Fuller, Dr. Thomas C.** Retired; formerly,  
Supervisor, Botany and Seed Laboratories,  
California Department of Food and  
Agriculture, Sacramento.

**Fulton, Dr. James W.** Monsanto Company,  
St. Louis, Missouri.

**Fung, Prof. Y. C.** Department of Applied  
Mechanics, University of California, San  
Diego.

**Furter, Dr. W. F.** Dean of Graduate Studies  
and Research, Royal Military College of  
Canada.

**Fusco, Roberto.** Istituto Guido Donegani,  
EniChem, Polymeric Materials Department,  
Novara, Italy.

**Futral, Prof. J. G.** Department of  
Agricultural Engineering, Georgia  
Agricultural Experiment Station,  
Experiment, Georgia.

**Futuyma, Dr. Douglas J.** Section of  
Ecology and Systematics, Cornell  
University.

## G

**Gaasch, Dr. William H.** Director of  
Cardiovascular Research, Section of  
Cardiovascular Diseases, Labey Clinic,  
Burlington, Massachusetts.

**Gagliardo, Reginald S.** Vice President,  
Engineering, Burns & Roe Enterprises, Inc.,  
Oradell, New Jersey.

**Gagne, Dr. Raymond J.** Systematic  
Entomology Laboratory, U.S. Department  
of Agriculture.

**Gaines, Dr. Alan M.** National Science  
Foundation.

**Gaines, Dr. George L.** Research and  
Development Center, General Electric  
Company, Schenectady, New York.

**Galambo, Prof. Theodore V.** Emeritus  
Professor, Department of Civil  
Engineering, University of Minnesota,  
Minneapolis.

**Gale, Dr. Douglas S.** National Science  
Foundation, Washington, D.C.

**Gale, Peter A.** Chief Naval Architect, John  
J. McMullen Associates, Inc., Arlington,  
Virginia.

**Gallant, Dr. Donald M.** Department of  
Psychiatry and Neurology, Tulane  
University School of Medicine.

**Galli, Prof. Stephen J.** Department of  
Pathology, Beth Israel Hospital, Boston,  
Massachusetts.

**Galston, Dr. Arthur W.** Department of  
Biology, Yale University.

**Gamble, Dr. Joe D.** National Aeronautics  
and Space Administration, Lyndon B.  
Johnson Space Center, Houston,  
Texas.

**Gamble, Dr. John.** Department of Geology,  
Victoria University, Wellington, New  
Zealand.

**Gambs, Gerard C.** Vice President (retired),  
Ford, Bacon, & Davis, Inc., New York.

**Garbassi, Fabio.** Istituto Guido Donegani,  
EniChem, Polymeric Materials Department,  
Novara, Italy.

**Garcia, Dr. John.** Department of  
Psychology, University of California, Los  
Angeles.

**Gardiner, Dr. Brian.** Linnean Society of  
London, Burlington House, Piccadilly,  
London, United Kingdom.

**Gardiner, Dr. Kathleen.** Eleanor Roosevelt  
Institute for Cancer Research, Denver,  
Colorado.

**Gardner, Prof. Chester S.** Department of  
Electrical Engineering and Computer  
Science, University of Illinois, Urbana.

**Gardner, Dr. Frank E.** Horticulturist,  
Agricultural Research Service, U.S.  
Department of Agriculture, Orlando,  
Florida.

**Gardner, Dr. Julian W.** Director of  
Nanotechnology Centre, Department of  
Engineering, University of Warwick,  
Coventry, United Kingdom.

**Gardner, Dr. Walter H.** Department of  
Agronomy and Soils, Washington State  
University.

**Garetz, Dr. Bruce A.** Department of  
Chemistry, Polytechnic University, New  
York.

**Garfield, Dr. Sol L.** Department of  
Psychology, Washington University.

**Garland, Dr. John.** Professor, Department  
of Forest Engineering, Oregon State  
University, Corvallis.

**Garrett, Prof. Alfred B.** Department of  
Chemistry, Ohio State University.

**Garrett, Dr. Roger E.** Department of  
Agricultural Engineering, University of  
California, Davis.

**Gasaway, Donald C.** E.A.R. Division,  
Cabot Corporation, San Antonio,  
Texas.

**Gass, Dr. Saul I.** Potomac, Maryland.

**Gastaldo, Dr. Robert A.** Department of  
Geology, Auburn University, Auburn,  
Alabama.

**Gastony, Prof. Gerald J.** Department of  
Plant Sciences, Indiana University.

**Gatchell, Charles J.** U.S. Department of  
Agriculture Forest Service, Forestry Sciences  
Laboratory, Princeton, West Virginia.

**Gaudin, Dr. Tim.** Department of Biological  
and Environmental Science, University of  
Tennessee, Chattanooga.

**Gauss, Dr. D.** Max-Planck Institut für  
Experimentelle Medizin, Göttingen,  
Germany.

**Gauss, F. Stephen.** Director, Astrometry  
Department, U.S. Naval Observatory,  
Washington, D.C.

**Gaylord, Prof. Charles N.** Deceased;  
formerly, Chairman, Department of Civil  
Engineering, University of Virginia.

**Gazzaniga, Dr. Michael S.** Professor of  
Psychology and Social Sciences in  
Medicine, State University of New York,  
Stony Brook.

**Geiger, Prof. Randall L.** Department of  
Electrical Engineering, Texas A&M  
University.

**Geist, Jon.** Radiometric Physics Division,  
National Institute of Standards and  
Technology, Washington, D.C.

**Gelfand, Prof. Erwin W.** Chief, Division of  
Immunology and Rheumatology, Hospital  
for Sick Children, Toronto, Ontario,  
Canada.

**Gemmell, Dr. Donald S.** Physics Division,  
Argonne National Laboratory, Argonne,  
Illinois.

**Genito, Dennis.** Pasture Systems and  
Watershed Management Research  
Laboratory, U.S. Department of  
Agriculture-Agricultural Research Service,  
University Park, Pennsylvania.

**Gensler, Prof. Walter J.** Deceased;  
formerly, Department of Chemistry, Boston  
University.

**George, Dr. Kathleen F.** Union Carbide  
Chemicals and Plastics Company, Inc.,  
South Charleston, West Virginia.

**George, Dr. Melvin R.** Agronomy and  
Range Science Extension, University of  
California, Davis.

**Georgorapadakou, Dr. Nafsika H.**  
Department of Infectious Diseases, DuPont  
Research Laboratories, Wilmington,  
Delaware.

**Gepts, Dr. Paul.** Department of Agronomy  
and Range Science, University of  
California, Davis.

**Gerber, Leah R.** National Center for  
Ecological Analysis and Synthesis, Santa  
Barbara, California.

**Gergely, Dr. John.** Department of Muscle  
Research, Boston Biomedical Research  
Institute, Boston, Massachusetts.

**Gerjuoy, Dr. Edward.** Department of  
Physics, University of Pittsburgh.

**Gerlach, Dr. Arch C.** Chief Geographer,  
Geological Survey, U.S. Department of the  
Interior.

**Gerrity, Dr. Joseph P.** National  
Meteorological Center, National Oceanic  
and Atmospheric Administration, Camp  
Springs, Maryland.

**Gersh, Prof. Isidore.** Research Professor,  
Department of Animal Biology, School of  
Veterinary Medicine, University of  
Pennsylvania.

**Gershoff, Prof. Stanley N.** Department of  
Nutrition, Harvard School of Public Health,  
Boston, Massachusetts.

**Gertler, Dr. Janos.** Department of Electrical  
and Computer Engineering, George Mason  
University, Fairfax, Virginia.

**Gertsch, Dr. Willis J.** American Museum of  
Natural History, New York.

**Gerwartowski, James W.** Bell Telephone  
Laboratories, Murray Hill, New Jersey.

**Getman, Dr. Thomas D.** Department of  
Chemistry, Northern Michigan University.

**Ghiorso, Dr. Albert.** Department of  
Chemistry, Lawrence Berkeley Laboratory,  
University of California, Berkeley.

- Giallorenzi, Dr. Thomas G.** Superintendent, Optical Science Division, Department of the Navy, Naval Research Laboratory, Washington, D.C.
- Giannasi, Dr. David E.** Department of Botany, University of Georgia.
- Gibbons, Dr. Ian.** Kewala Laboratory, University of Hawaii.
- Gibbs, Dr. Martin.** Institute for Photobiology of Cells and Organelles, Brandeis University.
- Giblon, Robert P.** President, George G. Sharp, Inc., New York.
- Gibson, Dr. John E.** Dean of Engineering, Oakland University.
- Giese, Raymond.** Department of Mechanical Engineering, University of Minnesota.
- Gigg, Roy H.** Chemistry Division, National Institute for Medical Research, London, England.
- Giguere, Paul A.** Emeritus Professor, St. Petersburg Beach, Florida.
- Gilardi, Dr. Gerald L.** Microbiology Laboratory, North General Hospital, New York.
- Gilbert, Barrie.** Analog Devices, Inc., Northwest Laboratories, Beaverton, Oregon.
- Gilbert, Dr. Edgar N.** Deceased; formerly, AT&T Bell Telephone Laboratories, Murray Hill, New Jersey.
- Gill, Dr. D. Michael.** Department of Molecular Biology and Microbiology, Tufts University.
- Gillespie, Dr. Ronald J.** Department of Chemistry, McMaster University, Hamilton, Ontario, Canada.
- Gilloteaux, Dr. Jacques.** Professor of Cell Biology and Anatomy, Lake Erie College of Osteopathic Medicine, Erie, Pennsylvania.
- Gingrich, Prof. Newell S.** Department of Physics, University of Missouri.
- Ginsburg, Dr. Robert N.** Rosenstiel School of Marine and Atmospheric Science, University of Miami.
- Girvin, Prof. Steven M.** Department of Physics, Indiana University, Bloomington.
- Glantz, Dr. Michael.** National Center for Atmospheric Research, Boulder, Colorado.
- Glasford, Prof. Glenn M.** Department of Electrical and Computer Engineering, Syracuse University.
- Glass, Dr. Roger I.** Chief, Viral Gastroenteritis Unit, Centers for Disease Control and Prevention, Atlanta, Georgia.
- Glasscock, Dwight L.** Deceased; formerly, Harza Engineering Company, Chicago, Illinois.
- Gledhill, Dr. S. J.** Harpenden Herts, United Kingdom.
- Glick, Dr. Benjamin.** University of Chicago, Cummings Life Science Center, Chicago, Illinois.
- Glowatz, Dr. Michael, Jr.** Environmental Health and Safety Department, AT&T Bell Laboratories, Murray Hill, New Jersey.
- Gnade, Dr. Bruce E.** Defense Advanced Research Projects Agency, Arlington, Virginia.
- Goddu, Dr. Robert F.** Manager, Fibers and Film Research Division, Hercules, Inc., Wilmington, Delaware.
- Goebel, Prof. Charles.** Department of Physics, University of Wisconsin.
- Goff, Dr. Fraser.** Los Alamos National Laboratories, Los Alamos, New Mexico.
- Gokel, Prof. George W.** Department of Molecular Biology & Pharmacology, Washington University School of Medicine, St. Louis, Missouri.
- Goland, Dr. Leonard.** Executive Vice President, Dynasciences Corporation, Los Angeles, California.
- Gold, Dr. Ronald.** Hospital for Sick Children, Toronto, Ontario, Canada.
- Goldberg, Prof. David E.** Department of General Engineering, University of Illinois, Urbana.
- Goldberg, Dr. Ira J.** Department of Medicine, Columbia College of Physicians and Surgeons, Division of Metabolism and Nutrition, New York.
- Goldenberg, Dr. Victor E.** Associate Professor in Pathology, University Hospital, Seattle.
- Goldfarb, Dr. Marjorie S.** School of Oceanography, University of Washington, Seattle.
- Goldhaber, Dr. Gerson.** Lawrence Berkeley Laboratory, University of California, Berkeley.
- Goldich, Dr. Samuel S.** Department of Geology, Colorado School of Mines, Golden.
- Goldman, Dr. Marvin.** Emeritus Professor, Department of Radiological Sciences, University of California, Davis.
- Goldstein, Dr. D. J.** Department of Biomedical Science, University of Sheffield, England.
- Goldstein, Dr. Irving S.** Department of Wood and Paper Science, North Carolina State University, Raleigh.
- Golley, Dr. Frank B.** Institute of Ecology, Athens, Georgia.
- Golub, Dr. Leon.** Harvard Smithsonian Center for Astrophysics, Smithsonian Astrophysical Observatory, Cambridge, Massachusetts.
- Gomer, Prof. Robert.** James Franck Institute, University of Chicago.
- Gonser, Dr. Bruce W.** Battelle Memorial Institute, Columbus, Ohio.
- Good, Dr. Irving J.** Department of Statistics and Statistical Laboratory, College of Arts and Sciences, Virginia Polytechnic Institute.
- Good, Prof. Roland H., Jr.** Department of Physics, Pennsylvania State University.
- Goodbody, Dr. Ivan.** Department of Zoology, University of the West Indies, Jamaica.
- Goodchild, Dr. Chauncey G.** Candler Professor of Biology, Emory University.
- Goodenough, Prof. John B.** Center for Materials Science and Engineering, University of Texas, Austin.
- Goodglass, Dr. Harold.** Director, Psychology Research, Veterans Administration Hospital, Boston, Massachusetts.
- Goodheart, Prof. Clarence F.** Department of Electrical Engineering, Union College.
- Gooding, Dr. James L.** Space Scientist, Planetary Materials Branch, NASA Lyndon B. Johnson Space Center, Houston, Texas.
- Goodison, Dr. Barry E.** Superintendent, Hydrometeorological Impact and Development Section, Canadian Climate Centre, Atmospheric Environment Service, Downsview, Ontario.
- Goodman, Prof. Bernard.** Department of Physics, University of Cincinnati.
- Goodman, Dr. Joseph W.** Stanford Electronics Laboratories, Stanford University.
- Goodman, Dr. Matthew S.** Bell Communications Research, Inc., Morristown, New Jersey.
- Goodman, Dr. Morris.** Department of Anatomy, Wayne State University College of Medicine, Detroit, Michigan.
- Goodman, Dr. Ralph R.** Naval Research Laboratory, Stennis Space Center, Mississippi.
- Goodman, Dr. Richard A.** Division of Public Health, Emory University.
- Goodman, Sidney H.** Manager, Materials Products Department, Technology Support Division, Hughes Aircraft Co., Culver City, California; Senior Lecturer, Department of Chemical Engineering, University of Southern California.
- Goodman, Dr. Steven R.** Chair, Department of Cell Biology and Neuroscience, University of South Alabama College of Medicine, Mobile, Alabama.
- Goodstein, David H.** Director, Inter/Consult, Cambridge, Massachusetts.
- Goosby, Dr. Eric P.** AIDS Education and Training Centers Program, U.S. Public Health Service, Rockville, Maryland.
- Gordon, Dr. Arnold L.** Lamont-Doherty Geological Observatory, Palisades, New York.
- Gordon, Dr. Gary D.** Program Development, Communication Satellite Corporation, Clarksburg, Maryland.
- Gordon, Prof. Louis.** Deceased; formerly, Case Institute of Technology.
- Gordon, Dr. William E.** Associate Professor of Physical Chemistry, Pennsylvania State University, and Consultant.
- Gore, Edward W., Jr.** Vice President, International Market Requirements, Office Products Division, IBM, Franklin Lakes, New Jersey.
- Gosling, Dr. William.** Consultant, Radio Communications, Rode, Bath, England.
- Gossard, Prof. Arthur C.** Materials Department, University of California, Santa Barbara.
- Gotelli, Dr. Nick.** Department of Biology, University of Vermont, Burlington.
- Gots, Dr. Joseph S.** Department of Microbiology, School of Medicine, University of Pennsylvania.

- Gould, Dr. Richard A.** Department of Anthropology, University of Hawaii.
- Gould, Dr. Stephen J.** Professor of Geology, Museum of Comparative Zoology, Harvard University.
- Goulding, Dr. Frederick S.** Lawrence Berkeley Laboratory, University of California.
- Govindjee, Dr.** Department of Botany and Department of Physiology and Biophysics, University of Illinois, Urbana.
- Govindjee, Dr. Rajni.** Retired; formerly, Department of Botany, University of Illinois, Urbana.
- Grabowski, Dr. Martha R.** Center for Industrial Innovation, Department of Decision Sciences and Engineering Systems, Rensselaer Polytechnic Institute, Troy, New York.
- Grace, Dr. Neville.** Biotechnology Division, Department of Scientific and Industrial Research, Palmerston North, New Zealand.
- Graham, Dr. Jeffrey B.** Scripps Institution of Oceanography, La Jolla, California.
- Grande, Dr. Lance.** Field Museum of Natural History, Chicago, Illinois.
- Granicher, Prof. H.** Laboratory of Solid State Physics, Swiss Federal Institute of Technology, Zurich.
- Granick, Dr. S.** Department of Biochemistry, Rockefeller University.
- Grasshoff, Dr. K.** Institut für Meereskunde an der Universität Kiel, Germany.
- Grau, Dr. Fred V.** Consulting Agronomist, College Park, Maryland.
- Graves, Dr. Arthur H.** Deceased; formerly, Consultant in Genetics, Connecticut Agricultural Experiment Station.
- Graves, Prof. Lawrence M.** Professor Emeritus of Mathematics, University of Chicago.
- Graves, Walter L.** San Diego, California.
- Gray, Dr. Ernest.** Variety Club Children's Hospital, Department of Pediatrics, University of Minnesota.
- Gray, G. Ronald.** Director, Syncrude Canada Ltd., Edmonton, Alberta, Canada.
- Gray, Dr. Gerald J.** Vice President, Forest Policy Center, American Forests, Washington, D.C.
- Gray, Dr. Harry B.** Division of Chemistry and Chemical Engineering, California Institute of Technology.
- Green, Dr. David M.** Graduate Research, Department of Psychology, University of Florida.
- Green, Dr. Louis C.** Department of Astronomy, Haverford College.
- Green, Dr. Richard F.** National Optical Astronomy Observatory, Tucson, Arizona.
- Green, Prof. Sheldon I.** Department of Mechanical Engineering, University of British Columbia, Vancouver, Canada.
- Greenberg, Prof. David M.** Department of Biochemistry, School of Medicine, University of California, San Francisco.
- Greenberger, Prof. Daniel M.** Department of Physics, City College of the City University of New York.
- Greenfield, Dr. Lazar J.** Department of Surgery, University of Michigan Hospitals, Ann Arbor.
- Greenler, Dr. Robert.** Department of Physics, University of Wisconsin.
- Greensfelder, Dr. Bernard S.** Deceased; formerly, Director of Oil Research, Shell Development Company, Emeryville, California.
- Greenspan, Prof. Ehud.** Department of Nuclear Engineering, University of California, Berkeley.
- Greenspan, Martin.** National Bureau of Standards.
- Greenstein, Prof. Jesse L.** Hale Observatories, Pasadena, California.
- Gregory, Dr. Bob Lee.** Sandia National Laboratories, Albuquerque, New Mexico.
- Gregory, Dr. Joseph T.** Professor of Paleontology and Curator of Lower Vertebrates, Museum of Paleontology, University of California, Berkeley.
- Greiling, Dr. Paul T.** Hughes Research Laboratories, Malibu, California.
- Greiner, Dr. Dale L.** Professor of Medicine, University of Massachusetts Medical School, Worcester.
- Greiner, Dr. Walter.** Institut für Theoretische Physik, Universität Frankfurt, Germany.
- Grest, Dr. Gary S.** Exxon Research and Engineering Company, Annandale, New Jersey.
- Grey, Jerry.** President, Greyrad Corporation, Princeton, New Jersey.
- Grierson, Dr. William.** Institute of Food and Agricultural Sciences, University of Florida.
- Griffen, Prof. Dana T.** Department of Geology, Brigham Young University, Provo, Utah.
- Griffin, Dr. James.** Graduate School of Oceanography, University of Rhode Island, Charleston.
- Griffiths, Dr. A. J. F.** Department of Botany, University of British Columbia, Vancouver, Canada.
- Griffiths, Prof. Peter R.** Chairman, College of Letters and Science, Department of Chemistry, University of Idaho.
- Grigg, Prof. Neil S.** Head, Department of Civil Engineering, Colorado State University, Fort Collins.
- Grilo, Dr. Carlos M.** Director of Psychology, Yale Psychiatric Institute, New Haven, Connecticut.
- Grim, Dr. Ralph E.** Department of Geology, University of Illinois, Urbana.
- Grimm, Robert A.** AC Spark Plug Division, General Motors Corporation, Flint, Michigan.
- Grindlay, Dr. Jonathan E.** Center for Astrophysics, Harvard University.
- Grine, Dr. Frederick E.** Department of Anthropology, State University of New York, Stony Brook.
- Grissino-Mayer, Dr. Henri D.** Department of Physics, Astronomy, and Geosciences, Valdosta State University, Valdosta, Georgia.
- Grivell, Dr. Les. A.** Afdeling Moleculaire Biologie, Laboratorium voor Biochemie, Universiteit van Amsterdam, Netherlands.
- Grodzins, Dr. Lee.** Physics Department, Massachusetts Institute of Technology.
- Grogan, Dr. R. G.** Department of Plant Pathology, University of California, Davis.
- Groggins, P. H.** Deceased; formerly, Chemical Division, Food Machinery and Chemical Corporation.
- Gronstol, Prof. Hallstein.** Department of Large Animal Clinical Sciences, Norwegian College of Veterinary Medicine, Oslo, Norway.
- Groody, Dr. E. Patrick.** Integrated Genetics, Framingham, Massachusetts.
- Grosch, Prof. Daniel S.** Department of Genetics, North Carolina State University.
- Gross, Prof. Jonathan L.** Department of Mathematics, Columbia University.
- Gross, Marjorie K.** Newport, North Carolina.
- Gross, William H.** Technical Editor, Corporate Communications, Dow Chemical Company, Midland, Michigan.
- Grossman, Dr. Lawrence.** Department of Geophysical Sciences, University of Chicago.
- Grosswald, Prof. Emit.** Deceased; formerly, Department of Mathematics, Temple University.
- Grotzinger, Dr. John.** Department of Earth, Atmosphere, and Space Sciences, Massachusetts Institute of Technology.
- Groves, Dr. Gordon W.** Institute de Geofisica, Torre de Ciencias, Ciudad Universitaria, Mexico.
- Gruen, Dr. Dieter M.** Argonne National Laboratory, Argonne, Illinois.
- Grunberg, Dr. Emanuel.** Director, Department of Chemotherapy, Hoffmann-LaRoche, Inc., Nutley, New Jersey.
- Gruver, Prof. William A.** School of Engineering Science, Simon Fraser University, Burnaby, British Columbia, Canada.
- Grzymala-Busse, Prof. Jerzy W.** Department of Computer Science, University of Kansas.
- Gschneider, Prof. Karl A., Jr.** Ames Laboratory, Iowa State University.
- Guggenheim, Prof. Stephen.** Department of Geological Sciences, University of Illinois, Chicago.
- Guido, Prof. Louis.** Associate Professor, Electrical and Computer Engineering, Virginia Tech, Blacksburg.
- Guidry, Dr. Mark R.** Fairchild Camera & Instrument Corp., Mountain View, California.
- Gunckel, Prof. James E.** Department of Botany, Rutgers University.
- Gunkler, Dr. Albert A.** Chief Process Engineer, Midland Division, Dow Chemical Company, Midland, Michigan.
- Gunning, Dr. Brian E. S.** Department of Botany, Queen's University, Belfast, Ireland.

- Gunning, Dr. Robert C.** Department of Mathematics, Princeton University.
- Gupta, Dr. Madan M.** Intelligent System Research Laboratory, College of Engineering, University of Saskatchewan, Saskatoon.
- Gupta, Dr. Y. M.** Department of Physics, Shock Dynamics Laboratory, Washington State University.
- Gurevich, Michael.** Masonary Consultants, Fair Lawn, New Jersey.
- Gurney, Dr. Ashley B.** Systematic Entomology Laboratory, Entomology Research Division, U.S. Department of Agriculture.
- Gustafson, Dr. David A.** Department of Computing and Information Science, Kansas State University, Manhattan.
- Gutzwiller, Dr. Martin C. T. J.** Watson Research Center, IBM Corporation, Yorktown Heights, New York.
- Guy, Dr. Arthur W.** Bioelectromagnetism Research Laboratory, School for Medicine and College of Engineering, University of Washington, Seattle.
- Guzinski, Dr. Gay M.** Chief, Section of Benign Gynecology, Department of Obstetrics and Gynecology, School of Medicine, University of Maryland, Baltimore.
- Gyakum, Dr. John R.** Department of Meteorology, McGill University, Montreal, Quebec, Canada.
- Gyftopoulos, Dr. Elias P.** Thermo Electron Corporation, Waltham, Massachusetts.
- Gönen, Prof. Turan.** Department of Electrical & Electronic Engineering, California State University, Sacramento.
- Gür, Dr. Turgut M.** Senior Research Associate, Department of Materials Science and Engineering, Stanford University.
- H**
- Haber, Bernard.** Hardesty & Hanover, New York.
- Hackl, Ralph R.** Manager, R&D Laboratory, Giant Bay Biotech, Burnaby, British Columbia, Canada.
- Hader, Rodney N.** Secretary, American Chemical Society, Washington, D.C.
- Hadler, Jacques B.** Webb Institute of Naval Architecture, Glen Cove, New York.
- Hadley, Dr. Elbert H.** Assistant Dean (retired), College of Liberal Arts and Sciences, and Professor of Chemistry, Southern Illinois University.
- Hadni, A.** Laboratoire Infrarouge Lointain, Université de Nancy I, France.
- Hagan, Dr. Maura.** National Center for Atmospheric Research, Boulder, Colorado.
- Hagan, Dr. William J., Jr.** Department of Chemistry, College of St. Rose, Albany, New York.
- Hagar, Prof. Charles F.** Department of Physics and Astronomy, San Francisco State University.
- Hagen, Dr. John P.** Department of Astronomy, Pennsylvania State University.
- Haggerty, Dr. Stephen E.** Department of Geology and Geography, University of Massachusetts.
- Hagist, Prof. Warren M.** Retired; formerly, Department of Mechanical Engineering, University of Rhode Island.
- Hagood, Mel A.** Irrigated Agriculture Research and Extension Center, Washington State University.
- Hague, Wilbur.** Oxy Metal Industries Corporation, Warren, Michigan.
- Hahn, Dr. John F.** Department of Psychology, University of Virginia.
- Haile, Dr. William.** Swales Aerospace, Inc., Beltsville, Maryland.
- Hailpern, Dr. Brent T.** IBM Research Laboratory, Yorktown Heights, New York.
- Haines, John E.** Deceased; formerly, Vice President, Minneapolis-Honeywell Regulator Company.
- Haines, Prof. Malcolm G.** Blackett Laboratory, Imperial College of Science and Technology, London, England.
- Haines, Roger W.** Professional Engineer, Laguna Hills, California.
- Hainline, Bernard C.** Systems Technology, Boeing Commercial Airplane Company, Seattle, Washington.
- Halbedel, Dr. Elaine M.** Carralitos Observatory, Los Cruces, New Mexico.
- Halbouty, Dr. Michael T.** Consulting Geologist and Petroleum Engineer, Houston, Texas.
- Halde, Dr. Carlyn.** Department of Microbiology and Immunology, School of Medicine, University of California, San Francisco.
- Hale, Dr. Mason E., Jr.** Smithsonian Institution.
- Hales, Dr. Milton R.** Professor of Pathology, School of Medicine, West Virginia University.
- Halkias, Prof. Christos C.** Chair of Electronics, National Technical University, Athens, Greece.
- Hall, Prof. Dennis G.** Director, The Institute of Optics, University of Rochester, New York.
- Hall, Dr. Richard P.** Deceased; formerly, Professor of Zoology, University of California, Los Angeles.
- Hall, Prof. Robert.** Director, SE Asia Research Group, Department of Geology, University of London, Egham, Surrey, United Kingdom.
- Hallam, Dr. Anthony.** Department of Geology, University of Birmingham, England.
- Haller, Prof. Gary L.** Professor of Engineering and Applied Science, Jonathan Edwards College, Yale University, New Haven, Connecticut.
- Hallet, Dr. John.** Director, Atmospheric Ice Physics Laboratory, Desert Research Institute, Atmospheric Sciences Center, University of Nevada.
- Halliday, Dr. Alex.** Department of Geological Sciences, University of Michigan, Ann Arbor.
- Halstead, Dr. Thora Waters.** American Society of Gravitational and Space Biology, Arlington, Virginia.
- Halvorson, Dr. Harlyn O.** Department of Biochemistry, University of Minnesota.
- Hamad, Dr. Falk.** Department of Mechanical and Medical Engineering, University of Bradford, United Kingdom.
- Hamer, Dr. Walter J.** Institute for Basic Standards, National Bureau of Standards.
- Hamilton, Prof. C. Howard.** Department of Mechanical and Materials Engineering, Washington State University, Pullman.
- Hamilton, Dr. Howard L.** (Retired) Department of Biology, University of Virginia.
- Hamilton, Dr. John.** Gemini Observatory, Hilo, Hawaii.
- Hamilton, Dr. Joseph H.** Department of Physics-Astronomy, Vanderbilt University.
- Hamilton, Dr. Mark F.** Department of Mechanical Engineering, University of Texas, Austin.
- Hamilton, Dr. R. I.** Research Branch, Agriculture Canada, Vancouver, British Columbia, Canada.
- Hammar, Dr. Samuel P.** The Diagnostic Specialties Laboratory, Washington.
- Hammen, Dr. C. S.** Department of Zoology, University of Rhode Island.
- Hammer, Edward E.** Retired; formerly, Fluorescent and High Intensity Systems Department, General Electric Company, Cleveland, Ohio.
- Hammond, Prof. Edwin H.** Department of Geography, University of Tennessee.
- Hand, Dr. Cadet.** Bodega Marine Laboratory, University of California, Bodega Bay.
- Handsfield, Dr. H. Hunter.** Director, Sexually Transmitted Disease Control Program, Seattle-King County Public Health Department, Harborview Medical Center, Seattle, Washington.
- Haney, Dr. Robert L.** Department of Meteorology, Naval Postgraduate School, Monterey, California.
- Hang, Prof. C. C.** Centre for Intelligent Control, Department of Electrical Engineering, National University of Singapore.
- Hankley, Prof. William.** Department of Computing and Information Science, Kansas State University, Manhattan.
- Hanlin, Dr. Richard T.** Department of Plant Pathology, University of Georgia, Athens.
- Hanna, Dr. Michael.** Assistant Professor of Biology, Rensselaer Polytechnic Institute.
- Hanna, Dr. Steven R.** Sigma Research Corporation, Concord, Massachusetts.
- Hanor, Jeffrey S.** Department of Geology, Louisiana State University.
- Hansch, Dr. Theo W.** Department of Physics, Stanford University.

- Hansel, Dr. Ardith K.** Illinois State Geological Survey, Champaign.
- Hansen, Arthur G.** President, Georgia Institute of Technology.
- Hansen, Dr. John.** Department of Neurobiology and Anatomy, University of Rochester Medical Center.
- Hansen, Dr. Katherine J.** Department of Earth Sciences, Montana State University, Bozeman.
- Hanson, Prof. Allen L.** Department of Chemistry, Saint Olaf College.
- Hanson, Dr. Clarence H.** Agricultural Research Service, U.S. Department of Agriculture, Beltsville, Maryland.
- Hanson, Dr. Phyllis.** Department of Cell Biology and Physiology, Washington University School of Medicine, St. Louis, Missouri.
- Happer, Dr. William.** Department of Physics, Columbia University.
- Haq, Dr. Bilal U.** Department of Marine Geology and Geophysics, National Science Foundation, Washington, D.C.
- Hardesty, Egbert R.** Hardesty & Hanover, New York.
- Hardgrove, Ralph M.** Sales Engineer, Stock Equipment Company, Cleveland, Ohio.
- Hardy, Prof. John.** Cyclotron Institute, Texas A & M University, College Station.
- Hardy, Dr. John W.** Lexington, Massachusetts.
- Hare, Dr. Jonathan.** School of Chemistry and Molecular Sciences, University of Sussex, United Kingdom.
- Hargis, Dr. William J., Jr.** Department of Marine Science, University of Virginia.
- Harker, Dr. Robert I.** Department of Geology, University of Pennsylvania.
- Harleman, Dr. Donald R. F.** Department of Civil Engineering, Massachusetts Institute of Technology.
- Harman, Prof. Jay R.** Department of Geography, Michigan State University, East Lansing.
- Harper, Dr. Michael J. K.** Department of Obstetrics and Gynecology, University of Texas Health Science Center, San Antonio.
- Harrigan, Prof. Kevin.** TeleLearning Network of Centres of Excellence, Department of Computer Science, University of Waterloo, Ontario, Canada.
- Harrington, Roy L.** Newport News, Virginia.
- Harrington, Clifford.** Shaw Pittman, McLean, Virginia.
- Harris, Dr. Cyril M.** Professor of Electrical Engineering and Architecture, Department of Electrical Engineering, Columbia University.
- Harris, Denise B.** Senior Mechanical Engineer, Westinghouse Electronic Systems Group, Baltimore, Maryland.
- Harris, Dr. Forest K.** Electrical Measurements Laboratory, National Institute of Standards and Technology, Gaithersburg, Maryland.
- Harris, Dr. J.** Postgraduate School of Studies in Chemical Engineering, University of Bradford, England.
- Harris, Prof. J. Donald.** U.S. Navy Submarine Medical Laboratory, Groton, Connecticut.
- Harris, Dr. J. Milton.** Department of Chemistry, University of Alabama, Huntsville.
- Harris, Lawrence A.** Oak Ridge National Laboratory, Oak Ridge, Tennessee.
- Harris, Prof. Richard W.** Department of Environmental Horticulture, University of California, Davis.
- Harrison, David B.** Public Relations Department, Goodyear Tire and Rubber, Akron, Ohio.
- Harrison, Prof. Edward R.** Department of Physics and Astronomy, University of Massachusetts.
- Harrison, George R.** Deceased; formerly, Dean Emeritus, School of Science, Massachusetts Institute of Technology.
- Harrison, Prof. John P.** Department of Physics, Queen's University, Ontario, Canada.
- Harrison, Dr. Marcia.** Department of Biology, Washington University, St. Louis, Missouri.
- Harrison, Prof. Terry.** Department of Anthropology, New York University, New York.
- Harrison, Dr. Walter A.** Department of Applied Physics, Stanford University.
- Hart, Prof. Gerald W.** Chair, Department of Biochemistry and Molecular Genetics, University of Alabama, Birmingham.
- Hart, Dr. Harold.** Professor Emeritus, Department of Chemistry, Michigan State University.
- Hartley, Dr. A. M.** Department of Chemistry and Chemical Engineering, University of Illinois, Urbana.
- Hartman, Dr. Olga.** Deceased; formerly, Allan Hancock Foundation, University of Southern California.
- Hartman, Dr. Standish C.** Department of Chemistry, Boston University.
- Hartman, Dr. Willard D.** Associate Professor of Biology and Curator in Invertebrate Zoology, Peabody Museum of Natural History, Yale University.
- Hartmann, Dr. Dennis L.** Department of Atmospheric Sciences, University of Washington, Seattle.
- Hartmann, Prof. Dieter H.** Department of Physics and Astronomy, Clemson University, Clemson, South Carolina.
- Hartmann, Prof. Hudson T.** Pomology Extension, University of California, Davis.
- Hartmann, Dr. William M.** Michigan State University, Department of Physics, East Lansing.
- Hartstein, Dr. Jack.** Assistant Professor of Clinical Ophthalmology, Washington University School of Medicine; Chairman of Ophthalmology, Missouri Baptist Hospital, St. Louis.
- Hartung, Dr. Walter H.** Formerly, Professor of Pharmaceutical Chemistry, Medical College of Virginia.
- Hartwig, Dr. William H.** Department of Electrical Engineering, University of Texas, Austin.
- Harvey, Dr. E. Newton.** Deceased, formerly, Henry Fairfield Osborne Professor of Biology, Princeton University.
- Harvey, Dr. John A.** Oak Ridge National Laboratory, Oak Ridge, Tennessee.
- Harvey, Dr. Paul H.** Department of Zoology, University of Oxford, United Kingdom.
- Harvey, Dr. Philip D.** Professor of Psychiatry, Mount Sinai School of Medicine, New York.
- Hasey, Dr. Janine K.** Cooperative Extension, University of California, Yuba City.
- Hasler, Dr. Arthur D.** Laboratory of Limnology, University of Wisconsin.
- Hassialis, M. D.** Krumb School of Mines, Columbia University.
- Hassibi, Dr. Babak.** Information Systems Laboratory, Stanford University, Stanford, California.
- Hassid, Prof. William Z.** Deceased; formerly, Department of Biochemistry, University of California, Berkeley.
- Hastings, Dr. Alan.** Division of Environmental Studies, University of California at Davis.
- Hastings, Prof. J. Woodland.** Biological Laboratories, Department of Cellular and Development Biology, Harvard University.
- Hatsopoulos, Dr. George N.** Thermo Electron Corporation, Waltham, Massachusetts.
- Haug, John R.** Motorola, Schaumburg, Illinois.
- Hausner, Henry H.** Consulting Engineer, New York.
- Haut, Dr. Arthur.** Professor of Medicine, Division of Hematology and Oncology, University of Arkansas for Medical Sciences.
- Havens, Dr. Donald P.** Filter Products, Rockwell International Corporation, Costa Mesa, California.
- Hawkins, Dr. W. Lincoln.** Bell Laboratories, Murray Hill, New Jersey.
- Hawksworth, Dr. Frank G.** U.S. Forest Service, Fort Collins, Colorado.
- Hawley, Dr. R. Scott.** Department of Genetics, Section of Molecular and Cellular Biology, University of California at Davis.
- Hawthorne, Dr. Frank C.** Department of Geological Sciences, University of Manitoba, Winnipeg, Canada.
- Hay, Prof. George W.** Department of Chemistry, Queen's University, Ontario, Canada.
- Hayes, Dr. Dennis E.** Lamont-Doherty Geological Observatory, Columbia University, Palisades, New York.
- Hayes, Prof. John P.** Department of Electrical Engineering and Computer Science, University of Michigan, Ann Arbor.
- Hayes, Dr. Thomas L.** Donner Laboratory, University of California, Berkeley.
- Hayes, William C.** Formerly, Editor in Chief, "Electrical World," McGraw-Hill Publications Company, New York.



- Hayes-Roth, Dr. Frederick.** Executive Vice President, Technology, Teknowledge Inc., Palo Alto, California.
- Hayflick, Prof. Leonard.** Center for Gerontological Studies, University of Florida.
- Haynes, David O.** Deceased; formerly, Consulting Industrial Engineer, Tucson, Arizona.
- Hazel, Prof. Jeffrey R.** Department of Zoology, Arizona State University.
- Hazen, Prof. David C.** Department of Aerospace-Mechanical Science, Princeton University.
- Hazen, Richard.** Hazen and Sawyer, Consulting Engineers, New York.
- Hazen, Ronald.** Consultant (retired), Indianapolis, Indiana.
- Heaney, Dr. Peter J.** Department of Geological and Geophysical Sciences, Princeton University.
- Hearmon, R. F. S.** Formerly, Timber Mechanics Section, Forest Products Research Laboratory, Princes Risborough, Bucks, England.
- Hearn, Dr. C. Jack.** Research Geneticist, Horticultural Research Laboratory, U.S. Department of Agriculture, Orlando, Florida.
- Heath, Michelle.** Canadian Energy Research Institute, Calgary, Alberta, Canada.
- Heckel, Dr. P. H.** Department of Geology, University of Iowa.
- Hedger, Dr. Mark.** Institute of Reproduction and Development, Monash University, Clayton, Australia.
- Hedgpeth, Dr. Joel W.** Marine Science Center, Oregon State University.
- Heezen, Dr. Bruce C.** Deceased; formerly, Lamont-Doherty Geological Observatory, Palisades, New York.
- Hein, Dr. James R.** U.S. Geological Survey, Branch of Pacific Marine Geology, Menlo Park, California.
- Heiney, Prof. Paul A.** Department of Physics, University of Pennsylvania, Philadelphia.
- Heinrich, Dr. Bernd.** Division of Entomology and Parasitology, College of Natural Resources, University of California, Berkeley.
- Heinrich, Dr. E. William.** Department of Geology and Mineralogy, University of Michigan.
- Heinrikson, Dr. Robert L.** Department of Biochemistry, University of Chicago.
- Heinzel, Dr. Frederick P.** Department of Medicine, Division of Infectious Diseases, University of California, School of Medicine, San Francisco.
- Held, Dr. Gilbert.** Director, 4-Degree Consulting, Macon, Georgia.
- Heldman, Dr. Dennis R.** Executive Vice President, Scientific Affairs, National Food Processors Association, Washington, D.C.
- Helfman, Dr. Gene S.** Department of Zoology, University of Georgia.
- Hellmers, Dr. Henry.** Botany Department, Duke University.
- Helman, Marc L.** Department of Geological Sciences, University of Durham, England.
- Helmers, Dr. Carl J.** Vice President, Applied Automation, Inc., Bartlesville, Oklahoma.
- Henker, Kevin J.** Department of Materials Science and Engineering, Stanford University.
- Henriquez, Oscar.** California State University of Long Beach, Department of Civil Engineering, Long Beach, California.
- Henry, Dr. Alyson E.** Department of Psychology, University of Illinois, Chicago.
- Henry, Dr. Charles H.** Bell Laboratories, Murray Hill, New Jersey.
- Herakovitch, Prof. Carl T.** Civil Engineering and Applied Mechanics, University of Virginia, Charlottesville.
- Herber, Prof. Rolfe H.** Department of Chemistry, Rutgers University.
- Herberman, Dr. Ronald B.** Chief, Biological Development Branch, National Cancer Institute, Frederick Cancer Research Facility, Frederick, Maryland.
- Herbst, Dr. Jan F.** Physics Department, General Motors Research Laboratories, Warren, Michigan.
- Hermach, Dr. F. L.** National Institute of Standards and Technology, Gaithersburg, Maryland.
- Herman, C. J.** Consulting Engineer, Advanced Processes and Products, Insulating Materials Department, General Electric Co., Schenectady, New York.
- Herring, Dr. Thomas A.** Department of Earth, Atmospheric, and Planetary Sciences, Massachusetts Institute of Technology, Cambridge.
- Herron, Dr. Norman.** Central Research and Development, DuPont Research, Wilmington, Delaware.
- Hersey, Dr. John B.** Office of Naval Research, U.S. Department of the Navy.
- Hershkowitz, Prof. Noah.** Department of Nuclear Engineering, University of Wisconsin, Madison.
- Hershleider, William.** Consulting Construction Engineer, New York.
- Herz, Prof. Carl S.** Department of Mathematics, McGill University.
- Herzberger, Max J.** Deceased; formerly, Consulting Professor, Department of Physics, Louisiana State University.
- Herzog, Prof. Gregory F.** Department of Chemistry, Rutgers University, Piscataway, New Jersey.
- Hess, Garry C.** Motorola, Schaumburg, Illinois.
- Hess, Dr. Ronald A.** Department of Mechanical and Aeronautical Engineering, University of California, Davis.
- Hesseltine, Dr. C. W.** Fermentation Laboratory, Agricultural Research Service, U.S. Department of Agriculture, Peoria, Illinois.
- Hester, Dr. Jeff.** Department of Physics and Astronomy, Arizona State University, Tempe.
- Hewson, Dr. E. Wendell.** Chairman, Department of Atmospheric Sciences, Oregon State University.
- Heyn, Dr. A. N. J.** Department of Biological Sciences, Louisiana State University.
- Heyne, Prof. E. G.** Professor of Plant Breeding, Department of Agronomy, Kansas State University.
- Heyneman, Dr. Donald.** Chair, Health and Medical Sciences Program, University of California, Berkeley.
- Hibbard, Robert R.** Technical Consultant for Propulsion Chemistry Division, NASA Lewis Research Center, Cleveland, Ohio.
- Hickman, Dr. Howard M.** Section Manager, Research and Development, Sherex Chemical Company, Dublin, Ohio.
- Hicks, Dr. Bruce B.** Atmospheric Turbulence and Diffusion Division, National Oceanic and Atmospheric Administration, Oak Ridge, Tennessee.
- Hicks, Dr. Glenn R.** Associate Director, Plant Biotechnology, Exelixis Pharmaceuticals, South San Francisco, California.
- Hicks, Dr. Philip E.** President, Hicks & Associates, Consulting Industrial Engineers, Orlando, Florida.
- Hicks, Steacy D.** Sterling, Virginia.
- Hicks, Tyler G.** Formerly, Publisher, Professional and Reference Book Division, McGraw-Hill, Inc., New York.
- Hieftje, Dr. Gary M.** Department of Chemistry, Indiana University.
- Higgins, Dr. Robert P.** Curator, Department of Invertebrate Zoology, National Museum of Natural History, Smithsonian Institution.
- Hildebrand, Dr. Joel H.** Deceased; formerly, Department of Chemistry, University of California, Berkeley.
- Hill, Dr. Armin J.** Dean, College of Physical and Engineering Sciences, Brigham Young University.
- Hill, Prof. Dorothy.** Research Professor, Department of Geology and Mineralogy, University of Queensland, Brisbane, Australia.
- Hill, Prof. Edward L.** Deceased; formerly, Professor of Physics and Mathematics, School of Physics, University of Minnesota.
- Hill, Dr. Lawrence S.** Department of Management, California State University.
- Hill, Robert T.** Radar Consultant, Bowie, Maryland.
- Hill, Dr. Rolla B., Jr.** Professor and Chairman, Department of Pathology, Upstate Medical Center, Syracuse.
- Hilliard, Dr. Ron.** Optomechanics Research, Inc., Vail, Arizona.
- Hines, Dr. M. E.** Vice President, Microwave Associates, Inc., Burlington, Massachusetts.
- Hingorani, Dr. Narian G.** Electric Power Research Institute, Palo Alto, California.
- Hinrichs, Thomas C.** Vice President, Magma Power, San Diego, California.
- Hinsch, Dr. Gertrude W.** Department of Biology, University of South Florida.
- Hintz, Dr. Kenneth J.** Department of Electrical and Computer Engineering,

- George Mason University, Fairfax, Virginia.
- Hipel, Prof. Keith W.** Departments of Systems Design Engineering and Statistical Actuarial Science, University of Waterloo, Ontario, Canada.
- Hirschberg, Prof. Daniel S.** Information and Computer Science, University of California, Irvine.
- Hirschfelder, Dr. J. O.** Department of Chemistry, University of Wisconsin.
- Hitchman, Dr. Matthew H.** Department of Meteorology, University of Wisconsin, Madison.
- Hodgdon, Dr. James.** Naval Health Research Center, San Diego, California.
- Hodge, Prof. Paul.** Department of Astronomy, University of Washington, Seattle.
- Hodge, Prof. Philip.** Chair of Polymer Chemistry, Department of Chemistry, University of Manchester, England.
- Hodges, Prof. Kip.** Department of Earth, Atmospheric, and Planetary Sciences, Massachusetts Institute of Technology, Cambridge.
- Hodgin, David M.** Senior Member, Institute of Electrical and Electronics Engineers, Cedar Rapids, Iowa.
- Hodgson, Brain J.** C & P Telephone, Bell Atlantic Company, Washington, D.C.
- Hodos, Dr. William.** Department of Psychology, University of Maryland, College Park.
- Hoering, Dr. Thomas C.** Geophysical Laboratory, Carnegie Institution of Washington.
- Hoff, Prof. C. Clayton.** Department of Biology, University of New Mexico.
- Hoffman, Dr. Edward G.** Hoffman & Associates, Colorado Springs, Colorado.
- Hoffman, Dr. Paul.** Department of Earth and Planetary Sciences, Harvard University.
- Hoffman, Dr. Paul.** Department of Microbiology and Immunology, Faculty of Medicine, Dalhousie University, Halifax, Nova Scotia, Canada.
- Hoffman, Dr. Ralph E.** Yale Psychiatric Institute, School of Medicine, Yale University.
- Hoffman, Richard A.** Senior Staff Engineer, Martin Marietta Aerospace, Denver, Colorado.
- Hoffman, Prof. Richard L.** Department of Biology, Radford College.
- Hofstadter, Dr. Robert.** Department of Physics, Stanford University.
- Hogan, Dr. Brigid.** Mill Hill Laboratories, Imperial Cancer Research Fund, London.
- Hogan, Dr. Robert.** Department of Psychology, Johns Hopkins University.
- Hogg, Dr. Helen S.** David Dunlap Observatory, University of Toronto.
- Hoist, Per A.** Foxboro Company, Foxboro, Massachusetts.
- Hold, Dr. Robert D.** Museum of Natural History, University of Kansas.
- Holdaway, Dr. M. J.** Department of Geological Sciences, Southern Methodist University.
- Holdeman, Dr. Louis B.** Communications Satellite Corporation (COMSAT), Clarksburg, Maryland.
- Holder, Dr. Nigel.** Anatomy and Human Biology Group, Biomedical Sciences Division, Kings College, University of London.
- Holland, Dr. Timothy J. B.** Department of Mineralogy and Petrology, University of Cambridge, England.
- Hollowell, Eugene A.** Consultant in Agronomy, Port Republic, Maryland.
- Hollweg, Prof. Joseph V.** Space Science Center, University of New Hampshire.
- Holmes, Dr. Jack K.** Holmes Associates, Los Angeles, California.
- Holmes, Dr. Robert W.** Department of Biological Sciences, University of California, Santa Barbara.
- Holt, Dr. Donald L.** Monsanto Company, St. Louis, Missouri.
- Holt, Dr. Perry C.** Department of Biology, Virginia Polytechnic Institute.
- Holton, Dr. Gerald.** Department of Physics, Harvard University.
- Holton, Prof. James R.** Department of Atmospheric Sciences, University of Washington.
- Holtzman, Dr. Eric.** Deceased; formerly, Department of Biological Sciences, Columbia University.
- Homann, Prof. Peter H.** Institute of Molecular Biophysics, Florida State University.
- Hooke, Dr. Roger LeB.** Deer Isle, Maine.
- Hoover, J. Edgar.** Deceased; formerly, Director, Federal Bureau of Investigation, U.S. Department of Justice.
- Horan, Dr. Michael.** National Heart, Lung and Blood Institute, National Institutes of Health, Bethesda, Maryland.
- Horen, Dr. D. J.** Nuclear Division, Oak Ridge National Laboratory, Oak Ridge, Tennessee.
- Horn, Dr. David J.** Department of Entomology, College of Agriculture, Ohio State University.
- Horsfall, Dr. James G.** Director, Connecticut Agricultural Experiment Station, New Haven.
- Horsnail, Dr. R. F.** Amax Exploration, Inc., Denver, Colorado.
- Horst, Dr. R. K.** Department of Plant Pathology, Cornell University.
- Horstadins, Prof. Sven.** Professor Emeritus of Zoology, University of Uppsala, Sweden.
- Horton, Prof. Derek.** Department of Chemistry, American University, Washington, D.C.
- Horton, G. A.** Manager, Engineering Laboratories, Westinghouse Electric Corporation, Cleveland, Ohio.
- Horton, Dr. William A.** Department of Pediatrics, Medical School, Health Science Center at Houston, University of Texas.
- Horwich, Dr. Arthur.** Yale University School of Medicine, Howard Hughes Medical Institute, New Haven, Connecticut.
- Hosford, Prof. William F.** Department of Materials Science and Engineering, College of Engineering, University of Michigan, Ann Arbor.
- Hotchkiss, Grosvenor.** Coordinating Engineer (retired), Western Union Telegraph Company, New York.
- Hotchkiss, Prof. Rollin D.** Department of Cellular Physiology, Rockefeller University.
- Hough, Dr. L. F.** Research Professor in Pomology, Department of Horticulture and Forestry, Rutgers University.
- Houghton, Dr. David D.** Department of Meteorology, University of Wisconsin, Madison.
- Hougie, Dr. Cecil.** Professor of Pathology, School of Medicine, University of California, San Diego.
- Howe, Prof. Carl E.** Deceased; formerly, Professor Emeritus of Physics, Oberlin College.
- Howell, Dr. Benjamin F., Jr.** Department of Geosciences, Pennsylvania State University.
- Howell, William E.** NASA Langley Research Center, Hampton, Virginia.
- Howells, Dr. T.** A Director of Continuing Education (retired), Institute of Paper Chemistry, Appleton, Wisconsin.
- Howells, Dr. William W.** Peabody Museum of Archeology and Ethnology, Harvard University.
- Hoxton, Prof. Llewellyn G.** Deceased; formerly, Professor Emeritus of Physics, University of Virginia.
- Hrones, Dr. John A.** Provost of Science and Technology, Case Western Reserve University.
- Hsieh, Dr. Samuel C.** Department of Computer Science, Southwestern Oklahoma State University, Weatherfort.
- Hu, Dr. A. S. L.** Department of Biochemistry, University of Kentucky.
- Hubbard, Dr. W. M.** Bell Communications Research (Bell-core), Red Bank, New Jersey.
- Hubert, Prof. John F.** Department of Geosciences, University of Massachusetts, Amherst.
- Hudlicky, Dr. Tomas.** Department of Chemistry, Illinois Institute of Technology.
- Hudson, Dr. Hugh S.** Institute of Space and Astronautical Science/Yohkoh, Sagamihara-shi, Kanagawa, Japan.
- Hudson, Dr. Ralph P.** Retired; formerly, Bureau International des Poids et Mesures, Sevres, France.
- Huebler, Dr. Jack.** Senior Vice President, Institute of Gas Technology, IIT Center, Chicago, Illinois.
- Huelsman, Prof. Lawrence P.** Department of Electrical and Computer Engineering, College of Engineering and Mines, University of Arizona.
- Huffman, E. O.** Consultant, Fertilizer Research and Development, Florence, Alabama.
- Hughes, Dr. John M.** Associate Dean, College of Arts and Science, Department of Geology, Miami University, Oxford, Ohio.

**Huizenga, Dr. John R.** Nuclear Structure Research Laboratory, University of Rochester.

**Hulbary, Dr. Robert L.** Department of Botany, University of Iowa.

**Hultsch, Dr. Roland A.** Department of Physics, University of Missouri.

**Humes, Dr. Arthur G.** Department of Biology, Boston University.

**Hummon, Dr. William D.** Department of Zoological and Biomedical Sciences, Ohio University.

**Hundhausen, Dr. Arthur J.** High Altitude Observatory, National Center for Atmospheric Research, Boulder, Colorado.

**Hungate, Prof. Robert E.** Department of Bacteriology, University of California, Davis.

**Hunter, Prof. Lloyd P.** Department of Electrical Engineering, University of Rochester.

**Hunter, Dr. R. H. F.** School of Agriculture, University of Edinburgh, Scotland.

**Huntington, Prof. H. B.** Department of Physics, Rensselaer Polytechnic Institute.

**Hurlbut, Prof. Cornelius S., Jr.** Professor of Mineralogy, Department of Geological Sciences, Harvard University.

**Hurley, Joseph D.** Westinghouse Electric Corporation, Orlando, Florida.

**Hurll, John.** Measurements Standards Laboratory, Marconi Instruments Ltd., Stevenage, Hertfordshire, England.

**Hurst, Dr. G. S.** Department of Physics, Oak Ridge National Laboratory, Oak Ridge, Tennessee.

**Hurst, Prof. James K.** Department of Biochemistry and Biophysics, Washington State University, Pullman.

**Hutcheon, Dr. Ian D.** Isotope Sciences Division, Lawrence Livermore National Laboratory, University of California, Livermore.

**Hutchinson, Prof. Ian H.** Massachusetts Institute of Technology, Plasma Science and Fusion Center, Cambridge, Massachusetts.

**Hutchison, Dr. Keith.** Department of Biology, Brandeis University.

**Hwang, Dr. Patrick.** Rockwell International, Cedar Rapids, Iowa.

**Hwang, Dr. Richard N.** Moh and Associates, Inc., Taipei, Taiwan.

**Hyde, Dr. Earl K.** Lawrence Berkeley Laboratory, University of California, Berkeley.

**Hyde, Dr. Geoffrey.** Retired; formerly, COMSAT Laboratories, Clarksburg, Maryland.

**Hynek, Dr. J. Allen.** Deceased; formerly, Department of Astronomy, Northwestern University.

## I

**Iachello, Dr. Franco.** Department of Physics, Yale University.

**Ibrahim, Dr. Aly M.** Agricultural Research Service, Western Region, U.S. Department of Agriculture, Salinas, California.

**Illis, Alexander.** Director, Process Technology, International Nickel Company of Canada, Ltd., Toronto, Ontario.

**Imai, Noriyoshi.** Toyo Ink Manufacturing Company, Tokyo, Japan.

**Imbembo, Prof. Anthony L.** Chairperson, Department of Surgery, University of Maryland Hospital, Baltimore.

**Ingels, Chuck A.** University of California Cooperative Extension, Sacramento.

**Ingersoll, Dr. Raymond V.** University of California at Los Angeles, Department of Earth and Space Science.

**Ingerson, Dr. Earl.** Department of Geology, University of Texas, Austin.

**Ingram, Dr. B. Lynn.** Department of Geology and Geophysics, University of California, Berkeley.

**Inman, Dr. Douglas L.** Professor of Oceanography, Scripps Institution of Oceanography, La Jolla, California.

**Irene, Dr. Eugene A.** Department of Chemistry, University of North Carolina.

**Ishida, Dr. Nakao.** Department of Bacteriology, Tohoku University School of Medicine, Sendai, Japan.

**Ishihara, Prof. Teruo.** Department of Mechanical and Aerospace Engineering, Rose Polytechnic Institute.

**Isley, Dr. Duane.** Department of Botany, Iowa State University.

**Israel, Dr. Yedy.** Department of Pharmacology, University of Toronto, Ontario, Canada.

**Issel, Dr. Charles J.** College of Agriculture, Veterinary Science, Gluck Equine Research Center, University of Kentucky, Lexington.

**Itano, Dr. Wayne M.** U.S. Department of Commerce, Time and Frequency Division, National Institute of Standards and Technology, Boulder, Colorado.

**Iverson, Dr. Brent L.** Department of Chemistry and Biochemistry, University of Texas, Austin.

**Ives, Dr. Anthony R.** Department of Zoology, University of Wisconsin, Madison.

**Izadian, Dr. Jamal S.** AntennaEM Communication, LLC, San Jose, California.

## J

**Jackiw, Prof. Roman.** Department of Physics, Massachusetts Institute of Technology.

**Jackson, Donald C.** Division of Biology and Medicine, Brown University.

**Jackson, G. A.** Deputy Division Manager, ERA Technology Ltd., Surrey, England.

**Jackson, Dr. Kenneth A.** AT&T Bell Telephone Laboratories, Murray Hill, New Jersey.

**Jackson, Dr. M. P. A.** Senior Research Scientist, Bureau of Economic Geology, University of Texas, Austin.

**Jackson, Dr. William D.** President, HMJ Corporation, Chevy Chase, Maryland.

**Jacobs, Prof. Stephen F.** Optical Sciences Center, University of Arizona.

**Jacobson, Prof. Nathan.** Department of Mathematics, Yale University.

**Jacobson, Dr. Robert.** Chief of the Clinical Branch, Department of Health and Human Services, Gillis W. Long Hansen's Disease Center, Carville, Louisiana.

**Jaep, William F.** Central Research Department, Experimental Station, E. I. du Pont de Nemours and Company, Wilmington, Delaware.

**Jafarey, Prof. S.** Behlen Laboratory of Physics, University of Nebraska.

**Jaffe, Prof. Robert L.** Department of Physics, Massachusetts Institute of Technology, Cambridge.

**Jahns, Dr. Richard H.** Department of Earth Sciences, Stanford University.

**Jain, Dr. P. C.** Central Electronics Engineering Research Institute, Pilani, India.

**Jain, Dr. Subodh K.** Department of Agronomy and Range Science, University of California, Davis.

**Jakobi, Prof. Hans.** Professor of Animal Physiology, Department of Zoology, University of Parana, Brazil.

**James, Prof. Arthur M.** Department of Chemistry, Bedford College, London, England.

**James, Dr. Gideon T.** Department of Earth Sciences, East Texas State University.

**James, John W.** Vice President, Research, McDonnell and Miller, Inc., Chicago, Illinois.

**James, Dr. Mark A.** Corriebruch House, Perthshire, United Kingdom.

**James, Dr. Richard W.** Head, Forecasting Branch, Oceanographic Prediction Division, U.S. Naval Oceanographic Office.

**Jamshidi, Dr. Mohamed.** Director, CAD Laboratory for Systems and Robotics, Department of Electrical and Computer Engineering, University of New Mexico.

**Janick, Prof. Jules.** Department of Horticulture, Purdue University.

**Janis, Dr. Christine.** Department of Ecology and Evolutionary Biology, Brown University, Providence, Rhode Island.

**Janna, Prof. William S.** Department of Mechanical Engineering, Memphis State University, Tennessee.

**Jannasch, Dr. Holger W.** Senior Scientist, Woods Hole Oceanographic Institution, Woods Hole, Massachusetts.

**Japikse, Dr. David.** President, Concepts ETI, Inc., Norwich, Vermont.

**Japuntich, Daniel A.** Occupational Health and Safety Products Division, 3M Company, St. Paul, Minnesota.

**Jarvis, J. Gordon.** Corporate Communications, Eastman Kodak Company, Rochester, New York.

**Jarvis, Dr. John F.** Robotics Systems Research Department, Bell Laboratories, Holmdel, New Jersey.

**Jeffries, Dr. R. P. S.** Department of Paleontology, British Museum of Natural History, London, England.

**Jegla, Dr. Dorothy E.** Department of Biology, Kenyon College, Gambier, Ohio.

**Jen, Dr. C. K.** Supervisor, Microwave Physics Group, Applied Physics Laboratory, Johns Hopkins University.

**Jenike, Andrew W.** Jenike & Johanson, Inc., North Billerica, Massachusetts.

**Jenike, Dr. Michael A.** Research Psychiatrist, Massachusetts General Hospital, Harvard Medical School.

**Jenkins, Prof. Francis A.** Deceased; formerly, Department of Physics, University of California, Berkeley.

**Jenkins, Dr. Julian L.** Director of Research, Bell Helicopter Company, Fort Worth, Texas.

**Jennings, Dr. Donald A.** Time and Frequency Division, National Institute of Standards and Technology, Boulder, Colorado.

**Jennings, Dr. J. B.** Department of Pure and Applied Zoology, University of Leeds, England.

**Jensen, Prof. Arthur R.** School of Education, University of California, Berkeley.

**Jensen, Dr. Howard B.** Research Supervisor, Laramie Energy Research Center, Energy Research and Development Administration, Wyoming.

**Jensen, Richard L.** Sirius Satellite Radio, New York.

**Jespersen, Dr. Neil D.** Department of Chemistry, St. John's University, New York.

**Joel, Amos E., Jr.** AT&T Bell Telephone Laboratories, Holmdel, New Jersey.

**Johansen, Dr. Kjell.** Department of Zoophysiology, University of Aarhus, Denmark.

**Johnson, Prof. Carl R.** Department of Chemistry, Wayne State University.

**Johnson, Dr. Donald Lee.** Department of Geography, University of Illinois, Urbana.

**Johnson, Dr. Edward.** Department of Cell Biology, Rockefeller University.

**Johnson, Dr. Ellis L.** Thomas J. Watson Research Center, IBM Corporation, Yorktown Heights, New York.

**Johnson, Dr. Francis S.** Acting President, University of Texas, Dallas.

**Johnson, Dr. Giles.** School of Biological Sciences, University of Manchester, United Kingdom.

**Johnson, Dr. James E.** Department of Chemistry, Texas Woman's University, Denton.

**Johnson, Dr. James G.** Department of Geology, Oregon State University.

**Johnson, Dr. Jon D.** Department of Forestry, University of Florida, Gainesville.

**Johnson, K. W.** President, Vibra-Grip Corporation, Jamestown, Ohio.

**Johnson, Philip C.** Research and Development Department, Chemicals and Plastics Operations Division, Union Carbide Corporation, South Charleston, West Virginia.

**Johnson, Dr. W. Hilton.** Department of Geology, University of Illinois, Urbana-Champaign.

**Johnson, Prof. Walter C.** Department of Electrical Engineering, Princeton University.

**Johnston, Dr. James D.** Senior Research Advisor, Pioneering Research, Ethyl Corporation, Baton Rouge, Louisiana.

**Johnston, Prof. Keith.** Department of Chemical Engineering, University of Texas, Austin.

**Joklik, Dr. W. K.** Department of Microbiology and Immunology, Duke University Medical Center.

**Jones, Prof. B. Frank, Jr.** Department of Mathematics, Weiss School of Natural Sciences, Rice University.

**Jones, Dr. Clive G.** Institute of Ecosystem Studies, New York Botanical Garden, Millbrook, New York.

**Jones, Dr. Daniel J.** Professor and Chairman, Department of Earth Sciences, California State College, Bakersfield.

**Jones, Dr. David R.** Department of Zoology, University of British Columbia, Canada.

**Jones, Dr. E. Ruffin.** Department of Zoology, University of Florida.

**Jones, Dr. Edwin C., Jr.** Department of Electrical and Computer Engineering, Iowa State University.

**Jones, Dr. Hugh D.** School of Biological Sciences, University of Manchester, United Kingdom.

**Jones, Dr. Jeremy B.** Department of Biological Sciences, University of Nevada, Las Vegas.

**Jones, Prof. Lawrence W. Harrison M.** Randall Laboratory of Physics, University of Michigan.

**Jones, Dr. Meredith L.** National Museum of Natural History, Smithsonian Institution, Washington, D.C.

**Jones, Dr. Morton E.** Director, Physical Sciences Research Laboratory, Texas Instruments, Inc., Dallas.

**Jones, Dr. Norman S.** Senior Lecturer, Marine Biological Station, University of Liverpool, England.

**Jones, Dr. Owen C.** Superintendent, Division of Electrical Science, National Physical Laboratory, Teddington, England.

**Jones, Dr. Patricia M.** Department of Mechanical and Industrial Engineering, University of Illinois, Urbana-Champaign.

**Jones, Prof. R. Alan.** School of Chemical Sciences, University of East Anglia, England.

**Jones, Dr. R. Gareth.** Division of Electrical Science, National Physical Laboratory, Teddington, England.

**Jones, Dr. Richard T.** Department of Biochemistry, University of Oregon Medical School.

**Joppa, Prof. Robert G.** Department of Aeronautics, University of Washington.

**Joravsky, Prof. David.** Professor of History, Northwestern University.

**Jordan, Dr. Elke.** Department of Health and Human Services, National Human Genome Research Institute, Bethesda, Maryland.

**Jory, Howard R.** Varian Associates, Palo Alto, California.

**Joseph, Earl C.** President, Planning and Development, Anticipatory Sciences Inc., Minneapolis, Minnesota.

**Joseph, Leonard M.** Lev Zetlin Associates, New York, New York.

**Joseph, Dr. Simpson.** Department of Chemistry and Biochemistry, University of California, La Jolla.

**Juang, Dr. Biing Hwang.** Lucent Technologies, Bell Laboratories, Murray Hill, New Jersey.

**Judd, Dr. Deane B.** Deceased; formerly, Office of Colorimetry, National Bureau of Standards.

**Judd, Dr. W. John.** Department of Pathology, University of Michigan, Ann Arbor.

**Judd, Dr. William R.** School of Civil Engineering, Purdue University.

**Juranek, Dr. Dennis D.** Center for Disease Control, Atlanta, Georgia.

**Jurisson, Dr. Silvia S.** Department of Chemistry, University of Missouri, Columbia.

**Just, Prof. Evan.** Department of Mining and Geology, Stanford University.

**Juvel, Prof. Richard S., Jr.** Department of Chemistry, Arizona State University.

## K

**Kaesler, Dr. Roger L.** Department of Geology, University of Kansas, Lawrence.

**Kahn, Dr. Bernd.** Environmental Resources Center, Georgia Institute of Technology, Atlanta.

**Kailath, Prof. Thomas.** Information Systems Laboratory, Stanford University, Stanford, California.

**Kaler, Prof. James B.** Department of Astronomy, College of Liberal Arts and Sciences, University of Illinois, Urbana-Champaign.

**Kalhammer, Dr. Fritz.** Electric Power Research Institute, Palo Alto, California.

**Kallen, Dr. Bengt.** Department of Embryology, University of Lund, Sweden.

**Kallio, Dr. R. E.** School of Life Sciences, University of Illinois, Urbana.

**Kalpakjian, Prof. Serope.** Mechanical and Aerospace Engineering Department, Illinois Institute of Technology.

**Kaminow, Dr. Ivan P.** Bell Telephone Laboratories, Holmdel, New Jersey.

**Kamrin, Dr. Michael A.** Center for Environmental Toxicology, Department of Pathology, Michigan State University.

**Kana, Dr. Todd M.** Horn Point Laboratory, Cambridge, Maryland.

**Kan-Mitchell, Dr. June.** School of Medicine, University of Southern California.

**Kanury, Dr. A. Murty.** Senior Mechanical Engineer, Stanford Research Center, Menlo Park, California.

- Kanzig, Prof. Werner.** Department of Physics, Massachusetts Institute of Technology.
- Kaplan, Dr. Louis.** Senior Chemist, Argonne National Laboratory, Argonne, Illinois.
- Kaplan, Robert A.** Vice President in Charge of Engineering, Automatic Burner Corporation, Chicago, Illinois.
- Kaplan, Prof. Thomas A.** Department of Physics and Astronomy, Michigan State University, East Lansing.
- Kapner, Robert S.** Department of Chemical Engineering, Cooper Union, New York.
- Kaprelian, Edward K.** Vice President and Technical Director, Keuffel and Esser Company, Morristown, New Jersey.
- Kapur, Prof. Kallash C.** Director, Industrial Engineering, University of Washington, Seattle.
- Karady, Dr. George G.** Department of Electrical Engineering, Arizona State University.
- Karash, Joseph I.** Manufacturing Engineer (retired), Reliance Electric Company, Wickliffe, Ohio.
- Kareiva, Prof. Peter.** Department of Zoology, University of Washington, Seattle.
- Karlson, Dr. Peter.** Institut für Physiologische Chemie, Philipps-Universität, Marburg, Germany.
- Karner, Dr. Garry D.** Lamont-Doherty Earth Observatory, Palisades, New York.
- Karni, Prof. Shlomo.** Department of Electrical and Computer Engineering, University of New Mexico.
- Karovska, Dr. Margarita.** Harvard-Smithsonian Center for Astrophysics, Cambridge, Massachusetts.
- Karp, Dr. Alan H.** IBM Scientific Center, Palo Alto, California.
- Katz, Dr. Jack L.** Department of Psychiatry, Montefiore Hospital and Medical Center, Bronx, New York.
- Katz, Dr. Joseph J.** Chemistry Division, Argonne National Laboratory, Argonne, Illinois.
- Katz, Dr. Leonard A.** Health Care Plan Medical Center, Buffalo, New York.
- Kaufmann, R. H.** Deceased; formerly, Consultant, Schenectady, New York.
- Kayan, Prof. Carl F.** Deceased; formerly, Department of Mechanical Engineering, School of Engineering, Columbia University.
- Kayden, Dr. Herbert J.** Department of Medicine, New York University School of Medicine, New York.
- Kays, Prof. John M.** Animal Industries Department, University of Connecticut.
- Keating, Richard E.** Time Service Division, U.S. Naval Observatory, Washington, D.C.
- Keddy, Prof. Rex J.** Schonland Research Center for Nuclear Sciences, University of Witwatersrand, Johannesburg, South Africa.
- Keefe, Dr. Richard S. E.** Department of Psychiatry, Duke University Medical Center, Durham, North Carolina.
- Keeton, Dr. William T.** Deceased; formerly, Professor and Chairman, Section of Neurobiology and Behavior, Langmuir Laboratory, Division of Biological Science, Cornell University.
- Keffer, Prof. Frederic.** Department of Physics, University of Pittsburgh.
- Keil, Dr. Stephen L.** Chief, Solar Research Branch, National Optical Astronomy Observatories, National Solar Observatory, Air Force Geophysics Laboratory, Sunspot, New Mexico.
- Keiser, Bernhard E.** President, Keiser Engineering, Inc., Vienna, Virginia.
- Keller, George V.** Department of Geophysics, Colorado School of Mines.
- Keller, Harold W.** Associate Professor, Department of Microbiology and Immunology, Wright State University.
- Keller, Dr. Joseph M.** Department of Physics, Iowa State University.
- Keller, Prof. Walter D.** Department of Geology, University of Missouri.
- Keller, Dr. William E.** Los Alamos Scientific Laboratory, Los Alamos, New Mexico.
- Kelley, Prof. Michael C.** Engineering and Theory Center, Cornell University.
- Kellogg, Dr. Douglas S.** Center for Disease Control, Atlanta, Georgia.
- Kells, Prof. Lyman M.** Deceased; formerly, Professor Emeritus, U.S. Naval Academy.
- Kelman, Dr. Arthur.** Department of Plant Pathology, University of Wisconsin.
- Kempers, Dr. Roger D.** Department of Obstetrics and Gynecology, Mayo Foundation, Mayo Graduate School of Medicine, Rochester, Minnesota.
- Kempainen, Prof. Robert J.** Department of Anatomy, Physiology and Pharmacology, Auburn University of Veterinary Medicine, Auburn, Alabama.
- Kendeigh, Dr. S. Charles.** Department of Zoology, University of Illinois, Urbana.
- Kenning, Dr. David B. B.** Department of Engineering Science, Oxford, United Kingdom.
- Kensler, Dr. Charles J.** Senior Vice President, Life Science Division, Arthur D. Little, Inc., Cambridge, Massachusetts.
- Kent, Dr. George C., Jr.** Professor Emeritus, Louisiana State University; Authors' Services, Inc., Baton Rouge, Louisiana.
- Ker, Dr. Robert F.** Department of Pure and Applied Biology, University of Leeds, United Kingdom.
- Kerr, Dr. Marilyn S.** Department of Biology, Syracuse University.
- Kerst, Prof. Donald W.** Department of Physics, University of Wisconsin.
- Kerstein, Prof. Morris. D.** Director, Graduate and Postgraduate Medical Education Programs, Department of Surgery, Hahnemann University, Philadelphia, Pennsylvania.
- Kessler, Prof. Edwin.** Director, National Severe Storms Laboratory, Norman, Oklahoma.
- Kessler, George W.** Vice President, Engineering and Technology, Power Generation Division, Babcock and Wilcox Company, Barberton, Ohio.
- Kester, Dr. Dale E.** Department of Pomology, College of Agriculture, University of California, Davis.
- Ketterle, Prof. Wolfgang.** Department of Physics, Massachusetts Institute of Technology, Cambridge.
- Ketterson, Dr. J. B.** Department of Physics, Northwestern University.
- Khan, Dr. Tanveer N.** Senior Plant Breeder, Division of Plant Industry, Western Australian Department of Agriculture.
- Kharasch, Prof. Norman.** Department of Biomedical Chemistry, University of Southern California.
- Kibble, Dr. Bryan P.** Division of Electrical Science, National Physical Laboratory, Teddington, Middlesex, England.
- Kilbey, Dr. Brian J.** Department of Genetics, Institute of Animal Genetics, University of Edinburgh, Scotland.
- Kilgore, Dr. Lee A.** Retired; formerly, Westinghouse Electric Corporation, East Pittsburgh, Pennsylvania.
- Kim, Prof. Chung W.** Department of Physics, Johns Hopkins University.
- Kimbark, Dr. Edward W.** Deceased; formerly, Head, Systems Analysis Group, Bonneville Power Administration, Portland, Oregon.
- Kinard, Joseph R.** Consultant, Darnestown, Maryland.
- Kindstedt, Dr. Paul S.** Agricultural Experiment Station, Department of Animal Sciences, University of Vermont, College of Agriculture and Life Sciences, Burlington.
- King, Dr. Bryan H.** Professor of Psychiatry and Pediatrics, Department of Psychiatry, Dartmouth Hitchcock Medical Center, Lebanon, New Hampshire.
- King, Dr. C. Judson.** Department of Chemical Engineering, University of California, Berkeley.
- King, Dr. Donald W., Jr.** Richard T Crane Professor of Pathology, Department of Pathology, University of Chicago.
- King, Dr. Elbert A.** Department of Geology, University of Houston.
- Kinnard, Dr. Isaac F.** Deceased; formerly, Manager of Engineering, Instrument Department, General Electric Company, Lynn, Massachusetts.
- Kinoshita, Prof. Toichiro.** Laboratory of Nuclear Studies, Cornell University.
- Kinsler, Prof. Lawrence E.** Professor of Physics, U.S. Naval Postgraduates School, Monterey, California.
- Kinsman, Prof. Blair.** College of Marine Studies, University of Delaware.
- Kirby, Dr. H. W.** Mound Facility, Monsanto Research Corporation, Miamisburg, Ohio.
- Kirby, Robert S.** Research Laboratories, NOAA, U.S. Department of Commerce, Boulder, Colorado.
- Kirby, Dr. Seth.** Dixon Spice Farms, Dixon, California.
- Kirk, Prof. Wiley P.** Department of Physics, Texas A & M University.

- Kirschner, Prof. Stanley.** Department of Chemistry, Wayne State University.
- Kissel, Dr. David E.** Department of Agronomy, Kansas State University.
- Kit, Dr. Saul.** Novagene Inc., Houston, Texas.
- Klein, Dr. Barbara P.** Department of Foods and Nutrition, University of Illinois.
- Klein, Cornelius.** Department of Geology, University of New Mexico.
- Klein, Dr. David H.** Department of Chemistry, Hope College.
- Klein, Dr. Jan.** Max Planck Insitut für Biologie, Abteilung Immunogenetik, Tubingen, Germany.
- Klein, Prof. Richard G.** Department of Anthropology, University of Chicago.
- Klein, Prof. Richard M.** Department of Botany, University of Vermont.
- Kleiner, Dr. Mendel.** Chalmers University of Technology, Applied Acoustics, Gotheberg, Sweden.
- Kleinsmith, Prof. Lewis J.** Division of Biological Sciences, University of Michigan.
- Klemens, Dr. Paul G.** Department of Physics, University of Connecticut.
- Klepper, Dr. David Lloyd.** Klepper Marshall King Associates, Inc., White Plains, New York.
- Kleppner, Prof. Daniel.** Department of Physics, Massachusetts Institute of Technology, Cambridge.
- Klich, Dr. Maren.** Microbiologist, Food and Feed Safety Research, U.S. Department of Agriculture–Agricultural Research Service, New Orleans, Louisiana.
- Klick, Dr. Clifford C.** Superintendent, Solid Sate Division, U.S. Naval Research Laboratory.
- Kliwer, Prof. K. L.** Department of Physics, Iowa State University.
- Klinger, Dr. Terry.** Friday Harbor Laboratories, Friday Harbor, Washington.
- Klivans, Dean S.** Rockwell International, El Segundo, California.
- Klock, Dr. Harold F.** Department of Electrical Engineering, Ohio University.
- Klutke, Dr. Georgia-Ann.** Associate Professor and Director, Institute for Manufacturing Systems, Department of Industrial Engineering, Texas A & M University, College Station.
- Knapp, Prof. Anthony W.** Department of Mathematics, Cornell University.
- Knebelman, Prof. Morris S.** Professor of Mathematics, Bucknell University.
- Knight, Dr. R. B. D.** Retired; formerly, Division of Electrical Science, National Physical Laboratory, Teddington, Middlesex, England.
- Knoteck, Dr. M. L.** Sandia National Laboratories, Albuquerque, New Mexico.
- Knowles, Prof. Paulden F.** Department of Agronomy and Range Science, University of California, Davis.
- Kobayashi, Dr. George.** Washington University School of Medicine, Saint Louis, Missouri.
- Kocan, Prof. Katherine M.** Department of Veterinary Pathology, Oklahoma State University, Stillwater.
- Koch, Prof. Arthur L.** Department of Biology, Indiana University.
- Koch, Dr. Peter M.** Department of Physics, State University of New York at Stony Brook.
- Koerker, Frederick W.** Technical Expert (retired), Dow Chemical Company, Midland, Michigan.
- Kogel, Dr. Jessica Elzea.** Thiele Kaolin Company, Sandersville, Georgia.
- Koglenik, Dr. Herwig.** Crawford Hill Laboratory, Bell Laboratories, Holmdel, New Jersey.
- Kohl, Arthur L.** Project Engineer, Advanced Development, Atomics International Division, North American Rockwell, Woodland Hills, California.
- Kohlmeier, Dr. Martin.** Department of Nutrition, University of North Carolina at Chapel Hill.
- Kohls, Dr. Glen M.** Sanitarian Director (retired), U.S. Public Health Service, Rocky Mountain Laboratory, Hamilton, Montana.
- Kohnhorst, Lloyd L.** Retired; formerly, Senior Research Specialist, Rockwell International, Columbus, Ohio.
- Koller, Dr. Noemie.** Department of Physics, Rutgers University.
- Kolvoord, Dr. Robert A.** College of Integrated Science and Technology, James Madison University, Harrisonburg, Virginia.
- Komai, Dr. Taku.** Professor Emeritus, Kyoto University, Japan.
- Kominz, Michelle.** Lamont-Doherty Geological Observatory, Palisades, New York.
- Koneman, Dr. Elmer W.** Department of Pathology, Denver Veterans Affairs Hospital, University of Colorado Medical School, Denver.
- Konigsberg, Dr. William H.** Department of Molecular Biophysics, Yale University.
- Konopka, Dr. Allan E.** Department of Biological Sciences, Purdue University.
- Konz, Dr. Stephan A.** Department of Industrial Engineering, Kansas State University.
- Konzo, Prof. Seichi.** Department of Mechanical Engineering, University of Illinois.
- Koopman, Dr. Karl F.** Department of Mammalogy, American Museum of Natural History, New York.
- Koral, Dr. Richard L.** Visiting Associate Professor, Pratt School of Architecture; Coordinator, Apartment House Institute, New York City Community College.
- Korth, Dr. Henry F.** Head, Database Principles Research, Murray Hill, New Jersey.
- Korth, Dr. William W.** Rochester Institute of Vertebrate Paleontology, Penfield, New York.
- Korus, Dr. Roger A.** Chairperson, Department of Chemical Engineering, College of Engineering, Buchanan Engineering Laboratory, University of Idaho.
- Kosikowski, Prof. Frank V.** Department of Food Science, Cornell University.
- Kosow, Dr. Irving L.** Series Editor, Electrical Engineering Technology, John Wiley & Sons, Marietta, Georgia.
- Kotter, Dr. F. Ralph.** National Bureau of Standards.
- Kovar, Dr. Dennis.** Hahn-Meitner Institut für Kernforschung, Berlin, Germany.
- Kow, Dr. Yoke Wah.** Department of Biochemistry, University of Wisconsin.
- Kowal, Dr. Charles T.** Department of Astrophysics, California Institute of Technology.
- Kraehenbuehl, Prof. John O.** Professor Emeritus of Electrical Engineering, University of Illinois, Urbana.
- Kramar, Dr. Ernst.** Deceased; formerly, Standard Elektrik Lorenz Aktien-gesellschaft, Stuttgart, Germany.
- Krasan, Dr. Graham P.** Lecturer in Pediatrics and Communicable Diseases, University of Michigan Medical School, Ann Arbor.
- Krauss, Prof. George.** Colorado School of Mines, Golden.
- Krauss, Dr. Lawrence M.** Center for Theoretical Physics, Yale University.
- Kreek, Dr. Mary Jeanne.** Rockefeller University.
- Krefeld, Prof. William J.** Deceased; formerly, Professor of Civil Engineering, Columbia University.
- Kreilik, Dr. Robert.** Department of Chemistry, University of Rochester.
- Kretschmann, Dr. David E.** Forest Products Laboratory, U.S. Department of Agriculture Forest Service, Madison, Wisconsin.
- Kreutel, Dr. Randall W.** Mechanical Engineering Manager, Atlanta Instrumentation Division, Atlanta, Georgia.
- Krider, Prof. E. Philip.** Director, Institute of Atmospheric Physics, University of Arizona.
- Krishnamurti, Dr. T. N.** Department of Meteorology, Florida State University.
- Kristensen, Dr. Reinhardt Møbjerg.** Zoological Museum, University of Copenhagen, Denmark.
- Kristofferson, Karl.** Public Information Branch, John F. Kennedy Space Center, Cape Canaveral, Florida.
- Krol, Dr. Edward.** Department of Computer Science, University of Illinois, Urbana.
- Krombein, Dr. Karl V.** Chairman, Department of Entomology, National Museum of Natural History, Smithsonian Institution.
- Kroto, Harold W.** School of Chemistry and Molecular Sciences, University of Sussex, United Kingdom.
- Kruse, Dr. Paul W.** Consultant, Infrared Technology, Edina, Minnesota.
- Krusius, Prof. Matti.** Low Temperature Laboratory, Helsinki University of Technology, Finland.

- Kryter, Dr. Karl D.** Director, Sensory Sciences Research Center, Stanford Research Institute, Menlo Park, California.
- Krzysztofowicz, Dr. Roman.** Department of Systems Engineering, University of Virginia.
- Kuchner, Dr. Marc J.** Department of Astronomy, California Institute of Technology, Pasadena, California.
- Kudo, Prof. Albert M.** Department of Earth and Planetary Sciences, University of New Mexico, Albuquerque.
- Kuhn, Dr. Wayne E.** Professional Engineer, Portland, Oregon.
- Kuis, Wietse.** Department of Molecular and Experimental Medicine, Research Institute of Scripps Clinic, La Jolla, California.
- Kulkarni, Prof. Shrinivas.** Department of Astronomy, California Institute of Technology, Pasadena, California.
- Kulkarni, Sudhir S.** Corporate Research Center, UOP Inc., Des Plaines, Illinois.
- Kullerud, Dr. Gunnar.** Department of Geosciences, Purdue University.
- Kulp, J. Laurence.** President, Teledyne Isotopes, Westwood, New Jersey.
- Kuntz, Glenn.** Regional Director, ETI of North America, Inc., Washington, D.C.
- Kunz, Dr. Kaiser S.** Research Professor of Physics, New Mexico State University.
- Kuo, Dr. Benjamin C.** Formerly, Department of Electrical Engineering, University of Illinois, Champaign.
- Kuo, Prof. John T.** Department of Mining Engineering, Columbia University.
- Kupchan, Prof. S. Morris.** Deceased; formerly, Department of Chemistry, University of Virginia.
- Kupke, Dr. Donald W.** Department of Biochemistry, School of Medicine, University of Virginia.
- Kupper, Dr. Walter E.** Manager, Technical Marketing Services, Mettler Instrument Corporation, Hightstown, New Jersey.
- Kusch, Prof. Polykarp.** Department of Physics, Columbia Radiation Laboratory, Columbia University.
- Kushner, Dr. D. J.** Department of Microbiology, University of Toronto, Ontario, Canada.
- Kusters, Dr., N. L.** Division of Electrical Engineering, National Research Council, Ottawa, Ontario, Canada.
- Kutal, Dr. Charles.** Department of Chemistry, University of Georgia.
- Kutzbach, Prof. John E.** Department of Meteorology, University of Wisconsin.
- Laarhoven, Prof. William H.** Department of Organic Chemistry, University of Nijmegen, The Netherlands.
- Labandeira, Dr. Conrad C.** Department of Paleobiology, National Museum of Natural History, Smithsonian Institution, Washington, DC.
- LaBerge, Dr. Stephen.** Department of Psychology, Stanford University, Stanford, California.
- Labi, Prof. Samuel.** Graduate Research Assistant, Purdue University, Civil Engineering, West Lafayette, Indiana.
- Labotka, Dr. Theodore C.** Department of Geological Sciences, College of Liberal Arts, University of Tennessee.
- Lacis, Dr. Andrew A.** NASA Goddard Institute for Space Studies, New York.
- Lackman, Dr. Leslie. M.** Rockwell International, El Segundo, California.
- Ladd, Dr. Carll.** Connecticut State Police Forensic Science Laboratory, Meriden.
- Ladd, Dr. Harry S.** (Retired) National Museum, Smithsonian Institution.
- LaFrey, Raymond R.** Lincoln Laboratory, Massachusetts Institute of Technology, Lexington.
- Lagler, Prof. Karl F.** School of Natural Resources, University of Michigan.
- Lagowski, Dr. J. J.** Department of Chemistry, University of Michigan.
- Lagunoff, Dr. David.** Department of Pathology, School of Medicine, University of Washington.
- Laidler, Dr. James J.** Director, Chemical Technology Division, Argonne National Laboratory, Argonne, Illinois.
- Laitinen, Prof. Herbert A.** Department of Chemistry, University of Florida.
- Lam, Dr. Stephen W.** Center for Excellence for Document Analysis and Recognition, University of Buffalo, Amherst, New York.
- Lamb, Prof. Dennis.** Department of Meteorology, Pennsylvania State University.
- Lamb, Prof. Richard C.** Space Radiation Laboratory, California Institute of Technology, Pasadena.
- Lambert, Dr. Jack L.** Department of Chemistry, Kansas State University.
- Lambert, Dr. Samuel.** Air Force Research Laboratory, Munition Directorate, Eglin Air Force Base, Florida.
- Lambert, Dr. W. David.** Louisiana School of Math, Science, and the Arts, Natchitoches.
- LaMotte, Dr. Clifford E.** Botany Department, Iowa State University.
- LaMotte, Dr. Robert.** Department of Anesthesiology, School of Medicine, Yale University.
- Land, Dr. Cecil E.** Sandia Laboratories, Kirtland Air Force Base East, Albuquerque, New Mexico.
- Landes, Dr. Hugh S.** Department of Electrical Engineering, University of Virginia.
- Landsberg, Dr. H. E.** Deceased; formerly, Institute for Physical Science and Technology, University of Maryland.
- Lane, Dr. John C.** Research and Development Department, Research Laboratories, Ethyl Corporation, Ferndale, Michigan.
- Lane, Dr. Meredith A.** Director, University of Kansas Herbarium, Lawrence.
- Lane, Dr. N. Gary.** Indiana University.
- Lanford, Dr. Pamela.** National Institute on Deafness and Other Communication Disorders, Rockville, Maryland.
- Lanford, Prof. William A.** Department of Physics, State University of New York, Albany.
- Lang, Dr. Anton.** Department of Botany, MUS-DOE Plant Research Laboratory, Michigan State University.
- Lang, Dr. Karl.** Director, Department of Invertebrates, Swedish State Museum of Natural History, Stockholm, Sweden.
- Langenberg, Prof. D. N.** Department of Physics, University of Pennsylvania.
- Langenheim, Prof. Jean H.** Division of Natural Sciences, University of California, Santa Cruz.
- Langford, Prof. George M.** Department of Biological Sciences, Dartmouth University.
- Lapedes, Daniel N.** Deceased; formerly, Editor in Chief, "McGraw-Hill Encyclopedia of Science and Technology," McGraw-Hill, Inc., New York.
- Laport, Edmund A.** Director, Communications Engineering, RCA, Princeton, New Jersey.
- Lappin-Scott, Hilary.** Department of Biology, University of Calgary, Alberta, Canada.
- Lapple, Charles E.** Consultant (retired), Fluid and Particle Technology, Air Pollution and Chemical Engineering, Los Altos, California.
- Larimer, Dr. J. L.** Department of Zoology, University of Texas, Austin.
- Larive, Dr. Cynthia K.** Department of Chemistry, University of Kansas, Lawrence.
- Larsen, Dr. David M.** Department of Physics and Applied Physics, University of Lowell, Massachusetts.
- Larsen, Prof. Edwin M.** Department of Chemistry, University of Wisconsin.
- Larsen, Dr. R. Paul.** Superintendent and Horticulturist, Tree Fruit Research Center, Washington State University.
- Larsen, Dr. Robert G.** Assistant to the Vice President, Shell Development Company, Emeryville, California.
- Larson, Dr. Roy A.** Department of Horticulture, North Carolina State University.
- Lass, Dr. Harry.** Research Specialist, Jet Propulsion Laboratory, California Institute of Technology.
- Lassila, Prof. Kenneth E.** Department of Physics, Iowa State University.
- Last, Prof. John M.** Faculty of Health Sciences, School of Medicine/Epidemiology and Community Medicine, University of Ottawa, Ontario, Canada.
- Latanision, Prof. R. M. H. H.** Ublig Corrosion Laboratory, Department of Materials Science and Engineering, Massachusetts Institute of Technology.
- Latham, Dr. David W.** Center for Astrophysics, Cambridge, Massachusetts.
- Lathl, Prof. B. P.** Department of Electrical and Electronic Engineering, California State University, Sacramento.

## L

- Lattman, Dr. Laurence H.** Dean of Mines, University of Utah.
- Laves, Dr. Friz H.** Deceased; formerly, Eidgenössische Technische Hochschule, Institut für Kristallographie und Petrographie, Zurich, Switzerland.
- Lavin, Prof. Stephen.** Department of Geography, University of Nebraska, Lincoln.
- Lavoie, Dr. Ronald L.** Chief, Program Requirements and Development Division, U.S. Department of Commerce, National Oceanic and Atmospheric Administration, Silver Spring, Maryland.
- Lawley, Dr. Alan.** College of Engineering, Drexel University.
- Lawrence, Dr. J. Dennis.** Lawrence Livermore Laboratory, University of California.
- Layton, Dr. J. Preston.** Deceased; formerly, RCA Astro-Electronics, Conceptual Design, Princeton, New Jersey.
- Layzer, Prof. David.** Department of Astronomy, Harvard University.
- Lazadder, Prof. Warren J.** Department of Engineering Graphics, Purdue University.
- Lazarides, Dr. E.** Department of Biology, California Institute of Technology.
- Leach, Dr. Richard E.** Fellow, Reproductive Endocrinology and Fertility, Department of Obstetrics and Gynecology, Mayo Graduate School of Medicine, Rochester, New York.
- Leach, Prof. William Marshall, Jr.** School of Electrical and Computer Engineering, Georgia Institute of Technology, Atlanta.
- Leadbetter, Prof. E. R.** Department of Biology, Amherst College.
- Leader, Dr. Robert W.** Center for Environmental Toxicology, Department of Pathology, Michigan State University.
- Lebowitz, Dr. Michael D.** Professor of Medicine and Associate Center Director, Respiratory Sciences Center, University of Arizona.
- LeBuhn, Dr. Gretchen.** Department of Biological Sciences, Florida State University, Tallahassee.
- Ledig, Dr. F. Thomas.** School of Forestry, Yale University.
- Lee, Prof. David M.** Department of Physics, Cornell University; Nobelist.
- Lee, Dorothy B.** Lyndon B. Johnson Space Center, National Aeronautics and Space Administration.
- Lee, Dr. Henry C.** Director, Connecticut State Police Forensic Laboratory, and Commissioner, Department of Public Safety, Middletown, Connecticut.
- Lee, Dr. J. T.** Cooperative Institute for Mesoscale Meteorological Studies, National Oceanic and Atmospheric Administration, University of Oklahoma.
- Lee, Lyndon C.** L. C. Lee & Associates, Inc., Seattle, Washington.
- Lee, Dr. Roberto.** Monsanto Company, St. Louis, Missouri.
- Lee, Prof. T. H.** Centre for Intelligent Control, Department of Electrical Engineering, National University of Singapore.
- Lee, Dr. Tae Young.** Department of Chemistry, Seoul National University, Seoul, Korea.
- Lee, Dr. Thomas H.** Strategic Planning Operation, General Electric Company, Fairfield, Connecticut.
- Lee, Dr. W. John.** Professor and L. F. Peterson Chair, Department of Petroleum Engineering, Texas A & M University, College Station.
- Leete, Prof. Edward.** Deceased; formerly, Department of Chemistry, University of Minnesota.
- Lefkowitz, Prof. Irving.** Systems Engineering Department, Case Western Reserve University.
- Legget, Prof. Anthony.** Department of Physics, University of Illinois, Urbana.
- Lehiste, Prof. Use.** Department of Linguistics, Ohio State University.
- Lehmann, Prof. Justus F.** Department of Rehabilitation Medicine, School of Medicine, University of Washington, Seattle.
- Lehn, Prof. Jean-Marie.** Collège de France, Paris, and Institut de Science et Ingénierie Supramoléculaires-Université Louis Pasteur, Strasbourg, France; Nobelist.
- Lehto, Dr. Mark R.** School of Industrial Engineering, Purdue University.
- Leibovich, Prof. Sidney.** Mechanical & Aerospace Engineering, Cornell University.
- Leigh, Dr. Hoyle.** Department of Psychiatry, University of California, San Francisco, and Director, Fresno Division, Fresno, California.
- Leland, Dr. Henry.** Department of Psychology, Ohio State University.
- Leland, Dr. Jonathan K.** IGEN, Inc., Rockville, Maryland.
- Lemont, Prof. Harvey.** Chairman, Department of Podiatric Medicine, Pennsylvania College of Podiatric Medicine, Philadelphia.
- Lenel, Dr. F. V.** Professor Emeritus, Department of Materials Engineering, Rensselaer Polytechnic Institute.
- Lennert, Richard.** Department of Chemical Engineering, University of Texas, Austin.
- Le Noble, Dr. William J.** Department of Chemistry, State University of New York, Stony Brook.
- Leon, Prof. Roberto T.** Roswell, Georgia.
- Leonard, Dr. Edward F.** Chemical Engineering Department, Columbia University.
- Leontis, Dr. Thomas E.** Magnesium Research Center, Battelle Columbus Laboratories, Columbus, Ohio.
- Leopold, Dr. Luna B.** Department of Geology and Geophysics, University of California, Berkeley.
- Lepard, Paul E.** Mettler Instrument Corporation, Hightstown, New Jersey.
- Lerner, Dr. I. Michael.** Department of Genetics, University of California, Berkeley.
- Lerner-Lam, Dr. Art.** Lamont-Doherty Geological Observatory of Columbia University, Palisades, New York.
- Lesins, Dr. Glen.** Department of Oceanography, Dalhousie University, Halifax, Nova Scotia, Canada.
- Lesso, Dr. William G.** Department of Mechanical Engineering, University of Texas, Austin.
- Levasheff, V. V.** American Potash and Chemical Corporation, Whittier, California.
- Levi, Prof. Herbert W.** Curator in Arachnology, Museum of Comparative Zoology, Agassiz Museum, Harvard University.
- Levine, Dr. I. E.** Chevron Research Company, Richmond, California.
- Levine, Prof. Ira N.** Department of Chemistry, Brooklyn College.
- Levine, Dr. Norman D.** College of Veterinary Medicine, University of Illinois, Urbana.
- Levine, Dr. Rachmiel.** City of Hope National Medical Center, Duarte, California.
- Levitan, Dr. Max.** Department of Cell Biology, Mount Sinai School of Medicine, New York.
- Lew, Dr. I. Paul.** Thornton-Tomasetti, Engineers, New York, New York.
- Lewandowski, Dr. Scott M.** Department of Computer Science, Brown University, Providence, Rhode Island.
- Lewis, Dr. Alcinda C.** Institute of Ecosystem Studies, New York Botanical Garden, Millbrook.
- Lewis, Prof. Edward B.** Department of Biology, California Institute of Technology; Nobelist.
- Lewis, Frank D.** Consultant, Lexington, Massachusetts.
- Lewis, Dr. Frank L.** School of Electrical Engineering, Georgia Institute of Technology.
- Lewis, Dr. James K.** Department of Animal Science, South Dakota State University.
- Lewis, Dr. John H.** Pratt & Whitney, East Hartford, Connecticut.
- Lewis, Prof. M. J.** Department of Food Science and Technology, University of California, Davis.
- Lewis, Dr. Richard S.** Department of Psychology, Pomona College, Claremont, California.
- Leventis, Nicholas.** Department of Chemistry, University of Missouri, Rolla.
- Ley, Dr. Willy.** Deceased; formerly, Fairleigh Dickinson University.
- Li, Dr. Ching Chun.** Graduate School of Public Health, University of Pittsburgh.
- Li, Prof. Choh Hao.** Deceased; formerly, Hormone Research Laboratory, University of California Medical Center, San Francisco.
- Li, Norman N.** Director, Separations Research, UOP Inc., World Headquarters, Des Plaines, Illinois.
- Lichtenberg, Dr. Don B.** Department of Physics, Indiana University.
- Liddicoat, Richard T., Jr.** Gemological Institute of America, Los Angeles, California.



- Liebman, Dr. Joel F.** Department of Chemistry and Biochemistry, University of Maryland, Baltimore.
- Liedholm, George E.** Department Head (retired), Petroleum Processing, Shell Development Company, Emeryville, California.
- Lieth, Dr. Helmut.** Department of Biochemistry, University of North Carolina.
- Liggett, Prof. James A.** School of Civil and Environmental Engineering, Cornell University, Ithaca, New York.
- Likens, Prof. Gene E.** Director, Institute of Ecosystem Studies, The New York Botanical Garden, Millbrook, New York.
- Liley, Prof. Peter E.** Lafayette, Indiana.
- Limpel, Eugene J.** Consulting Electrical Engineer, Eagle River, Wisconsin.
- Lin, Wen-Hwang.** Rocketdyne Propulsion & Power, The Boeing Company, Canoga Park, California.
- Linde, Dr. Ronald K.** President, Envirodyne, Inc., Los Angeles, California.
- Lindenmaier, Dr. Werner A.** Hoffmann-LaRoche, Inc., Nutley, New Jersey.
- Linderorth, Prof. L. Sigfred, Jr.** (Retired) Department of Mechanical Engineering, Duke University.
- Lindner, Dr. Hans R.** Department of Biodynamics, Weizmann Institute of Science, Rehovoth, Israel.
- Lindsay, J. S.** Liquid Carbonic Corporation, Chicago, Illinois.
- Lindsay, Prof. R. Bruce.** Deceased; formerly, Hazard Professor of Physics, Emeritus, Brown University.
- Lindzen, Prof. Richard S.** Center for Meteorology and Physical Oceanography, Massachusetts Institute of Technology.
- Lineback, Dr. David R.** Department of Food Science, North Carolina State University.
- Lineberger, Dr. W. C.** Joint Institute for Laboratory Astrophysics, National Institute for Standards and Technology, University of Colorado.
- Lines, Malcom E.** Bell Telephone Laboratories, Murray Hill, New Jersey.
- Linskey, Dr. Jeffrey.** Department of Astrophysics, University of Colorado, Boulder.
- Linsley, Prof. Ray K.** Department of Civil Engineering, Stanford University.
- Linthicum, Jack M.** Office of Science and Technology, Federal Communications Commission.
- Liou, Dr. J. G.** Department of Earth and Planetary Sciences, Tokyo Institute of Technology, Japan.
- Liou, Juhn G.** Department of Geology, Stanford University.
- Liou, Prof. Kuo-Nan.** Department Chair, Department of Atmospheric Sciences, University of California, Los Angeles.
- Lipin, Bruce R.** U.S. Department of the Interior, Reston, Virginia.
- Lipkens, Dr. Bart.** Assistant Professor, Department of Mechanical Engineering, Virginia Commonwealth University, Richmond, Virginia.
- Lipkowitz, Prof. Kenneth B.** Department of Chemistry, Indiana-Purdue University, Indianapolis.
- Lipner, Prof. Harry J.** Department of Biological Science, Florida State University.
- Lipshutz, Prof. Bruce H.** Department of Chemistry, University of California, Santa Barbara.
- Lister, Prof. C. J. A. W.** Wright Nuclear Structure Laboratory, Physics Department, Yale University.
- Litherland, Prof. Albert E.** Director, Isotrace Laboratory, Department of Physics, University of Toronto, Ontario, Canada.
- Little, Elbert L., Jr.** Dendrologist, Forest Service, U.S. Department of Agriculture.
- Little, Dr. James N.** Research Division, Waters Associates, Milford, Massachusetts.
- Liu, Benjamin Y. H.** Department of Mechanical Engineering, University of Minnesota.
- Liu, Prof. Clark C. K.** Department of Civil Engineering, University of Hawaii at Manoa.
- Liu, Dr. Sam H.** Department of Physics, Iowa State University.
- Liu, Dr. Tanzhuo.** Lamont-Doherty Earth Observatory, Columbia University, Palisades, New York.
- Livingston, Dr. William C.** National Optical Astronomy Observatories, National Solar Observatory, Tucson, Arizona.
- Ljung, Dr. Donovan A.** Fermi National Accelerator Laboratory, Batavia, Illinois.
- Lochhead, Dr. Allan G.** Microbiology Research Institute, Canada Department of Agriculture, Ottawa, Ontario.
- Lochhead, Dr. John H.** London, England.
- LoCicero, Prof. Joseph L.** Illinois Institute of Technology, Electrical and Computer Engineering Department, Chicago.
- Lockhart, Prof. Frank J.** Department of Chemical Engineering, University of Southern California.
- Loeb, John L.** ACLS Corporation, Silver Spring, Maryland.
- Loeblich, Dr. Alfred R., Jr.** Department of Earth and Space Sciences, University of California, Los Angeles.
- Loewenstein, Dr. Werner R.** College of Physicians and Surgeons, Columbia University.
- Loftus, Dr. Douglas J.** Laboratory of Cell Biology, National Cancer Institute, Bethesda, Maryland.
- Loftus, Prof. Elizabeth F.** Professor of Psychology, Department of Psychology, University of Washington, Seattle.
- Logan, Prof. Earl, Jr.** Department of Aerospace and Mechanical Engineering, Arizona State University, Tempe.
- Loneragan, Prof. J. F.** School of Environmental and Life Science, Murdoch University, Perth, Australia.
- Long, Prof. Franklin A.** Formerly, Department of Chemistry, Cornell University.
- Long, Joseph B.** Consultant, Columbus, Ohio.
- Longacre, Alan.** (Retired) Fluor Engineers and Constructors, Irvine, California.
- Longmoore, Dr. Kenneth.** Department of Chemistry, University of Massachusetts.
- Longo, Dr. Dan L.** Director, National Cancer Institute, Frederick Cancer Research Facility, Maryland.
- Longo, Luca.** Instituto Guido Donegani, EniChem, Polymeric Materials Department, Novara, Italy.
- Lonngren, Prof. Karl E.** Department of Electrical and Computer Engineering, University of Iowa, Iowa City.
- Lonsdale, Dr. Carol J.** Infrared Processing & Analysis Center, California Institute of Technology, Pasadena.
- Lonsdale, Dr. Peter.** Scripps Institution of Oceanography, La Jolla, California.
- Loope, Dr. David B.** Department of Geology, University of Nebraska Medical Center.
- Lopiano, Dr. Michael.** Chairman, Public Information Committee, American College of Radiology, Reston, Virginia.
- Lopresti, Dr. Philip V.** Retired; formerly, Engineering Research Center, AT&T Bell Laboratories, Princeton, New Jersey.
- Lorand, Dr. L.** Department of Biochemistry and Molecular Biology, Northwestern University.
- Lord, Prof. Richard C.** Department of Chemistry, Massachusetts Institute of Technology.
- Lordi, George M.** Department of Medicine, College of Medicine and Dentistry, Newark, New Jersey.
- Lorenz, Prof. Oscar A.** Department of Vegetable Crops, University of California, Davis.
- Lotz, Dr. Martin.** Department of Molecular and Experimental Medicine, Research Institute of Scripps Clinic, La Jolla, California.
- Loughlin, James E.** Chemical Process Pilot Plant, Textile Research Center, Texas Tech University.
- Love, Dr. Jeffrey J.** Institute of Geophysics and Planetary Physics, University of California, San Diego.
- Lovell, Dr. Mark A.** Director, Diagnostic Molecular Pathology Laboratory, Department of Pathology, University of Virginia Health Sciences Center, Charlottesville.
- Lowan, Dr. Arnold N.** Deceased; formerly, Chairman, Department of Physics, Yeshiva University.
- Lowe, Christopher R.** Institute of Biotechnology, Cambridge University, England.
- Lowe, Dr. David A.** Department of Fermentation Development, Industrial Division, Bristol-Myers Squibb Company, Syracuse, New York.
- Lowell, Cadence A.** Department of Biology, Central State University, Wiberforce, Ohio.
- Lowell, Prof. Wayne R.** Department of Geology, Indiana University.
- Lowenstein, Prof. Otto E.** Department of Zoology, University of Birmingham, England.

**Lowenthal, Dr. David.** Research Associate, American Geographical Society, New York.

**Luanda, Dr. Robert E.** Director of Extractive Research and Development, Zinc Smelting Division, St. Joseph Minerals Corporation, Monaca, Pennsylvania.

**Luban, Prof. Naomi L. C.** Department of Laboratory Medicine, Transfusion Medicine, Children's Hospital, George Washington University Medical Center, Washington, D.C.

**Luborsky, Dr. Fred E.** Research and Development Center, General Electric Company, Schenectady, New York.

**Lucas, Dr. Spencer G.** New Mexico Museum of Natural History, Albuquerque, New Mexico.

**Luckenbach, Edward C.** Exxon Research and Engineering Company, Florham Park, New Jersey.

**Ludlam, Prof. Frank H.** Deceased; formerly, Department of Meteorology, Imperial College, London, England.

**Ludvik, Dr. George F.** Insecticide Application Research, Agricultural Research and Development Department, Monsanto Company, St.

**Luebbers, Dr. Ralph H.** Department of Chemical Engineering, University of Missouri.

**Lunte, Dr. Susan M.** Associate Director, Center for Bioanalytical Research, University of Kansas, Lawrence.

**Luo, Dr. Zhexi.** Section of Vertebrate Fossils, Carnegie Museum of Natural History, Pittsburgh, Pennsylvania.

**Lusted, Dr. Lee B.** Department of Radiology, University of Chicago.

**Luth, Dr. William.** Department of Earth Sciences, Stanford University.

**Luthin, Prof. James N.** Department of Civil Engineering, University of California, Davis.

**Lutter, Dr. Leonard.** Molecular Biology Research Program, Henry Ford Hospital, Detroit, Michigan.

**Luttge, Prof. Ulrich.** Institut für Botanik, Technische Hochschule Darmstadt, Darmstadt, Germany.

**Luu, Dr. Jane.** Astronomy Department, University of Leiden, Netherlands.

**Lykken, Dr. David T.** Department of Psychiatry, University of Minnesota, Minneapolis.

**Lyman, Prof. Charles P.** Department of Medical Sciences, Harvard University.

**Lyman, Dr. John.** Department of Oceanography, University of North Carolina.

**Lynds, Dr. Beverly T.** Center for Astrophysics and Space Astronomy, University of Colorado.

**Lyon, Dr. W. S.** Analytical Division, Oak Ridge National Laboratory, Oak Ridge, Tennessee.

**Lyon, Dr. Waldo.** Arctic Submarine Research Laboratory, Naval Undersea Warfare Center, San Diego, California.

**Lyons, Prof. Walter.** Consultant in Telecommunications, Flushing, New York.

**Lyons, Dr. Walter A.** Certified Consulting Meteorologist, Forensic Meteorology Associates, Fort Collins, Colorado.

## M

**Ma, Dr. Yi Hua.** Department of Chemical Engineering, Worcester Polytechnic Institute.

**MacCarthy, Donnell D.** Manager, Voltage Regulator Engineering, Voltage Regulator Product Section, General Electric Company, Pittsfield, Massachusetts.

**MacCough, Neil.** Deceased; formerly, Lecturer in Mechanical Engineering, Columbia University.

**MacCrone, Prof. Robert K.** Department of Physics, Rensselaer Polytechnic Institute.

**MacDaniels, Dr. Lawrence H.** Professor Emeritus of Floriculture and Ornamental Horticulture, Cornell University.

**Macdonald, Dr. Gordon A.** Deceased; formerly, Institute of Geophysics, University of Hawaii.

**MacDonald, Dr. J. M.** Small Animal Clinic, Auburn University, Auburn, Alabama.

**MacDonald, Prof. Robert C.** Department of Biochemistry, Molecular and Cell Biology, Northwestern University.

**MacDonald Ruby I.** Department of Biochemistry, Molecular, and Cell Biology, Northwestern University.

**Macdoughall, Prof. J. Douglas.** Geological Research Division, Scripps Institution of Oceanography, La Jolla, California.

**MacDowell, Dr. Samuel W.** Department of Physics, Yale University.

**Macher, Dr. Abe M.** Medical Consultant, AIDS Education and Training Centers Programs, U.S. Public Health Service, Rockville, Maryland.

**Machiels, Albert.** Nuclear Engineer, Nuclear Radiation Laboratory, University of Illinois, Urbana-Champaign.

**Machlin, Dr. Laurence J.** Department of Vitamins and Clinical Nutrition, Hoffmann-LaRoche, Inc., Nutley, New Jersey.

**Mackay, Dr. Ian R.** Center for Molecular Biology and Medicine, Monash University, Clayton, Australia.

**MacKenzie, Prof. Innes K.** Department of Physics, University of Guelph, Ontario, Canada.

**Mackey, Prof. George W.** Department of Mathematics, Harvard University.

**Mackhann, Prof. Guy Mead.** Neurology Department, Johns Hopkins Hospital, Baltimore, Maryland.

**Madanshetty, Prof. Sameer I.** Department of Aerospace and Mechanical Engineering, Boston University, Boston, Massachusetts.

**Maddalon, Dal V.** NASA Langley Research Center, Hampton, Virginia.

**Maderson, Dr. Paul F.** Department of Biology, Brooklyn College.

**Madestau, L.** Deceased; formerly, Chemicals and Plastics Division, Union Carbide Corp., Bound Brook, New Jersey.

**Madin, Dr. Laurence P.** Associate Science, Biology Department, Woods Hole Oceanographic Institution, Woods Hole, Massachusetts.

**Madison, Dr. John H.** Environmental Horticulture Department, University of California, Davis.

**Madison, Dr. Vincent.** Department of Medicinal Chemistry, School of Pharmacy, University of Illinois, Chicago.

**Madore, Dr. Barry F.** NASA/IPAC Extragalactic Database, Jet Propulsion Laboratory, California Institute of Technology, Pasadena, California.

**Magee, Paul T.** Department of Microbiology, School of Medicine, Yale University.

**Maggenti, Dr. Armand R.** Division of Nematology, University of California, Davis.

**Mahle, Dr. Christoph E.** COMSAT Laboratories, Clarksburg, Maryland.

**Mahmoud, Dr. Aly A.** School of Engineering, Indiana University-Purdue University of Fort Wayne.

**Mahoney, Dr. Lee R.** Chemistry Department, Ford Motor Company, Dearborn, Michigan.

**Maisey, Dr. John G.** Assistant Curator, American Museum of Natural History, New York.

**Major, Dr. Jack.** Department of Botany, University of California, Davis.

**Makulec, Alfred.** Product Planning and Application Specialist, Large Lamp Department, General Electric Company, Cleveland, Ohio.

**Malacinski, Dr. George M.** Department of Biology, Indiana University.

**Maldonado-Moll, Dr. Jose F.** Special Assistant for Science and Technology, Sistema Universitario de la Fundacion Educativa Ana G. Mendez Rio Piedras, Puerto Rico.

**Malin, Dr. David F.** Anglo-Australian Observatory, Epping, Australia.

**Malina, Prof. Robert M.** Department of Anthropology, University of Texas.

**Mamantov, Dr. Gleb.** Chemistry Department, University of Tennessee.

**Mamay, Dr. Sergius H.** U.S. Geological Survey, National Museum.

**Mandel, Dr. Manley.** Department of Biology, M.D. Anderson Hospital, Houston, Texas.

**Mandler, Dr. George.** Department of Psychology, University of California, San Diego.

**Mangion, Charles.** Technology Laboratory, Science and Technology Division, Systems Group, TRW, Inc., Redondo Beach, California.

**Mangum, B. W.** Leader, Thermometry Group, Prouss Measurement Division, National Institute of Standards and Technology, Gaithersburg, Maryland.

**Mann, Prof. Alfred K.** Department of Physics, University of Pennsylvania.

- Mann, Dr. Kenneth H.** Fisheries Research Board of Canada, Dartmouth, Nova Scotia.
- Mann, Prof. Robert W.** Department of Mechanical Engineering, Massachusetts Institute of Technology.
- Mann, Prof. Stephen.** School of Chemistry, University of Bath, United Kingdom.
- Mann, William R.** Rockwell International Corporation, New Port Beach, California.
- Mannheim, Prof. Walter. Med.** Zentrum für Hygiene, Universität Marburg, Germany.
- Manning, Dr. James M.** Department of Biochemistry, Rockefeller University.
- Manning, Dr. Kenneth V.** Professor Emeritus, Pennsylvania State University.
- Manning, Dr. Paul D. V.** Professor of Chemical Engineering (retired), California Institute of Technology.
- Mansfield, Steve.** American Radio Relay League, Inc., Newington, Connecticut.
- Manson, Dr. John A.** Deceased; formerly, Department of Chemistry, Lehigh University.
- Mansouri, Freydoon.** Department of Physics, Yale University.
- Manspeizer, Prof. Warren.** Department of Geological Sciences, Faculty of Arts and Sciences, Rutgers University.
- Mantell, Dr. Charles L.** President, C. L. Mantell and Associates, Manhasset, New York.
- Mantler, Dr. Michael.** Institut für Angewandte und Technische Physik, Technische Universität Wien, Austria.
- Manwell, Dr. Reginald D.** Department of Zoology, College of Liberal Arts, Syracuse University.
- Maple, M. Brian.** Department of Physics, University of California, San Diego.
- Maramorosch, Dr. Karl.** Department of Entomology, Rutgers University, New Brunswick, New Jersey.
- March-Russell, Dr. John.** Theory Division, CERN, Geneva, Switzerland.
- Marchalonis, Dr. John J.** Chairperson, Department of Biochemistry, Medical University of South Carolina.
- Marchand, Prof. Alan P.** College of Arts and Sciences, Department of Chemistry, University of Texas, Denton.
- Marcus, Prof. Ernesto.** Deceased; formerly, Department of Zoology, University of Sao Paulo, Brazil.
- Marcus, Eveline.** Department of Zoology, University of Sao Paulo, Brazil.
- Marcus, Prof. Marvin.** Department of Computer Science, University of California, Santa Barbara.
- Marden, Dr. Albert.** School of Mathematics, University of Minnesota.
- Marek, Dr. John M.** Independent Mining Consultants, Inc., Tucson, Arizona.
- Margai, Prof. Florence Lansana.** Department of Geography, State University of New York at Binghamton.
- Margenau, Prof. Henry.** Department of Physics, Yale University.
- Margolis, Prof. Simeon.** Endocrinology and Metabolism, Johns Hopkins University, Baltimore, Maryland.
- Margollash, Dr. E.** Department of Biochemistry, Northwestern University.
- Margon, Dr. Bruce.** Space Sciences Laboratory, University of California, Berkeley.
- Margrave, Prof. John L.** Dean of Research, Rice University.
- Marino, Dr. Paul.** Department of Biology, College of Charleston, South Carolina.
- Mariño, Prof. Miguel A.** Hydrology Program, University of California, Davis.
- Maris, Prof. Humphrey J.** Department of Physics, Brown University.
- Mark, Dr. J. Carson.** Member of the Advisory Committee, Reactor Safeguards of U.S. Nuclear Regulatory Commission, Los Alamos, New Mexico.
- Markert, Prof. Clement L.** Department of Biology, Yale University.
- Markovitz, Dr. Hershel.** Department of Chemistry, Carnegie-Mellon University.
- Markowitz, Dr. William.** Oceanographic Center, Nova University; Editor, "Geophysical Surveys." Marks, Lawrence E. Pierce Foundation, New Haven, Connecticut.
- Marks, Dr. Jonathan.** Department of Sociology and Anthropology, University of North Carolina at Charlotte.
- Marks, Dr. Tobin J.** Department of Chemistry, Northwestern University.
- Markus, John.** Deceased; formerly, Consultant (retired), Sunnyvale, California.
- Marsh, Don.** Media Services Representative, Portland Cement Association, Skokie, Illinois.
- Marsh, Dr. Kenneth N.** Thermodynamic Research Center, Texas A & M University.
- Marshak, Dr. Harvey.** National Bureau of Standards.
- Marshall, Dr. H. G.** Crops Research Division, Agricultural Research Service and Department of Agronomy, Pennsylvania State University.
- Marshall, Dr. Norman B.** Retired; formerly, Senior Principal Scientific Officer, British Museum of Natural History, London, England.
- Marshall, Peter L.** Independent Consultant, Granville, Ohio.
- Marshall, Prof. William R., Jr.** Associate Dean, College of Engineering, University of Wisconsin.
- Marsland, Charles R.** Chief Technical Consultant, Handy and Harman, Fairfield, Connecticut.
- Martell, Dr. A. E.** Department of Chemistry, Texas A&M University.
- Martin, Prof. C. Samuel.** School of Civil Engineering, Georgia Institute of Technology, Atlanta.
- Martin, Dr. Daniel W.** Acoustics Consultant, Cincinnati, Ohio.
- Martin, Franklin W.** Mayaguez Institute of Tropical Agriculture, Mayaguez, Puerto Rico.
- Martin, Dr. Peter G.** McLennon Physical Laboratories, Canadian Institute for Theoretical Physics, University of Toronto, Canada.
- Martin, Prof. R. D.** Anthropologisches Institut, Universität Zurich-Irchel, Zurich, Switzerland.
- Martin, R. G.** National Institutes of Health, Bethesda, Maryland.
- Martin, Prof. Richard J.** Division of Neonatology, Rainbow Babies and Childrens Hospital, University Hospitals of Cleveland, Ohio.
- Martin, Stanley B.** Stanford Research Center, Menlo Park, California.
- Martínez-Carrera, Dr. D.** College of Postgraduates in Agricultural Sciences, Mushroom Biotechnology, Puebla, Mexico.
- Maruyama, Prof. Shige.** Department of Earth and Planetary Sciences, Tokyo Institute of Technology, Tokyo, Japan.
- Marvier, Dr. Michelle A.** Department of Biology, Santa Clara University, Santa Clara, California.
- Marx, Dr. Preston A.** California Primate Research Center, University of California, Davis.
- Marzilli, Dr. Luigi G.** Department of Chemistry, Emory University.
- Marzilli, Dr. Patricia A.** Department of Chemistry, Emory University.
- Mascarenhas, Prof. Joseph P.** Department of Biological Sciences, State University of New York, Albany.
- Mashoon, Prof. Bahram.** Department of Physics and Astronomy, College of Arts and Sciences, University of Missouri—Columbia.
- Mason, Dr. Basil J.** Program Director, Center for Environmental Technology, Imperial College of Science and Technology, London, England.
- Massey, Dr. Vincent.** Department of Biological Chemistry, University of Michigan.
- Massion, Dr. Jean.** Laboratoire de Neurobiologie et Mouvements, Centre de Recherche en Neurosciences Cognitives, Marseille, France.
- Mast, Dr. Roy C.** Miami Valley Laboratories, Proctor and Gamble Company, Cincinnati, Ohio.
- Masters, Dr. Colin L.** Head of the National Creutzfeldt-Jakob Disease Registry, Department of Pathology, University of Melbourne, Australia.
- Masucci, Dr. Maria G.** Microbiology and Tumor Biology Center, Karolinska Institute, Stockholm, Sweden.
- Mata-Toledo, Dr. Ramon A.** Associate Professor of Computer Science, James Madison University, Harrisonburg, Virginia.
- Mattei, Dr. Janet Akyüz.** Director, American Association of Variable Star Observers, Cambridge, Massachusetts.
- Matyas, Stephen M.** IBM Systems Communications Division, Kingston, New York.
- Mauchline, Dr. John.** Scottish Association for Marine Science, Argyll, Scotland.
- Mauk, Dr. Craighton S.** Research Associate, Department of Horticultural Science, Mountain Horticultural Crops Research and Extension Center, School of

- Agriculture and Life Sciences, North Carolina State University, Fletcher.
- Maul, Prof. George A.** Director, Division of Marine and Environmental Systems, Florida Institute of Technology, Melbourne.
- Maurer, Dr. Brian A.** Department of Fisheries and Wildlife, Michigan State University, East Lansing.
- Mausner, Dr. Leonard F.** Radionuclide/Radiopharmaceutical Research, Brookhaven National Laboratory, Upton, New York.
- May, Prof. Bella J.** Department of Physical Therapy, Medical College of Georgia, Augusta.
- May, F. H.** Consultant, Kerr-McGee Corporation, Whittier, California.
- May, James E.** Lockheed-California Company, Burbank, California.
- Mayall, Robert N.** Director, Planning and Research Associates, Boston, Massachusetts.
- Mayer, Dr. Rudolph L.** Deceased; formerly, Leonard Wood Memorial Hospital, Washington, D.C.
- Maykuth, Daniel.** Tin Research Institute, Inc., Columbus, Ohio.
- Maynard, Dr. Harold B.** President, Maynard Research Council, Inc., Pittsburgh, Pennsylvania.
- Mays, Rolland L.** Materials Systems Division, Union Carbide Corporation, Tarrytown, New York.
- Mazzo, Anthony.** Urban Substructures, Inc., East Elmhurst, New York.
- McAlister, Prof. Harold A.** Director, Center for High Angular Resolution Astronomy, Georgia State University, Atlanta.
- McBride, Dr. Earle F.** Department of Geology, University of Texas, Austin.
- McCabe, Dr. Allyssa.** Eliot-Pearson Department of Child Study, Tufts University.
- McCabe, Dr. Warren L.** Deceased; formerly, Department of Chemical Engineering, North Carolina State University.
- McCann, Dr. Mary B.** Nutrition Program, Center for Disease Control, Health Services and Mental Health Administration, U.S. Department of Health, Education and Welfare, Rockville, Maryland.
- McCarthy, Dr. Dennis D.** Time Service Division, U. S. Naval Observatory, Washington, D.C.
- McCarthy, Dr. John.** National Center for Atmospheric Research, Boulder, Colorado.
- McCarthy, Prof. Kathryn A.** Professor of Physics, and Dean of Graduate School of Arts and Sciences, Tufts University.
- McCarty, Dr. John E.** Structure Staff Supervisor, Boeing Company, Renton, Washington.
- McClain, Prof. Thomas E.** Head, Department of Forest Products, Oregon State University, Corvallis.
- McClellan, Leslie N.** Consulting Engineer, Engineering Consultants, Inc., Denver, Colorado.
- McClung, Dr. Leland S.** Professor Emeritus, Department of Microbiology, Indiana University.
- McClure, Dr. Michelle.** Northwest Fisheries Science Center, Seattle, Washington.
- McConnaughy, Dr. Bayard H.** Department of Biology, University of Oregon.
- McCormick, Prof. Barnes W., Jr.** Department of Aerospace Engineering, Pennsylvania State University.
- McCormick, Dr. Thomas R.** Department of Biomedical History, School of Medicine, University of Washington.
- McCoy, Prof. Barry M.** Division of Engineering and Applied Physics, Harvard University.
- McDonald, Prof. Alan T.** School of Mechanical Engineering, Purdue University.
- McDonald, Prof. John J.** Retired; formerly, Head, Textile Engineering Department, University of Lowell.
- McDowell, Dr. Robin S.** Senior Chief Scientist, Chemical Structure and Dynamics, Molecular Science Research Center, Battelle Pacific Northwest Laboratories, Richland, Washington.
- McEivilly, Dr. Thomas V.** Department of Geology, University of California, Berkeley.
- McEwan, Prof. Robert S.** Deceased; formerly, Professor Emeritus, Oberlin College.
- McEwen, Dr. Bruce.** Harold and Margaret Milliken Hatch Laboratory of Neuroendocrinology, Rockefeller University, New York.
- McFarland, Dr. Richard H.** Director Emeritus, Avionics Engineering Center, Ohio University, Athens.
- McGannon, Harold E.** Technical Editor, Research and Technology Division, United States Steel Corporation, Pittsburgh, Pennsylvania.
- McGaugh, Dr. James L.** Department of Psychobiology, University of California, Irvine.
- McGinley, Dr. John A.** Chief, Forecast Research Group, National Oceanic and Atmospheric Administration, Environmental Research Laboratory, Boulder, Colorado.
- McGinnies, Dr. William G.** Professor of Dendrochronology and Arid Land Ecologist, Office of Arid Land Studies, University of Arizona.
- McGinnis, Prof. William.** Department of Molecular Biophysics and Biochemistry, Yale University.
- McGuire, Ann B.** Aquaculture Program, University of California, Davis.
- McHugh, Dr. J. L.** Marine Sciences Research Center, State University of New York, Stony Brook.
- McIntire, Prof. Larry V.** Chairperson, Institute of Biosciences and Bioengineering, Rice University, Houston, Texas.
- McIntosh, Prof. J. Richard.** Department of Molecular, Cellular and Developmental Biology, Laboratory for High-Voltage Electron Microscopy, University of Colorado at Boulder.
- McIntyre, Dr. Andrew.** Lamont-Doherty Geological Observatory, Palisades, New York; Queens College of the City University of New York.
- McKenna, Dr. Malcolm C.** Frick Curator, American Museum of Natural History, New York.
- McKesson, Chris B.** John J. McMullen Associates, Bremerton, Washington.
- McKinney, Dr. Chester M.** Retired; formerly, Applied Research Laboratories, University of Texas, Austin.
- McKinney, Prof. Frank K.** Department of Geology, Appalachian State University, Boone, North Carolina.
- McKnight, Prof. Tom.** Department of Geography, University of California, Los Angeles, California.
- McLaughlin, Dr. Patsy.** Shannon Point Marine Center, Western Washington University, Anacortes.
- McMahon, Dr. John F.** Deceased; formerly, New York State Technical Service Program, Alfred, New York.
- McNamara, Dr. Ken J.** Senior Curator, Invertebrate Paleontology, Western Australian Museum, Perth, Western Australia.
- McNamara, Dr. Peter.** Department of Medical Microbiology, University of Wisconsin, Madison.
- McNaughton, Prof. Samuel J.** Department of Biology, Syracuse University.
- McNellis, Dr. Donald.** Center for Research of Mothers and Children, National Institute of Child Health and Human Development, National Institutes of Health, Bethesda, Maryland.
- McPartland, Brian J.** Electrical Design and Installation, Englewood Cliffs, New Jersey.
- McPartland, Joseph F.** Electrical Design and Installation, Englewood Cliffs, New Jersey.
- McPherson, Prof. George, Jr.** Department of Electrical Engineering, School of Engineering, University of Missouri.
- McQuillan, James P.** AT&T Federal Systems, Washington, D.C.
- McVey, Charles I.** Fluorescent and High Intensity Systems Department, General Electric Company, Twinsburg, Ohio.
- McWilliams, Dr. Michael O.** Department of Geophysics, School of Earth Sciences, Stanford University.
- Meade, Dr. Thomas J.** Division of Chemistry and Chemical Engineering, California Institute of Technology.
- Mebus, Dr. Charles A.** Laboratory Chief, Foreign Animal Disease Diagnostic Laboratory, U.S. Department of Agriculture, Greenport, New York.
- Meeus, Dr. Jean.** Consultant, Erps-Kwerps, Belgium.
- Meuse, Dr. Bastiaan J. D.** Department of Botany, University of Washington.
- Meggers, Dr. William F.** Deceased; formerly, National Bureau of Standards.

- Mehra, Prof. Raman K.** President, Scientific Systems, Inc., Cambridge, Massachusetts.
- Meijer, Prof. Paul H. E.** Department of Physics, Catholic University of America.
- Meijer, Dr. Roelof J.** Assistant Director of Research, Philips Research Laboratories, Eindhoven, Netherlands.
- Meiklejohn, Dr. Jane.** Senior Research Fellow, University College, Salisbury, Rhodesia.
- Meinke, Dr. David.** Department of Botany and Microbiology, Oklahoma State University.
- Meinke, Dr. W. Wayne.** Analytical Chemistry Division, National Bureau of Standards.
- Meinwald, Dr. J.** Department of Chemistry, Cornell University.
- Meisel, Dr. David D.** Department of Physics and Astronomy, State University of New York, Genesee.
- Meisel, Dr. Jerome.** Department of Electrical and Computer Engineering, Wayne State University.
- Meissner, Dr. Hans W.** Department of Physics, Stevens Institute of Technology, Hoboken, New Jersey.
- Meixner, Dr. Josef.** Director, Institute of Theoretical Physics, Aachen, Germany.
- Melander, John.** Portland Cement Association, Skokie, Illinois.
- Mellichamp, Prof. Duncan.** Department of Chemical and Nuclear Engineering, University of California, Santa Barbara.
- Melnick, Dr. Joseph L.** Department of Virology and Epidemiology, Baylor College of Medicine.
- Melosh, Prof. H. J.** Lunar and Planetary Laboratory, University of Arizona, Tucson.
- Meltzer, Dr. David J.** Department of Anthropology, Southern Methodist University, Dallas, Texas.
- Menkes, Joshua.** Science and Technology Division, Institute for Defense Analyses, Arlington, Virginia.
- Menzies, Dr. Robert J.** Department of Zoology, Duke University.
- Merold, John.** M. Rosenblatt and Son, Inc., Arlington, Virginia.
- Merritt, Frederick S.** Consulting Engineer, West Palm Beach, Florida.
- Merwin, Earl J.** McCormick and Company, Hunt Valley, Maryland.
- Mescher, Prof. Anthony L.** Anatomy Section, School of Medicine, Medical Sciences Program, Indiana University.
- Messenger, Dr. George C.** Vice President and Technical Director, Messenger & Associates, Las Vegas, Nevada.
- Messenger, Dr. John B.** Department of Zoology, University of Sheffield, United Kingdom.
- Messerschmitt, Prof. David.** Department of Electrical Engineering and Computer Science, University of California, Berkeley.
- Metcalf, William G.** Woods Hole Oceanographic Institution, Woods Hole, Massachusetts.
- Metzger, Dr. James D.** Research Physiologist, U.S. Department of Agriculture, Agricultural Research Service, Biosciences Research Laboratory, Fargo, Indiana.
- Meyer, Dr. Bernard S.** Department of Botany, Ohio State University.
- Meyer, Dr. Carl H.** Advisory Engineer, IBM Systems Communications Division, Kingston, New York.
- Meyer, Dr. David B.** Department of Anatomy, Wayne State University School of Medicine.
- Meyer, Prof. Henry O. A.** Department of Earth and Atmospheric Sciences, Purdue University.
- Meyer, Dr. John F.** Department of Electric Engineering and Science, College of Engineering, University of Michigan.
- Meyer, Dr. Judy L.** Institute of Ecology, University of Georgia.
- Meyer, Dr. Karl F.** Deceased; formerly, Professor Emeritus of Experimental Pathology, George Williams Hooper Foundation, San Francisco Medical Center, University of California.
- Meyers, Dr. Edward.** Research Group Leader, Department of Microbiology Squibb Institute, New Brunswick, New Jersey.
- Miall, Dr. Andrew D.** Department of Geology, University of Toronto, Ontario, Canada.
- Michalec, James R.** American Electric Power Company, Columbus, Ohio.
- Middleton, Dr. Gerard V.** Department of Geology, McMaster University, Hamilton, Ontario, Canada.
- Mikos, Prof. Antonios G.** Director of John W. Cox Laboratory of Biomedical Engineering, Department of Chemical Engineering, Rice University, Houston, Texas.
- Miles, Lawrence D.** Engineering Consultant, Easton, Maryland.
- Miles, Thomas K.** Shell Development Company.
- Mill, Dr. George S.** Research Chemist, Shell Oil Company, New York.
- Miller, Barry.** Formerly, Senior Editor, "Aviation Week and Space Technology," McGraw-Hill Publications Company, Los Angeles, California.
- Miller, Dr. Clyde A.** Falls Church, Virginia.
- Miller, Dr. David A. B.** AT&T Bell Laboratories, Holmdel, New Jersey.
- Miller, Dr. Dorothy A.** Wayne State University School of Medicine, Center for Molecular Medicine and Genetics, Detroit, Michigan.
- Miller, Prof. Erwin W.** Deceased; formerly Department of Physics, Pennsylvania State University.
- Miller, Dr. Frederick R.** Department of Soil and Crop Sciences, Texas A&M University.
- Miller, Dr. Glenn H.** Weapons Effects Division, Sandia National Laboratories, Albuquerque, New Mexico.
- Miller, Prof. J. Creighton, Jr.** Texas Agricultural Experiment Station, Department of Horticultural Science, College of Agriculture, Texas A & M University.
- Miller, Dr. Julian C.** Department of Horticulture, Louisiana State University.
- Miller, Prof. Maynard M.** Department of Geology, Michigan State University; Director, Foundation for Glacial and Environmental Research, Seattle, Washington.
- Miller, Dr. Milton A.** Department of Zoology, University of California, Davis.
- Miller, Prof. Orlando J.** Wayne State University School of Medicine, Center for Molecular Medicine and Genetics, Detroit, Michigan.
- Miller, R. A.** Engineering Department, Babcock and Wilcox, Barberton, Ohio.
- Miller, Dr. Regis B.** Project Leader, Center for Wood Anatomy Research, Forest Products Laboratory, U.S. Department of Agriculture, Forest Service, Madison, Wisconsin.
- Miller, Dr. Richard A.** Lawrence Berkeley National Laboratory, University of California, Berkeley.
- Miller, Dr. Shelby A.** Argonne National Laboratory, Argonne, Illinois.
- Miller, Prof. Sidney I.** Department of Chemistry, Illinois Institute of Technology.
- Miller, Terry A.** AT&T Bell Laboratories, Murray Hill, New Jersey.
- Miller, Thomas E.** Department of Biological Sciences, Florida State University, Tallahassee.
- Milliard, Dr. Ron.** Optomechanics Research Inc., Vail, Arizona.
- Milligan, Dr. W. O.** Robert A. Welch Foundation, Houston, Texas.
- Millman, Dr. Jacob.** Department of Electrical Engineering, Columbia University.
- Mills, Dr. Dennis.** Advanced Photon Source, Argonne National Laboratory, Argonne, Illinois.
- Mills, Dr. Harlow B.** State Natural History Survey, Urbana, Illinois.
- Mills, Prof. Ian M.** Department of Chemistry, University of Reading, United Kingdom.
- Mills, Thomas B.** National Semiconductor Corporation, Santa Clara, California.
- Milsom, Dr. William K.** Department of Zoology, University of British Columbia, Vancouver, Canada.
- Milstein, Prof. Laurence B.** Department of Electrical and Computer Engineering, University of California, San Diego.
- Milster, Dr. Tom D.** Optical Data Storage Center, Optical Sciences Center, University of Arizona, Tucson.
- Milus, Dr. E. A.** Department of Plant Pathology, University of Arkansas, Fayetteville.
- Minifie, Bernard W.** Knechtel Laboratories, Bristol, England.
- Minkler, Ward W.** Vice President, TIMET, Pittsburgh, Pennsylvania.
- Minnis, Dr. Wesley.** Formerly, Assistant to the Director of Research and Development, Allied Chemical Corporation, New York.

- Mitchell, Dr. Charles E.** Department of Geology, State University of New York at Buffalo.
- Mitchell, Dr. Jeffrey C.** Spaceport Graduate Center, Florida Institute of Technology, Satellite Beach.
- Mitchell, Dr. Malcolm S.** Comprehensive Cancer Center, Kenneth Norris, Jr. Cancer Research Institute, University of Southern California, Los Angeles.
- Mitsch, Prof. William J.** Graduate Program Environmental Science, School of Natural Resources, Ohio State University, Columbus.
- Mitterer, Dr. Richard M.** Department of Geosciences, University of Texas, Dallas.
- Miyawaki, Dr. Ritsuro.** Department of Geology, National Science Museum, Tokyo, Japan.
- Mizell, Dr. David W.** Project Leader, University of Southern California/Information Sciences Institute, Marina del Rey.
- Moder, Dr. Joseph J.** Chairman, Department of Management Science, University of Miami.
- Moe, Dr. Richard L.** Department of Botany, University of California, Berkeley.
- Moffat, Dr. Anthony F. J.** Department de Physique, Université
- Moffett, Dr. Mark B.** Naval Underwater Systems Center, New London Laboratory, New London, Connecticut.
- Moh, Dr. Za-Chieh.** Moh & Associates, Inc., Oriental Technopolises Tower, Taipei, Taiwan.
- Mohanakumar, Dr. T.** Department of Surgery, Washington University School of Medicine, St. Louis, Missouri.
- Mohr, Prof. David W.** Department of Geology, Texas A & M University.
- Mohr, Prof. Peter.** Department of Physics, Yale University.
- Moll, Dr. Gary A.** Director, Urban and Community Forestry, American Forestry Association, Washington, D.C.
- Møllar, Prof. Aage R.** Department of Neurological Surgery, University of Pittsburgh.
- Moment, Dr. Gairdner B.** Department of Biological Sciences, Goucher College, Towson, Maryland.
- Montville, Dr. Thomas J.** Department of Food Science, Cook College, Rutgers University.
- Mood, Dr. Alexander M.** Director, Public Policy Research Organization, University of California, Irvine.
- Moody, Capt. Alton B.** Navigation Consultant, La Jolla, California.
- Mook, Dr. Douglas G.** Department of Psychology, University of Virginia.
- Moore, Dr. Alice E.** Sloan-Kettering Institute of Cancer Research, New York.
- Moore, Prof. Charles A.** Department of Civil Engineering, Ohio State University.
- Moore, Prof. Clyde H., Jr.** Director, Applied Carbonate Research Program, Department of Geology, Agricultural and Mechanical College, Louisiana State University.
- Moore, Dr. James Alexander.** Department of Chemistry, University of Delaware.
- Moore, Dr. Jeffrey S.** Department of Chemistry, University of Illinois, Urbana-Champaign.
- Moore, Dr. Paul B.** Department of the Geophysical Sciences, University of Chicago.
- Moore, Dr. Raymond C.** Deceased; formerly, Department of Geology, University of Kansas.
- Moore, Dr. Richard K.** Center for Research in Engineering Science, University of Kansas.
- Moore, Dr. W. J. M.** Division of Electrical Engineering, National Research Council of Canada, Ottawa, Ontario.
- Moorer, Daniel F., Jr.** Ball Aerospace & Technologies, Boulder, Colorado.
- Mordes, Dr. J. P.** Department of Medicine, University of Massachusetts Medical School, Worcester.
- Moreno, Dr. Giuliana.** Institute of Cellular Pathology, Paris, France.
- Morgan, Dr. Anne H.** Deceased; formerly, Mount Holyoke College.
- Morgan, Prof. John W.** Department of Mathematics, Columbia University.
- Morgan, Dr. Karl Z.** Neely Professor, School of Nuclear Engineering, Georgia Institute of Technology.
- Moritz, Prof. Helmut.** Technische Universität Graz, Abteilung für Physikalische Geodäsie, Graz, Austria.
- Morrell, A. M.** Manager, Tube Development, Picture Tube Division, RCA Corporation, Lancaster, Pennsylvania.
- Morrell, Dr. Jeffrey J.** Department of Forest Products, Oregon State University, Corvallis.
- Morris, Prof. J. W., Jr.** Department of Materials Sciences and Mineral Engineering, University of California, Berkeley.
- Morris, Prof. Philip J.** Department of Aerospace Engineering, Pennsylvania State University, University Park.
- Morris, S. B.** Marconi Research Centre Materials Group, Towcester, Northants, England.
- Morris, Dr. William F.** Department of Zoology, Duke University, Durham, North Carolina.
- Morrison, Dr. David C.** Associate Director, Basic Research Programs, Department of Microbiology, University of Kansas Medical Center, Kansas City.
- Morrison, Dr. George H.** Professor of Chemistry and Director, Analytical Facility of Materials Science Center, Cornell University.
- Morrison, Dr. Kenneth J.** Cooperative Extension Service, Washington State University.
- Morse, Dr. Robert W.** Associate Director and Dean of Oceanographic Studies, Woods Hole Oceanographic Institute, Woods Hole, Massachusetts.
- Morse, Dr. Roger A.** Department of Entomology, Cornell University.
- Morse, Dr. Roy Earl.** Food Science Department, Cook College.
- Morse, Dr. Stephen A.** Director, Division of Sexually Transmitted Diseases Laboratory Research, Centers for Disease Control and Protection, Atlanta, Georgia.
- Mortenson, Leonard E.** Department of Biological Sciences, Purdue University.
- Morton, Dr. Andrew.** Department of Geology and Petroleum Geology, University of Aberdeen, Kings College, Aberdeen, United Kingdom.
- Moscowitz, Dr. Albert.** Department of Chemistry, University of Minnesota.
- Moseley, Dr. Steve L.** Department of Microbiology, University of Washington School of Medicine, Seattle.
- Moshell, Dr. Alan.** Director, Skin Diseases Program, National Institute of Arthritis and Musculoskeletal and Skin Diseases, National Institutes of Health, Bethesda, Maryland.
- Mosher, Dr. William.** Deceased; formerly, Chairman, Department of Chemistry, University of Delaware.
- Mossman, Prof. Harland W.** Emeritus Professor, Department of Anatomy, University of Wisconsin.
- Motekaitis, Dr. R. J.** Department of Chemistry, Texas A&M University.
- Mottershead, Dr. Allen.** Physical Science Department, Cypress College, California.
- Mottet, Dr. N. Karle.** Professor of Pathology and Director of Hospital Pathology, University Hospital, University of Washington.
- Moyer, Dr. Kenneth E.** Department of Psychology, Carnegie-Mellon University.
- Moyer, Dr. William W.** Applied Research Laboratory, Pennsylvania State University.
- Mrak, Dr. Emil M.** Office of Chancellor Emeritus, University of California, Davis.
- Mulligan, Dr. Pamela K.** Formerly, Department of Biochemistry, University of North Carolina.
- Mulliken, Prof. Robert S.** Institute of Molecular Biophysics, Florida State University.
- Munger, Prof. H. M.** Department of Plant Breeding and Biometry, New York State College of Agriculture and Life Sciences, Cornell University.
- Munson, Prof. Bruce R.** Department of Aerospace Engineering and Mechanics, Iowa State University, Ames.
- Murgatroyd, Dr. R. J.** Meteorological Office, Bracknell, England.
- Murphy, Dr. Frederick A.** Centers for Disease Control, Department of Health and Human Services, Tucker, Georgia.
- Murphy, Dr. Glenn.** Department of Nuclear Engineering, Iowa State University.
- Murphy, Dr. Robert L.** Division of Infectious Diseases, Northwestern University Medical School, Chicago, Illinois.
- Murphy, Dr. Terence M.** Department of Anesthesiology, School of Medicine, University of Washington.

- Murray, Dr. Haydn H.** Executive Vice President, Georgia Kaolin Company, Elizabeth, New Jersey.
- Murray, Dr. James W.** School of Oceanography, University of Washington, Seattle.
- Murray, Prof. M. John.** Department of Medicine, University of Minnesota Medical School, Minneapolis.
- Murray, Dr. Merritt J.** Formerly, A. M. Todd Company, Kalamazoo, Michigan.
- Murray, Prof. R. G. E.** Department of Microbiology and Immunology, Health Sciences Centre, University of Western Ontario, London, Canada.
- Murray, Dr. Royce W.** Department of Chemistry, University of North Carolina.
- Murray, Stephen S.** Center for Astrophysics, Harvard College Observatory, Cambridge, Massachusetts.
- Murray, Dr. Thomas P.** Applied Research Laboratory, United States Steel Corporation, Monroeville, Pennsylvania.
- Murray, Dr. William.** Teknowledge Corporation, Palo Alto, California.
- Musacchia, Dr. X. J.** Department of Physiology and Space Science Research Center, University of Missouri.
- Mushlitz, R. D.** Ore Department, American Smelting and Refining Company, New York.
- Muther, Richard.** Executive Director, Richard Muther & Associates, Inc., Kansas City, Missouri.
- Mutter, Dr. Carolyn Z.** Associate Research Scientist, Lamont-Doherty Earth Observatory, Columbia University, Palisades, New York.
- Mutter, Dr. John.** Lamont-Doherty Geological Observatory, Columbia University, Multichannel Seismics Group, Palisades, New York.
- Muus, Dr. Bent J.** Research Biologist, Danish Institute for Fishery and Marine Research, Charlottenund, Denmark.
- Myers, Prof. A. L.** Department of Chemical Engineering, University of Pennsylvania.
- Myklebust, Prof. Arvid.** Mechanical Engineering Department, Virginia Polytechnic Institute.
- Mynleiff, Dr. Michelle.** Department of Biology, Marquette University, Milwaukee, Wisconsin.
- N**
- Nacamulli, Laurette.** IGEN, Inc., Rockville, Maryland.
- Nace, Dr. Raymond L.** Geological Survey, U.S. Department of the Interior, Raleigh, North Carolina.
- Nachtrieb, Prof. Norman H.** Chairman, Department of Chemistry, University of Chicago.
- Nagel, David J.** Superintendent, Condensed Matter and Radiation, Sciences Division, Naval Research Laboratory, Department of the Navy, Washington, D.C.
- Nagel, Suzanne R.** Engineering Research Center, AT&T Bell Laboratories, Princeton, New Jersey.
- Nagel, Dr. Walter R.** NASA Goddard Space Flight Center, Greenbelt, Maryland.
- Naistat, Dr. Samuel S.** Department of Chemistry, Stephen F. Austin State College Nacogdoches, Texas.
- Namias, Jerome.** Climate Research Group, Scripps Institution of Oceanography, La Jolla, California.
- Napp-Zinn, Prof. Klaus.** Botanical Institute, Cologne, Germany.
- Nash, Dr. Irwin.** School of Medicine, Yale University.
- Nachtsheim, Dr. Philip R.** NASA Ames Research Center, Moffett Field, California.
- Natland, Prof. James H.** Rosentiel School of Marine and Atmospheric Science, University of Miami, Florida.
- Naumann, Dr. Robert J.** NASA Marshall Space Flight Center, Huntsville, Alabama.
- Navrotsky, Dr. Alexandra.** Department of Geological and Geophysical Sciences, Princeton University.
- Naylor, Dr. Arch.** Department of Electrical Engineering, University of Michigan.
- Naylor, Dr. Ernest.** Reader in Zoology, University College of Swansea, Wales.
- Nealson, Dr. Kenneth H.** Center for Great Lakes Studies, University of Wisconsin.
- Nedelsky, Prof. Leo.** Department of Physical Science, University of Chicago.
- Nedungadi, Dr. Ashok P.** Integrated Electronics Facility, Schlumberger Well Services, Houston, Texas.
- Nelms, Dr. W. P.** Deputy Chief, Aircraft Technology Division, National Aeronautics and Space Administration, Ames Research Center, Moffett Field, California.
- Nelson, Dr. Donna C.** Intelligent Transport Society of America, Washington, D.C.
- Nelson, Elton G.** Collaborator (WOC), Crops Research Division, U.S. Department of Agriculture, Beltsville, Maryland.
- Nelson, Dr. George C.** Department of Mathematics, University of Iowa, Iowa City.
- Nelsen, Dr. Olin E.** Department of Biology, University of Pennsylvania.
- Nelson, Prof. Raymond J.** Professor of Mathematics and Philosophy, Case Institute of Technology.
- Nelson, Dr. Richard B.** Chief Engineer, Varian Associates, Palo Alto, California.
- Nergaard, Dr. Leon S.** Director, Microwave Research Laboratory, RCA Laboratories, Princeton, New Jersey.
- Nesbitt, Dr. Herbert H. J.** Dean, Faculty of Science, Carleton University, Ottawa, Ontario, Canada.
- Nestle, Dr. Marion.** Chairperson, Department of Home Economics and Nutrition, Division of Education, New York University.
- Netravali, Dr. Arun.** President, Bell Laboratories, Murray Hill, New Jersey.
- Neubecker, T. F.** Manager, Engineering, High Intensity and Quartz Lamp Department, General Electric Company, Twinsburg, Ohio.
- Neudeck, Prof. Gerald W.** Department of Electrical Engineering, Purdue University.
- Neuhauser, Robert G.** Solid State Division, Electro Optics and Devices, RCA, Lancaster, Pennsylvania.
- Nevins, Dr. James L.** Charles Stark Draper Laboratory, Cambridge, Massachusetts.
- New, Dr. Ronald.** NOAA, U.S. Department of Commerce, Rockville, Maryland.
- Newcomb, Prof. Robert W.** Microsystems Laboratory, Electrical Engineering Department, University of Maryland.
- Newell, Dr. Allen.** Department of Computer Science, Carnegie-Mellon University.
- Newell, Dr. Homer E.** National Aeronautics and Space Administration Headquarters, Washington, D.C.
- Newhouse, Alan R.** Retired; formerly, U.S. Department of Energy.
- Newton, Dr. Chester W.** National Center for Atmospheric Research, Boulder, Colorado.
- Newton, Dr. R. C.** Department of the Geophysical Sciences, University of Chicago.
- Newton, Prof. Roger G.** Department of Physics, Indiana University, Bloomington.
- Ng, Dr. Tai P.** New Ground Resources Ltd., Alberta, Canada.
- Nicodemus, Dr. Fred E.** Deceased; formerly, Physicist, Optical Radiation Section, Heat Division, Institute for Basic Standards, National Bureau of Standards.
- Niebel, Benjamin W.** Professor Emeritus of Industrial Engineering, Pennsylvania State University; Industrial Engineering Consultant, State College, Pennsylvania.
- Nier, Prof. Alfred O.** School of Physics and Astronomy, University of Minnesota.
- Niesz, Dr. Dale E.** Director, Center for Ceramics Research, College of Engineering, Rutgers University.
- Nigrelli, Dr. Ross F.** Osborn Laboratories of Marine Sciences, New York Aquarium, New York.
- Nippes, Prof. Ernest F.** Department of Materials Engineering, Rensselaer Polytechnic Institute.
- Nix, Prof. William D.** Associate Chairman, Department of Materials Science and Engineering, Stanford University.
- Noback, Dr. Charles R.** Department of Anatomy, Columbia University.
- Nobel, Prof. Park S.** Department of Biology, University of California, Los Angeles.
- Noble, Dr. James A.** Geological Sciences, California Institute of Technology.
- Noble, R. H.** Optical Division, Institute National Astrofis, Puebla, Mexico.
- Noguchi, Dr. Thomas T.** Pasadena, California.
- Nolan, Dr. Robert P.** Environmental Sciences Laboratory, Brooklyn College, Brooklyn, New York.

- Noll, Dr. Kenneth.** Department of Microbiology, University of Illinois, Urbana-Champaign.
- Norberg, Dr. Ulla M.** Department of Zoomorphology, Zoological Institute, University of Goteborg, Sweden.
- Norcross, Prof. Neil L.** College of Veterinary Medicine, Cornell University, Ithaca, New York.
- Nordman, Prof. James E.** Department of Electrical and Computer Engineering, University of Wisconsin, Madison.
- Norris, Dr. H. Thomas.** Chairman, Department of Clinical Pathology and Diagnostic Medicine, East Carolina University School of Medicine.
- North, Dr. Gerald R.** Director, Climate System Research Program, Department of Meteorology, Texas A&M University.
- Northcutt, Dr. R. Glenn.** Department of Anatomy, Case Western Reserve University.
- Norton, Dr. Jeanette.** Department of Plants, Soils and Biometerology, Utah State University, Logan.
- Novikoff, Dr. Phyllis.** Department of Pathology, Albert Einstein College of Medicine, Bronx, New York.
- Novotny, Prof. Donald W.** Department of Electrical and Computer Engineering, University of Wisconsin, Madison.
- Noy, Dr. Noa.** Division of Nutritional Sciences, Cornell University, Ithaca, New York.
- Noyes, Richard M.** Department of Chemistry, College of Arts and Sciences, University of Oregon.
- Noyes, Dr. Robert W.** Harvard-Smithsonian Center for Astrophysics, Smithsonian Astrophysical Observatory, Harvard College Observatory, Cambridge, Massachusetts.
- Nuccitelli, Prof. Richard.** Zoology Department, University of California, Davis.
- Nussbaumer, Prof. Harry.** Institut für Astronomie, Zürich, Switzerland.
- Nygren, Dr. David R.** Physics Division, Lawrence Berkeley Laboratory, University of California, Berkeley.
- Nygren, Stephen.** Bell Telephone Laboratories, Reading, Pennsylvania.
- Nyhan, Prof. William L.** Department of Pediatrics, University of California, La Jolla.
- Nyman, Dr. Matthew W.** Senior Research Associate, Department of Earth and Planetary Sciences, University of New Mexico, Albuquerque.
- O'Connor, Dr. Donald J.** Department of Civil Engineering, Manhattan College.
- O'Donnell, Franklin.** Jet Propulsion Laboratory, Pasadena, California.
- Odom, Dr. Robert W.** Charles Evans Associates, Redwood City, California.
- Ogburn, Charles B.** Cooperative Extension Service, Auburn University.
- Ogle, Dr. Kenneth N.** Section of Biophysics, Mayo Clinic, Rochester, Minnesota.
- O'Hagan, Dr. David.** Department of Chemistry, University of Durham, United Kingdom.
- Ohlendorf, Dr. Douglas H.** Genex Corporation, Gaithersburg, Maryland.
- Ojemann, Dr. Linda M.** Regional Epilepsy Center, Harborview Medical Center, University of Washington.
- Okandan, Dr. Ender.** Department of Petroleum and Natural Gas Engineering, Middle East Technical University, Ankara, Turkey.
- Olcott, John W.** Editor and Publisher, Business and Commercial Aviation Aerospace and Defense Group, McGraw-Hill, White Plains, New York.
- Old, Dr. Bruce S.** Senior Vice President, Arthur D. Little, Inc., Cambridge, Massachusetts.
- Oldenburger, Prof. Rufus.** Director, Automatic Control Center, Purdue University.
- O'Leary, Dr. John E.** Department of Forest Engineering, Oregon State University.
- O'Lenic, Dr. Edward A.** Climate Analysis Center, National Weather Service, U.S. Department of Commerce, Washington, D.C.
- Oliver, Prof. John E.** Department of Geography, Geology, and Anthropology, Indiana State University, Terre Haute, Indiana.
- Olmstead, Prof. Richard.** Department of Botany, University of Washington, Seattle.
- Olness, Dr. John W.** Brookhaven National Laboratory, Associated Universities, Inc., Upton, New York.
- Olsen, Dr. Edward J.** Department of Geology, Field Museum of Natural History, Chicago, Illinois.
- Olson, Prof. Edward C.** Department of Astronomy, University of Illinois, Urbana.
- Olson, Dr. Everett C.** Department of Zoology, University of California, Los Angeles.
- Olson, Dr. Harry F.** Deceased; formerly, Staff Vice President, Acoustical and Electromechanical Research, RCA Laboratories, Princeton, New Jersey.
- Olson, Dr. Jerry S.** Oak Ridge National Laboratory, Oak Ridge, Tennessee.
- Olson, Dr. Norman.** Department of Food Science, University of Wisconsin.
- Onishi, Steven.** Fairchild Imaging, Milpitas, California.
- Oosthuizen, Dr. Patrick H.** Department of Mechanical Engineering, Queen's University, Kingston, Ontario, Canada.
- Oppenheimer, Dr. Ben R.** Department of Astronomy, University of California, Berkeley.
- Oppenheimer, Dr. Steven B.** Department of Biology, California State University, Northridge.
- O'Rahilly, Dr. Ronan.** Carnegie Embryological Laboratories, University of California, Davis.
- Orians, Dr. Gordon.** Department of Zoology, University of Washington, Seattle.
- Oris, Dr. James T.** Department of Zoology, Miami University, Oxford, Ohio.
- Orkin, Dr. Frederick K.** University of California, San Francisco, The Medical Center at the University of California School of Medicine.
- Orrego, Dr. Cristian.** Department of Biology, Brandeis University.
- Orr-Weaver, Dr. Terry.** Whitehead Institute for Biomedical Research, Cambridge, Massachusetts.
- Orville, Dr. Harold D.** Institute for Atmospheric Science, South Dakota School of Mines, Rapid City, South Dakota.
- Orville, Prof. Richard E.** Director, Cooperative Institute for Applied Meteorological Studies, Texas A & M University, College Station.
- Osberg, Prof. Philip H.** Department of Geological Sciences, University of Maine.
- Osborn, Dr. Jeffrey M.** Division of Science, Northeast Missouri State University, Kirksville.
- O'Shaughnessy, Dr. Douglas.** INRS-Telecom, Place Bonaventure, Montreal, Canada.
- Osofsky, Dr. Michael.** Naval Research laboratory Washington, D.C.
- Oster, Prof. Gerald.** Mount Sinai School of Medicine, City University of New York.
- Ostergaard, Dr. H. L.** Department of Biology, University of California, Los Angeles.
- Ostro, Dr. Steven J.** Jet Propulsion Laboratory, California Institute of Technology, Pasadena.
- Ostrom, Dr. John H.** Division of Vertebrate Paleontology, Peabody Museum of Natural History, Yale University.
- Othmer, Prof. Donald F.** Deceased; formerly, Department of Chemical Engineering, Polytechnic Institute of Brooklyn.
- Otis, Dr. Arthur B.** Department of Physiology, College of Medicine, University of Florida.
- Otten, Prof. Ernst Wilhelm.** Institut für Physik, Johannes Gutenberg-Universität Mainz, Germany.
- Otto, Dr. Gilbert F.** Zoology Department, University of Maryland.
- Otto, Dr. Norman.** Ford Motor Research Laboratory, Dearborn, Michigan.
- Over, Dr. Jeff.** Department of Geological Sciences, State University of New York at Geneseo.
- Overhauser, Dr. Albert W.** Department of Physics, Purdue University.

## O

- Obery, Leonard J.** Chief, Plans and Programs Offices, National Aeronautics and Space Administration, Cleveland, Ohio.
- O'Brien, Prof. Michael.** Department of Agricultural Engineering, University of California, Davis.
- O'Connell, Prof. John P.** Department of Chemical Engineering, University of Florida.



- Ovshinsky, Stanford R.** President, Energy Conversion Devices, Inc., Troy, Michigan.
- Owen, Dr. Denis F.** Department of Biology, Oxford Polytechnic.
- Owen, Prof. Guillermo.** Department of Mathematical Sciences, Rice University.
- Owen, Dr. Tobias C.** Department of Earth and Space Sciences, State University of New York, Stony Brook.

## P

- Pacella, Gary.** AMSTA-AR-CCH-C, United States Army Armament Research Development and Engineering Center, Picatinny Arsenal, New Jersey.
- Packer, Dr. Lester.** University of California, Department of Molecular and Cell Biology, Berkeley, California.
- Padian, Prof. Kevin.** Museum of Paleontology, University of California, Berkeley.
- Page, Dr. Roy C.** Research Center in Oral Biology, School of Medicine, University of Washington.
- Pake, Dr. George E.** Vice President, Xerox Corporation; General Manager, Xerox Palo Alto Research Center, Palo Alto, California.
- Palermo, Dr. David S.** Department of Psychology, Pennsylvania State University.
- Palevsky, Dr. Gerald.** Consulting Professional Engineer, Hastings-on-Hudson, New York.
- Palmer, Dr. Allison R.** Department of Earth and Space Sciences, State University of New York, Stony Brook.
- Palmer, Prof. Darwin L.** Chief, Veterans Administration Hospital, Medical Center, Department of Medicine, Infectious Disease Division, University of New Mexico School of Medicine.
- Palmer, Prof. Fred.** Lighting Research Center, Osram Sylvania, Beverly, Massachusetts.
- Palmer, Lawrence M.** Federal Communications Commission, Washington, D.C.
- Palmerlee, Prof. Albert S.** Deceased; formerly, Professor of Engineering Drawing, School of Engineering and Architecture, University of Kansas.
- Palzkill, Dr. David A.** Department of Plant Sciences, University of Arizona.
- Pandolfi, Dr. John M.** Department of Paleobiology, National Museum of Natural History, Smithsonian Institution, Washington, D.C.
- Pang, Prof. Stella.** Department of Electrical Engineering and Computer Science, University of Michigan, Ann Arbor.
- Pangbom, Dr. Jon B.** Director, Alternative Energy Systems Research, Institute of Gas Technology, Chicago, Illinois.
- Panish, Dr. Morton B.** Head, Materials Science Research Department, AT&T Bell Laboratories, Murray Hill, New Jersey.
- Pantell, Dr. Richard.** Electrical Engineering Department, Stanford University.
- Papageorgiou, George.** Research Associate, Department of Botany, University of Illinois, Urbana.
- Papagiannis, Prof. Michael D.** President, IAU Commission 51, Department of Astronomy, Boston University.
- Papendick, Dr. Robert I.** Research Leader, U.S. Department of Agriculture, Agricultural Research Service, Washington State University.
- Parente, Michael.** MP Technologies, Hendersenville, North Carolina.
- Park, Prof. David.** Department of Physics, Williams College.
- Parker, Dr. Ingrid M.** Department of Biology, Earth and Marine Sciences, University of California, Santa Cruz.
- Park, Prof. Jae-Woo.** Department of Civil Engineering, University of Hawaii at Manoa.
- Parker, Sybil P.** Formerly, Editor in Chief, "McGraw-Hill Encyclopedia of Science and Technology," McGraw-Hill Book Co., New York.
- Parker, Dr. Thomas E.** National Institute of Standards and Technology, Time and Frequency Division, Boulder, Colorado.
- Parma, Dr. Ana.** International Pacific Halibut Commission, Seattle, Washington.
- Parmentier, Prof. E. Mark.** Department of Geological Sciences, Brown University, Providence, Rhode Island.
- Parmesan, Dr. Camille.** National Center for Ecological Analysis and Synthesis, Santa Barbara, California.
- Parpia, Prof. Jeevak M.** Department of Physics, Cornell University.
- Parr, Dr. J. F.** Biological Waste Management and Organic Resources Laboratory, Beltsville, Maryland.
- Parr, Prof. Robert G.** Department of Chemistry, University of North Carolina.
- Parrish, Dr. Judith Totman.** Department of Geosciences, University of Arizona.
- Parry, Prof. David A. D.** Department of Structural Biology, Rosenstiel Basic Medical Science Research Center, Brandeis University, Waltham, Massachusetts.
- Parsons, Dr. Thomas S.** Department of Zoology, University of Toronto, Ontario, Canada.
- Partridge, Dr. Edward G.** Redondo Beach, California.
- Parvainen, Dr. Pekka.** Polar Image, Turku, Finland.
- Pasachoff, Dr. Jay M.** Hopkins Observatory, Williams College.
- Pascual, Dr. Miguel.** Centro Nacional Patagónico (CONICET), Chubut, Argentina.
- Pasternak, Dr. Gavril W.** Attending Neurologist, Department of Neurology, Memorial Hospital, Sloan-Kettering Institute Cancer Center, New York.
- Pasto, Prof. Daniel J.** Department of Chemistry, University of Notre Dame.
- Patel, Dr. C. K. N.** Bell Laboratories, Murray Hill, New Jersey.
- Paterson, Eric.** Iowa Institute of Hydraulic Research and Department of Mechanical Engineering, University of Iowa, Iowa City.
- Patrick, Norman W.** RCA Corporation, Lancaster, Pennsylvania.
- Patterson, Dr. David J.** Department of Zoology, University of Bristol, England.
- Patton, Dr. Donald J.** Department of Geography, Florida State University.
- Patton, Dr. Harry D.** Chairman, Department of Physiology-Biophysics, School of Medicine, University of Washington.
- Patton, Peter C.** Minnesota Supercomputer Institute, University of Minnesota.
- Patzkowsky, Dr. Mark E.** Department of Geosciences, Pennsylvania State University, University Park.
- Paul, Prof. Burton.** Department of Mechanical Engineering, University of Pennsylvania.
- Paul, Dr. Jacques.** Commissariat à l'Énergie Atomique, Direction des Sciences de la Matière, Gif-sur-Yvette, France.
- Payne, Prof. Joseph N.** School of Education, University of Michigan, Ann Arbor.
- Payne, Prof. Peter A.** Retired; formerly, Vice President for Academic Development, Department of Instrumentation and Analytical Science, University of Manchester, Institute of Science and Technology, Manchester, England.
- Peacey, Dr. John G.** Centre de Recherche Noranda, Pointe-Claire, Quebec, Canada.
- Pecor, Dr. Donald R.** Department of Geology, University of Michigan.
- Pearce, Prof. R. H.** Department of Pathology, Faculty of Medicine, University of British Columbia, Canada.
- Peaslee, Dr. Robert L.** Vice President, Stainless Steel Division, Wall Colmonoy Corp., Detroit, Michigan.
- Pecar, Dr. Joseph A.** Joseph A. Pecar & Associates, Inc., Potomac, Maryland.
- Pechenik, Dr. Jan.** Department of Biology, Tufts University, Medford, Massachusetts.
- Peck, Prof. Raymond E.** Department of Geology, University of Missouri.
- Peck, Dr. Stewart B.** Department of Biology, Carleton University, Ottawa, Ontario, Canada.
- Pecora, Prof. Robert.** Department of Chemistry, Stanford University.
- Pecoraro, Dr. Vincent.** Department of Chemistry, University of Michigan.
- Pedersen, Prof. Niels C.** School of Veterinary Medicine, University of California, Davis.
- Pegg, Prof. David J.** Department of Physics and Astronomy, University of Tennessee, Knoxville.
- Pehlke, Dr. Robert D.** Department of Materials Science and Engineering, University of Michigan.
- Peirce, Dr. G. R.** Engineer, Champaign, Illinois.

- Pelletier, Dr. S. William.** Director, Institute for Natural Product Research, University of Georgia, Athens.
- Pelosi, Dr. James J.** Colonel, U.S. Army, Retired, Houston, Texas.
- Pennak, Dr. Robert W.** Department of Biology, University of Colorado.
- Penneman, Dr. Robert A.** Los Alamos Scientific Laboratory, Los Alamos, New Mexico.
- Penner-Hahn, Prof. James E.** Department of Chemistry, University of Michigan, Ann Arbor.
- Penrose, Prof. Roger.** Mathematical Institute, University of Oxford, England.
- Pepper, Prof. Darrell W.** Department of Mechanical Engineering, University of Nevada, Las Vegas.
- Perch, Michael.** Koppers Company, Inc., Monroeville, Pennsylvania.
- Perl, Prof. Martin L.** Stanford Linear Accelerator Center, Stanford, California.
- Perlmann, Dr. Gertrude E.** Deceased; formerly, Rockefeller University.
- Perrin, Arthur M.** Deceased; formerly President, National Conveyors Company, Inc., Fairview, New Jersey.
- Perry, Astor.** Extension Agronomy Specialist, North Carolina State University.
- Perry, Stephen F.** Exxon Research, Florham Park, New Jersey.
- Perryman, Dr. Michael A. C.** Space Science Department, European Space Agency, ESTEC (SCI-SA), Noordwijk, Netherlands.
- Peskin, Prof. Michael E.** Stanford Linear Accelerator Center, Menlo Park, California.
- Peters, Prof. Philip C.** Department of Physics, University of Washington.
- Peters, Dr. William C.** Professor Emeritus, Mining and Geological Engineering, University of Arizona.
- Petershack, Dr. Victor D.** Rexnord, Inc., Milwaukee, Wisconsin.
- Peterson, Dr. Benjamin B.** Department of Engineering, United States Coast Guard Academy, New London, Connecticut.
- Peterson, Dr. Kirk D.** Department of Engineering, Calvin College, Grand Rapids, Michigan.
- Peterson, Dr. R. L.** Department of Botany, University of Guelph, Ontario, Canada.
- Petschek, Prof. Albert G.** Department of Physics, New Mexico Institute of Mining and Technology, Socorro.
- Pfaffmann, Dr. Carl.** Department of Psychology, Rockefeller University.
- Pfeffer, Dr. Robert A.** U.S. Army, Nuclear and Chemical Agency, Springfield, Virginia.
- Pfleeger, Dr. Charles P.** Trusted Information Systems, Inc., Computer and Communications Security, Networking Telecommunications, Glenwood, Maryland.
- Phadke, Prof. Arun G.** Director, Center for Power Engineering, Virginia Polytechnic Institute and State University, Blacksburg.
- Phaff, Dr. Herman J.** Department of Food Science and Technology, College of Agriculture and Environmental Science, University of California, Davis.
- Phaneuf, Prof. Ronald A.** Chair, Department of Physics, University of Nevada, Reno.
- Phelan, Prof. Richard M.** Department of Mechanical Systems and Design, Cornell University.
- Philander, Prof. S. George.** Program in Atmospheric and Oceanic Sciences, Princeton University.
- Philip, Dr. Cornelius B.** Department of Entomology, California Academy of Sciences, San Francisco.
- Philpison, Dr. William R.** Department of Botany, University of Canterbury, Christchurch, New Zealand.
- Phillips, Dr. James A.** CTR-Division Office, Los Alamos Scientific Laboratory, Los Alamos, New Mexico.
- Phillips, Prof. Tom L.** Department of Botany, University of Illinois, Urbana.
- Phillips, Dr. William D.** National Institute of Standards and Technology, Gaithersburg, Maryland; Nobelist.
- Phillips, William H.** NASA Langley Research Center, Hampton, Virginia.
- Pielou, Dr. E. C.** Department of Biology, University of Lethbridge, Alberta, Canada.
- Pience, Roger D.** Watson Technology, Portland, Maine.
- Pierce, Prof. Allan D.** School of Mechanical Engineering, Georgia Institute of Technology.
- Pierce, Prof. E. Lowe.** Department of Zoology, University of Florida.
- Pierce, Dr. F. J.** Department of Crop and Soil Sciences, Michigan State University, East Lansing.
- Pierotti, Prof. Robert A.** Department of Chemistry, Georgia Institute of Technology.
- Pierre, Dr. Donald A.** Department of Electrical Engineering, College of Engineering, Montana State University.
- Pierscionek, Dr. Barbara K.** Department of Biomedical Sciences, University of Bradford, United Kingdom.
- Pike, Dr. Andrew C.** Neotronics Scientific Ltd., United Kingdom.
- Pike-Tay, Dr. Anne.** Department of Anthropology, Vassar College, Poughkeepsie, New York.
- Pilbrow, Prof. John R.** Head, Department of Physics, Monash University, Clayton, Victoria, Australia.
- Pimm, Dr. Stuart.** Department of Zoology, University of Tennessee, Knoxville.
- Pinder, Dr. George F.** Department of Civil and Geological Engineering, Princeton University.
- Pinedo, Prof. Michael.** Statistics and Operations Research Department, Stern School of Business, New York University, New York.
- Pinkava, Dr. Donald J.** Director, ASU Herbarium, Department of Botany, Arizona State University.
- Pinkel, Benjamin.** Consulting Engineer, Santa Monica, California.
- Pinker, Prof. Rachel T.** Department of Meteorology, University of Maryland.
- Pionke, Dr. Harry B.** Pasture Systems and Watershed Management Research Laboratory, U.S. Department of Agriculture-Agricultural Research Service, University Park, Pennsylvania.
- Pipkin, Prof. Francis M.** Department of Physics, Harvard University.
- Pitchford, Dr. Leanne C.** Sandia National Laboratories, Albuquerque, New Mexico.
- Pitman, Waker C., III.** Lamont-Doherty Geological Observatory, Palisades, New York.
- Platt, Donald.** Adjunct Professor of Space Systems, Spaceport Graduate Center, Florida Institute of Technology, Satellite Beach.
- Plaut, Dr. Gerhard W. E.** Professor Emeritus of Biochemistry, Temple University School of Medicine, Philadelphia, Pennsylvania.
- Pleasants, Dr. Julian R.** International Committee on Laboratory Animals, Lobund Laboratory, University of Notre Dame.
- Plecnik, Prof. Joseph M.** Department of Civil Engineering, California State University at Long Beach.
- Plesset, Dr. Michael.** Aerospace Corporation, Los Angeles, California.
- Ploem, Dr. Johan S.** Laboratorium voor Cytochemie en Cytometrie, Rijksuniversiteit Leiden, Wassenaarseweg, Netherlands.
- Plotnick, Dr. Roy E.** Department of Geological Sciences, College of Liberal Arts and Sciences, University of Illinois.
- Plueddemann, Dr. Edwin P.** Organic Laboratories, Dow Corning Corporation, Midland, Michigan.
- Pocius, Dr. Alphonsus V.** AC&S Division, 3M Company, St. Paul, Minnesota.
- Pohl, Dr. D. W.** IBM Research Division, Zurich Research Laboratory, Ruschlikon, Switzerland.
- Pohl, Prof. Robert O.** Laboratory of Atomic and Solid State Physics, Cornell University.
- Pohlmann, Prof. Kenneth C.** School of Music, University of Miami, Coral Gables, Florida.
- Poknivar, Adolph L.** Formerly, Manager, Technical Publications, International Lead Zinc Research Organizations, Inc., New York.
- Polchinski, Prof. Joseph.** Institute for Theoretical Physics, University of California, Santa Barbara.
- Policy, Dr. Margaret J.** Department of Medicine, Cornell Medical Center, New York.
- Polking, Dr. John C.** Department of Mathematics, Rice University.
- Pollack, Dr. Henry N.** Department of Geological Sciences, University of Michigan.
- Pollack, Dr. James B.** Ames Research Center, Moffett Field, California.
- Pollard, Dr. Thomas.** Department of Cell Biology and Anatomy, Johns Hopkins

- University School of Medicine, Baltimore, Maryland.
- Pollard, Dr. William G.** Oak Ridge Associated Universities.
- Polly, Dr. P. David.** Department of Anatomy, Queen Mary and Westfield College, London, United Kingdom.
- Pomykalski, Dr. James J.** Assistant Professor, Integrated Science and Technology and Computer Science Programs, James Madison University, Harrisonburg, Virginia.
- Ponikvar, Ade L.** Formerly, Editor, Production and Drilling, "Petroleum Week," New York.
- Pont-Lezica, Dr. Rafael.** Department of Biology, Washington University, St. Louis, Missouri.
- Pontecorvo, Dr. Guido.** Imperial Cancer Research Fund Laboratories, London, England.
- Poole, Prof. Colin F.** Department of Chemistry, Wayne State University, Detroit, Michigan.
- Pope, Dr. Joseph.** Pope Engineering Company, Newton Centre, Massachusetts.
- Pope, Michael.** Pope, Evans and Robbins, Consulting Engineers, New York.
- Popelka, Dr. Gerald R.** Head of Audiology, Research Laboratories, Central Institute for the Deaf, St. Louis, Missouri.
- Popper, Dr. Arthur N.** Director, Neuroscience and Cognitive Science Program, Department of Biology, University of Maryland, College Park.
- Popper, Dr. Daniel M.** Department of Astronomy, University of California, Los Angeles.
- Porges, Dr. Steven.** Department of Human Development, University of Maryland, College Park.
- Porter, Dr. Richard D.** Chair, Department of Mathematics, Northeastern University, Boston, Massachusetts.
- Posada, German.** Research Associate, Department of Psychology, State University of New York, Stony Brook.
- Postgate, Prof. John R.** Department of Microbiology, University of Sussex, England.
- Postow, Dr. Elliot.** National Institutes of Health, Bethesda, Maryland.
- Potter, Dr. Kathleen N.** Department of Microbiology, University of Texas Southwestern Medical Center, Dallas.
- Potter, Prof. M. David.** School of Business, San Francisco State College.
- Potter, Prof. Norman N.** Department of Food Science, Cornell University.
- Potts, Dr. Kevin T.** Department of Chemistry, Rensselaer Polytechnic Institute.
- Poulson, Dr. Donald F.** Department of Biology, Yale University.
- Povey, Dr. Sue.** Galton Laboratory, University College, London, England.
- Povh, Dr. Bogdan.** Max Planck Institut für Kernphysik, Saupfercheckweg, Germany.
- Powell, Claud.** Consultant, Navigation, Bourton-on-the-Water, Gloucestershire, England.
- Powell, Jeffrey R.** Department of Biology, Yale University.
- Powell, Robert C.** Consultant, Physics, Gaithersburg, Maryland.
- Powell, Dr. Wayne B.** Vice President for Research and Associate Dean of the Graduate College, Oklahoma State University, Stillwater.
- Powers, Dr. Kerns H.** RCA David Sarnoff Laboratories, Princeton, New Jersey.
- Pozar, Prof. David M.** Department of Electrical and Computer Engineering, University of Massachusetts, Amherst.
- Pozos, Dr. Robert S.** Sustained Performance Program Manager, Department of the Navy, Naval Health Research Center, Department of Defense, San Diego, California.
- Praston, Dr. Lincoln F.** Research Scientist, Institute of Arctic and Alpine Research, Department of Geology, University of Colorado, Boulder.
- Prescott, David M.** Department of Molecular, Cellular and Developmental Biology, Boulder, Colorado.
- Prescott, Dr. Gerald W.** Department of Botany, University of Wisconsin.
- Presley, Dr. John.** McGill University, Department of Anatomy and Cell Biology, Montreal, Canada.
- Price, Dr. James F.** Department of Physical Oceanography, Woods Hole Oceanographic Institution, Massachusetts.
- Price, Dr. P. Buford, Jr.** Lawrence Berkeley Laboratory, University of California, Berkeley.
- Price, Dr. Peter W.** Department of Entomology, Northern Arizona University.
- Priester, Gayle B.** Consulting Engineer, Baltimore, Maryland.
- Primack, Prof. Joel R.** Physics Department, University of California, Santa Cruz, California.
- Princen, L. H.** Associate Center Director, North Regional Research Center, Department of Agriculture, Peoria, Illinois.
- Prinn, Prof. Ronald G.** Department of Earth, Atmosphere and Planetary Sciences, Massachusetts Institute of Technology, Cambridge.
- Prisbrey, Prof. Keith A.** Department of Metallurgical and Mining Engineering, College of Mines and Earth Resources, University of Idaho, Moscow.
- Pritchard, Prof. David E.** Department of Physics, Massachusetts Institute of Technology, Cambridge.
- Pritchard, Tram C.** Lockheed Missiles and Space Company, Sunnydale, California.
- Pritchett, Prof. Wilson S.** Senior Project Engineer, Noller Control Systems, Inc., Richmond, California.
- Pritsker, Prof. A. Alan B.** School of Industrial Engineering, Purdue University.
- Proctor, Mary C.** Department of Surgery, University of Michigan Hospitals, Ann Arbor.
- Prothero, Dr. Donald R.** Chair, Department of Geology, Occidental College, Los Angeles, California.
- Puchstein, Albert F.** Deceased; formerly, Consulting Engineer, Columbus, Ohio.
- Puck, Dr. Theodore T.** Department of Biophysics, University of Colorado Medical Center, Denver.
- Pugel, Andrew.** California State University at Long Beach, Department of Civil Engineering, Long Beach, California.
- Pullen, Dr. Keats A., Jr.** Ballistic Research Laboratories, Aberdeen Proving Ground, Maryland.
- Purchon, Dr. Richard D.** Department of Zoology, Chelsea College, University of London, England.
- Purvis, Dr. Andy.** Department of Zoology, University of Oxford, United Kingdom.
- Putnam, Prof. Russell C.** Professor Emeritus, Case Institute of Technology.
- Putterman, Dr. Seth.** Department of Physics, University of California, Los Angeles.
- Pyeritz, Prof. Reed E.** Director, Center for Medical Genetics, Allegheny Health, Education and Research Foundation, Pittsburgh, Pennsylvania.
- Pyrke, John K. M.** Slocum and Fuller, New York.

## Q

- Quaife, Carol.** Department of Pathology, University of Washington.
- Qualset, Dr. Calvin O.** Department of Agronomy and Range Science, University of California, Davis.
- Quarles, Dr. John M.** Department of Medical Microbiology & Immunology, Texas A & M University, College Station.
- Que, Prof. Lawrence Jr.** Center for Metals in Biocatalysis, University of Minnesota, Minneapolis.
- Quigg, Dr. Chris.** Lawrence Berkeley Laboratory, University of California, Berkeley.
- Quimby, Dr. Edith H.** Department of Radiology, College of Physicians and Surgeons, Columbia University.
- Quinn, Dr. T. J.** Bureau International des Poids et Mesures, Pavillon de Breteuil, Sèvres, France.
- Quirin, Edward J.** Consulting Engineer, Besier, Gibble & Quirin, Old Saybrook, Connecticut.
- Quiroga, Dr. Carlos.** Pacific Technical Documentation, Windsor, California.

## R

- Raab, Dr. Frederick H.** President and Owner, Green Mountain Radio Research Company, Winooski, Vermont.
- Raad, Prof. Peter E.** Mechanical Engineering Department, School of

- Engineering and Applied Science, Southern Methodist University, Dallas, Texas.
- Rabb, David D.** Mining Engineer-Metallurgist, Tucson, Arizona.
- Rabinowicz, Prof. Ernest.** Department of Mechanical Engineering, Massachusetts Institute of Technology.
- Rachubinski, Dr. Richard A.** Department of Cell Biology and Anatomy, University of Alberta, Edmonton, Alberta, Canada.
- Rademacher, Prof. Hans.** Deceased; formerly, Professor Emeritus of Mathematics, University of Pennsylvania.
- Radforth, Dr. Norman W.** Muskeg Research Institute, University of New Brunswick, Canada.
- Radin, Harley W.** Chairperson and Chief Executive, Direct Broadcasting Satellite Corporation, Washington, D.C.
- Radke, Dr. Rodney O.** Agricultural Product Research Laboratory, Monsanto Company, St. Louis, Missouri.
- Radok, Dr. Uwe.** Environmental Research (CIRES), University of Colorado.
- Rae, Dr. Peter M. M.** Molecular Diagnostics, Inc., West Haven, Connecticut.
- Raffel, Dr. Sidney.** Department of Medical Microbiology, School of Medicine, Stanford University.
- Rafferty, Vincent F.** Siemens Enterprise Networks, Reston, Virginia.
- Rahenkamp, Robert A.** International Business Machines, Lexington, Kentucky.
- Rahn, Frank J.** Nuclear Power Division, Electric Power Research Institute, Palo Alto, California.
- Raikhel, Dr. Natasha V.** Department of Energy, Michigan State University, East Lansing.
- Rajagopal, Dr. Krishna.** Lyman Laboratory of Physics, Harvard University.
- Rajan, Prof. Krishna.** Materials Engineering Department, Rensselaer Polytechnic Institute, Troy, New York.
- Raju, Prof. G. V. S.** Director, Division of Engineering, University of Texas, San Antonio.
- Rakovan, Prof. John.** Department of Geology, Miami University, Oxford, Ohio.
- Ram, Dr. Prahlad T.** Department of Pharmacology, Mount Sinai School of Medicine, New York.
- Ramberg, Dr. Edward G.** RCA Laboratories, Princeton, New Jersey.
- Ramdas, Prof. Anant K.** Department of Physics, Purdue University, West Lafayette, Indiana.
- Ramey, Dr. Robert L.** Department of Electrical Engineering, University of Virginia.
- Ramsey, Dr. Norman F.** Department of Physics, Harvard University.
- Randerson, Dr. Peter.** Department of Applied Biology, University of Wales Institute of Science and Technology, Cardiff.
- Rao, Dr. V. N. M.** Dupont Central Research and Development, Wilmington, Delaware.
- Raper, Dr. John R.** Professor of Botany, Harvard University.
- Rapp, Prof. George, Jr.** Dean, College of Letters and Science, University of Minnesota.
- Raps, Dr. Shirley.** Department of Biological Sciences, Hunter College, City University of New York.
- Raski, Dr. Dewey J.** Department of Nematology, University of California, Davis.
- Rasmussen, Dr. D. Tab.** Department of Anthropology, Washington University, St. Louis, Missouri.
- Rasmussen, Dr. Howard.** Department of Biochemistry, School of Medicine, University of Pennsylvania.
- Rasmussen, Dr. Norman C.** Department of Nuclear Engineering, Massachusetts Institute of Technology.
- Rasmussen, Dr. Eugene M.** Geophysical Fluid Dynamics Laboratory, Environmental Science Services Administration, Princeton, New Jersey.
- Ratay, Dr. Robert T.** Consulting Engineer, Manhasset, New York.
- Ratliff, Dr. Floyd.** Department of Psychology, Rockefeller University.
- Ratnoff, Dr. Oscar D.** Department of Medicine, Case Western Reserve University.
- Rau, Prof. A. R. P.** Department of Physics, Louisiana State University, Baton Rouge.
- Rauber, Prof. Robert M.** Department of Atmospheric Science, University of Illinois at Urbana-Champaign, Urbana.
- Rauchfuss, Dr. T. B.** School of Chemical Sciences, University of Illinois, Urbana.
- Raum, Dr. Donald.** Center for Blood Research, Boston, Massachusetts.
- Ravishankara, Dr. A. R.** National Oceanic and Atmospheric Administration, Aeronomy Laboratory, Boulder, Colorado.
- Rayner, Dr. G. H.** Consultant, Teddington, Middlesex, England.
- Raz, Prof. Tzvi.** Faculty of Management, Tel Aviv University, Ramat Aviv, Israel.
- Read, Prof. Clark P.** Deceased; formerly, Department of Biology, Rice University.
- Reay, Dr. Donald T.** King County Medical Examiner, Harborview Hospital, Seattle, Washington.
- Rebbi, Dr. Claudio.** Department of Physics, Brookhaven National Laboratory, Upton, New York.
- Rechtin, Dr. Eberhardt.** Retired; formerly, Department of Industrial and Systems Engineering, School of Engineering, University of Southern California.
- Reddish, Dr. George F.** Deceased; formerly, St. Louis College of Pharmacy and Allied Sciences.
- Redhead, Dr. Scott A.** Mycologist, Biosystematics Research Centre, Agriculture Canada, Research Branch, Central Experimental Farm, Ottawa, Ontario, Canada.
- Reed, Oscar, Jr.** Consulting Engineer, Telecommunications, Silver Spring, Maryland.
- Reed, Dr. Randall.** Department of Molecular Biology and Genetics, School of Medicine, Johns Hopkins University.
- Reeder, Dr. Richard J.** Geosciences Program, Department of Earth and Space Sciences, State University of New York, Stony Brook.
- Reed-Hill, Dr. Robert E.** Department of Metallurgical Science and Engineering, University of Florida.
- Rees, Dr. Bryant E.** Professor of Biology, Fresno State College.
- Rees, Jack.** Corporate Services Staff, Exxon Research and Engineering Company, Florham Park, New Jersey.
- Reeve, Dr. Roger M.** Western Regional Research Laboratory, U.S. Department of Agriculture, Albany, California.
- Regnery, Dr. Russell.** Supervisory Research Microbiologist, Viral and Rickettsial Zoonoses Branch, Department of Health and Human Services, Centers for Disease Control and Prevention, Atlanta, Georgia.
- Reich, Prof. Herbert J.** (Retired), Department of Engineering and Applied Science, Yale University.
- Reichman, Lee B.** Department of Medicine, College of Medicine and Dentistry, Newark, New Jersey.
- Reichmann, Dr. M. E.** Department of Microbiology, University of Illinois.
- Reid, Dr. David A.** Agricultural Research Service, U.S. Department of Agriculture, Tucson, Arizona.
- Reid, Prof. Evans B.** Professor Emeritus, Department of Chemistry, Colby College.
- Reid, Joseph L.** Scripps Institution of Oceanography, La Jolla, California.
- Reid, Dr. Walter V.** World Resources Institute, Washington, D.C.
- Reiling, Dr. Gilbert H.** Lighting Research and Technical Services Operation, General Electric Company, Cleveland, Ohio.
- Reilly, John C., Jr.** Naval Historical Center, Navy Department, U.S. Department of Defense.
- Reingold, Dr. Edward M.** Chairman, Department of Computer Science, Illinois Institute of Technology, Chicago, Illinois.
- Reinhardt, Dr. Nicholas.** Consultant, Lexington, Massachusetts.
- Reintjes, John F.** Naval Research Laboratory, Washington, D.C.
- Reischmann, Rev. Placidus G., O.S.B.,** Head, Department of Biology, St. Martin's College, Olympia, Washington.
- Reiter, Dr. Elmar R.** Department of Atmospheric Science, Colorado State University.
- Reitz, Dr. Louis P.** (Retired) Corps Research Division, Agricultural Research Service, U.S. Department of Agriculture, Beltsville, Maryland.
- Remde, Dr. Harry F.** Chief, Basic Physics Research Section, Johns-Manville Research and Engineering Center, Manville, New Jersey.
- Remley, Frederick M., Jr.** Retired; formerly, Center for Information Technology Integration, University of Michigan.
- Retallack, Dr. Gregory J.** Department of Geological Sciences, College of Arts and Sciences, University of Oregon.

- Rettinger, Michael.** Deceased; formerly, Consultant on Acoustics, Encino, California.
- Reynolds, Gardner M.** Dames & Moore, Los Angeles, California.
- Reynolds, Mark F.** Graduate Research Assistant, Department of Chemistry, University of Wisconsin, Madison.
- Ribbe, Dr. Paul H.** Department of Geological Sciences, Virginia Polytechnic Institute.
- Rich, Prof. Arthur.** Deceased; formerly, Department of Physics, University of Michigan.
- Rice, Dr. Mary E.** Associate Curator, Division of Worms, Smithsonian Institution.
- Rice, Dr. Michael.** Department of Fish, Animal and Veterinary Science, University of Rhode Island, Kingston, Rhode Island.
- Rich, Dr. Saul.** Connecticut Agricultural Experiment Station, New Haven, Connecticut.
- Richards, Dr. Frank F.** Department of Medicine, Yale University.
- Richards, Dr. Oscar W.** (Retired) College of Optometry, Pacific University.
- Richardson, Dr. Philip.** Department of Physical Oceanography, Woods Hole Oceanographic Institution, Woods Hole, Massachusetts.
- Richter, Reinhard H.** Manager, Polyurethane Research, Dow Chemical U.S.A., North Haven Laboratories, North Haven, Connecticut.
- Rickert, Richard M.** AT&T Consumer Products Laboratories, Indianapolis, Indiana.
- Ricksecker, Ralph E.** Director of Metallurgy, Chase Brass and Copper Company, Cleveland, Ohio.
- Riddle, Dr. Mark A.** Department of Psychiatry and Behavioral Sciences, Johns Hopkins Medical Institutions, Baltimore, Maryland.
- Riedel, Dr. Rupert J.** Department of Zoology, University of North Carolina.
- Ries, Dr. Harold C.** Stanford Research Institute, Menlo Park, California.
- Rigby, Dr. J. Keith.** Department of Geology, Brigham Young University.
- Riggs, Dr. Austen F.** Department of Zoology, University of Texas, Austin.
- Riggs, Dr. Lorrin A.** Department of Psychology, Brown University.
- Rijnsdorp, Prof. Johannes E.** University of Twente, Enschede, Netherlands.
- Riley, Frank.** Senior Vice-President, Bodine Assembly Systems, Bridgeport, Connecticut.
- Riley, Dr. Pete.** Science Applications International Corporation, San Diego, California.
- Riley, Dr. Ralph.** Plant Breeding Institute, Cambridge, England.
- Riley, Dr. Reed F.** Quantum Electronics Group, General Telephone and Electronics, Bayside, New York.
- Rillema, Prof. James A.** Professor of Physiology, Department of Physiology, School of Medicine, Wayne State University.
- Rindler, Dr. Michael.** Associate Professor of Cell Biology, New York University School of Medicine, New York.
- Riordan, Prof. James.** Center for Biochemical and Biophysical Sciences and Medicine, Harvard Medical School, Boston, Massachusetts.
- Risebrough, Dr. Robert W.** Research Ecologist, Bodega Marine Laboratory, University of California, Berkeley.
- Riser, Dr. Stephen C.** School of Oceanography, University of Washington, Seattle.
- Risser, Dr. Paul G.** Vice President for Research, University of New Mexico.
- Ritchey, Dr. H. W.** President, Thiokol Chemical Corporation, Ogden, Utah.
- Ritchie, Dr. J. C.** Department of Biology, Trent University, Peterborough, Ontario, Canada.
- Ritchie, Dr. Rufus H.** Oak Ridge National Laboratory, Oak Ridge, Tennessee.
- Rizack, Dr. Martin A.** Department of Medicine, Rockefeller University.
- Robb, D. D. D. D.** Robb and Associates, Consulting Engineers, Electric Power Systems, Salina, Kansas.
- Robbins, Dr. John A.** Great Lakes Environmental Research Laboratory, National Oceanic and Atmospheric Administration, Ann Arbor, Michigan.
- Robbins, Nathaniel, Jr.** Director of Engineering, Residential Division, Honeywell, Inc., Minneapolis, Minnesota.
- Roberts, Dr. Andrew.** Department of Oceanography, University of Southampton, Southampton Oceanography Centre, United Kingdom.
- Roberts, Dr. Arthur.** National Accelerator Laboratory, Batavia, Illinois.
- Roberts, J. K.** (Retired) Research and Development Department, Standard Oil Company, Chicago, Illinois.
- Roberts, Prof. Louis D.** Department of Physics, University of North Carolina.
- Roberts, Dr. Richard J.** Cold Spring Harbor Laboratories, Cold Spring Harbor, New York.
- Robertson, Dr. J. David.** Department of Anatomy, Duke University Medical Center.
- Robertson, Dr. James S.** Medical Department, Medical Physics Division, Brookhaven National Laboratory, Upton, New York.
- Robertson, Lemuel C.** Newport News Shipbuilding and Dry Dock Company, Newport News, Virginia.
- Robinovitch, Dr. Murray.** Department of Oral Biology, University of Washington School of Dentistry, Seattle.
- Robinson, Prof. Arthur H.** Department of Geography, University of Wisconsin.
- Robinson, Prof. Richard W.** Department of Seed and Vegetable Sciences, New York State Agricultural Experiment Station, Cornell University.
- Robinson, W. V.** Processor Technology Research Group, Bell Laboratories, Whippany, New Jersey.
- Rochow, Prof. Eugene G.** (Retired) Department of Chemistry, Harvard University.
- Rock, Dr. Irwin.** Department of Psychology, University of California, Berkeley.
- Rockett, Frank H.** Engineering Consultant, Charlottesville, Virginia.
- Rodden, Dr. William P.** Consulting Engineer, La Canada-Flintridge, California.
- Roddiss, Louis H., Jr.** President, Consolidated Edison Company of New York, Inc.
- Rodier, Dr. Patricia M.** Department of Anatomy, School of Medicine, University of Virginia.
- Rodman, Dr. James.** Program Director for Systematic Biology, National Science Foundation, Arlington, Virginia.
- Roe, K. Keith.** Chairman and President, Burns & Roe, Inc., Oradell, New Jersey.
- Roehl, Dr. Bernie.** Department of Electrical and Computer Engineering, University of Waterloo, Ontario, Canada.
- Rogallo, Francis M.** (Retired) NASA Langley Research Center, Hampton, Virginia.
- Rogers, Dr. Harry C.** Department of Metallurgical Engineering, Drexel University, Philadelphia, Pennsylvania.
- Rogowski, Prof. Augustus R.** Department of Mechanical Engineering, Massachusetts Institute of Technology.
- Rohde, Dr. Richard A.** Department of Plant Pathology, University of Massachusetts.
- Rohlf, Dr. James W.** Department of Physics, Boston University.
- Rohrlich, Prof. F.** Department of Physics, Syracuse University.
- Roller, Dr. Duane E.** Deceased; formerly, Harvey Mudd College, Claremont, California.
- Romano, Frank.** Consultant, Graphic Arts, Salem, New Hampshire.
- Romer, Prof. Alfred S.** Deceased; formerly, Museum of Comparative Zoology, Harvard University.
- Romick, Dr. Gerald J.** Applied Physics Laboratory, Johns Hopkins University, Laurel, Maryland.
- Rosen-Runge, Prof. Edward C.** Department of Biological Structure, School of Medicine, University of Washington.
- Roper, Dr. Stephen D.** University of Miami School of Medicine, Department of Physiology and Biophysics, Miami, Florida.
- Roper, Paul J.** Department of Geology, University of Southwestern Louisiana.
- Rosa, Dr. Patricia.** National Institutes of Health and Allergies, Rocky Mountain Laboratories, Hamilton, Montana.
- Rose, Dr. William Ingersoll, Jr.** Department of Geology and Geological Engineering, Michigan Technological University.
- Rosen, Prof. Barry.** Department of Biological Chemistry, University of Maryland.
- Rosen, Dr. Fred S.** President, Center for Blood Research, Department of Pediatrics, Harvard Medical School, Children's

- Hospital Medical Center, Boston, Massachusetts.
- Rosen, Dr. Kenneth H.** AT&T Laboratories, Holmdel, New Jersey.
- Rosen, Dr. Robert.** Department of Physiology and Biophysics, Faculty of Medicine, Dalhousie University, Halifax, Nova Scotia, Canada.
- Rosenbaum, Prof. Fred J.** Department of Electrical Engineering, Washington University.
- Rosenberg, Dr. Eugene.** Department of Microbiology, George S. Wise Faculty of Life Sciences, Tel Aviv University, Israel.
- Rosenberg, Leon T.** Senior Consultant, Generator Design, Generation, Installation, and Service, Allis-Chalmers Manufacturing Company, Milwaukee, Wisconsin.
- Roskoski, Dr. Robert, Jr.** Department of Biochemistry and Molecular Biology, Louisiana State University, New Orleans.
- Ross, Dr. Charles A.** Department of Geology, Western Washington State College.
- Ross, Dr. Edward S.** California Academy of Sciences, San Francisco.
- Ross, Dr. Herbert H.** Illinois State Natural History Survey, Urbana.
- Ross, Dr. J.** Central Science Laboratory, Surrey, United Kingdom.
- Ross, Dr. Malcolm.** Washington, D.C.
- Ross, Dr. Robert S.** Environmental Structures, Inc., Cleveland, Ohio.
- Ross, Prof. Sidney.** Department of Chemistry, Rensselaer Polytechnic Institute.
- Rossby, Prof. H. Thomas.** Graduate School of Oceanography, University of Rhode Island, Kingston.
- Rossing, Dr. Thomas D.** Department of Physics, Northern Illinois University, DeKalb.
- Rossini, Dr. Aldo A.** Professor of Medicine, and Director, Division of Diabetes, University of Massachusetts Medical School, Worcester.
- Rossmessl, Dr. Paul G.** Senior Research Scientist, American Institute for Research, Washington, D.C.
- Rostoker, Dr. William.** Department of Materials Engineering, University of Illinois, Chicago.
- Roth, Willard.** Engineer, Sunbeam Equipment Corporation, Meadville, Pennsylvania.
- Rothblum, Richard Stone.** David W. Taylor Naval Ship Research and Development Center, Bethesda, Maryland.
- Rothschild, Dr. Bruce M.** Youngstown, Ohio.
- Roundhill, Dr. D. Max.** Department of Chemistry, Tulane University.
- Rowe, Prof. D. M.** NEDO Centre for Thermoelectric Engineering, Division of Electronic Engineering, University of Wales, Cardiff, United Kingdom.
- Rowell, Prof. A. J.** Department of Geology, University of Kansas.
- Rowell, Prof. Roger M.** Project Leader, Modified Lignocellulosic Materials, Forest Products Laboratory, University of Wisconsin-Madison.
- Rowen, Prof. Alan L.** Webb Institute of Naval Architecture, Glen Cove, New York.
- Rowley, Dr. W. R. C.** Department of Trade and Industry, Division of Mechanical and Optical Metrology, National Physical Laboratory, Teddington, Middlesex, England.
- Rownd, Dr. Robert H.** Department of Molecular Biology, Northwestern Medical School.
- Roy, Natalie, U.** Director of Recycling and Legislative Affairs, Glass Packaging Institute, Washington, D.C.
- Rozeanu, Prof. L.** Department of Material Science, Technion, Israel Institute of Technology.
- Rubinstein, Sue R.** Marketing Program Services Group, The Aries Group, Rockville, Maryland.
- Rubis, Prof. David D.** Department of Plant Sciences, College of Agriculture, University of Arizona.
- Ruch, Prof. Fritz.** Department of General Botany, Swiss Federal Institute of Technology, Zurich.
- Ruch, Prof. Theodore C.** Director, Regional Primate Research Center; Professor, Department of Physiology and Biophysics, School of Medicine, University of Washington.
- Ruddat, Dr. Manfred.** Department of Molecular Genetics and Cell Biology, University of Chicago, Barnes Laboratory.
- Ruderman, Dr. Audrey J.** Department of Psychology, University of Illinois, Chicago.
- Rudnick, Dr. Dorothea.** Department of Biology, Albertus Magnus College, Yale University.
- Ruffing, Jaime.** AMSTA-AR-ASP, U.S. Army Armament Research Development and Engineering Center, Picatinny Arsenal, New Jersey.
- Rulfs, Dr. Charles L.** Department of Chemistry, University of Michigan.
- Rumble, Dr. Douglas, III.** Petrologist, Geophysical Laboratory, Carnegie Institution, Washington, D.C.
- Rumsey, Dr. James W.** Department of Agricultural Engineering, University of California, Davis.
- Rundman, Prof. Karl.** Department of Metallurgical Engineering, Michigan Technological University.
- Runham, Dr. Norman.** Department of Zoology, University College of North Wales, Bangor.
- Runnegar, Dr. Bruce.** Department of Earth and Space Sciences, University of California, Los Angeles.
- Ruouff, Dr. Kathryn L.** Francis Blake Bacteriology Laboratories, Department of Microbiology and Molecular Genetics, Massachusetts General Hospital, Harvard Medical School, Boston, Massachusetts.
- Rupp, Arthur F.** Oak Ridge National Laboratory, Oak Ridge, Tennessee.
- Rusk, Dr. Rogers D.** Mount Holyoke College.
- Russell, Dr. Allen S.** Vice President, Alcoa Laboratories, Aluminum Company of America, Pittsburgh, Pennsylvania.
- Russell, Dr. Howard W.** Deceased; formerly, Technical Director, Battelle Memorial Institute, Columbus, Ohio.
- Russell-Hunter, Prof. W. D.** Professor of Zoology, Department of Biology, Syracuse University.
- Rust, Dr. Brian R.** Department of Geology, University of Ottawa, Ontario, Canada.
- Rust, Dr. David M.** Applied Physics Laboratory, Johns Hopkins University, Laurel, Maryland.
- Rutger, J. N.** Department of Agronomy, University of California, Davis.
- Ruthroff, Clyde L.** Consultant, Holmdel, New Jersey.
- Rutkow, Dr. Ira M.** Hernia Center, Freehold, New Jersey.
- Rutledge, Dr. Steven A.** Department of Atmospheric Science, Colorado State University, Fort Collins.
- Ryan, Prof. James J.** Professor Emeritus of Mechanical Engineering, University of Minnesota.
- Ryan, Dr. Kenneth J.** Department of Pathology, University of Arizona Medical Center, Tucson.
- Ryge, Dr. Peter.** Vice President for Engineering, Ancore Corporation, Santa Clara, California.
- Ryland, Prof. John S.** Head of Biology, School of Natural Resources, University of the South Pacific, Laucala Bay, Suva, Fiji.

## S

- Saad, Prof. Michael L.** Department of Mechanical Engineering, Santa Clara University, Santa Clara, California.
- Saaty, Prof. Thomas L.** Graduate School of Business, University of Pittsburgh.
- Sabo, Dr. John L.** National Center for Ecological Analysis and Synthesis, Santa Barbara, California.
- Sadaway, Prof. Donald R.** Massachusetts Institute of Technology, Department of Materials Science and Engineering, Cambridge.
- Sadwick, Dr. Laurence P.** Electrical Engineering Department, University of Utah, Salt Lake City.
- Saenger, Dr. Peter.** Centre for Coastal Management, University of New England, Northern Rivers, Lismore, Australia.
- Saenger, Dr. Wolfram.** Max Planck-Institut für Experimentelle Medizin, Göttingen, Germany.
- Sage, Prof. Andrew P.** Founding Dean Emeritus and First American Bank Professor. University Professor, School of Information Technology and Engineering, George Mason University, Fairfax, Virginia.
- Saito, Dr. Tsunemasa.** Lamont-Doherty Geological Observatory, Palisades, New York.

- Šajgalík, Dr. Pavol.** Institute of Organic Chemistry, Slovak Academy of Sciences, Bratislava Slovak Republic, Bratislava, Czechoslovakia.
- Salam, Prof. Abdus.** Deceased; formerly, Director, International Centre for Theoretical Physics, Trieste, Italy.
- Salazar, Prof. Deborah A.** Department of Geography, Oklahoma State University, Stillwater.
- Salisbury, Dr. Alan B.** Chairman, Learning Tree International, Reston, Virginia.
- Salisbury, Dr. Frank B.** Plant Science Department, Utah State University.
- Salkin, Dr. Ira F.** Wadsworth Center, New York Department of Health, Albany, New York.
- Saltzman, Dr. W. Mark.** Department of Chemical Engineering, G. W. C. Whiting School of Engineering, Johns Hopkins University, Baltimore, Maryland.
- Salutsky, Dr. Murrell L.** Vice President, Research, Dearborn Chemical Division, W. R. Grace and Company, Lake Zurich, Illinois.
- Samios, Dr. Nicholas P.** Brookhaven National Laboratory, Upton, New York.
- Samson, Prof. Perry.** Department of Atmospheric, Oceanic, and Space Sciences, University of Michigan, Ann Arbor.
- Samter, Dr. Max.** Institute of Allergy and Clinical Immunology, Grant Hospital of Chicago.
- San Martin, Robert L.** Deputy Assistant Secretary for Renewable Energy, Department of Energy, Washington, D.C.
- Sanchez, Dr. Anthony.** Research Officer, Department of Health and Human Services, Centers for Disease Control and Prevention, Atlanta, Georgia.
- Sanchez-Sinencio, Dr. Edgar.** Department of Electrical Engineering, Texas A & M University.
- Sandage, Dr. Allan.** Mount Wilson and Palomar Observatories, Pasadena, California.
- Sandberg, Dr. Charles.** U.S. Geological Survey, Denver, Colorado.
- Sandberg, Dr. Philip A.** Department of Geology, University of Illinois at Urbana-Champaign.
- Sanders, Dr. Frederick.** Department of Meteorology, Massachusetts Institute of Technology.
- Sanders, Dr. Robert W.** Department of Zoology, University of Georgia.
- Sanders, Prof. Tom H., Jr.** Department of Materials Engineering, Purdue University.
- Sandier, Prof. Stanley I.** Department of Chemical Engineering, University of Delaware.
- Sandretto, Brig. Gen. Peter C.** Deceased; formerly, Director, Engineering Management, International Telephone and Telegraph Corporation.
- Sankey, Dr. Bruce M.** Petroleum Products Division, Imperial Oil, Ltd., Sarnia, Ontario, Canada.
- Sankey, E. W.** Marion Power Shovel Division, Dresser Industries, Inc., Marion, Ohio.
- Sarachik, Prof. Edward S.** Department of Atmospheric Sciences, University of Washington, Seattle.
- Sargent, Dr. Anneila I.** Owens Valley Radio Observatory, California Institute of Technology, Pasadena.
- Sasian, Prof. Jose M.** Optical Sciences Center, University of Arizona, Tucson.
- Sass, Prof. Stephen L.** Department of Materials Science and Engineering, Cornell University.
- Sathish, Dr. Shamachary.** University of Dayton Research Institute, Dayton, Ohio.
- Satir, Dr. Peter.** Chairman, Department of Anatomy and Structural Biology, Albert Einstein College of Medicine.
- Saucer, Prof. Helmut.** Department of Biology, Texas A&M University.
- Sauer, Fred.** Technical Service Department, Pfizer, Inc., Groton, Connecticut.
- Saul, Dr. Everett L.** Director of Scientific Liaison, Products Division, Bristol-Myers Company.
- Saunders, Dr. Gary W.** Department of Biology, University of New Brunswick, Fredericton, New Brunswick, Canada.
- Saunders, Dr. R. Stephen.** Jet Propulsion Laboratory, California Institute of Technology.
- Sauvage, Dr. Jean-Pierre.** Laboratoire de Chimie Organo-Minérale, Institut le Bel, Université Louis Pasteur, Strasbourg, France.
- Savage, Prof. Blair D.** Washburn Observatory, Department of Astronomy, University of Wisconsin.
- Savage, Dr. Donald E.** Department of Paleontology, University of California, Berkeley.
- Savage, Dr. George M.** Director, Product Research and Development, Upjohn International Inc., Kalamazoo, Michigan.
- Savage, Dr. Jay M.** Department of Biological Sciences, University of Southern California.
- Sawhney, Dr. V. K.** Department of Biology, University of Saskatchewan, Saskatoon, Canada.
- Sawyer, Dr. Donald.** Distinguished Professor, Department of Chemistry, Texas A&M University.
- Sayeed, Prof. Ali H.** Department of Electrical Engineering, University of California, Los Angeles.
- Sayler, Prof. John H.** Electrical Engineering and Computer Science Department, University of Michigan, Ann Arbor.
- Sayre, Dr. Albert N.** Deceased; formerly, Consulting Groundwater Geologist, Behre Dolbear and Company.
- Sayre, Prof. Lawrence M.** Department of Chemistry, Case Western Reserve University, Cleveland, Ohio.
- Scalzi, Dr. John B.** Program Director, National Science Foundation, Washington, D.C.
- Scanlan, Prof. J. O.** Department of Electrical and Electronic Engineering, University College, Dublin, Ireland.
- Schachter, Dr. Julius.** Department of Laboratory Medicine, University of California, San Francisco.
- Schaefer, Dr. Henry P., III.** Department of Chemistry, University of California, Berkeley.
- Schaeffer, Dr. Bobb.** Chairman and Curator, American Museum of Natural History, New York.
- Schaumann, Prof. Rolf.** Department of Electrical and Computer Engineering, Portland State University, Portland, Oregon.
- Schawlow, Prof. Arthur L.** Department of Physics, Stanford University.
- Scheeline, Dr. Alexander.** School of Chemical Sciences, University of Illinois, Urbana-Champaign.
- Scheer, Dr. Bradley T.** Professor Emeritus, Department of Biology, University of Oregon.
- Schelleng, John C.** (Retired) Bell Telephone Laboratories.
- Scheltema, Amelie H.** Woods Hole Oceanographic Institution, Woods Hole, Massachusetts.
- Scher, Dr. Robert M.** Senior Project Engineer, John J. McMullen Associates, Inc., Arlington, Virginia.
- Schetz, Prof. Joseph A.** Department of Aerospace and Ocean Engineering, Virginia Polytechnic Institute and State University, Blacksburg.
- Schimmel, Dr. Curt.** Silicon Graphics, Inc., Mountain View, California.
- Schindler, Dr. Anton.** Camille Dreyfus Laboratory, Research Triangle Institute, Research Triangle Park, North Carolina.
- Schindler, Dr. James E.** Department of Biological Sciences, College of Sciences, Clemson University.
- Schlecht, Dr. Matthew F.** Section Research Chemist, E. I. du Pont de Nemours & Company, Inc., Agricultural Products Department, Newark, Delaware.
- Schlitt, Dr. William Joseph.** Process Manager/Kvaerner Metals, Davy Nonferrous Division, San Ramon, California.
- Schmerling, Dr. Louis.** Research Associate, Universal Oil Products Company, Des Plaines, Illinois.
- Schmid, Dr. Rudolf.** Department of Botany, University of California, Berkeley.
- Schmidlin, Dr. Francis.** National Aeronautics and Space Administration, Observational Science Branch, Laboratory for Oceans, Goddard Space Flight Center, Wallops Flights Facility, Wallops Island, Virginia.
- Schmidt, Dr. Paul W.** Department of Physics, University of Missouri.
- Schmidt-Nielsen, Dr. Bodil.** Department of Zoology, Duke University.
- Schmitt, Dr. Raymond.** Woods Hole Oceanographic Institution, Woods Hole, Massachusetts.

- Schmitt, Dr. Waldo L.** Deceased; formerly, Zoologist Emeritus, Department of Zoology, Smithsonian Institution.
- Schnabel, Dr. Ronald.** Pasture Systems and Watershed Management Research Laboratory, U.S. Department of Agriculture–Agricultural Research Service, University Park, Pennsylvania.
- Schneider, Dr. Thomas R.** Electric Power Research Institute, Palo Alto, California
- Schneidewind, Dr. Norman F.** Computer Scientist, Computer Research, Pebble Beach, California.
- Schoch, Dr. Robert.** Attleboro, Massachusetts.
- Schoeffler, Dr. James D.** Department of Computer and Information Science, Cleveland State University.
- Scholle, Prof. Peter A.** Department of Geological Sciences, Southern Methodist University, Dallas, Texas.
- Scholz, Christopher H.** Lamont-Doherty Geological Observatory, Palisades, New York.
- Scholz, Dr. Nathaniel.** Northwest Fisheries Science Center, Environmental Conservation Division, Seattle, Washington.
- Schooler, Dr. Jonathan.** Learning, Research, and Development Center, University of Pittsburgh.
- Schoonmaker, G. R.** Retired; formerly, Vice President, Production-Exploration, Marathon Oil Company, Findlay, Ohio.
- Schowalter, Prof. Timothy D.** Department of Entomology, Oregon State University, Corvallis.
- Schreiber, Prof. B. Charlotte.** Department of Earth and Environmental Sciences, Queens College, New York.
- Schreibman, Dr. Martin P.** Department of Biology, Brooklyn College, City University of New York.
- Schroeder, Dr. Charles A.** Department of Botanical Sciences, University of California, Los Angeles.
- Schroeder, Dr. Lee S.** Lawrence Berkeley Laboratory, Berkeley, California.
- Schroeder, Dr. Thomas E.** Friday Harbor Laboratories, University of Washington.
- Schubert, Dr. Jack.** Radiation Health, Graduate School of Public Health, University of Pittsburgh.
- Schuchardt, Dr. Lee F.** Merck, Sharp, and Dohme, West Point, Pennsylvania.
- Schueler, Dr. Donald G.** Sandia Laboratories, Albuquerque, New Mexico.
- Schugar, Dr. Harvey.** Department of Chemistry, Wright and Rieman Laboratories, New Brunswick, Rutgers University.
- Schuller, Dr. Ivan K.** Physics Department, University of California, La Jolla.
- Schulman, Dr. James H.** U.S. Naval Research Laboratory.
- Schultz, Dr. Cheryl.** National Center for Ecological Analysis and Synthesis, University of California, Santa Barbara.
- Schultz, Dr. Jack.** Gypsy Moth Research Center, Department of Entomology, College of Agriculture, Pesticide Research Laboratory and Graduate Study Center, Pennsylvania State University.
- Schultz, Robert M.** General Manager, William Langer Jewel Bearing Plant, Bulova Watch Company, Inc., Rolla, North Dakota.
- Schultze, Dr. Hanns-Peter.** Curator of Vertebrate Paleontology, Museum of Natural History, University of Kansas.
- Schur, Dr. Peter H. Robert B.** Brigham Hospital, Boston, Massachusetts.
- Schuster, Prof. Frederick L.** Department of Biology, Brooklyn College.
- Schwab, Robert W.** Boeing Company, Commercial Airplane Group, Seattle, Washington.
- Schwartz, Dr. Karlene V.** Department of Biology, University of Massachusetts, Boston.
- Schwartz, Mel.** Materials Consultant, United Technologies Corporation, Stratford, Connecticut.
- Schwartz, Dr. Mel M.** Rohr Industries, Inc., Chula Vista, California.
- Schwartz, Dr. Morton K.** Department of Biochemistry, Memorial Hospital, New York.
- Schweizer, Ernest.** President, Schweizer Aircraft Corporation, Elmira, New York.
- Scotese, Dr. Christopher R.** Department of Geology, University of Texas, Arlington.
- Scott, Prof. Alwyn.** Program in Applied Mathematics, University of Arizona, Tucson.
- Scott, Dave.** Industrial Engineering Manager, Modular Computer Systems, Inc., Fort Lauderdale, Florida.
- Scott, Dr. Edward R. D.** Institute of Meteoritics, Department of Geology, University of New Mexico.
- Scott, Prof. James F.** Department of Physics, University of Colorado.
- Scott, Dr. John E., Jr.** Department of Aerospace Engineering and Engineering Physics, University of Virginia.
- Scott, Dr. John P.** Director, Center for Research on Social Behavior, Bowling Green State University.
- Scott, Dr. Richard A.** U.S. Geological Survey, Department of the Interior, Denver, Colorado.
- Scott, Prof. Robert L.** Department of Chemistry, University of California, Los Angeles.
- Scouten, Dr. Charles W.** Stoelting Company, Oakwood Centre, Wood Dale, Illinois.
- Scrutton, Dr. Colin T.** Department of Geological Sciences, University of Durham, United Kingdom.
- Seaborg, Dr. Glenn T.** Lawrence Berkeley Laboratory, University of California, Berkeley.
- Seagle, Stanley.** Vice President, Research and Technical Development, RMI Company, Niles, Ohio.
- Searles, Dr. Robert.** Rheumatology Division, University of New Mexico School of Medicine.
- Searson, Dr. Peter C. H. H.** Uhlig Corrosion Laboratory, Department of Materials Science and Engineering, Massachusetts Institute of Technology.
- Sebald, Joseph F.** Consulting Engineer and President, Heat Power Products Corporation, Bloomfield, New Jersey.
- Seed, Prof. John Richard.** Department of Epidemiology, School of Public Health, University of North Carolina, Chapel Hill.
- Segal, Dr. Bernard L.** Professor of Medicine, Cardiovascular Institute, Hahnemann Medical College and Hospital, Philadelphia, Pennsylvania.
- Segal, Dr. Nancy L.** Department of Psychology, California State University, Fullerton.
- Segeler, C. George.** Director, Technical Service, Dave Sage, Inc., New York.
- Sehgal, Dr. Amita.** Howard Hughes Medical Institute, Department of Neuroscience, University of Pennsylvania School of Medicine, Philadelphia.
- Seidelmann, Dr. P. K.** Director, Nautical Almanac Office, U.S. Naval Observatory, Washington, D.C.
- Seitz, Dr. W. Rudolf.** Department of Chemistry, College of Engineering and Physical Sciences, University of New Hampshire.
- Sekera, Prof. Zdenek.** Deceased; formerly, Department of Meteorology, Institute for Geophysics and Planetary Physics, University of California, Los Angeles.
- Selamet, Prof. Ahmet.** Center for Automotive Research, Ohio State University, Columbus.
- Selby, Prof. Michael J.** Department of Earth Science, University of Waikato, New Zealand.
- Seliskar, Dr. Denise M.** Associate Research Scientist, College of Marine Studies, University of Delaware.
- Sell, Dr. Heinz G.** Metals Development Section, Westinghouse Lamp Divisions, Bloomfield, New Jersey.
- Sellers, Dr. John R.** Manager, Engineering Mechanics Operations, TRW, Inc., Redondo Beach, California.
- Sellin, Dr. Ivan A.** Department of Physics, University of Tennessee.
- Sellmyer, Prof. David J.** Behlen Laboratory of Physics, University of Nebraska.
- Selverstone, Dr. Jane.** Department of Earth and Planetary Sciences, Hoffman Laboratory, Harvard University.
- Sepkoski, Dr. J. John, Jr.** Department of Geophysical Sciences, Henry Hinds Laboratory, University of Chicago.
- Seshadri, Sridhar.** Operations Management Department, Stern School of Business, New York University, New York.
- Sessions, Dr. John.** Department of Forest Engineering, Oregon State University, Corvallis.
- Sessler, Dr. Gerhard M.** Institut für Übertragungstechnik Elektroakustik, Technische Hochschule, Darmstadt, Germany.



- Sethares, Dr. William A.** Department of Electrical and Computer Engineering, University of Wisconsin, Madison.
- Setlow, Dr. Richard B.** Brookhaven National Laboratory, Upton, New York.
- Shack, Prof. Roland V.** Optics Science Center, University of Arizona.
- Shaffer, Dr. Albert L.** Clinical Professor of Medicine, Brigham and Women's Hospital, Boston, Massachusetts.
- Shanmugam, Dr. G.** Mobil Research and Development Corporation, Research Department, Dallas Research Laboratory, Dallas, Texas.
- Shannon, L. R.** "The New York Times," New York.
- Shannon, Prof. Robert R.** Optical Sciences Center, University of Arizona.
- Shapere, Prof. Dudley.** Wake Forest University, Winston-Salem, North Carolina.
- Shapiro, Hymin.** Research and Development Department, Ethyl Corporation, Baton Rouge, Louisiana.
- Sharkey, Dr. Thomas D.** Department of Botany, University of Wisconsin.
- Sharon, Prof. Nathan.** Department of Membrane Research and Biophysics, Weizmann Institute of Science, Rehovot, Israel.
- Sharpe, Dr. Ralph H.** Gainesville, Florida.
- Shaw, Brian R.** BHP Petroleum (Americas) Inc., Houston, Texas.
- Shaw, Dr. Cheng-Mei.** Laboratory of Neuropathy, Department of Pathology, University of Washington School of Medicine.
- Shaw, Jeffrey S.** 3M Industrial Tape & Specialties Division, Stopaul, Minnesota.
- Shaw, Prof. Peter.** Department of Physics, Pennsylvania State University.
- Shaw, Dr. Robert A.** Department of Chemistry, Birkbeck College, University of London, England.
- Shearer, Dr. Charles K.** Institute of Meteorites, Department of Earth and Planetary Sciences, University of New Mexico, Albuquerque.
- Shedlock, Dr. Kaye M.** U.S. Geological Survey, Administrative Officer, Denver, Colorado.
- Sheeley, Dr. Neil R., Jr.** Naval Research Laboratory, Washington, D.C.
- Sheffield, Dr. Harley G.** Laboratory of Parasitic Diseases, National Institutes of Health, Bethesda, Maryland.
- Sheft, Dr. Irving.** Chemistry Division, Argonne National Laboratory, Argonne, Illinois.
- Sheingold, Daniel H.** Analog Devices, Inc., Norwood, Massachusetts.
- Shelton, Dr. Frank H.** Chief Scientist, Kaman Sciences Corporation, Colorado Springs, Colorado.
- Shenoy, Dr. Gopal.** Senior Scientific Director, The Advanced Photon Source, Argonne National Laboratory, Illinois.
- Shephard, Dr. Bruce D.** Diplomates, American College of Obstetricians and Gynecologists, Tampa Obstetrics and Gynecology Associates, Tampa, Florida.
- Shepherd, Dr. Gordon M.** Yale University Medical School.
- Sheppard, Dr. Edith M.** Senior Lecturer in Zoology (retired), University of South Wales and Monmouthshire.
- Shergold, Dr. John. H.** Chairman, International Subcommission on Cambrian Stratigraphy, Masseret, France.
- Sheridan, Prof. Thomas B.** Department of Mechanical Engineering, Massachusetts Institute of Technology.
- Sheriff, Dr. Robert E.** Department of Geology, University of Houston.
- Sherwood, Robert S.** Deceased; formerly, Manager of Engineering, Steam Turbine Division, Worthington Corporation, Harrison, New York.
- Shevell, Prof. Richard S.** Department of Aeronautics, Stanford University.
- Sheviak, Dr. Charles J.** Senior Scientist and Curator of Botany, New York State Museum, Albany.
- Shiino, Dr. Suet M.** Faculty of Fisheries, Prefectural University of Mie, Japan.
- Shimek, Dr. Ronald L.** Reef Safe Enterprises, Inc., Wilsall, Montana.
- Shipman, Dr. Harry L.** Department of Physics, University of Delaware.
- Shires, Dr. G. Tom.** Department of Surgery, Texas Technical University, Lubbock.
- Shirley, Prof. David A.** Deceased; formerly, Department of Chemistry, University of Tennessee.
- Shivaram, Dr. Bellave S.** Department of Physics, John S. Beams Laboratory, University of Virginia.
- Shive, Prof. William.** Department of Chemistry and Clayton Foundation Biochemical Institute, University of Texas, Austin.
- Shively, R. R.** Supervisor, Processor Technology Research Group, Bell Laboratories, Whippany, New Jersey.
- Shoemaker, Dr. William C.** Martin Luther King, Jr./Charles R. Drew Medical Center, Los Angeles, California.
- Shortman, Dr. Ken.** Head, Lymphocyte Differentiation Unit, The Walter and Eliza Hall Institute of Medical Research, Melbourne, Australia.
- Shortreed, Dr. John.** Director, Institute for Risk Research, Waterloo, Ontario, Canada.
- Shprintzen, Dr. Robert J.** Director, Center for Crainofacial Disorders, Montifiore Medical Center, Albert Einstein College of Medicine, New York, New York.
- Shreve, Prof. R. Morris.** Professor Emeritus of Chemical Engineering, Purdue University.
- Shuman, E. C.** Regional Professional Engineer, State College, Pennsylvania.
- Shuman, Dr. Frederick B.** Director, National Meteorological Center, National Oceanic and Atmospheric Administration, Washington, D.C.
- Shuster, Dr. Carl N., Jr.** Ecologist (retired), Bureau of Water Hygiene, U.S. Public Health Service, Cincinnati, Ohio.
- Siebein, Dr. Gary W.** Department of Architecture, University of Florida, Gainesville.
- Siegbahn, Prof. Kai.** Institute of Physics, University of Uppsala, Sweden.
- Siegel, Prof. Benjamin M.** Department of Applied Physics, Cornell University.
- Siegel, Dr. Richard W.** Materials Science Division, Argonne National Laboratory, Argonne, Illinois.
- Siegman, Dr. A. E.** Stanford, California.
- Siegmund, C. W.** Exxon Research and Engineering Company, Linden, New Jersey.
- Siegmund, Dr. Walter P.** Director, Research and Development, Schott Fiber Optics, Inc., Southbridge, Massachusetts.
- Sieh, Prof. Kerry.** Seismological Laboratory, California Institute of Technology, Pasadena.
- Siekevitz, Dr. Philip.** Department of Cell Biology, Rockefeller University, New York.
- Sienko, Dr. Michell J.** Deceased; formerly, Department of Chemistry, Cornell University.
- Siever, Dr. Raymond.** Department of Geological Sciences, Harvard University.
- Siggia, Prof. Sidney.** Department of Chemistry, University of Massachusetts.
- Signorini, Dr. Sergio R.** Division of Ocean Sciences, National Science Foundation, Arlington, Virginia.
- Silberschatz, Dr. Abraham.** Information Sciences Research Center, Murray Hill, New Jersey.
- Šiljak, Prof. Dragoslav D.** School of Engineering, Santa Clara University, California.
- Silk, Dr. Joseph.** Department of Astronomy, University of California, Berkeley.
- Silman, Robert.** Robert Silman Associates, P.C., New York.
- Silva, Dr. Paul C.** Department of Botany, University of California, Berkeley.
- Silverman, Dr. Joseph.** Department of Chemical Engineering, University of Maryland.
- Simberloff, Prof. Daniel.** Department of Biological Science, Florida State University.
- Simmons, Dr. James A.** Walter S. Hunter Laboratory of Psychology, Brown University.
- Simmons, Dr. Nancy.** Department of Mammology, American Museum of Natural History, New York.
- Simmons, Dr. William H.** Department of Biochemistry and Biophysics, Loyola University Medical Center, Maywood, Illinois.
- Simon, Dr. Barry.** Department of Mathematics, Princeton University.
- Simon, Dr. George W.** Space Physics Division, Phillips Laboratory (AFSC), National Solar Observatory, New Mexico.
- Simon, Dr. Steven.** Department of Geophysical Science, University of Chicago, Illinois.
- Simonson, Dr. Roy W.** Director (retired), Soil Classification and Correlation, U.S.

- Department of Agriculture, Hyattsville, Maryland.
- Simpson, Dr. Carol.** Department of Earth and Planetary Sciences, Johns Hopkins University.
- Simpson, Dr. Joanne.** Head, Severe Storms Branch, Goddard Space Flight Center, NASA, Greenbelt, Maryland.
- Simpson, Prof. Robert H.** Retired; formerly, Director, Experimental Meteorology Laboratory, National Weather Service, Miami, Florida.
- Simpson, Prof. Stephen G.** Department of Chemistry, Massachusetts Institute of Technology.
- Sims, Dr. Chester T.** Department of Materials Engineering, Rensselaer Polytechnic Institute, New York.
- Sims, Dr. G. K.** Agricultural Research Service, U.S. Department of Agriculture, Urbana, Illinois.
- Sincerbox, Prof. Glenn T.** Optical Data Storage Center, Optical Sciences Center, University of Arizona, Tucson.
- Sinclair, Dr. Malcom W.** Procurement Executive, Ministry of Defense, Royal Signals and Radar Establishment, Great Malvern, Worcestershire, England.
- Singer, Dr. S. F.** Formerly, Deputy Assistant Secretary, U.S. Department of the Interior.
- Singer, Prof. Stanley.** Director, ATHENEX Research Associates.
- Singleton, John D.** Supervisor of Programming, Radio Division, National Broadcasting Company, New York.
- Sinha, Prof. Kumares C.** Professor and Head, Transportation and Infrastructure Systems Engineering, Purdue University, West Lafayette, Indiana.
- Sinha, Prof. P. K.** Department of Engineering, University of Reading, Whiteknights, Reading, England.
- Sinton, Dr. William M.** Department of Astronomy, University of Hawaii.
- Sircar, Dr. S.** Senior Research Associate, Air Products and Chemicals, Inc., Allentown, Pennsylvania.
- Sirignano, Prof. William A.** Dean of Engineering, University of California, Irvine.
- Sisler, C. W.** Corporate Engineering Department Monsanto Company, St. Louis, Missouri.
- Sisler, Dr. Harry H.** Department of Chemistry, University of Florida.
- Sisler, Dr. Hugh D.** Department of Botany, Division of Agricultural and Life Sciences, University of Maryland.
- Sistare, George, Jr.** (Retired) Consultant, Handy and Harman, Fairfield, Connecticut.
- Sittig, Marshall.** Assistant Director, Office of Research Project Administration, Princeton University.
- Sittner, Dr. W. Rex.** President, Electro Medical Systems, Inc.
- Skalak, Dr. Richard.** Deceased; formerly, Founding Director, Institute for Mechanics and Materials, University of California, San Diego.
- Skelly, Dr. David.** School of Forestry and Environmental Studies, Yale University, New Haven, Connecticut.
- Skilling, Prof. Hugh H.** Department of Electrical Engineering, Stanford University.
- Skinner, A. Douglas.** Head of Measurement Standards Laboratory, Marconi Instruments, Ltd., Stevanage, England.
- Skinner, Prof. Brian J.** Department of Geology and Geophysics, Yale University, New Haven, Connecticut.
- Skinner, E. N.** Assistant to the Director, Product Research and Development, International Nickel Company, Inc., New York.
- Skinner, Dr. Harry B.** Department of Orthopedic Surgery, School of Medicine, University of California, San Francisco.
- Skotland, Dr. C. B.** Irrigated Agriculture Research and Extension Center, Washington State University.
- Skrutskie, Dr. Michael F.** Department of Physics and Astronomy, University of Massachusetts, Amherst.
- Slabaugh, Dr. Wendell H.** Deceased; formerly, Department of Chemistry, Oregon State University.
- Slichter, Dr. Charles P.** Department of Physics, University of Illinois, Urbana.
- Slichter, Prof. Louis B.** Deceased; formerly, Institute of Geophysics, University of California, Los Angeles.
- Slocum, Dr. Donald W.** Argonne National Laboratory, Argonne, Illinois.
- Slomp, Dr. George.** Physical and Analytical Chemistry Division, Upjohn Company, Kalamazoo, Michigan.
- Slonecker, Dr. Charles E.** Associate Professor of Anatomy, University of British Columbia, Canada.
- Sluder, Dr. Greenfield.** Senior Scientist, Worcester Foundation for Experimental Biology, Shrewsbury, Massachusetts.
- Smartt, Dr. Raymond N.** National Solar Observatory, Sunspot, New Mexico.
- Smith, Dr. Andrew B.** Department of Paleontology, British Museum of Natural History, London, England.
- Smith, Prof. David M.** Morris K. Jeesup Professor of Silviculture, School of Forestry, Yale University.
- Smith, Fred W.** Western Union Telegraph Company, Rahway, New Jersey.
- Smith, Gaylord,** Director, High Nickel Alloys and Precious Metals, Product Development and Research Division, International Nickel Company, New York.
- Smith, Dr. Guy D.** Deceased; formerly, Soil Conservation Service, U.S. Department of Agriculture.
- Smith, Prof. Harlan J.** Department of Astronomy, University of Texas, Austin.
- Smith, Dr. Jerome A.** Marine Physics Laboratory, Scripps Institution of Oceanography, University of California, La Jolla.
- Smith, Dr. John Ward.** Deceased; formerly, Research Supervisor, Laramie Energy Research Center, Energy Research and Development Administration, Laramie, Wyoming.
- Smith, Prof. Julian C.** Department of Chemical Engineering, Cornell University.
- Smith, Dr. Julius O., III.** Center for Computer Research in Music and Acoustics, Department of Music, Stanford University, Stanford, California.
- Smith, Prof. Karl U.** Director, Behavioral Cybernetics Laboratory, and Professor of Psychology, University of Wisconsin.
- Smith, Dr. Kathleen K.** Department of Biological Anthropology and Anatomy, Duke University Medical Center, Durham, North Carolina.
- Smith, Rear Adm. Levering.** Director of Strategic Systems Project Office, U.S. Department of the Navy.
- Smith, Dr. Michael S.** Leader, Nuclear Astrophysics Research Group, Physics Division, Oak Ridge National Laboratory, Tennessee.
- Smith, Prof. Norman D.** Department of Geosciences, University of Nebraska, Lincoln.
- Smith, Prof. Paul G.** Department of Vegetable Crops, College of Agricultural and Environmental Sciences, University of California, Davis.
- Smith, Dr. Richard T.** Southwest Research Institute, San Antonio, Texas.
- Smith, Dr. Robert L.** College of Oceanic and Atmospheric Sciences, Oregon State University, Corvallis.
- Smith, Dr. Warren E.** Science Applications International Corporation, Tucson, Arizona.
- Smith, Dr. William F.** Department of Mechanical Engineering and Aerospace Sciences, College of Engineering, University of Central Florida, Orlando.
- Smithson, Dr. T. R.** Head of School, Science Maths and Information Technology, Cambridge Regional College, Kings Hedges Campus, Cambridge, United Kingdom.
- Smullyan, Dr. Raymond M.** Oscar Ewing Professor of Philosophy Emeritus, Indiana University, Bloomington.
- Smythe, Dr. William R.** Department of Physics, California Institute of Technology.
- Snavelly, Dr. Dianne.** Center for Photochemical Sciences, Bowling Green State University, Bowling Green, Ohio.
- Snelgrove, Prof. Martin.** Department of Electronics, Carleton University, Ontario, Canada.
- Snell, Dr. Arthur H.** Associate Director, Oak Ridge National Laboratory, Oak Ridge, Tennessee.
- Snell, Dr. Esmond E.** Department of Biochemistry, University of California, Berkeley.
- Snoke, Dr. David.** Los Angeles, California.
- Snook, Dr. Theodore.** Department of Anatomy, School of Medicine, University of North Dakota.
- Snow, William W.** Consulting Engineer, William W. Snow Associates, Inc., Woodside, New York.

- So, Dr. E.** Institute for National Measurement Standards, National Research Council of Canada, Ottawa, Ontario.
- Sochacki, Dr. James.** Department of Mathematics, James Madison University, Harrisonburg, Virginia.
- Soderblom, Dr. David.** Space Telescope Science Institute, Baltimore, Maryland.
- Sohon, Dr. Harry.** Deceased; formerly, Moore School, University of Pennsylvania.
- Sokol, Dr. Pamela A.** Department of Microbiology and Infectious Diseases, University of Calgary Health Sciences Center, Calgary, Alberta, Canada.
- Solberg, Dr. Myron.** Department of Food Science, Rutgers University, New Brunswick, New Jersey.
- Soldate, Dr. Mark.** Department of Physics, Yale University.
- Solem, Dr. G. Alan.** Curator and Head, Division of Invertebrates, Field Museum of Natural History, Chicago, Illinois.
- Solomon, Dr. James C.** Associate Curator, Missouri Botanical Garden, St. Louis.
- Somlo, Dr. Peter I.** CSIRO Division of Applied Physics, Lindfield, New South Wales, Australia.
- Somlyo, Dr. Andrew Paul.** Department of Physiology, School of Medicine, University of Virginia.
- Sommer, Dr. Alfred.** Director, International Center for Epidemiology and Preventive Ophthalmology, Dana Center, Wilmer Institute, Johns Hopkins School of Hygiene and Public Health, Baltimore, Maryland.
- Sommer, Dr. Alfred H.** Thermo Electron Corporation, Waltham, Massachusetts.
- Soost, Dr. R. K.** Department of Plant Science, University of California, Riverside.
- Sorensen, Dr. Robert M.** Coastal Engineering Research Center, Department of the Army, Fort Belvoir, Virginia.
- Sorensen, Prof. Robert M.** Department of Civil Engineering, Lehigh University, Bethlehem, Pennsylvania.
- Sorenson, Prof. S.** Department of Physics, University of Tennessee, Knoxville.
- Souder, Dr. Paul A.** Department of Physics, Yale University.
- Souders, Dr. Mott.** Deceased; formerly, Director, Oil Development, Shell Oil Company, Emeryville, California.
- Soulen, Dr. Robert J., Jr.** Naval Research Laboratory, Washington, D.C.
- Southwick, Dr. Stephen M.** Department of Pomology, University of California, Davis.
- Southwick, Dr. Steven.** Department of Psychiatry and Connecticut Mental Health Center, School of Medicine, Yale University.
- Sovonick-Dunford, Dr. S.** Department of Biological Sciences, University of Cincinnati.
- Spackman, Dr. William.** Department of Geology, Pennsylvania State University.
- Spearman, Dr. M. Leroy.** NASA Langley Research Center, Hampton, Virginia.
- Spector, Dr. David L.** Senior Staff Scientist, Cold Spring Harbor Laboratory, Cold Spring Harbor, New York.
- Spedding, Prof. Frank H.** Deceased; formerly, Ames Laboratory, Energy Research and Development Administration, Iowa State University.
- Speer, Dr. J. Alexander.** Department of Marine, Earth, and Atmospheric Sciences, School of Physical and Mathematical Sciences, North Carolina State University.
- Speight, Dr. James G.** Western Research Institute, Laramie, Wyoming.
- Spergel, Dr. David N.** Department of Astrophysics, Princeton University.
- Spiegel, Dr. Allen M.** National Institute of Diabetes and Kidney Diseases, National Institutes of Health, Bethesda, Maryland.
- Spiegel, Dr. Carol A.** Director, Clinical Microbiology, Department of Pathology and Laboratory Medicine, University of Wisconsin Hospital and Clinics, Madison.
- Spink, Dr. Wesley W.** Regents, Professor of Medicine, School of Medicine, University of Minnesota.
- Spinrad, Dr. Bernard I.** Department of Nuclear Engineering, Oregon State University.
- Splitstoesser, Dr. Don F.** New York State Agricultural Experiment Station and Department of Food Science and Technology, Cornell University.
- Sposito, Dr. Garrison.** Department of Plant and Soil Biology, University of California, Berkeley.
- Sprague, Prof. G. F.** Department of Agronomy, University of Illinois, Urbana.
- Sprague, Dr. Howard B.** Agricultural Consultant, Washington, D.C.
- Spratt, Dr. Nelson T., Jr.** Department of Zoology, University of Minnesota.
- Spreadbury, Dr. Peter J.** Department of Engineering, University of Cambridge, United Kingdom.
- Sprinkle, Dr. James.** Department of Geological Sciences, University of Texas, Austin.
- Spurgin, Robert A.** President, Spurgin & Associates, Irvine, California.
- Sreenivasan, Prof. K. R.** Engineering and Applied Sciences, Yale University.
- Srihari, Dr. Sargur N.** Center of Excellence for Document Analysis & Recognition, University of Buffalo, Amherst, New York.
- St. Geme, Dr. Joseph W.** Associate Professor of Pediatrics and Molecular Microbiology, Department of Pediatrics, Washington University School of Medicine, St. Louis, Missouri.
- St. Jean, Dr. Joseph, Jr.** Department of Geology, University of North Carolina.
- St. Pierre, Prof. George R.** Department of Metallurgical Engineering, Ohio State University.
- Stadtman, Dr. Theresa C.** Department of Health and Human Services, National Heart, Lung and Blood Institute, National Institutes of Health, Bethesda, Maryland.
- Stage, Dr. Steven A.** Baton Rouge, Louisiana.
- Stahnke, Dr. Herbert L.** Director, Poisonous Animal Research Laboratory, Arizona State University.
- Stall, Prof. Robert E.** Plant Pathology Department, Institute of Food and Agricultural Sciences, University of Florida.
- Stamm, Dr. Lola.** Department of Epidemiology, School of Public Health, University of North Carolina, Chapel Hill.
- Standiford, Ferris C., Jr.** W. L. Badger Associates, Inc., Consulting Engineers, Ann Arbor, Michigan.
- Stanford, Prof. John L.** Department of Physics and Astronomy, Iowa State University, Ames.
- Stanley, Dr. Bruce A.** Department of Cellular and Molecular Physiology, College of Medicine, Pennsylvania State University, Hershey.
- Starr, Dr. Eugene C.** Bonneville Power Administration, U.S. Department of the Interior, Portland, Oregon.
- Stauffer, Dr. Randy C.** Halogens Research Laboratory, Dow Chemical Company, Midland, Michigan.
- Stebbins, Prof. G. Ledyard.** Department of Genetics, College of Agriculture, University of California, Davis.
- Steele, Dr. William A.** Department of Chemistry, Pennsylvania State University.
- Steenrod, Norman E.** Department of Mathematics, Princeton University.
- Stefanovic, Dr. Victor R.** Electrical Engineering Department, University of Missouri.
- Stein, Prof. Dale F.** Retired; formerly, President Emeritus, Michigan Technological University, Houghton.
- Stein, Dr. Gary S.** Department of Biochemistry and Molecular Biology, J. Hillis Miller Health Center, College of Medicine, University of Florida.
- Stein, Dr. Janet L.** Department of Biochemistry and Molecular Biology, J. Hillis Miller Health Center, College of Medicine, University of Florida.
- Stein, Dr. Murray B.** Anxiety & Traumatic Stress Disorders Research Program, University of California, La Jolla.
- Steinberg, Dr. Aephrim M.** Department of Physics, University of California, Berkeley.
- Steinberg, Dr. Ellis P.** Senior Scientist, Argonne National Laboratory, Argonne, Illinois.
- Steinert, Emil F. (Retired)** Arc Welding Division, Westinghouse Electric Corporation.
- Steinschneider, Alfred.** President, American Sudden Infant Death Syndrome Institute, Atlanta, Georgia.
- Stephenson, Dr. R. J.** Department of Physics, Wooster College.
- Stepniowski, Wieslaw Z.** Aeronautical Consultant, Springfield, Pennsylvania.
- Steponkus, Prof. Peter L.** Department of Agronomy, Cornell University.
- Stern, Prof. Fred.** Iowa Institute of Hydraulic Research, University of Iowa, Iowa City.
- Stern, Dr. Robert J.** Department of Geosciences, University of Texas, Richardson.

- Sternberg, Dr. James C.** Applied Research Department, Beckman Instruments, Brea, California.
- Sternheim, Dr. Charles E.** Director of Undergraduate Studies, Department of Psychology, University of Maryland, College Park.
- Sterrer, Dr. W. E.** Bermuda Biological Station, St. George's West.
- Stevens, Dr. C. E.** College of Veterinary Medicine, North Carolina State University, Raleigh.
- Stevens, Dr. Calvin H.** Department of Geology, San Jose State University.
- Stevens, Dr. Mary Betty.** Division of Rheumatology, Johns Hopkins University School of Medicine, Baltimore, Maryland.
- Stevenson, Dr. Edward C.** Deceased; formerly, Department of Electrical Engineering, School of Engineering and Applied Sciences, University of Virginia.
- Steward, Dr. John W.** Department of Physics, University of Virginia.
- Stewart, Dr. David B.** Experimental Geochemistry and Mineralogy Branch, U.S. Geological Survey, Department of the Interior.
- Stewart, Dewey.** Crops Research Division, Agricultural Research Service, U.S. Department of Agriculture, Beltsville, Maryland.
- Stewart, Scott R. L.** C. Lee & Associates, Inc., Seattle, Washington.
- Steyn, Dr. Julian J.** Energy Resources International, Inc., Washington, D.C.
- Stidd, Prof. Benton M.** Department of Biological Science, Western Illinois University, Macomb, Illinois.
- Stiles, Dr. Martin.** Department of Chemistry, University of Kentucky.
- Stillman, Dr. Gregory E.** Department of Electrical Engineering, University of Illinois, Urbana.
- Stirton, Dr. Robert I.** Vice President (retired), Roger Williams Technical and Economic Services, Inc., Berkeley, California.
- Stirton, Prof. Ruben A.** Director, Museum of Paleontology, University of California, Berkeley.
- Stock, Prof. David.** School of Mechanical and Materials Engineering, Washington State University, Pullman, Washington.
- Stock, Prof. John T.** Department of Chemistry, University of Connecticut.
- Stocum, Dr. David L.** Department of Genetics and Development, University of Illinois.
- Stoller, Dr. Marshall L.** Department of Urology, University of California, San Francisco.
- Stoloff, Dr. Norman S.** Department of Materials Engineering, Rensselaer Polytechnic Institute.
- Stolper, Dr. Edward M.** Division of Geological and Planetary Science, California Institute of Technology.
- Stone, Prof. A. Douglas.** Department of Applied Physics, Yale University.
- Stone, Dr. Anthony J.** Department of Chemistry, University of Cambridge, University Chemical Laboratory, Cambridge, England.
- Stone, Dr. Jeffrey K.** Department of Botany and Plant Pathology, Oregon State University, Corvallis.
- Stone, Prof. Kenneth G.** Deceased; formerly, Department of Chemistry, Michigan State University.
- Storch, Dr. Henry H.** Deceased; formerly, Assistant Professor of Chemistry, New York University.
- Storer, Dr. Tracy I.** Deceased; formerly, Department of Zoology, University of California, Davis.
- Storey, Prof. William B.** Department of Botany and Plant Sciences, University of California, Riverside.
- Stott, Dr. Jeffrey L.** Department of Veterinary Microbiology and Immunology, School of Veterinary Medicine, University of California, Davis.
- Stout, Gary J.** AT&T Submarine Systems, Inc., Morristown, New Jersey.
- Strandness, Dr. D. Eugene, Jr.** Department of Surgery, University of Washington School of Medicine, Seattle.
- Strandtmann, Prof. Russell W.** Department of Biological Sciences, Texas Technological College.
- Stranks, Prof. Donald R.** Department of Physical and Inorganic Chemistry, University of Adelaide, Australia.
- Straus, Dr. Reuben.** Providence Medical Center, Portland, Oregon.
- Strausbaugh, Prof. Carl A.** Kimberly Research and Extension Center, University of Idaho, Kimberly.
- Streeter, Prof. Victor L.** Department of Civil Engineering, College of Engineering, University of Michigan.
- Strock, Dr. O. J.** Consultant, Sarasota, Florida.
- Strohl, Robert, J.** Senior Research Scientist, Battelle Laboratories, Columbus, Ohio.
- Stroke, Dr. George W.** Department of Electrical Sciences and Head, Electro-Optical Sciences Center, State University of New York, Stony Brook.
- Strom, Dr. Robert G.** Department of Planetary Sciences, Lunar and Planetary Laboratory, University of Arizona.
- Stroyan, Dr. Henry L. G.** Entomology Department, Ministry of Agriculture, Fisheries and Food, Harpenden, England.
- Stuart, Dr. Alastair M.** Department of Zoology, University of Massachusetts.
- Stuart, Dr. Edward G.** Deceased; formerly, West Virginia School of Medicine.
- Stuart, William T.** Deceased; formerly "Electrical Construction and Maintenance," McGraw-Hill Publications Company, New York.
- Stubbings, Dr. H. G.** Poole, England.
- Stuckas, Kenneth J.** Engineering Consultation Services, Jacksonville, Florida.
- Stumm, Prof. Erwin Charles.** Deceased; formerly, Department of Geology and Mineralogy, Museum of Paleontology, University of Michigan.
- Stunkard, Dr. Horace W.** Research Associate, American Museum of Natural History, New York.
- Sturges, Thomas B., III.** Pennsylvania Drilling Company, McKees Rock.
- Sturges, Dr. Wilton.** Department of Oceanography, Florida State University.
- Sturtevant, Prof. Alfred H.** Thomas Hunt Morgan Professor of Biology, Emeritus, California Institute of Technology.
- Sudarshan, Dr. S.** Computer Science and Engineering Department, Indian Institute of Technology-Bombay, Mumbai, India.
- Sudds, Dr. Richard.** Department of Biological Sciences, State University of New York, Pittsburgh.
- Sullivan, Prof. Michael J., Jr.** Department of Mathematics, Chicago State University, Chicago, Illinois.
- Sumi, Dr. S. Mark.** Professor of Neuropathology, School of Medicine, University of Washington.
- Summers, Dr. B. A. James A.** Baker Institute for Animal Health, Cornell University, Ithaca, New York.
- Sumners, Dr. Thomas E.** Plant Pathologist, Agricultural Research Service, U.S. Department of Agriculture.
- Suppe, John.** Department of Geological Sciences, Princeton University.
- Surles, Dr. Terry.** Limnetics, Inc., Milwaukee, Wisconsin.
- Suslick, Dr. Kenneth S.** Professor, School of Chemical Sciences, Noyes Laboratory, University of Illinois, Urbana.
- Sutherland, J. R.** Power Transformer Department, General Electric Company, Pittsfield, Massachusetts.
- Sutherland, Dr. S. S.** Senior Research Officer, Animal Health Laboratories, Department of Agriculture, Western Australia.
- Sutton, Dr. B. C.** Head of Taxonomic and Identification Services, Mycological Institute, Ferry Lane, Surrey, United Kingdom.
- Sutton, George P.** Consulting Engineer, Danville, California.
- Suzuki, Dr. Yoichiro.** Kamioka Observatory, Institute for Cosmic Ray Research, University of Tokyo, Higashi-Mozumi, Kamioka Gifu, Japan.
- Swanson, Dr. Eric.** Vice President, Technology, Crystal Semiconductor Corporation, Austin, Texas.
- Swanson, Dr. M. L.** Department of Physics and Astronomy, University of North Carolina.
- Swanson, Dr. R. Lawrence.** Director, Waste Management Institute, Marine Sciences Research Center, State University of New York, Stony Brook.
- Swearingen, Dr. Will.** NASA-Montana State University TechLink, Bozeman, Montana.
- Sweat, F. W.** Department of Chemistry, University of Utah.
- Swets, Dr. John A.** Bolt Beranek and Newman, Inc., Cambridge, Massachusetts.

**Swider, Dr. William, Jr.** Space Physics Division, Air Force Geophysics Laboratory, Hanscom Air Force Base, Bedford, Massachusetts.

**Swift, Dr. Gregory W.** Condensed Matter and Thermal Physics, Los Alamos National Laboratory, New Mexico.

**Switzer, Dr. George.** Curator, Department of Mineral Sciences, National Museum of Natural History, Smithsonian Institution.

**Sydenham, Dr. Peter H.** Systems Engineering and Evaluation Centre, University of South Australia, School of Electrical and Information Engineering, Mawson Lakes, Adelaide.

**Symko, Orest G.** Department of Physics, University of Utah.

**Symons, Dr. Frank.** Applied Research Laboratory, Pennsylvania State University, State College.

**Symons, Dr. Robert S.** Litton Electrical Devices Division, San Carlos, California.

**Sytsma, Prof. Kenneth J.** Department of Botany, University of Wisconsin at Madison.

**Szalay, Dr. Frederick S.** Department of Vertebrate Paleontology, American Museum of Natural History, New York.

**Szeri, Dr. Andras Z.** Professor and Chairperson, Department of Mechanical Engineering, University of Delaware, Newark.

**Szody, Dr. Paula.** Department of Astronomy, University of Washington, Seattle.

## T

**Tabor, Paul.** Soil Conservation Service, Athens, Georgia.

**Tait, Dr. David L.** Department of Obstetrics and Gynecology, Vanderbilt University Medical Center, Nashville, Tennessee.

**Talbot, Prof. Lawrence.** Department of Mechanical Engineering, University of California, Berkeley.

**Tan, Prof. K. C.** Centre for Intelligent Control, Department of Electrical Engineering, National University of Singapore.

**Tang, Prof. K. Y.** Deceased; formerly, Department of Electrical Engineering, Ohio State University.

**Tanihata, Dr. Isao.** Accelerator Facility, Institute of Physical and Chemical Research, Saritama, Japan.

**Tannas, Lawrence E., Jr.** Aerojet Electro Systems Company, Azusa, California.

**Tao, Dr. B. Y.** School of Agricultural and Biological Engineering, Purdue University, West Lafayette, Indiana.

**Tarling, Dr. D. H.** Department of Geophysics and Planetary Physics, University of Newcastle, England.

**Taube, Dr. Henry.** Department of Chemistry, Stanford University.

**Taylor, Prof. Angus E.** President's Office, University of California, Berkeley.

**Taylor, Dr. Danny L.** Chairperson, Department of Mining Engineering, Mackay School of Mines, University of Nevada.

**Taylor, Dr. Gordon S.** Connecticut Agricultural Experiment Station, Windsor.

**Taylor, Prof. J. Herbert.** Institute of Molecular Biophysics, Florida State University.

**Taylor, Prof. John W.** Department of Plant Biology, University of California, Berkeley.

**Taylor, Dr. R. E.** Associate Professor and Director, Radiocarbon Laboratory, University of California, Riverside.

**Taylor, Dr. Robert J.** Consultant, Microscopy, Falls Church, Virginia.

**Taylor, Dr. Stuart Ros.** Department of Geology, Australian National University, Canberra, Australia.

**Taylor, Prof. Thomas N.** Department of Biology, University of Kansas, Lawrence.

**Tchobanoglous, Prof. George.** Department of Civil Engineering, University of California, Davis.

**Teagarden, Dr. Dennis E.** Professor Emeritus of Forestry, University of California, Berkeley.

**Tease, Samuel C.** Pennsalt Chemicals Corporation, Philadelphia, Pennsylvania.

**Tedesco, Dr. Edward F.** Jet Propulsion Laboratory, California Institute of Technology.

**Tedford, Dr. Richard H.** Department of Vertebrate Paleontology, American Museum of Natural History, New York.

**Teichert, Dr. Curt.** Department of Geological Sciences, University of Rochester.

**Teleki, Dr. Geza.** Deceased; formerly, Department of Geology, George Washington University.

**Telionis, Prof. Demetri P.** Department of Engineering Science and Mechanics, Virginia Polytechnic Institute and State University, Blacksburg.

**Teller, Dr. Aaron J.** Teller Environmental Systems, Worcester, Massachusetts.

**Temin, Dr. Howard M.** McArdle Laboratory for Cancer Research, University of Wisconsin Medical Center.

**Teng, Lee C.** Fermi National Accelerator Laboratory, Batavia, Illinois.

**Tenney, Dr. Gerold H.** American Society for Nondestructive Testing, Inc., Los Alamos, New Mexico.

**Terrell, Dr. James.** Los Alamos National Laboratory, Los Alamos, New Mexico.

**Terrill, Dr. Clair E.** Chief, Sheep and für Animal Research Branch, U.S. Department of Agriculture, Beltsville, Maryland.

**Thelemaque, L. E.** Product Family Systems Engineering Center, AT&T Information Systems, Lincroft, New Jersey.

**Thiess, Helmut E.** Washington, D.C.

**Thomann, Dr. Gary C.** Power Technologies, Inc., Schenectady, New York.

**Thomas, Dr. David A.** Department of Materials Science and Engineering, Lehigh University, Bethlehem, Pennsylvania.

**Thomas, Dr. David Hurst.** American Museum of Natural History, New York.

**Thomas, Dr. J. Kerry.** Department of Chemistry, University of Notre Dame.

**Thompson, Prof. Gerald L.** Professor of Applied Mathematics and Industrial Administration, Graduate School of Industrial Administration, Carnegie-Mellon University.

**Thompson, Dr. Margaret R.** Departments of Medical Genetics and Pediatrics, University of Tronoto and the Hospital for Sick Children, Toronto, Ontario, Canada.

**Thompson, Dr. Stanley G.** Senior Staff Member, Lawrence Berkeley Laboratory, University of California, Berkeley.

**Thompson, Dr. T. E.** Department of Zoology, University of Bristol, England.

**Thompson, Tom.** Senior Training Specialist, Metrowerks, Hollis, New Hampshire.

**Thompson, William I., III.** Senior Systems Engineer, Science Applications International Corporation, Falls Church, Virginia.

**Thomson, Dr. Keith S.** President, Academy of Natural Sciences, Philadelphia, Pennsylvania.

**Thomson, Prof. Robb M.** Chairman, Department of Materials Science, State University of New York, Stony Brook.

**Thorn, Dr. Robert J.** Divisions of Chemistry and Materials Science, Argonne National Laboratory, Argonne, Illinois.

**Thorogood, Dr. Robert M.** Department of Chemical Engineering, North Carolina State University, Raleigh.

**Throp, Prof. H. Holden.** Department of Chemistry, University of North Carolina, Chapel Hill.

**Tibbitts, Capt. Barry F.** Retired, U.S. Navy.

**Tichy, Prof. Jiri.** Graduate Program in Acoustics, Pennsylvania State University, State College.

**Tigner, Dr. Maury.** Laboratory of Nuclear Studies, Cornell University.

**Tikofsky, Dr. Ronald S.** Department of Radiology, Medical College of Wisconsin, Milwaukee.

**Timoney, Dr. John F.** Department of Veterinary Science, University of Kentucky, Lexington.

**Ting, Dr. Irwin P.** Department of Botany and Plant Sciences, University of California, Riverside.

**Ting, Prof. Samuel C. C.** Department of Physics, Massachusetts Institute of Technology.

**Tinsley, Dr. Brian A.** Center for Space Science, Department of Physics, University of Texas, Dallas.

**Tolstoy, Dr. Alexandra I.** ATolstoy Sciences, Annandale, Virginia.

**Tomasetti, Richard L.** Senior Vice President, Lev Zetlin Associates, Inc. New York, New York.

**Tonkay, Prof. Gregory L.** Department of Industrial Engineering, Lehigh University, Bethlehem, Pennsylvania.

**Tonndorf, Prof. Jucrgcn.** Deceased; formerly, Department of Otolaryngology, College of Physicians and Surgeons, Columbia University.

**Toole, Dr. Floyd.** Oak Park, California.

**Torres, Dr. Alfonso.** Head, Diagnostic Services Section, National Veterinary Services Laboratory, U.S. Department of Agriculture, Greenport, New York.

**Toth, Dr. Nicholas.** Department of Anthropology, Indiana University.

**Townes, Prof. Charles H.** Department of Physics, University of California, Berkeley.

**Toy, Dr. Pearl.** San Francisco General Hospital, San Francisco, California.

**Toy, Dr. T. J.** Department of Geography, University of Denver, Colorado.

**Träbert, Prof. Elmar.** Experimentalphysik III, Ruhr-Universität Bochum, Germany.

**Tracy, Robert J.** Department of Geological Sciences, Harvard University.

**Trappe, Dr. James M.** Department of Forest Science, Oregon State University, Corvallis.

**Trautman, W. Dean.** Manager, Laboratory Administration Research and Development, Brush Beryllium Company, Cleveland, Ohio.

**Treffers, Dr. Henry P.** Professor of Pathology, School of Medicine, Yale University.

**Treiman, Prof. Sam B.** Deceased; formerly, Department of Physics, Princeton University, Princeton, New Jersey.

**Trendall, Dr. Alec.** Adjunct Professor, Department of Applied Physics, Curtin University of Technology, Perth, Western Australia.

**Treybal, Robert E.** Deceased; formerly, Department of Chemical Engineering, New York University.

**Triebe, Edward J.** Deceased; formerly, Kingsport Press, Inc., Kingsport, Tennessee; Consultant, Franklin Book Programs, Inc.

**Trinkaus, Dr. Erik.** Department of Anthropology, University of New Mexico.

**Trivett, Dr. Mary L.** Department of Environmental and Plant Biology, Ohio University, Athens.

**Trolinger, Dr. James D.** Vice President, Spectron Development Laboratories, Costa Mesa, California.

**Trowsdale, Dr. John.** Professor of Immunology, Department of Pathology, Cambridge University.

**Truant, J. P.** Advance Medical & Research Center, Inc., Pontiac, Michigan.

**Truax, Dr. Robert C.** Truax Engineering Company, Saratoga, California.

**Truman, Dr. James W.** Department of Zoology, University of Washington, Seattle.

**Trump, Benjamin F.** Professor and Chairman, Department of Pathology, University of Maryland Medical Center.

**Tsaur, Dr. Bor-Yeu.** Lincoln Laboratories, Lexington, Massachusetts.

**Tsong, Dr. Tien-Tzou.** Distinguished Research Fellow, Institute of Physics, Academia Sinica, Taipei, Taiwan.

**Tsuchiya, Prof. Henry M.** Department of Chemical Engineering, University of Minnesota.

**Tucker, Dr. David H.** Agriculture Research and Education Center, University of Florida.

**Tucker, John T.** (Retired) Beltsville Parasitological Laboratory, Agricultural Research Center, Beltsville, Maryland.

**Tucker, Dr. Wallace.** Harvard-Smithsonian Center for Astrophysics, Cambridge, Massachusetts.

**Tukey, Dr. Harold B.** Deceased; formerly, Professor Emeritus, Department of Horticulture, Michigan State University.

**Tully, Dr. R. Brent.** Institute for Astronomy, University of Hawaii at Manoa.

**Tur, Dr. Moshe.** School of Engineering, Tel Aviv University, Israel.

**Turk, Prof. J. L.** Department of Pathology, Royal College of Surgeons of England.

**Turley, Dr. J. A.** Marathon Oil Company, Littleton, Colorado.

**Turnbull, Prof. David.** Department of Applied Physics, Harvard University.

**Turner, Dr. Charles E.** Agricultural Research Service, U.S. Department of Agriculture, Albany, California.

**Turner, Prof. J. R. G.** Department of Genetics, University of Leeds, United Kingdom.

**Turner, Prof. John D.** Transport Research Laboratory, Crowthorne, Berks, United Kingdom.

**Turner, Joyce B.** Institute for Advanced Study.

**Turner, Dr. Noel H.** Chemistry Division, Naval Research Laboratory, Washington, D.C.

**Turner, Dr. Ruth D.** Museum of Comparative Zoology, Harvard University.

**Turner, Dr. Shirley.** National Institute of Standards and Technology, U.S. Department of Commerce, Gaithersburg, Maryland.

**Turner, Dr. Thomas B.** Professor of Microbiology and Dean Emeritus, School of Medicine, Johns Hopkins University.

**Turok, Dr. Neil.** Department of Physics, Joseph Henry Laboratories, Princeton University.

**Turro, Prof. Nicholas J.** Department of Chemistry, Columbia University.

**Turturro, Dr. Angelo.** National Center for Toxicological Research, Department of Health and Human Services, Jefferson, Arkansas.

**Tuttle, Alan H.** Vocational Division, State University of New York Agricultural and Technical Institute, Wellsville.

**Tuttle, Douglas E.** Pamarco, Roselle, New Jersey.

**Tuttle, Russell H.** Professor in Anthropology, Evolutionary Biology and The College, University of Chicago.

**Tyler, Prof. Albert.** Deceased; formerly, Division of Biology, California Institute of Technology.

**Tyrer, Dr. Louise B.** Medical Affairs Coordinator, Planned Parenthood Federation of America, New York.

## U

**Uchida, Dr. Tohru.** Professor of Zoology, Hokkaido University.

**Uebersax, Dr. Mark A.** Department of Food Sciences and Human Nutrition, Michigan State University.

**Uhl, Dr. Vincent W.** Department of Chemical Engineering, University of Virginia.

**Uhler, Dr. Michael D.** Department of Biological Chemistry, University of Michigan, Ann Arbor.

**Uhrhammer, Dr. Robert A.** Seismological Laboratory, University of California, Berkeley.

**Ullman, Dr. John E.** Department of Marketing-Management, Hofstra University.

**Ullrich, Dr. Robert C.** Department of Botany, University of Vermont, Burlington.

**Underwood, Dr. Erwin E.** Alcoa Professor, Georgia Institute of Technology, Inger, Walter H. Anaconda Company, Denver, Colorado.

**Underwood, Dr. James H.** Center for X-Ray Optics, Lawrence Berkeley National Laboratory, University of California, Berkeley.

**Unwin, Dr. Stephen C.** Owens Valley Radio Observatory, California Institute of Technology, Pasadena.

**Uppgren, Prof. Arthur R.** Van Vleck Observatory, Wesleyan University, Middletown, Connecticut.

**Upton, Dr. Arthur C.** Institute of Environmental Medicine, New York University Medical Center.

**U.S. Army Corps of Engineers.** Office of the Secretary of the Army, Washington, D.C.

**Uzsoy, Prof. Reha.** School of Industrial Engineering, Purdue University, West Lafayette, Indiana.

## V

**Vaanky, Dr. Kalman.** Botanisches Institut, Universität Tübingen, Germany.

**Vaickus, Dr. Louis.** Roswell Park Memorial Institute, Buffalo, New York.

**Valenti, Dr. Jeff A.** Space Telescope Science Institute, Baltimore, Maryland.

**Valentine, Dr. J. W.** Department of Geology, University of California, Santa Barbara.

**Vallee, Dr. Richard.** Principal Scientist, Worcester Foundation for Experimental Biology, Shrewsbury, Massachusetts.

**Van Allen, Dr. Margot I.** Staff Geneticist, Genetics Division, Hospital for Sick Children, Toronto, Ontario, Canada.

**Van Andel, Dr. Tjeerd H.** Department of Geology, Stanford University.

**Van Campenhout, Prof. Ernest L.** Deceased; formerly Professor of Anatomy,

- Histology, and Embryology, School of Medicine, University of Louvain, Belgium.
- Vanderkool, Dr. Jane M.** Department of Medicine, School of Medicine, University of Pennsylvania.
- Van der Pluijm, Prof. Ben.** Department of Geological Sciences, University of Michigan, Ann Arbor.
- Van der Spiegel, Prof. Jan.** Moore School of Electrical Engineering, University of Pennsylvania, Philadelphia.
- Vanderzee, Dr. Cecil E.** Department of Chemistry, University of Nebraska.
- Van Etten, Dr. James P.** Navigation Consultant, Nutley, New Jersey.
- Van Fleet, Dr. D. S.** Department of Botany, University of Georgia.
- Van Houten, Prof. Franklyn B.** Department of Geology, Princeton University.
- Vanick, James S.** Consultant, Foundry Castings, Sea Girt, New Jersey.
- Van Niel, Dr. Cornelius B.** Deceased; formerly, Hopkins Marine Station, Pacific Grove, California.
- Van Peteghem, Dr. Peter M.** Deceased; formerly, Electrical Engineering Department, Texas A&M University.
- Van Schmus, Prof. W. Randall.** Department of Geology, University of Kansas.
- Van Valkenburg, Dr. Mac E.** Department of Electrical Engineering, University of Illinois, Urbana.
- Van Vlack, Prof. Lawrence H.** Department of Materials Engineering, University of Michigan.
- Van Wagendonk, Dr. Willem J.** Veterans Administration Hospital, Miami, Florida.
- Van Wazer, Dr. John R.** Department of Chemistry, Vanderbilt University.
- Van Winkle, Prof. Quentin.** Department of Chemistry, Ohio State University.
- Vaughan, Prof. Wyman R.** Head, Department of Chemistry, University of Connecticut.
- Vaya, Dr. Jacob.** Migal-Galilee Technological Center, Rosh-Pina, Israel.
- Veale, Dr. Chris A.** Zeneca, Inc., Wilmington, Delaware.
- Veblen, Dr. David R.** Department of Earth and Planetary Sciences, Johns Hopkins University.
- Veillon, Dr. Claude.** Biophysics Research Laboratory, Peter Bent Brigham Hospital, Harvard Medical School.
- Vellozzi, Dr. Joseph.** Consulting Engineer, Ardsley, New York.
- Venditti, Dr. Ferdinand, Jr.** Head, Section of Cardiovascular Diseases, Lahey Clinic, Burlington, Massachusetts.
- Venkatesh, Prof. Alladi.** Graduate School of Management, University of California, Irvine.
- Ventura, Dr. Jose A.** Department of Industrial and Management Systems Engineering, Pennsylvania State University, University Park.
- Verma, Dr. Pramode K.** AT&T Information Systems, Morristown, New Jersey.
- Vessey, Dr. Judith A.** Department of Physiological Nursing, University of California School of Nursing, San Francisco.
- Vestal, Prof. Paul A. A. G.** Bush Professor of Science, A. G. Bush Science Center and Department of Biology, Rollins College, Winter Park, Florida.
- Veverka, Prof. Joseph.** Laboratory for Planetary Studies, Cornell University.
- Vickers, Douglas B.** Annapolis, Maryland.
- Vickers, Dr. Mary Lynne.** Department of Veterinary Science, Livestock Disease Diagnostic Center, University of Kentucky, Lexington.
- Vidone, Dr. Romeo A.** Chairman, Department of Pathology, School of Medicine, Yale University.
- Vierstra, Dr. Richard.** Horticulture Department, University of Wisconsin.
- Villiger, Peter.** Research Associate, Department of Molecular and Experimental Medicine, Research Institute of Scripps Clinic, La Jolla, California.
- Vinson, Prof. S. B.** Department of Entomology, Texas A & M University.
- Viro, Dr. Felix.** Kind & Knox, Sioux City, Iowa.
- Vitek, Dr. Charles.** Medical Epidemiologist, HIV Vaccine Section, Division of HIV/AIDS Prevention, Centers for Disease Control and Prevention, Atlanta, Georgia.
- Voelker, Dr. Richard P.** Science and Technology Corporation, Columbia, Maryland.
- Vogel, Dr. Friedrich.** Institute for Anthropology and Human Genetics, Im Neuenheimer Feld, Germany.
- Vogel, Prof. Steven.** Department of Zoology, Duke University, Durham, North Carolina.
- Vogt, Dr. Peter.** Department of the Navy, Naval Research Laboratory, Washington, D.C.
- Vogtle, Dr. Fritz.** Department of Chemistry, Friedrich-Wilhelms University, Bonn, Germany.
- Voit, Dr. Mark.** Space Telescope Science Institute, Baltimore, Maryland.
- Volk, Dr. Herbert F.** Carbon Products Division, Union Carbide Corporation, Parma, Ohio.
- Volk, Dr. Wesley A.** Department of Microbiology, School of Medicine, University of Virginia.
- Volkmar, Dr. Fred R.** Child Study Center, Yale University.
- Von Doenhoff, Albert E.** Deceased; formerly, Staff Scientist, National Aeronautics and Space Administration.
- Von Graevenitz, Alexander W. C.** Department of Medical Microbiology, University of Zurich, Switzerland.
- Von Puttkamer, Jesco.** Advanced Programs, Office of Space Transportation Systems, National Aeronautics and Space Administration, Washington, D.C.
- Vonder Haar, Prof. Thomas H.** Department of Atmospheric Sciences, Colorado State University.
- Vonnegut, Dr. Bernard.** Retired; formerly, Atmospheric Sciences Research Center, State University of New York, Albany.
- Voorhees, Dr. Frank R.** Department of Biology, Central Missouri State College.
- Vos, Dr. Willem L.** Geophysical Laboratory and Center for High Pressure Research, Carnegie Institution, Washington, D.C.
- Voss, Prof. Edward W., Jr.** Department of Microbiology, University of Illinois, Urbana.

## W

- Waddington, Prof. Thomas C.** Deceased; formerly, Department of Chemistry, University of Durham.
- Wade, Dr. Charles Edwin.** NASA Ames Research Center, Moffett Field, California.
- Waggoner, Dr. Ben.** Department of Biology, University of Central Arkansas, Conway.
- Wagner, Dr. Frank.** Technical Center, Celanese Chemical Company, Corpus Cristi, Texas.
- Wagner, Dr. Henry N., Jr.** Director, Divisions of Nuclear Medicine and Radiation Health Sciences, Johns Hopkins Medical Institutions.
- Wagner, Dr. Richard S.** AT&T Telephone Laboratories, Murray Hill, New Jersey.
- Wagner, Dr. Robert P.** Department of Zoology, University of Texas, Austin.
- Wagner, Dr. Warren H., Jr.** Department of Botany, University of Michigan.
- Wahl, Prof. Floyd M.** Professor and Chairman, Department of Geology, University of Florida.
- Waidelich, Dr. Donald L.** Department of Electrical Engineering, University of Missouri.
- Wainwright, Howard W.** Coal Research Center, U.S. Bureau of Mines, Morgan-town, West Virginia.
- Waisel, Prof. Y.** Department of Botany, Tel Aviv University, Israel.
- Wakeham, Dr. W. A.** Department of Chemical Engineering and Chemical Technology, Imperial College of Science and Technology, London, England.
- Walbot, Dr. Virginia.** Department of Biological Sciences, Stanford University.
- Walczak, Mary M.** Department of Chemistry, Iowa State University of Science and Technology.
- Wald, Prof. Robert M.** Department of Physics, University of Chicago, Illinois.
- Waldmann, Katherine S.** National Institutes of Health, Department of Health and Human Services, Bethesda, Maryland.
- Waldmann, Dr. Thomas A.** Chief, Metabolism Branch, National Institutes of Health, Department of Health and Human Services, Bethesda, Maryland.
- Walker, J. H.** Vice President, Portland Cement Association, Skokie, Illinois.
- Walker, Michelle Y.** Davis, California.
- Walker, Dr. R. M.** Department of Physics, Washington University.

- Walker, Dr. Warren F., Jr.** Department of Biology, Oberlin College.
- Walkley, Dr. S. U.** Department of Neuroscience, Rose F. Kennedy Center for Research in Mental Retardation and Human Development, Albert Einstein College of Medicine, Bronx, New York.
- Walkup, Dr. John T.** Yale University School of Medicine, New Haven, Connecticut.
- Walkup, Dr. Robert D.** Department of Chemistry and Biochemistry, Texas Tech University.
- Wall, Dr. Joseph S.** Northern Regional Research Center, U.S. Department of Agriculture, Peoria, Illinois.
- Wallace, Prof. John F.** Division of Metallurgy and Material Science, Case Western Reserve University.
- Wallace, Dr. John M.** Department of Atmospheric Sciences, University of Washington, Seattle.
- Walsh, John J.** Brookhaven National Laboratories, Upton, New York.
- Walsh, Prof. Joseph L.** Deceased; formerly, Department of Mathematics, University of Maryland.
- Walsh, Dr. Michael A.** Department of Biology, Utah State University.
- Walsh, Dr. Peter J.** Department of Physics, Fairleigh Dickinson University.
- Walstedt, Dr. R. E.** Bell Laboratories, Murray Hill, New Jersey.
- Walt, Prof. Alexander J.** Department of Surgery, Harper Hospital, Wayne State University, Detroit, Michigan.
- Walt, Dr. Martin.** Physical Sciences Laboratory, Lockheed Missiles and Space Company, Palo Alto, California.
- Walton, Dr. Peter D.** Department of Plant Science, University of Alberta, Edmonton, Canada.
- Walworth, Vivian K.** Polaroid Corporation, Cambridge, Massachusetts.
- Walz, Arthur H., Jr.** U.S. Committee on Large Dams, Corps of Engineers, Washington, D.C.
- Wamser, Prof. Carl C.** Department of Chemistry, California State University.
- Wane, Dr. Malcolm T.** Krumb School of Mines, Columbia University.
- Wang, Prof. C. Y.** Departments of Mathematics and Mechanical Engineering, Michigan State University, East Lansing.
- Wang, Dr. Changchang.** Visiting Scholar, Department of Electrophysics, University of Southern California, Los Angeles.
- Wang, Prof. K. K.** Sibley School of Mechanical and Aerospace Engineering, Cornell University.
- Wang, Prof. William S. Y.** Project On Linguistic Analysis, University of California, Berkeley.
- Ward, Dr. David.** Atomic Energy of Canada Limited, Chalk River Nuclear Laboratories, Ontario, Canada.
- Ward, Jeffrey.** American Radio, Newington, Connecticut.
- Ware, Dr. Bennie R.** Department of Chemistry, Syracuse University.
- Warf, Dr. James C.** Department of Chemistry, University of Southern California.
- Warner, Deborah Jean.** Curator, History of Astronomy, National Museum of American History, Washington, D.C.
- Warner, Dr. Frank L.** Royal Signals and Radar Establishment, Great Malvern, Worcestershire, England.
- Warner, Dr. Robert M.** Department of Horticulture, University of Hawaii at Manoa.
- Warren, Prof. Bertram E.** Department of Physics, Massachusetts Institute of Technology.
- Warren, Dr. John J. K.** Resources Pty. Ltd., Mitcham, Australia.
- Warren, Dr. Mial E.** Sandia National Laboratories, Albuquerque, New Mexico.
- Wartik, Prof. Thomas.** Department of Chemistry, Pennsylvania State University.
- Wasserman, Dr. Zelda R.** Department of Central Research and Development, E. I. du Pont de Nemours and Company, Wilmington, Delaware.
- Waters, Dr. Everett.** Department of Psychology, State University of New York, Stony Brook.
- Watkins, Dr. Thomas D.** Chabot College, Hayward, California.
- Watson, William W.** Professor Emeritus of Physics, Yale University.
- Wattenberg, Ben J.** President, Fairfield Publishers, Inc.
- Watterson, Dr. Ray L.** Department of Zoology, University of Illinois, Urbana.
- Watts, Dr. Anthony B.** Department of Earth Sciences, University of Oxford, England.
- Watts, Michael.** National Aeronautics and Space Administration, Ames Research Center, Moffett Field, California.
- Way, George H.** Retired; formerly, Vice President of Research and Test Development, Association of American Railroads, Washington, D.C.
- Wayne, Dr. Andrew W.** Department of Haematology, Kings College Hospital, London, England.
- Weaver, Prof. David L.** Department of Physics, Tufts University.
- Weaver, Dr. E. Eugene.** Research Scientist, Product Development Group, Ford Motor Company, Dearborn, Michigan.
- Weaver, James L.** Lockheed Missiles and Space Company, Palo Alto, California.
- Weaver, Prof. Robert J.** Department of Viticulture and Enology, College of Agricultural and Environmental Sciences, University of California, Davis.
- Weaver, S. E.** Northrop Aircraft, Inc.
- Webb, Prof. J. E.** Professor of Zoology, University College, Ibadan, Nigeria.
- Webb, Dr. Jacqueline.** Villa Nova, Pennsylvania.
- Webb, Dr. Richard A.** IBM Research Division, Thomas J. Watson Research Center, IBM Corporation, Yorktown Heights, New York.
- Webber, Bonnie.** Department of Computer and Information Science, Moore School, University of Pennsylvania.
- Weber, Erwin L.** Deceased; formerly, Trust Department, National Bank of Commerce, Seattle, Washington.
- Weber, Harold C.** Chemical Engineer, Boston, Massachusetts.
- Webster, Dr. Douglas B.** Department of Otorhinolaryngology and Biocommunication, Louisiana State University Medical Center.
- Wedell, Dr. Nina.** School of Biology, University of Leeds, United Kingdom.
- Wedgewood, Prof. Lewis E.** Department of Chemical Engineering, University of Washington, Seattle.
- Wefer, Dr. Gerold.** Department of Geosciences, Universität Bremen, Germany.
- Wegner, Dr. Harvey E.** Physics Division, Brookhaven National Laboratory, Upton, New York.
- Weibell, Dr. Fred J.** Biomedical Engineering Society, Culver City, California.
- Weichert, Dr. Charles K.** Professor of Zoology and Dean, College of Arts and Sciences, University of Cincinnati.
- Weigel, Dr. Fritz.** Institut für Anorganische Chemie, Universität München, Germany.
- Weil, Dr. Andrew T.** Division of Social Perspectives in Medicine, University of Arizona Health Science Center, Tucson.
- Weil, Jonathan F.** Staff Editor, "McGraw-Hill Encyclopedia of Science and Technology," McGraw-Hill, New York.
- Weil, Robert T., Jr.** Deceased; formerly, Dean, School of Engineering, Manhattan College.
- Weil, Rolf.** Department of Material and Metallurgical Engineering, Stevens Institute of Technology.
- Weiler, Dr. J. Marvin.** Professor Emeritus, Department of Geophysical Sciences, University of Chicago.
- Weiler, Prof. Robert A. A. W.** Wright Nuclear Structure Laboratory, Yale University.
- Weinberger, Dr. Peter.** Swales Aerospace, Inc., Beltsville, Maryland.
- Weiss, Dr. Allison.** Department of Molecular Genetics, Biochemistry, and Microbiology, University of Cincinnati, Ohio.
- Weiss, Prof. Gerald.** Department of Electrical Engineering, Polytechnic Institute of New York.
- Weiss, Dr. Marc.** National Institute of Standards and Technology, Time and Frequency Division, Boulder, Colorado.
- Weiss, Dr. Theodore J.** Technical Manager, Food Department, Hunt-Wesson Foods, Inc., Fullerton, California.
- Weitz, Dr. Martin.** Sektion Physik, Ludwig-Maximilians-Universität, München, Germany.
- Weitzenhoffer, Dr. Andre M.** Veterans Administration Hospital, Oklahoma City, Oklahoma.



- Wejsa, James.** AMSTA-AR-FSA-M, United States Army Armament Research Development and Engineering Center, Picatinny Arsenal, New Jersey.
- Welch, Dr. Winona H.** Department of Botany and Bacteriology, De Pauw University.
- Welham, Dr. Chris J.** Druck Ltd., United Kingdom.
- Welhener, Dr. Herb.** Independent Mining Consultants, Inc., Tucson, Arizona.
- Weller, Prof. Gunter.** Global Change and Arctic Systems, University of Alaska, Fairbanks.
- Wellner, Dr. Daniel.** Department of Biochemistry, Cornell University Medical College.
- Wellstead, Dr. Carl F.** Doane College, Crete, Nebraska.
- Wendlandt, Prof. Wesley W.** Department of Chemistry, University of Houston.
- Wendler, Dr. Helen E.** Department of Biology, Massachusetts Institute of Technology.
- Wenkert, Prof. Ernest.** Department of Chemistry, Indiana University.
- Wenner, Prof. Adrian M.** Department of Biological Sciences, University of California, Santa Barbara.
- Wentorf, Robert H., Jr.** General Electric Research and Development, Schenectady, New York.
- Wenzel, Dr. Elizabeth M.** Ames Research Center, National Aeronautics and Space Administration, Moffett Field, California.
- West, Dr. William.** Eastman Kodak Company, Rochester, New York.
- Westfall, Dr. Richard S.** Department of History and Philosophy of Science, Indiana University.
- Westheimer, Prof. F. H.** Chemistry Department, Harvard University, Cambridge, Massachusetts.
- Wetzel, Dr. Richard.** College of William and Mary, Virginia Institute of Marine Science, School of Marine Science, Gloucester Point, Virginia.
- Whaley, Dr. W. Gordon.** Cell Research Institute, University of Texas, Austin.
- Wheeler, Dr. Harry E.** Department of Plant Pathology, University of Kentucky.
- Whelan, Dr. Jean K.** Senior Research Specialist, Department of Chemistry, Woods Hole Oceanographic Institution, Woods Hole, Massachusetts.
- Whinnery, Prof. John R.** Department of Electrical Engineering and Computer Science, College of Engineering, University of California, Berkeley.
- Whistler, Prof. Roy L.** Department of Biochemistry, Purdue University.
- Whitcomb, Dr. Richard T.** NASA Langley Research Center, Langley Field, Virginia.
- White, Donald R. J.** International Training Centre, Don White Consultants, Inc., Gainesville, Virginia.
- White, Dr. Abraham.** Consulting Professor of Biochemistry, Stanford University; School of Medicine; Distinguished Scientist, Institute of Biological Sciences, Syntex Research.
- White, Prof. Colin.** Department of Epidemiology and Public Health, Yale University.
- White, Dr. C. Langdon.** Professor of Geography, Stanford University.
- White, Dr. Lawrence R.** Technical Director, "Popular Photography," New York.
- White, Dr. K. Preston, Jr.** Department of Systems Engineering, University of Virginia.
- White, Prof. Robert M.** Head, Department of Electrical and Computer Engineering, Carnegie-Mellon University, Pittsburgh, Pennsylvania.
- White, Dr. Sidney E.** Department of Geology and Mineralogy, Ohio State University.
- White, Dr. Stanley A.** President, Signal Processing and Controls Engineering, San Clemente, California.
- White, Dr. Stephanie.** Northrop Grumman, Bethpage, New York.
- White, Dr. Tim.** School of Forest Resources, University of Florida, Gainesville.
- Whitehead, Prof. W. Dexter.** Department of Physics, Center for Advanced Studies, University of Virginia.
- Whitmore, Dr. T. C.** Department of Geography, University of Cambridge, United Kingdom.
- Whitney, Eugene C.** Consulting Engineer, Pittsburgh, Pennsylvania.
- Whittingham, Dr. M. Stanley.** Director, Materials Research Center, State University of New York, Binghamton.
- Wicks, Dr. Fred J.** Department of Mineralogy, Royal Ontario Museum, Ontario, Canada.
- Wickstrom, Dr. Conrad.** Department of Biological Sciences, Kent State University.
- Widder, Prof. David V.** Department of Mathematics, Harvard University.
- Widom, Dr. Jennifer.** IBM Almaden Research Center, San Jose, California.
- Wiegand, Dr. Clyde E.** Lawrence Berkeley Laboratory, University of California, Berkeley.
- Wiens, Prof. Herold J.** Deceased; formerly, Department of Geography, Yale University.
- Wienski, Robert M.** District Manager, ISDN Architecture Planning, Bell Communications Research, Red Bank, New Jersey.
- Wiest, Dr. John M.** Department of Chemical Engineering, University of Alabama, Tuscaloosa.
- Wightman, Prof. Arthur S.** Department of Physics, Joseph Henry Laboratories, Princeton University.
- Wikle, Prof. Thomas A.** Professor and Head, Department of Geography, Oklahoma State University, Stillwater.
- Wilbur, Donald A., Sr.** Emeritus Professor of Entomology, Kansas State University.
- Wilbur, Prof. Paul J.** Department of Mechanical Engineering, Colorado State University.
- Wilcox, Dr. Hugh.** State University College of Forestry, Syracuse University.
- Wilcox, Dr. Kimerly J.** Dight Laboratories, University of Minnesota.
- Wilcox, Prof. William R.** Department of Chemical Engineering, Clarkson College of Technology.
- Wilczek, Prof. Frank.** Institute for Advanced Study, Princeton, New Jersey.
- Wilder, Dr. George J.** Department of Biological Sciences, University of Illinois, Chicago.
- Wildhack, William A.** Consultant; formerly, Associate Director, Institute for Basic Standards, National Bureau of Standards.
- Wilen, Dr. Samuel H.** Department of Chemistry, City University of New York.
- Wiles, Dr. D. M.** National Research Council of Canada, Ottawa, Ontario.
- Wiley, Prof. Edward O., III.** Curator, Natural History Museum, University of Kansas, Lawrence.
- Wilhelm, Dr. Harley A.** Principal Scientist, EMRR Institute and Ames Laboratory of U.S. Department of Energy, Iowa State University.
- Wilhoit, Dr. Randolph C.** Thermodynamics Research Center, Texas A & M University.
- Wilkening, Dr. M.** Department of Physics, New Mexico Institute of Mining and Technology.
- Wilkinson, Dr. Brian J.** Department of Biological Sciences, Illinois State University.
- Wilkinson, Prof. Denys H.** Department of Nuclear Physics, Oxford University, England.
- Wilkinson, Dr. Michael K.** Associate Director, Solid State Division, Oak Ridge National Laboratory, Oak Ridge, Tennessee.
- Willett, Prof. Hilda P.** Director of Graduate Studies, Department of Microbiology, Duke University Medical Center, Durham, North Carolina.
- Willett, Prof. Kurd C.** Department of Meteorology, Massachusetts Institute of Technology.
- Willey, Dr. Robert B.** Department of Biological Sciences, University of Illinois.
- Williams, Dr. D. B.** Department of Materials Science and Engineering, Lehigh University, Bethlehem, Pennsylvania.
- Williams, Prof. Dudley.** Department of Physics, Kansas State University.
- Williams, Dr. Earl G.** Structural Acoustics, Naval Research Laboratory, Washington, D.C.
- Williams, Dr. Earle R.** Department of Earth, Atmospheric and Planetary Sciences, Massachusetts Institute of Technology, Center for Meteorology and Physical Oceanography.
- Williams, Prof. Gary A.** Department of Physics, University of California, Los Angeles.
- Williams, Dr. Jack M.** Chemistry Division, Argonne National Laboratory, Argonne, Illinois.
- Williams, Dr. Kathleen M.** Extension Pomologist, Tree Fruit Research and

- Extension Center, Washington State University, Wenatchee.
- Williams, Dr. Peter.** Department of Chemistry, Arizona State University.
- Williams, Dr. Roger J.** Deceased; formerly, Department of Chemistry, University of Texas, Austin.
- Williams, S. A.** Department of Physics, Iowa State University.
- Williams, Prof. Todd D.** Department of Chemistry, University of Kansas, Lawrence.
- Williamson, Dr. K. D.** Los Alamos Scientific Laboratory, Los Alamos, New Mexico.
- Willingham, Dr. Mark C.** National Institutes of Health, National Cancer Institute, Bethesda, Maryland.
- Willis, Dr. William J.** European Organization for Nuclear Research (CERN), Geneva, Switzerland.
- Wilson, Dr. B. F.** Department of Forestry and Wildlife Management, University of Massachusetts.
- Wilson, Dr. Curtis B.** Department of Immunopathology, Scripps Clinic and Research Foundation, La Jolla, California.
- Wilson, Prof. George S.** Department of Chemistry, University of Kansas, Lawrence.
- Wilson, Grady W.** Deputy Director and Chief Test Pilot, Raspet Flight Research Laboratory, Mississippi State University.
- Wilson, Dr. Irwin B.** Department of Chemistry and Biochemistry, University of Colorado.
- Wilson, Dr. James B.** Department of Forest Products, Oregon State University, Corvallis.
- Wilson, Dr. James L.** Department of Geology and Mineralogy, University of Michigan.
- Wilson, Dr. Leonard R.** George Lynn Cross Research Professor of Geology and Geophysics, School of Geology and Geophysics, University of Oklahoma.
- Wilson, Prof. Mason P., Jr.** Department of Mechanical Engineering, University of Rhode Island, Kingston.
- Wilson, Dr. Therese.** Biological Laboratories, Harvard University.
- Wilt, Dr. Fred.** Department of Zoology, University of California, Berkeley.
- Winch, Prof. Ralph P.** Department of Physics, Williams College.
- Wing, Dr. Robert F.** Department of Astronomy, Ohio State University, Columbus.
- Winick, Dr. Herman.** Deputy Director, Stanford Synchrotron Radiation Laboratory, Stanford, California.
- Winn, Kevin.** American Sudden Infant Death Syndrome Institute, Atlanta, Georgia.
- Winston, Dr. Judith E.** Assistant Curator, Department of Invertebrates, American Museum of Natural History, New York.
- Winter, Dr. John M., Jr.** Department of Materials Science and Engineering, Johns Hopkins University, Baltimore, Maryland.
- Winter, Prof. Rolf G.** Department of Physics, College of William and Mary.
- Winter, Dr. Thomas C.** U.S. Geological Survey, Department of the Interior, Denver, Colorado.
- Winterer, Dr. Edward L.** Geological Research Division, Scripps Institution of Oceanography, La Jolla, California.
- Wise, Edmund M.** Consultant; formerly, Assistant to Vice President of Research, International Nickel Company, Inc., New York.
- Wittmann, H. G.** Max-Planck Institut für Molekulare Genetik, Berlin, Germany.
- Wittmers, Dr. L. E.** School of Medicine, University of Minnesota.
- Wnek, Prof. Gary E.** Director, Polymer Science and Engineering Program, Department of Chemistry, School of Science, Rensselaer Polytechnic Institute.
- Wold, Dr. Marc.** Department of Biochemistry, University of Iowa College of Medicine, Iowa City.
- Wolf, Dr. Peter.** IBM Zurich Research Laboratory, Switzerland.
- Wolf, Dr. Werner P.** Department of Physics, Yale University.
- Wolfe, Dr. Ralph S.** Marine Biological Laboratory, Woods Hole, Massachusetts.
- Wolfe, Dr. William L.** Optical Sciences Center, University of Arizona.
- Wolferz, Alfred H.** Chief (retired), Tachometer Systems Development, Weston Instruments Division, Daystrom, Inc., Newark, New Jersey.
- Wolford, Dr. James C.** Mechanical Engineering Department, University of Nebraska.
- Wollersheim, Prof. David.** Department of Mechanical and Aerospace Engineering, University of Missouri.
- Wollnik, Prof. H.** Physikalisches Institut, Justus Liebig-Universität, Giessen, Germany.
- Wolovich, Dr. William.** Department of Engineering, Brown University.
- Wonders, Dr. William C.** Department of Geography, University of Alberta, Canada.
- Wones, Dr. David R.** Department of Geological Sciences, Virginia Polytechnic Institute and State University.
- Wong, Dr. George S. K.** Acoustical Standards, Institute for National Measurement Standards, Ottawa, Ontario, Canada.
- Wood, Dr. Albert E.** (Retired) Department of Biology, Amherst College.
- Wood, Dr. B. J.** Department of the Geophysical Sciences, University of Chicago.
- Wood, Dr. Chris.** Electric Power Research Institute, Palo Alto, California.
- Wood, Dr. Earl H.** Mayo Foundation, Graduate School of Medicine, University of Minnesota.
- Wood, Dr. Frank B.** Department of Physics and Astronomy, University of Florida.
- Wood, Dr. H. William.** Consultant, Aerospace, Roaring Gap, North Carolina.
- Woodall, James E.** Division Manufacturing Manager, Westinghouse Electric Corporation, Pittsburgh, Pennsylvania.
- Woodall, Prof. Jerry M.** Yale University, Department of Electrical Engineering, New Haven, Connecticut.
- Woodcock, C. L. F.** Professor of Zoology, University of Massachusetts.
- Woods, Dr. Jon P.** Assistant Professor, Department of Medical Microbiology and Immunology, University of Wisconsin Medical School, Madison.
- Woodward, Prof. John B., III.** Department of Naval Architecture and Marine Engineering, University of Michigan.
- Woody, Dr. R. W.** Department of Biochemistry, Colorado State University.
- Wosley, Prof. Stan E.** Lick Observatory, Santa Cruz, California.
- Woram, John M.** Woram Audio Associates, New York.
- Wray, Dr. John L.** Marathon Oil Company, Littleton, Colorado.
- Wright, Elliott F.** Consulting Engineer (retired), Advanced Products Division, Studebaker-Worthington Corporation, Harrison, New Jersey.
- Wright, James A.** Strategic Marketing Manager, Motorola, Inc., Boynton Beach, Florida.
- Wright, Michael E.** National Semiconductor Corporation, Santa Clara, California.
- Wright, Prof. Raymond.** Department of Civil and Environmental Engineering, University of Rhode Island, Kingston.
- Wu, Prof. Tai Tsun.** Division of Engineering and Applied Physics, Harvard University.
- Wuensch, Dr. Bernhardt J.** Department of Metallurgy and Materials Science, Massachusetts Institute of Technology.
- Wulff, Dr. Verner J.** Associate Director of Research, Masonic Medical Research Laboratory, Utica, New York.
- Wurtele, Prof. Morgan G.** Department of Atmospheric Sciences, University of California, Los Angeles.
- Wyant, Prof. James C.** Optical Sciences Center, University of Arizona.
- Wygodzinsky, Dr. Pedro W.** Department of Entomology, American Museum of Natural History, New York.
- Wyke, Dr. John A.** Wolfson Laboratory for Molecular Pathology, The Beatson Institute for Cancer Research, Glasgow, Scotland.
- Wyllie, Dr. Peter J.** Chairman, Department of Geophysical Sciences, University of Chicago.
- Wyman, Dr. Richard E.** Director of Research, Canadian Hunter Exploration, Ltd., Calgary, Alberta.
- Wyrтки, Dr. Klaus.** Department of Oceanography, University of Hawaii, Manoa.
- Wüest, Dr. Alfred Johnny.** Applied Aquatic Ecology (APEC), Kastanienbaum, Switzerland.

## Y

**Yagi, Prof. Takehiko.** Institute of Solid State Physics, University of Tokyo, Japan.

**Yalow, Dr. Rosalyn S.** Senior Medical Investigator, Veterans Administration Hospital, New York.

**Yamaguchi, Prof. M.** Department of Vegetable Crops, University of California, Davis.

**Yang, Hongjun.** IGEN, Inc., Rockville, Maryland.

**Yankee, Prof. Herbert W.** Mechanical Engineering Department, Worcester Polytechnic Institute.

**Yates, Dr. S. F.** Allied Signal Research Center, Inc., Des Plaines, Illinois.

**Yeatman, Dr. Harry C.** Department of Zoology, University of the South, Sewanee, Tennessee.

**Yegulalp, Prof. Tuncel M.** Henry Krumb School of Mines, Columbia University, New York.

**Yell, Dr. Ralph W.** National Physical Laboratory, Teddington, Middlesex, England.

**Yelles, Marvin.** Formerly, Editor, "McGraw-Hill Encyclopedia of Science and Technology," McGraw-Hill Book Company, New York.

**Yellott, John I.** Emeritus Professor, College of Architecture, Arizona State University.

**Yeomans, Dr. Donald K.** Jet Propulsion Laboratory, California Institute of Technology.

**Yin, Prof. Frank C.-P.** Department of Medicine, Johns Hopkins Schools of Medicine, Baltimore, Maryland.

**Yochelson, Dr. Ellis L.** Geological Survey, U.S. Department of the Interior, Washington, D.C.

**Yokelson, Dr. Howard B.** Research and Development Department, Amoco Chemical Company, Naperville, Illinois.

**Yost, Prof. Don M.** Formerly, California Institute of Technology.

**Yost, Dr. William A.** Director, Parmlly Hearing Institute, Loyola University.

**Young, Dr. Anne B.** Department of Neurology, University of Michigan.

**Young, Dr. David A.** Department of Entomology, North Carolina State University.

**Young, Edward M.** Deceased; formerly, Associate Editor, "Engineering News Record," McGraw-Hill, Inc., New York.

**Young, Prof. Grant M.** Department of Earth Sciences, University of Western Ontario, London, Ontario, Canada.

**Young, Prof. N. J.** Department of Mathematics and Statistics, University of Lancaster, England.

**Young, Dr. Robert W.** Associate Editor, "Journal of the Acoustical Society of America," San Diego, California.

**Young, Prof. Thomas F.** Deceased; formerly, Department of Chemistry, of Chicago.

**Young, Wayne.** Director, Environmental Dredging, Maryland Environmental Service, Annapolis.

**Yunker, Dr. Leland W.** Earth Science Department, Lawrence Livermore National Laboratory, University of California.

**Yu, Dr. Ching-Sung.** Deceased; formerly, Professor Emeritus of Astronomy, Hood College.

**Yu, Dr. Robert K.** Department of Biochemistry and Molecular Biophysics, Virginia Commonwealth University School of Medicine, Richmond.

**Yuen, Prof. Horace P.** Department of Electrical Engineering and Computer Science, Northwestern University.

**Yungul, Dr. Sulhi H.** Chevron Resources Company, San Francisco, California.

## Z

**Zaitlin, Dr. Milton.** Associate Director, Biotechnology Program, Plant Pathology, Cornell University.

**Zander, Dr. Andrew T.** Varian Associates, Palo Alto, California.

**Zangerl, Dr. Rainer.** Chief Curator (retired), Department of Geology, Field Museum of Natural History, Chicago, Illinois.

**Zanoni, Thomas A.** Taxonomist, Jardín Botánico Nacional, Santo Domingo, Dominican Republic; and Honorary Research Associate, New York Botanical Garden.

**Zapffe, Dr. Carl A.** Consultant, Baltimore, Maryland.

**Zbar, Dr. Frederick.** Chevy Chase, Maryland.

**Zebroski, Dr. Edwin L.** Los Altos, California.

**Zeitlin, Dr. Andrew D.** MITRE Corporation, McLean, Virginia.

**Zelitch, Dr. Israel.** Department of Biochemistry and Genetics, Connecticut Agricultural Experiment Station, New Haven.

**Zelkowitz, Prof. Marvin V.** Department of Computer Science, University of Maryland, College Park Maryland.

**Zeller, Dr. Andreas.** Universität Passau, Lehrstuhl für Software-Systeme, Passau, Germany.

**Zeller, Prof. Michael E.** Department of Physics, Yale University.

**Zelnick, Dr. Ernest.** Dispensing Audiologist, New York.

**Zhang, Dr. Ruyuan.** Department of Geological and Environmental Sciences, Stanford University, Stanford, California.

**Zhao, Prof. Wei.** Department of Computer Science, Texas A & M University, College Station.

**Ziemer, Prof. Rodger, E.** Chairperson, Department of Electrical and Computer Engineering, University of Colorado, Colorado Springs.

**Zifcak, John H.** The Foxboro Company, Foxboro, Massachusetts.

**Zimmerman, Dr. John R.** Department of Mechanical Engineering, Pennsylvania State University.

**Zimmerman, Dr. Leroy H.** (Retired) U.S. Department of Agriculture, Tucson, Arizona.

**Zinder, Dr. Norton D.** Department of Microbial Genetics, Rockefeller University.

**Zink, Dr. Frank W.** Department of Vegetable Crops, University of California, Davis.

**Zinner, Dr. Ernst.** McDonnell Center for the Space Sciences, Washington University, St. Louis, Missouri.

**Zirin, Dr. Harold.** Department of Physics, California Institute of Technology.

**Zissis, Dr. George J.** Chief Scientist, Environmental Research Institute of Michigan, Ann Arbor.

**Zlotnik, Dr. I.** Microbiological Research Establishment, Wilts, England.

**Zohar, Dr. Joseph.** Deputy Director, Beer Sheva Mental Health Center, Beer Sheva, Israel.

**Zubay, Dr. Geoffrey.** Sherman Fairchild Center for the Life Sciences, Department of Biological Sciences, Columbia University.

**Zuk, Dr. William.** School of Architecture, University of Virginia.

**Zuman, Dr. Petr.** Department of Chemistry, Clarkson College of Technology.

**Zumberge, Dr. Mark A.** Institute of Geophysics and Planetary Physics, Scripps Institution of Oceanography, La Jolla, California.

**Zurek, Dr. Wojciech H.** Los Alamos National Laboratory, Los Alamos, New Mexico.

**Zweifel, Dr. Richard G.** Curator, Department of Herpetology, American Museum of Natural History, New York.

**Zwerman, Prof. Paul J.** Department of Agronomy, Cornell University.



# Index

Page numbers with an asterisk  
indicate an article title.

## A

- A15 phases, 1\*  
Aardvark, 1\*, 2280  
*Ab initio* theoretical methods, 1824-1825  
Abaca, 1-2\*  
Abalone, 2\*, 1182  
Abampere, 2304  
Abbe refractometer, 1882  
Abdomen, 2\*  
Abel, H., 1932  
Abelian groups, 1030  
Aberration (astronomy), 2-3\*, 721  
Aberration (optics):  
  adaptive optics, 24-25\*  
  chromatic, 396  
  coma, 447  
*Abies* species, 801  
Abiotic environment, 722, 828-829  
Ablation, 1504  
Ablation spheres, 502  
Ablative material, 187  
Abney level *see* Clinometer  
ABO blood group system, 269-270  
Abrasive, 3\*, 812-813  
Abrasive wear, 2377  
ABS resins, 1741  
Abscisic acid, 3-4\*, 698  
Abscission, 4\*, 1705  
Absolute humidity, 970, 1416  
Absolute magnitude, 1304  
Absolute pressure, 1769  
Absolute zero, 2226  
Absorbers, radar, 1840-1841\*  
Absorptimetric analysis *see*  
  Spectrophotometric analysis  
Absorption, 4-5\*  
  deliquescence, 632-633\*  
  dichroism, 656\*  
  digestive system, 667-668  
  electric power measurement, 747  
  electronic, 1661  
  sound, 2052  
  underwater sound, 2299  
Absorption (biology), 5\*, 656  
Absorption cycle, 1883  
Absorption dynamometer, 711  
Absorption of electromagnetic radiation,  
  5-6\*  
  color filter, 504\*  
  crystal absorption spectra, 590\*  
  extended x-ray absorption fine structure  
  (EXAFS), 862-863\*  
Absorption spectroscopy, 1152  
Absorption spectrum, 2076  
Absorptive optical bistability, 1551  
Abstract algebra, 6\*, 272  
Abstract Boolean algebra, 278  
Abstract data types, 6-7\*  
  data structure, 618  
  object-oriented programming, 1528\*  
Abvolt, 2304  
ac *see* Alternating current  
Acanthaceae, 1223  
Acantharia, 7\*, 21  
  Acanthometrida, 8\*  
  Acanthophractida, 8\*  
*Acanthaster*, 174, 187  
Acanthite, 7\*  
Acanthocephala, 7\*  
  Archiacanthocephala, 164\*  
  Eocanthocephala, 834\*  
  Palaeacanthocephala, 1595-1596\*  
*Acanthocystis*, 353  
Acanthodii, 7-8\*, 120  
Acanthometrida, 8\*  
Acanthophractida, 8\*  
*Acanthophymus*, 95  
Acanthopteri *see* Perciformes  
Acanthosomatidae, 944  
*Acanthostega*, 1126  
Acari, 8\*  
  Ixodides, 1199\*  
  Opilioacariformes, 1549  
  Sarcoptiformes, 1945\*  
  Trombidiformes, 2275\*  
Acasta Gneiss, 1037  
Acceleration, 8-9\*  
  centripetal, 353  
  force, 913\*  
  space biology, 2057  
  transducer, 2256  
  units of measurement, 2303  
Accelerator *see* Particle accelerator  
Accelerator mass spectrometry, 9-10\*  
Accelerometer, 10\*  
Acceptance sampling, 1821  
Acceptor atom, 10\*  
Access control (computer security), 524  
Access protocol, 1267  
Accessory buds, 300  
Accessory fruits, 842  
*Accipiter gentilis*, 260  
*Accipiter nisus*, 260  
Accipitridae, 260, 784  
Accumulator, 668  
Accumulator battery, 228, 259  
Acephala *see* Bivalvia  
Acephalina, 769  
Acer, 1316  
*Acer pseudoplatanus*, 698  
*Acer saccharum*, 1316  
Acetal, 10\*  
Acetic acid, 10-11\*  
Acetic anhydride, 12  
*Acetobacter*, 2340  
Acetone, 11\*  
Acetylcholine, 11\*  
  choline, 446\*  
  myasthenia gravis, 1458\*  
  synaptic transmission, 2181-2182\*  
Acetylene, 11\*, 2250  
  *see also* Alkyne  
Acetylsalicylic acid, 184  
Acholeplasmatales, 1459\*  
*Achras zapota*, 384  
Achromatiaceae, 232  
Acid and base, 11-12  
  amino acids, 97-98\*  
  base (chemistry), 256\*  
  buffers (chemistry), 340\*  
  coordination chemistry, 554\*  
  electrolyte, 770  
  hydroxide, 1111  
  pH, 1646-1647\*  
  superacid, 2152-2153\*  
Acid anhydride, 12\*  
Acid-base indicator, 12-13\*  
Acid-base titration, 2245  
Acid halide, 13\*  
Acid rain, 13-14\*, 2366  
Acinetobacter, 1426  
*Acipenser oxyrinchus*, 2137  
Acipenseridae, 14, 2136-2137  
Acipenseriformes, 14\*, 2136-2137  
Acmaeidae, 144  
Acne, 2018  
Acnidosporida *see* Haplosporea  
Acoela, 14\*  
Aconchulinida, 14-15\*  
Acorales, 15\*  
Acorn barnacle, 246  
Acorn worms, 826  
*Acorus*, 15  
Acoustic emission, 15\*  
Acoustic filters, 743  
Acoustic holography, 15-16\*  
Acoustic impedance, 15\*  
Acoustic interferometer, 16\*  
Acoustic levitation, 16\*, 2014  
Acoustic microscope, 16\*  
Acoustic mine, 16\*  
Acoustic noise, 15\*  
  acoustic signal processing, 17-18\*  
  airport noise, 66\*  
  architectural acoustics, 164-165\*  
  masking of sound, 1328\*  
  measurement, 1493  
  noise measurement, 1493  
Acoustic phonetics, 1657  
Acoustic pressure, 2051  
Acoustic radiation pressure, 17\*  
Acoustic radiometer, 17\*  
Acoustic resonator, 17\*  
Acoustic signal processing, 17-18\*  
Acoustic streaming, 1495  
Acoustic torpedo, 18\*  
Acoustic transponder, 2298  
Acoustic waves, 2371  
Acoustics, 18\*  
  anechoic chamber, 115\*  
  architecture *see* Architectural  
  acoustics  
  atmospheric, 202-203\*  
  bioacoustics, animal, 275-276\*  
  cavitation, 384  
  decibel, 625  
  earphones, 716  
  fuzzy-structure acoustics, 953\*  
  low-temperature acoustics, 1274-1275\*  
  musical, 1453-1454\*  
  nonlinear, 1494-1495\*  
  physiological, 1682\*  
  psychoacoustics, 1799\*  
  quantum, 1823-1824\*  
  siren, 2014\*  
  sonar, 2048-2049\*  
  sonobuoy, 2049-2050\*  
  sound, 2051-2052\*  
  thermoacoustics, 2223\*  
  tone, 2247\*  
  virtual, 2342\*  
  water hammer, 2365\*  
Acoustooptics, 18\*  
Acquired immune deficiency syndrome  
  (AIDS), 18-19\*  
  cytomegalovirus infection, 612  
  hospital infections, 1091  
  immunosuppression, 1133  
  lymphoma, 1282  
  medical parasitology, 1348  
  opportunistic infections, 1550  
  pneumonia, 1730  
  pregnancy disorders, 1768  
  skin disorders, 2018  
Acquired immune deficiency  
  syndrome—*cont.*  
  transfusion, 2259  
  tuberculosis, 2279  
Acquired immunological tolerance, 19\*  
Actinoids, 1581  
Acromegaly, 1694  
Acrophobia, 1656  
Acrothoracica, 19\*, 409  
Acrotretida, 1134  
Acrylic monomers, 1740-1741  
Acrylonitrile, 19-20  
ACTH *see* Adrenocorticotropin  
Actin, 1451  
  cell motility, 394  
  cytoskeleton, 612\*  
  muscle proteins, 1451  
Actinaria, 20\*, 1965  
Actinide elements, 20\*  
actinium, 20\*  
americium, 95\*  
berkelium, 267\*  
californium, 357\*  
curium, 599\*  
einsteinium, 740\*  
fermium, 877\*  
lawrencium, 1234\*  
mendeleevium, 1353\*  
neptunium, 1476, 1476\*  
nobelium, 1493\*  
plutonium, 1729-1730\*  
protactinium, 1789\*  
thorium, 2234-2235\*  
transuranium elements, 2264-2265\*  
uranium, 2308-2309\*  
*Actinidia deliciosa*, 1217  
Actinidaceae, 1217  
Actinium, 20\*  
*Actinobacillus*, 296  
Actinolite asbestos, 165, 179  
Actinolophus, 353  
Actinomycetes, 20-21\*  
Actinomycetida, 21\*, 1462  
Actinophage, 21\*  
Actinophryda, 21\*, 940  
Actinopoda, 21\*, 1945  
  Acantharia, 7\*  
  Heliozoa, 1062\*  
  Proteomyxidia, 1792\*  
  Radiolaria, 1862\*  
Actinopodium, 143  
*Actinopolyspora halophila*, 1044  
Actinopterygii:  
  Acipenseriformes, 14\*  
  Amiiformes, 96\*  
  Anguilliformes, 117\*  
  Atheriniformes, 199\*  
  Batrachoidiformes, 258\*  
  Beryciformes, 267-268\*  
  Cetomimiformes, 410\*  
  Chondrostei, 446-447\*  
  Clupeiformes, 479-480\*  
  Cypriniformes, 607-608\*  
  Gadiformes, 955\*  
  Gasterosteiformes, 970\*  
  Gobiociformes, 1010\*  
  Gonorynchiformes, 1013\*  
  Holostei, 1085\*  
  Lampridiformes, 1224\*  
  Lophiiformes, 1271\*  
  Osteoglossiformes, 1586\*  
  Palaeonisciformes, 1596\*  
  Pegasiformes, 1623\*

Actinopterygii.—*cont.*

Perciformes, 1628-1629\*  
 Percopsiformes, 1629\*  
 Pholidophoriformes, 1656\*  
 Pleuronectiformes, 1728\*  
 Polypteriformes, 1751\*  
 Semionotiformes, 1984\*  
 Siluriformes, 2010\*  
 Synbranchiformes, 2182\*  
 Teleostei, 2198\*  
 Tetraodontiformes, 2214\*  
 Action, 21-22\*  
 Activated carbon, 22\*  
 Activation analysis, 22\*  
 Activation overvoltage, 1589  
 Active filters, 744  
 Active-matrix LCDs (AMLCDs), 787  
 Active microwave diodes, 1397-1398  
 Active microwave solid-state devices, 1396-1397  
 Active mufflers, 1444  
 Active nuclei galaxies, 2401  
 Active-RLC filtering, 1164  
 Active sonar, 2048-2049  
 Active sound control, 22-23\*  
 Activity (thermodynamics), 23\*  
 Actuators, transducer, 2256  
 Aculeata, 984  
 Acupuncture, 116  
 Acute hemorrhagic pancreatitis, 1605  
 Acyl exchange *see* Acidolysis  
 Acylation, 23\*  
 Adams, W. S., 1024  
 Adanson, M., 1524\*  
 Adapoda, 1223  
 Adaptation (biology), 23-24\*  
 Adaptation (developmental psychology), 650-651  
 Adaptive control, 24\*  
 Adaptive immune response, 1128-1129  
 Adaptive management, 24\*  
 Adaptive optics, 24-25\*  
 Adaptive signal processing, 25\*  
 Adaptive systems, 25  
 Addictive disorders, 25-26\*, 69  
 Addison's disease, 1129  
 Addition, 26\*, 153-154  
 Addition polymerization, 1747  
 Additive pressures *see* Dalton's law  
 Adeleina, 768  
 Adeno-SV40 hybrid virus, 28\*, 983  
 Adenohypophysis hormone, 26-27\*  
 pituitary gland, 1693  
 pituitary gland disorders, 1694  
 Adenoiditis, 2248  
 Adenosine diphosphate (ADP), 27\*, 491  
 Adenosine monophosphate *see* Adenylic acid  
 Adenosine triphosphate (ATP), 27-28\*, 1421  
 coenzyme, 491  
 energy metabolism, 821  
 food, 907  
 Adenoviridae, 28\*  
 Adenylic acid, 525  
 Adesmecea, 1223  
 Adhesion, cellular, 398-399\*  
 Adhesion, molecular, 1230, 1417\*  
 Adhesive, 28-29\*  
 Adhesive bonding, 29\*  
 Adhesive joints, 29  
 Adhesive wear, 2377  
 Adiabatic demagnetization, 29\*, 634  
 Adiabatic process, 29\*  
 Adipose tissue, 29\*, 2230  
 Adler, Alfred, 1803  
 Admittance, 30\*  
 conductance, 532  
 immittance, 1127\*  
 short circuit, 2003  
 susceptance, 2173-2174\*  
 Adobe brick, 291, 332  
 Adocidae, 282  
 ADP *see* Adenosine diphosphate  
 Adrenal cortex, 30-31  
 Adrenal gland, 30\*, 848  
 Adrenal gland disorders, 30-31\*  
 Adrenal medulla:  
 adrenal gland disorders, 31  
 epinephrine, 838\*  
 Adrenaline *see* Epinephrine  
 Adrenocorticotropin (ACTH), 27  
 Adsorption, 31\*  
 activated carbon, 22\*  
 desiccant, 645\*  
 drying, 703, 704  
 molecular sieve, 1424-1425\*  
 Adsorption operations, 31-32\*

Advanced Very High Resolution Radiometer (AVHRR), 1378  
 Adventitious roots, 1931  
 Adzuki beans, 229, 260  
 Aedes, 573, 621, 2411  
 Aegialornithidae, 134  
 Aegidae, 803  
 Aegilops, 2385  
 Aegothelidae, 326  
 Aegyptiinae, 784  
 Aegyptopithecus zeuxis, 829  
 Aeration, 2368  
 Aerial photograph, 32\*, 1666  
 cameras, 321  
 photogrammetry, 1665\*  
 Aerobacter *see* Enterobacter  
 Aerodynamic force, 32-33\*, 203  
 Aerodynamic missile, 1408  
 Aerodynamic sound, 33\*  
 Aerodynamic wave drag, 33\*  
 Aerodynamics, 33-34\*  
 aircraft icing, 58  
 flight, 894-895\*  
 flutter (aeronautics), 904-905\*  
 Aeroelasticity, 34\*  
 Aeromonas, 34\*  
 Aeronautical engineering, 34-35\*  
 Aeronautical meteorology, 35\*  
 Aeronautics, 36\*  
 Aeronomy, 36\*, 722  
 Aerosol, 36-37\*  
 Aerospace medicine, 37-38\*  
 Aerospike engine, 38\*  
 Aerostatics, 38-39\*, 343  
 Aerothermodynamics, 39\*  
 Aesculus species, 299  
 AFC *see* Automatic frequency control  
 Affective disorders, 39-40\*  
 anorexia nervosa, 127\*  
 attention deficit hyperactivity disorder, 215-216\*  
 clinical syndromes, 39  
 depression, 577  
 etiology and treatment, 39-40  
 Afforestation, 1881  
 Aflatoxin, 40\*, 1460  
 Africa, 40-41\*, 924, 926  
 continental crust, 719  
 fossil apes, 923, 924  
 African apes:  
 fossil apes, 923  
 fossil primates, 928  
 African buffalo, 301  
 African elephant, 1777  
 African elephantnose, 1586  
 African great apes, 132, 148, 149  
 African horseshickness, 41\*  
 African lungfish, 619  
 African otter shrew, 1159  
 African sleeping sickness *see* Sleeping sickness  
 African trypanosomes, 1610  
 African violet, 1223, 1965  
 Afterburner, 41-42, 2286-2287  
 Afterglow, 1659  
 Agar, 42\*  
 Agaricales, 1453  
 Agaricus bisporus, 984  
 Agate, 42\*, 361  
 Agave fourcroydes, 946  
 AGC *see* Automatic gain control  
 Age of Dinosaurs, 676  
 Agents (expert systems), 861  
 Agglutination reaction, 42\*  
 Agglutinin, 42\*  
 Aggregation chimera, 385  
 Aggression, 42-43\*  
 Agile manufacturing, 2342  
 Aging, 43\*  
 Agitation *see* Mixing  
 Agnatha, 1202  
 Anaspida, 113-114\*  
 animal evolution, 120  
 Heterostraci, 1073\*  
 jawless vertebrates 1202\*  
 Myxiniiformes, 1461\*  
 Osteostraci, 1586-1587\*  
 Petromyzontida, 1646\*  
 Pteraspidoforma, 1805\*  
 Agnosia, 43\*, 172  
 Agonomycetes, 43\*, 585, 648  
 Agouti, 43-44\*  
 Agricultural aircraft, 44\*, 980  
 Agricultural chemistry, 44\*  
 Agricultural engineering, 44\*, 919  
 Agricultural machinery, 44-45\*  
 Agricultural meteorology, 45\*

Agricultural products, 46  
 Agricultural water:  
 conservation, 2364  
 Agriculture, 45-46\*  
 antibiotic, 138  
 breeding (animal), 330-331\*  
 breeding (plant), 331-332\*  
 corn, 559-560\*  
 farm crops, 871\*  
 fertilizer, 880-881\*  
 horticultural crops, 1090-1091\*  
 irrigation, 1191\*  
 land drainage, 1224\*  
 multiple cropping, 1446\*  
 nitrogen fixation, 1492  
 precision, 1766-1767\*  
 renewable resources, 1894\*  
 tomato, 2246-2247\*  
 Agricus bisporus, 1112  
 Agriocharis ocellata, 259  
 Agrobacterium tumefaciens, 517-518, 983  
 Agroecosystem, 46\*  
 Agronomy, 46-47\*  
 Agropyron, 2385  
 Agrostis alba, 1879\*  
 Aharonov, Y., 47  
 Aharonov-Bohm effect, 47\*  
 AIDS *see* Acquired immune deficiency syndrome  
 Aileron, 47\*, 806-807  
 Ailuropoda melanoleuca, 1605  
 Ailurus fulgens, 1605  
 Ainsworth, M., 650  
 Air, 47\*  
 moisture-content measurement, 1416  
 ventilation, 2329\*  
*see also* Atmosphere  
 Air Almanac, 87  
 Air-arc furnace, 140-141  
 Air armament, 47-48\*  
 Air-blast circuit breaker, 406-407  
 Air brake, 48\*, 202  
 Air capacitor, 324  
 Air compressor, 518  
 Air conditioning, 48-49\*  
 automotive, 228  
 degree-day, 631\*  
 heat pump, 1056\*  
 oil burner, 1536  
 Air conveyor, 303  
 Air cooling, 49-50\*  
 Air-core reactor, 1872\*  
 Air-cushion vehicle, 50\*  
 Air cycle (refrigeration), 1883  
 Air defense weapons, 171  
 Air embolism, 726  
 Air filter, 51\*  
 dry, 640  
 electret, 741  
 gas filters, 799  
 Air heater, 51\*  
 Air ionization chamber dosimeter, 699  
 Air-lift pumps, 628  
 Air navigation, 51-52\*  
 aircraft collision avoidance system, 58\*  
 automatic landing system, 225\*  
 direction-finding equipment, 684  
 microwave landing system, 1394\*  
 pilotage, 1687\*  
 sextant, 1993-1994\*  
 Air pollution, 52-53\*  
 acid rain, 13-14\*  
 aerosol, 36-37\*  
 catalytic converter, 379-380\*  
 climate modification, 473  
 diesel engine, 660  
 gas and atmosphere analysis, 964-965\*  
 smog, 2023-2024\*  
 Air-pollution, indoor, 53  
 Air pressure, 53-54\*  
 baroclinic field, 252\*  
 barometer, 252\*  
 barotropic field, 221\*, 252\*  
 isobar, 1193\*  
 solenoid (meteorology), 2043\*  
 Air register, 54\*  
 Air separation, 54-55\*  
 Air suspension system, automotive, 204  
 Air temperature, 55\*  
 isothermal chart, 1196\*  
 temperature inversion, 2208-2209\*  
 Air-traffic control (ATC), 55-57\*  
 airport surface detection equipment, 66\*  
 precision approach radar, 1767\*  
 surveillance radar, 2172\*

Air-Traffic Control Radar Beacon System (ATCRBS), 58, 789  
 Air transport aviation, 208  
 Air transportation, 57\*, 2264  
 Airborne radar, 58\*, 1839-1840  
 Airborne Warning and Control System (AWACS), 1401  
 Aircraft, 58\*  
 agricultural, 44\*  
 airborne radar, 58\*  
 airframe, 64\*  
 airship *see* Airship  
 army weapons, 155-156, 170-171  
 autogiro, 222\*  
 ballistic range, 246-247\*  
 conformal optics, 535  
 convertiplane, 551-552\*  
 dead reckoning, 621  
 drone, 701\*  
 flight controls, 895-896\*  
 flight dynamics, 896\*  
 flow-induced vibration, 897  
 flutter (aerodynamics), 904-905\*  
 fuselage, 952\*  
 fuzzy-structure acoustics, 953  
 glider, 1004\*  
 helicopter, 1059\*  
 landing gear, 1225\*  
 military, 1401\*  
 polar navigation, 1734  
 propeller, 1785-1786\*  
 seaplane, 1967\*  
 short takeoff and landing (STOL), 2003\*  
 sonic boom, 2049\*  
 sonobuoy, 2049-2050\*  
 stability augmentation, 2094\*  
 stabilizer, 2095\*  
 streamlining, 2126\*  
 tail assembly, 2190-2192\*  
 turbine propulsion, 2284-2285\*  
 turbofan, 2285-2286\*  
 turbojet, 2286\*  
 turboprop, 2286\*  
 turboramjet, 2286-2287\*  
 ultralight, 2294\*  
 vertical takeoff and landing, 2333-2334\*  
 weapons, 47-48  
 weather effect on, 35  
 wing *see* Wing  
 wing flutter, 897  
 Aircraft carriers, 1468  
 Aircraft collision avoidance system, 58\*  
 Aircraft compass system, 58-59\*  
 Aircraft design, 59-60  
 aerodynamic design, 59-60  
 aircraft systems design, 60  
 design phases, 59  
 propulsion design, 59  
 requirements, 59  
 structural design, 59-60  
 Aircraft engine, 60\*  
 fuel system, 942-943\*  
 gas turbine, 968  
 reciprocating aircraft engine, 1874-1875\*  
 specific fuel consumption, 2073  
 supercharger, 2153  
 Aircraft fuel, 60\*  
 Aircraft icing, 60-61\*  
 Aircraft instrumentation, 61  
 airspeed indicator, 67\*  
 altimeter, 91-92\*  
 automatic horizon, 225\*  
 autopilot, 231\*  
 ground proximity warning system, 1028\*  
 rate-of-climb indicator, 1871\*  
 stall-warning indicator, 2095\*  
 turn and bank indicator, 2287-2288\*  
 yaw indicator, 2410\*  
 Aircraft low-approach systems, 1839-1840  
 Aircraft propulsion, 61-62\*  
 Aircraft rudder, 62\*  
 Aircraft testing, 62-63\*  
 Airfoil, 63-64\*  
 aerodynamic force, 31-32  
 aspect ratio, 183-184\*  
 flight, 894  
 wing, 2390-2391\*  
 Airframe, 64\*, 952  
 Airglow, 64-65\*, 2201  
 Airplane, 65\*  
*see also* Aircraft  
 Airport engineering, 65-66\*  
 Airport noise, 66\*  
 Airport surface detection equipment (ASDE), 66\*  
 Airship, 54, 66-67\*, 266-267  
 Airspace, 56

- Airspeed indicator, 67\*  
Aistopoda, 67\*, 1244  
Aizoaceae, 336  
Akle dunes, 642  
Alariaceae, 1224  
Alarm clock, 418  
Alaska cedar, 344, 543  
*Albatrellus*, 984, 1112  
*Albatross* (research vessel), 1597  
Albedo, 67\*  
Albite, 67-68\*  
Albumin, 68\*  
Alcae, 365  
Alcedinidae, 494  
*Alces alces*, 1437  
*Alces americana*, 1437  
Alcidae, 365  
Alciopidae, 760  
Alcohol, 68\*  
  antiseptic, 145\*  
  ethyl, 765-766  
  fuel, 68-69\*  
  glycerol, 1007\*  
  lanolin, 1227  
  menthol, 1355-1356\*  
  methanol, 1381\*  
  nitration, 1489  
Alcohol dehydrogenase (ADH), 1179  
Alcohol fuel, 68-69\*, 91  
Alcoholic beverages:  
  malt, 1308\*  
  malt beverage, 1308\*  
  wine, 2390\*  
Alcoholic fermentation, 68, 789  
Alcoholism, 25, 26, 69\*  
  fetal alcohol syndrome, 881\*  
  toxicity of alcohol, 233-234  
Alcyonacea, 69-70  
Alcyonaria, 70\*  
  *Coenothecalia*, 491\*  
  *Gorgonacea*, 1013\*  
  *Pennatulacea*, 1625\*  
  *Stolonifera*, 2119\*  
  *Telestacea*, 2202\*  
*Alcyonium*, 70  
Aldebaran, 70\*  
Aldehyde, 70  
  formaldehyde, 922\*  
  hydroformylation, 1104\*  
  oxime, 1590-1591\*  
Alder, 70  
Aldosterone, 31, 70-71\*  
Alectoris, 259  
Alembert see d'Alembert  
*Aleurites fordii*, 2281  
Alexandrite, 401  
Aleyrodidae, 928  
Alfalfa, 71\*  
  legume, 1240  
  legume forages, 1240  
Alfalfa caterpillar, 1156  
Alfvén, H., 1302  
Alfvén waves, 71-72\*  
Algae, 72-74\*  
  *Bacillariophyceae*, 239\*  
  characteristics, 73  
  *Chlorophyceae*, 443-444\*  
  Chlorophyta, 392  
  Chromophycota, 451\*  
  *Chrysophyceae*, 455\*  
  Chrysophyta, 402  
  *Coccolithophorida*, 487\*  
  Corallinales, 558\*  
  *Cryptophyceae*, 589\*  
  *Cyanophyceae*, 602\*  
  *Dasycladales*, 616\*  
  *Dinophyceae*, 674\*  
  economic importance, 73-74  
  *Eustigmatophyceae*, 856, 856\*  
  fossil, 74  
  Fucales, 940\*  
  *Girvanella*, 1000\*  
  green, 73  
  Halimeda, 1040\*  
  Laminariales, 1224\*  
  limestone, 1255  
  microbiology, 1382\*  
  occurrence, 73  
  *Oedogoniales*, 1533\*  
  petroleum microbiology, 1642  
  *Phaeophyceae*, 1647\*  
  *phycobilin*, 1674\*  
  phytoplankton, 1684\*  
  plant evolution, 1702  
  plant phylogeny, 1712  
  *Prasinophyceae*, 1764\*  
  *Prymnesiophyceae*, 1798\*
- Algae—cont.  
*Raphidophyceae*, 1869\*  
  red, 42, 73  
  *Rhodophyceae*, 1915\*  
  *Xanthophyceae*, 2406-2407\*  
  *Zygnematales*, 2421\*  
Algebra, 74-75\*  
  abstract, 6\*  
  addition, 26\*  
  analytic geometry, 110-111\*  
  binomial theorem, 275\*  
  Boolean, 278-279  
  division, 693\*  
  equations, theory of, 841\*  
  exponent, 862\*  
  linear algebra, 1257\*  
  multiplication, 1447\*  
  quaternions, 1835-1836\*  
  ring theory, 1923\*  
  subtraction, 2142\*  
Algebraic geometry, 75-76\*  
Algebraic number theory, 1521  
Alginate, 76\*  
Algol (star), 1637, 2177-2178  
Algonkian see Proterozoic  
Algorithm, 76\*, 523  
  cryptographic, 523, 524  
  data mining, 617  
  data structure, 618  
  decibel, 625\*  
  evolutionary, 857  
  genetic, 981\*  
  mathematical software, 1336  
  programming languages, 1781-1783\*  
Alicyclic hydrocarbon, 76-77\*, 309  
Aliphatic hydrocarbon:  
  alkane, 79\*  
  alkyne, 80-81\*  
  nitroparaffin, 1493  
Aliphatic naphthas, 1465  
Alismataceae, 77  
Alismatales, 77\*  
Alismatidae, 77\*  
  *Hydrocharitales*, 1103\*  
  *Najadales*, 1463\*  
  *Triuridales*, 2275\*  
Alkadiene see Diolefin  
Alkali, 77-78\*, 770  
Alkali-chlorine process, 762  
Alkali emissions, 78\*  
Alkali feldspar, 788  
Alkali metals, 78\*  
  cesium, 408\*  
  francium, 931\*  
  lithium, 1264\*  
  potassium, 1759\*  
  rubidium, 1935\*  
  sodium, 2029\*  
Alkaline-earth metals, 78\*  
  beryllium, 268-269\*  
  radium, 1863-1864\*  
  strontium, 2130\*  
Alkaline error, 76\*  
Alkaloid, 78-79\*  
  atropine, 215\*  
  caffeine, 349\*  
  cocaine, 487\*  
  colchicine, 496\*  
  epinephrine, 79  
  indole, 1137\*  
  nicotine, 1488\*  
  poisonous plants, 1733  
  quinine, 1836\*  
  strychnine, 2136\*  
Alkane, 79\*  
  gasoline, 969  
  methane, 1380\*  
Alkene, 70-80\*  
Alkyds, 1743  
Alkylation (petroleum), 80\*  
Alkyne, 11, 80-81\*  
Allantois, 81\*  
Allele, 81\*  
  crossing-over (genetics), 582\*  
  dominance, 695\*  
  Allelopathic toxins, 1733-1734  
  Allelopathy, 81\*, 421-422  
Allen, B., 980-981  
Allende Meteorite, 1037  
Allergen, 81-82  
Allergic arteritis, 159  
Allergic asthma, 175, 188  
Allergic rhinitis see Hay fever  
Allergy, 81-82\*  
  antihistamine, 142\*  
  asthma, 188\*  
  hypersensitivity, 1117
- Allergy—cont.  
  nervous system disorders, 1479  
  skin disorders, 2018  
  weeds, 2381  
Alligator, 82\*, 581-582  
*Alligator mississippiensis*, 82  
Alligator pear, 1579  
*Alligator sinensis*, 82  
Alligatoridae, 82, 309, 515  
*Allium sativum*, 964  
*Allium* species, 860, 1543  
Alloeochoela, 82\*  
Allografts:  
  transplantation biology, 2263  
Allometry, 82\*  
Allomone, 370  
Allomyces, 402  
Allosome see Sex chromosome  
Allostatic load, 2128  
Allosteric enzyme, 83\*  
Allostichaster, 187  
Allotheria, 83\*  
  *Multituberculata*, 1448\*  
Allowance, 83\*  
  force fit, 913\*  
  running fit, 1935\*  
  shrink fit, 2003\*  
Alloy, 83-84\*  
  Alnico, 84  
  aluminum alloys, 93\*  
  amalgam, 94\*  
  beryllium, 268-269\*  
  brass, 327\*  
  bronze, 335\*  
  cast iron, 377\*  
  copper, 492  
  eutectics, 856\*  
  ferroalloy, 878\*  
  gold, 1010-1011\*  
  high-temperature materials, 1079\*  
  intermetallic compounds, 1173-1174\*  
  iron, 1191\*  
  laser alloying, 1230\*  
  lead, 1235\*  
  magnesium, 1289, 1290\*  
  mechanical alloying, 1342\*  
  metallic glasses, 1367-1368\*  
  metallography, 1369-1370\*  
  metallurgy, 1370\*  
  molybdenum, 1429, 1430\*  
  nickel, 1486-1487\*  
  pewter, 1646\*  
  shape memory, 1996\*  
  stainless steel, 2095\*  
  steel, 2108\*  
  steel manufacture, 2106  
  tempering, 2209\*  
  tin, 2242-2243\*  
  uranium, 2309  
Alloying, mechanical, 1342\*  
Alloys:  
  Kondo effect, 1218  
  nickel, 1487\*  
  structural materials, 2135  
  zinc, 2415  
Allred, A. L., 708, 786  
Allspice, 87\*, 984  
Aluminum alloys, 93\*  
Alluvial fans, 644  
Almanac, 87\*  
Almond, 87\*  
*Alnus rubra*, 70  
Aloe, 183  
Alosa, 948  
Alpaca, 87\*  
Alpha Boötis see Arcturus  
Alpha Canis Majoris see Sirius  
Alpha Canis Minoris see Procyon  
Alpha Centauri, 87\*  
Alpha fetoprotein, 87-88\*  
Alpha Orionis see Betelgeuse  
Alpha particles, 88\*  
  radioactive fallout, 1854  
  radioactivity, 1856-1857  
Alpha rhythm (brain), 692, 768  
Alpha Scorpii see Antares  
Alpha sulfur see Rhombic sulfur  
Alpha Tauri see Aldebaran  
Alpha Ursae Minoris see Polaris  
Alpha Virginis see Spica  
Alpher, H., 500  
Alpheratz (star), 1623  
Alpine marmot, 1326  
Alpine vegetation, 89\*  
Alsike clover, 422
- Astroemeria*, 1254  
Alternating current, 89-90\*, 755  
  electrical measurements, 758  
  hydroelectric generator, 1103  
  reactance, 1871-1872\*  
  skin effect (electricity), 2018-2019\*  
  susceptance, 2173-2174\*  
  synchronous converter, 2183\*  
  synchroscope, 2183\*  
  volt-ampere, 2353\*  
  voltage measurement, 2354-2355  
Alternating-current circuit theory:  
  admittance, 30\*  
  conductance, 532\*  
  power factor, 1762-1763\*  
  quadrature, 1819\*  
  resonance, 1904\*  
Alternating-current generator, 90\*  
  electric power generation, 746  
  magneto, 1300-1301\*  
  synchroscope, 2183\*  
Alternating-current motor, 90-91\*  
  commutation, 512  
  dynamic braking, 709  
  induction motor, 1138\*  
  reluctance motor, 1892-1893\*  
  repulsion motor, 1900-1901\*  
  synchronous motor, 2183\*  
  universal motor, 2305\*  
Alternating-field electrophoresis, 795  
Alternative fuel vehicle, 91\*  
Alternator, automotive, 202  
*Alteromonas*, 242  
*Althaea*, 1309  
Altimeter, 51, 91-92\*, 1769  
Altitudinal vegetation zones, 92\*  
Altruism, 2028  
Alum, 92\*  
Aluminum, 92-93\*  
  alloys, 93\*  
  alum, 92\*  
  bauxite, 228, 259  
  zinc alloys, 2416\*  
Aluminum alloys, 93\*  
Aluminum bronze, 288  
Aluminum chloride, 390  
Alunite, 931\*  
Alvarez, L. W., 1061  
Alydidae, 944  
Alzheimer's disease, 93-94\*, 1613  
AM see Amplitude modulation  
AM medium-frequency band radio  
  broadcasting, 1848  
Amalgam, 94\*, 1174  
Amantadine, 309  
Amaranth, 94\*  
Amaranthaceae, 94\*  
Amaranthus, 94  
Amateur radio, 94\*  
Amazonian white dolphin, 634  
Amber, 94\*  
Ambergris, 94-95\*  
Ambient noise, 2300  
*Amblyortus*, 234  
*Amblyomma*, 1053  
*Amblypygi*, 95\*  
Ameba, 95\*  
American alligator, 82  
American badger, 214  
American beech, 231  
American black bear, 230  
American chestnut, 383, 436  
American eagle, 260  
American elm, 725  
American linden, 226  
American marten, 1328  
American mink, 1406  
American moose, 1437  
American ostrich see Rhea  
American plane tree see Sycamore  
American Spanish mackerel, 1286  
American Standard Code for Information  
  Exchange see ASCII  
American sycamore see Sycamore  
Americium, 95\*  
Amethyst, 96\*  
*Amia calva*, 96  
Amide, 96\*  
Amidae, 96, 285  
Amififormes, 96\*  
Amine, 96\*  
  diazotization, 656\*  
  nitration, 1489  
Amino acid dating, 96-97\*  
Amino acids, 97-98\*  
  metabolic disorders, 1361  
  peptide, 1626-1627\*

## Amino acids—cont.

polyamide resins, 1741  
protein, 1790-1791\*  
protein metabolism, 1791-1792\*  
transamination, 2256\*  
urea, 2310\*

Amino sugar, 98\*

Ammeter, 98\*  
current measurement, 600\*  
electric power measurement, 747  
electrodynamical, 692  
resistance measurement, 1901-1902\*  
resistors, 1902-1903\*  
shunting, 2003

Ammine, 98\*  
Ammonation, 99  
Ammonia, 98-99\*  
amine, 96\*  
ammine, 98-99\*  
high-pressure processes, 1079  
nitrogen cycle, 1491-1492  
nitrogen fixation, 1492  
petrochemical, 1640  
Ammonium ion, 1183  
Ammonium salt, 99\*, 1835  
Ammonolysis, 99  
Amnesia, 99\*  
Amnion, 99-100\*  
amphibian, 102  
fetal membrane, 882  
Amniota, 100\*  
amnion, 99-100\*  
Anamnia, 112\*  
chorion, 448\*

*Amoeba proteus*, 100  
Amoebida, 95, 100\*, 1267  
Amor asteroids, 186  
Amorphous solid, 100\*  
glass, 1002\*  
glass transition, 1003\*  
low-temperature acoustics, 1275  
metallic glasses, 1367-1368\*

Ampeliscidae, 859, 963  
Ampère, A. M., 101, 627  
Ampère, definition of, 687  
Ampère's law, 101\*, 599, 1297  
Amperometric titration, 2245-2246  
Amphetamine, 101\*  
Amphiarthroses, 1203  
Amphibia, 101-102\*  
Aistopoda, 67\*  
Anamnia, 112\*  
animal evolution, 120  
Anthracosauria, 134\*  
Anura, 146\*  
Apoda, 151\*  
digestive system, 666  
ear, 713, 714  
Labyrinthodontia, 1221\*  
lateral line system, 1232  
Leptospondyli, 1245\*  
Lissamphibia, 1264\*  
Lysorophia, 1283\*  
metamorphosis, 1372  
Microsauria, 1391\*  
Nectridea, 1470-1472\*  
regeneration, 1884  
Terminospondyli, 2208\*  
Urodela, 2313-2314\*

Amphibocorisae, 943-944  
Amphibious cameras, 2299  
Amphibole, 102-103\*  
anthophyllite, 134\*  
biopyribole, 294\*  
cumingtonite, 598\*  
glaucophanes, 1003\*  
hornblende, 1089\*  
tremolite, 2269\*

Amphibolidae, 226  
Amphibolite, 103\*, 1089  
Amphidiscosa, 103\*  
Amphiliidea, 103\*, 358  
Amphimonadidae, 1216  
Amphinomidae, 760  
Amphionidacea, 103\*  
*Amphionides reynaudii*, 103  
Amphioptera, 1549  
Amphioxus see Branchiostoma  
Amphiphile (surfactant), 2172  
Amphipoda, 103\*  
Caprellidea, 365\*  
Gammaridea, 962-963\*  
Hyperidea, 1116-1117\*  
Amphisopidae, 1674  
Ampholytes, 1104  
Amplifier, 103-104\*  
audio, 195

## Amplifier—cont.

automatic gain control, 224-225\*  
cascade, 336, 376\*  
coincidence, 436-437  
comparator circuit, 514  
differential, 599, 661\*  
direct-coupled, 622, 682\*  
distortion, 690  
frequency distortion, 629  
gain, 955\*  
hearing aid, 1050  
instrumentation, 1161\*  
klystron, 1217\*  
laser, 1229  
light, 1251\*  
loudspeaker, 1273-1274\*  
maser, 1328-1329\*  
microwave, 1392  
negative-resistance circuit, 1471-1472  
operational, 1546-1547\*  
parametric, 1609\*  
power, 1762\*  
preamplifier, 1764\*  
push-pull, 1811-1812\*  
radio-frequency, 1849\*  
response, 1907\*  
sound-reinforcement system, 2054\*  
transistor, 2260-2261\*  
video, 2338\*  
voltage, 2353-2354\*  
volume control systems, 2357\*

Amplitude distortion, 629  
Amplitude modulation, 104\*  
radio broadcasting, 1847  
radio receiver, 1850-1851  
sideband, 2004\*

Amplitude-modulation detector, 104-105\*  
Amplitude-modulation radio, 105-106\*, 1853  
Amplitude modulator, 106-107\*, 1415  
Amplitude (wave motion), 104\*, 1414-1415, 2371  
*Amygdalus communis*, 87  
Amylase, 107\*  
Amyloid disease, 1361  
Amyloidosis, 107\*  
Amyloplasts, 338  
Amyotrophic lateral sclerosis, 1453  
Anabaena, 1382  
Anabolism, 243  
Anacanthini see Gadiformes  
*Anacardium occidentale*, 336  
Anachoropteridaceae, 433  
Anaconda, 272  
*Anadara granosa*, 431  
Anadyomenaceae, 477\*  
Anaerobic infections, 107\*  
Analcime, 107\*  
Analgesia, 116  
Analgesic, 107-108\*  
aspirin, 184\*  
narcotic, 1465\*  
Analog circuit, digital vs., 460  
Analog computer, 108-109\*, 519  
programming, 108-109  
types, 108  
Analog electronics, 792-793  
Analog states, 109\*  
Analog-to-digital conversion:  
electronic test equipment, 791-792  
pulse modulation, 1807  
Analog-to-digital converter, 109\*  
data reduction, 617-618\*  
digital recording, 612  
electromagnetic compatibility, 771  
Analog voltmeters, 2356  
Analysis of variance, 110\*  
Analytic geometry, 110-111\*, 553  
Analytic hierarchy, 111\*  
Analytic number theory, 1521, 1522  
Analytical chemistry, 111-112\*  
blowpipe, 307\*  
chemometrics, 432  
electroanalysis, 690  
forensic chemistry, 915\*  
polarographic analysis, 1738\*  
qualitative see Qualitative chemical analysis  
quantitative see Quantitative chemical analysis  
vacuum fusion, 2318\*

Anamnia, 112\*  
Anamniota, 112  
Anamorphic yeast, 265  
*Ananas*, 294, 1690  
Anaphase (meiosis), 1349  
Anaphylaxis, 112-113\*

*Anaplasma*, 113  
Anaplasmosis, 113\*  
Anapsida, 113\*  
Anasara, 665, 737  
Anaspidia, 113-114\*  
Anastrepha, 621  
Anatidae, 129  
Anatinae, 129  
Anatomy, regional, 114\*  
Ancalomicrobium, 300  
Anchor recoil escapement, 418, 846  
Anchovy, 479-480, 948  
*Ancylostoma duodenale*, 964, 1347  
AND gate (switching circuit), 2175, 2176  
Andalusite, 114\*  
Andean bear, 226  
Andean condor, 260, 784  
Anderson, D., 720  
Andesine, 114\*  
Andesite, 114\*  
Andraeopsida, 114\*  
Androgen, 114\*-115  
Andromeda Galaxy, 115\*, 1267, 2098  
Andromerogony, 1357  
Andropogon, 272  
Andropogoneae, 272  
Anechoic chamber, 115\*, 217  
Anemia, 115-116\*, 408  
anaplasmosis, 113\*  
equine infections, 757  
sickle cell disease, 2004\*  
Anemometer, 116\*, 533  
Anemone, 1869  
Anemotaxis, 2194  
Anencephaly, 30  
Anepitheliocystidia, 604  
Aneroid barometer, 221  
Anesthesia, 116\*  
*Anethum graveolens*, 612  
Aneuploidy, 400-401  
Aneurysm, 116\*  
ANFO (explosive), 265  
Angina pectoris, 1052  
Angiography, 1346  
*Angiopsis*, 1316  
Angiosperms:  
evolution, 1703  
plant kingdom, 1706  
plant phylogeny, 1712  
Poales, 1731\*  
seed, 1973  
see also Magnoliophyta  
Angle-closure glaucoma, 889  
Angle modulation, 116-117\*  
frequency modulation, 935\*  
phase modulation, 1652\*  
Angled loofa, 1579  
Anglerfish, 1271\*  
Anglesite, 117\*  
Angstrom, 2303  
Anguilliformes, 117\*, 666  
Angular-contact bearing, 139-141  
Angular correlations, 117\*  
Angular magnification, 1304  
Angular momentum, 117-118\*  
analog states, 109\*  
spin (quantum mechanics), 2084\*  
Angular unconformity, 2297  
Angular velocity, 2329  
Anharmonic oscillator, 118\*  
Anhimae, 1291  
Anhimidae, 129  
Anhydride, acid, 12\*  
Anhydrite, 118\*, 1034  
Anhydrobiosis, 522-523  
Animal, 118\*  
dispersion, population, 1754-1755\*  
ecotone, 736\*  
embryology, 810  
migratory behavior, 1400-1401\*  
Neolithic, 1474  
physiological ecology, 1682\*  
plant-animal interactions, 1701-1702\*  
polyploidy, 1750  
population dispersal, 1754  
predator-prey interactions, 1767\*  
regeneration, 1884\*  
Animal behavior:  
sociobiology, 2028-2029\*  
trace fossils, 2254\*  
Animal classification see Animal systematics  
Animal communication, 118-119\*, 1994  
Animal ecology, 735  
Animal evolution, 119-120\*, 1287-1288  
Animal fat, 785  
Animal feeds, 950  
Animal growth, 120-121\*

Animal kingdom, 121\*  
Animal morphogenesis, 122\*  
Animal symmetry, 122-123\*, 1370  
Animal systematics, 123\*  
importance, 109  
zoological nomenclature, 2419\*  
Animal virus, 123-125\*  
African horsesickness, 41\*  
avian leukosis, 234-235\*  
bluetongue, 272  
bovine virus diarrhoea, 323-324\*  
canine distemper, 362\*  
canine parvovirus infection, 362-363\*  
control of, 124-125  
coxsackievirus, 574\*  
dendrovirus, 640\*  
echovirus, 729\*  
enterovated egg culture, 811\*  
enterovirus, 826\*  
Epstein-Barr virus, 740\*, 840\*  
feline infectious peritonitis, 875\*  
feline leukemia, 875-876\*  
feline panleukopenia, 876\*  
hog cholera, 1082\*  
louping ill, 1274\*  
morphology, 123  
parainfluenza virus, 1607\*  
paramyxovirus, 1609-1610\*  
pathology, 124  
Picornaviridae, 1684\*  
polyoma virus, 1750\*  
respiratory syncytial virus, 1906-1907\*  
retrovirus, 1909-1910\*  
rhinovirus, 1913\*  
Sendai virus, 1984\*  
tumor viruses, 2281\*  
viral inclusion bodies, 2340\*  
viral nucleic acid, 123-124  
virus classification, 2344-2345

Animalia:  
classification, biological, 468  
Ediacaran biota, 738  
Anionic detergent, 583  
Anions:  
electrolyte, 770-771\*  
ion, 1183  
Anise, 125\*  
Anisomyaria, 125\*  
Anisoptera, 1532  
Anisotropy (physics), 721  
*Ankarapithecus*, 924  
Ankerite, 125\*  
Ankylosauria, 1580  
Annealing, 1057  
Annelida, 125-126\*  
animal evolution, 120  
Archannelida, 164\*  
endocrine system, 732, 815  
Errantia, 844-845\*  
Hirudinea, 1081\*  
Myzostomaria, 1462\*  
Oligochaeta, 1539\*  
Polychaeta, 1741-1742\*  
regeneration, 1884  
Sedentaria, 1971\*  
tubeworms, 2279\*

Annihilation radiation, 1758  
*Annona*, 1304  
Annoa species, 301  
Anodic coatings, 1366  
Anodic organic reactions, 765  
Anodizing, 716  
Anolis, 361  
Anomalies, quantum, 1824\*  
Anomalistic month, 1436  
Anomalistic year, 722, 2410  
Anomalodesmata, 1222  
Anomalous features, 1322  
Anomia, 125  
Anomura, 510, 562  
*Anopheles*, 621, 1439  
Anopla, 126\*, 1916  
Heteronemertini, 1072\*  
Palaeonemertini, 1596\*  
Anoplura, 126-127\*  
Anoplolepta nervosa, 127\*, 724  
Anorthite, 128\*, 1090  
Anorthoclase, 128\*, 875  
Anorthosite, 128\*  
Anosmia, 1538  
Anostraca, 128\*  
Anoxia, 991  
Anoxic zones, 128-129\*, 937  
Anoxybiosis, 523  
ANS see Astronomical Netherlands Satellite  
Anseres, 129  
Anseriformes, 129\*



- Ant, 129\*, 304  
Hymenoptera, 1112-1113\*  
social insects, 2027-2028\*
- Antarctic Circle, 129-130\*
- Antarctic Ice Sheet, 1001
- Antarctic Ocean, 130\*
- Antarctica, 130\*, 719
- Antares, 131\*, 1963
- Anteater, 120, 131\*
- Antelope, 131\*, 178
- Antenna (electromagnetism), 131-133\*  
communications satellite, 511  
corner reflector, 497  
dipole, 678  
direct broadcasting satellite systems, 681  
direction-finding equipment, 684  
gain, 955\*  
microwave, 1392  
microwave free-field standards, 1394\*  
monopulse radar, 1434\*  
nonlinear physics, 1498, 1498\*  
radar, 1839-1840\*  
radio broadcasting, 1848  
radome, 1864\*  
television receiver, 2205  
television transmitter, 2207  
Yagi-Uda, 2409\*
- Antennata see Mandibulata
- Anthocoridae, 944
- Anthocyanin:  
flavonoid, 893  
plant pigment, 1712-1713
- Anthomedusae, 943
- Anthophyllite, 134\*
- Anthophyllite asbestos, 178-179
- Anthosigmella, 282
- Anthozoa, 134\*  
Alcyonaria, 70  
Corallimorpharia, 558\*  
Ptychodactylaria, 1805\*  
sea anemone, 1965\*  
Tabulata, 2189\*  
Zoantharia, 2417\*
- Anthracitic coal, 424, 481
- Anthracosauria, 134\*
- Anthracotherioidea, 164
- Anthrax, 134-135\*
- Anthropoda, 1884
- Anthropoidea, 927
- Anthropoids, 1771
- Anthropology, 135\*  
dental anthropology, 636-637\*  
human variation, 1097\*  
molecular, 1417-1418\*  
physical, 1676-1677\*  
Pitldown man, 1687-1688\*
- Anthropometry, 135-136\*
- Anthroposcopy, 136\*
- Anthuridea, 136\*
- Anthurium*, 138
- Antiarmor weapons, 171
- Antibacterial agents, 137\*
- Antibiotic, 136-138\*  
animal virus, 124  
cephalosporins, 405\*  
cytochalasin, 608\*  
drug resistance, 702-703\*  
fungal biotechnology, 947\*  
mastitis, 1333\*  
medical bacteriology, 1345  
penicillin, 136-137, 143, 1624-1625\*  
phytoalexin, 1683\*  
syphilis, 2185
- Antibody, 138\*  
antigen, 141\*  
antigen-antibody reaction, 141-142\*  
antitoxin, 146\*  
blood groups, 304-305\*, 306  
catalytic, 339, 379\*  
immune complex disease, 1128  
immune serums, 252  
immunoassay, 1129\*  
immunonephelometry, 1132\*  
monoclonal, 1432-1433\*  
neutralization reaction, 1482\*  
neutralizing antibody, 1482\*
- Anticaking agents (food), 818
- Anticoagulant, 1067
- Anticyclonic circulation, 2388
- Antidepressants, 39-40
- Antidiuretic hormone, 591
- Antiferromagnetism, 138-139\*  
domains, 634, 695  
magnetic ferroelectrics, 1291  
magnetochemistry, 1301\*  
magnon, 1305-1306\*
- Antiferromagnetism—cont.  
susceptibility, 1295
- Antifreeze (biology), 139\*
- Antifreeze mixture, 139\*
- Antifriction bearing, 139-141\*  
fluid-film hydrodynamic bearings, 139-141  
fluid-film hydrostatic bearings, 139-141  
lubricants, 139-141  
materials, 139-141  
rolling-element bearings, 139-141
- Antifungal drug therapy, 1347
- Antigen, 141\*  
blood groups, 304-305\*, 306-307  
heterophile antigen, 1072\*  
histocompatibility, 1081-1082\*  
hypersensitivity, 1117-1118\*  
immunoassay, 1129\*  
immunoelectrophoresis, 1129\*  
immunogenetics, 1129-1130\*  
immunoglobulin, 1130  
immunonephelometry, 1132\*  
isoantigen, 1193\*  
oncofetal antigens, 1541\*  
serum, 1989  
vaccination, 2317\*
- Antigen-antibody reaction, 112-113, 141-142\*  
complement-fixation test, 514-515\*  
immunoelectrophoresis, 1129\*  
precipitin, 1766\*  
radioimmunoassay, 1860-1861\*  
serology, 1989\*
- Antihistamine, 142\*
- Antilocapra americana*, 1784
- Antilocapridae, 164
- Antilopinae, 131
- Antimatter, 142-143\*  
elementary particle, 802  
universe, 2306
- Antimicrobial agents, 143, 817-818
- Antimony, 143-144\*, 2116
- Antioxidant, 144\*  
food additives, 817-818  
vitamin, 2348\*
- Antiparticles:  
elementary particle, 802  
quarks, 1832
- Antipatharia, 144\*
- Antipsychotic drugs, 1802
- Antiresonance, 144-145\*
- Antiseptic, 145\*, 2115
- Antiserum, 252
- Antisubmarine warfare, 145-146\*, 2138-2139
- Antisubmarine weapons, 1467
- Antitank weapon, 155-156, 170-171
- Antitoxin, 146\*, 252, 2254
- Antivenin, 252
- Anura, 146\*
- Anxiety disorders, 147\*  
obsessive-compulsive disorder, 1528-1529\*  
posttraumatic stress disorder, 1758
- Anyons, 148\*
- Aornerpeton*, 67
- Aorta, 148\*, 158, 159
- Aortic arch, 131
- Apatite, 148\*, 1816-1817
- Aperiodic waveforms, 2373
- Aperture aberration see Spherical aberration
- Aperture correction, 2203
- Apes, 132, 148-149\*  
fossil primates, 928  
primates, 1771, 1772
- Aphasia, 149\*
- Aphelion, 136
- Aphelocheiridae, 943
- Aphelocheirus, 943
- Aphid, 149-150\*
- Aphididae, 963
- Aphidoidea, 963
- Aphis gossypii*, 2
- Aphroditidae, 760
- Aphyllidae, 944
- Apiaceae, 672
- Apiales, 150\*  
carrier, 375\*  
fennel, 876\*
- Apical dominance, 150\*
- Apical meristem, 150-151\*, 1714
- Apis mellifera*, 231
- Apium graveolens*, 345
- Aplacophora, 151\*
- Aplastic anemia, 115
- Aplite, 151\*
- Aplodontia rufa*, 230
- Aplodontidae, 230
- Apneumonomorphae, 139
- Apocrine gland, 2174
- Apocrita, 984
- Apocynaceae, 875, 984, 1871\*  
Apoda, 151\*  
Apodes see Anguilliformes
- Apodi, 134
- Apodida, 134, 960
- Apodidae, 134
- Apodiformes, 151\*
- Apogee, 136
- Apoidea, 231
- Apojove, 136
- Apollo*:  
space flight, 2059  
space power systems, 2061
- Apollo asteroids, 186
- Apollo-Soyuz* test program, 2066
- Apophyllite, 151-152
- Apoplexy, 409
- Apoptosis:  
animal morphogenesis, 122  
mitochondria, 1410
- Aporidea, 152
- Apostomatida, 152\*
- Apparent magnitude, 1304
- Apparent solar day, 557, 620
- Apparent solar time, 840
- Appendaged bacteria, 300
- Appendicitis, 152\*
- Appendicular skeleton, 2016-2017
- Appendicularia, 152\*
- Appendix (anatomy), 152-153\*, 971
- Apple, 153\*, 575, 1932
- Application programming interfaces (APIs), 1546
- Applications satellites:  
communications satellite, 510-511\*  
meteorological satellites, 1378-1379\*  
military satellites, 1401-1402\*
- Applied ecology, 664, 735-736\*
- Applied geophysics see Geophysical exploration
- Applied mathematics, 1498
- Approximation (numerical analysis), 1523
- Apraxia, 153\*
- Apricot, 153-154\*
- Apron conveyor, 302, 488
- Apsides, 154\*
- Aptenodytes forsteri*, 2082
- Apterygota, 154\*  
Archaeognatha, 160-161\*  
Collembola, 500\*  
Protura, 1797\*  
Thysanura, 2238\*
- Aphovirus*, 911
- Aqua regia, 154\*
- Aquaculture, 154\*
- Aquarius, 154-155\*
- Aquatic animals, 693
- Aquatic ecosystems, 2366
- Aquatic sow bugs, 1627
- Aquation, 1108  
see also Hydrolysis
- Aquifer, 155\*, 911  
artesian systems, 174\*  
geothermal reservoirs, 883
- Aquifoliaceae, 345
- Aquila chrysaetos*, 260
- Aquilegia*, 1869
- Aquitard, 911
- Arabellidae, 760
- Arabian camel, 320
- Arabica coffee, 434, 491
- Araceae, 138, 151, 551
- Arachidonic acid, 667
- Arachnida, 155\*, 367  
Acari, 8\*  
Araneae, 156-157\*  
Opiliones, 1549\*  
Palpigradi, 1604\*  
Pseudoscorpionida, 1798\*  
Ricnulei, 1920\*  
Scorpion, 1963\*  
Uropygi, 2314\*
- Arachnoid:  
meninges, 1354  
nervous system (vertebrate), 1478
- Arachnophobia, 1656
- Arachnula, 182
- Aradidae, 944
- Aradoidea, 944
- Araeolaimida, 155\*
- Araeolaimoidea, 138
- Araeoscelida, 155-156\*, 771
- Araeoscelidae, 138
- Arafura shelf, 723
- Aragonite, 156\*, 1545
- Arales, 151, 156\*, 167, 615
- Araneae, 156-157\*  
Araneida, 138
- Araucaria, 1688
- Arberiales, 999
- Arboretum, 157\*
- Arboriculture, 157\*
- Arborvitae, 157\*, 335
- Arboviral encephalitis, 157\*, 2411
- Arbovirus, 139-140
- Arc discharge, 157-158\*
- Arc furnace, 673
- Arc heating, 158\*
- Arc lamp, 158\*
- Arc welding, 158-159\*
- Arcaea, 125
- Arcade video games, 2339
- Arcas system, 1378
- Arcella*, 142, 159
- Arcellinida, 159\*, 1267
- Arch, 159-160\*
- Archaeobacteria, 160\*
- Archaeogastropoda, 972
- Archaeoceti, 359
- Archaeocyatha, 160\*
- Archaeognatha, 160-161\*
- Archaeopteridales, 161\*
- Archaeopteryx, 144, 161
- Archaeopterygiformes, 144
- Archaeopteryx*, 207, 233, 234, 1208
- Archaeomithes, 161\*
- Archaic ungulate, 161\*
- Archean, 161-162\*, 1765  
fossil, 923  
supercontinent, 2157
- Archeoastronomy, 162\*  
horizon-marking system, 146, 162  
Moon, 145-146, 162, 1436-1437\*  
Sun, 145, 162
- Archeological chemistry, 162-163\*
- Archeological chronology, 163\*
- Archeology, 163-164\*  
archeoastronomy, 145-146, 162  
bioarchaeology, 276-277\*  
chemistry, 146, 162-163\*  
dating methods, 620\*  
Paleoindian, 1599-1600\*
- Archeozoology, 2418\*
- Archer see Sagittarius
- Archiacanthocephala, 7, 164\*
- Archannelida, 125, 164\*
- Archidiidae, 164\*
- Archimedes, 148
- Archigregarinida, 164\*, 909
- Archimedes, 467
- Archimedes' principle, 164\*, 1196
- Archiostraca, 1675
- Archipelago, 2384
- Architectural acoustics, 164-165\*  
acoustical design of rooms, 149, 164-165  
noise control, 165  
psychoacoustics, 165  
sound absorption, 148-149, 2052\*  
sound fields in enclosures, 148, 165  
sound reinforcement, 165  
transmission through partitions, 149
- Architectural engineering, 148-149, 164-165, 165\*
- Architectural paints, 1595
- Architecture, landscape, 1225-1226\*
- Archosauria, 165-166\*, 674  
Crocodylia, 581-582\*  
Protrosauria, 1795\*  
Pterosauria, 1805\*  
Saurischia, 1951\*  
Thecodontia, 2218\*
- Arctidae, 431
- Arctic and subarctic islands, 166\*
- Arctic Circle, 166\*
- Arctic cod, 431
- Arctic Ocean, 166-167\*, 1124
- Arcturus, 167\*, 279, 1070
- Ardipithecus*, 219, 220, 924, 925
- Area, 167\*
- Area catechu*, 241
- Arecaeae, 151
- Arecales, 167\*  
coconut, 488\*  
vegetable ivory, 2328\*
- Arecidae, 167\*  
Arales, 156\*  
Arecales, 167\*  
Cyclanthales, 603\*  
Pandanales, 1605\*

- Arenaceous rocks, 168\*, 169-170  
 Argelander, F. W. A., 173  
 Argentines (fishes), 1941  
 Argentinoidae, 1941  
 Argillaceous rocks, 168\*  
 Argon, 54, 55, 168\*  
 Argon ion laser, 1229  
 Argonaut, 438, 1532\*  
*Argonauta argo*, 1532  
 Arhynchobdellae, 168\*  
 Aries, 169\*  
 Arisaema, 138  
 Aristolochia, 153  
 Aristolochiaceae, 153  
 Aristolochiales, 169\*  
 Aristotle:  
   logic, 1269  
   plant taxonomy, 1713  
 Arithmetic, 169\*  
 addition, 26\*  
 decimals, 154  
 division, 693\*  
 fractions, 154  
 multiplication, 1447\*  
 operations, 153-154  
 subtraction, 2142\*  
 whole numbers, 153  
 Arithmetic logic unit (ALU), 1389  
 Arizona cypress, 543  
 Arkose, 169-170\*  
 Armadillo, 120, 170\*  
 Armaments:  
   air, 47-48\*  
   army, 155-156, 170-171\*  
   ballistic missile, 246\*  
   ballistic range, 246-247\*  
   electronic warfare, 792\*  
   hydrogen bomb, 1105-1106\*  
   missile, 1408\*  
   naval, 1466-1468\*  
   smart weapons, 48  
 Armature, 170\*  
 Armature reaction, 170\*  
 Armature winding, 2390  
 Armbruster, P., 273, 928  
 Armilliferidae, 1756  
 Armor (army), 156, 171  
*Armoracia rusticana*, 966  
 Army armament, 170-171\*  
 Aromatic hydrocarbon, 171-172\*  
   benzene, 266\*  
   benzoic acid, 266\*  
   gasoline, 969  
   nitroaromatic compound, 1490\*  
   phenol, 1654\*  
   quinone, 1836-1837\*  
   thiophene, 2233\*  
 Aromatic naphthas, 1465  
 Aromatic polycarbonates, 1743  
 Aromatic polyesters, 1743  
 Aromatic polysulfones, 1752  
 Aromatics, 1489  
 Aromatization, 172\*  
 Arpanet, 1176  
 Array (antennas), 132  
 Array processing (supercomputer), 2153  
 Arrhenius-Ostwald theory of acids and bases, 11-12  
 Arrowworm, 411  
 Arsenic, 172\*  
   arsenopyrite, 172-173\*  
   realgar, 1874\*  
 Arsenopyrite, 172-173\*  
*Arsinoitherium*, 726  
 Arsonval see d'Arsonval  
*Artemisia tridentata*, 172  
 Arteries, 2327  
 Arteriole, 159  
 Arteriosclerosis, 173-174\*  
   aneurysm, 116\*  
   cholesterol, 445-446\*  
   heart disorders, 1052  
   thrombosis, 2235  
 Arteriovenous communications, 2327  
 Arteritis, 116, 475  
 Artery (aorta), 148\*  
 Artesian systems, 174\*  
 Arthonia, 992  
 Arthoniaceae, 992  
 Arthropodhymenoptera, 1798  
*Arthothelium*, 992  
 Arthritis, 174\*  
   paleopathology, 1602  
   pneumococcus, 1730  
   skeletal system, 2017  
 Arthrobaacter, 500  
 Arthropoda, 174-176\*, 1156  
   animal evolution, 119, 120  
   Chelicerata, 419\*  
   Diplopoda, 678\*  
   Loricifera, 1272-1273\*  
   Mandibulata, 1311\*  
   molting, 1429\*  
   Pentastomida, 1626\*  
   Trilobita, 2273\*  
   weeds, 2381  
 Arthrotardigrada, 951  
 Arthus reaction:  
   atopic, 194  
   dermatitis, 642\*  
   hypersensitivity, 1118  
   skin test, 2019\*  
 Artichoke, 176\*, 185  
 Articulata (Brachiopoda):  
   Orthida, 1580\*  
   Pentamerida, 1626\*  
   Rhynchonellida, 1916\*  
   Spiriferida, 2086\*  
   Strophomenida, 2131\*  
   Terebratulida, 2210\*  
 Articulata (Echinodermata), 176\*  
 Articulata (Inadunata), 1134  
 Articulation see Joint (anatomy)  
 Articulation (speech):  
   disorders, 2078\*  
   tests, 196  
 Artifacts:  
   Paleolithic, 1600, 1601  
   paleontology, 1602  
 Artificial body parts see Prosthesis  
 Artificial crystal see Artificially layered structures  
 Artificial intelligence, 176-177\*  
   automation, 225  
   expert control system, 860-861\*  
   expert systems, 861\*  
   game-playing machines, 858  
 Artificial satellite see Satellite (spacecraft)  
 Artificial sweeteners, 818  
   glycoside, 1008\*  
   saccharin, 1939\*  
 Artificially layered structures, 177-178\*  
   mesoscopic physics, 1359-1360\*  
   nanostructure, 1464\*  
 Artillery, 170  
 Artiodactyla, 178\*  
   animal evolution, 120  
   antelope, 131\*  
   bison, 299\*  
   buffalo, 340\*  
   camel, 360\*  
   chevrotain, 437\*  
   deer, 630-631\*  
   giraffe, 999-1000\*  
   hippopotamus, 1081\*  
   llama, 1266\*  
   moose, 1437\*  
   musk-ox, 1455-1456\*  
   Palaeodonta, 164  
   pecoran ruminants, 164-165, 178  
   pronghorn, 1784\*  
   reindeer, 1885\*  
   sheep, 1997\*  
   tylopod ruminants, 164  
   yak, 2409-2410\*  
   zebu, 2413\*  
*Artocarpus altilis*, 289  
*Asarum*, 153  
 Asbestos, 178-179\*, 1465  
 Asbestosis, 179  
 Ascaridida, 179\*  
 Ascaridoidea, 165, 166  
 Ascaris, 165, 1347, 1610  
 Ascaroidea see Ascaridoidea  
 Ascidiacea, 179\*, 1966  
 ASCII, 262  
 Ascites, 737  
 Asclepiadaceae, 875  
 Ascolichenes:  
   Caliciales, 357\*  
   Hysteriales (lichenized), 1122\*  
   Lecanorales, 1239\*  
   Pseudosphaeriales (lichenized), 1798\*  
   Pyrenulales, 1813\*  
 Ascomycetes, 949  
 Ascomycetous yeasts, 2410  
 Ascomycota, 179-180\*, 685  
 Ascomycotina:  
   Hemiascomycetes, 1062\*  
   Hysteriales (lichenized), 1122\*  
   Loculoascomycetes, 1268\*  
   Plectomycetes, 1727\*  
 Asconema, 1284  
*Ascophyllum*, 843  
 Ascorbic acid, 180\*  
 Ascospaeriales, 848  
 Ascothoracica, 180\*  
 ASCR see Asymmetrical silicon-controlled rectifier  
 Ascute, 412  
 Aselloidea, 167  
 Asellota, 180\*  
 Asellus, 167  
 Asexual reproduction:  
   animal, 1895-1896\*  
   plants, 1896  
 Ash gourd, 1579  
 Ash pumpkin, 1579  
 Ash (tree), 181\*, 1223  
 Asia, 181-183\*  
   climates, 168-169, 182  
   continental crust, 719  
   East Indies, 723-724\*  
   topography, 167-168, 181-182  
   vegetation, 169, 182-183  
 Asian elephant, 1777  
 Asian great apes, 132, 148-149  
 Asian pear, 1622  
 Asiatic buffalo, 301  
 Asiatic wild dog, 634  
 Asimuthal map projection, 1315-1316  
*Asio otus*, 260  
 Asisomyaria, 1223  
 Asparagales, 183\*  
 Asparagus, 183, 183\*  
 Asparagus bean, 1579  
 Asparagus lettuce, 1246  
*Asparagus officinalis*, 169  
 Aspartame, 183\*  
 Aspect ratio, 183-184\*  
 Asperger's syndrome, 221  
*Aspergillus*, 40, 170, 847, 1119, 1460  
 Asphalt and asphaltite, 184\*  
   imponite, 1134\*  
   oil sand, 1537\*  
   petroleum products, 1645  
   wurtzilite, 2399\*  
 Aspidobothria, 2268  
 Aspidochirotrida, 960  
 Aspidogastrea, 184\*  
 Aspidogastridae, 171  
 Aspidorhynchidae, 171  
 Aspidorhynchiformes, 184\*  
*Aspidorhynchus*, 171  
 Aspirin, 108\*, 184\*  
 Ass, 635  
   mule, 1444\*  
   Perissodactyla, 1633-1634\*  
 Assassin bug, 944  
 Assembly language, 1782  
 Assembly machines, 184-185\*  
 Astable multivibrator, 1449-1450  
 Astatine, 185\*  
 Asteraceae, 172  
 Asterales, 185\*  
   lettuce, 1246\*  
   sunflower, 2151-2152\*  
   tarragon, 2193\*  
 Asterias, 174  
 Asteridae, 185-186\*, 824  
 Asterales, 185\*  
   Callitrichales, 357\*  
   Calyceales, 358\*  
   Campanulales, 360\*  
   Dipsacales, 679\*  
   Gentianales, 984\*  
   Lamiales, 1223\*  
   Plantaginales, 1716\*  
   Rubiales, 1935\*  
 Asteroid, 186\*  
 Ceres, 408\*  
   nonlinear physics, 1498, 1498\*  
   Trojan, 2275-2276\*  
 Asteroidea, 186-187\*  
   Forcipulatida, 914\*  
   Notomyotina, 1504\*  
   Paxillosida, 1621\*  
   Platyasterida, 1725\*  
   Valvatida, 2320\*  
 Asteroxylales, 187\*  
*Asteroxylon*, 174  
 Asterozoa, 657  
   Echinodermata, 726  
   Ophiuroidea, 1549\*  
 Asthenosphere, 187-188\*  
   Earth interior, 721  
   earthquakes, 723  
 Asthma, 188\*, 701, 1907  
 Astomatida, 188\*  
 Astrapotheria, 188-189\*  
 Astrapotherium, 175  
 Astrapotheroidea, 175  
 Astrochemistry, 1178  
 Astrocompass, 1734  
 Astroglia, 1477  
 Astrolabe, prismatic, 1775\*  
 Astronomy, 189\*  
 Astronautical engineering, 189\*  
 Astronautics, 190\*  
 Astronomical Almanac, 87  
 Astronomical atlases, 190-191\*  
 Astronomical catalogs, 191\*  
 Astronomical coordinate systems, 191-192\*  
 Astronomical navigation, 386-386\*  
 celestial sphere, 387\*  
 ecliptic, 731\*  
 zenith, 2414\*  
 Astronomical maser, 1329  
 Astronomical observatory, 192-193\*  
 Astronomical photography, 193-194\*  
   color index, 504\*  
   Schmidt camera, 1959\*  
 Astronomical scintillation see Twinkling stars  
 Astronomical seeing see Twinkling stars  
 Astronomical spectroscopy, 194\*, 697, 834, 2076  
 Astronomical transit instrument, 194-195\*  
 Astronomical unit (AU), 195\*  
   Earth revolution around Sun, 722  
   light-year, 1252\*  
 Astronomy, 195-196\*  
   archeoastronomy, 162  
   astrometry, 189\*  
   astrophysics, 196-197\*  
   celestial reference system, 387\*  
   dating methods, 620  
   ephemeris, 835\*  
   magnitude, 1304\*  
   neutrino, 1482-1483\*  
   nutiation, 1524\*  
   parallax, 1608\*  
   phase, 1649\*  
   planetarium, 1699\*  
   quasar, 1833-1834\*  
   rocket, 1928\*  
   satellite astronomy, 1946\*  
   satellites, 1946\*  
   submillimeter, 2140\*  
   transit, 2261\*  
   ultraviolet, 2295\*  
   see also Gamma-ray astronomy; Infrared astronomy; Radio astronomy; X-ray astronomy  
 Astrophysics, 196-197\*  
   binary star, 243, 273-274\*  
   high-energy, 196-197\*  
   neutron stars, 1485  
   planetary physics, 1700-1701\*  
   ultraviolet astronomy, 2295  
   x-ray astronomy, 2401  
*Astroscopus*, 673  
 Astrotracker see Star tracker  
 Asymmetric synthesis, 197-198\*  
*Asymmetron*, 354  
 Asymptote, 198\*  
 Asymptotic freedom, 1825  
 Asymptotic giant branch (AGB), 2109  
 Asynchronous detection, 105  
 Asynchronous transfer mode (ATM), 1594  
 ATCRBS see Air-Traffic Control Radar Beacon System  
 Ateleopoidae, 359  
 Atelene, 1771  
 Ateloida, 1431, 1432  
 Atelostomata, 198\*  
 Aten asteroids, 186  
 Athalamida, 199\*  
 Athecanephria, 199\*, 1732  
 Atherinidae, 183  
 Atheriniformes, 199\*  
 Atheromas, 173-174  
 Atherosclerosis, 158, 173, 1143  
 Atlantic Ocean, 199-200\*  
   equatorial currents, 841, 842  
   Gulf Stream, 1032-1033\*  
   marine geology, 1321  
   ocean circulation, 1530  
 Atlantic sturgeon, 2137  
 Atlantic white cedar, 344  
 Atlas cedar, 344  
 Atmosphere, 200-202\*  
   biosphere, 295\*  
   climate modification, 473\*  
   cosmic rays, 565  
   deliquescence, 632-633\*

## Atmosphere—cont.

Earth, 718  
 electromagnetic pulse, 772  
 forest and forestry, 916  
 gas and atmosphere analysis, 964-965\*  
 greenhouse effect, 1025-1026\*  
 humidity, 1097\*  
 hydrometeorology, 1109\*  
 ionosphere, 1190\*  
 Jupiter, 1207  
 Mars, 1327  
 mesosphere, 1360\*  
 meteorological optics, 1377\*  
 meteorology, 1379-1380\*  
 middle-atmosphere dynamics, 1399\*  
 Neptune, 1476  
 pressure see Air pressure  
 psychrometrics, 1804-1805\*  
 radioactive fallout, 1854  
 radon, 1864  
 refraction of waves, 1882\*  
 stratosphere, 2123-2124\*  
 Sun, 2149-2150  
 tropopause, 2277\*  
 upper-atmosphere dynamics, 2307-2308\*  
 weather, 2377-2378\*

Atmospheric acoustics, 202-203\*, 2052  
 Atmospheric chemistry, 203-204\*  
 Atmospheric dynamics, 1379, 1380  
 Atmospheric electricity, 204\*  
 aurora, 218-219\*  
 lightning, 1252-1253\*  
 sferics, 1995\*  
 storm electricity, 2121\*  
 Atmospheric entry, 204-205\*, 1118  
 Atmospheric general circulation, 205\*  
 Atmospheric Infra-Red Sounder (AIRS), 1379  
 Atmospheric physics, 1379, 1380  
 Atmospheric pressure see Air pressure  
 Atmospheric sounders, 1379  
 Atmospheric tides, 205-206\*  
 Atmospheric transparency, 2141  
 Atmospheric waves, upper synoptic, 206\*  
 Atoll, 206\*, 1879  
 Atom, 206\*  
 antimatter, 142-143\*  
 chemistry, 431  
 donor atom, 696\*  
 electron capture, 777\*  
 free radical, 933\*  
 hadronic, 1037-1038\*  
 intermolecular forces, 1174  
 ion, 1183\*  
 isobar (nuclear physics), 1193\*  
 isotope, 1197\*  
 mass defect, 1330\*  
 mass number, 1330\*  
 neutron, 1483-1484\*  
 proton, 1794\*  
 quasiatom, 1834\*  
 Rydberg atom, 1936-1937\*  
 scattering experiments, 1954\*

Atom cluster, 206-207\*, 1464  
 Atom laser, 207-208\*  
 Atom optics, 208\*  
 atom interferometer, 188  
 diffraction gratings, 188  
 laser cooling, 1230

Atom-probe field-emission microscope, 798  
 Atomic absorption analysis, 802-803  
 Atomic beams, 208\*  
 Atomic bomb, 208-209\*, 1506-1507  
 Atomic clock, 209\*, 836  
 Atomic mass, 209-210\*  
 Atomic mass unit, 210\*  
 Atomic nucleus, 210\*  
 exotic nuclei, 859\*, 859-860\*  
 nuclear physics, 1512\*  
 nuclear radiation, 1513\*  
 nuclear reaction, 1514\*  
 nuclear structure, 1517-1518\*  
 radioactivity, 1856-1858\*  
 scattering experiments, 1954\*

Atomic number, 210\*, 1330  
 Atomic physics, 210\*, 1373  
 Atomic polarization, 1736  
 Atomic spectrometry, 210-211\*  
 Atomic structure and spectra, 211-214\*  
 Auger effect, 217-218\*  
 correspondence principle, 562\*  
 electron configuration, 777-779\*  
 electron spectroscopy, 783\*  
 hyperfine structure, 1116\*  
 isotope shift, 1198\*  
 line spectrum, 1256-1257\*  
 magnetochemistry, 1301\*

## Atomic structure and spectra—cont.

photoionization, 1667\*  
 Ritz's combination principle, 1924\*  
 Stark effect, 2100\*  
 Atomic theory, 214\*  
 Atomic time (AT), 214-215\*  
 atomic clock, 209\*  
 Dynamical Time, 711  
 Atomic vapor layer isotope separation (AVLIS), 1198  
 Atomic weight:  
 atomic mass, 209-210\*  
 atomic mass unit, 210\*  
 relative atomic mass, 1886\*  
 Atomization, 215\*  
 ATP see Adenosine triphosphate  
 Atriplex *hortense*, 2085  
 Atropa *belladonna*, 194  
 Atropa *betica*, 194  
 Atropine, 215\*  
 alkaloid, 79  
 belladonna, 265\*  
 AT&T Bell Labs, 1783  
 Attachment theory, 650  
 Attapulgitic clays, 469  
 Attention deficit hyperactivity disorder, 215-216\*  
 Attenuation, 216\*  
 atmospheric sound, 202  
 electricity, 216\*  
 sound absorption, 2052  
 Attenuator, microwave, 1392  
 Attractant, 1158  
 AU see Astronomical unit  
 Auchenorrhyncha, 927  
 Audio amplifier, 217\*  
 automatic gain control (AGC), 224-225\*  
 loudspeaker, 1273  
 mixer, 1412  
 Audio-frequency measurement, 836-837  
 Audio-frequency transformers, 2259  
 Audiogram, 196  
 Audiometry, 217\*  
 Auditory hallucinations, 1042  
 Auditory nervous system:  
 hearing (human), 1050  
 hearing impairment, 1051\*  
 Auger, P., 193, 213  
 Auger effect, 193, 217-218\*  
 atomic structure and spectra, 213  
 channel electron multiplier, 413\*  
 spectroscopy, 2076  
 surface physics, 2169, 2170  
 Auger electron spectroscopy (AES), 218\*  
 Auger electrons, 196-197  
 Auger mining, 426, 483  
 Auger recombination, 781  
 Augers (construction equipment), 479  
 Augite, 218\*  
 Auk, 365  
 Aulocystis, 1280  
 Aulolepididae, 531  
 Aulolepis, 531  
 Aureole, contact, 480, 543\*  
*Auricularia polytricha*, 984, 1112  
 Aurora, 36, 218-219\*, 1188  
 Australia, 219\*, 723  
 Australopithecine, 219-220\*  
*Australopithecus*, 219, 220, 829, 924, 925  
*Australopithecus afarensis*, 924-926, 926  
*Australopithecus africanus*, 219  
 Autecology, 735  
 Authigenic minerals, 220-221\*  
 Autistic disorder, 221-222\*  
 Autoalloleopathy, 81  
 Autogamy, 1895  
 Autogiro, 222\*  
 Autografts, 2263  
 Autoimmune disease see Autoimmunity  
 Autoimmunity, 222-223\*, 1129  
 Autoionization see Auger effect  
 Automata theory, 223-224\*  
 Automated decision making, 224\*  
 Automatic block signaling, 1865  
 Automatic cab signaling, 1865  
 Automatic frequency control (AFC), 224\*  
 Automatic gain control (AGC), 224-225\*, 1849  
 Automatic horizon, 225\*  
 Automatic landing system, 225\*  
 Automatic radar plotting aids (ARPA), 1324  
 Automatic sprinkler system, 225\*, 802  
 Automatic train control (ACT) subsystems, 1865  
 Automatic transmission (automobile), 200

## Automatic volume control see Automatic

gain control  
 Automation, 225-226\*  
 air-traffic control, 57  
 greenhouse technology, 1026  
 manufacturing engineering, 1314-1315  
 robotics, 1925\*  
 Turing machine, 223-224  
 Automobile, 226-227\*  
 Automotive brake, 226, 227-228\*  
 Automotive climate control, 228\*  
 Automotive drive axle, 228-229\*  
 Automotive electrical system, 229\*  
 Automotive engine, 226, 229\*  
 catalytic converter, 379-380\*  
 fuel system, 942-943\*  
 Automotive steering, 226, 229-230\*  
 Automotive suspension, 226, 230\*  
 shock absorber, 2000-2001\*  
 torsion bar, 2251-2252\*  
 Automotive transmission, 226-227, 230-231\*  
 clutch, 480\*  
 differential, 661\*  
 gear train, 974\*  
 Automotive vehicle:  
 automobile, 223-224  
 bus, 345\*  
 wheel base, 2386\*  
 Autonomic nervous system, 231\*, 1610-1611  
 Autonomous underwater vehicles (AUVs), 2300-2301  
 Autopilot, 231\*  
 flight control, 896  
 guidance systems, 1031\*  
 Autoradiogram, 205  
 Autoradiography, 231\*  
 Autoscopic hallucinations, 1042  
 Autotomy, 519-520  
 Autotransformer, 232\*  
 Autotrophic succession, 734  
 Autotrophs, 736  
 Autoxidation, 144, 232\*  
 Autumn crocuses, 1254  
 Auxin, 232-233\*, 1705  
 Avalanche, 233\*  
 Avalanche diodes, 1397-1398  
 Aves, 233-234\*  
 Amniota, 100\*  
 animal evolution, 120  
 Anseriformes, 129\*  
 Apodiformes, 151\*  
 Archaeornithes, 161\*  
 Caprimulgiformes, 365\*  
 Charradriiformes, 415\*  
 Coliiformes, 499\*  
 Columbiformes, 505\*  
 Coraciiformes, 558\*  
 Falconiformes, 870\*  
 Galliformes, 958\*  
 Gastornithiformes, 970\*  
 Gaviiformes, 974\*  
 Gruiformes, 1031\*  
 Hesperornithiformes, 1070-1071\*  
 Ichthyornithiformes, 1124-1125\*  
 Neognathae, 1473\*  
 Neornithes, 1475\*  
 Odontognathae, 1533\*  
 Opisthocomiformes, 1550\*  
 Passeriformes, 1618\*  
 Pelecaniformes, 1623-1624\*  
 Phoenicopteriformes, 1656\*  
 Piciformes, 1684\*  
 Procellariiformes, 1777-1778\*  
 Psittaciformes, 1799\*  
 Ratiites, 1871\*  
 Sphenisciformes, 2082\*  
 Strigiformes, 2128\*  
 Struthioniformes, 2136\*  
 Trogoniformes, 2275\*  
 see also Bird  
 Avian leukosis, 234-235\*  
 Aviation, 235\*  
 general, 873, 980-981\*  
 human-machine systems, 1097  
 instrument landing system (ILS), 1160\*  
 medicine, 37-38  
 Avocado, 235\*, 1233  
 Avocet, 364  
 Avogadro number, 235\*, 1015  
 Avogadro's law, 235\*  
 Axenic culture, 235-236\*  
 Axial skeleton, 2015-2016  
 Axillary buds, 300  
 Axinellida, 236\*

## Axis of rotation:

precession, 1765  
 precession of equinoxes, 1765-1766  
 Aye-aye, 236\*  
 Ayerton-Jones current balance, 535  
 Azeotropic distillation, 236-237\*  
 Azeotropic mixture, 237\*  
 Azide, 237\*  
 Azolla, 1943  
*Azotobacter*, 706, 1382  
 Azurite, 237\*

## B

B lymphocytes, 268, 350  
 B vitamins, 2348  
 Babbitt, I., 139  
 Babbitt metal, 139-141  
 Babcock, H. D., 2040  
 Bacillariophyceae, 239\*, 402  
 Bacillary dysentery, 239-240\*  
*Bacillus*, 211, 240  
*Bacillus anthracis*, 120-121  
*Bacillus cereus*, 909  
*Bacillus thuringiensis*:  
 insect pathology, 1156  
 pesticide, 1639  
 Back, E., 1618  
 Background count, 240\*  
 Backhoe, 773  
 Backscattering, 1186  
 Backswimmer (insect), 942  
 Bacteria, 240-241\*  
*Actinobacillus*, 20\*  
 Actinomycetes, 20-21\*  
 aerobic, 240  
*Aeromonas*, 34\*  
 anaerobic infection, 107\*  
 archaeobacteria, 160\*  
 bacteriophage, 244-245\*  
*Bordetella*, 318-319\*  
*Borrelia*, 320\*  
 chemolithotrophic, 381  
*Clostridium*, 477\*  
 Cyanobacteria, 601-602\*  
 digestive system, 667-668  
 endospores, 240-241  
 endotoxin, 819-820\*  
 Erysipelothrix, 845-846\*  
 food microbiology, 909  
 food poisoning, 909-910  
 Francisella, 931\*  
 fresh-water ecosystem, 938  
*Haemophilus*, 1038\*  
 hydrothermal vent, 1323  
*Klebsiella*, 1217\*  
 marine microbiology, 1322-1323\*  
*Meningococcus*, 1354\*  
 methanogenesis, 1381\*  
 microbiology, 1382\*  
*Moraxella*, 1437-1438\*  
 morphology, 240  
 nucleus of, 240  
*Pasteurella*, 1618-1619\*  
 petroleum microbiology, 1642-1643  
 plant pathology, 1710  
*Pneumococcus*, 1730\*  
 pneumonia, 1731  
 poison, 1732  
 Prokaryota, 1784  
*Pseudomonas*, 1798\*  
 recombination (genetics), 1875  
 Rhizobiaceae, 1913\*  
 siderophores, 2005  
 species concept, 2073  
*Staphylococcus*, 2096\*  
*Streptococcus*, 2126-2127\*  
 toxin, 2253, 2254  
 transduction, 2257, 2257\*  
 transformation, 2258, 2258\*  
 wood degradation, 2394  
*Yersinia*, 2411-2412\*  
 Bacterial disease, 1913  
 anaplasmosis, 113\*  
 anthrax, 134-135\*  
 bacillary dysentery, 239-240\*  
 brucellosis, 336\*  
 cat scratch disease, 378\*  
 chlamydial diseases, 442\*  
 diphtheria, 677\*  
 gonorrhoea, 1012-1013\*  
 granuloma inguinale, 1016\*

- Bacterial disease—*cont.*  
 Johne's disease, 1203\*  
 Legionnaire's disease, 1240\*  
 leprosy, 1245-1246\*  
 leptospirosis, 1246\*  
 listeriosis, 1264\*  
 Lyme disease, 1281  
 meningitis, 1354\*  
 mycobacterial diseases, 1458\*  
 plague, 1695-1696\*  
 pneumonia, 1730-1731\*  
 pseudotuberculosis, 1798\*  
 relapsing fever, 1885-1886\*  
 rheumatic fever, 1913\*  
 rickettsioses, 1920\*  
 salmonellosis, 1941\*  
 scarlet fever, 1954\*  
 sexually transmitted, 1994  
 syphilis, 2185\*  
 tetanus, 2214\*  
 toxic shock syndrome, 2253\*  
 tree, 2267  
 tuberculosis, 2279\*  
 tularemia, 2280\*  
 ulcer, 2293  
 vaccination, 2317  
 water-borne, 2363  
 whooping cough, 2387\*  
 yaws, 2410\*
- Bacterial genetics, 213, 241-242\*  
 Bacterial growth, 242\*  
 Bacterial luminescence, 242\*  
 Bacterial physiology and metabolism, 242-243\*  
 Bacterial resistance, 2147  
 Bacterial taxonomy, 243-244\*  
 Bacterial viruses, 2345  
 Bacteriochlorins, 1756  
 Bacteriochlorophylls, 1757  
 Bacteriology, 244\*, 1345  
 Bacteriophage, 244-245\*  
 coliphage, 499\*  
 lysogeny, 1282-1283\*  
 lytic infection, 1284\*  
 recombinant DNA, 576  
 transduction (bacteria), 213, 2257\*
- Bacteroides*, 214  
 Bactrian camel, 320  
 Badge meter *see* Film badge  
 Badger, 245\*  
 Balance, 245\*  
 postural equilibrium, 1758-1759\*  
 quantitative chemical analysis, 1821\*  
 vestibular system, 2334-2335\*  
 weight measurement, 2381
- Balanoglossus*, 742  
 Balanomorpha, 246\*, 2234  
 Balanopaceae, 784  
*Balantidium coli*, 1348  
 Bald cypress, 544  
 Bald eagle, 260  
 Ball-and-race-type pulverizer, 246\*  
 Ball bearings, 139-141  
 Ball clays, 413  
 Ball-point pens, 1154  
 Ballast resistor, 246\*  
 Ballistic cameras, 1562  
 Ballistic missile, 246\*, 2139  
 Ballistic pendulum, 1624  
 Ballistic range, 246-247\*  
 Ballistics, 247\*  
 Coriolis acceleration, 559\*  
 trajectory, 2256\*
- Balloon, 247\*  
 Balsa, 247-248\*  
 Balsam pear, 1579  
 Balsamic vinegar, 2340  
 Balsaminaceae, 884  
 Baltic Sea, 248\*  
 Bamboo, 248\*, 1019, 2266  
 Banana, 248\*, 2266  
 Banana aphid, 2  
 Band brake, 840  
 Band spectrum, 248\*, 2076  
 Band theory of solids, 248-249\*  
 conduction band, 533\*  
 de Haas-van Alphen effect, 631-632\*  
 electron-hole recombination, 780-781\*  
 hole states in solids, 1083\*  
 semiconductors, 1980-1981\*  
 valence band, 2320\*
- Banded gecko, 868  
 Banded iron formation, 249-250\*  
 Bandwidth:  
 pulse modulation, 1809  
 television, 2202-2203\*  
 wide-area networks, 2387-2388
- Bandwidth requirements (communications), 250\*  
 Bangiophycidae, 1915\*  
 Bang's disease *see* Brucellosis  
 Banting, F., 1604  
 Bar graph, 1017  
 Bar linkage, 1259-1260  
*Baragwanathia*, 1280  
*Barbarea verna*, 513  
 Barberry, 1869  
 Barbiturates, 250\*  
 Barchan dune, 642, 705, 706  
 Bardeen, J., 2155, 2157  
 Bardeen-Cooper-Schrieffer (BCS) theory, 2155, 2156-2157  
 Barges, 1154  
 Barite, 250\*  
 Barium, 250-251\*  
 Bark, 251\*, 2266  
 Bark lice, 1799  
 Barkhausen effect, 251\*  
 Barley, 251-252\*  
 Barn owl, 260, 2128  
 Barnacle, 252\*  
 Balanomorpha, 246\*  
 Cirripedia, 464\*  
 Lepadomorpha, 1242\*  
 Thoracica, 2234\*  
 Verrucomorpha, 2331\*  
 Baroclinic field, 252\*  
 Barometer, 252\*, 1313  
 Barotropic field, 252\*  
 Barracuda, 252-253\*  
 Barretter, 253\*  
 Barrier injection transit-time diode (BARRITT), 1397-1398  
 Barrier islands, 253\*  
 Barrier reef, 1879  
 Bartlett pear, 1622  
*Bartonella bacilliformis*, 335  
 Barycentric Dynamical Time (TDB), 711  
 Baryon, 253-255\*  
 delta resonance, 634\*  
 hypercharge, 1116\*  
 hyperon, 1117\*  
 quarks, 1832  
 strong nuclear interactions, 2129  
 symmetry laws, 2180  
 universe, 2305  
 Barytherioidea, 1777  
 Basal ganglia, 1442  
 Basal region, 1477  
 Basalt, 255-256\*, 955  
 Basaltic magmas, 1289  
 Basaltic melts, 1234  
 Bascule bridge, 292  
 Base (chemistry), 256\*, 770  
*see also* Acid and base  
 Basic Observations Program, 2379  
 Basic programming language, 2030  
 Basicladia, 411  
 Basidiomycetous yeasts, 2410  
 Basidiomycota, 256\*, 2310  
 Basidiomycotina, 864, 983-984  
 mushroom, 1453\*  
 Ustilaginomycetes, 2315\*  
 Basil, 256-257\*, 1223  
*Basillus*, 2092  
 Basin, 257\*, 628, 629  
 Basommatophora, 257\*, 1806  
 Basophil, 268  
 Bassanite, 1034  
 Basswood, 226  
 Bast fiber, 1211  
 Bat:  
 animal evolution, 120  
 Chiroptera, 440-441\*  
 echolocation, 729  
 Batales, 227, 257\*, 336  
 Bathocyroidae, 1266  
 Bathylaconoidei, 1941  
 Bathynellacea, 227  
 Bathydontoidea, 1434  
 Bathypelagic animals, 629-630  
 Bathysquillidae, 2119  
 Batis, 227  
 Batoidea, 257-258\*  
 Batophora, 551  
 Batrachoididae, 228  
 Batrachoidiformes, 258\*  
 Battery, 258-259\*  
 electromotive force, 776\*  
 energy storage, 821-822\*  
 galvanic cells, 690  
 mercury, 1356  
 nuclear, 1505\*  
 solid-state, 2043-2044\*
- Battleships, 1468  
 Bauxite, 259\*  
 gallium, 958  
 paleoclimatology, 1598  
 Bay laurel, 1233  
 Bay owl, 2128  
 Bayer, J., 478  
 Bayes, Thomas, 228  
 Bayesian statistics, 259\*  
 criticism, 228  
 noninformative and improper priors, 228-229  
 Bdelloidea, 260\*  
 Bdellonemertini, 260\*, 741  
 Beach hopper, 1307  
 Beaded lizard, 886, 2092  
 Beam, 260\*  
 cantilever, 363  
 composite *see* Composite beam  
 concrete, 530\*  
 loads, transverse, 1266\*  
 molecular, 1418\*  
 plate girder, 1723-1724\*  
 structural connections, 2133-2134\*  
 Beam bridge, 292  
 Beam column, 260\*  
 Beam-foil spectroscopy, 260\*  
 Beam-rider guidance system, 913  
 Bean, 260-261\*  
 farm crops, 871  
 oriental, 1579  
 winged, 2391\*  
 Bear, 261\*  
 Bear Driver *see* Boötes  
 Beard worms, 1732  
 Bearing:  
 antifriction *see* Antifriction bearing  
 jewel, 1203\*  
 lubrication, 1277  
 piloting, 1687  
 Bearing alloy, 83, 139-141  
 Beat, 261\*  
*Beauveria*, 1119  
 Beaver, 261\*, 1930  
 Beck, A. T., 1804  
 Becker process, 1198  
 Becker's muscular dystrophy, 1451  
 Becquerel, H., 1855  
 Bee, 261-262\*  
 Hymenoptera, 1112-1113\*  
 social insects, 2027-2028\*  
 Bee-eater (bird), 494  
 Beech, 262\*, 784, 870  
 Beekeeping, 262\*  
 Beer, 1308  
 Beer drinker's syndrome, 429  
 Beer's law, 5-6  
 Beet, 262\*, 336  
 Beet sugar, 2144  
*see also* Sucrose; Sugar  
 Beetle, 497-498, 1156  
 Beetle mite, 8  
 Beggatoaceae, 232  
 Behavior genetics, 262-263\*  
 Behavioral ecology, 263\*, 2218  
 Behavioral psychophysics, 263-264\*  
 Behavioral therapies, 1804  
 Behavioral toxicology, 264\*  
 Beijerinckia, 210  
 Belemnites, 234, 594  
 Belemnoidae, 264-265\*, 438  
 Belinfante, F. J., 1076  
 Bell, 265\*  
 Bell, J. S., 952, 1076  
 Belladonna, 265\*  
 Bellatrix, 1579  
*Belonostomus*, 171  
 Belostomatidae, 942  
 Belt conveyor, 302, 488, 552  
 Belt drive, 265\*, 1806  
 Belted bias tire, 2243  
*Benincasa cerifera*, 1579  
*Benincasa hispida*, 1579  
 Bennet Comet, 508  
 Bennettiales, 539  
*see also* Cycadeoidales  
 Bennettitopsida, 539  
*Bentheuphausia amblyops*, 770  
 Benthic organisms:  
 deep-sea fauna, 630  
 fresh-water ecosystem, 937-938  
 Benthos, 629-630  
 Bentonite, 265-266\*  
 clay, 469  
 commercial clay, 469  
 Benzal chloride, 391  
 Benzedrine, 101
- Benzene, 266\*  
 aromatic, 171  
 aromatic hydrocarbon, 171  
 resonance theory, 1904  
 Benzer, S., 454  
 Benzoic acid, 266\*  
 Benzotrithloride, 391  
 Benzoyl peroxide, 266\*  
 Benzyl chloride, 391  
*BeppoSAX*, 961  
 Berberidaceae, 1869  
*Berberis*, 1869  
 Bergy-bit, 1124  
 Beriberi, 2232  
 Bering Land Bridge, 1600  
 Bering Sea, 266-267\*  
 Bering Straits, 1600  
 Berkelium, 267\*  
 Bermuda grass, 267\*  
 Bernard, C., 1346  
 Bernier, François, 1087  
 Bernoulli, Jacques, 1241  
 Bernoulli's theorem, 47, 267\*  
 gas dynamics, 966  
 hydraulics, 1102  
 Bernstein, J., 246  
*Beroe*, 237  
 Beroida, 267\*  
 Berthelina, 1939  
*Bertholletia excelsa*, 288, 1239  
 Bertholide compounds, 1500  
 Bertrand lens, 1738  
 Beryciformes, 267-268\*  
 Beryl, 268\*, 812  
 Beryllides, 239  
 Beryllium, 268-269\*  
 beryl, 268-269\*  
 chrysoberyl, 455\*  
 Beryllium alloys, 269\*  
 Beryllium bronze, 295  
 Beryllium metallurgy, 239  
 Beryllium minerals, 269\*  
 Berytidae, 944  
*Besnoitia*, 2254  
 Bessel functions, 269-270\*  
 Bessemer, H., 2106  
 Bessemer matte, 1487  
 Best, C., 1604  
 Beta function, 2072  
 Beta Orionis *see* Rigel  
 Beta-particle decay, 1857  
 Beta particles, 270-271\*  
 radioactive fallout, 1854  
 radiochemical laboratory, 1859  
 Beta rhythm (brain), 692-693, 768  
 Beta sulfur *see* Monoclinic sulfur  
*Beta vulgaris*, 232, 336  
 Betatron, 271\*  
 Betel nut, 271\*  
 Betel pepper, 241  
 Betelgeuse, 271\*, 1579  
*Betula* species, 259, 698  
 Betulaceae, 259, 784  
 Bevel gears:  
 hypoid, 241-242  
 spiral, 241  
 straight, 241  
 zero, 241  
 Biampometric titration, 2246  
 Bias (electronics), 271-272\*  
 Bias tire, 2243  
 Bicarbonate, 329  
 Bichirs, 21  
 BiCMOS integrated circuits, 1165  
*Bicosoeca mediterranea*, 242  
 Bicosoecida, 272\*  
 Big bang theory, 272-273\*  
 cosmic background radiation, 564  
 cosmic microwave radiation, 500  
 cosmology, 569-570  
 universe, 2306  
 Big bluestem grass, 272  
 Big Horn Basin, 970  
 Bile:  
 bilirubin, 273\*  
 gallbladder, 957\*  
 jaundice, 1201-1202\*  
 Bile ducts, 957  
 Bilharziasis *see* Schistosomiasis  
 Biliary system, 667  
 Bilirubin, 273\*, 957  
 Bimetallic thermometer, 2229  
 Binary element *see* Bit  
 Binary fission (reproduction), 909, 1895  
 Binary number system, 616, 1522-1523  
 Binary star, 273-274\*  
 black hole, 300-301\*

- Binary star—*cont.*  
 blue straggler star, 307-308\*  
 cataclysmic variable, 244-245, 378\*  
 eclipsing variable stars, 731\*  
 evolution, 243-244  
 Mizar, 1412\*  
 observational techniques, 243  
 x-ray, 244
- Binaural hearing, 930  
 Binaural sound system, 274-275\*  
 Binding energy:  
 mass defect, 1330  
 nuclear, 1505\*
- Binet, Alfred, 1169  
 Binge eating disorder, 724-725  
 Bini, L., 766  
 Binoculars, 275\*  
 Binomial theorem, 275\*  
 Bioacoustics, animal, 275-276\*  
 Bioarcheology, 276-277\*  
 Bioassay, 277\*  
 Biocalorimetry, 277\*  
 Biochemical engineering, 245\*, 277\*  
 Biochemical genetics, 1095  
 Biochemistry, 277-278\*  
 biomedical chemical engineering,  
 289-290\*  
 cytochemistry, 608\*  
 paleobiochemistry, 1596\*  
 sulfur, 2148-2149  
 Biodegradation, 278\*  
 fungi, 950  
 industrial wastewater treatment, 1142  
 paleobotany, 1597  
 Biodiversity, 278-279\*, 645  
 Bioelectromagnetics, 279\*  
 Bioelectronics, 279-280\*  
 biosensors, 247  
 molecular electronics, 247  
 neuronal interfaces, 247  
 Bioenergetics see Energy metabolism  
 Biofacies, 783, 869  
 Biofilm, 280\*  
 Biogenic structure see Trace fossils  
 Biogeochemical cycles, 736  
 Biogeochemistry, 280-282\*  
 Biogeography, 282-283\*  
 animal systematics, 123\*  
 island, 1193\*  
 zoogeography, 2418-2419\*  
 Bioherm, 283\*  
 Bioinorganic chemistry, 283-284\*  
 Bioleaching, 284\*  
 Biologic-prosthetic systems, 1789  
 Biological clock, 284-285\*, 2019  
 Biological control:  
 forest pest control, 920  
 weeds, 2381  
 Biological oxidation, 285\*  
 oxidoreductases, 748  
 respiration, 1905-1906\*  
 Biological polymer, 255  
 Biological productivity, 285\*  
 Biological specificity, 285\*  
 Biologicals, 252, 285-286\*  
 Biology, 286-287\*  
 developmental, 649\*  
 ecology, 735\*  
 forensic, 914-915\*  
 magnetic reception, 1293\*  
 mathematical, 1335\*  
 microbiology, 1382\*  
 molecular, 1418-1419\*  
 neurobiology, 1480\*  
 nuclear radiation, 1513\*  
 paleontology, 1601-1602\*, 1602  
 radiation, 1842-1843\*  
 radioisotope, 1861\*  
 sociobiology, 2028-2029\*  
 space, 2057\*  
 transplantation, 2263\*  
 Bioluminescence, 242, 287-288\*  
 Biomagnetism, 288\*, 2154  
 Biomass, 288\*  
 ecosystem, 736  
 forest ecosystem, 917  
 solar energy, 2039  
 trophic ecology, 2276  
 Biome, 288\*  
 Biomechanics, 288-289\*  
 Biomedical chemical engineering, 289-290\*  
 Biomedical engineering, 290\*  
 Biomedical ultrasonics, 290-291\*  
 Biomes, 735  
 Biometeorology, 291-292\*  
*Biomyxa*, 182  
 Bioorganic chemistry, 292-293\*  
 Biophysics, 1419  
 Biopolymer, 293\*  
 Biopotentials and ionic currents, 293-294\*  
 Biopyrrole, 294\*  
 Bioreactor, 245  
 Bioremediation see Microbial degradation  
 Biorheology, 294\*  
 Biosensor, 247, 295\*, 2257  
 Biosphere, 295\*, 735  
 environment, 828-830\*  
 Tommot fauna, 2247\*  
 Biostrome, 295\*  
 Biosynthesis, 97-98, 295-296\*  
 Biot-Savart law, 296\*  
 Biotelemetry, 296-297\*  
 Biotic environment, 745, 828-829  
 Biotin, 297\*  
 Biotite, 297\*, 1125  
 gabbro, 955  
 mica, 1381  
 Bioturbate structure see Trace fossils  
 Biphenyl, 1742  
 Bipolar affective disorder, 39, 40  
 Bipolar integrated circuits, 1164  
 Bipolar junction transistors (BJTs),  
 1396-1397  
 Bipolar transistors, 2260  
 Bipolarina, 1462  
 Biradial symmetry, 123  
 Birch, 297\*, 784, 870  
 Bird:  
 Anamnia, 112  
 digestive system, 666  
 ear, 713, 714, 715  
 ethology, 849-850  
 Falconiformes, 870\*  
 feather, 874\*  
 flight, 894-895  
 Galliformes, 958\*  
 migratory behavior, 1400-1401\*  
 Newcastle disease, 1486\*  
 Oligocene, 1539  
 Podicipediformes, 1731\*  
 stomach, 606, 2119  
 thermoregulation, 2230  
 tongue, 2247-2248  
 uropygial gland, 2314\*  
 see also Aves  
 Bird-hipped dinosaur, 149  
 Bird lice, 1307-1308  
 Birefringence, 297\*  
 linearly polarized light, 1736  
 photoelasticity, 1664\*  
 Birth control, 297-298\*  
 Birth defect, see Congenital  
 anomalies  
 Birthwort, 153  
 Bismarck Archipelago, 655  
 Bismuth, 298\*  
 Bismuth alloys, 261  
 Bison, 299\*  
*Bison bison*, 262  
*Bison bonasus*, 262  
 Bisphenol compounds, 145  
 Bistability, optical, 1551\*  
 Bit, 299\*  
 Biting lice, 1307-1308  
 Bitter cucumber, 1579  
 Bitter gourd, 1579  
 Bitter melon, 1579  
 Bitter orange, 1565  
 Bitumen, 184, 299\*  
 Bituminous coal, 424, 481  
 Bituminous sand see Oil sand  
 Bivalvia, 263\*, 299-300\*  
 Anisomyaria, 125\*  
 boring bivalves, 319\*  
 cockle, 430-431  
 Lamellibranchia, 1223\*  
 Pliocene, 1728  
 Protobranchia, 1793\*  
 Septibranchia, 1986-1987\*  
 shipworm, 2000\*  
 Taxodonta, 2194  
 BL Lacertae objects, 1834  
 Black-backed jackal, 634  
 Black bear, 230  
 Black birch, 259  
 Black caiman, 309  
 Black coral, 144  
 Black cottonwood, 1754  
 Black currant, 534, 599  
 Black death, 1695  
 Black ebony, 656, 725  
 Black fly, 1156  
 Black-footed ferret, 790  
 Black granite see Diorite  
 Black hole, 197, 300-301\*  
 galaxy, external, 956-957  
 gravitational collapse, 1022-1023  
 quantum gravitation, 1827-1818,  
 1827-1828  
 supermassive stars, 2160  
 x-ray astronomy, 2401  
 Black locust, 1268  
 Black mica see Biotite  
 Black pepper, 301\*, 1691, 1692  
 Black powder, 265, 1817  
 Black Sea, 301\*  
 Black shale, 301-302\*  
 Black spruce, 2090  
 Black-tailed prairie dog, 1764  
 Black walnut, 2362  
 Black yeast, 265  
 Blackberry, 302\*  
 Blackbody, 302\*  
 emissivity, 813\*  
 incandescence, 1135\*  
 pyrometer, 1816\*  
 Blackeye cowpea, 229  
 Blackeye peas, 509  
 Blackleg, 302\*  
 Blacktree kangaroo, 1209  
 Bladder:  
 urinary, 2311\*  
 urinary tract disorders, 2313\*  
 Blast furnace, pressurized, 1770\*  
 Blastocladales, 402  
 Blastoidea, 302\*  
*Blastomyces dermatitidis*, 266  
 Blastomycetes, 302-303\*  
 Blastulation, 303\*  
 cleavage (embryology), 471\*  
 differentiation, 728  
 Blattidae, 431  
 Blazars, 956  
 Bleaching, 303\*  
 Bleaching agents (food), 818  
 Blende see Sphalerite  
 Blepharisma, 917  
 Blimp, 66-67, 303-304\*  
 Blind sac, 666  
 Blindness:  
 cataract, 380\*  
 glaucoma, 1003, 1003\*  
 visual impairment, 2348\*  
 Bloch theorem, 304\*  
 Block and tackle, 304\*  
 Block cipher, 524  
 Block diagram, 304\*  
 Blood, 304-305\*  
 coagulation, 269  
 disorders see Hematologic disorders  
 formed elements, 267-268  
 hematopoiesis, 1062\*  
 hemoglobin, 1066\*  
 immunoglobulin, 1130  
 plasma, 268  
 plasmin, 1720-1721\*  
 serology, 1989\*  
 serum, 1989\*  
 spleen, 2088  
 transfusion, 42, 2259-2260\*  
 Blood bank see Immunohematology  
 Blood clotting, 1720-1721\*  
 Blood groups, 304-305\*, 305-307\*  
 antibodies, 306  
 antigens, 306-307  
 genes, 306-307  
 significance, 270  
 systems, 269-270, 306-307  
 transplantation biology, 2263  
 Blood poisoning see Septicemia  
 Blood pressure, 1118  
 Blood vessels, 307\*, 1477  
 Bloody cockle, 431  
 Blow molding, 1723  
 Blowout coil, 307\*  
 Blowout dune, 642  
 Blowpipe, 307\*  
 Blue coral, 433  
 Blue-green algae, 1784  
 see also Cyanobacteria; Cyanophyceae  
 Blue jets, 1253  
 Blue spruce, 2090-2091  
 Blue straggler star, 307-308\*  
 Blueberry, 308\*  
 Bluefish, 308\*  
 Bluegrass, 308\*  
 Blueschist, 308\*, 1003  
 Blueschist facies, 783  
 Bluestem grass, 309\*  
 Bluetongue, 309\*  
 Boat propulsion, 309\*, 1320  
 Bobtail squid, 438  
 Bobwhite, 260  
 Bodonidae, 1216  
 Body louse, 126-127  
 Body rhythm, 733  
 Bog, 309-310\*  
 muskeg, 1456\*  
 peat mosses, 298  
 see also Swamp, marsh and bog  
 Bog iron ore, 1256  
 Boghead coal see Torbanite  
 Böhm, Corrado, 1782  
 Bohm, D., 47, 953  
 Bohr, N., 191, 498, 735  
 atomic structure and spectra, 211-212  
 determinism, 648  
 energy level, 820  
 Bohr magneton, 1302-1303  
 Bohr-Sommerfeld quantization, 568  
 Bohrium, 310\*, 928, 1351  
 Bohr's quantum theory, 498  
 Boidae, 272  
 Boiler, 310\*  
 fire-tube, 890\*  
 fuel oil, 942\*  
 marine, 1317-1318\*  
 steam engine, 2106\*  
 steam heating, 2106-2107\*  
 steam separator, 2107\*  
 water-tube, 2368\*  
 Boiler economizer, 274  
 Boiler feedwater, 310-311\*  
 Boiler feedwater regulation, 311\*  
 Boiling, 311\*  
 Boiling point, 311\*, 311-312\*  
 Bok, B. J., 1006  
 Bok choi, 1578  
*Boletus edulis*, 984, 1112  
 Bolinopsidae, 1266  
 Bolometer, 312\*, 747  
 barretter, 253\*  
 infrared astronomy, 1150  
 microwave, 1392  
 Bolt, 312\*, 1963-1964  
 screw fastener, 1963-1964\*  
 structural connections, 2133-2134\*  
 Bolted joint, 312\*  
 Boltzmann constant, 965-966  
 Boltzmann statistics, 312-313\*, 1719  
 Boltzmann transport equation, 276,  
 314\*  
 Bolyai, J., 1494  
 Bomb:  
 air armament, 48  
 atomic, 189, 208-209\*  
 hydrogen, 977, 1105-1106\*  
 naval armament, 1467-1468  
 nuclear explosion, 1506-1507\*  
 Bombacaceae, 1210  
 Bombers (aircraft), 1401  
 Bombidae, 231  
*Bonasa umbellus*, 260  
 Bond angle and distance, 314-315\*  
 Bonding:  
 adhesive, 29\*  
 chemical see Chemical bonding  
 wire, 2392\*  
 Bone, 315-316\*  
 parathyroid, 1611  
 skeletal system, 2015-2017\*  
 Bone char, 2144  
 Bone conduction audiograms,  
 196  
 Bone marrow transplantation,  
 417  
 Bonefish, 808  
 Bonellidae, 659, 728  
 Bonobo, 387, 923  
 Bonobo chimpanzee, 1772  
 Bonsai, 316\*  
 Bony fish see Osteichthyes  
 Bonytongues, 1586  
 Boobies, 1623  
 Book lice, 1799  
 Book manufacture, 316-317\*  
 Boole, George, 278, 1269,  
 1337  
 Boolean algebra, 317\*, 1233  
 Boolean ring, 278  
 Boötes, 317\*  
 Bopyridae, 751  
 Bopyrina, 751, 835  
 Boracite, 317\*  
 Borane, 317-318\*, 331, 1102  
 Borate minerals, 318\*  
 colemanite, 497\*  
 kernite, 1212\*

Borax, 279  
*Bordetella*, 296, 318-319\*  
*Bordetella bronchiseptica*, 1211  
*Bordetella pertussis*, 2387  
 Boreal forest see Taiga  
*Boreogadus saida*, 431  
 Boring, 281  
 Boring bivalves, 319\*  
 Boring sponges, 319\*  
 Borneo, 723, 724  
 Bornite, 319\*  
 Boron, 319-320\*  
   borate minerals, 318\*  
   kernite, 1212\*  
 Boron hydride see Borane  
*Borrelia*, 320\*, 1885-1886  
*Borrelia burgdorferi*, 1281  
 Borrelly, comet, 1186  
*Bos indicus*, 2413  
 Bose-Einstein condensation, 1231  
 Bose-Einstein statistics, 320-321\*, 2165  
 Boson:  
   elementary particle, 802  
   hadron, 1037  
   parity, 1612, 1613  
   supersymmetry, 2165, 2165\*  
   symmetry breaking, 2179  
 Botanical gardens, 321\*  
 Botany, 321-322\*  
   Earth sciences, 722  
   paleobotany, 1596-1597\*  
 Bothriochloa, 272  
*Bothriocidaris*, 284  
 Botryopteridaceae, 433  
 Bottle-nosed dolphin, 634  
 Bottomonium, 804  
*Botula*, 281  
 Botulism, 322\*, 419, 819, 909  
 Bouguer's law see Lambert's law  
 Bouista, 864  
 Boundary-layer flow, 322-323\*  
   fluid flow, 900  
   gas dynamics, 966  
 Boundary plate islands, 1593  
 Bovidae, 131, 164  
 Bovine spongiform encephalopathy, 1775  
 Bovine virus diarrhea, 323-324\*  
 Bowfin, 21, 2198  
 Bowlby, J., 650  
 Bowman's capsule, 1213  
 Box caisson, 309  
 Boyle, Robert, 191, 211, 285  
 Boyle's law, 324\*, 1341  
 Brachiation, 1772  
 Brachiopoda, 324\*  
   Anomopoda, 126\*  
   Articulata, 161  
   Ctenopoda, 596\*  
   Haplopoda, 1045\*  
   Inarticulata, 1134-1135\*  
   Kutorginida, 1219\*  
   Laevicaudata, 1222\*  
   Lingulida, 1259\*  
   lophophore, 1272\*  
   Obolellida, 1528\*  
   Onychopoda, 1544\*  
   Orthida, 1580\*  
   Paterinida, 1619\*  
   Pentamerida, 1626\*  
   Rhynchonellida, 1916\*  
   Spiriferida, 2086\*  
   Strophomenida, 2131\*  
   Terebratulida, 2210\*  
 Brachycera, 620  
 Brachypteraciidae, 494  
 Brachyura, 510, 562  
 Bracket fungi, 1112  
 Brackish water, 2365  
 Braconidae, 1124  
 Bradyodonti, 324\*  
 Bradyopodidae, 2022  
*Bradyrhizobium*, 1382  
 Bragg spectrometer, 2402  
 Brahman see Zebu  
 Braille (asteroid), 1186  
 Brain, 324-326\*  
   amnesia, 99\*  
   central nervous system, 401\*  
   cognition, 493\*  
   cranial nerve, 576\*  
   dopamine, 697  
   electrodiagnosis, 768  
   electroencephalography, 768  
   endorphins, 819\*  
   hemispheric laterality, 1065-1066\*  
   lateral line system, 1232  
   Mammalia, 1309

Brain—cont.  
   memory, 1353  
   meninges, 1354\*  
   monoamine oxidase, 1432\*  
   motor system control, 1442  
   nervous system (vertebrate), 1477  
   noradrenergic system, 1500-1501\*  
   reticular formation, 1909\*  
   schizophrenia, 1958  
   seizure disorders, 1978-1979\*  
   subdivisions of, 2333  
   vertebrate (evolution), 2332-2333\*  
 Brain death, 768  
 Brain electrical activity mapping (BEAM), 768  
 Brainstem, 1442  
 Brake, 326\*  
   air, 48\*  
   automotive, 202, 227-228\*  
   dynamic braking, 708-709\*  
   electromagnetic, 694-695  
   friction, 227, 840  
 Branch circuit, 287\*, 326-327\*  
 Branched polymer, 327\*  
 Brachiopoda, 327\*  
   Anostraca, 128\*  
   Notostraca, 1504\*  
 Branchiostoma, 354  
 Branchiura, 327\*  
*Branhamella*, 1437, 1438  
 Brans, C., 905  
 Brass, 327\*  
 Brass instruments, 1454  
*Brassica* species, 288, 293, 297, 307, 343, 441, 1209, 1218, 1456, 1578, 1869, 1936, 2288  
 Brassicaceae see Cruciferae  
 Brayton cycle, 288  
   gas turbines, 2284  
   power plant, 1763  
   refrigeration cycle, 1883-1884\*, 1884  
 Brazil nut, 328\*, 1239  
 Brazing, 328\*  
 Breadboarding, 328\*  
 Breadfruit, 328\*  
 Breakdown diode, 616-617  
 Breakdown potential, 328-329\*  
 Breast, 329\*  
 Breccia, 330\*  
 Breeding (animal), 262-263, 330-331\*, 1761  
 Breeding (plant), 331-332\*  
   forest genetics, 919  
   genetic engineering, 982-983\*  
   genetics, 984\*  
 Bremsstrahlung, 332\*  
 Brewers' malts, 221  
 Brick, 332\*  
 Bridge, 332-334\*  
   arch, 159  
   degradation, 334  
   fixed, 292, 333  
   movable, 292-293, 333-334  
   repair, 334  
   strengthening techniques, 334  
   substructure, 293, 334  
   vibration, 293  
 Bridge circuit, 334\*  
   Kelvin bridge, 1210\*  
   Wheatstone bridge, 2386\*  
 Brillouin, L., 2384  
 Brillouin scattering, 1497, 1955  
 Brillouin zone, 334\*  
 Brimstone see Rhombic sulfur  
 Brine:  
   petrography, 1640  
   playa, 1726  
   saline evaporites, 1941  
   solution mining, 2046  
 Brinell hardness, 926  
 Briquet's syndrome, 1803  
 Brisingidae, 824  
 Brisling, 948  
 Bristle tail see Silverfish  
 British thermal unit, 631  
 Brittle star:  
   Ophiurida, 1549  
   Stenurida, 2113\*  
 Brittleness  
 Broad bean, 229, 260  
 Broad-nosed caiman, 309  
 Broadcasting see Radio broadcasting  
 Broadwinged-hawk, 260  
 Broccoli, 334\*  
 Broegger, W. C., 1370  
 Bromegrass, 335\*  
 Bromeliaceae, 294

Bromeliads, 1731  
 Bromeliales, 335\*, 450, 1690  
 Bromine, 335\*  
*Bromus inermis*, 294  
 Bromyrite, 356  
 Bronchial asthma, 295  
 Bronchiectasis, 295  
 Bronchiolitis emphysema, 813-814\*  
 Bronchitis, 295  
   parainfluenza virus, 1607  
   respiratory system disorders, 1907  
 Brønsted acid, 2152  
 Brønsted-Lowry theory, 11-12, 96  
 Bronze, 335\*  
 Bronze Age, 1768  
 Bronze mica see Phlogopite  
 Brown bear, 230  
 Brown dwarf, 335-336\*, 1151  
 Brownian movement, 336\*, 2101-2102  
*Brucella*, 296  
 Brucellosis, 336\*  
 Brucite, 336\*  
 Brunei, 723  
 Brush turkey, 259-260  
 Brussels sprouts, 336-337\*  
 Bryales, 337\*  
 Bryidae, 337\*  
   Encalyptales, 814\*  
   Hypnales, 1119\*  
   Isobryales, 1193  
   Mittentiales, 1411\*  
 Bryophyta, 337\*, 2082  
 Bryophytes:  
   plant evolution, 1702-1703  
   plant kingdom, 1706  
 Bryopsida, 337-338\*  
   Archidiidae, 164\*  
   Bryoxiphiales, 338\*  
   Buxbaumiidae, 346\*  
   Dicranales, 657\*  
   Fissidentales, 891\*  
   Funariales, 944\*  
   Grimmiales, 1027\*  
   Hookeriales, 1088\*  
   Isobryales, 1193\*  
   Polytrichidae, 1752\*  
   Pottiales, 1761\*  
   Seligeriales, 1979\*  
   Splachnales, 2087\*  
   Tetraphididae, 2214\*  
 Bryopsidales, 338\*  
 Bryoxiphiales, 338\*  
*Bryoxiphium norvegicum*, 298  
 Bryozoa, 338-339\*  
   Cryptostomata, 589\*  
   Ctenostomata, 596-597\*  
   Cystoporata, 608\*  
   Gymnolaemata, 1033\*  
   Hederellida, 1058\*  
   lophophore, 1272\*  
   Phylactolaemata, 1674-1675\*  
   Stenolaemata, 2113\*  
   Trepotomata, 2269\*  
*Bubalus bubalis*, 301  
 Bubble chambers, 2407  
 Bubble detector dosimeter, 699  
 Bubble memory, 526, 878  
   see also Magnetic bubble memory  
*Bubo virginianus*, 260  
 Bubonic plague, 1695-1696  
 Bucerotidae, 494  
 Bucherer, A. H., 418  
 Buckler, H. P., 1333  
 Bucket conveyor, 302  
 Buckeye, 339\*  
 Buckminsterfullerene, 844, 1061, 1169  
 Buckthorn bumelia, 1191  
 Buckwheat, 339\*  
 Buckwheat tree, 1191  
 Bud, 339\*  
   apical dominance, 150  
   dormancy, 698\*  
 Bud mite, 2276  
 Budding, animal, 1895  
 Buerger's disease, 963  
 Buffalo, 262, 340\*  
 Buffering agents (food), 818  
 Buffers (chemistry), 340\*  
 Buffers (electronics), 340-341\*  
*Bufo*, 130  
 Bug (eavesdropping device), 710  
 Bug (insects), 1063-1065  
 Buhstone mill, 341\*  
 Buildings, 302, 341-342\*  
   architectural acoustics, 164-165\*  
   architectural engineering, 165\*  
   automatic sprinkler system, 225\*

Buildings—cont.  
   codes, 342  
   column, 505-506\*  
   district heating, 692\*  
   electrical codes, 681, 753\*  
   floor construction, 896\*  
   foundations, 929\*  
   hot-water heating system, 1091-1092\*  
   roof construction, 1931\*  
   safety, 342  
   skyscrapers, 342  
   wall construction, 2361-2362\*  
 Bulb, 698\*  
*Bulimia nervosa*, 724  
 Bulk-handling machines, 342-343\*  
   hoisting machines, 1082-1083\*  
   industrial trucks, 1142\*  
   solids pump, 2044-2045\*  
 Bulk micromachining, 1385\*  
 Bulkhead, 427  
 Bull see Taurus  
 Bulrush, 543  
 Bumblebee, 231  
*Bumelia lycioides*, 1047  
*Bumelia tenax*, 1047  
 Bunion, 822  
 Buoy, 343\*  
   instrumented, 1161-1162\*  
   piloting, 1687  
 Buoyancy, 343\*, 982  
 Bureau of Land Management, 921  
 Buret, 303  
 Burgess Shale, 343-344\*  
 Burchardia, 364  
*Burkholderia mallei*, 1002  
 Burkitt's lymphoma, 740  
 Burmanniaceae, 677  
 Burn, 344\*  
 Burrow (insect), 304  
 Burrowing animals, 344-345\*  
 Burrowing owl, 260  
 Bursa, 159, 345  
 Bursicon, 732  
 Bursitis, 159, 345\*  
 Bursters, 2401  
 Bus, 345\*  
 Bus-bar, 345\*  
 Bushbabies, 1771  
 Bushing, 345\*  
 Business-to-business (B2B), 1176  
 Business-to-consumer (B2C), 1176  
 Butadiene, 1741  
 Butane, 1261  
*Buteo* species, 260  
 Butomaceae, 77  
*Butomus umbellatus*, 77  
 Butt weld, 2372, 2382  
 Butter, 345-346\*  
 Butter oil, 305  
 Buttercup, 1869  
 Butterfly:  
   forest ecosystem, 917  
   Lepidoptera, 1242-1245\*  
 Buttermilk, 1402  
 Butternut, 1205  
 Button mushroom, 984, 1112  
 Buttonball see Sycamore  
 Buttonwood see Sycamore  
*Buxbaumia*, 305  
 Buxbaumiidae, 346\*  
 Buzzard, 260  
 Byte, 262  
 Bytownite, 346\*

## C

C (programming language), 1783  
 C++ (programming language), 524, 1783, 2030  
 C-H activation, 347\*  
 C-5A aircraft, 1225  
 C<sub>3</sub> photosynthesis, 1672  
 C<sub>4</sub> photosynthesis, 1672  
 Cabbage, 347\*  
 Cabbage butterfly, 1156  
 Cable television system, 347\*, 419, 451  
 Cableway construction, 479  
 Cacao, 348\*  
 Cachexia, 348\*  
 Cactaceae, 336  
 Cactus, 348-349\*  
 CAD/CAM see Computer-aided design and manufacturing

- Caddis fly, 308, 2270  
 Cadmium, 349\*, 1027  
 Cadmium metallurgy, 349\*  
 Caecidotea, 167  
 Caecilians, 151  
*Caecioniropsis*, 167  
 Caenogastropoda, 972  
 Caesalpiniaceae, 783  
 Caesalpinioidea, 1240  
 Caffeine, 349\*  
   alkaloid, 79  
   coffee, 491  
 Cage hydrocarbon, 349\*  
 Caiman, 581-582  
 Caisson foundation, 309-310, 349-350\*  
 Calamine, 350\*  
 Calamopityales, 999  
 Calanoida, 350\*, 1438\*  
 Calcarea, 350-351\*  
 Calcarenia, 151, 557  
 Calcaronea:  
   Leucosoleniida, 1247\*  
   Scyctetida, 2177\*  
 Calcichordates, 351\*  
 Calcilutite, 311  
 Calcinea:  
   Clathrinida, 468\*  
   Leucetida, 1246\*  
   Leucosoleniida, 1247\*  
   Pharetronida, 1648\*  
   Scyctetida, 2177\*  
 Calcite, 351\*  
   dolomite rock, 694  
   oolite, 1545  
 Calcium, 351-352\*  
 Calcium carbonate, 312  
 Calcium chloride, 312, 390  
 Calcium cyanamide, 536  
 Calcium EDTA, 851  
 Calcium fluoride, 526  
 Calcium hydroxide, 312  
 Calcium metabolism, 352\*  
   endocrine system (vertebrate), 816-817  
   parathyroid, 1611  
   parathyroid gland disorders, 1611  
   parathyroid hormone, 1611-1612\*  
   thyrocalcitonin, 2236-2237\*  
 Calcium oxide, 312  
 Calcium silicide, 312  
 Calcium sulfate, 312, 1721-1722  
 Calculators, 352\*, 2178  
 Calculus, 352-353\*  
   differentiation, 600-601  
   integration, 1167-1168\*  
   propositional, 1269-1270  
 Calculus of variations, 353\*  
   minimal surfaces, 1405-1406\*  
   optimal control theory, 1563\*  
 Calculus of vectors, 353\*  
   Gauss' theorem, 973\*  
   gradient of a scalar, 1014\*  
 Caldera, 355-356\*  
 Calendar, 356\*  
   month, 1436\*  
   solar, 146, 162  
 Calendring (plastics processing), 1723  
 Calibration, 356\*  
 Caliche, 357\*  
 Caliciaceae, 317  
 Caliciales, 357\*  
 California condor, 260  
 California jade, 1201  
 California red fir, 801  
 Californium, 357\*  
 Caligoida, 491  
 Caliper, 357\*, 1386  
 Caliper disk brake, 326, 840  
 Calixarenes, 1286  
 Callisto, 1208, 1701  
 Callistophytales, 999  
 Callitrichales, 357\*  
 Callitrichids, 1771  
 Callorhynchidae, 385  
 Calluna, 759  
 Calobryales, 357-358\*  
 Calobryum, 318  
 Calomel, 358\*  
 Calorimeter, 318  
   differential scanning, 245  
   electric power measurement, 747  
   isothermal titration, 245  
 Calorimetry, 358\*  
   biocalorimetry, 277\*  
   thermochemistry, 2224\*  
 Caluata, 864  
 Calycanthaceae, 1233  
*Calycanthus*, 1233  
 Calycerales, 358\*  
*Calymmatobacterium*, 296, 902  
 Calyptoblastea, 979  
 Cam mechanism, 358-359\*, 1930-1931  
 Cam photosynthesis, 1672-1673  
 Camallanoidea, 165  
 Cambarus, 497  
 Cambium, 2393  
 Cambrian, 359-360\*  
   animal evolution, 119-120  
   Burgess Shale, 343-344  
   Ediacaran biota, 737  
   macroevolution, 1287  
   Paleozoic, 1603  
 Camel, 120, 164, 178, 360\*  
 Camelidae, 87, 164, 178  
*Camellia sinensis*, 2195  
 Camel's hair, 360\*  
*Camelus bactrianus*, 320  
*Camelus dromedarius*, 320  
 Cameo, 360\*, 1544  
 Camera, 360\*  
   cinematography, 457-458  
   marine biological sampling, 1317  
   Schmidt, 1959\*  
   television, 2203-2204\*  
   underwater photography, 2299  
   underwater television, 2300\*  
   video microscopy, 2339\*  
   x-ray diffraction, 2402  
   zoom lens, 2419\*  
 Camerata, 360\*  
 Camics, 1748  
 Companion cells, 1655  
*Campanula medium*, 321  
 Campanulales, 173, 360\*  
   chicory, 437\*  
   cucumber, 597\*  
   guayule, 1031\*  
 Camphor, 360-361\*, 1233  
 Camphor tree, 361\*  
 Campodeidae, 618, 678  
 Campostromatoidea, 322, 728  
*Campylobacter jejuni*, 2363  
*Canabis sativus*, 1317\*  
 Canada balsam, 801  
 Canada bluegrass, 271, 308  
*Canaga odorata*, 1305  
 Canal, 361\*, 2367  
 Cancer (constellation), 361\*  
 Cancer (medicine), 361-362\*  
   biology, 1542  
   cachexia, 348\*  
   causes of cancer, 1542  
   chemotherapy, 435-436\*  
   Epstein-Barr virus, 740  
   Helicobacter, 1059\*  
   Hodgkin's disease, 1082\*  
   immunotherapy, 1133\*  
   leukemia, 1247\*  
   lymphoma, 1281-1282\*  
   mutagens and carcinogens, 1456-1457\*  
   oncofetal antigens, 1541\*  
   oncogenes, 1541\*  
   ovarian disorders, 1587-1588  
   paleopathology, 1602  
   prevention, 1542  
   radiation therapy, 1845\*  
   radiology, 1863  
   respiratory system disorders, 1907  
   skin disorders, 2018  
   treatment, 1542-1543  
   tumor, 2280-2281\*  
 Cancrinite, 362\*  
*Candida*, 266, 2410-2411  
 Candidiasis, 266  
   fungi, 950  
   medical mycology, 1347  
 Candlepower, 362\*  
 Candytuft, 325  
 Cane sugar, 2144  
   see also Sucrose; Sugar  
 Canidae, 323, 633, 693-694\*  
 Canine, 1539  
 Canine distemper, 362\*  
 Canine infections, 1211  
 Canine parvovirus infection, 362-363\*  
*Canis*, 157, 634, 693, 694  
*Canis Majoris*, 2015  
 Cannabinaceae, 1317  
*Cannabis sativa*, 946, 1317  
 Cannon, W. B., 1346  
 Canoidea, 333  
 Canonical transformations,  
   363\*  
 Cantaloupe, 363\*  
 Canterbury bell, 321  
*Cantharellus*, 1112  
*Cantharellus cibarius*, 984  
 Cantilever, 363\*, 1909  
 Cantilever bridge, 292  
 Cantor, G., 1337  
 Cap screw, 1964  
 Capacitance, 363\*  
   inductance measurement, 1137  
   static electricity, 2100  
 Capacitance measurement, 363-364\*  
 Capacitance multiplication, 364\*  
 Capacitor, 324\*, 364-365\*  
   capacitance, 364\*  
   capacitance measurement, 363-364\*  
   semiconductor rectifier, 1983  
   sense amplifier, 1985  
   switched, 2174-2175\*  
 Cape buffalo, 301  
 Cape hunting dog, 634  
 Capercaille, 260  
 Capgras syndrome, 1042  
 Capillary (anatomy), 270  
 Capillary electrophoresis, 794-795  
 Capillary hemangioma, 261  
 Capnocytophaga, 325  
 Capparaceae, 325  
 Capparales, 365\*  
   brussels sprouts, 336-337\*  
   cabbage, 347\*  
   cauliflower, 383\*  
   collard, 500\*  
   cress, 578\*  
   horseradish, 1090\*  
   kale, 1209\*  
   mustard, 1456\*  
   radish, 1863\*  
   rape, 1869\*  
   rutabaga, 1936\*  
   turnip, 2288  
 Caprellidea, 103, 365\*  
 Capricornus, 365\*  
 Caprifoliaceae, 620  
 Caprimulgi, 326  
 Caprimulgidae, 326  
 Caprimulgiformes, 365\*  
 Capsalidea, 1433  
*Capsicum* species, 1607, 1626  
 Captorhinida, 365-366\*  
 Capybara, 344  
 Car identification systems, 1865  
 Carabao, 301  
 Caracara, 784  
 Caracarinae, 784  
 Carbanion, 1872  
 Carbene, 1872  
 Carbocation, 1872  
 Carbocyclic compound see Alicyclic hydrocarbon; Aromatic hydrocarbon  
 Carbohydrate, 366\*  
   animal growth, 121  
   inositol, 1155\*  
   lectins, 1239  
   monosaccharide, 1434-1435\*  
   oligosaccharide, 1540\*  
   polysaccharide, 1752\*  
   L-rhamnose, 1911\*  
   ribose, 1918\*  
   starch, 2100\*  
   sugar see Sugar  
   xylose, 2408\*  
 Carbohydrate chemistry, 1735  
 Carbohydrate metabolism, 366-367\*  
   amylase, 107\*  
   diabetes mellitus, 590-591, 653  
   endocrine system (vertebrate), 817  
   glucagon, 1006\*  
   glycogen, 1007\*  
   hunger, 1098  
   liver, 1265  
   maltase, 1308\*  
   metabolic disorders, 1362  
   uridine diphosphoglucose, 2311\*  
 Carbon, 367-368\*  
   diamond, 654-655\*  
   fullerene, 943\*  
   graphite, 1018\*  
   organic chemistry, 1568-1569  
   organic geochemistry, 1571  
   radiocarbon dating, 1858-1859\*  
 Carbon-14, 9-10, 1861  
 Carbon arc lamp, 141  
 Carbon black, 368\*  
 Carbon cycle, 257  
   biogeochemistry, 280-281  
   ecosystem, 736  
 Carbon dioxide, 368\*  
   atmospheric chemistry, 203  
   dry ice, 703\*  
   fire extinguishing, 802  
   photorespiration, 1670-1671  
   photosynthesis, 1672, 1673  
   plant respiration, 1713  
   tree physiology, 2268  
 Carbon dioxide molecular laser, 1229  
 Carbon-electrode arc welding, 141  
 Carbon fiber, 903  
 Carbon monoxide:  
   metal carbonyl, 1364-1365\*  
   toxicity, 1732  
 Carbon-nitrogen-oxygen cycles, 368\*  
 Carbon star, 368-369\*  
 Carbon tetrachloride, 390-391  
 Carbonate minerals, 369\*  
   ankerite, 125\*  
   aragonite, 156\*  
   calcite, 351\*  
   cerussite, 408\*  
   dolomite, 694\*  
   magnesite, 1289\*  
   malachite, 1306\*  
   rhodochrosite, 1915\*  
   siderite, 2004-2005\*  
   smithsonite, 2023\*  
   strontianite, 2130\*  
   witherite, 2392\*  
 Carbonate rocks, 1971  
 Carbonate, 369\*, 1870  
 Carbonic acid, 2310  
 Carboniferous, 369-370\*  
   continent formation, 482  
   Mississippian, 1224, 1408-1409\*  
   Paleozoic, 1603  
   Pennsylvanian, 1625-1626\*  
   Permian, 1635\*  
   plant evolution, 1703  
 Carbonyl, 370-371\*, 1364-1365  
 Carborane, 371\*  
 Carboxylic acid, 371\*  
   benzoic acid, 266\*  
   ketene, 1212  
 Carburator, 371-372\*  
   automobile, 226  
   engine manifold, 823-824\*  
 Carburizing, 936  
 Carcerands, 1286  
 Carcinogen see Mutagens and carcinogens  
 Carcinoma, 2281  
*Carcinocroptis*, 1358  
 Cardamon, 372\*  
 Cardan joint, 2305  
 Cardiac muscle, 1450, 1260  
 Cardiidae, 430  
 Cardinal flower, 321  
 Cardinal points, 372\*  
 Cardiogenic shock, 2001  
 Cardiology see Electrocardiography  
 Cardiod, 372\*, 836  
 Cardiomyopathies, 932  
   degenerative, 568  
   heart disorders, 1053  
   see also Heart disorders  
 Cardiovascular system, 372-373\*  
   circulation, 462-463\*  
   heart (vertebrate), 1052\*  
   respiratory system disorders, 1907  
   see also Circulatory system  
 Cardiovascular system disorders:  
   circulation disorders, 463\*  
   phlebitis, 1655\*  
   vascular disorders, 2327\*  
*Cardium edule*, 431  
 Carex, 543  
 Caridea, 560  
 Caridoid facies, 1307  
 Caries (teeth), 574  
*Carludovicia palmata*, 540  
 Carnation, 336  
 Carnauba wax, 373\*  
 Carnivora, 373\*  
   badger, 245\*  
   bear, 261\*  
   civet, 466\*  
   coati, 485\*  
   digestive system, 666  
   Carnivorou plants, 1159  
 Carnot cycle, 373\*  
   fuel cell, 940-941  
   gas turbine, 968  
   power plant, 1763  
   refrigeration cycle, 1883-1884\*  
   third law of thermodynamics, 2226  
 Carnotite, 373-374\*

- Carolina allspice, 1233  
 Carolina hemlock, 944  
 Carotenoid, 374\*  
 Carotid body, 374\*  
 Carp, 374\*  
 Carpal tunnel syndrome, 374\*  
 Carpel, 810, 1703  
 Carpincho, 344  
*Carpinus* species, 965, 1047  
 Carpoidea, 335  
 Carpoids, 374-375\*, 961  
 Carpology, 842  
 Carrageenan, 375\*  
 Carriage bolt, 275  
 Carrier, 375\*  
 Carrot, 375\*  
 Cartan, E., 867  
 Carter, J., 473  
 Cartesian coordinate system, 489, 1338  
 Cartesian geometry *see* Analytic geometry  
*Carthamus tinctorius*, 1940  
 Cartilage, 375\*, 2015-2017  
 Cartilaginous fish *see* Chondrichthyes  
 Cartography, 375-376\*  
   globe (Earth), 1004-1006\*  
   manifold (mathematics), 1313  
   map design, 1315\*  
   map projections, 1315-1316\*  
   *see also* Topographic surveying and mapping  
 Cartridge brass, 492  
 Cartridge fuse, 850  
*Carum carvi*, 326  
*Carya*, 952, 1205, 1622  
 Caryophyllaceae, 336  
 Caryophyllales, 376\*  
   beet, 262\*  
   cactus, 348-349\*  
   quinoa, 1836\*  
   spinach, 2085\*  
 Caryophyllidae, 376\*  
   Batales, 257\*  
   Caryophyllales, 376\*  
   Plumbaginales, 1729\*  
   Polygonales, 1744\*  
 Cascade amplifier, 1546-1547  
 Cascode amplifier, 376\*  
 Casein, 376\*  
 Cashew, 376\*  
 Cashmere, 376\*  
 Casimir, H. B. G., 2156  
 Cassava, 377\*  
 Cassegrain system, 133  
 Cassiopeia, 377\*  
 Cassiterite, 377\*  
   heavy minerals, 1058  
   tin, 2243  
 Cast iron, 377\*  
*Castanea* species, 383  
 Castes, 1195-1196  
 Casting:  
   metal, 1365\*  
   plastics, 1723  
 Castle-Hardy-Weinberg law, 969  
 Castniidae, 1243-1244  
 Castnoidea, 1243-1244  
 Castor (star), 871  
*Castor canadensis*, 230  
 Castor plant, 377\*  
 Castoreum gland, 1955-1956\*  
 Castoridae, 230  
 Casuarina, 338  
 Casuarinaceae, 338  
 Casuarinales, 377\*, 1044  
 CAT *see* Clear-air turbulence  
 Cat, 377-378\*, 1539  
 Cat scratch disease, 378\*  
 Catabolism, 243  
 Cataclastic rocks, 330, 1371  
 Cataclysmic binaries, 338  
 Cataclysmic variable, 378\*  
 Catadioptric systems, 1557  
 Catalysis, 378-379\*  
   enzymes, 255, 832-833\*  
   heterogeneous, 1072\*  
   heterogeneous catalysis, 950  
   homogeneous catalysis, 1087\*  
   metallocene, 1368\*  
   polymer-supported reaction, 1746\*  
   polymerization, 1747  
   stereospecific catalyst, 2115\*  
 Catalytic antibody, 379\*  
 Catalytic converter, 379-380\*  
 Catalytic cracking, 1644  
 Catalytic reforming, 1881  
 Cataract, 380\*, 867  
 Catarrhines, 1771  
 Catastrophe theory, 380\*, 863  
 Catenanes, 380-381\*  
 Catenary, 382\*  
 Catenulida, 1911\*  
 Catfish, electric, 745  
*Cathartes aura*, 260  
 Cathartidae, 260, 402  
 Cathode-ray oscilloscope, 1584\*  
 Cathode-ray tube (CRT), 382-383\*  
   computer graphics, 521  
   electron lens, 781\*  
   electronic display, 786, 787  
   electronic test equipment, 791  
   flat-panel display device, 892\*  
   picture tube, 1685\*  
   television receiver, 2205  
 Cathode rays, 383\*  
 Cathodic organic reactions, 765  
 Cathodoluminescence, 383\*  
 Cationic detergent, 583  
 Cationic surfactant, 2172  
 Cations:  
   electrolyte, 770-771\*  
   ion, 1183  
 Catkins, 870  
 Catnip, 1223  
 Cat's eye (gem), 401  
 Cattle, 178  
   animal evolution, 120  
   Johne's disease, 1203  
   listeriosis, 1264  
   pasteurellosis, 1619  
   zebu, 2413\*  
 Cauchy, A. L., 343, 1167, 1168  
 Cauchy-Riemann equations, 662  
 Caudata *see* Urodele  
 Caudofoveata, 133  
 Cauleriales *see* Bryopsidales  
 Cauliflower, 383\*  
*Caulobacter*, 300  
 Causal structure (special relativity),  
   1888-1889  
 Causality, 383-384\*  
 Cave, 384\*, 2095  
 Cavendish, H., 1021  
 Cavendish banana, 217  
 Cavendish experiment, 1021  
 Cavenularia, 1625  
 Cavernous hemangioma, 261  
*Cavia aperea*, 344  
*Cavia porcellus*, 344  
 Cavies, 384\*  
 Caviidae, 344  
 Cavitands, 1286  
 Cavitation, 384\*, 2050  
 Cavity resonator, 384\*  
 Cayley-Klein parameters, 385\*  
*Caytonia*, 344  
 Caytoniales, 385\*, 999  
 CD *see* Charge-coupled devices  
 CD *see* Compact disk  
 CD-ROM *see* Compact disk-read-only  
   memory  
 Cecum, 666, 667  
 Cedar, 385\*, 543  
   Pinales, 1688  
   tree, 2266  
 Cedar of Lebanon, 344  
*Cedrela odorata*, 345  
*Cedrus atlantica*, 344  
*Cedrus libani*, 344  
*Ceiba pentandra*, 1210  
 Celastraceae, 345  
 Celastrales, 385\*  
 Celery, 385\*  
 Celery cabbage, 1578  
 Celery mustard, 1578  
 Celestial equator, 756, 841  
 Celestial mechanics, 385-386\*, 721-722  
 Celestial navigation, 386-386\*, 1469  
   polar navigation, 1734  
   sextant, 1993-1994\*  
   star tracker, 2099, 2099\*  
 Celestial reference system, 387\*  
 Celestial sphere, 191-192, 387\*  
 Celestite, 387-388\*  
 Celiac disease, 1129  
 Cell (biology), 388-389\*  
   egg (fowl), 738-739\*  
   electrical potentials, 256  
   second messengers, 1968\*  
   secretion, 1970\*  
   signal transduction, 2006\*  
   spectral analysis of, 389-390\*  
   stem cells, 2112-2113\*  
 Cell, spectral analysis of  
   389-390\*  
 Cell biology, 390-391\*  
   cytochemistry, 608\*  
   cytoplasm, 612\*  
   cytoskeleton, 612\*  
   plant cell, 1702\*  
   vacuole, 2317-2318\*  
   *see also* Endoplasmic reticulum;  
   Lysosome; Mitochondria  
 Cell constancy, 391\*  
 Cell cycle, 391-392\*  
 Cell differentiation, 392\*  
   animal morphogenesis, 122  
   developmental biology, 649  
 Cell division:  
   centriole, 402-403\*  
   cytokinesis, 610\*  
   meiosis, 1349-1350\*  
   mitosis, 1410-1411\*  
 Cell EMF *see* Electromotive force (cells)  
 Cell lineage, 392\*, 586  
   embryonic differentiation, 728  
   fate maps, 872  
 Cell membrane, 346, 392-393\*  
   digestive system, 668  
   endocytosis, 817-818\*  
   function, 393  
   Golgi apparatus, 1012\*  
   lipids, 393  
   membrane mimetic chemistry,  
     1351-1353\*  
   osmoregulatory mechanisms, 1585\*  
   phospholipid, 1659  
   secretion, 1970  
   unit membrane, 392-393  
 Cell metabolism, 393-394\*  
 Cell motility, 394-395\*  
 Cell nucleus, 395\*  
   cell (biology), 388  
   deoxyribonucleic acid (DNA), 638-640\*  
   endoplasmic reticulum, 818-819\*  
 Cell organization, 395-396\*  
 Cell permeability, 396\*, 2253  
 Cell plastids, 396-397\*  
   chloroplasts, 348-349  
   photorespiration, 1670-1671\*  
 Cell polarity (biology), 397\*  
 Cell senescence and death, 122, 397\*  
 Cell-surface ionization, 397\*  
 Cell walls (plant), 397-398\*  
   cellulose, 399  
   hemicellulose, 1062\*  
   lignin, 1254\*  
   plant cell, 1702  
 Cellophane, 398\*  
 Cellular adhesion, 398-399\*  
 Cellular dehydration, 2233-2234  
 Cellular immunology, 399\*  
   cytolysis, 611\*  
   histocompatibility, 1081-1082\*  
   thymus gland, 2236\*  
 Cellular recognition, 398-399  
 Cellular technology, 1413  
 Cellular telephone, 2199  
 Cellulitis, 2018  
 Cellulomonas, 500  
 Cellulose, 399-400\*  
   carbohydrate, 366\*  
   cellophane, 398\*  
   ester, 848  
   glucose, 1006\*  
   paper, 1606-1607\*  
   wood chemicals, 2394  
   wood degradation, 2394  
 Cellulosic fibers:  
   manufactured fiber, 1313  
   natural fiber, 1465\*  
 Celsius:  
   temperature, 2208  
   temperature measurement,  
     2209  
*Celtis occidentalis*, 919  
 Cement, 28, 400\*  
   commercial clay, 470  
   grout, 1030\*  
 Cementation coatings, 1365  
 Cenozoic, 400-401\*  
   animal evolution, 120  
   denudation, 638  
   Paleocene, 1597-1598\*  
   paleogeography, 1599  
   Quaternary, 1835\*  
   Tertiary, 2213\*  
 Centaurus, 401\*  
 Center of gravity, 401\*, 403-404  
 Center of mass, 401\*, 1876  
 Center of pressure, 401\*  
 Centipede, 865  
   *see also* Chilopoda  
 Central force, 401\*  
 Central heating and cooling, 401\*  
 Central nervous system, 401\*  
   brain, 323-324\*  
   endorphins, 819\*  
   nervous system disorders, 1478  
   vertebrate brain, 2332  
 Central processing unit (CPU), 1546  
 digital computer, 668-670  
   microprocessor, 1389-1390\*  
   supercomputer, 2153  
 Centrachidae, 226, 2151  
 Centrex service, 1775  
 Centrifugal force, 402\*, 718  
 Centrifugal pump, 402\*  
 Centrifugation, 402\*  
   sedimentation (industry), 1972  
   ultracentrifuge, 2293\*  
 Centriole, 402-403\*, 404  
 Centripetal acceleration, 353  
 Centripetal force, 403\*  
 Centrode, 403\*  
 Centroid, 403\*, 940  
 Centroids (mathematics), 403-404\*  
*Centropnyxis*, 142  
 Centrosome, 404\*  
*Centruroides gertschi*, 1963  
*Centruroides sculpturatus*, 1963  
 Cephalaspidomorpha, 404\*  
 Cephalina, 769  
*Cephalobaena*, 354  
 Cephalobaenida, 404\*, 1626  
 Cephalocarida, 404\*  
 Cephalochordata, 394, 404-405\*  
 Cephalopoda, 405\*, 544  
   Belemnoidea, 264-265\*  
   Coleoidea, 497\*  
   Nautiloidea, 1466\*  
   Octopoda, 1532\*  
   squid, 2093\*  
   Teuthoidea, 2215\*  
   Vampyromorpha, 2321\*  
 Cephalosporins, 405\*  
 Cepheid variables:  
   Hubble constant, 1092  
   Polaris, 1735  
 Cepheids, 405-406\*, 2325  
 Ceramic coatings, 1366  
 Ceramics, 406\*  
   cermet, 408\*  
   glazing, 1003\*  
   kaolinic clays, 413  
   kiln, 1214\*  
   materials science and engineering, 1334\*  
   nanostructure, 1464, 1464\*  
   perovskite, 1635  
   porcelain, 1755-1756\*  
   pottery, 1761\*  
   refractory, 1883\*  
   sintering, 2013\*  
   sol-gel process, 2037-2038\*  
 Cerapoda, 675  
 Cerargyrite, 406\*  
*Ceratium hirundinella*, 615  
 Ceratodontidae, 619, 681  
 Ceratophyllales, 406-407\*  
*Ceratophyllum*, 406-407\*  
 Ceratopsia, 1580  
 Cercaria, 407\*  
 Cercopidae, 962  
 Cercopitheciinae, 928  
 Cercopithecoidea, 1431-1432  
 Cercopithecoidea, 1771-1772  
 Cereal, 407\*  
   barley, 251-252\*  
   oats, 1527-1530\*  
   rice, 1919\*  
   rye, 1937\*  
   starch, 2100  
   Triticale, 2274\*  
   wheat, 2385-2386\*  
 Cerebral palsy, 407\*  
 Cerebellum, 287  
   motor systems, 1442  
   nervous system (vertebrate), 1477  
 Cerebral cortex, 1442  
 Cerebral hernia, 1069  
 Cerebral palsy, 407\*  
 Cerebrum, 287  
 Cereulose *see* Glucose  
 Cerenkov radiation, 407\*, 961  
 Ceres, 408\*  
*Cereus giganteus*, 308  
 Ceriantharia, 408\*  
*Cerianthus*, 357



- Cerium, 408\*, 1430  
 Cerletti, M., 766  
 Cermet, 408\*  
 Cern:  
   hadronic atom, 1038  
   particle accelerator, 1615  
 Cerussite, 408\*  
*Ceruus canadensis*, 567  
*Ceruus elaphus*, 567  
 Cervicitis, 389  
 Cervidae, 164, 567, 1437  
 Cervix, 1899  
 Cervoidea, 164  
 Cesium, 408\*  
 Cesium chloride, 526  
 Cestida, 408-409\*  
 Cestoda, 409\*  
   Aporidea, 152\*  
   Diphyllidea, 677\*  
   Gyrocotylidea, 1035\*  
   Lecanicephaloidea, 1238-1239\*  
   medical parasitology, 1348  
   Nippotaenidea, 1488\*  
   Protocephaloidea, 1792\*  
   Pseudophyllidea, 1798\*  
   Tetraphyllidea, 2214-2215\*  
   Trypanorhyncha, 2278\*  
 Cestodaria, 409\*  
   Amphilinidea, 103\*  
   Gyrocotylidea, 1035\*  
 Cestoidea, 409\*  
*Cestum*, 358  
 Cetacea, 178, 409-410\*, 729  
 Cetane number, 410\*  
 diesel fuel, 660  
   petroleum products, 1645  
 Cetomimiformes, 410\*  
 Cetomimoides, 359  
 Cetunculi, 359  
 Chabazite, 410-411\*  
*Chaenobryttus gulosus*, 2151  
 Chaetodermomorpha, 133, 411\*  
 Chaetomorpha, 411  
 Chaetonotida, 411\*, 866  
*Chaetonotus*, 360  
 Chain, E., 1624  
 Chain conveyor, 488  
 Chain dimensioning, 613  
 Chain drive, 411\*  
 Chain grate stoker, 2119  
 Chain isomer, 1421  
 Chain reaction (chemistry), 411\*  
   autoxidation, 144, 232\*  
   photolysis, 1668  
   polymerization, 1747-1748\*  
 Chain reaction (physics), 412\*, 580-581  
 Chalcantite, 412\*  
 Chalcedony, 412\*, 1162  
 Chalcidoidea, 984  
 Chalcocite, 412\*  
 Chalcopyrite, 412\*  
 Chalk, 412\*  
*Challenger*, 2060, 2065  
*Chamaecyparis* species, 344, 543, 544  
*Chamaeleo chamaeleon*, 361  
 Chamaeleontidae, 361  
 Chamaephytes, 1717  
 Chamberlin, Thomas, 1025  
 Chamaeleon, 412\*  
 Chamois, 411-412\*  
 Champsosaurus, 750  
 Chandrasekhar, S., 906  
 Chandrasekhar limit, 1022  
 Chanidae, 898  
 Channel electron multiplier, 413\*  
 Channeling in solids, 412\*  
*Chanos chanos*, 898  
 Chanterelles, 984, 1112  
 Chaos, 413-414\*, 1498  
 Chaotic inflation, 1147  
 Chaparral, 414\*  
 Chapman, L., 603  
 Chara, 366  
 Characoidei, 544  
 Character recognition, 415\*, 554  
 Characteristic curve, 415\*  
 Charadrii, 355  
 Charadriidae, 355  
 Charadriiformes, 415\*  
 Charadrioidae, 364  
 Charge-coupled device (CCD), 415-416\*  
   computer storage, 463  
   delay line, 632  
   light curves, 1251  
   photography, 1667  
   telescope, 2201  
 Charge-coupled device (CCD)—cont.  
   television camera, 2203  
   x-ray telescope, 2406  
 Charge-density wave, 416\*, 1631-1632, 1860  
 Charge measurement, 698  
 Charge-transfer compounds, 1569  
 Charged particle beams, 416-417\*  
 Charged particle optics, 417\*  
 Charged particle traps, 1616-1617  
 Charles' law, 417\*  
 Charm, 417-418\*, 721  
 Charmonium, 804  
 Charon:  
   Kuiper Belt, 1219  
   Pluto, 1729  
 Charophyceae, 418\*  
 Chasmosaurus, 165  
 Cheese, 418\*, 1895  
 Cheilostomata, 915, 1033  
 Chelating agent, 367  
 Chelation, 418\*  
   ethylenediaminetetraacetic acid, 851\*  
   siderophores, 2005\*  
 Chelotropic reactions, 1630  
 Chelicerata, 419\*  
 Arachnida, 155\*  
 Eurypterida, 856\*  
 Merostomata, 1358\*  
 Chelonethida, 138  
 Chelonia, 419\*  
 Anapsida, 113\*  
   animal evolution, 120  
*Chelura*, 88  
 Cheluridae, 859, 962  
 Chemical analysis:  
   polarimetric analysis, 1735\*  
   qualitative, 1819-1820\*  
   quantitative, 1821\*  
 Chemical bonding, 419-420\*  
   adhesive, 28  
   bond angle and distance, 314-315\*  
   cage hydrocarbon, 349\*  
   chemistry, 431  
   conjugation and hyperconjugation, 537-538\*  
   coordination chemistry, 554\*  
   ligand, 1250\*  
   ligand field theory, 1250\*  
   molecular mechanics, 1421-1422\*  
   molecular orbital theory, 1422-1423\*  
   photochemistry, 1661  
   quantum mineralogy, 1830  
   rearrangement reaction, 1874\*  
   supramolecular chemistry, 2166\*  
 Chemical burn, 304  
 Chemical compounds see Compound (chemistry)  
 Chemical conversion, 420\*  
 Chemical defense, 421-422  
 Chemical dynamics, 420-421\*  
   half-life, 1039\*  
   laser photochemistry, 1231\*  
   molecular dynamics, 368-369  
   organic reaction mechanism, 1572-1573\*, 1573  
   reaction kinetics, 368  
   reactive intermediates, 1872\*  
   relaxation methods, 369-370  
   stoichiometry, 2118\*  
   theoretical methods, 369  
 Chemical ecology, 421-422\*, 1655  
 Chemical energy, 422-423\*  
 Chemical engineering, 423\*  
   nuclear, 1505-1506\*  
   unit operations, 2301\*  
   unit processes, 2301\*  
 Chemical equilibrium, 423-425\*  
   activity and standard states, 372  
   chemical potential, 371  
   equilibrium constant, 372  
   heterogeneous, 372  
   homogeneous, 372  
   ionic equilibrium, 1188\*  
   Le Chatelier's principle, 1239\*  
   oscillatory reaction, 1583-1584\*  
   pK, 1694\*  
 Chemical fuel, 425\*  
 Chemical kinetics, 425-426\*  
   gas-phase reactions, 426  
   reaction kinetics, 425  
 Chemical lithosphere, 1265  
 Chemical microscopy, 162-163, 426-427\*  
 Chemical pathology, 474  
 Chemical potential, 371  
 Chemical process industry, 427\*  
 Chemical reaction, 1214-1215  
 Chemical reactor, 427\*  
 Chemical senses, 427-428\*  
   chemoreception, 433\*  
   olfaction, 1538-1539\*  
   taste, 2193\*  
 Chemical sensors, 2232  
 Chemical separation techniques, 428\*  
   chromatography, 448-449\*  
   extraction, 863\*  
   precipitation, 1766\*  
 Chemical signals, 119  
 Chemical structures:  
   chemical bonding, 419-420\*  
   condensed polyhedral structures, 376-377  
   electron-deficient, 377  
   ions, 374-375  
   polyhedral, 375-376  
 Chemical symbols and formulas, 377, 428\*  
 Chemical thermodynamics, 429-430\*  
   activity, 23\*  
   chemical equilibrium, 423-425\*  
   free energy, 932-933\*  
   fugacity, 943\*  
   phase equilibrium, 1651\*  
   phase rule, 1653\*  
   specific heat, 2073-2074\*  
   work function (thermodynamics), 2398\*  
 Chemical vapor deposition, 2324  
 Chemiluminescence, 430\*, 1278  
 bioluminescence, 285-286\*  
 cool flames, 803  
 sonochemistry, 2050  
 Chemiosmosis, 430-431\*  
 Chemisorption, 861  
 Chemistry, 431-432\*  
   agricultural, 44\*  
   archeological, 146, 162-163\*  
   atmospheric, 203-204\*  
   atoms, 431  
   biogeochemistry, 280-282\*  
   bioinorganic, 249-250, 283-284\*  
   bioorganic, 255, 292-293\*  
   bonds, 431  
   chemical symbols and formulas, 428\*  
   compounds, 431-432  
   element, 800-801\*  
   elements, 431  
   geochemistry, 985\*  
   high-pressure, 953-954  
   high-temperature, 954  
   inorganic, 1154\*  
   isotopes, 431  
   magnetochemistry, 1301\*  
   membrane mimetic, 1351-1352\*  
   microwave, 1393  
   nanochemistry, 1463-1464\*  
   nuclear, 1506\*  
   organic, 1568-1569\*  
   photochemistry, 1661-1662\*  
   physical, 1677\*  
   quantum, 1824-1825\*  
   radiation, 1842\*, 1843-1844\*  
   radiochemistry, 1859\*  
   solid-state, 2044\*  
   sonochemistry, 2050\*  
   structural, 2131-2133\*  
   supramolecular, 2166\*  
 Chemoautotrophs, 1323  
 Chemokines, 609, 610  
 Chemometrics, 432-433\*  
 Chemoreception, 433\*  
   carotid body, 374\*  
   chemical senses, 427-428\*  
   taste buds, 605  
 Chemoselectivity, 1574  
 Chemostat, 433-434\*  
 Chemostratigraphy, 434\*  
 Chemotaxis, 2194  
 Chemotaxonomy, 244, 434-435\*  
 Chemotherapy, 435-436\*, 1542-1543  
 Chemotropism, 1709  
 Chenopodiaceae, 336, 1836  
*Chenopodium quinoa*, 1836  
 Chermidae, 963  
 Chernobyl accident, 1854  
 Cherry, 436\*  
 Chert, 436\*  
 Chestnut, 436\*, 870  
 Chestnut blight, 383  
 Chevrel, R., 383  
 Chevrel phases, 436-437\*  
 Chevrotain, 164, 437\*  
 Chicken:  
   Galliformes, 958  
   poultry production, 1761-1762  
 Chickentox and shingles, 437\*  
 Chickpeas, 229, 1240  
 Chicle, 437\*, 656  
 Chicory, 437\*  
 Chigger, 2276  
 Child-Langmuir law, 437-438\*  
 Childhood eating disorders, 724  
 Chilopoda, 438\*  
 Chimaeridae, 385  
 Chimaeriformes, 438\*  
 Chimera, 438-440\*  
   animals, 385-386  
   fishes see Holocephali  
   plants, 386-387  
 Chimney, 440\*  
*Chimonanthus*, 1233  
 Chimpanzee, 132, 149  
   fossil apes, 923  
   fossil humans, 925  
   fossil primates, 928  
   primates, 1772  
 China clays, 413  
 China pea, 1579  
 Chinch bug, 944  
 Chinchilla, 440\*  
 Chinchillidae, 387  
 Chinese alligator, 82  
 Chinese cabbage, 307, 1578  
 Chinese chestnut, 383, 436  
 Chinese mustard, 1578  
 Chinese okra, 1579  
 Chinese preserving melon, 1579  
 Chinese winter melon, 1579  
 Chinese winter radish, 1578  
 Chinook, 440\*, 2091  
 Chlorapatite, 364  
 Chionidoidea, 364  
 Chipmunk, 440\*  
*Chironomus*, 725  
 Chiroptera, 440-441\*  
 Chitin, 441\*, 1750  
 Chiton, 1750  
 Chive, 1543  
 Chlamydia, 442\*  
*Chlamydia psittaci*, 442  
*Chlamydia trachomatis*, 442  
 Chlamydial diseases, 442\*  
 Chlamydomonadales, 2357  
*Chlamyphorus truncatus*, 154  
 Chloral, 391  
 Chlorapatite, 131  
 Chlorine, 442-443\*  
   bleaching, 303\*  
   electrolysis, 770  
   inorganic compounds, 390  
   manufacture, 390  
   organic compounds, 390-391  
   properties, 390  
 Chlorins, 1756  
 Chlorite, 443\*  
   bleaching, 303\*  
   clays, 468, 469  
   phyllite, 1675  
 Chloritoid, 443\*  
 Chlorobenzene, 391  
 Chlorocruorin, 1906  
 Chlorofluorocarbons (CFCs), 1004  
 Chloroform, 443\*  
 Chloromonadida, 443\*  
 Chloromonadophyceae see  
   Raphidophyceae  
 Chlorophyceae, 443-444\*  
   Bryopsidales, 338\*  
   Chlorococcales, 443-444\*  
   Dasycladales, 616\*  
   Oedogoniales, 1533\*  
   Volvocales, 2357\*  
   Zygnematales, 2421\*  
 Chlorophycophyta see Chlorophycota  
 Chlorophycota, 444\*  
   Charophyceae, 418\*  
   Chlorophyceae, 443-444\*  
   Prasinophyceae, 1764\*  
 Chlorophyll, 118, 444\*, 1757  
 Chloroplast, 3, 346, 348-349, 389  
 Chlorosulfonated polyethylene, 995  
 Choanate fishes, 582  
 Choanoflagellida, 444-445\*  
 Choanolaimoidea, 396  
 Chocolate see Cocoa powder and  
   chocolate  
 Choke (electricity), 445\*, 1872  
 Choked flow, 445\*  
   compressible flow, 517  
   with friction, 393  
   with heat addition, 393  
   through varying-area duct,  
   393  
   see also Throttled flow

- Cholecystitis, 957  
 Cholecystokinin, 1098, 1260  
 Cholera, 445\*  
 Cholesterol, 445-446\*  
   metabolic disorders, 1362  
   steroid, 2115-2116  
   sterol, 2116  
 Choline, 446\*  
 Chomsky, Noam, 1800  
 Chondrichthyes, 14, 446\*  
   animal evolution, 120  
   Bradyodonti, 324\*  
   Chimaeriformes, 438\*  
   Elasmobranchii, 740\*  
   Holocephali, 1084\*  
   Selachii, 1978\*  
 Chondrobrachii, 359  
 Chondrodite, 1098  
 Chondrophora, 979  
 Chondrostei, 446-447\*, 1596, 1751  
 Chondrosteidae, 14  
*Chondrus crispus*, 375  
 Chonotrichida, 447\*  
 Chopper-stabilized amplifier, 622  
 Chopping, 447\*  
 Chordaceae, 1224  
 Chordata, 447-448\*  
   animal evolution, 119, 120  
   calcichordates, 351\*  
   Cephalochordata, 404-405\*  
   Cyclostomata, 542  
   Tunicata, 2282\*  
   Vertebrata, 2332\*  
 Chordodes, 921  
 Chorioallantois, 81, 396  
 Chorion, 448\*  
 Choristida, 448\*  
 Choristodera, 750  
 Christie, S. H., 2386  
 Christmas disease, 269  
 Christmas poinsettia, 855  
 Christy, H., 516  
 Chromadorida, 448\*  
 Chromadoroidea, 396  
 Chromatic aberration, 448\*  
 Chromaticity diagram, 443-444, 502-503  
 Chromatography, 112, 448-449\*  
   amino acid dating, 96  
   column, 437  
   gas chromatography, 965\*  
   gel permeation, 868-869, 975-976\*  
   instrumentation, 449  
   interpretation, 449  
   liquid, 1262\*  
   methods, 449  
   subcritical-fluid, 2158\*  
   supercritical-fluid, 2158\*  
   uses, 449  
 Chromatophore, 450\*  
 Annelida, 125  
   protective coloration, 1789-1790\*  
 Chromite, 450\*  
   heavy minerals, 1058  
   peridotite, 1631  
   spinel, 2086  
   spinel, 2085-2086\*  
 Chromium, 450-451\*  
 Chromizing, 936  
 Chromophycota, 451\*  
   Chrysophyceae, 455\*  
   Cryptophyceae, 589\*  
   Dinophyceae, 674\*  
   Eustigmatophyceae, 771, 856  
   Phaeophyceae, 1647\*  
   Prymnesiophyceae, 1798\*  
   Raphidophyceae, 1869\*  
   Xanthophyceae, 2406-2407\*  
 Chromosome, 451-453\*  
   aberration, 400-401, 453-454  
   compaction, 451  
   deoxyribonucleic acid, 575-576, 638-640\*  
   gene, 978\*  
   human, 968  
   human chromosome mapping, 969  
   imprinting, 453  
   meiosis, 1349-1350\*  
   mitosis, 1410-1411\*  
   mosaicism, 1438-1439\*  
   mutation, 1457\*  
   nucleosome, 1519\*  
   number and size, 451-452  
   polyploidy, 1750, 1750\*  
   recombination, 1875\*  
   replication, 400  
   sex chromosomes, 400, 453  
   size and number, 400  
 Chromosome—cont.  
   staining, 452-453  
   structure, 452  
 Chromosome aberration, 453-454\*  
 Chromosphere, 454\*  
 Chronic fatigue immune dysfunction syndrome (CFIDS), 454\*, 884  
 Chronic pancreatitis, 1605  
 Chronoamperometry, 764  
 Chronograph, 454\*  
 Chronometer, 454-455\*  
 Chronopotentiometry, 765  
 Chroococcales, 538  
 Chrysothale, 455\*  
 Chrysochloromorpha, 1159  
 Chrysocolla, 455\*  
 Chrysomonadida, 455\*  
 Chrysopetalidae, 760  
 Chrysophyceae, 455\*  
 Chrysothale, 178, 455\*  
 Church, A., 895  
 Chylomicrons, 1260  
 Chymosin, 1895  
 Chytridiales, 402  
 Chytridiomycetes, 455\*  
 Cicada, 962  
 Cicadellidae, 962  
 Cicadidae, 962  
*Cicer arietinum*, 229  
*Cichorium intybus*, 384  
 Ciconiidae, 402  
 Ciconiiformes, 455-456\*  
 Cider vinegar, 2340  
 Cigarbox cedar, 345  
 Cilia and flagella, 456\*, 853  
 Ciliate, 456\*  
   Holotrichia, 1085-1086\*  
   Peritrichia, 1634\*  
   Spirotrichia, 2086-2087\*  
   Suctorina, 2143\*  
 Ciliophora, 456-457\*  
   Apostomatida, 152\*  
   Ciliata, 456\*  
   Hymenostomatida, 1113-1114\*  
   Odontostomatida, 1533\*  
   Oligotrichida, 1540\*  
   Tintinnida, 2243\*  
   Trichostomatida, 2270\*  
 CIM see Computer-integrated manufacturing  
*Cimex lectularius*, 231  
 Cimicidae, 230, 944  
 Cimicimorpha, 944  
 Cimicoidea, 944  
 Cinchona (tree), 457\*, 984, 1836  
 Cinematography, 457-458\*  
   cameras, 404-405  
   film, 405  
   photography, 1666  
   projectors, 405  
   wide-screen processes, 405  
 Cintheodolites, 1562  
 Cingulata, 665  
 Cinnabar, 458\*  
*Cinnamomum*, 1233  
*Cinnamomum camphora*, 321, 322  
*Cinnamomum zeylanicum*, 405  
 Cinnamon, 458\*  
   essential oils, 847  
   Laurales, 1233  
 Circle, 458\*  
   epicycloid, 836\*  
   radian measure, 1841\*  
 Circle graph, 1017  
 Circuit (electricity), 458-459\*  
   branch, 287  
   bridge, 293, 334\*  
   coupled circuits, 573\*  
   electric switch, 752\*  
   electric transient, 752\*  
   electrical energy measurement, 755\*287  
   electrical impedance, 755\*  
   electrical instability, 755-756\*  
   electrical loading, 757\*  
   electrical resistance, 759\*  
   equivalent circuit, 843\*  
   fuse (electricity), 950-951\*  
   inductance, 1137\*  
   Kirchhoff's laws of electric circuits, 1216\*  
   nonsinusoidal waveform, 1500\*  
   Ohm's law, 1533\*  
   open circuit, 1545\*  
   parallel circuit, 1608\*  
   pinch effect, 1688-1689\*  
   Q (electricity), 1819\*  
   rectifier, 1875-1876\*  
   relay, 1892\*  
 Circuit (electricity)—cont.  
   resistor, 1902-1903\*  
   series circuit, 1988\*  
   short circuit, 2002-2003\*  
   shunting, 2003-2004\*  
   susceptance, 2173-2174\*  
   switching circuit, 2175-2176\*  
   thermistor, 2223\*  
   vacuum tube, 2074-2075\*  
   voltage-multiplier, 2355\*  
   wiring diagram, 2392\*  
   wiring system, 2392\*  
 Circuit (electronics), 459-461\*  
   analog vs. digital, 460  
   biasing of, 460  
   breadboarding, 328\*  
   clamping, 411  
   comparator circuit, 514\*  
   conversion, 460  
   design, 461  
   differential amplifier, 661\*  
   digital, 460  
   distortion, 689-690\*  
   electronic power supply, 790-791\*  
   emitter follower, 813\*  
   feedback, 460  
   frequency divider, 934\*  
   frequency modulation, 935\*  
   frequency multiplier, 937\*  
   gate circuit, 972\*  
   integrated circuits, 1164-1166\*  
   limiter circuit, 1255-1256\*  
   logic circuits, 1271\*  
   Lamellibranchia, 1449-1450\*  
   negative-resistance circuits, 1471-1472\*  
   optical isolator, 1555-1556\*  
   oscillator, 1582-1583\*  
   phase inverter, 1651\*  
   phase modulator, 1652-1653\*  
   printed circuit, 1773\*  
   pulse generator, 1807\*  
   transistor, 460, 2260-2261\*  
   trigger circuit, 2271\*  
   wave-shaping circuits, 2372\*  
 Circuit (microwave), 1392  
 Circuit, magnetic see Magnetic circuits  
 Circuit analyzer see Multimeter  
 Circuit breaker, 461\*  
   electric contact, 742\*  
   short circuit, 2003  
 Circuit model transmission lines, 2262  
 Circuit switching:  
   data communications, 616  
   local-area networks, 1267  
   packet switching, 1594  
 Circuit testing (electricity), 462\*, 1550-1551  
 Circular dichroism, 1561  
 Circularly polarized light, 1737  
 Circulation, 462-463\*, 2358-2359  
   see also Ocean circulation  
 Circulation disorders, 463\*  
   arteriosclerosis, 173-174\*  
   embolism, 808\*  
   infarction, 1143\*  
   thrombosis, 2235\*  
 Circulatory system, 409\*  
   aorta, 148\*  
   blood, 304-305\*  
   blood vessels, 307\*  
   cardiovascular system, 372-373\*  
   circulation, 462-463\*  
   circulation disorders, 408-409  
   countercurrent exchange (biology), 572-573\*  
   lymphatic system, 1281\*  
   spleen, 2088\*  
 Cirrolanidae, 803  
 Cirque, 463\*, 1000, 1123  
 Cirrhosis, 463-464\*  
   alcoholics, 69  
   liver disorders, 1265  
   metabolic disorders, 1361  
 Cirripedia, 19, 464\*  
 Ascothoracica, 180\*  
   barnacle, 252\*  
   Thoracica, 2234\*  
*Cistus*, 1309  
 Citric acid, 409-410, 464-465\*  
 Citric acid cycle, 465\*, 1713  
   see also Krebs cycle  
*Citrobacter*, 741  
 Citron, 465-466\*  
 Citronella, 466\*  
*Citrus aurantifolia*, 1241\*, 1255  
 Citrus fruit:  
   citron, 465-466\*  
   essential oils, 847  
 Citrus fruit—cont.  
   grapefruit, 1016-1017\*  
   lime, 1255\*  
   mandarin, 1310\*  
   orange, 1565\*  
   tangerine, 2191\*  
*Citrus liman*, 1241  
*Citrus medica*, 410  
*Citrus paradisi*, 902, 1016-1017  
*Citrus reticulata*, 1310, 2191  
*Citrus sinensis*, 1565  
 Civet, 466\*  
 Civet gland, 1955  
 Civil defense system, 2196  
 Civil engineering, 466\*  
   coastal engineering, 484\*  
   engineering geology, 739-740, 825\*  
   highway engineering, 1079-1080\*  
   river engineering, 1924\*  
   water supply engineering, 2367-2368\*  
 Cladding, 466-467\*  
 Cladistia see Polypteriformes  
 Cladistics:  
   classification, biological, 468  
   macroevolution, 1287  
*Cladobotryum*, 1119  
 Cladograms, 1675  
 Cladophora, 411  
*Cladosealache*, 411  
*Cladosealachi*, 467\*  
 Clairvoyance, 779  
 Clam:  
   invertebrate pathology, 1182  
   Lamellibranchia, 1223  
 Clamshell, 773  
 Clarification, 467\*  
   filters, 799  
   sedimentation (industry), 1972  
 Clarifying agents (food), 818  
 Classical dynamics, 648  
 Classical field theory, 412, 467\*  
 Classical mechanics, 467\*  
   causality, 383-384  
   kinetics, 1215-1216\*  
   mechanics, 1344  
 Classics statistics see Boltzmann statistics  
 Classification, biological, 467-468\*  
   see also Systematics; Taxonomy  
 Classification, mechanical, 1342-1343\*  
 Classes, 720  
 Clathrate compounds, 468\*  
 Clathrina, 412  
*Clathrinida*, 312, 468\*, 1246  
*Clathruina elegans*, 646, 650  
*Clavxinellida*, 468\*  
*Claviceps*, 759, 843  
*Claviceps purpurea*, 1460  
 Clay, 468-469\*  
   attapulgite, 413-414  
   bentonite, 265-266\*, 413  
   commercial, 469-470\*  
   diaspore, 413  
   kaolinitic, 413  
   mullite, 413  
   pottery, 1761\*  
   properties, 413  
   tile, 2240\*  
 Clay minerals, 470\*  
   bentonites, 413  
   clathrate compounds, 468\*  
   clay, 468  
   diaspore, 413  
   glaucanite, 1003\*  
   halloysite, 1041-1042\*  
   illite, 1126\*  
   kaolinite, 413, 1209\*  
   loess, 1268  
   montmorillonite, 1436\*  
   mullite, 413  
   sepiolite, 1986\*  
   surfactant, 2172  
   vermiculite, 2331\*  
 Claystone, 152  
 Clear-air turbulence, 479-471\*  
 Cleavage (embryology), 415, 471\*, 585-586  
   blastulation, 303\*  
   cell lineage, 392\*  
 Cleft lip and cleft palate, 471\*  
 Cleland, M. R., 648  
*Cleome spinosa*, 325  
 Clerk, Dougald, 1174  
 Clevis pin, 471\*  
 Client-server system, 471-472\*, 527  
 Cliff, 847\*  
*Cliftonia monophylla*, 1047  
*Climacostomum*, 951

- Climate:  
 depositional systems and environments, 641  
 grassland ecosystem, 1019-1020  
 Jurassic, 1208  
 Pacific Islands, 1593  
 paleoclimatology, 1598\*  
 plants, life forms of, 1717  
 Climate control (automotive), 228\*  
 Climate history, 472\*, 1597  
 Climate modeling, 472-473\*  
 Climate modification, 473\*  
 Climate prediction, 1380  
 Climatography, 416  
 Climatology, 473\*  
 atmospheric general circulation, 205  
 climate history, 472\*  
 Earth sciences, 722  
 East Indies, 723  
 El Niño, 740\*  
 global climate change, 1004\*  
 sedimentology, 1972  
 urban, 2309-2310\*  
 weather modification, 2379\*
- Clingfishes, 1010  
 Clinical hypothermia, 1121  
 Clinical immunology, 474\*  
 Clinical microbiology, 417, 474\*  
 Clinical pathology, 474-476\*  
 Clinohumite, 1098  
 Clinopyroxene, 1125  
 kimberlite, 1214  
 layered intrusion, 1234  
 Clonidae, 282  
 Cloaca, 666  
 Clock, 476\*  
 atomic see Atomic clock  
 biological, 284-285\*  
 chronometer, 454-455\*  
 day, 620  
 escapement, 846\*  
 quartz clock, 1833\*  
 Clock paradox, 476\*  
 Clonal analysis, 872-873  
 Clonic convulsions, 766  
 Cloning, 983  
 Clonopora, 937  
 Closed-caption television, 476\*  
 Closed-circuit television, 476-477\*  
 Closed-cycle gas turbine, 863  
 Closed-loop control system, 484, 485  
 see also Feedback control system  
 Clostridia, 240  
 Clostridium, 211, 477\*  
 Clostridium botulinum, 909  
 Clostridium felsineum, 2217  
 Clostridium perfringens, 909  
 Clostridium tetani, 2214  
 Cloud, 477-478\*  
 molecular, 1419-1420\*  
 satellite meteorology, 1947  
 storm electricity, 2121  
 stratosphere, 2124  
 weather observations, 2380  
 Cloud physics, 478-479\*  
 Clove, 479\*  
 Clover, 479\*  
 legume, 1240  
 legume forages, 1240  
 sweet, 422  
 true, 421-422  
 Clovis culture, 1600  
 Club mosses, 1793-1794  
 Lycopodiales, 1280-1281\*  
 plant evolution, 1703  
 plant phylogeny, 1712  
 Selaginellales, 1978\*  
 Clubfoot, 822  
 Clupea harengus, 948  
 Clupeidae, 948  
 Clupeiformes, 479-480\*  
 herrings, 1069-1070\*  
 pike, 1686\*  
 Clupeomorpha, 2198  
 Cluster weapons, 48  
 Clusters see Star clusters  
 Clutch, 230, 480\*  
 Clypeasteroidea, 1943\*  
 CNC see Computer numerical control  
 Cnidaria see Coelenterata  
 Cnidospores, 480-481\*  
 Microsporidea, 1391\*  
 Myxosporida, 1461-1462\*, 1462  
 Myxosporidea, 1462\*  
 Coal, 481-482\*  
 coke, 495-496\*  
 cyclothem, 606\*
- Coal—cont.  
 jet (gemology), 1202\*  
 lignite, 1254, 1254\*  
 paleoclimatology, 1598  
 Pennsylvanian, 1625, 1626  
 smog, 2024  
 torbanite, 2250\*  
 Coal balls, 482\*  
 Coal chemicals, 482\*  
 Coal gasification, 482\*  
 Fischer-Tropsch process, 890\*  
 fluidized-bed combustion, 901\*  
 Coal liquefaction, 482-483\*  
 Coal mining, 483\*, 2297-2298  
 Coal paleobotany, 483\*  
 Coal rank, 481  
 Coal tar, 425  
 Coalbed methane, 483-484\*  
 Coalification, 424, 481  
 Coastal engineering, 484\*  
 Coastal hydraulics, 1102  
 Coastal landforms, 484\*, 484-485  
 Coastal marine ecosystems, 1319  
 Coastal plain, 484-485\*  
 Coat-of-mail shell, 1750  
 see also Chiton  
 Coati, 485\*  
 Coating see Metal coatings; Surface coating  
 Coaxial cable, 485-486\*  
 communication cables, 510  
 microwave filter, 1393-1394\*  
 submarine cable, 2139  
 telephone systems construction, 2200  
 television system, 307  
 transmission lines, 2262, 2262\*  
 Cobalamin see Vitamin B12  
 Cobalt, 486\*  
 Cobaltite, 487\*  
 Coca, 487\*  
 Cocaine, 26, 487\*  
 Coccidia, 487\*, 2207  
 Eucoccidia, 852\*  
 Protococcidia, 1793\*  
 Coccidioides immitis, 429  
 Coccoidea, 963  
 Coccothrophorida, 430\*  
 Cochlea:  
 hearing (human), 1049  
 sensory system regeneration, 1986  
 Cochlear fluid, 1049  
 Cochliodontidae, 286  
 Cockcroft, J. D., 430  
 Cockcroft-Walton accelerator, 717  
 Cockle:  
 invertebrate pathology, 1182  
 Lamellibranchia, 1223  
 Cockroach, 487-488\*  
 Exopterygota, 859  
 Isoptera, 1195  
 Orthoptera, 1581  
 Coco palm, 431  
 Cocoa powder and chocolate, 488\*  
 Coconut, 488\*, 495\*  
 Cocoon nebula, 1470  
 Cocos nucifera, 431  
 Code-division multiple access (CDMA), 1447  
 Codfish, 488\*  
 fisheries ecology, 890  
 Gadiformes, 955\*  
 Codiales see Bryopsidales  
 Codominance, 695  
 Codomonas annulata, 242  
 Codon, 874  
 Coelacanthiformes, 488-489\*  
 Coelacanthini, 120, 517  
 Coelenterata, 489-490\*  
 Anthozoa, 134\*  
 Antipatharia, 144\*  
 Ceriantharia, 408\*  
 Coenothecalia, 491\*  
 Conularida, 550\*  
 Corallimorpharia, 558\*  
 Coronatae, 561\*  
 Cubomedusae, 597\*  
 Gorgonacea, 1013\*  
 Heterocorallia, 1071\*  
 Hydrozoa, 1107-1108\*  
 Hydrozoa, 1111\*  
 Milleporina, 1403\*  
 Ptychodactylaria, 1805\*  
 Rhizostomeae, 1914\*  
 Rugosa, 1935\*  
 Scleractinia, 1962\*  
 Scyphozoa, 1965\*  
 sea anemone, 1965\*  
 Semaestomeae, 1979-1980\*  
 Siphonophora, 2014\*
- Coelenterata—cont.  
 Spongiomorpha, 2088\*  
 Stauromedusae, 2104-2105\*  
 Stolonifera, 2119\*  
 Stylasterina, 2137\*  
 Tabulata, 2189\*  
 Telestacea, 2202  
 Trachylina, 2255\*  
 Zoantharia, 2417\*  
 Zoanthidea, 2417\*  
 Coelom, 490\*  
 Coelomycetes, 490\*, 585, 648  
 Coelonyx variegatus, 868  
 Coenopteridales, 490-491\*  
 Coenothecalia, 491\*  
 Coenurosis, 491\*  
 Coenzyme, 491\*, 748  
 nicotinamide adenine dinucleotide, 1487\*  
 nicotinamide adenine dinucleotide phosphate, 1487-1488\*  
 phosphate, 1658  
 purine, 1811\*  
 pyrimidine, 1813\*  
 vitamin, 2348, 2348\*  
 Coesite, 491\*  
 Coffea arabica, 434  
 Coffee, 491-492\*  
 caffeine, 349\*  
 Gentianales, 984  
 Cofferdam, 492\*, 614  
 Cogeneration, 492\*  
 Cognition, 493\*, 650-651  
 Cognitive engineering, 1093-1094  
 Cognitive therapies, 1804  
 Cohen, P., 1337  
 Coherence, 493-494\*  
 optical coherence tomography, 1551-1552\*  
 synchrotron radiation, 2184  
 Coherent anti-Stokes Raman spectroscopy (CARS), 1497  
 Coherent effects, 1497  
 Cohesion (physics), 494-495\*, 1417  
 Coil, 495\*  
 Coincidence rangefinder, 1868  
 Coining, 495\*, 1998  
 Coir, 495\*  
 Coitus, 1898  
 Coke, 495-496\*  
 gasification, 425  
 petroleum products, 1645  
 Coke oven gas, 425  
 Coking (petroleum), 496\*  
 petrochemical, 1639  
 petroleum processing and refining, 1644  
 Cola, 496\*  
 Cola acuminata, 437  
 Colacium, 768, 853  
 Colchicine, 79, 496\*  
 Colchicum, 1254  
 Colchicum autumnale, 437  
 Cold, common, 450  
 Cold-cathode gas tubes, 863  
 Cold-cathode ionization gage, 1189  
 Cold hardiness (plants), 496-497\*  
 Cold rolling, 1367  
 Cold storage (food), 821-821  
 Coleaspis, 8  
 Colemanite, 497\*  
 Coleoidea, 497\*  
 Sepioidea, 1986\*  
 Teuthoidea, 2215\*  
 Coleoptera, 497-498\*  
 anatomy, 439  
 food specialization, 439  
 general biological features, 438-439  
 geographical distribution, 440  
 phylogenetic history, 440  
 special habits and adaptations, 497-498\*  
 water beetles, 439  
 Coleorrhyncha, 962  
 Colies, 499\*  
 Coliform bacteria, 762  
 Coliidae, 440  
 Coliiformes, 499\*  
 Colinus virginianus, 260  
 Coliphage, 499\*  
 Collagen, 499-500\*, 976\*  
 Collagen vascular disease see Connective tissue disease  
 Collard, 500\*  
 Collective behavior (plasma), 1717  
 Collembola, 500\*  
 Collenchyma, 500\*  
 Collision avoidance system (CAS):  
 aircraft, 58\*  
 marine navigation, 1324
- Collision (physics), 500-501\*  
 conservation of momentum, 540-541\*  
 scattering experiments, 1954  
 Colloid, 501\*  
 gel, 868  
 isoelectric point, 1194\*  
 Colloid goiter, 2237  
 Colloidal crystals, 501-502\*  
 Collotheceae, 1434  
 Collotype printing, 1774  
 Colobathristidae, 944  
 Colobinae, 928  
 Colocasia esculenta, 551  
 Cologne spirits, 765  
 Colon, 502\*, 607  
 digestive system, 667  
 gastrointestinal tract disorders, 971  
 intestine, 1178  
 Colonias, 827  
 see also Pedicellinida  
 Colony-stimulating factors (cytokines), 545, 609, 610  
 Color, 442-444, 502-503\*  
 colorimetry, 505\*  
 elementary particle, 803  
 protective coloration, 1789-1790\*  
 quarks, 1832  
 underwater photography, 2299  
 Color (quantum mechanics), 503\*, 1825-1826  
 Color balance, 2203  
 Color blindness, 503  
 color vision, 504-505  
 sex-linked inheritance, 1993  
 Color centers, 503\*  
 Color filter, 504\*, 1572  
 Color index, 504\*  
 Color photography:  
 additive, 445  
 one-step, 445  
 subtractive, 445  
 Color television:  
 picture tube, 1685\*  
 receiver, 2205-2206\*  
 television receiver, 2205-2206  
 Color vision, 504-505\*, 2347  
 color, 502-503  
 color blindness, 504-505  
 Coloraderpeton, 67  
 Colorado blue spruce, 2090-2091  
 Colorimetry, 444, 505\*  
 Coloring agents (food), 818, 909  
 Colugo, 642\*  
 Columbae, 446  
 Columbia (space flight), 2060  
 Columbiidae, 446, 447  
 Columbiformes, 505\*  
 Columbine, 1869  
 Columbite, 505\*  
 see also Niobium  
 Column, 505-506\*  
 beam, 260\*  
 concrete, 530\*  
 Colymboididae, 974  
 Coma-Sculptor Cloud, 1267  
 Comatulida, 161  
 Comb jellies see Ctenophora  
 Comb polymer, 287  
 Combinational circuits, 2175  
 Combinatorial synthesis, 507\*  
 Combinatorial theory, 507\*, 1017  
 Combining volumes, law of, 507\*  
 Combustion, 507\*  
 autooxidation, 232\*  
 coal gasification, 482\*  
 fire, 889\*  
 flame, 891-892  
 flameproofing, 892\*  
 fluidized-bed combustion, 901\*  
 oxidation process, 1589\*  
 smoke, 2024\*  
 Combustion chamber, 507-508\*  
 Combustion knock, 1532  
 Combustion turbines, 1763  
 Comesomatidae, 396  
 Comesomatoida, 396  
 Comet, 508\*  
 Halley's, 922, 1041\*  
 interplanetary matter, 1177  
 planetary physics, 1700  
 solar system, 2041  
 Comet Shoemaker-Levy, 1207  
 Comfort heating, 508\*  
 cogeneration, 492\*  
 degree-day, 631\*  
 heat pump, 1056\*  
 hot-water heating system, 1091-1092\*

- Comfort heating—*cont.*  
oil burner, 1536\*  
oil furnace, 1537\*  
panel heating and cooling, 1605\*  
radiant heating, 1842\*  
solar space heating, 2040  
steam heating, 2106-2107\*  
warm-air heating system, 2362\*
- Commelinaceae, 449  
Commelinales, 509\*  
Commelinidae, 509\*  
Bromeliales, 335\*  
Cyperales, 607\*  
Eriocaulales, 844\*  
Hydateliales, 1100\*  
Juncales, 1205\*  
Restionales, 1908\*  
Zingiberales, 2416-2417\*
- Commensalism, 663  
Commerce, Internet, 1176-1177  
Commercial finish (paint), 1595  
Common chimpanzee, 1772  
Common cold, 509\*, 1913  
Common Object Request Broker (CORBA), 690  
Communication cables, 2198, 2200  
Communications:  
bandwidth requirements, 218-219, 250\*  
electrical, 753-754\*  
information theory, 1149-1150\*  
microwave, 1393  
mobile radio, 1412-1413\*  
space, 2057-2058\*  
space communications, 2057-2058\*  
spread spectrum communication, 2089-2090\*  
switching systems, 2176-2177\*  
teleconferencing, 2196\*  
teleprocessing, 2201\*  
videotelephony, 2339-2340\*  
wide-area networks, 2387-2388\*  
*see also* Data communications; Optical communications  
Communications cable, 509-510\*  
Communications satellite, 510-511\*  
direct broadcasting satellite systems, 681-682\*  
radio broadcasting network, 1848-1849  
spread spectrum communication, 2090  
telephone service, 2199-2200\*  
television networks, 2204-2205\*  
Communications scrambling, 511\*  
Communications systems:  
data communications, 616\*  
demodulator, 634  
electrical noise, 759  
electrical noise generator, 759  
Communications systems protection, 511-512\*  
Communities *see* Ecological communities  
Community antenna television, 419  
Commutation, 512-513\*  
Commutator, 513\*  
Compact disk (CD), 513-514\*  
digitally encoded waveform, 452-453  
optical readout, 452  
optical recording, 1561  
signal processing, 453  
video disk, 453, 2338-2339\*  
Compact disk-read-only memory (CD-ROM), 526  
Compactors (construction equipment), 479  
Comparative primate morphology, 1676  
Comparator, 514\*  
Comparison microscope, 1557  
Compass:  
aircraft, 58-59\*  
dead reckoning, 621  
gyrocompass, 1034-1035\*  
magnetic, 1291\*  
radio compass, 1849\*  
Compass declinometer, 565  
Competition, ecological, 662, 732-733\*  
Compilers, software, 2030  
Complement, 514\*  
complement-fixation test, 514-515\*  
conglutination, 537\*  
lytic reaction, 1284\*  
microbiota (human), 1382-1383\*  
plasmin, 1721  
Complement-fixation test, 514-515\*  
Complementarity principle, 1829  
Complementary MOS (CMOS) circuits, 972  
Complementation (genetics), 515\*  
Complete expansion diesel cycle *see* Brayton cycle
- Complex compounds:  
coordination chemistry, 554\*  
hydrido complexes, 1102\*  
Complex instruction set computers (CISC), 670, 1389  
Complex lipids, 1260  
Complex numbers, 74, 515\*  
Complexation phenomena, 1286  
Compositae, 160, 172  
Composite beam, 515-516\*  
Composite laminates, 516\*  
Composite material, 516-517\*  
carbon fibers, 903  
cermet, 408\*  
materials science and engineering, 1334\*  
metal matrix composite, 1366-1367\*  
plastics, 1723  
plastics processing, 1723  
polymeric, 1746-1747\*  
polymeric composite, 1746-1747\*  
spacecraft structure, 2070  
structural materials, 2135  
Composite volcanoes, 2352  
Composition board, 517\*  
Composition resistor, 1903  
Compound (chemistry), 369, 380, 517\*  
chemistry, 431-432  
clathrate, 412  
definite composition, law of, 631\*  
fluxional compounds, 905-906\*  
heterocyclic, 949  
hypervalent, 1118-1119\*  
interhalogen compounds, 1172-1173\*  
intermetallic compounds, 1173-1174\*  
macrocyclic, 1286-1287\*  
metal cluster, 1365\*  
molecular isomerism, 1420-1421\*  
nitrogen complexes, 1491\*  
nonstoichiometric compounds, 1500\*  
organoactinides, 1575\*  
organometallic compound, 1575-1576\*  
organophosphorus compound, 1576\*  
organosulfur compound, 1577-1578\*  
pyrolysis, 1814-1815  
salt, 1941-1942\*  
structural chemistry, 2131-2133\*  
symbols and formulas, 383  
Compound-B ultrasonography, 660  
Compound eyes (invertebrate), 780  
Compound lens (optics), 1241  
Compound microscope, 1391  
Compound motor, direct-current, 623  
Compressible flow, 34, 517-518\*  
choked flow, 445\*  
fluid flow, 900  
Compression molding, 1723  
Compression ratio, 518\*  
Compression test, 1363-1364  
Compressor, 518\*  
gas turbine, 968  
mean effective pressure, 1341\*  
supercharger, 2153  
valves, 2321  
volume control system, 2357  
volumetric efficiency, 2357\*  
*Compsognathus*, 615  
Compton, A. H., 457  
Compton effect, 518\*  
gamma-ray detectors, 962  
radiation biology, 1842  
x-rays, 2406  
Compton electron, 772  
Compton Gamma Ray Observatory, 871  
gamma-ray astronomy, 961  
Geminga, 975  
Computational chemistry, 518-519\*, 1421-1422  
Computational fluid dynamics, 519\*  
applications, 458  
discretization, 457  
turbulence modeling, 457  
visualization, 457-458  
Computations, significant figures in, 2006-2007\*  
Computer, 519-520\*  
analog, 108-109\*  
artificial intelligence, 176-177\*  
automated decision making, 224\*  
bit, 299\*  
calculators, 352\*  
concurrent processing, 531\*  
cryotron, 587\*  
distributed systems, 629-630, 689\*  
fault-tolerant systems, 873-874\*  
game-playing machines, 858  
guidance systems, 881-882  
human-computer interaction, 1092-1093\*
- Computer—*cont.*  
and human interaction, 967  
multiaccess computer, 1444-1445\*  
multimedia technology, 1445-1446\*  
multiprocessing, 1447-1448\*  
natural language processing, 1466\*  
numerical representation, 1423-1424\*, 1523-1524\*  
object-oriented programming, 1528\*  
operating system, 1546\*  
real-time systems, 1873-1874\*  
seismic exploration for oil and gas, 1974  
simulation, 2012-2013\*  
speech recognition, 2079-2080\*  
supercomputer, 2153\*  
video games, 2339\*  
videotelephony, 2339-2340  
*see also* Digital computer; Programming  
Computer-aided design and manufacturing (CAD/CAM), 520\*, 700  
computer graphics, 521  
microwave filter, 1393-1394\*  
Computer-aided engineering (CAE), 520\*, 521  
Computer-assisted control, 746  
Computer-based systems, 520-521\*  
Computer conferencing, 2196  
Computer graphics, 521-522\*  
computer, 521-522\*  
display hardware, 459  
geographic information systems, 988-989\*  
hardcopy output, 459  
image synthesis, 460  
input devices, 459  
interactive, 459-460  
map design, 1315  
microcomputer, 1373  
models of nature, 460  
virtual reality, 2342-2343\*  
Computer-integrated manufacturing (CIM), 522\*  
Computer networks:  
Internet, 1176-1177\*  
local-area networks, 1267\*  
Computer numerical control (CNC), 522\*  
Computer peripheral devices, 522-523\*  
computer graphics, 521  
digital computer, 669  
operating system, 1546  
Computer programming *see* Programming  
Computer science:  
data mining, 617\*  
data structure, 618\*  
database management system, 618-619\*  
number theory, 1521-1522\*  
Computer security, 524-526\*  
access control, 461, 524  
cryptography, 587-589\*  
database, 462, 525  
encryption, 448, 524  
intrusion detection, 525-526  
network, 462, 525  
operating system, 462, 525, 1546\*  
perimeter, 525  
program, 461, 524-525  
Computer storage technology, 526-527\*  
digital computer, 668  
electronic data-processing systems, 554  
ferrite, 878\*  
holograms, 960  
holography, 1084-1085  
magnetic recording, 1294  
magnetic-tape units, 463-464, 526-527  
main memory, 526  
mass storage systems, 464, 527  
memory gap technologies, 463  
memory hierarchy, 462, 526  
memory organization, 462, 526  
multiaccess computer memory, 1444-1445\*  
secondary memory, 463, 526  
semiconductor memories, 1982-1983\*  
stored program digital computer, 608-609  
systems architecture, 464, 2186-2187\*  
Computer-system evaluation, 527\*  
Computer systems, embedded, 808\*  
Computer systems architecture, 527-528\*  
peripherals and communication, 465  
processing, 464-465  
storage, 464  
supercomputer, 2153\*  
Computer-telephony integration, 1148  
Computer vision, 528-529\*  
Computerized tomography (CT), 529\*, 1346  
Computing, symbolic, 2178\*  
Concentration overvoltage, 1589  
Concentration scales, 529\*
- Concrete, 530\*  
grout, 1030\*  
precast, 1765\*  
prestressed, 1770\*  
reinforced, 1885\*  
structural materials, 2135  
Concrete arch, 142, 159  
Concrete beam, 530\*  
Concrete column, 530\*  
Concrete slab, 531\*  
composite beam, 526  
floor construction, 896  
Concretion, 531\*  
Concurrent processing, 531\*, 670  
Concussion, 531\*  
Condensation, 531-532\*, 652\*  
Condensation reaction, 1747  
Condensed-matter physics, 2044  
Condenser:  
contact, 480  
surface, 2168-2169\*  
vapor, 2323\*  
Condenser microphones, 1388  
Conditioned reflex, 532\*, 1801  
Conditioning, instrumental, 1161\*  
Condon, E. U., 834  
Condor, 402  
Conductance, 532\*  
electrodermal response, 767  
electrolytic, 771\*  
Conducting polymer, 1569-1570  
Conduction (electricity), 532-533\*  
conductor, 469-470  
copper, 556\*  
electrical conduction in gases, 754\*  
relaxation time of electrons, 1891  
Conduction (heat), 533\*  
sound absorption, 2052  
thermal conduction in solids, 2220\*  
Conduction band, 533\*  
Conductivity, metals, 533  
Conductometric titration, 2245  
Conductor (electricity):  
copper loss, 557\*  
eddy current, 737\*  
electrical connector, 754\*  
electrode potential, 766-767\*  
grounding, 1029\*  
Joule's law, 1204\*  
semiconductor, 1980  
skin effect, 2018-2019\*  
transmission lines, 2262\*  
Condylarthra:  
archaic ungulate, 161\*  
ferret, 877\*  
fisher, 890\*  
hyena, 1111\*  
marten, 1328\*  
mink, 1406\*  
mongoose, 1431\*  
otter, 1587\*  
panda, 1605\*  
sable, 1939\*  
skunk, 2019\*  
weasel, 2377\*  
wolverine, 2393\*  
Condyllostoma, 951  
Cone (eye), 502, 503, 781  
Cone (geometry), 533-534\*, 537  
Cone clutch, 423  
Conenose bug, 944  
Configuration interaction, 1825  
Confocal microscopy, 534\*, 903  
Conformal mapping, 534\*  
Conformal optics, 534-535\*  
Conformational analysis, 535-536\*, 1572  
Congenital anomalies, 536\*  
cleft lip and cleft palate, 471\*  
foot, 822  
sudden infant death syndrome, 2143-2144\*  
Congenital heart disease, 890  
Congenital lung disease, 1053  
Conglomerate, 536-537\*, 1943  
Conglutination, 537\*  
Congo River, 41  
Conic section, 537\*  
circle, 458\*  
hyperbola, 1115\*  
Conifers:  
plant, 1701  
plant evolution, 1703  
Conjugation (reproduction), 213, 1895  
Conjugation and hyperconjugation, 537-538\*  
Conjunctivitis, 867

- Conk fungi, 1112
- Connecting circuits, 2176
- Connecting rod, 538\*
- Connective tissue, 538-539\*  
blood, 304-305\*  
bone, 315-316\*  
cartilage, 336, 375\*  
collagen, 499-500\*  
hyaluronic acid, 1099\*  
ligament, 1249-1250\*  
nervous system (vertebrate), 1478  
tendon, 2209-2210, 2209-2210\*
- Connective tissue disease, 174, 539\*
- Connugates see Zygnetatales
- Conodont, 539-540\*, 1136
- Conodontia, 1202
- Conservation biology:  
insect control, 1155  
population viability, 1755
- Conservation laws (physics), 540-541\*
- Conservation of chemical elements, 476
- Conservation of energy, 541\*  
electron-positron pair production, 782-783  
heat balance, 1054\*  
law, 476  
Lenz's law, 1242\*  
perpetual motion, 1636\*
- Conservation of mass, 541\*
- Conservation of momentum, 540-541\*  
electron-positron pair production, 782-783  
symmetry laws, 2179
- Conservation of resources, 541-542\*  
forest genetics, 919  
land-use planning, 1225\*  
marine conservation, 1318\*  
soil conservation, 2034  
water conservation, 2363-2365\*
- Constellation, 542\*  
Aquarius, 154-155\*  
Aries, 169\*  
Boötes, 317\*  
Cancer, 322  
Capricornus, 365\*  
Cassiopeia, 377\*  
Centaurus, 401\*  
Crux, 586\*  
Cygnus, 606-607\*  
Gemini, 977-978\*  
Leo, 1242\*  
Libra, 1248\*  
Lyra, 1282\*  
Orion, 1579\*  
Pegasus, 1623\*  
Perseus, 1636-1637\*  
Pisces, 1692\*  
Sagittarius, 1940\*  
Scorpius, 1963  
Taurus, 2194\*  
Ursa Major, 2314-2315\*  
Ursa Minor, 2315\*  
Virgo, 2340-2341\*  
zodiac, 2417\*
- Constipation, 970
- Constitutional isomers, 1420-1422
- Constraint, 542\*, 613
- Constrictor constrictor, 272
- Construction:  
masonry, 1329\*  
structural materials, 2135\*  
wood engineering design, 2395\*
- Construction engineering, 542\*  
construction equipment, 542-543\*  
construction methods, 542\*  
drilling, geotechnical, 701\*
- Construction equipment, 542-543\*, 1764
- Construction methods, 543\*  
cofferdam, 492\*  
dam, 614  
greenhouse technology, 1026  
nailing, 1463\*  
roof construction, 1931\*  
wall construction, 2361-2362\*  
wellpoint systems, 2384\*
- Contact aureole, 543\*
- Contact condenser, 543-544\*
- Contact dermatitis, 664-665
- Contact lenses, 867\*
- Contact metamorphism, 1372
- Contact microradiography, 2149\*
- Contact potential difference, 544\*
- Contagious abortion see Brucellosis
- Containerization:  
marine containers, 1318-1319\*  
transportation engineering, 2264
- Contamination:  
decontamination of radioactive materials, 627\*  
Contamination:—cont.  
water pollution, 2366-2367\*
- Continental code (telegraphy), 2197
- Continental crust, 719-721
- Continental drift, 545\*  
asthenosphere, 187-188\*  
dinosaur, 676  
Earth, 718  
Earth crust, 720  
paleoclimatology, 1598  
Triassic, 2269
- Continental magmatic arcs, 720
- Continental margin, 545-546\*  
coastal landforms, 484  
coastal plain, 484  
continental crust, 719  
marine geology, 1321-1322  
marine sediments, 1324-1325  
sediments, 1324-1325  
turbidity current, 2284\*
- Continental rift, 2269
- Continental rise, 483, 545
- Continental shelf, 483, 545, 717, 2364-2365
- Continental slope, 483, 545, 717
- Continent(s), 544-545\*  
Antarctica, 130\*  
Asia, 181-183\*  
Australia, 219\*  
Carboniferous, 370  
climate history, 472  
continental drift, 545\*  
Earth, 717  
Earth crust, 719  
Europe, 855\*  
evolution of, 546-547\*  
North America, 1501-1503\*  
paleogeography, 1599  
Permian, 1635  
South America, 2055-2056\*  
supercontinent, 2157\*
- Continuous bridge, 292
- Continuous spectrum, 2076
- Continuous-wave gas lasers, 1229
- Continuous-wave radar (CW), 547\*
- Continuous-wave radio transmitter, 1852-1853
- Continuous waveforms, 2373
- Contour, 547\*, 2249
- Contrast manipulation, 1127
- Control chart, 548\*
- Control systems, 548-550\*  
advantages of feedback control, 484-485, 549  
applications for feedback systems, 484  
automation, 225\*  
clock, 418  
closed-loop, 419, 548-549  
costs of feedback control, 485, 549  
design, 485, 549  
digital computer systems, 485, 549-550  
digital control, 670-671\*  
distributed, 630-631, 690-691\*  
electric power generation, 746  
electric power systems, 748  
expert control system, 860-861\*  
flight controls, 895  
greenhouse technology, 1026  
humidity, 1097-1098\*  
hydraulic actuator, 1100-1101\*  
large systems control theory, 1228\*  
medical, 1345-1346\*  
multilevel control theory, 1445\*  
multivariable control, 1448\*  
nonlinear control theory, 1495-1496\*  
nuclear reactor, 1516  
open- and closed-loop control, 484, 548-549  
optimal control (linear systems), 1563\*  
programmable controllers, 1781\*  
railroad, 1865\*  
real-time, 1873-1874\*  
remote, 1893\*  
robotics, 1925\*  
sampled-data control system, 1943\*  
servomechanism, 1989-1990\*  
stability augmentation, 2094\*  
stability of closed-loop systems, 485  
stochastic control theory, 2117\*  
traffic-control systems, 2255-2256\*  
ultralight aircraft, 2294  
valve, 2320-2321\*  
volume, 2357\*  
weeds, 2381
- Control unit (microprocessor), 1389
- Controlled-flight-into-terrain (CFIT) accidents, 1028
- Controlled potential electrolysis, 764
- Controlled rectifier, 550\*, 1983
- Controlled-release drug delivery systems, 702
- Conularida, 550\*
- Convection (heat), 550-551\*  
double diffusion, 699-700\*  
Sun, 2149  
supergranulation, 2159
- Convective instability, 551\*
- Convergent winds, 2388
- Conversion (conversion hysteria), 1481, 1803
- Converter, 551\*  
commutation, 513  
thermal, 2220-2221\*
- Convertiplane, 551-552\*
- Conveying machines, 479, 543
- Conveyor, 302-303, 552\*
- Convulsive ergotism, 759
- Cony, 1121-1122
- Cookeina, 685
- Cool flame, 803
- Cooling:  
engine, 822-823\*  
laser cooling, 1230-1231\*  
nuclear reactor, 1516  
Cooling tower, 552-553\*  
Cooper, L. N., 2155, 2157  
Cooper pairs, 1204  
Coordinate systems, 553\*  
astronomical, 178, 191-192\*  
terrestrial, 2211-2212\*
- Coordinated Universal Time (UTC), 620  
horology, 1090  
time, 2241
- Coordination chemistry, 554\*  
chelation, 418\*  
ligand, 1250\*  
ligand field theory, 1250  
macrocyclic compound, 1286  
polyhedral structures, 375-376
- Coordination complexes, 555\*
- Coordination compounds, 2415
- Coots, 1031
- Copeognatha, 1799
- Copepoda, 555\*  
Calanoida, 350\*  
Cyclopoida, 605\*  
Harpacticoida, 1047\*  
Misophrioida, 1408\*  
Monstrilloida, 1435\*  
Mormonilloida, 1438\*  
Poecilostomatoida, 1732\*
- Copernican theory, 2-3
- Copernicia cerifera, 333
- Copodontidae, 286
- Copolymer, 555\*, 1528
- Copolymers:  
polyacrylonitrile resins, 1741  
polyethylene, 1749  
polymers, 1745
- Copper, 556\*  
chalcocite, 412\*  
chalcopyrite, 412\*  
chrysocolia, 455\*  
cuprite, 598\*  
enargite, 814\*  
malachite, 1306\*  
metallochaperones, 1369  
zinc alloys, 2416\*
- Copper alloys:  
brass, 327\*  
bronze, 335\*  
Copper beech, 231  
Copper loss, 557\*  
Copper metallurgy, 557\*
- Coppice dunes, 706
- Copulation, 1898
- Copulatory organ, 557\*, 1625
- Coquina, 557\*
- Coracii, 494
- Coraciidae, 494
- Coraciiformes, 558\*
- Coral, 2189\*
- Coral reef, 1879  
atoll, 206\*  
dinoflagellates, 74
- Corallanidae, 803
- Corallimorpharia, 558\*
- Corallimorphus, 494
- Corallinaceae, 494
- Corallinales, 558\*
- Coralline algae see Corallinales
- Corbiculacea, 1223
- Corbino disk, 558\*
- Corchorus capsularis, 1208
- Corchorus olitorius, 1208
- Cordaitaceae, 494
- Cordaitales, 558\*, 928
- Cordierite, 558\*
- Cordilleran belt, 558-559\*, 1724
- Core, Earth, 717, 721  
see also Earth interior
- Core loss, 559\*
- Core-mantle coupling, 721
- Coreidae, 944
- Coreoidea, 944
- Cori cycle, 1222
- Coriander, 559\*
- Coriandrum sativum, 495
- Coriolis acceleration, 559\*  
geophysical fluid dynamics, 994  
middle-atmosphere dynamics, 1399\*
- Coriolis effect, 1530
- Coriolis force, 718
- Corixidae, 942
- Corixioidea, 942
- Cork, 1630
- Cormorants, 1623-1624
- Corn, 559-560\*  
crop, 496  
farm crops, 871  
processing, 496-497
- Corn sugar see Glucose
- Corn syrup, 2145
- Cornaceae, 497
- Cornagraph, 561\*
- Cornales, 560\*
- Cornet reflector antenna, 561\*
- Cornog, R., 1061
- Cornus florida, 694
- Cornus kousa, 694
- Cornus nuttallii, 694
- Cornus species, 498, 634
- Corona (Sun):  
solar radiation, 2041  
Sun, 2150
- Corona charging (electrostatics), 797
- Corona discharge (electrostatics), 561\*, 1940
- Coronary heart disease, 932, 1052-1053
- Coronatae, 561\*, 1965
- Coronaviruses, feline, 788, 875
- Coronilla varia, 2336
- Coronoidea, 561\*
- Corophiidae, 859, 962, 963
- Correspondence principle, 562\*, 1830
- Corrins, 1756
- Corrodentia, 1799
- Corrosion, 562-563\*, 767
- Corrosion fatigue, 498-499
- Corrosive wear, 2377
- Cortex (hypodermis), 1120\*
- Cortex (plant), 563\*
- Corticoid fungi, 1112
- Cortinarius, 984, 1112
- Corundum, 563-564\*  
emery, 812-813\*  
jewel bearing, 1203\*  
ruby, 1935\*  
sapphire, 1944-1945\*
- Corylus, 798
- Corynactis, 494
- Corynebacteriaceae, 500
- Corynebacterium, 500
- Corynebacterium diphtheriae, 617, 677
- Corynosoma reductum, 1596
- Cosmic Background Explorer (COBE), 1147  
gravitational redshift, 1024  
interplanetary matter, 1177
- Cosmic background radiation, 564-565\*  
satellite astronomy, 1947  
universe, 2307
- Cosmic electrodynamics, 692
- Cosmic rays, 565-566\*  
age, 502  
atmospheric, 501  
composition, 501-502  
cosmogenic nuclide, 569  
detection, 501  
elementary particle, 802  
gamma-ray astronomy, 960-962\*  
neutron, 1483  
origin, 502  
solar modulation, 501
- Cosmic spherules, 566\*
- Cosmic string, 566-567\*
- Cosmochemistry, 567-568\*, 985  
chemical compositions of meteorites, 503

- Cosmochemistry—*cont.*  
 isotopic compositions of meteorites, 503-504  
 minerals in meteorites, 503  
 Cosmogenic nuclide, 568-569\*  
 Cosmological redshifts, 2306-2307  
 Cosmological term, 1890  
 Cosmology, 569-571\*  
 age of universe, 569  
 antimatter, 143  
 big bang theory, 242-243, 272-273\*, 569-570  
 cosmic background radiation, 564-565\*  
 cosmic string, 566-567\*  
 cosmological models, 505  
 dark-matter, 570  
 expanding universe, 500, 505  
 formation of galaxies, 570-571  
 gravitation, 504-505, 1021-1022\*  
 Hubble constant, 1092\*  
 inflationary universe, 1146-1148\*  
 Olbers' paradox, 1537\*  
 origin of large-scale structure, 570-571  
 structure of the universe, 504  
 supernova, 2161  
 Cossidae, 1245  
 Cossoidea, 1245  
 Cotton, 571\*  
 farm crops, 871  
 fiber crops, 883  
 Cotton effect, 571\*  
 Cotton stainer, 944  
 Cottonwood, 1940  
 Cottonwood poplar, 1754  
 Cotylousauria, 113  
 Coulomb, C. A., 761  
 Coulomb, definition of, 687, 761  
 Coulomb excitation, 571-572\*  
 Coulomb explosion, 572\*, 786  
 Coulomb's law, 572\*, 761, 797  
 Coulometer, 572\*  
 Coulometric analysis, 770  
 Coulometric titration, 2245  
 Coulometry, 691, 765  
 Coulostatic analysis, 764  
 Countercurrent exchange (biology), 572-573\*, 2230  
 Countercurrent transfer operations, 573\*  
 Countermeasures (subsynchrotron resonance), 2142  
 Countershaft, 1996  
 Counting circuit, 2176  
 Country butter, 305  
 Couple, 573\*  
 Coupled circuits, 573\*  
 Coupled cluster theory, 1825  
 Coupling, 574\*  
 Coupling capacitor voltage transformer, 1161  
 Courtship (reproductive behavior), 1897  
 Cousteau, J. Y., 632  
 Covalent bonding, 367, 436, 494-495  
 Covalent hydride, 974  
 Covellite, 574\*  
 Cover crops, 574\*  
 Covered dry cargo, 1154  
*Cowdria ruminantium*, 1053  
 Cowling, T. G., 987  
 Cowpea, 229, 260, 574\*, 1240  
 Cocksackievirus, 574\*  
 Coyote, 634, 694  
 CPM *see* Critical path method  
 CPT theorem, 142-143, 575\*  
 symmetry laws, 2180  
 time reversal invariance, 2242  
 CPU *see* Central processing unit  
 Crab, 575\*, 852, 1307  
 Crab (constellation) *see* Cancer (constellation)  
 Crab louse, 126-127  
 Crab Nebula, 575\*, 961, 1470, 2401  
 Crab plover, 364  
 Crabapple, 575\*  
 Cracidae, 260  
 Cracking, 575\*  
 gasoline, 969  
 hydrocracking, 1103\*  
 petrochemical, 1639  
 petroleum processing and refining, 1644  
 Cranberry, 576\*  
 Crane (bird), 912  
 Crane (construction equipment), 479, 543, 773  
 Cranial nerve, 576\*  
 Craniata, 395  
*see also* Vertebrata  
 Crank, 576\*  
 Crank-and-rocker linkages, 832  
 Crappies, 2151  
*Crassius auratus*, 334  
 Crassulaceae, 1952  
 Craterostigmomorpha, 385  
 Craton, 576-577\*  
 Crawdad *see* Crayfish  
 Crawfish *see* Crayfish  
 Crayfish:  
 Decapoda, 559-562  
 invertebrate pathology, 1182  
 Creamery butter, 305  
 Creep (geological), 1332  
 Creep (materials), 577\*  
 metal, 1364  
 plasticity, 1722\*  
 rheology, 1912  
 Creeping flow, 577\*  
 Creeping water bug, 943  
 Creighton, H., 516  
 Creodonts, 577-578\*  
 Cress, 578\*  
 Cretaceous, 578-579\*  
 animal evolution, 120  
 dinosaur, 676  
 paleogeography, 1599  
 plant evolution, 1703  
 Creutzfeldt-Jakob disease, 1774, 1775  
 Cricetidae, 925, 1443  
*Cricetus cricetus*, 925  
 Cricket, 1581  
 Criminalistics, 579\*  
 Crimson clover, 422  
 Crinoidea, 579-580\*  
 Articulata (Echinodermata), 176\*  
 Camerata, 360\*  
 Flexibilia, 893\*  
 Inadunata, 1134, 1134\*  
 Crinzoa, 580\*, 657  
 Blastoida, 302\*  
 Coronoida, 561\*  
 Crinoidea, 580\*  
 Echinodermata, 726  
 Eocrinoidea, 834\*  
 Criollo, 488  
 Cristobalite, 1748  
 Critical care medicine, 580\*  
 Critical mass, 580-581\*  
 Critical phenomena, 581\*  
 Crocodile, 581\*  
 Crocodylia, 165-166, 581-582\*  
 crocodile, 581-582\*  
 gavia, 973\*  
 Triassic, 2269  
 Crocodyliidae, 515  
 Crocodylinae, 515  
 Crocodylus, 515  
 Crocoite, 582\*  
*Crocus sativus*, 1940  
 Crohn's disease, 1146, 1203  
 Cromwell Current, 842  
 Cross modulation, 629, 690  
 Cross pollination, 1739  
 Crossed coil meter *see* Phase meter  
 Crossed-field amplifiers, 785  
 Crossing-over (genetics), 582\*, 1875  
 Crossopterygii, 488-489, 582\*  
 Crossosomataceae, 612  
 Crosstalk, 582-583\*  
 Crossties (railroad), 1866  
 Crown ethers:  
 clathrate compounds, 468\*  
 macrocyclic compound, 1286, 12987  
 Crown gall, 583\*  
 cytokinins, 610  
 genetic engineering, 874-875  
 plant pathology, 1710  
 Crown gear, 241  
 Crown vetch, 2336  
 CRT *see* Cathode-ray tube  
 Cruciferae, 325, 1578  
 Crude oil:  
 oil analysis, 1533-1534\*  
 oil and gas storage, 1535\*  
 petroleum, 1640  
 petroleum geology, 1642  
 petroleum microbiology, 1642  
 petroleum processing and refining, 1643  
 petroleum reservoir engineering, 1645  
*see also* Petroleum  
 Cruise missiles, 1408  
 Cruisers (naval ships), 1468  
 Crushing and pulverizing, 583-584\*  
 ball-and-race-type pulverizer, 246\*  
 Buhrstone mill, 341\*  
 grinding mill, 1027-1028\*
- Crushing and pulverizing—*cont.*  
 pebble mill, 1622\*  
 tumbling mill, 2280\*  
 Crustacea, 584-586\*  
 Anostraca, 128\*  
 Anthuridea, 136\*  
 Asellota, 180\*  
 autotomy, 519-520  
 Balanomorpha, 246\*  
 barnacle, 252\*  
 biometrics and economics, 520, 586  
 body, 518-519  
 Branchiopoda, 327\*  
 Branchiura, 327\*  
 Caprellidea, 365\*  
 Cephalocarida, 404\*  
 Cirripedia, 464\*  
 Copepoda, 555\*  
 crab, 575\*  
 Cumacea, 598\*  
 Cyclopoida, 605\*  
 Decapoda, 622-625\*  
 endocrine system, 732, 815  
 Eumalacostraca, 854\*  
 Euphausiacea, 855\*  
 eye, 865  
 general morphology, 518, 584  
 geologic history, 585  
 Hoplocarida, 1089\*  
 invertebrate pathology, 1182  
 larvae, 519  
 Malacostraca, 1307\*  
 Maxillopoda, 1340\*  
 molting (ecdysis), 519, 585  
 Mysticocarida, 1461\*  
 Ostracoda, 1587\*  
 Phyllocarida, 1675\*  
 phylogeny, 520  
 Platycopida, 1725\*  
 Podocopa, 1731\*  
 Poecilostomatoidea, 1732\*  
 regeneration, 519-520, 585  
 Remipedia, 1893\*  
 reproduction, 519  
 Rhizocephala, 1913\*  
 Syncarida, 2183\*  
 Tantulocarida, 2192\*  
 taxonomy, 518  
 Crustal tomography, 1977  
 Crustacydione, 732  
 Crux, 586\*  
 Cryobiology, 586-587\*  
 Cryobiosis, 523  
 Cryogenics, 587\*, 1883  
 Cryolite, 587\*  
 Cryopreservation, 520-521  
 Cryosurgery, 521  
 Cryotron, 587\*  
 Cryptobiidae, 1216  
 Cryptobiosis, 587\*  
 Cromwell Current, 842  
 Cryptococcales, 2410  
 Cryptococcosis, 266  
*Cryptococcus*, 266  
*Cryptococcus neoformans*, 523  
 Cryptographic algorithm, 523, 524  
 Cryptography, 587-589\*  
 block ciphers, 524  
 computer data security, 461  
 Data Encryption Standard, 524  
 digital signatures, 524  
 number theory, 1521-1522\*  
 stream ciphers, 524  
 strong algorithms, 524  
 unbreakable ciphers, 523-524  
 Cryptomonadida, 589\*  
 Cryptoniscina, 751, 835, 1674  
 Cryptophyceae, 589\*  
*Cryptosporidium*, 1348  
*Cryptosporidium parvuum*, 2363  
 Cryptostomata, 589\*  
*Cryptotis*, 1159  
*Crysolophus pictus*, 260  
 Crystal, 589-590\*  
 colloidal, 442  
 defects, 527, 590-591\*  
 faces, 529  
 formation, 2131  
 growth, 526-527, 591-592\*  
 lattice vibrations, 1233\*  
 liquid, 1262-1263\*  
 manganese oxide minerals, 1312\*  
 Matthiessen's rule, 1340, 1340\*  
 metastable state, 1370-1371\*  
 optical materials, 1556-1557  
 pyroelectricity, 1813-1814\*  
 relaxation time of electrons, 1891\*  
 semiconductor, 1980
- Crystal—*cont.*  
 single crystal, 2013\*  
 structure, 525-526, 593-594\*  
 systems, 529  
 x-ray optics, 2405  
 Crystal absorption spectra, 590\*  
 Crystal counter, 590\*  
 Crystal defects, 527, 590-591\*  
 diffusion, 603-604  
 plastic deformation of metal, 1722  
 symmetry breaking, 2179  
 Crystal electric filter, 672  
 Crystal field theory, 554  
 Crystal growth, 526-527, 591-592\*  
 optical materials, 1556  
 snow, 2025  
 Crystal optics, 592-593\*, 2270  
 Crystal structure, 525-526, 593-594\*  
 channeling in solids, 412\*  
 diamond, 654  
 grain boundaries, 1014\*  
 halite, 1040\*  
 lattice inclusion compounds, 412  
 mineral, 1403  
 perovskite, 1635  
 plastic deformation of metal, 1722  
 symmetry breaking, 2178  
 Crystal whiskers, 594\*  
 Crystalline quartz, 1162  
 Crystalline regions, 1746  
 Crystalline solids, 632  
 Crystallization, 526, 590, 594\*  
 fused-salt phase equilibria, 951  
 polyfluoroolefin resins, 1743  
 Crystallography, 595-596\*  
 Brillouin zone, 334\*  
 color centers, 503\*  
 polarized light microscope, 1737-1738  
 polymorphism, 1748\*  
 twinning, 2289\*  
 x-ray, 2401\*  
 Cryptophytes, 1717  
 CSMA/CD protocol, 1267  
 Ctenophora, 596\*  
 Ceroida, 267\*  
 Cestida, 408-409\*  
 Cydippida, 606\*  
 Lobata, 1266-1267\*  
 Platyctenida, 1725\*  
 Ctenopoda, 596\*  
 Ctenostomata, 596-597\*, 1033  
 Ctenothrissidae, 531  
 Ctenothrissiformes, 597\*  
*Ctenothrissus*, 531  
 Cubane, 309  
 Cube, 597\*  
 Cubeb, 597\*  
 Cubomedusae, 597\*, 1965  
 Cuckoo, 532  
 Cuckoo-roller, 494  
 Cuculidae, 532  
 Cuculiformes, 597\*  
 cuckoo, 597\*  
 Opisthocomiformes, 1550\*  
 Cucumber, 597\*  
 Cucumber mosaic virus, 1711  
 Cucumber tree, 1304  
*Cucumis melo*, 323, 963, 1456, 1637  
*Cucumis sativus*, 532  
*Cucurbita* species, 1811, 2092-2093  
 Cucurbitaceae, 323, 1456  
 Culex, 621  
 Culicoides, 41, 272  
 Culture, 598\*  
 bacteria, 240  
 chemostat, 433-434\*  
 elective, 669  
 embryonated egg, 728  
 inoculation, 1154\*  
 Cumacea, 598\*  
 Cumim, 598\*  
 Cumingtonite, 598\*  
*Cun alpinus*, 694  
 Cup anemometer, 116  
 Cup fungi *see* Discomycetes  
*Cupressus* species, 543  
 Cuprite, 598\*  
 Cupronickel, 492  
 Curare, 2136  
 Curassow, 259, 260  
*Curcuma angustifolia*, 157  
*Curcuma longa*, 2287  
 Curie, Marie, 2261  
 Curie temperature, 599\*  
 ferromagnetism, 878\*, 879  
 symmetry breaking, 2179  
 Curie-Weiss law, 599\*, 1295

Curie's law, 1295, 1296  
 Curing, 534  
 Curium, 599\*  
 Curlew, 364  
 Curran, 599\*, 1952  
 Current:  
 decibel, 625  
 kuroshio, 1219  
 water, 2284  
*see also* Electric current; Ocean circulation  
 Current comparator, 599\*  
 Current density, 599-600\*  
 Current-limiting fuses, 850  
 Current measurement, 600\*  
 current comparator, 599\*  
 electrometer, 698\*  
 galvanometer, 958-959\*  
 Current sources and mirrors, 600\*  
 Current transformer, 1161  
 Curve fitting, 600-601\*  
 Cushing's disease:  
 adrenal gland disorders, 31  
 pituitary gland disorders, 1694  
 Cutaneous anthrax, 135  
 Cutaneous blastomycosis, 266  
 Cutaneous coccidioidomycosis, 430  
 Cutaneous sensation, 601\*  
 Cutting tools:  
 machining, 1285, 1286  
 water-jet cutting, 2366\*  
 welding and cutting of materials,  
 2382-2383\*  
 woodworking, 2396\*  
 Cuttlefish, 438, 865  
 Cuvier, Georges, 863  
 CW *see* Continuous-wave radar  
 Cyadopsida, 603\*  
 Cyanamide, 601\*  
 Cyanate, 601\*  
 Cyanic acid, 601  
 Cyanide, 601\*, 2233  
 Cyanobacteria, 601-602\*, 2129  
 Cyanocarbon, 602\*  
 Cyanogen, 602\*  
 Cyanophyceae, 602\*, 1674  
 Cyathaceae, 2267-2268  
 Cyatholaimoidea, 396  
 Cybernetics, 602-603\*  
 Cycadales, 603\*, 2266  
 Cycadeoideaceae, 539  
 Cycadeoidales, 603\*  
 Cycadophyta, 603  
 Cycadopsida, 603\*  
 Gnetales, 1009\*  
 Welwitschiales, 2384\*  
 Cycads, 1701  
*Cycas revoluta*, 539  
 Cyclanthaceae, 539  
 Cyclanthales, 151, 167\*, 603\*  
 Cyclic compounds, 1756-1757  
 Cyclic nucleotides, 603-604\*, 1539  
 Cyclic voltammetry, 764, 765, 776  
 Cyclophora, 604\*  
 Cycloaddition reactions, 1630  
 Cycloaliphatic compound *see* Alicyclic hydrocarbon  
 Cycloalkane *see* Alicyclic hydrocarbon  
 Cycloamylose, 604\*  
 Cyclocystoidea, 541\*  
 Cycloid, 604\*  
 Cyclone, 604-605\*  
 atmospheric general circulation, 205  
 atmospheric waves, upper synoptic, 206  
 hurricane, 970  
 storm surge, 2121\*  
 wind, 2388  
 Cyclone furnace, 605\*  
 Cycloparaffin *see* Alicyclic hydrocarbon  
 Cyclopes, 131  
*Cyclopes didactylus*, 131  
 Cyclophane, 605\*, 1286  
 Cyclophosphamide, 1133  
 Cyclophyllidea, 605\*  
 Cyclopoidea, 491, 605\*  
 Cyclops, 165-166  
 Cyclochloragida, 1216  
 Cyclotriphapha, 620  
 Cyclosteroidea, 659  
 Cyclostomata, 1202  
 Cyclostomata (Bryozoa), 606\*  
 Cyclostomi *see* Cyclostomata (Chordata)  
 Cyclothem, 606\*  
 Cyclotron-resonance devices, 785  
 Cyclotron resonance experiments, 606\*  
 Cyclotron resonance maser *see* Gyrotron  
 Cydippida, 606\*  
 Cydnidae, 944

*Cydonia oblonga*, 1836  
*Cygnus*, 606\*  
 Cygnus X-1:  
 black hole, 301  
 gravitational collapse, 1022  
 Cylinder, 607\*  
 Cylinder functions *see* Bessel functions  
 Cylindrical coordinates, 489  
 Cylindrical map projections, 1315  
*Cylindrobulla*, 1939  
*Cymbopogon nardus*, 410  
 Cymophane, 401  
 Cymothoidae, 803  
*Cynara scolymus*, 160  
 Cynipoidea, 984  
*Cynodon dactylon*, 237  
*Cynomys* species, 1764  
 Cyperaceae, 543  
 Cyperales, 449, 607\*  
 bamboo, 248\*  
 barley, 251-252\*  
 Bermuda grass, 267\*  
 bluegrass, 308\*  
 bluestem grass, 309\*  
 bromegrass, 335\*  
 citronella, 466\*  
 Dallis grass, 613\*  
 redtop grass, 1879\*  
 rice, 1919\*  
 timothy, 2242\*  
*Cyperus papyrus*, 543  
 Cypress, 607\*, 1688, 2266  
 Cyprinidae, 334, 544  
 Cypriniformes, 607-608\*, 738  
 Cyprinodontidae, 183  
 Cyprinoidei, 544  
*Cyprinus carpio*, 334  
*Cyrrilla racemiflora*, 1047  
 Cysteine, 544  
 Cystic fibrosis, 295, 1604-1605  
 Cystic hyperplasia (breast), 290  
*Cysticercus cellulosae*, 544  
 Cystinuria, 1361  
 Cystoporata, 606, 608\*  
 Cytherellidae, 1725  
 Cytochalasin, 608\*  
 Cytochemistry, 608\*  
 Cytochrome, 609\*  
 Cytokine, 609-610\*  
 Cytokinesis, 610\*  
 Cytokinins, 610-611\*, 1705  
 Cytolysis, 611\*  
 Cytomegalovirus, 1069  
 Cytomegalovirus infection, 19, 611-612\*  
 Cytoplasm, 612\*  
 Cytosine, 1813  
 Cytoskeleton, 388, 612\*  
 Cytotoxicity, immunologic, 1130-1331\*

## D

DAC *see* Digital-to-analog converter  
 Dacite, 613\*  
 Dacryoconarida, 473  
 Dactylanthus, 1805  
 Dactylocalyx, 1280  
 Dactylochirotrida, 960  
 Dacus, 621  
 Daddy-longlegs, 1549  
 Dadogram, 1287  
 Daedaleoid fungi, 1112  
 Daikon, 1578  
 Dairy products, 1619  
*see also* Milk  
 Dajidae, 751  
 D'Alembert, J., 412  
 D'Alembert's paradox, 613\*  
 D'Alembert's principle, 613\*  
 Dalitz plot, 613\*  
 Dallis grass, 613\*  
 Dalton *see* Atomic mass unit  
 Dalton, John, 191, 380, 613  
 atomic mass, 210  
 atomic structure and spectra, 211  
 Daltonides, 1500  
 Dalton's law, 613-614\*  
 Dam, 614\*  
 Damping, 614-615\*  
 vibrating linear system, 1343-1344  
 vibration, 2337\*  
 Damsel bug, 944  
 Daniell cell, 775

Dantzig, G. B., 1257  
*Daphne*, 1309  
*Daphnia*, 126  
 Daphniphyllales, 615\*, 1044  
*Daphniphyllum*, 551  
 Dark adaptation, 2347  
 Dark current, 615\*  
 Dark matter, 197  
 cosmology, 570  
 matter, 1340  
 universe, 2306  
 weakly interacting massive particle, 2377  
 Darmstadtium, 615\*  
 D'Arsonval galvanometer, 857, 958  
 Dart, R. A., 198  
 Dart, Raymond, 219  
 Darwin, Charles, 232, 262  
 ethology, 849  
 evolutionary computation, 857  
 island biogeography, 1193  
 speciation, 2072  
 Darwin's finches, 1193  
 Dasheen, 615\*  
 Dashpot, 2000-2001  
 Dassies, 1121-1122  
 Dasycladaceae, 551  
 Dasycladales, 616\*  
*Dasyprocta agouti*, 44  
*Dasyus novemcinctus*, 155  
 Data, 1148  
 Data analysis, 1017  
 Data assimilation, 1325  
 Data communications, 616\*  
 communications satellite, 510-511  
 cryptography, 587-589\*  
 packet switching, 1594\*  
 scrambling, 451  
 telephone service, 2199-2200  
 wide-area networks, 2387  
 Data compression, 616-617\*  
 direct broadcasting satellite systems, 681  
 image processing, 1127  
 television scanning, 2206  
 Data Encryption Standard, 524  
 Data glove, 521  
 Data manipulation, 619  
 Data mining, 617\*  
 Data-processing systems:  
 data-processing functions, 553-554  
 electronic, 554-555  
 neural network, 1479-1480\*  
 switching circuit, 2175-2176\*  
 teleprocessing, 2201\*  
 Data reduction, 617-618\*  
 Data set *see* Mixing  
 Data storage, optical, 1560-1561  
 Data structure, 618\*  
 Data switching, 616  
 Data transmission, 616  
 Data types, abstract, 6-7\*  
 Database, on-line, 712  
 Database management system (DBMS),  
 618-619\*  
 computer security, 525  
 cryptography, 587-589\*  
 Date, 619-620\*  
 Date palm, 619  
 Dating methods, 620\*  
 accelerator mass spectrometry, 9-10\*  
 amino acid, 96-97\*  
 archeological chronology, 163, 163\*  
 chemostratigraphy, 434\*  
 dendrochronology, 635\*  
 denudation, 638  
 fission track dating, 802-803  
 geochronometry, 985-986\*  
 paleontology, 1602  
 radiocarbon dating, 1858-1859\*  
 rock age determination, 1926-1927\*  
 stratigraphy, 2123  
 Datolite, 620\*  
 Datum dimensioning, 613  
*Datura* species, 194  
*Daubentonia madagascariensis*, 208  
 Daubentoniidae, 208  
*Daucus carota*, 335  
 Davy, Humphrey, 157  
 Dawn ape *see* Aegyptopithecus  
 Dawsonia, 557  
 Dawsoniidae, 620\*  
 Day, 620-621\*  
 core-mantle coupling, 721  
 Earth, 716, 717  
 time, 2240  
 Day, Joseph, 1174  
 Dayglow, 65  
 DC *see* Direct current

DC polarography, 1738  
 De Broglie, Louis, 559, 2371  
 De Broglie wavelength, 622\*  
 De Haas, W. J., 568  
 De Haas-van Alphen effect, 631-632\*  
 De Vries, H., 2045  
 Dead reckoning, 51, 557-558, 621\*  
 polar navigation, 1734  
 underwater navigation, 2298  
 Dead room *see* Anechoic chamber  
 Deadly nightshade:  
 belladonna, 265\*  
 Solanales, 2038  
 Deafness, 931, 1051  
 audiometry, 217\*  
 hearing aid, 1050-1051\*  
 hearing impairment, 1051\*  
 Death, 621-622\*  
 cell senescence, 349  
 cellular, 542  
 EEG pattern, 693  
 issues, 559  
 organ, 559  
 pathogenesis, 558-559  
 somatic, 558-559  
 Debugging, visual, 2348\*  
 Debye, P., 457  
 Debye length, 1717, 1718  
 Decaborane, 279  
 Decaffeinated coffee, 434, 491  
 Decapoda (Crustacea), 622-625\*  
 classification, 560-562  
 crab, 575\*  
 development, 560  
 phylogeny, 560-562  
 physiology, 559-560  
 Decapoda (Mollusca), 1986  
 Decay laws, 1856  
 Decibel, 234, 625\*  
 loudness, 1273\*  
 neper, 1475\*  
 Deciduous plants, 625\*, 2056  
 Decimal number system:  
 numbering systems, 1522  
 significant figures, 2006-2007\*  
 Decision analysis, 625-626\*  
 Decision support system, 224, 626\*  
 Decision theory, 626-627\*  
 operations research, 1547\*  
 optimization, 1564-1565\*  
 Decomposition potential, 627\*  
 Decompression illness, 627\*, 632, 692  
 Decontamination of radioactive materials,  
 627\*  
 Dedekind cut, 1874  
 Deep drawing, 1997  
 Deep inelastic collisions, 627-628\*  
 Deep-marine sediments, 628-629\*  
 Deep-sea fauna, 629-630\*  
 Deep-sea sediments, 1324-1325  
 Deep Space I, 1186  
 Deep-submergence research vessels  
 (DSRVs), 1317  
 Deep submersible vehicles (DSVs), 2300  
 Deer, 164, 178, 630-631\*, 1885  
 Defective virus, 2344\*  
 Definite composition, law of, 379-380, 631\*  
 Deflecting electrodynamic wattmeter, 2370  
 Deflection (of light), 1890-1891  
 Defoliant and desiccant, 631\*  
*see also* Desiccant  
 DeForest, L., 785  
 Degaussing, 631\*  
 Degeneracy (quantum mechanics), 631\*  
 Degenerative diseases, 1479  
 Degenerative joint disease, 159, 174  
 Deglutition, 605  
 Degradable food packaging, 820  
 Degradation:  
 stabilizer, 2095  
 wood, 2394-2395\*  
 Degree-day, 631\*  
 Degree of freedom (mechanics), 631\*  
 Hamilton's principle, 1045  
 mechanisms, 1344-1345\*  
 nonlinear physics, 1498, 1498\*  
 vibration, 2337  
 Degree of freedom (statistics):  
 constraint, 542\*  
 curve fitting, 600-601\*  
 Degrees of frost, 841  
 Dehumidifier, 632\*, 1097  
 Dehydrogenation, 632\*  
 Deimos, 478  
 Delay line, 632\*  
 Delayed neutron, 632\*  
 Delayed particle emissions, 1858

- Deletion mutants, 2344  
 Deliquescence, 632-633\*, 704  
 Delocalization, 633\*  
 Delphinidae, 634  
 Delphinium, 1869  
*Delphinus delphis*, 634  
 Delta, 633\*  
   depositional systems and environments, 641  
   Pleistocene, 1727  
 Delta electrons, 633-634\*  
 Delta rhythm (brain), 693, 768  
 Delusional misidentification syndromes, 1042  
 Delusions, 1803  
 Demagnetization, 631, 634\*  
 Dementia:  
   Alzheimer's disease, 93-94\*  
   Parkinson's disease, 1613  
 Dementia praecox see Schizophrenia  
 Democritus, 211  
 Demodulator, 634\*  
 Demolition, underwater, 2298\*  
 Demospongiae, 634\*  
   Archaeocyatha, 160\*  
   Axinellida, 236\*  
   boring sponges, 319\*  
   Choristida, 448\*  
   Clavxinellida, 468\*  
   Dendroceratida, 635\*  
   Dictyoceratida, 657\*  
   Hadromerida, 1037\*  
   Halichondrida, 1039-1040\*  
   Haplosclerida, 1045\*  
   Homosclerophorida, 1088\*  
   Poecilosclerida, 1732\*  
   Spirophorida, 2086\*  
 Denatured alcohol, 766  
 Dendritic macromolecule, 634-635\*  
 Dendritic polymer, 287  
 Dendroceratida, 635\*  
 Dendrochirotrida, 960  
 Dendrochronology, 635\*  
*Dendrohyrax*, 1122  
 Dendroidea, 904, 1018  
*Dendrolagus ursinus*, 1209  
 Dendrology, 635\*  
*Dendya*, 412  
 Density, 635\*  
   density measurement, 636\*  
   specific gravity, 2073\*  
 Density matrix, 635-636\*  
 Density measurement, 636\*, 1109  
 Dent corn, 496  
 Dental alloy, 83  
 Dental anthropology, 636-637\*  
 Dental caries, 637\*, 2248-2249  
 Dentistry, 637\*  
   dental anthropology, 636-637\*  
   tooth disorders, 2248-2249\*  
 Dentition, 637-638\*, 2248  
 Denudation, 638\*  
 Deoinotheridea, 1777  
 Deoxyribonucleic acid (DNA), 638-640\*  
   cell cycle, 391, 392  
   chromosome, 451-453\*  
   developmental biology, 649  
   drug resistance, 702  
   forensic biology, 914-915  
   forensic medicine, 915  
   gametogenesis, 960  
   gene, 978, 978\*  
   gene action, 979  
   gene mutations, 1457  
   genetic code, 981  
   genetic engineering, 982-983, 982-983\*  
   genetic variation, 639  
   Human Genome Project, 1095-1096  
   mitochondria, 1410  
   mutagens and carcinogens, 1456  
   nucleic acid, 1518  
   nucleotide, 1520-1521\*  
   numerical taxonomy, 1524  
   operon, 1548  
   plant taxonomy, 1714  
   plant viruses and viroids, 1715  
   recombinant technology, 639-649  
   recombination (genetics), 1875  
   replication, 576, 639  
   reverse transcriptase, 1910, 1910\*  
   ribonucleic acid, 1917  
   structure and function, 575-576, 639  
   transcription, 576, 639  
   transformation (bacteria), 2258  
   transposons, 2264\*  
   tumor viruses, 2281  
   variation, 576  
 Deoxyribonucleotide, 1539  
 Deoxyribose, 640\*  
 Department of Energy (DOE), 1141  
 Dependovirus, 640\*  
 Deposition region (atmosphere), 772  
 Depositional systems and environments, 640-642\*  
 Depression:  
   affective disorders, 39-40\*  
   psychopharmacology, 1801  
   psychosis, 1803  
 Dermaptera, 642\*  
 Dermatina, 1798  
 Dermatitis, 642\*, 2018  
 Dermatoglyphics, 1168  
 Dermatomyositis, 970  
 Dermatophytosis, 1347  
 Dermis, 2017  
 Dermoptera, 642\*  
 Derrick, 642\*  
   construction equipment, 479  
   hoisting machines, 1082-1083\*  
*Derris*, 643\*  
 Derxia, 210  
 Desalination see Saline water reclamation  
 Descartes, René, 648, 1338  
 Descriptive analysis, 2135  
 Descriptive geometry, 643-644\*  
   direct method, 579-580  
   projection method, 579  
 Descriptive mineralogy, 1405  
 Desert, 644\*  
   oasis, 1527\*  
   playa, 1726\*  
 Desert erosion features, 644-645\*  
 Desertification, 645\*  
 Desiccant, 645\*, 704  
   see also Defoliant and desiccant  
 Design standards, 645-646\*, 1256  
 Desman, 1158, 1159  
 Desmodontidae, 388  
 Desmodorida, 646\*  
 Desmoscolecida, 646\*  
 Desmostylia, 646\*  
 Desmorthoracida, 646\*  
 Desorption, 646-647\*  
   stimulated, 582-583  
   thermal, 583  
 Destriau, G., 693, 769  
 Destroyers (naval ships), 1468  
 Destructive distillation, 647\*  
 Desulfotomaculum, 211  
 Detergent, 647\*  
   emulsifiers, 731  
   soap, 2026\*  
 Determinant, 647\*  
 Determination:  
   developmental biology, 649  
   developmental genetics, 649-650  
 Determinism, 648\*  
 Detonator, 584\*  
 Deuteranopia, 444  
 Deuterium, 648\*  
   deuteron, 649\*  
   heavy water, 1058\*  
   isotope dilution techniques, 1197  
 Deuteromycotina, 648-649\*  
   Agonomycetes, 43\*  
   Blastomycetes, 302\*  
   Coelomycetes, 490\*  
   Hyphomycetes, 1119\*  
 Deuteron, 649\*  
 Developmental biology, 649\*  
   cellular totipotency, 586  
   embryogenesis, 567, 810\*  
   morphogenesis, 586  
   plant development, 586  
   see also Embryology  
 Developmental genetics, 649-650\*, 1086  
 Developmental psychology, 650-651\*  
 Devonian, 651-652\*  
   animal evolution, 120  
   Paleozoic, 1603  
   plant evolution, 1703  
 Dew, 652\*  
 Dew point, 652\*  
   drying, 704  
   fog, 907  
   temperature, 1804  
 Dewar, James, 590  
 Dewar flask, 652\*  
 Dewatering, 492  
 Dewaxing of petroleum, 652\*, 2376  
 Dexaminidae, 860, 963  
 Dextedrine, 101  
 Dextran, 652\*  
 Dextrin, 653\*
- Dextrose see Glucose  
 Diabase, 955  
 Diabetes, 653\*  
   autoimmunity, 222, 223  
   insulin, 1162  
   lactate, 1222  
 Diabetes insipidus, 1694  
 Diabetes mellitus:  
   metabolic disorders, 1362  
   pancreas disorders, 1605  
 Diabetic retinopathy, 867, 2348  
 Diadematacea, 653\*  
   Echinothuroidea, 657  
   Micropygoidea, 1390\*  
   Pedinoida, 1623\*  
   Pygasteroidea, 1812\*  
 Diadematoidea, 653\*  
 Diagenesis, 653\*, 1996, 2254  
 Dialysis, 653-654\*, 1352  
 Diamagnetism, 654\*  
   magnetochemistry, 1301\*  
   Meissner effect, 1350-1351\*  
   superconductivity, 2156  
   susceptibility, 1295  
 Diamantane, 309  
 Diamine, 1741  
 Diamond, 654-655\*  
   cutting, 593  
   heavy minerals, 1058  
   industrial, 593  
   kimberlite, 1214  
   occurrence and recovery, 592-593  
   placer mining, 1695  
   polymorphism, 1748  
   synthetic and imitation, 593  
 Diamond crystal structure, 526, 594  
 Diamond pyramid hardness, 926  
 Diamond ring effect, 730  
*Dianthus barbatus*, 336  
*Dianthus caryophyllus*, 336  
 Diapensiales, 655\*  
 Diaphragmatic hernia, 1069  
 Diapir, 655\*  
 Diapositive see Projection slides  
 Diapsida, 655\*  
   animal evolution, 120  
   Araeoscelida, 155-156\*  
   Nothosauria, 1504\*  
   Protosauria, 1795\*  
 Diarrhea, 655\*  
   bacillary dysentery, 239-240\*  
   bovine virus, 285, 323-324\*  
   cholera, 445  
   Escherichia, 847  
   infant, 1143\*  
 Diaspore clay, 413, 466  
 Diastem, 656\*  
 Diastereoisomer, 2193  
 Diathermy, 798  
 Diatom, 239, 402  
*Diatryma*, 234, 865, 970  
*Diatryma steini*, 970  
 Diazotization, 656\*  
 Dibenzoyl peroxide, 236  
 Diborane, 279  
*Dibothriocephalus latus*, 542, 1798  
 Dibranchia:  
   Belemnoidea, 264-265\*  
   Octopoda, 1532\*  
 Dibranchiata see Coleoidea  
 Dichanthium, 272  
 Dichlorobenzene, 391  
 Dichlorodifluoromethane, 836  
 Dichlorophenol, 391  
 Dichobunids, 178  
 Dichobunoidea, 164  
 Dichroic sheet polarizing filter, 1737  
 Dichroism, 656\*, 1736  
 Dichroism (biology), 656\*  
 Dichromate, 396  
 Dichromatism, 444, 504-505  
 Dick test, 2019  
 Dicke, R. H., 500, 905  
 Dicksoniaceae, 2267-2268  
 Dicotyledons, 657\*  
 Dicranales, 657\*  
 Dictyoceratida, 657\*  
*Dictyochoa*, 2008  
*Dictyonema*, 984, 1112  
 Dictyoptera:  
   cockroach, 487-488\*  
   Isoptera, 1195  
 Dictyosome, 897  
 Dicyemida, 657\*  
 Didelphidae, 1550  
*Didelphis marsupialis*, 1550  
 Didymelales, 657\*, 1044
- Die-casting alloys, 83  
 Dieffenbachia, 138  
 Dielectric:  
   electric insulators, 745  
   electric susceptibility, 752\*  
 Dielectric constant, 756  
 Dielectric heating, 657\*, 744, 2037  
 Dielectric materials, 657-658\*  
 Dielectric measurements, 658\*  
   bridge methods, 596  
   resonance methods, 596  
   submillimeter measurements, 596-597  
   time-domain methods, 597  
   transmission methods, 596  
 Dielectric strength:  
   capacitor, 324, 363-364\*  
   electret, 741\*  
   electrostriction, 798\*  
   piezoelectricity, 1685-1686\*  
   polarization of dielectrics, 1736\*  
 Dielectric waveguides, 2374  
 Diels-Alder reaction, 658-659\*  
 Diencephalon, 287  
   nervous system (vertebrate), 1477  
   reticular formation, 1909\*  
 Diene synthesis see Diels-Alder reaction  
 Diesel, Rudolf, 597, 1174  
 Diesel cycle, 659\*, 1763  
 Diesel engine, 659-660\*  
   boat propulsion, 309\*  
   combustion chamber, 508  
   fuel injection, 941  
   fuel pump, 942  
   locomotive, 1268  
   marine engine, 1320  
   supercharger, 2153\*  
 Diesel fuel, 660\*  
   cetane number, 410\*  
   petroleum products, 1645  
 Difference equation, 660-661\*  
   linear constant coefficients equations, 598  
   nonhomogeneous linear equations, 598  
 Differential, 227, 661\*  
 Differential amplifier, 661\*, 682, 2354  
 Differential calculus, 313, 662-663  
 Differential equation, 661-662\*  
   hypergeometric functions, 1116\*  
   integral equation, 1163\*  
   Laplace's, 1227\*  
   Maxwell's equations, 1340-1341\*  
   numerical analysis, 1523  
 Differential geometry, 662\*, 1405-1406  
 Differential protection (electric), 750  
 Differential pulse polarography, 1738  
 Differential scanning calorimeter, 245  
 Differential transformer, 662\*  
 Differentiation, 662-663\*  
 Diffugia, 142  
 Diffraction, 663-664\*  
   electron, 702-703, 779-780\*  
   Fraunhofer, 601-602  
   Fresnel, 602  
   fringe (optics), 938\*  
   neutron, 1484\*  
   sound, 2052  
   x-ray, 2402-2403\*, 2406  
 Diffraction grating, 208\*, 664\*  
 Diffraction patterns, 1835  
 Diffuse nebulae, 1470  
 Diffused resistor, 1903  
 Diffuser, 664-665\*, 2163  
 Diffusion, 665\*, 2158  
   double, 699-700\*  
   prehistoric technology, 1768  
   sound absorption, 2052  
 Diffusion flames, 892  
 Digenea, 407\*, 665-666\*  
 Digestion, 667  
 Digestive system, 666-668\*  
   anatomy, 604, 666  
   colon, 502\*, 607  
   deglutition, 605  
   esophagus, 605-606, 847\*  
   gallbladder, 957\*  
   intestine, 1178-1179\*  
   lipid metabolism, 1260\*  
   mouth, 605, 1443-1444\*  
   musculature, 667  
   nerve and endocrine tissue, 667  
   physiology, 604-605, 667-668  
   small intestine, 606-607  
   stomach, 606, 2119\*  
 Digestive system disorders:  
   gastrointestinal tract disorders, 970-971\*  
   ulcer, 2293\*  
 Digital audio broadcasting, 1848  
 Digital circuit, 460



- Digital communication, 616\*  
 Digital comparator, 453-454, 514  
 Digital compression, 2387-2388  
 Digital computer, 458, 519, 668-670\*  
   Boolean algebra, 317\*  
   characteristics, 609-610  
   CISCs and RISCs, 670  
   codes, 607-608  
   computer control systems, 485, 549-550  
   data reduction, 617-618\*  
   digital control, 670-671\*  
   evolution of capabilities, 609-610  
   logic components, 668  
   logical circuit elements, 608  
   mathematical software, 1336-1337\*  
   microcomputer, 1383-1384\*  
   performance measures, 669-670  
   physical components, 608  
   sampled-data control system, 1943\*  
   stored program computer, 608-609  
   structural analysis, 2131  
   system building blocks, 608  
   system organization, 668-669  
   vision, 465-466  
 Digital computer programming:  
   programming languages, 1781-1783\*  
   software engineering, 2031\*  
   see also Programming  
 Digital control, 670-671\*, 690-691  
 Digital counter, 671\*  
 Digital electric filter, 673  
 Digital electronics, 793  
 Digital facsimile, 784  
 Digital filter, 23, 671\*  
 Digital photography, 1667  
 Digital plotter, 1018  
 Digital signal processing (DSP), 792  
 Digital terrain model (DTM), 2249  
 Digital-to-analog converter (D/A, DAC), 612, 671-672\*  
 Digital transmission, 1776  
 Digital versatile disc (DVD), 1561  
 Digital voltmeters, 2356-2357  
 Digital wattmeters, 2370  
 Digitalin, 1701  
 Digitalis, 672\*  
 Digits (significant figures), 2006-2007\*  
 Dihedron, 2167  
 Dihydroergotamine, 759  
 Dihydroergotoxine, 759  
 Dihydroxylation, 983  
 Diocyanate, 1193-1194  
 Diisocyanate, 1752-1753  
 Dilatometer, 1975  
 Dill, 672\*  
 Dilleniaceae, 612, 672  
 Dilleniales, 672\*  
 Dilleniidae, 672\*  
   Diapensiales, 655\*  
   Ebanales, 725\*  
   Ericales, 844\*  
   Lecythidales, 1239\*  
   Malvales, 1309\*  
   Nepenthales, 1475\*  
   Primulales, 1772\*  
   Salicales, 1940\*  
   Thallobionta, 2217  
   Theales, 2217-2218\*  
   Violales, 2340\*  
 Dimensional analysis, 672-673\*, 1413  
 Dimensions (mechanics), 673\*  
 Dimethyl sulfoxide, 673\*  
 Dimorphism, sexual, 1994\*  
 Dingo, 634  
 Dinidoridae, 944  
 Dinitrogen trioxide, 1492  
 Dinitrogen dioxide, 1492  
 Dinitrogen pentoxide, 1492-1493  
 Dinitrogen tetroxide, 1492  
 Dinocerata, 674\*  
 Dinoflagellida, 674, 674\*  
 Dinophilidae, 148  
*Dinophilus*, 148  
 Dinophyceae, 674\*  
 Dinosaur, 674-676\*  
   animal evolution, 120  
   macroevolution, 1287  
   Ornithischia, 675, 1580\*  
   paleobiology, 675-676  
   Paleocene, 1598  
   Saurischia, 675, 1951\*  
   Triassic, 2269  
 Dinosauria, 674  
 Diactophymatoidea, 165  
 Diactophyma renale, 616  
 Diode, 676\*  
   detector circuit, 105  
 Diode—cont.  
   electric power measurement, 747  
   electron tube, 784-785  
   junction, 1205\*  
   light-emitting, 1251-1252\*  
   microwave solid-state devices, 1397-1398  
   rectifier circuits, 1876  
   Schottky barrier diode, 1959\*  
   semiconductor see Semiconductor diode  
   Zener, 2414\*  
 Diode (semiconductor) lasers, 1229-1230  
 Diode noise generator, 759  
 Diomedidae, 1777  
*Dionaea muscipula*, 1475, 2330  
 Diophantine approximation, 1522  
 Diophantine equations, 1521  
 Diopside, 218, 676\*  
 Diopler, 677\*  
 Diorite, 677\*  
 Dioscoreaceae, 677  
 Dioscoreales, 677\*  
*Diospyros*, 656, 725, 1637  
*Diospyros ebenenum*, 725\*  
 Dip brazing, 289  
*Diphasiastrum*, 1280  
 Diphenyl see Biphenyl  
 Diphtheria, 21, 677\*, 1229  
 Diphylloidea, 677\*  
 Diplocusis, 1051  
*Diploconus*, 8  
 Diplogasterida, 677\*  
 Diploid merogony, 1357  
 Diplomonadida, 677\*  
 Diplopoda, 678\*  
 Diplura, 678\*  
 Dipneumonomorphae, 139  
 Dipneusti see Dipnoi  
 Dipnoi, 678\*  
   animal evolution, 120  
   Dipteriformes, 681  
   Dipodidae, 1202  
   Dipolar-charge elctrets, 741  
   Dipole, 678\*, 699  
   Dipole-dipole interaction, 678\*  
   Dipole moment, 679\*  
   dipole, 678  
   polar molecule, 1734\*  
   Dipping refractometer, 1882  
   Dipsacales, 173, 679\*  
   *Dipsacus*, 620  
   Dipsacoroidea, 944  
 Diptera, 679\*  
   economic importance, 621  
   fly, 906\*  
   life cycle, 621  
   morphology, 620-621  
   mosquito, 1438\*  
   taxonomy, 679\*  
 Dipteriformes, 681\*  
 Dirac, P. A. M., 192, 1251  
   atomic structure and spectra, 212  
   magnetic monopoles, 1293  
   quantum electrodynamics, 1826  
   quantum field theory, 1827  
 Dirac equation, 2158  
 Dirac field, 1823  
   radio broadcasting, 1848  
 Direct-arc furnace, 140-141, 158  
 Direct-bandgap semiconductors, 781  
 Direct broadcasting satellite (DBS) systems, 681-682\*  
 Direct-coupled amplifier, 682\*  
 Direct current, 682\*  
   electric power measurement, 747  
   electrical energy measurement, 755  
   electrical measurements, 757-758  
   electrical resistivity, 758-760\*  
   electromotive force, 776\*  
   synchronous converter, 2183\*  
   voltage measurement, 2354  
 Direct-current ammeters, 1903  
 Direct-current generator, 513, 682\*  
 Direct-current motor, 683\*  
   commutation, 512-513  
   commutator, 513\*  
   dynamic braking, 708-709  
   electric rotating machinery, 751  
   motor, 1441  
   universal motor, 2305\*  
 Direct-current SQUID, 1302  
 Direct-current transmission, 683-684\*  
 Direction-finding equipment, 684\*, 1849  
 Directional antenna, 497  
 Directional coupler, 684\*, 2374  
 Directional gyro, 1734  
 Directivity, 684-685\*  
*Dirofilaria immitis*, 1053\*  
 Discoididae, 958  
 Discomycetes, 685\*  
 Disconformity, 2297  
 Discrete symmetries, 2179-2180  
 Discrete-time systems, 2413  
 Discriminant, 685\*  
 Disease, 685-686\*  
   abaca, 2  
   cachexia, 348\*  
   cell motility, 395  
   disease ecology, 686-687\*  
   epidemic, 836\*  
   epidemiology, 836-837\*  
   exogenous/endogenous causes of, 686  
   malnutrition, 1308\*  
   medical bacteriology, 1345\*  
   medical mycology, 1347\*  
   microbiota (human), 1383  
   mitochondria, 1410  
   molecular pathology, 1423-1424\*  
   paleopathology, 1602\*  
   pathogen, 1619\*  
   pathology, 1619-1620\*  
   sexually transmitted, 1994-1995\*  
   thermotherapy, 2231\*  
   virulence, 2343\*  
   water-borne, 2363\*  
   zoonoses, 2420\*  
   see also specific headings, e.g.: Bacterial disease  
 Disease ecology, 686-687\*  
   disease emergence, 687  
   population effects, 686-687  
   threshold theorem, 686  
 Disinfectant, 2115  
 Disk brake, 202, 326, 840  
 Disk clutch, 423  
 Disk memory equipment, 463  
 Disk recording:  
   compact disk, 513-514\*  
   distortion and noise, 627  
   magnetic recording, 1294  
   monophonic system, 626-627  
   quadraphonic system, 627  
   stereophonic system, 627  
   video see Video disk recording  
 Diskette, 554  
 Dislocation (crystal), 527  
 Dislocation metamorphism, 1372  
 Dispersal, population, 1754\*  
 Dispersion (radiation), 687\*  
 Dispersion, population, 1754-1755\*  
 Dispersion relations, 687\*  
 Displacement current, 687\*  
 Displacement pickup, 2338  
 Displacement pump, 687\*  
 Dissecting microscope, 1557-1558  
 Dissipative mufflers, 1444  
 Distance-measuring equipment (DME), 688\*, 789  
 Distance protection relays (electric), 750  
 Distillate fuel, 1212  
 Distillation, 688-689\*  
   azeotropic, 209  
   destructive, 583  
   evaporator, 857\*  
   fractional, 688  
   gasoline, 969  
   membrane, 1351\*  
   petroleum processing and refining, 1643  
   pressure for, 688-689  
   simple, 688  
   solar, 2039  
   vapor-liquid equilibria, 688  
   water desalination, 2365  
   see also Volatilization  
 Distillation column, 689\*  
 Distilled spirits see Alcoholic beverages  
 Distillers' malt, 221  
 Distortion (electronic circuits), 689-690\*  
   fidelity, 885\*  
   linearity, 1258  
 Distributed systems (computers), 689\*  
   client-server system, 471-472\*  
   computer-system evaluation, 527  
   distributed databases, 630  
   distributed processing, 630  
 Distributed systems (control systems), 690-691\*  
 Distribution (probability), 691\*, 2102-2104  
 District heating, 692\*  
 Divergent winds, 2388  
 Diverticulosis, 970  
 Diving, 627, 692\*  
 Diving animals, 693\*  
 Diving birds:  
   Gaviiformes, 974\*  
 Diving birds—cont.  
   Podicipediformes, 1731\*  
 Division, 153-154, 693\*  
 Dixon, R. S., 177, 191  
 Dizygotic twins, 2289  
 DME/DME, 1086  
 DNA see Deoxyribonucleic acid  
 Doco-donta, 693\*  
 Dodecahedrane, 309  
 Dodo, 447  
 Dog, 693-694\*  
   canine distemper, 362\*  
   canine parvovirus infection, 362-363\*  
   domestic breeds, 633-634, 693  
   kennel cough, 1211\*  
   social mammals, 2028  
   wild, 694  
   wild species, 634  
 Dogbane, 2130  
 Dogfish, 285  
 Dogwood, 497, 560, 694\*  
 Dolby Surround, 2055  
 Doldrum belt, 2388  
 Dolerite, 955  
*Dolichotis patagonum*, 344  
 Dolines, 1210  
 Doliolida, 2217  
 Dolomite, 694\*  
   limestone, 1255  
   marble, 1316\*  
   petroleum, 1641  
   skarn, 2015\*  
   stromatolite, 2129\*  
   stylolites, 2137\*  
 Dolomite rock, 694-695\*  
 Dolphin, 409-410\*  
 Domain (electricity and magnetism), 634-635\*, 695\*  
 Domain (expert systems), 861  
 Domain name, 1176, 2398-2399  
 Domain Name System (DNS), 1176  
 Dominance, 695\*, 1072  
 Dominants, 732  
 Donkeys and allies, 696\*  
   glanders, 1002  
   Perissodactyla, 1633-1634\*  
 Donnan, F. G., 246, 635, 696  
 Donnan equilibrium, 696\*  
 Donor atom, 696\*  
*Donovania granulomatis*, 902  
 Dootsen, F. W., 603  
 Dopamine, 696-697\*, 1613  
 Doppler:  
   radar meteorology, 1841  
   satellite navigation systems, 1948  
 Doppler, C., 697  
 Doppler effect, 697\*  
   aerodynamic sound, 33  
   atomic structure and spectra, 213  
   dead reckoning, 621  
   direction-finding equipment, 684  
   Doppler radar, 697\*  
   echocardiography, 729  
   electrophoresis, 795-795\*  
   laser cooling, 1230  
   planet, 1699  
   supergranulation, 2159  
   synthetic aperture radar, 2184, 2185  
 Doppler radar, 697\*  
   dead reckoning, 621  
   meteorological radar, 1377, 1378  
 Doppler shift:  
   heliogeomology, 1060  
   infrared astronomy, 1151  
 Doppler sonar, 2298  
 Doppler VOR, 697-698\*  
 Dormancy, 698\*  
   buds, 637  
   hibernation, 1073-1075\*  
   seed, 637, 1974  
 Dormouse, 698-699\*  
*Dorosoma cepedianum*, 948  
*Dorotaspis*, 8  
 Dorvilleidae, 760  
 Dory, 2414  
 Dorylaaimida, 699\*  
 Dorylinae, 129  
 Dosimeter, 699\*  
   electret, 741  
   thermoluminescence, 2229  
 Double-block brake, 326, 840  
 Double diffusion, 699-700\*  
 Double-potential-step chronoamperometry, 764  
 Double refraction see Birefringence  
 Double-rocker linkage, 832  
 Double star, 2097, 2177-2178

Douglas-fir, 700\*, 2266  
 Dove, 505  
 Down quark, 1832  
 Down syndrome, 700\*  
   gene action, 979  
   heart disorders, 1053  
   hereditary diseases, 1094  
 Dracontiasis *see* Guinea worm infection  
 Dracunculoidea, 165  
 Dracunculosis *see* Guinea worm infection  
*Dracunculus medinensis*, 165, 542, 913, 1347  
 Drafting, 700\*  
 Drag linkage, 832  
 Drag (wind), 2389  
 Dragline, 773  
 Dragonfly, 700-701\*, 1532-1533  
 Drainage basin, 226, 257  
 Drake, F., 864  
 Drawing *see* Drafting; Engineering drawing;  
   Pictorial drawing; Schematic drawing  
 Drawing of metal, 701\*, 2392\*  
 Dream *see* Sleep and dreaming  
 Dredge, 543  
 Dredging, 2365  
*Dreissena polymorpha*, 1179  
 Dreyer, J. L. E., 1361  
 Dreyer, L. E., 177, 191  
 Drier (paint), 701\*  
 Drill (construction), 479, 543  
 Drill rigs, 1466  
 Drilling, geotechnical, 701\*  
   *see also* Boring and drilling; Core drilling  
 Drinking water, 2368  
 Drip irrigation, 1192  
 Drive axle, automotive, 202  
 Driving paws, 1621  
 Dromadidae, 364  
 Dromedary camel, 320  
 Drone, 701\*, 1031  
 Drosy *see* Edema  
 Dropwise condensation, 531, 532  
*Drosera*, 1475, 2151  
 Droseraceae, 2151  
*Drosophila*, 649, 650  
 Drought, 645, 701-702\*  
 Drug:  
   chemotherapy, 435-436\*  
   effective dose 50, 738\*  
   marijuana, 1317  
   pharmaceutical chemistry, 1648\*  
   pharmacognosy, 1648-1649\*  
   pharmacology, 1649\*  
   pharmacy, 1649\*  
   psychopharmacology, 1801-1802\*  
   psychotomimetic, 1804\*  
   sulfonamide, 2146-2147\*  
 Drug addiction:  
   barbiturates, 250\*  
   cocaine, 487\*  
   narcotic, 1465\*  
 Drug delivery systems, 702\*  
 Drug resistance, 702-703\*  
   control, 703  
   genetic basis, 702  
   mechanisms of resistance, 702-703  
   promoters, 703  
 Drum-type brake, automotive, 202  
 Drumlin, 703\*, 1437  
 Dry-bulb temperature, 1804  
 Dry fruit, 842  
 Dry gangrene, 860  
 Dry ice, 703\*  
 Dry spinning, 1313  
 Drydocking, 703\*  
 Drying, 703-704\*  
   desiccant, 645\*  
   food preservation, 910\*  
   of gases, 704  
   of solids, 703-704  
 Drying oil, 704\*  
 Dryland blueberry, 271  
 Dryolestida, 704\*  
*Dryopithecus*, 829  
   fossil apes, 924  
   fossil primates, 928  
 Du Nuoy ring, 1170  
 Duality (physics), 705\*  
 Dubnium, 705\*  
 Duchenne's muscular dystrophy, 1451  
 Duck, 129, 1762  
 Duck-billed platypus, 1435  
 Duckweed, 138  
 Ducted fan, 705\*  
 Ductile polymers, 1746  
 Ductile-to-brittle transition, 1363  
 Dugong, 2014-2015

Dumb cane, 138  
 Dumortierite, 705\*  
*Dunaliella*, 1044  
 Dune, 705-706\*, 834-835  
 Dune field, 706  
 Dune vegetation, 706, 706\*  
 Dunite, 706-707\*  
 Duodenal ulcer, 938  
 Dura mater, 1354, 1478  
 Duranickel, 1487  
 Duration (musical acoustics), 1454  
*Durio*, 1309  
 Dust and mist collection, 707\*  
 Dust storm, 707\*, 1327  
 Dutch elm disease, 2267  
 Dutchman's pipe (plant), 153  
 Dwarf buffalo, 301  
 Dwarf sand cherry, 383  
 Dwarf star, 707\*  
   red, 1878\*  
   white, 2385-2387\*  
 Dwarfism and gigantism, 707\*, 1694  
 Dyadic, 707-708\*  
 Dye, 708\*, 2217  
 Dyeing, 708\*  
   diazotization, 656  
   mordant, 1438\*  
   nontextile materials, 644-645  
   textiles, 644  
 Dynamic analysis (geology), 2135  
 Dynamic braking, 708-709\*, 1268  
 Dynamic earphones, 653, 716  
 Dynamic-electrostatic earphones, 653, 716  
 Dynamic instability, 709\*, 1399  
 Dynamic invocation interface (DII), 690  
 Dynamic light scattering (DLS), 1835  
 Dynamic metamorphism, 1372  
 Dynamic meteorology, 709-711\*, 1379  
   baroclinic instability, 647  
   global climate modeling, 647  
   mesoscale convective systems, 647  
   middle-atmosphere dynamics, 1399\*  
   numerical weather prediction, 647  
   statics, 646  
 Dynamic microphones, 1388  
 Dynamic nuclear polarization, 711\*  
 Dynamic random access memory (DRAM), 1985  
 Dynamic similarity, 711\*  
 Dynamical Time, 711\*, 835  
 Dynamics, 711\*, 1215-1216  
 Dynamite, 265  
 Dynamitron accelerator, 717  
 Dynamometer, 711-712\*  
 Dyne-centimeters, 723  
 Dynein, 394-395  
 Dysentery, bacillary, 211-212, 239-240\*  
 Dysprosium, 712\*  
 Dysthymia, 39  
 Dzionaki, A., 720

## E

E (mathematics), 713\*  
 E-commerce, 1176-1177  
 E-mail, 788\*  
 Eagle, 260  
 Ear:  
   amphibians, 651, 714  
   birds and reptiles, 651-652, 714, 715  
   fishes, 651, 713-714  
   hearing (human), 1049-1050\*  
   hearing impairment, 1051\*  
   mammals, 652, 715  
   physiological acoustics, 1682\*  
   structure, 651, 713  
   Tetrapoda, 651  
   tetrapods, 714  
 Ear (vertebrate), 713-715\*  
   hearing (human), 1049  
   hearing (vertebrate), 1050  
   sensory system regeneration, 1986  
 Ear protectors, 715\*  
*Early Bird* (communications satellite), 451  
 Early Jurassic, 675  
 Early modern humans, 715-716\*  
 Earphones, 716\*  
 Earshell *see* Abalone  
 Earth, 716-718\*  
   age, 547, 654, 718, 1037  
   atmosphere, 654

Earth—*cont.*  
   crust, 546-547, 576-577, 719-720, 1549, 1724, 1943  
   geodynamics, 987\*  
   gravity field of, 718-719\*  
   heat flow in, 719\*  
   layers of, 717  
   lithosphere, 1264-1265\*  
   magnetosphere, 1303\*  
   mantle, 1540  
   massif, 1332\*  
   motions, 654  
   mountain, 1442\*  
   mountain systems, 1443\*  
   oceanic crust, 720  
   olivine, 1540  
   ophiolite, 1548-1549  
   parallax, 1608  
   phase (astronomy), 1649  
   planetary physics, 1700, 1701  
   plate tectonics, 1724\*  
   Preliminary Reference Earth Model, 720  
   Proterozoic, 1792-1793  
   radio astronomy, 1847  
   satellite (spacecraft), 1946  
   structure, 654  
   terrestrial coordinate system, 2211-2212\*  
   transit, 2261\*  
 Earth interior, 720-721\*  
   composition and state, 721  
   seismic structure, 720-721  
 Earth resource patterns, 724  
 Earth rotation and orbital motion, 721-722\*  
   ecliptic, 731\*  
   parallax, 1608\*  
 Earth sciences, 722\*  
 Earth tides, 722\*  
 Earthquake, 722-723\*  
   asthenosphere, 187-188\*  
   cause, 655  
   classification, 655  
   dam, 614  
   Earth seismic structure, 720  
   geodynamics, 987  
   paleoseismology, 1602\*  
   plate tectonics, 1724  
   seismic risk, 1975\*  
   seismology, 1976-1977\*  
   sequences, 655  
   size, 655  
   subduction zones, 2137  
   surface acoustic-wave devices, 2167  
 Earthstars, 864  
 Earthworm, 304  
 Oligochaeta, 1539\*  
   regeneration, 1884  
 Earwigs, 642  
 East Indian arrowroot, 157  
 East Indies, 723-724\*  
 East Pacific Rise, 1321  
 Eastern chipmunk, 387  
 Eastern equine encephalitis, 757  
 Eastern hemlock, 944  
 Eastern red cedar, 344  
 Eating disorders, 724-725\*  
   anorexia nervosa, 724  
   binge eating disorder, 724-725  
   bulimia nervosa, 724  
 Eavesdropping devices, 710, 788  
 Ebanales, 725\*  
 Ebenaceae, 656  
 Ebola virus, 725\*, 860  
 Ebony, 725\*  
 Ebria, 656  
 Ebrida, 725\*  
 Ecdysis *see* Molting  
 Ecdysone, 725\*  
 Echinida, 1435  
 Echinacea, 725-726\*  
   Echinoida, 725-726\*, 726-727\*  
   Phymosomatoida, 1676\*  
   Salenoida, 1940\*  
 Echinidae, 658  
 Echiniscoidea, 951  
*Echinochloa frumentacea*, 1403  
*Echinococcus granulosus*, 656  
 Echinocystis, 657  
 Echinodermata, 726\*  
   Articulata, 176\*  
   Blastoidea, 302\*  
   Camerata, 360\*  
   carpoids, 374-375\*  
   Crinoidea, 579-580\*, 580\*  
   Crinozoa, 580\*  
   Cyclocystoidea, 604\*  
   Diametatacea, 653\*  
   Echinacea, 725-726\*

Echinodermata—*cont.*  
   Echinoidea, 726-727\*  
   Echinozoa, 727-728\*  
   Eleutherozoa, 805\*  
   endocrine system, 732, 815  
   Eocrinoidea, 834\*  
   Euechinoidea, 852\*  
   Flexibilia, 893\*  
   Forcipulata, 914\*  
   Gnathostomata, 1009\*  
   Helicoplacoidea, 1059\*  
   Hemicaroida, 1063\*  
   Holasteroidea, 1083\*  
   Holectypoida, 1083\*  
   Homalozoa, 1086\*  
   Irregularia, 1191\*  
   Neognathostomata, 1473\*  
   Neolampadoidea, 1473-1474\*  
   Notomiotina, 1504\*  
   Oligopygoidea, 1539-1540\*  
   Ophiurida, 1549\*  
   Ophiuroidea, 1549\*  
   Parablastoidea, 1607\*  
   Paxilloidea, 1621\*  
   Pedinoidea, 1623\*  
   Pelmatozoa, 1624\*  
   Perischoechinoidea, 1633\*  
   Phrynophiurida, 1674\*  
   Phymosomatoida, 1676\*  
   Platyasterida, 1725\*  
   Pterasteroidea, 1812\*  
   regeneration, 1884  
   Regularia, 1885\*  
   Rhombifera, 1915-1916\*  
   Salenoida, 1940\*  
   sea urchin, 1966\*  
   Spatangoida, 2072\*  
   Stenurida, 2113\*  
   Temnopleuroidea, 2208\*  
   Valvata, 2320\*  
 Echinoida, 726-727\*  
 Echinoidea, 727\*  
   Atelostomata, 198\*  
   Echinozoa, 728  
   Euechinoidea, 852\*  
   Gnathostomata, 1009\*  
   Hemicaroida, 1063\*  
   Irregularia, 1191\*  
   Neognathostomata, 1473\*  
   Neolampadoidea, 1473-1474\*  
   Perischoechinoidea, 1633\*  
   Phymosomatoida, 1676\*  
   Regularia, 1885\*  
   sand dollar, 1943\*  
   sea urchin, 1966\*  
 Echinometridae, 658  
 Echinothuriidae, 659  
 Echinozoa, 723, 727-728\*  
   Cyclocystoidea, 604\*  
   Echinodermata, 726  
   Echinoidea, 727\*  
   Helicoplacoidea, 1059\*  
   Holothuroidea, 1085\*  
 Echiurida, 728\*  
 Echiuridae, 659, 728  
 Echiuroinea, 659, 728  
 Echo, 149, 728\*  
*Echo* (artificial satellite), 450, 451  
 Echo box, 728\*  
 Echo sounder, 728\*  
   hydrography, 1107  
   polar navigation, 1734-1735  
   sonar, 2048  
 Echocardiography, 728-729\*  
 Echolocation, 729\*  
 Echovirus, 729\*  
*Ecklonia*, 1224  
 Eclectic therapies, 1804  
 Eclipse, 729-731\*  
   eclipsing variable stars, 731\*  
   lunar, 661, 730-731  
   Moon, 1436  
   solar, 660-661, 729-730  
   suzgy, 2188\*  
 Eclipse year, 2410  
 Eclipsing variable stars, 731\*  
 Ecliptic, 731\*  
 Ecliptic coordinate system, 192  
 Eclogite, 731\*  
 Ecological communities, 731-732\*  
   ecological succession, 734-735\*  
   food web, 911\*  
   urban forestry, 921  
   mangrove, 1312\*  
   paleoecology, 1599  
   plant geography, 1704  
   predator-prey interactions, 1767

- Ecological communities—*cont.*  
*see also* Biome; Plant community
- Ecological competition, 732-733\*
- Ecological energetics, 733\*
- Ecological interactions, 421-422
- Ecological modeling, 733-734\*
- Ecological succession, 732, 734-735\*
- Ecological zoogeography, 2419
- Ecology, 735\*  
 adaptive management, 24\*  
 applied, 664, 735-736\*  
 approaches, 664  
 behavioral, 233  
 chemical, 370  
 conservation of resources, 541-542\*  
 disease, 686-687\*  
 Earth sciences, 722  
 environment, 828-830\*  
 fisheries, 890-891\*  
 fungal, 947-948\*  
 human, 1093\*  
 industrial, 1139-1140\*  
 invasion, 1179-1180\*  
 marine, 1319-1320\*  
 mathematical, 1335-1336\*  
 microbial, 1382\*  
 mutualism, 1457-1458\*  
 paleoecology, 1598-1599\*  
 physiological (animal), 1682\*  
 physiological (plant), 1682-1683\*  
 population, 1755\*  
 radioecology, 1859-1860\*  
 restoration, 1908\*  
 soil, 2035-2036\*  
 systems, 2187\*  
 theoretical, 2218\*  
 thermal, 2221\*  
 trophic, 276\*  
 trophic ecology, 2276\*
- Economic entomology, 742-743, 827\*
- Economizer, boiler, 274
- Ecosystem, 736\*  
 biodiversity, 278-279\*  
 biogeochemical cycles, 736  
 disease ecology, 687  
 ecological communities, 731-732\*  
 ecological energetics, 733\*  
 food web, 736, 911\*  
 forest, 825-826, 916-918\*  
 fresh-water, 937-938\*  
 grassland, 1019-1020\*  
 landscape ecology, 1226\*  
 mapping, 2328\*  
 marine conservation, 1318\*  
 paleoecology, 1599  
 terrestrial, 2212\*  
 trophic ecology, 2276  
 wetlands, 2384-2384\*  
*see also* Agroecosystem
- Ecotone, 736\*
- Ecotypes, 1682
- Ectoderm, 812
- Ectomycorrhizae, 1459
- Ectopic pregnancy, 1768, 1769\*
- Ectoprocta *see* Bryozoa
- Ectothiorhodospira halophila*, 1044
- Edaphosauria, 1624
- Eddies (wind), 2389
- Eddy current, 737\*
- Edema, 463, 737\*
- Edentata, 737\*  
 anteater, 131\*  
 armadillo, 170\*  
 sloth, 2022\*
- Edgeworth, K. E., 1219
- Ediacaran biota, 737-738\*
- Ediacaran period, 737-738
- Edison effect, 2319
- EDP *see* Electronic data processing systems
- EDTA *see* Ethylenediaminetetraacetic acid
- Edutainment software, 2030
- EEG *see* Electroencephalography
- EEG pattern, 693
- Eel, 738\*
- Eelgrass, 975
- Effective dose, 738\*
- Effective dose 50, 738\*
- Effector systems, 738\*
- Efficiency, 738\*, 2357
- Effluence, 738\*
- Effluent standards, 1991
- Egg:  
 fowl, 738-739\*  
 invertebrate embryology, 1181  
 poultry production, 1761-1762  
 primitive gut, 1772  
*see also* Ovum
- Eggplant, 739\*, 2038
- Ehrlich, Paul, 382, 435
- Ehrlichiosis, 739\*
- Eichinacea, 2208
- Eicosanoids, 739-740\*
- Eigenfrequencies, 721
- Eigenfunction, 740\*
- Eigenvalue (quantum mechanics), 740\*  
 eigenfunction, 740\*  
 quantum (mechanics), 1829
- Eikenella*, 740\*
- Eimeriina, 768
- Einstein, Albert, 569, 697, 1664, 2068  
 energy, 820  
 gravitation, 1021-1022  
 gravitational lens, 1023  
 hidden variables, 1076  
 hydrogen bomb, 1105  
 mass, 1330  
 mass defect, 1330  
 matter, 1340  
 photon, 1669  
 relativistic electrodynamics, 1886  
 relativity, 1887-1891  
 weightlessness, 2382
- Einstein field equations, 907
- Einstein-Podolsky-Rosen (EPR) experiment, 1076
- Einstein shift, 1024
- Einsteinium, 740\*
- El Niño, 740\*, 841
- El Niño-Southern Oscillation, 668, 1380
- Elaphomycetaceae, 771
- Elapidae, 429
- Elasipodida, 960
- Elasmobranchii, 394, 740\*  
 Batoidea, 257\*  
 Cladoselachii, 467\*  
 ray, 1697-1698\*  
 Xenacanthida, 2407\*
- Elastic cartilage, 336, 375
- Elasticity, 741\*, 2412
- Elastomers, 1744
- polymers, 1746  
 polyurethane resins, 1753
- Elderberry, 620
- Electret, 741\*
- Electret transducer, 741-742\*
- Electric accumulator *see* Storage battery
- Electric arc, 140, 157-158
- Electric-arc heaters, 744
- Electric battery *see* Battery
- Electric brake/braking, 287, 645
- Electric burn, 304
- Electric catfish, 673
- Electric cell:  
 battery, 258-259\*  
 electromotive force, 775-776\*  
 fuel cell, 940-941\*
- Electric charge, 742\*  
 dipole, 678  
 dipole moment, 679  
 electric current, 742\*  
 electric field, 743\*  
 electron, 776-777\*  
 electroscopes, 796\*  
 electrostatics, 797-798\*  
 hypercharge, 1116\*
- Electric circuit *see* Circuit (electricity)
- Electric contact, 742\*
- Electric current, 742\*  
 ammeter, 98\*  
 breakdown potential, 328-329\*  
 displacement current, 687\*  
 electrical breakdown, 753\*  
 magnetohydrodynamics, 1301-1302\*  
 neutral currents, 1481-1482\*  
 physical measurement, 1680  
 pinch effect, 1688-1689\*  
*see also* Alternating current; Direct current
- Electric dipole, 619, 678
- Electric distribution systems, 742-743\*  
 automotive, 199  
 direct-current transmission, 683-684\*  
 electric power transmission, 748-750\*  
 substation, 747-748\*  
 transmission lines, 2262\*  
 voltage regulator, 2355-2356\*
- Electric drive engines, 1320
- Electric dynamic braking, 708-709
- Electric eel, 666, 673, 728, 745
- Electric field, 743\*  
 Aharonov-Bohm effect, 47\*  
 electromagnetic field, 771\*  
 lines of force, 1258\*  
 magnetic monopoles, 1293\*
- Electric filter, 743-744\*  
 applications, 672  
 digital filters, 673  
 electromagnetic compatibility, 771  
 integrated circuit filter, 1163-1164\*  
 microwave, 1393-1394  
 special filters, 672-673  
 suppression, 2165
- Electric fish, 673-674, 745
- Electric furnace, 743\*, 744\*  
 arc heating, 158\*  
 electric furnace, 743\*, 744\*  
 electrochemical process, 762-763\*  
 induction heating, 1138\*  
 Joule's law, 1204\*  
 resistance heating, 1901\*
- Electric insulator, 683, 744-745\*  
 dielectric materials, 657-658\*  
 valence band, 2320\*
- Electric lamp *see* Lamp
- Electric-light bug, 942
- Electric motor *see* Motor
- Electric organ (biology), 119, 745\*
- Electric power generation, 745-746\*  
 coal gasification, 482  
 cogeneration, 492\*  
 generator, 981\*  
 geothermal power, 995-996\*  
 hydroelectric generator, 1103-1104\*  
 magnetohydrodynamic power generator, 1301\*  
 nuclear power, 1512\*  
 solar cell, 2038\*  
 space power systems, 2061\*  
 three-phase ac systems, 89-90  
 tidal power, 2239\*  
 transmission lines, 2262\*  
 wind power, 2389\*
- Electric power measurement, 746-747\*  
 audio and radio frequencies, 675  
 dc and ac power frequencies, 675  
 electrical energy measurement, 755  
 microwave frequencies, 675  
 watt-hour meter, 2370\*  
 wattmeter, 2370-2371\*
- Electric power substation, 747-748\*
- Electric power systems, 748\*  
 circuit breaker, 461\*  
 distribution systems, 742-743\*  
 electric distribution system, 742-743\*  
 generation, 745-746\*  
 power measurement, 746-747\*  
 substation, 675-676, 747-748\*  
 transmission, 748-750\*
- Electric power transmission, 748-750\*  
 overhead alternating-current transmission, 676-677, 749  
 submarine cables, 677, 750, 2139\*  
 underground power transmission, 677, 749-750
- Electric protective devices, 750-751\*  
 communications systems protection, 511-512\*  
 lightning and surge protection, 1253-1254\*  
 overcurrent, 678  
 overvoltage, 678, 1588-1589\*  
 phase unbalance, 679  
 relays, 678  
 reverse-current, 678-679  
 reverse-phase-rotation, 679  
 surge arrester, 2171\*  
 thermal, 679  
 underfrequency, 678  
 undervoltage, 678  
 uninterruptible power system, 2301\*
- Electric rotating machinery, 751\*  
 alternating-current *see* Alternating-current generator  
 armature reaction, 170\*  
 commutator, 513\*  
 direct-current generator, 682\*  
 direct-current motor, 683\*  
 dynamometer, 711-712\*  
 electrical degree, 754  
 generator, 981\*  
 hydroelectric generator, 1103-1104\*  
 motor, 1441\*  
 slip rings, 2022\*  
 windings in electric machinery, 2390\*
- Electric spark, 751\*, 2071
- Electric susceptibility, 599, 752\*
- Electric switch, 752\*  
 electric contact, 742\*  
 glass switch, 1002-1003\*  
 Electric transient, 752\*
- Electric vehicle, 752-753\*  
 Electric wiring *see* Wiring
- Electrical breakdown, 753\*
- Electrical codes, 753\*
- Electrical communications, 753-754\*  
 data communications, 616\*  
 electric filter, 743-744\*  
 electrical noise, 758-759\*  
 electromagnetic wave transmission, 773-774\*  
 electronic mail, 788\*  
 facsimile, 869-870\*  
 frequency division multiplex, 681  
 information theory, 1149-1150\*  
 intercommunicating system, 1170\*  
 multiplexing, 1446-1447\*  
 network configurations, 681  
 radio, 1846\*  
 signal amplification, 681  
 telegraphy, 2196-2197\*  
 television, 2202-2203\*  
 time division multiplex, 681-682  
 transmission media, 681
- Electrical conduction *see* Conduction (electricity)
- Electrical conduction in gases, 754\*  
 arc discharge, 157-158\*  
 corona discharge, 561\*  
 dark current, 615\*  
 electric spark, 751\*, 752\*  
 glow discharge, 1006\*  
 saturation current, 1950\*  
 Townsend discharge, 2253\*
- Electrical connector, 754\*
- Electrical degree, 754-755\*
- Electrical energy measurement, 755\*, 776
- Electrical engineering, 753-754, 755\*
- Electrical impedance, 755\*  
 immittance, 1127\*  
 impedance matching, 1133-1134\*  
 microwave measurements, 1394-1395\*, 1395  
 radio-frequency impedance measurements, 1849-1850\*  
 reactance, 1871-1872\*
- Electrical instability, 755-756\*
- Electrical insulation, 756-757\*  
 electric insulator, 744-745\*  
 properties, 756-757  
 requirements, 756
- Electrical interference, 757\*  
 communications systems protection, 512  
 electrical noise, 758-759\*  
 spread spectrum communication, 2089-2090\*  
 static, 2100\*  
 suppression, 2165-2166\*
- Electrical loading, 757\*
- Electrical measurements, 757-758\*  
 electric power measurement, 746-747\*  
 electrical energy measurement, 755\*  
 electrical noise generator, 759\*  
 electrical units and standards, 760-761\*  
 electrometer, 698\*  
 galvanometer, 856-857, 958-959\*  
 inductance measurement, 1137\*  
 instrument transformer, 1161  
 multimeter, 1446\*  
 Q meter, 1819\*
- Electrical model, 758\*  
 large-signal models, 685  
 small-signal modeling, 685
- Electrical musical instruments, 1455
- Electrical noise, 758-759\*  
 electrical interference, 757  
 electrical shielding, 760\*  
 microwave noise measurement, 1395, 1396\*  
 sferics, 1995\*  
 signal-to-noise ratio, 2006\*  
 static, 2100\*  
 suppression, 2165-2166\*
- Electrical noise generator, 759\*, 1396
- Electrical resistance, 759\*  
 insulation resistance testing, 1162\*  
 magnetoresistance, 1303\*  
 Q (electricity), 1595  
 resistor, 1902-1903\*  
 skin effect (electricity), 2018-2019
- Electrical resistivity, 756, 759-760\*, 2223
- Electrical shielding, 760\*  
 electromagnetic compatibility, 771  
 electromagnetic pulse, 772  
 suppression, 2165-2166
- Electrical units and standards, 760-761\*  
 electrical and magnetic units, 760-761  
 electrical standards, 761

Electrical units and standards—*cont.*  
 units of measurement, 2304  
 weight measurement systems, 2382

Electrically erasable programmable  
 read-only memories (EEPROMs), 1002

Electricity, 761-762\*  
 atmospheric *see* Atmospheric electricity  
 domain, 695\*  
 electrical measurements, 757-758\*  
 electromagnetic induction, 771-772\*  
 electromagnetism, 774\*  
 Q (electricity), 1819\*  
 relativistic electrodynamics, 1886\*  
 static, 2100-2101\*  
 storage, 821-822\*  
 storm, 2121\*  
 thermoelectricity, 2228\*  
 Electroacoustics, 741, 742  
 Electroanalysis, 770  
 Electroanalytical chemistry, 690, 765  
 Electrocardiography, 768  
 Electrochemical cells *see* Electrolysis  
 Electrochemical equivalent, 762\*  
 Electrochemical process, 762-763\*  
 electroless plating, 769\*  
 electrolysis, 769-770\*  
 electroplating of metals, 795-796\*  
 inorganic processes, 688, 762-763  
 organic processes, 689, 763  
 Electrochemical series, 763\*, 1590  
 Electrochemical techniques, 763-764\*  
 controlled potential, 764  
 polarographic analysis, 1738\*  
 variable potential, 764  
 Electrochemistry, 764-765\*  
 electroanalytical chemistry, 690, 765  
 electrochemical process, 762-763\*  
 electrodeposition, 690, 765  
 electrolytic conductance, 771\*  
 electrolytic processes, 690, 765  
 electromotive force, 776  
 electromotive force (cells), 774-776\*  
 galvanic cells, 690, 764  
 miscellaneous phenomena, 690  
 organic electrochemistry, 765  
 overvoltage, 1588-1589\*  
 Electrochromic devices, 765-766\*  
 Electroconvulsive therapy, 766\*  
 Electrode, 766\*  
 battery, 258-259  
 calomel, 318  
 electrochemical techniques, 763-764\*  
 ion-selective, 1186  
 pH, 1647  
 reference, 1879-1880\*  
 Electrode potential, 766-767\*  
 electromotive force (cells), 774-776\*  
 overvoltage, 1588-1589\*  
 Electrodeposition, 690  
 electrochemistry, 765  
 electroplating of metals, 795-796\*  
 electrostatic precipitator, 797\*  
 Electrodermal response (EDR), 767\*, 1249  
 Electrodes:  
 electrolysis, 769-770\*  
 solid-state battery, 2043  
 Electrodiagnosis, 768\*, 776  
 Electrolysis:  
 electrochemical process, 763  
 electrochemistry, 765  
 membrane separations, 1352\*  
 Electrodynamic levitation system (EDS or  
 EDL), 1292  
 Electrodynamics, 768\*  
 magnetohydrodynamics, 1301-1302\*  
 quantum, 1826\*  
 relativistic, 1886\*  
 Electrodynamicometer *see* Electrodynamic  
 instrument  
 Electroencephalography (EEG), 768\*,  
 2019-2020  
 Electroendosmosis, 689, 763  
 Electroforming, 688, 716, 765  
 Electrokinetic phenomena, 768-769\*,  
 795-795  
 Electroless plating, 769\*  
 Electroluminescence, 769\*, 1251-1252  
 Electrolysis, 769-770\*  
 alkali-chlorine processes, 688  
 aqueous solutions, 688  
 coulometer, 572\*  
 decomposition potential, 627\*  
 electrochemical equivalent, 762\*  
 electrochemical process, 762  
 electrodeposition analysis, 693-694  
 fused-salt, 688  
 overvoltage, 1588-1589\*

Electrolyte, 380, 770-771\*, 2043, 2044  
 conductivity, 533  
 ion transport, 1187  
 Electrolytic conductance, 771\*  
 Electrolytic processes:  
 electrochemistry, 765  
 electrochromic devices, 765-766\*  
 Electromagnet, 771\*  
 magnet, 1290  
 solenoid (electricity), 2042-2043\*  
 Electromagnetic compatibility, 771\*  
 Electromagnetic field, 771\*  
 Electromagnetic induction, 771-772\*  
 electromotive force, 776  
 Faraday's law of induction, 871\*  
 inductance, 1137\*  
 Lenz's law, 1242\*  
 Electromagnetic interaction, 847, 946  
 Electromagnetic interference (EMI), 757,  
 771  
 Electromagnetic pulse (EMP), 772\*  
 Electromagnetic pump, 772-773\*  
 Electromagnetic radiation, 773\*  
 absorption of, 5-6\*  
 bioelectromagnetics, 279\*  
 bremsstrahlung, 332\*  
 Compton effect, 518\*  
 diffraction, 663-664\*  
 dispersion, 687  
 gamma rays, 962\*  
 heat radiation, 1056\*  
 infrared radiation, 1152\*  
 lamp, 1224  
 light, 1250-1251\*  
 medical diagnosis and treatment, 247  
 microwave, 1391-1393\*  
 optics, 1563\*  
 photon, 1669\*  
 photovoltaic cell, 1673\*  
 photovoltaic effect, 1673-1674  
 quadrature, 1819\*  
 quantum electrodynamics, 1826\*  
 radiation pressure, 1845\*  
 radiometry, 1863\*  
 reflection and transmission coefficients,  
 1880\*  
 refraction of waves, 1882\*  
 relativistic electrodynamics, 1886\*  
 scattering of, 1955\*  
 spherics, 1995  
 solar energy, 2039\*  
 solar radiation, 2041\*  
 spectrum, 2076\*  
 submillimeter, 2140  
 submillimeter-wave technology, 2141\*  
 synchrotron radiation, 2183-2184\*  
 telescope, 2201-2202\*  
 terrestrial radiation, 2212-2213\*  
 ultraviolet radiation, 2295-2296\*  
 wave optics, 2372\*  
 x-rays, 2406\*  
 Electromagnetic suspension (EMS) systems,  
 1292  
 Electromagnetic theory, 1228  
 Electromagnetic wave, 773\*  
 laser, 1229-1230\*  
 magnon, 1305-1306\*  
 maser, 1328-1329\*  
 polarization of waves, 1736  
 wave motion, 2371-2372  
 Electromagnetic wave transmission,  
 773-774\*  
 Electromagnetism, 774\*  
 electromagnetic compatibility, 771\*  
 galvanomagnetic effects, 958\*  
 gauge theory, 972-973\*  
 geoelectricity, 988\*  
 Maxwell's equations, 1340-1341\*  
 Electrometallurgy, 688, 774\*  
 arc heating, 158\*  
 electroless plating, 769\*  
 Electrometer, 774\*, 796  
 Electromotive force (cells), 774-776\*  
 measurement, 691  
 origin, 775-776  
 Electromotive force (emf), 776\*  
 cells, 774-776\*  
 electromagnetic induction, 771-772\*  
 inductance, 1137\*  
 Seebeck effect, 1973\*  
 Electromyography, 768, 776\*  
 Electron, 776-777\*  
 atomic mass, 210  
 atomic nucleus, 210  
 delta electrons, 570-571, 633-634\*  
 electromagnetic pulse, 772  
 electron affinity, 777\*

Electron—*cont.*  
 electronvolt, 793\*  
 elementary particle, 802  
 fundamental interactions, 946, 947  
 Larmor precession, 1228  
 magic numbers, 1288-1289\*  
 magnetic moment, 699, 776-777  
 positronium, 1757-1758\*  
 quantized electronic structure, 1821-1822\*  
 relaxation time of electrons, 1891\*  
 spin, 212-213, 699, 777, 1661  
 Electron accelerators:  
 heavy-ion, 699  
 proton, 699  
 Electron affinity, 777\*, 786  
 Electron capture, 777\*  
 Electron configuration, 777-779\*  
 electron spectroscopy, 783\*  
 exclusion principle, 859\*  
 ions, 374-375  
 Rydberg atom, 1936-1937\*  
 Electron deposition printing, 1774  
 Electron diffraction, 779-780\*  
 gases and liquids, 703  
 in gases and liquids, 780  
 high-energy, 703, 779, 780  
 low-energy, 702-703, 779-780  
 Electron emission, 703, 780\*  
 Electron gun, 1685  
 Electron-hole droplet, 774  
 Electron-hole recombination, 780-781\*  
 Electron lens, 781\*  
 Electron magnetic moment, 192  
 Electron microprobe, 2403  
 Electron microscope, 781-782\*  
 magnetic lens, 1292\*  
 metallography, 1370  
 scanning electron microscope, 1953\*  
 x-ray fluorescence analysis, 2403  
 Electron paramagnetic resonance (EPR)  
 spectroscopy, 782\*, 2084, 2085  
 Electron paramagnetism, 1295  
 Electron-positron pair production, 782-783\*  
 Electron-probe microanalysis, 783\*  
 Electron spectrometry, 413  
 Electron spectroscopy, 783\*  
 Electron spectroscopy for chemical analysis  
 (ESCA), 706-707, 783  
 Electron spin:  
 atomic beam measurements, 784  
 calculation of g-factor anomaly, 784  
 electron magnetic moment, 783-784  
 Electron spin resonance (ESR) *see* Electron  
 paramagnetic resonance spectroscopy  
 Electron-transfer reaction, 784\*  
 Electron-transfer theory, 784  
 Electron tube, 784-785\*  
 cathode-ray tube, 380-381\*  
 gas tube, 968\*  
 klystron, 1217\*  
 magnetron, 1303-1304\*  
 phototube, 1673\*  
 television camera tube, 2204\*  
 thermionic tube, 2222-2223\*  
 traveling-wave tube, 2265-2266\*  
 vacuum tube, 2319\*  
 Electron wake, 785-786\*  
 Electron wave optics, 705  
 Electronegativity, 786\*, 1590  
 Electronic absorption, 1661  
 Electronic air cleaner, 786\*  
 Electronic charge integrators, 1291-1292  
 Electronic chart display and information  
 systems (ECDIS), 1324  
 Electronic circuit *see* Circuit (electronics)  
 Electronic data-processing systems, 554-555,  
 668-670  
 Electronic display, 786-788\*  
 cathode-ray tube, 380-381\*  
 computer graphics, 521-522\*  
 data-processing systems, 555  
 flat-panel display device, 892\*  
 oscilloscope, 1584  
 television scanning, 2206  
 Electronic dosimeter, 699  
 Electronic electrometers, 774  
 Electronic filters, 743, 840  
 Electronic listening devices, 788\*  
 Electronic mail, 788\*  
 Electronic musical instruments, 1455  
 Electronic navigation systems, 788-790\*  
 cooperative, 789-790  
 distance-measuring equipment, 688\*  
 microwave landing system, 1394\*  
 multiple-source, 789  
 point-source, 789  
 polar navigation, 1734

Electronic navigation systems—*cont.*  
 rho-theta systems, 1914\*  
 satellite navigation systems, 1948-1949\*  
 self-contained, 790  
 Tacan, 2189-2190\*  
 Electronic packaging, 790\*  
 first-level, 711, 790  
 hierarchy, 711, 790  
 printed circuitry, 711, 790  
 Electronic paramagnetism, 1608-1609  
 Electronic photochemistry, 1231  
 Electronic polarization, 1736  
 Electronic power supply, 744, 790-791\*  
 Electronic printing, 1774  
 Electronic publishing:  
 on-line databases, 712  
 video disk, 713, 2338-2339\*  
 videotext and teletext, 713  
 Electronic switch, 791\*, 2177  
 Electronic tablet, 459-460  
 Electronic test equipment, 791-792\*  
 electronic instruments, 713  
 embedded-computer regulators, 713  
 Electronic voltage regulator, 2355  
 Electronic voltmeters, 2356-2357  
 Electronic warfare, 792\*, 1201  
 Electronic weighing system, 215  
 Electronics, 792-793\*  
 analog, 792-793  
 bioelectronics, 279-280\*  
 buffers, 340-341\*  
 consumer, 480  
 digital, 793  
 electromagnetic compatibility, 771\*  
 electromagnetic pulse, 772\*  
 high-temperature, 954-955  
 magnetic thin films, 1296\*  
 quantum electronics, 1826\*  
 sigma-delta converter, 2005\*  
 work function, 2397-2398\*  
 Electronvolt, 793\*  
 Electrooptics, 793\*, 1212  
 Electroosmosis, 693  
 Electrophilic and nucleophilic reagents,  
 793-794\*, 1653  
 Electrophoresis, 112, 693, 794-795\*  
 alternating-field, 795  
 capillary electrophoresis, 794-795  
 electrophoretic deposition, 689  
 gel techniques, 794  
 immunoelectrophoresis, 1129\*  
 isoelectric focusing, 794  
 laser applications, 794  
 sickle cell disease, 2004  
 Electrophoretic deposition, 763  
*Electrophorus electricus*, 666, 673  
 Electrophotographic printing, 1774  
 Electrophotography, 797-798  
 Electrophysiology *see* Biopotentials and  
 ionic currents  
 Electroplating of metals, 688, 770,  
 795-796\*  
 Electropolishing, 688, 796\*  
 Electrorefining, 688, 765, 770  
 Electroscopie, 796\*  
 Electrospaying, 797  
 Electrostatic accelerators, 1614  
 Electrostatic earphone, 653  
 Electrostatic generator, 717  
 Electrostatic induction, 718  
 Electrostatic lens, 781, 796-797\*  
 Electrostatic microphones, 1388  
 Electrostatic precipitator, 689, 797\*  
 Electrostatic printing, 1774  
 Electrostatic technique, 763  
 Electrostatic theory, 490  
 Electrostatically suspended gyroscope  
 (ESG), 1036  
 Electrostatics, 572, 797-798\*  
 Electrostriction, 798\*  
 Electrotherapy, 766, 798\*  
 Electrothermal propulsion, 798-799\*  
 Electrothermics:  
 electrochemical process, 762  
 electrothermal propulsion, 798-799\*  
 Electroweak interaction, 799-800\*  
 gauge theory, 719  
 Higgs-Kibble mechanism, 720  
 neutral currents, 1481-1482\*  
 outlook for the theory, 720  
 strength, range, and symmetry, 719  
 supergravity, 2159  
 Electroweak theory:  
 elementary particle, 804  
 quantum field theory, 1827  
 Electrowinning, 688, 765  
 Element 111, 801\*

Element 112, 801\*  
 Element (chemistry), 721-723, 800-801\*  
 antimony, 143-144\*  
 argon, 168\*  
 arsenic, 172\*  
 astatine, 185\*  
 barium, 219-220  
 berkelium, 267\*  
 beryllium, 268-269\*  
 bismuth, 298\*  
 bohrium, 310\*  
 boron, 319-320\*  
 bromine, 335\*  
 cadmium, 349\*  
 calcium, 351-352\*  
 californium, 357\*  
 carbon, 367-368\*  
 cerium, 408\*  
 cesium, 408\*  
 chemistry, 431  
 chlorine, 442-443\*  
 chromium, 450-451\*  
 cobalt, 486\*  
 copper, 556\*  
 cosmic abundance, 722, 804  
 curium, 599\*  
 darmstadtium, 615\*  
 dubnium, 705\*  
 dysprosium, 712\*  
 Earth interior, 721  
 einsteinium, 740\*  
 electrochemical series, 763\*  
 element 111, 801\*  
 element 112, 801\*  
 equivalent weight, 843\*  
 erbium, 843\*  
 europium, 855-856\*  
 fermium, 877\*  
 fluorine, 813-814, 903-904\*  
 francium, 931\*  
 gadolinium, 955\*  
 gallium, 958\*  
 geochemical distribution of, 723, 804-805\*  
 geochemistry, 985  
 germanium, 997\*  
 gold, 1010-1011\*  
 hafnium, 1038\*  
 hassium, 1047-1048\*  
 helium, 1060-1061\*  
 holmium, 1083\*  
 hydrogen, 1104-1105\*  
 indium, 1136-1137\*  
 inert gases, 1143\*  
 iodine, 1183\*  
 iridium, 1190\*  
 iron, 1190-1191\*  
 isotope separation, 1198\*  
 krypton, 1218\*  
 lanthanum, 1227\*  
 lead, 1235\*  
 lithium, 1264\*  
 lutetium, 1280\*  
 magnesium, 1289-1290\*  
 manganese, 1311\*  
 meitnerium, 1351\*  
 mendeleevium, 1353\*  
 mercury, 1356\*  
 metal, 1362\*  
 metalloid, 1370\*  
 molybdenum, 1429-1430\*  
 native elements, 1465\*  
 neodymium, 1473\*  
 neon, 1474\*  
 neptunium, 1476\*  
 nickel, 1486-1487\*  
 niobium, 1488\*  
 nitrogen, 1490-1491\*  
 nobelium, 1493\*  
 nonmetal, 1498-1499\*  
 nucleosynthesis, 1519-1520\*  
 osmium, 1584-1585\*  
 oxygen, 1591\*  
 palladium, 1603-1604\*  
 periodic table, 1631-1632\*  
 phosphorus, 1659-1660\*  
 platinum, 1724-1735\*  
 plutonium, 1729-1730\*  
 polonium, 1740\*  
 potassium, 1759\*  
 praseodymium, 1764\*  
 promethium, 1784\*  
 protactinium, 1789\*  
 radium, 1863-1864\*  
 radon, 1864-1865\*  
 rhenium, 1991\*  
 rhodium, 1914-1915\*

Element (chemistry)—*cont.*  
 rubidium, 1935\*  
 ruthenium, 1936\*  
 rutherfordium, 1936\*  
 samarium, 1943\*  
 scandium, 1952-1953\*  
 seaborgium, 1967\*  
 selenium, 1979\*  
 silicon, 2008-2009\*  
 silver, 2010\*  
 sodium, 2029\*  
 strontium, 2130\*  
 sulfur, 2147-2149\*  
 symbols and formulas, 377  
 tantalum, 2192\*  
 technetium, 2195\*  
 tellurium, 2207\*  
 terbium, 2210\*  
 thallium, 2217  
 thorium, 2234-2235\*  
 thulium, 2235\*  
 titanium, 2244\*  
 transuranium elements, 2264-2265\*  
 tungsten, 2282\*  
 uranium, 2308-2309\*  
 valence, 2319-2320\*  
 vanadium, 2322-2323\*  
 xenon, 2407\*  
 ytterbium, 2412\*  
 yttrium, 2412\*  
 zinc, 2415-2416\*  
 zirconium, 2417\*  
 see also Actinide elements; Halogen elements; Rare-earth elements; Transition elements  
 Elementary number theory, 1520, 1521  
 Elementary particle, 802-804\*  
 baryon, 253-255\*  
 charm, 417-418\*  
 Dalitz plot, 613\*  
 deep inelastic collisions, 627-628\*  
 delta resonance, 634\*  
 electric charge, 742\*  
 electron, 776-777\*  
 exchange interaction, 858\*  
 Feynman diagram, 882\*  
 fundamental interactions, 946-947\*  
 gluons, 1007\*  
 hadron, 1037\*  
 Higgs boson, 1076-1077\*  
 hypercharge, 1116\*  
 hyperon, 1117\*  
 I-spin, 1123\*  
 intermediate vector boson, 1173\*  
 J/psi particle, 1201\*  
 lepton, 1246\*  
 meson, 1359\*  
 neutrino, 1482\*  
 neutron, 1483-1484\*  
 nuclear physics, 1512\*  
 positron, 1757\*  
 proton, 1794\*  
 quantum field theory, 1826-1827\*  
 quarks, 1831-1833\*  
 standard model, 2096\*  
 strange particles, 2122\*  
 strong nuclear interactions, 2129-2130\*  
 upson particles, 2308\*  
 wave mechanics, 2371\*  
 weak nuclear interactions, 2376\*  
 weakly interacting massive particle, 2377  
 Elephant, 805\*  
 animal evolution, 120  
 Oligocene, 1539  
 placentation, 1777  
 Proboscidea, 1777\*  
 Elephant ear (plant), 138  
 Elephant shrew, 1158, 1288  
 Elephantfish, 1586  
 Elephantidae, 723  
*Elephas maximum*, 805  
*Elephas maximus*, 723  
*Elettaria cardamomum*, 332  
*Eleusine coracana*, 1403  
 Eleutherozoa, 805\*  
 Elevating machines, 479, 805-806\*  
 Elevator, 806\*  
 Elevator (aircraft), 806\*  
 elevon, 806-807\*  
 tail assembly, 2190-2192\*  
 Elevon, 806-807\*  
*Eliomys quercinus*, 699  
 Elk, 567, 1437  
 Elliptic geometry, 1494  
 Ellipse, 807\*  
 Ellipsometry, 807\*

Elliptic function and integral, 807-808\*, 2072  
 Elliptical galaxy, 854  
 Elliptically polarized light, 1737  
 Ellipsoid see Parainsecta  
 Elobiidae, 226  
 Elm, 808\*, 2266  
 Elm yellow, 2267  
 Elongation (metal), 1363  
 Elopiformes, 808\*  
 Elsasser, W. M., 988  
 Elution chromatography, 397  
 Elves (lightning), 1253  
 Elysia, 1939  
 Emballonuridae, 388  
 Embedded systems, 808\*  
 Embioptera, 808\*  
 Embolism, 408-409, 808\*  
 Embolus:  
 phlebitis, 1655\*  
 thrombosis, 2235\*  
 Embossing, 1997  
 Embrithopoda, 809\*  
 Embrittlement, 499, 809\*  
 Embryobionta, 809\*  
 Lycopodiophyta, 1280\*  
 Magnoliophyta, 1305\*  
 plant phylogeny, 1712  
 Sphenophyta, 2083\*  
 Embryogenesis, 727, 810\*  
 Embryology, 810-811\*  
 animal morphogenesis, 122\*  
 animals, 810  
 cleavage, 415, 471\*  
 fate maps, 872-873\*  
 fetal membrane, 881-882\*  
 gastrulation, 972\*  
 germ layers, 996-997\*  
 gestation period, 997\*  
 histogenesis, 1082\*  
 invertebrate embryology, 1181-1182\*  
 nervous system (vertebrate), 1478  
 neural crest, 1479\*  
 placentation, 1694-1695\*  
 plants, 810-811  
 stem cells, 2112-2113\*  
 see also Developmental biology  
 Embryonated egg culture, 811\*  
 Embryonic differentiation, 586, 811\*  
 animal morphogenesis, 122  
 developmental biology, 649  
 Embryonic germ (EG) cells, 2112  
 Embryonic induction, 811-812\*  
 Emerald, 238, 239, 812\*, 1162  
 Emerald boa, 272  
 Emergency Broadcast Service, 2196  
 Emergency locator transmitters (ELTs), 1086  
 Emergency medicine, 812\*  
 Emery, 500, 729, 812-813\*  
 Emetine, 79  
 EMF see Electromotive force  
 Emission electron microscopes, 781  
 Emission flame photometry, 803-804  
 Emission spectrochemical analysis, 813\*  
 Emission spectrum, 2076  
 Emission tomography, 1347  
 Emissivity, 813\*  
 Emitter follower, 813\*  
 Emotion, 813\*, 1440-1441  
 EMP see Electromagnetic pulse  
 Empysemata, 813-814\*, 1907  
 Empirical method, 814\*  
 Emulsion, 814\*  
 colloid, 501  
 detergent, 647\*  
 food emulsifiers, 818  
 photographic materials, 1665  
 photography, 1666  
 surfactant, 2172  
 Enantiomer, 1421  
 asymmetric synthesis, 197-198\*  
 tartaric acid, 2193  
 see also Optical isomer  
 Energite, 814\*  
 Encalypta, 731  
 Encalyptales, 814\*  
 Encapsulation:  
 invertebrate pathology, 1182  
 plastics, 1723  
 Encephalitis:  
 exotic viral diseases, 860  
 listeriosis, 1264  
 Enchondromatosis see Dyschondroplasia  
 Encystment, 1074  
 End moraine, 1437  
 Endangered species, 814-815\*  
 marine conservation, 1318

Endangered species—*cont.*  
 population dispersal, 1754  
 Endocarditis, 1730  
 Endocrine atrophy, 194  
 Endocrine system (invertebrate), 815\*  
 animal growth, 121  
 annelids, 732, 815  
 crustaceans, 732, 815  
 echinoderms, 732, 815  
 insects, 732, 815  
 mollusks, 732, 815  
 neurosecretion, 1481\*  
 Endocrine system (vertebrate), 816-817\*  
 adenohypophysis, 26-27\*  
 calcium regulation, 816-817  
 carbohydrate regulation, 817  
 effector systems, 738\*  
 endocrine rhythms, 733  
 endocrine tissues, 732  
 gonad physiology, 1897  
 hormone, 817, 1089\*  
 nature of hormones, 816  
 neuroimmunology, 1480-1481\*  
 neurosecretion, 1481\*  
 pituitary gland and hypothalamus, 816  
 reproductive hormones, 817  
 roles, 733  
 salt and water regulation, 817  
 targets, 732-733  
 thyroid gland, 816  
 see also Adrenal gland; Ovary; Pancreas; Pituitary gland; Testis; Thyroid gland  
 Endocrine tissue, 667  
 Endocrinology, 817\*  
 Endocytosis, 817-818\*  
 Endodeoxyribonuclease, 1908  
 Endoderm, 812  
 Endodermis, 818\*  
 Endogenous pyrogen, 794  
 Endometriosis, 1588  
 infertility, 1145  
 reproductive system disorders, 1899  
 Endomycetales, 941  
 Endoparasites, 1711  
 Endoplasmic reticulum, 389, 818-819\*  
 Endopterygota, 819\*  
 Endorphins, 819\*, 1595, 2182  
 Endospores (bacteria), 240-241  
*Endothia parasitica*, 383  
 Endotoxin, 819-820\*  
 Energy, 735, 820\*  
 chemical, 370, 422-423  
 conservation of, 476-477  
 entropy, 828\*  
 free energy, 932-933\*  
 heat, 1053\*  
 internal, 1175\*  
 microwave, 1391-1393\*  
 molecular mechanics, 1421-1422\*  
 nuclear binding energy, 1505\*  
 radiation, 1842\*  
 solar, 2039\*  
 units of measurement, 2303-2304  
 universe, 2306  
 Energy conversion, 741-742, 820\*  
 Energy flow (ecological), 733\*  
 Energy level (quantum mechanics), 820-821\*  
 band theory of solids, 248-249\*  
 ground state, 1028\*  
 mesoscopic physics, 1359-1360\*  
 sum rules, 2149\*  
 Energy metabolism, 748, 821\*  
 Energy sources, 821\*  
 electric power generation, 745-746\*  
 flywheel, 906\*  
 geothermal power, 995-996\*  
 nuclear power, 1512\*  
 pumped storage, 1810\*  
 wind power, 2389\*  
 Energy storage, 821-822  
 Engelmann spruce, 2091  
 Engine, 822\*  
 dynamometer, 712  
 marine, 1320\*  
 mean effective pressure, 1341\*  
 rotary engine, 1933\*  
 steam, 2106\*  
 thermoacoustic, 2223  
 ultralight aircraft, 2294  
 vapor lock, 2324\*  
 see also Aircraft engine; Diesel engine; Internal combustion engine  
 Engine cooling, 822-823\*  
 Engine lubrication, 823\*  
 Engine manifold, 823-824\*



*Eucommia ulmoides*, 768  
 Eucommiales, 852\*, 1044  
 Eudicotyledons, 852\*  
 Euechinozoa, 852\*  
 Atelostomata, 198\*  
 Diadematacea, 653\*  
 Echinacea, 725-726\*  
 Gnathostomata, 1009\*  
 Holasteroidea, 1083\*  
 Holoctypoida, 1083\*  
 Spatangoida, 2072\*  
*Eugenia caryophyllata*, 421  
 Eugenic, 852\*  
*Euglena species*, 768, 1333  
 Euglenida, 852\*, 852-853\*  
 Euglenoidina see Euglenida  
 Euglenophyceae, 853\*  
 Eugregarinida, 853\*, 909  
 Eukaryotes, 853\*  
 cell (biology), 388-389  
 cell cycle, 391  
 cell membrane, 393  
 cell nucleus, 395  
 classification, biological, 467  
 fungal genetics, 948  
 Eukaryotes:  
 peroxisome, 1636\*  
 ribosomes, 1918  
 transposons, 2264  
*Eukrohnia hamata*, 360  
 Euler, L., 744, 769  
 Euler angles, 853-854\*  
 Euler's equations of motion, 854\*,  
 1760  
 Eumagnoliids, 854\*  
 Eumalacostraca, 854\*  
 Malacostraca, 1307  
 Mysidacea, 1460-1461\*  
 Eumycetozoida, 854\*  
 Eumycota, 854-855\*, 989  
 Oomycetes, 1545\*  
 Trichomycetes, 2270\*  
 Zygomycetes, 2421\*  
*Eunectes murinus*, 272  
 Eunicea, 760  
 Euniciidae, 760  
*Euonymus*, 345  
 Eupantotheria, 704  
 Euphausiacea, 767, 855\*  
*Euphorbia pulcherrima*, 770  
 Euphorbiaceae, 337, 770  
 Euphorbiales, 855\*  
 rubber tree, 1934\*  
 tung tree, 2281-2282\*  
 Euphrosinidae, 760  
*Euplectella*, 1284  
 Euploidy, 400  
 Eurasian hominoids, 923-924  
 Eurhampheidae, 1266  
 Europa, 1207, 1701  
 Europe, 855\*  
 European aspen, 1754  
 European beech, 231  
 European birch, 259  
 European bison, 262  
 European chestnut, 383, 436  
 European deer, 567  
 European hornbeam, 965  
 European Space Agency (ESA),  
 2058  
 European sparrowhawk, 260  
 Europium, 855-856\*  
 Eurotiaceae, 771  
 Euryalina, 1674  
 Euryapsida:  
 Placodontia, 1695\*  
 Sauropterygia, 1951\*  
 Euryptera, 856\*  
 Eurytomata, 1033  
 Eustigmatophyceae, 771, 856  
 Eustrongylides, 616  
*Eutamias*, 387  
 Eutardigrada, 856\*  
 Eutectic alloy, 83  
 Eutectics, 856\*  
 Euteleostei, 2198  
 Eutely see Cell constancy  
 Euthera, 856\*, 2219  
 Notoungulata, 1504\*  
 Xenungulata, 2408\*  
 Eutrophication, 647, 856-857\*  
 Evaluation, computer-system, 527\*  
 Evaporation, 857\*, 2230  
 Evaporator, 857\*  
 Eventognathi see Cypriniformes  
 Evergreen blueberry, 271  
 Evergreen plants, 700, 857\*

Evolution:  
 developmental biology, 649  
 dinosaur, 676  
 early modern humans, 715-716\*  
 Echinodermata, 726  
 heterochrony, 1071\*  
 macroevolution, 1287-1288\*  
 Miocene, 1407  
 organic, 1570-1571\*  
 paleontology, 1602  
 phylogeny, 1675-1676\*  
 plant, 1702-1703\*  
 plant phylogeny, 1712\*  
 of proteins, 1792\*  
 speciation, 2072\*  
 star, 2098  
 stellar, 2108-2110\*  
 tomot fauna, 2247\*  
 of universe, 2307  
 vertebrate brain, 2332-2333\*  
 Evolutionary computation, 857-858\*  
 Ewes, 1619  
 EXAFs see Extended x-ray absorption fine  
 structure  
 Excavating equipment, 479, 543  
 Exception controller (microprocessor), 1389  
 Exchange interaction, 858\*  
 Excimer laser, 1229  
 Excitation, 858\*  
 Excitation potential, 858\*  
 Excited magnets, 1290  
 Excited state, 858\*  
 excitation potential, 858\*  
 metastable state, 1373\*  
 nuclear isomerism, 1510\*  
 Exciton, 859\*  
 Exclusion principle, 192, 859\*  
 electron, 776  
 exchange interaction, 858  
 Fermi-Dirac statistics, 876-877\*  
 Excopulacae see Discellaceae  
 Excorallanidae, 803  
 Excretion:  
 uric acid, 2310-2311\*  
 urinary bladder, 2311\*  
 urine, 2313\*  
 Exhaustion atrophy, 194  
*Exobasidium*, 984, 1112  
 Exocoetidae, 183, 816  
 Exon, 859\*  
 Exopterygota, 859\*  
 Exosphere, 202, 2308  
 Exotic atom, 1691  
 Exotic nuclei, 859\*, 859-860\*  
 Exotic viral diseases, 860\*  
 Expected utility theory, 627  
 Experiential therapies, 1803-1804  
 Expert control system, 860-861\*  
 Expert systems, 177, 861\*  
 automation, 225  
 decision support system, 626\*  
 expert control system, 860-861\*  
 Explosive, 861-862\*  
 nuclear explosion, 1506-1507\*  
 underwater demolition, 2298\*  
 Explosive forming, 862\*  
 Exponent, 75, 862\*, 1268-1269  
 Exponential functions, 75  
 Exposure meter, 862\*  
 Expulsion fuse, 850  
 Extended continental crust, 720  
 Extended x-ray absorption fine structure  
 (EXAFS), 862-863\*  
 External galaxy, 854  
 External photoelectric effect see  
 Photoemission  
 External respiration, 1906  
 External-shoe brake, 840  
 Extinction (biology), 863\*  
 causes, 778, 863  
 dinosaur, 676  
 macroevolution, 1286, 1287  
 Paleocene, 1597-1598  
 record, 778, 863  
 Extracellular fluids, 1477  
 Extracorporeal shock-wave lithotripsy  
 (ESWL), 2295  
 Extraction, 863\*  
 food engineering, 908  
 leaching, 1235\*  
 Extraembryonic membrane, 881-882  
 allantois, 81\*  
 amnion, 99-100\*  
 amniota, 100\*  
 chorion, 448\*  
 yolk sac, 2412\*  
 Extragalactic nebulae, 1470

Extranets, 2388  
 Extrapolation, 863\*  
 Extrapulmonary tuberculosis, 2279  
 Extrasolar planets, 1698-1699, 2306  
 Extraterrestrial intelligence, 863-864\*  
 Extratropical cyclone, 541  
 Extreme-ultraviolet (EUV) radiation, 2404  
 Extremely low frequency electromagnetic  
 fields (ELF), 1843  
 Extrinsic semiconductor, 1980  
 Extrusion, 864\*, 1723  
 Eye (invertebrate), 864-865\*  
 compound, 780  
 nocturnal vision, 781  
 structure and function, 780  
 Eye (vertebrate), 865-867\*  
 cavities, 781, 866  
 color, 502-503\*  
 color vision, 504-505\*  
 cones, 866-867  
 electrophysiology of, 866-867  
 fibrous tunic, 865-866  
 glaucoma, 1003\*  
 lacrimal gland, 1221\*  
 lens, 781, 866  
 rods, 866-867  
 sensory tunic, 866  
 vascular tunic, 866  
 vision, 2346-2347\*  
 visual impairment, 2348\*  
 wall, 781, 865-866  
 Eye disorders, 867\*  
 cataract, 380\*, 867  
 conjunctivitis, 867  
 diabetic retinopathy, 867  
 glaucoma, 867  
 retinal degeneration, 867  
 retinal detachment, 867  
 Eyeglasses and contact lenses, 677, 867\*  
 Eyepiece, 868\*

## F

Fabaceae, 783  
 Fabales, 869\*  
 Fabricius, David, 1407  
 Fabry-Perot stellar interferometer, 1172  
 Facies (geology), 869\*  
 metamorphic, 783, 869  
 Paleocene, 1597  
 Paleozoic, 1603  
 sedimentary, 783, 869  
 seismic stratigraphy, 1975  
 Facilitation hypothesis, 734  
 Facioscapulohumeral muscular dystrophy,  
 1451  
 Facsimile, 869-870\*  
 FM transmission, 838  
 frequency-modulation radio, 936  
 Factor analysis, 870\*  
 see also Pattern recognition  
 Fagaceae, 231, 784  
 Fagales, 870\*  
 beech, 262\*  
 birch, 297\*  
 chestnut, 436  
 Hamamelidae, 1044  
 hickory, 1075-1076\*  
 hophornbeam, 1088\*  
 hornbeam, 1089\*  
 oak, 1527\*  
*Fagopyrum species*, 299, 1744  
*Fagus species*, 231, 784  
 Fahrenheit, 2208  
*Falco peregrinus*, 260  
*Falco rusticolus*, 260  
 Falcon, 260, 784  
 Falconidae, 260, 784  
 Falconiformes, 870\*  
 Fallopian tube, 870-871\*  
 disorders, 1899  
 pregnancy disorders, 1768  
 reproductive system disorders, 1899  
 False gavia, 515  
 Familial hypercholesterolemia, 1362  
 Family therapies, 1804  
 Fan, 642, 871\*  
 Fan-shaped nebula, 1470  
 Fancies (diamonds), 655  
 Fanconi's syndrome, 1361  
 Farad, definition of, 687, 761  
 Faraday, M., 761, 785  
 Faraday effect, 871\*, 1666  
 Faraday's law of induction, 871\*  
 Farm crops, 871\*, 883  
 Farming see Agriculture  
 Farsightedness see Hyperopia  
*Fasciola hepatica*, 785  
*Fasciolopsis buski*, 785  
 Fat and oil, 871-872\*  
 animal growth, 121  
 ester, 848\*  
 lipid, 1260\*  
 triglyceride, 2271\*  
 Fat and oil (food), 872\*  
 corn oil, 497  
 food, 907  
 margarine, 1317\*  
 olive oil, 1540  
 soybean oil, 2057  
 Fatal familial insomnia, 1775  
 Fate maps (embryology), 872-873\*  
 Fathometer see Echo sounder  
 Fatigue, metal, 1364  
 Fatty metamorphosis, 1265  
 Fault analysis, 873\*  
 Fault and fault structures, 873\*  
 earthquake, 722-723\*  
 escarpment, 847\*  
 graben, 1014\*  
 horst, 1090\*  
 rift valley, 1921\*  
 rock cleavage, 1927\*  
 transform fault, 2257-2258\*  
 Fault detection (electric), 750  
 Fault-tolerant systems, 873-874\*  
 Fauna, deep-sea, 629-630\*  
 Feather, 233, 874\*  
 Feather mosses, 1119  
 Featherback, 1586  
 Fechner, G., 1802, 1803  
 Federal Aviation Administration (FAA), 1141  
 Federal Emergency Management Agency  
 (FEMA), 2196  
 Federal Highway Administration (FHWA),  
 1141  
 Federal Telecommunications System, 874\*  
 Feed crops, 871  
 Feedback circuit, 874\*  
 regeneration (engineering), 1884\*  
 remote-control system, 1893  
 Feedback control system, 484  
 advantages, 484-485  
 applications, 484  
 costs, 485  
 functional analysis and modeling, 945  
 servomechanism, 1989-1990\*  
 see also Closed-loop control system  
 Feedback network, 2355-2356  
 Feeding disorder, 724  
 Feldspar, 875\*  
 albite, 67-68\*  
 andesine, 114\*  
 anorthite, 128\*  
 anorthoclase, 128\*  
 arkose, 169-170\*\*  
 bytownite, 346\*  
 halloysite, 1042  
 labradorite, 1221\*  
 microcline, 1383\*  
 oligoclase, 1539\*  
 orthoclase, 1580\*  
 perthite, 1638\*  
 sand, 1943  
 Feldspathic sandstone see Arkose  
 Feldspathoid, 875\*  
 nepheline, 1475\*  
 socialite, 2029\*  
 Felidae, 338  
 Feline distemper, 789  
 Feline infectious peritonitis, 875\*  
 Feline leukemia, 875-876\*  
 Feline panleukopenia, 876\*  
 Feloidae, 333  
 Felon DNA databanks, 915  
 Felsic, 1125  
 Femoral hernias, 1069  
 Fennel, 876\*  
 Fermat's principle (optics), 2326  
 Fermentation, 327, 876\*  
 alcohol, 68, 765  
 antibiotic, 137  
 food, 819  
 food preservation, 910\*  
 malt beverage, 1308\*  
 vinegar, 2340  
 wine, 2390\*  
 Fermi, E., 789  
 quantum field theory, 1827

- Fermi, E.—cont.  
radioactivity, 1857
- Fermi-Dirac statistics, 876-877\*  
electron, 776  
Fermi surface, 877\*  
Fermi surface, 877\*, 1077
- Fermion, 776  
elementary particle, 802, 804  
hadron, 1037  
supersymmetry, 2165, 2165\*
- Fermium, 877\*
- Fern:  
Coenopteridales, 490-491\*  
Marattiales, 1316\*  
Marsileales, 1328\*  
Ophioglossales, 1548\*  
plant, 1701  
plant phylogeny, 1712  
Polypodiales, 1750-1751\*  
Polypodiophyta, 1751\*  
Polypodiopsida, 1751\*
- Fern-leaved beech, 231
- Ferranti, S. Z. de, 761
- Fernet, 877\*
- Ferric oxide, 1878
- Ferric oxyhydroxide, 1191
- Ferricyanide, 877-878\*
- Ferrimagnetic garnets, 878\*
- Ferrimagnetism, 878\*  
Curie temperature, 599\*  
ferrite, 878  
ferrite devices, 878\*  
ferromagnetism, 879  
magnetic materials, 1292-1293\*  
Ferrite, 878\*  
Ferrite devices, 878\*  
Ferrous alloy, 878\*  
Ferrocene, 1369  
Ferrocyanide, 878-879\*  
Ferroelectric domain, 635, 792  
Ferroelectrics, 879\*  
magnetic, 1291\*  
photoferroelectric imaging, 1665\*  
Ferrohombic, 1089  
Ferromagnetic domain, 634  
Ferromagnetism, 879-880\*  
Barkhausen effect, 251\*  
Curie temperature, 599\*  
domains, 695  
magnetic materials, 1291-1293\*,  
1292-1293\*  
magnetic relaxation, 1295  
magnetic susceptibility, 1295\*  
magnetization, 1300  
magnetocaloric effect, 1301\*  
magnetostriction, 1303\*  
magnon, 1305-1306\*  
rock magnetism, 1927  
susceptibility, 1295\*  
symmetry breaking, 2178-2179
- Ferromagnetic power supplies, 791
- Ferrosilite, 197
- Ferry, 880\*
- Fertilization (invertebrate), 1181
- Fertilization (vertebrate):  
mammals, 1898  
ontogeny, 1543
- Fertilizer, 880-881\*  
application of, 45  
prilling, 1770  
soda niter, 2029\*
- Fertilizing, 881\*
- Fescue, 881\*
- Festuca, 794
- FET see Field-effect transistor
- Fetal alcohol syndrome, 881\*
- Fetal membrane, 448, 881-882\*
- Fever, 882\*
- Feynman, Richard P., 795
- Feynman diagram, 882\*
- Feynman integral, 705, 882-883\*
- Fiber:  
manufactured, 1313-1314\*  
natural, 1465\*  
optical, 1552, 1553-1554\*  
polyacrylonitrile resins, 1741  
polymers, 1746
- Fiber bundle, 883\*
- Fiber crops, 883\*
- Fiber-optic circuit, 883\*
- Fiber-optic gyros (FOGs), 1036
- Fiber-optic sensor, 884\*, 2257
- Fiber-optics imaging, 884\*
- Fiberboard, 456
- Fibrinogen, 269, 884\*
- Fibrinolysin see Plasmin
- Fibroblasts, 1477
- Fibrocarrilage, 336, 375
- Fibromyalgia syndrome, 884\*
- Fibrositis, 159-160, 174
- Fibrous protein, 499-500, 884-885\*
- Ficus, 798
- Fidelity, 885\*, 953
- Field artillery, 156, 170
- Field-effect transistors (FETs), 2260-261  
gate circuit, 972  
microwave solid-state devices, 1396, 1397
- Field emission, 784
- Field-emission microscopy, 730, 885-886\*  
atom probe field-ion microscope, 798  
field-ion microscope, 797
- Field pea, 1621
- Field theory, classical, 412, 467\*, 2157-2158
- Field theory (mathematics), 886\*
- Field winding, 2390
- Fig, 886\*
- Fighters (aircraft), 1401
- Filament, 1135
- Filbert, 887\*
- File transfer protocol (FTP), 1176
- FileSize metric, 2031-2032
- Filicales see Polypodiales
- Filicineae see Polypodiopsida
- Filled-system thermometer, 2229
- Fillet weld, 2372
- Film badge dosimeter, 699
- Film belt, 235
- Film (chemistry), 877\*  
monomolecular, 1434\*  
polyolefin resins, 1749  
vapor deposition, 2323-2324\*  
see also Photographic materials
- Film condensation, 531, 532
- Film recording, 1560
- Film-type resistor, 1903
- Filosia, 14-15, 877\*, 1914
- Filoviruses, 725
- Filter:  
air, 51  
color, 445  
electric, 672-673, 743-744\*  
microwave, 1392
- Filter choke, 393
- Filtering centrifuge, 352
- Filtration, 877\*, 908
- Filtration sterilization, 2115, 2294
- Fine structure (spectral lines), 877\*
- Fingerprint, 837, 877-888\*
- Finite Boolean algebra, 278
- Finite element method, 888\*
- Finite mathematics, 888-889\*
- Finite series, 1988
- Finite-state machines, 224
- Fins, paired, 2016-2017
- Fiord, 427, 889\*
- Fir, 889\*  
evergreen, 857  
Pinales, 1688
- Fir tree, 2266
- Fire, 889\*  
automatic sprinkler system, 225\*  
forest, 826-827  
see also Combustion
- Fire detector, 889\*
- Fire extinguisher, 889\*
- Fire technology, 889-890\*
- Fire-tube boiler, 890\*
- Firebrick, 291
- Fireclay, 413
- Firewall, 525
- Fireworks see Pyrotechnics
- Fischer, F., 802
- Fischer, G. E., 209-210
- Fischer-Tropsch process, 890\*  
coal liquefaction, 483  
hydroformylation, 1104\*
- Fish:  
Acanthodii, 7\*  
acid rain, 13  
Actinopterygii, 21\*  
adaptation, 23-24  
Anaminia, 112  
Anguilliformes, 117\*, 666  
Chondrichthyes, 14, 446\*  
Coelacanthiformes, 488-489\*  
Devonian, 652  
digestive system, 666  
ear, 713, 714  
intestine, 1178  
lateral line system, 1232  
metamorphosis, 1372  
olfaction, 1538  
Osteichthyes, 1585-1586\*  
Pisces (zoology), 1692\*
- Fish—cont.  
Placodermi, 1695\*  
regeneration, 1884  
respiratory system, 1907  
skeletal system, 2016-2017
- Fish hawk, 260, 784
- Fish lice see Branchiura
- Fish tapeworm, 542
- Fisher, 890\*
- Fisher, W., 728
- Fisheries, 1321
- Fisheries ecology, 890-891\*
- Fissidentales, 891\*
- Fission see Nuclear fission
- Fission bomb, 189, 208-210\*
- Fission-fusion bomb, 189
- Fission track dating, 891\*, 1926-1927
- Fissurellidae, 144
- Fit:  
location, 1267\*  
running, 1935\*  
shrink, 2003\*  
tolerance, 2246\*
- FitzGerald, G. F., 803
- FitzGerald-Lorentz contraction, 891\*
- Fixed bridge, 292, 333
- Fizeau interferometer, 1172
- Flabellifera, 891\*
- Flagella see Cilia and flagella
- Flagellata see Mastigophora
- Flame, 891-892\*  
combustion, 507  
fire, 889\*
- Flameproofing, 892\*
- Flamingo, 1656
- Flares, solar, 2150-2151
- Flash welding, 892\*, 1902
- Flat belt, 235
- Flat-panel display device, 892\*
- Flat-panel displays (FPDs), 786, 787
- Flatfish, 1728
- Flatworm see Platyhelminthes
- Flavonoid, 892-893\*
- Flavor, 893\*, 909  
see also Spice and flavoring
- Flavor symmetry, 2302
- Flax, 893\*
- Flea:  
plague, 1695  
Siphonaptera, 2013-2014\*
- Flea allergy dermatitis, 578
- Fleming, A., 1624  
electron tube, 784  
lysozyme, 1283
- Fleshy fruit, 842
- Flexibilia, 893\*
- Flexible manufacturing system, 893-894\*
- Flexible pavement, 1620-1621
- Flexographic printing, 1154
- Flexor reflex, 1477
- Flight, 894-895\*  
hypersonic, 988-989  
space, 2058-2060\*  
subsonic, 2141-2142\*  
supersonic, 2163-2164\*  
transonic, 2262
- Flight controls, 807, 895-896\*  
stability augmentation, 2094\*  
stabilizer, 2095\*  
wing, 2391
- Flight conveyer, 302
- Flight dynamics, 896\*
- Flight management computer system (FMCS), 57
- Flight planning, 55-56
- Flight science, 896\*
- Flight simulation, 63
- Flint corn, 496
- Floating caisson, 310
- Floating dry dock, 641
- Flood basalts, 2352
- Floodplain, 896\*  
coastal landforms, 484  
fluvial erosion landforms, 905  
fluvial sediments, 905  
river, 1924
- Floor construction, 896\*
- Floppy disk, 463, 554
- Flora, 1704
- Florey, H. W., 1624
- Floriculture, 896\*
- Florida arrowroot, 157
- Florideophycidae, 1915\*
- Flosculariacea, 1434
- Flotation, 896\*, 2416
- Flounder, 805, 1728
- Flour corn, 496
- Flourescent lamp, 903\*
- Flow-induced vibration, 896-897\*
- Flow measurement, 897\*  
metering orifice, 1380\*  
stream gaging, 2125\*  
Torricelli's theorem, 2251\*
- Flow of solids, 897-898\*
- Flower, 898-899\*  
anatomy, 810  
bud, 339\*  
Eudicotyledons, 852\*  
flora diversity, 808-809  
floriculture, 898-899\*  
flowering, 1705\*  
fruit, 939\*  
inflorescence, 1148\*  
legume, 1240  
orchid, 1566\*  
Oxalidales, 1589\*  
pollen, 1738-1739\*  
pollination, 1739-1740\*  
reproduction, 1896  
vernalization, 2331\*
- Fluid coupling, 899-900\*
- Fluid dynamics:  
computational, 457-458  
geophysical, 994\*  
hydrodynamics, 1103\*  
jet propulsion, 1203\*  
Kelvin's circulation theorem, 1210\*  
magneto-hydrodynamics, 1301-1302\*  
Fluid electrical insulation, 683
- Fluid-film hydrodynamic bearing, 139-141
- Fluid-film hydrostatic bearing, 139-141
- Fluid flow, 900\*  
boundary-layer flow, 322-323\*  
choked flow, 445\*  
compressible flow, 517-518\*  
computational fluid dynamics, 519\*  
creeping flow, 577\*  
d'Alembert's paradox, 613\*  
diffuser, 665  
dynamic similarity, 711\*  
flow-induced vibration, 896-897\*  
flow measurement, 897\*  
hydraulic jump, 1101\*  
incompressible flow, 1136\*  
isentropic flow, 1192\*  
jet flow, 1202-1203\*  
Kelvin's circulation theorem, 1210\*  
Kelvin's minimum-energy theorem, 1211\*  
laminar flow, 1223-1224\*  
Laplace's irrotational motion, 1227-1228  
Navier-Stokes equations, 1469\*  
non-newtonian fluids, 1499-1500\*  
nozzle, 1505\*  
nuclear reactor, 1515  
petroleum reservoir engineering, 1645  
pipe flow, 1691\*  
potential flow, 1760\*  
shadowgraph, 1995-1996\*  
streaming potential, 2125-2126\*  
turbulent flow, 2287\*  
two-phase flow, 2289-2290\*  
valve, 2320-2321\*  
viscosity, 2345-2346\*  
vortex, 2358\*  
vorticity, 2358-2359  
wake flow, 2361\*
- Fluid mechanics, 900\*  
Archimedes' principle, 164\*  
environmental, 830\*  
gas dynamics, 966-967\*  
hydraulics, 973-974, 1102\*  
hydrodynamics, 1103\*  
Kelvin's minimum-energy theorem, 1211\*  
Knudsen number, 1217\*  
Mach number, 1285\*  
Reynolds number, 1911\*
- Fluid meter see Flow measurement
- Fluid mining, 1406
- Fluid statics:  
buoyancy, 343\*  
hydrostatics, 1110\*
- Fluidic-flow measurement, 1693
- Fluidic-flow sensor, 811
- Fluidic-oscillator meter, 811
- Fluidics see Hydraulics
- Fluidized-bed combustion, 901\*
- Fluids, 901-902\*  
double diffusion, 699-700\*  
newtonian fluid, 1486\*  
non-newtonian, 1499-1500\*  
steam, 2105\*  
wave motion, 2372  
see also Fluid mechanics
- Fluorapatite, 131



- Fluorescence, 902\*  
 fluorescent lamp, 903\*  
 immunofluorescence, 1129\*  
 x-ray fluorescence analysis, 2403\*
- Fluorescence microscope, 902-903\*
- Fluorescent lamp, 903\*, 1224, 2295
- Fluoridation, water, 574
- Fluorine, 903-904\*  
 compounds, 814, 903, 904  
 fluoroolefins, 904  
 natural occurrence, 903  
 organic compounds, 904  
 properties, 813-814, 903  
 uses, 814, 903-904
- Fluorite, 904\*
- Fluorocarbon, 390, 904\*, 1043
- Fluorochrome, 1129
- Fluoroolefins, 904
- Fluoroscopy, 1346
- Fluosilicic acid, 815
- Flutter (aeronautics), 904-905\*
- Flutter echo, 728
- Fluvial erosion landforms, 905\*
- Fluvial sediments, 905\*
- Flux, 2183, 2184
- Fluxgate magnetometer, 1302
- Fluxional compounds, 905-906\*
- Fluxmeter, 1291
- Fly, 906\*  
 Diptera, 679\*  
 myiasis, 1460\*
- Flying gecko, 868
- Flying lemur, 642
- Flying reptile, 149
- Flyingfish, 182-183
- Flysch facies, 783
- Flywheel, 906\*
- FM *see* Frequency modulation
- FM radio, 936
- FM VHF band radio broadcasting, 1848
- Foam, 906\*
- Foam processes, 1723
- Focal length, 906\*, 992
- Focal motor epilepsy, 753
- Fock, V., 214, 866
- Foehn wind, 387
- Foeniculum vulgare*, 789
- Fog, 906-907\*
- Fold and fold systems, 907\*  
 anticline, 138\*  
 syncline, 2184\*
- Foliage fungicide, 849
- Folic acid, 907\*  
*para*-aminobenzoic acid, 98\*  
 anemia, 115, 116
- Follicle-stimulating hormone, 27, 1145
- Folliculina, 951
- Food, 907-908\*  
 carbohydrate, 366\*  
 dyeing, 708\*  
 fat and oil (food), 872\*  
 malnutrition, 1308\*  
 protein metabolism, 1791-1792\*  
 seed, 1973  
 spice and flavoring, 2084\*  
 starch, 2100
- Food additives, 817-818  
 food manufacturing, 908-909\*
- Food and Drug Administration, 909
- Food chain:  
 biomass pyramid, 253  
 ecological energetics, 733
- Food engineering, 908\*
- Food fermentation, 908\*  
 fungal biotechnology, 947\*  
 industrial microbiology, 1141
- Food manufacturing, 908-909\*, 1619
- Food microbiology, 818, 909\*
- Food packaging:  
 degradable, 820  
 indirect additives, 820  
 labeling, 820  
 materials, 820  
 nutrition labeling, 820  
 Universal Product Code, 820
- Food poisoning, 909-910\*  
 botulism, 322\*  
*Staphylococcus*, 2096
- Food preservation, 910\*  
 additives, 817  
 food engineering, 908  
 food manufacturing, 908-909
- Food science, 910\*
- Food web, 911\*  
 ecosystem, 736  
 marine ecology, 1320  
 parasitology, 1610  
 seawater fertility, 1968  
 terrestrial ecosystem, 2212  
 trophic ecology, 2276
- Fool's gold, 1813
- Foot-and-mouth disease, 911\*
- Foot disorders, 911-912\*
- Footings (foundations), 832
- Forage crops, 912\*
- Forages, legume, 1240\*
- Foraging behavior, 2218
- Foraminiferida, 911-913\*  
 Nummulites, 1524\*  
 Pliocene, 1728
- Forastero, 488
- Force, 913\*  
 central, 401\*  
 centrifugal, 351-352  
 centripetal, 353  
 couple, 573\*  
 dynamometer, 711-712\*  
 equilibrium of forces, 842\*  
 impact, 1133\*  
 impulse (mechanics), 1134\*  
 loads, dynamic, 1266\*  
 loads, transverse, 1266\*  
 mechanical impedance, 1343\*  
 mechanics, 1344\*  
 Newton's laws of motion, 1486\*  
 pressure, 1769\*  
 resultant of forces, 1908\*  
 statics, 2101\*  
 torque, 2251\*  
 transducer, 2256  
 units of measurement, 2303  
 work, 2397\*
- Force fit, 913\*, 1769\*
- Forced oscillation, 913-914\*
- Forcipulata, 173, 914\*
- Fordia*, 263
- Forearms, 720
- Forebrain, 2333
- Foredunes, 706
- Foregut, 666
- Forensic anthropology, 914\*
- Forensic anthropometry, 136
- Forensic biology, 914-915\*  
 DNA testing, 914-915  
 felon DNA databanks, 915  
 laboratory analysis, 914  
 transfer/collection, 914
- Forensic chemistry, 915\*
- Forensic medicine, 915\*
- Forensic toxicology, 824, 915\*
- Forest and forestry, 915-916\*  
 acid rain, 12-13  
 characteristics, 916  
 dendrology, 635\*  
 ecological processes, 916  
 forest management, 916  
 forest types, 916  
 hydrologic cycle, 916  
 law/policies, 916  
 rainforest, 1866-1867\*  
 reforestation, 1881\*  
 silviculture, 2011-2012\*  
 taiga, 2190\*  
 tree diseases, 2266-2267  
 urban forestry, 828  
 utilization of resources, 916
- Forest buffalo, 301
- Forest ecosystem, 916-918\*  
 concept of, 916-917  
 invertebrates, 917  
 microorganisms, 917-918  
 streams, 917  
 vertebrates, 917
- Forest fire, 918\*, 2012
- Forest genetics, 918-919\*  
 conservation, 919  
 genetic variation, 918-919  
 geographic variation, 918  
 natural forests, 918  
 tree breeding, 919  
 variation, 918-919
- Forest harvest and engineering, 919\*
- Forest management, 825, 919-920\*  
 forest and forestry, 916  
 forest measurement, 920\*  
 forest pest control, 919-920\*  
 forest recreation, 921\*  
 silviculture, 2011-2012\*  
 Forest measurement, 920\*
- Forest pest control, 920-921\*
- Forest recreation, 921\*
- Forestry, urban, 921\*
- Forficula auricularia*, 642
- Forging, 921\*
- Form perception, 1628
- Formaldehyde, 922\*  
 aldehyde, 70  
 urea-formaldehyde-type resins, 2310\*
- Formality scale, 466
- Formation, 922\*
- Formica, 129
- Formicidae, 129
- Formicinae, 129
- Forssman antigen, 950
- Fortran (programming language), 1782, 1783
- Fortunella*, 1219
- Fossil, 922-923\*  
 algae, 74  
 amber, 94\*  
 amino acid dating, 97  
 amphibian, 102  
 animal evolution, 119-120  
 annelids, 126  
 anthropometry, 135-136  
 coal balls, 482\*  
 Coelacanthiformes, 488, 489  
 Decapoda, 560  
 Devonian, 651  
 Edentata, 737\*  
 Ediacaran biota, 737-738\*  
 extinction, 863  
 fossilization, 922-923  
 Gastropoda, 972  
 Girvanella, 1000\*  
 index fossil, 1136\*  
 living, 1266\*, 1599  
 macroevolution, 1287  
 micropaleontology, 1387-1388, 1387-1388\*  
 Nautiloidea, 1466\*  
 paleobotany, 1596-1597\*  
 paleoclimatology, 1598  
 paleontology, 1601-1602\*  
 paleosol, 1602-1603\*  
 Paleozoic, 1603  
 palynology, 1604  
 Permian, 1635  
 petrification, 1639\*  
 Porifera, 1756  
 preservation, 923  
 Reptilia, 1900  
 sedimentology, 1973  
 shells, 923  
 skeletons, 923  
 taphonomy, 2192\*  
 Tommot fauna, 2247\*  
 trace, 923, 2254\*  
 Trilobita, 2273
- Fossil apes, 923-924\*
- Fossil fuel, 924\*  
 air pollution, 52  
 coal, 481-482\*  
 petroleum, 1640-1641\*
- Fossil human, 924-926\*  
 Australopithecine, 219-220\*  
 early *Homo*, 926  
 Early Pleistocene, 831  
*Homo erectus*, 831, 926  
 Neanderthals, 1469-1470\*  
 Piltdown man, 1687-1688\*  
 Pliocene Homininae, 924, 926  
 prehuman ancestry, 829, 924  
 premodern *Homo sapiens*, 831, 926  
 spread of modern humans, 831, 926
- Fossil plant, 1473
- Fossil primates, 926-928\*, 927  
 early primates, 927  
 Eocene primates, 927  
 higher primates, 927  
 Hominoids, 928  
 modern lower primates, 927  
 New World primates, 927-928  
 Old World monkeys, 928  
 spread of modern ape ancestors, 928  
*Tarsius*, 927
- Fossil record, 1701-1702
- Fossil seeds and fruits, 928-929\*  
 Ceratophyllales, 406-407\*  
 paleobotany, 1596-1597
- Foucault, J. B. L., 831
- Foucault current *see* Eddy current
- Foucault pendulum, 721, 929\*
- Foundations, 929\*  
 bridges, 293  
 caisson foundations, 309-310  
 pile foundation, 1686-1687\*  
 retaining wall, 1909\*
- Four-bar linkage, 929-930\*, 1259-1260, 2121  
 connecting rod, 538\*  
 pantograph, 1605-1606\*
- Four-o'clock (flower), 336
- Fourier, J., 18  
 Fourier series and transforms, 930  
 greenhouse effect, 1025
- Fourier analysis, 648
- Fourier series and transforms, 832-833, 930-931\*
- Fourier transform spectroscopy, 179, 194, 1153
- Fournierechinus*, 657
- Foveal vision, 2347
- Fowler, W. A., 967
- Fox, 23, 634, 694
- Foxglove, 612, 1701
- Fractals, 931\*
- Fractional distillation, 629
- Fragmentation (reproduction), 1895
- Frame of reference, 931\*  
 galilean transformations, 931\*  
 relative motion, 1886\*
- Franciscella*, 931\*
- Francium, 931\*
- Franck, J., 834
- Franck-Condon principle, 931-932\*, 1572\*
- Francoaceae, 996
- Fränkel, A., 1270
- Franklinite, 932\*
- Fraser fir, 801
- Fraunhofer diffraction, 601-602
- Fraunhofer lines, 932\*
- Fraxinus americana*, 698  
*Fraxinus* species, 167, 1223
- Free-electron lasers, 1230
- Free-electron theory of metals, 932\*
- Free energy, 932-933\*, 2398
- Free fall, 933\*
- Free-field room *see* Anechoic chamber
- Free neutrons, 1483
- Free oscillations, 720-721
- Free radical, 933\*, 1872  
 antioxidant, 144\*  
 electron paramagnetic resonance spectroscopy, 782  
 flame, 891-892  
 stabilizer, 2095
- Freeze-drying *see* Lyophilization
- Freezing point, 139
- Frégoli syndrome, 1042
- Frenatae, 1245
- Frenkel defect pairs, 1371
- Frenkel exciton model, 773, 859
- Frequency (wave motion) 933\*  
 Frequency counter, 933-934\*  
 Frequency distortion, 629, 690  
 Frequency divider, 934\*  
 Frequency-division multiple access (FDMA), 681, 1447  
 Frequency-division multiplexing (FDM), 1447
- Frequency locking, 1583
- Frequency measurement, 934-935\*  
 frequency counter, 933-934\*  
 Lissajous figures, 1263-1264\*  
 units of measurement, 2303
- Frequency modulation, 117, 935\*  
 demodulator, 634\*  
 modulation, 1414-1415\*  
 phase modulation, 1652  
 phase modulator, 1652-1653\*  
 radio broadcasting, 1847-1848  
 radio receiver, 1851  
 tuning, 2282\*
- Frequency-modulation detector, 935\*, 1652
- Frequency-modulation (FM) radio transmitter, 1853
- Frequency-modulation radio, 935-936\*  
 broadcasting, 838  
 facsimile, 838, 936  
 FM broadcasting, 936  
 mobile transmission, 838  
 radio relaying, 838, 936  
 stereophonic radio transmission, 2114\*, 2114-2115\*  
 telegraphy, 838, 936  
 telemetry, 838, 936

## 2600 Frequency modulator

Frequency modulator, 936\*, 1415  
 Frequency multiplier, 937\*  
 Fresh water:  
   water conservation, 2364  
   water desalination, 2365  
 Fresh-water ecosystem, 937-938\*  
   biota, 937-938  
   chemical environment, 937  
   interactions, 938  
   limnology, 1256\*  
   physical environment, 937  
 Fresnel diffraction, 602  
 Fretting corrosion, 499  
 Freud, Sigmund, 707, 730, 1481  
   developmental psychology, 650  
   neurotic disorders, 1481  
   psychoanalysis, 1799  
   psychotherapy, 1803  
 Friction, 938\*  
   electrification, 718  
   lubricant, 1276\*  
   lubrication, 1277  
   tribology, 2270  
   viscosity, 2345-2346\*  
   wear, 2377\*  
 Friction brake, 287  
 Friction clutch, 423  
 Friedel-Crafts reaction, 938\*  
 Friedmann, A., 242  
 Frigates (naval ships), 1468  
 Fringe (optics), 938\*  
 Fringing reef, 1879  
 Fritillaria, 1254  
 Frog, 146  
 Frogopper, 962  
 Frogmouth, 326  
 Fromia, 174  
 Front, 205, 938\*  
 Frost, 939\*  
 Frostbite, 1121  
 Froude number, 939\*  
 Fructose, 939\*  
 Fruit, 939\*  
   anatomy, 842  
   blackberry, 302\*  
   blueberry, 308\*  
   cranberry, 576\*  
   cubeb, 597\*  
   currant, 599\*  
   date, 619-620\*  
   fig, 886\*  
   fossil seeds and fruits, 928-929\*  
   gooseberry, 1013\*  
   grape, 1016\*  
   guava, 1031\*  
   kiwifruit, 1217\*  
   kumquat, 1219\*  
   lychee, 1280\*  
   morphology, 842  
   muskmelon, 1456\*  
   pineapple, 1690\*  
   plum, 1729\*  
   pumpkin, 1811\*  
   raspberry, 1870-1871\*  
   seed, 1973-1974\*  
   tomato, 2246-2247\*  
 Fruit, tree, 940\*  
   apple, 153\*  
   apricot, 153-154\*  
   avocado, 235\*  
   banana, 248\*  
   cherry, 436\*  
   citron, 465-466\*  
   crabapple, 575\*  
   grapefruit, 1016-1017\*  
   lemon, 1241\*  
   lime, 1255\*  
   macadamia nut, 1285\*  
   mandarin, 1310\*  
   mango, 1312\*  
   nectarine, 1470\*  
   olive, 1540\*  
   orange, 1565\*  
   peach, 1621\*  
   pear, 1622\*  
   persimmon, 1637\*  
   plum, 1729\*  
   pomegranate, 1753\*  
   quince, 1836\*  
   tangerine, 2191\*  
 Fu kua (balsam pear), 1579  
 Fucaeeae, 843  
 Fucales, 940\*  
 L-Fucose, 940\*  
 Fucus, 843  
 Fuel:  
   aircraft, 60

Fuel:—cont.  
   chemical, 372-373  
   diesel, 598, 660\*  
   distillate, 628  
   energy sources, 821\*  
   energy storage, 821-822  
   fossil see Fossil fuel  
   fuel cell, 941  
   fuel gas, 941\*  
   fuel oil, 942\*  
   gasoline, 969-970\*  
   jet, 1203\*  
   kerosine, 1212\*  
   metal-base, 1364\*  
   natural gas, 1466\*  
   nuclear, 1508-1509\*  
   nuclear fuels reprocessing, 1509\*  
   nuclear reactor, 1515  
   octane number, 1532\*  
   propellant, 1785\*  
   specific fuel consumption, 2073\*  
 Fuel cell, 940-941\*  
   space shuttle, 2064  
   space technology, 2067  
 Fuel gas, 941\*  
   liquefied natural gas, 1261  
   liquefied petroleum gas, 1261  
 Fuel injection, 941-942\*  
 Fuel oil, 942\*, 1645  
 Fuel pump, 942, 942\*  
 Fuel system, 942-943\*, 2324  
 Fugacity, 943\*  
 Fulgoroidea, 962  
 Full-wave rectifier, 1876  
 Fuller, R. Buckminster, 878  
 Fullerene, 943\*, 1464  
 Fuller's earth, 944\*  
 Fulminate, 944\*  
 Fulminic acid, 944\*  
 Fumaroles, 2352  
 Fumigant, 944\*, 1158  
 Funariales, 944\*  
 Function generator, 944\*  
 Functional analysis and modeling  
   (engineering), 944-945\*  
 Functional isomers, 1420  
 Fundamental constants, 945\*  
 Fundamental interactions, 946-947\*  
   electroweak interaction, 799-800\*  
   gauge theory, 972-973\*  
   grand unification theories, 1015\*  
   neutral currents, 1481-1482\*  
   parity, 1612  
   strong nuclear interactions, 2129-2130\*  
   supergravity, 2159-2160\*  
   superstring theory, 2164-2165\*  
   supersymmetry, 2165  
   weak nuclear interactions, 2376\*  
 Fungal biotechnology, 947\*  
 Fungal disease:  
   Deuteromycotina, 648  
   fungistat and fungicide, 950\*  
   medical mycology, 1347\*  
   skin disorders, 2018  
 Fungal ecology, 947-948\*  
 Fungal genetics, 948\*  
 Fungal infections, 948-949\*  
 Fungal meningitis, 1354\*  
 Fungal virus, 949\*  
 Fungi, 624, 949-950\*  
   Agonomycetes, 36\*, 43\*, 585  
   Ascomycota, 179-180\*  
   Basidiomycota, 256\*  
   Blastomycetes, 302\*  
   Chytridiomycetes, 455\*  
   classification, biological, 468  
   Coelomycetes, 490\*  
   Deuteromycotina, 43, 648-649\*  
   Discomycetes, 685\*  
   ergot, 783, 843  
   Eumycota, 854-855\*  
   forest ecosystem, 916-918  
   fungal ecology, 947-948\*  
   fungal genetics, 948\*  
   fungal infections, 948-949\*  
   fungistat and fungicide, 950  
   Hemiascomycetes, 1062\*  
   Hymenomycetes, 1112\*  
   Hyphochytriomycetes, 1119\*  
   Hyphomycetes, 1119\*  
   lichens, 1249  
   Mastigomycotina, 1332\*  
   medical mycology, 1347\*  
   microbiology, 1382\*  
   mushroom, 1453\*  
   mycology, 1458\*  
   Mycorrhizae, 1459\*

Fungi—cont.  
   mycotoxin, 1459-1460\*  
   Myxomycota, 1461\*  
   Oomycetes, 1545\*  
   plant pathology, 1710  
   Plectomycetes, 1727\*  
   poisonous plants, 1733-1734  
   Pyrenomycetes, 1812\*  
   rust, 1935-1936\*  
   smut, 2024\*  
   tree diseases, 2266-2267  
   Uredinales, 2310\*  
   vacuole, 2317  
   wood degradation, 2394  
   yeast, 179, 2410\*  
   Zygomycotina, 2421\*  
 Fungi Imperfecti:  
   Sphaerioidaceae, 2080-2081\*  
   yeast, 2410\*  
 Fungistat and fungicide, 950\*  
   forest pest control, 920  
   pesticide, 1639  
 Funnell flow, 897, 898  
 Furan, 950\*  
 Furipteridae, 388  
 Furnace:  
   arc, 140-141, 158  
   cyclone, 541  
   electric, 673, 743\*  
   fluidized-bed combustion, 901\*  
   fuel oil, 942\*  
   gas, 967\*  
   kiln, 1214\*  
   oil, 1537\*  
   pressurized blast furnace, 1770\*  
   resistance heating, 1901\*  
   steam-generating, 2106\*  
   stoker, 2118-2119\*  
   warm-air heating system, 2362\*  
 Furnace brazing, 289  
 Furnariidae, 1424  
 Fusarium, 1119  
 Fuse (electricity), 950-951\*, 2003  
 Fused-salt electrolysis, 688, 762  
 Fused-salt phase equilibria, 951\*  
 Fused-salt solution, 951-952\*  
 Fuselage, 952\*  
 Fusible alloys, 83  
 Fusion see Nuclear fusion  
   stellar evolution, 2109, 2110  
   supernova, 2161  
   vacuum fusion, 2318\*  
   welding, 2383  
 Fusion bomb, 189  
 Fusobacterium, 214  
 Fusulinacea, 952\*  
 Fusulinids, 1136  
 Fuzzy sets and systems, 952\*  
 Fuzzy-structure acoustics, 953\*

## G

G-factor anomaly, 784  
 Gabbro, 955\*  
 Gabor, Dennis, 959, 1084  
 Gadidae, 431  
 Gadiformes, 488, 955\*  
 Gadolinium, 955\*  
 Gadus macrocephalus, 431  
 Gadus morhua, 431  
 Gafftopsail catfish, 2010  
 Gagarin, Yuri A., 2058  
 Gage pressure (psig), 1769  
 Gages, 955\*, 1188  
 Gain, 955\*  
 Gal (unit), 1024  
 Galactic coordinate system,  
   192  
 Galactose, 955\*  
 Galactosemia, 1362  
 Galagids, 1771  
 Galápagos Islands, 1193  
 Galaxioidae, 1941  
 Galaxy:  
   celestial mechanics, 386  
   clusters, 197  
   external, 956-957\*  
   formation of, 570-571  
   gamma-ray sources, 961  
   Hubble constant, 1092, 1092\*  
   interstellar matter, 1177-1178\*

Galaxy:—cont.  
   Local Group, 1267\*  
   Milky Way Galaxy, 1402-1403\*  
   radio astronomy, 1847  
   star clouds, 2098\*  
   star clusters, 2098-2099\*  
   universe, 2306  
   Virgo Cluster, 2341\*  
   x-ray astronomy, 2401  
 Galaxy, external, 956-957\*  
   Hubble constant, 1092\*  
   Magellanic Clouds, 1288\*  
   Milky Way, 854, 1402-1403\*  
 Galeaspid, 1202  
 Galena, 957\*  
 Galilean transformations, 957\*  
 Galileo Galilei, 412  
   phase (astronomy), 1649  
   symmetry laws, 2179  
 Galileo spacecraft, 1207  
 Gall mite, 8, 2276  
 Gallbladder, 957\*  
   digestive system, 666  
   lipid metabolism, 1260\*  
 Gallbladder disorders, 857-958\*  
 Galliformes, 958\*, 1550  
 Gallionella, 300  
 Gallium, 958\*  
 Gallium arsenide, 1982  
 Gallium arsenide circuits, 1166  
 Gallstones:  
   gallbladder disorders, 957  
   pancreas disorders, 1605  
 Gallus gallus, 958  
 Galois, E., 1932  
 Galton, Francis, 262  
 Galvanic cells, 764  
 Galvanic skin response see Electrodermal response  
 Galvanizing, 958\*  
 Galvanomagnetic effects, 958\*  
   Hall effect, 1040-1041\*  
   magnetoresistance, 1303\*  
 Galvanometer, 958-959\*  
   electronic test equipment, 791  
   magnetic instruments, 1291-1292\*  
 Game birds, 259-260  
 Game theory, 959-960\*  
   classification of games, 857  
   continuous games, 858  
   decision theory, 626  
   game-playing machines, 858  
   games in extensive form, 857  
   games in normalized form, 857  
   nonzero-sum games, 857  
   simple games, 858  
 Games, video, 2339\*  
 Gamete see Ovum; Sperm cell  
 Gamete intrafallopian transfer, 1145, 1900  
 Gametogenesis, 960\*  
   meiosis, 1349-1350\*  
   oogenesis, 1544-1545\*  
   sex determination, 1992  
   spermatogenesis, 2081-2082\*  
 Gamma-amino butyric acid (GABA), 2182  
 Gamma correction, 2203  
 Gamma function, 960\*, 2072  
 Gamma irradiation, 2037  
 Gamma-ray astronomy, 960-962\*  
   extragalactic sources, 961  
   galactic sources, 961  
   gamma-ray bursts, 961-962  
   instrumentation, 961  
   satellite astronomy, 1947-1948  
   stellar sources, 961  
 Gamma-ray bursts, 961-962  
 Gamma-ray decay, 1857  
 Gamma-ray detectors, 962\*  
 Gamma rays, 962\*  
   electron-positron pair production, 782-783  
   Mössbauer effect, 1439-1440\*  
   nuclear medicine, 1511\*  
   radioactive fallout, 1854  
 Gamma sulfur see Plastic sulfur  
 Gammaridea, 103, 962-963\*  
 Gamow, G., 500  
 Gamow-Teller decay, 998  
 Gamow-Teller resonance, 998  
 Ganglion, 963\*  
 Gangrene, 963\*  
 Gangrenous ergotism, 759  
 Gantt chart, 963-964\*  
 Ganymede, 1208, 1701  
 Gar, 21, 1984  
 Garbanzo, 229  
 Garden beans, 1240  
 Garden cress, 513

- Garden peas, 1240, 1621  
Garlic, 964\*, 1543  
Garnet, 964\*, 1631  
Gas, 964\*  
Avogadro's law, 235\*  
Boyle's law, 324\*  
Charles' law, 417\*  
Dalton's law, 613-614\*  
diffusion, 665  
diving, 692  
drying of, 703, 704  
electrical conduction in, 754\*  
electron diffraction, 780  
filtration, 877\*  
fluid flow, 900  
fluids, 901-902  
gas constant, 965-966\*  
incompressible flow, 1136  
inert gases, 1143\*  
liquefaction of gases, 1261\*  
measuring water content, 1416  
moisture-content measurement, 1416  
natural gas, 1466\*  
plasma diagnostics, 1719-1720\*  
seismic exploration for, 1974-1975\*  
spray flow, 2088-2089\*  
virial equation, 2341\*  
volcanic, 2351-2352  
volcanology, 2352  
x-ray diffraction, 2402-2403  
Gas adsorption operations, 31-32\*  
absorption, 5  
stripping, 2128-2129\*  
Gas and atmosphere analysis, 964-965\*  
qualitative identification, 964-965  
quantitative analysis, 965  
Gas-blast circuit breaker, 406  
Gas capacitor, 324, 364  
Gas chromatography, 397, 449, 965\*  
Gas compressor, 456  
Gas constant, 965-966\*  
Gas discharge, 966\*  
Gas-discharge noise generator (noise tube), 759  
Gas-dynamic laser, 862\*  
Gas dynamics, 966-967\*  
pitot tube, 1693  
rarefied gas flow, 1870\*  
Gas field and gas well, 967\*  
Gas furnace, 967\*  
Gas gangrene, 419, 860, 963  
Gas lasers, 1229  
Gas maser, 1328-1329  
Gas mask see Respirator  
Gas-phase reactions, 426  
Gas separations, 1352  
Gas thermometry, 967-968\*  
Gas tube, 707, 968\*, 1875  
Gas turbine, 968-969\*  
Brayton cycle, 288  
marine engine, 1320, 1320\*  
power plant, 1763  
turbine propulsion, 2284  
turbofan, 2285-2286\*  
turbojet, 2286\*  
turbo-prop, 2286\*  
Gaseous-discharge lamp, 2324  
Gaseous fuel, 829  
Gaseous nebula:  
Crab Nebula, 575\*  
nebula, 1470\*  
Gasket, 969\*  
Gasoline, 969-970\*  
aircraft fuel, 60\*  
hydrocracking, 1103\*  
octane number, 1532\*  
petroleum processing and refining, 1644  
petroleum products, 1644, 1645  
refining processes, 1881-1882\*  
Gasteromycetes, 226  
Gasterophilus, 621  
Gasterosteidae, 2116  
Gasterosteiformes, 970\*, 2116  
Gastornis, 970  
Gastornithiformes, 865, 970\*  
Gastritis:  
gastrointestinal tract disorders, 970  
Helicobacter, 1059\*  
Gastrochaena, 281  
Gastrochaenidae, 281  
Gastroenteritis, epidemic viral, 752  
Gastrointestinal tract disorders, 970-971\*  
appendicitis, 152\*  
appendix, 971  
colon, 971  
diarrhea, 655\*
- Gastrointestinal tract disorders—cont.  
esophagus, 970-971  
inflammatory bowel disease, 1146\*  
small intestine, 971  
stomach, 971  
ulcer, 2293\*  
Gastrolith, 971\*  
Gastromyzontidae, 544  
Gastropoda, 544, 971-972\*  
animal evolution, 120  
classification and diversity, 866  
fossils, 866  
general characteristics, 865  
limpet, 1256\*  
Mesogastropoda, 1358\*  
Neogastropoda, 1473\*  
Nudibranchia, 1521\*  
Opisthobranchia, 1549-1550\*  
Pliocene, 1728  
Prosobranchia, 1787\*  
Pulmonata, 1806\*  
Sacoglossa, 1939\*  
snail, 2024-2025\*  
Gastrotricha, 972\*  
Chaetonotida, 411\*  
Macrodasyida, 1287\*  
Gastrulation, 586, 972\*  
animal morphogenesis, 122  
differentiation, 728  
invertebrate embryology, 1181-1182  
Gate circuit, 972\*, 2175-2176  
Gate valves, 2320-2321\*  
Gaucher's disease:  
metabolic disorders, 1362  
sphingolipid, 2083  
Gauge bosons, 802  
Gauge theory, 972-973\*, 1825  
fundamental interactions, 946-947  
renormalization, 1895  
Gaultheria procumbens, 759  
Gauss, C. F., 718  
Gauss, K. F., 1494  
Gauss-Markov model, 848  
Gauss' theorem, 973\*  
Gaussian year, 2410  
Gaussmeters, 1291  
Gauteriales, 864  
Gauthier, Jacques, 675  
Gavia, 867  
Gavial, 581-582, 973\*  
Gavialidae, 867  
Gavialis gangeticus, 515, 867  
Gaviidae, 867  
Gaviiformes, 974\*  
Gazelle, 164  
Gear, 241-242, 974\*  
Gear drive:  
harmonic speed changer, 1047\*  
torque converter, 2251\*  
Gear train, 226-227, 230-231\*, 867-868  
Gastrum, 864  
Gecko, 974\*  
Geiger, H., 1857  
Geiger counter:  
radioisotope (biology), 1861  
x-ray diffraction, 2402  
Geiger-Müller counter, 974\*  
Geikieite, 1127  
Gekko gekko, 868  
Gekkonidae, 868  
Gel, 974-975\*  
colloid, 501  
gelatin, 976\*  
sol-gel process, 2037-2038\*  
Gel permeation chromatography, 975-976\*  
Gel techniques, 794  
Gelastocoridae, 943  
Gelastocoroidea, 943  
Gelatin, 500, 976\*  
Gell-Mann, M., 987  
Gelsemiaceae, 984  
Gem, 976-977\*  
beryl, 268\*  
cameo, 360\*  
chrysoberyl, 455\*  
corundum, 563-564\*  
diamond, 654-655\*  
emerald, 812\*  
garnet, 860-861  
gemology, 978\*  
intaglio (gemology), 1162\*  
jet (gemology), 1202\*  
manufactured, 869-870  
natural, 869  
onyx, 1544\*  
opal, 1545\*  
precious stones, 1766\*
- Gem—cont.  
rubellite, 1935\*  
ruby, 1935\*  
sapphire, 1944-1945\*  
topaz, 2249\*  
tourmaline, 2252\*  
turquoise, 2288\*  
Geminga, 977\*  
Gemini, 977-978\*  
Gemini spacecraft:  
space flight, 2059  
space power systems, 2061  
Gemology, 978\*  
Gene, 978\*  
allele, 80\*  
blood groups, 306-307  
chromosome, 451-453\*  
crossing-over (genetics), 582\*  
exon, 859\*  
intron, 1179\*  
lethal, 1246\*  
linkage, 1259\*  
mutation, 1457\*  
oncogenes, 1541\*  
operon, 1548\*  
plasmid, 1720\*  
polymorphism (genetics), 1748  
Staphylococcus, 2096  
transposons, 2264\*  
Gene action, 978-980\*  
developmental genetics, 649-650\*  
dominance, 695\*  
homoeosis, 1086\*  
hybrid dysgenesis, 1100\*  
operon, 1548\*  
plant morphogenesis, 1708  
sex-influenced inheritance, 1993  
Gene amplification, 980\*  
Gene aviation, 980-981\*  
General theory of relativity, 1889-1890  
Generalized anxiety disorder (GAD), 147  
Generator, 981\*  
alternating-current see Alternating-current generator  
direct-current, 622-623  
electric, 674  
electric power generation, 745-746\*  
electrostatic, 717  
hydroelectric, 975, 1103-1104\*  
magneto, 1300-1301\*  
magnetohydrodynamic, 1301\*  
motor-generator set, 1441\*  
steam electric, 2105-2106\*  
thermionic, 2222\*  
thermoelectric power, 2227-2228\*  
ultrasonic, 2294  
Genetic algorithms, 981\*  
capabilities, 873  
mechanics, 873  
motivation, 873  
Genetic analysis, 915  
Genetic code, 981-982\*  
gene action, 978-980\*  
ribonucleic acid, 1917-1918\*  
ribosomes, 1918-1919\*  
Genetic engineering, 46, 982-983\*  
animals, 874-875  
applications, 983  
basic techniques, 982-983  
cloning vectors, 983  
plants, 874  
recombinant DNA, 576  
reverse transcriptase, 1910\*  
transformation (bacteria), 2258  
Genetic facies, 641  
Genetic homeostasis, 984\*  
Genetic mapping:  
human chromosomes, 968  
plant taxonomy, 1714  
Genetic reassortment, 1148  
Genetics, 984\*  
bacterial, 213, 241-242\*  
behavior, 232-233  
behavior genetics, 262-263\*  
birth defects, 536  
breeding (animal), 262-263, 330-331\*  
breeding (plant), 331-332\*  
chromosome, 451-453\*  
complementation, 454, 514  
deoxyribonucleic acid, 575-576, 638-640\*  
developmental, 587-588, 649-650\*  
forest genetics, 827, 918-919\*  
fungal genetics, 948\*  
Hardy-Weinberg formula, 1046\*  
heterosis, 1072\*  
human see Human genetics  
immunogenetics, 1129-1130\*
- Genetics—cont.  
Mendelism, 1353-1354\*  
mosaicism, 1438-1439\*  
mutation, 1457\*  
polymorphism, 1748\*  
population, 1755\*  
recombination, 1875\*  
sex determination, 1992-1993  
somatic cell, 2047-2048\*  
speciation, 2072  
transduction (bacteria), 2257  
transformation (bacteria), 2258\*  
Gentianaceae, 875, 984  
Gentianales, 173, 984\*  
Raouwolfia, 1871\*  
Strophanthus, 2130\*  
Strychnos, 2136\*  
Geobotany see Plant geography  
Geochemical prospecting, 985\*  
general principles, 876  
ore and mineral deposits, 1567  
survey design, 876-877  
Geochemistry, 985\*  
chemostratigraphy, 434\*  
cosmochemistry, 567-568\*  
Earth sciences, 722  
geochemical prospecting, 876-877  
lead isotopes, 1236\*  
organic, 1571\*  
paleoceanography, 1597  
radiosotope, 1861-1862\*  
soil chemistry, 2033-2034\*  
Geochronometry, 620, 985-986\*  
Geocorisae, 944  
Geode, 986\*, 1404  
Geodesic dome, 986\*  
Geodesy, 986-987\*  
gravity field of Earth, 719  
great circle, terrestrial, 1025\*  
military satellites, 1402  
Geodynamics, 987\*  
Geodynamo, 987-988\*  
Geoelectricity, 988\*  
lightning, 1252-1253\*  
rock, electrical properties of, 1926\*  
Geographic information systems (GIS), 920, 988-989\*  
hydrography, 1107  
vegetation and ecosystem mapping, 2328\*  
Geographical botany see Plant geography  
Geography, 989\*  
Earth sciences, 722  
ecotone, 736\*  
mathematical, 1336\*  
paleogeography, 1599\*  
physical, 1677-1678\*  
plant, 1703-1704\*  
zoogeography, 2418-2419\*  
Geologic basin, 226, 257  
Geologic creep, 1332  
Geologic thermometry, 989\*  
Geologic time scale, 989\*  
Archean, 161-162\*  
Cambrian, 359-360\*  
Carboniferous, 369-370  
Cenozoic, 400-401\*  
Cretaceous, 578-579\*  
Eocene, 834\*  
Hadean, 1037\*  
Holocene, 1083-1084\*  
Jurassic, 1208\*  
Mesozoic, 1360-1361\*  
Miocene, 1406-1407\*  
Mississippian, 1408-1409\*  
Oligocene, 1539\*  
Ordovician, 1566-1567\*  
Paleocene, 1597-1598\*  
Paleolithic, 1660  
Paleozoic, 1603\*  
Pennsylvanian, 1625-1626\*  
Permian, 1635\*  
Pleistocene, 1727\*  
Pliocene, 1728-1729\*  
Precambrian, 1764-1765\*  
Proterozoic, 1792-1793\*  
Quaternary, 1835\*  
Silurian, 2009-2010\*  
Tertiary, 2213\*  
Triassic, 2269\*  
Geological thermometry, 1728  
Geology, 989-990\*  
Earth sciences, 722  
economic, 664  
engineering, 739-740  
engineering geology, 825\*  
environmental, 830-831\*

- Geology—*cont.*  
 geochemistry, 985\*  
 glacial geology, 1000\*  
 marine, 1321-1322\*  
 Mars, 1326-1327  
 paleoceanography, 1597  
 paleoclimatology, 1598  
 paleontology, 1601-1602\*  
 petroleum geology, 1642\*  
 provenance, 1797-1798\*  
 structural, 2134-2135\*  
 Geomagnetic storms, 218-219  
 Geomagnetic variations, 990\*  
 Geomagnetism, 990-991\*  
 geodynamo, 987-988\*  
 geoelectricity, 988\*  
 paleomagnetism, 1601\*  
 Geomembrane, 995  
 Geometric phase, 991\*  
 Geometrical optics, 991-993\*  
 eyeglasses and contact lens, 867\*  
 focal length, 906\*  
 optical surfaces, 1561-1562\*  
 Geometrical units of measurement, 2302  
 Geometridae, 1244  
 Geometroidea, 1244  
 Geometry, 993\*, 1337  
 algebraic, 75-76\*  
 analytic, 110-111\*  
 area, 167\*  
 differential, 599-600  
 Euclidean, 767, 851-852\*  
 mathematics, 1337, 1338  
 noneuclidean, 1494\*  
 polygon, 1744\*  
 polyhedron, 1744\*  
 projective, 1784\*  
 riemannian, 1921\*  
 solid, 2042\*, 2043\*  
 sphere, 2083\*  
 spiral, 2086\*  
 Geomorphology, 722, 993\*  
 Geomyiidae, 898  
*Geomys bursarius*, 898  
 Geophagia, 993\*  
 Geophilomorpha, 385  
 Geophysical exploration, 993-994\*  
 borehole logging, 882  
 electrical and electromagnetic, 882  
 gravity, 882  
 magnetic, 882  
 petroleum geology, 1642  
 prospecting, 1787-1788\*  
 radioactivity, 882  
 remote sensing, 882  
 seismic, 882  
 seismic stratigraphy, 1975\*  
 seismology, 1976-1977\*  
 Geophysical fluid dynamics, 994\*  
 Geophysics, 994-995\*  
 Earth sciences, 722  
 geodynamics, 987\*  
 paleoceanography, 1597  
 George, Lake, 1226  
 Georgi, H., 900  
 Geostationary orbit (satellite), 1379  
 Geostrophic wind, 995\*, 1193  
 Geosynchronous orbit (GO), 1946  
 Geosyncline, 995\*  
 Geosynthetic, 995\*  
 Geotaxis, 2194  
 Geotechnical engineering, 995  
 Geotechnics, 739-740  
 Geotextiles, 995  
*Geothallus*, 2082  
 Geothermal power, 995-996\*  
 Geotropism, 1709  
 Geraniaceae, 883, 996  
 Geraniales, 883-884, 996\*  
 cassava, 377\*  
 mahogany, 1306\*  
 Geranium, 883  
 Gerbil, 996\*  
 Gerbillinae, 884  
 Geriatrics, 43\*  
 Germ layers, 996-997\*  
 differentiation, 728  
 histogenesis, 1082\*  
 German measles *see* Rubella  
 Germanium, 997\*  
 amorphous, 100  
 semiconductor, 1980, 1981  
 Germination, 1974  
 Gerontology, 43  
 Gerridae, 943-944  
 Gerroidea, 943
- Gerstmann-Straussier-Scheinker disease, 1775  
 Gert, 997\*  
 Gesneriaceae, 1223  
 Gestation period, 997\*  
 Geyman, R. P., 1826  
 Geyser, 997\*  
 Ghee, 305  
 Ghost image (optics), 997-998\*  
 Giaever, I., 2283  
 Giant magnetoresistance, 1303  
 Giant nuclear resonances, 998\*  
 Giant nuclear systems, 2157-2158  
 Giant panda, 1605  
 Giant planets, 1700  
 Giant star, 998\*  
 Giant water bug, 942  
*Giardia*, 618, 885  
*Giardia lamblia*, 2363  
 gastrointestinal tract disorders, 970  
 medical parasitology, 1348  
 Giardiasis, 998-999\*  
 Gibberellic acid, 698  
 Gibberellin, 999\*, 1705  
 Gibbon, 132, 148, 1772  
 Gibbs, J. Willard, 246, 1653  
 Gibbs, Willard J., 2102  
 Gibbs free energy, 23, 835  
 Gigantism, 643  
*Gigantopithecus*, 829  
 fossil apes, 924  
 fossil primates, 928  
 Giganturoidei, 359  
 Gila monster, 2092  
 Gilman, Alfred, 435  
 Ginger, 847, 999\*  
 Gingivitis, 1632-1633  
*Ginkgo*, 1701  
*Ginkgo biloba*, 887, 999, 2266  
 Ginkgoales, 999\*  
 Ginkgoopsida, 999  
 tree, 2266  
 Ginkgoopsida, 835, 999\*  
 Ginseng, 999\*  
*Giraffa camelopardalis*, 887  
 Giraffe, 164, 178, 999-1000\*  
 Giraffidae, 164, 887  
 Girder, plate, 1723-1724\*  
*Girvanella*, 1000\*  
 Gizzard shad, 948  
 Glacial epoch, 1000\*, 1727  
 Glacial geology, 1000\*  
 Glaciation, 1083-1084  
 Glacier:  
 Antarctica, 130  
 ice field, 1123\*  
 iceberg, 1124\*  
 moraine, 1437\*  
 snowfield and neve, 2026\*  
 till, 2240\*  
 Glaciology, 722, 1000-1001\*  
 Gland, 1001-1002\*  
 endocrinology, 817\*  
 lacrimal, 1221\*  
 liver, 1265\*  
 mammary, 1310\*  
 motor systems, 1441-1442\*  
 mouth, 1443  
 oral, 1565  
 pancreas, 1604\*  
 parathyroid, 1611\*  
 photophore, 1670\*  
 pineal, 1689-1690\*  
 pituitary, 1693-1694\*  
 poison, 1733\*  
 prostate, 1788\*  
 salt, 1942\*  
 scent, 1955-1956\*  
 sebaceous, 1968\*  
 sweat, 2174\*  
 thymus, 2236\*  
 thyroid, 2237\*  
 uropygial, 2314\*  
 Glanders, 1002\*  
 Glareolidae, 364  
 Glaser, Donald, 299  
 Glashow, S., 847, 900  
 Glashow-Weinberg-Salam theory, 1076  
 Glass, 1002\*  
 blowpipe, 307\*  
 glazing, 1003\*  
 lens, 1241\*  
 metallic, 1367-1368\*  
 optical materials, 1556  
 photographic materials, 1665  
 safety glass, 1939\*  
 sol-gel process, 2037-2038\*
- Glass—*cont.*  
 tektite, 2195\*  
 volcanic, 2351\*  
 Glass switch, 1002-1003\*  
 Glass transition, 1003\*  
 Glauber's salt, 738  
 Glaucoma, 867, 1003\*, 2348  
 Glaucinite, 1003\*  
 Glaucothane, 1003\*  
 Glazing, 1003\*  
*Gleditsia triacanthos*, 1268  
 Glial cells, 1476  
 Glide-path indicator, 1003-1004\*  
 Glider, 1004\*  
 Gliding flight, 895  
 Gliridae, 698-699  
*Glis glis*, 699  
 Global climate change, 687, 1004\*  
 greenhouse effect, 1004, 1025-1026\*  
 possible impact, 1004  
 Global Navigation Satellite System (GNSS), 1160  
 Global Positioning satellite:  
 piloting, 1687  
 satellite navigation systems, 1949  
 satellite (spacecraft), 1946  
 Global Positioning System (GPS), 51, 1160  
 dead reckoning, 621  
 geography, 989  
 homing, 1086  
 military satellites, 1401  
 polar navigation, 1735  
 Global virtual manufacturing, 2342  
 Global warming, 687  
 Globe (Earth), 1004-1006\*  
 Globigerinacea, 823  
 Globular protein, 1006  
 Globule, 1006\*  
 Globulin, 1006\*  
*Glomar Challenger* (research vessel), 1597  
 Glomerulus, 1213  
 GLONASS navigation system, 1401  
 Glossiphoniidae, 1916  
*Glossopteris*, 929  
*Glottidia*, 1259  
 Glottis, 2077  
 Glove box, 1859  
 Glow discharge, 1006\*  
 Glow tube, 863  
 Glucagon, 1006\*  
 Glucocorticoids, 2127, 2128  
 Glucose, 1006\*  
 cycloamylose, 604\*  
 liver, 1265  
 starch, 2100  
 Glue, 28  
 collagen, 500  
 mucilage, 1444\*  
 Glue force, 2302  
 Gluons, 1007\*  
 deep inelastic collisions, 628  
 elementary particle, 802, 803  
 fundamental interactions, 946, 947  
 quark-gluon plasma, 1831\*  
 quarks, 1832  
 relativistic heavy-ion collisions, 1886-1887  
 Glutamate, 2182  
 Glutamic acid, 1435  
 Gluten, 970  
 Glutton *see* Wolverine  
 Glyceridae, 760  
 Glyceride, 871-872  
 Glycerine *see* Glycerol  
 Glycerol, 1007\*  
 Glycine, 229  
 Glycogen, 1007\*  
 glucose, 1006\*  
 glycoprotein, 1008\*  
 hibernation, 1074  
 liver, 1265  
 Glycogenesis, 893  
 Glycogenolysis, 893  
 Glycol, 766, 1489  
 Glycolipid, 1007-1008\*, 1239, 1260  
 Glycolysis, 1221  
 Glyconeogenesis, 893  
 Glycoprotein, 98, 1008\*  
 Glycoside, 1008\*  
 flavonoid, 893  
 poisonous plants, 1733  
 Glycosphingolipids, 1007  
 Glycosyl glycerides, 1007  
 Glycosyl phosphatidylinositols, 1007  
 Glyphocypidae, 2208  
 Glyptocidarid, 1676  
 Gnat, 679  
 Gnathiidea, 1008-1009\*
- Gnathobdellae, 153  
 Gnathostomata, 120, 1009\*  
 Gnathostomes, 1695  
 Gnathostomulida, 1009\*  
 Gneiss, 705, 1009\*  
 Gnetales, 539, 1009\*  
 Gnetophytes, 1701  
 Gnetopsida, 895  
*Gnetum*, 895, 1009  
 Gnotobiotics, 1010\*  
*see also* Axenic culture  
 Goats:  
 Johne's disease, 1203  
 listeriosis, 1264  
 pasteurellosis, 1619  
 weeds, 2381  
 Goatsucker, 326  
*Gobiattherium*, 614  
 Gobiesociformes, 1010\*  
 Gödel, K., 895, 1270, 1337  
 Gödel's theorem, 1010\*  
 Goethite, 1010\*  
 Gouter, 2237  
 Gold, 1010-1011\*  
 compounds, 896  
 heavy minerals, 1058  
 occurrence, 896  
 placer mining, 1695  
 properties, 896  
 uses, 896  
 Gold alloys, 1011\*  
 Gold metallurgy, 1011\*  
 Golden-brown algae *see* Chrysophyceae  
 Golden currant, 599  
 Golden eagle, 260  
 Golden hamster, 925  
 Golden moles, 1159  
 Golden pheasant, 260  
 Goldfish, 334  
 Goldhaber, M., 938  
 Goldhaber triangle, 1011-1012\*  
 Golgi, Camillo, 1012  
 Golgi apparatus, 336, 1012\*  
 cell (biology), 389  
 secretion, 1970  
 spermatogenesis, 2081  
 Golgi stack, 1012  
 Gonad:  
 anatomy and physiology, 1897  
 sex determination, 1992  
*see also* Ovary; Testis  
 Gondwana:  
 Africa, 40-41\*  
 continental drift, 545  
 Cretaceous, 578  
 Jurassic, 1208  
 paleogeography, 1599  
 Paleozoic, 1603  
 Pennsylvanian, 1625, 1626  
 Permian, 1635\*  
 plant evolution, 1703  
 Silurian, 2009, 2010  
 supercontinent, 2157  
 Gonodactylidae, 2119  
 Gonorrhea, 1012-1013\*, 1899  
 Gonorynchiformes, 1013\*  
*Gonorynchus*, 898  
*Gonyostomum*, 391  
 Gonyopasture's syndrome, 1129  
 Goose, 129, 1762  
 Gooseberry, 1013\*  
 currant, 599  
 Saxifragales, 1952  
 Gopher, 1013\*, 1930  
 Gordioidea, 1473  
*Gordionus*, 921  
*Gordius*, 921  
 Gorgonacea, 1013\*  
 Gorgonocephalidae, 1674  
 Gorilla, 132, 149  
 fossil apes, 923  
 fossil primates, 928  
 primates, 1772  
 Gorter, C. J., 2156  
 Goshawk, 260  
*Gossamer Albatross* aircraft, 890  
*Gossamer Condor* aircraft, 890, 980-981  
*Gosslingia*, 2420  
*Gossypium*, 1309  
 Goudsmit, S., 192, 212, 699, 777  
 Gould's Belt, 961  
 Gout, 159, 174, 496, 1013\*  
 Governor, 1013-1014\*  
 GPS *see* Global Positioning System  
 Graafian follicle, 848, 1589  
 Graben, 1014\*, 1921  
 Graculavidae, 364

- Grader (construction equipment), 479, 543
- Gradient of a scalar, 1014\*
- Gradient wind, 1014\*
- Gradualism, 863
- Graecopithecus*:
- fossil apes, 924
  - fossil primates, 928
- Graft copolymer, 287
- Grafting (animal tissue) *see* Transplantation biology
- Grain alcohol *see* Ethyl alcohol
- Grain boundaries, 1014\*, 2154
- Grain crops, 1014-1015\*
- barley, 251-252\*
  - buckwheat, 339\*
  - cereal, 407\*
  - corn, 559-560\*
  - farm crops, 871
  - oats, 1527-1530\*
  - rice, 1919\*
  - sorghum, 2050-2051\*
  - wheat, 2385-2386\*
- Gram-equivalent weight, 1015\*
- Gram-molecular weight, 1015\*
- Gramineae, 217, 543, 1019
- Grand fir, 801
- Grand mal seizures, 753-754, 1978
- Grand unification theories, 1015\*
- baryon, 255
  - fundamental interactions, 947
  - supergravity, 2159-2160\*
  - superstring theory, 2164-2165\*
- Granite, 1015-1016\*
- aplite, 151\*
  - greisen, 1027\*
- Granite moss:
- Andreaeopsida*, 114\*
  - Bryophyta, 337
- Granodiorite, 1016\*
- Granulite, 869, 1016\*
- Granuloma inguinale, 1016\*
- Granuloreticulosis, 1016\*, 1914
- Athalamida, 199\*
- Foraminiferida, 911-913\*
  - Xenophyphorida, 2407-2408\*
- Grape, 1016\*, 2390
- Grape sugar *see* Glucose
- Grapefruit, 1016-1017\*
- Graph:
- algebra, 74
  - nomograph, 1493-1944\*
- Graph theory, 1017\*
- Graphic methods, 963-964, 1017\*
- Graphic recording instruments, 1017-1018\*
- Graphical user interface (GUI), 1092, 1546
- Graphics *see* Computer graphics
- Graphite, 1018\*
- fibers, 1018\*
  - polymorphism, 1748
  - synthetic, 1018\*
- Graptolithina, 1018-1019\*
- Graptoloidea, 904
- Grass, 543
- bamboo, 248\*
  - barley, 251-252\*
  - Bermuda, 267\*
  - bluegrass, 308\*
  - bluestem, 272
  - bromegrass, 335\*
  - cereal, 407\*
  - citronella, 466\*
  - dallis, 549
  - dune vegetation, 706
  - fescue, 881\*
  - millet, 1403\*
  - Poales, 1731
  - redtop, 1879\*
  - rye, 1937\*
  - sorghum, 2050-2051\*
  - sudangrass, 2143\*
  - sugarcane, 2146\*
  - timothy, 2242\*
  - Triticale, 2274\*
- Grass crops, 823, 1019\*
- Grasshopper:
- Eugregarinida, 853
  - Exopterygota, 859
  - Orthoptera, 1581
- Grassland, 1609
- Grassland ecosystem, 1019-1020\*
- Grätzel cell, 775
- Grizzly bear, 230
- Gravel, 536-537, 1020\*
- Grave's disease, 223, 2237
- Gravigrada, 665
- Gravimeter, 722, 1975
- Gravimetric analysis, 1020-1021\*
- Graving dock, 641
- Gravitational waves, 1736
- Gravitation, 1021-1022\*
- accuracy of newtonian gravitation, 905, 1021
  - celestial mechanics, 385, 386
  - gravitational constant, 905, 1021
  - gravitational lens, 1021
  - gravitational waves, 1022
  - graviton, 1024\*
  - gravity, 1021, 1024\*
  - gravity field of Earth, 718
  - mass, 1330
  - mass and weight, 905, 1021
  - Newton's law, 905, 1021
  - orbital motion, 1565-1566\*
  - quantum gravitation, 1827-1818\*, 1827-1828\*
  - relativistic theories, 906, 1021-1022
  - relativity, 1887-1891\*, 1889-1890
  - supergravity, 2159-2160\*
  - weightlessness, 2382\*
- Gravitational collapse, 1022-1023\*
- black hole, 300-301\*
  - stellar evolution, 2108-2110\*
- Gravitational constant, 905, 1021
- Gravitational interaction, 946
- Gravitational lens, 1021, 1023\*
- Gravitational radiation, 1023-1224\*
- detectors, 907
  - properties, 907
  - sources, 907
- Gravitational redshift, 1024\*, 1890
- Gravitational waves, 906, 1022
- Gravimeters, 636
- Graviton, 802, 1024\*, 1736
- Gravity, 1024\*
- center of, 401\*
  - free fall, 933\*
  - weight, 2381\*
  - weightlessness, 2382\*
- Gravity chute, 302, 488
- Gravity conveyor, 488, 552
- Gravity field (Earth), 718-719\*
- Gravity meter, 1024-1025\*
- Gravure printing, 1154, 1774
- Gray birch, 259
- Gray wolf, 634
- Graybody, 1025\*
- Grayling, 1941
- Graywacke, 1025\*
- Grazing-incidence telescope, 2406
- Great apes, 132, 148-149
- fossil apes, 923
  - primates, 1772
- Great Bear *see* Ursa Major
- Great circle, terrestrial, 1025\*
- Great gray kangaroo, 1209
- Great horned owl, 260
- Grebe, 1731
- Green algae:
- Halimeda, 1040\*
  - plant phylogeny, 1712
- see also* Chlorophyceae
- Green gram (bean), 1579
- Greenberg, O. W., 444
- Greenhouse effect, 53, 1025-1026\*
- atmospheric chemistry, 203
  - climate modification, 473
  - global climate change, 1004
- Greenhouse technology, 1026-1027\*
- Greenland Rise, 966
- Greenockite, 1027\*
- Green's function, 1027\*
- Green's theorem, 1027\*
- Greenschist facies, 869
- Gregarinia, 1027\*, 2207
- Archigregarinida, 164\*
  - Eugregarinida, 853\*
  - Neogregarinida, 1473\*
- Gregorian calendar, 316, 356
- Greisen, 1027\*
- Grenade launcher, 156
- Grenadier, 955
- Greyiaceae, 996
- Grignard reaction, 266, 1027\*
- Grimmiales, 1027\*
- Grinding, 246\*
- Grinding mill, 1027-1028\*
- roll mill, 1930\*
  - tumbling mill, 2280\*
- Grindle, 285
- Grizzly bear, 230
- Grodzins, L., 938
- Groin (engineering), 427
- Groin hernia, 1069
- Gromiida, 799, 1028\*
- Gross, D., 973
- Grossular garnet, 1090
- Ground-based infrared astronomy, 1151
- Ground-burrowing bug, 944
- Ground-effect machine *see* Air-cushion vehicle
- Ground-probing radar, 1028\*
- Ground proximity warning system, 1028\*
- Ground-roller (bird), 494
- Ground state, 1028\*
- excitation potential, 858\*
  - spin-density wave, 2085\*
- Ground water, 2366
- Ground-water hydrology, 1029\*
- aquifer, 155\*
  - artesian systems, 174\*
  - soil solution, 2034
  - spring, 2090\*
  - water table, 2368\*
- Ground-water resources, 2364
- Groundhog, 1326
- Grounding, 1029\*
- Group theory, 1029-1030\*
- Lie group, 1249\*
  - mathematical physics, 1336
  - ring theory, 1923\*
- Group therapies, 1804
- Group velocity, 1030\*
- Grouse, 259, 260
- Grout, 1030\*
- Growler, 1124
- Growth factor, 609, 610, 1030-1031\*
- Growth hormone, 1693
- Grub, 232
- Gruidae, 912
- Gruiiformes, 1031\*
- Grunerite asbestos, 179
- Gryllidae, 1581
- Guaiacum sanctum*, 1254
- Guava, 1031\*
- Guayule, 1031\*
- Guidance corridor, 203
- Guidance systems, 1031\*
- air armament, 48
  - inertial guidance system, 1143\*
- see also* Space navigation and guidance
- Guided missile, 1031\*, 1408, 1467
- Guided weapons, 48
- Guild, 1032\*
- Guinea fowl, 259, 260
- Guinea pig, 344
- Guinea worm, 165, 542
- Guldberg, C. M., 372
- Gulf Loop Current, 1032
- Gulf of California, 1032\*
- Gulf of Mexico, 1032\*
- Gulf Stream, 7, 1032-1033\*
- Intra-Americas Sea, 1179
  - Ocean, 1529
- Gull, 365
- Gulper eel, 117
- Gum, 1033\*, 1444
- Gum turpentine, 1689
- Gun metal, 295
- Gunn diodes, 1397-1398
- Gunnera*, 924, 1044
- Gunneraceae, 924
- Guns, 1467
- Gunsights, 1033\*
- Guppy, 183
- Gustatoreceptor *see* Taste bud
- Guth, A., 1146, 1147
- Guyot *see* Seamount and guyot
- Gymnarchidae, 1586
- Gymnarchus niloticus*, 673
- Gymnoasceae, 771
- Gymnoblastera, 979
- Gymnodinium breve, 615
- Gymnogyps californianus*, 260
- Gymnolaemata, 596-597, 1033\*
- Gymnophrys, 182
- Gymnosperm:
- plant evolution, 1703
  - seed, 1973
- see also* Pinophyta
- Gymnostomatida, 1034\*
- Gymnotidae, 666
- Gymnotiformes, 673
- Gymnotoidei, 544
- Gynandromorphism, 1439
- Gynomerogony, 1357
- Gyphierax angolensis*, 784
- Gypsum, 916\*, 1034\*, 1721-1722
- Gypsum plank, 916\*
- Gyrotor, 1034\*, 1392
- Gyrfalcon, 260
- Gyrinocheilidae, 544
- Gyro *see* Gyroscope
- Gyro motion, 1718
- Gyrocompass, 621, 1034-1035\*
- Gyrocoptilidea, 358, 1035\*
- Gyroductilidea, 1433
- Gyromagnetic effect, 1035\*
- Gyromagnetic ratio, 1035\*
- Gyroscope, 1035-1036\*
- automatic horizon, 225\*
  - gyrocompass, 916-917, 1034-1035\*
  - jewel bearing, 1203\*
  - polar navigation, 1734
  - slip rings, 2022\*
  - turn and bank indicator, 2288
- Gyrotor, 1036\*

## H

- Haber-Bosch synthesis, 99
- Habitats, 735
- disease ecology, 687
  - endangered species, 814735
- Hackberry, 1037\*
- Hackmatack, 1228
- Hadean, 1037\*
- Hadromerida, 1037\*
- Hadron, 720-721, 1037\*
- baryon, 253-255\*
  - deep inelastic collisions, 628
  - elementary particle, 802-804
  - meson, 1359, 1359\*
  - quark-gluon plasma, 1831
  - strong nuclear interactions, 2129-2130\*
- Haefl, A. V., 785
- Haemagogus*, 2411
- Haematopodidae, 364
- Haemophilus*, 296, 1038\*
- Haemophilus influenzae*, 1383
- Haemosporina, 768, 1038\*
- Hafele, J. C., 418
- Hafnia, 741
- Hafnium, 1038\*
- Hagen-Smit, A. J., 2024
- Hagfishes:
- jawless vertebrates, 1202
  - Myxiniiformes, 1461\*
- Hail, 1038-1039\*, 1766
- see also* Precipitation (meteorology)
- Hair, 1039\*
- Hair cells, 1232
- Hairworm, 1473
- Hairy moonrats, 1159
- Haldane, J. S., 692
- Hale, G. E., 2040
- Hale-Bopp Comet, 508
- Haemomorphi *see* Amiiiformes
- Half cells, 775
- Half-life, 615, 1039\*
- Half-wave dipole, 1394
- Half-wave rectifier, 1875-1876
- Haliateus leucocephalus*, 260
- Halibut, 805, 1728
- Halichondria panicea*, 1039
- Halichondrida, 1039-1040\*
- Halicyrtus*, 1770
- Halicitidae, 231
- Halide, 1040\*, 1172-1173
- Halimeda, 1040\*
- Haliotidae, 2
- Haliotis, 2, 144
- Halite, 1040\*
- gypsum, 1034
  - salt dome, 1942\*
- Hall, E. H., 1040-1041
- Hall coefficient, 1040, 1041
- Hall effect, 761, 1040-1041\*
- anyons, 148\*
  - magnetic instruments, 1291-1292\*
  - resistance measurement, 1902
- Hall-effect instruments, 1291
- Hall resistance, 1041
- Hall resistivity, 1040
- Halley's Comet, 508, 1041\*
- Halloysite, 1041-1042\*
- Hallucination, 1042\*
- psychosis, 1803
  - schizophrenia, 1957
- Hallucinogenic ergotism, 759, 843-844
- Halo, 1042\*, 1728, 2151
- Halobacterium*, 1044
- Halocarboxyl group, 13
- Halococcus morrhuae*, 1044

- Halocyprida, 1042\*
- Halogen elements, 1042-1043\*  
 astatine, 185\*  
 bromine, 335\*  
 chlorine, 442-443\*  
 fluorine, 903-904\*  
 interhalogen compounds, 1172-1173\*  
 iodine, 1183\*
- Halogen minerals, 1043\*
- Halogenated hydrocarbon, 1043\*  
 chlorine compounds, 390-391  
 fluorocarbon, 904\*
- Halogenation, 1040, 1043-1044\*
- Halophilic bacteria, 143, 160
- Halophilism (microbiology), 160\*, 1044\*
- Haloragaceae, 924
- Haloragales, 1044\*
- Haltbeak, 183
- Halteria*, 1540
- Ham radio *see* Amateur radio
- Hamamelidaceae, 924
- Hamamelidae, 1044\*  
 Casuarinales, 377\*  
 Daphniphyllales, 615\*  
 Didymiales, 657\*  
 Eucommiales, 852\*  
 Hamamelidales, 1044\*  
 Juglandales, 1205\*  
 Letineriales, 1240\*  
 Myricales, 1460\*  
 Trochodendrales, 2275\*
- Hamamelidales, 1044\*  
 Hamamelidae, 1044  
 sweetgum, 2174\*
- Hamamelis*, 924, 1044
- Hamburg, A., 1370
- Hamilton, W. R., 1835
- Hamilton's equations of motion, 1044-1045\*
- Hamilton's principle, 22, 1045\*, 2326
- Hammertoe, 822
- Hammett acidity function, 2152-2153
- Hamster, 1045\*
- Hanbury Brown, R., 436
- Hang gliders, 1004
- Hansen's disease *see* Leprosy
- Haplomacrobolus*, 772
- Haplopoda, 1045\*
- Haplorhines, 1771
- Haplosclerida, 1045\*
- Haplosporea, 1045-1046\*, 2088
- Haplosporida, 1046\*  
 Sarcosporida, 1945-1946\*
- Haplosporida, 1046\*
- Happ, H. H., 591
- Hapten, 339
- Haptophyceae *see* Prymnesiophyceae
- Haptotropism *see* Thigmotropism
- Harbors and ports, 1046\*
- Hard hat diving, 692
- Hard maple, 1316
- Hard water, 2367\*
- Hardboard, 456
- Hardness scales, 1046\*
- Hardness testing, 1364
- Hardwoods, 808, 2393-2394\*
- Hardy, G. H., 926
- Hardy-Weinberg formula, 969, 1046\*
- Hare, 164, 1222
- Harmonic motion, 1047\*  
 Lissajous figures, 1263-1264\*  
 mechanical impedance, 1343\*
- Harmonic oscillator, 1047\*
- Harmonic (periodic phenomena), 1046-1047\*
- Harmonic speed changer, 1047\*
- Haro, G., 947
- Haronic atom, 1037-1038\*
- Harpacticoida, 491, 1047\*
- Harrier (bird), 260
- Hartley, 263
- Hartree, D., 214
- Hartree-Fock equations, 1824
- Hartree-Fock method, 214
- Harvest fly, 962
- Harvesting, 919
- Harvestmen, 155, 1549
- Hashimoto's disease, 223
- Hashimoto's thyroiditis, 1129
- Hassium, 1047-1048\*
- Hatchette, 1048\*
- Hauling equipment, 479
- Hausdorff topological space, 1312-1313\*
- Hausmannite, 1048\*, 1312
- Hawaiian-Emperor seamount chain, 966
- Hawk, 260
- Hawking, S., 906
- Hazard identification (industrial health and safety), 1140-1141
- Hazardous waste, 1048\*  
 medical, 1348  
 nuclear fuels reprocessing, 1509\*  
 soil microbiology, 2037
- Hazelnut *see* Filbert
- Head, 1048\*
- Head lettuce, 1246
- Head louse, 126-127
- Head shaft, 1996
- Headache, 1048-1049\*
- Headgut, 666
- Headphones, electret, 669
- Health physics, 1049\*
- HEAO *see* High Energy Astronomical Observatory
- Hearing (human), 1049-1050\*  
 acoustic signal processing, 18  
 audiometry, 217\*  
 auditory nervous system, 1050  
 binaural hearing, 930  
 ear, 713, 715  
 ear protectors, 715\*  
 hearing impairment, 1051\*  
 loudness, 1273\*  
 masking of sound, 1328\*  
 pitch, 1692, 1692\*  
 response of auditory system, 930-931  
 role of ear, 1049-1050  
 sensory system regeneration, 1986  
 sound, 2051-2052\*  
 sound discrimination, 930-931  
 sound-reproducing systems, 2054  
 speech perception, 2079, 2079\*
- Hearing (vertebrate), 1050\*
- Hearing aid, 716, 1050-1051\*
- Hearing impairment, 1051\*, 2079
- Heart:  
 electrodiagnosis, 768  
 invertebrate, 1052\*  
 transplantation biology, 2263  
 vertebrate, 1052\*
- Heart attack, 1053
- Heart disease, 1768
- Heart disorders, 1052-1053\*  
 cardiomyopathies, 1053  
 congenital heart disease, 932-933, 1053  
 coronary disease, 1052-1053  
 coronary heart disease, 932  
 echocardiography, 728-729\*  
 heart failure, 1053  
 hypertensive heart disease, 1053  
 infections, 932  
 rheumatic fever, 932, 1676\*  
 sudden cardiac death, 1053  
 valvular heart disease, 1053  
*see also* Cardiomyopathies
- Heart failure, 1053
- Heartwater disease, 1053\*
- Heartwood, 2393
- Heartworms, 10553\*
- Heat, 1053\*  
 specific, 2073-2074\*  
 storage, 736  
 temperature, 2208\*  
 thermotherapy, 2231\*  
*see also* Thermal entries
- Heat balance, 1054\*
- Heat balance, terrestrial atmospheric, 1054\*
- Heat capacity, 1054-1055\*  
 chemical thermodynamics, 377-379  
 superconductivity, 2156
- Heat exchange, 2230
- Heat exchanger, 1055\*
- Heat flow (in Earth), 719\*
- Heat insulation, 1055\*
- Heat leaching, 1011
- Heat (physiology) *see* Estrus
- Heat pipe, 1055-1056\*
- Heat pump, 673, 1056\*
- Heat radiation, 1056\*  
 blackbody, 302\*  
 graybody, 1025\*  
 incandescence, 1135\*  
 Planck's radiation law, 1696\*  
 pyrometer, 1816\*  
 radiator, 1846\*
- Heat sterilization, 2115
- Heat transfer, 1057\*  
 conduction (heat), 533\*  
 convection, 486  
 countercurrent transfer operations, 573\*  
 food engineering, 908  
 heat exchanger, 1055\*  
 heat radiation, 1056\*
- Heat treatment (metallurgy), 1057\*  
 electric furnace, 743\*, 744\*  
 embrittlement, 809\*
- Heat treatment (metallurgy)—*cont.*  
 ferrous metals, 936  
 nonferrous metals, 936-937  
 tempering, 2209\*
- Heater, air, 51
- Heath, 759, 1733
- Heather, 759
- Heating system, 1057-1058\*  
 automotive, 228  
 central heating and cooling, 401\*  
 comfort, 449  
 dielectric, 595-596  
 district, 631  
 electric, 673, 744\*  
 hot-water, 1091\*  
 induction, 1138  
 panel heating and cooling, 1605\*  
 radiant, 1842\*  
 resistance, 1901\*  
 solar heating and cooling, 2039-2040\*  
 steam, 2106-2107\*  
 warm-air, 2362\*
- Heaviside, O., 1188
- Heavy cluster decays, 1857-1858
- Heavy force fit, 2003
- Heavy-ion accelerator, 699
- Heavy ions, 628
- Heavy metal poisoning, 1732-1733
- Heavy minerals, 937, 1058\*
- Heavy water, 1058\*  
 deuterium, 648\*  
 isotope separation, 1198
- Hebbian, 2182
- Hebridae, 944
- Hedenbergite, 197
- Hederella*, 937
- Hederella*, 1058\*
- Hederopsis, 937
- Hedgehog, 1058-1059\*
- Hedgehog fungi, 1112
- Hedophyllum*, 1224
- Heed *see* High-energy electron diffraction
- Heel spur, 822
- Heinrich layers, 1597
- Heisenberg, W., 457, 1251, 1960  
 determinism, 648  
 quantum electrodynamics, 1826  
 scattering matrix, 1955  
 uncertainty principle, 2296-2297
- Heisenberg uncertainty principle, 1201
- Helarctos malayanus*, 230
- Helianthemum*, 1309
- Helianthus annuus*, 2151-2152
- Heliantheridae, 824
- Helicity (quantum mechanics), 1059\*
- Helicobacter, 1059\*
- Helicoplacoida, 659, 728, 1059\*
- Helicopter, 44, 1059\*  
 armaments, 171  
 autogiro, 222\*  
 military aircraft, 1401  
 naval ships, 1468  
 vertical takeoff and landing,  
 2333-2334\*
- Helicosporida, 1059\*, 1462
- Helicosporidium parasiticum*, 939
- Helimagnetism, 1059-1060\*, 1305-1306
- Heliopora, 433
- Helioseismology, 1060\*
- Heliozoia, 21, 1062\*  
 Centrohelida, 403\*  
 Desmothoracida, 646\*
- Helium, 1060-1061\*, 1263
- Helium-cadmium laser, 1229
- Helium-neon laser, 1229
- Helix, 1061\*  
 Heller's syndrome, 221
- Helmholtz, H., 1454, 2231
- Helmholtz coils, 1061\*
- Helmholtz free energy, 835  
*see also* Work function (thermodynamics)
- Helmholtz resonator, 17
- Helmholtz theorem *see* Thévenin's theorem
- Helminths, 2363
- Helobiae, 77
- Helobiales, 77
- Heloderma horridum*, 886, 2092
- Heloderma suspectum*, 886, 2092
- Helodermatidae, 886, 2092
- Helotrepidae, 944
- Hematite, 1061\*, 1162
- Hematogenic shock, 2001
- Hematologic disorders, 1061-1062\*  
 anemia, 115-116\*  
 hemophilia, 1066\*
- Hematology, 475
- Hematoma, 1067
- Hematopoiesis, 1062\*
- Hemerythrin, 1906
- Hemiascomycetes, 1062\*
- Hemibranchii, 865
- Hemicellulose, 1062\*  
 wood chemicals, 2394  
 wood degradation, 2394
- Hemichordata, 1063\*  
 Enteropneusta, 826\*  
 Pterobranchia, 1805\*
- Hemicidaridae, 942
- Hemicidaroida, 1063\*
- Hemicryptophytes, 1717
- Hemidiscosa, 103, 1063\*
- Hemimorphite, 1063\*
- Hemiplegic processes, 628
- Hemiprocridae, 134
- Hemiptera, 1063-1065\*  
 morphology, 1063-1065\*  
 subdivisions, 942-944
- Hemispheric laterality, 1065-1066\*
- Hemlock:  
 Pinale, 1688  
 tree, 2266
- Hemocyanin, 1906
- Hemocytes, 1182
- Hemoglobin, 1066\*  
 anemia, 115-116\*  
 bilirubin, 273\*  
 erythrocytes, 267  
 invertebrates, 1906  
 oximetry, 1591\*  
 sickle cell disease, 2004\*
- Hemoglobin metabolism, 1191
- Hemolysis, 116, 270
- Hemolytic anemia, 1993
- Hemophilia, 1066\*  
 fibrinogen, 884  
 hematologic disorders, 1062  
 hereditary deficiency, 269
- Hemophilus*, 2254
- Hemorrhage, 408, 1066-1067\*,  
 1479
- Hemorrhagic fever disease, 725\*
- Hemorrhoids, 970, 1066\*
- Hemotologic disorders, 2259
- Hemp, 1067\*, 1317
- Henbane, 2038
- Henriquet, 1067\*
- Henley, A., 685
- Henry, definition of, 687, 761
- Heparin, 269, 1067\*
- Hepaticopsida:  
 Jungermanniidae, 1206\*  
 Marchantiidae, 1317\*
- Hepatitis, 1067\*  
 autoimmunity, 223  
 liver disorders, 1265  
 metabolic disorders, 1361
- Hepatitis B, 1768
- Hepatitis C, 1067
- Hepialidae, 1245
- Hepialoidea, 1245
- Herbarium, 1067-1068\*
- Herbicide, 231, 1068\*
- Herbig, G., 947
- Herbig-Haro objects, 1068\*
- Herbivores:  
 digestive system, 666  
 dinosaur, 675
- Herbivory, 1068\*  
 plant-animal interactions, 1702  
 predator-prey interactions, 1767
- Hereditary diseases:  
 human genetics, 1094-1095  
 Huntington's disease, 1099\*  
 skin, 2018
- Hereditarity:  
 gene, 978\*  
 mendelism, 1353-1354\*  
 sex-influenced inheritance, 1993\*
- Hermann, R., 500
- Hermaphroditism, 560, 1069\*
- Hershelium, 656
- Hermit crabs:  
 Decapoda, 622-625\*  
 Eucarida, 852\*
- Hemia, 1069\*
- Hérault, P. L. T., 2106
- Herpes, 1069\*  
 Herpes simplex virus 1, 1069  
 Herpesvirus, 740\*, 840  
*Herrerasaurus*, 675
- Herrings, 479-480, 1069-1070\*
- Herschel, W., 2309
- Hershel, W., 1152
- Hertz, H., 696, 707, 934

- Hertzprung, E., 707, 1070, 2097  
Hertzprung-Russell (HR) diagram, 1070\*, 2097, 2109, 2138  
Hesoniidae, 760  
Hesperidae, 1244  
Hesperioidea, 1244  
Hesperornithiformes, 1070-1071\*, 1124, 1533  
Heterakoidea, 2130\*  
Heterobasidion, 984, 1112  
Heterochrony, 1071\*  
Heterocoralia, 1071\*  
Heterocyclic compounds, 1071\*  
  furan, 950\*  
  indole, 1137\*  
  meso-ionic compound, 1358\*  
  purine, 1811\*  
  pyrimidine, 1813\*  
  pyrrole, 1818\*  
  thiophene, 2233\*  
Heterocyclic polymer, 1071-1072\*  
Heterodonta, 1223  
Heterodyne principle, 1072\*, 1394-1395  
Heterogeneous catalysis, 1072\*  
Heterohyrax, 1122  
Heterojunction bipolar transistors (HBTs), 1397  
Heteromi *see* Notacanthiformes  
Heteromyiidae, 1443  
Heteromyota, 659, 728  
Heteronemertini, 126, 1072\*  
Heteroneura, 1245  
Heterophile antigen, 1072\*  
Heterophone, 541  
Heterophrys, 353, 950  
Heteroploidy, 400  
Heteroptera *see* Hemiptera  
Heterostigma, 1869  
Heterosis, 1072\*  
Heterostraci, 1073\*  
Heterotardigrada, 1073\*  
Heterotrichida, 1073\*  
Heterotrophic succession, 734  
Heterotrophic transformations, 1323  
Heteroxenia, 70  
Heulandite, 1073\*  
Heuristics, 861  
Hevea brasiliensis, 770  
Hevelius, J., 478  
Hexactinellida, 1073\*  
  Hemidiscosa, 1063\*  
  Hexactinosa, 1073\*  
  Hexasterophora, 1073\*  
  Lychniscosa, 1280\*  
  Lyssacinososa, 1284\*  
  Reticulosa, 1909\*  
Hexactinosa, 1073\*  
Hexadecimal number system, 1522-1523  
Hexamita, 618  
Hexapoda, 678, 1156  
  *see also* Insecta  
Hexaprismane, 309  
Hexasterophora, 1073\*  
  Hexactinosa, 1073\*  
  Lychniscosa, 1280\*  
  Lyssacinososa, 1284\*  
  Reticulosa, 1909\*  
HGP *see* Human Genome Project  
Hibernation, 1073-1075\*  
  cold-blooded animals, 952  
  poikilotherm animals, 1074  
  warm-blooded vertebrates, 952, 1074-1075  
Hibiscus, 1211, 1309  
Hickory, 1075-1076\*, 1205  
Hidden variables, 1076\*  
Higgs, P. W., 720  
Higgs boson, 1076-1077\*, 2165  
Higgs field, 973  
High-definition television (HDTV), 2203  
  image processing, 1127  
  television camera, 2204  
  television standards, 2206-2207  
High-density lipoproteins (HDL), 1260  
High-density polyethylene (HDPE), 995, 1749  
High-energy cosmic neutrinos, 1483  
High-energy electron diffraction (HEED), 779, 780  
High-energy neutrino telescopes, 1483  
High fidelity, 796  
High-frequency radar, 1894  
High-information-content (HIC) displays, 786, 787  
High-intensity arc discharge (HID) lamps, 1224  
High magnetic fields, 107\*  
High-pressure chemistry, 1077\*  
High-pressure liquid chromatography (HPLC), 1262  
High-pressure low-density polyethylene (LDPE), 1749  
High-pressure physics, 1078\*  
High-pressure processes, 1078-1079\*  
High-speed networking, 2342  
High-speed passenger trains, 1866  
High-speed photography, 1666  
High-temperature chemistry, 1079\*  
High-temperature materials, 1079\*  
High-voltage direct current (HVDC), 746  
High-voltage electron microscopes, 781-782  
Highbush blueberry, 271  
Highway engineering, 1079-1080\*  
  pavement, 1620-1621\*  
  transportation engineering, 2263  
Hii regions, 1847  
Hilbert, David, 955  
Hilbert space, 955-956  
  generalizations of euclidean space, 955  
  mathematics, 1338  
  role of, 955-956  
Hill and mountain terrain, 1080-1081\*  
Himalayan bear, 230  
Hindbrain, 2333  
Hindgut, 666  
Hinich, M. J., 1333  
Hinny, 1444  
Hiodontidae, 1586  
Hipparchus, 2096  
Hipparcos satellite, 975  
Hipparcos space telescope, 1099  
Hippocrateaceae, 345  
Hippopotamidae, 956  
Hippopotamus, 164, 1081\*  
Hippopotamus amphibius, 956  
Hiroshima nuclear explosion, 1507  
Hirsutella, 1119  
Hirsutia bathyalis, 1399  
Hirudinea, 125, 1081\*  
  Arhynchobdellae, 168\*  
  Rhynchobdellae, 1916\*  
Histamine, 1081\*  
  antihistamine, 142\*  
  complement, 514  
  hypersensitivity, 1117-1118\*  
Histidine, 1081  
Histocompatibility, 1081-1082\*  
Histogenesis, 1082\*  
Histogram, 1017, 2103  
Histology, 1082\*, 1477-1478  
Histoplasma capsulatum, 957  
Historadiography, 1082\*  
Historical geology, 722, 880  
Historical zoogeography, 2419  
Histriobdellidae, 760  
Hitchhikers (invasion ecology), 1179  
HIV *see* Human immunodeficiency virus  
Hla complex, 1082  
Hoarseness, 1229  
Hoatzin, 1550  
Hoazinoides, 1550  
Hodgkin, A. L., 246  
Hodgkin's disease, 1082\*, 1282  
Hodotermitidae, 1195  
Hoffman, R., 1630  
Hoffmann, Roald, 2396  
Hog cholera, 1082\*  
Hogan, C. L., 916  
Hohenbuehelia, 984, 1112  
Hoisting machines, 1082-1083\*  
  construction equipment, 479, 543  
  derrick, 642\*  
Holasteroidea, 182, 1083\*  
Holding pawl, 1621  
Hole states in solids, 1083\*  
  electron-hole recombination, 780-781\*  
  semiconductors, 1980-1981\*  
Holectypidae, 958  
Holectypoida, 1083\*  
Hollow-pipe waveguides, 2374  
Holly, 345, 1083\*  
Holmes, Arthur, 482  
Holmium, 1083\*  
Holobasidiomycetidae, 983-984  
Holocene, 1083-1084\*  
Holocestridae, 238  
Holocephali, 394, 438, 1084\*  
Holographic interferometry, 1172  
Holography, 1084-1085\*  
Holostei, 184, 1085\*  
Holothuroidea, 659, 1085\*  
  Echinodermata, 726  
  Echinozoa, 728  
Holotrichia:  
  Apostomatida, 152\*  
  Astatomatida, 188\*  
  Chonotrichida, 447\*  
  Ciliata, 403  
  Gymnostomatida, 1034\*  
  Hymenostomatida, 1113-1114\*  
  Thigmotrichida, 2233\*  
  Trichostomatida, 2270\*  
Holywood lignumvita, 1254  
Homalopteridae, 544  
Homalorhagida, 1216  
Homalozoa, 657, 1086\*  
  carpoids, 374-375\*  
  Echinodermata, 726  
Homeosis, 1086\*  
Homeostasis, 1086\*  
  disease, 625-626\*  
  endocrine system, 733  
  pH regulation (biology), 1647\*  
Homeotic transformation *see* Homeosis  
Homing, 1086-1087\*  
Homing guidance systems, 913  
Homing torpedo *see* Acoustic torpedo  
Hominidae, 198, 831  
  fossil primates, 928  
  primates, 1772  
Hominoidea, 132, 1771  
Hominoidea:  
  fossil apes, 923-924  
  fossil primates, 928  
  primates, 1771-1772  
Homo, 924-926, 926  
Homo erectus, 831, 925  
  fossil humans, 925, 926  
  Paleolithic, 1661  
  Pleistocene, 1727  
Homo habilis, 831, 925  
  fossil humans, 926  
  Pleistocene, 1727  
Homo heidelbergensis, 938  
Homo neanderthalensis, 1469, 1727  
Homo rudolfensis, 925, 926  
Homo sapiens, 831, 925  
  fossil humans, 924-926, 926  
  Neanderthals, 1469  
  Pleistocene, 1727  
Homo sapiens mauritanicus, 925  
Homo sapiens neanderthalensis, 831  
Homo sapiens sapiens, 829  
  paleoindian, 1600  
  Paleolithic, 1660  
Homogeneous catalysis, 339  
Homoneura, 1245  
Homopolymers, 1747  
  polyethylene, 1749  
  polystyrene resin, 1752  
Homoptera, 1087-1088\*  
  aphid, 149-150\*  
  Auchenorrhyncha, 962  
  Coleorrhyncha, 962  
  Sternorrhyncha, 962-963  
Homosclerophorida, 1088\*  
Honey Dew melon, 1088\*  
Honey locust, 1240, 1268  
Honeybee, 262  
Honeysuckle, 620  
Hookeriales, 1088\*  
Hooke's joint, 2305  
Hooke's law, 1088\*  
Hoopoe, 494  
Hop, 964  
Hop clover, 422  
Hophornbeam, 1088\*, 1191  
Hoplocarida, 770, 1089\*, 2119  
Hoplomertini, 741, 1089\*  
Hordeum distichum, 220  
Hordeum vulgare, 220  
Horizon, 191, 1089\*, 2032-2033  
Hormone, 1089\*  
  animal growth, 121  
  ecdysone, 725\*  
  eicosanoids, 739-740\*  
  endocrine system (vertebrate), 816, 817  
  epinephrine, 838\*  
  estrogen, 848\*  
  glucagon, 1006\*  
  gonads, 1897  
  growth factor, 1030-1031\*  
  insulin, 1162\*  
  neurohypophysis hormone, 1480\*  
  neurosecretion, 1481\*  
  parathyroid hormone, 1611-1612\*  
  pituitary gland, 1693-1694\*  
  plant *see* Plant hormones  
  progesterone, 1781\*  
  stress, 2127-2128  
Hormone—cont.  
  thymosin, 2236\*  
  thyrocalcitonin, 2236-2237\*  
  thyroid gland, 2237  
  thyroxine, 2237-2238\*  
  *see also* Endocrine system [invertebrate];  
  Endocrine system [vertebrate]  
Hornbeam, 965, 1191  
Hornbill, 494  
Hornblende, 955, 1089\*, 1125  
Hornfels, 1089-1090\*  
Hornwort:  
  plant, 1701  
  plant phylogeny, 1712  
Horny coral:  
  Antipatharia, 144\*  
  Gorgonacea, 1013\*  
Horology, 1090\*  
Horse, 178  
  equine infectious anemia, 842\*  
  glanders, 1002\*  
  mule, 1444\*  
  Oligocene, 1539  
  Perissodactyla, 1633-1634\*  
  Pliocene, 1729  
  strangles, 2122\*  
Horse chestnut, 299, 1944  
Horse mule, 1444  
Horsehair worm *see* Hairworm  
Horseradish, 1090\*  
Horseshoe crab:  
  eye, 865  
  Merostomata, 1358\*  
  Trilobita, 2273  
Horsetail:  
  Equisetales, 842-843\*  
  Gnetales, 1009  
  plant, 1701  
Horst, 1090\*  
Horticultural crops, 1090-1091\*  
Horticulture:  
  arboriculture, 157\*  
  floriculture, 896\*  
Hospital infections, 1091\*  
Host (infectious disease), 1144  
Hot-cathode gas tube, 863  
Hot-dipped coatings, 1365  
Hot-filament ionization gage, 1189  
Hot rolling, 1367  
Hot spots (geology), 1091\*  
Hot springs, 2008, 2352  
Hot-water heating system, 1091-1092\*  
  oil burner, 1536\*  
  radiator, 1846\*  
  solar, 2040  
Hot-water spring, 2090  
Hot-wire noise generator, 685  
Hot-wire noise source, 759  
Housed cameras, 2299  
Hovercraft, 50  
Hox gene, 649  
Hubble, Edwin P., 177, 406, 504, 967, 1878, 1879  
Hubble constant, 505, 620, 1092\*  
Hubble Space Telescope, 871, 2067-2068\*  
  Gemina, 975  
  gravitational lens, 1023  
  gyroscope, 1035  
  Hubble constant, 1092  
  interplanetary matter, 1177  
  Jupiter, 1207  
  satellite astronomy, 1947  
  space shuttle, 2065  
  telescope, 2202  
  ultraviolet astronomy, 2295  
Hübel rule, 171  
Huebnerite, 1092\*  
Hulse, R., 907  
Human biogeography, 249  
Human-computer interaction, 1092-1093\*, 2342-2343  
Human ecology, 1093\*  
Human-environment interaction:  
  endangered species, 814-815\*  
  mass wasting, 1332  
  water conservation, 2364  
  water pollution, 2366-2367\*  
  wetlands, 2385  
Human-factors engineering, 1093-1094\*  
Human genetics, 1094-1095\*  
  behavior genetics, 262-263\*  
  biochemical genetics, 1095  
  chromosome mapping, 969  
  chromosomes, 932-933  
  determination of inheritance pattern, 968  
  Down syndrome, 700\*  
  eugenics, 852\*

- Human genetics—*cont.*  
 hereditary diseases, 1094-1095  
 Human Genome Project (HGP), 1095-1096\*  
 population analysis, 969  
 sex determination, 1992-1993, 1992-1993\*  
 sex-influenced inheritance, 1993  
 sex-linked inheritance, 1993\*  
 sickle cell disease, 2004  
 Human Genome Project (HGP), 1095-1096\*  
 findings, 1096  
 future research, 1096  
 history, 1095-1096  
 model organisms, 1096  
 scientific strategy, 1096  
 Human immunodeficiency virus (HIV), 18-19  
 hospital infections, 1091  
 infectious disease, 1144  
 Human-machine systems, 1096-1097\*  
 expert systems, 861\*  
 human-computer interaction, 1092-1093\*  
 human-factors engineering, 967-968\*, 1093-1094\*  
 remote manipulators, 1893\*  
 speech recognition, 2079-2080\*  
 Human-powered aircraft, 890  
 Human variation, 1097\*, 1676-1677  
 Humans:  
 early modern, 715-716\*  
 intestine, 1178  
 listeriosis, 1264  
 primates, 1771, 1772  
 Humason, M. L., 505  
 Humidification, 1097\*  
 Humidistat, 1097\*  
 Humidity, 1097\*  
 air conditioning, 49  
 dehumidifier, 632\*  
 humidification, 1097\*  
 humidistat, 1097\*  
 hygrometer, 1111-1112\*  
 measurement, 1416  
 meteorological instrumentation, 1376  
 mixing ratio, 970  
 moisture-content measurement, 1416  
 weather observations, 2380  
 Humidity control, 1097-1098\*  
 Humite, 1098\*  
 Hummingbird, 134  
*Humulus lupulus*, 964  
 Humus, 1098\*, 2037  
 Hunger, 1098\*  
 Huntington's disease, 1099\*  
*Huperzia*, 1280  
 Hurler's disease, 1362  
 Hurricane, 1099\*  
 satellite meteorology, 1947  
 storm surge, 2121  
 tropical meteorology, 2277  
*Hutchinsoniella macracantha*, 354  
 Huxley, A. F., 246  
 Huygens, C., 971  
 Huygens eyepiece, 868  
 Huygens' principle, 601-602, 1099\*  
 Hyades, 1099\*, 2194  
 Hyacinthidae, 983  
 Hyaelodontidae, 571  
 Hyaline cartilage, 336, 375  
*Hyalonema*, 103  
 Hyaluronic acid, 1099\*  
 Hyaluronidase, 1099-1100\*  
*Hyattichinus*, 657  
 Hybrid:  
 heterosis, 1072\*  
 Mendelism, 1353-1354\*  
 Hybrid computers, 109  
 Hybrid dysgenesis, 1100\*  
 Hybrid underwater vehicles, 2300, 2301  
 Hydatellales, 1100\*  
 Hydatid disease see Echinococcosis  
 Hydatosis see Echinococcosis  
 Hydra, 1111  
 Hydrate, 1100\*  
 Hydration, 1100\*  
 Hydraulic accumulator, 1100\*  
 Hydraulic actuator, 1100-1101\*  
 Hydraulic cement, 350  
 Hydraulic jump, 1101\*  
 Hydraulic nozzle, 193-194  
 Hydraulic press, 1101\*  
 Hydraulic torque converter, 2251  
 Hydraulic turbine, 1101\*  
 Hydraulic valve lifter, 1101-1102\*  
 Hydraulics, 899-900, 1102\*  
 Hydrazine, 1102\*  
 Hydride, 1102\*  
 hydrido complexes, 1102\*  
 metal hydrides, 1366\*  
 Hydrido complexes, 1102\*  
 Hydro-Quebec, 683  
 Hydrobatidae, 1778  
 Hydroboration, 1102\*  
 Hydrocarbon:  
 aromatization, 172\*  
 cage, 309  
 cyanocarbon, 602\*  
 isomerization, 1194-1195\*  
 petrochemical, 1639  
 petroleum microbiology, 1642-1643  
 see also Alicyclic hydrocarbon; Aliphatic hydrocarbon; Aromatic hydrocarbon; Halogenated hydrocarbon  
 Hydrocharitaceae, 975  
 Hydrocharitales, 1103\*  
 Hydrochloric acid, 154  
 Hydrochlorofluorocarbons (HFCs), 1043  
*Hydrochoerus hydrochaeris*, 344  
 Hydrocorisae, 942-943  
 Hydrocracking, 1103\*  
 high-pressure processes, 1079  
 reforming processes, 1881  
 Hydrodesulfurization, 1079  
 Hydrodynamic bearings, 1277  
 Hydrodynamic brake, 287  
 Hydrodynamic fluid-film bearing, 139-141  
 Hydrodynamics, 1103\*  
 magnetohydrodynamics, 1301-1302\*  
 nuclear reactor, 1515  
 Hydroelectric generator, 1103-1104\*  
 Hydroelectric power, 614, 674  
 Hydroelectric storage see Pumped storage  
 Hydrofluorocarbons (HFCs):  
 halogenated hydrocarbon, 1043  
 marine refrigeration, 1324  
 Hydrofoil craft, 1104\*  
 Hydroformylation, 1104\*  
 Hydrogen, 1104-1105\*  
 alternative fuel vehicle, 91  
 atomic structure and spectra, 211-212  
 deuterium, 648\*  
 hydride, 1102\*  
 hydrogenation, 1107\*  
 metal hydrides, 1366\*  
 preparation, 977  
 principal compounds, 977  
 properties, 976  
 tritium, 2274-2275\*  
 uses, 976  
 Hydrogen bomb, 1105-1106\*, 1506-1507  
 Hydrogen bond, 380, 1106\*  
 Hydrogen chloride, 390  
 Hydrogen cyanamide, 536  
 Hydrogen embrittlement, 498, 562, 563, 727, 809  
 Hydrogen fluoride, 1106\*  
 Hydrogen ion, 1106\*  
 hydrolysis, 1108\*  
 pH, 1646-1647\*, 1646-1647\*  
 Hydrogen line, 1847  
 Hydrogen peroxide, 1106-1107\*, 1635-1636  
 Hydrogenation, 1107\*  
 hydrocracking, 1103\*  
 petroleum processing and refining, 1644  
 Hydrography, 1107\*, 1532  
 Hydroidea, 983, 1107-1108\*, 1111  
 Hydrolases, 833  
 Hydrologic cycle, 916  
 Hydrology, 1108\*  
 Earth sciences, 722  
 ground water, 911  
 hydrography, 1107\*  
 hydrometeorology, 1109\*  
 limnology, 1256\*  
 river, 1924\*  
 spring, 2090\*  
 stream gaging, 2125\*  
 surface water, 2170-2171\*  
 terrestrial water, 2213\*  
 Hydrolysis, 1108\*  
 Hydrolytic processes, 1108-1109\*  
 Hydrometallurgy, 1109\*  
 Hydrometeorology, 1109\*  
 Hydrometer, 1109\*  
 Hydrometridae, 944  
 Hydropericardium, 737  
 Hydrophone, 1109\*, 1493  
 Hydrophytes, 2385  
 Hydroponics, 1026-1027, 1109-1110\*  
 Hydroprocesses, 1644  
 Hydrosphere, 1110\*  
 Hydrostatic bearings, 1277  
 Hydrostatic fluid-film bearing, 139-141  
 Hydrostatics, 1110\*  
 Archimedes' principle, 164\*  
 buoyancy, 343\*  
 Pascal's law, 1618\*  
 Hydrothermal clays, 469  
 Hydrothermal minerals, 1404  
 Hydrothermal vent, 1110-1111\*  
 bacteria, 1323  
 Hydrothorax, 737  
 Hydroxide, 1111\*  
 Hydroxyapatite, 131  
 Hydroxyl, 1111\*, 1312  
 Hydrozoa, 1111\*  
 Hydroidea, 1107-1108\*  
 Milleporina, 1403\*  
 Siphonophora, 2014\*  
 Spongiomorphida, 2088\*  
 Stylasterina, 2137\*  
 Trachylina, 2255\*  
*Hyemoschus aquaticus*, 384  
 Hyena, 1111\*  
 Hyenales, 1111\*  
 Hygrometer, 1111-1112\*  
 Hyloabates, 886  
 Hylobatidae, 1772  
 Hylobatids, 1772  
 Hymenogastrales, 864  
 Hymenomyces, 226, 1112\*  
 Hymenoptera, 1112-1113\*  
 ant, 129\*  
 bee, 261-262\*  
 biology, 984-985  
 ichneumon, 1124\*  
 morphology, 984  
 social insects, 2027-2028\*  
 Hymenostomatida, 1113-1114\*  
 Hyocephalidae, 944  
 Hypabyssal rock, 1125  
 Hyperactivity see Attention deficit hyperactivity disorder  
 Hyperbaric oxygen chamber, 1114-1115\*  
 Hyperbola, 1115\*  
 Hyperbolic fixing, 2030  
 Hyperbolic function, 382, 1115-1116\*  
 Hyperbolic geometry, 1494  
 Hyperbolic navigation system, 1116\*, 1272  
 Hypercalcemia, 312  
 Hypercharge, 1116\*  
 Hyperconjugation see Conjugation and hyperconjugation  
 Hyperemia, 408  
 Hyperfine structure, 213, 1116\*  
 Hypergeometric functions, 1116\*, 2072  
 Hypoglobulinemia, 1361  
 Hyperglycemia, 1006  
*Hypericum*, 2218  
 Ichthyodactylidae, 1916  
 Ichthyodectidae, 1586  
 Ichthyopterygia, 1124\*  
*Ichthyornis*, 1124-1125  
 Ichthyornithiformes, 1124-1125\*  
 Ichthyosauria, 1124  
 Ichthyostegia, 1125\*  
 Ichthyotomidae, 760  
 Icosahedral quasicrystals, 1835  
 Idiopathic colitis, 440  
 IgA, 1130  
 IgD, 1130  
 IgE:  
 immunoglobulin, 1130  
 immunosuppression, 1132  
 IGFET see Insulated-gate field-effect transistor  
 IgG, 1130  
 Igneous minerals, 1404  
 Igneous rocks, 1125\*  
 aplite, 151\*  
 basalt, 255-256\*  
 breccia, 330  
 carbonatite, 369\*  
 contact aureole, 543\*  
 diorite, 677\*  
 dunite, 706-707\*  
 formation, 922  
 gabbro, 955\*  
 granite, 1015-1016\*  
 granodiorite, 1016\*  
 greisen, 1027\*  
 kimberlite, 1214\*  
 lamprophyre, 1224\*  
 lava, 1233-1234\*  
 layered intrusion, 1234\*  
 leucite rock, 1247\*  
 magma, 1289\*  
 nephelinite, 1475\*  
 oligoclase, 1539\*  
 Hypoproteinemia, 1361  
 Hyposmia, 1538  
 Hypothalamus, 287  
 endocrine system (vertebrate), 816  
 nervous system (vertebrate), 1477  
 pituitary gland, 1693  
 pituitary gland disorders, 1694  
 Hypothermia, 1120-1121\*  
 clinical, 1121  
 frostbite, 1121  
 primary, 1120-1121  
 secondary, 1121  
 Hypothesis, 1121\*  
 Hypotrichida, 1121\*  
 Hypovolemia, 2234  
 Hypoxia, 1121\*, 1907  
 Hyracoidea, 1121-1122\*  
 Hyrax, 1121-1122  
 Hysteresis, 1122\*  
 magnetic see Magnetic hysteresis  
 thermal, 2221\*  
 Hysteresis motor, 1122\*  
 Hysteriales (lichenized), 1122\*  
 Hystrichis, 616  
 Hystricidae, 1756



- Igneous rocks—*cont.*  
 pegmatite, 1623\*  
 peridotite, 1631\*  
 phenocryst, 1654\*  
 phonolite, 1657\*  
 picrite, 1684\*  
 pluton, 1729  
 porphyry, 1757\*  
 pyroxenite, 1817-1818\*  
 rhyolite, 1917\*  
 spilitite, 2084\*  
 syenite, 2177\*  
 trachyte, 2255\*  
 xenolith, 2407\*  
 Ignimbrite, 1126\*  
 Ignition system, 1126\*  
   induction coil, 1137-1138\*  
   magneto, 1300-1301, 1300-1301\*  
   spark plug, 2071\*  
*Ilex* species, 345, 959, 1126  
 Illiciales, 1126\*  
 Illite, 468, 469, 1126\*  
 Illuminance, 1126\*  
 Illumination, 1127\*, 1279  
   *see also* Lamp  
 Illusions, 1042  
 Ilmenite, 1127\*  
 Image *see* Acoustical image; Optical image  
 Image intensifier *see* Light amplifier  
 Image orthicon, 2204  
 Image processing, 1127\*, 2206  
 Imaging devices, infrared, 1151\*  
 Imaging microwave radiometers, 1379  
 Imaging systems *see* Medical imaging  
 Imitation gem, 593, 870  
 Immersion coatings, 1365  
 Immersion electron microscope, 729  
 Immersion refractometer, 1882  
 Immittance, 1127\*  
 Immune serum, 252  
 Immunity, 1128-1129\*  
   adaptive immune response, 1128-1129  
   animal virus, 124  
   autoimmunity, 1129  
   biologicals, 285-286\*  
   catalytic antibody, 379\*  
   immunization, 1129  
   natural or innate immunity, 1128  
   passive immunization, 1129  
   serum, 1989  
   skin test, 2019  
   vaccination, 2317\*  
 Immunization, 1129  
   catalytic antibody, 379\*  
   diphtheria, 677  
   disease ecology, 686  
   vaccination, 2317\*  
 Immunoassay, 1129\*  
   antigen-antibody reaction, 142  
   radioimmunoassay, 1860-1861\*  
 Immunochromatography, 1129\*  
 Immunocytes, 1182  
 Immunodeficiency *see* Immunological deficiency  
 Immunoelectrophoresis, 1129\*  
 Immunofluorescence, 1129\*  
 Immunogenetics, 1129-1130\*  
 Immunoglobulin, 268, 1130\*  
   antibody, 138\*  
   globulin, 1006\*  
   immunochemistry, 1129\*  
   neutralizing antibody, 1482\*  
 Immunohematology, 475  
 Immunologic cytotoxicity, 1130-1131\*  
 Immunological deficiency, 1131\*  
   clinical immunology, 474\*  
   cytomegalovirus infection, 611-612  
 Immunological ontogeny, 1131\*  
 Immunological phylogeny, 1131-1132\*  
 Immunology, 1132\*  
   antibody, 138\*  
   antigen, 141\*  
   antigen-antibody reaction, 141-142\*  
   autoimmunity, 222-223\*  
   cellular *see* Cellular immunology  
   clinical, 474\*  
   complement-fixation test, 514-515\*  
   cytolysis, 611\*  
   isoantigen, 1193\*  
   monoclonal antibodies, 1432-1433\*  
   neuroimmunology, 1480-1481\*  
   neutralization reaction, 1482\*  
   opsonin, 1550\*  
   radioimmunoassay, 1860-1861\*  
   tissue typing, 2244\*  
   transplantation biology, 2263\*  
 Immunonephelometry, 1132\*  
 Immunosuppression, 1132\*  
   immunosuppressors, 1132  
   stress, 2128  
   suppressor cells, 1132  
   transplantation biology, 2263  
 Immunosuppressors, 1132  
 Immunotherapy, 1133\*  
 Impace avalanche and transit-time diodes (IMPATs), 1397-1398  
 Impact, 1133\*, 1375-1376  
 Impact spheres, 502  
 Impact tube *see* Pitot tube  
 Impatiens, 884  
 Impedance:  
   antiresonance, 144-145\*  
   mechanical, 1343\*  
   *see also* Electrical impedance  
 Impedance matching, 1133-1134\*  
 Impetigo, 2018  
 Implanted drug delivery systems, 702  
 Imprinting:  
   developmental genetics, 650  
   ethology, 850  
   sex-influenced inheritance, 1993  
 Improper ferroelectrics, 791  
 Impsonite, 1134\*  
 Impulse (mechanics), 1134\*, 2074  
 Impulse generator, 1134\*  
 Impulse turbine, 1134\*  
 Impulsive force *see* Impact  
 Impurity (crystal defect), 527  
 Inadunata, 1134\*  
 Inarticulata, 1134-1135\*  
   Lingulida, 1259\*  
   Oboloida, 1528\*  
   Paterinida, 1619\*  
 Incandescence, 1135\*  
 Incandescent lamp, 1135\*, 1151-1152, 1224  
 Incense cedar, 344  
 Incineration, 901  
 Inclined plane, 1135\*  
   lever, 1248\*  
   screw, 1963\*  
 Inclined-tube manometer, 1313  
 Inclusion bleb, 389  
 Inclusion blennorrhoea, 389  
 Incompressible flow, 517, 1136\*  
 Incurvariidae, 1245  
 Incurvarioidea, 1245  
 Indeterminacy, 648  
 Indeterminacy principle *see* Uncertainty principle  
 Index fossil, 1136\*  
 Index of refraction, 1882  
 Indian buffalo, 301  
 Indian chevrotain, 384  
 Indian civet, 410  
 Indian cobra, 429  
 Indian gaviol, 867  
 Indian Ocean, 1136\*  
 Indian pipe, 759  
 Indian python, 2092  
 Indicating electrodynamic wattmeter, 2370  
 Indirect-arc furnace, 140-141  
 Indirect-bandgap semiconductors, 781  
 Indium, 1136-1137\*  
 Indole, 1137\*  
 Indole-3-acetic acid, 206  
 Indonesia, 723  
 Inductance, 1137\*  
   inductor, 1139\*  
   saturable reactor, 1949\*  
 Inductance measurement, 1137\*  
 Induction, 771-772  
   induction charging, 797  
   induction coil, 1137-1138\*  
   induction electric machines, 751  
   induction generator, 90  
   induction heaters, 744  
   induction heating, 1138\*  
   induction motor, 90, 91, 1138\*, 2022  
   inductive coordination, 1138-1139\*  
   inductive voltage divider, 1139\*  
   inductor, 1139\*, 1872  
   industrial alcohol, 765  
   industrial coating, 1595  
   industrial control, 691  
   industrial crops, 871  
   industrial diamond, 593  
   industrial ecology, 1139-1140\*  
   industrial elevator, 724  
   industrial engineering, 1140\*, 1306  
   industrial health and safety, 964-965, 1140-1141\*  
   industrial meteorology, 1141\*  
   industrial microbiology, 1141-1142\*  
 Industrial radiography, 1860  
 Industrial robot *see* Robotics  
 Industrial trucks, 1142\*  
 Industrial wastewater treatment, 1142\*  
 Industrial water consumption, 2364  
 Inert gases, 1143\*  
   helium, 1060-1061\*, 1061\*  
   krypton, 1218\*  
   neon, 1474\*  
   radon, 1864-1865\*  
   xenon, 2407\*  
 Inertia, 1143\*  
   mass, 1330\*  
   moment of, 1430-1431\*  
   product of, 1779\*  
 Inertia welding, 1143\*  
 Inertial guidance system, 621, 1143\*  
 Inertial mass *see* Rest mass  
 Infant diarrhea, 1143\*  
 Infant respiratory distress syndrome, 1143\*  
 Infantile eczema, 664  
 Infantile glaucoma, 889, 1003  
 Infantry armament, 170-171  
 Infarction, 1143\*  
 Infection, 1144\*  
   anaerobic, 107\*  
   hospital, 966, 1091\*  
   immunology *see* Immunology  
   nervous system disorders, 1478-1479  
   opportunistic infections, 1550\*  
 Infectious disease, 1144\*  
   anthrax, 134-135\*  
   antibiotic, 137-138  
   bacillary dysentery, 239-240\*  
   brucellosis, 336\*  
   chickenpox and shingles, 437\*  
   chlamydial diseases, 442\*  
   clinical microbiology, 474\*  
   common cold, 509\*  
   diagnostic reagents, 252  
   diphtheria, 677\*  
   ehrlichiosis, 739\*  
   epidemic viral gastroenteritis, 836\*  
   foot-and-mouth disease, 911\*  
   gonorrhoea, 1012-1013\*  
   granuloma inguinale, 1016\*  
   herpes, 1069\*  
   infectious mononucleosis, 1145\*  
   infectious papillomatosis, 1145\*  
   influenza, 1148\*  
   John's disease, 1203\*  
   leprosy, 1245-1246\*  
   leptospirosis, 1246\*  
   malaria, 1307\*  
   measles, 1341\*  
   medical bacteriology, 1345  
   mumps, 1450\*  
   paleopathology, 1602  
   Pasteurellosis, 1619\*  
   plague, 1695-1696\*  
   pneumonia, 1730-1731\*  
   poliomyelitis, 1738\*  
   rabies, 1839\*  
   relapsing fever, 1885-1886\*  
   rickettsioses, 1920\*  
   rubella, 1934-1935\*  
   scarlet fever, 1954\*  
   skin, 2018  
   smallpox, 2023\*  
   strangles, 2122\*  
   syphilis, 2185\*  
   tetanus, 2214\*  
   tuberculosis, 2279\*  
   vaccination, 2317\*  
   whooping cough, 2387\*  
   yaws, 2410\*  
   zoonoses, 2420\*  
 Infectious-disease transmission, 836-837  
 Infectious mononucleosis, 740, 1145\*  
 Infectious myxomatosis, 1145\*  
 Infectious papillomatosis, 1145\*  
 Inference engine, 860-861  
 Inferior fruit, 842  
 Infertility, 1145\*, 1900  
 Infinite Boolean algebra, 278-279  
 Infinite series, 1988  
 Infinity, 1145-1146\*  
 Inflammation, 1146\*  
   complement, 514  
   mastitis, 1333\*  
   meningitis, 1354\*  
   nervous system disorders, 1479  
   phlebitis, 1655  
   reproductive system disorders, 1899, 1900  
   salmonellosis, 1941  
   spinal cord disorders, 2085  
 Inflammatory arthritis, 174  
 Inflammatory bowel disease, 1146\*  
 Inflammatory skin disease, 2018  
 Inflationary universe cosmology, 1146-1148\*  
   "new" inflationary cosmology, 1147  
   "old" inflationary model, 1146-1147  
   open inflation and cosmological constant, 1147-1148  
   primordial fluctuations, 1147  
   successes of inflation, 1147  
 Inflation, 809-810, 1148\*  
 Influenza, 1148\*  
 Influenza virus, 1731  
 Information content binary unit *see* Shannon  
 Information content decimal unit *see* Hartley  
 Information management, 1148-1149\*  
 Information systems, optical, 1555\*  
 Information systems engineering, 1149\*, 2187  
 Information technology, 1149\*  
   data communications, 616\*  
   data mining, 617\*  
   database management system, 618-619\*  
   digital computer, 668-670\*  
   digital-to-analog converter, 671-672\*  
   direct broadcasting satellite systems, 681-682\*  
   magnetic recording, 1293-1294\*  
   neural network, 1479-1480\*  
   word processing, 2397\*  
 Information theory, 1149-1150\*  
 Infrared astronomy, 1150-1151  
   astronomical targets, 1150-1151  
   color index, 504\*  
   ground-based, 1151  
   satellite astronomy, 1947  
   space missions, infrared, 1151  
   technology, infrared, 1150  
*Infrared Astronomy Satellite (IRAS)*, 1151, 1177  
 Infrared brazing, 289  
 Infrared imaging devices, 1151\*  
 Infrared lamp, 1151-1152\*  
 Infrared photography, 1666  
 Infrared radiation, 1152\*  
   radiology, 1863  
   radiometry, 1863\*  
   remote sensing, 1893-1894\*  
   wavelength measurement, 2375  
*Infrared Space Observatory (ISO)*, 1151  
 Infrared spectroscopy, 1152-1153\*  
 Infrared, 202-203, 1153\*  
 Ingolfiellidea, 103  
 Ingrown toenail, 822-823  
 Inguinal hernia, 1069  
 Inhibition hypothesis, 734  
 Inhibitor (chemistry), 1154\*  
   antioxidant, 144\*  
   enzyme inhibition, 833-834\*  
 Initial nuclear radiation (INR), 772  
 Injection chimera, 385  
 Injection electroluminescence, 769  
 Injection molding, 1722-1723, 1762  
 Ink, 1154\*  
 Ink-jet printing, 1774  
 Inland waterways transportation, 1154\*  
 Innate immunity, 1128  
 Innovation, prehistoric, 1768  
 Inoculation, 1154\*  
 Inorganic chemistry, 1154\*, 1404-1405  
 Inorganic compounds, 770  
 Inorganic electrochemistry, 688  
 Inorganic fibers, 1313  
 Inorganic photochemistry, 1154-1155\*  
 Inorganic polymer, 1155\*, 2009  
 Inositol, 1155\*  
 Input-output tubes, 785  
 INR *see* Initial nuclear radiation  
 Insect control, biological, 370, 743, 1155-1156\*  
 Insect pathology, 1156\*  
 Insecta, 1156-1158\*  
   Anoplura, 126-127\*  
   ant, 129\*  
   aphid, 149-150\*  
   Apterygota, 154\*  
   Archaeognatha, 160-161\*  
   bee, 261-262\*  
   beetle, 232  
   classification, 1156-1157  
   cockroach, 488\*  
   Coleoptera, 497-498\*  
   Collembola, 500\*  
   Diptera, 679\*  
   dragonfly, 700-701\*  
   ecdysone, 725\*

## Insecta—cont.

Embioptera, 726, 808\*  
 endocrine system, 815, 815\*  
 Endopterygota, 819\*  
 entomology, 827  
 Ephemeroptera, 835\*  
 eye, 865  
 flight, 894, 895  
 fly, 906\*  
 fossils, 1158  
 Hemiptera, 1063-1065\*  
 Homoptera, 1087-1088\*  
 Hymenoptera, 1112-1113\*  
 ichneumon, 1124\*  
 internal anatomy, 1157  
 metamorphosis, 1157-1158  
 morphology, 1157  
 Parainsecta, 1607-1608\*  
 wood degradation, 2394  
 Insecticide, 1158\*  
 detritus, 643  
 pesticide, 1639  
 Insectivora, 1158\*  
 hedgehog, 1058-1059\*  
 mole, 1417  
 shrew, 2003\*  
 Solenodon, 2042\*  
 tenrec, 2210\*  
 Insectivorous plants, 1159\*  
 pitcher plant, 1692\*  
 sundew, 2151  
 Venus' flytrap, 2330\*  
 Insolation, 1159\*  
 Insomnia, 2021  
 Inspection and testing, 1159\*  
 quality control, 1820-1821\*  
 software, 2032\*  
 Instant coffee, 434, 491  
 Instinctive behavior, 1159-1160\*  
 Instrument flight rules (IFR), 55-57  
 Instrument landing system (ILS), 1160\*  
 air navigation, 52  
 automatic landing system, 225\*  
 electronic navigation systems, 789  
 homing, 1086  
 Instrument science, 1160-1161\*  
 Instrument transformer, 1161\*  
 Instrumental conditioning, 1161\*  
 Instrumentation:  
 calibration, 356\*  
 Instrumentation amplifier, 1161\*  
 Insulation (heat), 934, 1055\*  
 Insulation board, 456  
 Insulation resistance testing, 1162\*  
 Insulator:  
 electric, 744-745\*  
 polaron, 1738\*  
 traps in solids, 2265\*  
 see also Electrical insulation  
 Insulin, 1162\*  
 diabetes mellitus, 590-591, 653  
 pancreas, 1604\*  
 Intaglio (gemology), 1162\*, 1544  
 Intaglio printing, 1774  
 Integers, 1521-1522  
 Integral equation, 1163\*  
 Integral transform, 1163\*, 1227  
 Integrated-circuit filter, 1163-1164\*  
 Integrated circuits, 711, 1164-1166\*  
 BiCMOS integrated circuits, 1165  
 bipolar integrated circuits, 1164  
 design of, 1166  
 differential amplifier, 661  
 digital computer, 668, 670  
 digital-to-analog converter, 672  
 fabrication of, 1165-1166  
 gallium arsenide circuits, 1166  
 microprocessor, 1389-1390\*  
 microwave, 1392  
 MOS integrated circuits, 1164-1165  
 power integrated circuits, 1763\*  
 printed circuits, 1773\*  
 resistor, 1903  
 semiconductor memories, 1982-1983\*  
 surface-acoustic-wave devices, 2167-2168  
 switched capacitor, 2174-2175\*  
 Integrated optical circuit, 1166  
 Integrated optics, 1166\*, 1554-1555  
 Integrated services digital network (ISDN), 1166-1167\*  
 Integrated thermionic circuit, 955  
 Integration, 1167-1168\*  
 Integrative therapies, 1804  
 Integument:  
 chromatophore, 450\*  
 pigmentation, 1686\*  
 scale (zoology), 1952\*

## Integument—cont.

skin, 2017-2018\*  
 Integumentary pattern, 837, 1168\*  
 Intelligence, 1168-1169\*  
 developmental psychology, 650-651  
 extraterrestrial intelligence, 863-864\*  
 mental retardation, 1355\*  
 Intelligence quotient (IQ), 1169  
 Intelligence test, 1168-1169  
 Intelligent machine, 1169\*  
 Intelligent meters, 2370  
 Intelligent networks, 2200  
 Intelligent transportation systems (ITS), 2255  
 Intelsat, 451  
 Intensity fluctuation spectroscopy, 1835  
 Intercalation compounds, 1169-1170\*  
 Intercom see Intercommunicating system  
 Intercommunicating system, 1170\*  
 Interface of phases, 1170\*  
 emulsion, 814\*  
 monomolecular film, 1434\*  
 surface physics, 2169-2170\*  
 surface tension, 2170\*  
 Interfacial polarization, 1736  
 Interference:  
 electrical, 757\*  
 virus, 2345\*  
 Interference filter, 1170\*  
 Interference microscope, 1170\*  
 Interference of waves, 1171\*  
 electron diffraction, 779-780\*  
 fringe (optics), 938\*  
 interference filter, 1170\*  
 Interference phenomena, 2406  
 Interferometric fiber-optic gyro (IFOG), 1036  
 Interferometric synthetic aperture radar (InSAR), 987  
 Interferometry, 1171-1172\*  
 acoustic interferometer, 16\*  
 astronomical observations, 179, 194  
 atom optics, 208\*  
 Fabry-Perot stellar interferometer, 1172  
 Fizeau interferometer, 1172  
 holographic, 960, 1172  
 holography, 1084  
 Mach-Zehnder interferometer, 1172  
 Michelson interferometer, 1171-1172  
 Michelson stellar interferometer, 1172  
 phase-shifting, 1172  
 plasma diagnostics, 1719  
 shearing interferometer, 1172  
 speckle, 1172, 2074\*  
 spectroscopy, 2076  
 Twyman-Green interferometer, 1172  
 Interferon, 545, 609, 610  
 Interhalogen compounds, 1172-1173\*  
 Interleukin, 545, 609-610  
 Intermediate-frequency amplifier, 1173\*  
 Intermediate vector boson, 1173\*  
 Intermetallic compounds, 1173-1174\*  
 Intermodal transportation, 2264  
 Intermodulation, 629  
 see also Cross modulation  
 Intermolecular forces, 1174\*  
 dipole-dipole interaction, 678\*  
 gel, 975  
 molecular adhesion, 1417\*  
 supramolecular chemistry, 2166\*  
 surface physics, 2170  
 Internal combustion engine, 1174-1175\*  
 automotive engine, 226, 229\*  
 boat propulsion, 309\*  
 carburetor, 371-372\*  
 chemical fuel, 425\*  
 combustion chamber, 507-508\*  
 diesel cycle, 659\*  
 diesel engine, 659-660\*  
 engine cooling, 822-823\*  
 engine lubrication, 823\*  
 engine manifold, 823-824\*  
 fuel injection, 941-942\*  
 fuel pump, 942\*  
 gasoline, 969-970\*  
 hydraulic valve lifter, 1101-1102\*  
 ignition system, 1126\*  
 marine engine, 1320\*  
 Otto cycle, 1587\*  
 reciprocating aircraft engine, 1874-1875\*  
 rotary engine, 1933\*  
 spark knock, 2071\*  
 spark plug, 2071\*  
 supercharger, 2153\*  
 valve train, 2321\*  
 vapor lock, 2324\*  
 volumetric efficiency, 2357\*  
 Internal EMP, 772  
 Internal energy, 1175\*

Internal-shoe brake, 840  
 International Atomic Time (TAI), 711, 2240  
 International Celestial Reference Frame (ICRF), 189  
 International Code of Nomenclature of Bacteria, 244  
 International Code of Zoological Nomenclature, 2419  
 International Date Line, 1175-1176\*  
 International Practical Temperature Scale, 863  
 International Space Station, 2060, 2066  
 satellite (spacecraft), 1946  
 space flight, 2060  
 space power systems, 2061  
 International System of Units (SI), 760, 1678-1680  
 measure, 1341\*  
 time, 2240  
 units of measurement, 2302  
 International units (electrical), 760  
 Internet, 1176-1177\*  
 commerce on, 1176-1177  
 domain name system, 1176  
 TCP/IP, 1176  
 technological features, 1176  
 wide-area networks, 2388  
 see also World Wide Web  
 Internet Protocol (IP), 1176  
 Interpersonal therapies, 1804  
 Interplanetary matter, 1177\*  
 Interplanetary propulsion, 1177\*  
 Interpolation, 1177\*  
 curve fitting, 600-601\*  
 numerical analysis, 1523  
 Interpreted programming language, 524  
 Interrupt controller, 1389  
 Interstellar dust, 1150  
 Interstellar extinction, 1177\*, 1419-1420  
 Interstellar materials, 2306  
 Interstellar matter, 1177-1178\*  
 astrochemistry, 1178  
 globule, 1006\*  
 Herbig-Haro objects, 1068\*  
 molecular cloud, 1419-1420\*  
 molecules, 1178  
 nebula, 1470  
 Interstellar Convergence Zone (ITCA), 723  
 Interventional radiology, 1347  
 Intestine, 1178-1179\*  
 colon, 502\*, 607  
 digestive system, 666, 667  
 gastrointestinal tract disorders, 971  
 small, 606-607  
 Intra-Americas Sea, 1179\*  
 Intraclastic, 330  
 Intranets, 2388  
 Intraplate earthquake, 655, 723  
 Intraplate islands, 1593  
 Intrinsic semiconductor, 1980  
 Introduced species, 1179  
 Intron, 1179\*  
 Intrusion detection, 525-526  
 Invasion ecology, 1179-1180\*  
 Invasive species:  
 endangered species, 814  
 invasion ecology, 1179, 1180  
 Invention, prehistoric, 1768  
 Inventory control, 1180\*, 1333-1334  
 Inverse scattering theory, 1180\*  
 Inverse-square law, 1180-1181\*  
 Inverse-square law for stationary charges, 761  
 Inverse Zeeman effect, 2413  
 Invertebrate embryology, 1181-1182\*  
 Invertebrate pathology, 1156, 1182\*  
 Invertebrates:  
 endocrine system, 732\*  
 eye, 864-865\*  
 forest ecosystem, 917  
 heart, 1052\*  
 migratory behavior, 1400-1401\*  
 nervous system, 1476-1477\*  
 Permian, 1635  
 Inverted microscope, 1557  
 Involuntary muscle, 1450  
 Involute, 1182\*  
 Io, 1207, 1701  
 Iodine, 1183\*  
 antiseptic, 145\*  
 thyroxine, 2237-2238\*  
 Ion, 1183\*  
 deep inelastic collisions, 627-628\*  
 Donnan equilibrium, 696\*  
 electrolyte, 770-771\*

## Ion—cont.

electromagnetic pulse, 772  
 electron affinity, 777\*  
 electron capture, 777\*  
 hydrogen, 1106\*  
 hydrolysis, 1108\*  
 negative, 1471\*  
 properties, 374-375  
 Ion beam mixing, 1183-1184\*  
 Ion channels, 2006  
 Ion clocks, 1090  
 Ion deposition printing, 1774  
 Ion engines, 798  
 Ion exchange, 1184-1185\*  
 applications, 1184-1185  
 electrode potential, 767  
 materials, ion-exchange, 1184  
 membranes, 1185  
 sugar, 2144  
 Ion implantation, 1185\*, 1981  
 Ion-permeable membrane cells, 762  
 Ion probing see Secondary ion mass spectrometry  
 Ion propulsion, 1185-1186\*  
 Ion-selective membranes and electrodes, 1186\*  
 electrochemical process, 762\*, 762-763\*  
 electrode potential, 767  
 Ion-solid interactions, 1186-1187\*  
 Ion sources, 1187\*  
 Ion transport, 1187\*  
 absorption (biology), 5\*  
 ionophore, 1189-1190\*  
 Ionic bonding, 367  
 cohesion, 436, 495  
 ionic crystals, 1187  
 Ionic crystals, 1187-1188\*, 1288  
 Ionic currents see Biopotentials and ionic currents  
 Ionic equilibrium, 1188\*  
 pK, 1694\*  
 solubility product constant, 2046\*  
 Ionization, 1188\*  
 cell-surface, 397\*  
 delta electrons, 633-634  
 plasma (physics), 1718  
 Ionization chamber, 796, 1188-1189\*  
 Ionization detector, 1615-1616  
 Ionization gage, 1189\*  
 Ionization potential, 1189\*  
 electron affinity, 777\*  
 electron configuration, 777-779\*  
 Ionizing radiation:  
 dosimeter, 699\*  
 ionophore, 1189-1190\*  
 radiation biology, 1842-1843  
 radiation chemistry, 1843-1844  
 radiation shielding, 1845\*  
 radiology, 1863\*  
 Ionosphere, 202, 1190\*  
 rocket astronomy, 1928\*  
 upper-atmosphere dynamics, 2308  
 Iosipidae, 760  
*Ipomoea aquatica*, 1579  
*Ipomoea batatas*, 1760  
 IQ see Intelligence quotient  
 Iridaceae, 1940  
 Iridium, 1190\*  
 Iridophore, 397  
 Irish potato, 1759-1760\*  
 Irome, 2314  
 Iron, 1190-1191\*  
 goethite, 1010\*  
 hematite, 1061\*  
 magnetite, 1300\*  
 metabolism, 2005  
 siderophores, 2005  
 steel manufacture, 2108\*  
 taconite, 2190\*  
 Iron Age, 1768  
 Iron alloys, 1191\*  
 cast iron, 377\*  
 steel, 2108\*  
 wrought iron, 2399\*  
 Iron-core reactor, 1872\*  
 Iron formation, banded, 249-250\*  
 Iron metabolism, 1191\*  
 Iron metallurgy, 1191\*  
 Iron meteorites, 1375  
 Ironwood, 1191\*  
 Irradiation:  
 food, 821  
 isotopic, 1198-1199\*  
 Irrational number, 74  
 Irregularity, 1191\*  
 Irrigation (agriculture), 361, 1191\*  
 Ischemia, 408

ISDN see Integrated services digital network  
 Isentropic deceleration, 1693  
 Isentropic flow, 1192\*, 1760  
 Isentropic process, 1192\*  
 Isentropic surfaces, 1192\*  
 Ising model, 1192-1193\*  
 Island:  
   arctic and subarctic islands, 166\*  
   Australia, 219\*  
   barrier islands, 253\*  
   Earth, 718  
   East Indies, 723-724\*  
   invasion ecology, 1179  
   marine geology, 1322  
   mid-oceanic ridge, 1321  
   New Zealand, 1485-1486\*  
   oceanic islands, 1531\*  
   ophiolite, 1549  
   Pacific islands, 1593\*  
 Island arcs, 720  
 Island biogeography, 1193\*  
 Islands of Langerhans, 1604  
 Isoantigen, 1193\*  
 Isobar (meteorology), 1193\*  
 Isobar (nuclear physics), 1193\*  
 Isobaric process, 1193\*  
 Isobryales, 1193\*  
 Isocrinida, 161  
 Isocyanate, 1192-1193  
 Isocyanic acid, 1193  
 Isoelectric focusing, 794  
 Isoelectric point, 1194\*  
 Isoelectronic sequence, 1194-1195\*  
 Isoetiales, 1195\*  
 Isolaimeida, 1195\*  
 Isolaimeoidea, 1195  
 Isolator, 2374  
 Isomer:  
   molecular isomerism, 1420-1421\*  
   nuclear isomerism, 1510\*  
 Isomerase, 748, 833  
 Isomerization, 1195\*  
 Isometric process, 1195\*  
 Isopoda, 1195\*  
   Anthuridea, 136\*  
   Asellota, 180\*  
   Epicaridea, 835-836\*  
   Flabellifera, 891\*  
   Gnathiidea, 1008-1009\*  
   Oniscoidea, 1543\*  
   Phreatoicoidea, 1674\*  
   Valvifera, 2321\*  
 Isoprene:  
   terpene, 2210\*  
   triterpene, 2274\*  
 Isopropyl alcohol, 130  
 Isoptera, 1195-1196\*  
   Lepidoptera, 1242-1245\*  
   Mallophaga, 1307-1308\*  
   Mecoptera, 1345\*  
   metamorphosis, 1372\*  
   mosquito, 1438\*  
   Neuroptera, 1481\*  
   Plecoptera, 1726\*  
   Protura, 1797\*  
   Psocoptera, 1799\*  
   Pterygota, 1805\*  
   Siphonaptera, 2013-2014\*  
   social insects, 2027-2028\*  
   Thysanoptera, 2238\*  
   Thysanura, 2238\*  
   Trichoptera, 2270\*  
   Zoraptera, 2420\*  
 Isopycnic, 1196\*  
 Isospora, 1348  
 Isostasy, 1196\*  
 Isotach, 1196\*  
 Isotactic polymer, 1747  
 Isothermal chart, 1196\*  
 Isothermal process, 1197\*  
 Isothermal titration calorimeter, 245  
 Isotone, 1197\*  
 Isotope:  
   chemistry, 431  
   dating methods, 620  
   heat-producing, 719  
   lead isotopes, 1236\*  
   organic geochemistry, 1571  
   radioisotope, 1861\*  
 Isotope dilution techniques, 1197-1198\*  
 Isotope separation, 1198\*  
 Isotope separator on-line (ISOL) technique, 1854  
 Isotope shift, 1198\*  
 Isotopic anomalies, 1375  
 Isotopic irradiation, 1198-1199\*, 1978-1979\*

## J

Isotopic spin, 109  
 Isotope geochemistry, 985  
 Isovalent hyperconjugation, 987  
 Isovel see Isotach  
 Italian chestnut, 383  
 Italian cypress, 543  
 IUE see International Ultraviolet Explorer  
 Ivory, vegetable, 2328\*  
*Ixodes*, 1281  
*Ixodidae*, 1199\*  
  
 J particle, 721  
*J/psi* particle, 1201\*  
 Jacana, 364  
 Jacanidae, 364  
 Jacanoidea, 364  
 Jack-in-the-pulpit, 138  
 Jackal, 634, 694  
 Jacopini, Giuseppe, 8782  
*Jaculus jaculus*, 1202  
 Jade, 1201\*  
 Jadeite, 1201\*  
 Jahn, H. A., 1201  
 Jahn-Teller effect, 1201\*  
 Jamming, 1201\*  
*Jamoytius*, 113-114  
 Japanese chestnut, 383, 436  
 Japanese dogwood, 634  
 Japanese marten, 1328  
*Japygidae*, 618  
 Jar fly, 962  
 Jasmine, 847  
 Jasper, 1201\*  
 Jaundice, 1201-1202\*, 1265  
 Java, 524, 1783, 2030  
 Jawless vertebrates, 1202\*  
 Jellyfish, 1111  
 Jenner, Edward, 2023, 2317  
 Jerboa, 1202\*  
 Jersey type sweet potato, 1760  
 Jesus Cristo lizard, 2092  
 Jet (gemology), 1202\*  
 Jet compressor, 456, 518  
 Jet engine:  
   pulse jet, 1807\*  
   ramjet, 1867-1868\*  
   turbojet, 2286\*  
 Jet flow, 1202-1203\*  
 Jet fuel, 1103, 1203\*  
 Jet propulsion, 968, 1203\*  
   see also Jet engine  
 Jet stream, 1203\*  
   effect on aircraft, 35  
   tropical meteorology, 2277  
 Jet velocity, 1203\*  
 Jetty, 427  
 Jewel bearing, 1203\*  
 Jewitt, David, 1219  
 JFET see Junction-gate field-effect transistor  
 Jicama, 1579  
 Jimson weed, 2038  
 Jobst, G., 785  
 John's disease, 1203\*  
 Johnson noise, 959  
 Joint (anatomy), 1203-1204\*  
   ligament, 1249-1250\*  
   tendon, 2210  
 Joint (structures), 1204\*  
   bolted joint, 312\*  
   mechanism, 1344-1345  
   structural connections, 2133-2134\*  
   universal joint, 2305\*  
   welded joint, 2382\*  
 Joint disorders:  
   arthritis, 174\*  
   foot disorders, 911-912\*  
   rheumatism, 1913\*  
 Joint replacement, 1788  
 Jojoba, 1204\*  
 Jordan, P., 905, 1251  
 Josephson, Brian D., 1204, 2283  
 Josephson arrays, 775  
 Josephson effect, 761, 1204\*  
 SQUID, 2093-2094\*  
   superconducting devices, 2154  
   tunneling in solids, 2283\*  
 Josephson junction, 1204  
 Joule, 671  
 Joule, J. P., 477, 685, 743, 1204  
 Joule cycle see Brayton cycle

Joule heat, 759  
 Joule's law, 1204\*  
 Jugatae, 1245  
 Juglandaceae, 1205  
 Juglandales, 1205\*  
   Hamamelidae, 1044  
   walnut, 2362\*  
*Juglans*, 1205  
 Jumping plant lice, 963  
 Juncaceae, 1205  
 Juncus, 449, 1205\*  
 Junction detector, 527, 1205\*  
 Junction diode, 1205\*  
   semiconductor rectifier, 1983  
   tunnel diode, 2283\*  
   varactor, 2324\*  
   Zener diode, 2414\*  
 Junction transistor, 1205\*  
 Jung, Carl, 1803  
 Jungermanniales, 1206\*  
 Jungermannidae, 1206\*  
   Calobryales, 357-358\*  
   Metzgeriales, 1381\*  
   Takkakiales, 2191\*  
 Juniper:  
   evergreen, 857  
   Pinales, 1688  
*Juniperus virginiana*, 344  
 Jupiter, 1206-1207\*  
   atmosphere, 1207  
   infrared astronomy, 1151  
   interior composition and structure, 1207  
   magnetosphere, 1207  
   planet, 1698  
   planetary physics, 1700, 1701  
   radio astronomy, 1847  
   red spot, 1206, 1207  
   ring, 1207  
   satellites, 1207-1208  
   telescopic appearance, 1206  
   transit, 2261  
 Jurassic, 1208\*  
   animal evolution, 120  
   dinosaur, 675  
   Jute, 1208\*  
 Juvenile hormone, 732  
 Juvenile-onset diabetes, 591, 1129

## K

Kagu, 912  
 Kairone, 370  
 Kalanchoes, 1952  
 Kale, 1209\*  
 Kaliophyllite, 1209\*  
 Kallmann's syndrome:  
   olfaction, 1538  
   pituitary gland disorders, 1694  
 Kalotermitidae, 1195  
 Kalsilite, 1209\*  
 Kaman filter, 848  
 Kame, 1209\*  
 Kang kong, 1579  
 Kangaroo, 1209\*  
 Kaolinite, 1209\*  
   commercial clay, 469  
   clay minerals, 470  
   clays, 413, 468  
   halloysite, 1041-1042\*  
 Kapitza, P. L., 1209  
 Kapitza resistance, 1209-1210\*  
 Kapok tree, 1210\*  
 Kaposi's sarcoma, 19, 2018  
 Kármán vortex street, 1210\*  
 Karmarkar, N. K., 1257  
 Karst topography, 1210\*  
 Kater's reversible pendulum, 1624  
 Kauri, 1688  
 Keating, R. E., 418  
 Keenan, P. C., 2073  
 Kekule, F. A., 1904  
 Kellman, E., 2073  
 Kelp, 1647  
 Kelvin, William Thomson, Lord, 719, 2208, 2234  
 Kelvin (temperature scale), 2208, 2209  
 Kelvin bridge, 1210\*  
 Kelvin cores, 1597  
 Kelvin's circulation theorem, 1210\*  
 Kelvin's minimum-energy theorem, 1211\*  
 Kelvin's theorem, 2359  
  
 Kenaf, 1211\*  
 Kennel cough, 1211\*  
 Kennelly, A. E., 1188  
 Kennelly-Heaviside layer, 1188  
 Kentucky bluegrass, 271, 308  
*Kenyapithecus*, 829  
 Kepler, Johannes, 385, 1565, 1698, 1886  
 Kepler's laws, 1211-1212\*, 1698, 1699  
 Kernite, 279  
 Kerogen, 1212\*, 1537  
 Kerosine, 1212\*  
   aircraft fuel, 60\*  
   petroleum products, 1644-1645  
 Kerr, John, 1212  
 Kerr effect, 715, 1212\*, 1666  
   see also Magneto-optic Kerr effect  
 Ketene, 1212\*  
 Ketone, 1212-1213\*  
   acetone, 11  
   camphor, 360-361\*  
 Key deer, 567  
 Key service unit (KSU), 1213  
 Key telephone system, 1213\*  
 Keyboard instruments, 1455  
 Keyhole limpet, 144  
 Kiang, 635  
 Kibble, T. W. B., 720  
 Kidney, 1213\*, 2312  
   countercurrent exchange (biology), 507-508  
   parathyroid, 1611  
   transplantation biology, 2263  
 Kidney disorders, 1213-1214\*  
 Killer cells, 546  
 Killifish, 182-183  
 Kiln, 1214\*  
 Kimberlite, 654, 1214\*, 1655  
 Kinematic analysis, 2135  
 Kinematics, 1214\*, 1344-1345  
 Kinesin, 394-395  
 Kinetic energy:  
   diffuser, 665  
   virial theorem, 2341\*  
 Kinetic methods of analysis, 1214-1215\*  
 Kinetic theory of matter, 1215\*  
   Avogadro's law, 235\*  
   Boyle's law, 324\*  
   Brownian movement, 336\*  
   diffusion, 665  
   mean free path, 1341\*  
   thermal conduction in solids, 2220\*  
   viscosity, 2345-2346\*  
 Kinetics:  
   chemical, 425-426\*  
   classical mechanics, 1215-1216\*  
   organic reaction mechanism, 1573  
 Kinetoplastida, 1216, 2278  
 King Bolete, 984, 1112  
 King cobra, 429, 2092  
 King orange, 1310  
 King vulture, 260  
 Kingfisher, 494  
 Kinorhyncha, 1216\*, 1272-1273  
 Kirchhoff's law of heat radiation, 935  
 Kirchhoff's laws of electric circuits, 1216\*  
 Kirchhoff's voltage law, 776  
 Kite, 260, 1216-1217\*  
 Kiwifruit, 1217\*  
*Kiyohimeidae*, 1266  
*Klebsiella*, 1217\*  
*Klebsiellaceae*, 741  
 Klein, F., 1338  
 Klystron, 1217\*  
   electron tube, 785  
   noise generator, 685  
 Klystron amplifier, 1392  
*Kneriidae*, 898  
*Knifefish*, 673  
 Knowledge base, 860, 861  
 Knudsen number, 966, 1217\*  
 Koala, 1217-1218\*  
 Kohlberg, L., 651  
 Köhler, W., 1432  
 Kohlrabi, 1218\*  
 Kolbe reaction, 765  
 Komodo dragon, 1193, 1431  
 Kompfner, R., 785  
 Kondo effect, 1218\*  
 Korsakoff's syndrome, 233  
 Korteweg, D. J., 2045  
 Kowalski, Rboert A., 1783  
 Krabbe disease, 2083  
 Kramers, H. A., 627, 2384  
 Kremer, H., 980

Krill, 855  
 Kron, G., 591  
 Kronig, R., 627  
 Kronig-Penney model, 1218\*  
 Krypton, 1218\*  
 Kudzu, 1218-1219\*  
 Kugelberg-Wielander disease, 1453  
 Kuiper, G., 177, 1219, 1476  
 Kuiper Belt, 186, 1219\*  
   interplanetary matter, 1177  
   satellite astronomy, 1946  
   solar system, 2041  
 Kulan, 635  
 Kumar, S. S., 335  
 Kumquat, 1219\*  
 Kuroshio, 1219, 1529  
*Kurthia*, 500  
 Kutorgina, 161, 1219\*  
 Kwashiorkor, 1361  
 Kyanite, 1219-1220\*

**L**

Laboratory, radiochemical, 1859\*  
 Laboulbeniales, 848  
 Labradorite, 1221\*  
 Labyrinthodontia, 1221\*, 2208  
 Labyrinthulia, 1221\*, 1914  
 Labyrinthulida, 1221  
 Lac insect, 1998  
 Lace bug, 944  
 Lacquer, 1221\*  
 Lacquer tree 1944  
   see also Varnish tree  
 Lacquers, 1741  
 Lacrimal gland, 1221\*  
 Lactam, 1221\*  
 Lactase, 1221\*  
 Lactate, 1221-1222\*  
 Lactation, 289, 1222\*  
   mammary gland, 1310\*  
   mastitis, 1333\*  
 Lactic acid, 1221-1222  
 Lactone, 1221, 1222\*  
 Lactose, 1222\*, 2145  
*Lactuca sativa*, 1246  
 Lacydonidae, 760  
 Laevicaudata, 1222\*  
 Lagenostomales, 539  
 Lagomorpha, 1222\*  
*Lagopus* species, 260  
 Lagrange, J. L., 412  
 Lagrange density functions, 2326  
 Lagrange's equations, 1222\*  
 Lagrangian function, 1223\*  
 Lake, 1223\*  
   biogeochemistry, 282  
   eutrophication, 856  
   fresh-water ecosystem, 937, 938  
   limnology, 1256\*  
   meromictic lake, 1358\*  
   reservoir, 1901\*  
 Lake Turkana, 924, 926  
*Lama glama*, 1266  
*Lama guanicoe*, 1266  
*Lama pacos*, 87  
*Lama vicugna*, 1266  
 Lambert's law, 5  
 Lambs, 1619  
 Lamellibranchia, 1223, 1223\*, 2194  
 Lamellisabellidae, 2218  
 Lamiaceae, 1223, 2072  
 Lamiales, 173, 1223\*  
   basil, 256-257\*  
   sage, 1940\*  
   spearmint, 2072\*  
 Laminar flow, 285, 1223-1224\*  
*Laminaria japonica*, 1224  
 Laminariaceae, 1224  
 Laminariales, 1224\*  
 Laminates, composite, 516\*  
 Lamp, 1224\*  
   arc, 141  
   fluorescent, 813, 903\*  
   incandescent lamp, 1135\*  
   infrared lamp, 1151-1152\*  
   mercury-vapor, 1357\*  
   metal halide, 1366\*  
   neon glow, 1474-1475\*  
   polarized light, 1736-1737\*  
   sodium-vapor, 2029-2030\*

Lamp—cont.  
   sun, 2152\*  
   ultraviolet, 2295\*  
   vapor, 2324  
   xenon, 2407  
 Lamp oil see Kerosine  
 Lampreys:  
   jawless vertebrates, 1202  
   Petromyzontida, 1646\*  
 Lampridiformes, 1224\*  
 Lamproites, 654  
 Lamprophyre, 1224\*  
 LAN see Local-area network  
 Lancelet, 404-405  
 Land drainage (agriculture), 1224\*  
 Land ice, 1966  
 Land management, 2364  
 Land plants, 1702-1703  
 Land reclamation, 1224-1225\*, 1695  
 Land-use planning, 1225\*  
   forest management, 919  
   urban forestry, 921  
 Land-use practice, 645  
 Landfills, 1142  
 Landforms, volcanic, 2352  
 Landing craft, air-cushioned (LCAC), 1468  
 Landing gear, 1225\*  
 Landscape architecture, 1225-1226\*  
 Landscape ecology, 1225, 1226\*  
 Landslide, 1226\*  
   earthquake, 723  
   mass wasting, 1332  
 Langevin function, 1227\*  
 Langmuir circulation, 1226-1227\*  
 Langmuir probe, 1719  
 Languages, 2077  
   see also Programming languages  
 Lanolin, 1227\*  
 LANS see Local-area networks  
 Lantern fly, 962  
 Lanthanide contraction, 1227\*  
 Lanthanum, 20, 1227\*  
 Lap weld, 2372, 2382  
 Lapis lazuli, 1235  
 Laplace, P. S., 412, 744, 1227  
 Laplace, Pierre Simonn de, 648  
 Laplace equation, 1760  
 Laplace transform, 1227\*, 2413  
 Laplace's differential equation, 1227\*  
 Laplace's irrotational motion, 1227-1228  
 Laplace's law see Ampère's law  
 Laplacian, 1228\*  
 Lapwing, 364  
 Larch, 1228\*  
 Larch tree, 1688, 2266  
 Large control systems, 2186  
 Large Electron Positron Storage Ring (LEP), 1076  
 Large Hardon Collider (LHC), 1077  
 Large intestine, 666  
   see also Colon  
 Large Magellanic Cloud, 1267, 1288, 2160  
 Large-signal models, 758  
 Large systems control theory, 1228\*  
 Lari, 365  
 Lariat ethers, 1286  
 Laridae, 365  
*Larix* species, 1228  
 Larkspur, 1869  
 Larmor precession, 1228\*  
 Larmor theorem, 1228  
 Larnite, 1228\*  
 Lartet, E., 516  
 Laryngitis, 1229  
 Larynx, 1228\*  
   speech, 2077, 2078  
   vocal cords, 2350\*  
 Larynx disorders, 1229\*  
 Laser, 1229-1230\*  
   atom, 207-208\*  
   atom optics, 208\*  
   chemical, 373  
   chemical dynamics, 421  
   coherence, 494  
   continuous-wave gas lasers, 1229  
   electrophoresis, 794  
   free-electron, 834, 1230  
   gas-discharge, 862  
   gas-dynamic, 862  
   high-power, short-pulse, 953  
   monochromaticity, 1230  
   optical fibers, 1554  
   optical guided waves, 1554-1555\*  
   optical isolator, 1555-1556  
   optical pulses, 1559\*  
   optical pumping, 1560\*  
   quantum electronics, 1826, 1826\*

Laser—cont.  
   schlieren photography, 1958-1959  
   semiconductor (diode) lasers, 1229-1230  
   short-pulsed gas lasers, 1229  
   solid-state lasers, 1229  
   speckle, 2074  
   thermotherapy, 2231  
   time-interval measurement, 2241  
   tunable, 1230  
 Laser alloying, 1230\*  
 Laser cooling, 1230-1231\*  
 Laser photobiology, 1231\*  
 Laser photochemistry, 1231\*  
 Laser radar see Lunar laser ranging  
 Laser-scanning fluorescence microscopy, 902-903  
 Laser-solid interactions, 1231\*  
 Laser spectroscopy, 1232\*, 2076  
 Laser Tracking Network, 2068-2069  
 Laser trap, 1617  
 Laser video disk see Video disk recording  
 Laser welding, 1232\*  
*Lasius flavus*, 129  
 Lassa fever, 860  
 Lassell, W., 1476  
 Latent image, 1232\*  
 Lateral bud, 300  
 Lateral line system, 1232\*  
 Lateral meristem, 150, 1232\*, 1714  
 Laterite, 1232\*  
*Latimeria*, 120  
*Latimeria chalumnae*, 488-489  
 Latitude and longitude, 1232-1233\*  
   Antarctic Circle, 129-130\*  
   Arctic Circle, 166\*  
   meridian, 1357\*  
   terrestrial coordinate system, 2211  
   Tropic of Cancer, 2276-2277\*  
   Tropic of Capricorn, 2277\*  
 Lattice (mathematics), 1233\*  
 Lattice models, 1826  
 Lattice vibrations, 1233\*, 1340  
 Laue method (x-ray diffraction), 961, 2402  
 Launch complex, 1233\*  
 Lauraceae, 208, 322, 405, 1233  
 Laurales, 854, 1233\*  
 Laurasia:  
   Pennsylvanian, 1626  
   Permian, 1635\*  
   supercontinent, 2157  
 Lauratonematidae, 741  
 Laurel, 857  
 Lava, 1233-1234\*  
   hot spots (geology), 1091\*  
   magma, 1289\*  
   obsidian, 1529\*  
   pumice, 1810\*  
   spilite, 2084\*  
   volcanic glass, 2351\*  
   volcanology, 2353  
*Lavandula*, 1223  
 Lavender, 1223  
 Law:  
   of additive pressure see Dalton's law  
   of conservation of matter and energy, 379-380  
   of definite composition see Definite composition, law of  
   of gravitation (Newton), 905  
   of motion (Newton), 824, 1486, 1486\*  
   of multiple proportions, 380, 1446, 1446\*  
   nomograph, 1493  
   of reflection, 1396, 1880  
   of refraction, 1396  
   of segregation (genetics), 1353  
 Lawrencium, 1234\*  
 Lawson, J. D., 1234  
 Lawson criterion, 1234\*  
 Lawson cypress, 344, 543  
 Lawsonite, 1234\*  
 Layered intrusion, 1234\*  
 Layout drawing, 1234\*  
 Lazurite, 1235\*  
 Leaching, 1235\*, 2047  
 Lead, 1235\*  
   galena, 957\*  
   pyromorphite, 1816-1817\*  
 Lead alloys, 1235\*  
   copper, 492  
   pewter, 1646\*  
 Lead bronze, 295  
 Lead isotopes (geochemistry), 1236\*  
 Lead metallurgy, 1236\*

Leading-edge coast, 427  
 Leaf, 1236-1238\*  
   abscission, 4\*  
   anatomy, 1238  
   deciduous plants, 625\*  
   morphology, 1237-1238  
 Leaf bud, 300  
 Leafhopper, 962  
 Leafy liverwort, 1206  
 Leakage inductance, 1139  
 Leakey, L. S. B., 831, 926  
 Leap seconds, 620  
 Learning theory:  
   conditioned reflex, 532\*  
   instrumental conditioning, 1161\*  
 Least-action principle, 1238\*, 2326  
 Least-squares method, 600-601, 1238\*  
 Leather, 708  
 Leavitt, Henrietta, 406  
 Lebesgue, H. L., 1168  
 Lecanophalloidea, 1238-1239\*  
 Lecanorales, 1239\*  
 Le Chatelier's principle, 1239\*  
 Lecithin, 1658  
 Leclanche cell, 640  
*Leclercqia complexa*, 1794  
 Lectins, 1239\*  
 Lecythidales, 328, 613, 1239\*  
 LED see Light-emitting diode  
 Lederberg, J., 241  
 Ledocarpaceae, 996  
 Leech:  
   Annelida, 125  
   Hirudinea, 1081\*  
 Leed see Low-energy electron diffraction  
 Leek, 1543  
 Legendre functions, 1239-1240\*  
*Legionella pneumophila*, 1240  
 Legionnaire's disease, 1240\*  
 Legume, 1240\*  
   alfalfa, 71\*  
   bean, 260-261\*  
   clover, 479\*  
   cowpea, 574\*  
   Fabales, 869\*  
   forage crops, 912\*  
   kudzu, 1218-1219\*  
   lentil, 1241\*  
   lespedeza, 1246\*  
   lupine, 1280\*  
   peanut, 1621\*  
   soybean, 2057\*  
 Legume forages, 1240\*  
 Leguminosae:  
   derris, 643\*  
   lectins, 1239  
 Leibniz, G., 895  
 Leighton, R., 2159  
*Leipodiren paradoxa*, 681  
*Leishmania*, 1348, 2278  
*Leitneria floridana*, 1240  
 Leitneriales, 1044, 1240\*  
 Lemaitre, G., 242  
 Lemniaceae, 1223  
 Lemming, 1240\*  
*Lemmus lemmus*, 1240  
 Lemnaceae, 138, 149  
 Lemniscate of Bernoulli, 1241\*  
 Lemon, 1241\*  
 Lemuroids, 1771  
 Length, 1241\*, 1679-1680, 2303  
 Lens (eye), 781  
 Lens (optics), 1241\*  
   diopter, 677\*  
   electrostatic, 796-797\*  
   eyepiece, 868\*  
   focal length, 906\*  
   gravitational lens, 1023\*  
   gunsights, 1033\*  
   magnetic, 1292\*  
   magnification, 1304\*  
   microscope, 1391  
   optical surfaces, 1561-1562\*  
   systems, 1241  
   types, 1241  
   x-ray telescope, 2405  
   zoom lens, 2419\*  
*Lens esculenta*, 1241  
 Lentic systems, 937  
 Lentil, 1240, 1241\*  
*Lentiniula edodes*, 984, 1112  
 Lenz's law, 1242\*  
 Leo, 1242\*  
 Leonid stream, 1374  
 Lepadomorpha, 1242\*, 2326

- Lepidium sativum*, 513  
 Lepidodendrales, 1242\*  
   Isoetales, 1195  
   Isotales, 1195  
   Protolpidodendrales, 1793-1794\*  
*Lepidodermella*, 360  
 Lepidoite, 1242\*, 1381  
*Lepidophloios*, 1242  
 Lepidoptera, 1242-1245\*  
   biological aspects, 1245  
   classification, 1243-1245  
   developmental stages, 1245  
   morphology, 1245  
 Lepidosauria, 1245\*  
   Eosuchia, 835\*  
   Rhynchocephalia, 1916  
   Sphenodonta, 2082-2083\*  
 Lepidosirenidae, 619, 681  
 Lepisosteidae, 1984  
*Lepisosteus*, 860, 1984  
 Leporidae, 1222  
 Lepospondyli, 1245\*  
   Aistopoda, 67\*  
   Lysorophia, 1283\*  
   Nectridea, 1470-1472\*  
*Lepraria*, 1249  
 Leprosy, 1245-1246\*  
   paleopathology, 1602  
   sulfonamide, 2147  
*Leptodora kindtii*, 925  
 Leptolepididae, 1246  
 Leptolepiformes, 1246\*  
 Lepton, 720-721, 1246\*  
   baryon, 253-255\*  
   deep inelastic collisions, 627-628\*  
   elementary particle, 802, 804  
   fundamental interactions, 946, 947  
   muonium, 1450\*  
   neutrino, 1482\*  
   quarks, 1832  
*Leptorhynchoides thecatus*, 1596  
 Leptosomatidae, 494, 741  
 Leptosporosis, 1246\*  
 Leptostraca, 1246\*, 1675  
 Leptostrobales, 999  
 Leptotrichia, 214  
*Lernaepodoida*, 491  
*Lesothosaurus*, 675  
 Lespedeza, 1246\*  
*Lessonia*, 1224  
 Lessoniaceae, 1224  
 Lestoniidae, 944  
 Lethal dose 50, 1246\*  
 Lethal gene, 1246\*  
 Lethiscidae, 67  
*Lethiscus*, 67  
*Lethocerus*, 942  
 Letterpress printing, 1154  
 Letters patent, 1619  
 Lettuce, 185, 1246\*  
 Lettuce necrotic yellows virus, 1715  
 Leucaltidae, 1246  
*Leucandra walfordi*, 311  
 Leucascidae, 1246  
 Leucettida, 311, 1246\*  
*Leucippus*, 648  
 Leucite, 1125, 1246\*  
 Leucite rock, 1247\*  
*Leuconostoc*, 590  
 Leucophore, 397  
 Leucosoleniida, 311, 1247\*  
 Leucothoidae, 1266  
 Leucothoidae, 860, 963  
 Leucotrichaceae, 232  
 Leukemia, 1247\*  
   feline, 789  
   tumor viruses, 2281  
 Leukocyte:  
   blood, 304-305\*  
   hematopoiesis, 1062  
   leukemia, 1247  
 Leukodystrophy, 2083  
 Leukopenia, 1062  
 Leukotriene, 667, 739-740  
 Level measurement, 1247-1248\*  
   liquid, 1247-1248  
   solid, 1248  
 Lever, 1248\*  
 Leverrier, U. J. J., 1021  
 Levitation, magnetic, 1292\*  
 Levulose fruit sugar see Fructose  
 Lewis, G. N., 11, 489, 844  
 Lewis, W. H., 733  
 Lewis blood group system, 269  
 Lianas, 1009  
*Libocedrus decurrens*, 344  
 Libra, 1248\*  
 Licensed practical nurse, 1524  
 Lichens, 1249\*  
 Lidar, 1249\*  
   atmospheric, 1249  
   meteorological instrumentation,  
   1376-1377  
   ranging and altimeter systems, 1249  
 Lie, S., 867  
 Lie detector, 767, 1249\*  
 Lie group, 1030, 1249\*, 1895  
 Life expectancy, 43  
 Life span, 43  
 Ligament, 1249-1250\*  
 Ligand, 1250\*  
   chelation, 418\*  
   coordination chemistry, 554\*  
 Ligand field theory, 1250\*  
 Ligases, 833  
 Light, 1250-1251\*  
   aberration (astronomy), 2-3\*  
   acoustooptics, 18\*  
   albedo, 67\*  
   corpuscular phenomena, 1251  
   diffraction, 663-664\*  
   dispersion, 627, 687  
   Doppler effect, 697  
   electromagnetic wave transmission,  
   773-774\*  
   geometrical optics, 991-993\*  
   Huygens' principle, 1099\*  
   incandescent lamp, 1135  
   laser cooling, 1230  
   laser photochemistry, 1231  
   luminescence see Luminescence  
   luminous efficacy, 1279\*  
   luminous efficiency, 1279\*  
   luminous energy, 1279\*  
   luminous flux, 1279\*  
   luminous intensity, 1279\*  
   magneto-optics, 1303\*  
   optical communications, 1552-1553  
   optical phase conjugation, 1558\*  
   optics, 1563\*  
   photochemistry, 1661-1662\*  
   photochrome, 1683  
   photometer, 1668\*  
   photometry, 1668\*  
   photon, 1669\*  
   photosynthesis, 1671-1673\*  
   pigmentation, 1686  
   principal effects, 1250  
   quantum theories, 1251  
   quasielastic light scattering, 1835\*  
   reflection of electromagnetic radiation,  
   1880-1881\*  
   relativity, 1890-1891  
   underwater photography, 2299  
   wave optics, 2372\*  
   wave phenomena, 1250-1251  
   zodiacal light, 2417-2418\*  
 Light amplifier, 1251\*  
   see also Laser  
 Light curves, 1251\*  
 Light detection and ranging see Lidar  
 Light-emitting diode, 616, 617, 1251-1252\*  
   nanostructure, 1464, 1464\*  
   optical isolator, 1555-1556\*  
   optical materials, 1556  
 Light filter see Color filter  
 Light microscope, 1557  
 Light microscopy, 1369  
 Light panel, 769, 1252\*  
 Light-scattering photometry, 1252\*  
 Light-sensitive diode, 616  
 Light-year, 1252\*  
 Lightfish, 1941  
 Lighthouse, 1252\*, 1687  
 Lighting, 1127  
   Lighting, 1252-1253\*  
   cloud physics, 478  
   effect on aircraft, 35  
   electrical breakdown, 753  
   sferics, 1995  
   storm detection, 2121  
   storm electricity, 2121  
 Lightning and surge protection, 1253-1254\*  
   communications systems protection,  
   511-512\*  
   surge arrester, 2171\*  
   thunder, 2235-2236\*  
   thunderstorm, 2236\*  
 Lightning detection systems, 2380  
 Lightning rod, 1253-1254  
 Lignin, 1254\*, 2394  
 Lignite, 928, 1202, 1254\*  
 Lignitic coal, 424, 481  
 Lignumvitae, 1254\*  
 Lilac, 1965  
 Liliaceae, 437  
 Liliales, 1254\*  
   asparagus, 183\*  
   garlic, 964\*  
   onion, 1543\*  
 Orchidales, 1566\*  
   saffron, 1940\*  
 Lilies, 1254  
 Liliidae, 1254\*  
 Liliopsida, 1254-1255\*  
   Alismatidae, 77\*  
   Arales, 156\*  
   Arecales, 167\*  
   Arecidae, 167\*  
   Bromeliales, 335\*  
   Commelinales, 509\*  
   Commelinidae, 509\*  
   Cyclanthales, 539-540\*  
   Cyperales, 607\*  
   dicotyledons, 657  
   Dioscoreales, 677\*  
   Eriocaulales, 844\*  
   Hydrotalales, 1100\*  
   Hydrocharitales, 1103\*  
   Junciales, 1205\*  
   Liliidae, 1254\*  
   Najadales, 1463\*  
   Orchidales, 1566\*  
   Pandanales, 1605\*  
   Restionales, 1908\*  
   tree, 2266  
   Triuridales, 2275\*  
   Zingiberales, 2416-2417\*  
   Zingiberidae, 2417\*  
*Lilium*, 1254  
 Lima bean, 229, 260-2612  
*Limapontia*, 1939  
 Limb-girdle muscular dystrophy, 1451  
 Limb prosthetics, 1788  
 Lime (botany), 1255\*  
 Lime (industry), 1255\*, 1438\*  
 Lime tree, 226  
 Limestone, 1255\*  
   caliche, 357\*  
   chalk, 412\*  
   coquina, 557\*  
   dolomite rock, 694\*  
   lime (industry), 1255\*  
   Paleozoic, 1603  
   sandstone, 1943  
   skarn, 2015\*  
   stalactites and stalagmites, 2095\*  
   stromatolite, 2129\*  
   stylonites, 2137\*  
   travertine, 2266\*  
   tufa, 2280\*  
 Limiter circuit, 1255-1256\*  
 Limits and fits, 1256\*  
 Limits of Acceptable Change (LAC), 921  
 Limnocharitaceae, 77  
 Limnology, 722, 735, 1256\*  
 Limnosedusae, 979  
*Limnoria*, 103, 1195  
 Limnoriidae, 803  
 Limonite, 1256\*  
 Limnopsacea, 125  
 Limpet, 1256\*, 1787  
 Limulina, 2408  
*Limulus*, 1052  
*Limulus polyphemus*, 1358  
 Linacs:  
   particle accelerator, 1614, 1615  
   radiation chemistry, 1843  
 Linales, 487, 1256\*  
*Linckia*, 174  
 Lindauer, Martin, 1293  
*Lindera*, 1233  
 Line graphs, 1017  
 Line integral, 1256\*  
 Line spectrum, 783, 1256-1257\*, 2076  
 Linear algebra, 1257\*  
 Linear dunes, 706  
 Linear low-density polyethylene (LLDPE),  
   1749  
 Linear momentum, 1431  
 Linear programming, 1257\*, 1547  
 Linear speed, 2080  
 Linear sweep voltammetry (LSV), 764,  
   765  
 Linear system analysis, 1257-1258\*  
 Linear systems, 1523  
 Linear systems of equations, 1258\*  
   determinant, 647\*  
   polynomial systems of equations,  
   1748-1749\*  
 Linear velocity, 2328, 2329  
 Linear viscoelasticity, 1912  
 Linearity, 1258\*  
   linear systems analysis, 1257  
   superposition principle, 2162  
 Linearly polarized light, 1736-1737  
 Linen, 805  
 Lines of force, 1258\*  
 Linewidth, 1258-1259\*  
*Linguatula*, 1756  
 Linguatuloidae, 1756  
 Linguistics, 1259\*  
   anthropology, 135\*  
   psycholinguistics, 1800\*  
*Lingula*, 1259  
 Lingulacea, 1259  
 Lingulida, 1134, 1259\*  
 Linhomoeoidea, 1431  
 Link, 1259\*  
   pawl, 1621\*  
   ring, 1923\*  
 Linkage (genetics), 1259\*  
 Linkage (mechanism), 1259-1260\*  
   cam mechanism, 358-359\*  
   connecting rod, 538\*  
   crank, 576\*  
   four-bar, 929-930\*  
   slider-crank mechanism, 2021-2022\*  
   toggle, 2246\*  
 Linnaean classification:  
   plant taxonomy, 1713-1714  
   species concept, 2073  
   taxonomic categories, 2194-2195  
 Linnaeus, Carolus, 244  
   human variation, 1087  
   plant taxonomy, 1713-1714  
   zoological nomenclature, 2419  
 Linseed oil:  
   Linales, 1255  
   seed flax, 805  
*Linum usitatissimum*, 805, 1255  
 Lion (astronomy) see Leo  
 Liphistiomorphae, 139  
 Lipid, 1260\*  
   adipose tissue, 29  
   cell membranes, 393  
   cholesterol, 445-446\*  
   digestive system, 667, 668  
   glycolipid, 1007-1008\*  
   phospholipid, 1658-1659\*  
   plasmal, 1720\*  
   sphingolipid, 2083-2084\*  
   steroid, 2115-2116\*  
   triglyceride, 2271\*  
 Lipid metabolism, 1260\*  
   metabolic disorders, 1361-1362  
   peroxisome, 1636  
   phosphate, 1658  
 Lipid vesicles see Liposomes  
 Lipoid acid, 1578  
 Lipoprotein, 1260-1261\*  
 Liposarcoma, 1362  
 Liposomes, 1261\*  
   Liquefaction of coal, 482-483\*  
   Liquefaction of gases, 1261\*  
   Liquefied natural gas (LNG), 1261\*  
   Liquefied petroleum gas (LPG), 1261\*  
 Liquid, 1261-1262\*  
   atomization, 215\*  
   boiling point, 311-312\*  
   cavitation, 384\*  
   crystal, 590  
   diffusion, 665  
   distillation, 688-689\*  
   drying, 703-704\*  
   electron diffraction, 780  
   electron paramagnetic resonance  
   spectroscopy, 782  
   evaporation, 857\*  
   filtration, 877\*  
   fluid flow, 900  
   fluids, 901-902\*  
   hydraulics, 1102  
   measurement of water content, 1416  
   moisture-content measurement, 1416  
   spray flow, 2088-2089\*  
   surface tension, 2170\*  
   vapor pressure, 2324\*  
   viscosity, 2345-2346\*  
   water hammer, 2365\*  
   wave motion, 2372  
   x-ray diffraction, 2403  
 Liquid chromatography, 397, 449, 975-976,  
   1262\*  
 Liquid-crystal displays (LCDs), 787  
 Liquid crystals, 1262-1263\*  
   applications of, 1262-1263  
   nematic structure, 1262

- Liquid crystals—*cont.*  
 optical materials, 1556, 1557  
 second sound, 1968-1969\*  
 smectic structure, 1262
- Liquid extraction *see* Solvent extraction
- Liquid fertilizer, 794
- Liquid fuel, 829
- Liquid helium, 1263\*  
 low-temperature acoustics, 1275  
 low-temperature physics, 1275-1276  
 second sound, 1968-1969\*  
 superfluidity, 2159\*
- Liquid-in-glass thermometer, 2229
- Liquid/liquid extraction, 778, 863
- Liquid-metal embrittlement, 499
- Liquid propellant, 1785
- Liquid separations, 1352
- Liquid/solid extraction, 778, 863
- Liquidambar*, 924, 1044
- Liriodendron*, 1305
- Lissajous figures, 1263-1264\*
- Lissamphibia, 1245, 1264\*
- Listeria ivanovii*, 1264
- Listeria monocytogenes*, 1264
- Listeriosis, 1264\*
- Litchi chinensis*, 1280
- Lithionite, 1242  
*see also* Lepidolite
- Lithium, 1264\*  
 alkali emissions, 77  
 manic-depressive disorders, 577  
 spodumene, 2088\*
- Lithium (drug), 40
- Lithium mica *see* Lepidolite
- Lithobiomorpha, 385
- Lithofacies, 783, 869
- Lithographic printing, 1154
- Lithography, 1773-1774
- Lithophaga*, 281
- Lithosphere, 1264-1265\*  
 Earth interior, 721  
 earthquakes, 723  
 hot spots (geology), 1091\*
- Lithothamnion*, 1255
- Lithotripsy, 1495, 2295
- Litopterna, 1265\*
- Little Bear *see* Ursa Minor
- Little bluestem grass, 271
- Little Dipper *see* Ursa Minor
- Live-roller conveyor, 488, 552
- Liver, 1265\*  
 cirrhosis, 69, 463-464\*  
 digestive system, 666  
 gallbladder, 957  
 peroxisome, 1636
- Liver disorders, 1265\*  
 hepatitis, 1067\*  
 jaundice, 1201-1202\*
- Liverwort:  
 Hepaticopsida, 1067  
 Jungermanniales, 1206\*  
 Jungermanniales, 1206\*
- Marchantiales, 1317\*  
 Marchantiidae, 1317\*  
 Metzgeriales, 1381\*  
 Monocleales, 1432\*  
 plant, 1701  
 plant phylogeny, 1712  
 Sphaerocarpaceae, 2082\*  
 Takakiales, 2191\*
- Livestock products, 46
- Living fossils, 1266\*, 1358
- Lizard:  
 chameleon, 412\*  
 Sauria, 2092  
 Squamata, 2092  
 tongue, 2248
- Lizard-hipped dinosaur, 149
- Lizardfish, 1941
- Llama, 164, 1266\*
- LNG *see* Liquefied natural gas
- Load-break switches, 752
- Loading, electrical, 757\*
- Loads:  
 column, 505, 506  
 dynamic, 1266\*  
 shear center, 1996, 1997\*  
 structural analysis, 2131  
 structure (engineering), 2136  
 transverse, 1266\*
- Lob paak, 1578
- Lobachevski, N. I., 1494
- Lobata, 1266-1267\*
- Lobefin fish:  
 Crossopterygii, 582\*  
 Sarcopterygii, 1945
- Lobelia cardinalis*, 321
- Lobiger*, 1939
- Lobok, 1578
- Lobopods, 1543-1544\*
- Lobosia, 1267\*, 1914  
 Amoebida, 100\*  
 Arcellinida, 159\*
- Lobster, 604, 1307  
 Decapoda, 622-625\*  
 Eucarida, 852\*  
 heart, 1052  
 invertebrate pathology, 1182
- Lobularia maritima*, 325
- Local-area networks, 1267\*  
 client-server system, 471-472\*  
 computer security, 525  
 security, 462  
 teleprocessing, 2201
- Local Group, 1267\*
- Local Supercluster, 1267
- Location fit, 1267\*
- Lock (canal), 322
- Lockjaw *see* Tetanus
- Lockout circuits, 2176
- Locomotion, 2016-2017
- Locomotive, 1267-1268\*, 1866
- Loculoascomycetes, 1268\*
- Locust (forestry), 1268\*
- Locust (Orthoptera), 1581
- Loess, 152, 1268\*
- Logania*, 2218
- Loganiaceae, 875, 2136
- Logarithm, 75, 82, 1116\*
- Logging *see* Well logging
- Logging (forestry), 1269\*
- Logic, 1269-1271\*  
 foundations of mathematics, 1337  
 Gödel's theorem, 895  
 mathematical, 1270-1271, 1337  
 propositional calculus, 1269-1270  
 theorem, 2218\*  
 unit operations, 2301\*
- Logic circuits, 1271\*  
 Boolean algebra, 317\*  
 digital computer, 668  
 digital computer elements, 608  
 oscillator, 1582-1583  
 switching circuit, 2175, 2176  
 switching gate, 866
- Logic gate, 866
- Logic gate multivibrator, 1449-1450
- London, F., 867, 1350
- London, H., 1350
- Long-beaked river dolphin, 634
- Long-eared owl, 260
- Long-range electron transfer, 784
- Long-term memory, 435, 1352-1353
- Longitude *see* Latitude and longitude
- Longitudinal dune, 642, 706
- Loon, 974
- Lopadorrhynchidae, 760
- Lophiiformes, 1271\*
- Lophobranchii, 865
- Lophodermium pinastri*, 685
- Lophophore, 1272\*
- Lophopodella*, 2104
- Lophura nycthemera*, 260
- Loran, 1272\*  
 electronic navigation systems, 789  
 homing, 1086  
 polar navigation, 1734
- Lorentz, H. A., 803
- Lorentz transformations, 1272\*  
 relativity, 1887-1891\*  
 space-time, 2068\*
- Lorenz, A., 761
- Lorenz, Konrad, 849, 850
- Loricata *see* Chiton
- Loricifera, 1272-1273\*
- Lorisoids, 1771
- Lossy filters, 771
- Lou Gehrig's disease, 1907
- Loudness, 1273\*, 1454
- Loudspeaker, 1273-1274\*  
 response, 1907\*  
 sound-reinforcement system, 2054\*  
 sound-reproducing systems, 2054-2055\*,  
 2055
- Louping ill, 1274\*
- Louse:  
 Exopterygota, 859  
 Mallophaga, 1307-1308\*  
 pediculosis, 1622\*  
 relapsing fever, 1885-1886  
 skin disorders, 2018
- Low birth weight, 1768
- Low-density lipoproteins (LDL), 1260
- Low-density polyethylene, 1749
- Low Energy Antiproton Ring (LEAR), 1038
- Low-energy electron diffraction (LEED),  
 779-780
- Low-frequency electrotherapy, 798
- Low-frequency radio beacon, 1160
- Low-level counting, 1274\*
- Low-level counting, 1274-1275\*  
 solid materials, 1274-1275  
 superfluid helium, 1275
- Low-temperature physics, 1275-1276\*,  
 2155-2157
- Low-temperature thermometry, 967-968,  
 1276\*
- Lowbush blueberry, 271
- Loxodonta africana*, 723, 805
- Loxosomatida, 743, 827
- LPG *see* Liquefied petroleum gas
- LSD-25 *see* Lysergic acid diethylamide
- Lubbock, John, 1474, 1600
- Lubricant, 1276\*, 1277  
 antifiction bearing lubricants, 139-141  
 engine lubrication, 737, 823\*  
 friction, 938\*
- Lubrication, 1277\*, 2270
- Lubrication, engine, 823\*
- Lucerne *see* Alfalfa
- Luciferase, 252
- Luciferin, 252
- Luders, G., 509
- Lufengpithecus*, 924
- Luffa acutangula*, 1579
- Lumbar vertebrae, 2332
- Lumber, 1277-1278\*, 2135
- Lumbrineridae, 760
- Lumbrineris*, 125
- Luminance, 1278\*
- Luminescence, 1278\*  
 bioluminescence, 285-286\*  
 cathodoluminescence, 383\*  
 chemiluminescence, 430\*  
 electroluminescence, 769\*  
 fluorescence, 902\*  
 luminous paint, 1279\*  
 phosphorescence, 1659\*  
 photoluminescence, 1667\*  
 thermoluminescence, 2228-2229\*  
 traps in solids, 2265\*
- Luminescence analysis, 1278-1279\*
- Luminescent species, 630
- Luminous efficacy, 1279\*
- Luminous efficiency, 1279\*
- Luminous energy, 1279\*, 1330
- Luminous flux, 1126, 1279\*
- Luminous intensity, 1279\*  
 candlepower, 362\*  
 luminance, 1278\*  
 physical measurement, 1680
- Luminous paint, 1279\*
- Lunar eclipse, 661, 730-731
- Lung, 1279-1280\*  
 respiration, 1905-1906\*  
 respiratory system, 1907  
 spirometry, 2086\*
- Lung disorders:  
 emphysema, 813-814\*  
 pneumonia, 1730-1731\*
- Lungfish, 619  
 animal evolution, 120  
 Dipnoi, 678\*  
 Dipteriformes, 681\*  
 hibernation, 1074  
 Sarcopterygii, 1945
- Lupine, 1280\*
- Lupus erythematosus, 223, 475
- Luteinizing hormone, 27, 1145
- Lutetium, 1280\*
- Luu, Jane, 1219
- Lyase, 748, 833
- Lycodon pictus*, 634, 694
- Lychee, 1280\*
- Lychniscosa, 952, 1280\*
- Lycoperdales, 864
- Lycopersicon*, 2246-2247
- Lycophyta, 1280\*  
 Lycopodiales, 1280-1281\*  
*Lycopodiella*, 1280
- Lycopodiophyta *see* Lycophyta
- Lycopodiopsida *see* Lycopodiopsida
- Lycopodiopsida, 1280
- Lycopodiophyta, 187
- Lycopsida, 174, 1281\*  
 Isoetales, 1195\*  
 Isoetales, 1195  
 lepidodendrols, 1242\*  
 Lycophyta, 1280
- Lycopodiales, 1280-1281\*  
 plant evolution, 1703
- Lycopsidea—*cont.*  
 Selaginellales, 1978\*  
 Lygaeidae, 944  
 Lygaeoidea, 944  
 Lyginopteridopsida, 539  
 Lyme disease, 687, 1281\*  
 Lymph node, 2122  
 Lymphatic system, 1281\*  
 lymphoma, 1281-1282\*  
 thymus gland, 2236\*  
 tonsil, 2248\*
- Lymphatic system disorder, 1082
- Lymphatics, 2327
- Lymphocyte, 267-268  
 cellular immunology, 399  
 immunological deficiency, 1131\*  
 immunological ontogeny, 1131\*
- Lymphogranuloma venereum, 389
- Lymphoma, 1281-1282\*  
 Epstein-Barr virus, 740  
 tumor viruses, 2281
- Lyophilization, 1282\*
- Lycopomii *see* Notacanthiformes
- Lyra, 1282\*
- Lysaretidae, 760
- Lyserkoism, 1282\*
- Lysergic acid diethylamide (LSD), 1610,  
 1804
- Lysin, 1282\*
- Lysiosquillidae, 2119
- Lysogeny, 244-245, 1282-1283\*
- Lysorophia, 1283\*
- Lysosome, 346, 1283\*  
 cell (biology), 389  
 vacuole, 2317
- Lysozyme, 1283-1284\*
- Lyssacinosa, 952, 1284\*
- Lytic infection, 1284\*
- Lytic reaction, 1282, 1284\*

## M

- M-carcinotron, 212
- M-type backward-wave oscillator, 212
- Macadamia nut, 1285\*
- Macadamia ternifolia*, 1285
- Macaques, 928
- MacCreedy, P. D., Jr., 980-981
- Mac number, 1285\*  
 gas dynamics, 966  
 incompressible flow, 1136  
 jet flow, 1202  
 sonic boom, 2049  
 transonic flight, 2262
- Mach waves, 2164
- Mach-Zehnder interferometer, 1172
- Machine, 1285\*  
 electric rotating machinery, 751\*  
 elevating, 805-806\*  
 human-factors engineering, 1093  
 limits and fits, 1256\*  
 molecular, 1421\*  
 motor, 1441\*  
 power shovel, 1764\*  
 simple, 2012\*  
 speed regulation, 2080  
 vibration, 2338\*  
 work, 2397\*
- Machine bolt, 274
- Machine key, 1285\*
- Machine language, 1782
- Machine screw, 1963
- Machine vision *see* Computer vision
- Machinery, 1285\*  
 marine, 1322\*  
 valve, 2320-2321\*
- Machining, 1285-1286\*  
 abrasive, 3\*  
 limits and fits, 1256\*  
 numerical control, 522\*  
 wood, 2395
- Mackerel, 1286\*
- Macracanthorhynchus hirudinaceus*, 147
- Macrauchenidae, 1265
- MacReady, Paul B., 890
- Macrostela*, 531
- Macrostelidae, 531
- Macrostium*, 531
- Macroclimatology, 416
- Macrocycles, 380-381
- Macrocyclic compound, 1286-1287\*  
 applications, 1286-1287

- Macrocyclic compound—*cont.*  
 classes of polyethers, 1286  
 complexation phenomena, 1286  
*Macrocystis*, 1224  
*Macrodasyda*, 866, 1287\*  
 Macroevolution, 1287-1288\*  
 developmental processes, 1287-1288  
 long-term trends, 1288  
 phylogenetic reconstruction, 1287  
 Macromolecule, dendritic, 572  
*Macrophomina phaseolina*, 1208  
 Macropodidae, 1209  
*Macropus giganteus*, 1209  
*Macropus rufus*, 1209  
 Macroscelidea, 1158, 1288\*  
 Macroscelididae, 1158, 1288\*  
 Macrostromida, 1911  
*Macrostylus*, 167  
*Macrura*, 560-562  
 Mactracea, 1223  
 Macular degeneration, n2348  
 Mad cow disease, 1755  
 Madagascar, 40  
 Madelung constant, 1288\*  
 Mafic, 1125, 1234  
*Magellan* space shuttle, 2065  
 Magellanic Clouds, 1288\*  
 Maggot, 1460  
 Magic numbers, 1288-1289\*  
 Magma, 1289\*  
 aureoles, 543  
 dunite, 707  
 gabbro, 955  
 igneous rocks, 1125\*  
 lava, 1233-1234, 1233-1234\*  
 pluton, 1729  
 pneumatolysis, 1730  
 rhyolite, 1917\*  
 volcanology, 2352, 2353  
 xenolith, 2407\*  
 Magmatic minerals, 1404  
 Magnesiohornblende, 1089  
 Magnetite, 1289\*  
 Magnesium, 1289-1290\*  
 Magnesium alloys, 1290\*  
 Magnesium ion, 1183  
 Magnesium-iron mica *see* Biotite  
 Magnet, 1290-1291\*  
 dipole, 678  
 high-field, 1077  
 superconducting, 1615  
 Magnet wire, 1291\*  
 Magnetic bubble memory:  
 computer storage, 463  
 ferrite, 878  
 Magnetic circuits:  
 magnetism, 1296-1297  
 magnetomotive force, 1302\*  
 permeance, 1634-1635\*  
 reluctance, 1892\*  
 Magnetic compass, 58-59, 1291\*  
 Magnetic densimeters, 636  
 Magnetic dipole, 619  
 Magnetic dipole-dipole interaction, 619  
 Magnetic disk, 554  
 Magnetic double refraction *see* Voigt effect  
 Magnetic earphone, 653, 716  
 Magnetic ferroelectrics, 1291\*  
 Magnetic field:  
 Aharonov-Bohm effect, 47\*  
 biomagnetism, 288\*  
 degaussing, 631\*  
 demagnetization, 634  
 effect on biological systems, 246-247  
 electrical shielding, 760  
 electromagnetic field, 771\*  
 electromagnetism, 774\*  
 geodynamo, 987-988\*  
 geomagnetic variations, 990\*  
 high, 107\*  
 inductance measurement, 1137  
 Larmor precession, 1228  
 lines of force, 1258\*  
 magnetic reversals, 1295\*  
 magnetism, 1296-1298  
 magnetochemistry, 1301\*  
 magnetohydrodynamics, 1301-1302\*  
 magnetometer, 1302\*  
 magnetooptics, 1303\*  
 magnetosphere, 1303\*  
 solar, 2040\*  
 stellar, 2110\*  
 Magnetic flux:  
 Faraday's law of induction, 871\*  
 magnetism, 1298-1299  
 Magnetic hysteresis:  
 magnetic recording, 1294  
 Magnetic hysteresis—*cont.*  
 magnetism, 1300  
 Magnetic induction, 296  
 Magnetic ink character recognition, 363  
 Magnetic instruments, 1291-1292\*  
 electronic charge integrators, 1291-1292  
 fluxgate magnetometer, 1291  
 fluxmeter, 1291  
 Hall-effect instruments, 1291  
 rotating-coil gaussmeter, 1292  
 Magnetic lens, 781, 1292\*  
 Magnetic levitation, 1292\*  
 Magnetic materials, 1291-1293\*,  
 1292-1293\*  
 alloys, 84  
 ferrite, 878, 878\*  
 Kondo effect, 1218\*  
 magnetic thin films, 1296\*  
 Magnetic microphones, 1388-1389  
 Magnetic mirroring, 1718  
 Magnetic moment:  
 electron, 776-777\*, 783-784  
 magnetism, 1299  
 magneton, 1302-1303\*  
 nuclear magnetic resonance, 1510-1511\*  
 Magnetic monopoles, 1293\*  
 Magnetic polarization, 1299-1300  
 Magnetic reception (biology), 1293\*,  
 1400-1401  
 Magnetic recording, 1293-1295\*  
 Magnetic relaxation, 1295\*  
 Magnetic resonance, 1295\*  
 electron paramagnetic resonance  
 spectroscopy, 782\*  
 nuclear quadrupole resonance,  
 1512-1513\*  
 Magnetic resonance imaging (MRI), 1346  
 Magnetic reversals, 1295\*  
 Magnetic separation methods, 1295\*, 1567  
 Magnetic susceptibility, 1295\*  
 Curie-Weiss law, 599\*  
 diamagnetism, 654\*  
 Magnetic tape:  
 memory device, 463-464  
 units, 526-527  
 Magnetic thermometer, 1295-1296\*  
 Magnetic thin films, 1296\*  
 Magnetic trap, 207, 1617  
 Magnetism, 1296-1300\*  
 biomagnetism, 288\*  
 domain, 695\*  
 electromagnetic induction, 771-772\*  
 electromagnetism, 774\*  
 ferrimagnetism, 878\*  
 geomagnetism, 990-991\*  
 magnetic circuits, 1296-1297  
 magnetic field strength, 1297-1298  
 magnetic flux and flux density, 1298  
 magnetic flux linkage, 1298-1299  
 magnetic hysteresis, 1300  
 magnetic moment, 1299  
 magnetic polarization, 1299-1300  
 magnetostatics, 1299  
 neutron, 1483  
 paramagnetism, 1608-1609\*  
 relativistic electrodynamics, 1886\*  
 solar magnetic field, 2040\*  
 stellar magnetic field, 2110  
 units of measurement, 2304  
 Magnetite, 1300\*  
 emery, 812-813\*  
 spinels, 2085-2086\*  
 Magnetization, 1300\*  
 Barkhausen effect, 251\*  
 degaussing, 631\*  
 demagnetization, 634\*  
 electromagnet, 771\*  
 ferromagnetism, 879-800  
 magnet, 1290-1291\*  
 rock magnetism, 1927\*  
 Magneto, 1300-1301\*  
 Magnetocaloric effect, 1301\*  
 Magnetochemistry, 1301\*  
 Magnetographic printing, 1774  
 Magnetohydrodynamic power generator,  
 1301\*  
 Magnetohydrodynamics, 71-72, 1301-1302\*  
 Magnetometer, 566, 1291-1292, 1302\*  
 Magnetomotive force, 170, 1302\*  
 Magneton, 1302-1303\*  
 Magneto-optic hybrid trap, 1617  
 Magneto-optics, 871, 1303\*  
 Magneto-plasmadyamic (MPD) thruster,  
 1720  
 Magneto-resistance, 1303\*  
 Magnetosphere, 202, 1303\*  
 aurora, 218-219\*  
 Magnetosphere—*cont.*  
 Jupiter, 1207  
 planetary physics, 1701  
 Magnetostatic trap, 1616-1617  
 Magnetostatics, 1299  
 Magnetostratigraphy, 1601  
 Magnetostriction, 1303\*, 2256  
 Magnetron, 785, 1303-1304\*  
 Magnification, 1304\*  
 enlarging lens, 1241  
 microscope, 1391\*  
 optical microscope, 1557-1558\*  
 Magnitude (astronomy), 1304\*  
 blue straggler star, 307-308\*  
 Hertzsprung-Russell diagram, 1070\*  
 redshift, 1878-1879\*  
 star, 2096, 2097  
 Magnolia, 857, 1304\*  
*Magnolia acuminata*, 1304  
 Magnoliaceae, 2280  
 Magnoliales, 1304-1305\*  
 camphor tree, 361\*  
 cinnamon, 458\*  
 Eumagnoliids, 854  
 Laurales, 1233  
 nutmeg, 1524-1515\*, 1524-1525\*  
 sassafras, 1946\*  
 tulip tree, 2280\*  
 Magnoliidae, 1305\*  
 Aristolochiales, 169\*  
 Magnoliales, 1304-1305\*  
 Nymphaeales, 1525\*  
 Papaverales, 1606\*  
 Piperales, 1691-1692\*  
 Ranunculales, 1869\*  
 Magnoliids, 657  
 Magnoliophyta, 1305\*, 1805  
 Arales, 156\*, 167\*  
 Asterales, 185\*  
 Commelinales, 509\*  
 dicotyledons, 657\*  
 Dilleniaceae, 672\*  
 Dipsacales, 679\*  
 fossil seeds and fruits, 928  
 Juglandales, 1205, 1205\*  
 Lecythidales, 1239, 1239\*  
 Leitneriales, 1240\*  
 Liliopsida, 1254-1255\*  
 Linales, 1256\*  
 Magnoliopsida, 1305\*  
 Malpighiales, 1308\*  
 Orchidales, 1566\*  
 Plumbaginales, 1729\*  
 Solanales, 2038\*  
 Theales, 2217-2218\*  
 Magnoliopsida, 1304-1305\*  
 Apiales, 150\*  
 Aristolochiales, 169\*  
 Asteridae, 185-186\*  
 Batales, 257\*  
 Callitrichales, 357\*  
 Calycerales, 358\*  
 Campanulales, 360\*  
 Caryophyllales, 376\*  
 Caryophyllidae, 376\*  
 Casuarinales, 377\*  
 Celastrales, 385\*  
 Cornales, 560\*  
 Daphniphyllales, 615\*  
 Diapensiales, 655\*  
 Didymelales, 657\*  
 Dilleniidae, 672\*  
 Ericales, 844\*  
 Eucommiales, 852\*  
 Euphorbiales, 855\*  
 Fagales, 870\*  
 Gentianales, 984\*  
 Geraniales, 996\*  
 Haloragales, 1044\*  
 Hamamelidaceae, 1044\*  
 Hamamelidales, 1044\*  
 Lamiales, 1223\*  
 Laurales, 1233\*  
 Illiciales, 1126\*  
 Magnoliales, 1304-1305\*  
 Magnoliidae, 1305\*  
 Malvales, 1309\*  
 Myrtales, 1460\*  
 Myrtales, 1460\*  
 Nymphaeales, 1525\*  
 Papaverales, 1606\*  
 Piperales, 1691-1692\*  
 Plantaginales, 1716\*  
 Plumbaginales, 1729\*  
 Podostemales, 1731\*  
 Polygalales, 1744\*  
 Polygonales, 1744\*  
 Magnoliopsida—*cont.*  
 Primulales, 1772\*  
 Proteales, 1789\*  
 Rafflesiales, 1865\*  
 Ranunculales, 1638\*  
 Rhizophorales, 1913-1914\*  
 Rosales, 1932\*  
 Rosidae, 1933\*  
 Rubiales, 1935\*  
 Salicales, 1940\*  
 Santalales, 1944\*  
 Sapindales, 1944\*  
 Scrophulariales, 1964-1965\*  
 tree, 2266  
 Trochodendrales, 2275\*  
 Violales, 2340\*  
 Magnon, 1305-1306\*, 2179  
 Mahogany, 1306\*  
 Maidenhair tree, 887  
 Mail, electronic, 788\*  
 Maillard, L.-C., 1306  
 Maillard reaction, 1306\*  
 Main memory (computer), 462-  
 463  
 Main-sequence star *see* Dwarf star  
 Maintainability, 1892  
 Maintenance, industrial and production,  
 1306\*  
 Malvales, 613  
 balsa, 247-248\*  
 basswood, 257\*  
 cola, 496\*  
 cotton, 571\*  
 Major histocompatibility complex (MHC),  
 1081-1082  
 Majorana effect, 2413-2414  
 Malachite, 1306\*  
 Malacostraca, 1307\*  
 Amphipoda, 103\*  
 Cumacea, 598\*  
 Eucarida, 852\*  
 Eumalacostraca, 854  
 Isopoda, 1195\*  
 Leptostraca, 1246\*  
 Mysidacea, 1460-1461\*  
 Peracarida, 1627\*  
 Phyllocarida, 1675\*  
 Spelaeogriphacea, 2080-2081\*  
 Stomatopoda, 2119\*  
 Syncarida, 2183\*  
*Malapterurus electricus*, 673  
 Malaria, 1307\*  
 Eucoicida, 852  
 quinine, 1836\*  
 Malay chevrotain, 384  
 Malayan gaviel, 867  
 Malaysia, 723  
 Maleic anhydride, 12  
 Malignant neoplasm *see* Cancer (medicine);  
 Tumor  
 Mallein test, 2019  
 Malleus, 1049  
 Mallophaga, 1307-1308\*  
 Malnutrition, 127, 1308\*  
 Malpighian tubules, 1157  
 Malpighiales, 1308\*  
 Malt, 2340  
 Malt beverage, 221, 1308\*  
 Malt sugar *see* Maltose  
 Malta fever *see* Brucellosis  
 Maltase, 1308\*  
 Maltose, 1308-1309\*  
*Malus* species, 135, 510  
 Malvaceae, 1211  
 Malvales, 1309\*  
 kapok tree, 1210\*  
 okra, 1537\*  
 Mammal:  
 digestive system, 666, 667  
 dogs, 693-694\*  
 Dryolestida, 704\*  
 ear, 713, 714, 715  
 Edentata, 737\*  
 gestation period\*, 997  
 grassland ecosystem, 1020  
 hibernation, 1075  
 Jurassic, 1208  
 nutrition, 1525  
 pineal gland, 1689  
 Pinnipeds, 1690-1691\*  
 placentation, 1694-1695  
 social, 2028\*  
 Solenodon, 2042\*  
 yolk sac, 2412  
 Mammalia, 1309-1310\*  
 ardvark, 1\*  
 agouti, 43-44

## Mammalia—cont.

Allotheria, 83\*  
 alpaca, 87\*  
 Amniota, 100\*  
 Anamnia, 112  
 animal evolution, 120  
 anteater, 131\*  
 antelope, 131\*  
 apes, 148-149\*  
 Archaic ungulate, 161\*  
 armadillo, 170\*  
 Artiodactyla, 178\*  
 Astrapotheria, 188-189\*  
 aye-aye, 236\*  
 badger, 245\*  
 bear, 261\*  
 beaver, 261\*  
 bison, 299\*  
 buffalo, 340\*  
 camel, 360\*  
 Carnivora, 373\*  
 cat, 377-378\*  
 cavies, 384\*  
 Cetacea, 409-410\*  
 chamois, 411-412\*  
 chevrotain, 437\*  
 chinchilla, 440\*  
 chipmunk, 440\*  
 civet, 466\*  
 coats, 485\*  
 Creodonta, 577-578\*  
 deer, 630-631\*  
 Dermoptera, 642\*  
 Desmostylia, 646\*  
 Dinocerata, 674\*  
 Docodonta, 693\*  
 donkeys and allies, 696\*  
 elephant, 805\*  
 Embriothopoda, 809\*  
 Eutheria, 856\*  
 ferret, 877\*  
 fisher, 890\*  
 gerbil, 996\*  
 gestation period, 997\*  
 giraffe, 999-1000\*  
 gopher, 1013\*  
 hair, 1039\*  
 hamster, 1045\*  
 hedgehog, 1058-1059\*  
 hibernation, 959, 1074-1075  
 hippopotamus, 1081\*  
 hyena, 1111\*  
 Hyracoidea, 1121-1122\*  
 Insectivora, 1158\*  
 jerboa, 1202\*  
 kangaroo, 1209\*  
 koala, 1217-1218\*  
 Lagomorpha, 1222\*  
 lemming, 1240\*  
 Litopterna, 1265\*  
 llama, 1266\*  
 Macroscelidea, 1288\*  
 mammary gland, 1310\*  
 marmot, 1326\*  
 Marsupialia, 1328\*  
 marten, 1328\*  
 Metatheria, 1373\*  
 mink, 1406\*  
 mole (zoology), 1417\*  
 mongoose, 1431\*  
 monkey, 1431-1432\*  
 Monotremata, 1435\*  
 moose, 1437\*  
 mouse, 1443\*  
 mouth, 1444\*  
 mule, 1444\*  
 Multituberculata, 1448\*  
 muskrat, 1456\*  
 Notoungulata, 1265\*, 1504\*  
 opossum, 1550\*  
 otter, 1587\*  
 panda, 1605\*  
 Pantodonta, 1605\*  
 Perissodactyla, 1633-1634\*  
 Pholidota, 1656\*  
 platypus, 1726\*  
 Pleistocene, 1727  
 Pliocene, 1728-1729  
 porcupine, 1756\*  
 prairie dog, 1764\*  
 Primates, 1770-1772\*  
 Proboscidea, 1777\*  
 pronghorn, 1784\*  
 Prototheria, 1795\*  
 Pyrotheria, 1817\*  
 rabbit, 1613\*  
 raccoon, 1839\*

## Mammalia—cont.

rat, 1871\*  
 reindeer, 1885\*  
 rhinoceros, 1913\*  
 Rodentia, 1930\*  
 sable, 1939\*  
 sheep, 1997\*  
 shrew, 2003\*  
 Sirenia, 2014-2015\*  
 skunk, 2019\*  
 stomach, 2119  
 Symmetrodonta, 2178\*  
 Taeniodonta, 2190\*  
 tapir, 2192\*  
 tenrec, 2210\*  
 Theria, 2219\*  
 thermoregulation, 2229-2230  
 Tillodontia, 2240\*  
 Triassic, 2269  
 Triconodonta, 2270-2271\*  
 Tubulidentata, 2280\*  
 vacuole, 2317  
 vicuna, 2338\*  
 weasel, 2377\*  
 wolverine, 2393\*  
 Xenungulata, 2408\*  
 yak, 2409-2410\*  
 zebra, 2413\*  
 zebu, 2413\*  
 Mammary gland, 1310\*  
 astitiis, 1333\*  
 breast, 329\*  
 lactation, 1222\*  
 reproductive system, 1898  
 Mammography, 1310\*  
 Mammoth, 1727  
 Man-machine system see Human-machine systems  
 Manatee, 2014-2015  
 Mandarin, 1310\*  
 Mandibulata, 1311\*  
 Manganese, 1311\*  
 hausmannite, 1048\*  
 manganese oxide minerals, 1312\*  
 manganite, 1312\*  
 pyrolusite, 1814\*  
 rhodochrosite, 1915\*  
 Manganese bronze, 295  
 Manganese nodules, 1311\*  
 Manganese oxide minerals, 1312\*, 1931  
 Manganite, 1312\*  
*Mangifera indica*, 1312  
 Mango, 1312\*  
 Mangrove, 497, 1223, 1312\*  
 Mania:  
 affective disorders, 39-40\*  
 psychopharmacology, 1801-1802  
 psychosis, 1803  
 Manifold (mathematics), 1312-1313\*  
 topology, 2249, 2250  
 torus, 2252\*  
 Manifold, engine, 737, 823-824\*  
*Manihot esculenta*, 337  
*Manikara sapota*, 656, 725  
 Manila hemp see Abaca  
 Manioc see Cassava  
 Manis, 1656  
 Manometer, 1313\*  
*Mansonia*, 621  
 Mantis shrimp, 964, 2119  
 Mantle, Earth, 187-188, 717, 721  
 Mantoux test, 2019  
 Manual transmission (automotive), 204  
 Manubrium, 1049  
 Manufactured fiber, 1313-1314\*  
 dyeing, 708\*  
 textile, 2215\*  
 Manufactured gem, 869-870  
 Manufacturing:  
 food manufacturing, 908-909\*  
 virtual, 2342\*  
 Manufacturing engineering, 1314-1315\*  
 assembly machines, 184-185\*  
 computer-aided design and manufacturing, 520\*  
 computer-integrated manufacturing, 522\*  
 flexible manufacturing system, 893-894\*  
 material resource planning, 1333-1334\*  
 measured daywork, 1342\*  
 production engineering, 1780\*  
 production methods, 1780\*  
 production planning, 1780-1781\*  
 Manufacturing processes:  
 electrochemical, 762-763\*

## Manufacturing processes—cont.

electroplating of metals, 795-796\*  
 mechanical alloying, 1342\*  
 metal casting, 1365\*  
 metal forming, 1366\*  
 metal rolling, 1367\*  
 poly(ethylene glycol) in, 1740  
 polystyrene resin, 1752  
 polyurethane resins in, 1753  
 powder metallurgy, 1762  
 process engineering, 1778\*  
 production methods, 1780\*  
 unit processes, 2301\*  
 wire bonding, 2392\*  
 wire drawing, 2392\*  
 wood processing, 2395\*  
 woodworking, 2396\*  
 Many-body problem, 1831  
 Map:  
 globe (Earth), 1004-1006\*  
 weather, 2379\*  
 weather map, 2379\*  
 see also Cartography; Topographic surveying and mapping  
 Map design, 1315\*  
 Map projections, 1315-1316\*  
 Maple, 1316\*  
 Sapindales, 1944  
 tree, 2266  
 Maple sugar, 2145  
 Mapping:  
 conformal, 470-471, 534\*  
 memory mapping (computer), 464  
 meteorological radar, 1378  
 plant geography, 1704  
 sea-floor imaging, 1965-1966\*  
 topographic, 2249\*  
 vegetation and ecosystem, 2328\*  
 Maquis, 363  
 Mara, 344  
*Maranta arundinacea*, 157  
*Marattia*, 1316  
 Marattiales, 1316\*, 1751  
 Marble, 1316\*  
 Marburg, 860  
 Marcasite, 1317\*  
 Marchantiales, 1317\*  
 Marchantiidae, 1317\*  
 Marchantiales, 1317\*  
 Monocleales, 1432\*  
 Sphaerocarpaceae, 2082\*  
 Marconi, G., 1188  
 Marek, L., 473  
 Margarine, 1317\*  
 Marginal seas, 1322  
 Marginocephalia, 675  
 Mariana Trench, 718  
 Mariculture, 137  
 Marijuana, 1317\*  
 Marine biological sampling, 1317\*  
 Marine biome, 253  
 Marine boiler, 1317-1318\*  
 Marine borers, 2394  
 Marine containers, 1318-1319\*  
 Marine ecology, 1319-1320\*  
 deep-sea fauna, 629-630\*  
 ecological processes, 1319-1320  
 environments, 1319  
 estuaries, 764  
 Marine engine, 309, 1320\*  
 Marine engineering, 1320-1321\*  
 Marine environments, 630  
 Marine fisheries, 154\*, 1321\*  
 Marine geology, 1321-1322\*  
 anomalous features, 1322  
 basins, 1321  
 continental margins, 1321-1322  
 marginal seas, 1322  
 marine sediments, 1324-1325\*, 1324-1325\*  
 mid-oceanic ridge, 1321  
 submarine canyon, 2139-2140\*  
 Marine invertebrates:  
 Devonian, 651-652  
 metamorphosis, 1372  
 Marine machinery, 1322\*  
 Marine microbiology, 1322-1323\*  
 chemautotrophs, 1323  
 heterotrophic transformations, 1323  
 hydrothermal vent bacteria, 1323  
 marine microbial sulfur cycle, 1323  
 photoautotrophs, 1323  
 Marine mining, 1323\*  
 Marine navigation, 1323-1324\*  
 electronic navigation systems, 789  
 traffic-control systems, 2256  
 vessel traffic service, 2334\*

## Marine oil, 785

Marine plants, 1968  
 Marine railway, 641  
 Marine refrigeration, 1324\*  
 Marine sediments, 1324-1325\*  
 chemostratigraphy, 434\*  
 continental margins, 1324-1325  
 deep-marine sediments, 628-629\*  
 deep-sea, 1325  
 nearshore processes, 1470\*  
 paleoceanography, 1597  
 sapropel, 1945  
 sequence stratigraphy, 1987  
 turbidity current, 2284\*  
 Marine sextant, 1993-1994  
 Marine soil microbiology, 2037\*  
 Mariotte, Edme, 285  
 Mariotte's law, 285  
 Marisat, 451  
 Marital therapies, 1804  
 Maritime meteorology, 1325-1326\*  
 Marjoram, 1326\*  
*Marjorana hortensis*, 1326  
 Markov chains, 1777  
 operations research, 1547  
 queueing theory, 1836\*  
 Markov process, 2117  
 Marl, 1326\*  
 Marlstone, 1326  
 Marmot, 1326\*  
 Mapping:  
 surface exploration, 1327  
 Mars Pathfinder, 1327  
 Marseille fever see *Yersinia pestis*  
 Marsh see Swamp, marsh, and bog  
 Marsh gas see Methane  
 Marsilea, 1328  
 Marsiliales, 1328\*, 1751  
 Marsupialia, 1328\*, 1373  
 animal evolution, 120  
 anteater, 131\*  
 kangaroo, 1209\*  
 koala, 1217-1218\*  
 Mammalia, 1309  
 opossum, 1550\*  
 Marten, 1328\*  
 Martensitic transformations, 1748  
*Martes* species, 802, 1328  
 Martin, Herman, 1293  
 Martingale (stochastic process), 2117  
 Marx, E., 1134  
 Maser, 1328-1329\*  
 astronomical, 1329  
 coherence, 494  
 gas, 1328-1329  
 quantum electronics, 1826, 1826\*  
 solid-state, 1329  
 Maskelyne, N., 905  
 Masking of sound, 1328\*  
 Maslow, Abraham, 1637  
 Masonry, 1329\*  
 Masonry arch, 159-160  
 Mass, 1330\*  
 conservation of, 477  
 density, 635\*  
 density measurement, 636\*  
 gravitation, 1021  
 inertia, 1143\*  
 physical measurement, 1679  
 units of measurement, 2303  
 weight, 2381\*  
 Mass defect, 1330\*  
 Mass flow, 897-898  
 Mass-luminosity relation, 1330\*  
 Mass number, 1330\*  
 Mass spectrometry, 1330-1331\*  
 accelerator mass spectrometry, 9-10\*  
 electron multiplier, 413\*  
 Mass spectroscopy, 1331-1332\*  
 Mass spectroscopy, 964-965, 2076  
 Mass spectrum, 2076  
 Mass-spring-damper system, 1343-1344\*  
 Mass storage systems, 527  
 Mass-transfer operation:  
 countercurrent transfer operations, 573\*  
 diffusion, 665\*  
 Mass wasting, 1332\*  
 avalanche, 233\*  
 landslide, 1226\*  
 submarine canyon, 2140



- Massif, 1332\*
- Massive compact halo objects (MACHOs), 1023
- Mast cells, 1081
- Mastic, 28
- Mastigamoeba*, 1333
- Mastigias*, 1913
- Mastigomycotina, 455\*, 989, 1332\*
- Mastigophora, 1332-1333\*
- Mastitis, 1333\*
- Mastotermitidae, 1195
- Mat foundations, 832
- Mattheria, 1328\*
- Matched-field processing, 1333\*
- Matched filter, 673
- Material requirements planning (MRP), 1956
- Material resource planning, 1333-1334\*
- Materials handling, 1314, 1334\*
- Materials-handling equipment, 1334\*
- bulk-handling machines, 342-343\*
- elevating machines, 805-806\*
- hoisting machines, 1082-1083\*
- industrial trucks, 1142\*
- monorail, 1434\*
- Materials science and engineering, 1334\*
- composite material, 516-517\*
- diffusion, 665
- Maternal behavior, 1334\*
- Mathematical biology, 1335\*
- applications, 1335
- metaphor, 1335
- surrogacy and models, 1335
- Mathematical biophysics, 255-256
- Mathematical ecology, 732, 1335-1336\*
- Mathematical geography, 1336\*
- Antarctic Circle, 129-130\*
- cardinal points, 372\*
- Equator, 841\*
- great circle, terrestrial, 1025\*
- North Pole, 1503\*
- solstice, 2045-2046\*
- South Pole, 2056\*
- Tropic of Cancer, 2276-2277\*
- Tropic of Capricorn, 2277\*
- Mathematical logic, 1270-1271
- Mathematical physics, 1336\*
- Mathematical software, 1336-1337\*, 2178
- Mathematics, 1337-1338\*
- algebra, 74-75\*
- algebraic geometry, 75-76\*
- analytic geometry, 110-111\*
- arithmetic, 169\*
- calculus, 352-353\*
- classical field theory, 467\*
- conformal mapping, 534\*
- constructiveness, 1337-1338
- creative formulas, 1337
- decision theory, 626
- determinism, 648
- differential equation, 661-662\*
- differential geometry, 662\*
- dipole moment, 679
- division, 693\*
- dyadic, 707-708\*
- e, 713\*
- equations, theory of, 841\*
- exponent, 862\*
- extrapolation, 863\*
- finite mathematics, 800-801
- Fourier series and transforms, 930-931\*
- geometry, 993\*
- graph theory, 1017\*
- group theory, 1029-1030\*
- infinity, 1145-1146\*
- interpolation, 1177\*
- lattice, 1233\*
- linear algebra, 1257\*
- linear programming, 1257\*
- manifold, 1312-1313\*
- mathematical logic, 1337
- minimal surfaces, 1405-1406\*
- nonlinear programming, 1498\*
- normal, 1501, 1501\*
- numbering systems, 1522-1523\*
- perturbation, 1638\*
- progression, 1783-1784\*
- queuing theory, 1836\*
- random matrices, 1868
- relation to science, 1337
- root, 1932\*
- scalar, 1952\*
- set theory, 1990\*
- space, 1338
- sphere, 2083\*
- topology, 2249-2250\*
- variable, 2324-2325\*
- vector, 2327\*
- Mathematics—cont.
- wavelets, 2375-2376\*
- zero, 2415\*
- Mating, 1898
- Matrix isolation, 1338-1339\*
- Matrix mechanics, 1339\*, 1955
- Matrix theory, 1339-1340\*
- Matsutake mushroom, 984, 1112
- Matter (physics), 1340\*
- quantum theory of, 1830-1831\*
- quark-gluon plasma, 1831
- universe, 2305
- Matthiessen's rule, 1340\*
- Matthiola*, 325
- Maturity-onset diabetes, 591
- Maxillopoda, 1340\*, 2192
- Maxwell (unit of measurement), 2304
- Maxwell, J. C., 627, 692, 696, 761, 765, 773, 1340, 1563
- light, 1250-1251
- magnetohydrodynamics, 1302
- polarization of waves, 1736
- quantum field theory, 1827
- relativistic electrodynamics, 1886
- relativity, 1887
- Maxwell-Boltzmann distribution, 276
- Maxwell field equations, 907
- Maxwell's demon, 1340\*
- Maxwell's equations, 1340-1341\*
- plasma (physics), 1717
- relativistic electrodynamics, 1886
- relativity, 1887
- supergravity, 2159
- superposition principle, 2162
- symmetry laws, 2180
- Maxwell's law, 2134
- Mayfly, 835
- Maynard, J. D., 15
- McClintock, B., 516
- McLeod gage, 1341\*
- Meadow saffron, 496\*
- Meadow spittle bug, 962
- Mealy machine, 610-611
- Mealybug, 963
- Mean (statistics), 2103
- Mean effective pressure, 1341\*
- Mean free path, 1341\*
- Mean sidereal day, 557
- Mean solar day, 557, 620, 621
- Mean solar time, 2240
- Measles, 1341\*
- Measure, 1341\*
- Measure theory, 1341-1342\*, 1405-1406
- Measured daywork, 1342\*
- Measurement:
- echo, 728
- physical, 1678-1680\*
- quantum theory of, 1831\*
- units of, 2302-2305\*
- Mechanical advantage, 1342\*
- Mechanical alloying, 1342\*
- Mechanical classification, 1342-1343\*
- Mechanical electric filter, 672
- Mechanical engineering, 1343\*
- Mechanical impedance, 1343\*
- Mechanical lift dock, 641
- Mechanical metamorphism, 1372
- Mechanical rectifier, 1343\*
- Mechanical separation techniques, 1343\*
- centrifugation, 402\*
- clarification, 467\*
- classification, 1343
- magnetic separation methods, 1295\*
- ore dressing, 1567\*
- sedimentation (industry), 1971-1972\*
- thickening, 2232-2233\*
- Mechanical torque converter, 2251
- Mechanical vibration, 1343-1344\*
- complex systems, 1344
- effect, 1344
- effect of, 1344
- fuzzy-structure acoustics, 953\*
- mass-spring-damper system, 1343-1344, 1343-1344\*
- shaft balancing, 1996\*
- sources, 1344
- sources of, 1344
- vibration, 2336
- vibration damping, 2337\*
- vibration isolation, 2337-2338\*
- Mechanics, 1344\*
- biomechanics, 288-289\*
- degree of freedom (mechanics), 631\*
- kinematics, 1214\*
- matrix mechanics, 1339\*
- Mechanics—cont.
- Newton's laws of motion, 1486\*
- nutation, 1524\*
- quantum, 1818-1830\*
- rock mechanics, 1927-1928\*
- statics, 2101\*
- statistical, 2101-2102\*
- strength of materials, 2126\*
- units of measurement, 2302-2304
- virial theorem, 2341\*
- wave, 2371\*
- Mechanism, 1344-1345\*
- linkage, 1259-1260\*
- machine, 1285
- Mechanoreceptors, 1345\*, 2338
- Mecoptera, 1345\*
- Medial sclerosis, 173, 174
- Median (statistics), 2103
- Median effective dose, 738
- Medicago falcata*, 71
- Medicago sativa*, 71
- Medical bacteriology, 474, 1345\*
- Medical control systems, 1345-1346\*
- Medical imaging, 1346-1348\*
- computerized tomography, 529\*
- emission tomography, 1347
- fiber-optics imaging, 796
- medical ultrasonic tomography, 1348\*
- nuclear magnetic resonance, 1346, 1510-1511\*
- radioactive tracer, 1855
- schizophrenia, 1958
- seizure disorders, 1978
- superconducting devices, 2155
- ultrasound, 1346
- x-ray methods, 1180
- Medical microbiology, 2095
- Medical mycology, 1347\*, 2018
- Medical parasitology, 1347-1348\*
- cestodes, 1348
- nematodes, 1347
- protozoa, 1348
- trematodes, 1347-1348
- Medical ultrasonic tomography, 1348\*
- Medical waste, 1348\*
- Medicine, 1349\*
- biomedical engineering, 290\*
- critical care, 514
- drug delivery systems, 702\*
- emergency, 729, 812\*
- forensic medicine, 915\*
- microwave applications, 1393
- molecular pathology, 1423-1424\*
- nuclear, 1511, 1511\*
- nursing, 1524\*
- pathogen, 1619\*
- pathology, 1619-1620\*
- public health, 1805-1806\*
- radiography, 1860\*
- radiology, 1863\*
- sports, 2088
- surgery, 2172\*
- ultronics, 2295
- see also Disease; Veterinary medicine
- Mediterranean Sea, 1348\*
- ocean circulation, 1530
- saline evaporites, 1941
- Medulla oblongata, 287, 1477
- Megachiroptera, 226, 388
- Megadermatidae, 388
- Megalomycteroidei, 359
- Megaphone, 624
- Megapodes, 260
- Megapodiidae, 260
- Meibomian gland, 1968
- Meinertellidae, 144
- Meiosis, 1349-1350\*
- details of prophase, 1349-1350
- divisions, 1349
- errors of, 1350
- fungal genetics, 948
- gametogenesis, 960\*
- mitosis vs., 1350
- oogenesis, 1544
- recombination, 1350
- reproduction, 1896
- spermatogenesis, 2081-2082\*
- Meissner, W., 1350, 2155
- Meissner effect, 1350-1351\*
- Meissner-Ochsenfeld effect, 2155, 2156
- Meitnerium, 928, 1351\*
- Melanin, 2017
- Melanogastrales, 864
- Melanophore, 397
- Melanterite, 1351\*
- Melatonin, 1689, 1690
- Meleagrididae, 259
- Meleagris gallapavo*, 259, 958
- Meles meles*, 214
- Melanthaceae, 996
- Melianthus*, 996
- Mellitite, 1351\*
- Melilotus, 422
- Meliolaceae, 761
- Melon:
- cantaloupe, 363\*
- Honey Dew melon, 1088\*
- muskmelon, 1456\*
- Persian melon, 1637\*
- watermelon, 2369\*
- Melonosuchus*, 309, 515
- Melt spinning, 1313-1314
- Melting point, 1351\*
- Membracidae, 962
- Membrane:
- ion exchange, 1185
- ion-selective, 1186
- Membrane distillation, 1351\*
- Membrane mimetic chemistry, 1351-1352\*, 1351-1353\*
- Membrane separations, 1352\*
- Donnan equilibrium, 696
- membrane distillation, 1351\*
- Memory, 1352-1353\*
- amnesia, 99\*
- cognition, 493\*
- physiology, 1352-1353
- stages, 1352
- Memory (computer):
- computer, 526
- microcomputer, 1373
- microprocessor, 1389
- see also Computer-storage technology
- Memory tube see Storage tube
- MEMS see Micro-electro-mechanical systems
- Mendel, Gregor, 695, 1353-1354
- Mendelevium, 1353\*
- Mendelism, 1353-1354\*
- dominance, 695\*
- genetic homeostasis, 984\*
- independent assortment, 1354
- law of segregation, 1353
- Ménière's disease, 1051
- Meninges, 1354\*, 1478
- Meningitis, 1354\*
- pneumococcus, 1730
- spinal cord disorders, 2085
- Meningococcus, 1354\*
- Menispermaceae, 1869
- Menopause, 1354-1355\*
- Menstruation, 1355\*, 1898
- menopause, 1354-1355\*
- reproductive system, 1898
- uterus, 2315\*
- Mental age, 1169
- Mental retardation, 1355\*
- behavior genetics, 263
- Down syndrome, 700\*
- Mentha*, 1223, 1626, 2072
- Menthol, 1355-1356\*
- Mephitis mephitis*, 2019
- Mercaptan, 1356\*, 1577-1578
- Merchant ship, 1318-1319, 1356\*
- Mercurial compound, 145
- Mercury (element), 1356\*
- amalgam, 94\*
- cinnabar, 458\*
- Mercury (planet), 1356-1357\*
- gravitation, 1021
- planet, 1698
- planetary physics, 1700, 1701
- transit, 2261
- Mercury barometer, 221
- Mercury chloride, 358
- Mercury space flight, 2059
- Mercury-vapor lamp, 1357\*
- sunlamp, 2152\*
- ultraviolet lamp, 2295\*
- Meridian, 1357\*
- polar navigation, 1734
- terrestrial coordinate system, 2211-2212
- Meristem:
- apical, 133
- lateral, 1232\*
- Merocrine gland, 2174
- Merogony, 1357\*
- Meromictic lake, 1358\*
- Meropes, 494
- Meropidae, 494
- Merostomata, 367, 1358\*
- Eurypterida, 856\*
- Xiphosurida, 2408\*
- Mescaline, 1610, 1804

Mesencephalon, 287, 1477  
 Meso-ionic compound, 1358\*  
*Mesocricetus auratus*, 925  
 Mesoderm, 812  
 Mesogastropoda, 1358\*  
 Mesometeorology, 1358-1359\*  
*Mesomyzostomum*, 1462  
 Meson, 1359\*  
 elementary particle, 804  
 parity, 1612, 1613  
 quark-gluon plasma, 1831  
 quarks, 1832  
 supercritical fields, 2158  
 symmetry laws, 2179  
 Mesoproterozoic, 1793  
 Mesosauria, 1359\*  
*Mesosaurus*, 1359  
 Mesoscale (weather), 2378  
 Mesoscopic physics, 1325-1360\*  
 charging effects, 1359-1360  
 interference effects, 1359  
 nanostructure, 1464\*  
 quantum size effects, 1359  
 Mesosphere, 184, 201, 1360\*  
 Mesostigmata, 1360\*  
 Mesothelioma, 179  
 Mesoveliidae, 944  
 Mesozoa, 1360\*  
 Dicyemida, 657\*  
 Orthonectida, 1581\*  
 Mesozoic, 1360-1361\*  
 animal evolution, 120  
 dinosaur, 675, 676  
 dolomite rock, 694  
 Dryolestida, 704  
 Jurassic, 1208\*  
 Pterosauria, 1805\*  
 Triassic, 2269\*  
 Message switching, 1594  
 Messenger RNA (mRNA):  
 gene, 978  
 gene action, 979  
 genetic code, 981-982  
 intron, 1179  
 ribonucleic acid, 1918  
 Messier, Charles, 1361  
 Messier catalog, 1361\*  
 Meta-inert gas welding, 142  
 Metabolic bone disease, 2017  
 Metabolic disorders, 1361-1362\*  
 carbohydrates, 1362  
 lipids, 1361-1362  
 muscle symptoms, 1452-1453  
 muscular system disorders, 1453  
 nucleic acids, 1361  
 proteins, 1361  
 Metabolism, 1362\*  
 adenosine diphosphate (ADP), 27\*  
 adenosine triphosphate (ATP), 27-28\*  
 amino acids, 97-98\*  
 bacterial, 242-243\*  
 calcium, 352\*  
 carbohydrate, 366-367\*  
 cell, 393-394\*  
 cryptobiosis, 587\*  
 energy, 821\*  
 enzyme, 832-833\*  
 iron metabolism, 1191\*  
 obesity, 1528\*  
 organosulfur compound, 1578  
 phosphate, 1658\*  
 physiological (plant), 1682-1683  
 plant, 1707\*  
 protein, 1791-1792\*  
 thermoregulation, 2230  
 urine, 2313\*  
 see also Carbohydrate metabolism; Lipid metabolism; Protein metabolism  
*Metacrinus*, 161  
 Metal, 1362\*  
 alkali, 78, 78\*  
 alkaline-earth, 78  
 alloy see Alloy  
 aluminum, 92-93\*  
 arsenic, 172\*  
 barium, 250-251\*  
 beryllium, 268-269\*  
 bismuth, 298\*  
 cadmium, 349\*  
 calcium, 351-352\*  
 cerium, 408\*  
 cesium, 408\*  
 chromium, 450-451\*  
 cobalt, 486\*  
 conduction (electricity), 533  
 coordination chemistry, 554\*  
 copper, 556\*

Metal—cont.  
 corrosion, 562-563\*  
 curium, 599\*  
 dysprosium, 712\*  
 electrical resistivity in, 760  
 electrochemical series, 763\*  
 eutectics, 856\*  
 free-electron theory of metals, 932\*  
 gadolinium, 955\*  
 gallium, 958\*  
 germanium, 997\*  
 gold, 1010-1011\*  
 hafnium, 1038\*  
 heat treatment, 936-937  
 high-temperature materials, 1079\*  
 holmium, 1083\*  
 indium, 1136-1137\*  
 iridium, 1190\*  
 iron, 1190-1191\*  
 lanthanum, 1227\*  
 lithium, 1264\*  
 magnesium, 1289-1290\*  
 manganese, 1311\*  
 Matthiessen's rule, 1340\*  
 mercury, 1356\*  
 metallography, 1369-1370\*  
 metallurgy, 1370\*  
 molybdenum, 1429-1430\*  
 neodymium, 1473\*  
 neptunium, 1476\*  
 nickel, 1486-1487\*  
 niobium, 1488\*  
 organometallic compound, 1575-1576\*  
 osmium, 1584-1585\*  
 palladium, 1603-1604\*  
 periodic table, 1632  
 plastic deformation of, 1722\*  
 platinum, 1724-1735\*  
 plutonium, 1729-1730\*  
 polymorphism, 1748  
 protactinium, 1789\*  
 rare-earth elements, 1869-1870\*  
 reflectivity, 1880-1881  
 refractory, 1883\*  
 rhenium, 1991\*  
 rhodium, 1914-1915\*  
 ruthenium, 1936\*  
 shape memory alloys, 1996\*  
 silver, 2010\*  
 spin-density wave, 2085\*  
 tantalum, 2192\*  
 terbium, 2210\*  
 thorium, 2234-2235\*  
 thulium, 2235\*  
 tungsten, 2282\*  
 vanadium, 2322-2323\*  
 wire, 2391\*  
 work function, 2397-2398  
 ytterbium, 2412\*  
 yttrium, 2412\*  
 zinc, 2415-2416\*  
 zirconium, 2417\*  
 Metal, mechanical properties of, 1362-1364\*  
 compression test, 1363-1364  
 creep and stress rupture, 1364  
 ductile-to-brittle transition, 1363  
 elongation, 1363  
 fatigue, 1364  
 hardness testing, 1364  
 notch tensile test, 1363  
 notched-bar impact test, 1364  
 stress states, 1362-1363  
 tensile strength, 1363  
 tension, 1363  
 tension test, 1363  
 torsion, 1363  
 yield point, 1363  
 yield strength, 1363  
 Metal-base fuel, 1364\*  
 Metal carbonyl, 1364-1365\*  
 Metal casting, 83, 1365\*  
 Metal cluster compound, 1365\*  
 Metal coatings, 716, 1365-1366\*  
 galvanizing, 958\*  
 machining, 1285-1286\*, 1286  
 vapor deposition, 2324  
 zinc, 2415-2416  
 Metal forming, 1366\*  
 coining, 495\*  
 drawing of metal, 701\*  
 explosive forming, 862\*  
 extrusion, 864\*  
 forging, 921\*  
 metal rolling, 1367\*  
 sheet, 1997-1998\*  
 titanium, 2245  
 Metal halide lamp, 1366\*

Metal hydrides, 974, 1366\*  
 Metal matrix composite, 1366-1367\*  
 Metal oxide semiconductor (MOS):  
 gate circuit, 972  
 radiation hardening, 1844  
 Metal oxide semiconductor field-effect transistor (MOSFET), 1397  
 Metal rolling, 1367\*  
 Metal semiconductor field-effect transistors (MESFETs), 1397  
 Metal toxicity, 486  
 Metallic bonding, 367, 436, 495  
 Metallic glasses, 100, 1367-1368\*  
 Metallic materials, 1334  
 Metallocene catalyst, 1368\*  
 Metallocenes, 1368-1369\*  
 Metallochaperones, 1369\*  
 Metallography, 1369-1370\*  
 Metalloid, 1370\*  
 boron, 319-320\*  
 silicon, 2008-2009\*  
 Metalloporphyrins, 1757  
 Metallurgical microscope, 1558  
 Metallurgy, 1370\*  
 arc heating, 158\*  
 copper, 557\*  
 diffusion, 665  
 electrochemical process, 762  
 electrometallurgy, 774\*  
 gold, 1011\*  
 hydrometallurgy, 1109\*  
 nickel, 1487\*  
 powder metallurgy, 1762\*  
 pyrometallurgy, 1815\*  
 solid solution, 2043\*  
 steel manufacture, 2106  
 tin, 2243\*  
 titanium, 2244-2245\*  
 uranium, 2309\*  
 vacuum, 2318\*  
 zinc, 2416\*  
 Metalworking, prehistoric, 1768  
 Metameres, 1370\*  
 Metamerism, 175  
 Metamict state, 1370-1371\*  
 Metamorphic minerals, 1404  
 Metamorphic rocks, 1371\*  
 amphibolite, 102-103\*  
 cataclastic, 1371  
 eclogite, 731\*  
 facies, 869  
 granulite, 1016\*  
 hornfels, 1089-1090\*  
 marble, 1316\*, 1317\*  
 mylonite, 1460\*  
 phyllite, 1675\*  
 porphyroblast, 1757\*  
 quartzite, 1833\*  
 recrystallized, 1371  
 serpentinite, 1989\*  
 skarn, 2015\*  
 slate, 2019\*  
 Metamorphism, 271-272, 308\*, 1371-1372\*  
 Metamorphosis, 1372\*  
 insecta, 1157-1158  
 Lepidoptera, 1245  
 Metaphase (meiosis), 1349  
 Metaphor, 1335  
*Metarhizium*, 1119  
 Metasomatism, 1372-1373\*  
 Metastable state, 1373\*  
 Metastrongyloidea, 2130\*  
 Metathesia, 1373\*, 2219  
 Metazoa, 1373\*  
 Meteor, 1371-1374\*, 2049  
 Meteorite, 1374-1376\*  
 chemical composition, 503  
 cosmochemistry, 567-568  
 impact, 1375-1376  
 iron, 1375  
 isotopic anomalies, 1375  
 isotopic composition, 503-504  
 from Mars, 1327  
 micrometeorite, 1385-1386\*  
 minerals, 503  
 Paleocene, 1597  
 stony, 1374-1375  
 Meteorological instrumentation, 1376-1377\*  
 Meteorological navigation see Ship routing  
 Meteorological optics, 1377\*  
 halo, 1042\*  
 rainbow, 1866\*  
 Meteorological radar, 1377-1378\*  
 Meteorological rocket, 1378\*

Meteorological satellites, 1378-1379\*  
 active sensors, 1379  
 imaging microwave radiometers, 1379  
 optical imaging sensors, 1378-1379  
 satellite (spacecraft), 1946  
 sounding sensors, 1379  
 storm detection, 2120-2121\*  
 Meteorology, 1379-1380\*  
 aeronautical, 35\*  
 agricultural, 45\*  
 air pressure, 53-54\*  
 air temperature, 55\*  
 biometeorology, 291-292\*  
 climatology, 416, 473\*  
 continentality, 483  
 Earth sciences, 722  
 hydrometeorology, 1109\*  
 industrial meteorology, 1141\*  
 maritime, 1325-1326\*  
 mesometeorology, 1358-1359\*  
 micrometeorology, 1386\*  
 monsoon, 1435\*  
 mountain, 1443\*  
 polar, 1734\*  
 precipitation, 1766\*  
 radar, 1841\*  
 satellite, 1948\*  
 solenoid, 2043\*  
 storm detection, 2120-2121\*  
 tropical, 2277\*  
 weather, 2377-2378\*  
 weather forecasting and prediction, 2378-2379\*  
 Metering orifice, 1380\*  
 Methadone, 26  
 Methane, 1100, 1380\*  
 air pollution, 52  
 coalbed, 483-484\*  
 halogenated hydrocarbon, 1043  
 industrial wastewater treatment, 1142  
 methanogenesis (bacteria), 1381  
 petroleum, 1641  
 Methane-producing bacteria, 143, 160  
 Methanogen, 143, 160  
 Methanogenesis (bacteria), 1381\*  
 Methanol, 1381\*  
 fuel cell, 941  
 high-pressure processes, 1079  
 Methods engineering, 1381\*  
 Methyl chloride, 390  
 Methyl methacrylate, 1741  
 Methylcarbinol, 765  
 Methylene chloride, 390  
 Metric system, 1381\*, 1678, 2302-2305  
 Metzgeriales, 1381\*  
 Mexican jade, 1201  
 Miacoidea, 333  
 Mica, 1381-1382\*  
 biotite, 297\*  
 muscovite, 1451\*  
 phlogopite, 1655-1656\*  
 Micelle, 1382\*  
 Michelson, A. A., 436, 697\*, 1887  
 Michelson interferometer, 1153, 1171-1172  
 Michelson stellar interferometer, 1172  
 MICR see Magnetic ink character recognition  
 Microbial ecology, 735, 1382\*  
 Microbial sulfur cycle, 1323  
 Microbiology, 1382\*  
 clinical, 417  
 clinical pathology, 475-476  
 gnotobiotics, 1010\*  
 halophilism, 1044\*  
 industrial microbiology, 1141-1142\*  
 marine, 1322-1323\*  
 petroleum, 1642-1643\*  
 soil, 2037\*  
 textile, 2216-2217\*  
 textile microbiology, 2216-2217  
 Microbiota (human), 1382-1383\*  
 Microchiroptera, 227, 729  
 Microclimatology, 416  
 Microclimate, 1383\*  
 Microcomputer, 1383-1384\*  
 consumer products, 480  
 embedded systems, 808\*  
 magnetic-tape unit, 463-464  
 memory chip, 462-463  
 Microdialysis sampling, 1384\*  
 Micro-electro-mechanical systems (MEMS), 1384-1385\*  
 applications, 1385  
 microfabrication technology, 1384-1385  
 Microfabrication technology, 1384-1385  
 Microfossil, 1387-1388  
 Microglia, 1477  
 Micromanipulation, 1385\*

- Micrometeorite, 1385-1386\*  
 Micrometeorology, 1386\*  
   climate modification, 473\*  
   crop, 516  
   wind, 2388  
 Micrometer, 1386\*  
 Micro-opto-electro-mechanical systems (MOEMS), 1386-1387\*  
 Micro-opto-mechanical systems (MOMS), 1387\*  
 Microorganisms:  
   forest ecosystem, 917-918  
   infectious disease, 1144  
   virulence, 2343\*  
 Micropaleontology, 1387-1388\*  
 Microphone, 1388-1389\*  
   active sound control, 23  
   electret, 669  
   electret transducer, 742  
   measurement, 1493  
   response, 1907\*  
   sound recording, 2054\*  
   sound-reinforcement system, 2054\*  
   sound-reproducing systems, 2054-2055\*  
 Microphysidae, 944  
 Microprocessor, 1389-1390\*  
   calculators, 352\*  
   digital computer, 668  
   microcomputer, 1383  
 Micropterygidae, 1245  
 Micropterygoidea, 1245  
 Micropygoida, 1390\*  
 Microradiography, 1390-1391\*  
 Microsauria, 1244, 1391\*  
 Microscope, 1391\*  
   acoustic, 16\*  
   chemical microscopy, 426-427\*  
   confocal microscopy, 534\*  
   electron, 704-705, 780-781\*  
   field-emission microscopy, 885-886\*  
   fluorescence, 812-813, 902-903\*  
   interference microscope, 1170\*  
   microtechnique, 1391\*  
   optical, 1557-1558\*  
   phase-contrast microscope, 1650-1651\*  
   polarized light, 1737-1738\*  
   reflecting, 1880\*  
   scanning electron, 1953\*  
   scanning tunneling, 1953-1954\*  
   video, 2339\*  
   x-ray microscope, 2149\*  
 Microscopic (BSC) theory, 2156-2157  
 Microscopy:  
   metallography, 1369-1370\*  
   video, 2339\*  
 Microsensor, 1391\*  
 Microsporidea, 423, 1391\*  
*Microsporium*, 578  
 Microsystems *see* Micro-electro-mechanical systems  
 Microtechnique, 1391\*  
 Microtubule, 346  
   cell motility, 394-395  
   centriole, 402, 403  
   cilia and flagella, 456\*  
   cytoskeleton, 612\*  
   mitosis, 1410  
 Microwave, 1391-1393\*  
   applications, 1393  
   chemistry, 1393  
   circuit elements, 1392  
   cosmic background radiation, 564-565\*  
   generation, 1392  
   integrated circuits, 1392  
   physics, 1393  
   propagation, 1393  
   radiation biology, 1843  
   receiver, 1392-1393  
   submillimeter-wave technology, 2141  
   transmitter, 1393  
   wavelength measurement, 2374-2375  
 Microwave filter, 673, 1393-1394\*  
 Microwave free-field standards, 1394\*  
 Microwave holography, 1085  
 Microwave integrated circuits (MICs), 1392  
 Microwave landing system (MLS), 1394\*  
 Microwave measurements, 1394-1395\*  
   computer use, 1395  
   heterodyne, 1395  
   impedance, 1395  
   noise, 1395, 1396\*  
   power, 1395  
   scattering coefficients, 1395  
   use of computers, 1395  
 Microwave noise standards, 1396\*  
 Microwave optics, 1396\*  
 Microwave radar, 1894  
 Microwave radiometers, 1379  
 Microwave solid-state devices, 1396-1398\*  
   active, 1396-1397  
   active microwave diodes, 1397-1398  
   passive, 1396  
   submillimeter-wave technology, 2141  
 Microwave spectroscopy, 1398-1399\*  
 Microwave spectrum analyzer, 2077  
 Microwave tube, 1399\*  
   gyrotron, 1036\*  
   magnetron, 1303-1304\*  
   traveling-wave tube, 2265-2266\*  
 Microwave weather radar, 1377  
 Micrurgy *see* Micromanipulation  
 Mictacea, 1399\*  
*Mictocaris halope*, 1399  
 Mid-Atlantic Ridge, 1321  
 Mid-Oceanic Ridge, 1400\*  
   Earth, 718  
   hydrothermal vent, 1110-1111\*  
   marine geology, 1321  
   oceanic crust, 720  
   seamount and guyot, 1967\*  
   submarine canyon, 2139-2140\*  
   transform fault, 2257-2258\*  
 Midbrain, 2333  
 Middle-atmosphere dynamics, 36, 1399\*  
 Midge, 679  
 Midgut, 666  
 Midnight sun, 1399-1400\*  
 Migmatite, 1400\*  
 Mignonette, 325  
 Migraine, 929  
 Migration, 1754, 1768  
 Migratory behavior, 1400-1401\*  
 Mildew, 949  
 Milestone chart, 964  
 Miliary tuberculosis, 2279  
 Military aircraft, 1401\*  
   *see also* Air armament; Naval armament  
 Military aviation, 208  
 Military explosives, 861, 862  
 Military satellites, 1401-1402\*, 2089  
 Milk, 1402\*  
   butter, 345-346\*  
   casein, 336, 376\*  
   cheese, 418\*  
   glycoside, 1008  
   ice cream, 1123\*  
   lactation, 1222\*  
   lactose, 1222  
   lysozyme, 1284  
   mammary gland, 1310\*  
   pasteurization, 1619  
   processing, 1402  
   products, 1402  
   sugar, 2145  
 Milk sugar *see* Lactose  
 Milkfish, 898  
 Milkweed bug, 944  
 Milky disease, 1639  
 Milky Way Galaxy, 1402-1403\*  
   galaxy, external, 956  
   gravitational lens, 1023  
   Hyades, 1099\*  
   infrared astronomy, 1151  
   interstellar matter, 1177  
   Local Group, 1267\*  
   molecular cloud, 1419-1420\*  
   nova, 1505  
   planetary nebula, 1700  
   solar system, 2041-2042  
   star, 2097  
   star clouds, 2098  
   star cluster, 2098, 2099  
   structure and contents, 1402-1403  
   superluminal motion, 2160\*  
   supernova, 2161  
   x-ray astronomy, 2401  
 Mill tailings, 1855-1856  
 Milleporina, 983, 1111, 1403\*  
 Miller indices, 530, 2402  
 Millerite, 1403\*  
 Millet, 1403\*  
 Mills, R. L., 867  
   gauge theory, 973  
   supergravity, 2159  
 Milnesium, 772  
 Milstein, C., 1432  
 Mimicry:  
   plant-animal interactions, 1702  
   polymorphism (genetics), 1748  
 Mimosa, 1240  
 Mimosaceae, 783  
 Mimosoids, 1240  
 Mine (armaments):  
   acoustic, 16\*  
   Mine (armaments):—*cont.*  
   warfare, 156, 171  
 Mine Safety and Health Administration (MSHA), 1141  
 Minelayer ships, 1468-1469  
 Mineral, 1403-1404\*  
   acanthite, 7\*  
   albite, 67-68\*  
   alunite, 93\*  
   amethyst, 96  
   amphibole, 102-103\*  
   ancalime, 107\*  
   andalusite, 114\*  
   andesine, 114\*  
   anglesite, 117  
   anhydrite, 118\*  
   ankerite, 125\*  
   anthophyllite, 134\*  
   apatite, 148\*  
   apophyllite, 151-152\*  
   aragonite, 156\*  
   arsenopyrite, 172-173\*  
   asbestos, 165, 178-179\*  
   augite, 218\*  
   authigenic, 198, 220-221\*  
   azurite, 237\*  
   barite, 250\*  
   beryl, 268\*  
   biopyribole, 294\*  
   biotite, 297\*  
   borate, 279-280, 318\*  
   bornite, 319\*  
   brucite, 336\*  
   bytownite, 346\*  
   calcite, 351\*  
   cancrinite, 362\*  
   carbonate *see* Carbonate minerals  
   carnotite, 373-374\*  
   cassiterite, 377\*  
   celestite, 387-388\*  
   cerargyrite, 406\*  
   cerussite, 408\*  
   chabazite, 359\*, 410-411\*  
   chalcanthite, 412\*  
   chalcedony, 412\*  
   chalcocite, 412\*  
   chalcopyrite, 412\*  
   chromite, 450\*  
   chrysoberyl, 455\*  
   chrysocola, 455\*  
   chrysotile, 455\*  
   cinnabar, 458\*  
   classification, 1403-1404  
   clay *see* Clay minerals  
   cobaltite, 487\*  
   coesite, 491\*  
   columbite, 505\*  
   cordierite, 558\*  
   corundum, 563-564\*  
   covellite, 574\*  
   crocoite, 516  
   cryolite, 587\*  
   cummingtonite, 598\*  
   cuprite, 598\*  
   datolite, 620\*  
   diamond, 592-593, 654-655\*  
   diopside, 676\*  
   dolomite, 694\*  
   dolomite rock, 694-695\*  
   dumortierite, 705\*  
   Earth interior, 721  
   economic importance, 1404  
   emerald, 812\*  
   enargite, 814\*  
   enstatite, 826\*  
   epidote, 838\*  
   epsomite, 740\*, 840\*  
   feldspar, 788, 875\*  
   feldspathoid, 875\*  
   flotation, 896\*  
   fluorite, 904\*  
   food, 907  
   formation, 1404  
   franklinite, 932\*  
   galena, 957\*  
   garnet, 860-861  
   gem, 976-977\*  
   glauconite, 890  
   glaucophanite, 1003\*  
   goethite, 1010\*  
   greenockite, 1027\*  
   gypsum, 1034\*  
   halite, 1040\*  
   halloysite, 1041-1042\*  
   halogen minerals, 1043\*  
   hausmannite, 1048\*  
   heavy, 937, 1058\*  
 Mineral—*cont.*  
   hematite, 1061\*  
   hemimorphite, 1063\*  
   heulandite, 1073\*  
   hornblende, 1089\*  
   huebnerite, 1092\*  
   humite, 1098\*  
   igneous rock-forming minerals, 1126  
   ilmeneite, 1127\*  
   jade, 1201\*  
   jadeite, 1201\*  
   jasper, 1201\*  
   kaliophyllite, 1209\*  
   kalsilite, 1209\*  
   kaolinite, 1209\*  
   kernite, 1212\*  
   kyanite, 1219-1220\*  
   labradorite, 1221\*  
   larnite, 1228\*  
   lawsonite, 1234\*  
   lazurite, 1235\*  
   lepidolite, 1242\*  
   leucite, 1246\*  
   magnesite, 1289\*  
   magnetite, 1300\*  
   malachite, 1306\*  
   manganite, 1312\*  
   marcasite, 1317\*  
   marine mining, 1323\*  
   melanterite, 1351\*  
   mellite, 1351\*  
   metamict state, 1370-1371\*  
   mica, 1381-1382\*  
   millerite, 1403, 1403\*  
   mineralogy, 1404-1405\*  
   mining, 1406\*  
   molybdenite, 1429\*  
   monazite, 1430\*  
   montmorillonite, 1436\*  
   muscovite, 1451\*  
   names, 1404  
   native elements, 1465\*  
   natrolite, 1465\*  
   nepheline, 1475\*  
   niter, 1488\*  
   occurrence, 1404  
   olivine, 1540\*  
   onyx, 1544\*  
   oolite, 1545  
   opal, 1545\*  
   ore and mineral deposits, 1567\*  
   ore dressing, 1567\*  
   orpiment, 1580\*  
   orthorhombic pyroxene, 1581-1582  
   pectolite, 1622\*  
   pentlandite, 1626\*  
   perovskite, 1635\*  
   petalite, 1639\*  
   petrifaction, 1639\*  
   phlogopite, 1655-1656\*  
   phosphate minerals, 1658\*  
   pigeonite, 1686\*  
   in plant nutrition, 1707-1708\*  
   pleochroic halos, 1728\*  
   pneumatolysis, 1730\*  
   prehnite, 1768\*  
   prospecting, 1787-1788\*  
   proustite, 1797\*  
   pyrargyrite, 1812\*  
   pyrite, 1813\*  
   pyrolusite, 1814\*  
   pyromorphite, 1816-1817\*  
   pyrophyllite, 1817\*  
   pyroxene, 1817\*  
   pyrrhotite, 1818\*  
   quartz, 1833\*  
   radioactive *see* Radioactive minerals  
   realgar, 1874\*  
   rhodochrosite, 1915\*  
   ruby, 1935\*  
   rutile, 1936\*  
   sapphire, 1944-1945\*  
   scapolite, 1954\*  
   scheelite, 1956\*  
   sepiolite, 1986\*  
   serpentine, 1989\*  
   siderite, 2004-2005\*  
   silica minerals, 2007\*  
   silicate *see* Silicate minerals  
   sillimanite, 2009\*  
   soda niter, 2029\*  
   sodalite, 2029\*  
   soils, 2034  
   sphalerite, 2082\*  
   spodumene, 2088\*  
   staurolite  
   stibnite, 2116\*

- Mineral—*cont.*  
 stibite, 2116\*  
 stishovite, 2117\*  
 sulfur, 2149  
 tantalite, 2192\*  
 tetrahedrite, 2214\*  
 thorianite, 2234\*  
 thorite, 2234\*  
 topaz, 2249\*  
 tourmaline, 2252\*  
 tremolite, 2269\*  
 turquoise, 2288\*  
 uraninite, 2308\*  
 vivianite, 2350\*  
 wavellite, 2376\*  
 willemitite, 2388\*  
 witherite, 2392\*  
 wolframite, 2393\*  
 wollastonite, 2393\*  
 wulfenite, 2399\*  
 wurtzite, 2399\*  
 zeolite, 2414-2415\*  
 zirconite, 2416\*  
 zircon, 2417\*
- Mineral spring, 2090  
 Mineralogy, 880, 1404-1405\*  
 crystal chemistry, 1404-1405  
 descriptive, 1405  
 Earth sciences, 722  
 geochronometry, 985-986\*  
 high-pressure, 1077-1078\*  
 paragenetic, 1405  
 petrography, 1640  
 quantum, 1830\*  
 quantum mineralogy, 1830\*  
 solid solution, 2043\*, 2044\*  
 taxonomic, 1405
- Mines (naval armament), 1468  
 Minimal principles, 1405\*  
 Minimal surfaces, 1405-1406\*  
 Mining, 1406\*  
 coal, 426, 481, 483\*  
 diamond, 654  
 land reclamation, 1224  
 marine, 1323\*  
 marine, 1323\*  
 open pit, 1545-1555\*  
 placer, 1695\*  
 rock burst, 1927\*  
 solution, 2046-2047\*  
 surface, 2169\*  
 underground, 2297-2298\*  
 Mink, 1406\*  
 Minkowski, Hermann, 2068  
 Minkowski universe, 2068  
 Minkowsky, O., 1604  
 Mint:  
 Lamiales, 1223  
 peppermint, 1626\*  
 spearmint, 2072\*  
 Miocene, 923-924, 1406-1407\*  
 Mir:  
 space flight, 2059, 2060  
 space station, 2066  
 spacecraft structure, 2070  
 Mira, 1407\*, 2325  
*Mirabilis jalapa*, 336  
 Mirage, 1407\*  
 Mirapinnatoidei, 359  
 Mirafak, 1637  
 Miridae, 944  
 Miripinnati, 359  
 Mirror optics, 1407-1408\*, 1880-1881  
 Mirrors, 2405-2405  
 Miscarriages, 1768  
 Misophroidea, 1408\*  
 Missile, 1408\*  
 ballistic, 246\*  
 ballistic range, 246-247\*  
 conformal optics, 535  
 flight dynamics, 896\*  
 guidance systems, 1031\*  
 guided missile, 1031\*  
 naval armament, 1467  
 nose cone, 1504\*  
 rocket staging, 1929-1930\*  
 submarine, 2139  
 Mississippian, 1408-1409\*  
 Mistletoe, 1409\*  
 Mite, 138, 155  
 Acari, 8\*  
 Mesostigmata, 1360\*  
 Sarcopiformes, 1945\*  
 Trilobita, 2273  
 Trombidiformes, 2276\*  
 Mitochondria, 346, 1409-1410\*  
 cell (biology), 389  
 Mitochondria—*cont.*  
 cell membrane, 393  
 DNA analysis, 916  
 spermatogenesis, 2081  
 Mitosis, 1410-1411\*  
 cytokinesis, 610\*  
 meiosis vs., 1350  
 oogenesis, 1544  
 reproduction, 1896  
 Mitotic fungi, 648  
 Mitten-tree, 1946  
 Mitteniales, 1411\*  
 Mixer, 1411-1412\*  
 Mixing (digital signals), 1414\*  
 Mixing (of matter), 1412\*  
 Mizar, 1412\*  
*Mkilua fragrans*, 1305  
 MKSA units (electrical), 760  
 MLS see Microwave landing system  
 MMF see Magnetomotive force  
 Mnesarchaeidea, 1245  
 Mobile radio, 1412-1413\*  
 FM transmission, 838  
 switching systems, 2177  
 Möbius strip, 883  
 Mode, 1159, 2103  
 Mode-locked laser, 953  
 Mode of vibration, 1413\*  
 Model theory, 1413-1414\*  
 optimization, 1564-1565  
 systems analysis, 2186  
 Models and modeling:  
 computer-based systems, 521  
 ecological, 733-734\*  
 electrical, 758\*  
 environmental fluid mechanics, 830  
 functional analysis and modeling,  
 944-945\*  
 mathematical biology, 1335  
 mathematical geography, 1336  
 prototype, 1795-1796\*  
 simulation, 2012-2013, 2012-2013\*  
 weather forecasting and prediction, 2378  
 Moderate-resolution Imaging  
 Spectroradiometer (MODIS), 1378  
 Modulation, 1414-1415\*  
 amplitude modulator, 106-107\*  
 demodulator, 634\*  
 sideband, 2004\*  
 see also Amplitude modulation; Angle  
 modulation; Frequency modulation;  
 Pulse modulation  
 Modulator, 1415\*  
 MOEMS see Micro-opto-electro-mechanical  
 systems  
 Moeritheroidea, 1777  
 Mohair, 1415\*  
 Moho (Mohorovičić discontinuity), 1415\*  
 Earth, 717  
 Earth interior, 721  
 lithosphere, 1264  
 Mohorovičić, A., 1415  
 Moiré pattern, 1415\*  
 Moist gangrene, 963  
 Moisture-content measurement, 1416\*  
 gases, 1416  
 liquids and solids, 1416  
 psychrometer, 1804  
 psychrometrics, 1804-1805\*  
 Mola, 2151  
 Molality, 466  
 Molarity, 466  
 Molasses, 2145  
 Mole (chemistry), 1416\*, 1680  
 Mole (zoology), 115, 1158, 1417\*, 1930  
 Molecular adhesion, 1417\*  
 Molecular anthropology, 1417-1418\*, 1676  
 Molecular beams, 1418\*, 1954  
 Molecular biology, 1418-1419\*  
 biophysical analysis, 1419  
 Earth sciences, 722  
 flow of molecular information,  
 1419  
 recombinant DAN, 1419  
 Molecular biophysics, 255  
 Molecular cloud, 1419-1420\*, 1795  
 Molecular dipole, 619, 678  
 Molecular electronics, 247  
 Molecular isomerism, 1420-1421\*  
 constitutional isomers, 1420-1421  
 prochirality, 1778  
 stereoisomers, 1421  
 tautomerism, 2194\*  
 Molecular laser isotope separation (MLIS),  
 1198  
 Molecular lines, 1847  
 Molecular machine, 1421\*
- Molecular mechanics, 1421-1422\*  
 Molecular orbital theory, 1422-1423\*  
 conjugation and hyperconjugation,  
 537-538\*  
 coordination chemistry, 554\*  
 quantum chemistry, 1824-1825\*  
 triplet state, 2274\*  
 Molecular pathology, 1423-1424\*  
 Molecular physics, 1424\*  
 Molecular recognition, 1424\*, 1464  
 Molecular sieve, 1424-1425\*  
 Molecular simulation, 1425\*  
 Molecular structure and spectra, 1425-1426\*  
 band spectrum, 248\*  
 bond angle and distance, 314-315\*  
 correspondence principle, 562\*  
 dipole moments, 1426  
 Franck-Condon principle, 931-932\*  
 hyperfine structure, 1116\*  
 magnetochemistry, 1301\*  
 molecular energy levels, 1426  
 molecular polarizability, 1426  
 molecular sizes, 1425-1426  
 molecular spectra, 1426  
 nonlinear physics, 1498  
 organic photochemistry, 1572\*  
 quantum chemistry, 1824-1825\*  
 resonance, 1904\*  
 Molecular weight, 1426-1428\*  
 gram, 900  
 relative molecular mass, 1886\*  
 Molecule, 1427\*  
 cyclophane, 605\*  
 free radical, 933\*  
 intermolecular forces, 1174  
 interstellar matter, 1178  
 nuclear, 1511\*  
 polar, 1734\*  
 scattering experiments, 1954\*  
 spin label, 2084-2085\*  
 Molidae, 2151  
 Mollicutes, 1459\*  
 Mollie (fish), 183  
 Mollusca, 1427-1429\*  
 abalone, 2\*  
 animal evolution, 120  
 Anisomyaria, 125\*  
 Aplacophora, 151\*  
 Archaeogastropoda, 144  
 Basommatophora, 257\*  
 Bivalvia, 299\*  
 boring bivalves, 319\*  
 Cephalopoda, 405\*  
 chiton, 441\*  
 classification, 1427  
 Coleoidea, 497\*  
 distributional ecology, 1428-1429  
 endocrine system, 732, 815  
 functional morphology, 1427-1428  
 Gastropoda, 971-972\*  
 invertebrate pathology, 1182  
 Lamellibranchia, 1223\*  
 limpet, 1256\*  
 Monoplacophora, 1434\*  
 Nautiloidea, 1466\*  
 Neogastropoda, 1473\*  
 Neomeniomorpha, 1474\*  
 Nudibranchia, 1521\*  
 Octopoda, 1532\*  
 Opisthobranchia, 1549-1550\*  
 pearl, 1622\*  
 Polyplacophora, 1750\*  
 Prosobranchia, 1787\*  
 Protobranchia, 1793\*  
 Pulmonata, 1806\*  
 Sacoglossa, 1939\*  
 Scaphopoda, 1954\*  
 Sepioidea, 1986\*  
 Septibranchia, 1986-1987\*  
 shipwonn, 2000\*  
 slug, 2023\*  
 snail, 2024-2025\*  
 squid, 2093\*  
 Systellommatophora, 2185\*  
 Taxodonta, 2194\*  
 Teuthoidea, 2215\*  
 Triassic, 2269  
 Vampyromorpha, 2321\*  
*Molniva*, 451  
 Molossidae, 388  
 Molpadida, 134, 960  
 Molting:  
 Arthropoda, 1429\*  
 Crustacea, 519, 585  
 Molting hormone, 725, 732  
 Molybdenite, 1429\*, 2149  
 Molybdenum, 1429-1430\*
- Molybdenum alloys, 1430\*  
 Moment of force see Torque  
 Moment of inertia, 1430-1431\*, 1864  
 Momentum, 1431\*  
 angular, 117-118\*  
 conservation of, 477  
 rigid-body dynamics, 1922  
*Momordica charantia*, 1579  
 Momotidae, 494  
 MOMS see Micro-opto-mechanical  
 systems  
 Monadidae, 1216  
 Monas, 1332  
 Monatomic ions, 375  
 Monazite, 1058, 1430\*  
 Monel, 1487  
 Mongolian horse, 965  
 Mongolism see Down syndrome  
 Mongoose, 1431\*  
 Monhysterida, 1431\*  
 Monhysterioidea, 1431  
*Moniliformis moniliformis*, 147  
*Monilinia fructicola*, 685  
 Monitoring of ionizing radiation:  
 dosimeter, 699\*  
 ionization chamber, 1188-1189\*  
 Monkey, 1431-1432\*  
 fossil primates, 927-928  
 primates, 1770-1772\*  
 Monoamine oxidase, 1432\*  
 Monoamine oxidase (MAO) inhibitors,  
 1989  
 Monoblepharidales, 402  
 Monochromaticity, 1230  
 Monochromatism, 444  
 Monochromata, 1434  
*Monoclea*, 1433  
 Monocleales, 1432\*  
 Monoclonal antibodies, 138, 1432-1433\*  
 Monocotyledoneae, 183  
 see also Liliopsida  
 Monocotyledons, 1433\*  
 Monocyte, 267-268  
 Monogenea, 1433\*, 2268  
 Monogononta, 1433-1434\*  
 Monohydroxylation, 983  
 Monolayer see Monomolecular film  
 Monolithic microwave integrated circuit  
 (MMIC), 1397  
 Monomiaceae, 1233  
 Monomolecular film, 1434\*, 1464  
 Mononchida, 1434\*  
 Mononchoidea, 1434  
 Monopisthocotylea, 1433  
 Monophonic sound, 2054\*  
 Monoplacophora, 544, 1434\*  
 Monopulse radar, 1434\*  
 Monopylina, 1532  
 Monorail, 1434\*  
*Monorhaphis*, 103  
 Monosaccharide, 1434-1435\*  
 fructose, 939\*  
 L-fructose, 940\*  
 galactose, 955\*  
 glucose, 1006\*  
 oligosaccharide, 1540\*  
 L-rhamnose, 1911\*  
 Monosodium glutamate, 1435\*  
 Monostable multivibrator, 1449  
 Monostylifera, 929  
 Montremata, 1435\*, 1795  
 ant eater, 131\*  
 Mammalia, 1309  
 platypus, 1726\*  
*Monotropa uniflora*, 759  
 Monozygotic twins, 2289  
 Moonshot meteorology, 1435\*, 2277  
*Monstera*, 138  
 Monstrellioidea, 491, 1435\*  
 Monte Carlo method, 1436\*  
 Monte Verde, Chile, 1600  
 Monterey cypress, 543  
 Month, 1436\*  
 Montmorillonite, 944, 1436\*  
 Mood disorders see Affective disorders  
 Moon, 1436-1437\*  
 Earth tides, 722  
 eclipse, 661, 729-731\*  
 gravity field of Earth, 718  
 halo, 1042\*  
 Jupiter, 1207-1208  
 occultation, 1529  
 phase (astronomy), 1649  
 planetary physics, 1700, 1701  
 Sun, 2150  
 surface characteristics, 1436-1437  
 Mooneye, 1586

- Moonstone, 1638  
 Moore machine, 610-611  
 Moored buoys, 1161  
 Moose, 289, 1437\*  
 Moraceae, 886  
 Moraine, 1437\*  
 Moral development, 651  
*Moraxella*, 296, 1437-1438\*  
*Morchella*, 685  
 Mordant, 1438\*  
 Morgan, W. W., 2073  
 Morley, E. W., 697\*, 1887  
 Mormon tea, 1009  
 Mormonilloida, 1438\*  
 Mormyridae, 1586  
 Mormyriiformes, 673  
*Mormyrus probosciostris*, 1586  
 Morphine:  
 alkaloid, 79  
 analgesic, 108  
 Morphogenesis:  
 developmental biology, 649  
 plant, 1708\*  
 Morphogenetic field, 122  
 Morphology:  
 metamorphosis, 1372\*  
 nervous system (vertebrate), 1477  
 Morse, Samuel F. B., 2196  
 Morse code, 2196-2197  
 Mortality risk, 1682  
 Mortar, 1329, 1438\*  
 Mortar weapons systems, 170-171  
 Morton's neuroma, 911-912\*  
*Morus*, 1444  
 MOS see Metal oxide semiconductor  
 MOS integrated circuits, 1164-1165  
 Mosaic-scaled fish, 359  
 Mosaic virus:  
 plant pathology, 1711  
 plant viruses and viroids, 1715  
 Mosaicism, 1438-1439\*  
 Mosander, C. G., 1227  
 Moseley, G., 210  
 MOSFET see Metal oxide semiconductor  
 field-effect transistor  
 Mosquito, 1156, 1438\*  
 Diptera, 679\*  
 parasitology, 1610  
 yellow fever, 2411  
 Mosquito fish, 183  
 Moss:  
 Bryophyta, 337\*  
 Bryopsida, 298\*  
 Dawsoniidae, 620\*  
 Encalyptales, 814\*  
 Funariales, 944\*  
 Grimmiaceae, 1027\*  
 Hookeriales, 1088\*  
 Hypnales, 1119\*  
 isobryales, 1193\*  
 Lycopodiales, 1280-1281\*  
 plant, 1701  
 plant phylogeny, 1712  
 Polytrichidae, 1752\*  
 Pottiales, 1761\*  
 Schistostegales, 1957  
 Seligeriales, 1979\*  
 Splachnales, 2087\*  
 Tetraphididae, 2214\*  
 Mössbauer, R. L., 1439  
 Mössbauer effect, 1439-1440\*  
 Moth:  
 forest ecosystem, 917  
 Lepidoptera, 1242-1245\*  
 Motility:  
 cell, 394-395\*  
 digestive system, 667  
 Motion, 1440\*  
 Hamilton's equations of, 924-925  
 Hamilton's principle, 1045\*  
 harmonic, 926-927  
 kinetic theory of matter, 1215\*  
 kinetics, 1215-1216\*  
 Lagrange's equations, 1222\*  
 Newton's laws, 1486, 1486\*  
 orbital, 1565-1566  
 periodic, 1631  
 perpetual, 1636\*  
 rectilinear, 1876\*  
 relative, 1886\*  
 rigid-body dynamics, 1922\*  
 rotational, 1933\*  
 Motion perception, 1628  
 Motion picture:  
 camera, 360, 404-405  
 cinematography, 457-458\*  
 Motivation, 1440-1441\*  
 Motmot, 494  
 Motoneuron damage, 1453  
 Motor, 1441\*  
 alternating-current see Alternating-current  
 motor  
 brush-shifting, 297-297  
 direct-current see Direct-current motor  
 hysteresis, 992, 1122\*  
 induction, 1138\*  
 motor-generator set, 1441\*  
 reluctance, 1892-1893\*  
 repulsion, 1900-1901\*  
 stepping, 2113\*  
 synchronous, 2183\*  
 universal, 2305\*  
 Motor-generator set, 1441\*  
 Motor systems, 1441-1442\*  
 cerebral cortex, 1442  
 components of skeletal motor system, 1441-1442  
 skeletal muscle, 1441, 1450  
 Mountain, 1442\*  
 hill and mountain terrain, 1080-1081\*  
 ophiolite, 1549  
 Triassic, 2269  
 Mountain beaver, 230  
 Mountain coat, 427  
 Mountain meteorology, 1443\*  
 Mountain spinach, 2085  
 Mountain systems, 1443\*  
 cordilleran belt, 558-559\*  
 Devonian, 651  
 Earth, 717  
 orogeny, 1580\*  
 Mountain tallow see Hatchettite  
 Mouse, 1443\*  
 Mouse deer see Chevrotain  
 Mousebird, 440, 499  
 Mouth, 605, 1443-1444\*  
 oral glands, 1565\*  
 palate, 1596\*  
 salivary glands, 605  
 tongue, 605, 2247-2248\*  
 tooth, 605, 2248\*  
 Movable bridge, 292-293, 333-334  
 Moving-target indication, 1444\*  
 MRI see Magnetic resonance imaging  
 MSG see Monosodium glutamate  
 Mucilage, 28, 1444\*  
 Mudfish, 285  
 Mudflows, 2351-2352  
 Mudminnow, 1941  
 Mudstone, 152  
 Muffler, 823-824, 1444\*  
 Mulberry, 1444\*  
 Mule, 635, 1002, 1444\*  
 Mule deer, 567  
 Muller, H. J., 1457266  
 Mulliken, R. S., 708, 786  
 Mullite, 469  
 Multiaccess computer, 1444-1445\*  
 software capabilities, 1445  
 system components, 1445  
 system operating requirements, 1445  
 Multichip devices, 1773  
 Multilevel control theory, 1445\*  
 Multimedia technology, 1445-1446\*  
 Multimeter, 1446\*  
 Multiphonon emission, 781  
 Multiple access see Multiplexing and multiple  
 access  
 Multiple cropping, 1446\*  
 Multiple fruit, 842  
 Multiple myeloma, 1361  
 Multiple proportions, law of, 1446\*  
 Multiple sclerosis, 1129, 1446\*  
 autoimmunity, 223  
 olfaction, 1538  
 spinal cord disorders, 2085  
 Multiple stars, 2097  
 Multiplexing and multiple access, 1446-1447\*  
 spread spectrum communication, 2089  
 telephone service, 2199  
 teleprocessing, 2201  
 Multiplication, 153-154, 1447\*  
 Multiplier phototube see Photomultiplier  
 Multipole radiation, 1447\*  
 Multiprocessing, 1447-1448\*, 2153  
 Multiscan echocardiography, 660  
 Multispectral photography, 1894  
 Multispectral scanning system, 1894  
 Multisynaptic arc, 1477  
 Multituberculata, 83, 1448\*  
 Multivariable control, 1448\*  
 Multivibrator, 1449-1450\*  
 astable, 1449-1450  
 comparator, 453  
 logic gate, 1449-1450  
 monostable, 1449  
 symmetrical bistable, 1449  
 unsymmetrical bistable circuits, 1449  
 Mummies, 1602  
 Mummification, 860, 963  
 Mumps, 1450\*  
 Mung bean, 229, 260, 261, 1579  
 Muon, 628, 1359  
 Muonium, 1450\*  
 Muridae, 884  
 Murine leukemia virus, 124  
 Murray loop test, 407  
 Murre, 365  
*Musa* species, 1, 217  
 Musaceae, 217  
 Muscadinia, 902  
*Muscadinia rotundifolia*, 902  
*Muscardinus avellanarius*, 699  
 Musci see Bryopsida  
 Muscle, 1450\*  
 digestive system, 667  
 electrical potentials, 256  
 electromyography, 776\*  
 mechanics, 1452  
 motor systems, 1441-1442\*  
 Muscle proteins, 1450-1451\*  
 Muscovite, 1451\*  
 mica, 1381  
 phyllite, 1675  
 Muscular artery, 159  
 Muscular dystrophy, 1451\*, 1993  
 Muscular system, 1451-1452\*  
 anatomy, 1451-1452  
 muscle mechanics, 1452  
 Muscular system disorders, 1452-1453\*  
 metabolic diseases, 1452, 1453  
 motoneuron damage, 1452, 1453  
 muscular dystrophy, 1451\*  
 myasthenia gravis, 1458\*  
 myopathy, 1452, 1453  
 myotonia, 1452, 1453  
 neuromuscular junction, 1452, 1453  
 Mushroom, 949, 1453\*  
 Musical acoustics, 1453-1454\*  
 harmonic (periodic phenomena), 1046-1047\*  
 tone, 2247\*  
 Musical instruments, 1454-1455\*  
 brass, 1454  
 electrical, electronic, software, 1455  
 keyboard, 1455  
 percussion, 1454  
 stringed, 1454-1455  
 woodwind, 1454  
 Musk, 567  
 Musk deer, 567  
 Musk gland, 1955  
 Musk-ox, 1455-1456\*  
 Muskeg, 1456\*  
 Muskmelon, 1456\*  
 cantaloupe, 363\*  
 Honey Dew melon, 1088\*  
 Persian melon, 1637\*  
 Muskrat, 1456\*, 1930  
 Musophagidae, 532  
 Muspiceoidea, 165  
 Mustard, 1456\*  
*Mustela*, 790, 1328, 1406  
 Mustelidae, 214, 323, 790  
 Mutagens and carcinogens, 1456-1457\*, 2253  
 Mutation, 1457\*  
 bacterial genetics, 213, 241-242\*  
 chromosomal, 1457  
 chromosomal alterations, 400-401  
 chromosomal changes, 1457266  
 complementation (genetics), 515\*  
 dominance, 695  
 gene, 1457, 1457266  
 lethal gene, 1246\*  
 mutagens and carcinogens, 1456-1457\*  
 operon, 1548\*  
 origins, 1457, 1457266  
 radiation biology, 1842-1843  
 significance, 1457, 1457266  
 speciation, 2072  
 virus, defective, 2344\*  
 Mutual inductance, 1137  
 Mutualism, 662-663, 1457-1458\*  
 Muzenberg, G., 273, 928  
 Myacea, 1223  
 Myalgic encephalomyelitis see Chronic  
 fatigue immune dysfunction  
 syndrome  
 Myasthenia gravis, 223, 1129, 1458\*  
 Mycelia Sterilia, 585  
 Mycelium, 949-950  
*Mycena citricolor*, 984, 1112  
 Mycetozoa, 770, 854, 1914  
 Mycobacterial diseases, 1458\*, 2279  
*Mycobacterium leprae*, 1245  
*Mycobacterium paratuberculosis*, 1203  
*Mycobacterium* species, 500  
*Mycobacterium tuberculosis*, 1007, 1144,  
 1479  
 Mycogone, 1119  
 Mycology, 1458\*  
 fungal ecology, 947-948\*  
 fungal infections, 949  
 medical, 1347\*  
*Mycoplasma capricolum*, 982  
*Mycoplasma pneumoniae*, 1731  
 Mycoplasmas, 1459\*  
 Mycoplasmatales, 1459\*  
 Mycoporaceae, 1798  
*Mycoporellum*, 1798  
 Mycorrhizae, 1459\*  
 forest ecosystem, 917, 918  
 fungal ecology, 948  
 soil microbiology, 2037  
 Mycorrhizal symbiosis, 917  
 Mycosis fungoides, 2018  
 Mycotoxin, 1459-1460\*  
 Myctophoidae, 1941  
 Myelencephalon, 287  
 Mygalomorphae, 139  
 Myiasis, 1450\*, 1460\*  
 Myiidae, 281  
 Mylonite, 1460\*  
 Myocardial infarction, 1052-1053  
 Myodocopa, 1042\*  
 Myodocopida, 1268\*, 1460\*  
 Myopathy, 1452, 1453  
 Myopia, 867  
*Myoprocta*, 44  
 Myosin, 1450-1451  
 Myotonia, 1452, 1453  
 Myotonic dystrophy, 1451  
 Myriapoda:  
 Chilopoda, 384-385  
 Paupropoda, 1620\*  
 Symphyla, 2181\*  
 Myrica, 1460  
 Myricaceae, 1460268  
 Myricales, 1044, 1460\*  
*Myriophyllum*, 924, 1044  
*Myristica fragrans*, 124, 1305, 1524  
 Myristicaceae, 1524  
*Myrmecophaga tridactyla*, 131  
 Myrmecophagidae, 131  
 Myrmecinae, 129  
 Myrtaceae, 421, 767, 851  
 Myrtales, 1460\*  
 allspice, 87\*  
 clove, 479\*  
 Eucalyptus, 851\*  
 guava, 912  
 pomegranate, 1753\*  
 tupelo, 2283-2284\*  
 Mysididae, 1460-1461\*  
 Mystacinidae, 388  
 Mystacocarida, 1461\*  
 Mysticeti, 359  
 Mytilacea, 125, 1223  
 Mytilidae, 281  
 Myxiformes, 1202, 1461\*  
 Myxoma virus, 1145  
 Myxomycota, 1461\*  
 Myxosporida, 1461-1462\*  
 Myxosporidea, 423, 1462\*  
 Actinomyxida, 21\*  
 Helicosporida, 1059\*  
 Myxovirus, 1609-1610\*  
 Myzopodidae, 388  
 Myzostomaria, 125, 1462\*  
 Myzostomidae, 1462  
 Myzostomum, 1462  
 Nabidae, 944  
 NAD see Nicotinamide adenine dinucleotide  
 Nailing, 1463\*

- Naive quark model, 803-804  
*Naja* species, 429  
 Najadales, 1463\*  
 Naked bud, 300  
 Nanochemistry, 1463-1464\*, 2166  
 Nanostructure, 1464\*  
 mesoscopic physics, 1359-1360\*  
 multilayers and clusters, 1464  
 supramolecular chemistry, 2166\*  
 synthesis and properties, 1464  
 Nanotechnology, 1464\*, 2166  
 Nanovoltmeters, 959  
 NAPD see Nicotinamide adenine dinucleotide phosphate  
 Naphtha, 1465\*  
 petroleum processing and refining, 1644  
 petroleum products, 1644, 1645  
 Naphthoquinones, 1837  
 Narcoclepsy, 2020  
 Narcomedusae, 2255  
 Narcotic, 1465\*  
 addictive disorders, 25-26\*  
 analgesic, 108  
 betel nut, 271\*  
 drug dependence, 1465  
 pharmacology, 1465  
 NASA see National Aeronautics and Space Administration, 1186  
 Nasal cavities, 1503-1504  
 Nastic movement, 1709  
*Nasturtium officinale*, 513  
*Nasua* species, 427  
 Natalidae, 388  
*Natantia*, 560  
 National Aeronautics and Space Administration (NASA):  
 ion propulsion, 1186  
 space flight, 2058, 2060  
 space shuttle, 2064  
 spacecraft ground instrumentation, 2068-2069\*  
 National Electrical Code, 681, 753  
 National Environmental Protection Act, 746  
 National Forest Service, 919  
 National Institute of Standards and Technology, 2095  
 National Meteorological Center, 2379  
 National Park Service, 921  
 National Research Council, 1755  
 National Television Systems Committee (NTSC), 2206, 2207  
 Native Americans, 1599-1600  
 Native elements, 1465\*  
 Natrolite, 1465\*  
 Natural fiber, 1465\*  
 abaca, 1-2\*  
 alpaca, 87\*  
 asbestos, 178-179\*  
 camel's hair, 320  
 cashmere, 376\*  
 coir, 495\*  
 cotton, 571\*  
 flax, 893\*  
 hemp, 1067\*  
 henequen, 1067\*  
 jute, 1208\*  
 mohair, 1415\*  
 piña, 1688\*  
 ramie, 1867\*  
 silk, 2009\*  
 sisal, 2015\*  
 textile, 2215\*  
 vicuna, 2338\*  
 Natural fibers, 2396-2397  
 Natural gas, 1466\*  
 alternative fuel vehicle, 91  
 coal gasification, 482\*  
 coalbed methane, 483-484\*  
 gas field and gas well, 967\*  
 liquefied, 1261\*  
 oil and gas, offshore, 1534\*  
 oil and gas field exploitation, 1534-1535\*  
 oil and gas storage, 1535  
 oil and gas well completion, 1535-1536\*  
 oil and gas well drilling, 1536\*  
 oil field waters, 1536-1537\*  
 petrochemical, 1639-1640\*  
 petroleum geology, 1642  
 petroleum products, 1644  
 Natural immunity, 1128  
 Natural inorganic polymers, 1744  
 Natural language processing, 1466\*  
 Natural logarithm, 1269  
 Natural remanent magnetization, 1927  
 Natural resource, conservation of, 477-478
- Natural selection:  
 island biogeography, 1193  
 sociobiology, 2028  
 Naucoridae, 943  
 Nauplius larva, 519, 560, 585  
*Nausithoe*, 498  
 Nautical Almanac, 87  
 Nautical mile, 2303  
 Nautiloidea, 1466\*  
 Nautilus, 594, 1466  
 Naval architecture, 1466\*  
 ship design, 1998\*  
 ship powering, maneuvering, and seakeeping, 1998-1999\*  
 Naval armament, 1466-1468\*  
 antisubmarine weapons, 1467  
 bombs, 1467-1468  
 guided missiles, 1467  
 guns, 1467  
 mines, 16, 1468  
 rockets, 1467  
 torpedoes, 1467  
 Naval surface ship, 1468-1469\*  
 combatant, 1468-1469  
 noncombatant, 1469  
 Navier-Stokes equations, 457, 1469\*  
 Navigation, 1469\*  
 buoy, 343\*  
 dead reckoning, 621\*  
 digital system, 611-612  
 direction-finding equipment, 684\*  
 Doppler radar, 697\*  
 electronic navigation systems, 788-790\*  
 guidance systems, 1031\*  
 gyrocompass, 1034-1035\*  
 homing, 1086-1087\*  
 hyperbolic navigation system, 1116\*  
 lighthouse, 1252\*  
 marine, 1323-1324\*  
 piloting, 1687\*  
 polar, 1734-1735\*  
 satellite navigation systems, 1948-1949\*  
 underwater, 2298\*  
 see also Air navigation; Celestial navigation; Space navigation and guidance  
 Navigation canal, 322  
 Navigation instruments, 1993-1994  
 NDE see Nondestructive evaluation  
 Neanderthals, 925, 1469-1470\*  
 fossil humans, 926  
 Paleolithic, 1660, 1661  
 Near-field optical microscope, 1558  
 Near-infrared microscope, 1558  
 Nearshore marine ecosystems, 1319  
 Nearshore processes, 1470\*  
 Nearshore sedimentary processes, 633  
 Nearsightedness, 867  
 see also Myopia  
 Nebula, 1470\*  
 Crab, 510  
 globule, 1006\*  
 Messier catalog, 1361\*  
 Orion Nebula, 1579-1580\*  
 planetary, 1700\*  
 solar system, 2041-2042  
 symbiotic star, 2177  
 Nebulizer, 193-194  
*Necator americanus*, 964, 1347  
 Necklace poplar, 1754  
 Necrosis, 1710  
 Nectarine, 1470\*  
 Nectary (flower), 809  
*Nectonema*, 921  
 Nectonematoidea, 921, 1473  
 Nectridea, 1244, 1470-1472\*  
 Needlefish, 182  
 Néel, L., 790  
 Néel point, 138-139  
 Neel temperature, 534  
 Negative differential resistance (NDR), 1397-1398  
 Negative distortion, 629  
 Negative ion, 777, 1471\*  
 Negative-resistance circuits, 1471-1472\*, 2283  
 Negative-resistance device:  
 diodes, 676\*  
 microwave solid-state devices, 1396-1398\*  
 Negative temperature, 1472\*  
 Negri bodies, 1839  
 Negro bugs, 944  
 Neididae, 944  
*Neis*, 237, 267  
*Neisseria gonorrhoeae*, 1012-1013  
*Neisseria meningitidis*, 1383
- Neisseria* species, 898, 1354  
 Nemata, 1472-1473\*  
 Araeclimida, 155\*  
 Ascaridida, 179\*  
 Chromadorida, 448\*  
 Desmodorida, 646\*  
 Desmoscolecida, 646\*  
 Isolaimida, 1195, 1195\*  
 medical parasitology, 1347  
 Monhysterida, 1431\*  
 Mononchida, 1434\*  
 nematocide, 1473\*  
 Oncholaimida, 1540-1541\*  
 plant pathology, 1711  
 Rhabditida, 1911\*  
 Sphaerularioida, 2082\*  
 Spiruroidea, 2087  
 Nematocida, 1473, 1473\*  
 Nematocera, 620  
 Nematoda see Nemata  
 Nematomorpha, 1473\*  
 Nematophytales, 1473\*  
 Neocallimastigales, 402  
 Neocathartidae, 784  
*Neoceratodus*, 619  
*Neoceratodus forsteri*, 681  
 Neodymium, 1473\*  
 Neogastropoda, 1473\*  
 Neognathae, 1473\*, 1533  
 Neognathostomata, 1473\*, 1539-1540  
 Neogregarinida, 909, 1473\*  
 Neolampadoida, 1473-1474\*  
 Neolithic, 1474\*, 1660  
 Neomeniomorpha, 133, 1474\*  
 Neon, 1474\*  
 Neon glow lamp, 1474-1475\*  
 Neonatal adrenoleukodystrophy, 1636  
 Neopalynology, 1604  
 Neoplasia:  
 oncogenes, 1541\*  
 tumor, 2280-2281\*  
 Neoplasm:  
 nervous system disorders, 1479  
 ovarian disorders, 1588  
 skeletal system, 2017  
 skin, 2018  
 Neoproterozoic, 1793  
 Neopseustidae, 1245  
 Neoptera, 1805  
 Neorhabdozoela, 1911  
 Neornithes, 1475\*  
 Neoteny, 948, 1475\*  
*Neotragus pygmaeus*, 131  
 Nepenthaeaceae, 1692  
 Nepenthales, 1475\*  
 pitcher plant, 1692\*  
 sundew, 2151\*  
 Venus' flytrap, 2330\*  
 Neper, 563, 625, 1475\*  
*Nepeta*, 1223  
 Nepetoideae, 1223  
 Nepheline, 1125, 1475\*  
 Nephelinite, 1475\*  
 Nephelometric analysis, 1132  
 Nephelometry, 1252  
 Nephridia, 126  
 Nephrite, 1201  
 Nephthyidae, 760  
 Nepidae, 942  
 Nepoidea, 942  
 Nepticulidae, 1245  
 Nepticuloidea, 1245  
 Neptune, 1475-1476\*  
 Kuiper Belt, 1219  
 planet, 1698  
 planetary physics, 1700  
 Neptunium, 1476\*  
 Nereid, 1476  
 Nereidae, 760  
 Nereocystis, 1224  
*Nerilla*, 148  
 Nerillidae, 147  
 Neritacea, 144  
 Neritida, 972  
 Nerst, W., 246  
 Nerve, 1476\*  
 digestive system, 667  
 electrical potentials, 256  
 ganglion, 963\*  
 neuron, 1481\*  
 vibrotaction, 2338\*  
 Nervous system (invertebrate), 1476-1477\*  
 Nervous system (vertebrate), 1477-1478\*  
 autonomic nervous system, 204-205, 231\*  
 brain, 323-324\*  
 central, 351
- Nervous system (vertebrate)—cont.  
 comparative embryology, 1478  
 comparative histology, 1477-1478  
 comparative morphology, 1477  
 cranial nerve, 576\*  
 effector systems, 738\*  
 endorphins, 819\*  
 motor systems, 1441-1442\*  
 nerve, 1476, 1476\*  
 neurobiology, 1480\*  
 neuroimmunology, 1480-1481\*  
 neuron, 1481\*  
 neurosecretion, 1481\*  
 neurulation, 1481\*  
 parasympathetic nervous system, 1610-1611\*  
 spinal cord, 2085\*  
 sympathetic nervous system, 2180-2181\*  
 synaptic transmission, 2181-2182\*  
 Nervous system disorders, 1478-1479\*  
 cerebral palsy, 407\*  
 degenerative diseases, 1479  
 infection, 1478-1479  
 inflammation, 1479  
 malformation, 1478  
 multiple sclerosis, 1446\*  
 neoplasm, 1479  
 Parkinson's disease, 1613\*  
 prion disease, 1774-1775\*  
 Tourette's syndrome, 2252\*  
 vascular disease, 1479  
 vascular disorders, 2327\*  
 Net slime mold, 1221  
 Nettle, 1867  
 Network theory:  
 superposition theorem, 2163\*  
 Thévenin's theorem, 2231\*  
 Y-delta transformations, 2409\*  
 Networking software, 2030  
 Networks see Computer networks  
 Neufeld, F., 1550  
 Neural crest, 1479\*  
 Neural network, 1479-1480\*  
 Neural stem cells, 2113  
 Neural tube, 1481  
 Neurobiology, 1480\*, 1498  
 Neurodermatitis, 665  
 Neurogenic shock, 2001  
 Neurohypophysin, 1480\*  
 Neurohypophysin hormone, 1480\*, 1693  
 Neuroimmunology, 1480-1481\*, 1800-1801  
 Neurolemma, 1477  
 Neurology, 1480  
 Neuromasts, 1232  
 Neuromuscular junction disorders, 1453  
 Neuromyasthenia, epidemic, 751  
 Neuron, 1481\*  
 nervous system (vertebrate), 1477, 1478  
 neurosecretion, 1481\*  
 synaptic transmission, 2181-2182\*  
 Neuropeptides, 2182  
 Neuropharmacology, 2234  
 Neuroptera, 1481\*  
 Neuroscience, 1384  
 Neurosecretion, 1481\*, 1693  
*Neurospora crassa*, 983  
 Neurotic disorders, 1481\*  
 obsessive-compulsive disorder, 1528-1529\*  
 phobia, 1656\*  
 Neurotransmitters:  
 dopamine, 696-697\*  
 pituitary gland, 1693-1694  
 Neurulation, 1481\*  
 Neutral currents, 1481-1482\*  
 Neutral-particle traps, 1617  
 Neutralization reaction (immunology), 1482\*  
 Neutralizing antibody, 1482\*  
 Neutrino, 1482\*  
 deep inelastic collisions, 628  
 elementary particle, 802  
 emission, 2161  
 neutrino astronomy, 1483-1484\*  
 radioactivity, 1857  
 solar, 2040-2041\*  
 Neutrino astronomy, 1482-1483\*  
 high-energy cosmic neutrinos, 1483  
 high-energy neutrino telescopes, 1483  
 stellar neutrinos, 1482  
 supernovae, 1482-1483  
 Neutron, 1483-1484\*  
 atomic mass, 210  
 atomic nucleus, 189, 210  
 delayed, 569  
 I-spin, 1123

- Neutron—*cont.*  
 magic numbers, 1288-1289\*  
 nuclear structure, 1517-1518\*  
 nucleon, 1518-1519\*  
 quarks, 1831-1832  
 radiation biology, 1842  
 radiography, 1860\*  
 slow neutron spectroscopy, 2022-2023\*  
 strange particles, 2122  
 thermal neutrons, 2221\*
- Neutron activation analysis, 22, 162, 1820  
 Neutron diffraction, 1484\*  
 Neutron optics, 1484\*  
 Neutron spectrometry, 1484-1485\*  
 Neutron star, 196-197, 1485\*  
 gamma-ray astronomy, 961  
 Geminga, 977\*  
 stellar evolution, 2108-2110\*  
 supernova, 2161\*  
 x-ray astronomy, 2401
- Neutrophil, 268  
 Neutrophilia, 1062  
 Névė *see* Snowfield and névė  
 Nevus *see* Mole (medicine)  
 New Guinea, 656, 723, 724  
 New Stone Age *see* Neolithic  
 New World vulture, 260, 402  
 New York State Barge Canal, 1154  
 New Zealand, 197, 1485-1486  
 New Zealand spinach, 2085  
 Newcastle disease, 1486\*  
 Newman, M. H. A., 278  
 Newton, Isaac, 244, 412, 687, 1565  
 celestial mechanics, 385  
 determinism, 648  
 gravitation, 1021  
 weightlessness, 2382  
 Newtonian fluid, 1486\*  
 Newton's law of gravitation, 905, 1021  
 Newton's laws of motion, 1486\*  
 first law, 1486  
 physical law, 1678  
 plasma (physics), 1717  
 second law, 1431, 1486  
 third law, 61, 1486  
 weightlessness, 2382\*
- Next Generation Weather Radars (NEXRAD), 1378
- NHC *see* National Hurricane Center
- Niacin, 1486\*  
 Nickel, 1486-1487\*  
 garnierite, 861  
 millerite, 1403\*  
 nickeline, 1487\*  
 pentlandite, 1626\*  
 silver, 492  
 Nickel alloys, 1487\*  
 Nickel metallurgy, 1487\*  
 Nickeline, 1487\*  
 Nicol prism, 1736  
 Nicotiana, 2246  
 Nicotinamide adenine dinucleotide (NAD), 1487\*  
 coenzyme, 491  
 intron, 1179  
 Nicotinamide adenine dinucleotide phosphate (NADP), 1487-1488\*  
 Nicotine, 1639  
 Nicotine alkaloids, 1488\*  
 Nicotinia, 1488  
 Nidulariales, 864  
 Niemann-Pick disease:  
 lysosome, 1283  
 metabolic disorders, 1362  
 sphingolipid, 2083  
 Niger River, 41  
 Night vision, 2347  
 Nightglow, 65, 78  
 Nightjar, 326  
 Niobium, 1488\*  
 Nippotaeniidea, 1488\*  
 Nishijima, K., 987  
 Nitella, 366  
 Niter, 1488\*  
 Nitrate ion, 1183  
 Nitrate minerals, 1488\*  
 niter, 1488\*  
 soda niter, 2029\*  
 Nitrate poisoning, 1733-1734  
 Nitration, 1488-1489\*  
 Nitric acid, 154, 1489\*  
 Nitric oxide, 1489\*, 1492  
 Nitride ion, 1183  
 Nitrile, 19-20, 1489\*  
 Nitrolicacetic acid, 367  
 Nitro and nitroso compounds, 1490\*  
 Nitroalkanes *see* Nitroparaffin
- Nitroaromatic compound, 1490\*  
 Nitrogen, 1490-1491\*  
 air separation, 54-55  
 diving, 692  
 nitric acid, 1489, 1489\*  
 nitrile, 1489\*  
 nitro and nitroso compounds, 1490\*  
 nitrogen cycle, 1491-1492\*  
 nitrogen fixation, 1492\*  
 Nitrogen complexes, 1491\*  
 Nitrogen cycle, 247-248, 257, 1491-1492\*  
 biogeochemistry, 281  
 forest ecosystem, 917  
 soil, 2037  
 Nitrogen fixation, 1492\*  
 biological, 1492  
 chemical, 1492  
 forest ecosystem, 917  
 lichens, 1249  
 Nitrogen laser, 1229  
 Nitrogen narcosis, 632, 692  
 Nitrogen oxides, 1492-1493\*  
 dioxide, 1492  
 nitric oxide, 1492  
 nitrous oxide, 1492  
 pentoxide, 1492-1493  
 tetroxide, 1492  
 trioxide, 1492  
 Nitroparaffin, 1493\*  
 Nitrous oxide:  
 atmospheric chemistry, 203  
 nitrogen oxides, 1492  
 NMR *see* Nuclear magnetic resonance  
 NCSS *see* Navy Navigation Satellite System  
 Nobelium, 1493\*  
 Noble fir, 801  
 Noble gas *see* Inert gases  
 Nocardia, 21, 500  
 Nocardiaceae, 21  
 Noctilionidae, 388  
 Noctuidae, 1244  
 Nodical month, 1436  
 Noeggerathiales, 1493\*  
 Noguchia, 296  
 Noise:  
 electrical, 758-759\*  
 electrical noise generator, 759\*  
 electrical shielding, 760\*  
 measurement, 1395, 1493  
 microwave, 1393, 1395  
 microwave noise standards, 1396\*  
 sensitivity, 1985  
 smoothing, 1127  
 tube, 759  
 underwater sound, 2300  
 Nomadism, 1754  
 Nomenclature, zoological, 2419\*  
 Nomograph, 1493-1944\*  
 Non-Hodgkin's lymphoma, 1282  
 Non-newtonian fluid, 1499-1500\*  
 Nonarticular rheumatism, 159-160, 174  
 Nonbaryonic particles, 2306  
 Nonconformity, 2297  
 Noncrystalline solid *see* Amorphous solid  
 Nondestructive evaluation (NDE), 1494\*, 1737  
 Nondestructive testing:  
 acoustic emission, 15  
 x-ray fluorescence analysis, 2403\*  
 Nonequilibrium behavior, 314\*  
 Noneuclidean geometry, 1494\*  
 Nonferrous metals, 1815-1816  
 Nongonococcal urethritis (NGU), 389  
 Nonionic detergent, 583  
 Nonionizing radiation, 1843  
 Nonlinear acoustics, 1494-1495\*  
 Nonlinear control theory, 24, 1495-1496\*  
 Nonlinear optical devices, 1496\*  
 Nonlinear optics, 1496-1498\*  
 coherent effects, 1497  
 nonlinear materials, 1497  
 nonlinear spectroscopy, 1497  
 optical phase conjugation, 1558\*  
 phase conjugation, 1497  
 photorefractive effect, 1497-1498  
 self-action and related effects, 1497  
 stimulated scattering, 1497  
 Nonlinear physics, 1498\*  
 failure of perturbation theory, 1498  
 KAM theory, 1498  
 linearity in nonlinear systems, 1498  
 Nonlinear programming, 1498\*  
 Nonlinear spectroscopy, 1497  
 Nonlinear viscoelasticity, 1912-1913  
 Nonmetal, 1498-1499\*, 1632  
 Nonmetallic coatings, 1365  
 Nonprimitive data structures, 618
- Nonrandom electrical noise, 685  
 Nonrelativistic quantum mechanics:  
 matrix mechanics, 1339\*  
 mechanics, 1344  
 Nonsinusoidal waveform, 1500\*  
 Nonstoichiometric compounds, 1500\*  
 Nonvascular plants, 1701  
 Nootka cypress, 544  
 Noradrenaline, 2127  
*see also* Norepinephrine  
 Noradrenergic system, 1500-1501\*  
 Norbergite, 1098  
 Norepinephrine, 30, 1500-1501  
 Normal (mathematics), 1501\*  
 Normal distribution (probability), 631  
 Normality scale, 466  
 Normative decision theory, 626-627  
 North America, 1501-1503\*  
 Appalachian Highlands, 1501-1502  
 Canadian Shield, 1501  
 Central Lowlands, 1502  
 Eastern Seaboard Highlands, 1501  
 geologic structure, 1501  
 Great Plains, 1502  
 Interior Domes and Basins Province, 1502  
 location, 1501  
 Ozark and Ouachita Highlands, 1502  
 Southeastern Coastal Plain, 1501  
 Western Cordillera, 1502-1503  
 North American Air Defense (NORAD), 2196  
 North American bison, 262  
 North American elk, 567  
 North Equatorial Countercurrent, 841-842  
 North Pole, 1503\*  
 North Sea, 1503\*  
 North Star *see* Polaris  
 Northern Australia, 723  
 Northern pocket gopher, 898  
 Northern white cedar, 344  
 Norway lemming, 1240  
 Norway spruce, 2091  
 Norwegian lobster, 604  
 Nose, 1503-1504\*, 1538-1539  
 Nose cone, 1504\*  
 Nosocomial infection, 966, 1091  
 Nostoc, 1382  
 Notacanthiformes, 1504\*  
 Notacanthus nasus, 1504  
 Notch tensile test, 1363  
 Notched-bar impact test, 1364  
 Nothosauria, 1504\*  
 Notodelphoidea, 491  
 Notomyotina, 1504\*  
 Notonectidae, 942  
 Notonectoidea, 942  
 Notoryctes, 1328  
 Notostigmophora, 385  
 Notostraca, 1504\*  
 Notoungulata, 1504\*  
 Nova, 1504-1505\*  
 binary systems, 244  
 cataclysmic variable, 378  
 supernova, 2161\*  
 symbiotic star, 2178  
 Nowcasting, 2379  
 Nozzle, 1134, 1505\*  
 NSSFC *see* National Severe Storms Forecast Center  
 Nitric oxide synthase, 1489  
 Nuclear battery, 1505\*  
 Nuclear binding energy, 1505\*  
 Nuclear bomb, 208-209  
 Nuclear chemical engineering, 1505-1506\*  
 Nuclear chemistry, 1506\*, 1859  
 Nuclear engineering, 1506\*  
 Nuclear explosion, 1506-1507\*  
 atomic bomb, 208-209\*  
 electromagnetic pulse (EMP), 772\*  
 hydrogen bomb, 1105-1106\*  
 radioactive fallout, 1854\*  
 Nuclear fission, 1507-1508\*  
 chain reaction (physics), 412\*  
 critical mass, 580\*, 580-581\*  
 delayed neutron, 632\*  
 experimental consequences, 1507-1508  
 fission probability, 1508  
 liquid-drop model, 1507  
 meitnerium, 1351\*  
 nuclear fuels, 1508  
 nuclear power, 1512\*  
 nuclear reactor, 1514-1516\*  
 postscission phenomena, 1508  
 probability, 1508  
 radiation chemistry, 1843-1844\*  
 shell corrections, 1507
- Nuclear fuel cycle, 1508\*  
 Nuclear fuels, 1508-1509\*  
 nuclear fuel cycle, 1508\*  
 nuclear fuels reprocessing, 1509\*  
 nuclear reactor, 1514-1516\*  
 radioactive waste management, 1855-1856\*  
 reprocessing, 1509\*  
 uranium, 2308-2309\*  
 Nuclear fuels reprocessing, 1509\*  
 Nuclear fusion, 1509-1510\*  
 hydrogen bomb, 1105-1106\*  
 Lawson criterion, 1234\*  
 nuclear fuels, 1508  
 proton-proton chain, 1794-1795\*  
 thermonuclear reaction, 2229\*  
 Nuclear gamma resonance fluorescence *see* Mössbauer effect  
 Nuclear isomerism, 1510\*  
 Nuclear magnetic resonance (NMR), 1510-1511\*  
 magnetic resonance, 1295  
 magnetic thermometer, 1296  
 medical imaging, 1346  
 nuclear quadrupole resonance, 1512-1513\*  
 spectrometry, 162-163  
 spectroscopy, 112  
 Nuclear magnetism, 1295  
 Nuclear magnetometer, 1302  
 Nuclear medicine, 1346, 1511\*  
 isotopic irradiation, 1198-1199\*  
 medical imaging, 1346  
 radioactive tracer, 1855  
 Nuclear molecule, 1511\*  
 Nuclear moments, 1511\*  
 atomic structure and spectra, 213  
 magneton, 1302-1303\*  
 nuclear quadrupole resonance, 1512-1513\*  
 Nuclear orientation, 711, 1511-1512\*  
 Nuclear paramagnetism, 1609  
 Nuclear physics, 1512\*  
 metastable state, 1373  
 nuclear chemistry, 1506\*  
 Nuclear power, 1512\*, 1763-1764  
 Nuclear quadrupole resonance, 1512-1513\*  
 Nuclear radiation, 1513\*  
 multipole radiation, 1447\*  
 nuclear spectra, 1516-1517\*  
*see also* Alpha particles; Beta particles:  
 Gamma rays  
 Nuclear radiation (biology), 1513\*  
 Nuclear reaction, 1514\*  
 activation analysis, 22  
 alpha particles, 88\*  
 carbon-nitrogen-oxygen cycles, 368\*  
 mechanism, 1514  
 meitnerium, 1351\*  
 nuclear cross section, 1514  
 nuclear radiation, 1513\*  
 nuclear spectra, 1516-1517\*  
 proton-proton chain, 1794-1795\*  
 reaction mechanism, 1514  
 solar neutrinos, 2040-2041\*  
 spallation reaction, 2071\*  
 types of nuclear interaction, 1514  
*see also* Nuclear fission; Nuclear fusion  
 Nuclear reactor, 569, 1514-1516\*  
 applications, 1516  
 control, 1516  
 coolant system components, 1516  
 core design, 1516  
 electromagnetic pumps, 772-773\*  
 fluid flow and hydrodynamics, 1515  
 fuel and moderator, 1515  
 heat removal, 1515  
 nuclear chemical engineering, 1506  
 nuclear fuel cycle, 1508\*  
 nuclear fuels, 1508-1509\*  
 nuclear power, 1512\*  
 nuclear reaction, 1514\*  
 pinch effect, 1688-1689\*  
 plant balance, 1515  
 radiation damage, 1844\*  
 radioactive waste management, 1855-1856\*  
 reactor coolants, 1515  
 reactor physics, 1872-1873\*  
 ship nuclear propulsion, 1998\*  
 thermal stress, 1515-1516  
 Nuclear Regulatory Commission (NRC), 1141  
 Nuclear spectra, 1516-1517\*  
 Nuclear structure, 1517-1518\*  
 analog states, 109\*

## Nuclear structure—cont.

atom, 206\*  
 binding energy, 1505\*  
 Coulomb excitation, 571-572\*  
 excited states, 1517  
 exotic nuclei, 859-860  
 isotope shift, 1198\*  
 magic numbers, 1288-1289\*  
 masses and binding energies, 1517  
 neutron, 1483-1484\*  
 neutron spectrometry, 1484-1485\*  
 nuclear isomerism, 1510\*  
 nuclear models, 1517-1518  
 nuclear physics, 1512\*  
 nuclei at high excitation energies, 1518  
 resonance ionization spectroscopy, 1905  
 size/shape/density distributions, 1517  
 Nuclear systems, 2157-2158  
 Nucleation, 526, 591, 1518\*  
 Nuclei, exotic, 859-860  
 Nucleic acid, 1518\*  
 deoxyribonucleic, 638-640\*  
 deoxyribose, 640\*  
 genetic code, 981-982\*  
 metabolic disorders, 1361  
 nucleoprotein, 1519\*  
 purine, 1811\*  
 pyrimidine, 1813\*  
 ribonuclease, 1917\*  
 ribonucleic acid, 1917-1918\*  
 ribose, 1918\*  
 Nucleon, 1518-1519\*  
 deep inelastic collisions, 627-628\*  
 quark-gluon plasma, 1831  
 Nucleophilic reagent, 794  
 see also Electrophilic and nucleophilic reagents  
 Nucleoprotein, 1519\*  
 Nucleosome, 1519\*  
 Nucleosynthesis, 1519-1520\*  
 big bang, 242, 272-273\*  
 supernova, 2161  
 Nucleotide, 1520-1521\*  
 see also Cyclic nucleotides  
 Nucleus:  
 cell, 395\*  
 quasisatom, 1834\*  
 Nuclide, 1521\*  
 cosmogenic, 504, 568-569\*  
 relative atomic mass, 1886\*  
 relative molecular mass, 1886\*  
 Nucleosome, 1519\*  
 Nuculacea, 1793  
 Nuculanacea, 1793  
 Nudibranchia, 1521\*, 1549, 1550  
 Number theory, 1521-1522\*  
 algebraic, 1521  
 analytic, 1521, 1522  
 diophantine approximation, 1522  
 diophantine equations, 1521  
 elementary, 1520, 1521  
 Numbering systems, 1522-1523\*  
 arithmetic, 169\*  
 binary, 243-244  
 decimal, 563  
 octal, 1522-1523  
 Numbers:  
 e, 713\*  
 quantum, 1830\*  
 zero, 2415\*  
 Numerical analysis, 1523\*  
 differential equations, 1523  
 finite element method, 888\*  
 interpolation and approximation, 1523  
 solution of linear systems, 1523  
 Numerical representation (computers), 1523-1524\*  
 Numerical taxonomy, 244, 1524\*  
*Numida meleagris*, 260  
 Numididae, 260  
 Nummulites, 1524\*  
 Nursing, 1524\*  
 Nut:  
 almond, 87\*  
 betel, 271\*  
 Brazil, 288-289  
 cashew, 376\*  
 chestnut, 436\*  
 cola, 437  
 filbert, 887\*  
 macadamia, 1285\*  
 pecan, 1622\*  
 pine nut, 1689\*  
 pistachio, 1692\*  
 Nut (engineering), 1524\*  
 bolt, 312\*  
 screw fastener, 1963-1964\*

Nutation (astronomy and mechanics), 722, 1524\*

Nutmeg, 1524-1525\*  
 Nutrition, 1525\*  
 amino acids, 97-98\*  
 fat and oil, 872\*  
 food, 907-908\*  
 food package labeling, 820  
 malnutrition, 1308\*  
 obesity, 1528\*  
 oncology, 1542  
 osteoporosis, 1586  
 plant mineral, 1707-1708\*  
 poultry production, 1761  
 protein, 1790-1791\*  
 sugar, 2144-2145  
 vitamin, 2348\*  
 Nutrition management (greenhouse), 1026-1027  
 Nuttall, J. M., 1857  
 NWS see National Weather Service  
 Nybble, 262-263  
 Nyctaginaceae, 336  
*Nyctea scandiaca*, 260  
 Nycteridae, 388  
 Nyctibiidae, 326  
 Nylon, 1741, 1742\*  
 Nymphaeales, 1525\*  
 Nyquist sampling, 552  
*Nyssa sylvatica*, 497  
 Nyssaceae, 497, 2283-2284

## O

O-carcinotron, 212  
 O-type backward-wave oscillator, 212  
 Oak, 784, 870, 1527\*, 2266  
 evergreen, 857  
 tree diseases, 2267  
 OAO see Orbiting Astronomical Observatory  
 Oarfish, 1224  
 Oasis, 1527\*  
 Oats, 1527-1530\*  
 Oaxlate poisoning, 1734  
 Obesity, 724-725, 1528\*  
 Object Management Group, 690  
 Object-oriented programming, 1528\*, 2030  
 abstract data types, 6-7  
 distributed systems, 689  
 programming, 524  
 Object request broker (ORB), 690  
 Obolellida, 1134, 1528\*  
 Obsessive-compulsive disorder (OCD), 1481, 1528-1529\*  
 Obsidian, 1529\*  
 Occultation, 1529\*, 2188  
 Occupational Health and Safety Administration (OSHA), 1141  
 Occupational safety health sciences, 1049  
 Ocean basins, 257  
 Gulf of California, 1032\*  
 marine geology, 1321  
 Ocean circulation, 1530\*  
 Arctic Ocean, 167  
 deep-marine sediments, 628  
 East Indies, 723  
 equatorial currents, 841-842\*  
 Gulf of Mexico, 1032  
 Gulf Stream, 1032-1033\*  
 Miocene, 1407  
 nearshore processes, 1470\*  
 upwelling, 2308\*  
 wind stress, 2389-2390\*  
 Ocean waves, 1530-1531\*  
 nearshore processes, 1470\*  
 tsunami, 2278-2279\*  
 wind stress, 2389-2390\*  
 Oceanic birds, 1777-1778  
 Oceanic crust, 720, 721  
 Oceanic islands, 1531\*, 1593  
 Oceanic mountain systems, 1443  
 Oceanic plateaus, 1322  
 Oceanographic vessels, 1531\*, 2298  
 Oceanography, 1532\*  
 anoxic zones, 128-129  
 deep-marine sediments, 628-629\*  
 double diffusion, 699-700  
 Earth sciences, 722  
 ecology, 735  
 estuarine, 848-849\*  
 hydrography, 1107\*  
 paleoceanography, 1597\*

Oceans and seas, 1529-1530\*  
 Antarctic Ocean, 130\*  
 Arctic Ocean, 166-167\*  
 Atlantic Ocean, 199-200\*  
 Baltic Sea, 248\*  
 Bering Sea, 266-267\*  
 Black Sea, 301\*  
 Earth, 717-718  
 Gulf of Mexico, 1032\*  
 Indian Ocean, 1136\*  
 Langmuir circulation, 1226-1227  
 manganese nodules, 1311\*  
 Mediterranean Sea, 1348\*  
 Mid-Oceanic Ridge, 1400\*  
 North Sea, 1503\*  
 Pacific Ocean, 1593-1594  
 ranching, 154  
 Red Sea, 1878\*  
 scattering layer, 1955\*  
 Southeast Asian waters, 2057\*  
 submarine volcanism, 2352  
 thermal energy, 2039  
 see also Marine entries  
 Ocellated turkey, 259  
 Ochotonidae, 1222  
*Ochroma lagopus*, 217  
*Ochromonas*, 1333  
 Ochsenfeld, R., 2155  
 Ochteridae, 943  
 Ochteroidea, 943  
*Ocimum*, 1223  
*Ocimum basilicum*, 226  
 OCR see Optical character recognition  
 Octal number system, 1522-1523  
 Octane number, 969-970, 1532\*  
 Octave, 1692  
 Octopoda, 438, 1532\*  
 Octopus, 438, 1532  
*Octopus vulgaris*, 1532  
 Ocular see Eyepiece  
 Oculosida, 1532\*  
 Ocyropsidae, 1266  
*Ocyropsis*, 1267  
*Odocoileus* species, 550  
 Odonata, 700-701, 1333\*  
 Odontoceti, 359  
 Odontognathae, 1124, 1533\*  
 Odontostomatida, 1533\*  
 Oecophylla, 129  
 Oedogoniales, 1533\*  
 Oedogonium, 1533  
 Oegophiurida, 1533\*, 1549  
 Oersted, H. C., 761  
 Offset printing, 1774  
 see also Lithographic printing  
 Offshore, oil and gas, 1534\*  
 petroleum engineering, 1641  
 underwater demolition, 2298\*  
 Oganessian, Y. T., 273  
 Ohio buckeye, 299  
 Ohm:  
 definition, 687  
 definition of, 761  
 resistance measurement, 1901-1902\*  
 Ohm's law, 746, 759, 776, 1533\*  
 Oikomonadidae, 1216  
 Oil see Fat and oil  
 Oil analysis, 1533-1534\*  
 Oil and gas, offshore, 1534\*  
 petroleum engineering, 1641  
 underwater demolition, 2298\*  
 Oil and gas field exploitation, 1534-1535\*  
 gas field and gas well, 967\*  
 general considerations, 1534  
 petroleum enhanced recovery, 1641-1642\*  
 production instruments, 1535\*  
 production methods in producing wells, 1534  
 seismic exploration for, 1974-1975\*  
 Oil and gas storage, 1535\*  
 Oil and gas well completion, 1535-1536\*  
 petroleum engineering, 1641  
 Oil and gas well drilling, 1536\*  
 oil and gas, offshore, 1534\*  
 turbodrill, 2285\*  
 Oil burner, 1536\*  
 Oil circuit breaker, 406  
 Oil field waters, 1536-1537\*  
 Oil furnace, 942  
 Oil gland see Uropygial gland  
 Oil sand, 1537\*  
 petroleum, 1641  
 petroleum geology, 1642  
 Oil shale, 170, 1537\*  
 Oilbird, 326  
 Okapi, 164

Okra, 1537\*, 1579  
 Olbers paradox, 1537\*  
 Old Stone Age see Paleolithic  
 Old World monkeys, 1771  
 Old World vulture, 260  
 Olduvai, 926  
 Oleaceae, 1223  
 Olefin, 1640-1641  
 see also Alkene  
*Oleo europaea*, 1540  
 Oleoresinous varnishes, 2326-2327  
 Olethreutidae, 1243  
 Olfaction, 374, 1538-1539\*  
 chemical senses, 427-428  
 chemoreception, 433  
 flavorings, 2084  
 nose, 1503-1504\*  
 Olfactory receptor, 1985  
 Olfactory epithelium, 1986  
 Oligemia, 408  
 Oligobrachiidae, 182  
 Oligocene, 1539\*  
 Oligochaeta, 125, 1539\*  
 Oligochromemia, 408  
 Oligoclase, 1539\*  
 Oligocythemia, 408  
 Oligodendroglia, 1477  
 Oligonucleotide, 1539\*  
 Oligopygoida, 1539-1540\*  
 Oligosaccharide, 327-328, 1540\*  
 amino sugar, 98\*  
 carbohydrate metabolism, 366-367\*  
 maltose, 1308-1309\*  
 raffinose, 1865\*  
 Oligotrichida, 1540\*  
 Olive, 1223, 1540\*  
 Olivine, 1125, 1540\*  
 dunite, 707  
 Earth interior, 721  
 gabbro, 955  
 kimberlite, 1214  
 layered intrusion, 1234  
 peridotite, 1631  
 solid solution, 2043  
 Ollier's disease see Dyschondroplasia  
 Ombrophilous bog, 273  
 Omithischia, 165  
 Omniscient calculator, 648  
 Omnivores, 666  
 Omphacite, 1540\*  
 On-line data-base publishing, 712  
 ON-OFF switches, 972  
 Onager, 635  
 Onchididae, 2185  
*Onchocerca volvulus*, 1347  
 Oncholaimida, 1540-1541\*  
*Oncicola canis*, 147  
 Oncofetal antigens, 1541\*  
 Oncogenes, 1456, 1541\*  
 Oncology, 1541-1543\*  
 alpha fetoprotein, 87-88  
 antibiotic, 137  
 avian leukosis, 234-235\*  
 cancer, 322, 361-362\*  
 cancer biology, 1542  
 cancer prevention, 1542  
 causes of cancer, 1542  
 chemotherapy, 435-436\*  
 diagnosis, 1542  
 Epstein-Barr virus, 740\*, 840\*  
 mutagens and carcinogens, 1456-1457\*  
 oncofetal antigens, 1541\*  
 oncogenes, 1541\*  
 pancreas disorders, 1605  
 treatment, 1542-1543  
 tumor, 1542, 2280-2281\*  
 tumor viruses, 2281\*  
*Ondatra zibethica*, 1456  
 One-way synchronous ranging, 790  
 Onion, 1543\*  
 Oniscoidea, 1543\*  
 Ontogeny, 1543\*, 1598  
 Onuphidae, 760  
 Onychophora, 1543-1544\*  
 Onychopoda, 1544\*  
 Onygenaceae, 771  
 Onyx, 1544\*  
 Oogenesis, 960, 1544-1545\*  
 Oolite, 1255, 1545\*  
 Oomycetes, 989, 1545\*  
 Oort cloud, 508  
 Opah, 1224  
 Opal, 1545\*  
 colloid, 501  
 colloidal crystals, 501-502\*  
 Opalescence, 1545\*



- Open-angle glaucoma, 889  
 Open caisson, 310  
 Open channel, 361, 1545\*  
 Open circuit, 1545\*  
 Open hopper, 1154  
 Open-loop control system, 484  
 Open pit mining, 1545-1555\*, 2169  
 Open Systems Interconnection (OSI) model, 616, 2201  
 Opencast mining, 1406  
   *see also* Surface mining  
 Operating system, 1546\*  
   optimization, 1564-1565  
   security, 462, 525, 1546\*  
   software, 2030  
 Operational amplifier, 1546-1547\*, 2354  
   comparator, 453  
   magnetic instruments, 1291-1292\*  
 Operations research, 1547\*  
   mathematical programming, 1547  
   methodology, 1547  
   nonlinear programming, 1498\*  
   scope of application, 1547  
   stochastic processes, 1547  
   systems analysis, 2186  
 Operator theory, 1547-1548\*  
 Operator training, 1548\*  
 Operculate discomyces, 685  
 Operon, 1548\*  
 Ophiacantha, 1549  
 Ophiacodonta, 1624  
*Ophiderpeton*, 67  
 Ophiderpetonidae, 67  
 Ophiocistioida, 728  
 Ophioglossales, 1548\*, 1751  
 Ophiolite, 720, 1548-1549\*  
 Ophiomyxidae, 1674  
*Ophiphagus hannah*, 2092  
*Ophiura*, 1549\*  
 Ophiurida, 1549\*  
 Ophiuroidea, 1549\*  
   Oegophiurida, 1533\*  
   Phrynophiurida, 1674\*  
   Stenurida, 2113\*  
 Opiates, 1549\*  
   addictive disorders, 25-26\*  
   analgesic, 108  
   endorphins, 819\*  
   narcotic, 1465\*  
 Opioloacariiformes, 1549\*  
 Opiliones, 1549\*  
 Opisthobranchia, 866, 1549-1550\*  
   Gastropoda, 972  
   Nudibranchia, 1521\*  
   Sacoglossa, 1939\*  
 Opisthocomidae, 1550  
 Opisthocomiformes, 1550\*  
*Opisthorchis sinensis*, 218  
 Opium:  
   opiates, 1549\*  
   poppy, 1754\*  
 Opossum, 1550\*  
 Oppenheimer, J. R., 906, 1022  
 Opportunistic infections, 1550\*  
   acquired immune deficiency syndrome (AIDS), 18-19\*  
   medical mycology, 1347  
   pneumonia, 1730-1731\*  
 Opsonin, 1550\*  
 Optic nerves, 2347  
 Optical activity, 1550-1551\*  
   asymmetric synthesis, 197-198\*  
   enantiomer, 731  
   polarimetric analysis, 1735\*  
   racemization, 1839\*  
   structural chemistry, 2133  
 Optical bistability, 1551\*  
 Optical bleaching, 266  
 Optical cables, 1267  
 Optical character recognition (OCR), 415\*, 554  
 Optical coherence tomography, 1551-1552\*  
 Optical communications, 1552-1553\*  
   coherent, 1553  
   communications cables, 509-510  
   communications systems protection, 512  
   electrical noise, 759  
   Federal Telecommunications System, 874\*  
   fiber-optic circuit, 883\*  
   integrated optics, 1026-1027\*, 1166  
   optical fiber communications, 1552  
   optical guided waves, 1554-1555  
   optical receivers, 1553  
   optical transmitters, 1552-1553  
   photonic interconnects, 1553  
   telephone systems construction, 2200  
 Optical comparator, 453  
 Optical data storage, 1560-1561  
 Optical detectors, 1553\*  
   communication system receivers, 1553\*  
   optical isolator, 1555-1556\*  
 Optical fibers, 1553-1554\*  
   cable television system, 347\*  
   fiber-optic circuit, 883\*  
   fiber-optic sensor, 884\*  
   fiber-optics imaging, 884\*  
   interference filter, 1170\*  
   optical guided waves, 1554-1555\*  
   submarine cable, 2139  
   telephone systems construction, 2200  
   transmission lines, 2262  
   waveguides, 2374  
 Optical flat, 1554\*  
 Optical guided waves, 1554-1555\*  
 Optical image, 1555\*  
   electronic display, 786-788\*  
   geometrical optics, 992  
   ghost image (optics), 997-998\*  
   holography, 1084-1085\*  
   magnification, 1304\*  
   mirage, 1407\*  
   mirror optics, 1407-1408\*  
 Optical imaging sensors, 1378-1379  
 Optical information systems, 1555\*  
 Optical isolator, 1555-1556\*  
 Optical isomer, 1550  
 Optical mark reading, 363  
 Optical materials, 1556-1557\*  
 Optical methods of chemical analysis:  
   polarimetric analysis, 1735\*  
   refractometric analysis, 1882-1883\*  
 Optical microscope, 1557-1558\*  
   catadioptric systems, 1557  
   comparison microscope, 1557  
   condensers, 1557  
   dissecting microscope, 1557-1558  
   fluorescence microscope, 902-903\*  
   inverted microscope, 1557  
   light microscope, 1557  
   magnification, 1557  
   metallography, 1369  
   metallurgical microscope, 1558  
   near-field optical microscope, 1558  
   near-infrared microscope, 1558  
   phase-contrast microscope, 1650-1651\*  
   reflecting microscope, 1880\*  
 Optical mixing spectroscopy, 1835  
 Optical modulators, 1558\*  
 Optical phase conjugation, 1558\*  
 Optical prism, 1559\*  
   dioptr, 677\*  
   linearly polarized light, 1736  
 Optical projection systems, 405, 1559\*  
 Optical pulses, 1559\*  
 Optical pumping, 1560\*  
 Optical pyrometer, 1816  
 Optical radar *see* Lunar laser ranging  
 Optical recording, 1445-1446, 1560-1561\*  
 Optical rotation, 1550-1551  
 Optical rotatory dispersion, 1561\*, 1735  
 Optical spectrum analyzer, 2077  
 Optical surfaces, 1561-1562\*  
 Optical telescope, 194-195, 1562  
 Optical tracking instruments, 1562-1563\*  
   ballistic cameras, 1562  
   cinetheodolite, 1562  
   tracking telescopes, 1562  
 Optical wavelength, 2375  
 Optics, 1563\*  
   acousto-optics, 18\*  
   adaptive, 24-25\*  
   atom, 188  
   conformal, 534-535\*  
   crystal optics, 592-593\*  
   Doppler effect, 697  
   electro-optics, 793\*  
   geometrical, 881, 991-993\*  
   interferometry, 1171-1172\*  
   magneto-optics, 1303\*  
   meteorological, 1377\*  
   microwave optics, 1396\*  
   mirror, 1407-1408\*  
   neutron, 1484\*  
   nonlinear, 1496-1498\*  
   physical, 1680\*  
   resolving power, 1903-1904\*  
   wave, 2372\*  
   x-ray, 2404-2405\*  
 Optimal control (linear systems), 1563\*  
 Optimal control theory, 1563\*  
   classes of problems, 1563  
   differential games, 1563  
   stochastic optimal control theory, 1563  
 Optimization, 1564-1565\*, 2320  
 Optoacoustic spectroscopy *see*  
   Photoacoustic spectroscopy  
 Optocoupler *see* Optical isolator  
 Optoisolator *see* Optical isolator  
 OR gate, 2175, 2176  
 Oral glands, 1565\*  
 Oral pathology, 574  
 Oral surgery, 574  
 Orange, 1565\*  
 Orangutan, 132, 148-149  
   fossil apes, 923  
   fossil humans, 925  
   fossil primates, 928  
   primates, 1772  
 Orbit (communications satellite), 510  
 Orbital motion, 1565-1566\*  
   apsides, 154\*  
   celestial mechanics, 386  
   Dynamical Time, 711  
   Earth, 721-722\*  
   Kepler's laws, 1211-1212\*  
   molecular orbital theory, 1422-1423  
   perturbation, 1638\*  
   retrograde motion (astronomy), 1909\*  
 Orbivirus, 272  
 Orchid, 1566\*, 2079, 2323  
 Orchidaceae, 1566  
 Orchidales, 1566\*  
 Ordovician, 1566-1567\*  
   Paleozoic, 1603  
   plant evolution, 1703  
 Ore:  
   barite, 250\*  
   bauxite, 228, 259\*  
   beryl, 268\*  
   bornite, 319\*  
   cassiterite, 377\*  
   celestite, 387-388\*  
   cerargyrite, 406\*  
   chalcocite, 412\*  
   chalcopyrite, 412\*  
   chromite, 450\*  
   chrysocola, 455\*  
   cinnabar, 458\*  
   cobaltite, 487\*  
   columbite, 505\*  
   cuprite, 598\*  
   enargite, 814\*  
   franklinite, 834  
   galena, 957\*  
   garnierite, 861  
   goethite, 1010\*  
   hausmannite, 1048\*  
   hematite, 1061\*  
   hemimorphite, 1063\*  
   hydrometallurgy, 1109\*  
   illmenite, 1127\*  
   limonite, 1256\*  
   magnetite, 1300\*  
   malachite, 1306\*  
   manganite, 1312\*  
   millerite, 1403\*  
   mineral, 1404  
   molybdenite, 1429\*  
   nickel, 1487\*  
   nickeline, 1487\*  
   pentlandite, 1626\*  
   pyrrargenite, 1812\*  
   pyromorphite, 1816-1817\*  
   rutile, 1936\*  
   scheelite, 1956\*  
   sphalerite, 2082\*  
   spodumene, 2088\*  
   stibnite, 2116\*  
   taconite, 2190\*  
   tantallite, 2192\*  
   uraninite, 2308\*  
   willemite, 2388\*  
   zincite, 2416\*  
   zircon, 2417\*  
 Ore and mineral deposits, 1567\*, 2047  
 Ore dressing, 1567\*  
   flotation, 896\*  
   magnetic separation methods, 1295  
 Oregon, 1223, 1567-1568\*  
*Oregano*, 1223  
*Oreopithecius*, 924  
 Organ transplantation, 2263  
 Organic chemical synthesis:  
   chelates, 367  
   hydroboration, 1102\*  
   hydroformylation, 1104\*  
   organoactinides, 1575\*  
 Organic chemistry, 1568-1569\*  
   acyclic compounds, 1569  
   bioorganic chemistry, 292-293\*  
   carbocyclic compounds, 1569  
   heterocyclic compounds, 1569  
   physical, 1680-1681\*  
   synthesis reactions, 1569  
 Organic compounds, 770  
 Organic conductor, 1569-1570\*  
   charge-transfer compounds, 1569  
   conducting polymers, 1569-1570  
   superconductivity, 2155  
 Organic electrochemistry, 689, 765  
 Organic evolution, 1570-1571\*  
   genetic algorithms, 981\*  
   phylogeny, 1675-1676\*  
 Organic geochemistry, 985, 1571\*  
 Organic halides, 1040  
 Organic material decomposition, 848  
 Organic nomenclature, 1571-1572\*  
 Organic photochemistry, 1572\*  
 Organic reaction mechanism, 1572-1573\*  
   activation parameters, 1573  
   classification, 1572  
   kinetics, 1573  
   potential energy diagrams, 1572-1573  
   stereochemistry, 1573  
 Organic solvent, 2047  
 Organic synthesis, 1573-1575\*  
   cage hydrocarbon, 349\*  
   chemoselectivity, 1574  
   selectivity, 1574  
 Organoactinides, 1575\*  
 Organoborane, 1102  
 Organometallic compound, 1575-1576\*  
   chelates, 367  
   Grignard reaction, 1027\*  
   hydroboration, 1102\*  
   metallocenes, 1368-1369\*  
 Organophosphorus compound,  
   1576\*  
 Organopolysiloxane *see* Silicone resins  
 Organoselenium compound, 1576\*  
 Organosilicon compound, 1576-1577\*  
 Organosulfur compound, 1577-1578\*  
   mercaptan, 1356\*  
   saccharin, 1939\*  
   sulfonamide, 2146-2147\*  
   sulfur, 2148  
   thiophene, 2233\*  
 Orbitidae, 8  
 Oriental jackal, 634  
 Oriental vegetables, 1578-1579\*  
 Orientation polarization, 1736  
*Origanum*, 1326  
 Orion, 1579\*  
 Orion Nebula, 1419-1420, 1579-1580\*  
 Ormer *see* Abalone  
 Ormithischia, 149, 674, 675, 1580\*  
 Ormithopoda, 675, 1580  
 Ormithorhynchidae, 1435, 1726  
*Ormithorhynchus anatinus*, 1726  
 Orobanchaceae, 1223  
 Orogens, 720  
 Orogeny, 1580\*  
   cordilleran belt, 558-559\*  
   Paleocene, 1597  
   Paleozoic, 1603  
   Pennsylvanian, 1625, 1626  
   plate tectonics, 1724  
   Pliocene, 1728  
   subduction zones, 2139  
   Triassic, 2269  
 Orpiment, 1580\*, 1874  
 Orthida, 161, 1580\*  
 Orthidina, 1580  
 Orthite *see* Allanite  
 Orthoarsenic acid, 2393  
 Orthoclase, 1580\*  
 Orthodontics, 574  
 Orthodynamic earphones, 716  
 Orthogneiss, 894  
 Orthogonal polynomials, 1580-1581\*  
 Orthographic view, 579  
 Orthomyxoviridae, 1148  
 Orthonectida, 1581\*  
 Orthoptera, 1581\*  
 Orthopyroxene, 1125  
   kimberlite, 1214  
   layered intrusion, 1234  
 Orthorhombic pyroxene, 1581-1582\*  
 Orthorrhapha, 620  
 Orthotrichales, 1582\*  
*Orthotopus*, 1, 2280  
*Oryctolagus*, 1145  
 Oscillating conveyor, 302-303  
 Oscillation, 1582\*  
   atmospheric tides, 205-206\*

Oscillation—*cont.*  
 damping, 614-615\*  
 forced oscillation, 913-914\*  
 giant nuclear resonances, 998\*  
 seiche, 1974\*  
 thermoacoustics, 2223

Oscillator, 1582-1583\*  
 anharmonic, 118\*  
 blocking, 267  
 frequency counter, 933  
 frequency locking, 1583  
 frequency measurement, 934-935  
 harmonic, 927  
 klystron, 1217\*  
 phase-locked loops, 1652\*  
 quartz clock, 1833\*  
 relaxation oscillator, 1582  
 sine-wave oscillator, 1583  
 traveling-wave tube, 2265-2266  
 vibration, 2337

Oscillatory reaction, 1583-1584\*  
 Oscilloscope, 1584\*  
 cathode-ray tube, 380-381\*, 1584\*  
 electronic test equipment, 791  
 waveforms, 2373

Osmium, 1584-1585\*  
 Osmoregulatory mechanisms, 1585\*  
 absorption (biology), 5\*  
 plant-water relations, 1716  
 thirst and sodium appetite, 2233-2234\*  
 Osmosis, 1585\*  
 Donnan equilibrium, 696  
 osmoregulatory mechanisms, 1585\*

Osprey, 260, 784  
 Ostariophys, 2198  
 Osteichthyes, 1585-1586\*  
 Acipenseriformes, 14\*  
 Amiiformes, 96\*  
 Anguilliformes, 117\*  
 animal evolution, 120  
 Atheriniformes, 199\*  
 Beryciformes, 267-268\*  
 bowfin, 285  
 Cetomimiformes, 410\*  
 Chondrostei, 446-447\*  
 Clupeiformes, 479-480\*  
 codfish, 488\*  
 Crossopterygii, 582\*  
 Ctenothrissiformes, 597\*  
 Cypriniformes, 607-608\*  
 Dipnoi, 678\*  
 Elopiformes, 808\*  
 Gadiformes, 955\*  
 Gasterosteiformes, 970\*  
 Gobiesociformes, 1010\*  
 Gonorynchiformes, 1013\*  
 Holosteii, 1085\*  
 Lampridiformes, 1224\*  
 Leptolepiformes, 1246\*  
 Lophiiformes, 1271\*  
 mackerel, 1286\*  
 Notacanthiformes, 1504\*  
 Osteoglossiformes, 1586\*  
 Paleonisciformes, 1596\*  
 Pegasiformes, 1623\*  
 Perciformes, 1628-1629\*  
 Percopsiformes, 1629\*  
 Pholidophoriformes, 1656\*  
 pike, 1686\*  
 Polypteriformes, 1751\*  
 Pycnodontiformes, 1812\*  
 Salmoniformes, 1941\*  
 Sarcopterygii, 1945\*  
 scale (zoology), 1952\*  
 Semionotiformes, 1984\*  
 Siluriformes, 2010\*  
 sturgeon, 2136-2137\*  
 sunfish, 2151\*  
 swim bladder, 2174\*  
 Synbranchiformes, 2182\*  
 Teleostei, 2198\*  
 Zeiformes, 2414\*

Osteoarthritis, 159, 174  
 Osteoarthritis, 2017  
 Osteoglossiformes, 1586\*  
 Osteolaemus, 515  
 Osteomyelitis, 2017  
 Osteoporosis, 1586\*  
 Osteostracans, 1202  
 Osteostraci, 1586-1587\*  
 Ostracoda, 1587\*  
 Halocyprida, 1042\*  
 Heterostraci, 1073\*  
 Myodocopida, 1460\*  
 Podocopa, 1598\*  
 Platycoptida, 1725\*

Ostracoda—*cont.*  
 Podocopa, 1731\*  
 Podocopida, 1731\*  
 Ostracoderm, 1202  
 Ostracoderm, 1202  
 Ostracoda, 125, 1223  
 Ostrich, 2136  
 Ostrya species, 964, 1047  
 Ostwald process, 1489  
 Otinidae, 226  
 Otto, N. A., 1174  
 Otto cycle, 229, 1587\*, 1763  
 Otto engine, 229, 597, 1175  
 Otus asio, 260  
 Ouranopithecus, 924  
 Ovalbumin, 68, 893  
 Ovarian disorders, 1587-1588\*  
 Ovary, 1588\*  
 anatomy and physiology, 1897-1898  
 androgen, 114-115\*  
 estrogen, 848\*  
 ovum, 1589\*  
 progesterone, 1781\*  
 Overcurrent protection, 750  
 Overrunning clutch, 423  
 Overuse syndrome, 335  
 Overvoltage, 750, 1588-1589\*  
 Ovis moschatus, 1455-1456  
 Ovonic threshold switch (OTS), 889, 1002  
 Ovonic memory switch (OMS), 889, 1002  
 Ovule, 810  
 Ovum, 1589\*  
 merogony, 1357\*  
 oogenesis, 1544-1545\*  
 primitive gut, 1772\*  
 sex determination, 1992  
 Owen, Richard, 615, 674  
 Owl, 260, 2128  
 Owlet-frogmouth, 326  
 Oxalate poisoning, 1733-1734  
 Oxalidaceae, 883  
 Oxalidales, 1589\*  
 Oxalis, 883  
 Oxidation:  
 antioxidant, 144\*  
 autooxidation, 232\*  
 biological see Biological oxidation  
 combustion, 507\*  
 electrochemical process, 762  
 flame, 891-892  
 number, 1590  
 thermoregulation, 2230  
 Oxidation process, 1589\*  
 Oxidation-reduction, 1589-1590\*  
 oxidizing agent, 1590  
 oxidizing agent, 1590\*  
 reactions, 1590  
 Oxidative dehydrogenation, 569  
 Oxide, 1590\*  
 Oxide glass, 100  
 Oxidizing agent, 1590\*  
 ozone, 1592  
 peroxide, 1635-1636\*  
 Oxidoreductase, 748, 833  
 Oxime, 1590-1591\*  
 Oximetry, 1591\*  
 Oxirane see Ethylene oxide  
 Oxycetylene flames, 11  
 Oxyaenidae, 571  
 Oxydendrum arboreum, 2055  
 Oxygen, 1591\*  
 air separation, 54, 55  
 biogeochemistry, 282  
 hyperbaric oxygen chamber, 1114-1115\*  
 origin in the atmosphere, 185, 200  
 oxidation process, 1589\*  
 oxide, 1590\*  
 ozone, 1592\*  
 peroxide, 1635-1636\*  
 superoxide chemistry, 2162\*  
 Oxygen toxicity, 1111, 1591-1592\*  
 Oxymonadida, 1592\*  
 Oxytocin, 1480  
 Oxyurina, 166  
 Oxyuroidea, 2130\*  
 Oyashio, 1219  
 Oyster:  
 invertebrate pathology, 1182  
 Lamellibranchia, 1223  
 Oyster catcher, 364  
 Ozone, 718, 1592\*  
 atmospheric, 187, 203  
 ozonolysis, 1592\*

Ozone—*cont.*  
 smog, 2024  
 stratosphere, 2123-2124  
 Ozonolysis, 1592\*

## P

PABA see *para*-Aminobenzoic acid  
 Pachycephalosauria, 1580  
 Pachyrrizus erosus, 1579  
 Pacific dogwood, 634  
 Pacific islands, 1593\*  
 Pacific mackerel, 1286  
 Pacific Ocean, 1593-1594\*  
 El Niño, 740\*  
 equatorial currents, 841, 842  
 marine geology, 1321, 1322  
 ocean circulation, 1530  
 Sea of Okhotsk, 966\*  
 Pacific silver fir, 801  
 Pacific yew, 2412  
 Packaging (electronic), 790\*  
 Packet switching, 1594\*  
 data communications, 616  
 local-area networks, 1267  
 networks, 712, 1267, 2387  
 wide-area networks, 2387  
 Packing, 1594\*  
 Paddlefish, 14, 21  
 Paddy Straw mushroom, 984, 1112  
 Paeonia lactiflora, 612  
 Paeoniaceae, 612, 672  
 Paget's disease, 1688  
 Paging, 1413  
 Paging systems, radio, 1850\*  
 Pagodane, 309  
 Pain, 1594-1595\*  
 analgesic, 107-108\*  
 anesthesia, 116\*  
 endorphins, 819\*  
 headache, 1048-1049\*  
 Paint, 1595\*  
 drier, 639  
 grinding, 1930  
 luminous, 1279\*  
 primer, 1772  
 surface coating, 2168  
 thinner, 2233\*  
 Painted snipe, 364  
 Pak choy, 1578  
 Palaeacanthocephala, 7, 1595-1596\*  
 Palaeandontoda, 737  
 Palaeodonta, 164  
 Palaeonemertini, 126, 1596\*  
 Palaeonisciformes, 1596\*  
 Palaeoniscoidei, 1596  
 Palaeoryctidae, 571  
 Palate, 1596\*  
 Paleoanthropology, 1676  
 Paleobiology, 1596\*  
 plant-animal interactions, 1702  
 taphonomy, 2192\*  
 Paleobotany, 1596-1597\*  
 coal, 483\*  
 petrified forests, 1639\*  
 Paleoceanography, 1597\*  
 Paleocene, 1597-1598\*  
 Paleoclimatology, 1598\*  
 Paleozoic, 1603  
 Pennsylvanian, 1626  
 Paleocopa, 1598\*  
 Paleocology, 1598-1599\*, 2254  
 Paleogeography, 1599\*, 1626  
 Paleoherpetology, 1900  
 Paleoindian, 1599-1600\*  
 Paleolithic, 1600-1601\*  
 Paleomagnetism, 1601\*, 1878  
 Paleontology, 880, 1601-1602\*  
 Earth sciences, 722  
 fossil, 922-923\*  
 geology, 990  
 micropaleontology, 1387-1388\*  
 paleobotany, 1596-1597\*  
 paleoceanography, 1597\*  
 paleoecology, 1598-1599\*  
 paleogeography, 1599\*  
 trace fossils, 2254  
 Paleopalynology, 1604  
 Paleopathology, 1602\*  
 Paleoprimatology, 1676  
 Paleoproterozoic, 1793  
 Paleoptera, 1805

Paleoseismology, 1602\*  
 Paleosol, 1602-1603\*  
 Paleosuchus species, 309, 515  
 Paleozoic:  
 Graptolithina, 1018-1019\*  
 Mississippian, 1408-1409\*  
 Paleozoic Era, 1603\*  
 animal evolution, 120  
 Cambrian, 359-360\*  
 Carboniferous, 369-370\*  
 Devonian, 651-652\*  
 dolomite rock, 694  
 Ordovician, 1566-1567\*  
 paleogeography, 1599  
 Pennsylvanian, 1625-1626\*  
 Permian, 1635\*  
 Silurian, 2009-2010\*  
 Palhinhaea, 1280  
 Palladium, 1603-1604\*  
 Pallium, 1477  
 Palm:  
 Arecales, 167\*  
 betel nut, 271\*  
 coconut, 488\*  
 date, 619  
 tree, 2266  
 see also Cycadales  
 Palm-nut vulture, 784  
 Palmaceae, 619  
 Palmae see Arecaeae  
 Palmyridae, 760  
 Palpigradi, 1604\*  
 Palpigradida, 138  
 Palynology, 426, 1596, 1604\*  
 Palynomorphs, 1604  
 PAM see Pulse-amplitude modulation  
 Pan species, 387  
 Panax (ginseng), 999  
 Pancaria, 770, 2230  
 Pancreas, 1604\*  
 anatomy, 1604  
 diabetes mellitus, 591, 653  
 digestive system, 666, 667  
 glucagon, 1006\*  
 insulin, 1162  
 lipid metabolism, 1260\*  
 physiology, 1604  
 secretions, 606-607  
 Pancreas disorders, 1604-1605\*  
 Pancreozymin, 1260  
 Pancytopenia, 408, 1062  
 Panda, 1605\*  
 Pandanales, 151, 167, 1605\*  
 Pandemic, 751  
 Pandion haliaetus, 260  
 Pandionidae, 260, 784  
 Panel heating and cooling, 1605\*  
 Pangaea:  
 paleogeography, 1599  
 Pennsylvanian, 1626  
 supercontinent, 2157  
 Pangolin, 1656  
 Panic disorder (PD), 147  
 Panicum milaceum, 1403  
 Panleukopenia, feline, 789  
 Panoramic camera, 321  
 Pantodontia, 1605\*  
 Pantograph, 1605-1606\*  
 Pantothenic acid, 1606\*  
 Pantothenia, 2219  
 Dryolestida, 704  
 Symmetrodonta, 2178\*  
 Papaver somniferum, 1754  
 Papaveraceae, 1754  
 Papaverales, 1606\*  
 broccoli, 334\*  
 poppy, 1754\*  
 Paper, 1606-1607\*  
 cellulose, 399  
 dyeing, 708\*  
 Paper birch, 259  
 Paper chromatography, 804  
 Paper tape (electronic dataprocessing systems), 554  
 Papilionoidea, 1244-1245  
 Papilionoids, 1240  
 Papovavirus:  
 adeno-SV40 hybrid virus, 28\*  
 polyoma virus, 1750  
 Paprika, 1607\*  
 Papyrus, 543  
 PAR see Precision approach radar  
 Parablastoidea, 1607\*  
 Parabola, 1607\*  
 Parabolic dune, 642, 706

- Parachordodes, 921  
Parachute, 1607\*  
*Paracoccus halodentrificans*, 1044  
Paraconformity, 2297  
Paraffin, 1607\*  
Paraffin hydrocarbon *see* Alkane  
Paragenetic mineralogy, 1405  
Paragneiss, 894  
Paragonite, 1381  
*Paragordius*, 921  
Parainfluenza virus, 1607\*, 1984  
Parainsecta, 1607-1608\*  
Parallax (astronomy), 721, 1608\*  
Parallel circuit, 1608\*  
Parallel computing, 1337, 2153  
Parallel-plate ionization chamber, 1188-1189  
Parallel postulate, 851-852  
Parallelepiped, 597  
Paramagnetism, 1300, 1608-1609\*  
  adiabatic demagnetization, 29\*  
  electron paramagnetic resonance spectroscopy, 782\*  
  Langevin function, 1227\*  
  magnetic susceptibility, 1295  
  magnetocaloric effect, 1301\*  
  susceptibility, 1295  
*Paramecium*, 985  
Parameter, 1609\*  
Parametric amplifier, 1609\*  
Parametric arrays, 1609\*  
Parametric equation, 1609\*  
Paramo, 1609\*  
Paramyxovirus, 1609-1610\*  
  canine distemper, 362\*  
  parainfluenza virus, 1607\*  
  respiratory syncytial virus, 1906-1907\*  
  Sendai virus, 1984\*  
Paranasal sinus disease, 1538  
Paranoia, 1610\*  
*Paranthropus*, 219-220, 829, 924, 925  
Paraseleniidae, 658  
Paraselloidea, 167  
Parasites:  
  Moraxella, 1437-1438\*  
Parasitic disease:  
  coenurosis, 491\*  
  giardiasis, 998-999\*  
  malaria, 1307\*  
  myiasis, 1460\*  
  paleopathology, 1602  
  schistosomiasis, 1957\*  
  sexually transmitted, 1995  
  skin disorders, 2018  
Parasitic meningitis, 1354\*  
Parasitica, 984  
Parasitology, 1347-1348, 1610\*  
Parasympathetic nervous system, 1610-1611\*  
Parathyroid gland, 1611\*  
Parathyroid gland disorders, 1611\*  
Parathyroid hormone, 1611-1612\*  
Parazoa, 1612\*  
Parenchyma, 1612\*, 1692-1693  
Parenchyma cells, 1655  
Parenting, 1897  
Pareto's law, 1612\*  
Pareulepidae, 760  
Paris green, 157  
Parity (quantum mechanics), 1612-1613\*  
  analog states, 109\*  
  symmetry laws, 2179  
Parker, E. N., 988  
Parkinson's disease, 1613\*  
  dopamine, 697  
  olfaction, 1538  
  spinal cord disorders, 2085  
Parrot, 1799  
Parrot's feather (plant), 924  
Parsley, 1613\*  
Parsnip, 1613\*  
*Parthenium argentatum*, 912  
Parthenogenesis, 1896  
Partial differential equation, 661-662  
Partial differentiation, 1613-1614\*  
Partial productivity, 1781  
Particle accelerator, 1614-1615\*  
  advanced linacs, 1615  
  betatron, 271\*  
  electron *see* Electron accelerators  
  electrostatic accelerators, 1614  
  quantum (physics), 1823\*  
  relativistic electrodynamics, 1886\*  
  storage rings, 1615  
  superconducting magnets, 1615  
  time-varying field accelerator, 1614-1615  
Particle beams, charged, 416-417\*  
Particle board, 456  
Particle detector, 1615-1616\*  
  Cerenkov radiation, 407\*  
  channel electron, 413\*  
  cosmic-ray detection, 501  
  crystal counter, 590\*  
  scintillation counter, 1961-9162\*  
  time-projection chamber, 2241-2242\*  
  transition radiation detectors, 2261\*  
Particle dynamics, 648  
Particle flow, 1616\*  
Particle optics, charged, 417\*  
Particle resonances, 802  
Particle track etching, 1616\*  
Particle trap, 207, 1616-1617\*  
Particulates, 36-37, 1617-1618\*  
Parton, 1831  
Partridge, 259  
Parvoviridae, 577  
Pascal's law, 1618\*  
Paschen, F., 1618  
Paschen-Back effect, 1618\*  
*Paspalum dilatatum*, 549  
*Paspalum scrobiculatum*, 1403  
Passenger ship, 1356  
Passeriformes, 1618\*  
Passive immunization, 1129  
Passive-matrix LCD, 787  
Passive microwave solid-state devices, 1396  
Passive radar, 1618\*  
Passive sonar, 2048, 2049  
Pasteur, Louis, 1618  
  amino acid dating, 96  
  pasteurization, 1619  
  tartaric acid, 2193  
  vaccination, 2317  
*Pasteurella*, 296, 1618-1619\*  
*Pasteurella pestis*, 1695-1696  
*Pasteurella pseudotuberculosis*, 1798  
Pasteurellosis, 1619\*  
*Pasteuria*, 300  
Pasteurization, 821, 1619\*  
*Pastinaca sativa*, 1613  
Patagonian cavy, 344  
Patches (landscape ecology), 1226  
Patellacea, 144  
Patellidae, 144  
Patellogastropoda, 972  
Patent, 1619\*  
Paterinida, 1134, 1619\*  
Paternity:  
  blood group tests, 270  
  forensic biology, 916  
*Pateroperca*, 531  
Pathogen, 1619\*  
  disease ecology, 686-687\*  
  medical bacteriology, 1345\*  
  medical mycology, 1347\*  
  water-borne, 2363  
Pathogenesis, 625  
Pathology, 1619-1620\*  
  clinical, 474-476\*  
  insect pathology, 1156\*  
  molecular, 1423-1424\*  
  paleopathology, 1602\*  
  *see also* Plant pathology  
Pathotoxin, 1620\*  
Patrol ships, 1468-1469  
Pattern formation (biology), 1620\*  
Paua *see* Abalone  
Paul trap, 1617  
Pauli, Wolfgang, 192, 212, 509, 774, 859, 1251, 1826  
Pauli exclusion principle, 1174, 2165  
  *see also* Exclusion principle  
Pauli paramagnetism, 1608  
Paving, Linus, 708, 786  
Pauropoda, 1620\*  
Pavement, 65, 1620-1621\*  
Paver, 479, 543  
Pavlov, I. P., 468, 532  
Pavlovian conditioning, 1801  
Pawl, 1621\*, 1871  
Paxillosida, 173, 1621\*  
PBX *see* Private branch exchange  
PCB *see* Polychlorinated biphenyls  
PCM *see* Pulse-code modulation  
PDM *see* Pulse-duration modulation  
Pe-t'ai, 1578  
Pea, 1578-1579  
Peach, 1470, 1621\*  
Peacock, 1994  
Peacock ore *see* Bornite  
Peafowl, 259  
Peaking circuit, 2271  
Peanut, 1621\*  
  farm crops, 871  
  legume, 1240  
Peanut worm, 2014  
Pear, 1622\*, 1932  
Pearl, 1622\*  
Pearl millet, 1403, 1403\*  
Peat, 970, 1622\*  
  bog, 309-310\*  
  coal, 424-425, 481  
  coal balls, 482\*  
  muskeg, 1456  
Peat moss:  
  Bryophyta, 337  
  Sphagnopsida, 2082\*  
Pebble mill, 1622  
Pecan, 952, 1205, 1622\*  
Peccary, 164, 178  
Pecora, 164, 178  
Pectin, 1622\*  
Pectinacea, 125  
Pectolite, 1622\*  
Pectoral girdle, 2016  
Pedicellariae, 187  
Pedicellinida, 743, 827  
Pediculosis, 1622\*  
*Pediculus humanus*, 126-127, 1622  
Pedinidae, 659  
Pedinoida, 1623\*  
*Pediola salincola*, 344  
Pedodontics, 574  
Pedology, 1623\*, 2032-2033  
Pedomorphosis, 948  
Peebles, P. J. E., 500  
Pegasidae, 1623  
Pegasiformes, 1623\*  
Pegasus, 1623\*  
Pegmatite, 1623\*  
  dumortierite, 705  
  rare-earth minerals, 1870  
Pesticididae, 760  
Peking man, 1661  
Pelagic animals, 629-630  
Pelagic processes, 628  
Pelagic rain, 1321  
*Pelargonium*, 883, 996  
Pelecaniformes, 1623-1624\*  
Pelecanoididae, 1778  
Peléean eruptions (volcanoes), 2353  
Pelican, 1623  
Pellagra, 1486  
Pellat current balance, 535  
Pelletron accelerator, 717  
Pelmatozoa, 1624\*  
  Blastoidea, 302\*  
  Eocrinoidea, 834\*  
Pelagonidae, 943  
Peltaspermales, 999  
Peltier, J. C. A., 1624  
Peltier effect, 1624\*, 2228  
*Pelvetia*, 843  
Pelvic gridle, 2016  
Pelycosauria, 1624\*  
*Pemphigus vulgaris*, 1129  
Penaidea, 560  
Penardia, 14-15  
Pendulum, 1624\*  
  center of oscillation, 1624  
  Foucault, 831  
  motion, 1624  
  Schuler pendulum, 1960\*  
  types, 1624  
Penguin, 2082  
Penicillin, 136-137, 1624-1625\*  
  antimicrobial agents, 143  
  fungal biotechnology, 847-848  
  pasteurellosis, 1619  
*Penicillium*, 137, 1119  
Penis, 557, 1625\*  
Pennatulacea, 1625\*  
Penning trap, 1617  
Pennsylvanian, 330, 1625-1626\*  
  animal evolution, 120  
  coal, 481  
  coal balls, 482\*  
Penrose, R., 906  
Pentaborane, 279  
*Pentalonia nigronervosa*, 2  
Pentamerida, 161, 1626\*  
Pentaprismane, 309  
Pentastomida, 1626\*  
  Cephalobaenida, 404\*  
  Porocephalida, 1756\*  
Pentatomidae, 944  
Pentatomidae, 944  
Pentatomorpha, 944  
Pentlandite, 1626\*  
Pentoxylales, 999  
Penumbral eclipse, 730  
Penzias, A., 500  
Peony, 612, 1952  
Pepper, 1626\*  
  black, 264  
  paprika, 1607\*  
  pimento, 1688\*  
  Solanales, 2038  
Peppermint, 1626\*  
Pepsin, 1626\*  
Peptic ulcer, 970, 2293  
Peptide, 1626-1627\*  
  biopolymer, 293\*  
  endorphins, 819\*  
  protein, 1790-1791\*  
  somatostatin, 2048\*  
Peracarida, 770, 1627\*  
  Caprellidea, 365\*  
  Eumalacostraca, 854  
  Mictacea, 1399, 1399\*  
  Tanaidacea, 2191\*  
Peraluminous granite, 901  
Peramorphosis, 948  
Percent, 1627\*  
  comparing any two quantities, 1627  
  part of a whole, 1627  
  rate, 1627  
Perception, 1627-1628\*  
  agnosia, 43\*  
  cognition, 493\*  
  constancy, 1627-1628  
  form, 1628  
  geometrical illusions, 1628  
  hallucination, 1042\*  
  motion, 1628  
  speech, 2079\*  
  vision, 2347  
Perching birds, 1618  
Perchloroethylene, 391  
Percidae, 551  
Perciformes, 1628-1629\*  
  barracuda, 252-253\*  
  bluefish, 271  
  mackerel, 1286\*  
  sunfish, 2151\*  
  tuna, 2281\*  
Percopsiformes, 1629\*  
Percussion instruments, 1454  
Percussion welding, 1902  
Perdix, 259  
Peregrine falcon, 260  
Perfluorocarbon, 904, 1043  
Performance (computer-system), 527  
Performance rating, 1629\*  
Perfume, 94-95, 95\*  
Pericarditis:  
  pneumococcus, 1730  
  tuberculosis, 2279  
Periclinical chimera, 386  
Pericycle, 1629\*  
Pericyclic reaction, 1629-1630\*  
Periderm, 1630-1631\*  
Peridotite, 1214, 1631\*, 1655  
Perigee, 136  
Perihelion, 136, 1890  
Perijove, 136  
Period doubling, 1631\*  
Periodic motion, 1047, 1631\*  
Periodic perturbation (astronomy), 1638  
Periodic table, 1631-1632\*  
  darmstadtium, 615  
  nonmetal, 1498-1499\*  
Periodic waveforms, 2373  
Periodicity in organisms, 733  
Periodontal disease, 1632-1633\*, 2249  
Periodontics, 574  
Periodontitis, 1632-1633  
Peripheral vision, 2347  
*Periphylia*, 497  
Perischoechinoidea, 657, 1633\*  
Periscope, 1633\*  
Perissodactyla, 1633-1634\*  
  donkeys and allies, 696\*  
  rhinoceros, 1913\*  
  zebra, 2413\*  
Periteneum, 1634\*  
Peritonitis, 152, 1634\*  
  feline infectious, 788-789  
  pneumococcus, 1730  
*Peritrichia*, 403, 1634\*  
Permafrost, 1634\*  
Permalloy, 84

- Permanent magnet, 98, 1290  
 Permeability:  
   cell, 396\*  
   petroleum reservoir engineering, 1645  
 Permeance, 1634-1635\*  
 Permian, 1635\*  
   Paleozoic, 1603  
   plant evolution, 1703  
 Permianization, 482  
 Permittivity, 658, 1635\*  
 Pernicious anemia, 115, 2085  
*Pernisetum typhoideum*, 1403  
 Perovskite, 721, 1635\*  
 Peroxide, 1635-1636\*  
   benzoyl peroxide, 266\*  
   bleaching, 303\*  
 Peroxisome, 389, 1636\*  
 Peroxynitrite, 1636\*  
 Peroxysulfate see Persulfate  
 Perpendicular (mathematics), 1501  
 Perpetual motion, 1636\*  
*Persea americana*, 208, 1233  
 Perseus, 1636-1637\*  
 Persian clover, 422  
 Persian melon, 1637\*  
 Persian walnut, 2362  
 Persimmon, 656, 725, 1637\*  
 Personal computer see Microcomputer  
 Personality theory, 1637\*  
 Perspective (descriptive geometry), 579  
 PERT, 1637-1638\*  
 Perthite, 1638\*  
 Perturbation (astronomy), 386, 1638\*  
 Perturbation (mathematics), 1638\*  
 Perturbation (quantum mechanics), 1638-1639\*  
 Perturbation theory (quantum chemistry), 1825  
 Pertussis see Whooping cough  
 Peruvian lilies, 1254  
 Pest control, forest see Forest pest control  
 Pesticide, 1639\*  
   agroecosystem, 46  
   application of, 45  
   forest pest control, 920  
   fumigant, 944\*  
   insecticide, 1158\*  
   nematicide, 1473\*  
   rodenticide, 1930\*  
 PET see Positron emission tomography  
 Petalite, 1639\*  
 Petalodontidae, 286  
*Petaurus*, 1328  
 Petchia, 1067  
 Petit mal seizure, 754  
*Petricola*, 281  
 Petricolidae, 281  
 Petrification, 1639\*  
 Petrified forests, 1639\*  
 Petrochemical, 1639-1640\*  
 Petrofabric analysis, 1640\*, 2135  
 Petrography, 1640\*, 1737-1738  
 Petrolacosauridae, 138  
 Petrolatum, 1640\*  
 Petroleum, 1640-1641\*  
   East Indies, 724  
   gas field and gas well, 967\*  
   oil analysis, 1533-1534\*  
   oil and gas, offshore, 1534\*  
   oil and gas storage, 1535\*  
   oil sand, 1537\*  
   Pennsylvanian, 1626  
   petrochemical, 1639-1640\*  
   petrography, 1640  
 Petroleum engineering, 1641\*  
   oil and gas field exploitation, 1534-1535\*  
   well logging, 2383-2384\*  
 Petroleum enhanced recovery, 1641-1642\*  
   petroleum, 1641  
   petroleum microbiology, 1643  
 Petroleum geology, 1642\*  
   oil and gas, offshore, 1534  
   oil field waters, 1536-1537\*  
   petroleum, 1641  
 Petroleum microbiology, 1642-1643\*  
 Petroleum processing and refining,  
   1643-1644\*  
   alkylation, 80\*  
   aromatization, 172\*  
   coking, 437, 496\*  
   cracking, 575-576\*  
   destructive distillation, 647\*  
   dewaxing, 590, 2376  
 Petroleum processing and refining—cont.  
   distillation, 1643  
   hydroprocesses, 1644  
   reforming processes, 1881-1882\*  
   solvent extraction, 2047\*  
   thermal processes, 1643-1644  
 Petroleum products, 1644-1655\*  
   asphalt, 168-169  
   distillate fuel, 628  
   fuel oil, 942\*  
   jet fuel, 1203\*  
   kerosine, 1212\*  
   liquefied petroleum gas, 1261\*  
   lubricant, 1276  
   naphtha, 1465\*  
   petrochemical, 1639-1640\*  
   wax, 2376\*  
 Petroleum reserves, 1642, 1645\*  
 Petroleum reservoir engineering,  
   1645-1646\*  
   oil and gas well completion, 1535-1536\*  
   petroleum engineering, 1641  
 Petrology, 880, 1646\*  
   Earth sciences, 722  
   geology, 990  
   petrofabric analysis, 1640\*  
   rock, 1925-1926\*  
   structural petrology, 2135\*  
 Petromyzontida, 1646\*  
 Petromyzontiformes, 1202  
*Petroselinum crispum*, 1613  
 Petzval curvature, 536  
 Pewter, 1646\*  
 pH, 1646-1647\*  
 pH regulation (biology), 1647\*  
 Phaeodarea, 1862  
 Phaeophyceae, 1647\*  
   Fucales, 940\*  
   Laminariales, 1224\*  
 Phage:  
   actinophage, 21\*  
   bacteriophage, 244-245\*  
   coliphage, 499\*  
 Phagocytosis, 1647-1648\*  
   absorption (biology), 5\*  
   endocytosis, 818  
   invertebrate pathology, 1182  
 Phalarope, 364  
 Phallales, 864  
 Phane, 541  
 Phanerophytes, 1717  
 Phanerozoica, 1504  
 Phanodermatidae, 741  
 Phantotron, 863  
 Pharetronidia, 1648\*  
 Pharmaceutical chemistry, 1648\*  
 Pharmaceuticals testing, 1648\*  
 Pharmacognosy, 1648-1649\*  
 Pharmacology, 1649\*  
 Pharmacy, 1649\*  
 Pharyngobdellae, 153  
 Pharynx, 605, 1649\*  
 Phase (astronomy), 1649\*  
 Phase (periodic phenomena), 1649-1650\*  
 Phase-angle measurement, 1263-1264, 1650\*  
 Phase conjugation, 1495, 1497  
 Phase-contrast microscope, 1650-1651\*  
 Phase distortion, 629, 690  
 Phase equilibrium, 1651\*  
   boiling point, 311-312\*  
   fused-salt phase equilibria, 951\*  
   ice point, 1123-1124\*  
   Le Chatelier's principle, 1239\*  
   melting point, 1351\*  
   phase rule, 1653\*  
   silicate phase equilibria, 2008\*  
   sulfide, 2146\*  
   transition point, 2261\*  
   triple point, 2273-2274\*  
 Phase inverter, 1651\*  
 Phase-locked loops, 1498, 1652\*  
 Phase modulation, 117, 1652\*  
   modulation, 1414-1415\*  
   radio transmitter, 1853  
   spread spectrum communication, 2089  
 Phase-modulation detector, 1652\*  
 Phase modulator, 1652-1653\*  
 Phase rule, 1653\*  
 Phase-shifting interferometry, 1172  
 Phase-transfer catalysis, 1653\*  
 Phase-transfer technique, 1286  
 Phase transitions, 1653-1654\*  
   boiling point, 311-312\*  
   Ising model, 1192-1193\*  
 Phase unbalance protection, 751  
 Phase velocity, 1654\*  
*Phaseolus*, 229, 1579  
 Phasianidae, 259  
*Phasianus colchicus*, 260  
 Phasmatodea, 1581  
 Phasmodae, 1581  
 Pheasant, 259  
 Phellem, 1630  
 Phellogen, 1630  
 Phenol, 1079, 1654\*  
 Phenolic resin, 1654\*  
 Phenotype, 872  
 Phenotyping, 2244  
 Phenylbenzene see Biphenyl  
 Phenylketonuria, 1094, 1654\*  
   autistic disorder, 221  
   behavior genetics, 263  
 Pheromone, 370, 1655\*  
   animal communication, 119  
   forest pest control, 920  
*Pheronema*, 103  
 Philippe, Odelle, 1016  
 Philippines, 723  
 Philips, Frederick S., 435  
 Philodendron, 138  
 Philology, 648  
 Phlebitis, 1655\*  
*Phlebotomus*, 2218  
*Phlebotomus*, 621  
*Phlegethonia*, 67  
 Phlegethoniidae, 67  
*Phlegmarius*, 1280  
*Phleum pratense*, 2242  
 Phloeidae, 944  
 Phloem, 1655\*, 1770  
 Phloem translocation, 1715  
 Phlogopite, 1655-1656\*  
   kimberlite, 1214  
   mica, 1381  
 Phyladacea, 1223  
 Phobia, 1481, 1656\*  
*Phodilus badius*, 2128  
 Phoenicopteridae, 1656  
 Phoenicopteriformes, 1656\*  
 Phoeniculidae, 494  
*Phoenix dactylifera*, 557  
 Pholadacea, 281  
 Pholadidae, 281  
 Pholidophoridae, 1246  
 Pholidophoriformes, 1656\*  
*Pholidophorus bechei*, 1657  
 Pholidota, 1656\*  
   anteater, 131\*  
   edentata, 737  
 Phon scale, 1273  
 Phoneme, 2080  
 Phonetics, 1656-1657\*  
 Phonoatomic effect, 1823-1824  
 Phonograph record see Disk recording  
 Phonolite, 1657\*  
 Phonon, 1657\*  
   quantum acoustics, 1823, 1824  
   symmetry breaking, 2179  
 Phonoreception, 1657-1658\*  
   hearing (human), 1049-1050\*  
   hearing (vertebrate), 1050\*  
   invertebrates, 1657-1658  
   vertebrates, 1050\*, 1657  
 Phonoreceptor, 1985  
*Phoradendron flavescens*, 1409  
 Phoronida, 1272, 1658\*  
 Phoronis, 1658  
 Phoronopsis, 1658  
 Phosphate metabolism, 1658\*  
   parathyroid, 1611  
   parathyroid hormone, 1611-1612\*  
   thyrocalcitonin, 2236-2237\*  
 Phosphate minerals, 1658\*  
   apatite, 148\*  
   wavelite, 2376\*  
 Phosphatide, 1260  
 Phospholipid, 1658-1659\*  
   see also Phosphatide  
 Phosphor, 903  
 Phosphor bronze, 295  
 Phosphorane, 2412  
 Phosphorescence, 1659\*  
 Phosphorus, 1659-1660\*  
   organophosphorus compound, 1576\*  
   oxychloride, 390  
   trichloride, 390  
 Phosphorus cycle, 248, 281-282  
 Photic zone, 629  
 Photidae, 859, 963  
 Photoacoustic spectroscopy, 1660-1661\*, 2076  
 Photoaffinity labeling, 1661\*  
 Photoautotrophs, 736, 1323  
*Photobacterium*, 242  
 Photobiography, 2293-2294  
 Photobiology, laser, 1231\*  
 Photocathodes, 1673  
 Photochemistry, 1661-1662\*  
   chain reactions, 360-361  
   electronic absorption, 1661  
   energy transfer, 1662  
   inorganic photochemistry, 1154-1155\*  
   photochemical mechanisms, 1662  
   photodegradation, 1663-1664\*  
   photophysics, 1662  
   transitions, 1661-1662  
   ultrafast molecular processes, 2293-2294\*  
 Photochrome, 1683\*  
 Photocinometer, 1662-1663\*  
 Photoconductive cell, 1663\*  
 Photoconductive exposure meter, 777, 862  
 Photoconductivity, 1663\*, 2265  
 Photoconductor television camera tube, 2204  
 Photocopying processes, 1663\*  
 Photodegradation, 1663-1664\*, 2095  
 Photodetector:  
   photomultiplier, 1669\*  
   phototube, 1673\*  
   see also Optical detectors  
 Photodiode, 1664\*  
   facsimile, 869-870  
   optical communications, 1553  
 Photoelasticity, 1664\*  
 Photoelectric colorimetry, 446  
 Photoelectric devices, 1664\*  
   photoconductive cell, 1663\*  
   photodiode, 1664\*  
   phototransistor, 1673\*  
   solar cell, 2038\*  
 Photoelectric effect, 217-218  
 Photoelectricity, 1673-1674  
 Photoelectrochemical cells, 775  
 Photoemission, 1664-1665\*  
   electron tube, 784  
   surface physics, 2170  
   work function (electronics), 2397-2398\*  
 Photofluorescence imaging, 1665\*  
 Photogrammetry, 32, 1665\*, 2249  
 Photographic materials, 1665\*, 1667-1668  
   cinematography, 458  
 Photography, 1665-1667\*  
   aerial photograph, 32  
   astronomical, 179, 193-194\*  
   autoradiography, 231\*  
   camera, 360\*  
   cinematography, 457-458\*  
   color, 504, 504\*  
   digital, 1667  
   exposure meter, 862\*  
   high-speed, 1666  
   infrared, 1666  
   latent image, 1232\*  
   microradiography, 1390-1391\*  
   photographic photometry, 1665\*  
   radiography, 1860\*  
   remote sensing, 1666-1667, 1893-1894  
   schlieren, 1958-1959\*  
   Schmidt camera, 1959\*  
   spectrography, 2074-2075\*  
   stroboscopic, 2129\*  
   ultraviolet, 1666  
   underwater, 2299\*  
   xenon, 2407  
 Photoionization, 1667\*  
 Photoluminescence, 769, 1278-1279  
 Photolysis, 1667-1668\*  
 Photometer, 1668\*  
 Photometric brightness see Luminance  
 Photometry, 1668\*  
   exposure meter, 862\*  
   light-scattering, 1252\*  
   luminous efficiency, 1279\*  
   luminous energy, 1279\*  
   luminous flux, 1279\*  
   luminous intensity, 1279\*  
   photomultiplier, 1669\*  
   phototube, 1673\*  
   units of measurement, 2304

- Photomorphogenesis, 1668-1669\*, 1683
- Photomultiplier, 1669\*
- Photon, 1669\*  
coherence, 494  
de Broglie wavelength, 622  
elementary particle, 802  
gamma rays, 859, 962  
polarization of waves, 1736  
quantum, 1823
- Photon correlation spectroscopy (PCS), 1835
- Photon detector:  
optical detectors, 1553  
radiometry, 1863
- Photonastic movement, 1709
- Photonic interconnects, 1553
- Photoperiodism, 1669-1670\*  
animal responses, 1670  
cold hardiness (plants), 496  
mechanisms, 1670  
seasonal responses, 1670
- Photophore gland, 1670\*
- Photophysics, 1662, 2293-2294
- Photopic vision, 2346, 2347
- Photorealism, 521-522
- Photoreception, 1670\*  
eye (invertebrate), 780-781, 864-865\*  
eye (vertebrate), 865-867\*
- Photoreceptor, 1985
- Photorefractive effect, 1497-1498
- Photorespiration, 1670-1671\*
- Photosphere, 1671\*
- Photosynthesis, 1671-1673\*  
C<sub>3</sub>, 1672  
C<sub>4</sub>, 1672  
CAM, 1672-1673  
chlorophyll, 444\*  
forest ecosystem, 917  
lichens, 1249  
marine ecology, 1319-1320  
photolysis, 1668  
photorespiration, 1670-1671\*  
phyco bilin, 1674  
plant pigment, 1712  
porphyrin, 1757  
radioisotope (biology), 1861  
sulfur, 2149  
tree physiology, 2268
- Phototaxis, 2194
- Phototransistor, 1673\*
- Phototropism, 1709
- Phototube, 1669, 1673\*
- Photovoltaic cell, 1673\*, 2039
- Photovoltaic effect, 776, 1673-1674\*
- Photovoltaic exposure meter, 777, 862
- Photovoltaic solar power system, 2038
- Phractolaemidae, 898
- Phragmobasidiomycetidae, 983-984
- Phreatoicidae, 1674
- Phreatoicoidea, 1674\*
- Phrynopuridae, 1549, 1674\*
- Phthalic anhydride, 12
- Phthirus pubis*, 126-127
- Phycobilin, 1674\*
- Phylactolaemata, 1674-1675\*, 2104
- Phyllite, 1675\*
- Phyllocarida, 1246, 1307, 1675\*
- Phyllococidae, 760
- Phylloglossum*, 1280
- Phyllostomatidae, 388
- Phylogenetic systematics, 1287
- Phylogeny, 1675-1676\*  
animal systematics, 123\*  
macroevolution, 1287
- Phylosomatoida, 1676\*
- Physeter catodon*, 94
- Physical adsorption, 862
- Physical anthropology, 1676-1677\*  
anthropometry, 135-136\*  
anthroposcopy, 136\*  
forensic anthropology, 914\*  
human variation, 1676-1677  
molecular, 1676  
paleoanthropology, 1676  
paleoprimatology, 1676  
primate behavior and ecology, 1676  
primate morphology, 1676
- Physical chemistry, 1677\*  
chemical dynamics, 420-421\*  
chemical kinetics, 425-426\*  
Dalton's law, 613-614\*  
equilibrium properties, 1677
- Physical chemistry—cont.  
physical and chemical change, 1677  
structure, 1677  
thermochemistry, 2224\*
- Physical geography, 1336, 1677-1678\*
- Physical geology, 880
- Physical law, 1678\*
- Physical measurement, 1678-1680\*  
International System of Units, 1678-1680  
metric system, 1678
- Physical metallurgy, 665, 1370
- Physical meteorology, 1379-1380
- Physical optics, 1680\*
- Physical organic chemistry, 1680-1681\*  
chemical kinetics, 1681  
chemical reaction mechanisms, 1680-1681  
isomers, 1681  
stereochemistry, 1681
- Physical science, 1681\*
- Physical theory, 1681\*
- Physics, 1681-1682\*  
atmospheric, 1379-1380  
cloud, 478-479\*  
conservation laws, 476  
duality, 705\*  
electrooptics, 793\*  
fiber bundle, 883\*  
geophysical fluid dynamics, 994\*  
geophysics, 994-995\*  
high-pressure, 954, 1078\*  
magneto-optics, 1303\*  
mathematical, 1336\*  
matter, 1340\*  
microwave, 1393  
molecular, 1424\*  
nonlinear, 1498\*  
nuclear, 1512\*  
planetary, 1700-1701\*  
plasma, 1717-1719\*  
quantum, 1823\*  
quantum anomalies, 1824  
statistical mechanics, 2101-2102\*  
surface, 2169-2170\*  
symmetry breaking, 2178-2179\*  
symmetry laws, 2179-2180\*  
theoretical, 2218-2219\*  
variational methods, 2326\*  
vector methods, 2327-2328\*  
wave, 2371\*  
work, 2397\*
- Physiological acoustics, 1682\*
- Physiological biophysics, 255
- Physiological ecology (animal), 1682\*
- Physiological ecology (plant), 1682-1683\*
- Physisorption see Physical adsorption
- Phytamastigophorea, 1683\*  
Chryomonadida, 455\*  
Cryptomonadida, 589\*  
Dinoflagellida, 674\*  
Ebrida, 725\*  
Euglenida, 852\*, 852-853\*  
Silicoflagellida, 2008\*  
Volvocida, 2357\*
- Phytelephas macrocarpa*, 2328
- Phytoalexin, 1683\*
- Phytochorology see Plant geography
- Phytochrome, 1686
- Phylogeography see Plant geography
- Phytohemagglutinin see Lectins
- Phytohormone see Plant hormones
- Phytolectin see Lectins
- Phytomastigophora, 455
- Phytoplankton, 1684\*  
deep-sea fauna, 629  
ecology, 735  
fresh-water ecosystem, 937
- Phytotronics, 1684\*
- Pi meson, 1823
- Pia mater (meninges), 1354, 1478
- Piaget, Jean, 650-651
- Piazza, G., 357
- Pica, 724
- Picea* species, 2090-2091
- Pichia pastoris*, 847
- Pichiego, 154
- Piciformes, 1684\*
- Pickering, Edward C., 2097
- Picornaviridae, 1684\*  
coxsackievirus, 574\*  
echovirus, 729\*  
enterovirus, 826\*  
rhinovirus, 1913\*
- Picrite, 1684\*
- Pictorial drawing, 1684-1685\*
- Picture tube, 1685\*, 2205
- Pie chart, 1017
- Piesmidae, 944
- Piezoelectric crystal, 879
- Piezoelectric earphone, 653, 716
- Piezoelectric effect, 776
- Piezoelectric microphone, 1388
- Piezoelectricity, 1685-1686\*  
applications, 1686  
molecular theory, 1685  
piezoelectric materials, 1686  
quartz clock, 1833\*  
surface acoustic-wave devices, 2167  
titanium, 2244
- Piezoresistive sensors, 2232
- Pig, 164, 178
- Pig iron, 2106
- Pigeon, 446, 447, 505
- Pigeonite, 197, 1686\*
- Pigment, 1686\*  
carotenoid, 374\*  
chlorophyll, 444\*  
chromatophore, 450\*  
dye, 708  
Maillard reaction, 1306  
photochrome, 1683\*  
phycobilin, 1674\*  
plant, 1712-1713\*  
respiratory pigments (invertebrate), 1906\*  
riboflavin, 1917\*  
surface coating, 2168
- Pigmentation, 1686\*
- Pigmented nevi, 260
- Pigmy chimpanzee, 387
- Pika, 1222
- Pike, 1686\*, 1941
- Pilargidae, 760
- Pile foundation, 1686-1687\*
- Pile hammer, 479
- Pileworm see Shipworm
- Pill bug, 1543
- Pilocene, 924
- Pilot production, 1687\*, 1795-1796
- Pilotage, 1687\*
- Piloting, 1687\*  
buoy, 343\*  
lighthouse, 1252\*
- Pittdown man, 1687-1688\*
- Pimento, 1626, 1688\*
- Pimento officinalis*, 87
- Pimpinella anisum*, 125
- Pin diode, 1396
- Piña, 1688\*
- Pinales, 1688\*  
arbovitae, 157\*  
cedar, 385\*  
cypress, 607\*  
fir, 889\*  
larch, 1228\*  
pine, 1689\*  
redwood, 1879\*  
spruce, 2090-2091\*  
tree, 2266
- Pinch effect, 1688-1689\*
- Pincushion distortion, 629
- Pine, 1689\*  
evergreen, 857  
Pinales, 1688  
plant, 1701  
redwood, 1879\*  
spruce, 2090-2091\*  
tree, 2266
- Pine marten, 1328
- Pine nut, 1689\*
- Pine oil, 847
- Pine terpene, 1689\*
- Pineal gland, 1689-1690\*
- Pineapple, 294, 1688, 1690\*
- Pinnacle reef, 249
- Pinnipeds, 1690-1691\*
- Pinnophyta, 1691\*
- Pinnopsida, 1691\*
- Pinocytosis see Endocytosis
- Pinon pine, 1689
- Pinophyta, 1805  
Cycadales, 603\*  
Ephedrales, 835\*  
Ginkgoales, 999\*  
Ginkgoopsida, 999\*  
Pinales, 1688\*  
Pinnopsida, 1691\*  
Welwitschiales, 2384\*
- Pinus* species, 1689
- Pion, 1123, 1832
- Pionium, 1691\*
- Pipe flow, 1102, 1691\*
- Pipefish, 970
- Pipeline, 1691\*, 2256
- Pipelining:  
digital computer, 670  
supercomputer, 2153
- Piper* species, 241, 264, 531
- Piperaceae, 264, 531
- Piperales, 1691-1692\*  
cubeb, 597\*  
Eumagnoliids, 854  
Laurales, 1233
- Piping systems:  
valve, 2320-2321\*  
water supply engineering, 2367
- Pirani gage, 1692\*
- Pisanosaurus*, 675
- Pisces (constellation), 1692\*
- Pisces (zoology), 1692\*
- Pisionidae, 760
- Pistachio, 1692\*
- Pistia*, 139
- Piston attenuator, 195
- Piston engine, 60
- Pisum arvense*, 1621
- Pisum sativum*, 1578, 1621
- Pitch, 1692\*  
musical acoustics, 1454  
scale, 1952  
scale (music), 1952\*  
tone, 2247\*  
tuning fork, 2282-2283\*
- Pitcher plant, 1692\*
- Pitchstone, 1692\*
- Pith, 1692-1693\*, 2393
- Pithecanthropus*, 831, 926
- Pitheciines, 1771
- Pitot tube, 1693\*
- Pituitary gland, 1693-1694\*  
endocrine system (vertebrate), 816  
hormone, 26-27  
neurohypophysis hormone, 1480\*
- Pituitary gland disorders, 591, 653, 1694\*
- PIXE see Proton-induced x-ray emission
- Pixel (electronic display), 709, 1694
- PKU see Phenylketonuria
- Placenta:  
estrogen, 848\*  
progesterone, 1781\*
- Placentals:  
animal evolution, 120  
Mammalia, 1309  
Proboscidea, 1777\*
- Placentation, 1694-1695\*
- Placer mining, 1695\*
- Placodermi, 120, 1695\*
- Placodontia, 748, 1695\*
- Plagioclase, 788, 875, 1125, 1234
- Plague, 1695-1696\*
- Plaice, 805
- Plains, 1696\*
- Planaria, 2270
- Planck, Max, 936, 1696, 1828  
photon, 1669  
quantum acoustics, 1823
- Planck's constant, 1696\*  
gauge theory, 973  
quantum mechanics, 1828
- Planck's law, 1150
- Planck's radiation law, 936, 1696\*
- Plane angle units, 2302
- Plane curve, 1696-1697\*
- Plane four-bar linkage, 832
- Plane geometry, 1744
- Plane polygon, 1744
- Plane tree, 1044
- Plane waves, 2051
- Planer, 1697\*
- Planet, 1697-1699\*  
asteroid, 186\*  
Earth, 716-718\*  
extrasolar, 1698-1699, 2306  
interplanetary matter, 1177\*  
Jupiter, 1206-1207\*  
magnitude, 1304\*  
Mars, 1326-1328\*  
Mercury, 1356-1357\*  
Neptune, 1475-1476\*  
orbital motion, 1565-1566\*  
physics see Planetary physics  
Pluto, 1729\*  
Saturn, 1950-1951\*  
of solar system, 1697-1698

Planet—*cont.*

Uranus, 2309\*  
 Venus, 2330\*  
 Planetarium, 1699\*  
 Planetary gear train, 1699-1700\*  
 Planetary nebula, 1470, 1700\*  
 Planetary physics, 1700-1701\*  
 atmospheres, 1701  
 chemical composition, 1700  
 giant planets, 1700  
 Kepler's laws, 1211-1212\*  
 magnetospheres, 1303\*,  
 1701  
 satellites, 1701  
 terrestrial planets, 1700-1701  
 Planetary precession, 1766  
 Planetary scale (weather), 2378  
 Plankton, 937  
 Planographic printing, 1773  
 Plant, 1701\*  
 cell (biology), 389  
 deciduous plants, 625\*  
 dicotyledons, 657\*  
 dispersion, population, 1754-1755\*  
 dormancy, 698\*  
 ecotone, 736\*  
 embryology, 810-811  
 evergreen, 857\*  
 herbarium, 1067-1068\*  
 Neolithic, 1474  
 photosynthesis, 1671-1673\*  
 plant-animal interactions, 1701-  
 1702\*  
 poisonous, 1733-1734\*  
 polyploidy, 1750  
 population dispersal, 1754  
 reproduction, 1896\*  
 vacuole, 2318  
 Plant anatomy, 1701\*  
 Plant-animal interactions, 1701-1702\*  
 Plant cell, 1702\*  
 cell plastids, 347\*  
 chloroplasts, 346  
 walls, 349  
 Plant communication, 1702\*  
 Plant community:  
 chapparal, 414\*  
 paramo, 1609\*  
 puma, 1811\*  
 rainforest, 1866-1867\*  
 Plant ecology, 735  
 Plant evolution, 1702-1703\*  
 angiosperms, 1703  
 Devonian, 652  
 land plants, 1702-1703  
 plant taxonomy, 1713-1714\*  
 seed plants, 1703  
 Plant geography, 89, 249, 1703-  
 1704\*  
 Plant growth, 1704-1705\*  
 abscisic acid, 3-4\*  
 apical dominance, 150\*  
 auxin, 231\*  
 controls, 1705  
 cytokinins, 610-611\*  
 dormancy, 1705\*  
 fate maps, 873  
 flowering, 1705\*  
 fruits and seeds, 1705\*  
 leaf abscission, 1705\*  
 photorespiration, 1671  
 plant morphogenesis, 1708  
 sites of cell division, 1704-1705  
 Plant hazards, 1140  
 Plant hormones, 1705-1706\*  
 abscisic acid, 3-4\*  
 auxin, 231\*  
 cytokinins, 610-611\*  
 dormancy, 698  
 gibberellin, 999\*  
 Plant keys, 1706\*  
 Plant kingdom, 1706-1707\*  
 Plant metabolism, 1707\*  
 Plant mineral nutrition, 1707-1708\*  
 plant morphogenesis, 1708\*  
 soil fertility, 2036\*  
 tree physiology, 2268  
 Plant morphogenesis, 1708\*  
 development, 586  
 photomorphogenesis, 1668-1669\*  
 Plant movements, 1708-1709\*  
 abiogenic, 1709  
 biogenic, 1709  
 Plant organs, 1709\*  
 Plant pathology, 1709-1711\*  
 bacteria, 1710  
 crown gall, 583\*

Plant pathology—*cont.*

disease ecology, 687  
 epidemiology, 1711  
 forest pest control, 920-921\*  
 fungi, 1710  
 fungistat and fungicide, 950  
 kinds of diseases, 1709-1710  
 nematodes, 1711  
 noninfectious agents, 1711  
 pathotoxin, 1620\*  
 phytoalexin, 1683\*  
 rust (microbiology), 1935-1936\*  
 symptoms of diseases, 1710  
 tree diseases, 2266-2267\*  
 viruses and viroids, 1710-1711  
 Plant phylogeny, 1712\*, 1713-1714  
 Plant physiology, 1712\*  
 cold hardiness (plants), 496-497\*  
 tree, 2266  
 Plant pigment, 1712-1713\*  
 Plant propagation, 1713\*  
 Plant respiration, 1670-1671, 1713\*  
 Plant science, 1682-1683  
 Plant taxonomy, 1713-1714\*  
 Plant tissue systems, 1714\*  
 endodermis, 818\*  
 epidermis, 837-838\*  
 parenchyma, 1612\*  
 periderm, 1630-1631\*  
 phloem, 1655\*  
 pith, 1692-1693\*  
 primary vascular system, 1770\*  
 xylem, 2408\*  
 Plant transport of solutes, 1714-1715\*,  
 2268  
 Plant viruses and viroids, 1715-1716\*,  
 2345  
 Plant-water relations, 1716-1717\*,  
 2268  
 Plantae, 468  
 Plantaginaceae, 1223, 1716  
 Plantaginales, 173, 1716\*  
*Plantago major*, 1716  
 Plantain, 217, 1716  
 Plants, life forms of, 1717\*  
 Plasma, 268  
 fibrinogen, 884\*  
 quark-gluon plasma, 1831\*  
 Plasma (physics), 1471\*, 1717-1719\*  
 Plasma diagnostics, 1719-1720\*  
 Plasma membrane, 347-348, 388  
 Plasma propulsion, 1720\*  
 Plasma torch, 158  
 Plasmal, 1720\*  
 Plasmalemma, 347  
 Plasmid, 576, 1720\*  
 Plasmin, 1720-1721\*  
 Plasminogen, 1721  
*Plasmodium*, 768  
 Eucoccidia, 852  
 malaria, 1307, 1307\*  
 Plasmon, 1721\*  
 Plaster, 1721\*  
 Plaster of paris, 1721-1722\*  
 Plastic:  
 crystal, 590  
 optical materials, 1353  
 Plastic deformation of metal, 1722\*  
 Plasticity, 1722\*, 2162  
 Plastics processing, 1722-1723\*  
 blow molding, 1723  
 calendaring, 1723  
 casting and encapsulation, 1723  
 compression and transfer molding,  
 1723  
 extrusion, 1723  
 foam processes, 1723  
 injection molding, 1722-1723  
 reinforced plastics/composites, 1723  
 rotational molding, 1723  
 thermoforming, 1723  
 Platanaceae, 924  
*Platanus*, 924, 1044  
 Plataspidae, 944  
 Plate boundary earthquake, 655, 723  
 Plate girder, 1723-1724\*  
 Plate tectonics, 1724\*  
 asthenosphere, 187-188\*  
 Carboniferous, 370  
 coastal landforms, 484  
 continent formation, 482  
 depositional systems and environments,  
 641  
 Devonian, 651  
 Earth, 718  
 earthquake, 722-723\*  
 East Indies, 723-724

Plate tectonics—*cont.*

heat flow in Earth, 719  
 Miocene, 1406-1407  
 orogeny, 1580\*  
 Pacific islands, 1593  
 paleomagnetism, 1601\*395\*  
 sedimentology, 1972  
 Silurian, 2009-2010  
 subduction zones, 2137-2138\*  
 Plateau, 1724\*  
 Plateau basalts, 2352  
 Platelet, 269  
 Plating see Electroless plating; Electroplating  
 of metals  
 Platinum, 1724-1735\*  
 Platysterida, 173, 1725\*  
 Platycoepoda, 1725\*  
 Platycytenida, 1725\*  
 Platylfish, 183  
 Platyhelminthes, 1725-1726\*  
 Acoela, 14  
 Cestoidea, 409\*  
 Digenea, 665-666\*  
 Trematoda, 2268-2269\*  
 Turbellaria, 2284\*  
*Platyodon*, 281  
 Platypus, 1435, 1726\*  
 Platyrhines, 1771  
 Platysoidei, 1596  
 Playa, 1726\*  
 Plecoptera, 1726\*  
 Plectoidea, 138  
 Plectomycetes, 1727\*  
 Pleiades, 1727\*, 2194  
 Pleidae, 943  
 Pleistocene, 887, 1727\*  
 paleoindian, 1600  
 varve, 2327  
 Pleochroic halos, 1728\*  
 Pleochroism, 1728\*  
 Pleoidea, 943  
 Plesiadapiformes, 927  
 Plesiosauria, 1728\*  
 Nothosauria, 1504\*  
 Sauropterygia, 1951  
 Plethora, 408  
 Pleuritis see Pleurisy  
 Pleuronectiformes, 1728\*  
 Pleurostigmophora, 385  
*Pleurotus*, 984, 1112  
 Plinian eruptions (volcanoes),  
 2353  
 Pliocene, 220, 924, 926, 1728-1729\*  
 Ploima, 1433, 1434  
 Plokiophilidae, 944  
 Plosives, 2078  
 Plotters, 1018  
 Plover, 364  
 Plum, 1729\*  
 Plumaginales, 336, 1729\*  
 Plumes, 546  
 Plums, 1932  
 Pluripotent stem cells, 2112  
 Pluto, 1729\*  
 Kuiper Belt, 1219  
 planet, 1698  
 Pluton, 1729\*  
 aureoles, 480  
 gabbro, 955  
 Plutonic rock, 1125, 1126, 1400  
 Plutonium, 1729-1730\*  
 nuclear fuels, 1508-1509\*  
 transuranium elements, 2264  
 Plywood, 1730\*, 2135  
 PM see Phase modulation  
 pn junction, 1981  
 Pneumatic atomizer, 194  
 Pneumatic caisson, 310  
 Pneumatic comparator, 453  
 Pneumatic conveyor, 303  
 Pneumatic weight measurement systems,  
 2381  
 Pneumatolysis, 1730\*  
*Pneumatophorus diego*, 1286  
*Pneumococcus*, 1730\*  
*Pneumocystis*, 1348  
 Pneumonia, 1730-1731\*  
 Legionnaire's disease, 1089\*  
 parainfluenza virus, 1607  
 pneumococcus, 1730\*  
 respiratory system disorders,  
 1907  
*Poa compressa*, 271  
*Poa pratensis*, 271  
 Poales, 1731\*  
 Pockels effect, 715, 793, 1212  
 Podargidae, 326

Podaxales, 864  
 Podicipediformes, 1731\*  
*Podocarpus*, 1688  
 Podocopa, 1731\*  
 Podocopida, 1731\*  
 Podolsky, B., 1076  
 Podostemaceae, 1731  
 Podostemales, 1731\*  
 Poeciiliidae, 183  
 Poeciosclerida, 1732\*  
 Poecilostomatoida, 1732\*  
*Poepagus grunniens*, 2409  
 Pogonophora, 1732\*  
 Athecanephria, 199\*  
 Thecanephria, 2218\*  
 Poikilotherm, 1074  
 Poinsettia, 770  
 Point-to-point dimensioning, 613  
 Poison, 1732\*  
 botulism, 322\*  
 food, 820  
 poison ivy, 1733\*  
 poison sumac, 1733\*  
 poisonous plants, 1733-1734\*  
 toxin, 2253-2254\*  
 see also Toxicology  
 Poison gland, 1733\*  
 Poison ivy, 1733\*  
 L-rhamnose, 1911\*  
 Sapindales, 1944  
 Poison sumac, 1733\*  
 Poisonous plants, 1733-1734\*  
 Poisson bracket, 1824  
 Poisson distribution, 631  
 Poisson's ratio, 741  
 Pokeweed, 1733  
 Polar bear, 230  
 Polar coordinate system, 489  
 Polar jet, 1203  
 Polar meteorology, 1734\*  
 Polar molecule, 619, 1734\*  
 Polar motion, 722  
 Polar navigation, 1734-1735\*  
 Polarimetric analysis, 1735\*  
 Polarimetry, 1735\*  
 Polaris, 717, 1735\*  
 Polarity (cell), 349  
 Polarization:  
 magnetic, 1299-1300  
 nonlinear optics, 1497  
 polarimetry, 1735\*  
 pyroelectricity, 1814  
 x-rays, 2406  
 Polarization-division multiplexing,  
 1447  
 Polarization of dielectrics, 1736\*  
 electric susceptibility, 752\*  
 piezoelectricity, 1685-1686\*  
 Polarization of waves, 1736\*  
 Polarized light, 1736-1737\*  
 analyzing devices, 1737  
 circular and elliptical polarizing devices,  
 1737  
 dichroism, 656\*  
 Faraday effect, 871\*  
 linear polarizing devices, 1736-  
 1737  
 optical activity, 1550-1551\*  
 optical fibers, 1554  
 polarization by scattering, 1737  
 polarization of waves, 1736\*  
 types, 1737  
 Polarized light microscope, 1737-  
 1738\*  
 Polarographic analysis, 690, 1738\*  
 Polarography, 765, 776  
 Polaroid-Land camera, 321  
 Polaroid sheet polarizer, 1737  
 Polaron, 1738\*  
 Polemoniales, 739  
 Polestar see Polaris  
 Poliomyelitis, 1452, 1738\*, 2085  
 Polishing, 796  
 Politzer, H. D., 973  
 Poljes, 1210  
 Pollen, 1738-1739\*  
 index fossil, 1136  
 palynology, 1604, 1604\*  
 pollination, 1739-1740\*  
 reproduction, 1896  
 Pollination, 1739-1740\*  
 bee, 261-262\*  
 flower attractants, 1739-1740  
 plant-animal interactions, 1702  
 reproduction, 1896  
 self- and cross-pollination,  
 1739

- Pollution:  
acoustic noise, 16-17  
endangered species, 814-815  
petroleum microbiology, 1642-1643  
plant pathology, 1711  
stream pollution, 2125\*  
water conservation, 2364-2365  
see also Air pollution; Water pollution
- Pollux, 871
- Polonium, 1740\*
- Polyacetate, 1740\*
- Polycarbonate resins, 1740-1741\*
- Polyakov, A. M., 1293
- Poly( $\alpha$ -olefins), 1749-1750
- Polyamide resins, 1742\*
- Polychaeta, 125, 1741-1742\*  
Errantia, 844-845\*  
Myzostomaria, 1462\*  
Sedentaria, 1971\*  
tubeworms, 2279\*
- Polychlorinated biphenyls, 259, 1742\*
- Poly(chlorotrifluoroethylene), 1743
- Polycladida, 1742\*, 2284
- Polyctenidae, 944
- Polycystic ovarian syndrome (PCOS), 1588
- Polycystineae, 1862
- Polycythemia, 408
- Polydiallyl esters, 1743
- Polyembryony, 1895
- Polyester resins, 1742-1743\*
- Polyether:  
classes of, 1286  
macrocyclic compound, 1286
- Polyether resins, 1740, 1743\*
- Polyethylene, 766, 1749
- Poly(ethylene glycol), 1740\*
- Polyfluoroolefin resins, 1743-1744\*
- Poly(4-methyl-1-pentene), 1749
- Polygalales, 1744\*
- Polygon, 1744\*
- Polygonaceae, 299, 1744
- Polygonales, 336, 1744\*  
buckwheat, 339\*  
rhubarb, 1916\*
- Polygordius, 148
- Polyhalides, 1173
- Polyhedral chemical structure, 375-376
- Polyhedron, 1744\*  
geodesic dome, 878  
prism, 1775\*  
regular polytopes, 1885\*
- Polyhydric alcohol, 1007  
see also Polyol
- Polyisobutylenes, 1749-1750
- Polyisocyanate see Polyurethane resins
- Polymer, 1744-1746\*  
additives, 1746  
biological, 255  
boron, 283  
branched, 287  
composition, 1745  
conducting, 468-469, 1569-1570  
gel permeation chromatography, 975  
heterocyclic, 949  
inorganic, 1155\*  
manufactured fiber, 1313-1314\*  
materials, 1746  
molecular properties, 1745-1746  
nomenclature, 1744-1745  
phenolic resin, 1654\*  
polyacetal, 1740\*  
polyamide resins, 1742\*  
polyether resins, 1743\*  
poly(ethylene glycol), 1740\*  
polymeric composite, 1746-1747\*  
polymerization, 1747-1748\*  
polyolefin resins, 1749-1750\*  
polysaccharide, 1752\*  
polystyrene resin, 1752\*  
polysulfide resins, 1752\*  
polysulfone resins, 1752\*  
polyurethane resins, 1752-1753\*  
polyvinyl resins, 1753\*  
primary structure, 1745  
quaternary structure, 1745  
resin, 1901\*  
rheology, 1912-1913\*  
secondary structure, 1745  
silicone resins, 2009\*  
surfactant, 2172  
synthesis, 1745  
tertiary structure, 1745  
ultracentrifuge, 2293\*  
urea-formaldehyde-type resins, 2310\*  
wood chemicals, 2394
- Polymer products (petrochemical), 1640
- Polymer-supported reaction, 1746\*
- Polymeric composite, 1746-1747\*  
advanced composites, 455-456  
structural materials, 2135
- Polymeric materials, 1334
- Polymerization, 1747-1748\*  
chain reactions, 361  
stereospecific catalyst, 2115\*
- Polymerurus, 360
- Poly(methyl methacrylate), 1741
- Polymorphism (crystallography), 1748\*, 1804
- Polymorphism (genetics), 1748\*  
blood groups, 304-305\*, 305-307\*  
genetic homeostasis, 984\*
- Polymorphism (object-oriented programming), 1528
- Polyomyositis, 475
- Polyonidae, 760
- Polynomial systems of equations, 1748-1749\*  
algebraic geometry, 75-76\*  
discriminant, 685\*  
equations, theory of, 841\*  
linear systems of equations, 1258\*  
orthogonal polynomials, 1580-1581\*
- Polynuclear hydrocarbon, 1749\*
- Polyodon *spathula*, 14
- Polyodontidae, 14, 760
- Polyol, 1748\*
- Polyolefin resins, 1749-1750\*
- Polyoma virus, 1750\*
- Poly(1-butene), 1749
- Polyopisthocotylea, 1433
- Polyoxymethylene resin, 1743
- Polyphase induction motor, 1138
- Polypheylene oxide, 1743
- Polyplocophora, 441-442, 1750\*
- Polyploidy, 400-401, 1750\*
- Polypodiales, 1750-1751\*  
Polypodiophyta, 1751\*, 1805  
Marsileales, 1328\*  
Polypodiales, 1750-1751\*  
Polypodiopsida, 1751\*  
Salviniales, 1943\*
- Polypodiopsida, 1548, 1751\*  
*Polyporus*, 984
- Polypropylene, 1743, 1749
- Polypteridae, 1751
- Polypteriformes, 1751\*
- Polypterus*, 1751
- Poly(*p*-xylylene) resins, 1752\*
- Polysaccharide, 327-328  
biopolymer, 293\*  
carbohydrate metabolism, 366-367\*  
cellulose, 399-400\*  
chitin, 441\*  
glycogen, 1007\*  
hemicellulose, 1062\*  
hyaluronic acid, 1099\*  
pectin, 1622\*  
xylose, 2408\*
- Polystylifera, 964
- Polystyrene resin, 1752\*, 2137
- Polysulfide resins, 1752\*
- Polysulfone resins, 1752\*
- Polyterpene, 974
- Poly(tetrafluoroethylene), 1743
- Polytrichidae, 1752\*
- Polytropic process, 1752\*
- Polyurethane resins, 1752-1753\*  
Poly(vinyl acetals), 1753  
Poly(vinyl acetate), 1753  
Poly(vinyl alcohol), 1753  
Poly(vinyl butyral), 1753  
Poly(vinyl carbazole), 1753  
Poly(vinyl chloride), 995, 1753  
Poly(vinyl ethers), 1753  
Poly(vinyl fluoride), 1753  
Poly(vinyl formal), 1753  
Poly(vinyl pyrrolidone), 1753  
Polyvinyl resins, 1753\*  
Poly(vinylidene chloride), 1753  
Poly(vinylidene fluoride), 1743
- Polyzoa see Bryozoa
- Pomatomidae, 271
- Pomatomus saltatrix*, 271
- Pomegranate, 1753\*
- Pompe's disease, 1362
- Pond:  
limnology, 1256\*  
reservoir, 1901\*  
Ponerinae, 129
- Pongidae, 1772
- Ponginae, 928
- Pontodoridae, 760
- Pontomyxa*, 182
- Poplar, 1754\*, 2266
- Popper, D. M., 1024
- Poppet valves, 2321
- Poppy, 1549, 1754\*
- Population dispersal, 1754\*
- Population dispersion, 1754-1755\*
- Population dynamics, 1767
- Population ecology, 735, 1755\*  
ecological modeling, 733-734\*  
ecological succession, 734-735\*  
theoretical ecology, 2218
- Population genetics, 1755\*  
genetic homeostasis, 984\*  
Hardy-Weinberg formula, 1046\*  
human population analysis, 969
- Population (statistics), 2103
- Population viability, 1755\*
- Populus* species, 1754, 1940
- Porcelain, 1220, 1755-1756\*
- Porcellanasteridae, 1621
- Porcupine, 1756\*
- Porifera, 1756\*  
Archaeocyatha, 160\*  
Calcarea, 350-351\*  
Choristida, 448\*  
Clathrinida, 468\*  
Clavaxinellida, 468\*  
Demospongiae, 634\*  
Dendroceratida, 635\*  
Hadromerida, 1037\*  
Halichondrida, 1039-1040\*  
Haplosclerida, 1045\*  
Hemidiscosa, 1063\*  
Hexactinellida, 1073\*  
Hexactinosa, 1073\*  
Hexasterophora, 1073\*  
Homosclerophorida, 1088\*  
Leucetida, 1246  
Leucosoleniida, 1246\*  
Lychniscosa, 1280\*  
Lysacinosa, 1284\*  
Phaetronida, 1648\*  
Poecilosclerida, 1732\*  
Reticulosa, 1909\*  
Sclerospongiae, 1962\*  
Sphaeractinoidea, 2082\*  
Spirophorida, 2086\*  
Sycetida, 2177\*
- Porocephalida, 1421, 1756\*
- Porocephalidae, 1756
- Porocephaloidea, 1756
- Porus printing see Screen printing
- Porphyrin, 1756-1757\*
- Porphyroblast, 1757\*
- Porphyry, 1757\*
- Porpoise, 634  
Cetacea, 409-410\*  
echolocation, 729
- Port Orford cedar, 344, 543
- Port wine stain (birthmark), 261
- Portland cement, 1438
- Ports, 1046\*
- Portuguese man-of-war, 1111
- Portulaca grandiflora*, 336
- Portulacaceae, 336
- Poruloida, 1757\*
- Positional isomer, 1420
- Positive clutch, 422
- Positive-negative theory of acids and bases, 12
- Positron, 1757\*  
electron-positron pair production, 782-783\*  
elementary particle, 802  
positronium, 1757-1758\*  
quantum, 1823  
supercritical fields, 2157, 2158
- Positron emission tomography (PET), 1347
- Positronium, 804, 1757-1758\*
- Post, E. L., 1270
- Post dates pregnancy, 1768
- Postglacial see Holocene
- Posttraumatic stress disorder (PTSD), 147, 1758\*
- Postulate, 1758\*
- Postural equilibrium, 1758-1759\*
- Postviral fatigue see Chronic fatigue immune dysfunction syndrome
- Potash feldspar, 1125
- Potash mica see Muscovite
- Potassium, 1759\*  
alkali emissions, 77  
heat flow in Earth, 719
- Potassium chlorate, 390
- Potassium chloride (KCl):  
halide, 1040  
potassium, 1759
- Potato:  
farm crops, 871  
Solanales, 2038
- Potato, Irish, 1759-1760\*
- Potato, sweet, 1760\*
- Potential energy diagrams, 1572-1573
- Potential flow, 1760\*
- Potentials, 1760\*
- Potentiometer, 691, 1760-1761\*
- Potentiometric titration, 2245
- Poteriodendron petiolum*, 242
- Potocytosis, 818
- Potoo, 326
- Pottery, 355-356, 1761\*
- Pottiales, 1761\*
- Poultry:  
avian leukosis, 234-235\*  
egg, 738-739\*
- Poultry production, 1761-1762\*
- Pourtalesia*, 658
- Powder coating, 1366
- Powder metallurgy, 1762\*, 2013
- Powder method (x-ray diffraction), 2402
- Powdery mildew, 761
- Power, 1762\*  
decibel, 625  
dynamometer, 711-712\*  
efficiency, 738\*  
electric power measurement, 746-747\*  
nuclear, 1512\*  
units of measurement, 2304
- Power amplifier, 1762\*, 1811-1812
- Power brake, automotive, 202
- Power factor, 1762-1763\*
- Power-factor meter, 1763\*
- Power grids, 748
- Power-integrated circuits, 1763\*
- Power plant, 1763-1764\*  
chemical fuel, 425\*  
electric power generation, 745-746\*  
nuclear reactor, 1514-1516\*  
prime mover, 1772\*  
ship nuclear propulsion, 1998\*
- Power series, 1988
- Power shovel, 773, 1764\*
- Power steering, 199
- Power system:  
uninterruptible, 2301  
voltage regulator, 2356  
wind, 2389\*
- Power transformer, 2258-2259
- Power transmission lines, 2262
- Poynting's vector, 1764\*
- PPLO see Pleuropneumonia-like organism
- PPM see Pulse-position modulation
- Prader-Willi syndrome, 650
- Prairie dog, 1764\*
- Prairie pocket gopher, 898
- Praseodymium, 1764\*
- Prasinophyceae, 1764\*
- Pratincole, 364
- Prausnitz-Kiistner reaction, 194
- Prawn, 560, 1182
- Praying mantid, 1581
- Preamplifier, 1764\*
- Prebiotic organic synthesis, 1764\*
- Precambrian, 1764-1765\*  
dolomite rock, 694  
paleogeography, 1599  
Proterozoic, 1792-1793\*
- Precast concrete, 1765\*
- Precision, 1765\*  
Precision, larmor, 1228\*  
Precision of equinoxes, 722, 1765-1766\*  
Precious-metal alloy, 84  
Precious stones, 1766\*  
Precipitation (chemistry), 1518, 1766\*  
Precipitation (meteorology), 1766\*  
acid rain, 13-14\*  
cloud physics, 478-479\*  
drought, 701-702\*  
hail, 1038-1039\*  
meteorological instrumentation, 1376  
snow, 2025\*  
snow gauge, 2025\*  
thunderstorm, 2236\*
- Precipitation measurement, 1766\*
- Precipitin, 1766\*
- Precision agriculture, 1766-1767\*
- Precision approach radar (PAR), 1767\*
- Precision declinometer, 566

- Precognition, 779  
Predation, 662  
Predator, 2276  
Predator-prey interactions, 1767\*  
Preen gland see Uropygial gland  
Pregnancy, 1767-1768\*  
  alpha fetoprotein, 87-88\*  
  congenital anomalies, 536\*  
  fetal alcohol syndrome, 881\*  
  prenatal diagnosis, 1769\*  
  uterus, 2315\*  
Pregnancy disorders, 1768\*  
Prehistoric culture:  
  Neolithic, 1474\*  
Prehistoric technology, 1768\*  
  paleoindian, 1600  
  Paleolithic, 1660-1661  
Prehnite, 1768\*  
Preliminary Reference Earth Model (PREM), 720, 721  
Premixed flames, 892  
Prenatal diagnosis, 1769\*  
Preprogrammed drone (aircraft), 639, 701  
Preputial gland, 1956  
Presbyornithidae, 364  
Press fit, 1769\*  
Pressing (powder metallurgy), 1762  
Pressure, 1769\*  
  center of, 351  
  mean effective pressure, 1341\*  
  units of measurement, 2303  
  vapor pressure, 2324\*  
  weather observations, 2380  
  wind, 2389  
Pressure altimeter, 91  
Pressure measurement, 1769\*  
  barometer, 252\*  
  manometer, 1313\*  
  pressure transducer, 1769-1770\*  
  vacuum measurement, 2318\*  
Pressure seal, 1769\*  
  gasket, 864  
  packing, 1594\*  
Pressure-sensitive adhesive, 28, 29  
Pressure transducer, 1769-1770\*  
Pressure vessel, 1770\*  
Pressure waves, 2299-2300  
Pressurized blast furnace, 1770\*  
Prestressed concrete, 530, 1770\*  
Priapulida, 1272-1273, 1770\*  
Priapulid, 1770  
Priestley, J. B., 761  
Prigent, J., 383  
Prilling, 1770\*  
Primary battery, 228, 258, 259  
Primary dunes, 706  
Primary gneiss, 894  
Primary root, 1931  
Primary vascular system (plant), 1770\*  
Primate behavior and ecology, 1676, 2028  
Primates, 1770-1772\*  
  animal evolution, 120  
  apes, 148-149\*  
  aye-aye, 236\*  
  fossil apes, 923-924  
  fossil human, 924-925\*  
  fossil primates, 926-928\*  
  molecular anthropology, 1417-1418\*  
  monkey, 1431-1432\*  
  physical anthropology, 1676  
Prime mover, 1772\*  
  governor, 1013-1014\*  
  internal combustion engine, 1174-1175\*  
  reaction turbine, 1872\*  
Primer (surface coating), 1772\*  
Primitive data structures, 618  
Primitive gut, 1772\*  
Primordial Earth, 1764  
Primulales, 1772\*  
Principle of equivalence (relativity), 1889-1890  
Printed circuit, 711, 1773\*  
  electronic, 790  
  electronic packaging, 790  
Printed wiring, 1773  
Printer, 554  
Printing, 1773-1774\*  
  color, 504  
  ink, 1154  
  textile, 2217\*  
  type, 2290-2291\*  
*Priondotes giganteus*, 154  
Prion disease, 1774-1775\*  
  disorders, 1775  
  human-to-human transmission, 1775  
Prism, 1775\*  
Prism (optics) see Optical prism  
Prism binoculars, 244, 275  
Prismane, 309  
Prismatic astrolabe, 1775\*  
Prismatic sulfur see Monoclinic sulfur  
Private branch exchange, 1775-1776\*, 2176  
Probability, 1776-1777\*  
  bayesian statistics, 259\*  
  conditional probability-independence, 1776  
  distribution, 631  
  estimation theory, 848\*  
  events, 1776  
  expectations, 1777  
  finite spaces, 1776  
  independent trials, 1776  
  information theory, 1149-1150\*  
  laws of large numbers, 1777  
  Markov chains, 1777  
  Monte Carlo method, 1436\*  
  quantum (mechanics), 1829  
  random variables and their distributions, 1777  
  reliability, availability, and maintainability, 1892  
  sample space, 1776  
  statistics, 2102-2104\*  
  stochastic process, 2117-2118\*  
Proboscidea, 805, 1777\*  
Procampodeidae, 618  
*Procavia*, 1122  
Procellariidae, 1777-1778  
Procellariiformes, 1777-1778\*  
Process control, 1778\*  
  adaptive control, 24\*  
  quality control, 1820-1821  
Process engineering, 1778\*  
Process metallurgy, 1370  
Process planning (manufacturing engineering), 1314  
Process reengineering, 1879  
Prochirality, 1778\*  
Prochlorophyceae, 1778\*  
*Proconsul*, 829, 928  
Proconsulidae, 925  
Proconsulids, 923  
Proctotrupoidea, 984  
*Procyon*, 1070, 1778-1779\*  
Procyonidae, 323, 427, 1605  
Product design, 1779\*  
  manufacturing engineering, 1314  
  prototype, 1795-1796\*  
  wood, 2395\*  
Product of inertia, 1779\*  
Product quality, 1779\*  
Product reengineering, 1879  
Product usability, 1779-1780\*  
Production ecology see Ecological energetics  
Production engineering, 1780\*  
  maintenance, industrial and production, 1306\*  
  manufacturing engineering, 1314-1315\*  
  pilot production, 1687\*  
Production methods, 1780\*  
  machining, 1285-1286\*  
  manufactured fiber, 1313  
Production planning, 1780-1781\*  
Productivity, 1781\*  
  biological, 285\*  
  methods engineering, 1381\*  
Productivity ratio, 1781  
Profilers (radar), 1378  
Progenesis, 948  
Progesterone, 1781\*, 1898  
Programmable calculator, 313  
Programmable controllers, 1781\*  
Programmable read-only memory, 1982-1983  
Programming, 523-524\*  
  abstract data types, 6-7\*  
  analog computer, 108-109  
  computer security, 524-525  
  nonlinear, 1498\*  
  operating system, 1546\*  
  optimization, 1564-1565  
  software, 2030-2031\*  
  software engineering, 2031\*  
  stored program digital computer, 608-609  
  symbolic computing, 2178  
  visual debugging, 2348\*  
  see also Software engineering  
Programming languages, 1781-1783\*  
  assembly language, 1782  
  concurrent programs, 467  
  current models, 1783  
  database management systems, 619  
  high-level, 1782  
Programming languages—cont.  
  machine language, 1782  
  mathematical software, 1336-1337\*  
  object-oriented programming, 1528\*  
  software engineering, 2031  
  stored-program computer, 608-609  
  structure of, 1782-1783  
Progression (mathematics), 1783-1784\*  
Progymnospermopsida, 144, 161  
Projapygidae, 618  
Projection system see Optical projection systems  
Projection welding, 1902  
Projections (map), 1315-1316\*  
Projective geometry, 1784\*  
Projectors (cinematography), 458  
Prokaryotae, 1784\*  
  cell (biology), 388  
  classification, biological, 467  
  ribosomes, 1918  
Prolactin, 1693  
Prolog, 1783  
Promethium, 1784\*  
Prominences, 2150  
Pronghorn, 164, 1784\*  
Propagation:  
  radio-wave, 1853-1854\*  
  sound, 2051-2052  
Propagator (field theory), 1784-1785\*  
Propane:  
  alternative fuel vehicle, 91  
  liquefied petroleum gas, 1261\*  
  nitration, 1489  
Propellant, 1785\*  
  liquid, 1785  
  solid, 1785  
  specific impulse, 2074\*  
Propeller (aircraft), 1785-1786\*  
Propeller (marine craft), 880, 1786\*  
Proper ferroelectrics, 791  
Prophase (meiosis), 1349  
*Propionibacterium*, 20-21  
*Propiophilthecus*, 924, 925  
*Propiophilthecus zeuxis*, 829  
Propositional calculus, 1269-1270  
Proprioception, 1786-1787\*  
Propulsion, 1787\*  
  aircraft, 61-62  
  aircraft fuel, 60\*  
  boost, 2069-2070  
  electromagnetic, 695  
  electrothermal propulsion, 798-799\*  
  interplanetary, 1177\*  
  ion propulsion, 1185-1186\*  
  marine machinery, 1322\*  
  plasma, 1720\*  
  rocket propulsion, 1928-1929\*  
  ship nuclear propulsion, 1998\*  
  thrust, 2235\*  
  turbine propulsion, 2284-2285\*  
  see also Jet propulsion; Spacecraft propulsion  
Prosencephalon, 1477  
Prosobranchia, 866, 1787\*  
Prospagnosia, 43  
Prospecting, 1787-1788\*  
  geochemical prospecting, 985\*  
  geophysical exploration, 881-882  
  oil and gas, offshore, 1534\*  
*Prosseria grandis*, 1798  
Prostaglandin, 667, 739-740  
Prostate gland, 1788\*  
  oncofetal antigens, 1541  
  reproductive system disorders, 1899  
Prostereoisomerism see Prochirality  
*Prosthecomicrobium*, 300  
Prosthesis, 1788-1789\*  
Prosthetic alloys, 84  
Prosthodontics, 574  
Protactinium, 1789\*  
*Protamphisopus wianamatensis*, 1674  
Protandry, 1789\*  
Protophobia, 444  
Proteales, 1789\*  
Protection zones (electric), 750  
Protective coloration, 450, 1789-1790\*  
Proteaceae, 741  
Protein, 1790-1791\*  
  albumin, 68\*  
  amino acids, 97-98\*  
  animal growth, 121  
  antibody, 138\*  
  cell membranes, 393  
  complement, 514  
  cytochrome, 609\*  
  fibrous protein, 884-885\*  
Protein—cont.  
  food, 907  
  genetic code, 981-982\*  
  globulin, 1006\*  
  glycoprotein, 1008\*  
  hemoglobin, 1066\*  
  lectins, 1239\*  
  lipoprotein, 1260-1261\*  
  metallochaperones, 1369\*  
  muscle, 1450-1451\*  
  nucleoprotein, 1519\*  
  ribosomes, 1918-1919\*  
  secretion, 1970  
  vacuole, 2317  
Protein (dietary), 667  
Protein-calorie malnutrition, 1308  
Protein fibers, 1465  
Protein metabolism, 1791-1792\*  
  gout, 1013\*  
  metabolic disorders, 1361  
  phenylketonuria, 1654\*  
  urea, 2310\*  
  uric acid, 2310-2311\*  
Proteins, evolution of, 1792\*  
Protocephaloidea, 1792\*  
Protoemysidae, 21, 1792\*  
Proteoplast, 348  
Proterothricidae, 1265  
Proterozoic, 1765, 1792-1793\*  
  Ediacaran biota, 737-738\*  
  fossil, 923  
*Proteus*, 741  
Protista, 1793\*  
Protobranchia, 1793\*  
Protoceratidae, 164  
*Protoceratops*, 616  
Protococcida, 429, 1793\*  
Protocols (network), 2387  
Protocontinent, 482  
Protodrilidae, 148  
*Protodrilus*, 148  
Protogyny, 1793\*  
Protolipidodendralis, 1793-1794\*  
Proton, 1794\*  
  atomic mass, 210  
  atomic nucleus, 210  
  atomic number, 210  
  fundamental interactions, 946  
  hydrogen ion, 1106\*  
  I-spin, 1123  
  magic numbers, 1288-1289\*  
  neutron, 1483  
  nuclear structure, 1517-1518\*  
  nucleon, 1518-1519\*  
  quarks, 1831-1832  
  radioactivity, 1858  
  radiography, 1860\*  
  strange particles, 2122  
Proton accelerator, 699  
Proton-induced x-ray emission (PIXE), 1187, 1794\*  
Proton-proton chain, 1794-1795\*  
Protonic theory of acids and bases, 11-12  
Protohyta, 1793  
*Protopterus*:  
  Dipteriformes, 681  
  hibernation, 1074  
  Protosauria, 1795\*  
  Protostar, 1795\*  
  Prototheria, 1795\*  
Prototype, 1795-1796\*  
Protozoa, 1792, 1796-1797\*  
  Acantharia, 7\*  
  Acanthometrida, 8\*  
  Acanthophractida, 8\*  
  Aconchulinida, 14-15\*  
  Actinomoxida, 21\*  
  Actinophryida, 21\*  
  Actinopoda, 21  
  ameba, 95\*  
  Amoebida, 100\*  
  animal evolution, 119  
  Apostomatida, 152\*  
  Arcellinida, 159\*  
  Archigregarinida, 164\*  
  Aromatida, 188\*  
  Athalamida, 199\*  
  Bicosoecida, 272\*  
  Centrohelida, 403\*  
  Chloromonadida, 443\*  
  Choanoflagellida, 444-445\*  
  Chonotrichida, 447\*  
  Ciliata, 456\*  
  Ciliophora, 456-457\*  
  classification, biological, 467-468  
  Cnidosporea, 480-481\*  
  Coccidia, 487\*



- Protozoa—cont.  
 Coccolithophorida, 487\*  
 Cryptomonadida, 589\*  
 Diplomonadida, 677\*  
 Ebrida, 725\*  
 Entodiniomorphida, 826-827\*  
 Eucoccidia, 852\*  
 Euglenida, 852\*, 852-853\*  
 Eugregarinida, 853\*  
 Filosia, 877\*  
 Foraminiferida, 911-913\*  
 Fusulinacea, 952\*  
 Granuloreticulosa, 1016\*  
 Gregarina, 1027\*  
 Gromiida, 1028\*  
 Gymnostomatida, 1034\*  
 Haemosporina, 1038\*  
 Haplosporea, 1045-1046\*  
 Haplosporida, 1046\*  
 Helicosporida, 1059\*  
 Heliozoa, 1062\*  
 Heterotrichida, 1073\*  
 Holotrichia, 1085-1086\*  
 Hymenostomatida, 1113-1114\*  
 Hypermastigida, 1117\*  
 Hypotrichida, 1121\*  
 Kinetoplastida, 1216\*  
 Labyrinthulia, 1221\*  
 Lobosia, 1267\*  
 Mastigophora, 1332-1333\*  
 medical parasitology, 1348  
 Microsporidea, 1391\*  
 morphology, 1796  
 Myxosporida, 1461-1462\*  
 Neogregarinida, 1473\*  
 Nummulites, 1524\*  
 nutrition, 1797  
 Oculosida, 1532\*  
 Odontostomatida, 1533\*  
 Oligotrichida, 1540\*  
 Oxymonadida, 1592\*  
 parasitic, 1797  
 Peritrichia, 1634\*  
 Phytomastigophorea, 1683\*  
 Proteomyxidia, 1792\*  
 Protococcidia, 1793\*  
 Radiolaria, 1862\*  
 regeneration, 1884  
 reproduction, 1797  
 Retortamonadida, 1909\*  
 Rhizopoda, 1914\*  
 Sarcodina, 1945\*  
 Sarcosporida, 1945-1946\*  
 Silicoflagellida, 2008\*  
 Spirotrichia, 2086-2087\*  
 Sporozoa, 2088\*  
 Suctoria, 2143\*  
 Telosporia, 2207\*  
 Thigmotrichida, 2233\*  
 Tintinnida, 2243\*  
 Toxoplasma, 2254\*  
 Trypanosomatidae, 2278\*  
 Volvocida, 2357\*  
 Xenophyophorida, 2407-2408\*  
 Zoomastigophorea, 2419-2420\*  
 Protura, 1797\*  
 Proustite, 1797\*  
 Provenance (geology), 1797-1798\*  
*Prunus armeniaca*, 153  
*Prunus persica*, 1621\*  
*Prunus* species, 87, 136, 383, 1470, 1729  
 Pymnesiophyceae, 1798\*  
 Przewalski's horse, 965  
*Psammitta*, 2408  
 Psammodontidae, 286  
*Pseudobornia ursina*, 1798  
 Pseudoborniales, 1798\*  
 Pseudohalogen, 602  
*Pseudolycopodiella*, 1280  
*Pseudomonas*, 1798\*  
*Pseudomonas fluorescens*, 1044  
 Pseudophyllidea, 1798\*  
 Pseudopod, 95  
 Pseudoranging, 789-790  
 Pseudoscorpionida, 138, 1798\*  
 Pseudosphaeriales (lichenized), 1798\*  
 Pseudosporidae, 1792  
*Pseudotsuga menziesii*, 638, 698  
 Pseudotuberculosis, 1798\*  
*Psidium guajava*, 912  
 Psilophytales, 1798\*  
 Psilotophyta, 1799\*  
*Psilotum complanatum*, 1799  
*Psilotum nudum*, 1799  
 Psittacidae, 1798  
 Psittaciformes, 1799\*  
 Psocoptera, 1799\*  
*Psophocarpus tetragonolobus*, 2391  
 Psoriasis, 2018  
 Psrosobranchia, 972  
 Psychoacoustics, 165, 1799\*  
 Psychoanalysis, 1799-1800\*  
 Psychodynamic therapies, 1803  
 Psychokinesis, 779  
 Psycholinguistics, 1800\*  
 Psychology, 1800\*  
 behavioral psychophysics, 263-264\*  
 decision theory, 626  
 developmental psychology, 650-651\*  
 emotion, 813\*  
 motivation, 1440-1441\*  
 stress, 2127-2128\*  
 Psychoneuroimmunology:  
 brain-immune system interactions,  
 1800-1801\*  
 conditioning, 1801  
 prospects, 1801  
 stress and immunity, 1801  
 Psychopathology, 651  
 Psychopharmacology, 1801-1802\*  
 paranoia, 1610  
 schizophrenia, 1958  
 serotonin, 1989  
 tranquilizer, 2256\*  
 Psychophysical methods, 1802-1803\*  
 Psychophysics, behavioral, 233, 263-264\*  
 Psychosis, 1803\*  
 monoamine oxidase, 1432\*  
 paranoia, 1610\*  
 psychotomimetic drug, 1804\*  
 schizophrenia, 1957-1958\*  
 Psychosomatic disorders, 1803\*  
 neurotic disorders, 1481  
 stress, 2127  
 Psychotherapy, 1800, 1803-1804\*  
 psychoanalysis, 1799-1800\*  
 schizophrenia, 1958  
 Psychotomimetic drug, 1804\*  
 Psychrometer, 1804\*  
 Psychrometrics, 1804-1805\*  
 Psyllidae, 963  
 Ptarmigan, 260  
 Pteraspodomorpha, 1805\*  
 Pterocletes, 446  
 Pteriacea, 125  
 Pteridospermae, 928  
 Pteridosperms, 1805\*  
 Pterobranchia, 1805\*  
 Pteroclididae, 446  
 Pterodactyl, 149  
 Pterophoridae, 1243  
 Pteropodidae, 388  
 Pteropsida, 1493, 1805\*  
 Pterosauria, 149, 165, 675, 1805\*  
 product quality, 1779\*  
 Pteroylglutamic acid see Folic acid  
 Pterygota, 1805\*  
 Endopterygota, 819\*  
 Exopterygota, 859\*  
 Ptolemy, 478  
 Ptrolusite, 1312  
 Ptychodactaria, 1805\*  
*Ptychodactis*, 1805  
*Ptychozoon homocephalum*, 868  
 Public address system see  
 Sound-reinforcement system  
 Public health, 1349, 1805-1806\*  
*Pueraria phaseolides*, 1219  
*Pueraria thunbergiana*, 1219  
 Puffballs, 864, 970  
 Puffer, 2214  
 Puffin, 365  
 Pulley, 235, 1806\*  
 Pulmonary artery, 159  
 Pulmonary coccidioidomycosis, 429-  
 430  
 Pulmonary disease, 1458  
 Pulmonata, 866, 1806\*  
 Basommatophora, 257\*  
 Gastropoda, 972  
 slug, 2023\*  
 snail, 2024-2025\*  
 Stylommatophora, 2137\*  
 Systellommatophora, 2185\*  
 Pulp (paper), 1606  
 Pulsar, 1806-1807\*  
 gamma-ray astronomy, 961  
 Geminga, 977\*  
 gravitational radiation, 1023-1024\*  
 x-ray astronomy, 2401  
 Pulsating combustion (thermoacoustics),  
 2223  
 Pulsating variable stars, 2325  
 Pulse altimeter, 91  
 Pulse-amplitude modulation:  
 pulse modulation, 1807-1808  
 pulse modulator, 1809  
 Pulse-code modulation, 1808-1810  
 Pulse demodulator, 1807\*  
 Pulse Doppler radar, 636, 697  
 Pulse generator, 1807\*  
 Pulse ionization chamber, 1189  
 Pulse jet, 1807\*  
 Pulse modulation, 1807-1809\*  
 analog-to-digital conversion, 1807  
 applications, 1809  
 bandwidth requirements, 1809  
 pulse-amplitude modulation, 1807-1808  
 pulse-code modulation, 1808-1810  
 pulse-position modulation, 1808  
 pulse-width modulation, 1808  
 radio transmission, 1846\*  
 time-division multiplexing, 1808-1809  
 Pulse modulator, 1809-1810\*  
 pulse-code modulation, 1809-1810  
 pulse-position modulation, 1809  
 pulse-width modulation, 1809  
 Pulse polarography, 1738  
 Pulse-position modulation:  
 pulse modulation, 1808  
 pulse modulator, 1809  
 Pulse-width modulation:  
 pulse modulation, 1808  
 pulse modulator, 1809  
 Pulsed gas laser, 953  
 Pulsed magnets, 1290  
 Pulverizing see Crushing and pulverizing  
 Pumice, 1810\*  
 Pump, 1810\*  
 centrifugal, 352  
 displacement, 628  
 drug delivery system, 702  
 electromagnetic, 696, 772-773\*  
 mean effective pressure, 1341\*  
 supercharger, 2153  
 vacuum, 2318-2319\*  
 Pumped storage, 674, 1810\*  
 Pumping machinery, 1810-1811\*,  
 2044-2045  
 Pumpkin, 1811\*  
 Pumps, 2367-2368  
 Puna, 1811\*  
 Punched card, 554  
*Punica granatum*, 1753  
 Pure culture, 212-213  
 Pure imaginary number, 74  
 Purine, 1811\*  
 deoxyribonucleic acid, 575  
 gout, 1013\*  
 Purple beech, 231  
 Push-bar conveyor, 488  
 Push-pull amplifier, 1651, 1811-1812\*  
 PVC see Polyvinyl chloride  
 Pycnodontiformes, 1812\*  
 Pycnogonida, 367, 1812\*  
 Pygasteroidea, 1812\*  
 Pygmy chimpanzee, 1772  
 Pyralidae, 1243  
 Pyralidoidea, 1243  
 Pyrrargyrite, 1812\*  
 Pyrenomyces, 1812\*  
 Pyrenulales, 1813\*  
 Pyrethrins, 1639  
*Pyriform pallium*, 1477  
 Pyrimidine, 1813\*  
 Pyrite, 1813\*, 2149  
 Pyrocatechol, 341  
 Pyrocatechuic acid, 341  
 Pyroclastic rocks, 1813\*  
 Pyroclastic sandstone, 1943  
 Pyroelectricity, 1813-1814\*  
 Pyroelectricity (biology), 1814\*  
 Pyrolusite, 1312, 1814\*  
 Pyrolysis, 1814-1815\*  
 Pyrometallurgy, 688, 1815\*  
 Pyrometallurgy, nonferrous, 1815-1816\*  
 Pyrometer, 1816\*  
 Pyromorphite, 1816-1817\*  
 Pyrophanite, 1127  
 Pyrophyllite, 1817\*  
 Pyrosomida, 2217  
 Pyrotechnics, 1817\*  
*Pyrotheria*, 1817\*  
 Pyrotheriidae, 1817  
 Pyroxene, 1817\*  
 augite, 218\*  
 biopyrbole, 294\*  
 diopside, 676\*  
 enstatite, 826\*  
 gabbro, 955  
 Pyroxene—cont.  
 omphacite, 1540\*  
 orthorhombic pyroxene, 1581-1582\*  
 pigeonite, 1686\*  
 spodumene, 2088\*  
 Pyroxenite, 1817-1818\*  
 Pyroxenoid, 1818\*  
 Pyrrhocoroidea, 944  
 Pyrrhotite, 1818\*, 2146  
 Pyrrite, 2146  
 Pyrrrole, 1818\*  
*Pyrus communis*, 1622  
*Pyrus pyrifolia*, 1622  
 Pyruvic acid, 1221  
 Pythagoras, 1454  
 Pythagorean theorem, 1818\*  
*Python reticulatus*, 2092

## Q

- Q (electricity), 936, 1819\*  
 Q fever, 1920  
 Q meter, 1819\*  
 QCD see Quantum chromodynamics  
 QSO see Quasistellar object  
 Quadrant electrometers, 774  
 Quadraphonic disk recording system, 627  
 Quadruphonic systems, 2055  
 Quadratic Zeeman effect, 2413  
 Quadrature, 1819\*  
 Quadratic surface, 1819\*, 2167  
 Quail, 259  
 Quaking aspen, 1754  
 Qualitative chemical analysis, 1819-1820\*  
 gas chromatography, 965\*  
 inorganic, 1819-1820  
 organic, 1820  
 Quality control (QC), 1159, 1820-1821\*  
 inspection and testing, 1159\*  
 manufacturing engineering, 1314  
 pharmaceuticals testing, 1648  
 Quantitative chemical analysis, 1821\*  
 gravimetric analysis, 1020-1021\*  
 mass spectrometry, 1330-1331\*  
 Quantitative structure activity relations  
 (QSAR), 432  
 Quantization, 1829  
 Quantized electronic structure (QUEST),  
 1359-1360, 1821-1822\*  
 Quantized vortices, 1823\*  
 Quantum (physics), 1823\*  
 Quantum acoustics, 1823-1824\*  
 Quantum anomalies, 1824\*  
 Quantum chemistry, 1677, 1824-1825\*  
 molecular orbital theory, 1422-1423\*  
 photochemistry, 1662  
 Quantum chromodynamics (QCD),  
 1825-1826\*  
 baryon, 253-255\*  
 gluons, 1007  
 quarks, 1832  
 relativistic heavy-ion collisions, 1886  
 unitary symmetry, 2302  
 Quantum electrodynamics, 692, 1826\*  
 coherence, 494  
 electron-positron pair production,  
 782-783\*  
 Feynman diagram, 882\*  
 muonium, 1450\*  
 standard model, 2095  
 supercritical fields, 2157  
 supersymmetry, 2165  
 Quantum electronics, 1826\*  
 Quantum field theory, 1826-1827\*  
 CPT theorem, 142-143, 575\*  
 Feynman integral, 882-883\*  
 motion, 1440  
 positron, 1757  
 relativistic quantum theory, 1887\*  
 renormalization, 1895\*  
 Quantum gravitation, 1827-1828\*  
 Quantum mechanics, 1829-1830\*  
 atomic physics, 210\*  
 atomic theory, 214\*  
 causality, 383-384  
 complementarity, 1829  
 correspondence principle, 562\*, 1830  
 de Broglie wavelength, 622\*  
 determinism, 648  
 eigenvalue, 740\*  
 electron diffraction, 779-780\*  
 energy level, 820-821\*

Quantum mechanics—*cont.*  
 gauge theory, 972-973\*  
 helicity, 938  
 hidden variables, 1076\*  
 l-spin, 1123\*  
 matter, 1340  
 parity, 1612-1613\*  
 perturbation, 1638-1639\*  
 phonon, 1657\*  
 Planck's constant, 1696\*, 1828  
 Planck's radiation law, 936, 1696\*  
 probability considerations, 1829  
 quantization, 1829  
 quantized electronic structure, 1821-1822\*  
 quantum chemistry, 1824-1825\*  
 quantum statistics, 1830\*  
 random matrices, 1868  
 relaxation time of electrons, 1891  
 Schrödinger's wave equation, 1829-1830, 1960\*  
 spin (quantum mechanics), 2084\*  
 sum rules, 2149\*  
 supermultiplet, 2160-2161\*  
 superposition principle, 2162-2163  
 superstring theory, 2164  
 symmetry laws, 2180  
 uncertainty principle, 1828, 2296-2297\*  
 variational methods, 2326  
 wave function, 1829  
 wave mechanics, 2371\*  
 wave-particle duality, 1828-1829

Quantum mineralogy, 1830\*  
 Quantum numbers, 859, 1830\*  
 Quantum solids, 1830\*  
 Quantum statistics, 1830\*  
 anyons, 148\*  
 Fermi-Dirac statistics, 876-877\*  
 Quantum theory of matter, 1830-1831\*  
 Quantum theory of measurement, 1831\*  
 Quantum well injection transit-time diodes (QWITT), 1397-1398

Quark-gluon plasma, 1831\*  
 Quarkonium, 804, 1825-1826  
 Quarks, 721, 1831-1833\*  
 baryon, 253-255\*  
 deep inelastic collisions, 628  
 elementary particle, 802, 804  
 flavor, 893\*  
 fundamental interactions, 946, 947  
 gluons, 1007\*  
 l-spin, 1123\*  
 lepton, 1246  
 meson, 1359  
 nucleon, 1519  
 quantum chromodynamics, 1825-1826\*  
 relativistic heavy-ion collisions, 1886-1887  
 strange particles, 2122\*  
 supercritical fields, 2158  
 upson particles, 2308\*

Quarrying, 1833\*  
 Quarter evil see Blackleg  
 Quartz, 1125, 1833\*  
 agate, 42\*  
 amethyst, 96\*  
 chalcedony, 412\*  
 jasper, 1201\*  
 loess, 1268  
 onyx, 1544\*  
 phyllite, 1675  
 piezoelectric materials, 1686  
 polymorphism, 1748  
 quartzite, 1833\*  
 sand, 1943  
 sandstone, 1943

Quartz clock, 1833\*  
 Quartz diorite see Tonalite  
 Quartzite, 1833\*  
 Quasar, 197, 1833-1834\*  
 galaxy, external, 956  
 gravitational lens, 1023  
 superluminal motion, 2160  
 universe, 2306  
 x-ray astronomy, 2401

Quasiatom, 1834\*, 2157  
 Quasicrystal, 1834-1835\*  
 Quasielastic light scattering, 1835\*  
 Quaternary, 1835\*  
 Holocene, 1083-1084\*  
 Pleistocene, 1727\*

Quaternary ammonium compound, 145  
 Quaternary ammonium salts, 1835\*  
 Quaternions, 1835-1836\*  
 Quebracho, 1836\*  
 Queensland arrowroot, 157  
 Quelching, 1233-1234  
 Quercus, 784, 1527  
 Query By Example (QBE), 619

QUEST see Quantized electronic structure  
 Queueing theory, 1836\*  
 Quince, 1836\*  
 Quinine, 457, 984, 1836\*  
 Quinone, 1836-1837\*  
 QWERTY keyboard, 2291

## R

R Coronae Borealis stars, 2326  
 Rabbit, 164, 1145  
 Rabbit pox see Infectious myxomatosis  
 Rabies, 1839\*  
 Racoon, 1839\*  
 Racemization, 96-97, 1839\*  
 Radar, 1839-1840\*  
 air-traffic control, 56-57  
 airborne, 58\*  
 automatic landing system, 225\*  
 continuous-wave, 483, 547\*  
 Doppler, 636, 697\*  
 echo box, 728\*  
 electrical noise generator, 759  
 ground-probing, 1028\*  
 meteor, 1374  
 meteorological, 1377-1378\*  
 microwave, 1393  
 mixer, 1412  
 monopulse, 1434\*  
 moving-target indication, 1444\*  
 passive, 1618\*  
 piloting, 1687  
 polar navigation, 1734  
 precision approach, 1767\*  
 radio altimeter, 92  
 remote sensing, 1894  
 storm detection, 2120-2121\*  
 surveillance, 2172\*  
 synthetic aperture radar, 2184-2185\*  
 thunderstorm, 2236  
 tuning, 2282\*  
 weather observations, 2380

Radar-absorbing materials, 1840-1841\*  
 Radar altimeter, 91-92  
 Radar astronomy, 2160  
 Radar meteorology, 1841\*  
 Radar surveillance, 2120  
 Radial bearing, 139-141  
 Radial symmetry, 122-123  
 Radial tire, 2243  
 Radian measure, 1841\*  
 Radiance, 1841-1842\*  
 Radiant heating, 1842\*, 1846  
 Radiation, 1842\*  
 alpha particles, 88\*  
 cosmic background, 2307  
 dosimeter, 699\*  
 electromagnetic see Electromagnetic radiation  
 emissivity, 813\*  
 food preservation, 820-821  
 light curves, 1251  
 nuclear radiation, 1513\*  
 radioactivity and radiation applications, 1858\*  
 radiology, 1863\*  
 solar, 2041\*  
 synchrotron, 2183-2184\*  
 terrestrial, 2212-2213\*  
 units of measurement, 2304-2305  
 Van Allen radiation, 2321-2322\*

Radiation biology, 1842-1843\*  
 health physics, 1049  
 ionizing radiation, 1842-1843  
 nonionizing radiation, 1843  
 space medicine, 38  
 sterilization, 2115\*  
 ultraviolet radiation (biology), 2296\*

Radiation biophysics, 255  
 Radiation chemistry, 1843-1844\*  
 Radiation chimera, 386  
 Radiation damage to materials, 1844\*  
 Radiation detector:  
 radiometry, 1862-1863  
 scintillation counter, 1961-9162\*  
 see also Particle detector  
 Radiation hardening, 1844-1845\*  
 Radiation law, Planck's, 936, 1696\*  
 Radiation pressure, 1845\*  
 Radiation pyrometer, 1816  
 Radiation shielding, 1049, 1845\*  
 Radiation therapy, 1845, 1863

Radiative corrections, 214  
 Radiative electron-hole recombination, 781  
 Radiative transfer, 1845-1846\*  
 Radiator, 937, 1846\*  
 Radical ion, 835-836, 1872  
 Radio, 1846\*  
 amateur, 94\*  
 amplitude-modulation, 105-106\*  
 antenna (electromagnetism), 131-133\*  
 bandwidth requirements, 218, 250\*  
 frequency-modulation, 935-936\*  
 mobile, 1412-1413\*  
 navigation aids, 56  
 stereophonic radio transmission, 2114\*  
 Radio altimeter, 92  
 Radio astronomy, 175-176, 189  
 Radio astronomy, 1846-1847\*  
 extraterrestrial intelligence, 864  
 galaxies and radio galaxies, 1847  
 high-energy astrophysics, 181, 196-197\*  
 Hill regions, 1847  
 hydrogen line, 1847  
 molecular cloud, 1419-1420\*  
 molecular lines, 1847  
 radio stars, 1847  
 radio universe, 1846-1847  
 solar system astronomy, 1847  
 superconducting devices, 2154  
 superluminal motion, 2160\*  
 supernova remnants, 1847  
 Radio broadcasting, 1847-1848\*  
 AM medium-frequency band, 1848  
 amplitude modulation, 104\*  
 digital audio, 1848  
 FM VHF band, 1848  
 frequency division multiplex, 681  
 frequency modulation, 935\*  
 frequency-modulation radio, 935\*  
 jamming, 1201\*  
 radio spectrum allocations, 1851-1852\*  
 satellite, 1848  
 shortwave, 1848  
 Radio broadcasting network, 1848-1849\*  
 Radio compass, 1849\*  
 Radio detection and ranging see Radar  
 Radio-frequency amplifier, 1849\*  
 Radio-frequency impedance measurements, 1849-1850\*  
 Radio-frequency interference (RFI), 757  
 Radio-frequency measurement, 837  
 Radio-frequency spectrum analyzer, 2077  
 Radio-frequency SQUID, 1302  
 Radio-frequency transformer, 2259  
 Radio galaxies:  
 quasar, 1834  
 radio astronomy, 1847  
 Radio navigation, 1469  
 Radio paging systems, 1850\*  
 Radio range, 697-698  
 Radio receiver, 1850-1851\*  
 automatic frequency control (AFC), 224\*  
 automatic gain control (AGC), 224-225\*  
 heterodyne principle, 1072\*  
 intermediate-frequency amplifier, 1173  
 mixer, 1411-1412\*  
 selectivity, 1979\*  
 spectrum analyzer, 2076-2077\*  
 tuning, 2282\*

Radio sources (astronomy):  
 pulsar, 1806-1807\*  
 supernova, 2161\*  
 Radio spectrum allocations, 1851-1852\*, 2207  
 Radio star:  
 electrical noise generator, 759  
 radio astronomy, 1847  
 Radio telescope, 1846, 1852\*  
 Radio time delay, 1891  
 Radio tower, 2252  
 Radio transmitter, 1852-1853\*  
 Radio universe, 1846-1847  
 Radio wave, 2374-2375  
 Radio-wave propagation, 1853-1854\*  
 electromagnetic wave transmission, 773-774\*  
 tropospheric scatter, 2277\*  
 Radioactive beams, 1854\*  
 Radioactive decay:  
 radon, 1864-1865\*  
 time-interval measurement, 2241  
 see also Radioactivity  
 Radioactive fallout, 1854\*  
 Radioactive isotope:  
 radiochemistry, 1859  
 radiology, 1863  
 Radioactive materials, 627

Radioactive minerals, 1854-1855\*  
 carnotite, 373-374\*  
 thorianite, 2234\*  
 thorianite, 2234\*  
 uraninite, 2308\*

Radioactive nuclide, 1861-1862  
 Radioactive tracer, 1855\*  
 radiochemistry, 1859\*  
 radioecology, 1859-1860\*  
 Radioactive waste management, 1509, 1855-1856\*  
 Radioactivity, 1856-1858\*  
 activation analysis, 22  
 alpha-particle decay, 1856-1857  
 angular correlations, 117\*  
 background count, 240\*  
 beta-particle decay, 1857  
 beta particles, 270-271\*  
 decontamination of radioactive materials, 627\*  
 delayed particle emissions, 1858  
 environmental, 931\*  
 environmental radioactivity, 831\*  
 gamma-ray decay, 1857  
 gamma-ray detectors, 962\*  
 half-life, 1039\*  
 heat flow in Earth, 719  
 heavy cluster decays, 1857-1858  
 low-level counting, 1274\*  
 metnium, 1351\*  
 metamict state, 1370-1371\*  
 proton radioactivity, 1858  
 radiation chemistry, 1843-1844\*  
 radioactive series decay, 1856  
 rock age determination, 1926-1927\*  
 spontaneous fission, 1857  
 transition rates and decay laws, 1856  
 Radioactivity and radiation applications, 1858\*  
 Radioactivity standards, 1858\*  
 Radioautography see Autoradiography  
 Radiobiology see Radiation biology  
 Radiocarbon dating, 9-10, 1858-1859\*  
 Radiochemical laboratory, 1859\*  
 Radiochemistry, 1859\*  
 Radioecology, 1859-1860\*  
 Radiography, 1860\*  
 autoradiography, 231\*  
 computerized tomography, 529\*  
 mammography, 1310\*  
 microradiography, 1390-1391\*  
 Radioimmunoassay, 1860-1861\*  
 Radioisotope, 1861\*  
 isotope dilution techniques, 1197-1198\*  
 isotopic irradiation, 1198-1199\*  
 nuclear medicine, 1511\*  
 radioactive tracer, 1855\*  
 radiocarbon dating, 1858-1859\*  
 radiochemistry, 1859\*  
 radioecology, 1859-1860\*  
 Radioisotope (biology), 1861\*  
 Radioisotope geochemistry, 1861-1862\*  
 Radioisotopic assay, 1632\*  
 Radiolaria, 21, 1862\*  
 Oculosida, 1532\*  
 Porulosida, 1757\*  
 Radiology, 1346, 1845  
 isotopic irradiation, 1198-1199\*  
 medical imaging, 1346-1348\*  
 nuclear medicine, 1511\*  
 nuclear radiation, 1513\*  
 oncology, 1542-1543  
 Radiometer:  
 acoustic, 17\*  
 meteorological satellites, 1379  
 radiance, 1841-1842\*  
 Radiometric dating, 620  
 Radiometry, 312, 1863\*  
 Radiosondes, 2380  
 Radish, 1863\*  
 Radium, 1854-1855, 1863-1864\*  
 Radius of gyration, 1864\*  
 Radome, 1864\*  
 Radon, 1864-1865\*  
 Raffinose, 1865\*  
 Rafflesiales, 1865\*  
 Raft foundation, 832  
*Raillietia*, 354  
 Raillietellidae, 354  
 Railroad control systems, 1865\*  
 subway engineering, 2143  
 traffic-control systems, 2255-2256  
 Railroad engineering, 1865-1866\*  
 locomotive, 1267-1268\*  
 subway engineering, 2142  
 transportation engineering, 2263-2264  
 Railroad terminal, 1865

- Rails, 1031  
Rain, 1766  
  see also Acid rain; Precipitation (meteorology)  
Rain shadow, 1866\*  
Rainbow, 1866\*  
Rainforest, 1866-1867\*  
Rajidae, 673  
Rallidae, 912  
RAM see Random-access memory  
Ram see Aries  
Raman, C. V., 1955  
Raman effect, 1867\*, 2076  
Raman scattering, 1497  
Raman spectroscopy, 1820  
*Ramapithecus*, 829  
*Ramaria*, 1112  
Ramie, 1867\*  
Ramjet, 1867-1868\*, 2073  
Ramsden eyepiece, 782, 868  
Random-access memory (RAM), 462-463, 526, 1546  
  digital computer, 669  
  semiconductor memories, 1982-1983\*  
  sense amplifier, 1985\*  
Random electrical noise, 685  
Random matrices, 1868\*  
Rangefinder (optics), 1868\*  
Rank (coal), 481  
Rankine cycle, 1868-1869\*  
  power plant, 1763  
  solar cooling, 2040  
Ranunculaceae, 1869\*  
Ranunculales, 1869\*  
*Ranunculus*, 1869\*  
Rape, 1869\*  
*Raphanus sativus*, 1578  
Raphidae, 447  
Raphidophyceae, 1869\*  
Rapid eye movement (REM) sleep, 2019-2021  
Rapid prototyping, 2342  
Rapture of the deep, 632  
Rare-earth elements, 1869-1870\*  
  cerium, 408\*  
  dysprosium, 712\*  
  electron paramagnetic resonance spectroscopy, 782  
  erbium, 843\*  
  europium, 748, 855-856\*  
  ferromagnetic garnets, 878\*  
  gadolinium, 955\*  
  holmium, 1083\*  
  lanthanide contraction, 1227\*  
  lanthanum, 1227\*  
  lutetium, 1280\*  
  neodymium, 1473\*  
  praseodymium, 1764\*  
  promethium, 1784\*  
  samarium, 1943\*  
  scandium, 1952-1953\*  
  terbium, 2210\*  
  thulium, 2235\*  
  ytterbium, 2412\*  
  yttrium, 2412\*  
Rare-earth minerals, 1870\*  
Rarefied gas flow, 1870\*  
Raspberry, 1870-1871\*  
Rat, 1871\*  
  instrumental conditioning, 1161  
  plague, 1695  
  Rodentia, 1930  
Ratchet, 1621, 1871\*  
Rate gyro, 918  
Rate-of-climb indicator, 1871\*  
Ratfish, 438  
Rathke's pouch, 1693  
Rathousiidae, 2185  
Rational number, 74  
Ratites, 1871\*, 2136  
Rattail, 955  
Raunkiaer, C., 1717  
*Rauwolfia*, 1871\*  
Raw water, 1871\*  
Ray (sound), 2052  
Ray (zoology), 257  
Rayet, Georges, 2393  
Rayfin fish:  
  Sarcopterygii, 1945  
  Teleostei, 2198  
  see also Actinopterygii  
Rayleigh, Lord, 916, 1955, 2167  
Rayleigh current balance, 520  
Rayleigh scattering, 518, 1955  
Reactance, 1595, 1871-1872\*  
Reaction kinetics, 425  
Reaction turbine, 1872\*  
Reactive dyes, 708  
Reactive intermediates, 1575-1576, 1872\*  
Reactive mufflers, 1444  
Reactor see Chemical reactor; Nuclear reactor  
Reactor (electricity), 1872\*  
Reactor physics, 1872-1873\*  
  concepts, 1873  
  criticality, 1873  
  reactivity, 1873  
  reactor control physics, 1873  
  reactor dynamics, 1873  
  reactor kinetics, 1873  
  reflectors, 1873  
Read-only memory, 462-463  
  microprocessor, 1389-1390\*  
  semiconductor memories, 1982-1983\*  
Reagent chemicals, 1873\*  
Real-charge electrets, 741  
Real number system, 74  
Real-time software, 2030  
Real-time systems, 786-788, 1873-1874\*  
Real variable, 1874\*  
Realgar, 1874\*  
Rearrangement reaction, 1874\*  
Reasoning, 493  
Receiver, 1392-1393  
  see also Radio receiver; Television receiver  
Recent see Holocene  
Receptor cell, 2006  
Receptor-mediated endocytosis, 818  
Receptor organ see Sense organ  
Reciprocating aircraft engine, 1874-1875\*, 2153  
Reciprocating compressor, 456  
Reciprocating pump, 628  
Reciprocity principle, 1875\*  
*Reckertia*, 391  
Reclamation, 2169  
Recognition, molecular, 1424\*  
Recoil escapement, 418  
Recombinant DNA, 576  
  industrial microbiology, 1141  
  molecular biology, 1419  
Recombination (genetics), 1875\*  
  crossing-over, 516, 582\*  
  deoxyribonucleic acid, 639-649  
  intron, 1179  
  linkage, 1259  
  meiotic, 1350  
Recombination, electron-hole, 780-781\*  
Recommended Dietary Allowances (RDAs), 1525  
Reconnaissance aircraft, 1401  
Reconnaissance satellites, 1401-1402  
Recording, 2054  
  see also Disk recording; Graphic recording instruments; Magnetic recording; Optical recording  
Recreation, 921  
Recreation Opportunity Spectrum (ROS), 921  
Recrystallized rock, 1371  
Rectification:  
  semiconductor, 1981  
  surface electronics, 1981  
Rectifier, 1875-1876\*  
  controlled, 485-486  
  mechanical, 1343\*  
  semiconductor see Semiconductor rectifier  
Rectifier diode, 616  
Rectilinear motion, 1876\*  
Recursive function, 1876\*  
Recurvirostridae, 364  
Recycling technology, 1877-1878\*  
  glass, 1877  
  metals, 1877  
  paper, 1877-1878  
  plastic, 1877  
  polymers, 1746  
  wood, 1877-1878  
Red algae see Rhodophyceae  
Red-bellied marmot, 1326  
Red blood cell see Erythrocytes  
Red bug, 2276  
Red clover, 422  
Red currant, 534, 599  
Red deer, 567  
Red dwarf star, 1878\*  
Red fir see Douglas-fir  
Red fox, 634  
Red giant star:  
  Aldebaran, 70\*  
  variable star, 2325  
Red grouse, 260  
Red-legged partridge, 259  
Red marmot, 1326  
Red panda, 1605  
Red Sea, 1878\*  
  ocean, 1529  
  ocean circulation, 1530  
Red sprite, 1253  
Red spruce, 2090  
Red supergiant star, 271  
Red-tailed hawk, 260  
Redbeds, 1878\*  
Redbud locust, 1240  
Redgum see Sweetgum  
Redox potentials, 767  
Redox titration, 2245  
Redshift, 1878-1879\*  
  cosmological, 2306-2307  
  Doppler effect, 697  
  gravitational, 1024\*, 1890  
  infrared astronomy, 1151  
  quasar, 1834  
  universe, 2306-2307  
Redtop grass, 1879\*  
Reduced instruction set computers (RISCs), 670, 1389  
Reducing sugar, 327  
Reduction see Oxidation-reduction  
Redundant arrays of independent disks (RAID), 619  
Reduviidae, 944  
Reduivoidea, 944  
Redwood, 1688, 1879\*  
Reedfish, 21  
Reef, 206, 427, 1879\*  
Reef knoll, 249  
Reengineering, 1879\*  
Reeve's pheasant, 260  
Reference electrodes, 1879-1880\*  
Reference-line dimensioning, 613  
Reflecting microscope, 1880\*  
Reflection and transmission coefficients, 1880\*  
Reflection grating, 602  
Reflection high-energy electron diffraction (RHEED), 780  
Reflection nebula, 1470  
Reflection of electromagnetic radiation, 1880-1881\*  
  mirror optics, 1407-1408\*  
  optical guided waves, 1554-1555\*  
Reflection of sound, 728, 1881\*, 2052  
Reflection x-ray microscopy, 2149\*  
Reflective filters, 771  
Reflectivity, 1880-1881  
Reflex, 1881\*  
Reflex, conditioned, 468, 532\*  
Reflex camera, 320-321  
Reflux esophagitis, 970  
Reforestation, 1881\*  
Reforming processes, 1881-1882\*  
Refraction (x-rays), 2406  
Refraction of waves, 1882\*  
  atmospheric refraction, 1882  
  chromatic aberration, 448\*  
  optical prism, 1559  
  radio-wave propagation, 1853-1854\*  
  seismic waves, 1882  
  seismology, 1976-1977  
  Snell's law, 1882  
  sound waves, 202-203, 1882  
  water waves, 1882  
Refractive index, 687  
Refractive optical bistability, 1551  
Refractometer, 1882-1883  
Refractometric analysis, 1882-1883\*  
Refractory, 356, 413, 1883\*  
Refrigerant, 1324, 1883  
Refrigeration, 1883\*  
  antifreeze mixture, 139\*  
  cold storage, 438  
  cryogenics, 587  
  dry ice, 640-641  
  food preservation, 820-821  
  liquefaction of gases, 1261  
  marine, 1324\*  
  solar cooling, 2040  
  ton of, 2247\*  
Refrigeration cycle, 1883-1884\*  
Refrigerator, 1884\*, 2223  
Refsum disease, 1636  
Regeneration (biology), 1884\*  
  sensory system, 1986\*  
  silviculture, 2011-2012  
Regeneration (engineering), 1884\*  
Regenerative braking, 287  
Regenerative comparator, 453, 514  
Regional metamorphism, 1372  
Register circuits, 2176  
Registered nurses, 1524  
Registration (television camera), 2203  
Regolith, 1884-1885\*  
Regular polygon, 951-952  
Regular polytopes, 1885\*  
Regularia, 1885\*  
Regulator, 1885\*  
Reheating, 1885\*  
*Reighardia*, 354  
Reighardiidae, 354  
Reindeer, 1885\*  
Reinforced concrete, 530, 1885\*  
Reinforced plastics, 1723  
Relapsing fever, 1885-1886\*  
Relative atomic mass, 189, 1886\*  
Relative humidity, 970, 1111-1112, 1416  
Relative molecular mass, 1886\*  
Relative motion, 1886\*  
Relative nucleic mass, 1886  
Relativistic electrodynamics, 192, 692, 1886\*  
Relativistic gravitation (theory), 1021-1022  
Relativistic heavy-ion collisions, 1886-1887\*  
Relativistic jet model, 2160  
Relativistic quantum mechanics, 1344, 1828  
Relativistic quantum theory, 1887\*  
Relativity, 1887-1891\*  
  aberration (astronomy), 2-3\*  
  astrophysics, 196-197\*  
  black hole, 300-301\*  
  causal structure in special relativity, 1888-1889  
  consequences, 1889  
  conservation of mass, 541\*  
  cosmological term, 1890  
  deflection of light, 1890-1891  
  FitzGerald-Lorentz contraction, 891\*  
  general theory, 1889  
  gravitation, 905  
  gravitational lens, 1023  
  gravitational redshift, 1024\*, 1890  
  graviton, 1024\*  
  Lorentz transformations, 1272\*  
  motion of test bodies, 1890  
  perihelion shift, 1890  
  principle of equivalence, 1889-1890  
  radio time delay, 1891  
  relativistic electrodynamics, 1886  
  Schwarzschild solution, 1890  
  simultaneity in prerelativity physics, 1887-1888  
  space-time, 1889, 2068\*  
  special theory, 1887  
  superluminal motion, 2160  
  superstrenuous theory, 2164  
  symmetry laws, 2179  
  tensor field equations, 1890  
Relaxation oscillator, 1582  
  pulse generator, 1807  
Relaxation time of electrons, 1891\*  
Relay, 678, 750, 1892\*  
Reliability, availability, and maintainability, 1892\*  
Relief printing, 1773, 1774  
Reluctance, 1634-1635, 1892\*  
Reluctance motor, 1892-1893\*  
Remipedia, 1893\*  
Remote-control system, 1893\*  
Remote manipulators, 1893\*  
Remote method invocation (RMI), 690  
Remote sensing, 1893-1894\*  
  Doppler effect, 697  
  high-frequency radar, 1894  
  infrared, 1894  
  infrared imaging devices, 1151\*  
  maritime meteorology, 1325  
  meteorological instrumentation, 1376  
  meteorological satellites, 1378-1379  
  microwave radar, 1894  
  military satellites, 1402  
  multispectral imagery, 1894  
  photography, 1666-1667, 1893-1894  
  sonar, 2048-2049\*  
  topographic surveying and mapping, 2249\*  
  wind measurement, 2389  
Remotely operated vehicles (ROVs), 2300  
Remotely piloted drone, 639  
Remotely piloted vehicles (RPVs), 701, 1317  
Renal pelvis, 2313  
Rendering, 521  
Renewable fuse, 850  
Renewable resources, 1894\*  
*Renilla*, 1625  
Renin-angiotensin systems, 2234  
Renner-Teller effect, 1201, 1894-1895\*

- Rennin, 1895\*  
 Renormalization, 1895\*  
 Reoviridae, 272  
 Repeated loads, 1266  
 Repellent, 1158  
 Reproduction (animal), 1895-1896\*  
 animal communication, 119  
 asexual, 1895  
 estrus, 848\*  
 ontogeny, 1543  
 radiation biology, 1842-1843  
 sex determination, 1992  
 sexual, 1895-1896  
 sexual dimorphism, 1994  
 Reproduction (fungi), 948, 950  
 Reproduction (plant), 1896\*  
 ecological communities, 732  
 flower, 898-899\*  
 mushroom, 1453  
 plant evolution, 1702  
 pollen, 1738-1739\*  
 pollination, 1739-1740\*  
 sex determination, 1992  
 sexual dimorphism, 1994  
 Reproductive behavior, 1897\*, 2027  
 Reproductive hormones, 817  
 Reproductive system, 1897-1898\*  
 anatomy, 1897-1898  
 copulatory organ, 557\*  
 fallopian tube, 870-871\*  
 ovary, 1588\*  
 penis, 1625\*  
 physiology, 1898  
 testis, 2213-2214\*  
 urogenital system, 2314\*  
 uterus, 2315\*  
 Reproductive system disorders, 1899-1900\*  
 hermaphroditism, 947  
 infertility, 1145\*  
 Reproductive technology, 1900\*  
 Reptantia, 560  
 Reptaria, 937  
 Reptilia, 1900\*  
 alligator, 82\*  
 Amniota, 100\*  
 Anamnia, 112  
 Anapsida, 113\*  
 animal evolution, 120  
 Araeocellidia, 155-156\*  
 Archosauria, 165-166\*  
 caiman, 309\*  
 chameleon, 412\*  
 crocodile, 581-582\*  
 Crocodylia, 581-582\*  
 digestive system, 666  
 dinosaur, 674-676\*  
 ear, 713, 714, 715  
 Eosuchia, 835\*  
 Euryapsida, 777  
 gavial, 973\*  
 gecko, 974\*  
 Ichthyopterygia, 957-958, 1124\*  
 Lepidosauria, 1245\*  
 Mesosauria, 1359\*  
 Nothosauria, 1504\*  
 Ornithischia, 1580\*  
 Pelycosauria, 1624\*  
 Permian, 1635  
 Placodontia, 1695\*  
 Plesiosauria, 1728\*  
 Protosauria, 1795\*  
 Pterosauria, 1805\*  
 Saurischia, 1951\*  
 Sauropterygia, 1951\*  
 scale (zoology), 1952\*  
 skink, 2019\*  
 Sphenodontia, 2082-2083\*  
 Squamata, 2092\*  
 Synapsida, 2181\*  
 Thecodontia, 2218\*  
 Therapsida, 2219\*  
 thermoregulation, 2229, 2230  
 tongue, 2248  
 Repulsion motor, 1900-1901\*  
 Research aircraft, 1401  
 Reseda, 325  
 Resedaceae, 325  
 Reservoir, 1901\*  
 dam, 614  
 water supply engineering, 2367  
 Residential water consumption, 2364  
 Residual fuel oil, 843  
 Residual insecticides, 1158  
 Residual nuclear radiation (RNRR), 772  
 Resin, 1901\*  
 advanced composites, 455-456  
 amber, 94\*  
 Resin—cont.  
 polyacrylate, 1740-1741\*  
 polyacrylate resins, 1740-1741\*  
 polyamide, 1742\*  
 polyester, 1742-1743\*  
 polyether, 1743\*  
 polyolefin, 1749-1750\*  
 poly(p-xylylene), 1752\*  
 polystyrene, 1752\*  
 polysulfone, 1752\*  
 polyvinyl, 1753\*  
 rosin, 1933\*  
 silicone, 2009\*  
 urea-formaldehyde-type, 2310\*  
 Resistance (biological):  
 bacterial, 2147  
 microbial, 137  
 plant pathology, 1710  
 Resistance (electrical) see Electrical resistance  
 Resistance (flow), 2126  
 Resistance brazing, 289  
 Resistance heating, 744, 1901\*  
 Resistance measurement, 1901-1902\*  
 electrometer, 698\*  
 Kelvin bridge, 1210\*  
 Wheatstone bridge, 2386\*  
 Resistance thermometer, 2229  
 Resistance welding, 1902  
 flash welding, 892\*  
 spot welding, 2088\*  
 Resistivity see Electrical resistivity  
 Resistor, 1902-1903\*  
 ballast, 215, 246\*  
 resistance measurement, 1901-1902\*  
 rheostat, 1913\*  
 ripple voltage, 1823\*  
 varistor, 2326\*  
 Resolving power (optics), 601-602,  
 1903-1904\*  
 Resonance (acoustics and mechanics),  
 1498, 1904\*  
 Resonance (alternating-current circuits),  
 1904\*  
 antiresonance, 144-145  
 Q (electricity), 1595  
 subsynchronous resonance, 2142\*  
 Resonance (molecular structure), 1904\*  
 Resonance (quantum mechanics),  
 1831-1832, 1905\*  
 Resonance fluorescence analysis, 804  
 Resonance ionization spectroscopy, 1905\*  
 Resonant fiber-optic gyro (RFOG), 1036  
 Resonator:  
 acoustic, 17\*  
 cavity, 384\*  
 Respiration, 1905-1906\*  
 cytochrome, 609  
 diving, 692  
 hemoglobin, 1066\*  
 plant, 1713\*  
 respiratory pigments (invertebrate),  
 1906\*  
 respiratory system, 1907\*  
 spirometry, 2086\*  
 Respirator, 1906\*  
 Respiratory pigments (invertebrate),  
 1906\*  
 Respiratory syncytial virus, 1906-1907\*  
 Respiratory system, 1907\*  
 countercurrent exchange (biology),  
 572-573\*  
 lung, 1279-1280\*  
 respiration, 1905-1906\*  
 Respiratory system disorders, 1907\*  
 asthma, 188\*  
 emphysema, 813-814\*  
 infant respiratory distress syndrome,  
 1143\*  
 influenza, 1148\*  
 stranglers, 2122\*  
 Response, 1907\*  
 Rest mass, 1907-1908\*  
 Restio, 1731  
 Restionales, 449, 1908\*  
 Restoration ecology, 1908\*  
 Restriction enzyme, 1908\*  
 Resultant of forces, 1908\*  
 center of gravity, 401\*  
 center of pressure, 401\*  
 Retaining wall, 1909\*  
 Reticular formation, 1909\*  
 Reticulosa, 952, 1909\*  
 Retina:  
 eye disorders, 867  
 sensory system regeneration, 1986  
 Retortamonadida, 1909\*  
 Retrograde motion (astronomy), 1909\*  
 Retrovirus, 757, 1909-1910\*  
 reverse transcriptase, 1910  
 transduction (bacteria), 2257  
 tumor viruses, 2281  
 Rett's syndrome, 221  
 Reverberation, 165, 1910\*, 2300  
 Reverberation chamber, 196  
 Reverse osmosis:  
 membrane separations, 1352\*  
 water desalination, 2365  
 Reverse-phase-rotation protection, 751  
 Reverse transcriptase, 1910\*  
 Revetment, 427, 1910\*  
 Reye's syndrome, 184, 1265  
 Reynaud's disease, 963  
 Reynolds number, 577, 1911\*  
 hydrodynamics, 1103  
 jet flow, 1202  
 laminar flow, 1223-1224  
 pipe flow, 1691  
 rarefied gas flow, 1870  
 turbulent flow, 2287  
 Rh blood group system, 269  
 Rh disease, 1768  
 Rh incompatibility, 1911\*  
 Rhabditida, 1911\*  
*Rhabdocalyptus*, 1284  
 Rhabdozoela, 1911\*, 2284  
*Rhagoletis*, 621  
 L-Rhamnose, 1911\*  
 RHEED see Reflection high-energy electron  
 diffraction  
 Rhenium, 1991\*  
 Rheology, 1912-1913\*  
 deep-marine sediments, 628  
 viscosity, 2345-2346\*  
 Rheophilous bog, 267  
 Rheostat, 1913\*  
 Rheotaxis, 2194  
 Rheumatic fever, 932, 1913\*  
 Rheumatism, 159-160, 174, 1913\*  
 Rheumatoid arthritis, 159-160, 174, 222,  
 223, 1129, 2017  
 Rhinitis, allergic, 928  
 Rhinocerotidae, 1539, 1913\*  
*Rhinoceros*, 178, 1633-1634, 1913\*  
 Rhinochimaeridae, 385  
 Rhinolphidae, 388  
*Rhinophrynus*, 130  
 Rhinopomatidae, 388  
 Rhinotermitidae, 1195  
 Rhinovirus, 509, 1913\*  
*Rhizidiomyces apophysatus*, 989, 1119  
 Rhizobiaceae, 1913-1914  
*Rhizobium*, 1382  
 lectins, 1239  
 legume, 1240  
 Rhizocephala, 409, 1913  
*Rhizoctonia*, 984, 1112  
 Rhizomastigida, 1913\*  
 Rhizomorph, 1242  
*Rhizophora mangle*, 497  
 Rhizophoraceae, 497, 1913-1914  
 Rhizopoda, 1914, 1945  
 Filosia, 877\*  
 Foraminiferida, 911-913\*  
 Granuloreticulosa, 1016\*  
 Labyrinthulia, 1221\*  
 Lobosia, 1267\*  
 Rhizosphere, 1914\*  
*Rhizostoma*, 1914\*  
 Rhizostomeae, 1914\*  
 Rho-theta system, 1914\*  
*Rhodinia*, 2157  
 Rhodium, 1914-1915\*  
 Rhodochrosite, 1915\*  
 Rhododendron, 759, 857  
*Rhodomicrobium*, 300  
 Rhodonite, 1674, 1915\*  
 Rhodophyceae, 1915\*  
 carrageenan, 375\*  
 Corallinales, 558\*  
 Rhoipteleaceae, 1205  
 Rhombencephalon, 1477  
 Rhombifera, 1915-1916\*  
 Rhopalidae, 944  
*Rhopalosiphum nymphaeae*, 2  
 Rhubarb, 1744, 1916\*  
 Rhynchobellae, 1916\*  
 Rhynchocephalia, 1245  
 Rhynchozoela, 1916\*  
 Anopla, 126\*  
 Bdellonemertini, 260\*  
 Enopla, 825-826\*, 826\*  
 Heteronemertini, 1072\*  
 Hoplonemertini, 1089\*  
 Rhynchonellida, 161, 1916\*  
 Rhynchonelliformea, 1916\*  
 Rhynchopidae, 365  
 Rhynchosauria, 1917\*  
*Rhyniella praecursor*, 441  
 Rhyniophyta, 1917\*  
 Rhyniophyte, 1703  
 Rhyniopsida, 1798, 1917\*  
 Rhynochetidae, 912  
 Rhynolite, 1917\*  
 Rhyolitic magmas, 1289  
 Ribbonfish, 1224  
 Ribbonworm, 1916  
*Ribes*, 534, 898  
 Riboflavin, 1917\*  
 Ribonuclease, 1917\*  
 Ribonucleic acid (RNA), 1917-1918\*  
 catalytic, 1918  
 deoxyribonucleic acid, 638,  
 639  
 DNA function, 576  
 Ebola virus, 725  
 exon, 859\*  
 gene, 978  
 gene action, 979  
 genetic code, 981-982  
 messenger, 1918  
 nucleic acid, 1518  
 nucleotide, 1520-1521\*  
 numerical taxonomy, 1524  
 oogenesis, 1544-1545  
 operon, 1548  
 plant viruses and viroids, 1715  
 reverse transcriptase, 1910  
 ribose, 1918, 1918\*  
 ribosomes, 1918-1919\*  
 ribozyme, 1919\*  
 small nuclear, 1918  
 structure, 1917-1918  
 transfer, 1918  
 tumor viruses, 2281  
 viral, 1918  
 Ribonucleoprotein, 1519\*  
 Ribooligonucleotide, 1539  
 Ribose, 1917, 1918\*  
 Ribosomal RNA, 1918  
 Ribosome, 348, 1918-1919\*  
 endoplasmic reticulum, 818-819\*  
 ribonucleic acid, 1917-1918\*  
 Ribozyme, 1919\*  
 Ribs, 2331-2332  
 Ribulose, 1919\*  
 Rice, 871, 1919\*  
 Richards, P. L., 500  
 Ricinulei, 1920\*  
*Ricinus communis*, 338  
*Rickettsia* species, 751, 798  
 Rickettsial meningitis, 1354\*  
 Rickettsiales, 1920  
 Rickettsioses, 1920\*  
 anaplasmosis, 113\*  
 heartwater disease, 1053\*  
 Ridge, 847  
 Riebeckite asbestos, 179  
 Riellaceae, 2082  
 Riemann, G. F. B., 1167  
 Riemann surface, 1920-1921\*  
 Riemannian geometry, 1921\*  
 Riesz, F., 1168  
 Rift, 720  
 Rift valley, 1921\*  
 Rift Valley fever, 860, 1921\*  
 Rigel, 1579, 1921\*  
 Rigid body, 1921\*  
 Rigid-body dynamics, 1922\*  
 centre, 403\*  
 couple, 573\*  
 Euler's equations of motion, 854\*  
 Rigid pavement, 1621  
 Rim clutch, 423  
 Rimannian, B., 1921  
 Rinderpest, 1922-1923\*  
 Ring, 1923\*  
 Ring gear, 1699  
 Ring laser gyro (RLG), 1036  
 Ring-necked pheasant, 260  
 Ring-tailed coati, 427  
 Ring theory, 1923\*  
 Ringworm, 578, 1347  
 Rio Grande Rise, 966  
 Ripple see Capillary wave  
 Ripple voltage, 1823\*  
 Risk assessment and management,  
 1923-1924\*  
 Ritz, Walter, 1924  
 Ritz's combination principle, 1924\*  
 River, 1924\*  
 delta, 633\*

- River—*cont.*  
 depositional systems and environments, 641  
 estuaries, 764  
 floodplain, 896\*  
 fluvial sediments, 905\*  
 fresh-water ecosystem, 937  
 Pliocene, 1728  
 River birch, 259  
 River engineering, 1910\*, 1924\*  
 River ice, 1966  
 River tides, 1924-1925\*, 2238  
 Rivet, 1925\*, 2133-2134  
 RNA see Ribonucleic acid  
 RNR see Residual nuclear radiation  
 Roach see Cockroach  
*Robinia pseudoacacia*, 1268  
 Robotics, 1925\*  
 real-time, 1873  
 remote manipulators, 1893  
 robot computer control system, 485  
 Roccellaceae, 992  
 Roche limit, 1925\*  
 Rochelle-electrics, 791  
 Rochelle salt, 1686  
 Rochow, E. G., 708, 786  
 Rock, 1925-1926\*  
 diaphir, 655\*  
 dolomite, 694-695\*  
 gneiss, 1009\*  
 lithosphere, 1264-1265\*  
 metasomatism, 1372-1373\*  
 petrofabric analysis, 1640\*  
 petrography, 1640\*  
 petrology, 1646\*  
 pluton, 1729\*  
 pneumatolysis, 1730\*  
 Precambrian, 1764-1765  
 regolith, 1884-1885\*  
 schist, 1957\*  
 soapstone, 2026\*  
 stone and stone products, 2119\*  
 stratigraphy, 2122-2123\*  
 structural geology, 2134-2135\*  
 see also Igneous rocks; Metamorphic rocks; Sedimentary rocks  
 Rock, electrical properties of, 1926\*  
 Rock age determination, 985-986, 1926-1927\*  
 Rock burst, 1927\*  
 Rock cleavage, 1927\*, 1957  
 Rock magnetism, 1601, 1927\*  
 Rock maple, 1316  
 Rock mechanics, 1927-1928\*  
 engineering properties of rock, 739  
 rock burst, 1927\*  
 Rock ptarmigan, 260  
 Rock salt see Halite  
 Rock varnish, 1928\*  
 Rocket, 1378, 1928\*  
 guidance systems, 1031\*  
 naval armament, 1467  
 Rocket astronomy, 1928\*  
 Rocket engine:  
 aerospike engine, 38  
 fuels, 373  
 propellant, 1785\*  
 spacecraft propulsion, 2069\*  
 Rocket propulsion, 1928-1929\*  
 applications, 1928  
 hybrid, 1928  
 liquid-propellant rocket engines, 1928  
 performance, 1928-1929  
 solid-propellant rocket motors, 1928  
 testing, 1928  
 Rocket-sled testing, 1929\*  
 Rocket staging, 1929-1930\*  
 Rockweeds, 843, 1647  
 Rockwell hardness, 926  
 Rocky Mountain spotted fever, 1920  
 Rod (eye), 781  
 Rodentia, 1930\*  
 agouti, 43-44\*  
 animal evolution, 120  
 beaver, 261\*  
 cavies, 384\*  
 chinchilla, 440\*  
 chipmunk, 440\*  
 dormouse, 698-699\*  
 gerbil, 996\*  
 gopher, 1013\*  
 hamster, 1045\*  
 jerboa, 1202\*  
 lemming, 1240\*  
 Rodentia—*cont.*  
 marmot, 1326\*  
 mouse, 1443\*  
 muskrat, 1456\*  
 polyoma virus, 1750  
 porcupine, 1756\*  
 prairie dog, 1764\*  
 rat, 1871\*  
 social mammals, 2028  
 Rodenticide, 1930\*  
 Rodinia, 1599, 1793  
 Roentgen, W. C., 2404  
 Roentgen optics see X-ray optics  
 Roentgen rays see X-rays  
 Roesleriaceae, 317  
 Rogers, Carl, 1637, 1803  
 Roll, R. G., 500  
 Roll mill, 1930\*  
 Roll-spot welding, 1902  
 Roller (bird), 494  
 Roller chain, 361  
 Rolling, metal, 1367\*  
 Rolling contact, 1930-1931\*  
 Rolling contact bearings, 1277  
 Rolling-element bearing, 139-141  
 ROM see Read-only memory  
 Romaine lettuce, 1246  
 Romanachite, 1931\*  
 Roof construction, 1931\*, 2278  
 Root (biology):  
 hair, 1931  
 Root (botany), 1931\*  
 apical meristem, 150-151\*  
 bark, 251\*  
 cortex (plant), 563  
 function, 1931  
 growth environments, 1931  
 origin, 1931  
 plant-water relations, 1716  
 reproduction, 1896  
 seed, 1973  
 tree, 2266  
 Root (mathematics), 1932\*  
 Root-mean-square, 1932\*  
 Rope, 1932\*  
 Rosaceae, 135  
 Rosales, 1932\*  
 alfalfa, 71\*  
 almond, 87\*  
 apple, 153\*  
 bean, 260-261\*  
 cherry, 436\*  
 clover, 479\*  
 crabapple, 575\*  
 currant, 599\*  
 gooseberry, 1013\*  
 nectarine, 1470, 1470\*  
 peanut, 1621\*  
 quince, 1836\*  
 raspberry, 1870-1871\*  
 strawberry, 2124\*  
 sycamore, 2177\*  
 vetch, 2335-2336\*  
 ROSAT all-sky survey, 2401  
 Rose, 847  
 Rose curve, 1932\*  
 Rose moss, 336  
 Rosemary, 1932-1933\*  
 Rosen, N., 1076  
 Rosidae, 1933\*  
 Apiales, 150\*  
 Celastrales, 385\*  
 Euphorbiales, 855\*  
 Fabales, 869\*  
 Geraniales, 996\*  
 Haloragales, 1044\*  
 Linales, 1256\*  
 Myrtales, 1460\*  
 Podostemales, 1731\*  
 Polygalales, 1744\*  
 Proteales, 1789\*  
 Rafflesiales, 1865\*  
 Rhizophorales, 1913-1914\*  
 Rosales, 1932\*  
 Santalales, 1944\*  
 Sapindales, 1944\*  
 Rosin, 1933\*, 2189  
 Ross Ice Shelf, 1001  
 Rossella, 1284  
 Rostratulidae, 364  
 Rotary atomizer, 194  
 Rotary compressor, 456, 518  
 Rotary engine, 1933\*  
 Rotary power source, 2301  
 Rotary pump, 628  
 Rotary swaging see Swaging  
 Rotary tool drill, 2285  
 Rotary-vane attenuator, 195  
 Rotating-coil gaussmeter, 1292  
 Rotating crystal method (x-ray diffraction), 2402  
 Rotating machinery see Electric rotating machinery  
 Rotation camera, 2402  
 Rotational molding, 1723  
 Rotational motion:  
 Earth, 721-722\*  
 stellar rotation, 2111\*  
 Rotatory dispersion, 506, 1561  
 Rotenone, 1639  
 Rotifera, 1933\*  
 Bdelloidea, 260\*  
 Monogononta, 1433-1434\*  
 Seisonacea, 1977\*  
 Rotor balancing see Shaft balancing  
 Rough-legged hawk, 260  
 Roundworm, 165, 1610  
 Rous sarcoma, 1934\*  
 Router, 1176  
 RR Lyrae stars, 2325  
 Rubber:  
 antifriction bearings, 139-141  
 shock isolation, 2001  
 silicone resins, 2009  
 Rubber tree, 770, 855, 1934\*  
 Rubella, 1934-1935\*  
 autistic disorder, 222  
 pregnancy disorders, 1768  
 Rubellite, 1935\*  
 Rubiaceae, 434  
 bark, 491-492\*  
 Gentianales, 984  
 Rubiales, 173, 1935\*  
 Rubidium, 1935\*  
 Rubus, 265, 1870-1871  
 Ruby, 500, 1203, 1935\*  
 Rudder, aircraft, 62\*  
 Ruffed grouse, 260  
 Rugosa, 1935\*  
 Ruminant:  
 air pollution, 52  
 anaplasmosis, 113\*  
 Artiodactyla, 178  
 bluetongue virus, 272  
 pasteurellosis, 1619  
 pecoran, 164-165  
 stomach, 606  
 tylopod, 164  
 Rumination disorder, 724  
 Runge vector, 1935\*  
 Runnegar, S., 473  
 Running fit, 1935\*  
 Runway (airport), 65-66  
 Rupellaria, 281  
 Rupicapriini, 411-412  
 Rushes, 1731  
 Russell, Bertrand, 1270  
 Russell, Henry Norris, 707, 1070, 2097  
 Russell, John Scott, 2045  
 Rust (microbiology), 949, 1935-1936\*  
 Rust (weeds), 2381  
 Rut see Estrus  
 Rutabaga, 1936\*  
 Ruthenium, 1936\*  
 Rutherford, Ernest (Lord), 191, 270  
 atomic structure and spectra, 211  
 ion-solid interactions, 1186  
 Rutherford backscattering analysis (RBS), 1187  
 Rutherfordium, 1936\*  
 Rutile, 1058, 1936\*  
 Rydberg, Johannes, 735  
 Rydberg atom, 1936-1937\*  
 Rydberg constant, 1937\*  
 Rye, 1937\*  
 Saccoglossus, 742  
 Sachs, R. K., 1024  
 Sacoglossa, 1550, 1939\*  
 Sacrifical hyperconjugation, 987  
 Safety glass, 1939\*  
 Safety valve, 1939-1940\*  
 Safflower, 1940, 1940\*  
 Saffron, 1940\*  
 Sage, 1223, 1940\*  
 Sagebrush, 172, 185  
 Sagenopteris phillipsi, 344  
 Sagitta, 359  
 Sagittaria, 77  
 Sagittariidae, 784  
 Sagittarius, 1940\*, 2099  
 Sago palm, 539  
 Saguaro cactus, 308  
 Sahara, 40  
 Seal shelf, 723  
 Sailplanes, 1004  
 Saint Elmo's fire, 1940\*  
 Saint John's dance see Saint Vitus' dance  
 Saint Vitus' dance, 759  
 Sakuma frequency changer, 683  
 Salam, Abdus, 847, 900  
 gauge theory, 973  
 Urodela, 2313-2314\*  
 Salamander:  
 neoteny, 1475\*  
 tongue, 2248  
 Saldoidea, 944  
 Saleniidae, 1940  
 Salenoida, 1940\*  
 Salicaceae, 1754, 1940  
 Salicales, 613, 1940\*  
 poplar, 1754\*  
 willow, 2388\*  
 Salicylate, 108, 1940-1941\*  
 Salicylic acid, 1941  
 Saline evaporites, 1941\*  
 halite, 1040  
 sedimentary rocks, 1971  
 solution mining, 2046  
 Saline water reclamation:  
 electrochemistry, 765  
 water desalination, 2365\*  
 Salivary gland, 605  
 Salix, 1940  
 Salmon, 1401, 1941  
 Salmonella, 741  
 food microbiology, 909  
 food poisoning, 909  
 toxin, 2254  
 Salmonella enterica, 2363  
 Salmonellosis, 1941\*  
 Salmonidae, 1941  
 Salmoniformes, 1941\*  
 Salmonoidei, 1941  
 Salpida, 2217  
 Salt (chemistry), 1941-1942\*  
 ammonium, 99  
 deliquescence, 632  
 ion transport, 1187  
 thiosulfate, 2233\*  
 water desalination, 2365  
 Salt (food), 821, 1942\*  
 Salt-desert cavy, 344  
 Salt dome, 1942\*  
 Salt-effect distillation, 1942\*  
 Salt gland, 1942\*  
 Salt marsh, 1942-1943\*  
 Salt regulation, 817  
 Salvage, ship, 1999-2000\*  
 Salvia, 1223  
 Salvinia, 1943  
 Salviniales, 1751  
 Salyut:  
 space flight, 2059, 2060  
 space station, 2065  
 Samarium, 1943\*  
 Sambonidae, 1756  
 Sambucus, 620  
 Samburupithecus:  
 fossil apes, 924  
 fossil primates, 928  
 Sampled-data control system, 1943\*  
 Sampling:  
 marine biological, 1317\*  
 microdialysis, 1384\*  
 mole (chemistry), 1416\*  
 quality control, 1821  
 quantitative chemical analysis, 1821  
 statistics, 2103-2104  
 Sampling gate, 866  
 Sampling voltmeters, 2357  
 Sand, 1943\*  
 Sand boa, 272

- Sand dollar, 852, 1943\*  
 Sand dune, 642, 705-706  
 Sandage, A., 271  
 Sandalwood, 1943-1944\*, 1944  
 Sandgrouse, 446, 447  
 Sandpiper, 364  
 Sandstone, 1944\*  
   arenaceous rocks, 168\*  
   arkose, 169-170\*\*  
   graywacke, 1025\*  
   oil sand, 1537\*  
   petroleum, 1641  
   quartzite, 1833\*  
 Sandstorm, 707\*  
 Sanitation, 908  
 Santalales, 1944\*  
   mistletoe, 1409\*  
   sandalwood, 1943-1944\*  
 Santalum, 1943-1944  
 Sap, 1715  
 Sapindaceae, 1280  
 Sapindales, 1944\*  
   buckeye, 339\*  
   cashew, 376\*  
   kumquat, 1219\*  
   lignumvitae, 1254\*  
   lychee, 1280\*  
   mandarin, 1310\*  
   mango, 1312\*  
   maple, 1316\*  
   pistachio, 1692\*  
   quebracho, 1836\*  
   varnish tree, 2327\*  
 Sapotaceae, 384, 656  
 Sapphire, 500, 1203, 1944-1945\*  
 Saproel, 1945\*  
 Sapwood, 2393  
 Saracenia, 1475  
 Sarcina, 240  
 Sarcocystis, 1348, 2254  
 Sarcodina, 1945\*  
   Actinopodea, 21  
   Rhizopodea, 1914\*  
 Sarcoma, 2281  
 Sarcomastigophora, 1945\*  
   Ebrida, 725\*  
   Phytamastigophorea, 1683\*  
   Sarcodina, 1945  
   Zoomastigophorea, 2419-2420\*  
 Sarcoterygii, 582, 1945\*  
 Sarcotiformes, 1945\*  
 Sarcorhamphus papa, 260  
 Sarcoscypha, 685  
 Sarcosporida, 1945-1946\*  
 Sardina pilchardus, 948  
 Sardine, 479-480, 948  
 Sardonyx, 1544  
 Sargassaceae, 843  
 Sargassum, 843  
 Sarraceniaceae, 1692  
 Sarraceniales see Nepenthales  
 SAS see Small Astronomy Satellite  
 Sassafras, 1233, 1946\*  
 Sassafras albidum, 1233  
 Sassafras albidum, 1946  
 Satellite (communications), 1848-1849  
 Satellite (spacecraft), 1946\*  
   communications satellite, 510-511\*  
   electromagnetic pulse, 772  
   military, 1401-1402\*  
   optical tracking instruments, 1563  
   rocket astronomy, 1928  
   scientific, 1961\*  
   space communications, 2057-2058\*  
   space technology, 2067  
   spacecraft structure, 2070  
 Satellite astronomy, 1946-1948\*  
   cosmic background radiation, 1947  
   gamma-ray astronomy, 1947-1948  
   infrared astronomy, 1947  
   orbital motion, 1565-1566\*  
   planetary physics, 1701  
   ultraviolet astronomy, 1947  
   x-ray astronomy, 1947  
 Satellite (astronomy), 1946\*  
   Mars, 1328  
   Moon, 1436-1437\*  
   parallax, 1608  
   ultraviolet astronomy, 1947, 2295  
 Satellite broadcasting, 1848  
 Satellite cells, 1477  
 Satellite laser ranging (SLR), 986, 987  
 Satellite meteorology, 1948\*  
   meteorological satellites, 1378-1379\*  
   meteorology, 1380  
   weather observations, 2380  
 Satellite navigation systems, 1948-1949\*  
 Satellite surveillance, 2120  
 Saturable reactor, 1949\*  
 Saturated aliphatic polyester, 1743  
 Saturation, 1949-1950\*  
 Saturation current, 1950\*  
 Saturation diving, 632, 692  
 Saturn, 1950-1951\*  
   planet, 1698  
   planetary physics, 1700, 1701  
   radio astronomy, 1847  
 Saturnioidea, 1244  
 Sauria, 2092  
 Saurischia, 149, 165, 674, 675, 1951\*  
 Sauropoda, 674  
 Sauropodomorpha, 675  
 Sauropterygia, 771, 1728, 1951\*  
 Savanna, 1951\*, 2056  
 Savory, 1951\*  
 SAW see Surface-acoustic-wave devices  
 Sawdonia, 2420  
 Sawfly, 1112-1113  
 Saxifragales, 1951-1952\*  
 SBR see Butadiene-styrene rubber  
 Scabies, 2018  
 Scalar, 1952\*, 2328  
 Scalded skin syndrome, 2096  
 Scale (instrument), 2381  
 Scale (music), 1952\*  
 Scale (zoology), 1952\*  
 Scale insect, 963  
 Scallop, 1182  
 Scaly anteater, 1656\*  
 Scaly bud, 300  
 Scandentia, 1158  
 Scandium, 1952-1953\*  
 Scanning (facsimile), 869-870  
 Scanning electron microscope (SEM), 112, 781, 1953\*  
 Scanning tunneling microscope, 1464, 1953-1954\*  
 Scaphopoda, 1954\*  
 Scapolite, 1955\*  
 Scarlet fever, 1954\*  
 Scars, ocean, 1322  
 Scattering:  
   nonlinear optics, 1497  
   sound, 2052  
   underwater sound, 2300  
 Scattering experiments (atoms and molecules), 1484, 1954\*  
 Scattering experiments (nuclei), 1954-1955\*  
 Scattering layer, 1955\*  
 Scattering matrix, 1955\*  
 Scattering of electromagnetic radiation, 1955\*  
   extended x-ray absorption fine structure (EXAFS), 862  
   nonlinear optics, 1497  
   opalescence, 1545\*  
   quasielastic light scattering, 1835\*  
   Raman effect, 1867\*  
   Tyndall effect, 2290\*  
 Scent gland, 1955-1956\*, 2314  
 Schawlow, A. L., 1563  
 Scheduling, 1956\*  
 Scheele's green, 157  
 Scheelite, 1956\*  
 Scheffer stroke function, 1270  
 Schematic drawing, 1956-1957  
 Schick test, 2019  
 Schinopsis lorentzii, 1836  
 Schisandraceae, 1126  
 Schist, 705, 1957\*  
 Schistosoma, 1957  
 Schistosomiasis, 1957\*  
 Schistostegales, 1957\*  
 Schizachyrium, 272  
 Schizodontia, 1223  
 Schizogony, 1895  
 Schizomida, 1957\*  
 Schizophrenia, 1957-1958\*  
   dopamine, 697  
   psychopharmacology, 1801-1802  
   psychosis, 1803  
 Schizopteridae, 944  
 Schizosaccharomyces, 1062  
 Schlieren photography, 1958\*, 2002  
 Schlumberger photodiodometer, 1662  
 Schmidt camera, 1959\*  
 Schmitt triggers, 514  
 Schottky anomaly, 1959\*  
 Schottky barrier diode (SBC), 1959\*  
   photovoltaic cell, 1673  
   semiconductor rectifier, 1983  
 Schottky effect, 1959-1960\*  
 Schrieffer, J. R., 2155, 2157  
 Schrödinger, Erwin, 457, 1251, 1960  
 Schrödinger's wave equation, 1960\*  
   atomic theory, 214\*  
   gauge theory, 973  
   parity, 1612  
   quantum (mechanics), 1829-1830  
   quantum chemistry, 1824  
   relativistic quantum theory, 1887  
   scattering matrix, 1955  
   soliton, 2045  
   Wentzel-Kramers-Brillouin method, 2384\*  
 Schuler pendulum, 1034-1035, 1960\*  
 Schultz-Charlton blanching test, 2019  
 Schwann cells, 1476, 1477  
 Schwarzschild, Karl:  
   gravitational collapse, 1022  
   relativity, 1890  
 Schwarzschild solution, 1890  
 Schwinger, J. S., 509, 847, 1826  
 Sciana, D. W., 905  
 Sciatica, 1960\*  
 Science, 1960-1961\*  
   Earth sciences, 722\*  
   evolutionary computation, 857-858\*  
   relation of mathematics to, 1337  
 Scientific methods, 1961\*  
 Scientific satellites, 1961\*  
 Scincidae, 2019  
 Scintillation counter, 1961-9162\*  
   particle detector, 1615  
   photomultiplier, 1669  
 Scirpus, 543  
 Sciridae, 387  
 Scleractinia, 1962\*  
 Sclerenchyma, 1962\*  
 Scleroderma, 475  
 Sclerodermales, 864  
 Scleroscope hardness, 926  
 Sclerospongiae, 1962\*  
 Scelopacidae, 364  
 Scolopendromorpha, 385  
 Scomber scombrus, 1286  
 Scomberomorus maculatus, 1286  
 Scombridae, 1286  
 Scorpion flies, 1345\*  
 Score (satellite), 451  
 Scorpion (astronomy) see Scorpion  
 Scorpion (insect), 95, 138, 155, 1962-1963\*  
 Scorpiones, 1962-1962\*  
 Scorpis, 1963  
 Scotopic vision, 2346, 2347  
 SCR see Silicon-controlled rectifier  
 Scrapie, 1755  
 Scree see Talus  
 Screech owl, 260  
 Screen printing, 1774  
 Screening, 1567, 1963\*  
 Screenless printing, 1774  
 Screw, 1963\*  
 Screw conveyor, 302  
 Screw fastener, 1963-1964\*  
   bolt, 312\*  
   nut, 1524\*  
   washer, 2362\*  
 Screw jack, 1964\*  
 Screw pine, 1605  
 Screw-plug fuse, 850  
 Screw propeller, 1786  
 Screw threads, 1964\*  
   thread fastener, 1964  
   types, 1964  
 Scrophulariaceae, 612, 1223  
 Scrophulariales, 172, 1964-1965\*  
   ash, 180\*  
   digitalis, 672\*  
 Scrotum:  
   reproductive system disorders, 1899  
   testis, 2214  
 Scuba diving, 632, 692  
 Scurvy:  
   hematologic disorders, 1062  
   vitamin C, 166, 180  
 Scutelleridae, 944  
 Scutellinia, 685  
 Scutigera coleoptrata, 385  
 Scutigermorpha, 385  
 Scyphozoa, 1965  
   Coronatae, 497-498  
   Cubomedusae, 597\*  
   Rhizostomeae, 1914\*  
 Sea see Oceans and seas  
 Sea anemone, 1965  
 Actinaria, 20  
 Corallimorpharia, 558\*  
 Sea breeze, 1965\*  
 Sea butterfly, 1549  
 Sea cow:  
   animal evolution, 120  
   Sea cow:—cont.  
     Sirenia, 2014-2015\*  
 Sea cradles, 1750  
 Sea dragon, 1623  
 Sea-floor imaging, 1965-1966\*  
 Sea Goat see Capricornus  
 Sea hare, 1549  
 Sea ice, 1124, 1966\*  
 Sea lion, 1690  
 Sea moth, 1623  
 Sea of Okhotsk, 966\*  
 Sea pen, 1625\*  
 Sea scorpion see Sculpin  
 Sea slug, 1549  
 Sea spider, 1812  
 Sea squirt, 1966\*  
 Sea star, 1621, 1725  
 Sea surface, 2238-2239  
 Sea urchin, 1676, 1966\*  
   Echinoidea, 727\*  
   Euechinoidea, 852  
 Seaborgium, 1967\*  
 Seahorse, 865  
 Seakeeping, 1999  
 Seal, 1690-1691  
 Seam welding, 1902  
 Seamound and guyot, 1967\*  
 Seaplane, 1967\*  
 Search radar, 1840  
 Seasonal affective disorder (SAD), 39  
 Seasons, 722, 1967\*  
 Seawall, 427  
 Seawater, 1967-1968\*  
   estuaries, 764  
   marine mining, 1323\*  
   ocean, 1529  
   upwelling, 2308\*  
   water desalination, 2365  
 Seawater fertility, 1968\*  
 Sebaceous gland, 1968\*  
 Sebekidae, 1756  
 Seborrheic dermatitis, 578  
 Secale, 2385  
 Second battery see Storage battery  
 Second law of motion see Newton's laws of motion  
 Second law of thermodynamics, 1192  
 Second messengers, 1968\*, 2182  
 Second-order nonlinearity, 1496  
 Second-order transition, 2261  
 Second sound, 1968-1969\*  
 Secondary dunes, 706  
 Secondary emission, 784, 1969\*  
 Secondary ion mass spectrometry (SIMS), 1969-1970\*  
   channel electron multiplier, 413\*  
   ion-solid interactions, 1187  
   mass spectrometry, 1331  
 Secretary bird, 784  
 Secretin, 1260  
 Secretion, 1970\*  
 Secretory structures (plant), 809, 1970\*  
 Sectorgram, 1017  
 Secular perturbation (astronomy), 1638  
 Sedative, 1970-1971\*  
 Sedentaria, 1741, 1971\*  
 Sedge, 543  
 Sedges, 1731  
 Sediment:  
   marine geology, 1321, 1322  
   marl, 1326\*  
   saproel, 1945\*  
   siliceous, 2008\*  
   tidalites, 2239\*  
 Sedimentary minerals, 1404  
 Sedimentary rocks, 1971\*  
   arenaceous rocks, 151  
   argillaceous rocks, 152  
   arkose, 154  
   authigenic minerals, 219-220\*  
   banded iron formation, 249-250\*  
   breccia, 330  
   chemostratigraphy, 434\*  
   chert, 436\*  
   clay, 468-469  
   cyclothem, 606\*  
   dolomite rock, 694\*  
   facies, 869  
   formation, 922  
   graywacke, 1025\*  
   heavy minerals, 1058\*  
   kerogen, 1212  
   limestone, 1255\*  
   oil shale, 1537\*  
   petroleum geology, 1642  
   redbeds, 1878\*  
   rock varnish, 1928

- Sedimentary rocks—cont.  
 saline evaporites, 1941\*  
 sandstone, 1944\*  
 seismic stratigraphy, 1975\*  
 shale, 1996\*  
 siliceous sediment, 2008\*  
 stratigraphy, 2122-2123\*  
 turbidite, 2284\*
- Sedimentation (geology):  
 diapir, 655\*  
 deep-marine sediments, 628-629\*  
 depositional systems and environments, 641-642  
 diagenesis, 653\*  
 diastem, 656\*  
 estuarine, 849  
 fluvial sediments, 905\*  
 loess, 1268\*  
 marine sediments, 1324-1325\*  
 river, 1924  
 sedimentary rocks, 1971\*  
 turbidite, 2284\*  
 varve, 2327\*
- Sedimentation (industry), 1971-1972\*  
 Sedimentation potential, 693  
 Sedimenting centrifuge, 352  
 Sedimentology, 1972-1973\*  
 biological effects, 1972  
 chemical sedimentation, 1972  
 environments and facies, 1973  
 formation, 922  
 major controls, 1972  
 paleosol, 1602-1603  
 Seebeck, J., 1973  
 Seebeck effect, 1973\*, 2228  
 Seed, 1973-1974\*  
 abscission, 4\*  
 dormancy, 698\*, 1974  
 dune vegetation, 706  
 economic importance, 1973  
 fossil seeds and fruits, 928-929\*  
 germination, 1974  
 growth, 1705\*  
 physiology, 1973-1974  
 plant phylogeny, 1712  
 structure, 1973  
 Seed fern, 1805\*  
 Seed flax, 805  
 Seed plants:  
 evolution, 1703  
 Pinnophyta, 1691\*  
 Seed snipe, 364  
 Seeley, H. G., 674  
 Seiche, 1974\*  
 Seif dune, 642-643  
 Seignette-electrics, 791  
 Seignette salt see Rochelle salt  
 Seismic exploration for oil and gas, 1974-1975\*  
 Seismic risk, 1975\*  
 Seismic source imaging, 1977  
 Seismic stratigraphy, 1975\*  
 Seismic waves, 1736  
 Seismographic instrumentation, 1975\*  
 Seismology, 1976-1977\*  
 asthenosphere, 188  
 Earth sciences, 722  
 earthquake, 722-723\*  
 earthquake intensity, 655  
 Earth's interior, 720-721  
 helioseismology, 1060\*  
 Moho (Mohorovičić discontinuity), 717, 1415\*  
 paleoseismology, 1602\*  
 refraction of waves, 1882  
 seismic source imaging, 1977  
 seismographic instrumentation, 1975\*  
 theoretical, 1976-1977  
 two- and three-dimensional imaging, 1977  
 Seismometer, 1975  
 Seismoscope, 1975  
 Seasonacea, 1933, 1977\*  
 Seizure disorders, 1768, 1977-1978\*  
 Selachii, 1978\*  
 Selaginellales, 1978\*  
 Selection circuits, 2175-2176  
 Selection rules (physics), 1978-1979\*\*  
 Selective serotonin reuptake inhibitors (SSRIs), 1989  
 Selectivity, 1979\*  
*Selenarctos tibetanus*, 230  
 Selenidium, 148  
 Selenium, 1576, 1979\*  
 Self-action (nonlinear optics), 1497  
 Self-contained breathing apparatus (SCBA), 1906  
 Self dunes, 706  
 Self-electrooptic-effect device (SEED), 793  
 Self-inductance, 1137  
 Self-pollination, 1739  
 Self-tolerance, 1130  
 Seligeriales, 1979\*  
 SEM see Scanning electron microscope  
 Semaestomeae, 1965, 1979-1980\*  
 Semiclosed cycle gas turbine, 864  
 Semiconductor, 1980-1981\*  
 acceptor atom, 10\*  
 amorphous, 100  
 charge-coupled devices, 415-416\*  
 circuit breaker, 407  
 computer storage, 462-463  
 conductivity, 532, 1980  
 donor atom, 696\*  
 electrical resistivity, 760  
 electron-hole recombination, 780-781\*  
 extrinsic, 1980  
 glass switch, 1002-1003\*  
 Hall coefficient, 922  
 high-pressure physics, 1078  
 high-temperature technology, 955  
 hole conduction, 958  
 impurities, 527  
 injection electroluminescence, 693, 769  
 intrinsic, 1980  
 ion implantation, 1185  
 junction diode, 1205\*  
 materials, 1980-1981  
 optical detectors, 1553  
 optical materials, 1556-1557  
 phototube, 1673  
 photovoltaic effect, 1673-1674  
 polaron, 1738\*  
 radiation hardening, 1844-1845\*  
 rectification in, 1981  
 saturation current, 1950\*  
 Schottky barrier diode, 1959\*  
 secondary emission, 1969\*  
 solar cell, 2038\*  
 superconductivity, 2155  
 surface electronics, 1981  
 traps in solids, 2265\*  
 valence band, 2320\*  
 Semiconductor detector, 1615  
 Semiconductor devices:  
 electrical noise, 759  
 sputtering, 2091  
 Semiconductor diode, 617, 1205, 1981-1982\*  
 frequency modulator, 936  
 laser, 1229-1230  
 microwave solid-state devices, 1396-1398\*  
 semiconductor rectifier, 1983-1984\*  
 tunnel diode, 2283\*  
 varactor, 2324\*  
 varistor, 2326\*  
 Zener diode, 2414\*  
 Semiconductor heterostructures, 1982\*  
 mesoscopic physics, 1359-1360\*  
 nanostructure, 1464\*  
 Semiconductor memories, 1982-1983\*  
 Semiconductor rectifier, 1205, 1983-1984\*  
 circuits, 1983  
 controlled, 485-486  
 light-emitting diode, 1251-1252\*  
 Schottky diodes, 1983  
 silicon rectifier diodes, 1983  
 thyristors, 1983  
 varistor, 2326\*  
 Seminole bread plant, 157  
 Semionotiformes, 1984\*  
 Sendai virus, 1984\*  
 Senegal River, 41  
 Senescence, 397  
 Senile eczema, 665  
 Senile gangrene, 860  
 Sensation, 1984-1985\*  
 cutaneous, 536  
 mechanoreceptors, 1345\*  
 proprioception, 1786-1787\*  
 sense organ, 1985\*  
 somesthesia, 2048\*  
 see also Chemical senses  
 Sense amplifier, 1985\*  
 Sense organ, 1985\*  
 Sensitivity (engineering), 1985\*  
 Sensor (microsensor), 1391\*  
 Sensory memory, 1352  
 Sensory system, 1232, 1986  
 Separation of isotopes by laser excitation (SILEX), 1198  
 Sepioidea, 438, 1986\*  
 Sepiolite, 944, 1986\*  
 Septibranchia, 1986-1987\*  
 Septic arthritis, 2017  
 Septic tank, 1987\*  
 Septicemia, 34  
 pasteurellosis, 1619  
 salmonellosis, 1941  
 Septicemic anthrax, 135  
*Septobasidium*, 984  
 Sequence stratigraphy, 1987\*, 2123  
 Sequence variation (DNA testing), 915-916  
 Sequential circuits, 2175  
 Sequoia, 1987-1988\*, 2266  
*Sequoia gigantea*, 1987  
 Sergeant, M., 383  
 Series, 1988\*  
 convergence and divergence, 1988  
 finite, 1988  
 Fourier see Fourier series  
 power, 1988  
 uniform convergence, 1988  
 Series circuit, 1988\*  
 Series motor, 623  
 Serology, 1989\*  
 agglutination reaction, 42\*  
 conglutination, 537\*  
 heterophile antigen, 1072\*  
 lytic reaction, 1284\*  
 opsonin, 1550\*  
 toxin-antitoxin reaction, 2254\*  
 Serotonin, 1989\*  
 Serpentine, 470, 1989\*  
 Serpentine, 1989\*  
*Serpula*, 984, 1112  
 Serpulidae, 2279  
 Serranidae, 226  
 Serratia, 741  
 Serritermitidae, 1195  
 Sertoli cells, 2081, 2082  
 Serum, 1989\*  
 albumin, 68  
 globulin, 1006\*  
 immune, 252  
 plasma, 268  
 Servomechanism, 1943, 1989-1990\*  
 Sesame, 1223  
*Sesamum*, 1223  
 Set screw, 1963  
 Set theory, 1145, 1990\*  
*Setaria italica*, 1403  
 Seuratoidea, 165  
 Severe combined immunodeficiency syndrome (SCIDS), 1361  
 Sewage, 1990\*  
 Sewage collection systems, 1990-1991\*  
 Sewage disposal, 1142, 1991\*  
 Sewage solids, 1991\*  
 Sewage treatment, 1987, 1991-1992\*  
 Sewer, 1990  
 Sewing machine, 1992  
 Sex chromosome, 400, 453, 1439  
 Sex determination, 1992-1993\*  
 humans, 968  
 sex-influenced inheritance, 1993\*  
 sex-linked inheritance, 1993\*  
 Sex-influenced inheritance, 1993\*  
 Sex-linked inheritance, 968, 1993\*  
 Sextant, 1993-1994\*  
 Sexual dimorphism, 1994\*  
 Sexual reproduction see Reproduction (animal); Reproduction (plants)  
 Sexually transmitted diseases, 1994-1995\*  
 chlamydial diseases, 442\*  
 gonorrhea, 1012-1013\*  
 syphilis, 2185\*  
 Seyfert galaxies:  
 external, 956  
 quasar, 1834  
 Sferics, 1995\*, 2100  
 Shade trees, 2026  
 Shadow, 1995\*  
 Shadowgraph, 1995-1996\*  
 Shaft balancing, 1996\*  
 Shafting, 1996\*  
 coupling, 574\*  
 fluid coupling, 899-900\*  
 gear, 974\*  
 gear train, 974\*  
 splines, 2088\*  
 universal joint, 2305\*  
 Shagbark hickory, 952  
 Shake tables, 2338  
 Shale, 152, 264, 1996\*  
 Shallot, 1543  
 Shannon, C. E., 250  
 Shannon (unit), 263  
 Shannon's equation, 250  
 Shape memory alloys, 84, 1996\*
- Shaper, 1697  
 Shapley, H., 2099  
 Shark:  
 Cladoselachii, 467\*  
 placentalion, 1694  
 Shear, 1996\*, 2033  
 Shear center, 1997\*  
 Shear stress, 1362  
 Shearing interferometer, 1172  
 Sheathbill, 364  
 SHEED see Scanning high-energy electron diffraction  
 Sheep, 164, 178, 1997\*  
 Johne's disease, 1203  
 listeriosis, 1264  
 louping ill, 1274  
 pasteurellosis, 1619  
 Sheet-metal forming, 1997-1998\*, 2086  
 Sheldon, William, 121  
 Shelf circulation, 546  
 Shell cameo, 320  
 Shellac, 1998\*, 2326  
 Shepard, Alan, 2058  
 Shephard control chart, 484  
 Shield bug, 944  
 Shield volcanoes, 2352  
 Shields (Earth crust), 720  
*Shigella*, 2363  
 bacillary dysentery, 239-240\*  
*Escherichia*, 847  
 Shiitake mushroom, 984, 1112  
 Shingles see Chickenpox and shingles  
 Ship:  
 dead reckoning, 621  
 degaussing, 631  
 electronic navigation systems, 789  
 fuzzy-structure acoustics, 953  
 guidance systems, 1031\*  
 hydrofoil craft, 1104\*  
 icebreaker, 1124\*  
 marine machinery, 1322\*  
 marine refrigeration, 1324\*  
 merchant ship, 1356\*  
 naval surface ship, 1468-1469\*  
 oceanographic vessels, 1531\*  
 submarine, 2138-2139\*  
 Ship design, 1998\*  
 icebreaker, 1124\*  
 marine engineering, 1320-1321\*  
 naval architecture, 1466\*  
 submarine, 2139  
 Ship nuclear propulsion, 1998\*  
 Ship powering, maneuvering, and seakeeping, 1998-1999\*  
 marine engine, 1320\*  
 propeller, 1786  
 Ship routing, 1999\*  
 Ship salvage, 1999-2000\*  
 Shipboard radar, 1864  
 Shipbuilding, 2000\*  
 Shipping fever, 2000, 2000\*  
 Shipworm, 2000\*  
 Shipyard eye see Keratoconjunctivitis  
 Shock absorber, 2000-2001\*  
 automotive suspension, 230  
 vibration damping, 2337\*  
 Shock isolation, 2001\*  
 Shock syndrome, 2001\*  
 see also Anaphylaxis  
 Shock tube, 2001\*  
 Shock wave, 72, 2002\*  
 aerodynamic wave drag, 33\*  
 atmospheric entry, 203  
 pitot tube, 1693  
 shock tube, 2001\*  
 sonic boom, 2049, 2049\*  
 supernova, 2161  
 supersonic flow, 2164  
 Shock-wave display, 1958-1959  
 Shope fibroma virus, 1145  
 Shope papilloma see Infectious papillomatosis  
 Shoreline see Strand line  
 Short circuit, 2002-2003\*  
 Short-nosed sturgeon, 2137  
 Short-pulsed gas lasers, 1229  
 Short takeoff and landing (STOL), 2003\*  
 Short-term memory, 435, 1352  
 Shortwave radio broadcasting, 1848  
 Shot noise, 759  
 Shot peening see Peening  
 Shrew, 1158, 2003\*  
 Shrimp, 1307  
 Anostraca, 128  
 Decapoda, 622-625\*  
 Eucarida, 852\*  
 Euphausiacea, 855\*

- Shrimp—*cont.*  
 invertebrate pathology, 1182  
 squid, 2093
- Shubnikov-de Haas effect, 1077
- Shunt motor, direct-current, 623
- Shunting, 2003-2004\*
- Shui ung tsoi, 1579
- SI see International System of Units
- Siamang, 132, 1772
- Siboglinidae, 182
- Sickle cell disease, 1361, 2004\*
- Side-swimmer, 1627
- Sideband (single), 2004\*
- Sidereal time, 2004\*  
 clocks, 2240  
 day, 557, 620-621  
 month, 1436  
 year, 722, 2410
- Siderella*, 144, 161
- Siderite, 2004-2005\*
- Siderophores, 2005\*
- SIDS see Sudden infant death syndrome
- Siemens, 761, 2304
- Sieve elements, 1655
- Sigalionidae, 760
- Sigma-delta converter, 2005\*
- Sigmatropic shifts, 1630
- Signal detection theory, 2005\*
- Signal generator, 2005-2006\*
- Signal processing:  
 acoustic, 17-18\*  
 adaptive, 25\*  
 matched-field processing, 1333\*
- Signal processing, acoustic see Acoustic signal processing
- Signal-to-noise ratio, 1173, 2006\*
- Signal transduction, 1968, 2006\*
- Significant figures, 2006-2007\*
- Silencer see Muffler
- Silica, 1002
- Silica minerals, 2007\*  
 stishovite, 2117\*  
 talc, 2189\*
- Silicate minerals, 2007-2008\*  
 amphibole, 102-103\*  
 analcime, 107\*  
 andalusite, 114\*  
 apophyllite, 151-152\*  
 cancrinite, 362\*  
 chabazite, 359, 410-411\*  
 chlorite, 443\*  
 chloritoid, 443\*  
 chrysocolla, 455\*  
 clay minerals, 470\*  
 cordierite, 558\*  
 datolite, 620\*  
 dumortierite, 705\*  
 epidote, 838\*  
 feldspar, 875\*  
 feldspathoid, 875\*  
 garnet, 964\*  
 hemimorphite, 1063\*  
 heulandite, 1073\*  
 humite, 1098\*  
 kaliophyllite, 1209\*  
 kalsilite, 1209\*  
 kyanite, 1219-1220\*  
 larnite, 1228\*  
 lawsonite, 1234\*  
 lazurite, 1235\*  
 lepidolite, 1242\*  
 leucite, 1246\*  
 melilite, 1351\*  
 mica, 1381-1382\*  
 muscovite, 1451\*  
 olivine, 1540\*  
 opal, 1545\*  
 orthorhombic pyroxene, 1581-1582\*  
 pectolite, 1622\*  
 phlogopite, 1655-1656\*  
 prehnite, 1768\*  
 pyrophyllite, 1817\*  
 rhodonite, 1915\*  
 sepiolite, 1986\*  
 serpentine, 1989\*  
 silicate phase equilibria, 2008\*  
 sillimanite, 2009\*  
 staurolite  
 stilbite, 2116\*  
 thortite, 2234\*  
 topaz, 2249\*  
 tourmaline, 2252\*  
 vesuvianite, 2335\*  
 willemite, 2388\*  
 wollastonite, 2393\*  
 zeolite, 2414-2415\*, 241402415\*  
 zircon, 2417\*
- Silicate perovskite, 1078
- Silicate phase equilibria, 2008\*
- Siliceous sediment, 2008\*
- Siliceous sinter, 2008\*
- Silicoflagellata, 2008\*
- Silicoflagellida, 2008\*
- Silicon, 2008-2009\*  
 amorphous, 100  
 organosilicon compound, 1576-1577\*  
 semiconductor, 1980, 1981  
 silica minerals, 2007\*  
 silicate minerals, 2007-2008\*
- Silicon bronze, 295
- Silicon intensifier camera tube, 2204
- Silicon microphones, 1389
- Silicon rectifier diodes, 1983
- Silicone resins, 2009\*
- Silk, 2009\*
- Silk-cotton tree see Kapok tree
- Silk tree, 1240
- Silkworm, 1156
- Sillerpeton*, 67
- Silliman, Benjamin, 1404
- Sillimanite, 2009\*
- Siltstone, 152
- Silurian, 2009-2010\*  
 animal evolution, 120  
 Paleozoic, 1603  
 plant evolution, 1703
- Siluriformes, 2010\*
- Siluroidei, 341
- Silver, 2010\*  
 cerargyrite, 406\*  
 photographic materials, 1665  
 pyrargyrite, 1812\*  
 Silver alloys, 2011\*  
 Silver halide, 1667-1668  
 Silver metallurgy, 2011\*  
 Silver pheasant, 260  
 Silver sulfide, 7  
 Silversides, 182-183  
 Silviculture, 2011-2012\*  
 forest measurement, 920  
 forest pest control, 921
- Simon, H. A., 1346
- Simple eye (invertebrate), 780
- Simple fruit, 842
- Simple gear train, 868
- Simple harmonic motion see Harmonic motion
- Simple lens (optics), 1241
- Simple lipids, 1260
- Simple machine, 2012\*  
 block and tackle, 304\*  
 inclined plane, 1135\*  
 lever, 1248\*  
 mechanical advantage, 1342\*  
 screw jack, 1964\*  
 wedge, 2380-2381\*  
 wheel and axle, 2386\*
- Simple microscope, 1391
- Simple polygon, 1744
- Simpson, G. G., 1287
- SIMS see Secondary ion mass spectrometry
- Simulation, 2012-2013\*  
 molecular, 1425\*  
 Monte Carlo method, 1436\*  
 robotics, 1925
- Simulium*, 1347
- Simultaneity, 1887-1888
- Sine wave, 2013\*  
 alternating current, 89-90\*  
 phase velocity, 1654\*  
 Sine-wave oscillator, 1583
- Single-axis gyroscope, 918
- Single-block brake, 326
- Single crystal, 594, 2013\*
- Single-ended amplifiers, 2353-2354
- Single-phase induction motor, 1138
- Single-phase reluctance, 1893
- Single-photon emission computed tomography (SPECT), 1346-1347
- Single sideband, 2013\*
- Single-sideband transmitter, 1853
- Sink flow, 637-638
- Sinkholes, 1210
- Sintering, 1762, 2013\*
- Sinus, 2013\*
- Siphonaptera, 2013-2014\*
- Siphonatiidae, 226
- Siphonolaimoidea, 1431
- Siphonophora, 983, 1111, 2014\*
- Siphonostomatoidea, 2014\*
- Sipuncula, 2014\*
- Siren (acoustics), 2014\*
- Sirenia, 2014-2015\*
- Sirius, 2015\*
- Sirmondsia chinensis*, 1204
- Sirocco, 2015\*
- Sisal, 2015\*
- Sitka spruce, 2091
- Sivatherium*, 164
- Sivapithecus*, 829, 924
- Size reduction, 1567
- Sjögren's disease, 475, 1129
- Skarn, 2015\*
- Skate, 257
- Skeletal muscle, 1450  
 electrodiagnosis, 768  
 innervation, 1441
- Skeletal system, 2015-2017\*  
 appendicular skeleton, 2016-2017  
 axial skeleton, 2015-2016  
 bone, 315-316\*  
 joint (anatomy), 1203-1204\*  
 vertebra, 2331-2332\*
- Skeletal system disorders, 2017\*  
 arthritis, 174\*  
 dwarfism and gigantism, 707\*  
 osteoporosis, 1586\*
- Skew four-bar linkage, 832
- Skimmer (bird), 365
- Skin, 2017-2018\*  
 chromatophore, 450\*  
 cutaneous sensation, 601\*  
 effects of ultraviolet radiation, 2296  
 electrodermal response, 767\*  
 epidermal ridges, 837\*  
 integumentary patterns, 1168  
 pigmentation, 1686\*
- Skin disorders:  
 dermatitis, 642\*  
 ulcer, 2293\*
- Skin diving, 633, 692
- Skin effect (electricity), 2018-2019\*
- Skin test, 2019\*
- Skink, 2019\*
- Skipjack see Bluefish
- Skua, 365
- Skull, 2015-2016
- Skunk, 2019\*
- Skutterudite, 2019\*
- Sky compass, 1734
- Skylab*:  
 space flight, 2060  
 space station, 2065-2066
- Skyscrapers, 342
- Slab:  
 concrete, 531\*  
 foundation, 832
- Slat conveyor, 488
- Slate, 2019\*, 2119
- Slater, 1543
- Slater, J. C., 214
- Slaty cleavage, 2019
- Sleep and dreaming, 2019-2021\*  
 dreams, 2021  
 EEG pattern, 693  
 evolution and function of sleep, 2020-2021  
 nature of sleep, 2019  
 pituitary gland disorders, 1694  
 psychosis, 1803  
 sleep cycle, 2019-2020  
 sleep disorders, 2021\*
- Slackhead, 1941
- Slide, 628
- Slider-crank mechanism, 2021-2022\*
- Slime mold:  
 Eumycetozoida, 854\*  
 Myxomycota, 1461\*
- Slip (electricity), 2022\*
- Slip face, 705, 706
- Slip rings, 2022\*
- Slipher, V. M., 505
- Slope, 2022\*
- Slope environments, 628-629
- Sloth, 120, 2022\*
- Slow neutron spectroscopy, 2022-2023\*
- Sludge see Sewage solids
- Slug (zoology), 972, 2023\*
- Slump:  
 deep-marine sediments, 628  
 submarine canyon, 2140
- Small intestine, 606-607  
 absorption, 607  
 bile, 607  
 digestive system, 666  
 gastrointestinal tract disorders, 971  
 pancreatic secretion, 607
- Small Magellanic Cloud, 1288
- Small-signal models, 758
- Smallpox, 124, 2023\*
- Smart drone (aircraft), 639, 701
- Smart meters, 2370
- Smart weapons, 48
- Smectite, 1126
- Smell see Olfaction
- Smelt, 1941
- Smelting, 2416
- Smithsonite, 2023\*
- Smog, 53, 2023-2024\*  
 fog, 907  
 stratosphere, 2124  
 see also Air pollution
- Smoke, 2024\*
- Smooth muscle, 1450
- Smut (microbiology), 2024\*
- Snail, 2024-2025\*  
 Gastropoda, 972  
 hibernation, 1074  
 Neogastropoda, 1473\*  
 parasitology, 1610  
 Prosobranchia, 1787\*
- Snake:  
 phobia, 1656  
 Serpentes, 2092  
 Squamata, 2092  
 tongue, 2248
- Snap ring, 2025\*
- Snell's law, 1882, 2405
- Snipe, 364
- Snipefish, 970
- Snow, 2025\*  
 avalanche, 233\*  
 precipitation measurement, 1766\*  
 see also Precipitation (meteorology)
- Snow gage, 2025\*
- Snow line, 2025\*
- Snow molds, 1112
- Snow pea, 1578
- Snow sampler see Snow gage
- Snow surveying, 2025-2026\*
- Snowfield and névé, 2025, 2026\*
- Snowy owl, 260
- Snyder, H., 1022
- Soap, 730-731, 2026\*
- Soapstone, 2026\*
- Soboliphyme*, 616
- Social animals:  
 dinosaur, 676  
 prairie dog, 1764\*  
 rabbit, 1839\*
- Social anxiety disorder (SAD), 147
- Social hierarchy, 2026-2027\*
- Social insects, 2027-2028\*  
 ant, 129\*  
 bee, 261-262\*  
 Hymenoptera, 1112-1113\*  
 Isoptera, 1195-1196\*  
 pheromone, 1655\*
- Social mammals, 2028\*
- Social science, 626
- Sociobiology, 2028-2029\*
- Sociopathy see Psychopathy
- Soda niter, 2029\*
- Sodalite, 1125
- Sodium, 77, 2029\*
- Sodium bicarbonate, 802
- Sodium chlorate, 390
- Sodium chloride, 390, 526  
 halide, 1040  
 salt (food), 1942\*
- Sodium-vapor lamp, 2029-2030\*
- Sofar, 2030\*
- Software, 2030-2031\*  
 map design, 1315  
 microcomputer, 1383, 1384  
 virtual manufacturing, 2342
- Software, mathematical, 1336-1337\*
- Software engineering, 2031\*  
 functional analysis and modeling, 944-945\*  
 multiaccess computer, 1444-1445\*  
 security, 461  
 software metric, 2031-2032\*  
 systems architecture, 2186-2187\*  
 visual debugging, 2348\*
- Software metric, 2031-2032\*  
 Software musical instruments, 1455
- Software testing and inspection, 2031, 2032\*
- Softwoods, 2393-2394\*, 2408
- Soil, 2032-2033\*  
 grassland ecosystem, 1020  
 humus, 1098\*  
 origin and classification, 2032-2033  
 paleosol, 1602-1603\*  
 pedology, 1623\*  
 physical properties, 2033  
 regolith, 1884-1885  
 rhizosphere, 1914\*



- Soil—cont.  
surveys, 2033  
wetlands, 2384
- Soil chemistry, 2033-2034\*  
elemental composition, 2033-2034  
ion exchange, 2034  
minerals, 2034  
soil solution, 2034
- Soil conservation, 2034-2035\*  
causes of mismanagement, 2034  
cover crops, 574\*  
erosion, 844\*, 2034-2035  
fertilizer, 880-881\*  
terracing (agriculture), 2210-211\*
- Soil degradation, 2035\*
- Soil ecology, 2035-2036\*
- Soil fertility, 2036\*
- Soil fungicide, 849
- Soil mechanics, 2036-2037\*  
mass wasting, 1332\*  
properties of soil, 2036-2037
- Soil microbiology, 1914, 2037\*
- Soil sterilization, 2037\*
- Sojourner, 1327
- Sokolov, S., 989
- Sol-gel process, 2037-2038\*
- Solanaceae, 1421
- Solanales, 2038\*  
eggplant, 739\*  
paprika, 1607\*  
potato, Irish, 1759-1760\*  
tobacco, 2246\*
- Solar battery, 762
- Solar cell, 1673-1674, 2038\*
- Solar constant, 2038\*
- Solar corona, 2038\*  
coronagraph, 561\*  
solar wind, 2042\*
- Solar day, 557, 620, 722
- Solar eclipse, 660-661, 729-730
- Solar-electric power generation, 2038
- Solar energy, 2039\*  
altitudinal vegetation zones, 92\*  
heat balance, terrestrial atmospheric, 1054\*  
heat flow in Earth, 719  
photoelectrochemical cells, 775  
solar cell, 2038\*  
solar constant, 2038\*  
solar radiation, 2041\*  
spacecraft propulsion, 2069\*  
storage, 736
- Solar flare, 2110
- Solar heating and cooling, 2039-2040\*  
cooling, 2040  
distillation, 2039  
service water heating, 2040  
solar energy, 2039  
space heating, 2040  
swimming pool heating, 2039
- Solar magnetic field, 2040\*  
Fraunhofer lines, 834  
solar wind, 2042\*
- Solar nebula, 503
- Solar neutrinos, 2040-2041\*
- Solar radiation, 2041\*  
atmospheric general circulation, 205  
effect on climate, 416  
greenhouse effect, 1025-1026\*  
insolation, 1159\*  
solar energy, 2039\*  
Sun, 2149  
zodiacal light, 2417-2418\*
- Solar system, 2041-2042\*  
composition, 2041  
cosmic abundance of elements, 804\*  
cosmochemistry, 567-568\*  
Kuiper Belt, 1219\*  
occultation, 1529\*  
origin, 2041-2042  
planets of, 1697-1698  
Sun, 2149-2151\*  
syzygy, 2188\*  
T Tauri star, 2189\*  
ultraviolet astronomy, 2295  
universe, 2306
- Solar system astronomy, 1847
- Solar time, 621  
Earth rotation and orbital motion, 722  
time, 2240
- Solar wind, 2042\*  
aurora, 218-219\*  
interplanetary matter, 1177  
magnetosphere, 1303\*  
solar radiation, 2041
- Solarium melongena*, 667
- Soldering, 2042\*
- Sole (fish), 805, 1728
- Solenichthyes, 865
- Solenodon*, 1159, 2042\*
- Solenodontidae, 1159
- Solenoid (electricity), 2042-2043\*
- Solenoid (meteorology), 252, 2043\*
- Solid:  
diffusion, 665  
domain, 695\*  
drying of, 641, 703-704  
elasticity, 741\*  
electron paramagnetic resonance spectroscopy, 782  
flow of, 897-898\*  
ion-solid interactions, 1186-1187\*  
melting point, 1351\*  
moisture-content measurement, 1416  
polyhedron, 1744\*  
quantum, 1830\*  
rare-earth minerals, 1870\*  
sewage, 1991\*  
traps in, 2265\*  
Umklapp process, 2296\*
- Solid (geometry), 1744, 2043\*
- Solid electrical insulation, 683
- Solid fertilizer, 794
- Solid fuel, 373, 829
- Solid of revolution *see* Surface and solid of revolution
- Solid propellant, 1785, 1929
- Solid solution, 2043\*  
copper alloys, 556-557\*  
eutectics, 856\*
- Solid-state battery, 2043-2044\*
- Solid-state chemistry, 2044\*
- Solid-state devices, 1396-1398
- Solid-state lasers, 1229
- Solid-state maser, 1329
- Solid-state physics, 2044\*  
quantum theory of matter, 1830-1831\*  
surface physics, 2169-2170\*
- Solid-state uninterruptible power system, 2301
- Solids pump, 2044-2045\*
- Solifugae, 2045\*
- Solitaria, 827
- Soliton, 2045\*
- Solstice, 145, 162, 2045-2046\*
- Solubility product constant, 2046\*
- Solubizing of samples, 2046\*
- Solution, 2046\*  
azeotropic mixture, 209  
concentration scales, 529\*  
osmosis, 1585\*  
solid *see* Solid solution  
solvent, 2047  
solvent extraction, 2047\*  
supersaturation, 2163\*
- Solution mining, 2046-2047\*
- Solvation, 2047\*
- Solvent, 2047\*  
dimethyl sulfoxide, 673\*  
ester, 848  
ethyl alcohol, 850  
fused-salt solution, 951-952\*  
solution, 2046\*  
solvation, 2047\*  
thinner, 2233\*
- Solvent extraction, 2047\*
- Somatic cell genetics, 2047-2048\*
- Somatic muscle, 1450
- Somatization disorder, 1803
- Somatostatin, 2048\*
- Somesthesia, 2048\*
- Sommerfeld, A., 192, 212
- Sonar, 2048-2049\*  
acoustic mine, 16  
acoustic signal processing, 17-18\*  
antisubmarine warfare, 145-146\*  
echo sounder, 659-660, 728\*  
hydrophone, 1109\*  
polar navigation, 1735  
sea-floor imaging, 1965  
sofar, 2030\*  
sonobuoy, 2049-2050\*  
spectrum analyzer, 2077
- Sonic boom, 2049\*
- Sonneborn, B., 177, 191
- Sonobuoy, 2049-2050\*  
hydrophone, 1109\*  
sonar, 2049
- Sonochemistry, 2050\*
- Sonography, 1346
- Sooty mold, 761
- Soret, J. L., 603
- Sorghum, 2050-2051\*, 2143
- Soricidae, 1159, 2003
- Soricomorpha, 1159
- Sotalia fluviatilis*, 634
- Sound, 2051-2052\*  
absorption of, 2052  
acoustic emission, 15  
acoustic pressure, 2051  
active sound control, 22-23\*  
aerodynamic, 33  
animal communication, 119  
architectural acoustics, 164-165\*  
atmospheric acoustics, 202-203\*  
bioacoustics, animal, 275-276\*  
cavity resonator, 384  
decibel, 625\*  
description of, 2051  
diffraction and scattering, 2052  
harmonic (periodic phenomena), 1046-1047\*  
harmonic waves, 18  
infrasound, 1153\*  
loudness, 1273\*  
masking, 1328\*  
phonoreception, 1657-1658\*  
pitch, 1692\*  
plane waves, 2051  
propagation of, 2051-2052  
quantum acoustics, 1823  
rays, 2052  
reflection of, 1881\*, 2052  
refraction of waves, 1882  
reverberation, 1910\*  
siren (acoustics), 2014  
speech, 2077-2078\*  
transmission of, 2052  
ultrasonics, 2294\*  
underwater, 2299-2300\*  
*see also* Acoustics; Binaural sound; Monophonic sound; Stereophonic sound; Underwater sound
- Sound absorption, 4-5, 2052\*  
atmospheric, 202  
building materials, 148-149, 165
- Sound field enhancement, 2052-2053\*
- Sound intensity, 2051, 2053\*  
acoustic radiometer, 17\*  
decibel, 563  
sound absorption, 2052
- Sound navigation and ranging *see* Sonar
- Sound pressure, 2053\*  
acoustic impedance, 16  
acoustic radiation pressure, 17\*
- Sound recording, 2054\*  
magnetic recording, 1294  
monophonic, 2054  
stereophonic, 2054  
*see also* Acoustic entries; Disk recordings; Magnetic recording
- Sound-recording studio, 2054\*
- Sound-reinforcement system, 2054\*
- Sound-reproducing systems, 2054-2055\*  
binaural sound system, 274-275\*  
digital recording, 672-673\*  
fidelity, 885\*
- Sound waves, 2371  
acoustic holography, 15-16\*  
radiology, 1863  
upper-atmosphere dynamics, 2307-2308
- Sounding sensors, 1379
- Sour cherry, 383
- Sour clover, 422
- Sour gum, 497, 560
- Sour orange, 1565
- Source region (atmosphere), 772
- Sourwood, 2055\*
- South African jade, 1201
- South America, 2055-2056\*
- South American trypanosomiasis, 360
- South Equatorial Current, 841
- South Indian Yellow-Throated marten, 1328
- South Pole, 130, 2056\*
- Southeast Asian waters, 723, 2057\*
- Southern Cross *see* Crux
- Southern white cedar, 344
- Sow bug, 1543
- Soybean, 229, 260, 871, 1240, 2057\*
- Soyuz*, 2059, 2060
- Space, 2057\*  
aerospike engine, 38  
mathematics, 1338  
observatory, 192, 196  
relativity, 1887-1891\*  
space-time, 2068\*
- Space and time, 2179
- Space biology, 774, 2057\*
- Space charge, 437-438, 2057\*
- Space-charge polarization, 1736
- Space communications, 2057-2058\*  
antenna (electromagnetism), 132  
space technology, 2067  
spacecraft ground instrumentation, 2068
- Space-division multiple access (SDMA), 1447
- Space flight, 2058-2060\*  
aerospace medicine, 37-38\*  
astronautical engineering, 189\*  
astronautics, 177  
atmospheric entry, 203-204  
crewed spacecraft, 2058-2059  
escape velocity, 846\*  
infrared space missions, 1151  
International Space Station, 2060  
launch complex, 1233\*  
*Skylab*, 2060  
Soviet/Russian programs, 2059  
space transportation system, 2060  
United States programs, 2059  
weightlessness, 2382\*
- Space heating (solar), 2040
- Space Infrared Telescope Facility (SIRTF), 1151
- Space navigation and guidance, 2060-2061\*, 2099
- Space perception (vision), 2347
- Space power systems, 2058, 2061\*
- Space probe, 2061-2063\*  
attitude-control subsystem, 2063  
command and data subsystem, 2063  
power subsystem, 2061  
propulsion subsystem, 2063  
satellite astronomy, 1946\*  
scientific instruments, 2061  
space navigation and guidance, 2060-2061\*  
spacecraft subsystems, 2061, 2063  
telecommunications subsystem, 2061, 2063  
thermal control subsystem, 2063
- Space processing, 15, 2063-2064\*
- Space shuttle, 2064-2065\*  
remote manipulators, 1893  
satellite (spacecraft), 1946  
space flight, 2060  
space power systems, 2061  
space station, 2065-2066\*  
spread spectrum communication, 2089
- Space station, 2065-2066\*  
*Apollo-Soyuz* test program, 2066  
International Space Station, 2066  
*Mir*, 2066  
*Salyut*, 2065  
*Skylab*, 2065-2066  
space flight, 2059
- Space Station Freedom*, 2066
- Space technology, 2066-2067\*
- Space telescope, 2202
- Space Telescope, Hubble, 2067-2068\*
- Space-time, 2068\*  
causality, 383-384  
Lorentz transformations, 1272\*
- Space-time diagram, 1888
- Space-time geometry, 1889
- Space Transportation System:  
space flight, 2060  
*see also* Space shuttle
- Sounding sensors, 1379
- Spaceborne radar, 1840
- Spacecraft:  
guidance systems, 1031\*  
satellite, 1946\*  
space power systems, 2061\*  
space probe, 2061, 2063
- Spacecraft ground instrumentation, 2068-2069\*
- Spacecraft propulsion, 2069\*  
electromagnetic propulsion, 798-799\*  
electrothermal propulsion, 798-799\*  
interplanetary propulsion, 1177\*  
ion propulsion, 1185-1186\*  
rocket staging, 1929-1930\*  
Spacecraft structure, 2069-2071\*  
boost, 2069-2070  
nose cone, 1504, 1504\*  
reentry phase, 2070-2071  
space phase and design considerations, 2070  
structures, 2071  
testing, 2069
- Spacelab*:  
space flight, 2060  
space shuttle, 2064
- Spallation reaction, 2071\*
- Spandrel-braced arch, 142
- Spanish mackerel, 1286

- Spanish moss, 294  
 Spark, electric, 679, 751\*  
 Spark gap, 2071\*  
 Spark knock, 2071\*  
 Spark plug, 2071\*  
   ignition system, 1126  
   kyanite, 1220  
 Sparking potential *see* Breakdown potential  
 Spatangoida, 182, 2072\*  
 Speaker *see* Loudspeaker  
 Spearmint, 2072\*  
 Special functions, 2072\*  
 Special theory of relativity, 1887-1889  
   magnetism, 1296  
   mass, 1330  
 Specialized mobile radio (SMR), 1413  
 Speciation, 1287, 2072\*  
 Species concept, 2072-2073\*  
 Specific charge, 2073\*  
 Specific fuel consumption, 2073\*  
 Specific gravity, 2073\*  
   density, 635  
   hydrometer, 1109\*  
 Specific heat, 2073-2074\*  
 Specific humidity, 970  
 Specific impulse, 2074\*  
 Specific resistance *see* Electrical resistivity  
 Speckle, 2074\*  
 Speckle interferometry, 1172  
 SPECT *see* Single photo emission computed tomography  
 Spectacled bear, 230  
 Spectacled caiman, 309  
 Spectacled cobra, 429  
 Spectral analysis of cells, 389-390  
 Spectral classes, 2097  
 Spectral type, 2074\*  
   color index, 504\*  
   star, 2074\*  
 Spectrograph, 2074-2075\*  
 Spectroheliograph, 2075\*, 2159  
 Spectrometer, 2241  
 Spectrometry:  
   atomic, 190  
   photomultiplier, 1669  
 Spectrophotometric titration, 2245  
 Spectroscope, 664  
 Spectroscopic ellipsometry, 725  
 Spectroscopy, 112, 2075-2076\*  
   astronomical *see* Astronomical spectroscopy  
   beam-foil, 229, 260\*  
   electron paramagnetic resonance, 705-706, 782\*  
   electron spectroscopy, 783\*  
   emission spectrochemical analysis, 813\*  
   infrared spectroscopy, 1152-1153\*  
   instruments, 2075-2076  
   isoelectronic sequence, 1194-1195\*  
   laser, 1232\*  
   line spectrum, 1256-1257\*  
   mass spectrometry, 1330-1331\*  
   mass spectroscopy, 1331-1332\*  
   matrix isolation, 1338-1339\*  
   methods and applications, 2076  
   microwave, 1398-1399\*  
   Mössbauer effect, 1439-1440\*  
   neutron spectrometry, 1484-1485\*  
   nonlinear, 1497  
   nuclear magnetic resonance, 1510-1511\*  
   origin of spectra, 2075  
   photoacoustic spectroscopy, 1660-1661\*  
   photochemistry, 1662  
   quasielastic light scattering, 1835  
   Raman, 1820, 1867\*  
   resonance ionization, 1905\*  
   secondary ion mass, 1969-1970\*  
   slow neutron, 2022-2023\*  
   spectrography, 2074-2075\*  
   x-ray spectrometry, 2405\*  
 Spectrum, 2076\*  
   atomic *see* Atomic structure and spectra band, 217-218  
   diffraction grating, 664\*  
   fine structure (spectral lines), 877\*  
   molecular *see* Molecular structure and spectra  
   nuclear spectra, 1516-1517\*  
   Paschen-Back effect, 1618\*  
   spectroscopy, 2075, 2076\*  
   Stark effect, 2100\*  
   Zeeman effect, 2413-2414\*  
 Spectrum analyzer, 2076-2077\*  
 Speech, 2077-2078\*  
   acoustic signal processing, 18  
   aphasia, 149\*  
   cleft palate, 415  
   Speech—*cont.*  
     development of, 2078  
     hemispheric laterality, 1066  
     phonetics, 1656-1657\*  
     production of, 2077-2078  
     recognition, 2078  
     speech technology, 2078  
     vocal cords, 2350\*  
 Speech disorders, 2078\*  
 Speech hearing test, 196  
 Speech perception, 2079\*  
 Speech recognition, 2079-2080\*  
 Speech synthesis, 2350-2351  
 Speed, 2080\*, 2303  
 Speed regulation, 1913, 2080\*  
 Speedometer, 2080\*  
*Spelaeogriphacea*, 2080-2081\*  
*Spelaeogriphus lepidops*, 2080  
 Spencer, W. K., 186  
*Spengleria*, 281  
 Spent fuel elements, 1855  
*Speotyto cunicularia*, 260  
 Sperm cell, 1992, 2081\*  
 Sperm whale, 94-95  
 Spermatogenesis, 2081-2082\*  
   gametogenesis, 960  
   invertebrate embryology, 1181  
   oogenesis, 1544  
   testis, 2214  
 Sphaeractinoidea, 2082\*  
*Sphaerobolus*, 864  
 Sphaerocarpaceae, 2082\*  
*Sphaerocarpos*, 2082  
 Sphaerodoridae, 760  
 Sphaeromatidae, 803  
 Sphaerularioida, 2082\*  
 Sphagnopsida, 2082\*  
 Sphagnum bog, 298, 309  
 Sphalerite, 2082\*  
*Sphaciospongia*, 282  
 Sphenacodontia, 1624  
 Sphenisciformes, 2082\*  
 Sphenodonta, 2082-2083\*  
 Sphenophyllales, 2083\*  
*Sphenophyllum*, 2083  
 Sphenophyta, 2082\*, 2083\*  
 Sphenopsida, 1493  
 Spherands, 1286  
 Sphere, 2083\*  
 Spherical coordinates, 489  
   astronomical, 178, 191-192  
   map projections, 1315-1316\*  
 Spherical four-bar linkage, 832  
 Spherical harmonics, 2083\*  
 Spherical pendulum, 1624  
 Spherical polygon, 1744  
 Spheroid *see* Ellipsoid and spheroid  
 Sphincter of Oddi:  
   gallbladder, 957  
 Sphingidae, 1244  
 Sphingoidea, 1244  
 Sphingolipid, 1260, 2083-2084\*  
 Sphingomyelin, 1659  
 Sphyraena, 221  
*Sphyraena barracuda*, 221  
 Spica, 2084\*  
 Spice and flavoring, 2084\*  
   allspice, 87\*  
   anise, 125\*  
   basil, 256-257\*  
   black pepper, 301\*  
   clove, 479\*  
   coriander, 559\*  
   cumin, 598\*  
   fennel, 876\*  
   flavoring agents, 817-818  
   ginger, 999\*  
   marjoram, 1326\*  
   nutmeg, 1524-1525\*  
   rosemary, 1932-1933\*  
   sage, 1940\*  
   savory, 1951\*  
   tarragon, 2193\*  
   thyme, 2236\*  
   turmeric, 2287\*  
   vanilla, 2323\*  
 Spice bush, 1233  
 Spider, 139  
   Araneida, 138, 155  
   phobia, 1656  
   Trilobita, 2273  
 Spider flower, 325  
 Spider mite, 8, 2276\*  
 Spillite, 2084\*  
 Spin (quantum mechanics), 2084\*  
   electron, 776-777\*  
   helicity, 1059\*  
 Spin (quantum mechanics)—*cont.*  
   magnetic relaxation, 1295  
 Spin-density wave, 2085\*  
 Spin glass, 2084\*  
 Spin label, 2084-2085\*  
 Spinach, 336, 2085\*  
*Spinacia oleracea*, 336, 2085  
 Spinal anesthesia, 116  
 Spinal cord, 2085\*  
   central nervous system, 401\*  
   meninges, 1354\*  
   vertebra, 2331-2332\*  
 Spinal cord disorders, 1354, 2085\*  
 Spinal nerve, 2085  
 Spindle, 1996  
 Spine, 1477  
 Spinel, 1078, 2085-2086\*  
 Spinicaudata, 2086\*  
 Spinning (metals), 1998, 2086\*  
 Spinning (textiles), 2086\*  
 Spintheridae, 760  
 Spinulosida, 173  
 Spiny eel, 1504  
 Spiny-headed worm *see* Acanthocephala  
 Spiral, 2086\*  
 Spiral bevel gear, 241  
 Spiral conveyor, 302, 552  
 Spiral galaxy, 854  
 Spirastrellidae, 282  
 Spiriferida, 161, 2086\*  
 Spirit varnishes, 2326  
*Spirochona*, 394  
*Spirodela*, 139  
 Spirometry, 2086\*  
 Spiroonucleus, 618  
 Spirophorida, 2086\*  
*Spirostomum*, 951  
 Spirotrichia, 403  
   Entodiniomorpha, 826-827\*  
   Heterotrichida, 1073\*  
   Hypotrichida, 1121\*  
   Odontostomatida, 1533\*  
   Oligotrichida, 1540  
   Tintinnida, 2243\*  
 Spittle bug, 962  
 Spitzer Space Telescope, 1151  
 Spizellomycetales, 402  
 Splachnales, 2087\*  
 Spleen, 2087\*  
 Spleen disorders, 2088\*  
 Splines, 2088\*  
 Split gene:  
   exon, 859\*  
   intron, 1179\*  
 Spodumene, 2088\*  
 Sponge:  
   animal evolution, 119  
   Dendroceratida, 635\*  
   Halichondrida, 1039-1040\*  
   Hexactinellida, 1073\*  
   Parazoa, 1612\*  
   *see also* Porifera  
 Spongiomorpha, 1111, 2088\*  
 Spongomorpha, 411  
 Spontaneous fission, 1857  
 Spontaneous polarization, 1814  
 Spontaneous symmetry breaking,  
 2178-2179  
 Spore:  
   index fossil, 1136  
   palynology, 1604  
*Sporolactobacillus*, 211  
*Sporosarcina*, 211, 240  
 Sporozoa, 2088\*  
   Archigregarinida, 164\*  
   Haemosporina, 1038\*  
   Haplosporea, 1045-1046\*  
   Neogregarinida, 1473\*  
   Sarcosporida, 1945-1946\*  
   Telosporia, 2207\*  
   Toxoplasmea, 2254\*  
 Sports medicine, 2088\*  
 Sporulation, 1895  
 Spot welding, 1902, 2088\*  
 Spotted skunk, 2019  
 Sprat, 948  
 Spray flow, 2088-2089\*  
 Spread spectrum communication,  
 2089-2090\*  
 Spreader stoker, 2118  
 Spring (hydrology), 997, 2090\*  
 Spring (machines), 2090  
   automotive suspension, 230  
   shock absorber, 2000-2001\*  
   snap ring, 2025\*  
   torsion bar, 2251-2252\*  
   vibrating linear system, 1343-1344  
 Spring cress, 513  
 Sprinkler systems (irrigation), 1192  
 Sprites, 1253  
 Spruce, 2090-2091\*  
   evergreen, 857  
   Pinales, 1688  
   tree, 2266  
 Sprue (intestinal disorder), 115  
*Sputnik*, 2059  
 Sputtering, 1905, 2091\*  
 SQL *see* Structured Query Language  
 Squad automatic weapon, 156  
 Squalene, 2091\*  
 Squall, 2091\*, 2121  
 Squall line, 2091\*  
 Squamata, 1245  
   gecko, 974\*  
   Sauria, 2092  
   skink, 2019\*  
 Squash, 2092-2093\*  
 Squash bug, 944  
 Squeezed quantum states, 2093\*  
 SQUID, 2093-2094\*, 2154  
 Squid, 438, 2093\*  
 SQUID magnetometer, 1302  
 Squillidae, 2119  
 Squirrel, 1930  
 Squirrelfish, 238  
 SSB *see* Single sideband  
 Stability augmentation, 2094\*, 2190-2192  
 Stabilizer (aircraft), 2095\*  
 Stabilizer (chemistry), 2095\*, 2172  
 Stain (microbiology), 2095\*  
 Stainless steel, 2095\*  
 Stalactites and stalagmites, 2095\*  
 Stalked bacteria, 300  
 Stall-warning indicator, 2095\*  
 Standard, 2096\*  
 Standard Generalized Markup Language  
 (SGML), 2399  
 Standard model, 2096\*  
 Standards:  
   design, 581  
   electrical, 761  
   electrical codes, 753  
   environmental test, 831-832  
   pharmaceuticals testing, 1648  
   wavelength, 2375\*  
   work standardization, 2398\*  
 Standby power source, 2301  
 Stanford Linear Collider (SLC), 1076-1077  
 Stannic chloride, 2243  
 Stannic oxide, 2243  
*Stannophyllum*, 2408  
 Stannous chloride, 2243  
 Stannous oxide, 2242-2243  
*Stanomma*, 2408  
 Staples, 1049  
*Staphylococcus*, 1383\*, 2096\*  
   enzymes, 243-244  
   food microbiology, 909  
   food poisoning, 908\*, 909  
   microbiota (human), 1383  
   opportunistic infections, 1550  
   skin disorders, 2018  
   toxic shock syndrome, 2253  
*Staphylococcus aureus*, 331, 1382-1383  
 Star, 2096-2098\*  
   absolute magnitudes, 2097  
   Aldebaran, 70\*  
   Alpha Centauri, 87\*  
   Antares, 131\*  
   Arcturus, 167\*  
   Betelgeuse, 271\*  
   binary, 243, 273-274\*  
   blue straggler, 271  
   carbon, 329, 368-369\*  
   carbon-nitrogen-oxygen cycles, 368\*  
   clusters, 2098  
   color index, 504\*  
   colors, 2096-2097  
   distances, 2097  
   distribution and motions, 2097  
   double, 2097  
   dwarf, 643  
   dwarf star, 707\*  
   eclipsing variable, 661, 731\*  
   evolution, 2098  
   fundamental, 847  
   Geminga, 977\*  
   giant star, 998\*  
   gravitational collapse, 1022-1023\*  
   Hertzsprung-Russell diagram, 1070\*,  
   2097, 2098  
   interstellar matter, 1177-1178\*  
   magnitude, 1304\*  
   magnitudes, 2096

Star—*cont.*

mass-luminosity relation, 1330\*  
masses and main-sequence properties, 2097-2098  
Mira, 1407\*  
Mizar, 1412\*  
multiple, 2097  
names of, 2096  
neutron, 1485\*  
neutron star, 1485\*  
nova, 1504-1505\*  
nucleosynthesis, 1519-1520\*  
Polaris, 1735\*  
Procyon, 1778-1779\*  
proton-proton chain, 1794-1795\*  
protostar, 1795\*  
red dwarf, 1878\*  
Rigel, 1921\*  
Sirius, 2015\*  
spectral classes, 2097  
spectral type, 2074\*  
Spica, 2084\*  
stellar atmospheres, 181  
stellar magnetic field, 2110\*  
stellar rotation, 2111\*  
subgiant star, 2138\*  
Sun, 2149-2151\*  
supergiant star, 2159\*  
supermassive, 2160\*  
supernova, 2161\*  
symbiotic, 2177-2178\*  
thermonuclear reaction, 2229\*  
twinkling, 2288-2289\*  
universe, 2305-2306  
variable, 2098, 2325-2326\*  
Vega, 2328\*  
white dwarf star, 2385-2387\*  
Wolf-Rayet, 2393\*

Star clouds, 2098\*  
Star clusters, 2098-2099\*  
celestial mechanics, 386  
Hyades, 1099\*  
Magellanic Clouds, 1288  
Messier catalog, 1361\*  
star, 2098  
universe, 2306  
Star polymer, 287  
Star ruby, 500  
Star sapphire, 500  
Star tracker, 2099\*  
Starburst polymer, 287  
Starburst galaxy, 1151, 2999-2100\*  
Starch, 2100\*  
arrowroot, 153  
carbohydrate, 366\*  
glucose, 1006\*  
sugar, 2145  
Starfish, 1884  
*see also* Asteroidea  
Stark, J., 2100  
Stasis dermatitis, 665  
Static, 2100\*  
Static electricity, 761, 2100-2101\*  
*see also* Electrostatics  
Static var compensator, 2101\*  
Statics, 2101\*  
Statigraphy, 722  
Station:  
railroad, 1865  
stopping, 1865  
subway, 2143  
Stationary state:  
excited state, 858\*  
ground state, 1028\*  
metastable state, 1373\*  
Statistical climatology, 416  
Statistical mechanics, 2101-2102\*  
Boltzmann constant, 312\*  
Bose-Einstein statistics, 320-321\*0, 321\*  
density matrix, 573-574  
Fermi-Dirac statistics, 876-877\*  
methods, 2102  
quantum statistics, 1830\*  
scope, 2101-2102  
Statistical quality control, 1159  
Statistics, 2102-2104\*  
analysis of variance, 110\*  
Bayesian, 228-229  
Boltzmann statistics, 312-313\*  
Bose-Einstein, 283, 320-321\*  
control chart, 548\*  
distribution, 691\*  
estimation theory, 848\*  
experimental design, 2104  
Monte Carlo method, 1436\*  
probability, 1776-1777\*  
quantum, 1830\*

Statistics—*cont.*

quantum statistics, 1830\*  
regression and correlation, 2104  
root-mean-square, 1932\*  
sampling, 2103-2104  
statistical mechanics, 2101-2102\*  
tests of hypotheses, 2104  
Statoblasts, 2104\*  
Stator, 155  
Statoreceptor, 1985  
Staurikosaurus, 675  
Stauriolite, 2104\*  
Stauromedusae, 1965, 2104-2105\*  
Steam, 2105\*  
Steam condenser, 2105\*  
Steam distillation, 628, 689  
Steam electric generator, 2105-2106\*  
Steam engine, 2106\*  
locomotive, 1268  
valves, 2320-2321  
Steam flash process, 996  
Steam-generating furnace, 2106\*  
Steam-generating unit, 2106\*  
air heater, 51\*  
boiler, 310\*  
boiler economizer, 310\*  
fire-tube boiler, 890\*  
fluidized-bed combustion, 901\*  
marine boiler, 1317-1318\*  
steam temperature control, 2107\*  
superheater, 2160\*  
water-tube boiler, 2368\*  
Steam heating, 1846, 2106-2107\*  
Steam-jet cycle, 1883  
Steam-jet ejector, 2107\*  
Steam pump, 628  
Steam separator, 2107\*  
Steam temperature control, 2107\*  
Steam turbine, 2107-2108\*  
marine engine, 1320  
reheating, 1885\*  
Steatomithes, 326  
Steatomithidae, 326  
Steel, 2108\*  
ferroalloy, 791  
heat treatment, 1057\*  
reinforced concrete, 1888  
stainless, 2095\*  
structural, 2136\*  
structural plate, 2135-2136\*  
surface hardening, 2169\*  
Steel arch, 142, 159  
Steel castings, 2135  
Steel manufacture, 2108\*  
Steering *see* Automotive steering; Ship  
powering and steering  
Stefan-Boltzmann law, 936  
Stegosauria, 1580  
Stelechopidae, 1462  
Stelechopus, 1462  
Stellar evolution, 2108-2110\*  
asymptotic giant branch, 2109  
binary stars, 243-244, 273-274\*  
black hole, 300-301\*  
blue straggler star, 307-308\*  
early evolution, 2109  
Herbig-Haro objects, 1068\*  
high-mass evolution, 2110  
intermediate mass evolution, 2109  
mass loss and planetary nebulae, 2109-2110  
neutron star, 1485\*  
planetary nebula, 1700\*  
protostar, 1795\*  
star, 2098  
star formation, 2108-2109  
subgiant star, 2138\*  
supernova, 2110, 2161\*  
symbiotic star, 2177  
T Tauri star, 2189\*  
universe, 2305-2306  
white dwarf star, 2385-2387\*  
Stellar magnetic field, 2110\*  
Stellar neutrino, 1482  
Stellar population, 2110-2111\*  
Stellar rotation, 2111\*  
Stelleroida, 173-174, 186-187  
Steller's sea cow, 2014-2015  
Stem, 2111-2112\*  
apical dominance, 150\*  
apical meristem, 150-151\*  
bark, 251\*  
cortex (plant), 563  
external features, 2111-2112  
general characteristics, 2111  
internal features, 2112  
reproduction, 1896

Stem—*cont.*

seed, 1973  
tree diseases, 2267  
Stem cells, 2112-2113\*  
Stem lettuce, 1246  
Stem rust, 2267  
Stencil printing, 1774  
Stenetroidea, 167  
Steno, Nicolaus, 2123  
Stenolaemata, 937, 2113\*  
Cryptostomata, 589\*  
Cyclostomata, 606\*  
Cystopora, 608\*  
Trepotomata, 2269\*  
Stenopodidae, 560  
Stenothoidae, 860, 963  
Stentor, 951  
Stenurida, 1549, 2113\*  
Step recovery diode, 1397-1398  
Stephanocodon *stellatum*, 242  
Stepping motor, 2113\*  
Steradian, 2302  
Stereobilin, 243  
Stereobilinogen, 243  
Stereocariidae, 365  
Stereo camera, 321  
Stereochemistry, 2113-2114\*  
conformational analysis, 535-536\*  
optical activity, 1550-1551  
optical rotatory dispersion, 1561  
organic reaction mechanism, 1573  
prochirality, 1778\*  
stereospecific catalyst, 2115\*  
Woodward-Hoffmann rule, 2396\*  
Stereoisomer, 1421, 2113-2114\*  
Stereophonic earphones, 716  
Stereophonic radio transmission, 2114\*  
Stereophonic sound, 2114-2115\*  
disk recording system, 627  
recording, 2054  
Stereopsis, 2115  
Stereoregular polymer, 1747  
Stereoscopic rangefinder, 1868  
Stereoscopy, 2115\*  
Stereospecific catalyst, 2115\*  
Steric effect (chemistry), 2115\*  
Sterilization, 820-821, 2115\*  
Stern-Gerlach effect, 208  
Sternorrhyncha, 962-963  
Steroid, 1260, 2115-2116\*  
adrenal gland hormones, 30\*  
aldosterone, 70-71\*  
androgen, 114-115\*  
ergosterol, 758-759, 843\*  
estrogen, 848\*  
progesterone, 1781\*  
signal transduction, 2006  
sterol, 2116\*  
Sterol, 445-446, 2116\*  
Steward, B., 1188  
Stibnite, 1874, 2116\*  
Stichocotylidae, 171  
Stichopathes, 144  
Stichosomida, 2116\*  
Stick insect, 1581  
Stickleback, 865, 970, 2116\*  
Stilbite, 2116\*  
Stilt (bird), 364  
Stimulated photoluminescence, 1667  
Stimulated scattering, 1497  
Stimuli, 1985  
Stingray, 227  
Stink bug, 944  
Stinkhorns, 864, 970  
Stirling engine, 2117\*  
Stishovite, 1078, 2117\*  
STM *see* Scanning tunneling microscope  
Stochastic control theory, 1563, 2117\*  
Stochastic process, 2117-2118\*  
Stoch (plant), 325  
Stoichiometry, 2118\*  
Stoker, 2118-2119\*  
Stokes shift, 1662  
Stokes' theorem, 2119\*  
Green's theorem, 1027\*  
Kelvin's circulation theorem, 1210  
STOL *see* Short takeoff and landing  
Stolonifera, 2119\*  
Stomach, 606, 2119\*  
birds, 606  
digestive system, 666, 667  
gastrointestinal tract disorders, 971  
ruminants, 606  
simple, 606  
Stomatopoda, 964, 2119\*  
Stomiatoidei, 1941

## Stone Age:

Neolithic, 1474  
prehistoric technology, 1768  
Stone and stone products, 2119\*  
quarrying, 1833\*  
structural materials, 2135  
Stone cameo, 320  
Stone marten, 1328  
Stone pine, 1689  
Stone tools, 1768  
Stonecrops, 1952  
Stonefly, 1726  
Stonewort, 365  
Stony coral, 1962  
Stony meteorites, 1376  
Storage, oil and gas, 1535\*  
Storage battery, 228, 258, 259  
electromotive force *see* Electromotive force  
energy storage, 821-822\*  
Storage rings (particle accelerator), 1615  
Storage tank, 2120\*  
Stored-program computer, 608-609  
Stork, 402  
Storm, 2120\*  
electrical activity, 186-187  
hurricane, 1099\*  
thunderstorm, 2236\*  
tornado, 2250-2251\*  
Storm detection, 2120-2121\*  
cloud-to-ground lightning detectors, 2121  
radar surveillance, 2120  
satellite surveillance, 2120  
storm electricity, 2121  
surface observing systems, 2120-2121  
Storm electricity, 2121\*, 2235-2236  
Storm surge, 2121\*  
Stove bolt, 275  
Straight-line mechanism, 2121\*  
Strain gage, 2121\*  
Strake, 2122\*  
Strand line, 2122\*  
Strange particles, 2122\*, 2302  
Strange quark, 1832  
Strangles, 2122\*  
Stratigraphic anticline, 138  
Stratigraphy, 880, 2122-2123\*  
archaeology, 163-164\*  
chemostratigraphy, 434\*  
depositional systems and environments, 640-642\*  
diastem, 656\*  
geology, 990  
seismic, 1975\*  
sequence, 1987\*  
unconformity, 2297\*  
Stratosphere, 184, 201, 2123-2124\*  
air pollution, 53  
atmospheric chemistry, 203  
middle-atmosphere dynamics, 1399\*  
tropopause, 2277\*  
Stratospheric ozone, 2124\*  
Stratovolcanoes, 2352  
Strawberry, 1932, 2124\*  
Strawberry clover, 422  
Strawberry hemangioma, 261  
Stream:  
fluvial erosion landforms, 905  
forest ecosystem, 917  
limnology, 1256\*  
water conservation, 2364  
Stream cipher, 524  
Stream function, 2125\*  
Stream gaging, 2125\*  
Stream pollution, 917, 2125\*  
Stream transport and deposition, 2125\*  
floodplain, 896\*  
fluvial sediments, 905\*  
Streaming potential, 2125-2126\*  
Streamline flow:  
Bernoulli's theorem, 267\*  
laminar flow, 1223-1224\*  
streamlining, 2126\*  
Streamlining, 2126\*  
Strength of materials, 2126\*  
Strepsirrhines, 1771  
Strepsirhini, 927  
Streptococcus, 240, 574, 2126-2127\*  
pneumococcus, 1730\*  
pneumonia, 1731  
rheumatic fever, 1913  
scarlet fever, 1954  
skin disorders, 2018  
strangles, 2122\*  
Streptomyces, 21  
Streptothricosis, 2127\*  
Stress (psychology), 1758, 2127-2128\*

- Stress and strain, 2128\*  
 creep (materials), 577\*  
 elasticity, 741\*  
 Hooke's law, 1088\*  
 loads, dynamic, 1266\*  
 metal, 1362-1364  
 photoelasticity, 1664\*  
 plasticity, 1722, 1722\*  
 strength of materials, 2126  
 structural analysis, 2131\*  
 structural deflections, 2134  
 thermal stress, 2222\*  
 units of measurement, 2303  
 wind, 2389-2390\*  
 Young's modulus, 2412\*
- Stress-corrosion cracking, 498, 563, 809  
 Stress wave emission *see* Acoustic emission  
 Striated muscle, 1450  
 Strigidae, 2128  
 Strigiformes, 2128\*  
 String, cosmic *see* Cosmic string  
 String coral, 1403  
 Stringed instruments, 1454-1455  
 Strip lines, 2262  
 Strip mining, 483  
 Stripline, 1392  
 Stripping, 2128-2129\*  
 Stroboscope, 2129\*  
 Stroboscopic photography, 1559, 2129\*  
 Stroke, 1067  
   *see also* Apoplexy  
 Stromatolite, 2129\*  
 Stromatoporoidea, 1965, 2129\*  
 Strombidae, 466  
 Strombolian eruptions (volcanoes), 2353  
 Strongren system (color index), 445  
 Strong acids, 770  
 Strong bases, 770  
 Strong nuclear interactions, 821, 946,  
 2129-2130\*  
   quantum chromodynamics, 1825-1826\*  
   unitary symmetry, 2302  
 Strongly electric fishes, 745  
 Strongylida, 2130\*  
 Strongylocentrotidae, 658  
 Strontianite, 2130\*  
 Strontium, 387-388, 2130\*  
*Strophanthus*, 2130\*  
 Strophomenida, 161, 2131\*  
 Stroustrup, Bjarne, 1783  
 Structural analysis, 2131\*  
 Structural anticline, 138  
 Structural chemistry, 2131-2133\*  
 Structural connections, 2133-2134\*  
   joint, 1204\*  
   welded joint, 2382  
 Structural deflections, 2134\*  
 Structural design, 2135\*  
 Structural geology, 2134-2135\*  
   Earth sciences, 722  
   ophiolite, 1548-1549\*  
 Structural materials, 2135\*  
 Structural petrology, 1640, 2135\*  
 Structural plate, 2135-2136\*  
 Structural steel, 2136\*  
 Structure (engineering), 2136\*  
 Structure functions, 628  
 Structured Query Language (SQL),  
 2030  
   data mining, 617  
   database management systems, 619  
 Structures (engineering), 2269  
 Struthioniformes, 2136\*  
 Strychnine alkaloids, 2136\*  
*Strychnos*, 2136\*  
 Studio camera, 2203  
 Sturgeon, 14\*, 21, 2136-2137\*  
 Stylasterina, 983, 1111, 2137\*  
 Stylolites, 2137\*  
 Stylomatophora, 1806, 2137\*  
 Styrene, 1752, 2137\*  
 Sualbardia, 144  
 Subalpine fir, 801  
 Subatomic particles, 783  
 Subbituminous coal, 424, 481  
 Subclover, 422  
 Subcritical-fluid chromatography, 2158\*  
 Subduction zones, 546-547, 2137-2138\*  
 Subgiant star, 2138\*  
 Subirrigation, 1192  
 Sublimation, 2138\*  
   *see also* Volatilization  
 Submarine, 2138-2139\*  
   naval architecture, 1466\*  
   periscope, 1633\*  
   underwater navigation, 2298  
 Submarine cable, 750, 2139\*  
 Submarine canyon, 628, 2139-2140\*  
 Submarine trenches, 718  
 Submarine volcanism, 2352  
 Submerged-arc furnace, 140-141, 158  
 Submersible, 2139  
 Submillimeter astronomy, 2140\*  
 Submillimeter-wave technology, 2141\*  
 Subsonic flight, 2141-2142\*  
   aerodynamic force, 32-33\*  
   Mach number, 1285  
 Subsonic flow, 2126  
 Substation, electric power, 675-676,  
 747-748\*  
 Substitution balance, 214-215, 245  
 Substitution reaction, 2142  
   Friedel-Crafts reaction, 938\*  
   halogenation, 1043-1044\*  
 Subsynchronous resonance, 2142\*  
 Subtraction, 153-154, 2142\*  
 Subtriqueidae, 1756  
 Subtropical jet, 1203  
 Subuluroidea, 165  
 Subway engineering, 2142-2143\*  
 Succession, ecological *see* Ecological  
   succession  
 Sucking lice, 126-127  
 Sucrose, 2143\*  
 Suctoria, 403, 2143\*  
 Sudangrass, 2143\*  
 Sudden cardiac death, 1053  
 Sudden infant death syndrome (SIDS),  
 2143-2144\*  
 Sugar, 2144-2146\*  
   amino, 98\*  
   beet sugar, 2144  
   cane sugar manufacture, 2144  
   carbohydrate metabolism, 366-367\*  
   farm crops, 871  
   fructose, 939\*  
   glucose, 1006\*  
   glycolipid, 1007-1008\*  
   lactose, 1222\*  
   maltose, 1308-1309\*  
   monosaccharide, 1434-1435\*  
   nutritional value, 2144-2145  
   oligosaccharide, 1540\*  
   raffinose, 1865\*  
   ribose, 1918\*  
   ribulose, 1919\*  
   sucrose, 2143\*  
   syrups, 2145-2146  
   xylose, 2408\*  
 Sugar derivatives, 1008\*  
 Sugar maple, 1316  
 Sugar pea, 1578  
 Sugarbeet, 2146\*  
 Sugarcane, 2146\*  
 Sulawesi *see* Celebes  
 Sulfide, 1577-1578  
 Sulfide phase equilibria, 2146\*  
 Sulfonamide, 1578, 2146-2147\*  
 Sulfonation and sulfation, 2147\*  
 Sulfone, 1752  
 Sulfonic acid, 1578, 2147\*  
 Sulfur, 2147-2149\*  
   biochemistry, 2148-2149  
   organosulfur compound, 1577-1578\*,  
   2148  
   principal inorganic compounds, 2148  
   pyrite, 1813  
   sulfide minerals, 2149  
   sulfuric acid, 2149\*  
   thiocyanate, 2233\*  
   thiophene, 2233\*  
 Sulfur cycle, 282  
 Sulfur dioxide (SO<sub>2</sub>), 1004  
 Sulfur-metabolizing bacteria, 143, 160  
 Sulfuric acid, 203-204, 2149\*  
 Sum rules, 2149\*  
 Sumatra, 724  
 Summer solstice, 2045  
 Summer squash, 2092  
 Sun, 2149-2151\*  
   chromosphere, 454\*  
   cosmic-ray modulation, 501, 565  
   dwarf star, 707  
   Earth, 716  
   Earth rotation and orbital motion,  
   721-722  
   earth tides, 722  
   eclipse, 729-731\*  
   ecliptic, 731\*  
   geodynamo, 988  
   halo, 1042\*  
   helioseismology, 1060\*  
   Hertzsprung-Russell diagram, 1070  
   infrared astronomy, 1151  
   interplanetary matter, 1177  
   midnight, 1399-1400\*  
   parallax, 1608  
   phase (astronomy), 1649  
   photosphere, 1671\*  
   photovoltaic cell, 1673  
   planet, 1698-1699  
   planetary physics, 1701  
   polar meteorology, 1734  
   radio astronomy, 1847  
   rocket astronomy, 1928\*  
   solar activity, 2150-2151  
   solar physics, 181  
   solar structure, 2149-2150  
   solar system, 2041, 2042  
   solstice, 2045-2046\*  
   spectroheliograph, 2075\*  
   stellar magnetic field, 2110  
   sun dog, 2151\*  
   thermonuclear reaction, 2229\*  
   transit, 2261  
   upper-atmosphere dynamics, 2308  
   *see also* Solar entries  
 Sun bear, 230  
 Sun compass, 1400, 1734  
 Sun dog, 2151\*  
 Sun gear, 1699  
 Sunda Shelf, 723  
 Sundaland, 723  
 Sundew, 2151\*  
 Sundial, 2151\*  
 Sunfish, 2151\*, 2214  
 Sunflower, 2151-2152\*  
 Sunlamp, 2152\*  
 Sunlight *see* Solar radiation  
 Sunspots, 2110, 2150  
 Sunyar, A., 938  
 Suoidea, 164, 178  
 Super Loki-Datasonde, 1378  
 Supercid, 2152-2153\*  
 Supercavitating propeller, 1786  
 Supercharger, 2153\*  
 Supercomputer, 2153\*  
 Superconducting alloy, 84  
 Superconducting devices, 2153-2155\*  
   cryotron, 587\*  
   Josephson junction, 1204  
   large-scale, 2154-2155  
   magnetic monopoles, 1293  
   particle accelerator, 1614  
   small-scale, 2154  
   SQUID, 2093-2094\*  
 Superconducting magnets, 1290-1291, 1615  
 Superconducting quantum interference  
 device *see* SQUID  
 Superconductivity, 2155-2157\*  
   A15 phases, 1\*  
   Chevreton phases, 436-437\*  
   cryogenic engineering, 521  
   high magnetic fields, 1077  
   Josephson effect, 1204\*  
   magnetic properties, 2156  
   Meissner effect, 1350-1351\*  
   microscopic (BSC) theory, 2156-2157  
   occurrence, 2155-2156  
   perpetual motion, 1636\*  
   relaxation time of electrons, 1891  
   superconducting devices, 2153-2155\*  
   thermal properties, 2156  
   transition temperatures, 2155  
   two-fluid model, 2156  
 Supercontinent, 2157\*  
   marine geology, 1321  
   paleogeography, 1599  
   Proterozoic, 1793  
 Supercritical fields, 2157-2158\*  
 Supercritical-fluid chromatography, 2158\*  
 Supercritical wing, 2158-2159\*  
 Superfecundation, 2289  
 Superfluidity, 2159\*  
   liquid helium, 1263\*  
   low-temperature physics, 1276  
   quantized vortices, 1823\*  
   second sound, 1968-1969\*  
   *see also* Superconductivity  
 Supergiant star, 2159\*, 2325  
 Supergranulation, 2159\*  
 Supergravity, 1818, 2159-2160\*  
   electroweak theory, 799-800\*  
 Superheater, 2160\*  
 Superheavy element *see* Supertransuranics  
 Superheavy quasimolecule, 2157  
 Superheterodyne receiver:  
   heterodyne principle, 1072\*  
   spectrum analyzer, 2076-2077\*  
 Superionic conductor, 2043-2044  
 Superior fruit, 842  
 Superlattice *see* Artificially layered structures  
 Superluminal motion, 2160\*  
 Supermassive stars, 2160\*  
 Supermultiplet, 2160-2161\*  
 Supernova, 196, 2161\*  
   neutrino astronomy, 1482-1483  
   stellar evolution, 2108-2110\*, 2110  
   variable star, 2325  
 Superoxide chemistry, 1636, 2162\*  
 Superplasticity, 2162\*  
 Superposition principle, 2162-2163\*  
 Superposition theorem (electric networks),  
 2163\*  
 Supersaturation, 1518, 2163\*  
 Supersonic diffuser, 2163\*  
 Supersonic flight, 2163-2164\*  
   aerodynamic wave drag, 33\*  
   atmospheric entry, 203-204  
   Mach number, 1285  
   sonic boom, 2049\*  
   streamlining, 2126\*  
 Supersonic flow, 34, 517-518, 2164\*  
 Superstring theory, 2164-2165\*  
   classical solutions, 2164-2165  
   duality in, 705  
   quantum gravitation, 1818  
   string concept, 2164  
 Supersymmetry, 2165\*  
   supergravity, 2160  
   weakly interacting massive particle, 2377  
 Supertwisted nematic (STN) LCDs, 787  
 Superventilated propeller, 1786  
 Supervision control and data acquisition  
 (SCADA), 2197-2198  
 Supervisory control, 691  
 Suppression (electricity), 2165-2166\*  
 Suppressor cells, 1132  
 Supramolecular chemistry, 2166\*  
   nanotechnology, 1463-1464\*  
   nanotechnology, 1464\*  
 Surf clams, 1223  
 Surface acoustic-wave devices, 2167-2168\*  
 Surface-active agent *see* Detergent; Soap;  
   Surfactant  
 Surface and interfacial chemistry, 2168\*  
 Surface and solid of revolution:  
   cone, 533-534\*  
   conic section, 537\*  
   cylinder, 607\*  
   quadratic surface, 1819\*  
   sphere, 2083\*  
   torus, 2252\*  
 Surface coating, 2168\*  
 Surface paint, 1595\*  
 Surface primer, 1772  
 Surface varnish, 2326\*  
 Surface condenser, 2105, 2168-2169\*  
 Surface-conversion coatings, 1366  
 Surface fatigue wear, 2377  
 Surface geometry:  
   dihedron, 2167  
   methods of description, 2166-2167  
   quadratic surfaces, 1819\*, 2167  
 Surface hardening of steel, 1057  
 Surface irrigation, 1192  
 Surface micromachining (SMM), 1385\*  
 Surface mining, 2169\*  
   coal mining, 483  
   land reclamation, 1224-1225  
   open pit, 1545-1555\*  
   placer mining, 1695  
 Surface physics, 2169-2170\*  
   desorption, 646-647\*  
   ellipsometry, 807\*  
 Surface tension, 2170\*  
 Surface water, 1924, 2170-2171\*  
 Surface waves, 720  
 Surfactant, 2172\*  
 Surfactant therapy, 1143  
 Surge arrester, 2171\*  
 Surge suppressor, 2171-2172\*  
 Surgery, 2172\*  
   anesthesia, 116\*  
   laser photobiology, 1231\*  
   oral, 574  
 Surveillance:  
   direction-finding equipment, 684  
   electronic listening devices, 788\*  
 Surveillance radar, 1840, 2172\*  
 Surveillance satellites, 1401-1402  
 Surveying, 2172-2173\*  
   angular measurement, 2173  
   astronomical observations, 2173  
   distance measurement, 2172  
   elevation differences, 2173  
   horizontal control, 2172

Surveying—*cont.*  
 photogrammetry, 1662-1663\*  
 photogrammetry, 1665\*  
 prismatic astrolabe, 1775\*  
 satellite navigation systems, 1949  
 snow, 2025-2026\*  
 topographic, 2249\*  
 transit declinometer, 565-566  
 Surveying instruments, 2173\*  
 Survivorship, 1682  
 Surwell clinograph, 1663  
 Susceptance, 2173-2174\*  
 Suspension bridge, 292  
 Swamp, marsh, and bog, 2174\*  
 limnology, 1256\*  
 mangrove, 1312\*  
 Swamp cabbage, 1579  
 Swamp cyrilla, 1047  
 Swamp ironwood, 1047  
 Swan, 129  
 Swan (constellation) see Cygnus  
 Sweat bee, 231  
 Sweat gland, 2018, 2174\*  
 Sweet alyssum, 325  
 Sweet birch, 259  
 Sweet cherry, 383  
 Sweet clover, 422  
 Sweet orange, 1565  
 Sweet pepper, 1626  
 Sweet potato, 1760\*  
 Sweet william, 336  
 Sweetener:  
 aspartame, 183\*  
 saccharin, 1939\*  
 Sweetgum, 924, 1044, 2174\*  
*Suietenia mahagonni*, 1306  
 Swift (bird), 134  
 Swim bladder, 2174\*  
 Swine, 1619  
 Swine fever, 958  
 Swing bridge, 293  
 Swinging choke, 393  
 Swiss stone pine, 1689  
 Switch see Electric switch; Electronic switch  
 Switched capacitor, 2174-2175\*  
 Switched-capacitor:  
 circuits, 632  
 filters, 1164  
 Switched filter, 673  
 Switching circuit, 2175-2176\*  
 basic combinational circuits, 2175  
 basic sequential circuits, 2175  
 connecting circuits, 2176  
 counting circuit, 2176  
 lockout circuits, 2176  
 register circuits, 2176  
 selecting circuits, 2175-2176  
 translating circuits, 2176  
 Switching gate, 866  
 Switching systems (communications),  
 2176-2177\*  
 packet switching, 1594\*  
 private branch exchange, 1775-1776\*  
 switching circuit, 2175-2176\*  
 Swordtail, 183  
 Sycamore, 924, 1044, 2177\*  
 Sycettida, 311, 2177\*  
 Syenite, 2177\*  
 Syllidae, 760  
 Sylvan yellow fever, 2411  
*Sylvilagus*, 1145  
 Symbiotic star, 2177-2178\*  
 Symbolic computing, 1336-1337, 2178\*  
 Symmetrical bistable multivibrator, 1449  
 Symmetrodonta, 2178\*  
 Symmetry, 796-797  
 Symmetry (animal), 1370  
 Symmetry breaking, 566, 567, 2178-2179\*  
 Symmetry laws (physics), 2179-2180\*  
 supersymmetry, 2165\*  
 time reversal invariance, 2242  
 unitary symmetry, 2302\*  
 Symmorphosis, 2180\*  
 Sympathetic nervous system, 2180-2181\*  
 Sympathetic vibration, 2181\*  
 Sympetidae see Metachlamydeae  
 Symphyla, 2181\*  
 Symptomatic anthrax see Blackleg  
 Synapsida, 2181\*  
 Mammalia, 1310  
 Pelycosauria, 1624\*  
 Therapsida, 2219\*  
 Synaptic transmission, 2181-2182\*  
 acetylcholine, 11\*  
 dopamine, 696-697  
 myasthenia gravis, 1458\*  
 neuromuscular junction, 1441

Synarthroses, 1203  
 Synbranchiformes, 2182\*  
 Synchrona, 2183\*  
 Bathynellacea, 257\*  
 Eumalacostraca, 854  
 Syncerus, 301  
 Synchondrosis, 1203-1204  
 Synchronization, 2183\*  
 Synchronous converter, 2183\*  
 Synchronous detection, 104-105  
 Synchronous electric machines, 751  
 Synchronous generator, 90, 2106  
 Synchronous motor, 91, 2183\*  
 hysteresis motor, 1122\*  
 reluctance motor, 1892-1893\*  
 Synchroscope, 2183\*  
 Synchrotron radiation, 2183-2184\*  
 Syncline, 995, 2184\*  
 Synchrotron radiation, 1615  
 Syndiotactic polymer, 1747  
 Syngamy, 1181, 1895  
 Syngnathiformes, 865  
 Synodic month, 1436  
 Synoptic scale (weather), 2378  
 Synoptic Weather Program, 2379  
 Syntactic foam, 1161-1162  
 Synthesized speech, 2078  
 Synthetases, 748-779, 833  
 Synthetic aperture radar (SAR), 2184-2185\*  
 Synthetic chemistry, 1286  
 Synthetic detergent, 583  
 Synthetic diamond, 593, 655, 708  
 Synthetic fiber, 1313  
 Synthetic fuel, 2185\*  
 Synthetic gem, 870  
 Synthetic graphite, 1018\*  
 Synthetic materials, 995  
 Synthetic polymers:  
 polyester resins, 1742  
 polymer, 1744  
 polymeric composite, 1746  
 Synthetic speech see Voice response  
 Synzophosurina, 2408  
 Syphilis, 1768, 2185\*  
*Syrmatiscus reevesii*, 260  
 Syrups, 2145-2146  
 Systelommatophora, 1806, 2185\*  
 System design evaluation, 2185-2186\*  
 System-generated EMP, 772  
 Systematics:  
 animal, 108-109  
 phylogeny, 1675-1676\*  
 Systemic blastomycosis, 266  
 Systemic fungicide, 849  
 Systemic insecticides, 1158  
 Systemic lupus erythematosus, 1129  
 Systemic vasculitis, 475  
 Systems analysis, 2186\*  
 linear system analysis, 1257-1258\*  
 systems ecology, 2187\*  
 Systems architecture, 2186-2187\*  
 Systems ecology, 2187\*  
 Systems engineering, 2187\*  
 decision support system, 626\*  
 functional analysis and modeling,  
 944-945\*  
 information, 1149\*  
 linear systems analysis, 1257  
 maintenance, industrial and production,  
 1306\*  
 sensitivity, 1985\*  
 system design evaluation, 2185-2186\*  
 Systems integration, 2187\*  
 advantages, 2187  
 life-cycle activities, 2187  
 primary uses, 2187  
 Systems-management reengineering, 1879  
 Syzygy, 2188\*

## T

T cells, 1132-1133  
 T lymphocyte, 268, 350  
 T Tauri star, 2189\*  
 Tabasco pepper, 1626  
 Tabulata, 2189\*  
 Tacamahac poplar, 1754  
 Tacan, 2189-2190\*  
 Tachometer, 2190\*  
 Tachyglossidae, 1435  
*Tachyglossus*, 1435  
 Tachyon, 2190\*  
*Tachypleus*, 1358  
 Taconite, 2190\*  
 Tadpole shrimps, 1504  
*Taenia*, 491  
 Taeniodonta, 2190\*  
 Tago-Sato-Kosaka Comet, 508  
 Taiga, 2190\*  
 Tail assembly, 2190-2192\*  
 Tailed whip scorpion, 2314  
 Takakiales, 2191\*  
 Talc, 2026, 2189\*  
 Tall oil, 2189\*, 2192\*  
 Talpidae, 1159, 1417  
 Talus, 290  
*Tamandua longicaudata*, 131  
*Tamandua tetradactyla*, 131  
 Tamarack, 1228  
 Tamarau, 301  
*Tamias striatus*, 387  
 Tanaidacea, 2191\*  
 Tandem electrostatic accelerator, 717  
 Tangelo, 1310  
 Tangent, 2191\*  
 Tangerine, 1310, 2191\*  
 Tank barge, 1154  
 Tannin, 1836  
 Tantalite, 2192\*  
 Tantalum, 2192\*  
 Tantularcarida, 2192\*  
 Tape grass, 975  
 Tape recording see Magnetic recording  
 Taper pin, 2192\*  
 Tapeworm, 134  
 Cestoda, 409\*  
 Cestodaria, 409\*  
 Cestoidea, 409\*  
 Cyclophyllidea, 606\*  
 Diphyllidea, 677\*  
 Gyrocotylidea, 1035\*  
 Lecanicephaloidea, 1238-1239\*  
 medical parasitology, 1348  
 Nippotaeniidea, 1488\*  
 parasitology, 1610  
 Proteocephaloidea, 1792\*  
 Pseudophyllidea, 1798\*  
 Tetraphyllidea, 2214-2215\*  
 Trypanorhyncha, 2278\*  
 Taphonomy, 2192\*  
*Taphrina*, 1062  
 Taphrinales, 941  
 Tapir, 178, 2192\*  
 Oligocene, 1539  
 Perissodactyla, 1633-1634\*  
 Tapiridae, 2192  
 Tar sand see Oil sand  
 Tardigrada, 2192-2193\*  
 Eutardigrada, 856\*  
 Heterotardigrada, 1073\*  
 Loricifera, 1272-1273\*  
 Tarpon, 808  
 Tarragon, 2193\*  
 Tarsal gland, 1968\*  
 Tarsier, 1771  
 Tarsiiformes, 927-928  
*Tarsius*, 927  
 Tartaric acid, 2193\*  
 Tasmania, 198  
 Taste, 374, 605, 2193\*  
 chemical senses, 427, 428  
 chemoreception, 433  
 flavorings, 2084  
 tongue, 2247-2248\*  
 Taste bud, 605, 1985, 1986  
 Tatum, E., 241  
*Taurotragus derbianus*, 131  
 Taurus, 1727, 2194\*  
 Tautomerism, 2194\*  
 Taxales, 2412  
*Taxidea taxus*, 214  
 Taxis, 2194\*  
*Taxodium distichum*, 544  
 Taxodonta, 1223, 2194\*  
 Taxon, 2419  
 Taxonomic categories, 1675-1676,  
 2194-2195\*  
 Taxonomic mineralogy, 1405  
 Taxonomy, 2195\*  
 animal systematics, 108-109\*, 123\*  
 bacterial, 243-244\*  
 chemotaxonomy, 434-435\*  
 numerical, 1524\*  
 phylogeny, 1675-1676\*  
 plant, 1713-1714\*  
 plant kingdom, 1706-1707\*  
 species concept, 2072-2073\*  
 Tay-Sachs disease:  
 lysosome, 1283

Tay-Sachs disease—*cont.*  
 metabolic disorders, 1362  
 sphingolipid, 2084  
 Taylor, J., 907  
 Taylor series, 1988  
 TCAS see Traffic Alert and Collision  
 Avoidance System  
 TCP/IP, 1176  
 Tea, 2195\*, 2217  
 Teak, 1223  
 Teasel, 620  
 Technetium, 2195\*  
 Technology, 2195\*  
*Tectona*, 1223  
 Tectonic earthquake, 655, 723  
 Tektite, 2195\*  
 Telecast, 2195-2196\*  
 Telecine camera, 2204  
 Telecommunications:  
 modulation, 1414-1415\*  
 multiplexing, 1446-1447\*  
 phase modulation, 1652\*  
 private branch exchange, 1775-1776\*  
 switching systems, 2176-2177\*  
 teleconferencing, 2196\*  
 Telecommunications civil defense system,  
 2196\*  
 Teleconferencing, 2196\*, 2339-2340  
 Telegraphy, 1846, 2196-2197\*  
 bandwidth requirements, 218, 250\*  
 FM transmission, 838  
 frequency-modulation radio, 936  
 Telemetering, 2196  
 Telemetering, 2197-2198\*  
 FM transmission, 838  
 frequency-modulation radio, 936  
 Telemetry:  
 biotelemetry, 296-297\*  
 telemetering, 2197-2198\*  
 Telencephalon, 287, 1477  
 Teleostei, 2198\*  
 Cetomimiformes, 359  
 Clupeiformes, 422  
 Ctenothrissiformes, 597\*  
 Elopiformes, 808\*  
 Gastrosteiformes, 970\*  
 Gonorynchiformes, 1013\*  
 Lampridiformes, 1224\*  
 Leptolepiformes, 1246\* 1095\*  
 Salmoniformes, 1941\*  
 Tetraodontiformes, 2214\*  
 Zeiformes, 2414\*  
 Teleostomi, 7, 2198\*  
 Teleosts, 21  
 Telepathy, 779  
 Telephone, 2198\*  
 directional coupler, 684  
 electronic listening devices, 788  
 private branch exchange, 1776  
 queuing theory, 1836  
 videotelephony, 2339-2340\*  
 Telephone private branch exchange see  
 Private branch exchange  
 Telephone service, 2199-2200\*  
 communications cables, 450, 509-510\*  
 communications satellite, 510  
 crosstalk, 582\*  
 facsimile, 869-870\*  
 Federal Telecommunications System, 874\*  
 infrastructure, 2199  
 intelligent networks, 2200  
 key telephone system, 1213\*  
 out-of-band signaling systems, 2199-2200  
 switching and transmission designs, 2199  
 switching systems, 2177  
 wireless, 2200  
 Telephone systems construction, 2200\*  
 amplitude modulation, 91, 106-107  
 bandwidth requirements, 218, 250\*  
 Teleprinter see Teletypewriter  
 Teleprocessing, 2201\*  
 Telescope, 2201-2202\*  
 aberration (astronomy), 2-3\*  
 astronomical observatory, 192-193\*  
 astronomy, 195-196  
 coronagraph, 561\*  
 high-energy neutrino, 1483  
 Hubble Space Telescope, 2067-2068\*  
 Jupiter, 1206  
 optical tracking instruments, 1562  
 radio, 1852\*  
 Schmidt camera, 1959\*  
 submillimeter, 2140  
 ultraviolet astronomy, 2295  
 x-ray, 2405-2406\*  
 Teleseminar, 2196  
 Telestacea, 2202\*

- Telesto, 2202  
 Teletypewriter, 1846  
 Teletypewriter exchange (TWX) service, 451  
 Television, 2202-2203\*  
 amplitude modulation, 106  
 bandwidth requirements, 218, 250\*  
 cable system, 307  
 closed-caption, 476\*  
 closed-circuit, 419, 476-477\*  
 color see Color television  
 communications satellite, 510-511  
 direct broadcasting satellite systems, 681-682\*  
 fidelity, 885\*  
 heterodyne principle, 1072\*  
 mixer, 1411-1412\*  
 picture tube, 1685\*  
 scrambling, 451  
 signals, 307  
 synchronization, 2183\*  
 telecast, 2195-2196\*  
 underwater, 2300\*  
 Television camera, 2203-2204\*, 2206  
 Television camera tube, 2204\*  
 electron lens, 781\*  
 image orthicon, 2204  
 photoconductive tubes, 2204  
 silicon intensifier, 2204  
 solid-state imagers, 1963  
 Television networks, 2204-2205\*  
 Television receiver, 2205-2206\*  
 automatic frequency control (AFC), 224\*  
 cathode-ray tube, 380-381\*  
 tuning, 2282\*  
 Television scanning, 2206\*  
 Television standards, 2206-2207\*  
 Television studio, 2207\*  
 Television tower, 2252  
 Television transmitter, 2207\*  
 Teliomycetes, 226  
 Teliospores, 2024  
 Tellegen, D. H., 785  
 Teller, E., 1201  
 Tellinacea, 1223  
 Tellurium, 2207\*  
 Telnet, 1176  
 Telospora, 2088, 2207\*  
 Archigregarinida, 164\*  
 Coccidia, 487\*  
 Gregarinia, 1027\*  
 Neogregarinida, 1473\*  
 Telstar (communications satellite), 451  
 Temnopleuridae, 2208\*  
 Temnospondyli, 2208\*  
 Temperature, 2208\*  
 air, 55  
 density measurement, 636  
 ice point, 1123-1124\*  
 meteorological instrumentation, 1376  
 negative, 1472\*  
 negative temperature, 1472\*  
 physical measurement, 1680  
 pressure-volume-temperature diagram, 2226-2227  
 temperature-entropy diagram, 2227  
 upper-atmosphere dynamics, 2308  
 weather observations, 2380  
 Temperature adaptation, 2208\*  
 Temperature inversion, 2208-2209\*  
 Temperature measurement, 2209\*  
 calorimetry, 358\*  
 gas thermometry, 967-968\*  
 geologic thermometry, 989\*  
 low-temperature thermometry, 1276\*  
 pyrometer, 1816\*  
 thermocouple, 2224\*  
 thermometer, 2229\*  
 Temperature sensors, 2232  
 Tempering, 2209\*  
 Temple orange, 1310  
 Temporal lobe seizure (epilepsy), 753  
 Temporary structure (engineering), 2209\*  
 10/20 system, 768  
 Tendon, 2209-2210\*  
 Tendonitis, 159  
 Tenrec, 2210\*  
 Tensile strength, 1363  
 Tension, 1363  
 Tensor analysis, 2210\*  
 Tensor field equations, 1890  
 Tentaculata, 408-409  
 Tentaculitida, 473  
 Teosinte, 496  
 Tepary bean, 229  
 Teratology, 536  
 Teratomorphidae, 784  
 Terbium, 2210\*  
 Terebratulida, 161, 2210\*  
 Terebinthaceae, 281, 2000  
 Terminal bud, 300  
 Terminal moraine, 1437  
 Termitaphididae, 944  
 Termite, 304  
 Exopterygota, 859  
 Isoptera, 1195-1196\*  
 social insects, 2027-2028\*  
 Termitidae, 1195  
 Tern, 365  
 Ternnopleuroida, 2208\*  
 Terpene, 1689, 2210\*  
 Terpenoid, 3-4  
 Terracing (agriculture), 2210-2211\*  
 Terrain areas, 2211\*  
 Terrapins, 419\*  
 Terrestrial atmospheric heat balance, 933  
 Terrestrial biome, 253  
 Terrestrial coordinate system, 2211-2212\*  
 Terrestrial Dynamical Time (TDT), 711  
 Terrestrial ecology, 735  
 Terrestrial ecosystem, 736, 2212\*  
 Terrestrial electricity see Geoelectricity  
 Terrestrial great circle, 908, 1025\*  
 Terrestrial magnetism see Geomagnetism  
 Terrestrial planets, 1700-1701  
 Terrestrial radiation, 2212-2213\*  
 heat balance, terrestrial atmospheric, 1054\*  
 middle-atmosphere dynamics, 1399\*  
 Terrestrial Time (TT), 1090  
 Terrestrial water, 2213\*  
 Terrigenous clastic depositional systems, 641  
 Territoriality, 1897, 2213\*  
 Tertiary, 2213\*  
 Eocene, 834\*  
 Miocene, 1406-1407\*  
 Oligocene, 1539\*  
 Paleocene, 1597-1598\*  
 Pliocene, 1728-1729\*  
 Tesla, definition of, 761  
 Tassaratomidae, 944  
 Test, environmental, 831-832\*  
 Testing, inspection and, 1159\*  
 Testis, 2213-2214\*  
 anatomy and physiology, 1897  
 androgen, 114-115\*  
 estrogen, 848\*  
 Testosterone, 2214  
 Tetanus, 419, 2214\*, 2253-2254  
 Tetrabranchia, 1466\*  
 Tetrachloroethane, 391  
 Tetractinomorpha:  
 Axinellida, 236\*  
 Choristida, 448\*  
 Clavaxinellida, 468\*  
 Homosclerophorida, 1088\*  
 Spirophorida, 2086\*  
 Tetracyanoethylene, 537  
 Tetradontium, 2214  
 Tetrahydrene, 309  
 Tetrahedrite, 2214\*  
 Tetrahymena, 985  
 Tetranchyroderma, 1287  
 Tetrao urogallus, 260  
 Tetraodontiformes, 2214\*  
 Tetraonidae, 260  
 Tetraphidaceae, 2214\*  
 Tetraphididae, 2214\*  
 Tetrphyllidea, 2214-2215\*  
 Tetrapod limbs, 2017  
 Tetrapoda, 101-102, 713-715, 2215\*  
 Tetrasodium EDTA, 851  
 Tetrasporales, 2357  
 Tetragonia expansa, 2033  
 Tettigoniidae, 1581  
 Teuthoidea, 438, 2093, 2215\*  
 Text-to-speech synthesis (TTS) see Voice response  
 Textile, 2215\*  
 bleaching, 303\*  
 cotton, 571\*  
 dyeing, 708\*  
 flameproofing, 804  
 manufactured fiber, 1313-1314\*  
 natural fiber, 1465\*  
 silk, 2009\*  
 spinning, 2086\*  
 wool, 2396-2397\*  
 see also Manufactured fiber  
 Textile chemistry, 2216\*  
 Textile microbiology, 2216-2217\*  
 Textile printing, 2217\*  
 Texturing agents (food), 909  
 Thalamus, 287, 1477  
 Thalarctos maritimus, 230  
 Thalassemia, 1361  
 Thalattosauria, 750  
 Thaliacea, 2217\*  
 Thallium, 2217  
 Thallobionta, 2217  
 Thaumastocoridae, 944  
 Thaumastocoroidea, 944  
 Thaumatomastix, 391  
 Thea sinensis, 2195  
 Theaceae, 2195  
 Theales, 613, 2217-2218\*  
 cacao, 348\*  
 tea, 2195\*  
 Thecamoeba verrucosa, 100  
 Thecanephria, 1732, 2218\*  
 Thecodontia, 149, 2218\*  
 THEED see Transmission high-energy electron diffraction  
 't Hooft, G.:  
 gauge theory, 973  
 magnetic monopoles, 1293  
 Thelephora, 1112  
 Thelodontia, 2218\*  
 Theobroma, 1309  
 Theobroma cacao, 307, 488  
 Theophrastus, 1713  
 Theorem, 2218\*  
 Theoretical biophysics, 255-256  
 Theoretical ecology, 2218\*  
 Theoretical physics, 2218-2219\*  
 mathematical physics, 1336\*  
 physical law, 1678  
 Theoretical seismology, 1976-1977  
 Therapsida, 2219\*  
 Theria, 856, 2219\*  
 Thermal analysis, 2219-2220\*  
 Thermal burn, 303-304  
 Thermal conduction in solids, 2156, 2220\*  
 Thermal converters, 2220-2221\*  
 Thermal cracking, 1639  
 Thermal desorption, 583  
 Thermal detector:  
 optical detectors, 1553  
 radiometry, 1863  
 Thermal ecology, 2221\*  
 Thermal electrical noise, 685  
 Thermal energy, 2039  
 Thermal expansion, 2221\*  
 Thermal hysteresis, 2221\*  
 Thermal infrared radiation, 1984  
 Thermal insulation see Heat insulation  
 Thermal metamorphism, 1372  
 Thermal neutrons, 2221\*  
 Thermal noise, 759  
 Thermal processes, 1643-1644  
 Thermal protection, 751, 2058  
 Thermal reforming, 1881-1882  
 Thermal stress, 2222\*  
 Thermal wind, 882, 2222\*  
 Thermionic converter see Thermionic power generator  
 Thermionic emission, 2222\*  
 Schottky effect, 1959-1960\*  
 thermionic tube, 2222-2223\*  
 work function (electronics), 2397-2398\*  
 Thermionic power generator, 2222\*  
 Thermionic tube, 2222-2223\*  
 Thermistor, 2223\*, 2229  
 Thermoacoustics, 2223\*  
 Thermochemistry, 2224\*, 2246  
 Thermocouple, 747, 2224\*  
 radiometry, 1863  
 Seebeck effect, 1973  
 Thermocouple alloy, 84  
 Thermodynamic cycle, 2224-2225\*  
 Brayton cycle, 288  
 Carnot cycle, 373\*  
 diesel cycle, 659\*  
 Otto cycle, 1587\*  
 Rankine cycle, 1868-1869\*  
 refrigeration cycle, 1883-1884\*  
 vapor cycle, 2323\*  
 Thermodynamic equilibrium, 2156  
 Thermodynamic principles, 2225-2226\*  
 enthalpy, 826\*  
 entropy, 828\*  
 first law of thermodynamics, 2225  
 free energy, 932-933\*  
 heat, 1053\*  
 heat capacity, 1054-1055\*  
 internal energy, 1175\*  
 Maxwell's demon, 1340\*  
 second law of thermodynamics, 2225-2226  
 third law of thermodynamics, 2226  
 Thermodynamic principles—cont.  
 van der Waals equation, 2322\*  
 virial equation, 2341\*  
 zeroth law of thermodynamics, 2225  
 Thermodynamic processes, 2226-2227\*  
 adiabatic process, 29\*  
 isentropic process, 1192\*  
 isobaric process, 1193\*  
 isometric process, 1195\*  
 isothermal process, 1197\*  
 Kapitza resistance, 1209-1210\*  
 liquefaction of gases, 1261  
 polytropic process, 1752\*  
 pressure-volume-temperature diagram, 2226-2227  
 refrigeration cycle, 1883-1884\*  
 reversible and irreversible, 2227  
 systems and processes, 2226  
 temperature-entropy diagram, 2227  
 thermodynamic cycle, 2224-2225\*  
 Thermodynamics:  
 aerothermodynamics, 39\*  
 Charles' law, 417\*  
 chemical see Chemical thermodynamics  
 first law of, 2225  
 gas dynamics, 862-863  
 second law of, 2226  
 statistical mechanics, 2102  
 thermoacoustics, 2223\*  
 third law of, 2226  
 work function, 2398\*  
 zeroth law of, 2225  
 Thermoelectric power generator, 2227-2228\*  
 Thermoelectricity, 2228\*  
 electromotive force, 776  
 Peltier effect, 1624\*  
 Seebeck effect, 1973\*  
 thermocouple, 2224\*  
 Thomson effect, 2234\*  
 Thermofforming, 1723  
 Thermography, 1984  
 Thermoluminescence, 2228-2229\*  
 Thermoluminescent dosimeter, 699  
 Thermomagnetic effects, 2229\*  
 Thermometer, 2229\*  
 bimetallic, 2229  
 filled-system, 2229  
 liquid-in-glass, 2229  
 magnetic, 1295-1296\*  
 resistance, 2229  
 temperature, 2208  
 temperature measurement, 2209\*  
 thermistor, 2223\*, 2229  
 vapor-pressure thermal system, 2229  
 Thermometric titration, 2246  
 Thermometry:  
 gas, 863  
 geologic, 879  
 Thermonuclear reaction, 2229\*  
 hydrogen bomb, 1105-1106\*  
 stellar evolution, 2108-2110\*  
 supernova, 2161  
 Thermophile, 160\*  
 Thermoplastic polyurethane elastomers (TPU), 1194  
 Thermoplastics:  
 polyether resins, 1743\*  
 polymers, 1746  
 polystyrene resin, 1752\*  
 polyvinyl resins, 1753  
 Thermoregulation, 2229-2230\*  
 adaption (biology), 23  
 fever, 882\*  
 homeostasis, 1086  
 temperature adaptation, 2208\*  
 Thermos Bottle, 590  
 Thermosbaenacea, 2230\*  
 Thermosetting resins, 1747  
 Thermosiphon, 934-935  
 Thermosphere, 184, 201-202, 2230\*, 2308  
 Thermostat, 2231\*  
 Thermotherapy, 2231\*  
 Therophytes, 1717  
 Theropoda, 674, 675  
 Theta rhythm (brain), 693, 768  
 Thévenin, M. L., 2231  
 Thévenin's theorem (electric networks), 2231\*  
 Thiamine, 2232\*  
 Thick-film capacitor, 365  
 Thick-film circuits, 1773  
 Thick-film sensor, 2232\*  
 Thick-knee (bird), 364  
 Thickening, 2232-2233\*  
 Thigmotaxis, 2194  
 Thigmotrichida, 2233\*

- Thigmotaxis, 1709  
Thin-film capacitor, 365  
Thin-film circuits, 1773  
Thin-film electroluminescence (TFEL), 769  
Thin-film shields, 771  
Thin films:  
  magnetic, 1296\*  
  metal coatings, 1365-1366\*  
Thin-layer chromatography, 804  
Thinner, 2233\*  
Thinocoridae, 364  
Thio alcohol see Mercaptan  
Thiocyanate, 2233\*  
Thiocyanic acid, 2233  
Thiol see Mercaptan  
Thiophene, 2233\*  
Thiosulfate, 2233\*  
Third-order nonlinearity, 1496  
Thirst and sodium appetite, 2233-2234\*  
Thirty-five-millimeter camera, 320  
Thismiacae, 677  
Thixotropy, 1913  
Thom, R., 340  
*Thomomys talpoides*, 898  
Thomson, C., 1768  
Thomson, Ken, 1783  
Thomson, J. J., 191, 211, 699, 761  
Thomson effect, 2234\*  
Thoracic vertebra, 2331  
Thoracica, 409, 2236\*  
  Balanomorpha, 246\*  
  barnacle, 252\*  
  Lepadomorpha, 1242\*  
  Verrucomorpha, 2331\*  
Thoracostei, 865  
Thoracostomopsidae, 741  
Thorianite, 2234\*  
Thorite, 1855, 2234\*  
Thorium, 2234-2235\*  
  heat flow in Earth, 719  
  lead isotopes, 1236  
  nuclear fuels, 1508-1509\*  
  radioactive minerals, 1854-1855\*  
  titanite, 2244  
Threatened species, 814  
Three Age System, 1768  
Three-dimensional imaging, 1977  
Threshold theorem (disease), 686  
Throat, 2235\*  
Thromboangitis obliterans see Buerger's disease  
Thrombosis, 408, 2235\*  
  infarction, 1143  
  phlebitis, 1655\*  
Thromboxanes, 739-740  
Thrombus, 2235  
Thrust, 2235\*  
  specific fuel consumption, 2073\*  
  specific impulse, 2074\*  
Thrust bearing, 139-141  
*Thuja* species, 139  
Thulium, 2235\*  
Thunder, 2121, 2235-2236\*  
Thunderstorm, 2236\*  
  electrical activity, 186-187  
  lightning, 1252-1253\*  
  serics, 1995, 1995\*  
  squall, 2091  
  storm detection, 2121  
  tornado, 2250  
Thurniaceae, 1205  
*Thylacinus*, 1328  
Thyme, 2236\*  
Thymine, 1813  
Thymosin, 2236\*  
Thymus gland, 2236\*  
*Thymus vulgaris*, 2236  
Thyatron, 863  
Thyreophora, 675  
Thyristor see Controlled rectifier  
Thyrocalcitonin, 2236-2237\*  
Thyroid gland, 2237\*  
  endocrine system (vertebrate), 816  
  parathyroid, 1611\*  
  thyrocalcitonin, 2236-2237\*  
  thyroxine, 2237-2238\*  
Thyroid gland disorders, 2237\*  
Thyroid hormone, 2237\*  
Thyroid-stimulating hormone (TSH), 27  
Thyroiditis, 2237  
Thyropteridae, 388  
Thyroxine, 2237-2238\*  
Thysanoptera, 2238\*  
Thysanura, 2238\*
- Tick, 739  
Acar, 8\*  
Araneida, 155  
heartwater disease, 1053  
Ixodidae, 1199\*  
Lyme disease, 1281  
relapsing fever, 1885-1886  
rickettsioses, 1920  
Tick paralysis, 2238\*  
Tics (Tourette's syndrome), 2252\*  
Tidal bore, 2238\*  
Tidal datum, 2238-2239\*  
Tidal power, 2238\*, 2239  
Tidal wave, 2045  
Tidalites, 2239\*  
Tide, 2239-2240\*  
  atmospheric, 205-206\*  
  Earth rotation, 721  
  earth tides, 722\*  
  ocean waves, 1530  
  river, 1924-1925\*  
  tidal bore, 2238\*  
  upper-atmosphere dynamics, 2307  
Tie rod, 2240\*  
Tilandsia, 294  
Tile, 2135, 2240\*  
*Tilia* species, 226  
Tiliaceae, 1208\*  
Till, 2240\*  
Tillodontia, 2240\*  
Tiltmeter, 722, 1975  
Timber wolf, 634  
Timbre, 1454  
Time, 2240-2245\*  
  atomic, 193, 214-215\*  
  atomic clock, 208-209\*  
  bases, 2240-2241  
  civil, 2241  
  day, 557, 620-621\*  
  dynamical, 648  
  Dynamical Time, 711\*  
  Earth rotation, 721  
  ephemeris time, 750  
  equation of time, 840\*  
  geologic time scale, 989\*  
  horology, 1090\*  
  International Date Line, 1175-1176\*  
  measurement, 2240  
  month, 1436\*  
  relativity, 1887-1891\*  
  space-time, 2068\*  
  standard, 2241  
  sundial, 2151\*  
  units of measurement, 2303  
  year, 2410\*  
  see also Clock; Watch  
Time, arrow of, 13407  
Time constant, 2241\*  
Time-controlled systems see Clock control systems  
Time dilation, 418  
Time-division multiple access (TDMA), 1447  
Time-division multiplexing (TDM), 681, 1447, 1808-1809  
Time-interval measurement, 2241\*  
  chronograph, 454\*  
  time-of-flight spectrometer, 2241\*  
Time intervals, 754-755, 1680  
Time-of-flight spectrometer, 886, 2241\*  
Time perception, 2347  
Time-projection chamber, 2241-2242\*  
Time reversal, 1495  
Time reversal invariance, 2180, 2242\*  
Time sequence, 632  
Time-varying field accelerator, 1614-1615  
Timetabling, 1956  
Timing belt, 235  
Timothy, 2242\*  
Tin, 2242-2243\*  
  cassiterite, 377\*  
  copper alloys, 556-557\*  
  semiconductor, 1980  
Tin alloys, 2243\*  
  bronze, 335\*  
   pewter, 1646\*  
Tin metallurgy, 2243\*  
Tinbergen, Niko, 849  
*Tinea*, 1347  
Tineoidea, 1245  
Tingidae, 944  
Tingoidea, 944  
Tinnitus, 1051  
Tintinnida, 2243\*  
Tire, 2243\*  
Tiselius cell, 715  
Tissue, 2243\*  
  adipose tissue, 29\*
- Tissue—cont.  
  epidermis (plant), 837-838\*  
  epithelium, 839\*  
  gangrene, 963\*  
  polyploidy, 1750  
Tissue culture, 1713, 2244\*  
Tissue typing, 2244\*  
Titan, 1701  
Titanium metallurgy, 2244-2245\*  
Titanite, 2244\*  
  see also Sphene  
Titanium, 2244\*  
  illmenite, 1127\*  
  organometallic compound, 1575  
  placer mining, 1695  
  rutile, 1936\*  
  titanite, 2244\*  
Titanium metallurgy, 2244-2245\*  
Titanium tetrachloride, 390  
Titration, 2245-2246\*  
  biocalorimetry, 277\*  
  classification by chemical reaction, 2245  
  classification by end-point techniques, 2245-2246  
  coulometric, 2245  
  electroanalytical chemistry, 765  
  quantitative chemical analysis, 1821  
Titrimetric analysis see Volumetric analysis  
*Tmesipteris tannensis*, 1799  
Toad, 146  
Toad bug, 943  
Toadfish, 258  
Tobacco, 2246\*  
  farm crops, 871  
  Solanales, 2038  
Tobacco mosaic virus (TMV):  
  plant pathology, 1711  
  plant viruses and viroids, 1715  
Tocopherol see Vitamin E  
Todidae, 494  
Todie (bird), 494  
Toggle, 2246\*  
Tokamak, 1689  
Tokay (lizard), 868  
Token-passing protocol, 1267  
Tolerance, 2246\*  
Tolerance hypothesis, 734  
Tomato, 2038, 2246-2247\*  
Tomato planta macho viroid, 1716  
Tomistoma, 515, 867  
Tomot fauna, 2247\*  
Tomography see Acoustic tomography; Computerized tomography  
  crystal, 1977  
  optical coherence tomography, 1551-1552\*  
  paleopathology, 1602  
Tomonaga, S., 1826  
Tomopteridae, 760  
Ton of refrigeration, 2247\*  
Tone (music and acoustics), 2247\*  
Tongue, 2247-2248\*  
  function, 605  
  taste, 2193\*  
Tongue worm:  
  Enteropneusta, 826\*  
  Pentastomida, 1626\*  
Tonguesole, 1728  
Tonic convulsions, 766  
Tonsil, 2248\*  
Tonsillitis, 2248\*  
Tools, prehistoric, 1768  
Tooth, 1443, 2248\*  
  dental anthropology, 636-637\*  
  dentition, 637-638\*  
Tooth disorders, 2248-2249\*  
  decay, 574  
  dentistry, 637\*  
  periodontal disease, 1632-1633\*  
Top shell, 144  
Topaz, 2249\*  
Topographic coupling, 721  
Topographic surveying and mapping, 2249\*  
  aerial photograph, 32\*  
  contour, 547\*  
  geodesy, 986-987\*  
Topography:  
  depositional systems and environments, 641  
  desert erosion features, 644-645\*  
  Earth, 717-718  
  eolian landforms, 834-835\*  
Topology, 2249-2250\*  
  graph theory, 1017\*  
  Lie group, 1249\*  
  Riemannian geometry, 1921  
Topsoil, 1225
- Torbanite, 2250\*  
Torch, 2250\*  
Torch brazing, 289  
Tornado, 2250-2251\*  
Torpedinidae, 673  
Torpedo:  
  acoustic, 18\*  
  guidance systems, 1031\*  
  naval armament, 1467  
Torque, 2251\*  
  dynamometer, 711-712\*  
  torsion, 2251\*  
  units of measurement, 2304  
Torque converter, 2251\*  
Toricelli's theorem, 2251\*  
Torsion, 2251\*  
  metal, 1363  
  torque, 2251\*  
Torsion bar, 230, 2251-2252\*  
Tortoise, 419\*  
Tortricidae, 1243  
Tortricoidae, 1243  
Torus, 2252\*  
Total factor productivity, 1781  
Total productivity, 1781  
Totipotent stem cells, 2112  
Toucans, 1684  
Touch-me-not, 884  
Tough bumelia, 1047  
Tourette's syndrome, 2252\*  
Tourmaline, 1935\*, 2252\*  
Towboat, 1154  
Tower, 2252\*, 2269  
Towing tank, 2252-2253\*  
Townes, C. H., 1563  
Townsend, J. S., 2253  
Townsend discharge, 615, 2253\*  
Toxic goiter, 2237  
Toxic shock syndrome, 2096, 2253\*  
*Toxicodendron*, 1733  
*Toxicodendron vernicifluum*, 2327  
Toxicology, 2253\*  
  behavioral, 233-234  
  environmental, 832\*  
  forensic, 824, 915\*  
  intake of toxicants through a lifetime, 746  
  lead poisoning, 1235  
  pesticide, 1639  
  poison, 1732\*  
  radioecology, 1859-1860  
Toxin, 2253-2254\*  
  aflatoxin, 40\*  
  allelopathy, 81\*, 421-422  
  antitoxin, 146\*  
  botulism, 322\*  
  endotoxin, 819-820\*  
  mycotoxin, 1459-1460\*  
  pathotoxin, 1620\*  
  poison, 1732-1733\*  
  tetanus, 2214\*  
  toxic shock syndrome, 2253  
  water pollution, 2366  
Toxin-antitoxin reaction, 2254\*  
Toxid, 252  
*Toxoplasma*, 1348, 2254\*  
Toxoplasma, 2088, 2254\*  
Toxoplasma, 2254\*  
Toxopneustidae, 2208  
Trace analysis, 22  
Trace fossils, 923, 2254\*  
Tracer see Radioactive tracer  
Trachea, 1228  
*Trachelomonas*, 768  
*Trachelomonas volvocina*, 852-853  
Tracheophyta, 727  
Trachoma, 389  
Trachylina, 983, 1111, 2255\*  
Trachyte, 2255\*  
Track etch dosimeter, 699  
Track gage, 1866  
Tracking:  
  multivariable control, 1448\*  
  optical tracking instruments, 1562-1563\*  
  radar, 1839-1840\*  
Tracking and Data Relay Satellite System (TDRSS):  
  space communications, 2058  
  space shuttle, 2065  
  spacecraft ground instrumentation, 2068  
Tractor, 2255\*  
Tractrix, 2255\*  
Tradescantia, 449  
Traffic Alert and Collision Avoidance System (TCAS), 58  
Traffic-control systems, 2255-2256\*  
  marine navigation, 1324  
  railroad, 1865\*

## Traffic engineering:

highway engineering, 1079-1080\*  
 traffic-control systems, 2255-2256\*  
 vessel traffic service, 2334\*

Traffic signals, 1080

Tragulidae, 164, 384

Traguloidea, 164

*Tragus* species, 384

Trailing-edge coast, 427

Training, operator, 1548\*

Trajectory, 2256\*

Tranquilizer, 2256\*

Trans-Golgi network, 1012

Transactinide elements, 2264-2265

Transamination, 2256\*

Transcendental function, higher, 2072

Transconductance-C filters, 1164

Transdermal controlled-delivery devices, 702

Transducer, 2256-2257\*  
 earphones, 653, 716\*  
 electret, 741-742\*  
 magnetostriction, 1303\*  
 pressure, 1769-1770\*  
 surface acoustic-wave devices, 2167  
 telephone, 2198  
 vibration pickup, 2338\*

Transduction (bacteria), 213, 2257\*

Transesophageal echocardiography, 729

Transfer cells, 2257\*

Transfer molding, 1723

Transfer RNA (tRNA):  
 gene, 978  
 gene action, 979  
 genetic code, 981-982  
 intron, 1179  
 ribonucleic acid, 1918

Transferase, 748, 833

Transferrin, 1191

Transform fault, 2257-2258\*

Transformation (bacteria), 213, 241, 2258\*

Transformer, 2258-2259\*  
 autotransformer, 232\*  
 differential, 600  
 inductive voltage divider, 1139\*  
 phase inverter, 1651  
 radio-frequency impedance  
 measurements, 1850

Transforming growth factors (TGF)  
 (cytokines), 609, 610

Transforms, 930-931

Transfusion, 2259-2260\*  
 blood, 304-305\*  
 blood groups, 305-307\*

Transgenes, 2048

Transient waveforms, 2373

Transistor, 2260-2261\*  
 amplitude distortion, 629  
 bias, 271-272  
 circuit (electronics), 460  
 field-effect see Field-effect transistor  
 integrated circuit filter, 1163-1164\*  
 junction, 1205\*  
 microwave solid-state devices, 1396  
 nanostructure, 1464\*  
 phototransistor, 1673\*  
 quantized electronic structure, 1821-1822\*  
 semiconductor rectifier, 1984  
 switching circuit, 2175

Transistor amplifier, 2353-2354

Transit (astronomy), 180, 194-195, 1698,  
 1699, 2261\*

Transit clinometer, 565-566

Transition elements, 2261\*  
 cadmium, 349\*  
 chromium, 450-451\*  
 cobalt, 486\*  
 electron paramagnetic resonance  
 spectroscopy, 782  
 gallium, 958\*  
 gold, 1010-1011\*  
 hafnium, 1038\*  
 indium, 1136-1137\*  
 iridium, 1190\*  
 iron, 1190-1191\*  
 lutetium, 1280\*  
 manganese, 1311\*  
 mercury, 1356\*  
 molybdenum, 1429-1430\*  
 nickel, 1486-1487\*  
 niobium, 1488, 1488\*  
 nonstoichiometric compounds, 1500  
 osmium, 1584-1585\*  
 palladium, 1603-1604\*  
 platinum, 1724-1735\*  
 rhodium, 1911\*  
 rhodium, 1914-1915\*  
 ruthenium, 1936\*

## Transition elements—cont.

scandium, 1952-1953\*  
 silver, 2010\*  
 tantalum, 2192\*  
 technetium, 2195\*  
 tellurium, 2207\*  
 thallium, 2217  
 titanium, 2244\*  
 tungsten, 2282\*  
 vanadium, 2322-2323\*  
 yttrium, 2412\*  
 zinc, 2415-2416\*  
 zirconium, 2417\*

Transition point, 2261\*

Transition radiation detectors, 2261\*

Transition rates, 1856

Transition temperatures, 2155

Transition zones:  
 Earth interior, 721  
 ecotone, 736\*

Translating circuits, 2176

Translucent medium, 2261-2262\*

Transmission see Automotive transmission  
 digital, 1776  
 infectious disease, 1144  
 of sound, 2052  
 stereophonic radio transmission, 2114\*

Transmission Control Protocol (TCP),  
 1176

Transmission dynamometer, 711

Transmission electron microscope, 704,  
 781

Transmission gate, 866

Transmission grafting, 602

Transmission high-energy electron diffraction  
 (THEED), 780, 984

Transmission lines, 2262\*  
 attenuation (electricity), 195  
 coaxial cable, 485-486\*  
 conductor constructions, 470  
 delay line, 632\*  
 dielectric measurements, 658  
 direct-current transmission, 683-684\*  
 electrical loading, 757  
 electromagnetic wave transmission,  
 696-697, 773-774\*  
 microwave filter, 1393-1394\*  
 neper, 1475\*  
 radio-frequency impedance  
 measurements, 1850  
 short circuits, 2002-2003\*  
 submarine cable, 2139\*

Transmission tower, 2252

Transmitter:  
 microwave, 1393  
 radio, 933  
 telephone, 2198

Transmutation, 1844, 2262\*

Transonic flight, 2262\*  
 Mach number, 1285  
 sonic barrier, 2049\*

Transonic flow, 34

Transplantation biology, 2263\*  
 acquired immunological tolerance, 19\*  
 cytomegalovirus infection, 611-612  
 histocompatibility, 1081-1082\*  
 tissue typing, 2244\*

Transponder, 511, 2189

Transport processes, 2263\*

Transportation engineering, 2263-2264\*  
 bridge, 332-334\*  
 canal, 361\*  
 space transportation system, 2060  
 subway, 2142-2143\*  
 traffic-control systems, 2255-2256\*  
 Transposable elements, 1100

Transposons, 2264\*  
 bacterial genetics, 241  
 fungal genetics, 948  
 reverse transcriptase, 1910

Transuranic waste, 1855

Transuranium elements, 2264-2265\*  
 actinide elements, 20\*  
 americium, 95\*  
 berkelium, 267\*  
 bohrium, 310\*  
 californium, 357\*  
 curium, 599\*  
 darmstadtium, 615\*  
 dubnium, 705\*  
 einsteinium, 740\*  
 fermium, 877\*  
 hassium, 1047-1048\*  
 lawrencium, 1234\*  
 meitnerium, 1351\*  
 mendelevium, 1353\*  
 neptunium, 1476\*

## Transuranium elements—cont.

plutonium, 1729-1730\*  
 rutherfordium, 1936\*  
 seaborgium, 1967\*

Transverse dune, 642, 705, 706

Transverse loads, 1266\*

Transverse ray aberration (optics), 3

Transverse ridge dune, 642

Trapped plasma avalanche triggered  
 transit-time (TRAPATT) diode,  
 1397-1398

Traps in solids, 2228-2229, 2265\*

Trauma, 2017, 2265\*

Traveling-grate stoker, 2118

Traveling-wave theory, 1976

Traveling-wave tube, 785, 2265-2266\*

Traveling wave tube (TWT) amplifiers, 1392

Travertine, 2266\*

Treated gem, 869-870

*Trebouxia*, 1249

Tree, 2266\*  
 arboretum, 157\*  
 arboriculture, 157\*  
 arborvitae, 157\*  
 carbon relations, 2268  
 classification, 2266  
 cold resistance, 2268  
 deciduous plants, 625\*  
 dendrochronology, 635  
 dogwood, 694\*  
 Douglas-fir, 700\*  
 elm, 808\*  
 eucalyptus, 851\*  
 growth, 2266  
 magnolia, 1304\*  
 mineral nutrition, 2268  
 morphology, 2266  
 Pinales, 1688\*  
 pistachio, 1692\*  
 silviculture, 2011-2012\*  
 transport and support, 2268  
 water relations, 2268  
 wood anatomy, 2393-2394\*

Tree diseases, 2266-2267\*

Tree ferns, 2267-2268\*

Tree physiology, 2268\*  
 carbon relations, 2268  
 cold resistance, 2268  
 mineral nutrition, 2268  
 transport and support, 2268  
 water relations, 2268

Tree shrew, 1158

Treeshopper, 962

*Tremarctos ornatus*, 230

Trematoda, 1725, 2268-2269\*  
 Aspidogastrea, 184\*  
 Cercaria, 407\*  
 Digenea, 665-666\*  
 Monogenea, 1433\*  
 Trematodea, 1347-1348  
 Trembling aspen, 1754

Tremolite, 179, 2269\*

Trenches:  
 Earth, 718  
 marine geology, 1322  
 subduction zones, 2137-2138\*

*Trentonia*, 391

*Trepomonas*, 618

*Treponema pallidum*, 1479, 2185

*Treponema pertenuis*, 2410

Trepostomata, 2269\*

Trestle, 2269\*

Triamantane, 309

Triangle:  
 pythagorean theorem, 1818\*  
 trigonometry, 2271-2273\*

Triassic, 120, 2269\*

Triasterane, 309

Tribocharging, 797

Tribology, 2270\*

Tricarboxylic acid cycle see Krebs cycle

*Triceratops*, 676

*Trichinella spiralis*, 1347, 2420

Trichlorethylene, 391

Trichlorofluoromethane, 836

Trichocomeaceae, 771

*Tricholoma*, 984, 1112

Trichomycetes, 848, 2270\*

Trichophyton, 578

Trichoptera, 1245, 2270\*

Trichostomatida, 2270\*

Trichostongyloidea, 2130\*

Trichroism, 2270\*

*Trichuris trichiura*, 1347

Tricladida, 2270\*, 2284

Triconodonta, 2270-2271\*  
*Trifolium*, 421

## Trigger circuit, 1807\*, 2271\*

Triggerfish, 2214

Triglyceride, 1260, 2271\*  
 fat and oil, 871-872\*  
 lipid metabolism, 1260\*

*Trigona*, 231

Trigonocarpales, 539

Trigonometry, 2271-2273\*  
 functions, 2271-2272  
 hyperbolic function, 1115-1116\*  
 infinite series representation, 2273  
 inverse functions, 2272  
 plane, 2271  
 properties of functions, 2272  
 solution of oblique triangles, 2272-2273  
 solution of right triangles, 2272  
 sum and difference formulas, 2272

Trigonostylopoidea, 175

Trihedron, 2273\*

Triiodomethane see Iodoform

Trills (speech), 2078

Trilobita, 1603, 2273\*

Trimerellaceae, 1259

Trimerophytosida, 1799, 1917

Trimmer capacitor, 324

Trimusculidae, 226

Triode, 2319

Triple point, 2273-2274\*  
 gas thermometry, 967  
 ice point, 1124

Triplet state, 2274\*  
 photochemistry, 1661, 1662  
 photolysis, 1668

Tripylina, 1532

Tritanopia, 444

Triterpene, 2274\*

Triterpenoid hydrocarbon, 2091

*Triticale*, 2274\*, 2385

*Triticum*, 2385

Tritium, 2274-2275\*

Triton, 1476, 2275\*

Triuridales, 2275\*

Trochacea, 144

Trocheta, 153

Trochili, 134

Trochilidae, 134

Trochodendrales, 1044, 2275\*

Trochophore, 2275\*

Trogoniformes, 2275\*

Trojan asteroids, 386, 2275-2276\*

Trojan horse, 525

Trombiculidae, 2276

Trombidiformes, 2276\*

Tropaeolaceae, 883

Tropaeolum, 883

Trophic ecology, 276\*

Tropic of Cancer, 322, 2276-2277\*

Tropic of Capricorn, 326, 2277\*

Tropical cyclone, 541

Tropical ecosystem, 1866-1867

Tropical meteorology, 1099, 2277\*

Tropical month, 1436

Tropical year, 722, 2410

Tropism, 1709

Tropomyosin, 1451

Tropopause, 36, 201, 2277\*

Troposphere, 184, 2277\*  
 air pollution, 52  
 atmospheric chemistry, 203  
 atmospheric general circulation,  
 205  
 atmospheric tides, 205  
 front, 938\*  
 tropical meteorology, 2277

Tropospheric scatter, 2277\*

Tropsch, H, 802

Truck, 1142\*, 2278\*

True crabs, 559-562

True fruit, 842

True fungi, 2421

True mosses, 1411

Truffle, 949

Trunkfish, 2214

Truss, 159, 2134, 2278\*

Truss bridge, 292

Trypanorhyncha, 2278\*

*Trypanosoma*, 360, 1348, 2278

Trypanosomatidae, 1216, 2278

Trypophan, 1989

Tsetse flies, 1610

*Tsuga* species, 944-945

Tsunami, 2278-2279\*  
 earthquake, 723  
 ocean waves, 1530

Tsutsugamushi disease see Scrub typhus

Tube-snout, 970

Tuber, 698



Tuberculosis, 21, 2279\*  
infectious disease, 1144  
opportunistic infections, 1550  
paleopathology, 1602  
pneumonia, 1731  
sulfonamide, 2146  
Tubeworms, 2279\*  
Tubulidentata, 2280\*  
aardvark, 1\*  
anteater, 131\*  
Tufa, 2280\*  
Tuff, 2280\*  
Tularemia, 2280\*  
Tulip tree, 1305, 2280\*  
Tulipa, 1254  
Tulips, 1254  
Tulostomatales, 864  
Tuma phase meter see Phase meter  
Tumble-plating, 2416  
Tumbling mill, 1622, 2280\*  
Tumor, 2280-2281\*  
detection, 1542  
gallbladder disorders, 957-958  
larynx disorders, 1229  
olfaction, 1538  
oncology, 1542  
ovarian disorders, 1587-1588  
pancreas disorders, 1605  
pituitary gland disorders, 1694  
polyoma virus, 1750  
radiation chemistry, 1844  
reproductive system disorders, 1899  
spinal cord disorders, 2085  
Tumor necrosis factors (cytokines), 545-546, 609, 610  
Tumor viruses, 2281\*  
avian leukosis, 234-235\*  
reverse transcriptase, 1910\*  
Rous sarcoma, 1934\*  
Tuna, 2281\*  
Tunable lasers, 1230  
Tundra, 2281\*  
Tung kwa, 1579  
Tung tree, 2281-2282\*  
Tungar, 863  
Tungsten, 2282\*  
scheelite, 1956\*  
wolframite, 2393\*  
Tungsten-halogen lamp, 1135  
Tungsten-inert gas welding, 142  
Tunicata, 2282\*  
Appendicularia, 152\*  
Asciacea, 179\*  
sea squirt, 1966\*  
Thaliacea, 2217\*  
Tunics, 865-866  
Tuning, 2282\*  
Tuning fork, 1692, 2282-2283\*  
Tunnel, 2283\*  
subway engineering, 2143  
wind, 2390\*  
Tunnel diode, 1397-1398, 2283\*  
Tunneling in solids, 2283\*  
Josephson effect, 1204\*  
surface physics, 2169-2170  
tunnel diode, 2283\*  
Zener diode, 2414\*  
Tupaiidae, 1158  
Tupelo, 2283-2284\*  
Turbanella, 1287  
Turbellaria, 1725, 2284\*  
Acoela, 14\*  
Alloecocoela, 82\*  
Polycladida, 1742\*  
Tricladida, 2270\*  
Turbidimetry, 1252  
Turbidite, 2284\*  
Turbidite facies, 783  
Turbidity current, 2284\*  
Turbine, 2284\*  
airfoil, 63-64\*  
hydraulic, 973  
impulse turbine, 1134\*  
power plant, 1763  
reaction, 1872\*  
steam see Steam turbine  
wind, 2389  
Turbine engine:  
fuels, 60  
gas, 968-969\*  
valve, 2320  
Turbine propulsion, 2284-2285\*  
Turbocharger, 2285\*  
Turbofan, 2285-2286\*  
ducted fans, 705\*  
general aviation, 980

Turbojet, 2286\*  
afterburner, 41-42\*  
ducted fans, 705\*  
general aviation, 980  
Turbojet, 980, 2286\*  
Turboramjet, 2286-2287\*  
Turbot, 805  
Turbulence (atmospheric), 35, 203  
Turbulent flow, 2287\*  
boundary layer, 285  
computational fluid dynamics, 519\*  
hydrodynamics, 1103  
wake flow, 2361\*  
Turing, A., 223, 895  
Turing machine, 223-224  
Turkey, 259, 958  
Turkey buzzard, 260  
Turkey vulture, 260  
Turmeric, 2287\*  
Turn and bank indicator, 2287-2288\*  
Turnbuckle, 2288\*  
Turner syndrome, 1094  
Turning (woodworking), 2288\*  
Turnip, 2288\*  
rape, 1869\*  
rutabaga, 1936\*  
Turpentine:  
essential oils, 847  
pine terpene, 1689\*  
Turquoise, 2288\*  
Tursiops species, 634  
Turtle, 1907  
see also Chelonia  
Tweeter, 1273-1274  
Twilight, 2288\*  
Twilight glow, 65  
Twin clock effect, 418  
Twinkling stars, 2288-2289\*  
Twinning (crystallography), 2289\*  
Twins see Gemini  
Twins (human), 263, 2289\*  
Twiss, R., 436  
Two-dimensional imaging, 1977  
Two-fluid model, 2156  
Two-phase flow, 2088-2089, 2289-2290\*  
TWX see Teletypewriter exchange service  
Twyman-Green interferometer, 1172  
Tylopoda, 164  
Tyndall, John, 1025  
Tyndall cone, 2290  
Tyndall effect, 1955, 2290\*  
Type (printing), 2290-2291\*  
classification, 2290  
for desktop publishing, 2291  
families, 2291  
fonts, 2290-2291  
measurements, 2290  
Typewriter, 2291\*  
Typhales, 449  
Typhlosoleidae, 760  
Typhoid fever, 1941  
Typhula, 984, 1112  
Typhus, 751, 1920  
Tyranosaurus, 676  
Tyrosine, 1361  
Tyson's gland, 1955-1956  
Tyto alba, 260  
Tytonidae, 2128

## U

U-tube manometer, 1313  
UBV system (color index), 445  
Uda, S., 2409  
UDPG see Uridine diphosphoglucose  
Uhlenbeck, G. E., 192, 212, 699, 777  
Uintatherer see Dinocerata  
Uintatheriidae, 614  
Uintatherium, 614  
Ulcer, 2293\*  
Ulcerative colitis, 1146, 2293  
Ulmus, 725, 808  
Ultimobranchial body, 2236-2237  
Ultracentrifuge, 2293\*  
Ultracold neutron, 1484  
Ultrafast molecular processes, 2293-2294\*  
Ultrafiltration, 1352, 2294\*  
Ultralight aircraft, 2294\*  
Ultraprophosphate glass, 361  
Ultrasonics, 2294\*  
acoustic interferometer, 16\*  
analytical uses, 2295  
Ultrasonics—cont.  
biomedical, 290-291\*  
echocardiography, 728-729\*, 729\*  
engineering applications, 2294-2295  
generators and detectors, 2294  
medical applications, 2295  
medical imaging, 1346-1347\*  
medical ultrasonic tomography, 1348\*  
sonochemistry, 2050\*  
Ultrasound:  
medical imaging, 1346  
thermotherapy, 2231  
Ultraviolet astronomy, 1947, 2295\*  
Ultraviolet lamp, 2152, 2295\*  
Ultraviolet light:  
dichroism, 656  
Ultraviolet photography, 1666  
Ultraviolet radiation, 1843, 2295-2296\*, 2308  
Ultraviolet radiation (biology), 2296\*  
clinical use, 2296  
effects on the skin, 2296  
photobiological effects, 2296  
Ulvalves:  
carrot, 375\*  
celery, 345  
parsley, 1613\*  
parsnip, 1613\*  
Umbelliferae, 326, 495, 559  
Umbral eclipse, 730  
Umklapp process, 2296\*  
Uncertainty principle, 648, 1828, 2296-2297\*  
Unconformity, 1987, 2297\*  
Underfeed stoker, 2118-2119  
Under-frequency protection, 750-751  
Under-ground mining, 1406, 2297-2298\*  
coal, 426, 483  
surface mining, 2169  
Under-ground power transmission, 749-750  
Undersea vehicles, 2298  
Undervoltage protection, 750  
Underwater acoustics, 1333  
Underwater camera, 321  
Underwater demolition, 2298\*  
Underwater navigation, 2298\*  
acoustic transponders, 2298  
dead reckoning, 2298  
Underwater photography, 2299\*  
Underwater sound, 2299-2300\*  
absorption of sound, 2299  
ambient noise, 2300  
antisubmarine warfare, 145-146\*  
echo sounder, 728\*  
hydrophone, 1109\*  
parametric arrays, 1609\*  
pressure waves, 2299-2300  
scattering and reverberation, 2300  
sofar, 2030\*  
sonar, 2048-2049\*  
sonobuoy, 2049-2050\*  
sound absorption, 2052  
sound speed, 2299  
wave propagation, 2300  
Underwater television, 2300\*  
Underwater vehicle, 2138-2139, 2300-2301\*  
Undulant fever see Brucellosis  
Ungulate:  
archaic, 161\*  
Artiodactyla, 178\*  
Uniconformity:  
seismic stratigraphy, 1975  
stratigraphy, 2123  
Unification theories (fundamental interactions), 847  
Uniform Resource Locator (URL), 1176, 2398-2399  
Uninterruptible power system (UPS), 2301\*  
Unionacea, 1223  
Unipolarina, 1462  
Unit operations, 2301\*  
chemical conversion, 420\*  
food engineering, 908  
Unit processes, 2301\*  
Unitary symmetry, 2302\*  
Units of measurement, 2302-2305\*  
dimensions (mechanics), 673\*  
electrical, 760-761, 2304  
geometrical, 2302  
length, 1241\*  
mechanical, 2302-2304  
metric system, 1381\*  
photometric, 2304  
radiation, 2304-2305  
Universal joint, 2305\*  
Universal motor, 2305\*

Universal Product Code, 820  
Universal Time (UT), 711  
Universe, 2305-2307\*  
big bang theory, 272-273\*, 2306  
constituents, 2305-2306  
cosmic background radiation, 2307  
cosmochemistry, 567-568\*  
cosmological redshifts, 2306-2307  
cosmology, 569-571\*  
evolution of, 2307  
extrasolar planets, 2306  
galaxies, 2306  
groups, clusters, large-scale structure, 2306  
inflationary universe cosmology, 1146-1148\*  
interstellar materials, 2306  
nucleosynthesis, 1519-1520\*  
origin and fate, 2306  
quasars, 2306  
solar system, 2306  
ultimate fate of, 2307  
Unsaturated polyesters, 1743  
Unsprung axle, 205  
Unsymmetrical bistable multivibrator, 1449  
Up quark, 1832  
UPC see Universal Product Code  
Upland cress, 513  
Upland game birds, 259-260  
Upper-atmosphere dynamics, 2307-2308\*  
Upset welding, 1902  
Upsilon particles, 2308\*  
Upupidae, 494  
Urwelling, 2308\*  
Uracil, 1813  
Uraninite, 2308\*  
Uranite, 1855  
Uranium, 2308-2309\*  
fission track dating, 802-803  
heat flow in Earth, 719  
isotope separation, 1198  
lead isotopes, 1236  
nuclear fuel cycle, 1508  
nuclear fuels, 1508-1509\*  
radioactive minerals, 1854-1855  
radioactive waste management, 1855  
titanite, 2244  
uraninite, 2308\*  
Uranium metallurgy, 2309\*  
Uranus, 2309\*  
planet, 1698  
planetary physics, 1700  
Urban epidemic yellow fever, 2411  
Urban forestry, 921\*, 2309-2310\*  
Urea, 2310\*  
Urea-formaldehyde-type resins, 2310\*  
Uredinales, 2310\*, 2381  
Ureters, 2313  
Urethane, 1752-1753  
Urethra, 2313  
Urey, Harold C., 1764  
Uric acid, 1013, 2310-2311\*  
Uridine diphosphoglucose (UDPG), 2311\*  
Urinalysis, 2311\*  
Urinary bladder, 2311\*, 2312  
Urinary system, 2311-2313\*  
kidneys, 1213\*, 2312  
physiology, 2312-2313  
urinary bladder, 2311\*, 2312  
urine, 2313\*  
urogenital system, 2314\*  
Urinary tract disorders, 2313\*  
Urine, 2311, 2311\*, 2313\*  
Urobilin, 243  
Urobilinogen, 243  
Urochordata see Tunicata  
Urodela, 2313-2314\*  
Urogenital system, 2314\*  
Urokinase, 2314\*  
Uropycni, 2314\*  
Uropygial gland, 2314\*  
Urospora, 411  
Urostyleidae, 944  
Ursa Major, 1412, 2314-2315\*  
Ursa Minor, 2315\*  
Ursidae, 230  
Ursus arctos, 230  
Ursus americanus, 230  
Urticaceae, 964  
Urticales:  
breadfruit, 328\*  
Hamamelidae, 1044  
hop, 1088\*  
marijuana, 1317\*  
mulberry, 1444\*  
U.S. Army Corps of Engineers, 1154  
U.S. Coast Guard, 1141

U.S. Department of Agriculture Forest Service, 921  
 U.S. Food and Drug Administration (FDA), 1648  
 Usability, product, 1779-1780\*  
 Usanovich, M., 12  
 Ustilaginales, 2024  
 Ustilaginomycetes, 2315\*  
 Uterus, 2315\*  
 pregnancy, 1767-1768\*  
 reproductive system disorders, 1899

## V

V-belt, 235  
 Vaccination, 2317\*  
 inoculation, 1154\*  
 pneumococcus, 1730  
 rubella, 1935  
 salmonellosis, 1941  
 smallpox, 2023  
 strangles, 2122  
 toxin, 2254  
 Vaccine, 252  
 animal virus, 124-125  
 antibody, 138  
 antigen, 141  
 drug resistance, 703  
 poliomyelitis, 1738  
 Vaccinium, 271, 510, 759  
 Vacuole, 2317-2318\*  
 Vacuum (atomic beams), 208\*  
 Vacuum capacitor, 324, 364  
 Vacuum circuit breaker, 407  
 Vacuum distillation, 688-689, 1643  
 Vacuum fusion, 2318\*  
 Vacuum measurement, 2318\*  
 ionization gage, 1189\*  
 McLeod gage, 1341\*  
 Pirani gage, 1692\*  
 Vacuum metallurgy, 2318\*, 2323-2324  
 Vacuum pressure, 1769  
 Vacuum pump, 628, 2318-2319\*  
 Vacuum tube, 707, 2319\*  
 magnetron, 1303-1304\*  
 microwave tube, 1399\*  
 saturation current, 1950\*  
 thermionic emission, 2222\*  
 Vacuum-tube rectifier, 1875  
 Vagina, 1899  
 Valence, 2319-2320\*  
 chemical bonding, 420  
 electron affinity, 777\*  
 electronegativity, 786\*  
 structural chemistry, 2132  
 valence-bond theory, 376  
 Valence band, 2320\*  
 Valence bond theory, 490  
 Vallisia, 1433  
 Vallisneria spiralis, 975  
 Value engineering, 2320\*  
 Valvata, 173, 2320\*  
 Valve, 1939-1940, 2320-2321\*  
 Valve train, 1101-1102, 2321\*  
 Valvifera, 2321\*  
 Valvular heart disease, 1053  
 Vampire bat, 227  
 Vampire squid, 438  
 Vampyrellidae, 1792  
 Vampyromorpha, 438, 2321\*  
 Van Allen radiation, 510, 2321-2322\*  
 Van Alphen, P. M., 568  
 Van de Graaff, R. J., 717  
 Van de Graaf generator, 761  
 Van der Waals radius, 1174  
 Van der Waals equation, 2322\*  
 Vanadium, 2322-2323\*  
 Vanilla, 2323\*  
 Vapor-compression cycle, 1883  
 Vapor compressor, 456, 518  
 Vapor condenser, 480, 2323\*  
 distillation column, 689  
 steam condenser, 2105\*  
 Vapor cycle, 2323\*  
 Vapor deposition, 2323-2324\*  
 diamond, 655  
 metal coatings, 1365  
 nanostructure, 1464, 1464\*  
 Vapor lamp, 1357  
 Vapor lock, 2324\*

Vapor pressure, 2324\*  
 deliquescence, 632-633\*  
 distillation, 688  
 Vaporization, 857  
 see also Volatilization  
 Varactor, 1392, 2324\*  
 Varactor diode, 838-839, 1396  
 Varactor modulator circuit, 936  
 Varanidae, 1431  
 Varanus griseus, 1431  
 Varanus komodoensis, 2092  
 Variable capacitance diode see Varactor  
 Variable capacitor, 324, 364  
 Variable (mathematics), 2324-2325\*  
 Variable number of tandem repeats (VNTRs), 915-916  
 Variable-reactance diode see Varactor  
 Variable resistor, 1913  
 Variable star, 2098, 2325-2326\*  
 binary systems, 244  
 cataclysmic variable, 378\*  
 cepheids, 405-406\*  
 eclipsing, 661, 731\*  
 light curves, 1251  
 Mira, 1407\*  
 Polaris, 1735  
 star, 2098  
 Variables (symbolic computing), 2178  
 Varian, R., 785  
 Varian, S., 785  
 Variational methods (physics), 2326\*  
 Varicella see Chickenpox and shingles  
 Variegated chimera, 386  
 Variola major see Smallpox  
 Varistor, 2326\*  
 Varley loop test, 407  
 Varnish, 2326\*  
 rock, 1928\*  
 shellac, 1998\*  
 surface coating, 2168  
 thinner, 2233\*  
 Varnish tree, 2327\*  
 Varve, 2327\*  
 Vascular atrophy, 475  
 Vascular disorders, 2327\*  
 embolism, 808\*  
 nervous system disorders, 1479  
 Vascular nevi, 261  
 Vascular plants, 1701, 1706  
 Vascular system, 1066-1067  
 Vasogenic shock, 2001  
 Vasopressin:  
 diabetes insipidus, 653  
 neurohypophysis hormone, 1480\*  
 Vector (mathematics), 2327\*  
 calculus of vectors, 353\*  
 multiplication, 454-455  
 Poynting's vector, 1764\*  
 Vector methods (physics), 2327-2328\*  
 Vector (parasitology), 1610  
 Vector processing, 2153  
 Vega, 1070, 1282, 2328\*  
 Vega-excess stars, 1177  
 Vegetable ivory, 2328\*  
 Vegetable oil, 785  
 Vegetation:  
 dune, 706\*  
 grassland ecosystem, 1019-1020\*  
 mangrove, 1312\*  
 mapping, 2328\*  
 plant geography, 1704  
 wetlands, 2385  
 Vegetation and ecosystem mapping, 2328\*  
 Vegetation zones, altitudinal, 92\*  
 Vegetative propagation, 1713  
 Vehicle:  
 electric, 752-753\*  
 guidance systems, 1031\*  
 marine biological sampling, 1317  
 tractor, 2255\*  
 truck, 2278\*  
 underwater, 2300-2301\*  
 wheel base, 2386\*  
 Vein, 270  
 phlebitis, 1655\*  
 vascular disorders, 2327  
 Velamen, 358  
 Velidae, 944  
 Velocipedidae, 944  
 Velocity, 2328-2329\*  
 acceleration, 8-9\*  
 areal, 151  
 escape, 846\*  
 speed, 2080\*  
 units of measurement, 2303  
 Velocity analysis, 2329\*  
 Velocity pickup, 2338

Vendian period, 737-738\*  
 Veneer, 2329\*  
 Venereal bubo see Lymphogranuloma venereum  
 Venereal disease:  
 gonorrhoea, 1012-1013\*  
 syphilis, 2185\*  
 Venezuelan equine encephalitis, 757, 860  
 Venoms, 1732  
 Vent, hydrothermal, 1110-1111\*, 2351  
 Ventilation, 2329\*  
 Ventroplicida, 133  
 Venturi tube, 2329-2330\*  
 Venus, 2330\*  
 planet, 1698  
 planetary physics, 1700, 1701  
 radar astronomy, 1841\*  
 transit, 2261  
 Venus flytrap, 2330\*  
 Verbenaceae, 1223  
 Veretillum, 1625  
 Vermiculite, 1126, 2331\*  
 Vermiform mollusk see Aplacophora  
 Vermilingua, 665  
 Vernal equinox, 2240  
 Vernalization, 2331\*  
 Vernier, 2331\*  
 Veronicellidae, 2185\*  
 Verrucomorpha, 2234, 2331\*  
 Verspertilionidae, 388  
 Vertebra, 2085, 2331-2332\*  
 Vertebral column, 2016  
 Vertebrata, 2332\*  
 Amniota, 100\*  
 Amphibia, 101-102\*  
 Anamnia, 112\*  
 animal evolution, 120  
 Gnathostomata, 1009\*  
 Paleozoic, 1603  
 Permian, 1635  
 respiratory system, 1907  
 stomach, 2119  
 see also Craniata  
 Vertebrate brain (evolution), 2332-2333\*  
 central nervous system, 2332  
 development, 2332-2333  
 subdivisions, 2333  
 Vertebrates:  
 digestive system, 666-668\*  
 ear, 713-715\*  
 endocrine system, 816-817\*  
 eye, 865-867\*  
 forest ecosystem, 917  
 hearing, 1050\*  
 intestine, 1178  
 lateral line system, 1232  
 migratory behavior, 1400-1401\*  
 nervous system, 1477-1478\*  
 postural equilibrium, 1758  
 urinary system, 2311-2313\*  
 Vertical-lift bridge, 292-293  
 Vertical takeoff and landing (VTOL), 2333-2334\*  
 convertiplane, 551-552\*  
 helicopter, 1059\*  
 yaw indicator, 2410  
 Verticillium, 1119  
 Very high frequency omnidirectional radio range (VOR), 789, 1850, 2357-2358\*  
 air navigation, 52  
 air-traffic control, 56  
 Doppler VOR, 697-698\*  
 homing, 1086  
 Very long-baseline interferometry (VLBI):  
 geodesy, 986, 987  
 horology, 1090  
 Very low density lipoproteins (VLDL), 1260  
 Vesicular-arbuscular mycorrhizae, 1459  
 Vessel traffic service (VTS), 1324, 2334\*  
 Vestibular system, 2334-2335\*  
 Vestimentifera, 2335\*  
 Vesuvianite, 1090, 2335\*  
 see also Idocrase  
 Vetch, 2335-2336\*  
 Veterinary medicine:  
 blackleg, 302\*  
 coenurosis, 491\*  
 foot-and-mouth disease, 911\*  
 glanders, 1002\*  
 heartwater disease, 1053\*  
 heartworms, 10553\*  
 infectious myxomatosis, 1145  
 myiasis, 1460\*  
 Newcastle disease, 1486\*  
 pseudotuberculosis, 1798\*  
 rabies, 1839\*  
 strangles, 2122\*

Veterinary medicine:—cont.  
 tularemia, 2280\*  
 zoonoses, 2420\*  
 Viability, population, 1755\*  
 Vibrating conveyor, 302-303, 552  
 Vibration, 2336\*  
 bridges, 293  
 flow-induced, 896-897\*  
 flutter (aeronautics), 904-905\*  
 fuzzy-structure acoustics, 953\*  
 harmonic motion, 1047\*  
 mechanical, 1343-1344\*  
 mode of, 1413\*  
 nonlinear physics, 1498, 1498\*  
 oscillation, 1582\*  
 periodic motion, 1631\*  
 resonance (acoustics and mechanics), 1904\*  
 superstring theory, 2164  
 sympathetic, 2181\*  
 Vibration damping, 2000-2001, 2337\*  
 Vibration isolation, 2337-2338\*  
 Vibration machine, 2338\*  
 Vibration pickup, 2338\*  
 Vibrational photochemistry, 1231  
 Vibrator, 1343  
 Vibrio, 242  
 Vibrio cholerae, 393, 445, 2363  
 Vibrio costicola, 1044  
 Vibration, 2338\*  
 Vicia, 229, 2336  
 Vickers hardness, 926  
 Victor Meyer process, 1489  
 Vicuna, 1266, 2338\*  
 Video amplifier, 2338\*  
 Video camera, 360  
 Video disk, 463, 2338-2339\*  
 Video games, 2339\*  
 Video microscopy, 2339\*  
 Video recording:  
 disk recording, 513-514  
 magnetic recording, 1294  
 Videotelephony, 2339-2340\*  
 Videotext and teletext, 480, 713  
 View camera, 321  
 Vigna species, 229, 509, 1579  
 Viking, 1327-1328  
 Vinegar, 2340\*  
 Vinyl chloride, 391, 850  
 Vinylidene chloride, 391, 1741  
 Violaes, 613, 2340\*  
 cantaloupe, 363\*  
 Honey Dew melon, 1088\*  
 muskmelon, 1456\*  
 Persian melon, 1637\*  
 pumpkin, 1811\*  
 Viral disease:  
 coxsackievirus, 574\*  
 exotic, 752, 860\*  
 feline infectious peritonitis, 875\*  
 infectious myxomatosis, 1145\*  
 infectious papillomatosis, 1145\*  
 influenza, 1148\*  
 louping ill, 1274\*  
 nervous system disorders, 1479  
 Viral inclusion bodies, 1839, 2340\*  
 Viral infections, 123-124  
 Viral pneumonia, 1731  
 Viral RNA, 1918  
 Virginia deer, 567  
 Virgo, 2340-2341\*  
 Virgo Cluster, 2341\*  
 Virial equation, 2341\*  
 Virial theorem, 2341\*  
 Viroids, 2341-2342\*  
 plant, 1715-1716  
 plant pathology, 1710-1711  
 Virtual acoustics, 2342\*  
 Virtual manufacturing, 2342\*  
 Virtual memory (computer), 464, 618  
 Virtual private networks (VPN), 525  
 Virtual reality, 2342-2343\*  
 applications, 2343  
 hardware, 2342-2343  
 virtual manufacturing, 2342  
 Virtual work principle, 2343\*  
 Virulence, 2343\*  
 Virus, 2343-2344\*  
 adeno-SV40 hybrid virus, 28  
 adenoviridae, 28  
 agglutination reaction, 42\*  
 animal, 123-125\*  
 bacteriophage, 244-245\*  
 colloidal crystals, 501-502\*  
 defective, 2344\*  
 dependovirus, 640\*  
 Ebola, 725\*

## Virus—cont.

food poisoning, 910  
 microbiology, 1382\*  
 nucleoprotein, 1519\*  
 plant, 1715  
 plant pathology, 1710-1711  
 polyoma, 1750\*  
 Prokaryotae, 1784, 1784\*  
 reverse transcriptase, 1910\*  
 ribonucleic acid, 1917-1918\*  
 Rous sarcoma, 1934\*  
 tumor, 2281\*  
 viral inclusion bodies, 2340\*  
 Virus classification, 2344-2345\*  
 Virus disease:  
   arboviral encephalitides, 157\*  
   bovine virus diarrhea, 323-324\*  
   chickenpox and shingles, 437\*  
   common cold, 509\*  
   cytomegalovirus infection, 611-612\*  
   epidemic viral gastroenteritis, 775-776,  
     836\*  
   Epstein-Barr virus, 740\*  
   foot-and-mouth disease, 911\*  
   herpes, 1069\*  
   infectious mononucleosis, 1145\*  
   measles, 1341\*  
   meningitis, 1354\*  
   mumps, 1450\*  
   Newcastle disease, 1486\*  
   poliomyelitis, 1738\*  
   rabies, 1613\*, 1839\*  
   rubella, 1934-1935\*  
   sexually transmitted, 1994  
   smallpox, 2023\*  
   ulcer, 2293  
   vaccination, 2317  
   water-borne, 2363  
   yellow fever, 2411\*  
 Virus infection, 653  
 Virus interference, 2345\*  
 Visbreaking, 1644  
 Visceral muscle, 1450  
 Viscoelasticity:  
   linear, 1912  
   nonlinear, 1912-1913  
   non-newtonian fluid, 1499  
 Viscosity, 2345-2346\*  
   diffusion, 665  
   lava, 1234  
   non-newtonian fluid, 1499  
   Reynolds number, 1911  
   soils, 2036  
 Viscous flow, 322-323  
 Viscum, 1409  
 Vision, 2346-2347\*  
   anatomical basis for, 2346  
   color see Color vision  
   computer, 465-466, 528-529\*  
   eye (vertebrate), 865-867\*  
   luminous efficiency, 1279\*  
   optics, 1563\*  
   photometry, 1668  
   photopic, 2346, 2347  
   scotopic, 2346, 2347  
   space and time perception, 2347  
   stereoscopy, 2115\*  
 Visual Basic, 1783  
 Visual colorimetry, 446  
 Visual cortex, 2347  
 Visual debugging, 2348\*  
 Visual disorders:  
   eye disorders, 867\*  
   eyeglasses and contact lenses, 867\*  
 Visual flight rules (VFR), 55, 56  
 Visual impairment, 2348\*  
 Visual signaling, 119  
 Vitamin, 2348\*  
   ascorbic acid, 180\*  
   para-aminobenzoic acid, 98\*  
   biotin, 297\*  
   folic acid, 907\*  
   food, 907  
   niacin, 1486\*  
   pantothenic acid, 1606\*  
   riboflavin, 1917\*  
   sugar, 2145  
   thiamine, 2232\*  
 Vitamin A 1606, 2348\*  
 Vitamin B see Thiamine  
 Vitamin B2 see Riboflavin  
 Vitamin B6, 2349\*  
 Vitamin B12, 115, 116, 2349\*  
 Vitamin C, 1062, 2348  
   see also Ascorbic acid  
 Vitamin D, 2348, 2349\*  
   ergosterol, 843\*

## Vitamin D—cont.

osteoporosis, 1586  
 parathyroid, 1611  
 parathyroid gland disorders, 1611  
 parathyroid hormone, 1612  
 phosphate, 1658  
 Vitamin E, 2348, 2349-2450\*  
 Vitamin K, 1837, 2348, 2350\*  
 Viticulture, 902  
 Vitis species, 902  
 Vitreoscillaceae, 232  
 Vitreous enamel coatings, 1365-1366  
*Viverra zibetha*, 410  
 Viverridae, 410  
 Vivianiaceae, 996  
 Vivianite, 2350\*  
 Viviparae, 133  
 VLBI see Very long-baseline interferometry  
 Vocabulary (speech recognition), 2080  
 Vocal cords, 2350\*  
 Vocal folds, 2077  
 Voice:  
   artificial, 162-163  
   disorders, 2078  
 Voice prints, 2078  
 Voice response, 2350-2351\*  
 Voice simulator, 162  
 Volatilization, 2351\*  
 Volcanic earthquake, 655, 723  
 Volcanic glass, 2351\*  
   obsidian, 1529\*  
   pitchstone, 1692\*  
   rhyolite, 1917\*  
   tuff, 2280\*  
 Volcanic rock, 1126  
   dacite, 613\*  
   ignimbrite, 1126\*  
   pyroclastic rocks, 1813\*  
   rhyolite, 1917\*  
   sandstone, 1943  
   trachyte, 2255\*  
 Volcano, 2351-2352\*  
   andesite, 114\*  
   basalt, 255-256\*  
   caldera, 355-356\*  
   distribution of, 2352  
   Earth, 718  
   Earth crust, 720  
   East Indies, 723  
   fumaroles, 2352  
   gases, 2351-2352  
   geodynamics, 987  
   hot spots (geology), 1091\*  
   hot springs, 2352  
   lava, 1233-1234\*  
   magma, 1289\*  
   oceanic islands, 1531\*  
   Pacific islands, 1593  
   pneumatolysis, 1730  
   sedimentary rocks, 1971  
   subduction zones, 2139  
   submarine, 2352  
   tsunami, 2279  
   vents, 2351  
   volcanic landforms, 2352  
   volcanic products, 2351  
 Volcanology, 2352-2353\*  
 Volt, definition of, 687, 760-761  
 Volt-ampere, 2353\*  
 Volt-ohm-milliammeter, 1446\*  
 Volta, A., 761  
 Voltage:  
   decibel, 625  
   ripple voltage, 1823\*  
 Voltage amplifier, 1764, 2353-2354\*  
 Voltage measurement, 2354-2355\*  
   alternating-current, 2354-2355  
   direct-current, 2354  
   electrometer, 698\*  
   electromotive force, 775-776\*  
   potentiometer, 1760-1761\*  
   voltmeter, 2356-2357\*  
 Voltage-multiplier circuit, 2355\*  
 Voltage regulation, 746, 2355\*  
 Voltage regulator, 2355-2356\*  
   automotive, 204  
   electronic, 2355  
   feedback network, 2355-2356  
   power-system, 2356  
 Voltage transformer, 1161  
 Voltammeter analysis, 770  
 Voltmeter, 2356-2357\*  
   electric power measurement, 747  
   resistance measurement, 1901-1902\*  
   resistor, 1902-1903\*, 1903  
 Volume (units of measurement), 2302-2305\*  
 Volume control systems, 2357\*

Volume flow rate meter, 695  
 Volume unit (VU), 2357\*  
 Volumetric analysis, 2245-2246  
 Volumetric efficiency, 2357\*  
 Voluntary muscle, 1450  
*Volvariella volvacea*, 984, 1112  
*Volvatella*, 1939  
 Volvocaceae, 2357  
 Volvocales, 2357\*  
 Volvocida, 2357\*  
 Von Gierke's disease, 1362  
 Von Mering, J., 1604  
 Von Neumann, J., 952, 1076  
 VOR see Very high-frequency  
   omnidirectional radio range  
 VORDME, 1086  
 Vortex, 2358\*  
   Kármán vortex street, 1210\*  
   quantized, 1823, 1823\*  
 Vortex line, 2359  
 Vortex tube, 2359  
*Vorticella*, 1634  
 Vorticity, 2358-2359\*  
 Vostok, 2059  
 Vowel sounds, 2077  
 Voyager, 980  
*Voyager 1*, 1207  
*Voyager 2*, 1207  
 VSB see Vestigial-sideband modulation  
 VTOL see Vertical takeoff and landing  
*Vulpes fulva*, 634, 684  
*Vulpes vulpes*, 634, 684  
*Vultur gryphus*, 260  
 Vulture, 260, 784  
 Vulval gland, 1956

## W

W particles, 1173  
 W Virginis stars, 2325  
 Waage, P., 372  
 Wake, electron, 785-786\*  
 Wake flow, 2361\*  
 Walkthroughs, 2031  
 Wall construction, 2361-2362\*  
 Wallace, Alfred Russell, 2072  
 Wallacea, 723  
 Walnut, 870, 1205, 2362\*  
 Walrus, 1690  
 Walton, E., 430  
 Wandering Jew (plant), 449  
 Wannier exciton model, 773, 859  
 Wapiti, 567  
 Ward, J. C., 847  
 Warfare, electronic, 792\*  
 Warm-air heating system, 2362\*  
 Warmouth sunfish, 2151  
 Warrior see Orion  
 Washer, 2362\*  
 Wasp:  
   Hymenoptera, 1112-1113\*  
   social insects, 2027-2028\*  
 Waste management, 1855-1856  
 Wastewater:  
   sewage, 1990\*  
   water pollution, 2366-2367\*, 2367  
   water treatment, 2368\*  
 Watch, 2362\*  
   chronometer, 454-455\*  
   escapement, 846, 846\*  
   jewel bearing, 1203\*  
 Water, 2362-2363\*  
   animal growth, 121  
   digestive system, 668  
   food, 907  
   gaseous state, 2362-2363  
   hydrate, 1100, 1100\*  
   hydration, 1100\*  
   hydrogen ion, 1106\*  
   hydrology, 1108\*  
   hydrolysis, 1108\*  
   hydrosphere, 1110\*  
   Langmuir circulation, 1226-1227  
   liquid state, 2363  
   Mars, 1327  
   moisture-content measurement, 1416,  
     1416\*  
   plant-water relations, 1716-1717\*  
   potassium and, 1759  
   properties, 2363  
   raw water, 1871\*  
   seawater, 1967-1968\*

## Water—cont.

solid state, 2363  
 steam, 2105\*  
 terrestrial, 2213\*  
 Water analysis, 985-986  
 Water Bearer (Aquarius), 137  
 Water-bearing formation see Aquifer  
 Water beetle, 439  
 Water boatman (insect), 942  
 Water-borne disease, 1144, 2363\*  
 Water buffalo, 301  
 Water chevrotain, 384  
 Water conservation, 2363-2365\*  
 Water convolvulus, 1579  
 Water desalination, 2365\*  
 Water flea, 165  
 Water gel, 265  
 Water hammer, 2365\*  
 Water-jet cutting, 2366\*  
 Water lettuce, 139  
 Water pollution, 2366-2367\*  
   eutrophication, 856-857\*  
   industrial wastewater treatment, 1142\*  
   petroleum microbiology, 1642-1643  
   placer mining, 1695  
   stream pollution, 2125\*  
   water supply engineering, 2367-2368\*  
 Water regulation (endocrine system), 817  
 Water scorpion, 942  
 Water softening, 2367\*  
 Water spinach, 1579  
 Water supply engineering, 2367-2368\*  
   reservoir, 1901\*  
   water treatment, 2368\*  
 Water table, 2368\*  
 Water transportation, 2264  
 Water treatment, 2367, 2368\*  
 Water-tube boiler, 2368\*  
 Water tunnel, 2369\*  
 Water vapor:  
   deliquescence, 632-633\*  
   dew, 652\*  
   efflorescence, 738\*  
 Watercress, 513  
 Waterfall model, 2031  
 Waterfalls, 905  
 Waterfowl, 129  
 Waterhemlock, 1733-1734  
 Watermelon, 2369\*  
 Watersheds, 2364  
 Waterspout, 2369-2370\*  
 Waterways, inland, 1154\*  
 Watt, James, 2121  
 Watt-hour meter, 2370\*  
 Wattmeter, 2370-2371\*  
   electric power measurement, 747  
   power factor, 1762-1763  
 Wave aberration (optics), 3  
 Wave drag (aerodynamic), 33\*  
 Wave equation, 1960, 2371\*  
 Wave mechanics, 2371\*  
 Wave motion, 2371-2372\*  
   amplitude, 104\*  
   electromagnetic wave, 773\*, 2371-2372  
   in fluids, 2372  
   frequency (wave motion), 933\*  
   fundamental relations, 2371  
   in liquids, 1882, 1974, 2121, 2372  
   media, 2371  
   periodic motion, 1631\*  
   phase velocity, 1654\*  
   phonon, 1657\*  
   shock wave, 2002\*  
   soliton, 2045\*  
 Wave optics, 2372\*  
 Wave packet, 1030\*  
 Wave-particle duality, 1828-1829  
 Wave (physics), 2371\*  
   coherence, 493-494\*  
   nonsinusoidal waveform, 1500\*  
   polarization of, 1736\*  
   superposition principle, 2162-2163\*  
   waveform, 2372-2373\*  
   wavelength, 2374\*  
 Wave propagation (underwater sound),  
   2300  
 Wave-shaping circuits, 2271, 2372\*  
 Waveform, 2372-2373\*  
   electrical communications, 753  
   sine wave, 2013\*  
 Waveform determination, 2372\*  
 Waveguide, 2374\*  
   directional coupler, 684\*  
   electromagnetic wave transmission,  
     773-774\*  
   horn, 1394  
   microwave, 1391-1392

- Waveguide—cont.  
 microwave filter, 1393-1394\*  
 optical guided waves, 1554-1555\*
- Wavelength, 2374\*  
 dielectric measurements, 658  
 measurement, 2374-2375\*  
 standards, 2375\*
- Wavelength-division multiplexing (WDM), 1447
- Wavelength measurement, 2374-2375\*
- Wavelength standards, 2375\*
- Wavelets, 2375-2376\*
- Wavellite, 2376\*
- Wax, animal and vegetable, 1260, 2376\*  
 carnauba wax, 373\*, 2376  
 lanolin, 1227\*
- Wax, petroleum, 2376\*  
 dewaxing, 590  
 paraffin, 1607\*
- Wax gourd, 1579
- Wax palm, 333
- Weak bosons, 802
- Weak nuclear interactions, 847, 946, 2376\*  
 intermediate vector boson, 1173  
 neutral currents, 1481-1482\*  
 parity, 1612
- Weakly electric fishes, 745
- Weakly interacting massive particle (WIMP), 2376-2377\*  
 supersymmetry, 2165  
 universe, 2306
- Weapon see Armaments
- Wear, 2377\*  
 friction, 938\*  
 lubricant, 1276\*  
 lubrication, 1277  
 tribology, 2270
- Weasel, 2377\*
- Weather, 2377-2378\*  
 fog, 906-907\*  
 satellite meteorology, 1947  
 see also Climatology; Meteorology
- Weather forecasting and prediction, 2378-2379\*  
 climate modeling, 472-473\*  
 climate prediction vs., 1380  
 industrial meteorology, 1141\*  
 maritime meteorology, 1325-1326\*  
 mesometeorology, 1358-1359\*  
 meteorological satellites, 1378-1379\*  
 meteorology, 1379-1380\*  
 numerical weather prediction, 647  
 radar meteorology, 1841\*  
 storm detection, 2120-2121\*
- Weather map, 1196, 2379\*
- Weather modification, 479, 2379\*
- Weather observations, 2379-2380\*
- Weather routing see Ship routing
- Weather station instrumentation, 1376
- Weathering processes, 2380\*  
 denudation, 638\*  
 desert erosion features, 644-645\*  
 elemental composition of soil, 2033-2034  
 sand, 1943  
 sedimentology, 1972  
 soil formation, 2034
- Web spinner, 808
- Weber, W. E., 760
- Weber (unit), definition of, 687, 761
- Wedge, 1963, 2380-2381\*
- Weeds, 2381\*
- Wegener, Alfred, 482
- Weight, 2381\*  
 equivalent, 843\*  
 gram-equivalent, 1015\*  
 gravitation, 1021  
 molecular weight, 1426-1428\*  
 work, 2397\*
- Weight measurement, 2381-2382\*  
 balance, 245\*  
 density, 635
- Weightlessness, 2057, 2382\*
- Weil's disease see Leptospirosis
- Weinberg, S., 900, 973
- Weinberg, W., 926
- Weir, 2125
- Welded joint, 2382\*
- Welding and cutting of materials, 2366, 2382-2383\*  
 arc welding, 158-159\*  
 flash welding, 892\*  
 inertia welding, 1143\*  
 laser welding, 1232\*  
 resistance welding, 1902\*  
 sintering, 2013\*  
 spot welding, 2088
- Welding and cutting of materials—cont.  
 torch, 2250\*  
 welded joint, 2382\*  
 Well, 2367, 2383\*  
 aquifer, 155\*  
 artesian systems, 174\*  
 Well drilling, oil and gas, 1536\*  
 Well logging, 2383-2384\*  
 see also Borehole logging  
 Well-type manometer, 1313  
 Wellpoint systems, 2384\*  
 Welsh onion, 1543  
*Welwitschia*, 895, 1009  
 Welwitschiales, 539, 895, 2384\*  
 Wentzel, G., 2384  
 Wentzel-Kramers-Brillouin method, 2384\*  
 Werdnig-Hoffmann disease, 1452  
 Werner, Alfred, 490  
 West Comet, 508  
 West Indian arrowroot, 157  
 West Indian cedar, 345  
 West Indian hurricane, 1179  
 West Indies, 2384\*  
 Western chipmunk, 387  
 Western equine encephalitis, 757  
 Western larch, 1228  
 Western sand cherry, 383  
 Western Walvis, 966  
 Weston, Edward, 698  
 Weston cell, 775  
 Wet spinning, 1313  
 Wetlands, 2384-2384\*  
 mangrove, 1312\*  
 swamp, marsh, and bog, 2174\*  
 water conservation, 2365
- Weyl, H., 866-867
- Whale:  
 ambergris, 94-95\*  
 Cetacea, 409-410\*  
 echolocation, 729  
 Whale lice, 325  
 Whalefish, 359
- Wheat, 2385-2386\*  
 farm crops, 871  
 Triticale, 2274\*
- Wheatstone, Charles, 2386
- Wheatstone bridge, 2386\*  
 Kelvin bridge, 1210\*  
 radio-frequency impedance  
 measurements, 1849  
 resistance measurement, 1902
- Wheel and axle, 2386\*  
 automotive steering, 226, 229-230\*  
 landing gear, 1225
- Wheel base, 2386\*
- Wheelchairs, 2143
- Wheeler, J. A., 505, 1955
- Whelk:  
 Neogastropoda, 1473\*  
 Prosobranchia, 1787\*
- Whey, 1222
- Whippoorwill, 326
- White blood cell see Leukocyte
- White clover, 422
- White currant, 535
- White dwarf star, 2385-2387\*  
 cataclysmic variable, 378  
 gravitational collapse, 1022  
 stellar evolution, 2108-2110\*  
 symbiotic star, 2177  
 x-ray astronomy, 2401
- White elm, 725
- White fir, 801
- White iron pyrite see Marcasite
- White mica see Muscovite
- White spruce, 2090
- White-tailed deer, 567
- White-tailed prairie dog, 1764
- White-tailed ptarmigan, 260
- White vinegar, 2340
- Whitefish, 1941
- Whitefly, 963
- Whitehead, Alfred North, 1270
- Whiteware, 356
- Whooping cough, 2387\*
- Wide-area networks, 2387-2388\*  
 client-server system, 471-472\*  
 computer security, 525  
 security, 462  
 teleprocessing, 2201
- Wide-field camera, 321
- Wiedemann-Franz law, 2388\*
- Wien, W., 761
- Wien-bridge oscillator, 2006
- Wigner, E.:  
 random matrices, 1868  
 supermultiplet, 2161
- Wilczek, F., 973
- Wild ass, 635
- Wild dog, 634
- Wild dwarf buffalo, 301
- Wild ginger, 1692
- Wild turkey, 259
- Wilkinson, D. T., 500
- Willemite, 2388\*
- Williams, E. G., 15
- Williamsoniaceae, 539
- Willow, 1940, 2388\*  
 Willow ptarmigan, 260
- Wilson, R. W., 500
- Wilson's disease, 1361
- WIMP see Weakly interacting massive  
 particle
- Winchester technology, 463
- Wind, 2388-2389\*  
 anemometer, 116\*  
 chinook, 440\*  
 dust storm, 707\*  
 geostrophic, 995\*  
 gradient wind, 1014\*  
 isotach, 1196\*  
 jet stream, 1203\*  
 Langmuir circulation, 1226-1227  
 loess, 1268  
 meteorological instrumentation,  
 1376  
 ocean, 1529-1530  
 sirocco, 2015\*  
 solar energy, 2039  
 squall, 2091\*  
 storm, 2120\*  
 tornado, 2250-2251\*, 2251  
 upper-atmosphere dynamics, 2307  
 waterspout, 2369-2370\*  
 weather observations, 2380
- Wind flower, 1869
- Wind measurement, 2389, 2389\*
- Wind power, 2389\*
- Wind rose, 2389\*
- Wind shear, 35, 2197-2198
- Wind stress, 2389-2390\*  
 ocean circulation, 1530\*  
 ocean waves, 1530-1531\*  
 storm surge, 2121\*
- Wind tunnel, 2390\*  
 aircraft testing, 62, 63  
 arc furnace, 141  
 shadowgraph, 1996
- Windings in electric machinery, 2390\*  
 armature, 170\*  
 autotransformer, 232\*  
 commutation, 512  
 steam electric generator, 2105
- Wine, 1016, 2390\*
- Wing, 2390-2391\*  
 aileron, 47\*  
 airfoil, 63-64\*  
 aspect ratio, 183-184\*  
 stroke, 2122\*
- Wing flutter (aircraft), 897
- Wing-in-ground-effect (WIG) craft, 50
- Winged bean, 2391\*
- Winged Horse see Pegasus
- Winter bud, 300
- Winter solstice, 2046
- Winter squash, 2092
- Winterales:  
 Eumagnoliids, 854  
 Laurales, 1233  
 Wintergreen, 759  
 Wintersweet, 1233
- Wire, 2391\*  
 magnet wire, 1291\*  
 resistor, 1903
- Wire bonding, 2392\*
- Wire drawing, 2392\*
- Wireless media, 2387
- Wireless telephone service, 2200
- Wiring, 2392\*  
 branch circuit, 326-327\*  
 bus-bar, 305\*, 345\*  
 electrical codes, 753\*  
 electrical connector, 754\*  
 printed, 1773
- Wiring diagram, 2392\*
- Wisent, 262
- Witch hazel, 924, 1044, 1952
- Withdrawal from drugs, 1803
- Witherite, 219, 2392\*
- WMO see World Meteorological  
 Organization
- Wolf, 634
- Wolf, Charles, 2393
- Wolf-Rayet star, 961, 2393\*
- Wolfe, A. M., 1024
- Wolframite, 2393\*
- Wollastonite, 1090, 2393\*
- Wolverine, 2393\*
- Wolves, 694, 2028
- Wood:  
 antifriction bearings, 139  
 dyeing, 708\*  
 Lamiales, 1223  
 mahogany, 1306\*  
 willow, 2388\*  
 xylem, 2408
- Wood anatomy, 2393-2394\*  
 structural materials, 2135  
 tree, 2266
- Wood arch, 142, 159
- Wood chemicals, 1689, 2394\*
- Wood degradation, 2394-2395\*
- Wood Ear, 984, 1112
- Wood engineering design, 2395\*
- Wood finishing, 1998
- Wood grouse, 260
- Wood hoopoe, 494
- Wood louse, 1543
- Wood preservation, 2394
- Wood processing, 2395\*
- Wood products, 2395\*  
 composition board, 517\*  
 lumber, 1277-1278\*  
 paper, 1606-1607\*  
 plywood, 1730\*  
 veneer, 2329\*  
 wood chemicals, 2394\*
- Wood properties, 2395-2396\*
- Wood sorrel, 883
- Wood turpentine, 1689
- Woodchuck, 1326
- Woodpecker, 1684
- Woodward, R. B., 1630, 2396
- Woodward-Hoffmann rule, 2396\*
- Woodwind instruments, 1454
- Woodworking, 2396\*  
 planer, 1697\*  
 turning, 2288\*
- Woody, D., 500
- Woofer, 1273-1274
- Wool, 2396-2397\*  
 alpaca, 87\*  
 camel's hair, 360\*  
 cashmere, 376\*  
 lanolin, 1227  
 mohair, 1415\*  
 vicuna, 2338\*
- Word processing, 415, 2397\*
- Words (computer), 668
- Work, 2397\*  
 power, 1762\*  
 units of measurement, 2303-2304  
 virtual work principle, 2343\*
- Work-force scheduling, 1956
- Worker function (electronics), 2397-  
 2398\*
- Work function (thermodynamics),  
 2398\*
- Work measurement, 2398\*  
 measured daywork, 1342\*  
 methods engineering, 1381\*  
 work standardization, 2398\*
- Work standardization, 2398\*
- World Wide Web, 1176, 2398-2399\*
- Worms, 125  
 eye, 865  
 fossil, 1602
- Wound healing, 609, 610
- Wow and flutter, 815
- Wrack line, 706
- Wrench-head bolt, 274
- Wright, Orville, 1004
- Wright, S., 695
- Wrist, 374
- Wrought iron, 2399\*
- Wulfenite, 2399\*
- Wurtzilite, 2399\*
- Wurtzitane, 309
- Wurtzite, 2399\*



X chromosome, 400, 453  
 sex determination, 1992, 1993  
 sex-linked inheritance, 1993  
 X-ray astronomy, 1947, 2401\*  
 X-ray crystallography, 1661, 2401\*

X-ray diffraction, 2402-2403\*  
 techniques, 2402  
 uses, 2402  
 X-ray fluorescence analysis, 2403\*  
 X-ray microscope, 2403-2404\*  
 X-ray optics, 2404-2405\*  
 X-ray powder methods, 2405\*  
 X-ray spectrometry, 2405\*  
 X-ray star:  
   binaries, 244  
   black hole, 300-301\*  
   x-ray astronomy, 2401  
 X-ray telescope, 196, 2201, 2405-2406\*  
 X-ray tube, 2406\*  
 X-ray wavelengths, 2303  
 X-rays, 2406\*  
   ionosphere, 1188  
   medical imaging, 1346  
   radiography, 1860\*  
   radiology, 1863  
 Xanthophore, 397  
 Xanthophyceae, 402, 856, 2406-2407\*  
 Xenacanthida, 2407\*  
 Xenarthra, 665, 737  
 Xenia, 70  
 Xenolith, 2407\*  
 Xenon, 2407\*  
 Xenophyphorida, 902, 2407-2408\*  
 Xenopneusta, 659, 728  
 Xenorhabdus, 242  
 Xenungulata, 2408\*  
 Xerogel, 2038  
 Xerography, 1663  
 Xiphosurida, 2408\*  
 XML, 2399  
 Xylem, 2408\*  
   phloem, 1655  
   plant-water relations, 1716, 1717  
   primary vascular system (plant), 1770\*  
   tree, 2266  
 Xylose, 2408\*  
 Xyridaceae, 449

## Y

Y chromosome:  
   sex determination, 1992, 1993  
   sex-linked inheritance, 1993  
 Y-delta transformations, 2409\*  
 Yagi, H., 2409  
 Yagi-Uda antenna, 2409\*  
 Yak, 2409-2410\*  
 Yam, 1760  
 Yang, C. N., 867  
   gauge theory, 973  
   supergravity, 2159  
 Yang-Mills theory, 973  
 Yam, spinning, 2086\*

Yaw indicator, 2410\*  
 Yaws, 2410\*  
 Year, 2410\*  
   anomalous, 722  
   Earth, 716  
   Earth rotation and orbital motion, 722  
   sidereal, 722  
   tropical, 722  
 Yeast, 179, 2410\*  
   food microbiology, 909  
   fungal biotechnology, 947\*  
   fungi, 949, 950  
   Hemiascomycetes, 1062\*  
   transposons, 2264  
   vacuole, 2317-2318  
 Yeast infection, 2410-2411\*  
 Yellow birch, 259  
 Yellow buckeye, 299  
 Yellow fever, 860, 2411\*  
 Yellow giant star, 167\*  
 Yellow-green algae, 402  
   see also Xanthophyceae  
 Yellow poplar see Tulip tree  
 Yellow rice disease, 1460  
 Yellow supergiant stars, 2325  
 Yellow-throated marten, 1328  
 Yersinia, 741, 2411-2412\*  
 Yersinia pestis, 1695  
 Yersiniaceae, 741  
 Yew, 1688, 2412\*  
 Yield, 1363  
 Yield strength, 1363  
 Ylide, 2412\*  
 Yochelson, E. L., 473  
 Yogurt, 1402  
 Yolk, 1589\*  
 Yolk sac, 2412\*  
 Young, T., 1171, 1736  
 Young stellar objects, 1151  
 Youngina, 750  
 Younginiformes, 750  
 Young's modulus, 669, 2412\*  
 Young's two-slit interference, 1171  
 Ytterbium, 2412\*  
 Yttrium, 2412\*  
 Yucatan Current, 1032  
 Yucca, 2266  
 Yukawa, H.:  
   meson, 1359  
   quantum field theory, 1827

## Z

Z particles, 1173  
 Z transform, 2413\*  
 Zaglossus, 1435  
 Zambezi River, 41  
 Zamia floridana, 157

Zapodidae, 1443  
 Zea mays, 495, 559  
 Zea mexicana, 496  
 Zebra, 1633-1634, 2413\*  
 Zebra mussel, 1179  
 Zebryna, 449  
 Zebu, 2413\*  
 Zeeman, P., 2413  
 Zeeman effect, 2040, 2413-2414\*  
 Zeiformes, 2414\*  
 Zellweger syndrome, 1636  
 Zener diode, 775, 1983, 2414\*  
 Zenith, 2414\*  
 Zeolite, 1169-1170, 2414-2415\*  
   adsorption operations, 31  
   chabazite, 410-411\*  
   heulandite, 1073\*  
   molecular sieve, 1424-1425\*  
   natrolite, 1465\*  
   stilbite, 2116\*  
 Zermelo, E., 1337  
   logic, 1270  
   mathematics, 1337  
 Zero, 2415\*  
 Zero bevel gear, 241  
 Zeugobranchia, 144  
 ZFC axiom system, 1270  
 Zhongyuanus, 970  
 Zinc, 2415-2416\*  
   franklinite, 932\*  
   hemimorphite, 1063\*  
   sphalerite, 2082\*  
   willemite, 2388\*  
   zincite, 2416\*  
 Zinc alloys, 2416\*  
   brass, 327\*  
   copper alloys, 556-557\*  
 Zinc blende crystal structure, 526  
 Zinc metallurgy, 2416\*  
 Zinc sulfide crystal structure,  
   594  
 Zincite, 2416\*  
 Zingiber officinale, 887  
 Zingiberaceae, 332, 887  
 Zingiberales, 450, 2416-2417\*  
   abaca, 1-2\*  
   banana, 248\*  
   cardamon, 372\*  
   ginger, 999\*  
   turmeric, 2287\*  
 Zingiberidae, 335, 2417\*  
 Zircon, 2417\*  
 Zirconium, 2417\*  
   organometallic compound,  
   1575  
   zircon, 2417\*  
 Zoantharia, 2417\*  
   Actiniaria, 20\*  
   Antipatharia, 144\*  
   Ceriantharia, 408\*  
   Corallimorpharia, 558\*  
   Scleractinia, 1962\*

Zoantharia—cont.  
   Tabulata, 2189\*  
   Zoanthidea, 2417\*  
 Zoanthidea, 2417\*  
 Zodiac, 2417\*  
   Aquarius, 154-155\*  
   Aries, 169\*  
   Cancer (constellation), 361\*  
   Capricornus, 365\*  
   Gemini, 977-978\*  
   Leo, 1242\*  
   Libra, 1248\*  
   Pisces, 1692\*  
   Sagittarius, 1940\*  
   Scorpius, 1963\*  
   Taurus, 2194\*  
   Virgo, 2340-2341\*  
 Zodiacal light, 2417-2418\*  
 Zoa, 560  
 Zone plates, 2405  
 Zone refining, 688, 1981, 2418\*  
 Zones, 1225  
 Zooarcheology, 2418\*  
 Zochoy, 1754  
 Zoogeography, 2418-2419\*  
 Zoological nomenclature, 2419\*  
 Zoology, 2419\*  
   animal systematics, 123\*  
   Earth sciences, 722  
 Zoom lens, 2419\*  
 Zoomastigophorea, 2419-2420\*  
   Bicosoecida, 272\*  
   Choanoflagellida, 444-445\*  
   Diplomonadida, 677\*  
   Hypermastigida, 1117\*  
   Kinetoplastida, 1216\*  
   Oxymonadida, 1592\*  
   Retortamonadida, 1909\*  
   Rhizomastigida, 1913\*  
 Zoonoses, 2420\*  
   cat scratch disease, 378\*  
   coenurosis, 491\*  
   exotic viral diseases, 860\*  
   glanders, 1002\*  
 Zooplankton, 2420\*  
   ecology, 735  
   fresh-water ecosystem, 937  
 Zoraptera, 2420\*  
 Zoroasteridae, 824  
 Zosterophylloids, 1280, 1798, 1917,  
   2420\*  
 Zosterophyllum, 2420  
 Zupus, Giovanni, 1649  
 Zwicky, Fritz, 2377  
 Zygaenidae, 1243  
 Zygematales, 2421\*  
 Zygomycetes, 2421\*  
 Zygomycotina, 2421\*  
 Zygophyllales, 2421\*  
 Zygoptera, 1532  
 Zygopteridaceae, 433  
 Zygote, 1181